

SN106 NEUTRON ACER TENDL-2023 LIBRARY; T=0.K

Principal cross sections

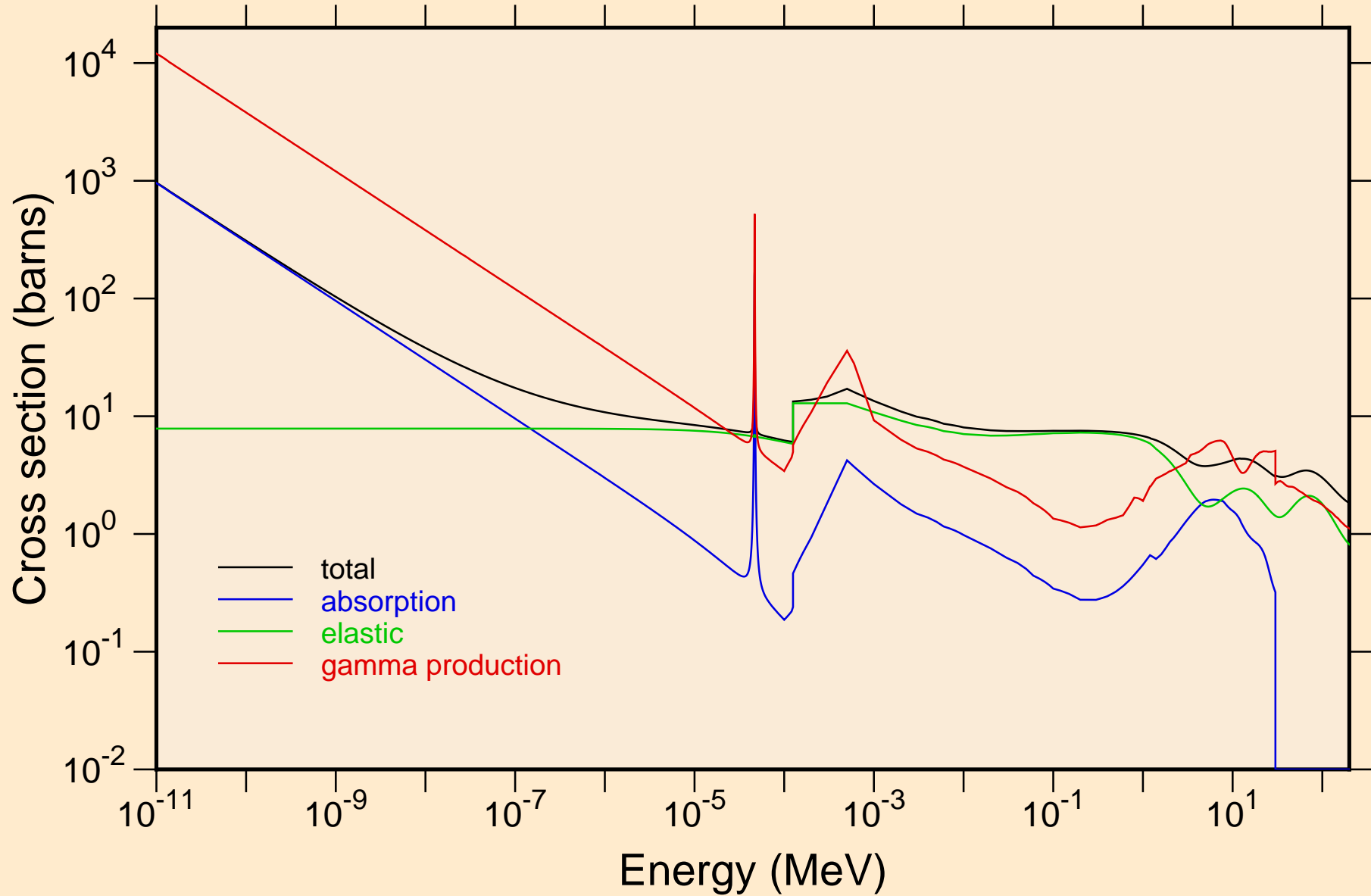

SN106 NEUTRON ACER TENDL-2023 LIBRARY; T=0.K

Heating

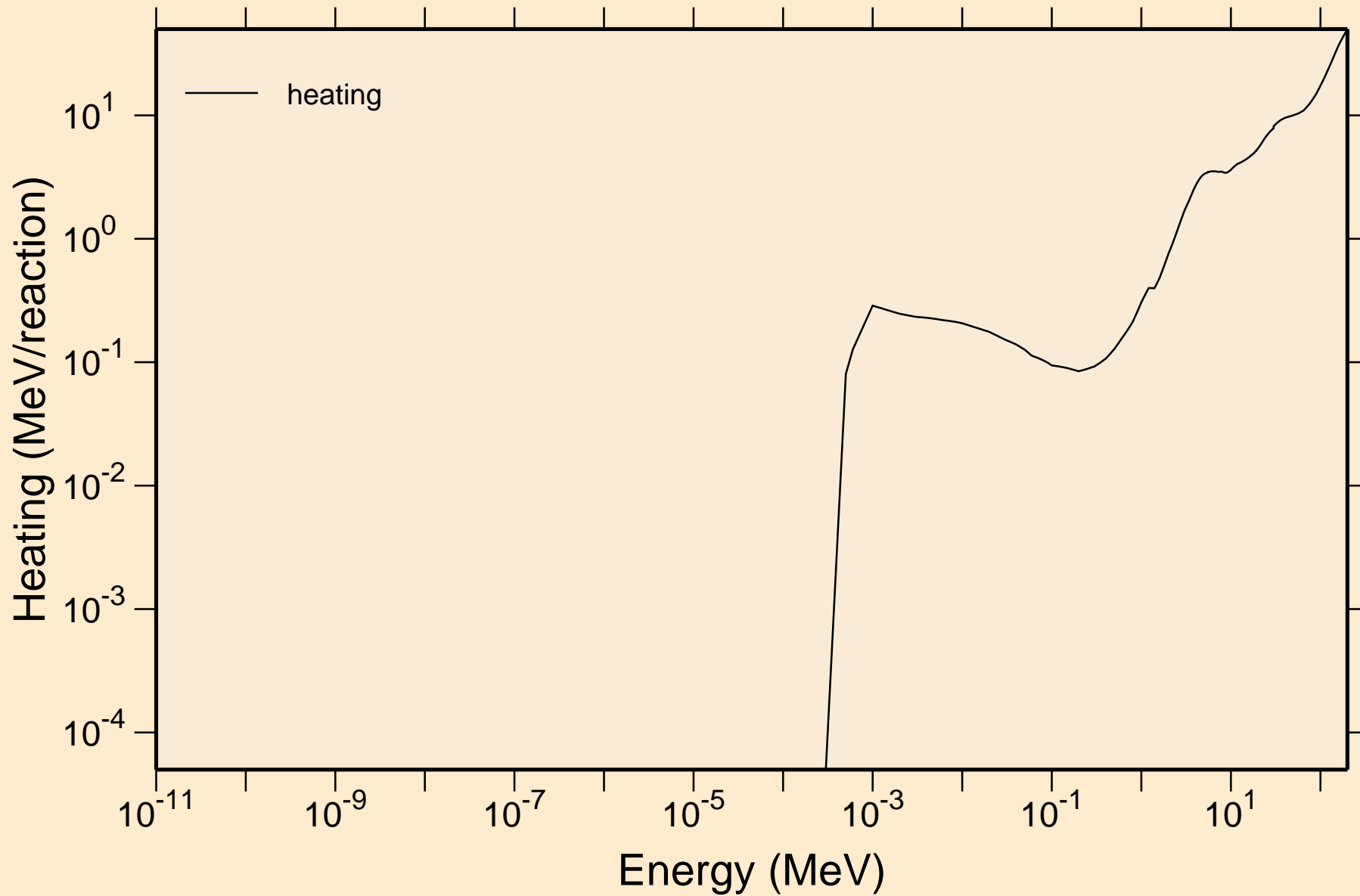

SN106 NEUTRON ACER TENDL-2023 LIBRARY; T=0.K

Damage

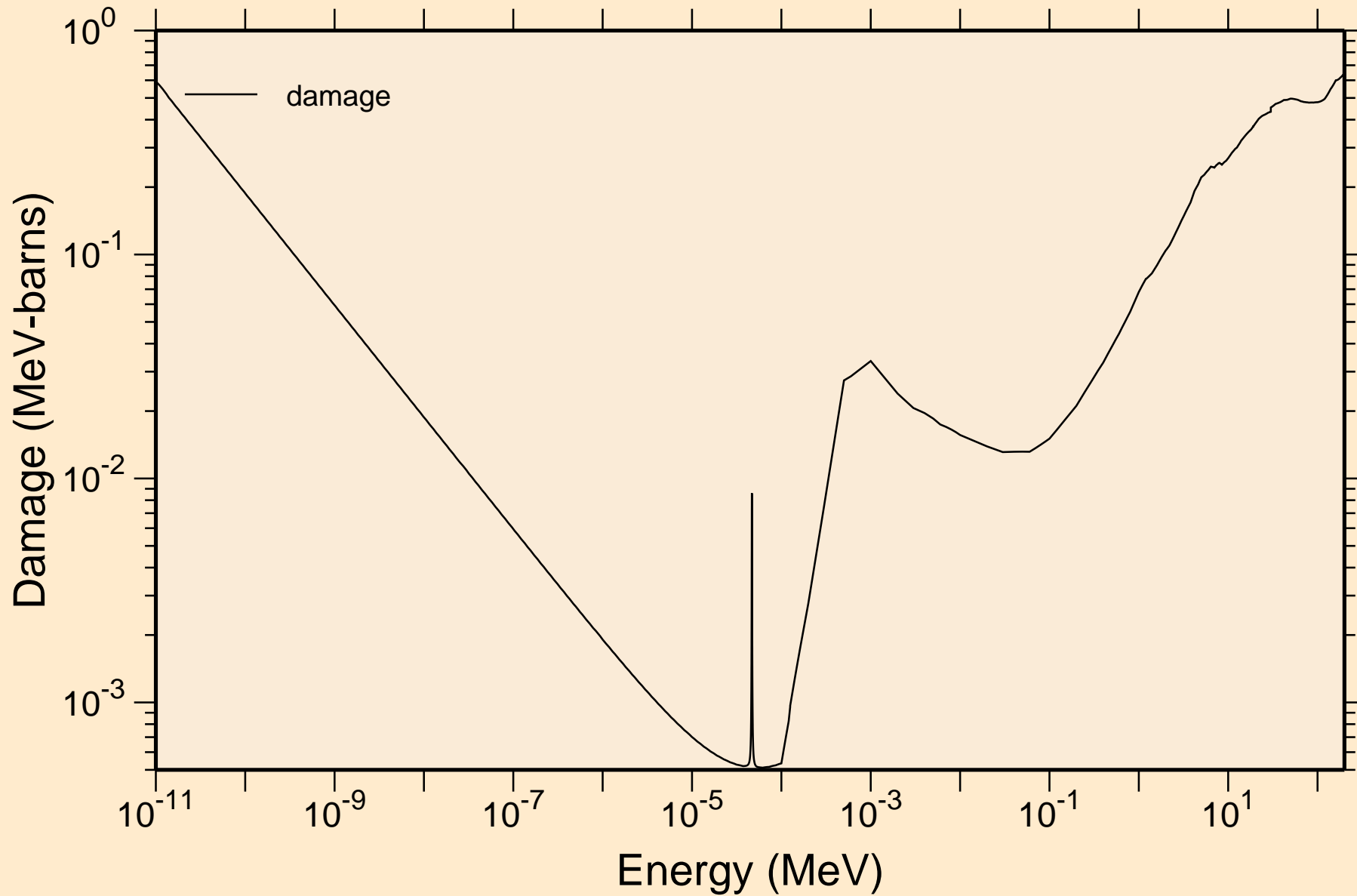

SN106 NEUTRON ACER TENDL-2023 LIBRARY; T=0.K
Non-threshold reactions

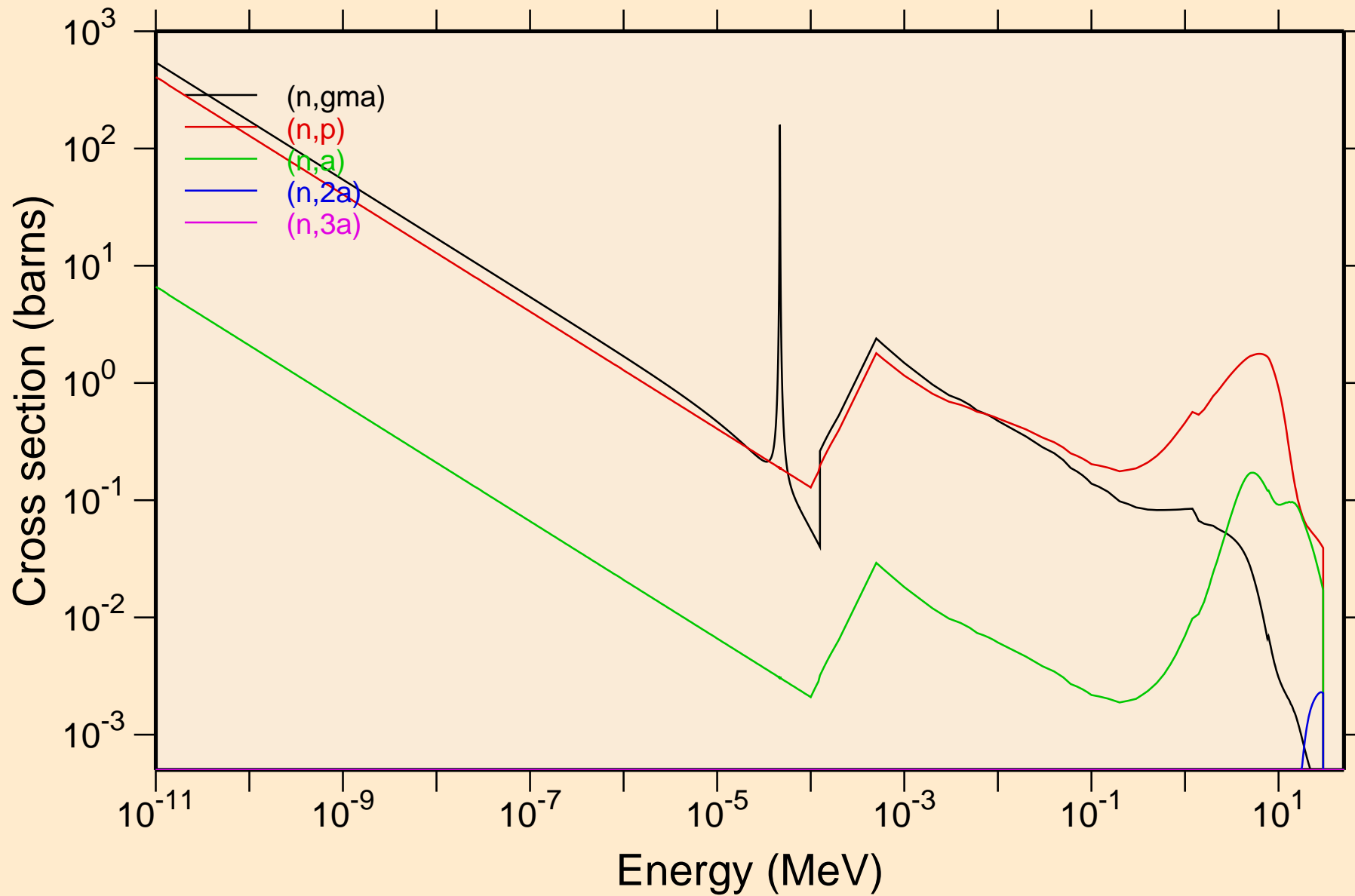

SN106 NEUTRON ACER TENDL-2023 LIBRARY; T=0.K

Non-threshold reactions

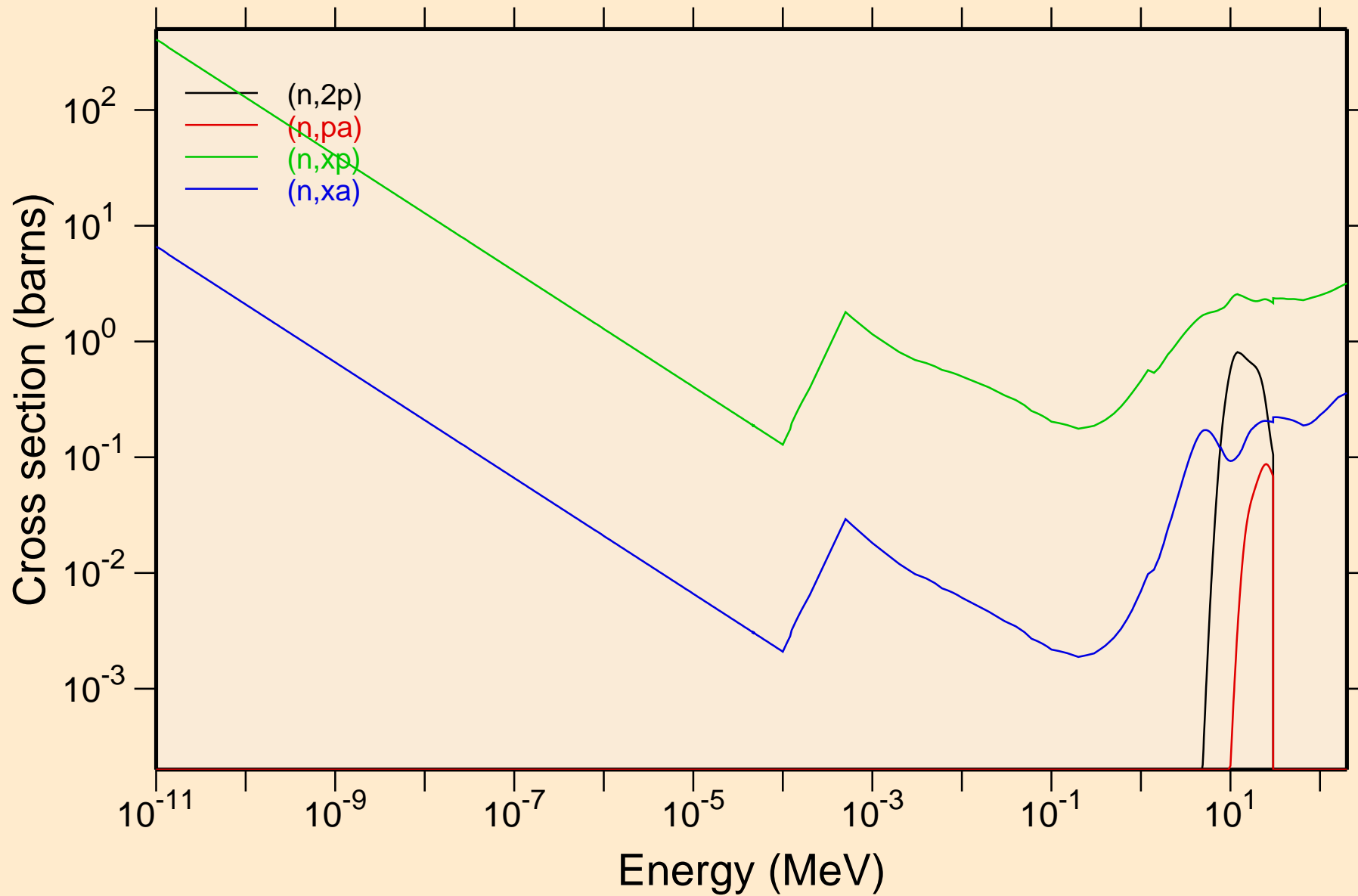

SN106 NEUTRON ACER TENDL-2023 LIBRARY; T=0.K

Principal cross sections

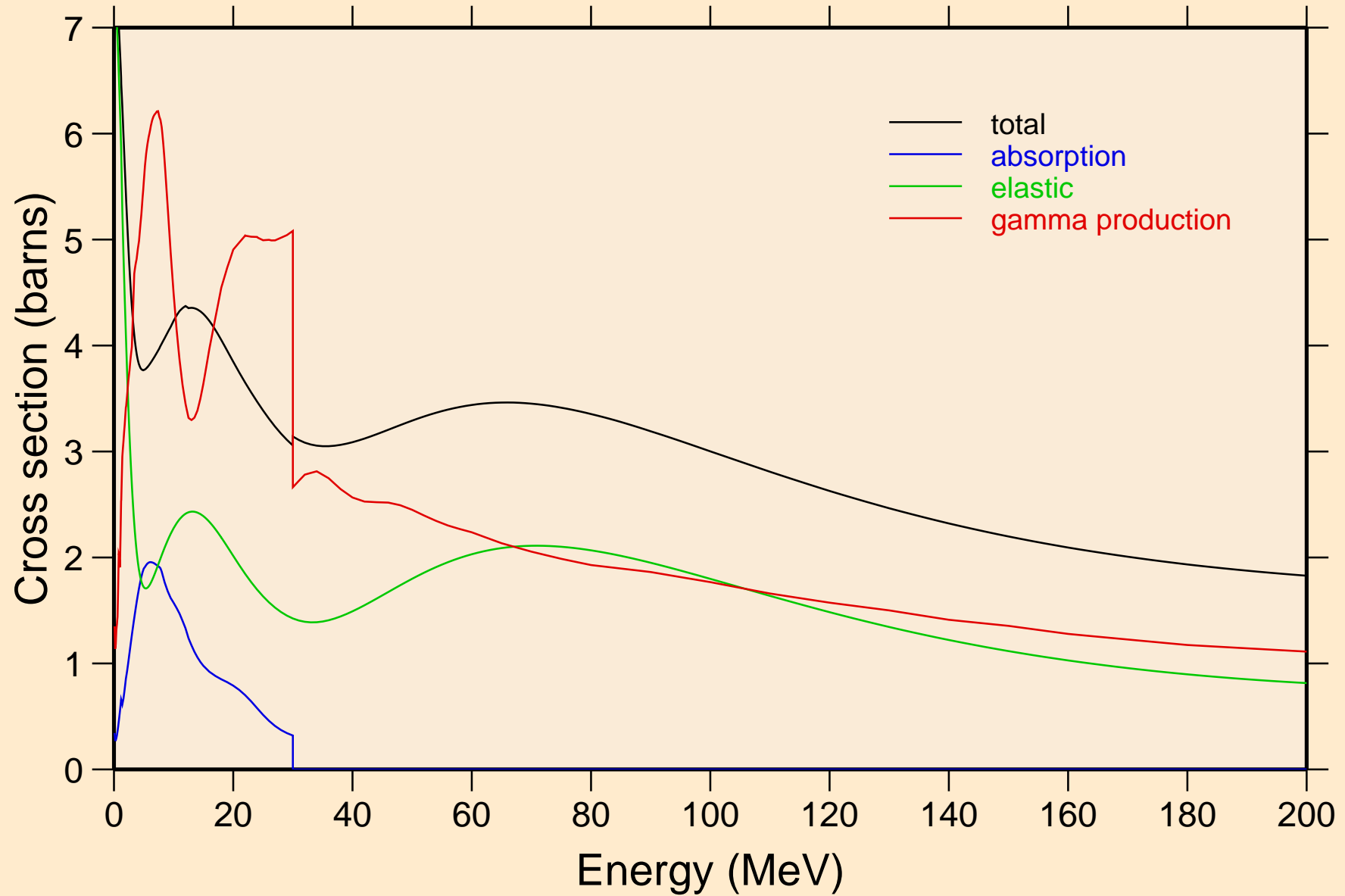

SN106 NEUTRON ACER TENDL-2023 LIBRARY; T=0.K

Heating

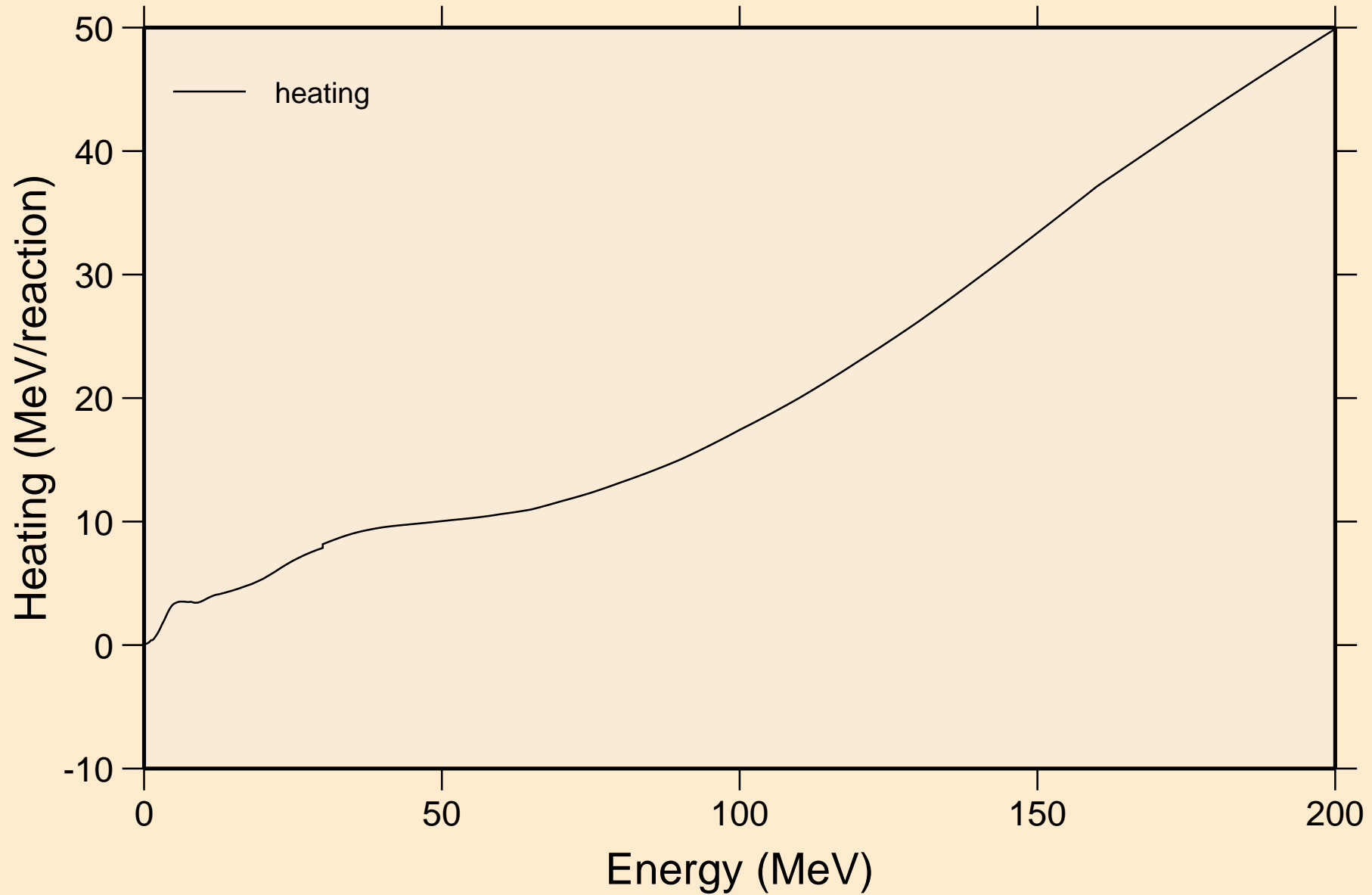

SN106 NEUTRON ACER TENDL-2023 LIBRARY; T=0.K

Damage

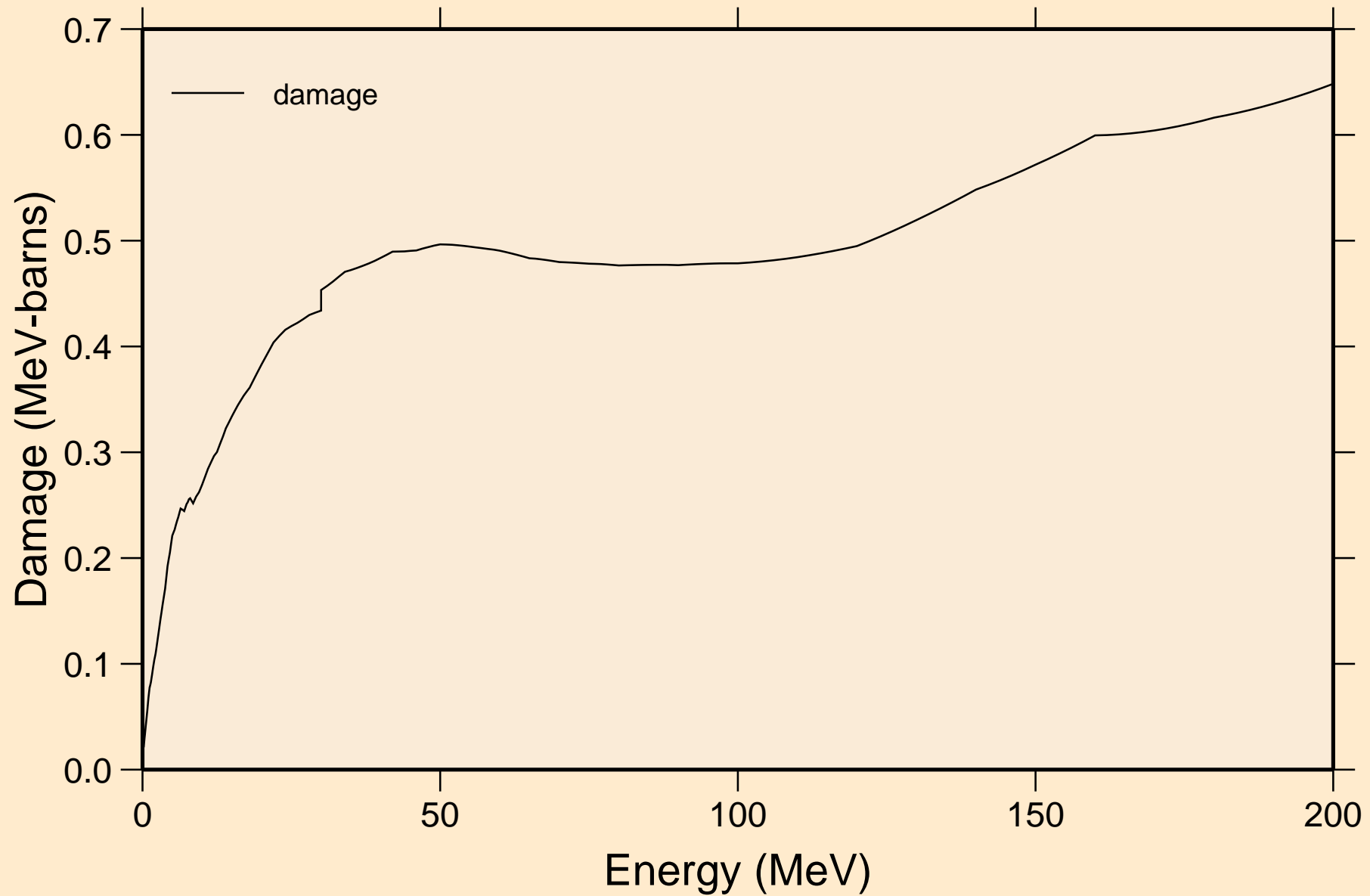

SN106 NEUTRON ACER TENDL-2023 LIBRARY; T=0.K

Non-threshold reactions

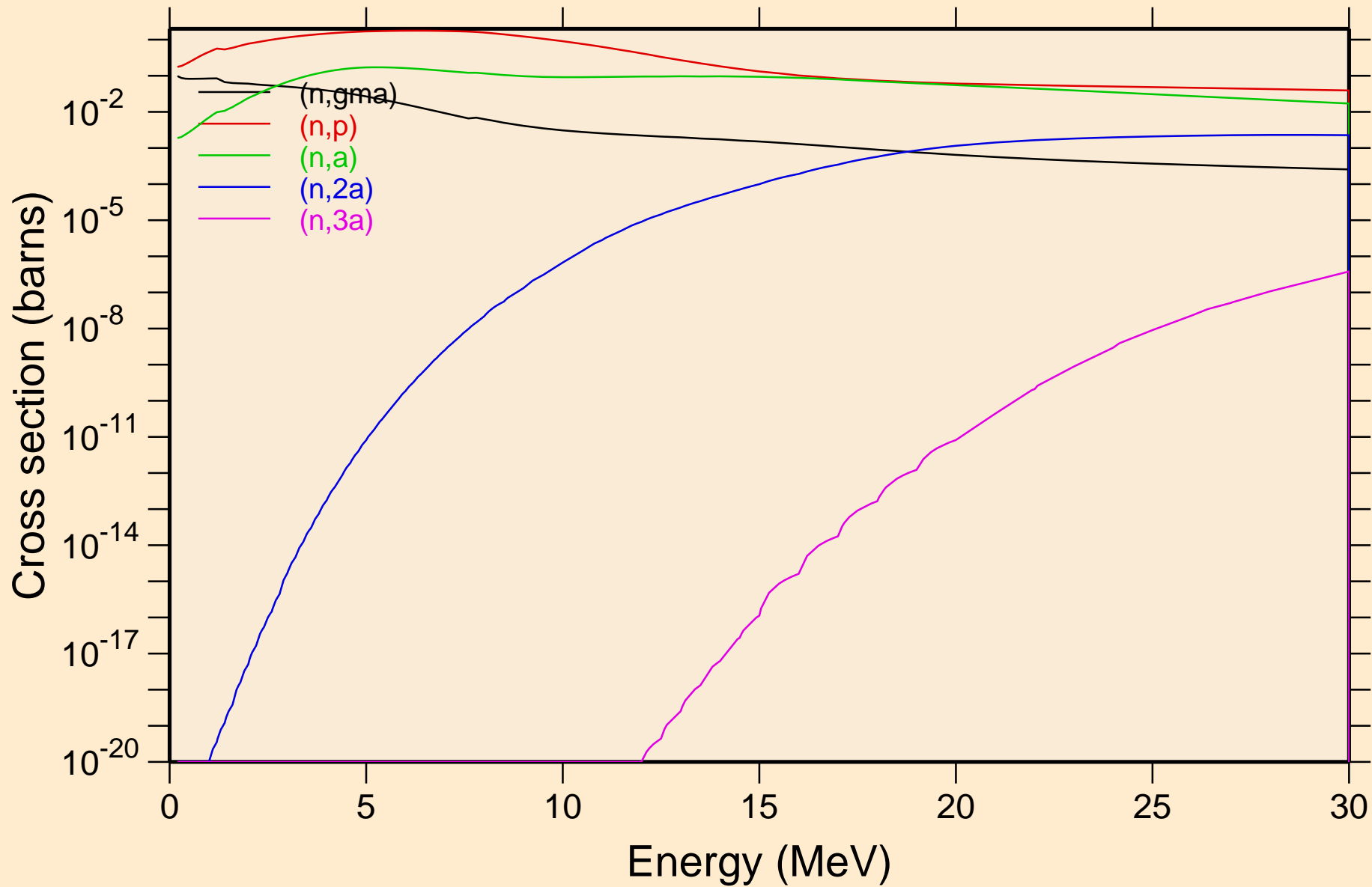

SN106 NEUTRON ACER TENDL-2023 LIBRARY; T=0.K

Non-threshold reactions

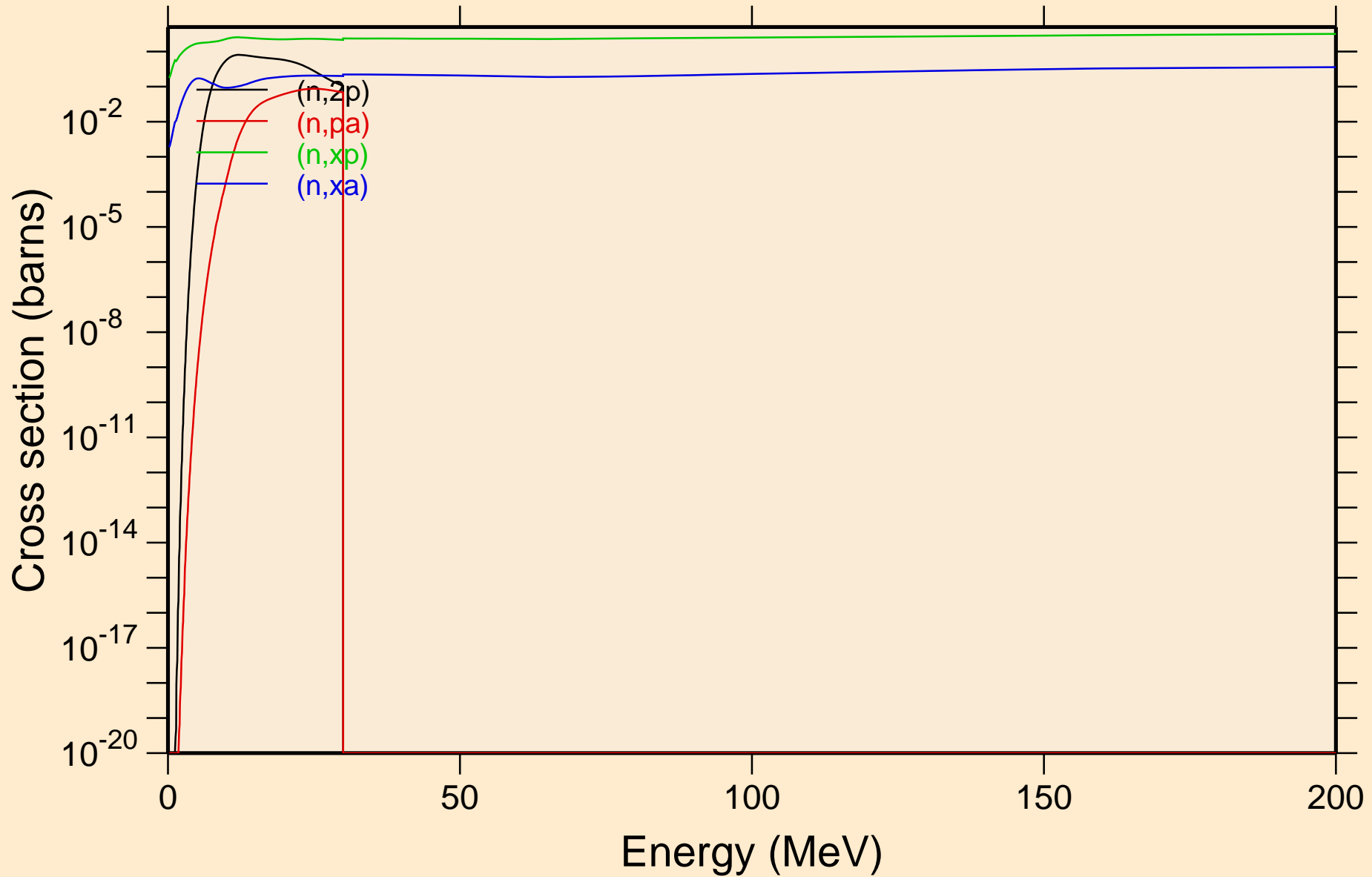

SN106 NEUTRON ACER TENDL-2023 LIBRARY; T=0.K

Inelastic levels

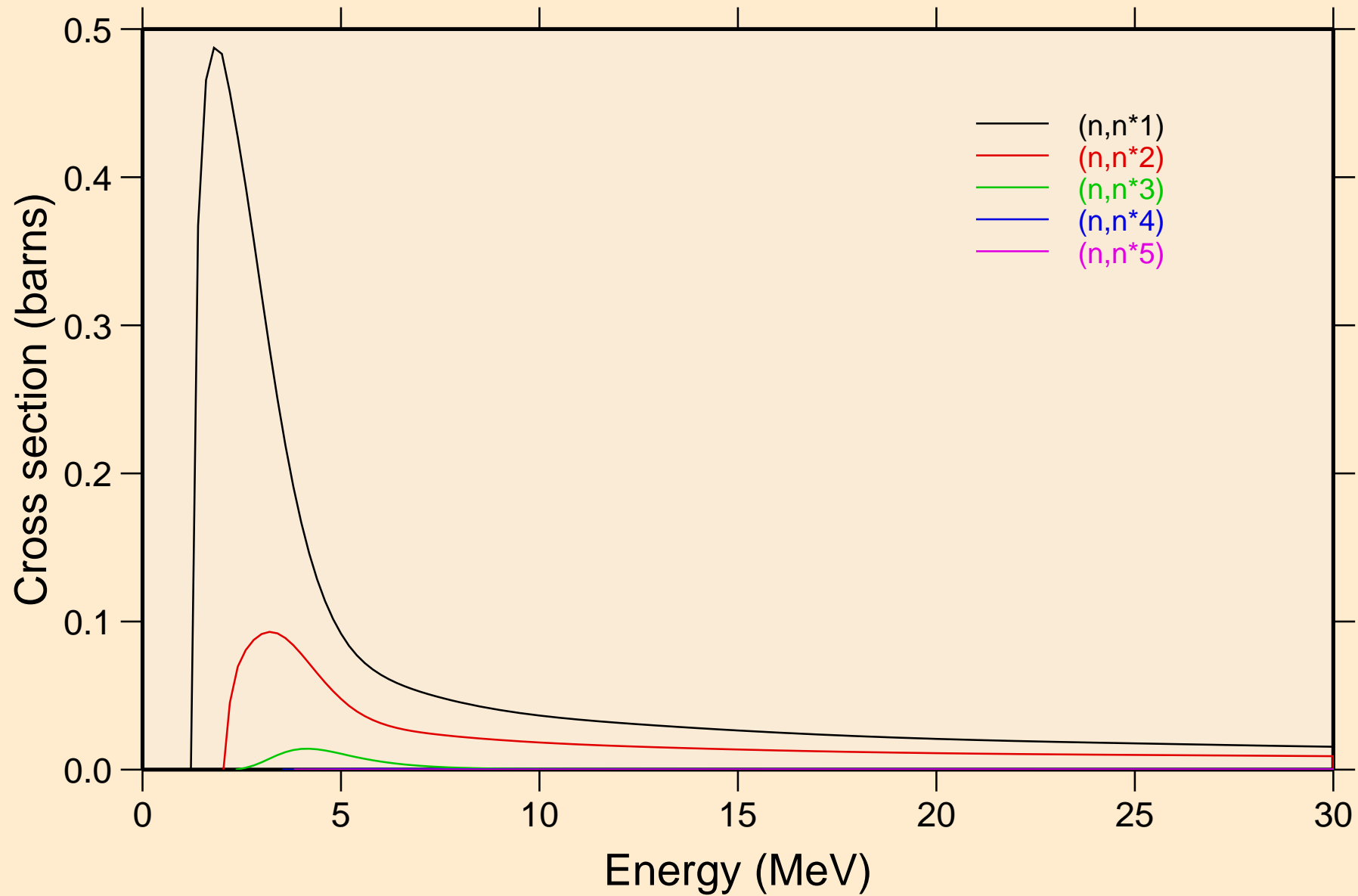

SN106 NEUTRON ACER TENDL-2023 LIBRARY; T=0.K

Inelastic levels

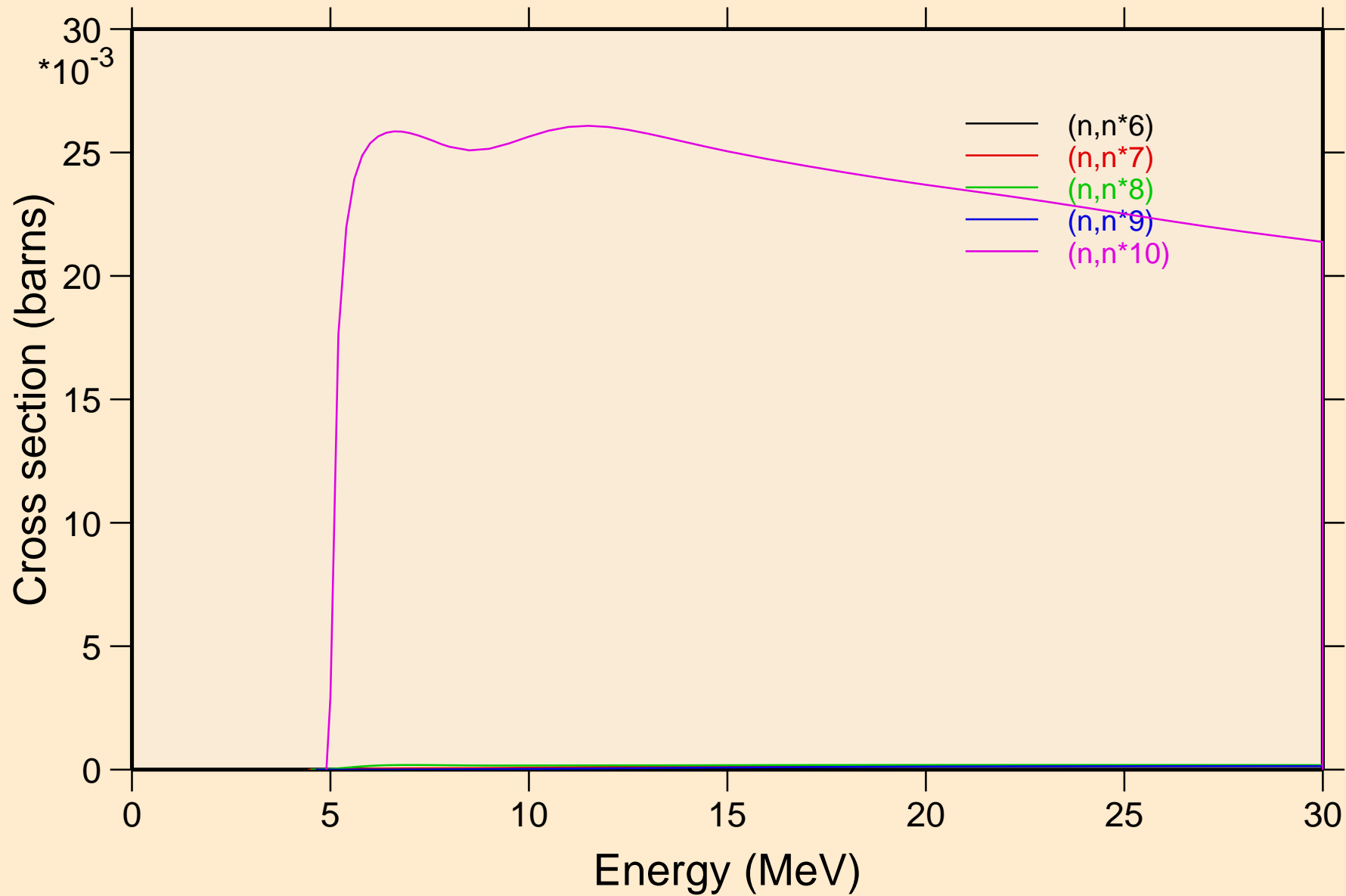

SN106 NEUTRON ACER TENDL-2023 LIBRARY; T=0.K

Threshold reactions

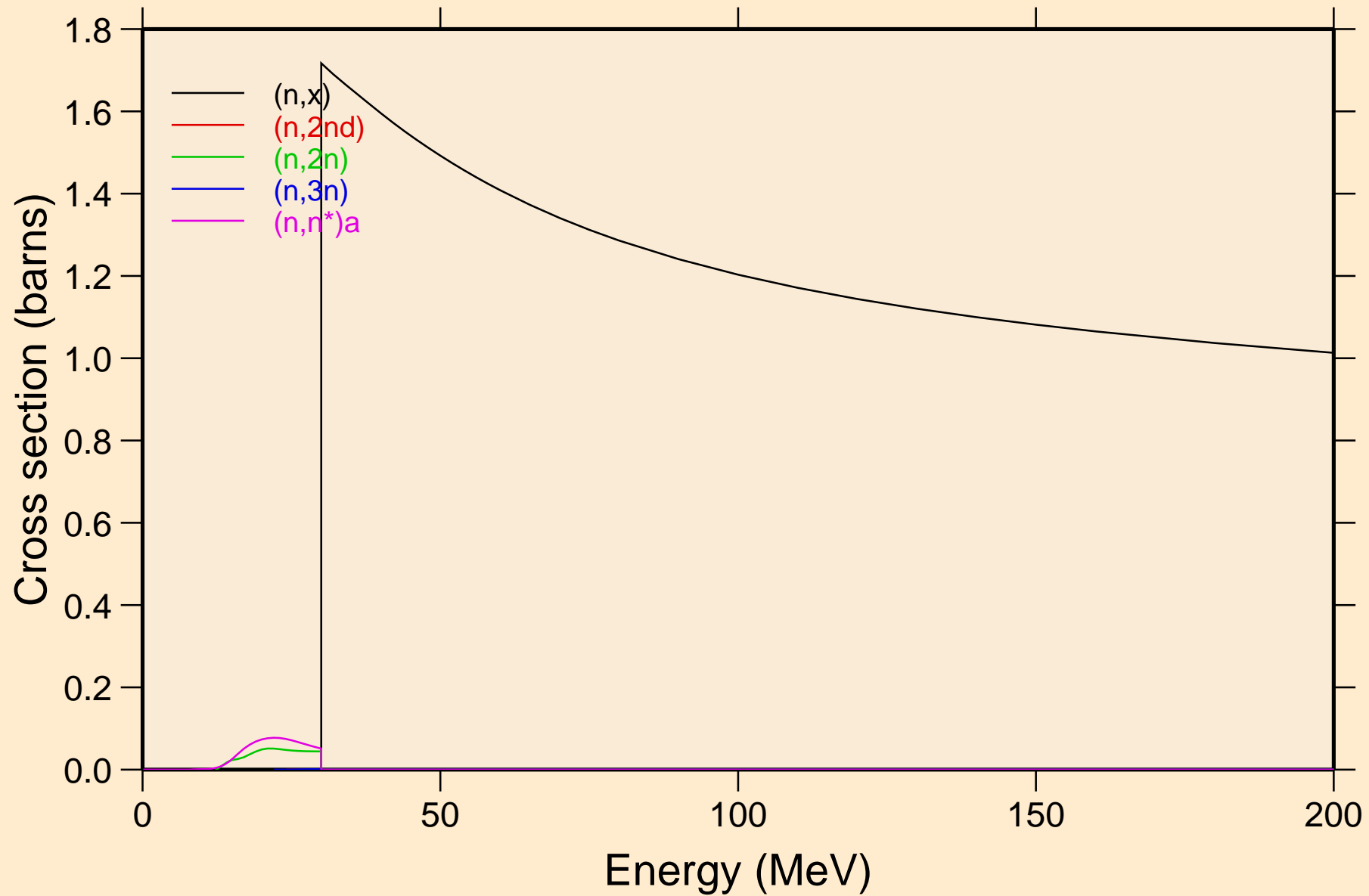

SN106 NEUTRON ACER TENDL-2023 LIBRARY; T=0.K

Threshold reactions

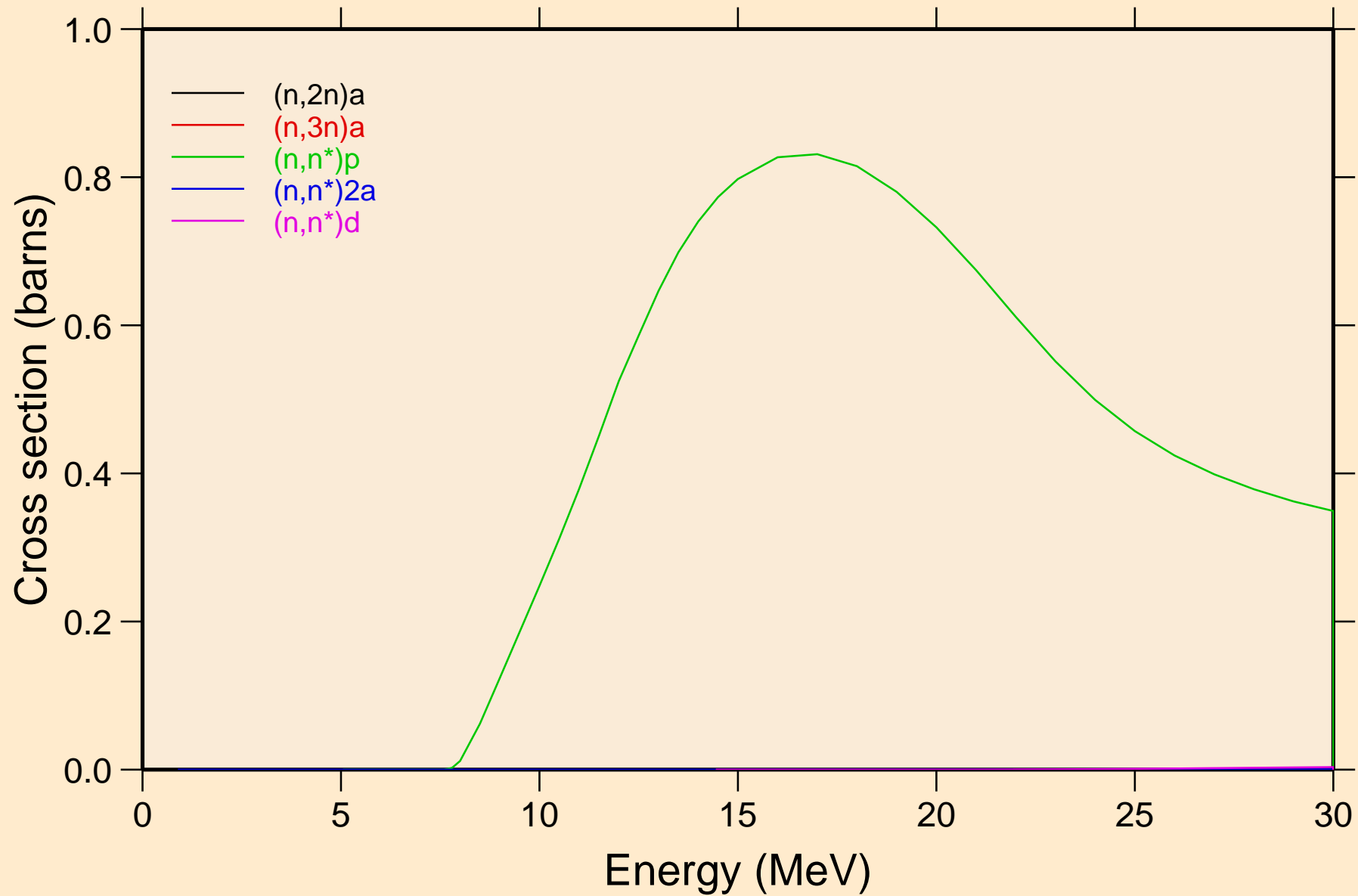

SN106 NEUTRON ACER TENDL-2023 LIBRARY; T=0.K

Threshold reactions

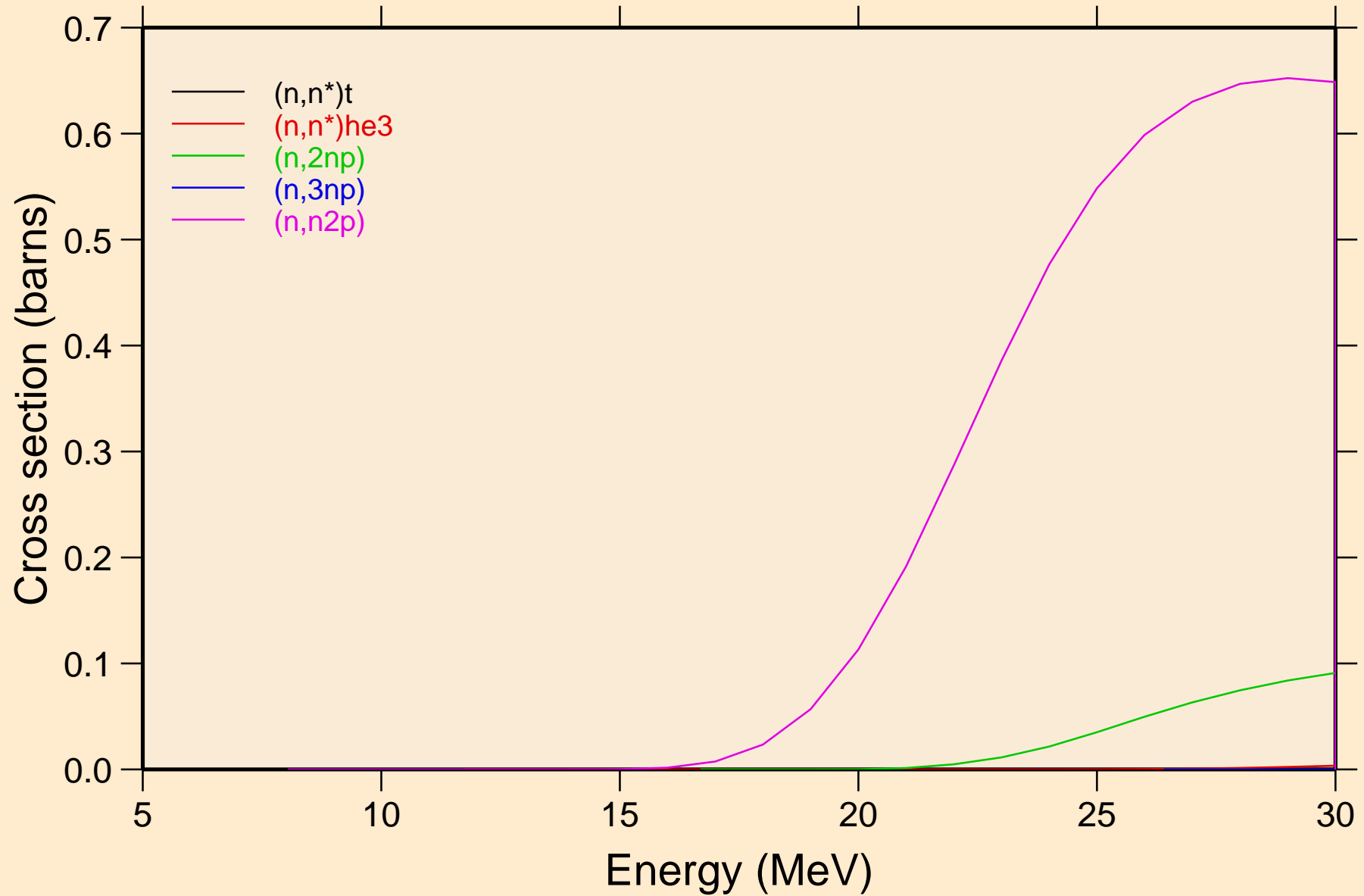

SN106 NEUTRON ACER TENDL-2023 LIBRARY; T=0.K

Threshold reactions

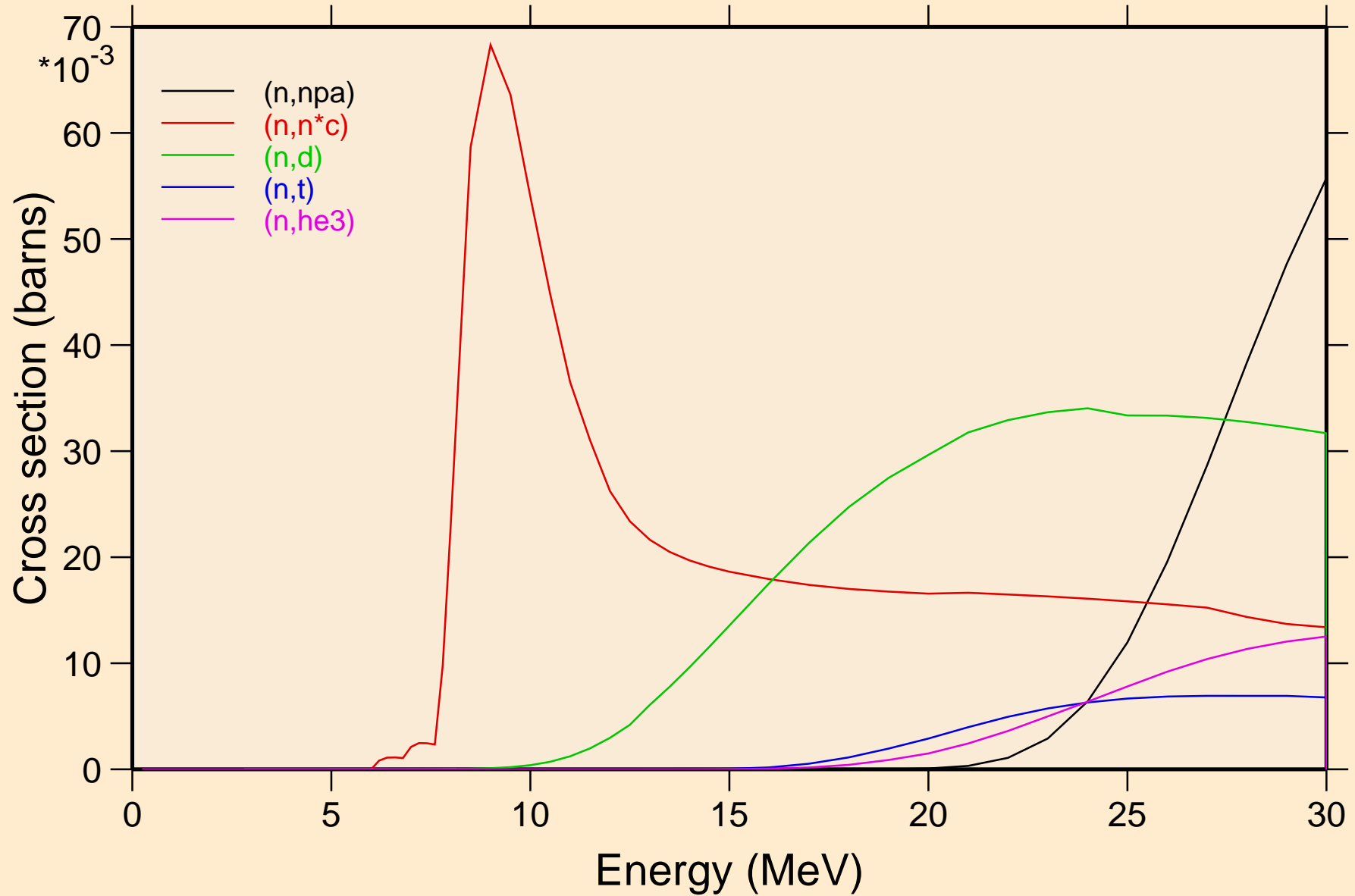

SN106 NEUTRON ACER TENDL-2023 LIBRARY; T=0.K

Threshold reactions

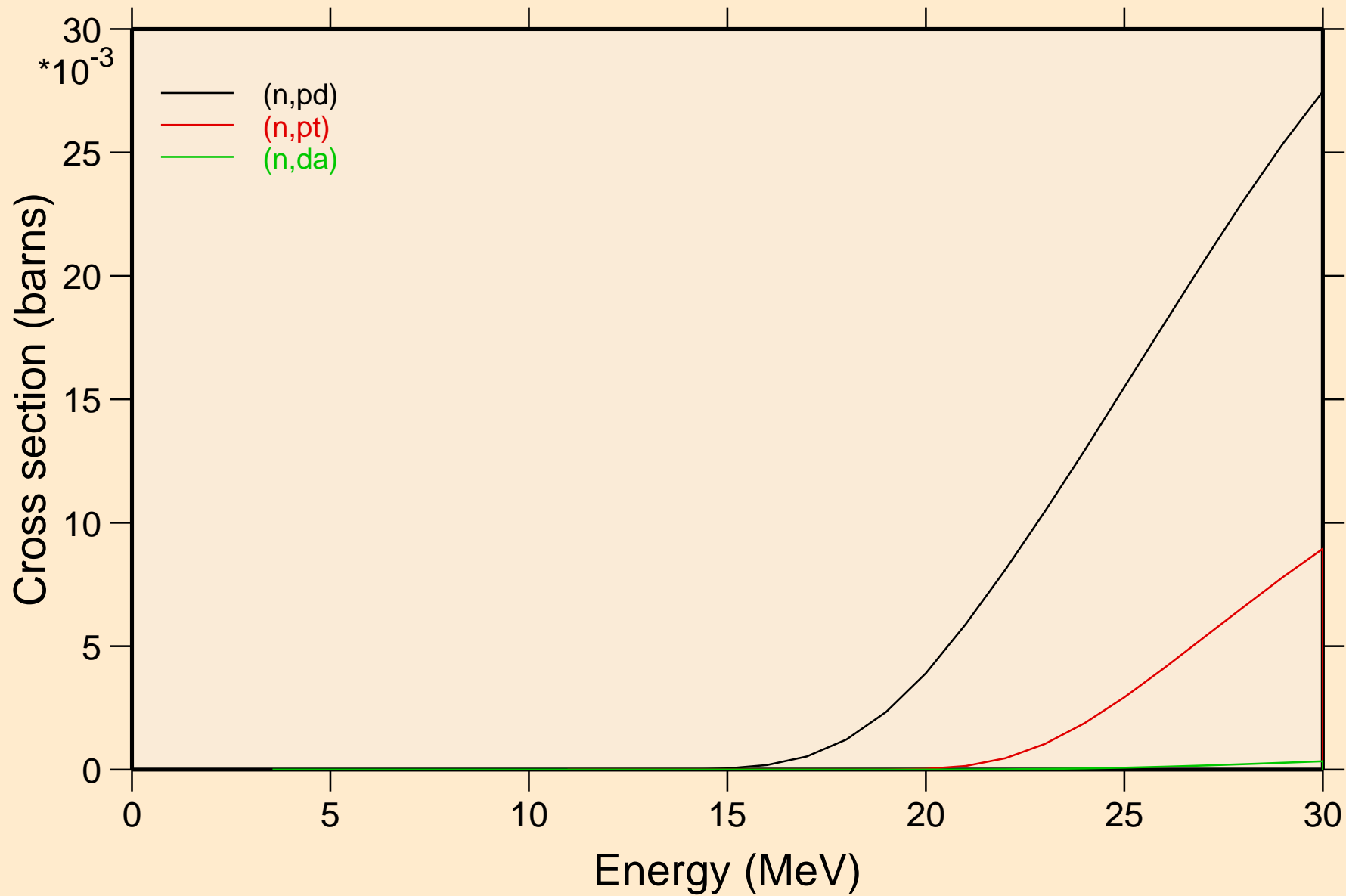

SN106 NEUTRON ACER TENDL-2023 LIBRARY; T=0.K

Threshold reactions

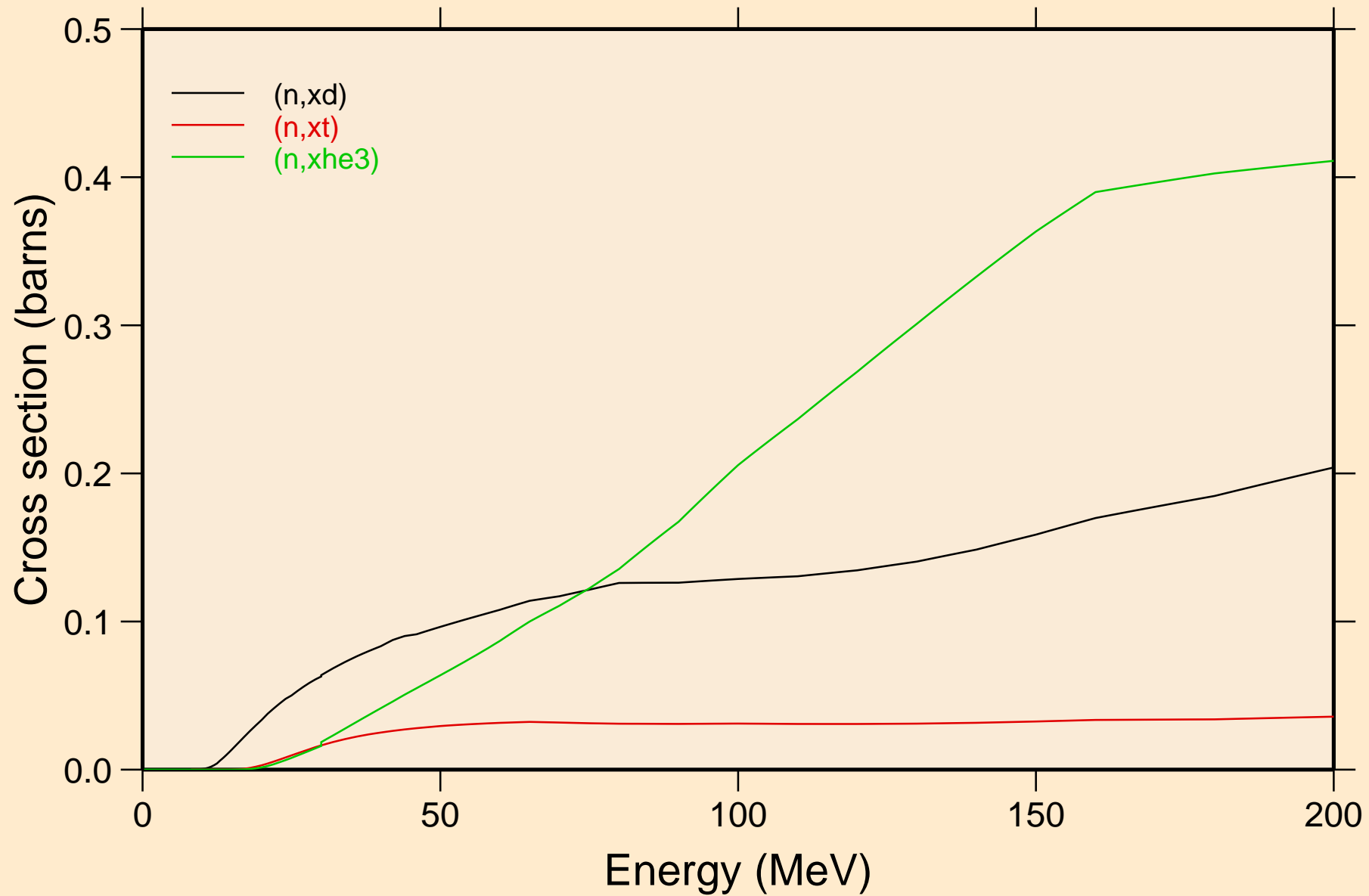

SN106 NEUTRON ACER TENDL-2023 LIBRARY; T=0.K
angular distribution for elastic

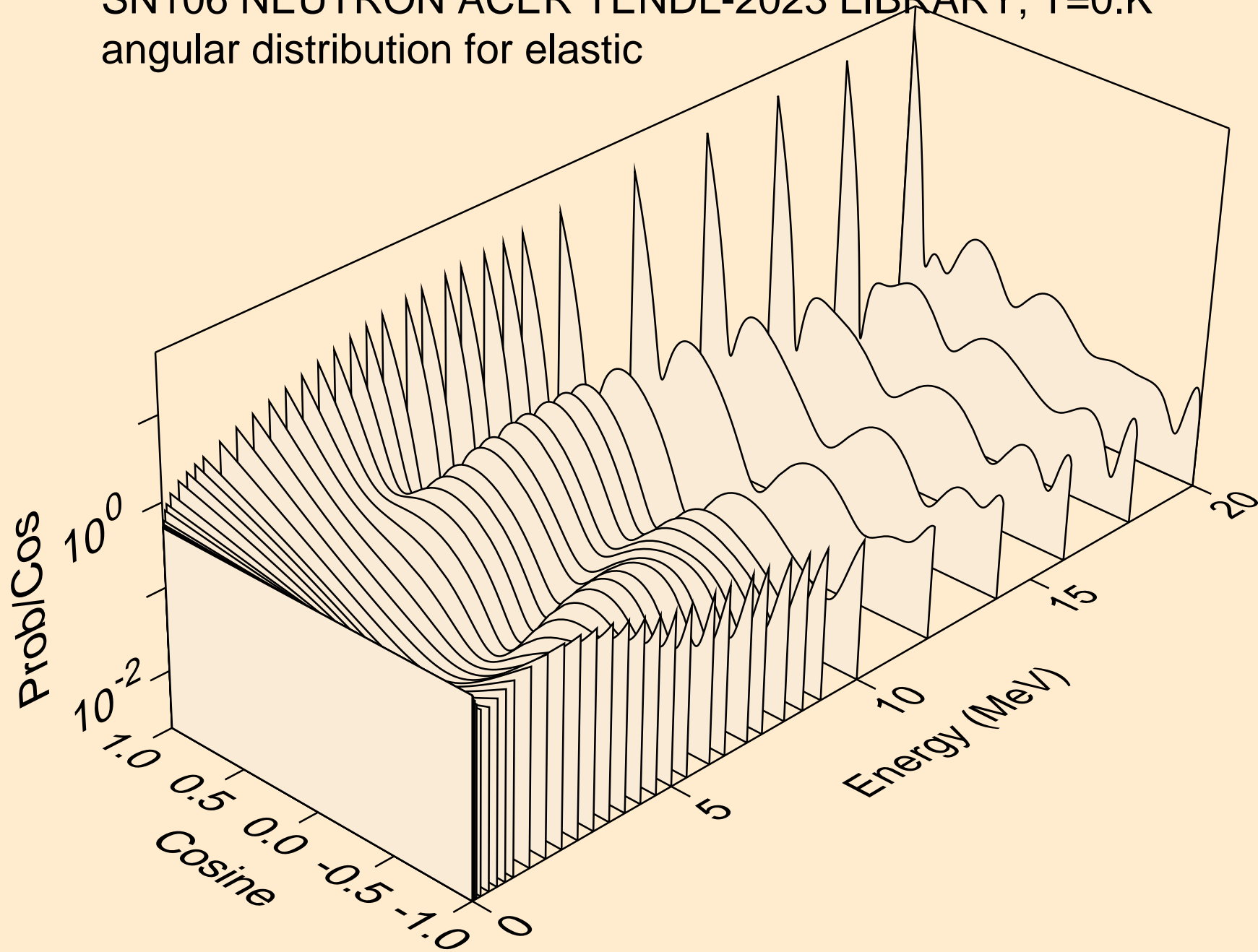

SN106 NEUTRON ACER TENDL-2023 LIBRARY; T=0.K
angular distribution for elastic

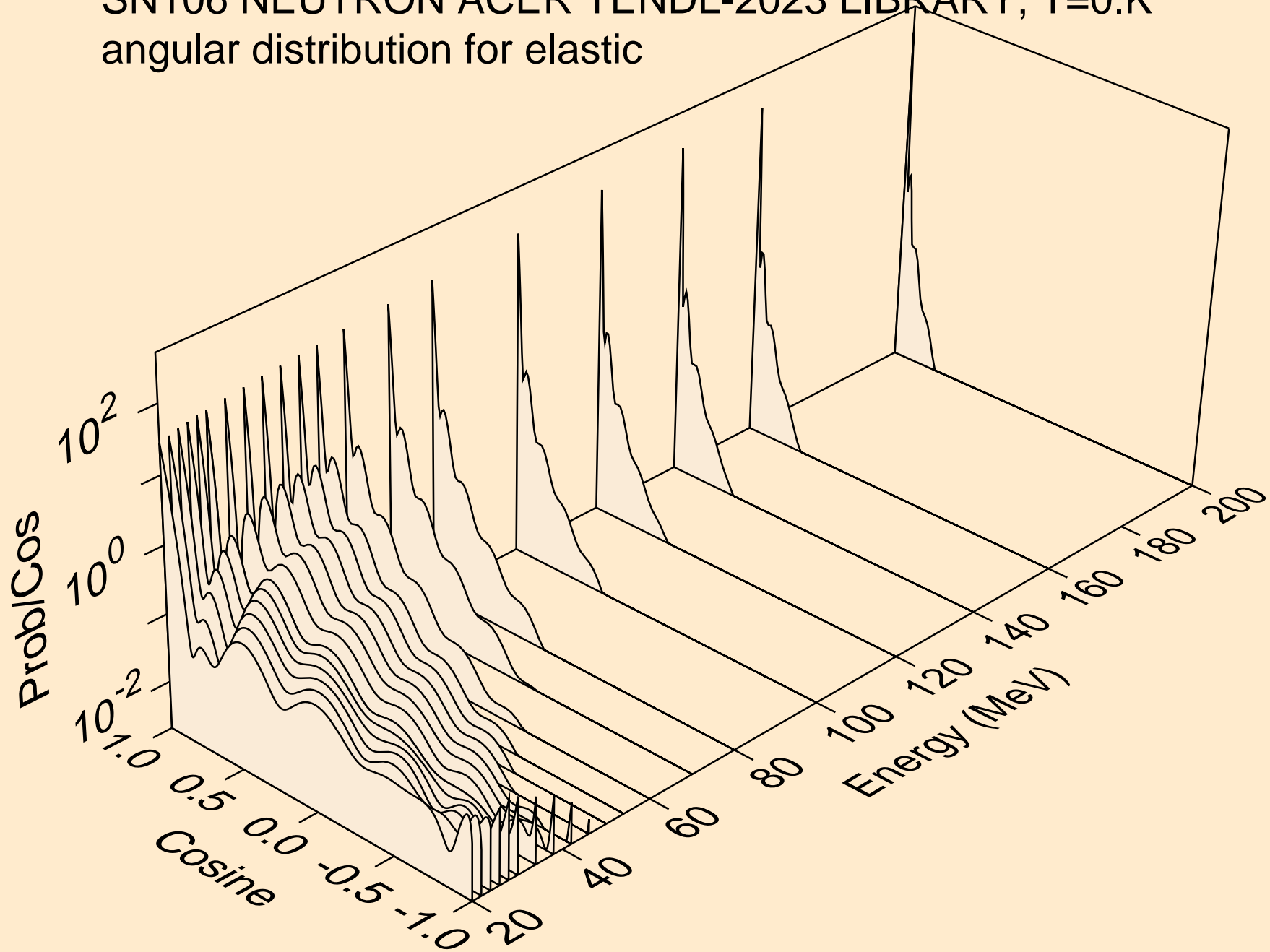

SN106 NEUTRON ACER TENDL-2023 LIBRARY; T=0.K
angular distribution for (n,n*1)

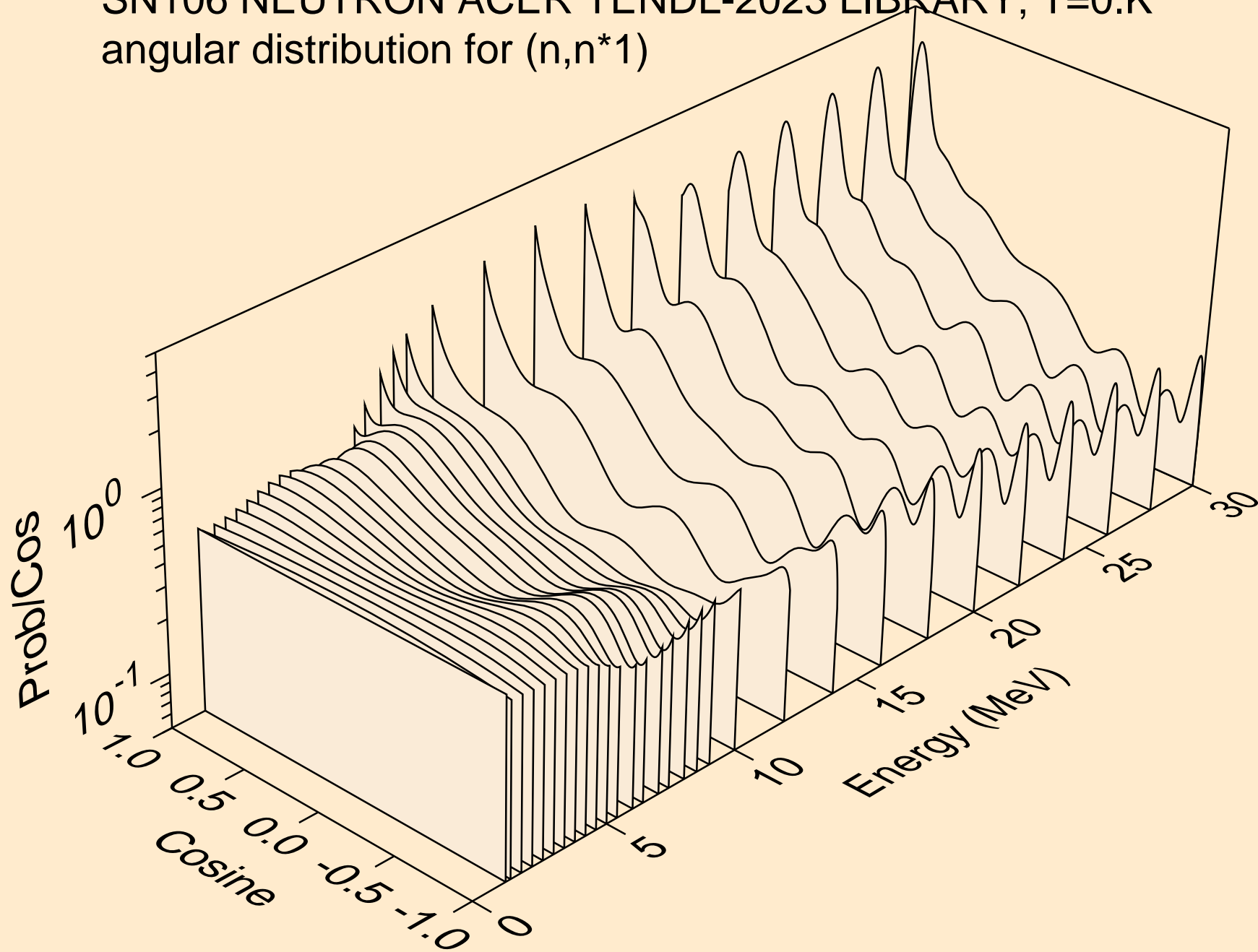

SN106 NEUTRON ACER TENDL-2023 LIBRARY; T=0.K
angular distribution for (n,n*2)

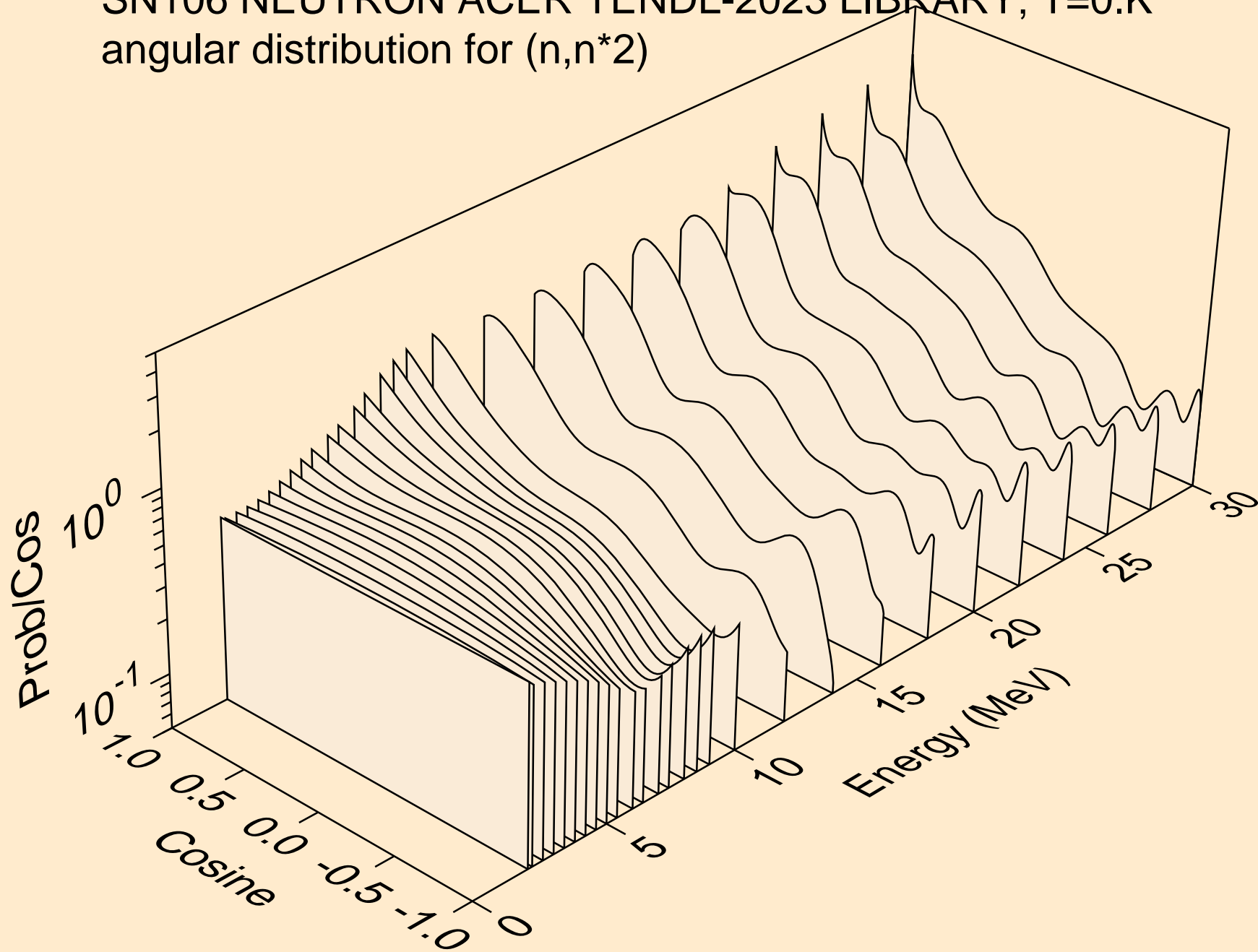

SN106 NEUTRON ACER TENDL-2023 LIBRARY; T=0.K
angular distribution for (n,n*3)

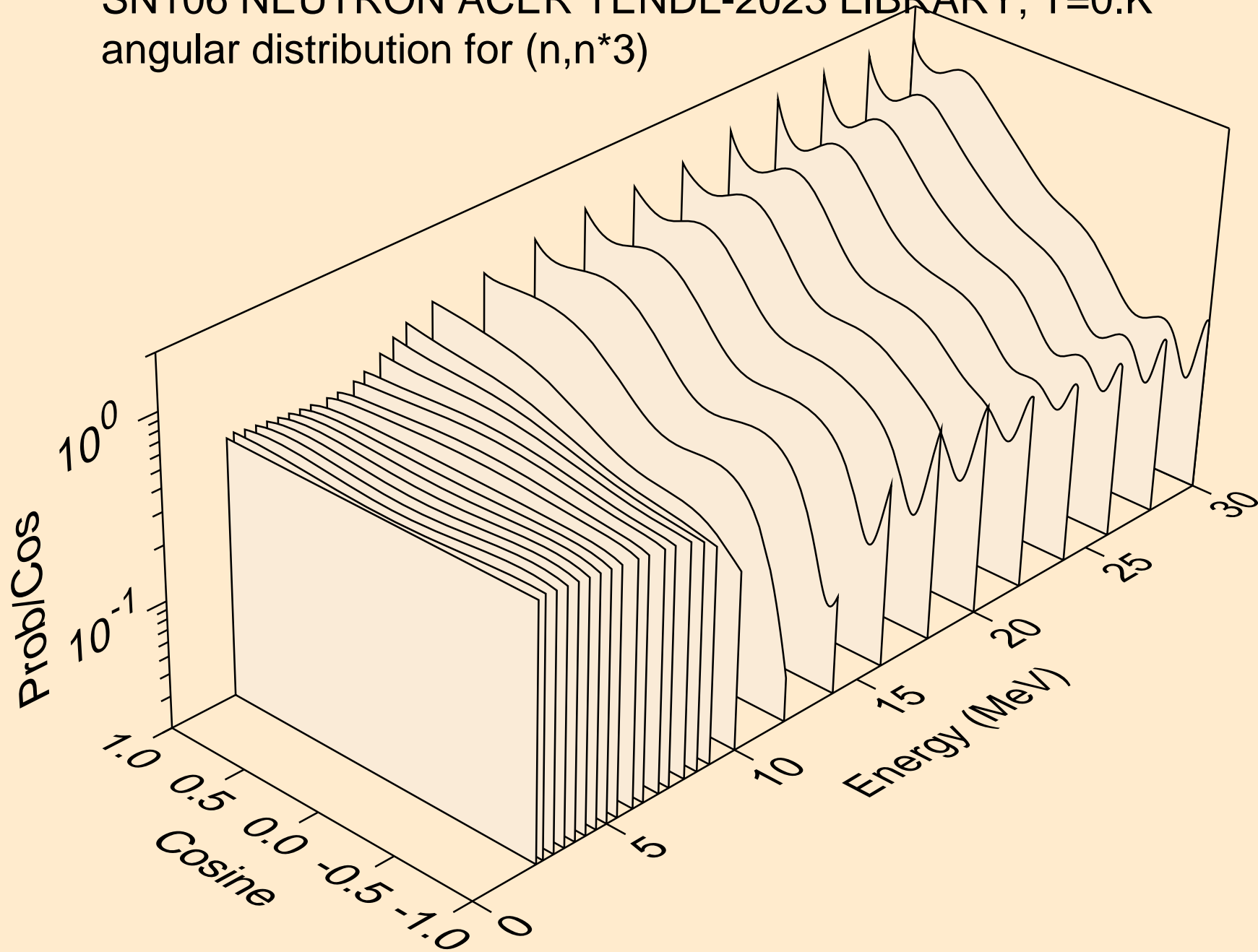

SN106 NEUTRON ACER TENDL-2023 LIBRARY; T=0.K
angular distribution for (n,n*4)

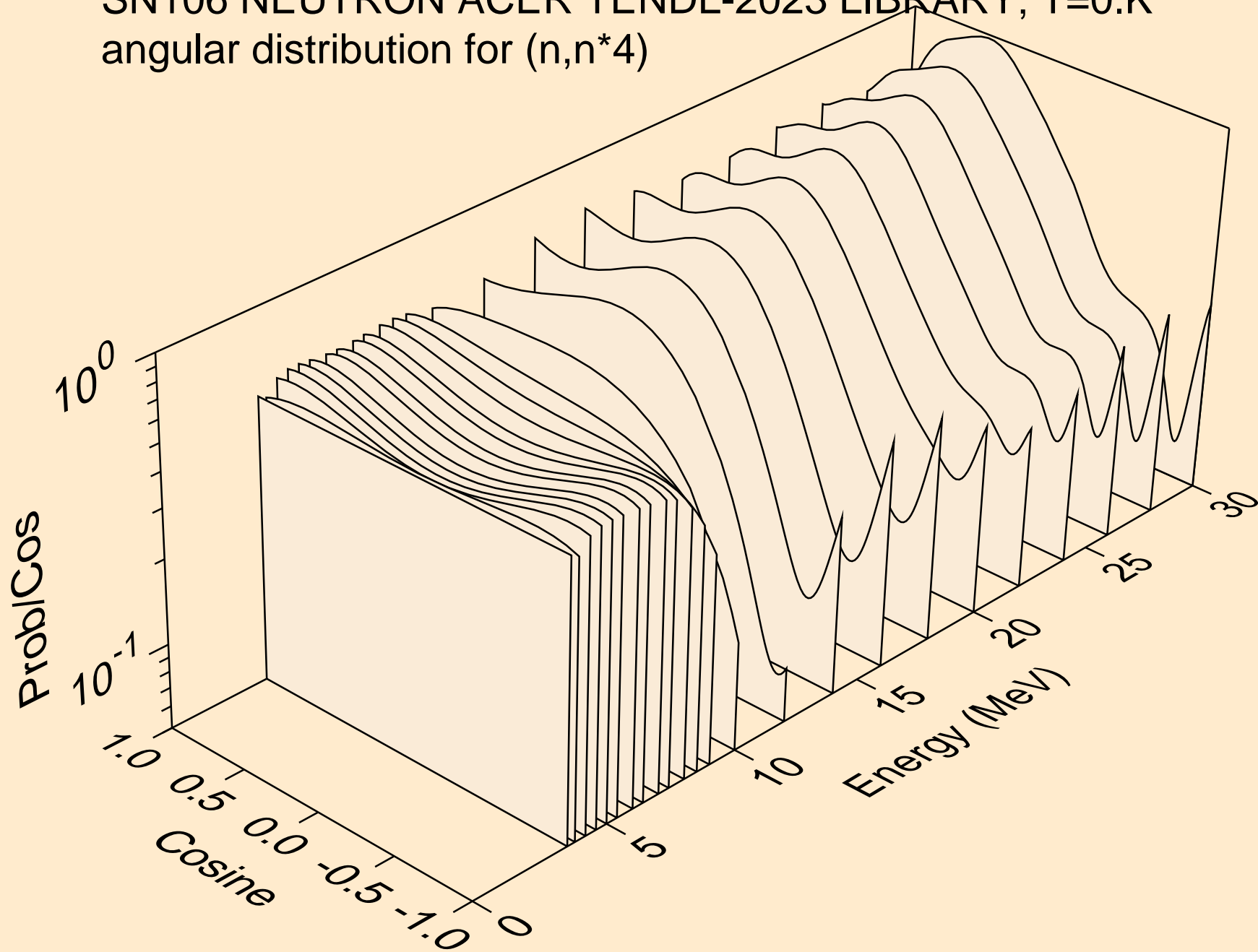

SN106 NEUTRON ACER TENDL-2023 LIBRARY; T=0.K
angular distribution for (n,n*5)

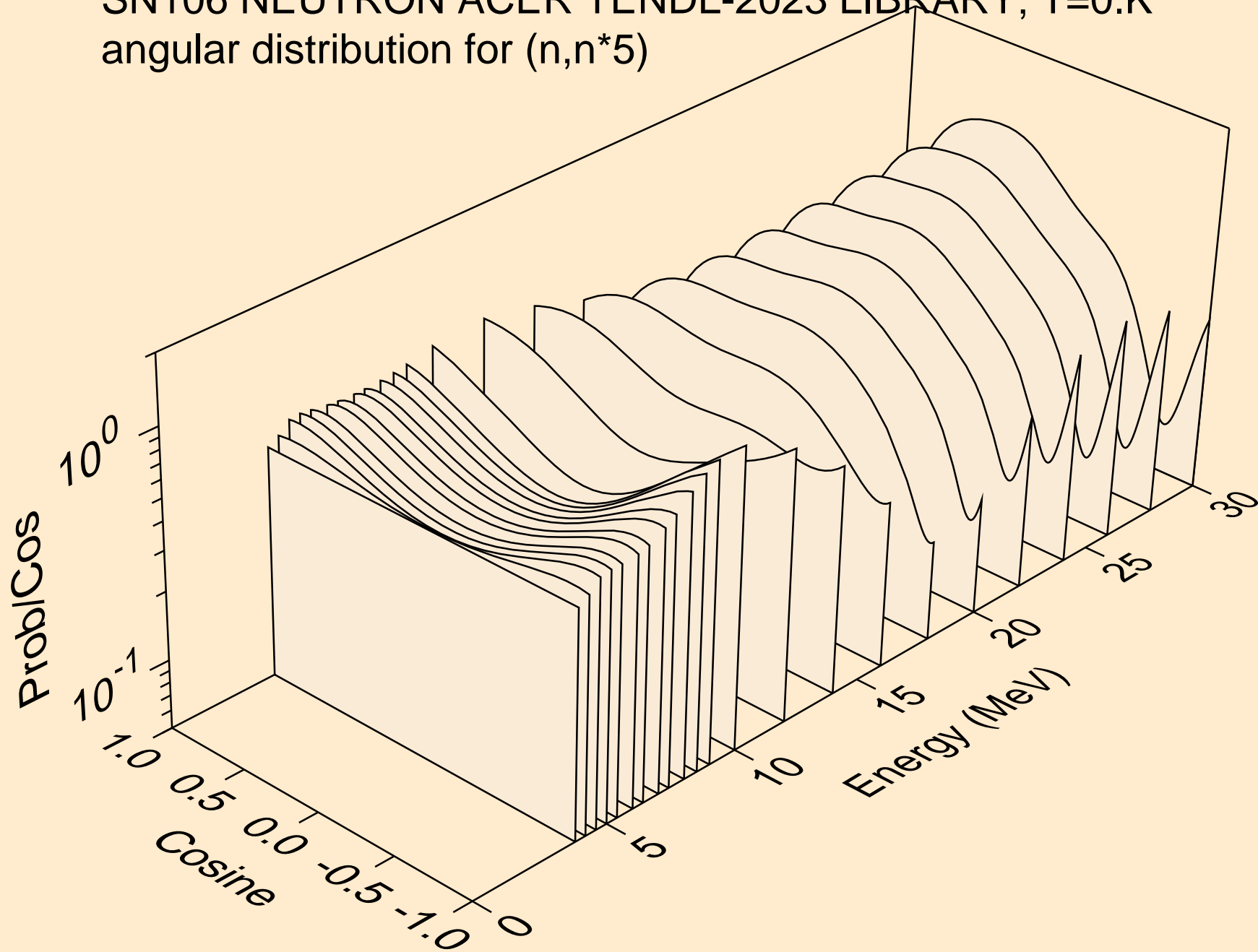

SN106 NEUTRON ACER TENDL-2023 LIBRARY; T=0.K
angular distribution for (n,n*6)

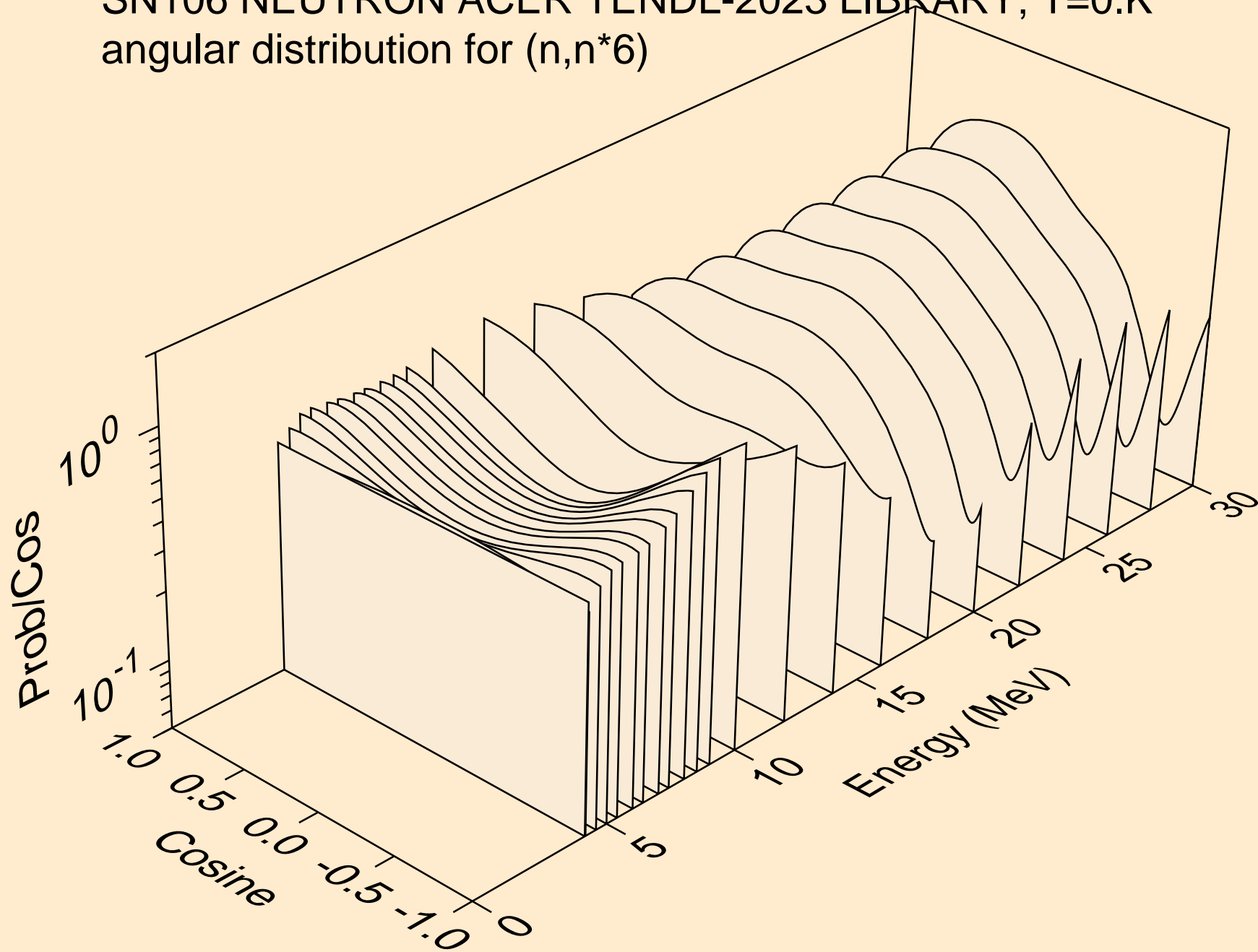

SN106 NEUTRON ACER TENDL-2023 LIBRARY; T=0.K
angular distribution for (n,n*7)

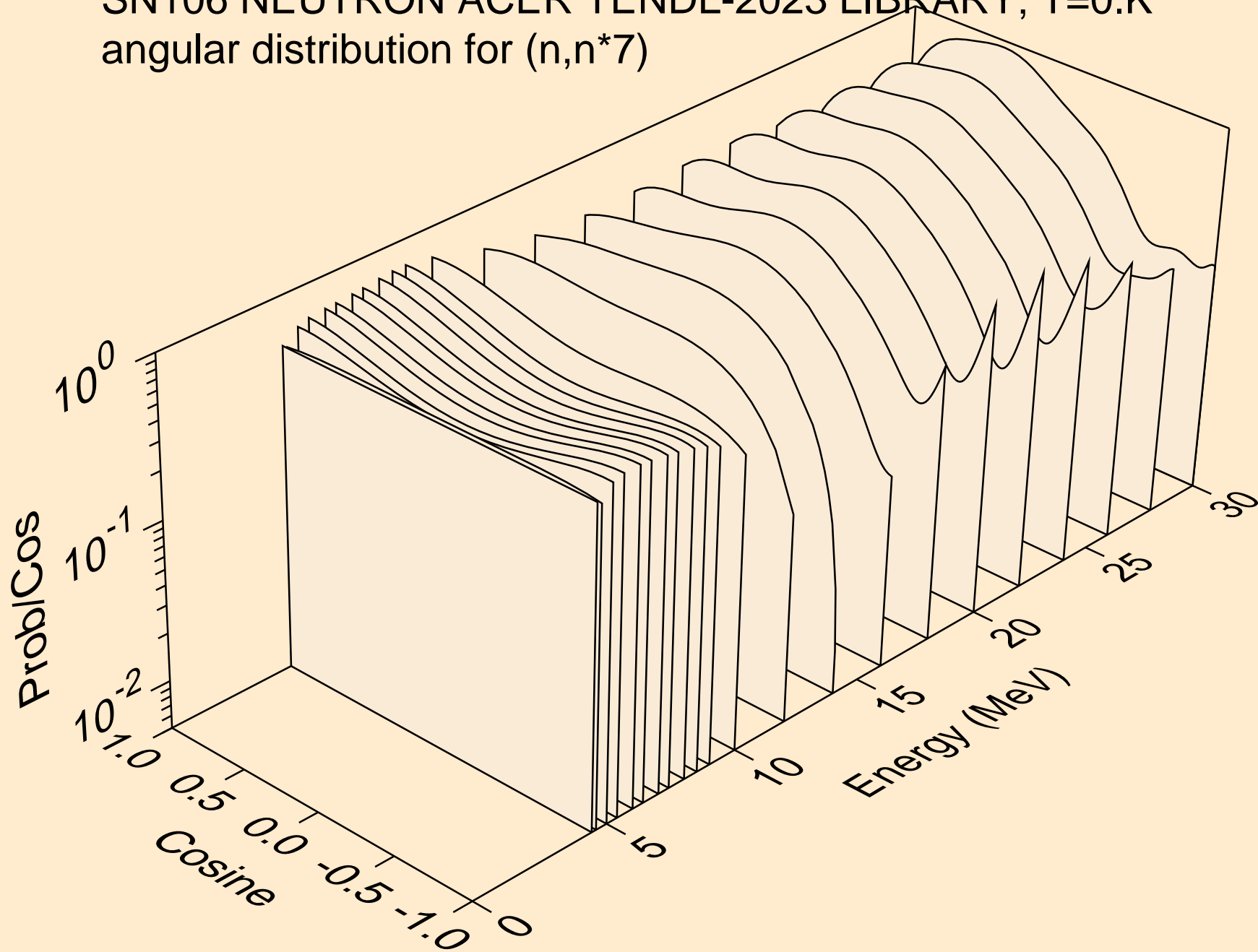

SN106 NEUTRON ACER TENDL-2023 LIBRARY; T=0.K
angular distribution for (n,n*8)

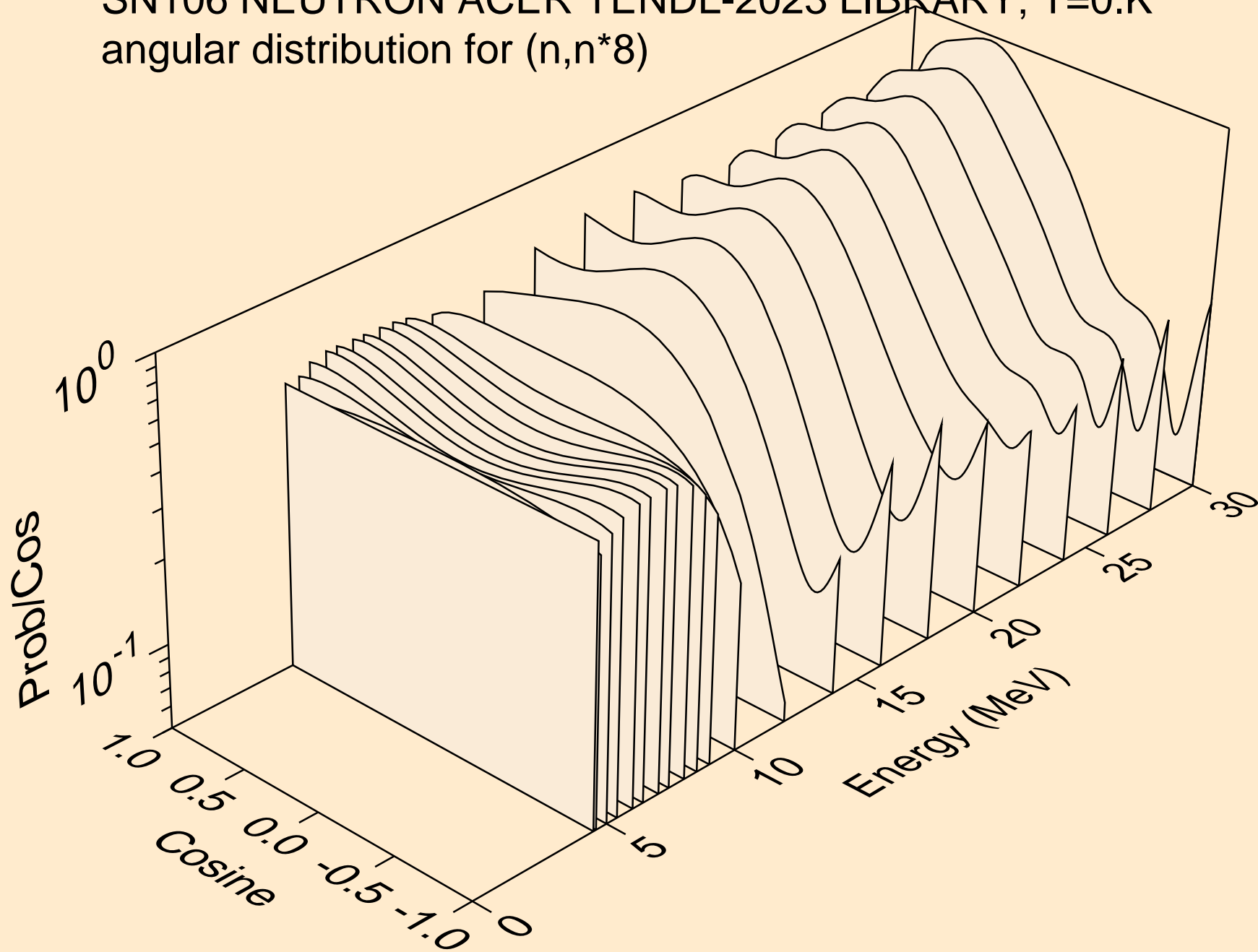

SN106 NEUTRON ACER TENDL-2023 LIBRARY; T=0.K
angular distribution for (n,n*9)

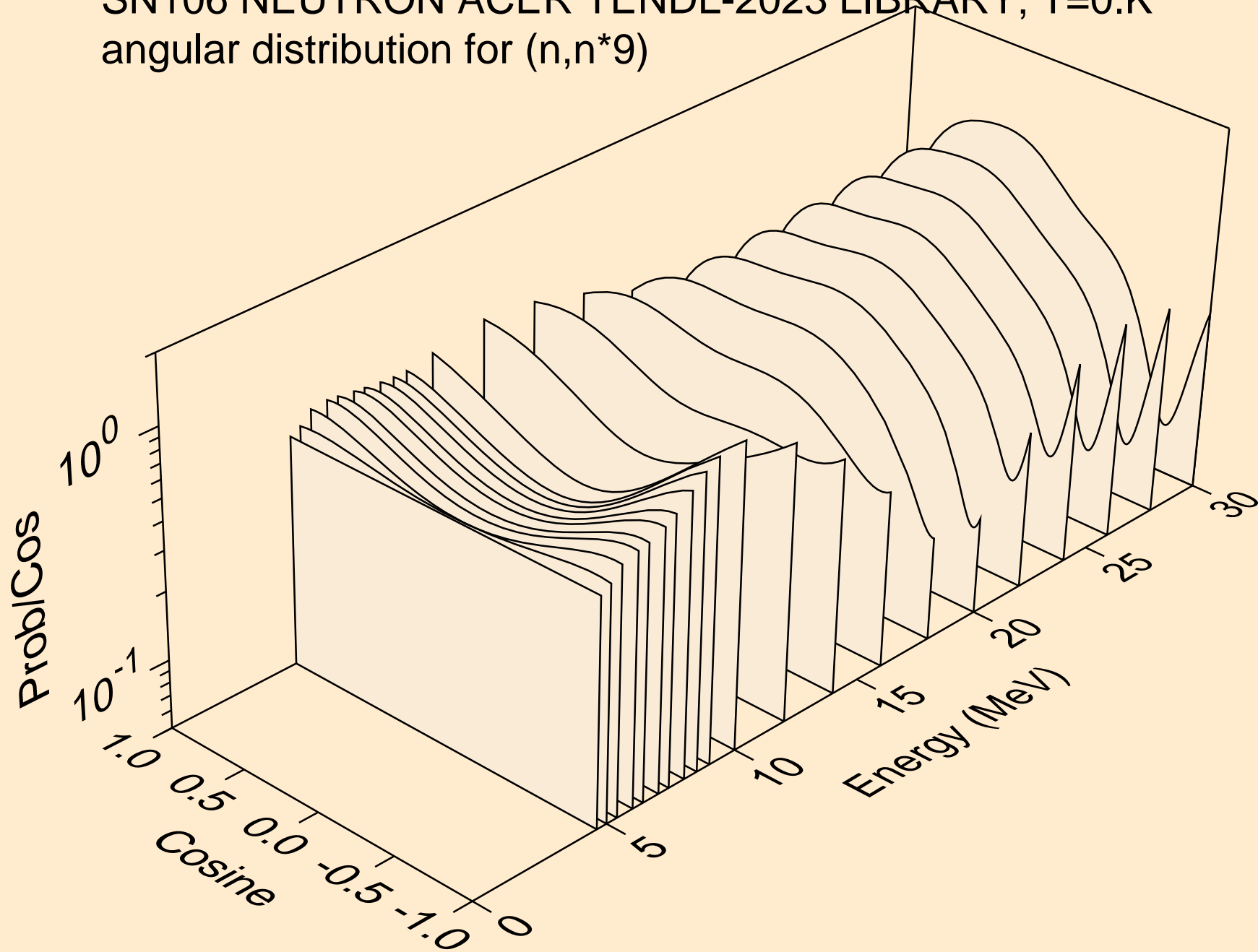

SN106 NEUTRON ACER TENDL-2023 LIBRARY; T=0.K
angular distribution for (n,n*10)

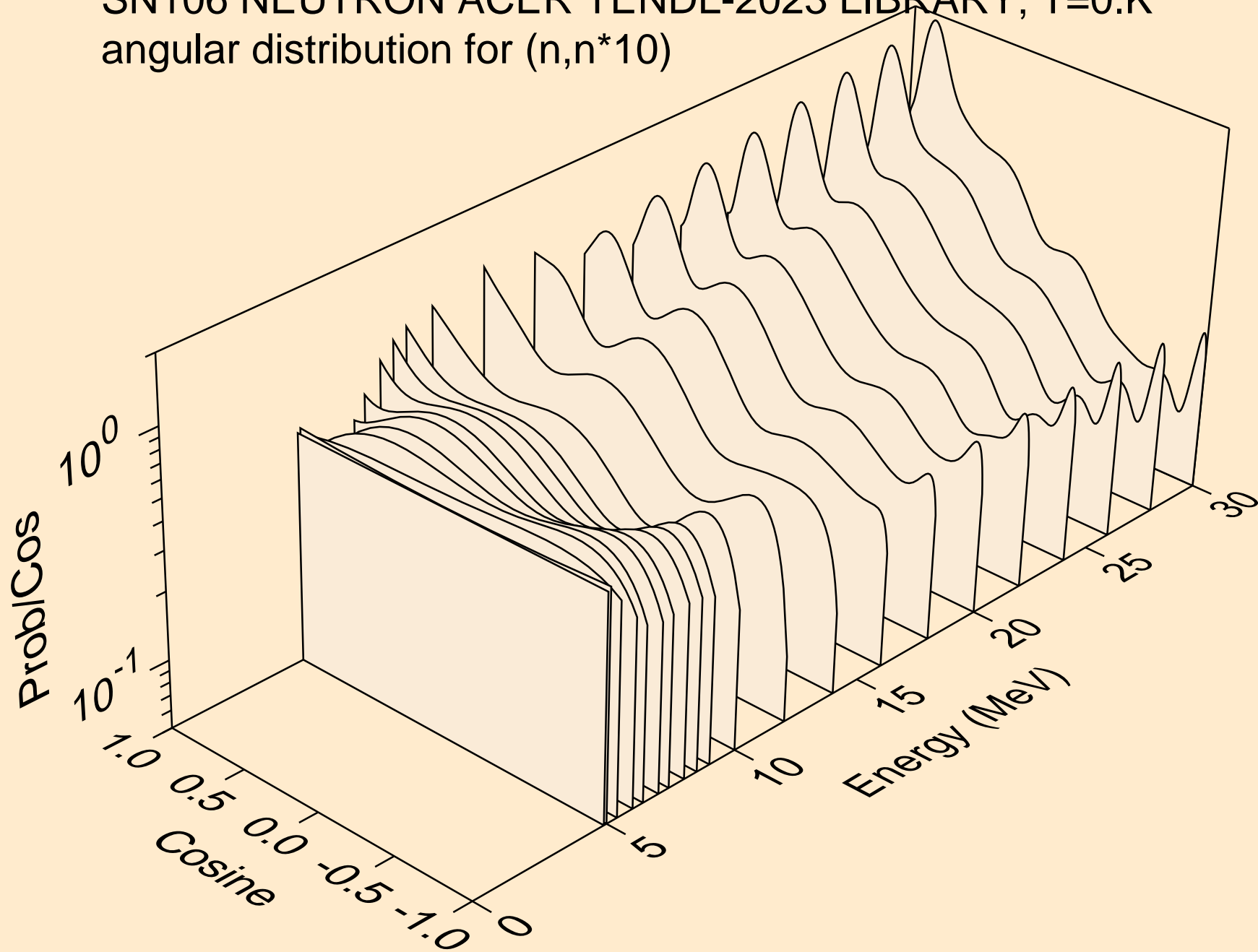

SN106 NEUTRON ACER TENDL-2023 LIBRARY; T=0.K
Neutron emission for (n,x)

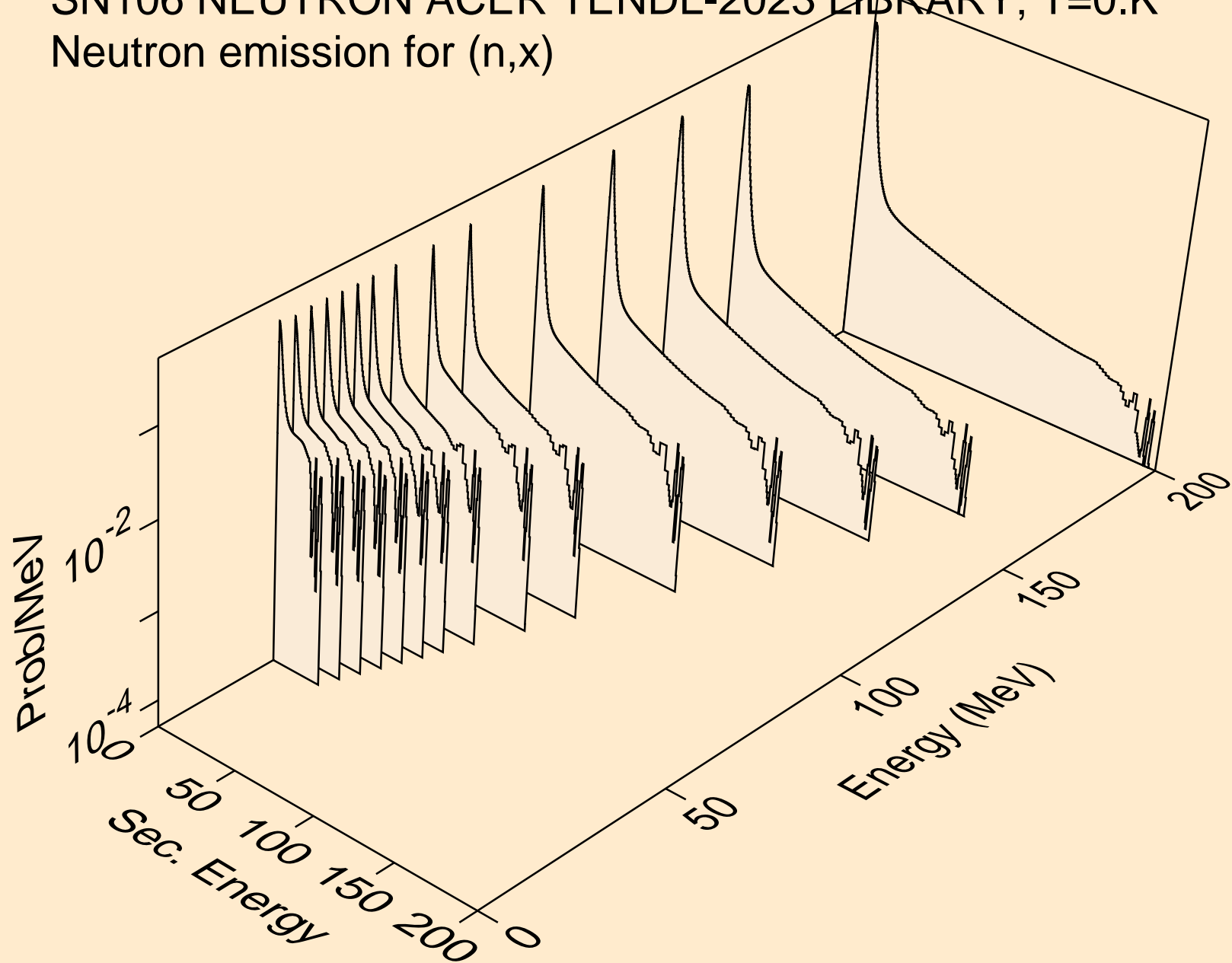

SN106 NEUTRON ACER TENDL-2023 LIBRARY; T=0.K
Neutron emission for (n,2nd)

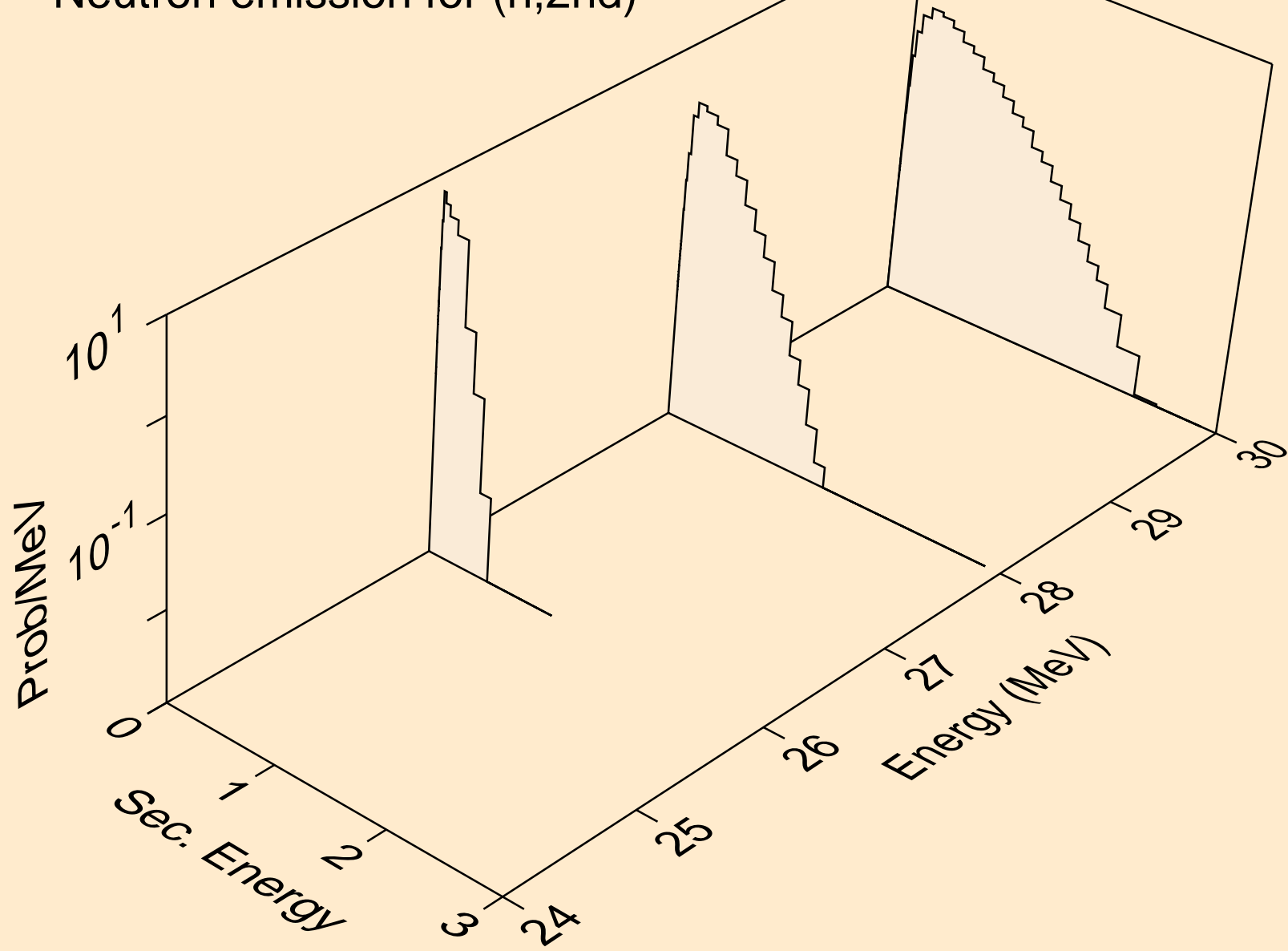

SN106 NEUTRON ACER TENDL-2023 LIBRARY; T=0.K
Neutron emission for (n,2n)

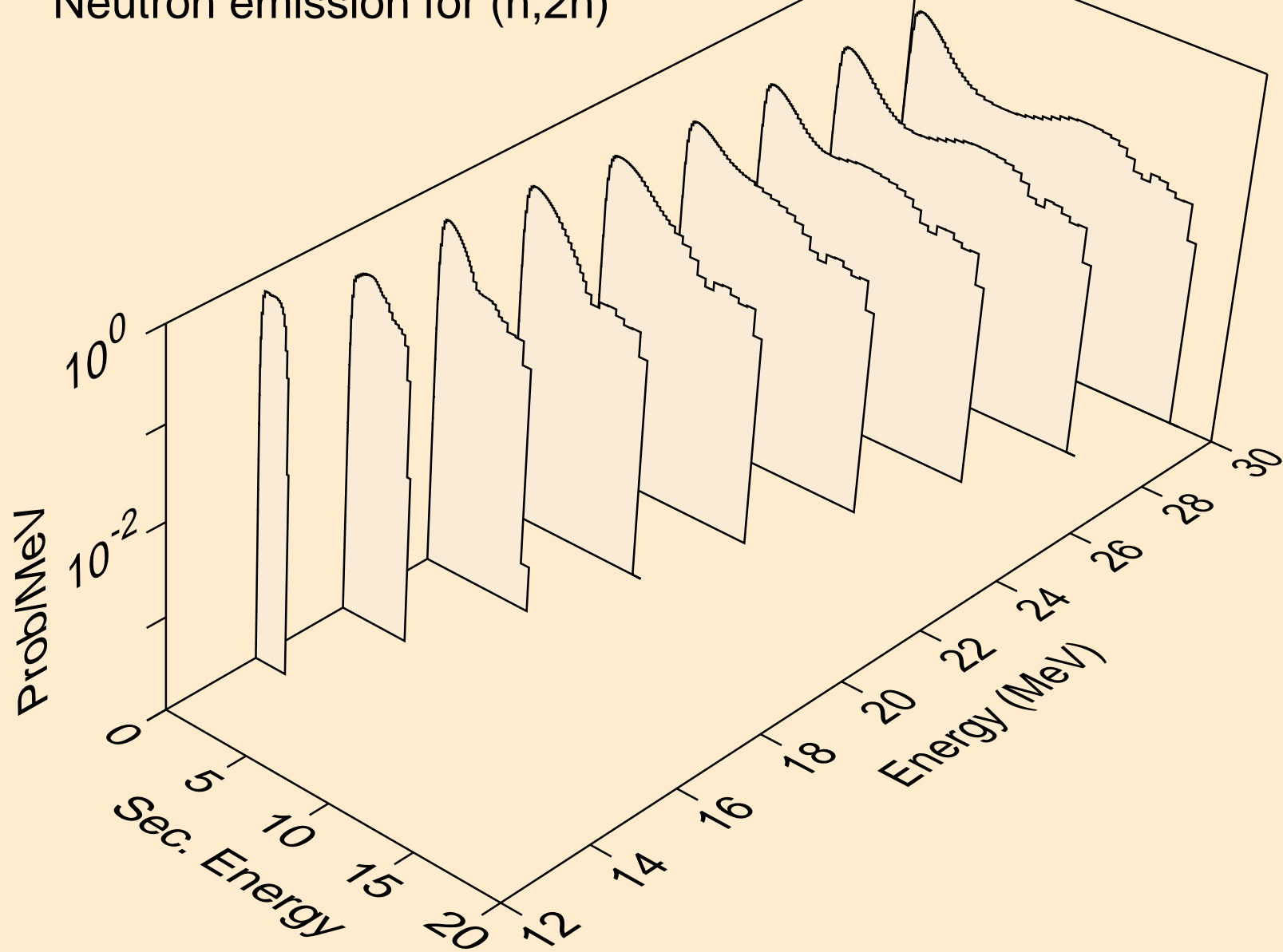

SN106 NEUTRON ACER TENDL-2023 LIBRARY; T=0.K
Neutron emission for (n,3n)

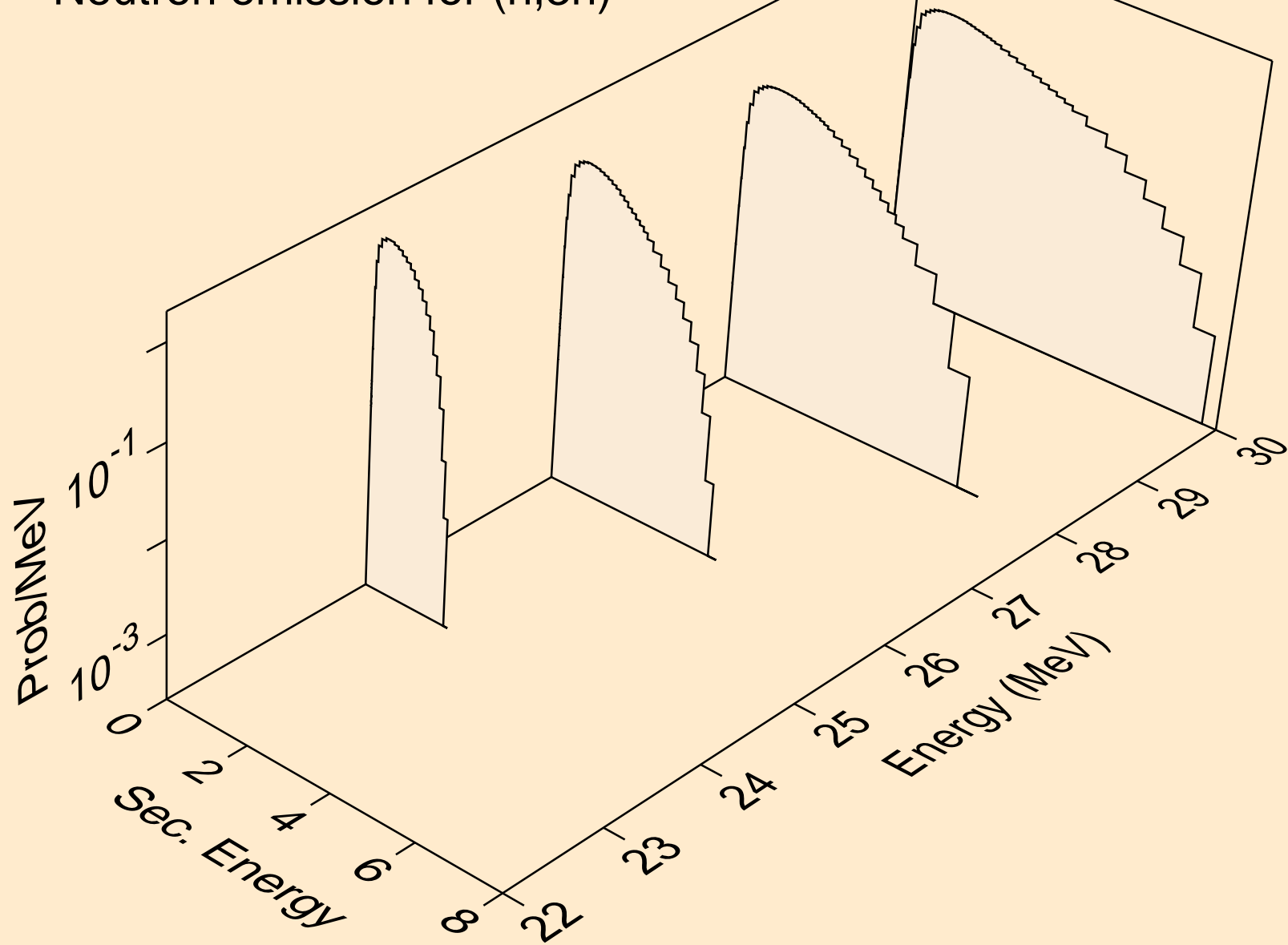

SN106 NEUTRON ACER TENDL-2023 LIBRARY; T=0.K
Neutron emission for (n,n*)a

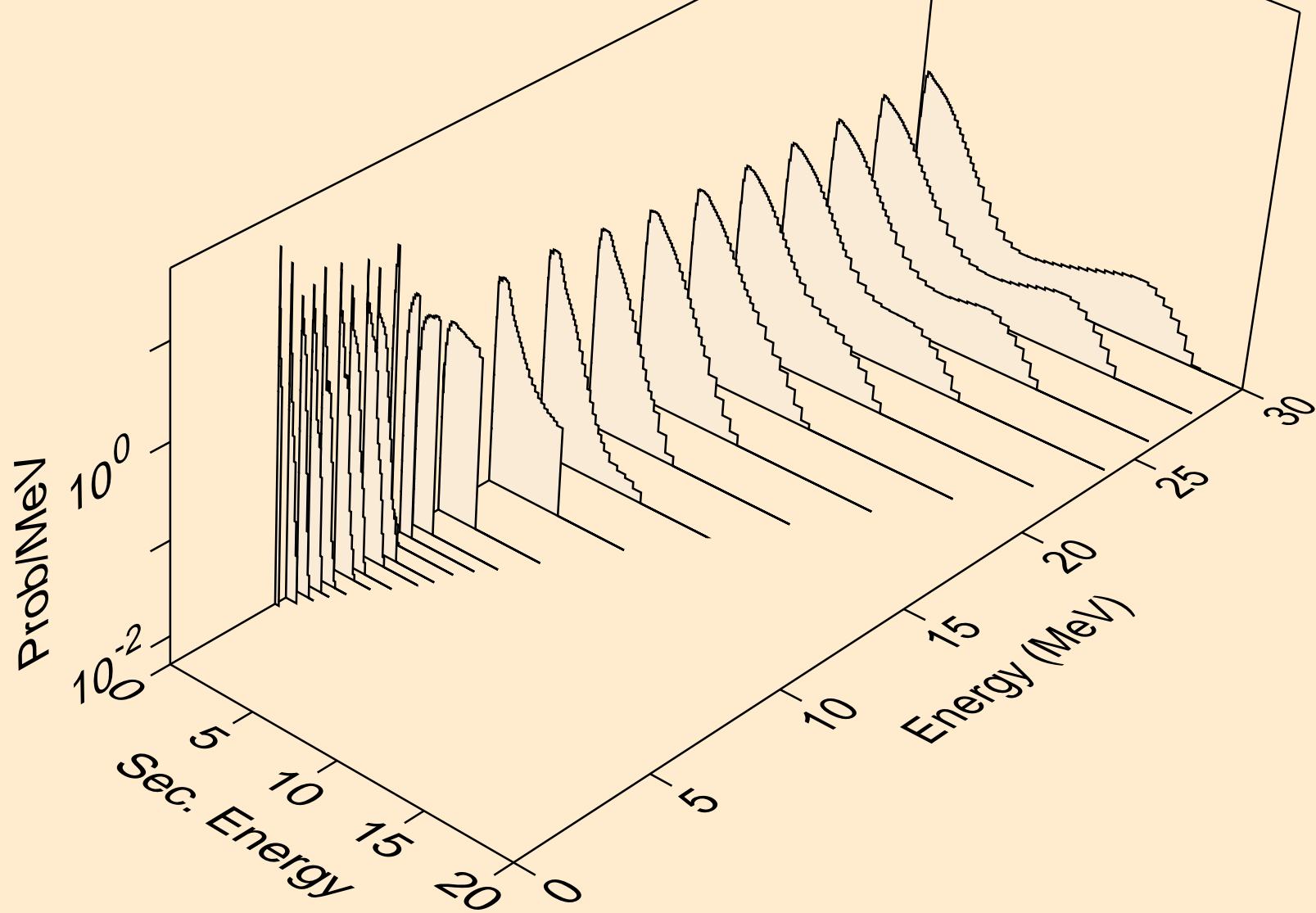

SN106 NEUTRON ACER TENDL-2023 LIBRARY; T=0.K
Neutron emission for (n,2n)a

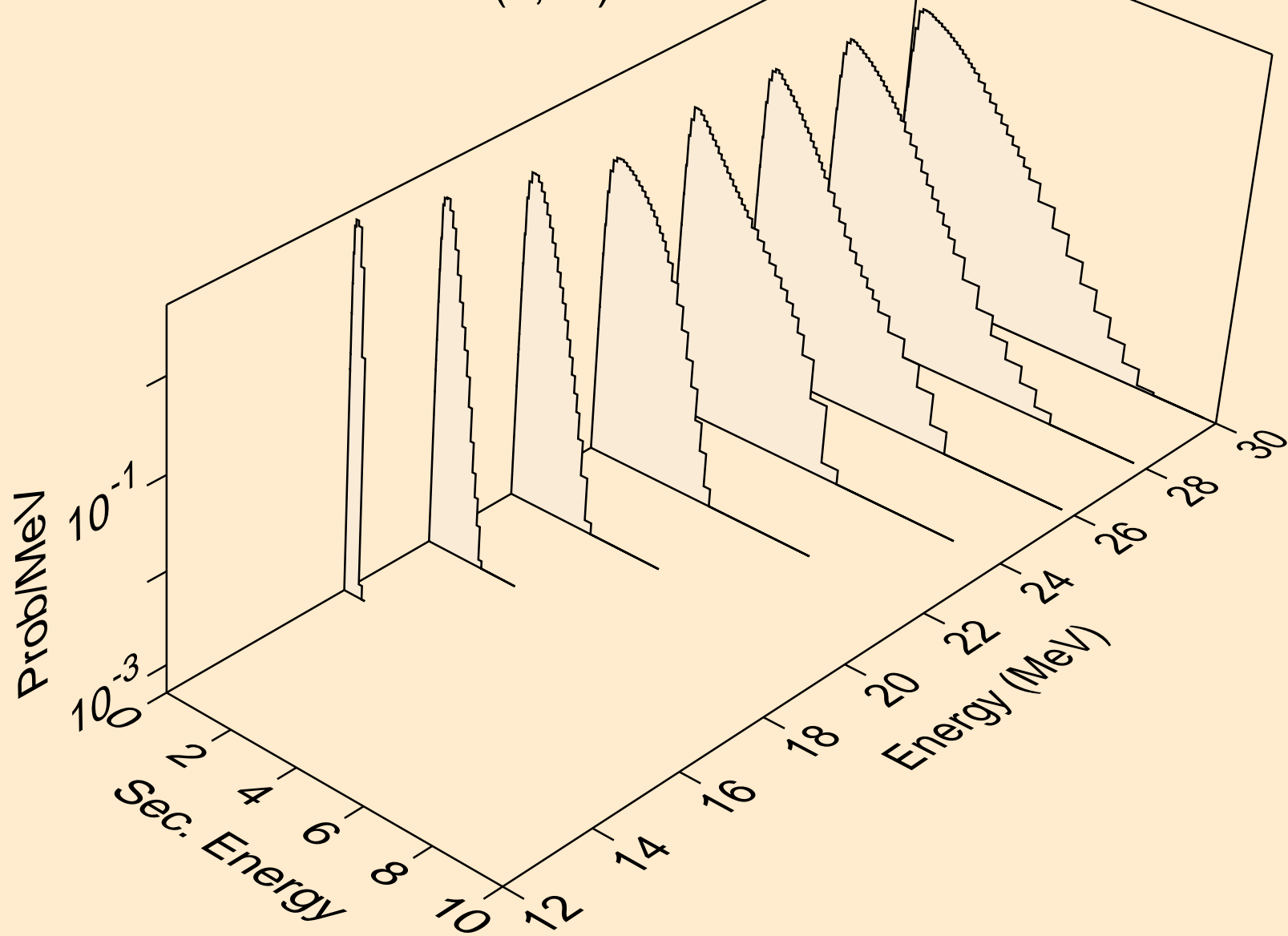

SN106 NEUTRON ACER TENDL-2023 LIBRARY; T=0.K
Neutron emission for (n,3n)a

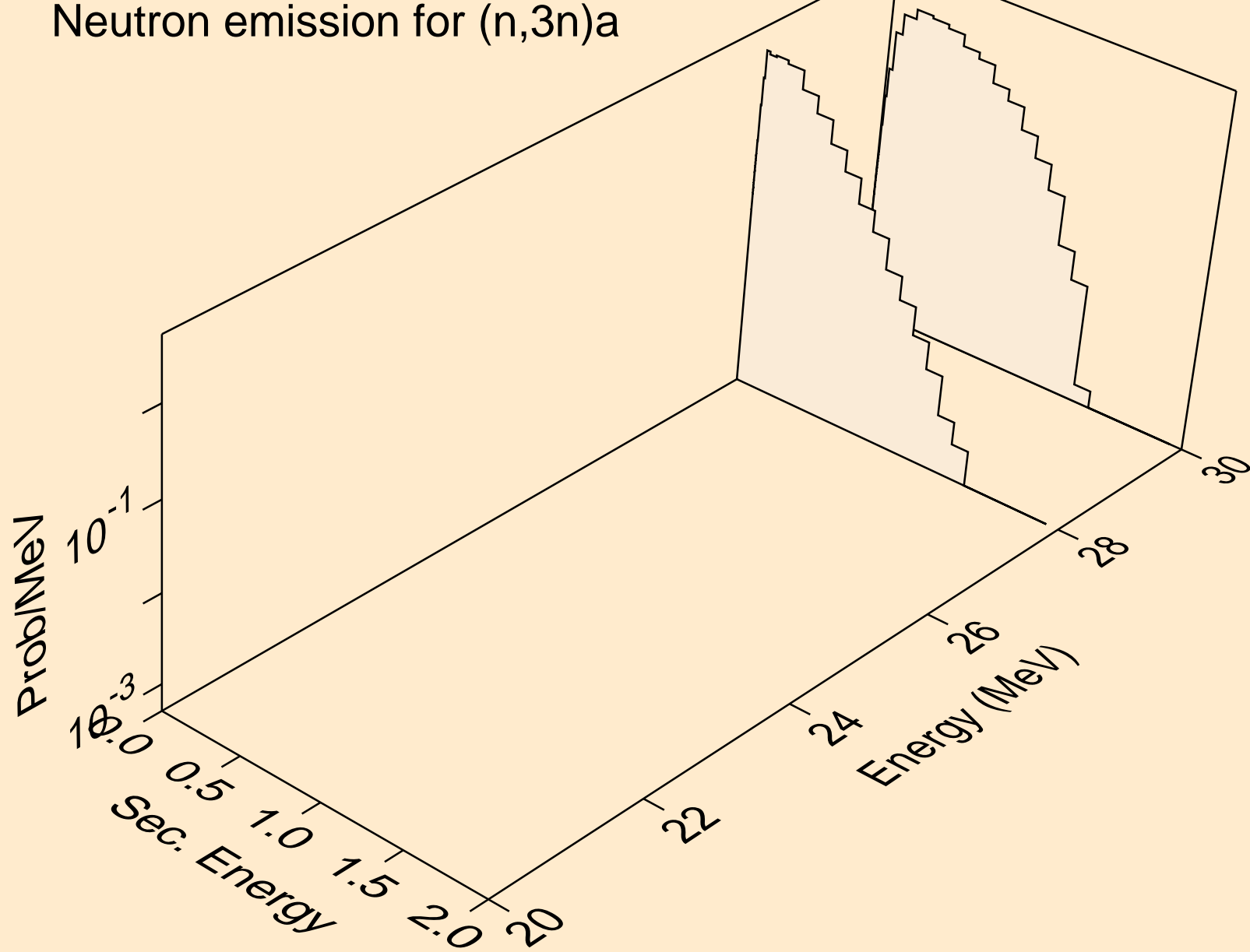

SN106 NEUTRON ACER TENDL-2023 LIBRARY; T=0.K
Neutron emission for (n,n*)p

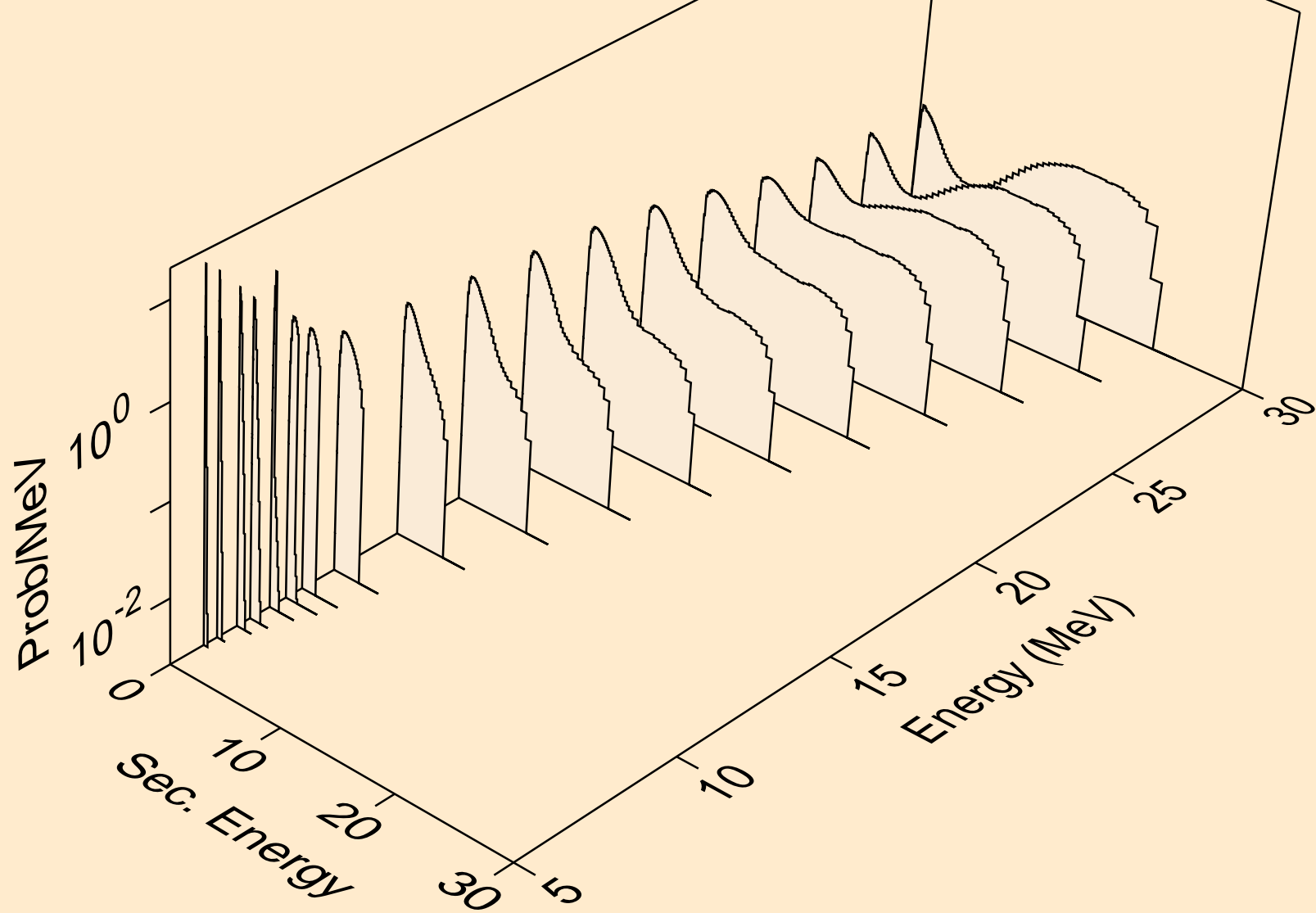

SN106 NEUTRON ACER TENDL-2023 LIBRARY; T=0.K
Neutron emission for (n,n*)2a

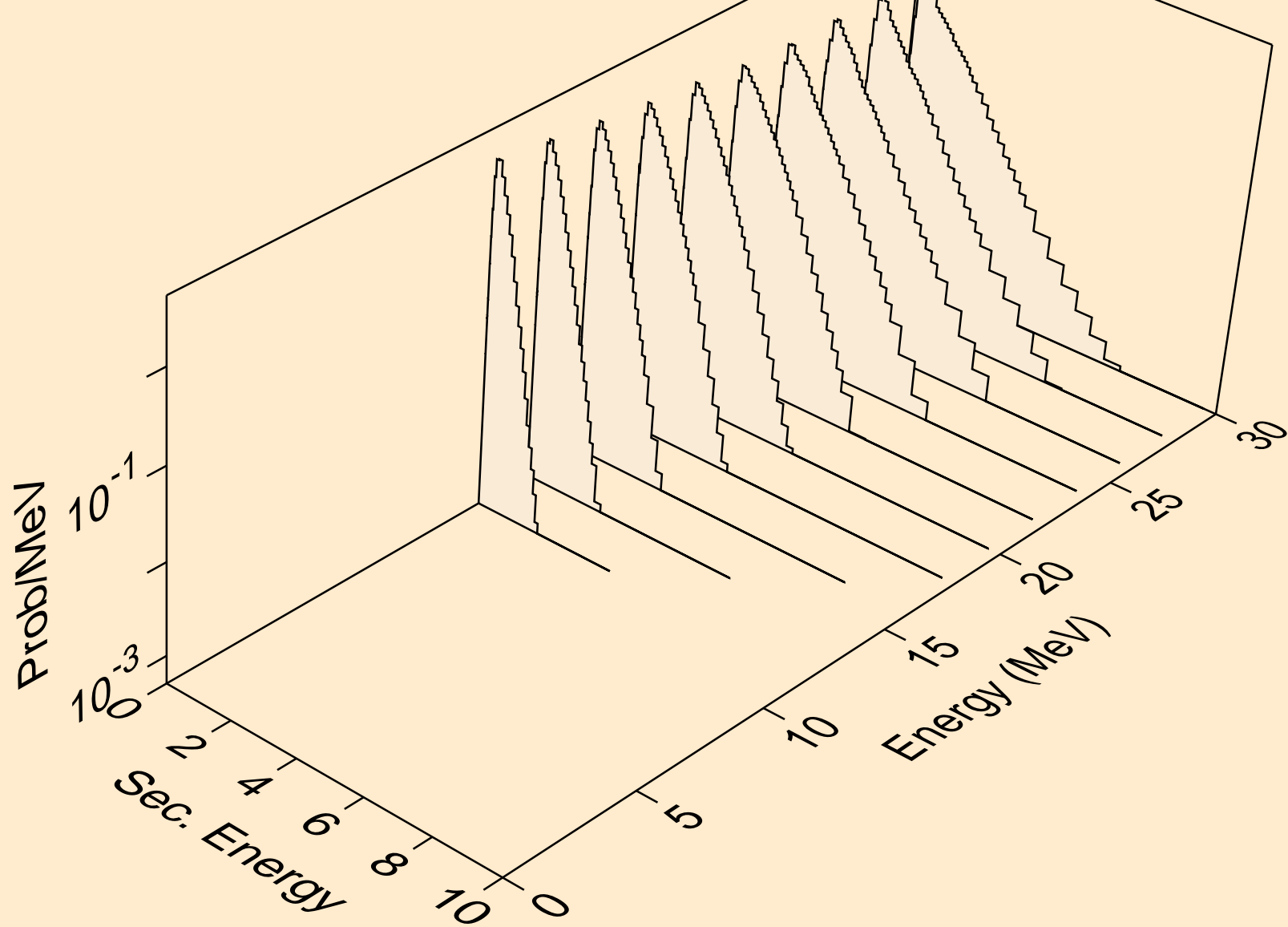

SN106 NEUTRON ACER TENDL-2023 LIBRARY; T=0.K
Neutron emission for (n,n*)d

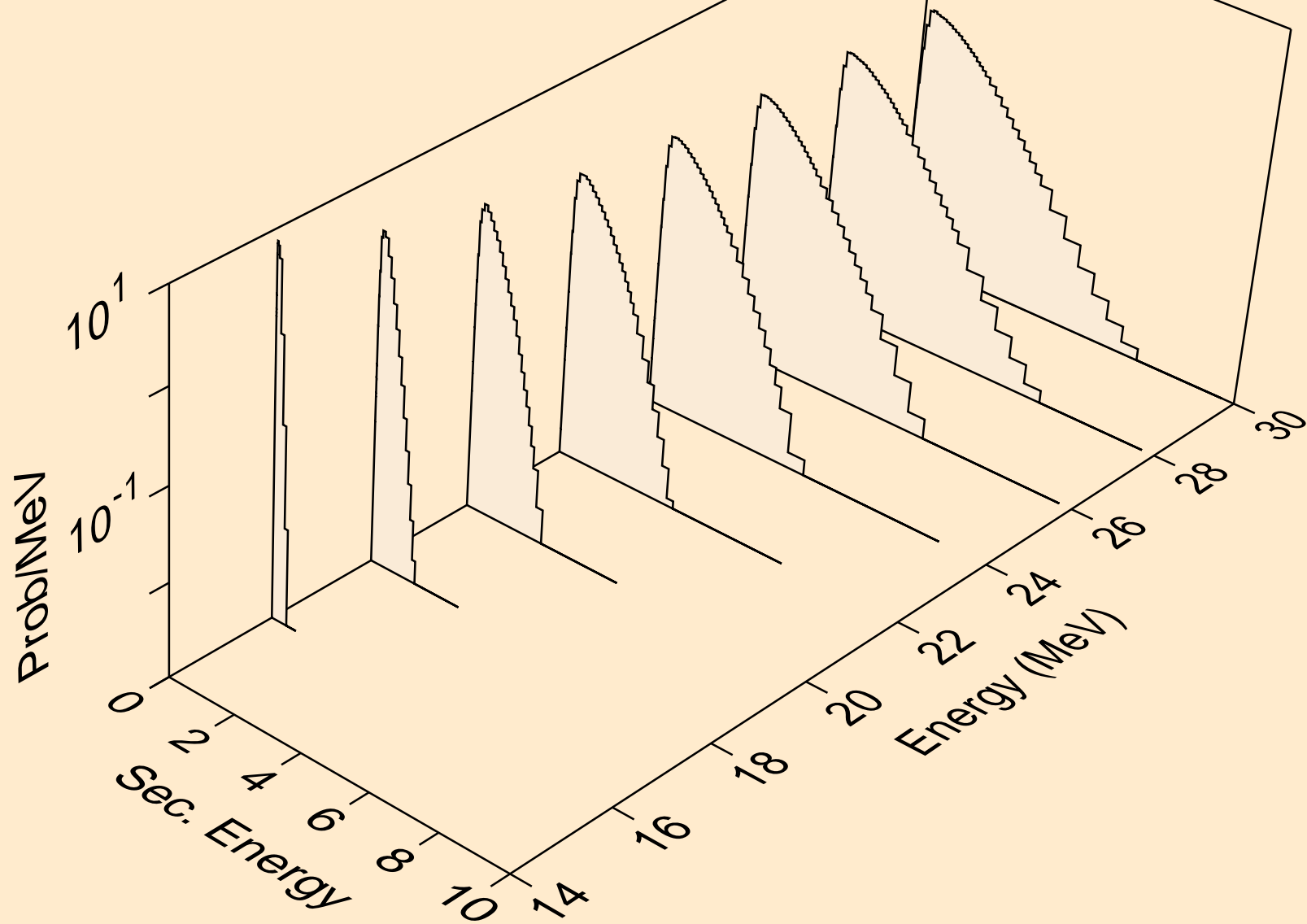

SN106 NEUTRON ACER TENDL-2023 LIBRARY; T=0.K
Neutron emission for (n,n*)t

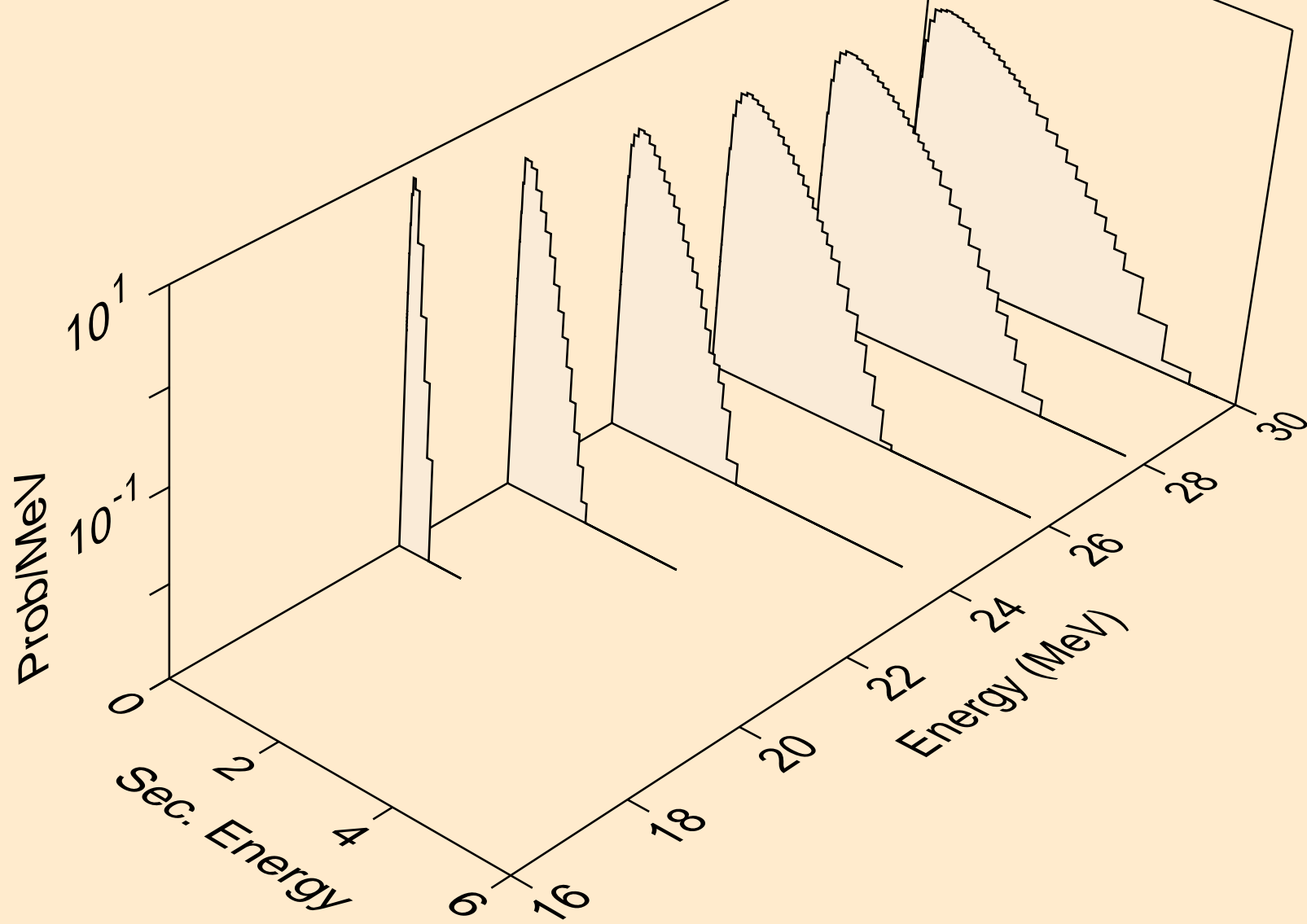

SN106 NEUTRON ACER TENDL-2023 LIBRARY; T=0.K
Neutron emission for (n,n*)he3

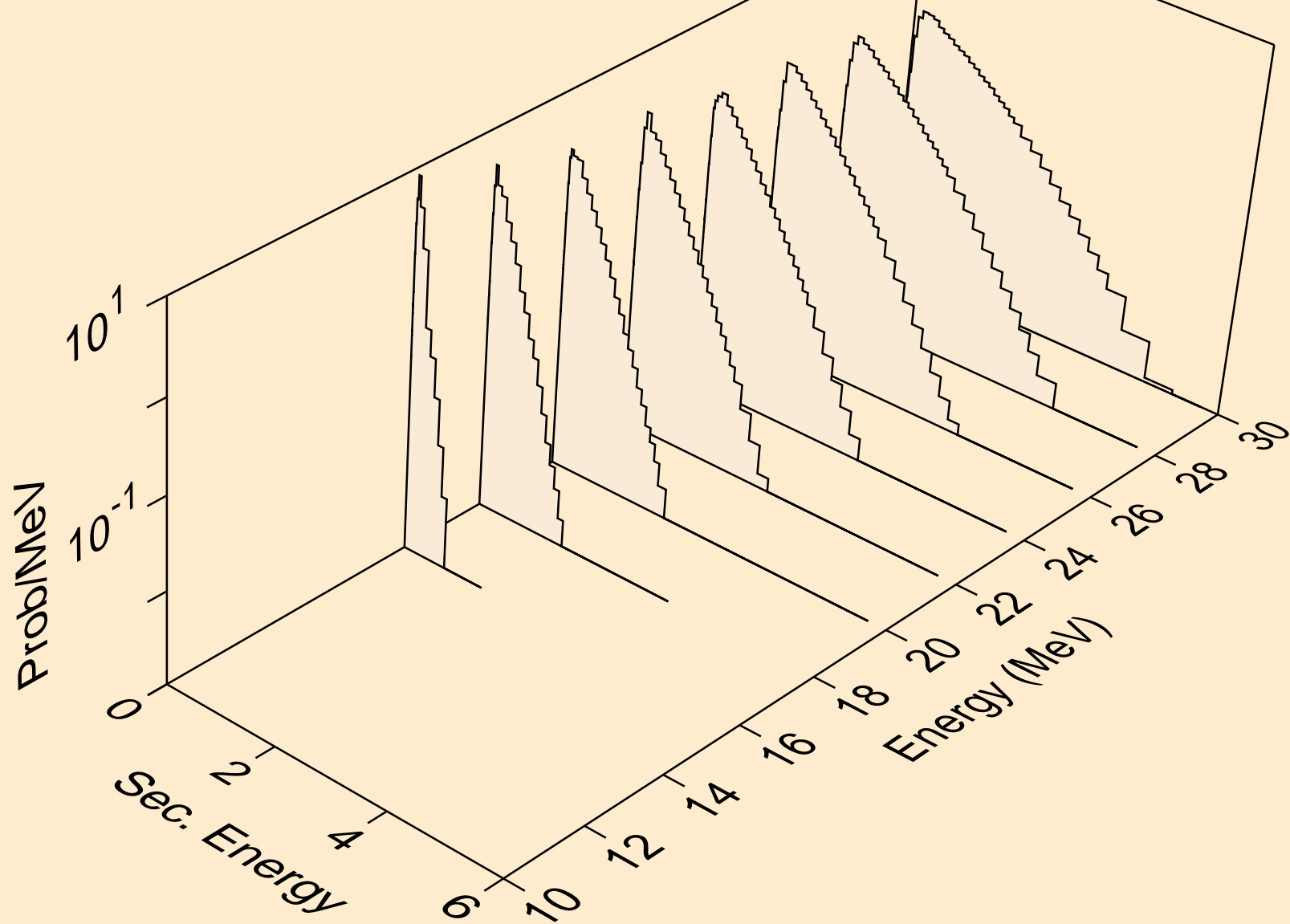

SN106 NEUTRON ACER TENDL-2023 LIBRARY; T=0.K
Neutron emission for (n,2np)

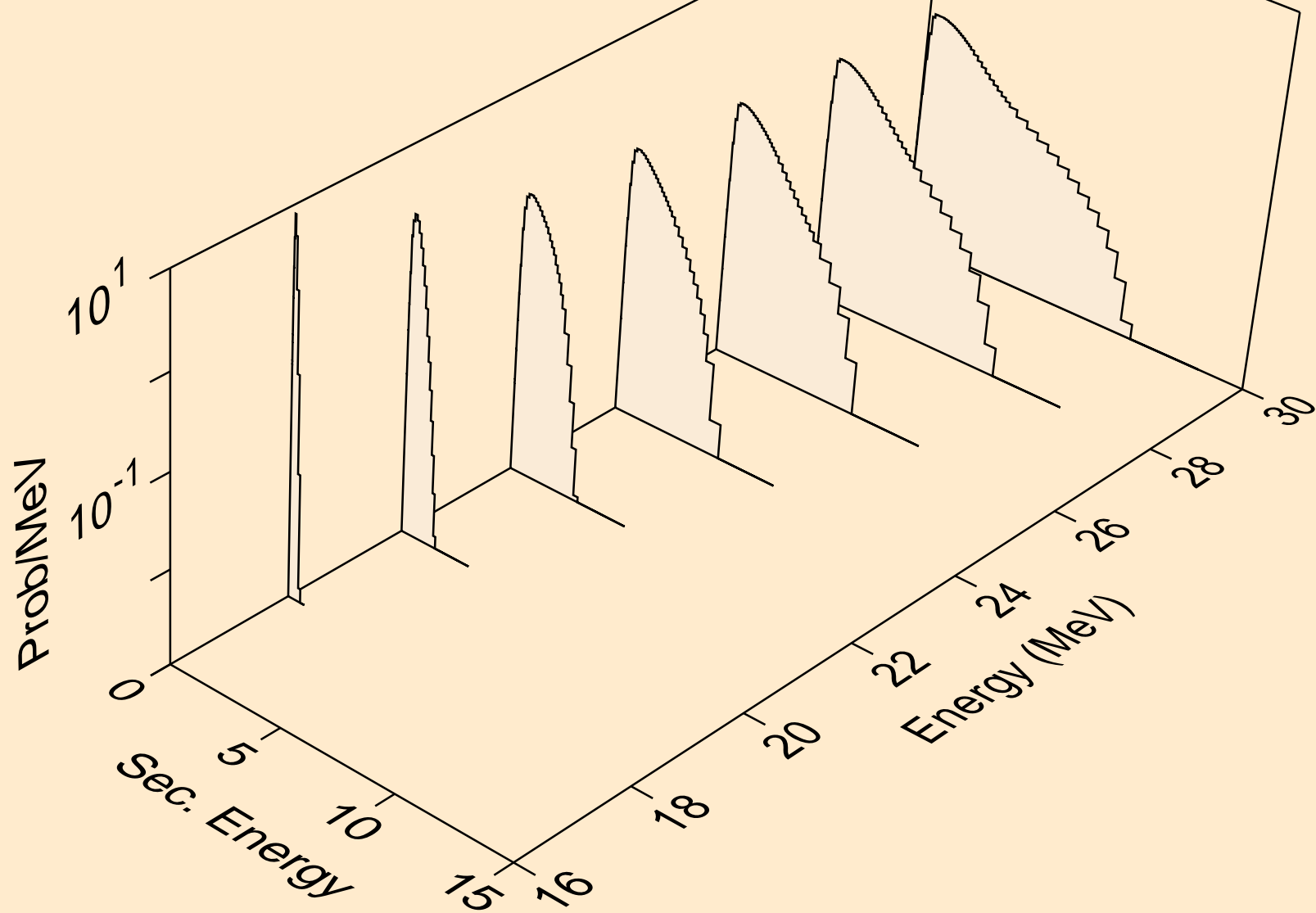

SN106 NEUTRON ACER TENDL-2023 LIBRARY; T=0.K
Neutron emission for (n,3np)

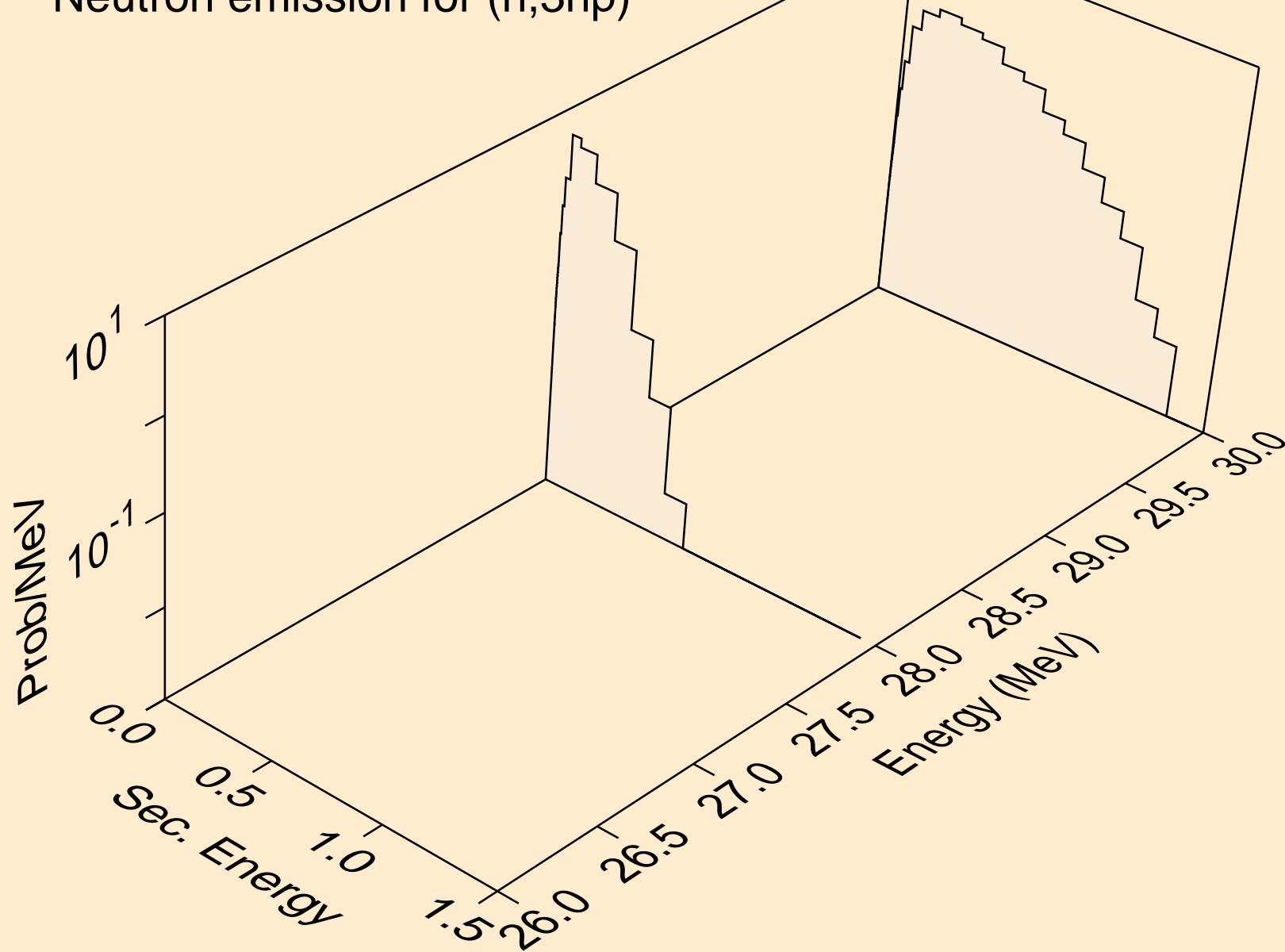

SN106 NEUTRON ACER TENDL-2023 LIBRARY; T=0.K
Neutron emission for (n,n2p)

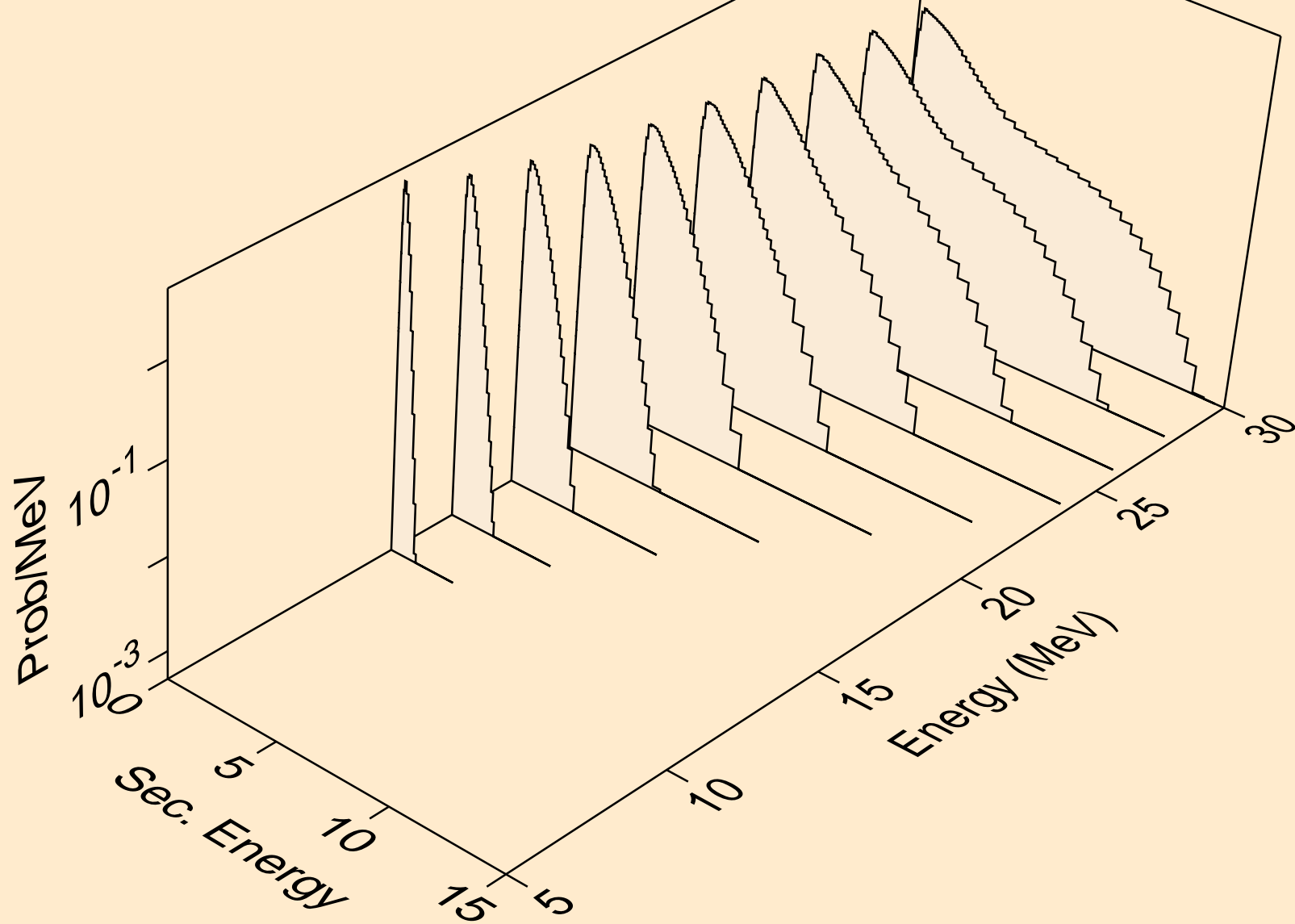

SN106 NEUTRON ACER TENDL-2023 LIBRARY; T=0.K
Neutron emission for (n,npa)

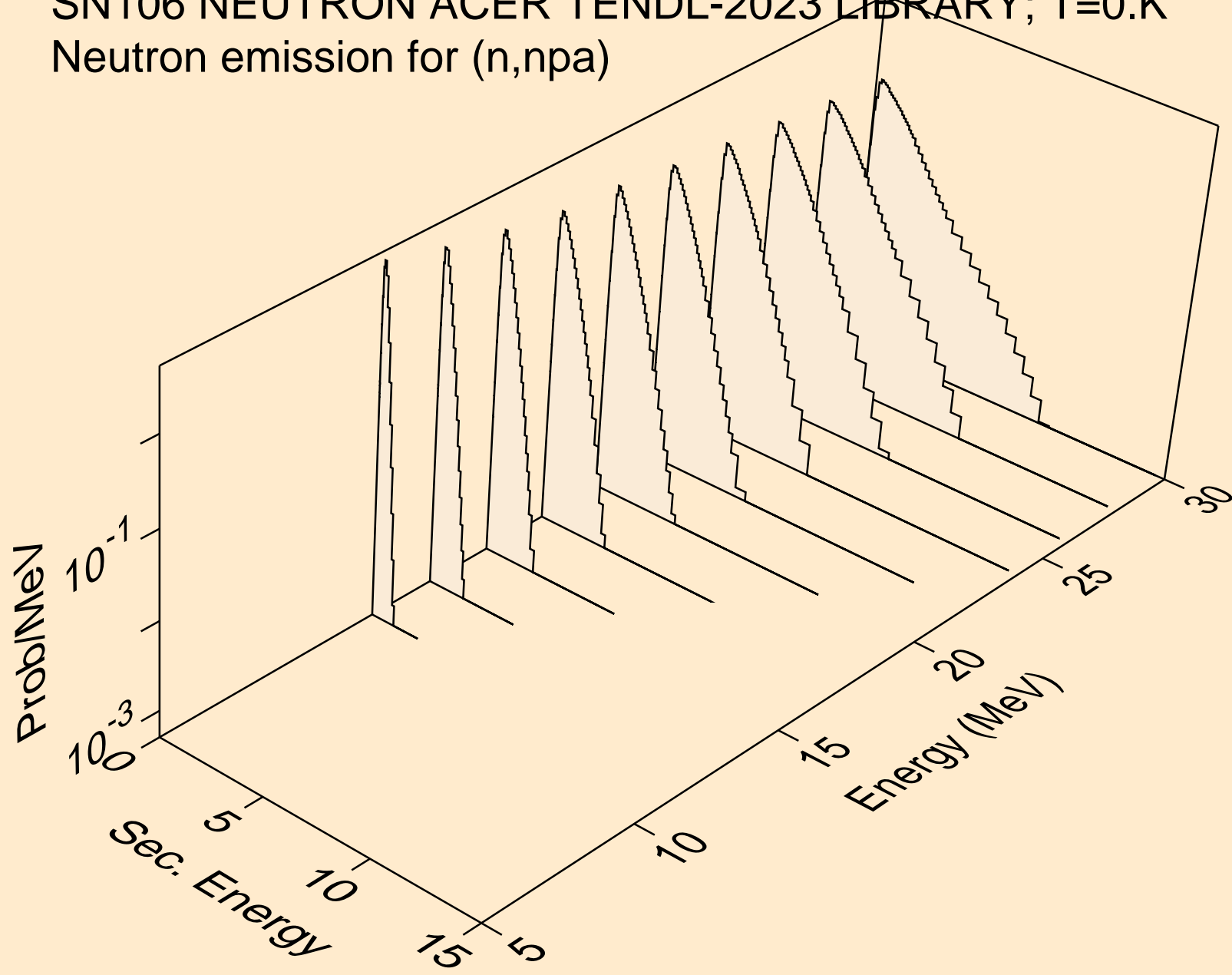

SN106 NEUTRON ACER TENDL-2023 LIBRARY; T=0.K
Neutron emission for (n,n*c)

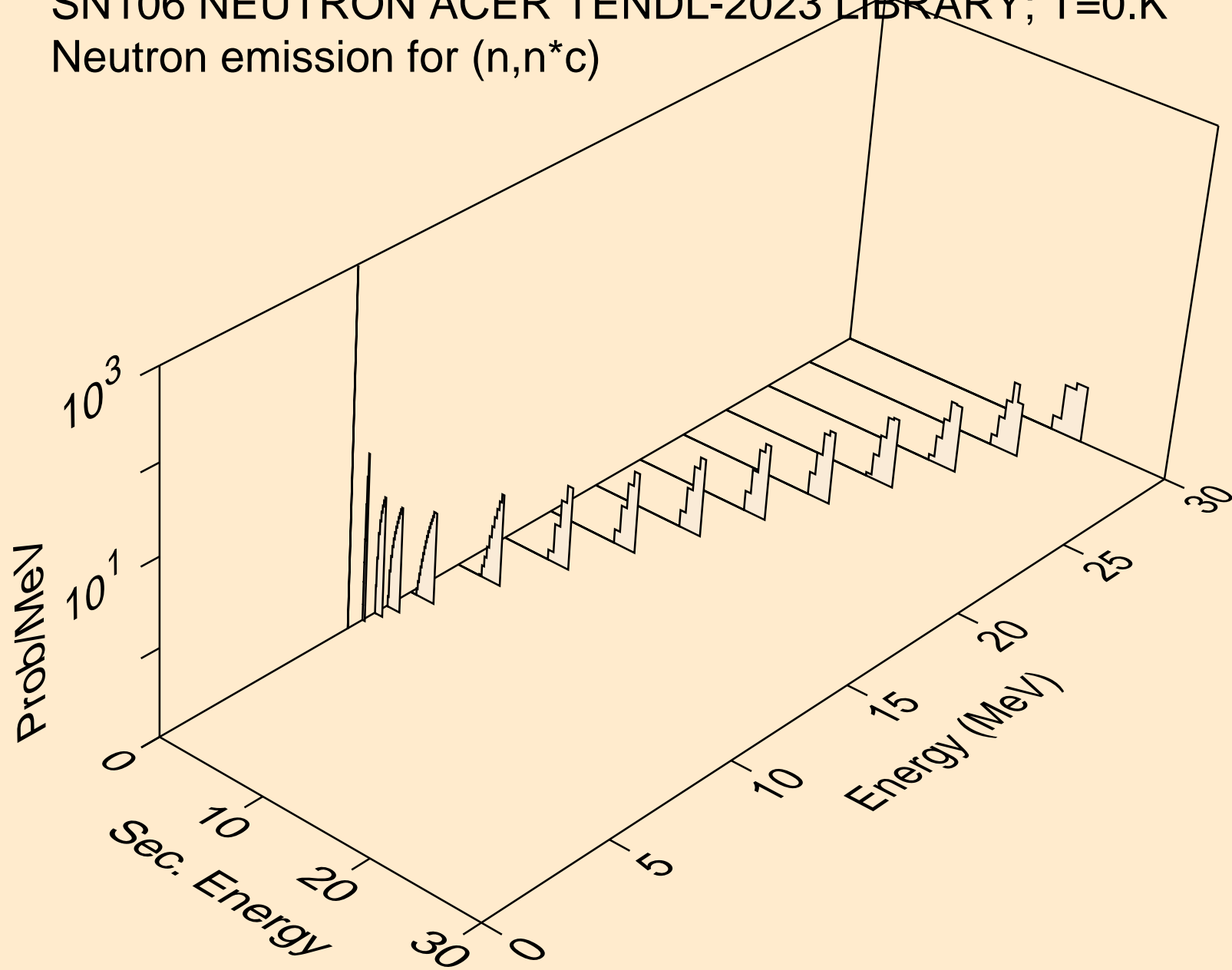

SN106 NEUTRON ACER TENDL-2023 LIBRARY; T=0.K
Photon emission for (n,x)

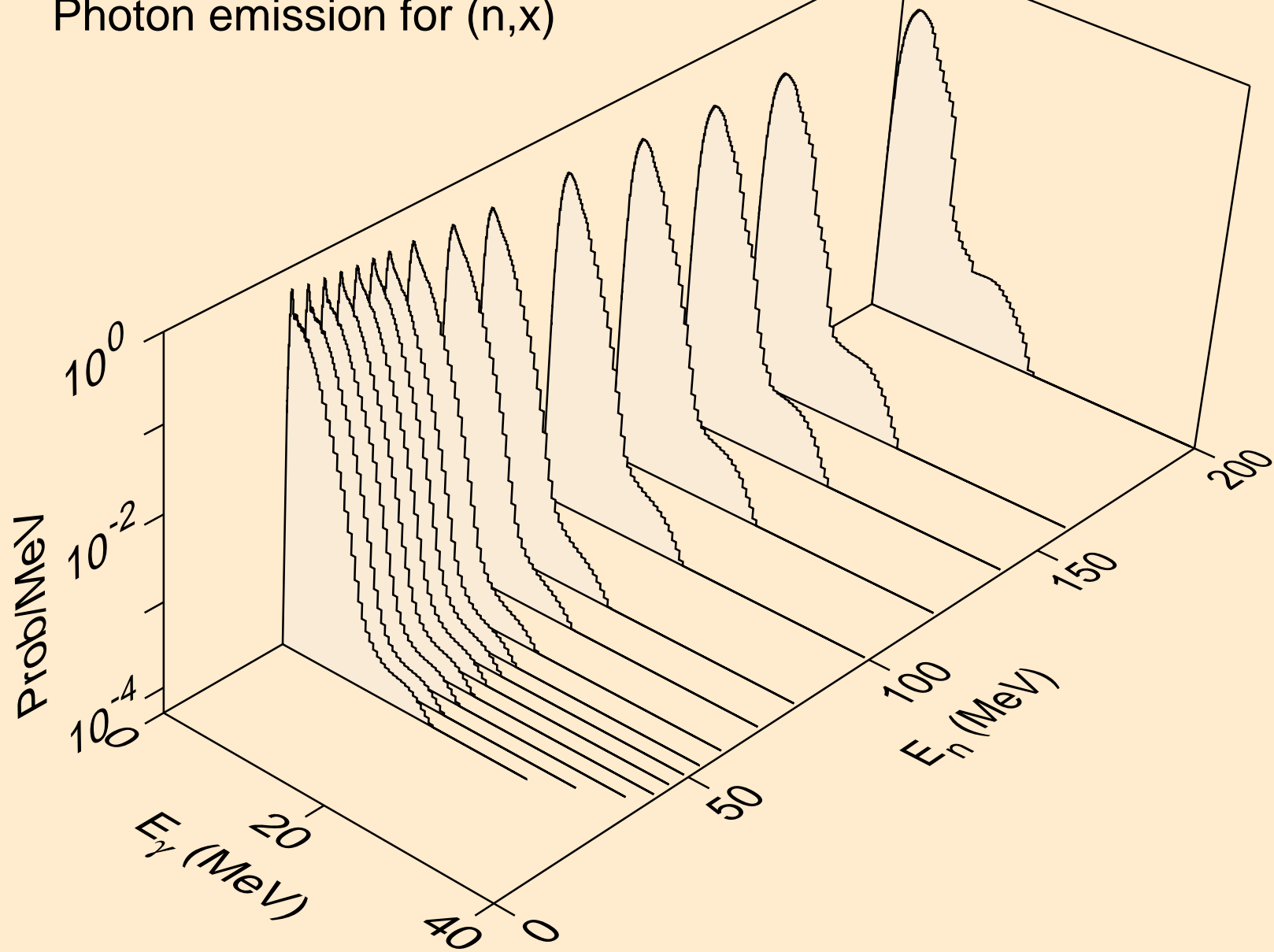

SN106 NEUTRON ACER TENDL-2023 LIBRARY; T=0.K
Photon emission for (n,2nd)

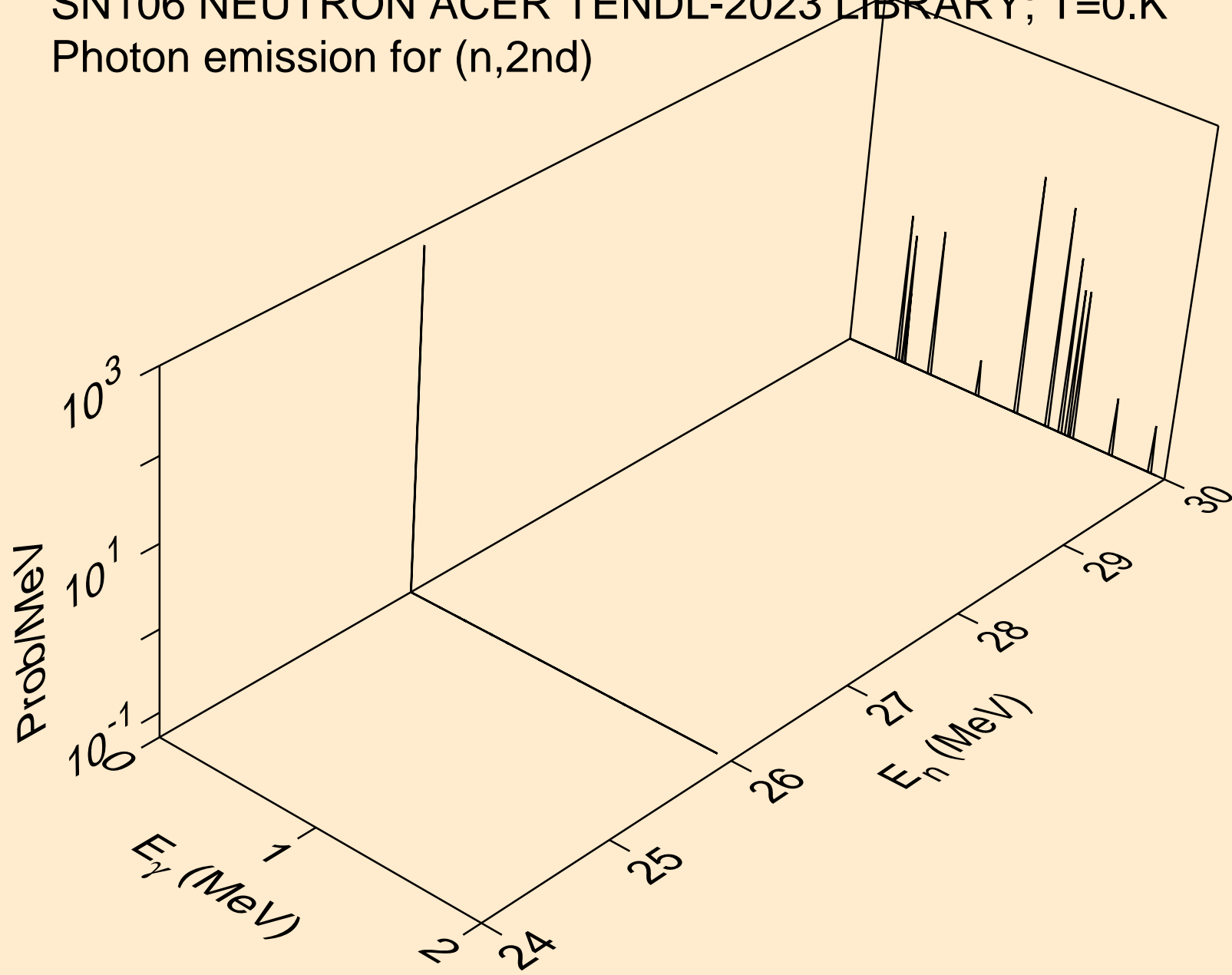

SN106 NEUTRON ACER TENDL-2023 LIBRARY; T=0.K
Photon emission for (n,2n)

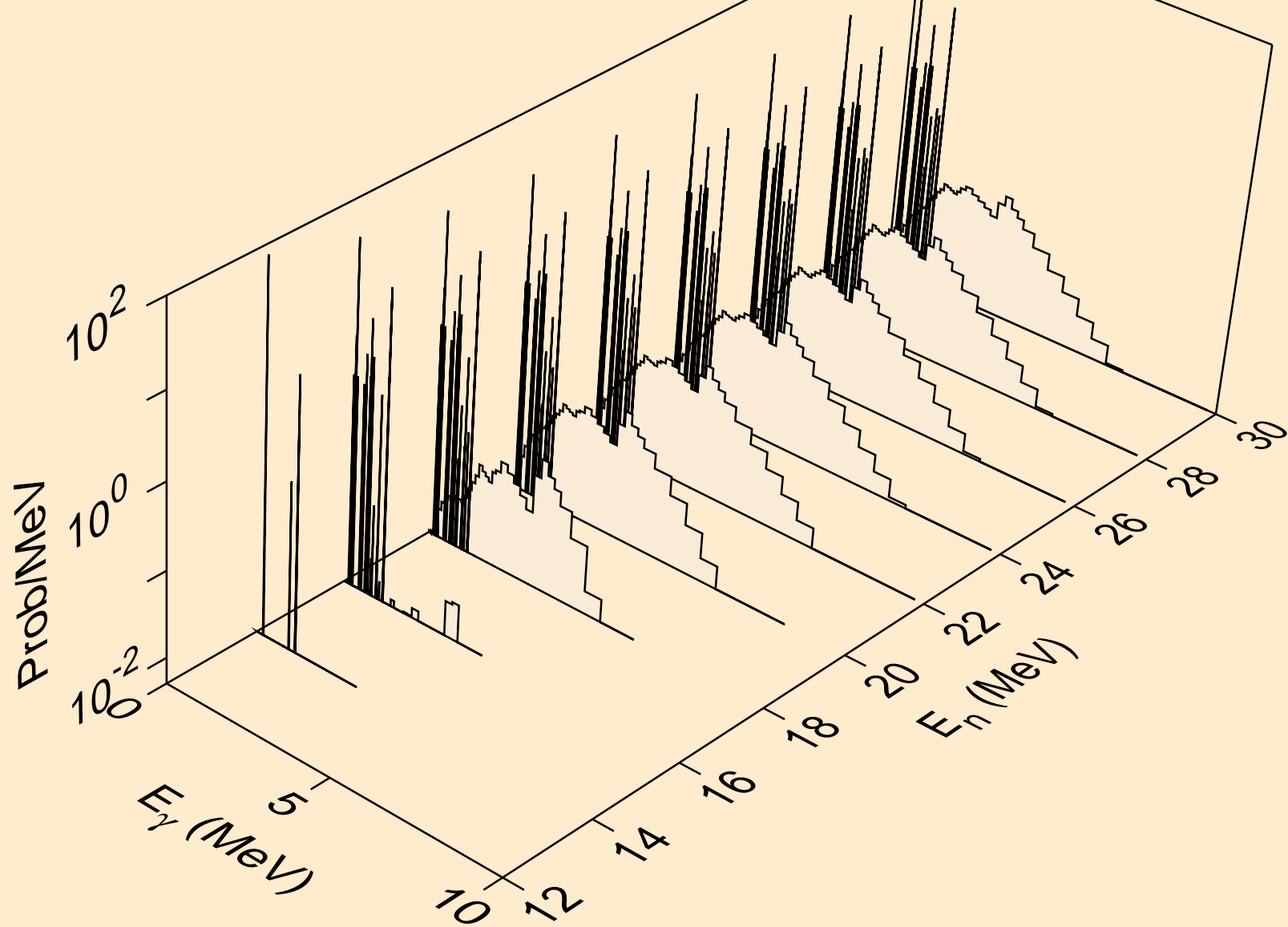

SN106 NEUTRON ACER TENDL-2023 LIBRARY; T=0.K
Photon emission for (n,3n)

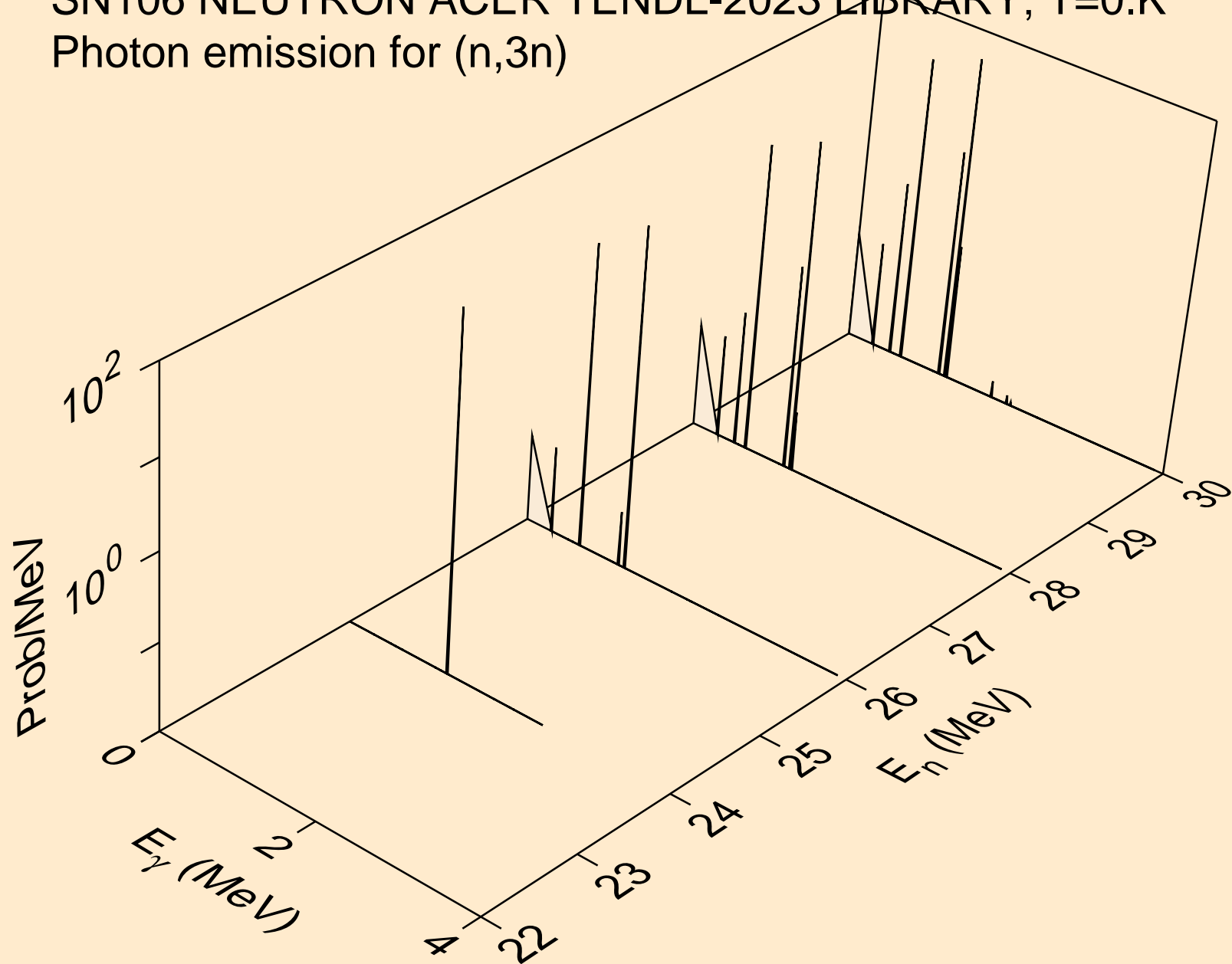

SN106 NEUTRON ACER TENDL-2023 LIBRARY; T=0.K
Photon emission for (n,n*)a

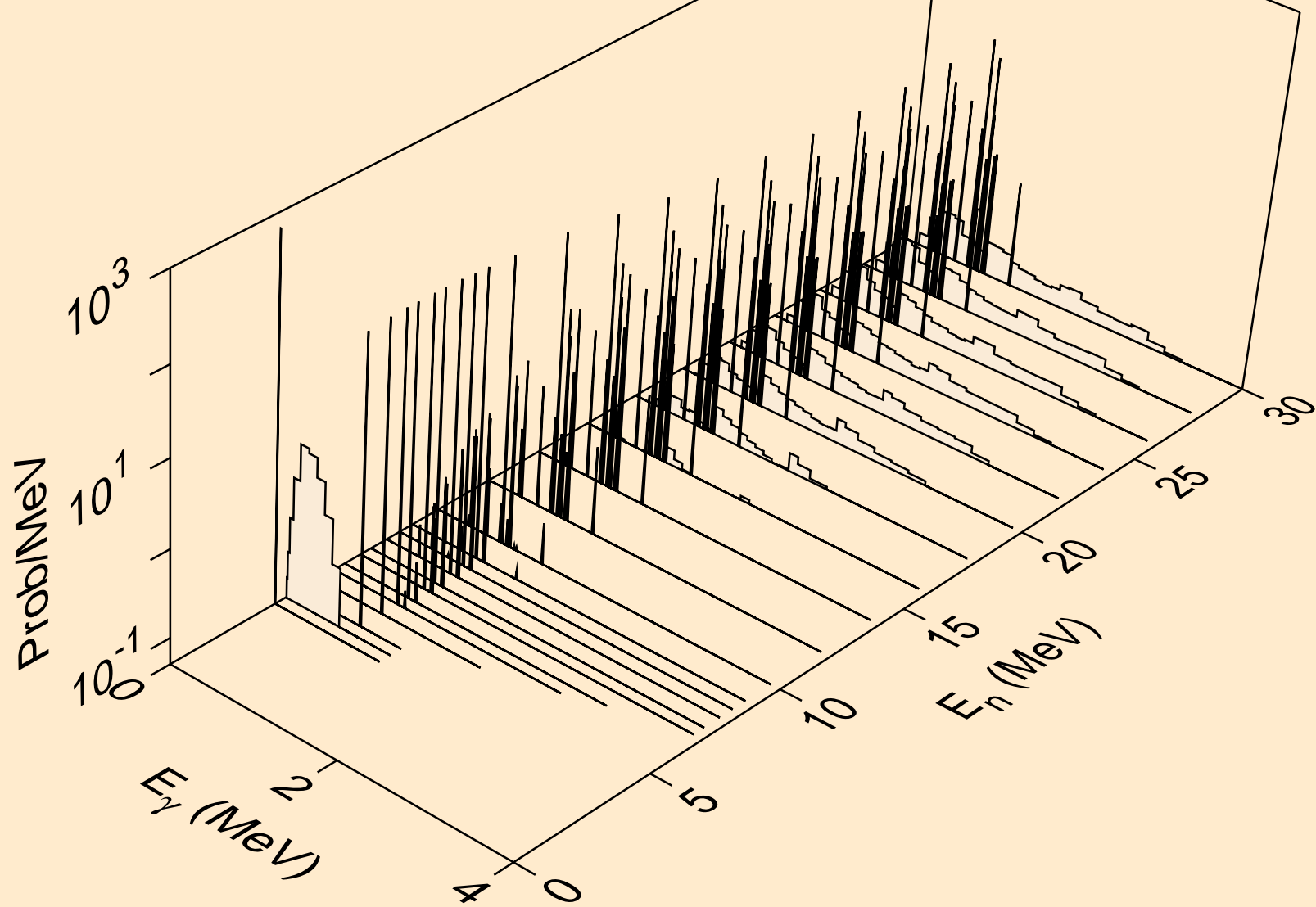

SN106 NEUTRON ACER TENDL-2023 LIBRARY; T=0.K
Photon emission for (n,2n)a

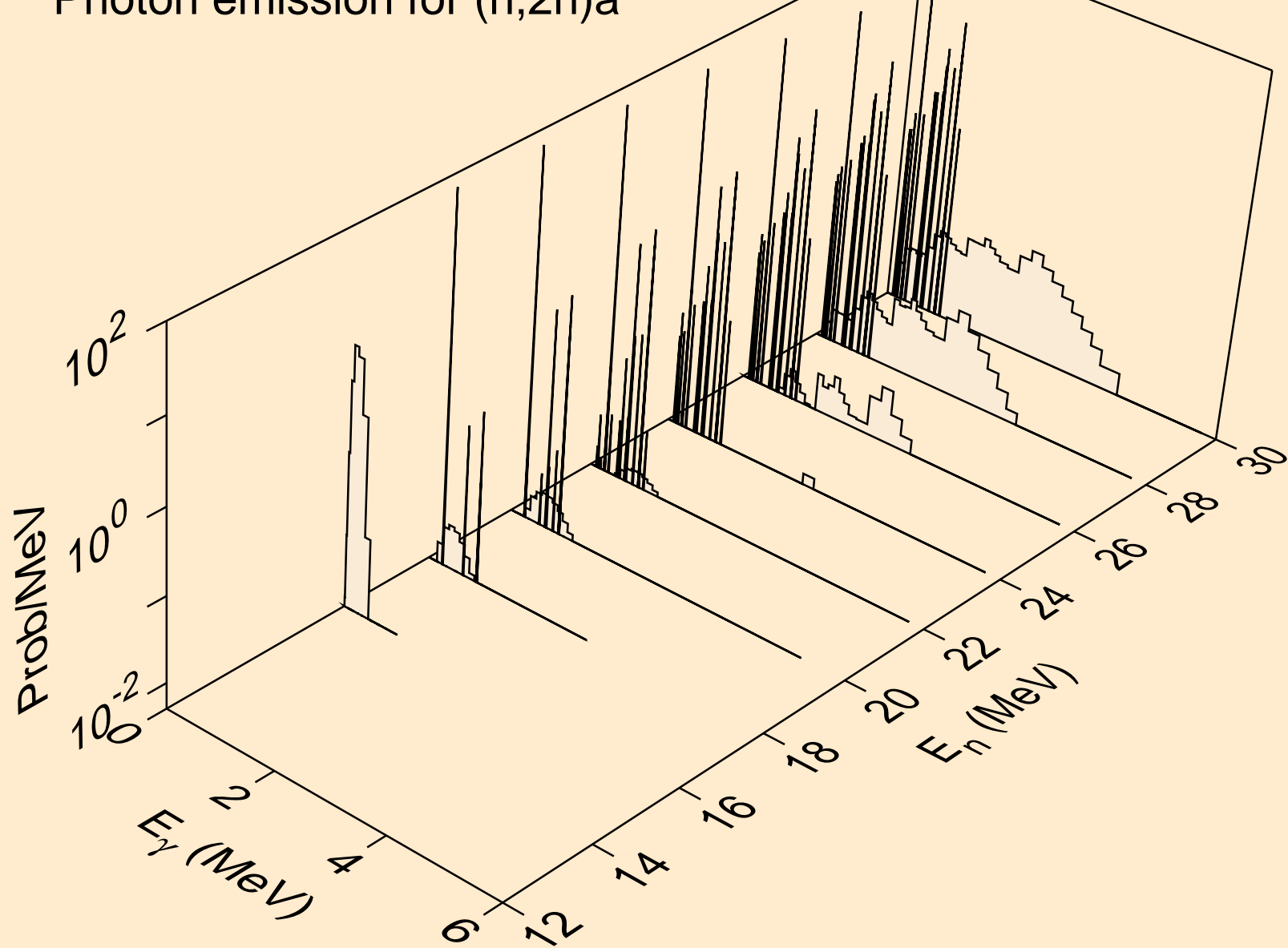

SN106 NEUTRON ACER TENDL-2023 LIBRARY; T=0.K
Photon emission for (n,3n)a

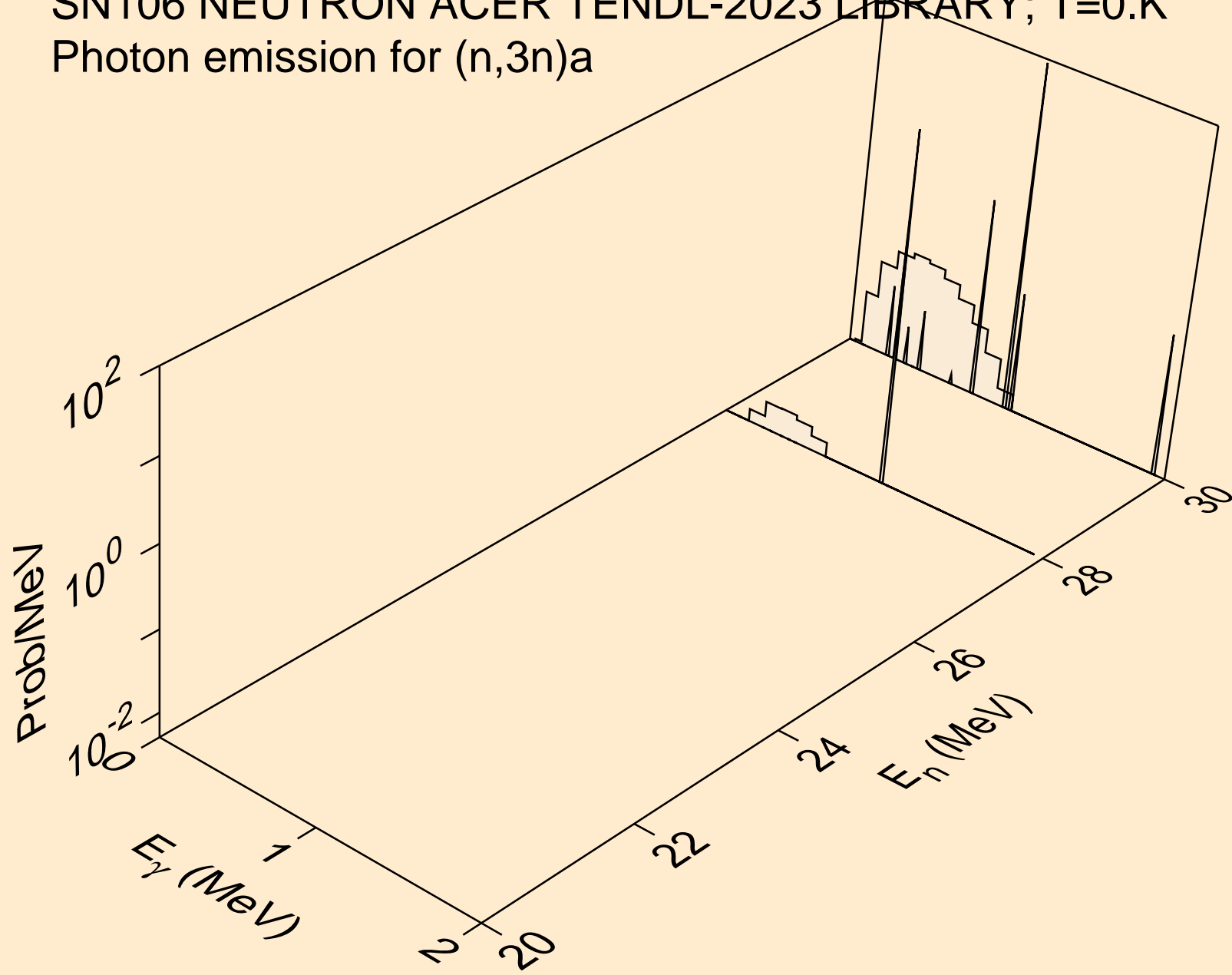

SN106 NEUTRON ACER TENDL-2023 LIBRARY; T=0.K
Photon emission for (n,n*)p

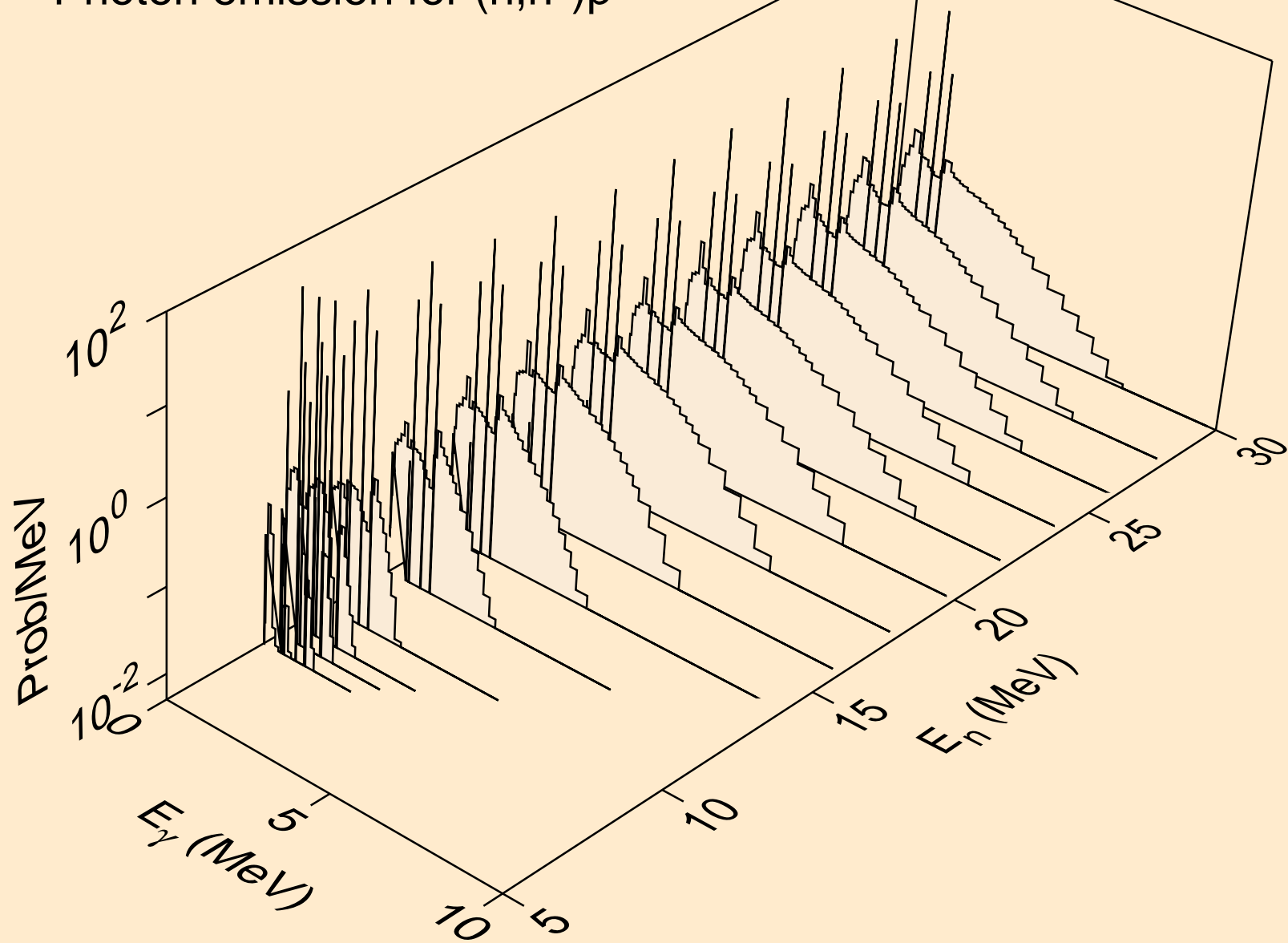

SN106 NEUTRON ACER TENDL-2023 LIBRARY; T=0.K
Photon emission for (n,n*)2a

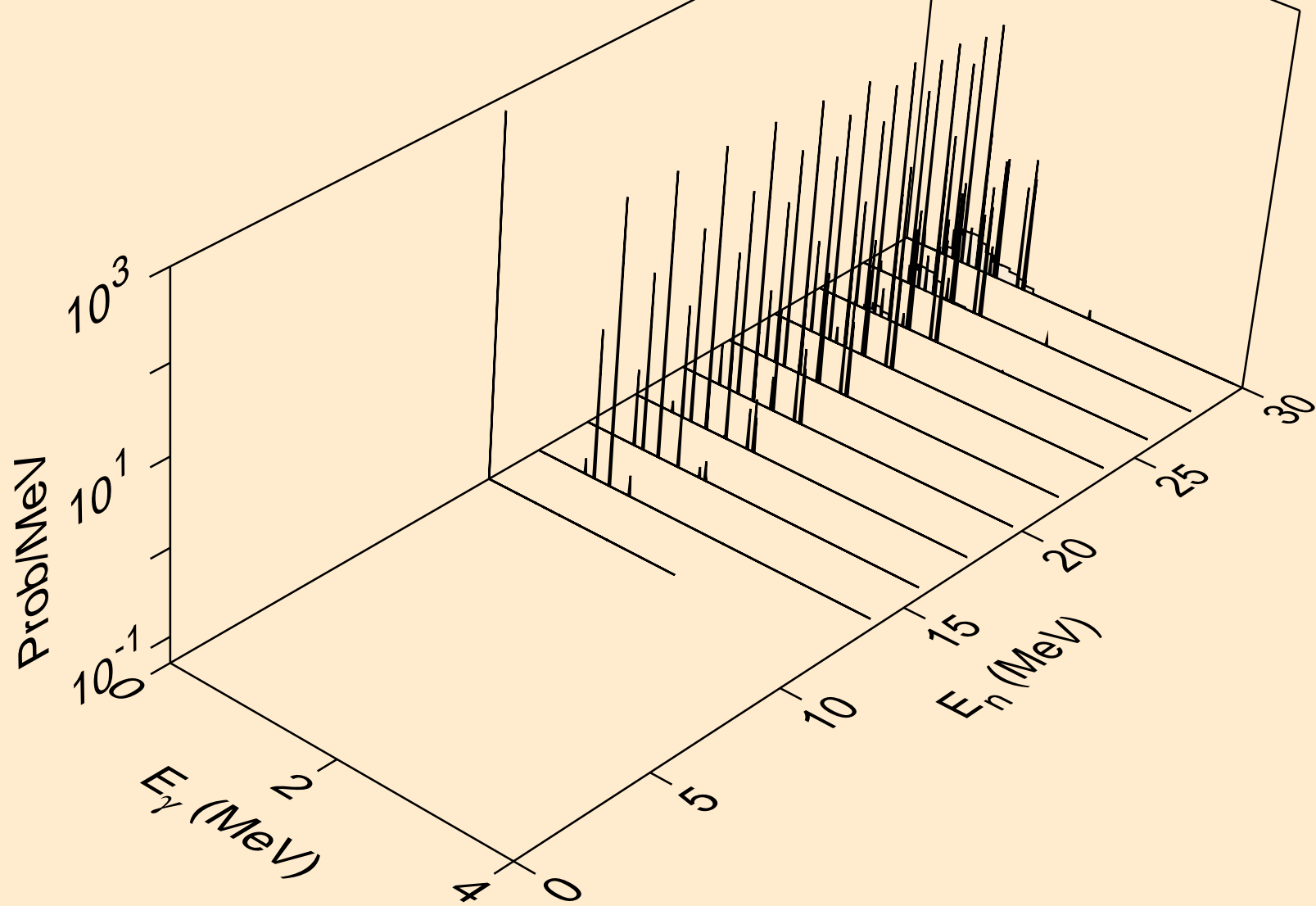

SN106 NEUTRON ACER TENDL-2023 LIBRARY; T=0.K
Photon emission for (n,n*)d

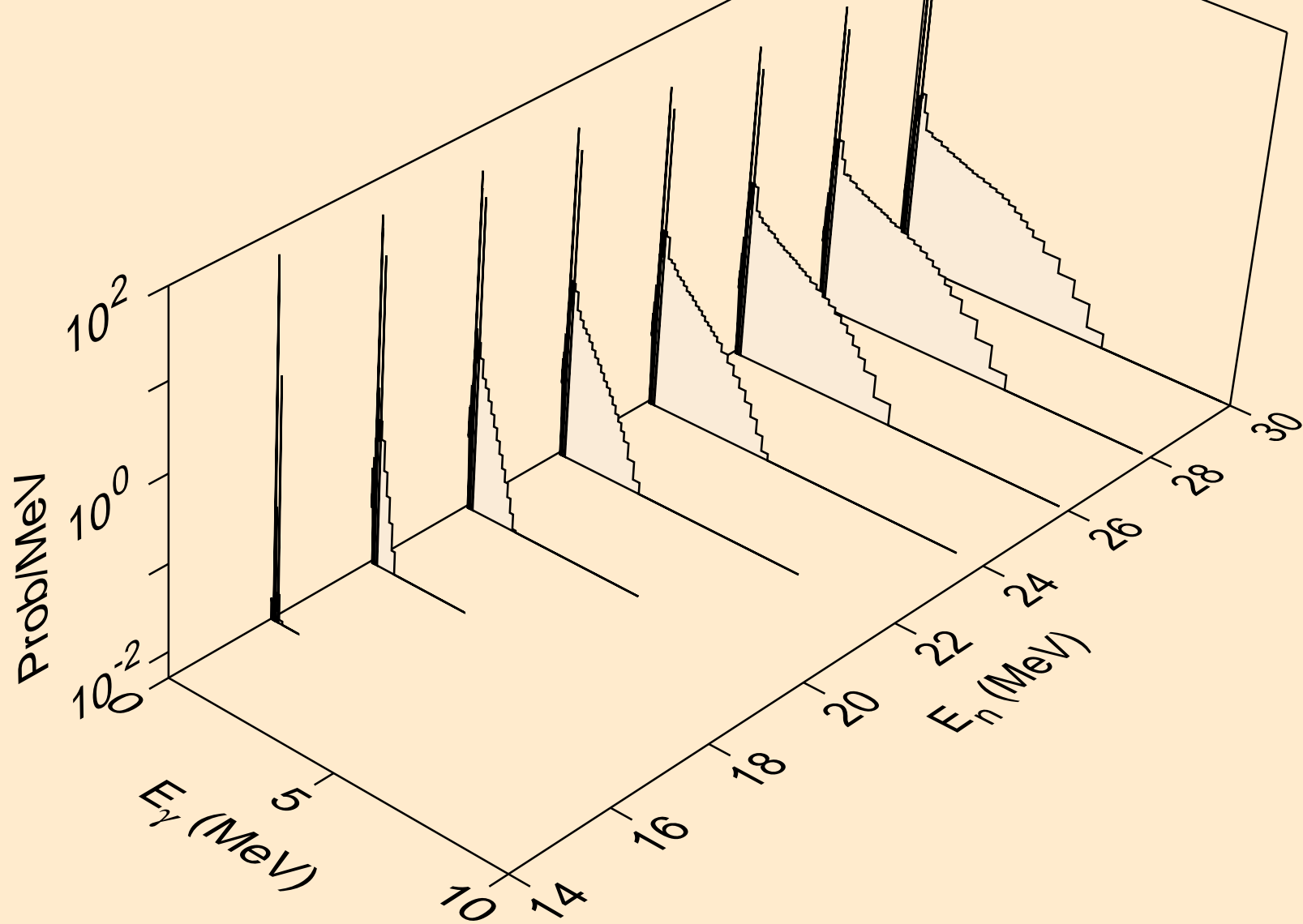

SN106 NEUTRON ACER TENDL-2023 LIBRARY; T=0.K
Photon emission for (n,n*)t

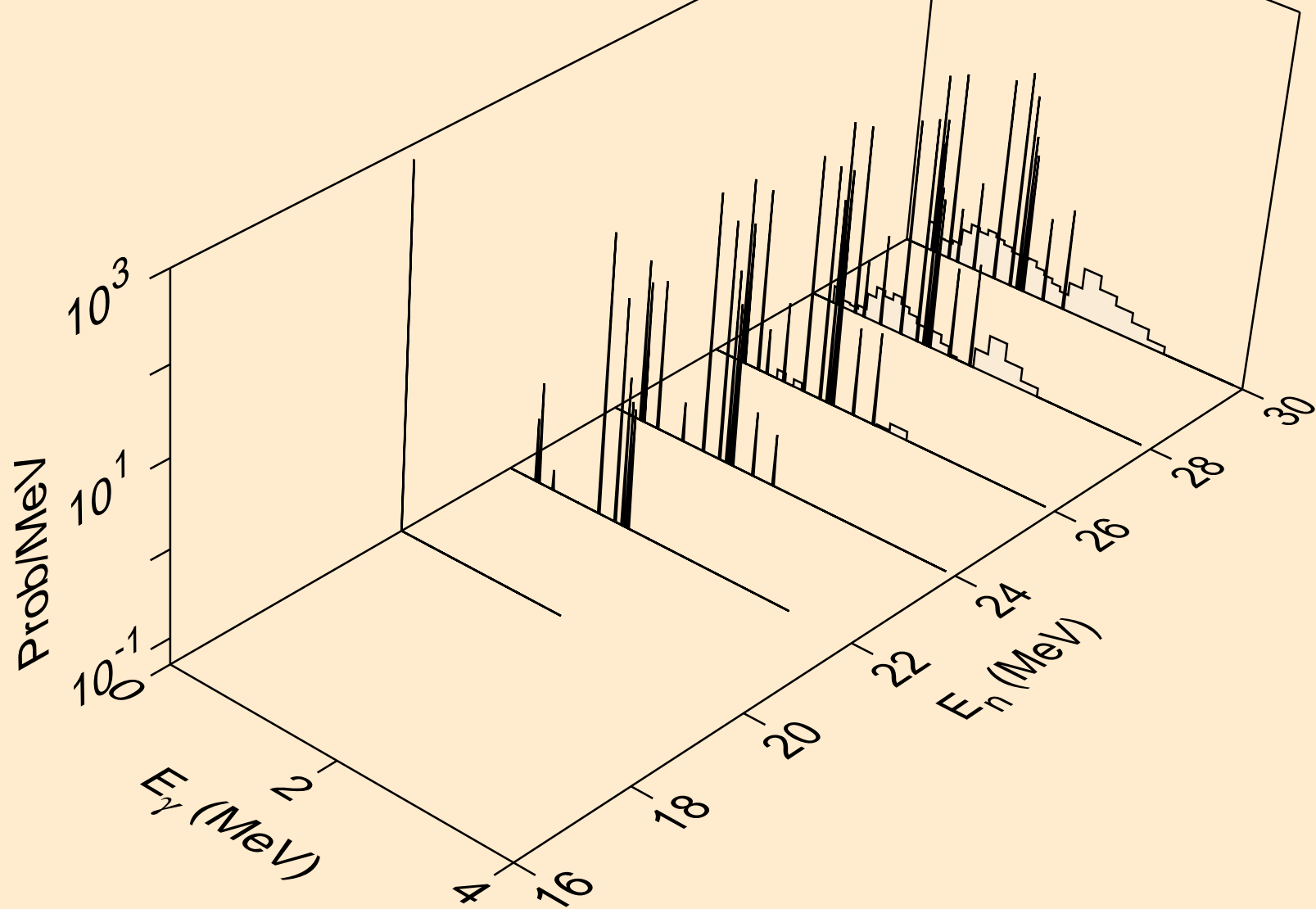

SN106 NEUTRON ACER TENDL-2023 LIBRARY; T=0.K
Photon emission for (n,n*)he3

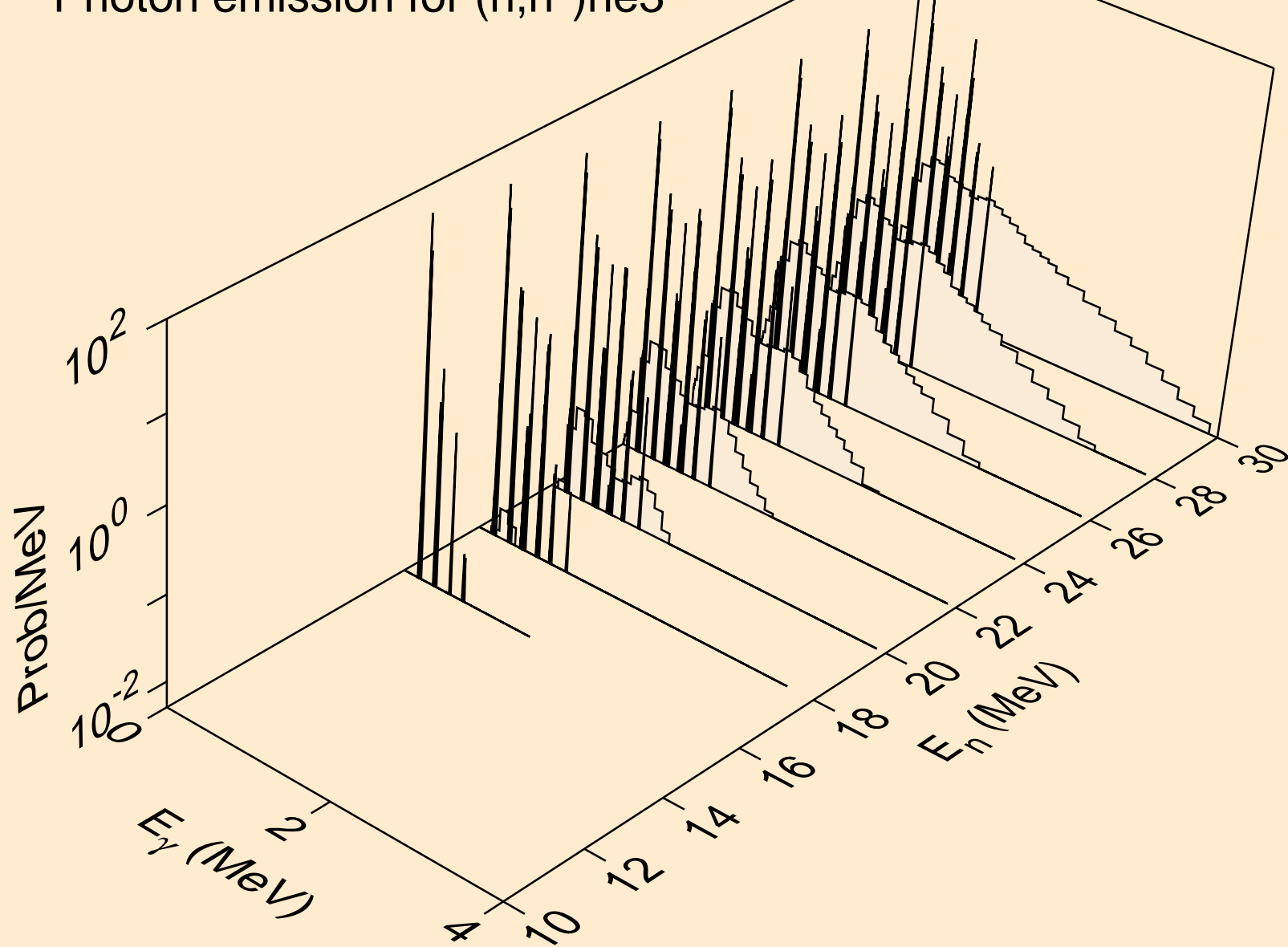

SN106 NEUTRON ACER TENDL-2023 LIBRARY; T=0.K
Photon emission for (n,2np)

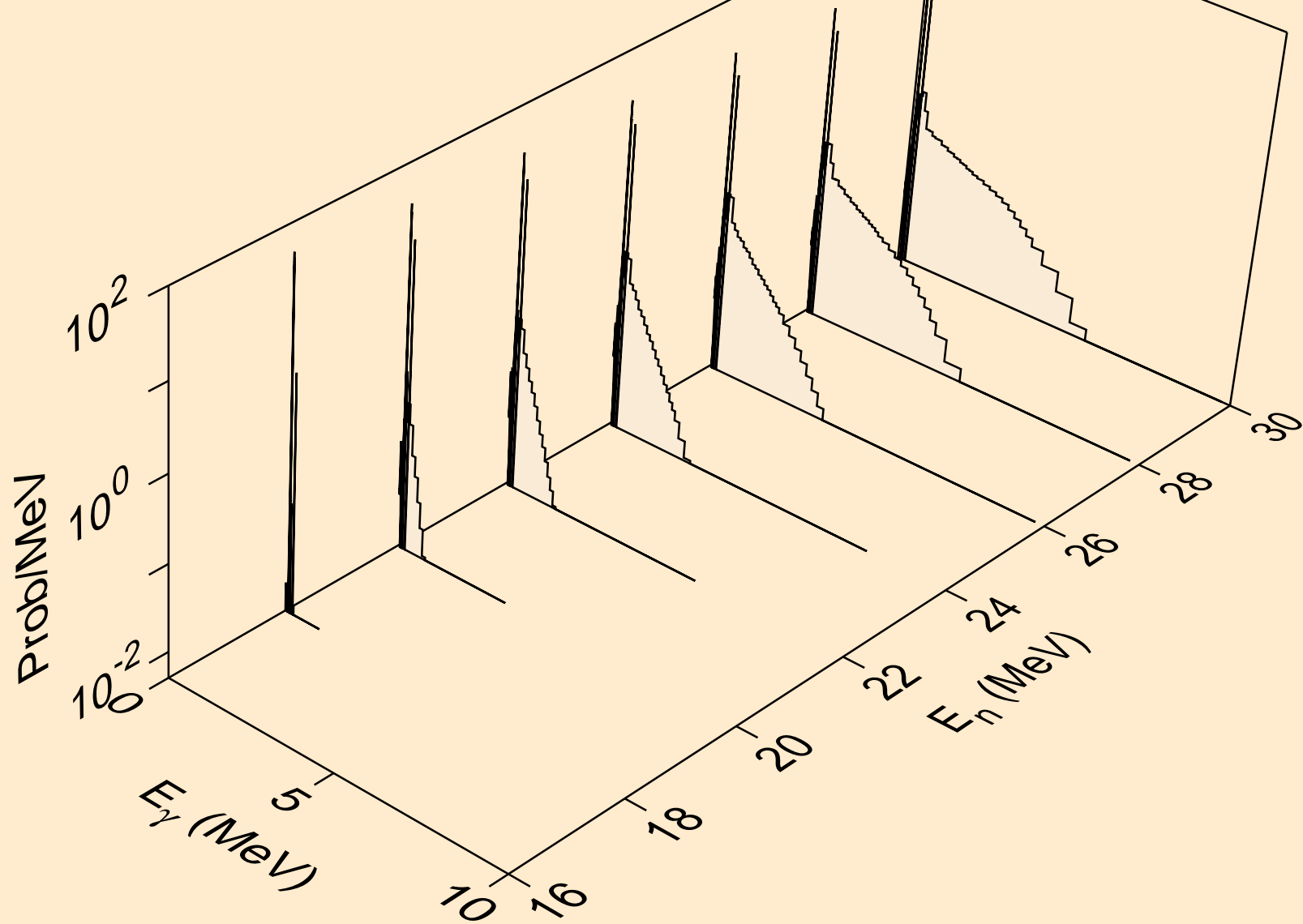

SN106 NEUTRON ACER TENDL-2023 LIBRARY; T=0.K
Photon emission for (n,3np)

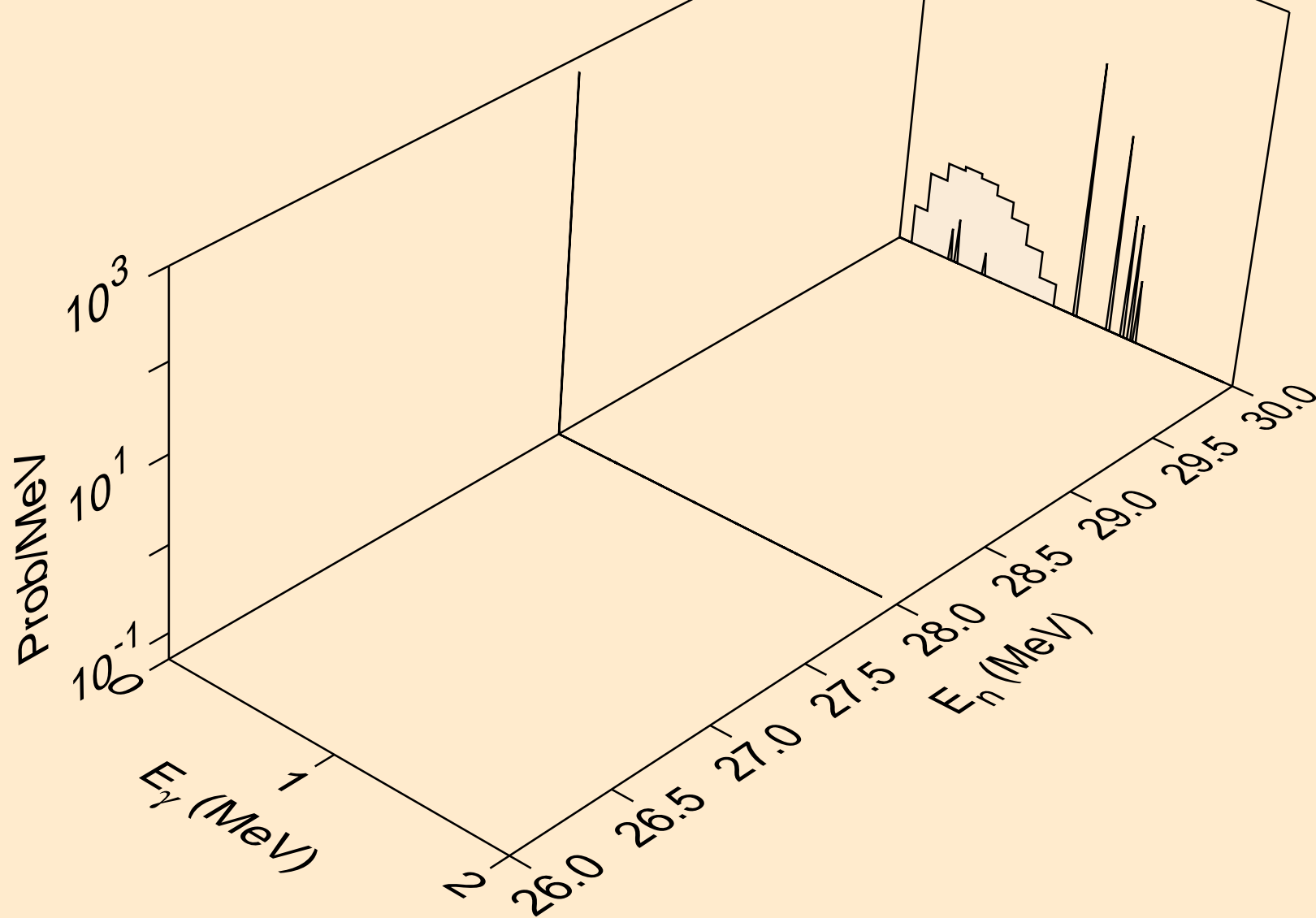

SN106 NEUTRON ACER TENDL-2023 LIBRARY; T=0.K
Photon emission for (n,n2p)

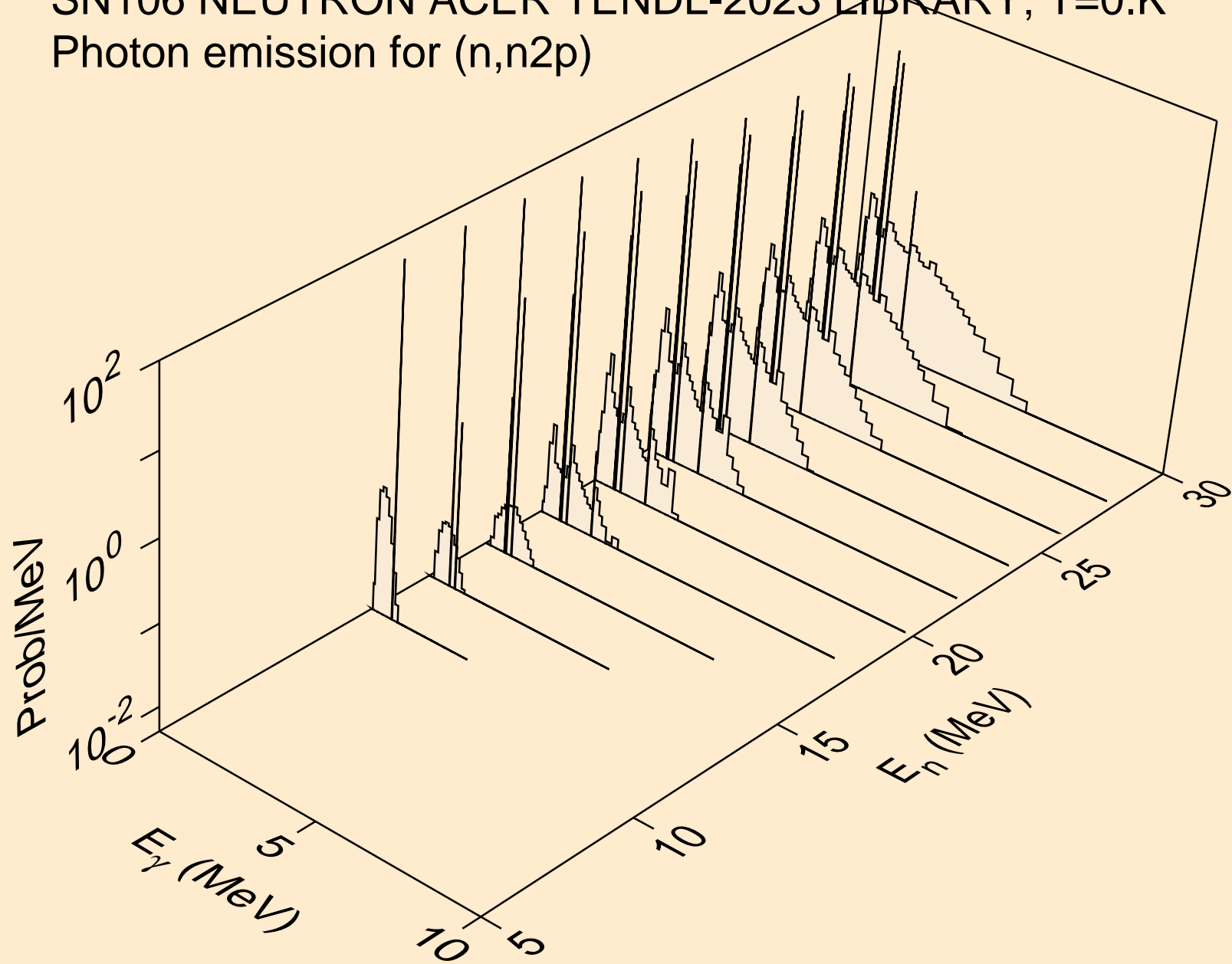

SN106 NEUTRON ACER TENDL-2023 LIBRARY; T=0.K
Photon emission for (n,npa)

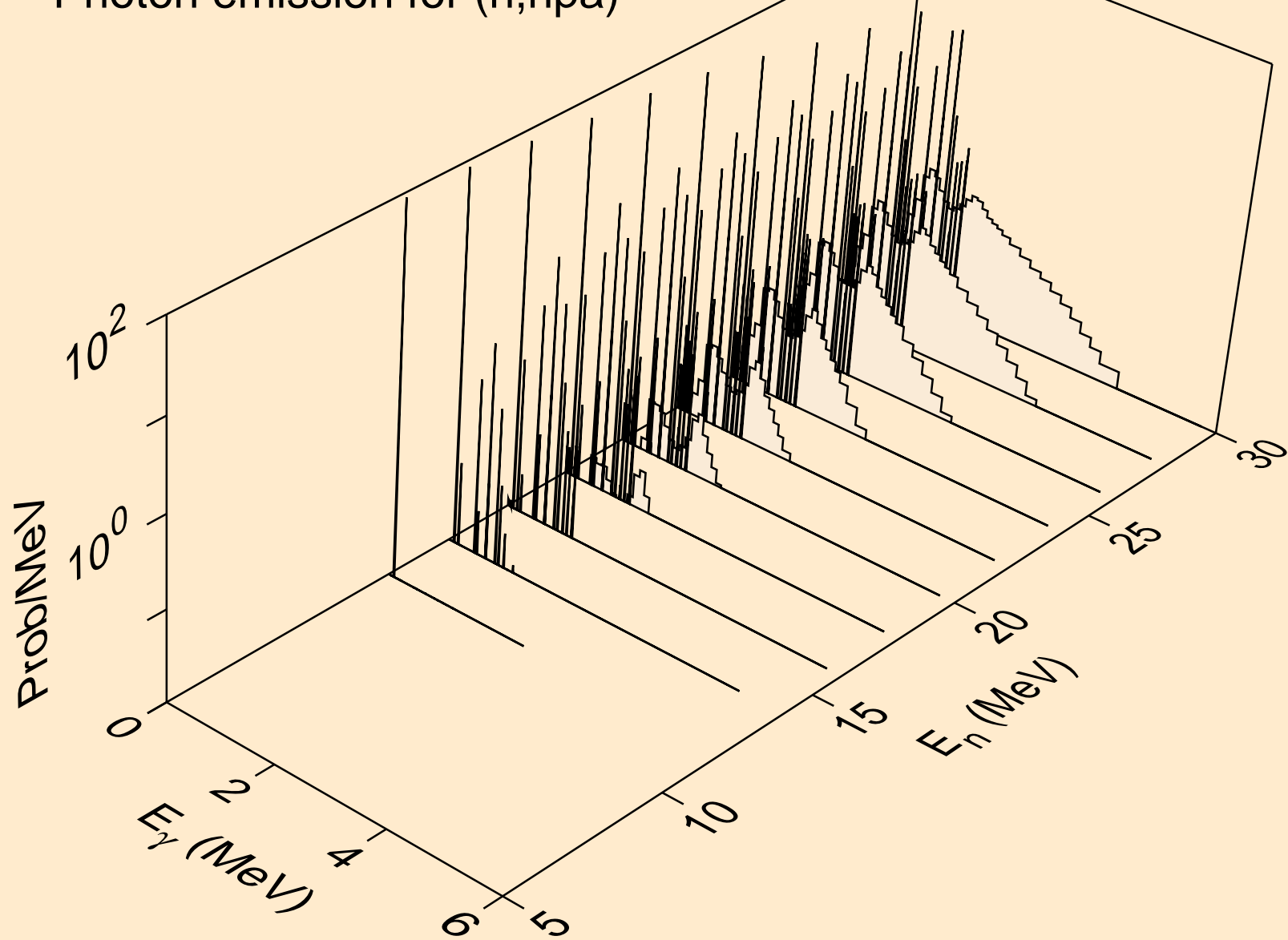

SN106 NEUTRON ACER TENDL-2023 LIBRARY; T=0.K
Photon emission for (n,n*c)

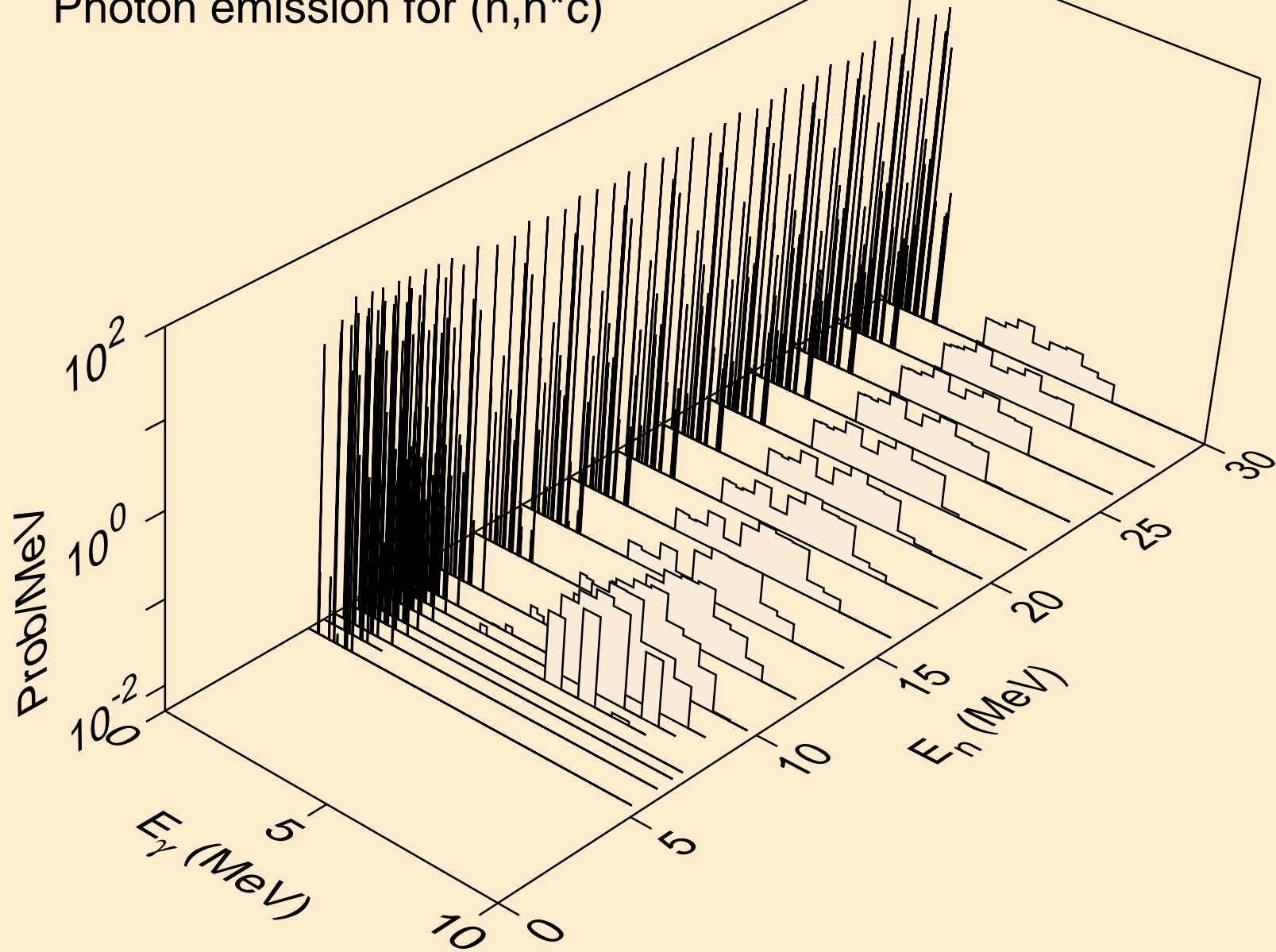

SN106 NEUTRON ACER TENDL-2023 LIBRARY; T=0.K
Photon emission for (n,gma)

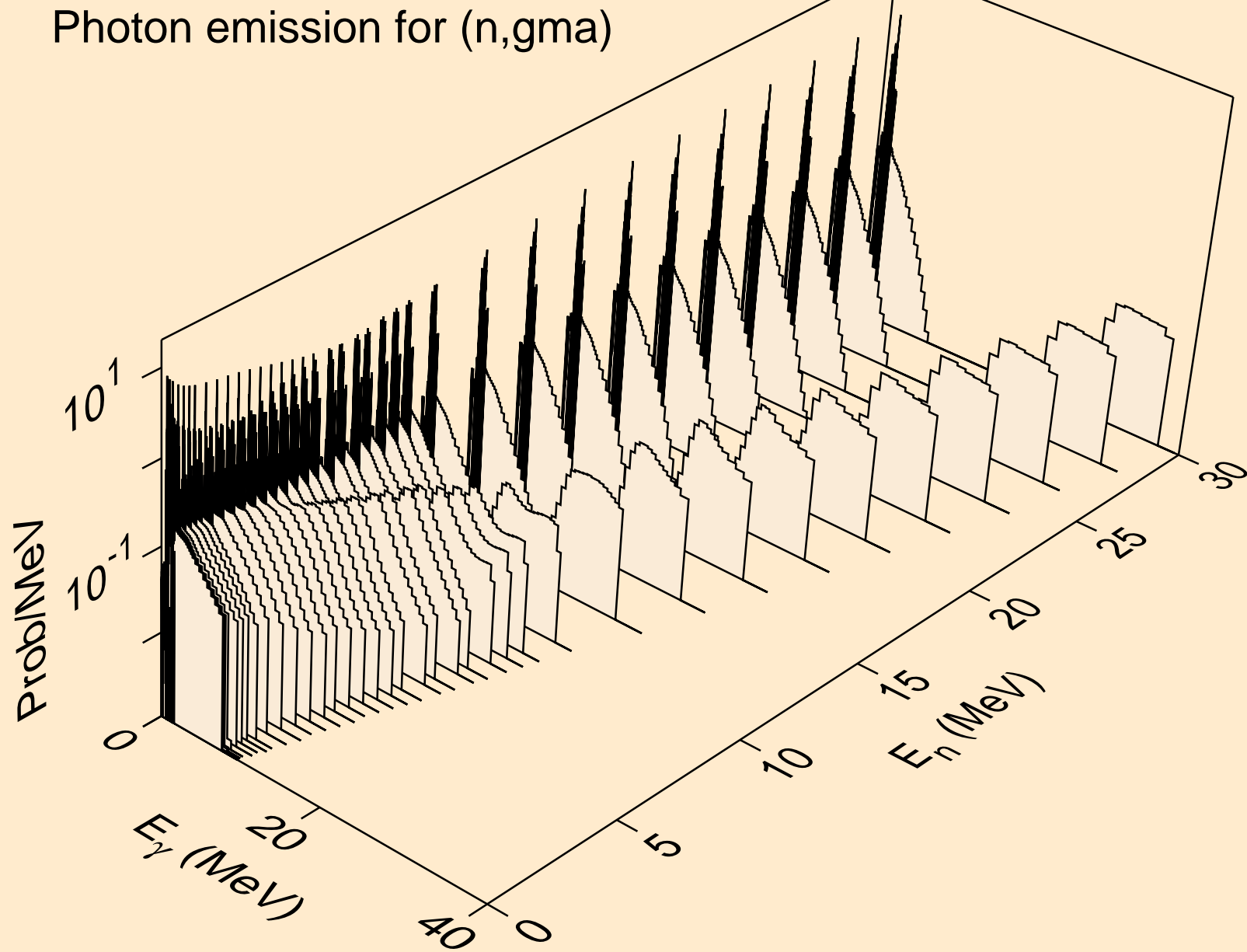

SN106 NEUTRON ACER TENDL-2023 LIBRARY; T=0.K
Photon emission for (n,p)

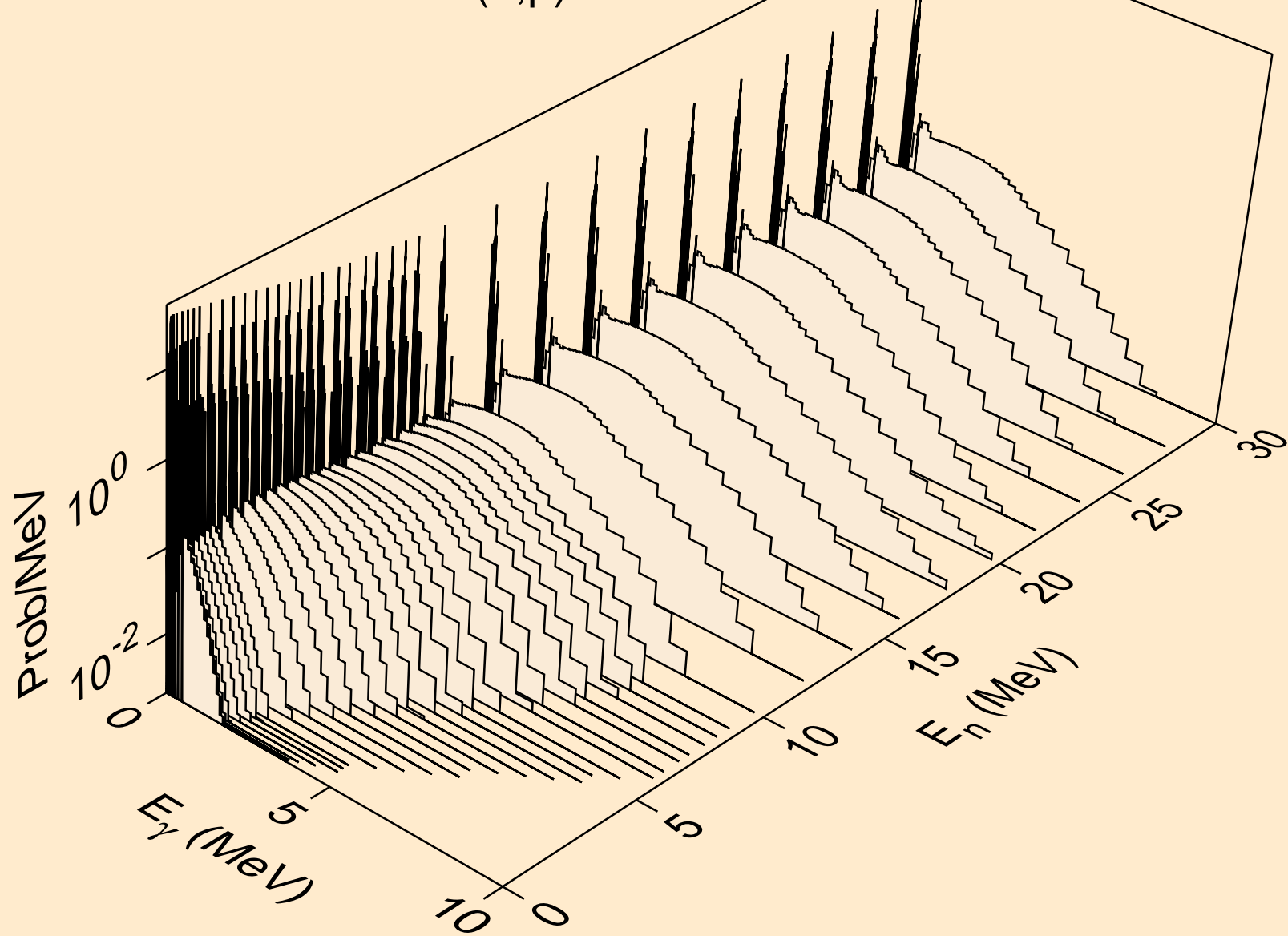

SN106 NEUTRON ACER TENDL-2023 LIBRARY; T=0.K
Photon emission for (n,d)

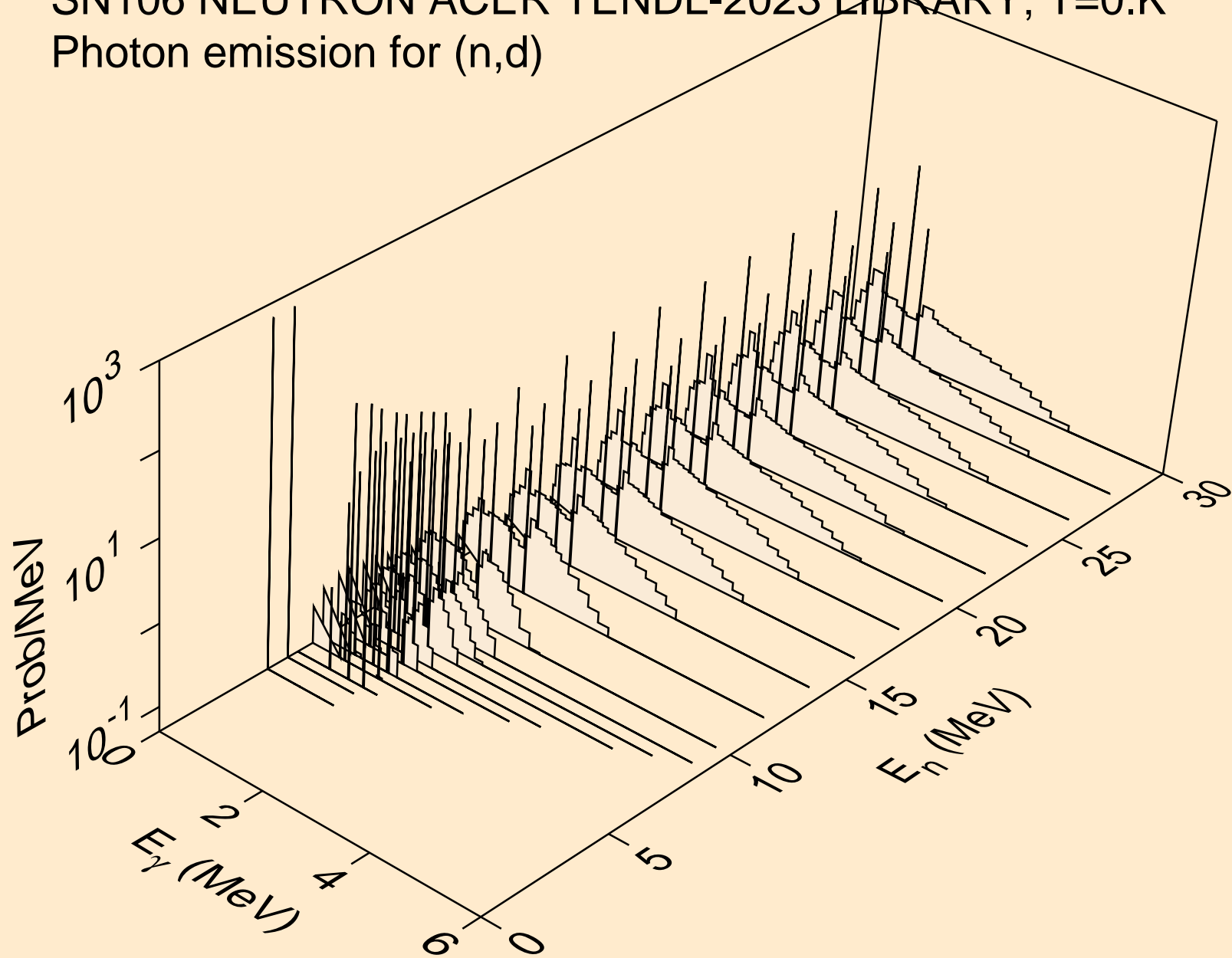

SN106 NEUTRON ACER TENDL-2023 LIBRARY; T=0.K
Photon emission for (n,t)

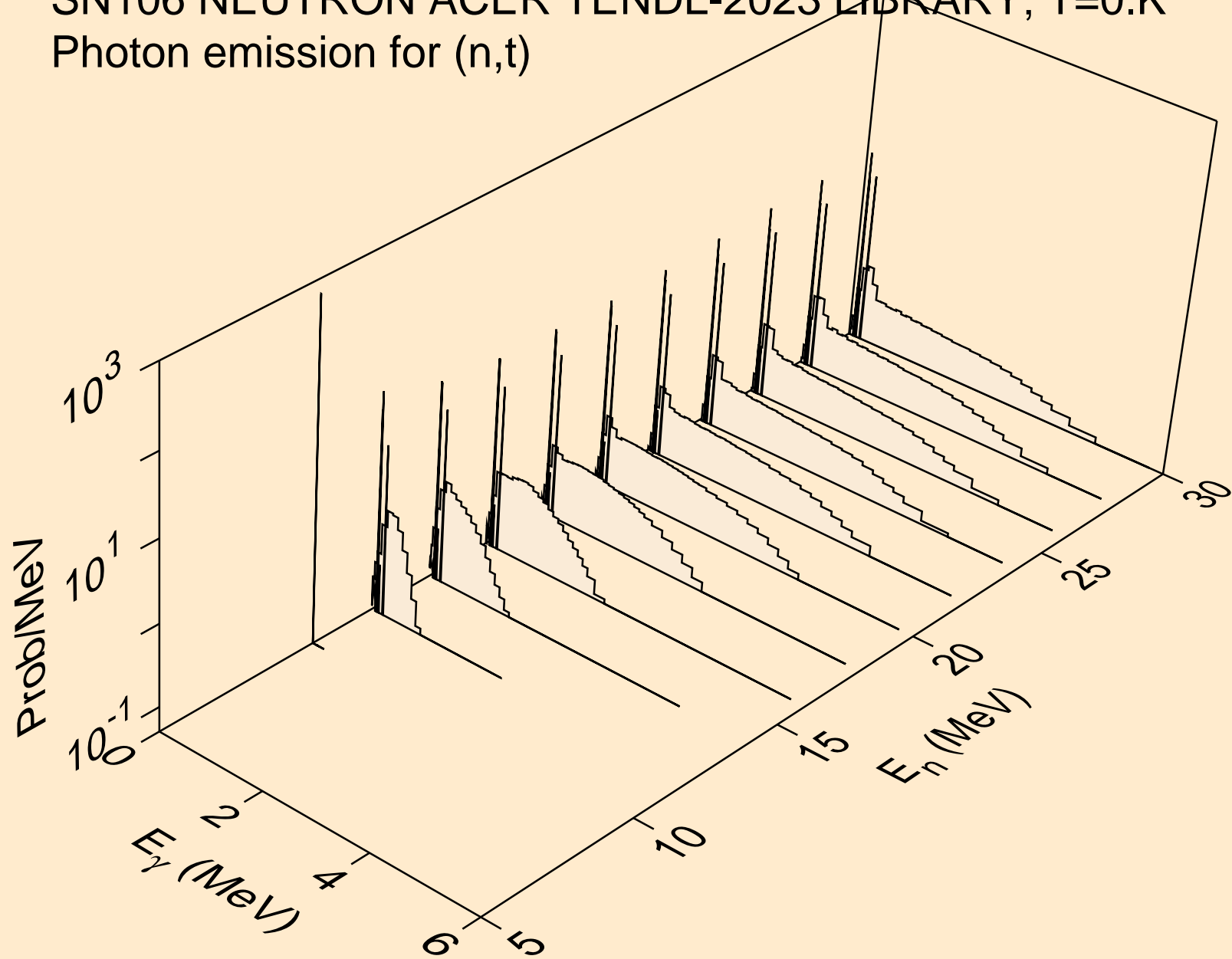

SN106 NEUTRON ACER TENDL-2023 LIBRARY; T=0.K
Photon emission for (n,he3)

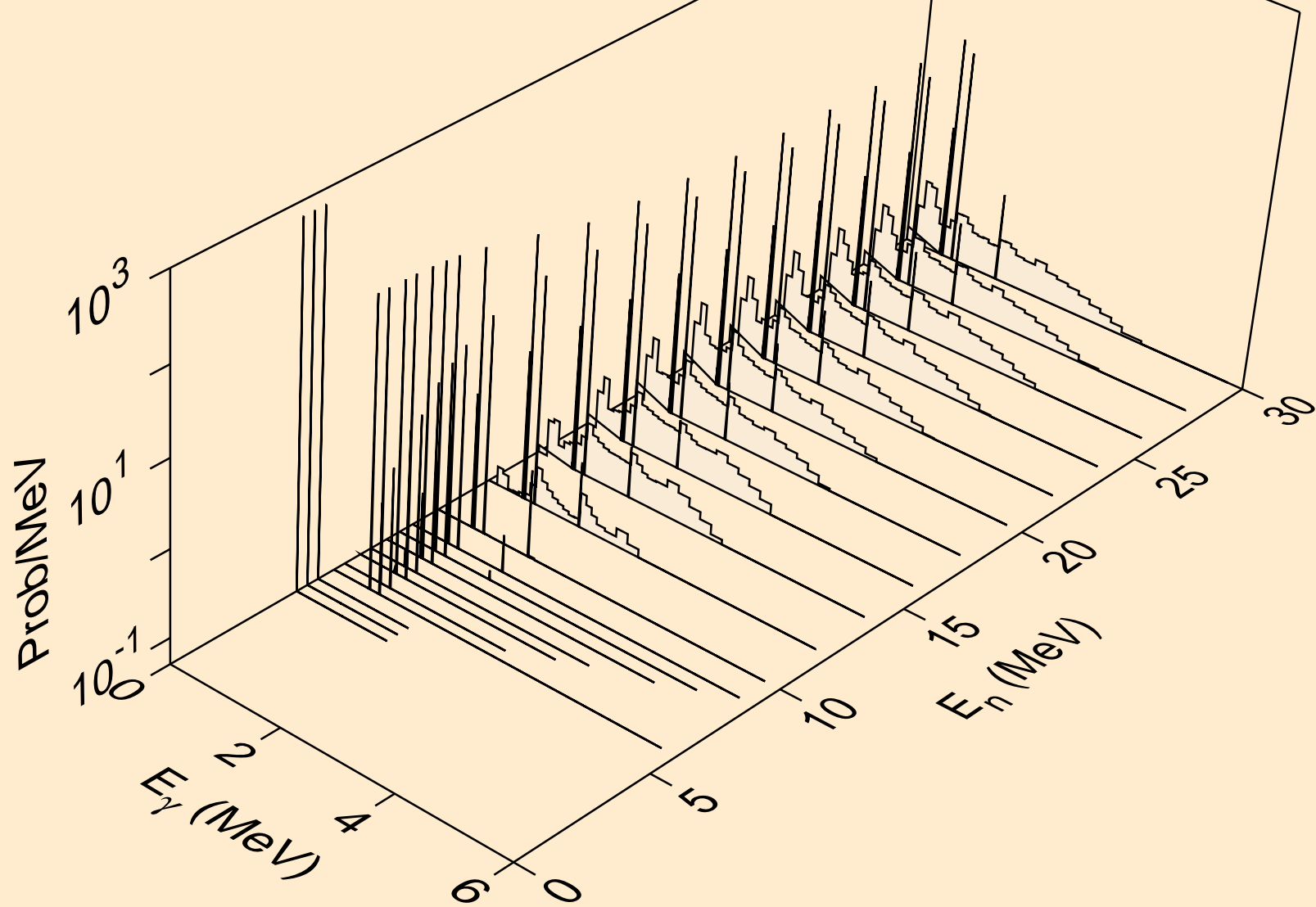

SN106 NEUTRON ACER TENDL-2023 LIBRARY; T=0.K
Photon emission for (n,a)

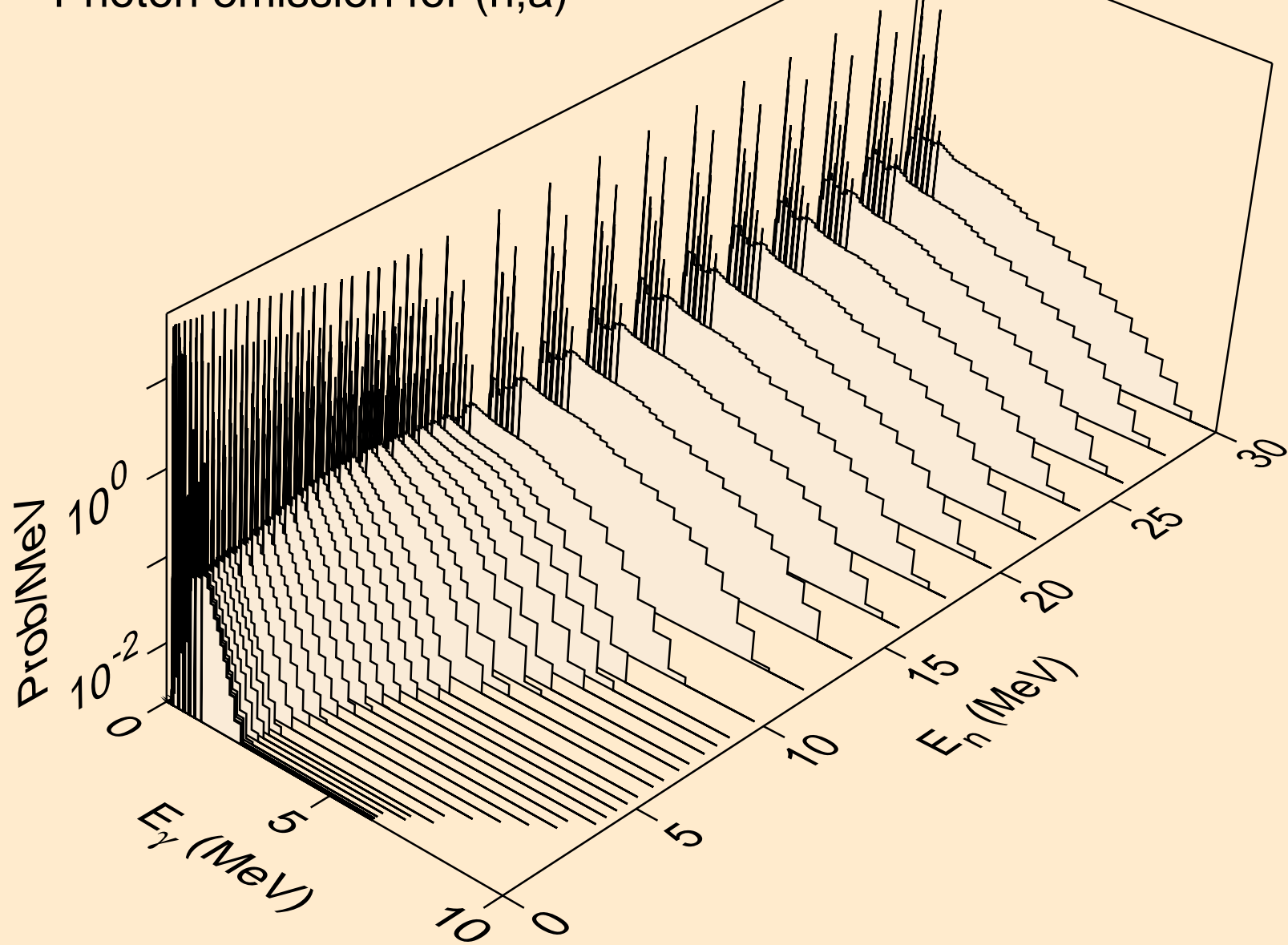

SN106 NEUTRON ACER TENDL-2023 LIBRARY; T=0.K
Photon emission for (n,2a)

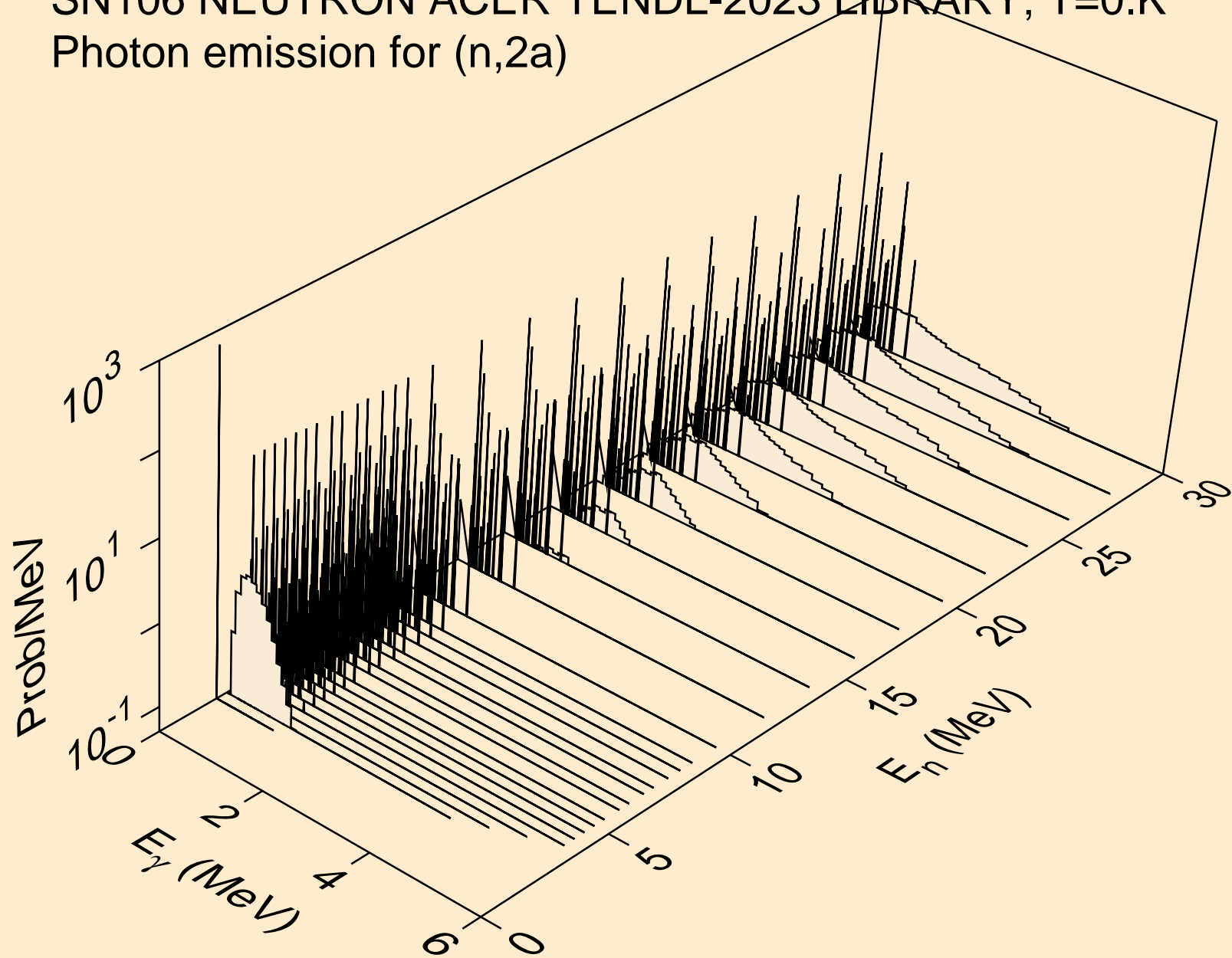

SN106 NEUTRON ACER TENDL-2023 LIBRARY; T=0.K
Photon emission for (n,3a)

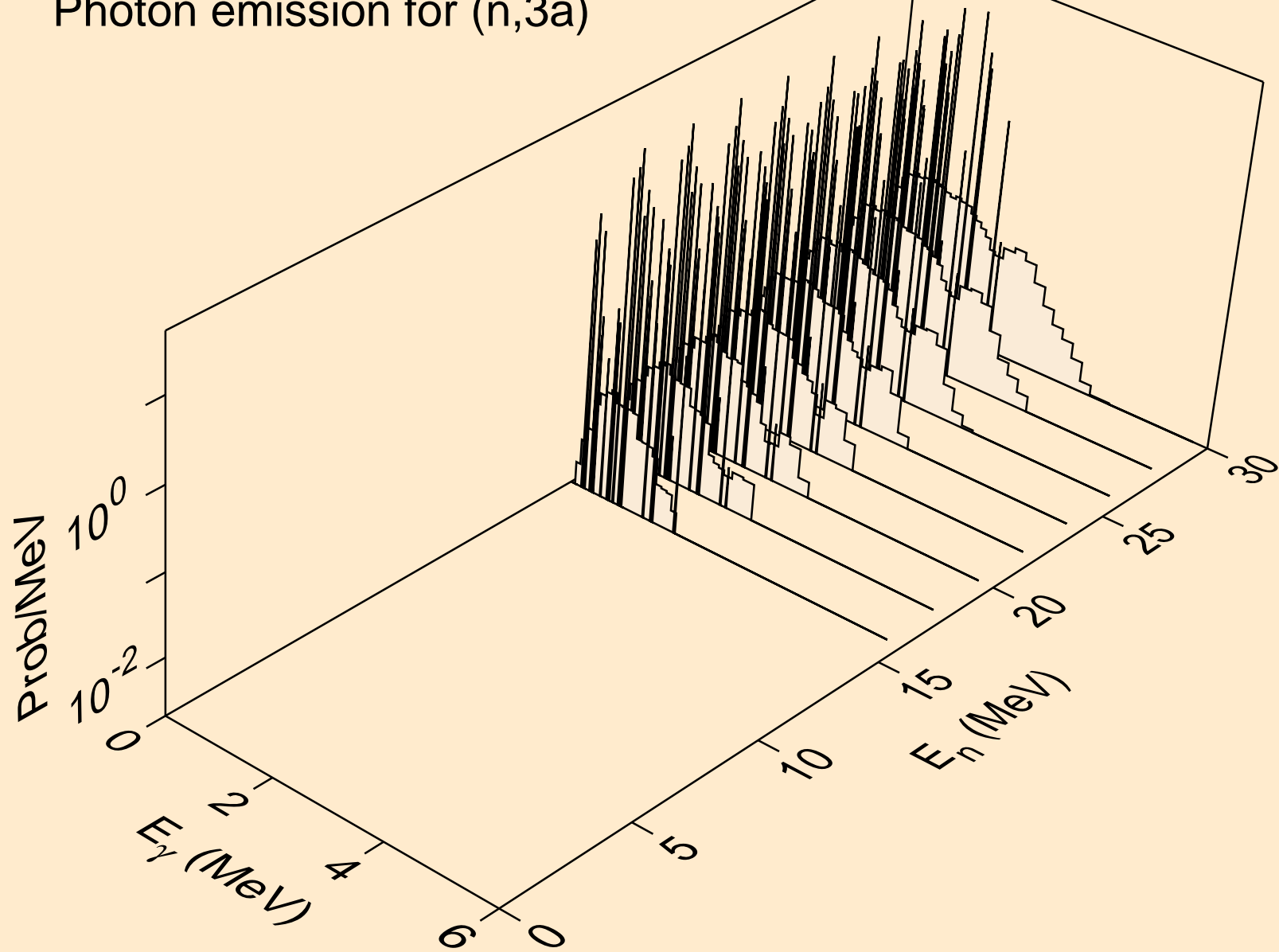

SN106 NEUTRON ACER TENDL-2023 LIBRARY; T=0.K
Photon emission for (n,2p)

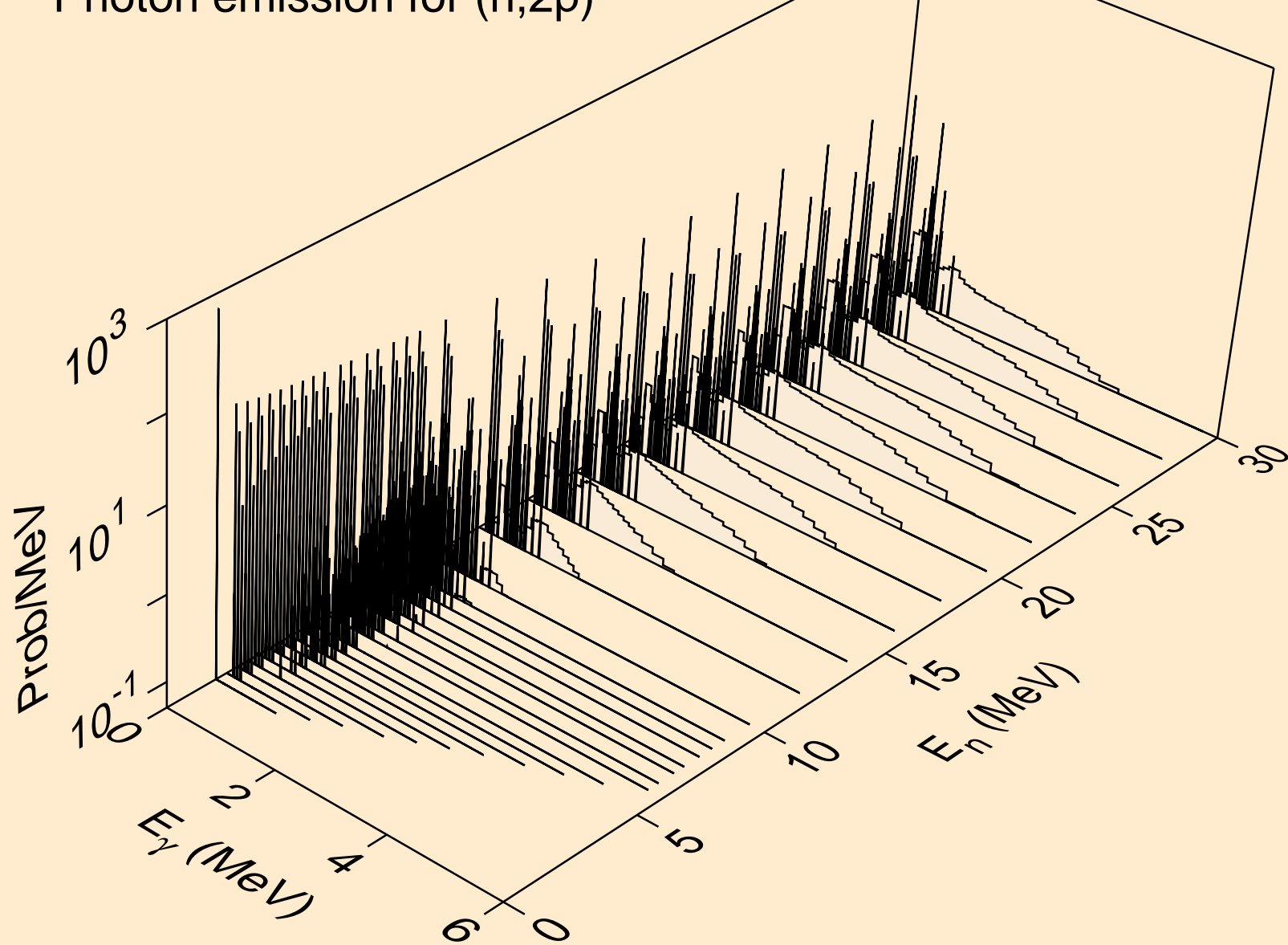

SN106 NEUTRON ACER TENDL-2023 LIBRARY; T=0.K
Photon emission for (n,p)

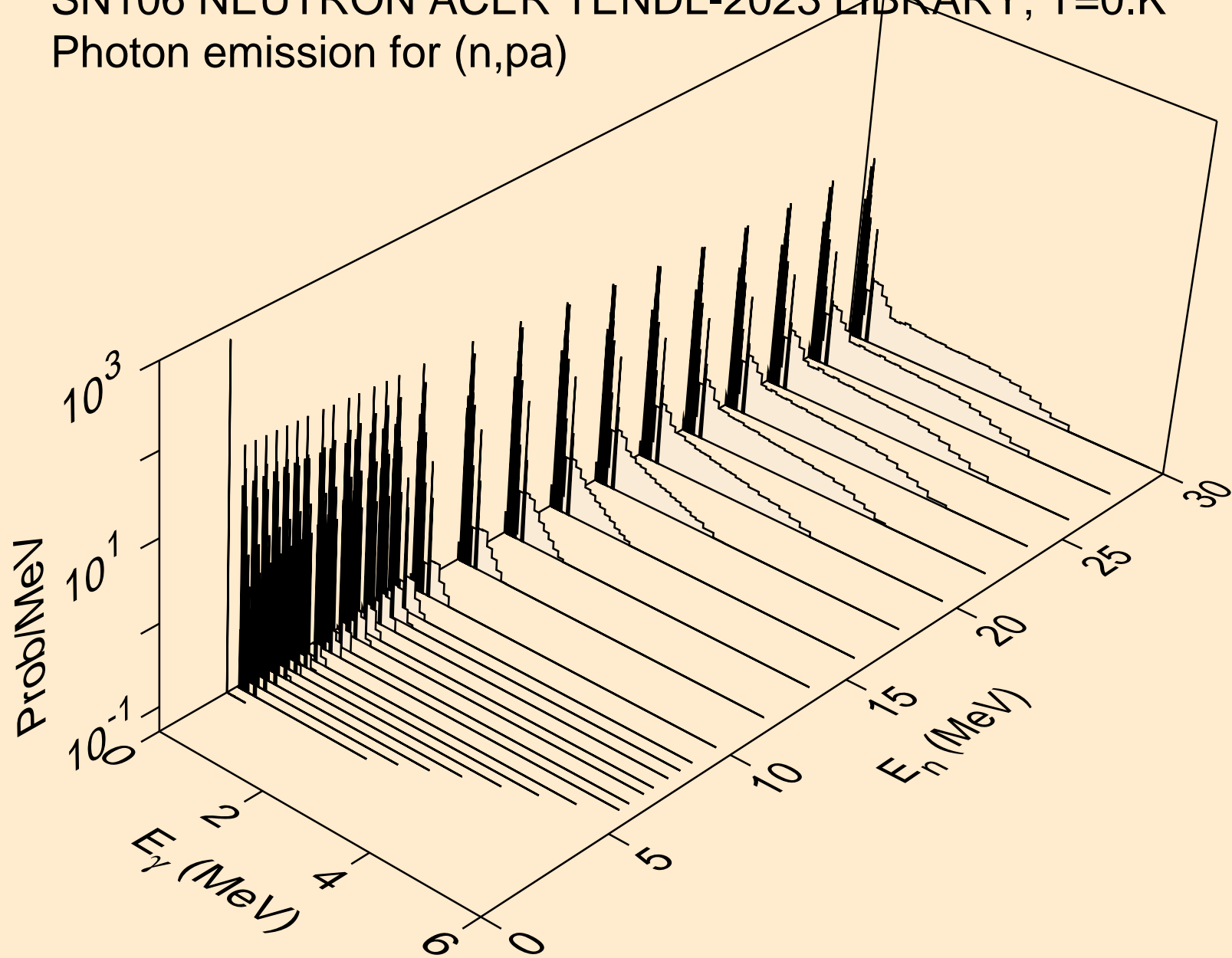

SN106 NEUTRON ACER TENDL-2023 LIBRARY; T=0.K
Photon emission for (n,pd)

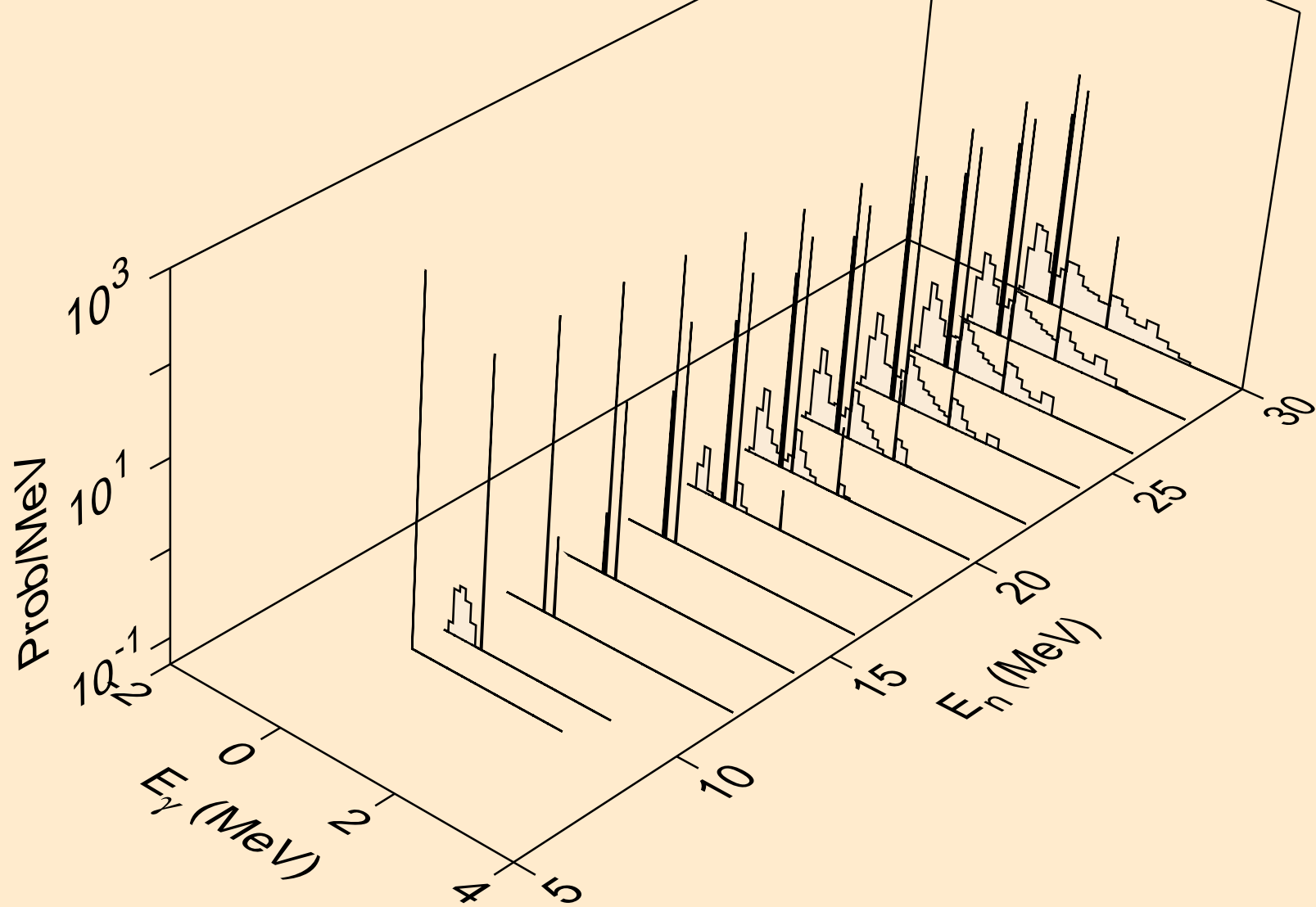

SN106 NEUTRON ACER TENDL-2023 LIBRARY; T=0.K
Photon emission for (n,pt)

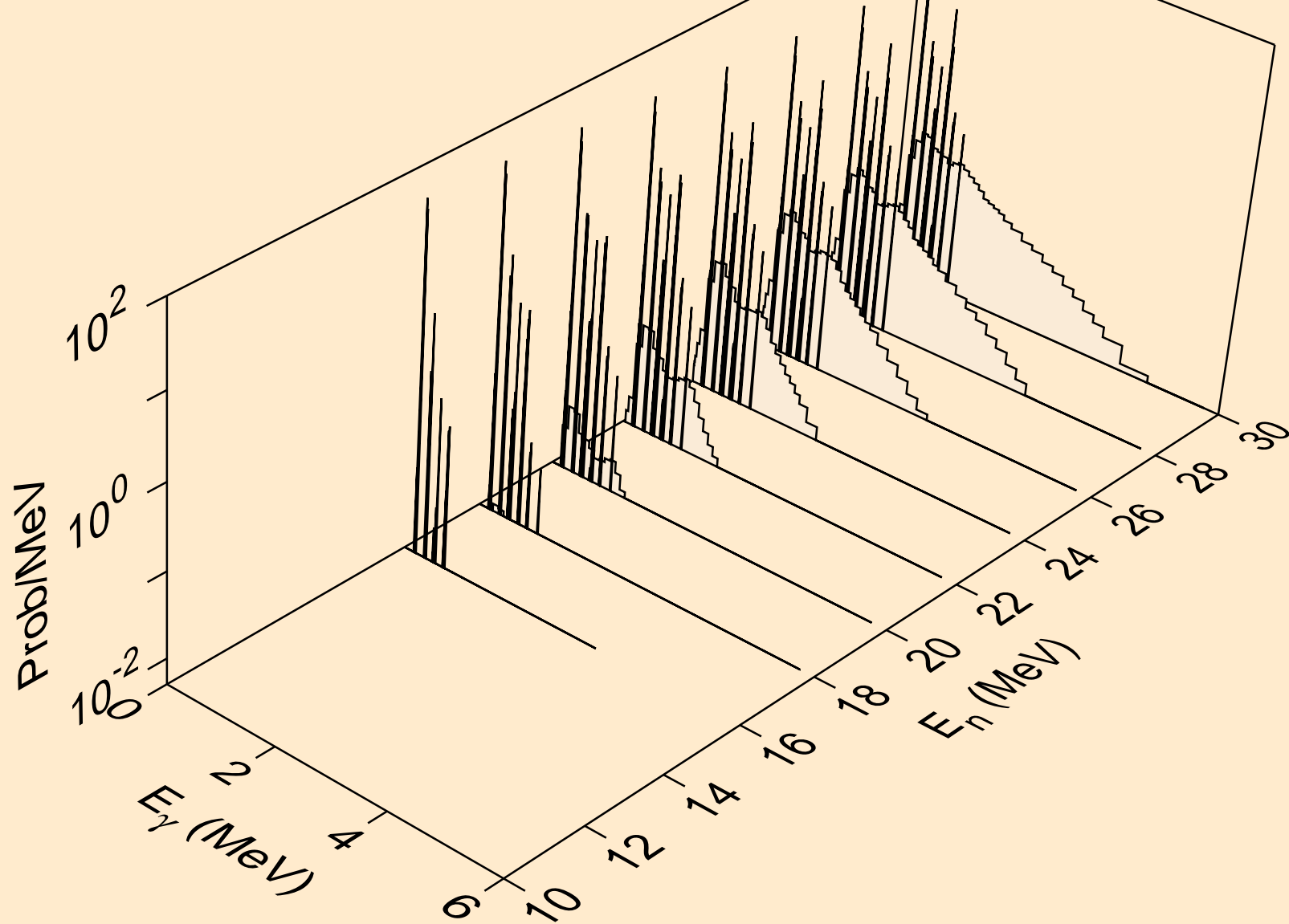

SN106 NEUTRON ACER TENDL-2023 LIBRARY; T=0.K
Photon emission for (n,da)

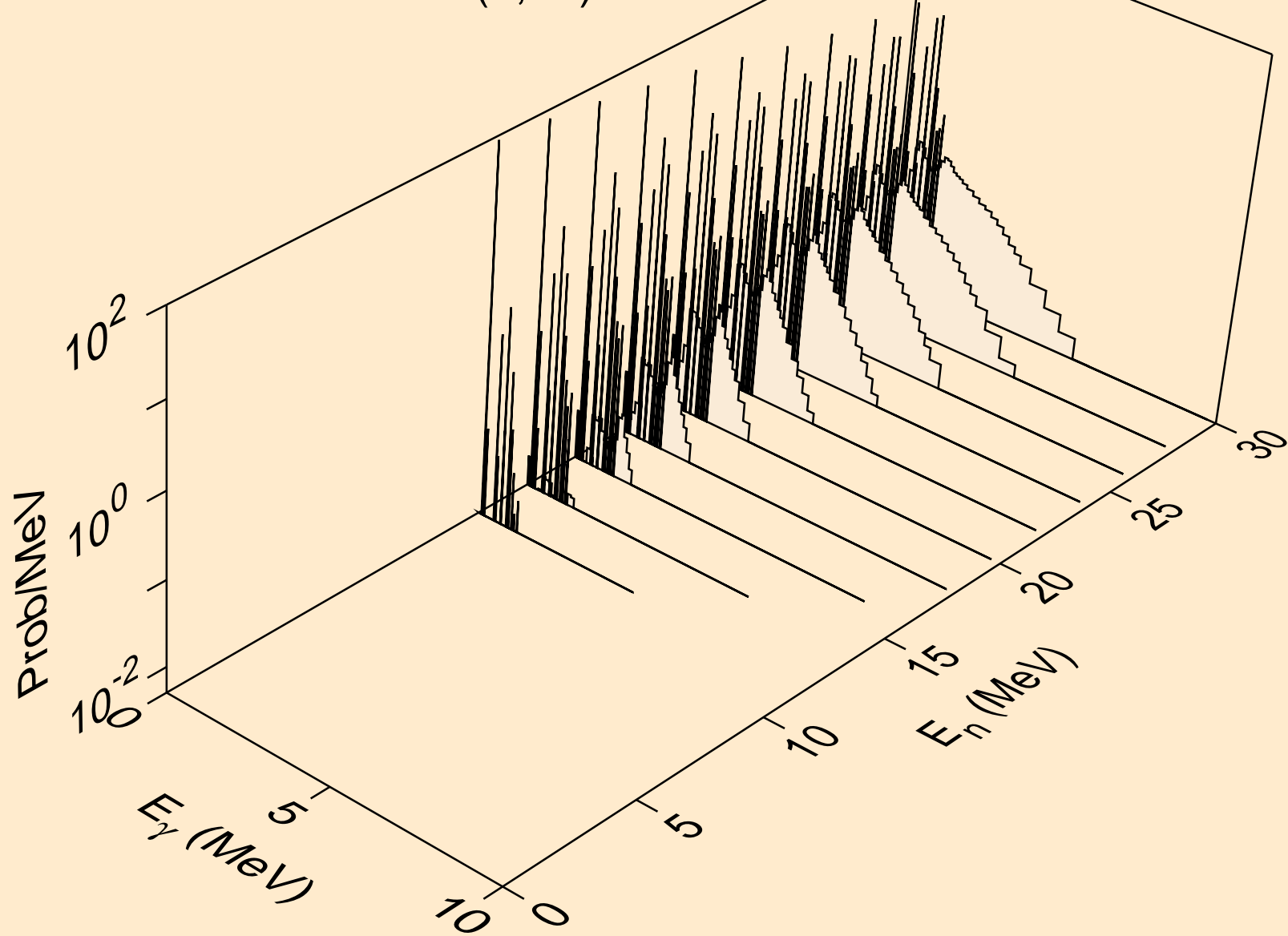

SN106 NEUTRON ACER TENDL-2023 LIBRARY; T=0.K
thermal capture photon spectrum

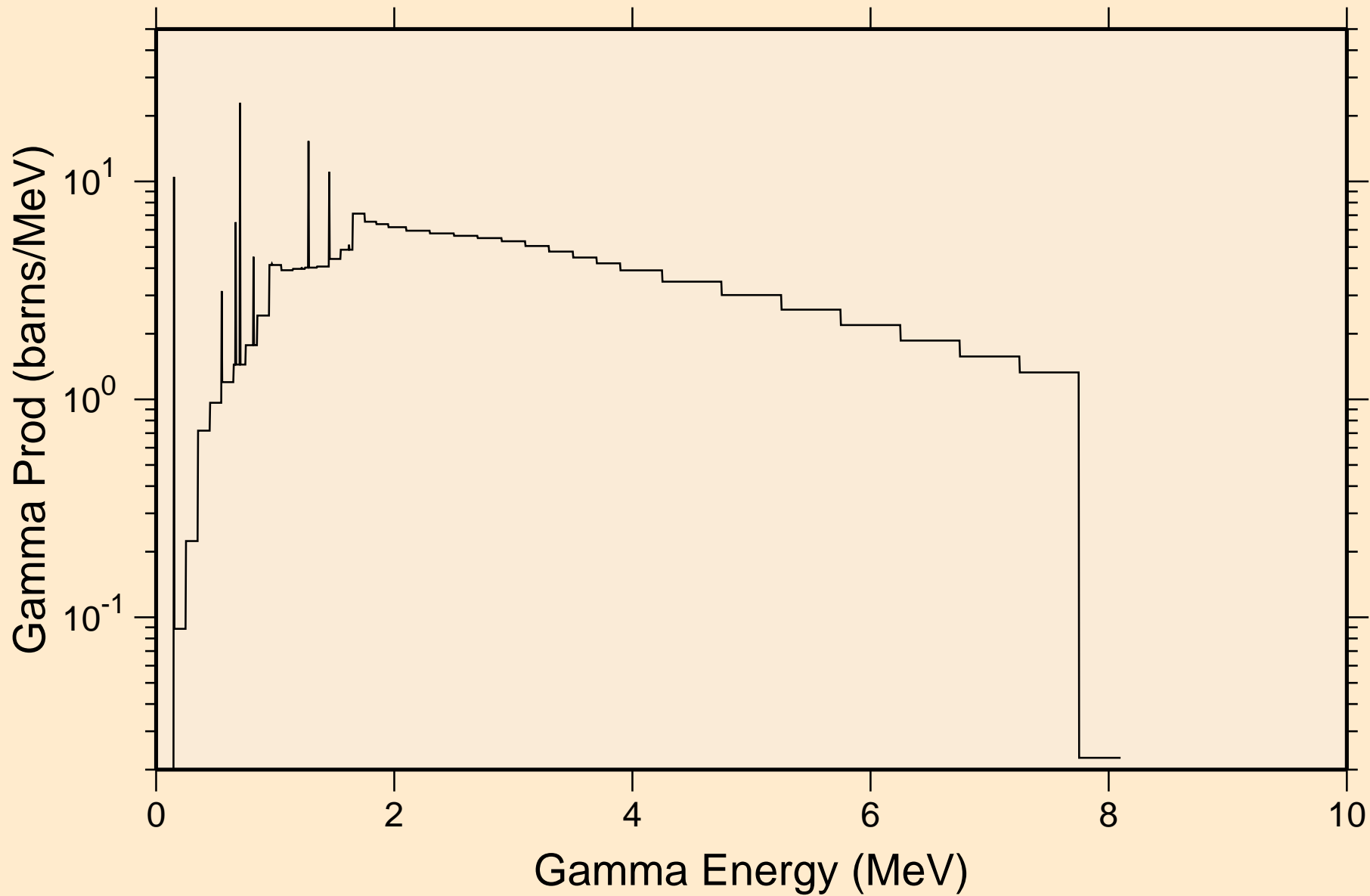

SN106 NEUTRON ACER TENDL-2023 LIBRARY; T=0.K
14 MeV photon spectrum

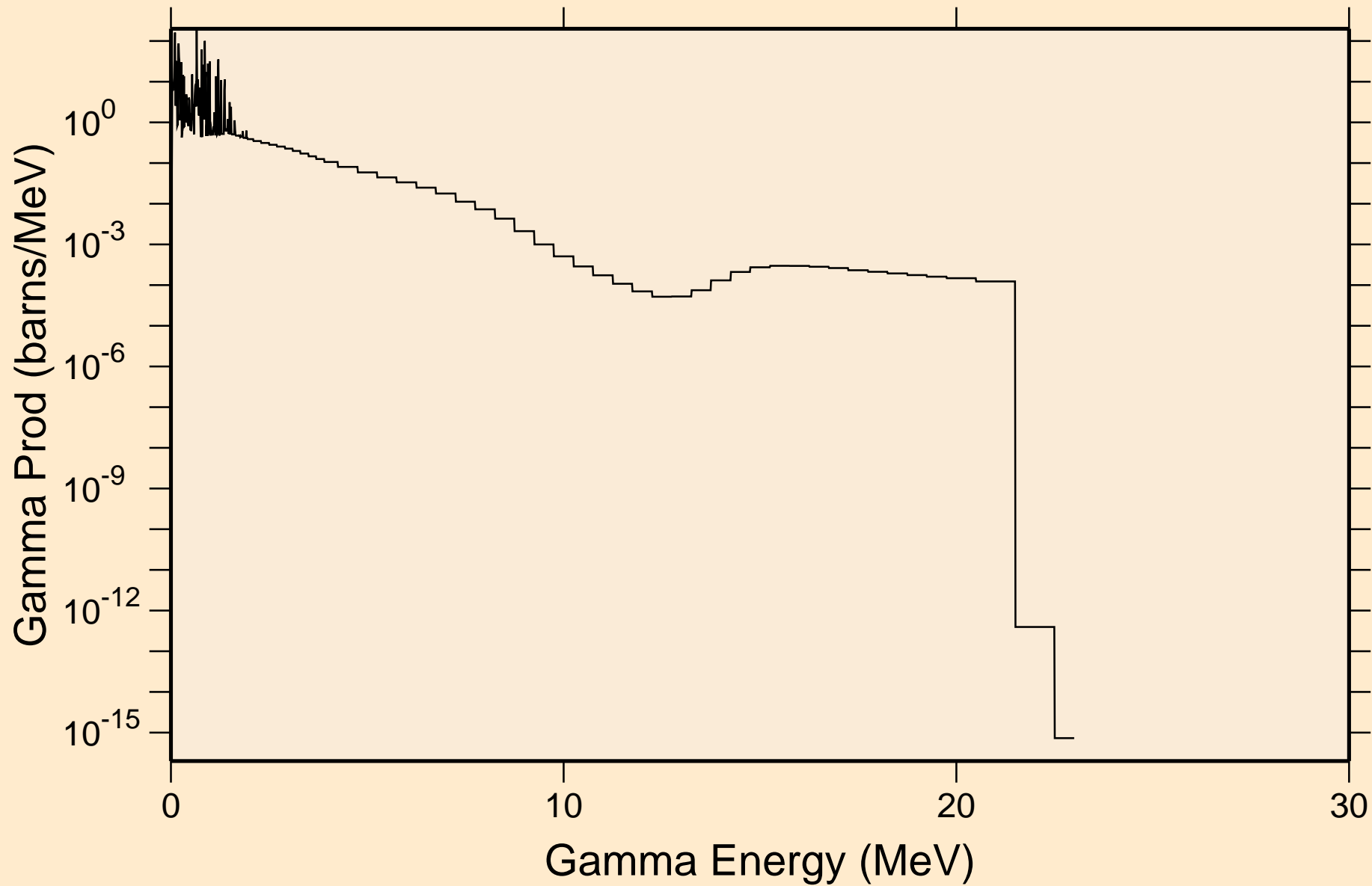

SN106 NEUTRON ACER TENDL-2023 LIBRARY; T=0.K

Particle heating contributions

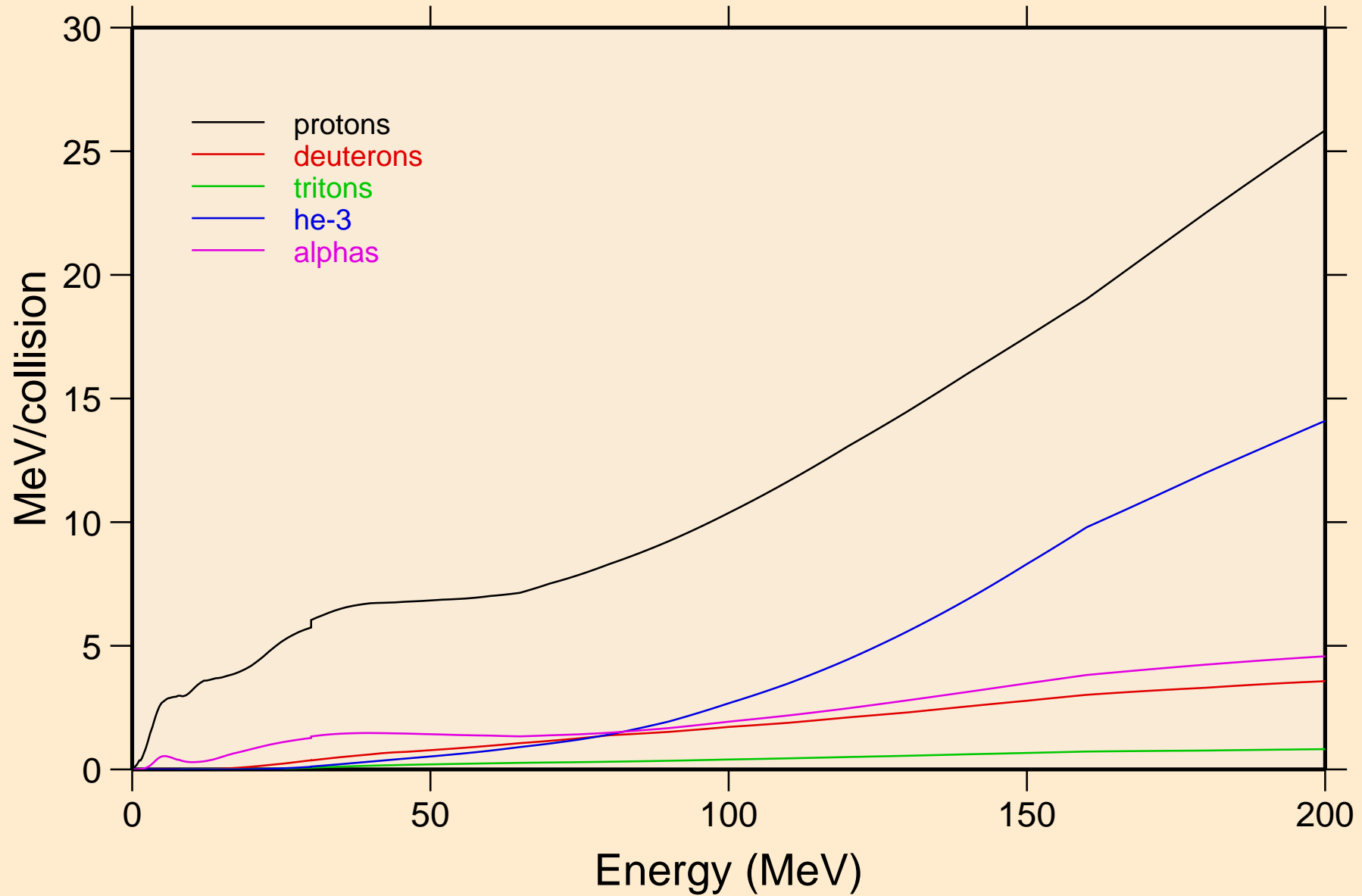

SN106 NEUTRON ACER TENDL-2023 LIBRARY; T=0.K

Recoil Heating

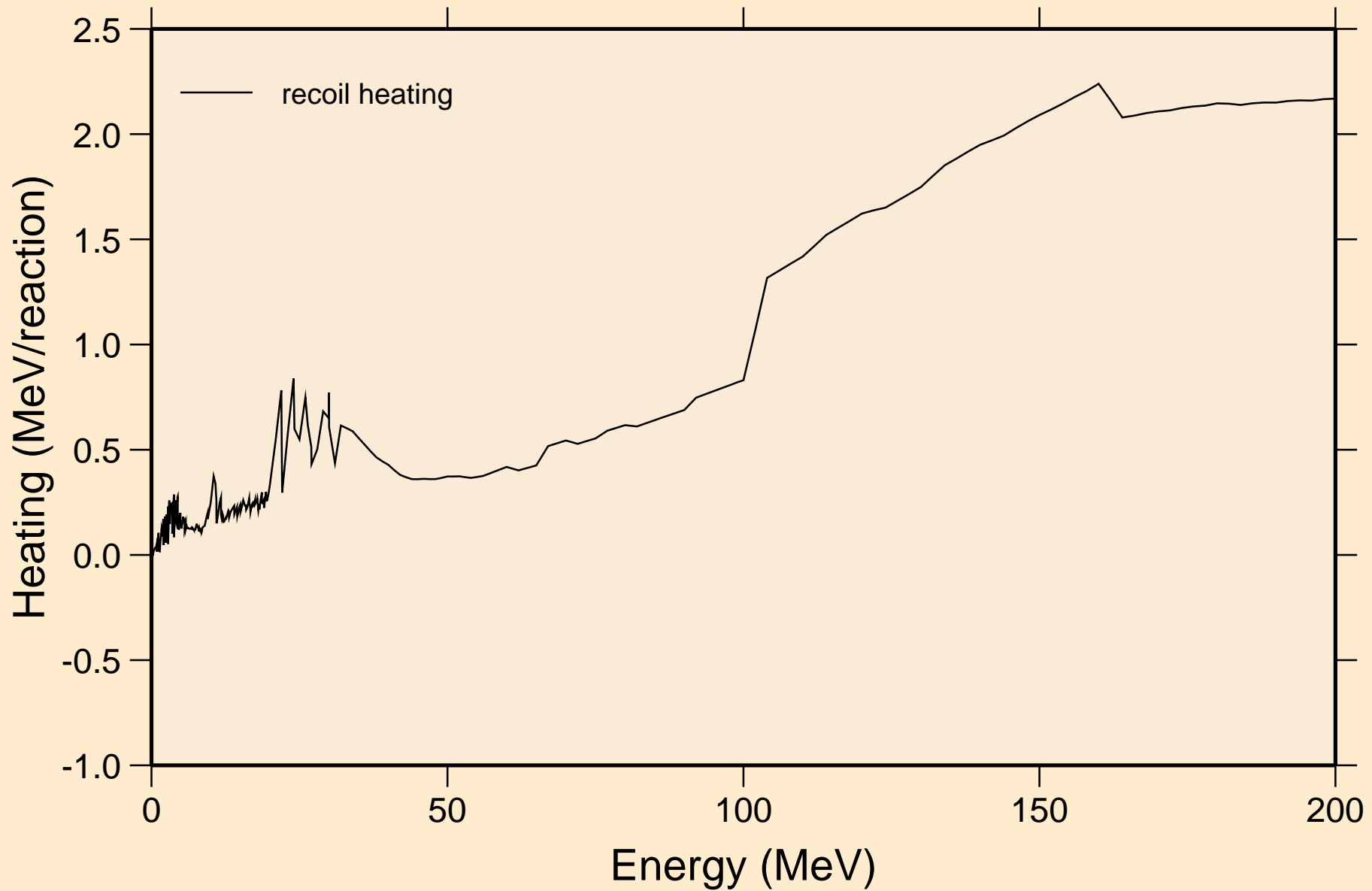

SN106 NEUTRON ACER TENDL-2023 LIBRARY; T=0.K

Particle production cross sections

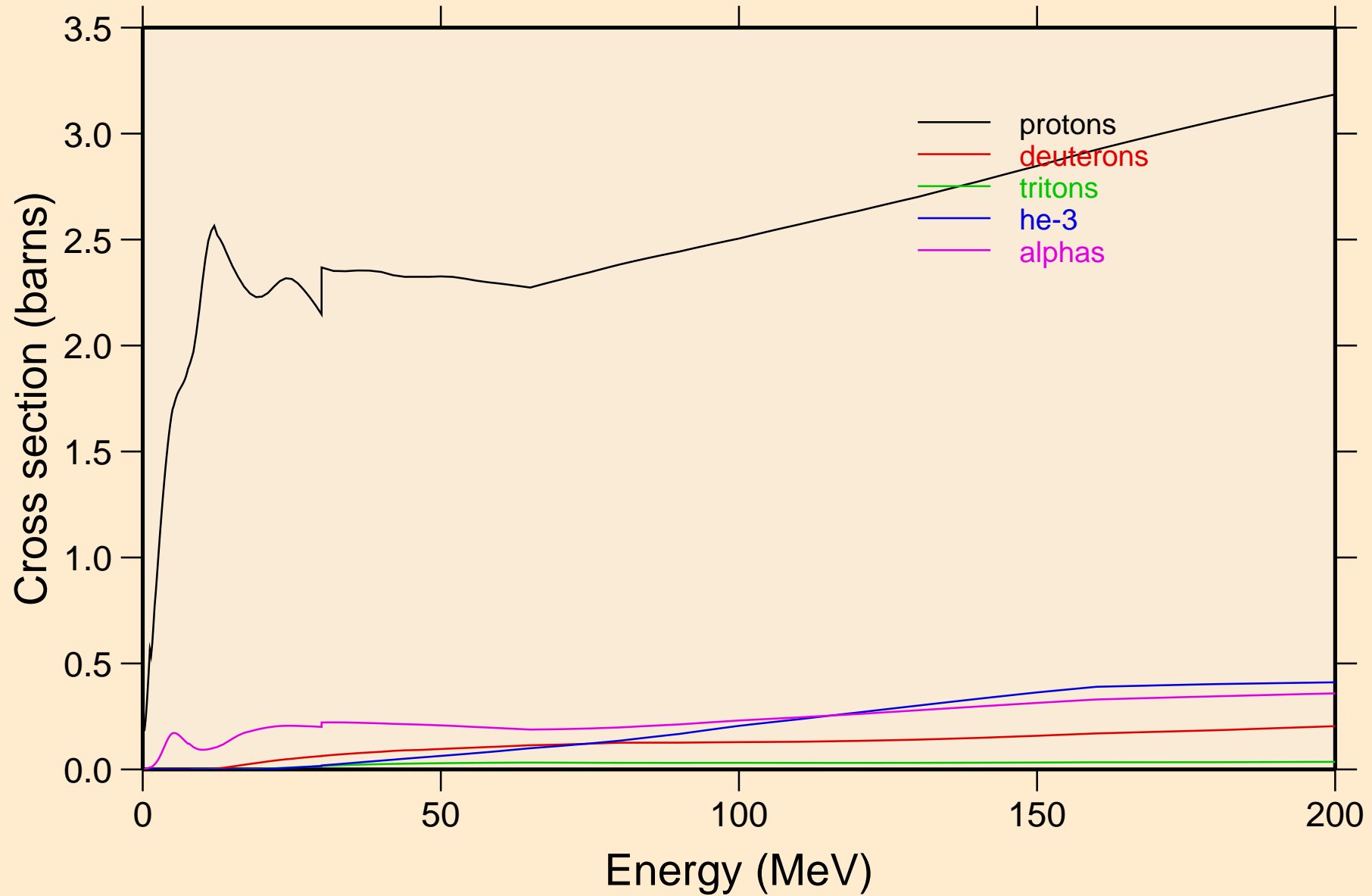

SN106 NEUTRON ACER TENDL-2023 LIBRARY; T=0.K
protons from (n,x)

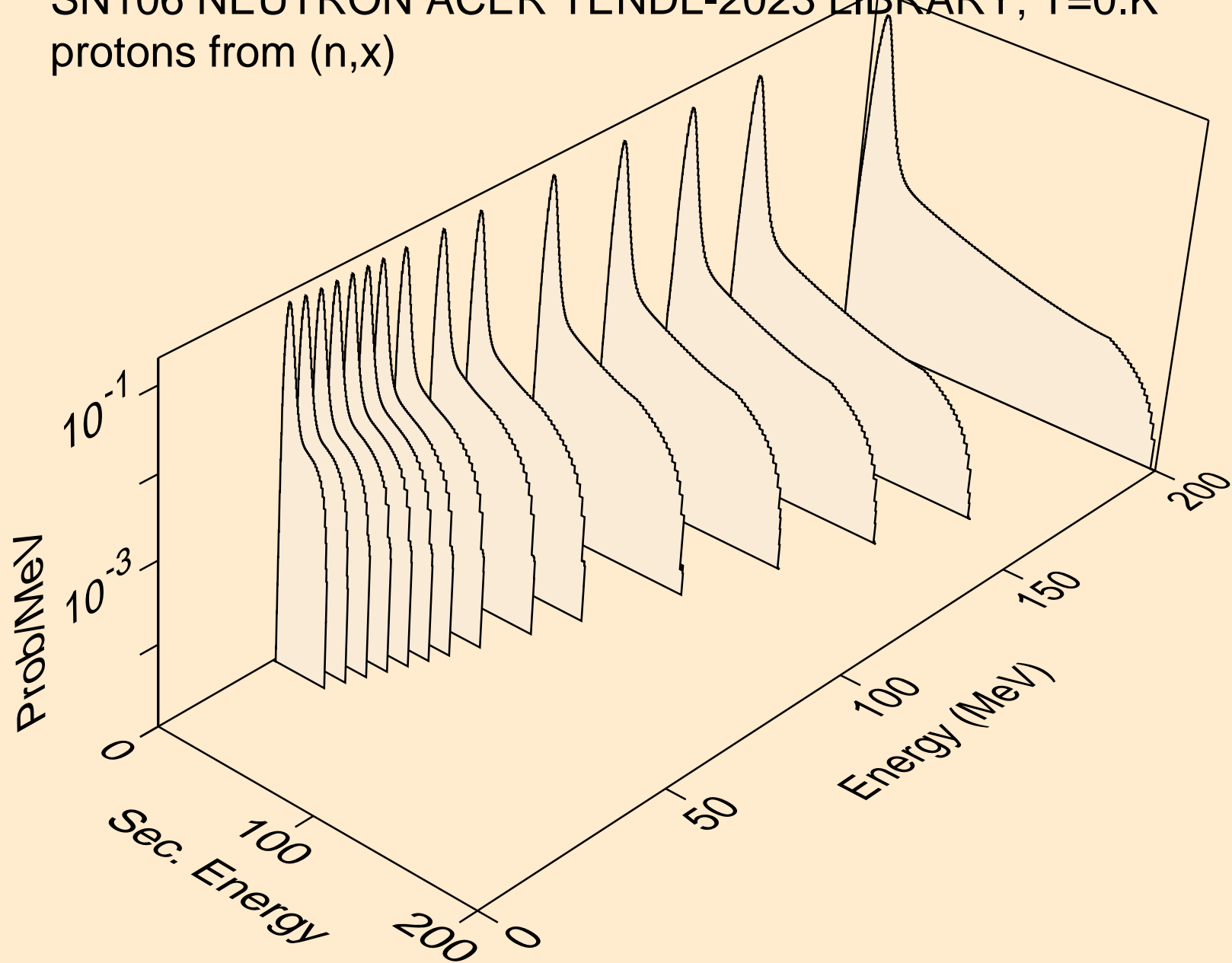

SN106 NEUTRON ACER TENDL-2023 LIBRARY; T=0.K
protons from (n,n*)p

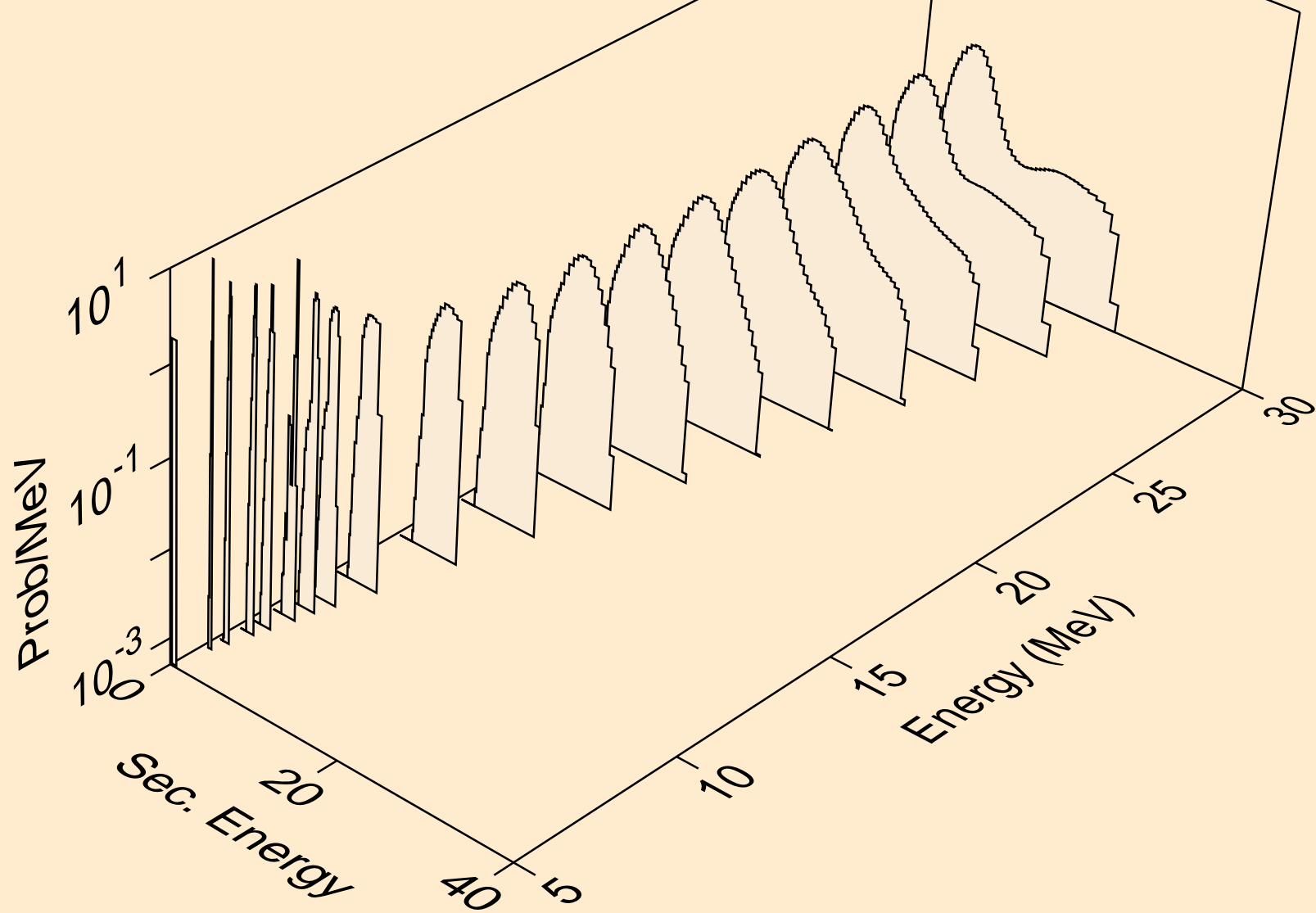

SN106 NEUTRON ACER TENDL-2023 LIBRARY; T=0.K
protons from (n,2np)

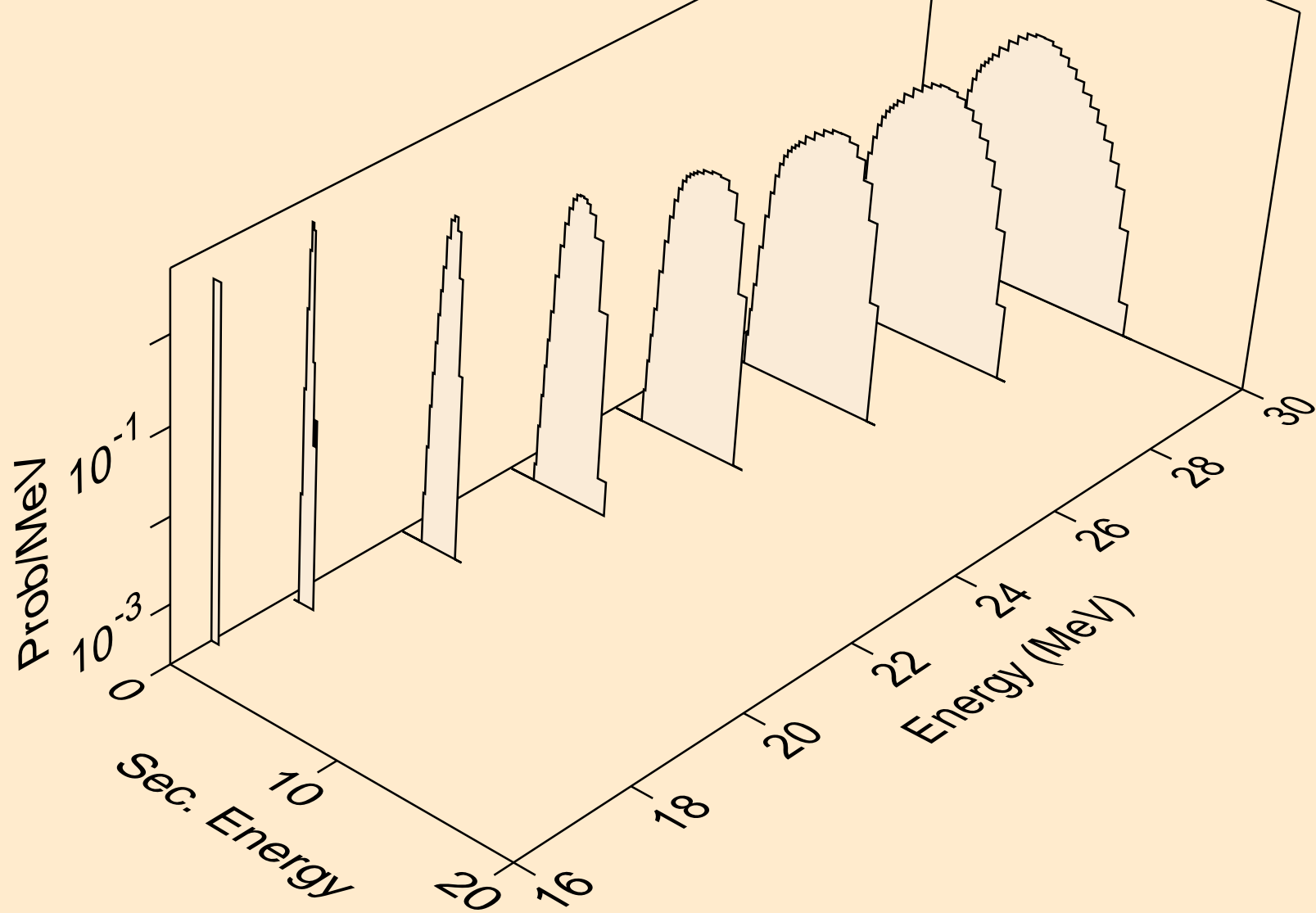

SN106 NEUTRON ACER TENDL-2023 LIBRARY; T=0.K
protons from (n,3np)

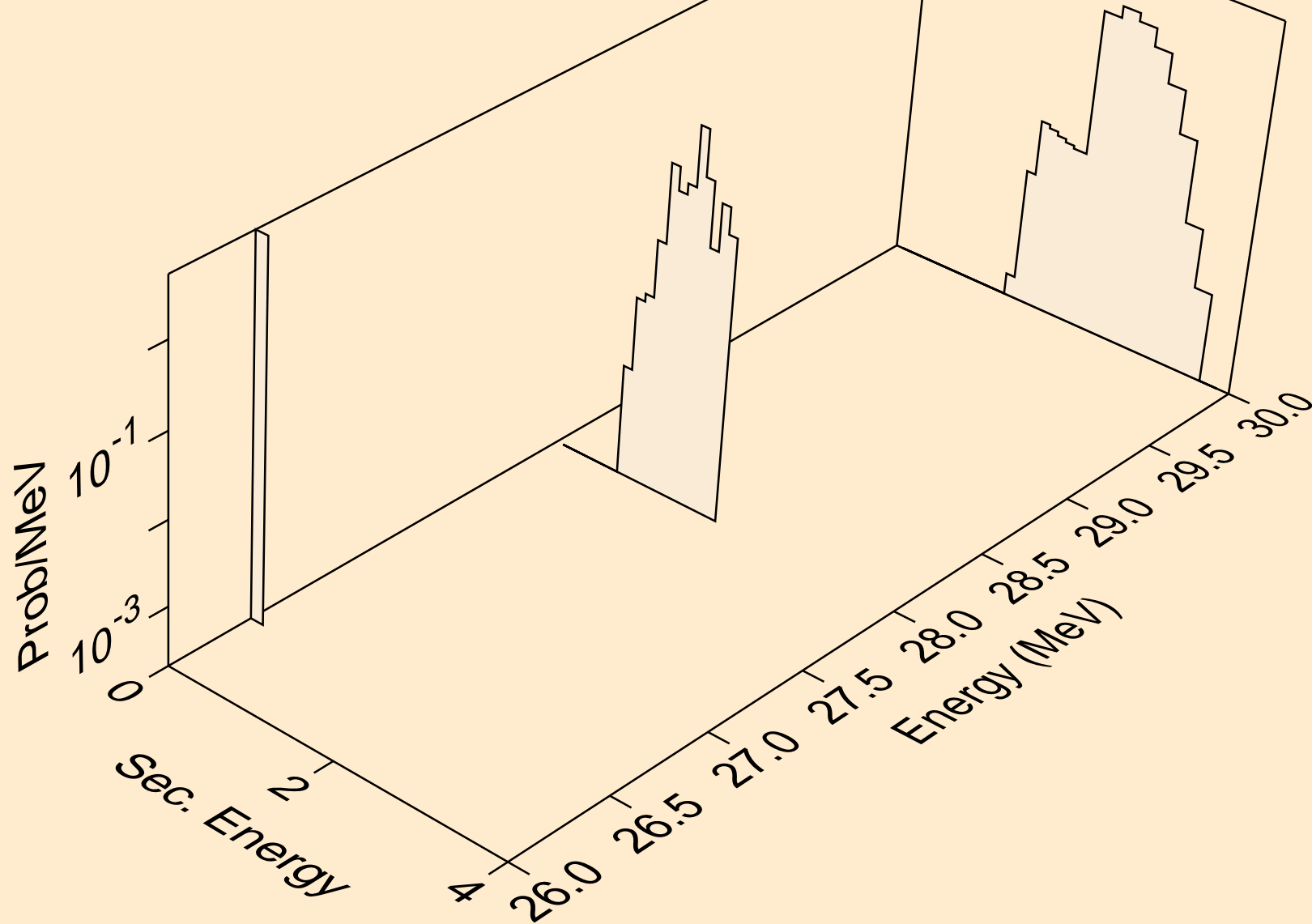

SN106 NEUTRON ACER TENDL-2023 LIBRARY; T=0.K
protons from (n,n2p)

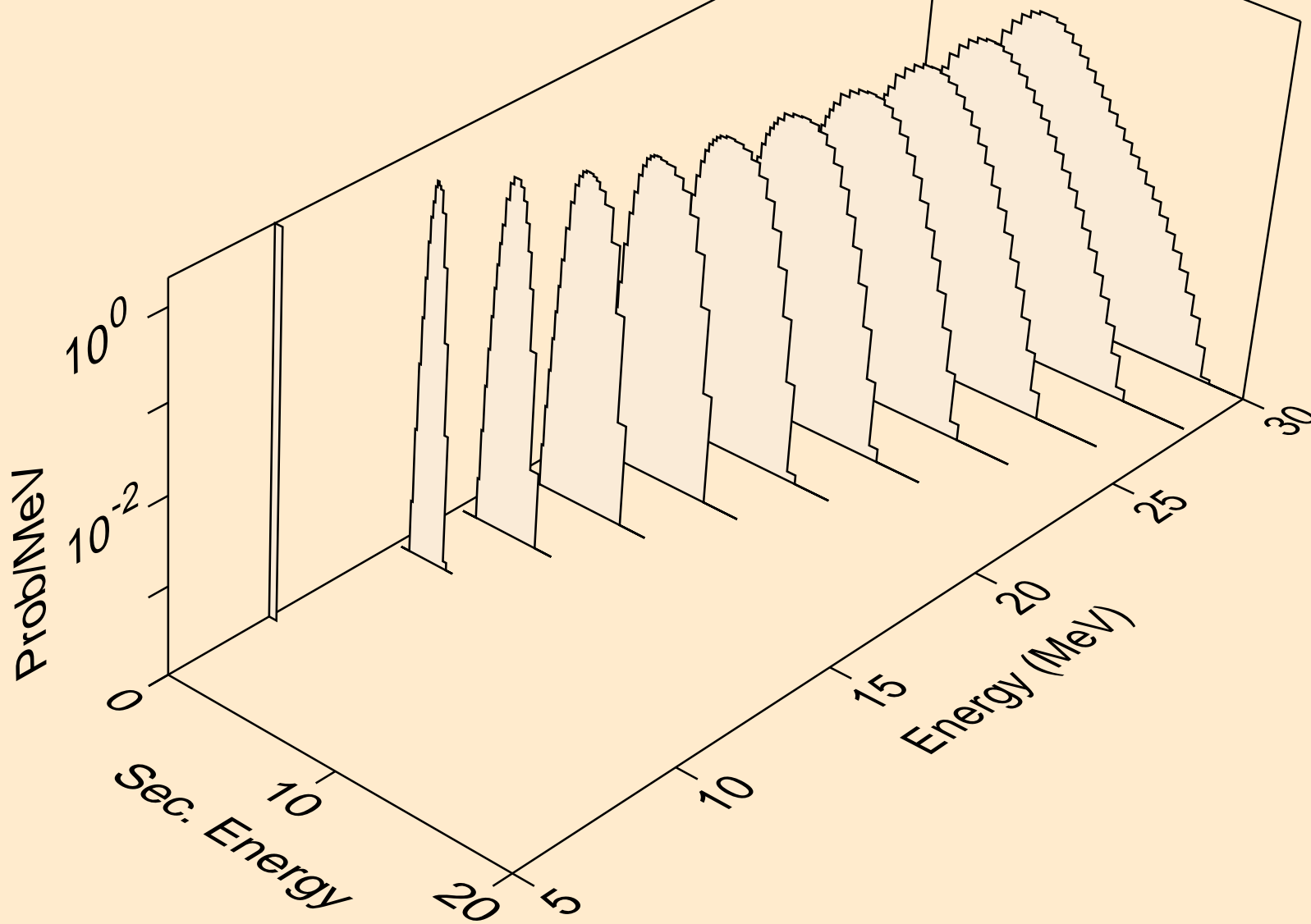

SN106 NEUTRON ACER TENDL-2023 LIBRARY; T=0.K
protons from (n,npa)

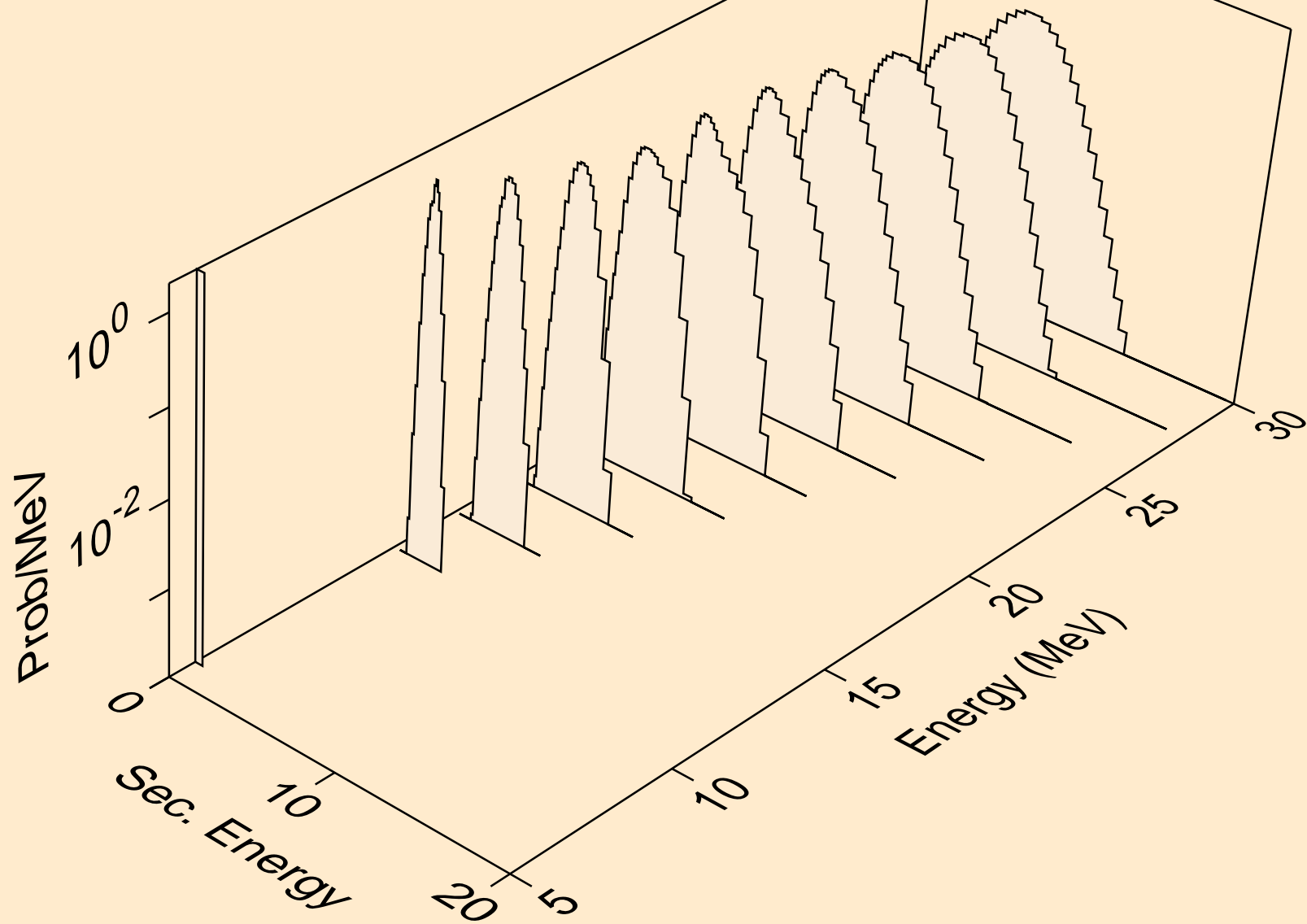

SN106 NEUTRON ACER TENDL-2023 LIBRARY; T=0.K
protons from (n,p)

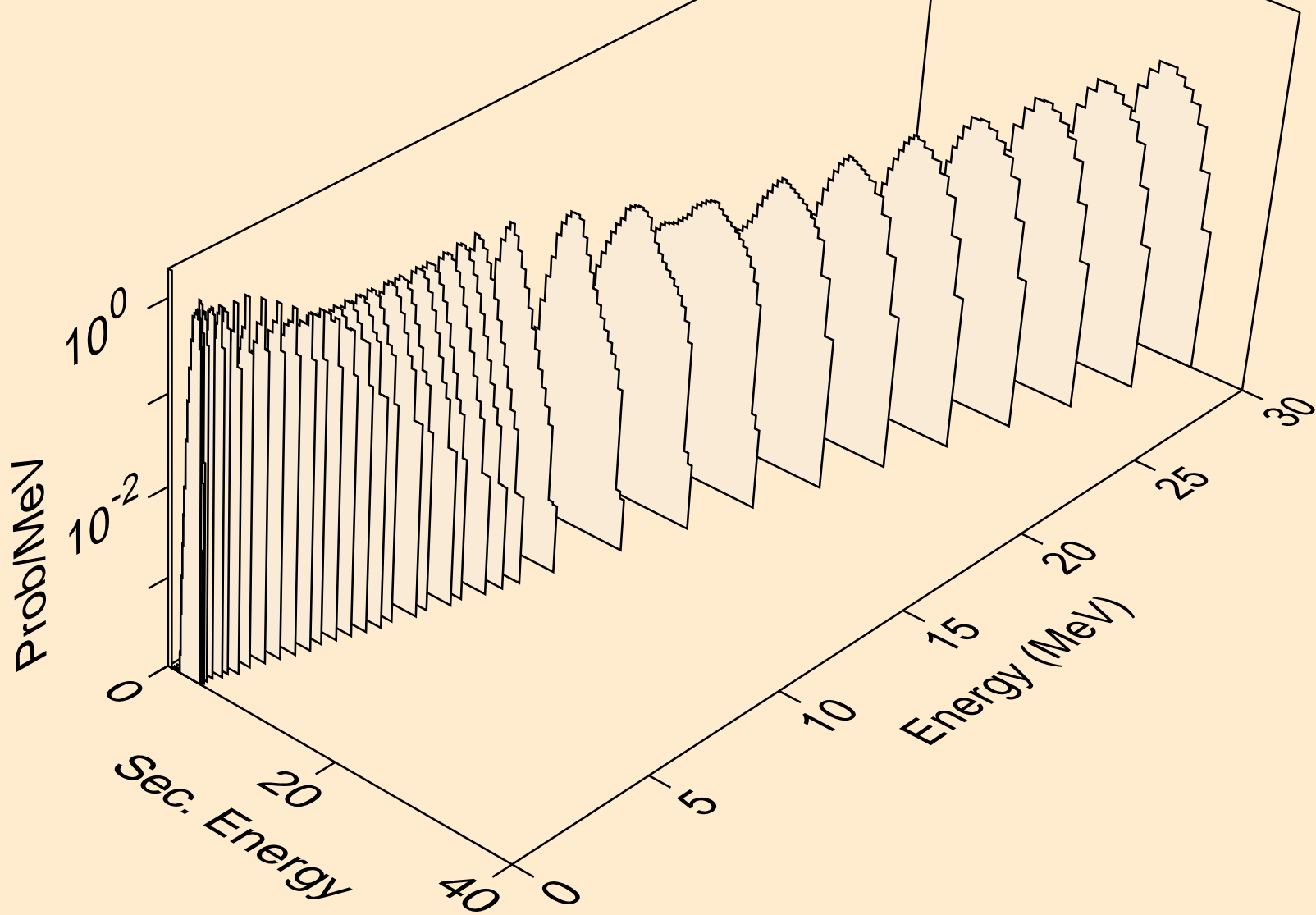

SN106 NEUTRON ACER TENDL-2023 LIBRARY; T=0.K
protons from (n,2p)

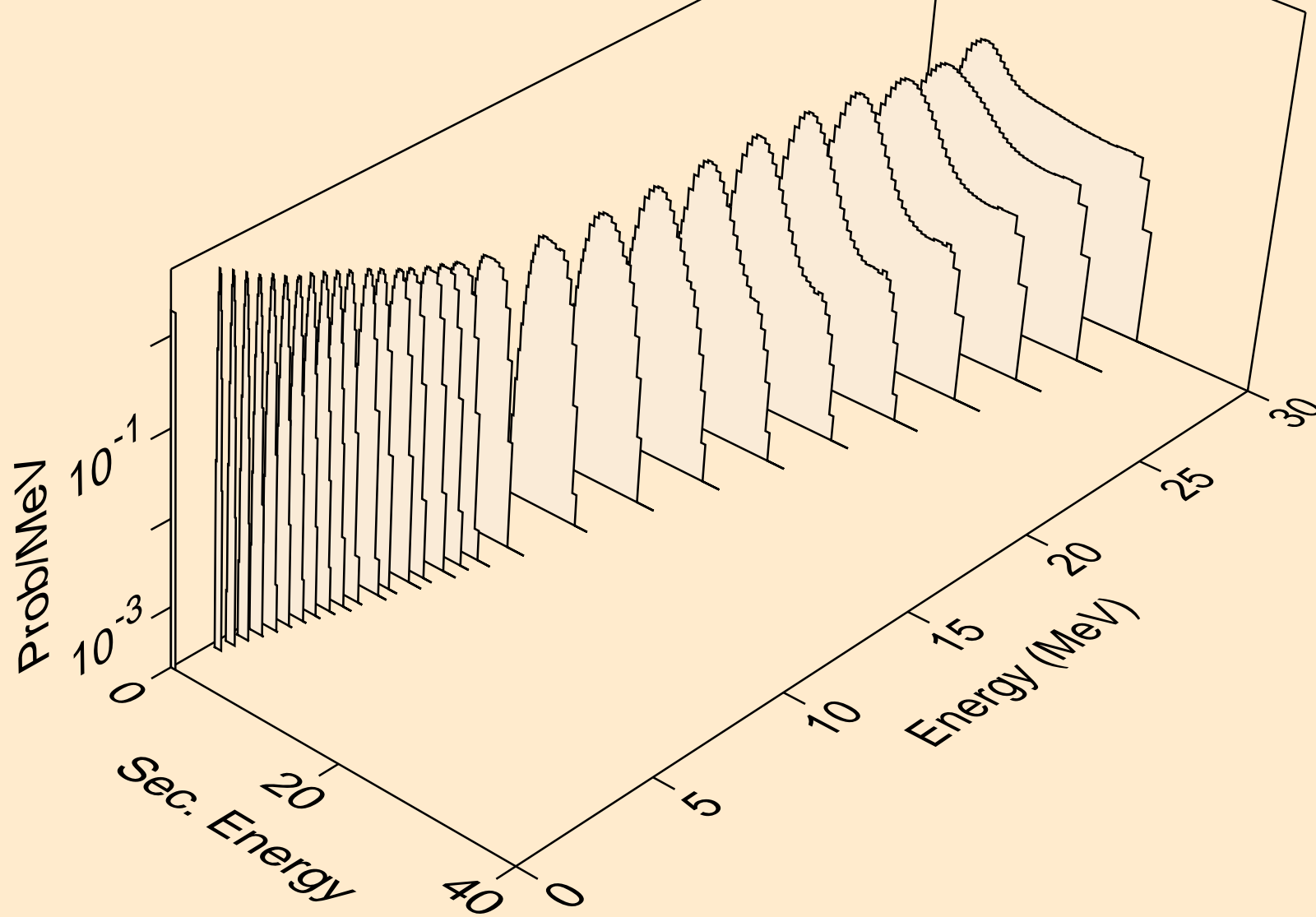

SN106 NEUTRON ACER TENDL-2023 LIBRARY; T=0.K
protons from (n,p)

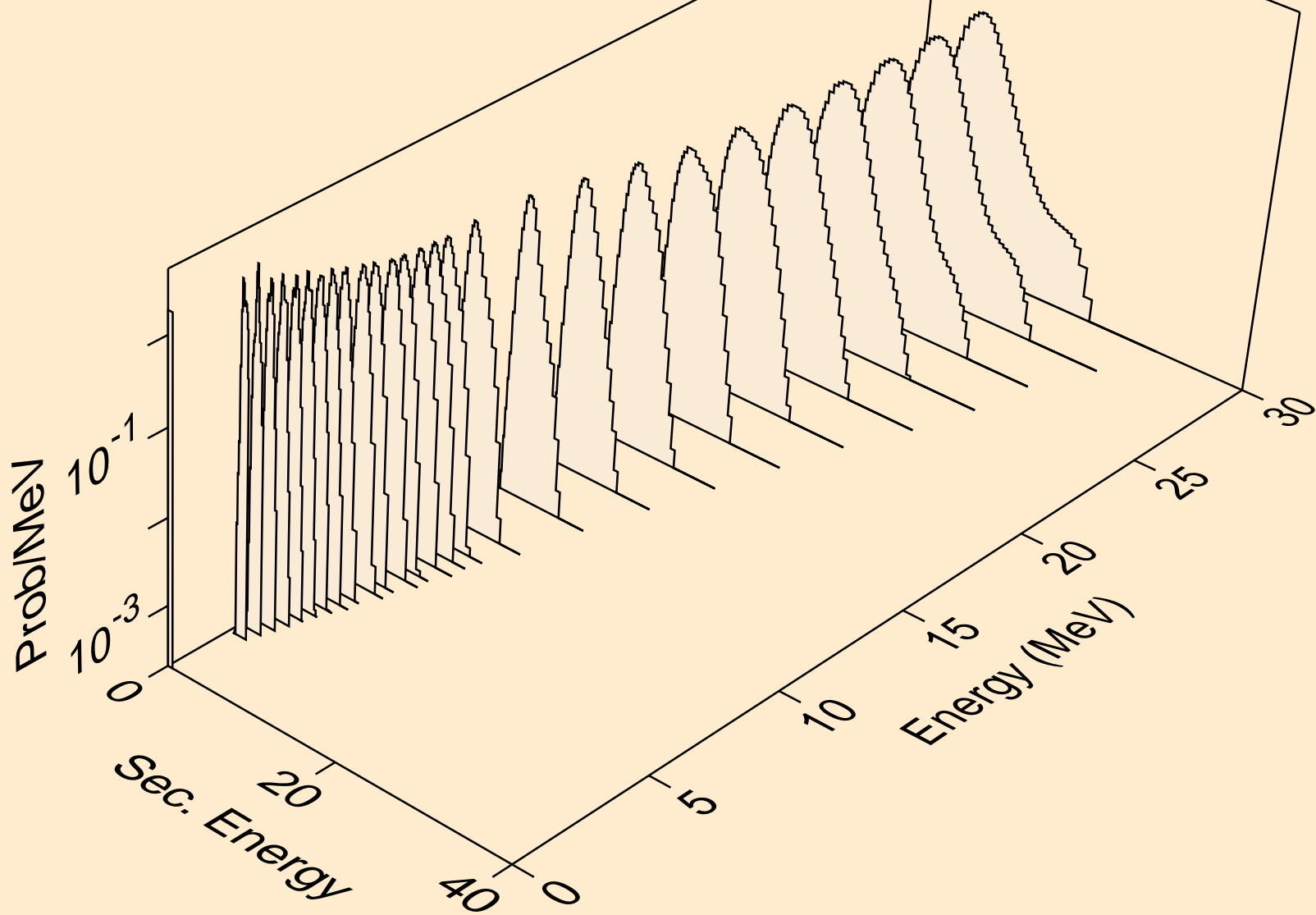

SN106 NEUTRON ACER TENDL-2023 LIBRARY; T=0.K
protons from (n,pd)

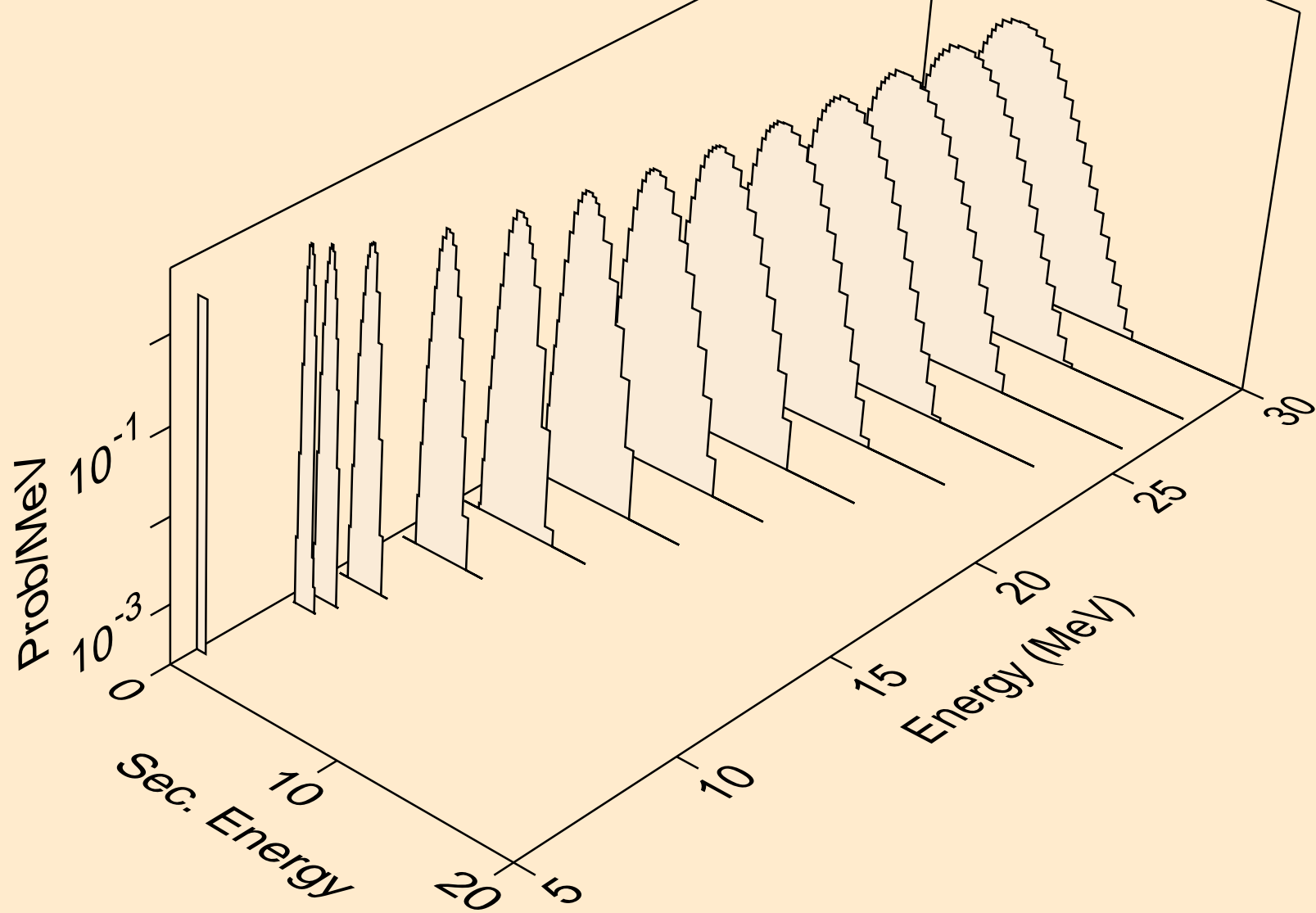

SN106 NEUTRON ACER TENDL-2023 LIBRARY; T=0.K
protons from (n,pt)

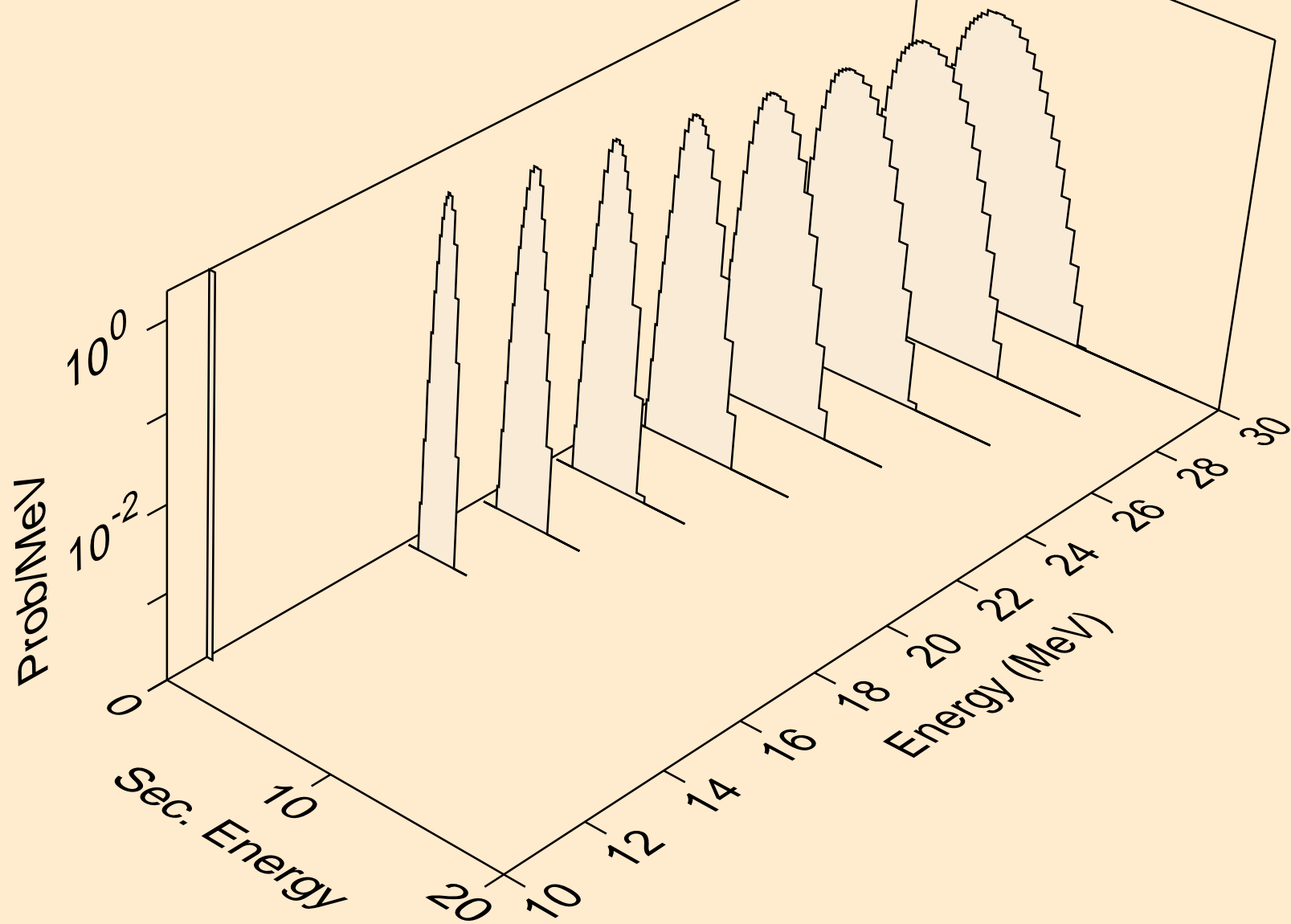

SN106 NEUTRON ACER TENDL-2023 LIBRARY; T=0.K
deuterons from (n,x)

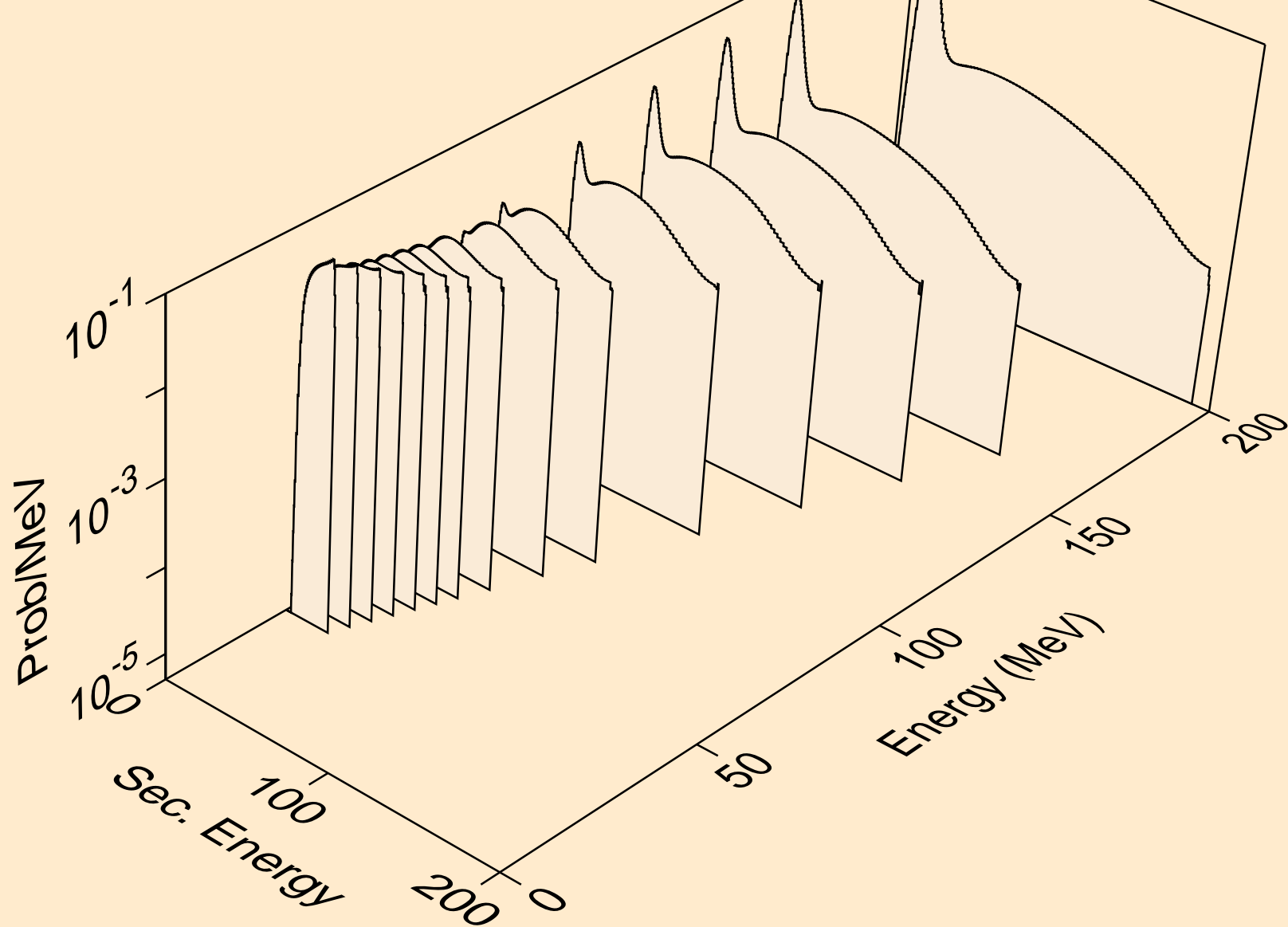

SN106 NEUTRON ACER TENDL-2023 LIBRARY; T=0.K
deuterons from (n,2nd)

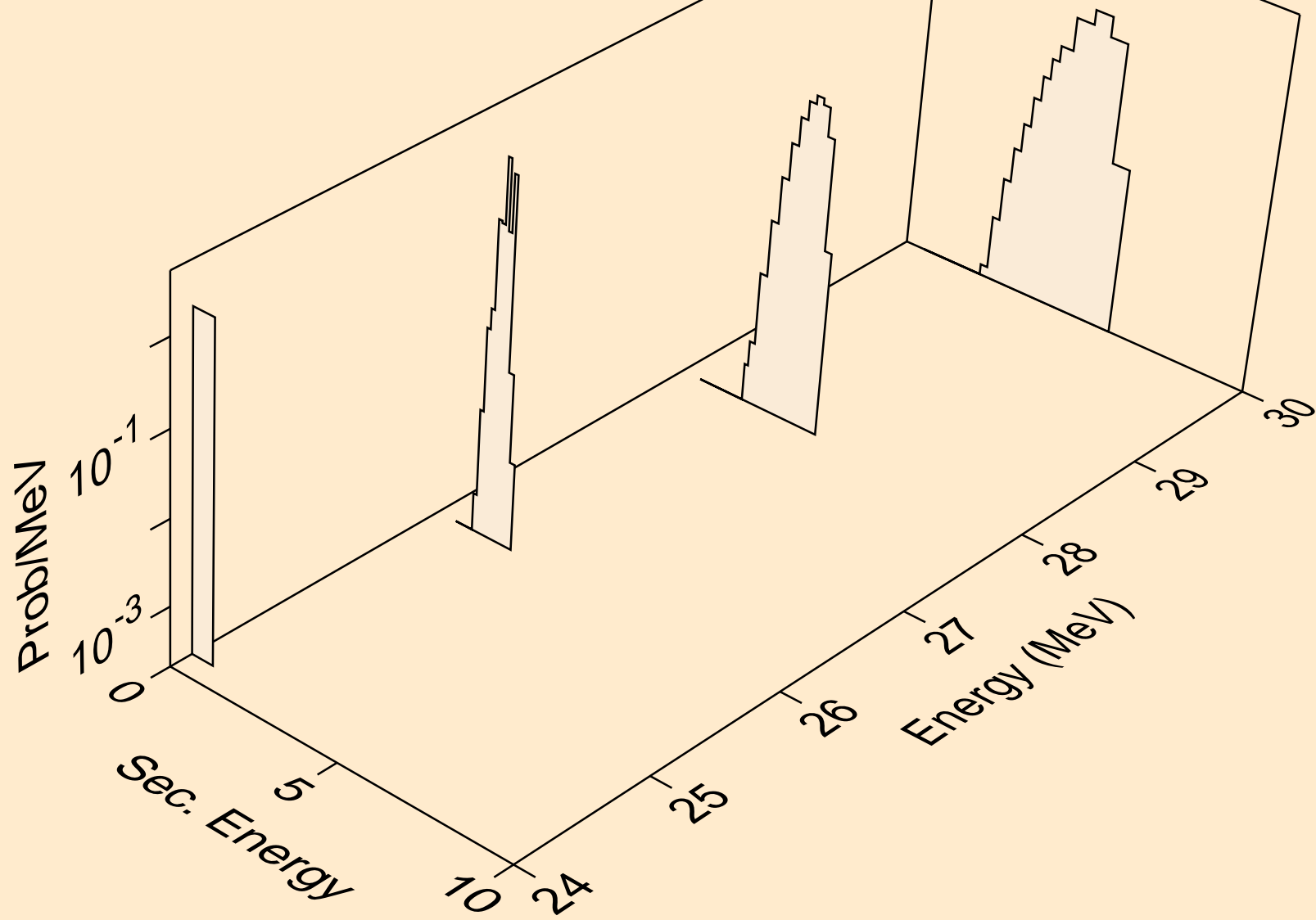

SN106 NEUTRON ACER TENDL-2023 LIBRARY; T=0.K
deuterons from (n,n*)d

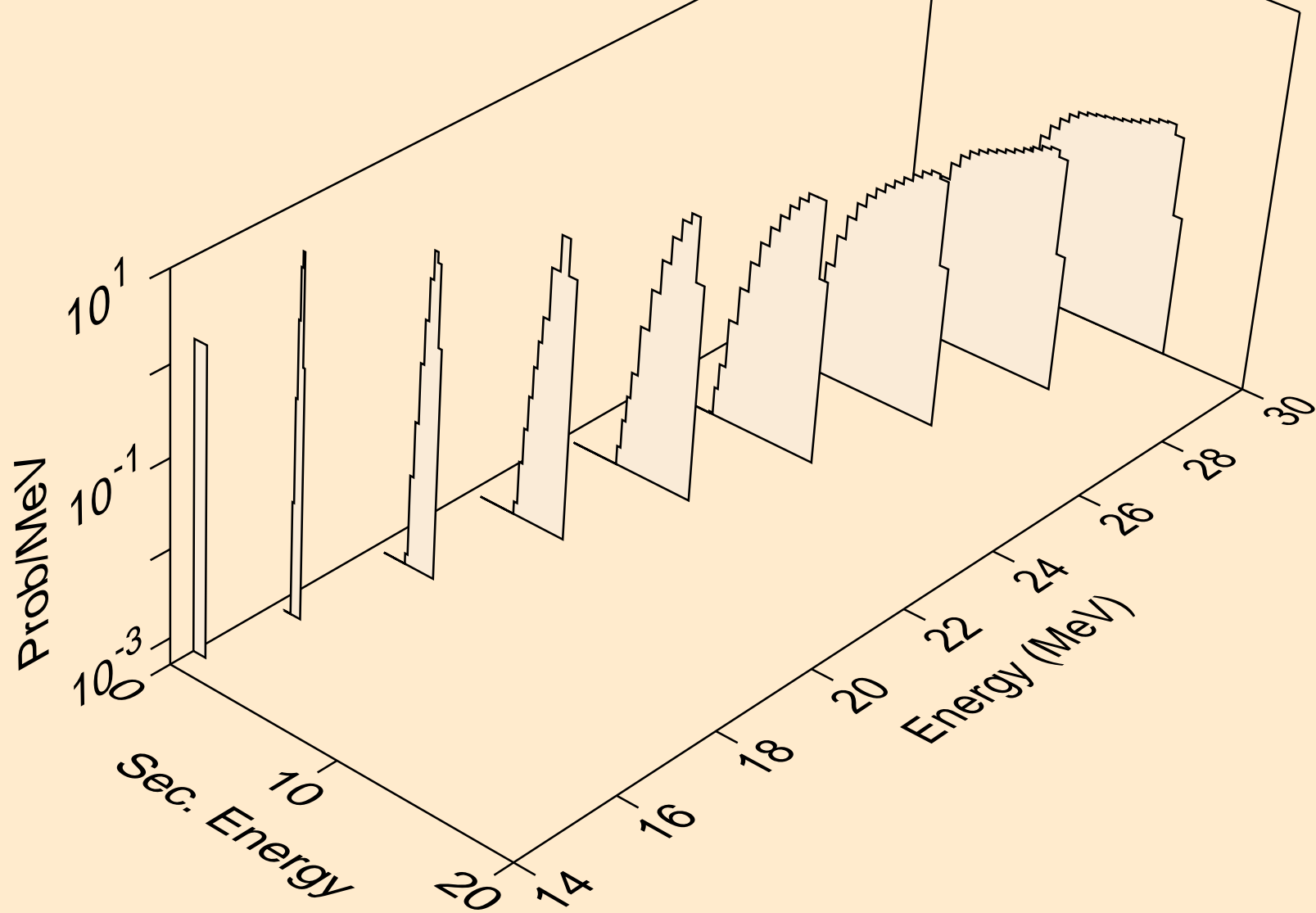

SN106 NEUTRON ACER TENDL-2023 LIBRARY; T=0.K
deuterons from (n,d)

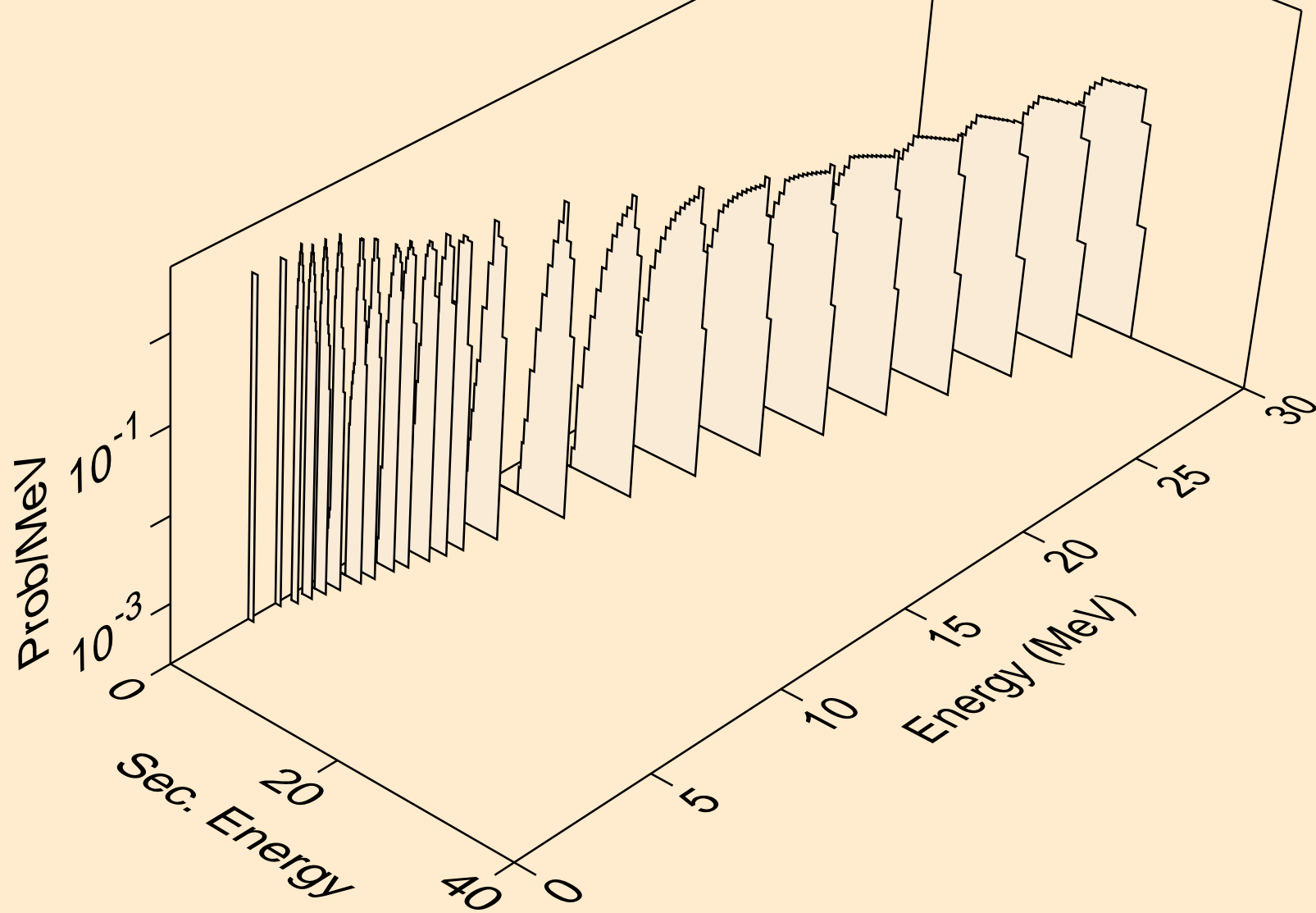

SN106 NEUTRON ACER TENDL-2023 LIBRARY; T=0.K
deuterons from (n,pd)

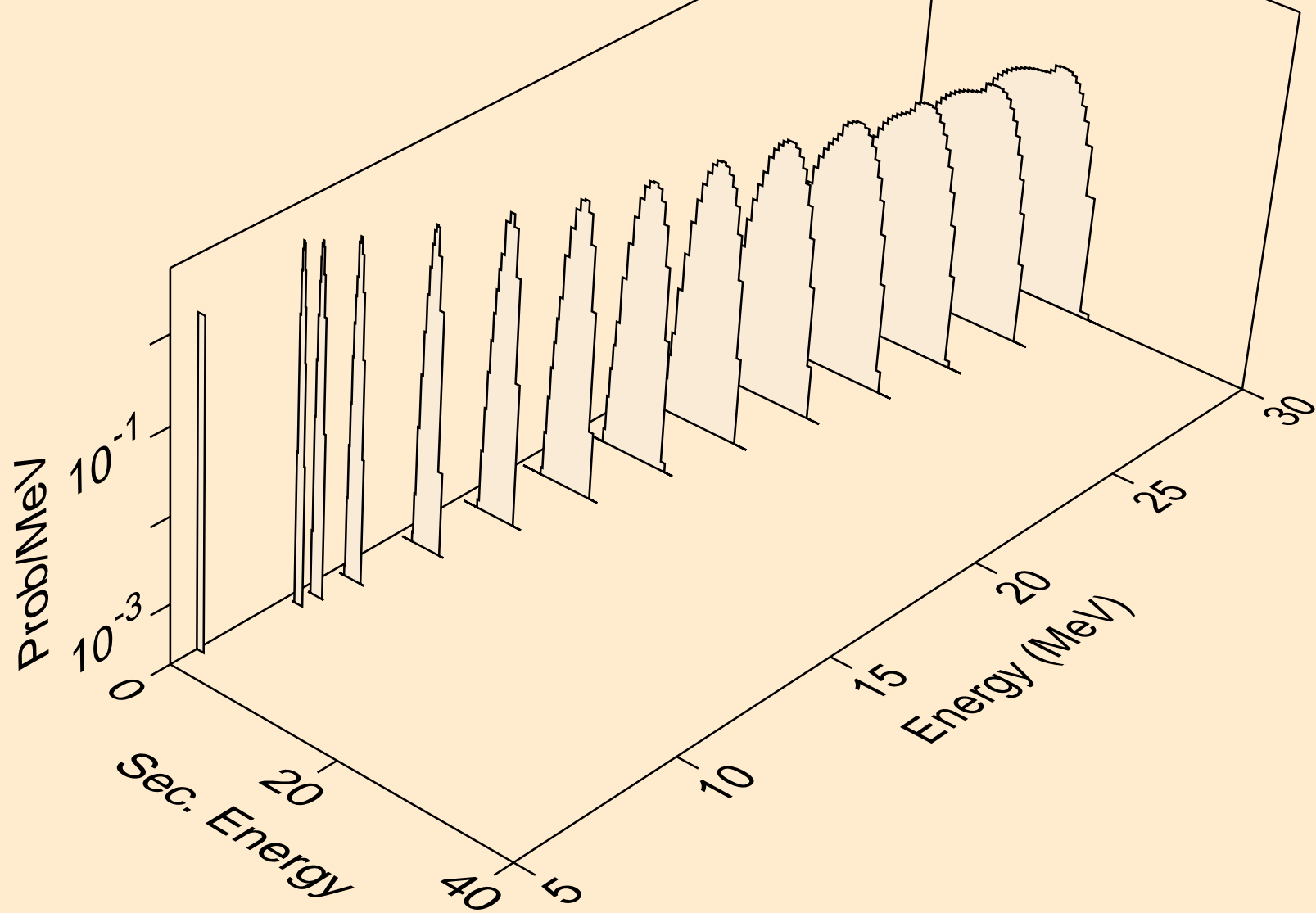

SN106 NEUTRON ACER TENDL-2023 LIBRARY; T=0.K
deuterons from (n,da)

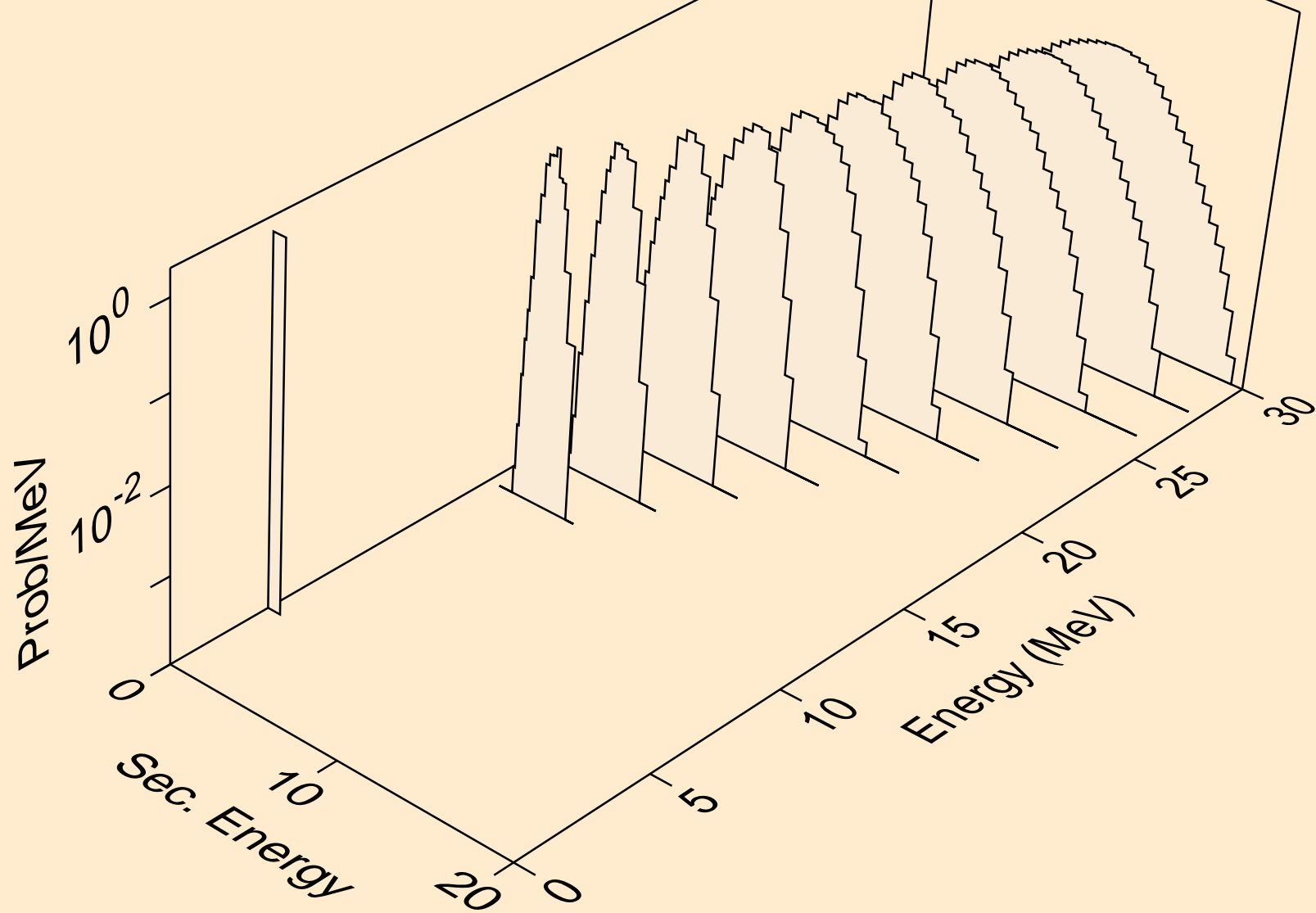

SN106 NEUTRON ACER TENDL-2023 LIBRARY; T=0.K
tritons from (n,x)

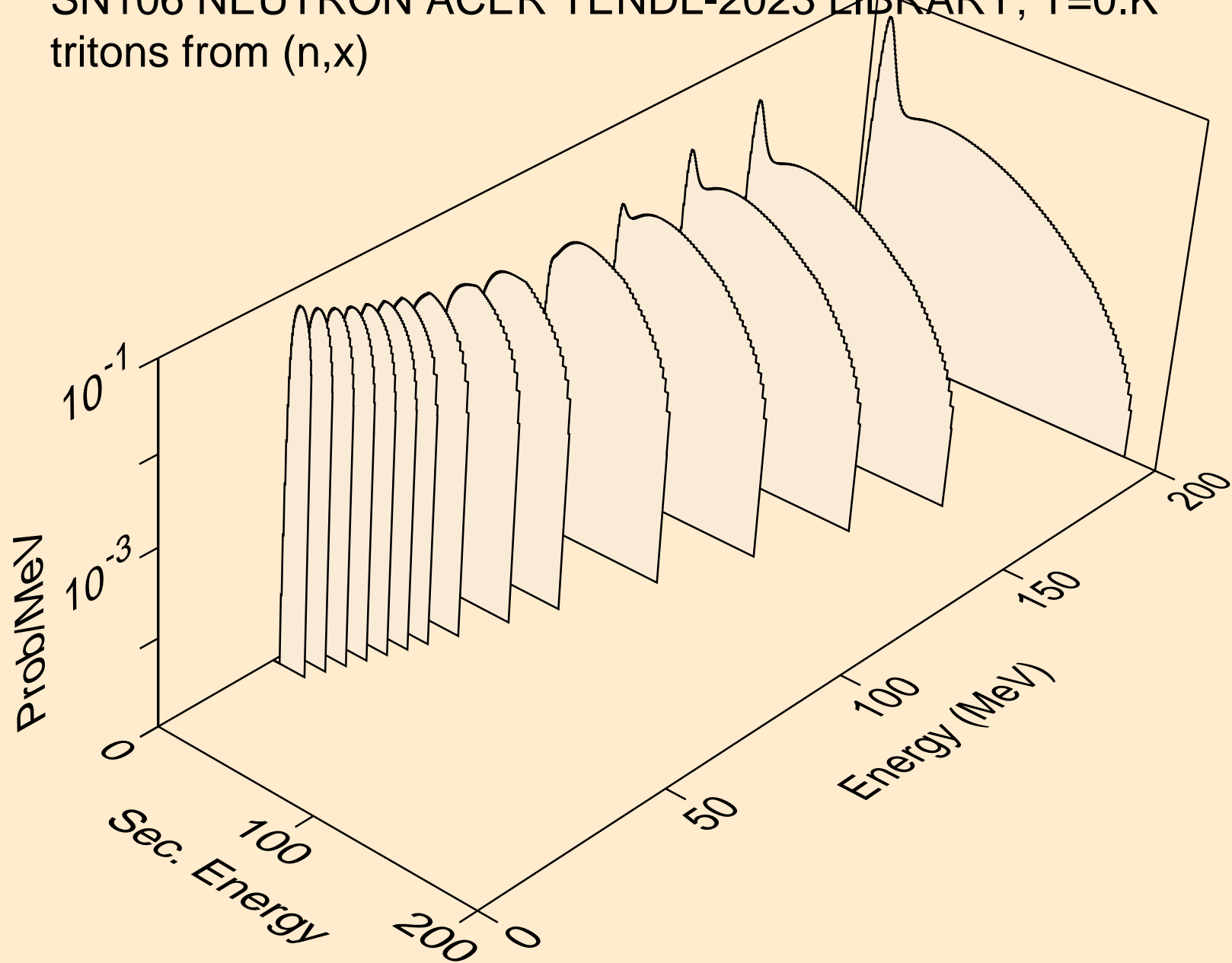

SN106 NEUTRON ACER TENDL-2023 LIBRARY; T=0.K
tritons from (n,n*)t

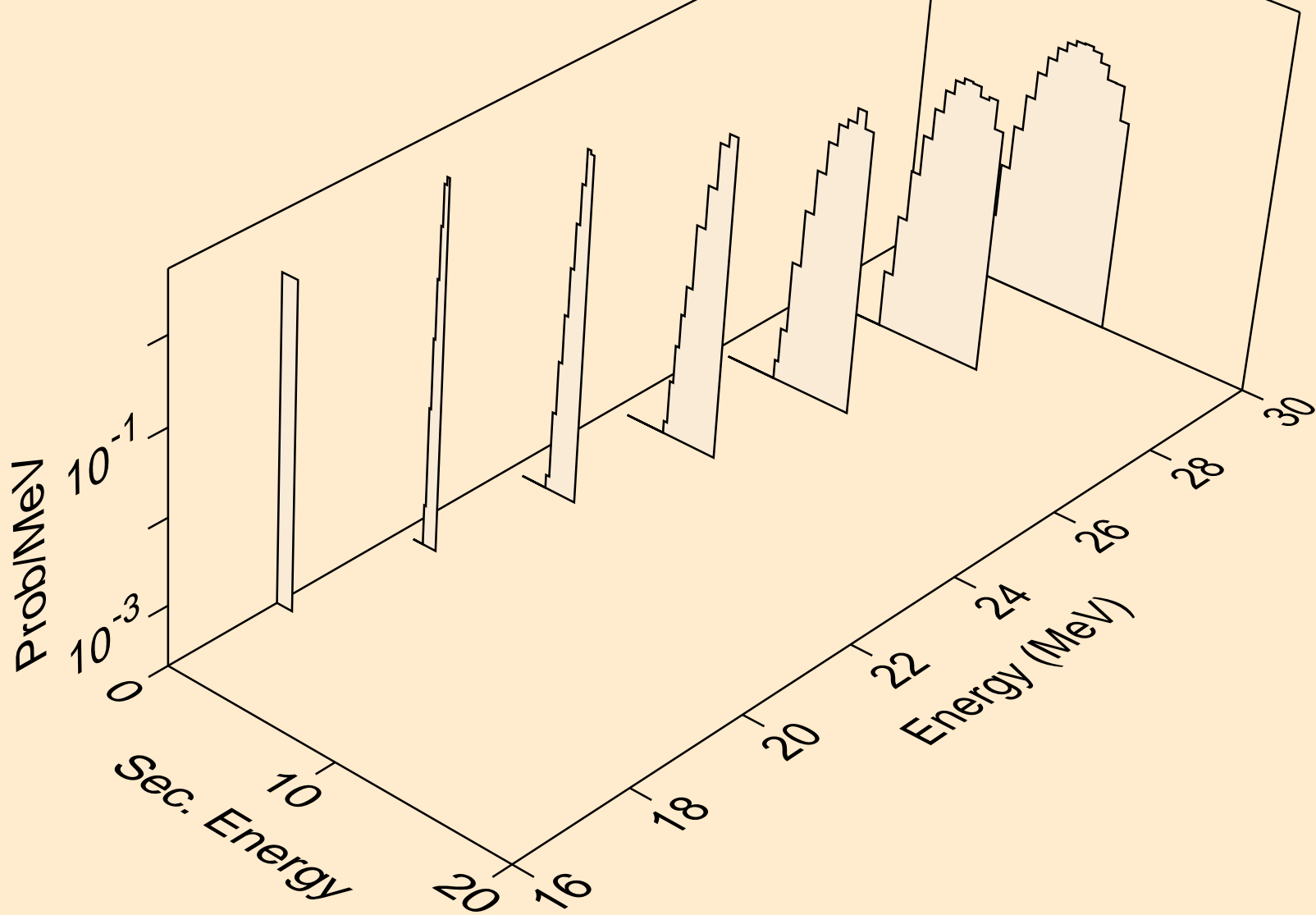

SN106 NEUTRON ACER TENDL-2023 LIBRARY; T=0.K
tritons from (n,t)

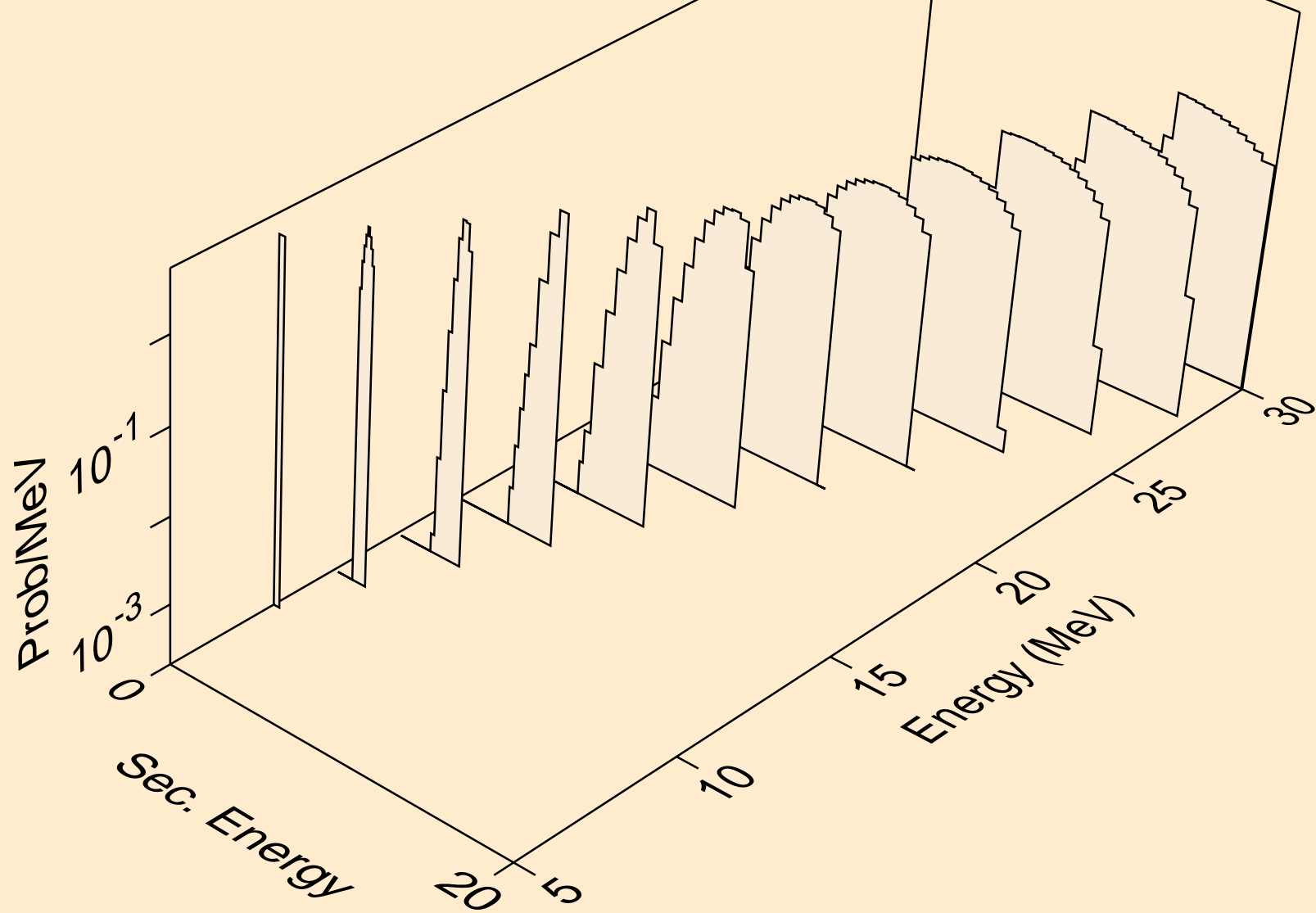

SN106 NEUTRON ACER TENDL-2023 LIBRARY; T=0.K
tritons from (n,pt)

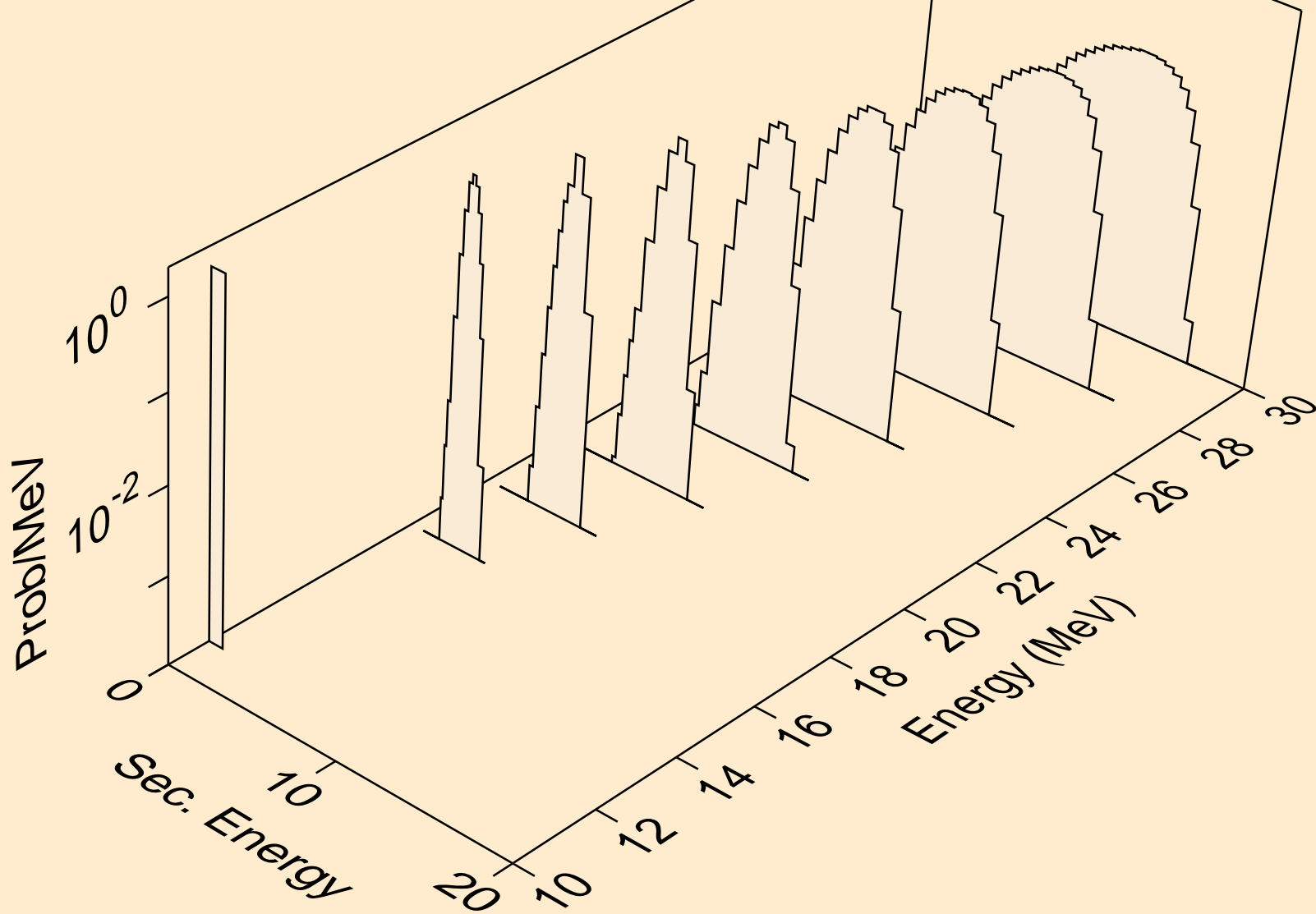

SN106 NEUTRON ACER TENDL-2023 LIBRARY; T=0.K
he3s from (n,x)

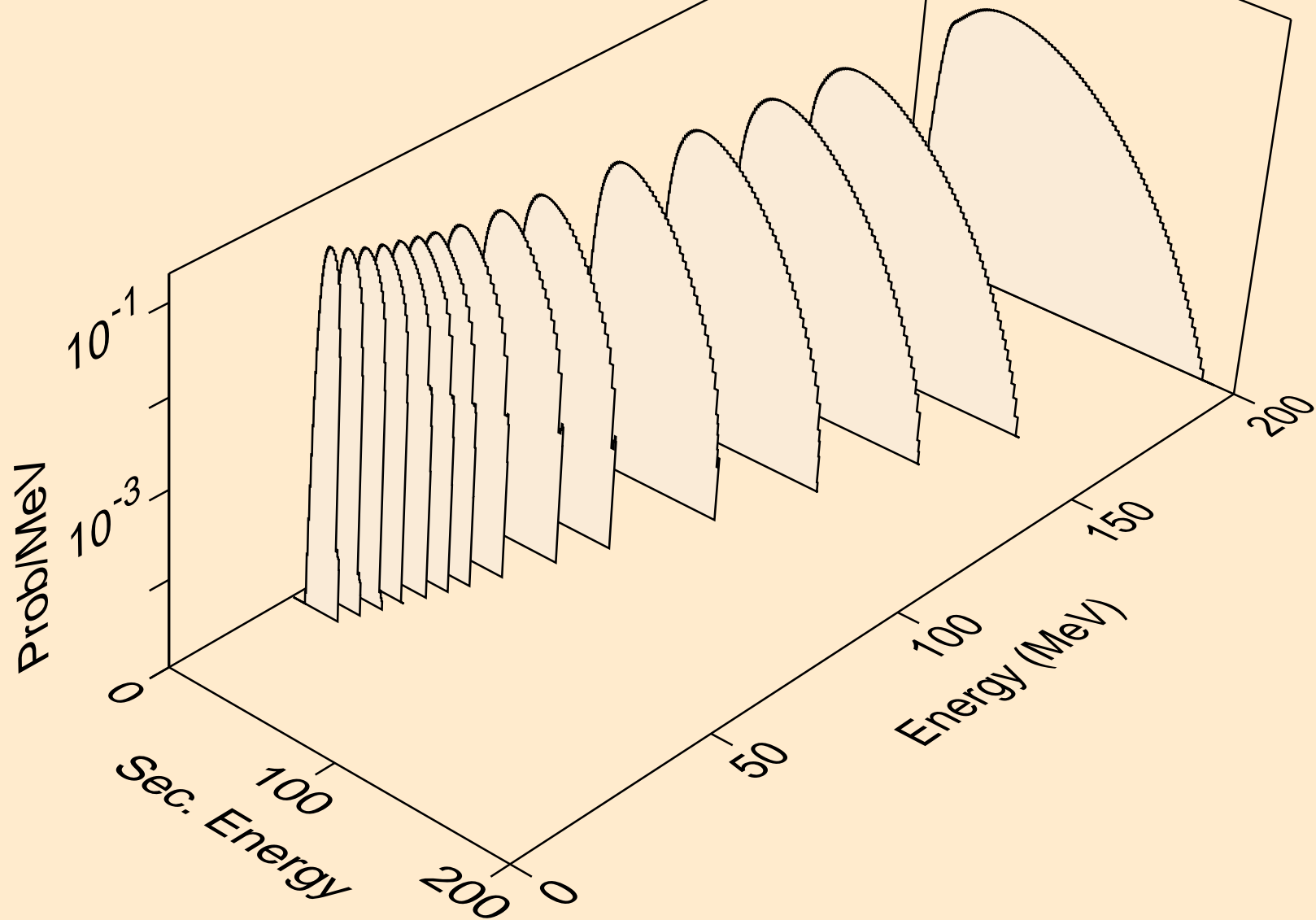

SN106 NEUTRON ACER TENDL-2023 LIBRARY; T=0.K
he3s from (n,n*)he3

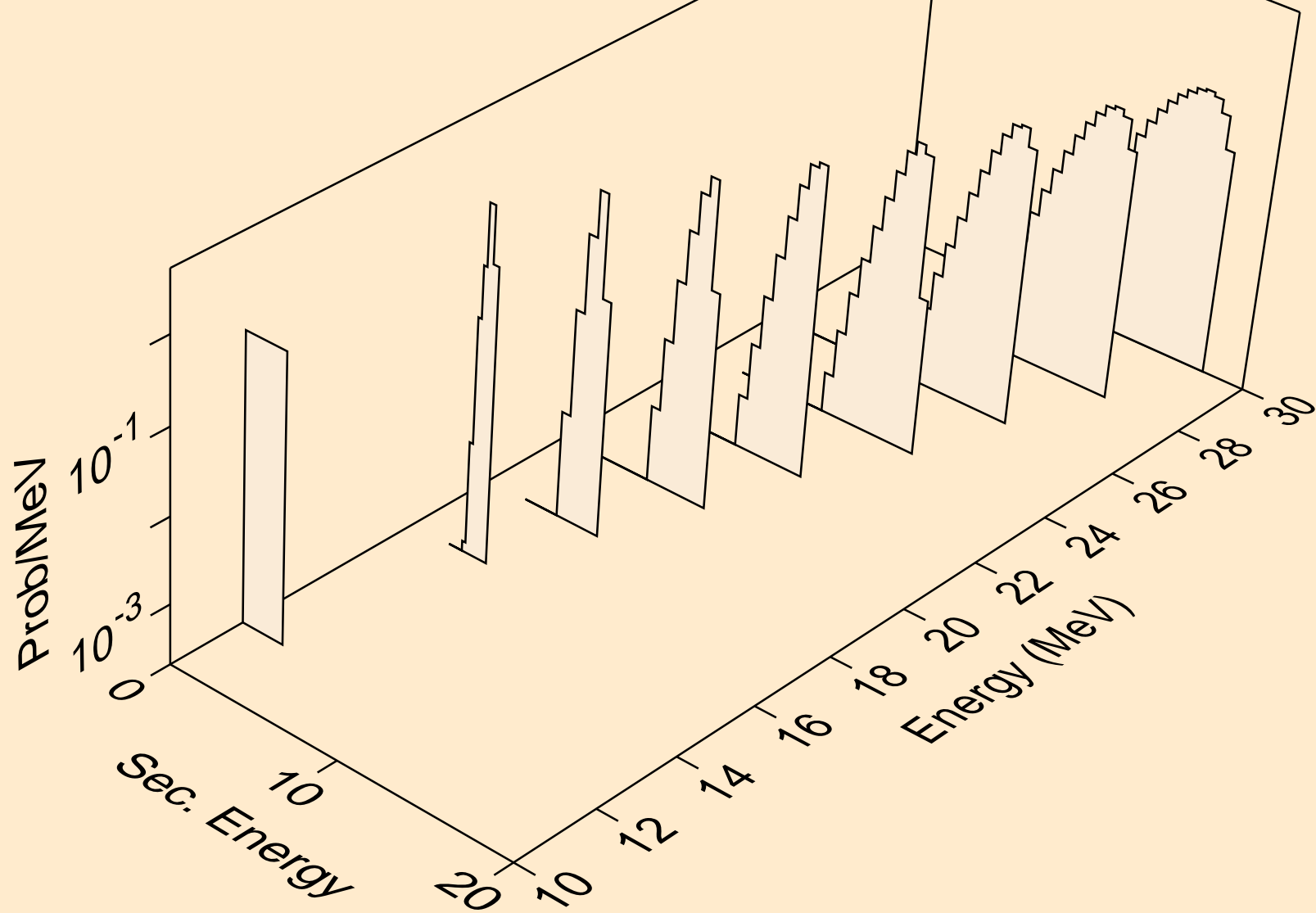

SN106 NEUTRON ACER TENDL-2023 LIBRARY; T=0.K
he3s from (n,he3)

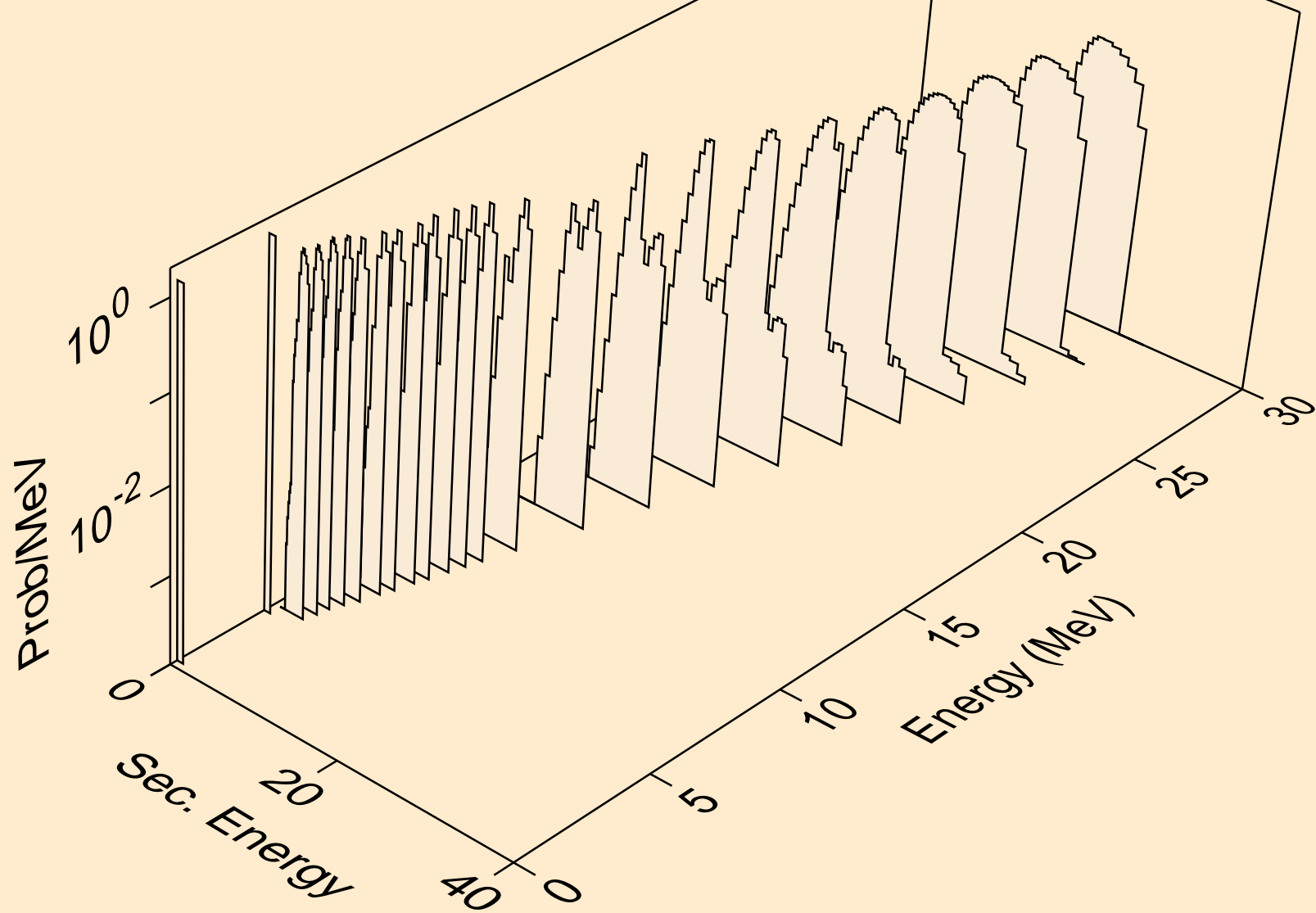

SN106 NEUTRON ACER TENDL-2023 LIBRARY; T=0.K
alphas from (n,x)

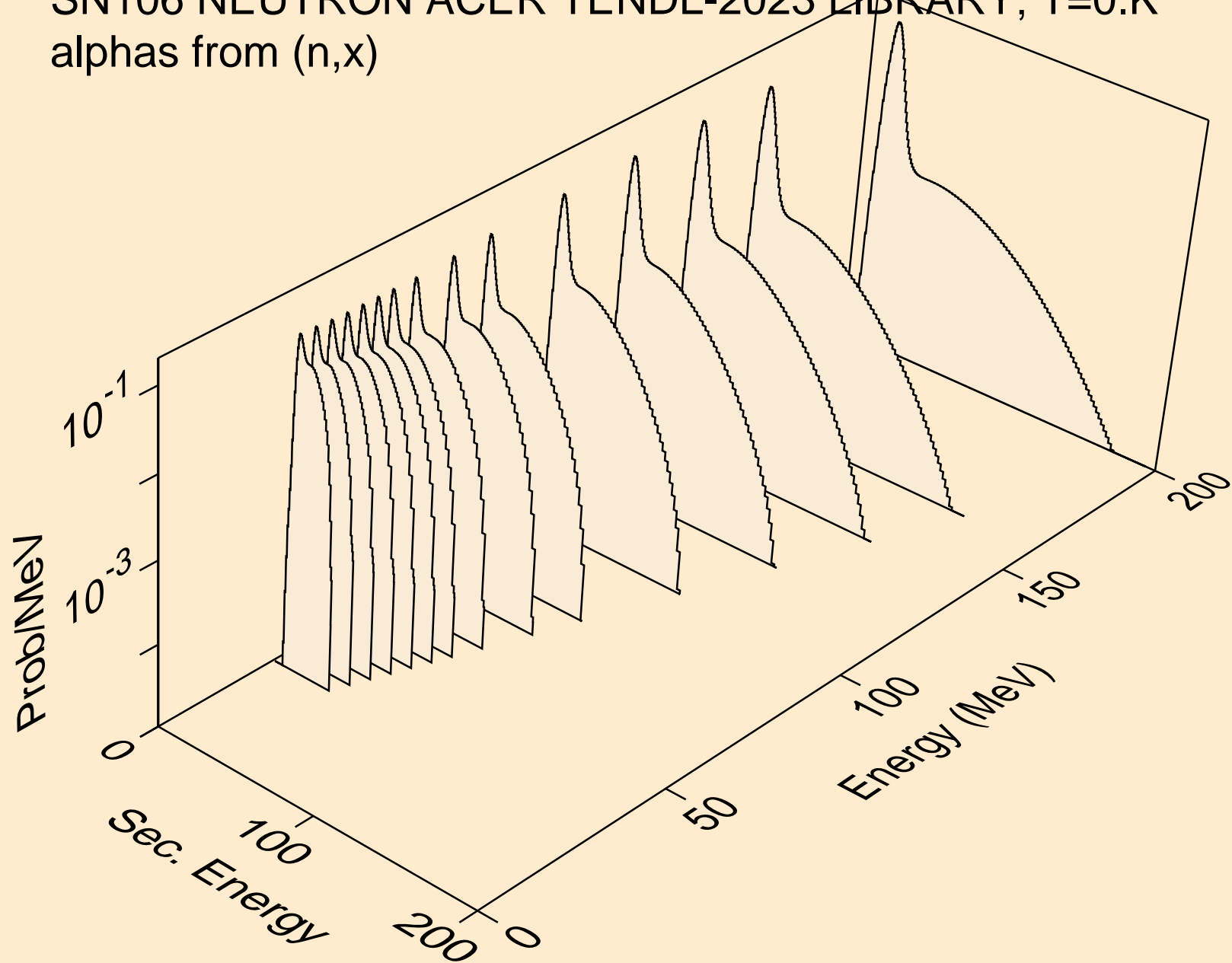

SN106 NEUTRON ACER TENDL-2023 LIBRARY; T=0.K
alphas from (n,n*)a

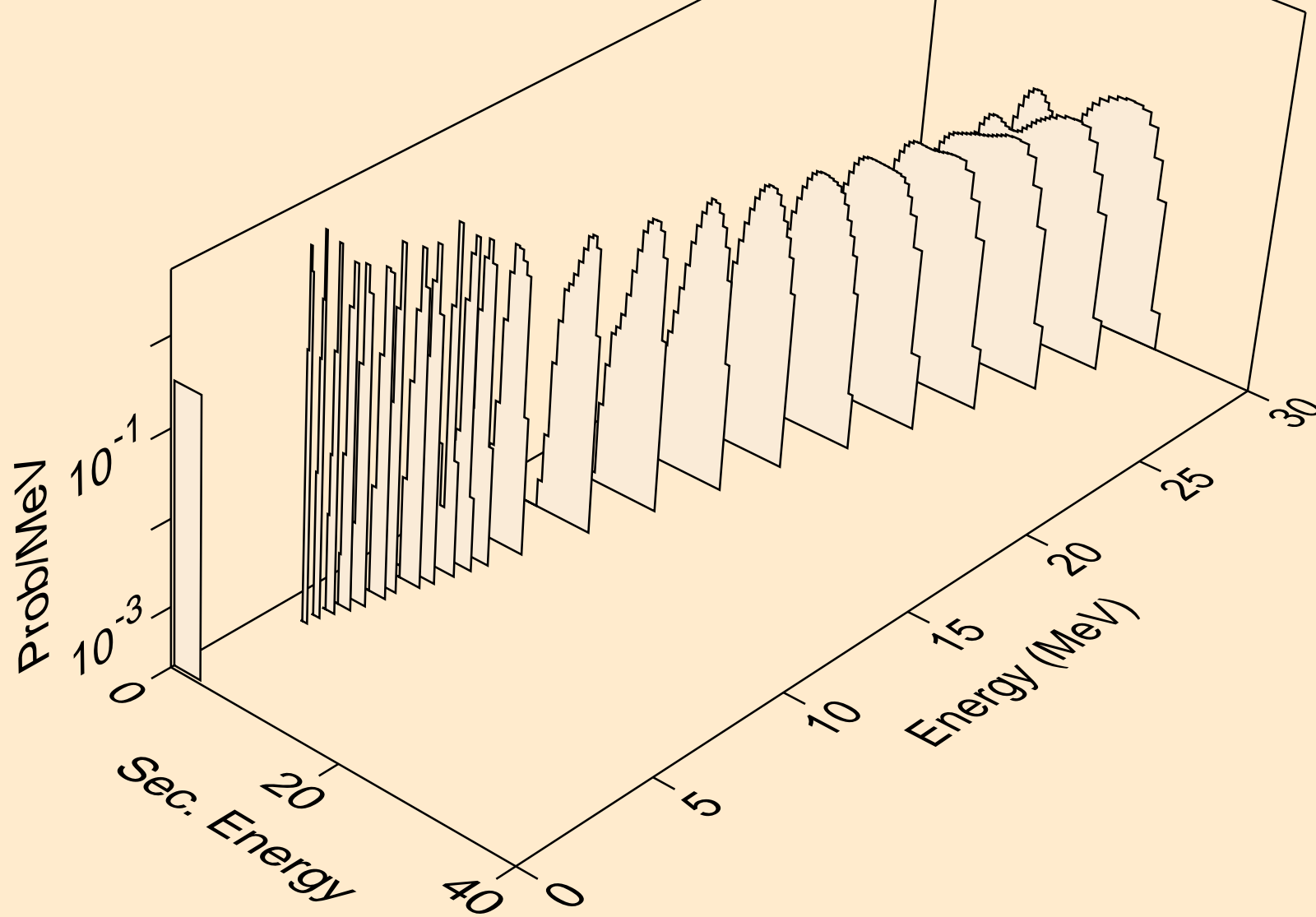

SN106 NEUTRON ACER TENDL-2023 LIBRARY; T=0.K
alphas from (n,2n)a

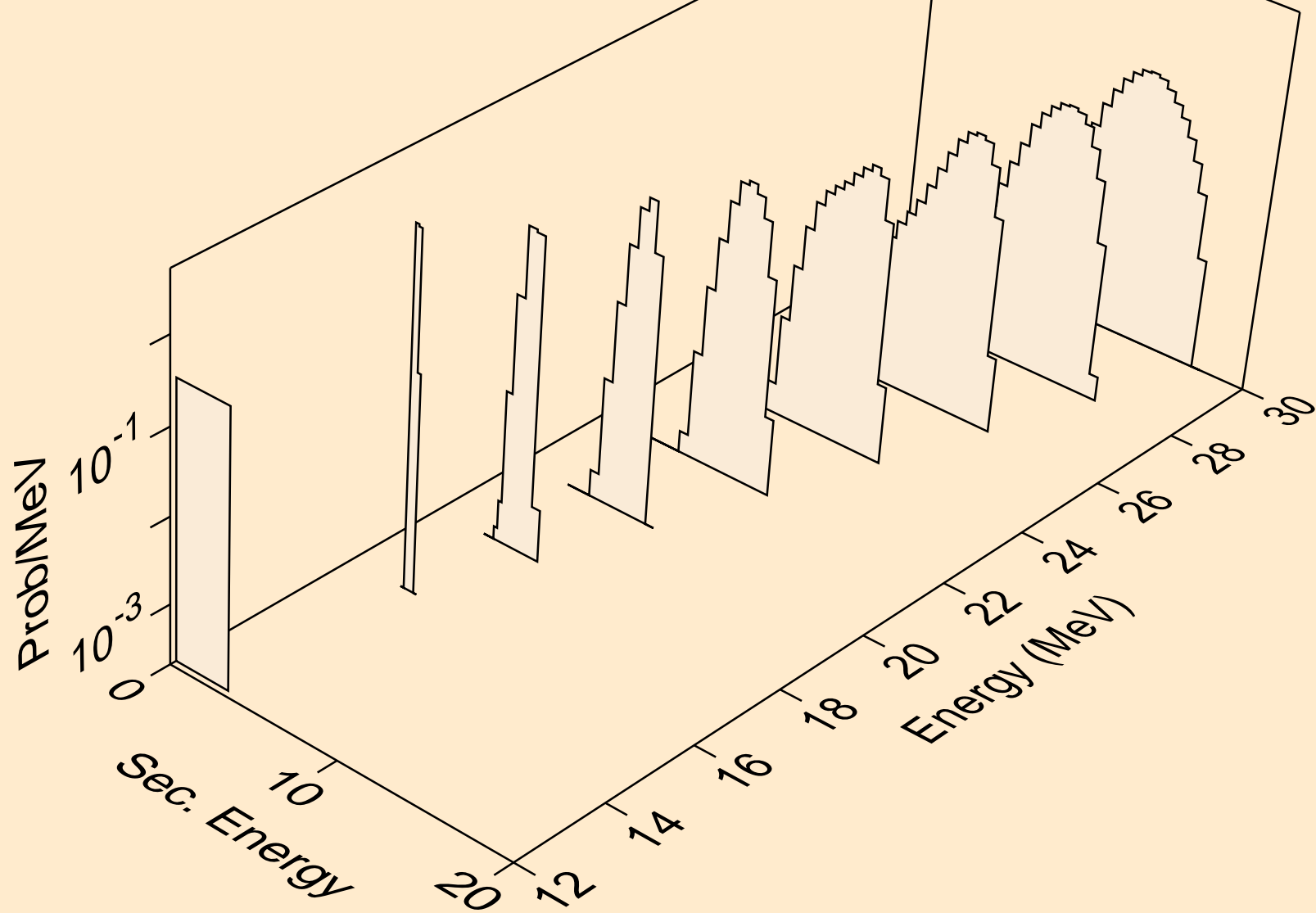

SN106 NEUTRON ACER TENDL-2023 LIBRARY; T=0.K
alphas from (n,3n)a

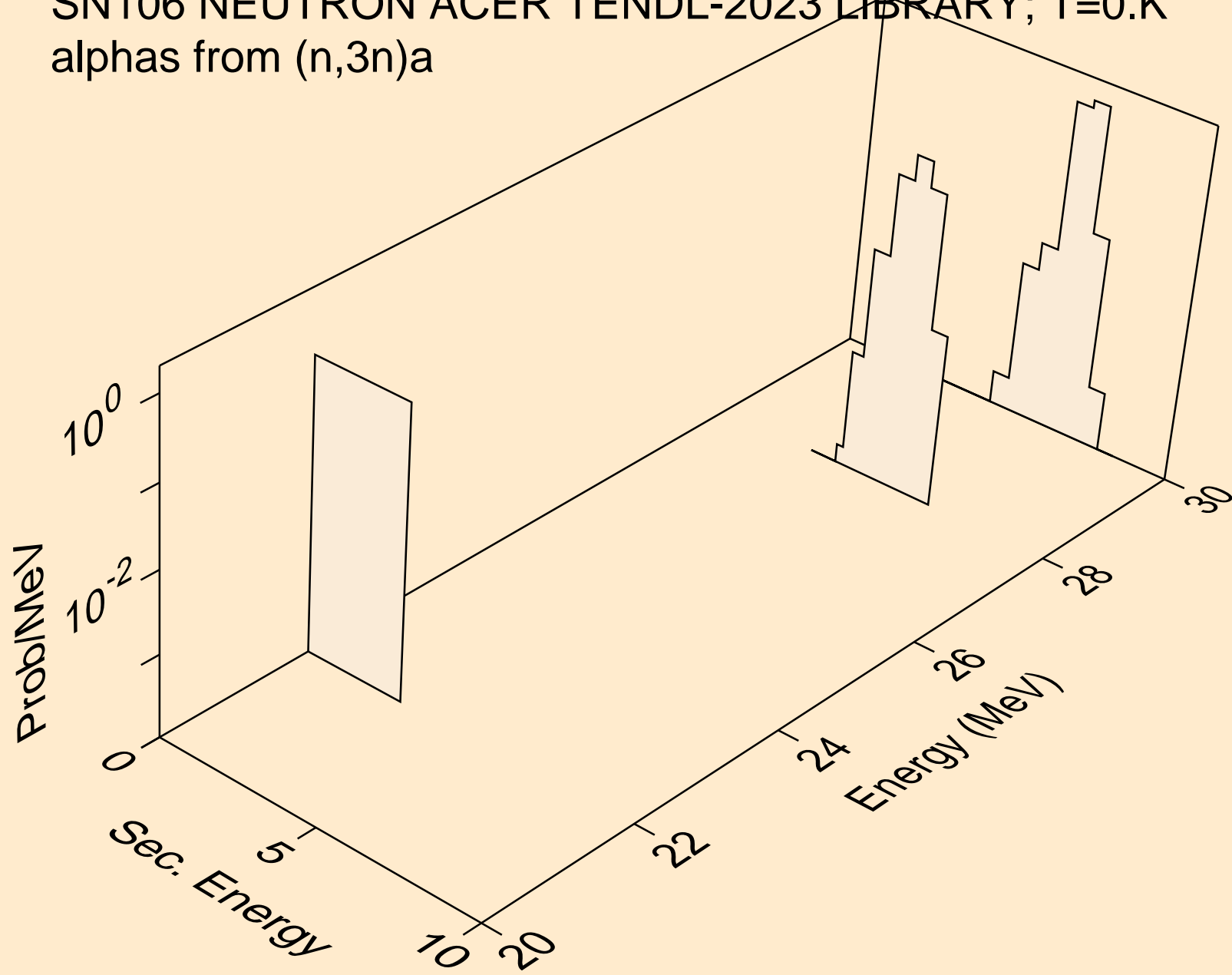

SN106 NEUTRON ACER TENDL-2023 LIBRARY; T=0.K
alphas from (n,n*)2a

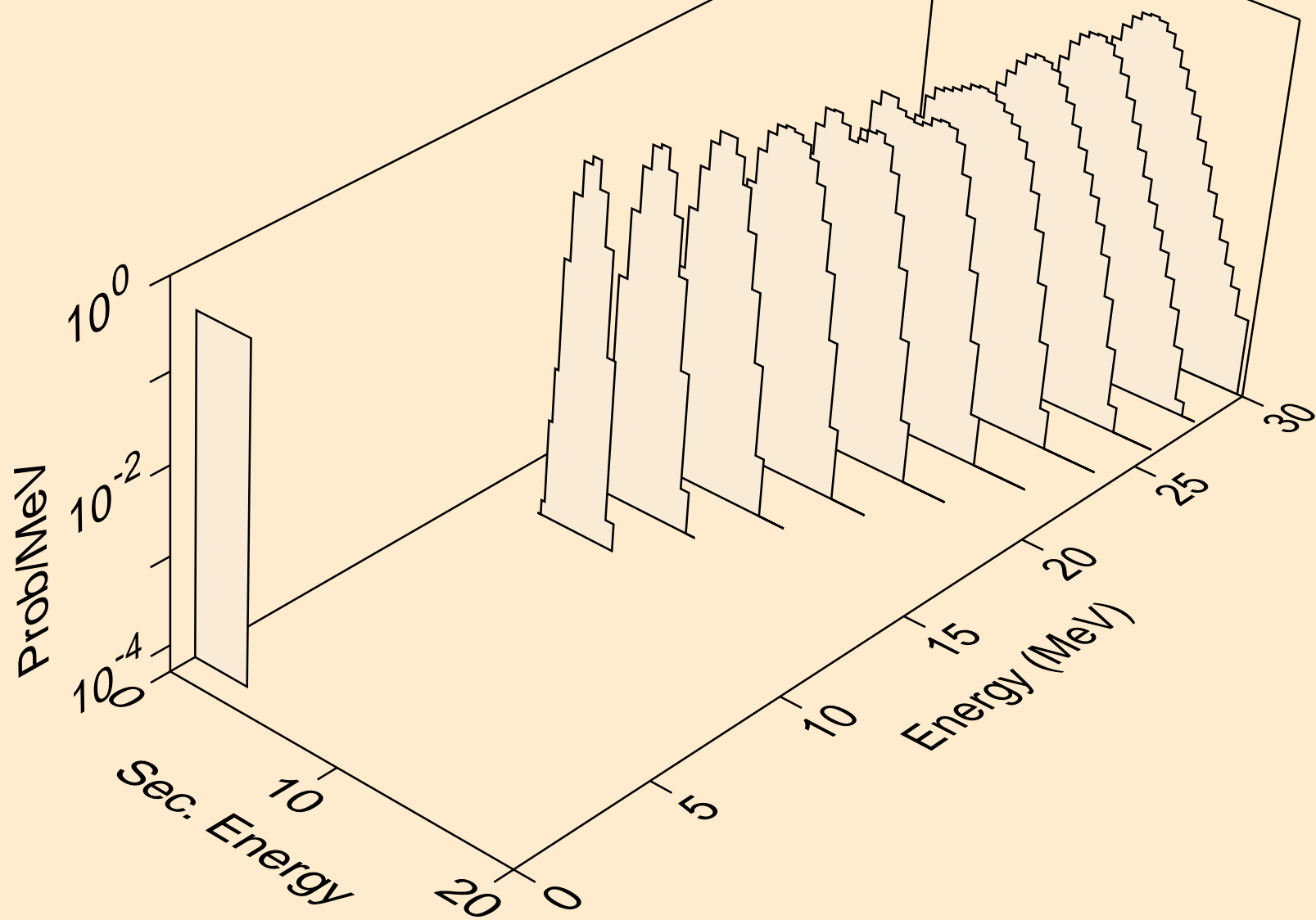

SN106 NEUTRON ACER TENDL-2023 LIBRARY; T=0.K
alphas from (n,npa)

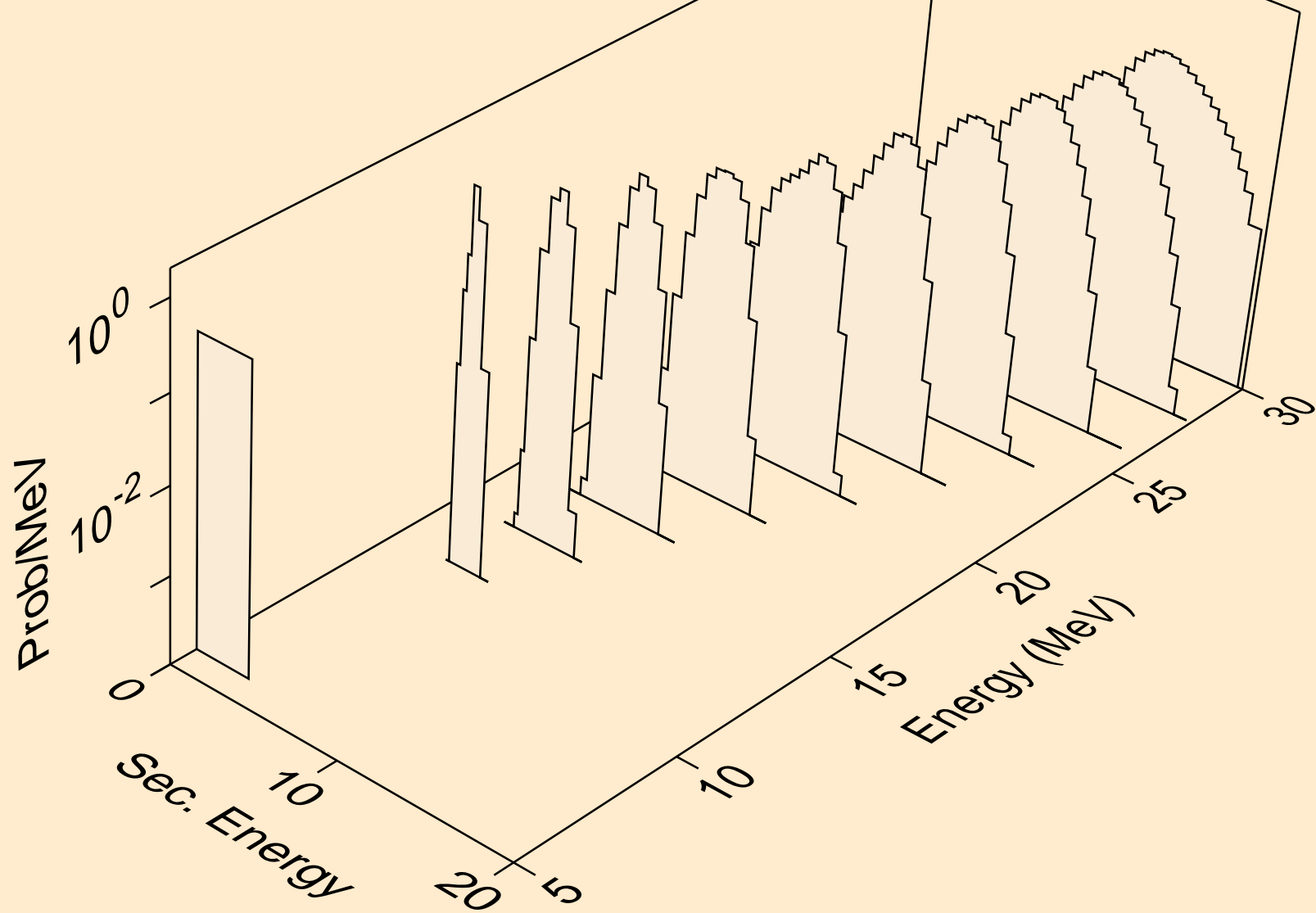

SN106 NEUTRON ACER TENDL-2023 LIBRARY; T=0.K
alphas from (n,a)

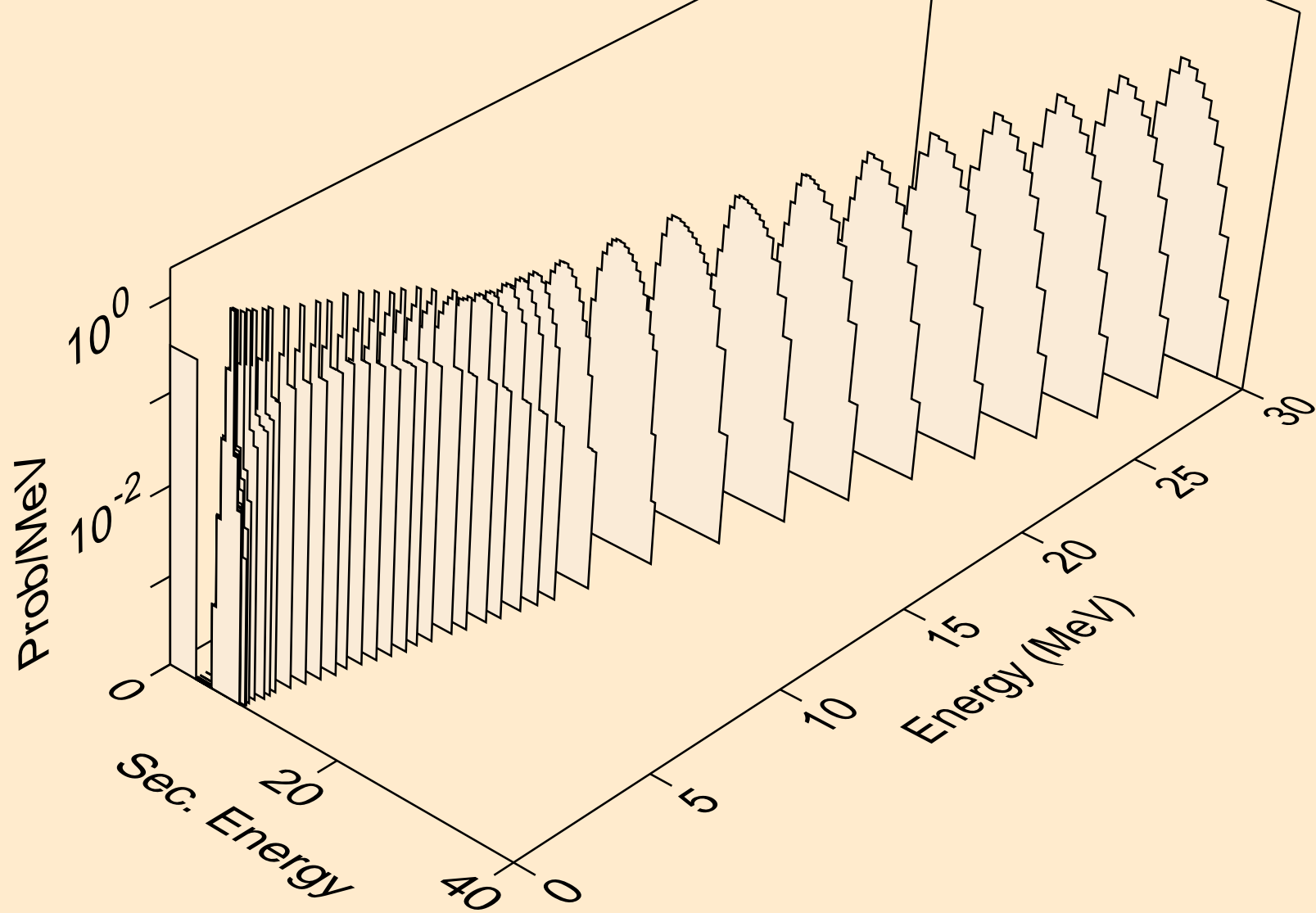

SN106 NEUTRON ACER TENDL-2023 LIBRARY; T=0.K
alphas from (n,2a)

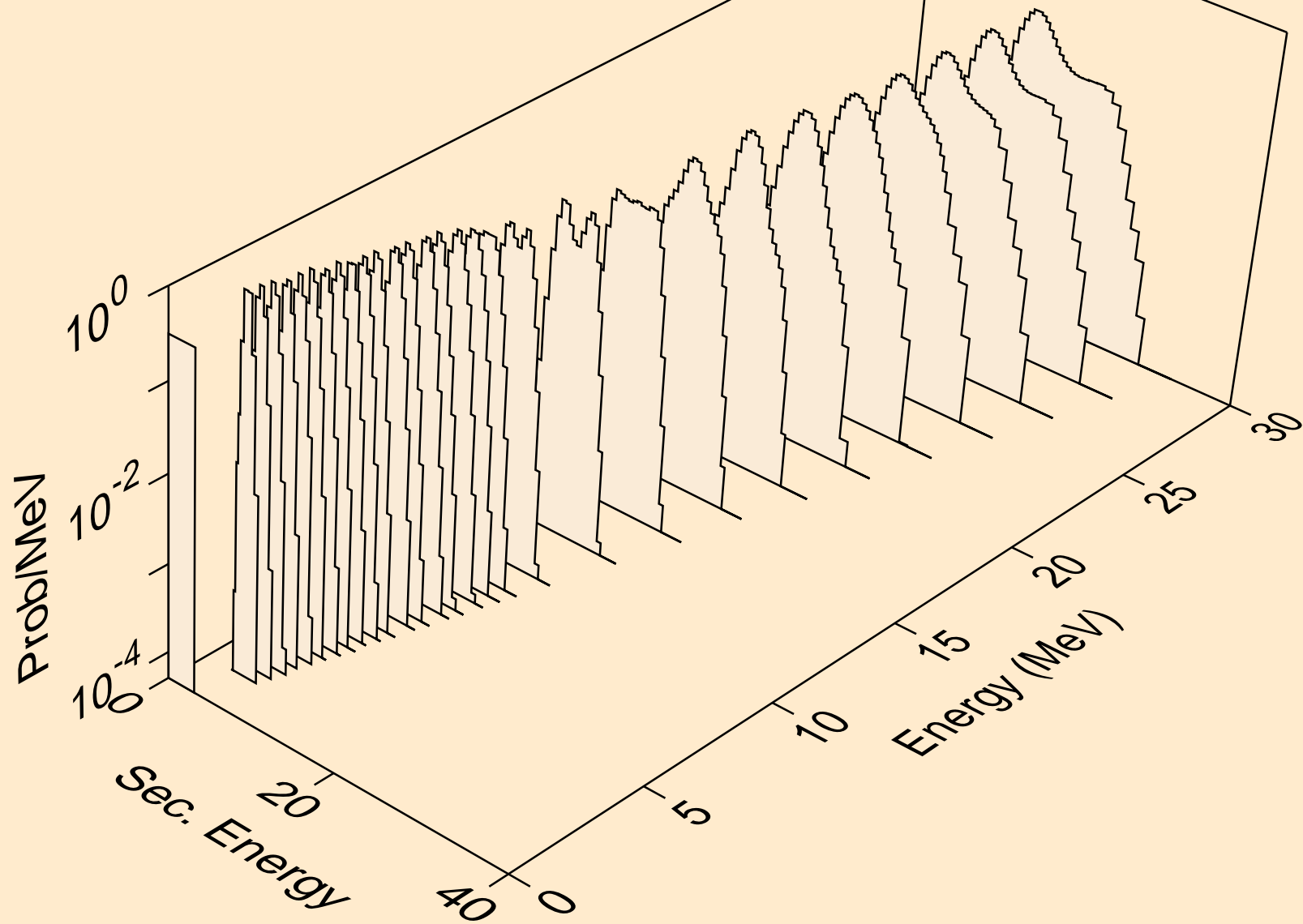

SN106 NEUTRON ACER TENDL-2023 LIBRARY; T=0.K
alphas from (n,3a)

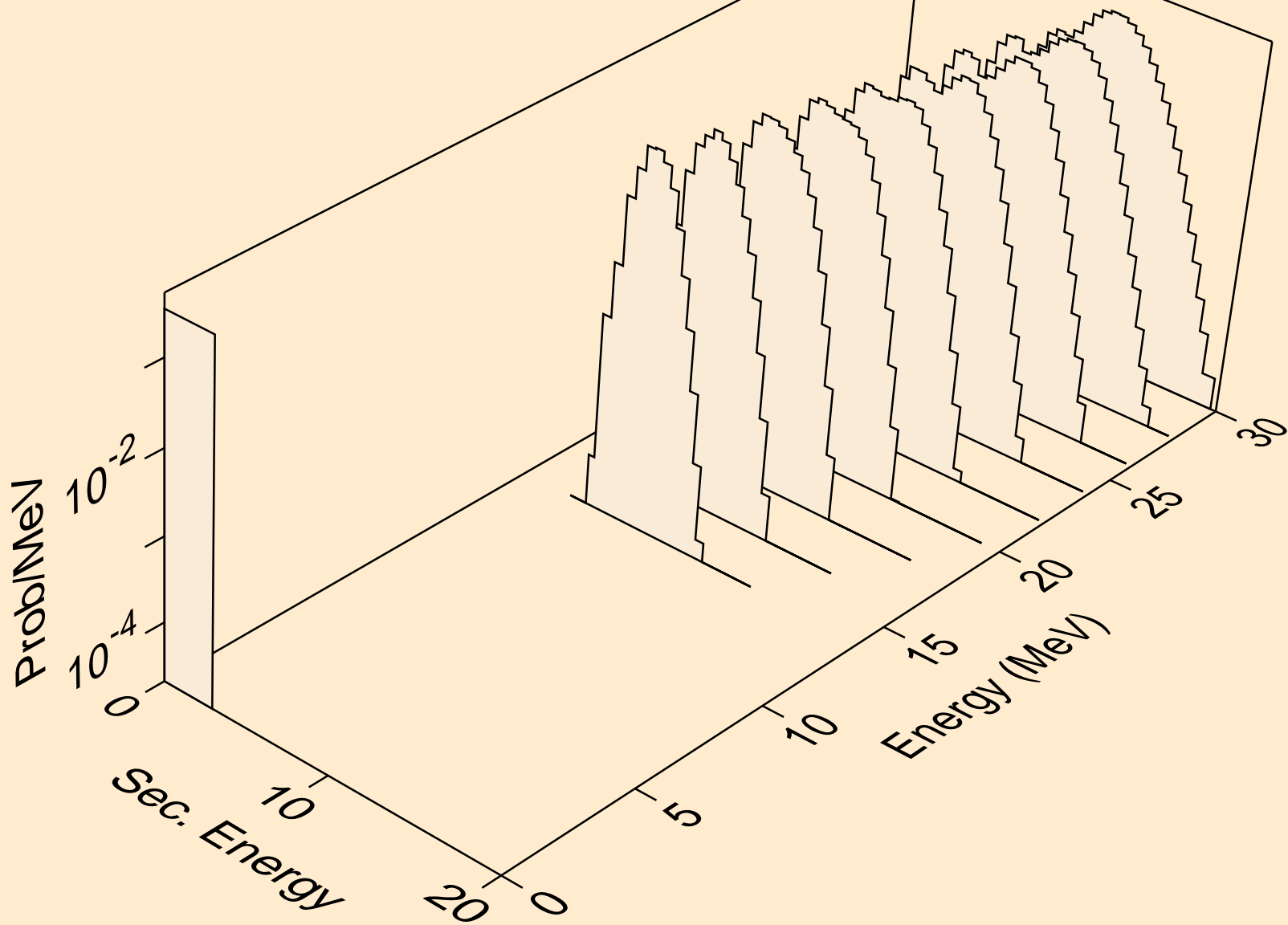

SN106 NEUTRON ACER TENDL-2023 LIBRARY; T=0.K
alphas from (n,pa)

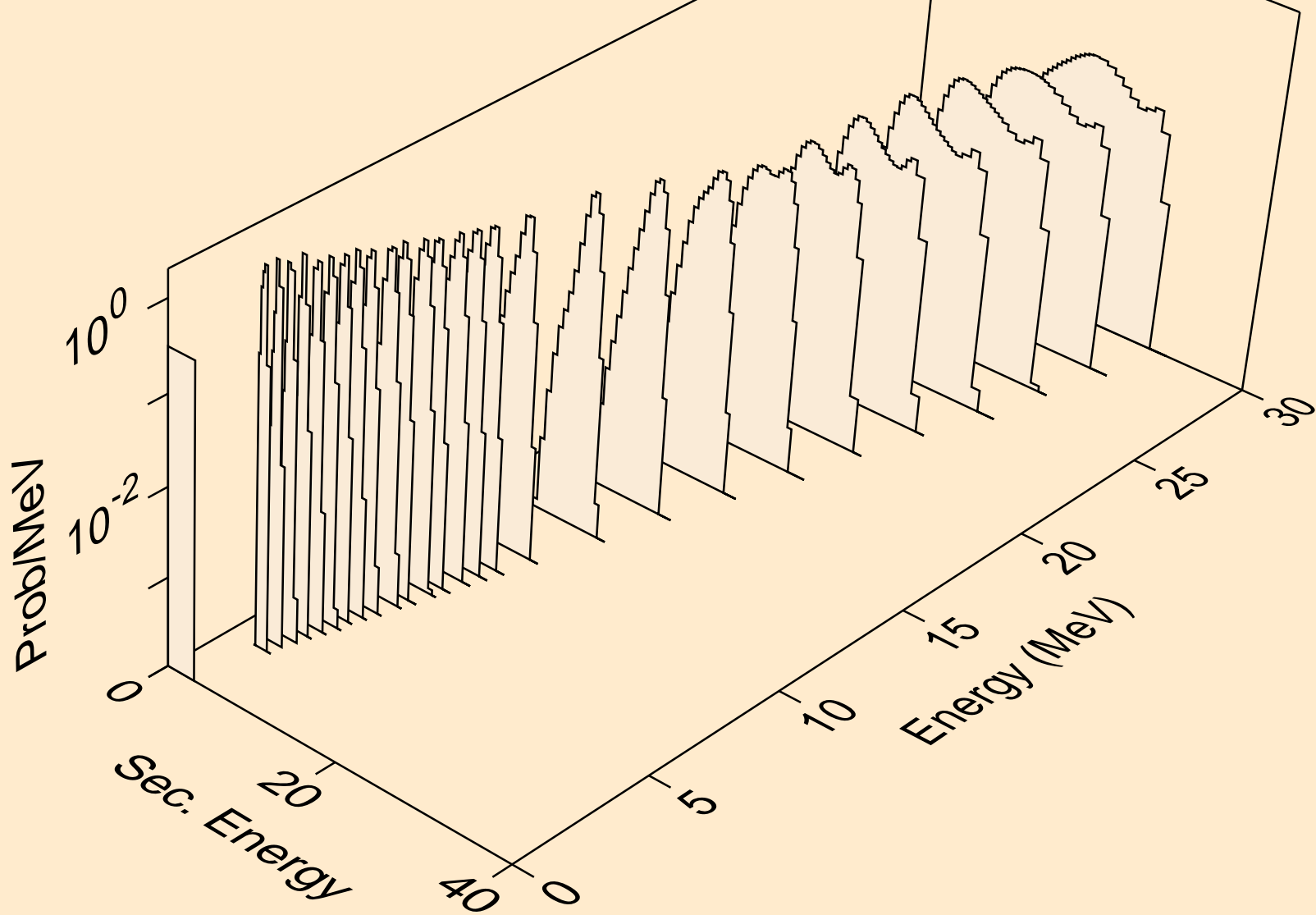

SN106 NEUTRON ACER TENDL-2023 LIBRARY; T=0.K
alphas from (n,da)

