

# SN132 NEUTRON ACER TENDL-2023 LIBRARY; T=0.K

## Principal cross sections

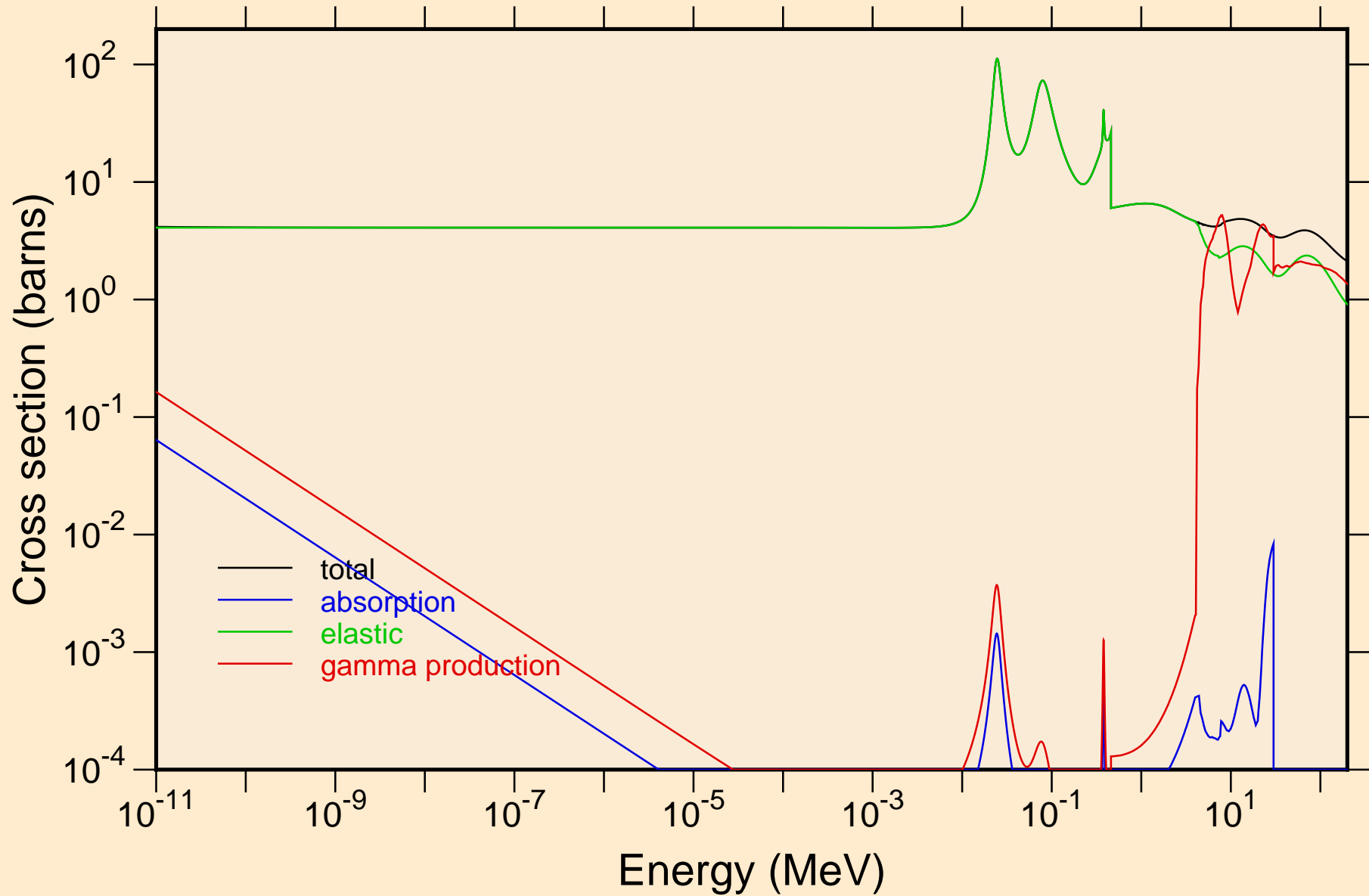

# SN132 NEUTRON ACER TENDL-2023 LIBRARY; T=0.K

## Heating

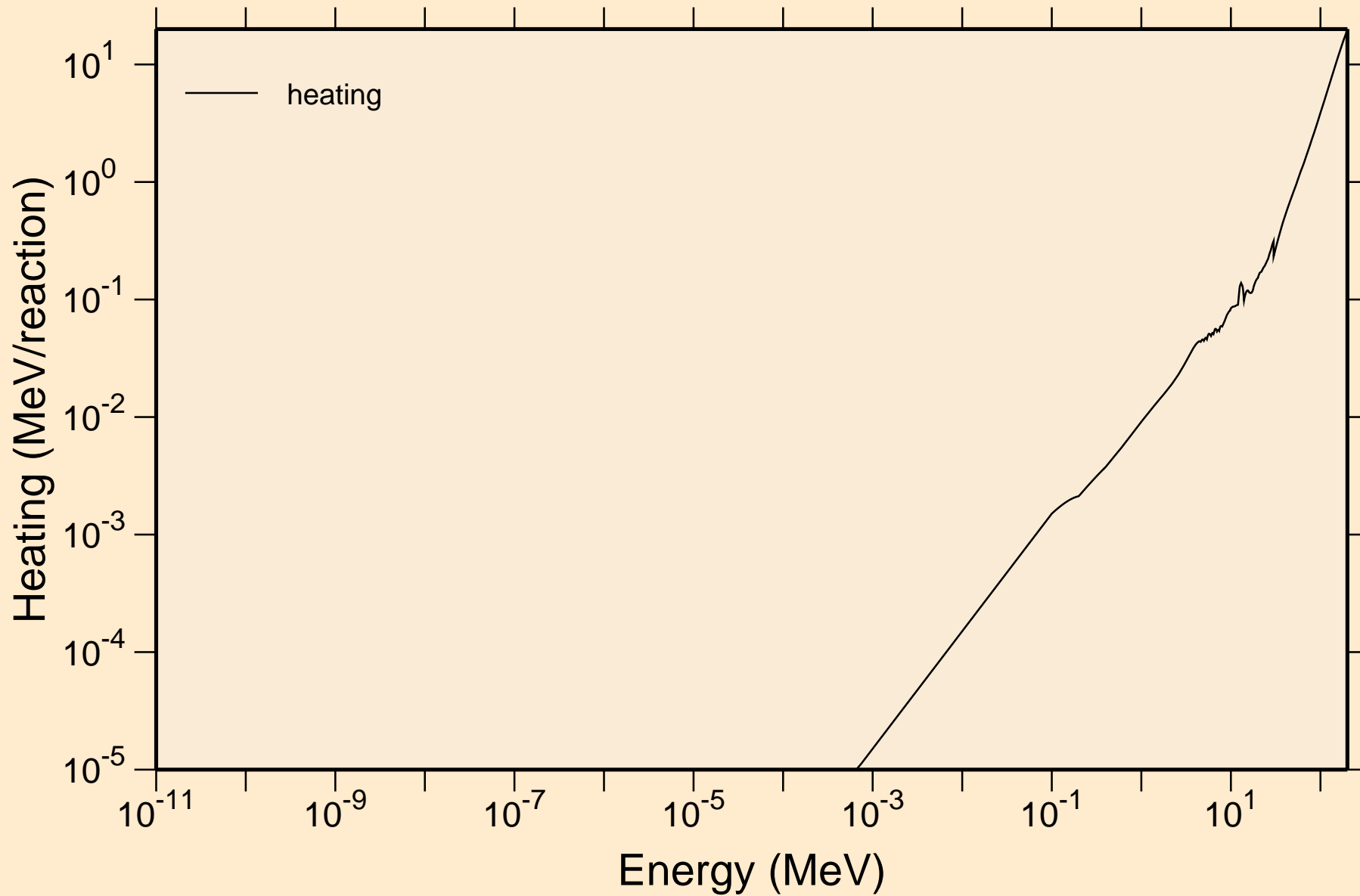

# SN132 NEUTRON ACER TENDL-2023 LIBRARY; T=0.K

## Damage

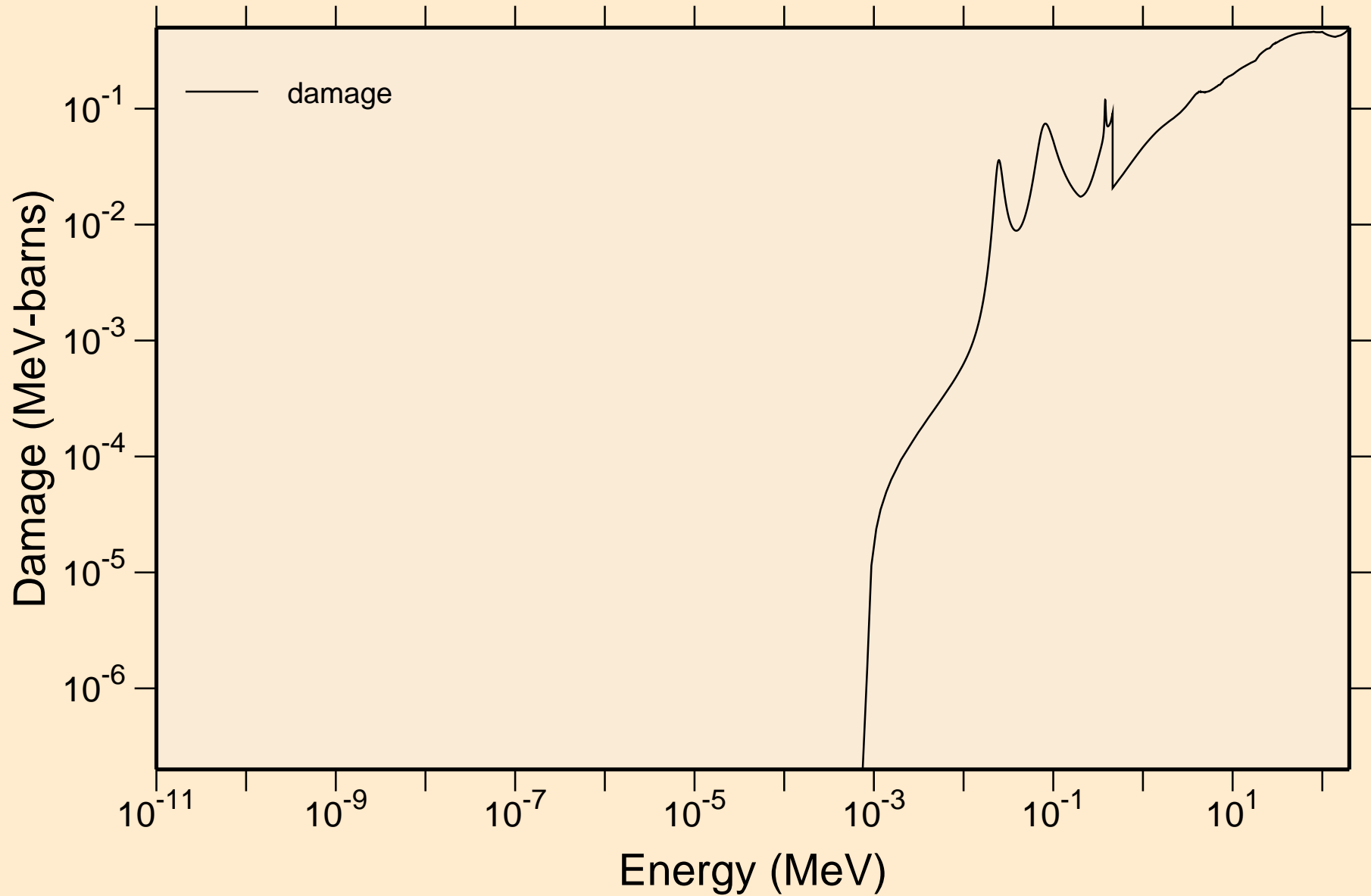

SN132 NEUTRON ACER TENDL-2023 LIBRARY; T=0.K  
Non-threshold reactions

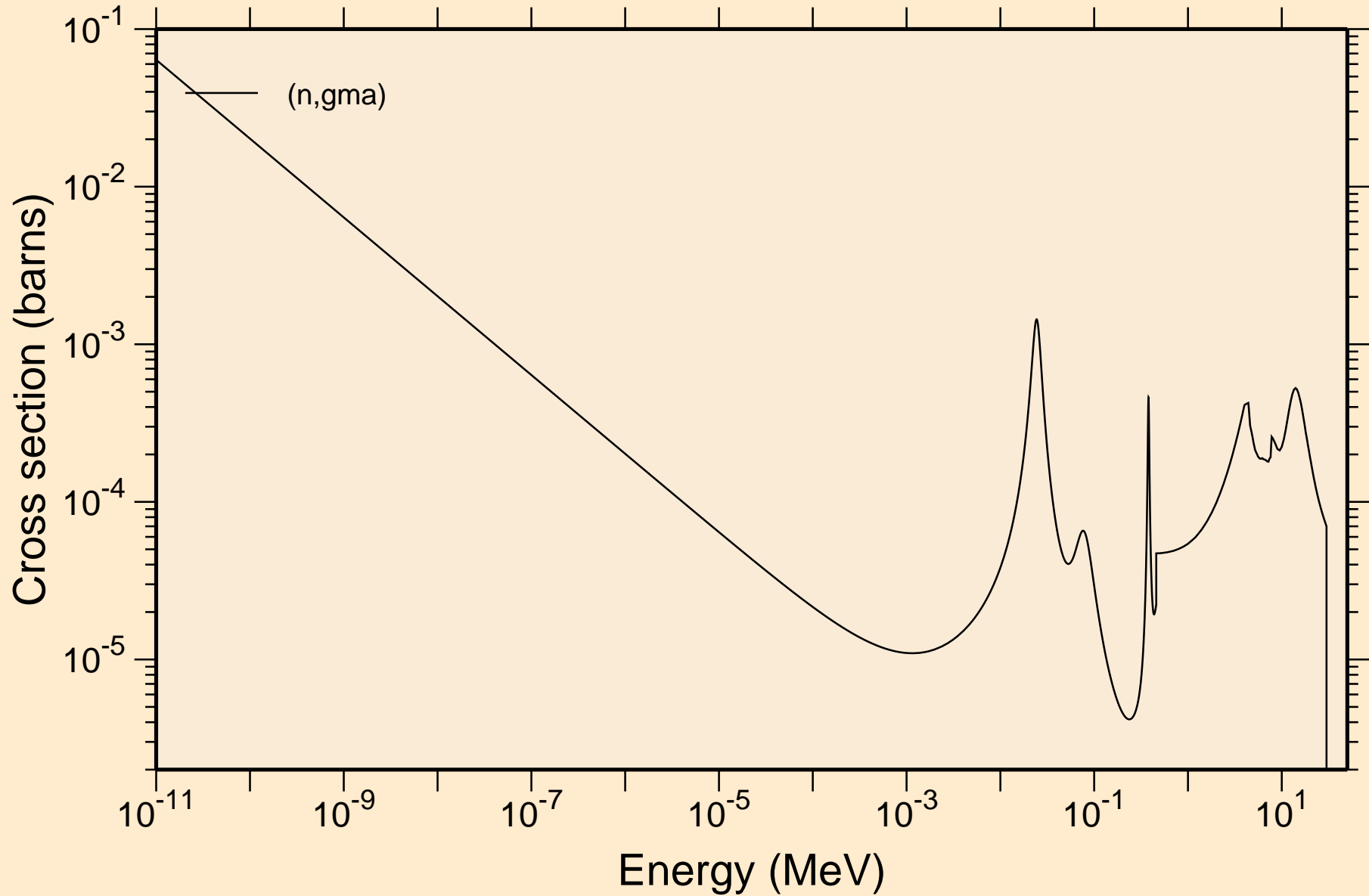

# SN132 NEUTRON ACER TENDL-2023 LIBRARY; T=0.K

## Principal cross sections

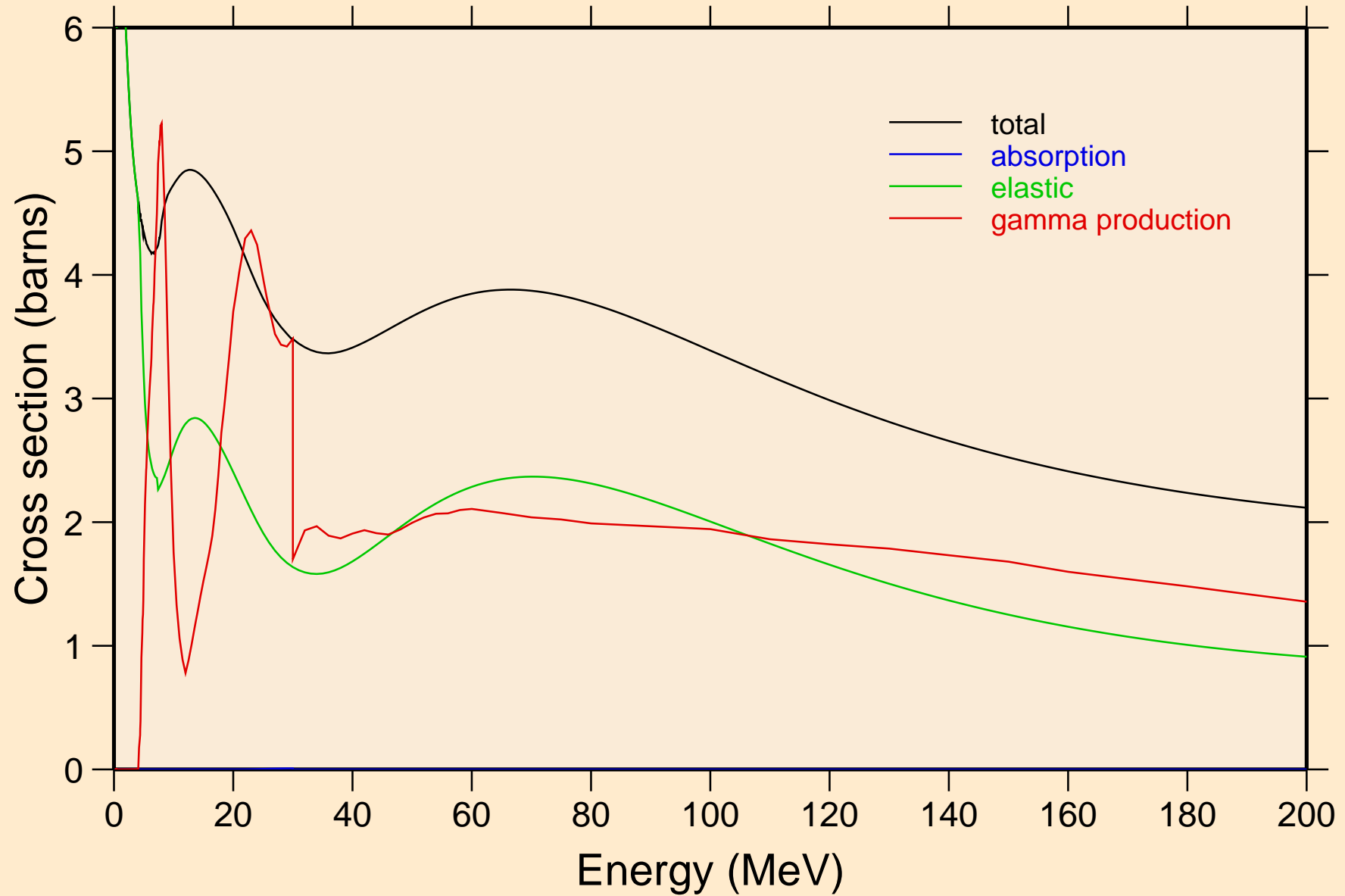

# SN132 NEUTRON ACER TENDL-2023 LIBRARY; T=0.K

## Heating

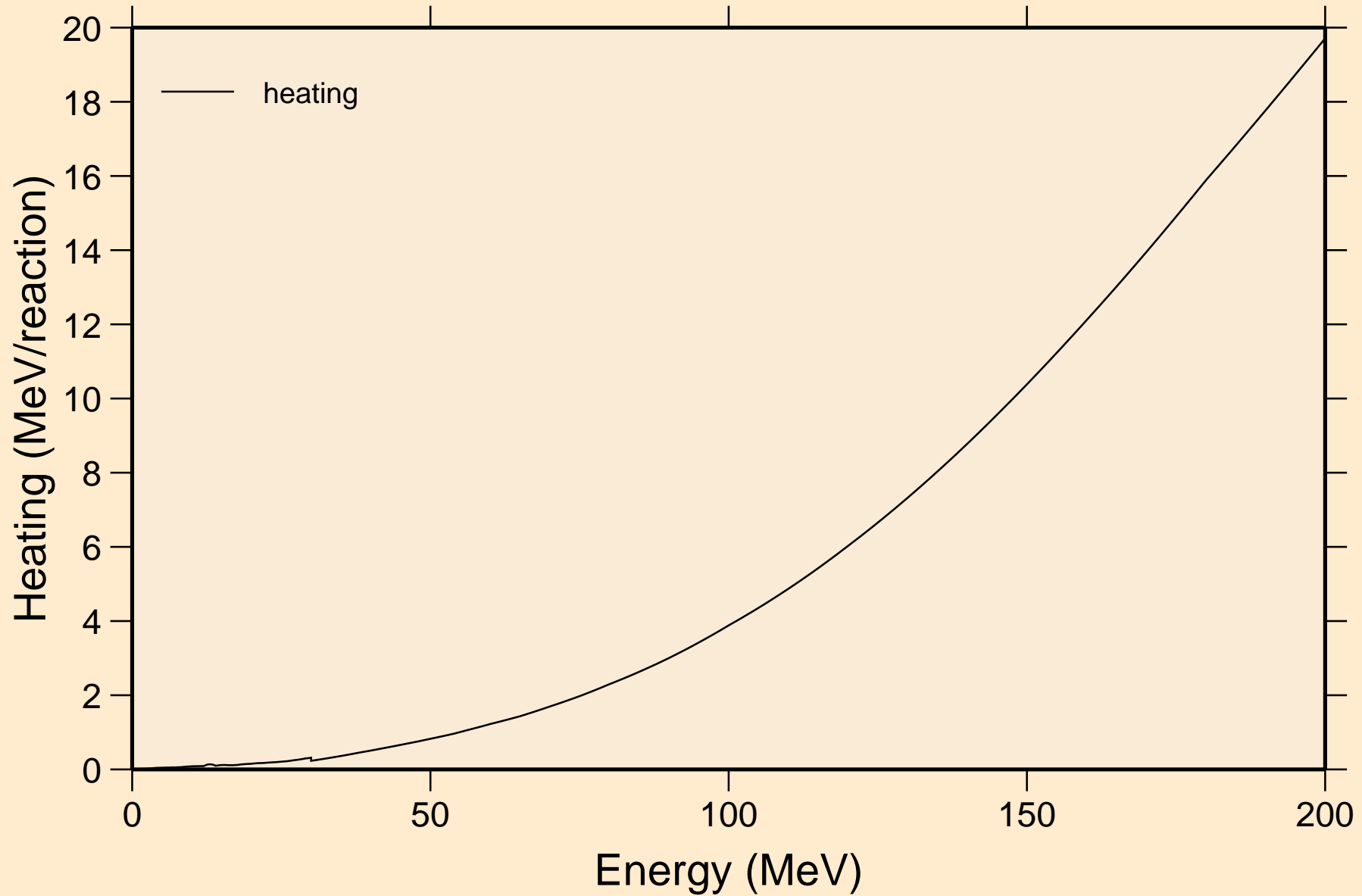

# SN132 NEUTRON ACER TENDL-2023 LIBRARY; T=0.K

## Damage

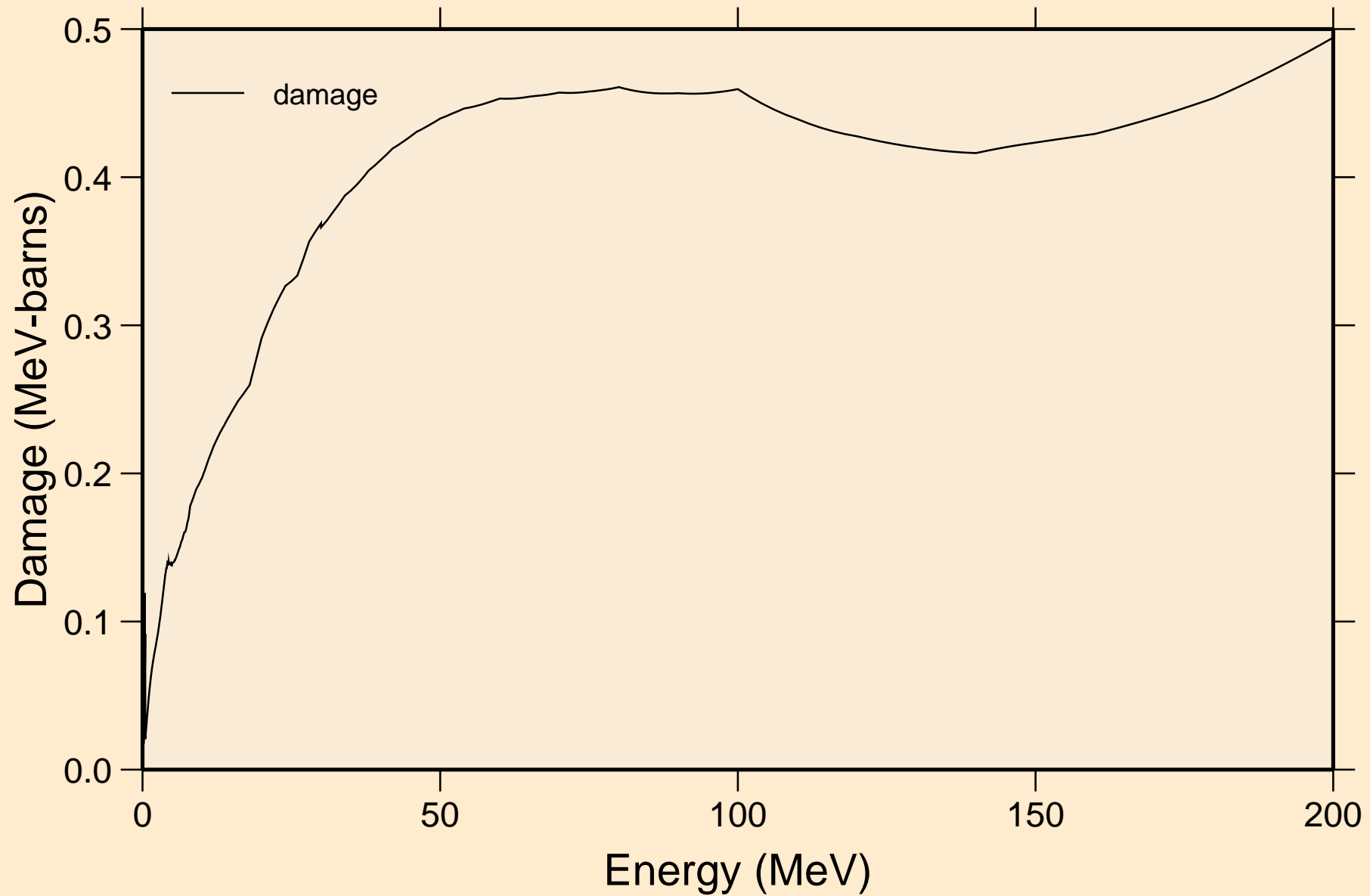

SN132 NEUTRON ACER TENDL-2023 LIBRARY; T=0.K  
Non-threshold reactions

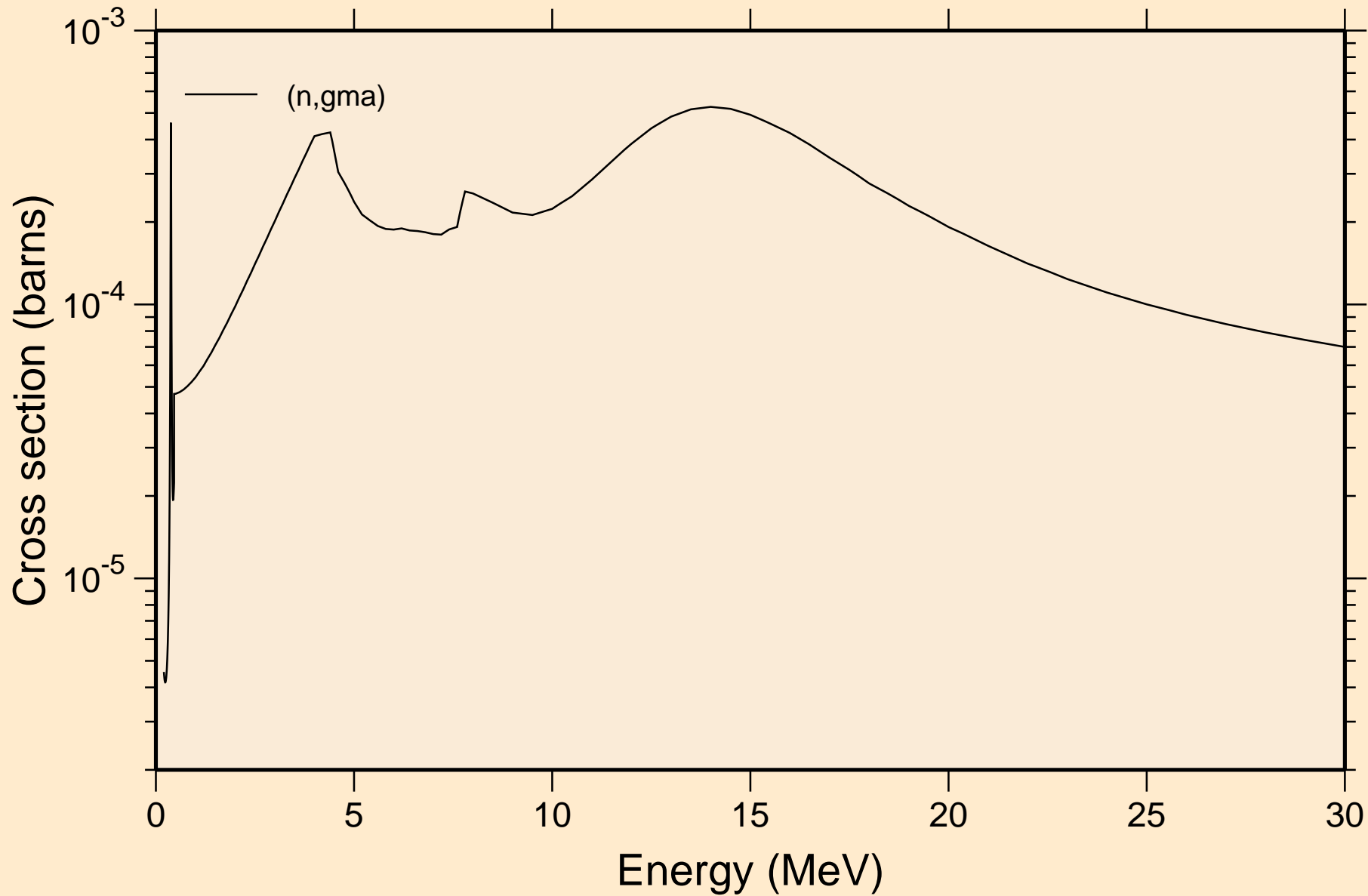



SN132 NEUTRON ACER TENDL-2023 LIBRARY; T=0.K  
Inelastic levels

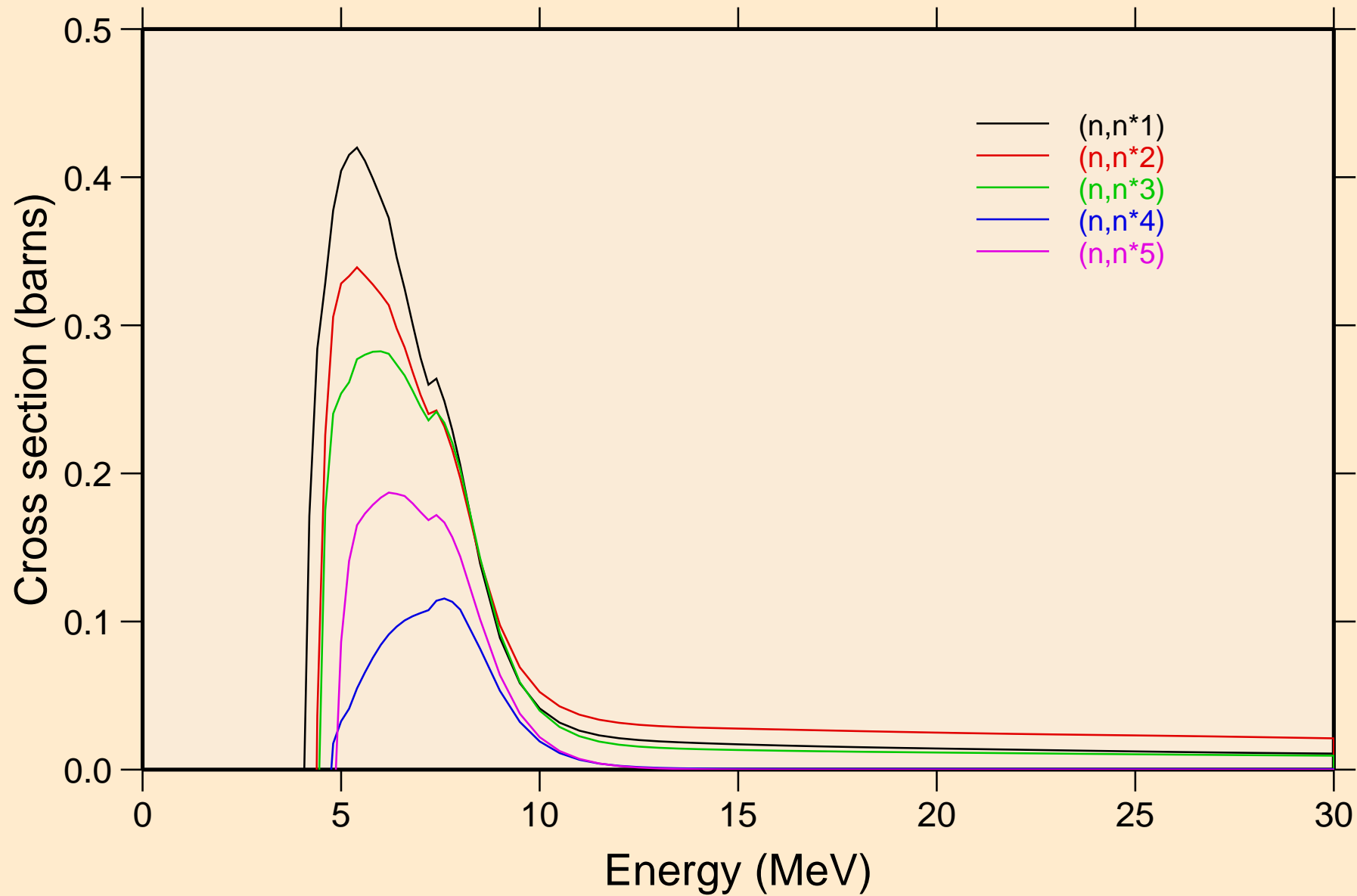

# SN132 NEUTRON ACER TENDL-2023 LIBRARY; T=0.K

## Inelastic levels

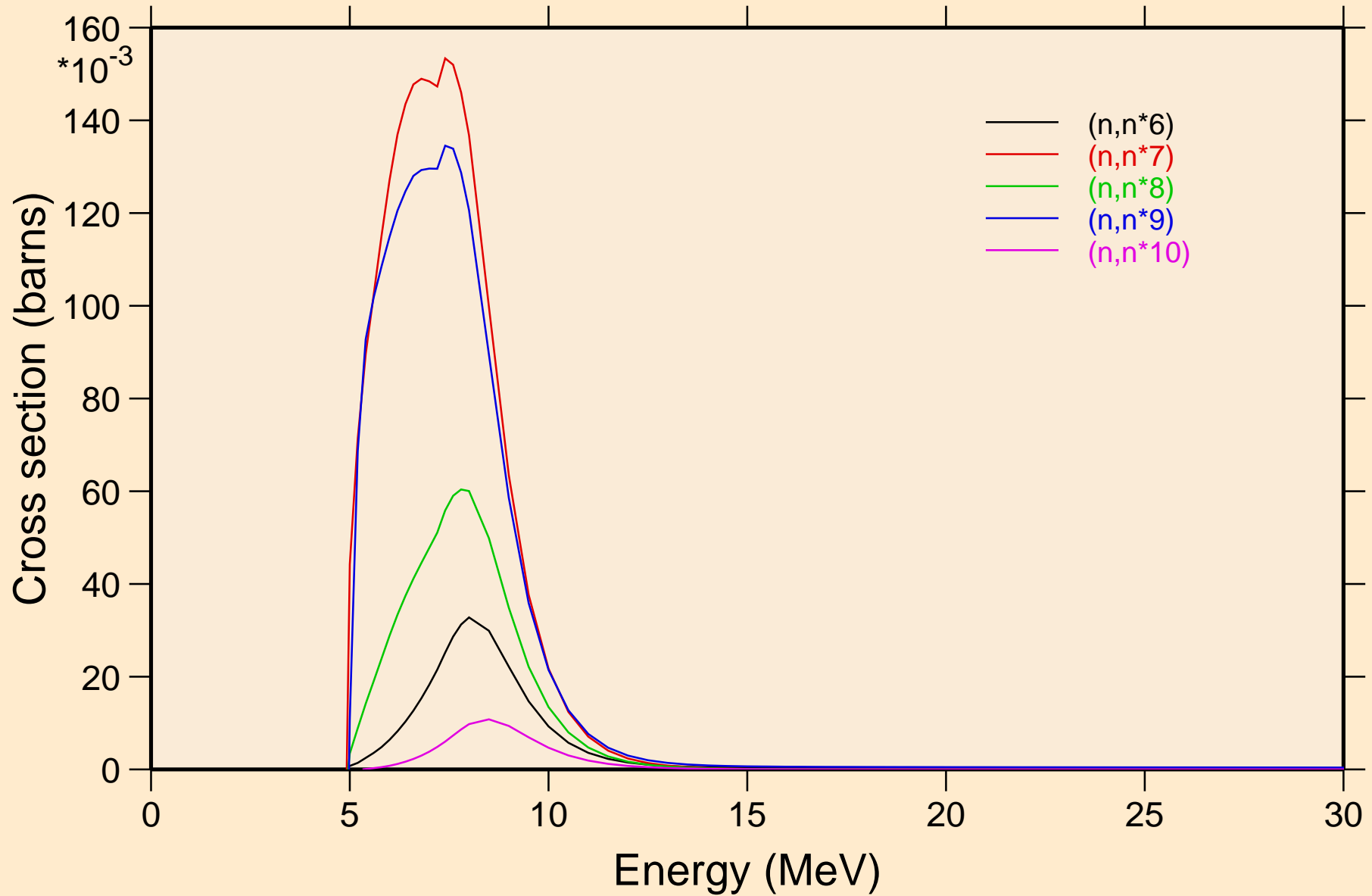

# SN132 NEUTRON ACER TENDL-2023 LIBRARY; T=0.K

## Inelastic levels

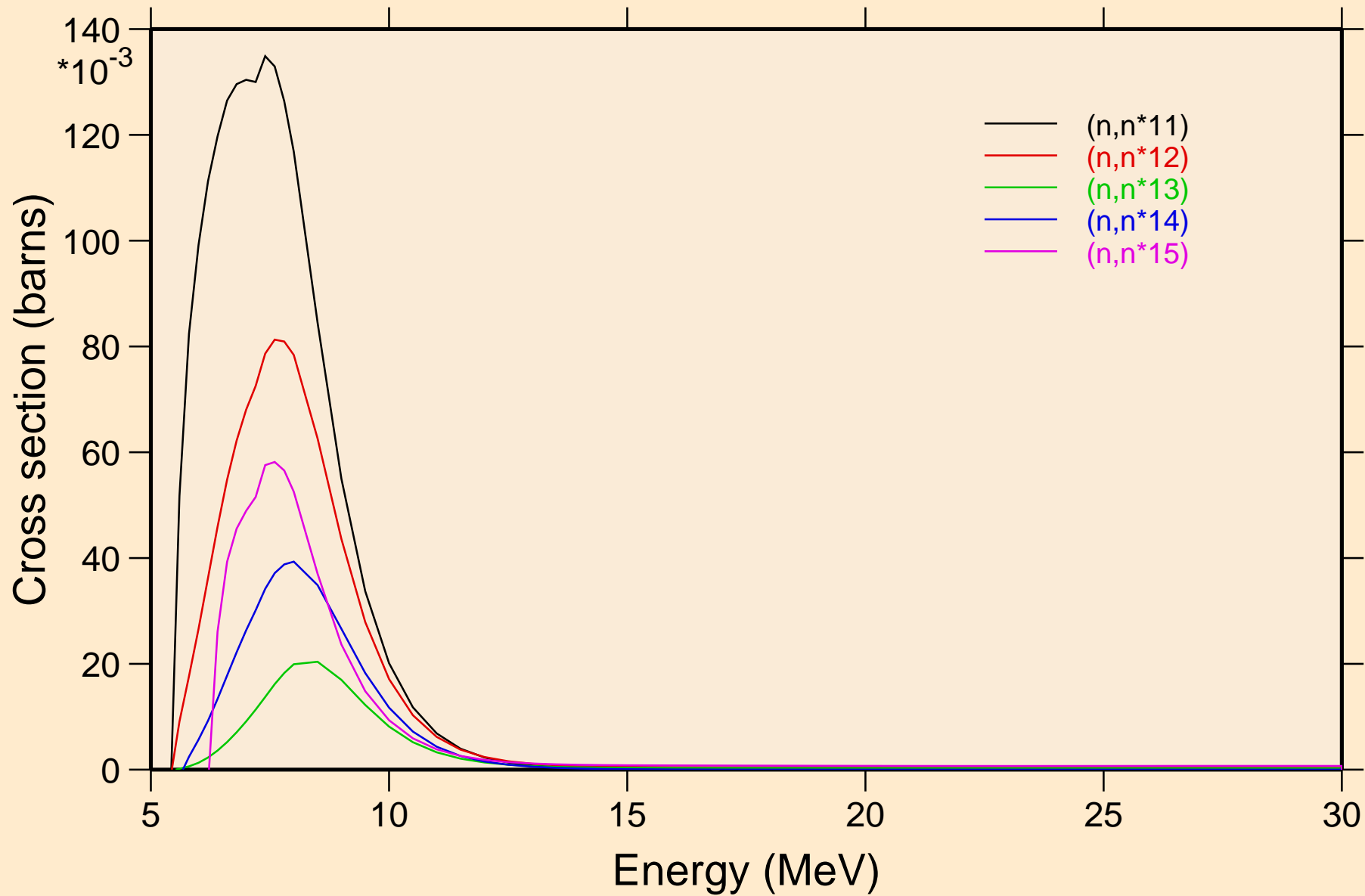

# SN132 NEUTRON ACER TENDL-2023 LIBRARY; T=0.K

## Inelastic levels

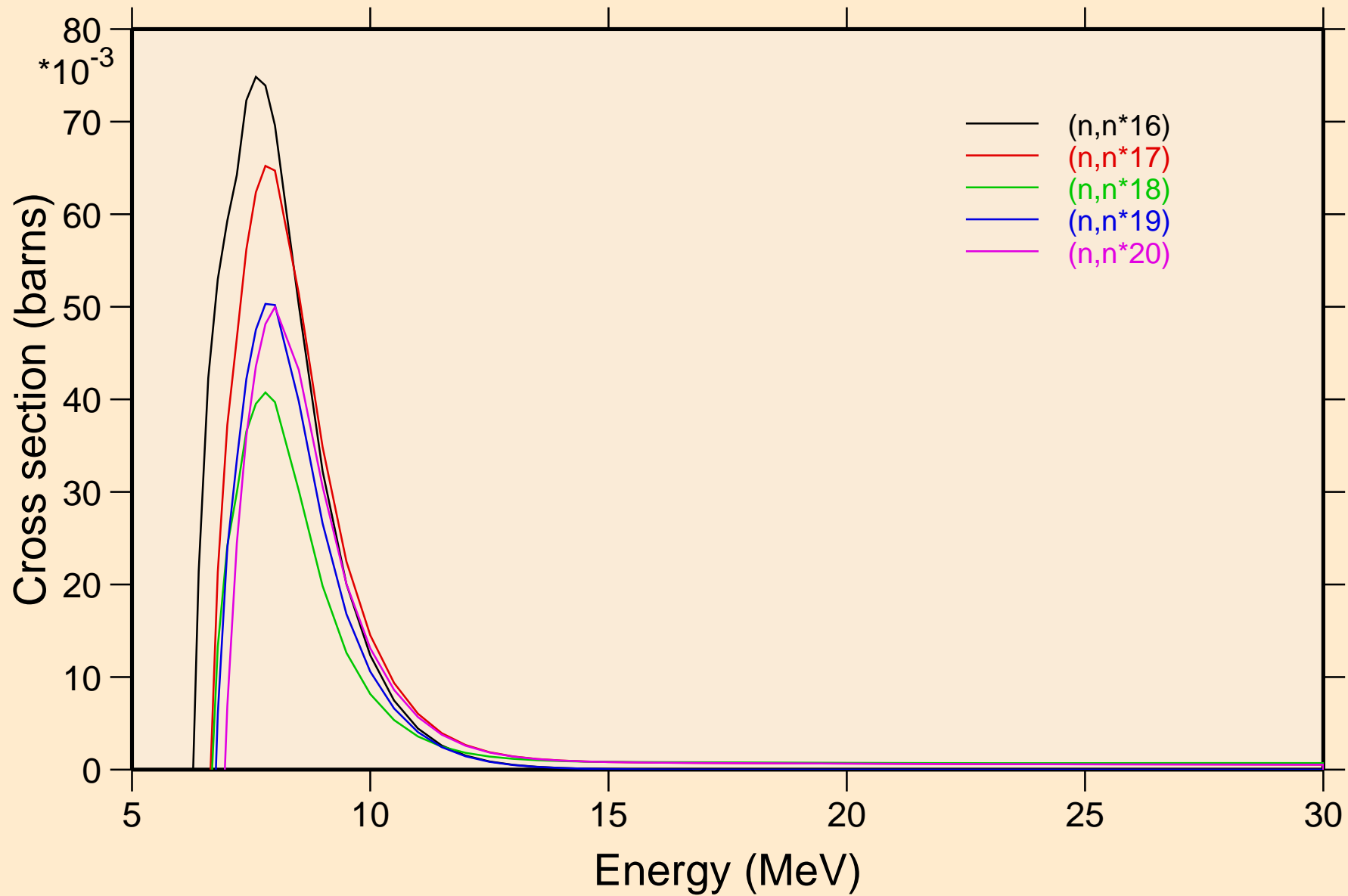

# SN132 NEUTRON ACER TENDL-2023 LIBRARY; T=0.K

## Inelastic levels

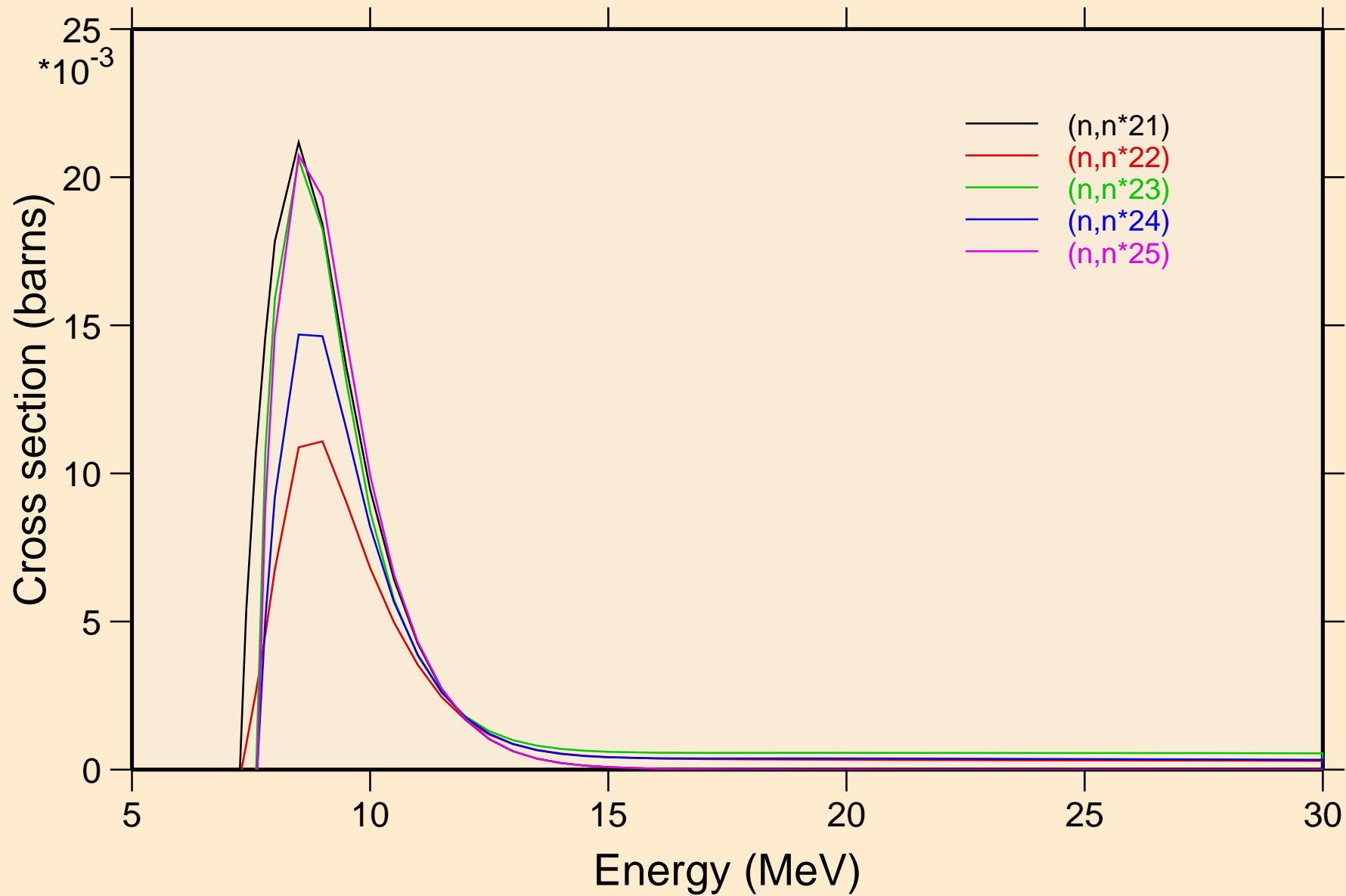

# SN132 NEUTRON ACER TENDL-2023 LIBRARY; T=0.K

## Inelastic levels

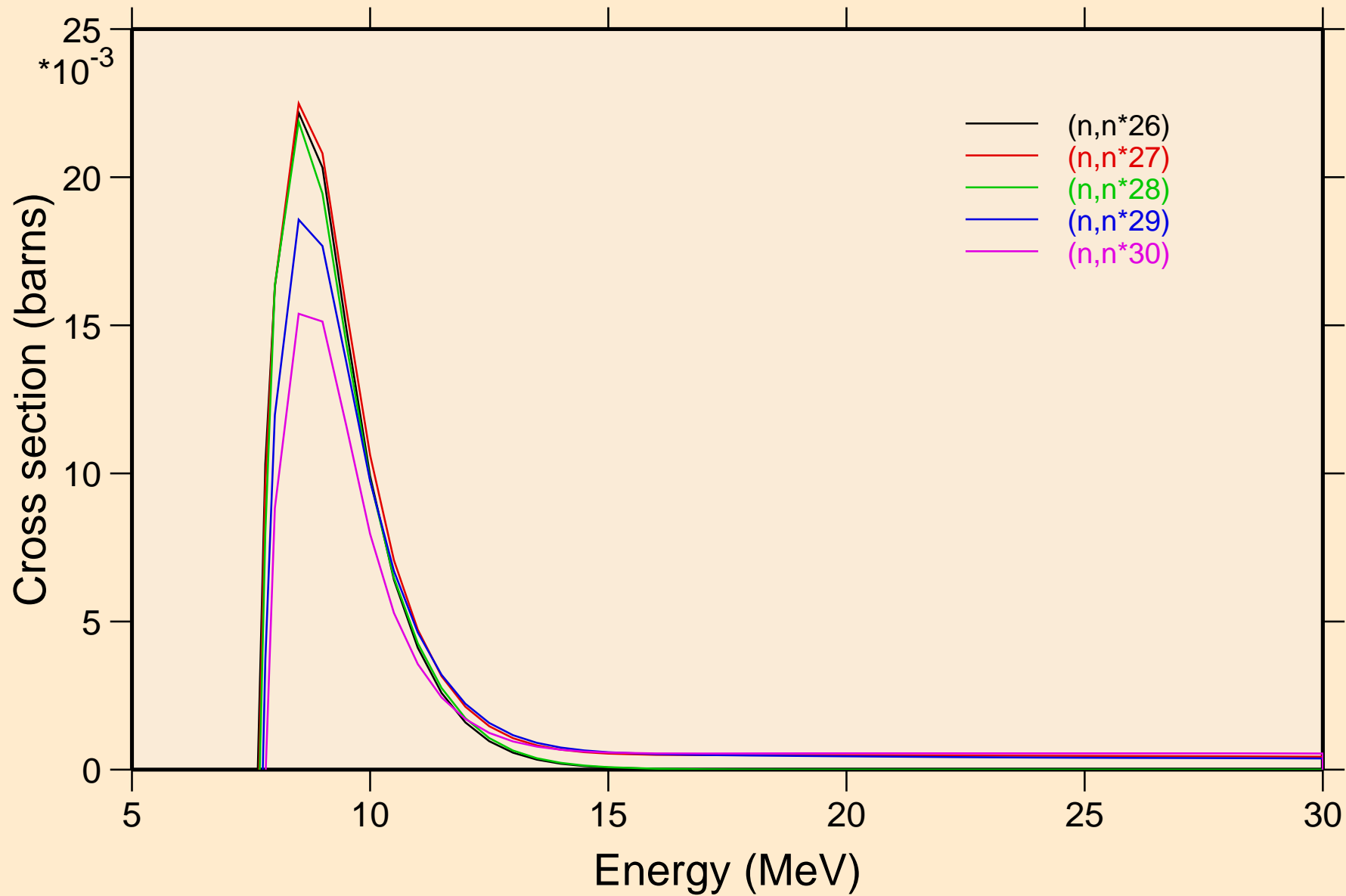

# SN132 NEUTRON ACER TENDL-2023 LIBRARY; T=0.K

## Threshold reactions

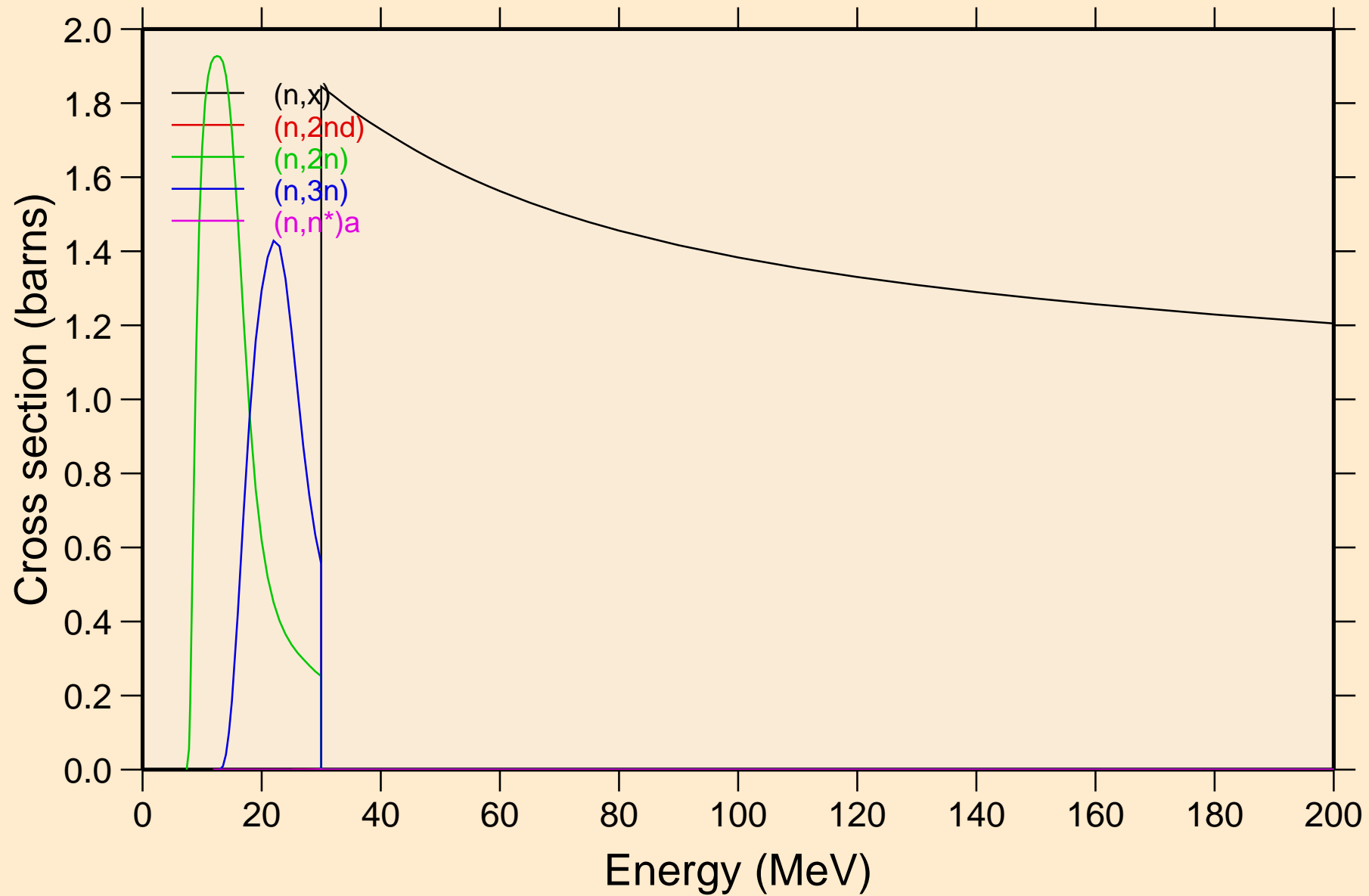

# SN132 NEUTRON ACER TENDL-2023 LIBRARY; T=0.K

## Threshold reactions

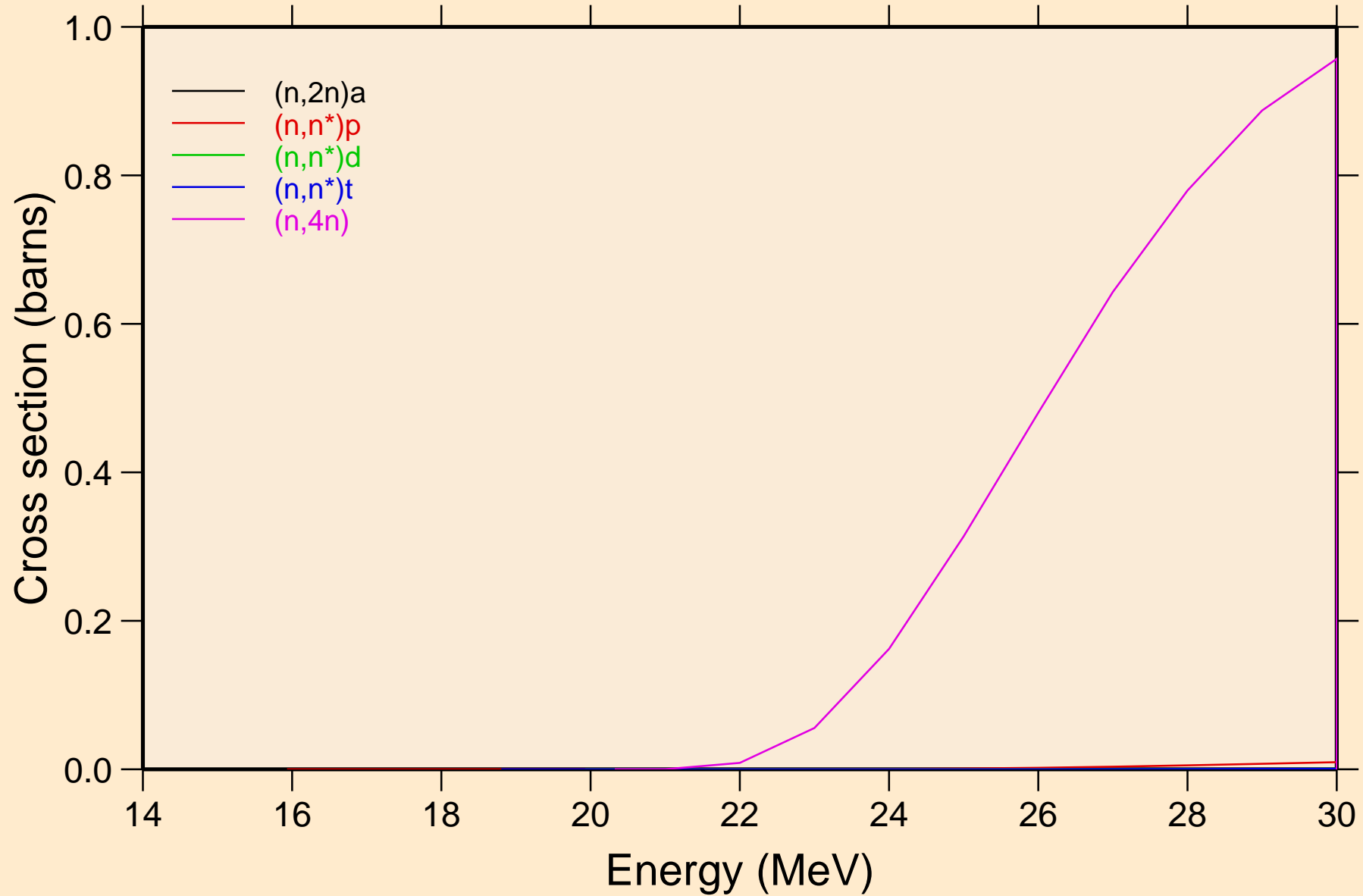



# SN132 NEUTRON ACER TENDL-2023 LIBRARY; T=0.K

## Threshold reactions

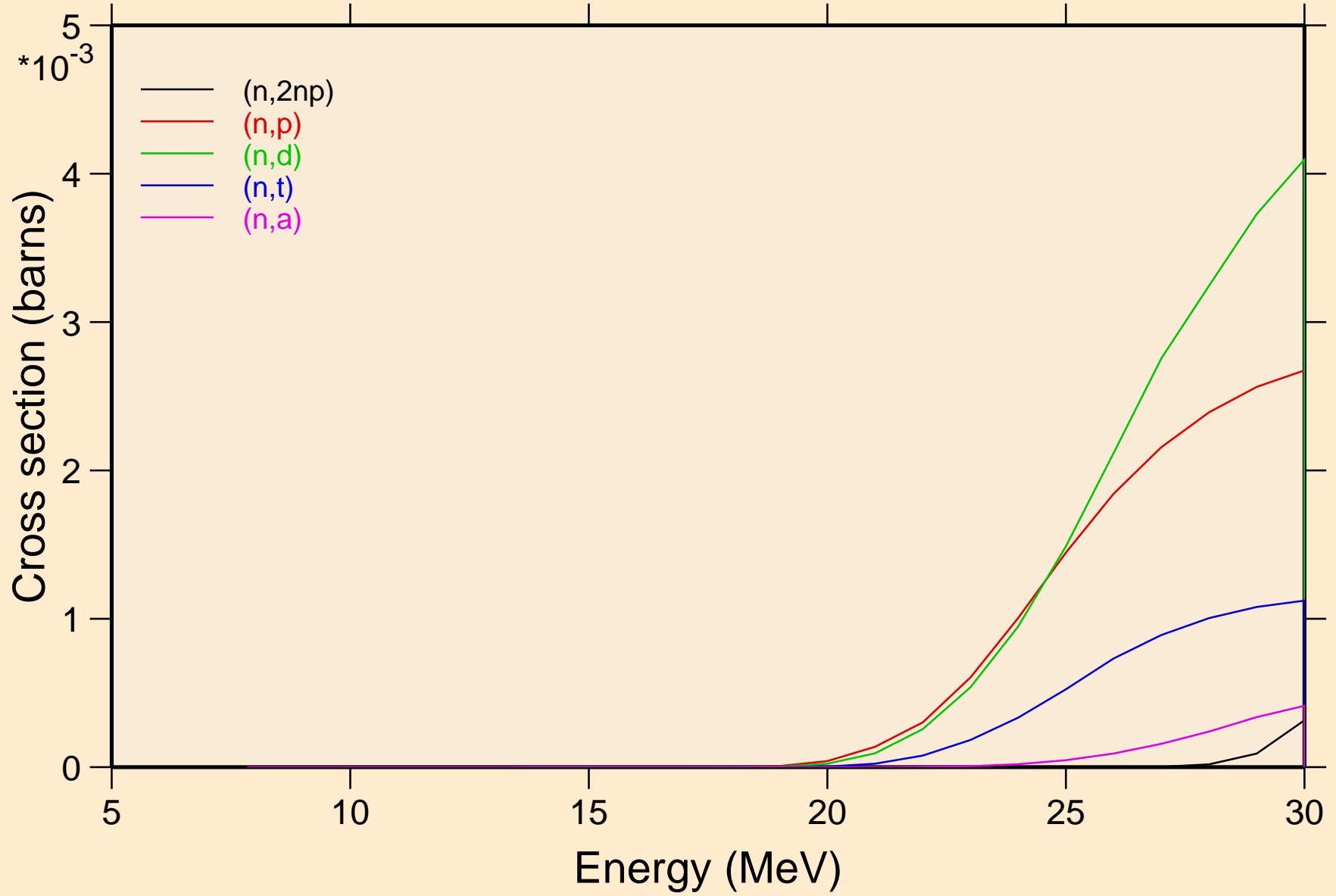

# SN132 NEUTRON ACER TENDL-2023 LIBRARY; T=0.K

## Threshold reactions

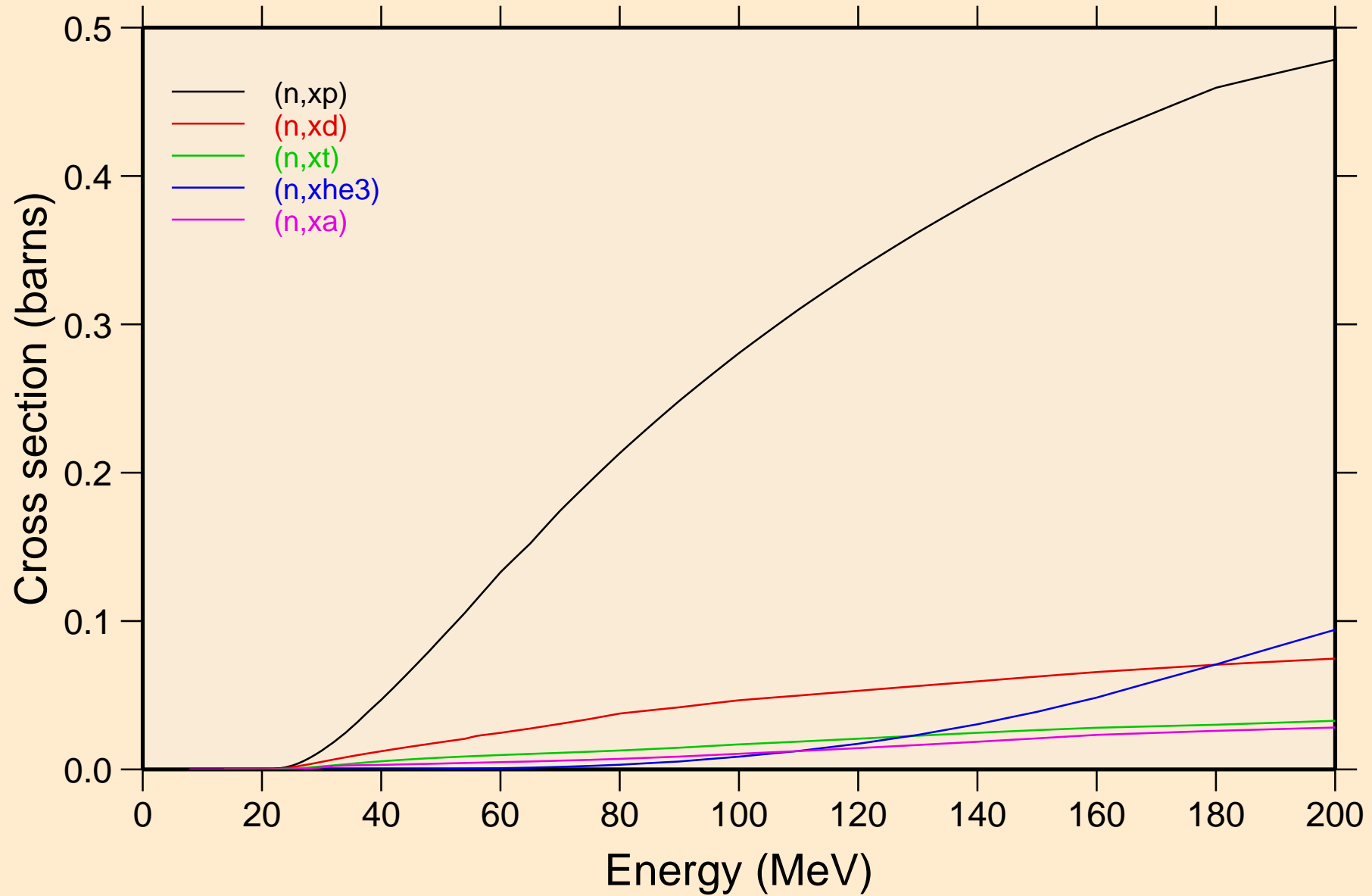

SN132 NEUTRON ACER TENDL-2023 LIBRARY; T=0.K  
angular distribution for elastic

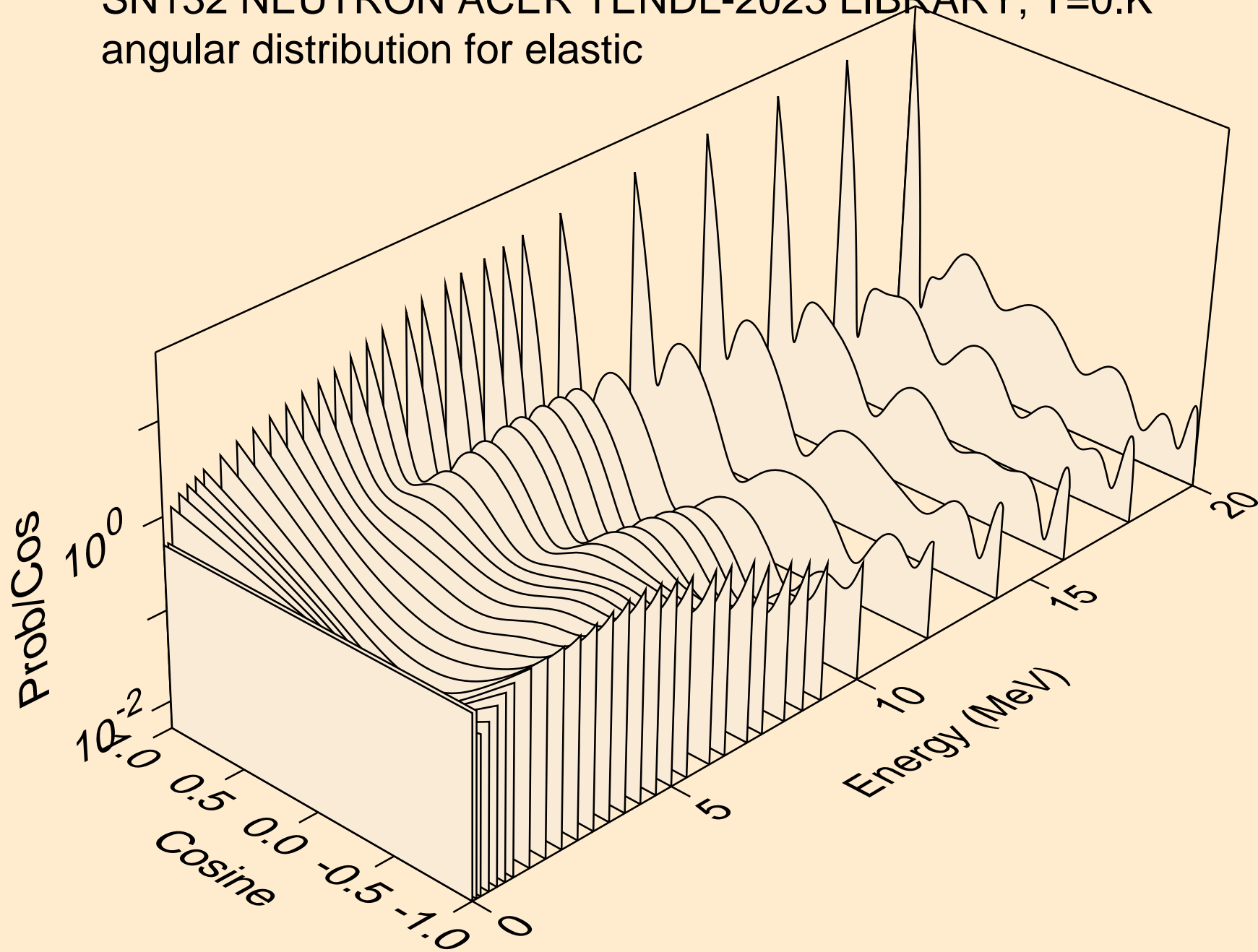

SN132 NEUTRON ACER TENDL-2023 LIBRARY; T=0.K  
angular distribution for elastic

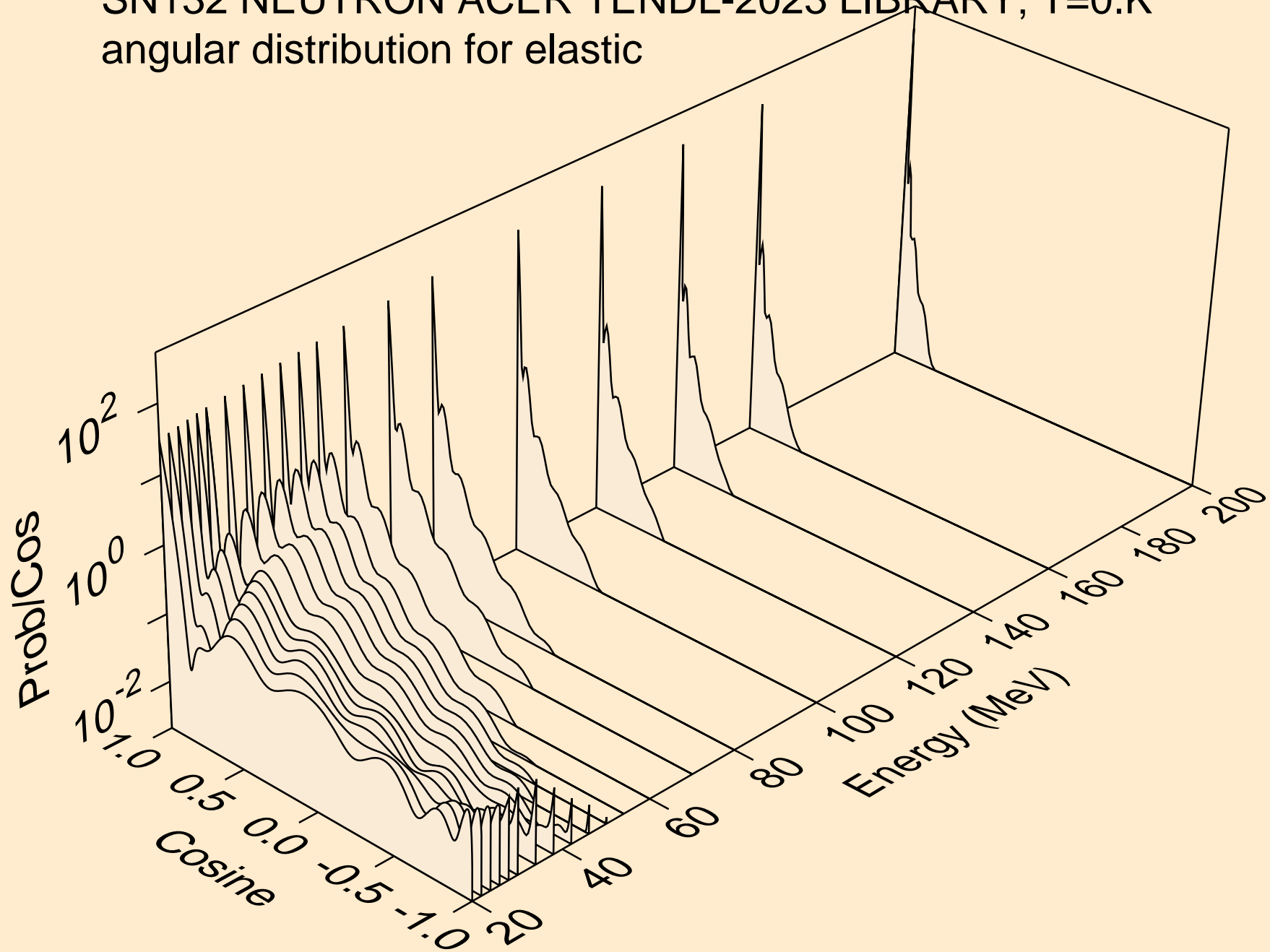

SN132 NEUTRON ACER TENDL-2023 LIBRARY; T=0.K  
angular distribution for (n,n\*1)

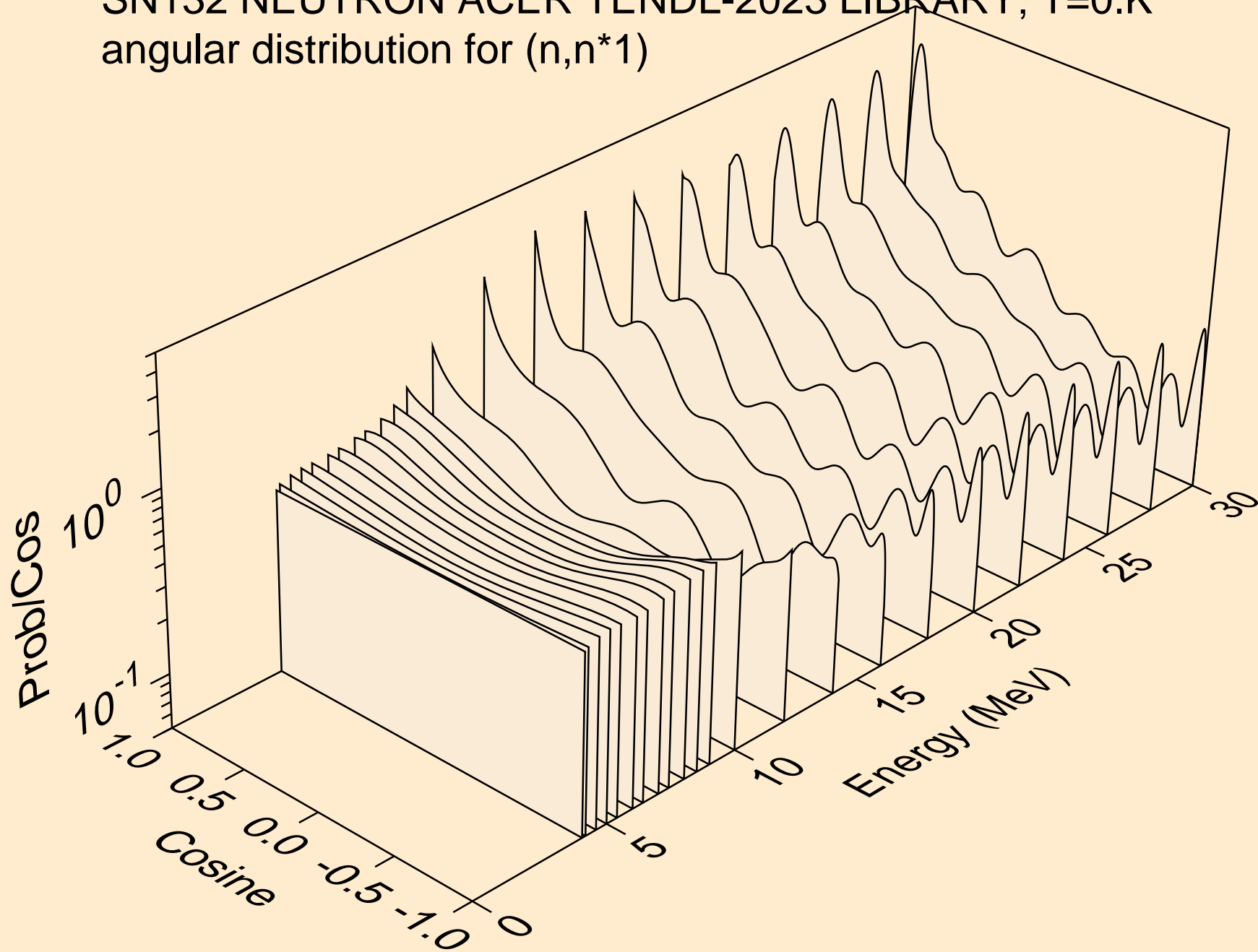

SN132 NEUTRON ACER TENDL-2023 LIBRARY; T=0.K  
angular distribution for (n,n\*2)

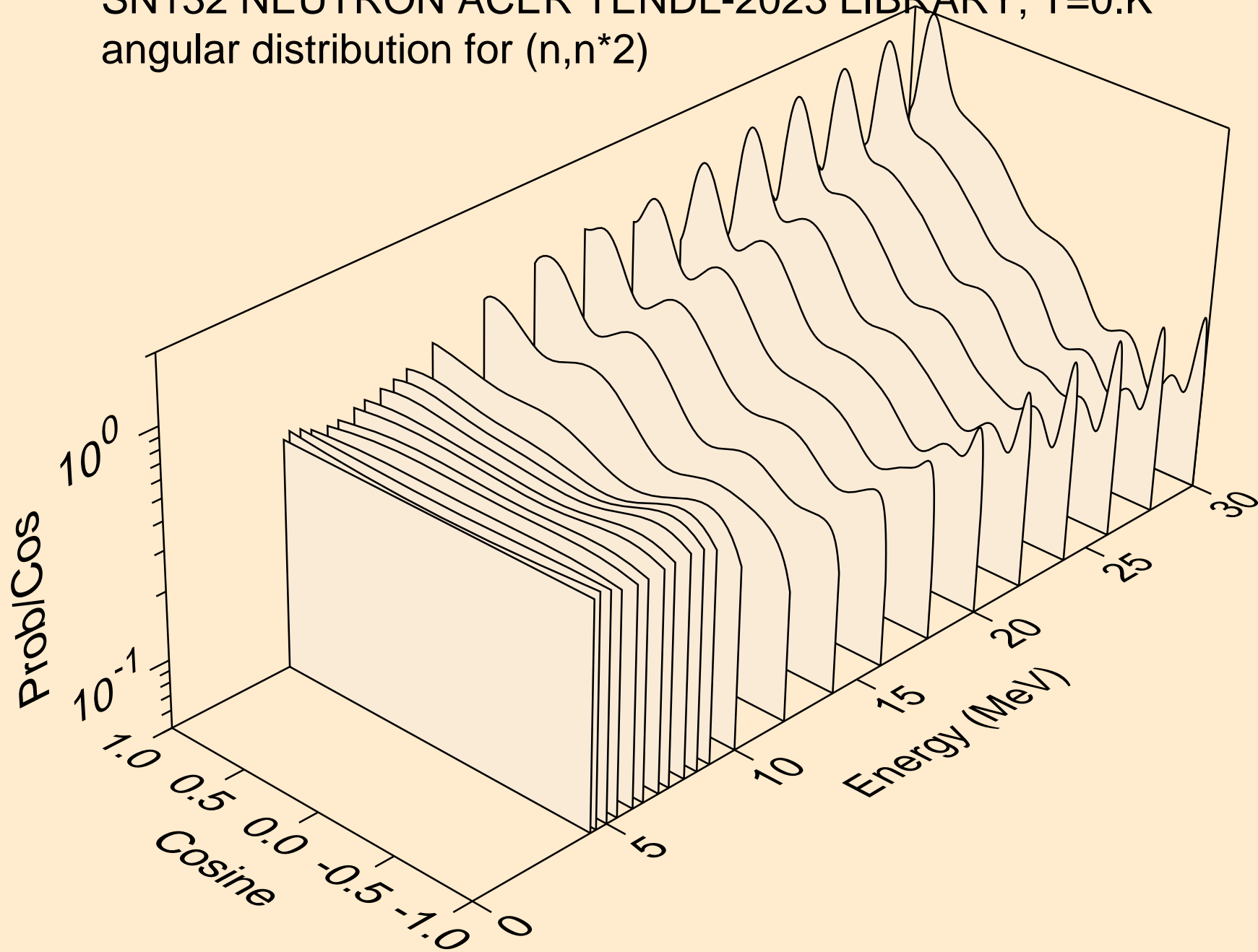

SN132 NEUTRON ACER TENDL-2023 LIBRARY; T=0.K  
angular distribution for (n,n\*3)

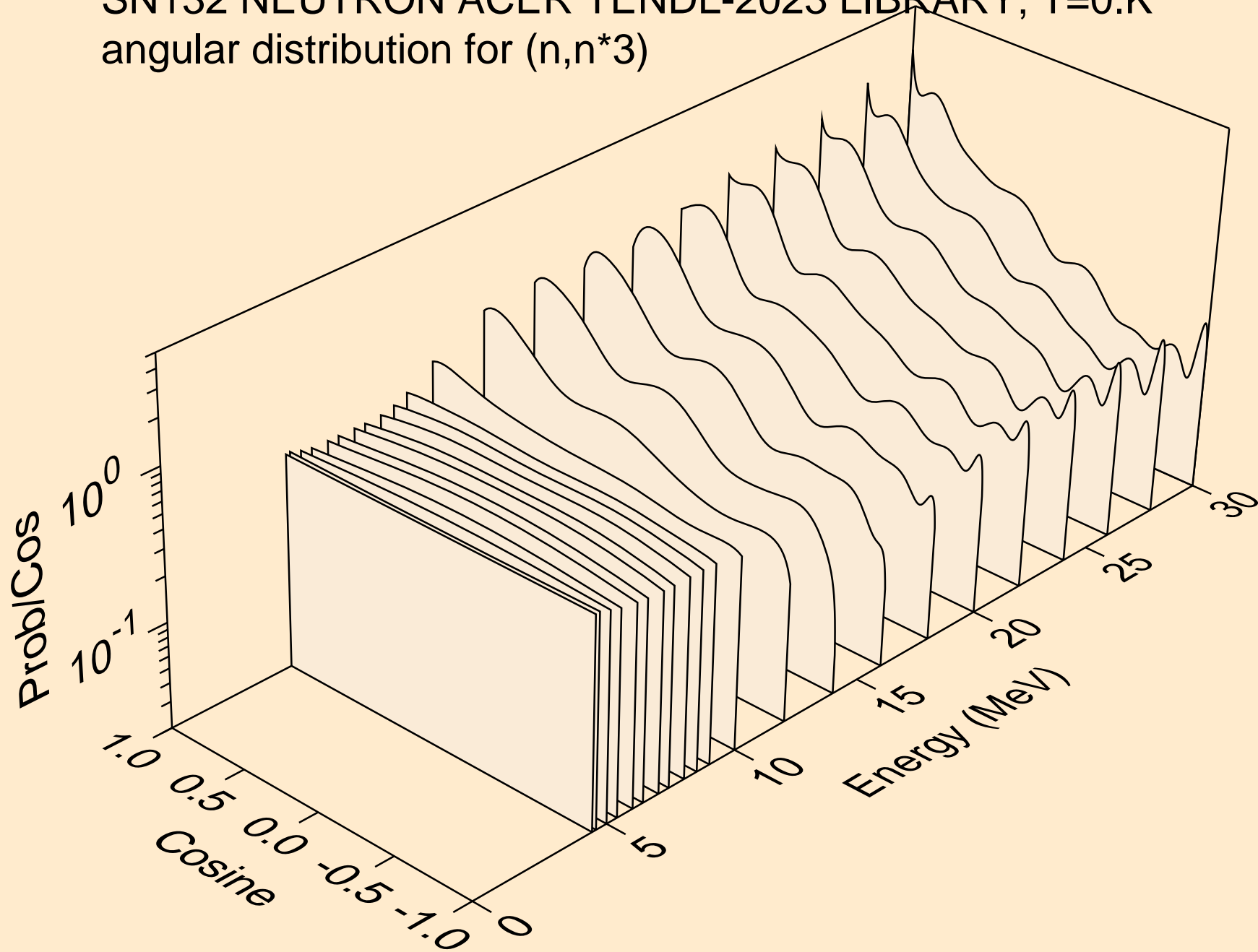

SN132 NEUTRON ACER TENDL-2023 LIBRARY; T=0.K  
angular distribution for (n,n\*4)

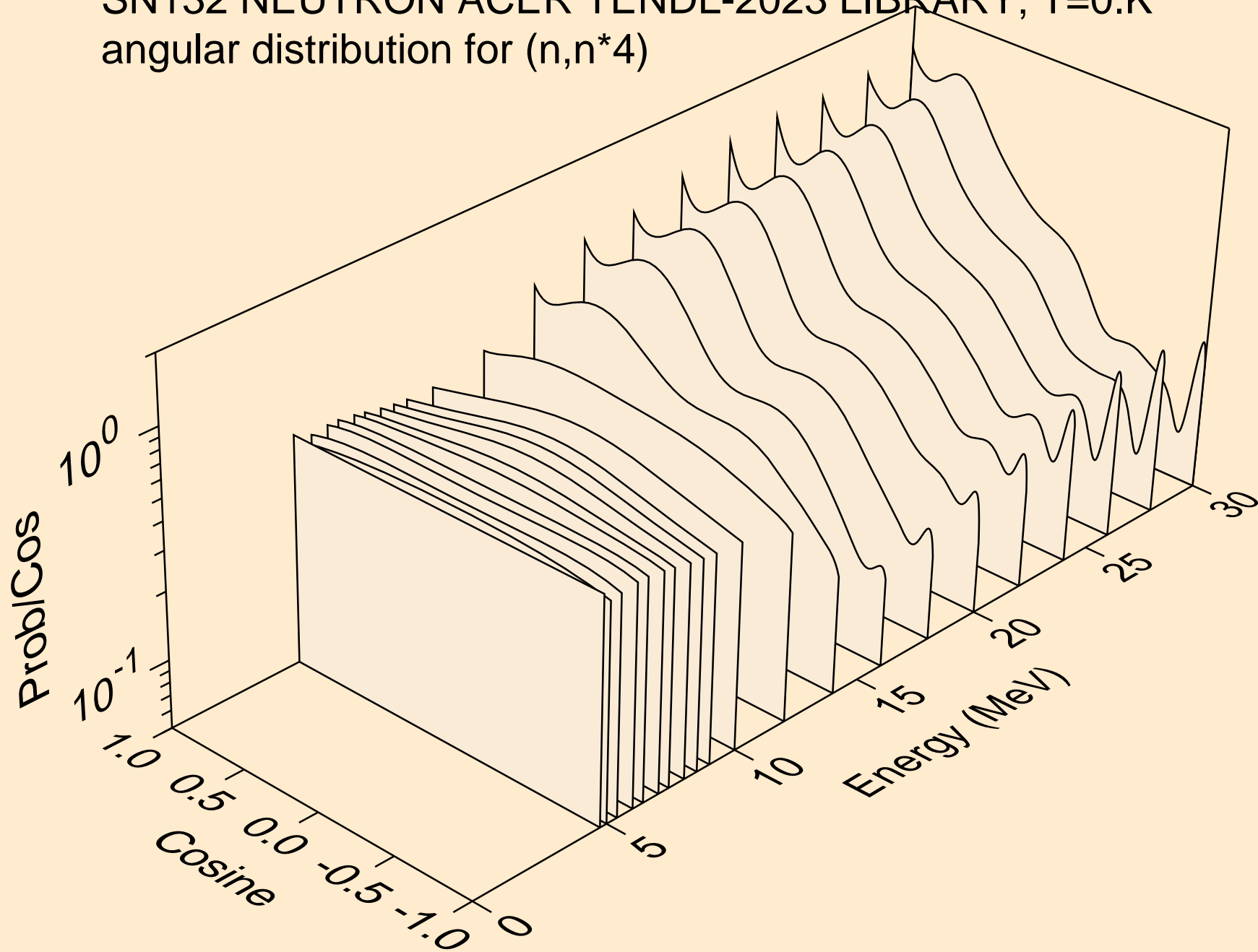



SN132 NEUTRON ACER TENDL-2023 LIBRARY; T=0.K  
angular distribution for (n,n\*5)

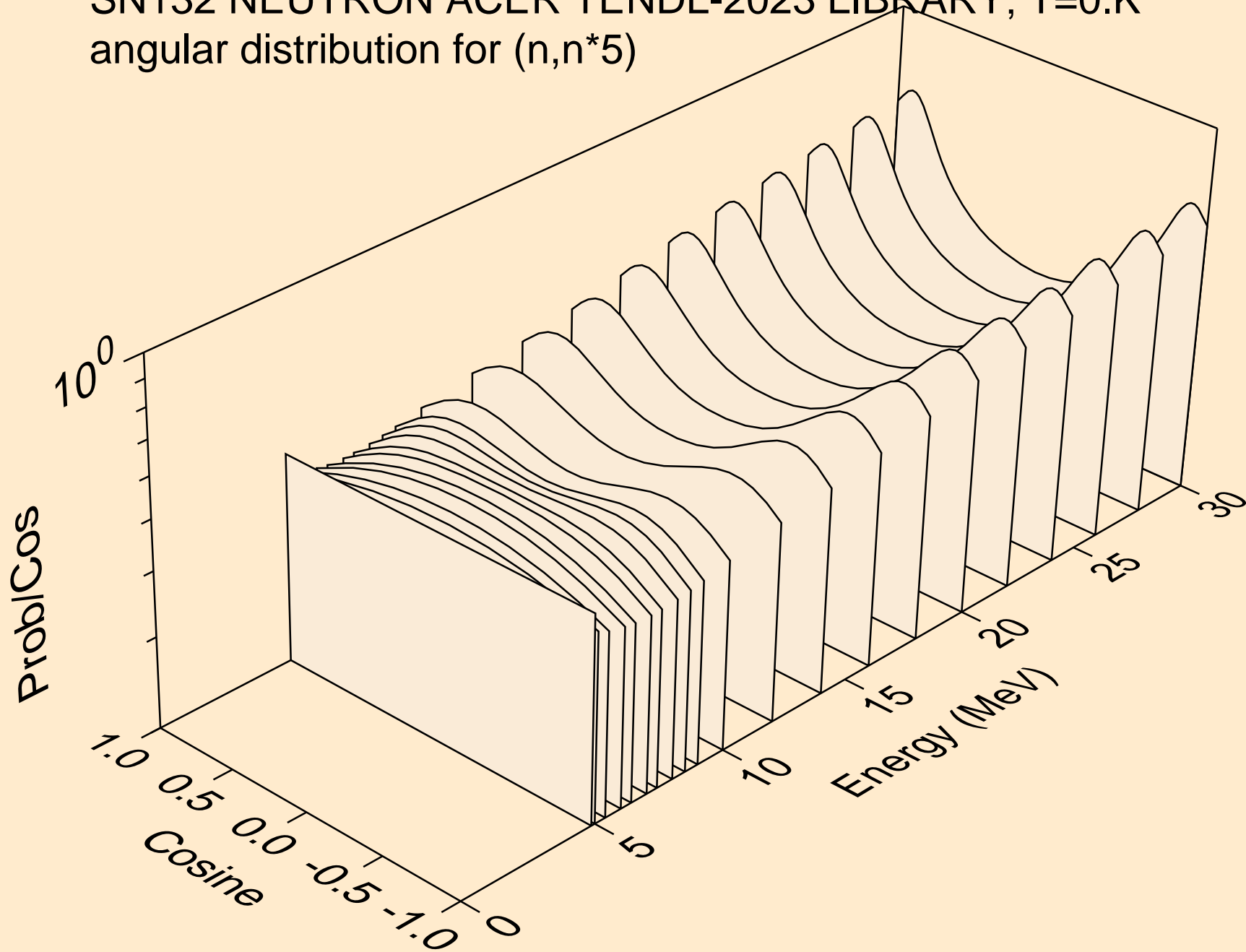

SN132 NEUTRON ACER TENDL-2023 LIBRARY; T=0.K  
angular distribution for (n,n\*6)

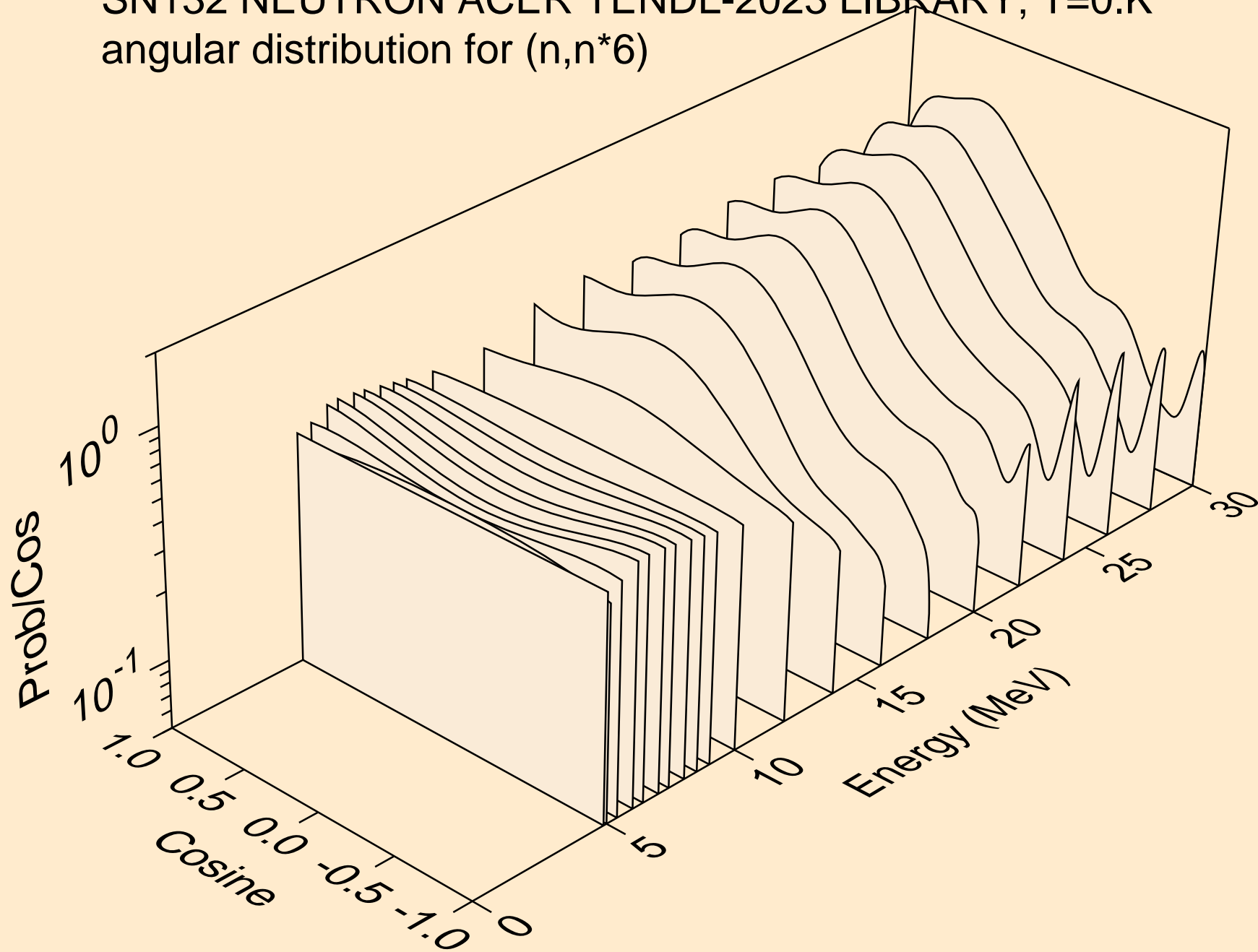

SN132 NEUTRON ACER TENDL-2023 LIBRARY; T=0.K  
angular distribution for (n,n\*7)

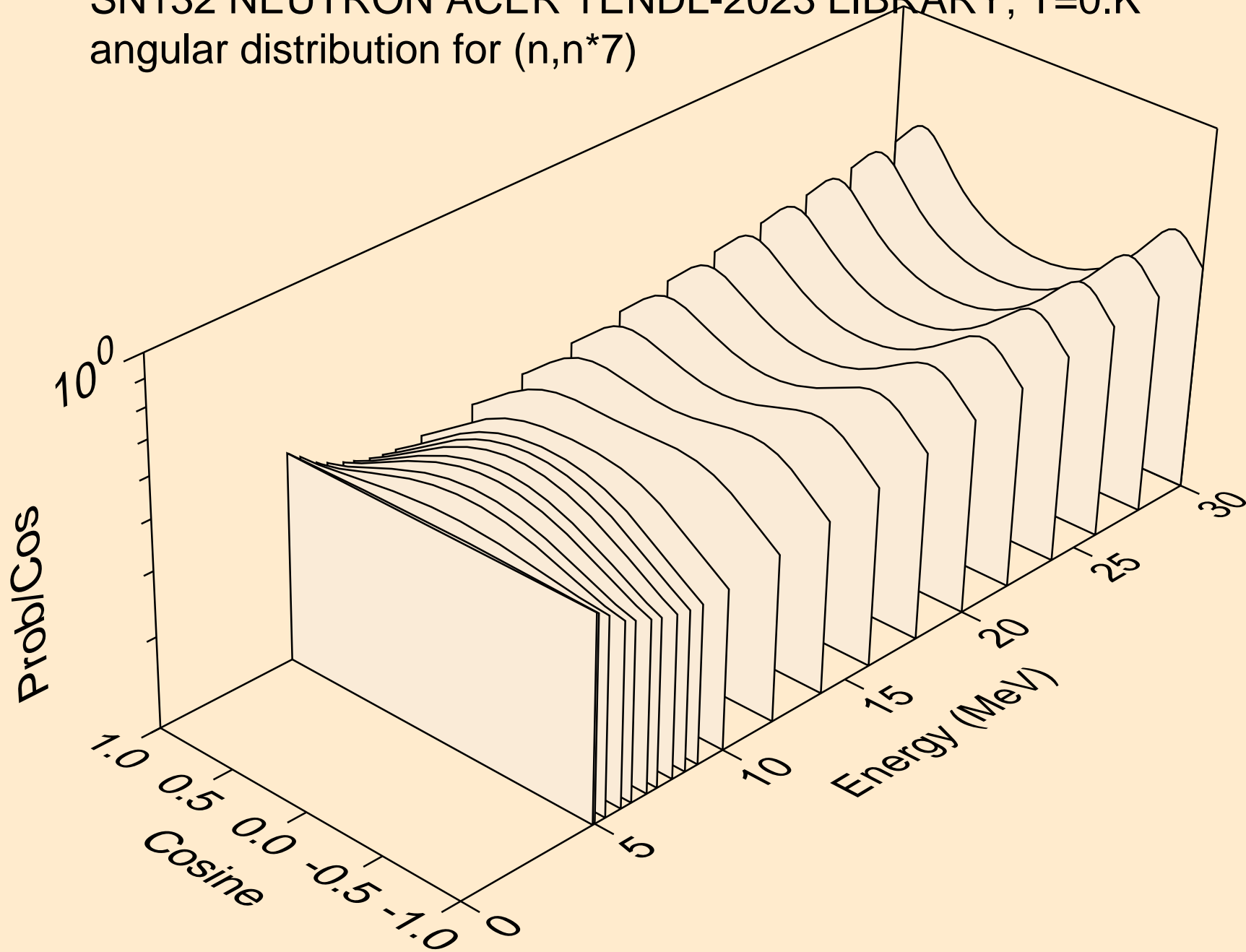

SN132 NEUTRON ACER TENDL-2023 LIBRARY; T=0.K  
angular distribution for (n,n\*8)

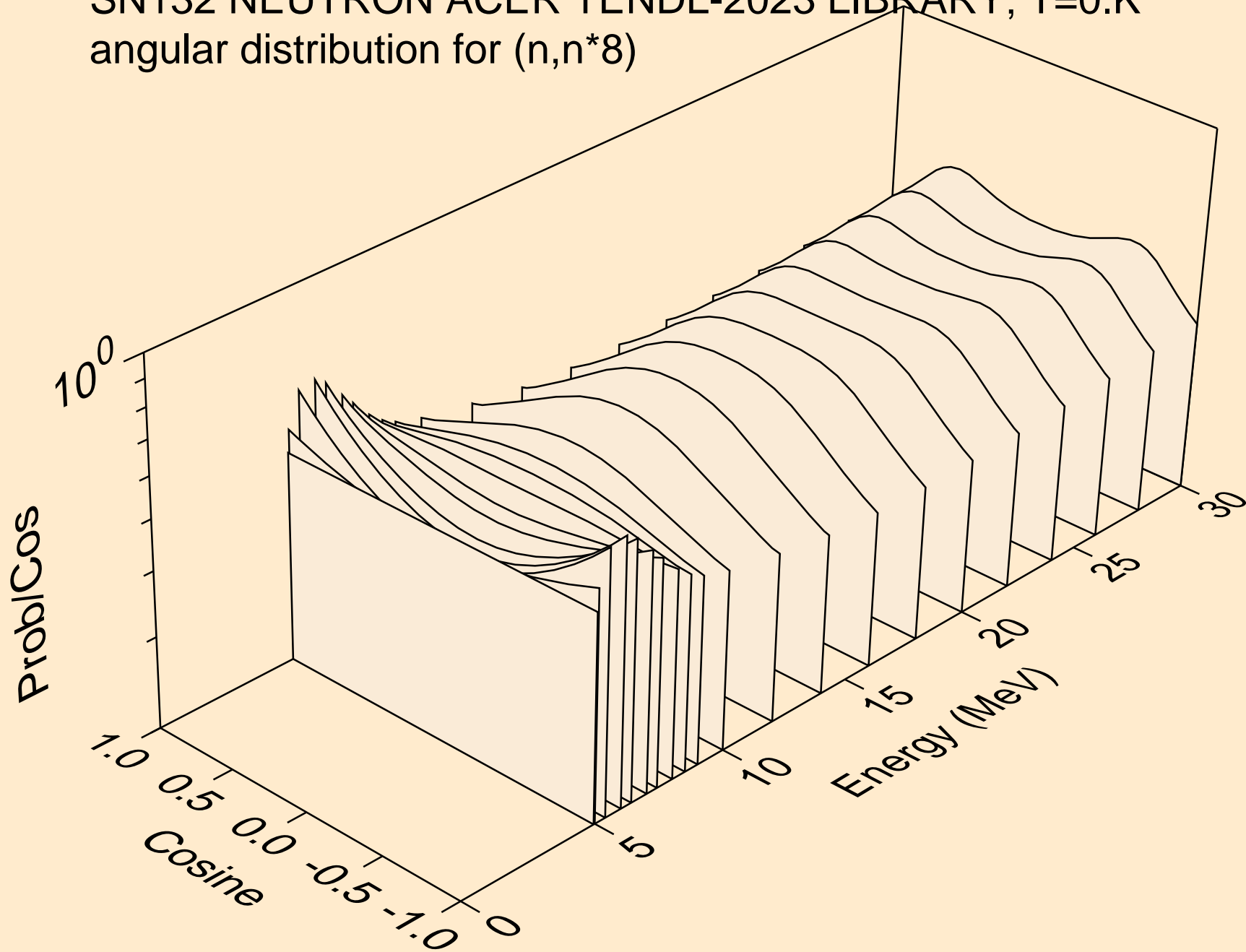

SN132 NEUTRON ACER TENDL-2023 LIBRARY; T=0.K  
angular distribution for (n,n\*9)

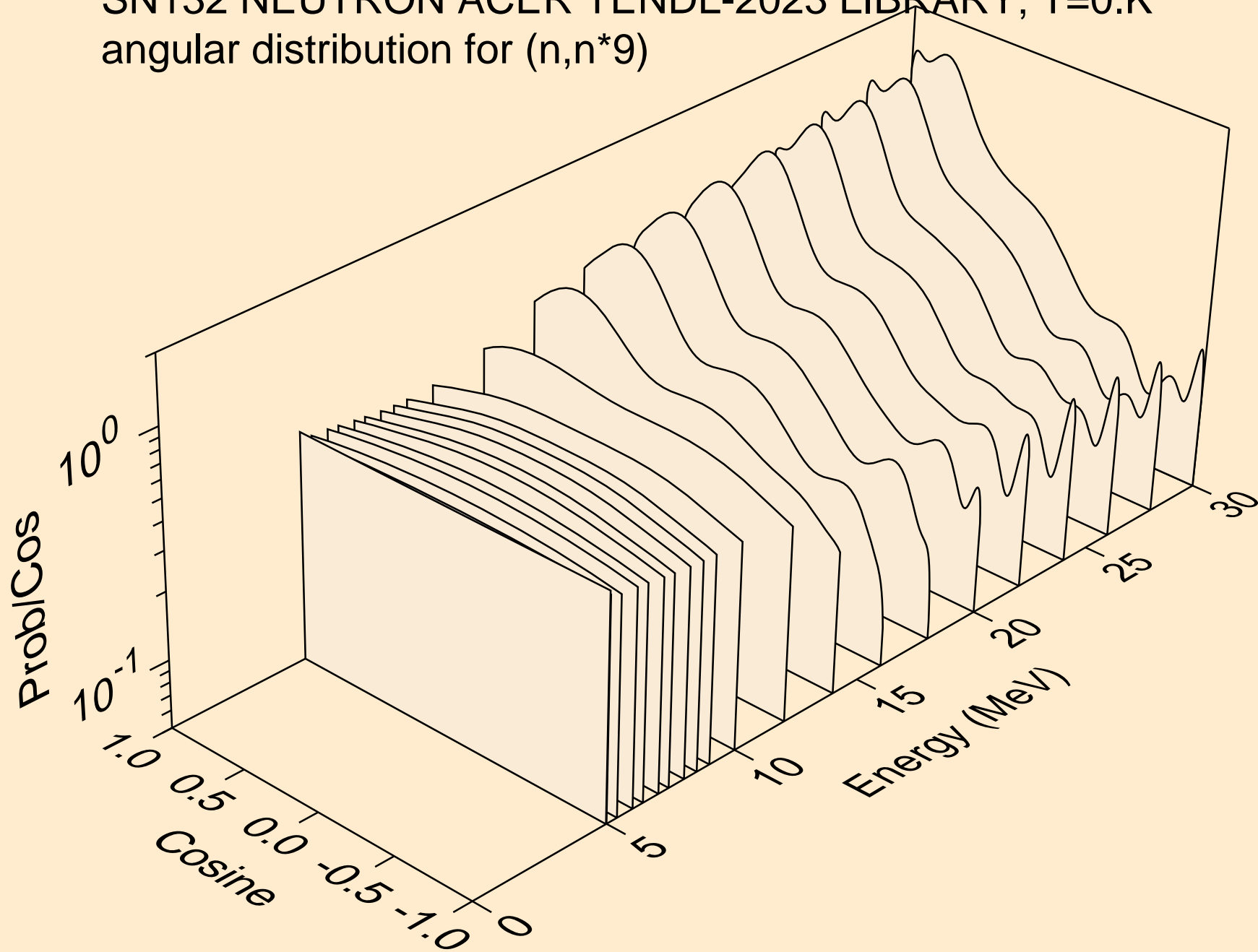

SN132 NEUTRON ACER TENDL-2023 LIBRARY; T=0.K  
angular distribution for (n,n\*10)

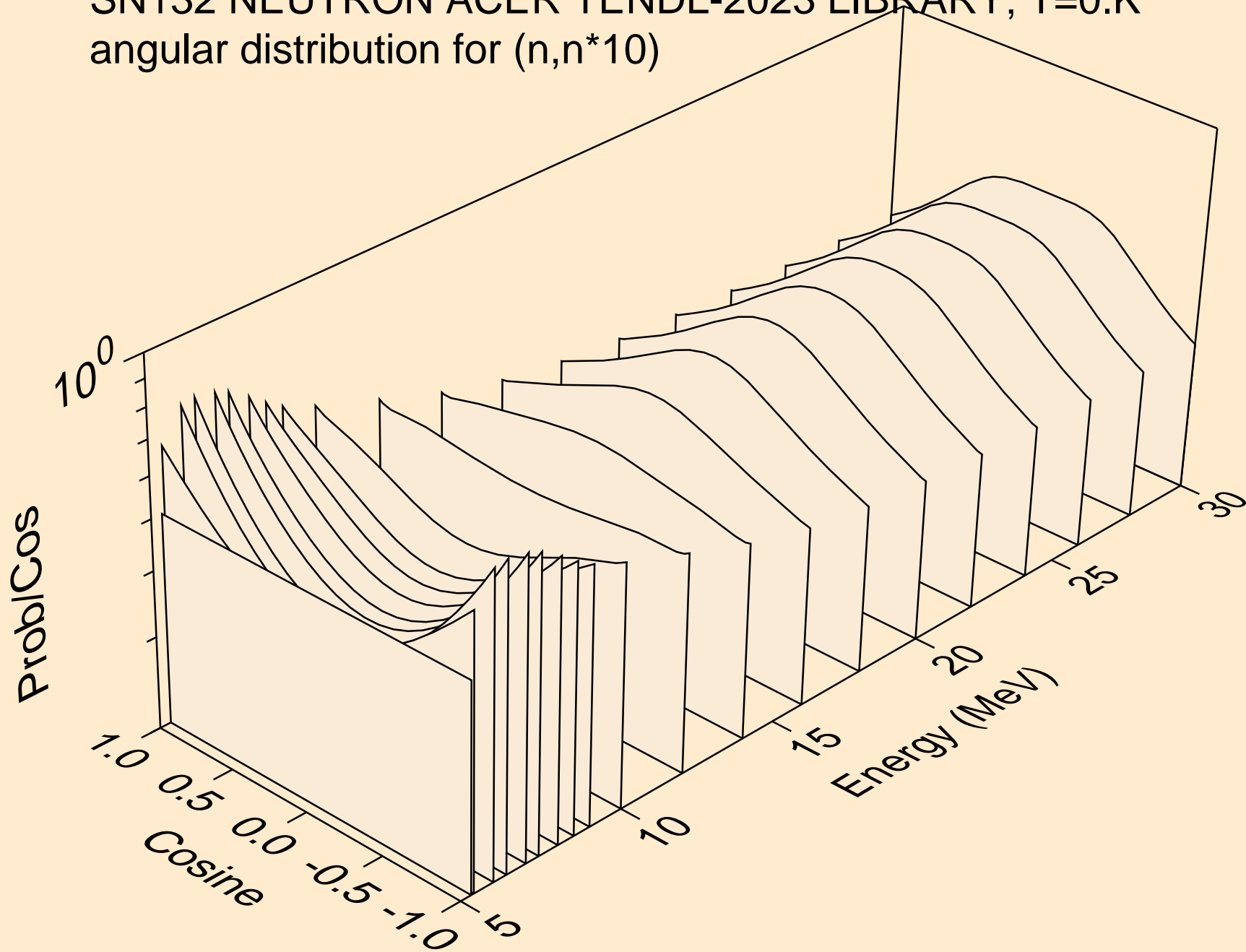

SN132 NEUTRON ACER TENDL-2023 LIBRARY; T=0.K  
angular distribution for (n,n\*11)

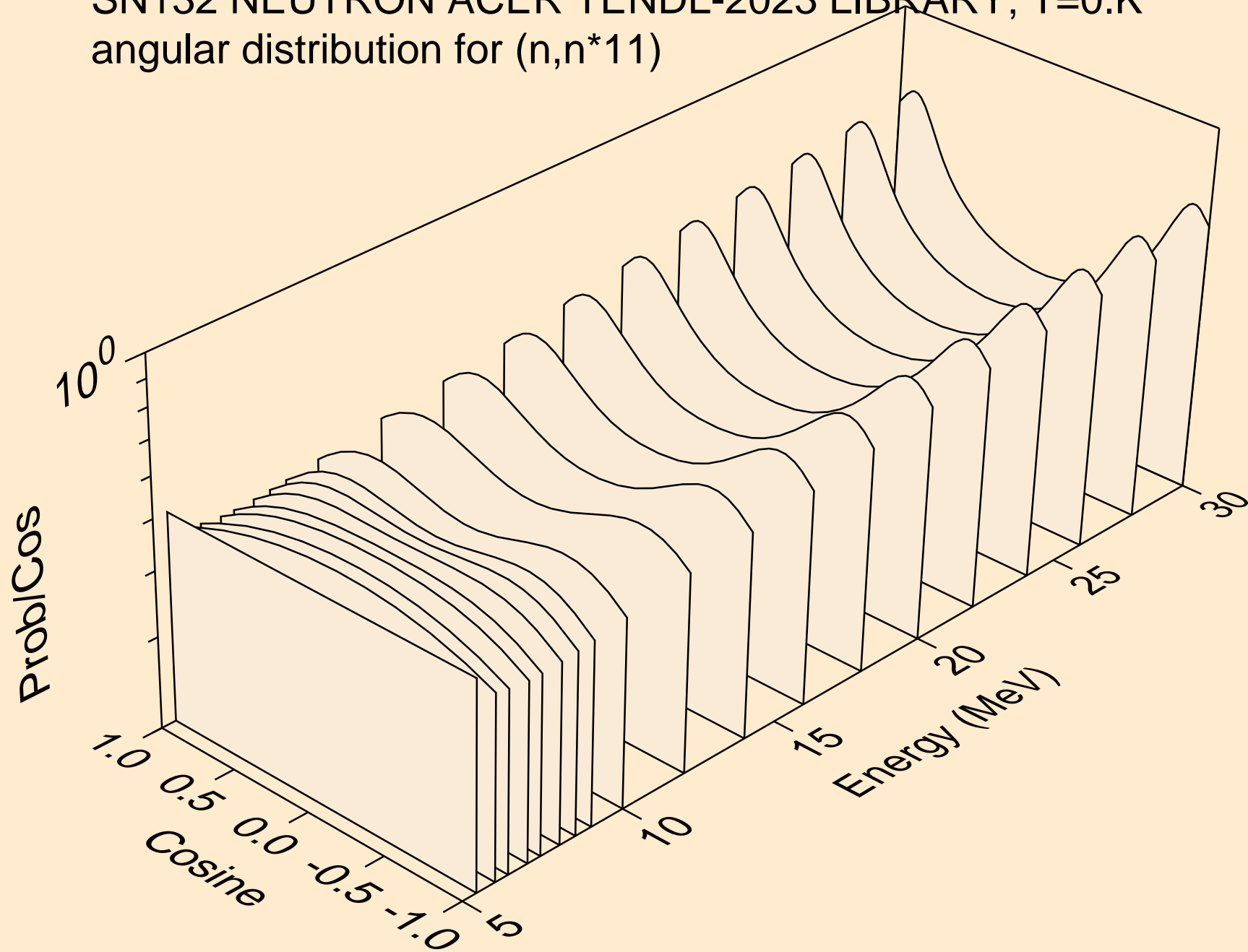

SN132 NEUTRON ACER TENDL-2023 LIBRARY; T=0.K  
angular distribution for (n,n\*12)

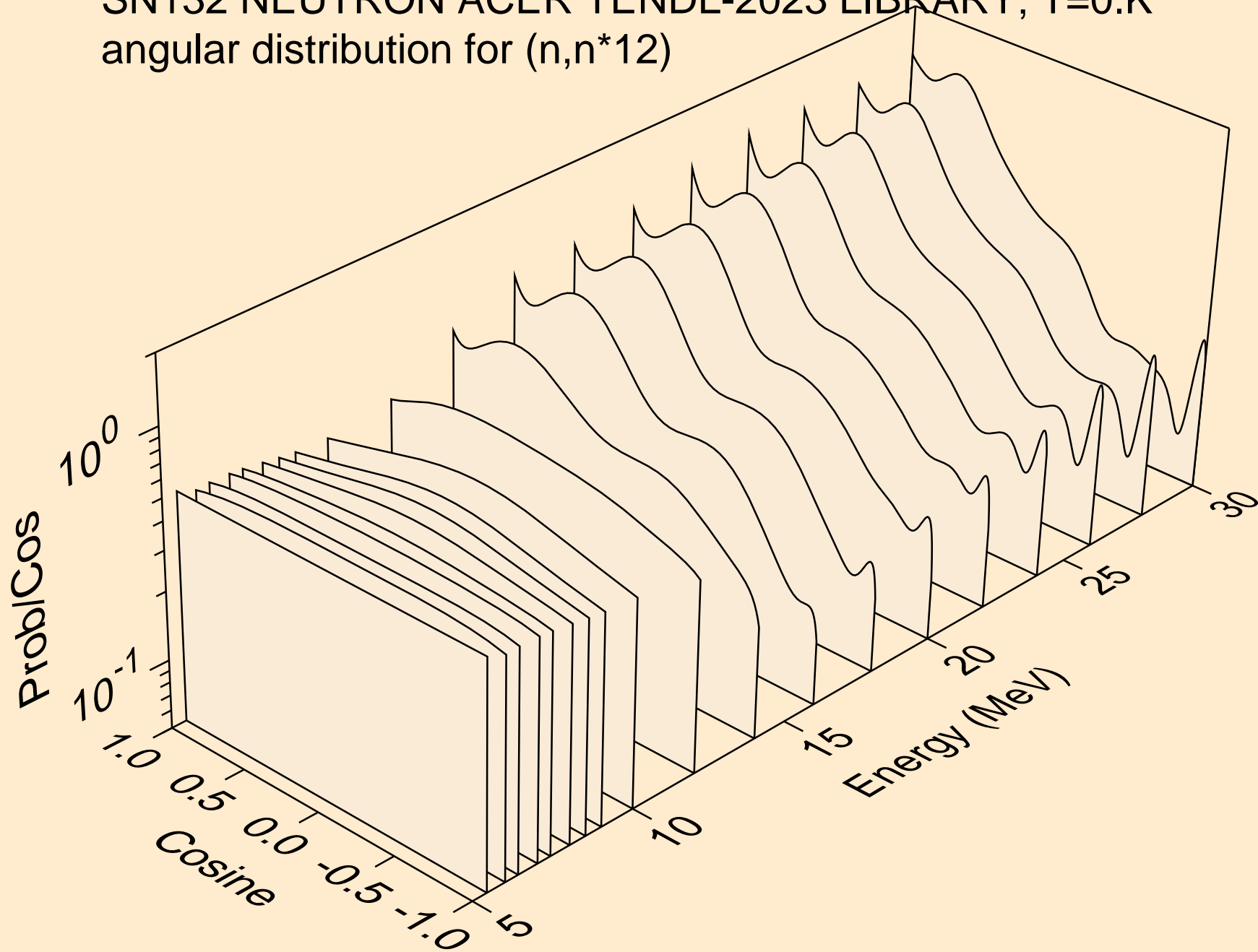



SN132 NEUTRON ACER TENDL-2023 LIBRARY; T=0.K  
angular distribution for (n,n\*13)

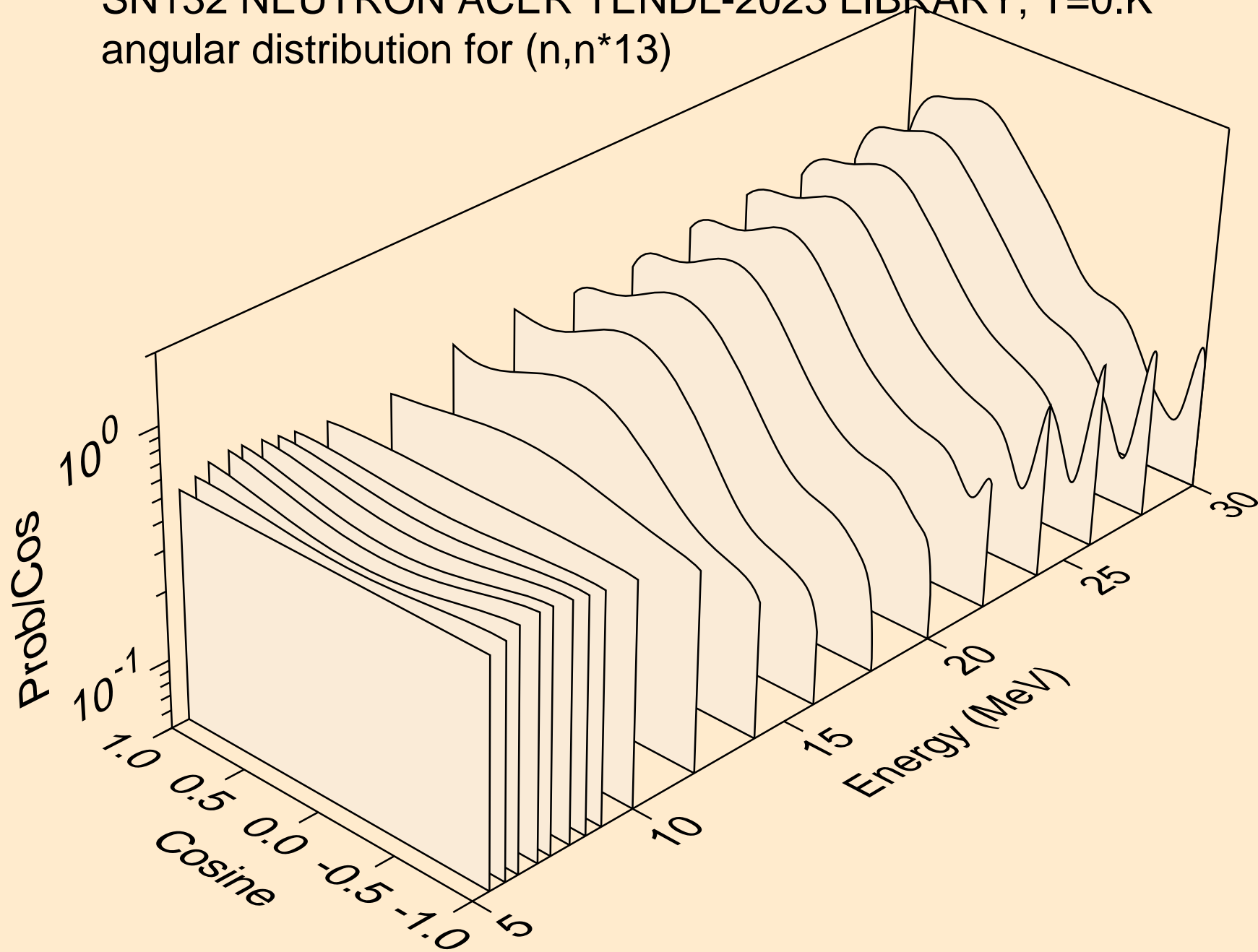

SN132 NEUTRON ACER TENDL-2023 LIBRARY; T=0.K  
angular distribution for (n,n\*14)

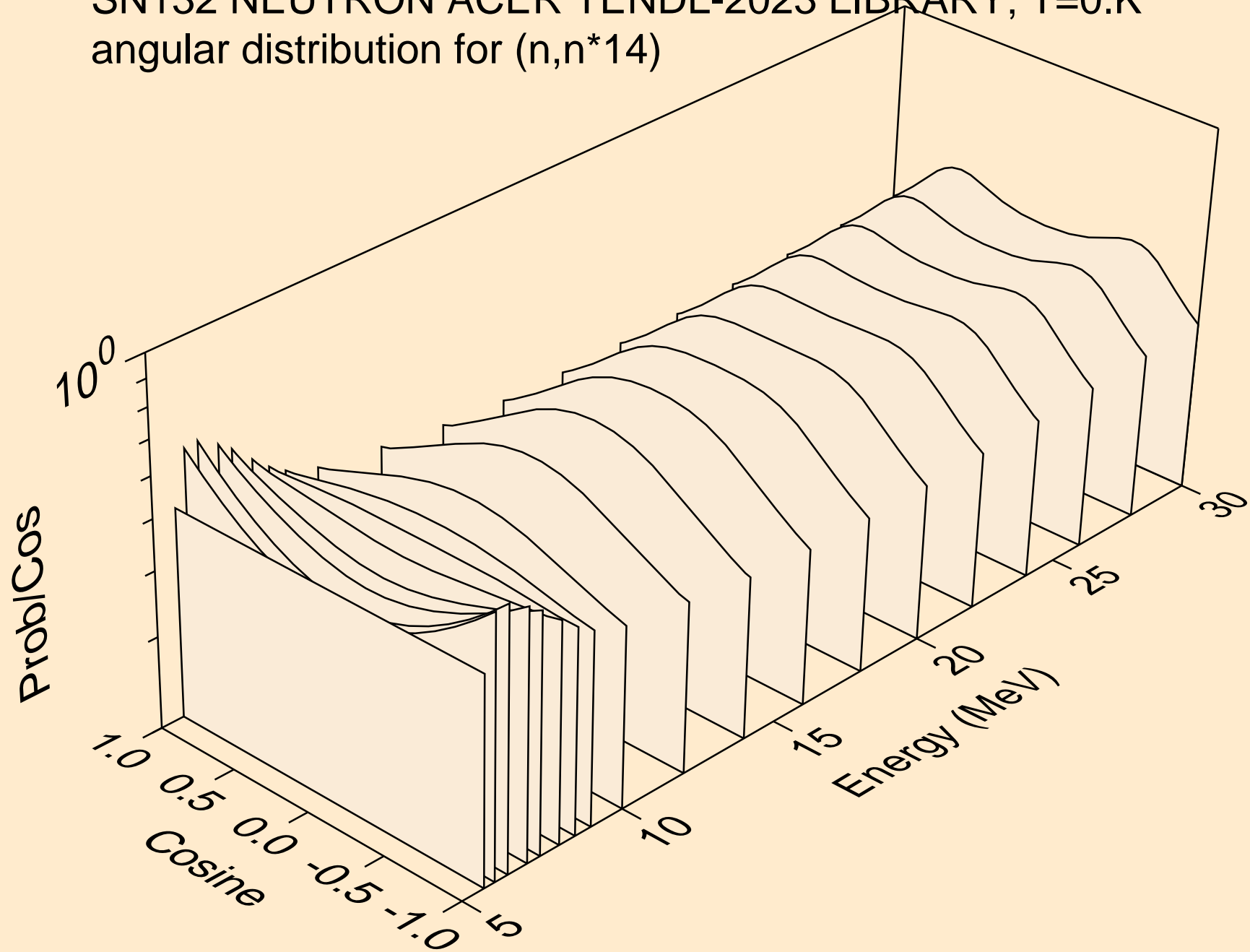

SN132 NEUTRON ACER TENDL-2023 LIBRARY; T=0.K  
angular distribution for (n,n\*15)

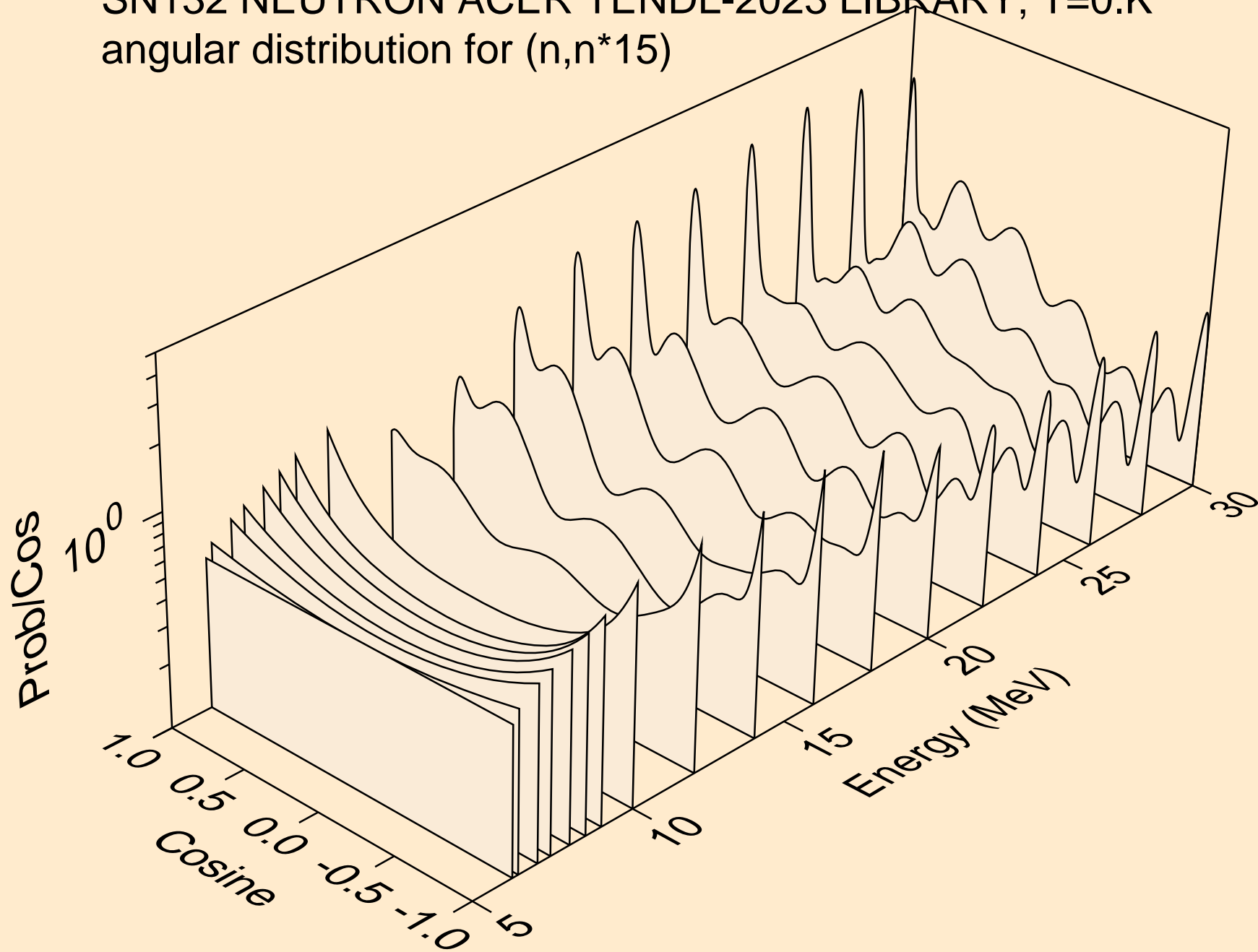

SN132 NEUTRON ACER TENDL-2023 LIBRARY; T=0.K  
angular distribution for (n,n\*16)

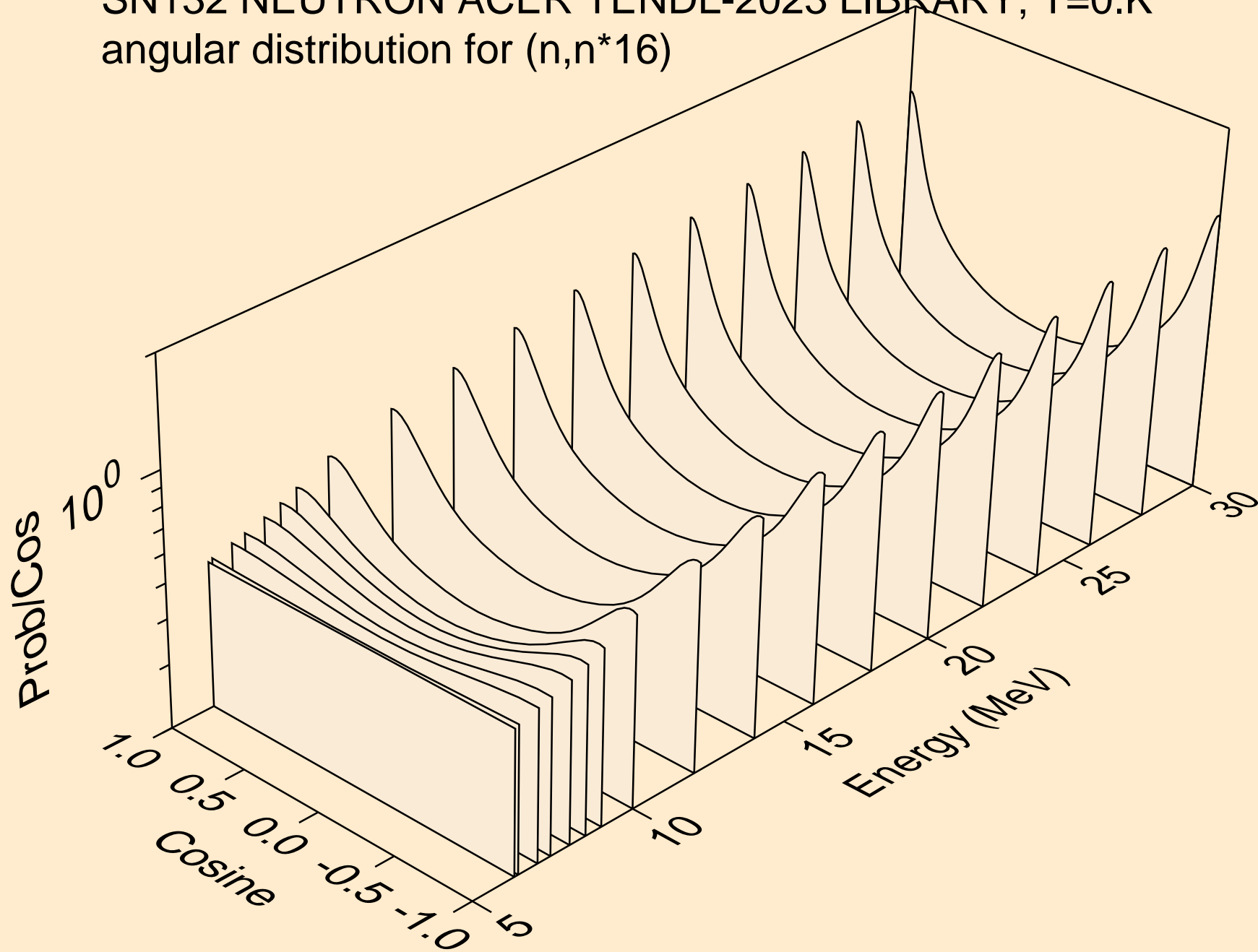

SN132 NEUTRON ACER TENDL-2023 LIBRARY; T=0.K  
angular distribution for (n,n\*17)

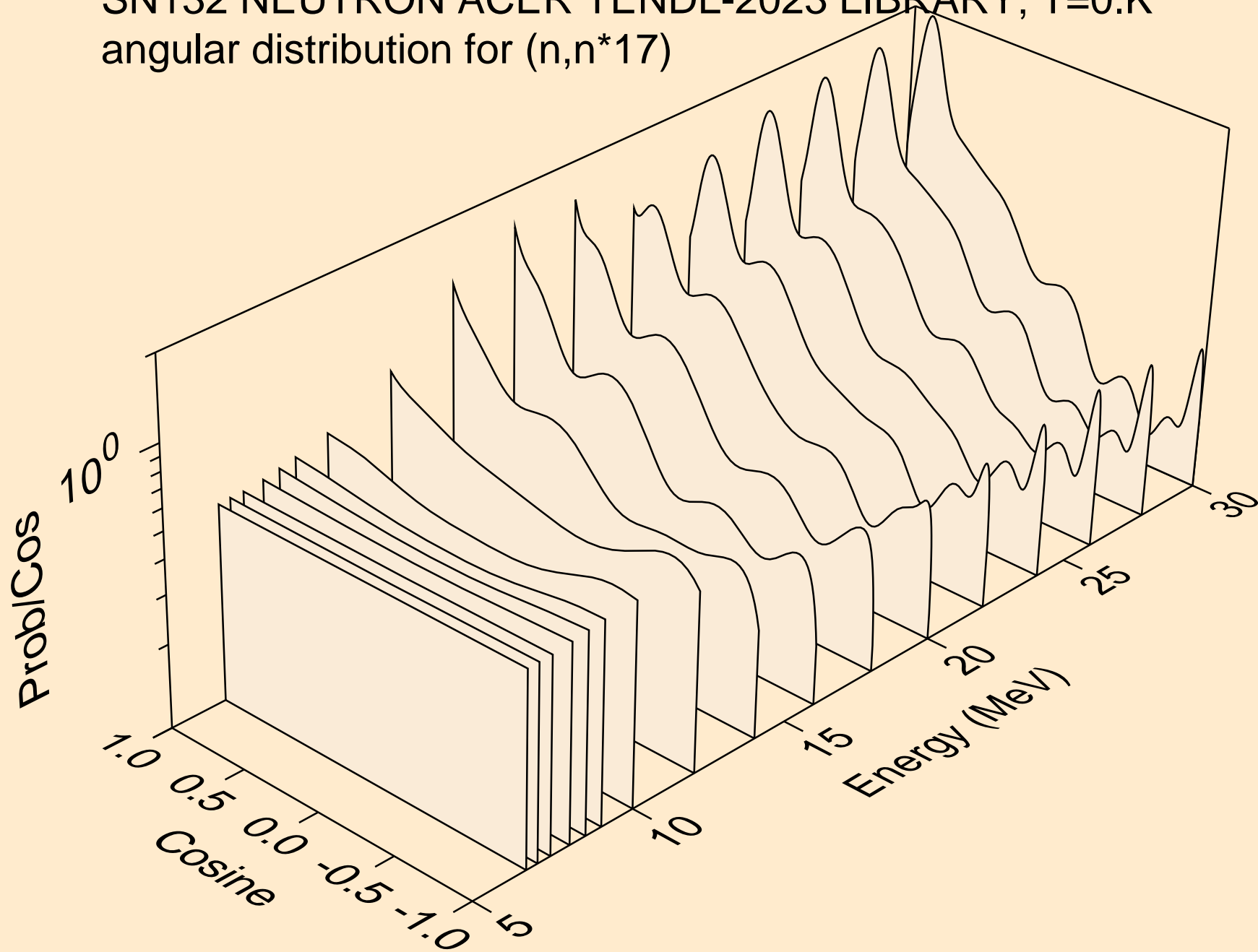

SN132 NEUTRON ACER TENDL-2023 LIBRARY; T=0.K  
angular distribution for (n,n\*18)

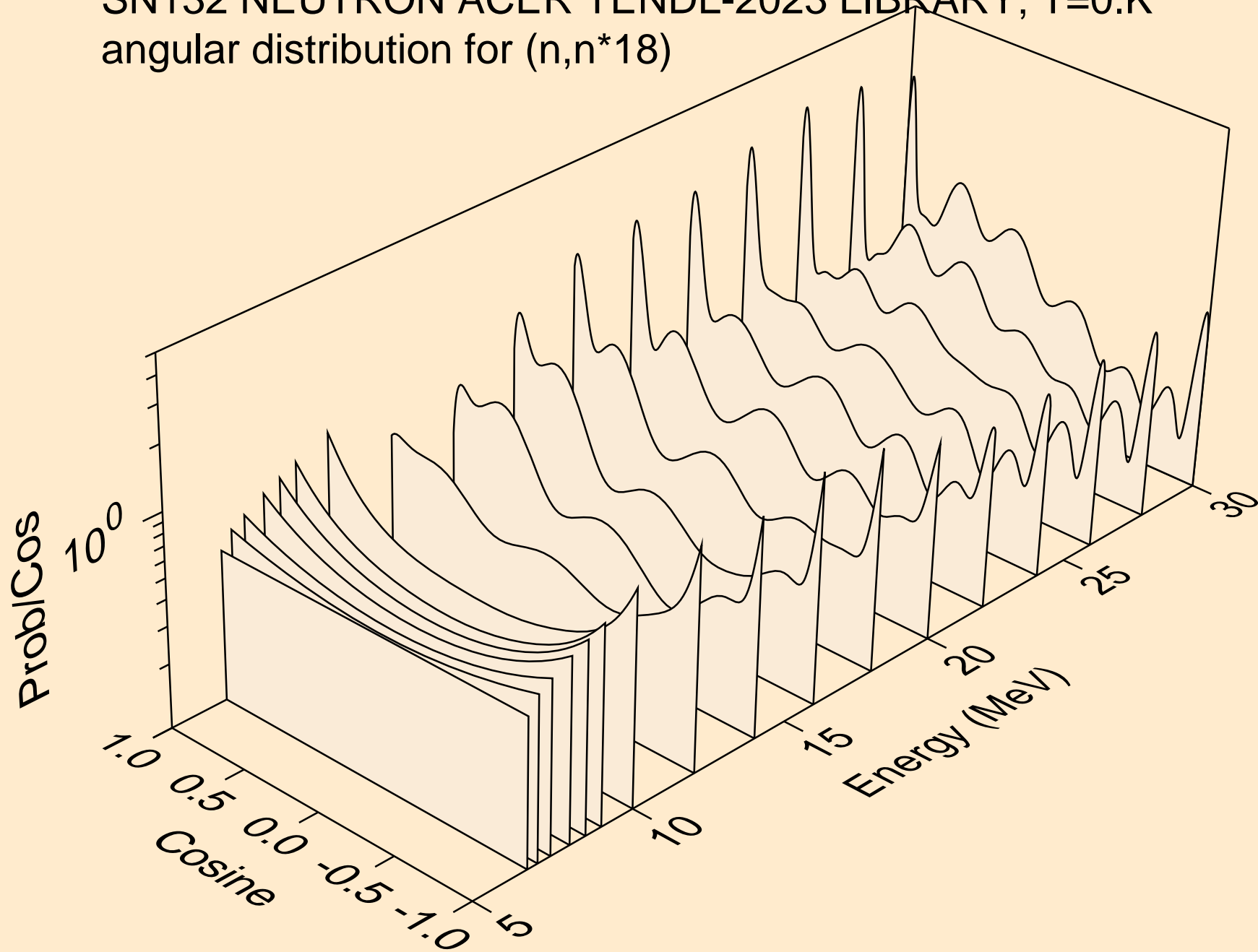

SN132 NEUTRON ACER TENDL-2023 LIBRARY; T=0.K  
angular distribution for (n,n\*19)

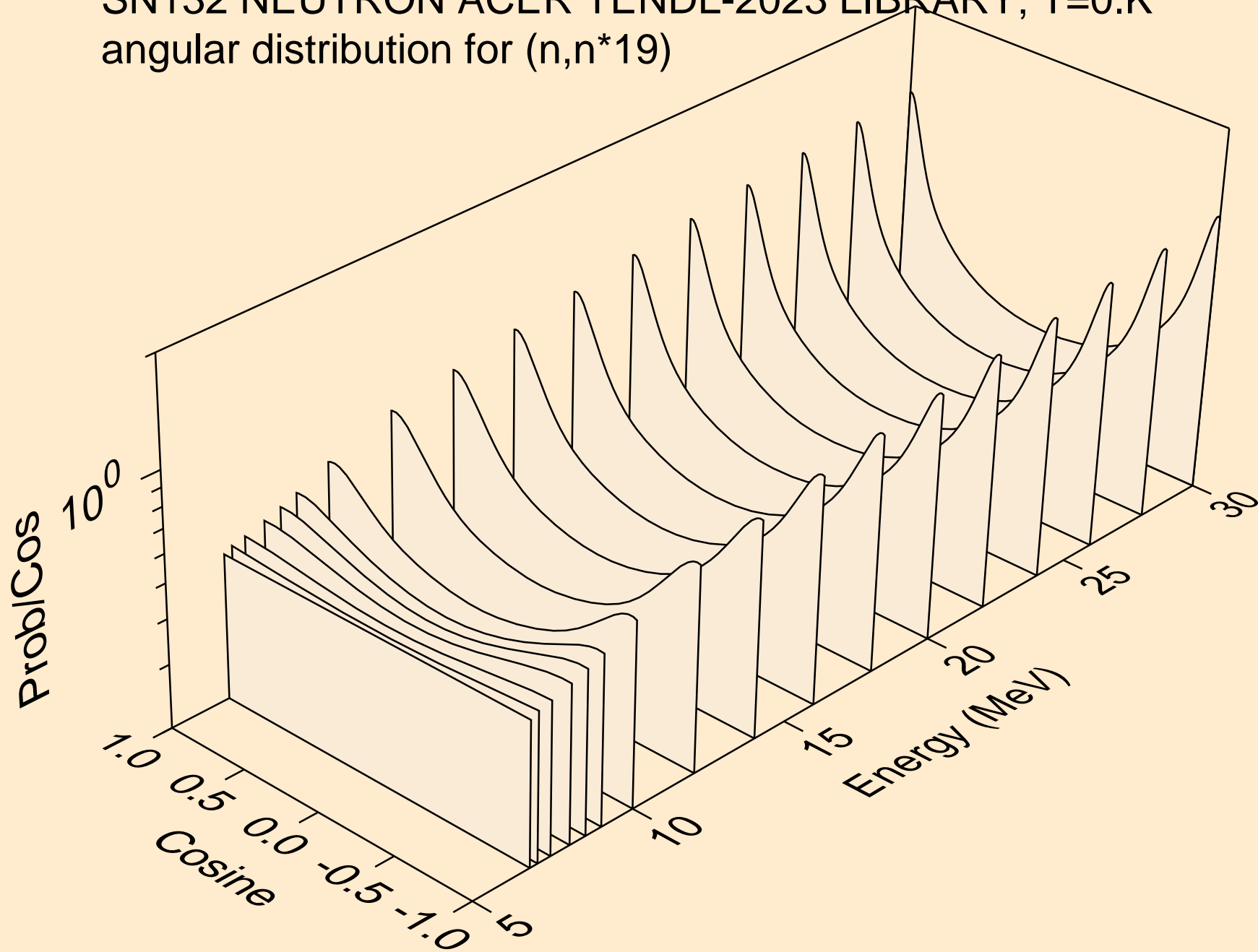

SN132 NEUTRON ACER TENDL-2023 LIBRARY; T=0.K  
angular distribution for (n,n\*20)

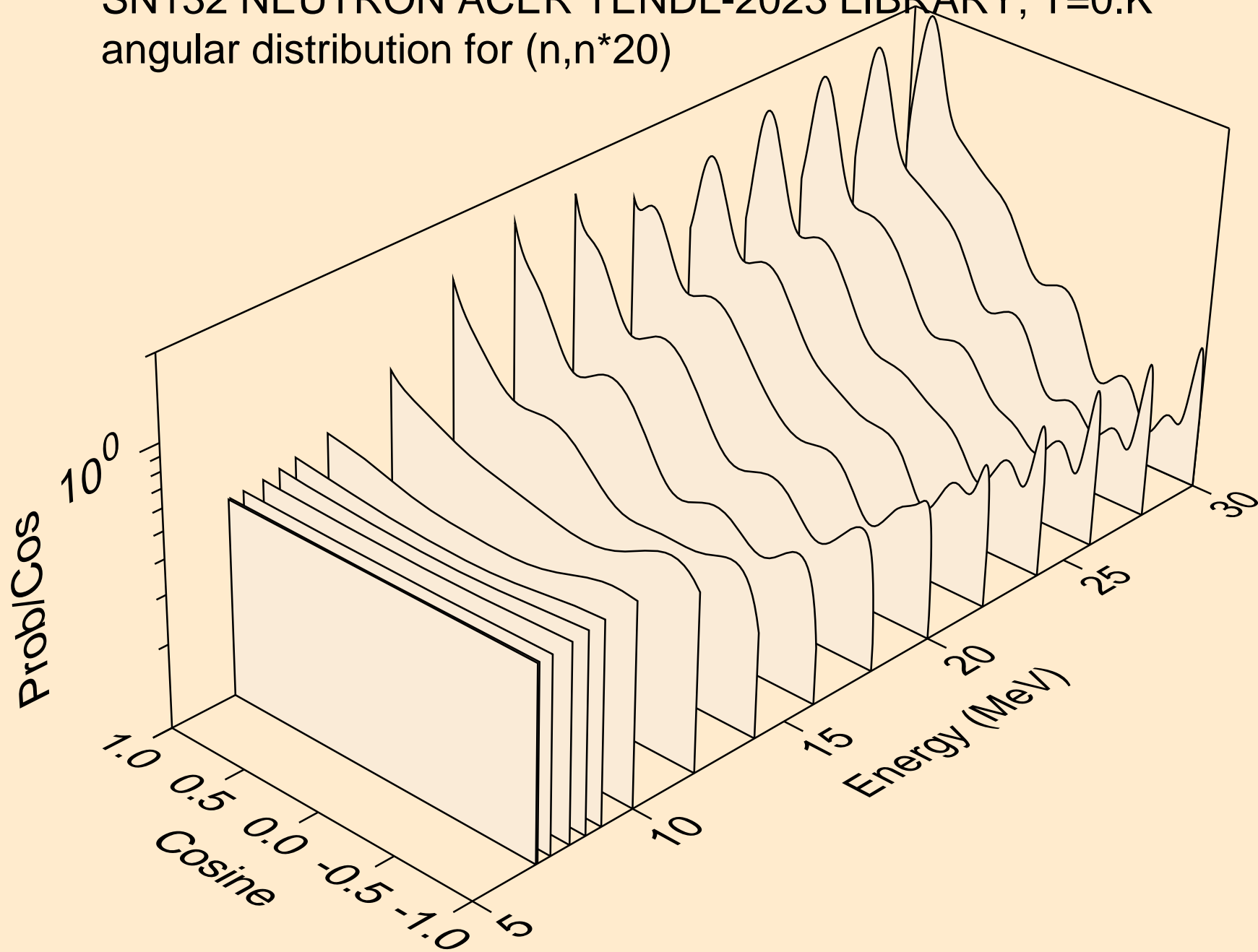



SN132 NEUTRON ACER TENDL-2023 LIBRARY; T=0.K  
angular distribution for (n,n\*21)

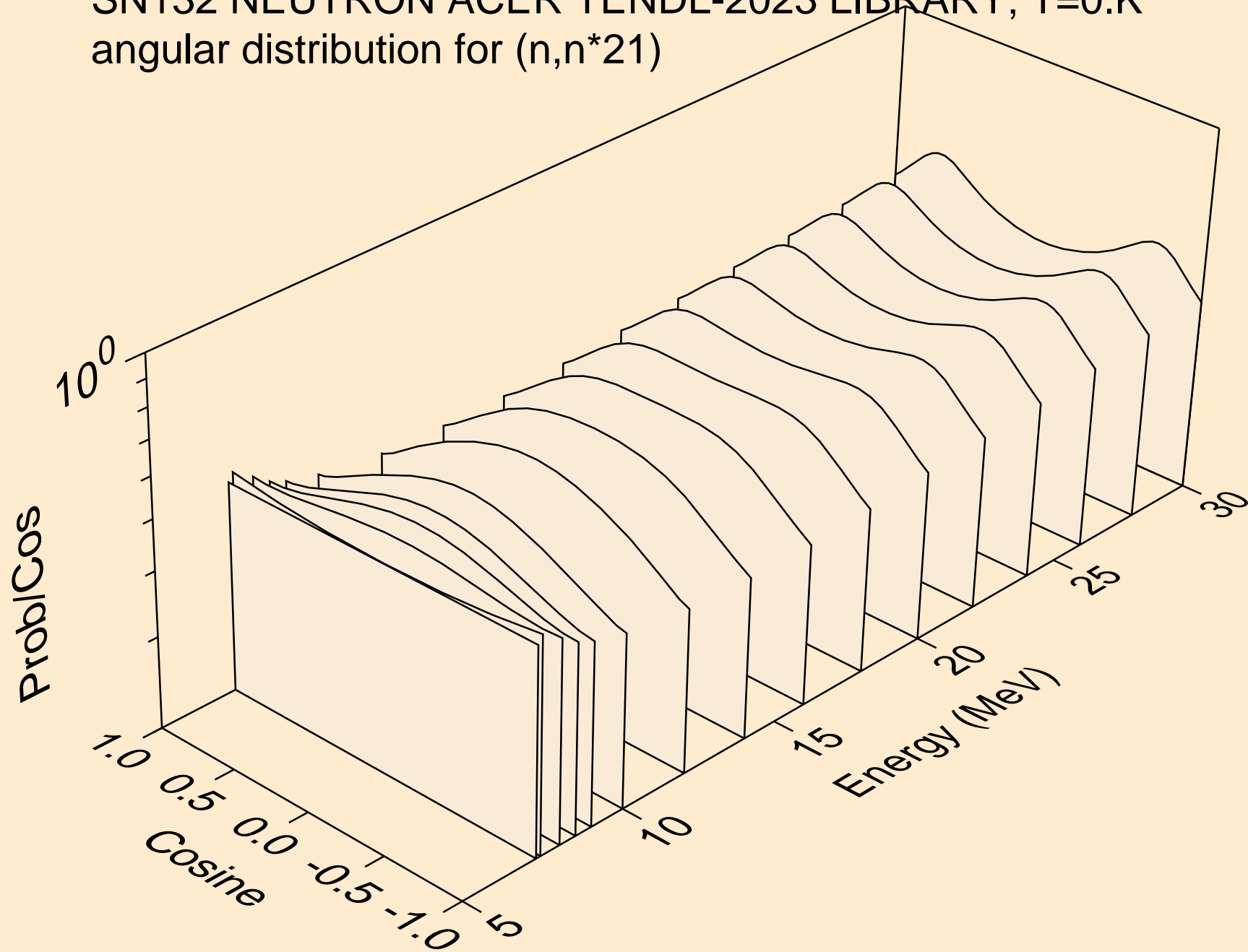

SN132 NEUTRON ACER TENDL-2023 LIBRARY; T=0.K  
angular distribution for (n,n\*22)

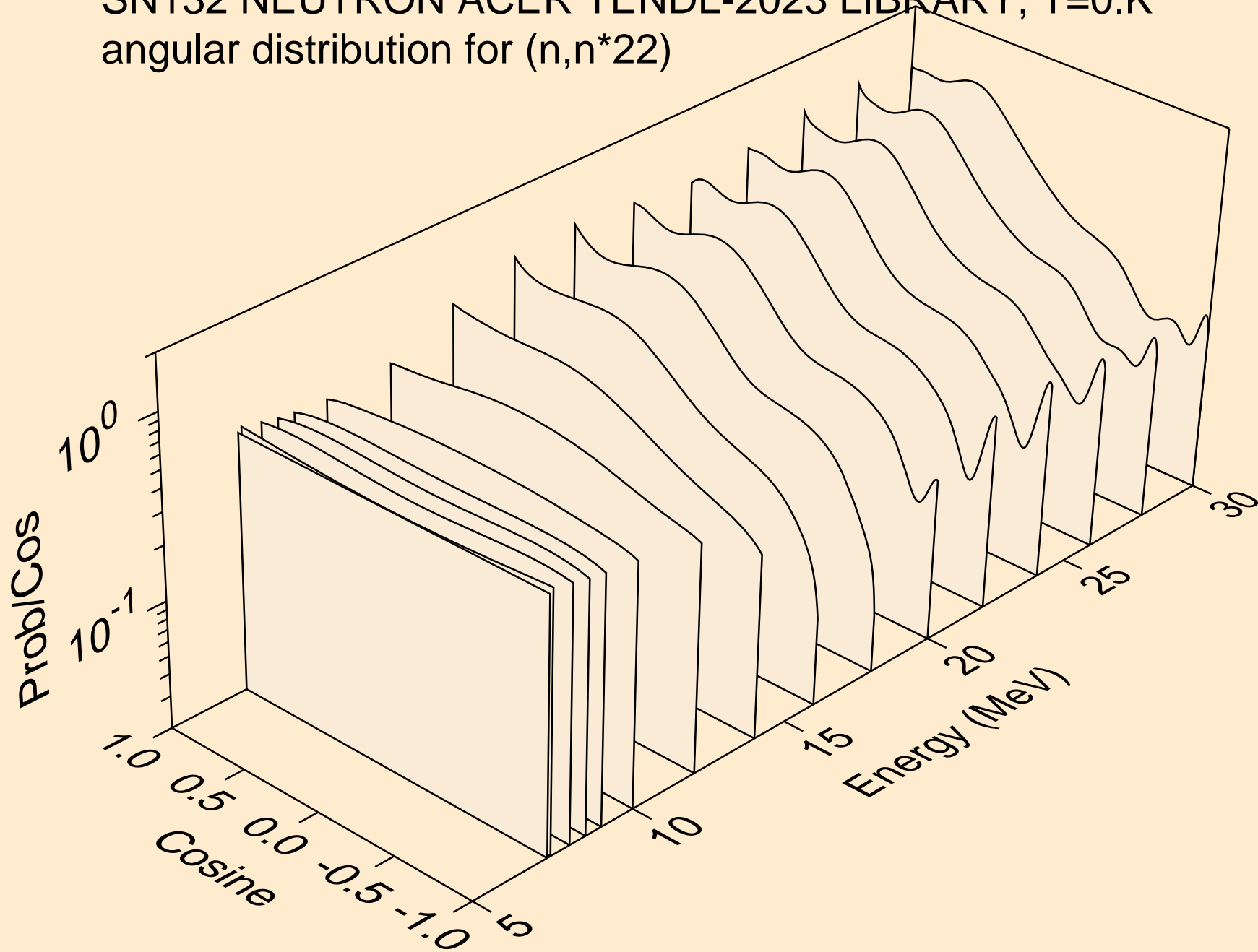

SN132 NEUTRON ACER TENDL-2023 LIBRARY; T=0.K  
angular distribution for (n,n\*23)

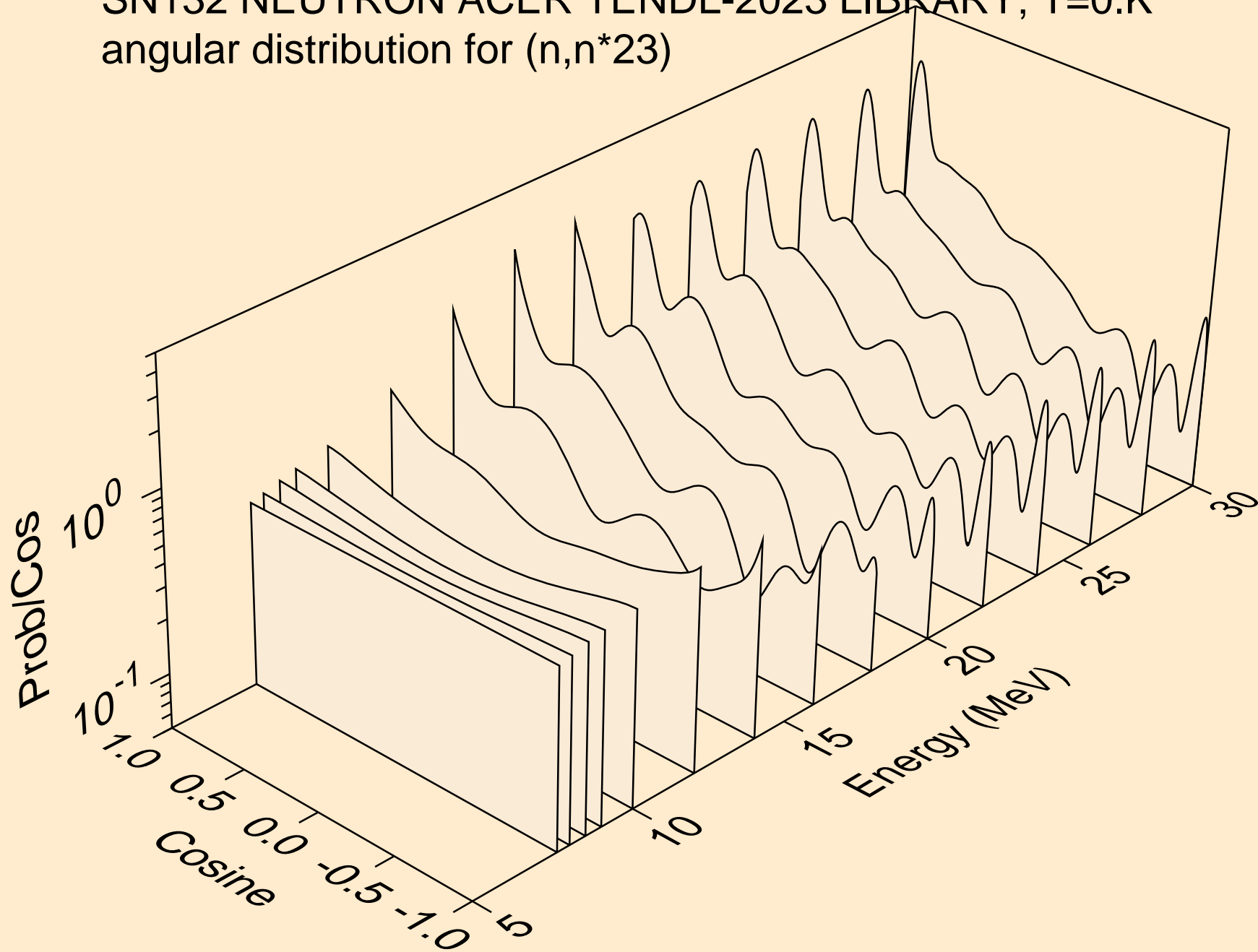

SN132 NEUTRON ACER TENDL-2023 LIBRARY; T=0.K  
angular distribution for (n,n\*24)

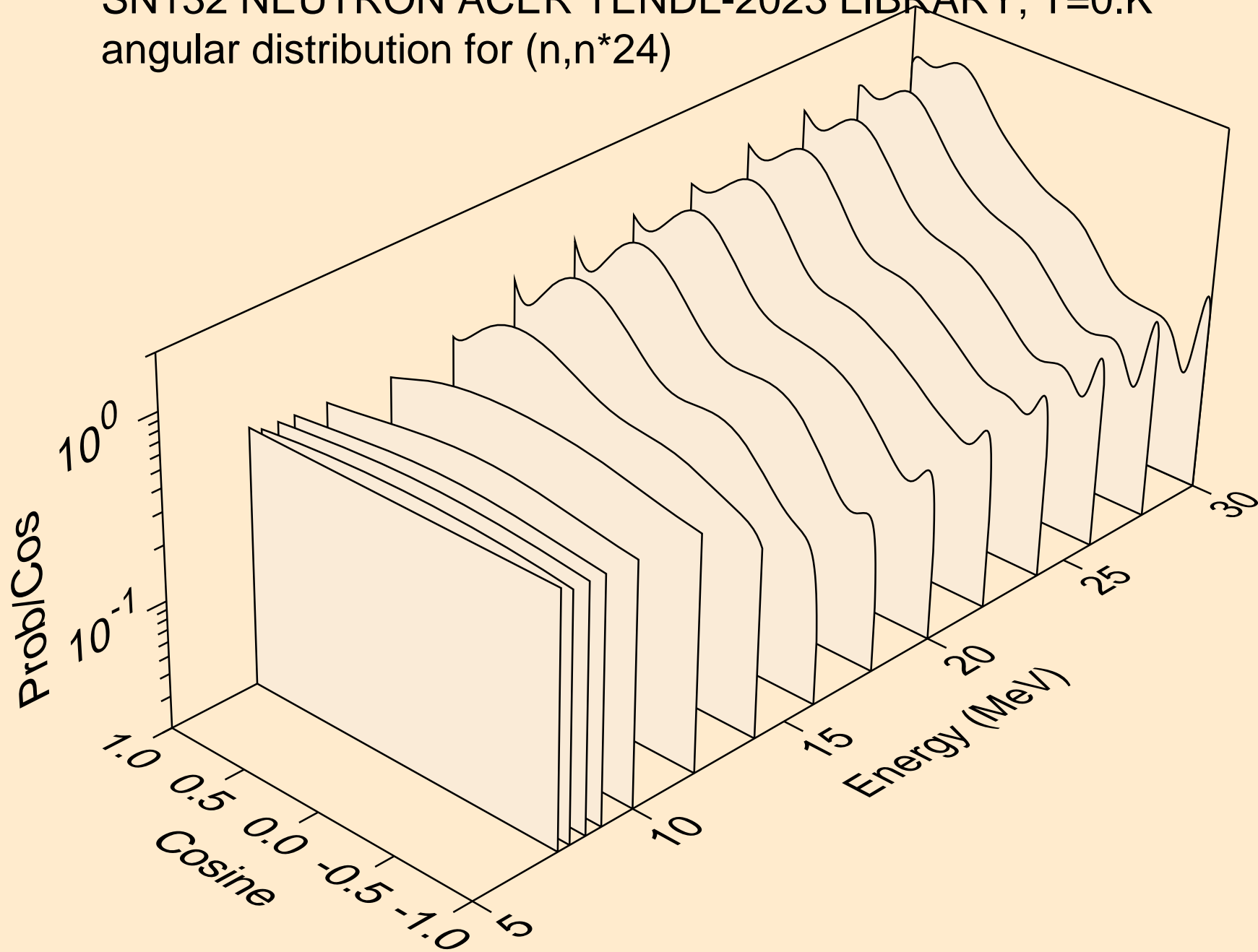

SN132 NEUTRON ACER TENDL-2023 LIBRARY; T=0.K  
angular distribution for (n,n\*25)

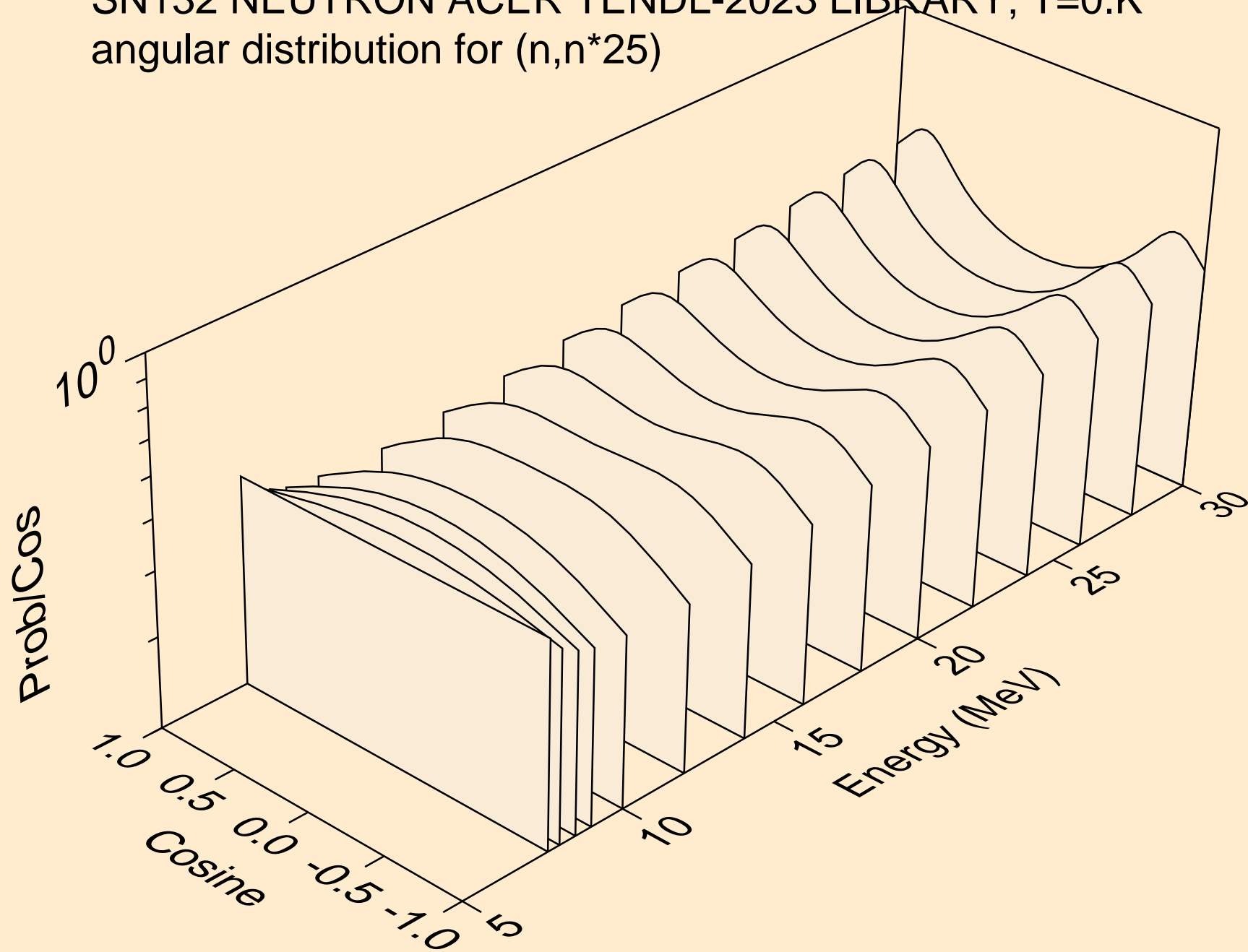

SN132 NEUTRON ACER TENDL-2023 LIBRARY; T=0.K  
angular distribution for (n,n\*26)

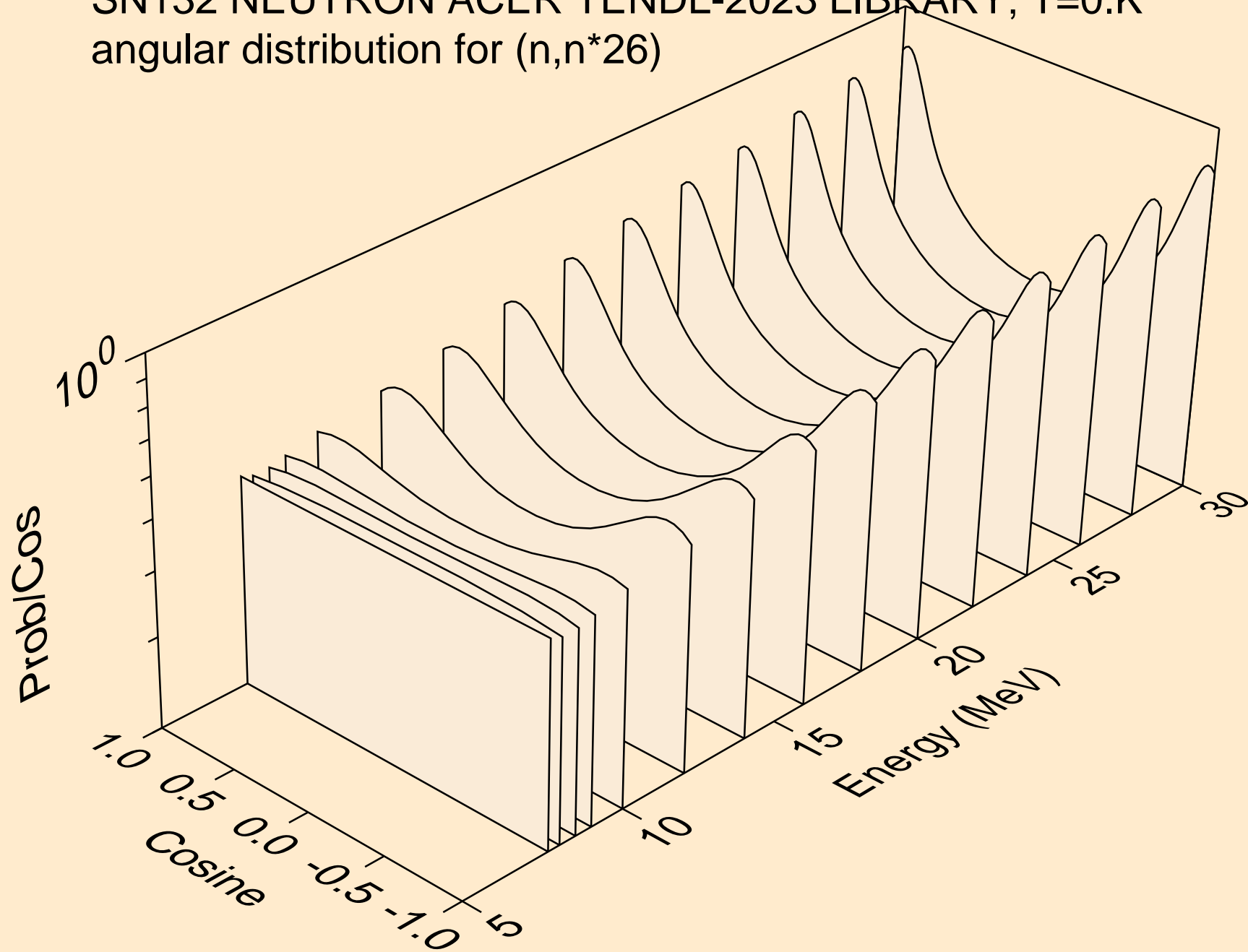

SN132 NEUTRON ACER TENDL-2023 LIBRARY; T=0.K  
angular distribution for (n,n\*27)

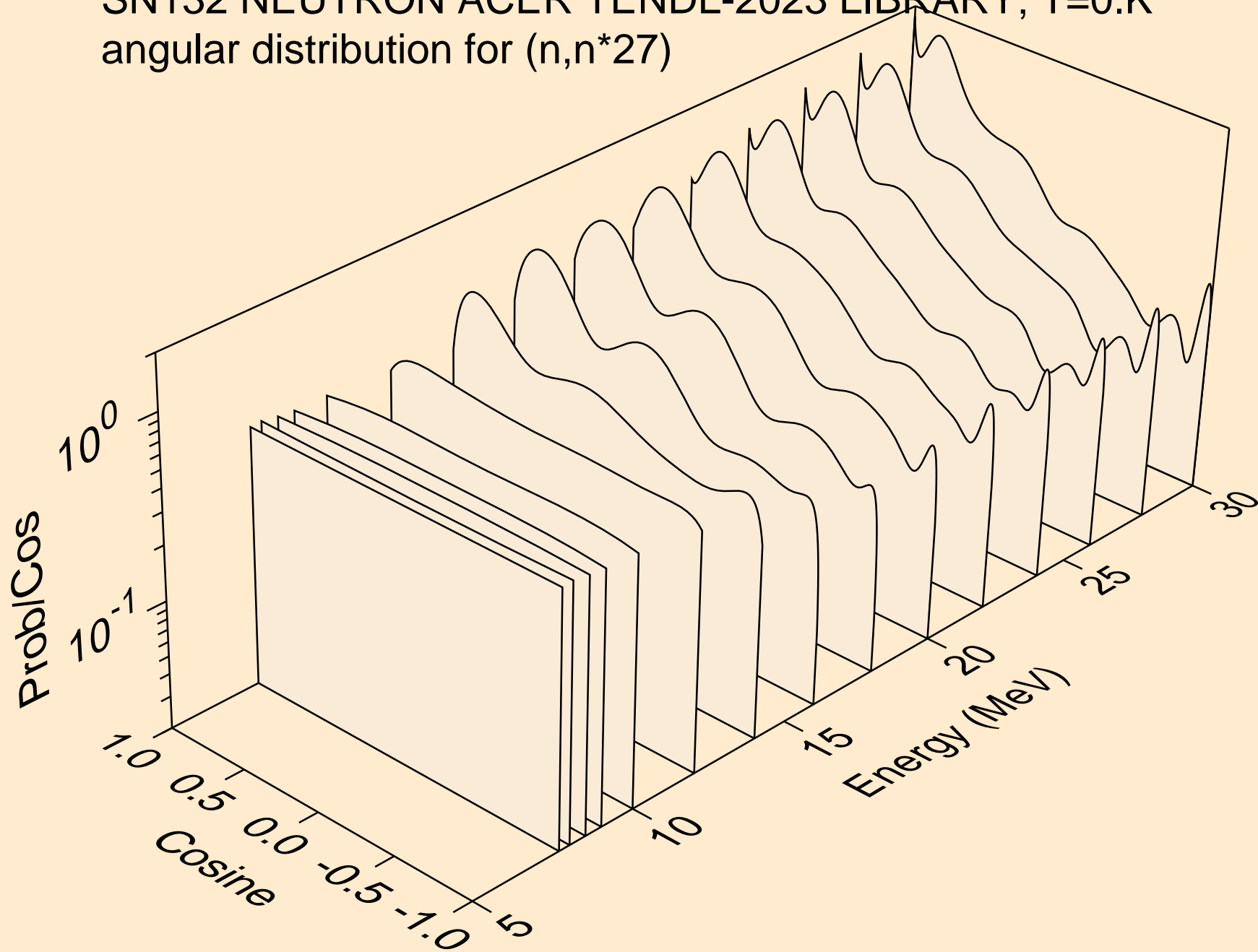

SN132 NEUTRON ACER TENDL-2023 LIBRARY; T=0.K  
angular distribution for (n,n\*28)

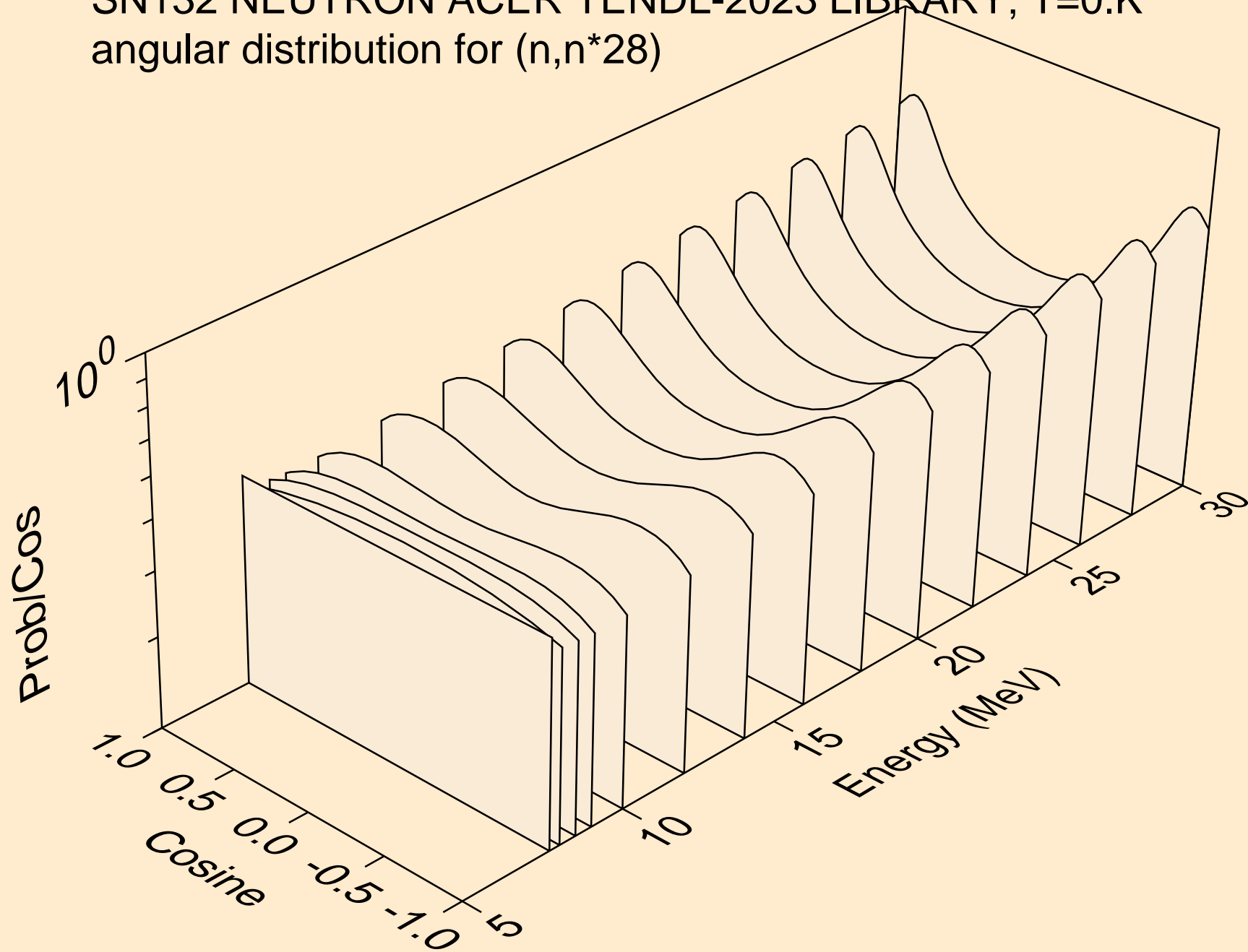



SN132 NEUTRON ACER TENDL-2023 LIBRARY; T=0.K  
angular distribution for (n,n\*29)

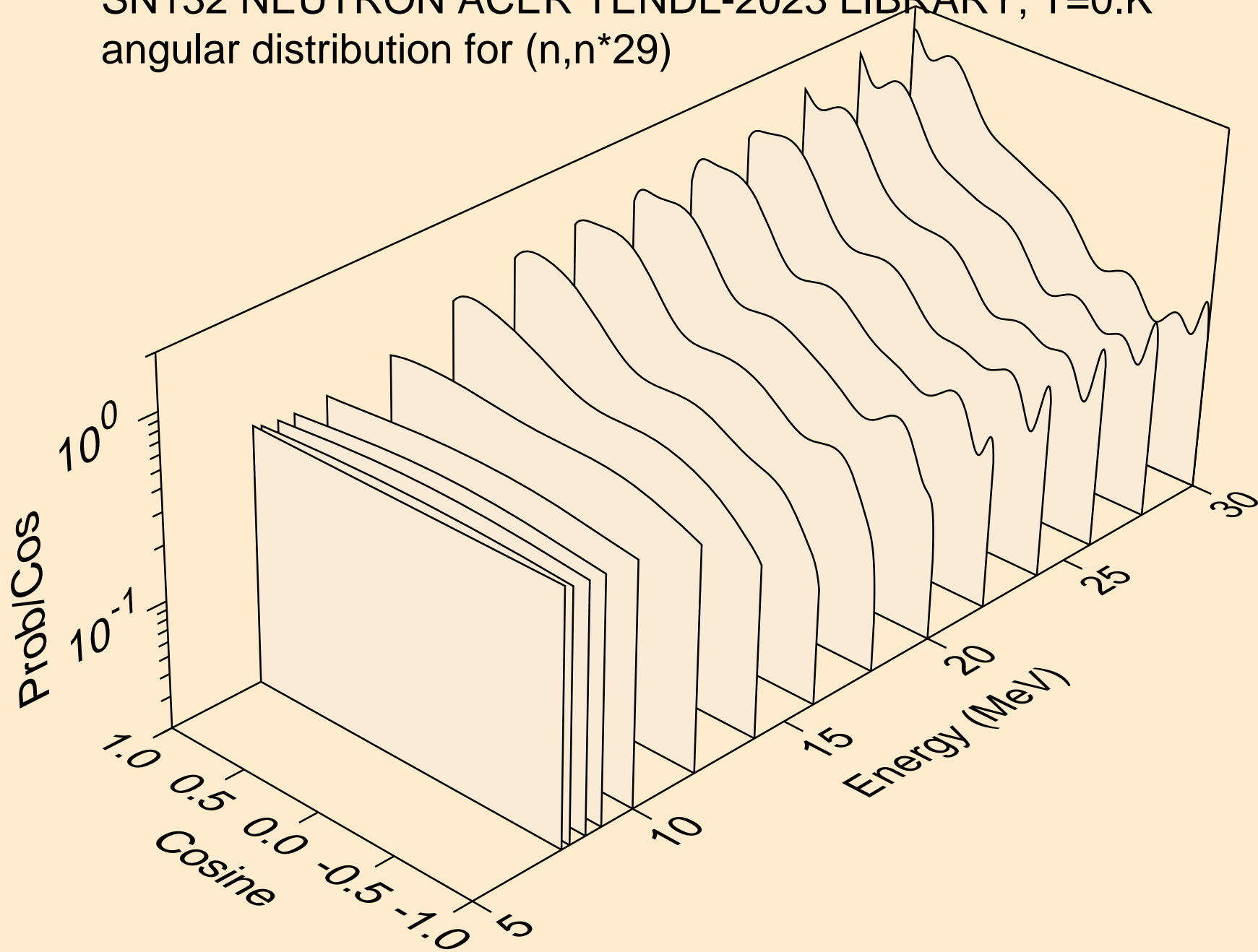

SN132 NEUTRON ACER TENDL-2023 LIBRARY; T=0.K  
angular distribution for (n,n\*30)

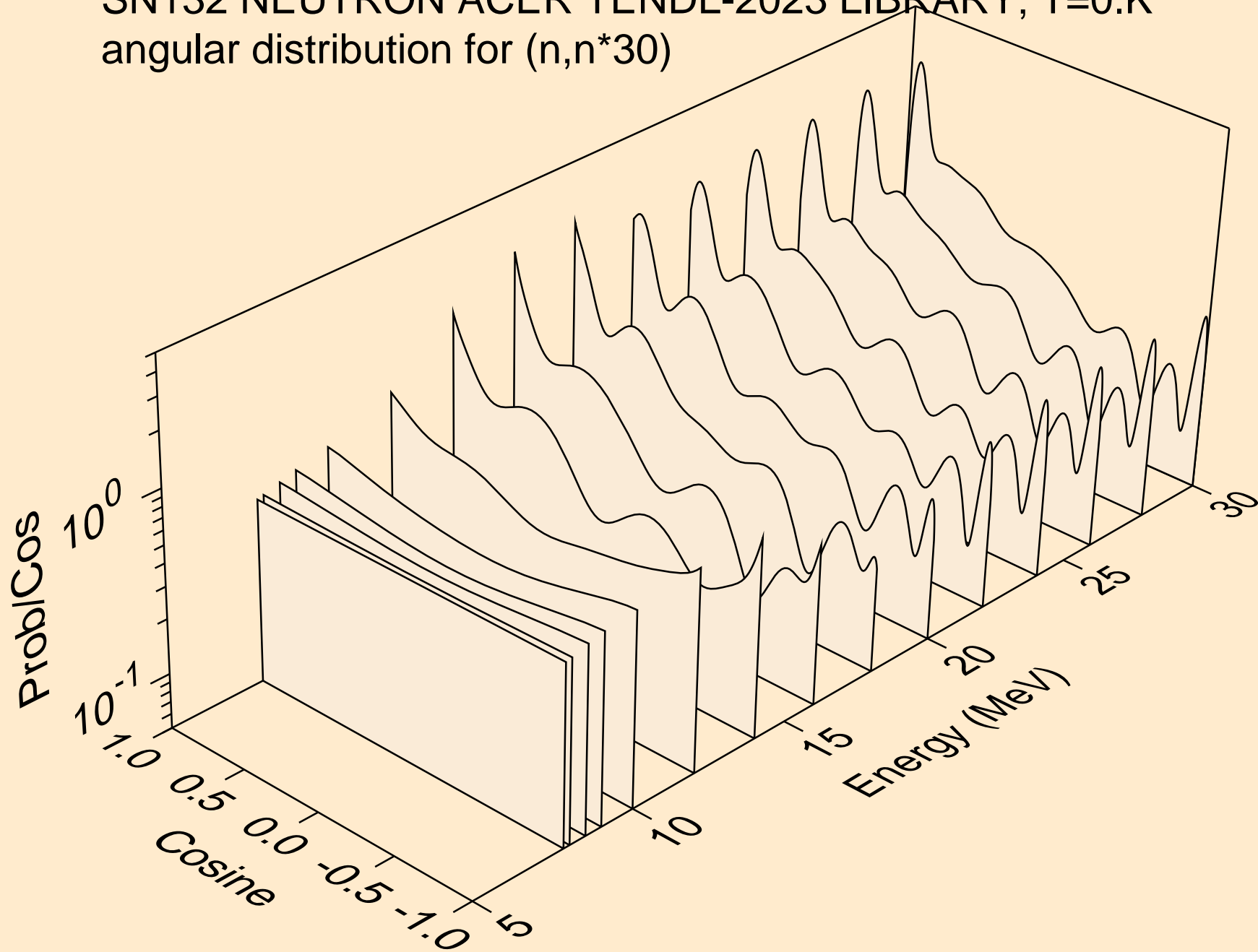

SN132 NEUTRON ACER TENDL-2023 LIBRARY; T=0.K  
Neutron emission for (n,x)

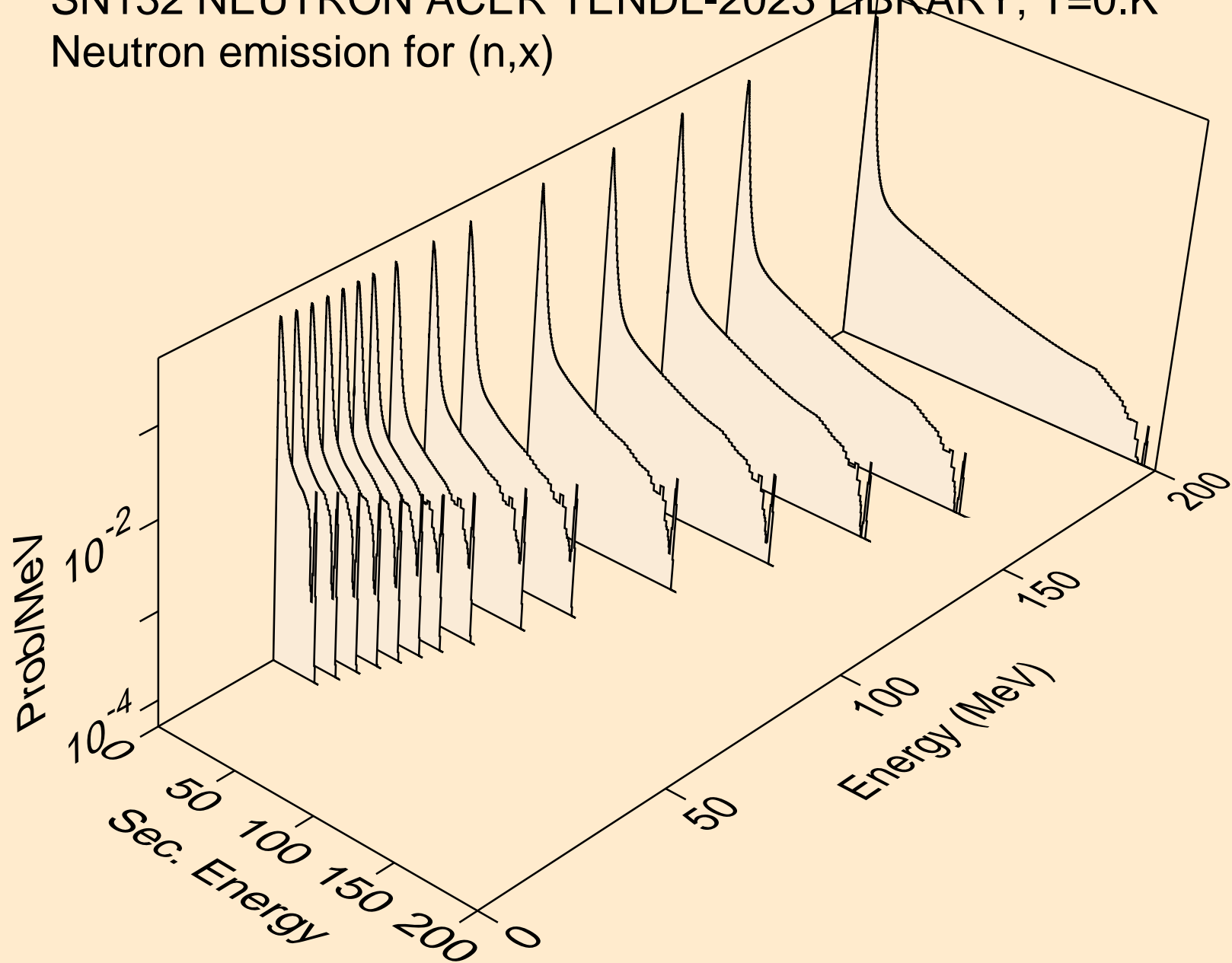

SN132 NEUTRON ACER TENDL-2023 LIBRARY; T=0.K  
Neutron emission for (n,2nd)

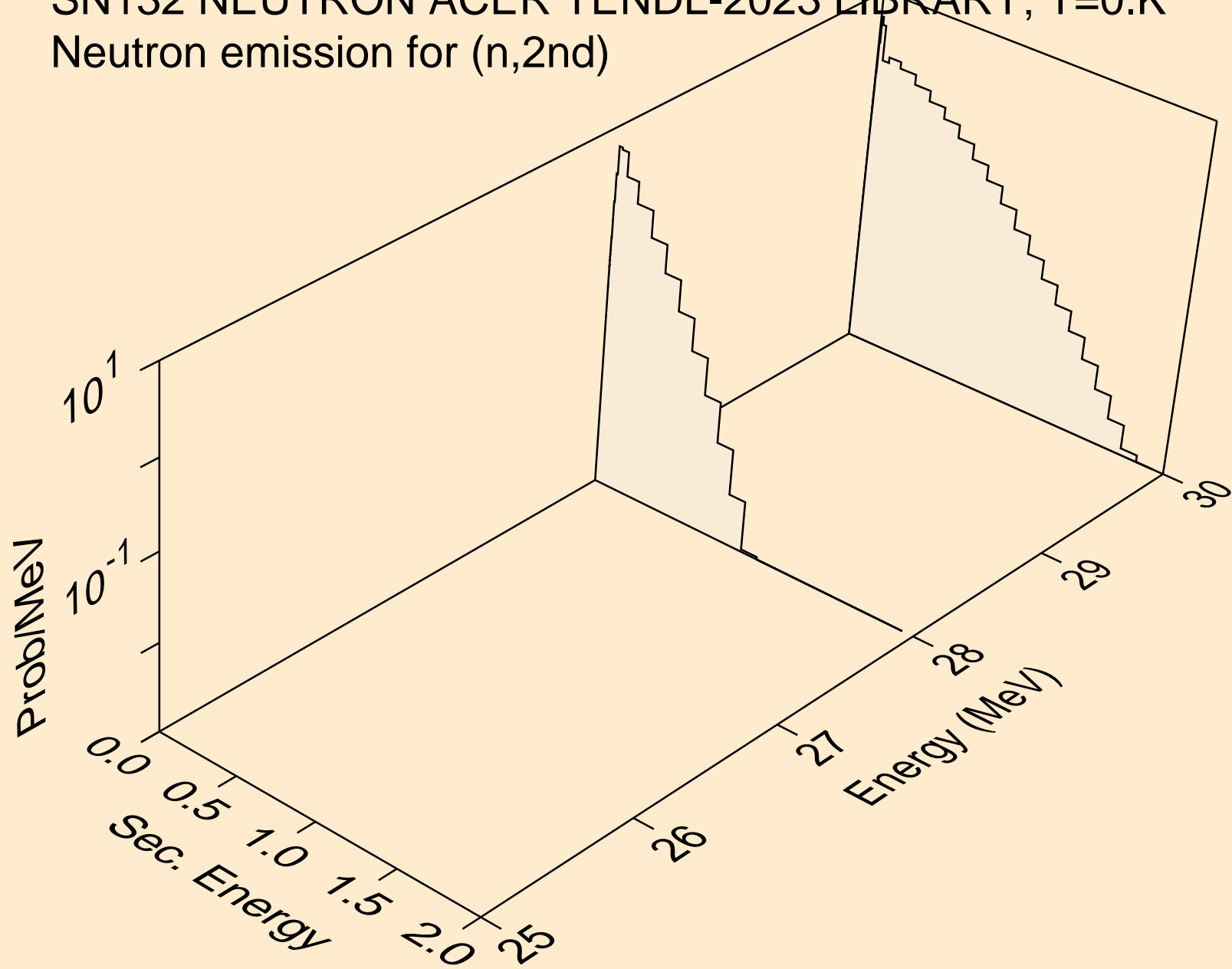

SN132 NEUTRON ACER TENDL-2023 LIBRARY; T=0.K  
Neutron emission for (n,2n)

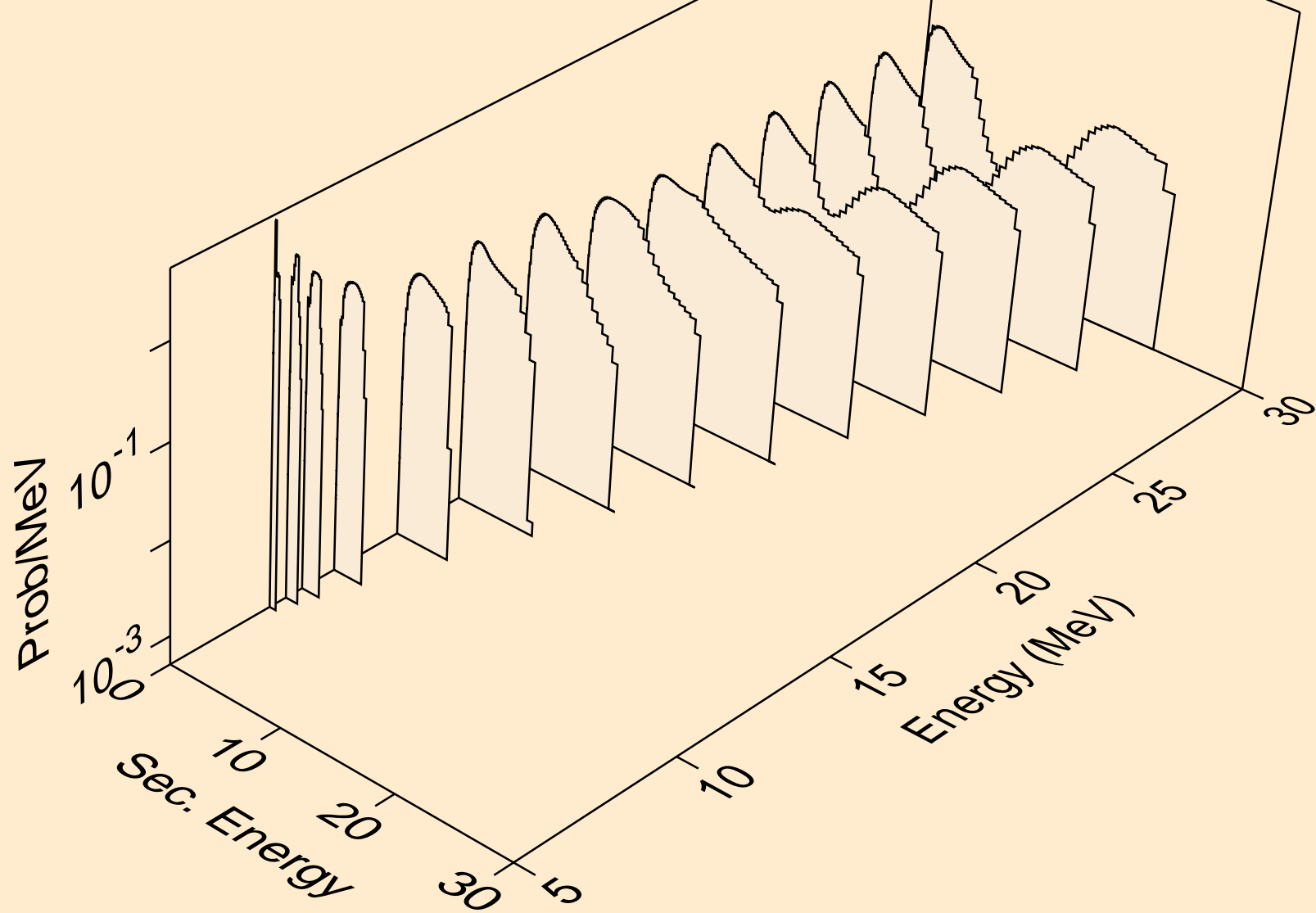

SN132 NEUTRON ACER TENDL-2023 LIBRARY; T=0.K  
Neutron emission for (n,3n)

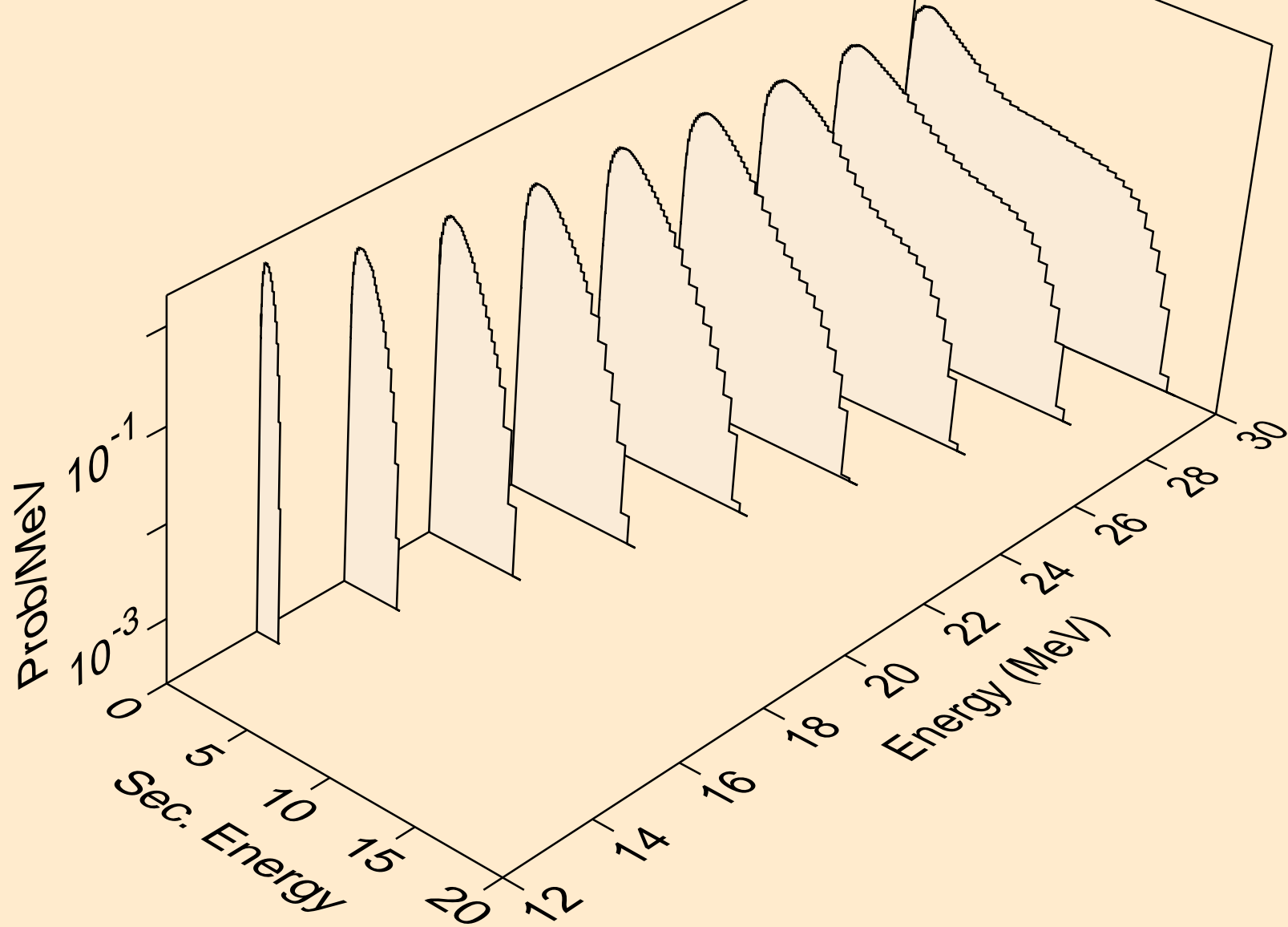

SN132 NEUTRON ACER TENDL-2023 LIBRARY; T=0.K  
Neutron emission for (n,n\*)a

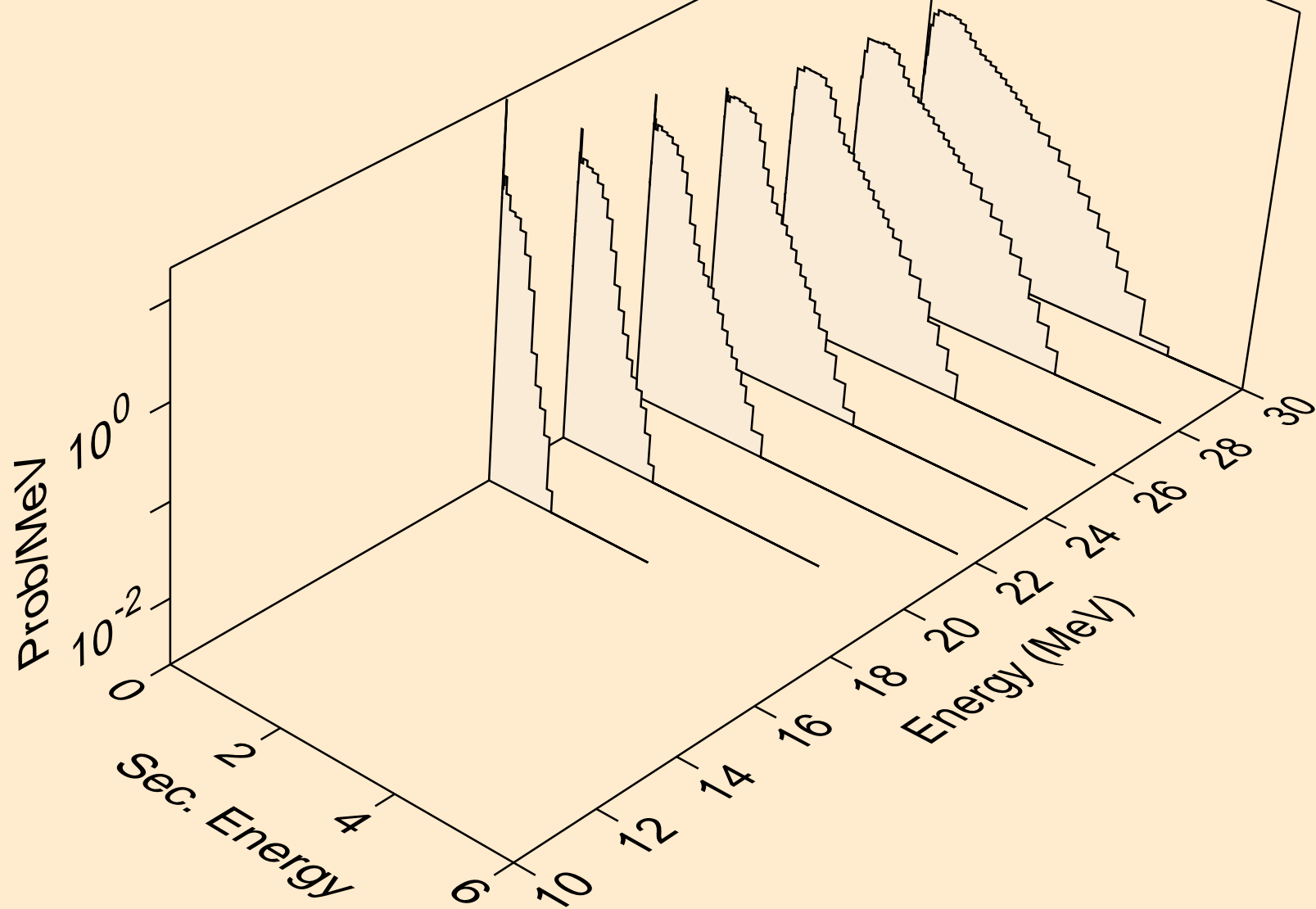

SN132 NEUTRON ACER TENDL-2023 LIBRARY; T=0.K  
Neutron emission for (n,2n)a

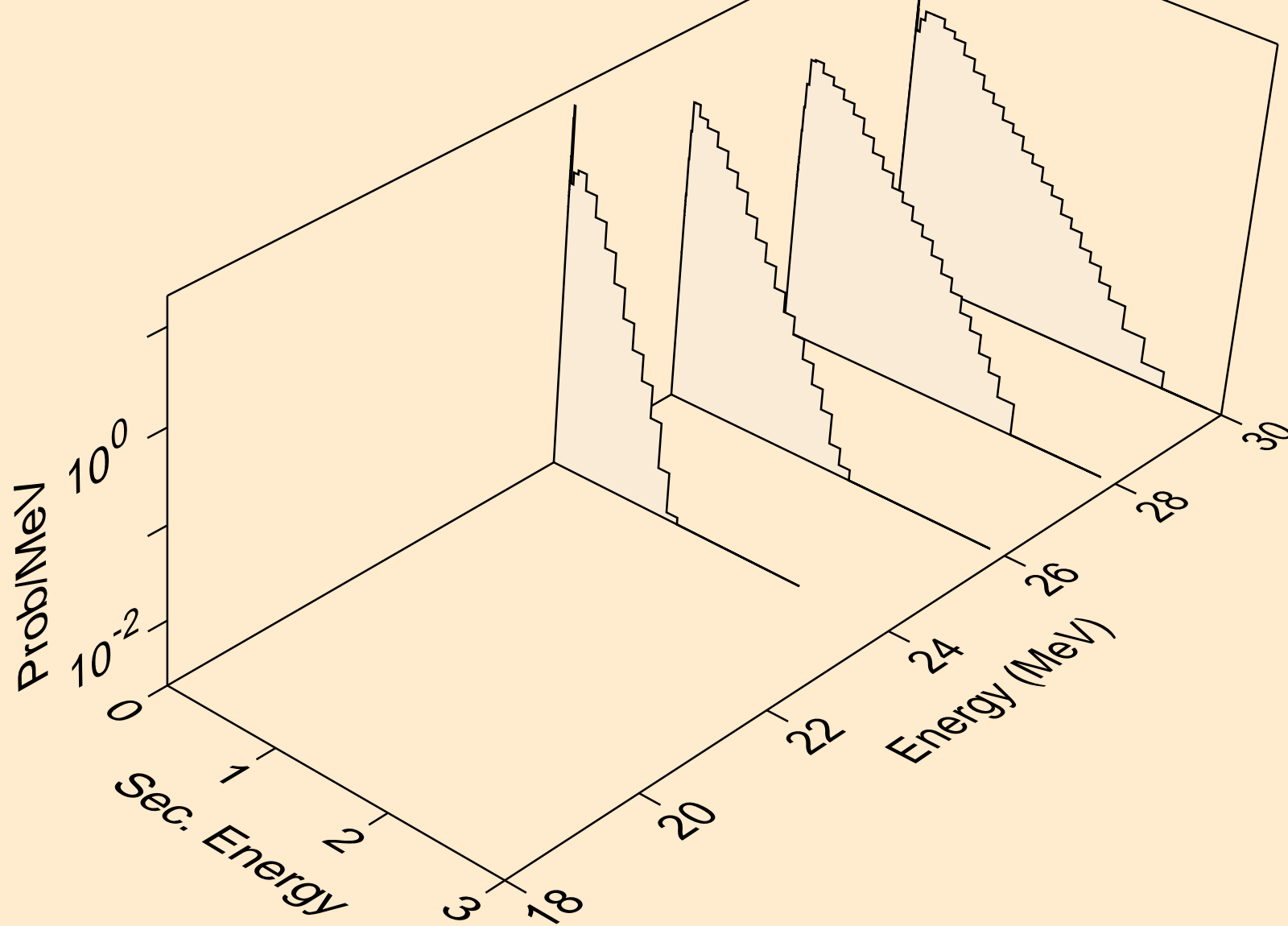



SN132 NEUTRON ACER TENDL-2023 LIBRARY; T=0.K  
Neutron emission for (n,n\*)p

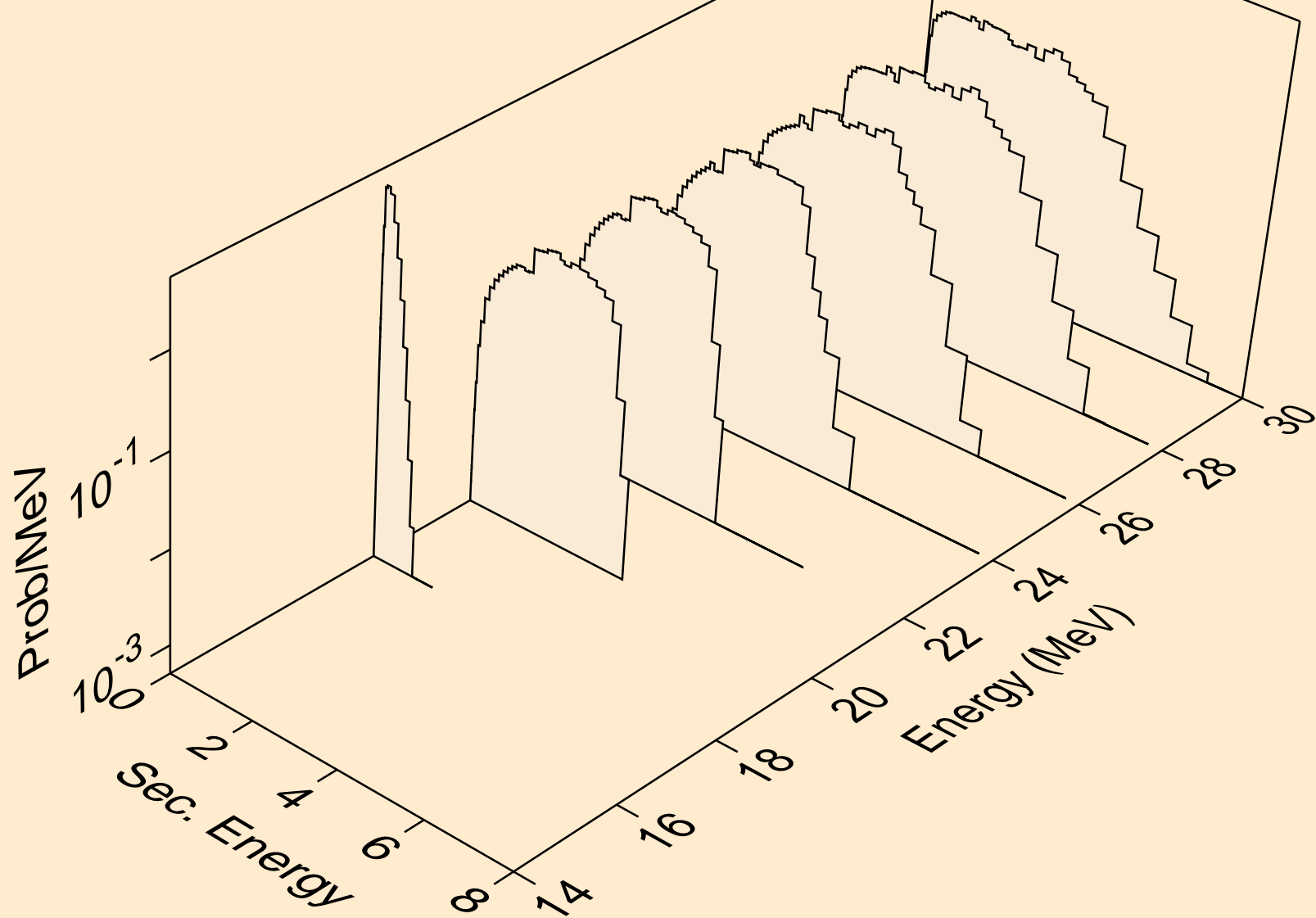

SN132 NEUTRON ACER TENDL-2023 LIBRARY; T=0.K  
Neutron emission for (n,n\*)d

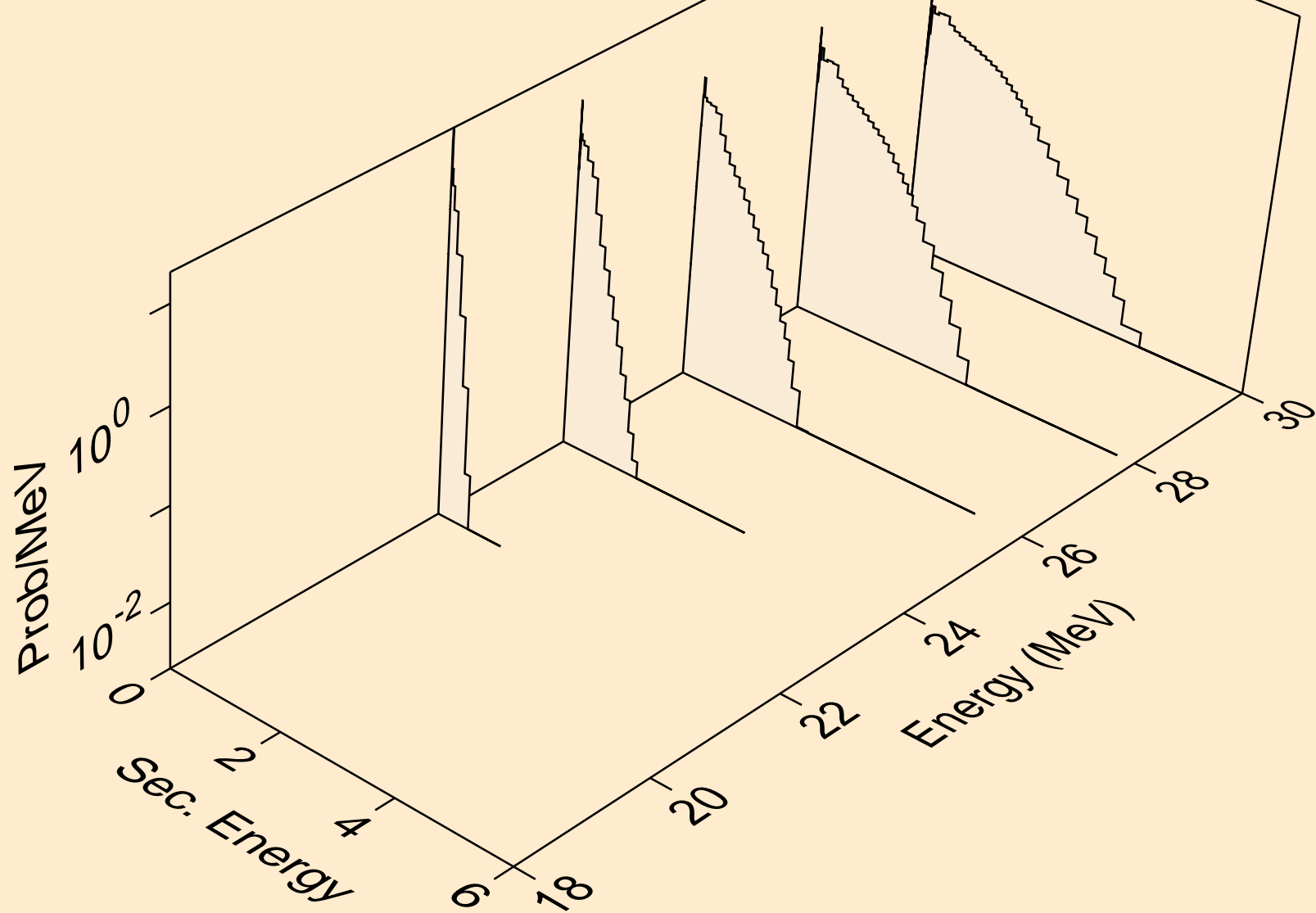

SN132 NEUTRON ACER TENDL-2023 LIBRARY; T=0.K  
Neutron emission for (n,n\*)t

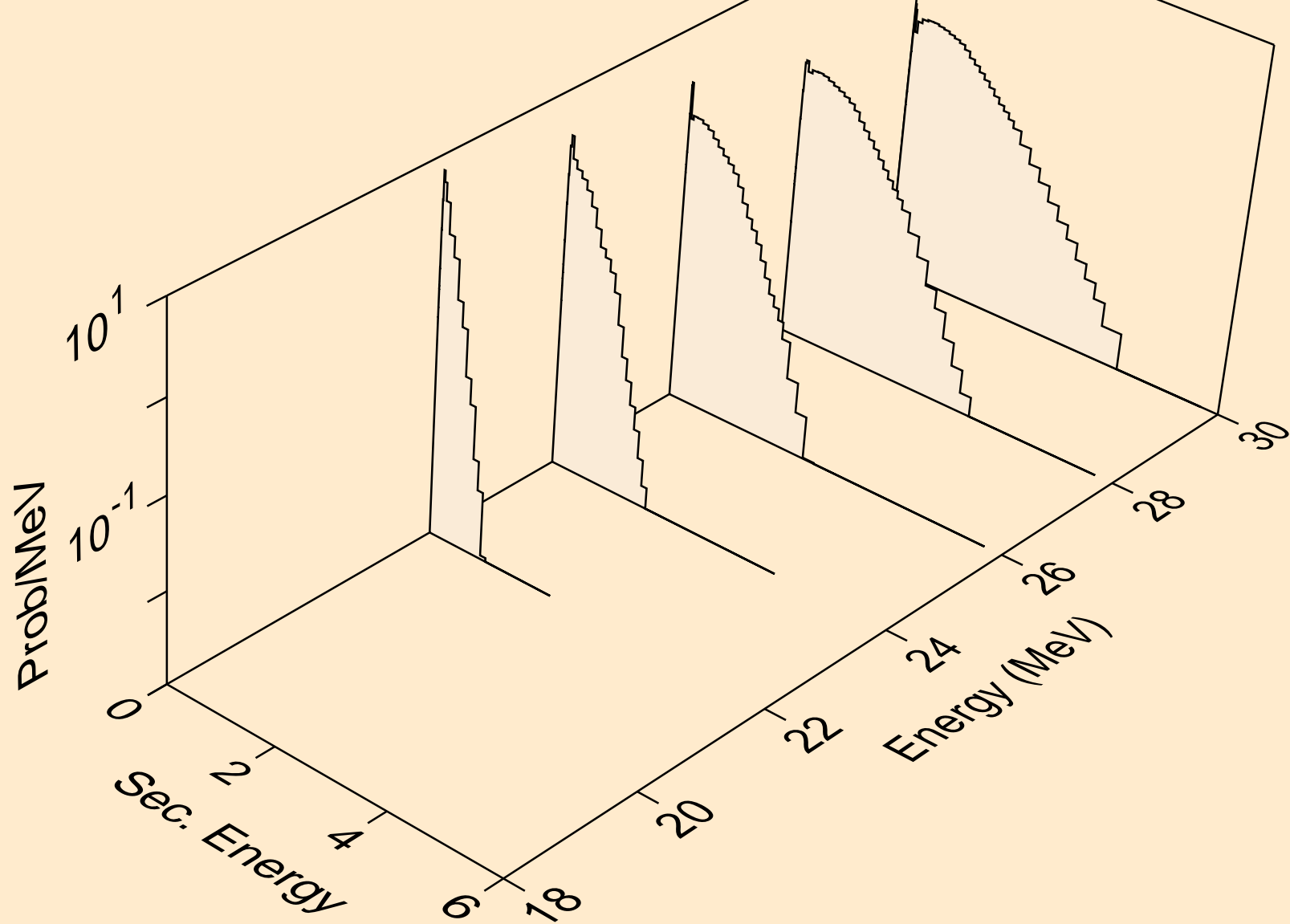

SN132 NEUTRON ACER TENDL-2023 LIBRARY; T=0.K  
Neutron emission for (n,4n)

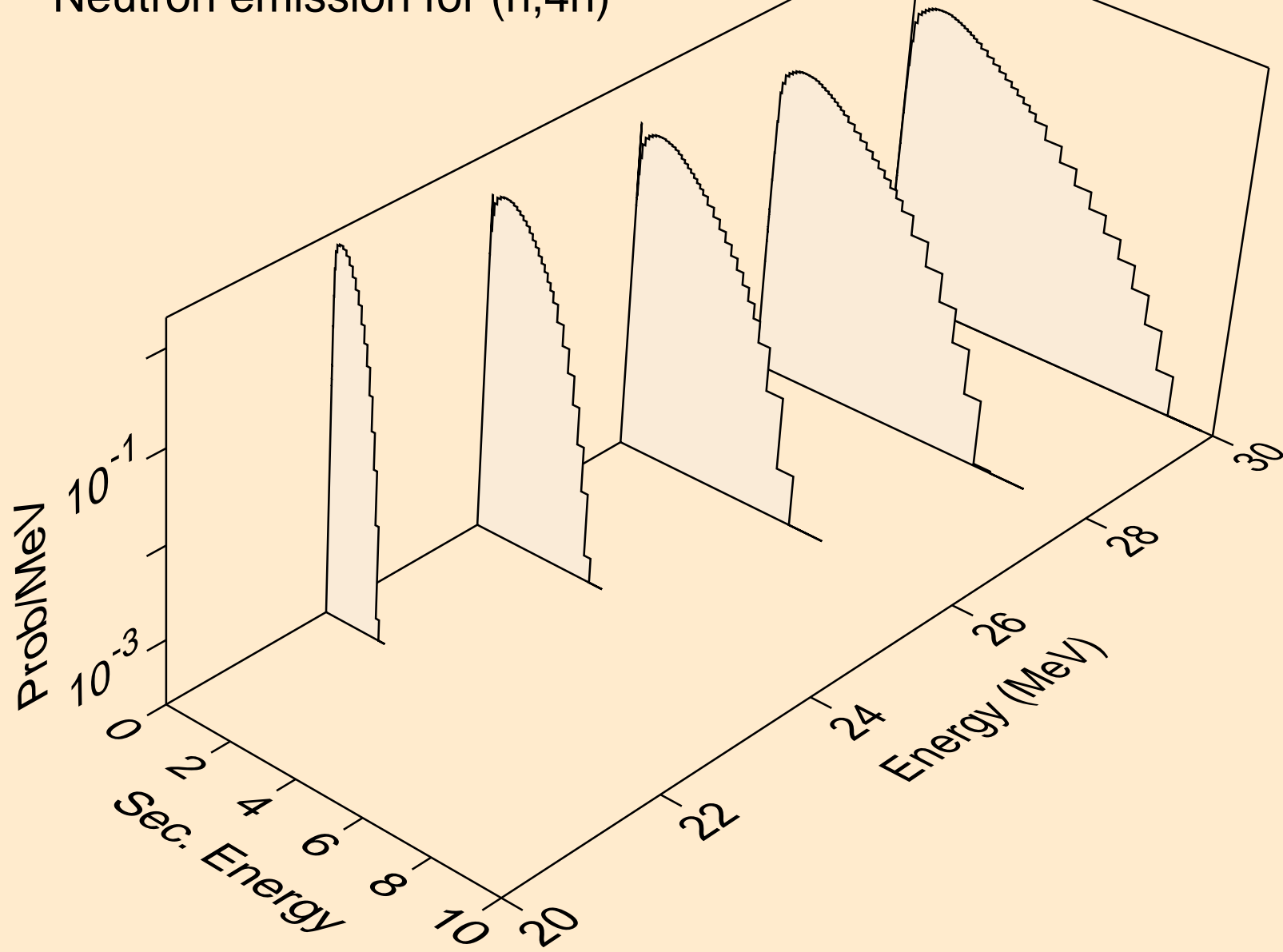

SN132 NEUTRON ACER TENDL-2023 LIBRARY; T=0.K  
Neutron emission for (n,2np)

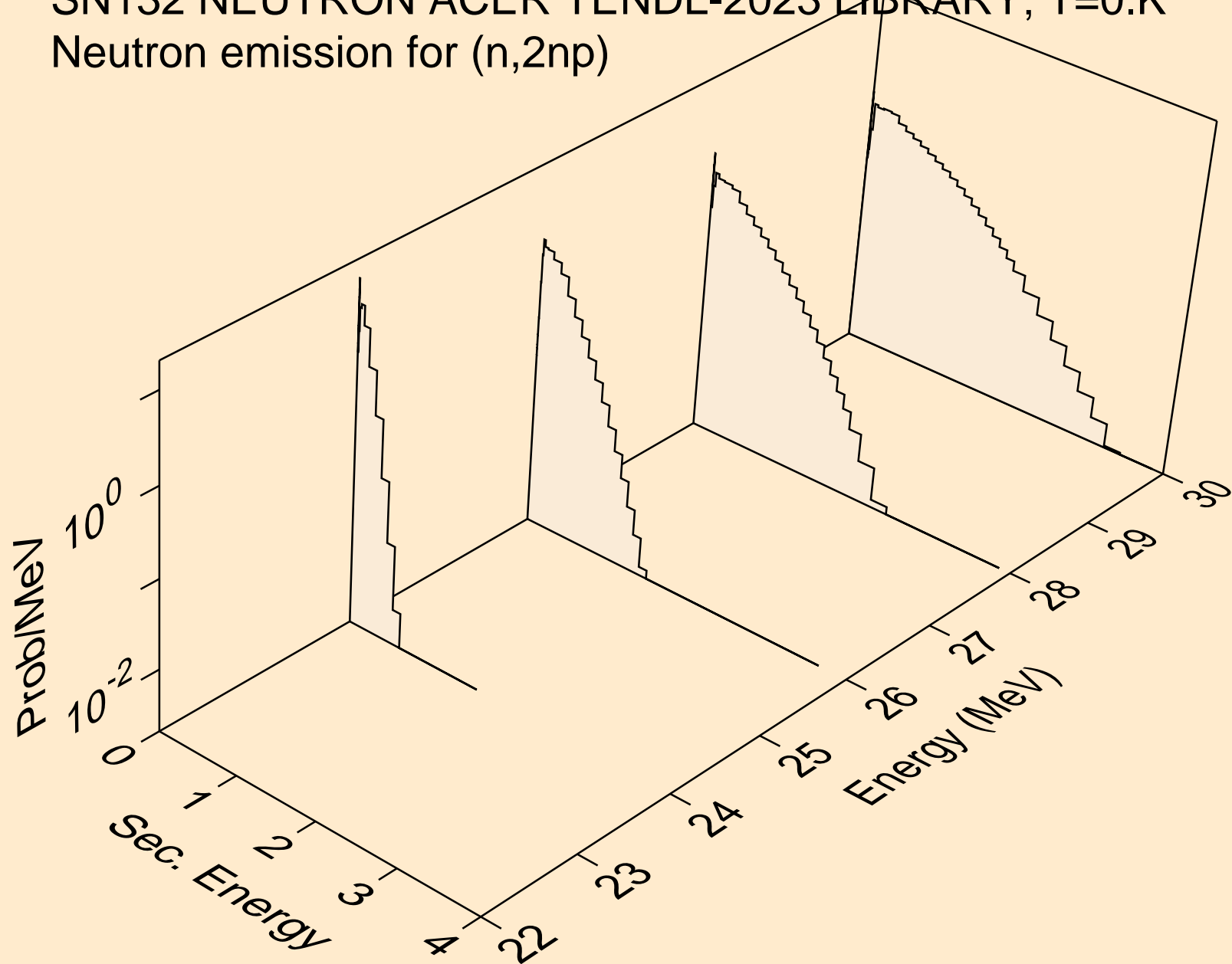

SN132 NEUTRON ACER TENDL-2023 LIBRARY; T=0.K  
Photon emission for (n,x)

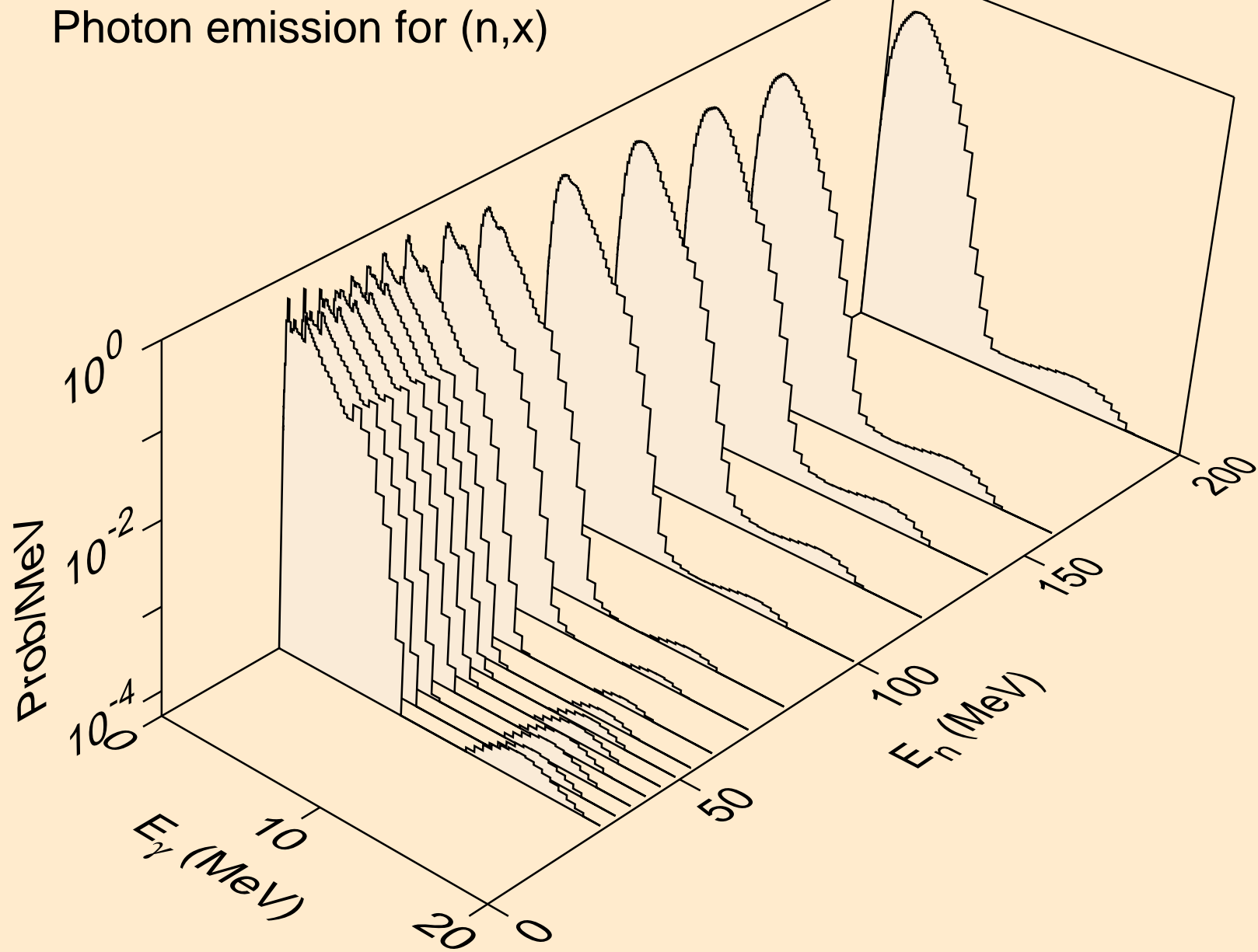

SN132 NEUTRON ACER TENDL-2023 LIBRARY; T=0.K  
Photon emission for (n,2nd)

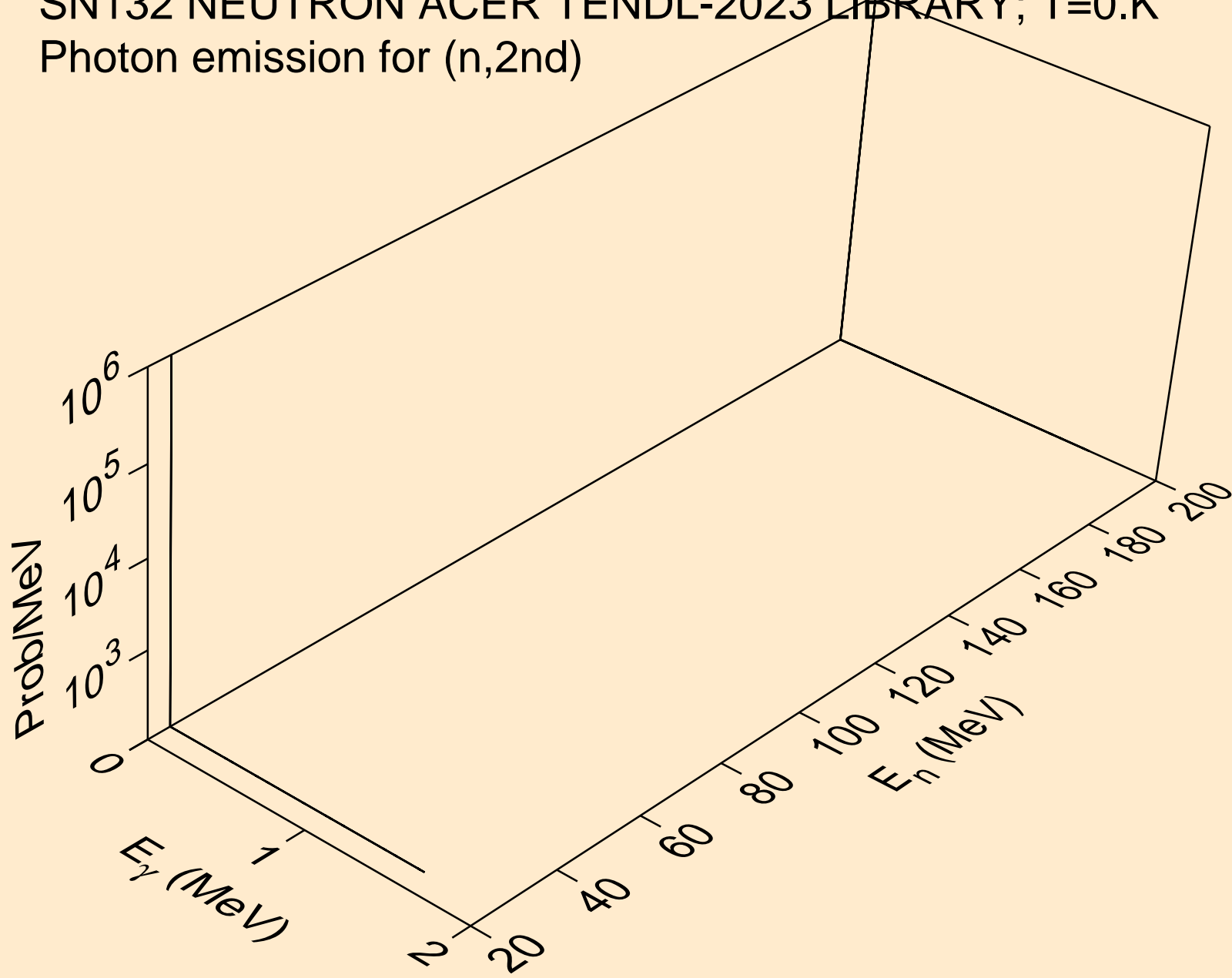

SN132 NEUTRON ACER TENDL-2023 LIBRARY; T=0.K  
Photon emission for (n,2n)

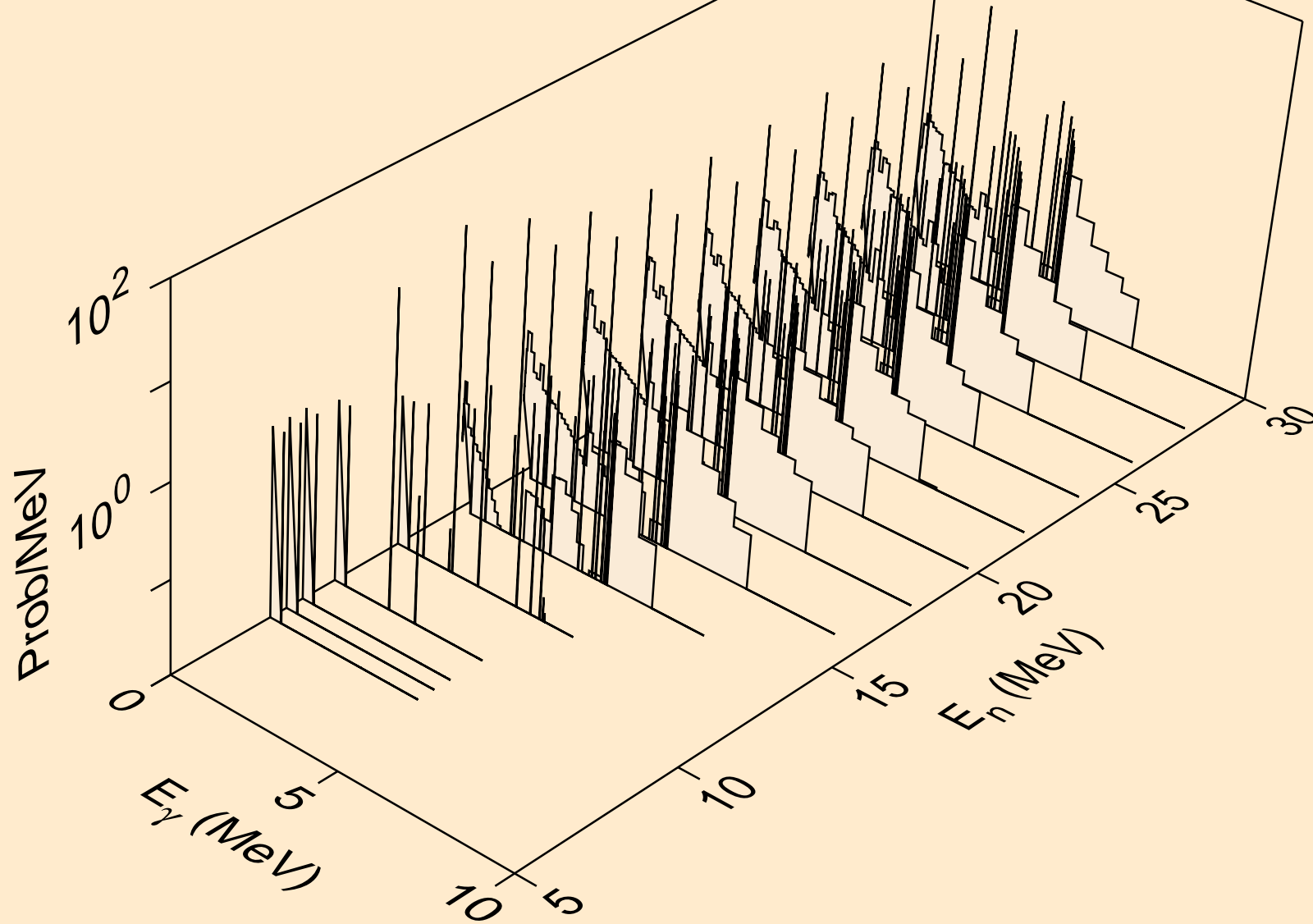



SN132 NEUTRON ACER TENDL-2023 LIBRARY; T=0.K  
Photon emission for (n,3n)

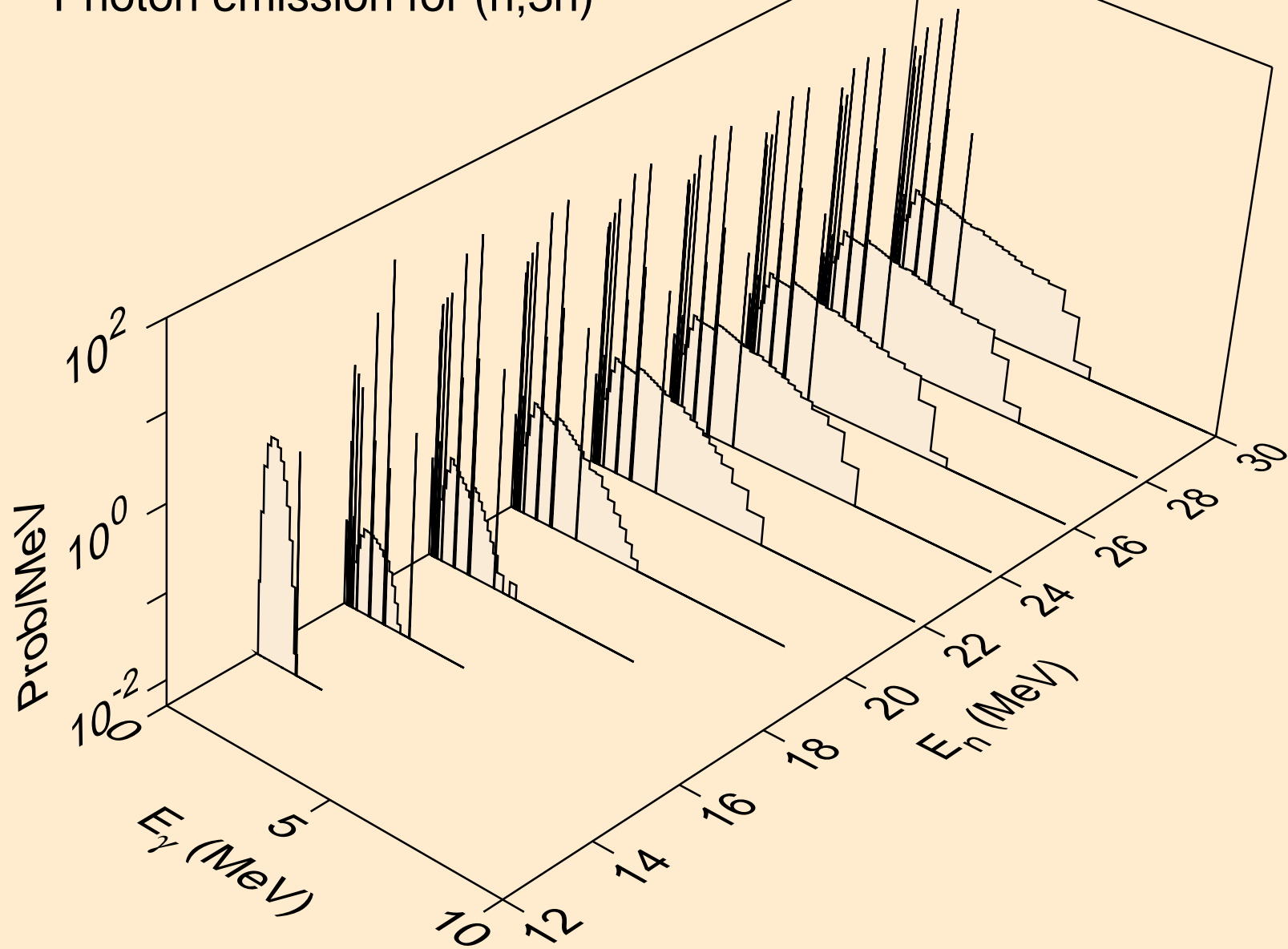

SN132 NEUTRON ACER TENDL-2023 LIBRARY; T=0.K  
Photon emission for (n,n\*)a

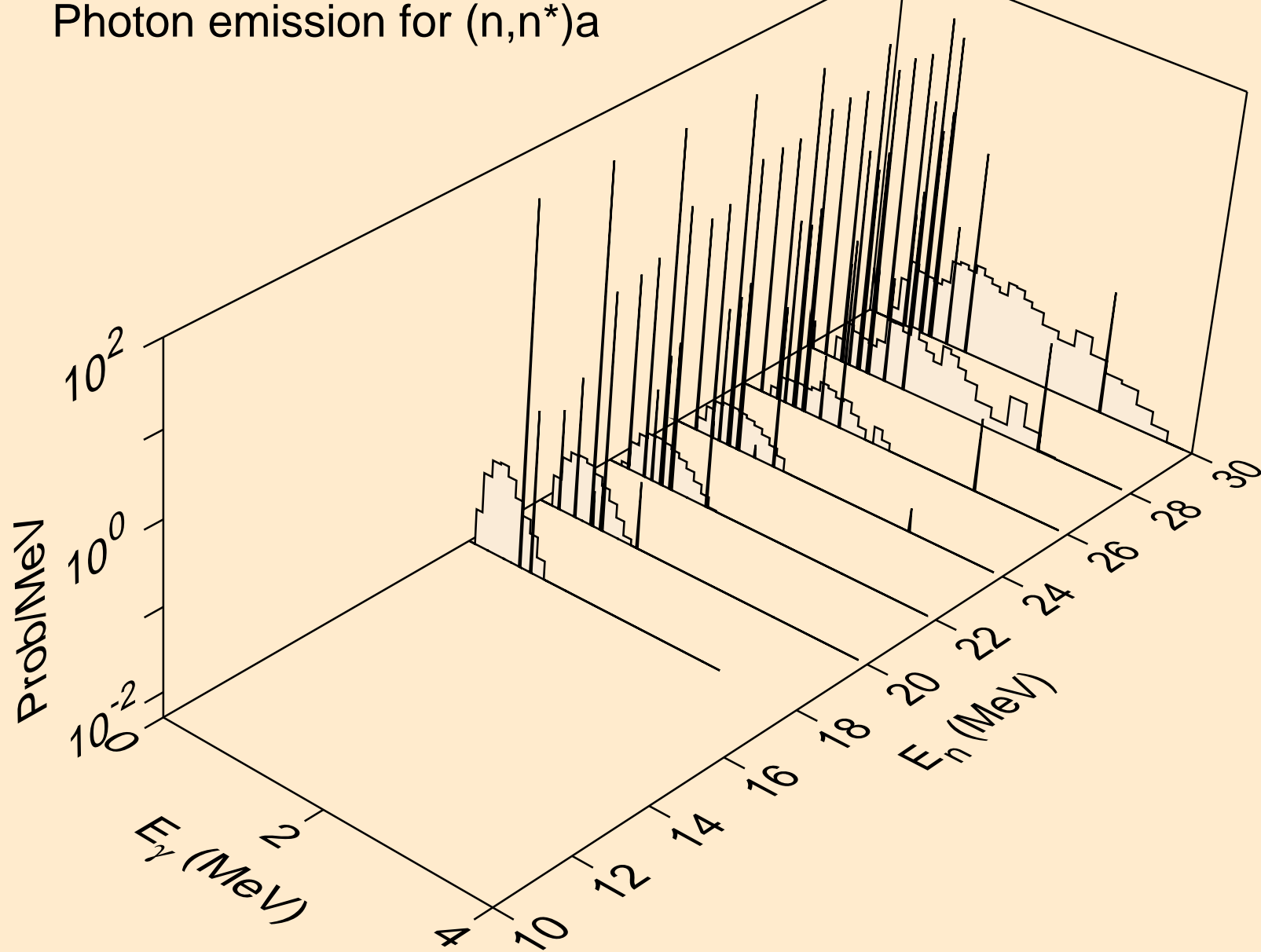

SN132 NEUTRON ACER TENDL-2023 LIBRARY; T=0.K  
Photon emission for (n,2n)a

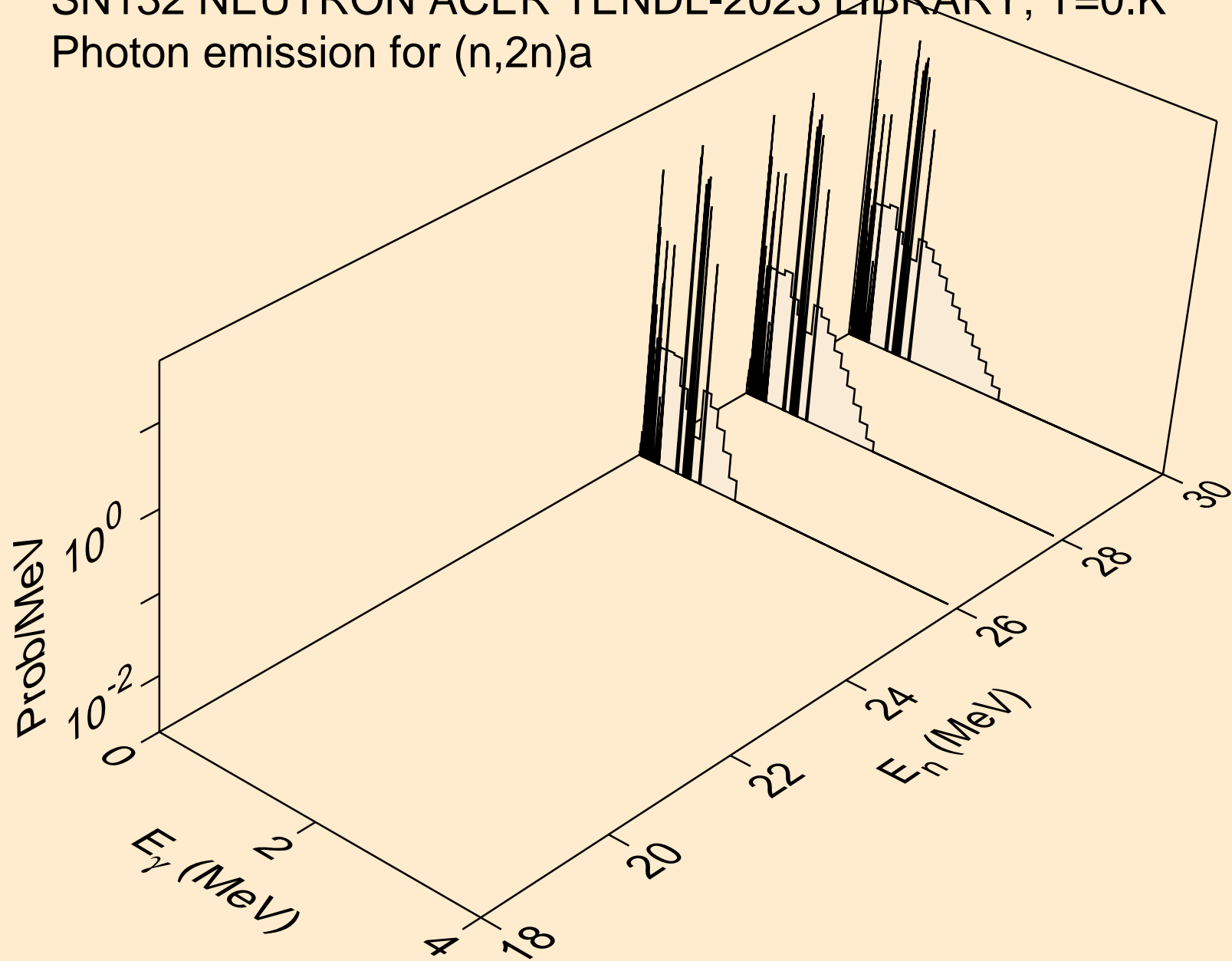

SN132 NEUTRON ACER TENDL-2023 LIBRARY; T=0.K  
Photon emission for (n,n\*)p

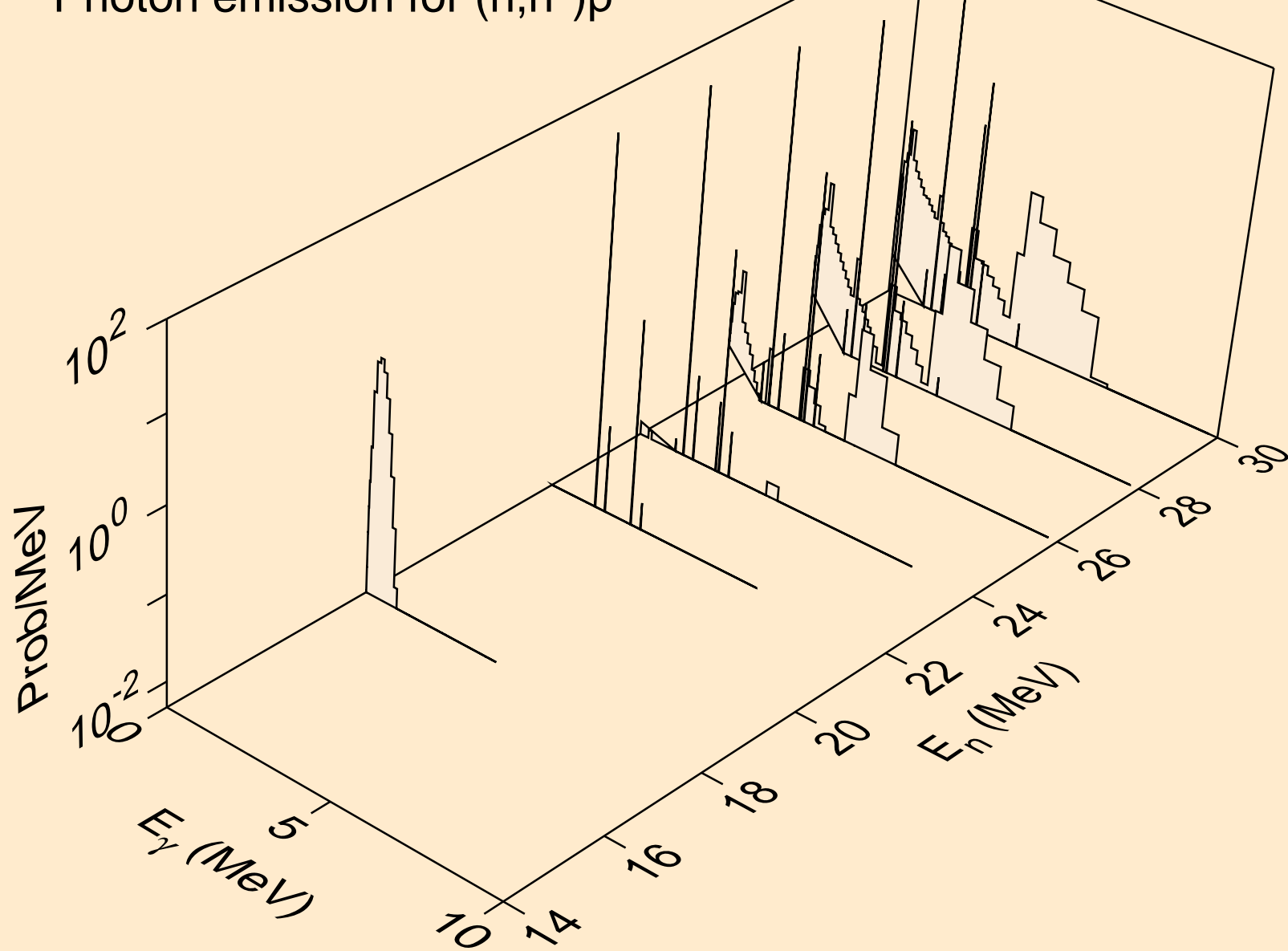

SN132 NEUTRON ACER TENDL-2023 LIBRARY; T=0.K  
Photon emission for (n,n\*)d

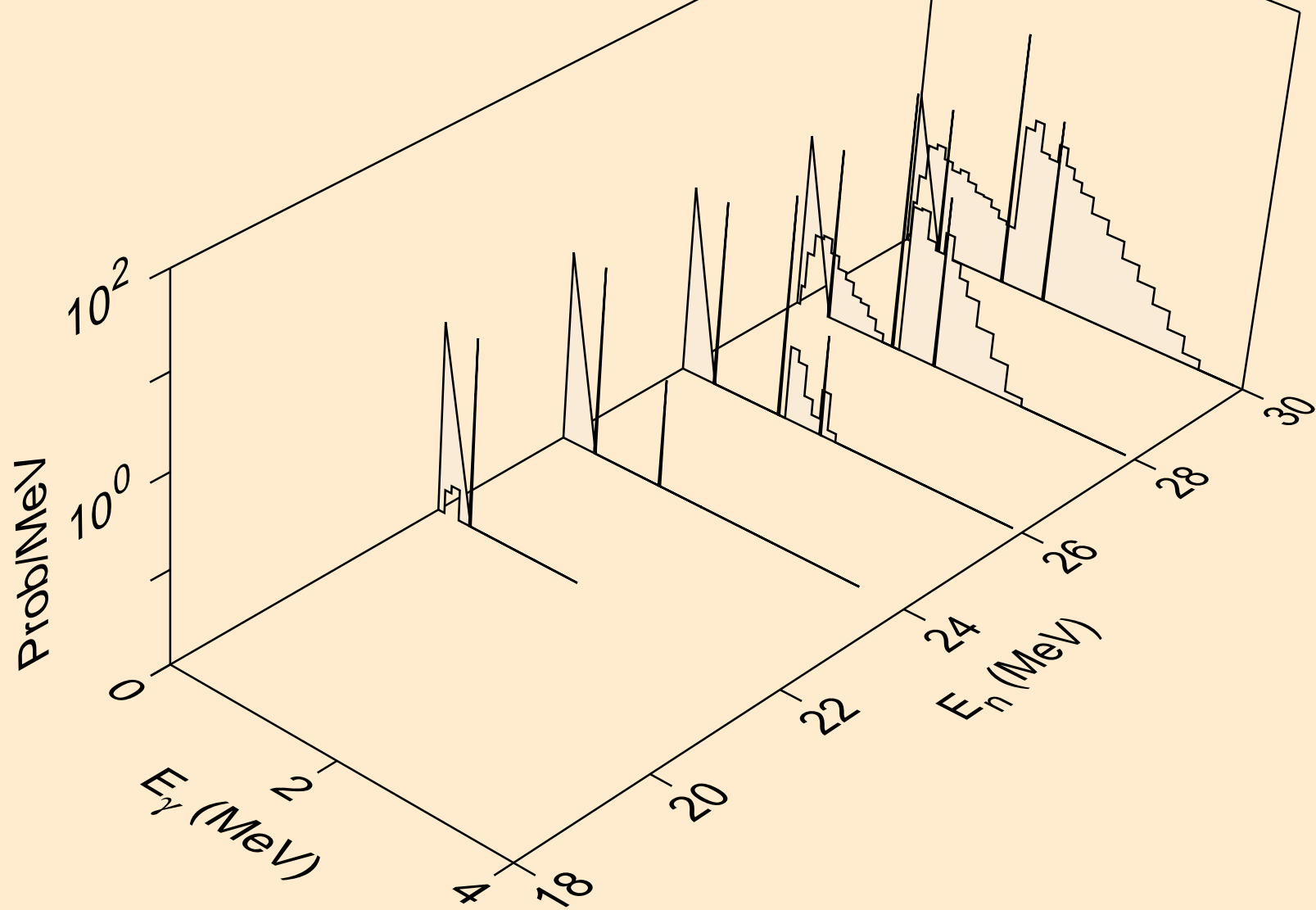

SN132 NEUTRON ACER TENDL-2023 LIBRARY; T=0.K  
Photon emission for (n,n\*)t

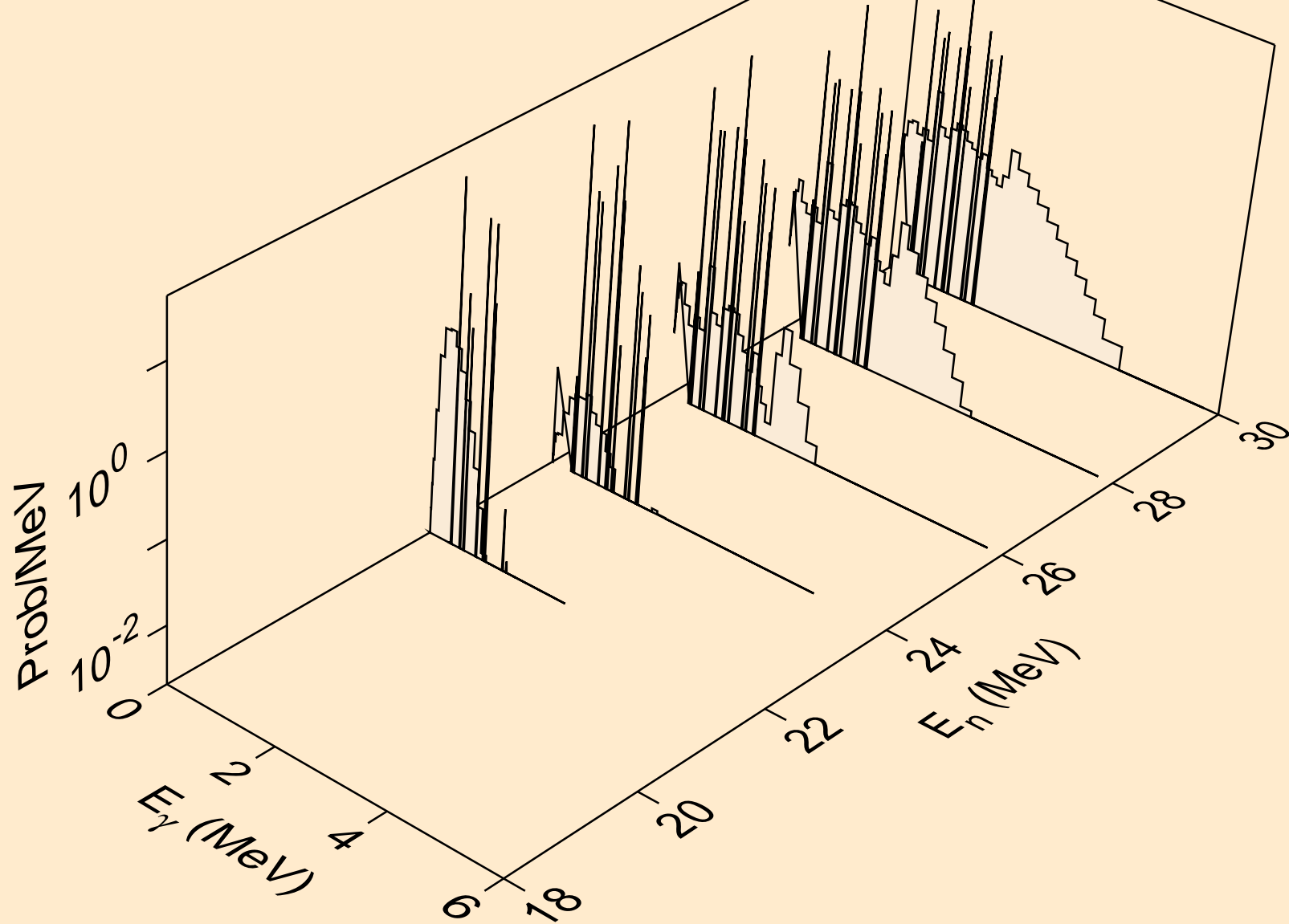

SN132 NEUTRON ACER TENDL-2023 LIBRARY; T=0.K  
Photon emission for (n,4n)

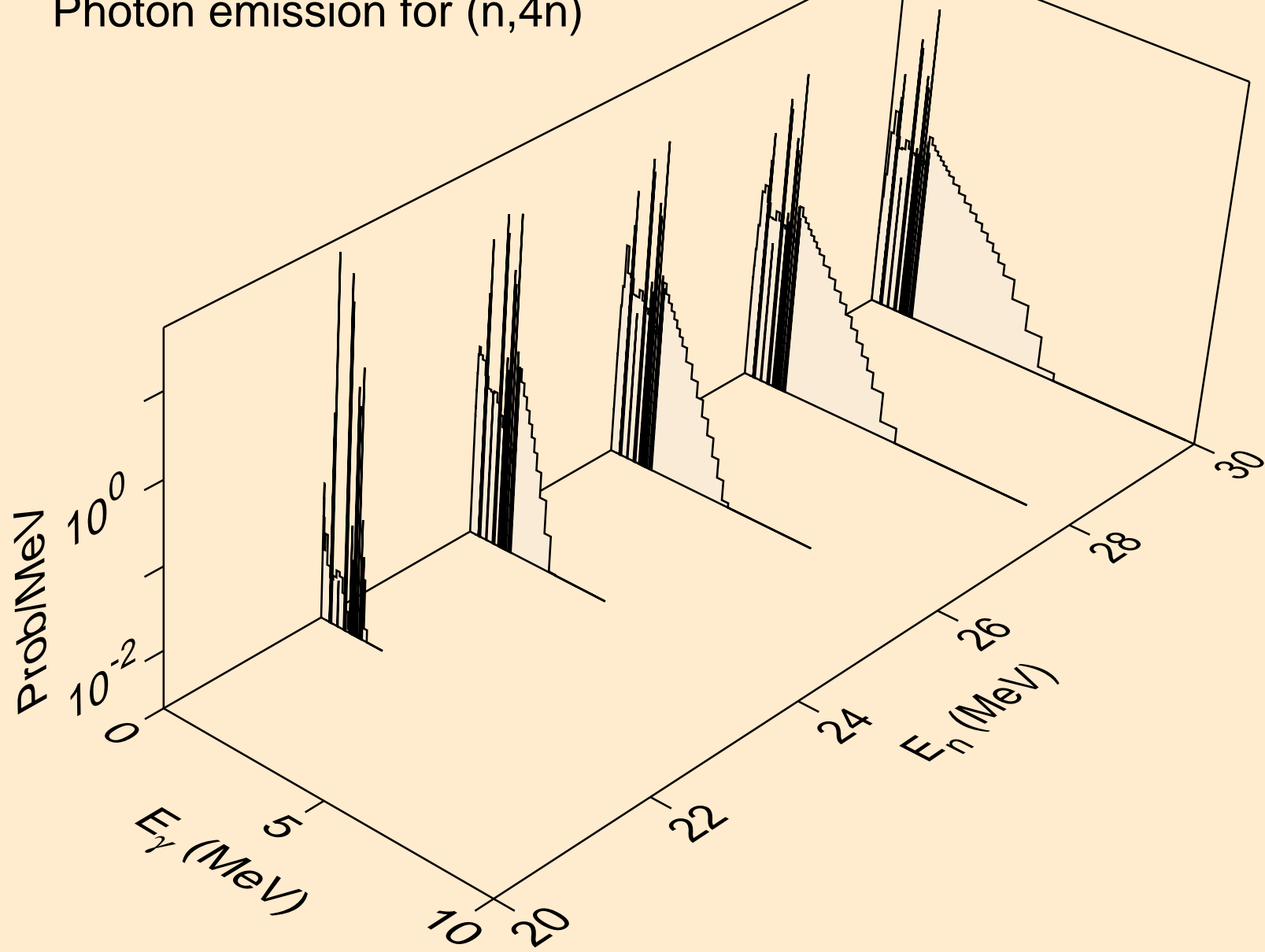

SN132 NEUTRON ACER TENDL-2023 LIBRARY; T=0.K  
Photon emission for (n,2np)

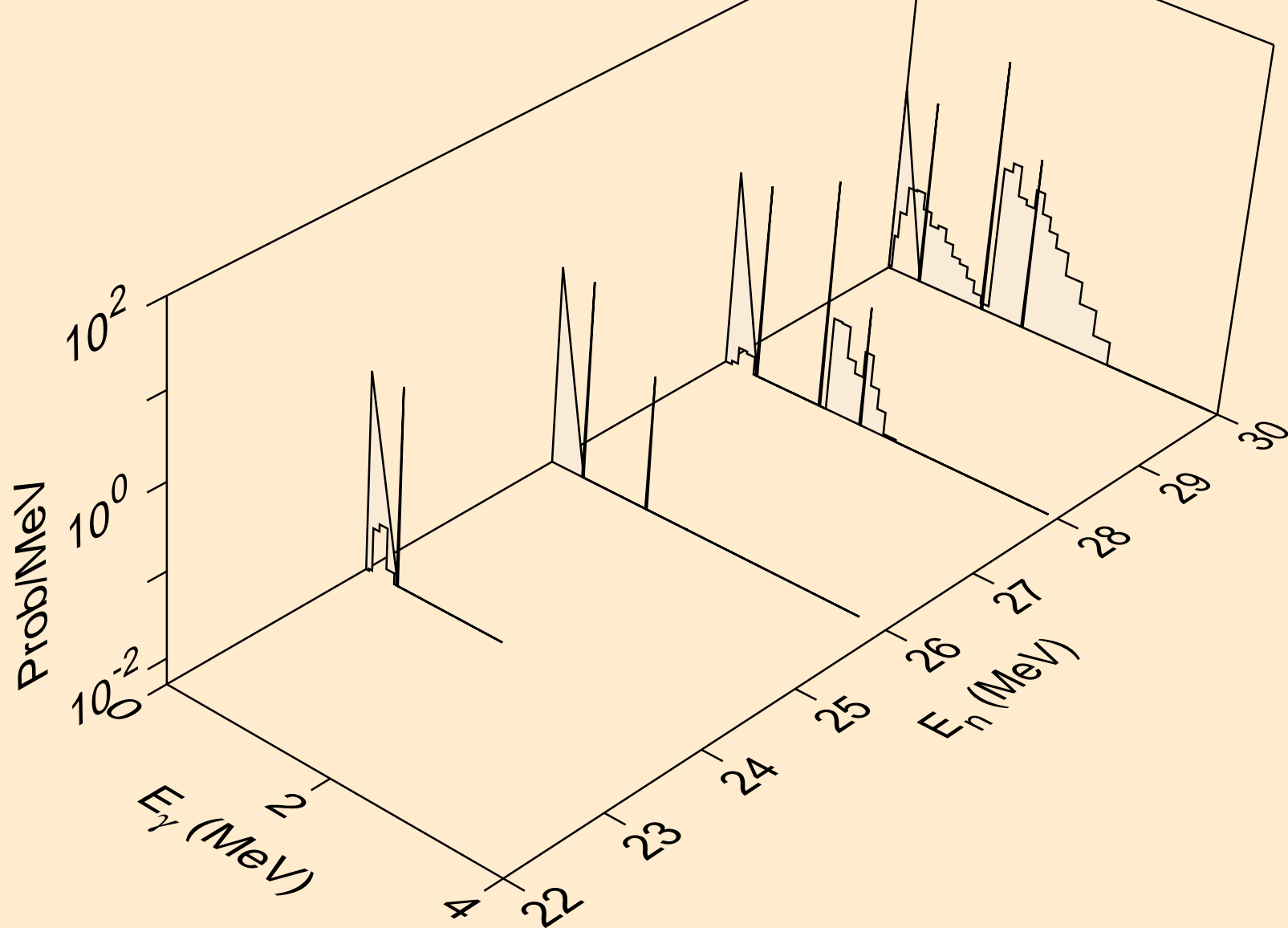



SN132 NEUTRON ACER TENDL-2023 LIBRARY; T=0.K  
Photon emission for (n,gma)

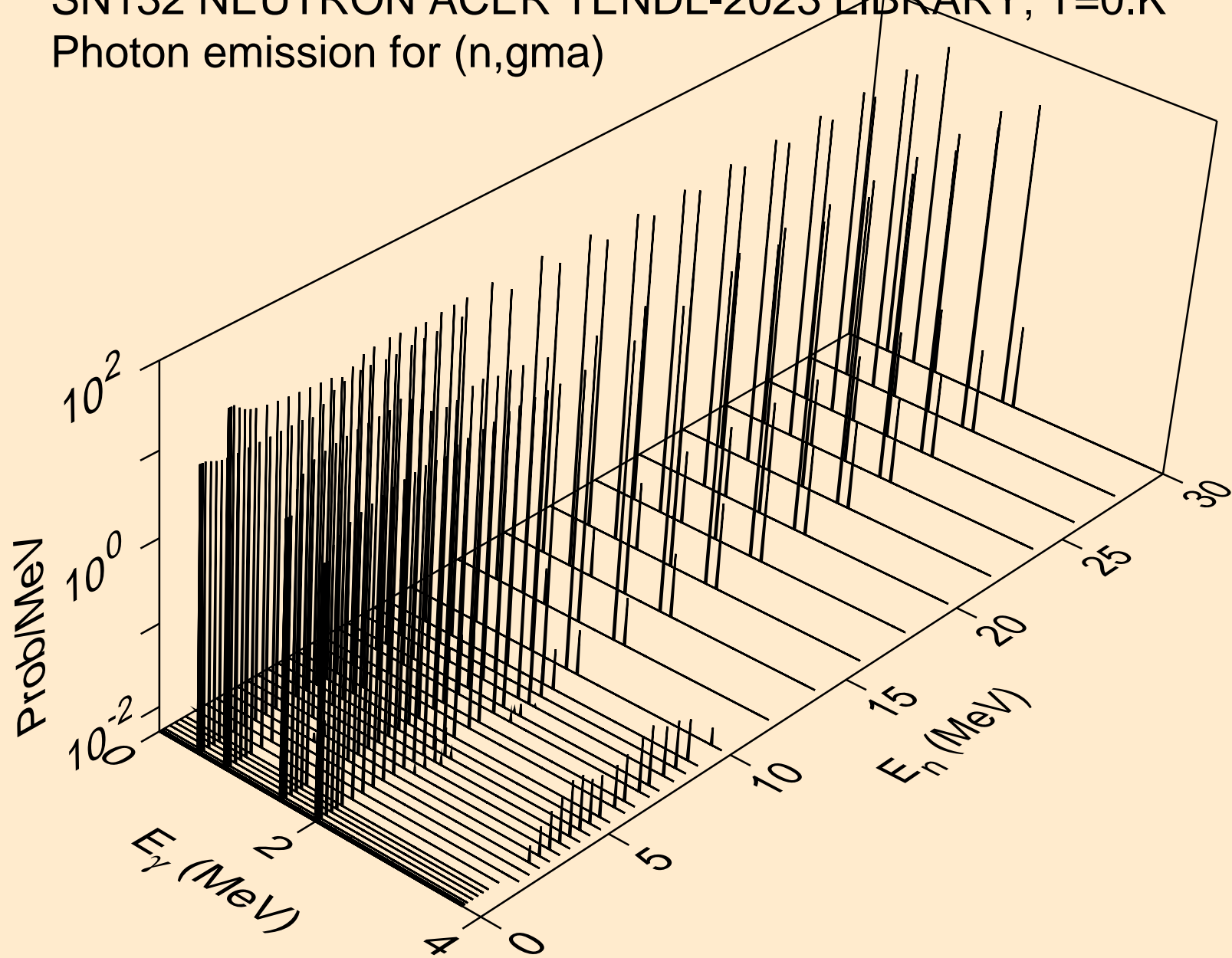

SN132 NEUTRON ACER TENDL-2023 LIBRARY; T=0.K  
Photon emission for (n,p)

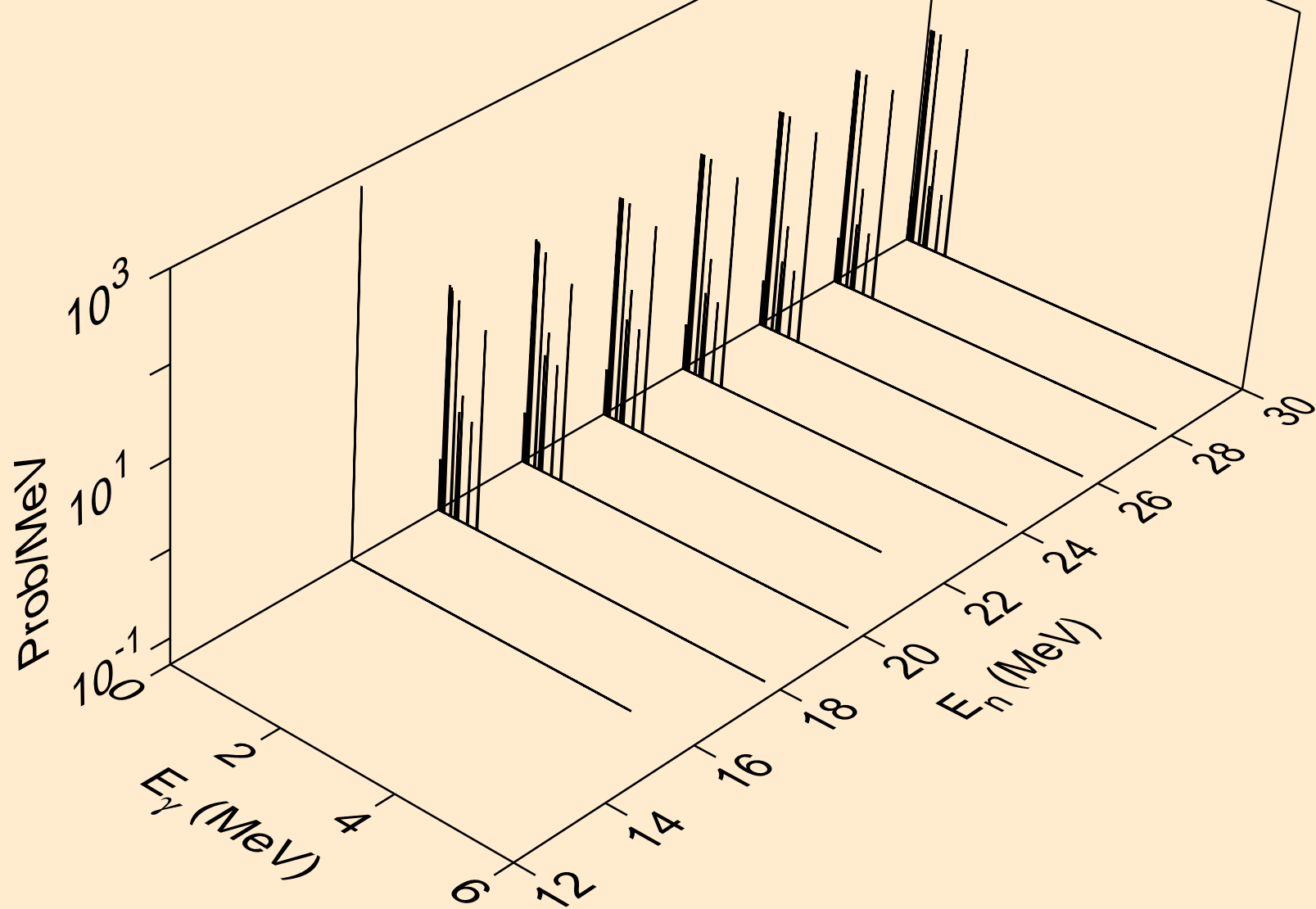

SN132 NEUTRON ACER TENDL-2023 LIBRARY; T=0.K  
Photon emission for (n,d)

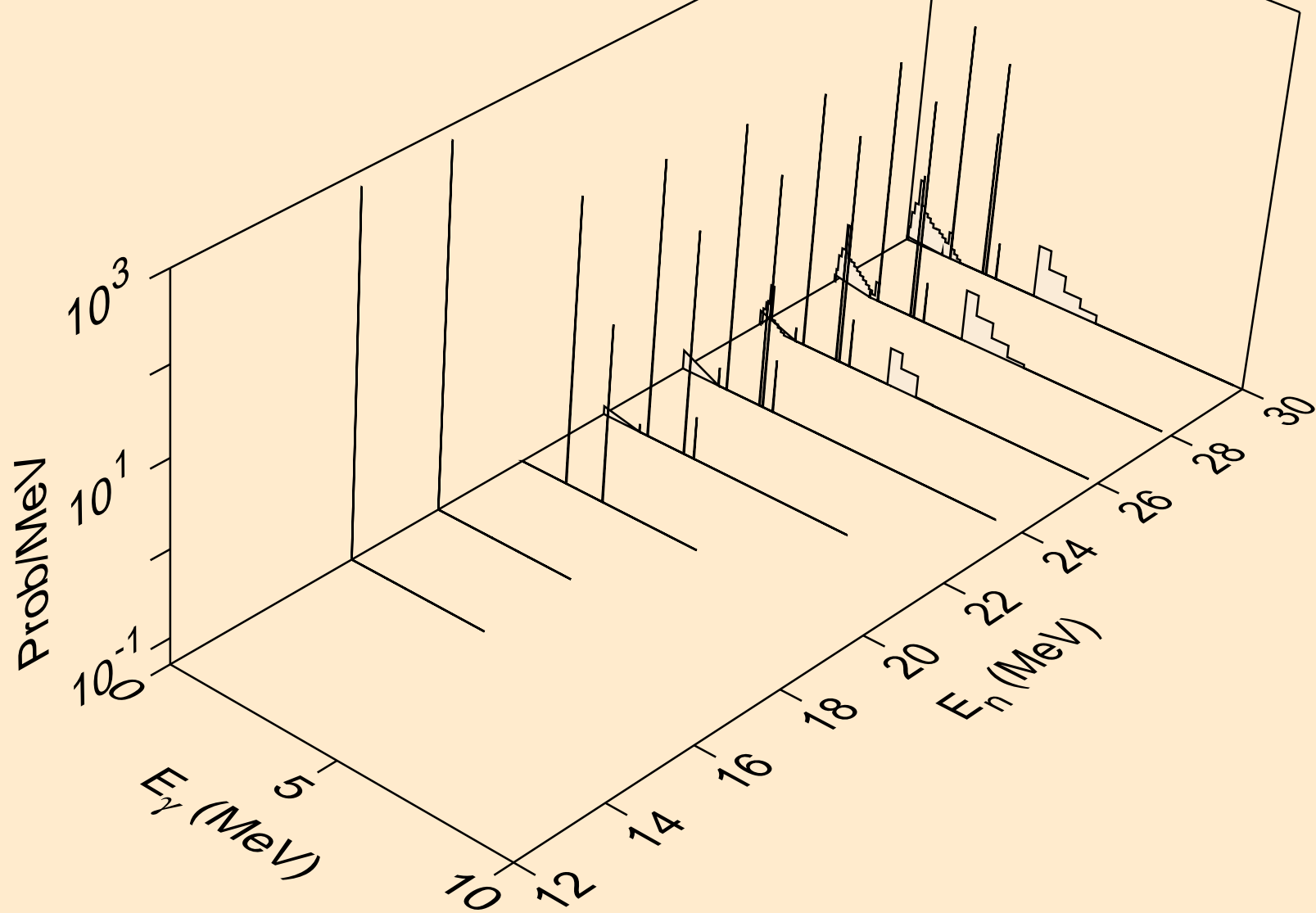

SN132 NEUTRON ACER TENDL-2023 LIBRARY; T=0.K  
Photon emission for (n,t)

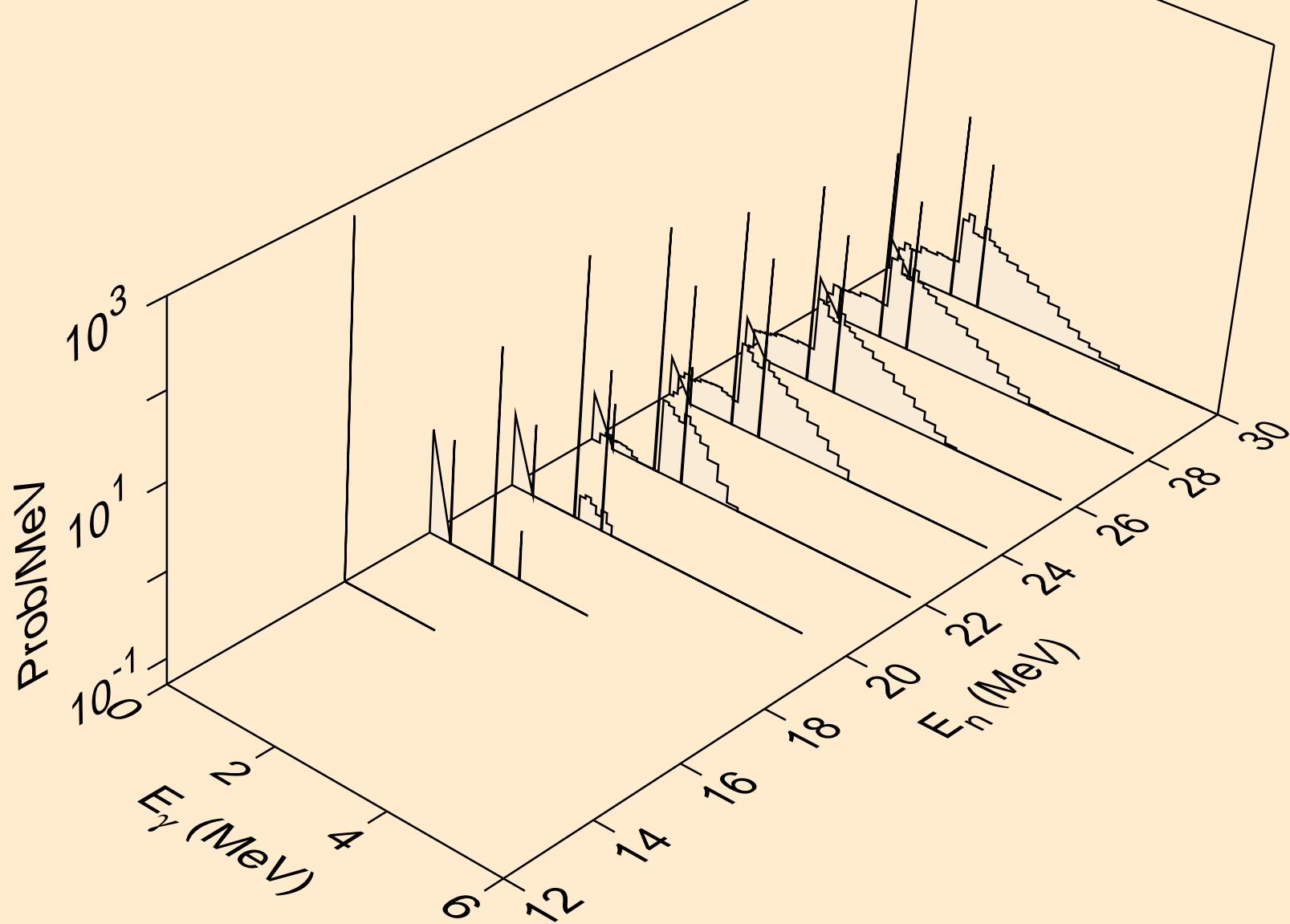

SN132 NEUTRON ACER TENDL-2023 LIBRARY; T=0.K  
Photon emission for (n,a)

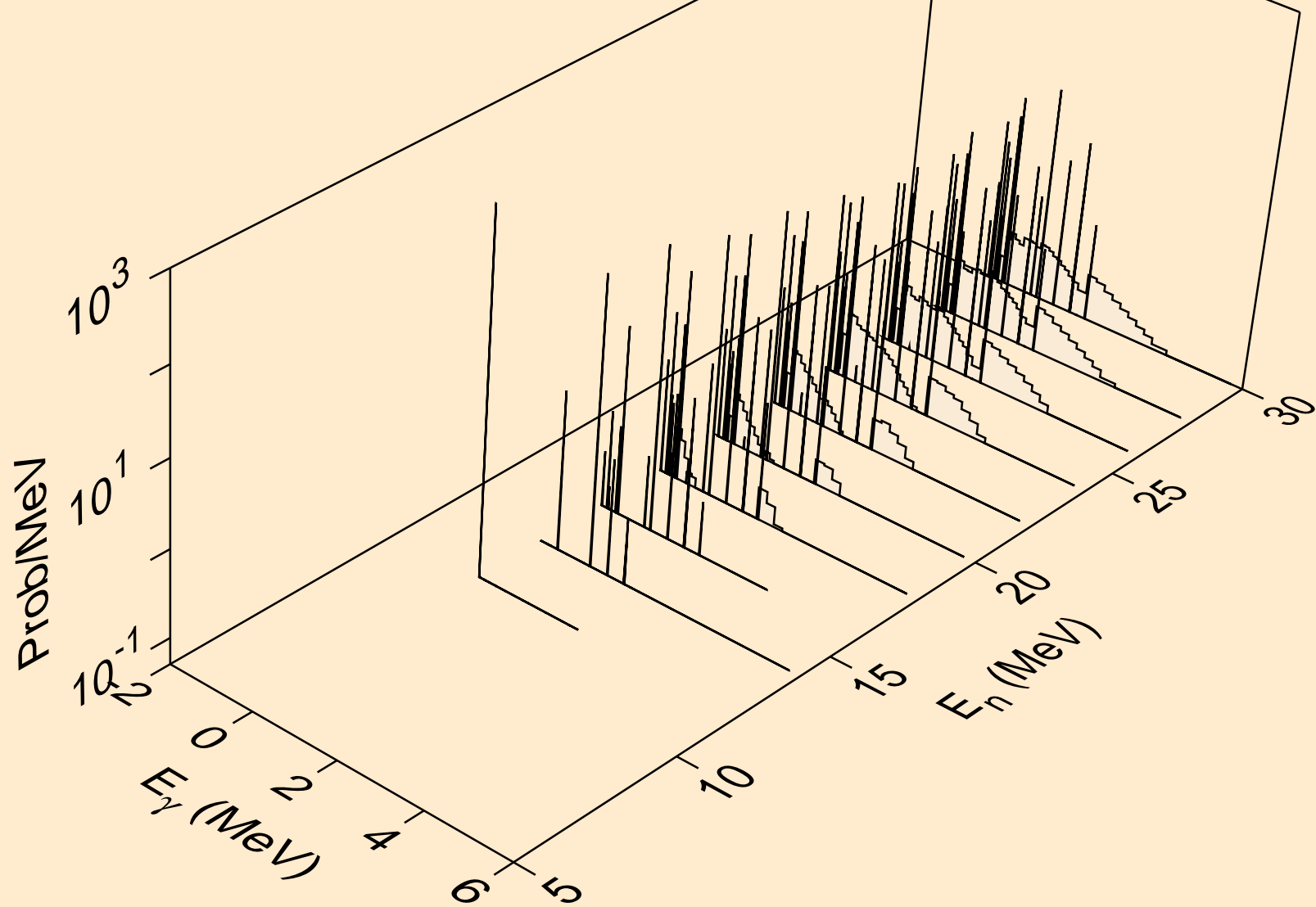

SN132 NEUTRON ACER TENDL-2023 LIBRARY; T=0.K  
thermal capture photon spectrum

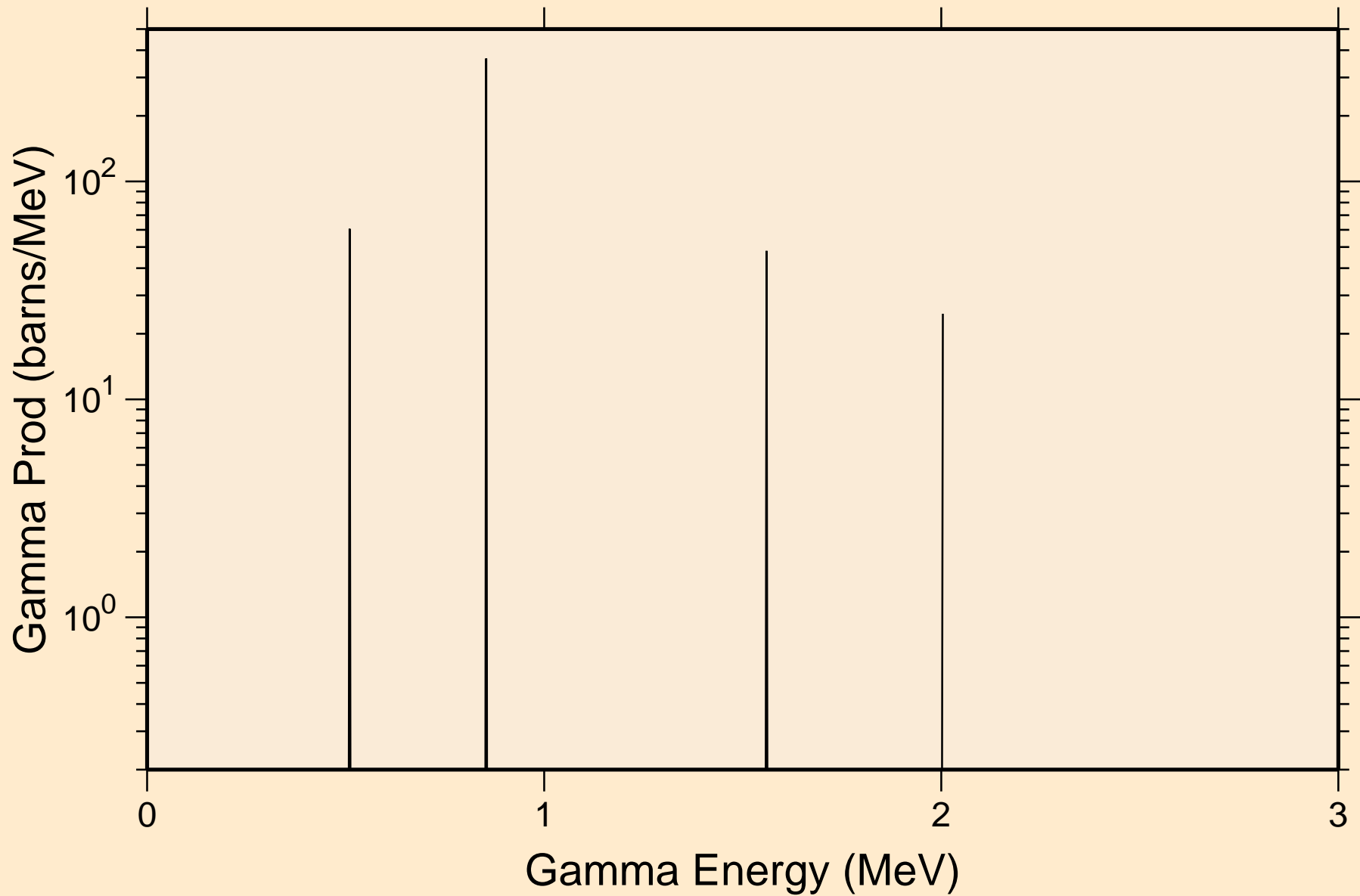

SN132 NEUTRON ACER TENDL-2023 LIBRARY; T=0.K  
14 MeV photon spectrum

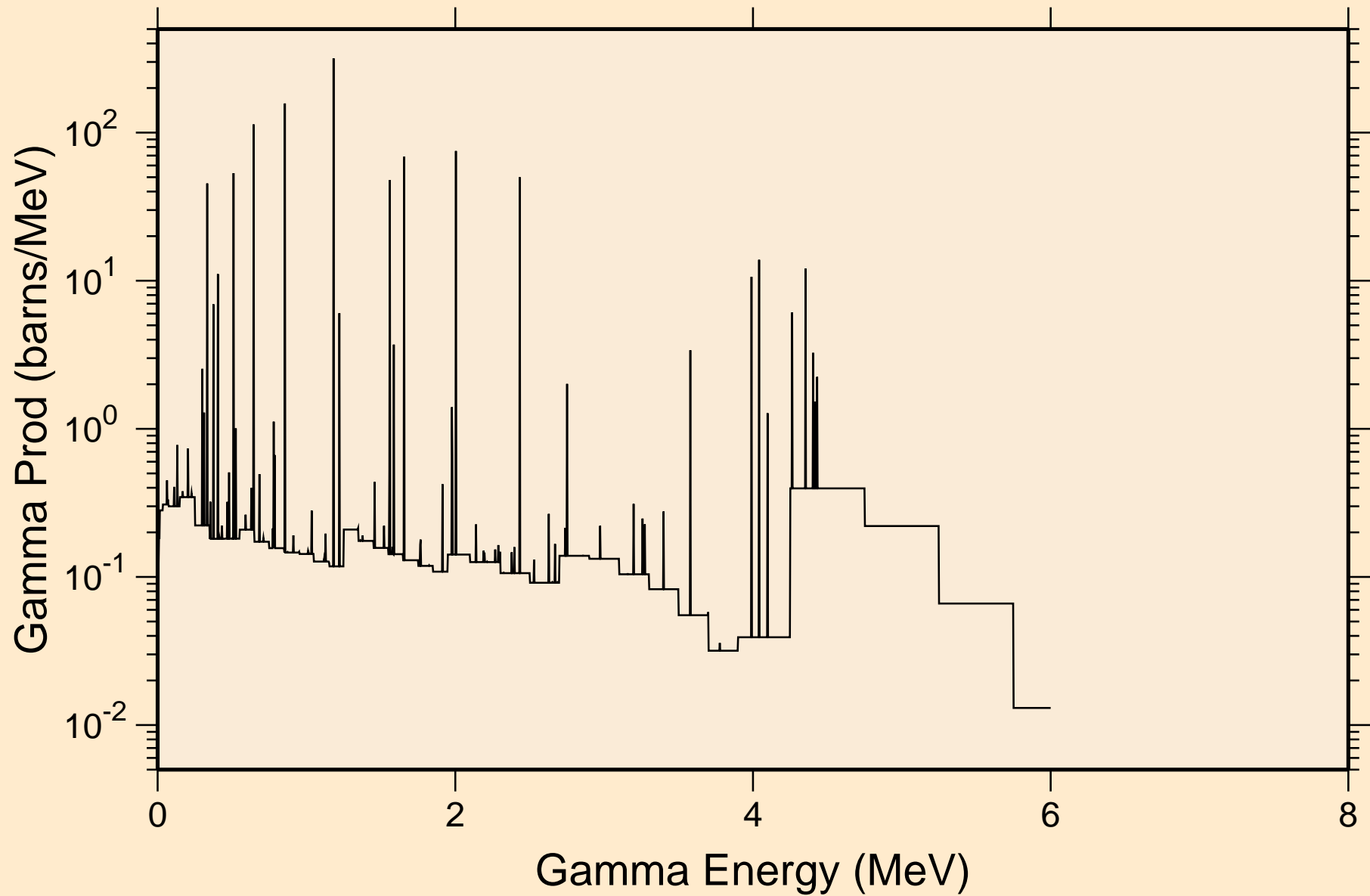

# SN132 NEUTRON ACER TENDL-2023 LIBRARY; T=0.K

## Particle heating contributions

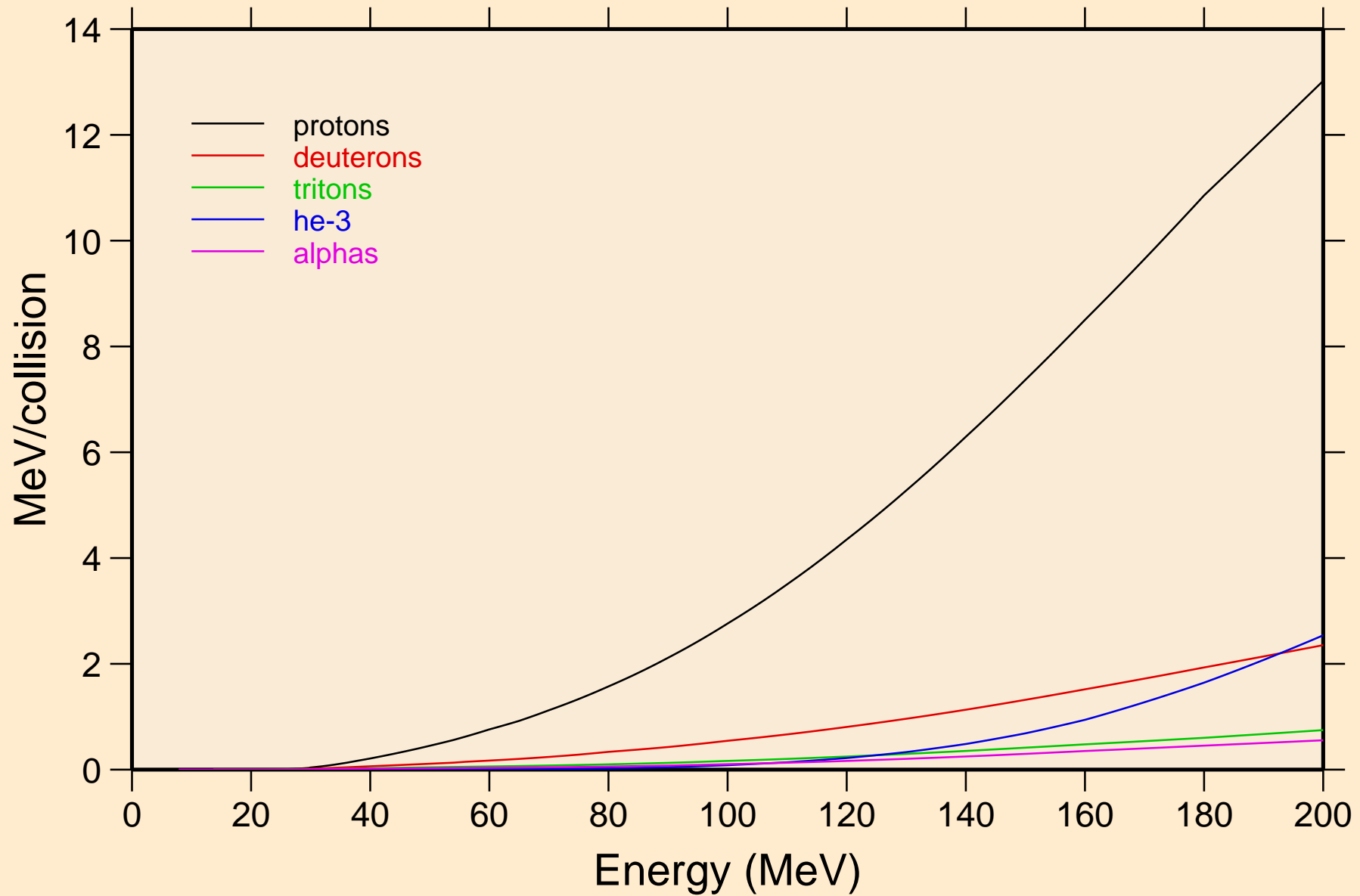



# SN132 NEUTRON ACER TENDL-2023 LIBRARY; T=0.K

## Recoil Heating

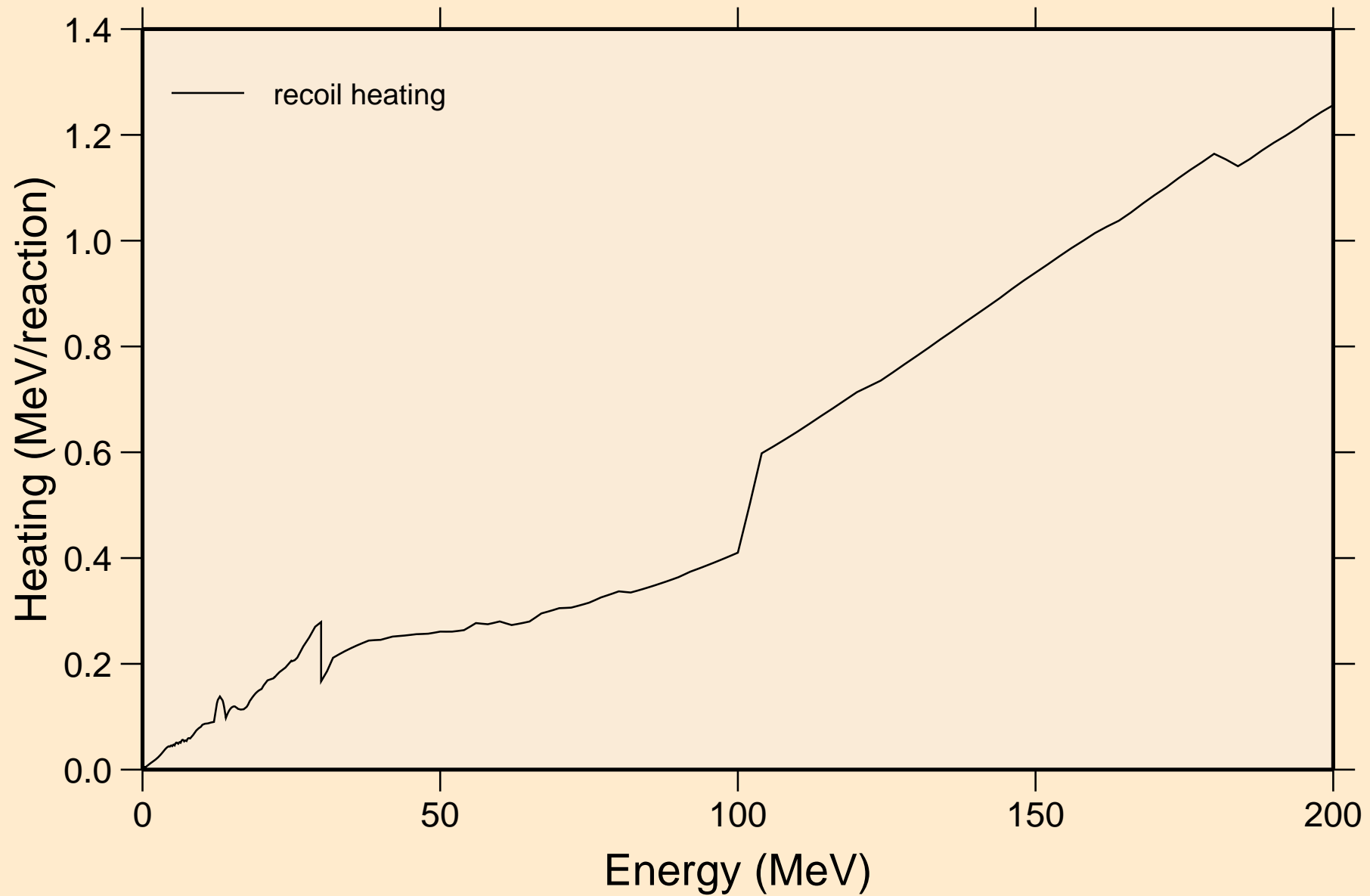

# SN132 NEUTRON ACER TENDL-2023 LIBRARY; T=0.K

## Particle production cross sections

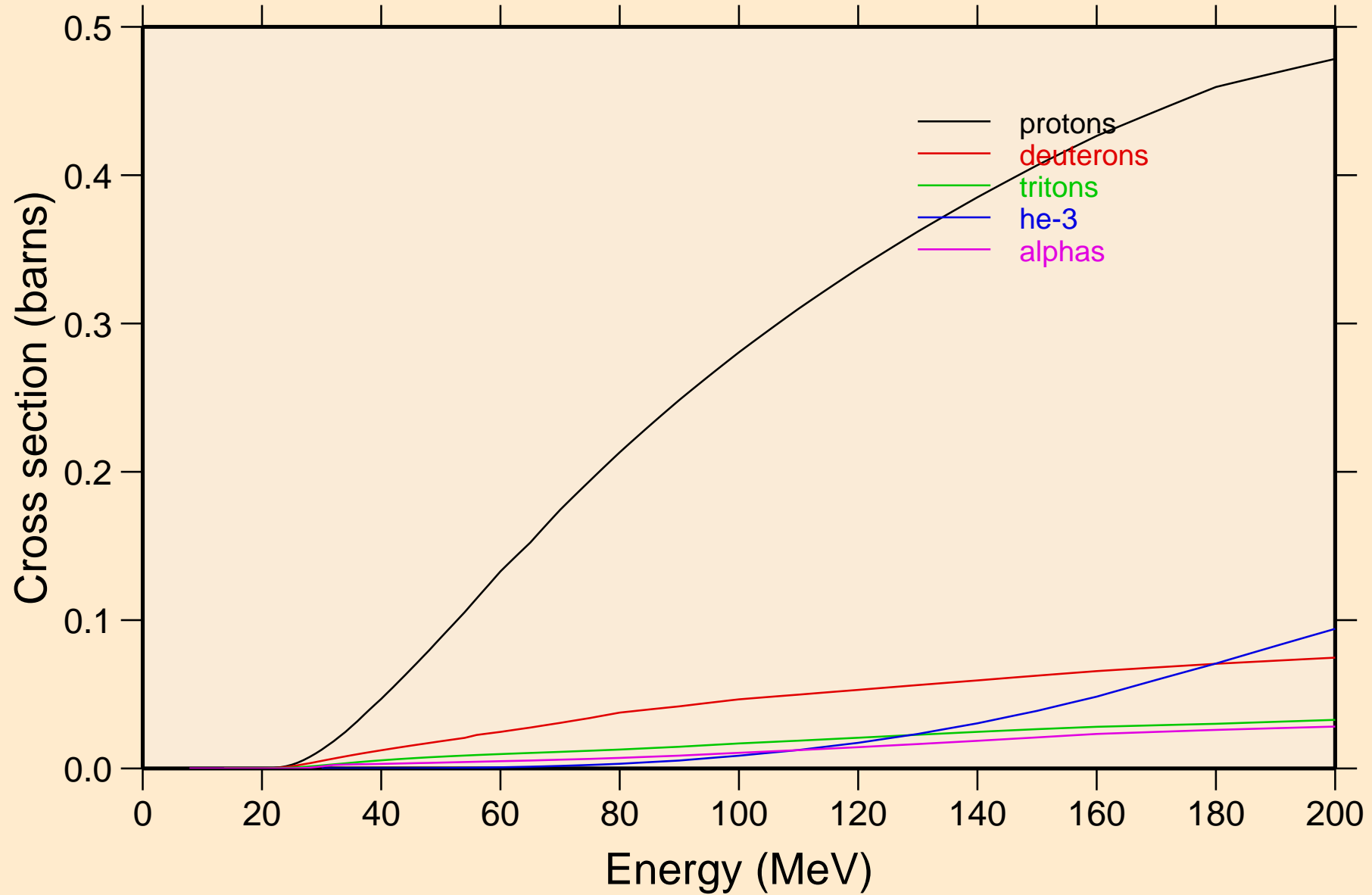

SN132 NEUTRON ACER TENDL-2023 LIBRARY; T=0.K  
protons from (n,x)

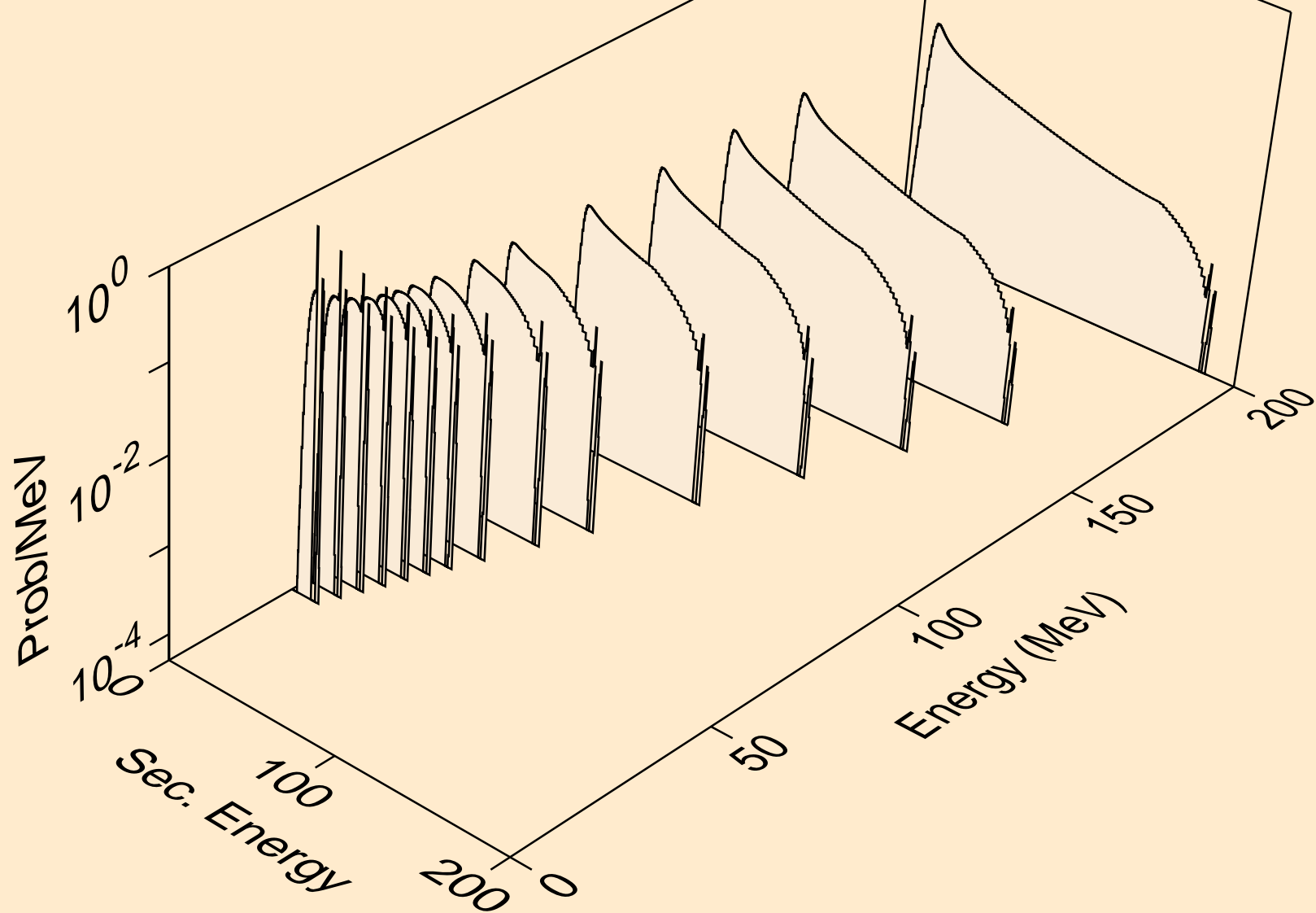

SN132 NEUTRON ACER TENDL-2023 LIBRARY; T=0.K  
protons from (n,n\*)p

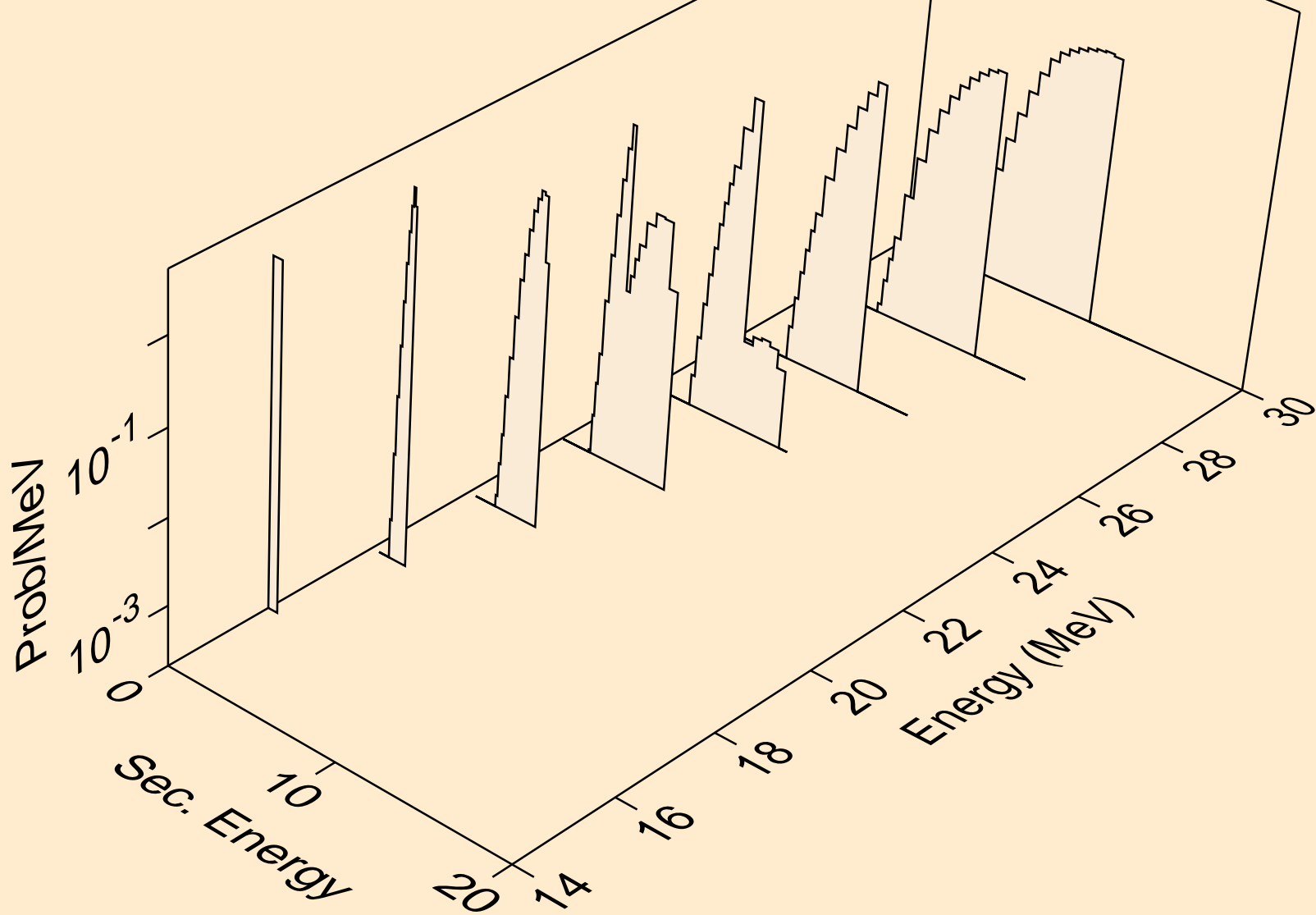

SN132 NEUTRON ACER TENDL-2023 LIBRARY; T=0.K  
protons from (n,2np)

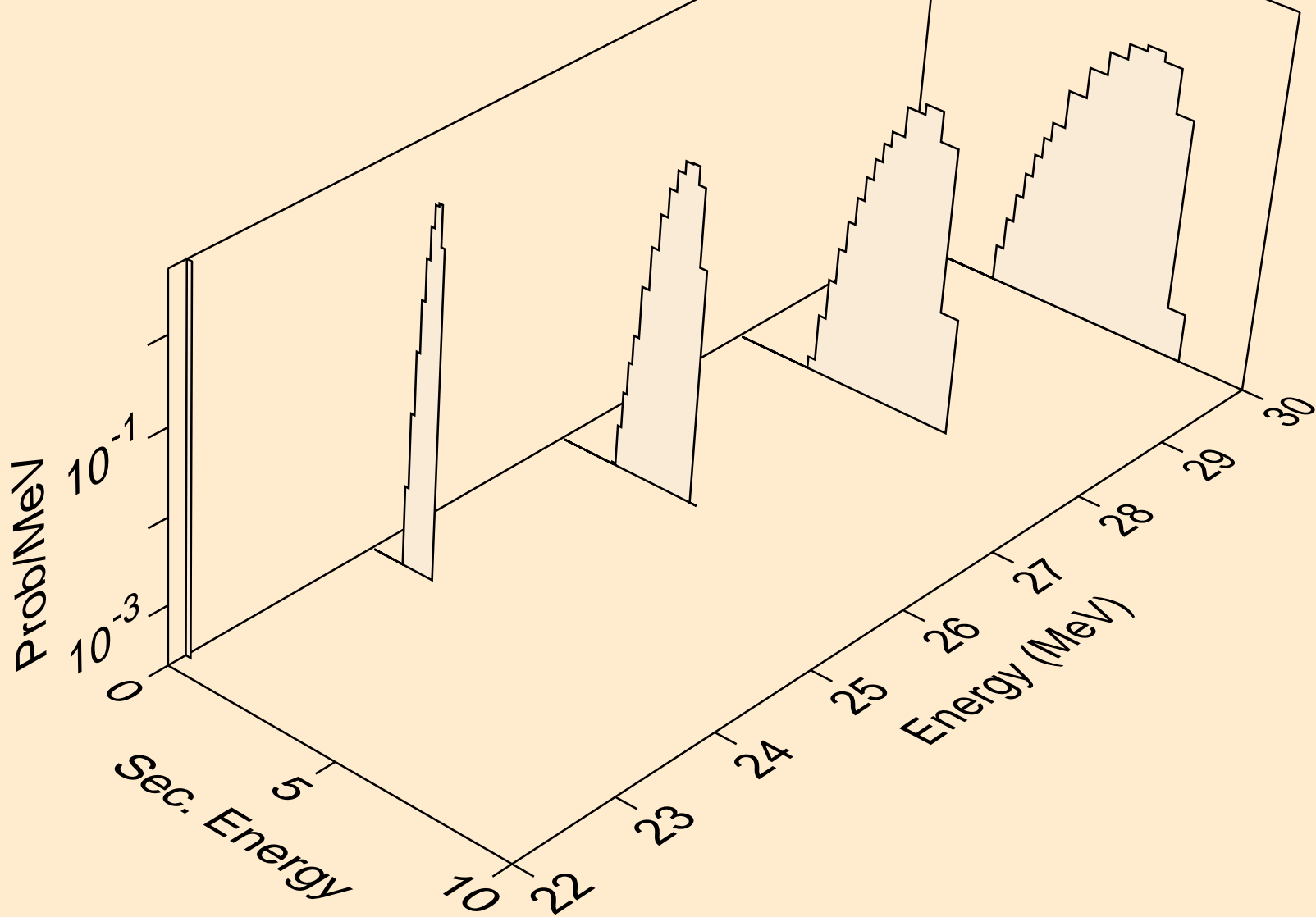

SN132 NEUTRON ACER TENDL-2023 LIBRARY; T=0.K  
protons from (n,p)

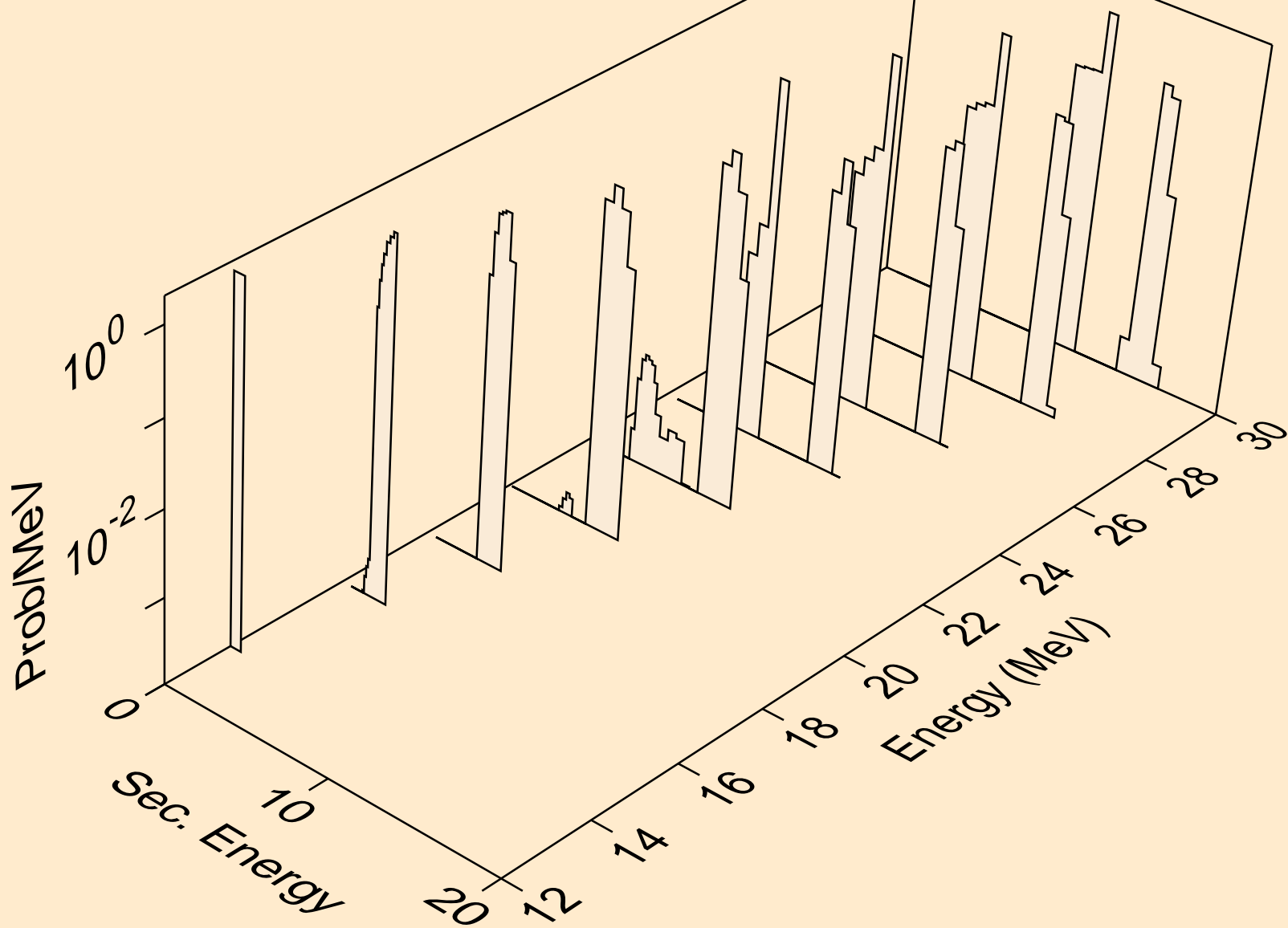

SN132 NEUTRON ACER TENDL-2023 LIBRARY; T=0.K  
deuterons from (n,x)

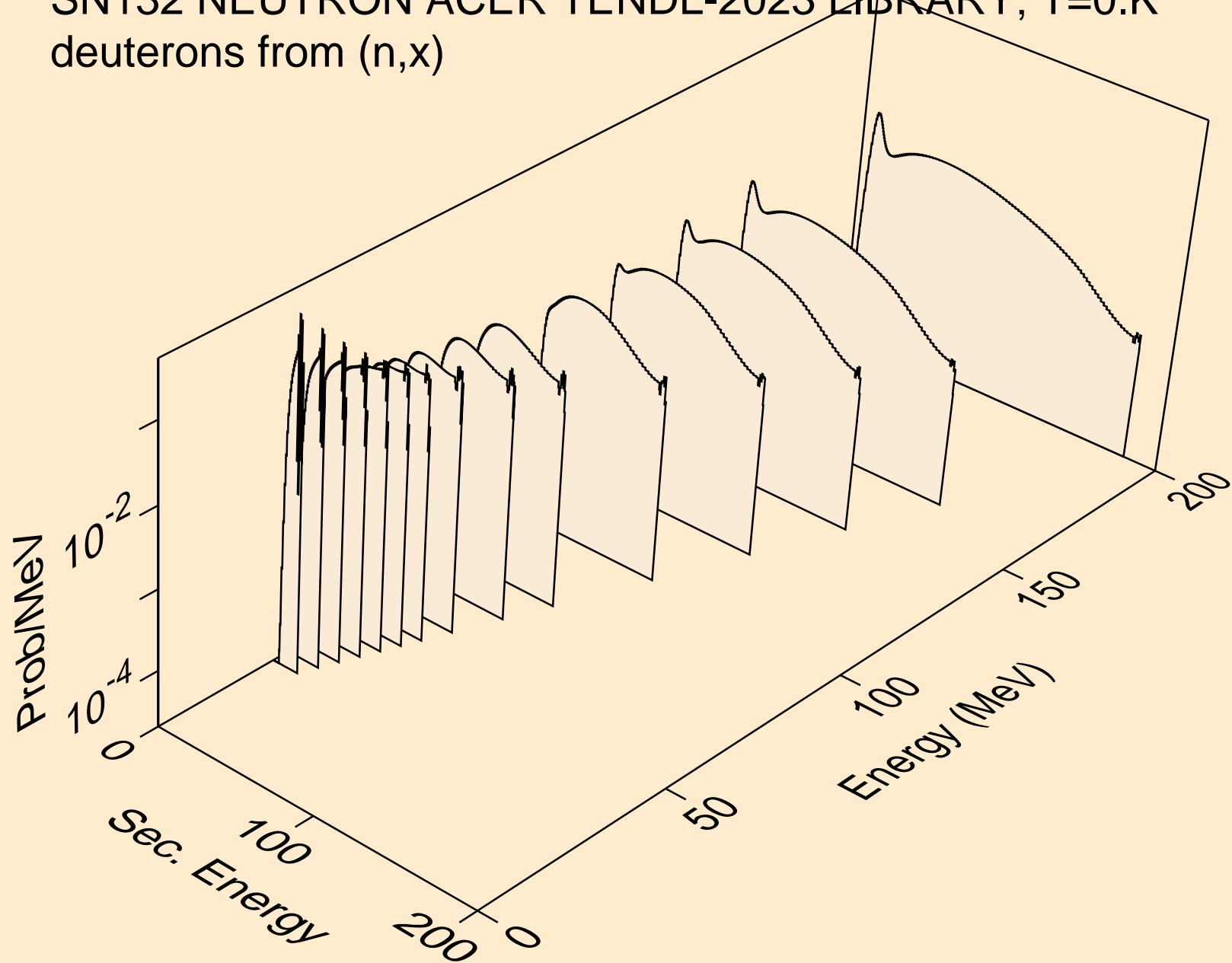

SN132 NEUTRON ACER TENDL-2023 LIBRARY; T=0.K  
deuterons from (n,2nd)

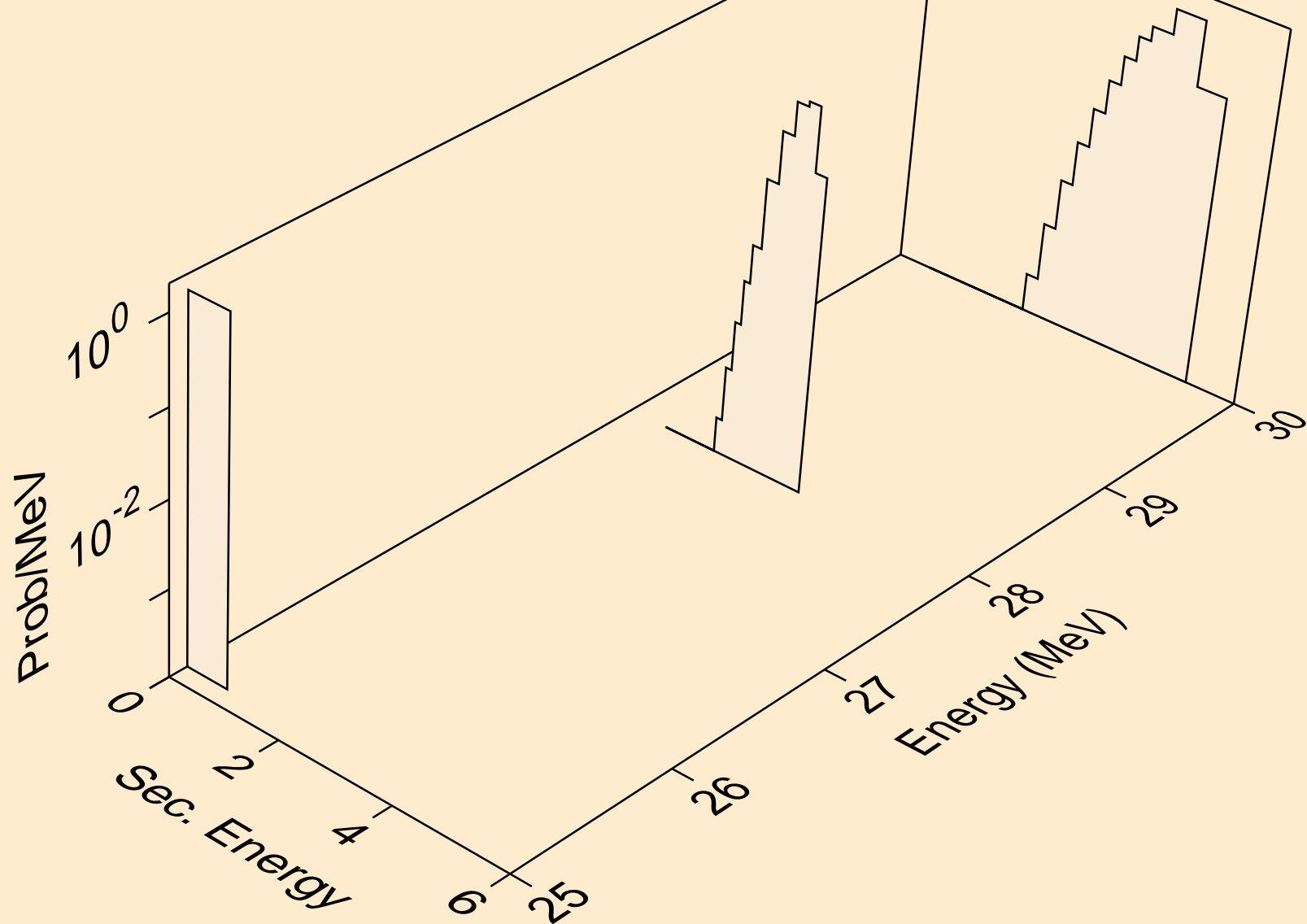



SN132 NEUTRON ACER TENDL-2023 LIBRARY; T=0.K  
deuterons from (n,n\*)d

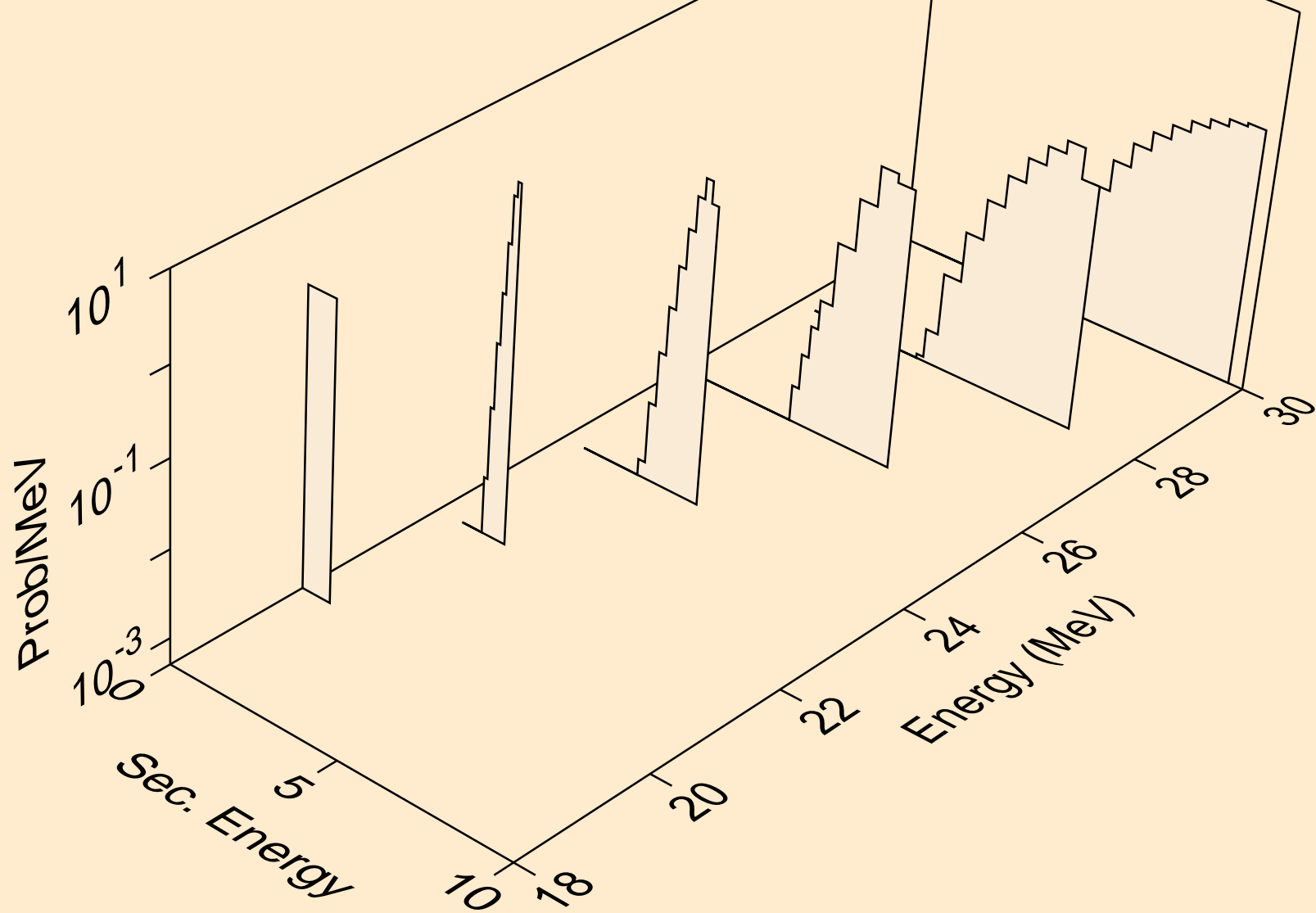

SN132 NEUTRON ACER TENDL-2023 LIBRARY; T=0.K  
deuterons from (n,d)

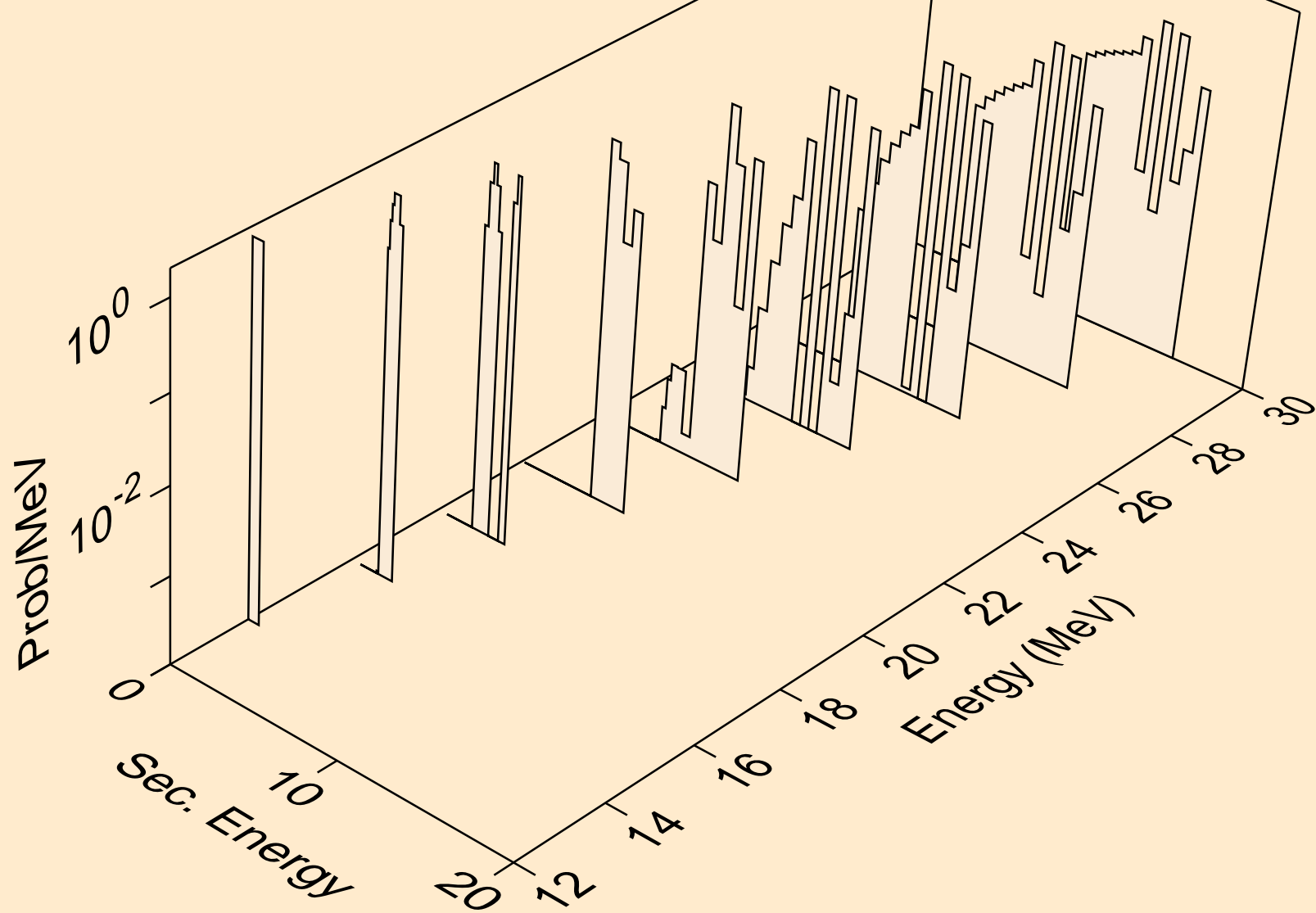

SN132 NEUTRON ACER TENDL-2023 LIBRARY; T=0.K  
tritons from (n,x)

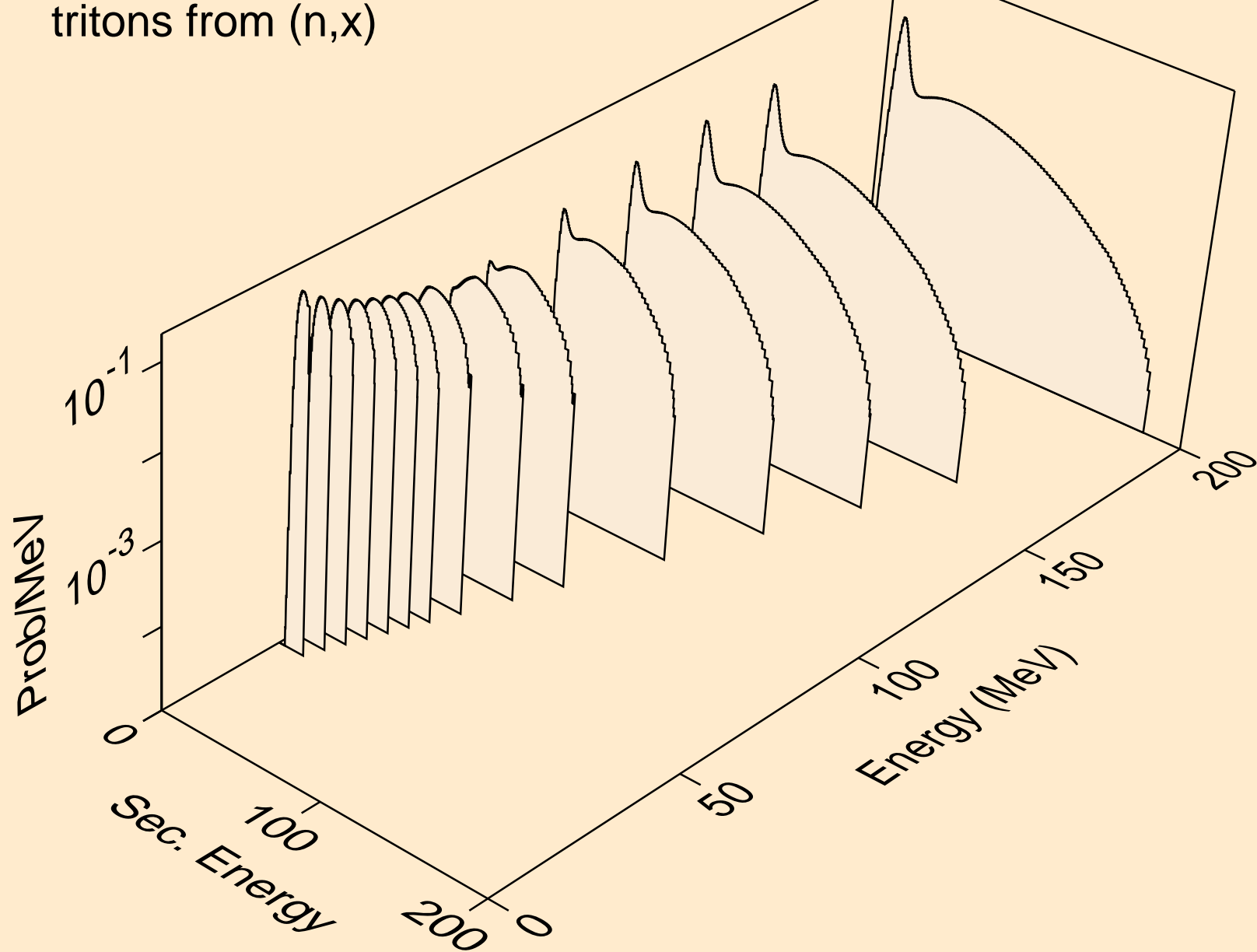

SN132 NEUTRON ACER TENDL-2023 LIBRARY; T=0.K  
tritons from (n,n\*)t

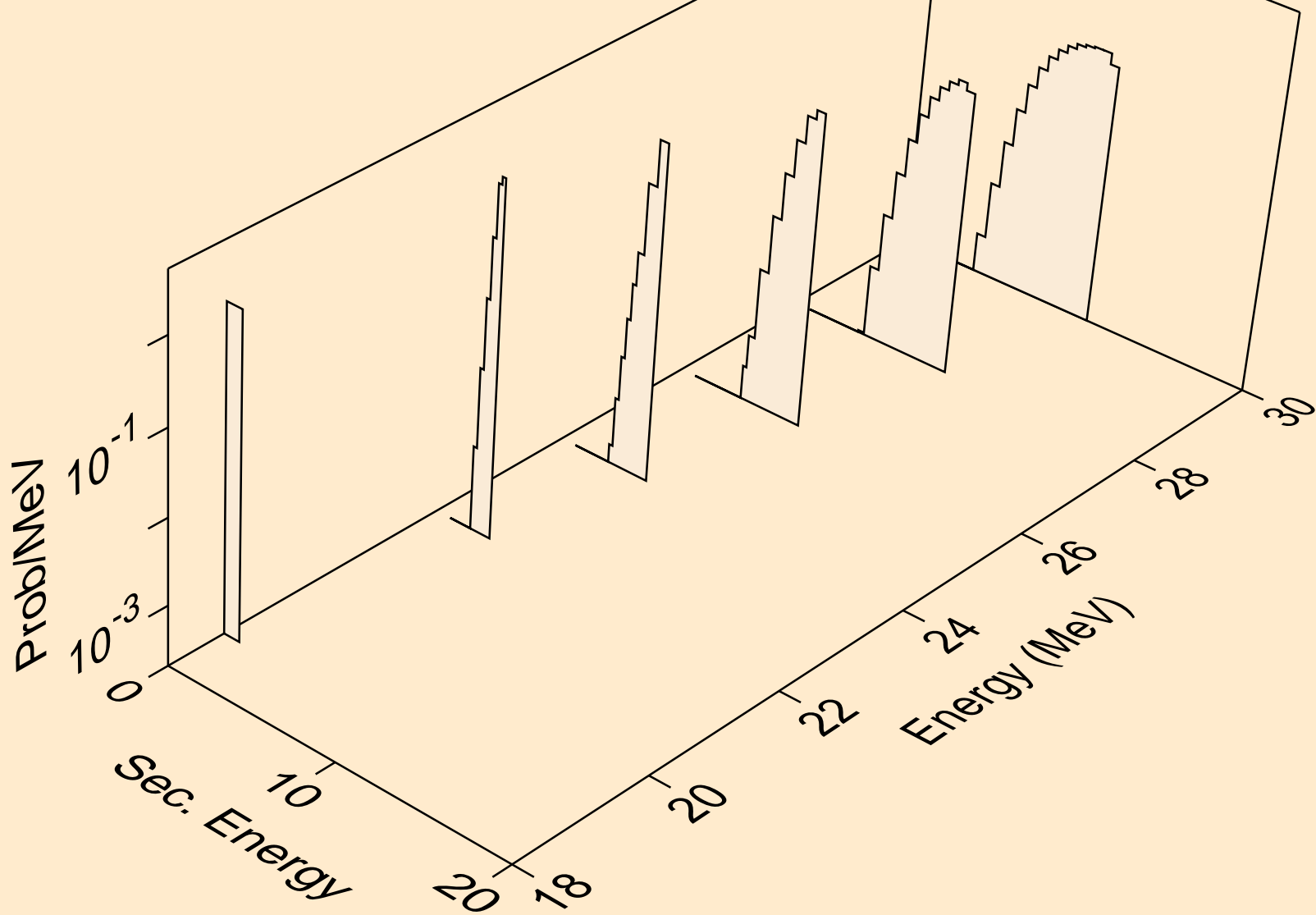

SN132 NEUTRON ACER TENDL-2023 LIBRARY; T=0.K  
tritons from (n,t)

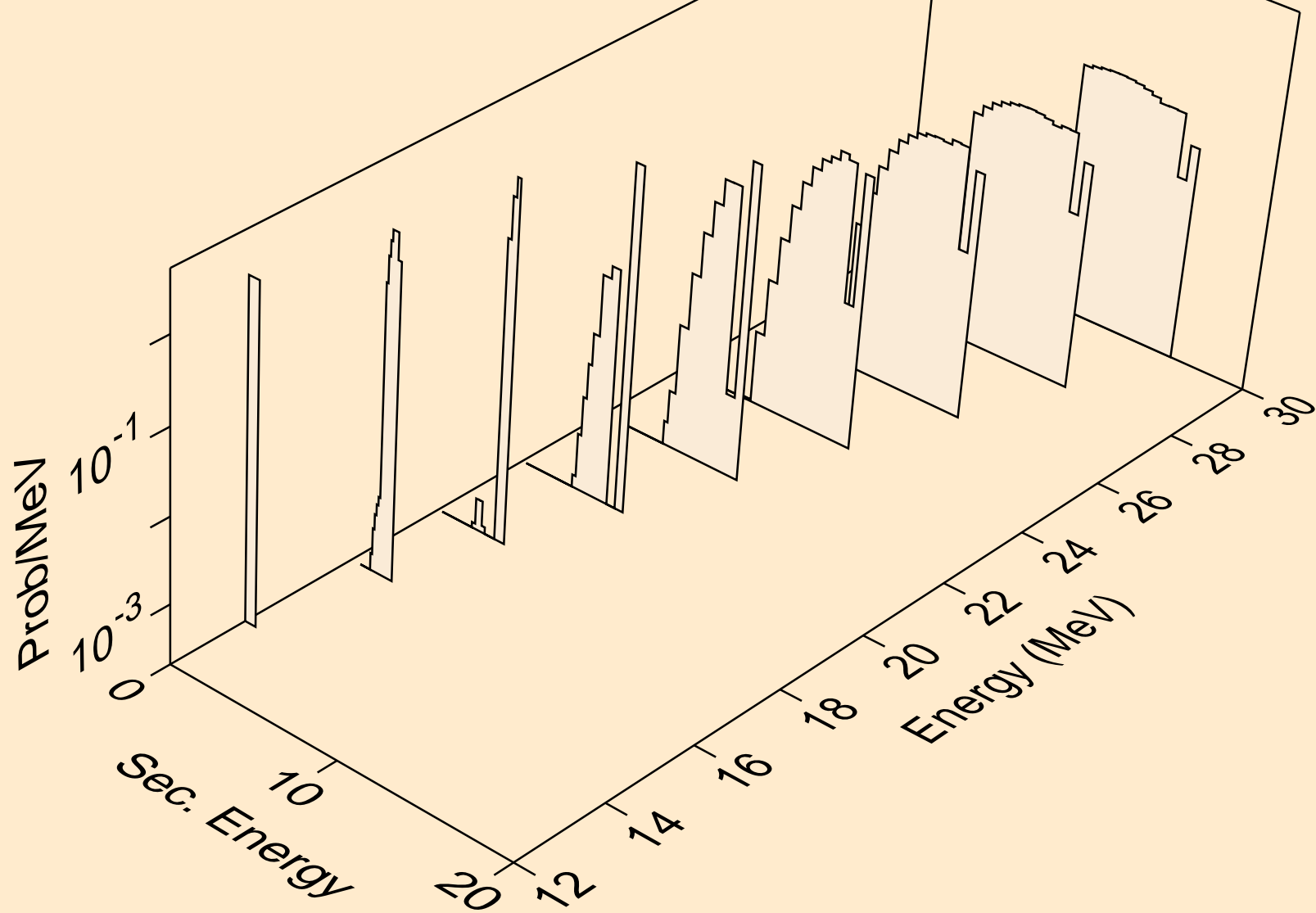

SN132 NEUTRON ACER TENDL-2023 LIBRARY; T=0.K  
he3s from (n,x)

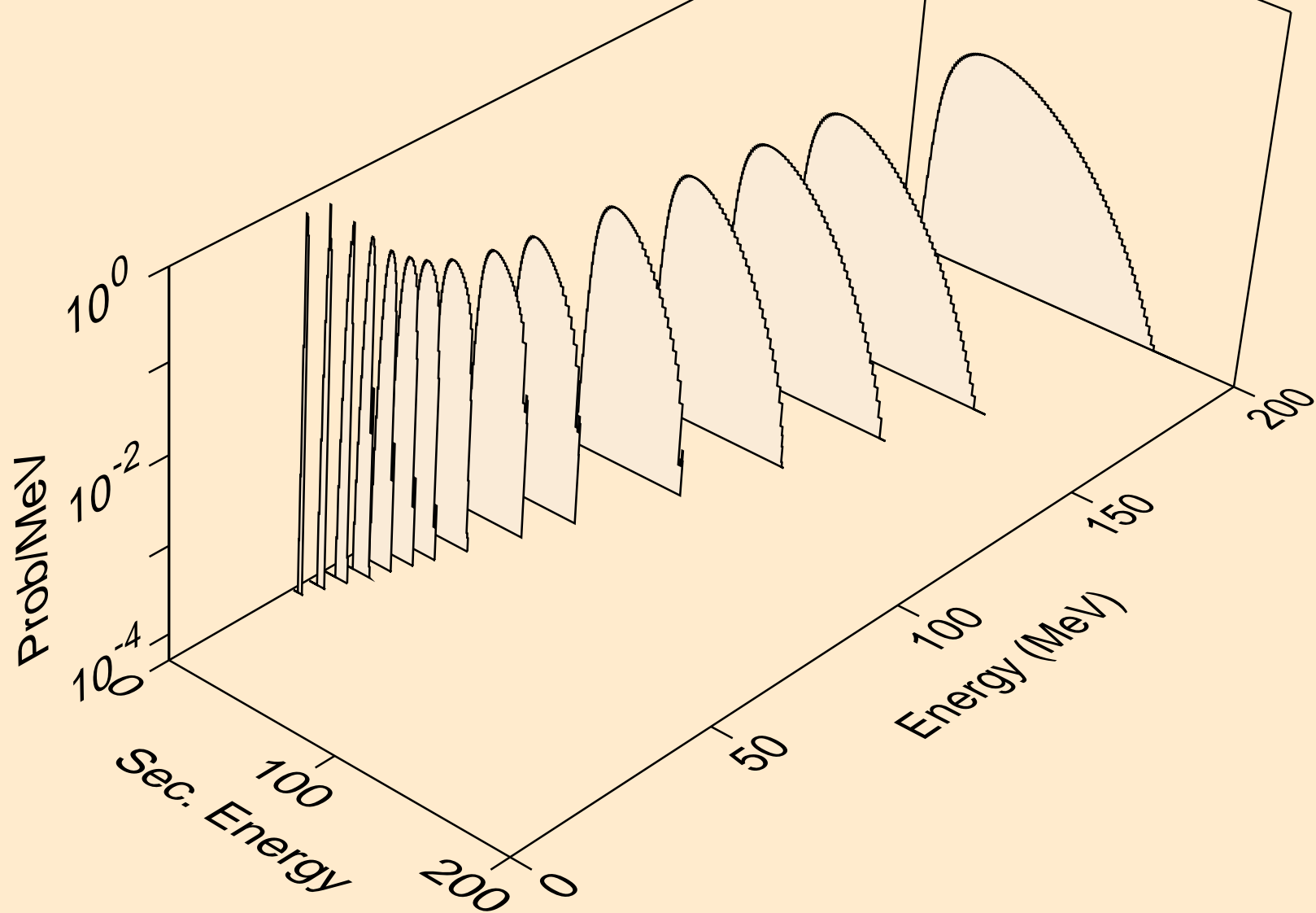

SN132 NEUTRON ACER TENDL-2023 LIBRARY; T=0.K  
alphas from (n,x)

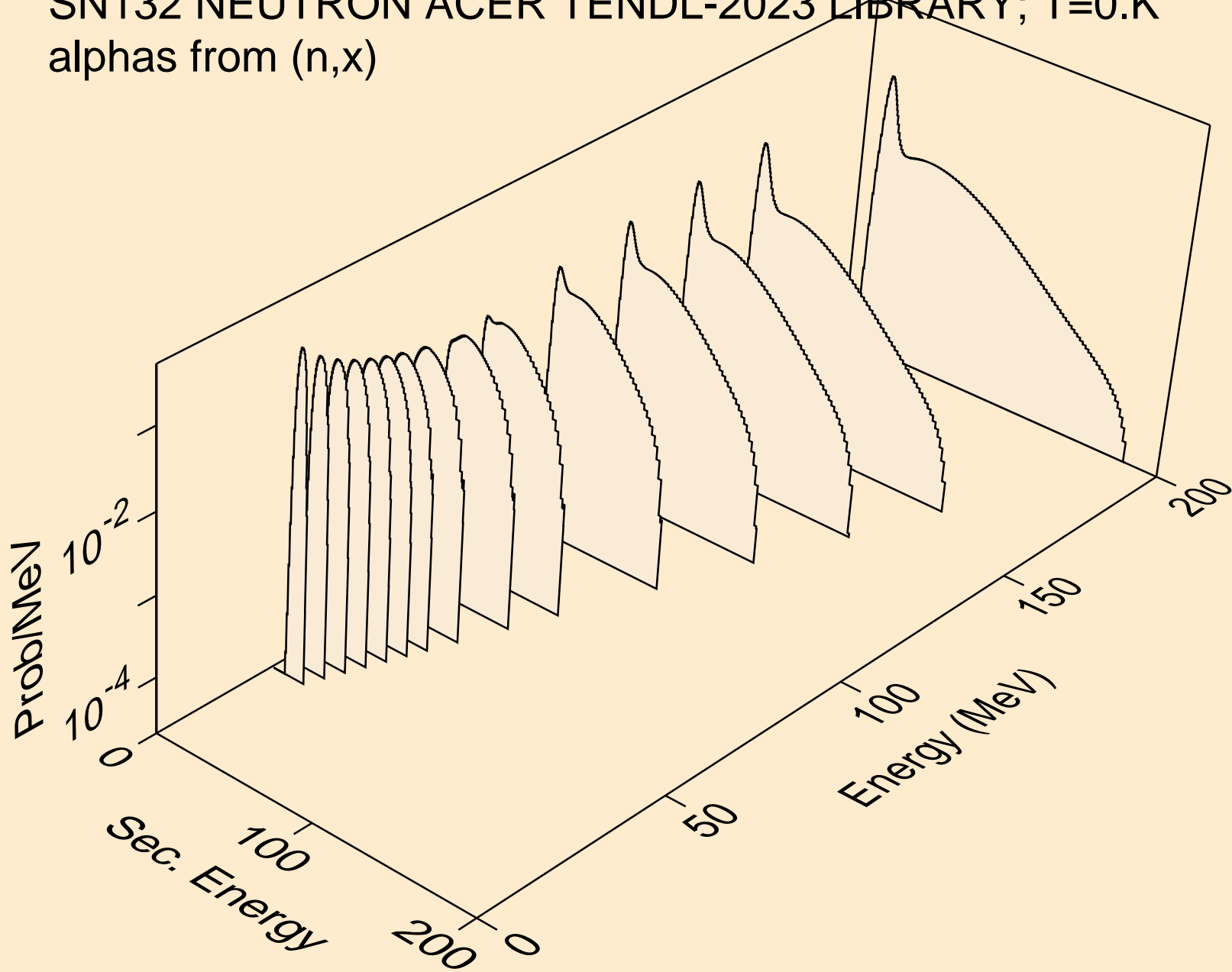

SN132 NEUTRON ACER TENDL-2023 LIBRARY; T=0.K  
alphas from (n,n\*)a

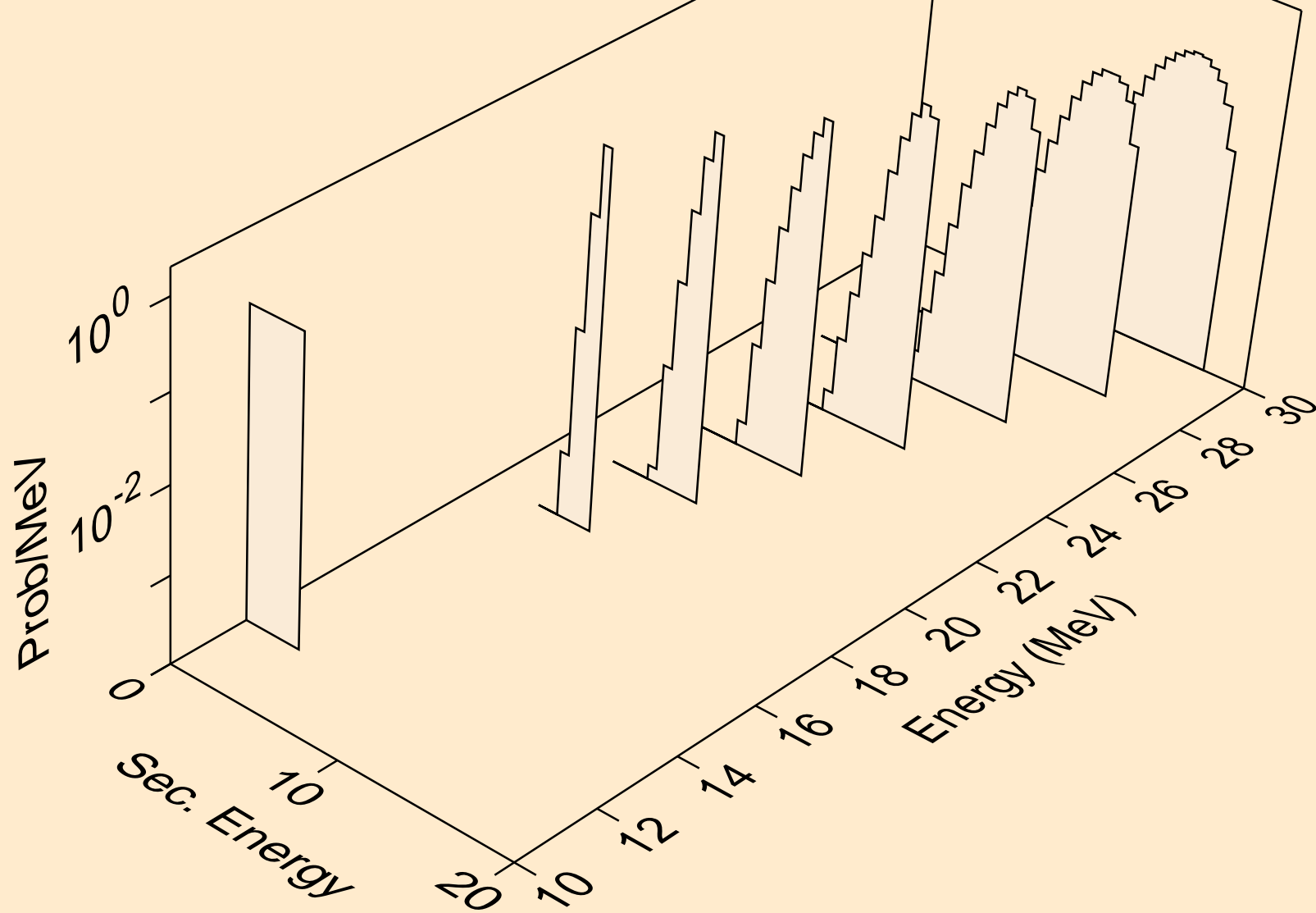



SN132 NEUTRON ACER TENDL-2023 LIBRARY; T=0.K  
alphas from (n,2n)a

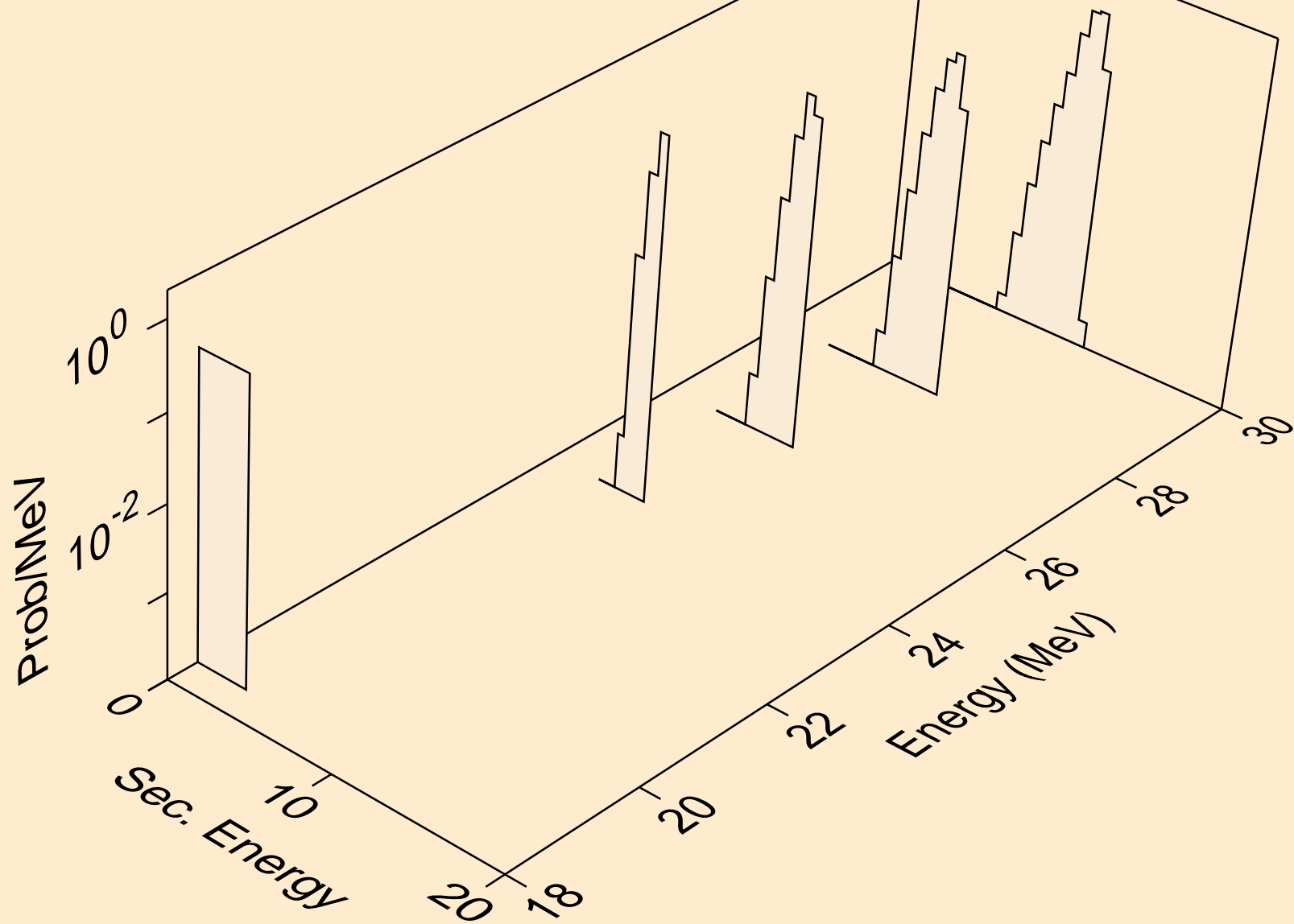

SN132 NEUTRON ACER TENDL-2023 LIBRARY; T=0.K  
alphas from (n,a)

