

TH238 NEUTRON ACER TENDL-2023 LIBRARY; T=0.K

Principal cross sections

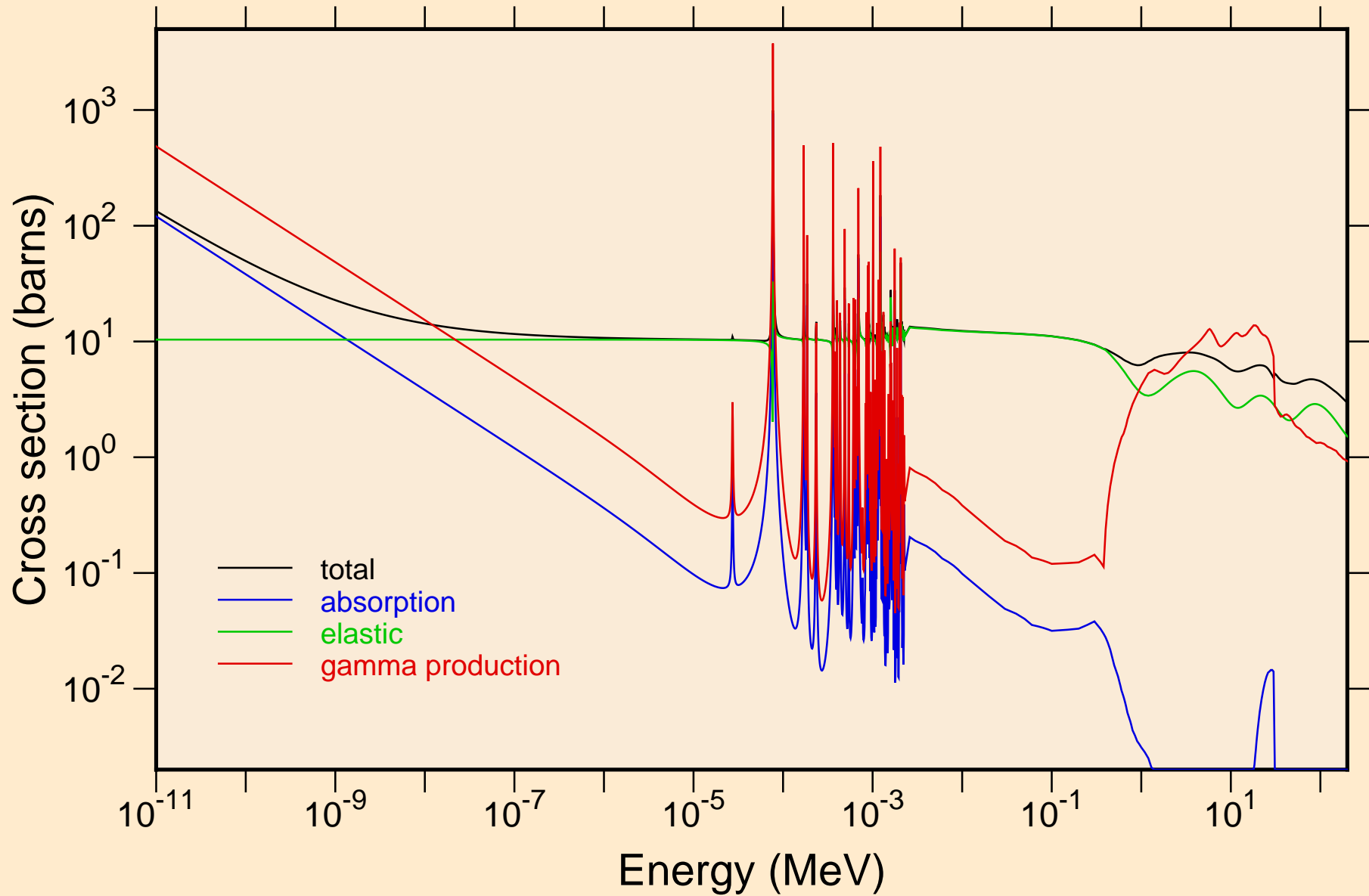

TH238 NEUTRON ACER TENDL-2023 LIBRARY; T=0.K
resonance total cross section

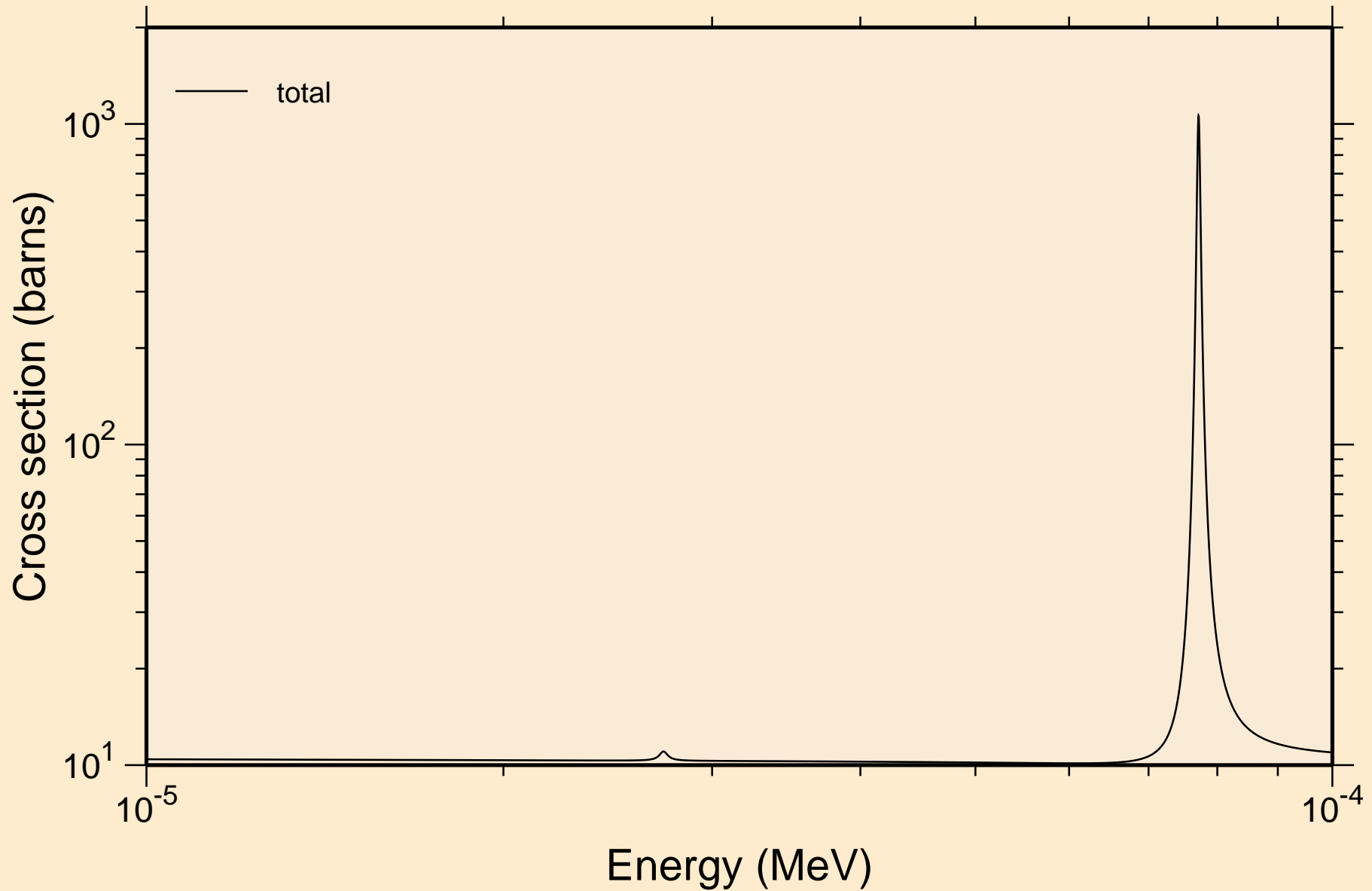

TH238 NEUTRON ACER TENDL-2023 LIBRARY; T=0.K
resonance total cross section

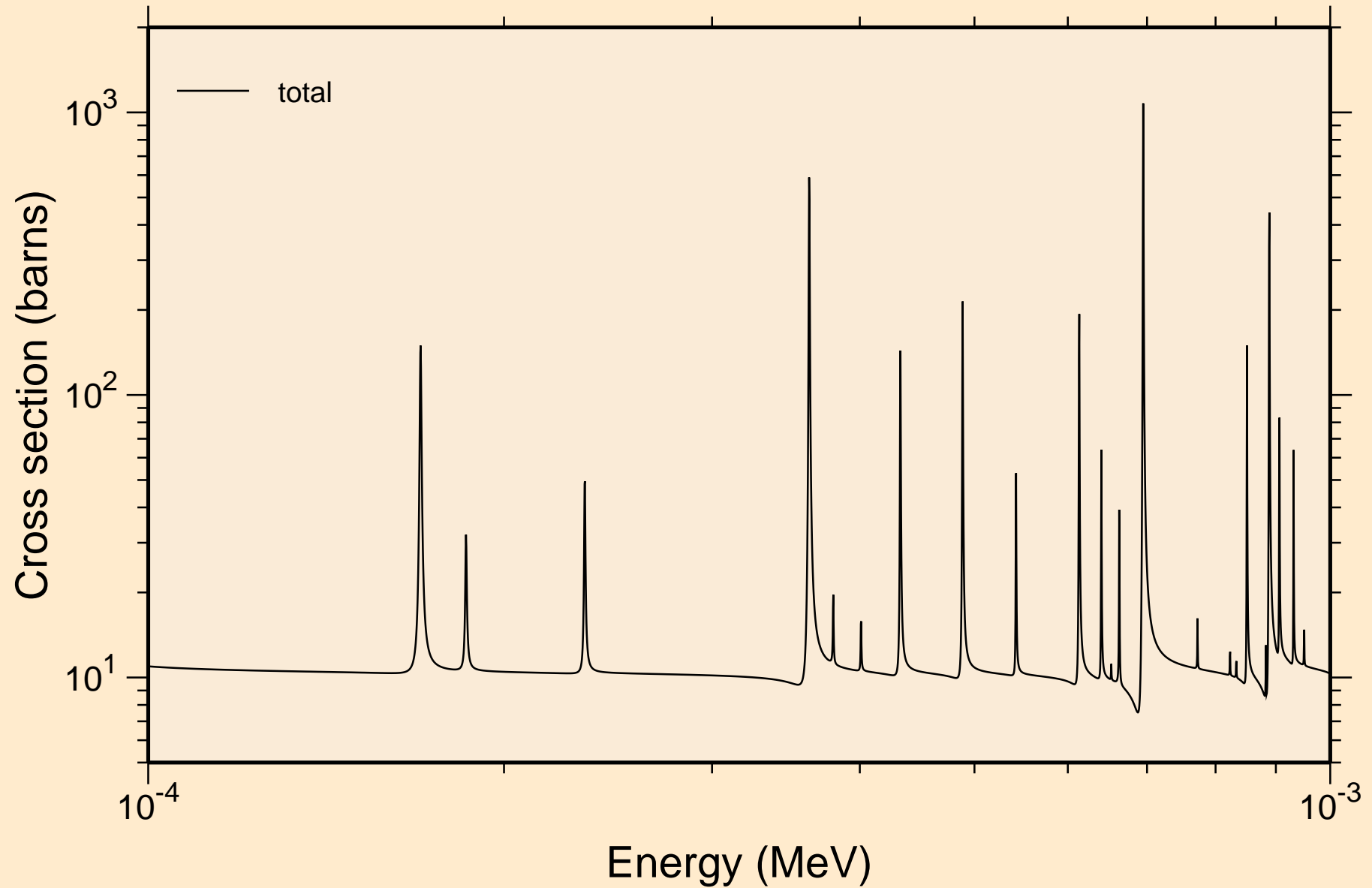

TH238 NEUTRON ACER TENDL-2023 LIBRARY; T=0.K
resonance total cross section

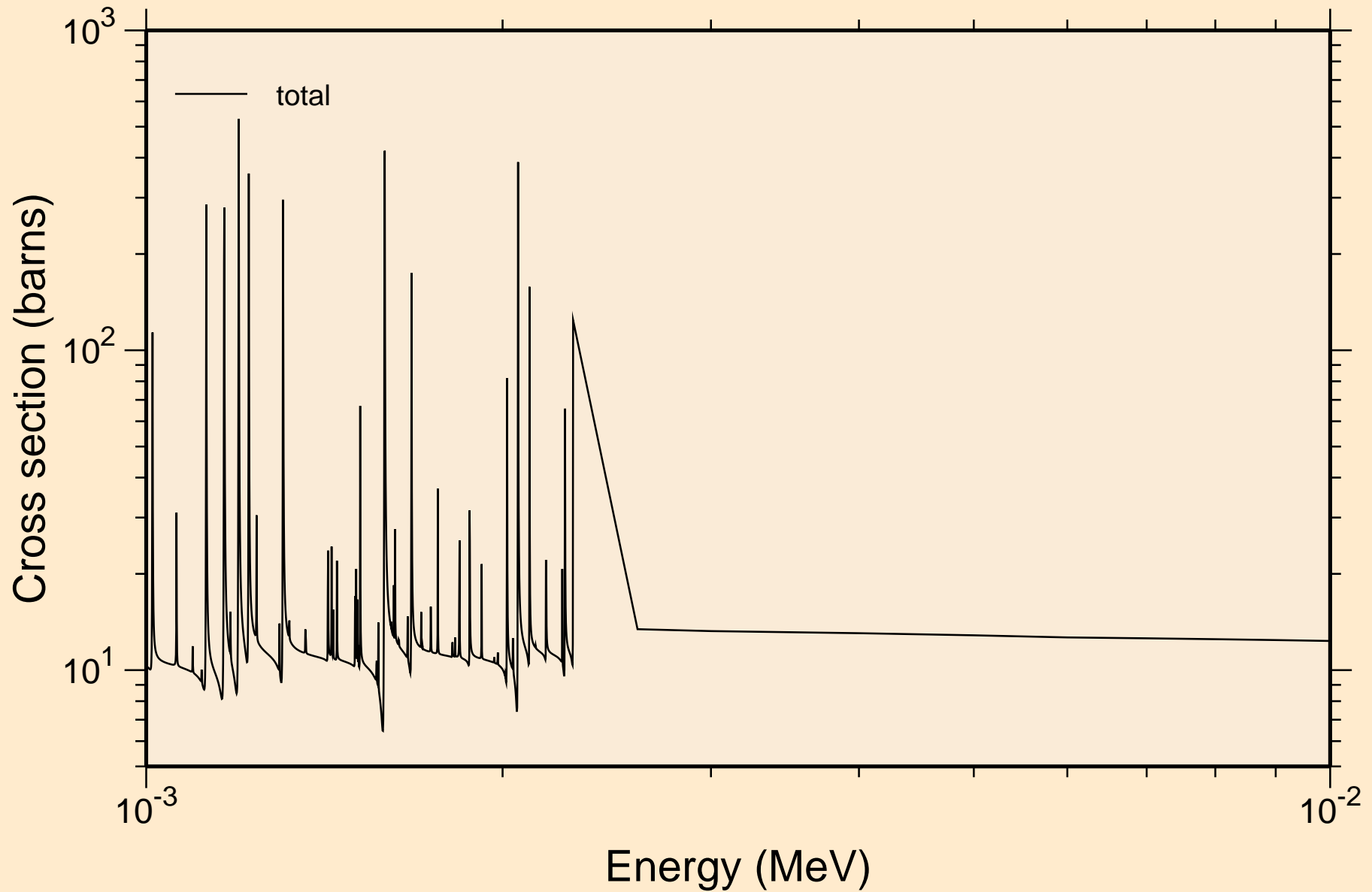

TH238 NEUTRON ACER TENDL-2023 LIBRARY; T=0.K
resonance total cross section

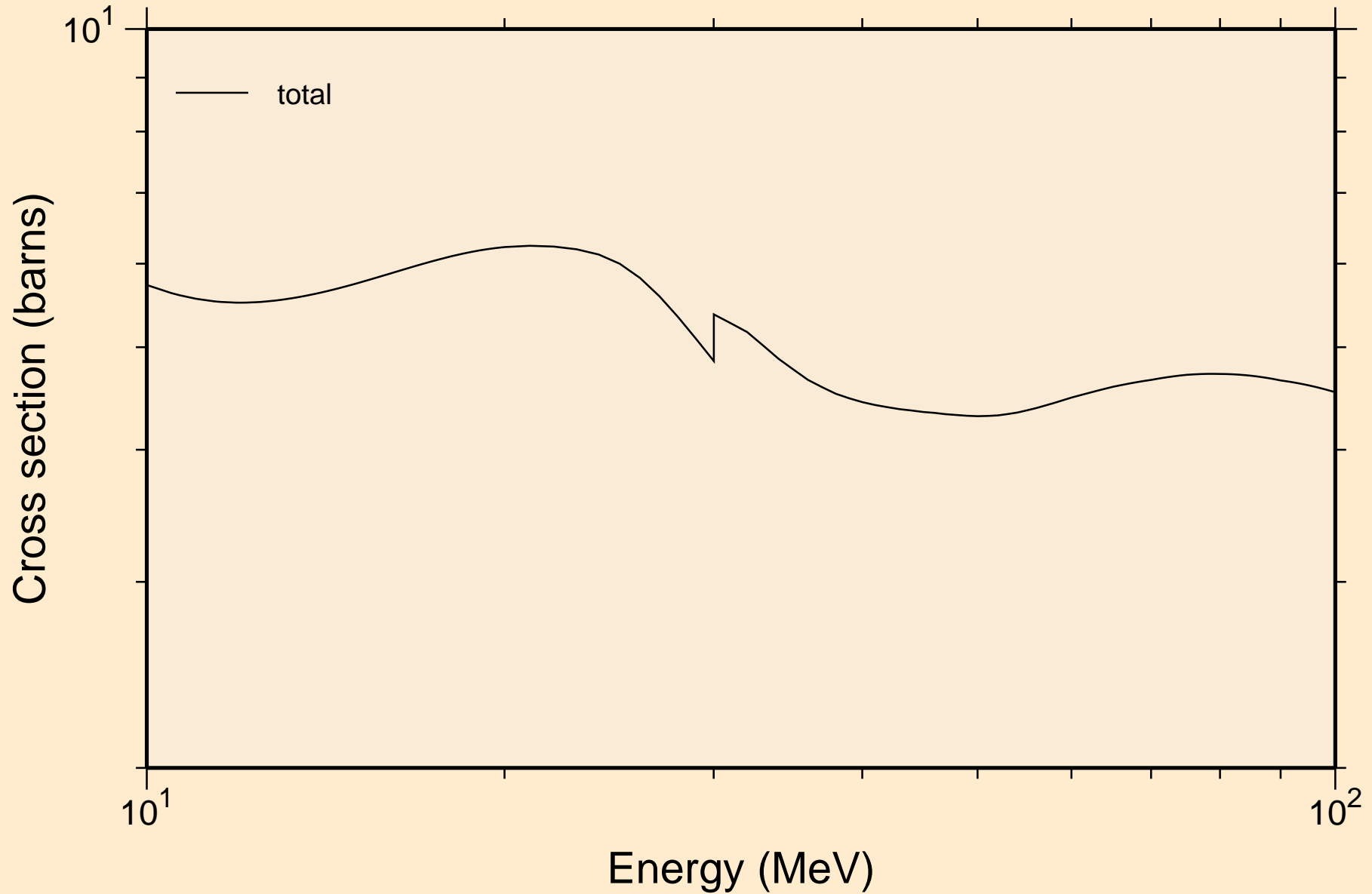

TH238 NEUTRON ACER TENDL-2023 LIBRARY; T=0.K
resonance absorption cross sections

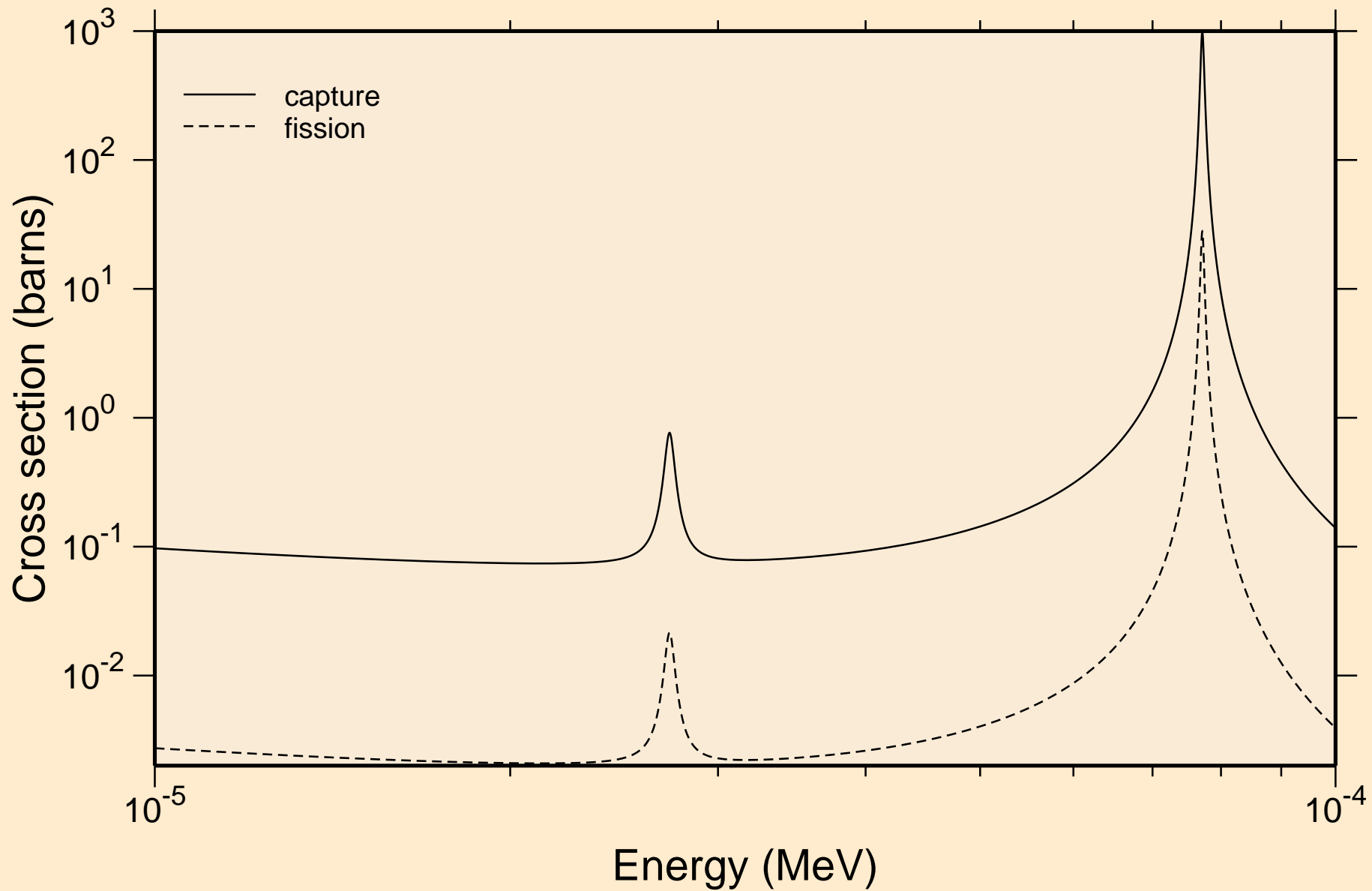

TH238 NEUTRON ACER TENDL-2023 LIBRARY; T=0.K
resonance absorption cross sections

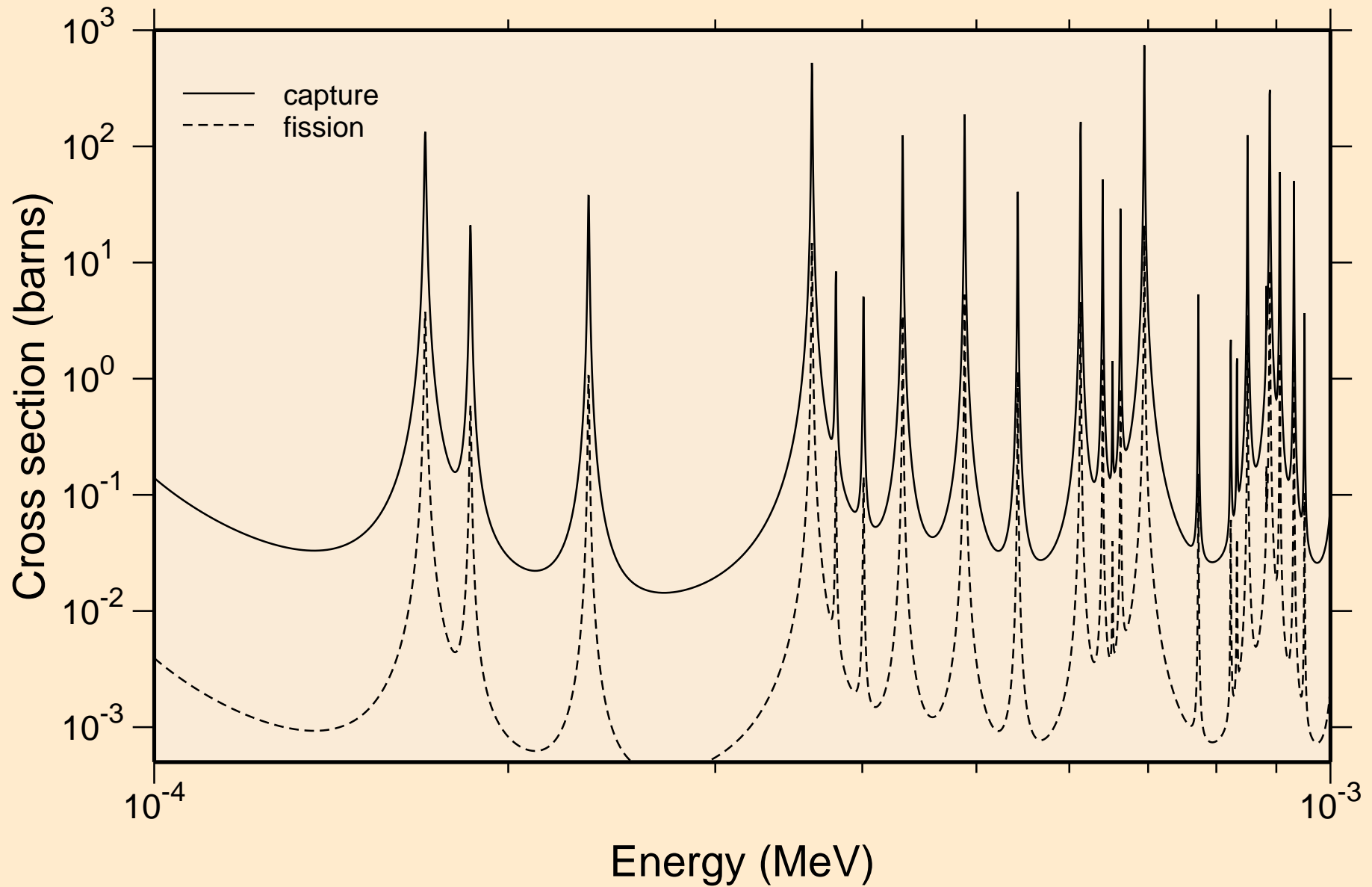

TH238 NEUTRON ACER TENDL-2023 LIBRARY; T=0.K
resonance absorption cross sections

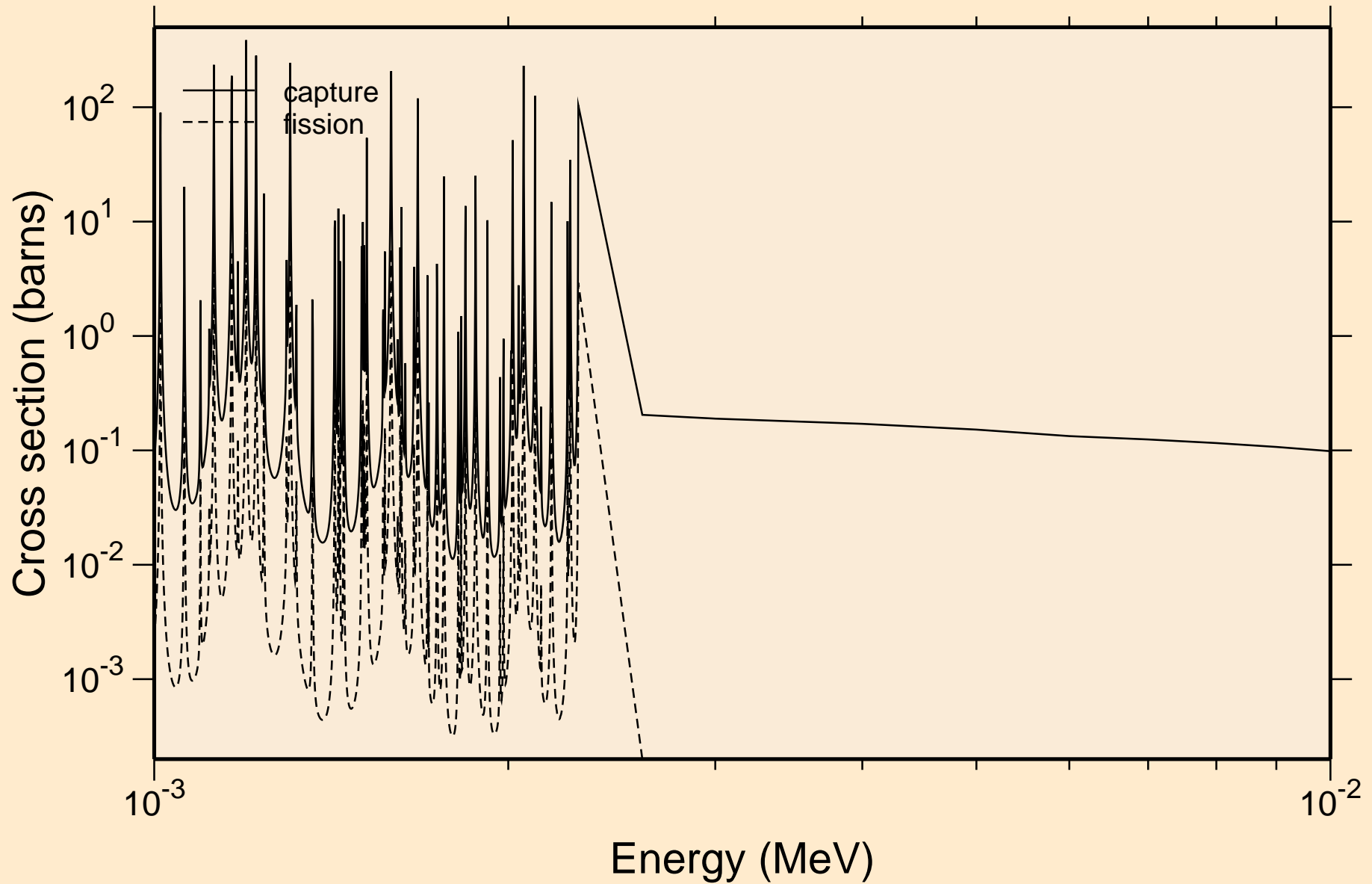

TH238 NEUTRON ACER TENDL-2023 LIBRARY; T=0.K
resonance absorption cross sections

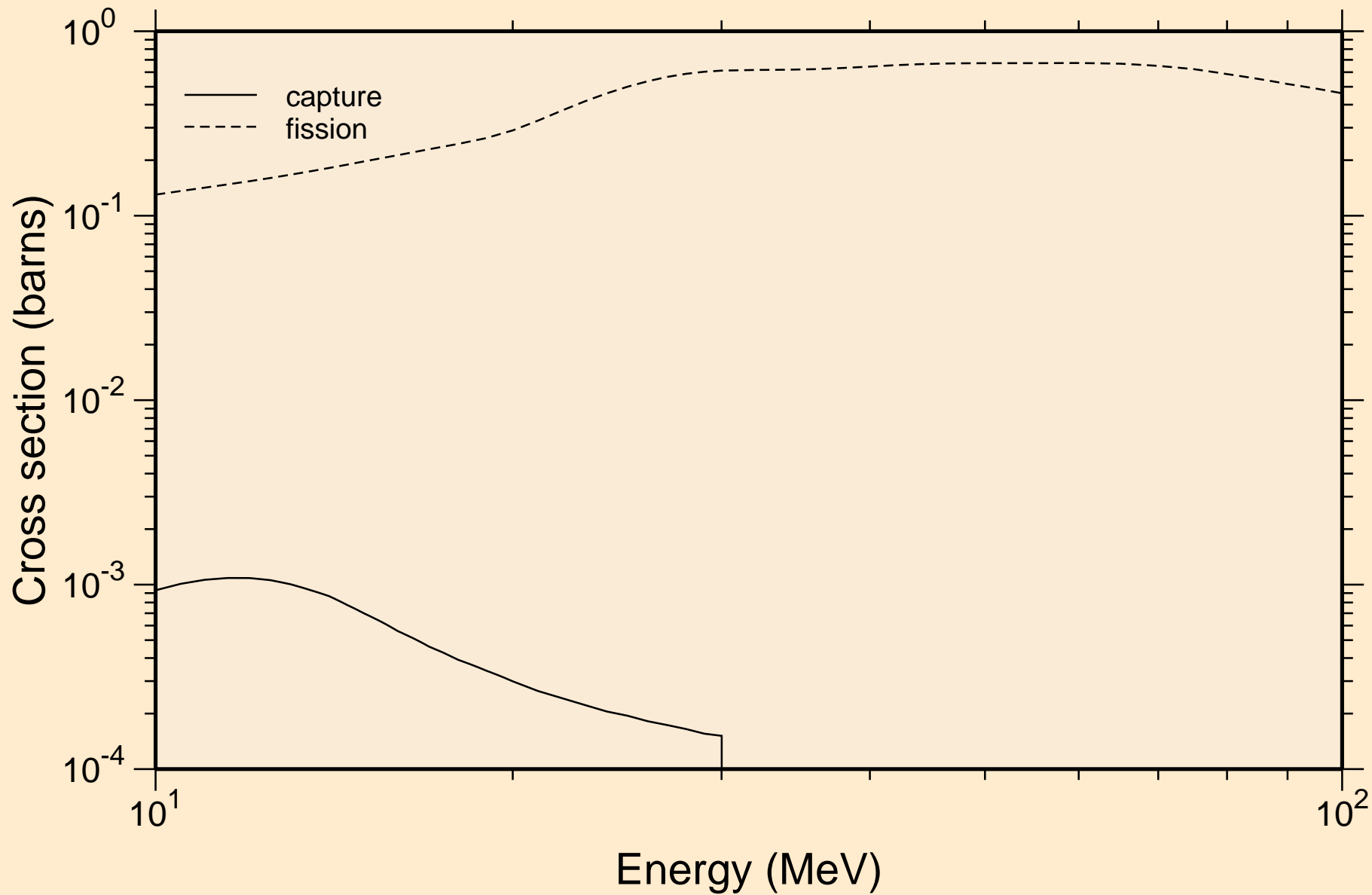

TH238 NEUTRON ACER TENDL-2023 LIBRARY; T=0.K

Heating

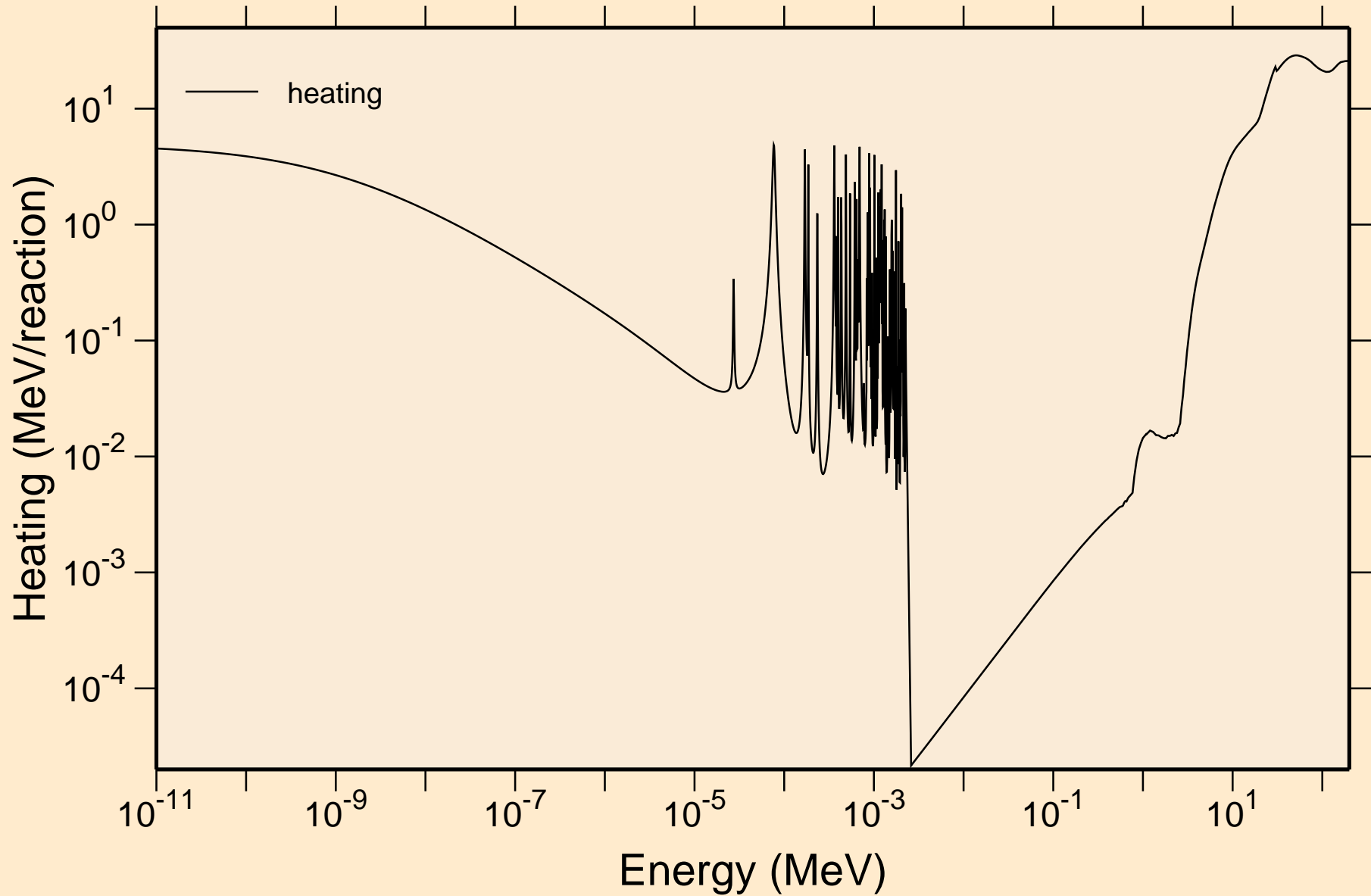

TH238 NEUTRON ACER TENDL-2023 LIBRARY; T=0.K
Damage

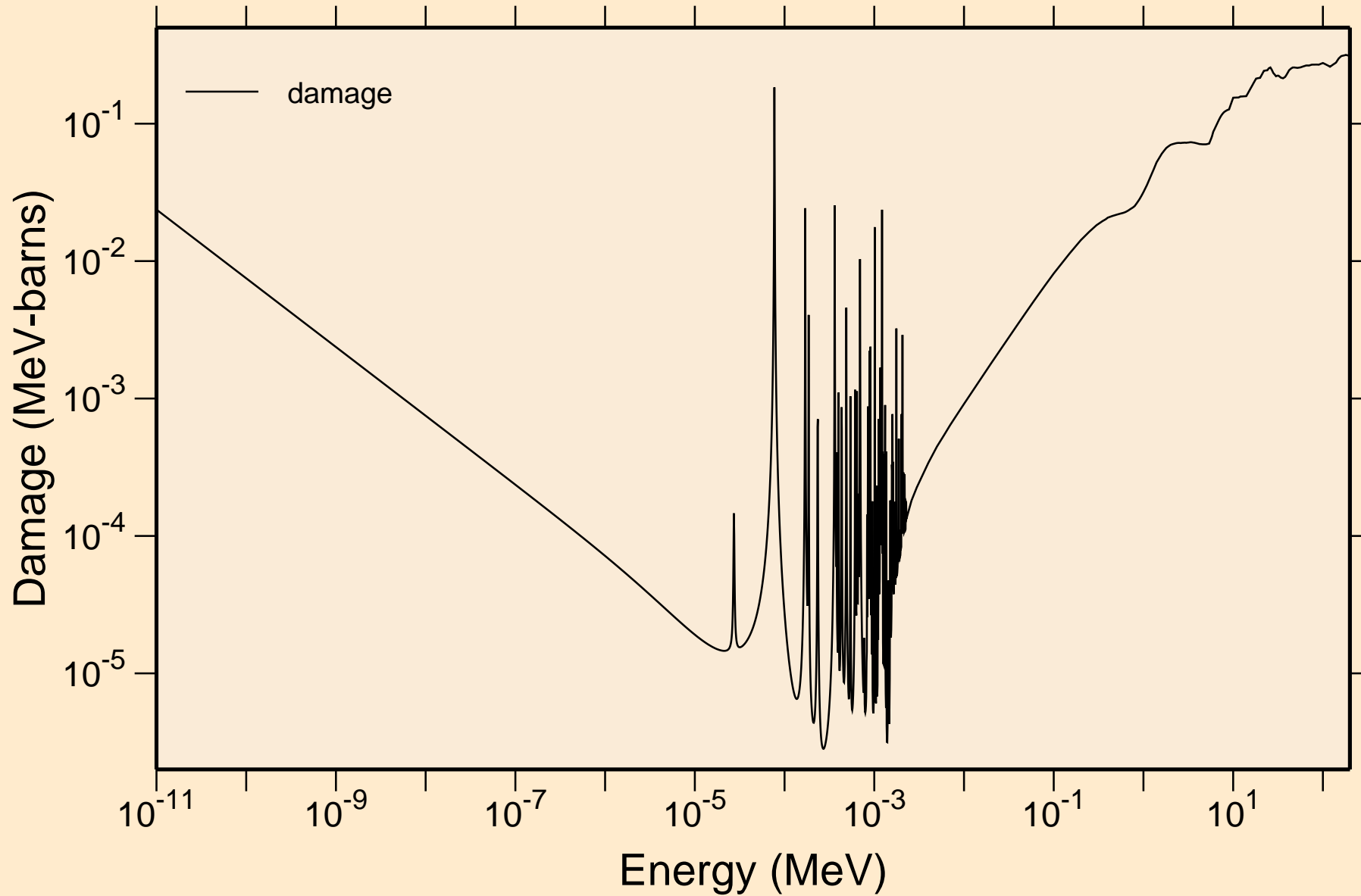

TH238 NEUTRON ACER TENDL-2023 LIBRARY; T=0.K

Non-threshold reactions

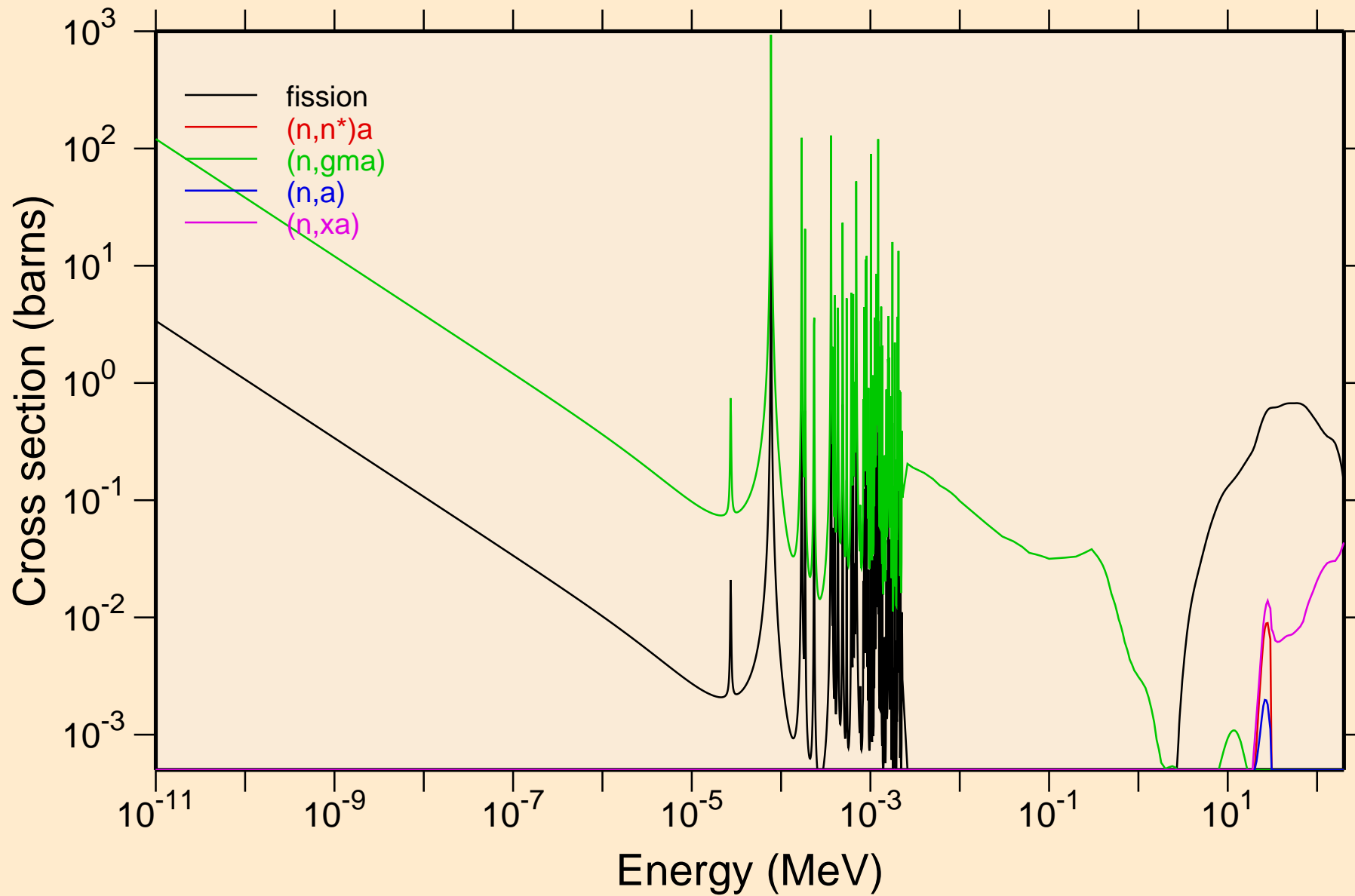

TH238 NEUTRON ACER TENDL-2023 LIBRARY; T=0.K

Principal cross sections

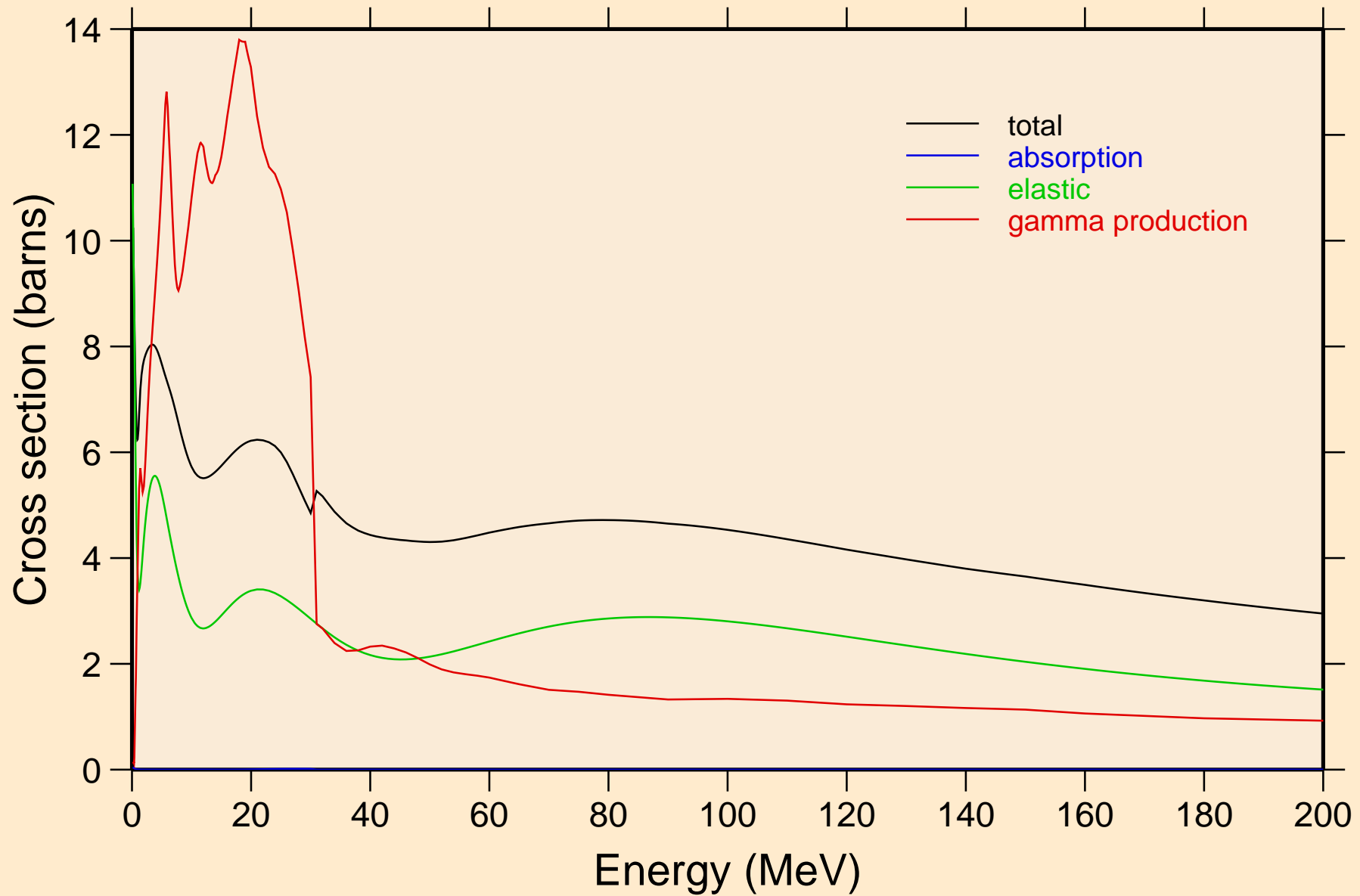

TH238 NEUTRON ACER TENDL-2023 LIBRARY; T=0.K

Heating

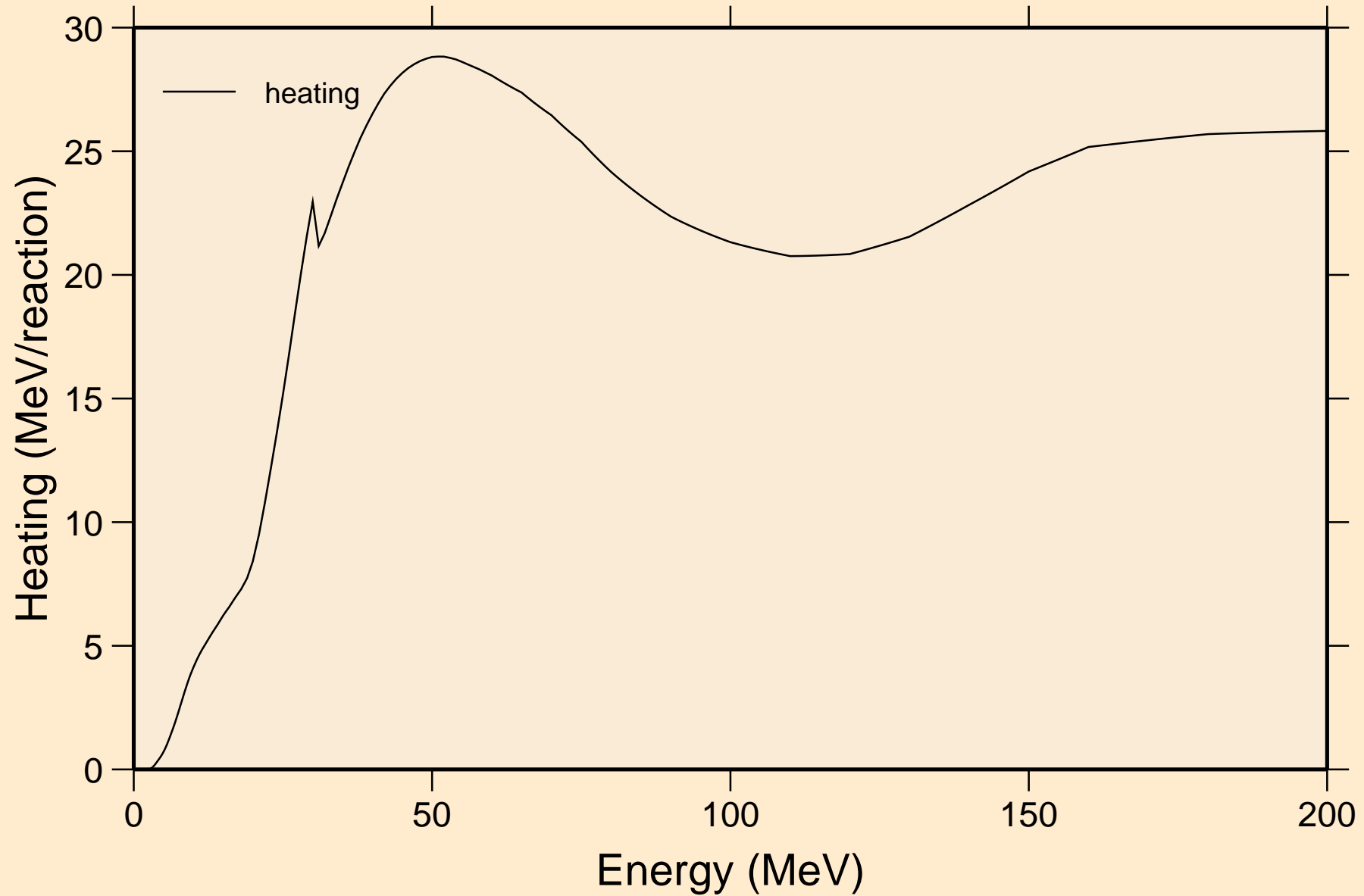

TH238 NEUTRON ACER TENDL-2023 LIBRARY; T=0.K
Damage

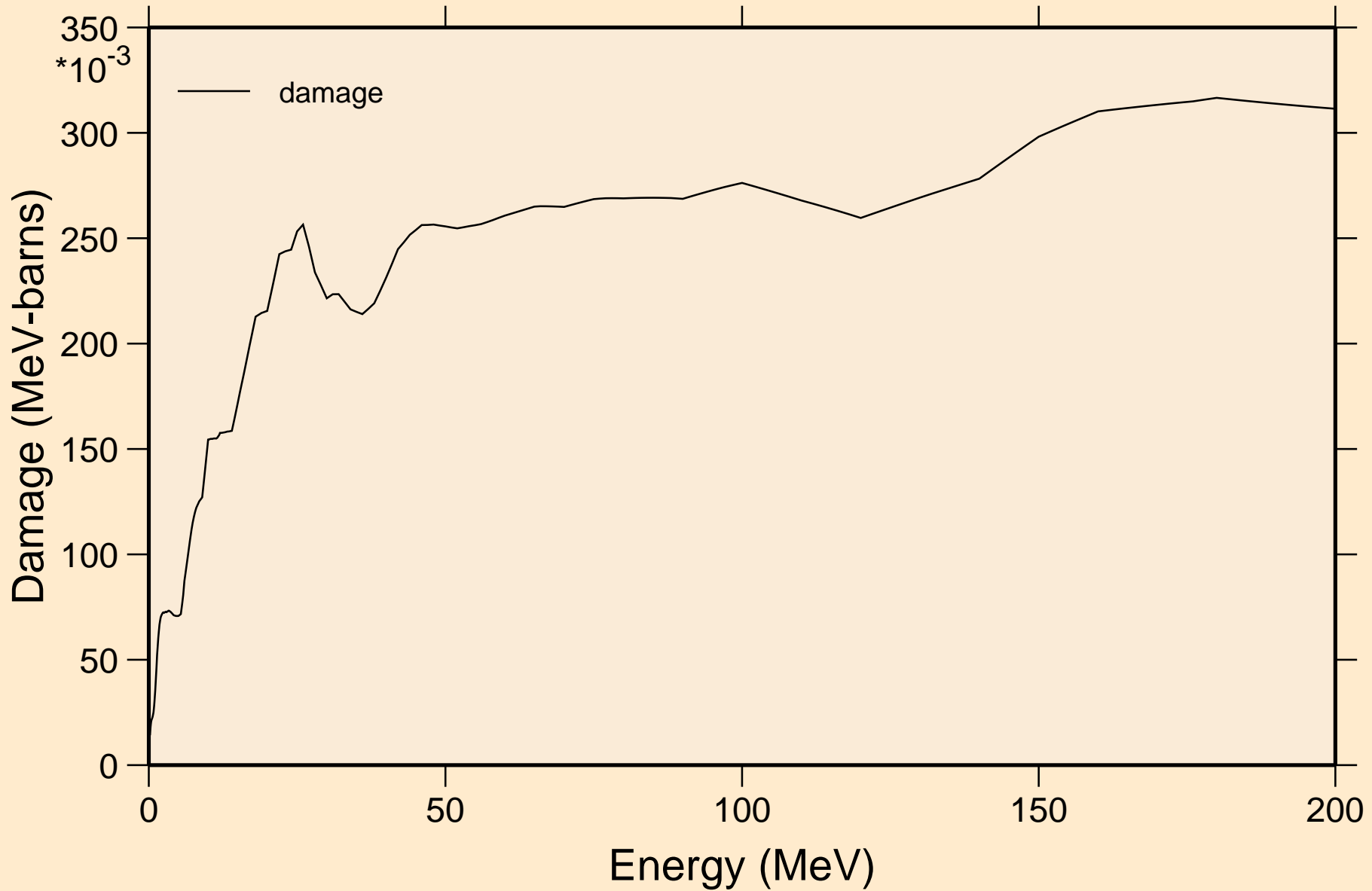

TH238 NEUTRON ACER TENDL-2023 LIBRARY; T=0.K

Non-threshold reactions

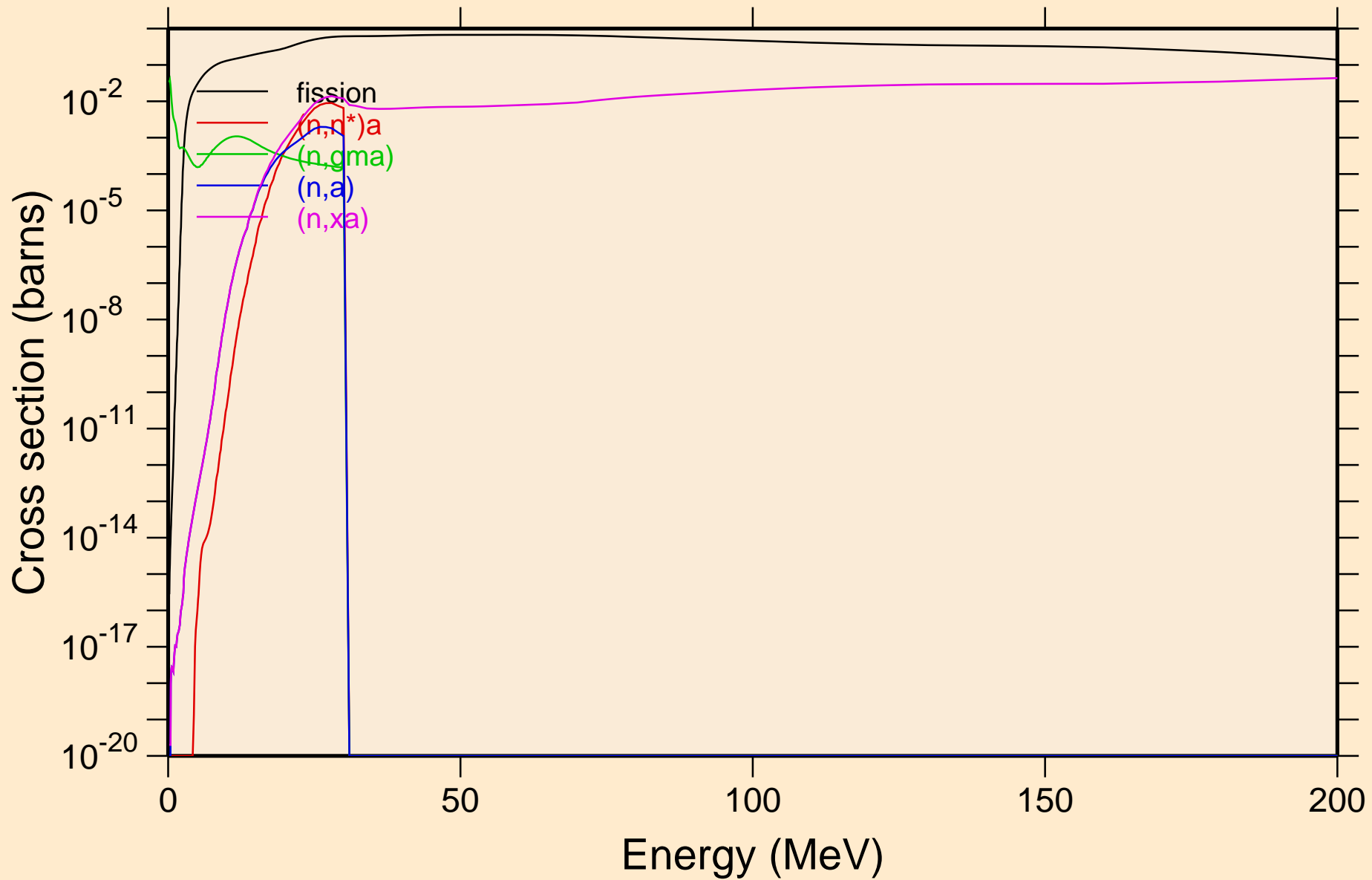

TH238 NEUTRON ACER TENDL-2023 LIBRARY; T=0.K
Inelastic levels

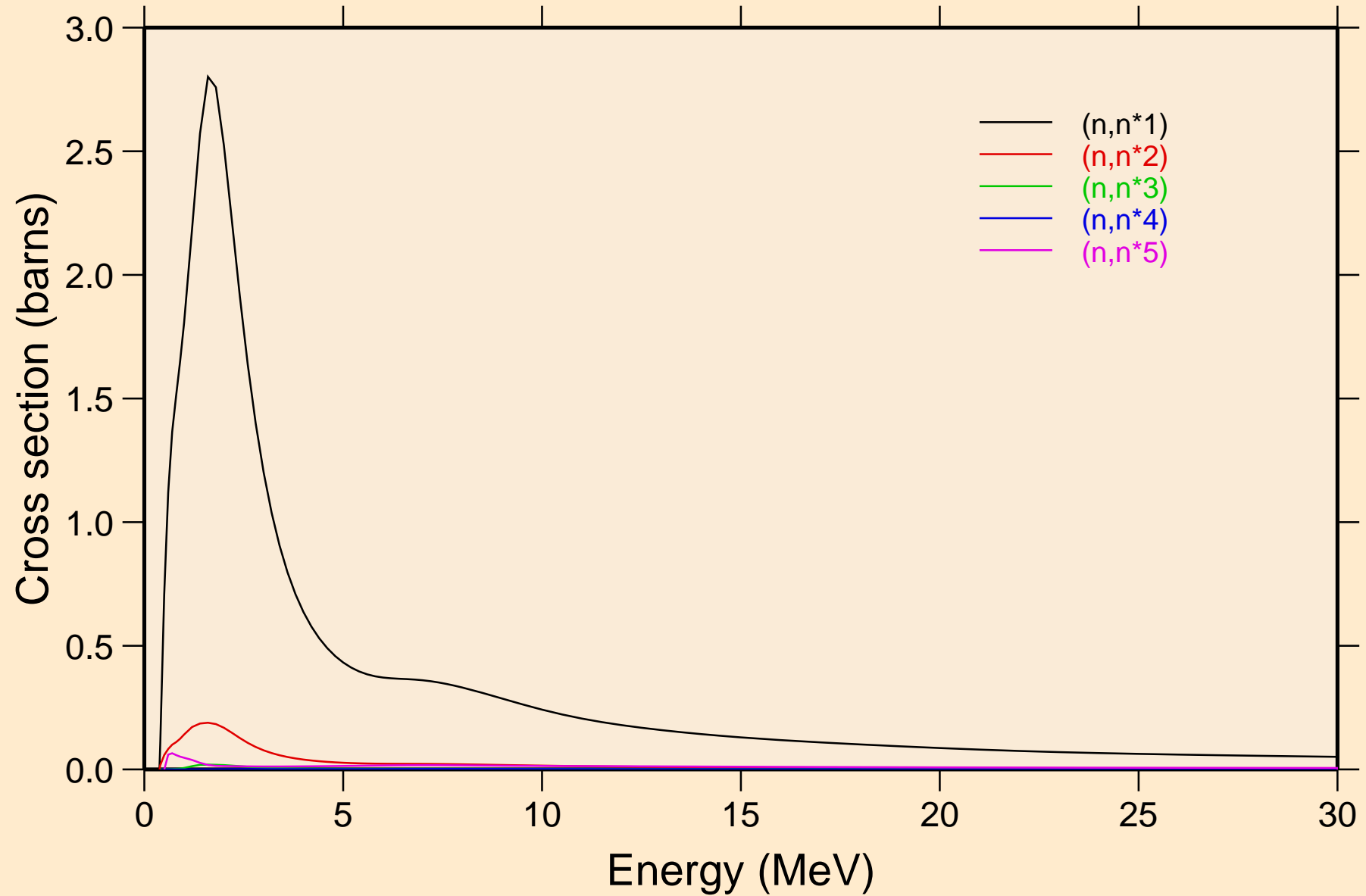

TH238 NEUTRON ACER TENDL-2023 LIBRARY; T=0.K
Inelastic levels

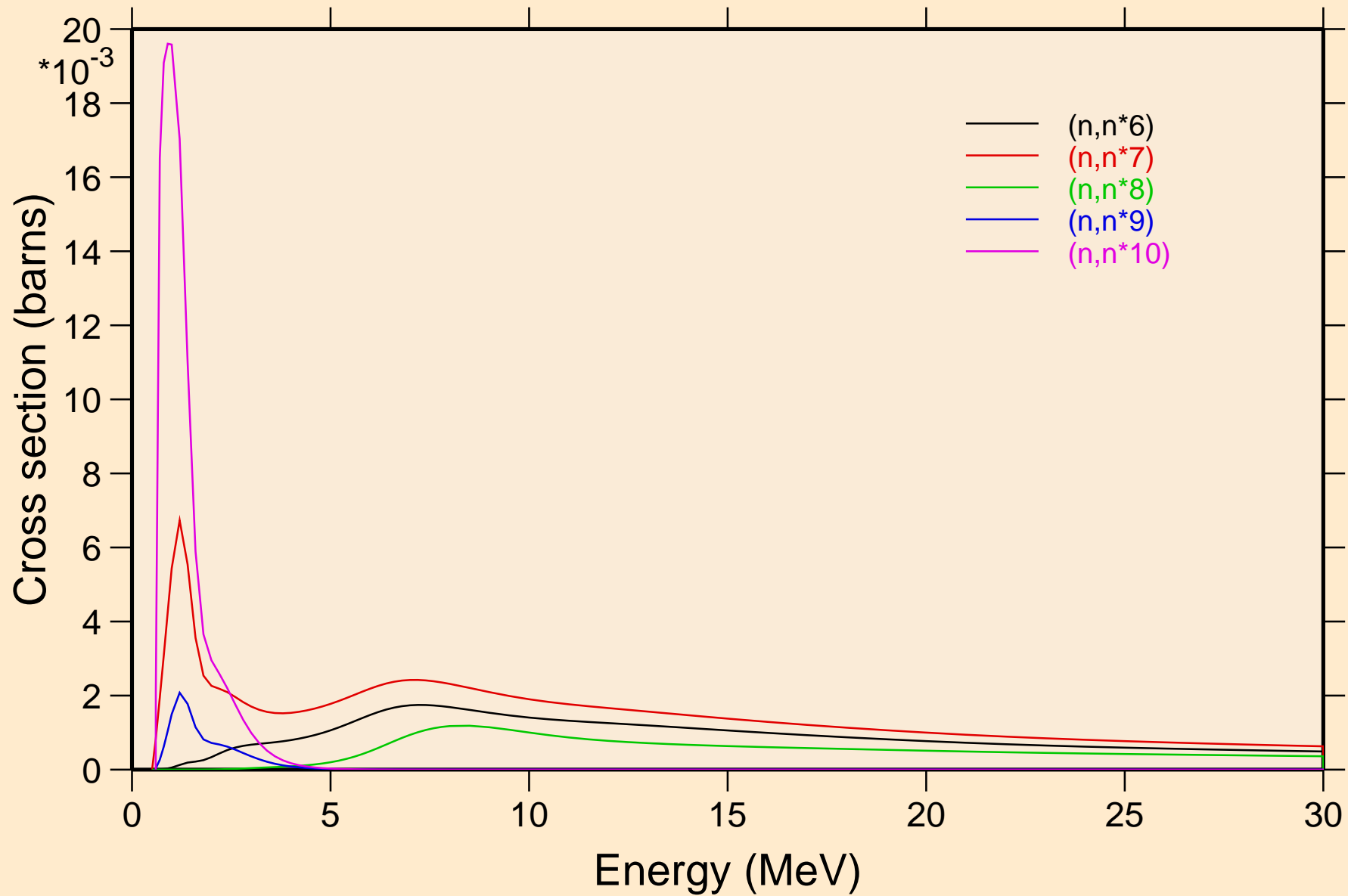

TH238 NEUTRON ACER TENDL-2023 LIBRARY; T=0.K
Inelastic levels

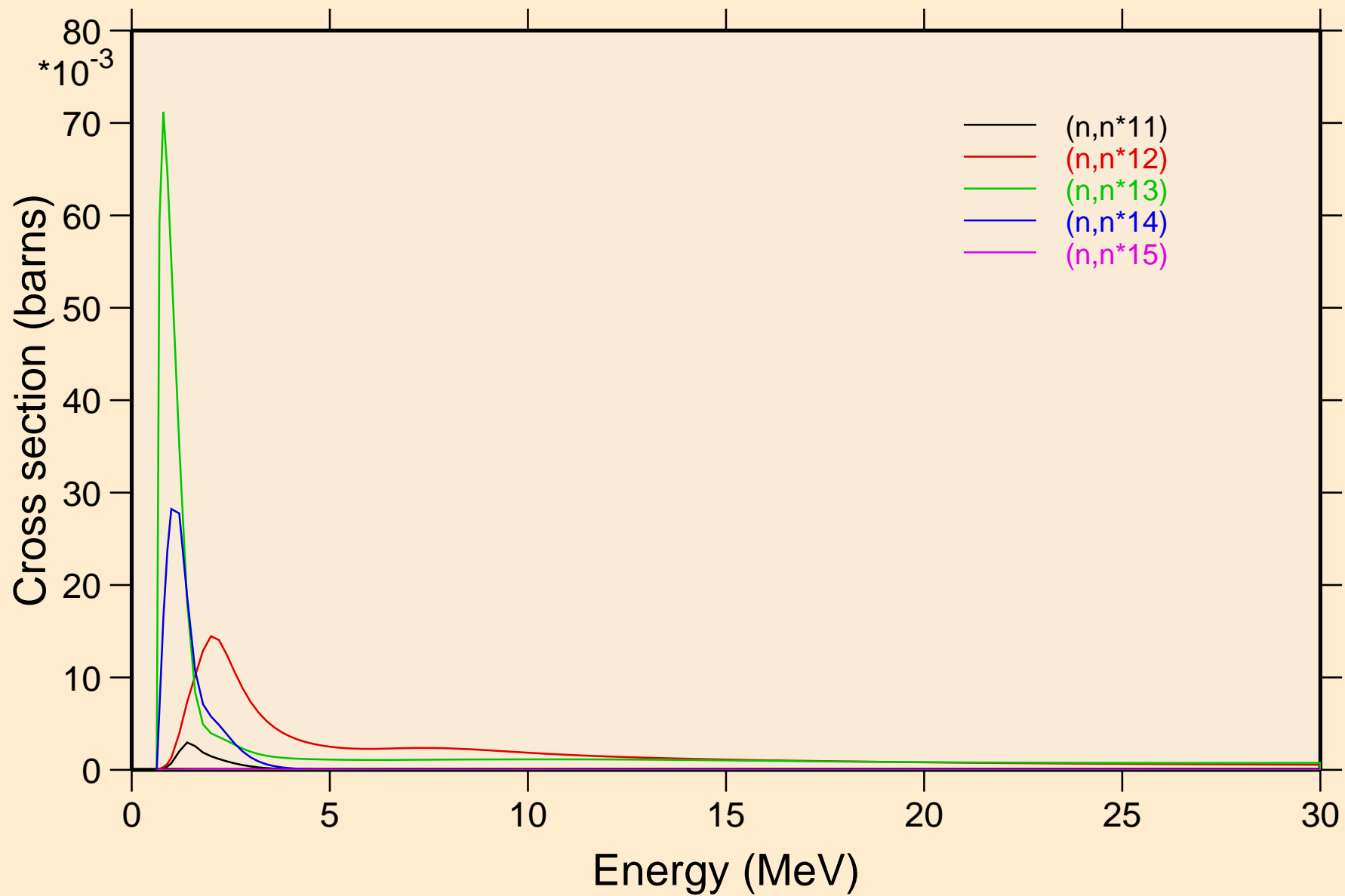

TH238 NEUTRON ACER TENDL-2023 LIBRARY; T=0.K
Inelastic levels

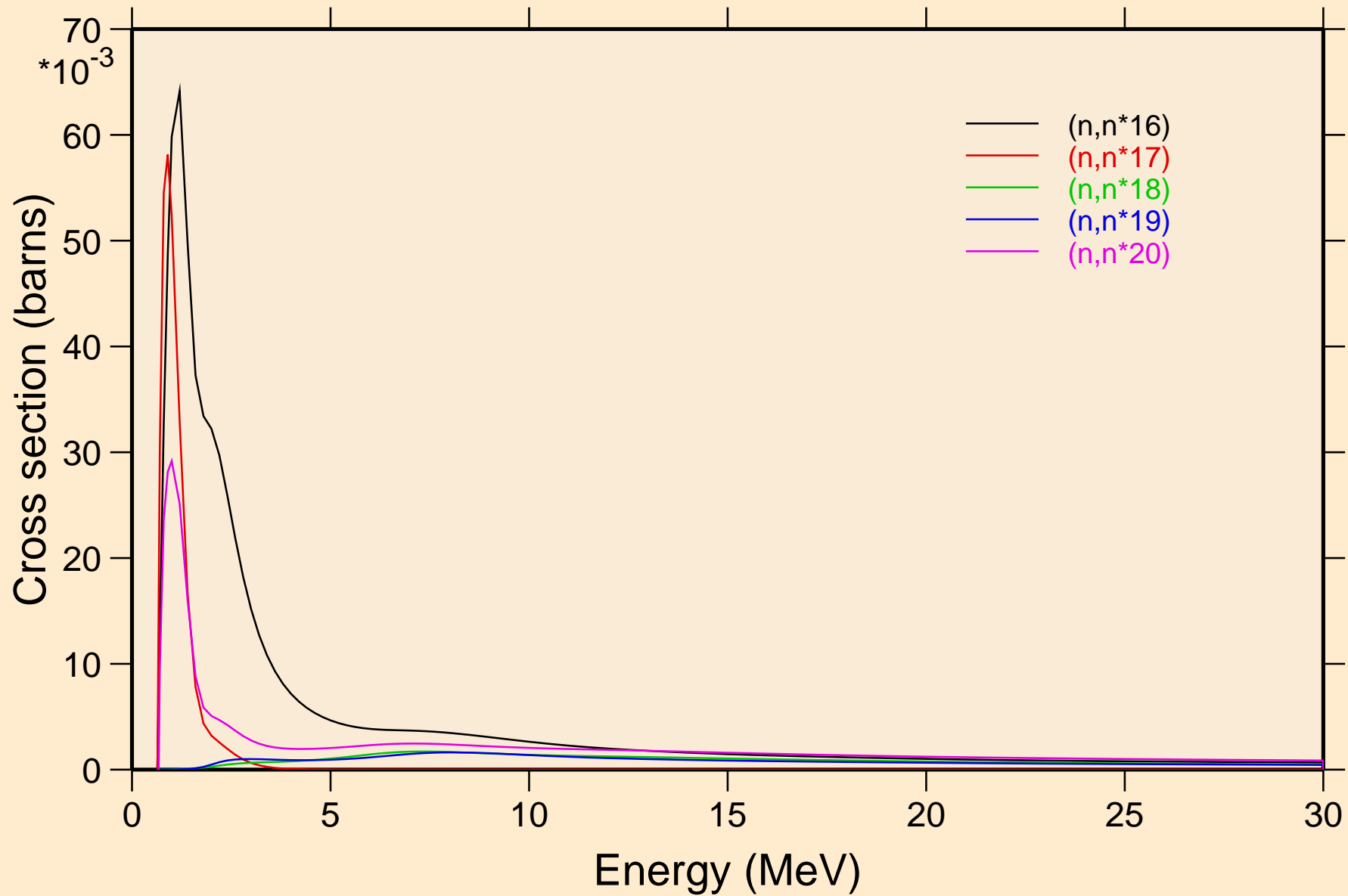

TH238 NEUTRON ACER TENDL-2023 LIBRARY; T=0.K
Inelastic levels

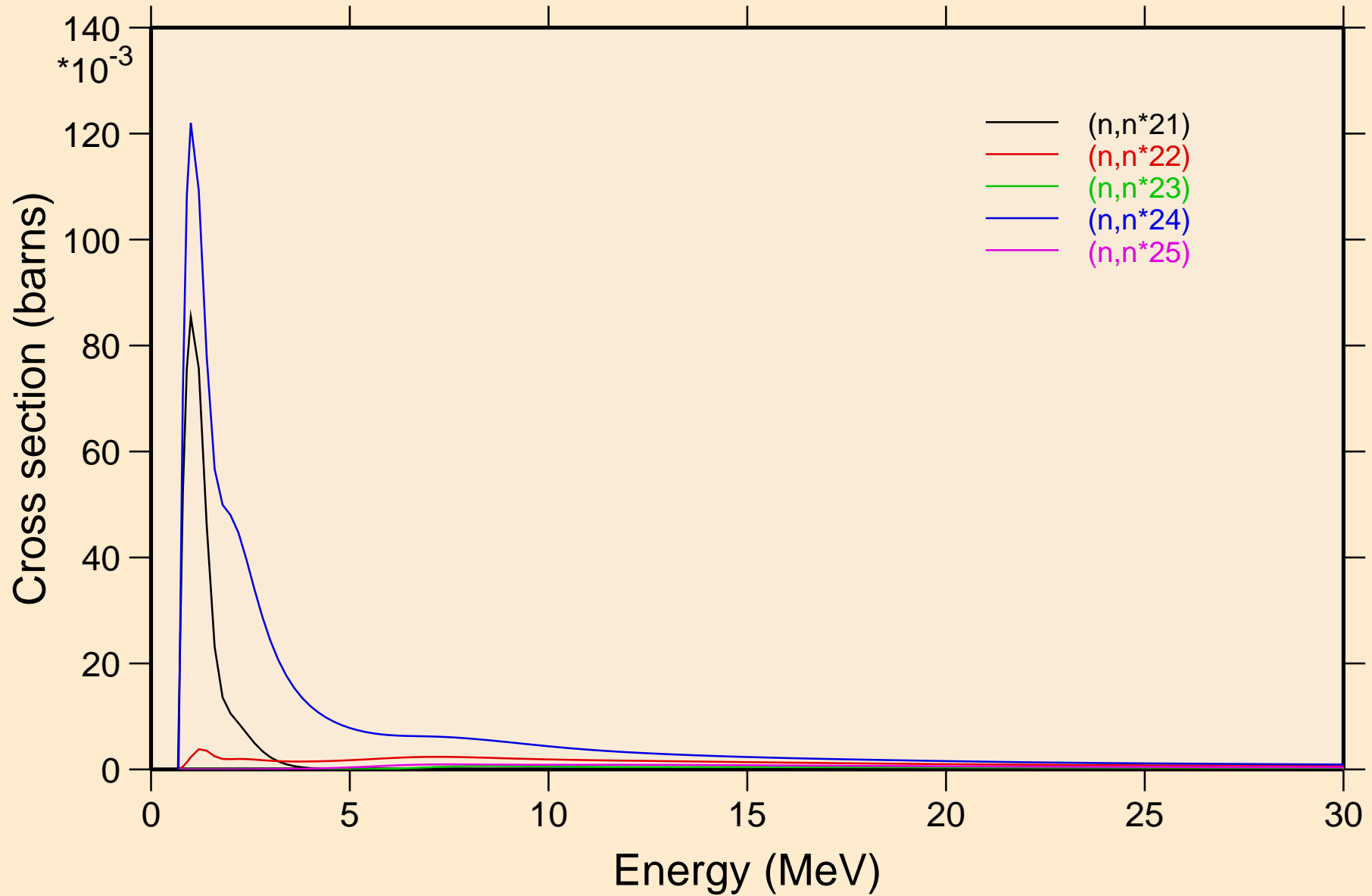

TH238 NEUTRON ACER TENDL-2023 LIBRARY; T=0.K
Inelastic levels

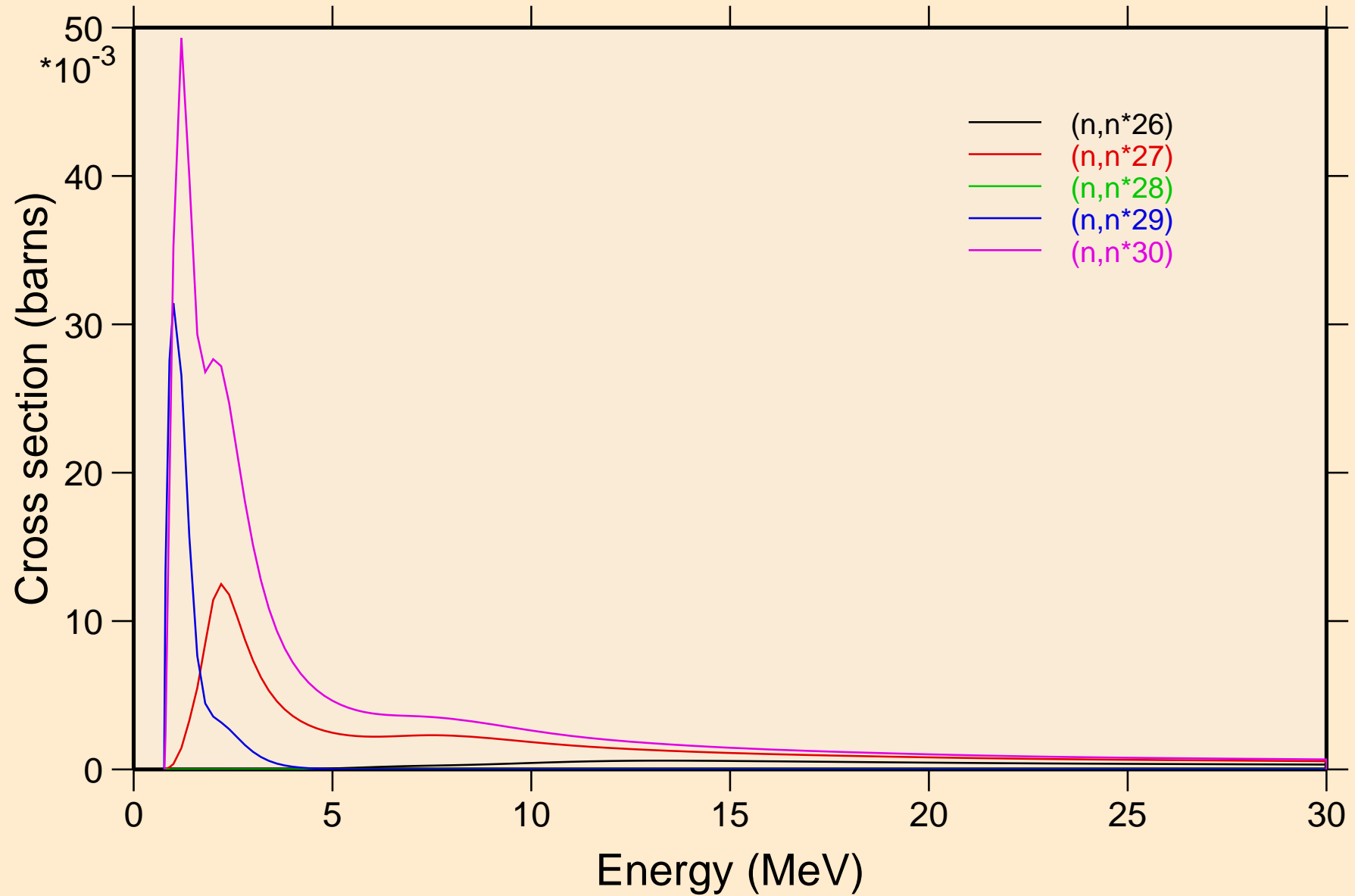

TH238 NEUTRON ACER TENDL-2023 LIBRARY; T=0.K

Threshold reactions

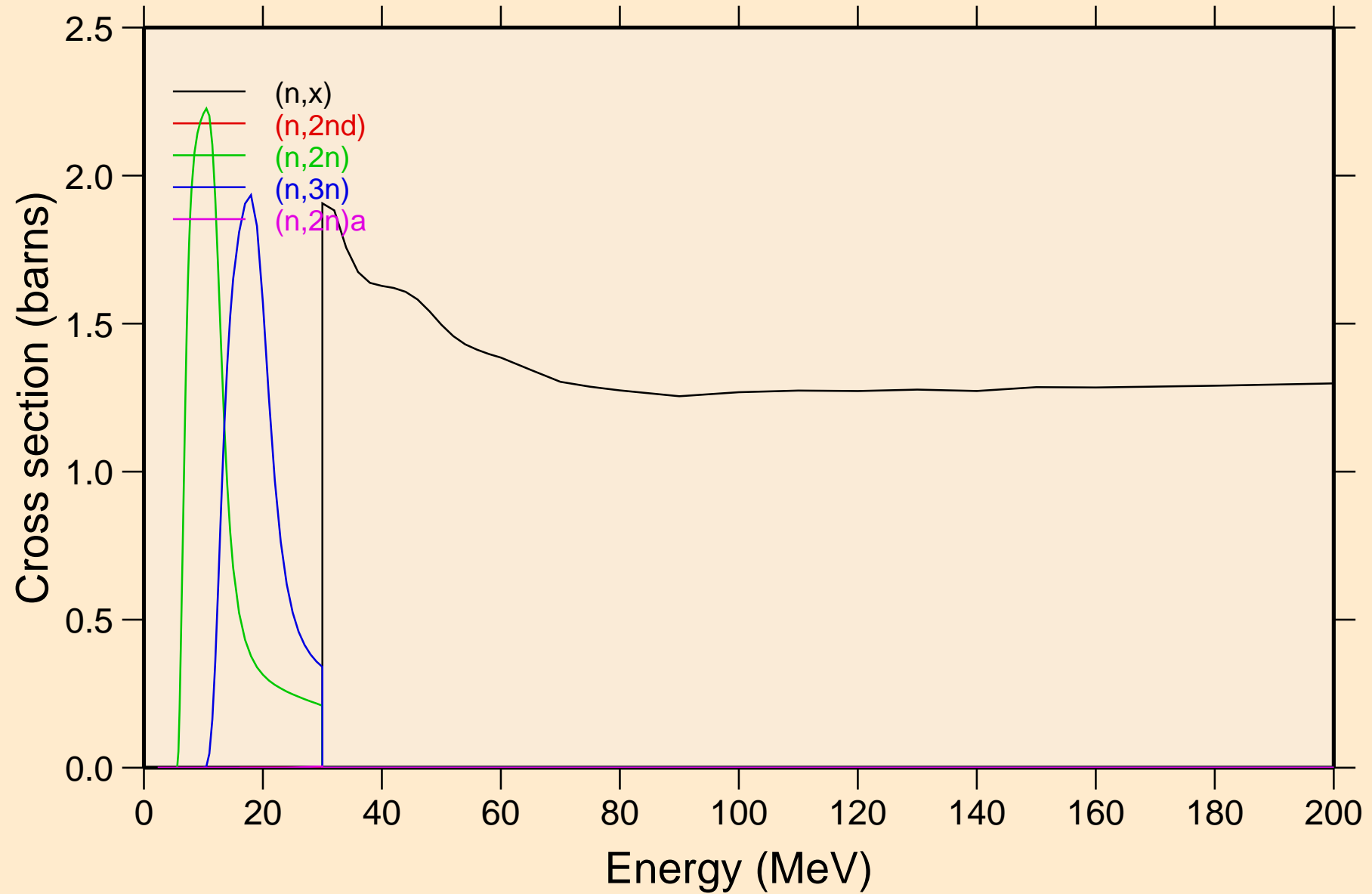

TH238 NEUTRON ACER TENDL-2023 LIBRARY; T=0.K

Threshold reactions

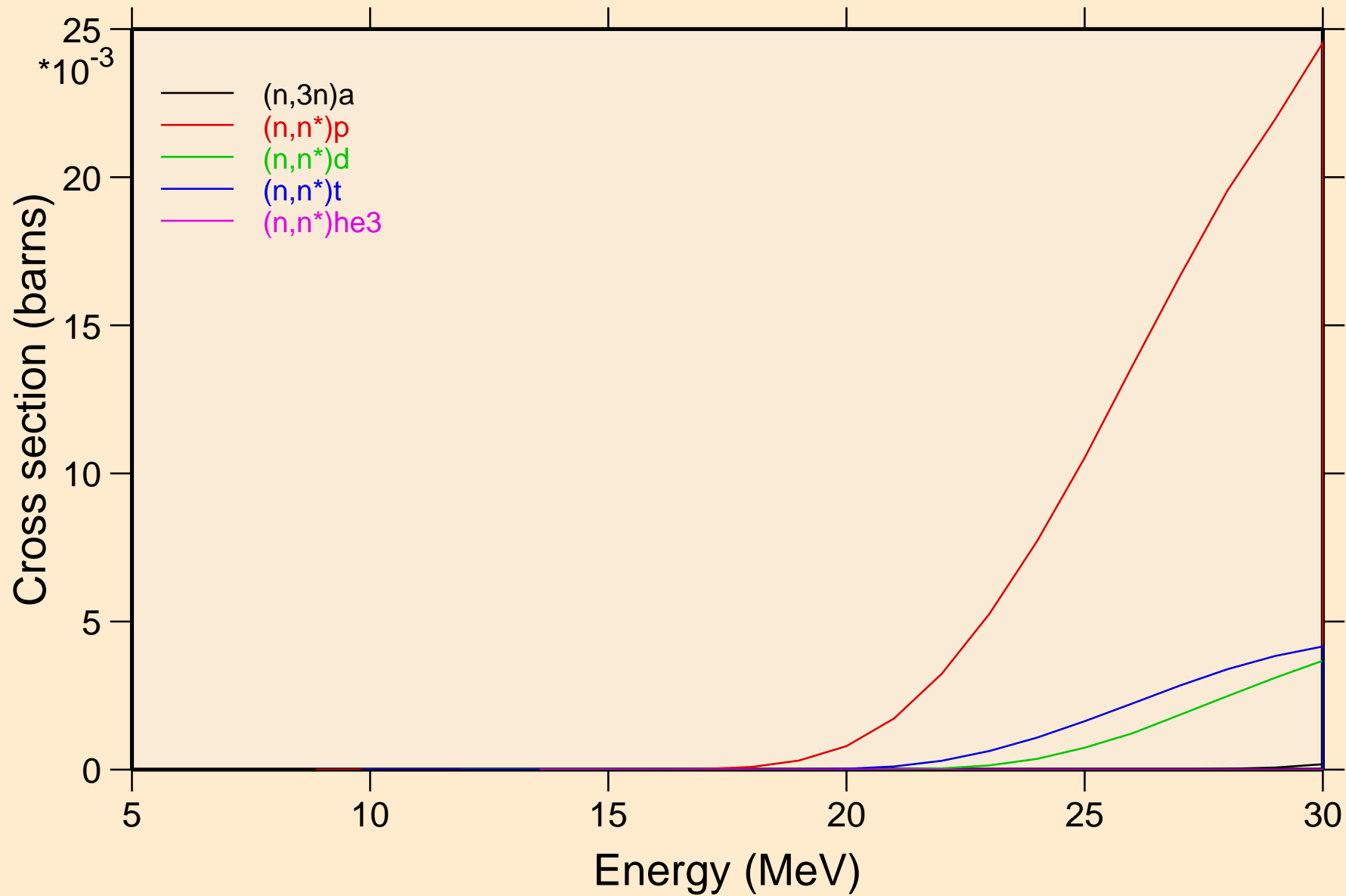

TH238 NEUTRON ACER TENDL-2023 LIBRARY; T=0.K
Threshold reactions

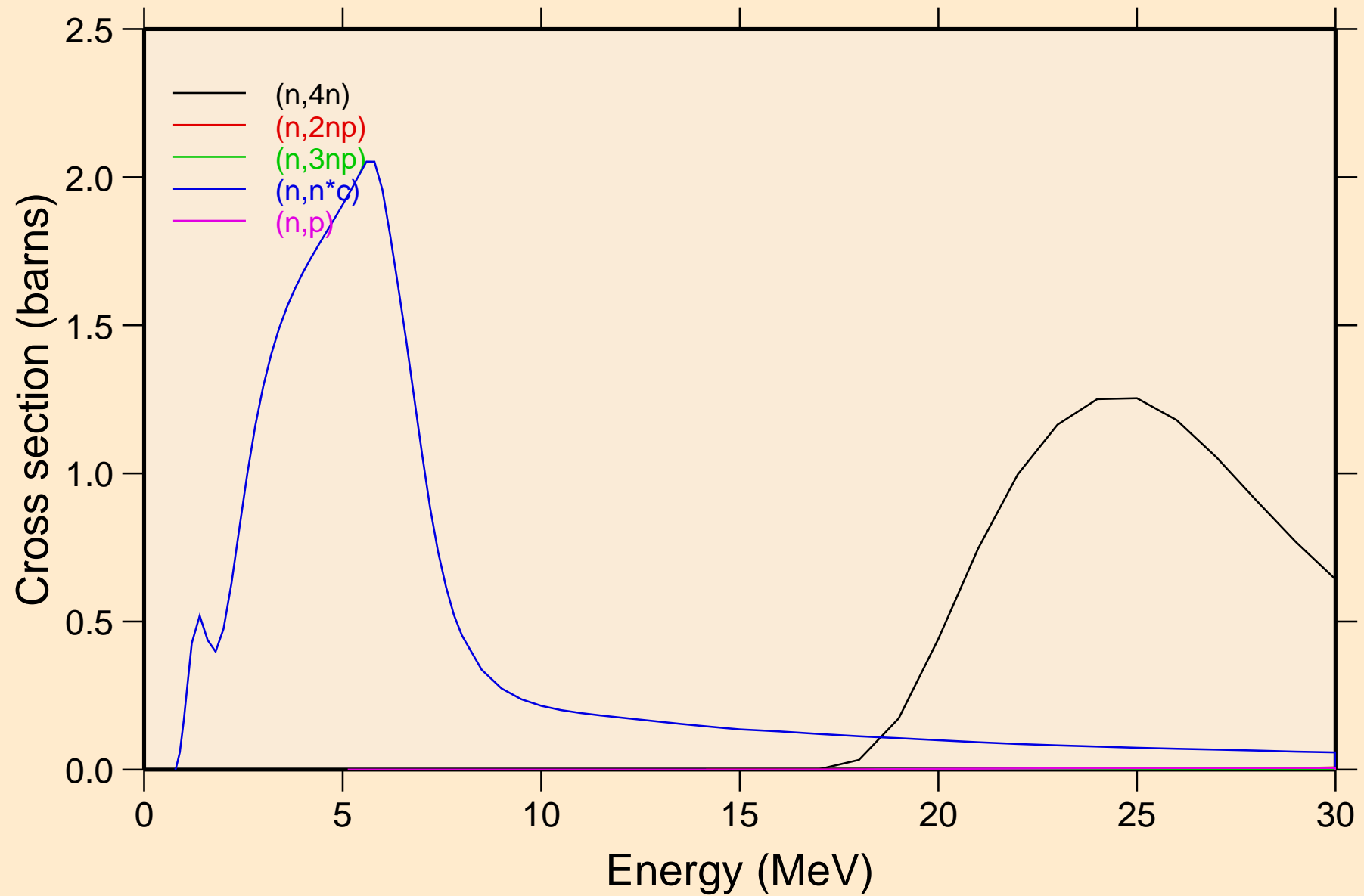

TH238 NEUTRON ACER TENDL-2023 LIBRARY; T=0.K
Threshold reactions

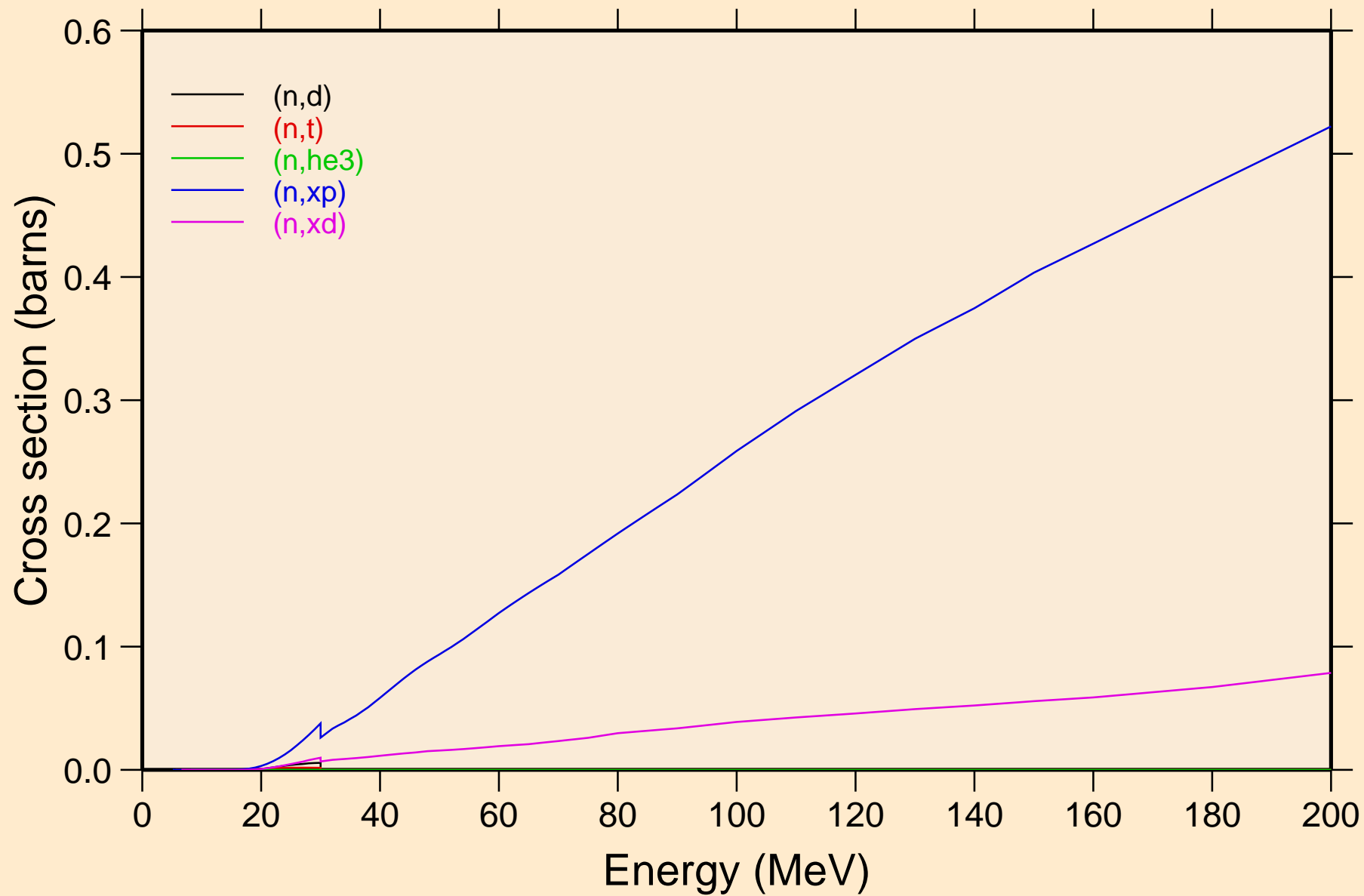

TH238 NEUTRON ACER TENDL-2023 LIBRARY; T=0.K
Threshold reactions

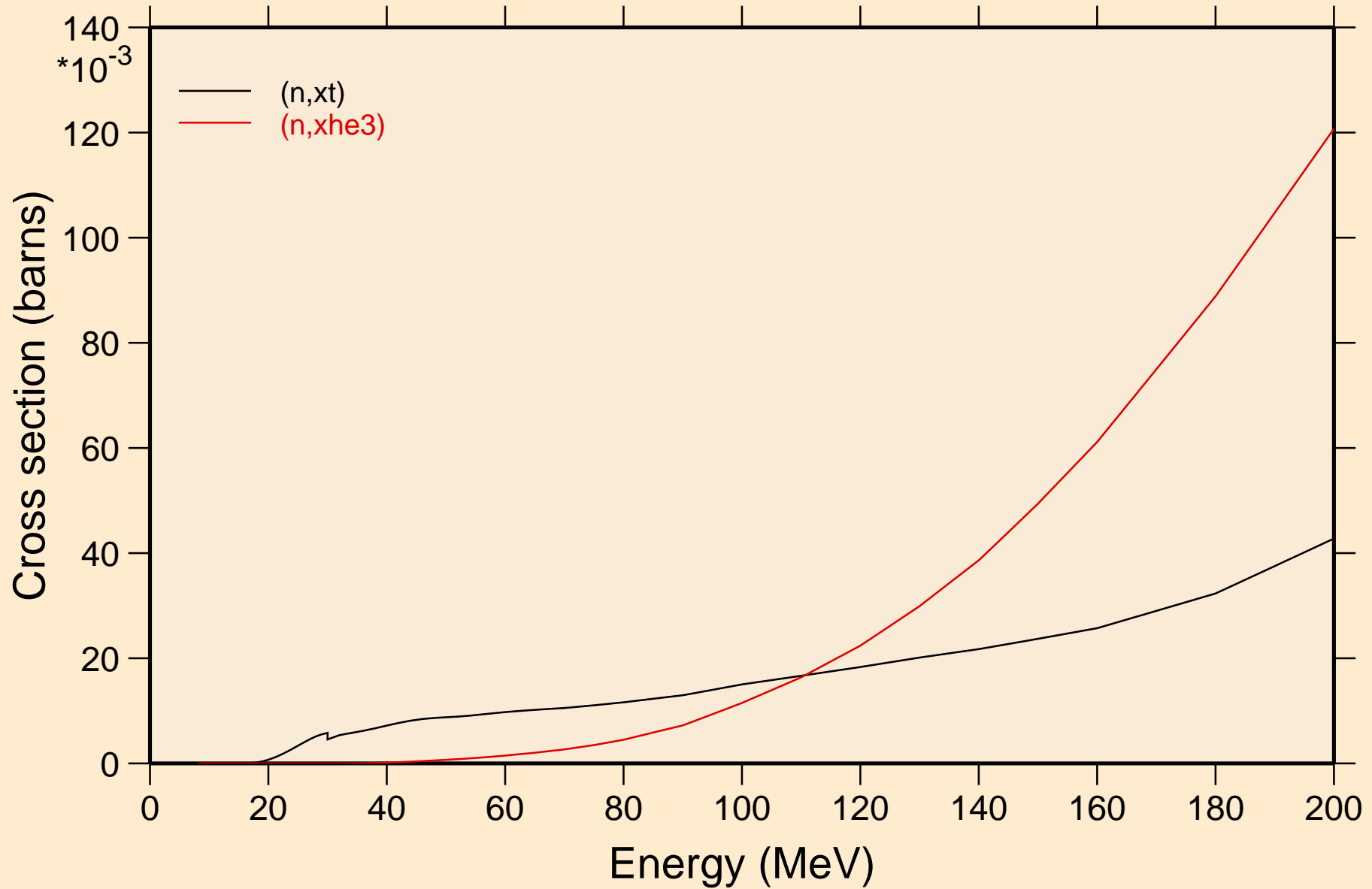

TH238 NEUTRON ACER TENDL-2023 LIBRARY; T=0.K
angular distribution for elastic

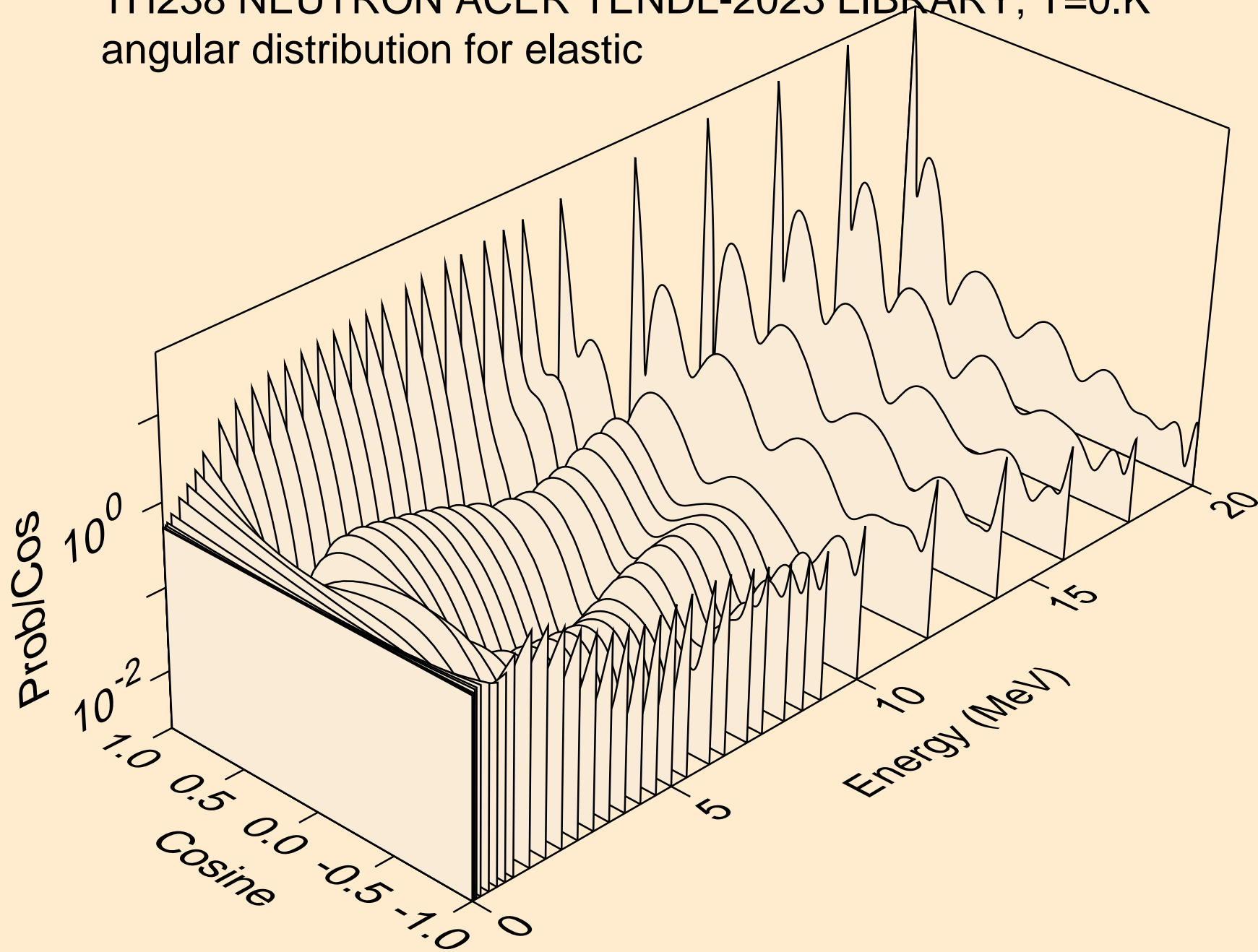

TH238 NEUTRON ACER TENDL-2023 LIBRARY; T=0.K
angular distribution for elastic

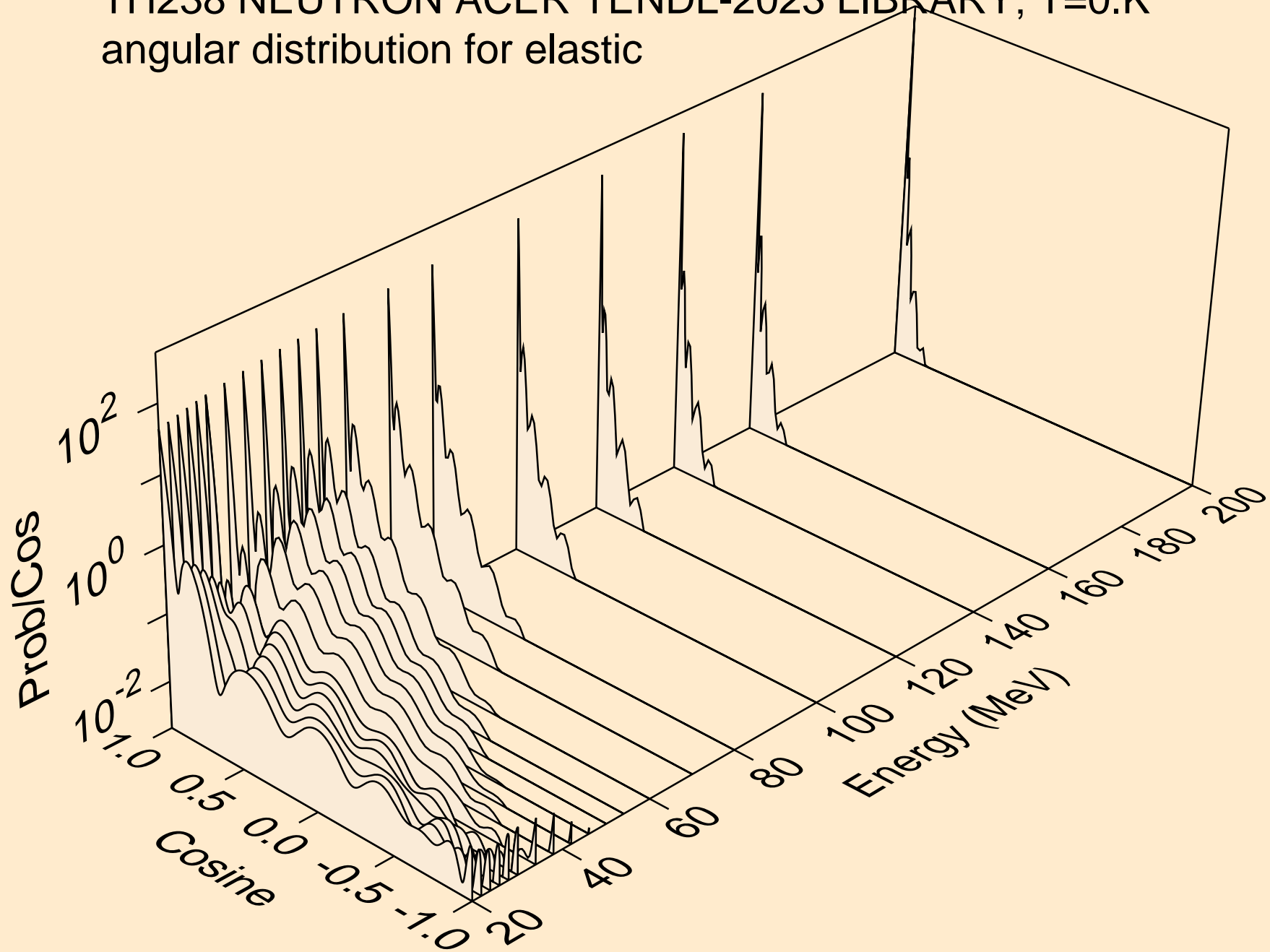

TH238 NEUTRON ACER TENDL-2023 LIBRARY; T=0.K
angular distribution for (n,n*1)

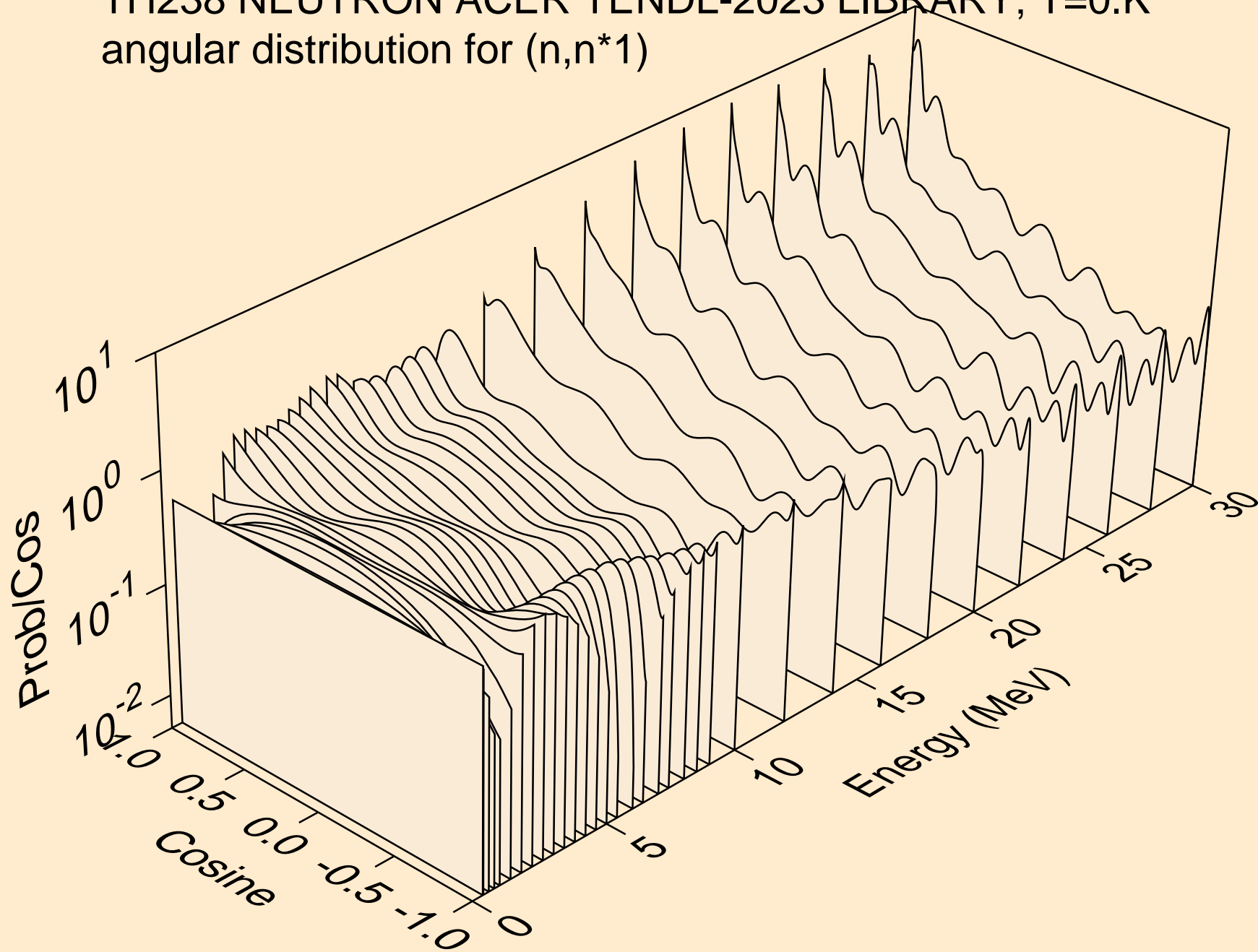

TH238 NEUTRON ACER TENDL-2023 LIBRARY; T=0.K
angular distribution for (n,n*2)

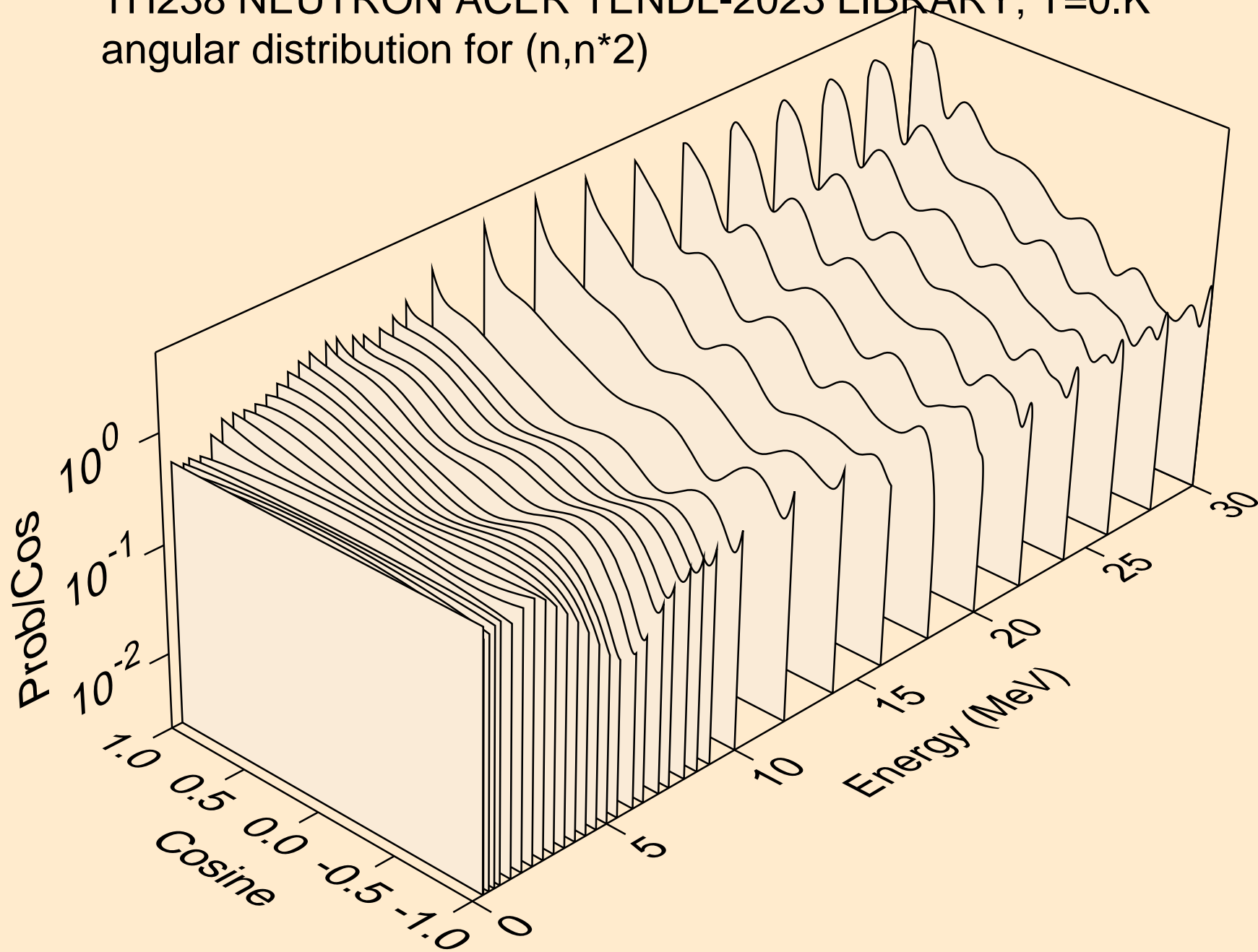

TH238 NEUTRON ACER TENDL-2023 LIBRARY; T=0.K
angular distribution for (n,n*3)

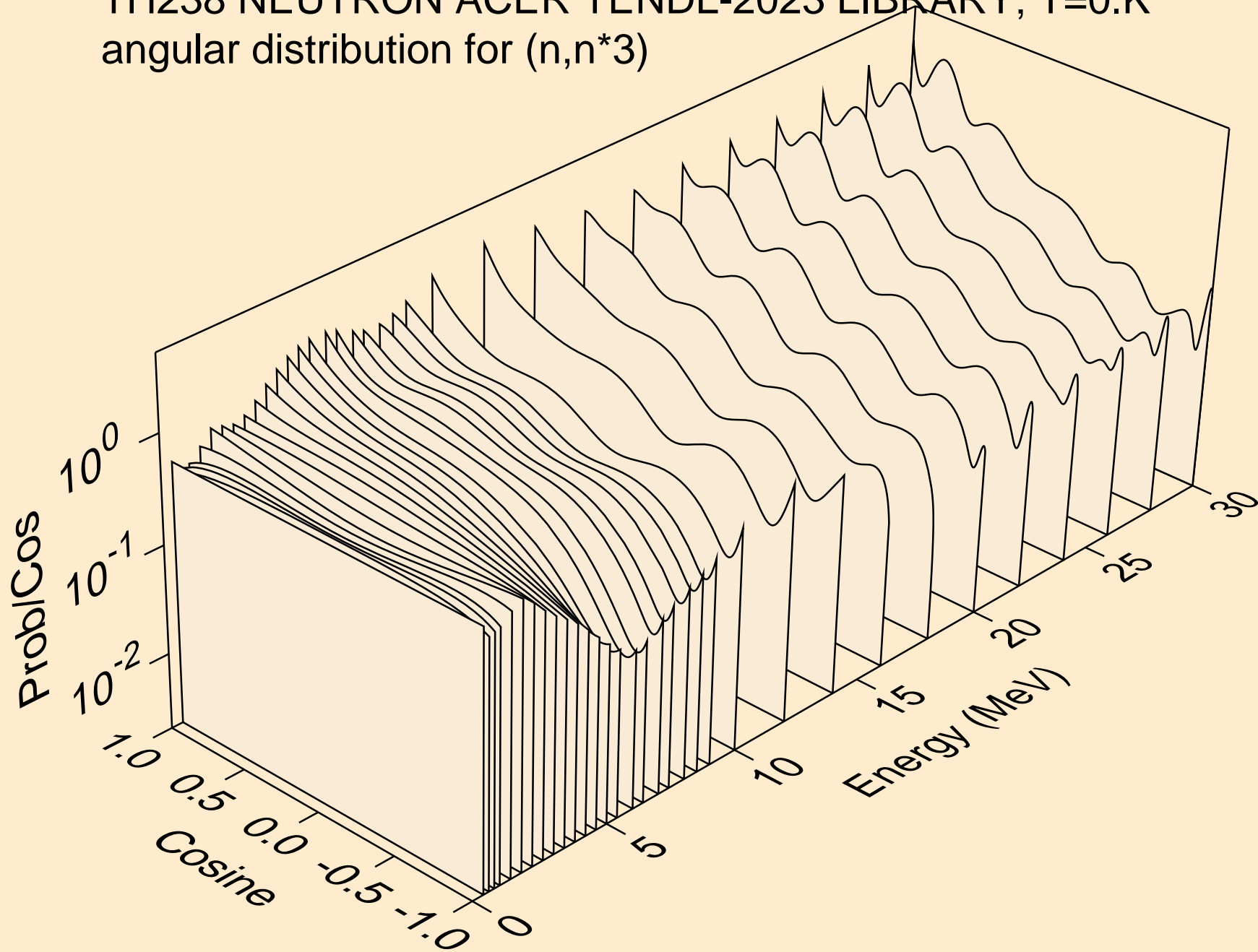

TH238 NEUTRON ACER TENDL-2023 LIBRARY; T=0.K
angular distribution for (n,n*4)

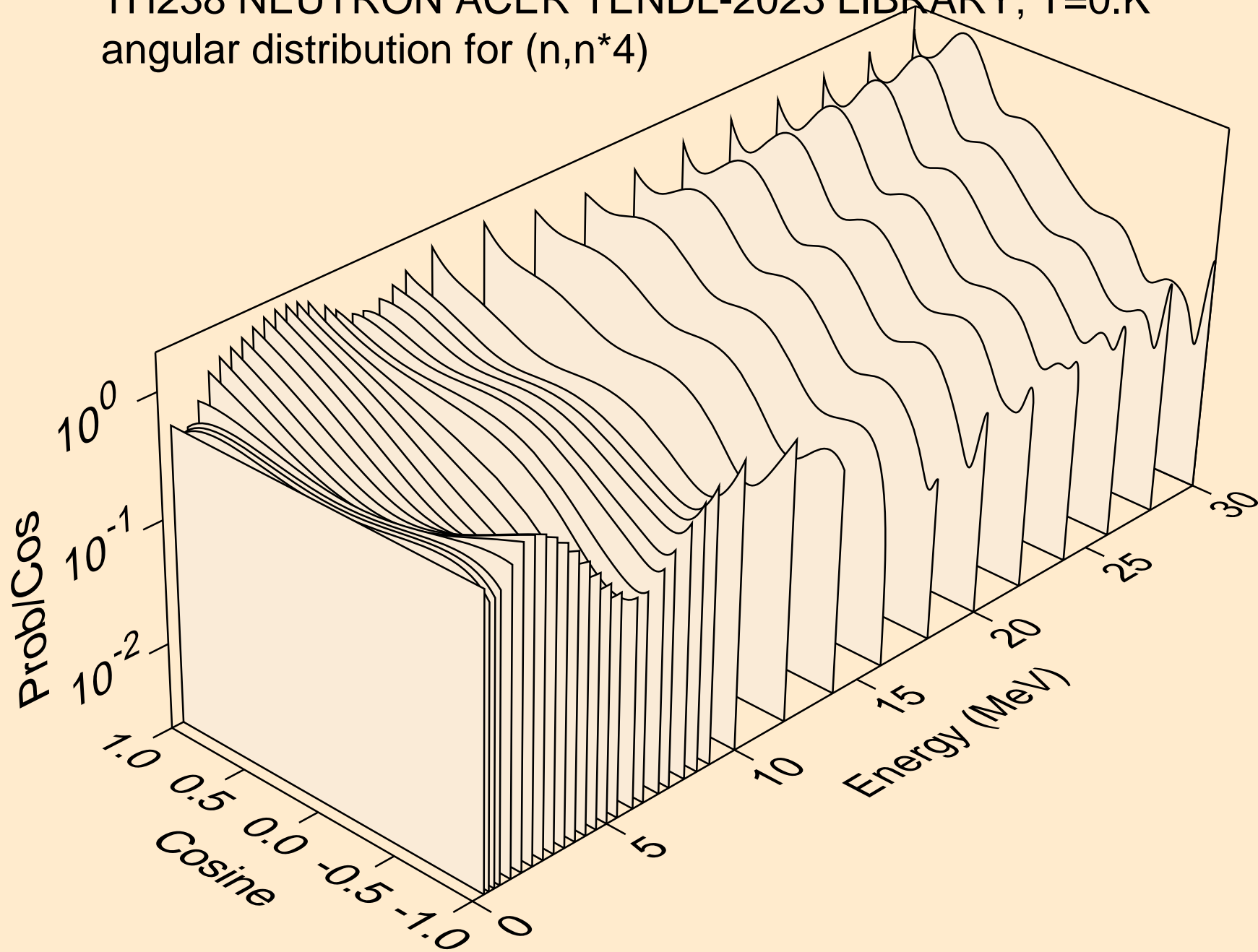

TH238 NEUTRON ACER TENDL-2023 LIBRARY; T=0.K
angular distribution for (n,n*5)

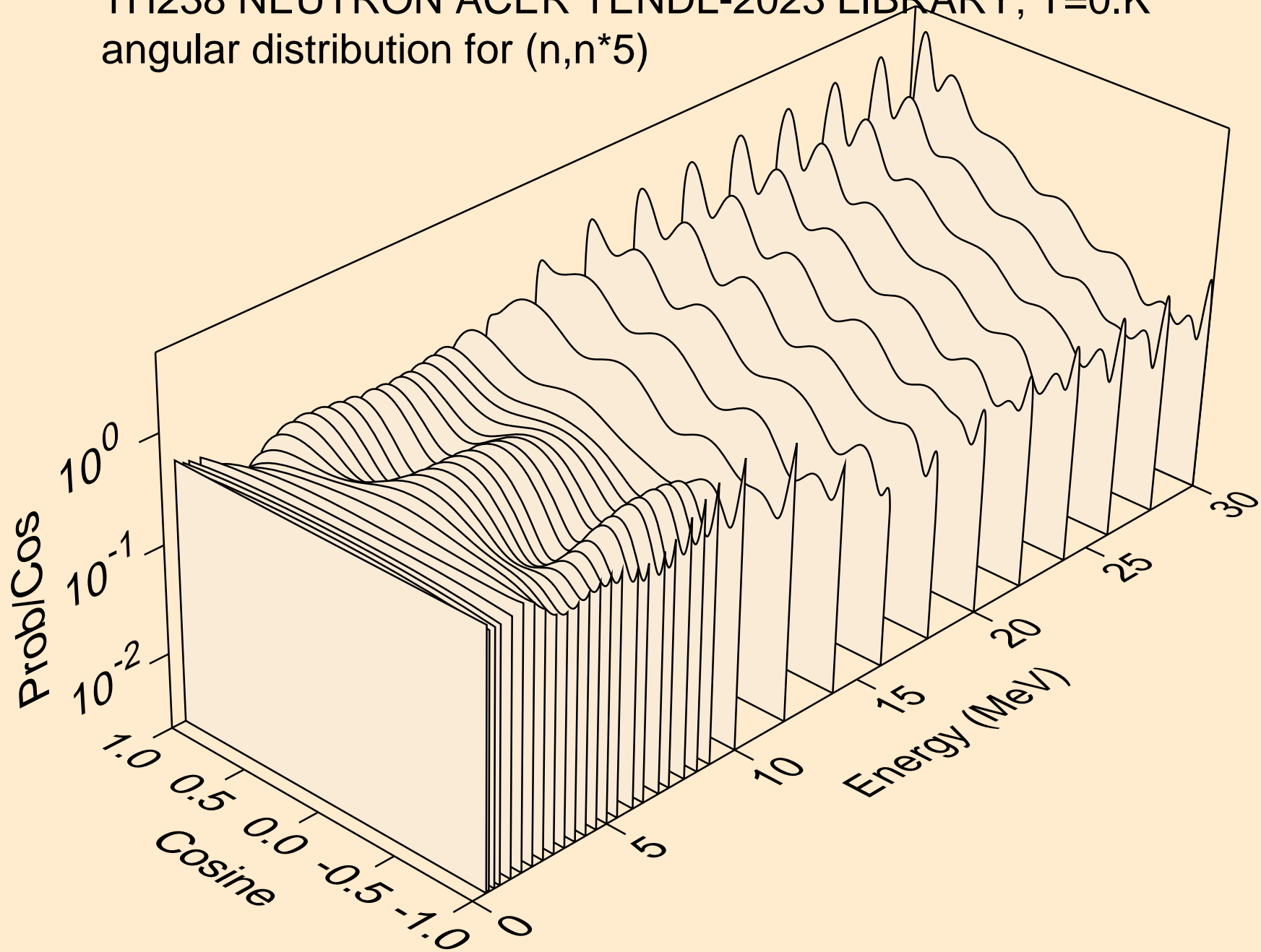

TH238 NEUTRON ACER TENDL-2023 LIBRARY; T=0.K
angular distribution for (n,n*6)

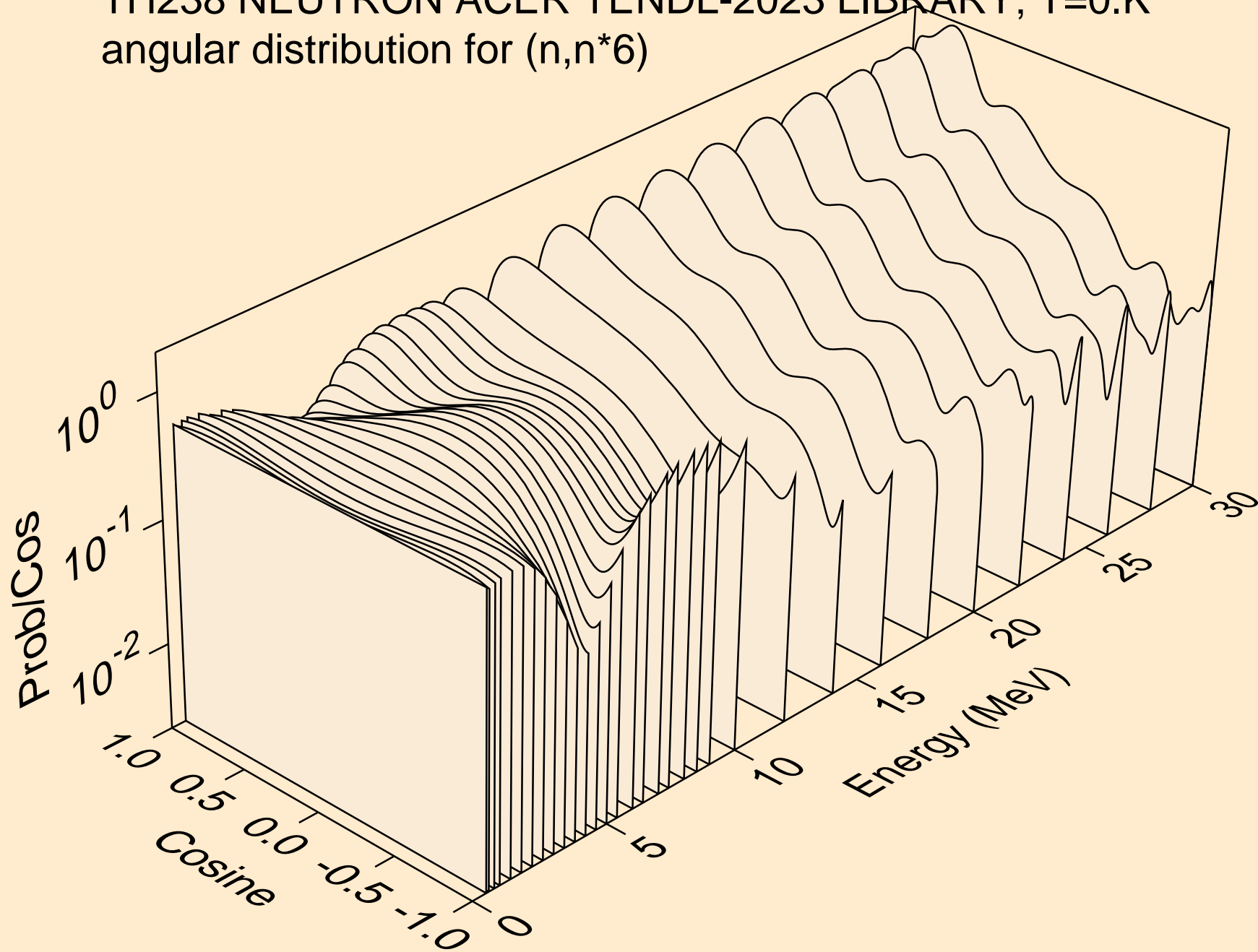

TH238 NEUTRON ACER TENDL-2023 LIBRARY; T=0.K
angular distribution for (n,n*7)

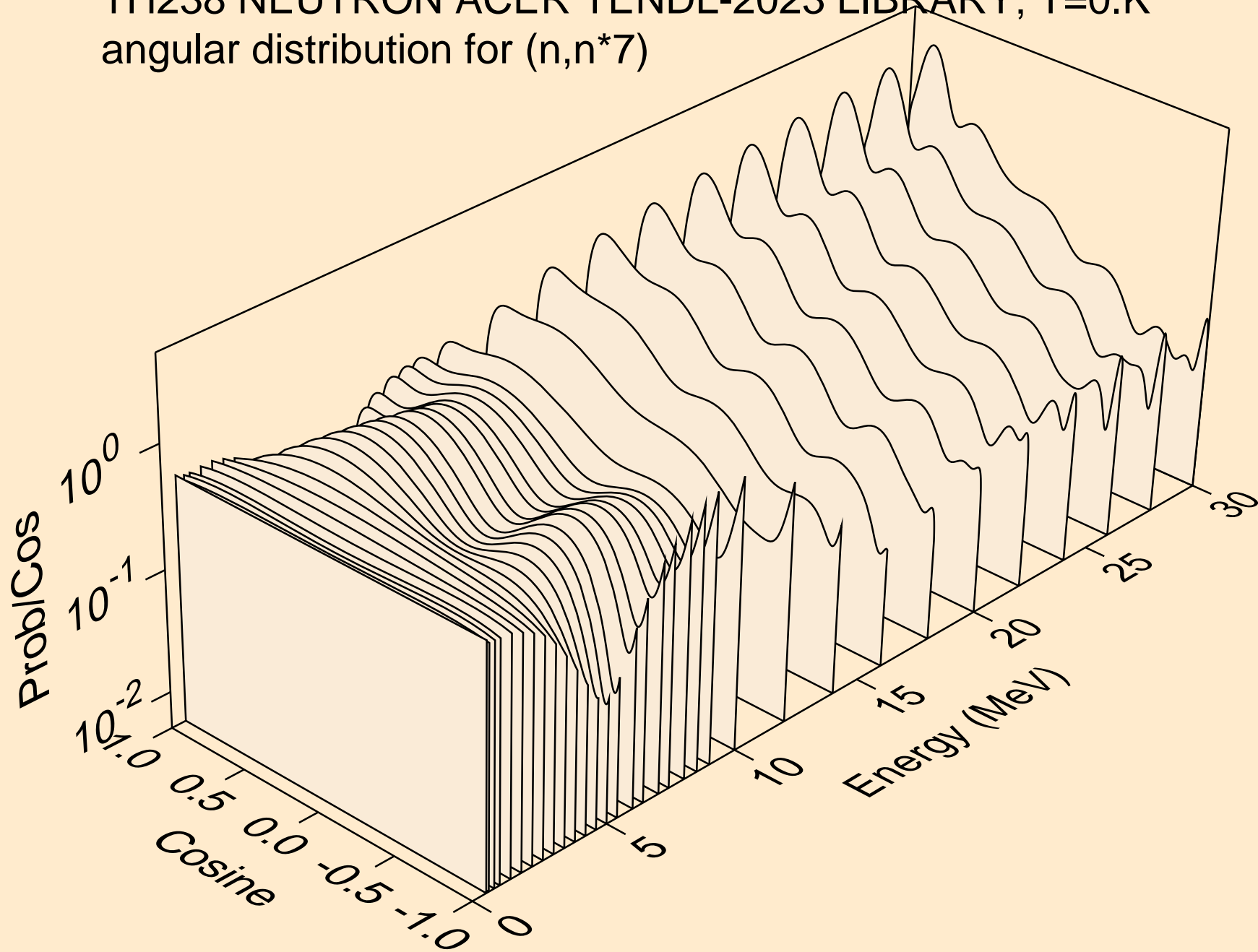

TH238 NEUTRON ACER TENDL-2023 LIBRARY; T=0.K
angular distribution for (n,n*8)

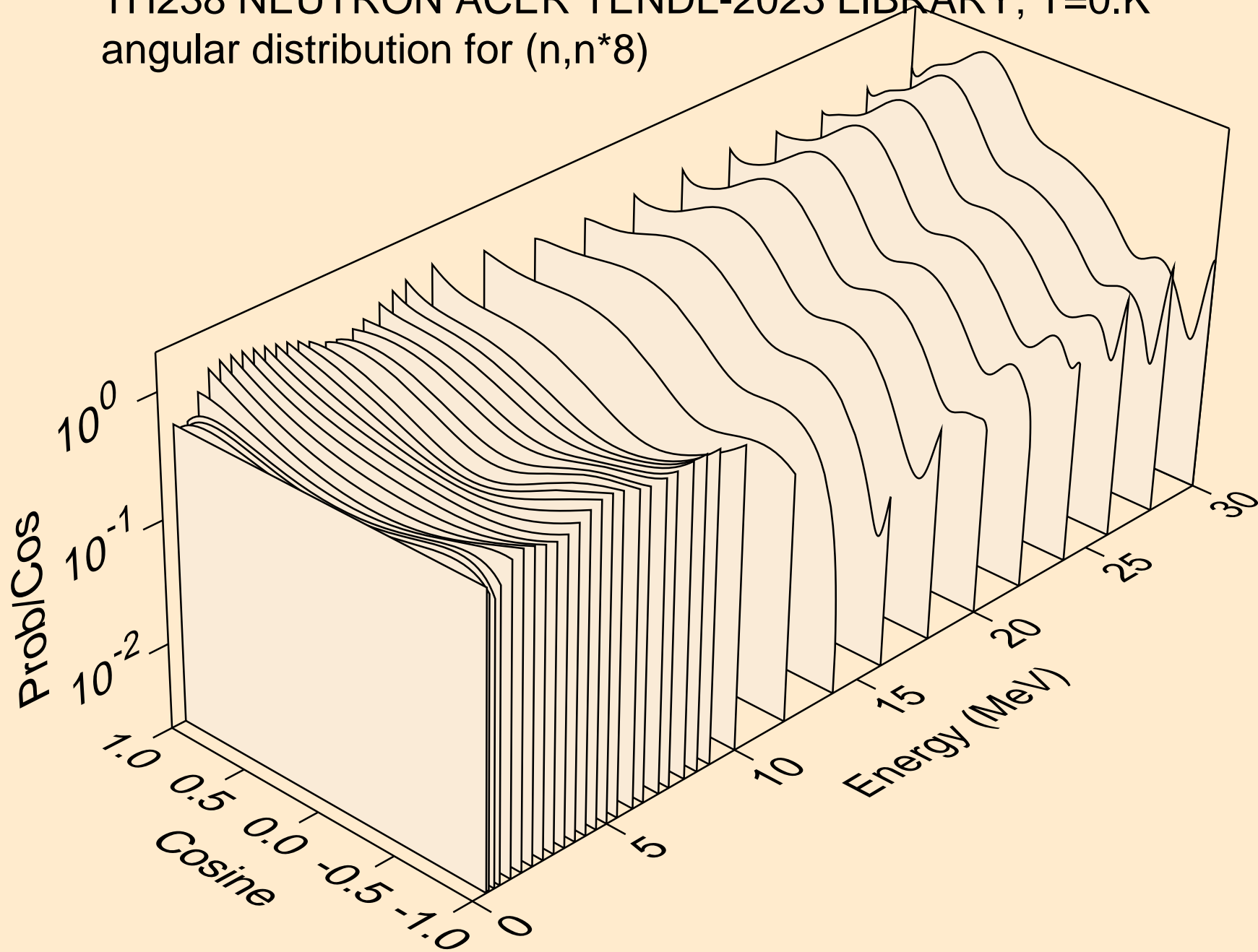

TH238 NEUTRON ACER TENDL-2023 LIBRARY; T=0.K
angular distribution for (n,n*9)

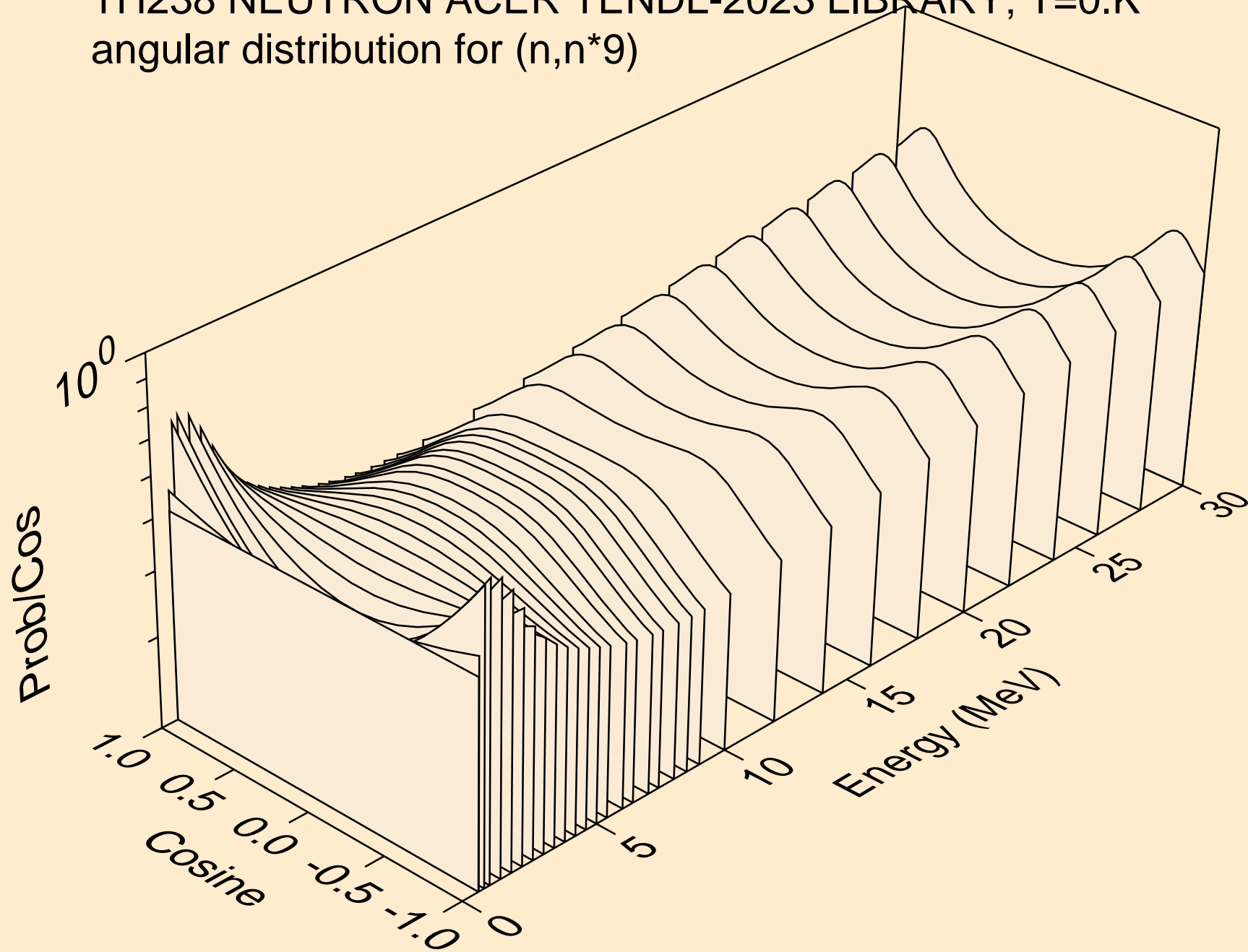

TH238 NEUTRON ACER TENDL-2023 LIBRARY; T=0.K
angular distribution for (n,n*10)

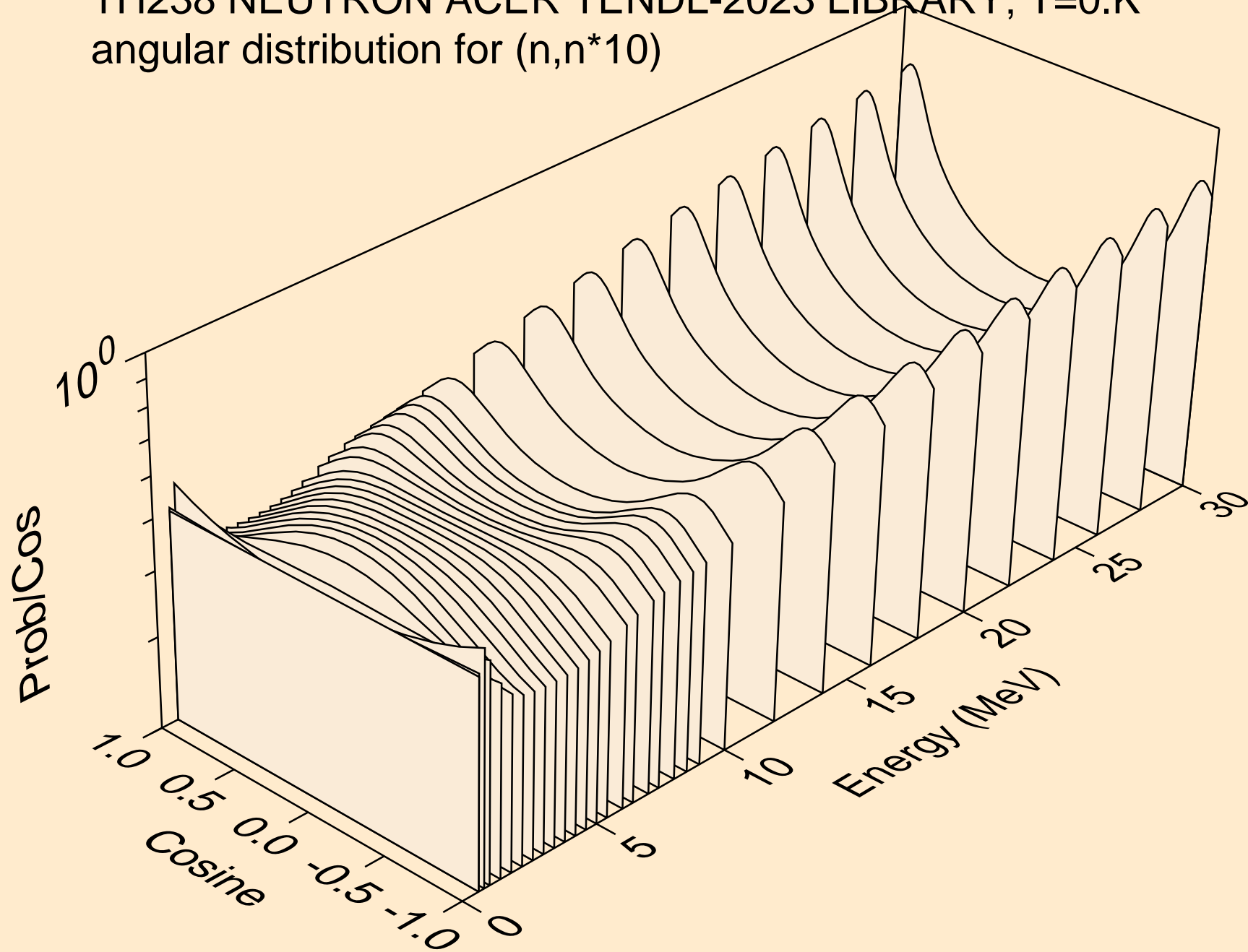

TH238 NEUTRON ACER TENDL-2023 LIBRARY; T=0.K
angular distribution for (n,n*11)

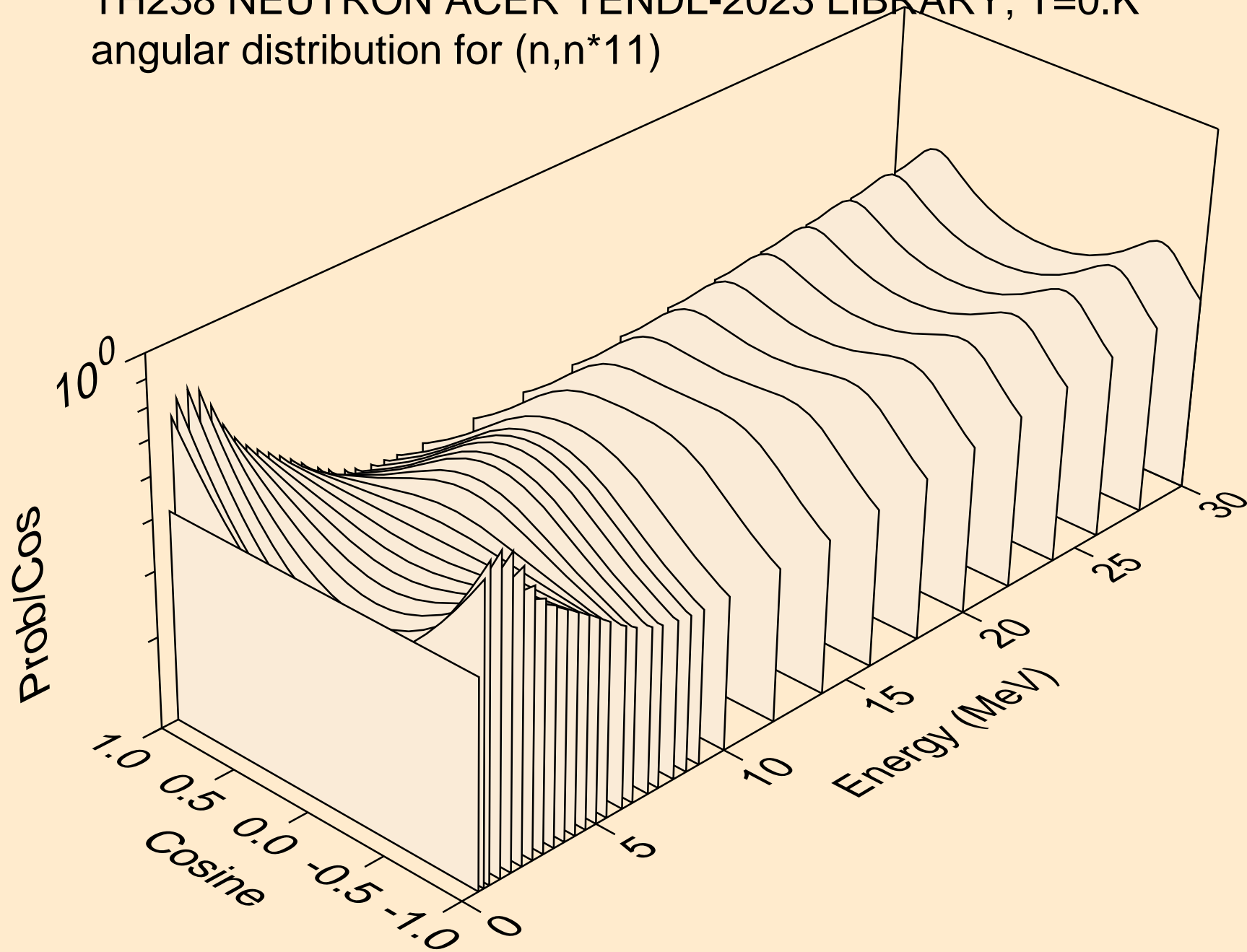

TH238 NEUTRON ACER TENDL-2023 LIBRARY; T=0.K
angular distribution for (n,n*12)

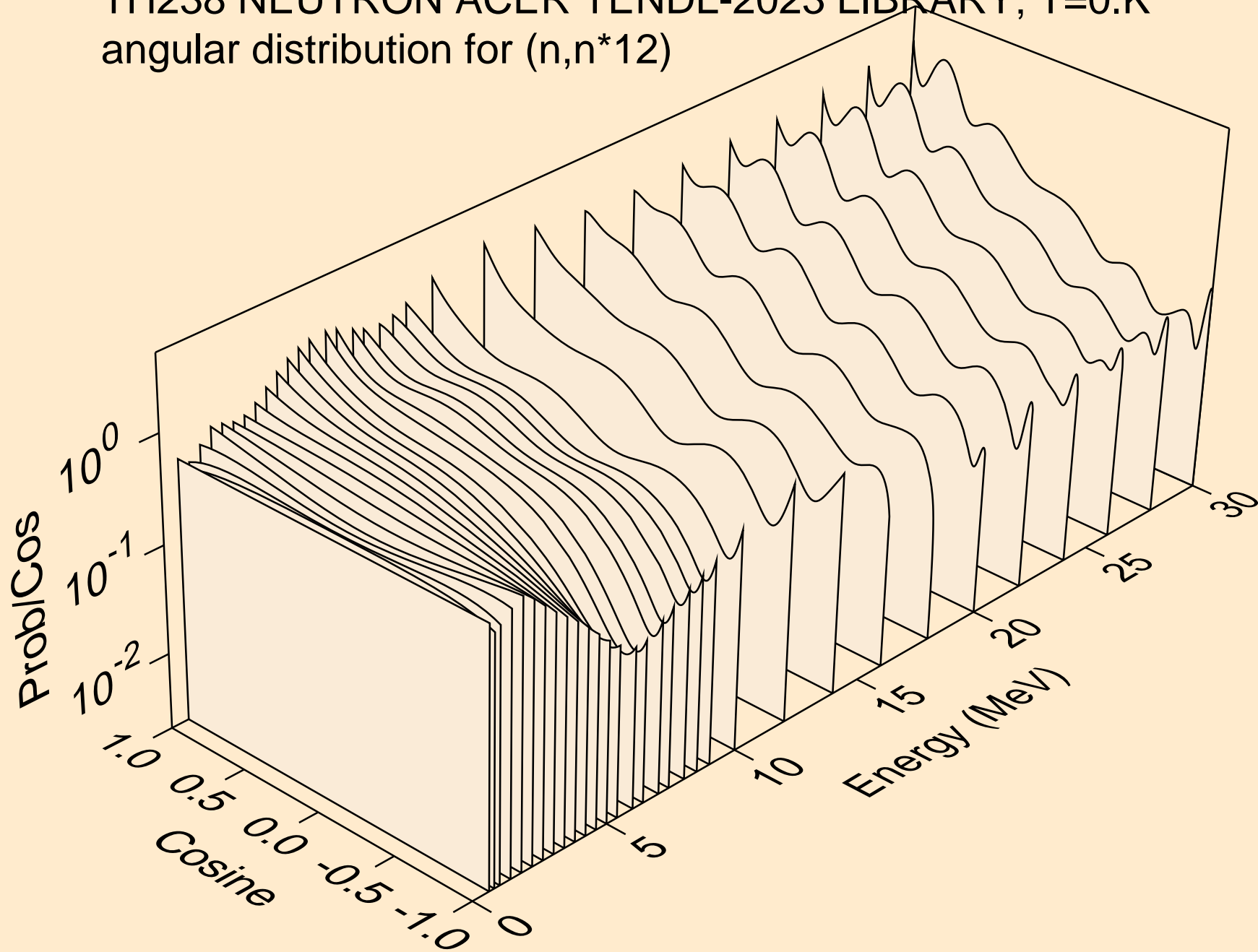

TH238 NEUTRON ACER TENDL-2023 LIBRARY; T=0.K
angular distribution for (n,n*13)

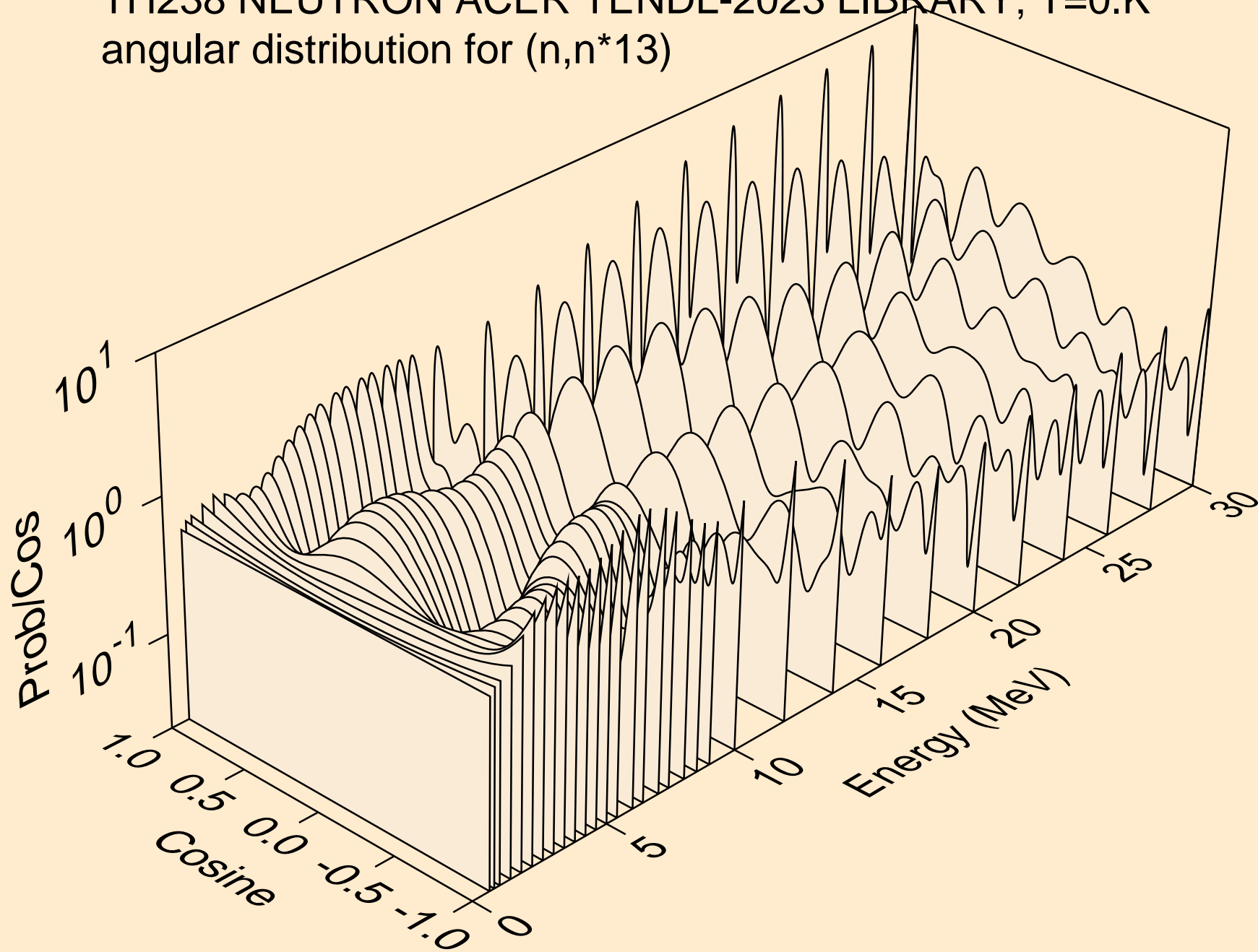

TH238 NEUTRON ACER TENDL-2023 LIBRARY; T=0.K
angular distribution for (n,n*14)

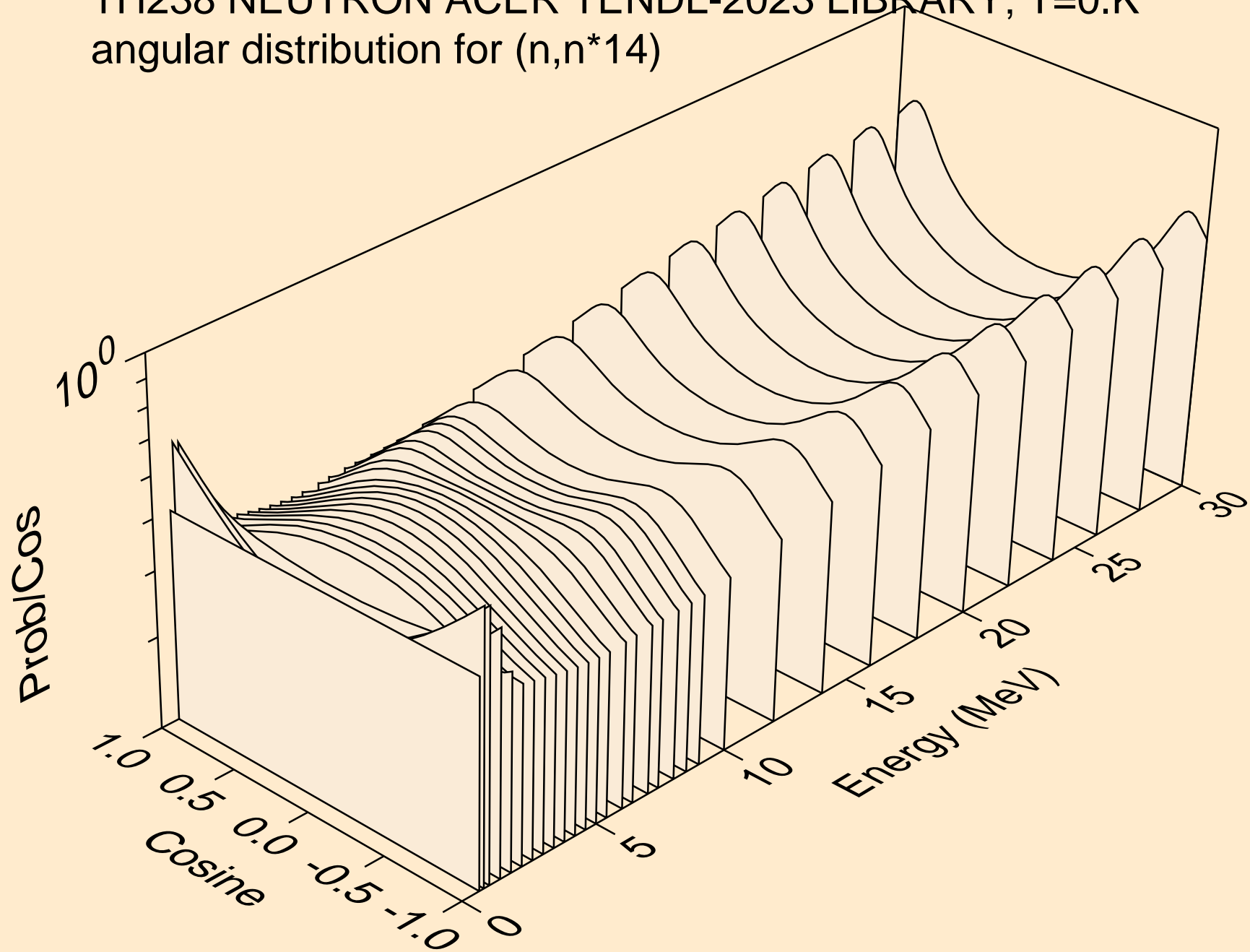

TH238 NEUTRON ACER TENDL-2023 LIBRARY; T=0.K
angular distribution for (n,n*15)

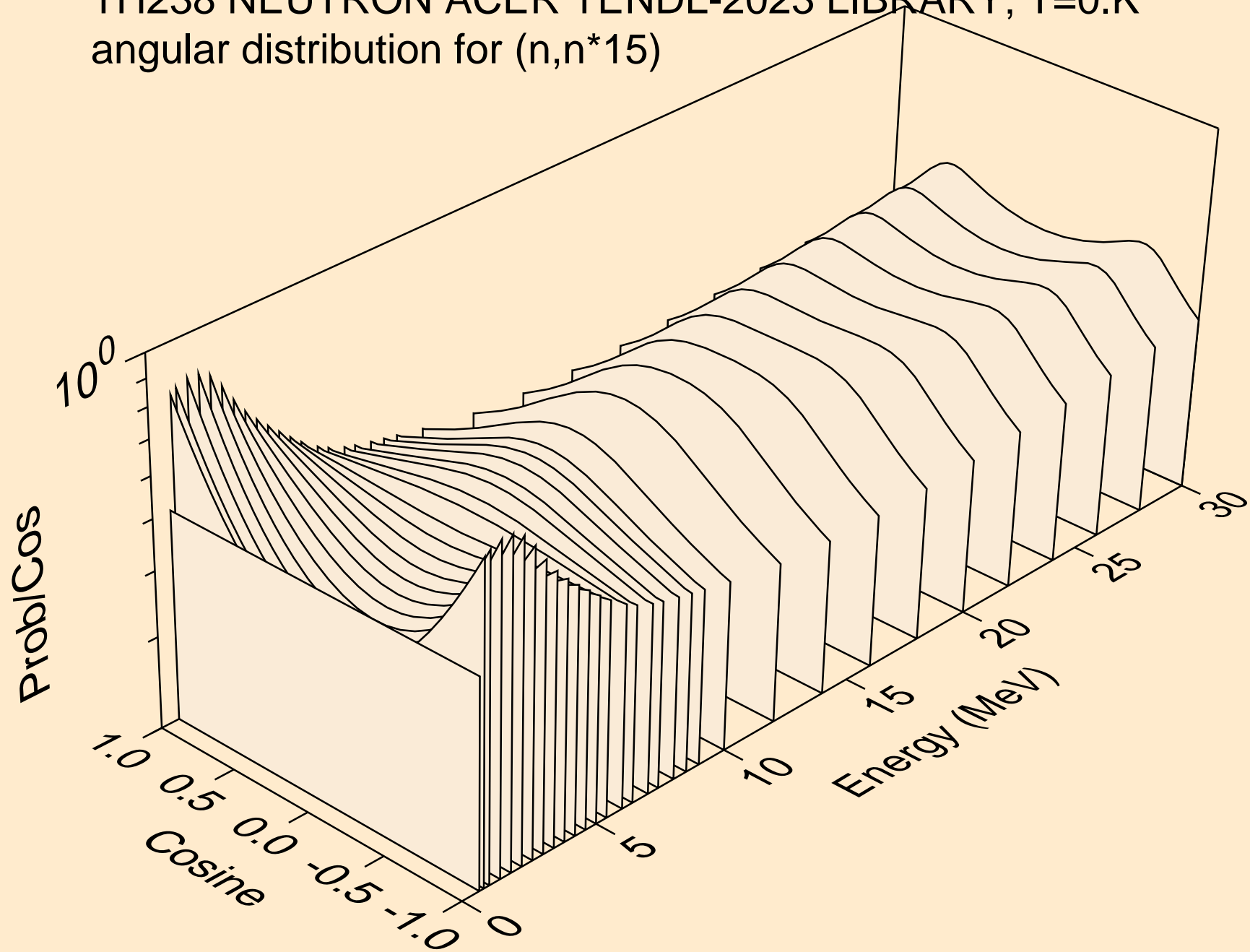

TH238 NEUTRON ACER TENDL-2023 LIBRARY; T=0.K
angular distribution for (n,n*16)

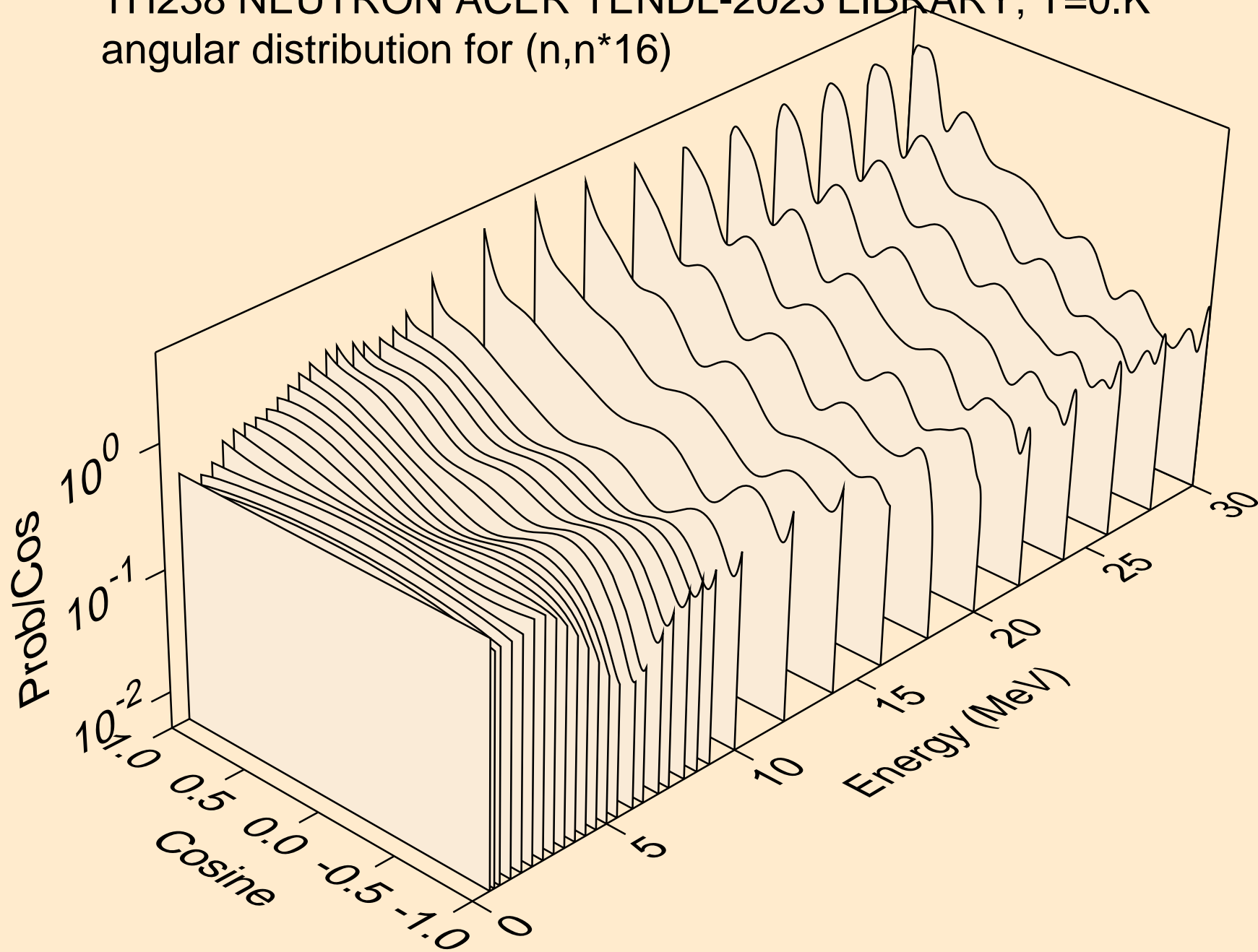

TH238 NEUTRON ACER TENDL-2023 LIBRARY; T=0.K
angular distribution for (n,n*17)

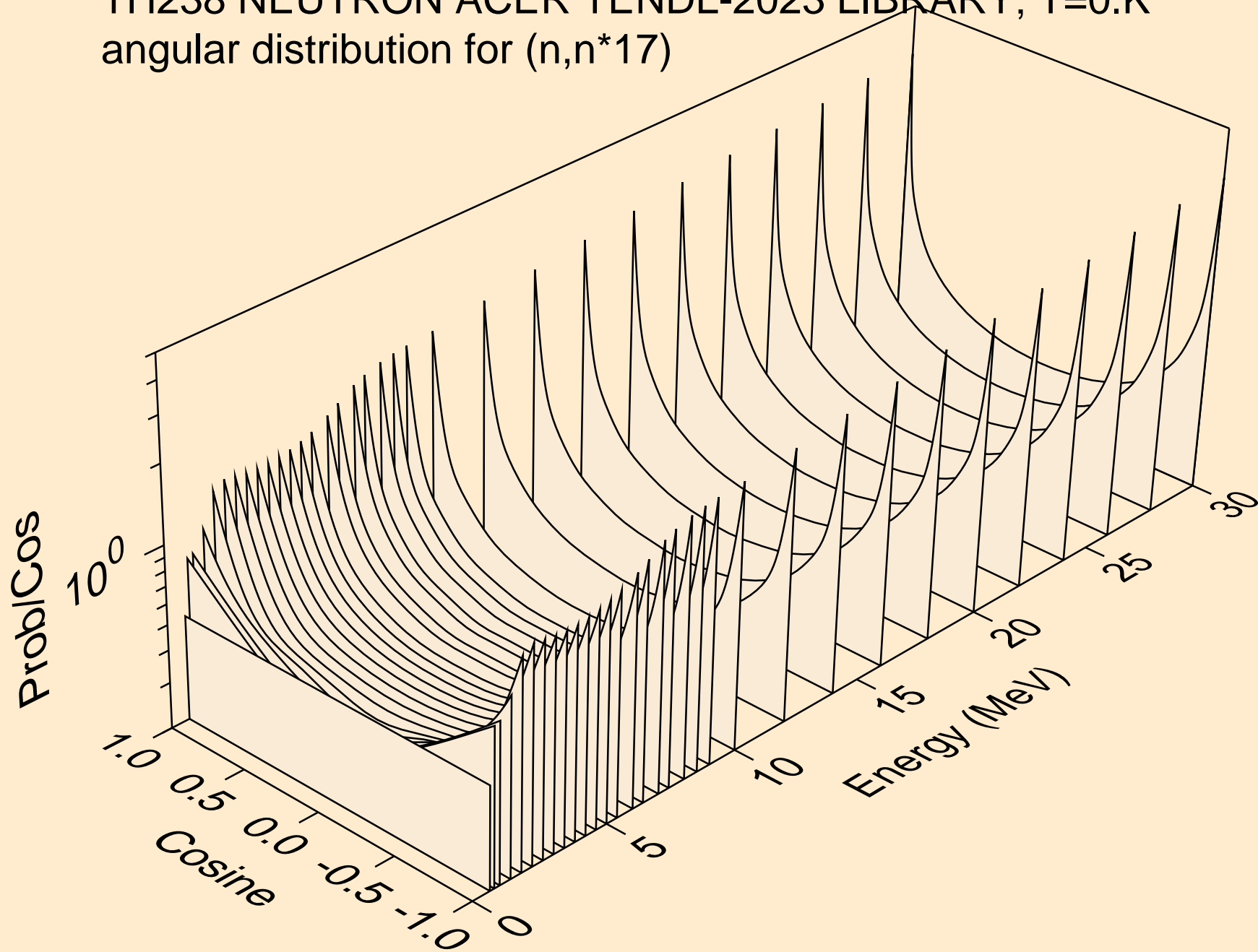

TH238 NEUTRON ACER TENDL-2023 LIBRARY; T=0.K
angular distribution for (n,n*18)

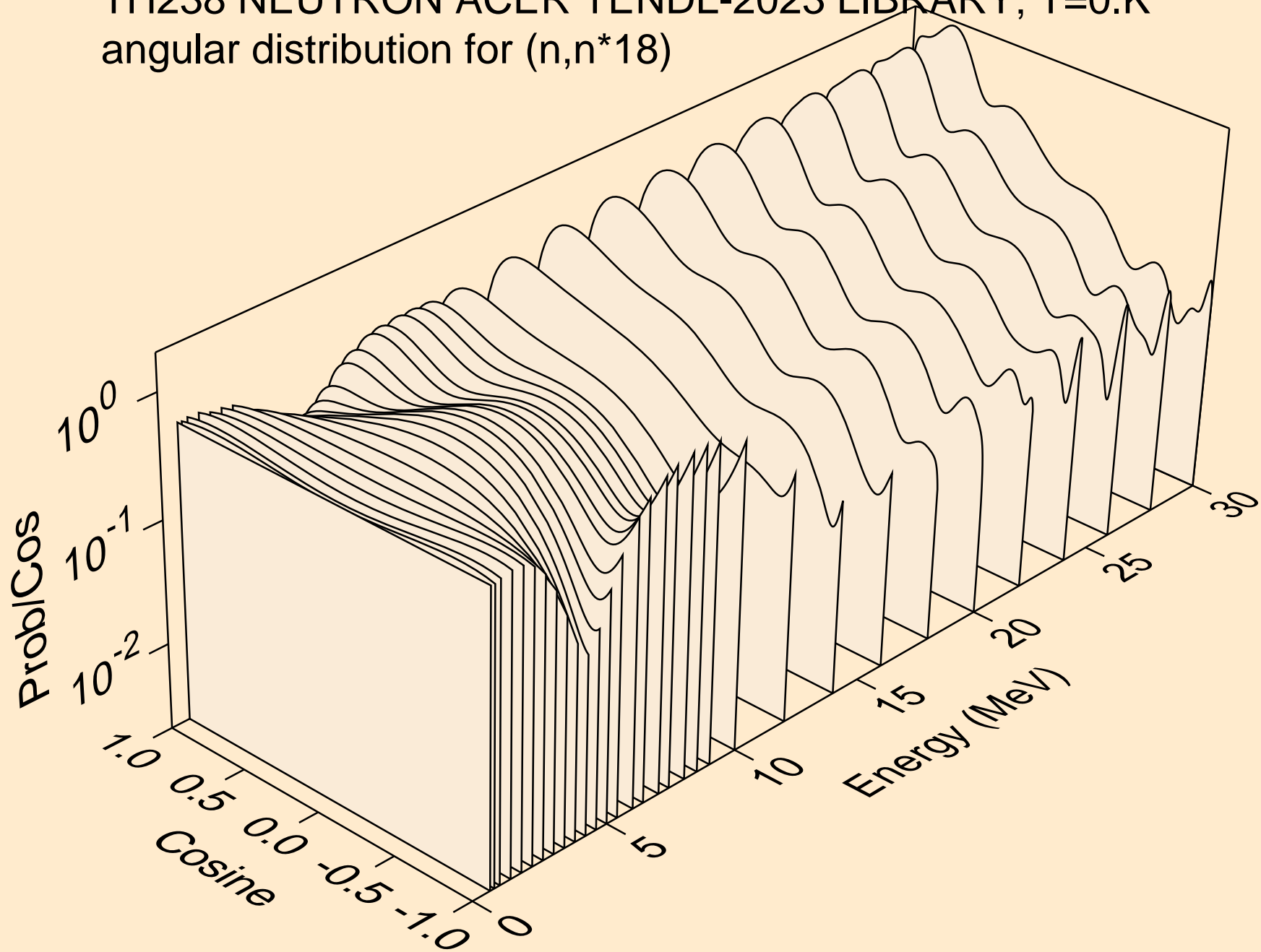

TH238 NEUTRON ACER TENDL-2023 LIBRARY; T=0.K
angular distribution for (n,n*19)

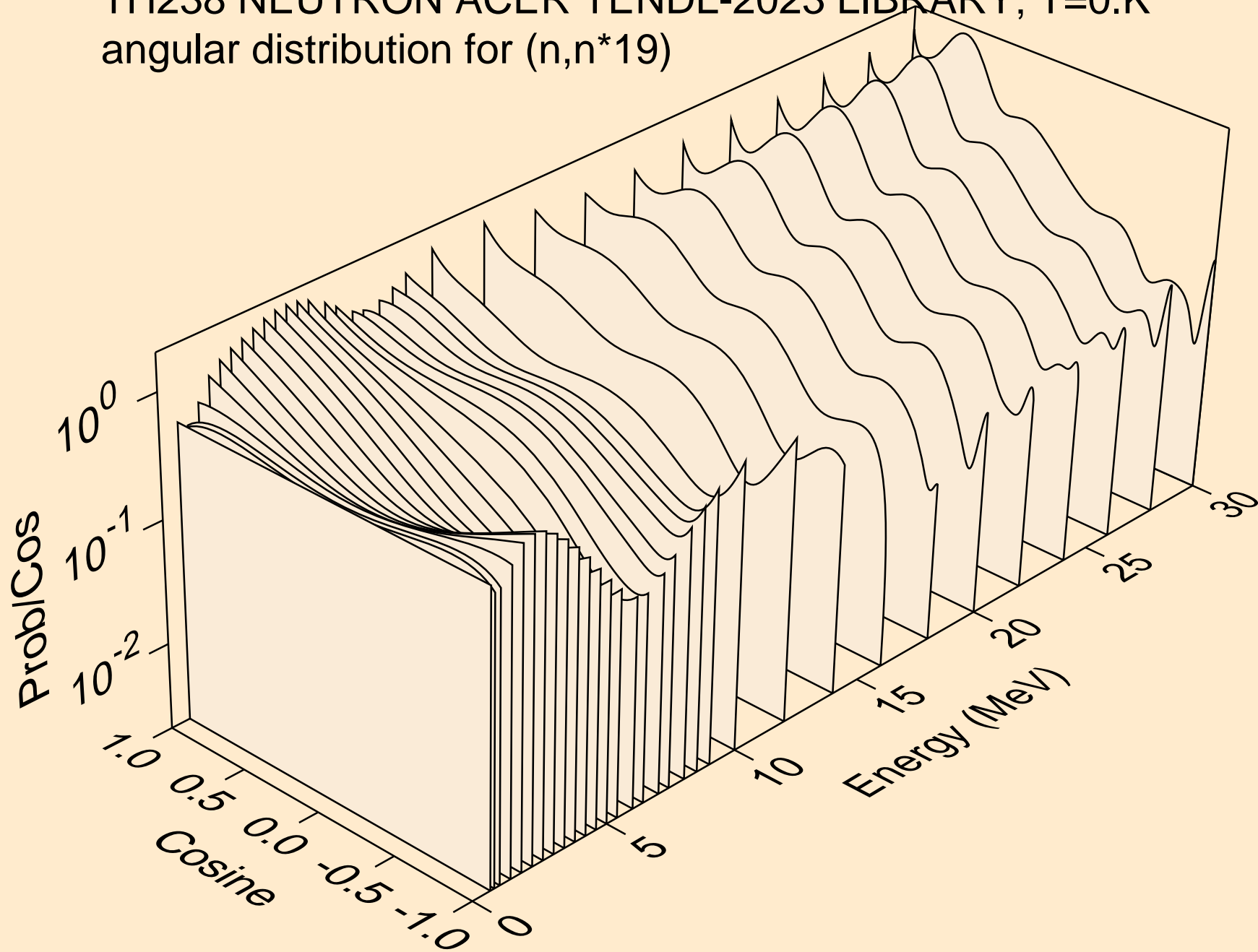

TH238 NEUTRON ACER TENDL-2023 LIBRARY; T=0.K
angular distribution for (n,n*20)

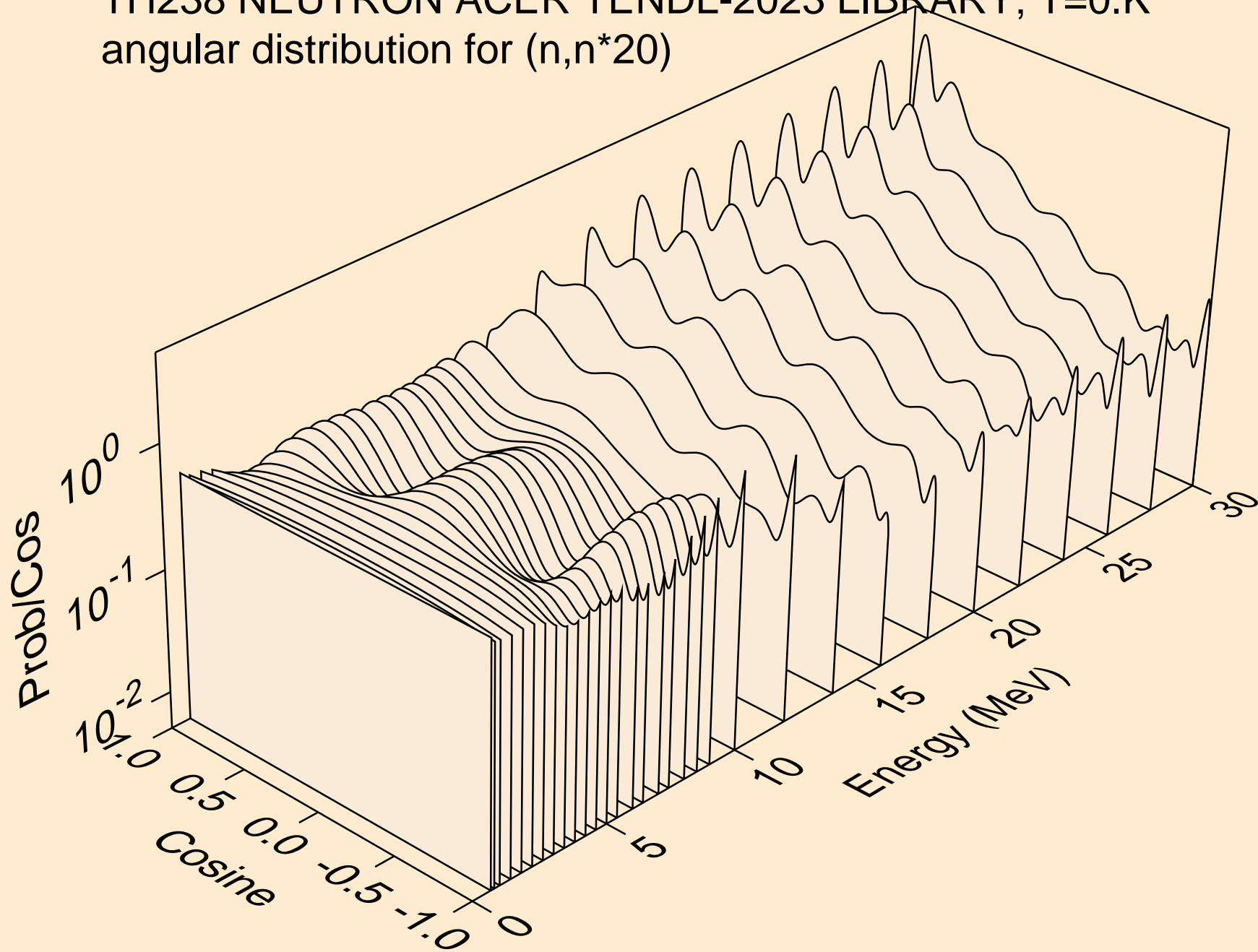

TH238 NEUTRON ACER TENDL-2023 LIBRARY; T=0.K
angular distribution for (n,n*21)

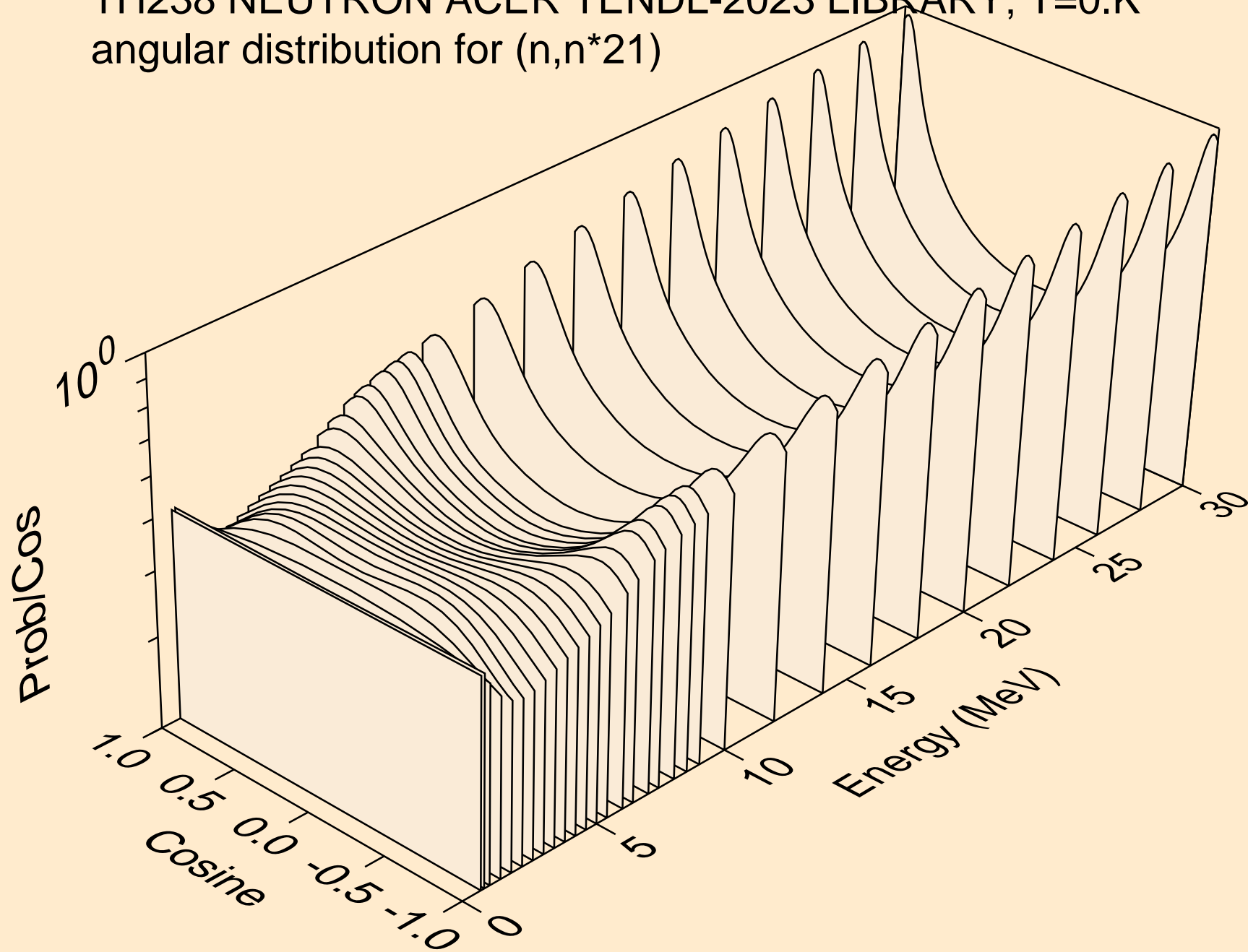

TH238 NEUTRON ACER TENDL-2023 LIBRARY; T=0.K
angular distribution for (n,n*22)

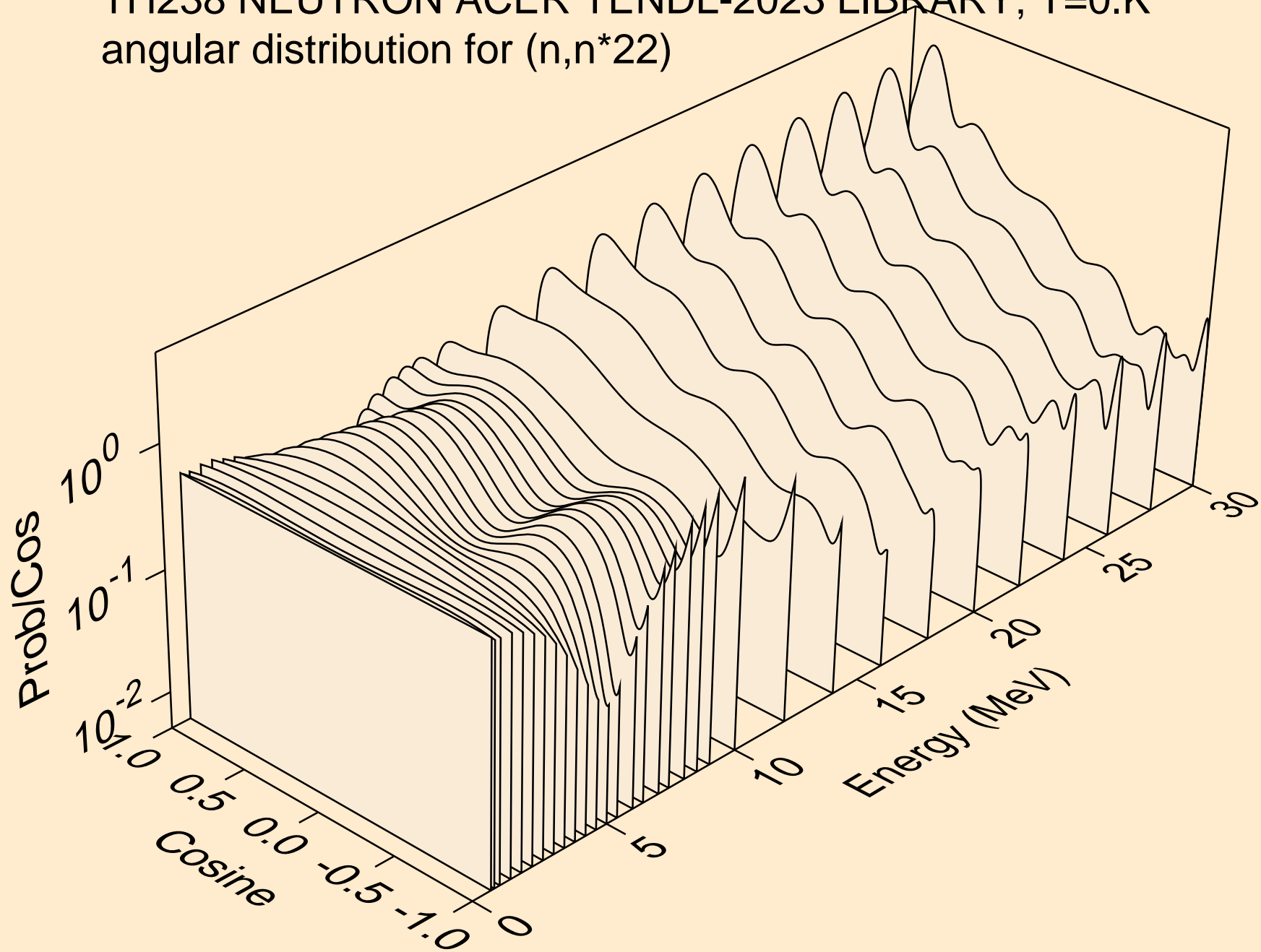

TH238 NEUTRON ACER TENDL-2023 LIBRARY; T=0.K
angular distribution for (n,n*23)

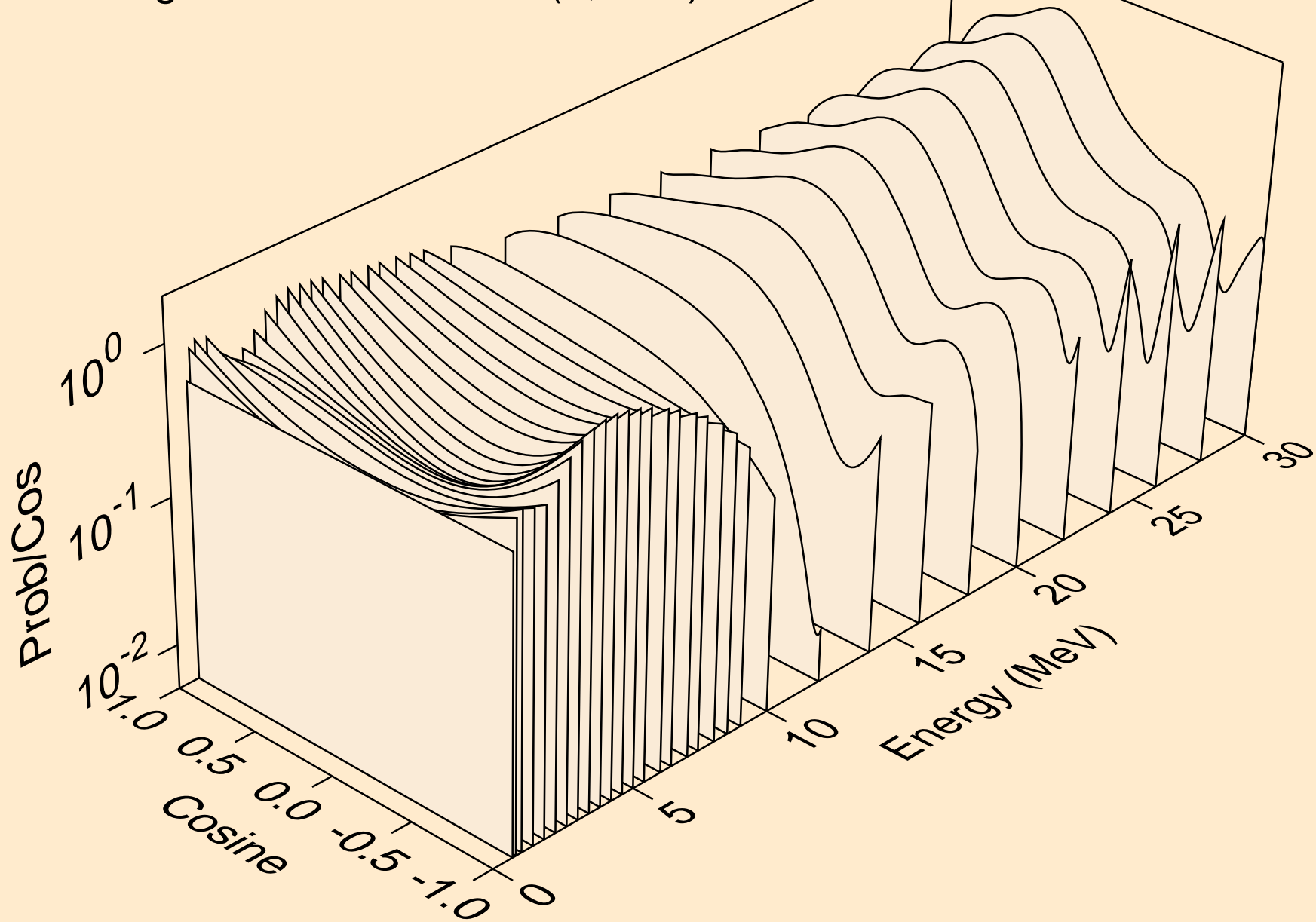

TH238 NEUTRON ACER TENDL-2023 LIBRARY; T=0.K
angular distribution for (n,n*24)

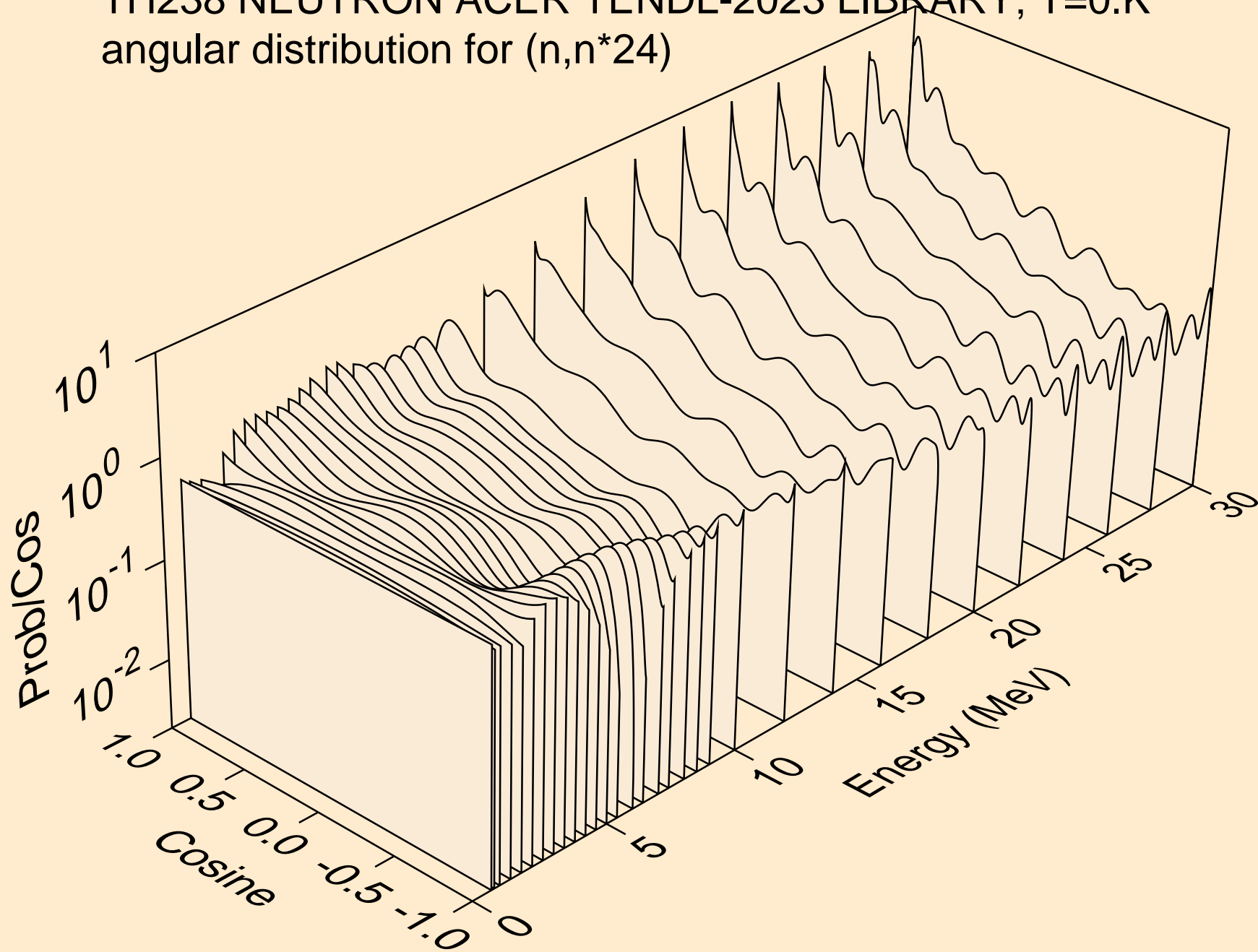

TH238 NEUTRON ACER TENDL-2023 LIBRARY; T=0.K
angular distribution for (n,n*25)

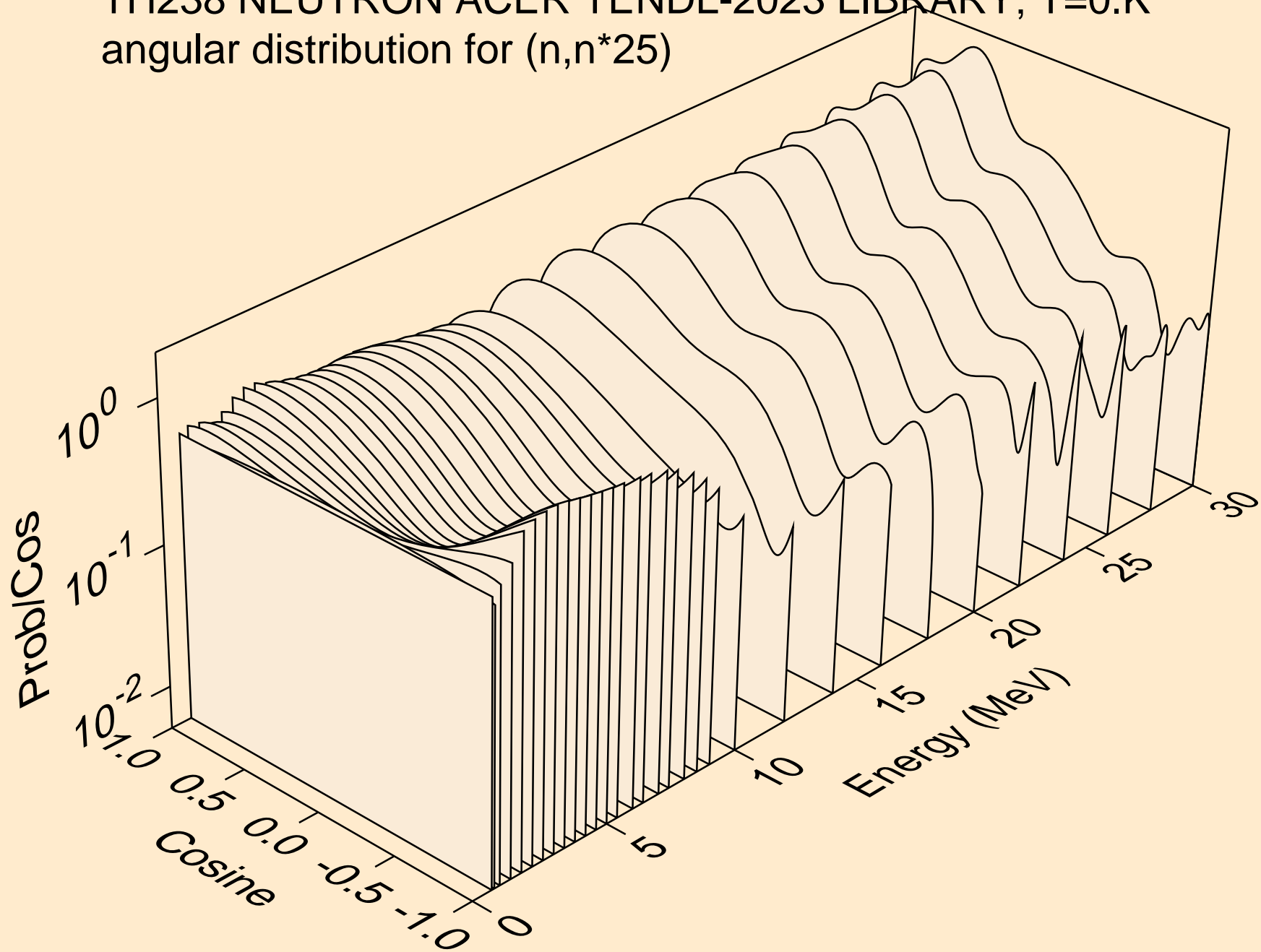

TH238 NEUTRON ACER TENDL-2023 LIBRARY; T=0.K
angular distribution for (n,n*26)

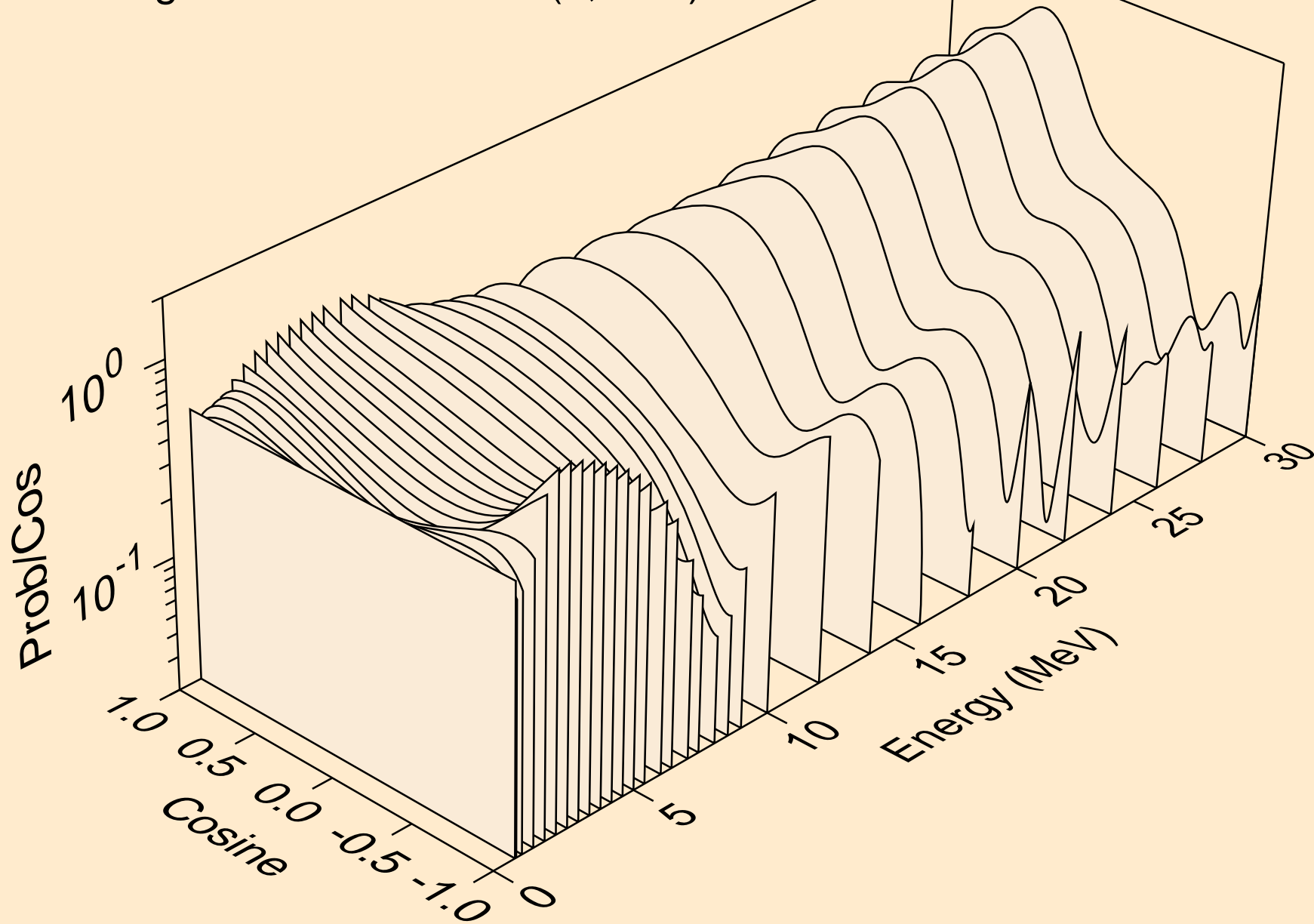

TH238 NEUTRON ACER TENDL-2023 LIBRARY; T=0.K
angular distribution for (n,n*27)

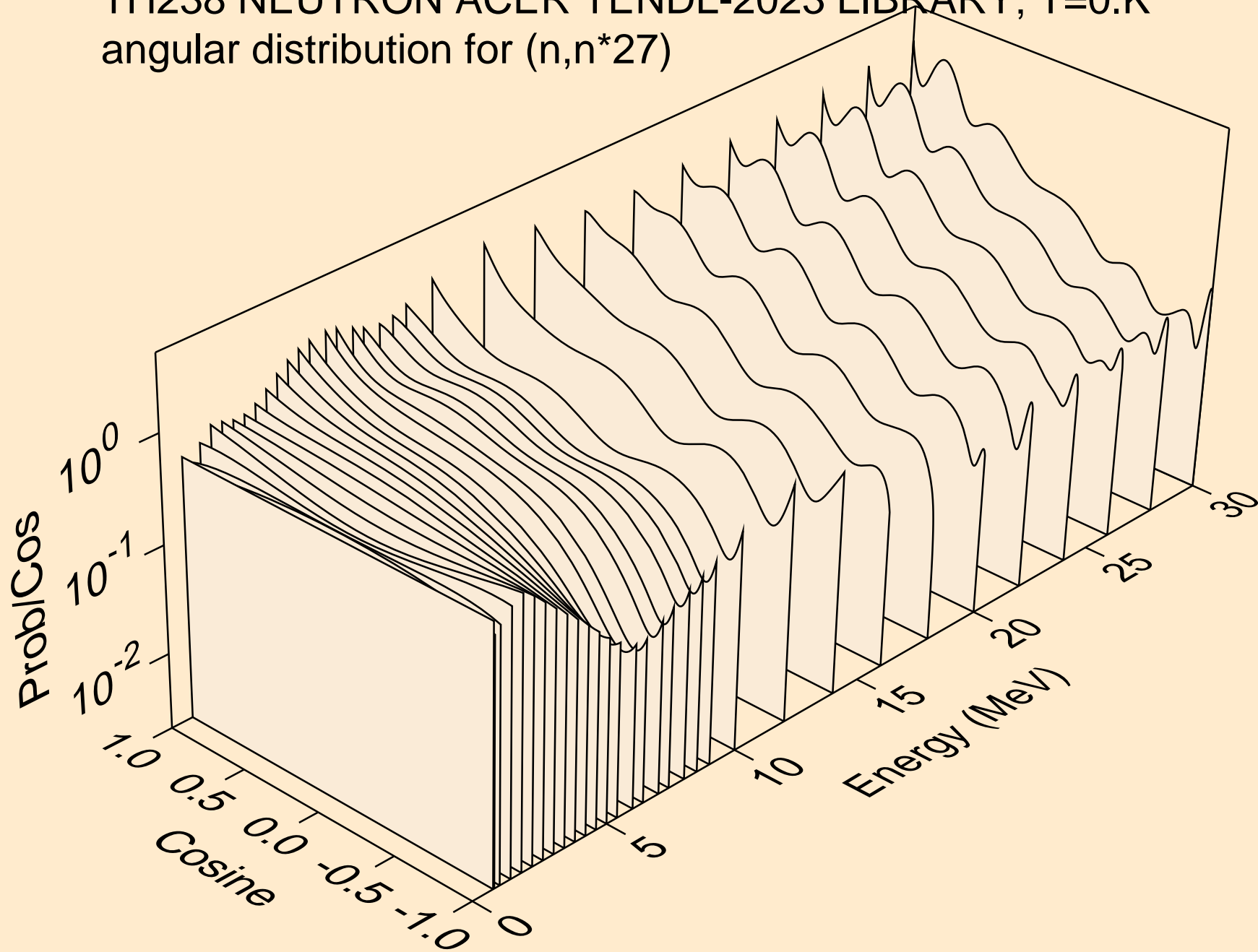

TH238 NEUTRON ACER TENDL-2023 LIBRARY; T=0.K
angular distribution for (n,n*28)

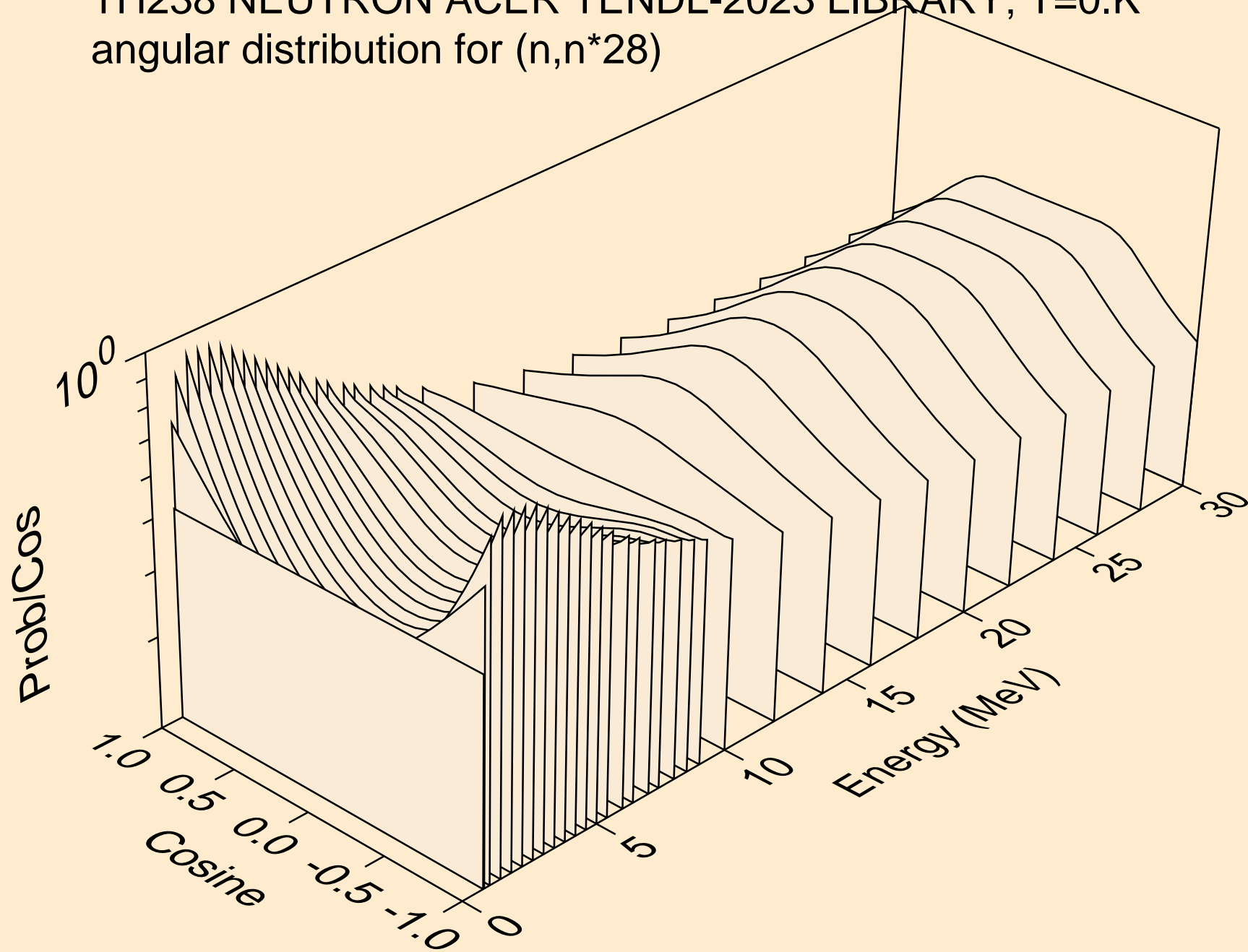

TH238 NEUTRON ACER TENDL-2023 LIBRARY; T=0.K
angular distribution for (n,n*29)

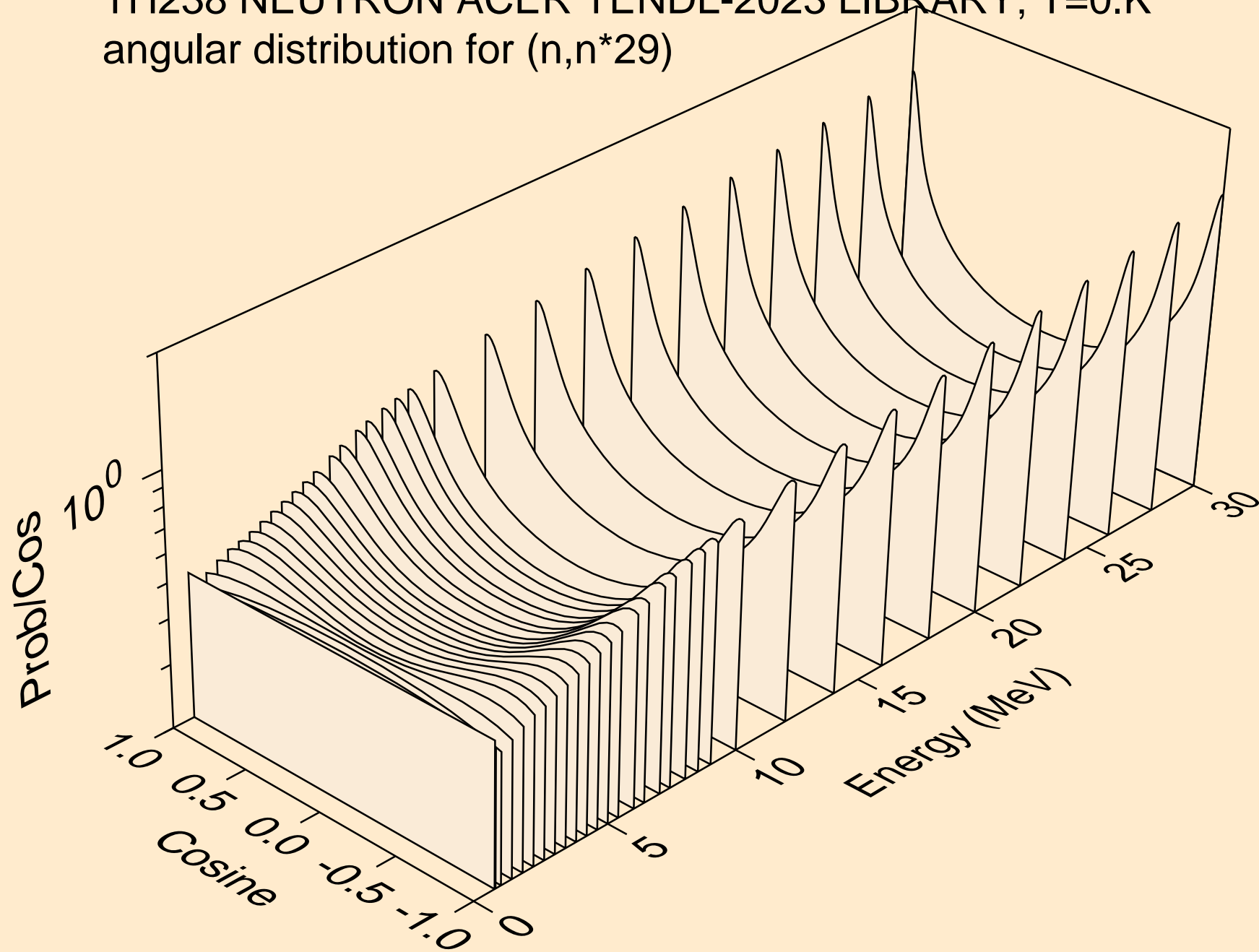

TH238 NEUTRON ACER TENDL-2023 LIBRARY; T=0.K
angular distribution for (n,n*30)

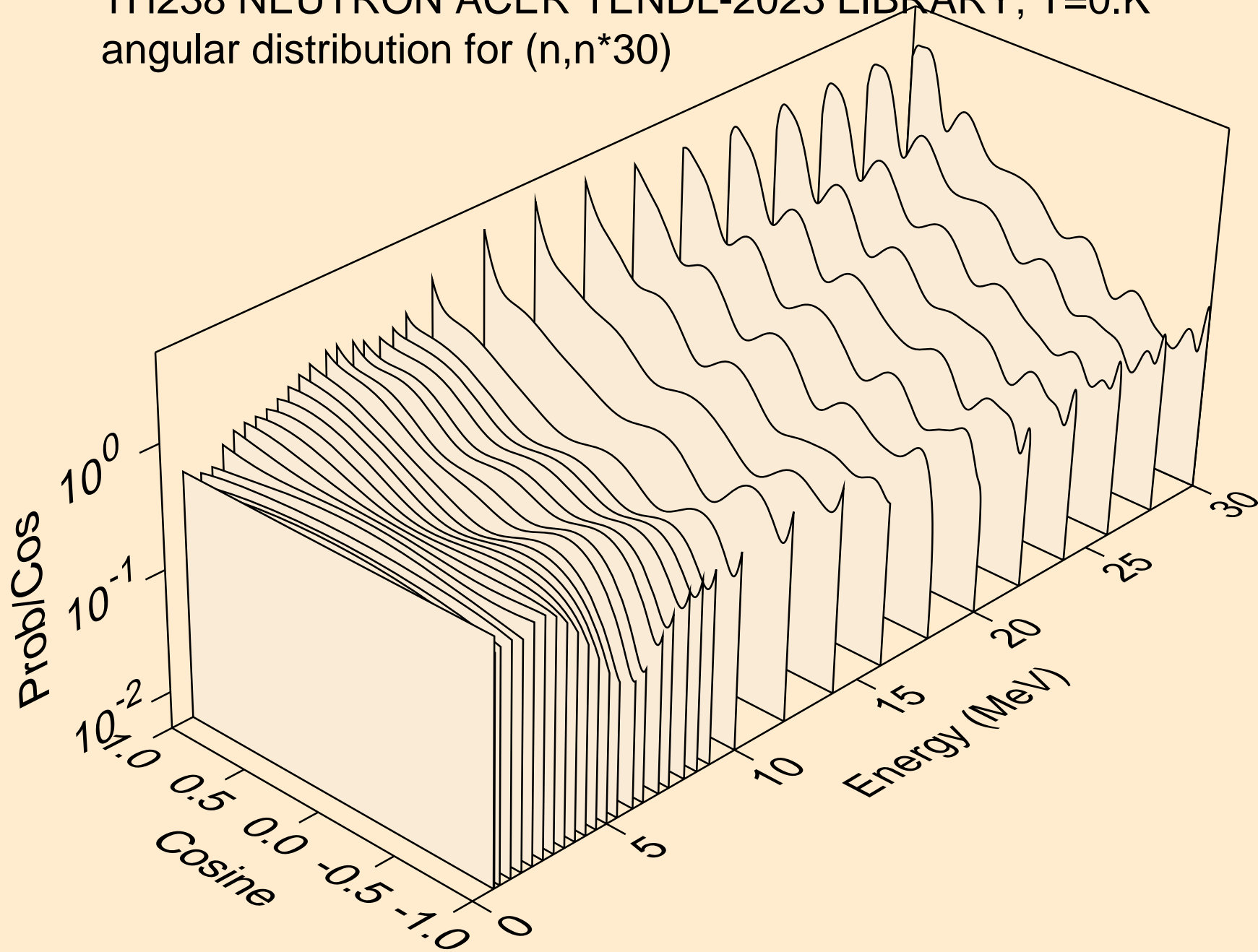

TH238 NEUTRON ACER TENDL-2023 LIBRARY; T=0.K
Total fission nubar

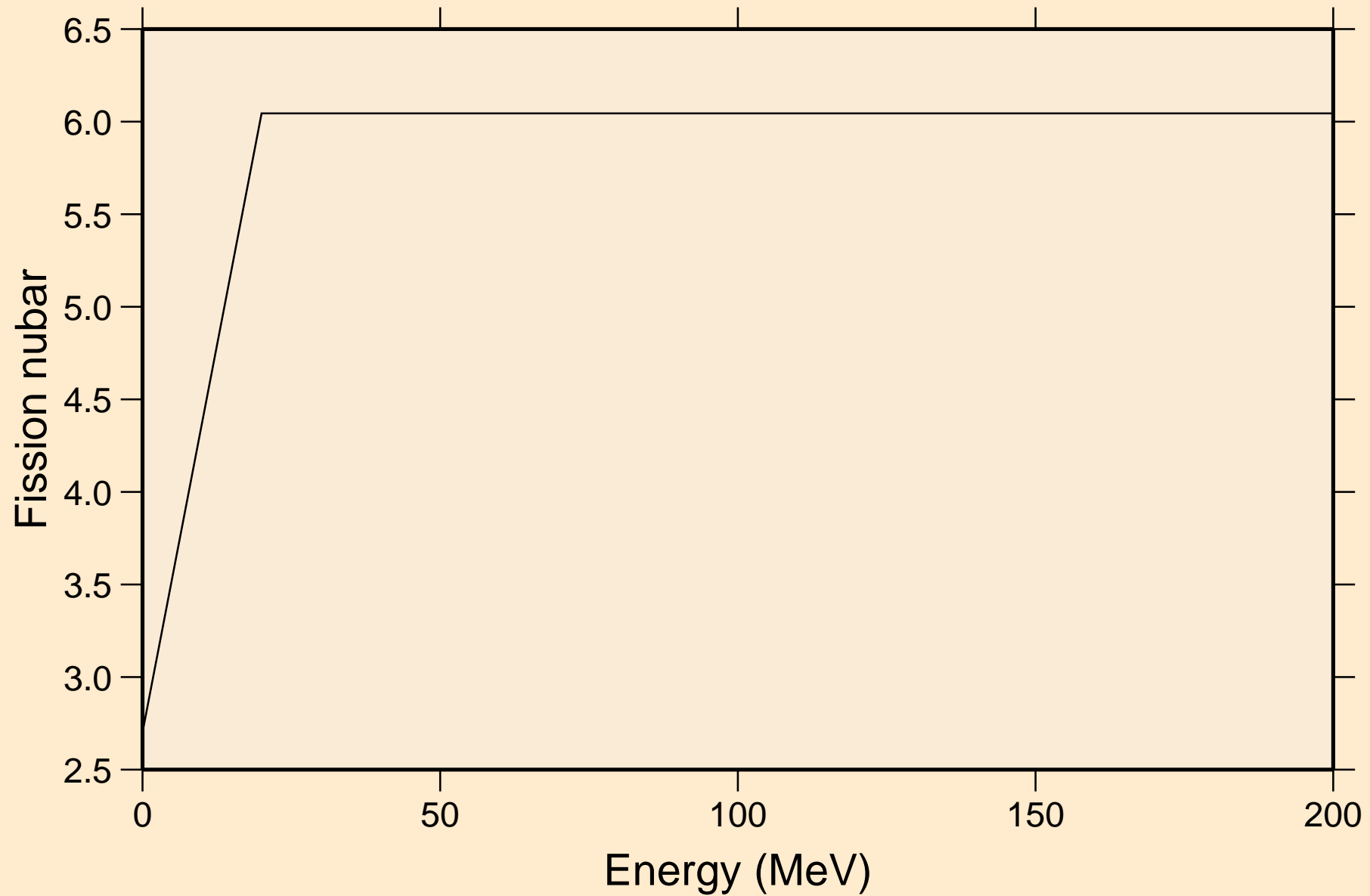

TH238 NEUTRON ACER TENDL-2023 LIBRARY; T=0.K
Neutron emission for (n,x)

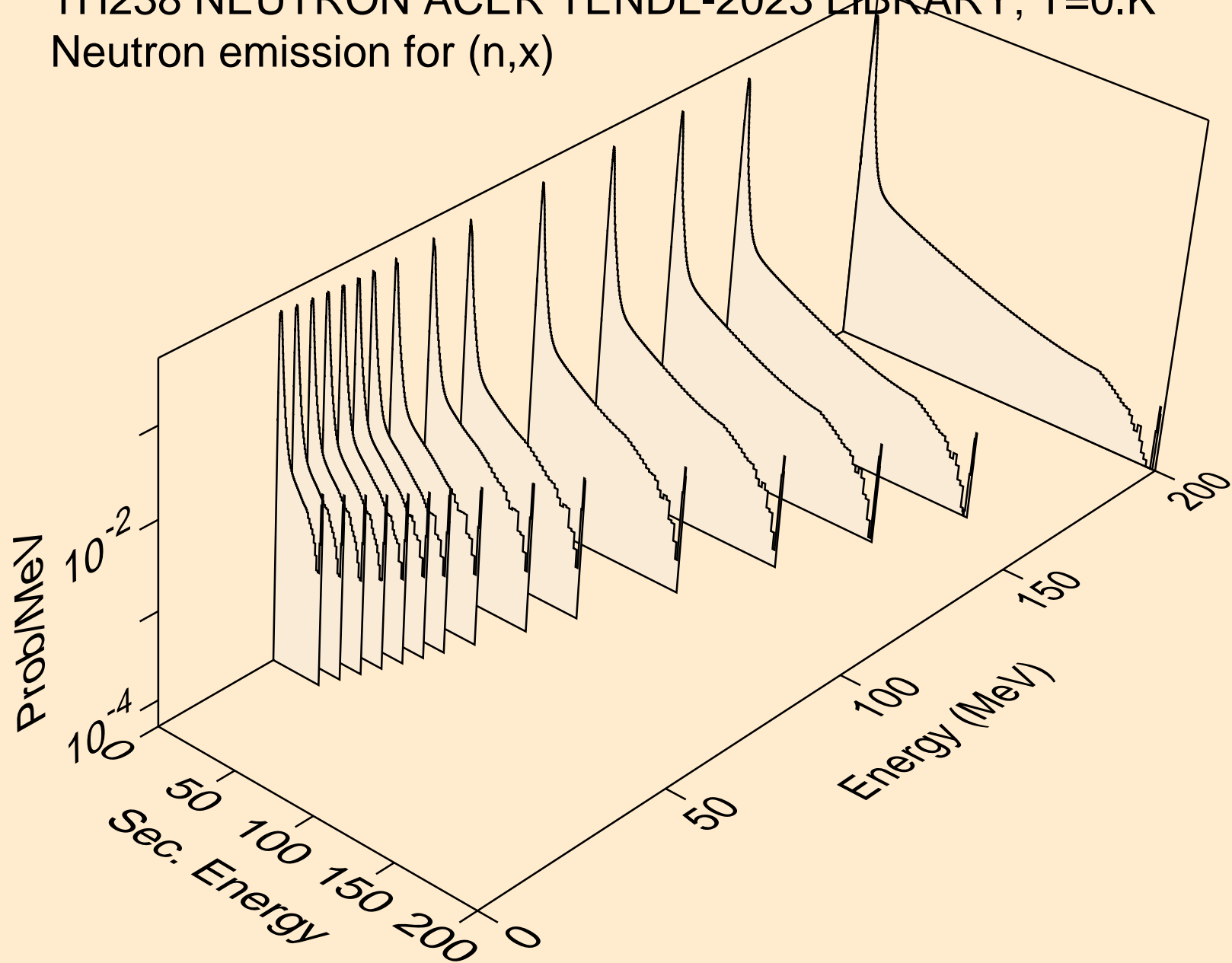

TH238 NEUTRON ACER TENDL-2023 LIBRARY; T=0.K
Neutron emission for (n,2nd)

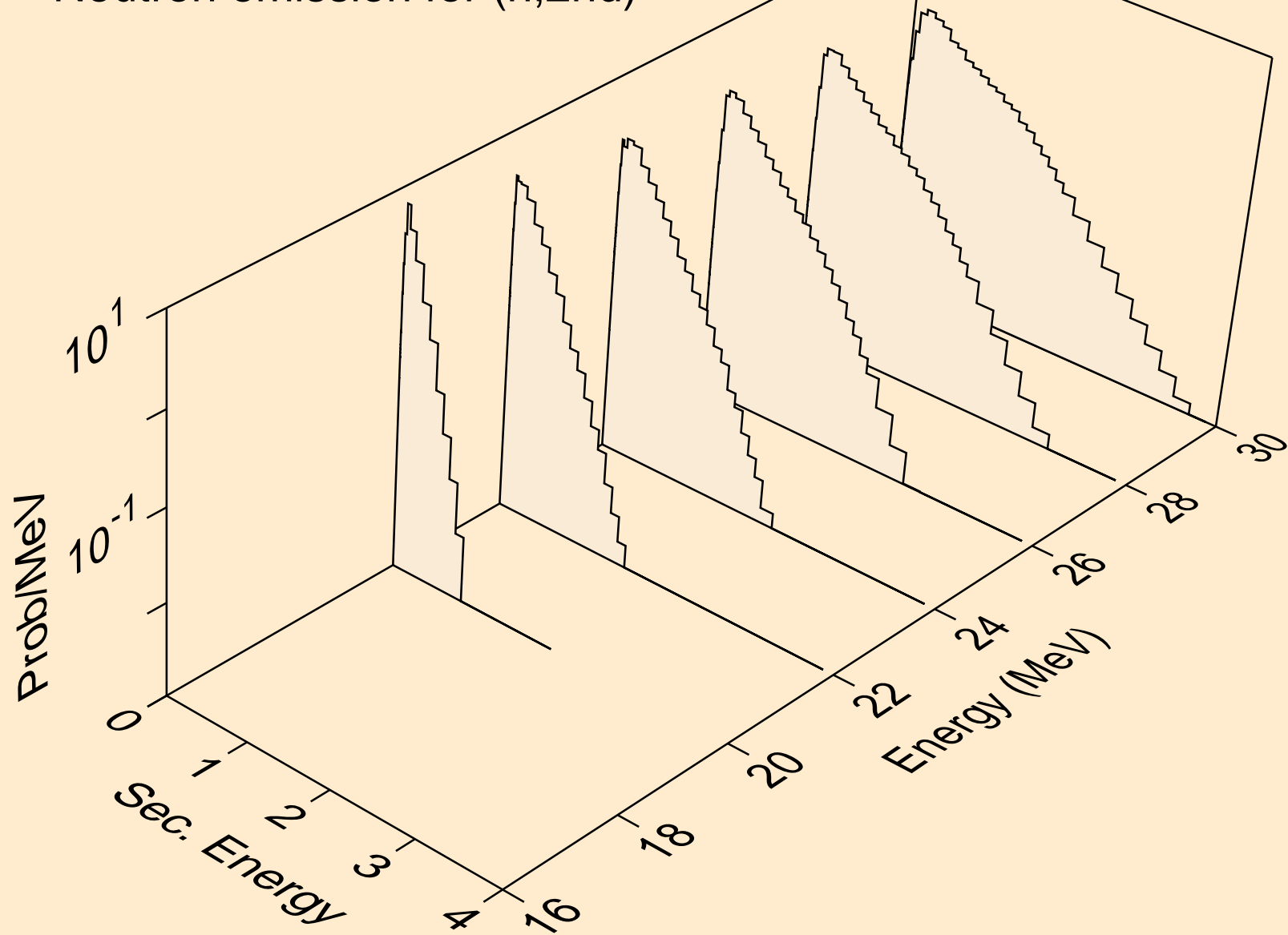

TH238 NEUTRON ACER TENDL-2023 LIBRARY; T=0.K
Neutron emission for (n,2n)

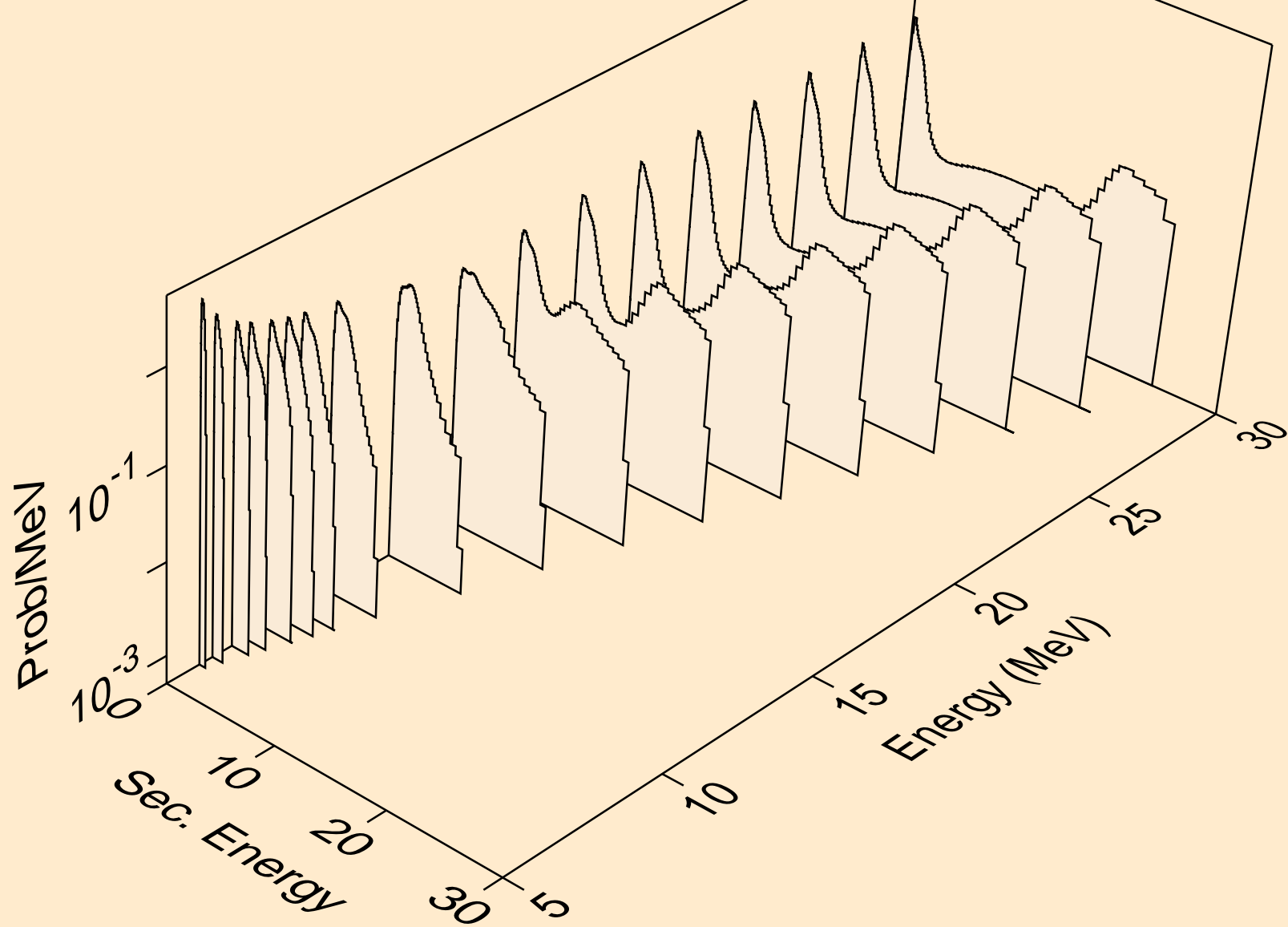

TH238 NEUTRON ACER TENDL-2023 LIBRARY; T=0.K
Neutron emission for (n,3n)

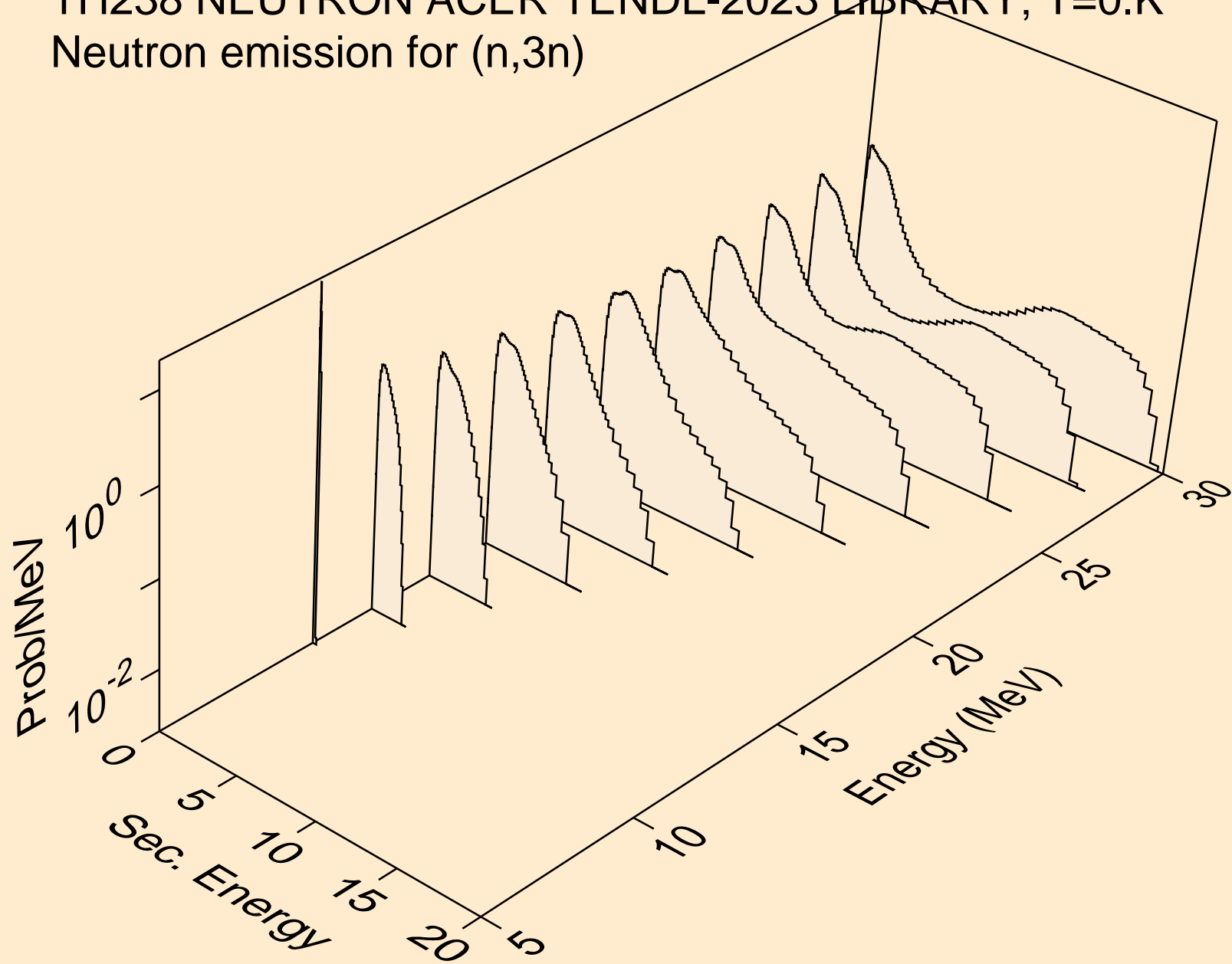

TH238 NEUTRON ACER TENDL-2023 LIBRARY; T=0.K
Neutron emission for fission

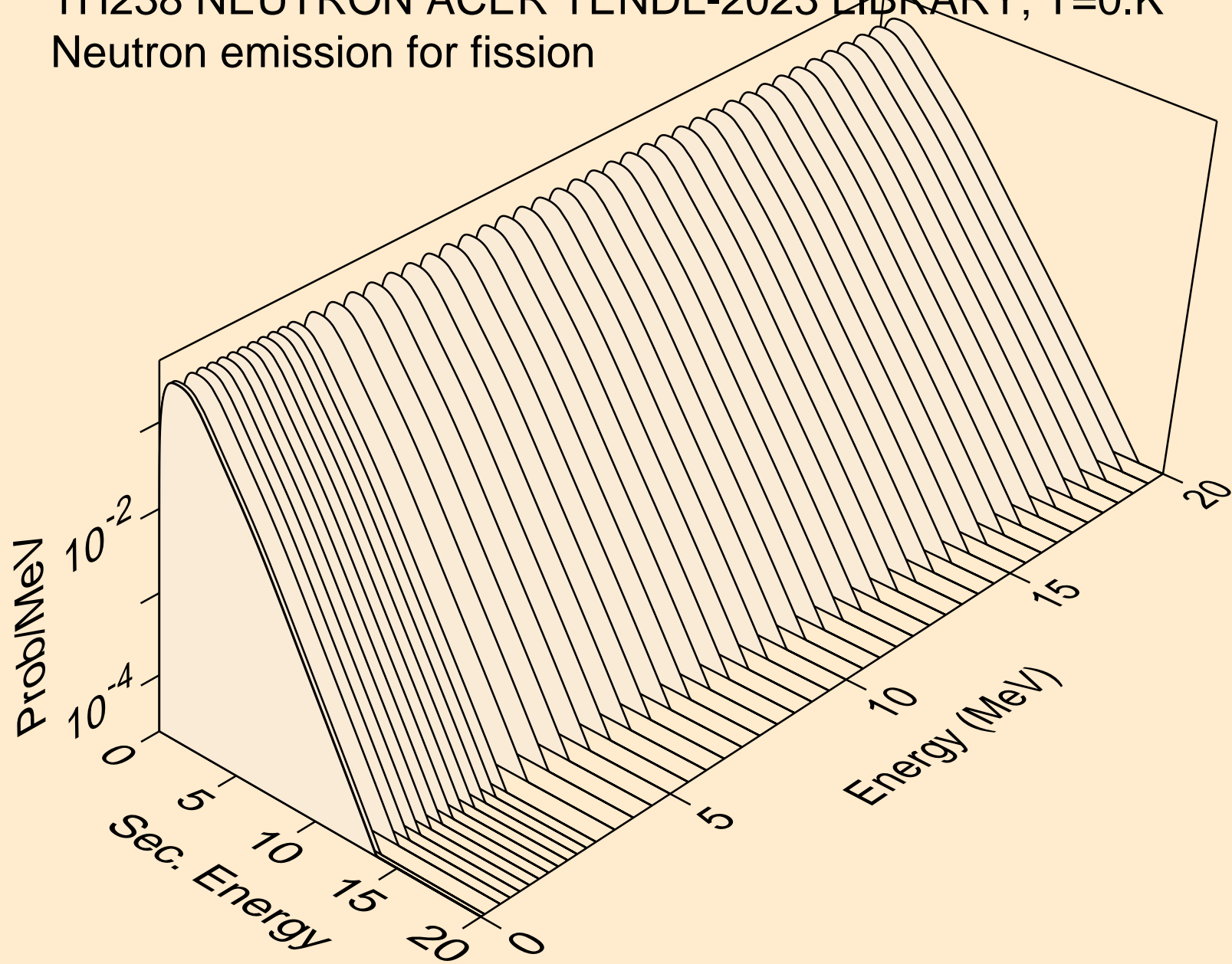

TH238 NEUTRON ACER TENDL-2023 LIBRARY; T=0.K
Neutron emission for (n,n*)a

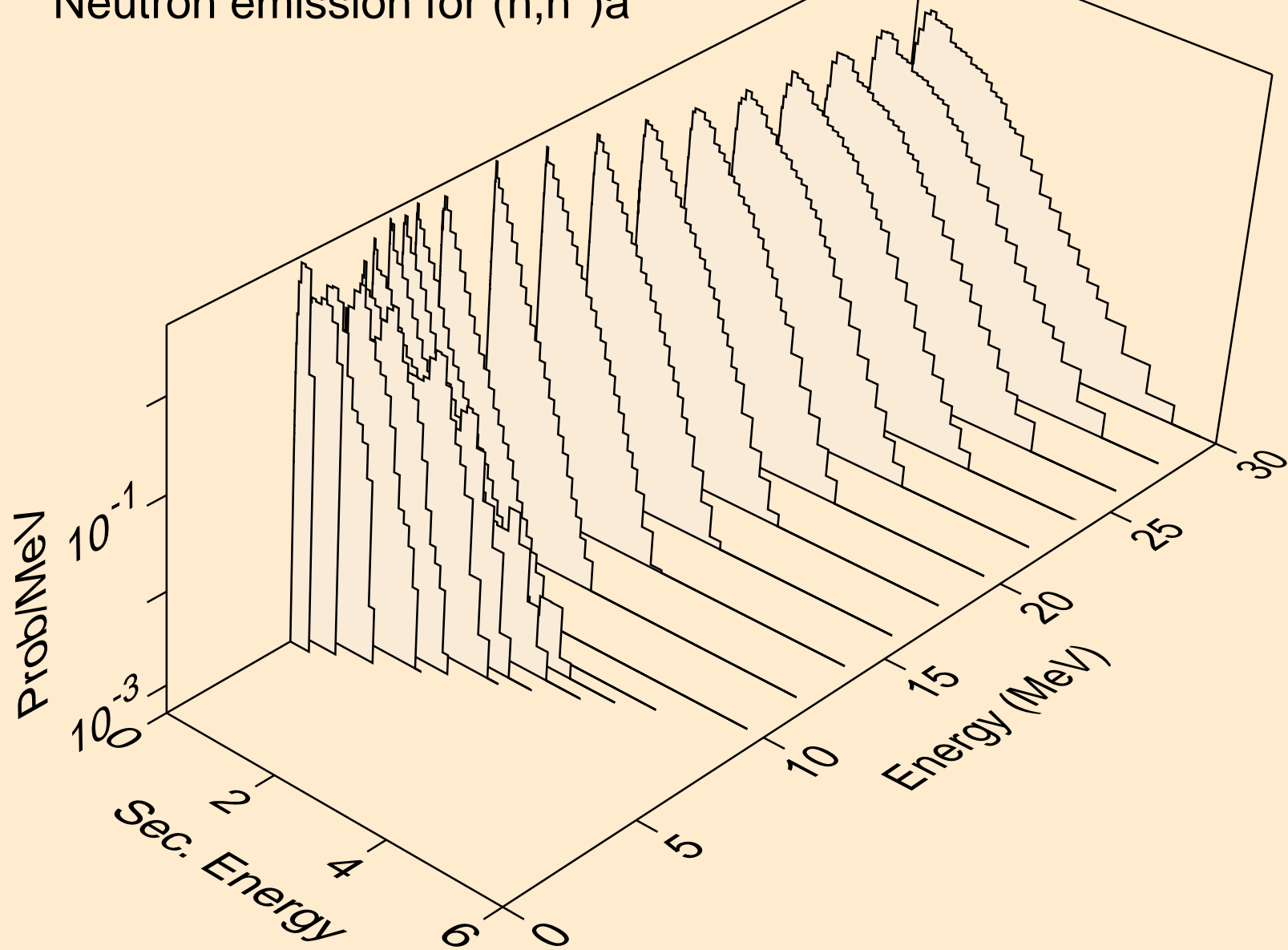

TH238 NEUTRON ACER TENDL-2023 LIBRARY; T=0.K
Neutron emission for (n,2n)a

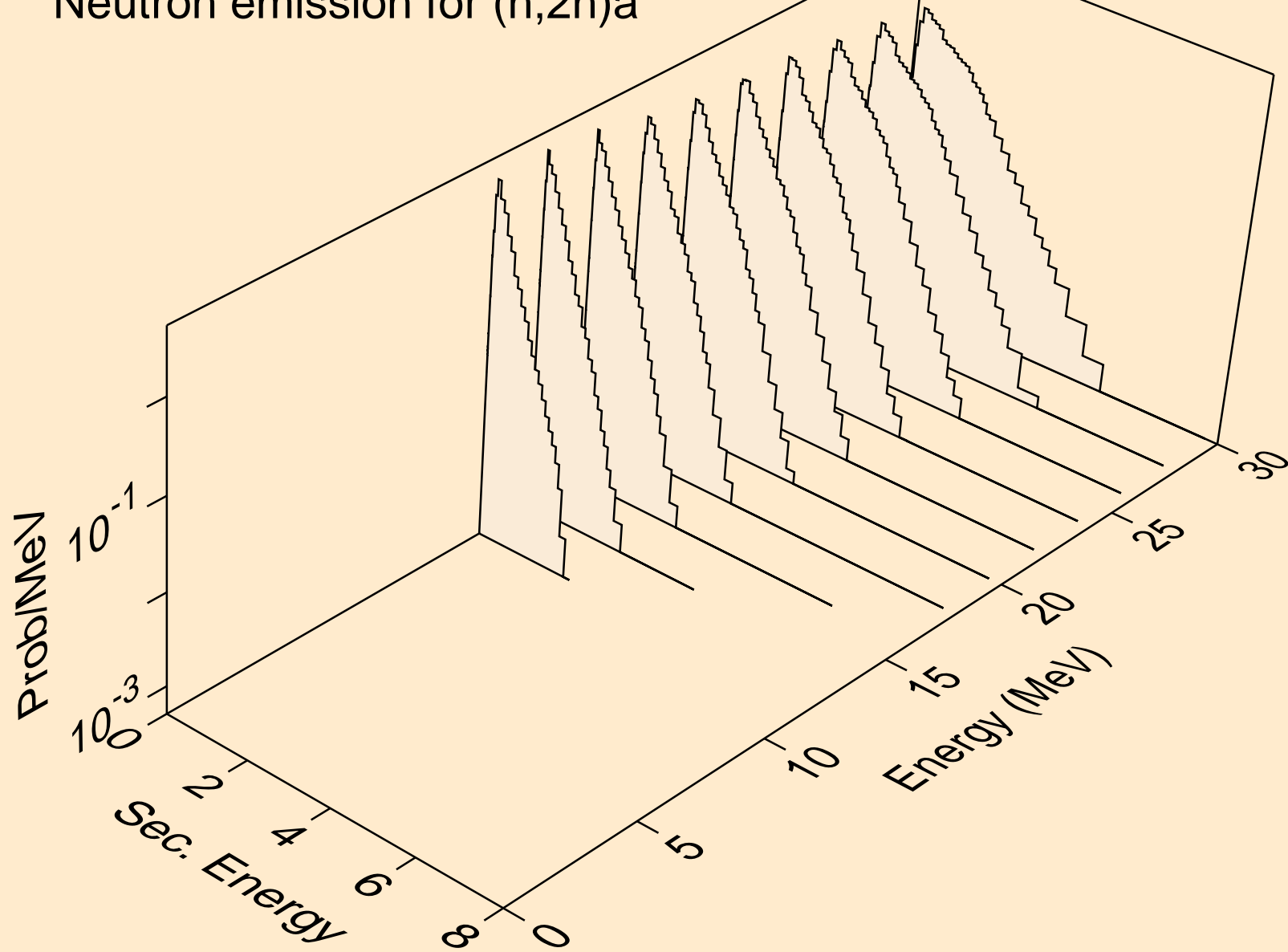

TH238 NEUTRON ACER TENDL-2023 LIBRARY; T=0.K
Neutron emission for (n,3n)a

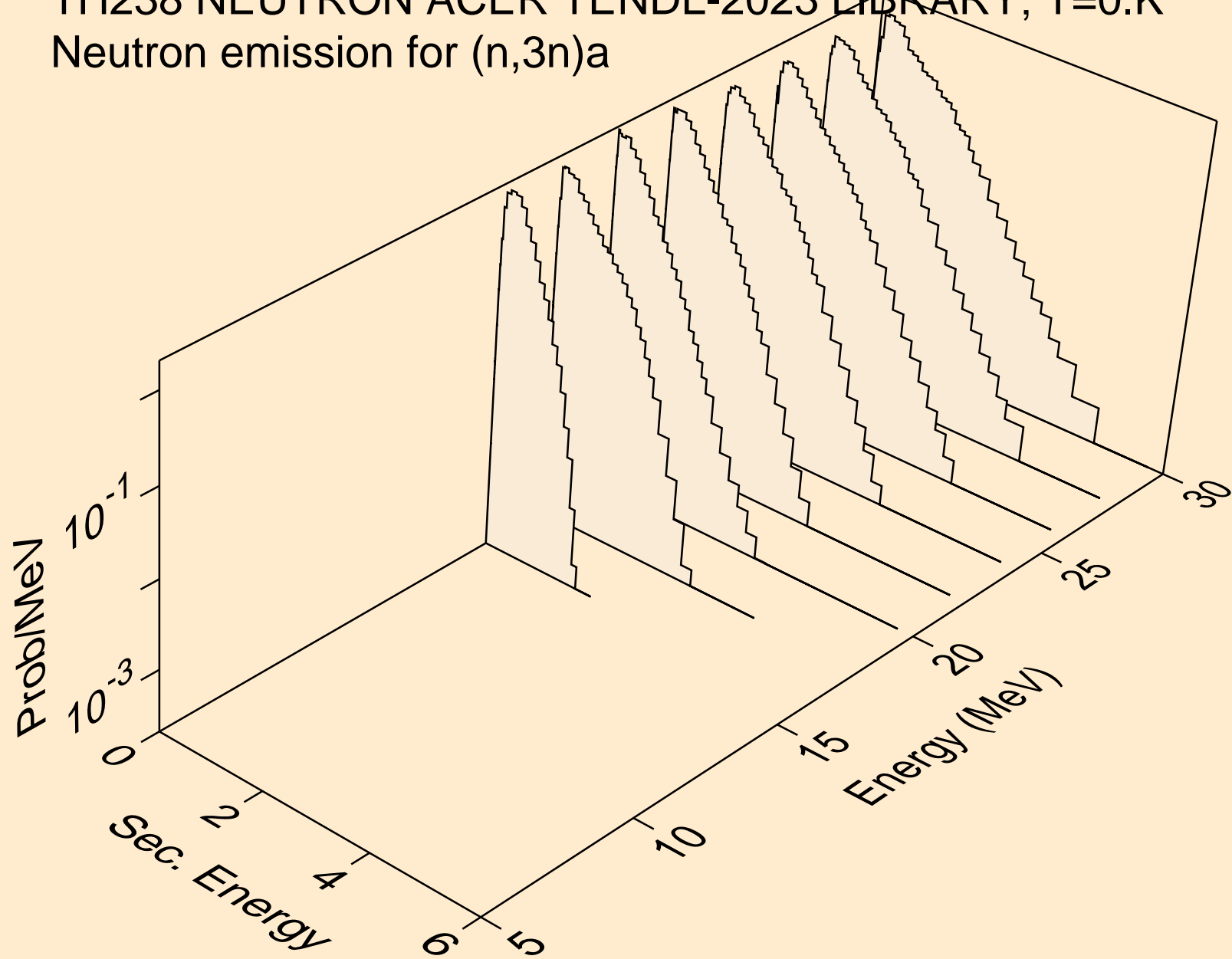

TH238 NEUTRON ACER TENDL-2023 LIBRARY; T=0.K
Neutron emission for (n,n*)p

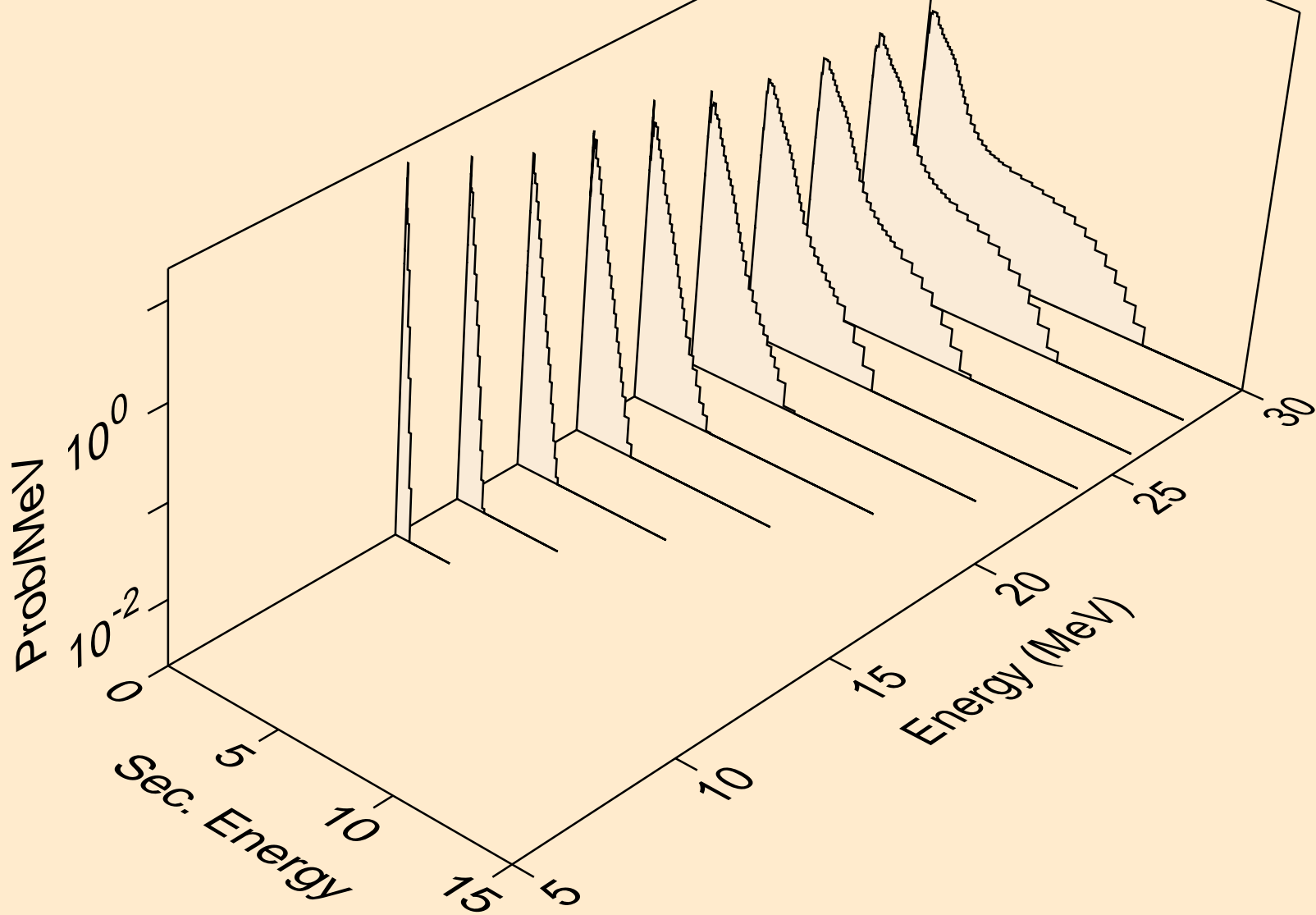

TH238 NEUTRON ACER TENDL-2023 LIBRARY; T=0.K
Neutron emission for (n,n*)d

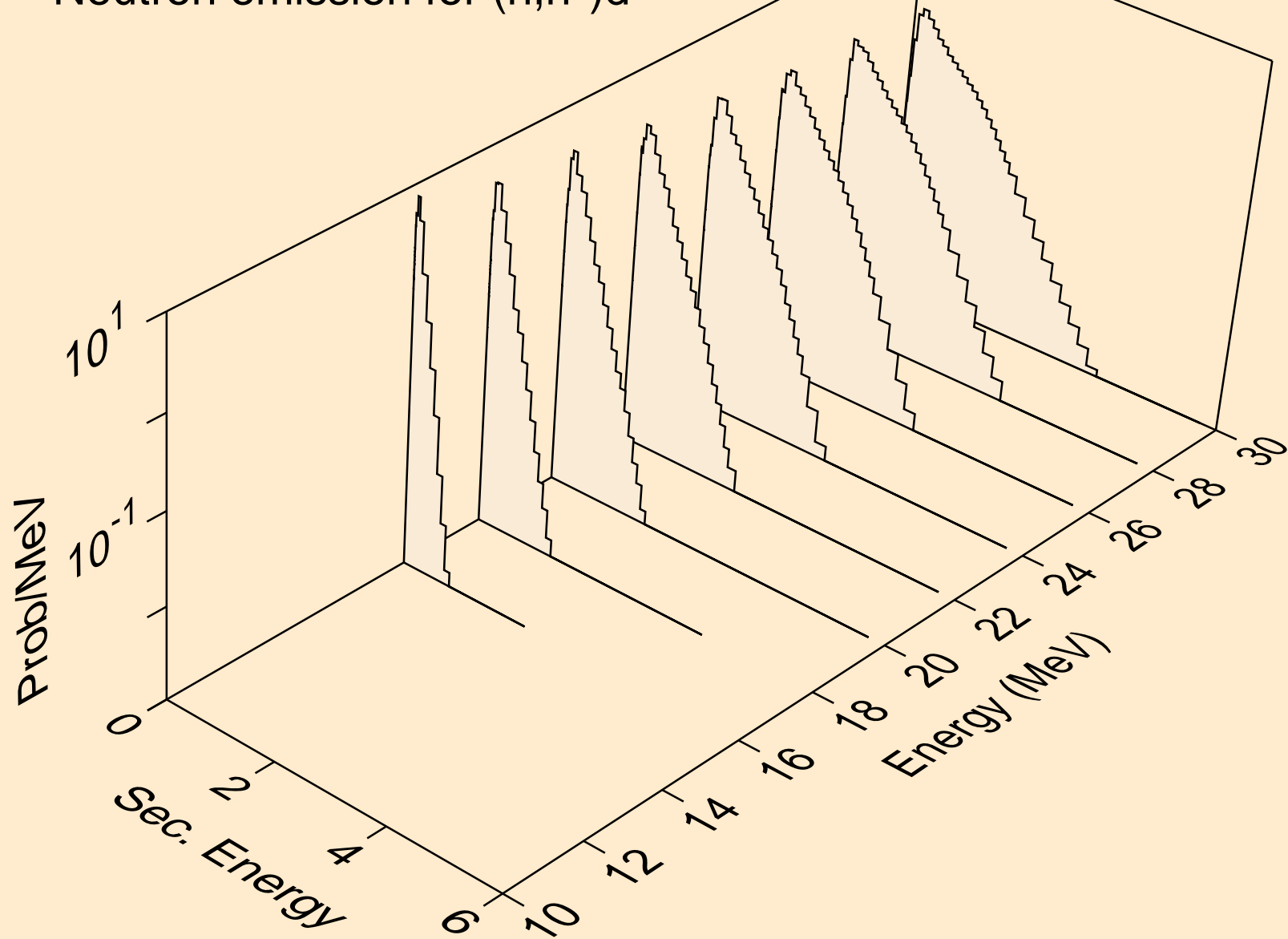

TH238 NEUTRON ACER TENDL-2023 LIBRARY; T=0.K
Neutron emission for (n,n*)t

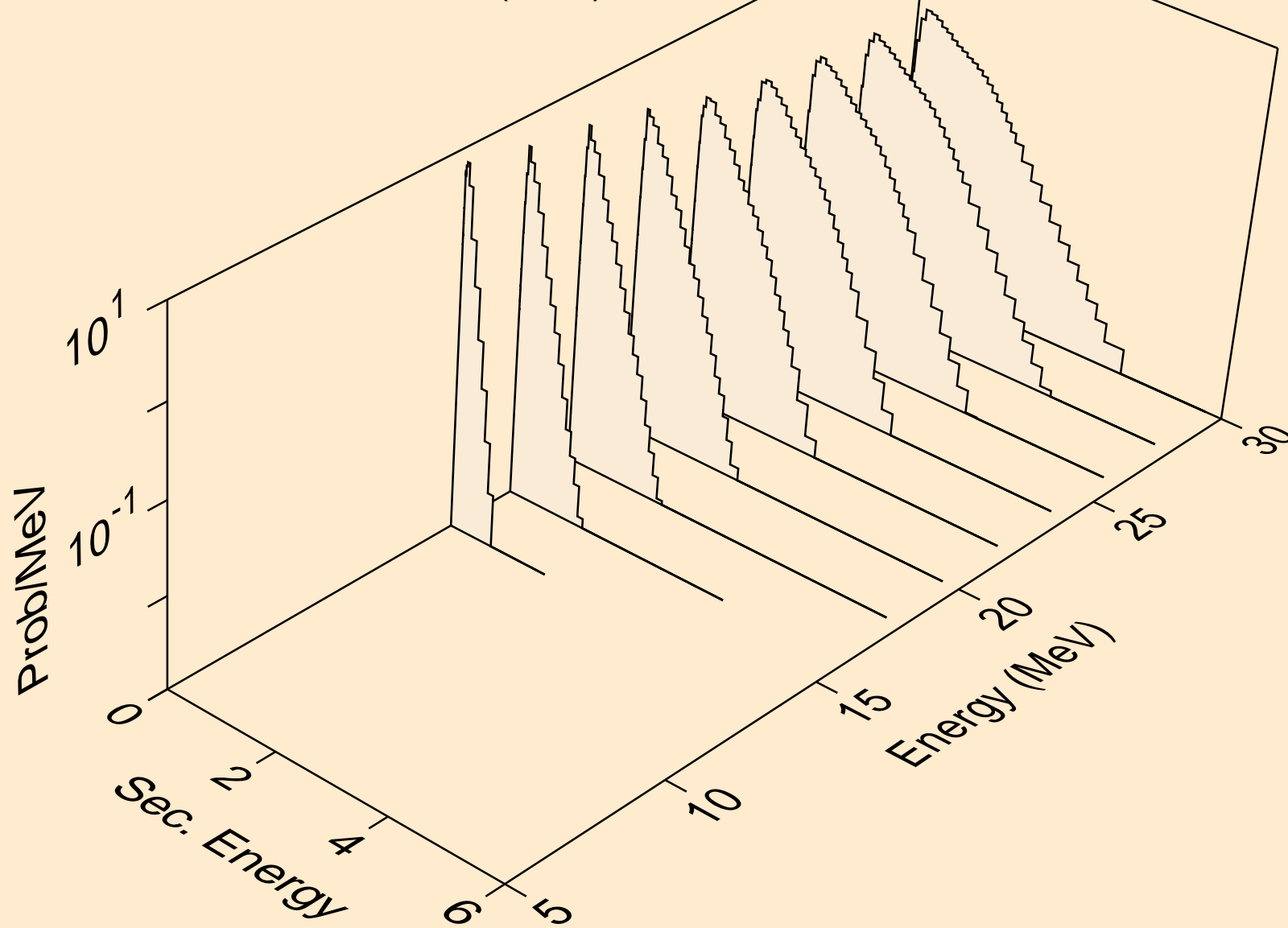

TH238 NEUTRON ACER TENDL-2023 LIBRARY; T=0.K
Neutron emission for (n,n*)he3

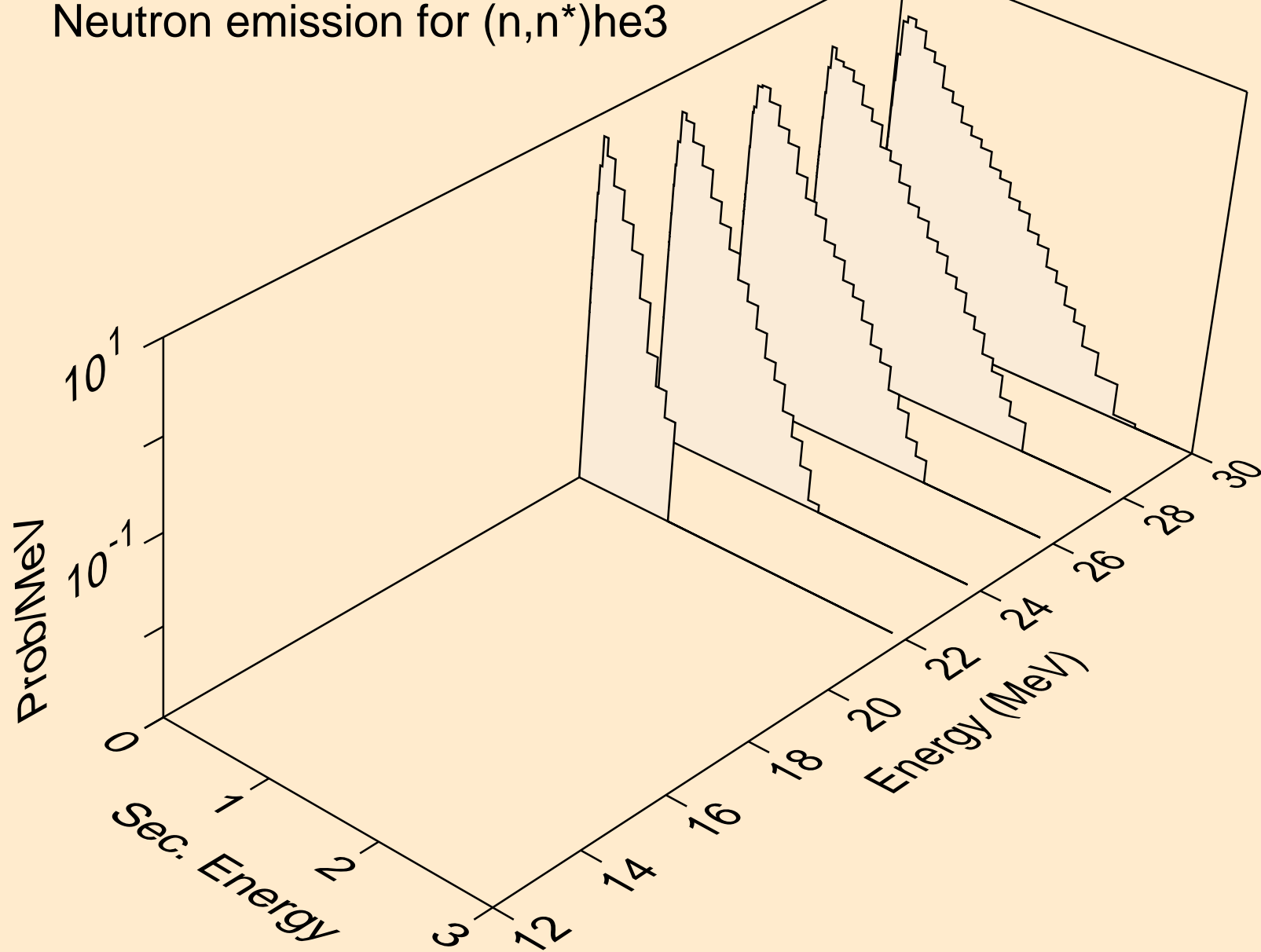

TH238 NEUTRON ACER TENDL-2023 LIBRARY; T=0.K
Neutron emission for (n,4n)

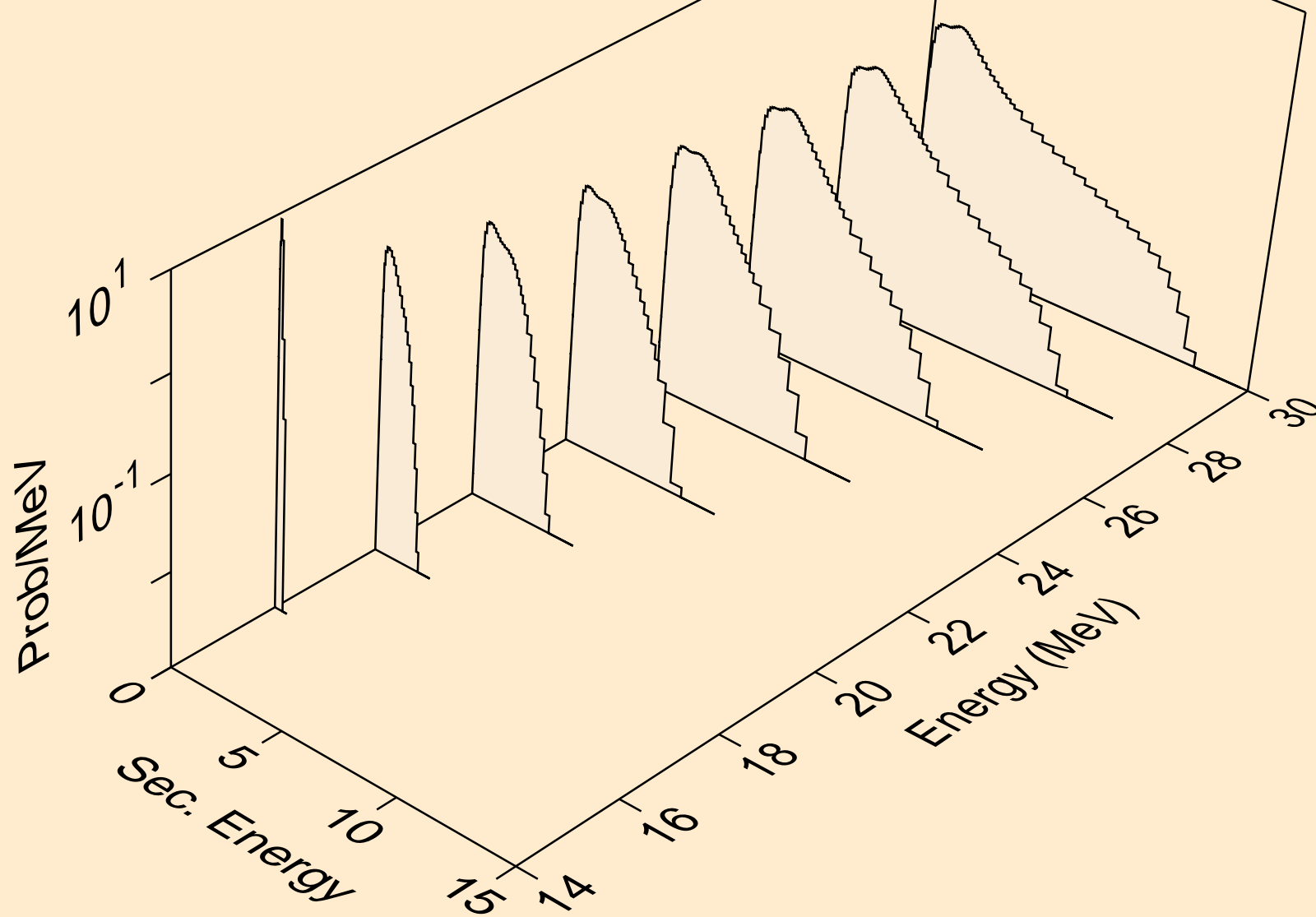

TH238 NEUTRON ACER TENDL-2023 LIBRARY; T=0.K
Neutron emission for (n,2np)

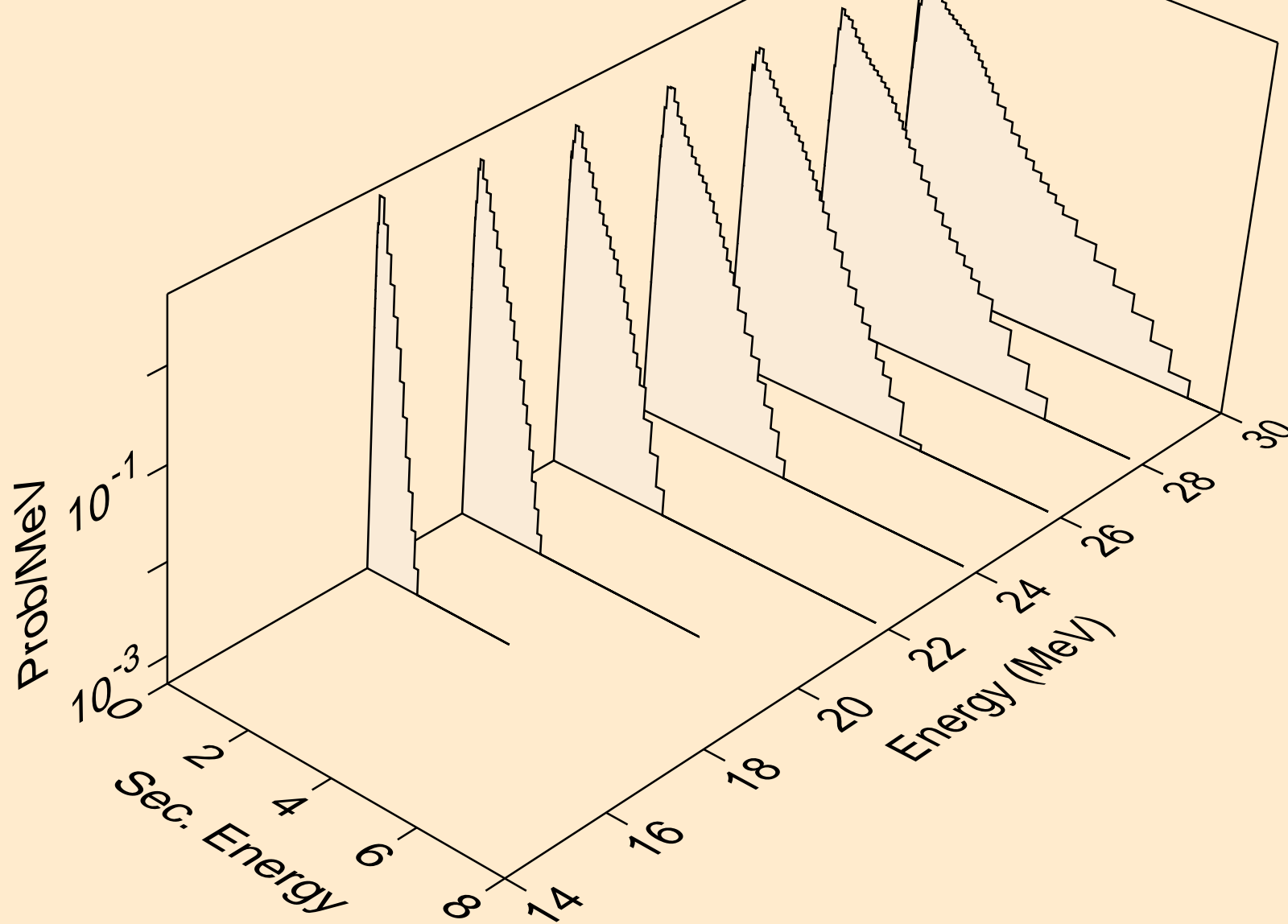

TH238 NEUTRON ACER TENDL-2023 LIBRARY; T=0.K
Neutron emission for (n,3np)

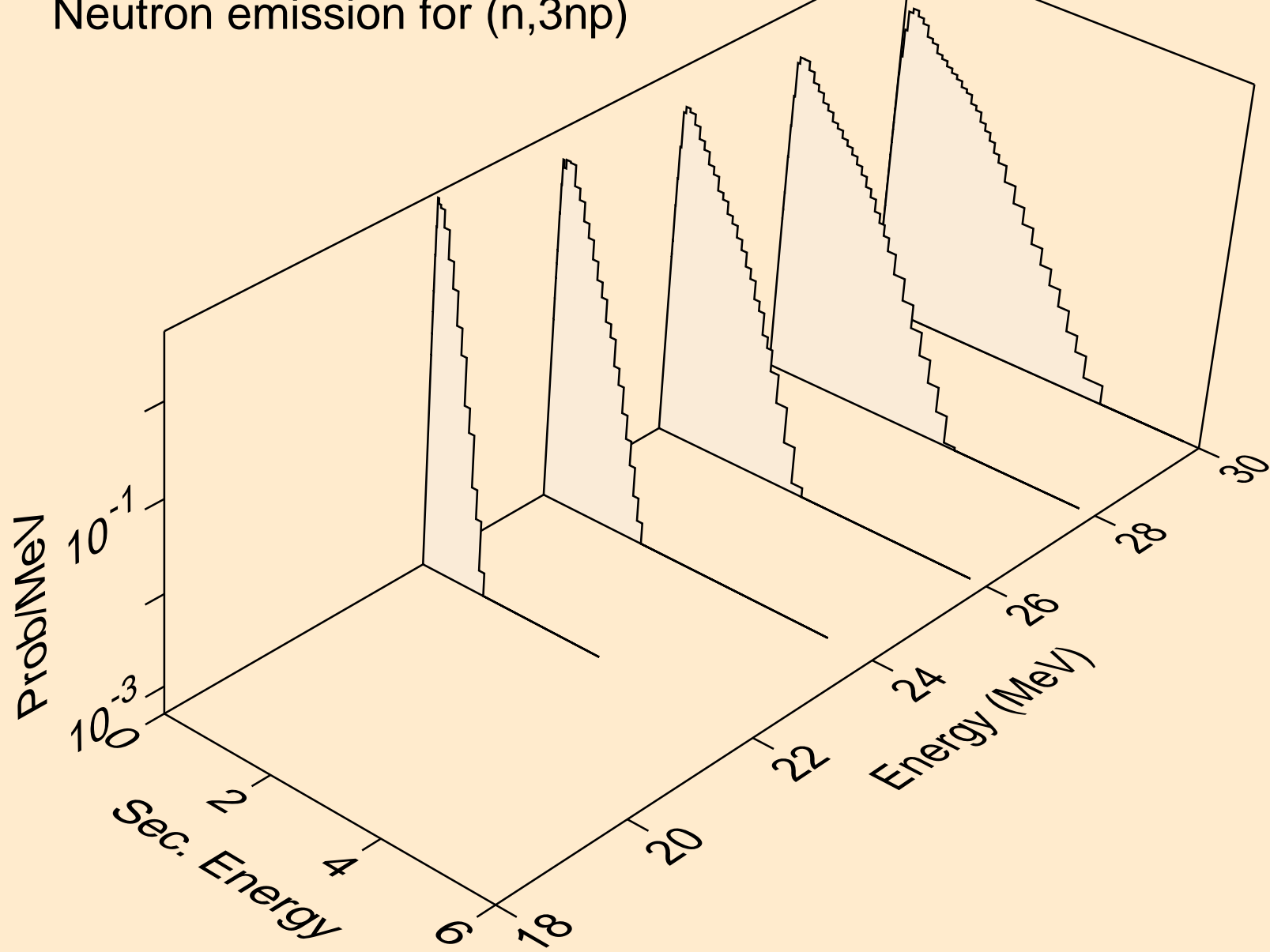

TH238 NEUTRON ACER TENDL-2023 LIBRARY; T=0.K
Neutron emission for (n,n*c)

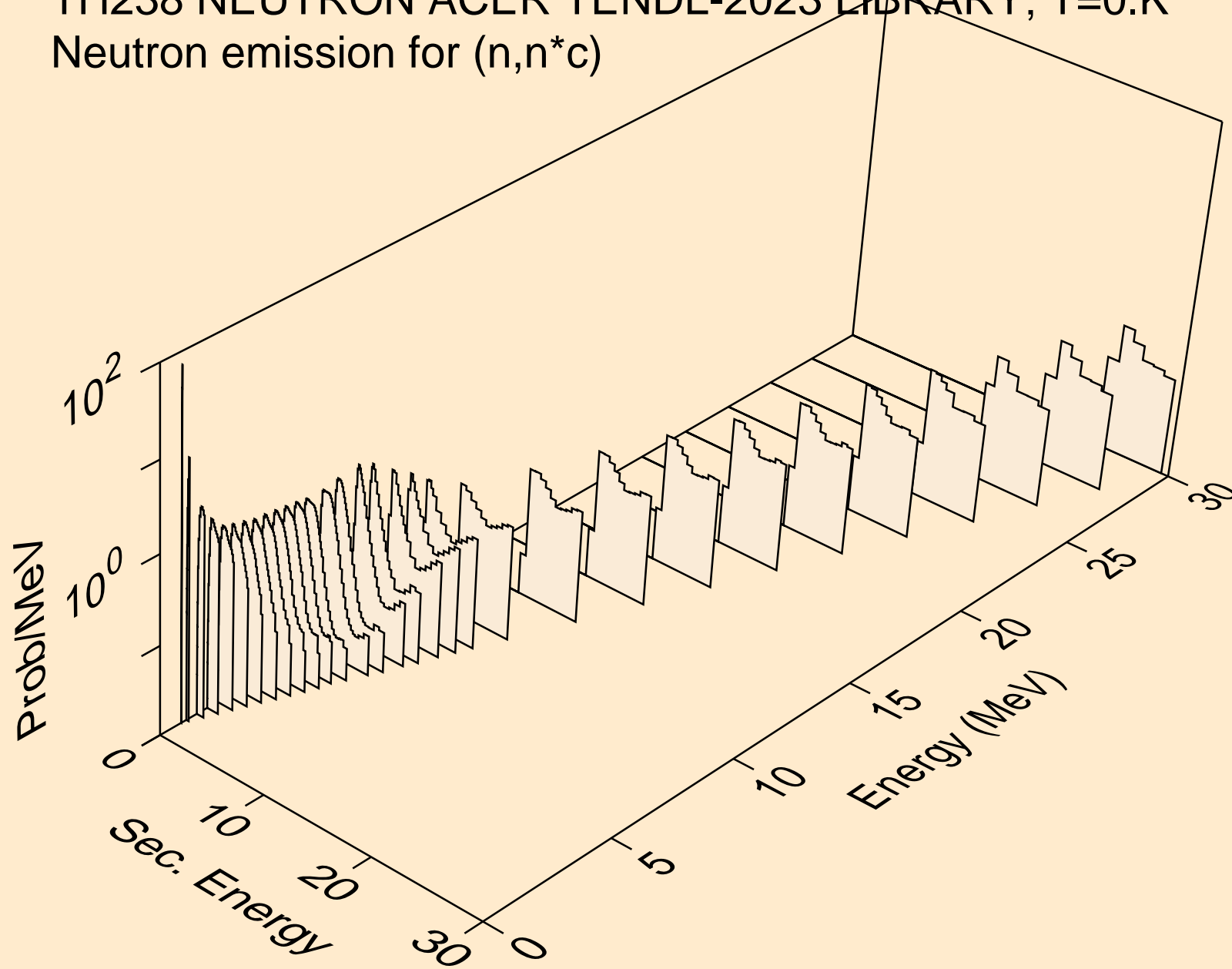

TH238 NEUTRON ACER TENDL-2023 LIBRARY; T=0.K

Delayed nubar

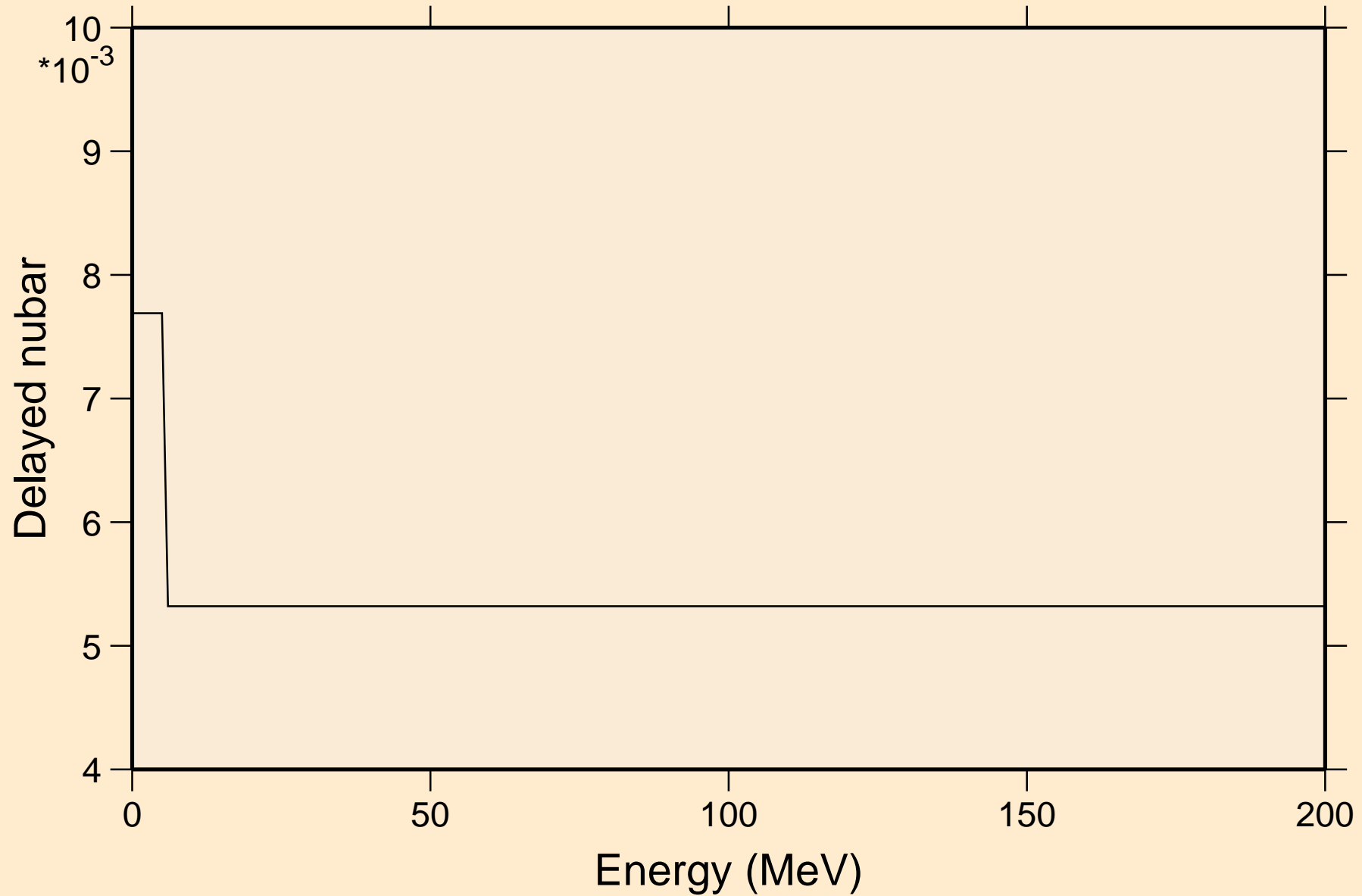

TH238 NEUTRON ACER TENDL-2023 LIBRARY; T=0.K

Delayed neutron spectra

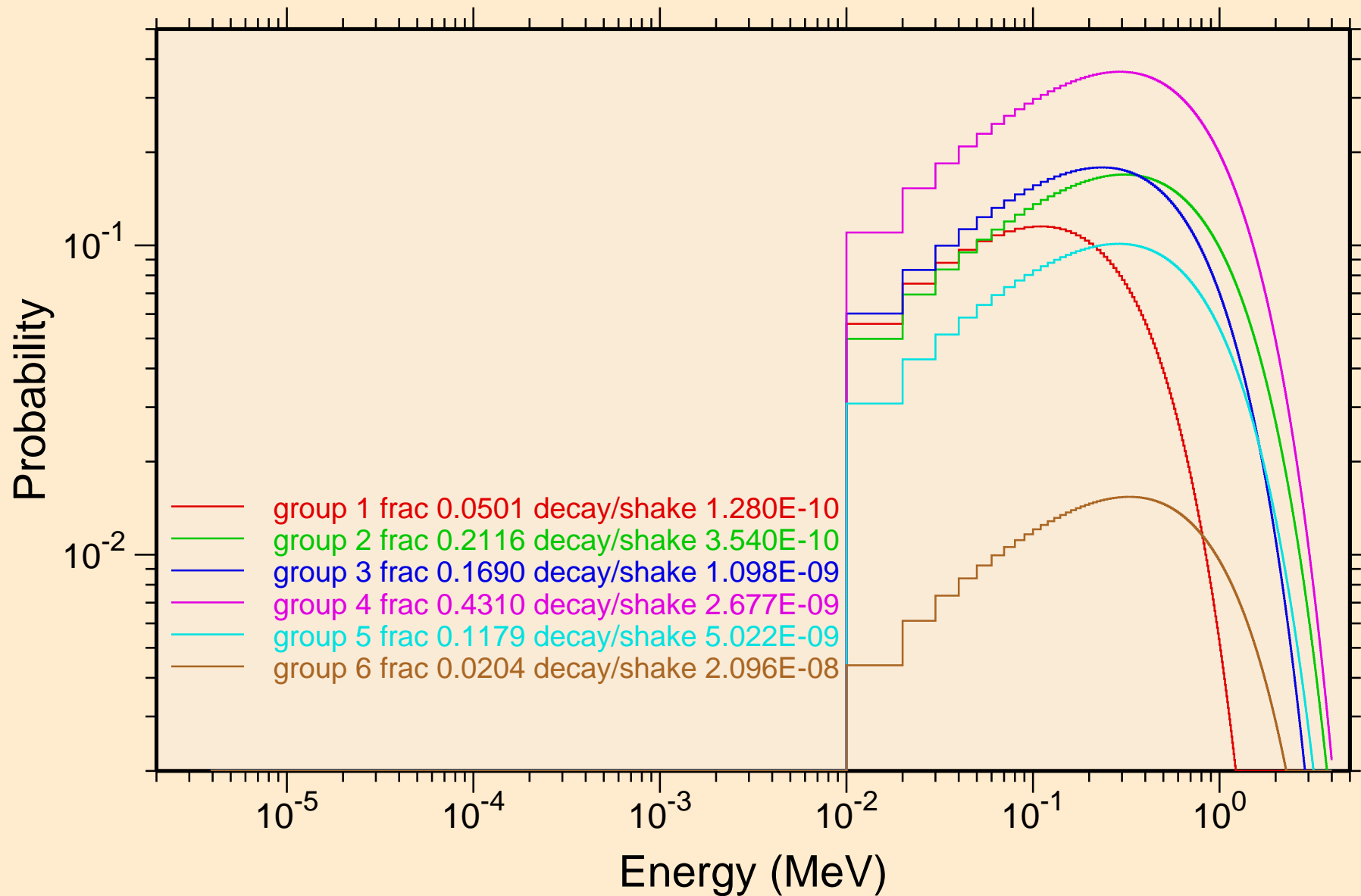

TH238 NEUTRON ACER TENDL-2023 LIBRARY; T=0.K
Photon emission for (n,x)

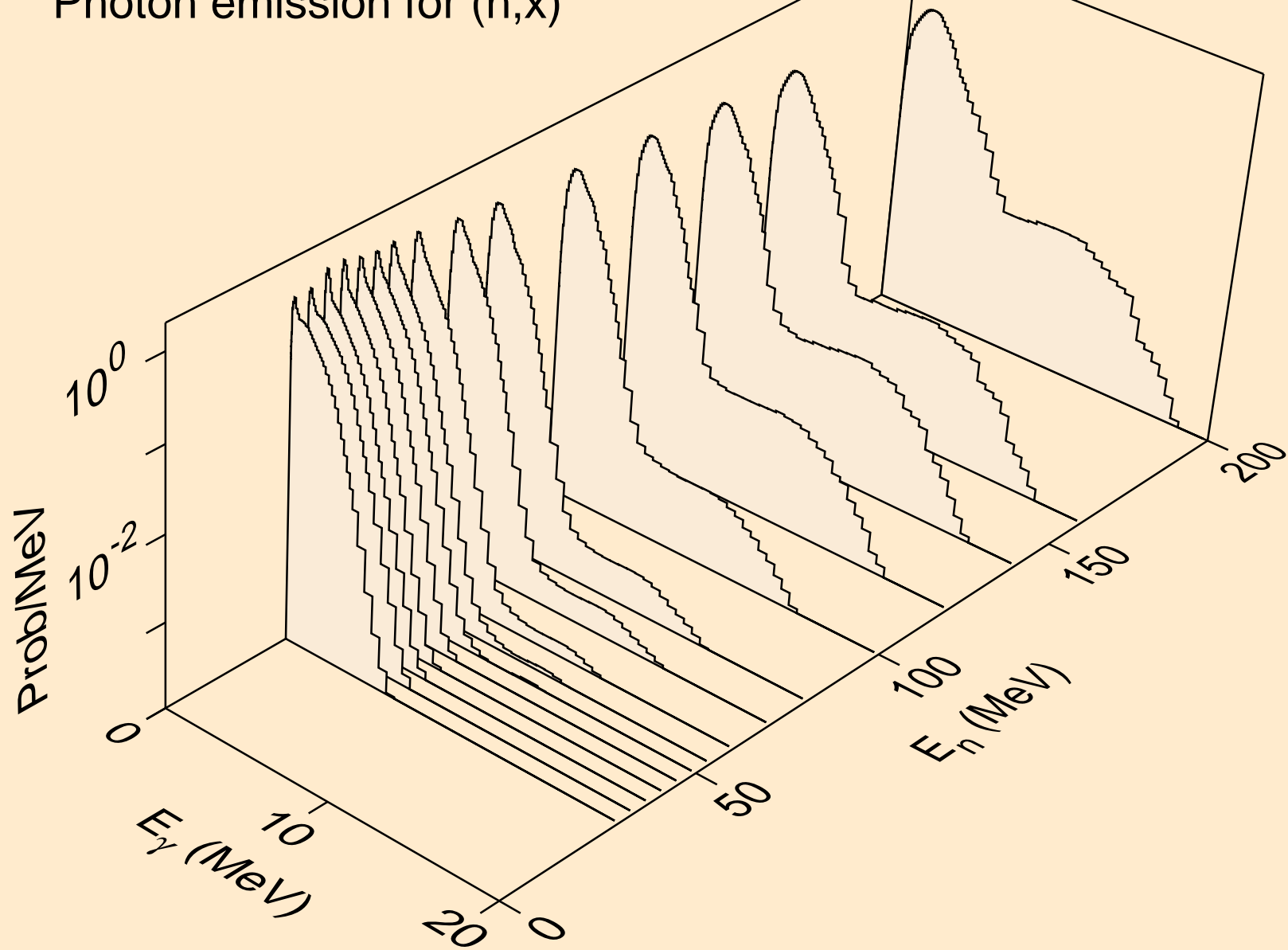

TH238 NEUTRON ACER TENDL-2023 LIBRARY; T=0.K
Photon emission for (n,2nd)

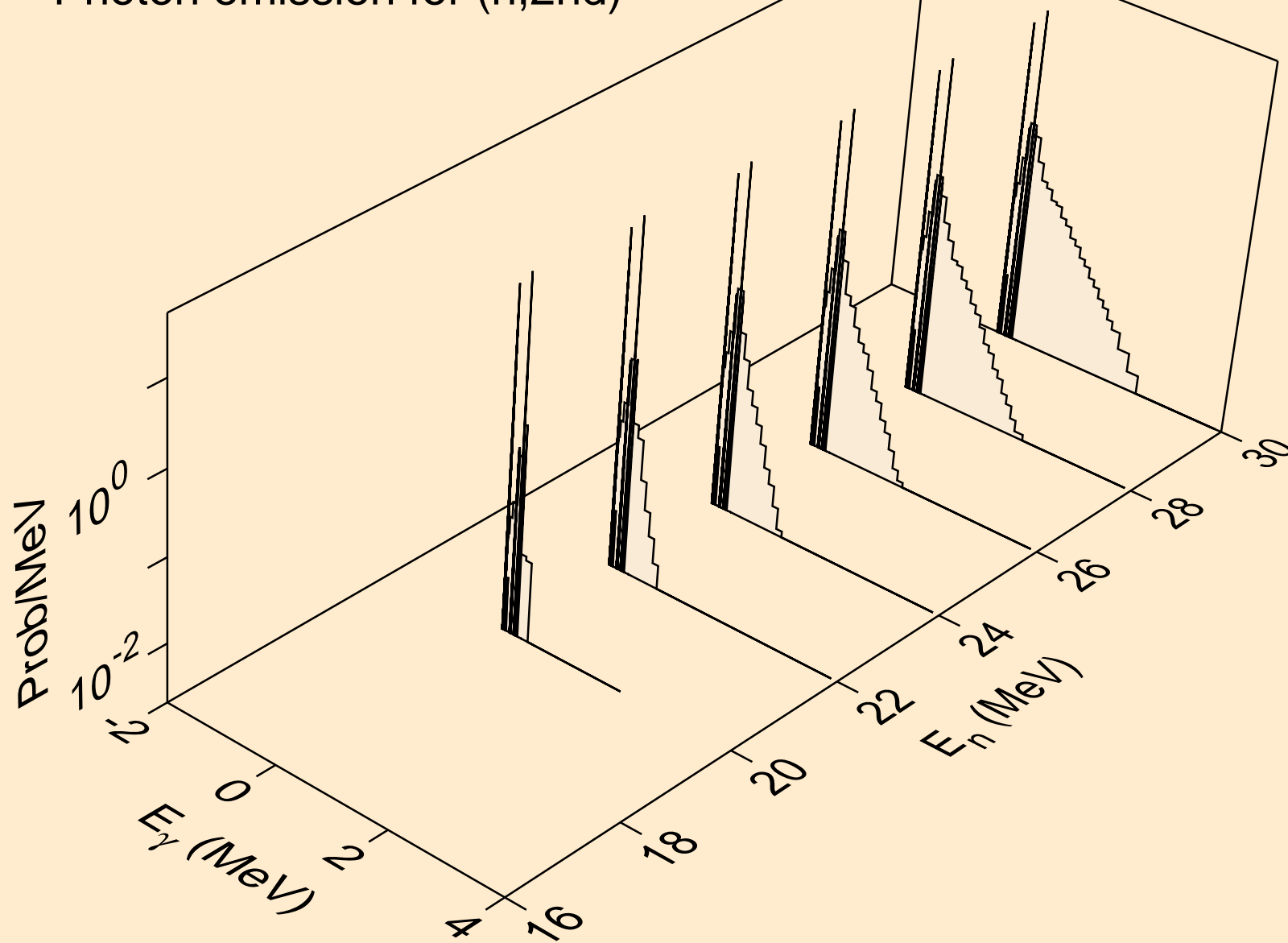

TH238 NEUTRON ACER TENDL-2023 LIBRARY; T=0.K
Photon emission for (n,2n)

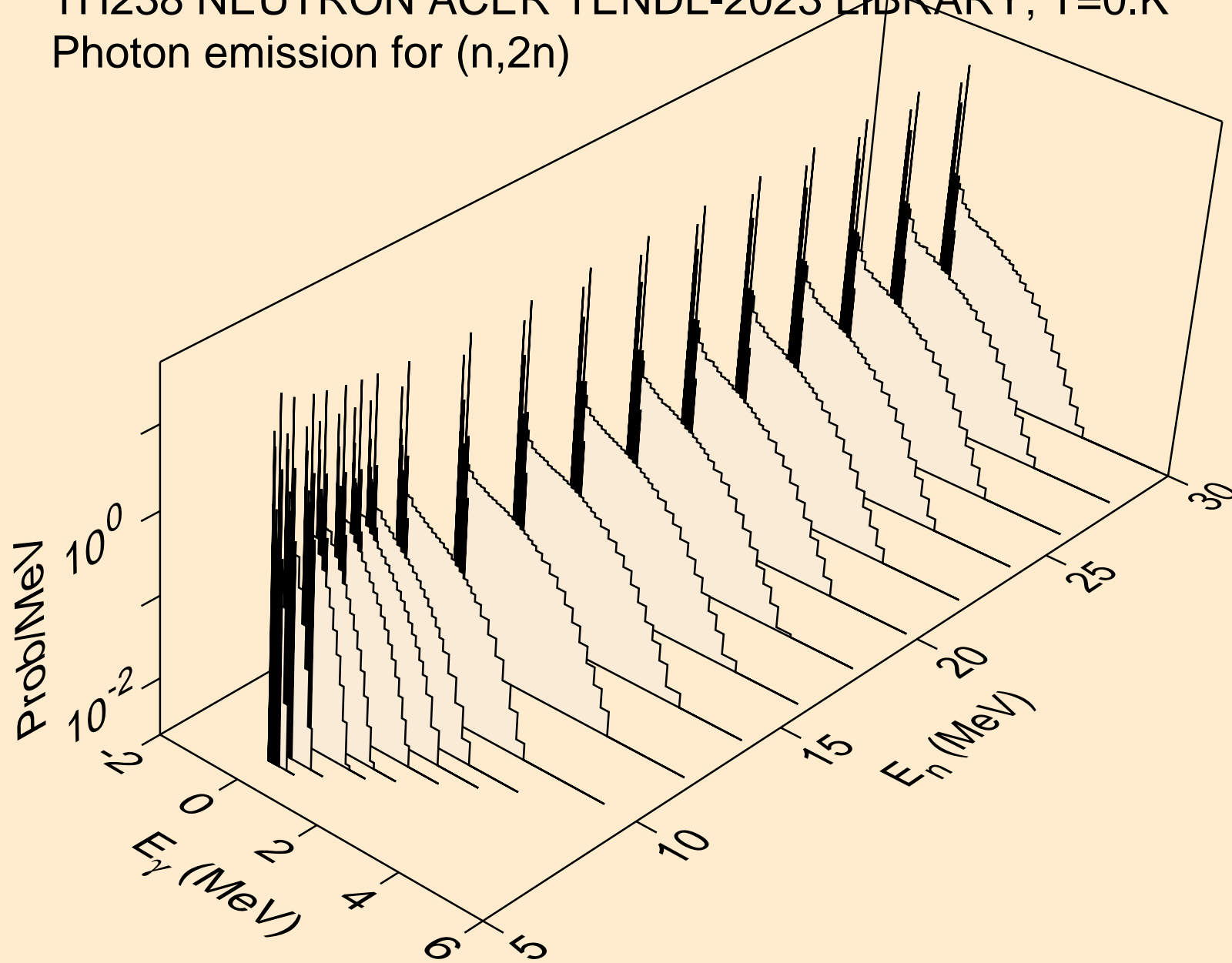

TH238 NEUTRON ACER TENDL-2023 LIBRARY; T=0.K
Photon emission for (n,3n)

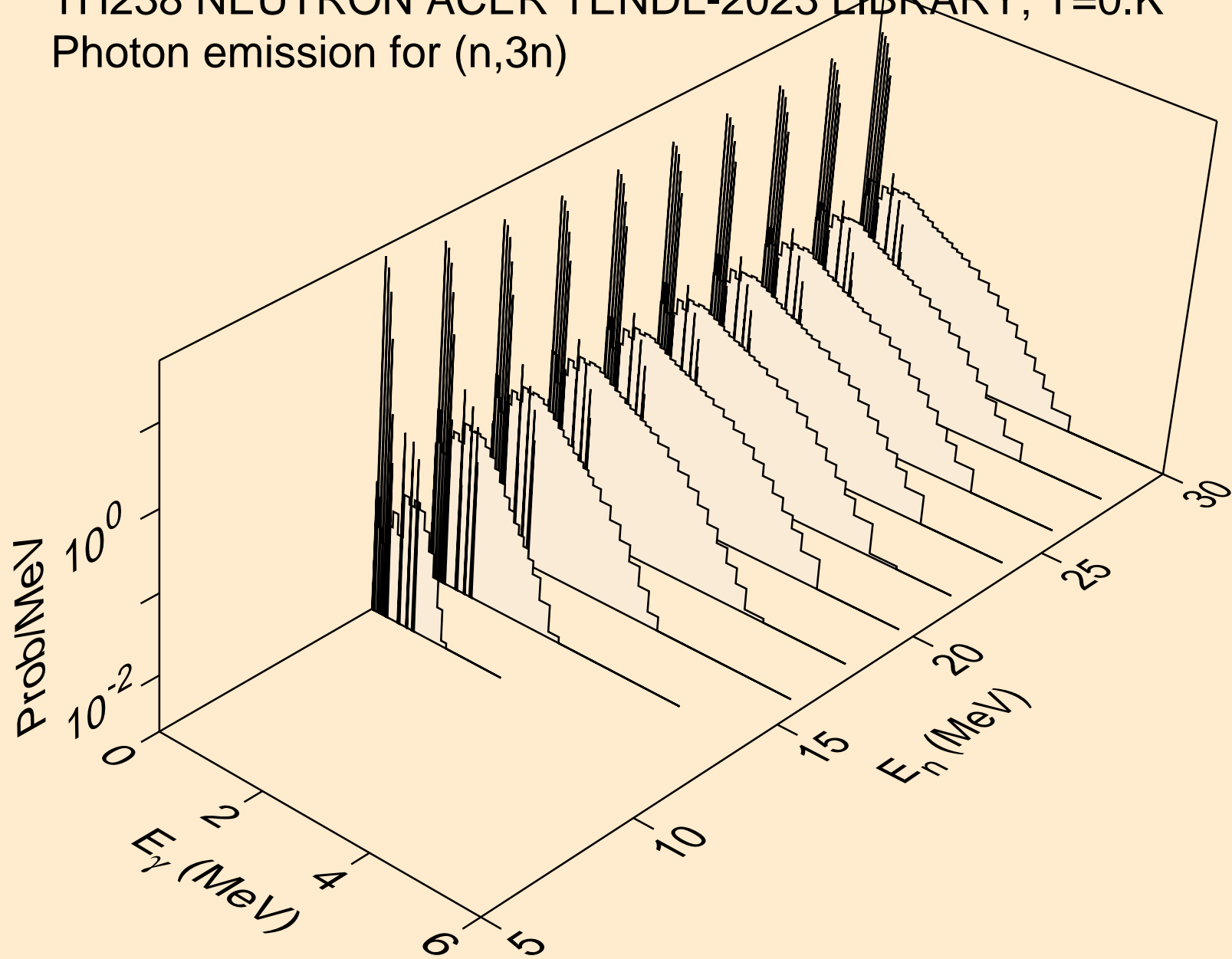

TH238 NEUTRON ACER TENDL-2023 LIBRARY; T=0.K
Photon emission for (n,n*)a

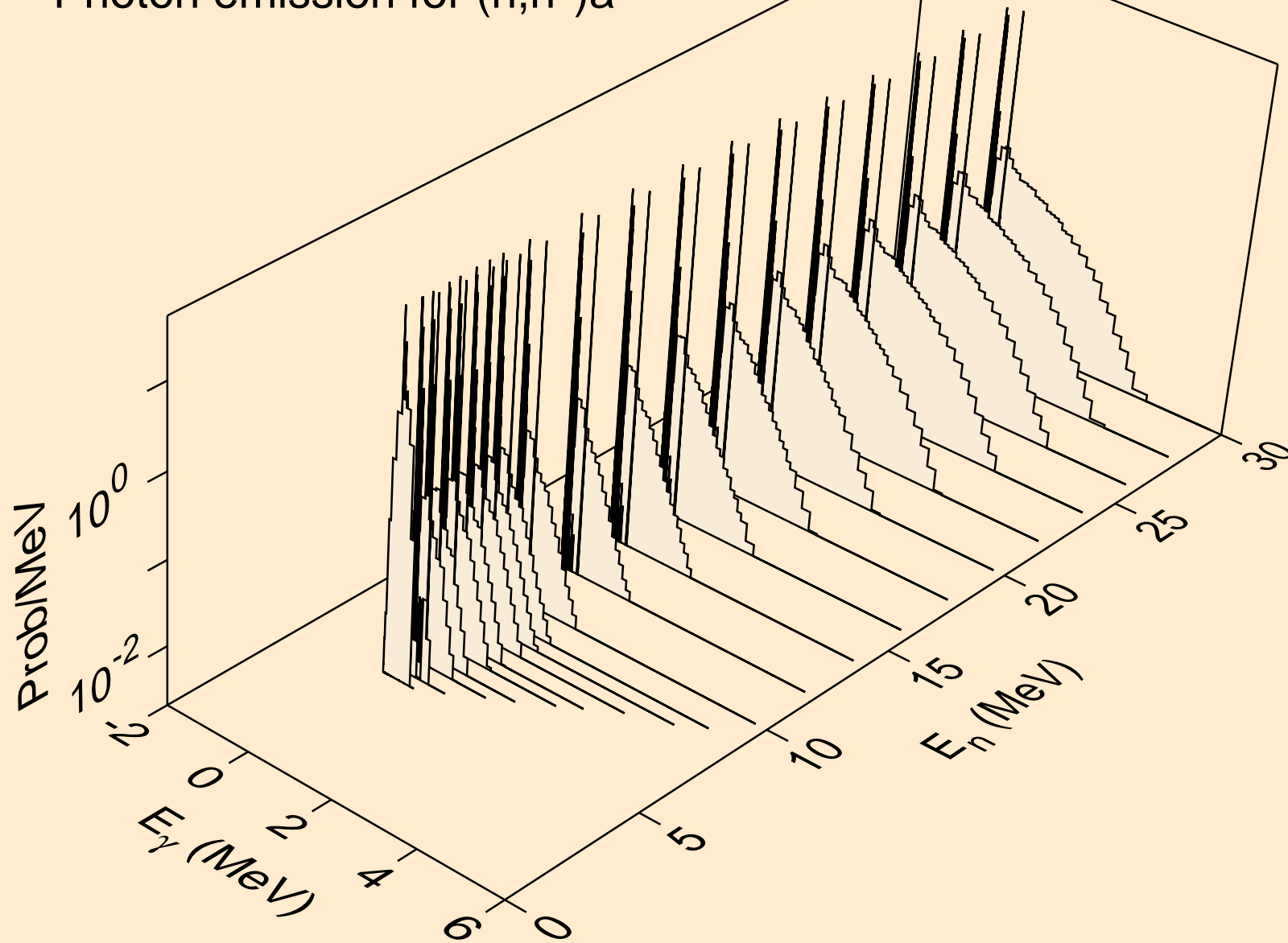

TH238 NEUTRON ACER TENDL-2023 LIBRARY; T=0.K
Photon emission for (n,2n)a

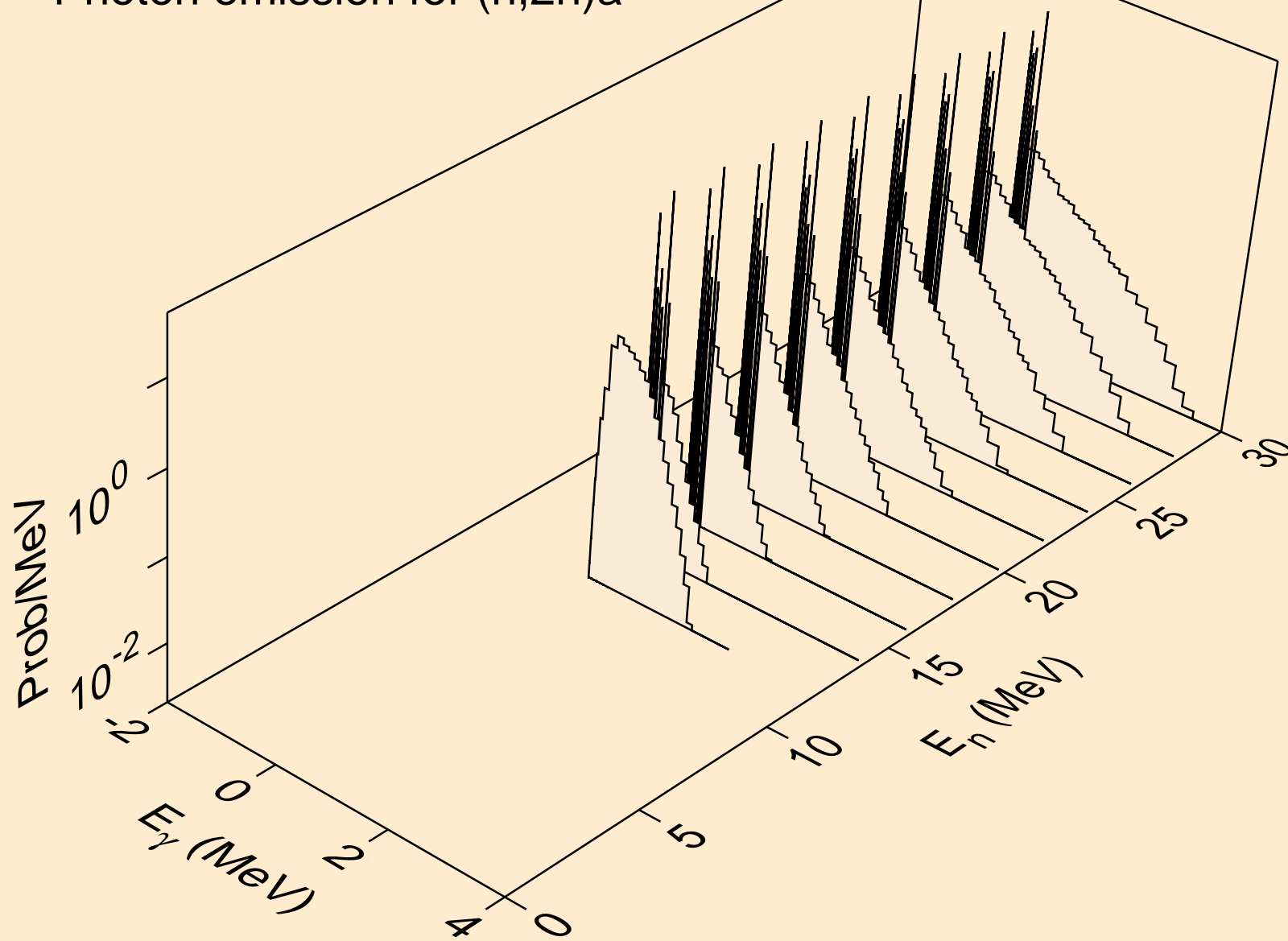

TH238 NEUTRON ACER TENDL-2023 LIBRARY; T=0.K
Photon emission for (n,3n)a

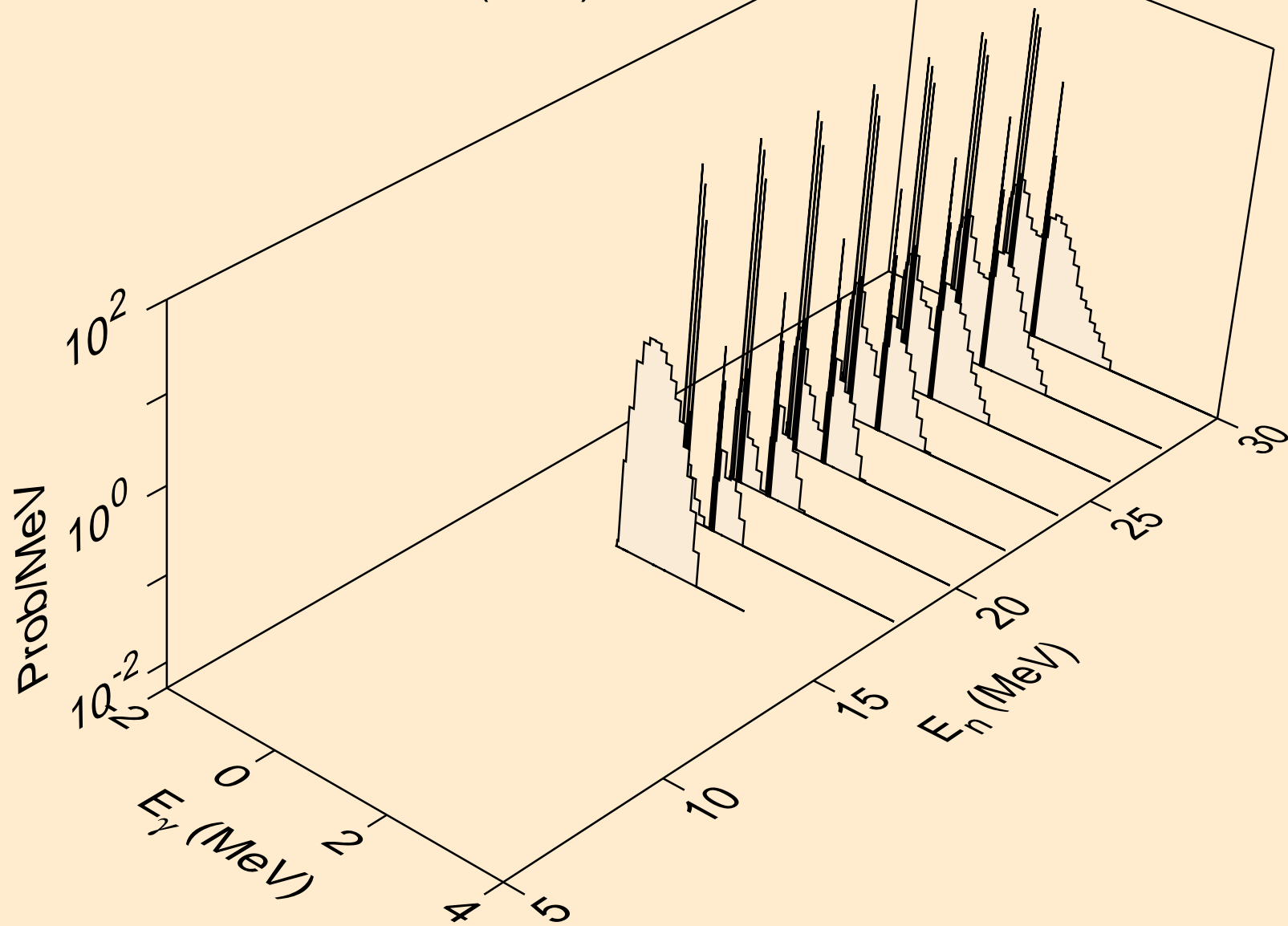

TH238 NEUTRON ACER TENDL-2023 LIBRARY; T=0.K
Photon emission for (n,n*)p

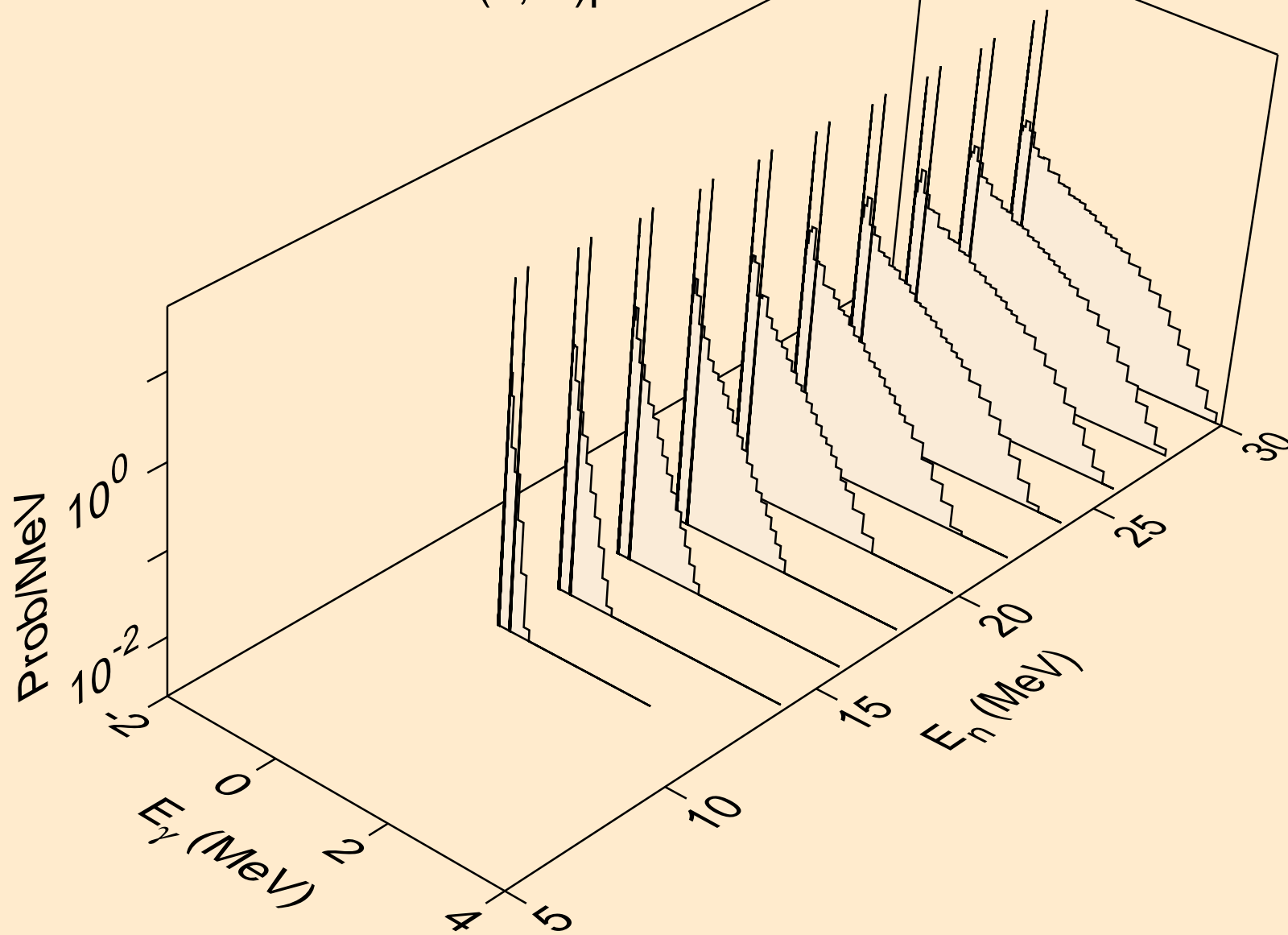

TH238 NEUTRON ACER TENDL-2023 LIBRARY; T=0.K
Photon emission for (n,n*)d

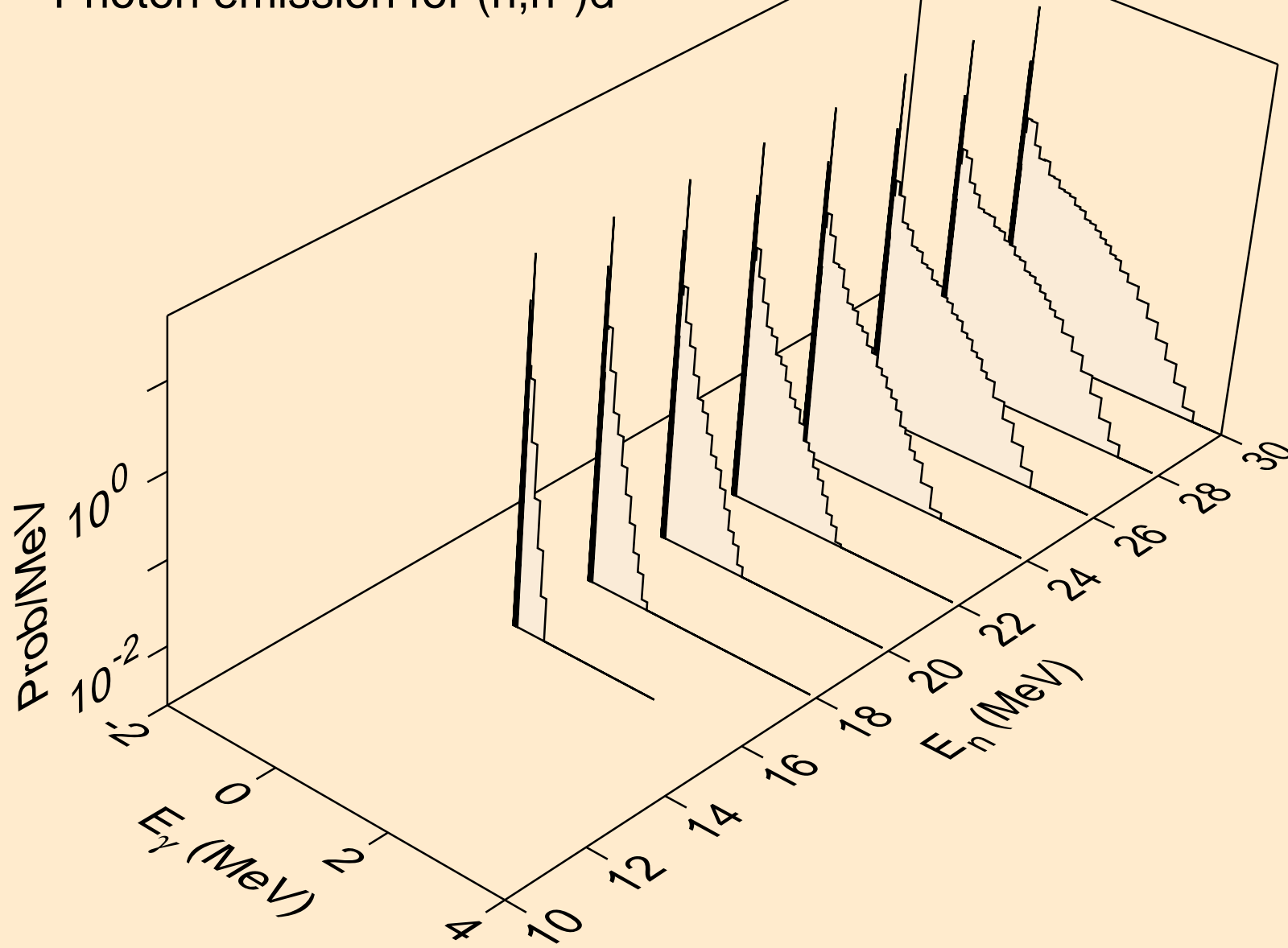

TH238 NEUTRON ACER TENDL-2023 LIBRARY; T=0.K
Photon emission for (n,n*)t

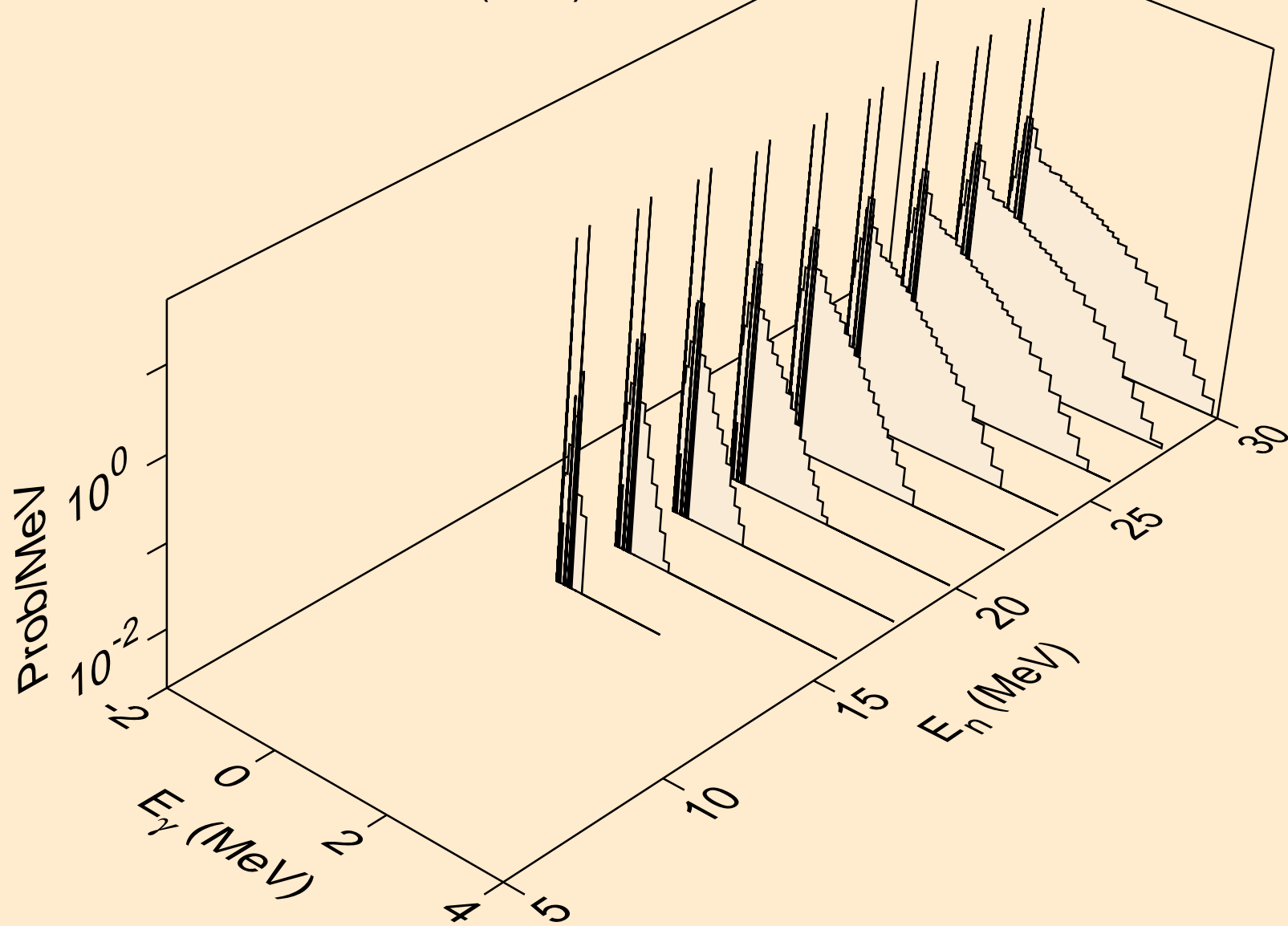

TH238 NEUTRON ACER TENDL-2023 LIBRARY; T=0.K
Photon emission for (n,n*)he3

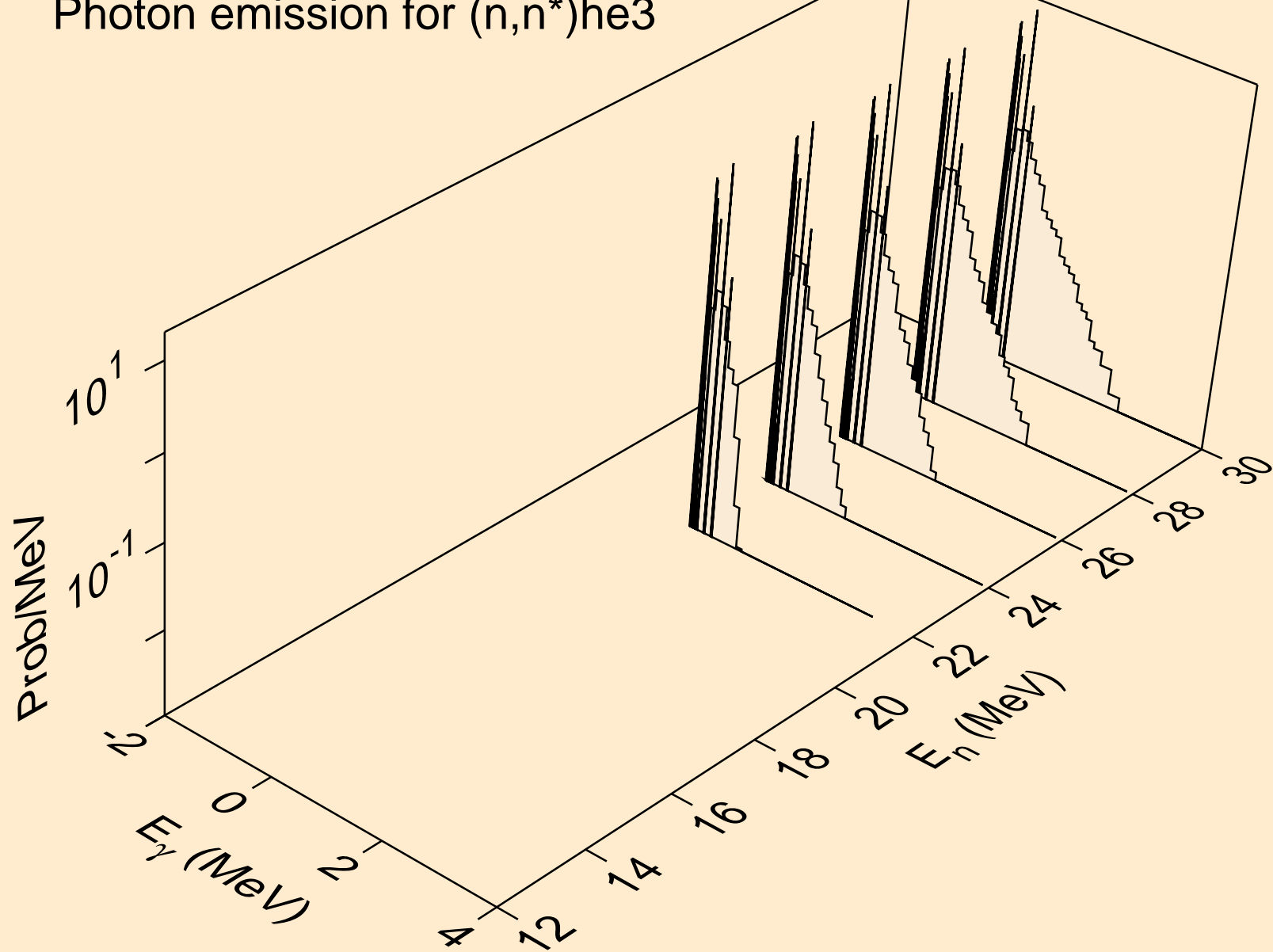

TH238 NEUTRON ACER TENDL-2023 LIBRARY; T=0.K
Photon emission for (n,4n)

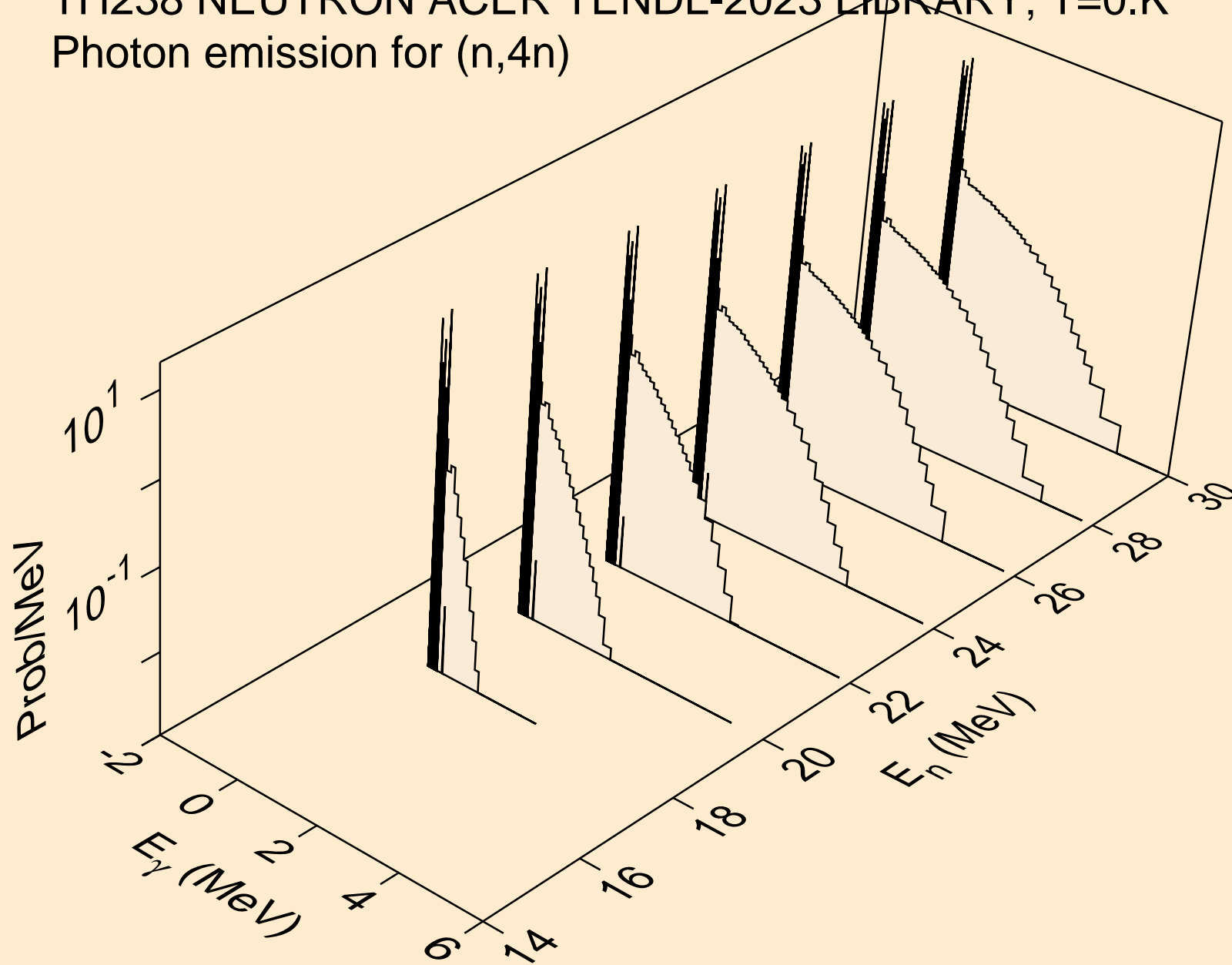

TH238 NEUTRON ACER TENDL-2023 LIBRARY; T=0.K
Photon emission for (n,2np)

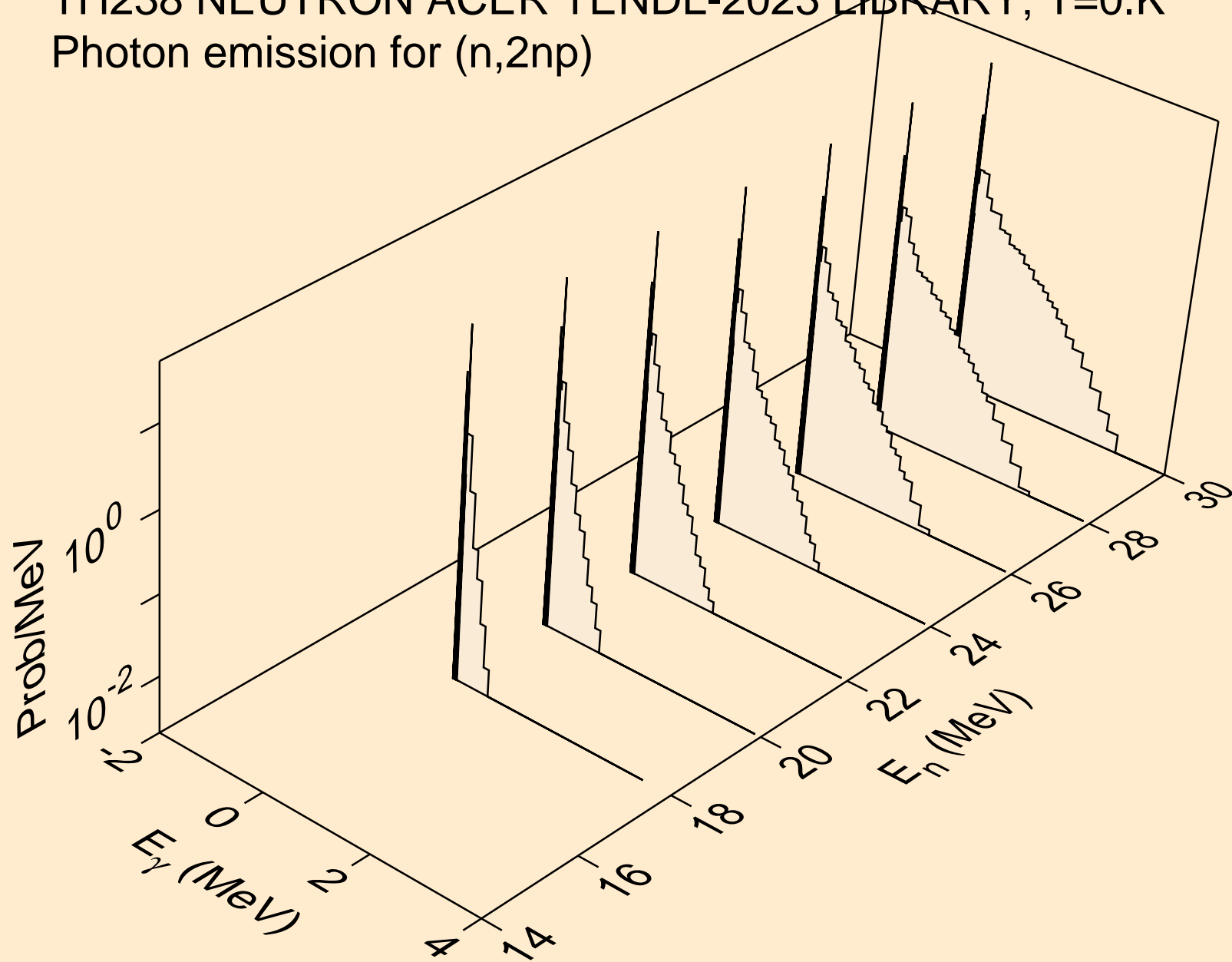

TH238 NEUTRON ACER TENDL-2023 LIBRARY; T=0.K
Photon emission for (n,3np)

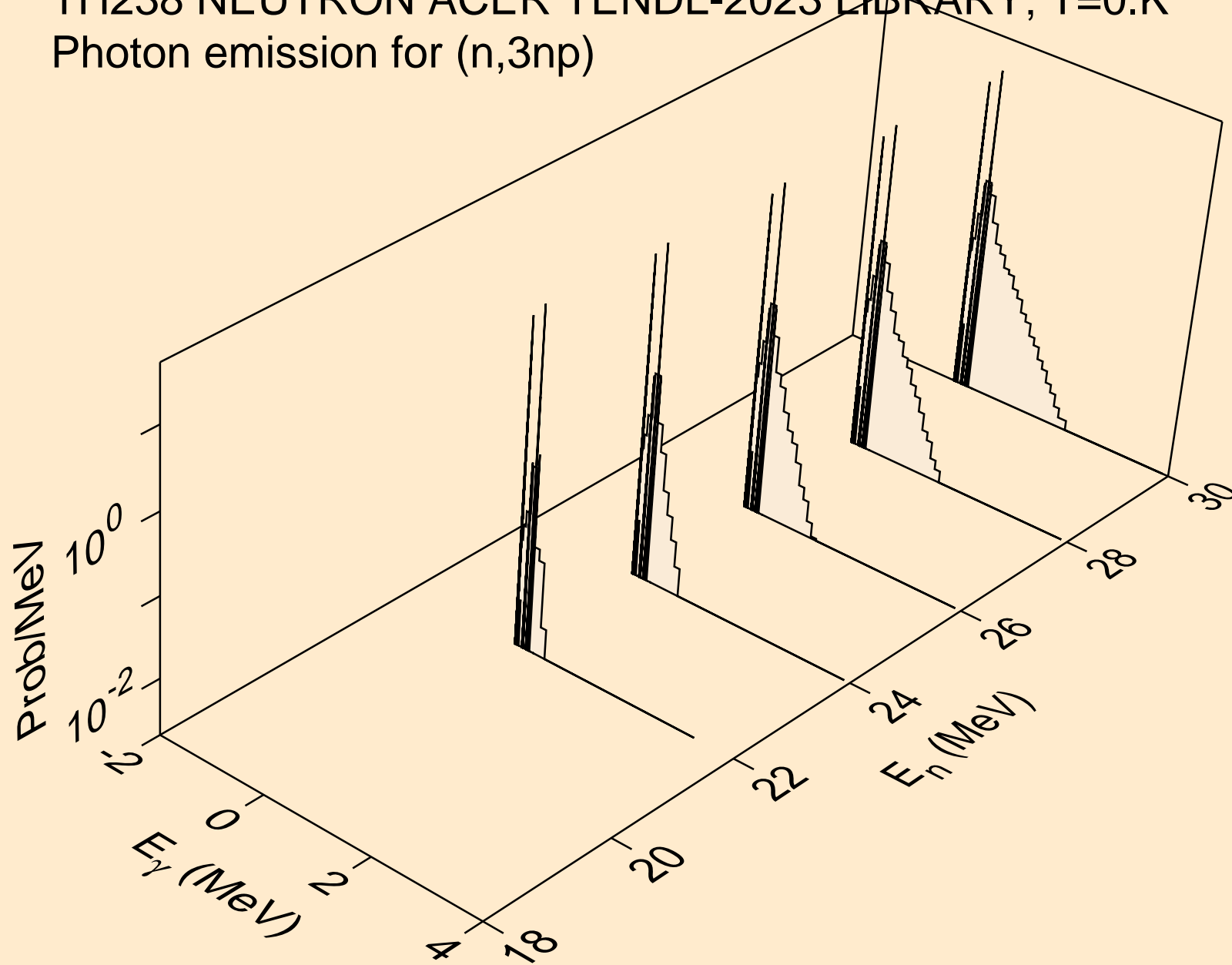

TH238 NEUTRON ACER TENDL-2023 LIBRARY; T=0.K
Photon emission for (n,n*c)

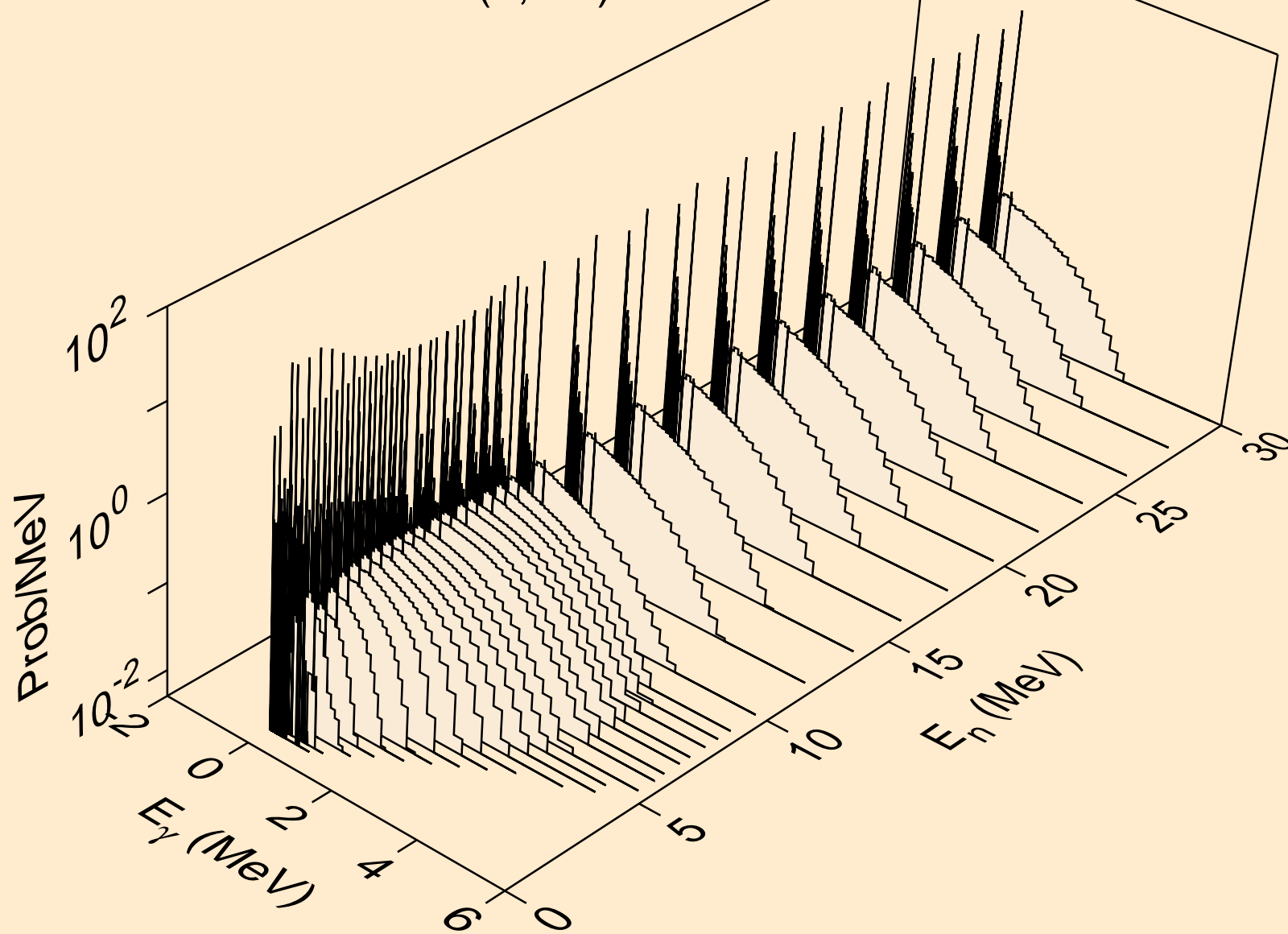

TH238 NEUTRON ACER TENDL-2023 LIBRARY; T=0.K
Photon emission for (n,gma)

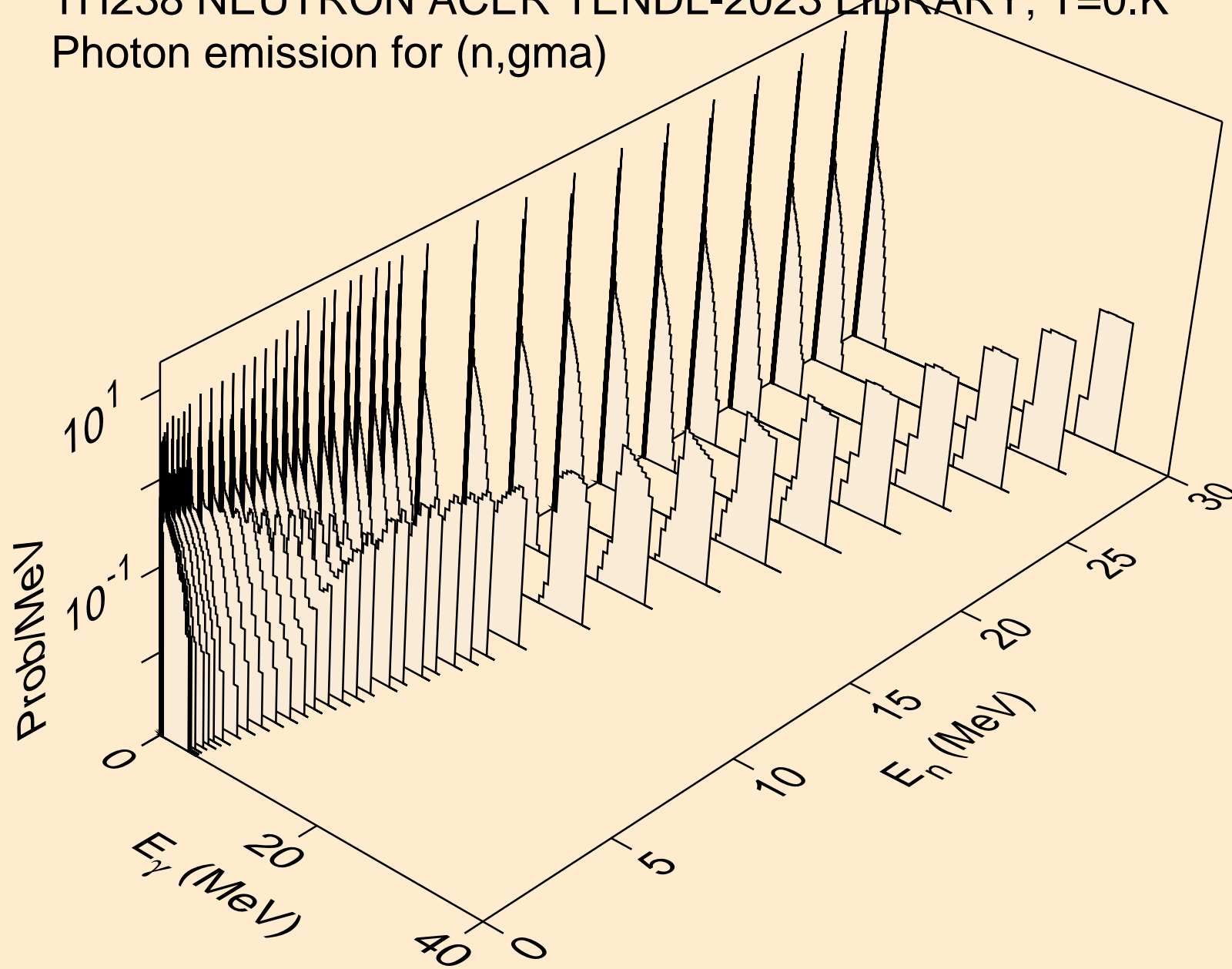

TH238 NEUTRON ACER TENDL-2023 LIBRARY; T=0.K
Photon emission for (n,p)

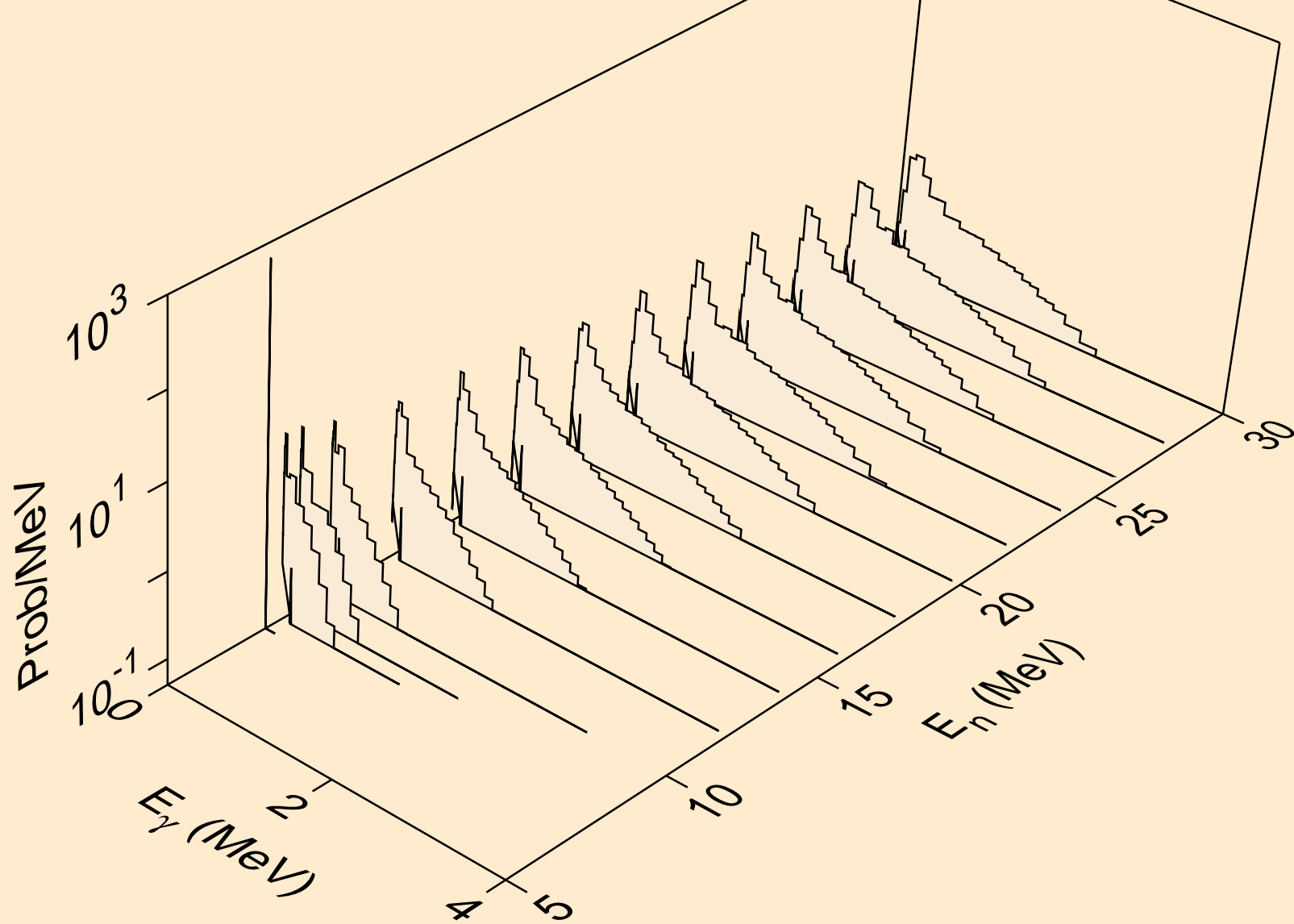

TH238 NEUTRON ACER TENDL-2023 LIBRARY; T=0.K
Photon emission for (n,d)

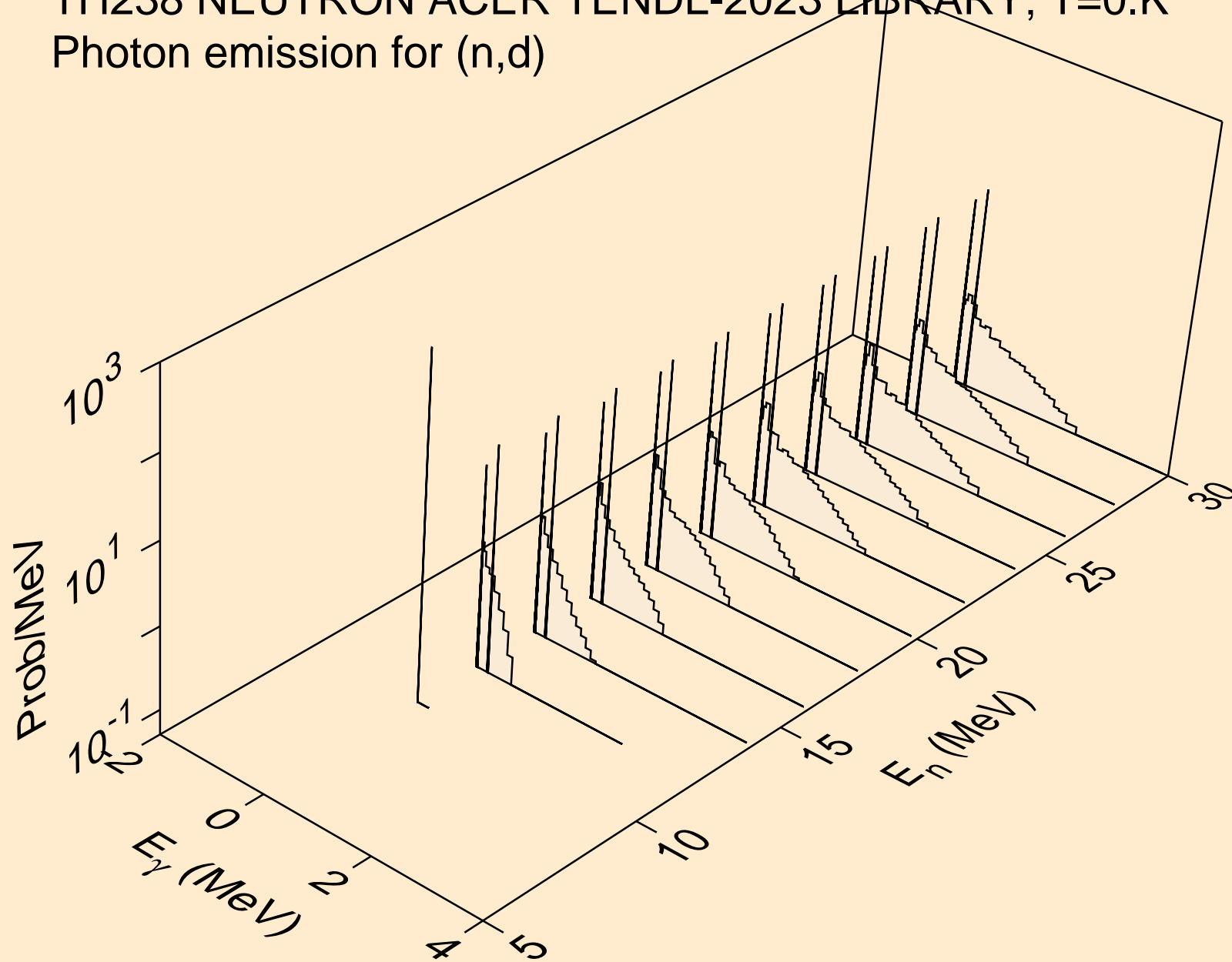

TH238 NEUTRON ACER TENDL-2023 LIBRARY; T=0.K
Photon emission for (n,t)

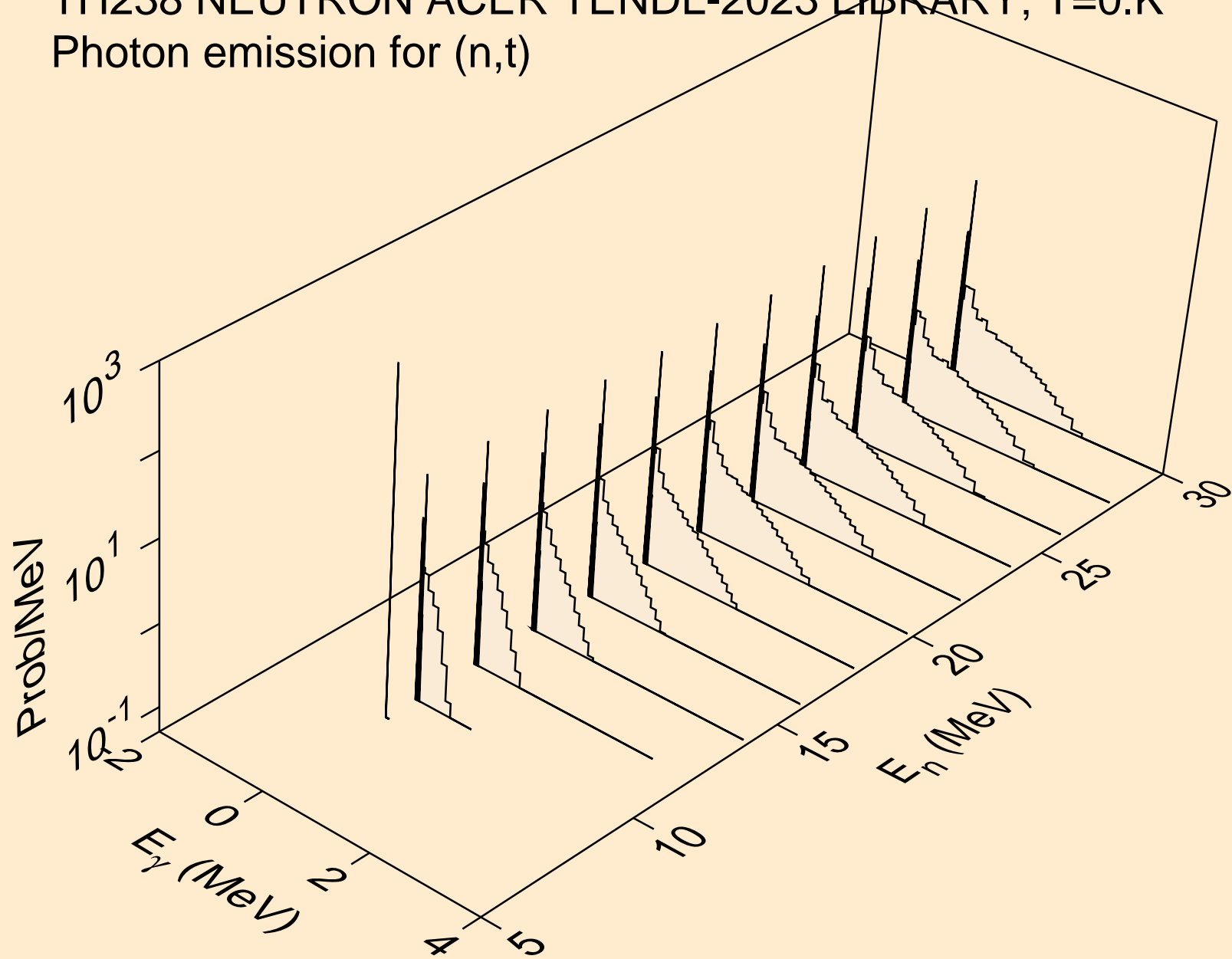

TH238 NEUTRON ACER TENDL-2023 LIBRARY; T=0.K
Photon emission for (n,he3)

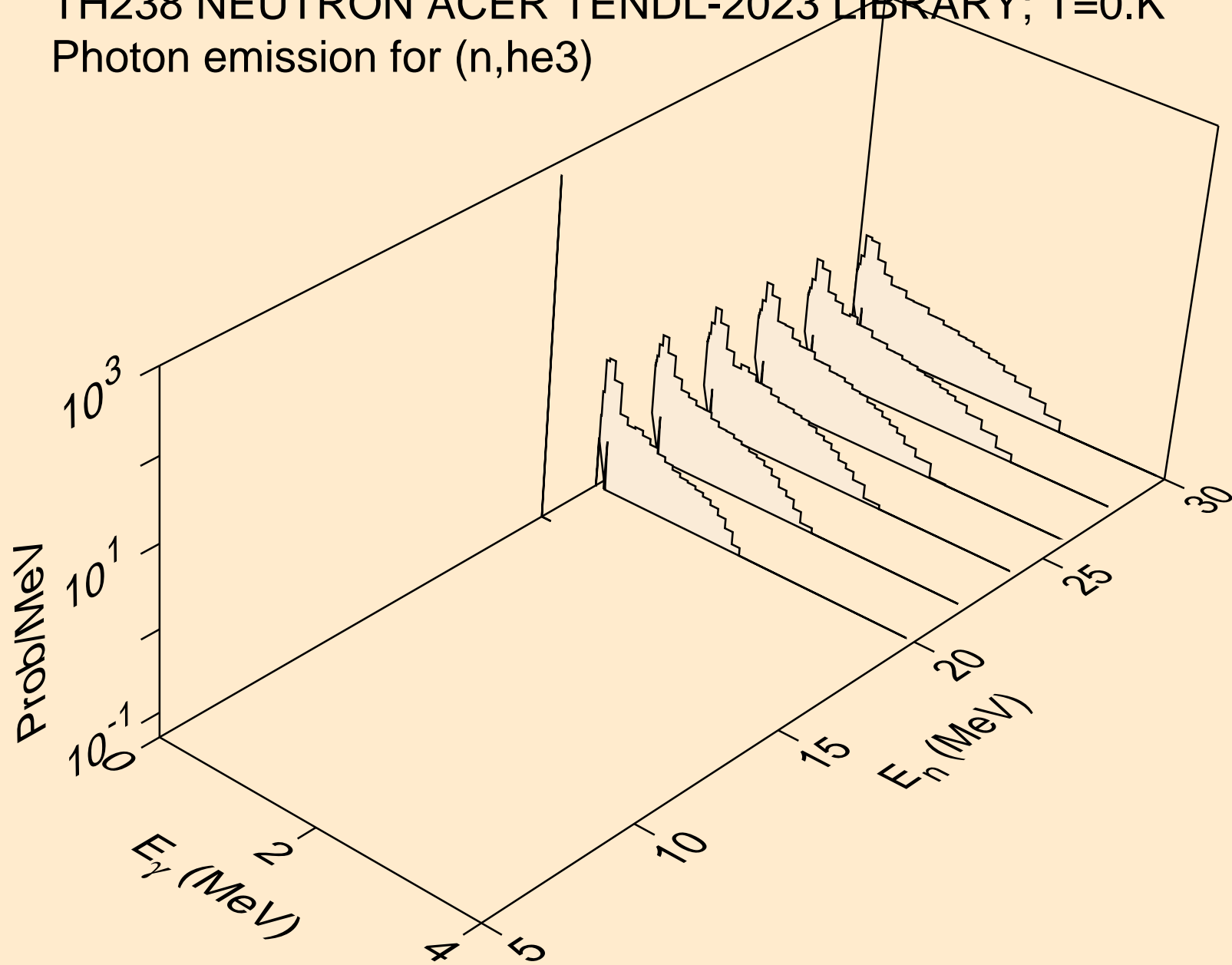

TH238 NEUTRON ACER TENDL-2023 LIBRARY; T=0.K
Photon emission for (n,a)

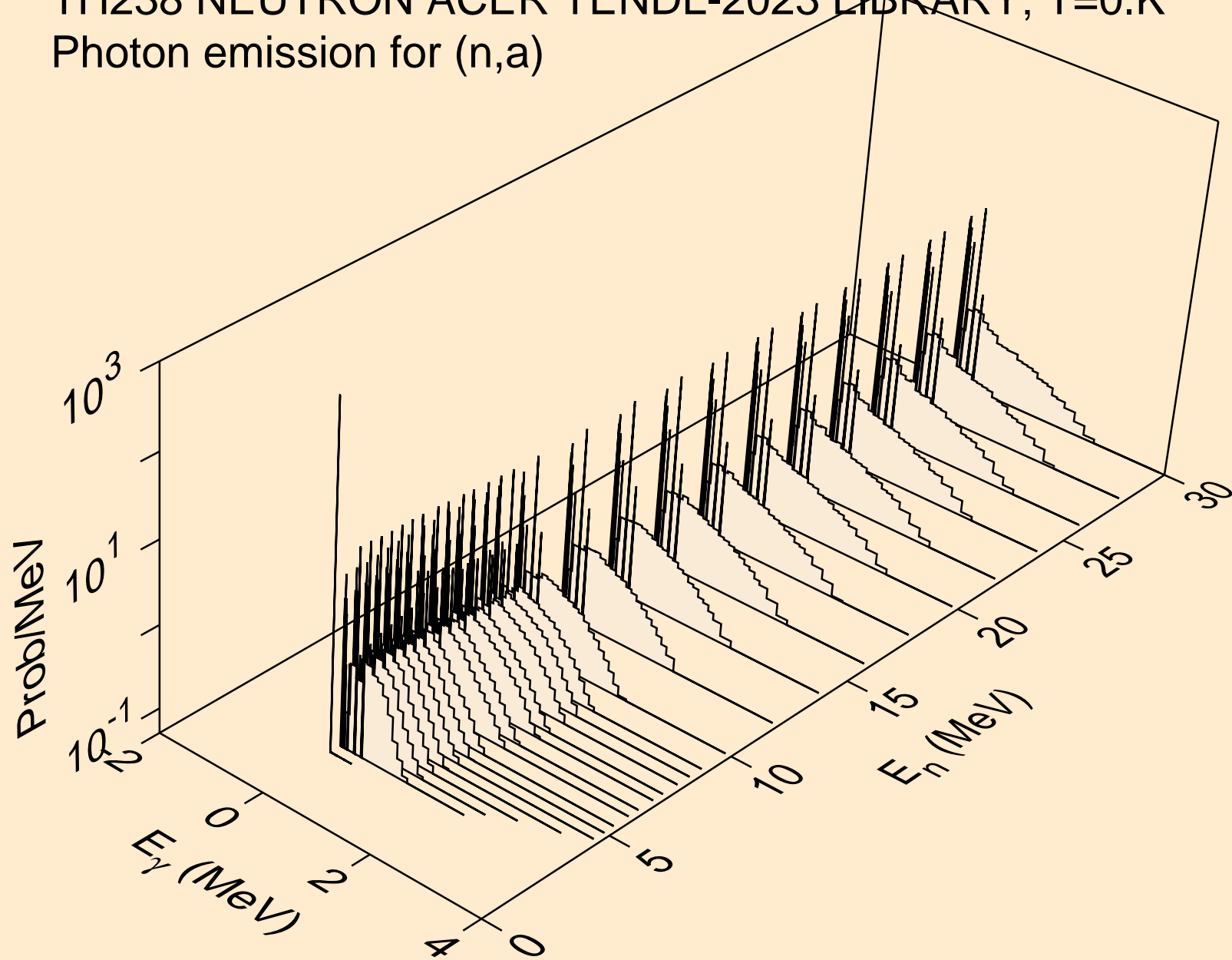

TH238 NEUTRON ACER TENDL-2023 LIBRARY; T=0.K
thermal capture photon spectrum

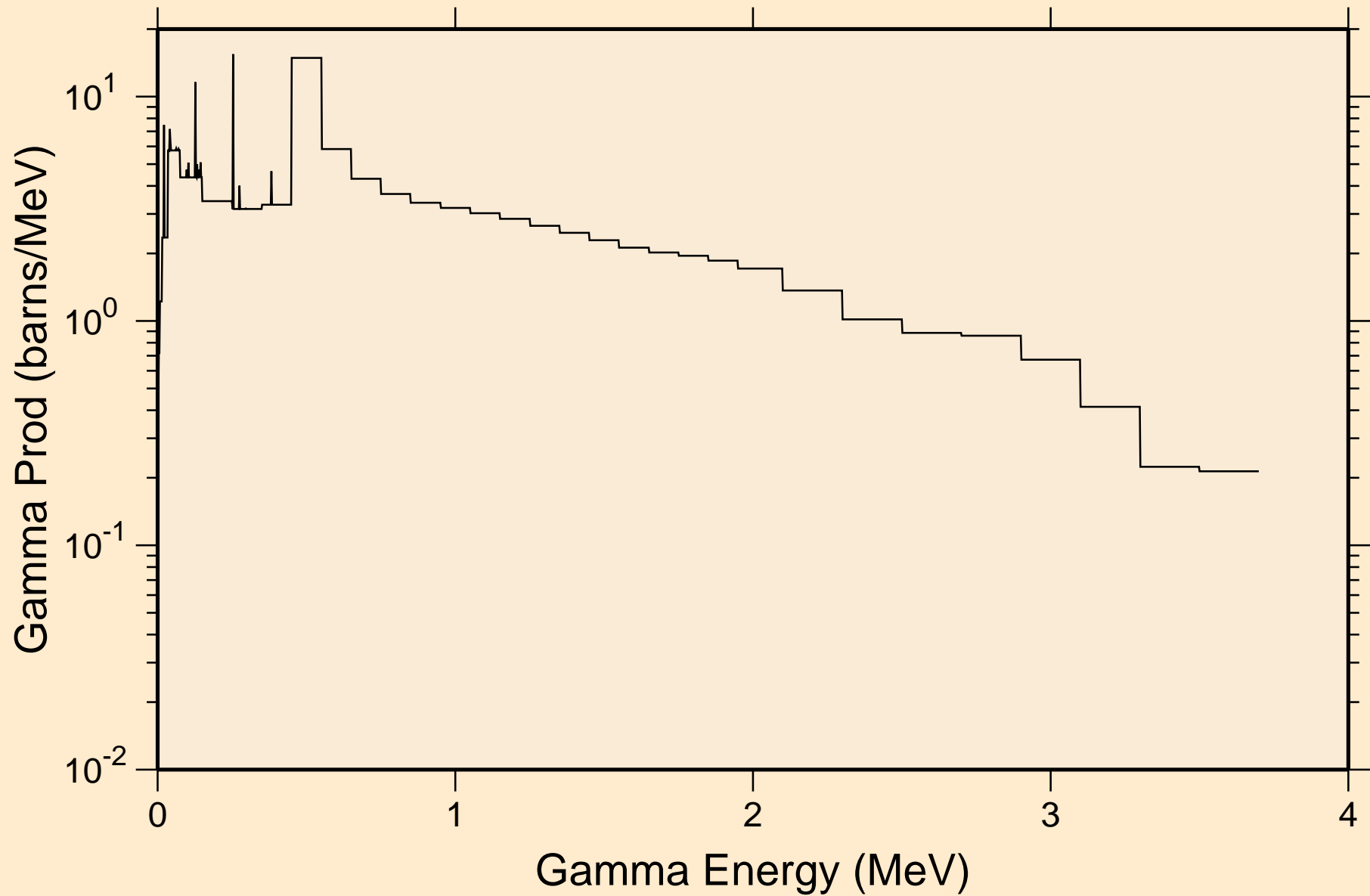

TH238 NEUTRON ACER TENDL-2023 LIBRARY; T=0.K
14 MeV photon spectrum

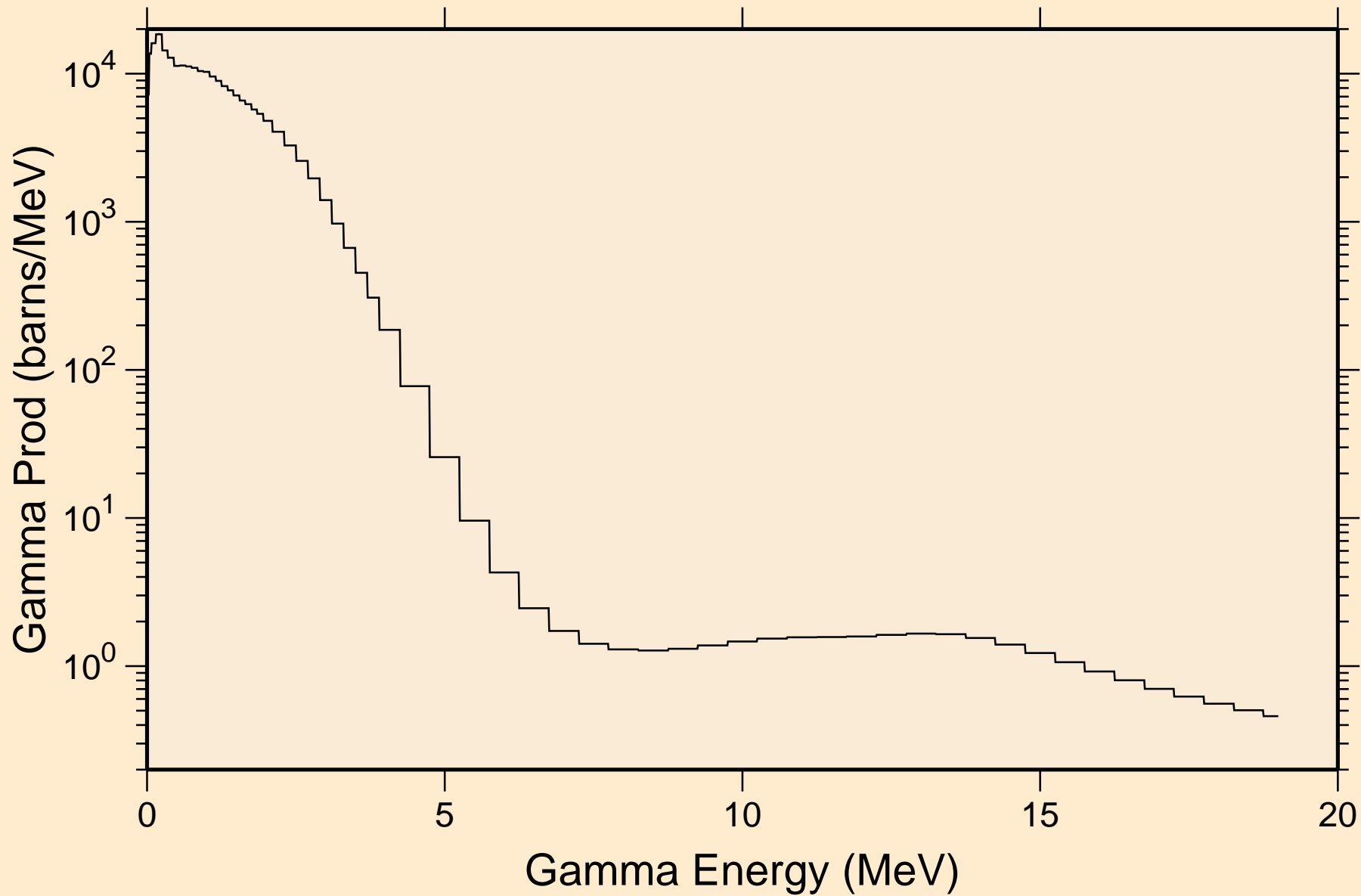

TH238 NEUTRON ACER TENDL-2023 LIBRARY; T=0.K

Particle heating contributions

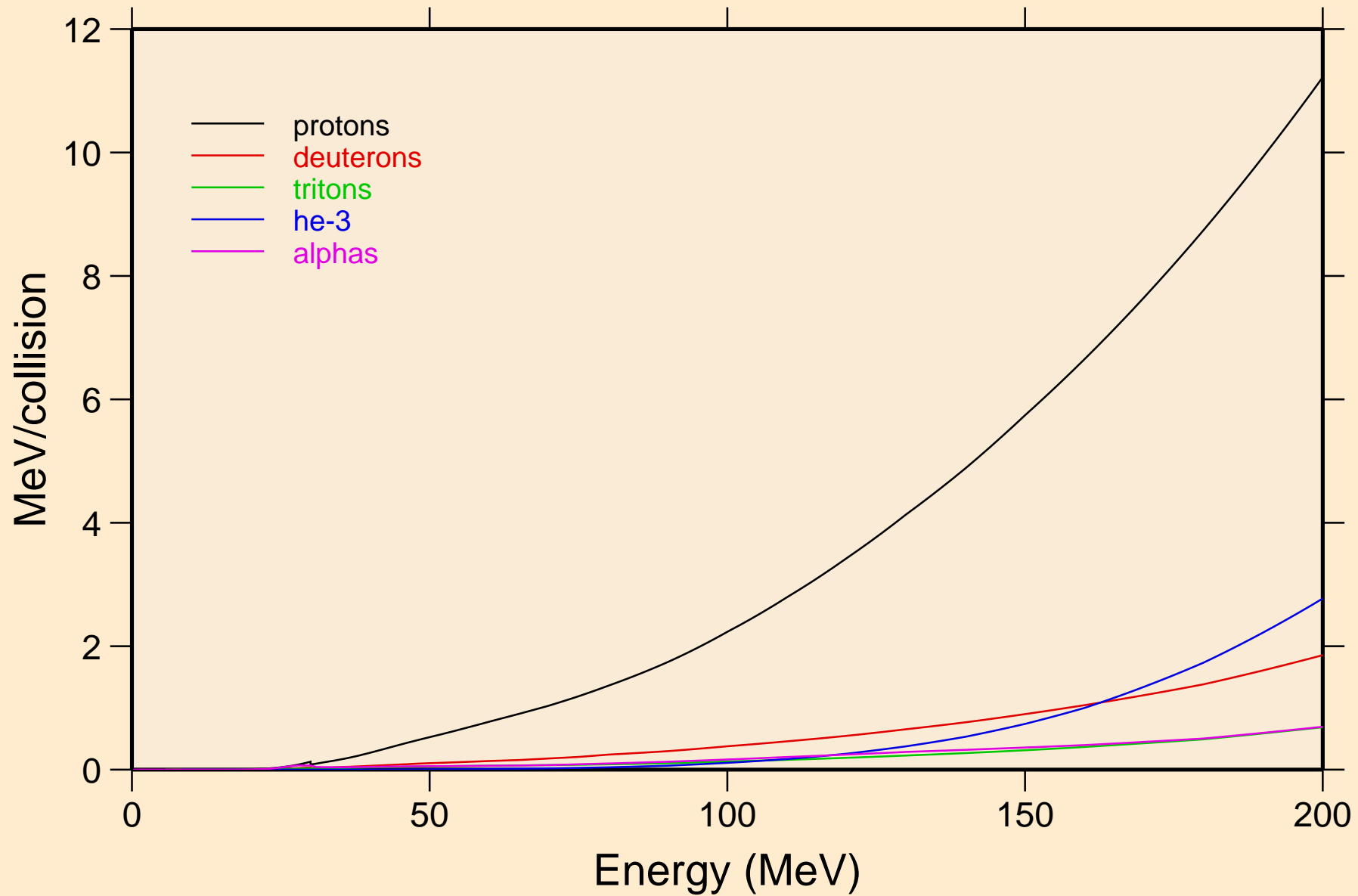

TH238 NEUTRON ACER TENDL-2023 LIBRARY; T=0.K
Recoil Heating

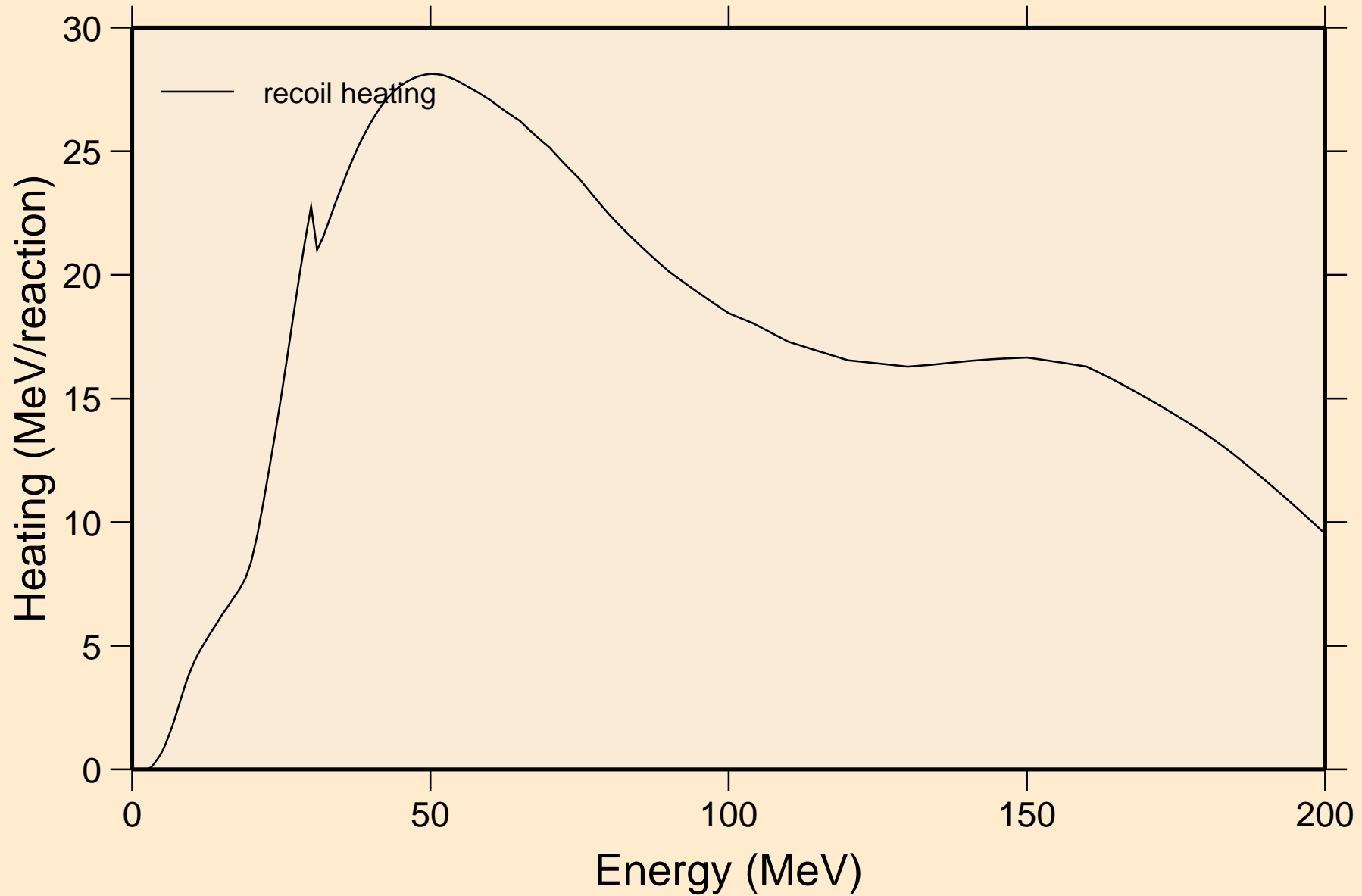

TH238 NEUTRON ACER TENDL-2023 LIBRARY; T=0.K

Particle production cross sections

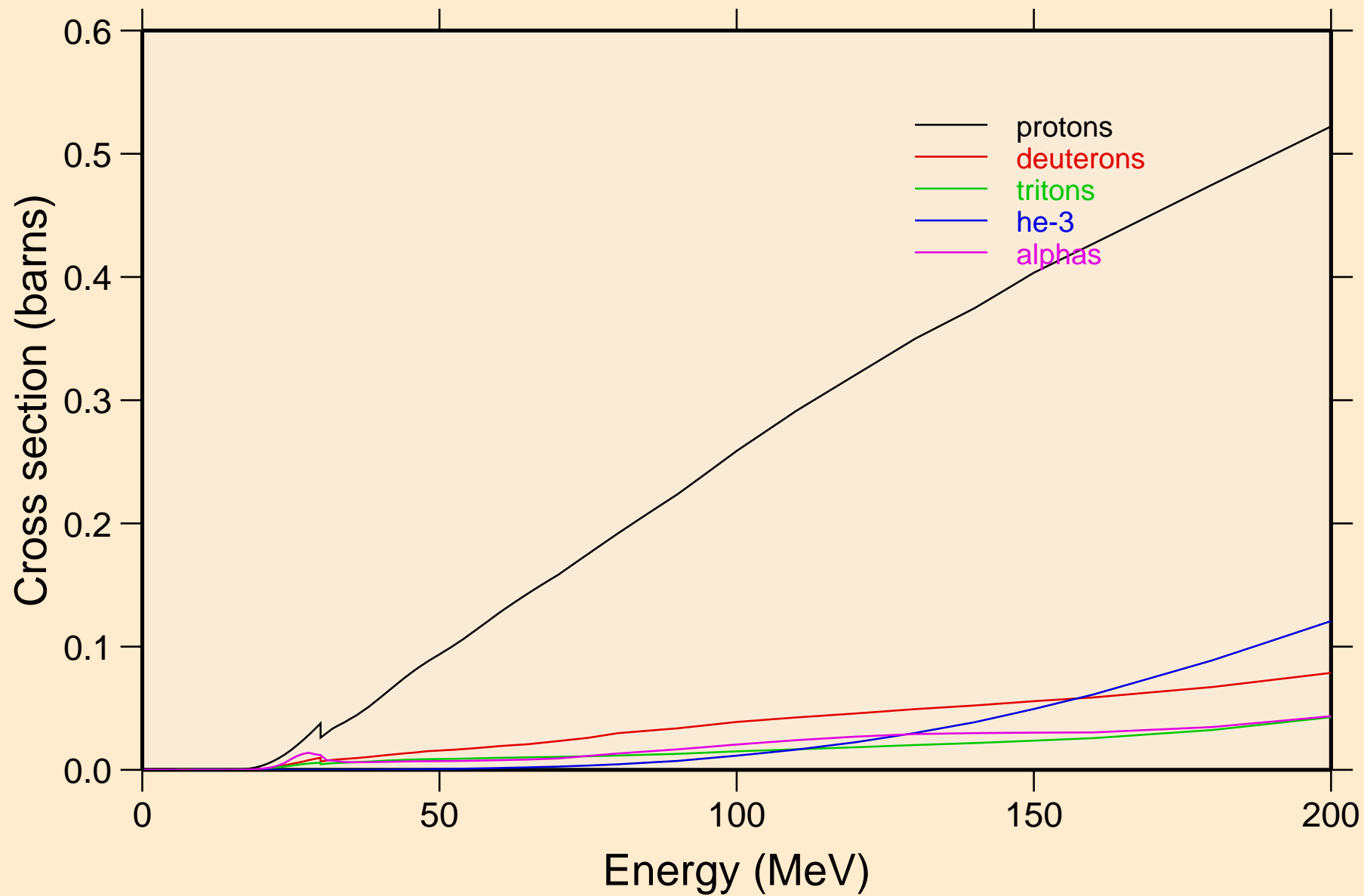

TH238 NEUTRON ACER TENDL-2023 LIBRARY; T=0.K
protons from (n,x)

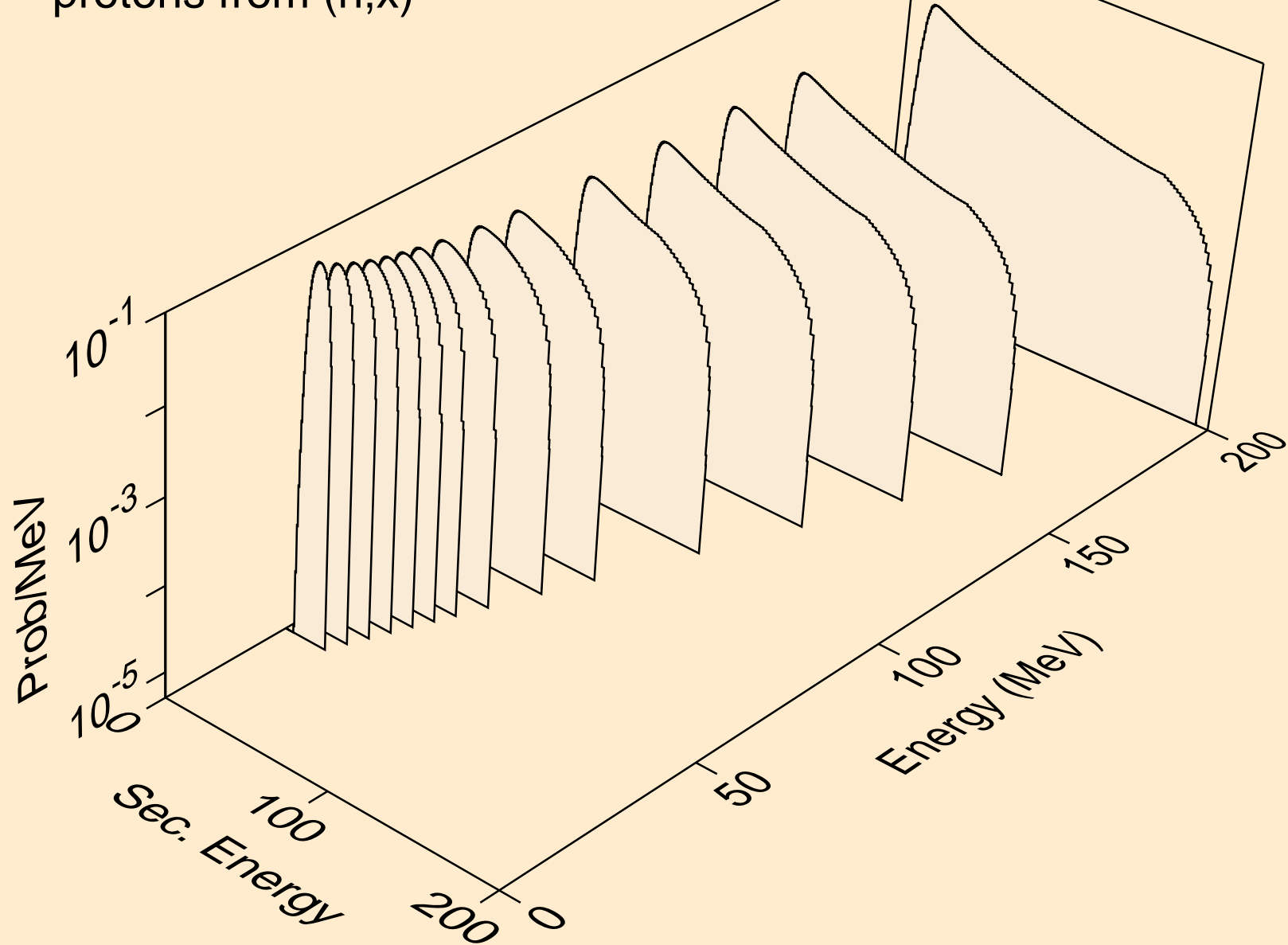

TH238 NEUTRON ACER TENDL-2023 LIBRARY; T=0.K
protons from (n,n*)p

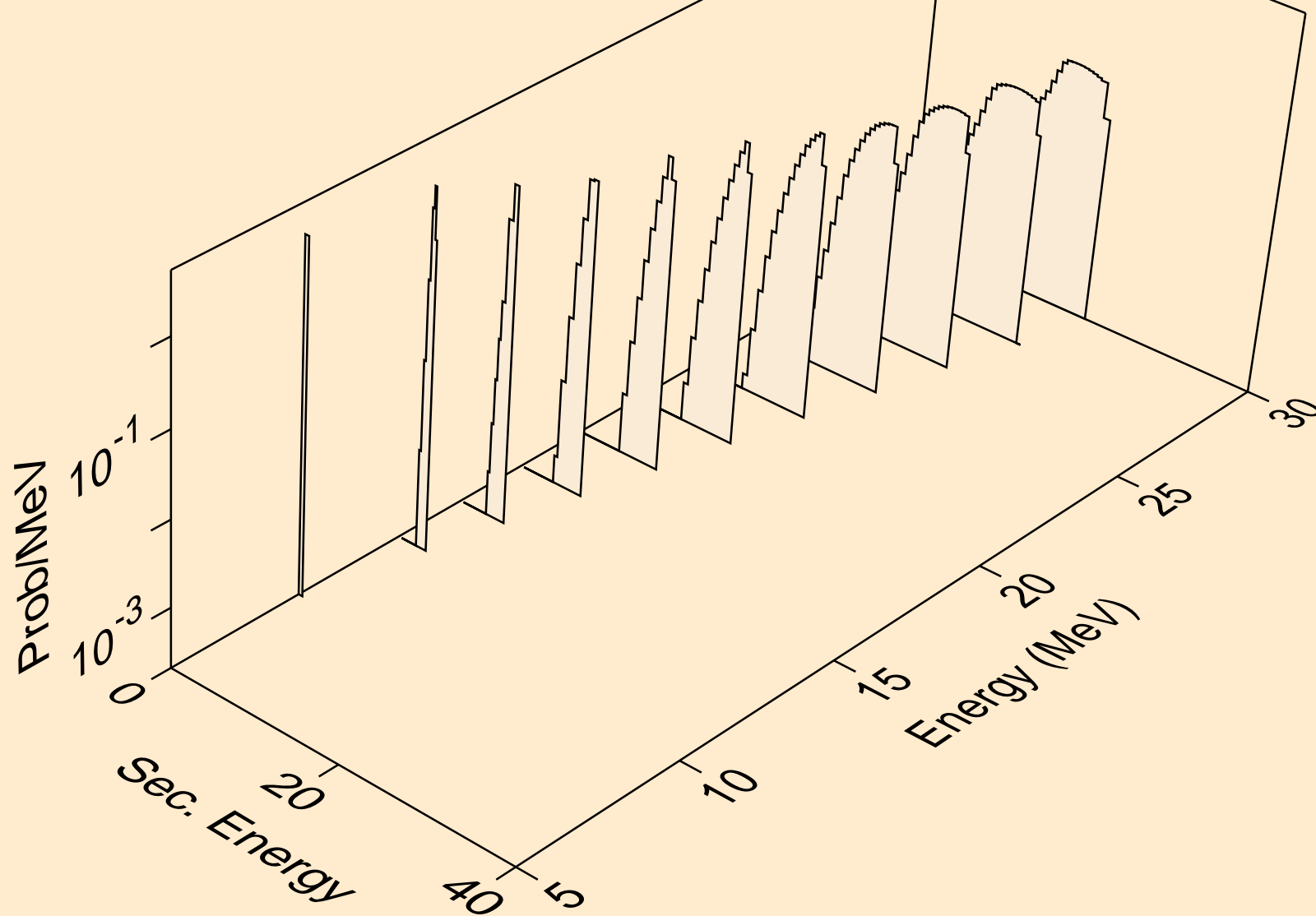

TH238 NEUTRON ACER TENDL-2023 LIBRARY; T=0.K
protons from (n,2np)

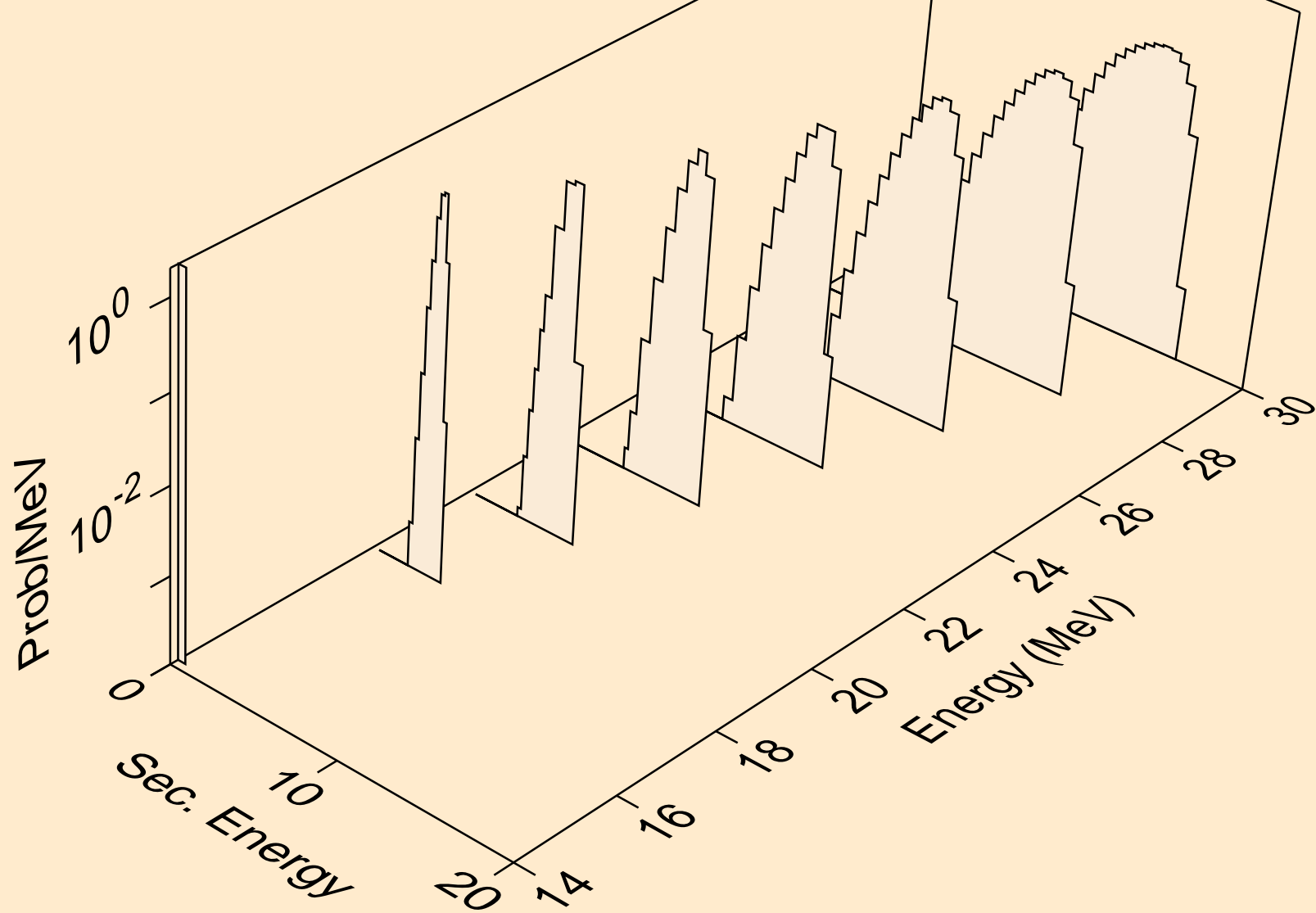

TH238 NEUTRON ACER TENDL-2023 LIBRARY; T=0.K
protons from (n,3np)

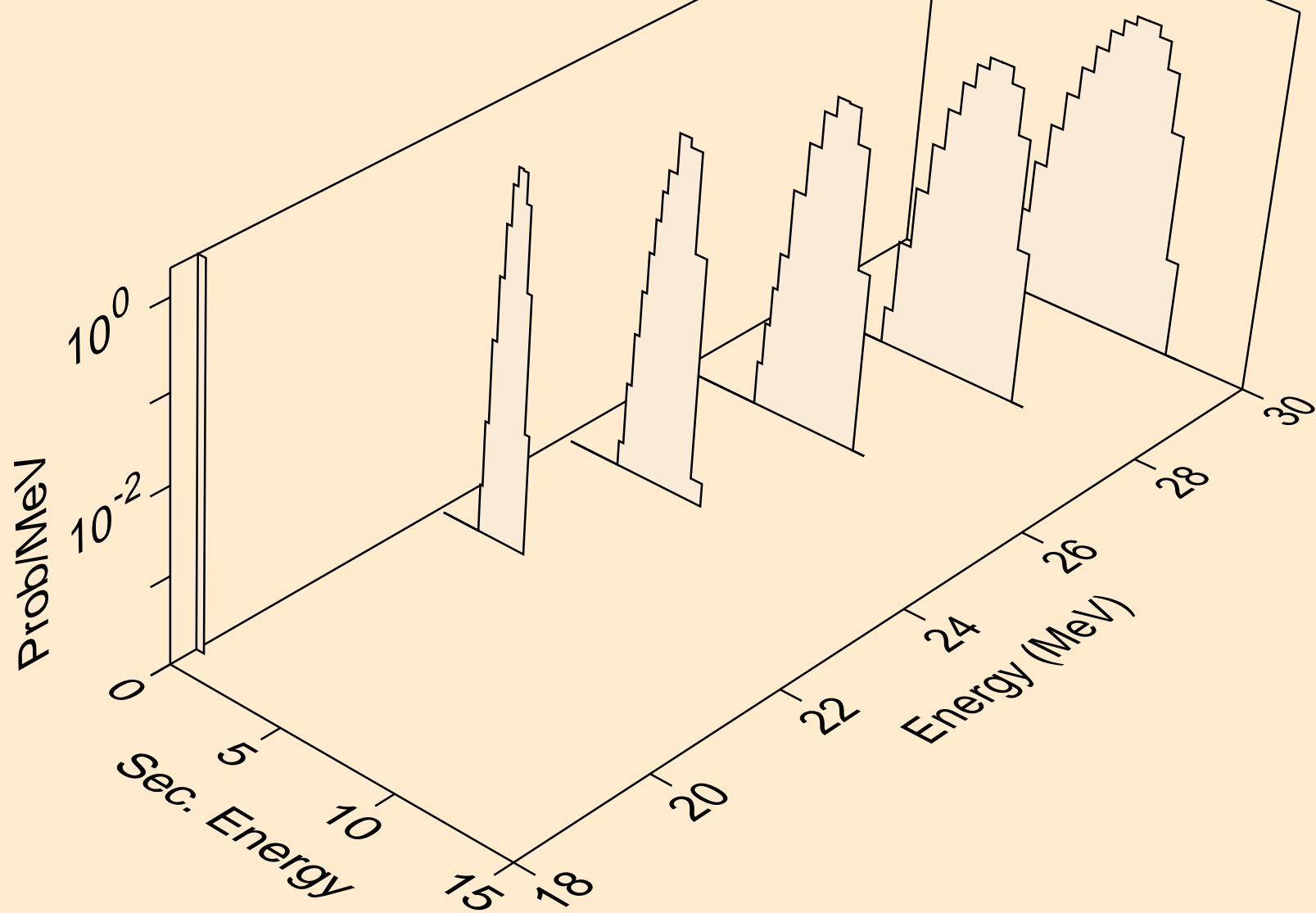

TH238 NEUTRON ACER TENDL-2023 LIBRARY; T=0.K
protons from (n,p)

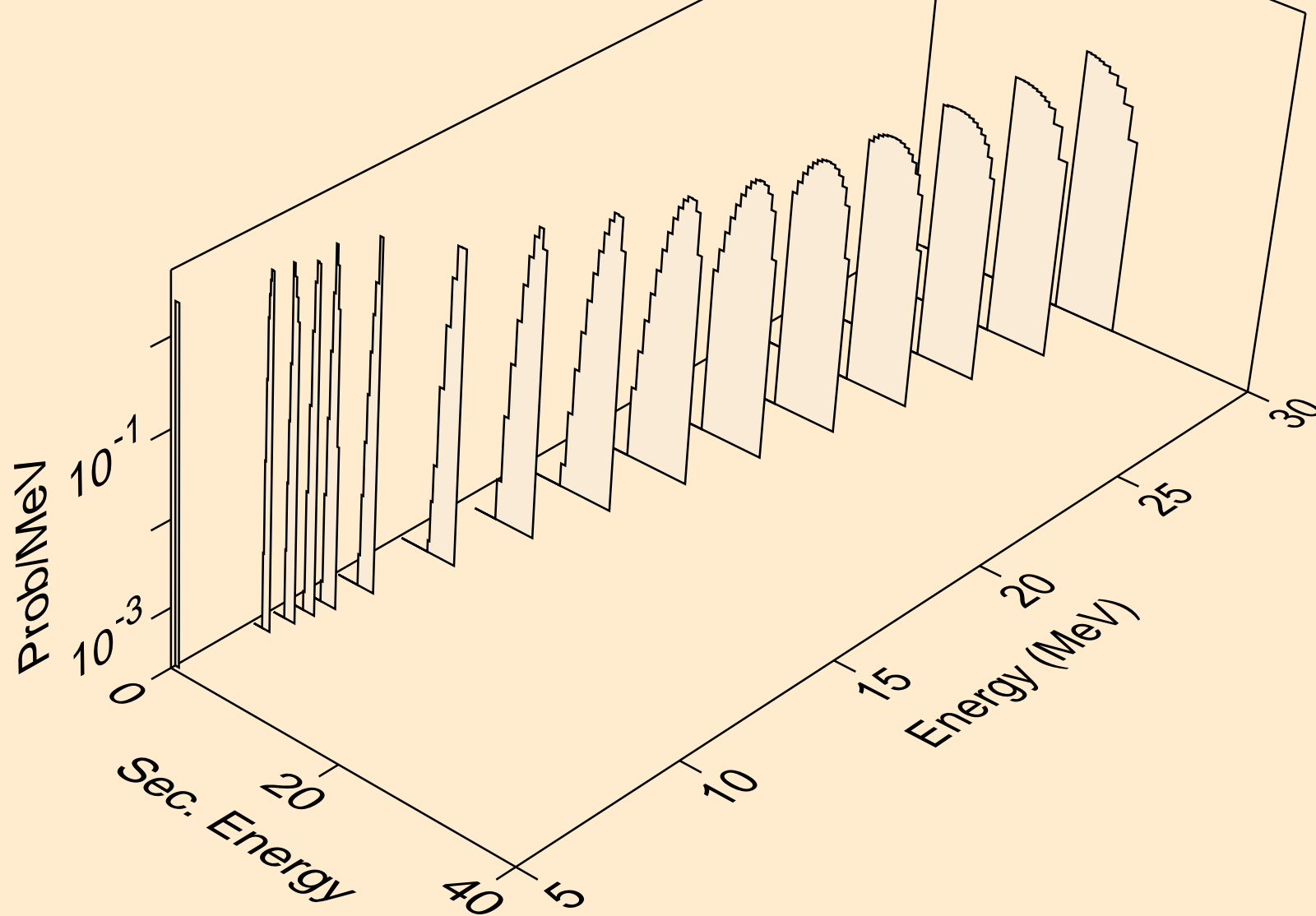

TH238 NEUTRON ACER TENDL-2023 LIBRARY; T=0.K
deuterons from (n,x)

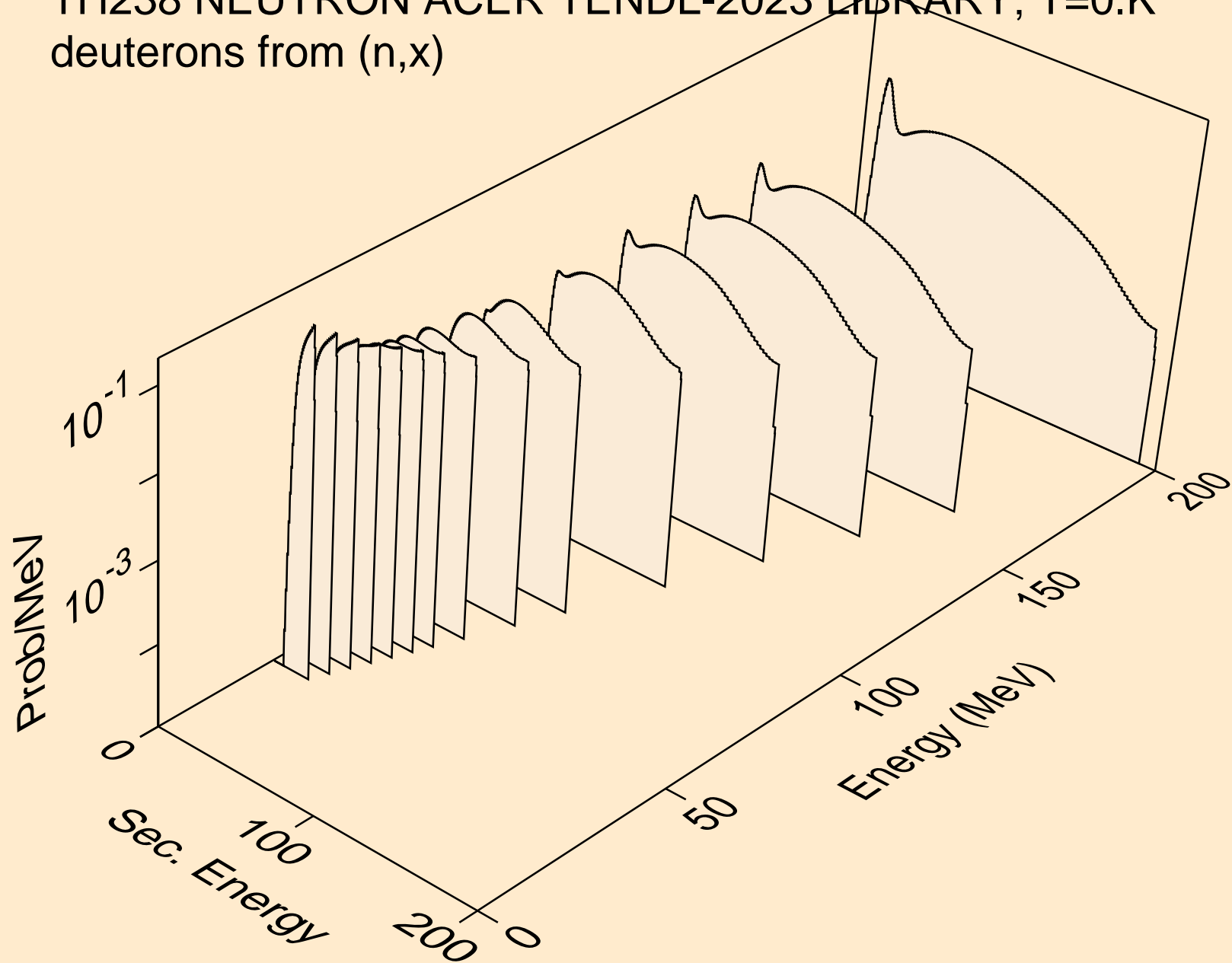

TH238 NEUTRON ACER TENDL-2023 LIBRARY; T=0.K
deuterons from (n,2nd)

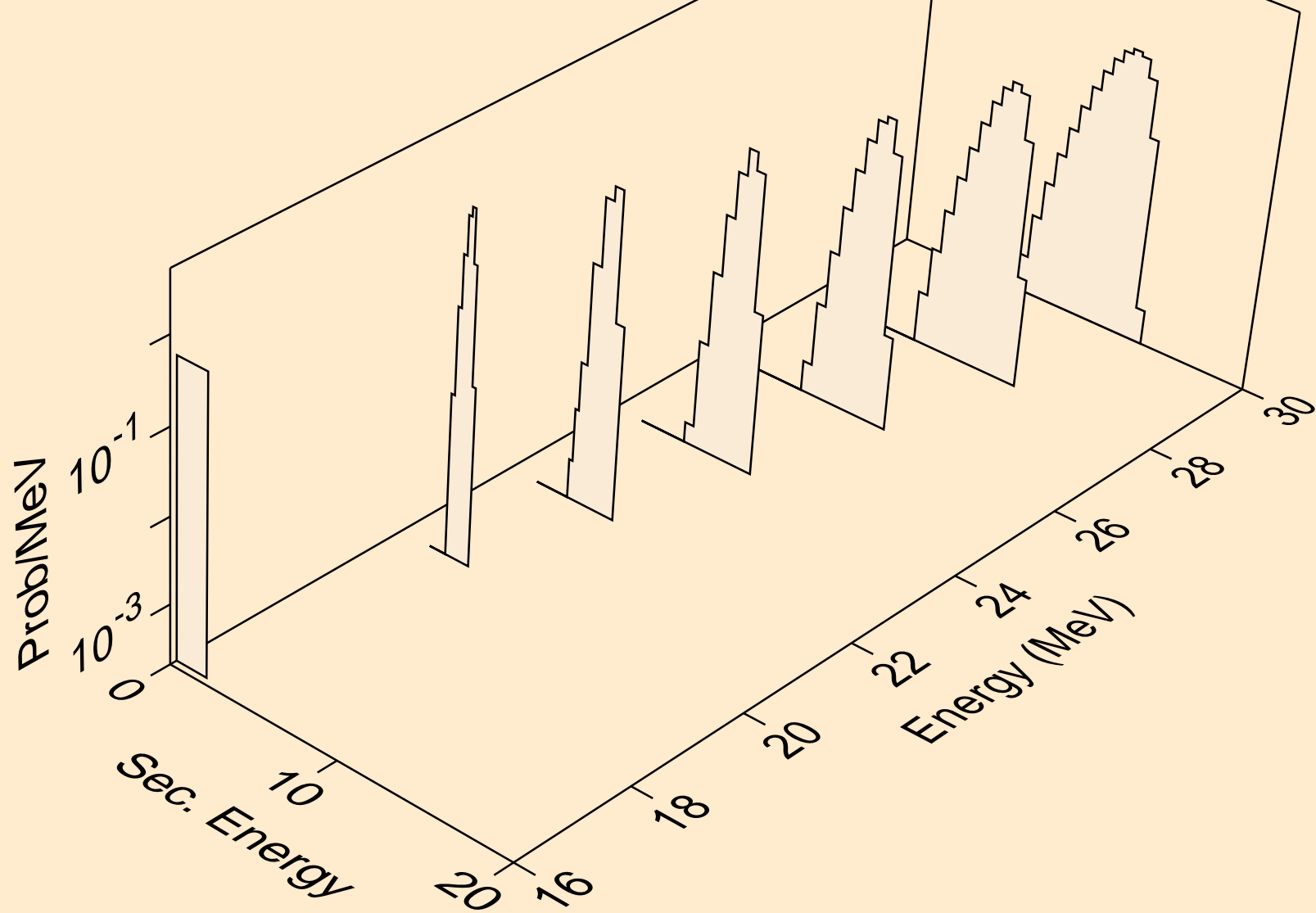

TH238 NEUTRON ACER TENDL-2023 LIBRARY; T=0.K
deuterons from (n,n*)d

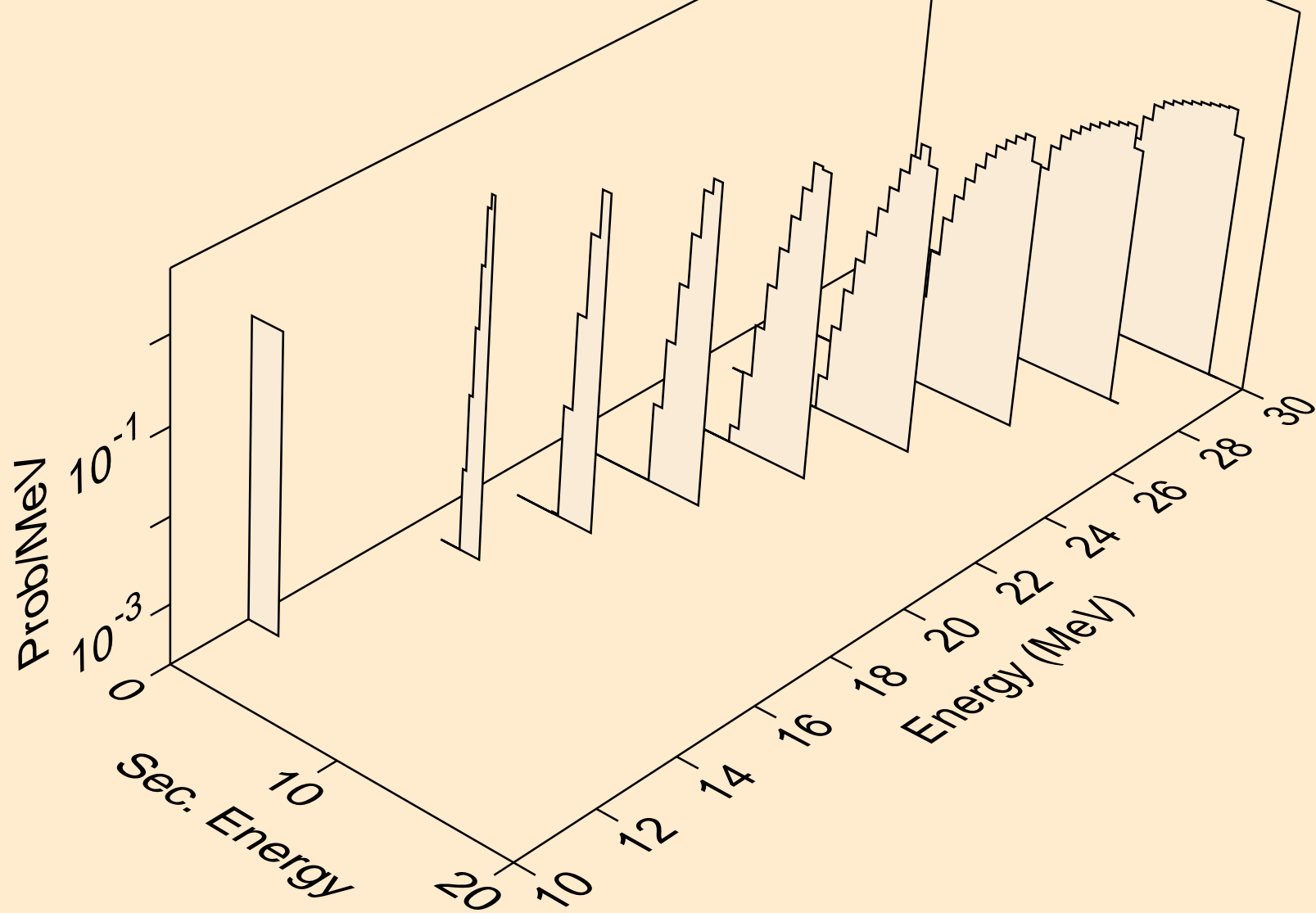

TH238 NEUTRON ACER TENDL-2023 LIBRARY; T=0.K
deuterons from (n,d)

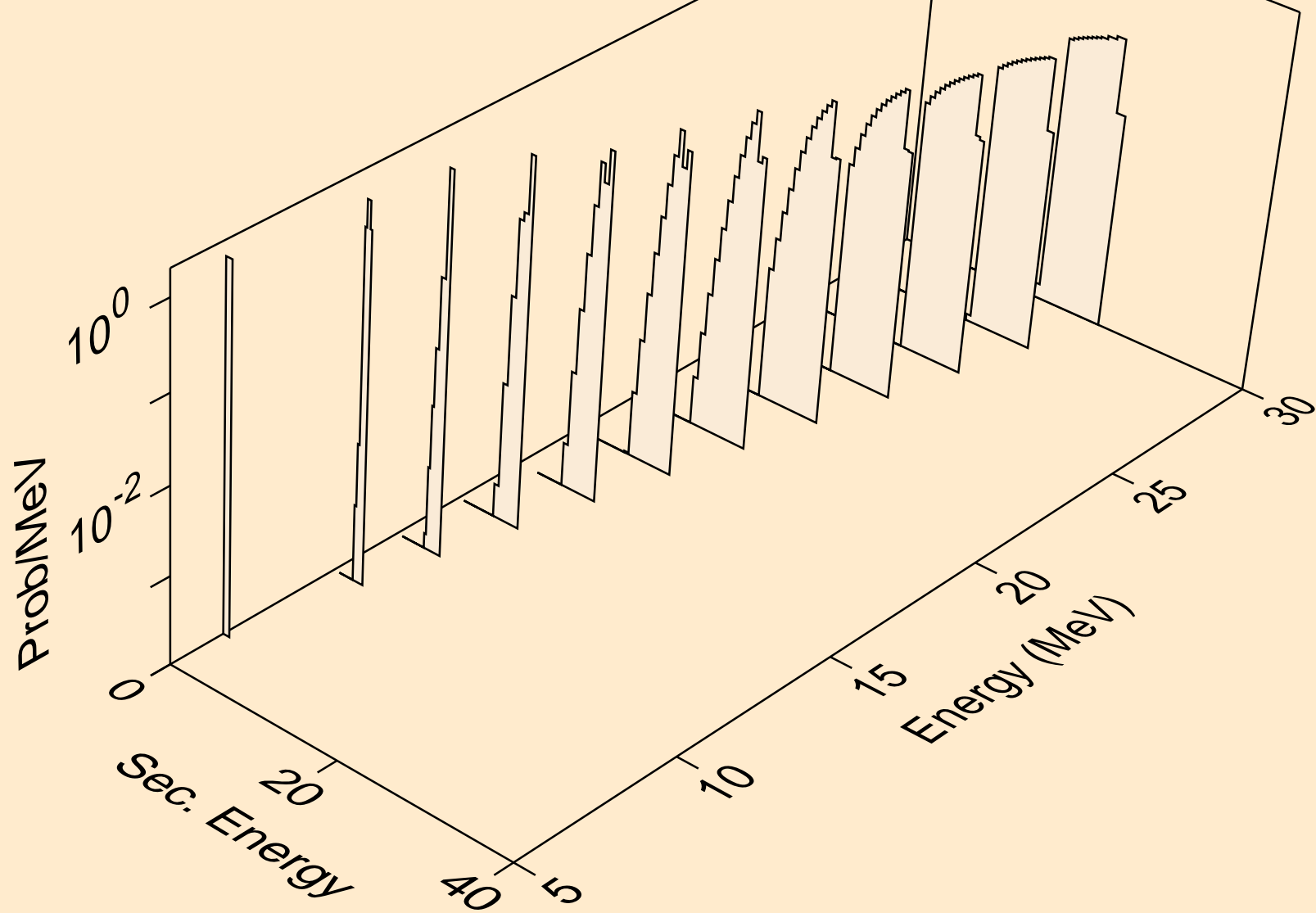

TH238 NEUTRON ACER TENDL-2023 LIBRARY; T=0.K
tritons from (n,x)

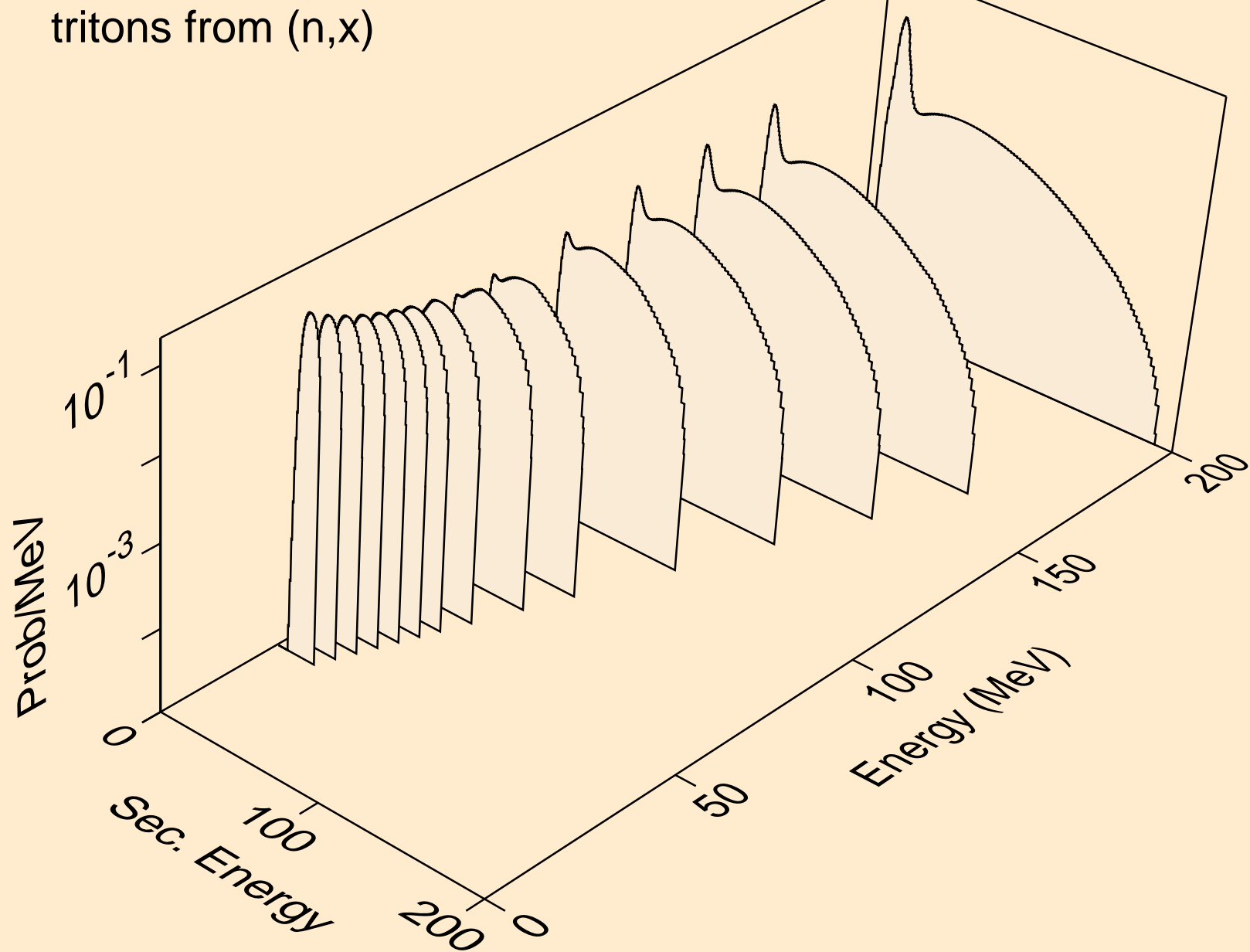

TH238 NEUTRON ACER TENDL-2023 LIBRARY; T=0.K
tritons from (n,n*)t

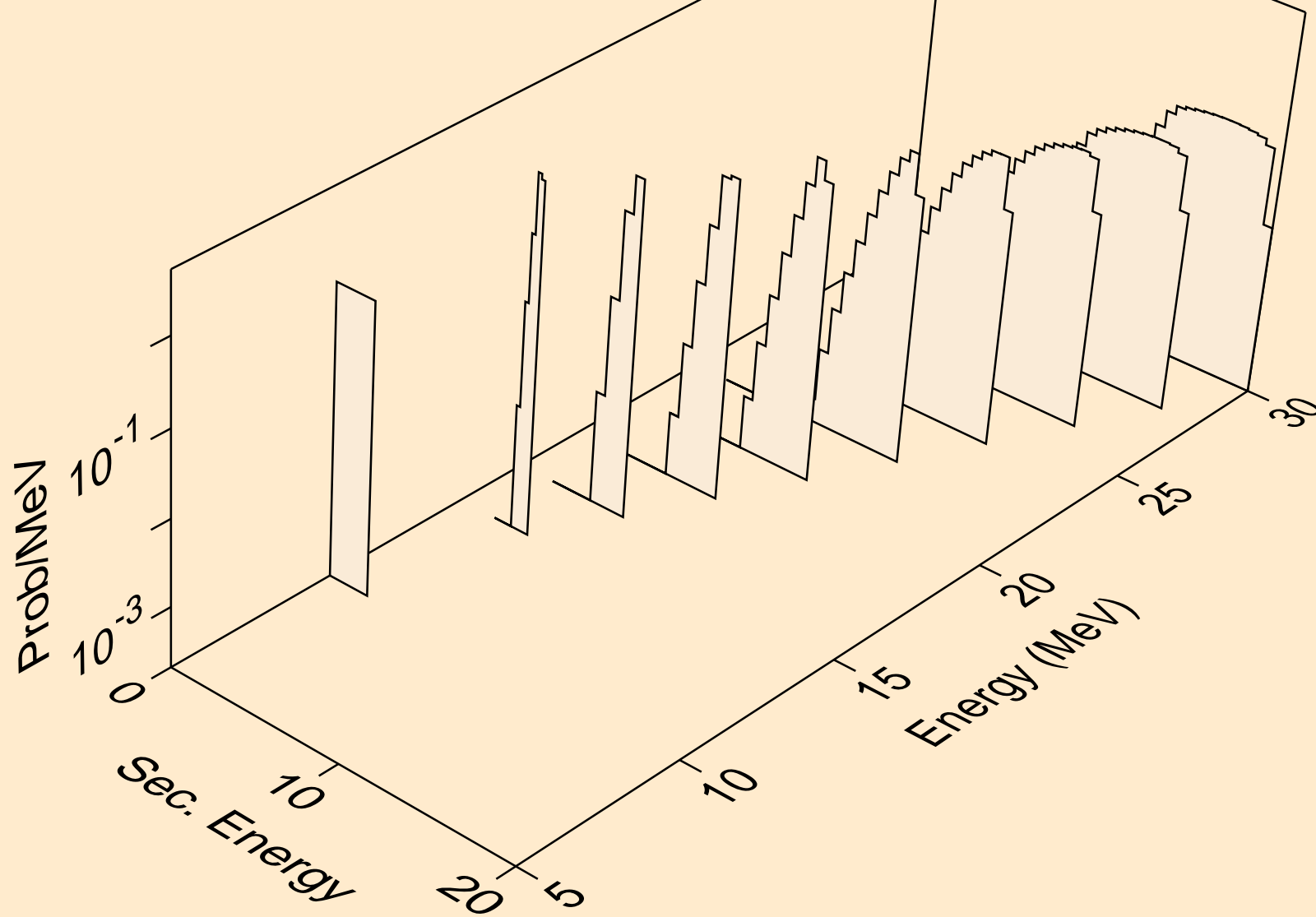

TH238 NEUTRON ACER TENDL-2023 LIBRARY; T=0.K
tritons from (n,t)

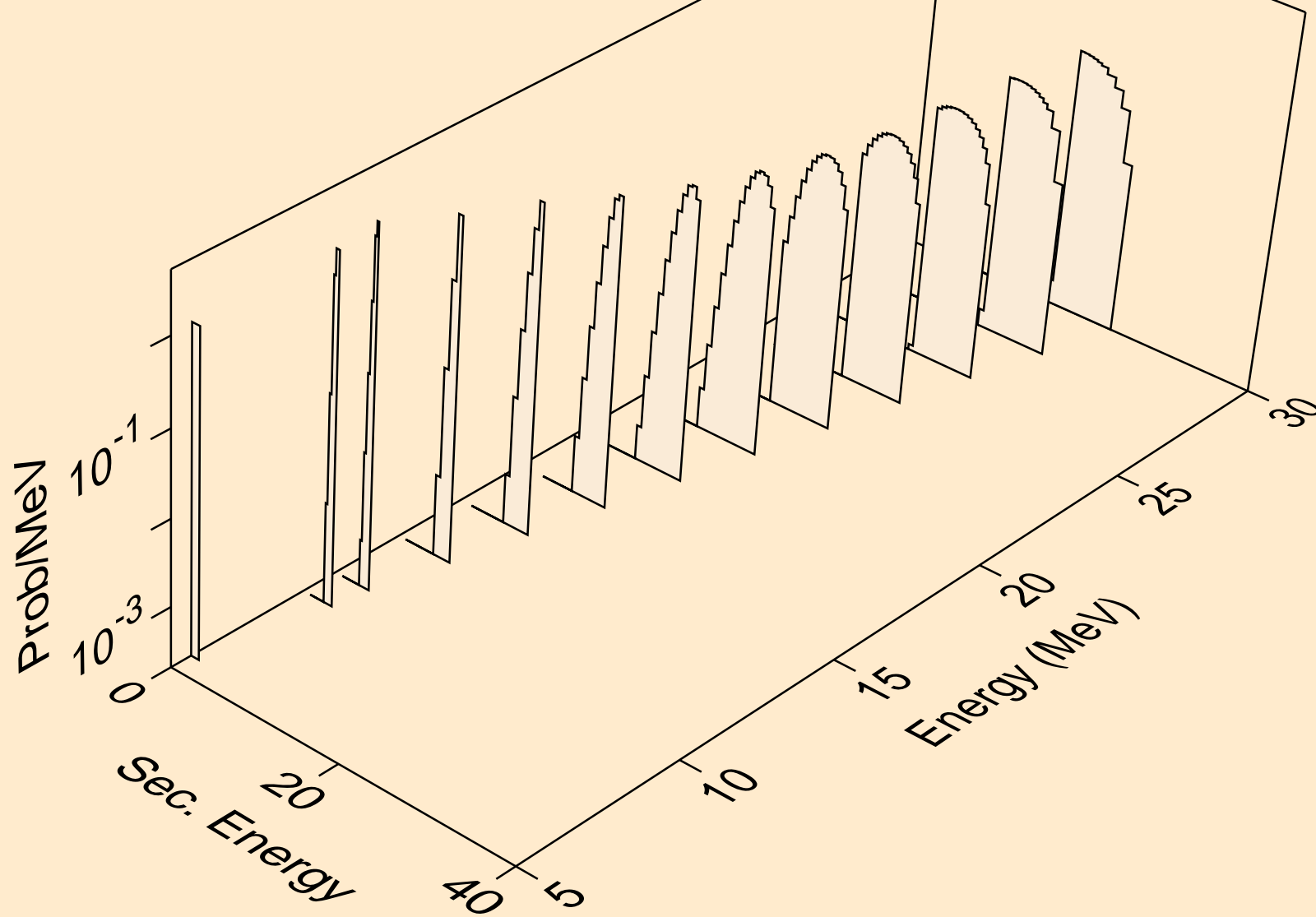

TH238 NEUTRON ACER TENDL-2023 LIBRARY; T=0.K
he3s from (n,x)

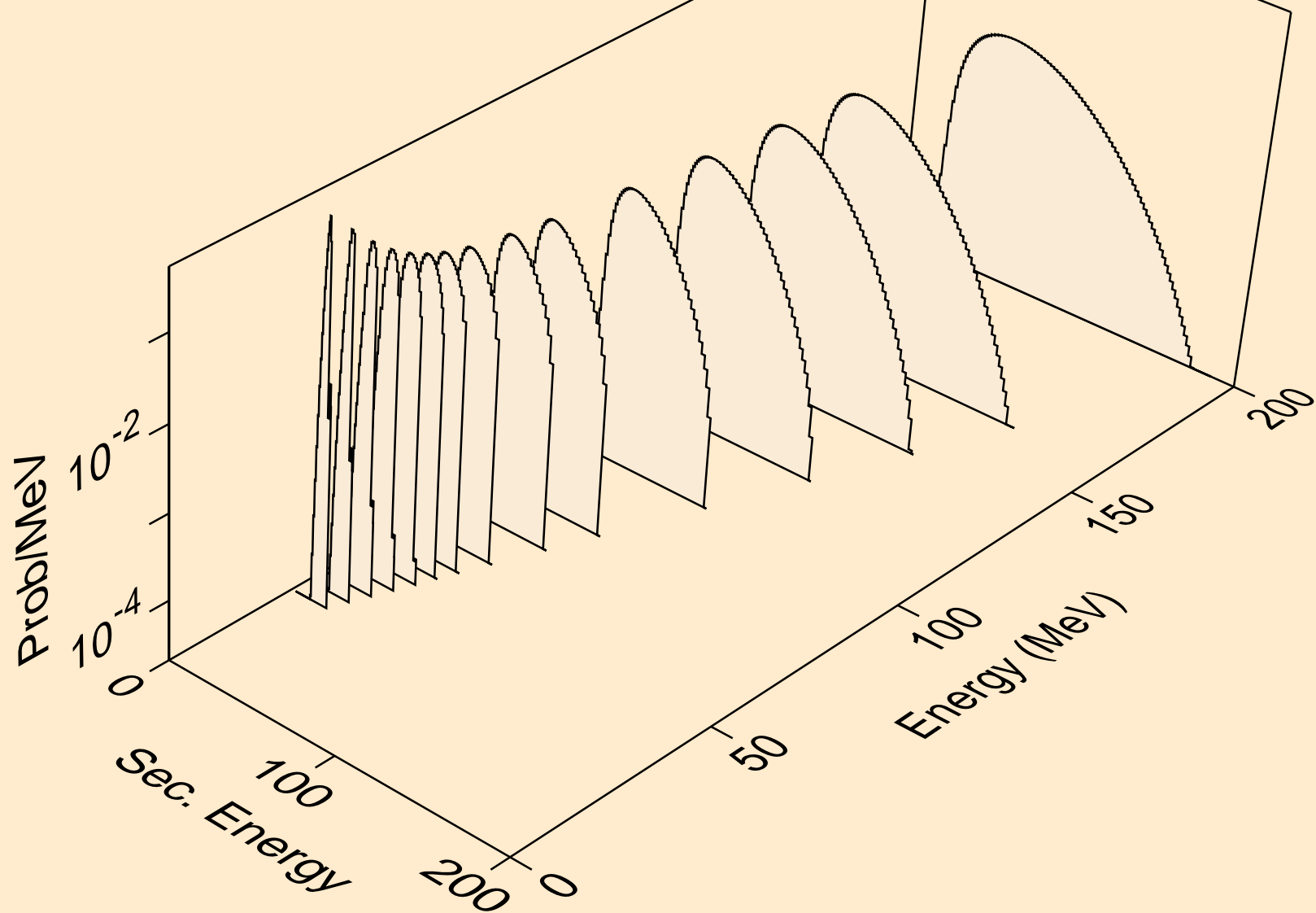

TH238 NEUTRON ACER TENDL-2023 LIBRARY; T=0.K
he3s from (n,n*)he3

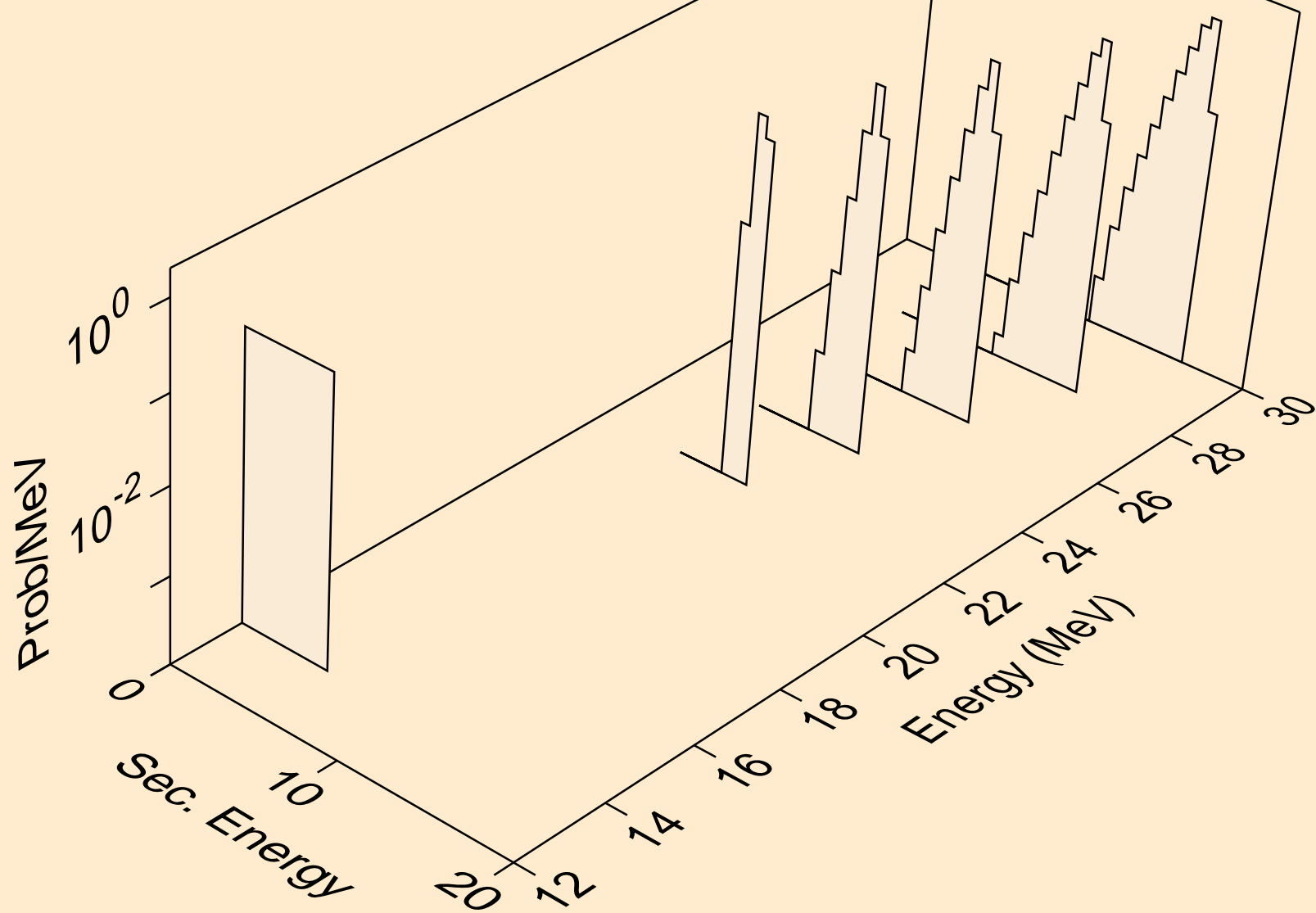

TH238 NEUTRON ACER TENDL-2023 LIBRARY; T=0.K
he3s from (n,he3)

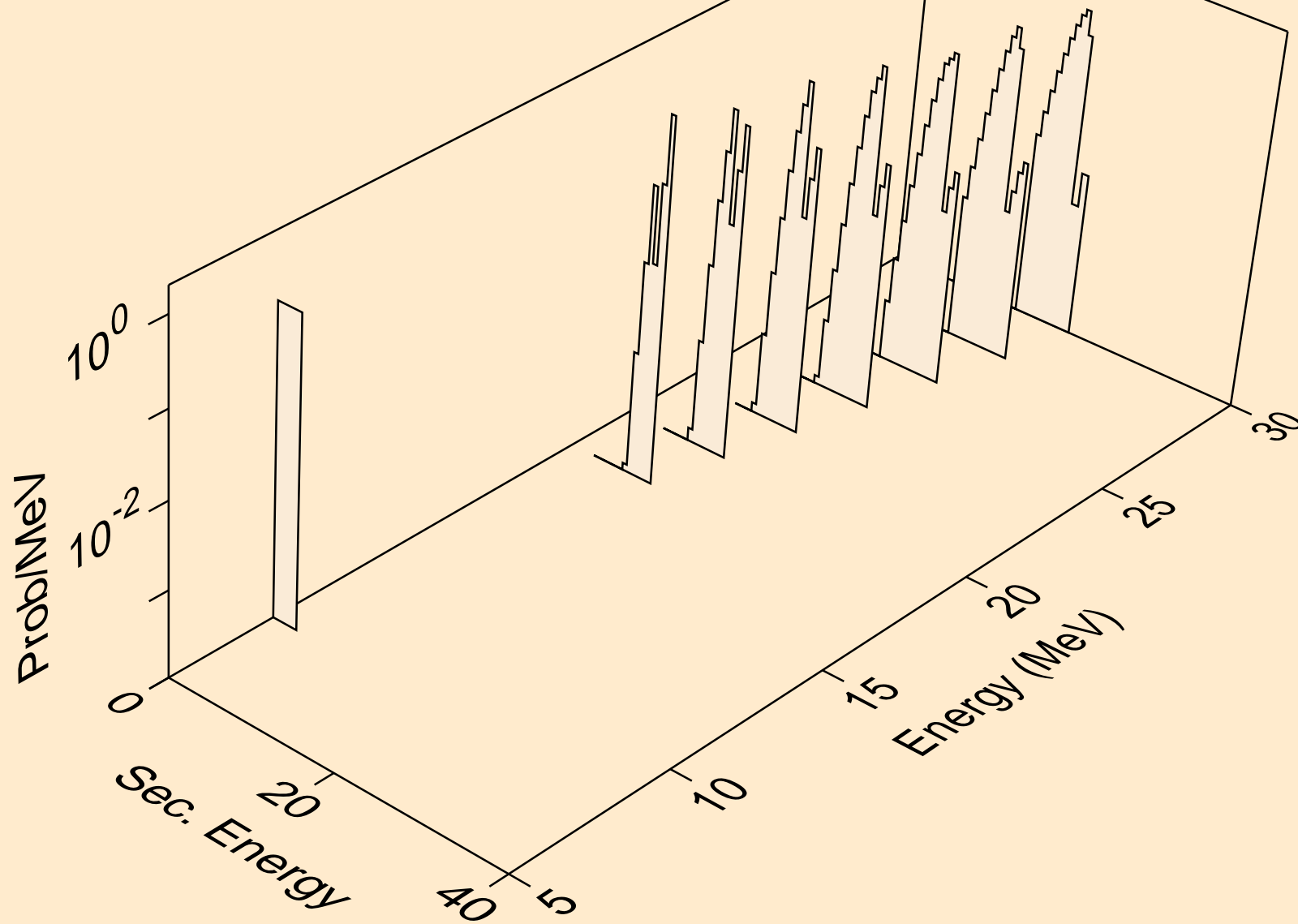

TH238 NEUTRON ACER TENDL-2023 LIBRARY; T=0.K
alphas from (n,x)

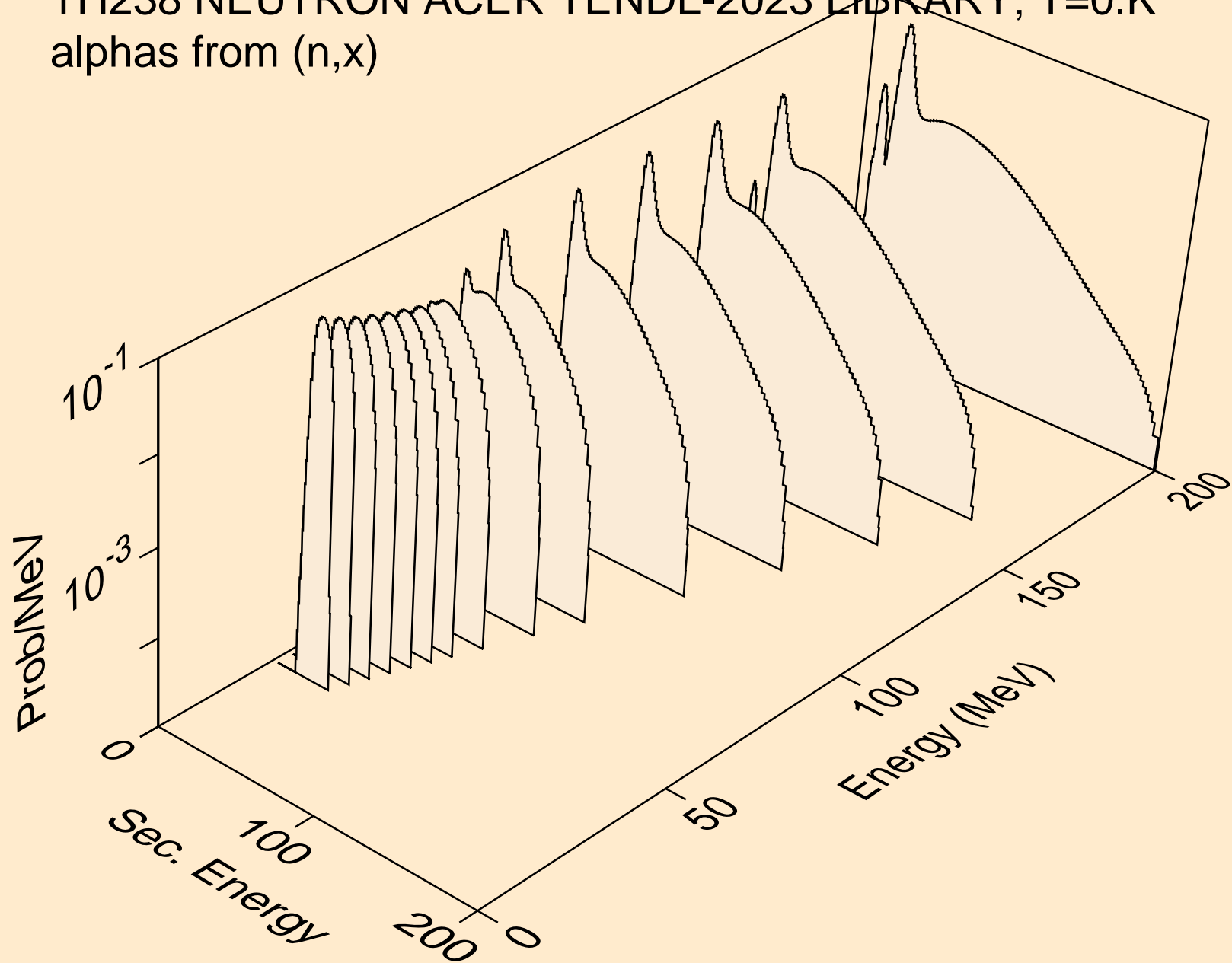

TH238 NEUTRON ACER TENDL-2023 LIBRARY; T=0.K
alphas from (n,n*)a

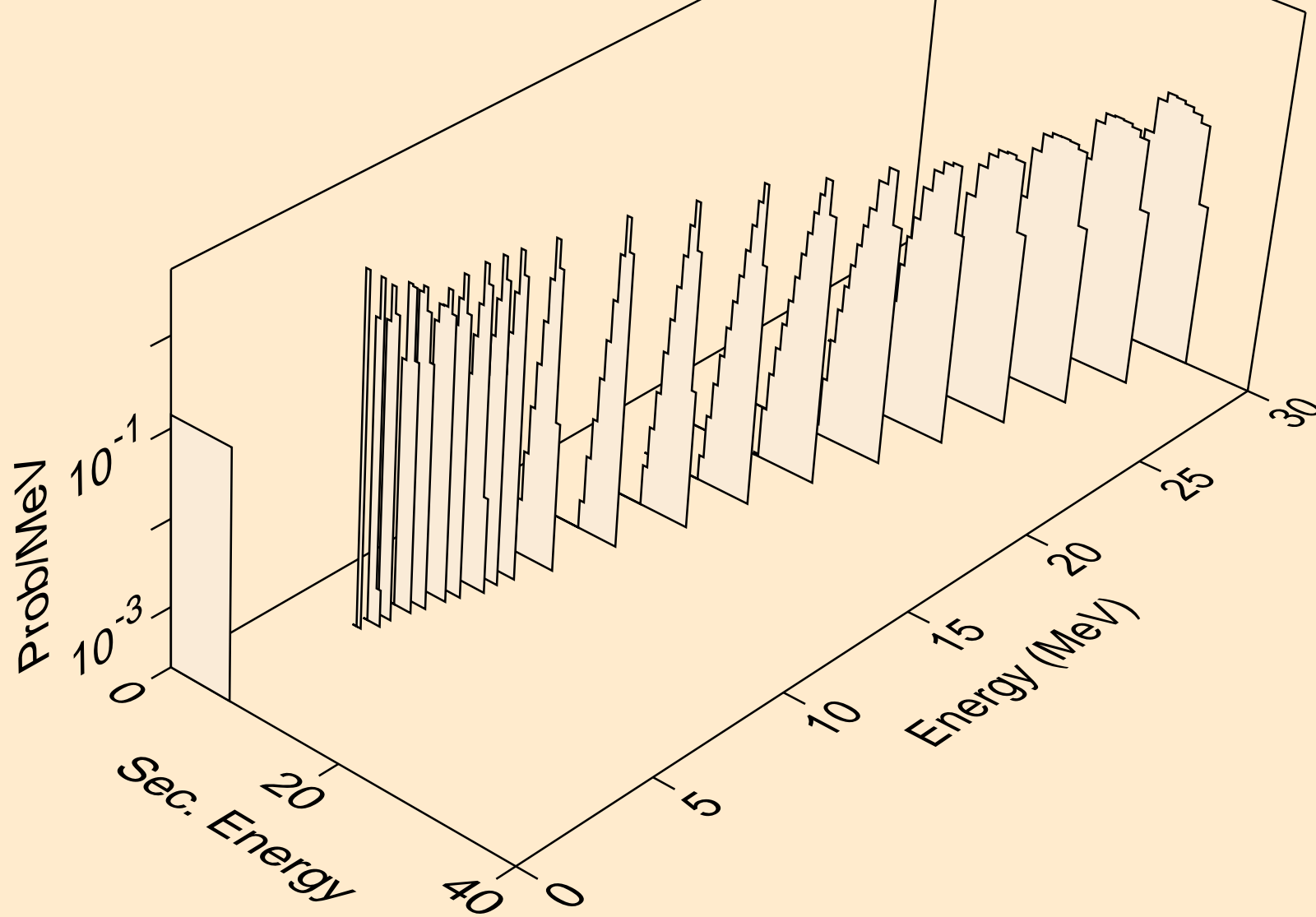

TH238 NEUTRON ACER TENDL-2023 LIBRARY; T=0.K
alphas from (n,2n)a

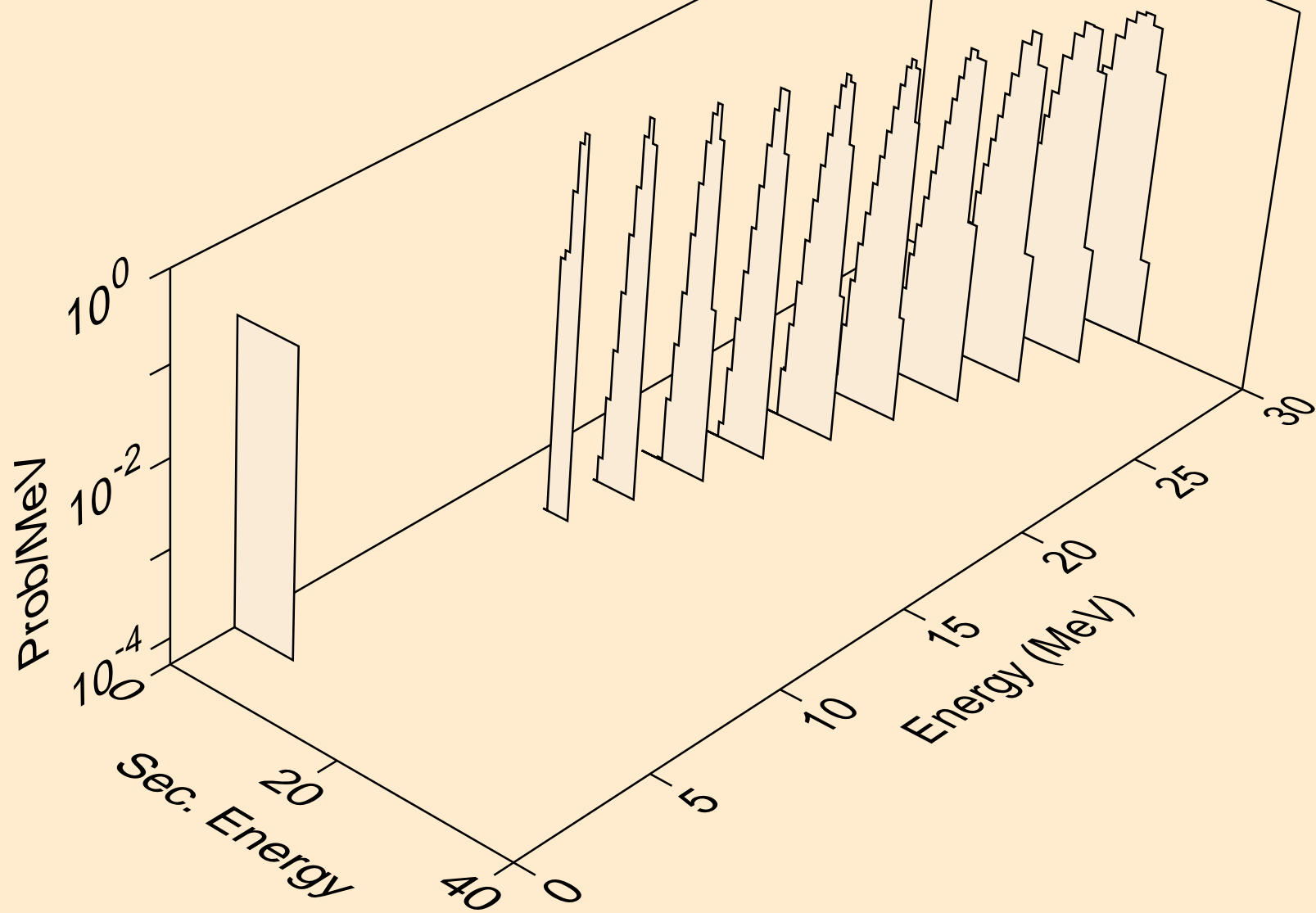

TH238 NEUTRON ACER TENDL-2023 LIBRARY; T=0.K
alphas from (n,3n)a

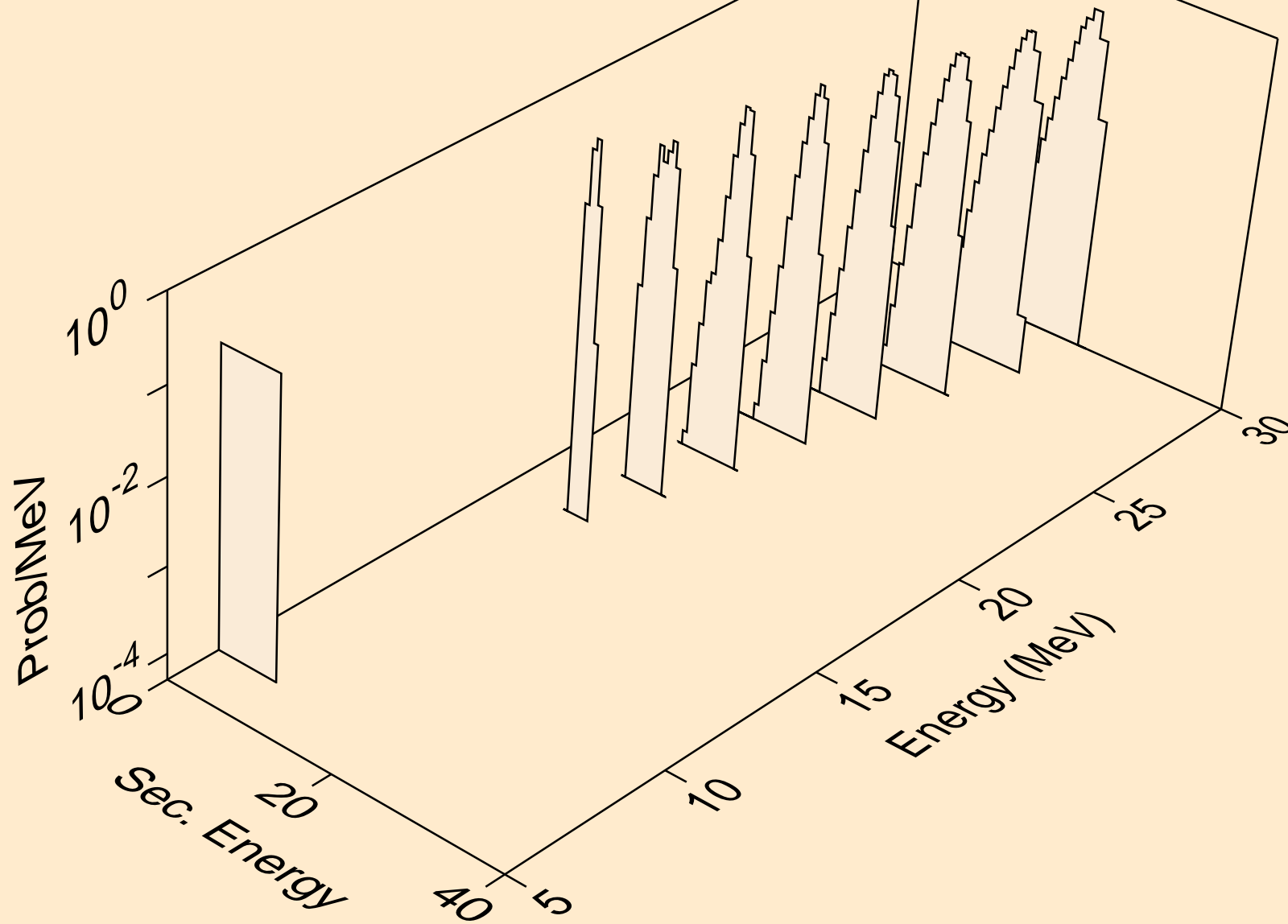

TH238 NEUTRON ACER TENDL-2023 LIBRARY; T=0.K
alphas from (n,a)

