

U235M NEUTRON ACER TENDL-2023 LIBRARY; T=0.K

Principal cross sections

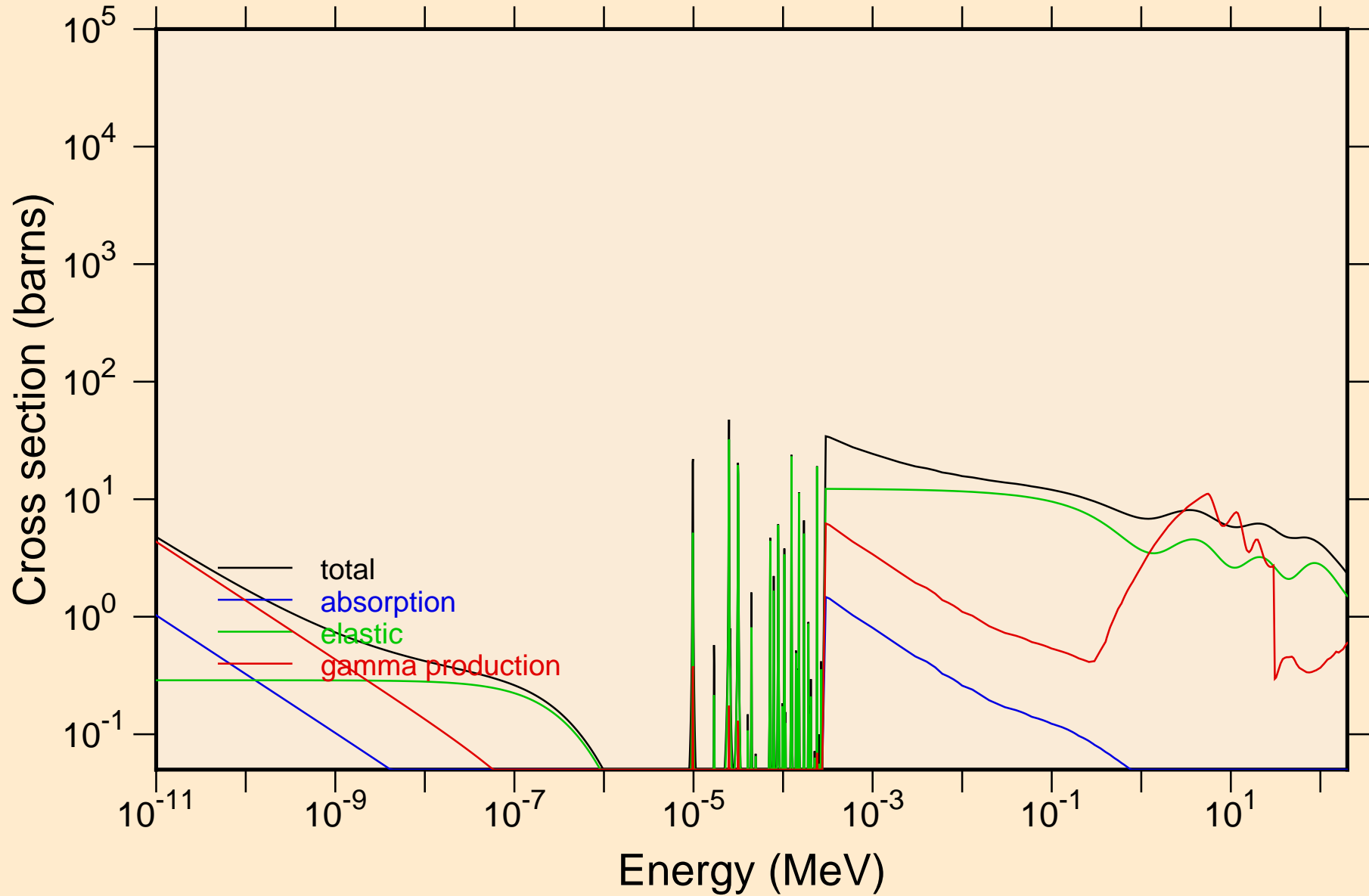

U235M NEUTRON ACER TENDL-2023 LIBRARY; T=0.K
resonance total cross section

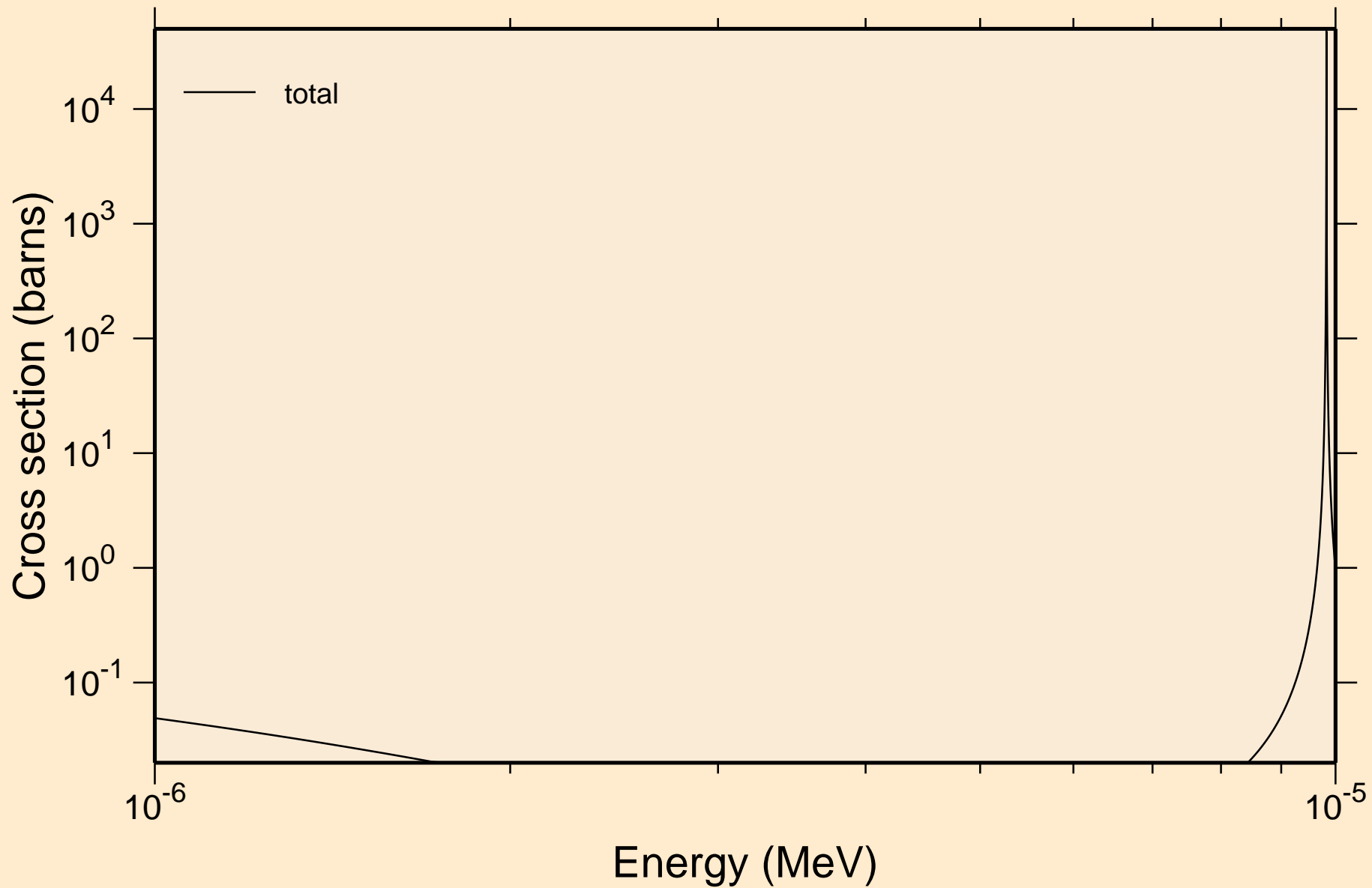

U235M NEUTRON ACER TENDL-2023 LIBRARY; T=0.K
resonance total cross section

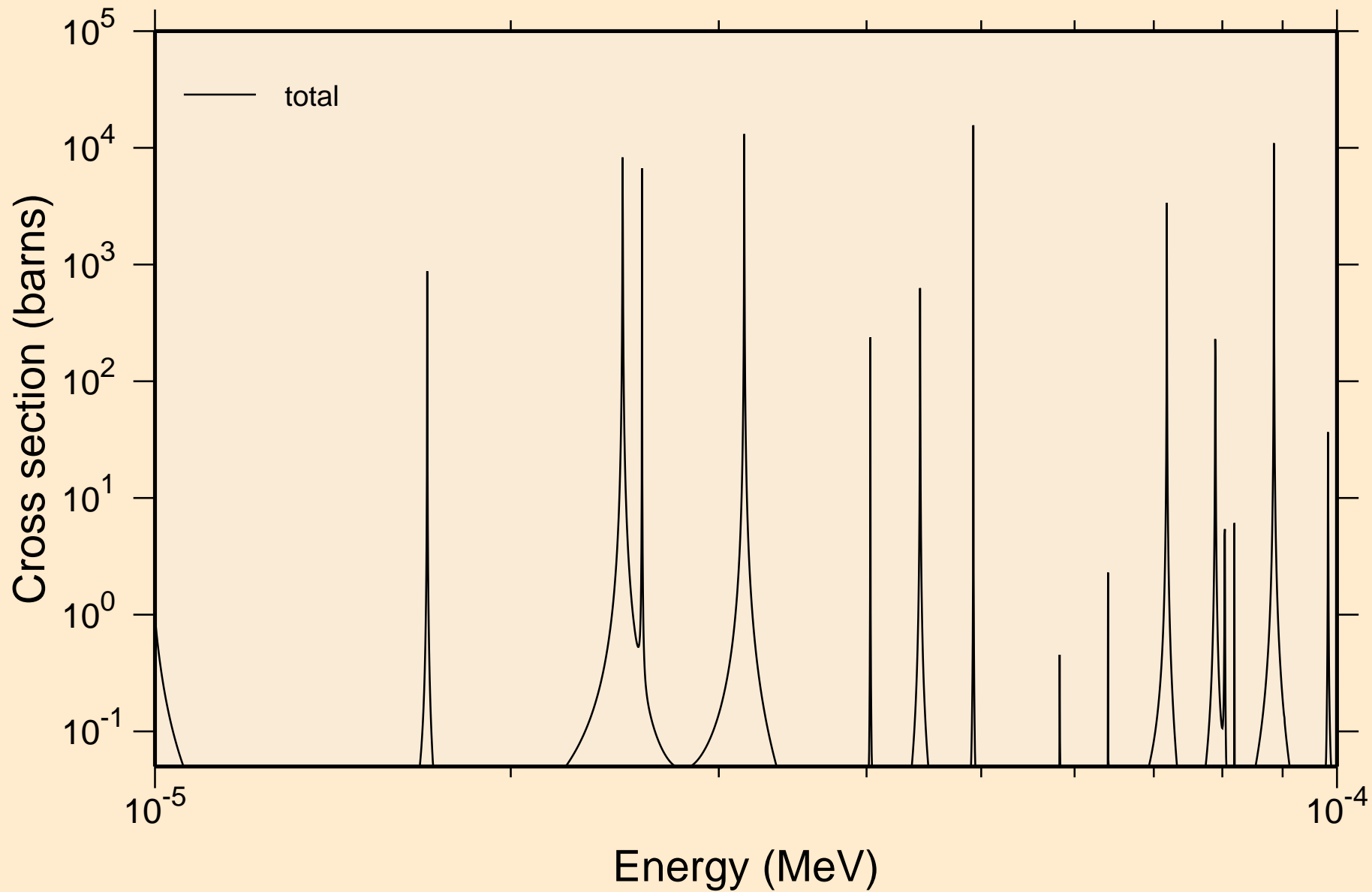

U235M NEUTRON ACER TENDL-2023 LIBRARY; T=0.K
resonance total cross section

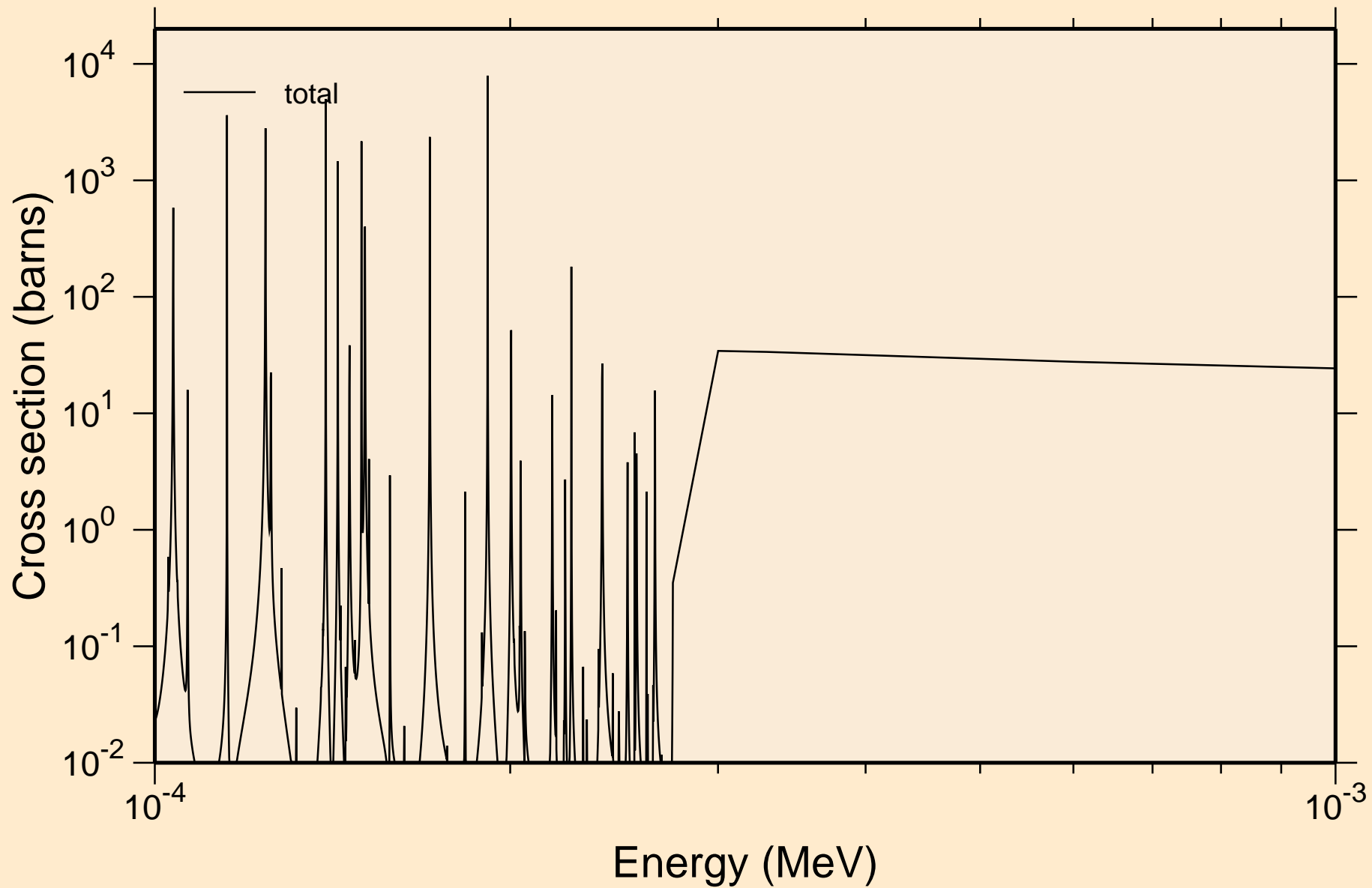

U235M NEUTRON ACER TENDL-2023 LIBRARY; T=0.K
resonance total cross section

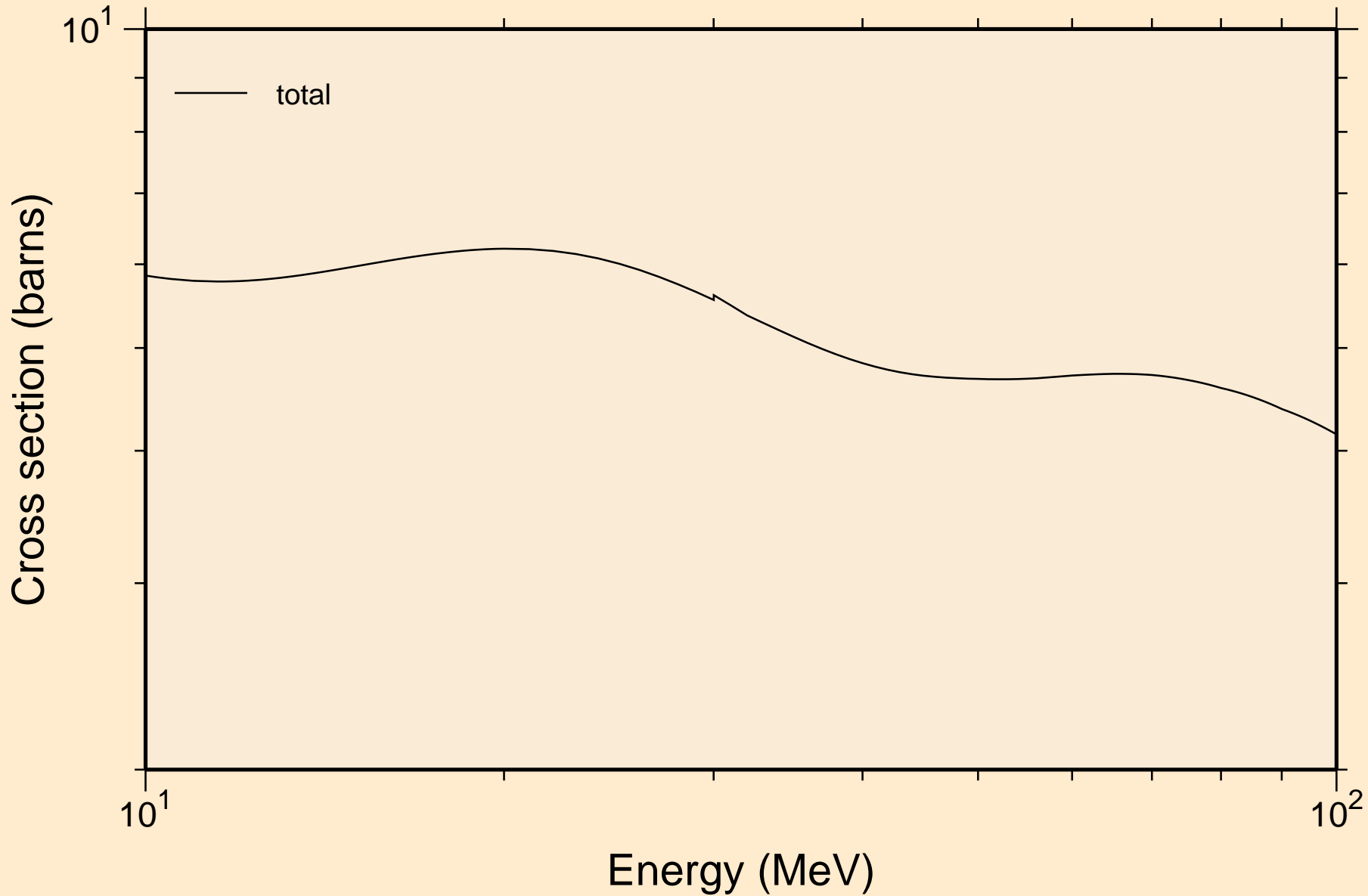

U235M NEUTRON ACER TENDL-2023 LIBRARY; T=0.K
resonance absorption cross sections

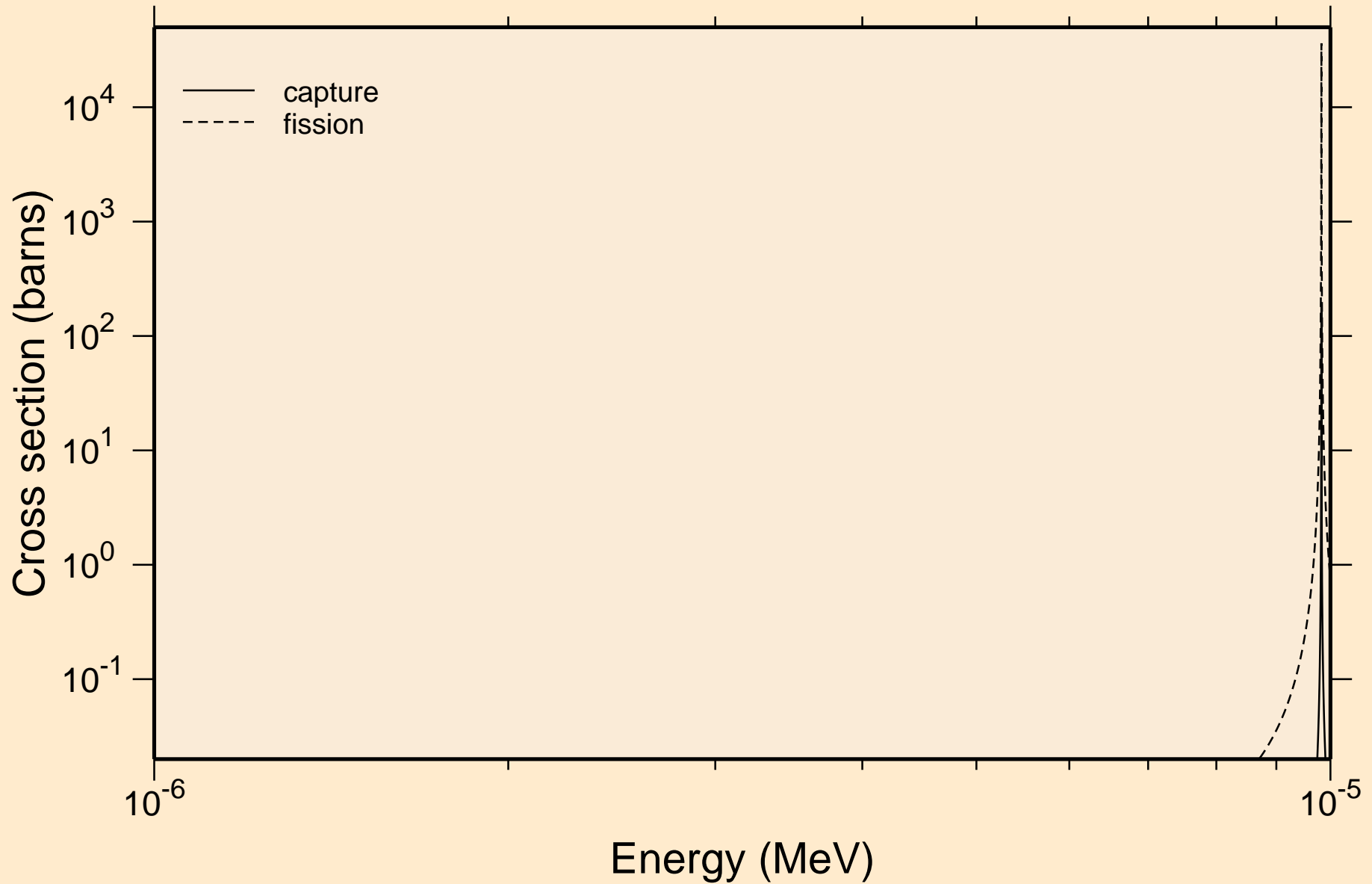

U235M NEUTRON ACER TENDL-2023 LIBRARY; T=0.K

resonance absorption cross sections

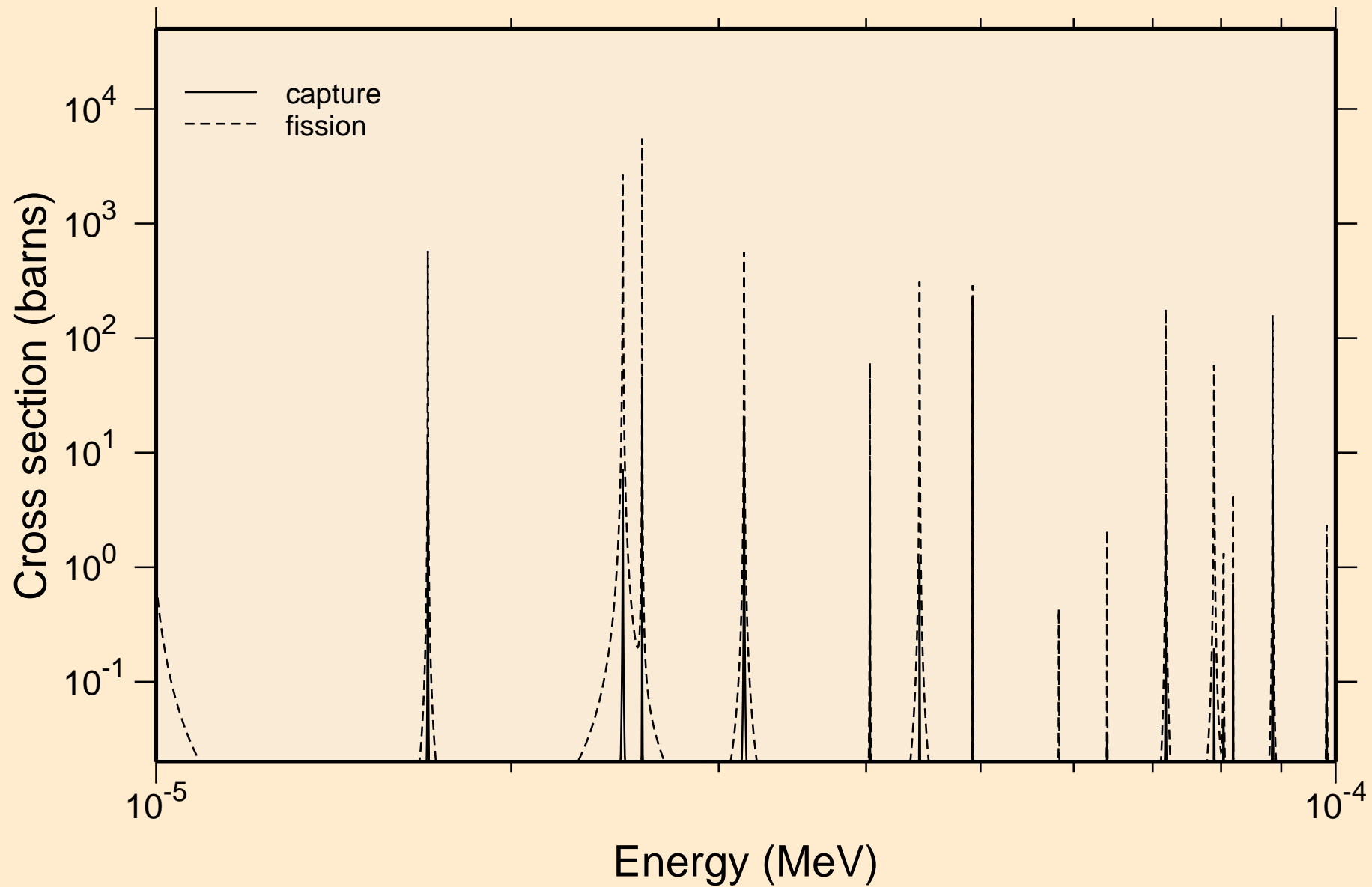

U235M NEUTRON ACER TENDL-2023 LIBRARY; T=0.K
resonance absorption cross sections

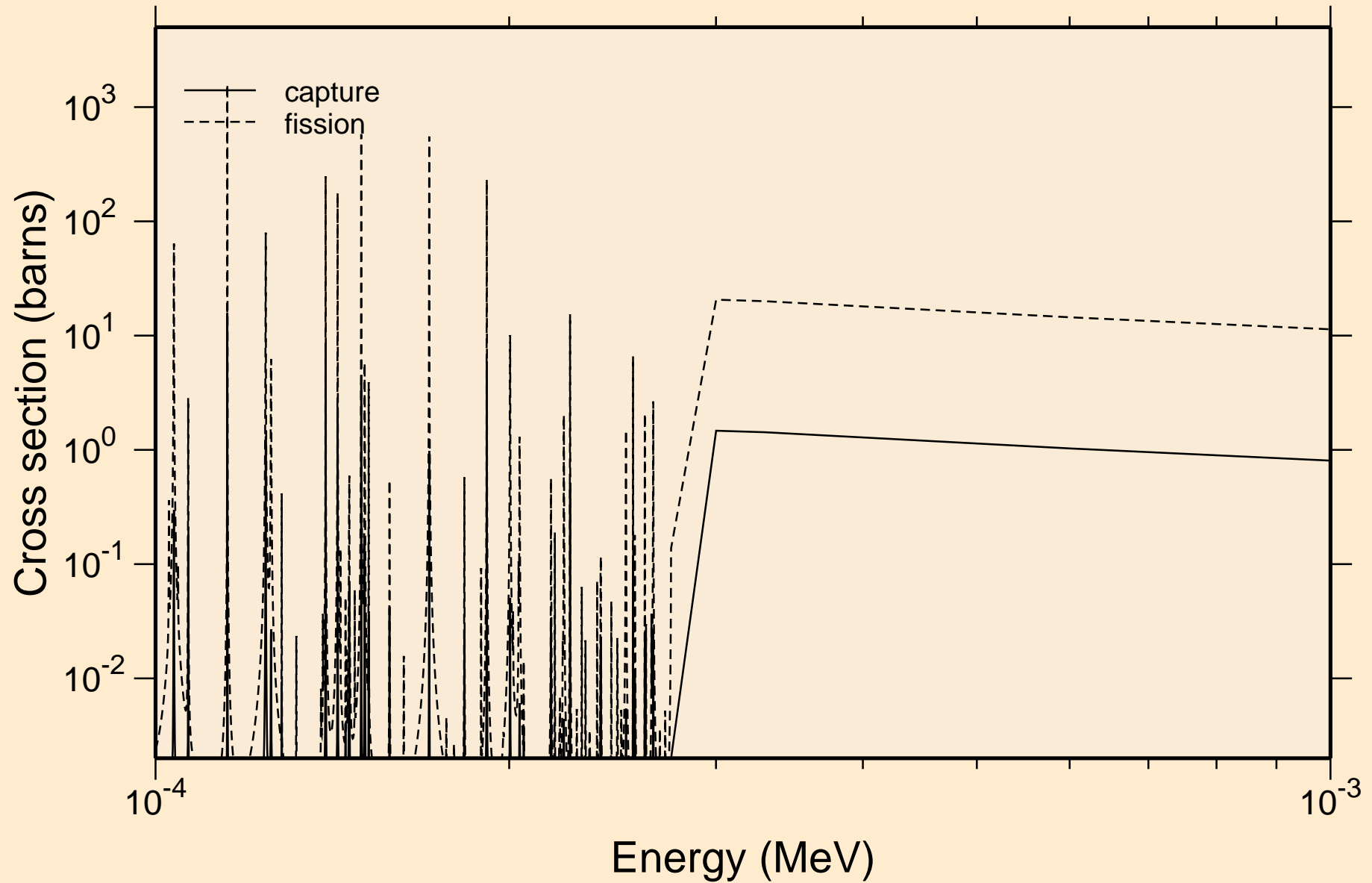

U235M NEUTRON ACER TENDL-2023 LIBRARY; T=0.K
resonance absorption cross sections

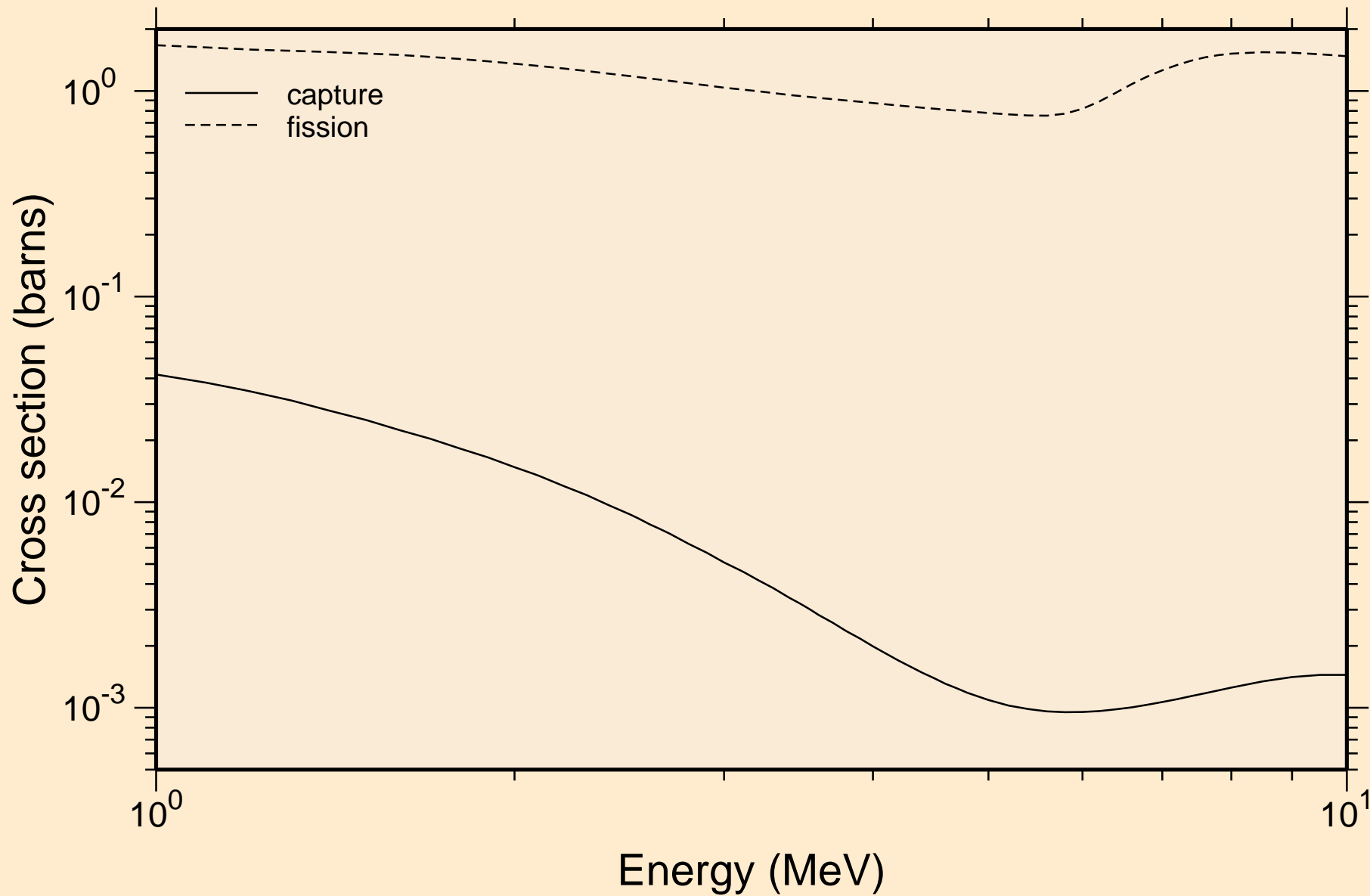

U235M NEUTRON ACER TENDL-2023 LIBRARY; T=0.K

Heating

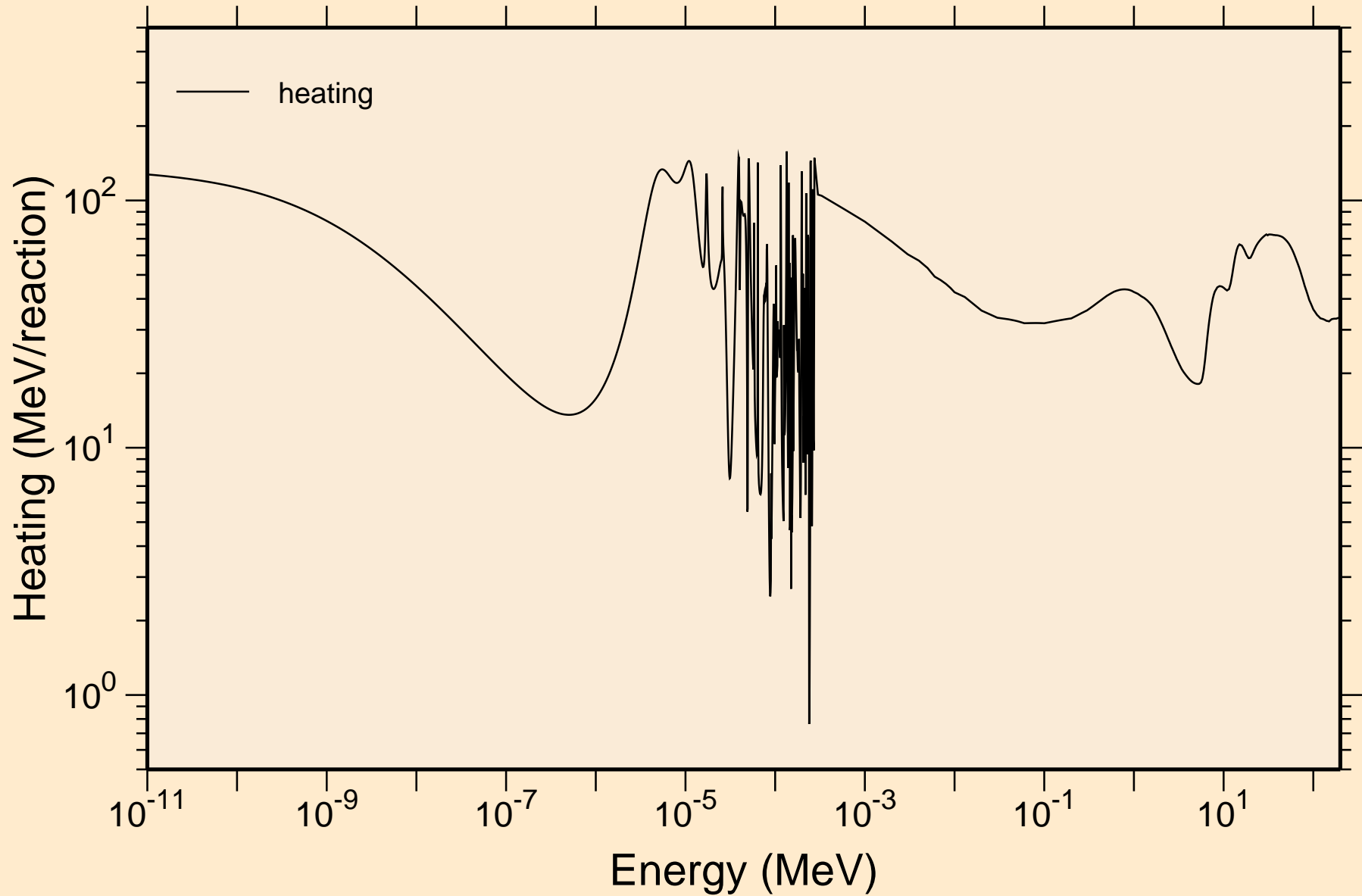

U235M NEUTRON ACER TENDL-2023 LIBRARY; T=0.K

Damage

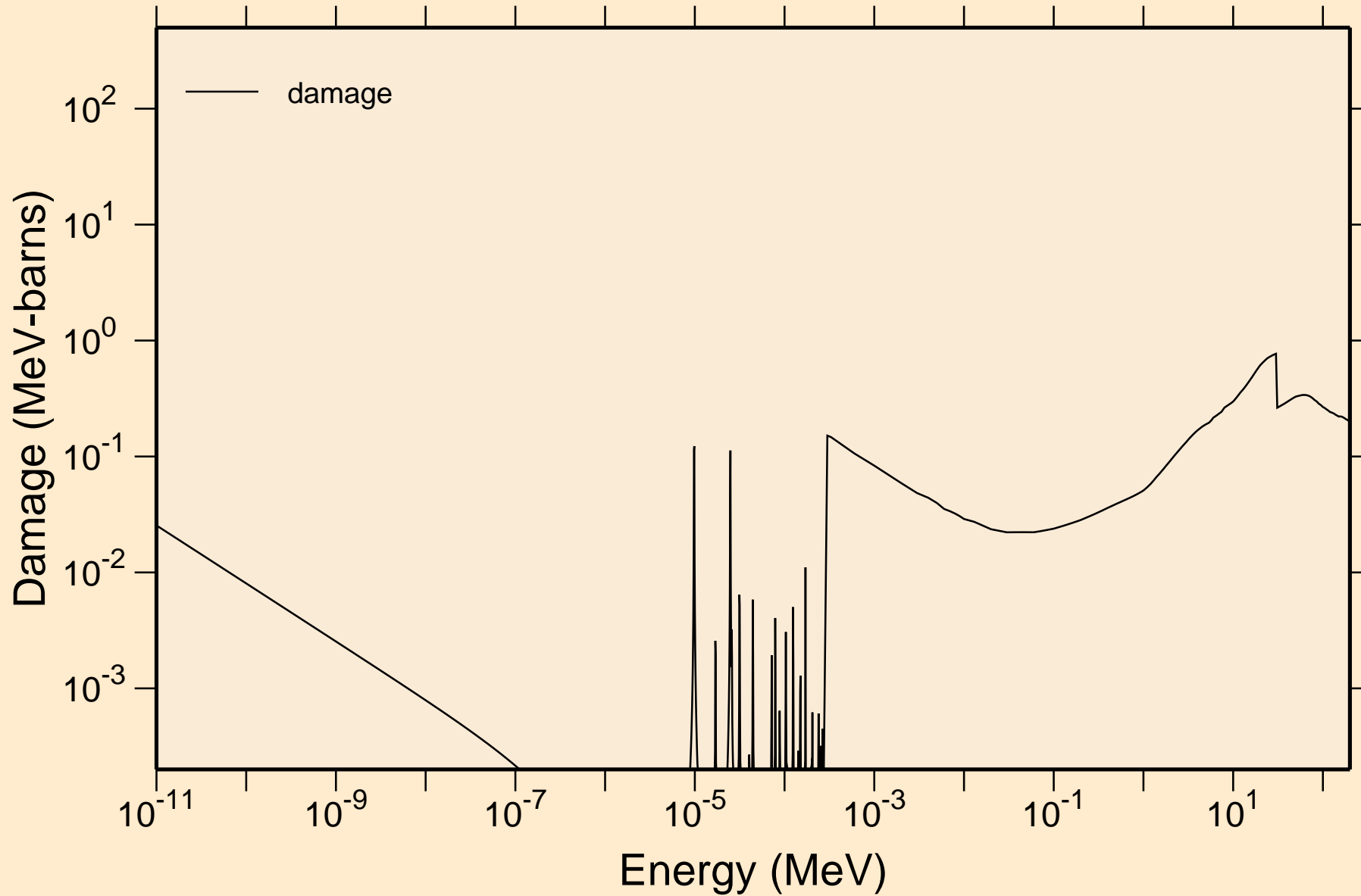

U235M NEUTRON ACER TENDL-2023 LIBRARY; T=0.K

Non-threshold reactions

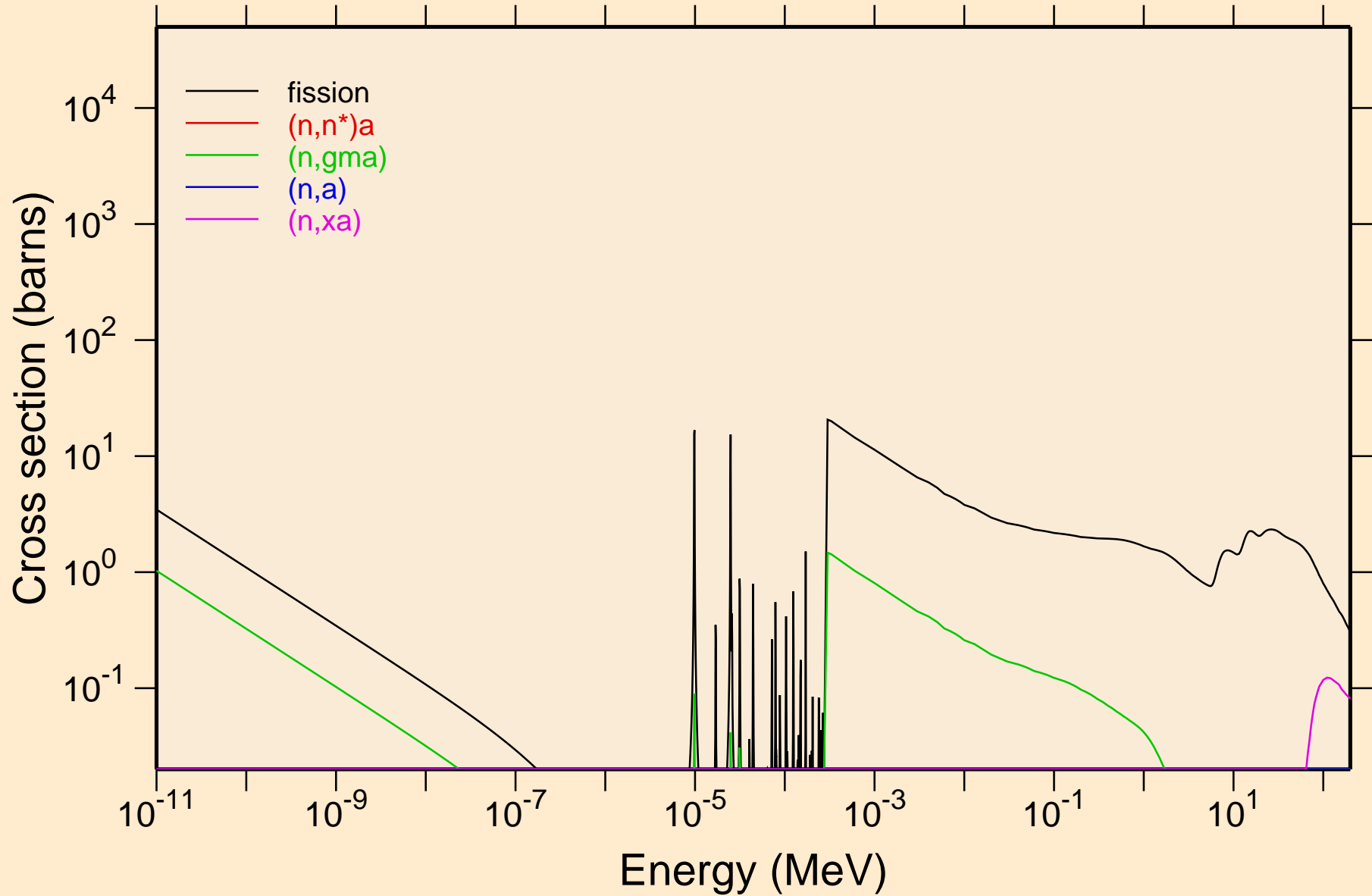

U235M NEUTRON ACER TENDL-2023 LIBRARY; T=0.K
Principal cross sections

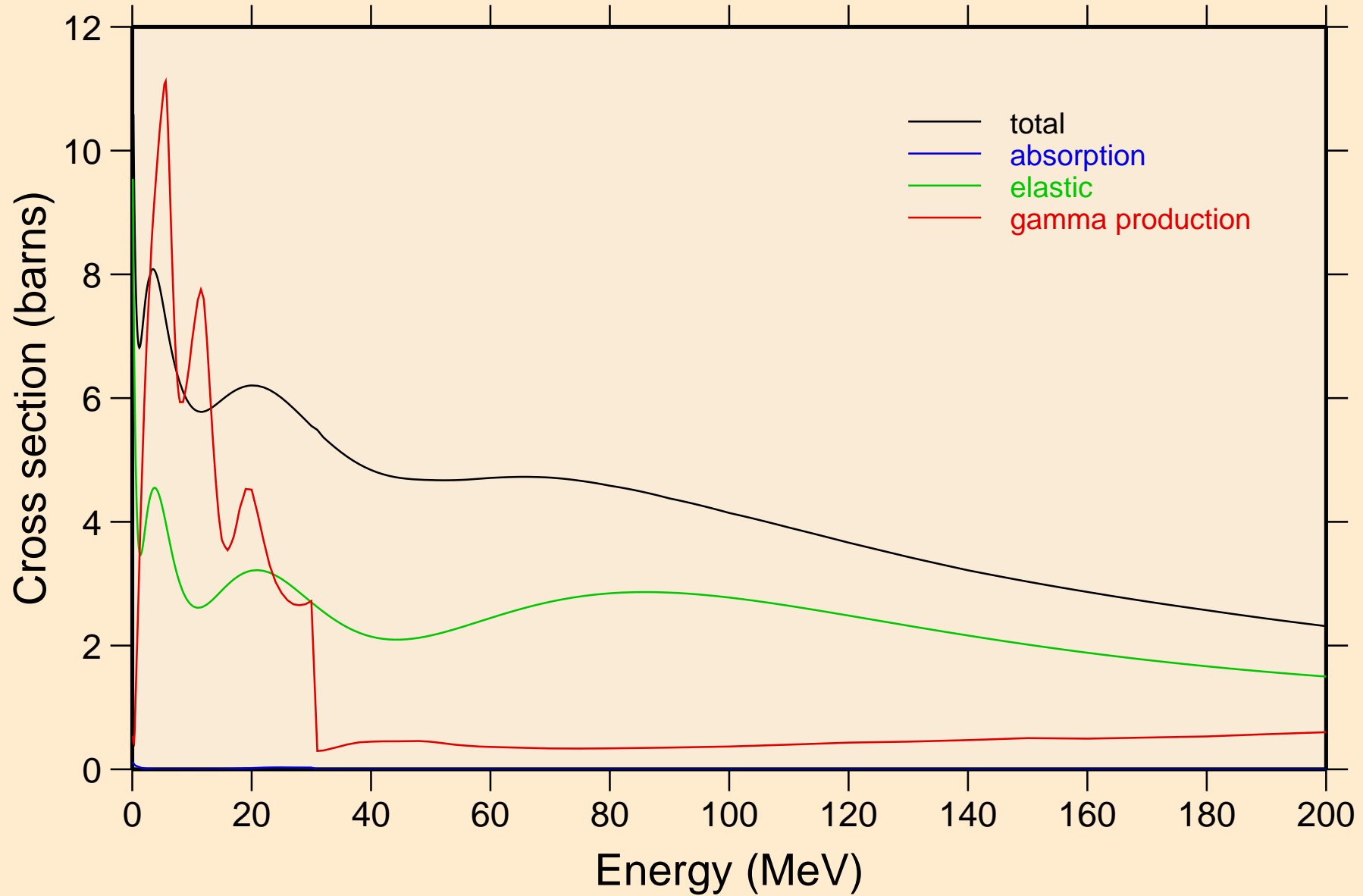

U235M NEUTRON ACER TENDL-2023 LIBRARY; T=0.K

Heating

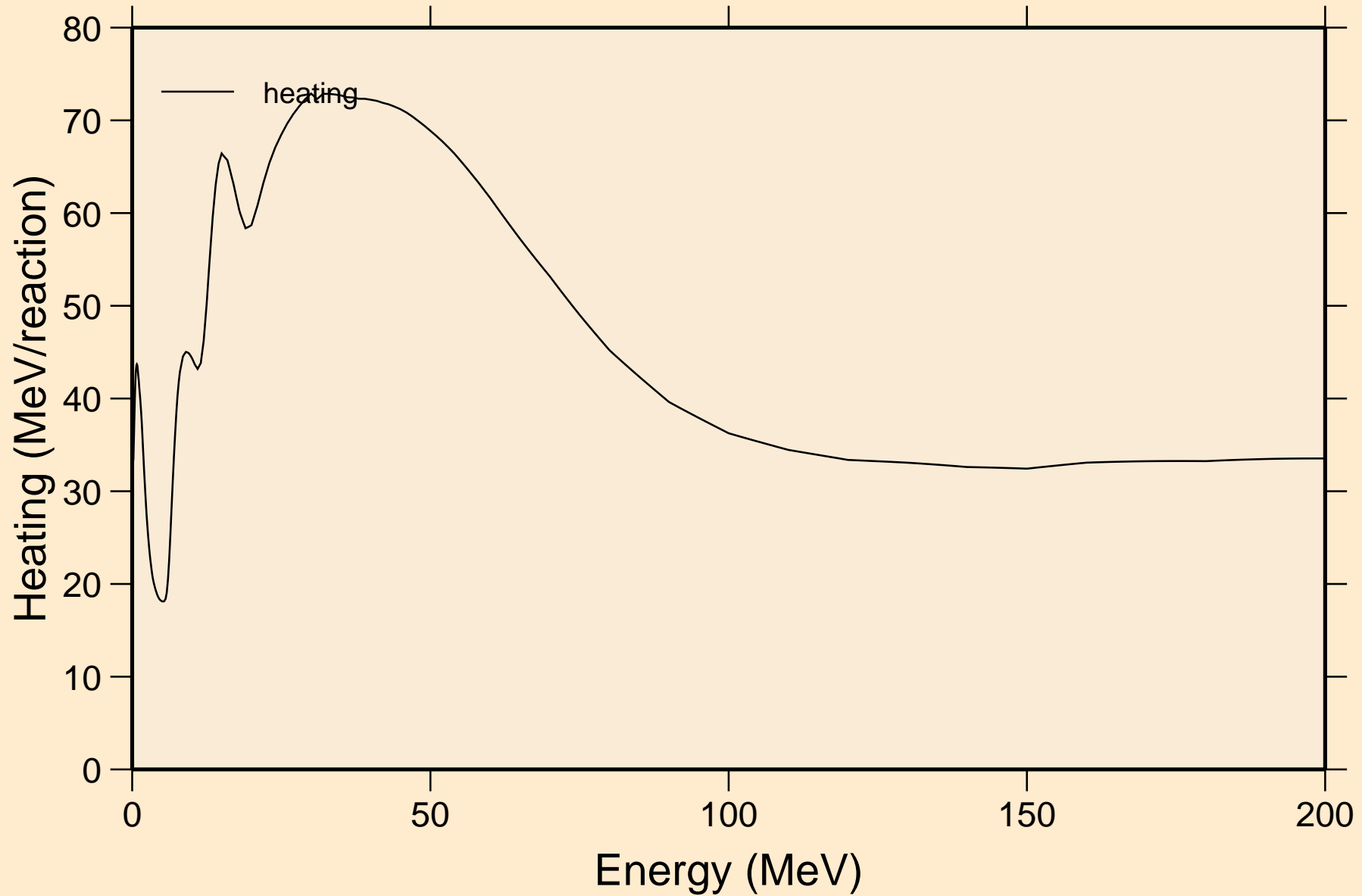

U235M NEUTRON ACER TENDL-2023 LIBRARY; T=0.K

Damage

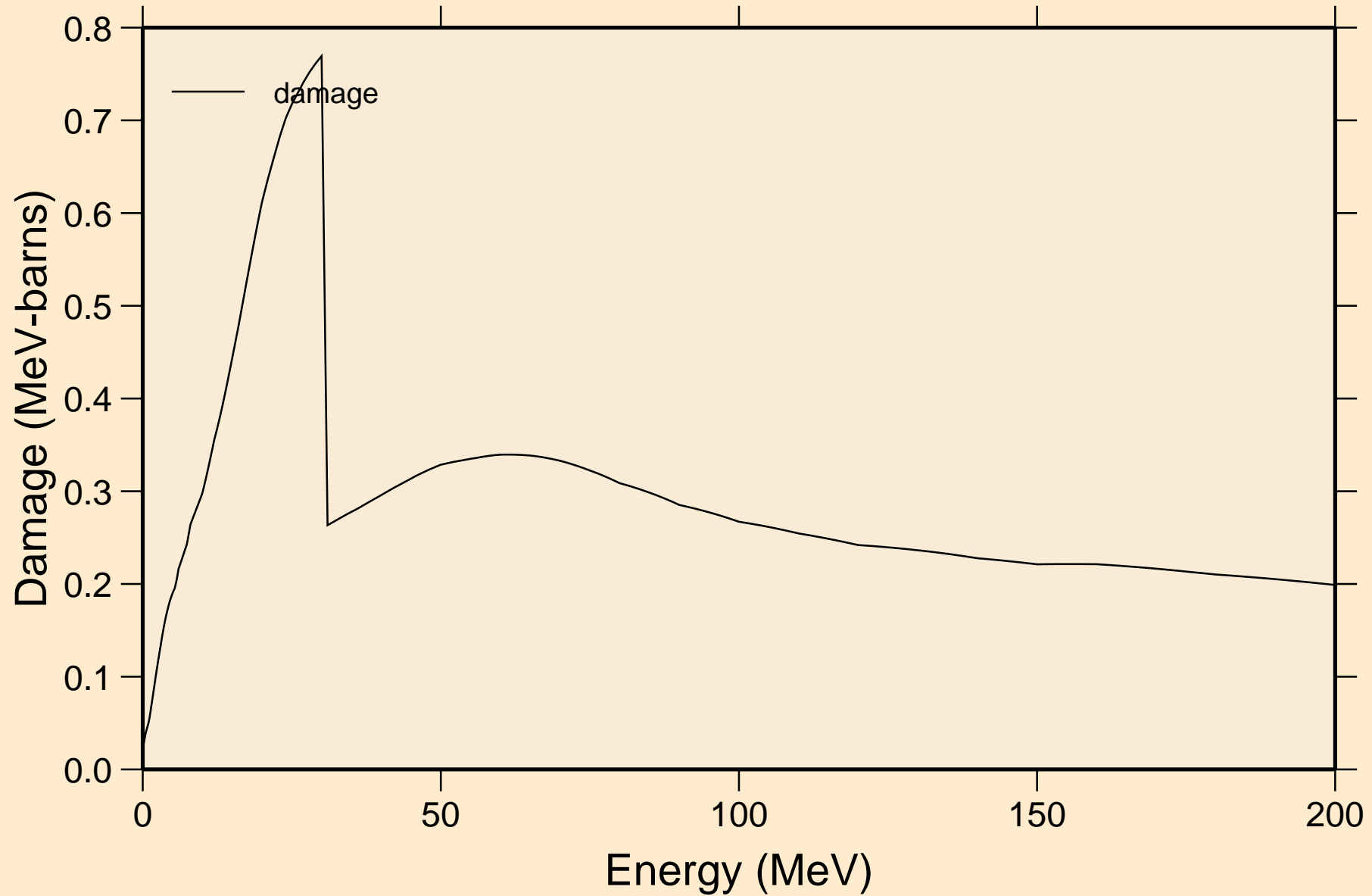

U235M NEUTRON ACER TENDL-2023 LIBRARY; T=0.K

Non-threshold reactions

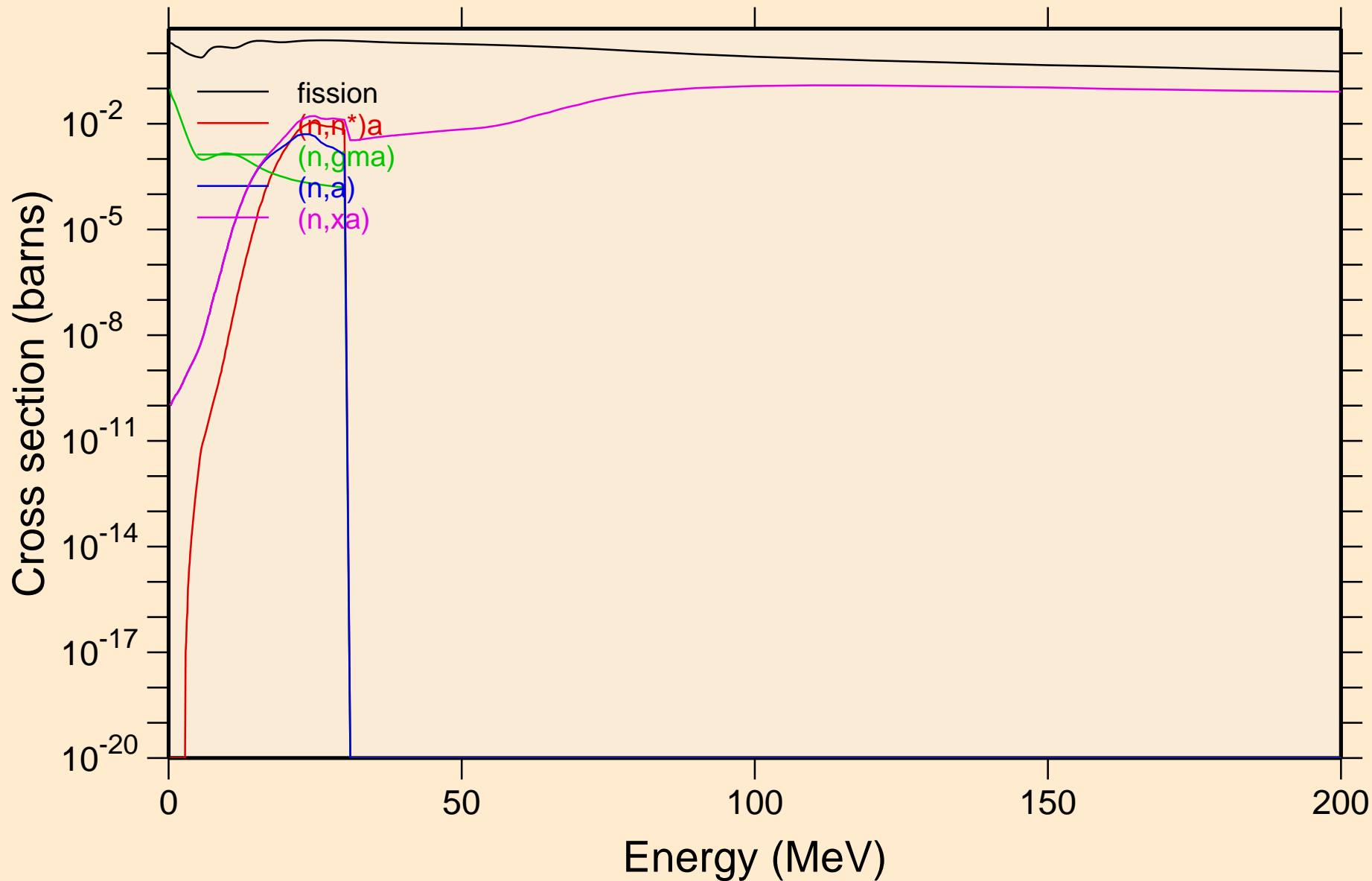

U235M NEUTRON ACER TENDL-2023 LIBRARY; T=0.K
Inelastic levels

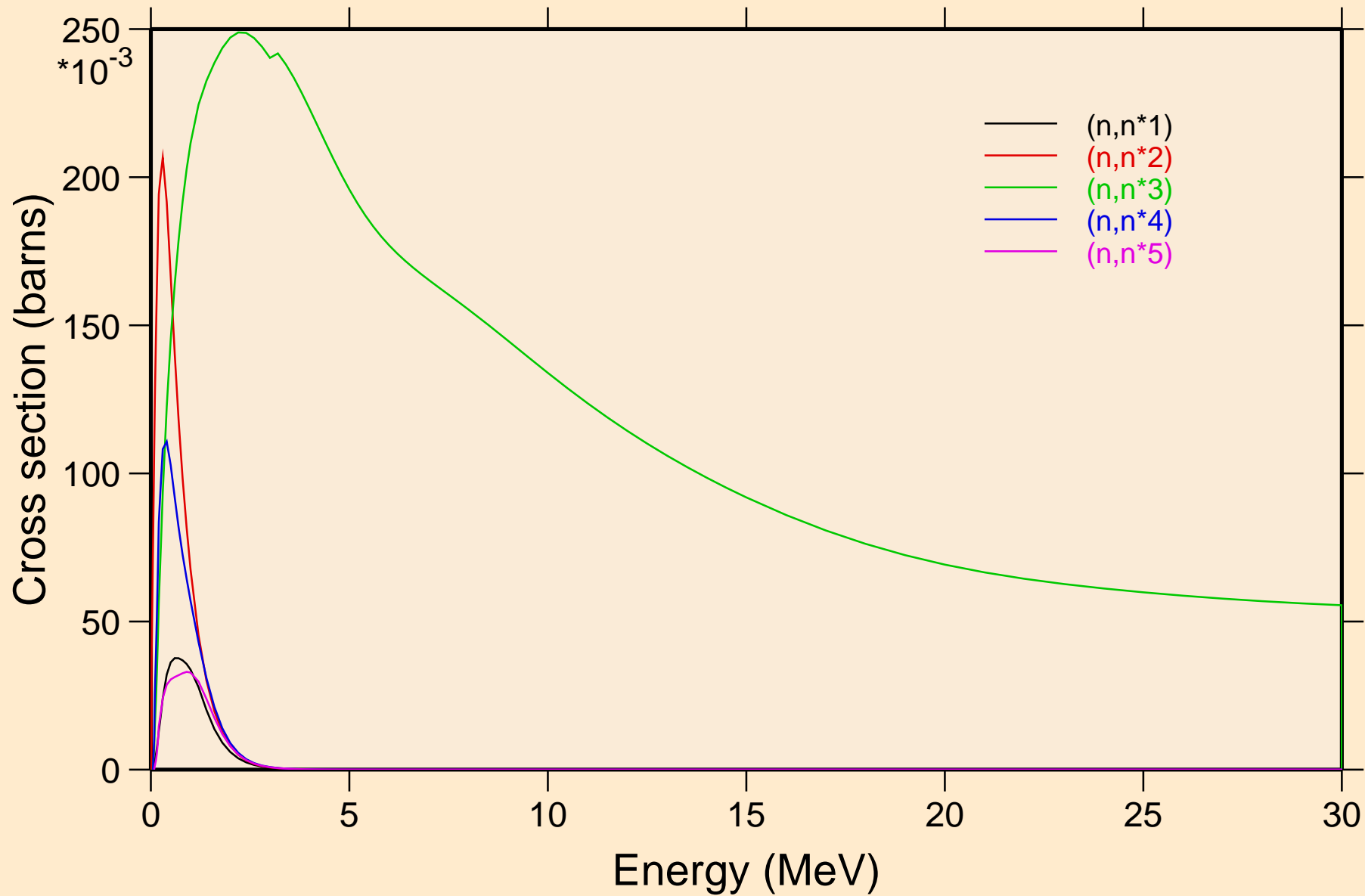

U235M NEUTRON ACER TENDL-2023 LIBRARY; T=0.K

Inelastic levels

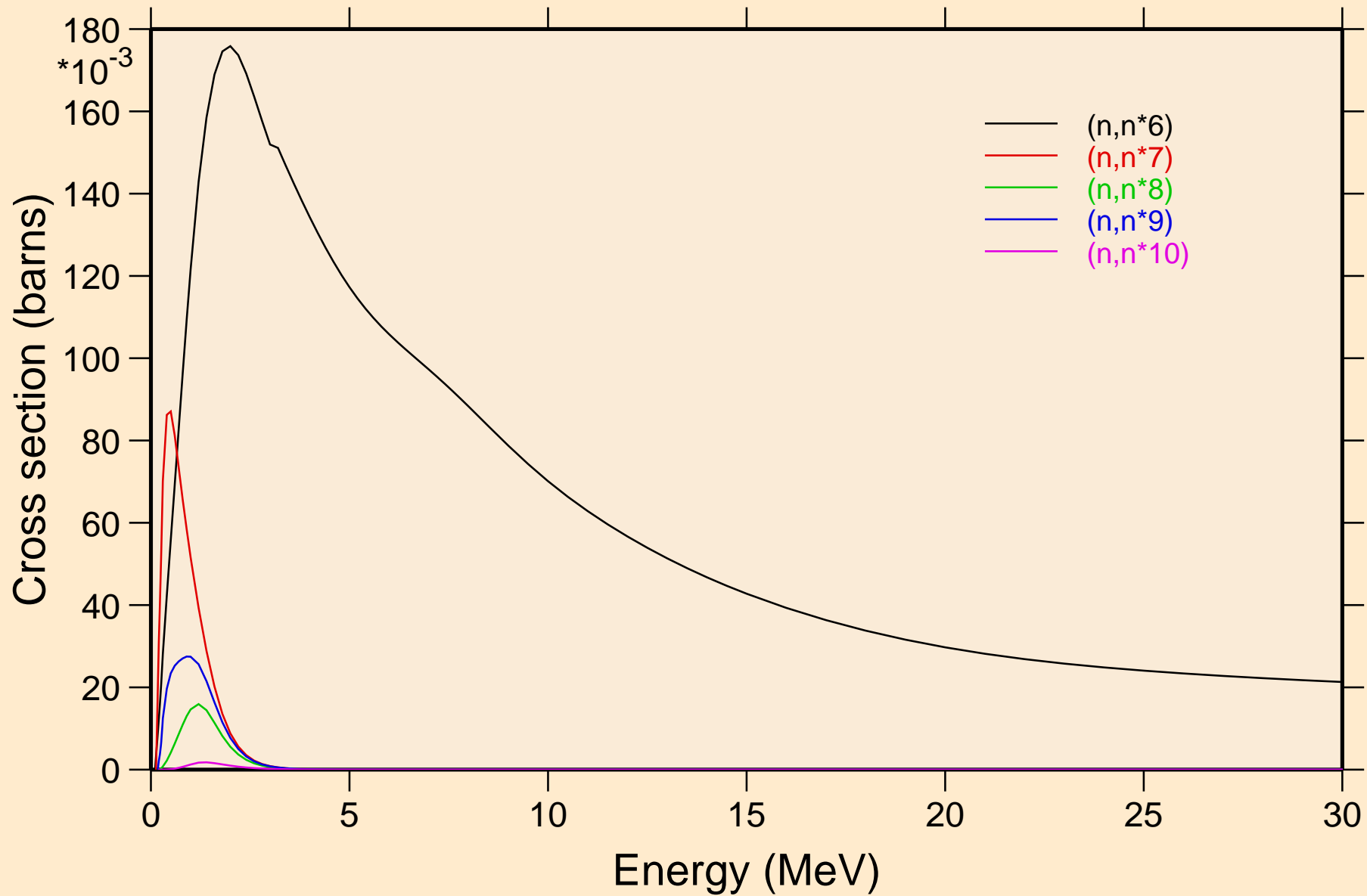

U235M NEUTRON ACER TENDL-2023 LIBRARY; T=0.K
Inelastic levels

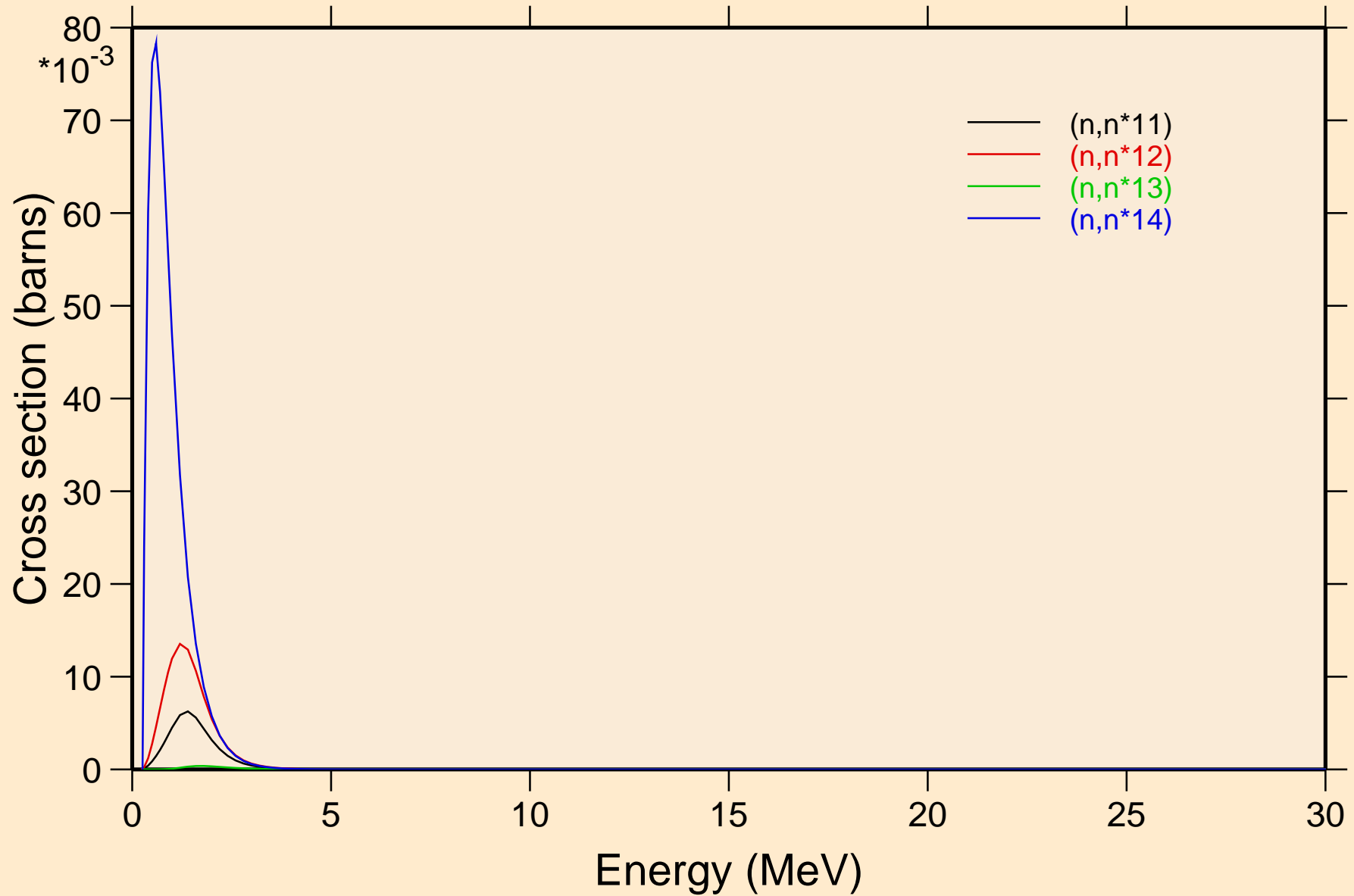

U235M NEUTRON ACER TENDL-2023 LIBRARY; T=0.K
Threshold reactions

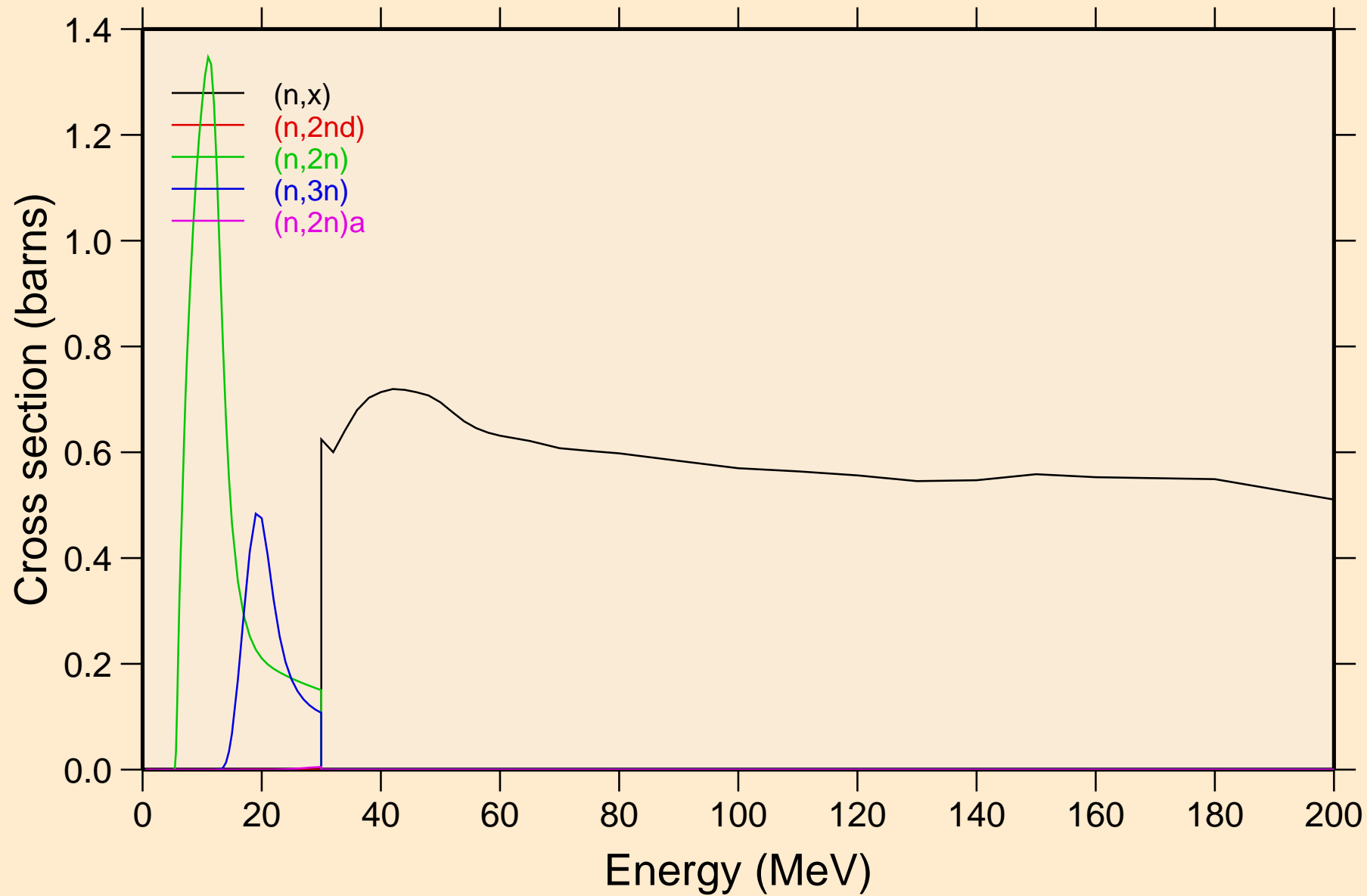

U235M NEUTRON ACER TENDL-2023 LIBRARY; T=0.K

Threshold reactions

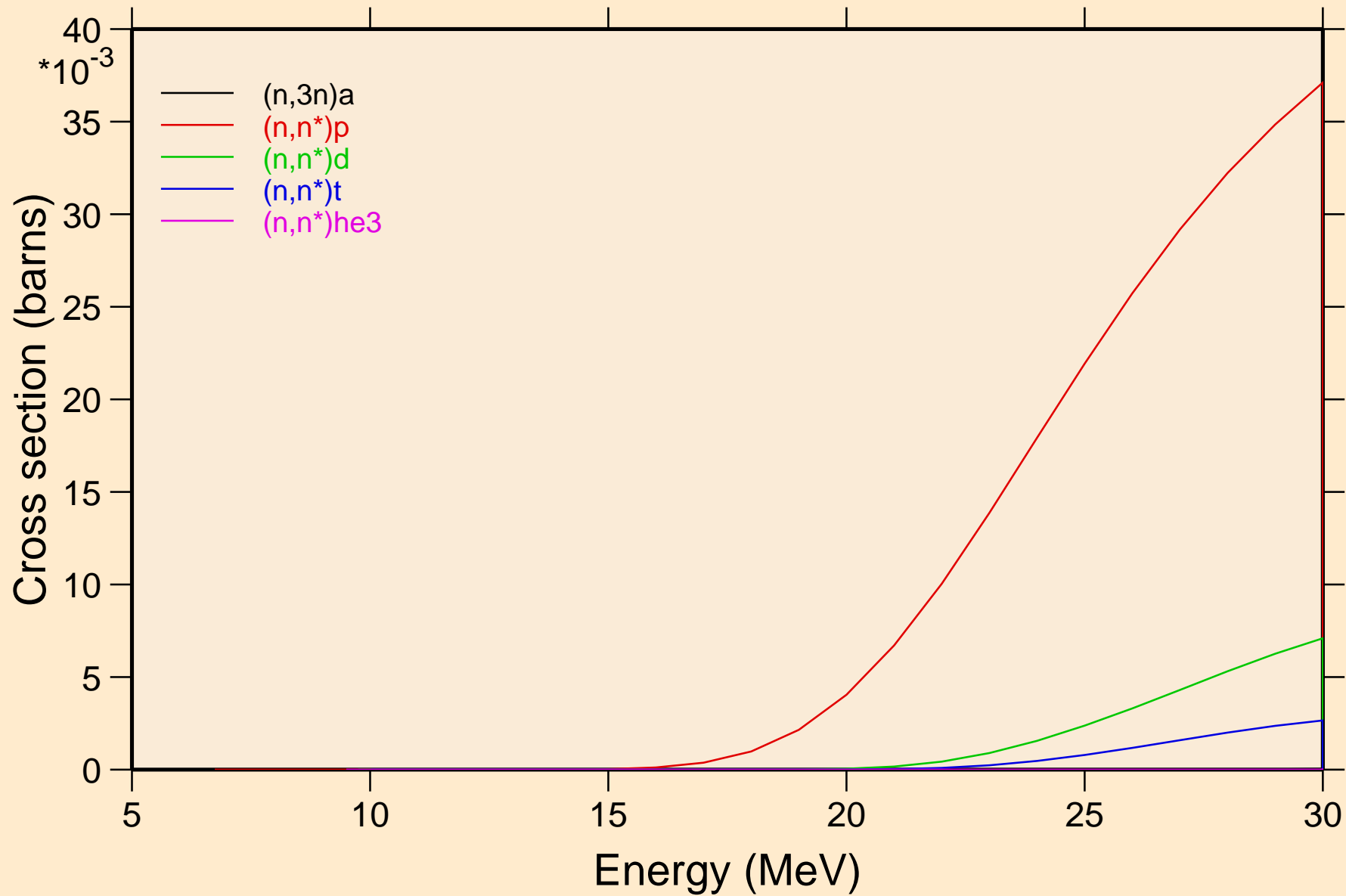

U235M NEUTRON ACER TENDL-2023 LIBRARY; T=0.K

Threshold reactions

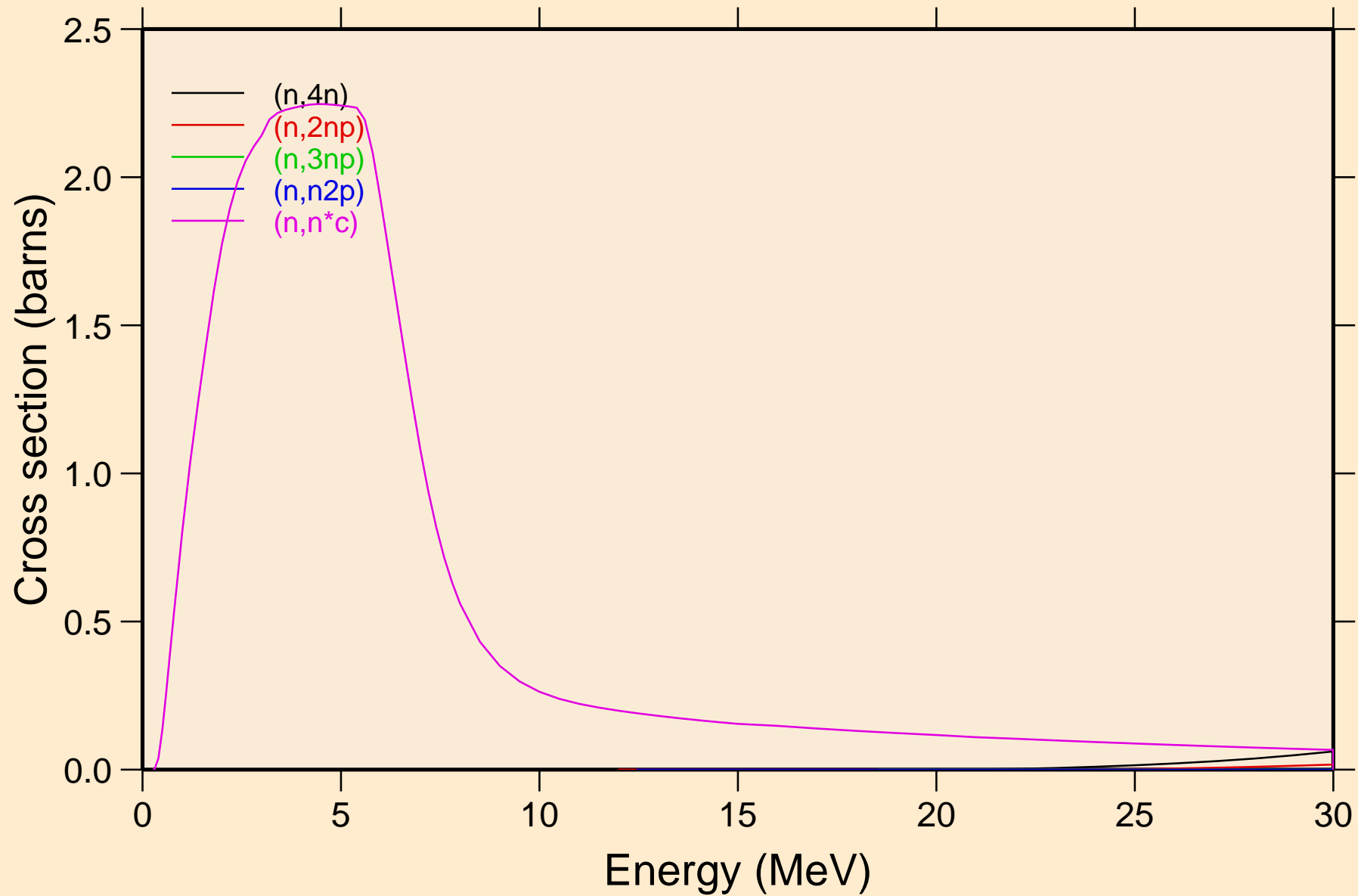

U235M NEUTRON ACER TENDL-2023 LIBRARY; T=0.K

Threshold reactions

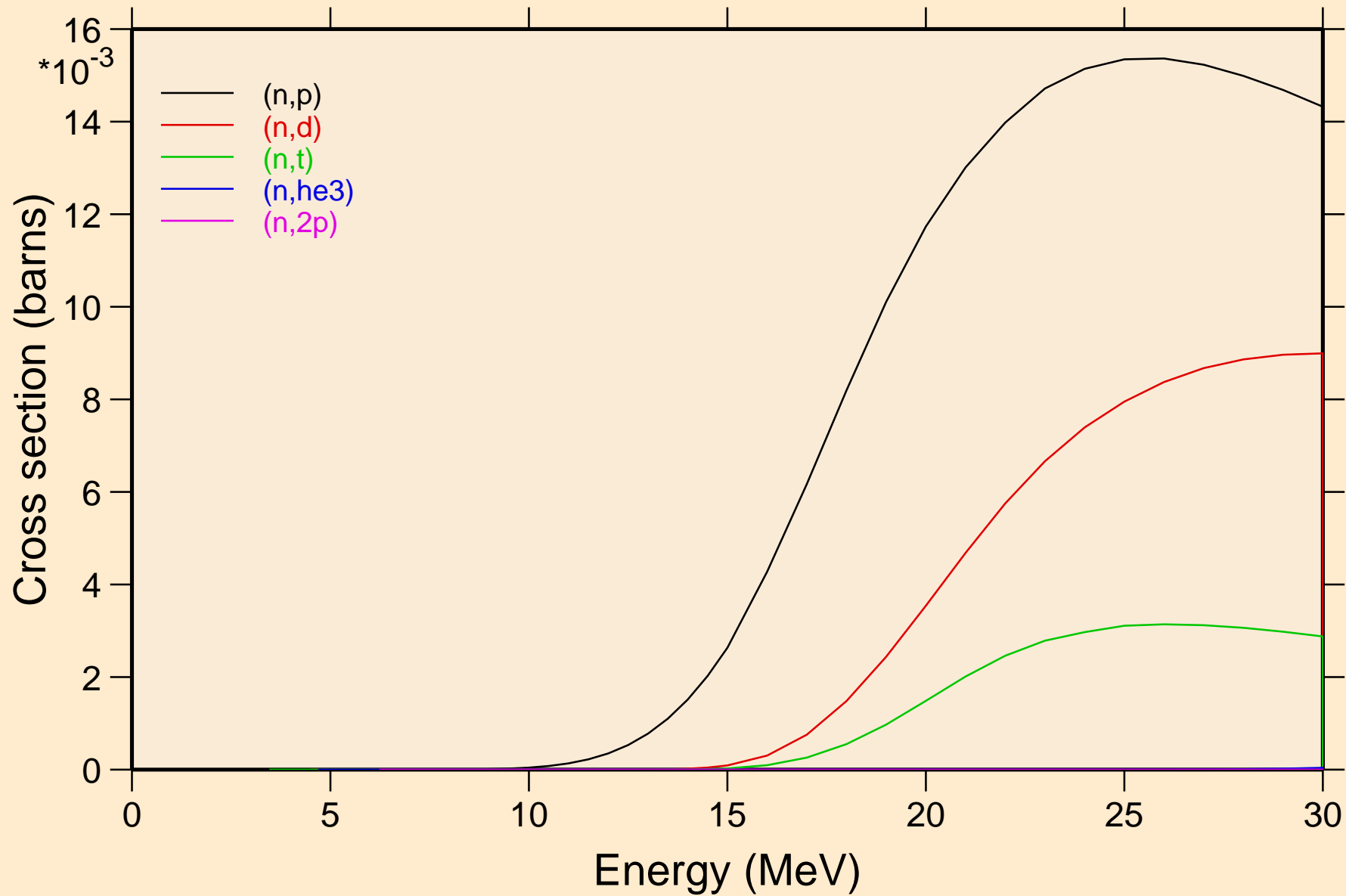

U235M NEUTRON ACER TENDL-2023 LIBRARY; T=0.K

Threshold reactions

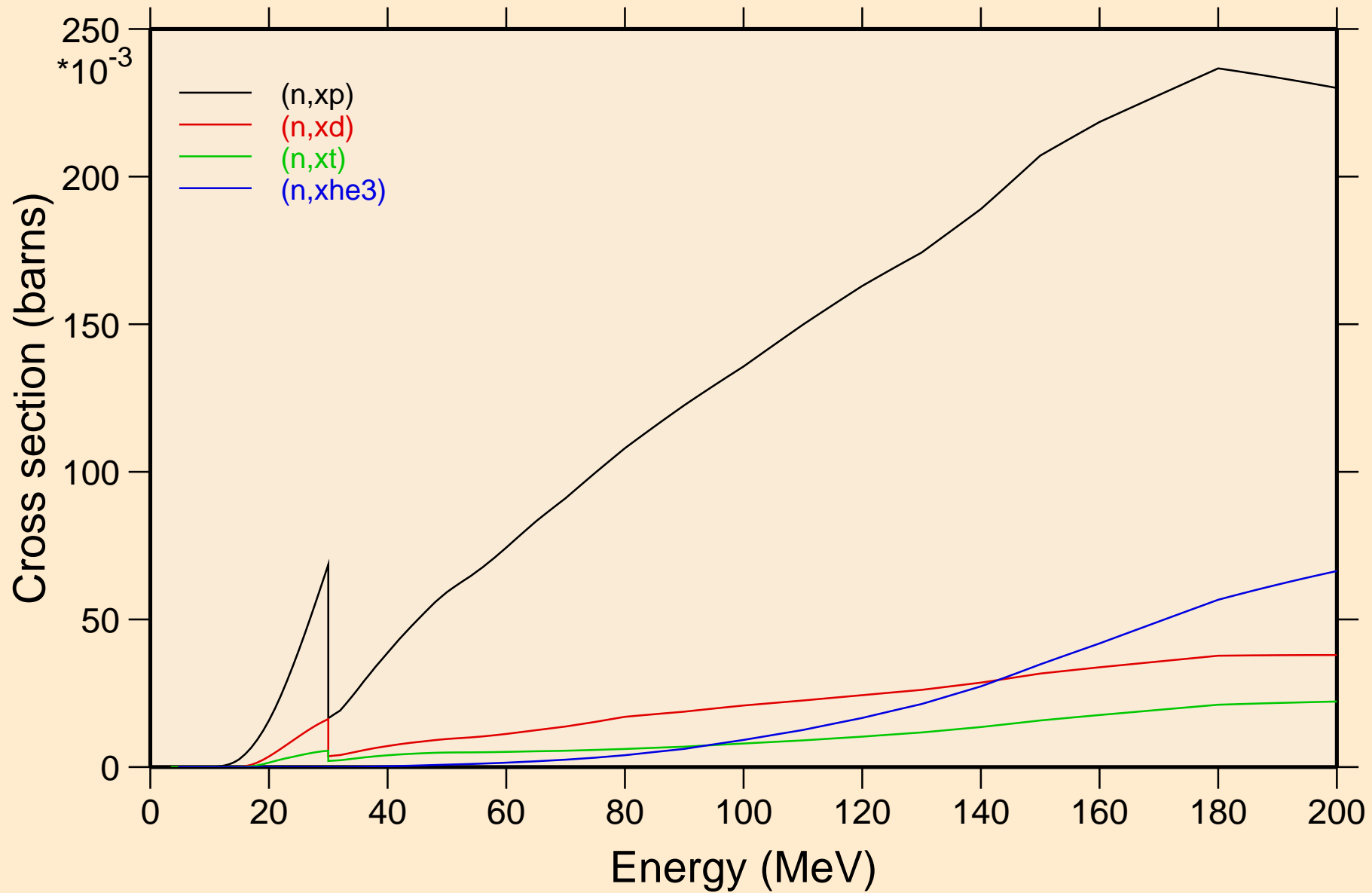

U235M NEUTRON ACER TENDL-2023 LIBRARY; T=0.K
angular distribution for elastic

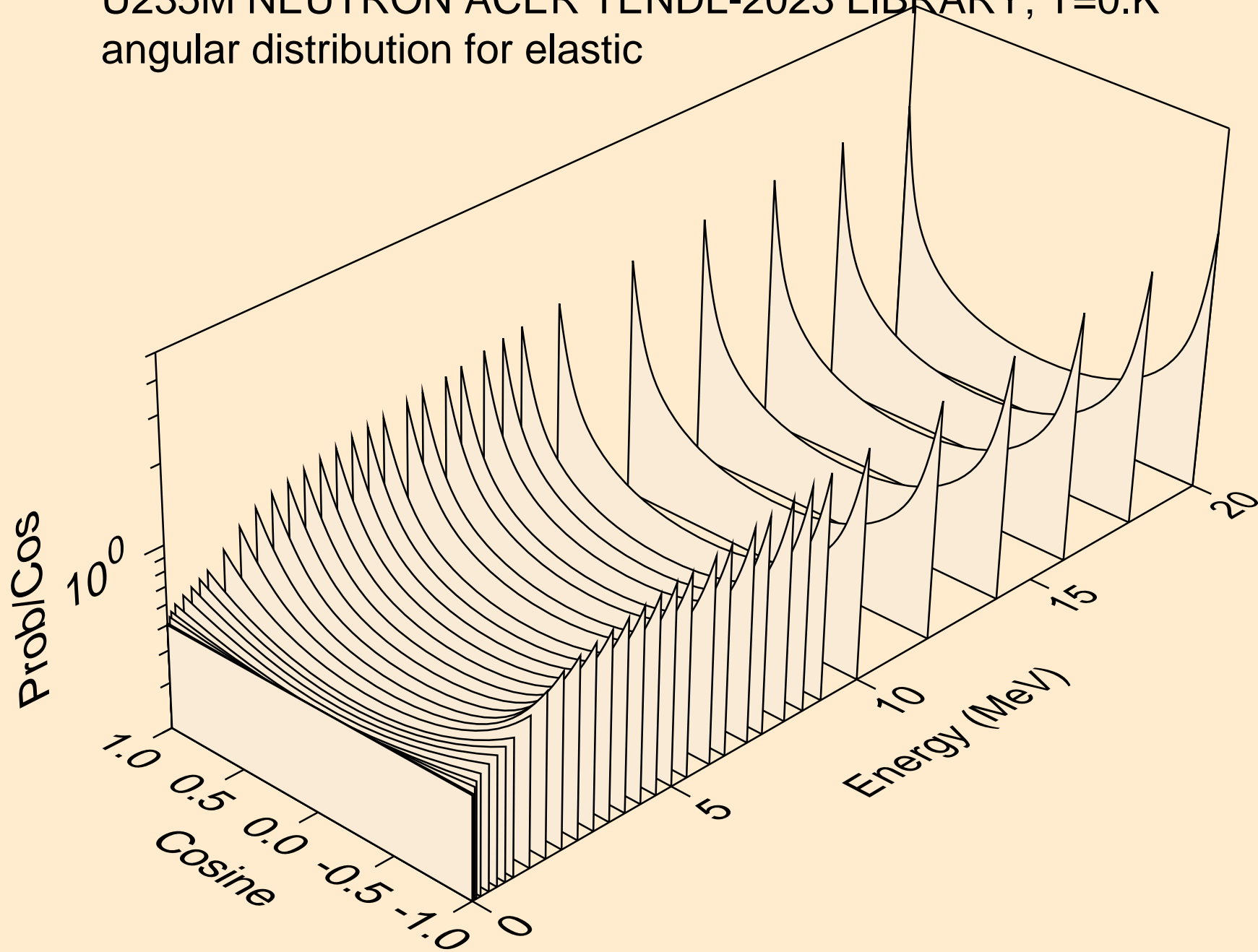

U235M NEUTRON ACER TENDL-2023 LIBRARY; T=0.K
angular distribution for elastic

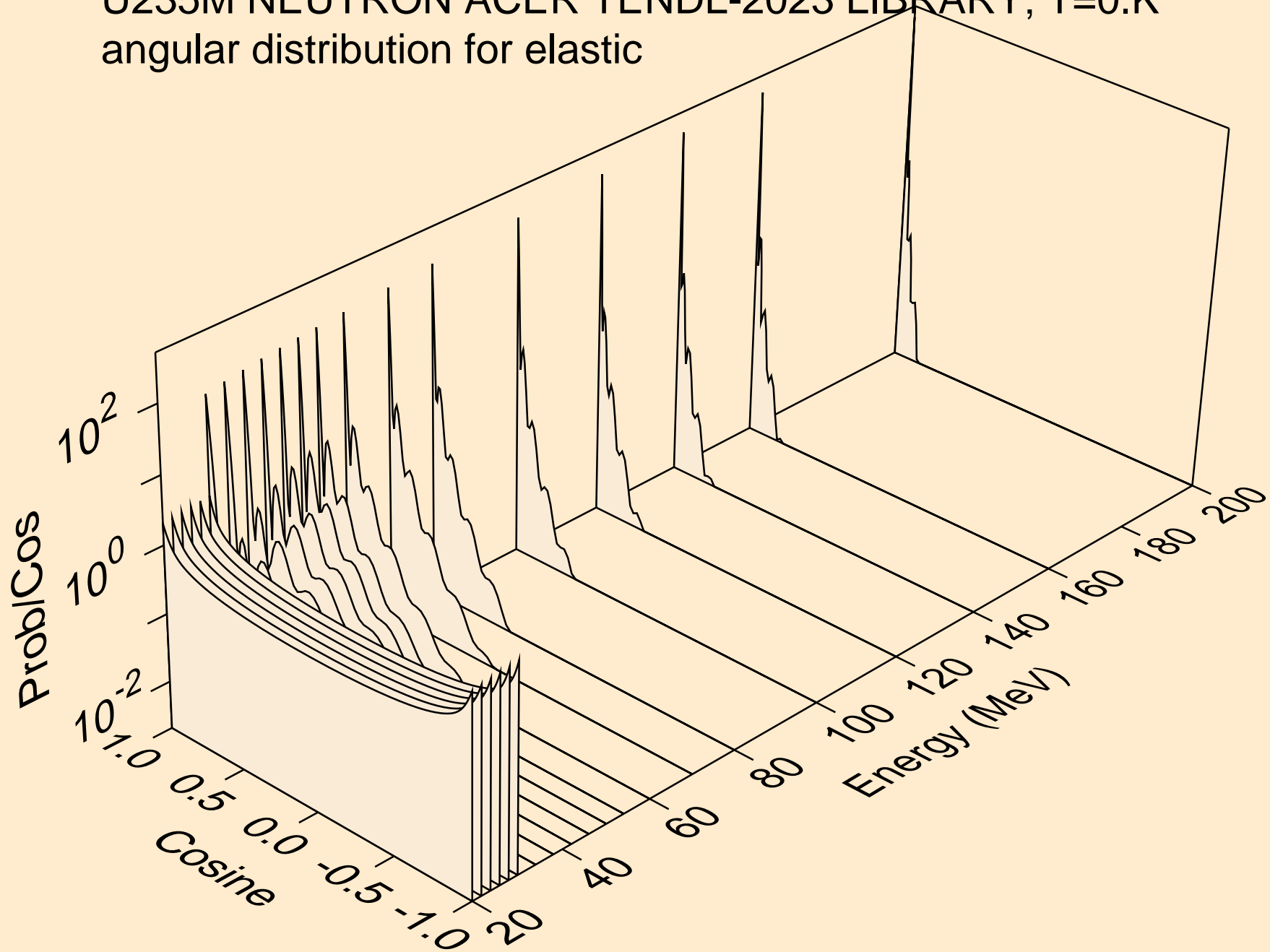

U235M NEUTRON ACER TENDL-2023 LIBRARY; T=0.K
angular distribution for (n,n*1)

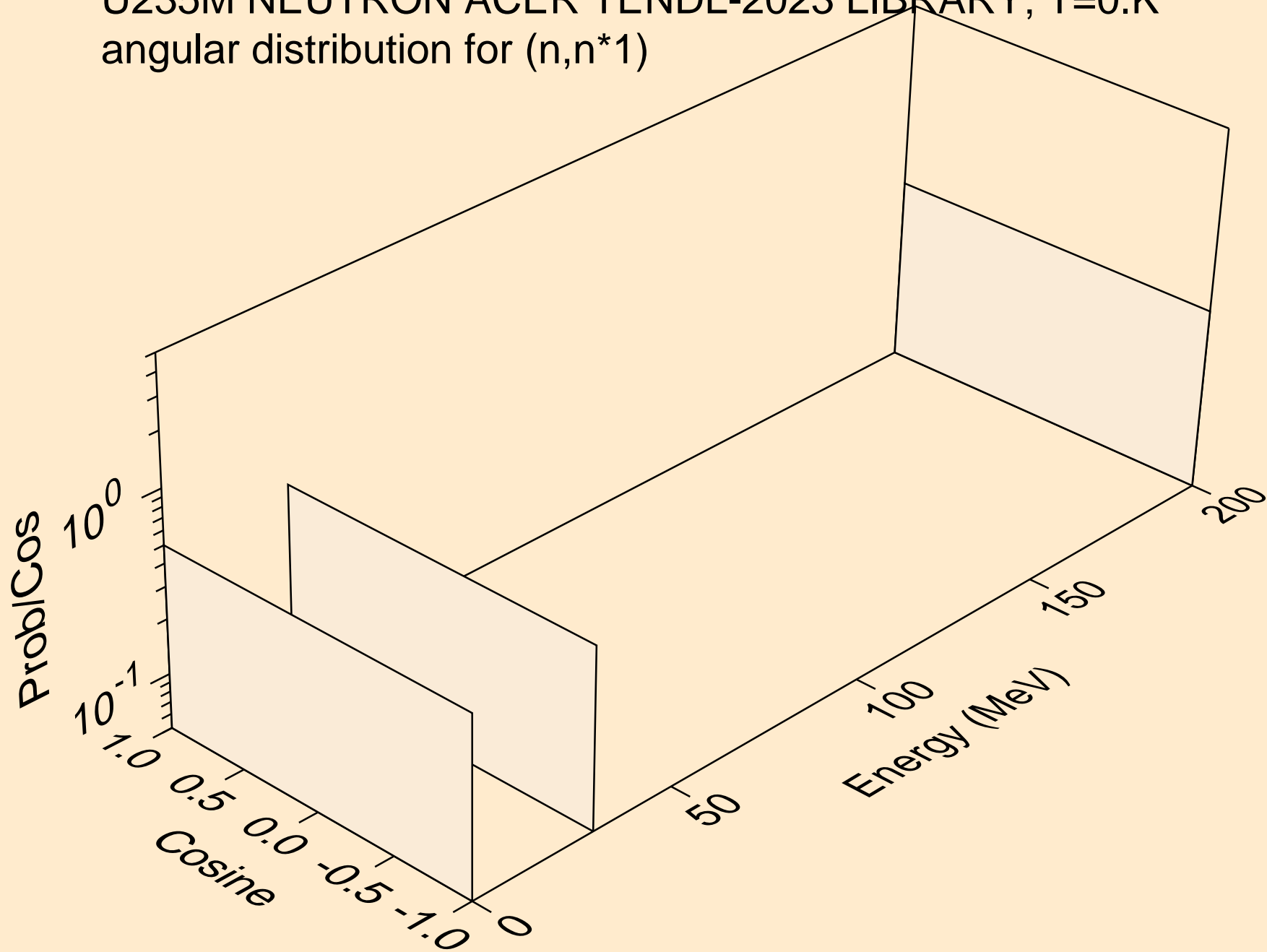

U235M NEUTRON ACER TENDL-2023 LIBRARY; T=0.K
angular distribution for (n,n*2)

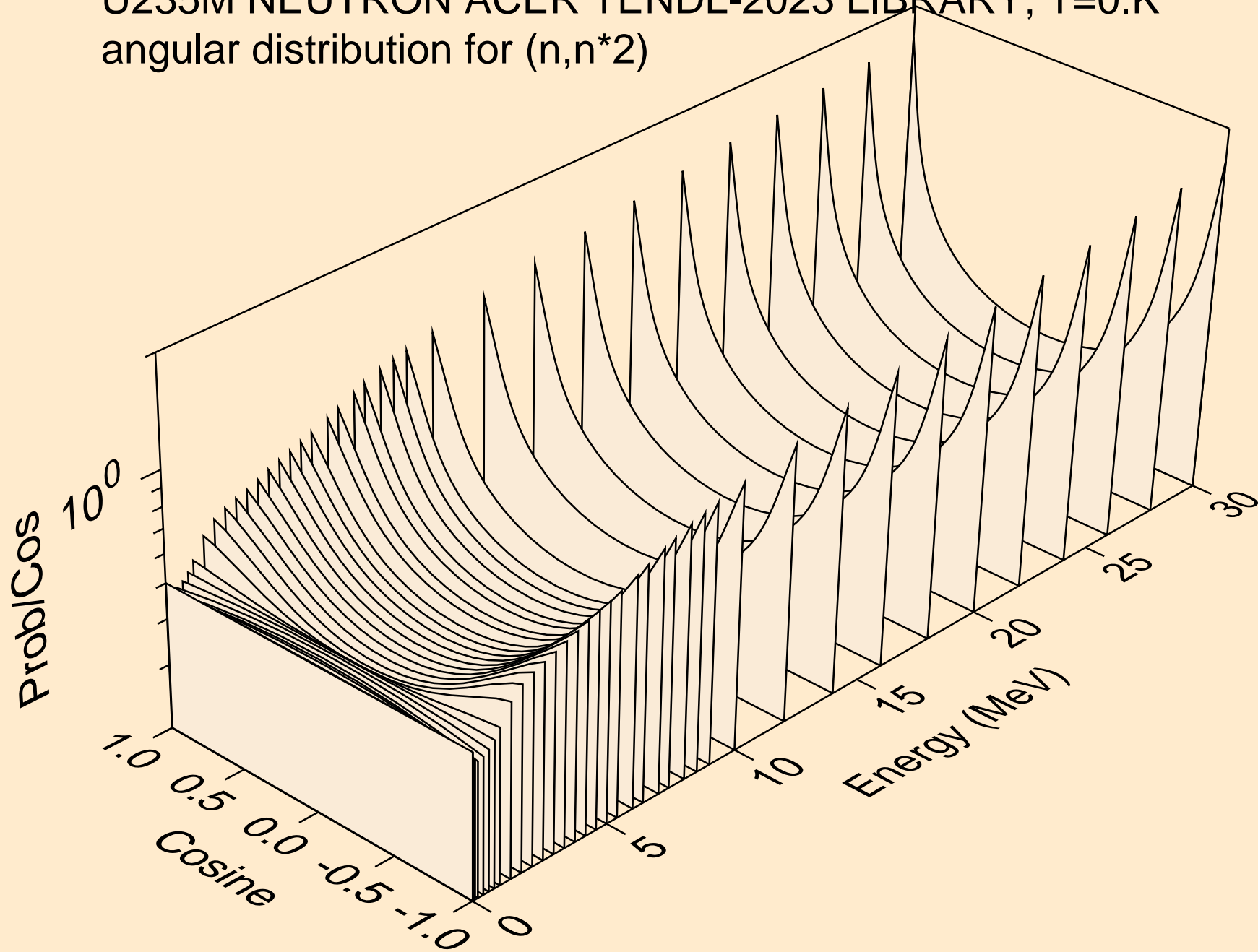

U235M NEUTRON ACER TENDL-2023 LIBRARY; T=0.K
angular distribution for (n,n*3)

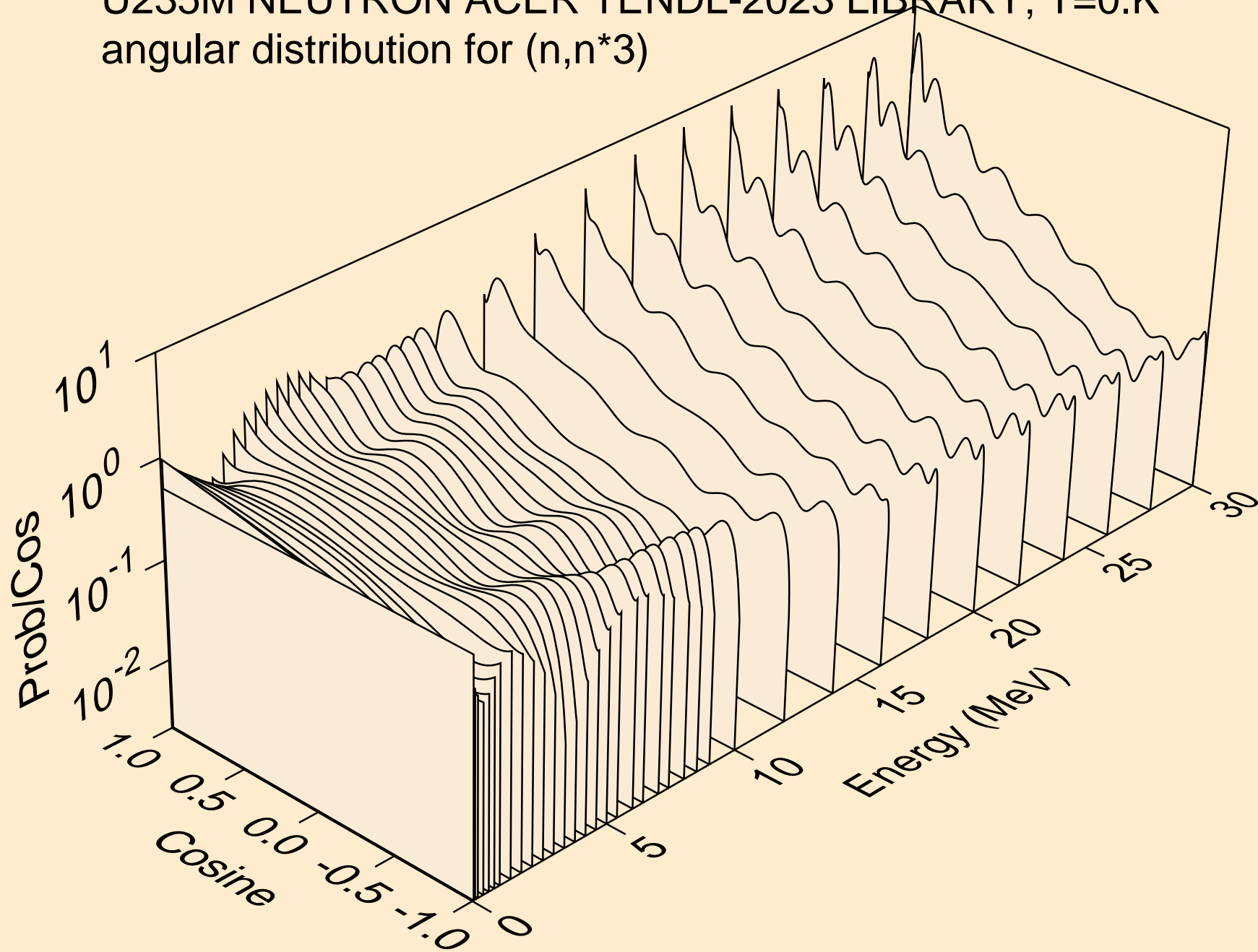

U235M NEUTRON ACER TENDL-2023 LIBRARY; T=0.K
angular distribution for (n,n*4)

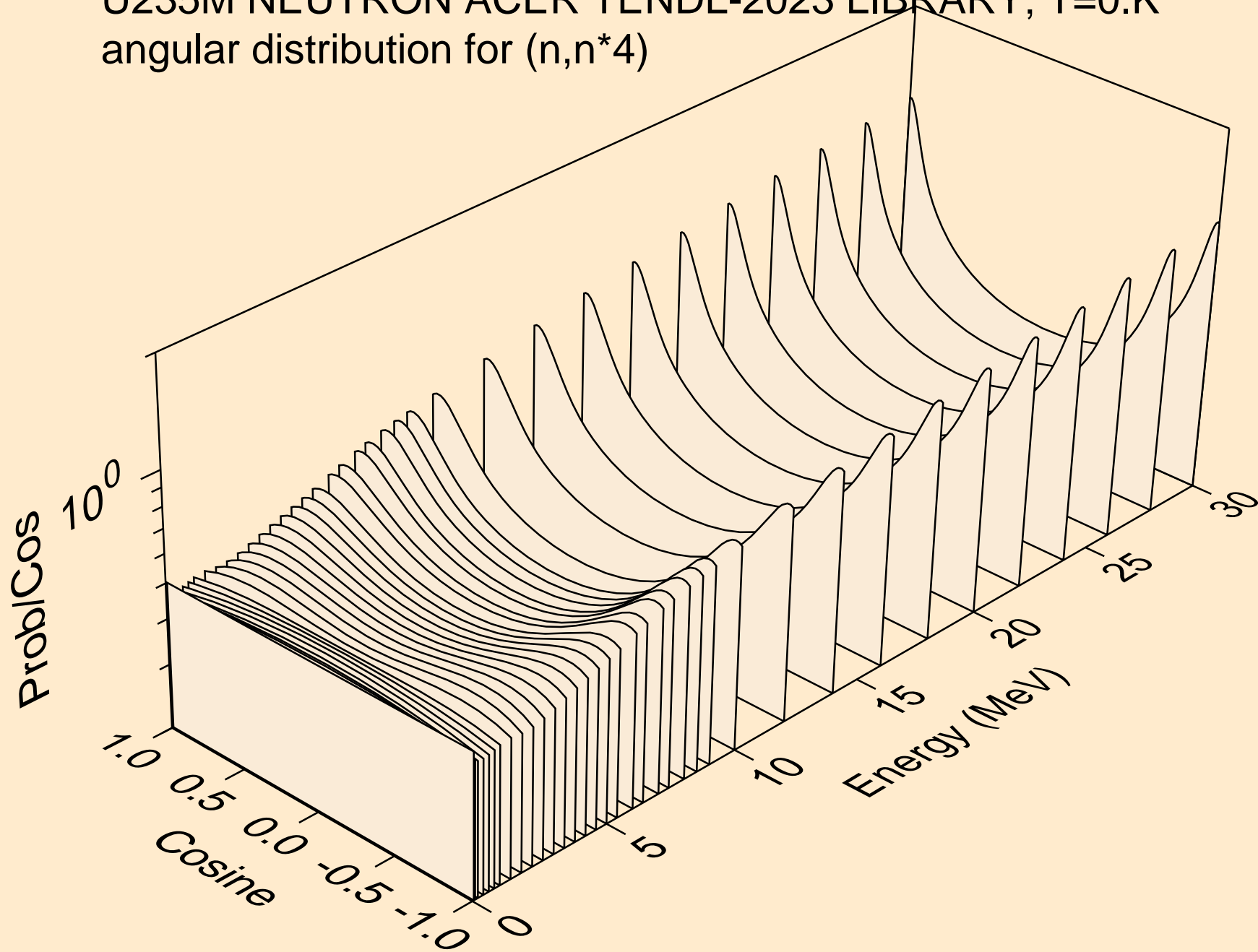

U235M NEUTRON ACER TENDL-2023 LIBRARY; T=0.K
angular distribution for (n,n*5)

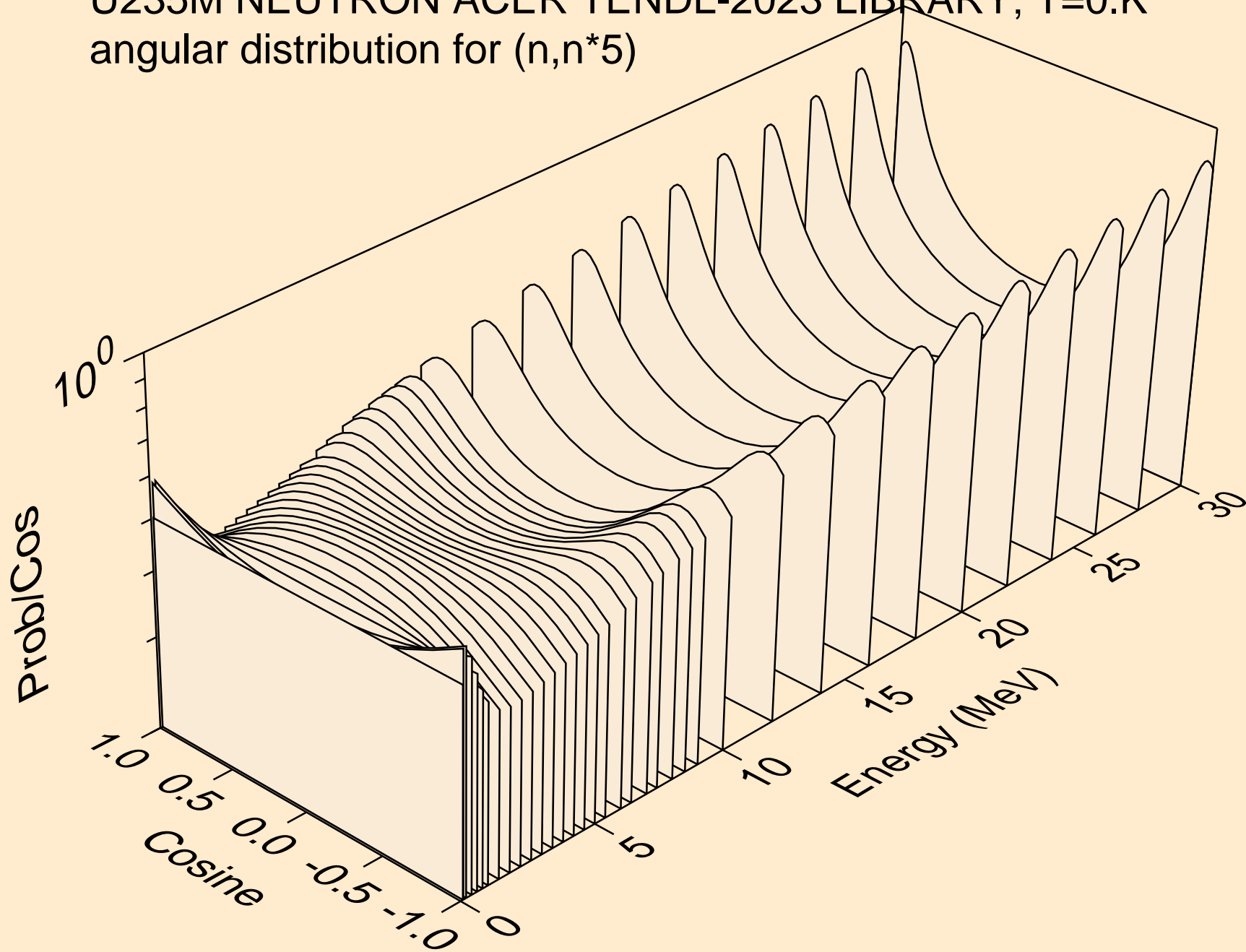

U235M NEUTRON ACER TENDL-2023 LIBRARY; T=0.K
angular distribution for (n,n*6)

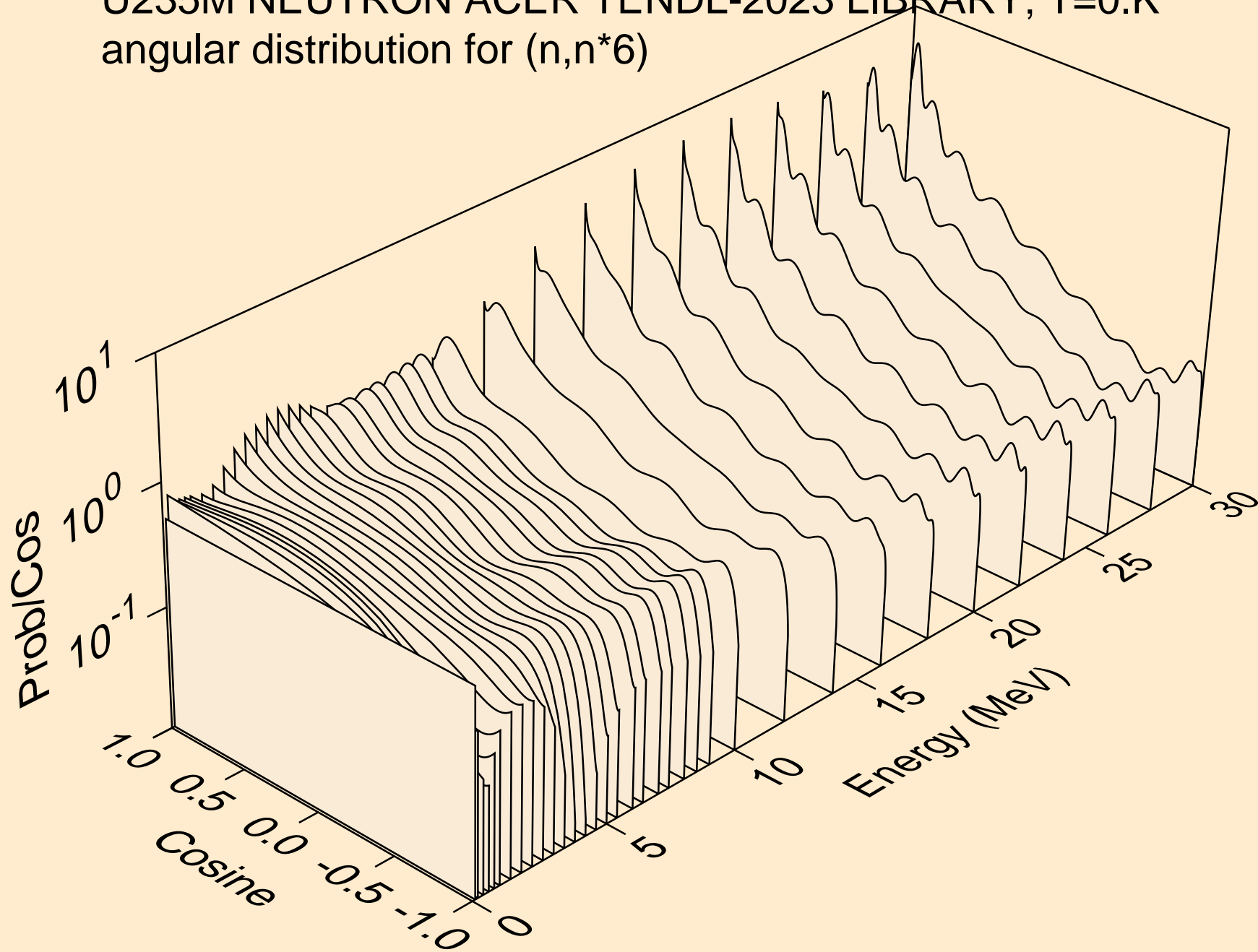

U235M NEUTRON ACER TENDL-2023 LIBRARY; T=0.K
angular distribution for (n,n*7)

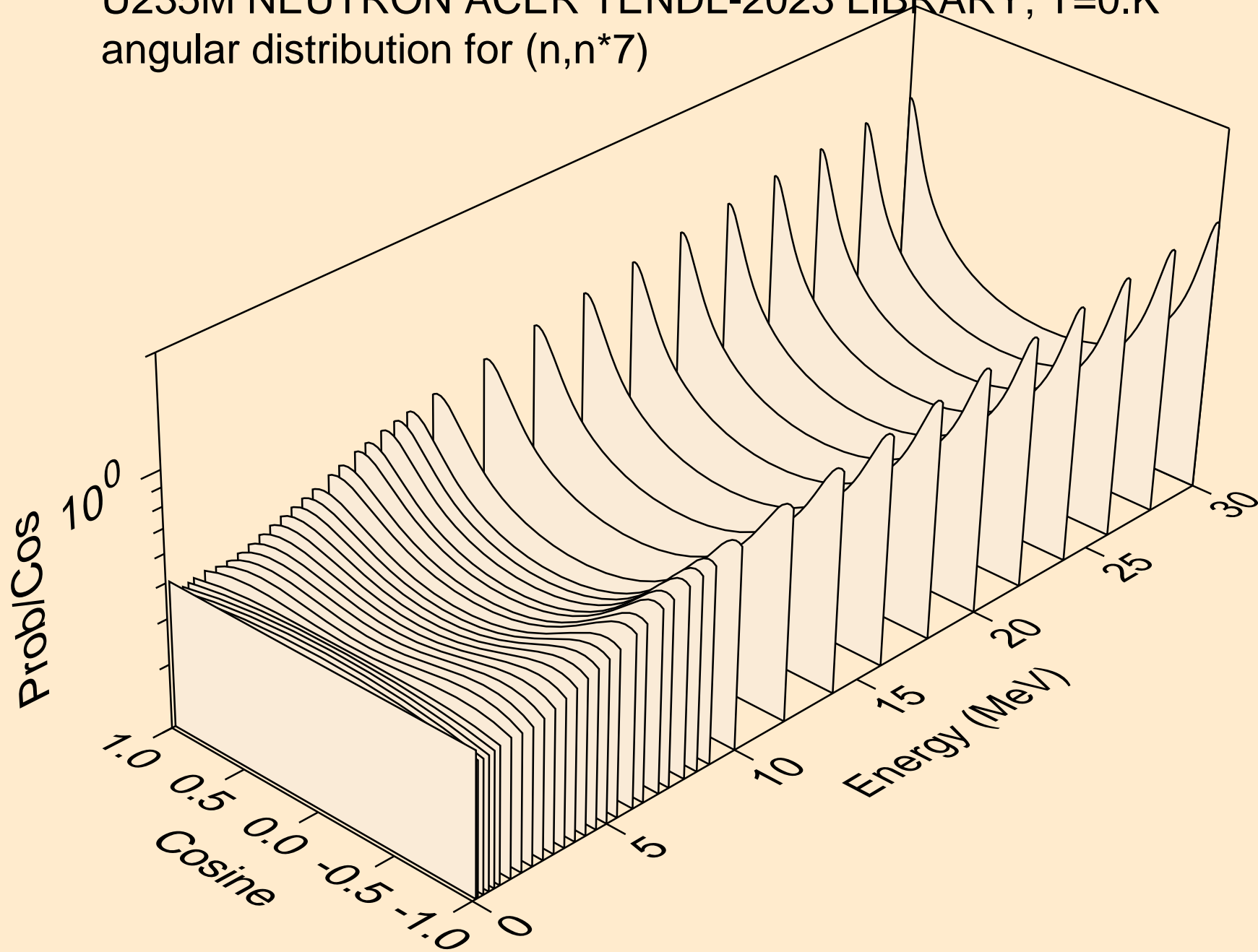

U235M NEUTRON ACER TENDL-2023 LIBRARY; T=0.K
angular distribution for (n,n*8)

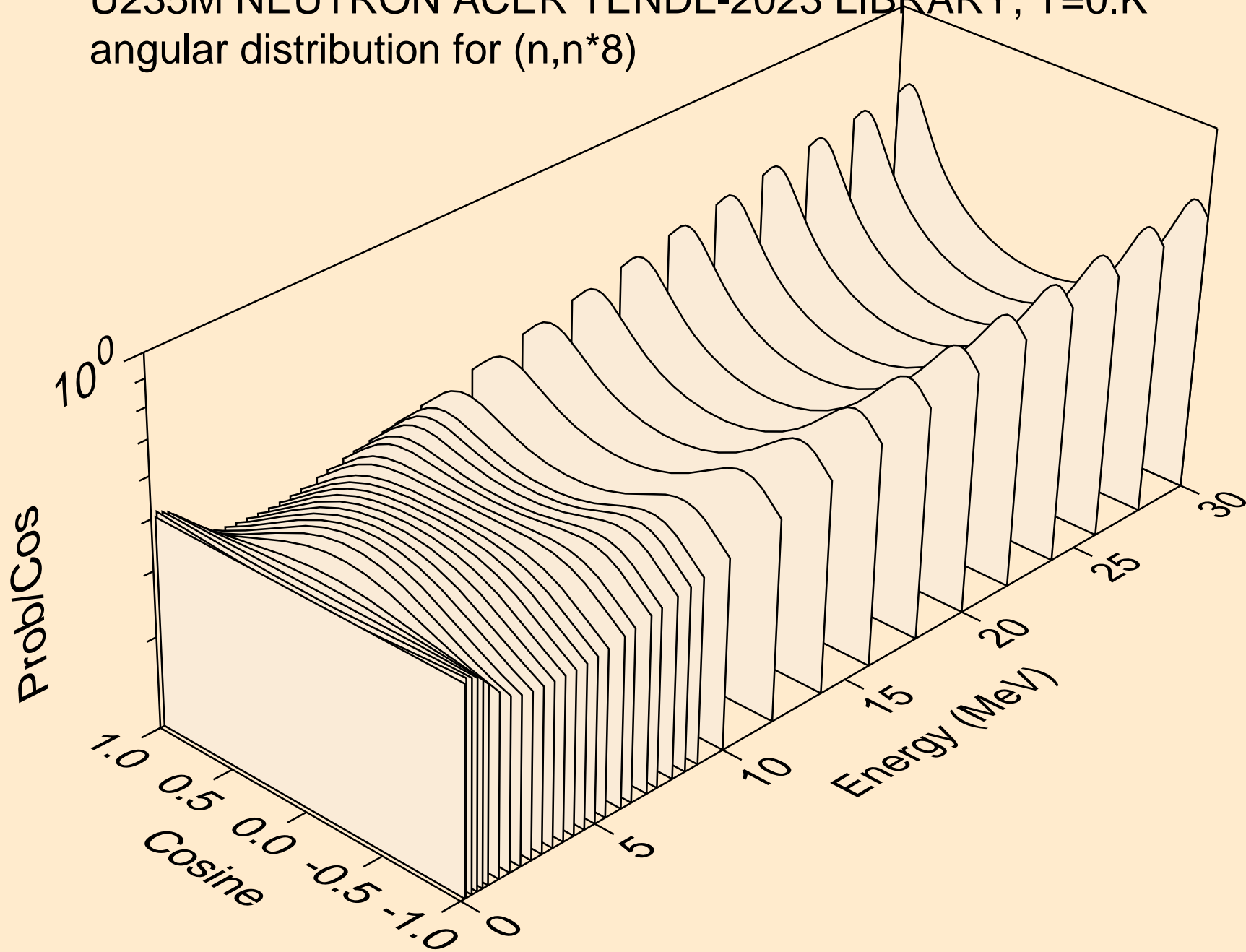

U235M NEUTRON ACER TENDL-2023 LIBRARY; T=0.K
angular distribution for (n,n*9)

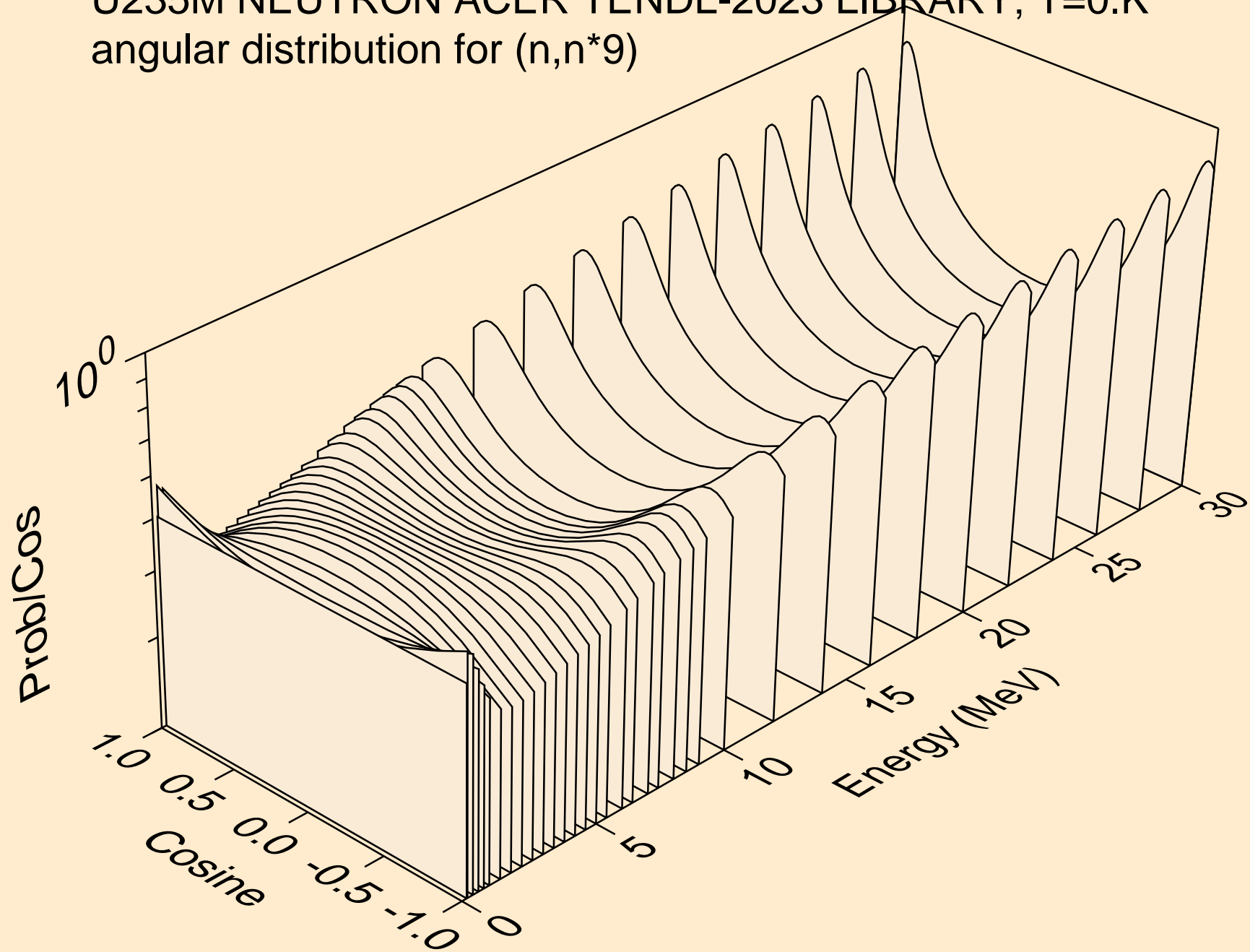

U235M NEUTRON ACER TENDL-2023 LIBRARY; T=0.K
angular distribution for (n,n*10)

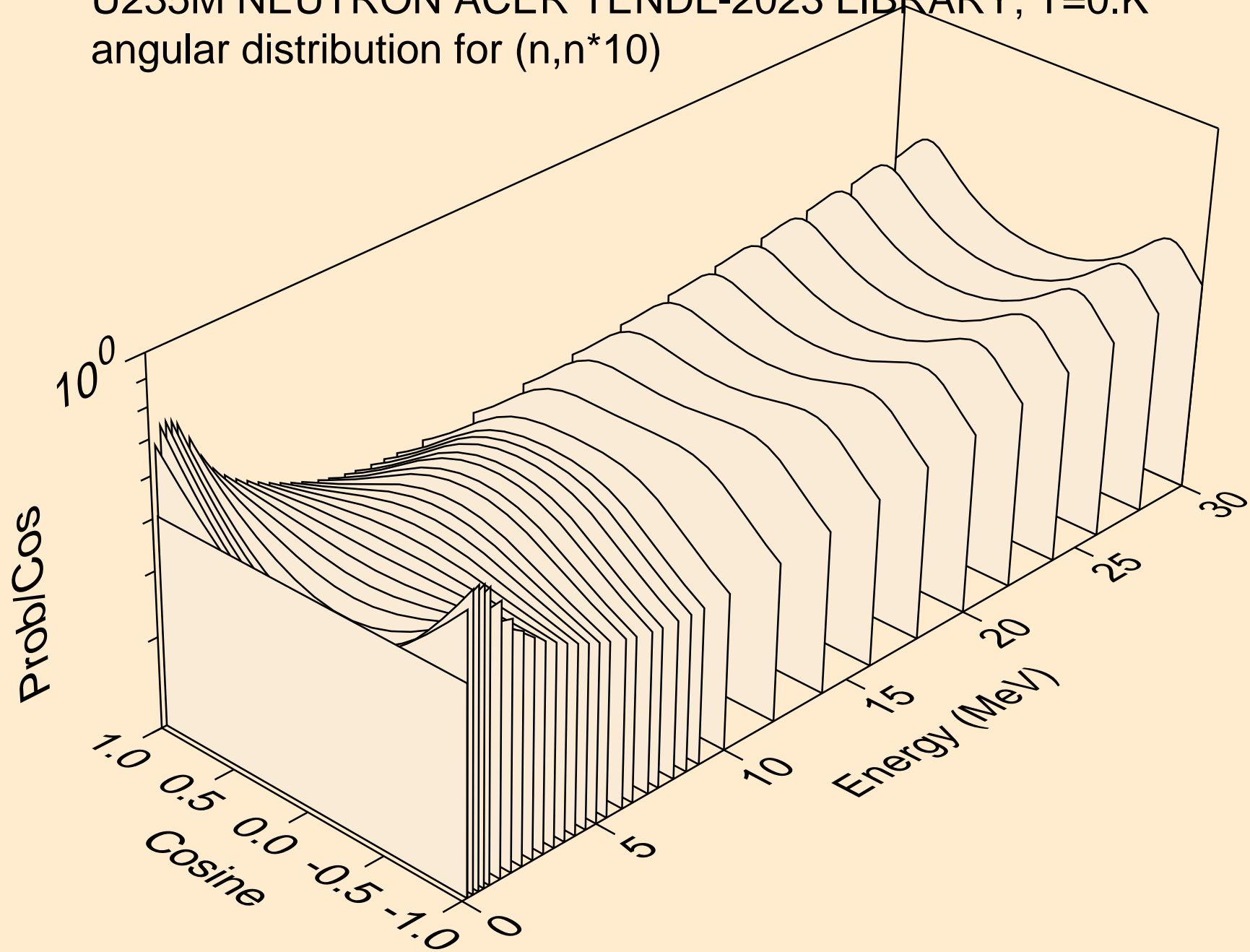

U235M NEUTRON ACER TENDL-2023 LIBRARY; T=0.K
angular distribution for (n,n*11)

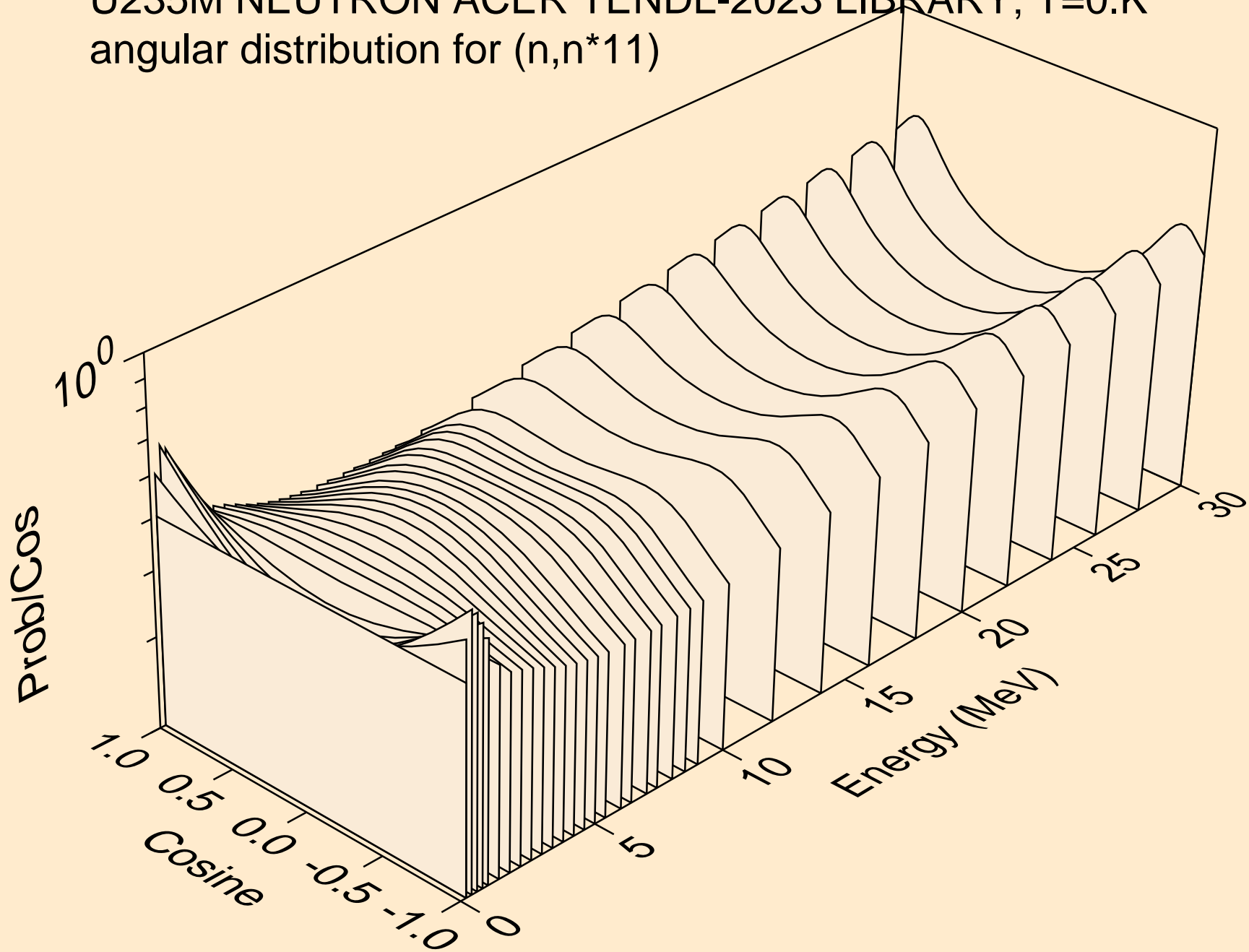

U235M NEUTRON ACER TENDL-2023 LIBRARY; T=0.K
angular distribution for (n,n*12)

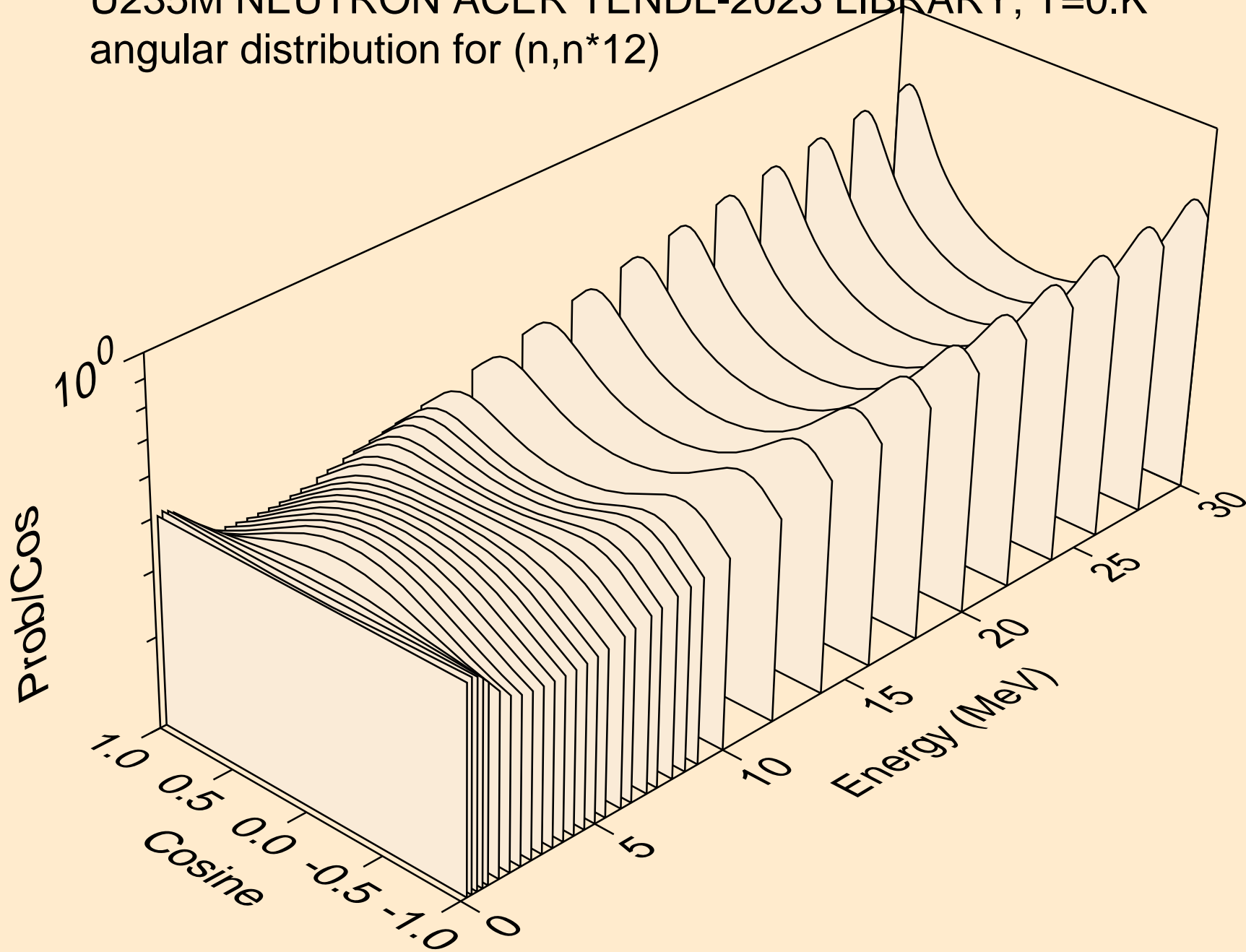

U235M NEUTRON ACER TENDL-2023 LIBRARY; T=0.K
angular distribution for (n,n*13)

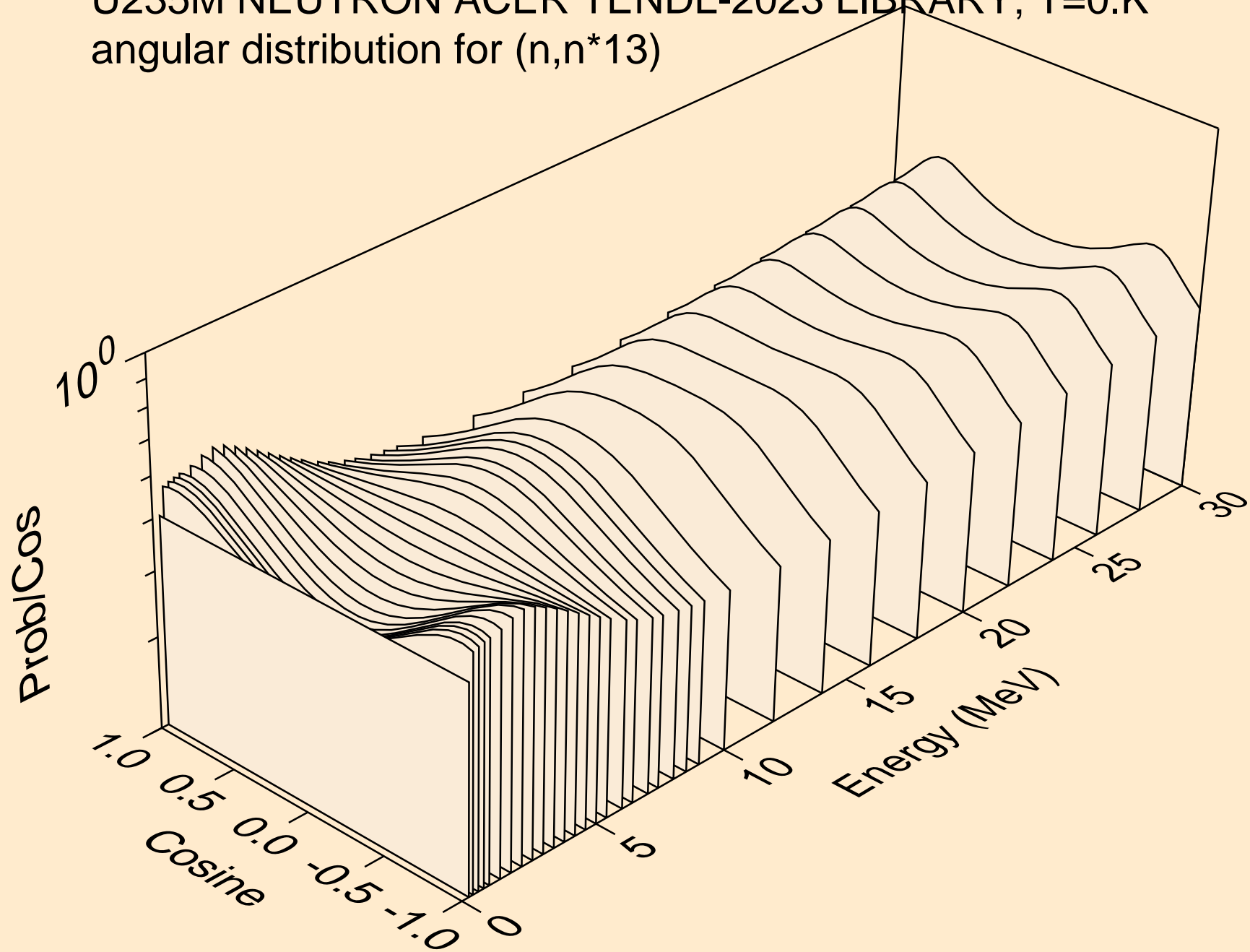

U235M NEUTRON ACER TENDL-2023 LIBRARY; T=0.K
angular distribution for (n,n*14)

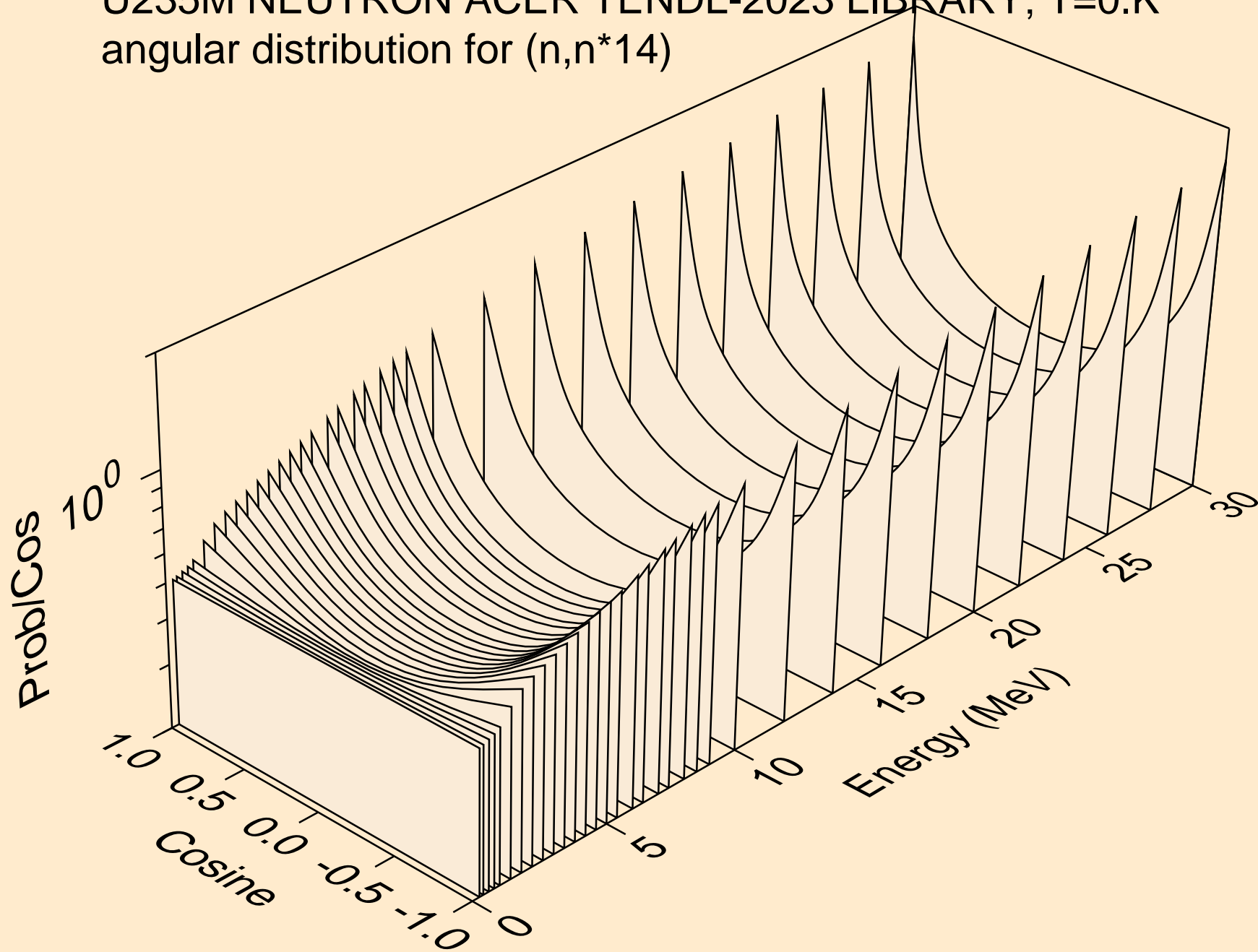

U235M NEUTRON ACER TENDL-2023 LIBRARY; T=0.K

Total fission nubar

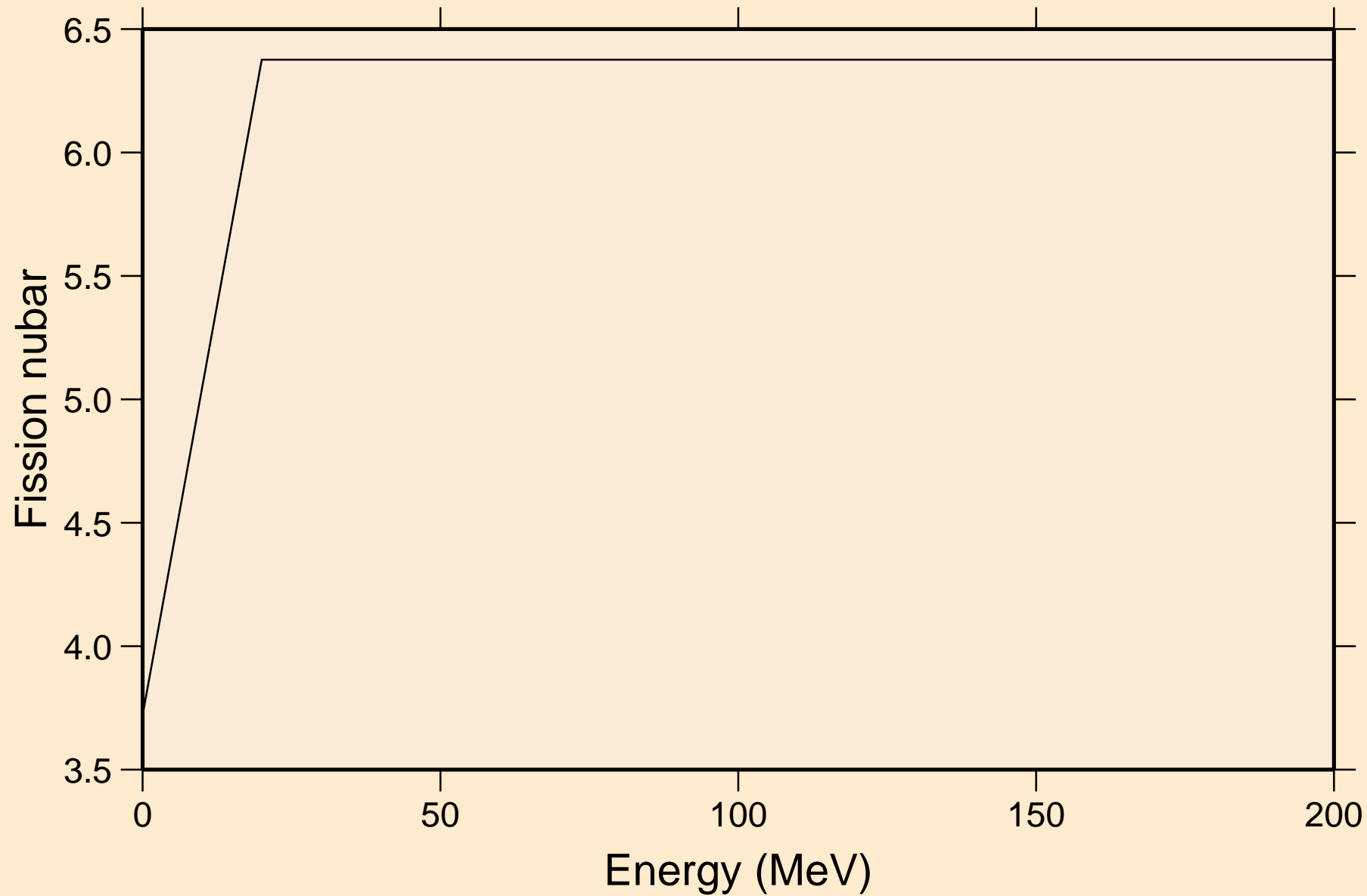

U235M NEUTRON ACER TENDL-2023 LIBRARY; T=0.K
Neutron emission for (n,x)

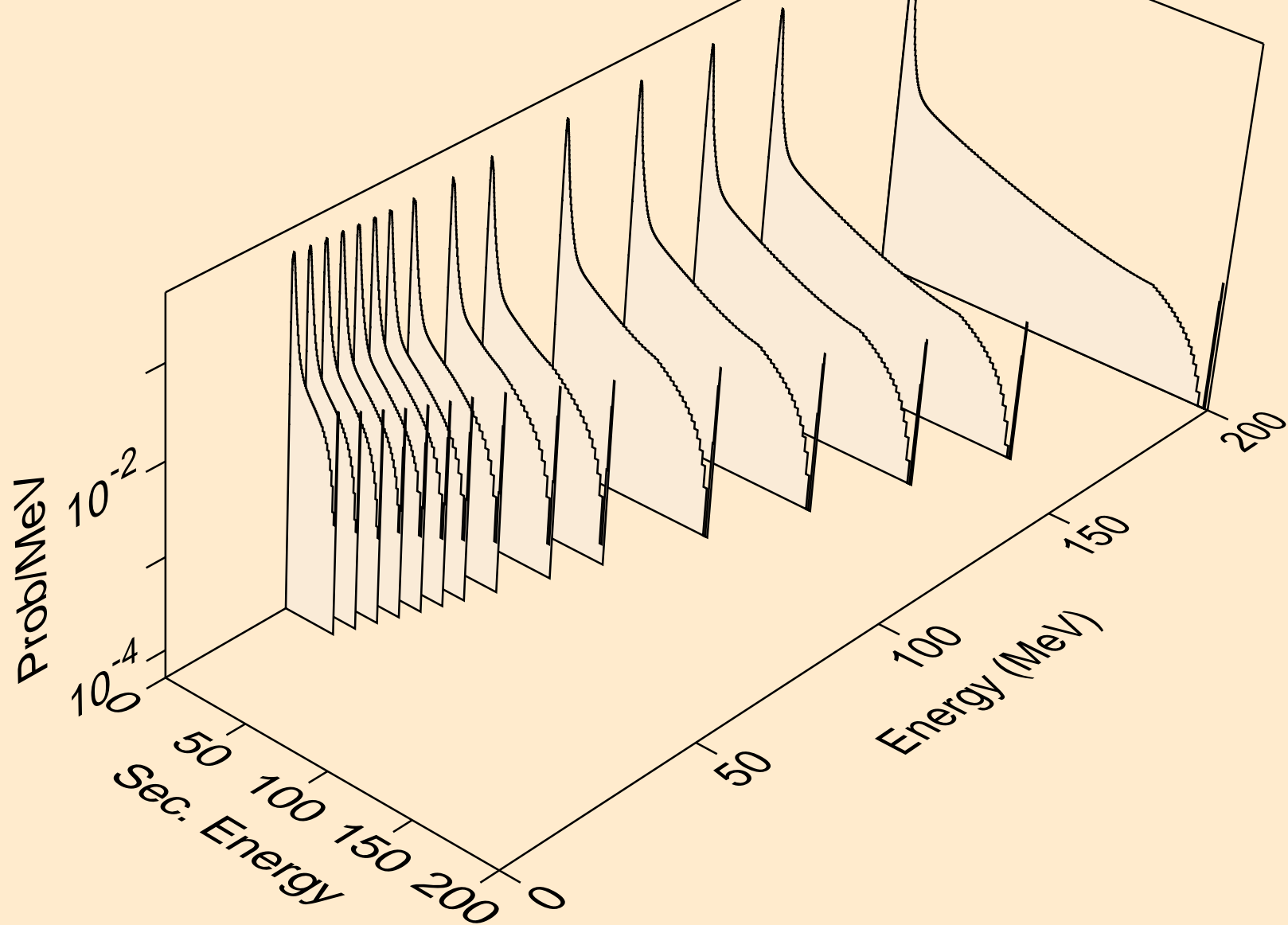

U235M NEUTRON ACER TENDL-2023 LIBRARY; T=0.K
Neutron emission for (n,2nd)

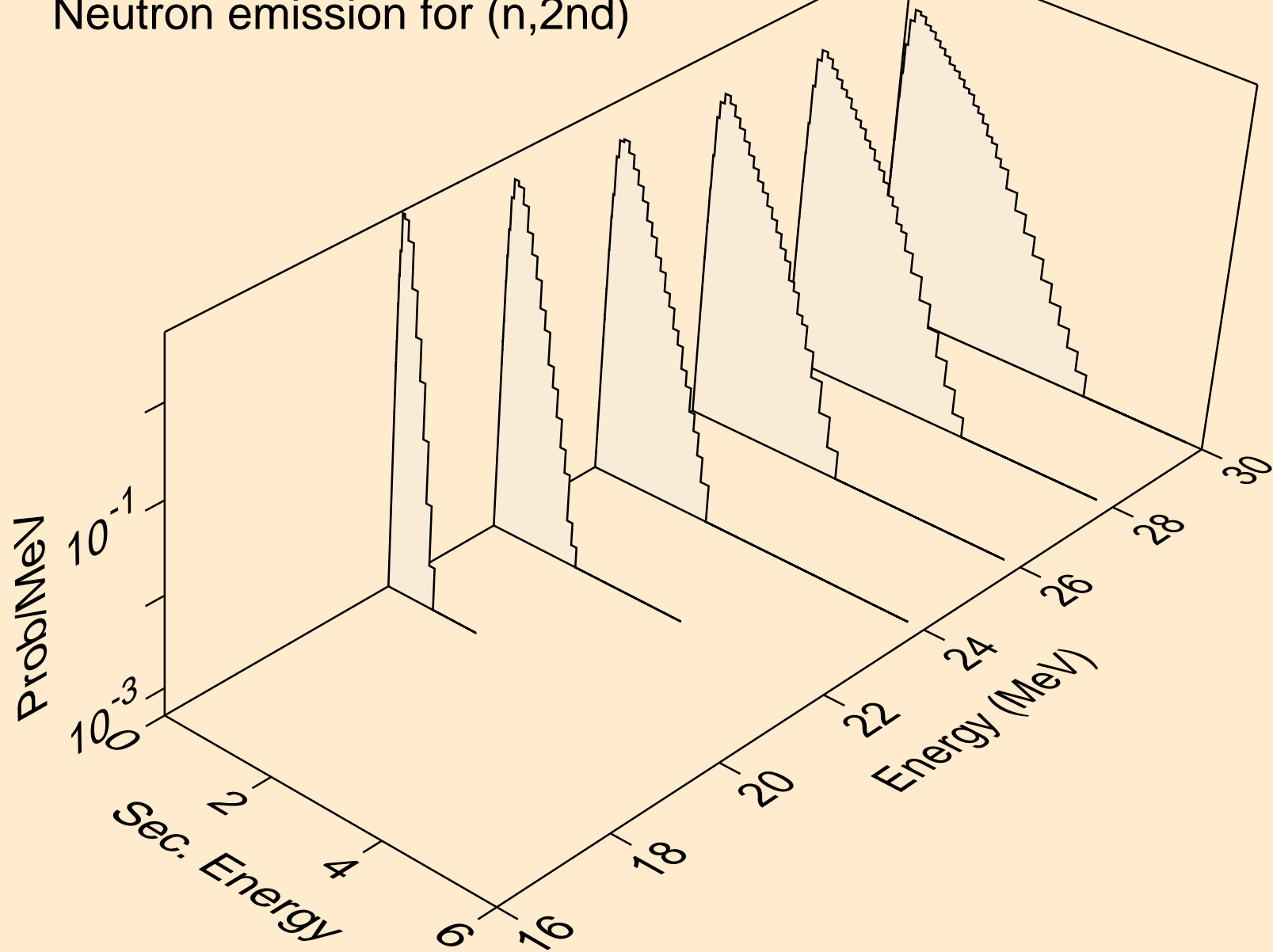

U235M NEUTRON ACER TENDL-2023 LIBRARY; T=0.K
Neutron emission for (n,2n)

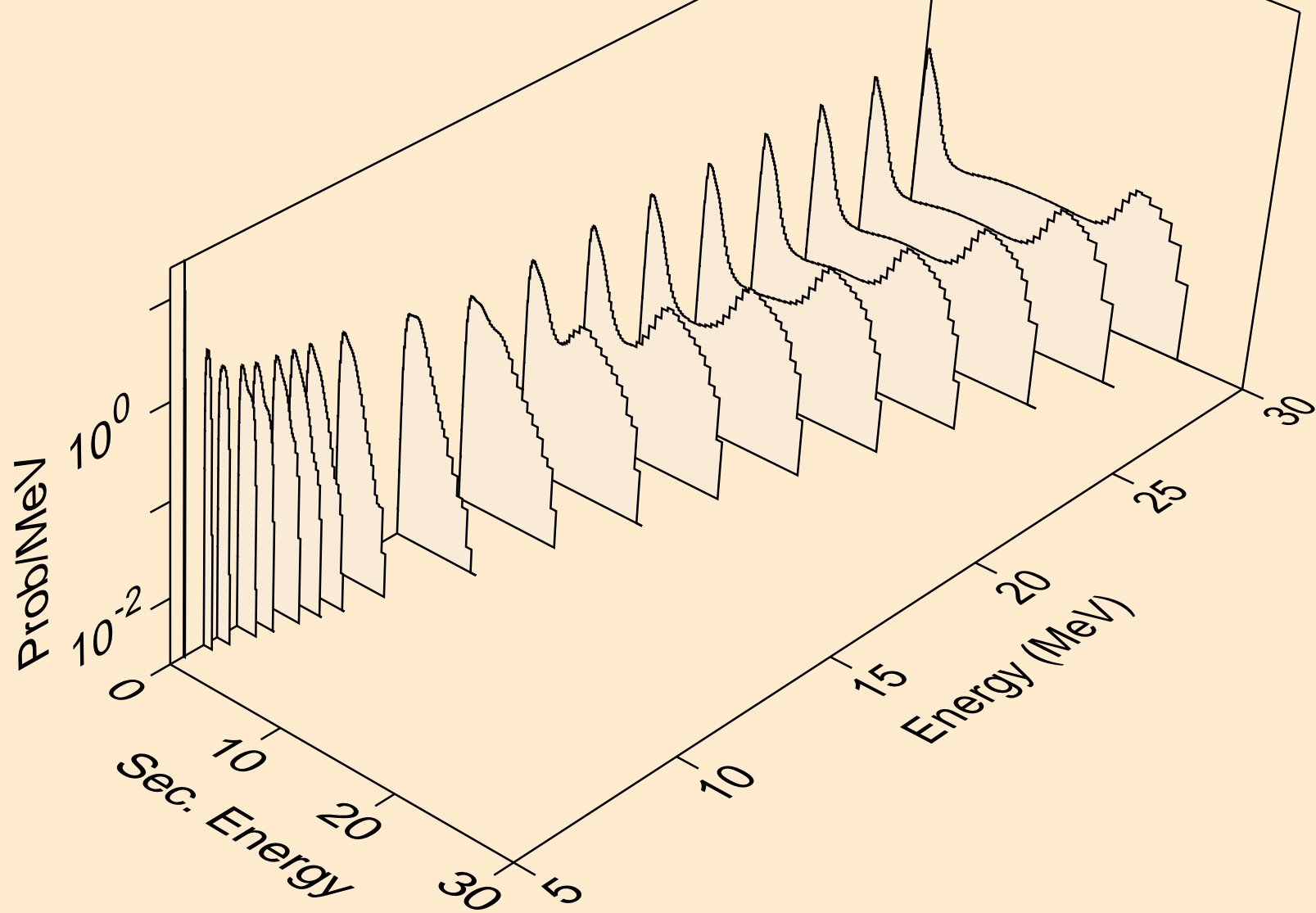

U235M NEUTRON ACER TENDL-2023 LIBRARY; T=0.K
Neutron emission for (n,3n)

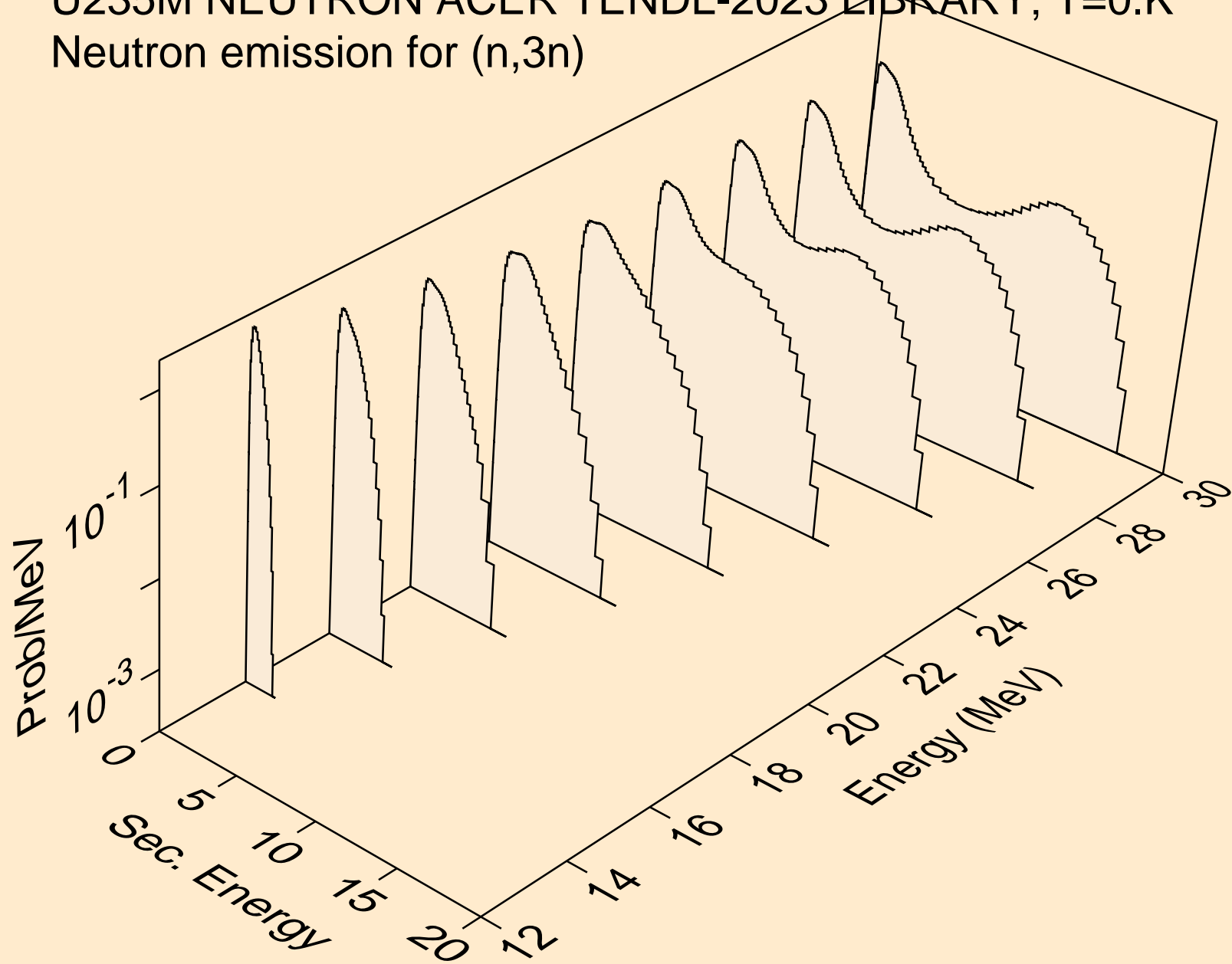

U235M NEUTRON ACER TENDL-2023 LIBRARY; T=0.K
Neutron emission for fission

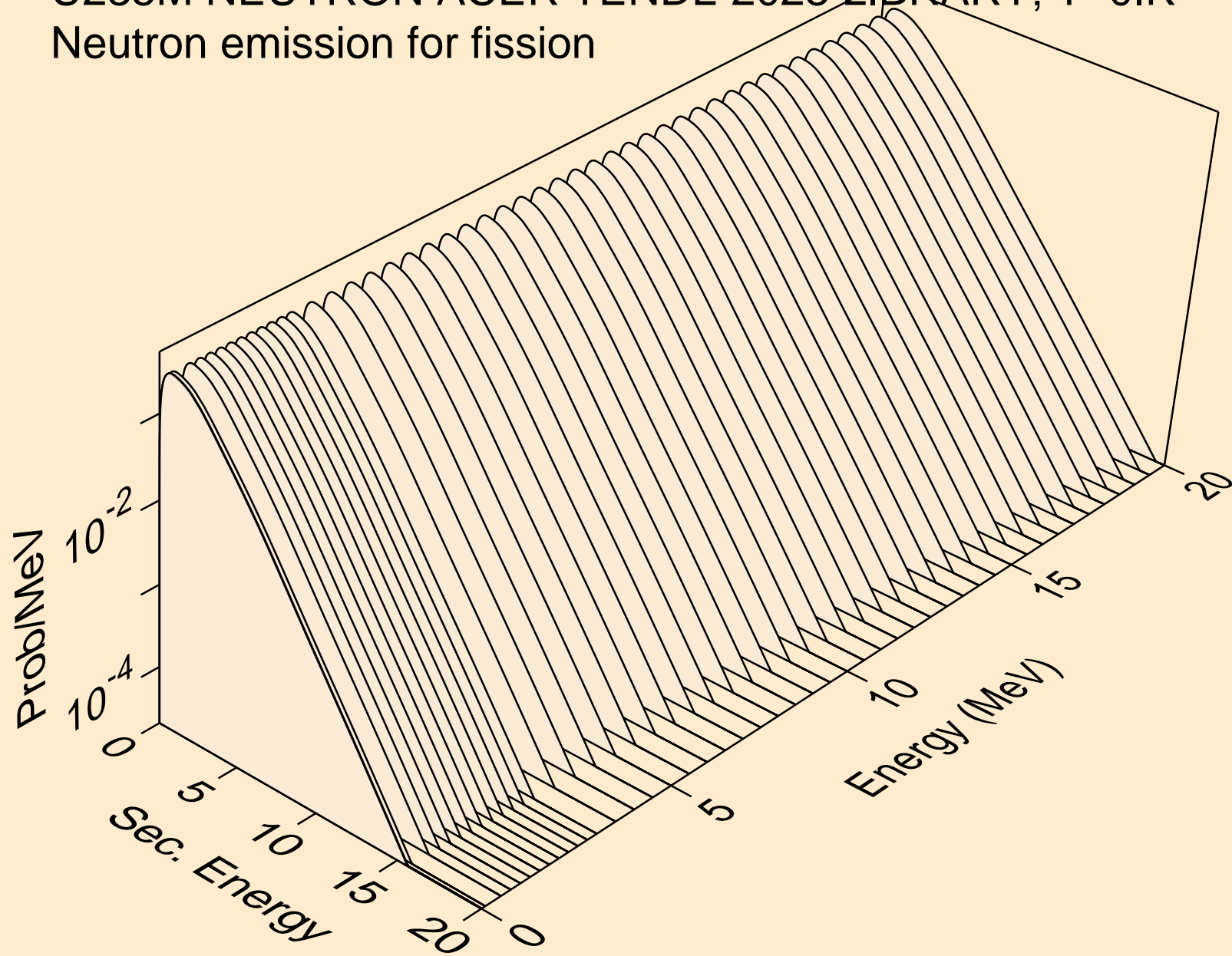

U235M NEUTRON ACER TENDL-2023 LIBRARY; T=0.K
Neutron emission for (n,n*)a

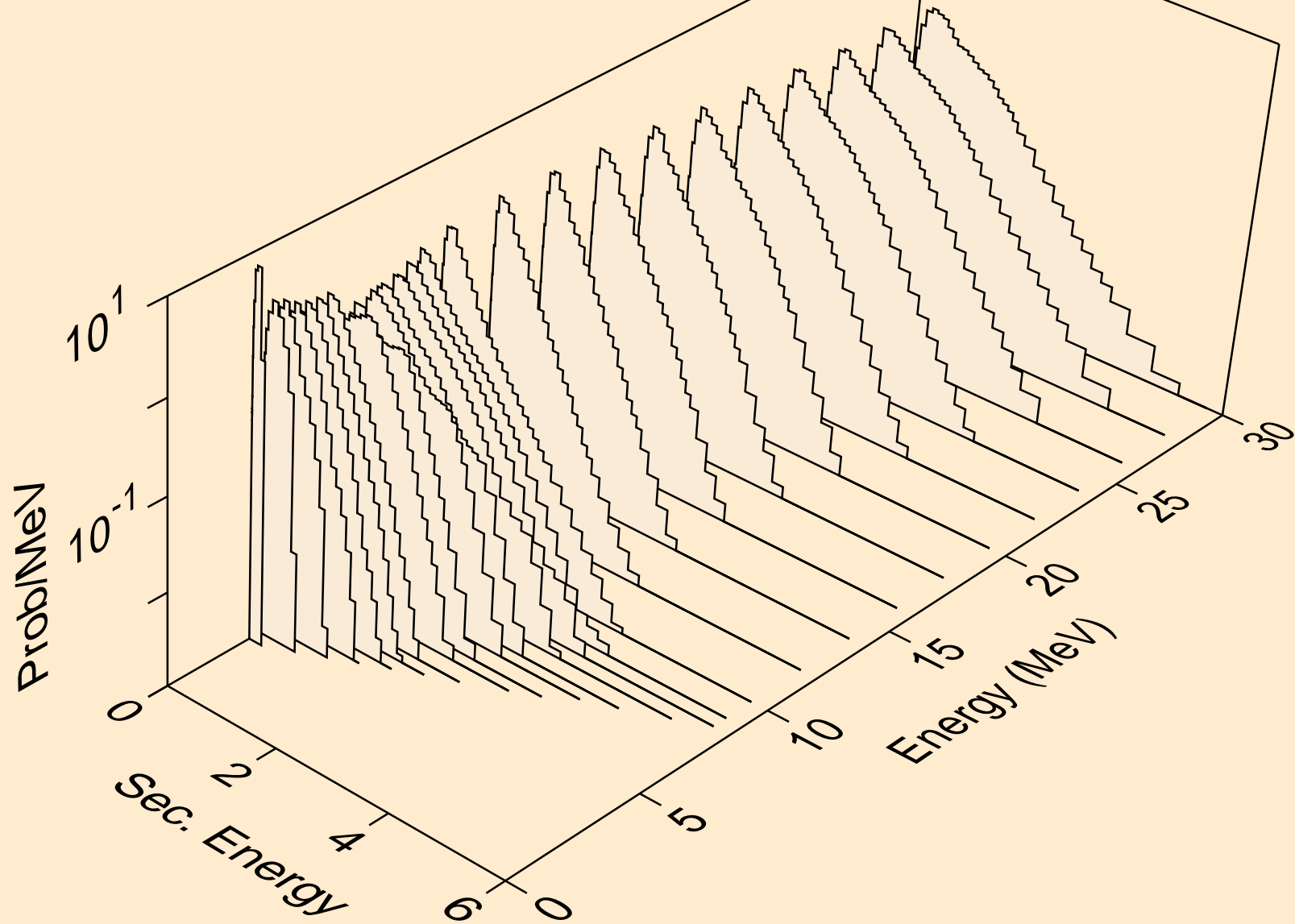

U235M NEUTRON ACER TENDL-2023 LIBRARY; T=0.K
Neutron emission for (n,2n)a

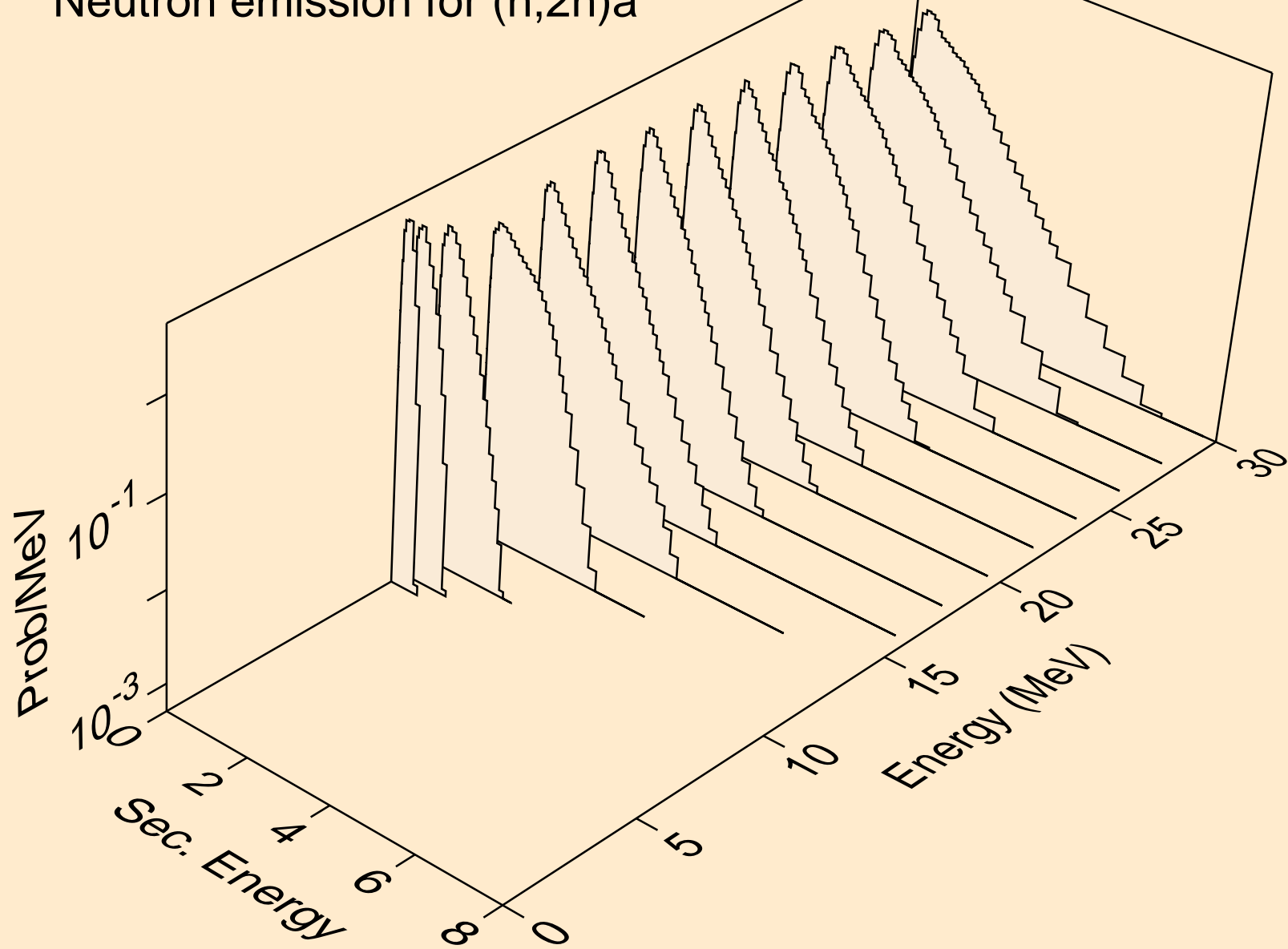

U235M NEUTRON ACER TENDL-2023 LIBRARY; T=0.K
Neutron emission for (n,3n)a

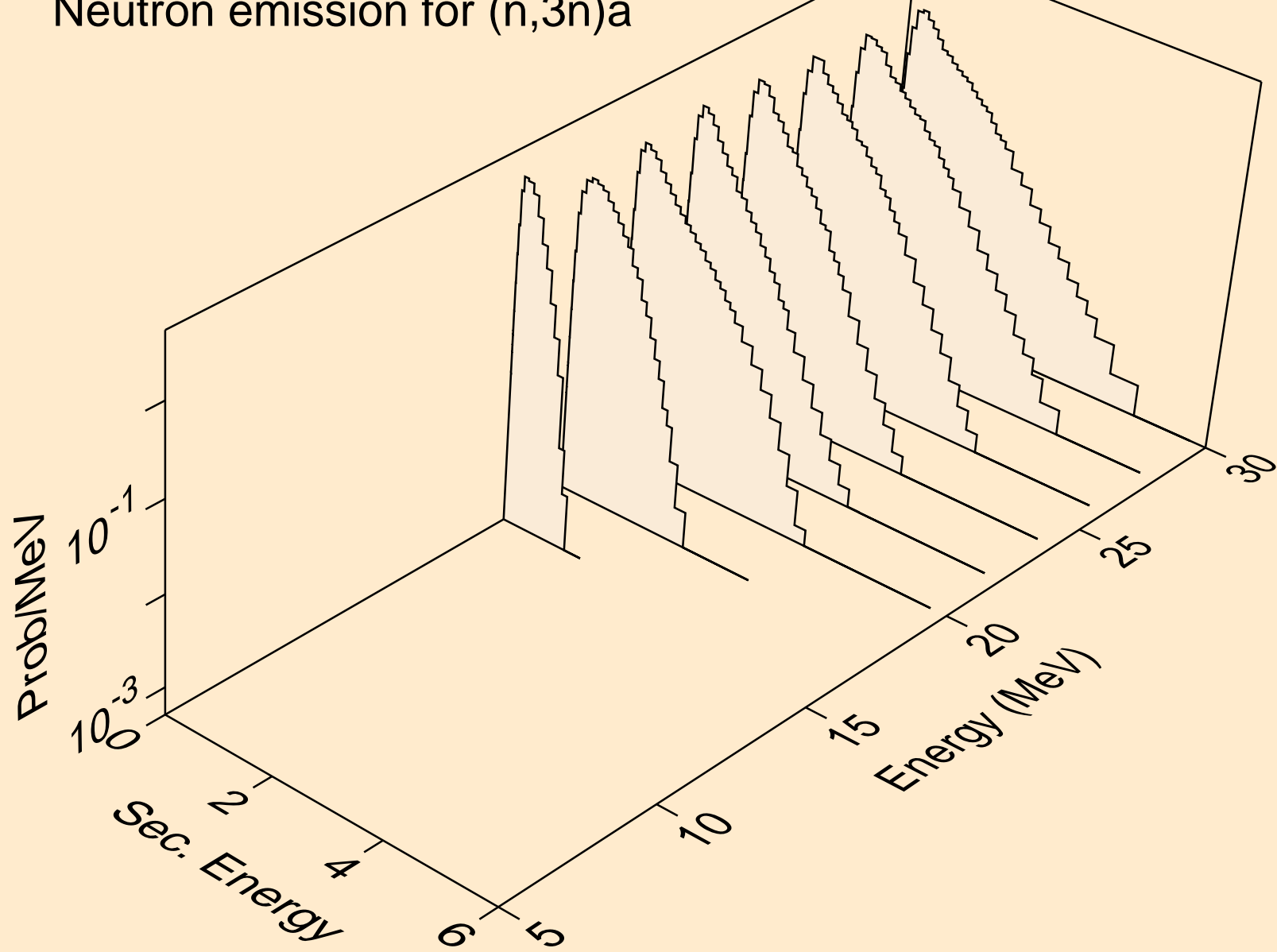

U235M NEUTRON ACER TENDL-2023 LIBRARY; T=0.K
Neutron emission for (n,n*)p

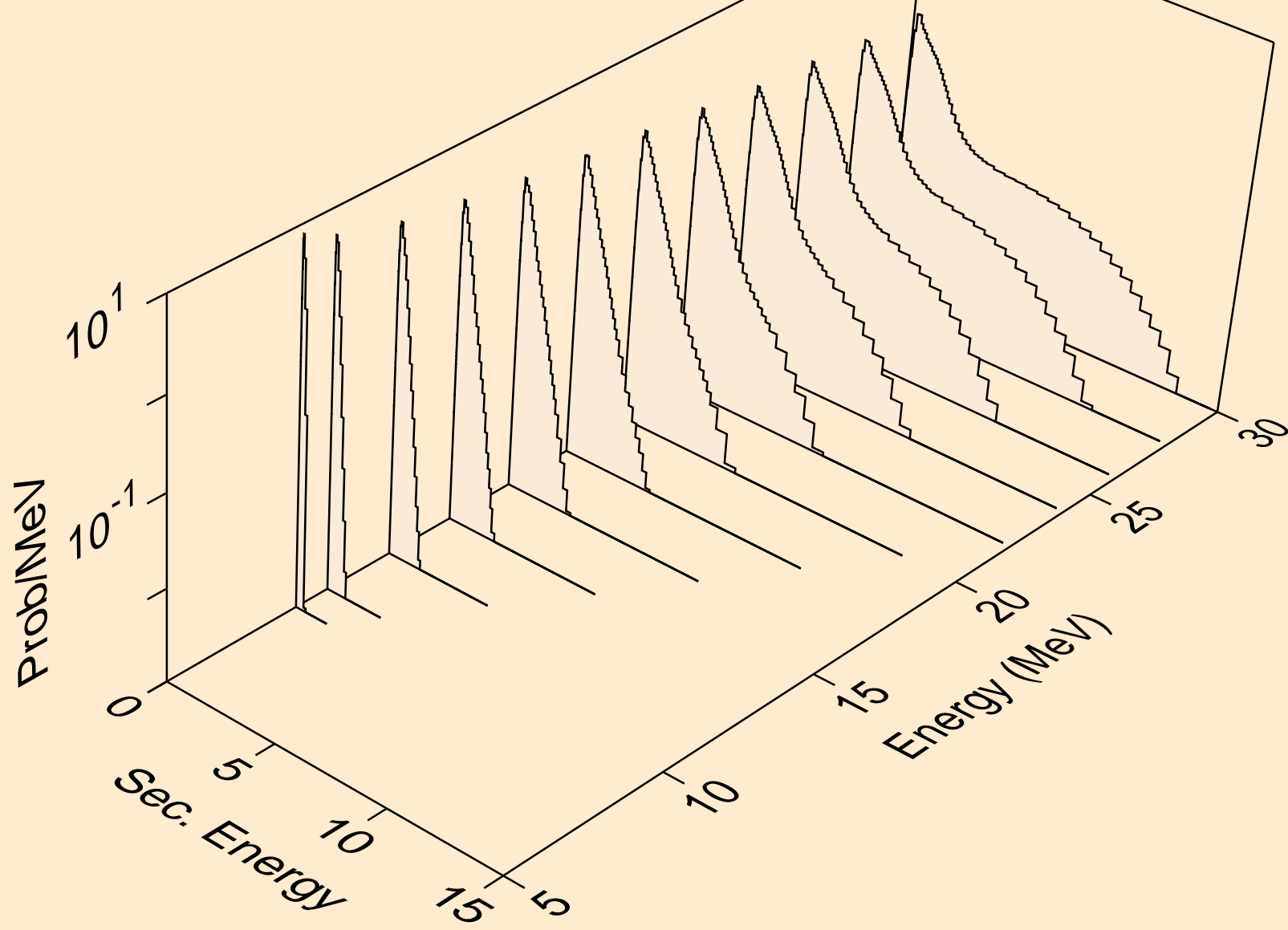

U235M NEUTRON ACER TENDL-2023 LIBRARY; T=0.K
Neutron emission for (n,n*)d

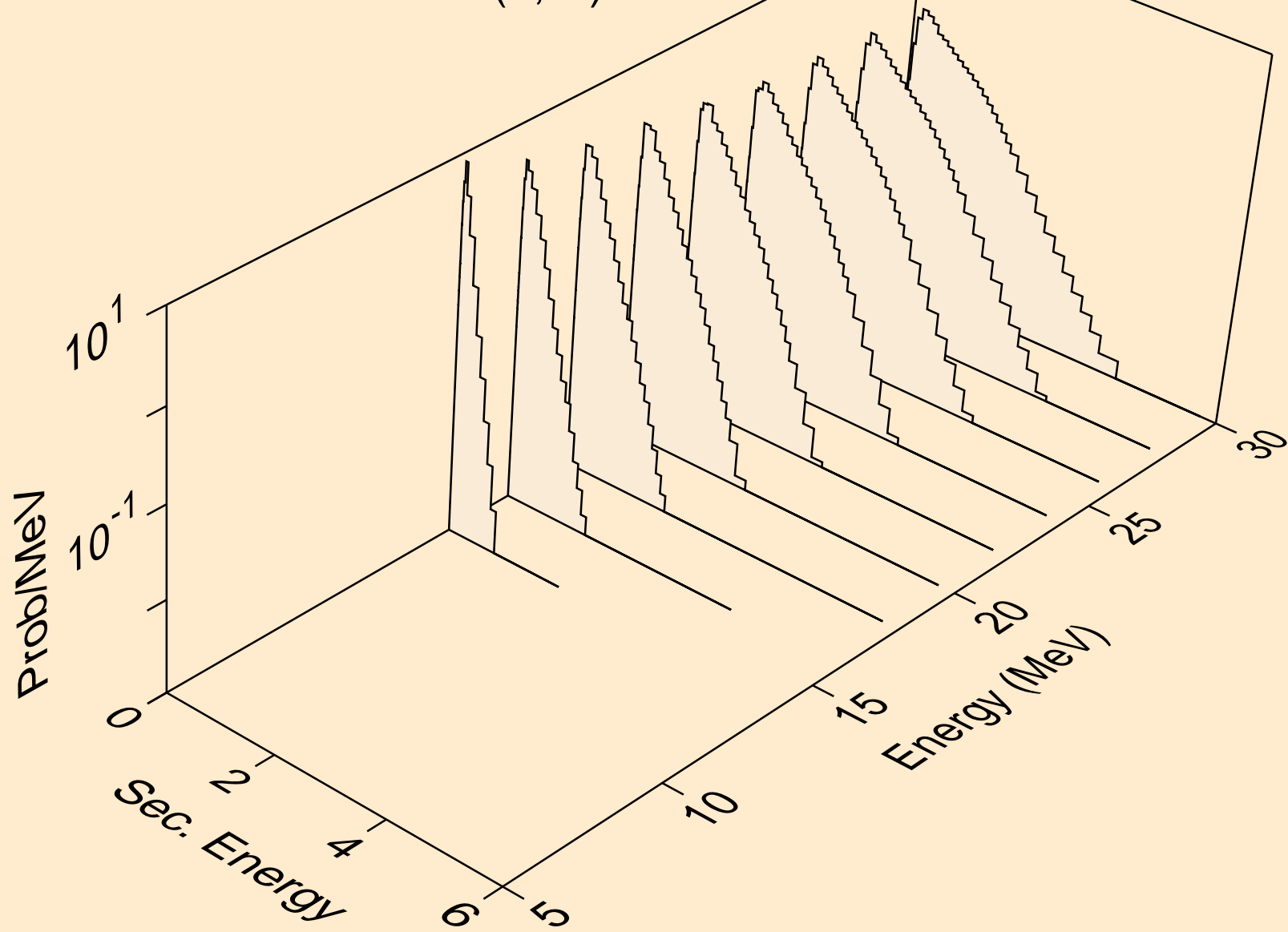

U235M NEUTRON ACER TENDL-2023 LIBRARY; T=0.K
Neutron emission for (n,n*)t

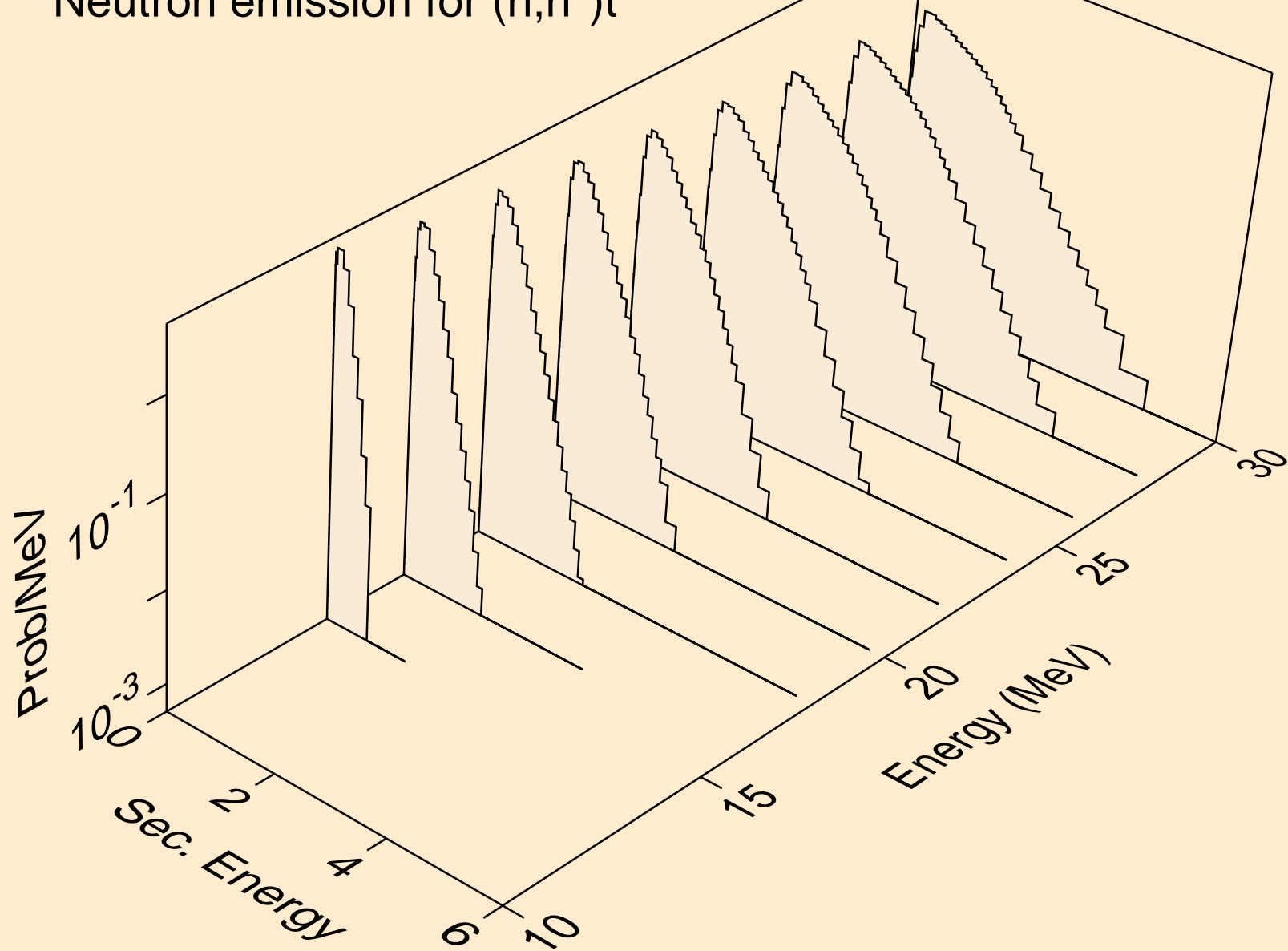

U235M NEUTRON ACER TENDL-2023 LIBRARY; T=0.K
Neutron emission for (n,n*)he3

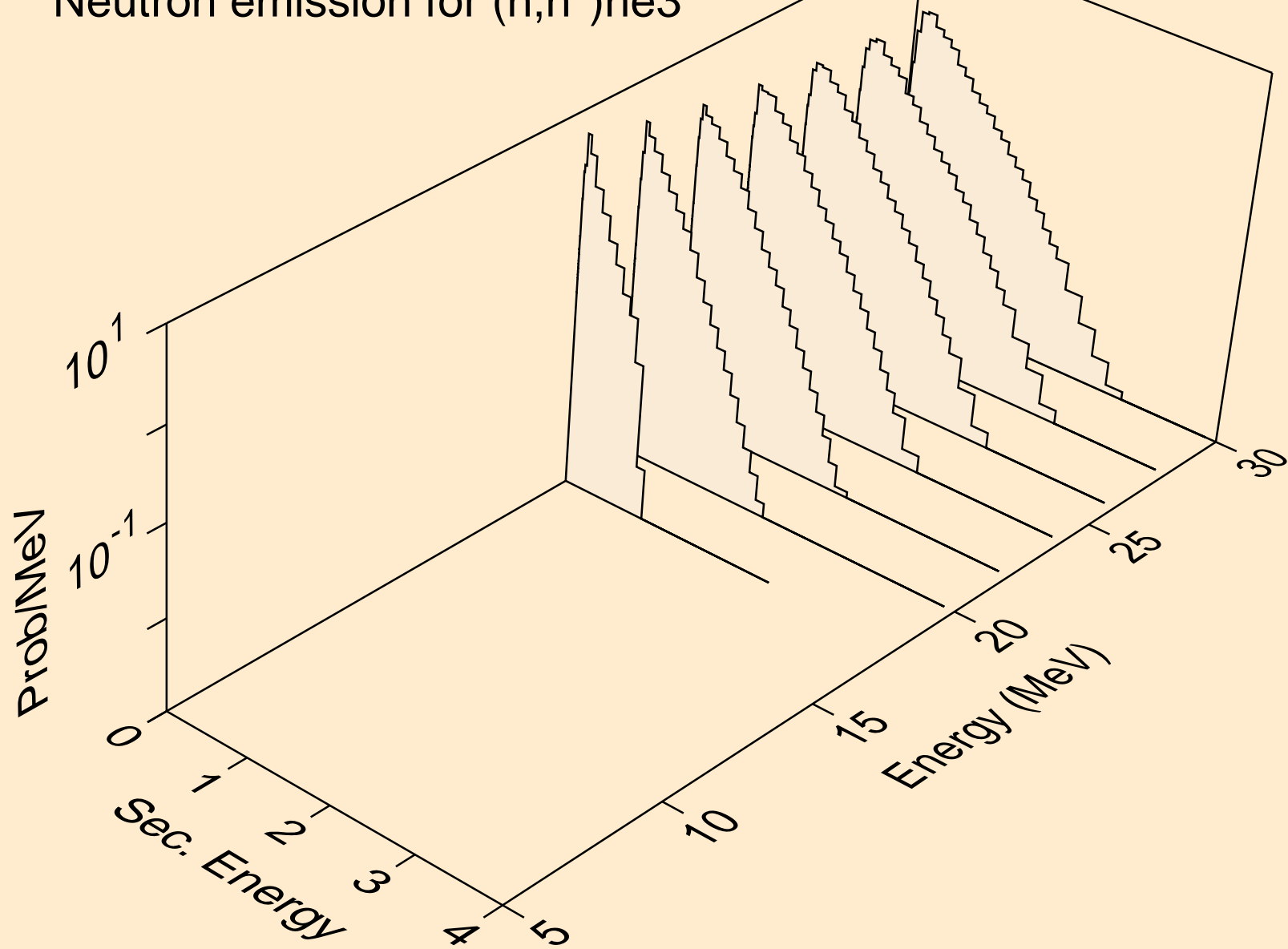

U235M NEUTRON ACER TENDL-2023 LIBRARY; T=0.K
Neutron emission for (n,4n)

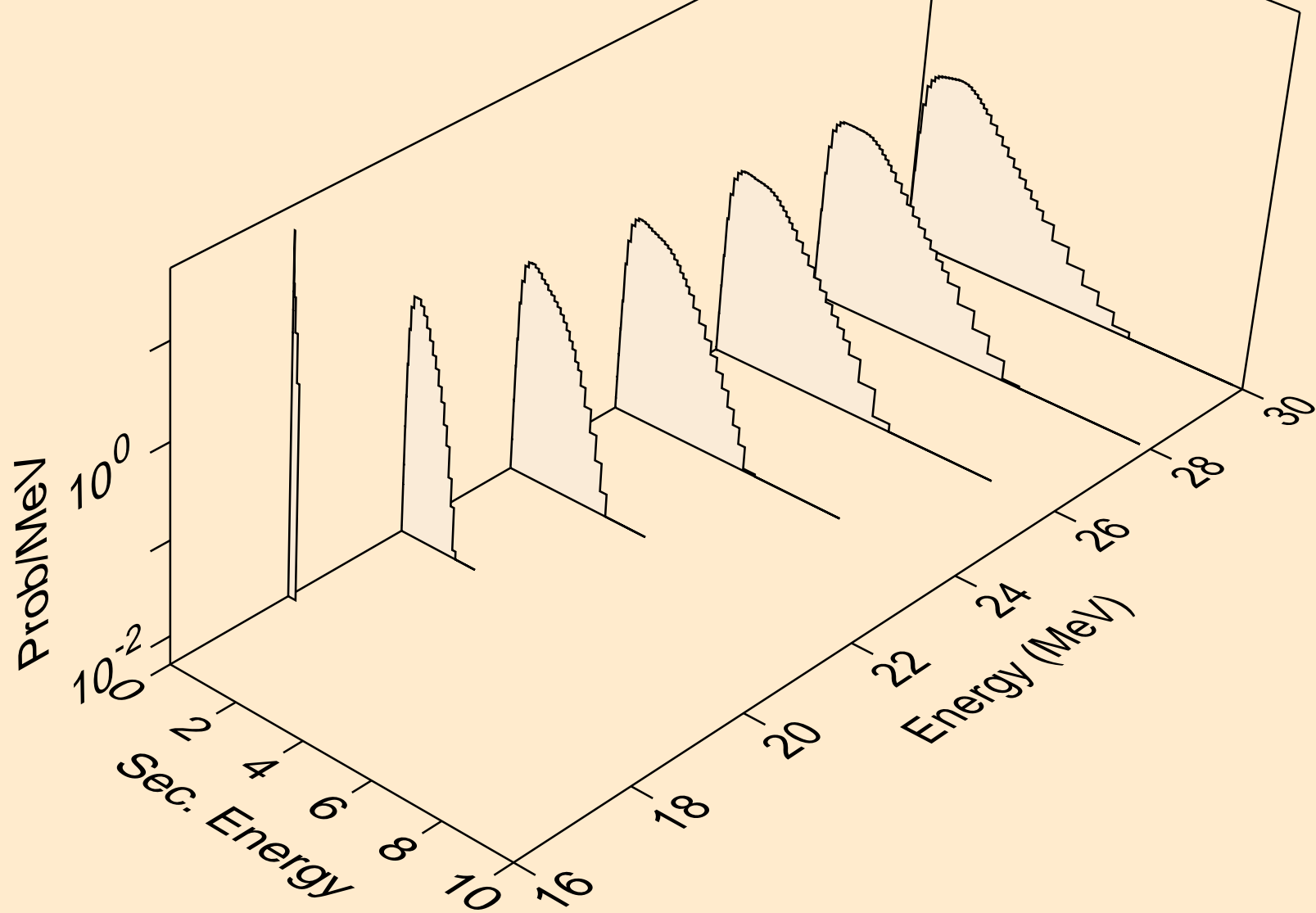

U235M NEUTRON ACER TENDL-2023 LIBRARY; T=0.K
Neutron emission for (n,2np)

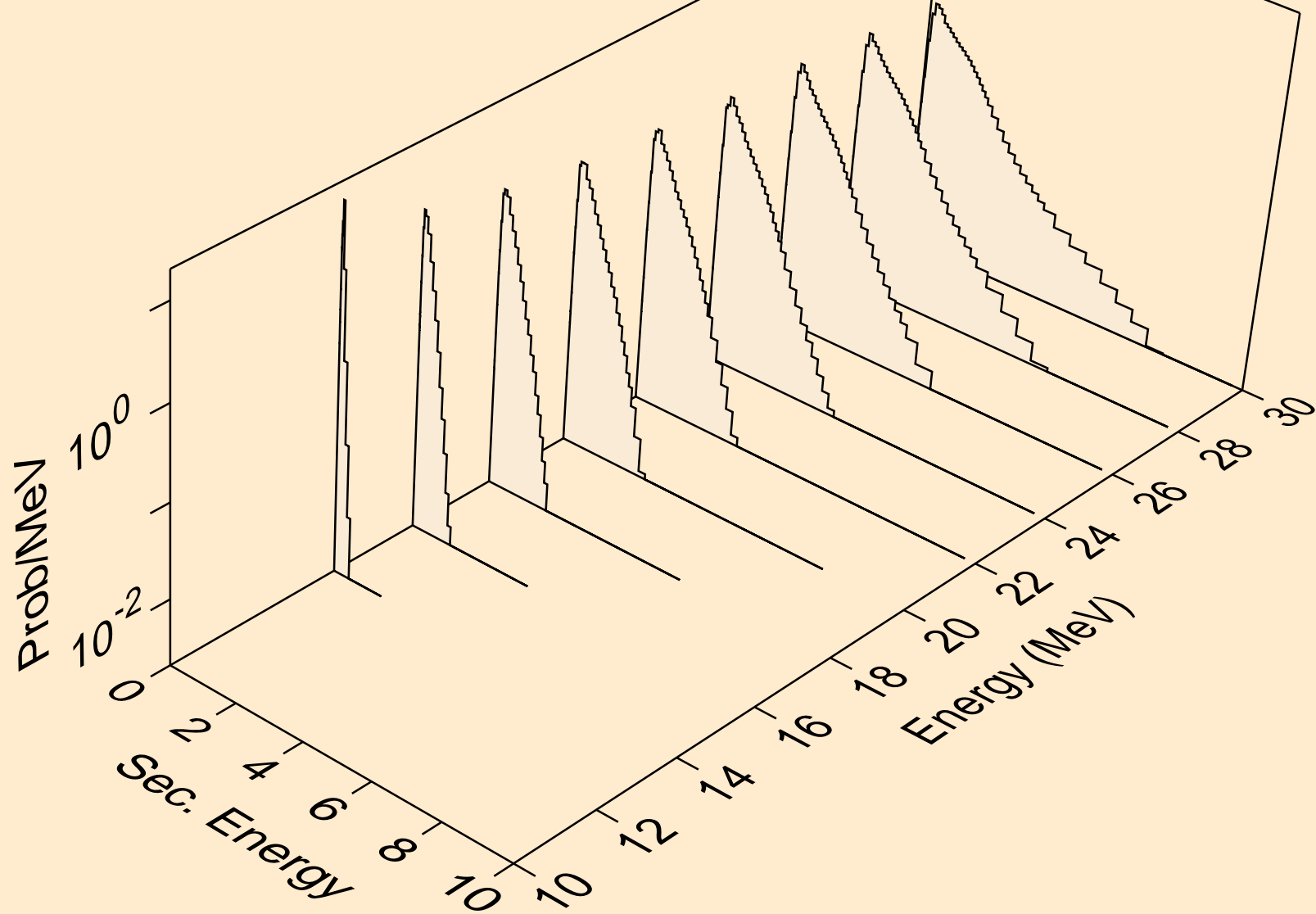

U235M NEUTRON ACER TENDL-2023 LIBRARY; T=0.K
Neutron emission for (n,3np)

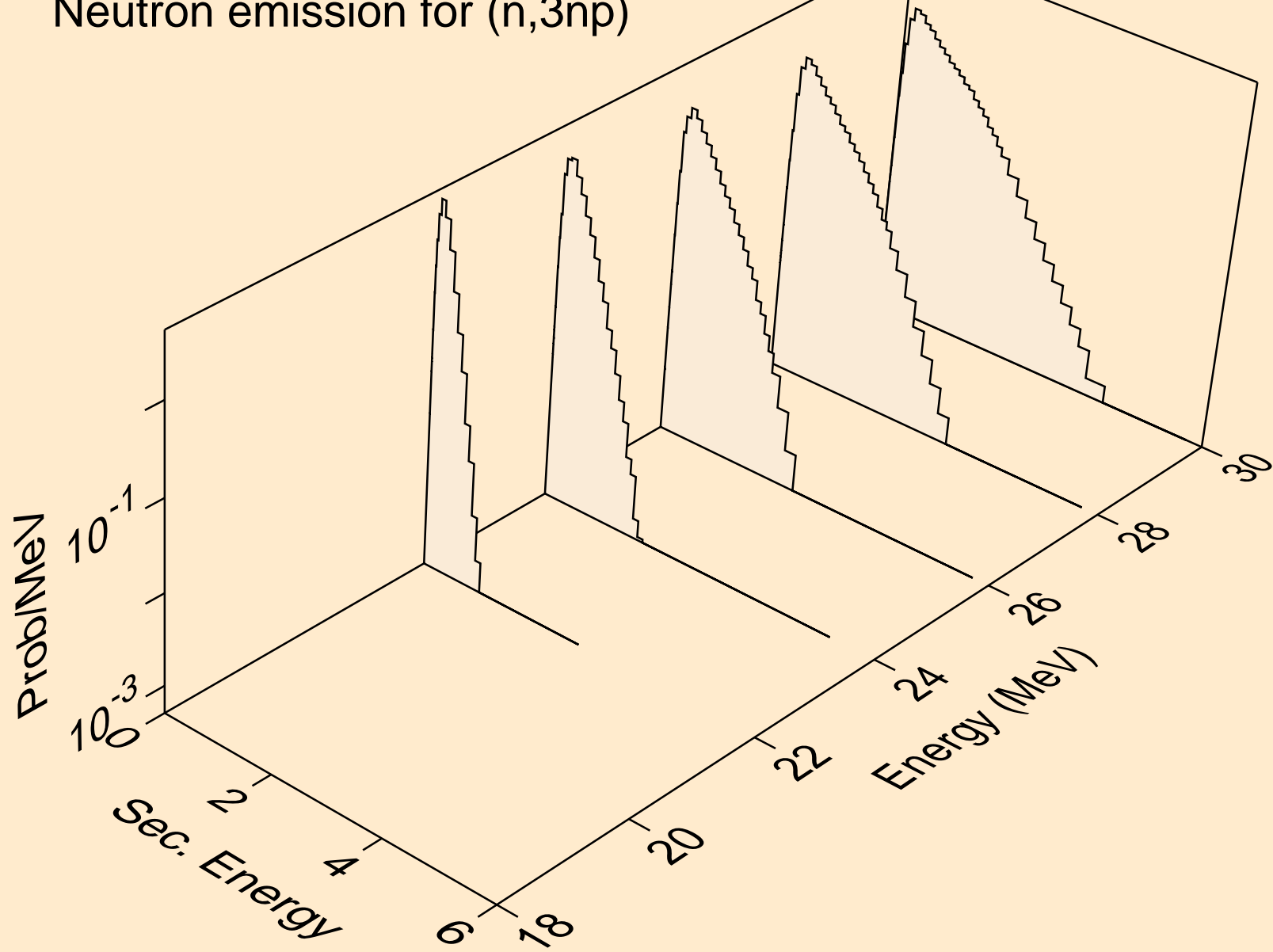

U235M NEUTRON ACER TENDL-2023 LIBRARY; T=0.K
Neutron emission for (n,n2p)

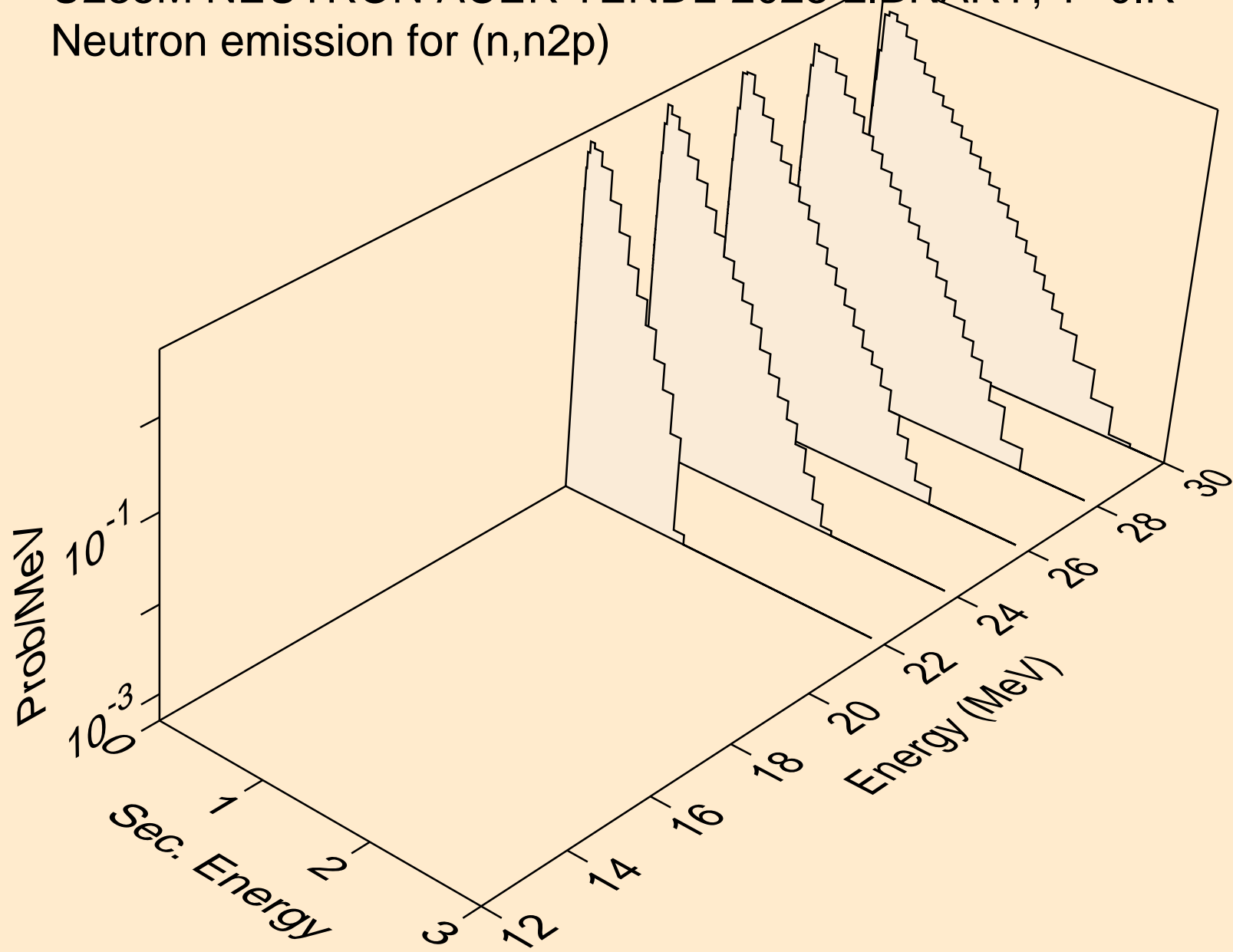

U235M NEUTRON ACER TENDL-2023 LIBRARY; T=0.K
Neutron emission for (n,n*c)

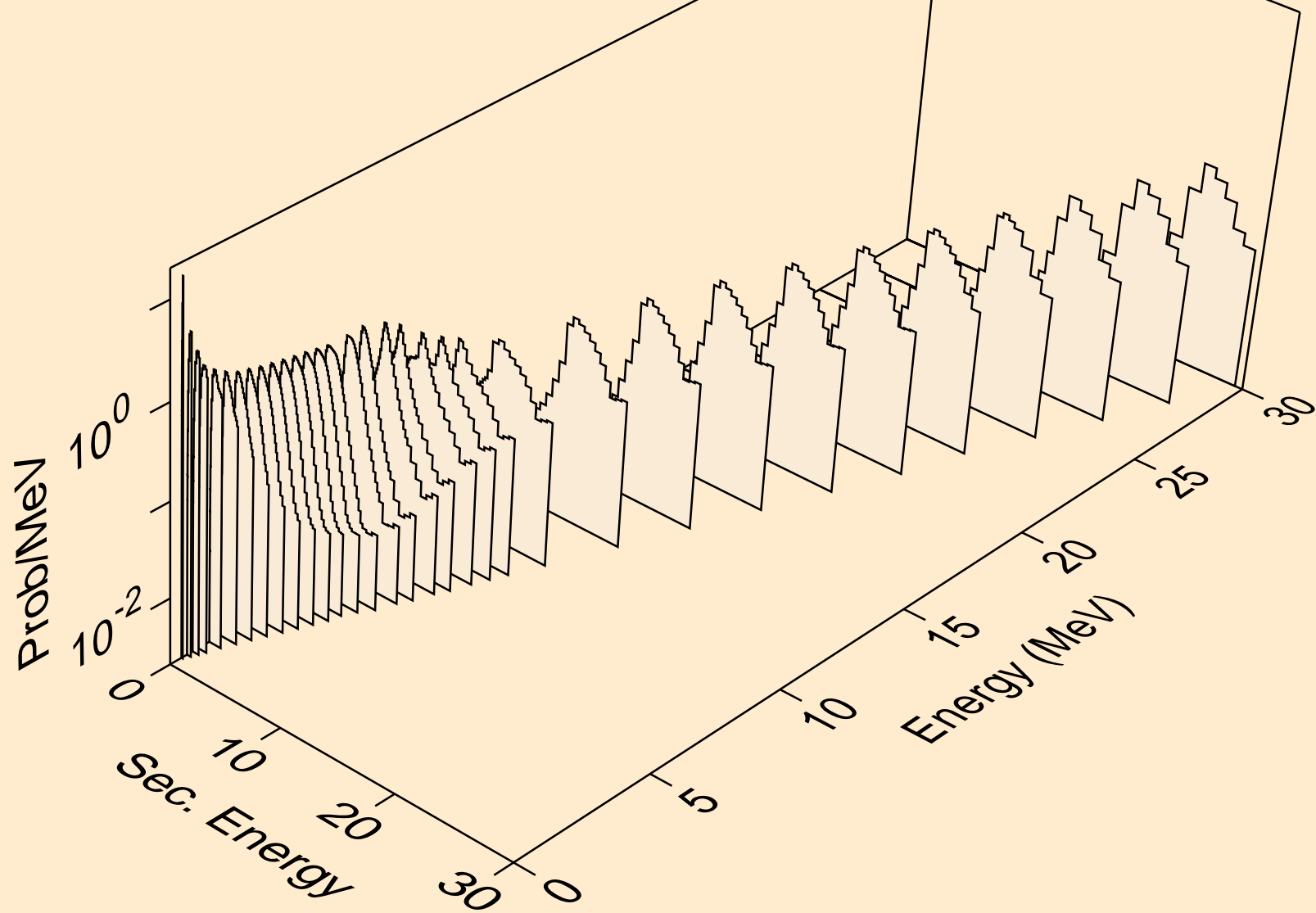

U235M NEUTRON ACER TENDL-2023 LIBRARY; T=0.K

Delayed nubar

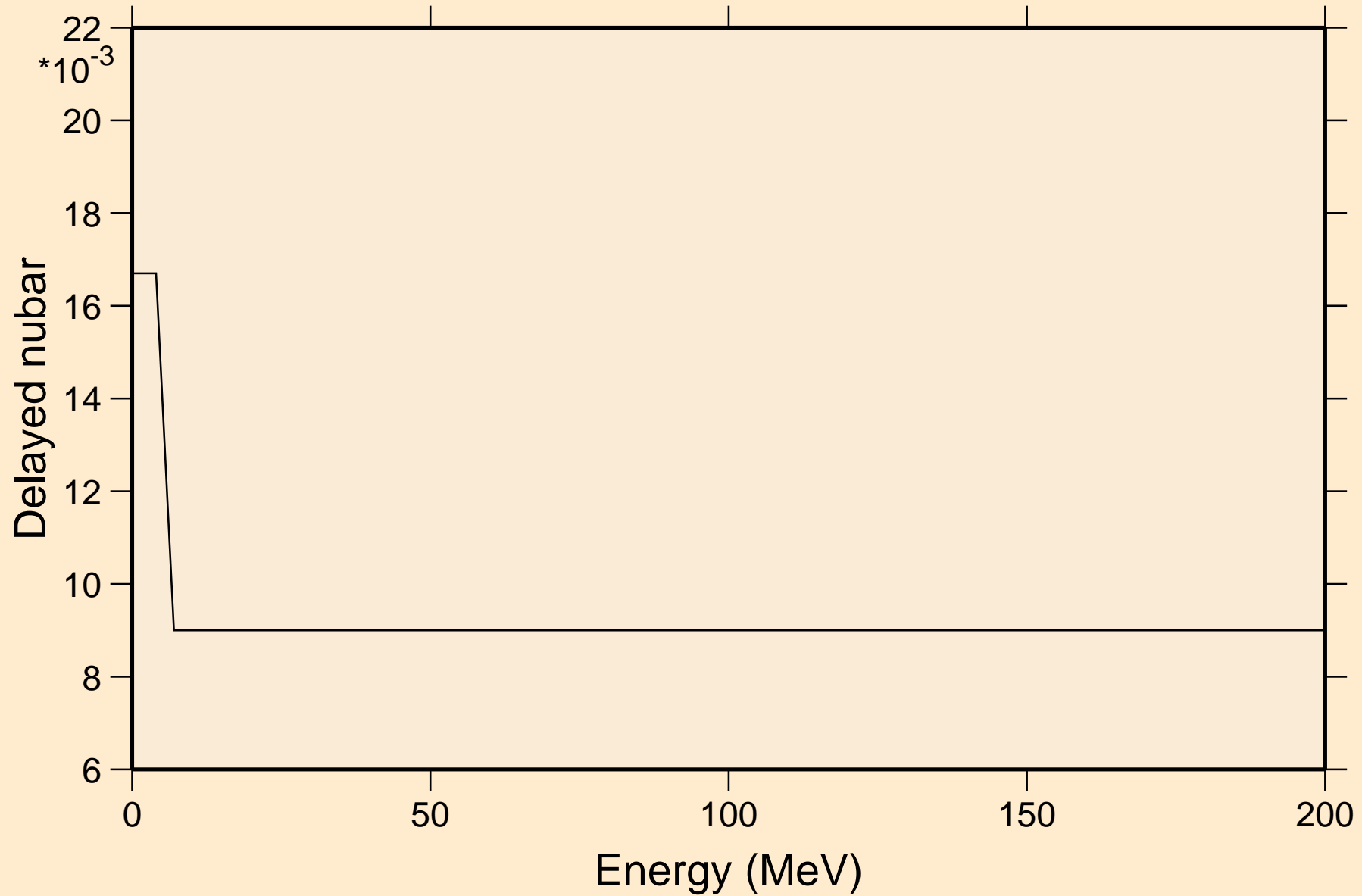

U235M NEUTRON ACER TENDL-2023 LIBRARY; T=0.K

Delayed neutron spectra

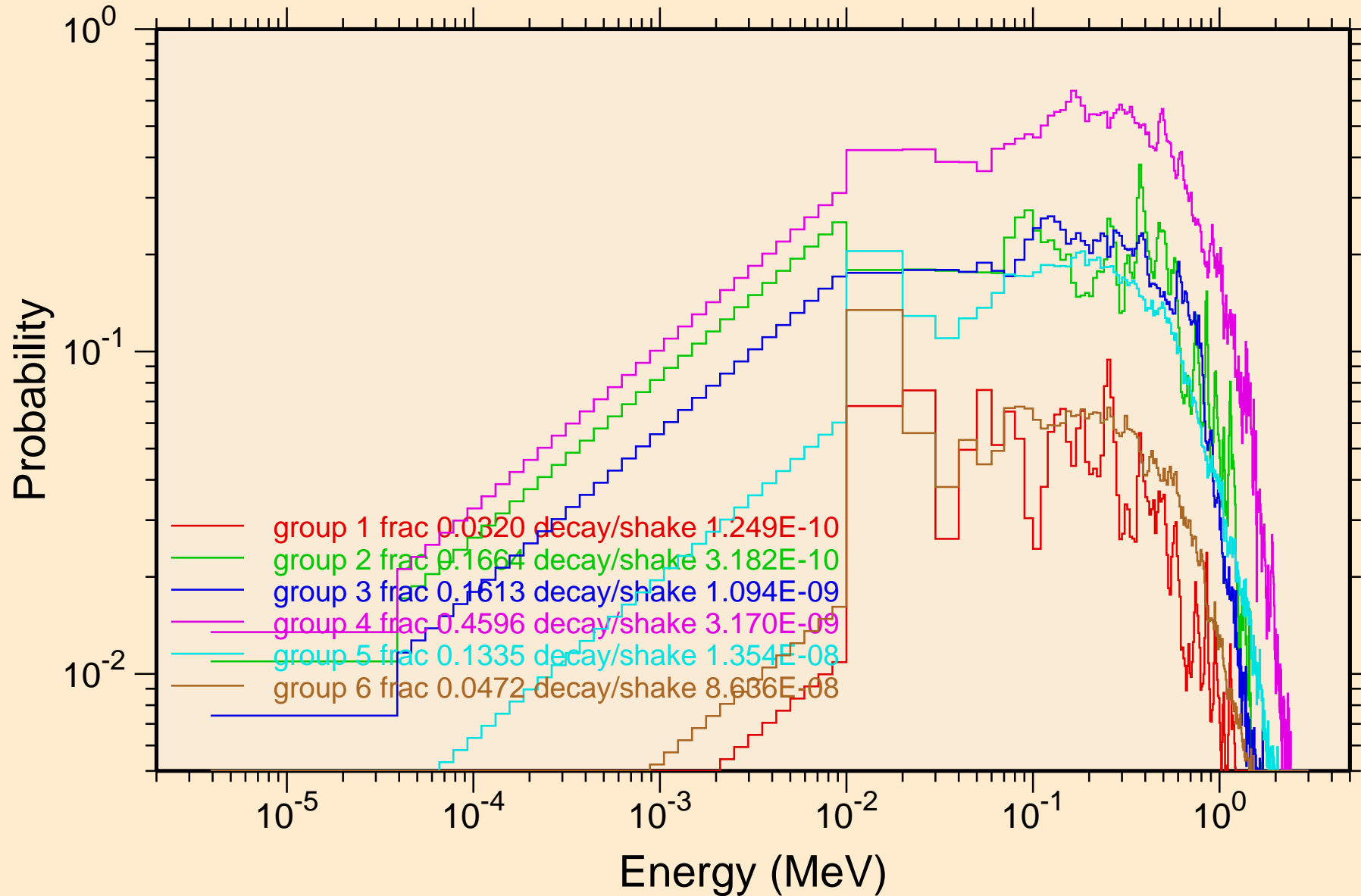

U235M NEUTRON ACER TENDL-2023 LIBRARY; T=0.K
Photon emission for (n,x)

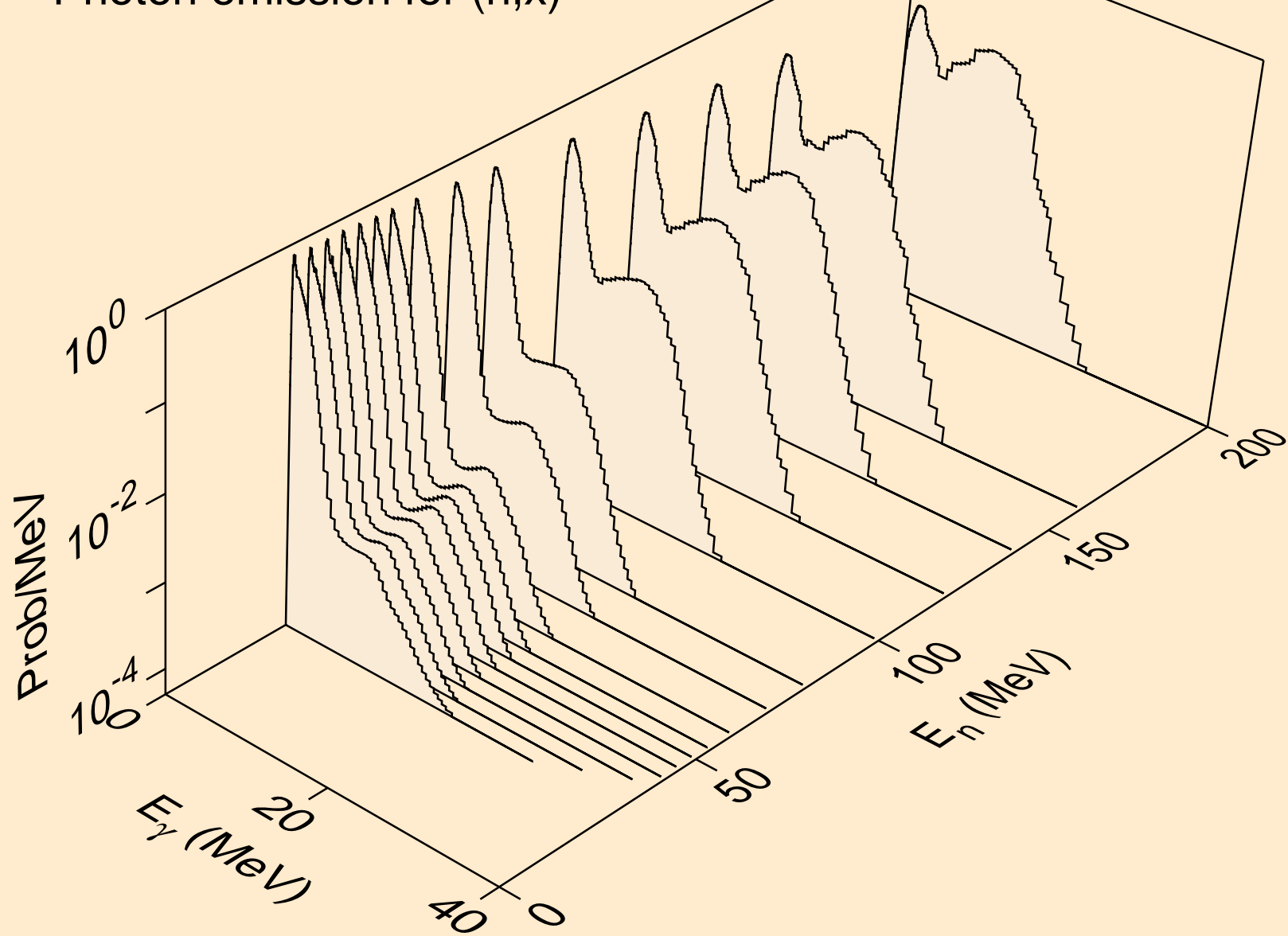

U235M NEUTRON ACER TENDL-2023 LIBRARY; T=0.K
Photon emission for (n,2nd)

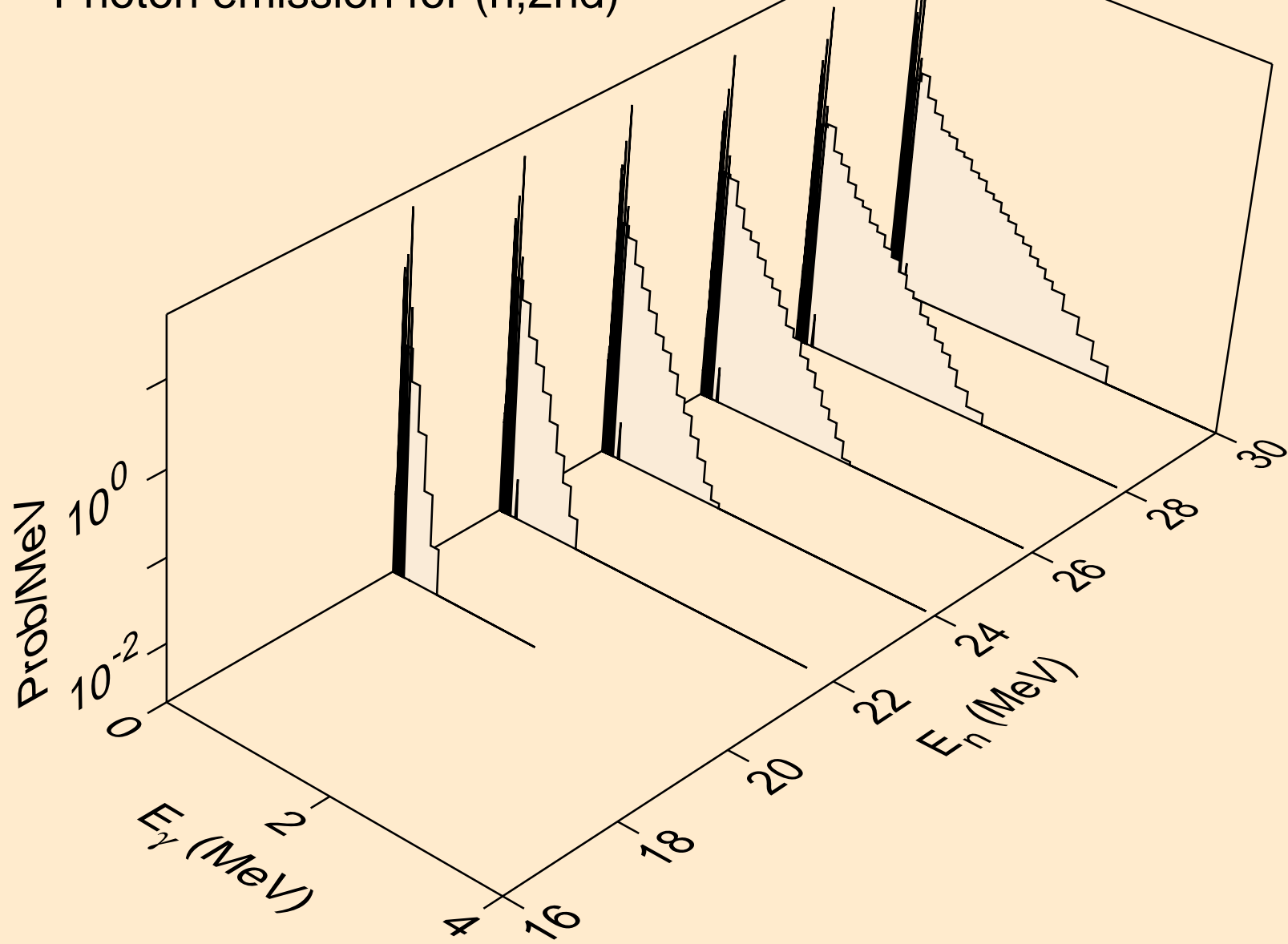

U235M NEUTRON ACER TENDL-2023 LIBRARY; T=0.K
Photon emission for (n,2n)

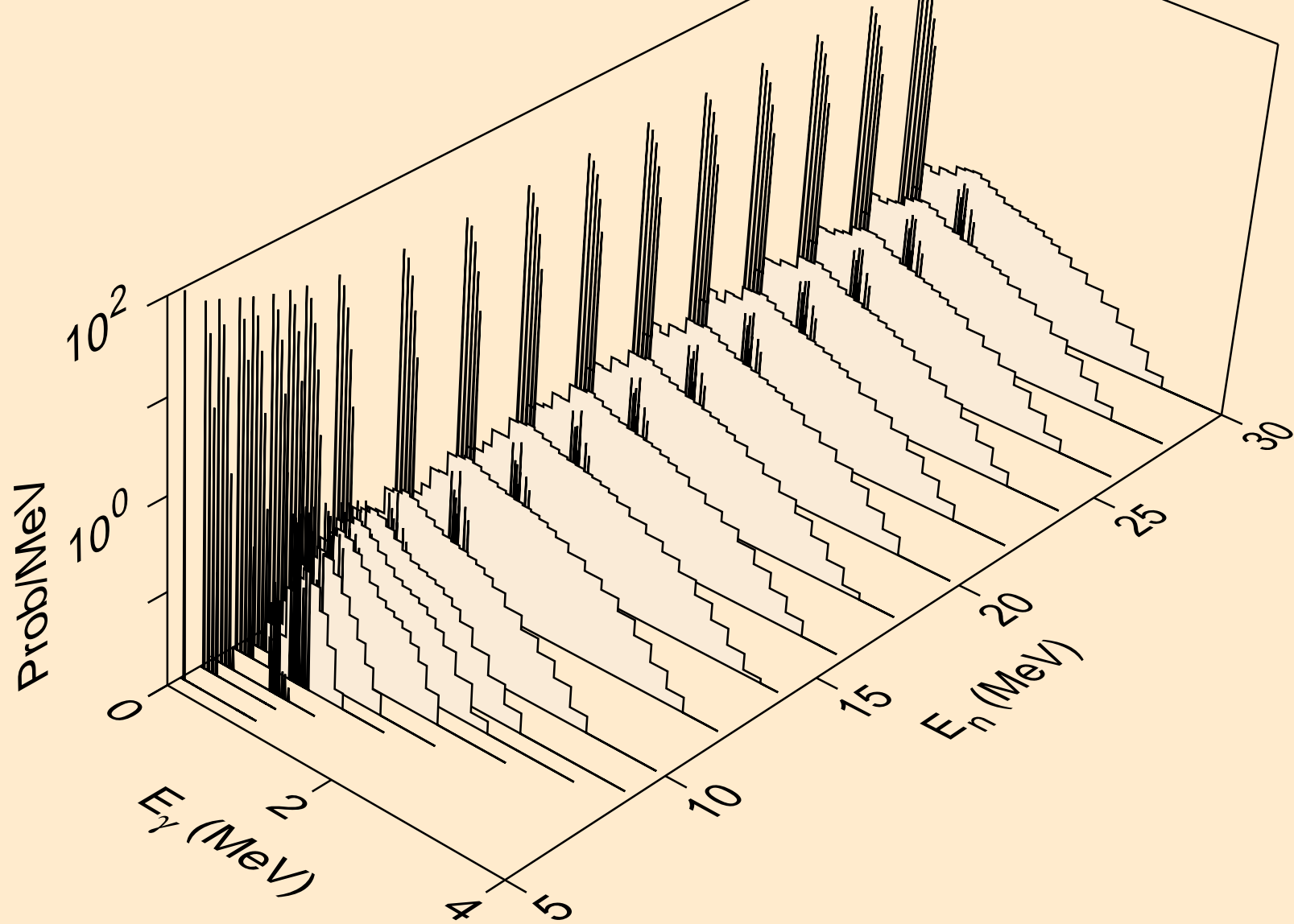

U235M NEUTRON ACER TENDL-2023 LIBRARY; T=0.K
Photon emission for (n,3n)

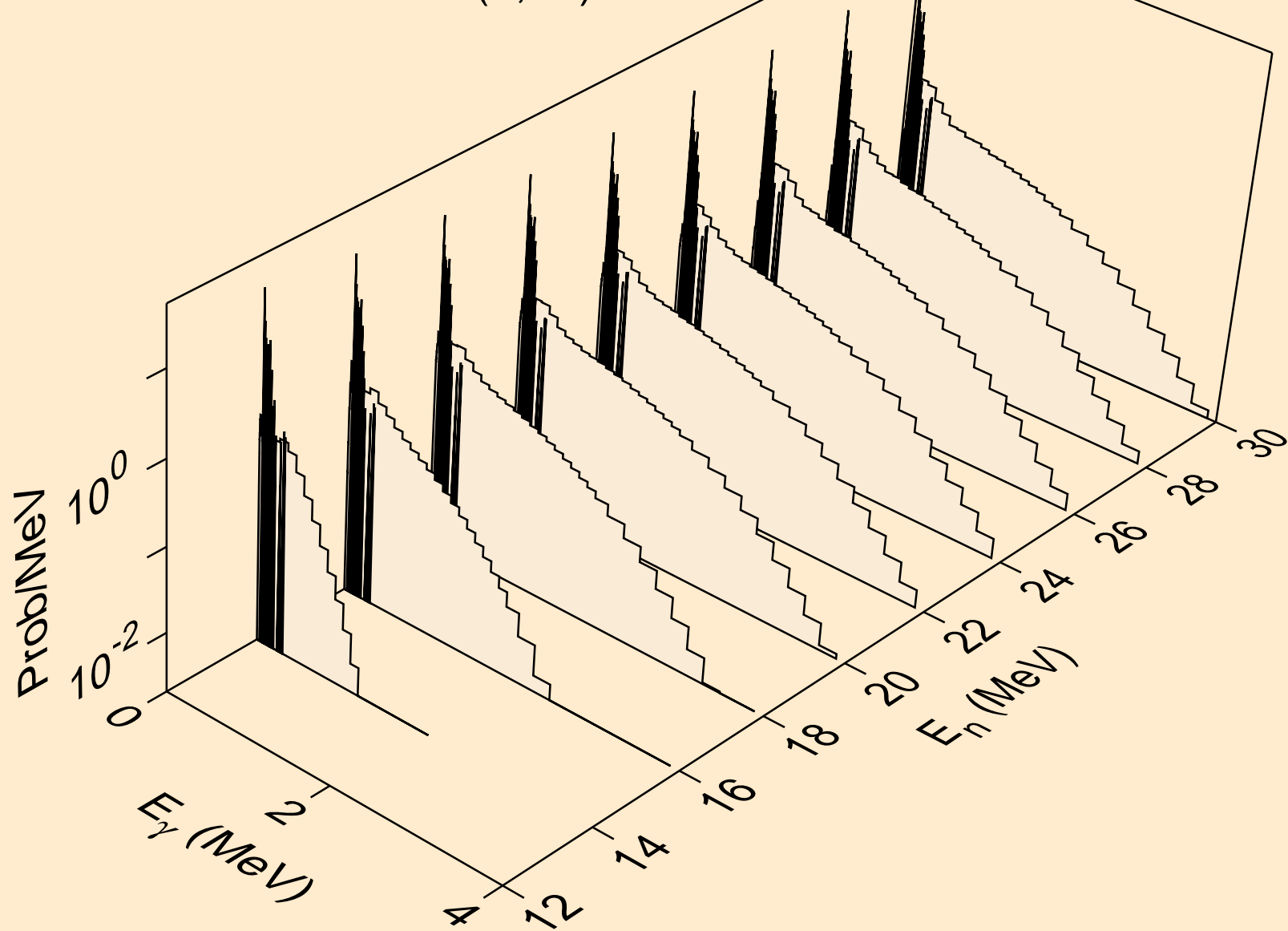

U235M NEUTRON ACER TENDL-2023 LIBRARY; T=0.K
Photon emission for (n,n*)a

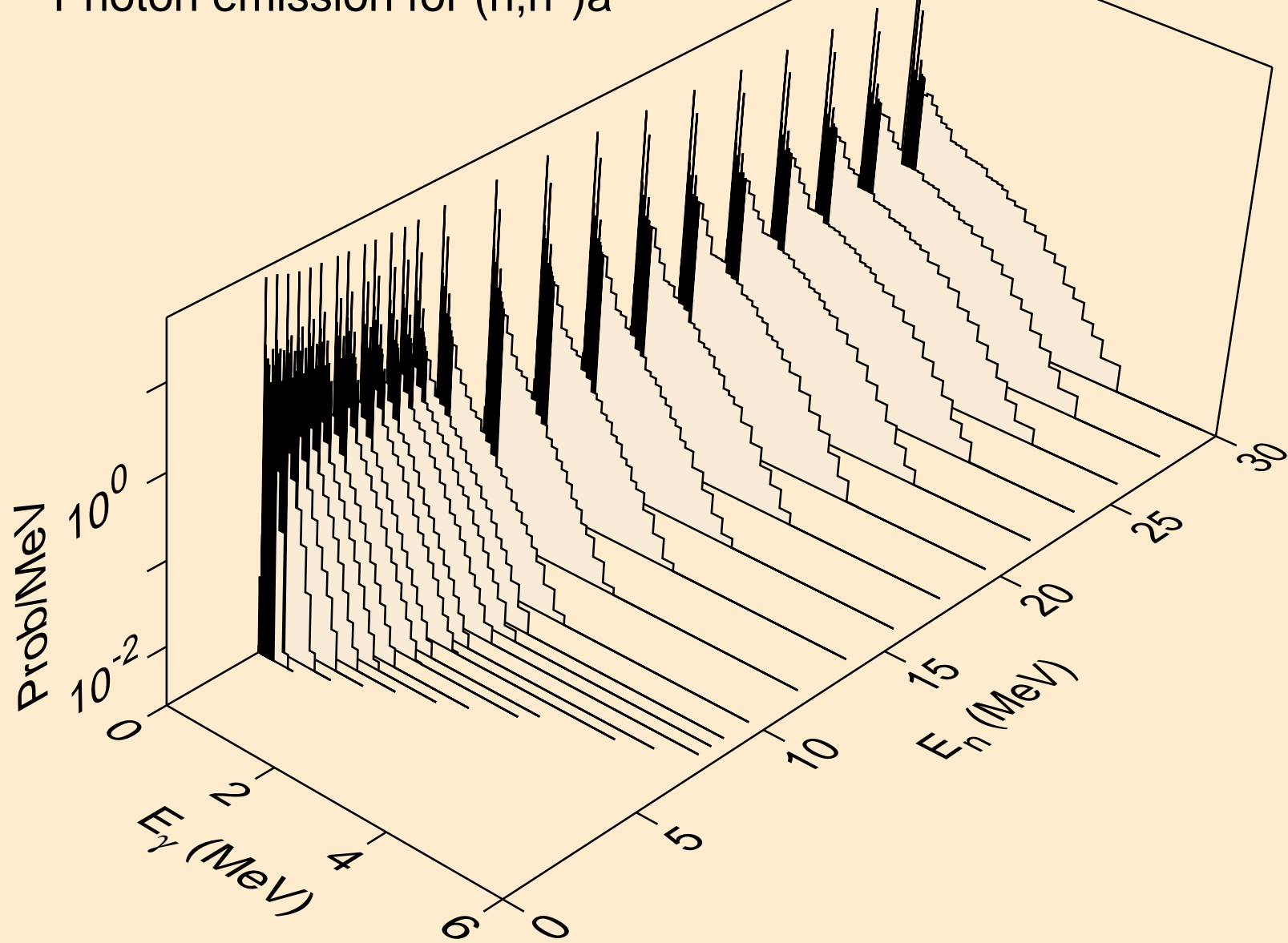

U235M NEUTRON ACER TENDL-2023 LIBRARY; T=0.K
Photon emission for (n,2n)a

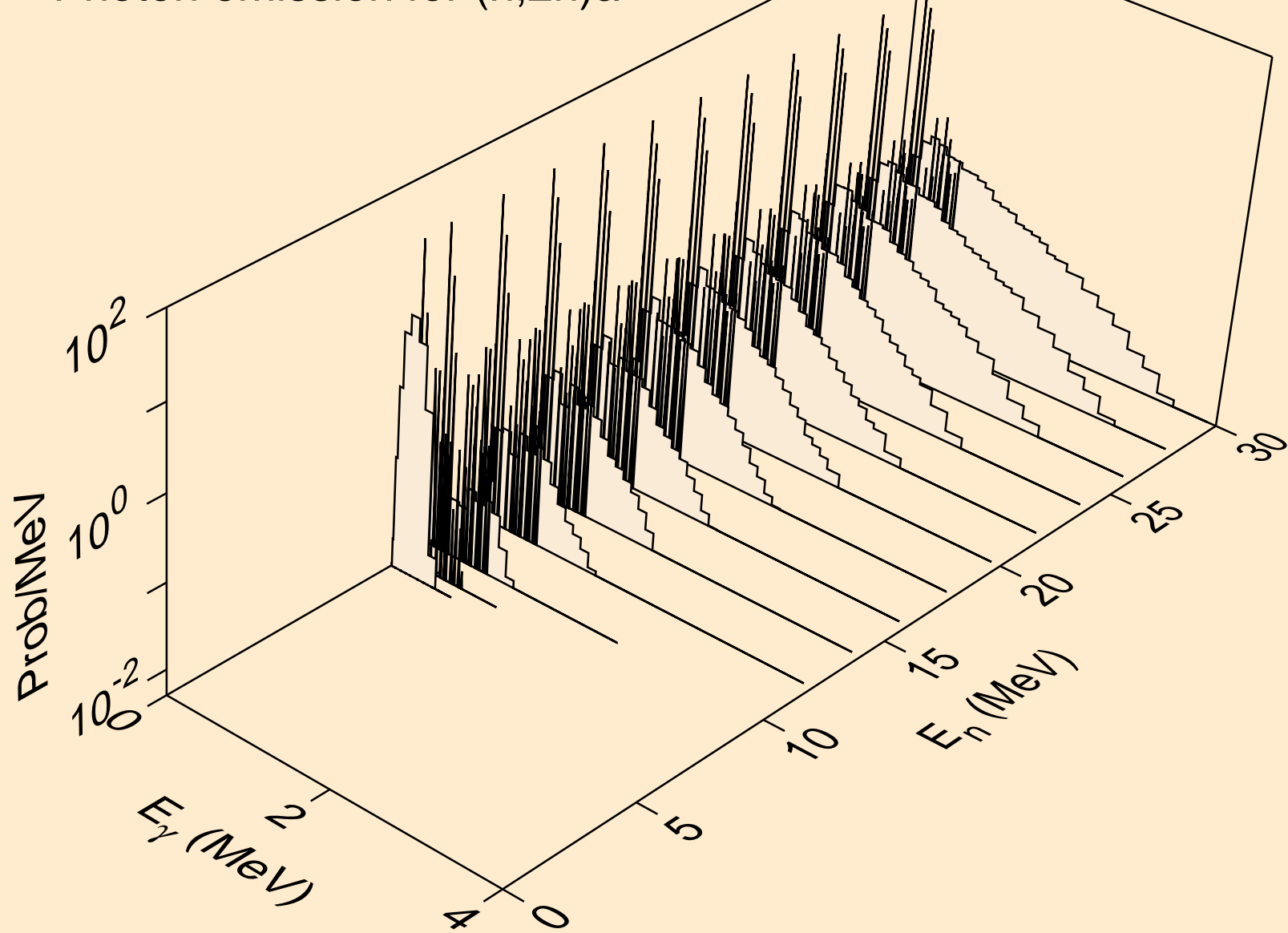

U235M NEUTRON ACER TENDL-2023 LIBRARY; T=0.K
Photon emission for (n,3n)a

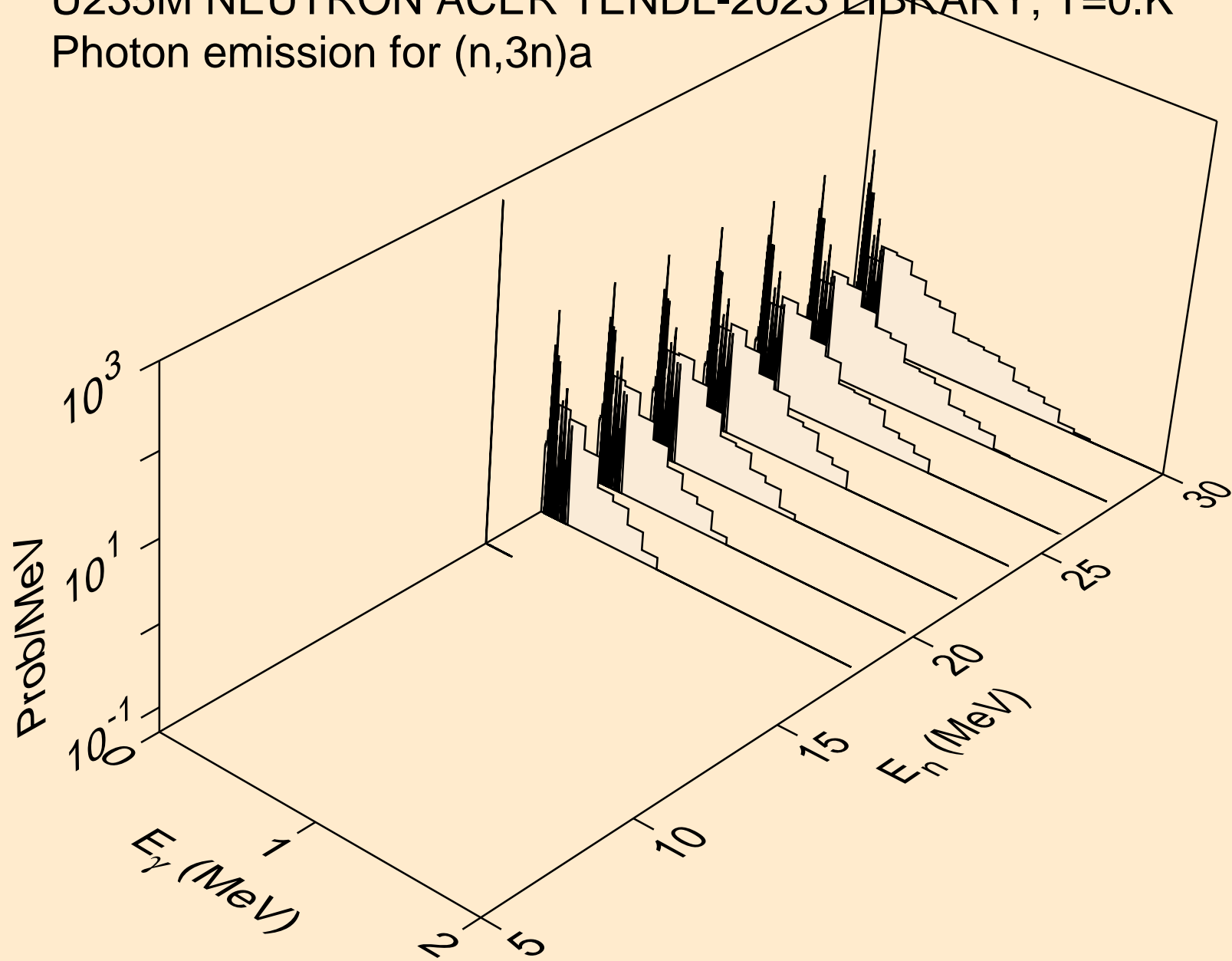

U235M NEUTRON ACER TENDL-2023 LIBRARY; T=0.K
Photon emission for (n,n*)p

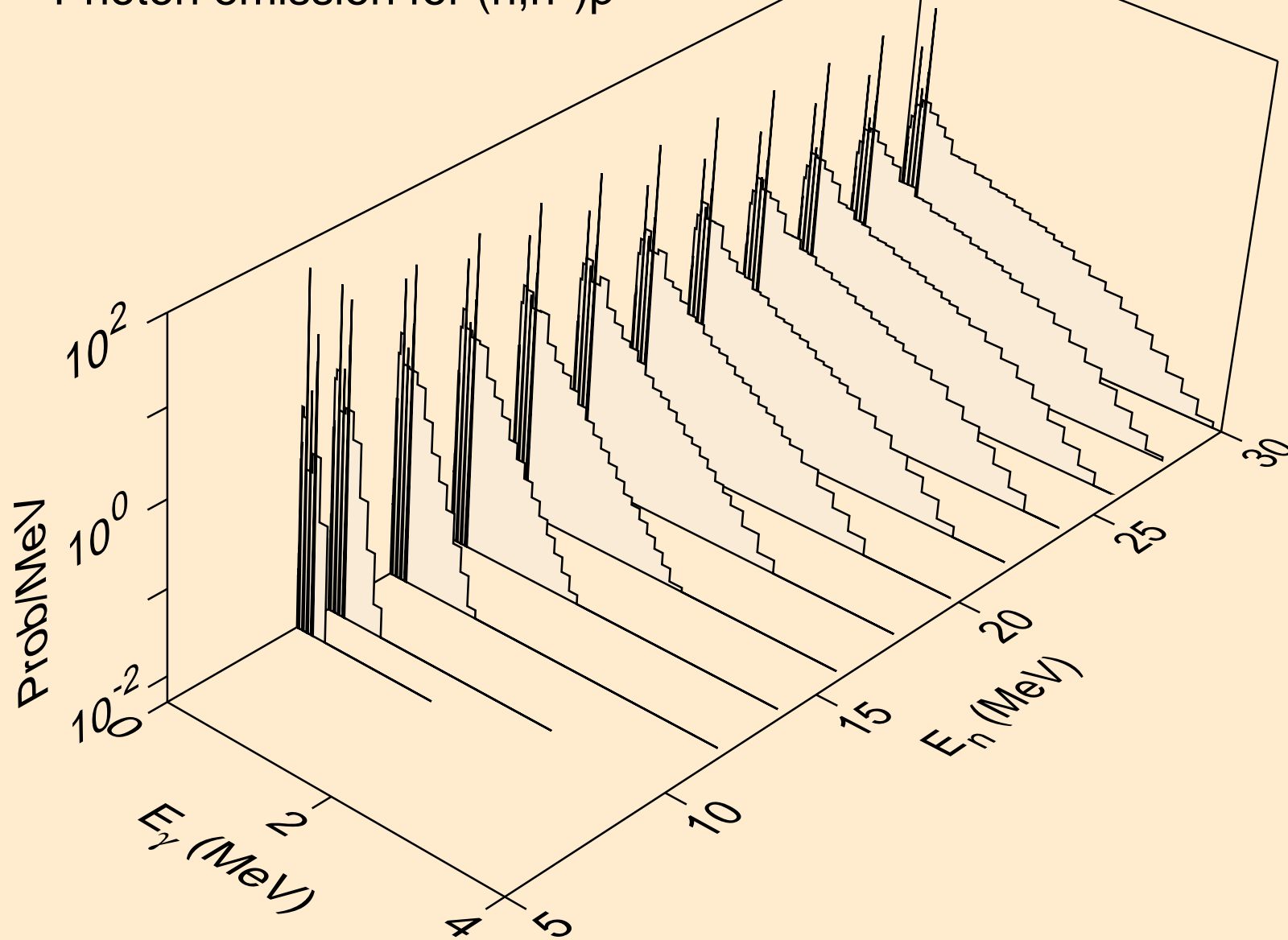

U235M NEUTRON ACER TENDL-2023 LIBRARY; T=0.K
Photon emission for (n,n*)d

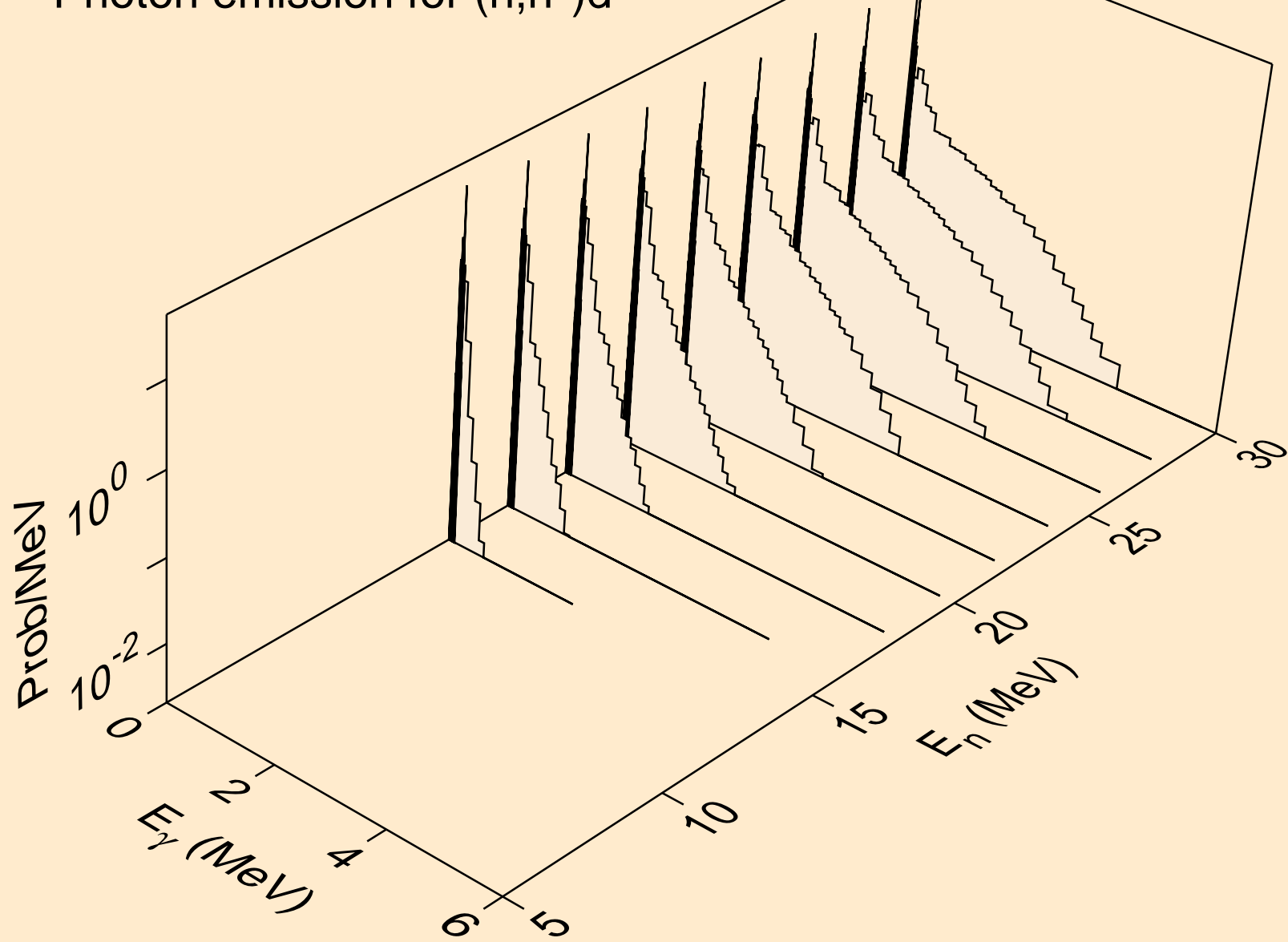

U235M NEUTRON ACER TENDL-2023 LIBRARY; T=0.K
Photon emission for (n,n*)t

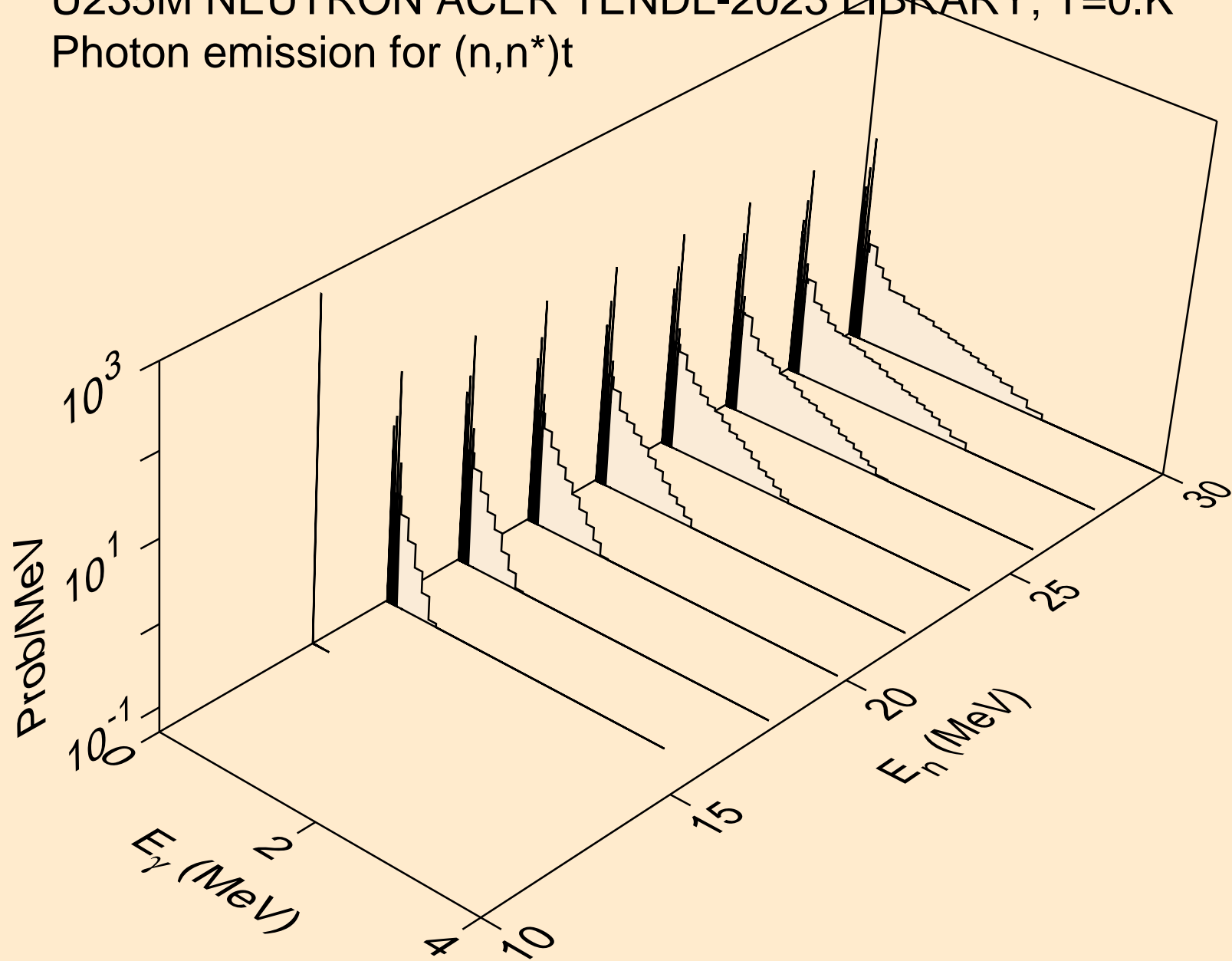

U235M NEUTRON ACER TENDL-2023 LIBRARY; T=0.K
Photon emission for (n,n*)he3

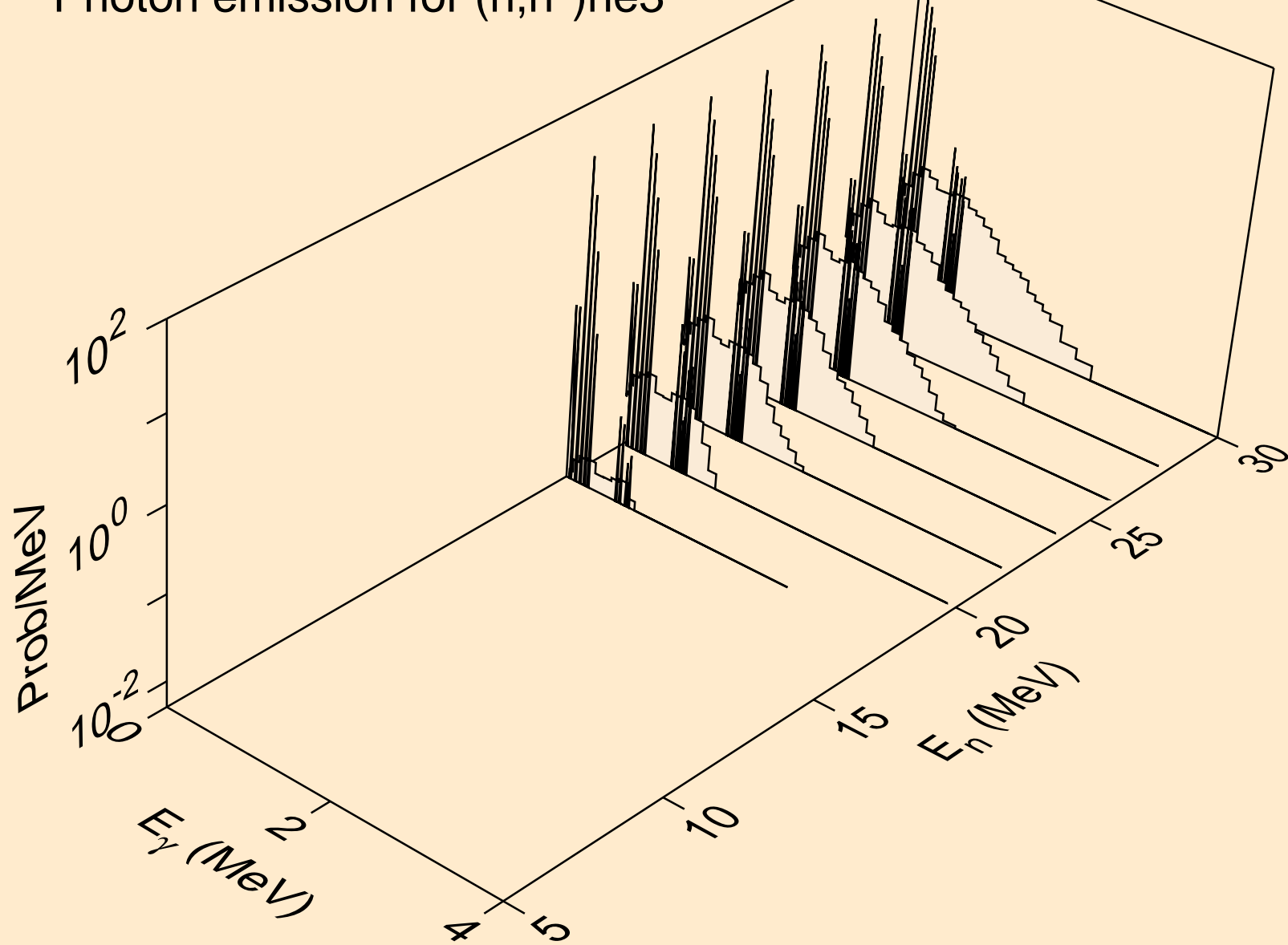

U235M NEUTRON ACER TENDL-2023 LIBRARY; T=0.K
Photon emission for (n,4n)

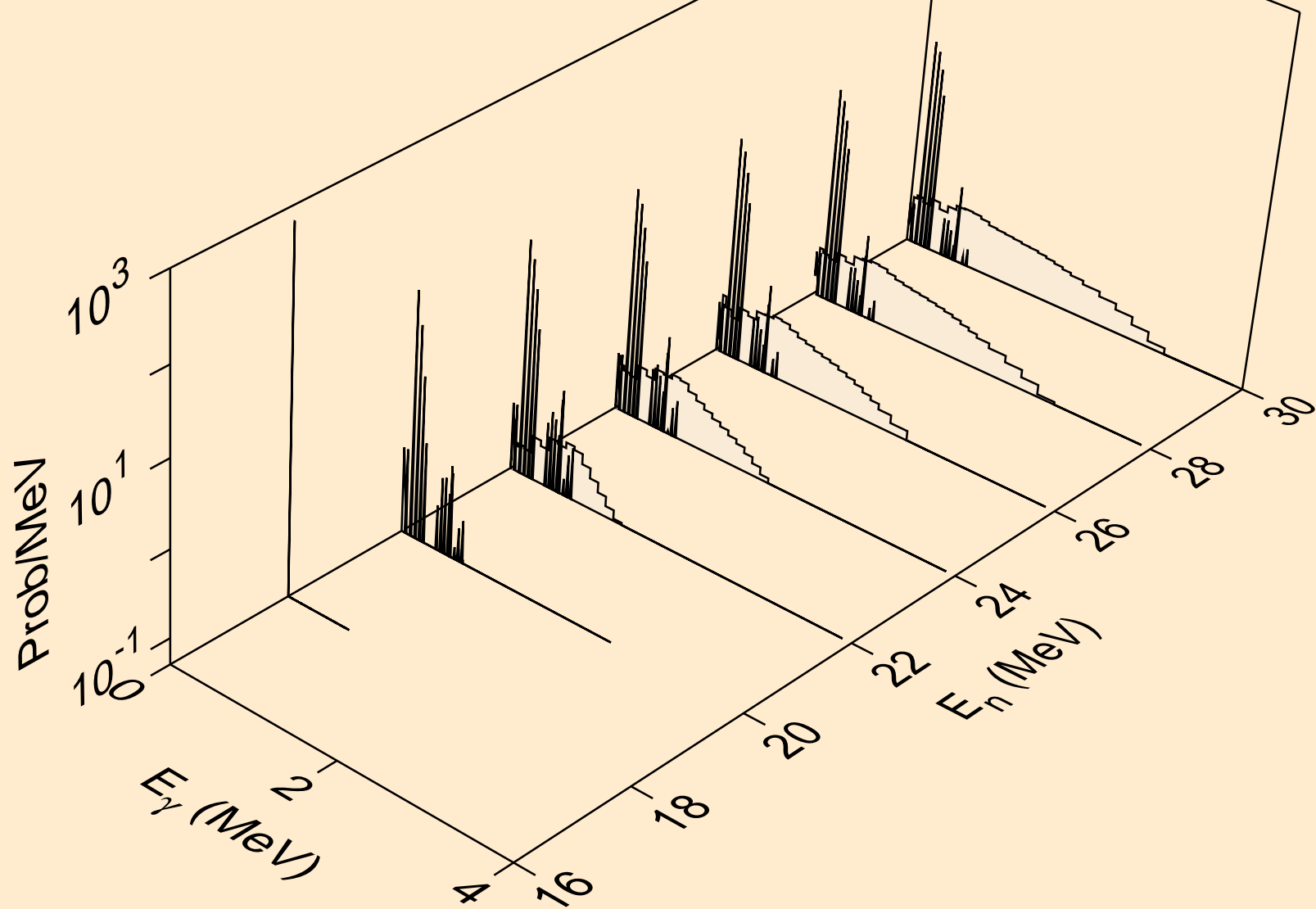

U235M NEUTRON ACER TENDL-2023 LIBRARY; T=0.K
Photon emission for (n,2np)

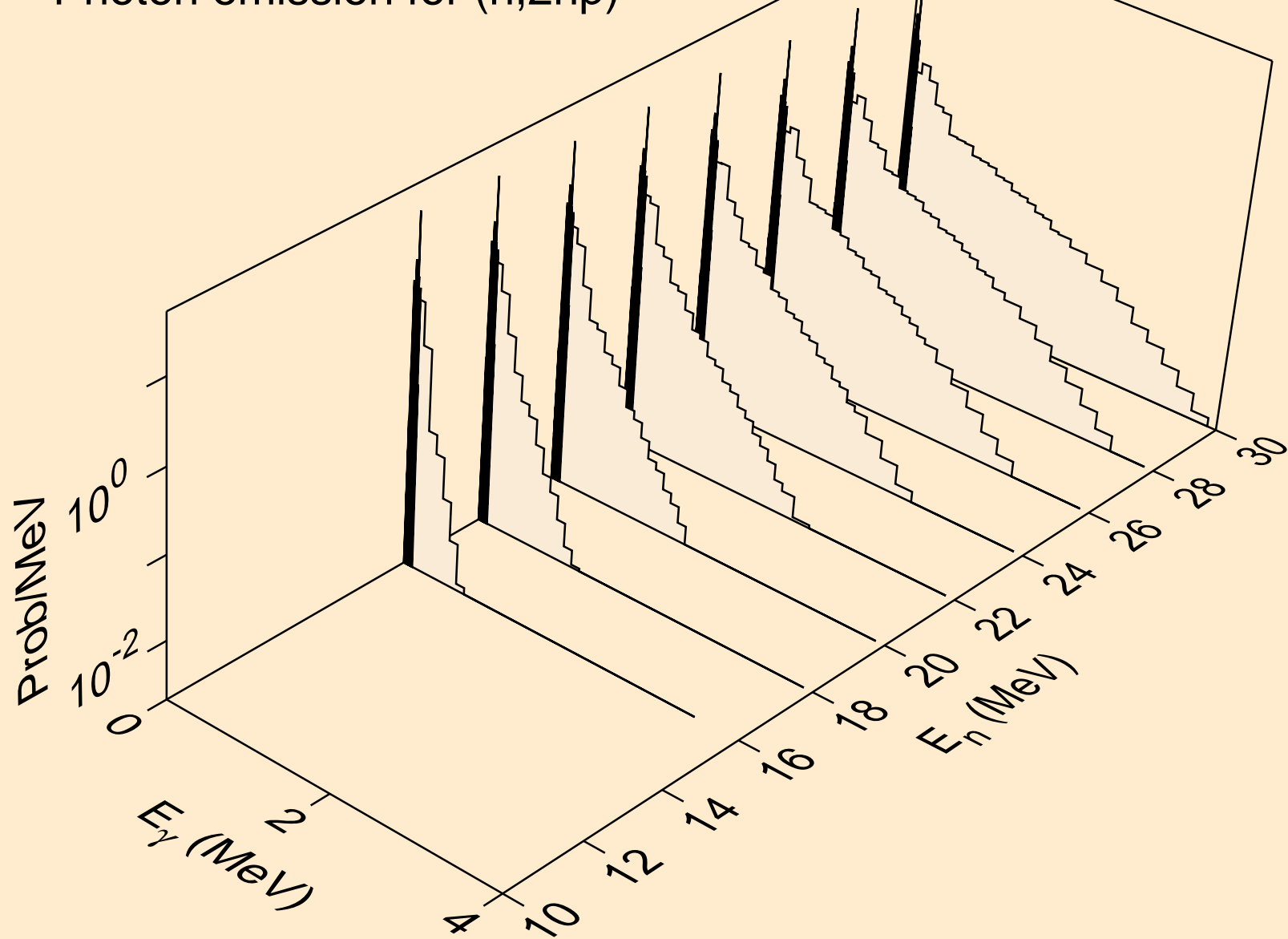

U235M NEUTRON ACER TENDL-2023 LIBRARY; T=0.K
Photon emission for (n,3np)

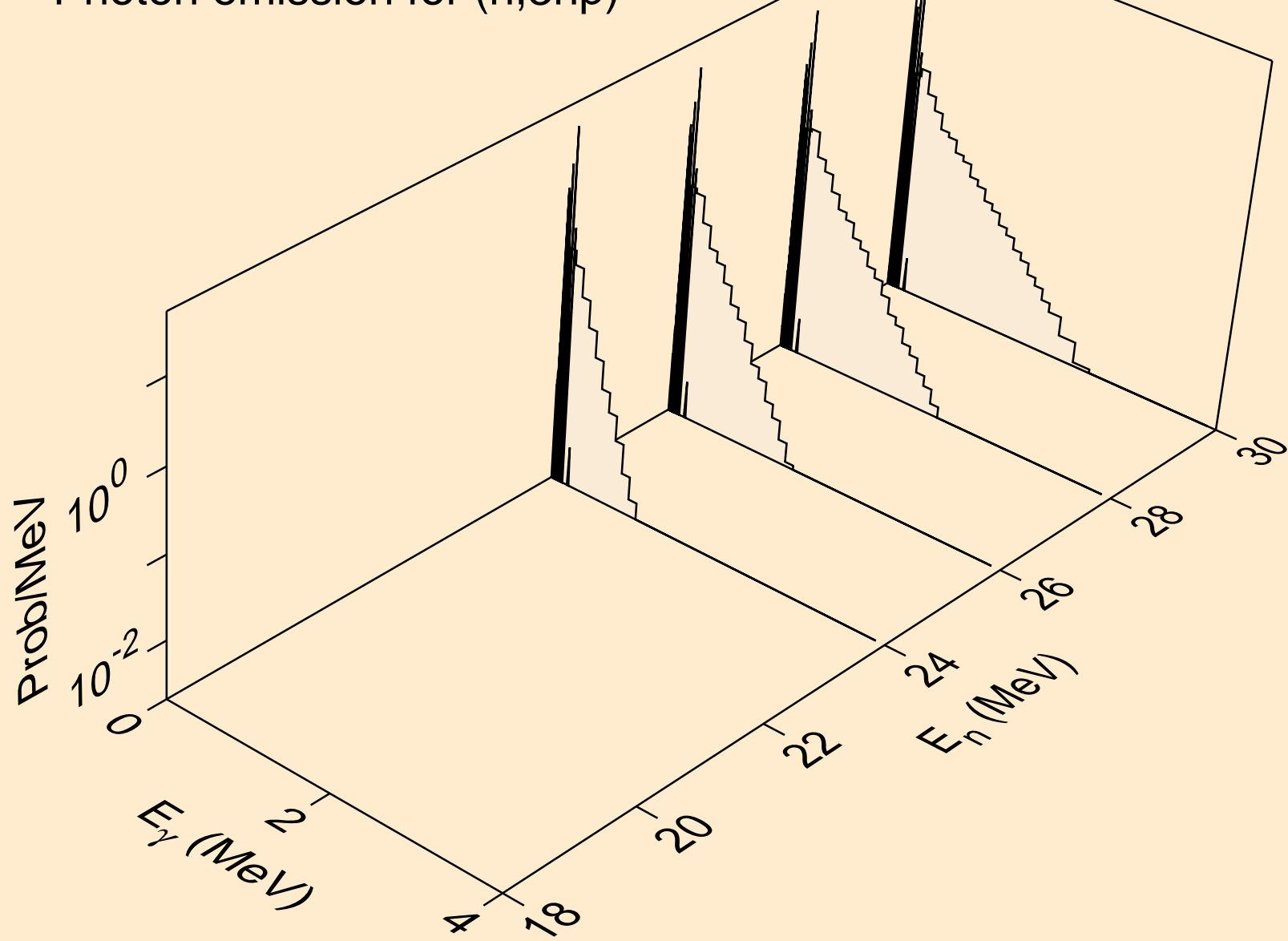

U235M NEUTRON ACER TENDL-2023 LIBRARY; T=0.K
Photon emission for (n,n2p)

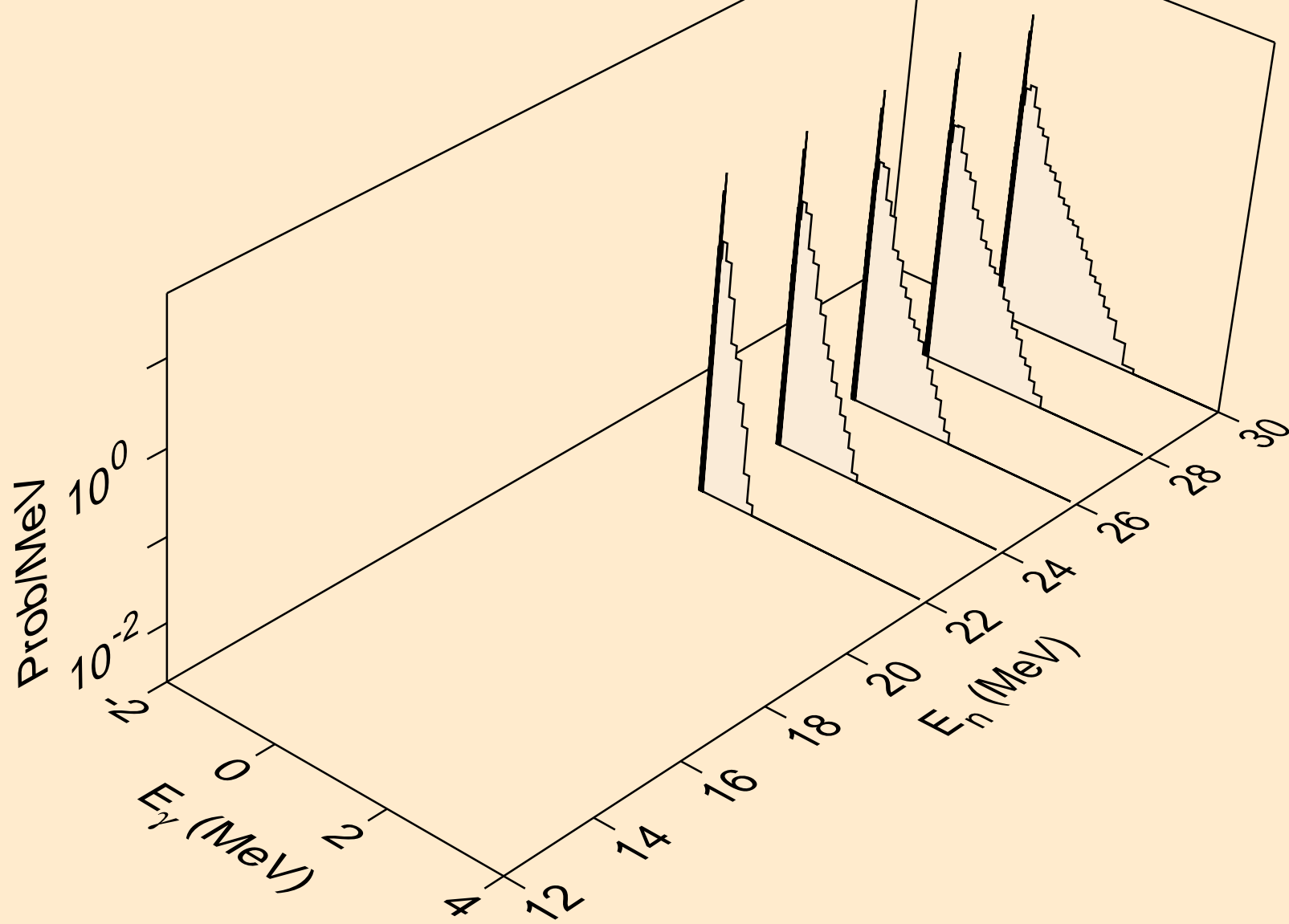

U235M NEUTRON ACER TENDL-2023 LIBRARY; T=0.K
Photon emission for (n,n*2)

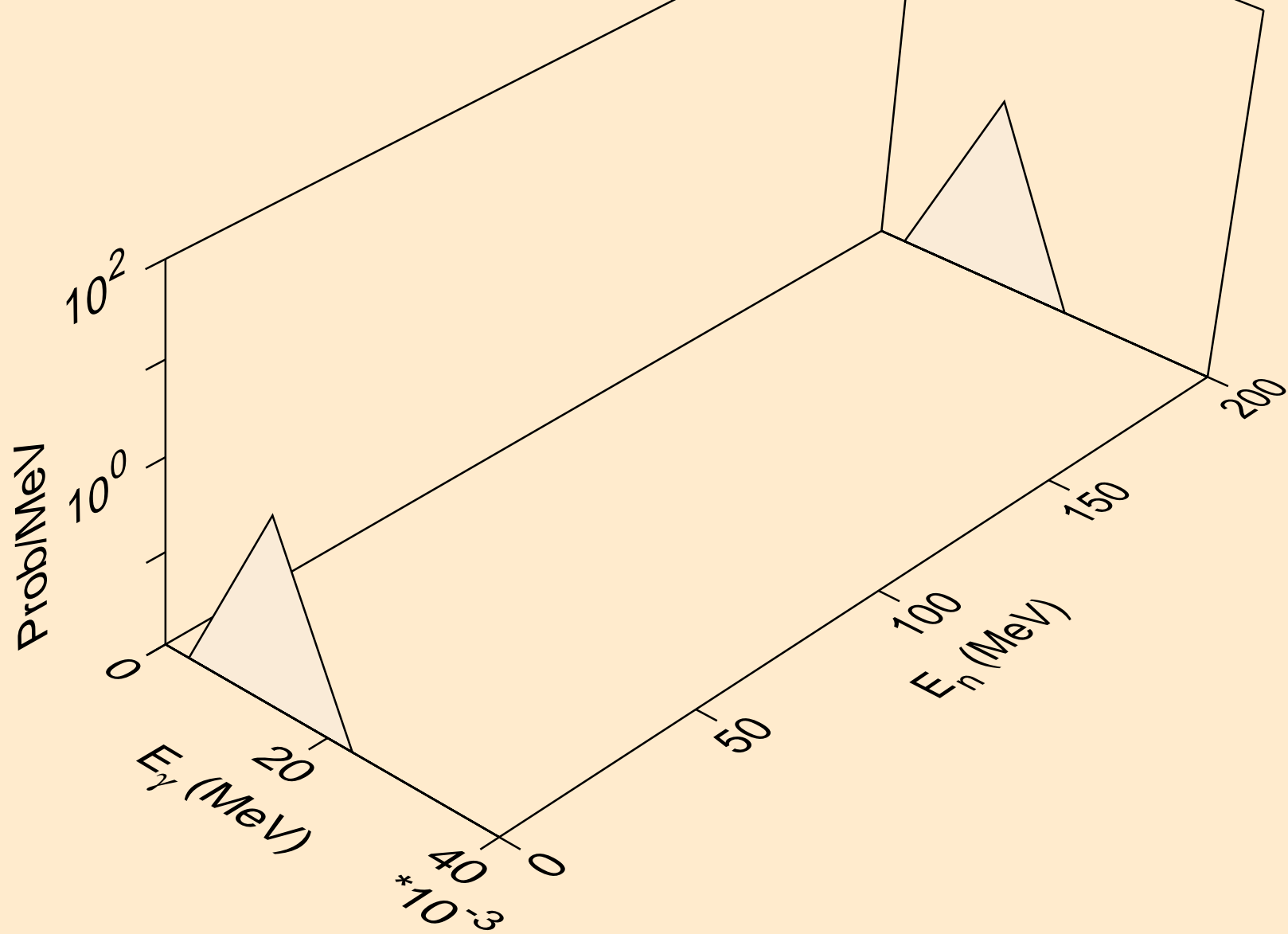

U235M NEUTRON ACER TENDL-2023 LIBRARY; T=0.K
Photon emission for (n,n*3)

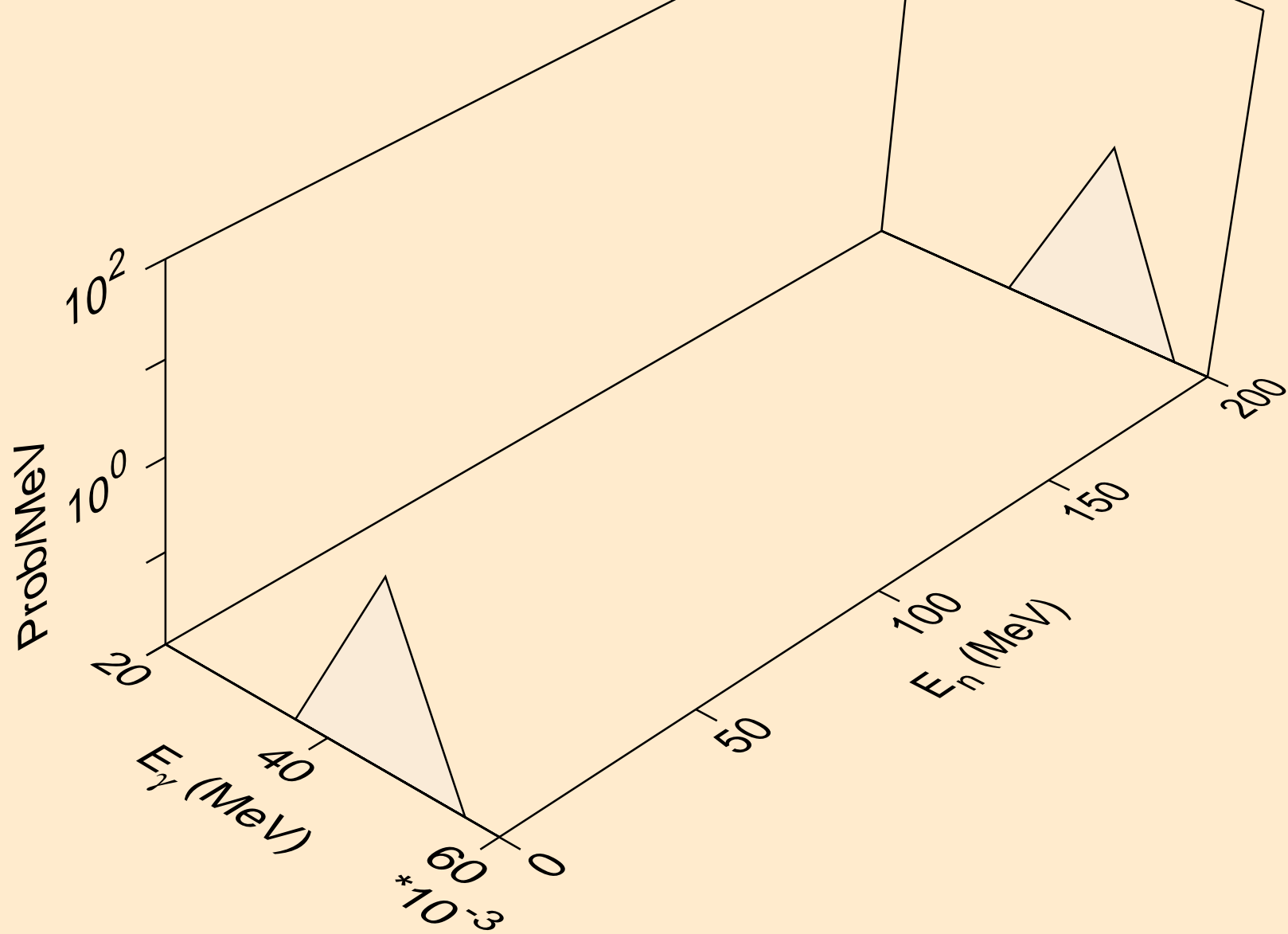

U235M NEUTRON ACER TENDL-2023 LIBRARY; T=0.K
Photon emission for (n,n*4)

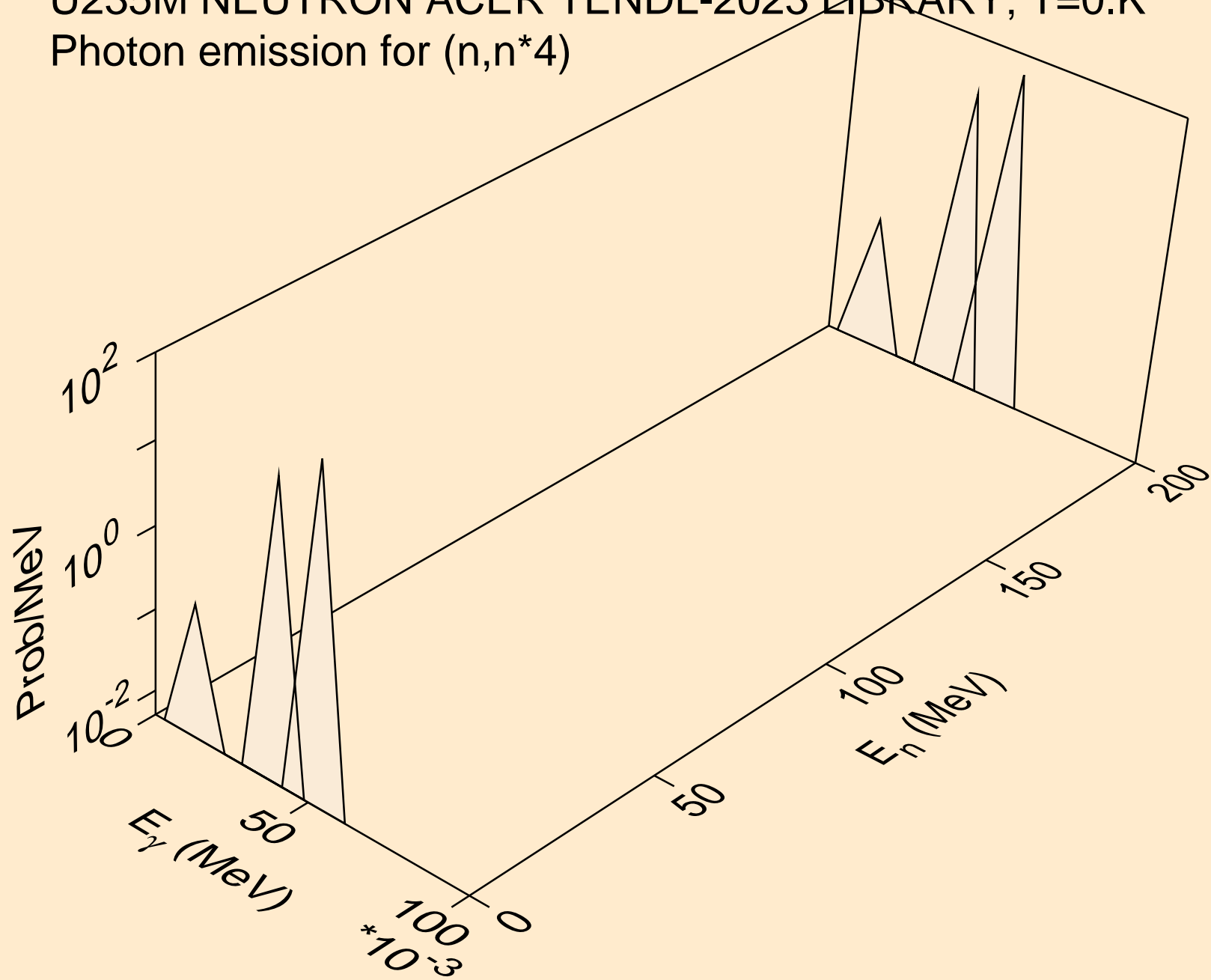

U235M NEUTRON ACER TENDL-2023 LIBRARY; T=0.K
Photon emission for (n,n*5)

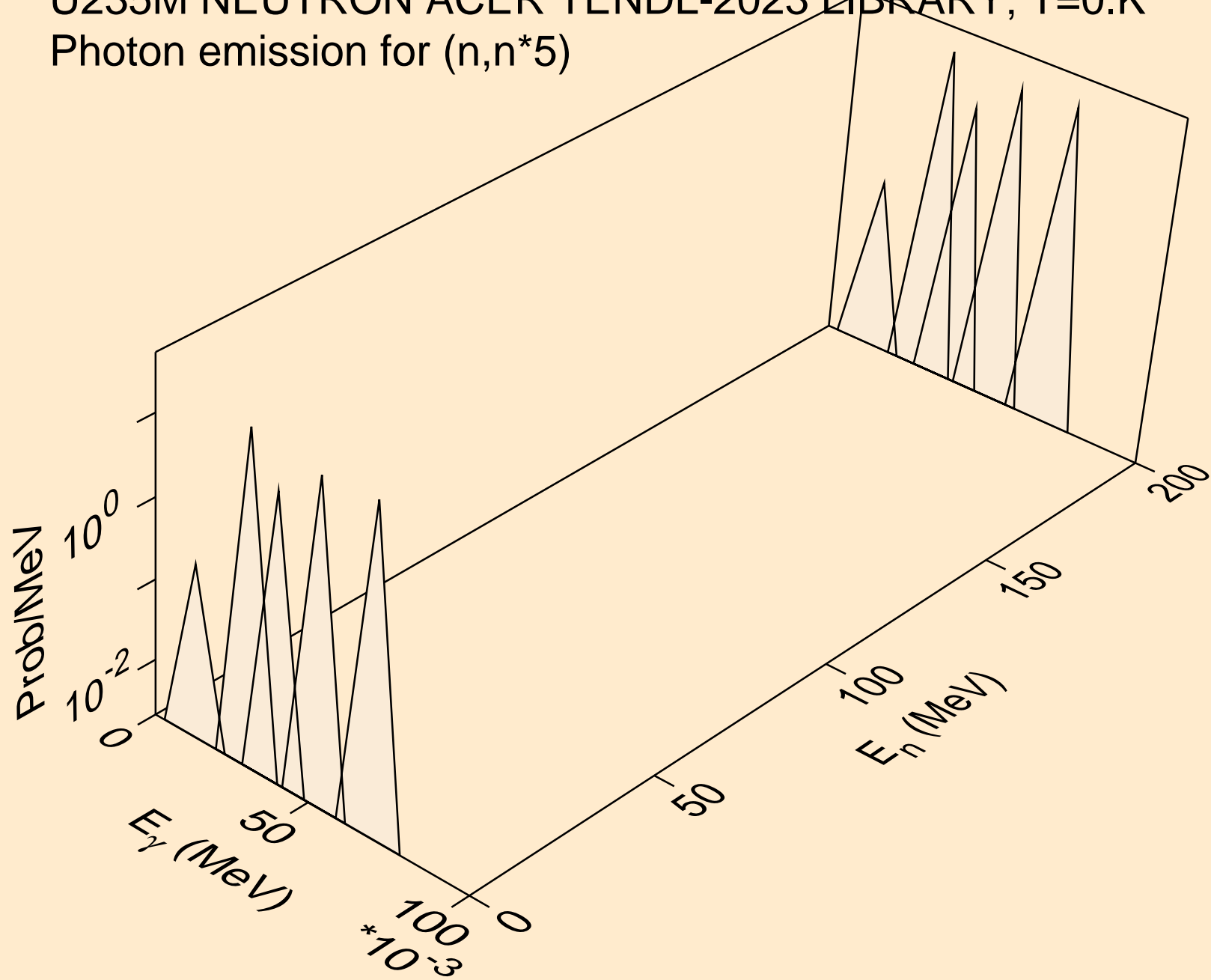

U235M NEUTRON ACER TENDL-2023 LIBRARY; T=0.K
Photon emission for (n,n*6)

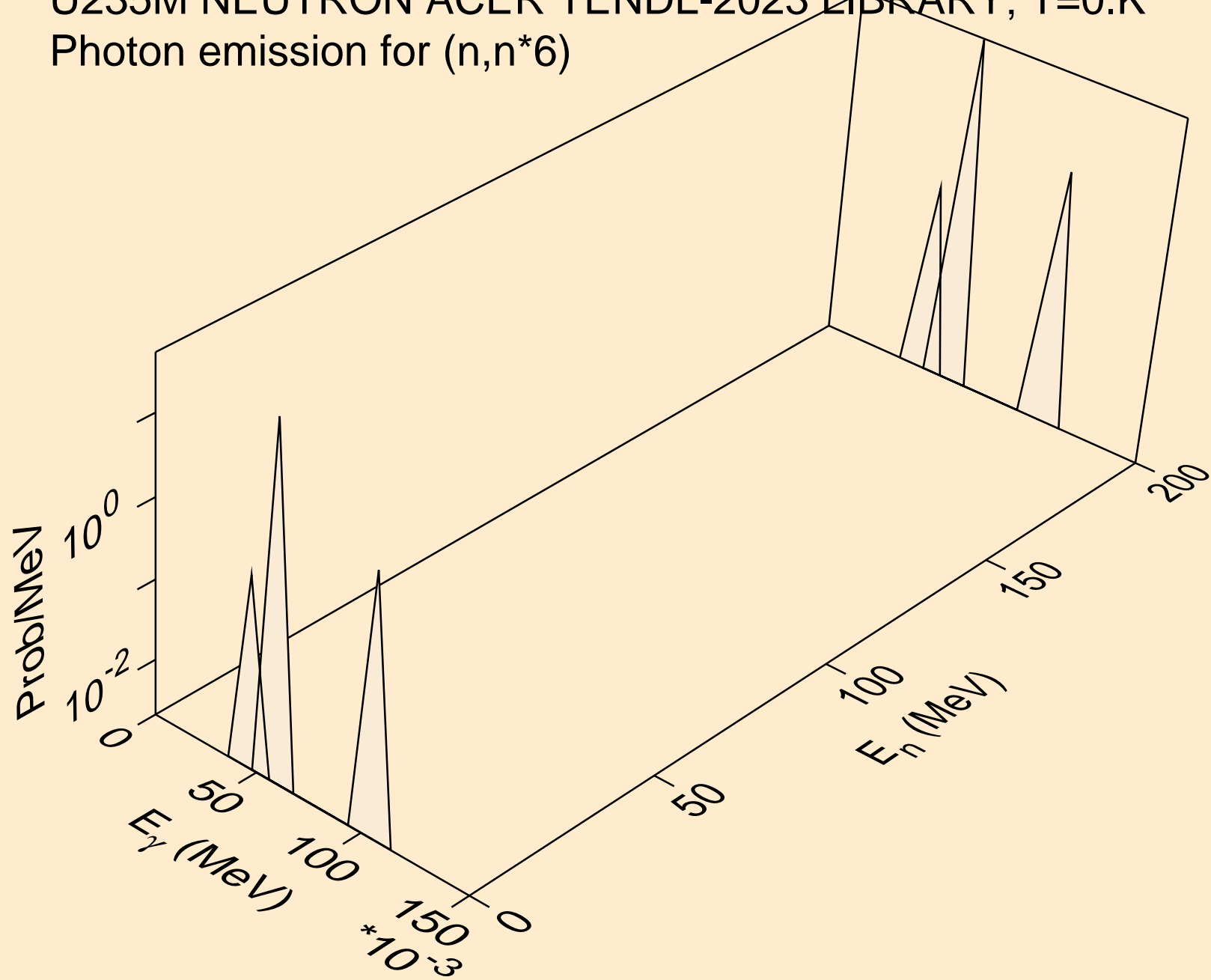

U235M NEUTRON ACER TENDL-2023 LIBRARY; T=0.K
Photon emission for (n,n*7)

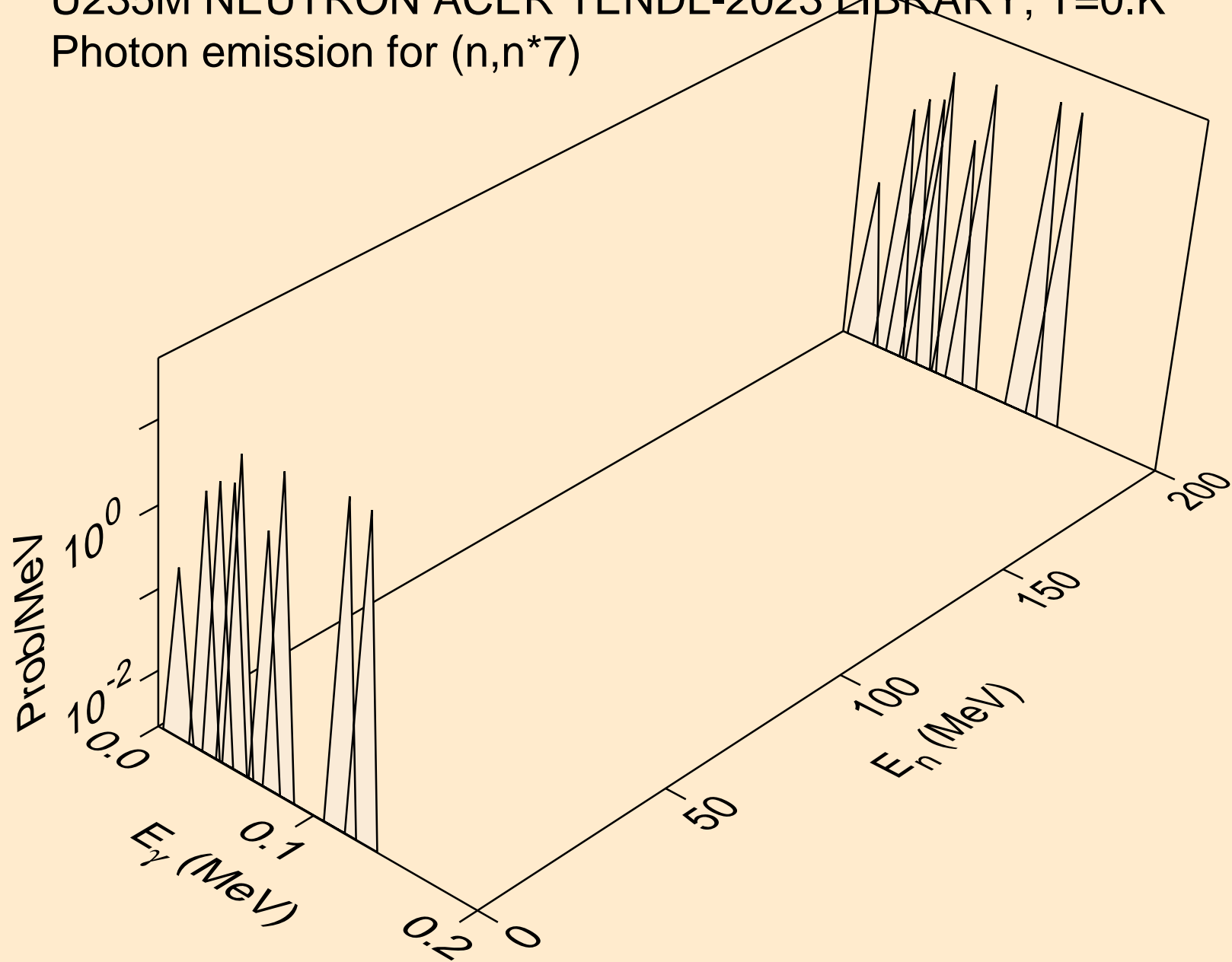

U235M NEUTRON ACER TENDL-2023 LIBRARY; T=0.K
Photon emission for (n,n*8)

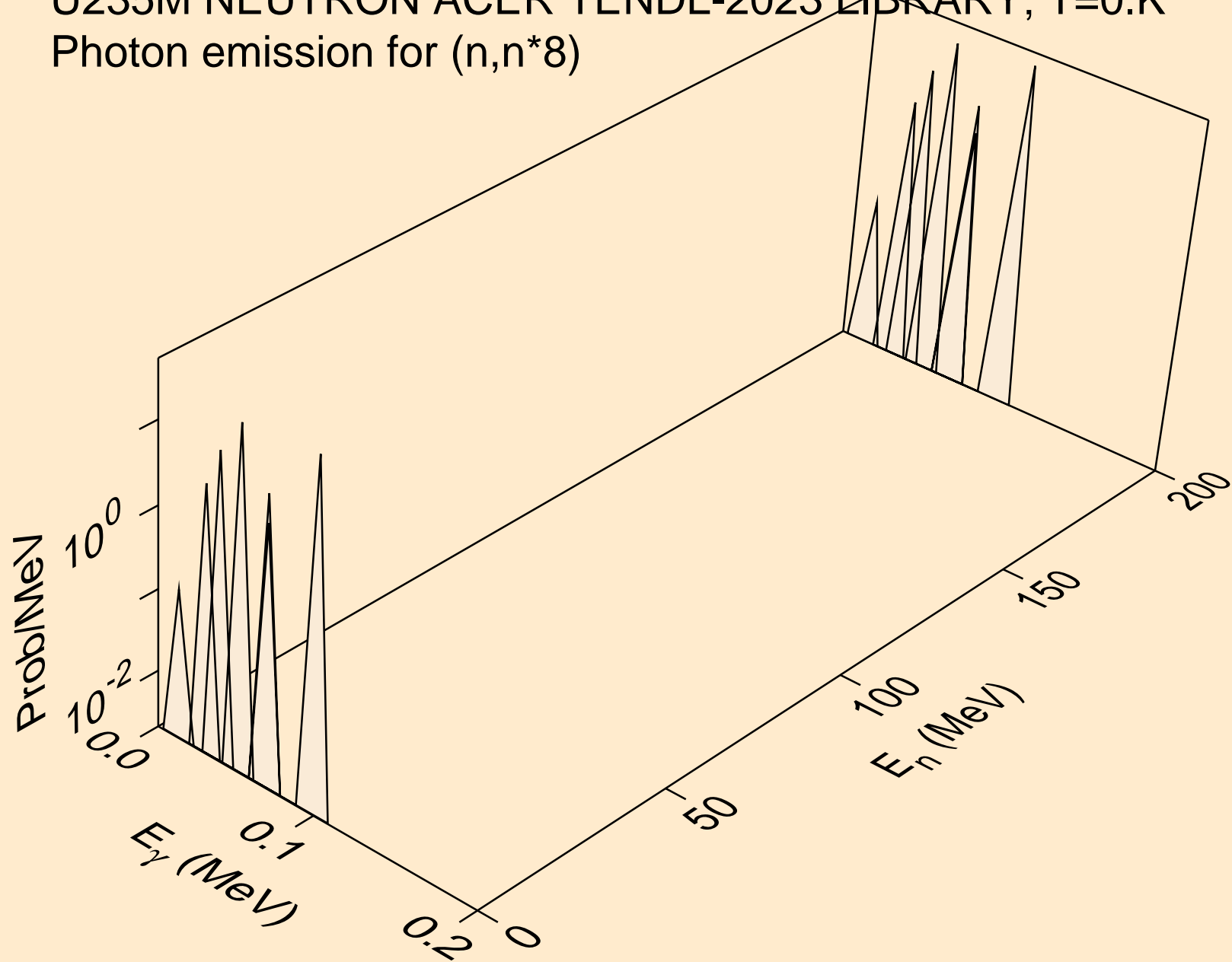

U235M NEUTRON ACER TENDL-2023 LIBRARY; T=0.K
Photon emission for (n,n*9)

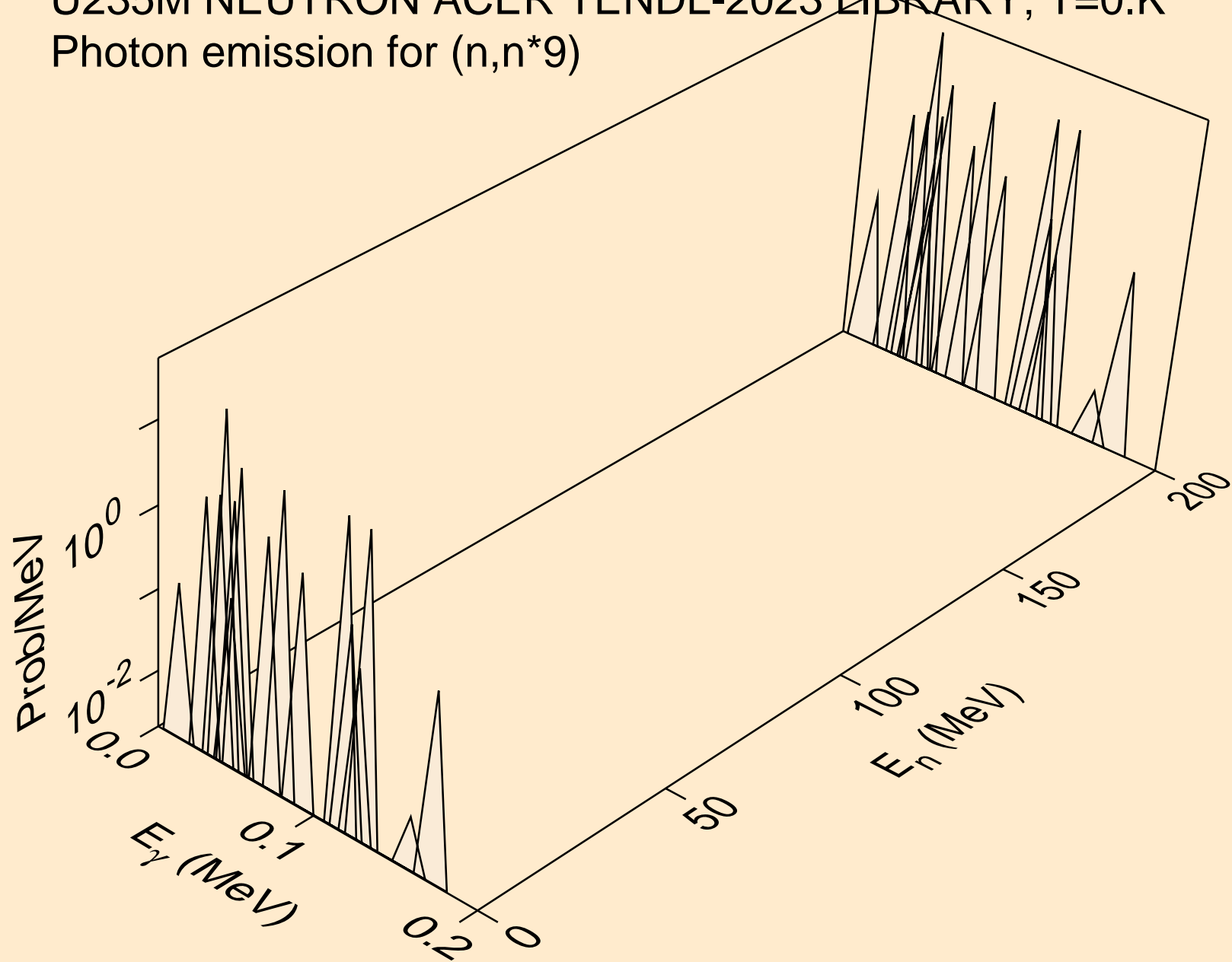

U235M NEUTRON ACER TENDL-2023 LIBRARY; T=0.K
Photon emission for (n,n*10)

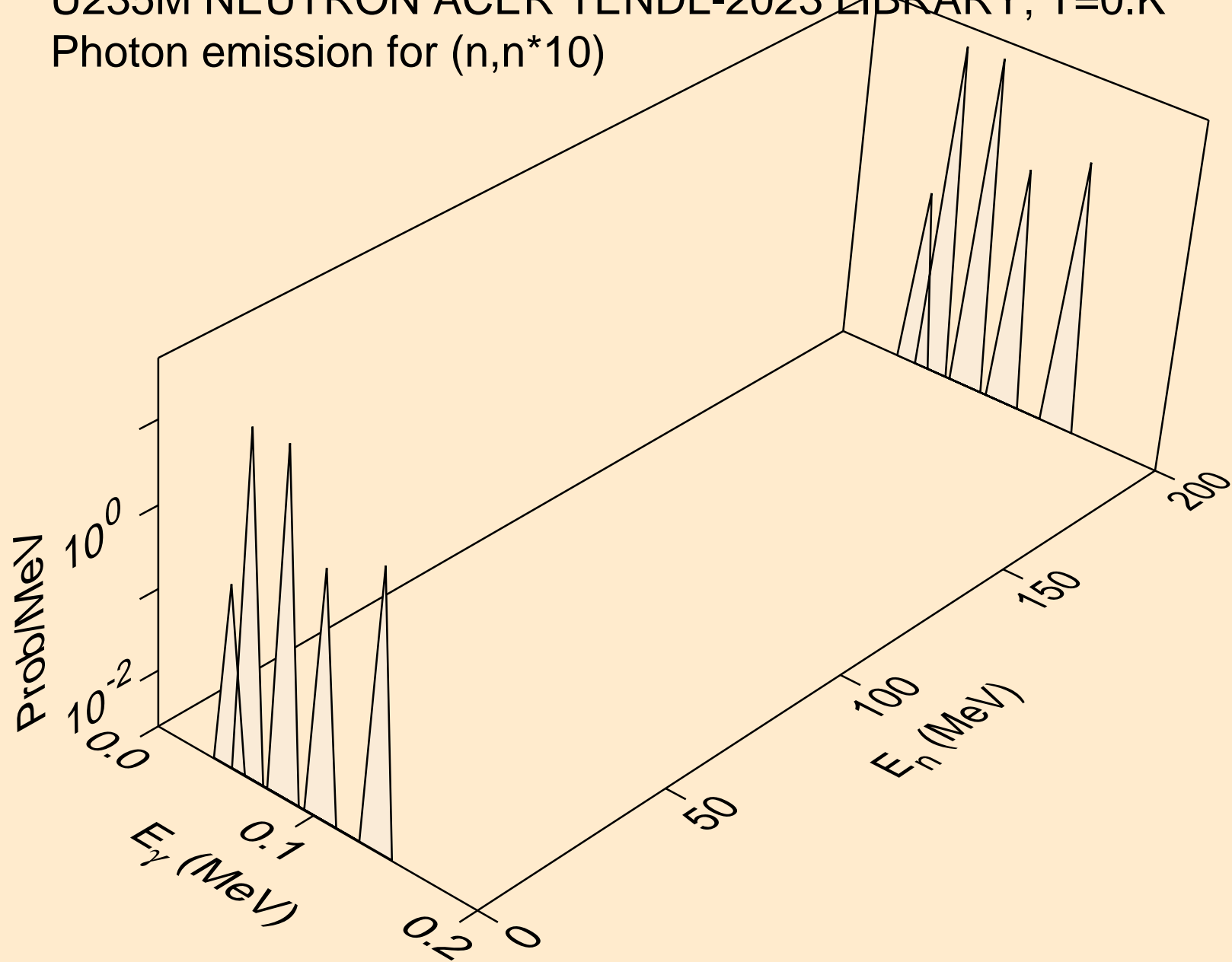

U235M NEUTRON ACER TENDL-2023 LIBRARY; T=0.K
Photon emission for (n,n*11)

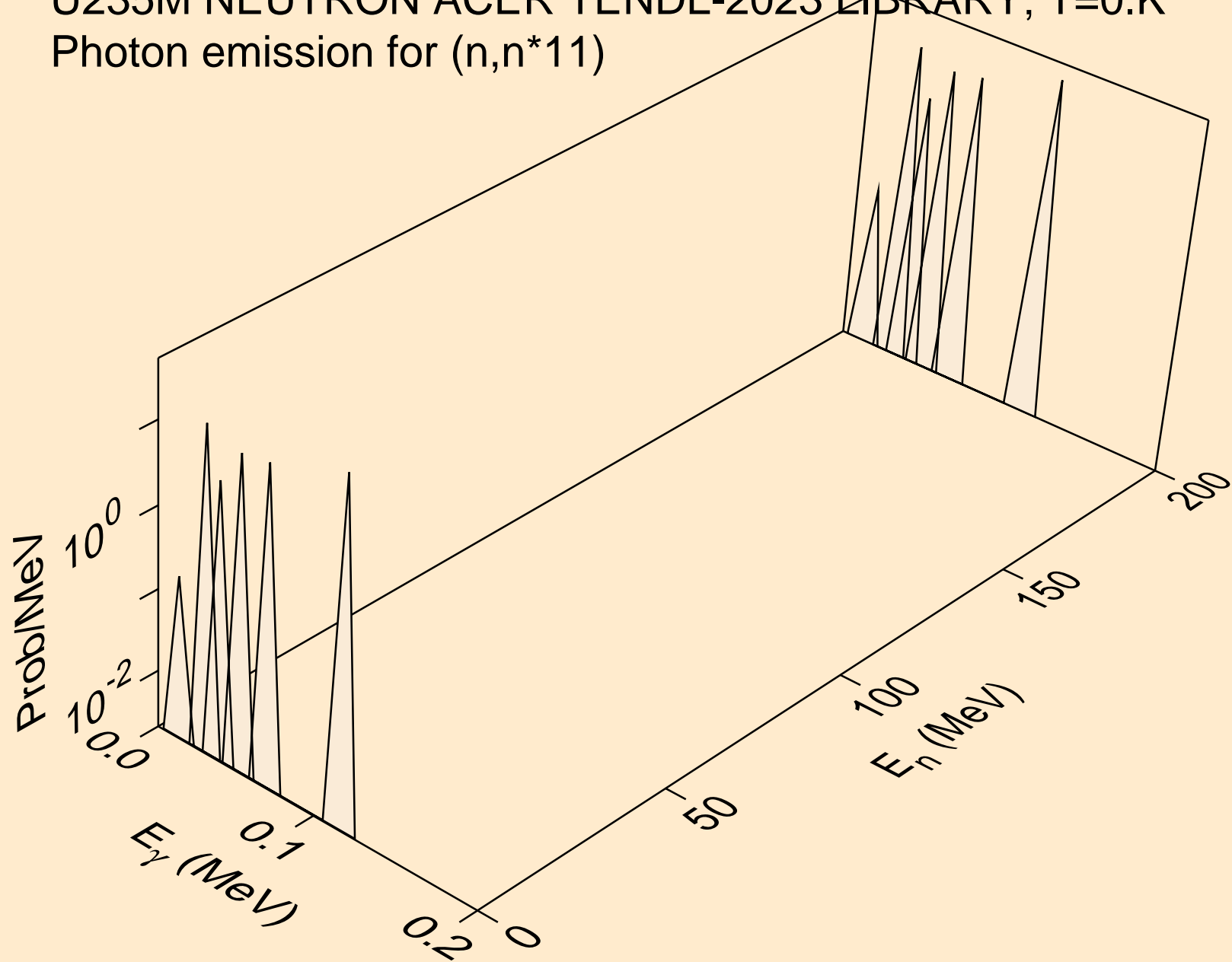

U235M NEUTRON ACER TENDL-2023 LIBRARY; T=0.K
Photon emission for (n,n*12)

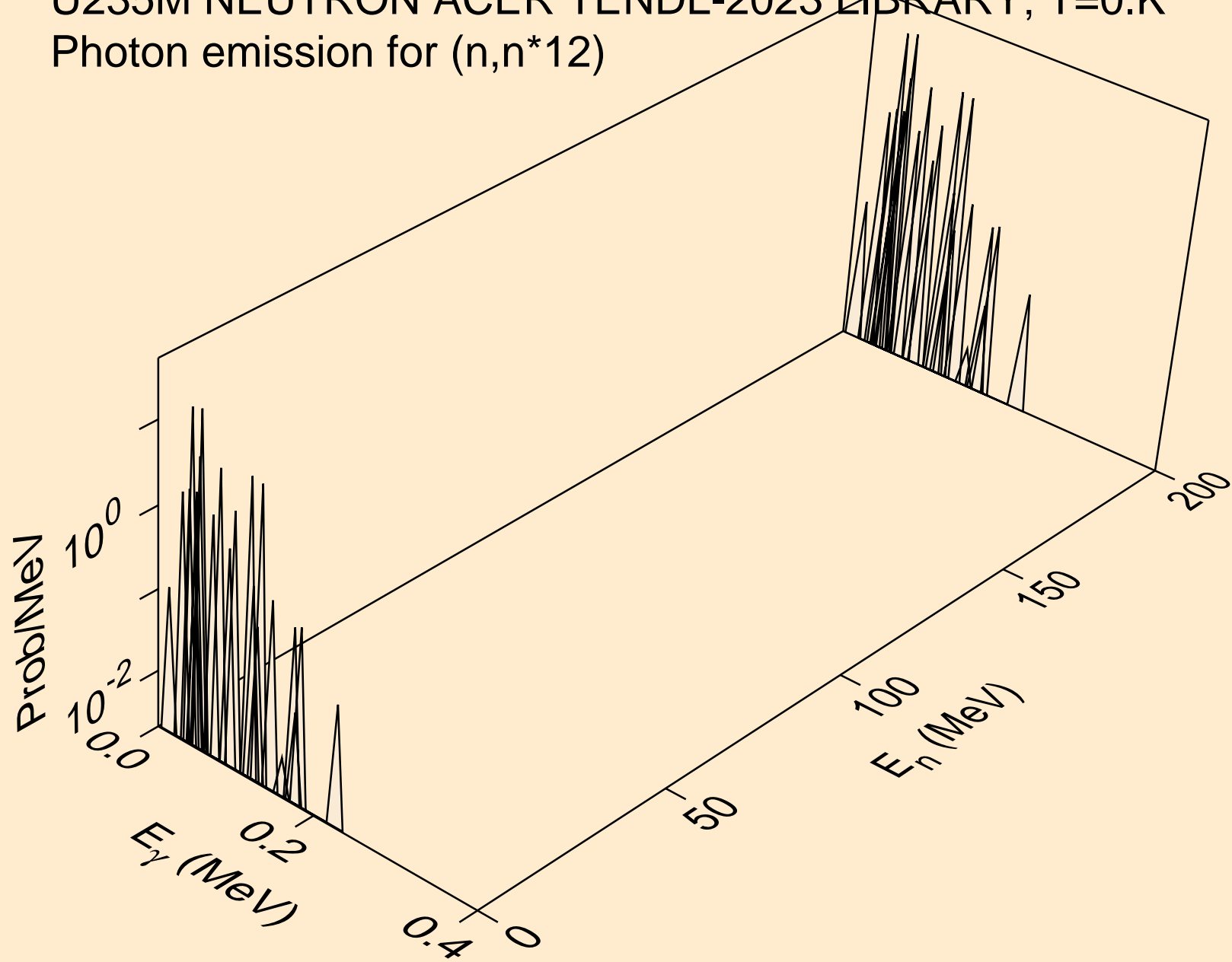

U235M NEUTRON ACER TENDL-2023 LIBRARY; T=0.K
Photon emission for (n,n*13)

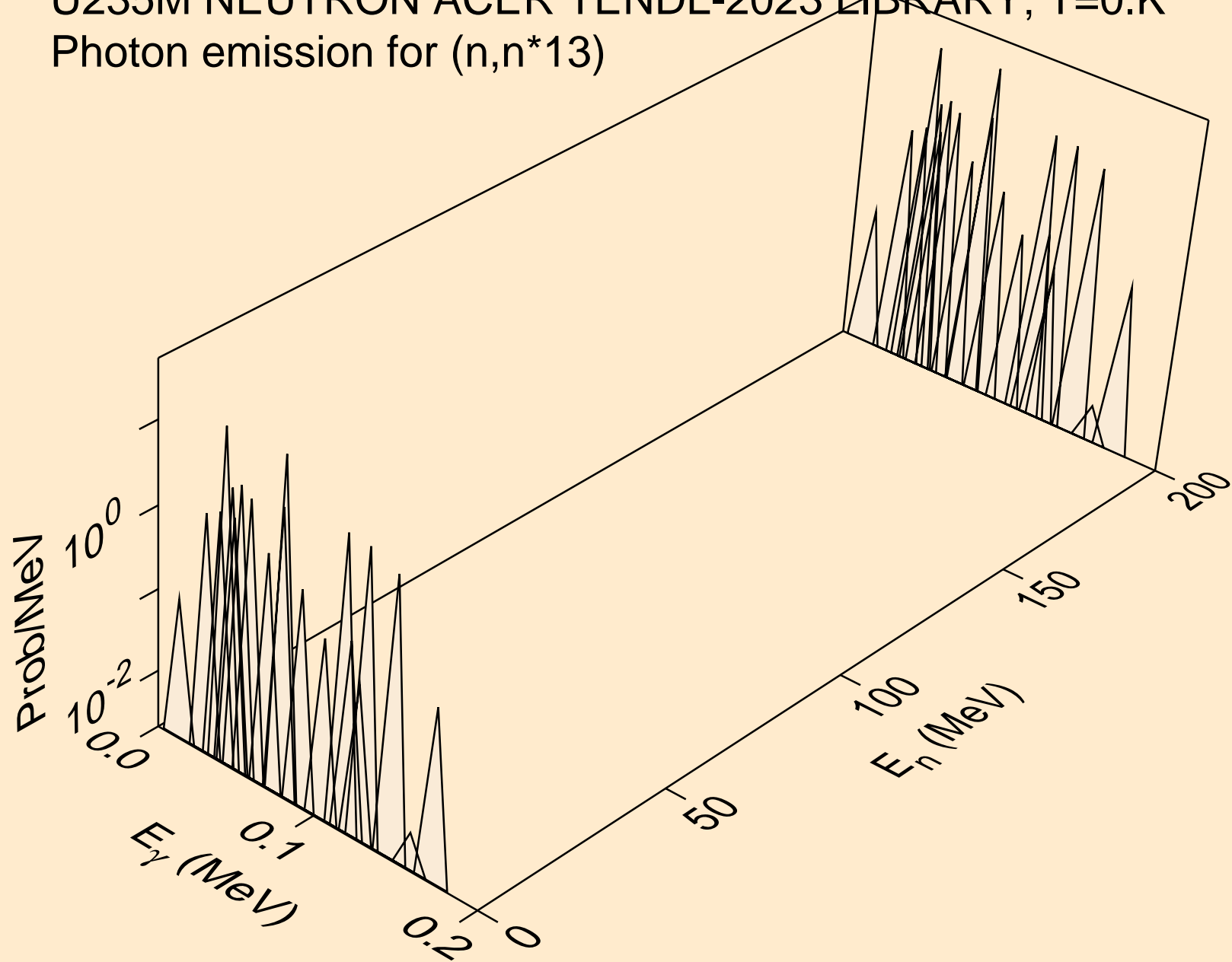

U235M NEUTRON ACER TENDL-2023 LIBRARY; T=0.K
Photon emission for (n,n*14)

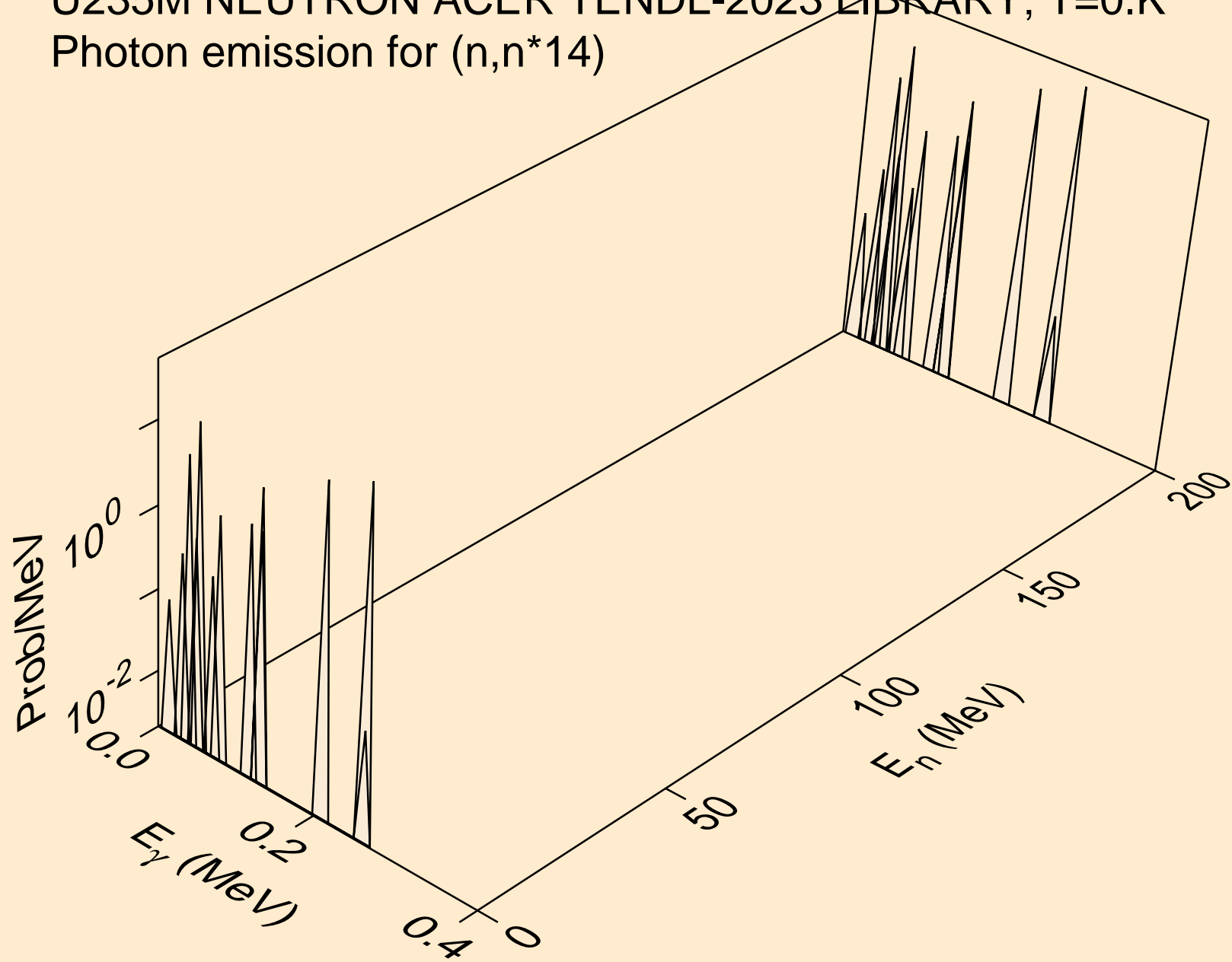

U235M NEUTRON ACER TENDL-2023 LIBRARY; T=0.K
Photon emission for (n,n*c)

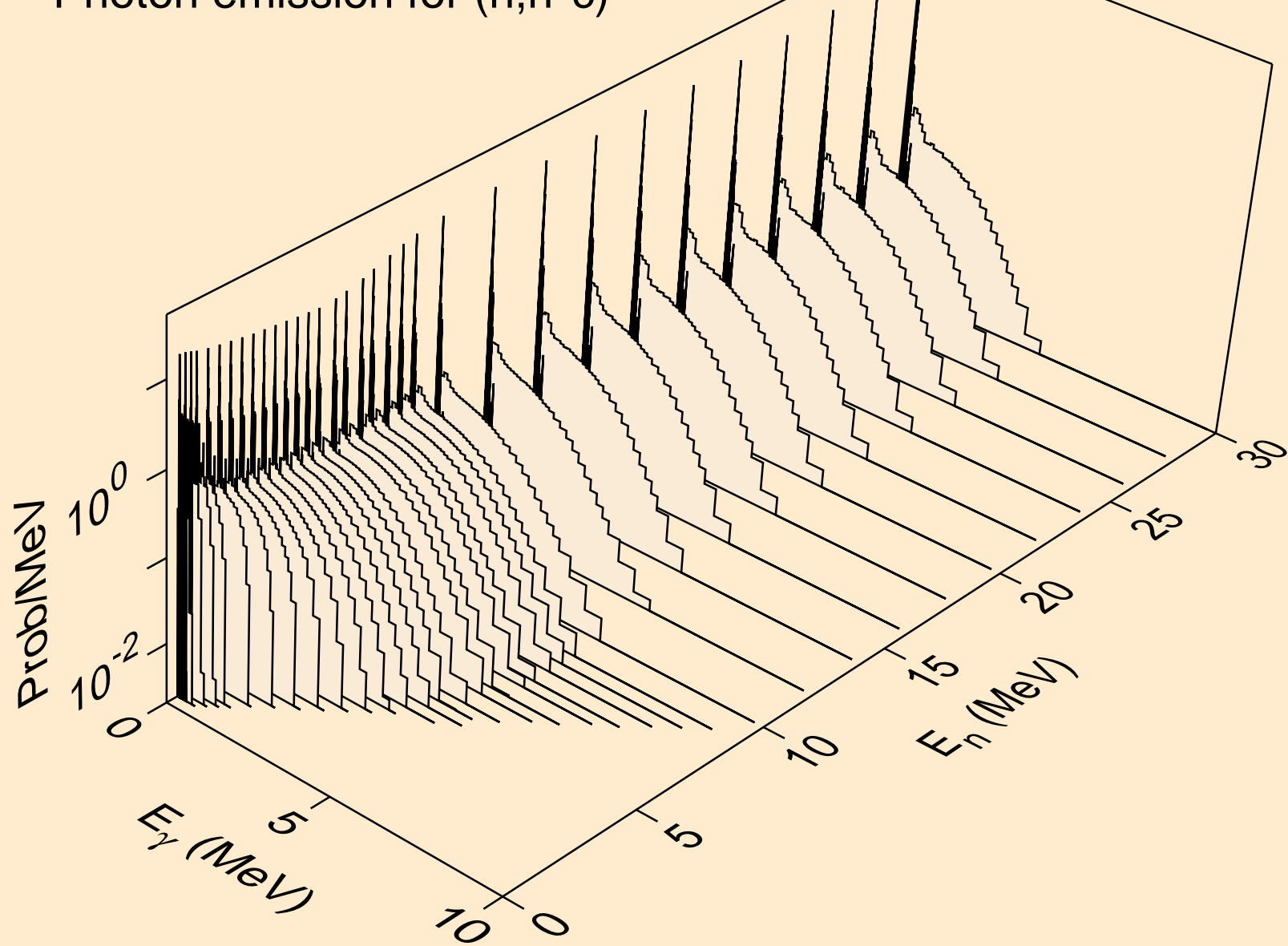

U235M NEUTRON ACER TENDL-2023 LIBRARY; T=0.K
Photon emission for (n,gma)

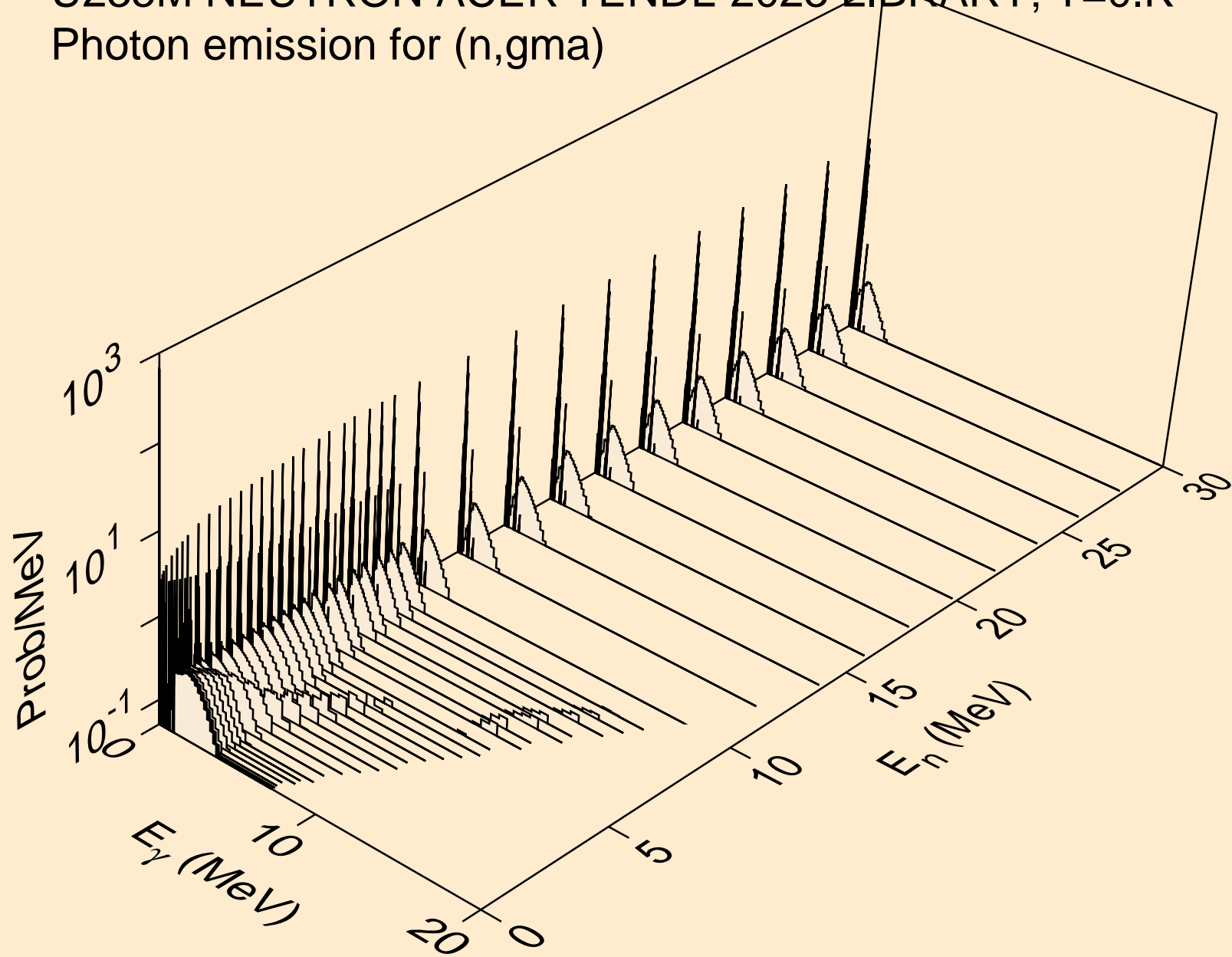

U235M NEUTRON ACER TENDL-2023 LIBRARY; T=0.K
Photon emission for (n,p)

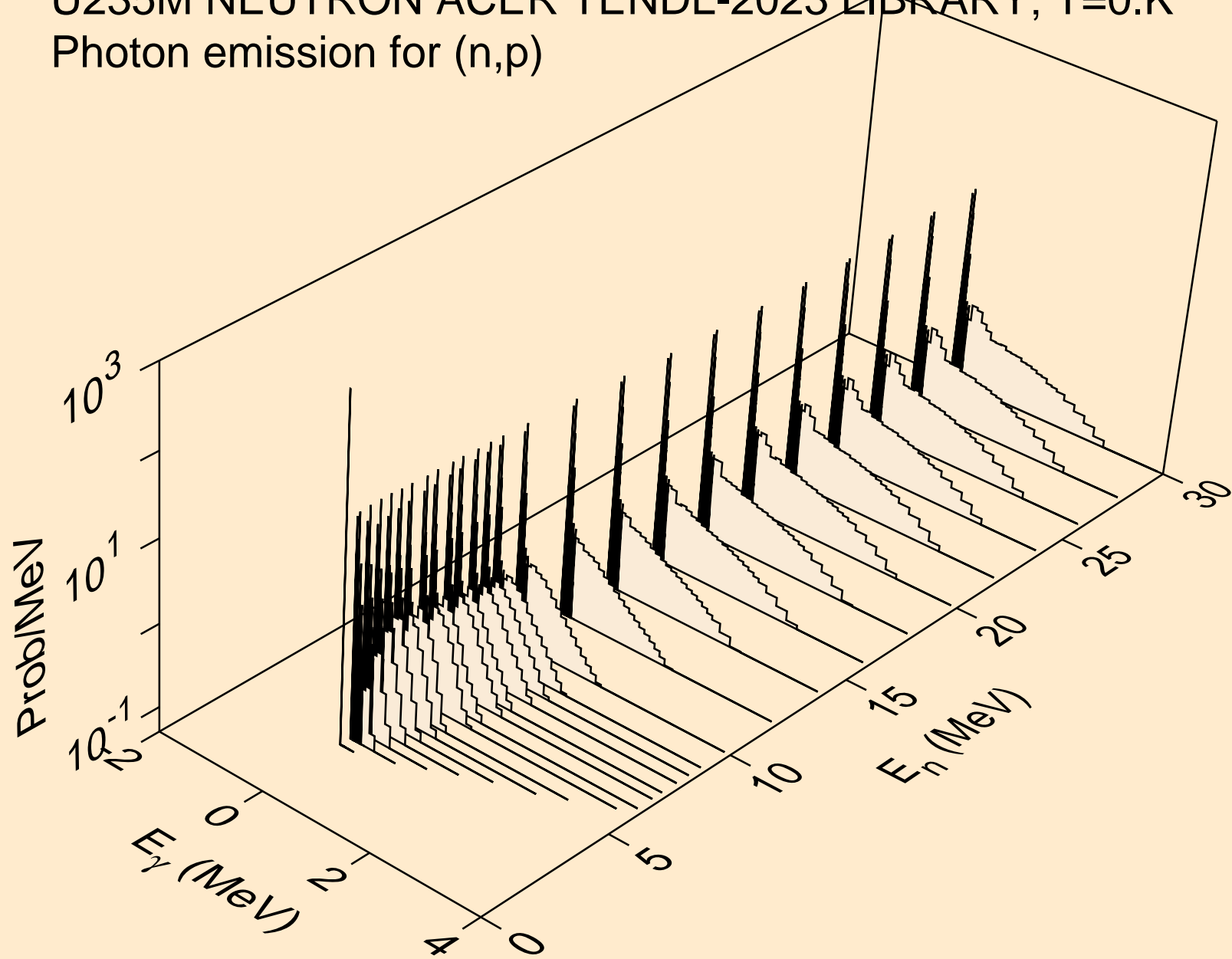

U235M NEUTRON ACER TENDL-2023 LIBRARY; T=0.K
Photon emission for (n,d)

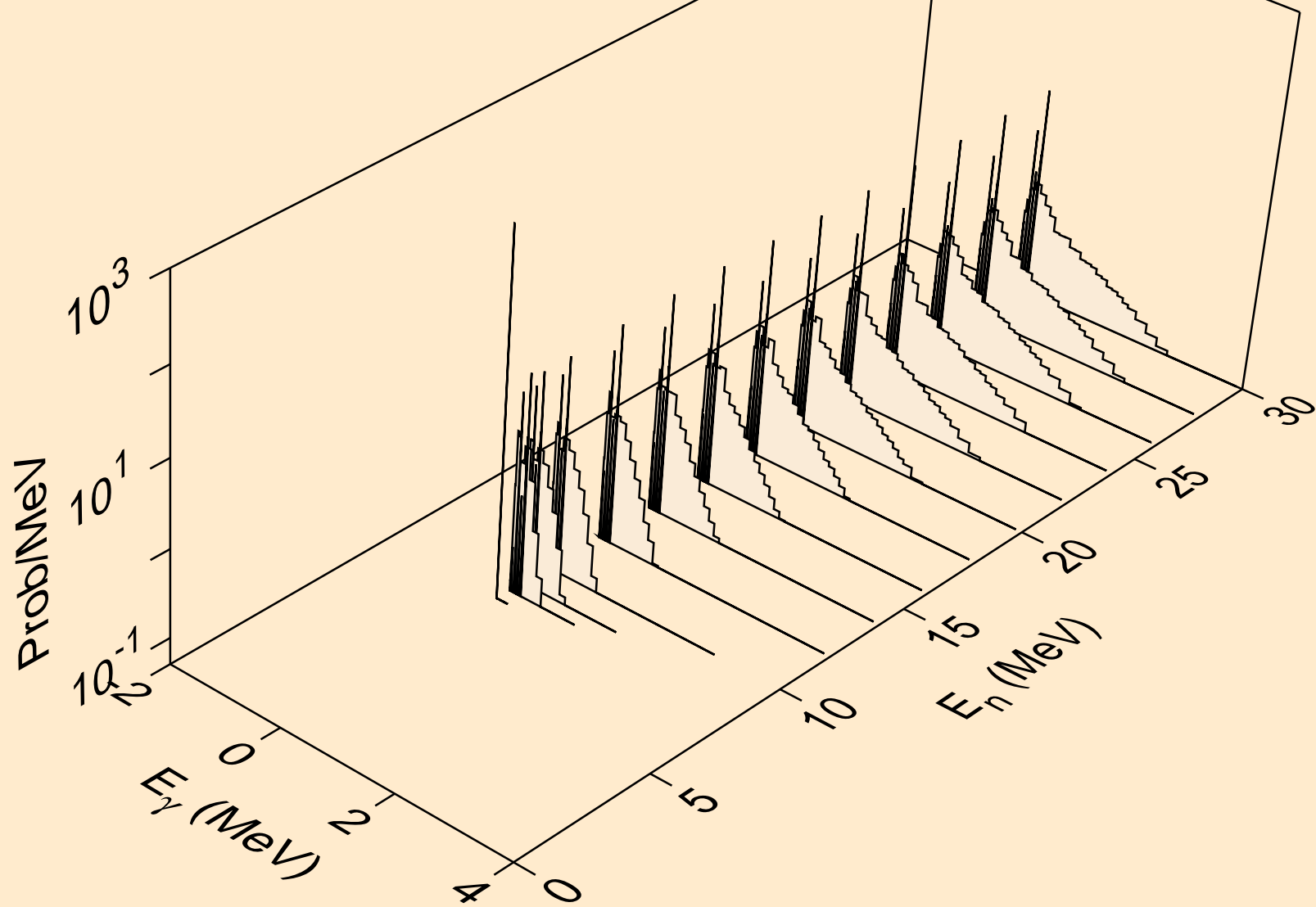

U235M NEUTRON ACER TENDL-2023 LIBRARY; T=0.K
Photon emission for (n,t)

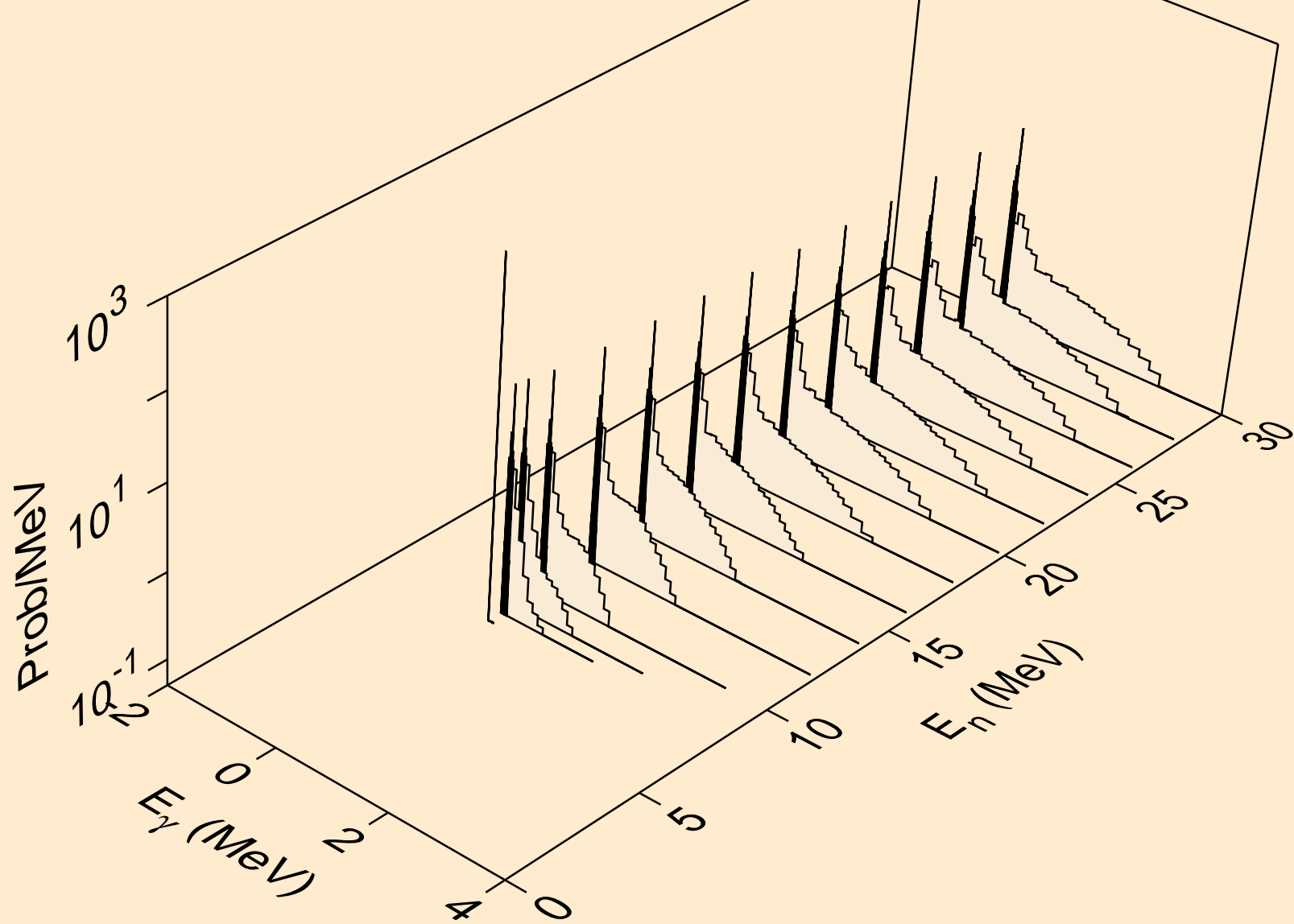

U235M NEUTRON ACER TENDL-2023 LIBRARY; T=0.K
Photon emission for (n,he3)

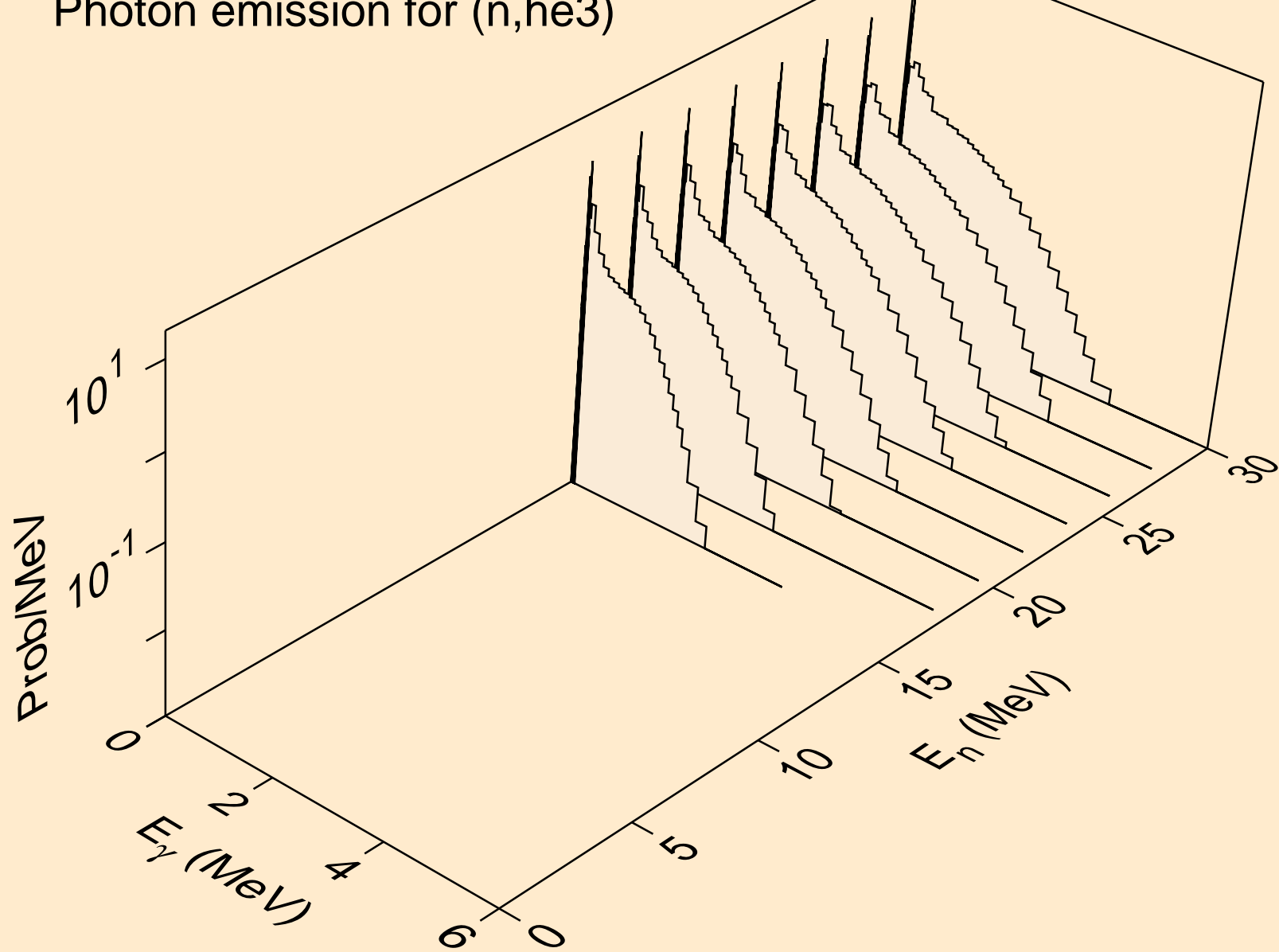

U235M NEUTRON ACER TENDL-2023 LIBRARY; T=0.K
Photon emission for (n,a)

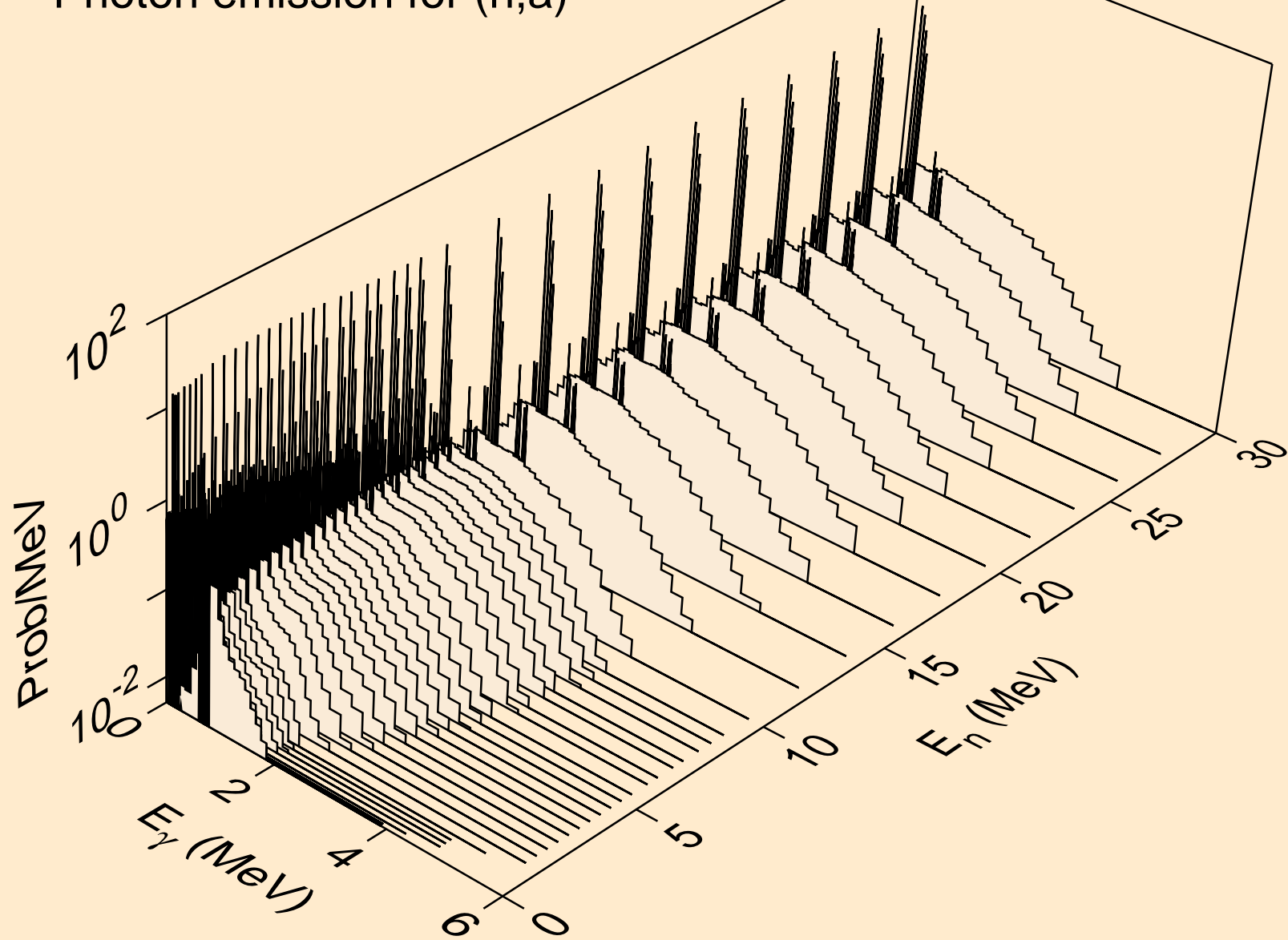

U235M NEUTRON ACER TENDL-2023 LIBRARY; T=0.K
Photon emission for (n,2p)

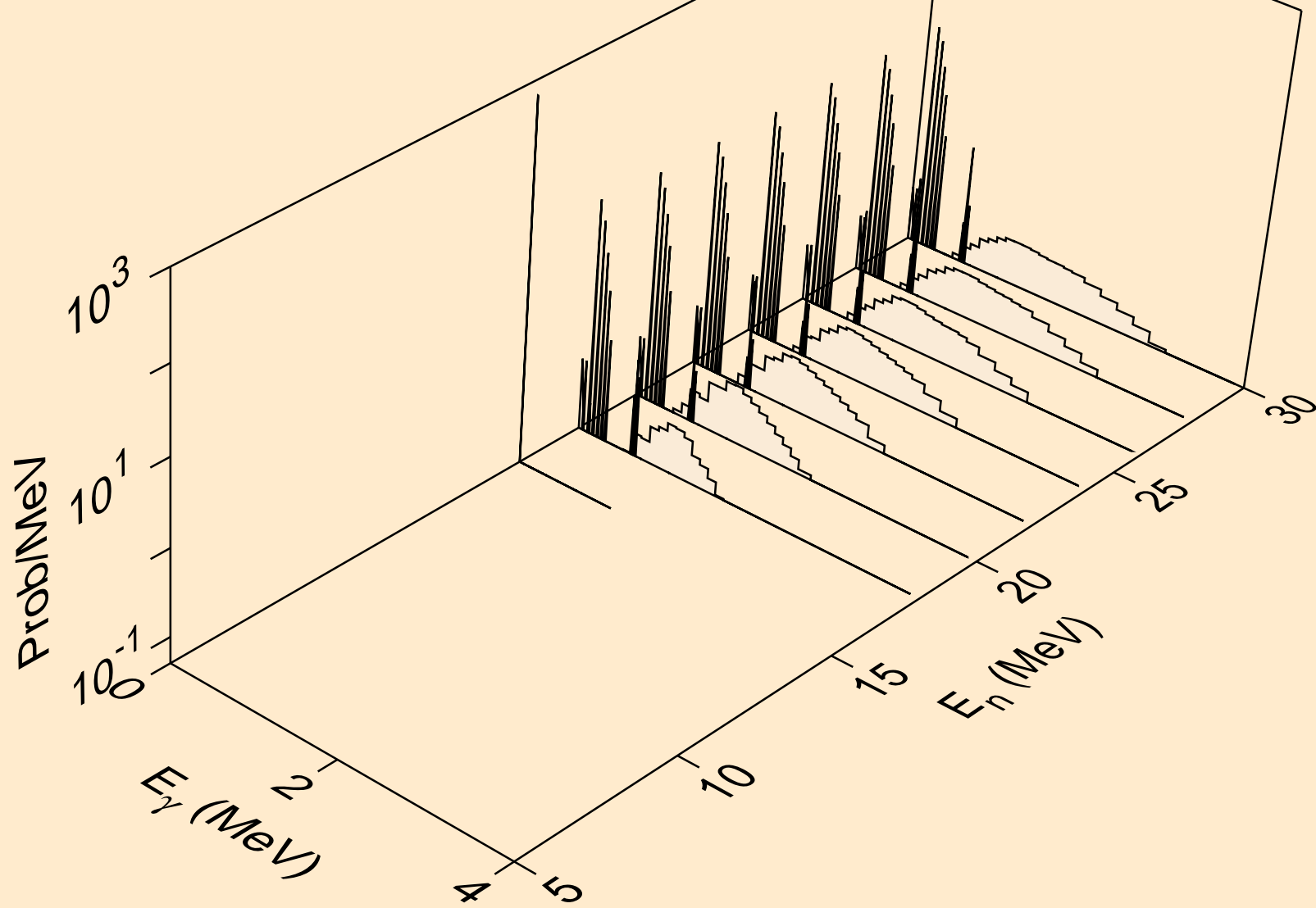

U235M NEUTRON ACER TENDL-2023 LIBRARY; T=0.K
14 MeV photon spectrum

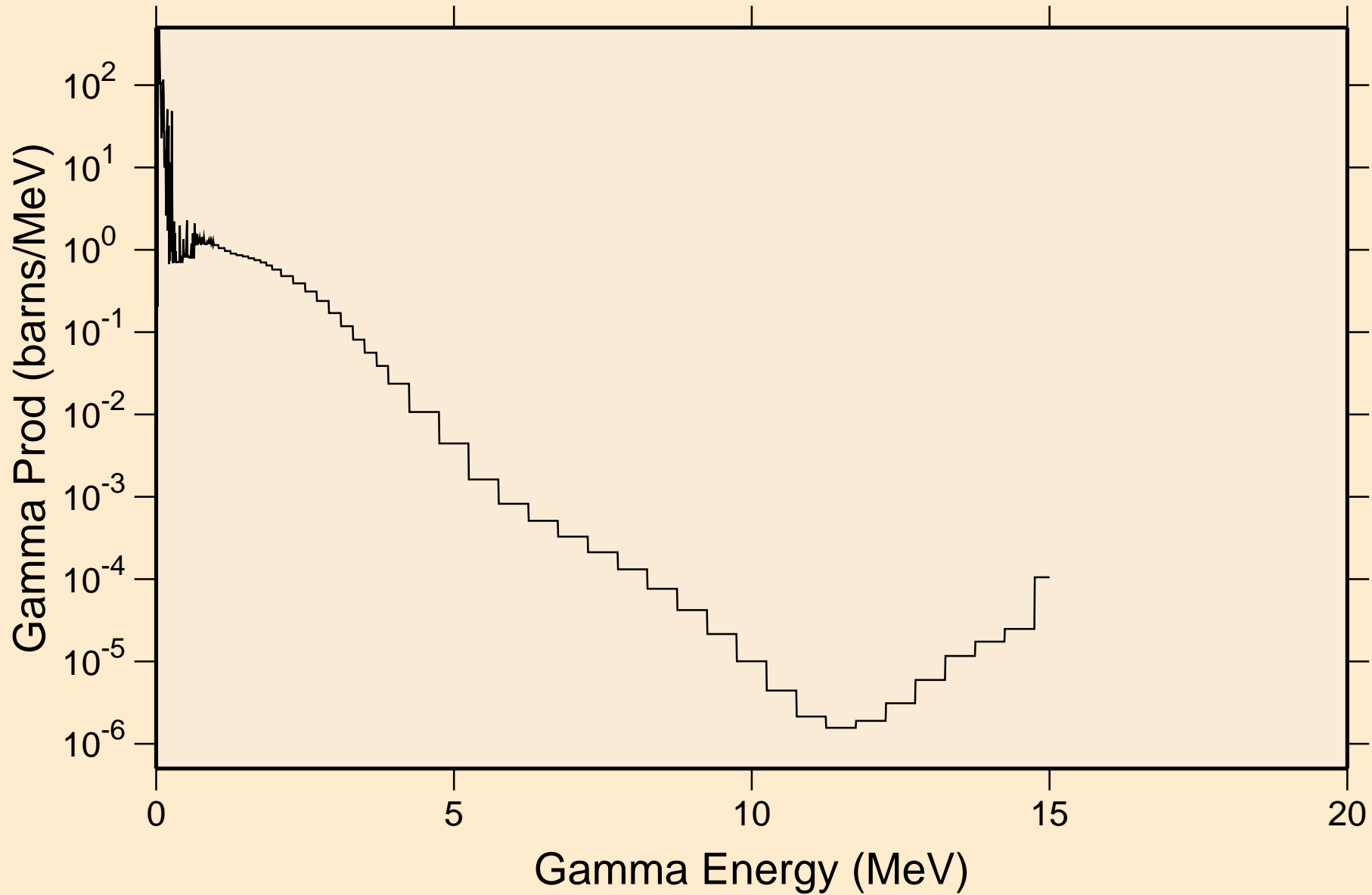

U235M NEUTRON ACER TENDL-2023 LIBRARY; T=0.K
Particle heating contributions

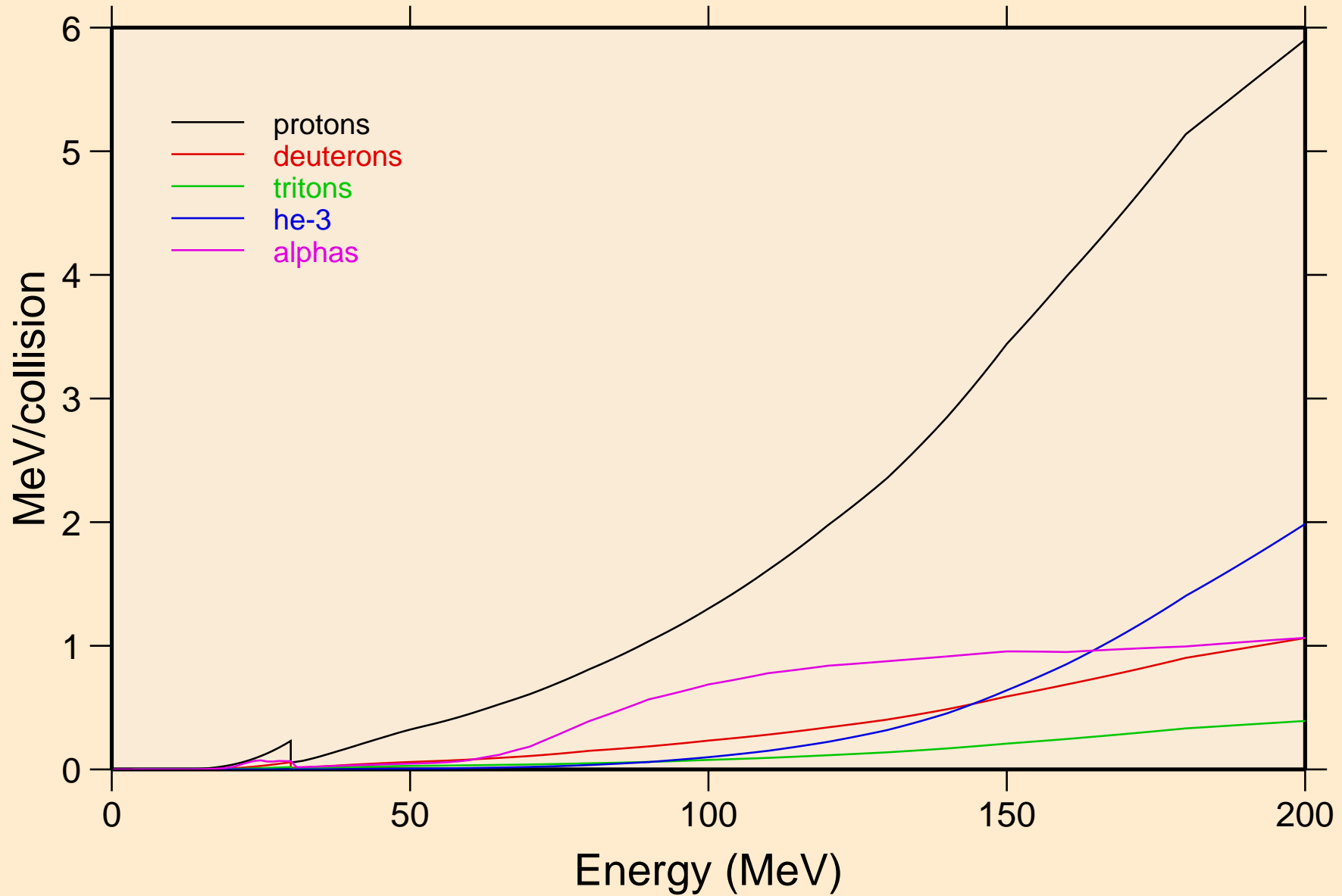

U235M NEUTRON ACER TENDL-2023 LIBRARY; T=0.K

Recoil Heating

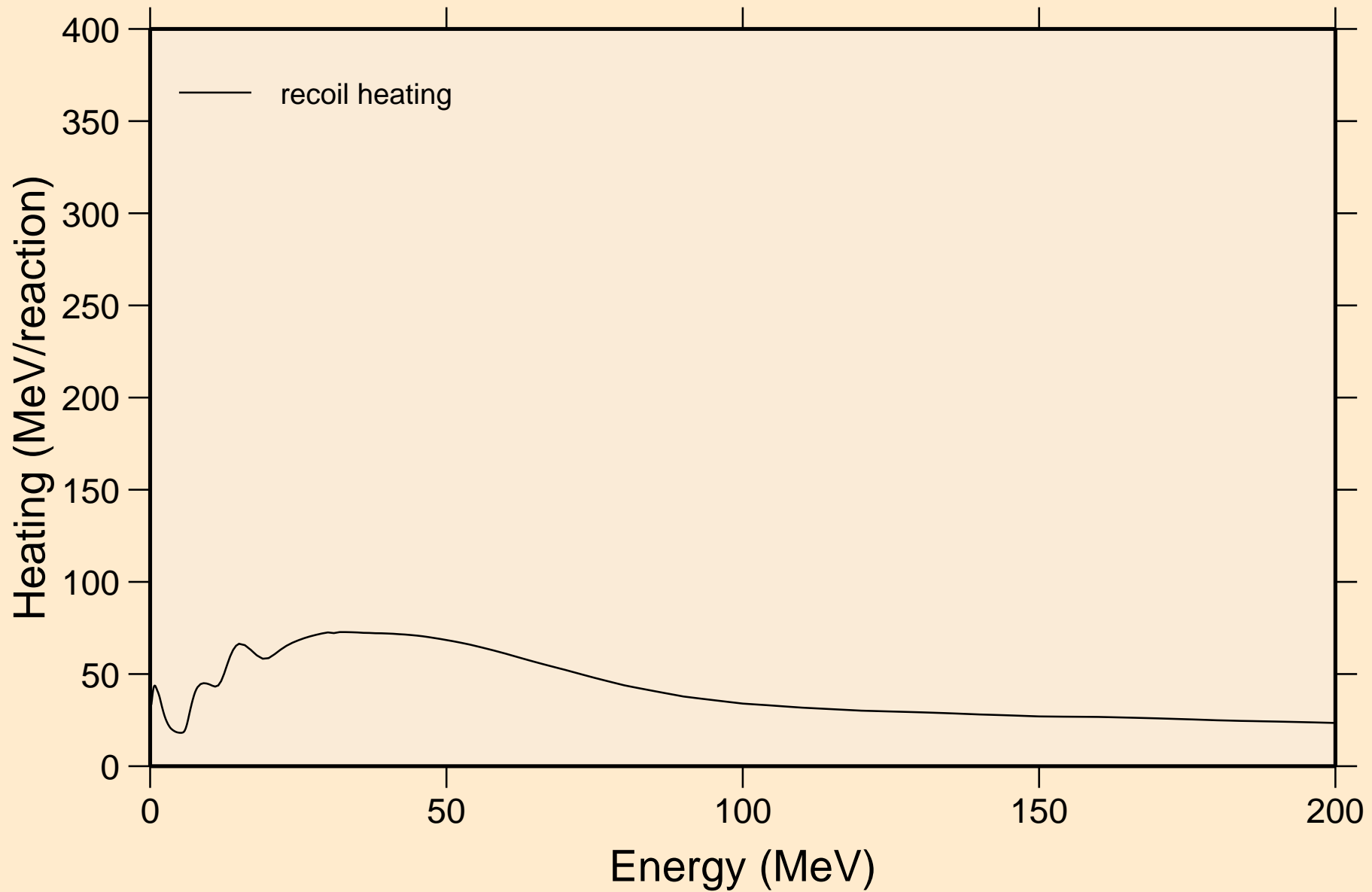

U235M NEUTRON ACER TENDL-2023 LIBRARY; T=0.K

Particle production cross sections

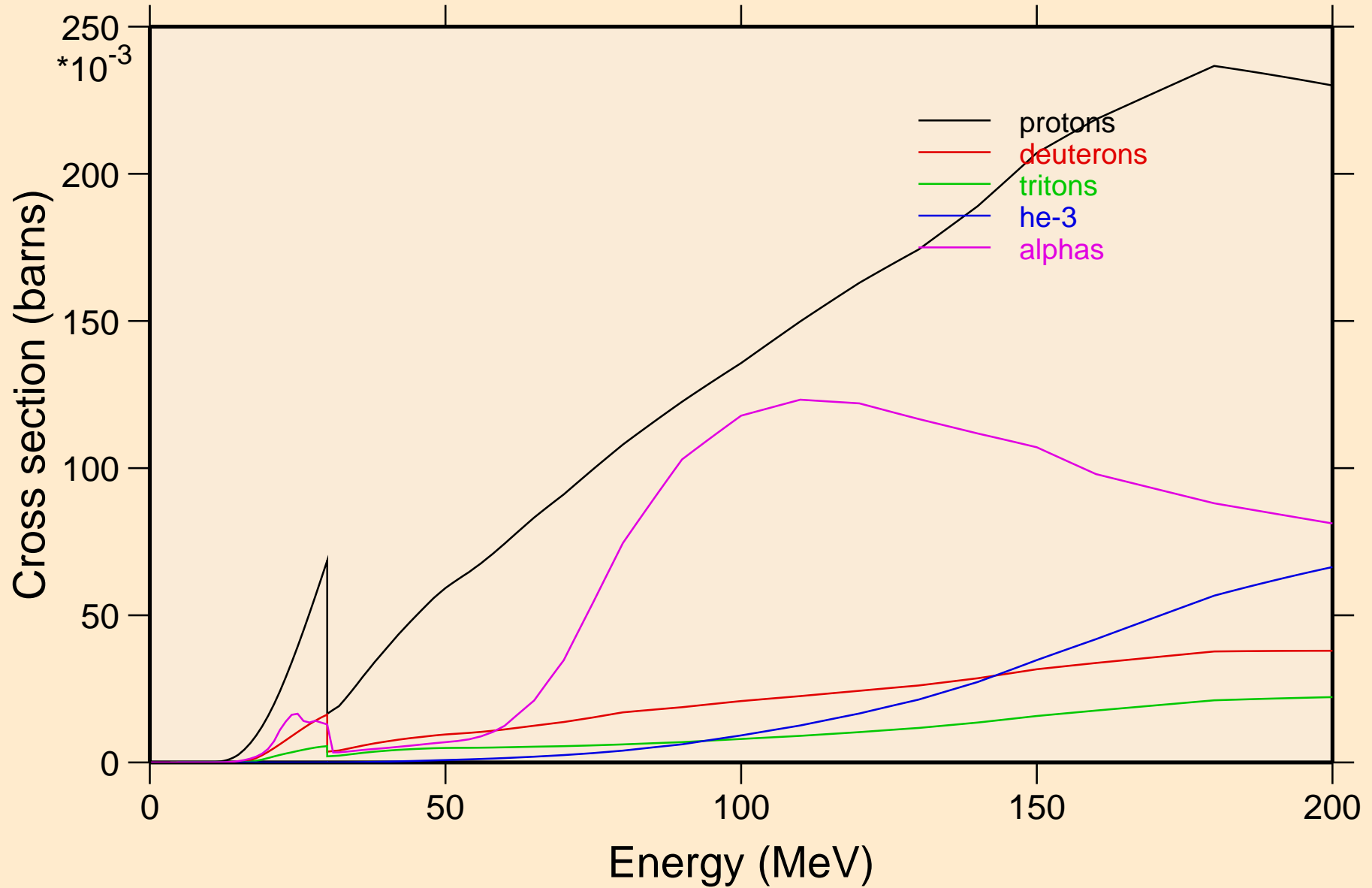

U235M NEUTRON ACER TENDL-2023 LIBRARY; T=0.K
protons from (n,x)

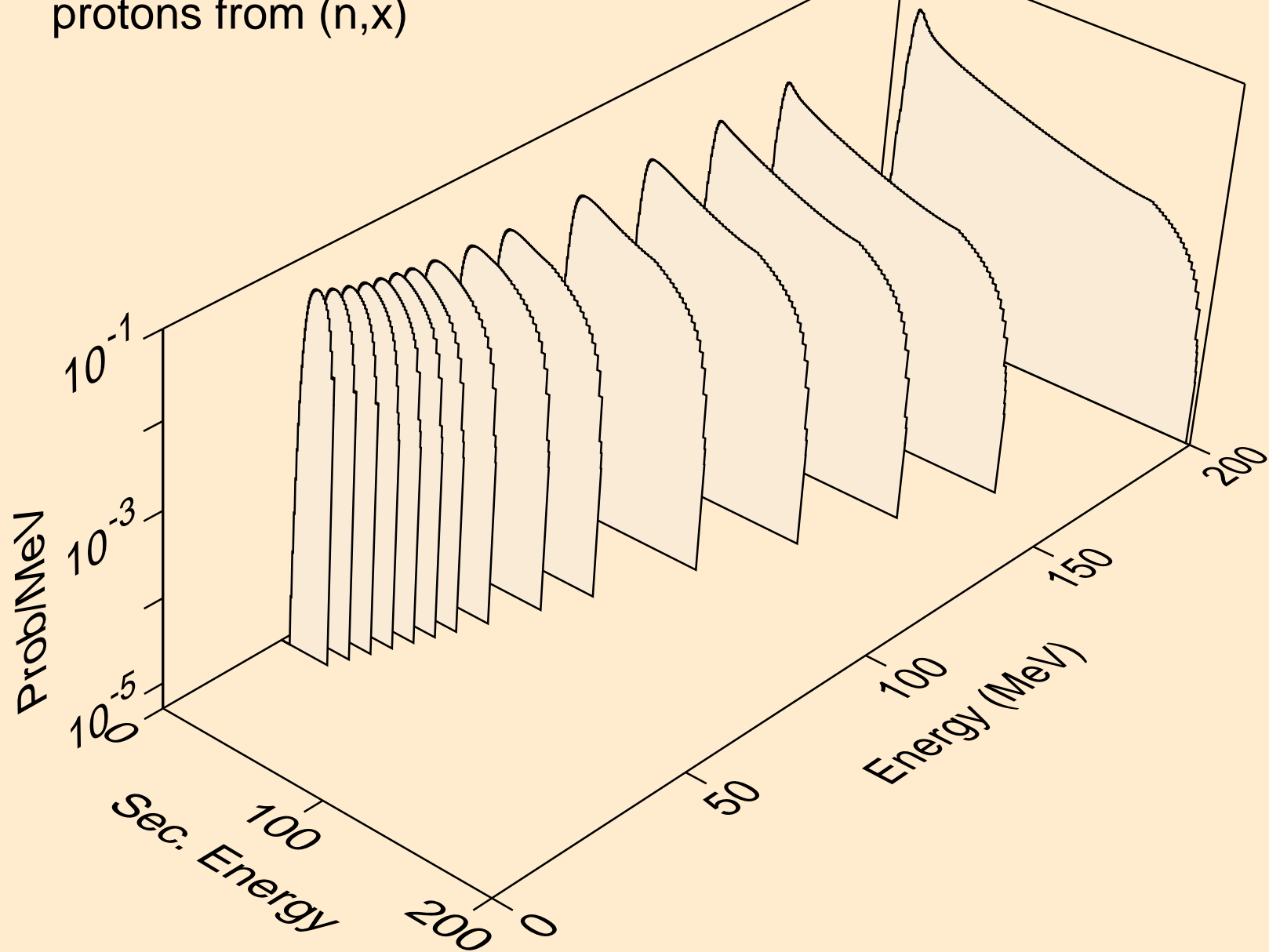

U235M NEUTRON ACER TENDL-2023 LIBRARY; T=0.K
protons from (n,n*)p

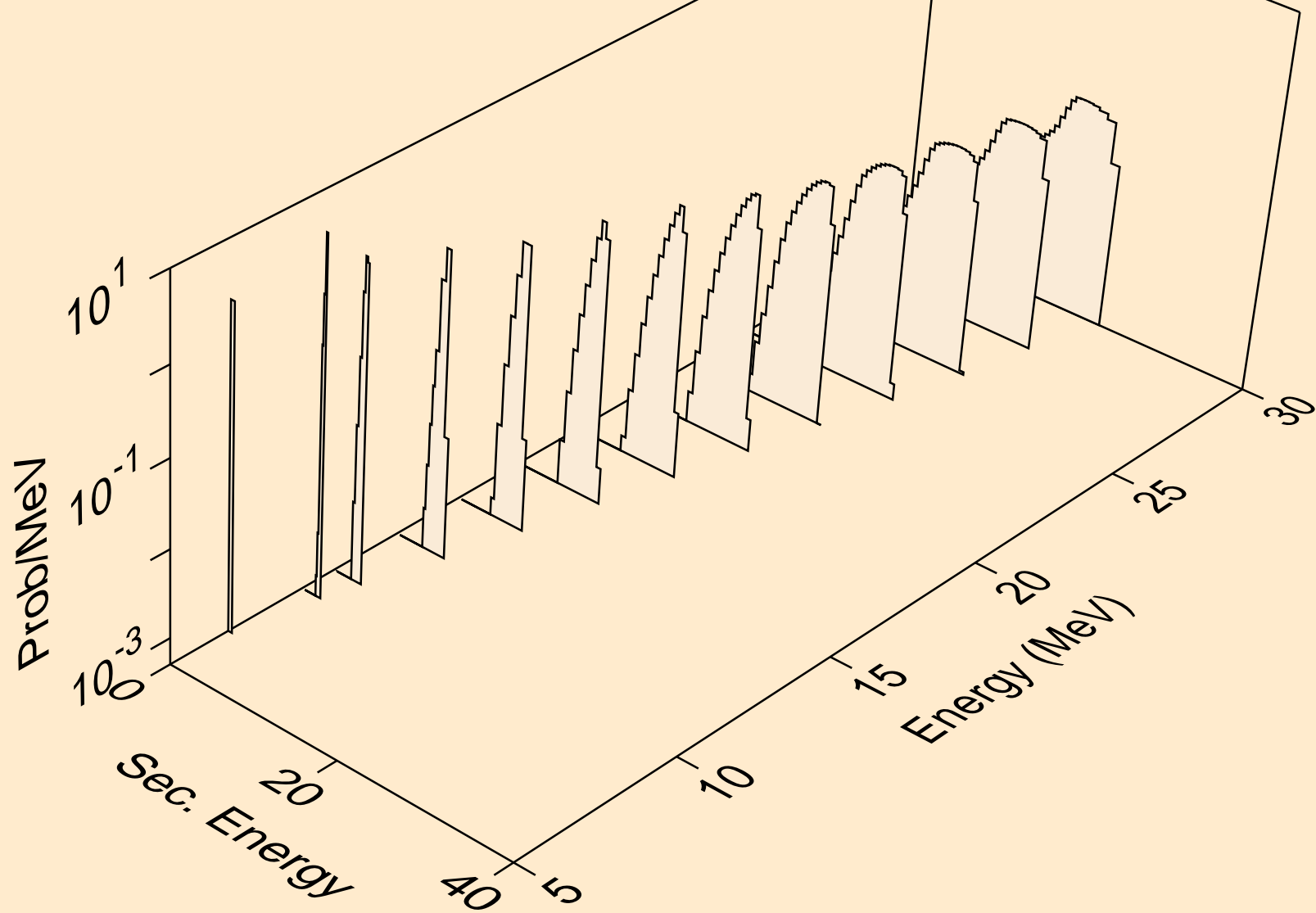

U235M NEUTRON ACER TENDL-2023 LIBRARY; T=0.K
protons from (n,2np)

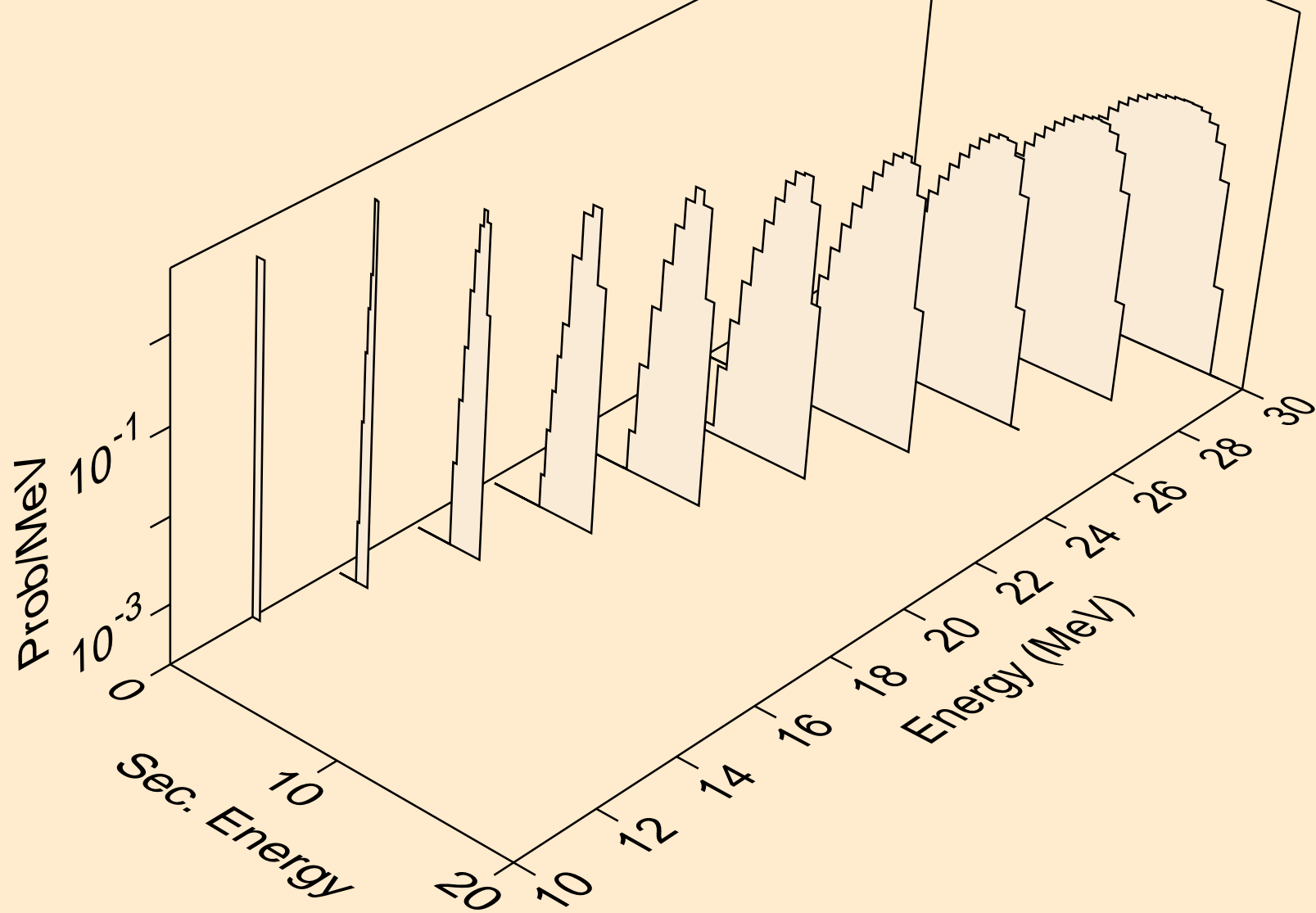

U235M NEUTRON ACER TENDL-2023 LIBRARY; T=0.K
protons from (n,3np)

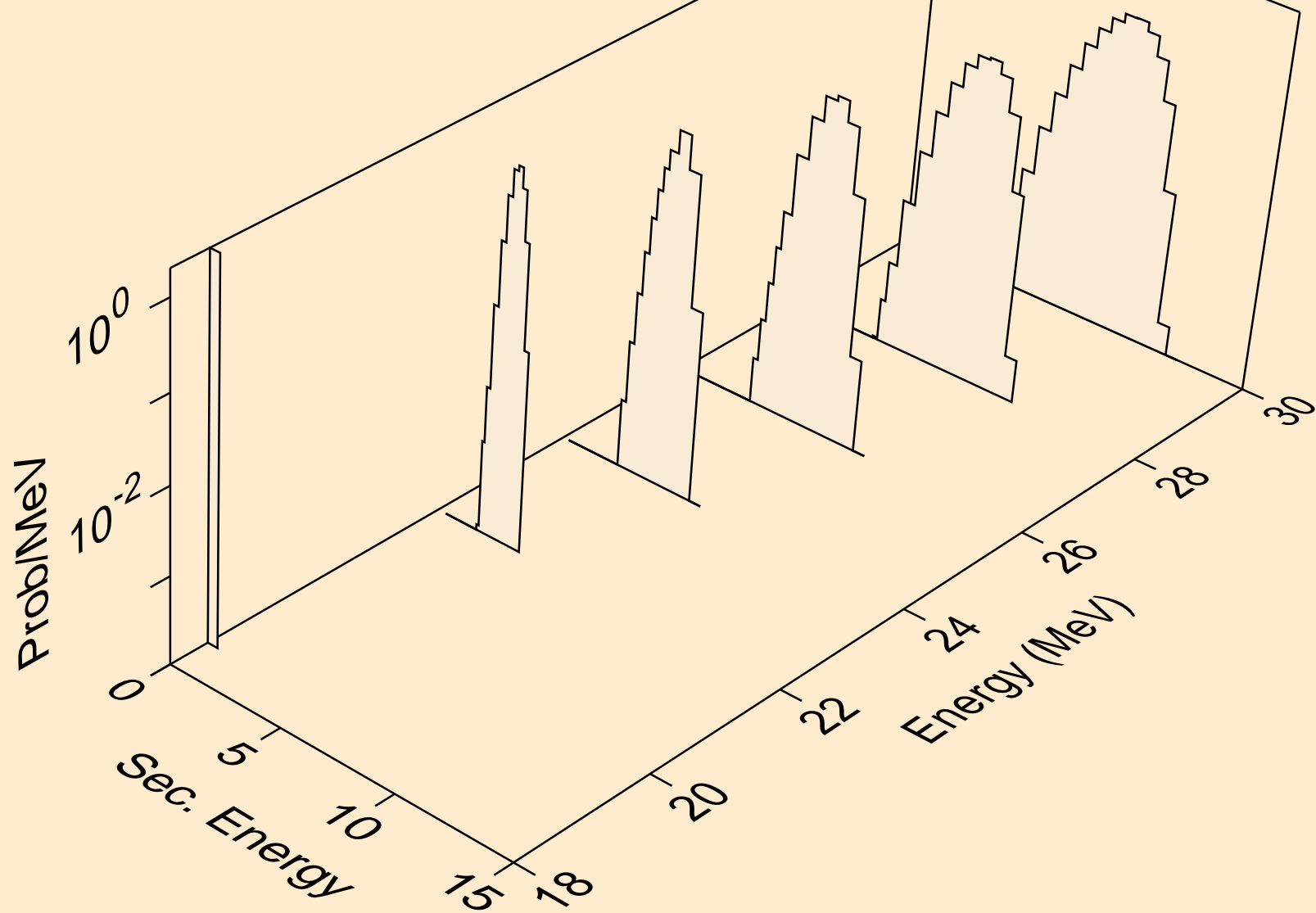

U235M NEUTRON ACER TENDL-2023 LIBRARY; T=0.K
protons from (n,n2p)

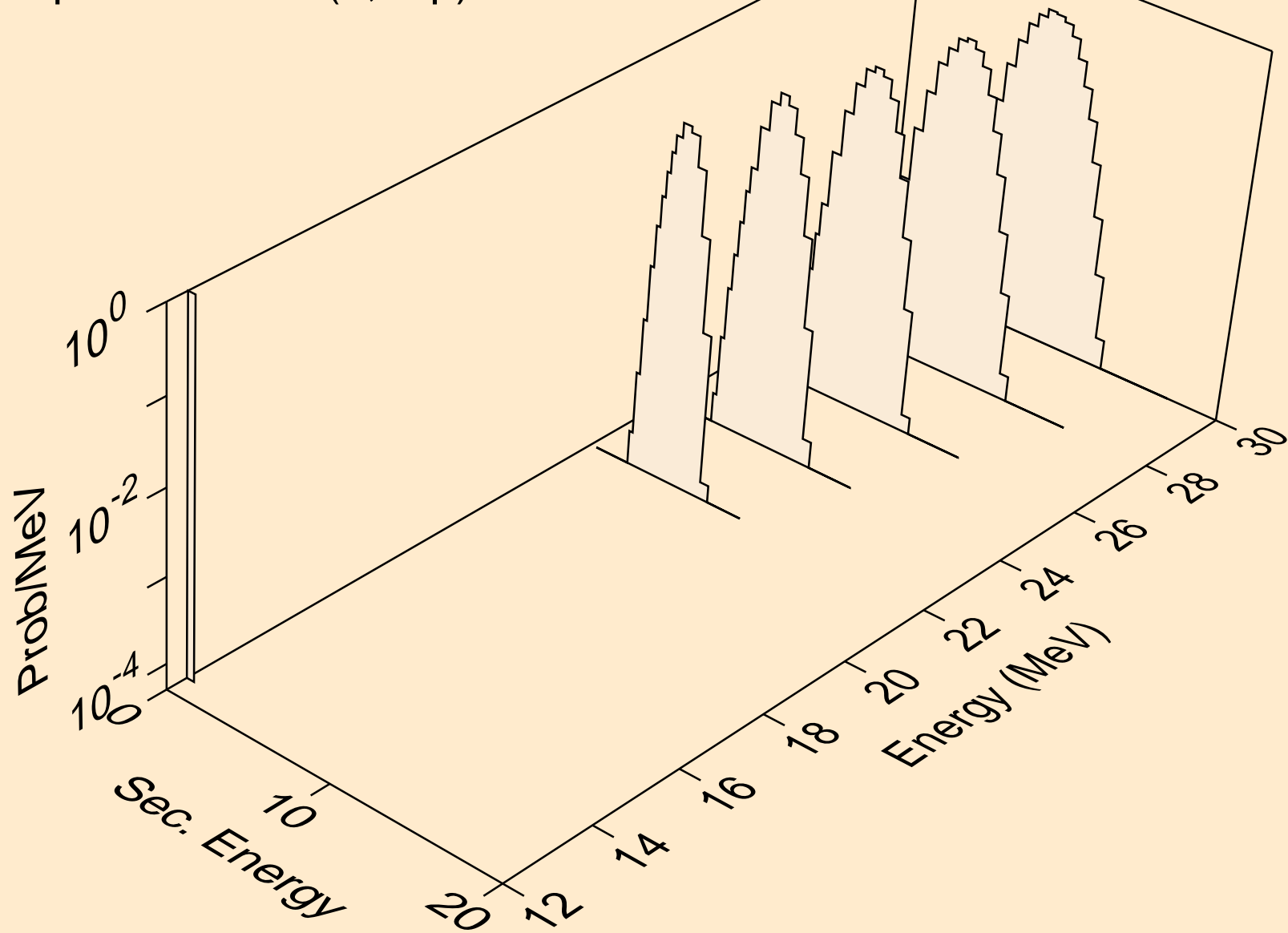

U235M NEUTRON ACER TENDL-2023 LIBRARY; T=0.K
protons from (n,p)

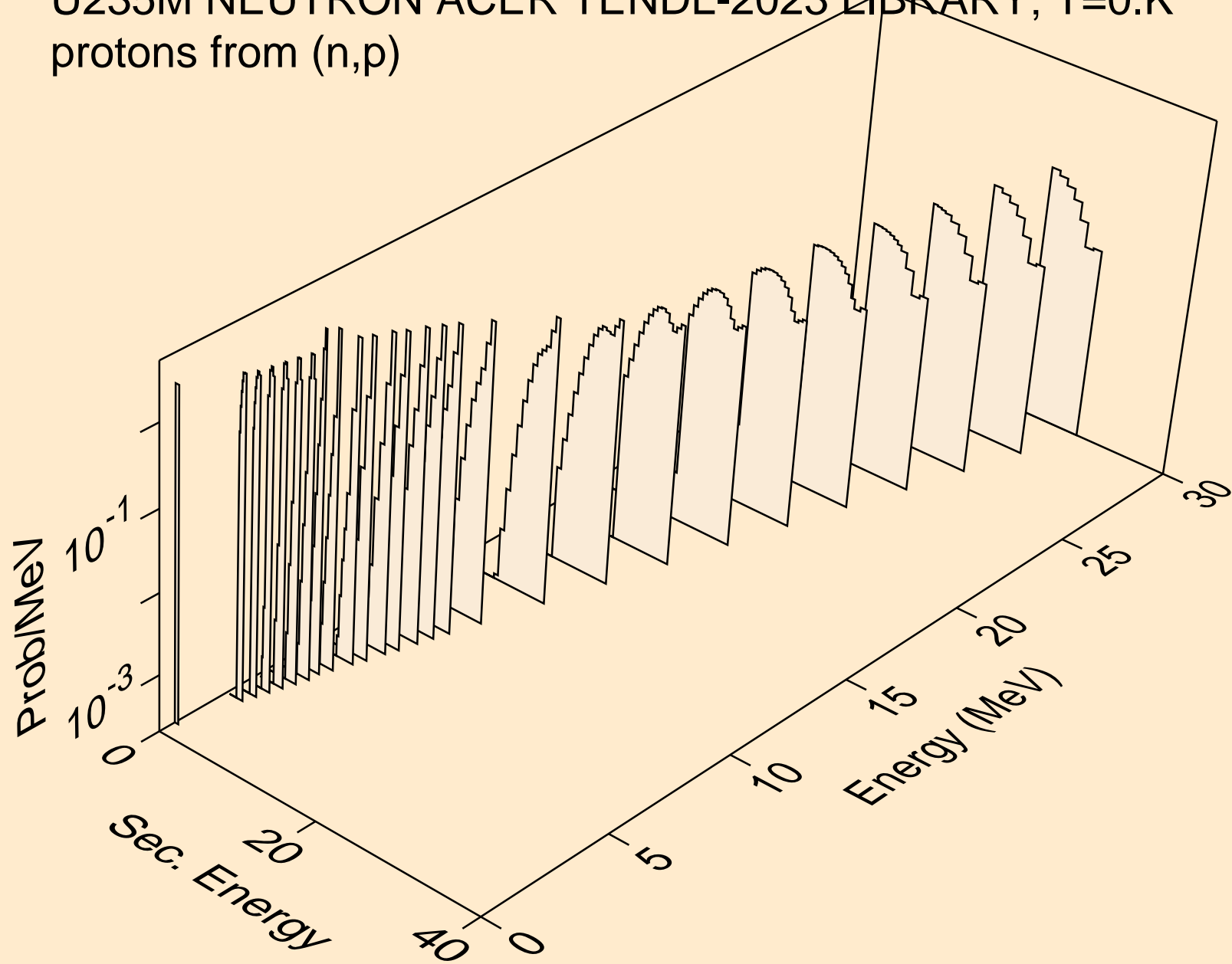

U235M NEUTRON ACER TENDL-2023 LIBRARY; T=0.K
protons from (n,2p)

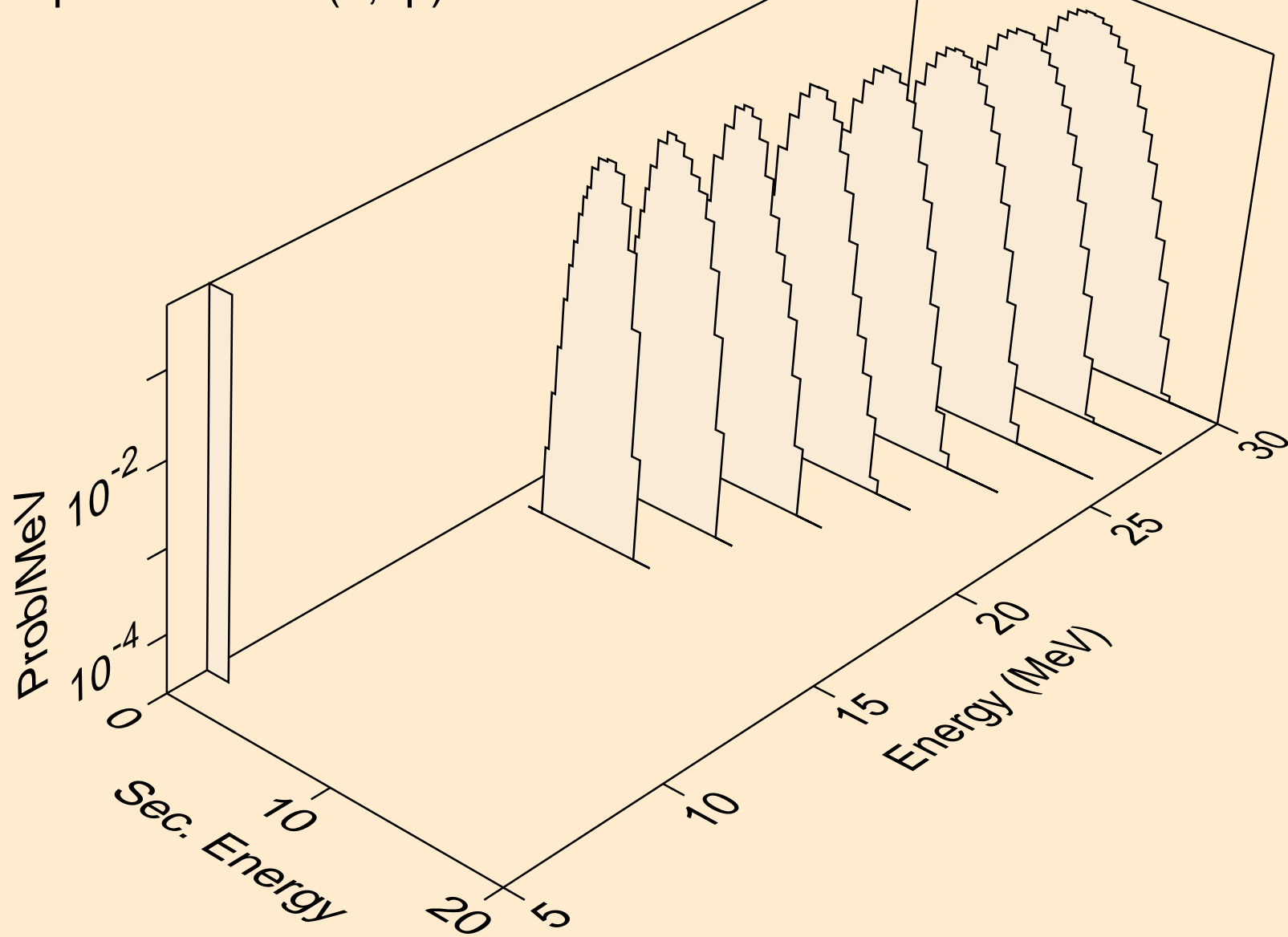

U235M NEUTRON ACER TENDL-2023 LIBRARY; T=0.K
deuterons from (n,x)

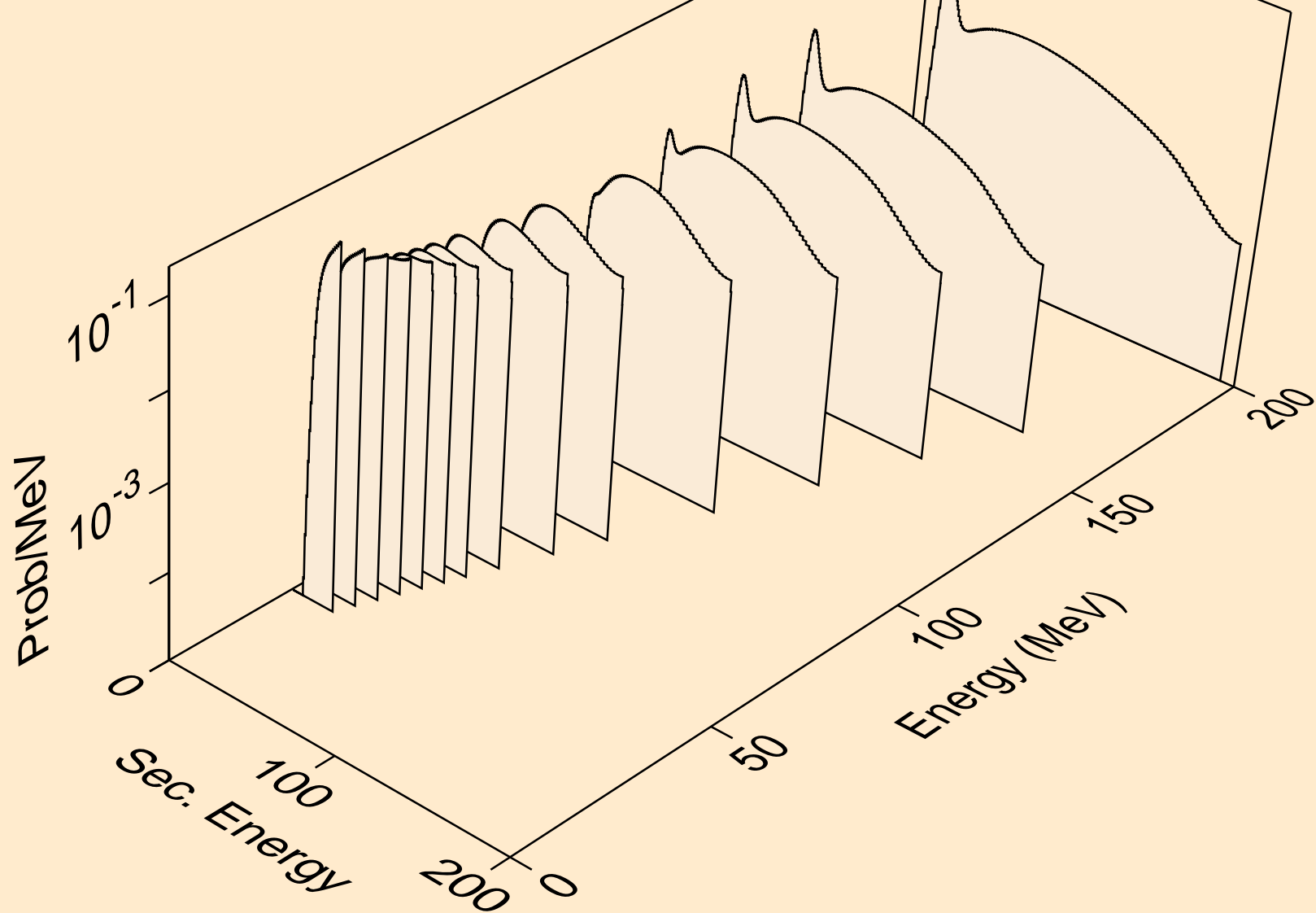

U235M NEUTRON ACER TENDL-2023 LIBRARY; T=0.K
deuterons from (n,2nd)

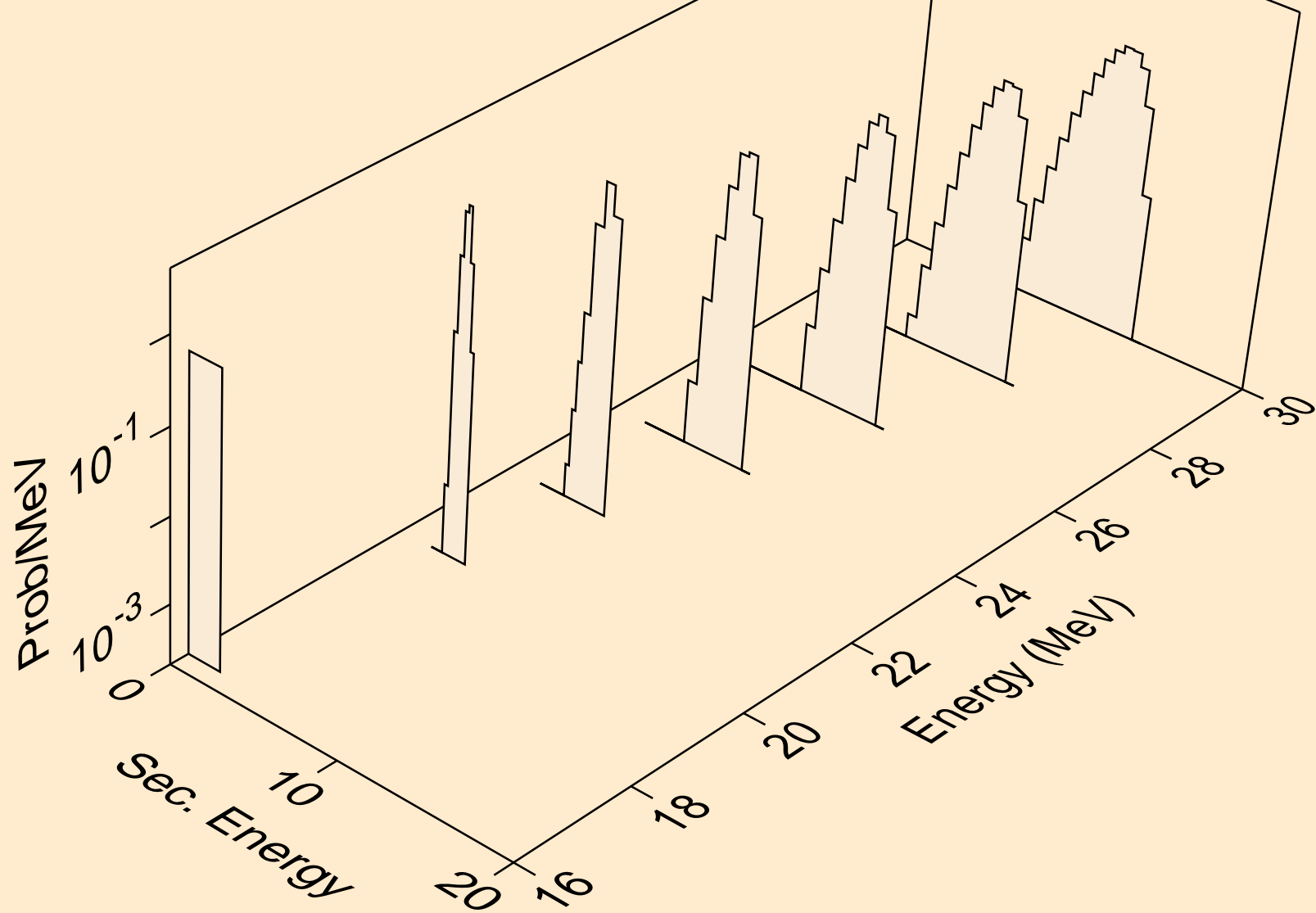

U235M NEUTRON ACER TENDL-2023 LIBRARY; T=0.K
deuterons from (n,n*)d

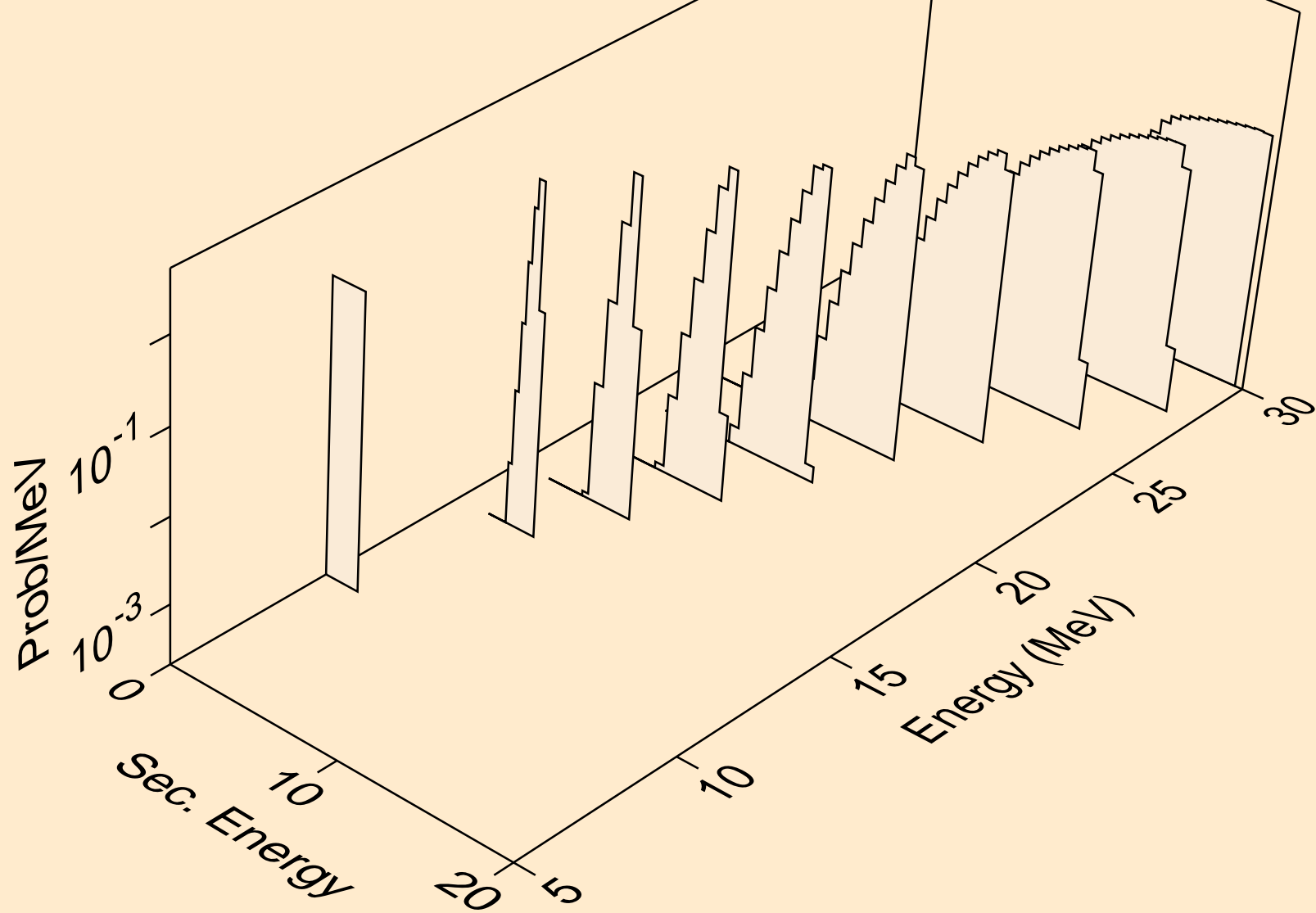

U235M NEUTRON ACER TENDL-2023 LIBRARY; T=0.K
deuterons from (n,d)

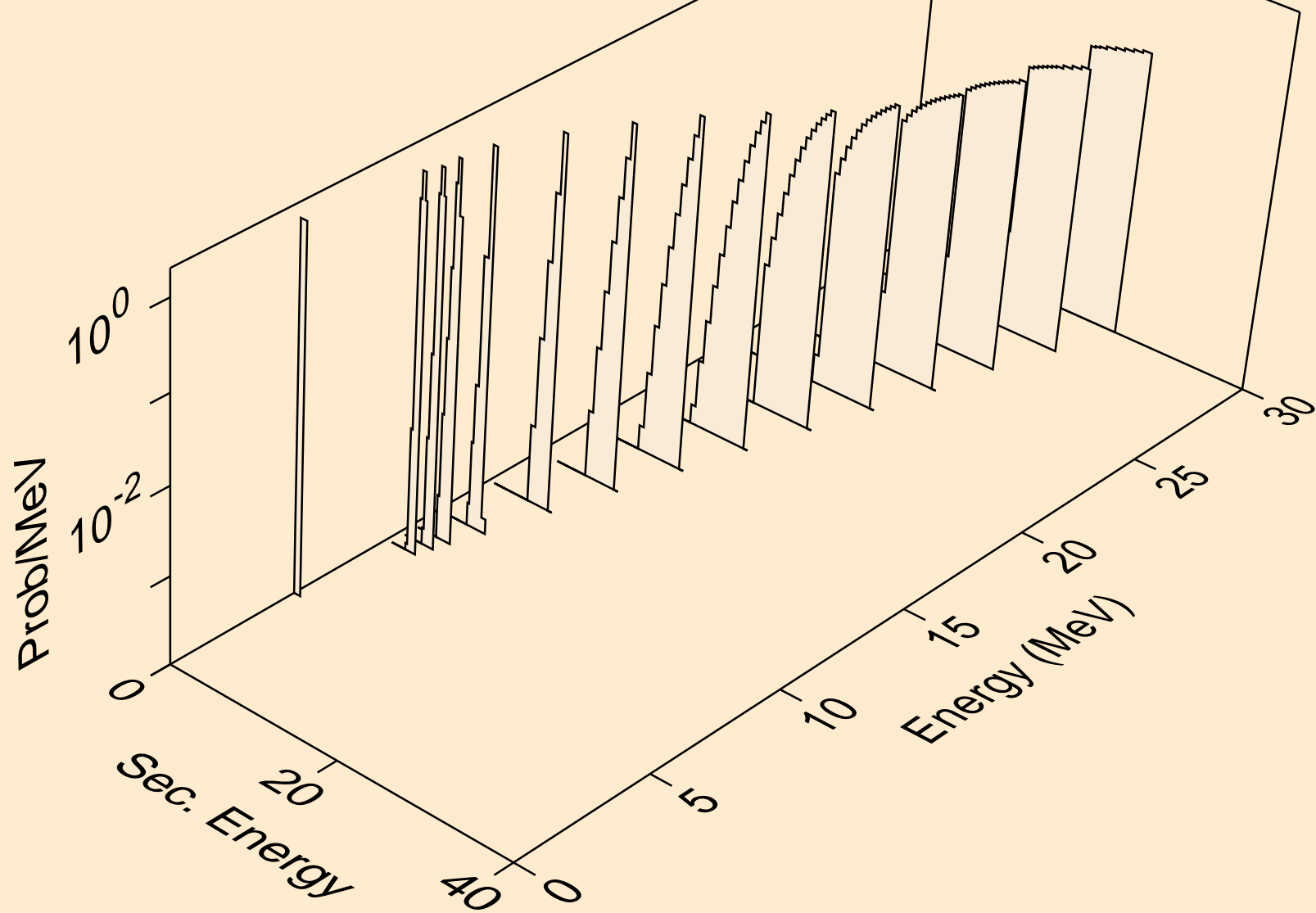

U235M NEUTRON ACER TENDL-2023 LIBRARY; T=0.K
tritons from (n,x)

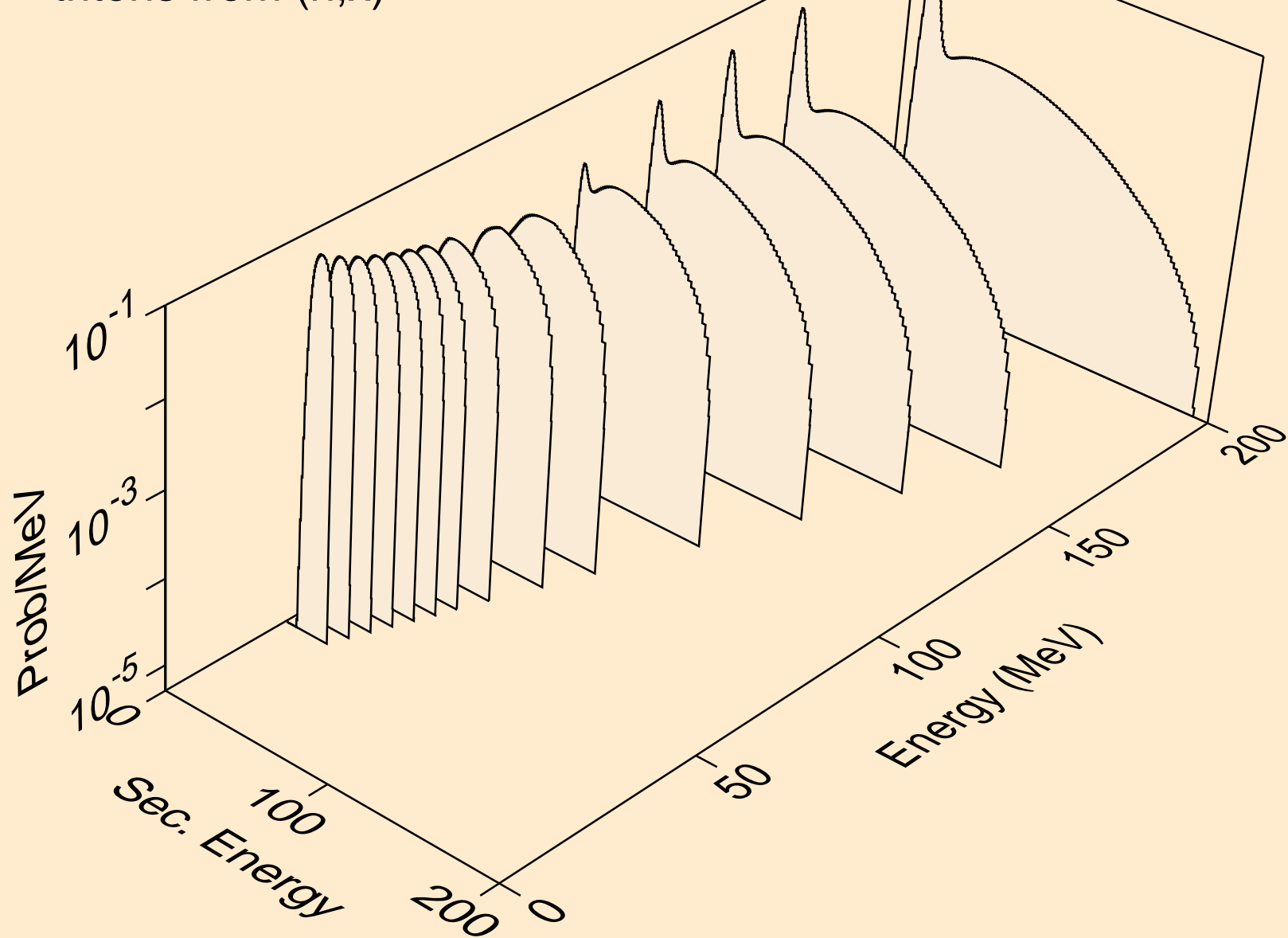

U235M NEUTRON ACER TENDL-2023 LIBRARY; T=0.K
tritons from (n,n*)t

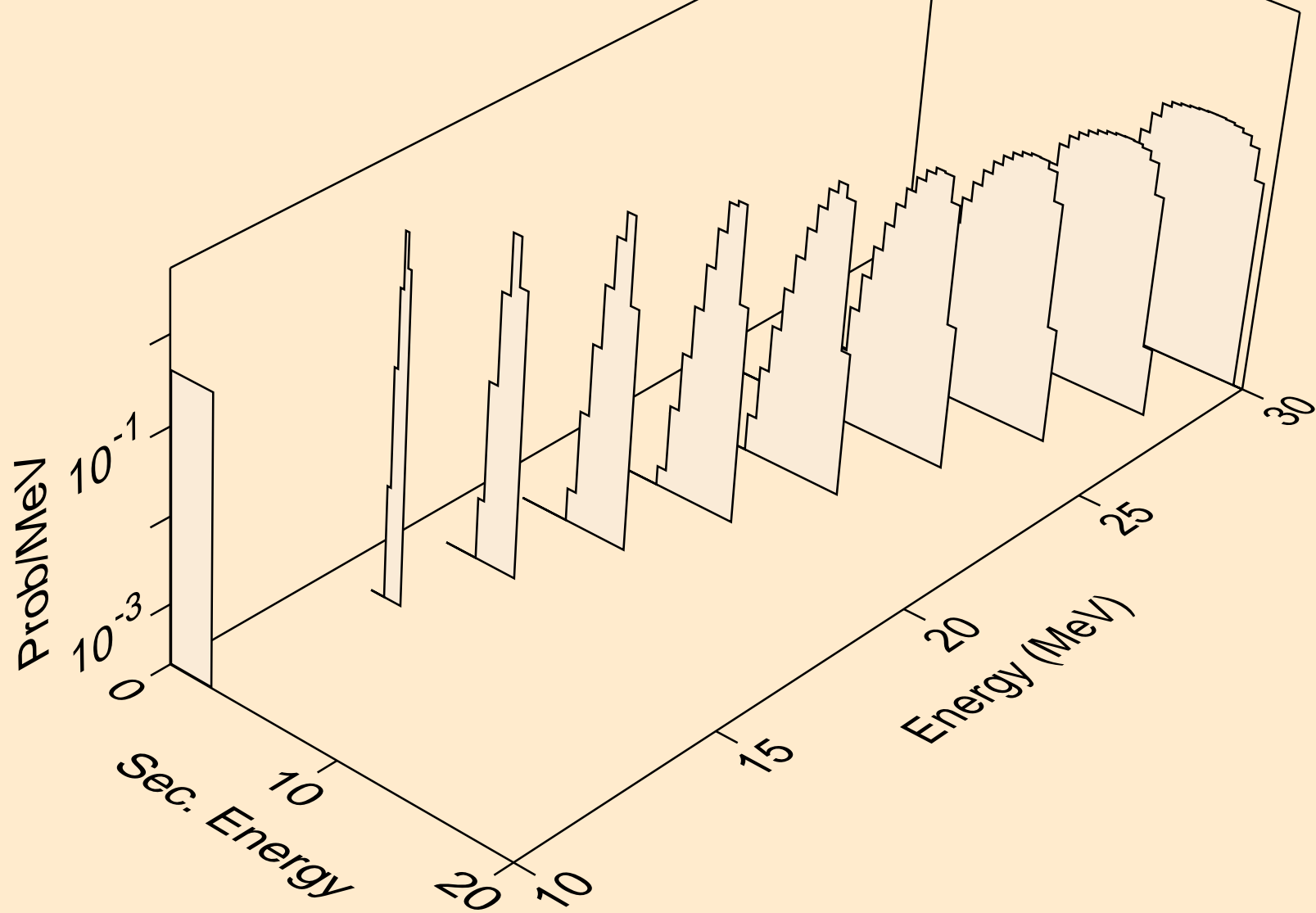

U235M NEUTRON ACER TENDL-2023 LIBRARY; T=0.K
tritons from (n,t)

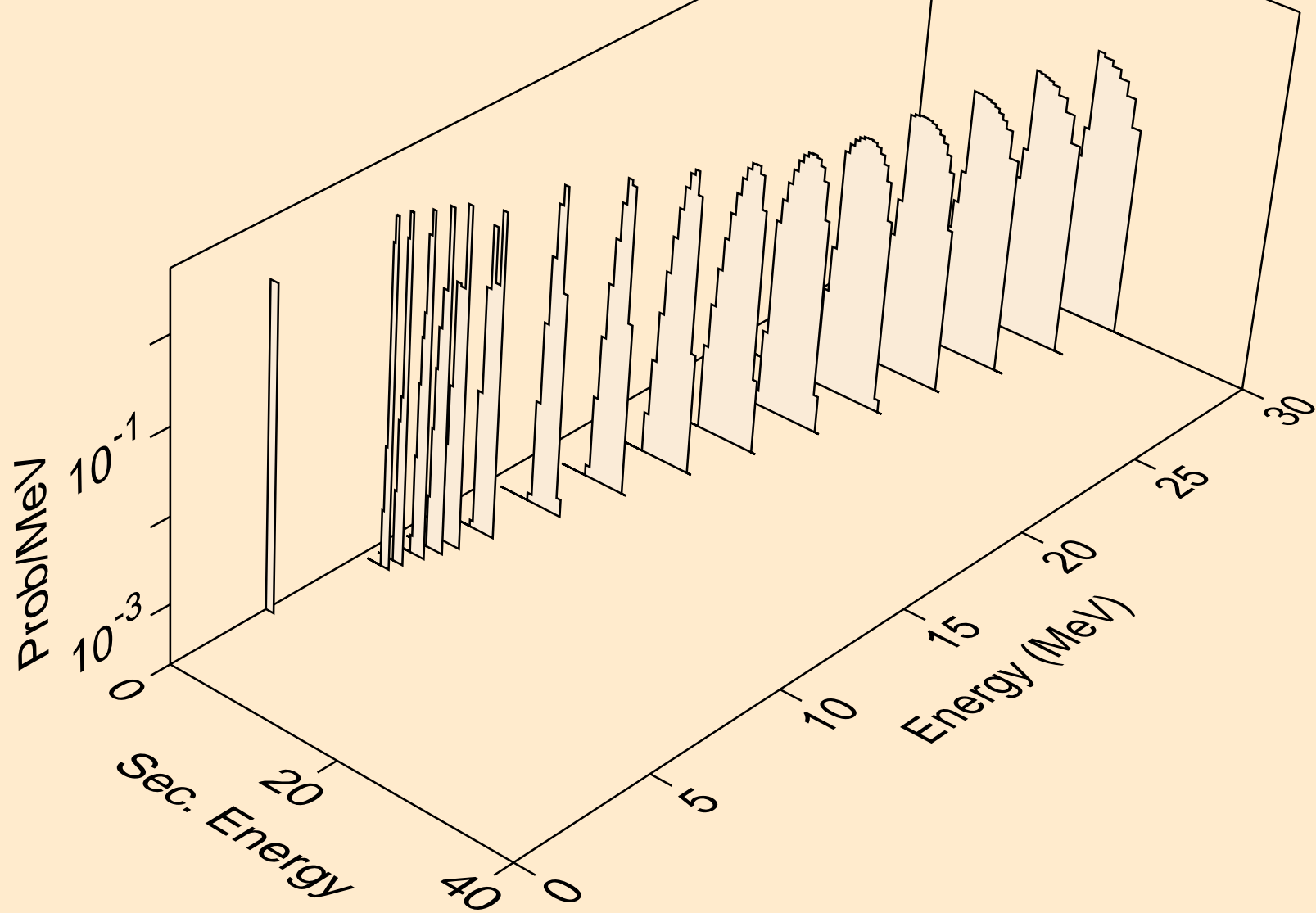

U235M NEUTRON ACER TENDL-2023 LIBRARY; T=0.K
he3s from (n,x)

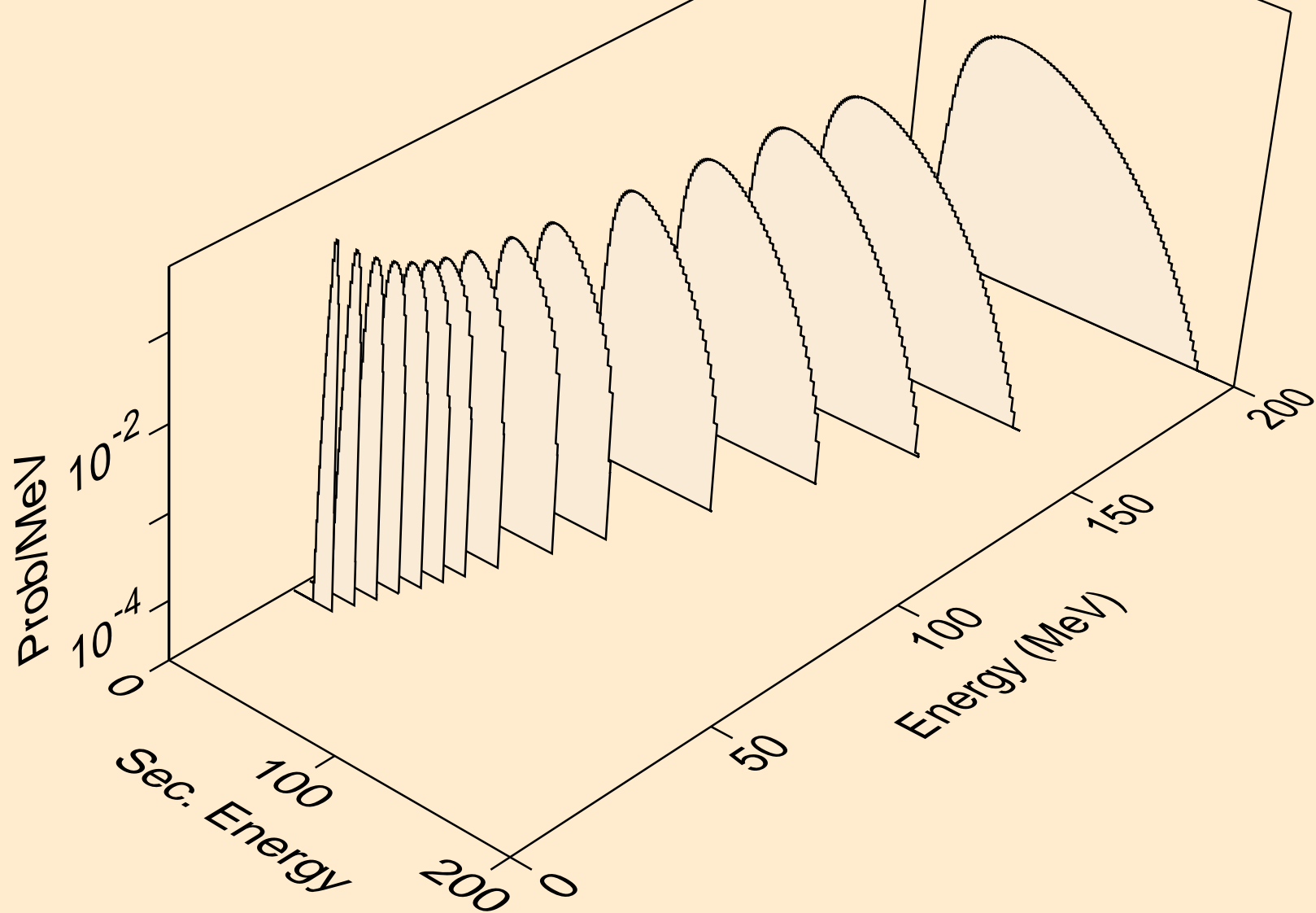

U235M NEUTRON ACER TENDL-2023 LIBRARY; T=0.K
he3s from (n,n*)he3

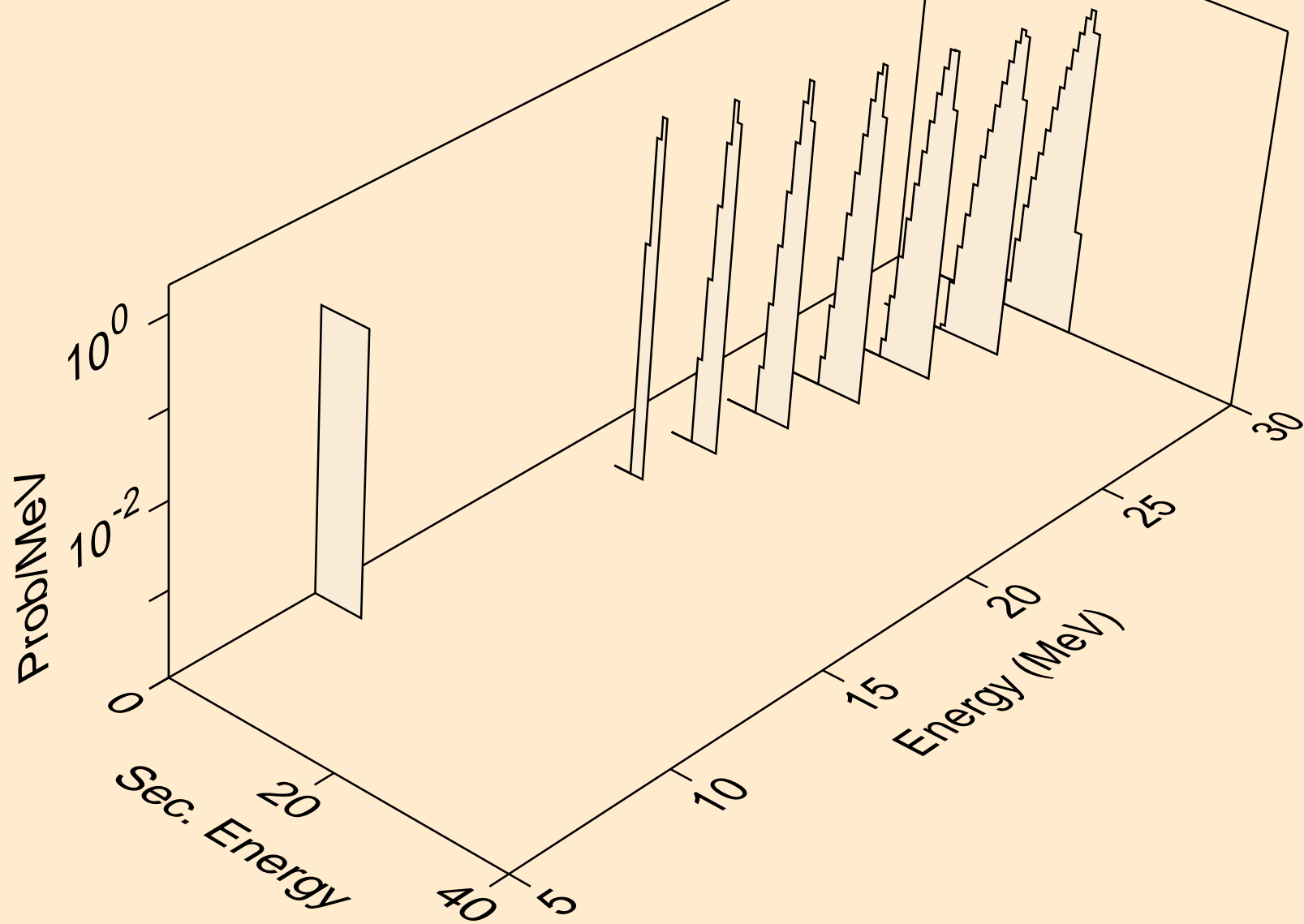

U235M NEUTRON ACER TENDL-2023 LIBRARY; T=0.K
he3s from (n,he3)

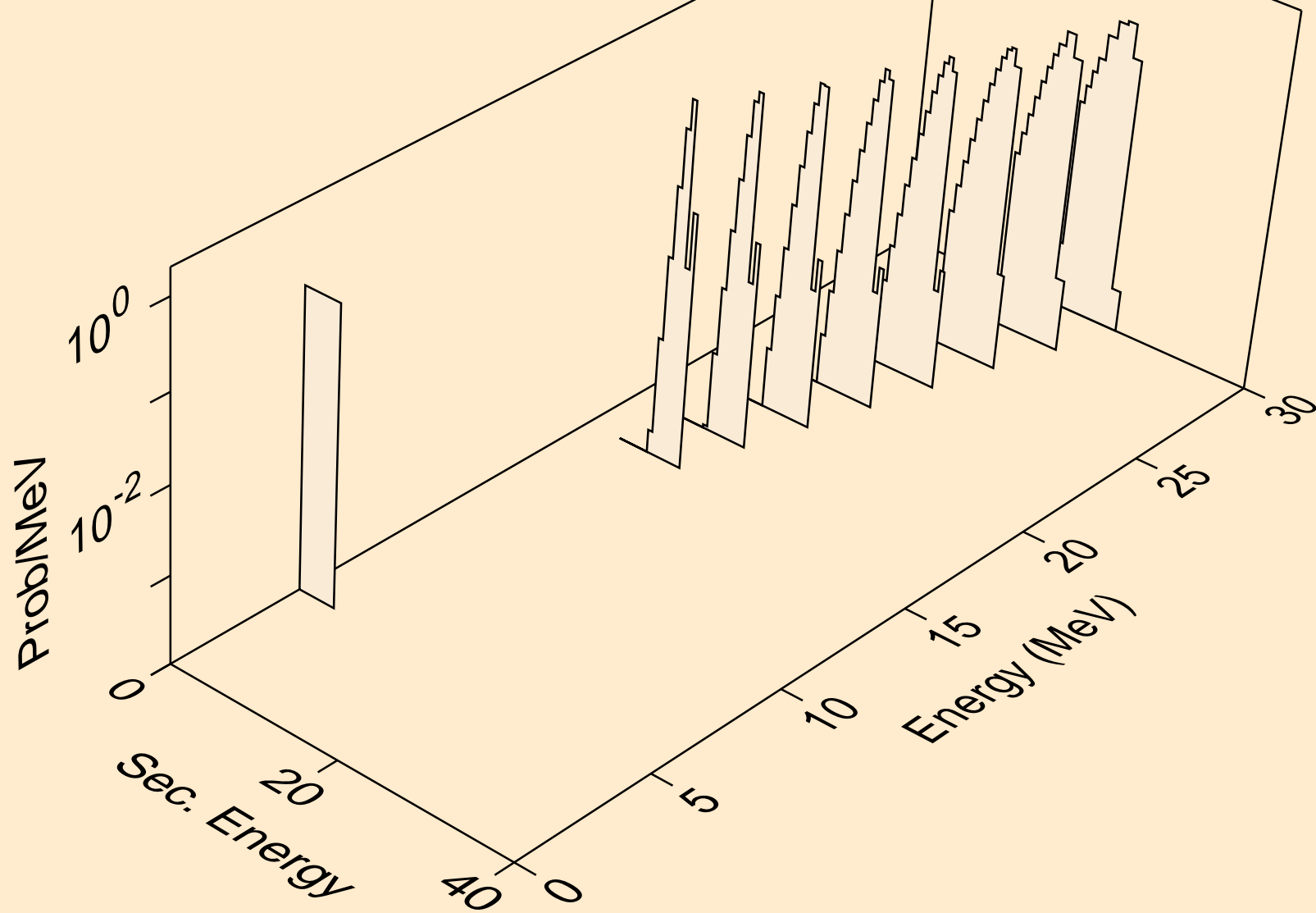

U235M NEUTRON ACER TENDL-2023 LIBRARY; T=0.K
alphas from (n,x)

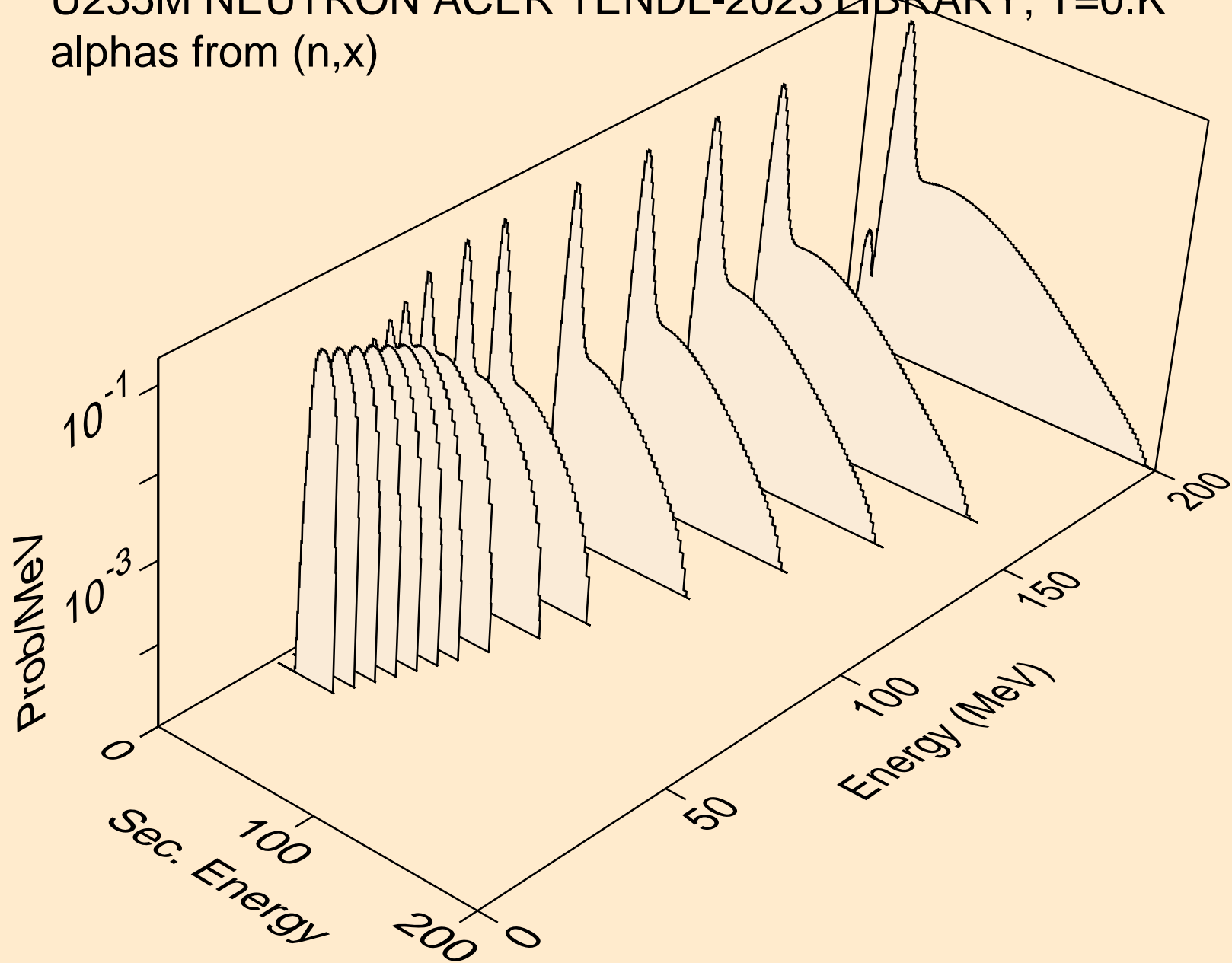

U235M NEUTRON ACER TENDL-2023 LIBRARY; T=0.K
alphas from (n,n*)a

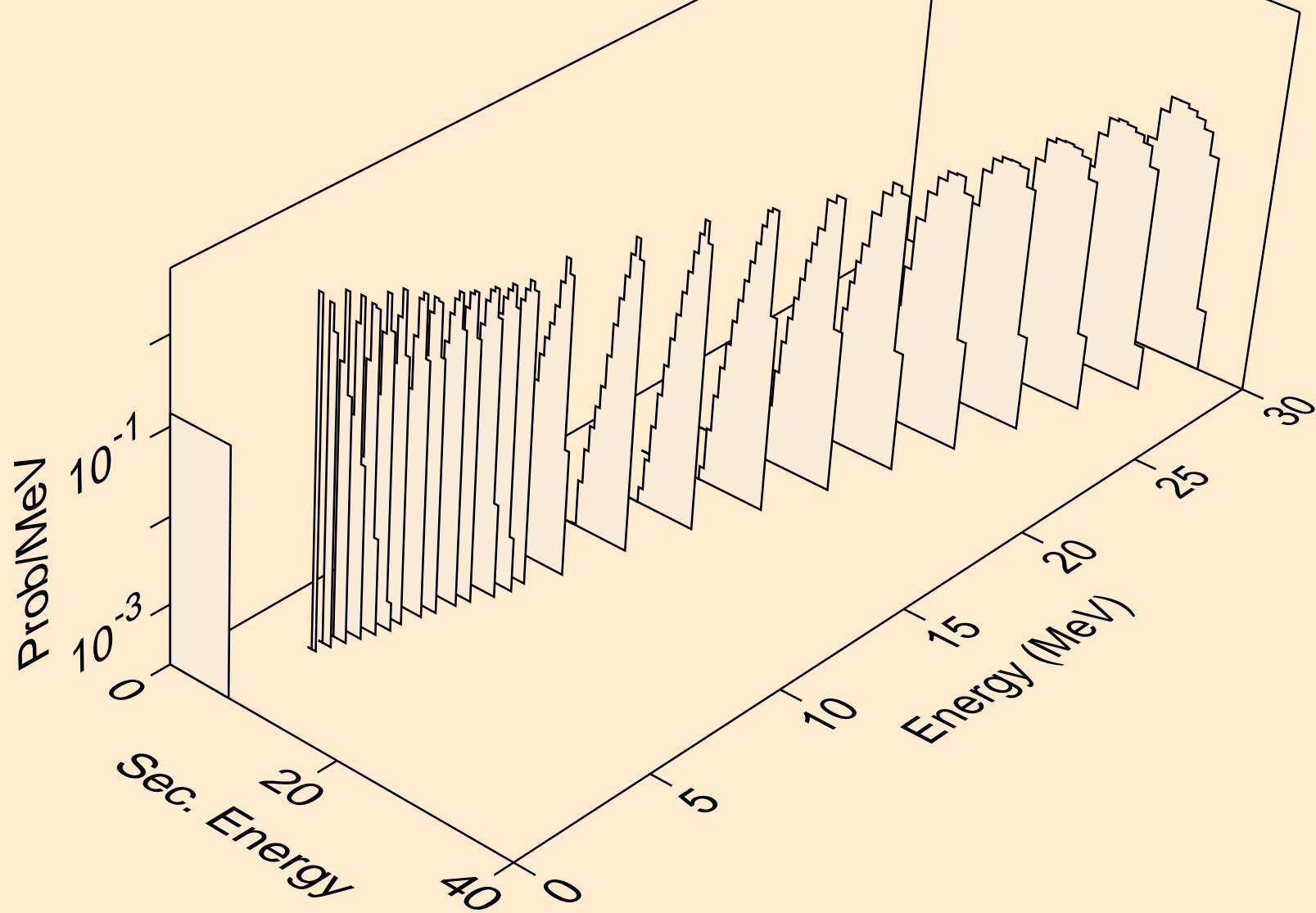

U235M NEUTRON ACER TENDL-2023 LIBRARY; T=0.K
alphas from (n,2n)a

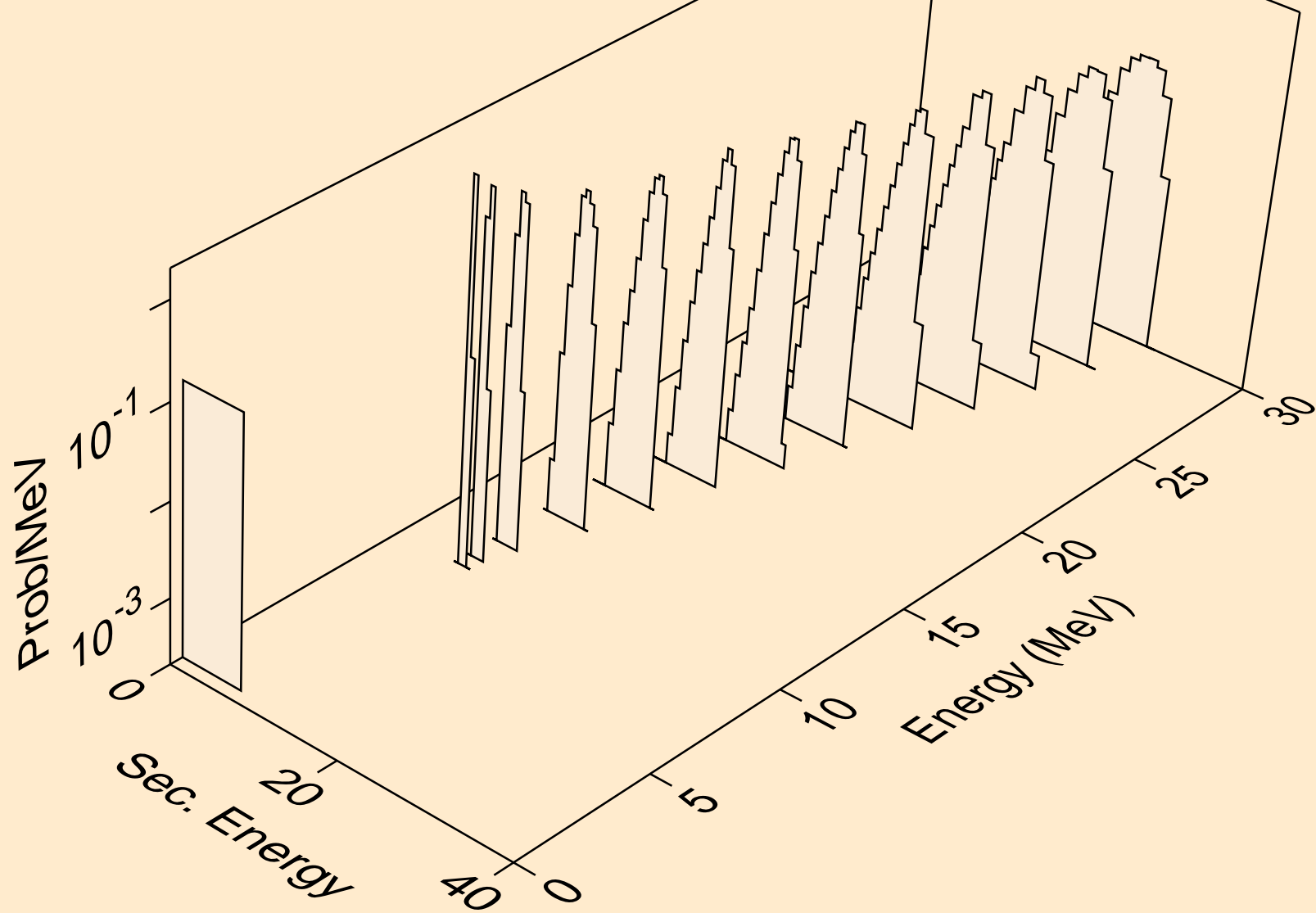

U235M NEUTRON ACER TENDL-2023 LIBRARY; T=0.K
alphas from (n,3n)a

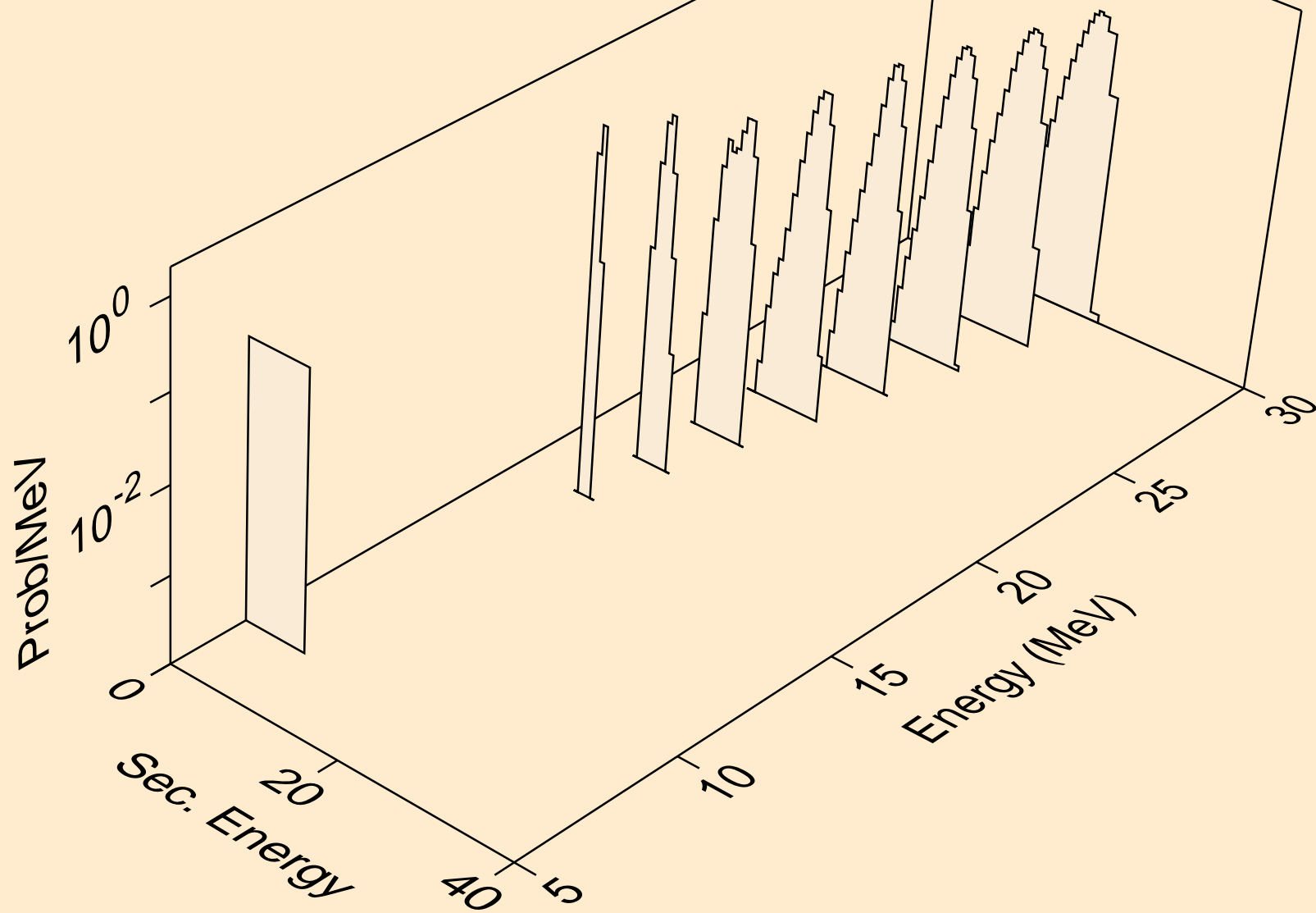

U235M NEUTRON ACER TENDL-2023 LIBRARY; T=0.K
alphas from (n,a)

