

# ZN069M NEUTRON ACER TENDL-2023 LIBRARY; T=0.K

## Principal cross sections

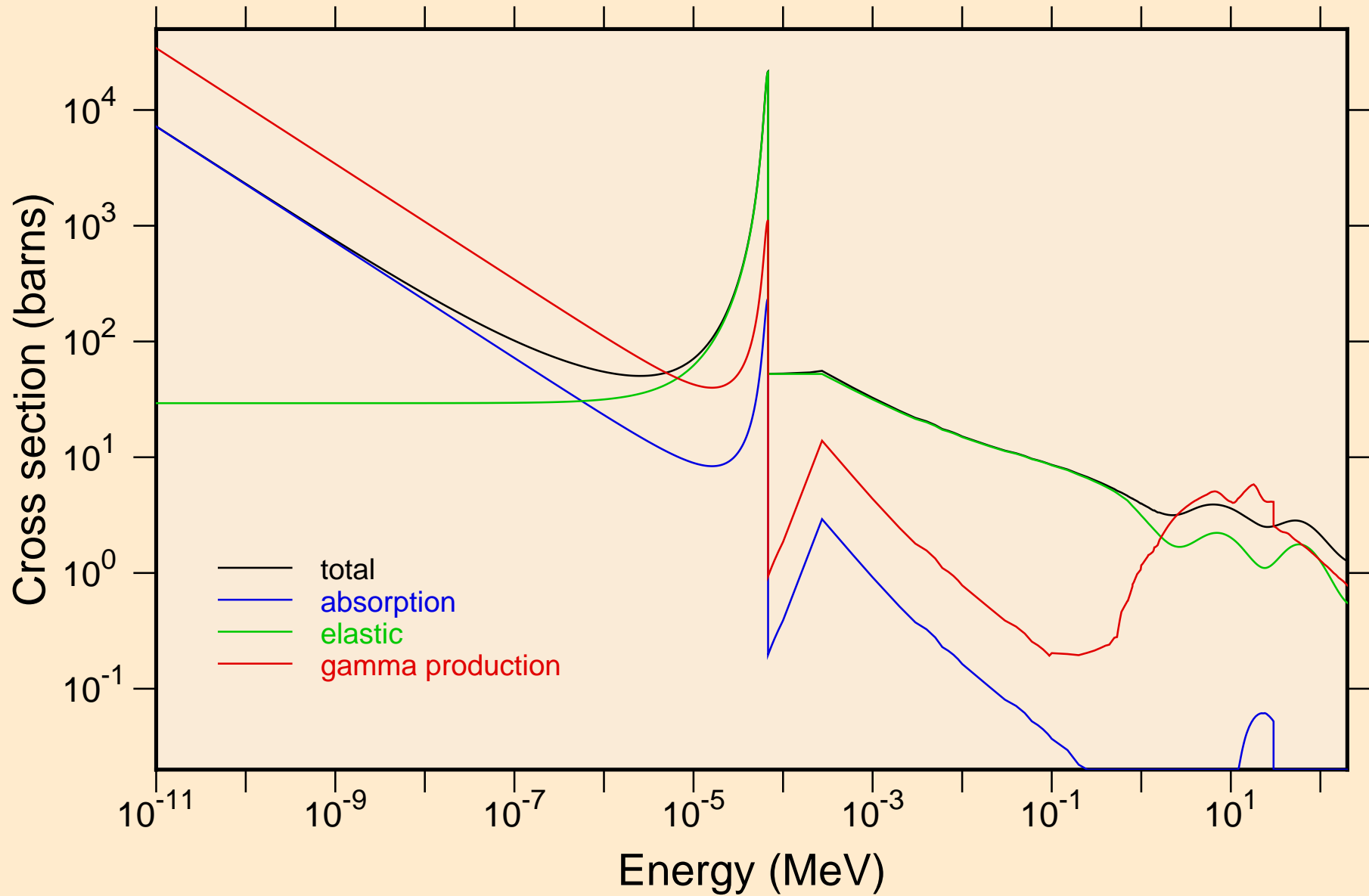

# ZN069M NEUTRON ACER TENDL-2023 LIBRARY; T=0.K

## Heating

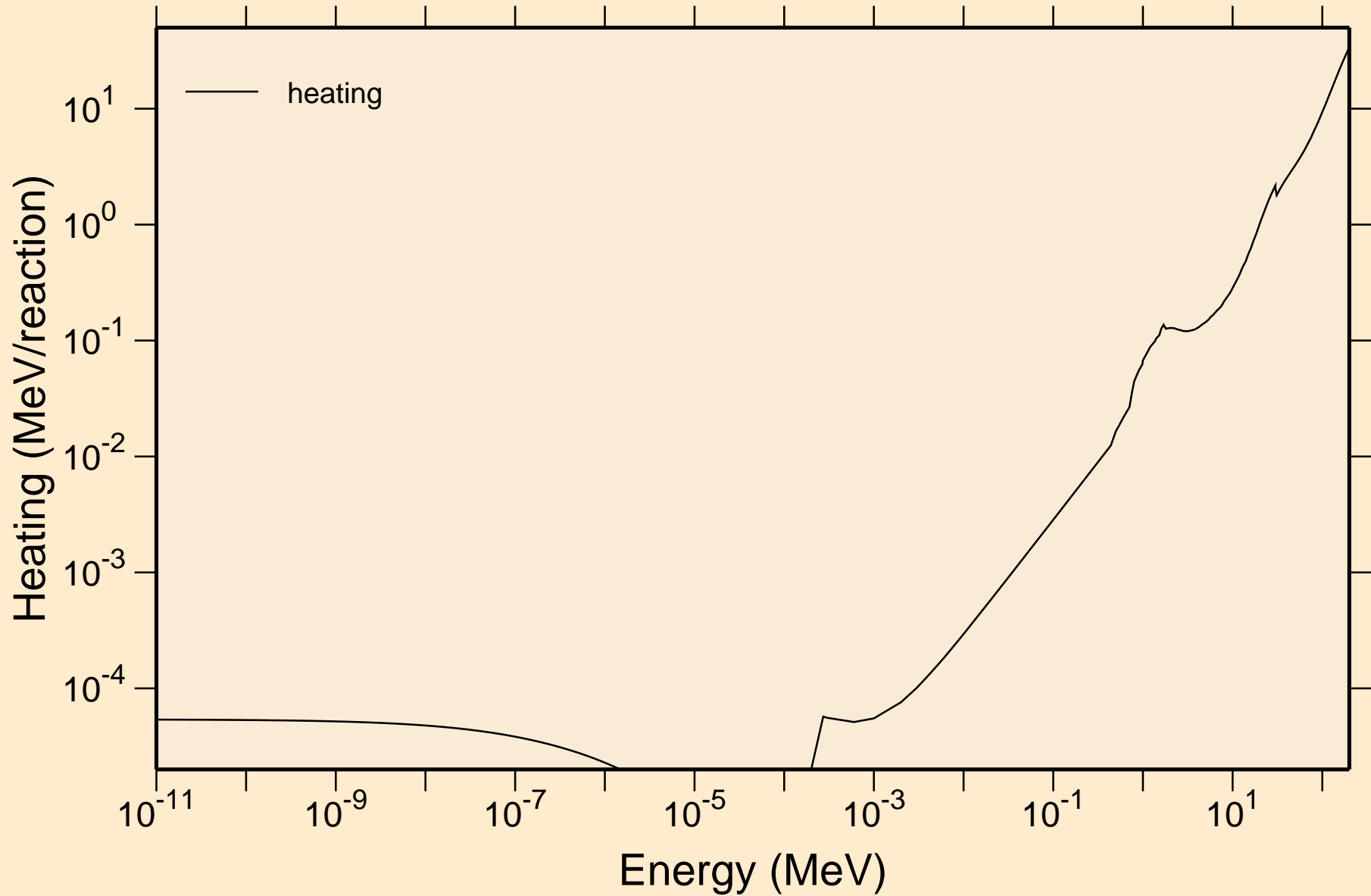

# ZN069M NEUTRON ACER TENDL-2023 LIBRARY; T=0.K

## Damage

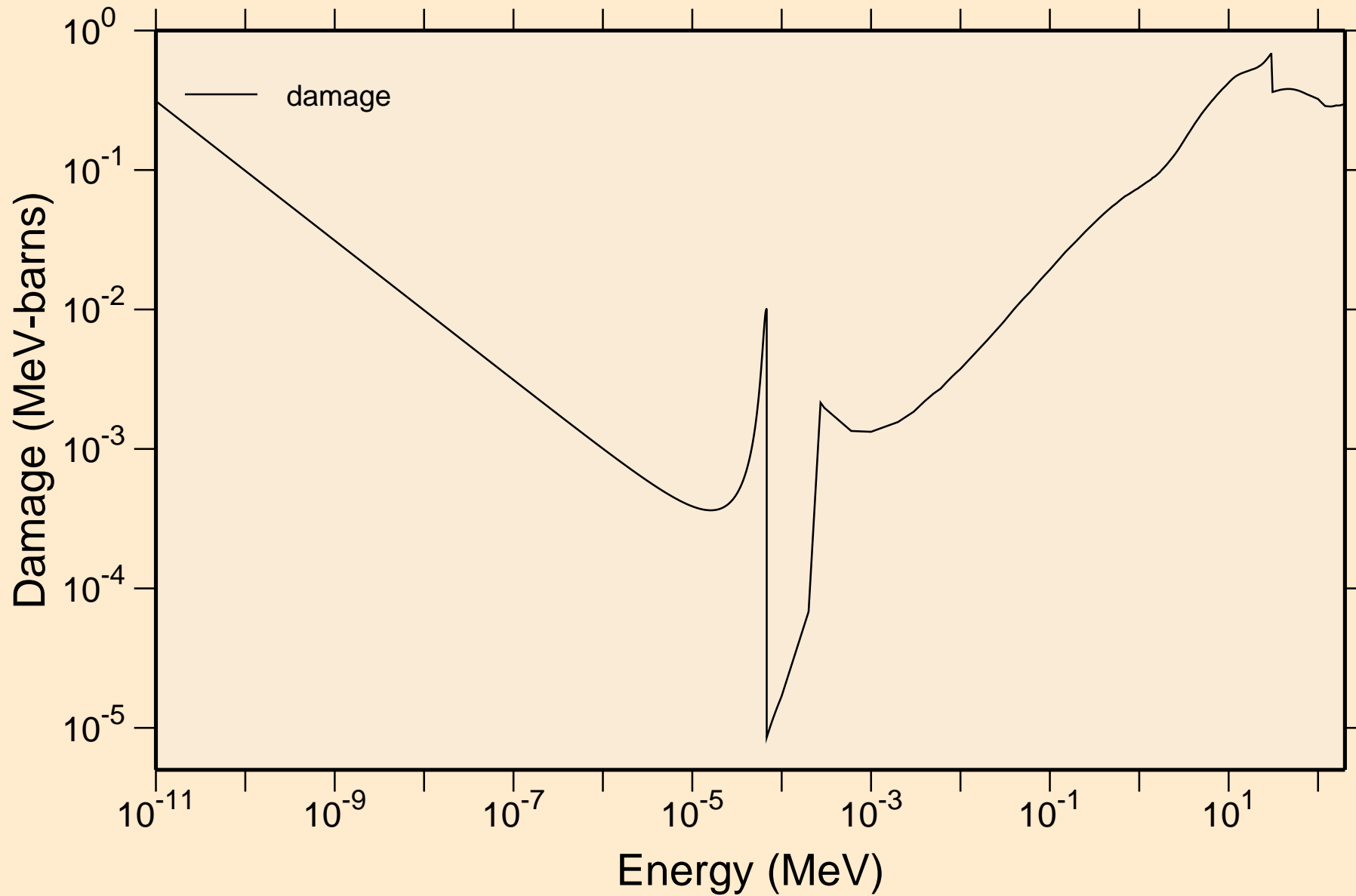

ZN069M NEUTRON ACER TENDL-2023 LIBRARY; T=0.K  
Non-threshold reactions

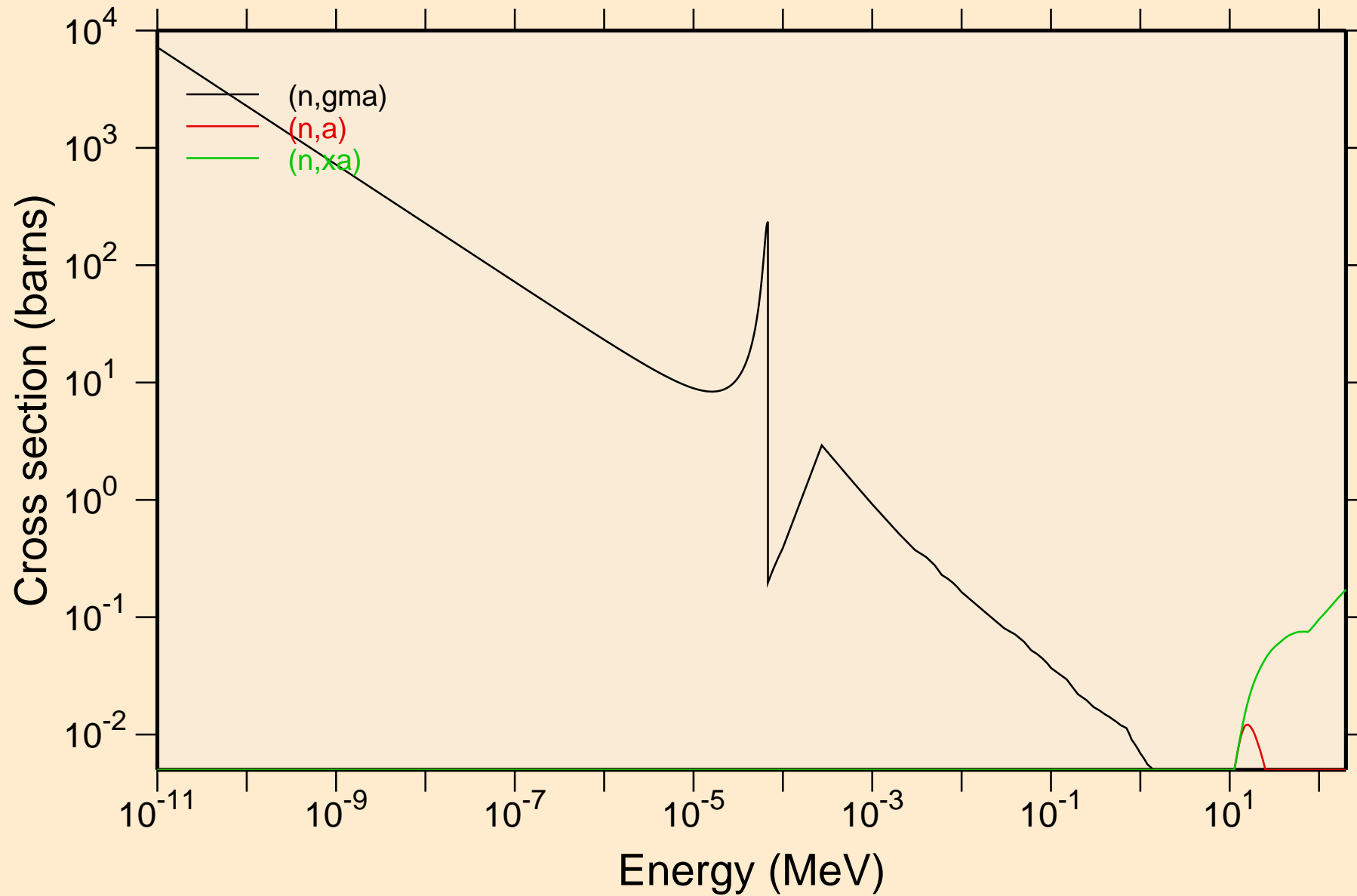

# ZN069M NEUTRON ACER TENDL-2023 LIBRARY; T=0.K

## Principal cross sections

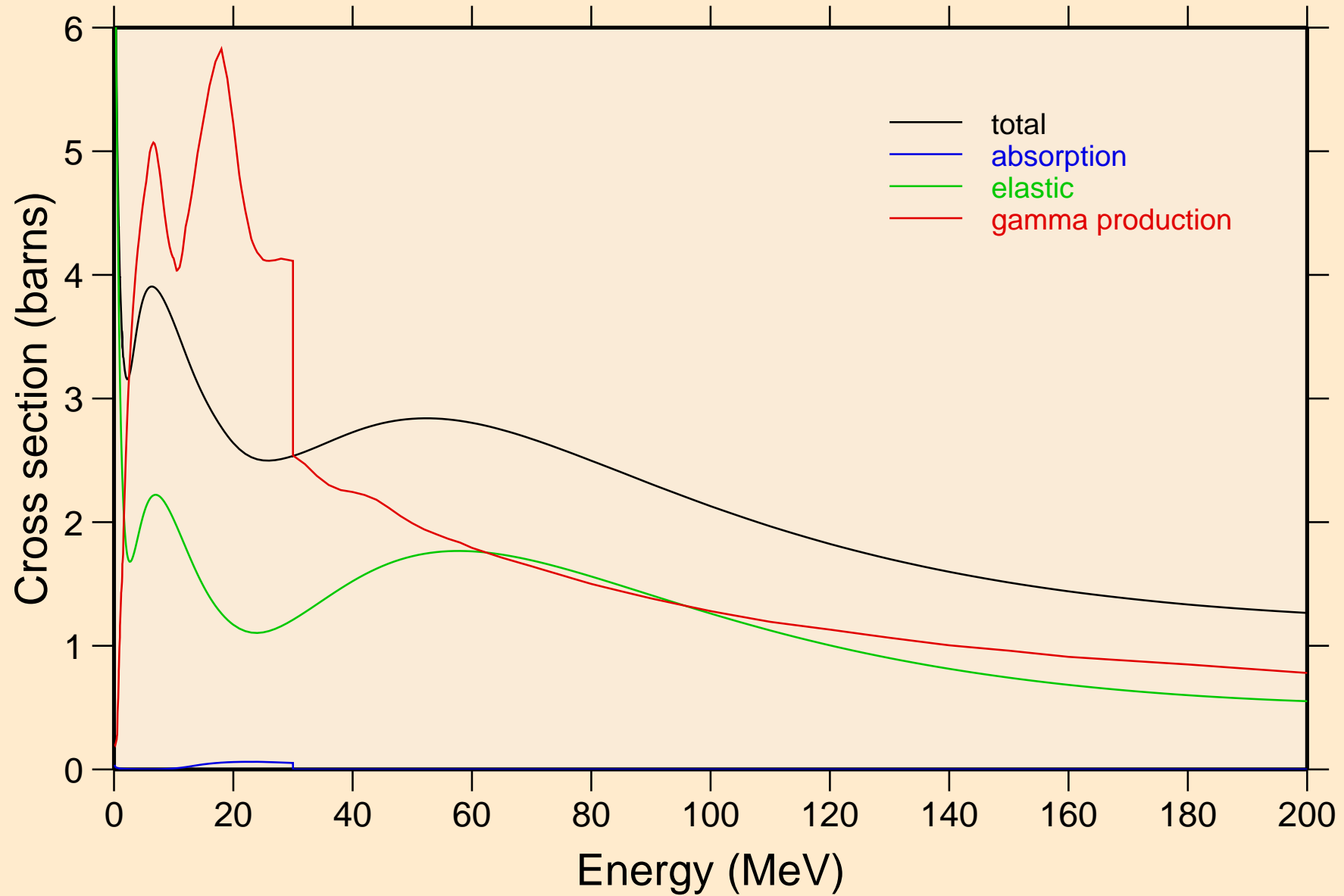

# ZN069M NEUTRON ACER TENDL-2023 LIBRARY; T=0.K

## Heating

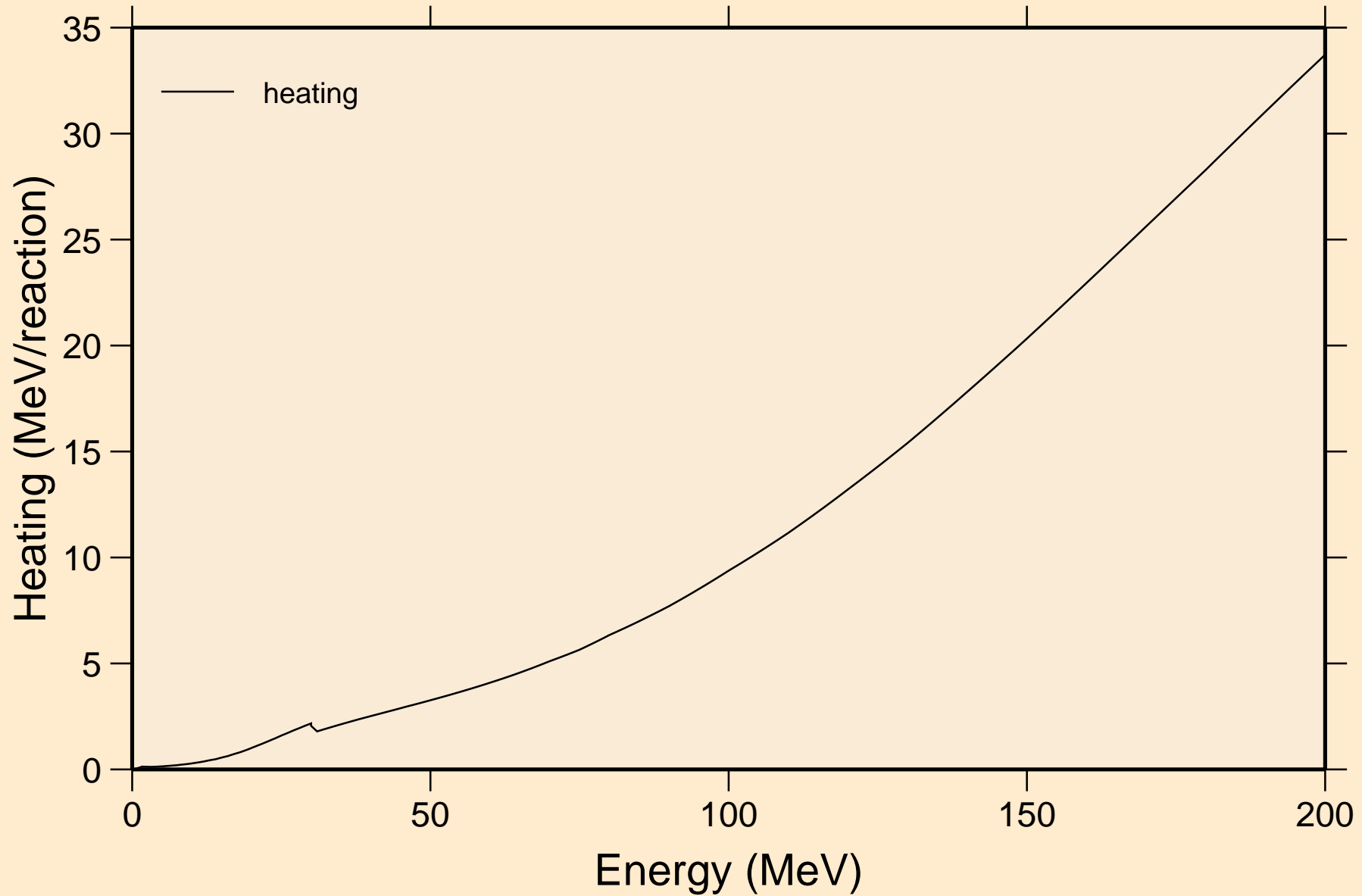

# ZN069M NEUTRON ACER TENDL-2023 LIBRARY; T=0.K

## Damage

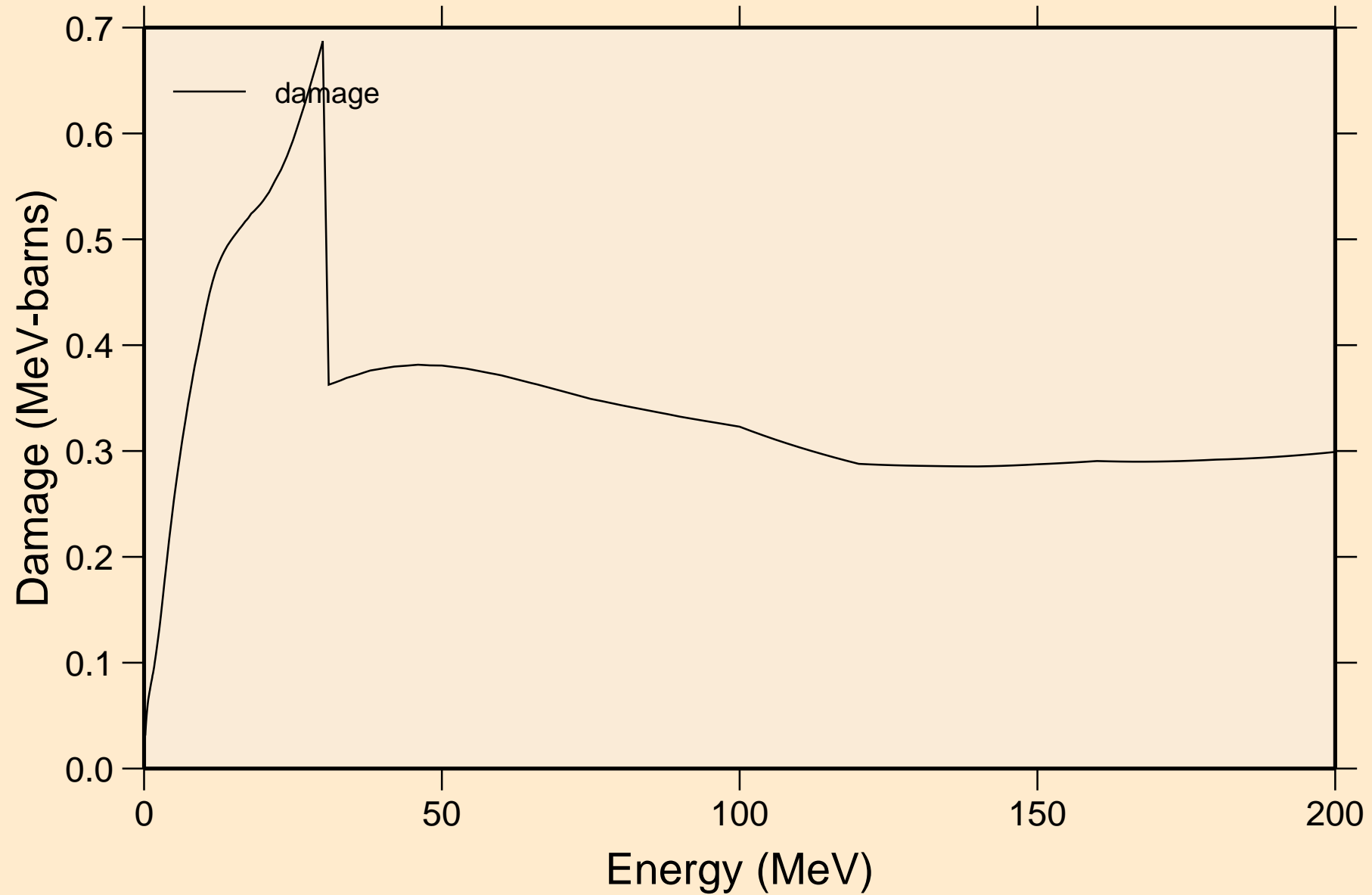

ZN069M NEUTRON ACER TENDL-2023 LIBRARY; T=0.K  
Non-threshold reactions

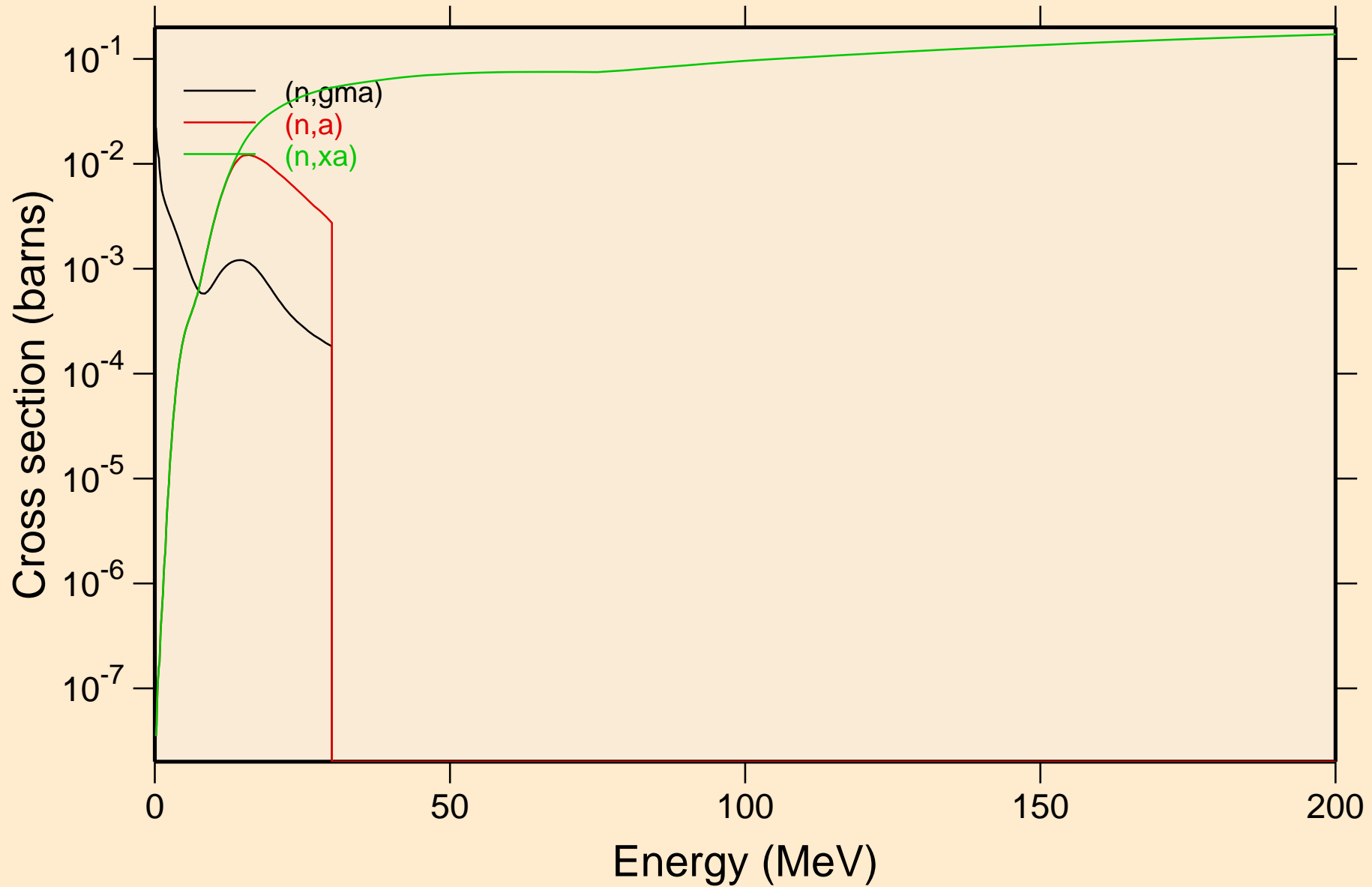



ZN069M NEUTRON ACER TENDL-2023 LIBRARY; T=0.K  
Inelastic levels

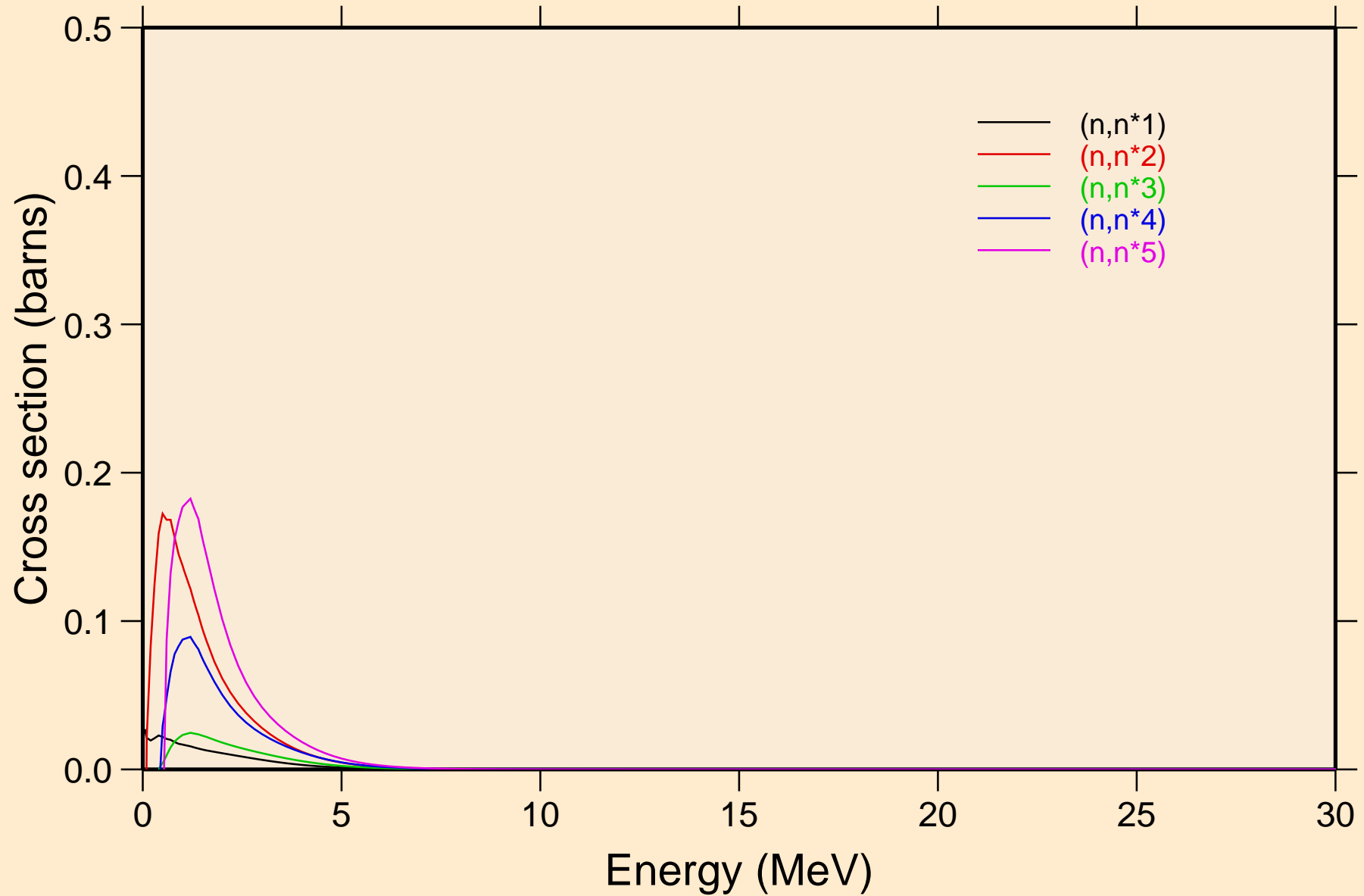

ZN069M NEUTRON ACER TENDL-2023 LIBRARY; T=0.K  
Inelastic levels

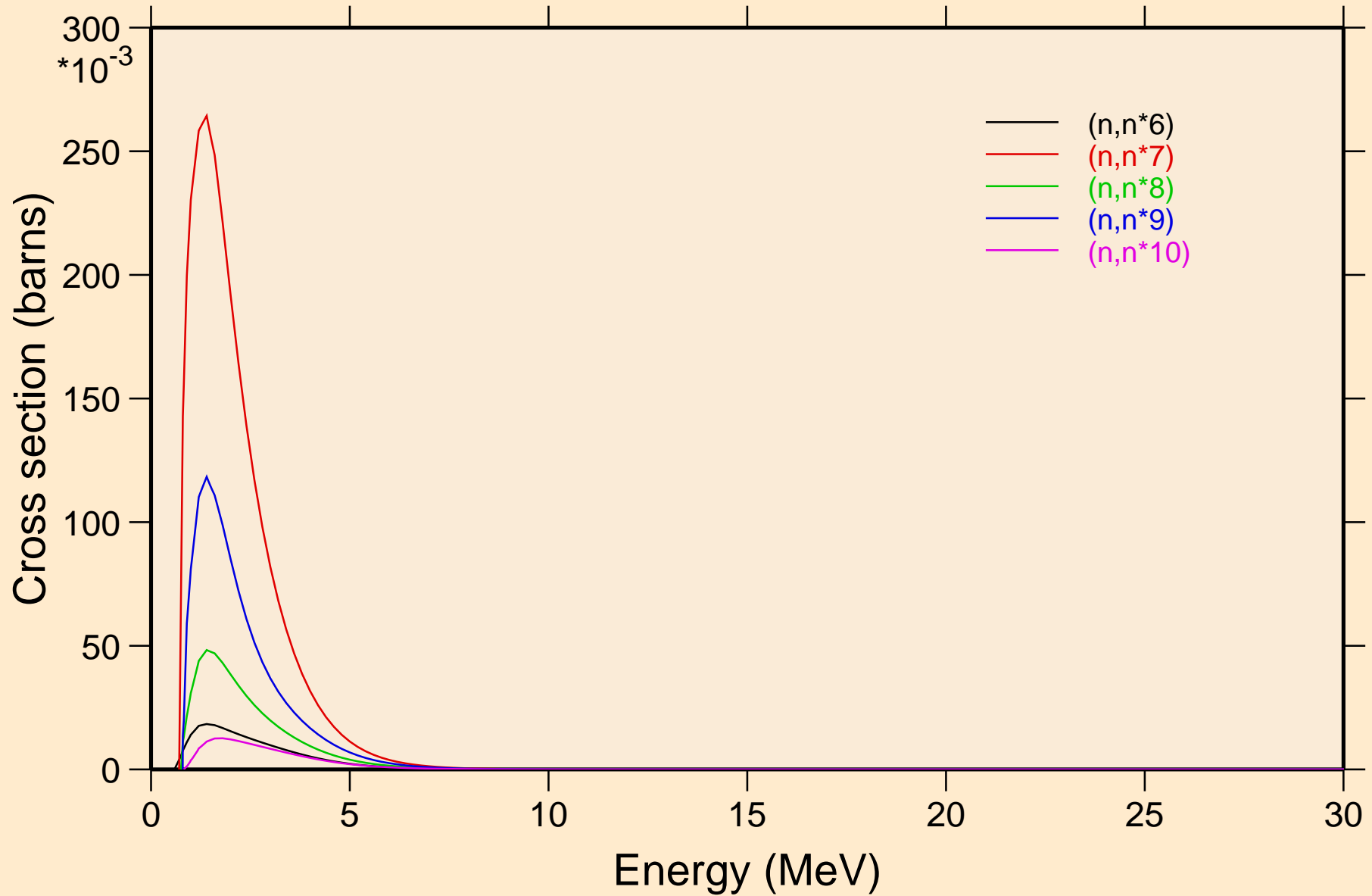

ZN069M NEUTRON ACER TENDL-2023 LIBRARY; T=0.K  
Inelastic levels

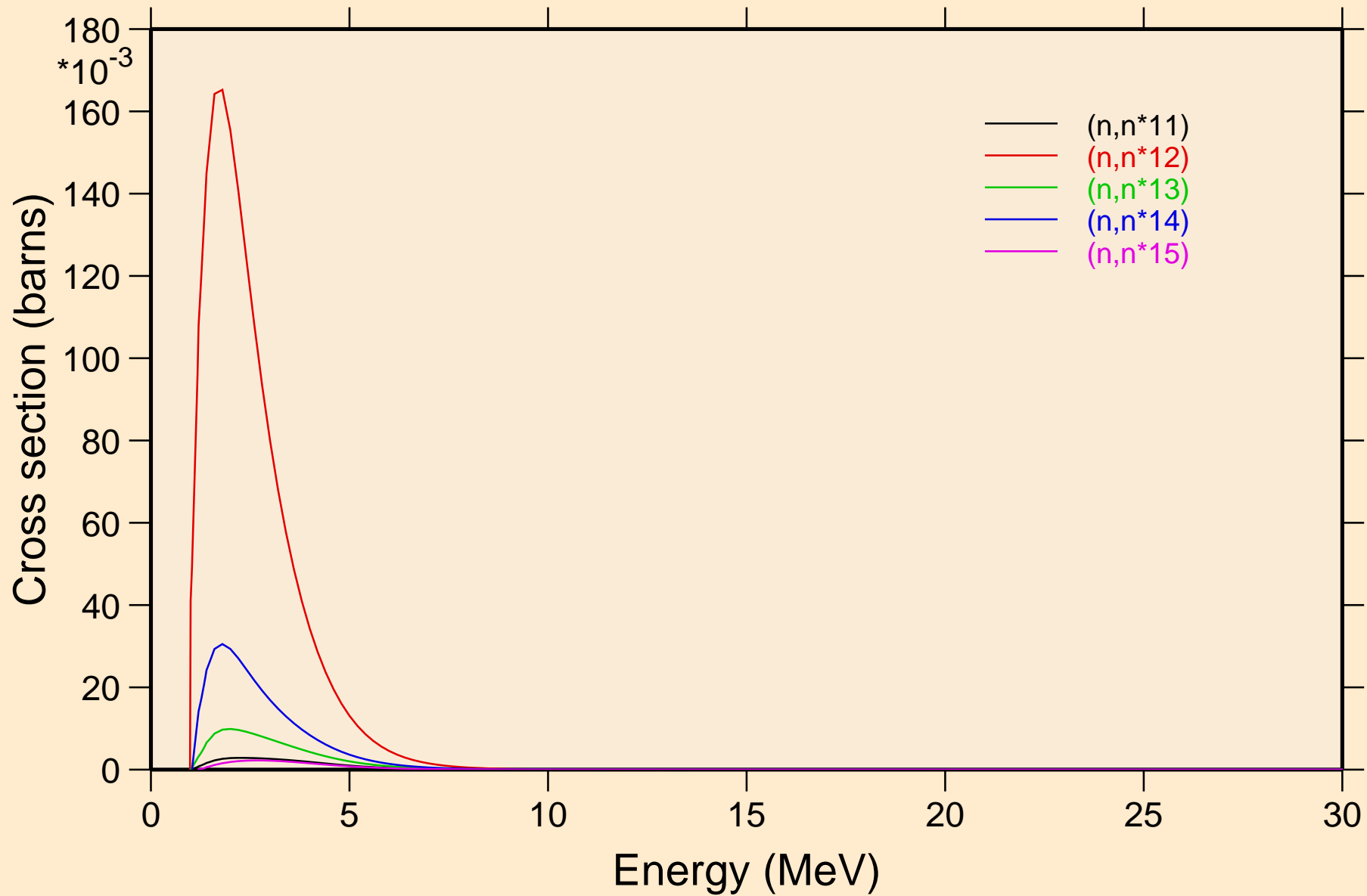

ZN069M NEUTRON ACER TENDL-2023 LIBRARY; T=0.K  
Inelastic levels

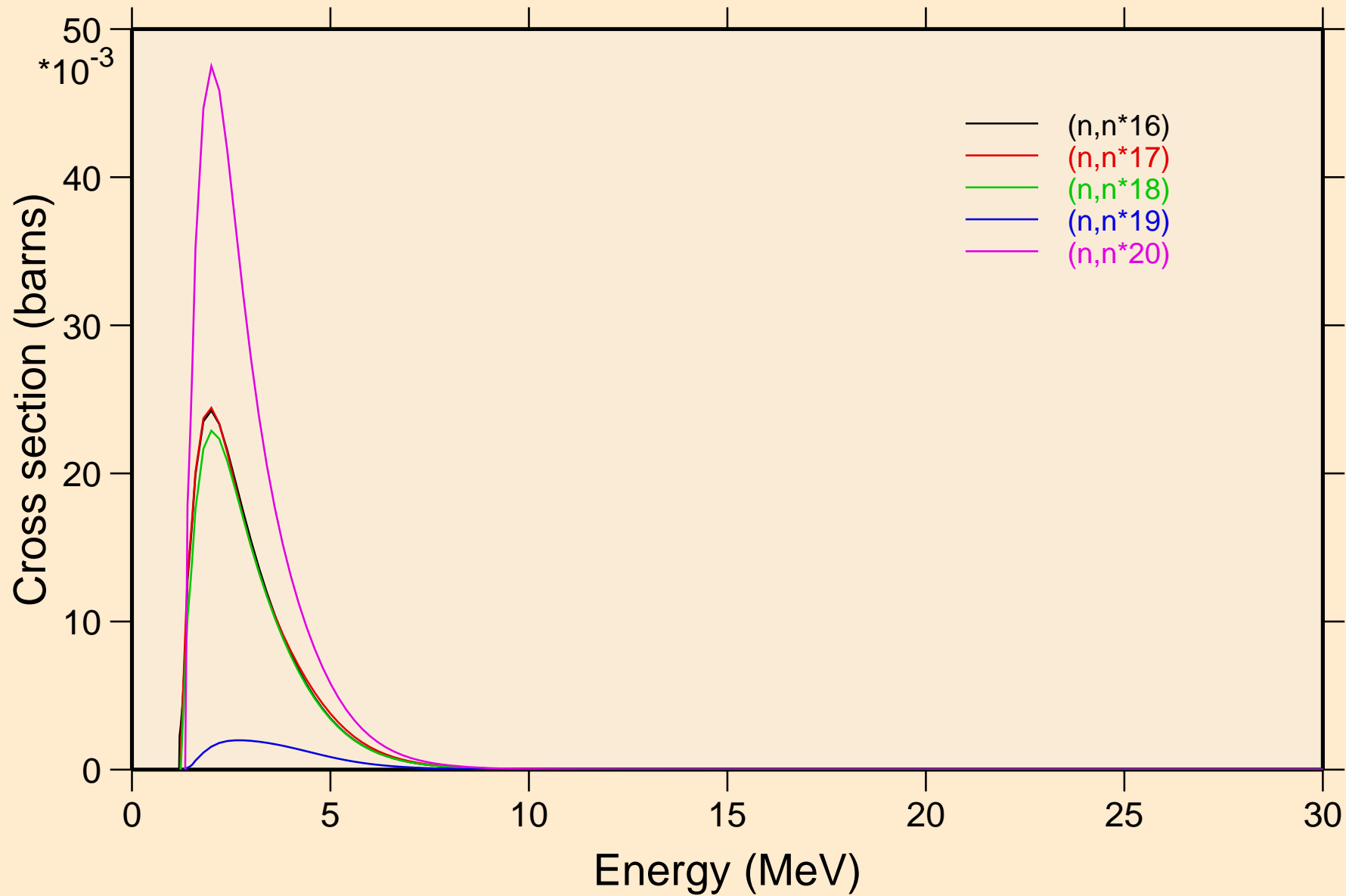

# ZN069M NEUTRON ACER TENDL-2023 LIBRARY; T=0.K

## Inelastic levels

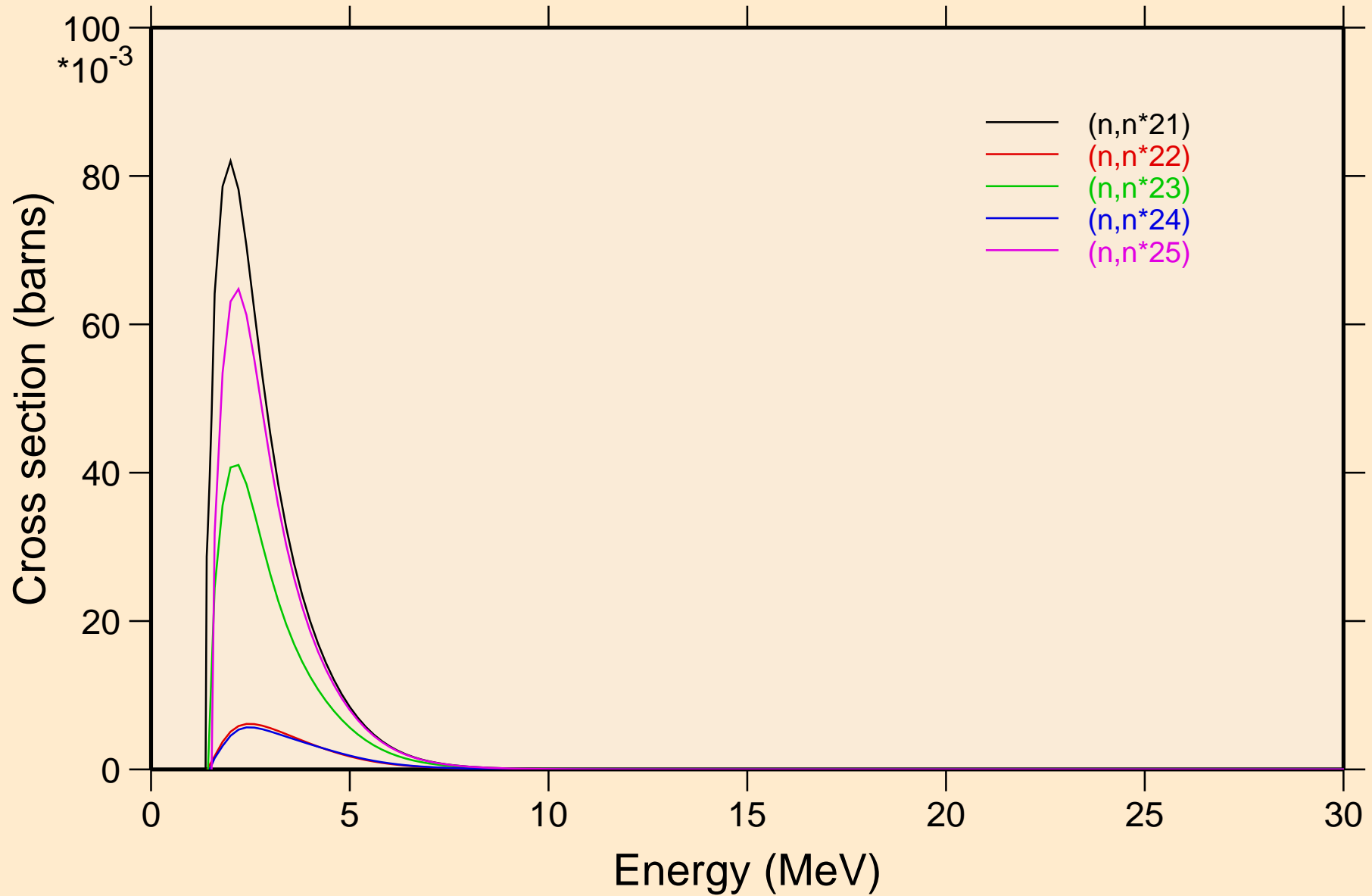

ZN069M NEUTRON ACER TENDL-2023 LIBRARY; T=0.K  
Threshold reactions

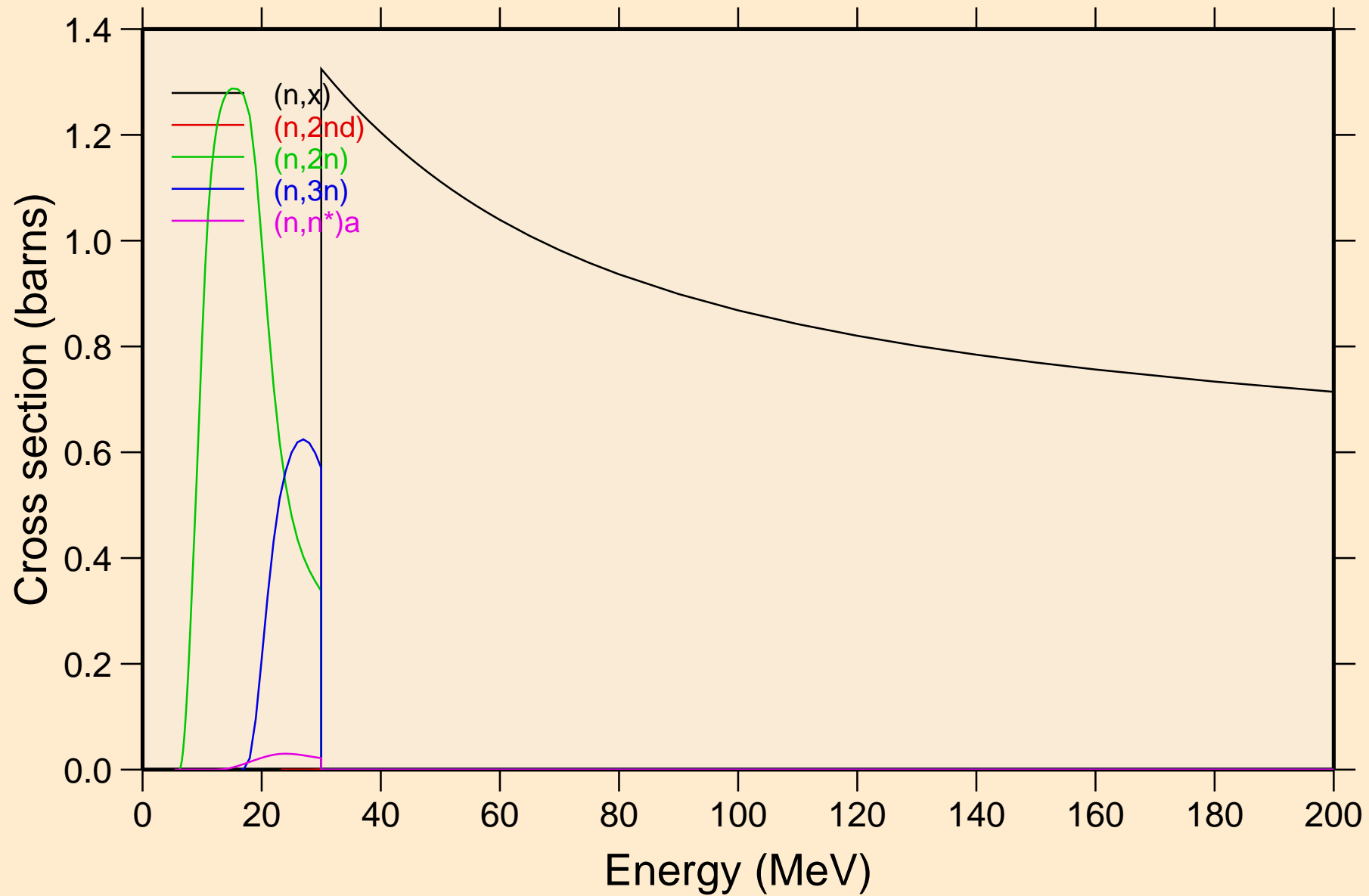

# ZN069M NEUTRON ACER TENDL-2023 LIBRARY; T=0.K

## Threshold reactions

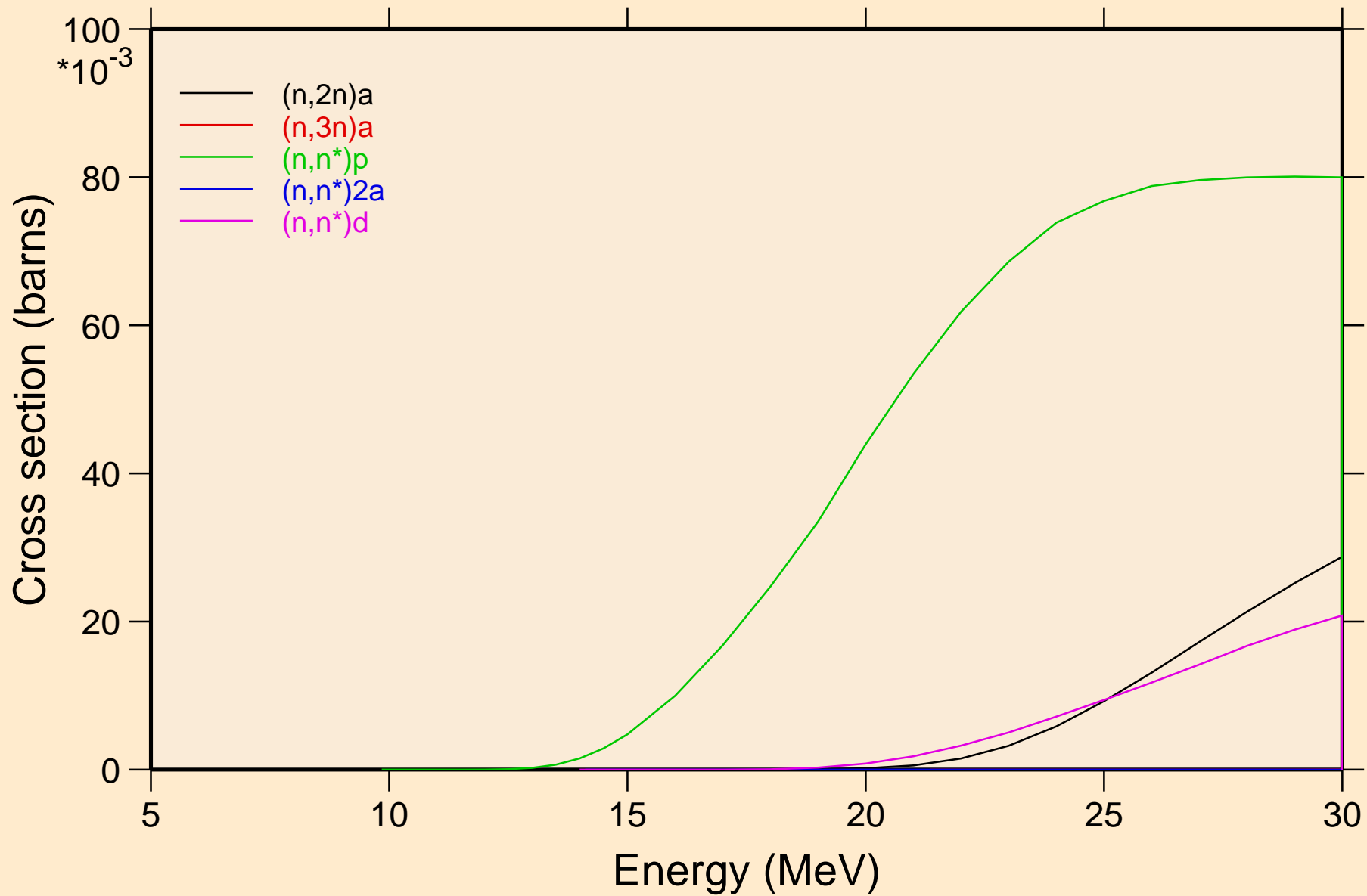

# ZN069M NEUTRON ACER TENDL-2023 LIBRARY; T=0.K

## Threshold reactions

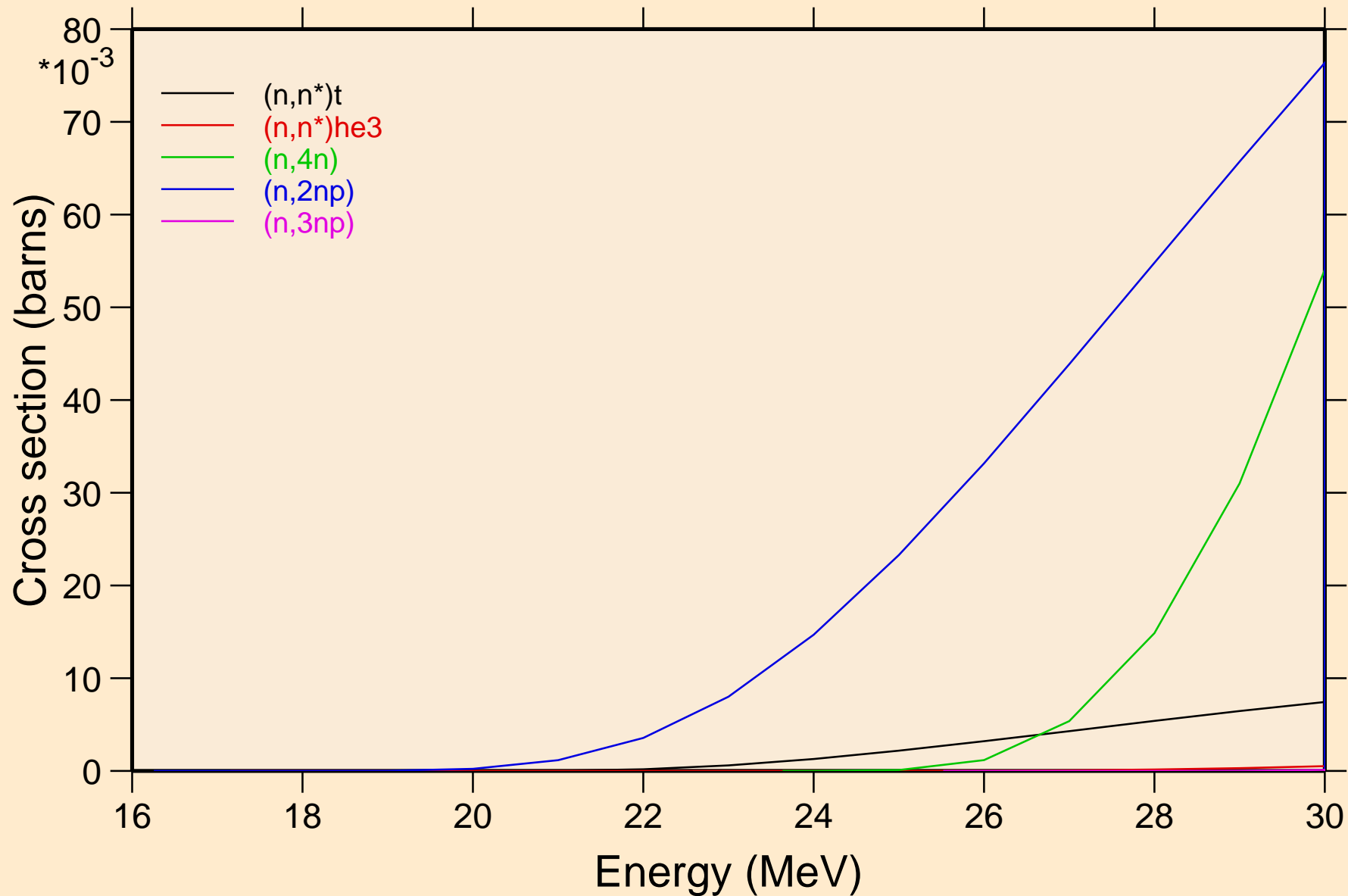



ZN069M NEUTRON ACER TENDL-2023 LIBRARY; T=0.K  
Threshold reactions

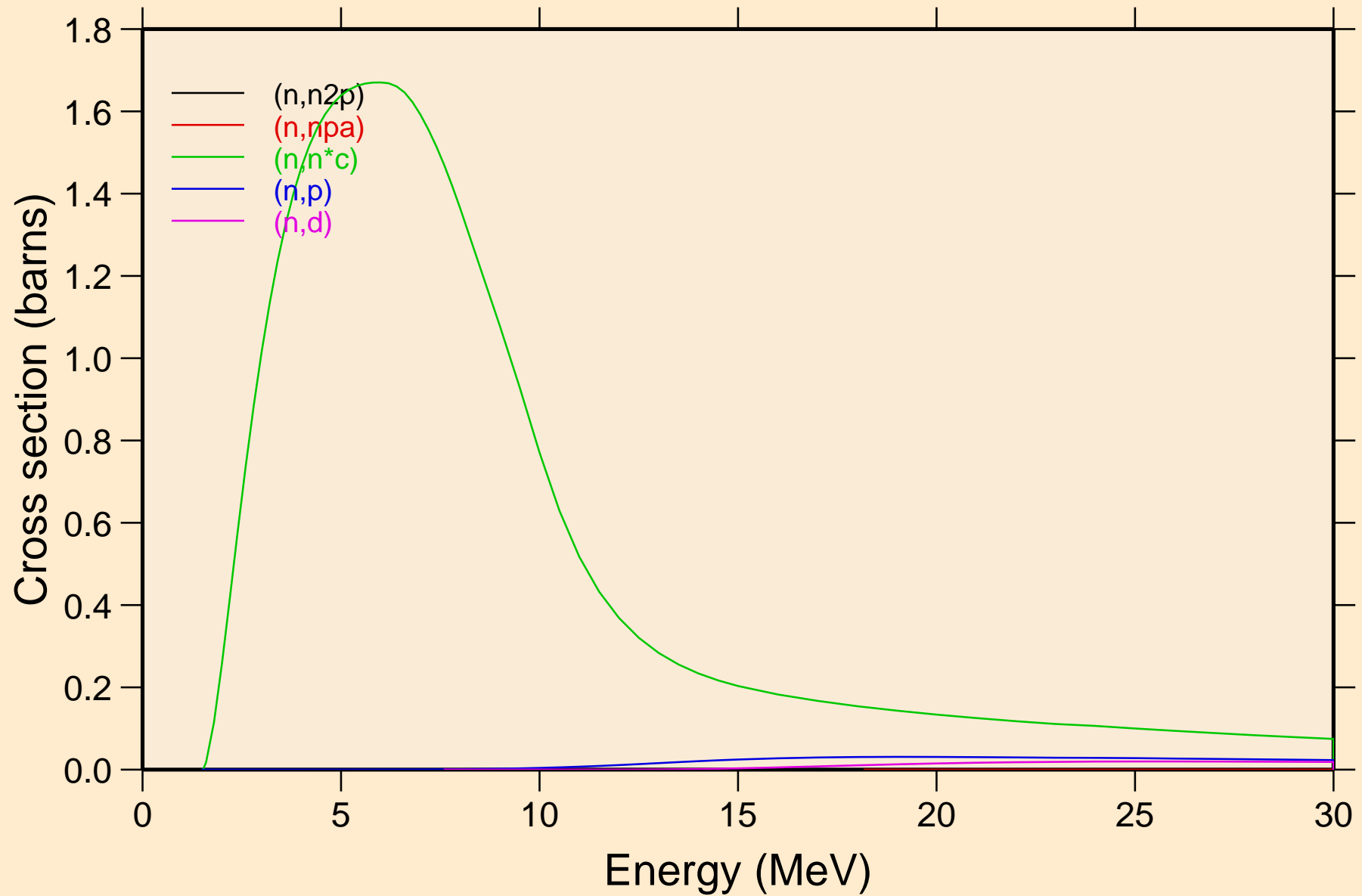

ZN069M NEUTRON ACER TENDL-2023 LIBRARY; T=0.K  
Threshold reactions

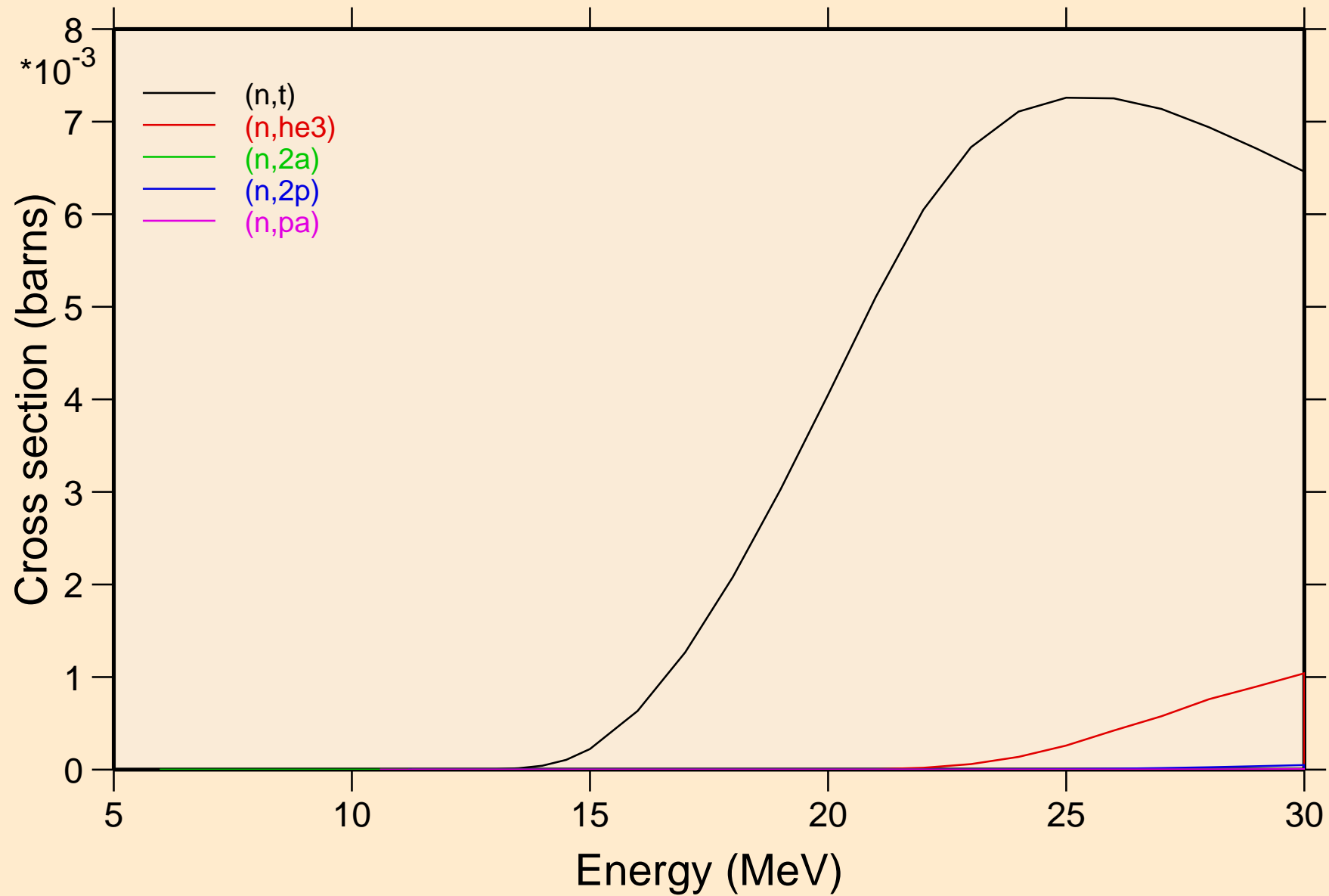

# ZN069M NEUTRON ACER TENDL-2023 LIBRARY; T=0.K

## Threshold reactions

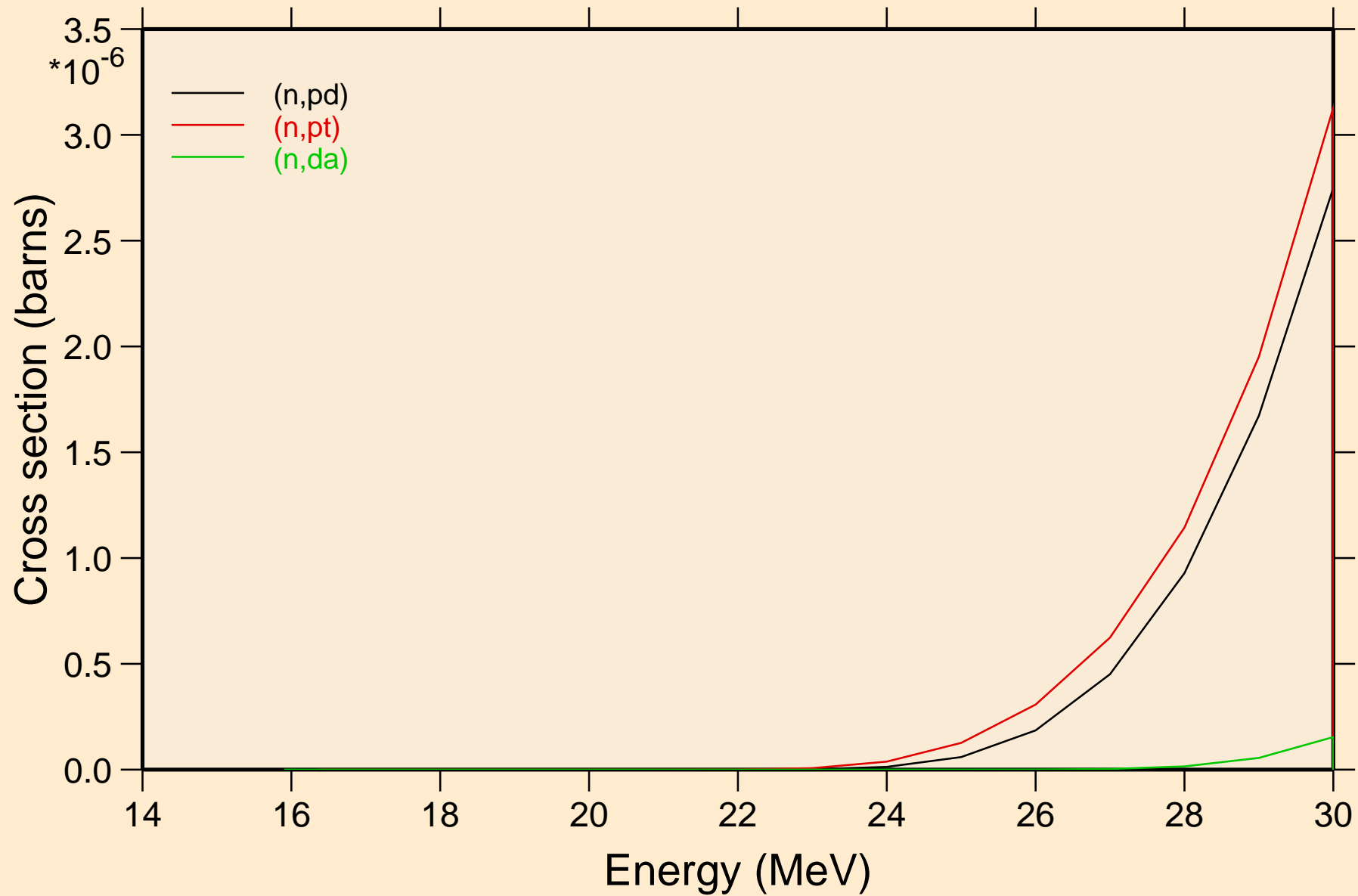

# ZN069M NEUTRON ACER TENDL-2023 LIBRARY; T=0.K

## Threshold reactions

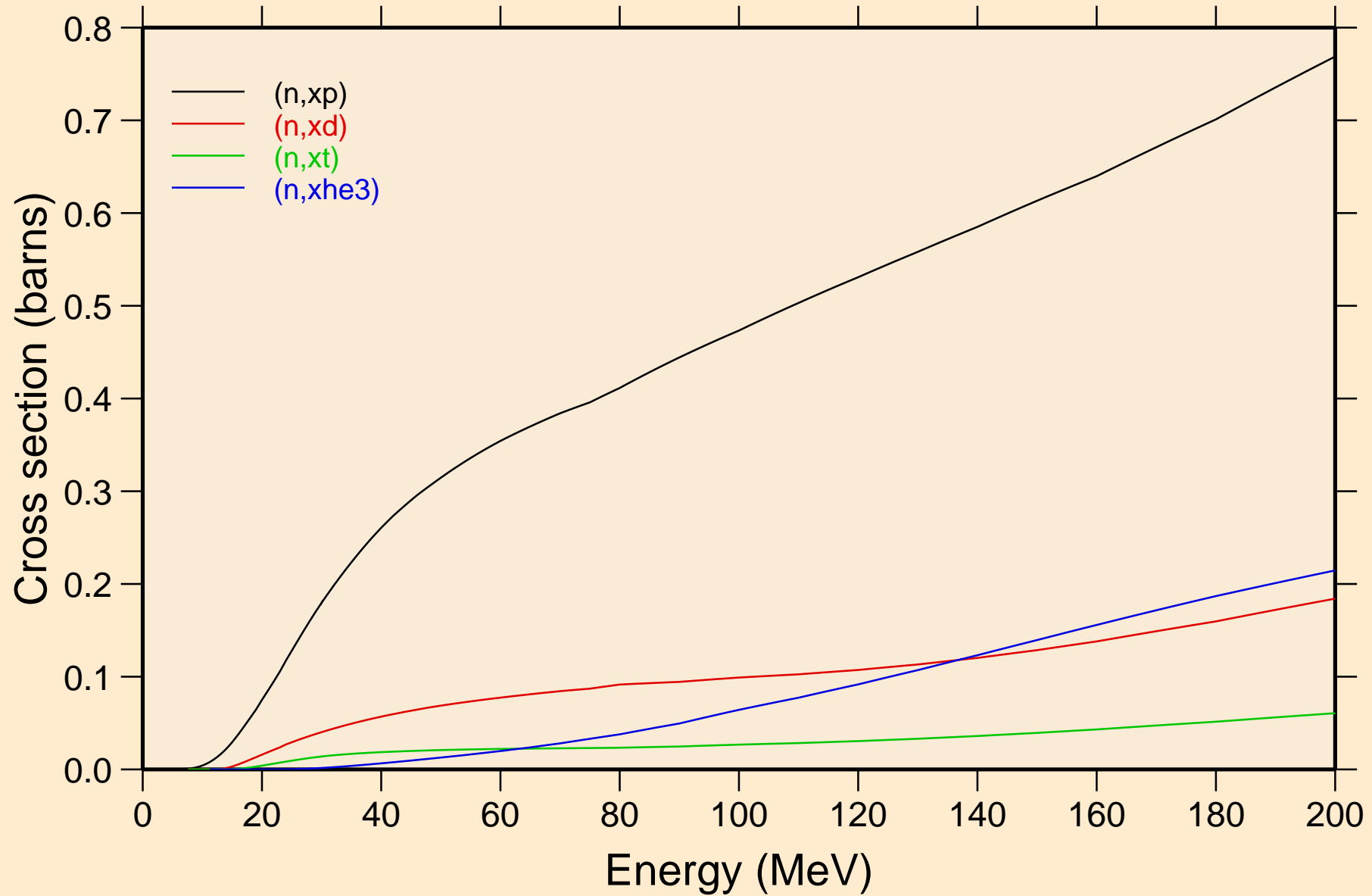

ZN069M NEUTRON ACER TENDL-2023 LIBRARY; T=0.K  
angular distribution for elastic

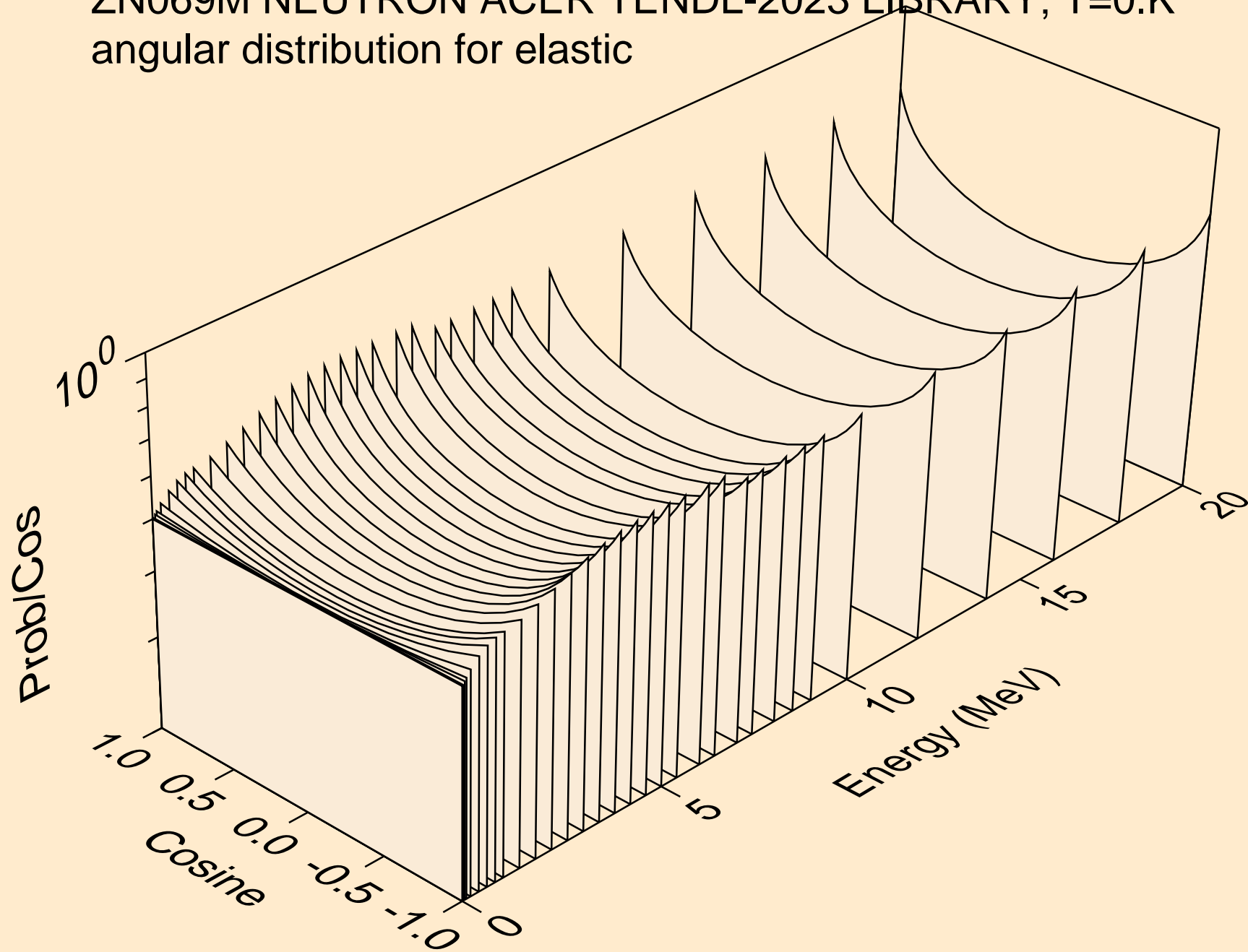

ZN069M NEUTRON ACER TENDL-2023 LIBRARY; T=0.K  
angular distribution for elastic

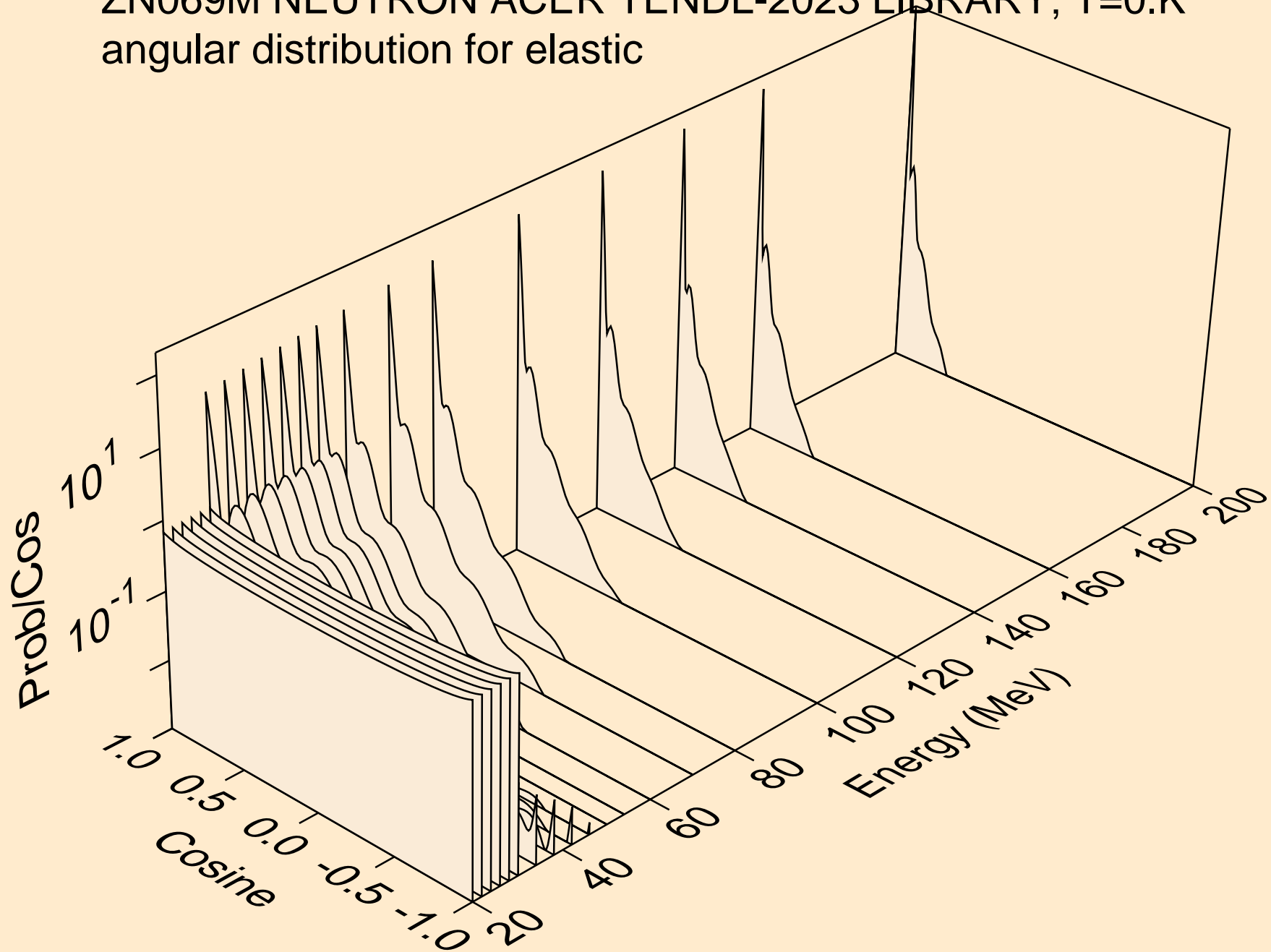

ZN069M NEUTRON ACER TENDL-2023 LIBRARY; T=0.K  
angular distribution for (n,n\*1)

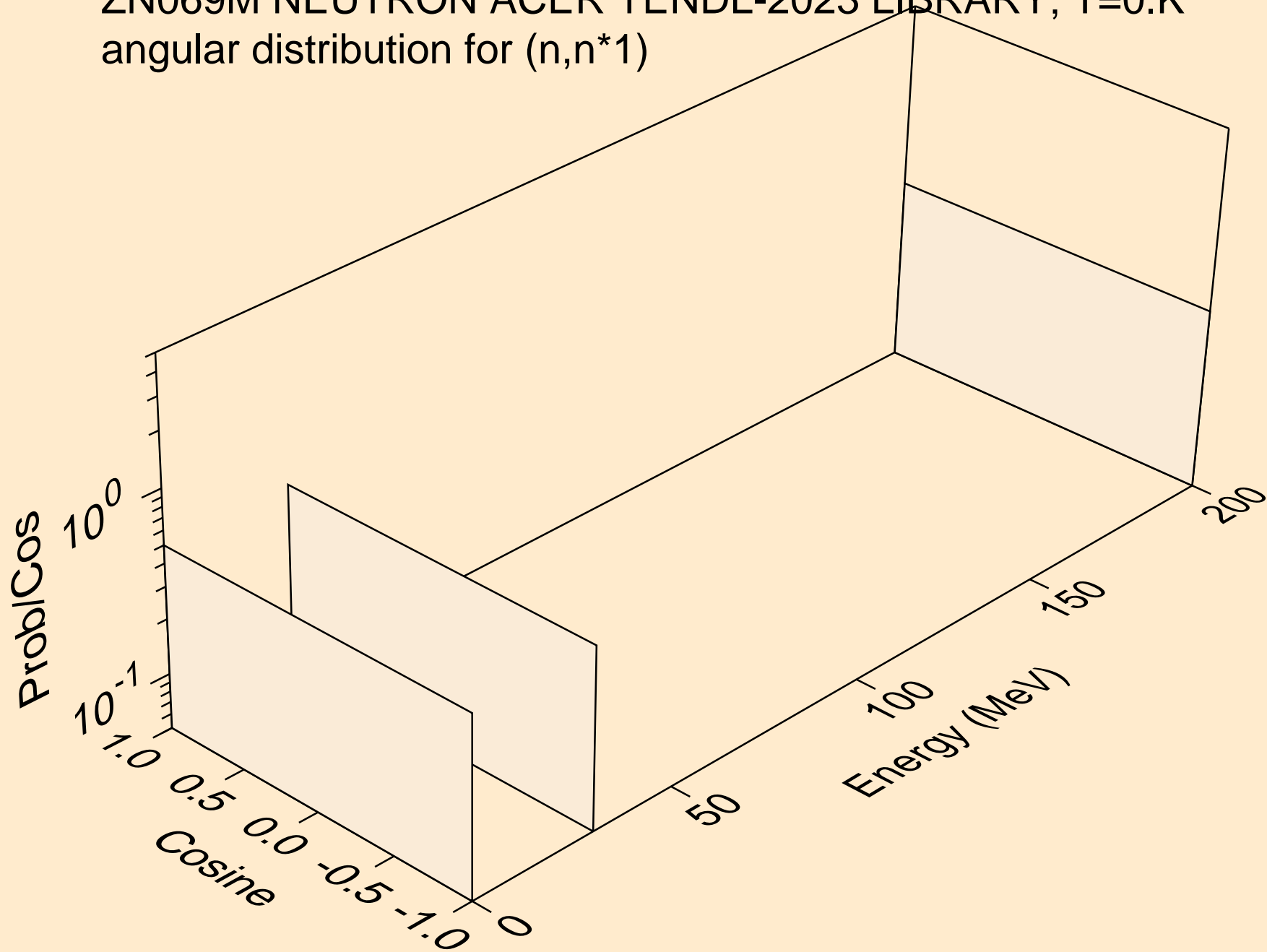

ZN069M NEUTRON ACER TENDL-2023 LIBRARY; T=0.K  
angular distribution for (n,n\*2)

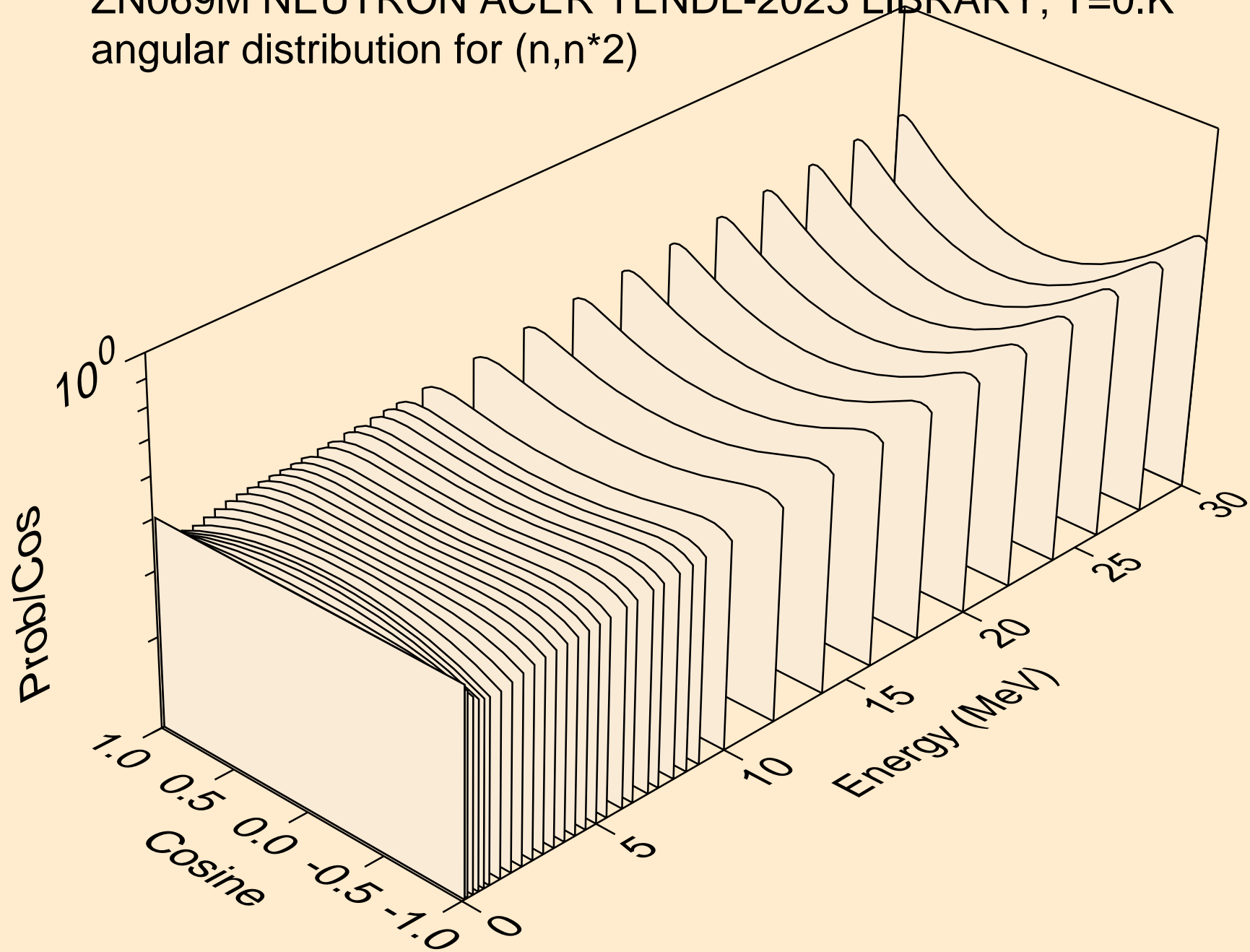



ZN069M NEUTRON ACER TENDL-2023 LIBRARY; T=0.K  
angular distribution for (n,n\*3)

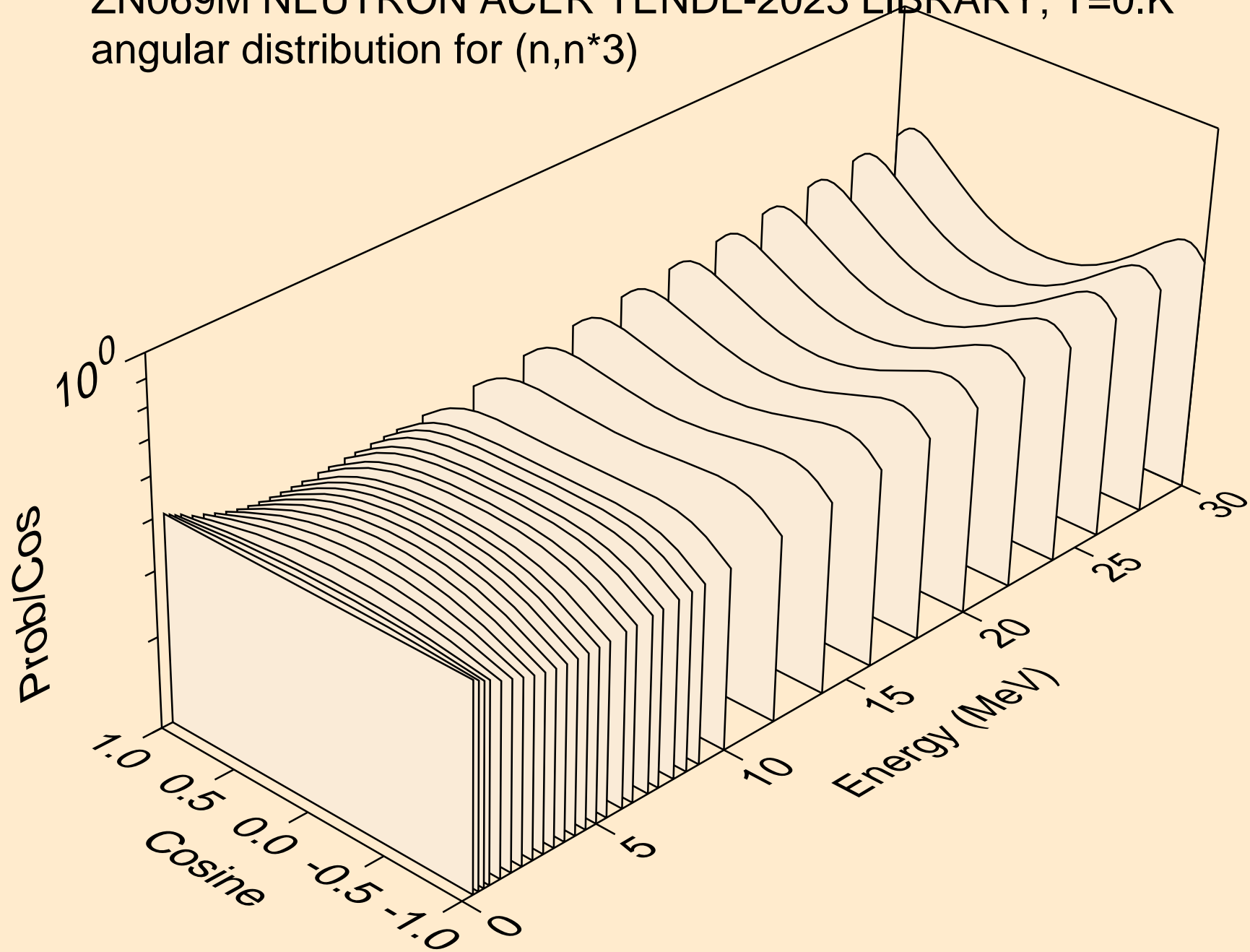

ZN069M NEUTRON ACER TENDL-2023 LIBRARY; T=0.K  
angular distribution for (n,n\*4)

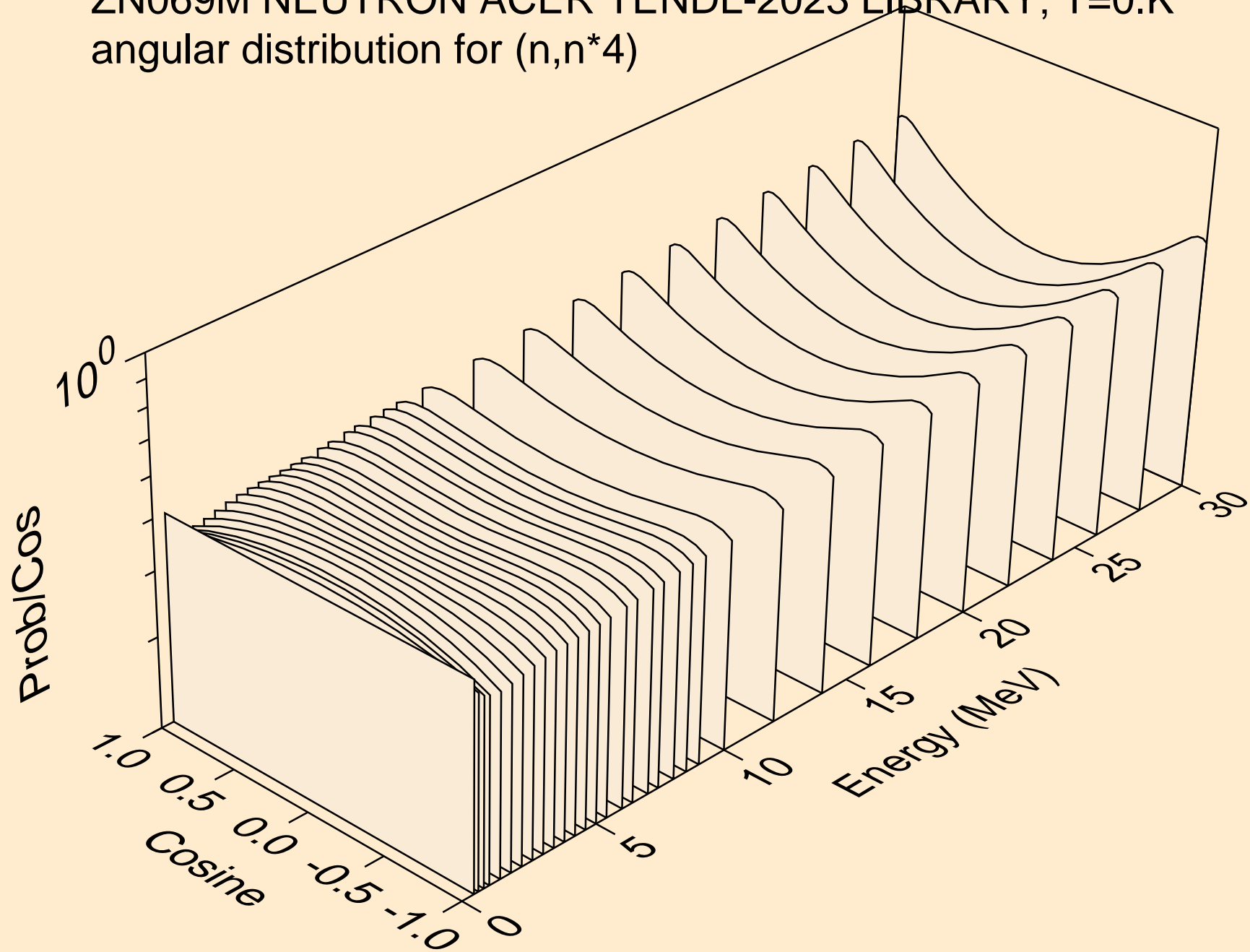

ZN069M NEUTRON ACER TENDL-2023 LIBRARY; T=0.K  
angular distribution for (n,n\*5)

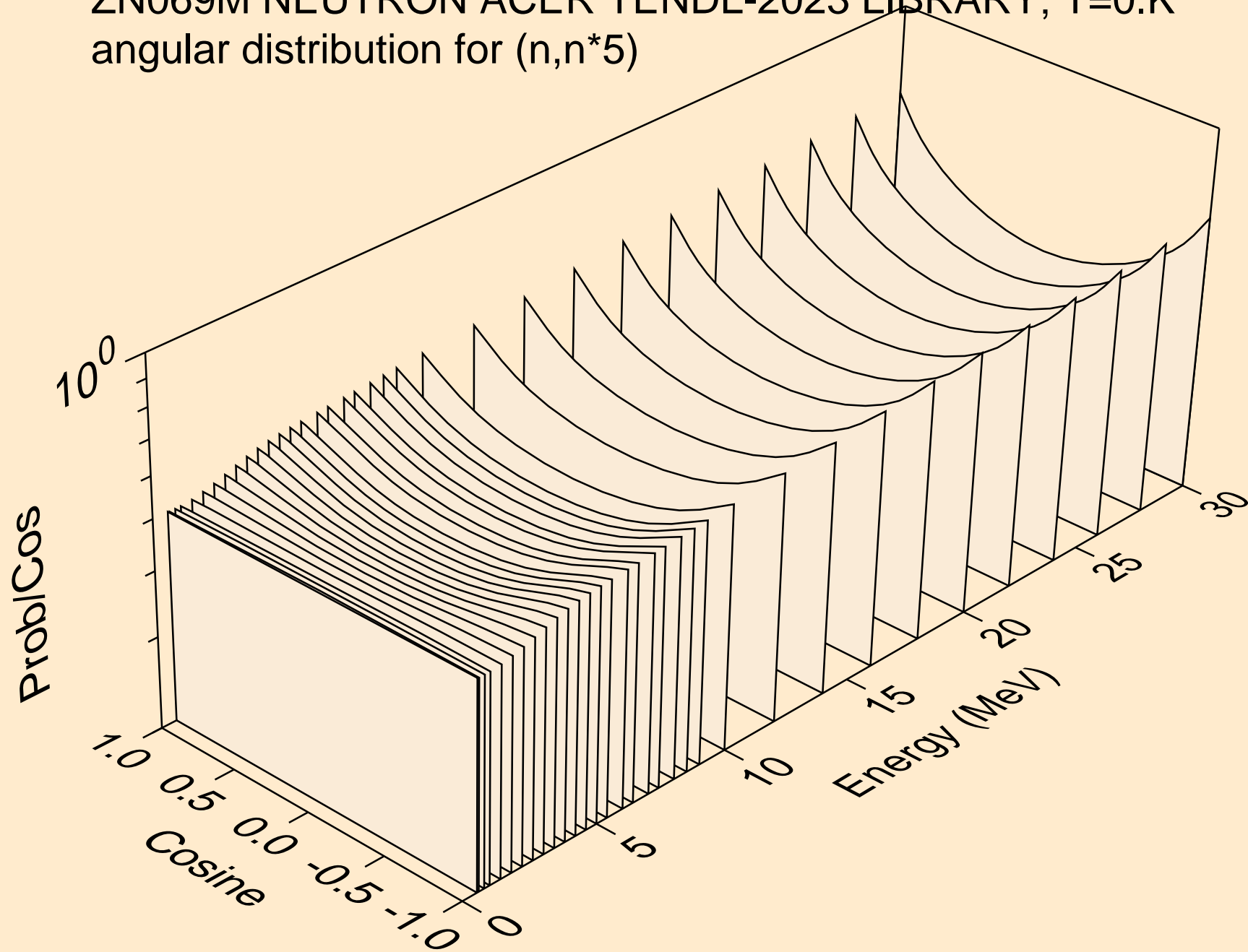

ZN069M NEUTRON ACER TENDL-2023 LIBRARY; T=0.K  
angular distribution for (n,n\*6)

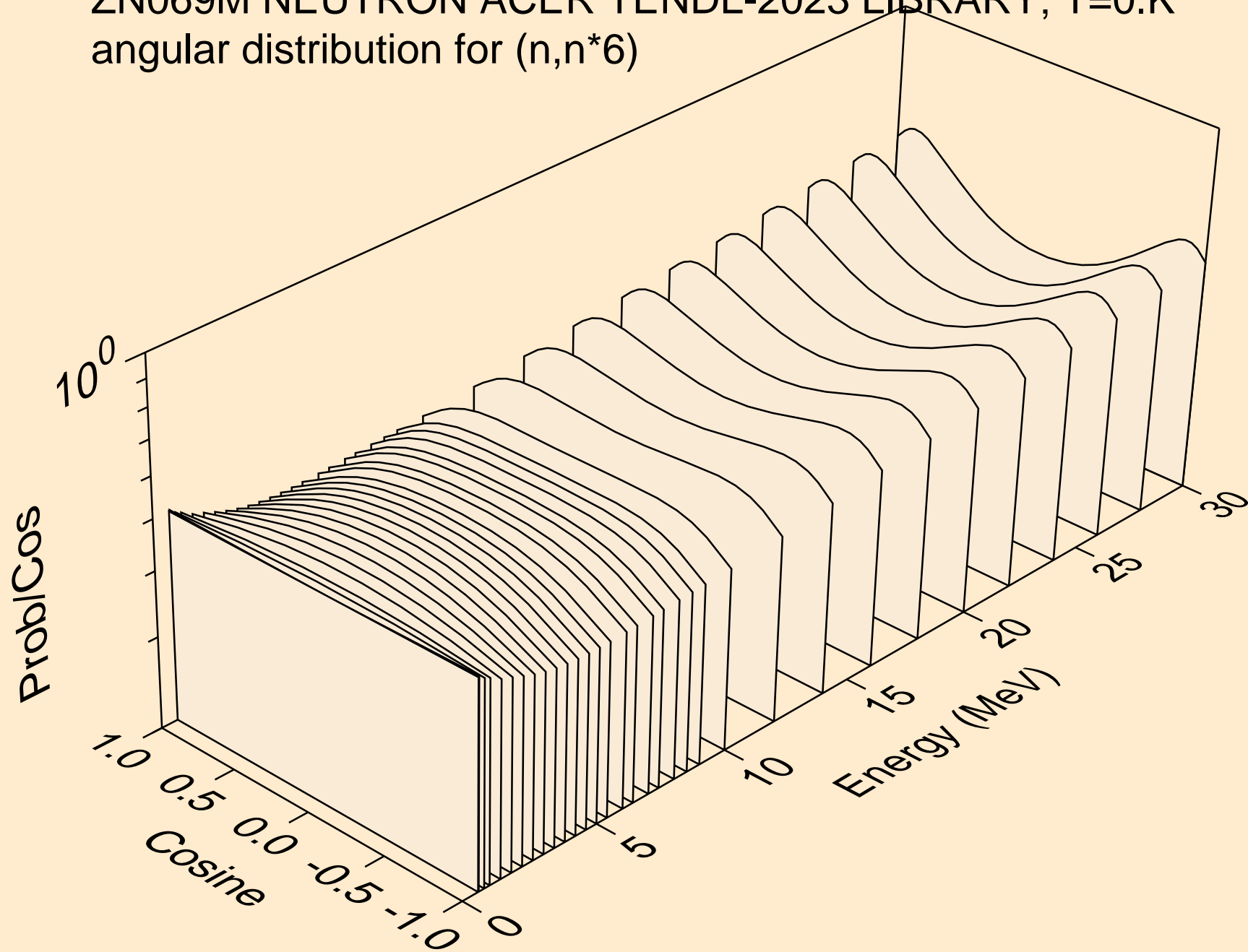

ZN069M NEUTRON ACER TENDL-2023 LIBRARY; T=0.K  
angular distribution for (n,n\*7)

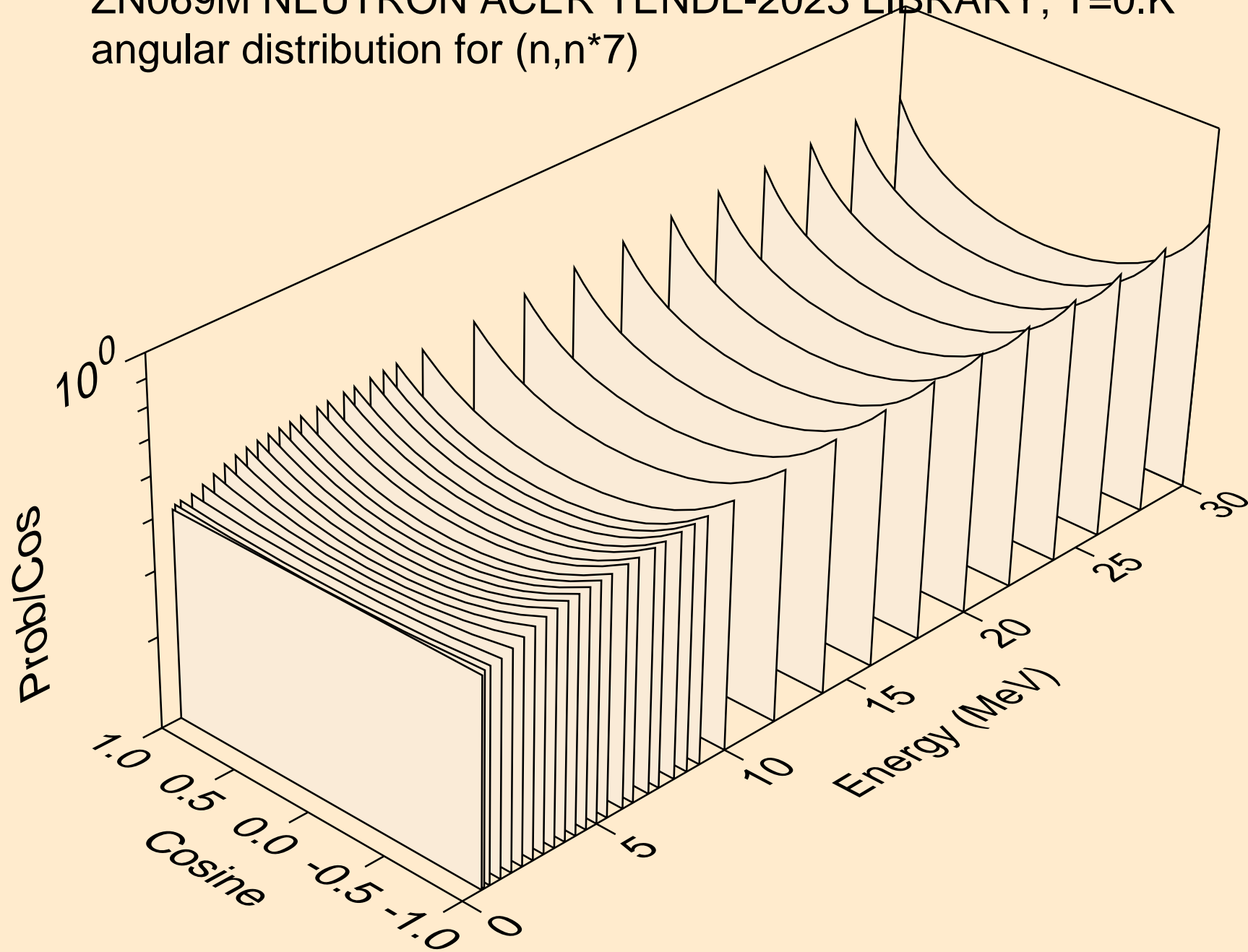

ZN069M NEUTRON ACER TENDL-2023 LIBRARY; T=0.K  
angular distribution for (n,n\*8)

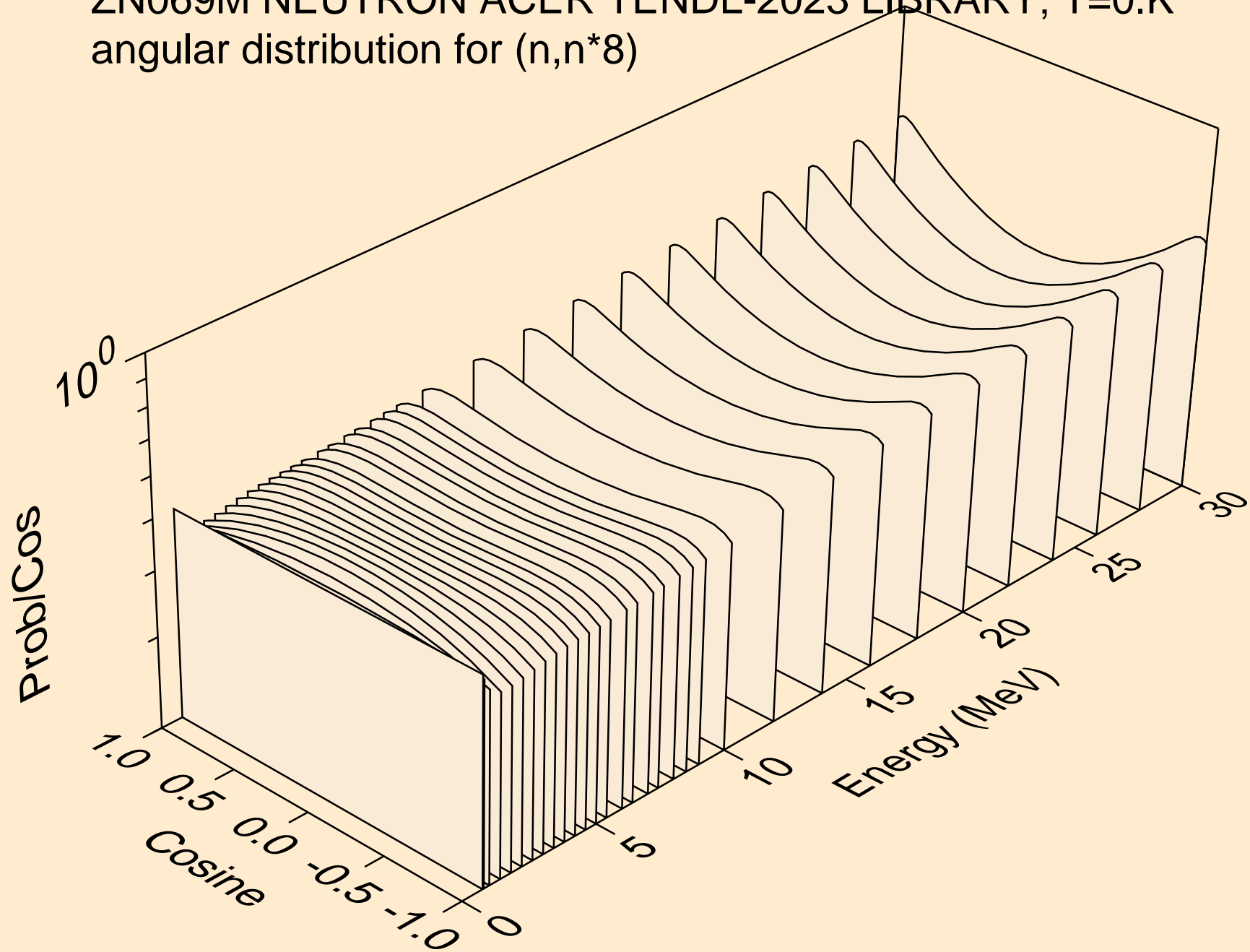

ZN069M NEUTRON ACER TENDL-2023 LIBRARY; T=0.K  
angular distribution for (n,n\*9)

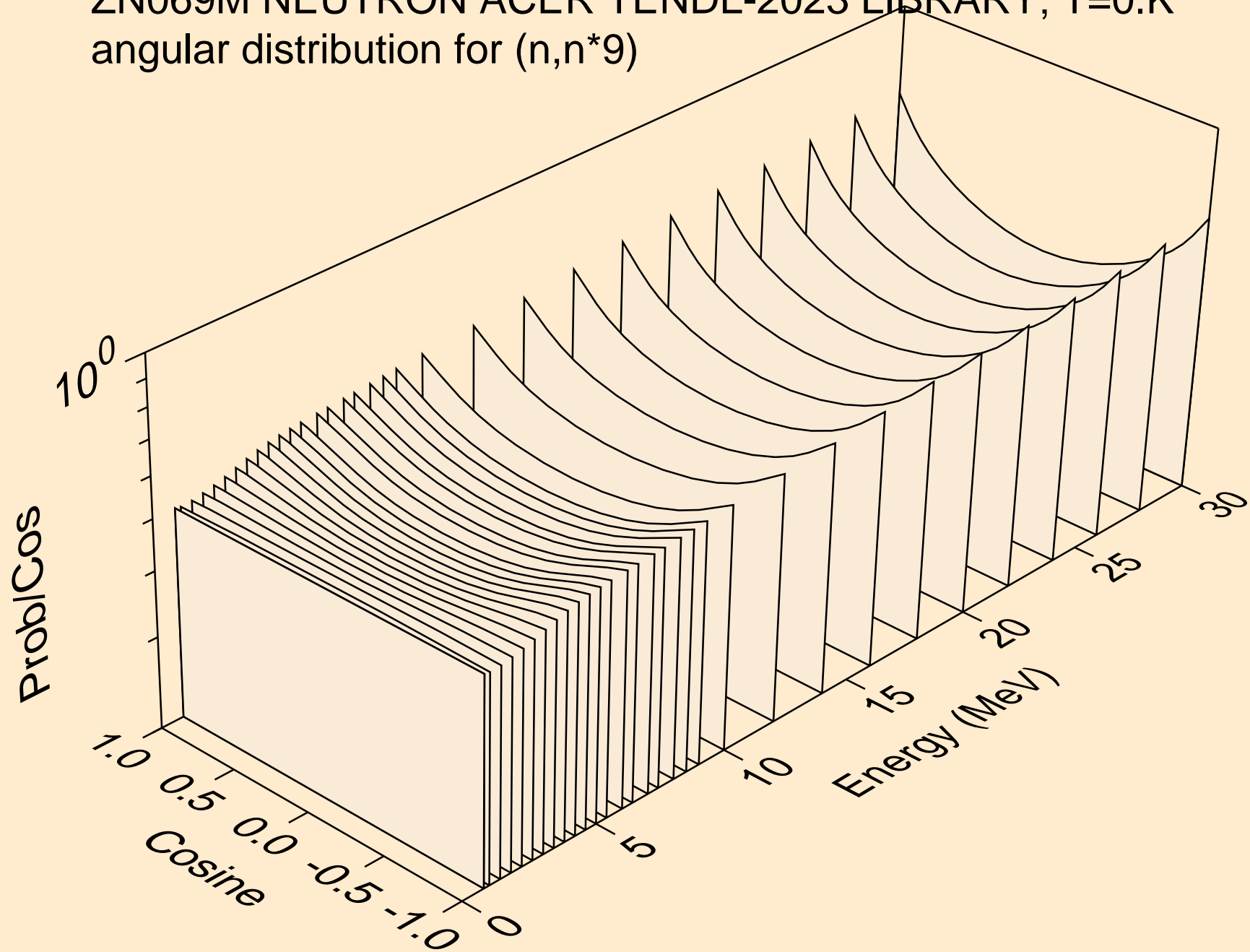

ZN069M NEUTRON ACER TENDL-2023 LIBRARY; T=0.K  
angular distribution for (n,n\*10)

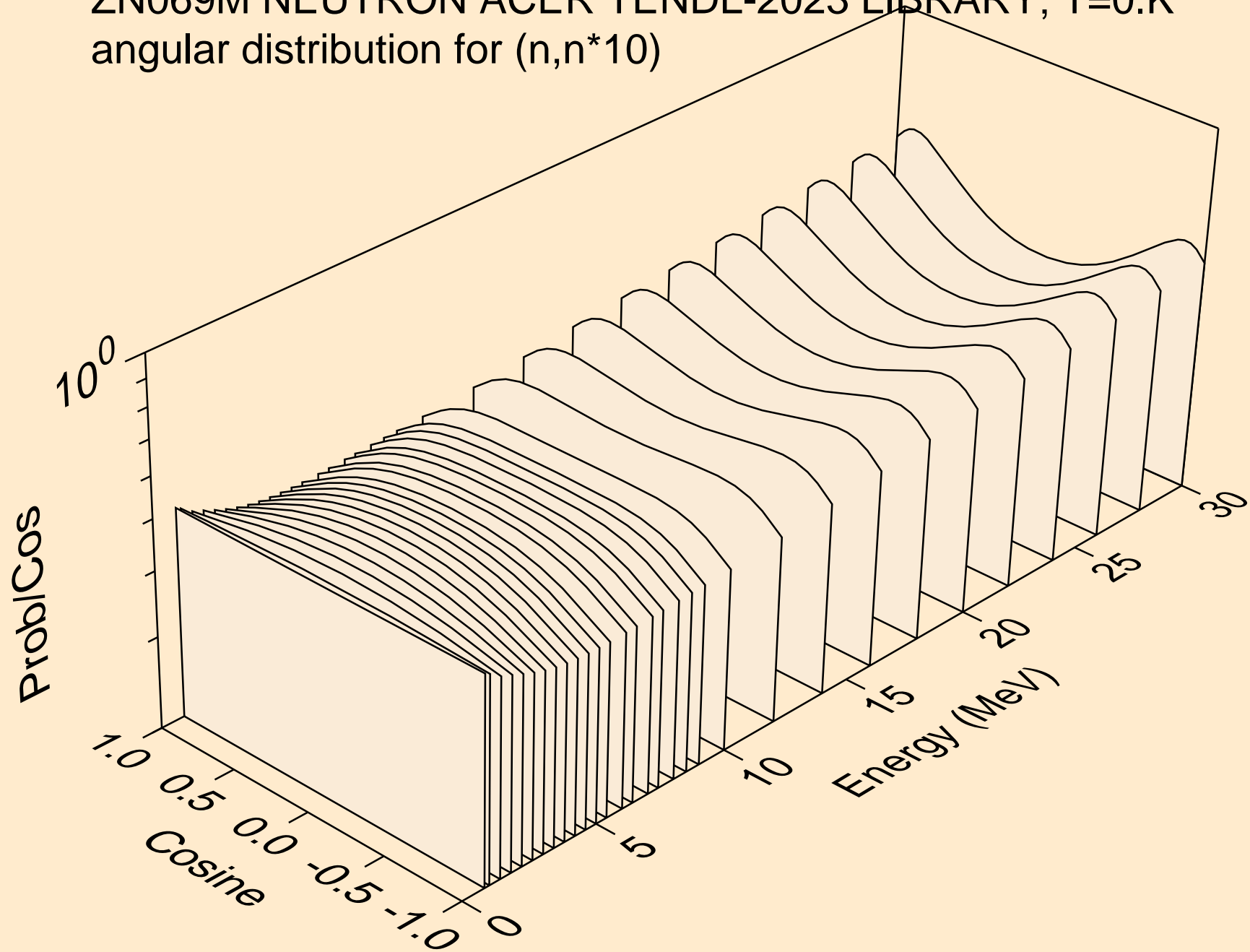



ZN069M NEUTRON ACER TENDL-2023 LIBRARY; T=0.K  
angular distribution for (n,n\*11)

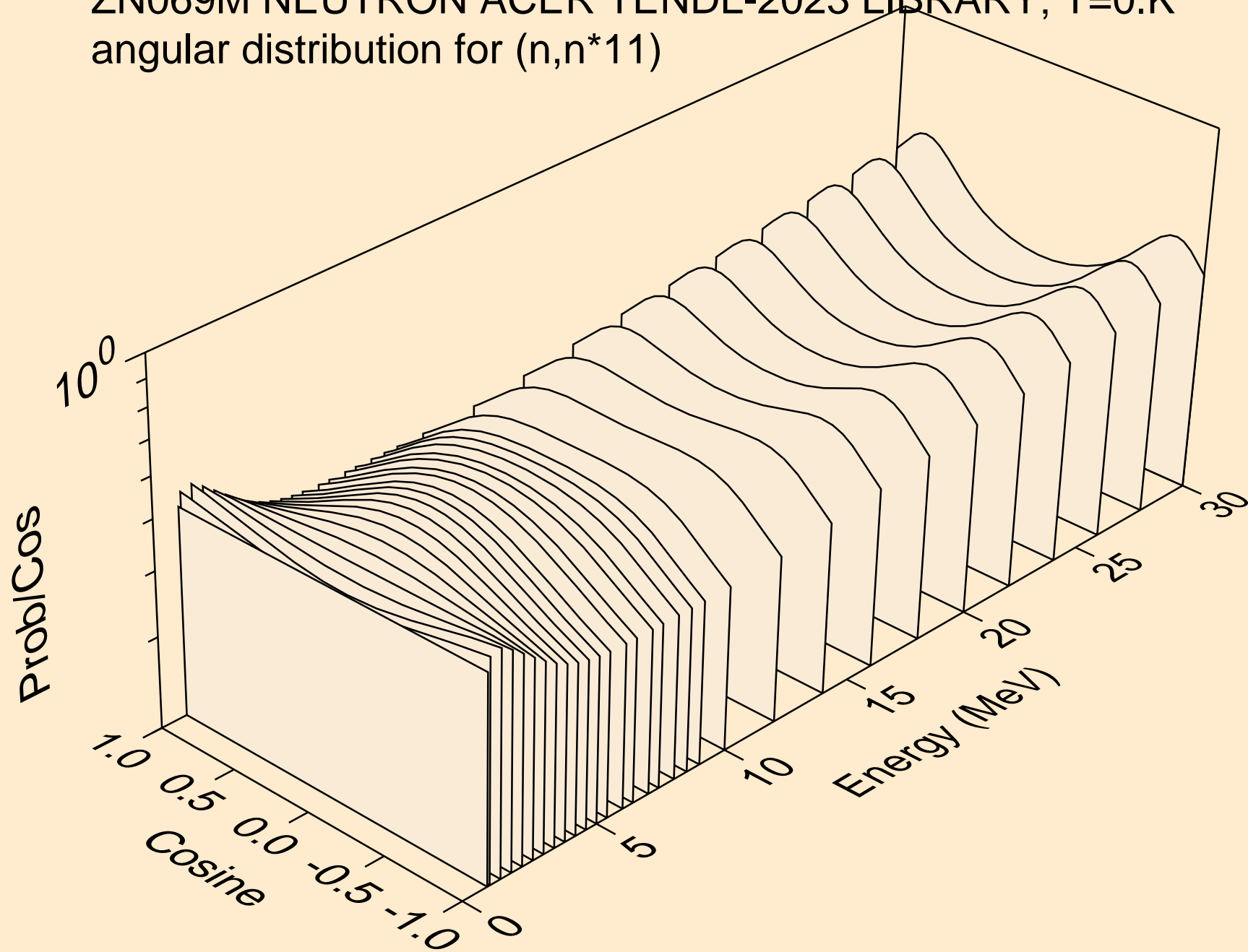

ZN069M NEUTRON ACER TENDL-2023 LIBRARY; T=0.K  
angular distribution for (n,n\*12)

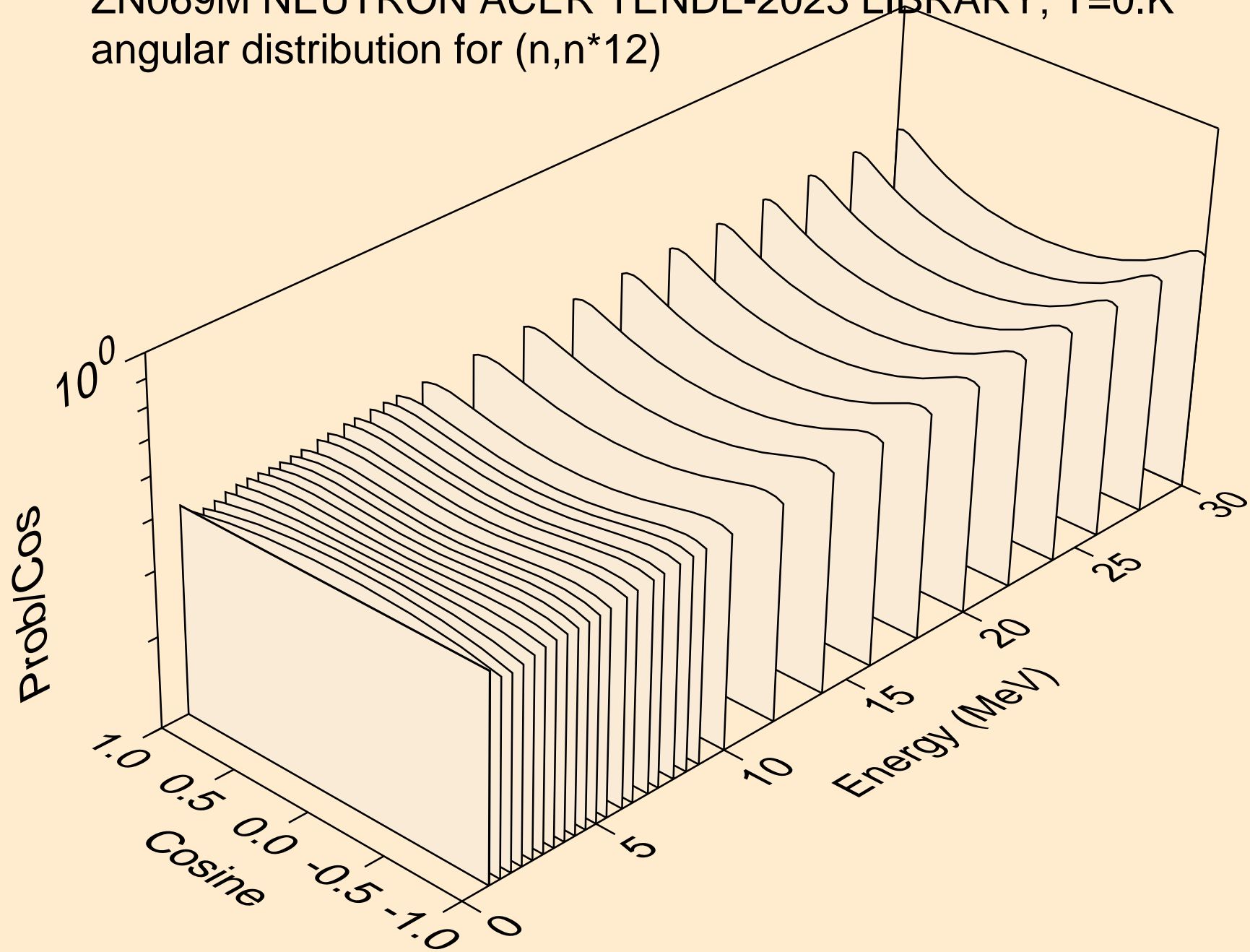

ZN069M NEUTRON ACER TENDL-2023 LIBRARY; T=0.K  
angular distribution for (n,n\*13)

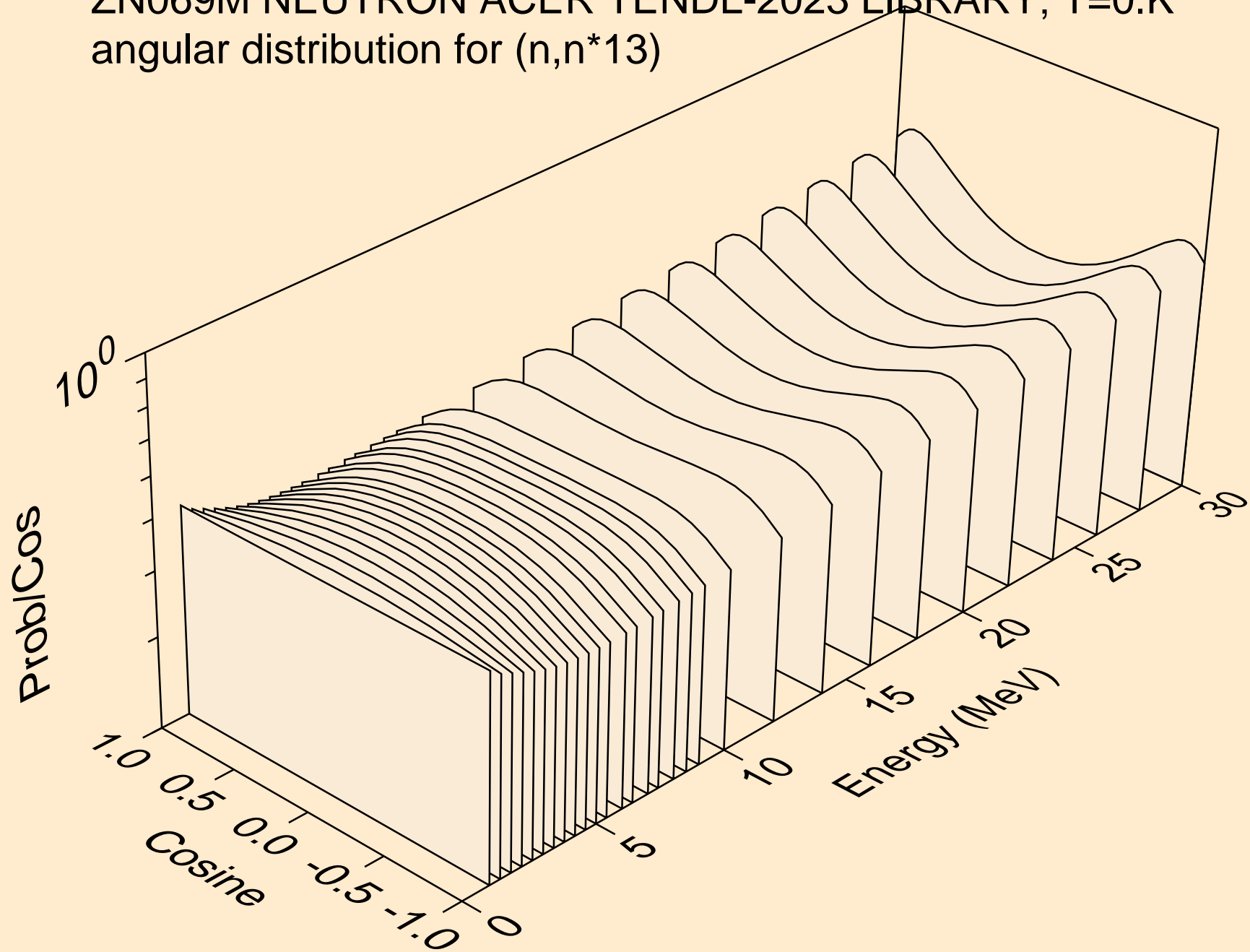

ZN069M NEUTRON ACER TENDL-2023 LIBRARY; T=0.K  
angular distribution for (n,n\*14)

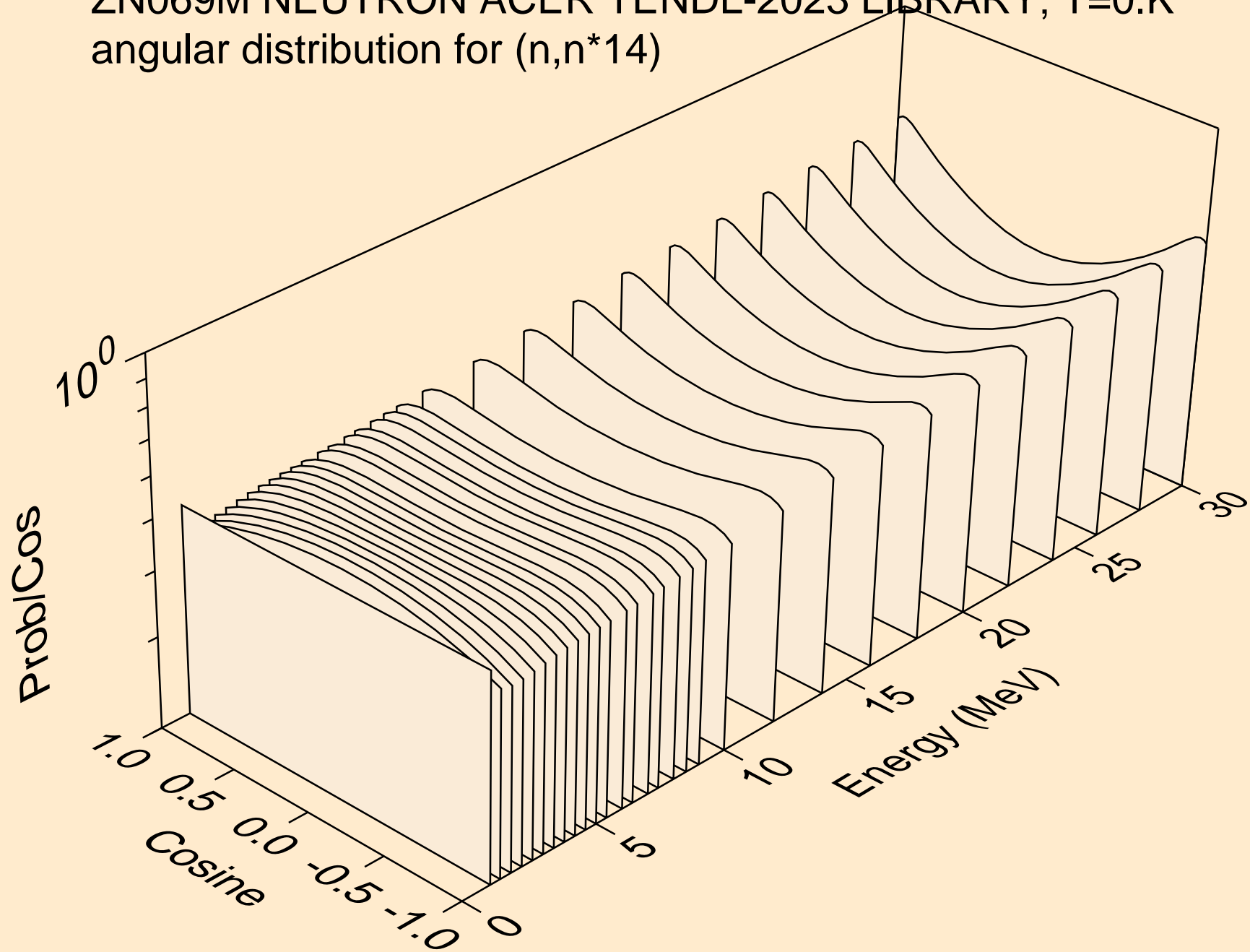

ZN069M NEUTRON ACER TENDL-2023 LIBRARY; T=0.K  
angular distribution for (n,n\*15)

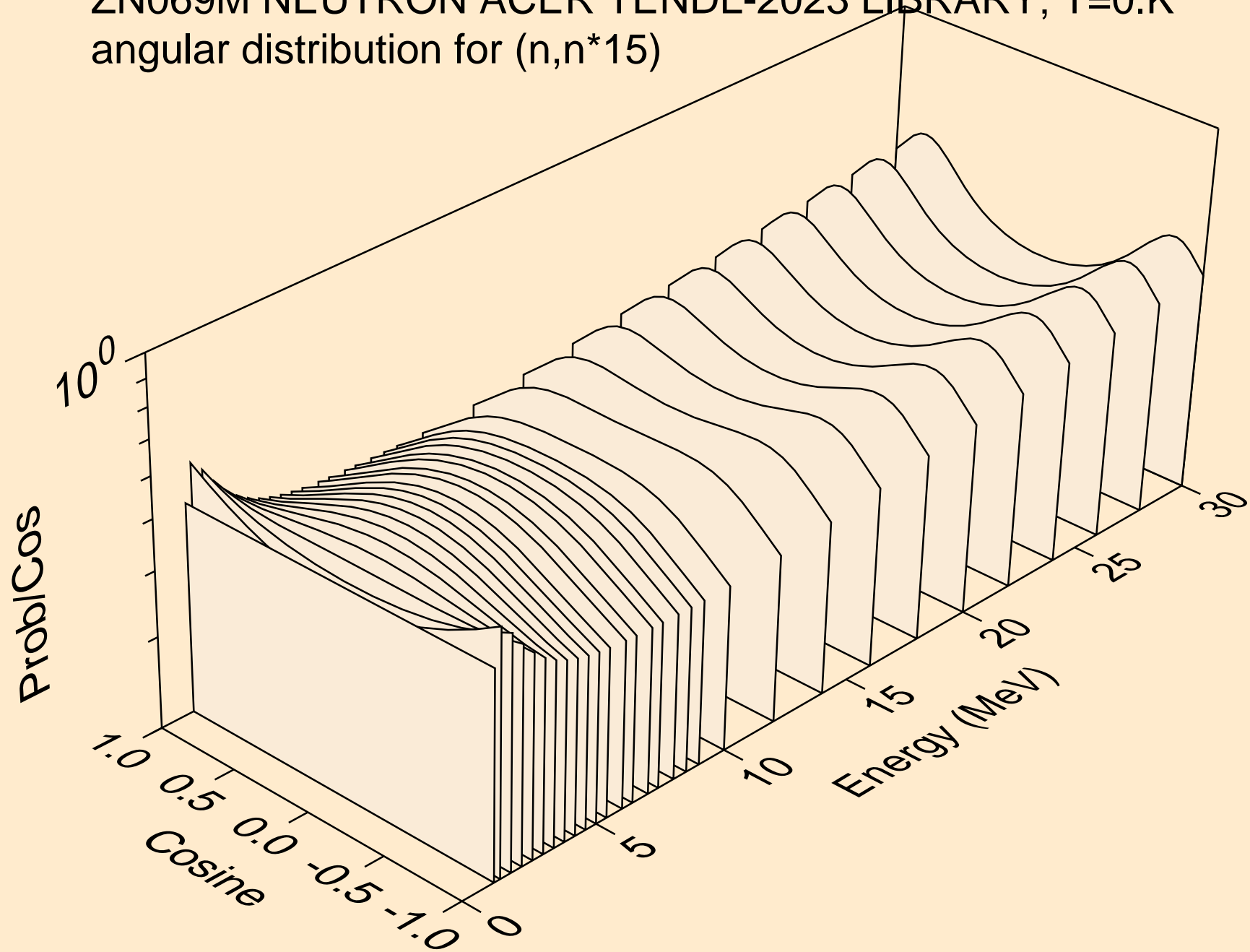

ZN069M NEUTRON ACER TENDL-2023 LIBRARY; T=0.K  
angular distribution for (n,n\*16)

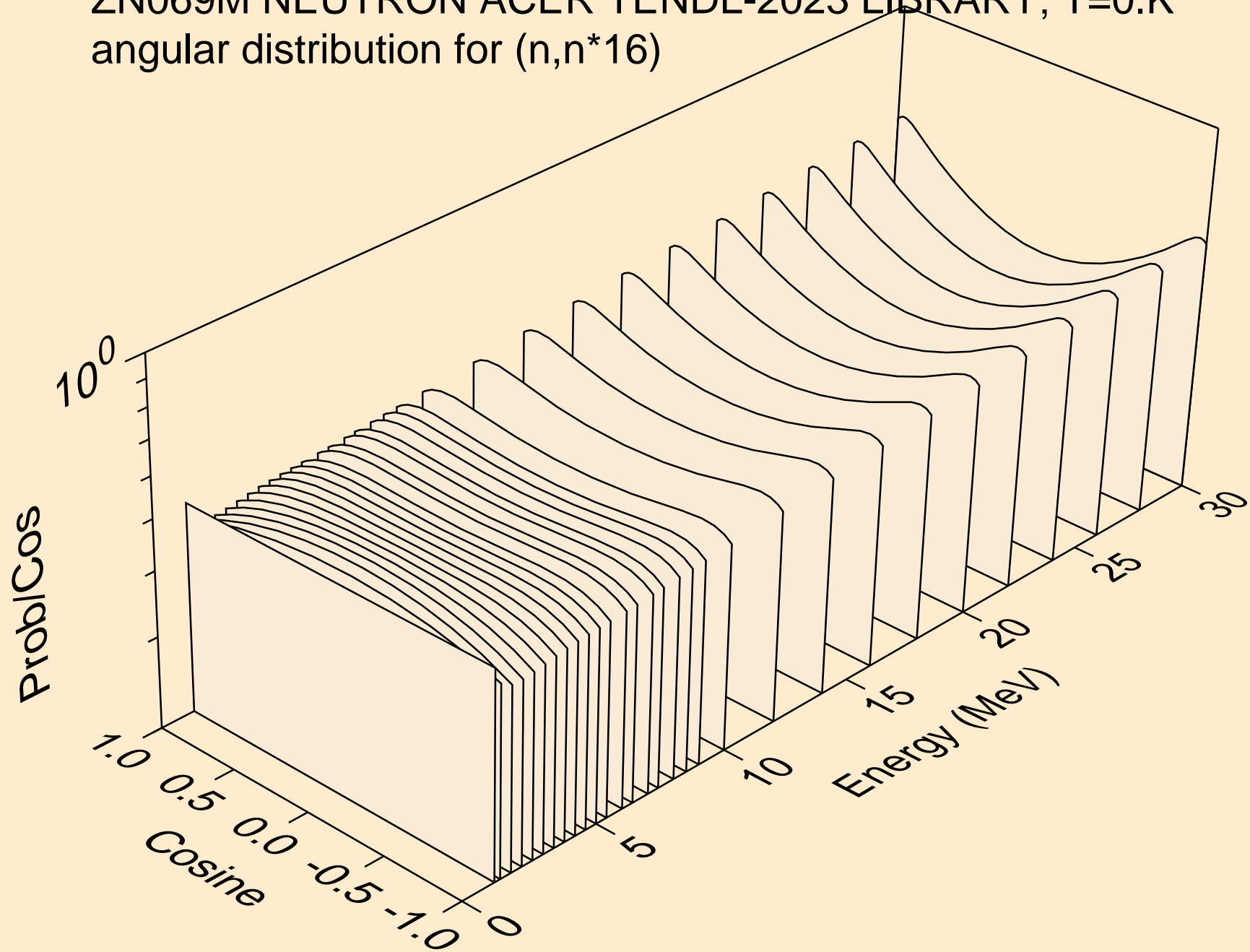

ZN069M NEUTRON ACER TENDL-2023 LIBRARY; T=0.K  
angular distribution for (n,n\*17)

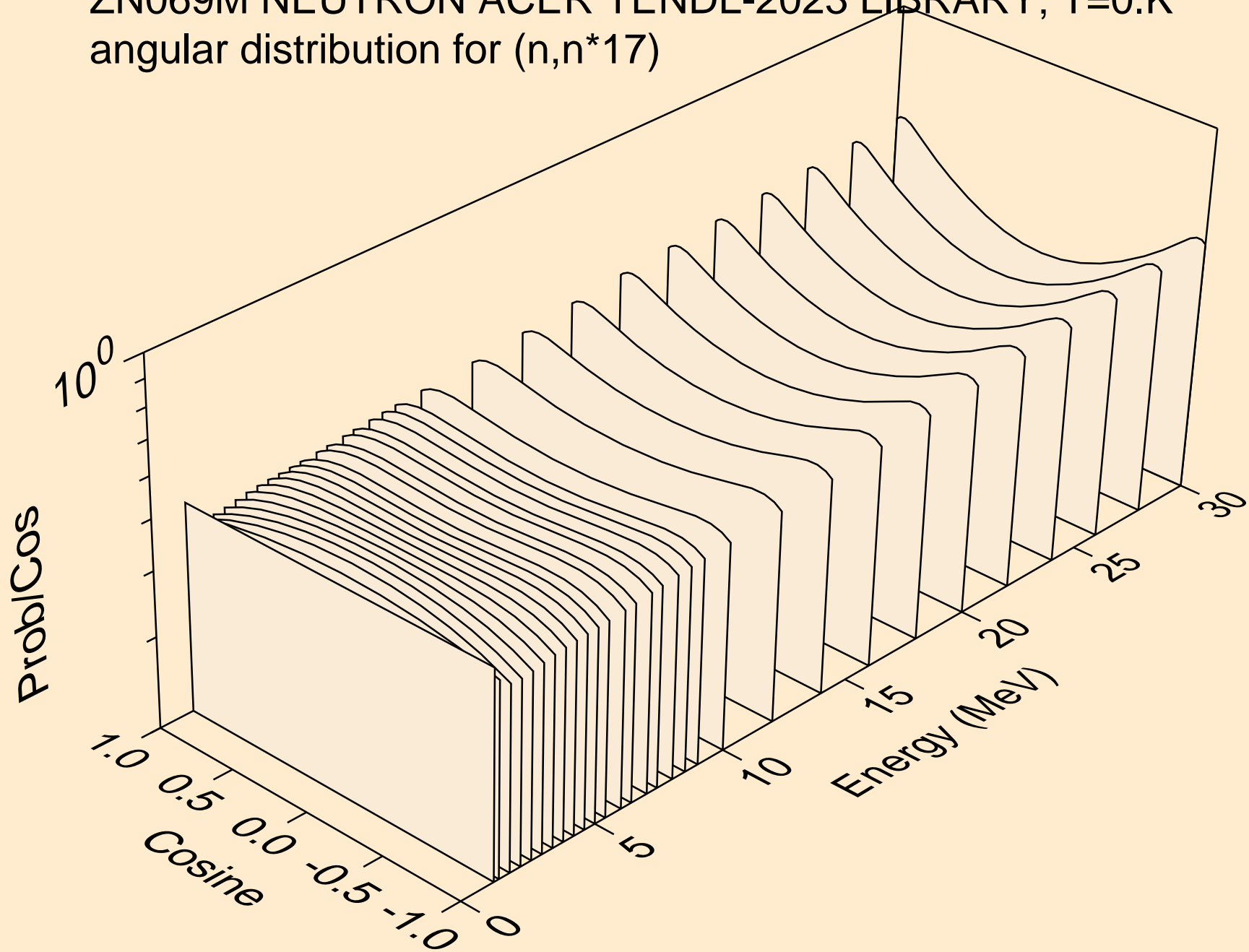

ZN069M NEUTRON ACER TENDL-2023 LIBRARY; T=0.K  
angular distribution for (n,n\*18)

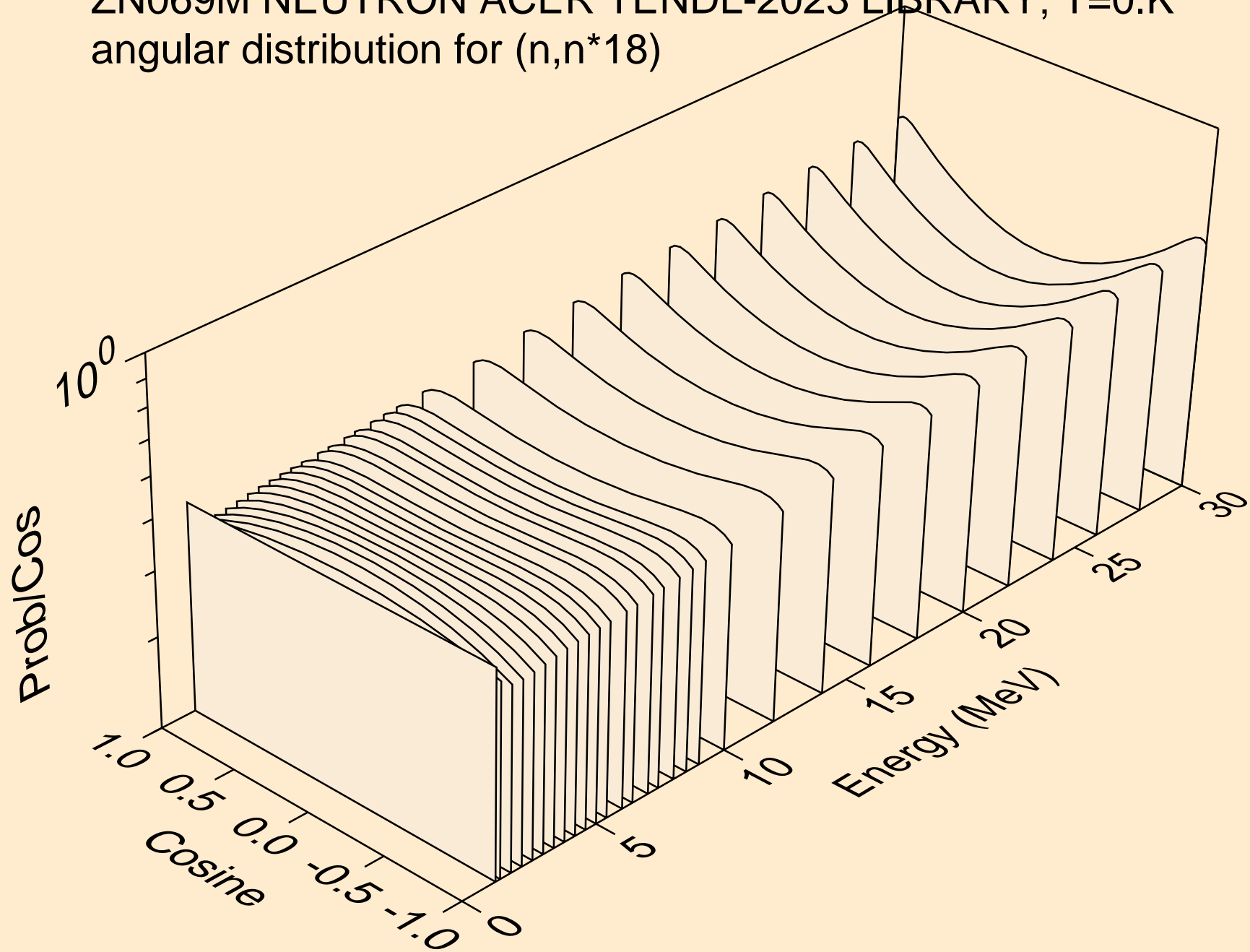



ZN069M NEUTRON ACER TENDL-2023 LIBRARY; T=0.K  
angular distribution for (n,n\*19)

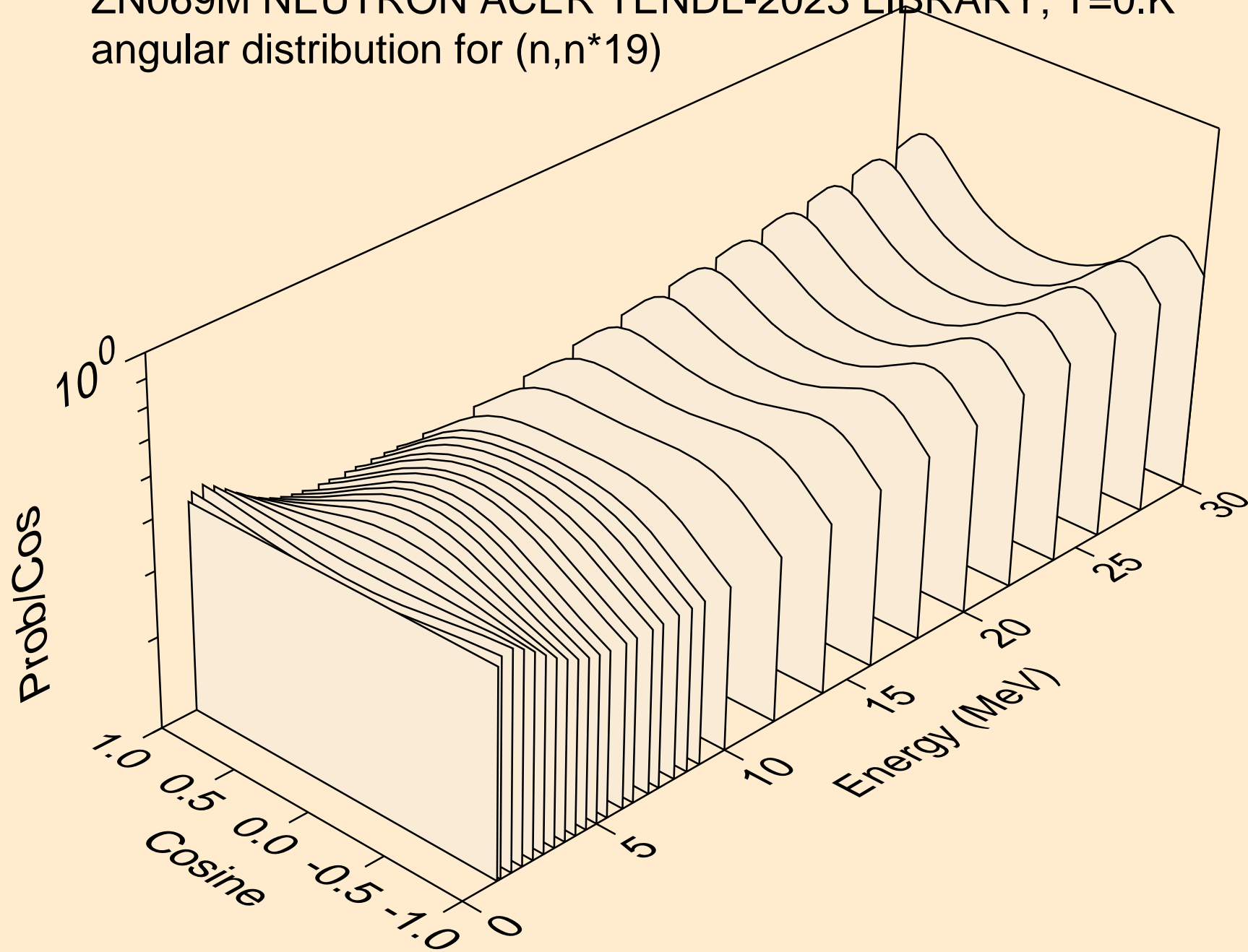

ZN069M NEUTRON ACER TENDL-2023 LIBRARY; T=0.K  
angular distribution for (n,n\*20)

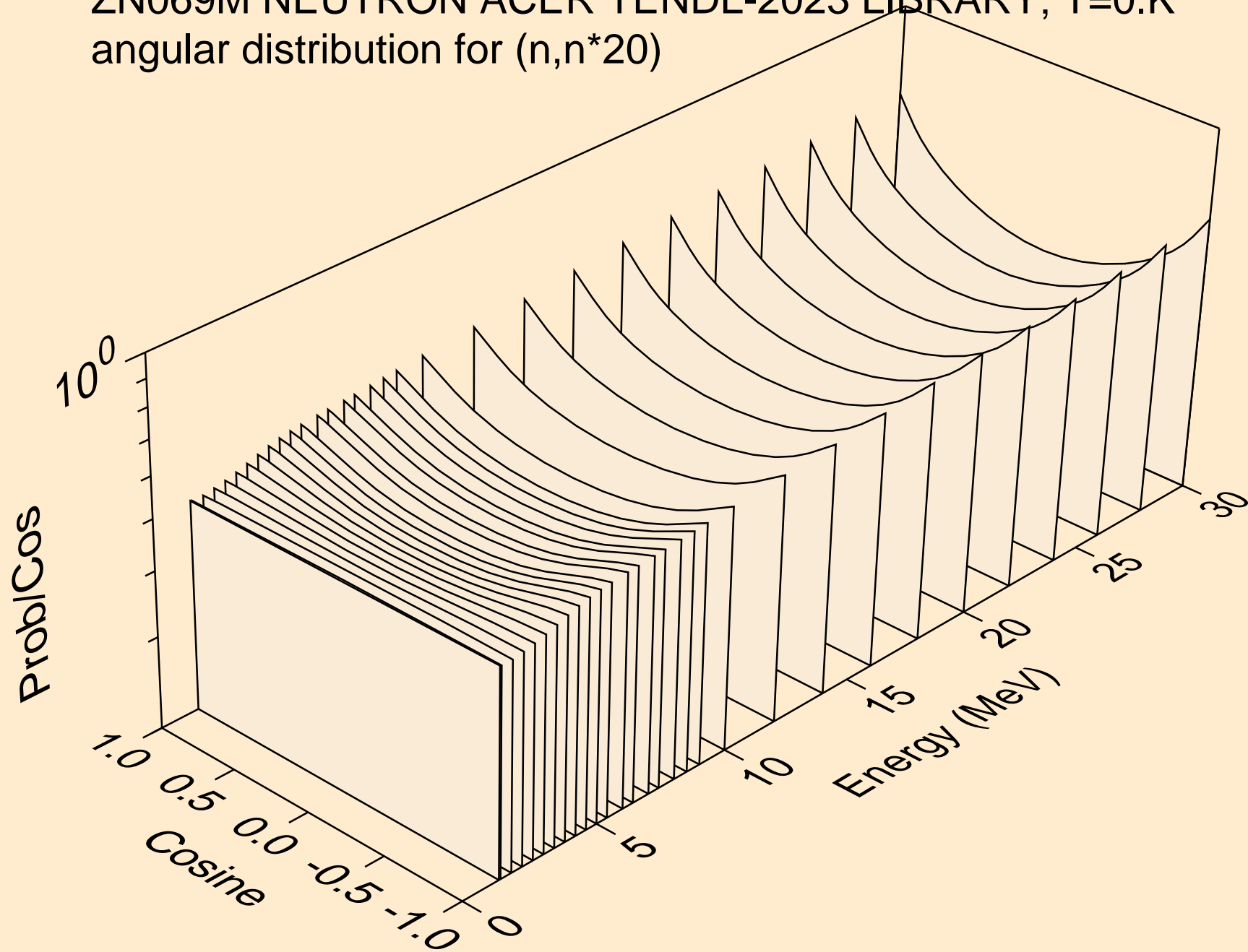

ZN069M NEUTRON ACER TENDL-2023 LIBRARY; T=0.K  
angular distribution for (n,n\*21)

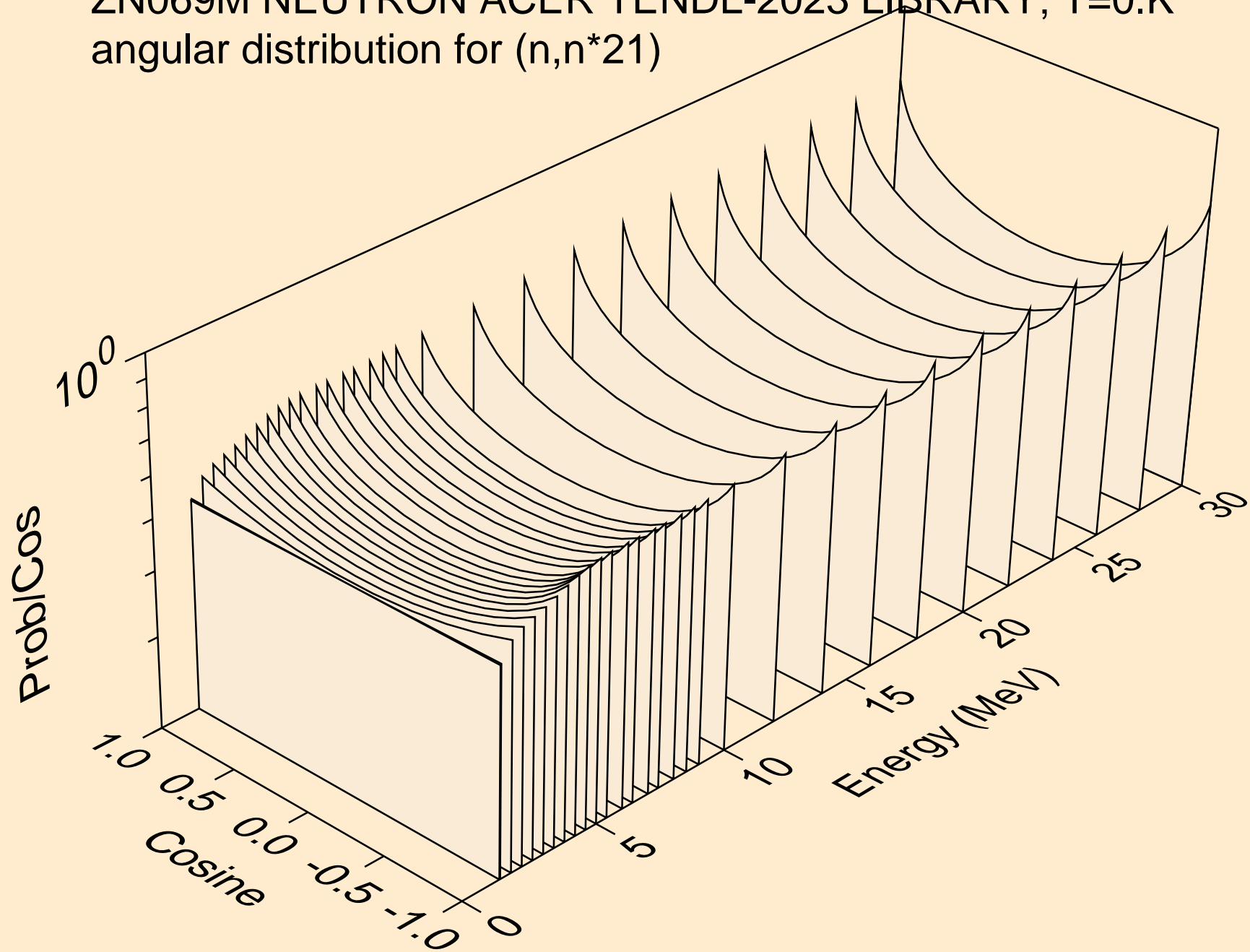

ZN069M NEUTRON ACER TENDL-2023 LIBRARY; T=0.K  
angular distribution for (n,n\*22)

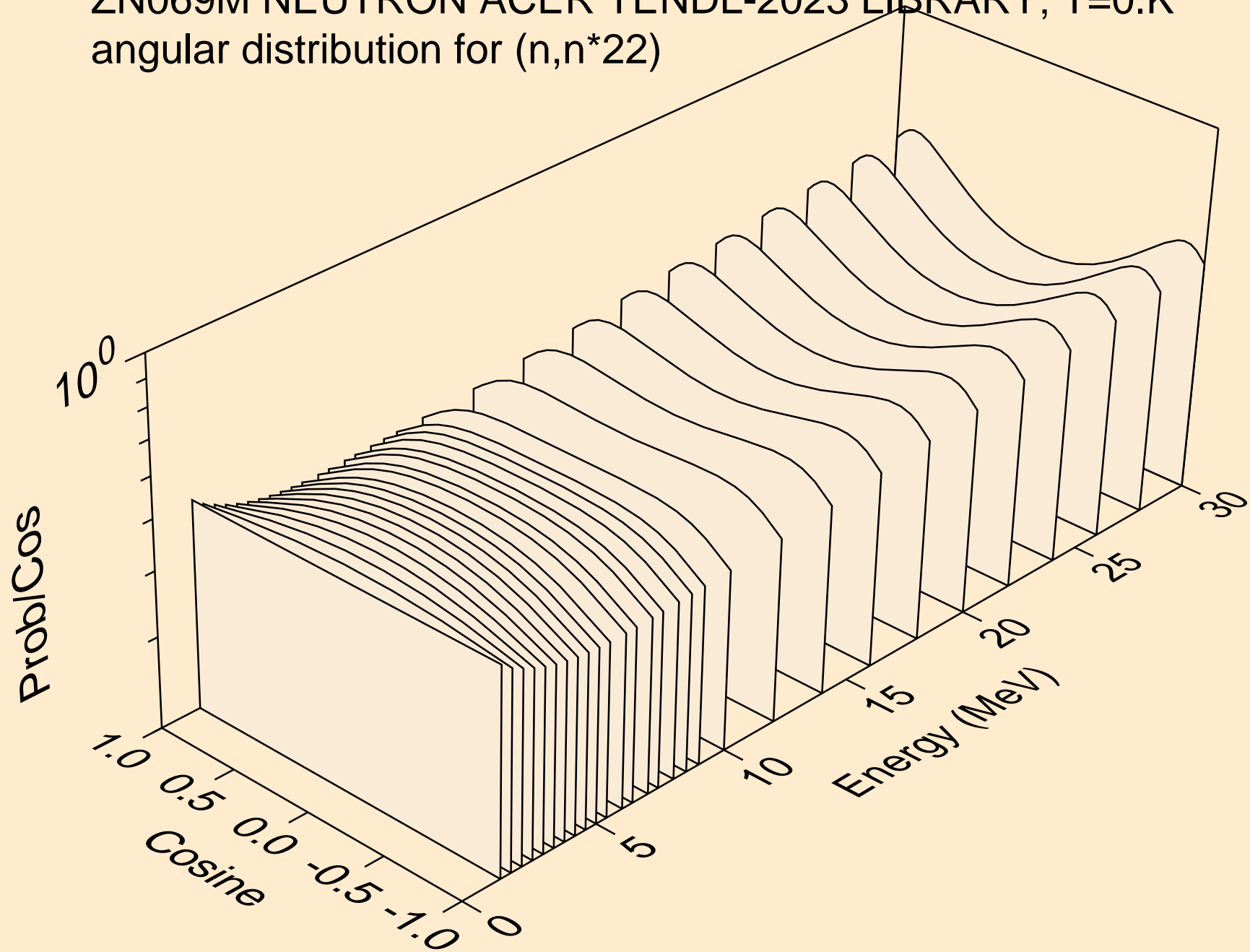

ZN069M NEUTRON ACER TENDL-2023 LIBRARY; T=0.K  
angular distribution for (n,n\*23)

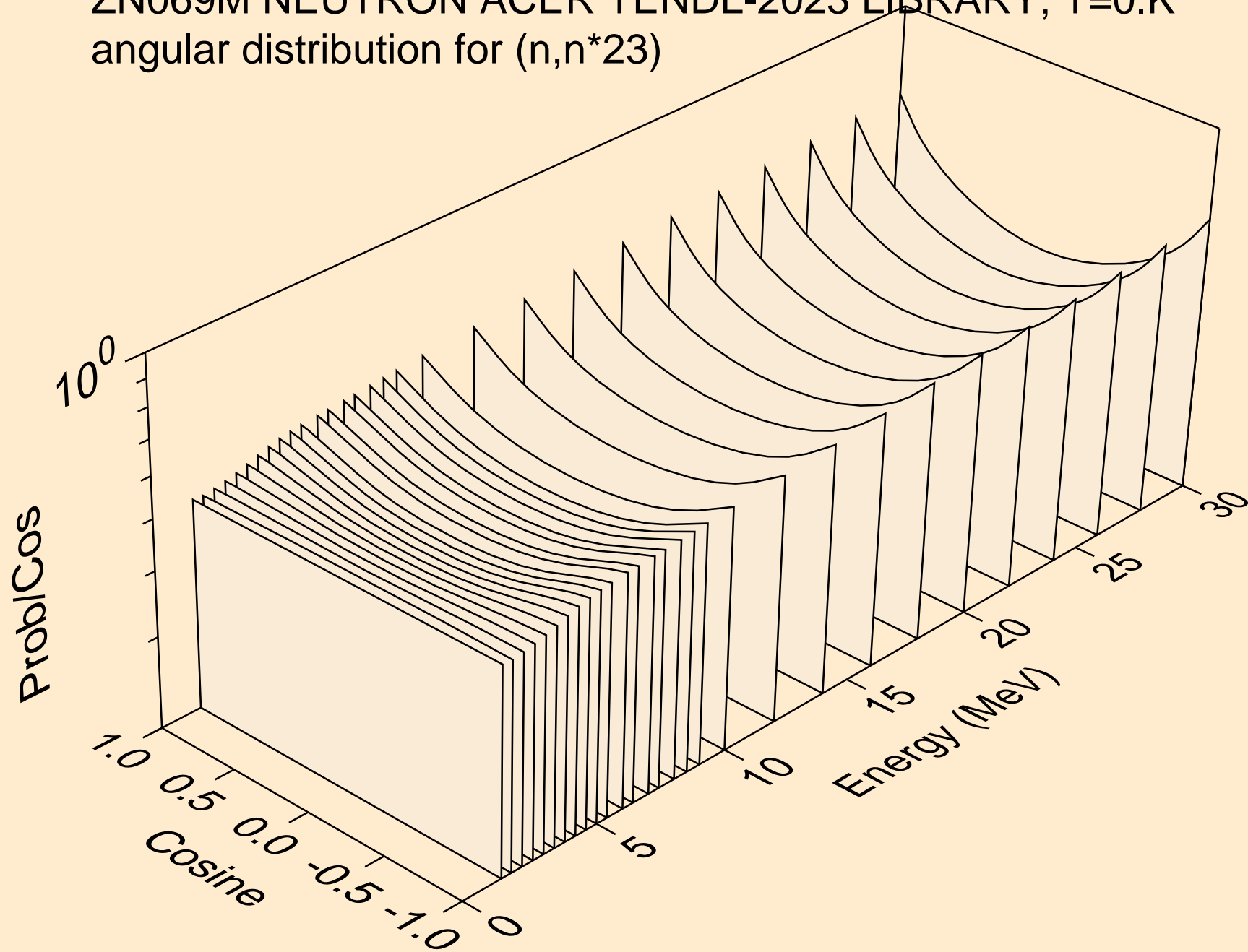

ZN069M NEUTRON ACER TENDL-2023 LIBRARY; T=0.K  
angular distribution for (n,n\*24)

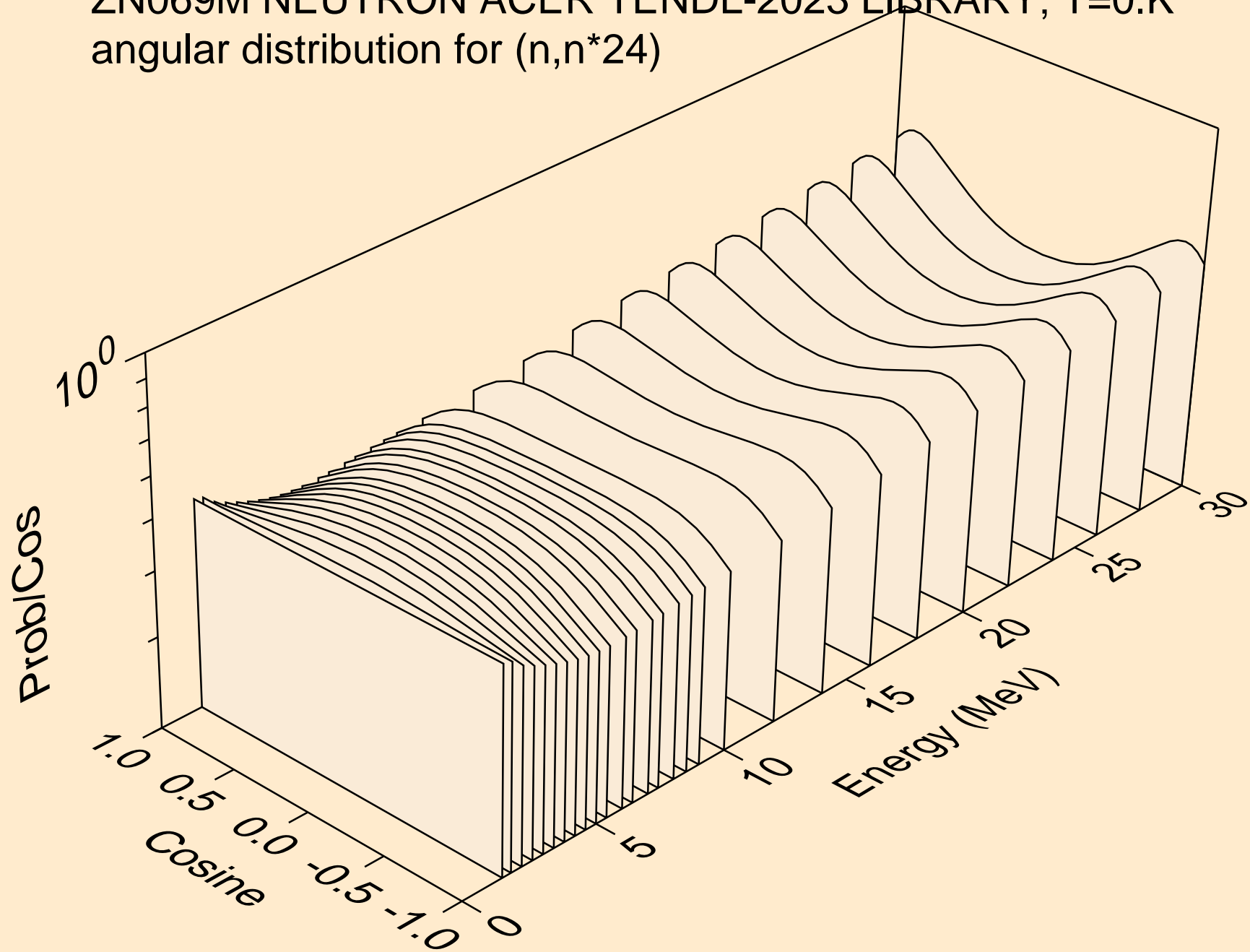

ZN069M NEUTRON ACER TENDL-2023 LIBRARY; T=0.K  
angular distribution for (n,n\*25)

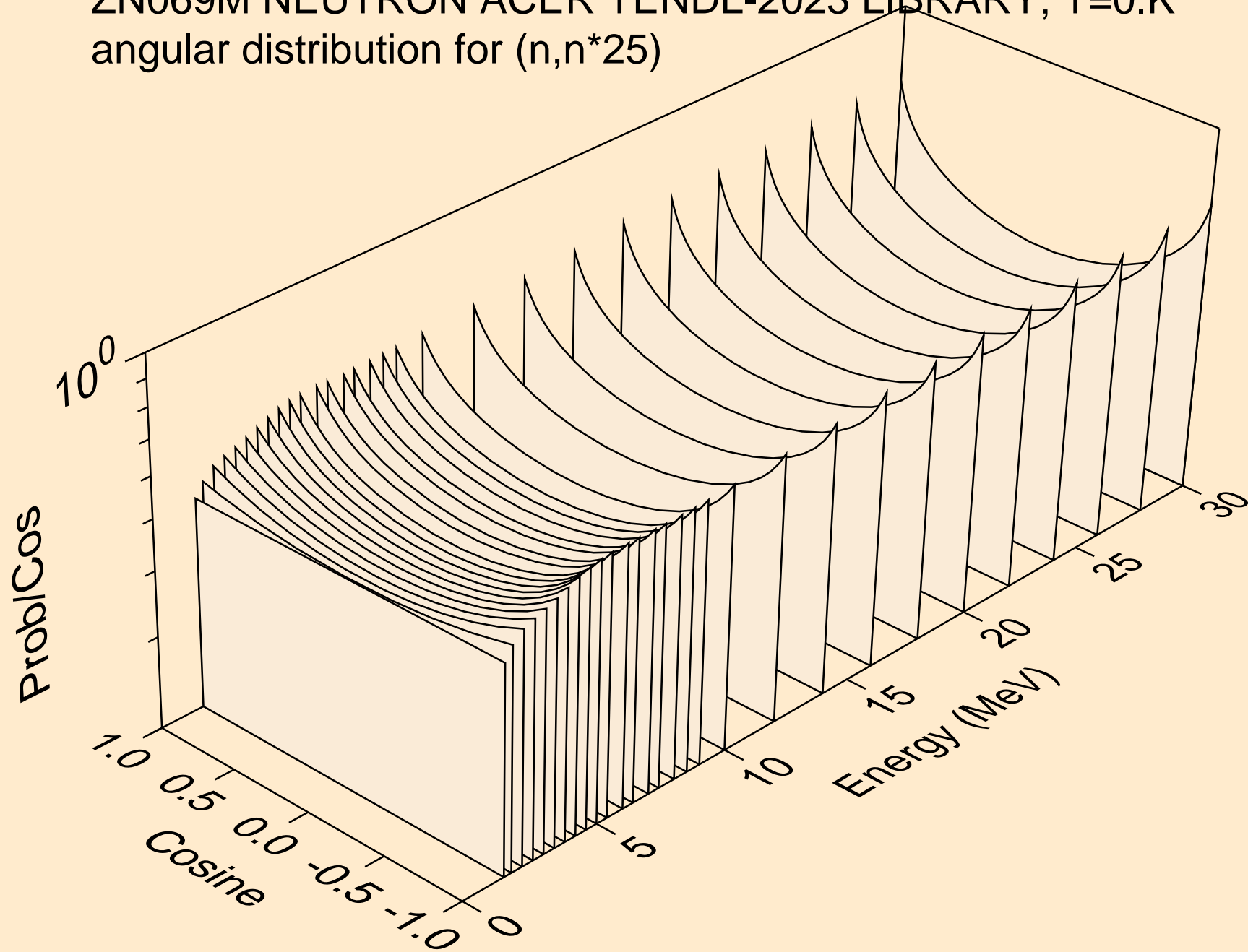

ZN069M NEUTRON ACER TENDL-2023 LIBRARY; T=0.K  
Neutron emission for (n,x)

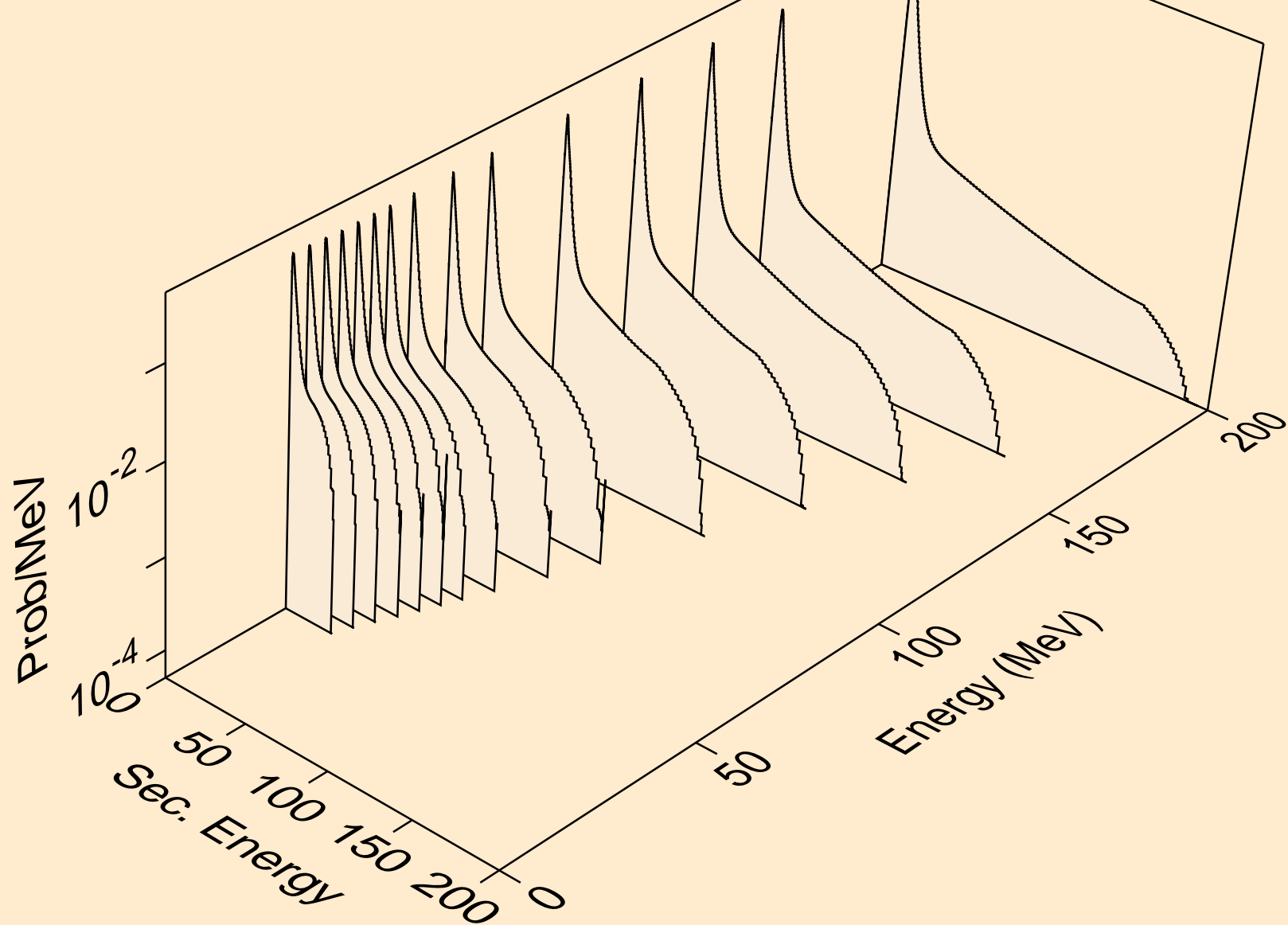



ZN069M NEUTRON ACER TENDL-2023 LIBRARY; T=0.K  
Neutron emission for (n,2nd)

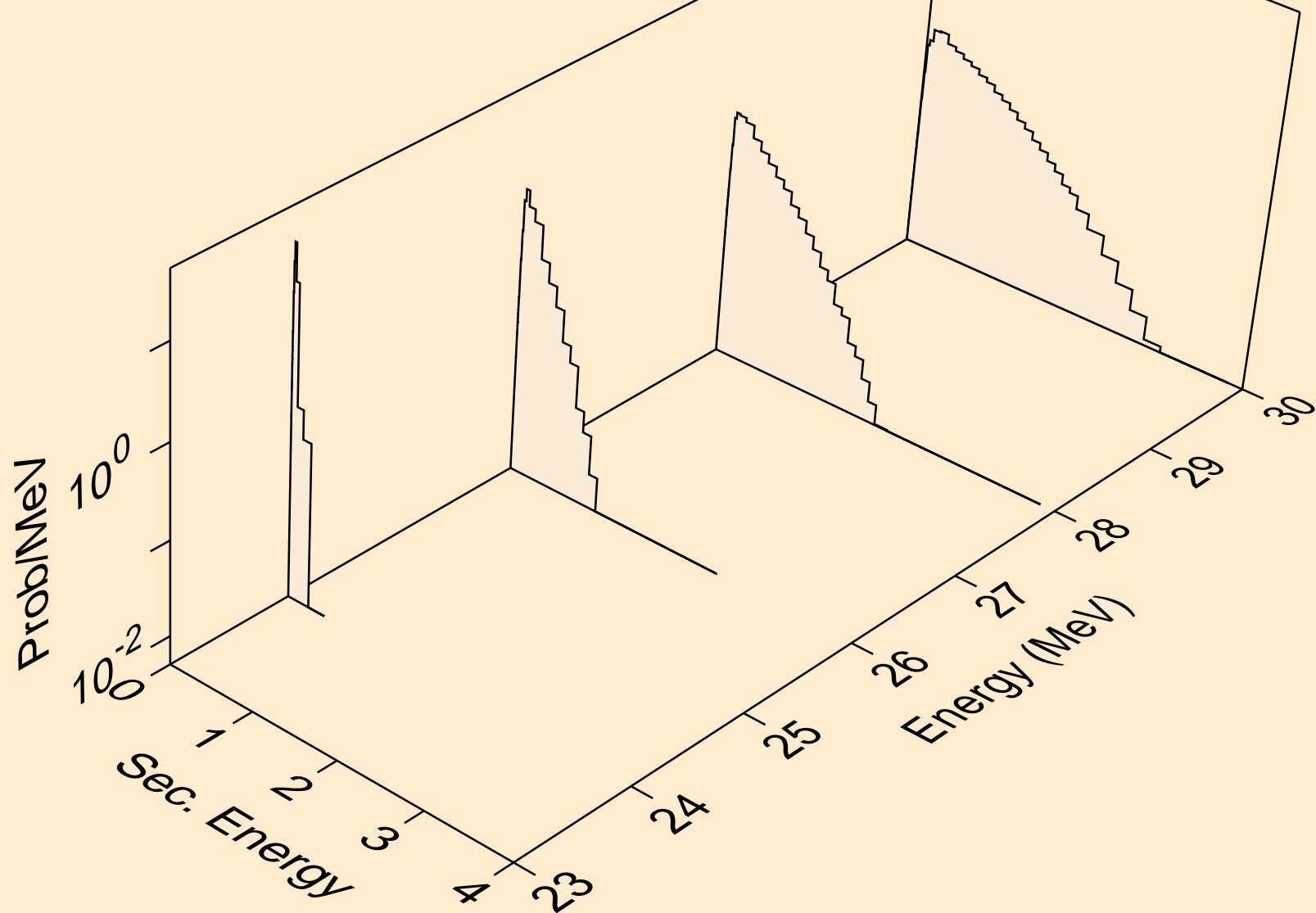

ZN069M NEUTRON ACER TENDL-2023 LIBRARY; T=0.K  
Neutron emission for (n,2n)

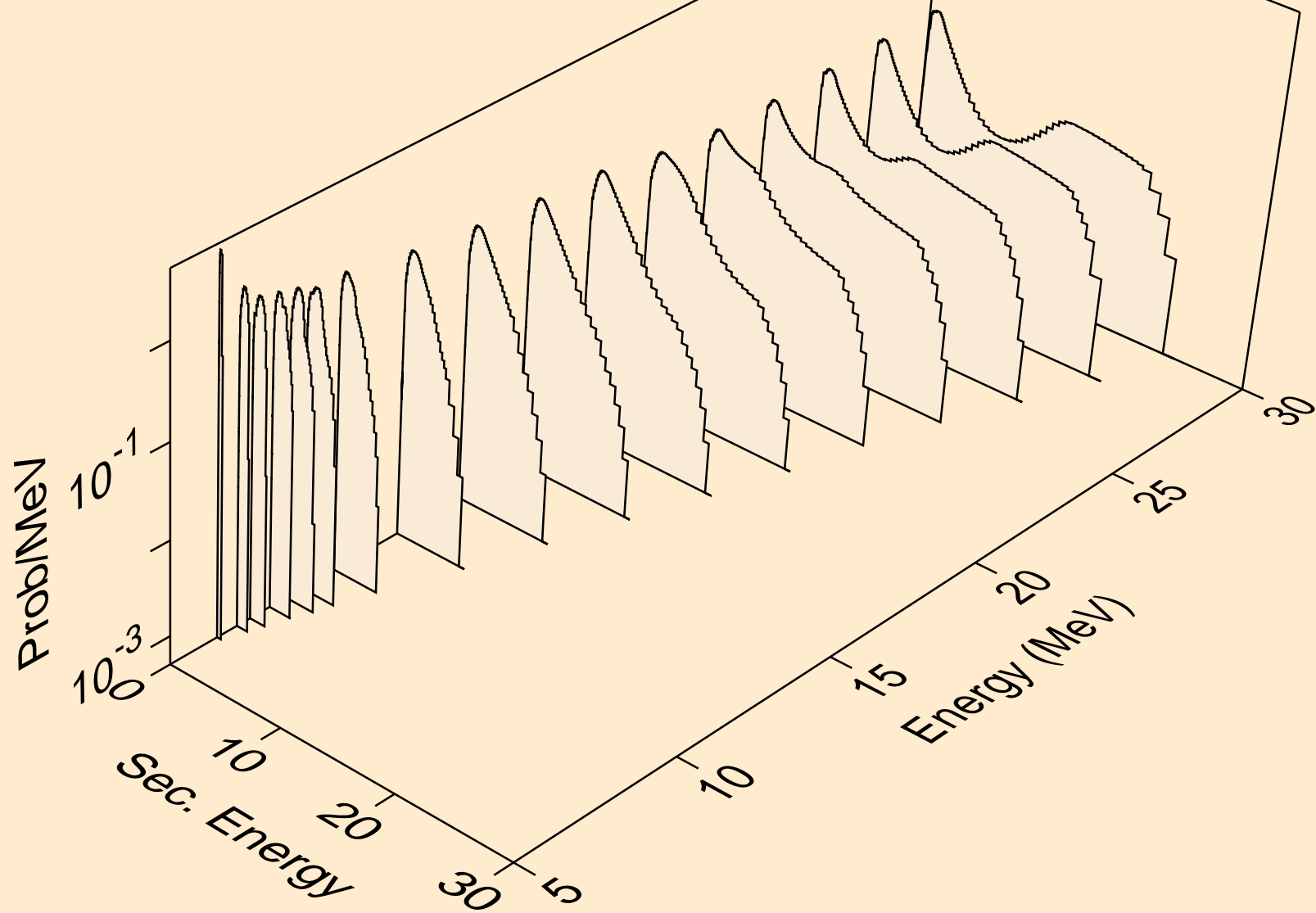

ZN069M NEUTRON ACER TENDL-2023 LIBRARY; T=0.K  
Neutron emission for (n,3n)

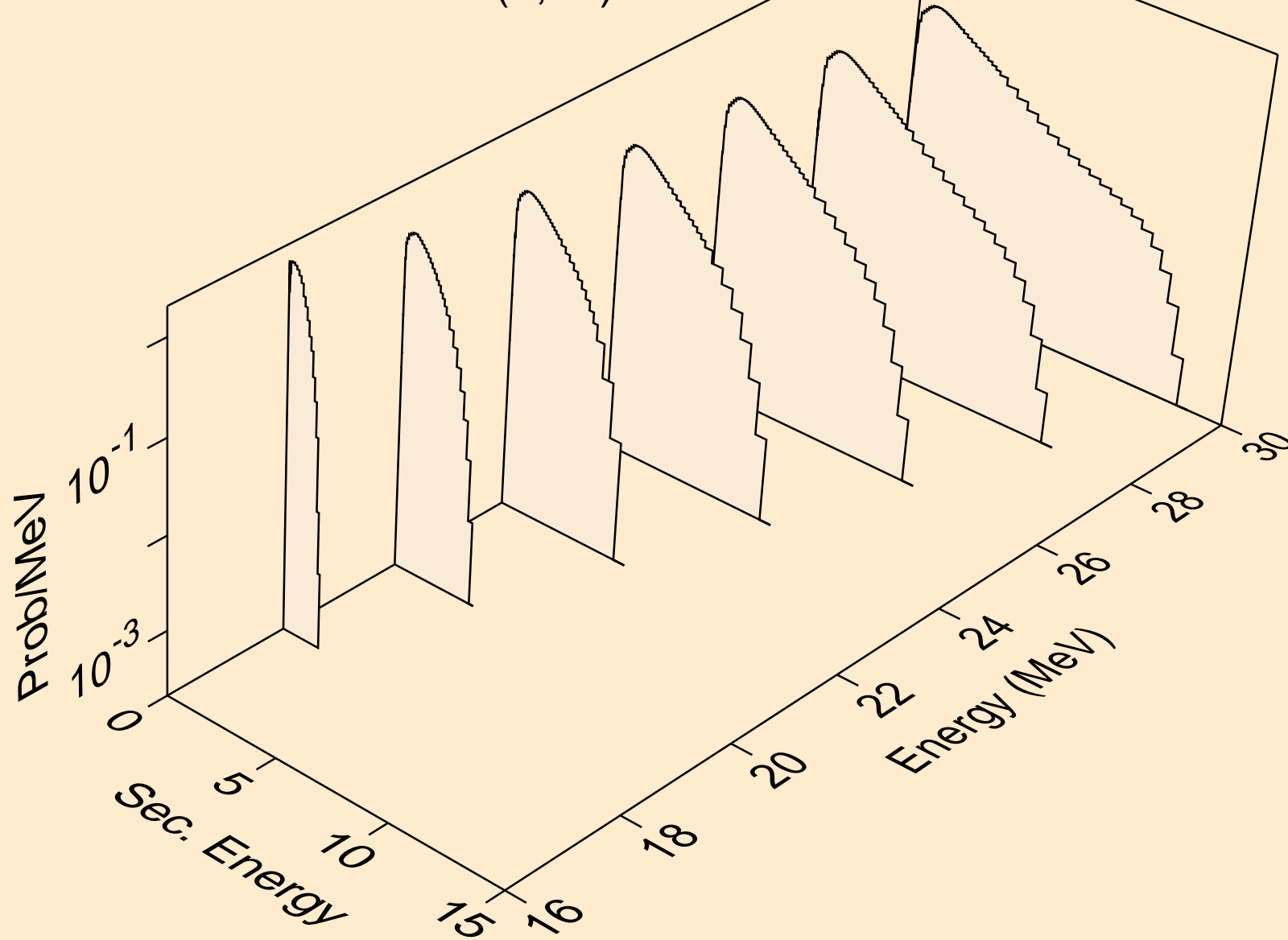

ZN069M NEUTRON ACER TENDL-2023 LIBRARY; T=0.K  
Neutron emission for (n,n\*)a

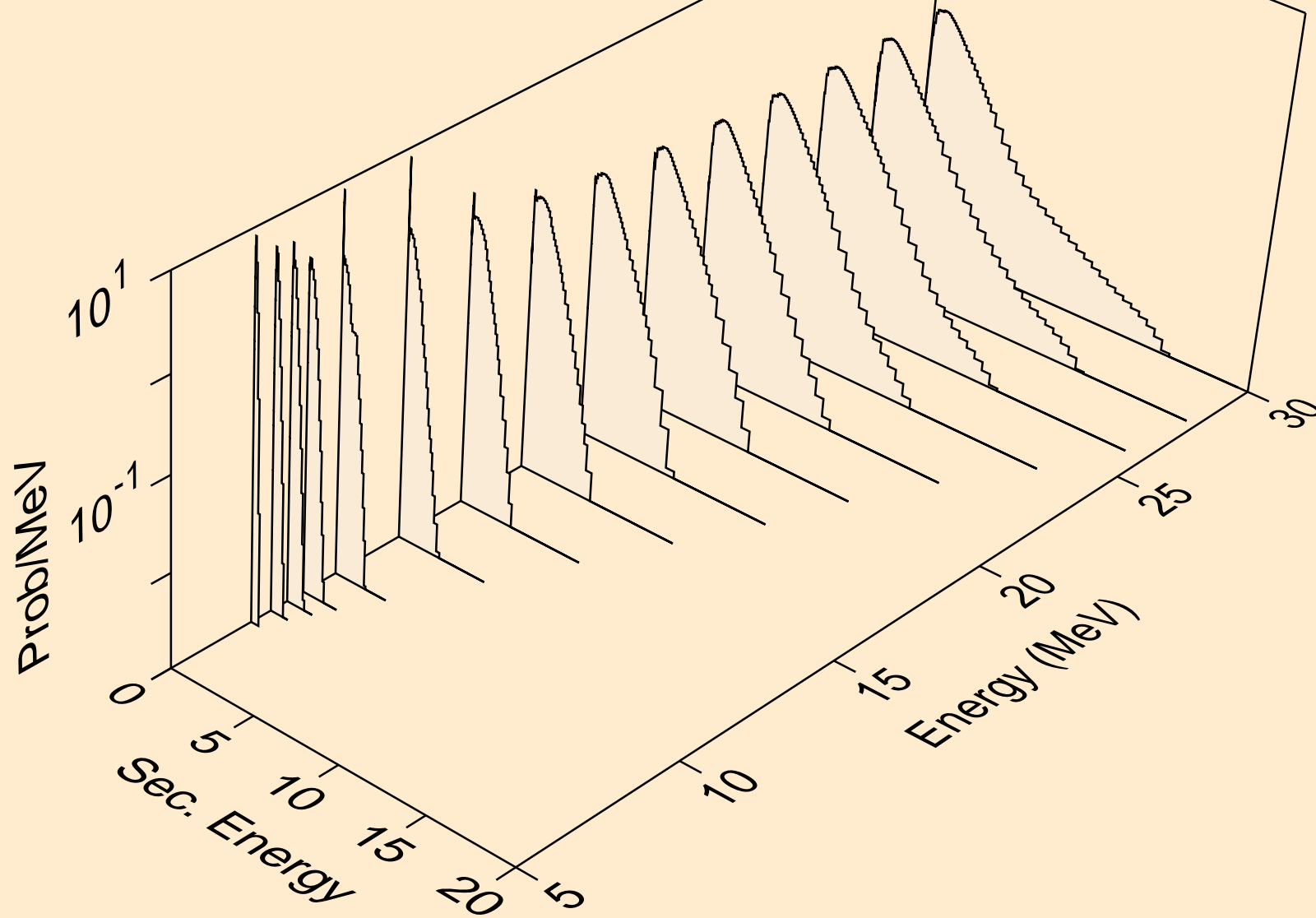

ZN069M NEUTRON ACER TENDL-2023 LIBRARY; T=0.K  
Neutron emission for (n,2n)a

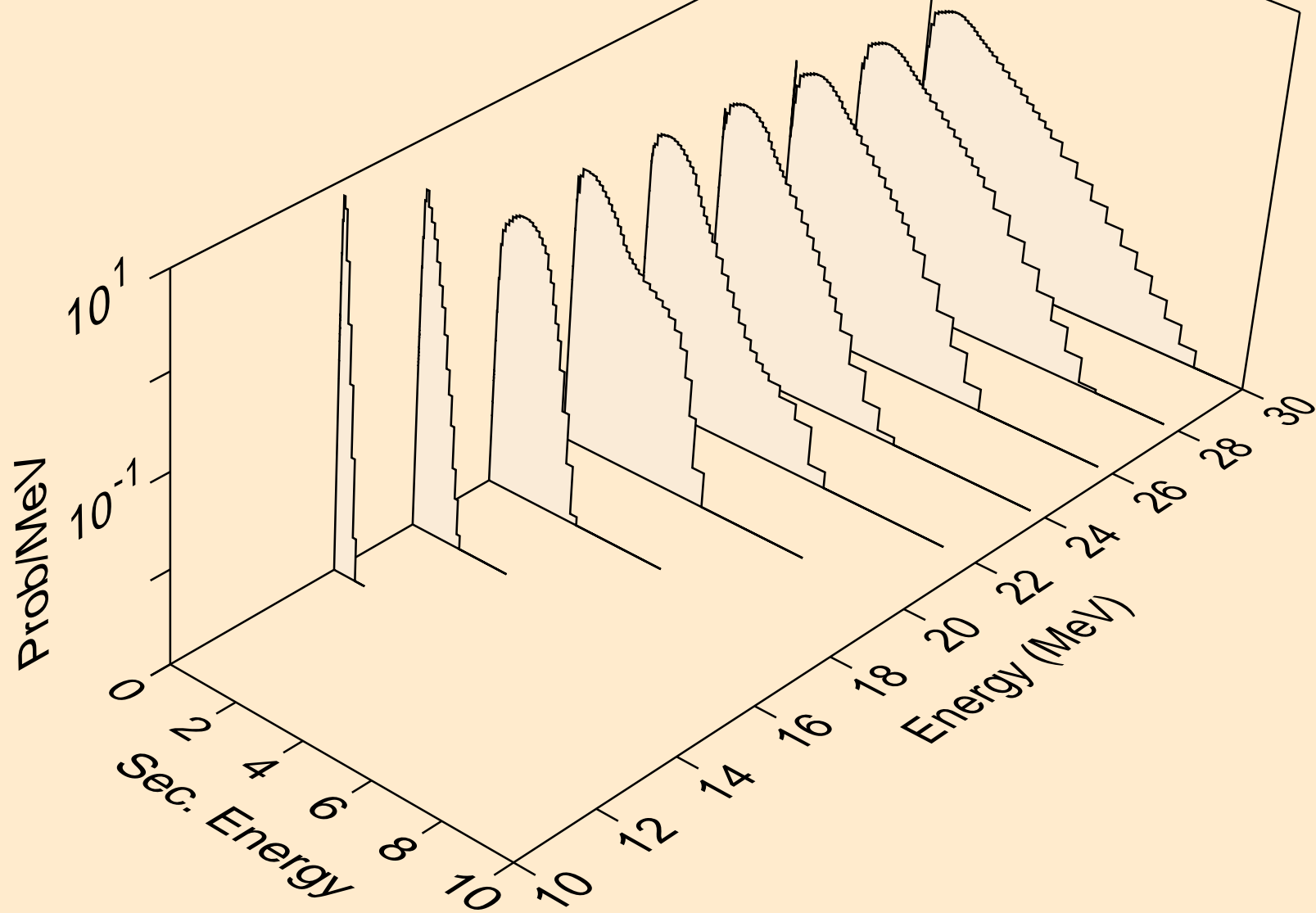

ZN069M NEUTRON ACER TENDL-2023 LIBRARY; T=0.K  
Neutron emission for (n,3n)a

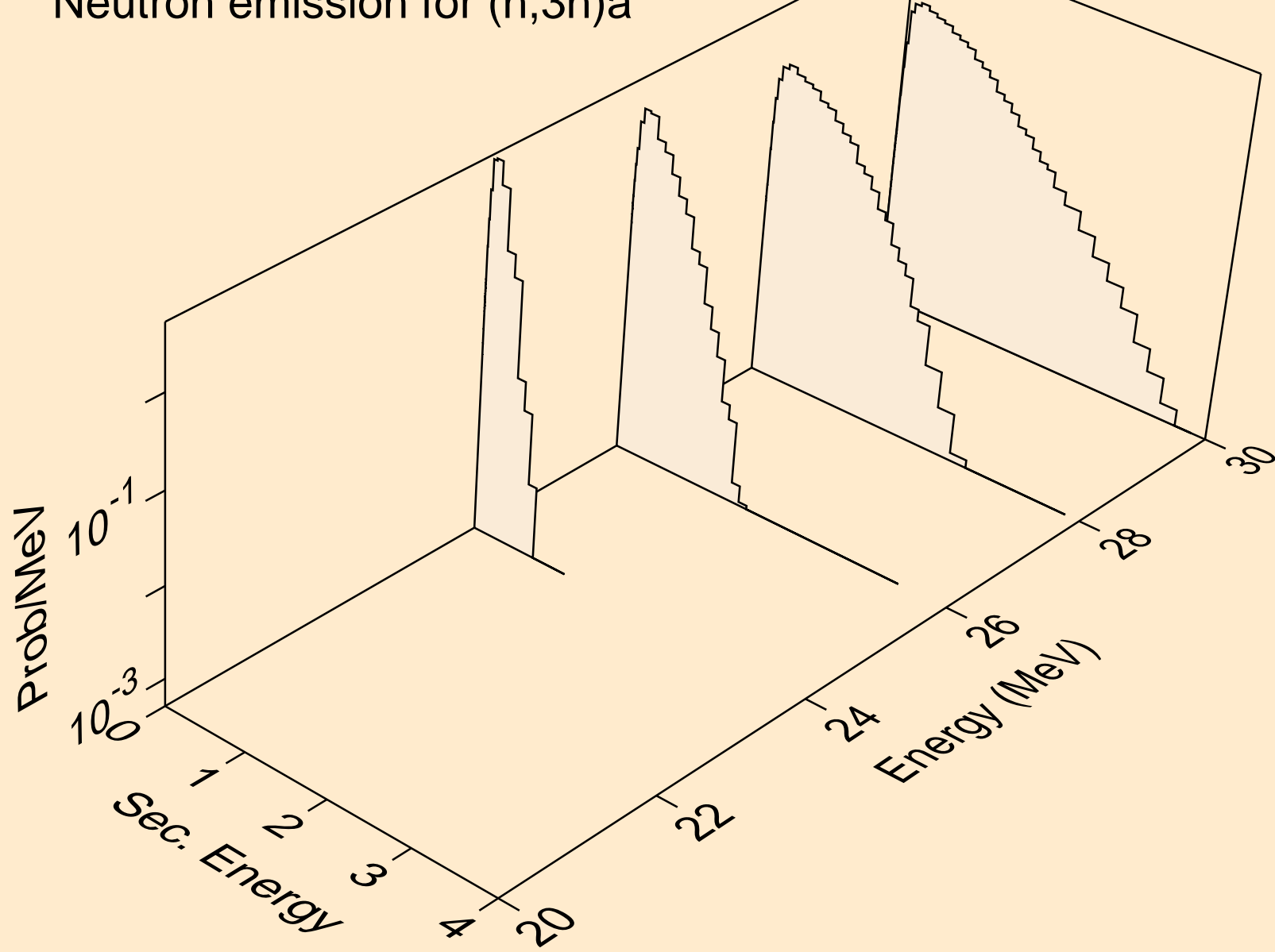

ZN069M NEUTRON ACER TENDL-2023 LIBRARY; T=0.K  
Neutron emission for (n,n\*)p

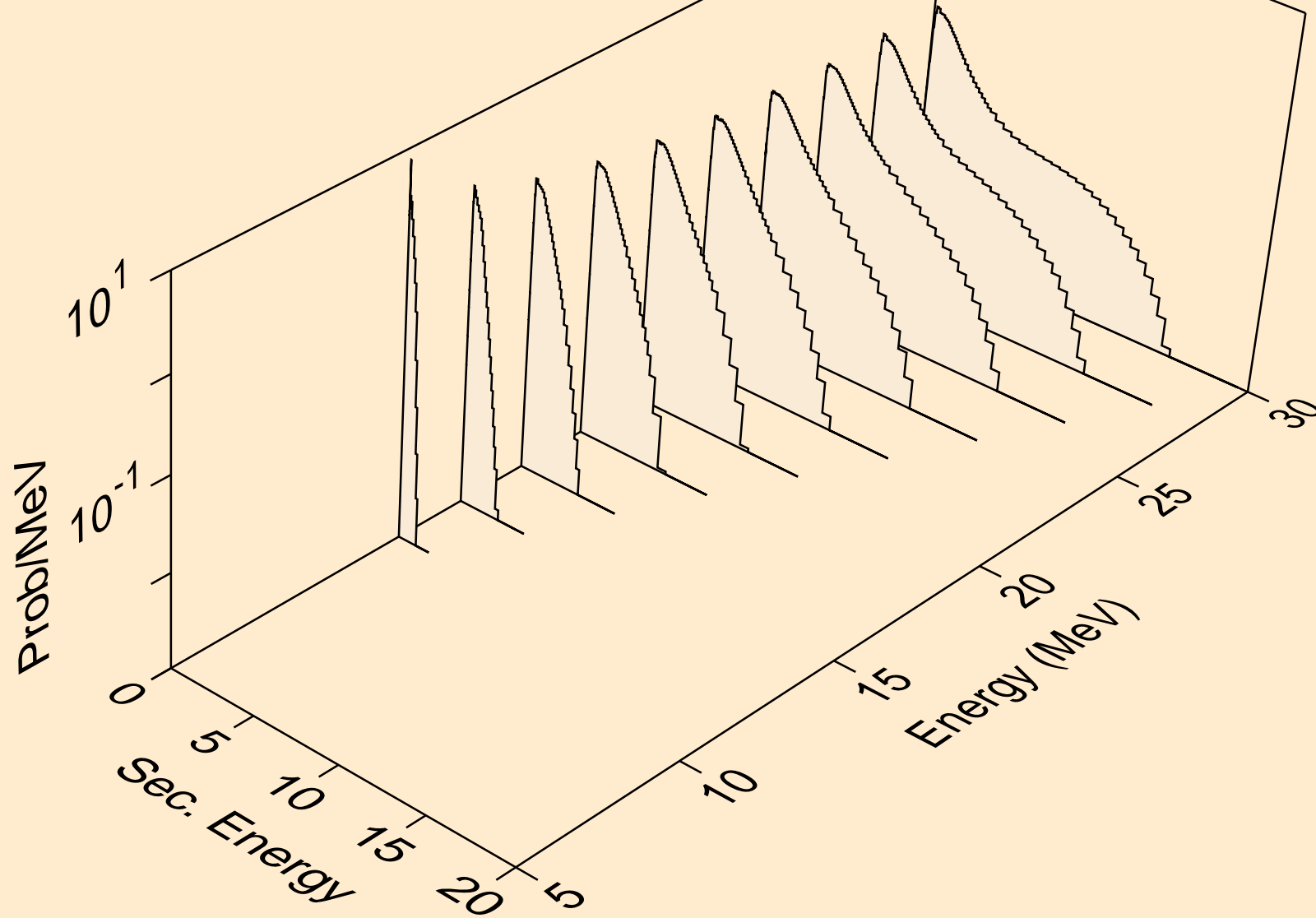

ZN069M NEUTRON ACER TENDL-2023 LIBRARY; T=0.K  
Neutron emission for (n,n\*)2a

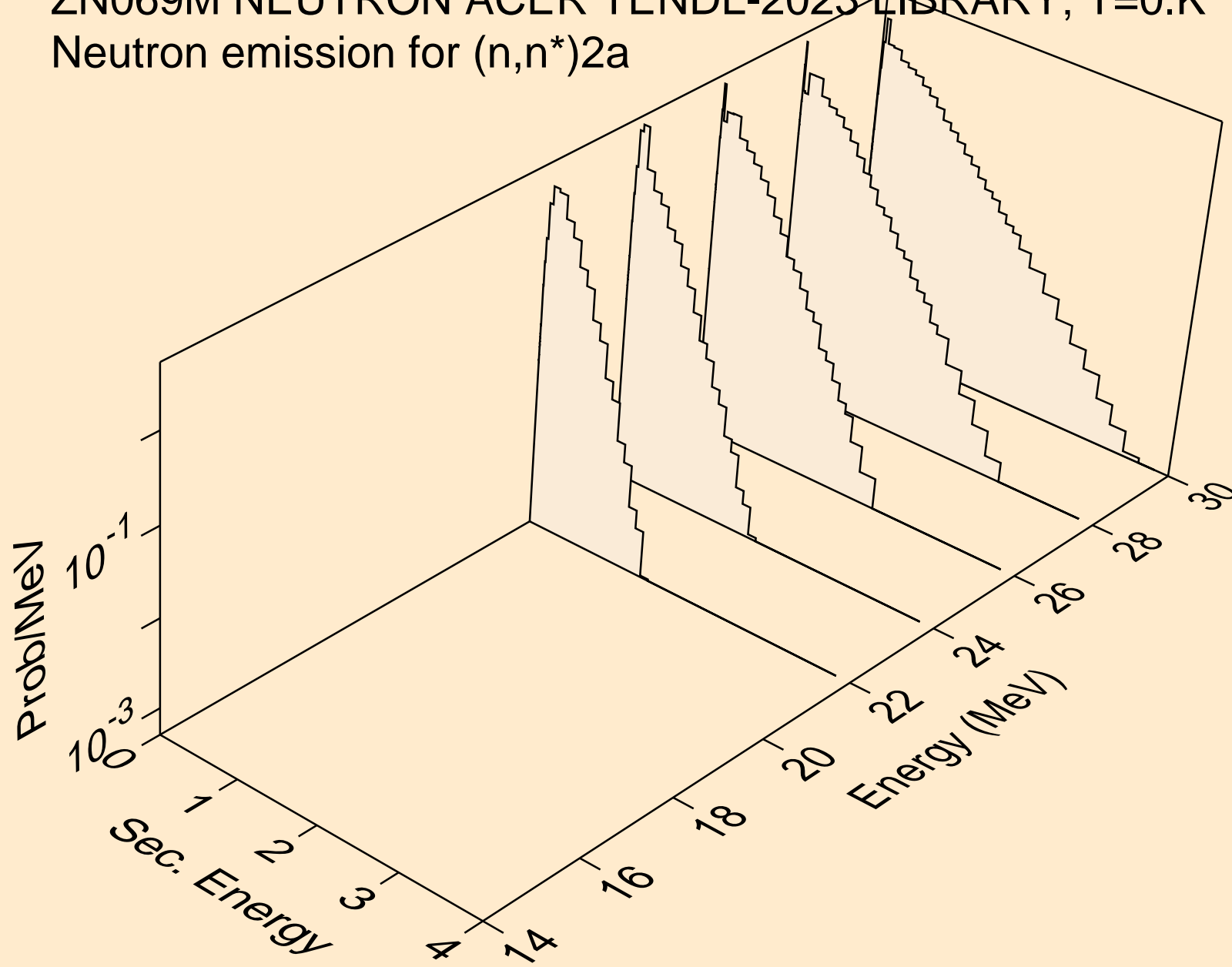



ZN069M NEUTRON ACER TENDL-2023 LIBRARY; T=0.K  
Neutron emission for (n,n\*)d

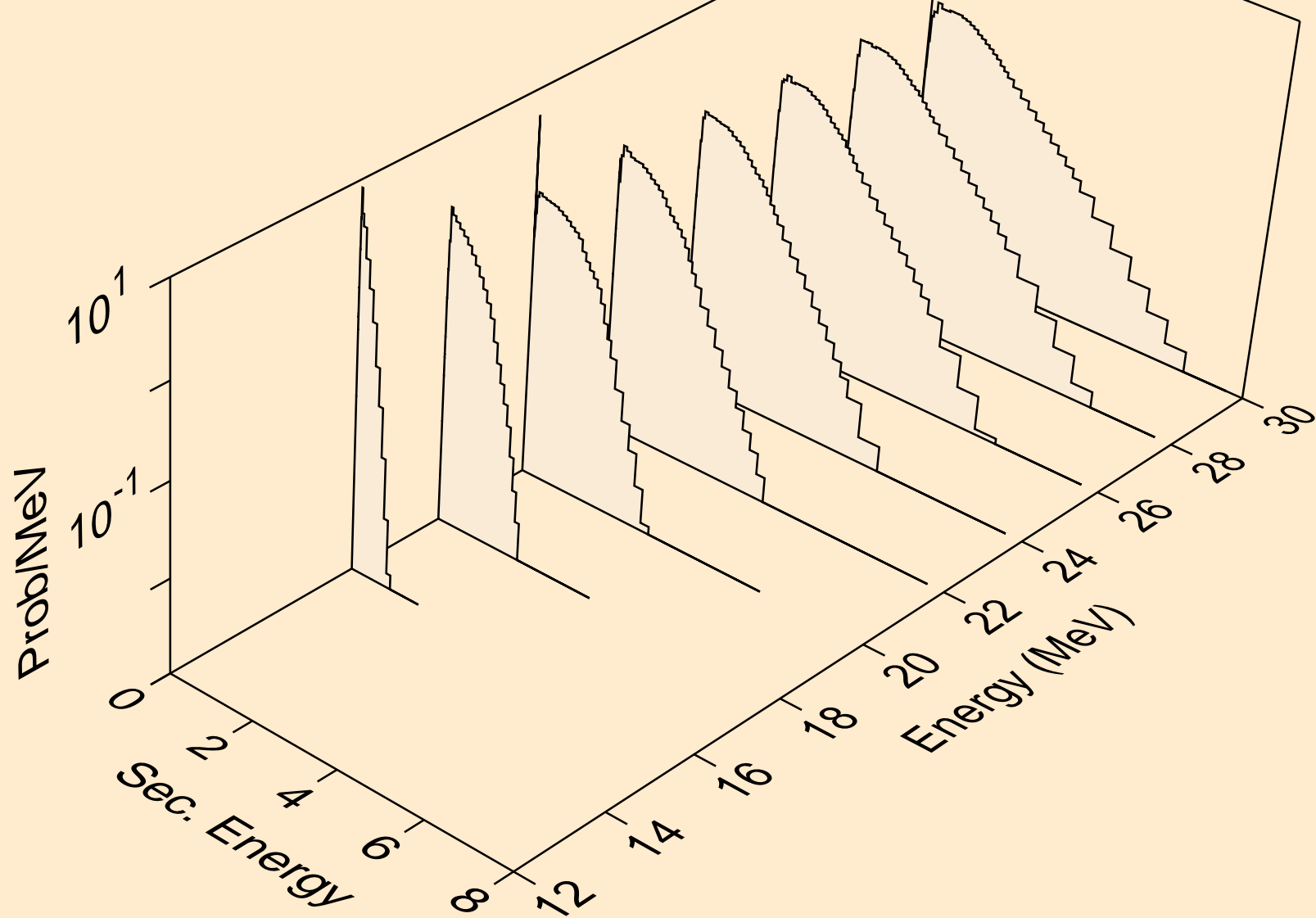

ZN069M NEUTRON ACER TENDL-2023 LIBRARY; T=0.K  
Neutron emission for (n,n\*)t

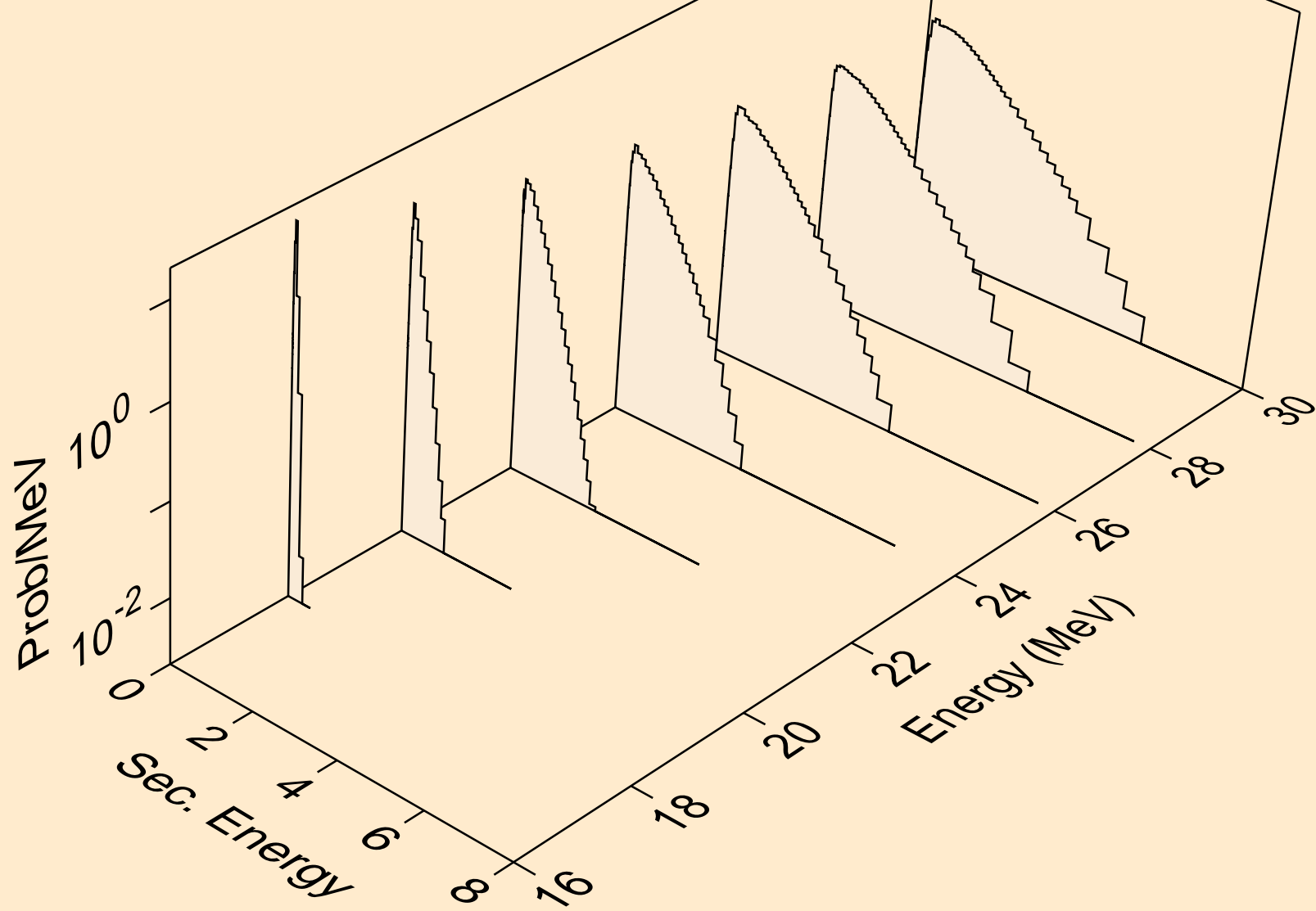

ZN069M NEUTRON ACER TENDL-2023 LIBRARY; T=0.K  
Neutron emission for (n,n\*)he3

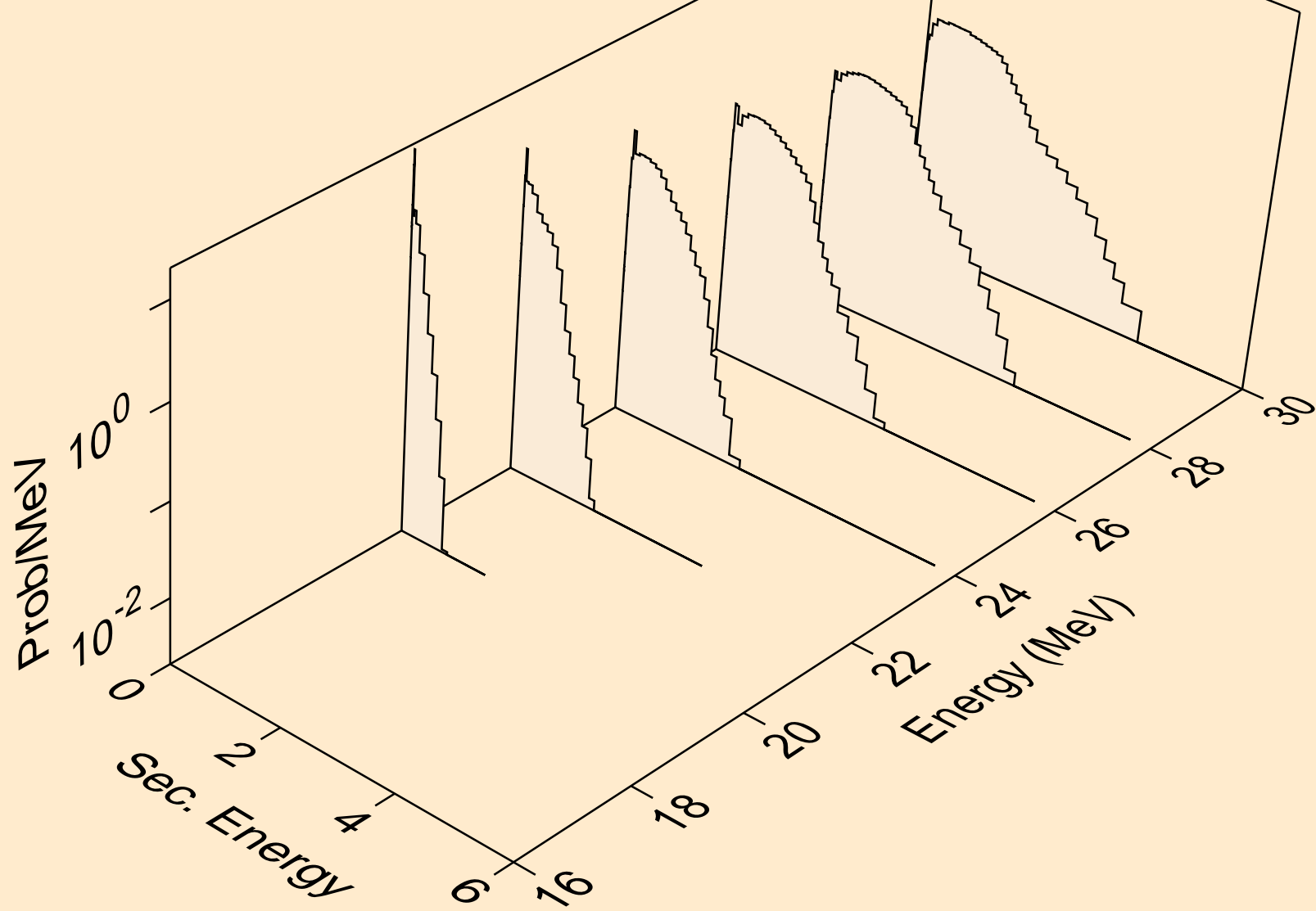

ZN069M NEUTRON ACER TENDL-2023 LIBRARY; T=0.K  
Neutron emission for (n,4n)

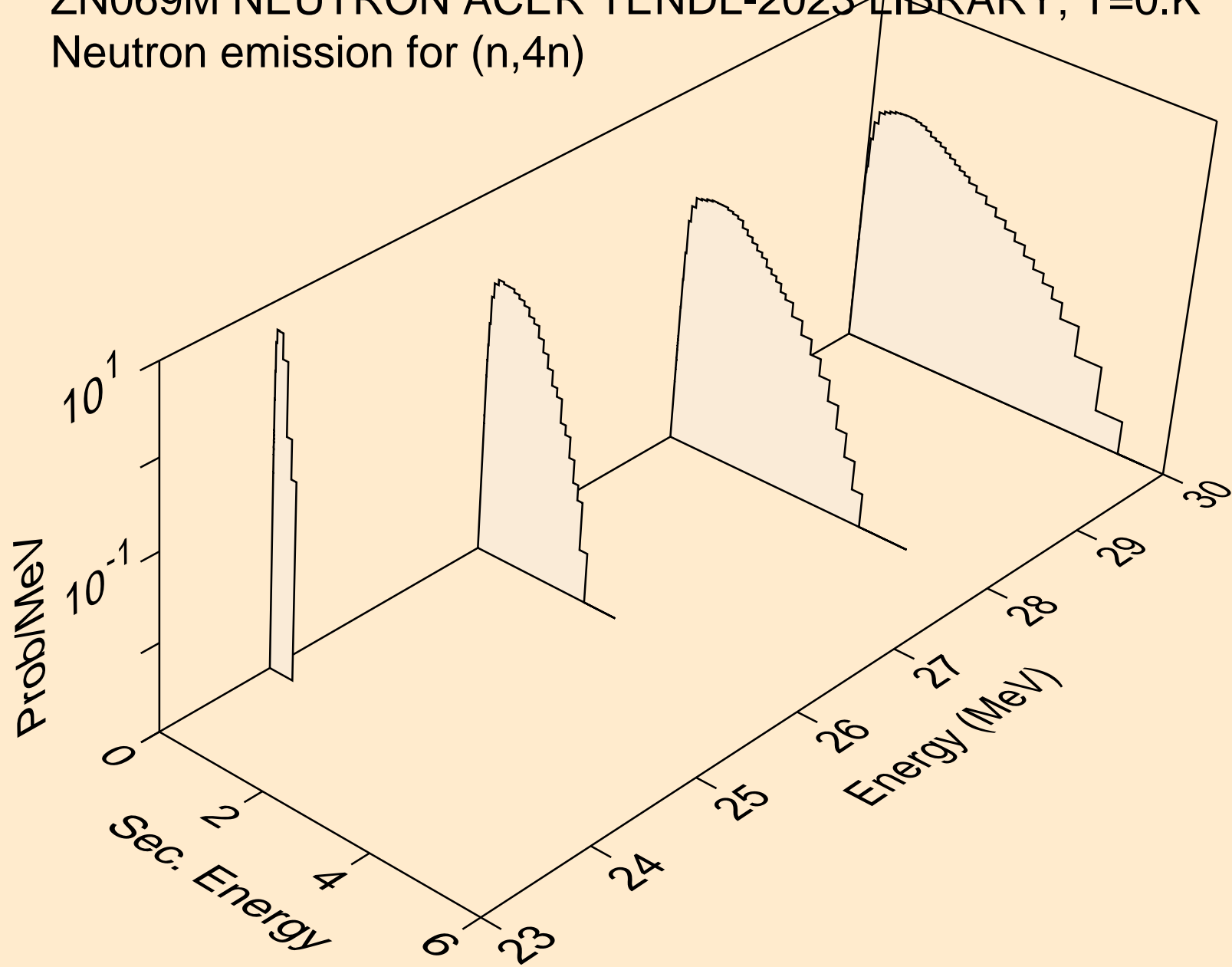

ZN069M NEUTRON ACER TENDL-2023 LIBRARY; T=0.K  
Neutron emission for (n,2np)

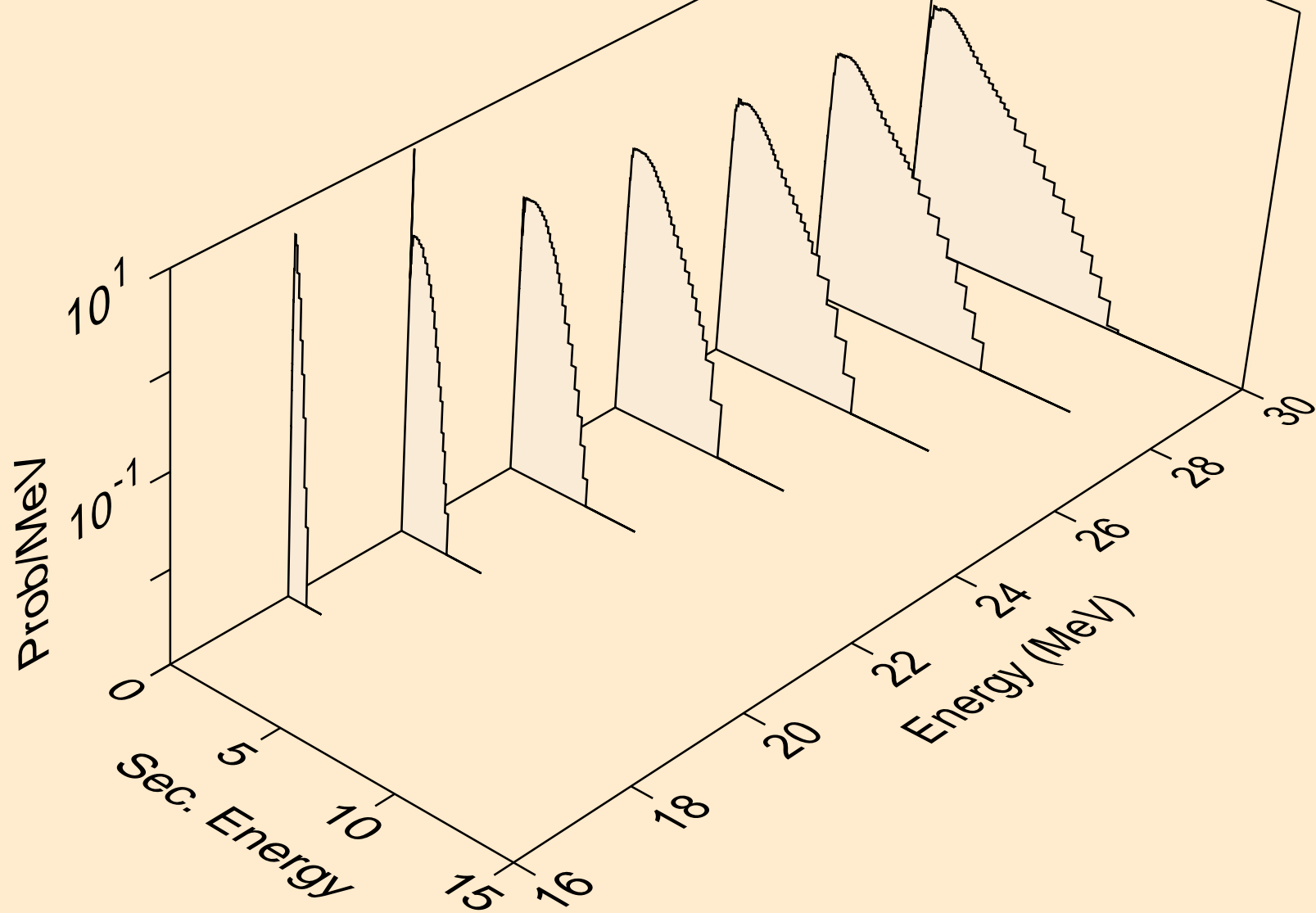

ZN069M NEUTRON ACER TENDL-2023 LIBRARY; T=0.K  
Neutron emission for (n,3np)

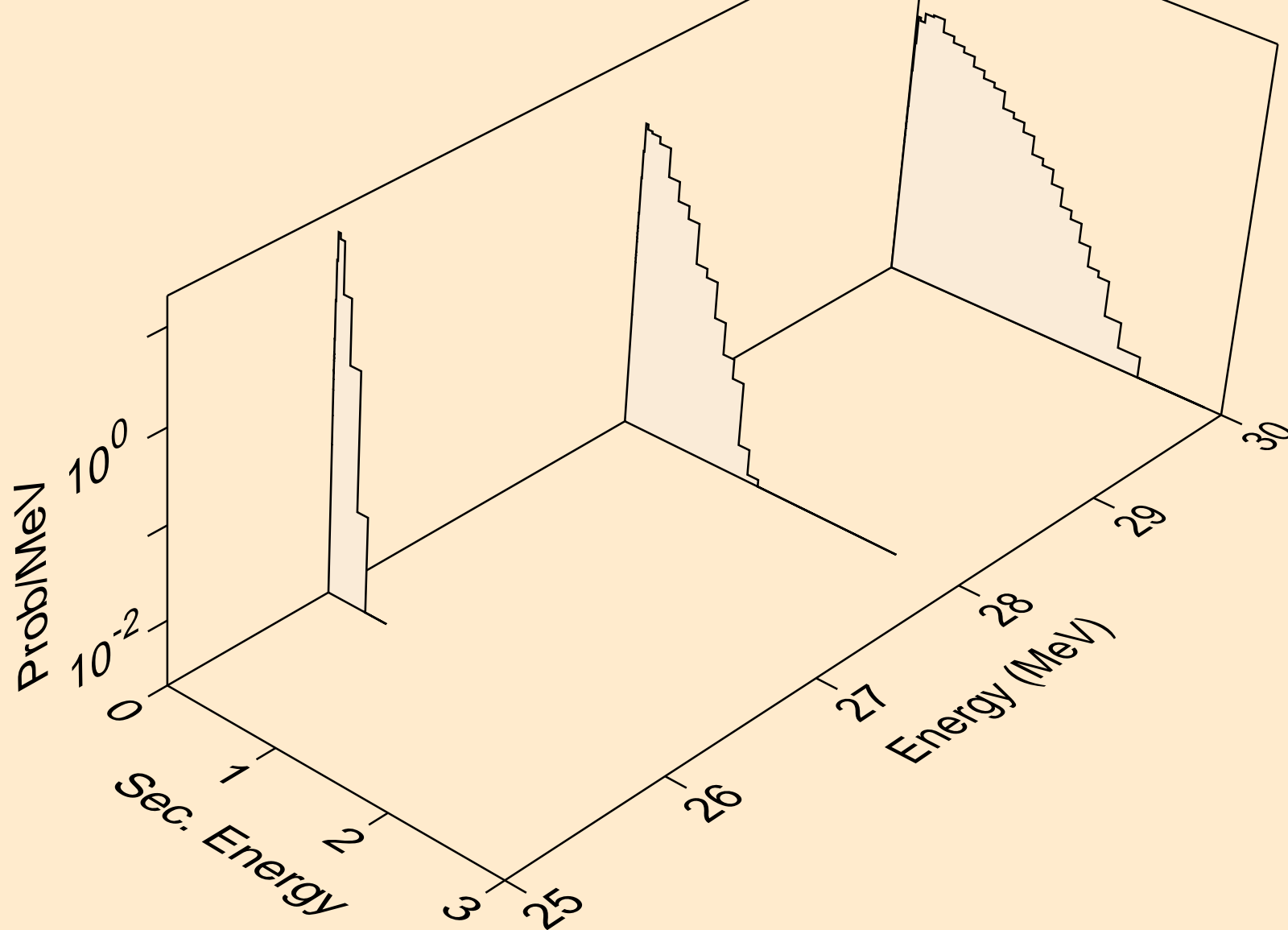

ZN069M NEUTRON ACER TENDL-2023 LIBRARY; T=0.K  
Neutron emission for (n,n2p)

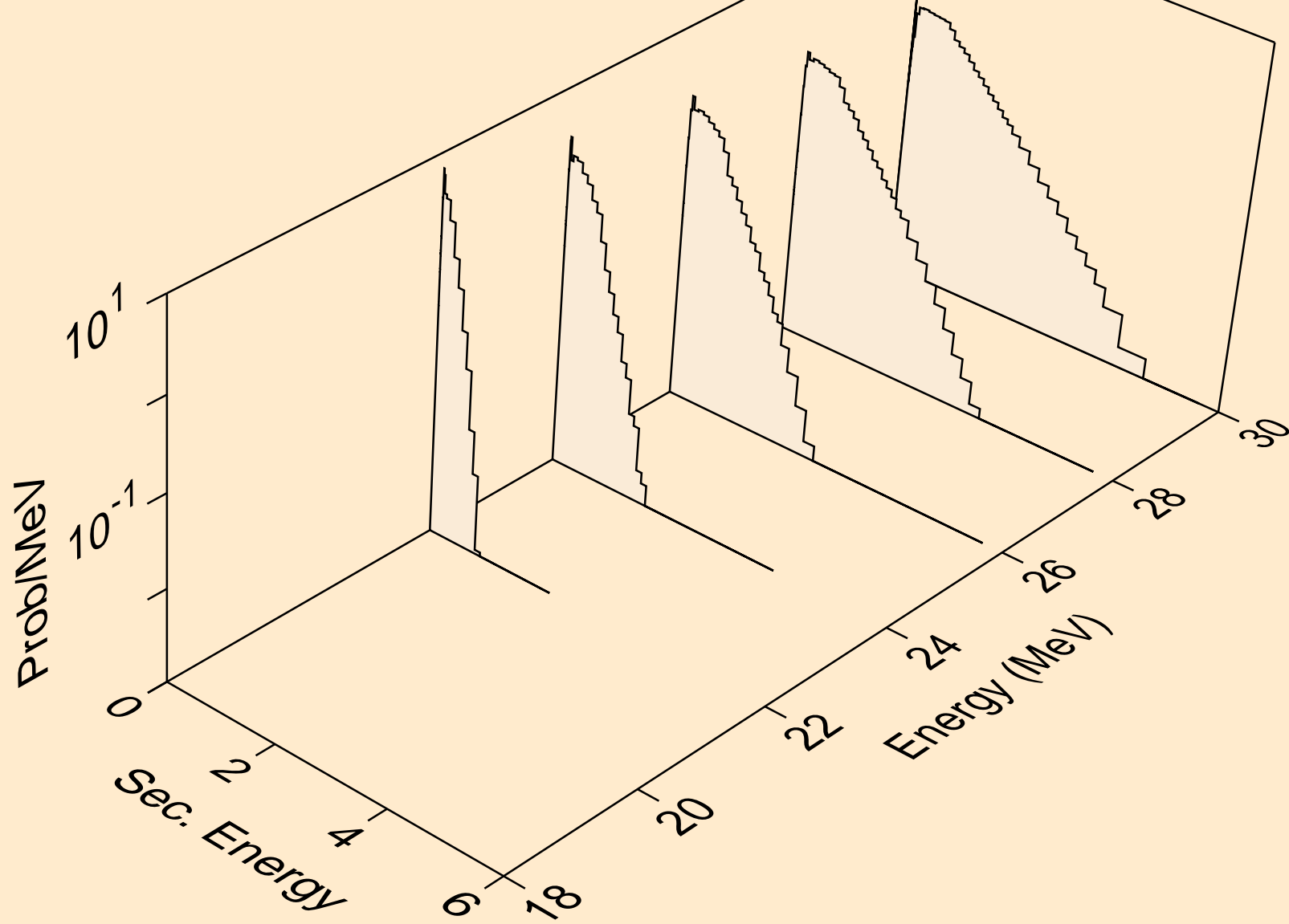

ZN069M NEUTRON ACER TENDL-2023 LIBRARY; T=0.K  
Neutron emission for (n,npa)

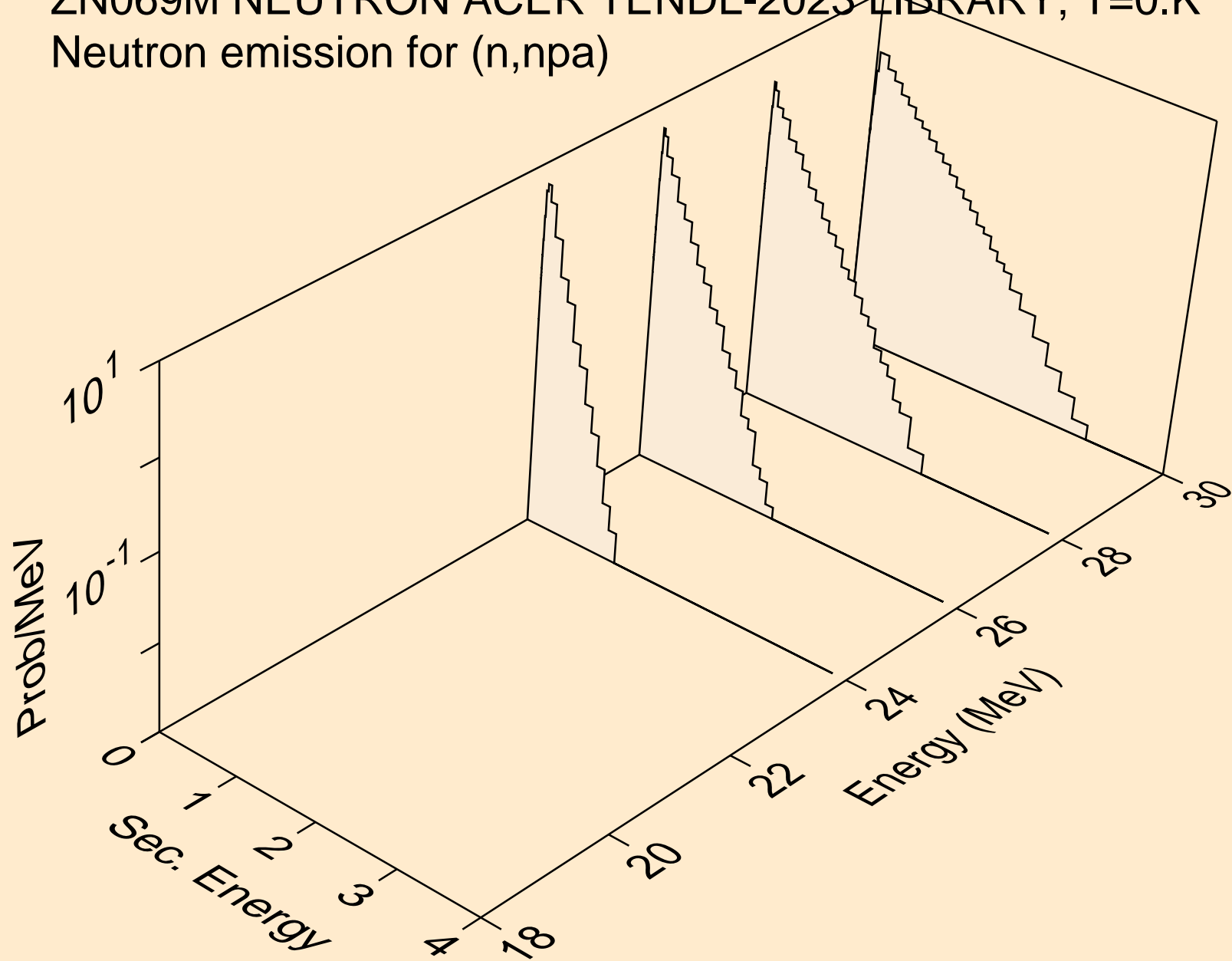



ZN069M NEUTRON ACER TENDL-2023 LIBRARY; T=0.K  
Neutron emission for (n,n\*c)

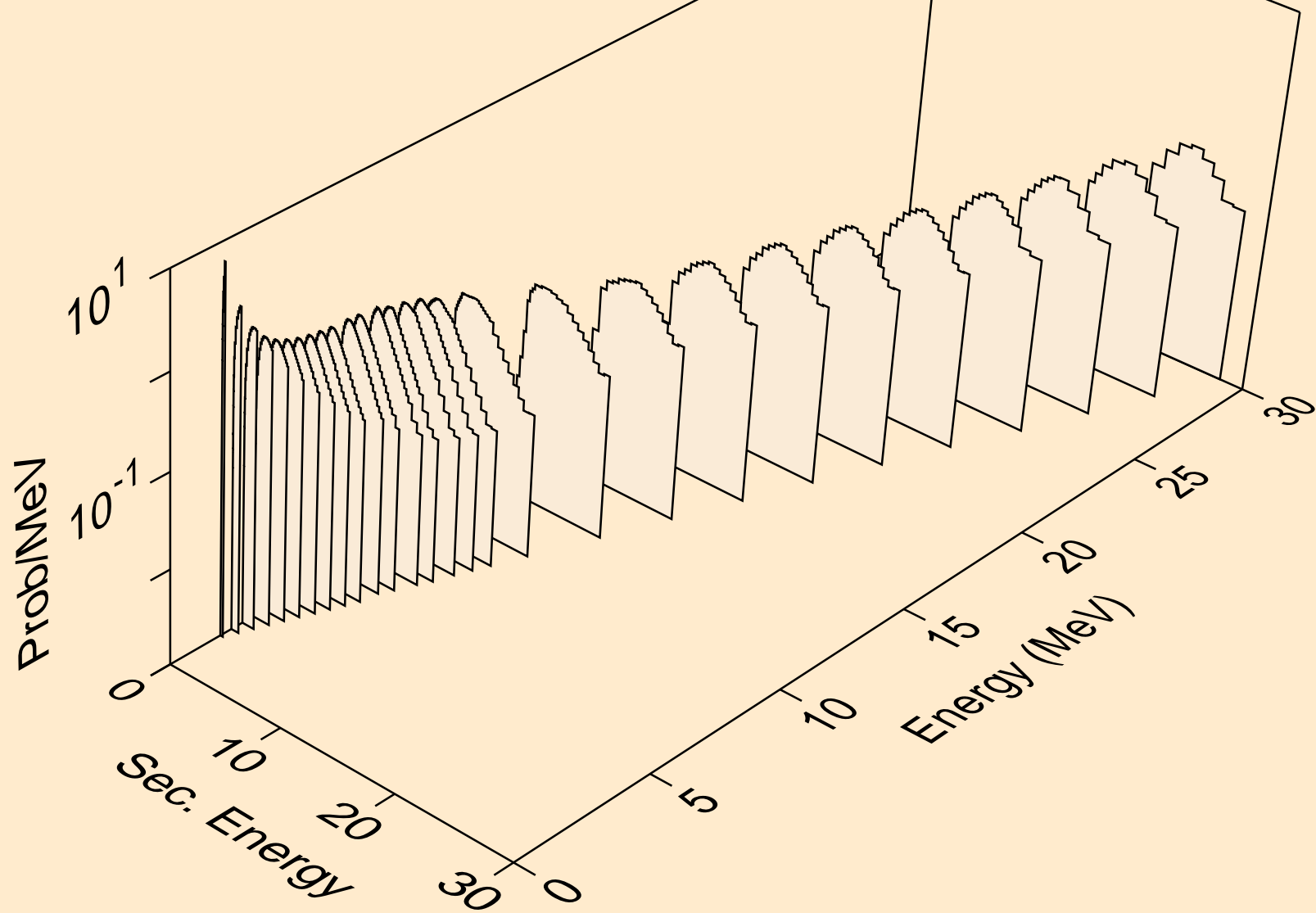

ZN069M NEUTRON ACER TENDL-2023 LIBRARY; T=0.K  
Photon emission for (n,x)

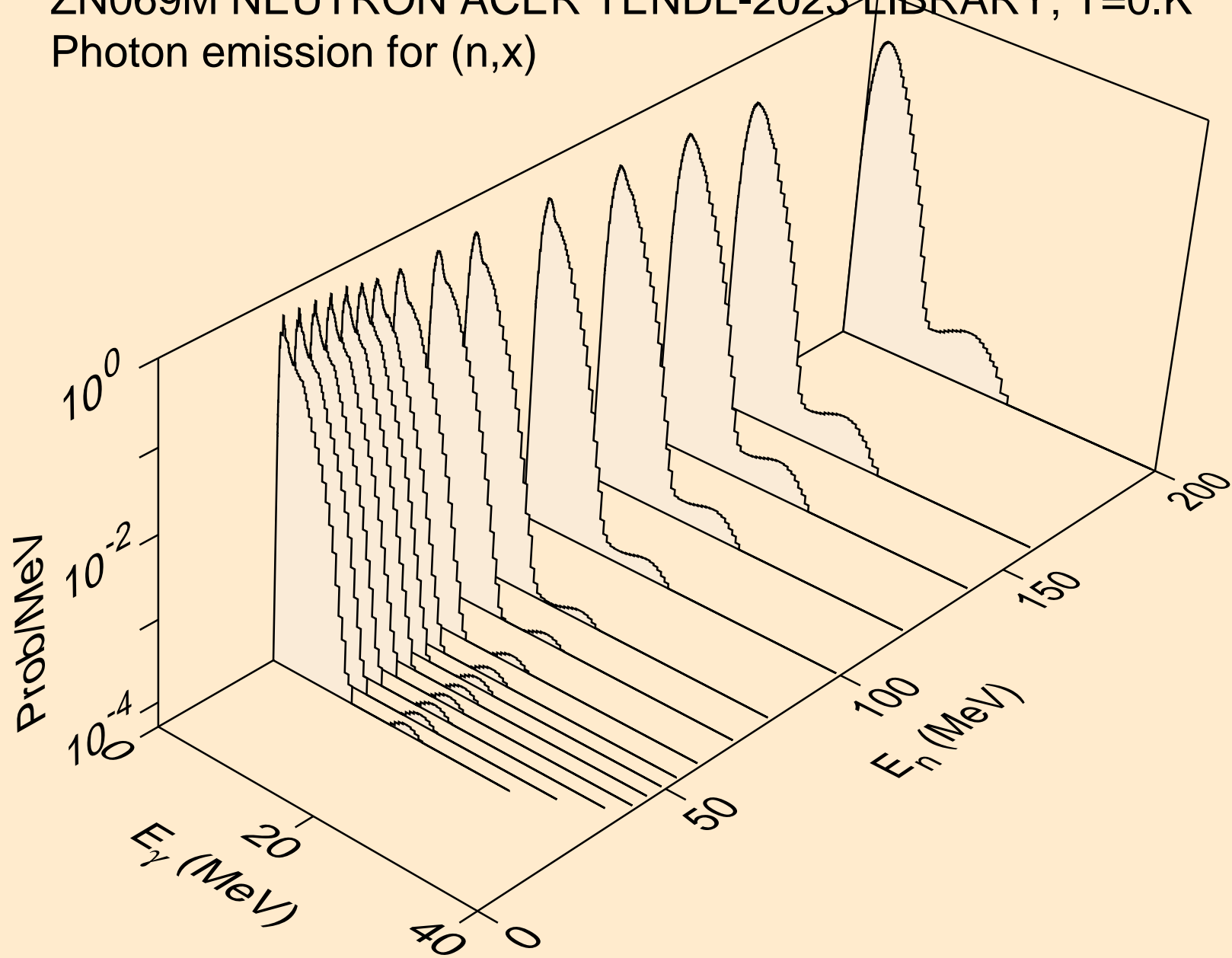

ZN069M NEUTRON ACER TENDL-2023 LIBRARY; T=0.K  
Photon emission for (n,2nd)

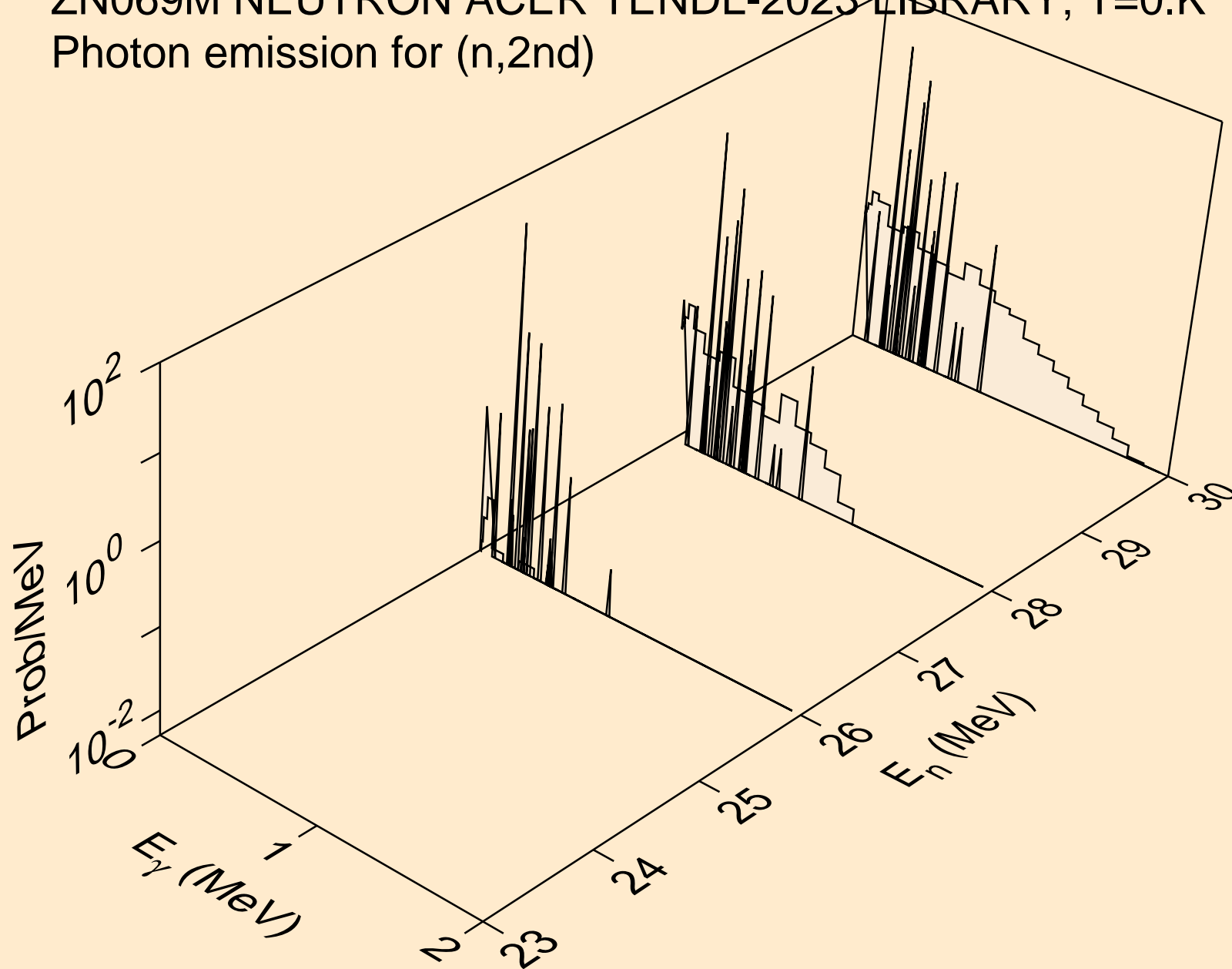

ZN069M NEUTRON ACER TENDL-2023 LIBRARY; T=0.K  
Photon emission for (n,2n)

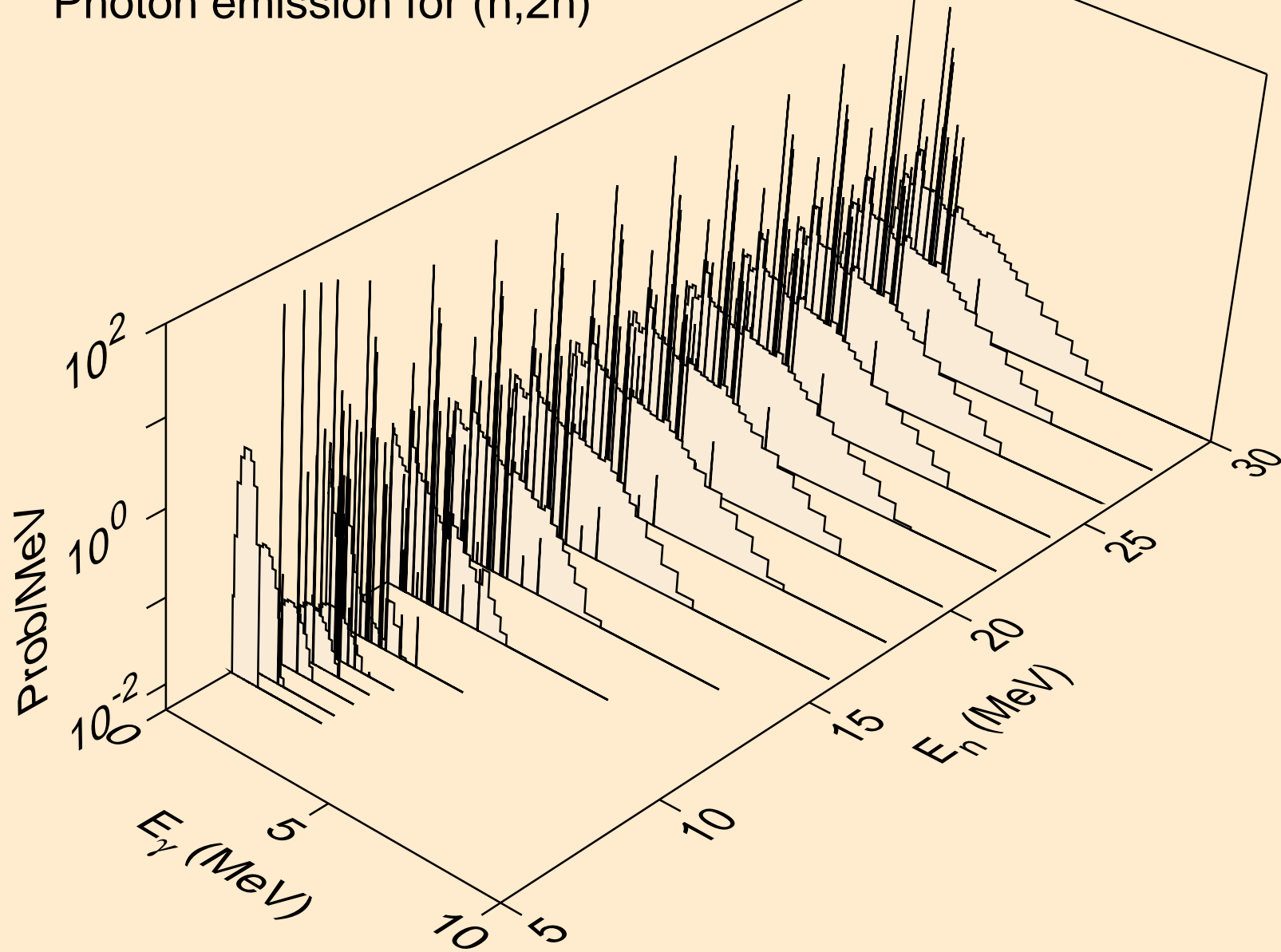

ZN069M NEUTRON ACER TENDL-2023 LIBRARY; T=0.K  
Photon emission for (n,3n)

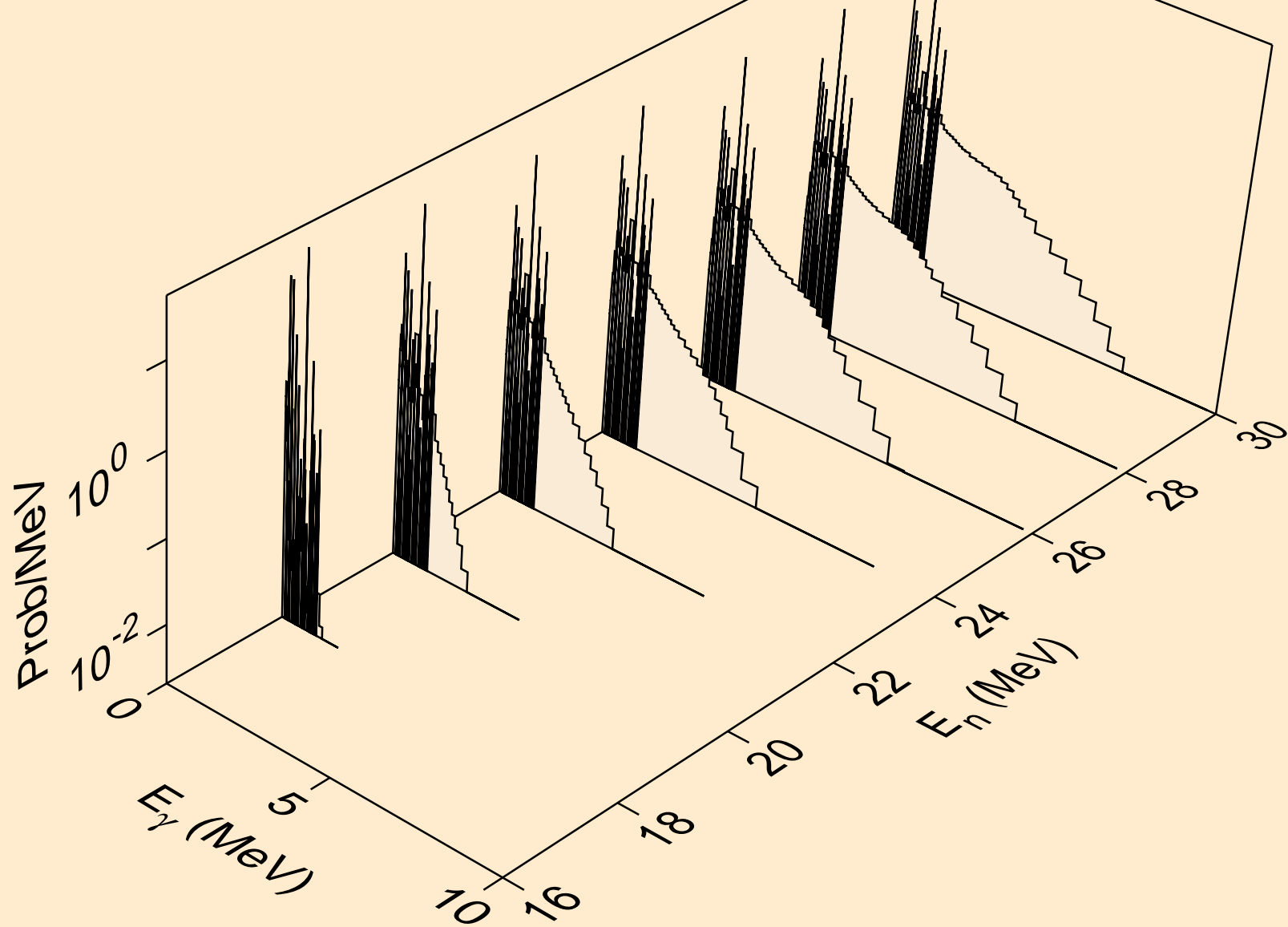

ZN069M NEUTRON ACER TENDL-2023 LIBRARY; T=0.K  
Photon emission for (n,n\*)a

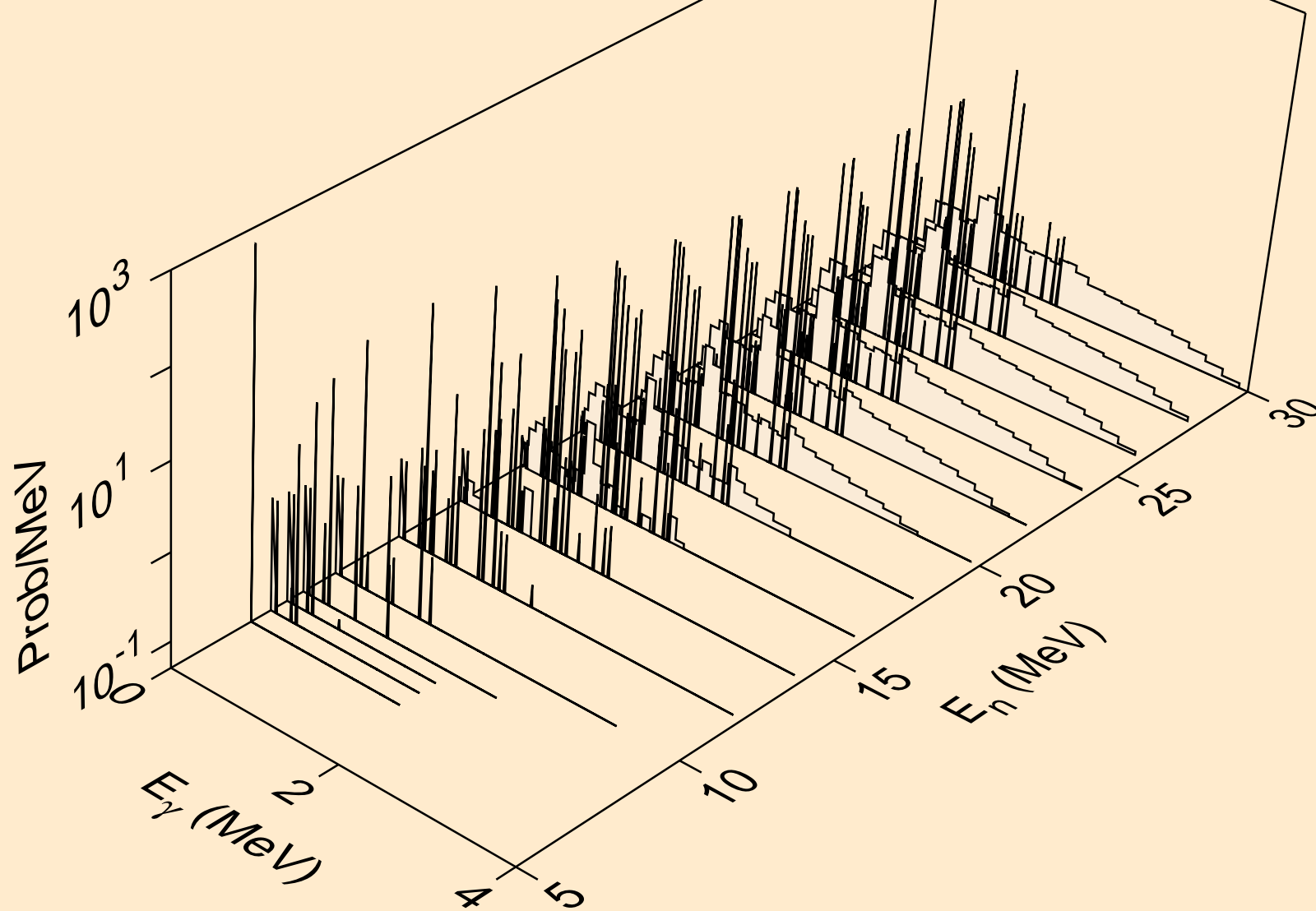

ZN069M NEUTRON ACER TENDL-2023 LIBRARY; T=0.K  
Photon emission for (n,2n)a

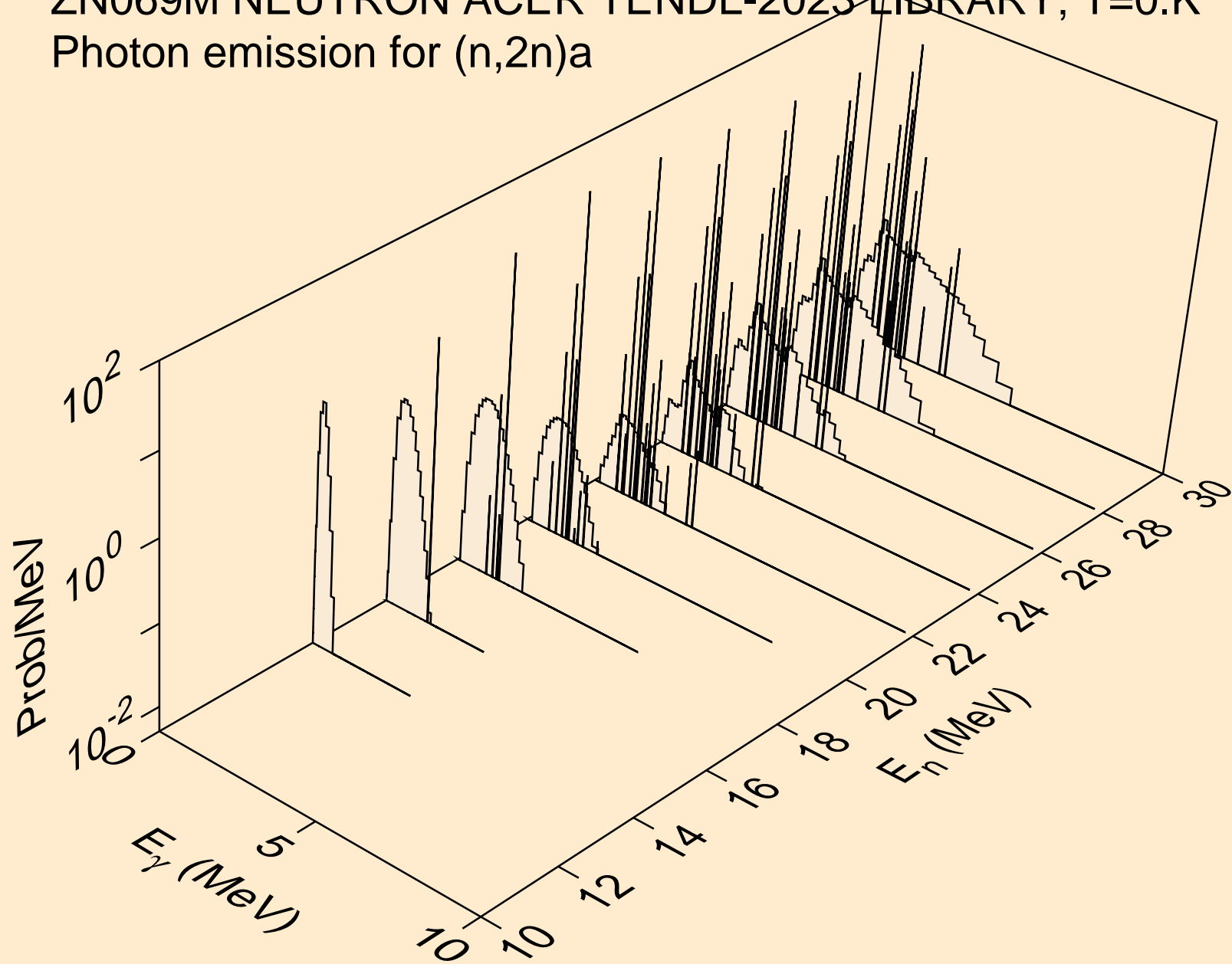

ZN069M NEUTRON ACER TENDL-2023 LIBRARY; T=0.K  
Photon emission for (n,3n)a

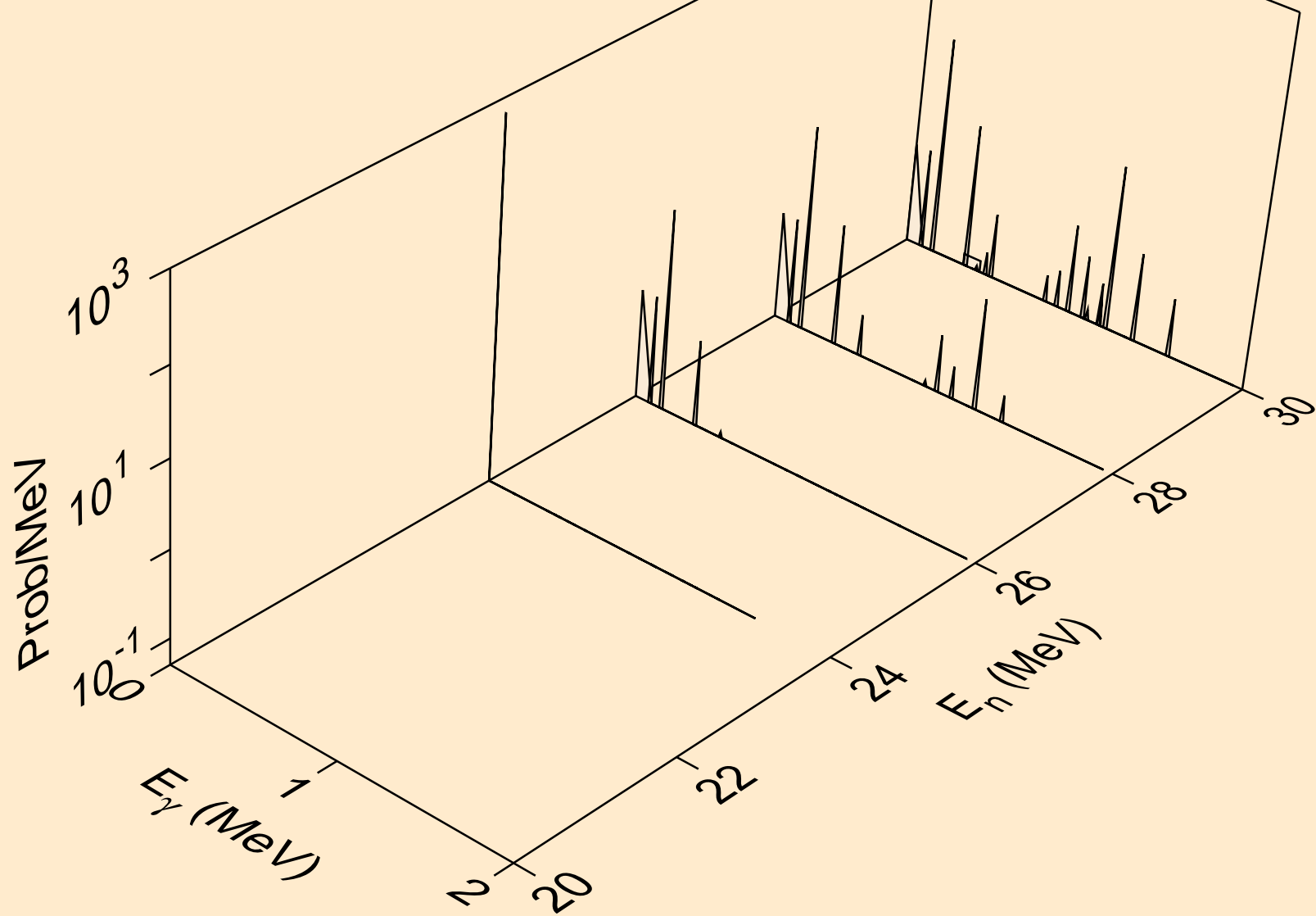



ZN069M NEUTRON ACER TENDL-2023 LIBRARY; T=0.K  
Photon emission for (n,n\*)p

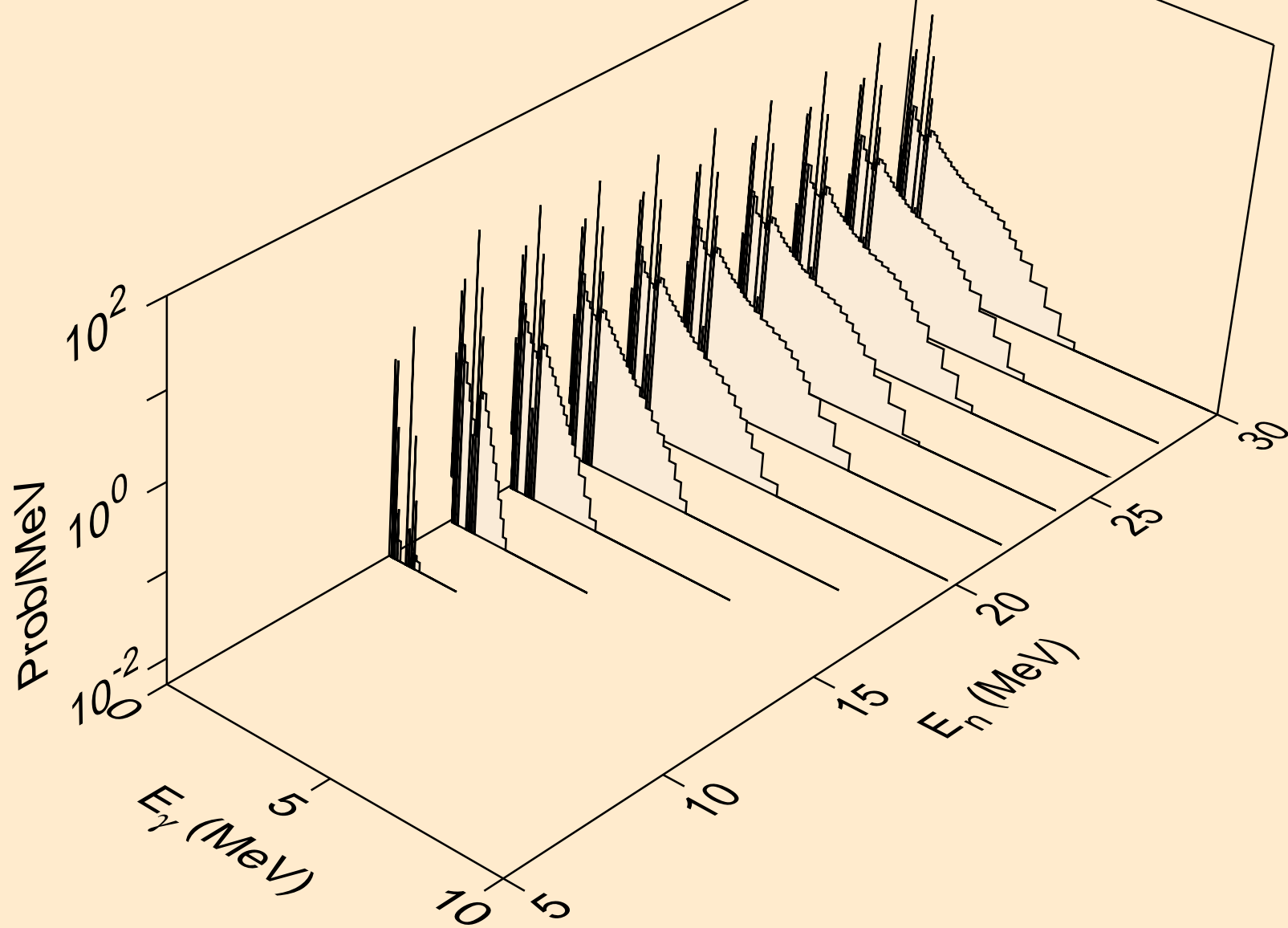

ZN069M NEUTRON ACER TENDL-2023 LIBRARY; T=0.K  
Photon emission for (n,n\*)2a

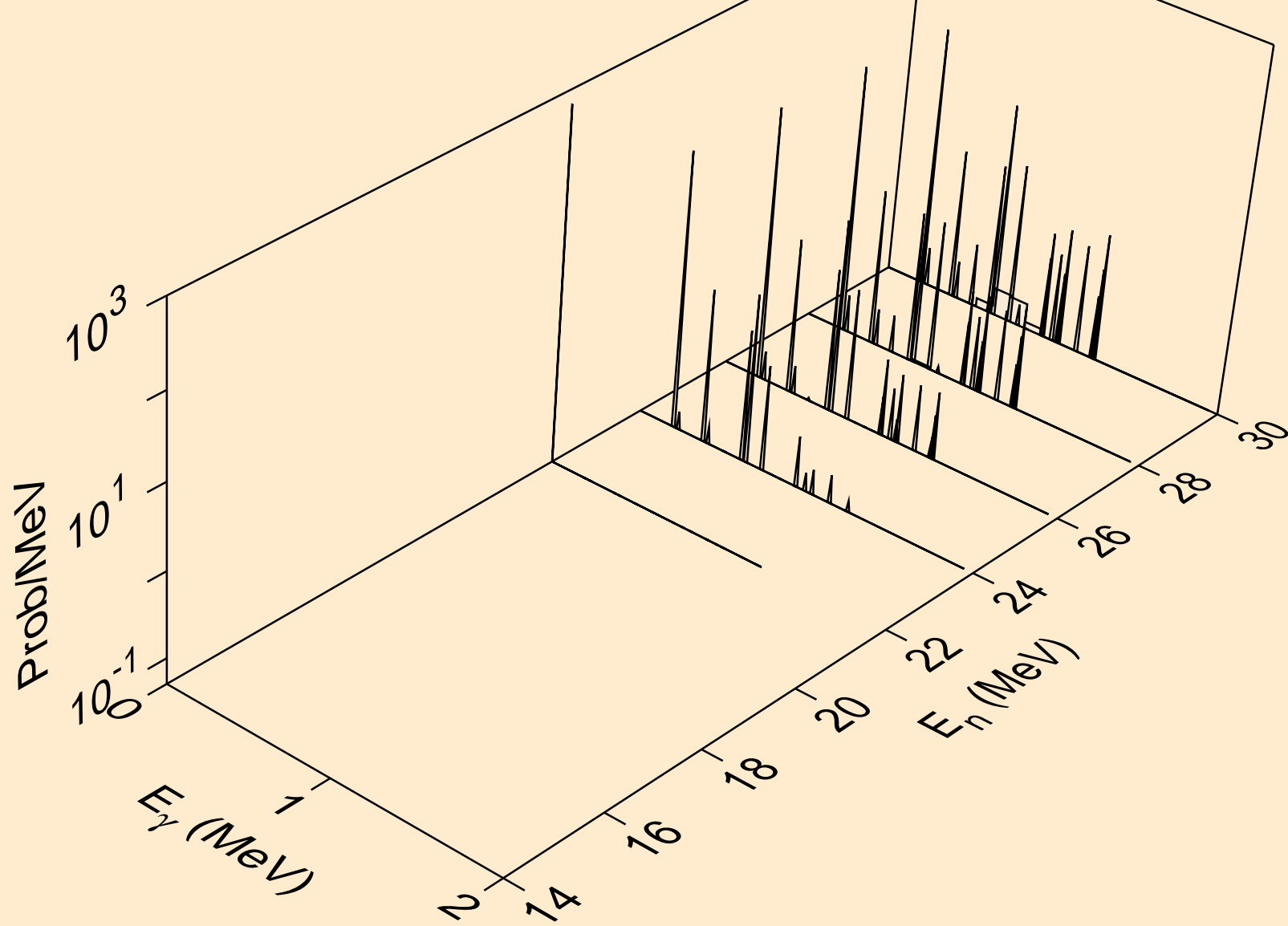

ZN069M NEUTRON ACER TENDL-2023 LIBRARY; T=0.K  
Photon emission for (n,n\*)d

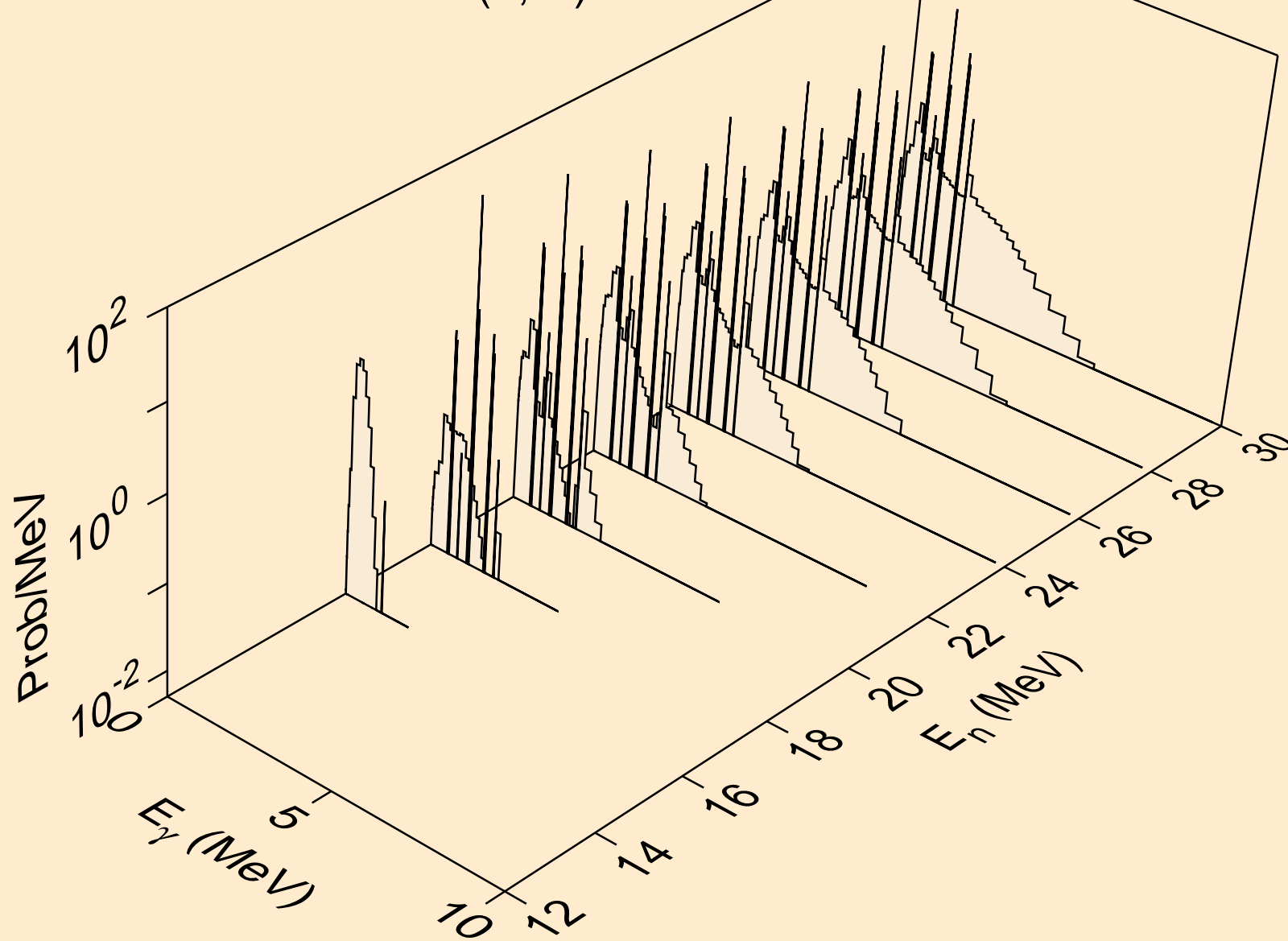

ZN069M NEUTRON ACER TENDL-2023 LIBRARY; T=0.K  
Photon emission for (n,n\*)t

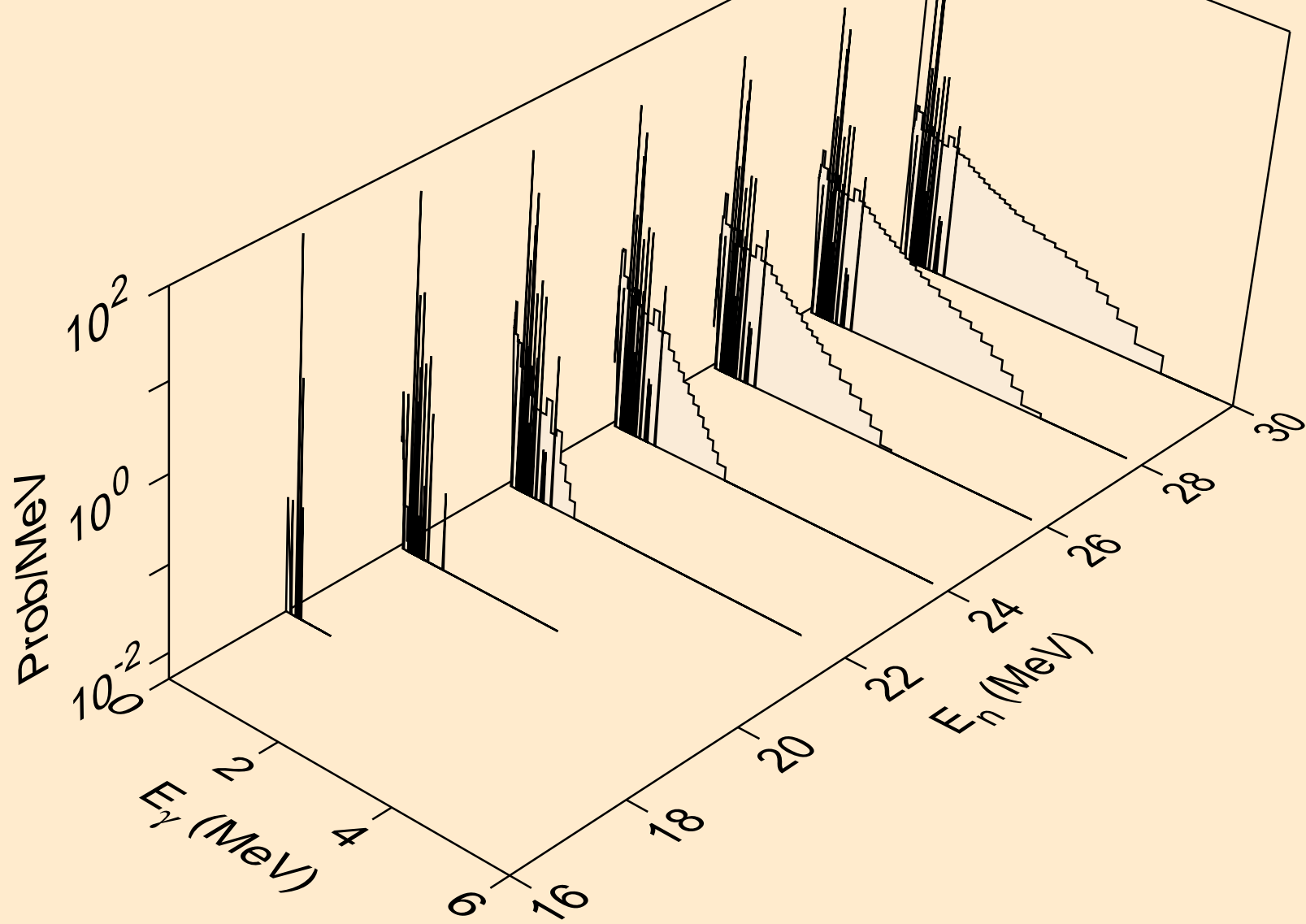

ZN069M NEUTRON ACER TENDL-2023 LIBRARY; T=0.K  
Photon emission for (n,n\*)he3

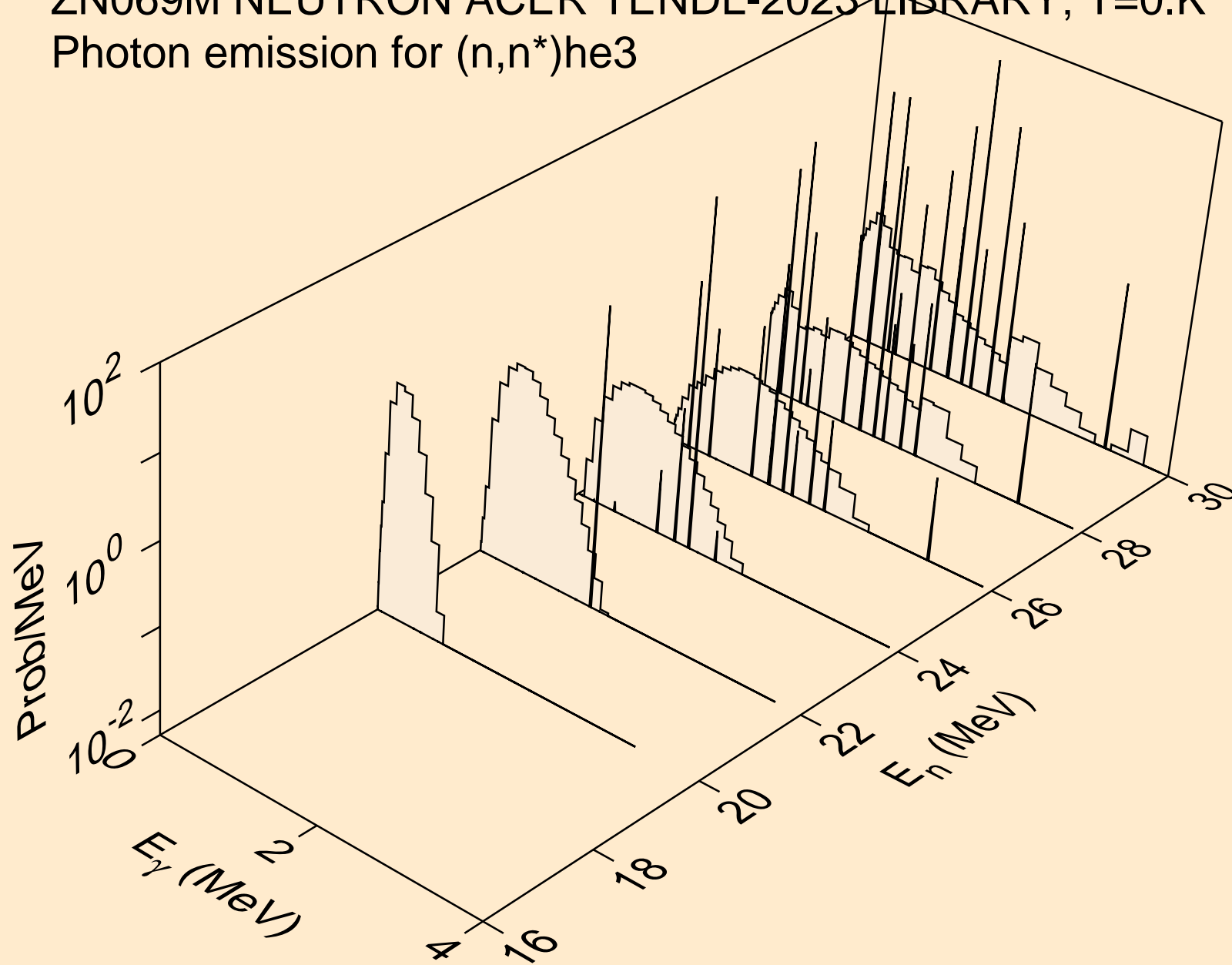

ZN069M NEUTRON ACER TENDL-2023 LIBRARY; T=0.K  
Photon emission for (n,4n)

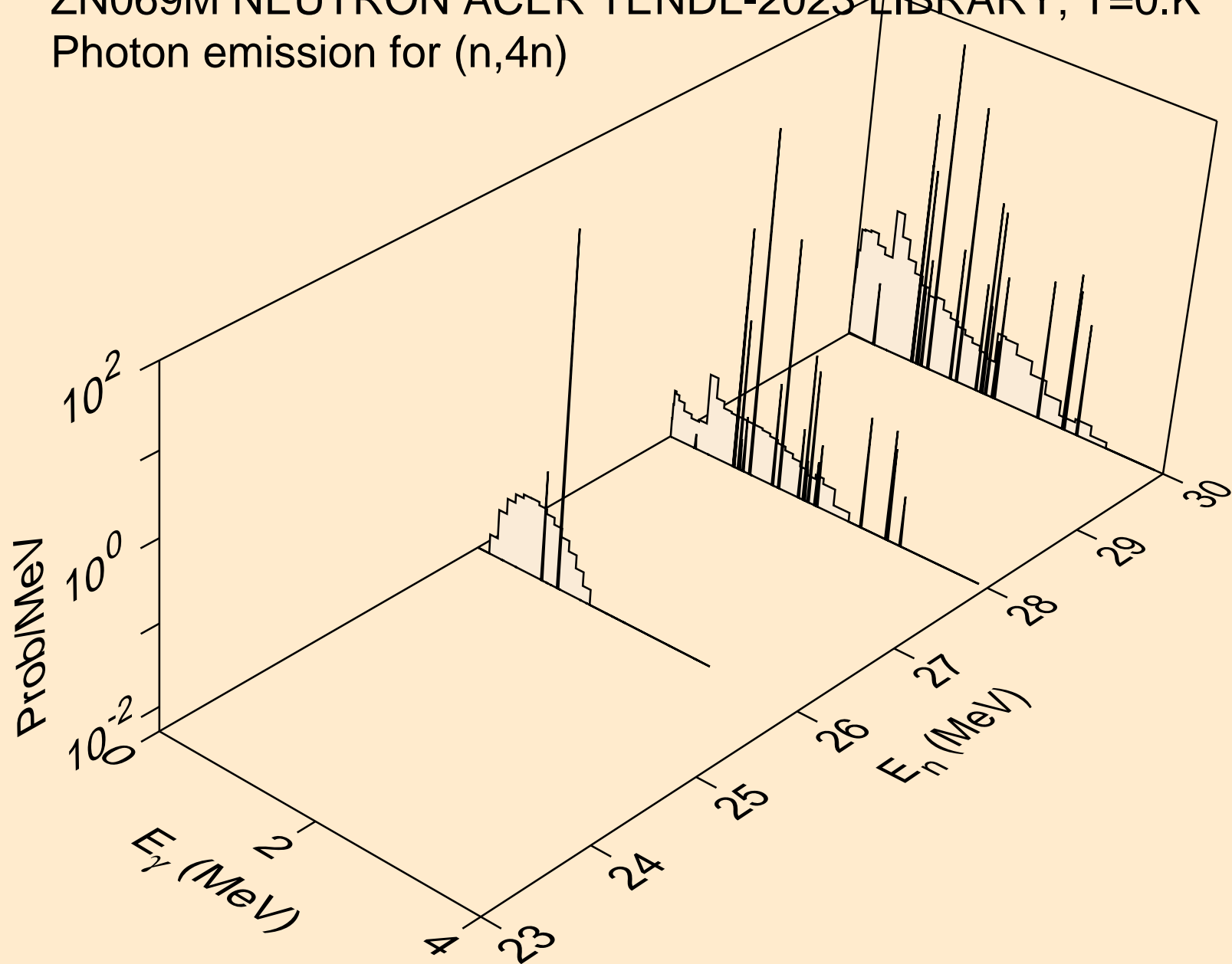

ZN069M NEUTRON ACER TENDL-2023 LIBRARY; T=0.K  
Photon emission for (n,2np)

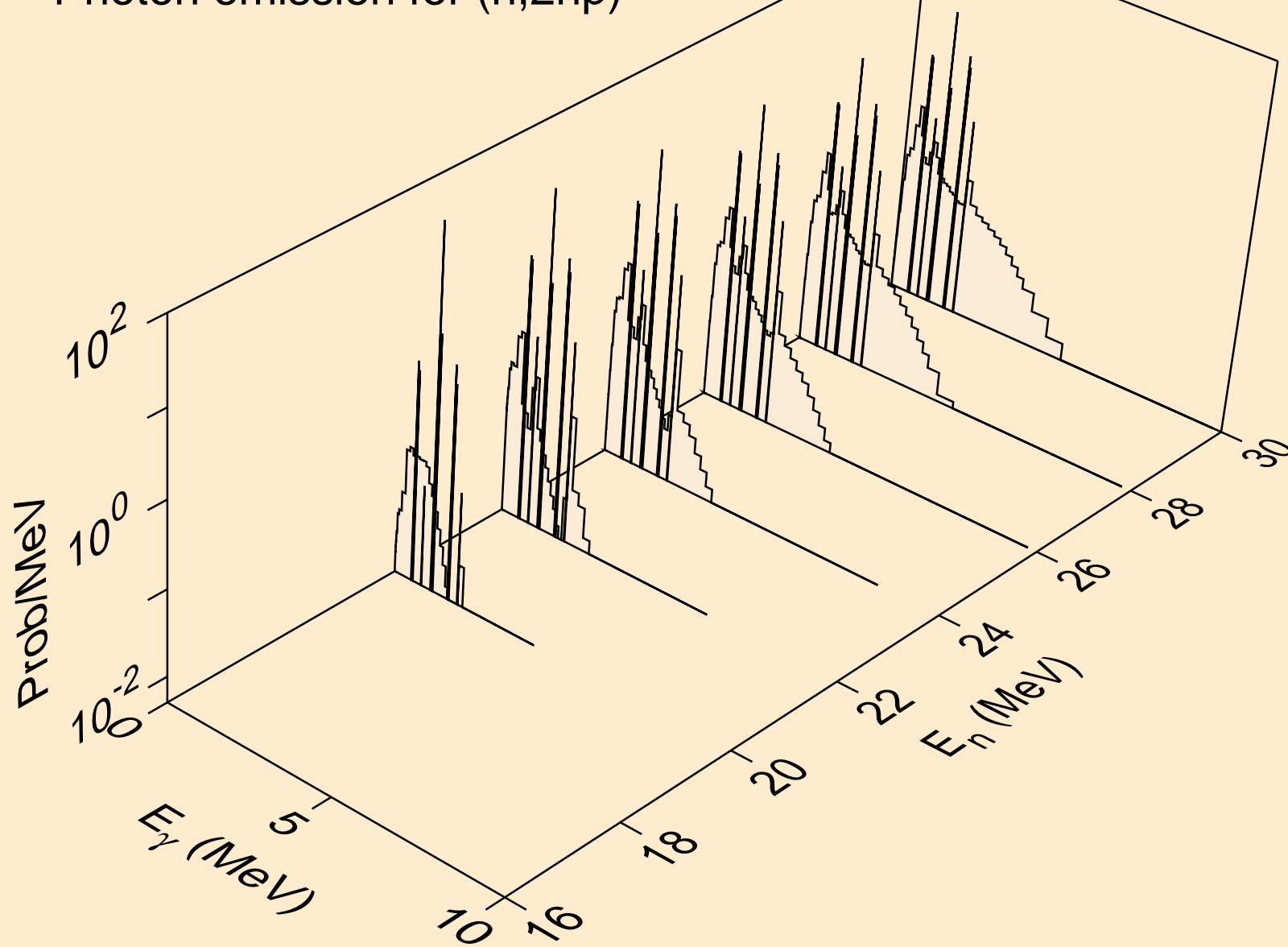

ZN069M NEUTRON ACER TENDL-2023 LIBRARY; T=0.K  
Photon emission for (n,3np)

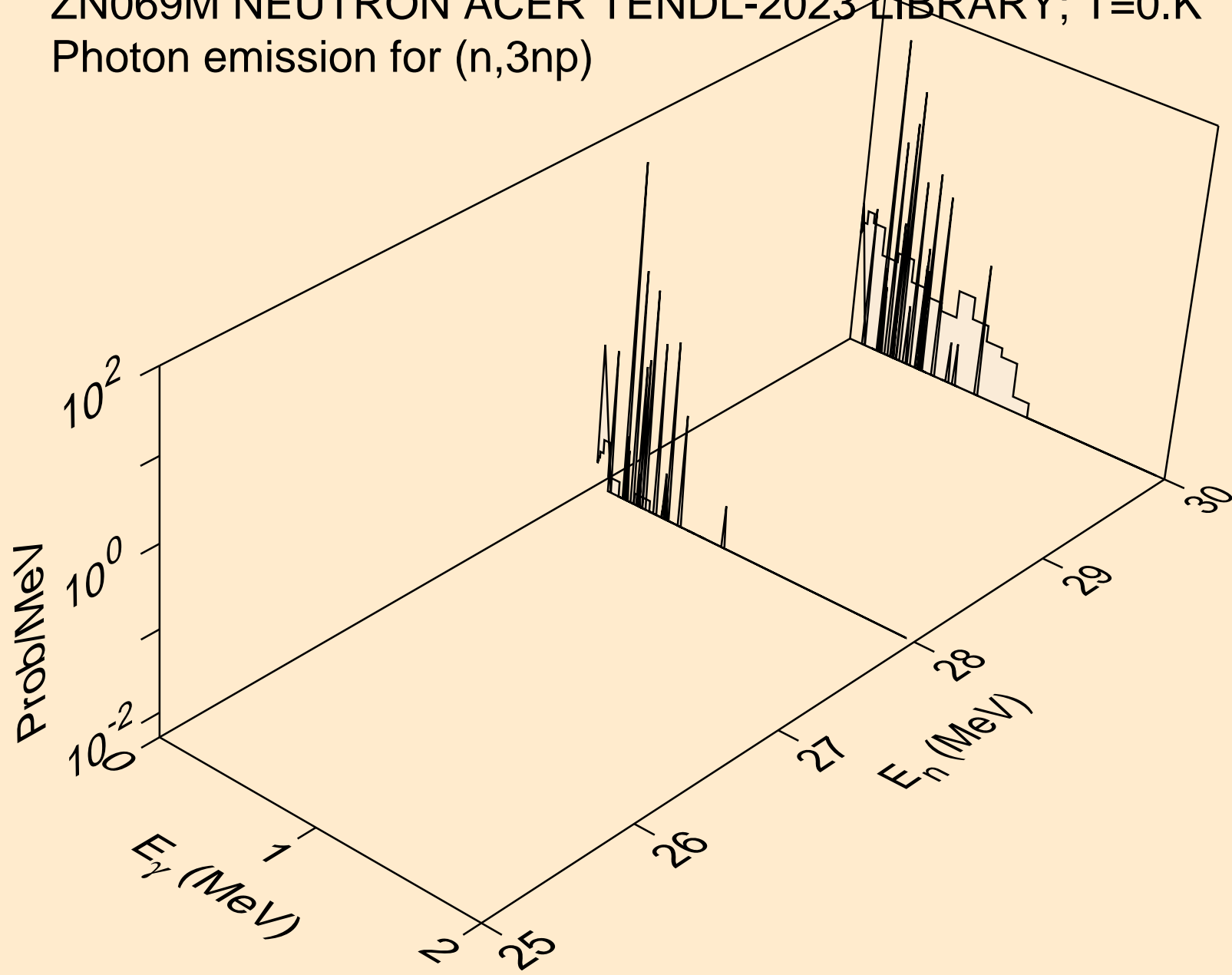



ZN069M NEUTRON ACER TENDL-2023 LIBRARY; T=0.K  
Photon emission for (n,n2p)

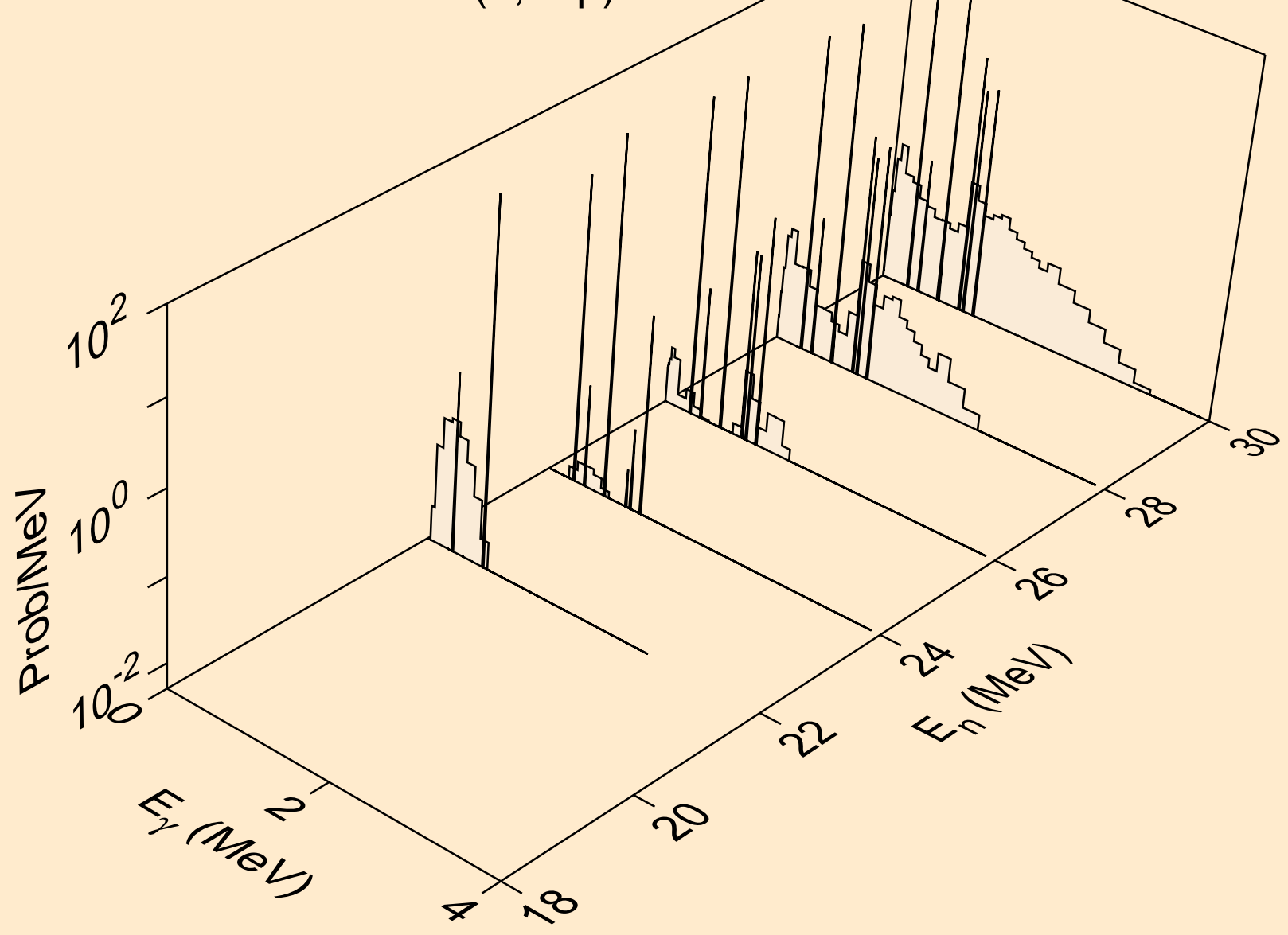

ZN069M NEUTRON ACER TENDL-2023 LIBRARY; T=0.K  
Photon emission for (n,npa)

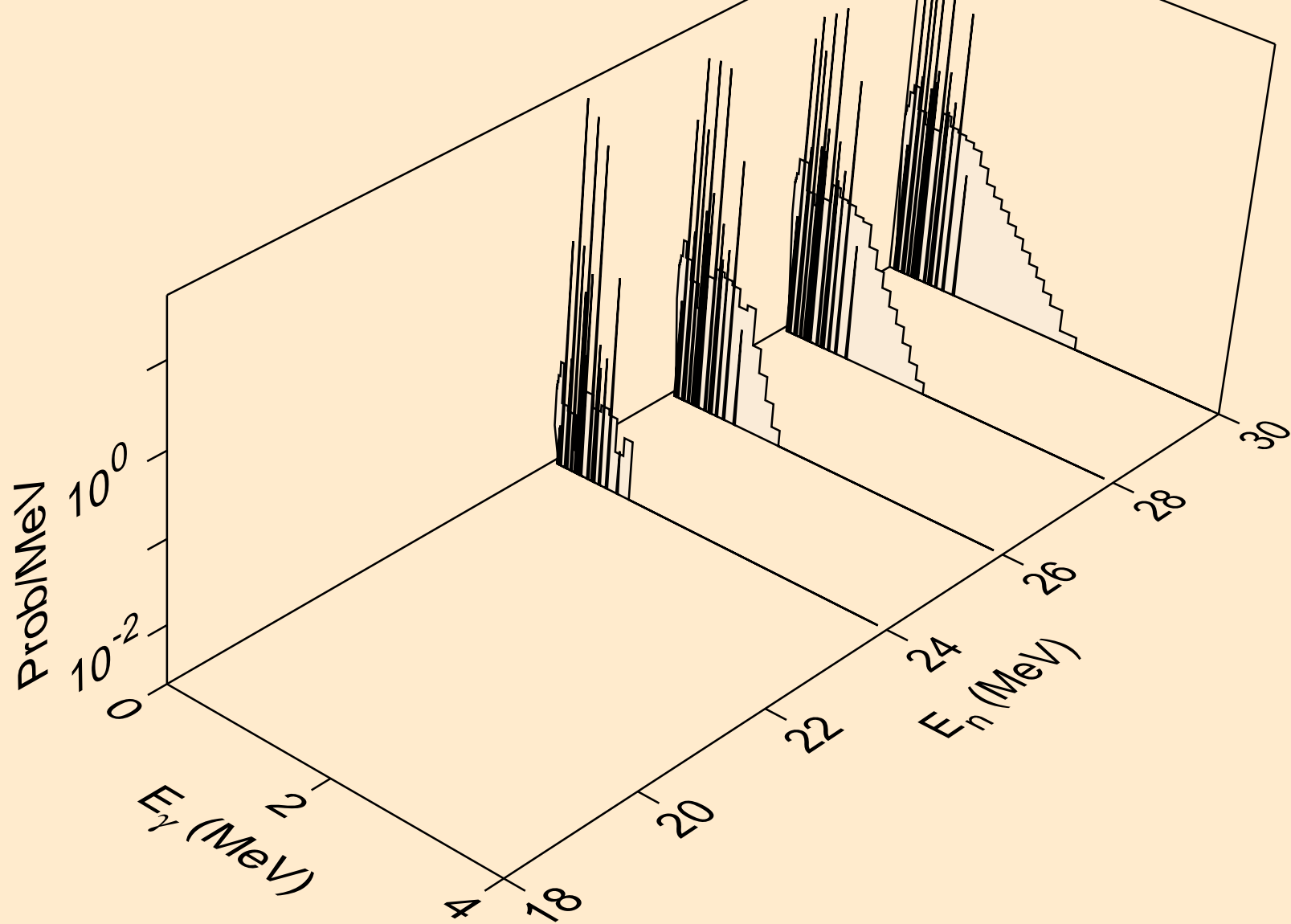

ZN069M NEUTRON ACER TENDL-2023 LIBRARY; T=0.K  
Photon emission for (n,n\*2)

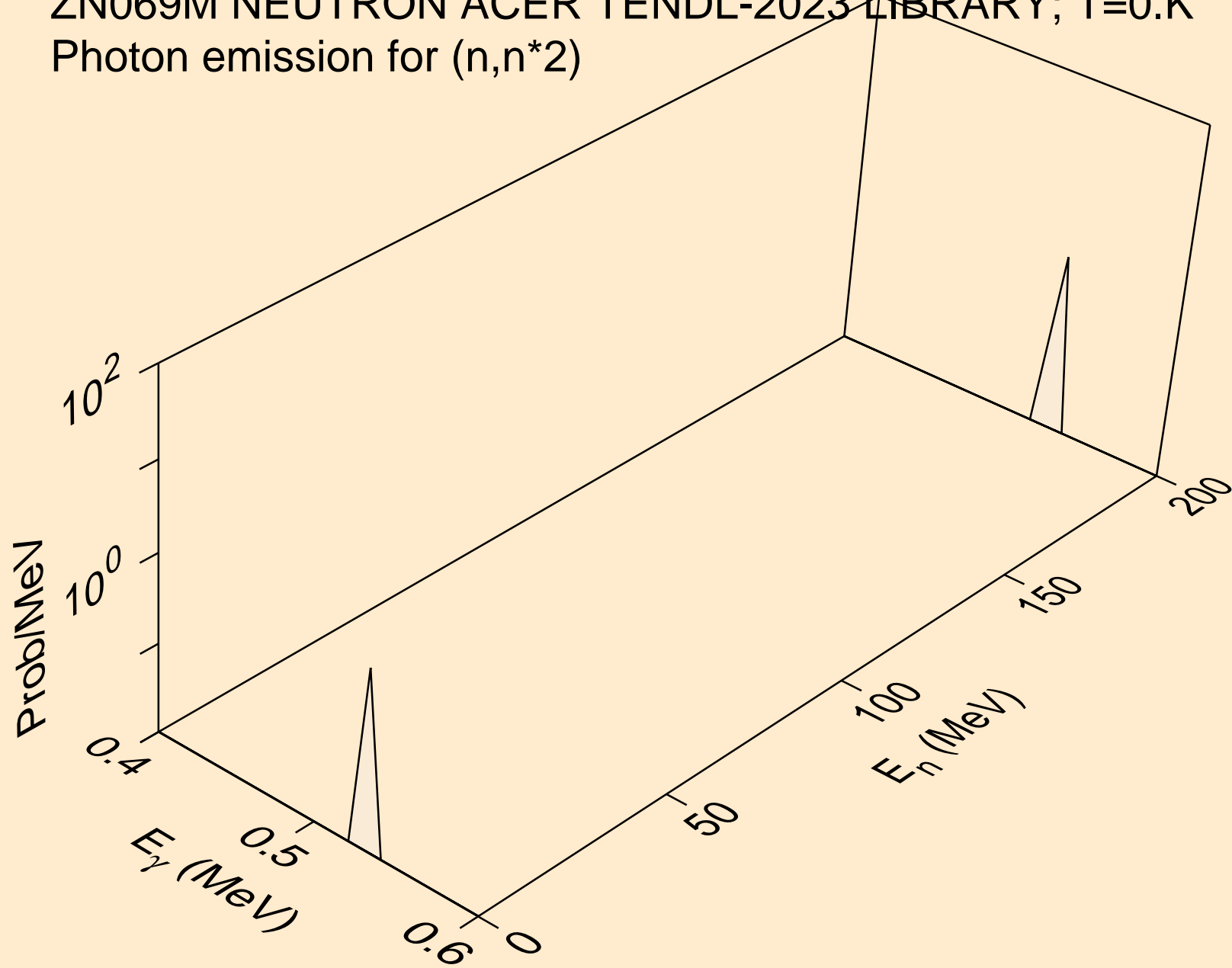

ZN069M NEUTRON ACER TENDL-2023 LIBRARY; T=0.K  
Photon emission for (n,n\*3)

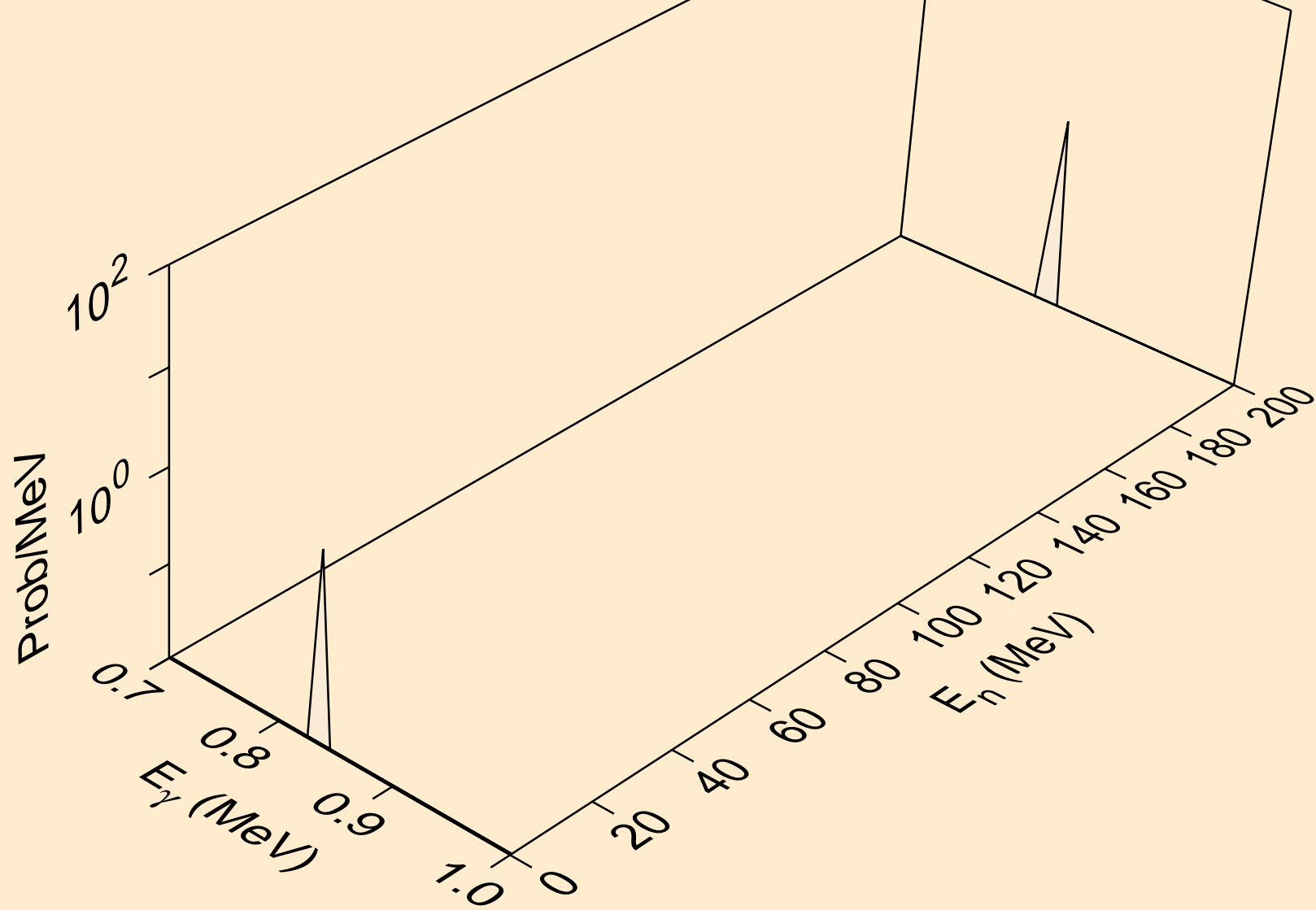

ZN069M NEUTRON ACER TENDL-2023 LIBRARY; T=0.K  
Photon emission for (n,n\*4)

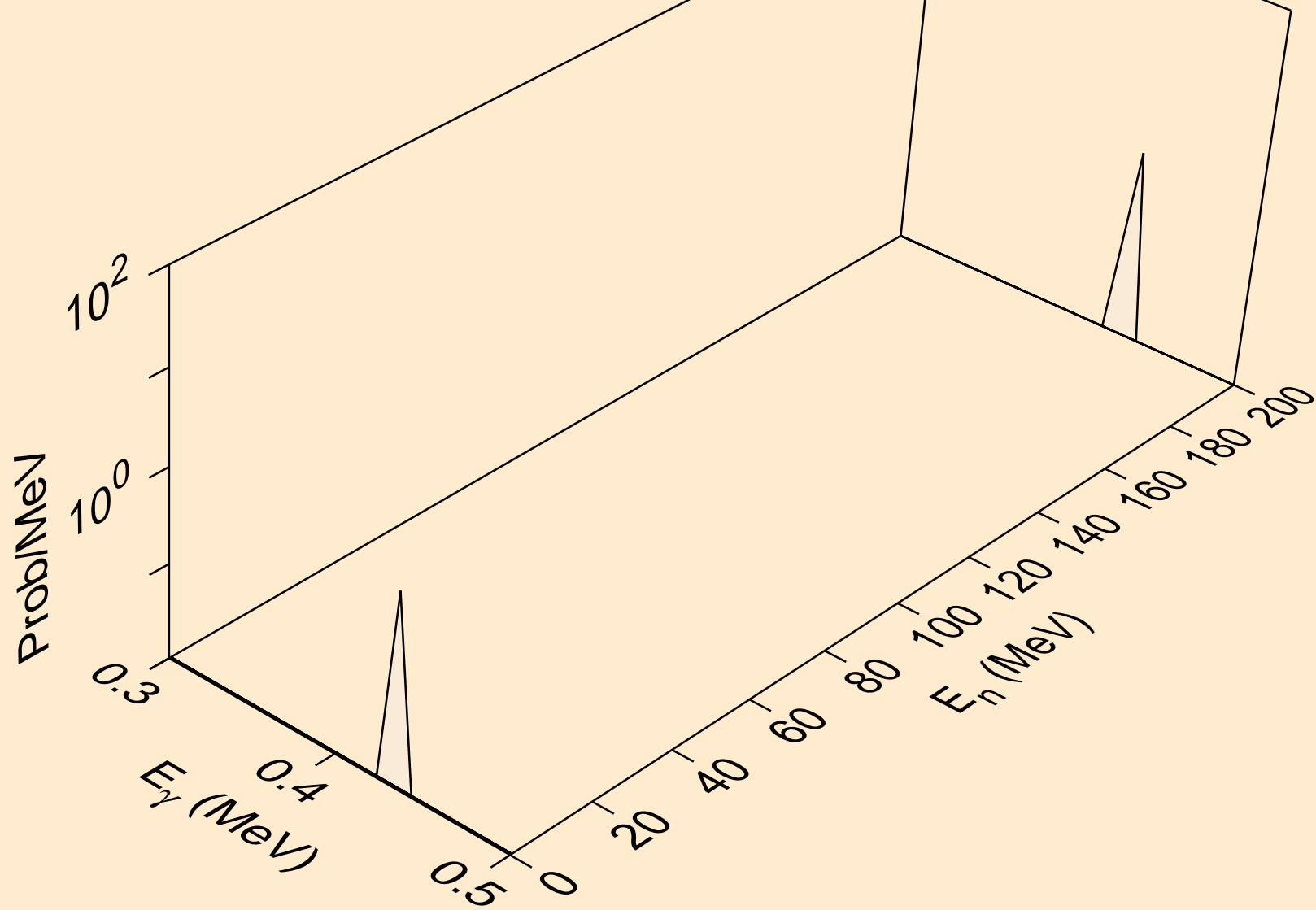

ZN069M NEUTRON ACER TENDL-2023 LIBRARY; T=0.K  
Photon emission for (n,n\*5)

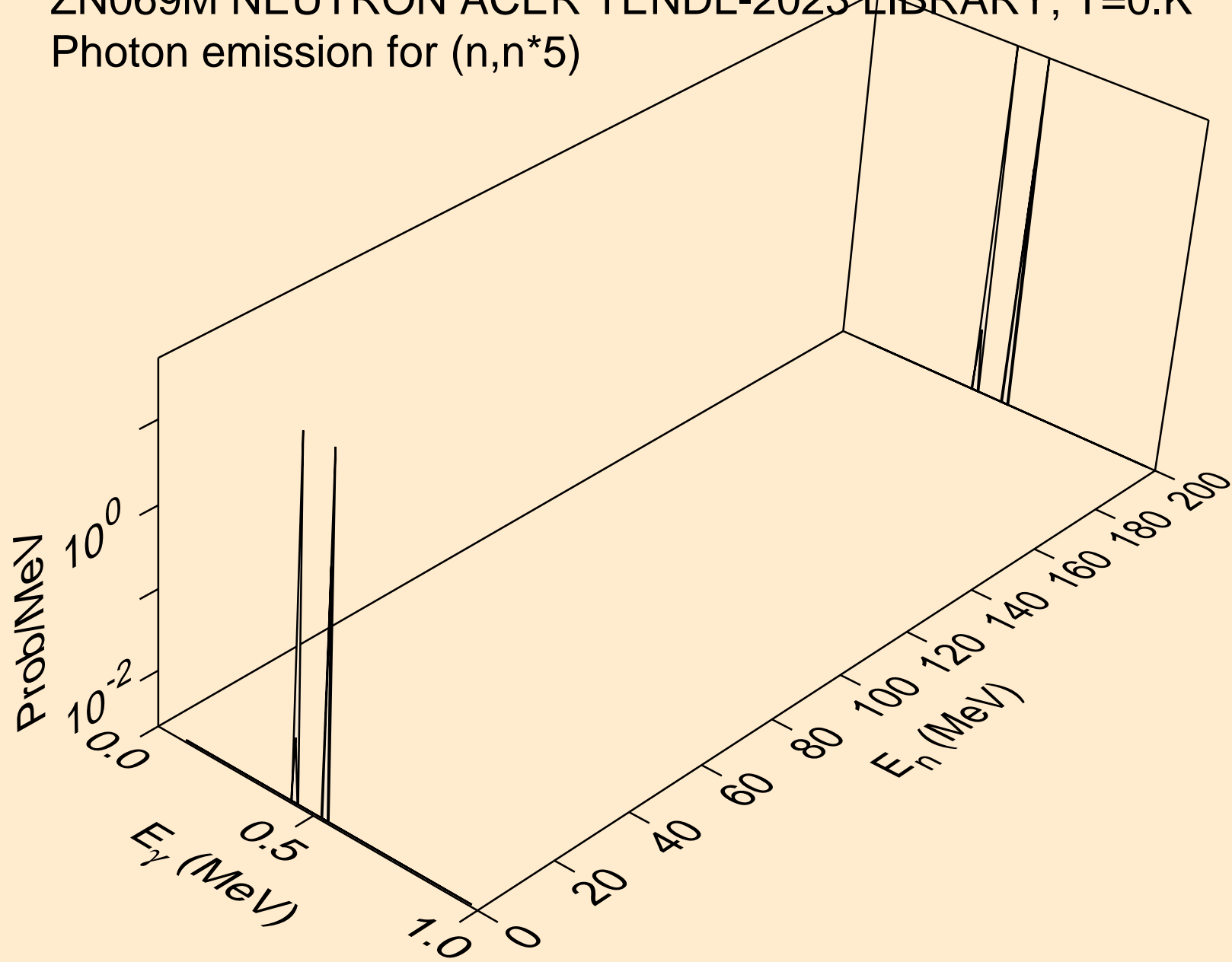

ZN069M NEUTRON ACER TENDL-2023 LIBRARY; T=0.K  
Photon emission for (n,n\*6)

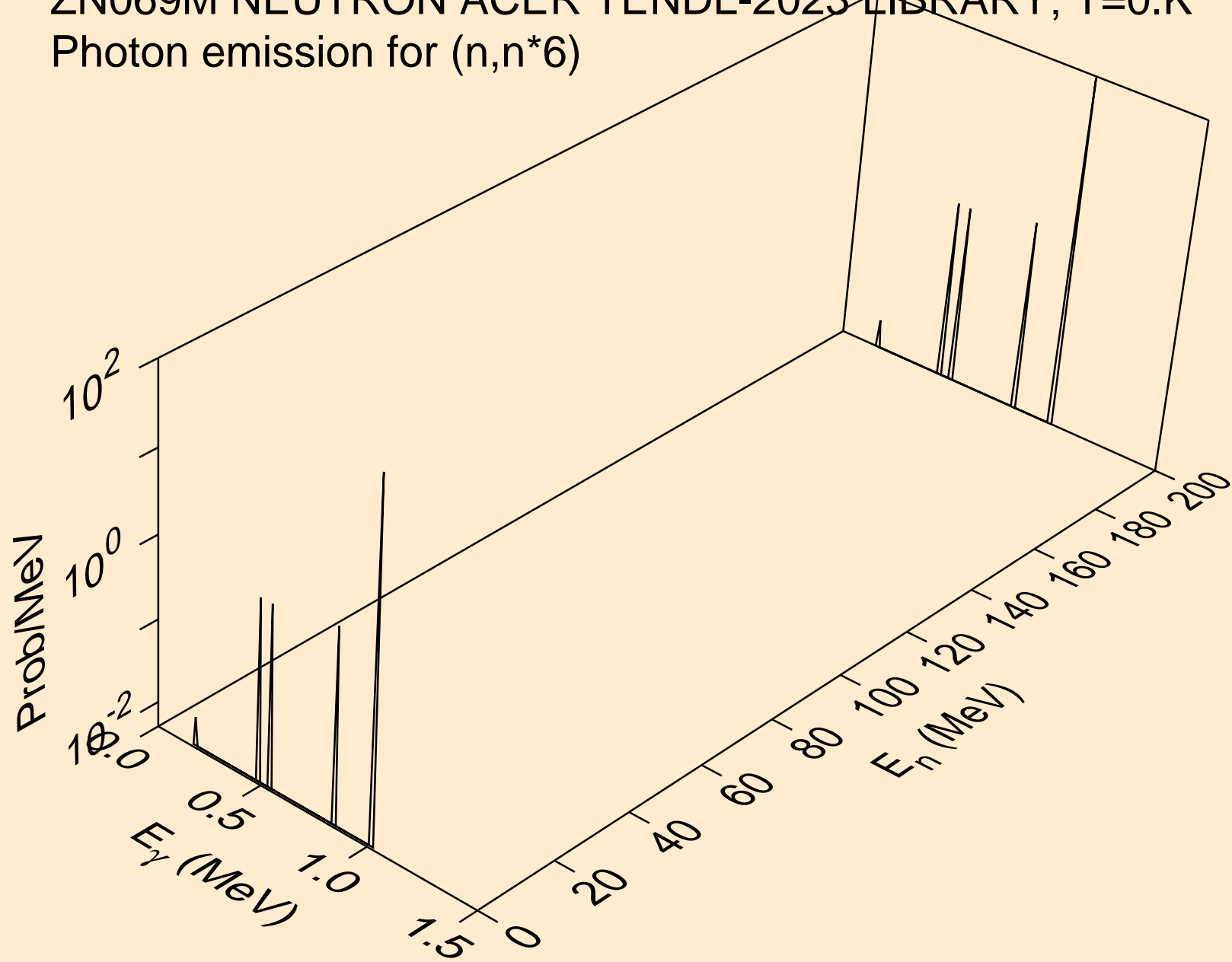

ZN069M NEUTRON ACER TENDL-2023 LIBRARY; T=0.K  
Photon emission for (n,n\*7)

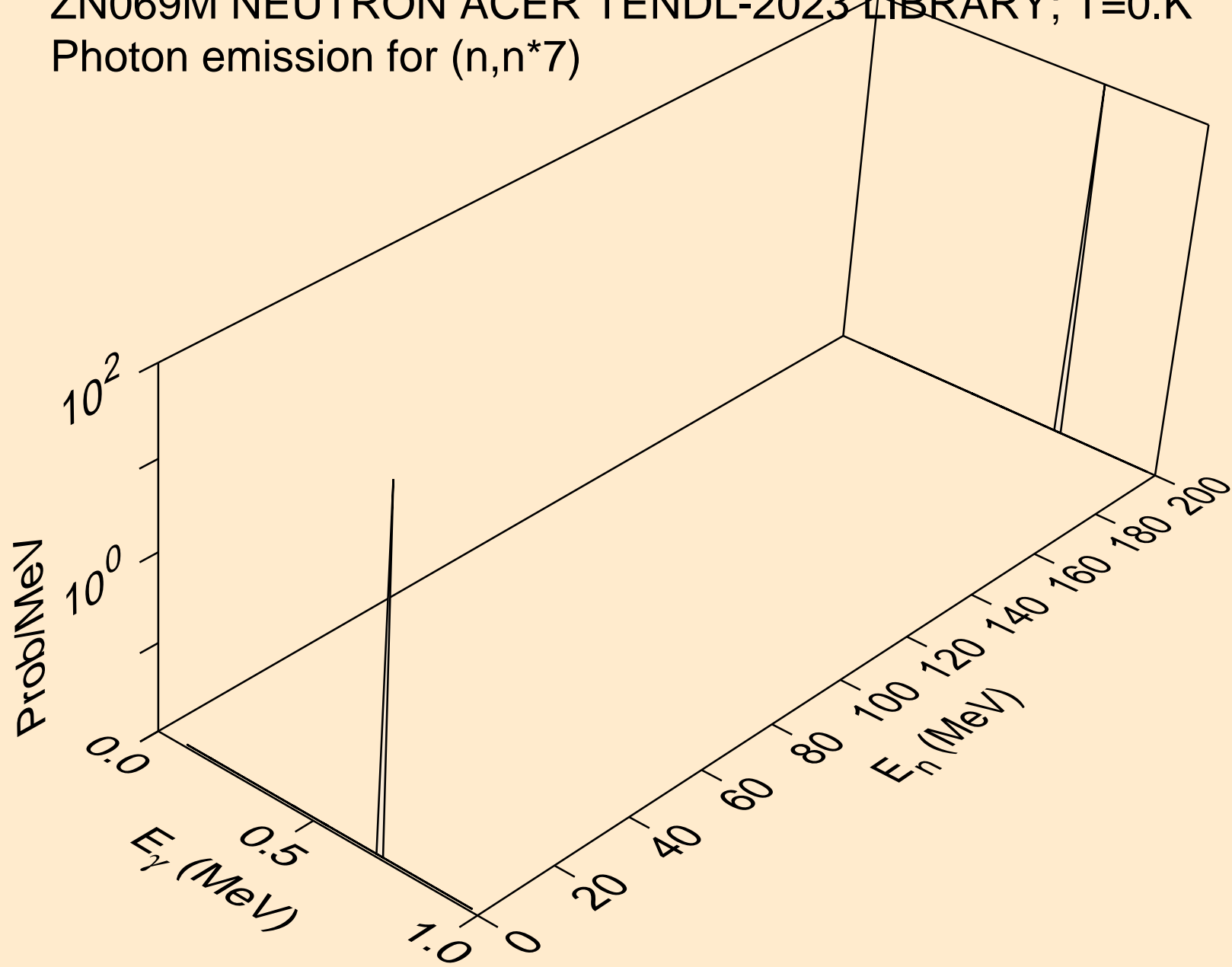



ZN069M NEUTRON ACER TENDL-2023 LIBRARY; T=0.K  
Photon emission for (n,n\*8)

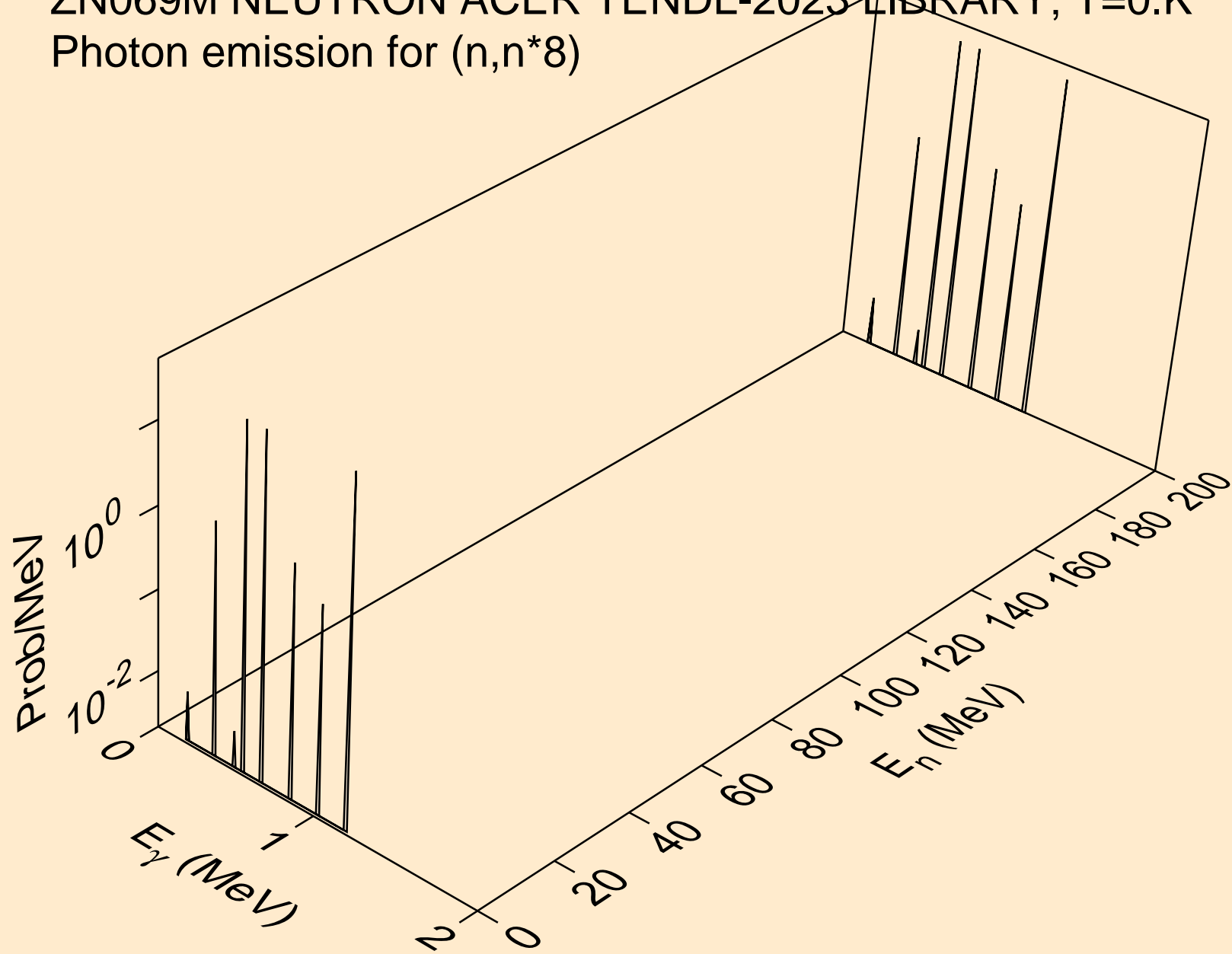

ZN069M NEUTRON ACER TENDL-2023 LIBRARY; T=0.K  
Photon emission for (n,n\*9)

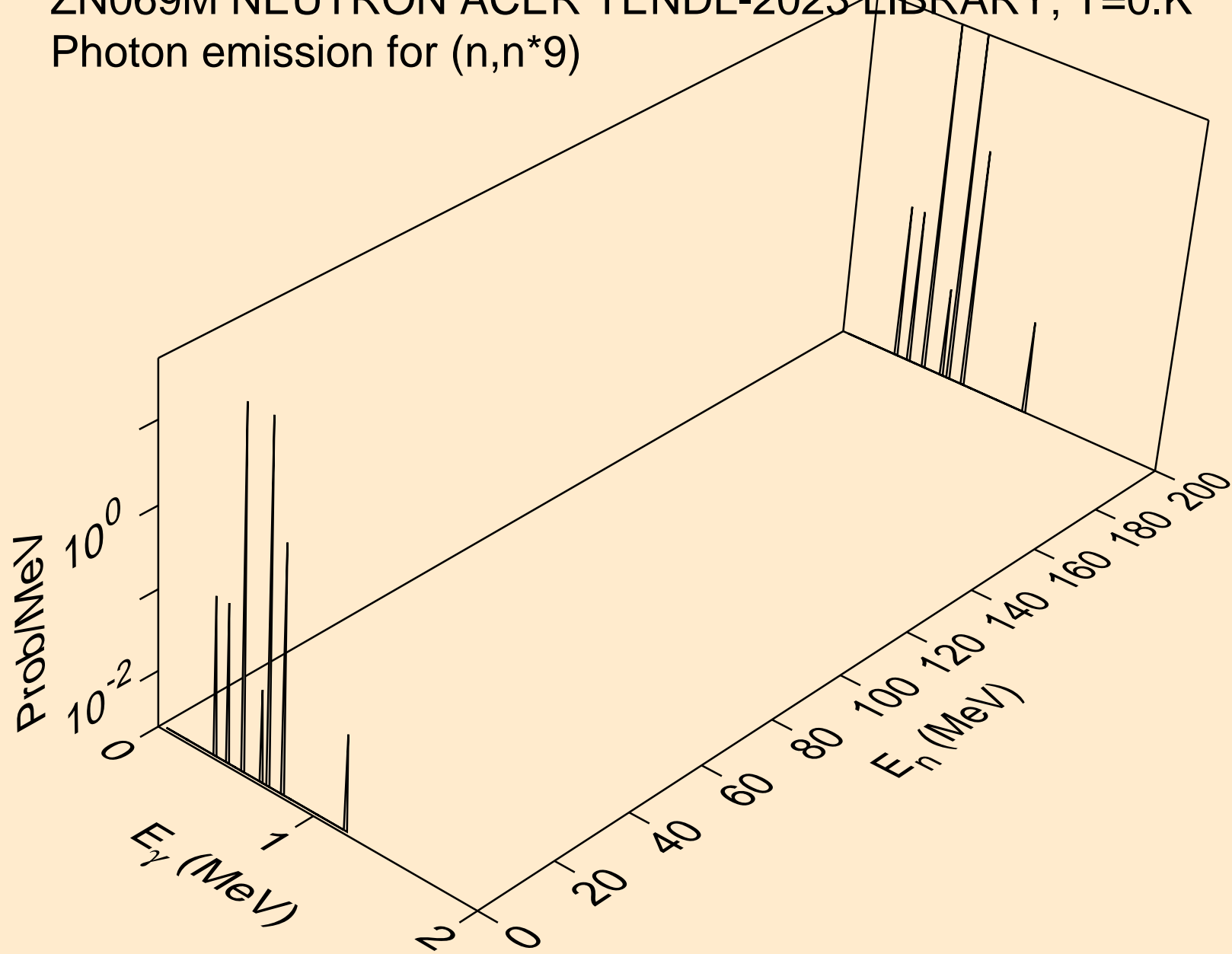

ZN069M NEUTRON ACER TENDL-2023 LIBRARY; T=0.K  
Photon emission for (n,n\*10)

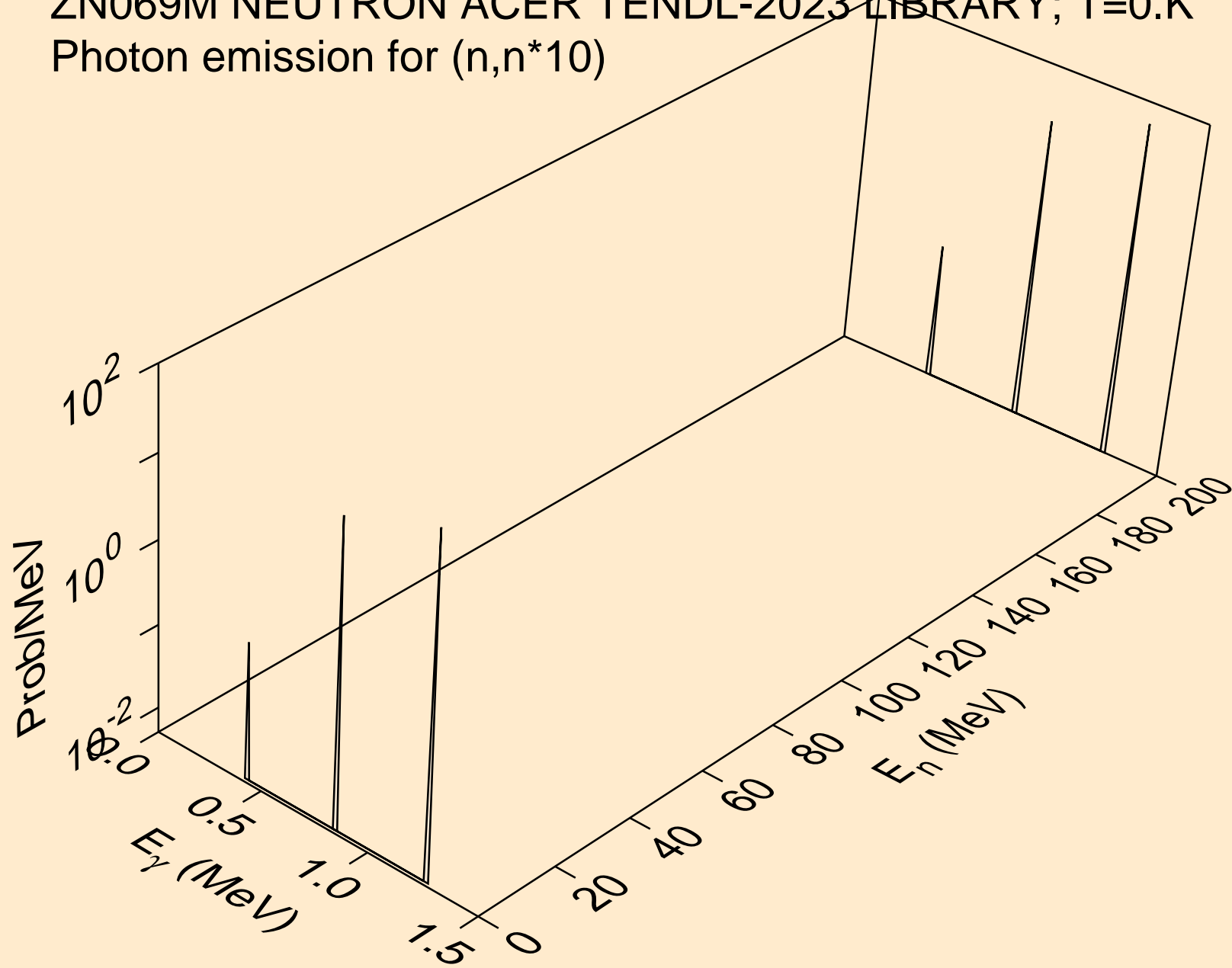

ZN069M NEUTRON ACER TENDL-2023 LIBRARY; T=0.K  
Photon emission for (n,n\*11)

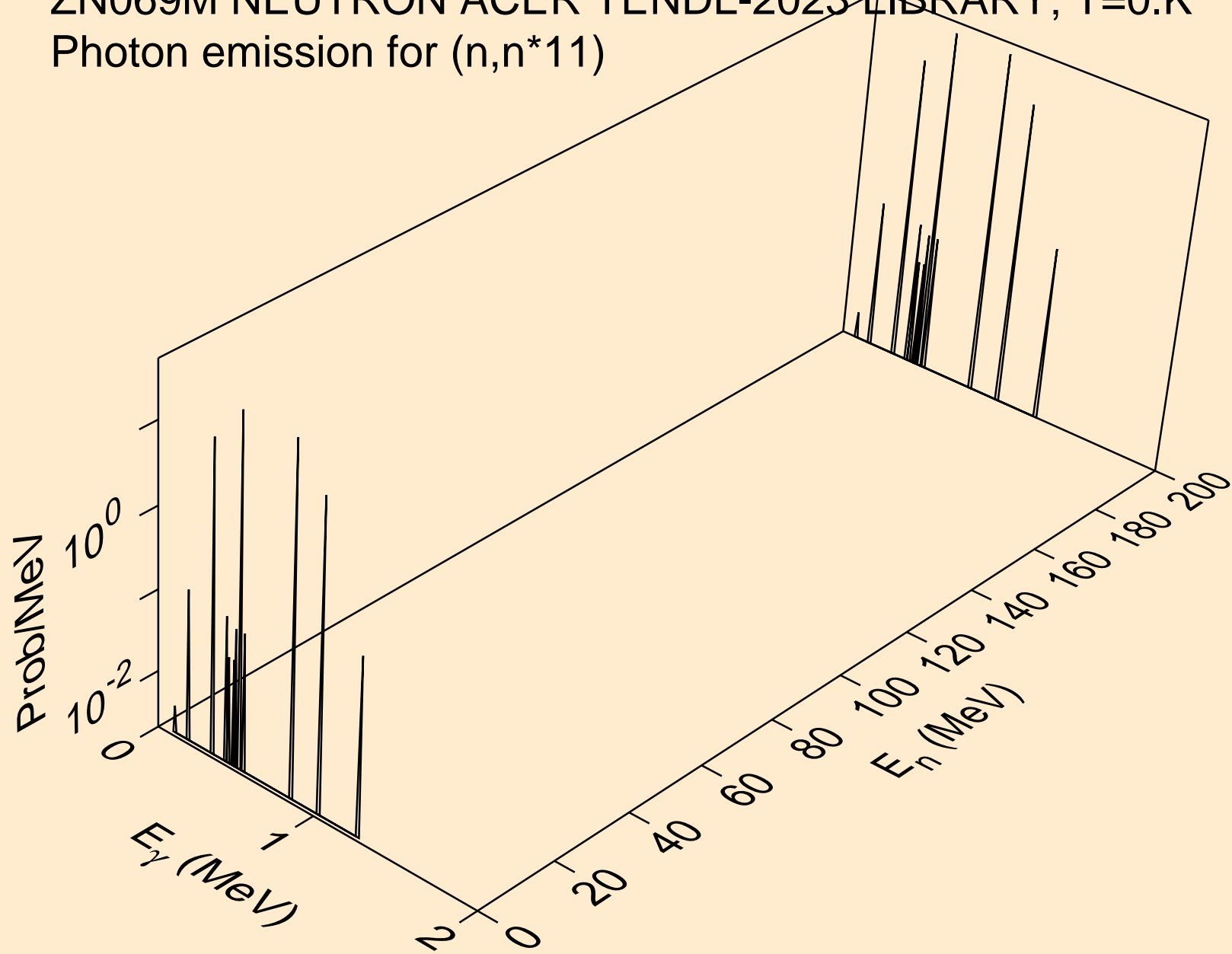

ZN069M NEUTRON ACER TENDL-2023 LIBRARY; T=0.K  
Photon emission for (n,n\*12)

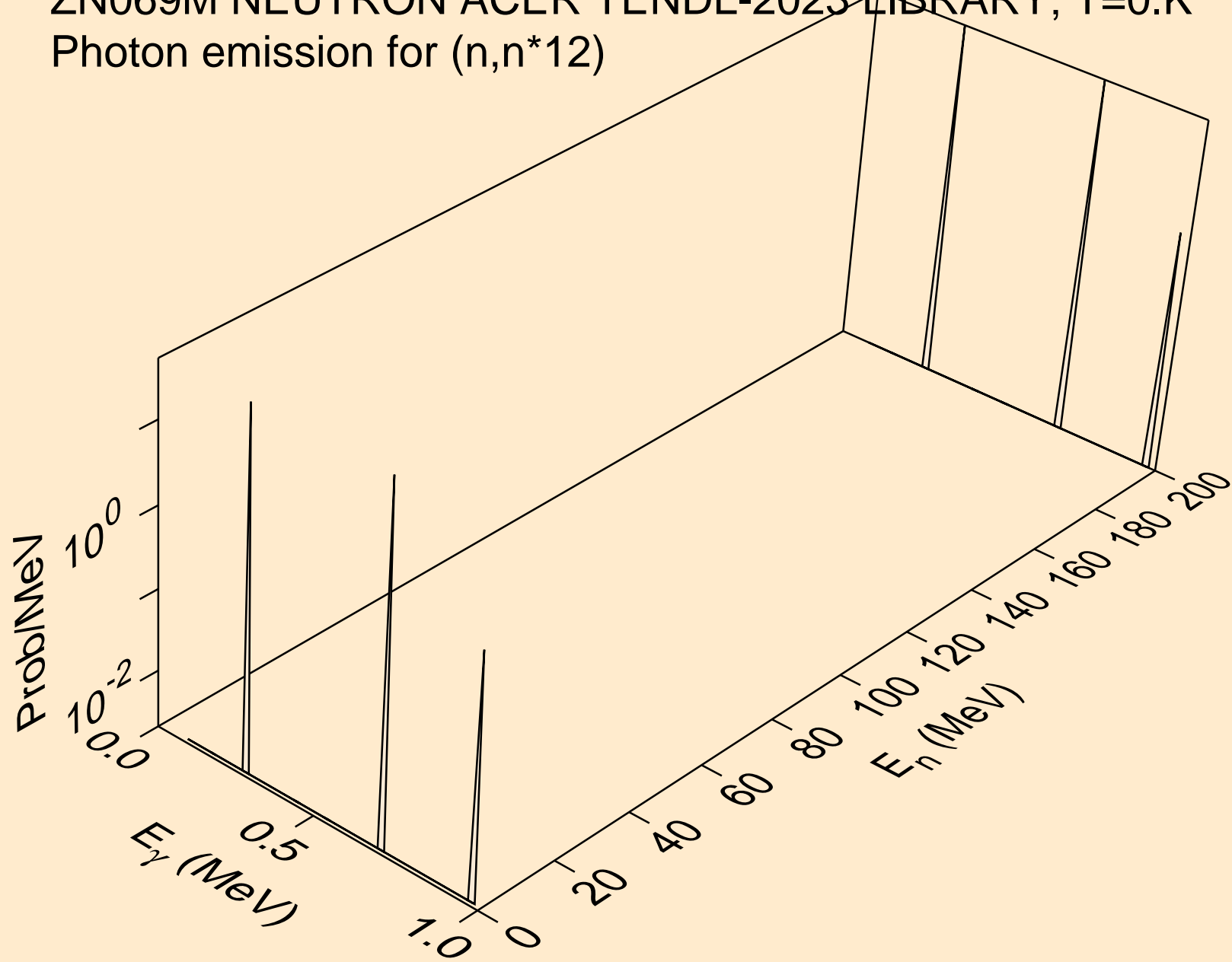

ZN069M NEUTRON ACER TENDL-2023 LIBRARY; T=0.K  
Photon emission for (n,n\*13)

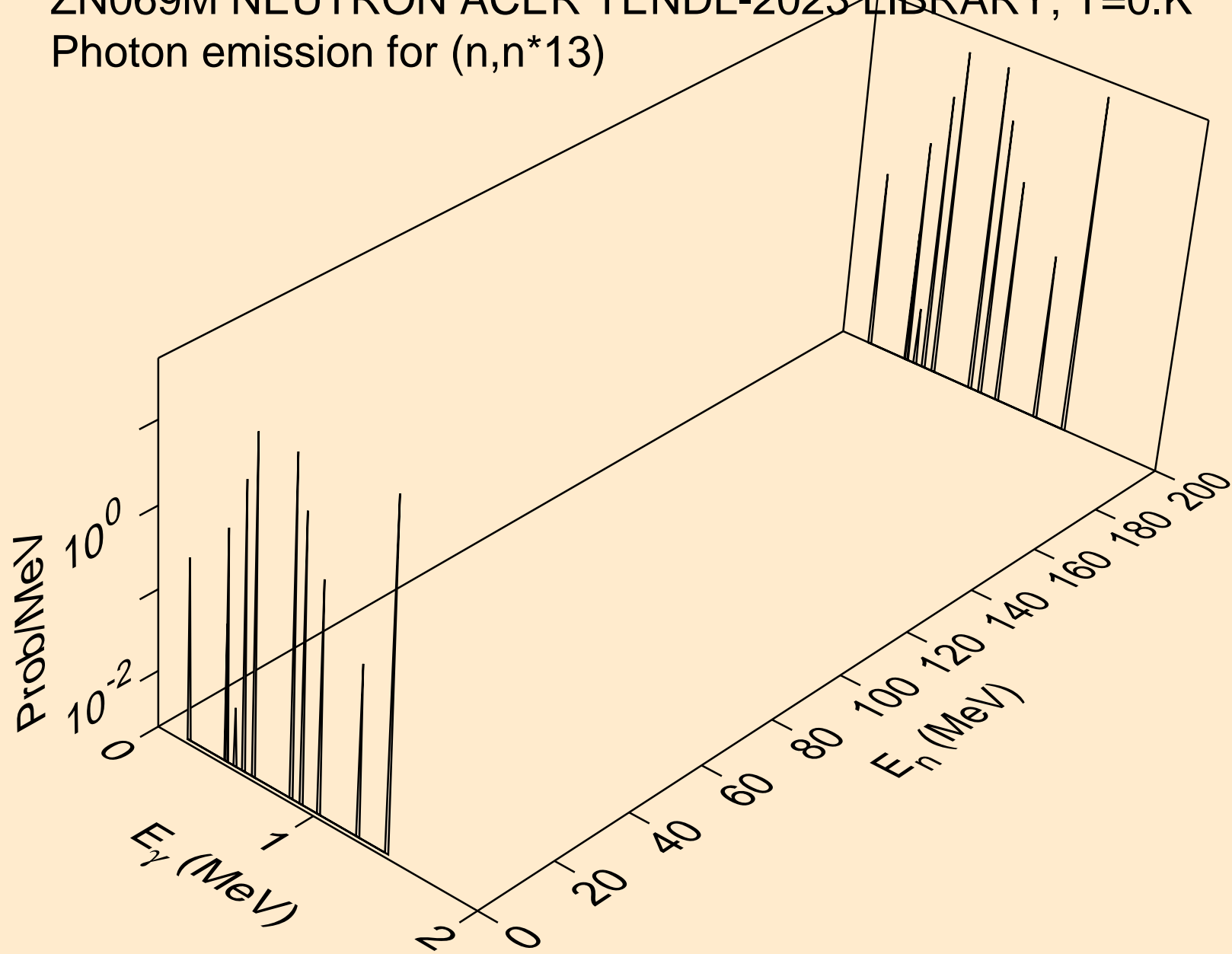

ZN069M NEUTRON ACER TENDL-2023 LIBRARY; T=0.K  
Photon emission for (n,n\*14)

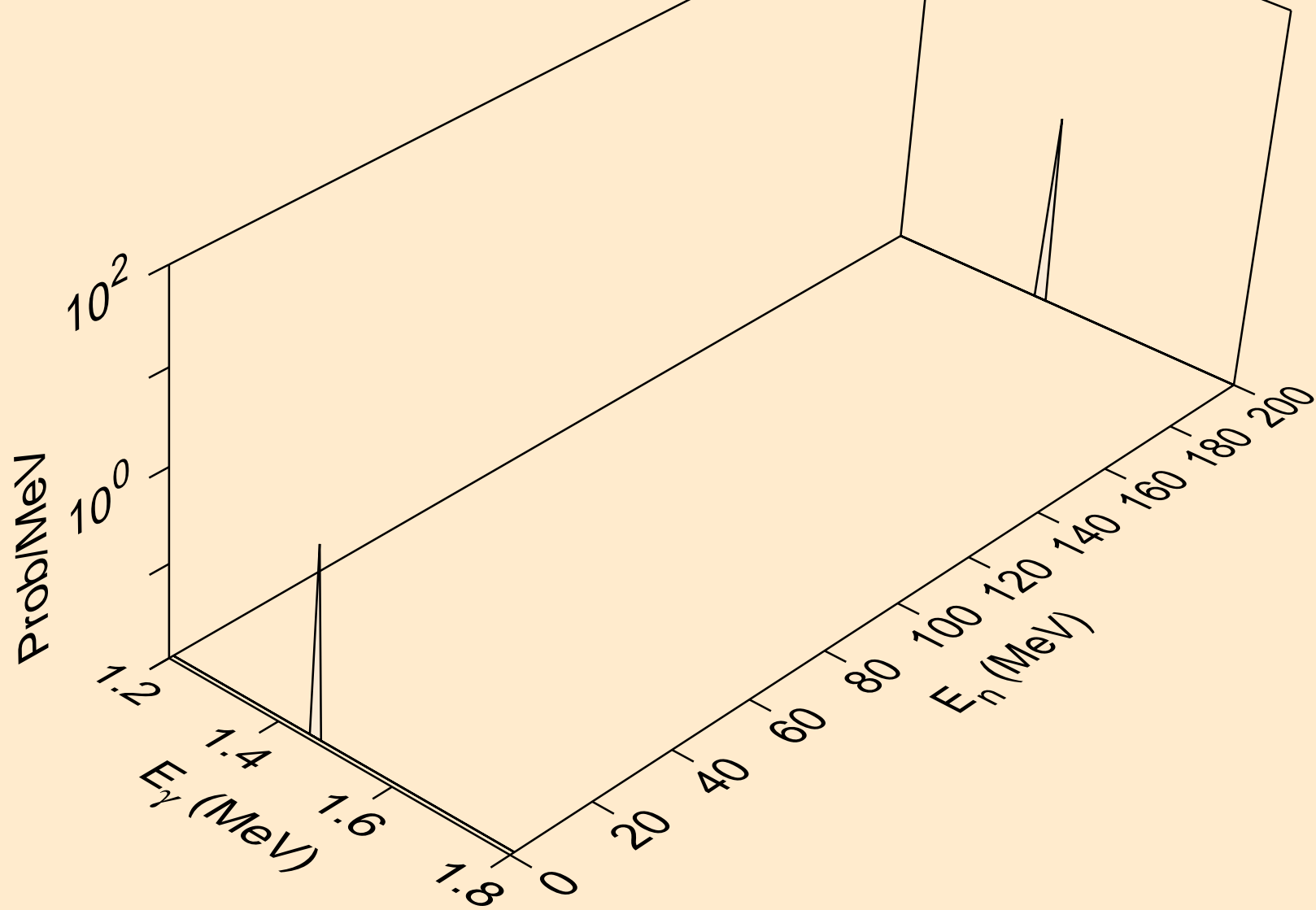

ZN069M NEUTRON ACER TENDL-2023 LIBRARY; T=0.K  
Photon emission for (n,n\*15)

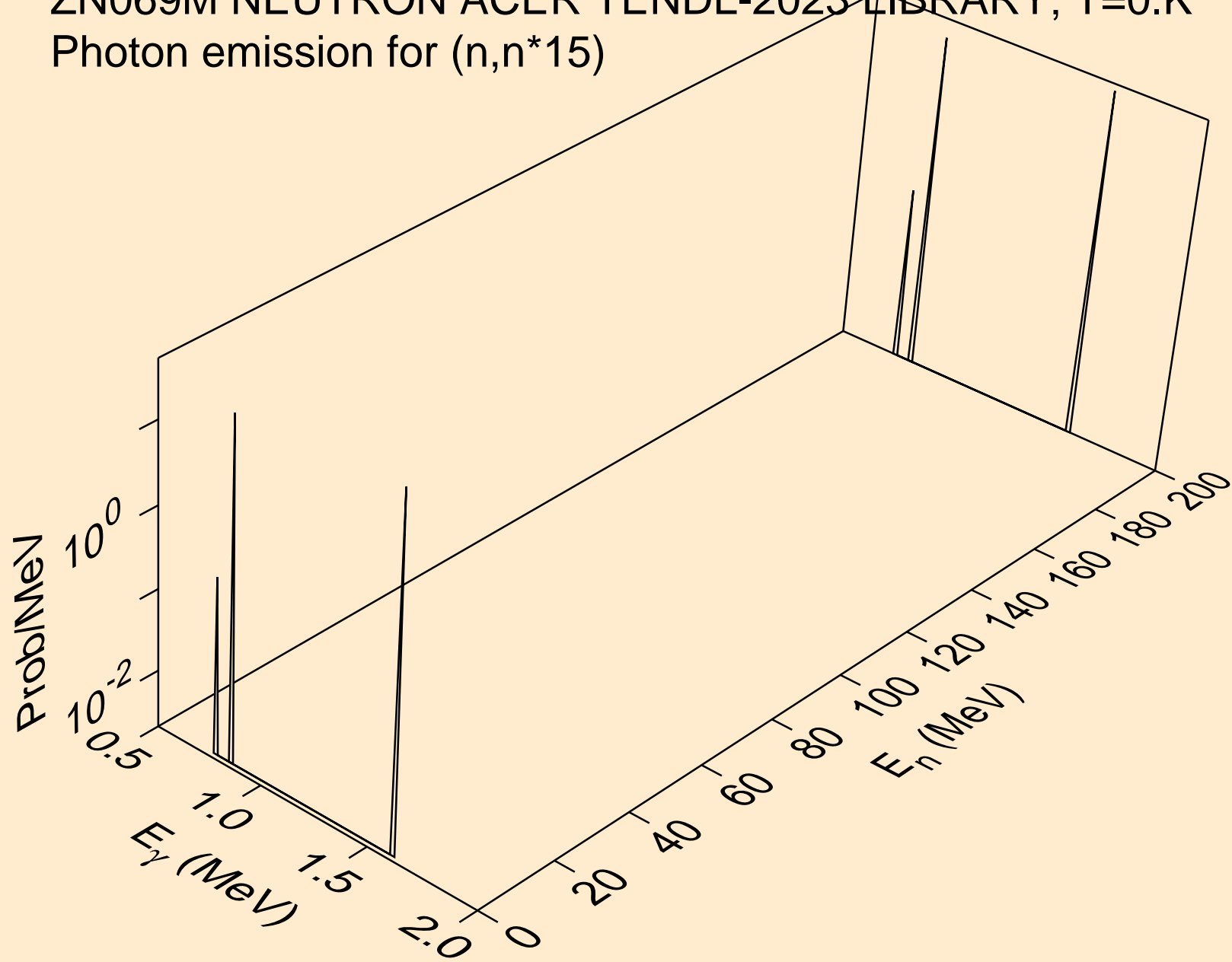



ZN069M NEUTRON ACER TENDL-2023 LIBRARY; T=0.K  
Photon emission for (n,n\*16)

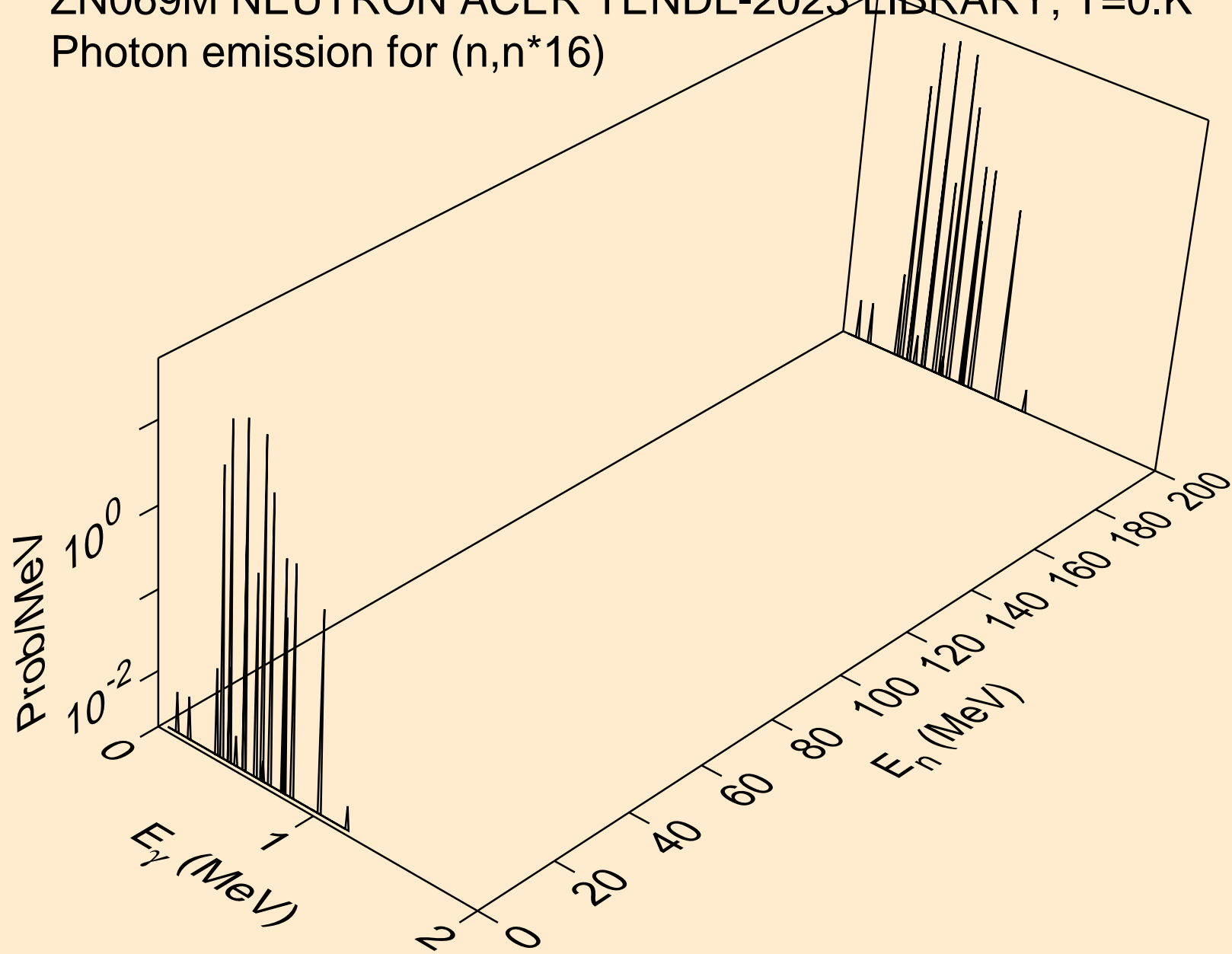

ZN069M NEUTRON ACER TENDL-2023 LIBRARY; T=0.K  
Photon emission for (n,n\*17)

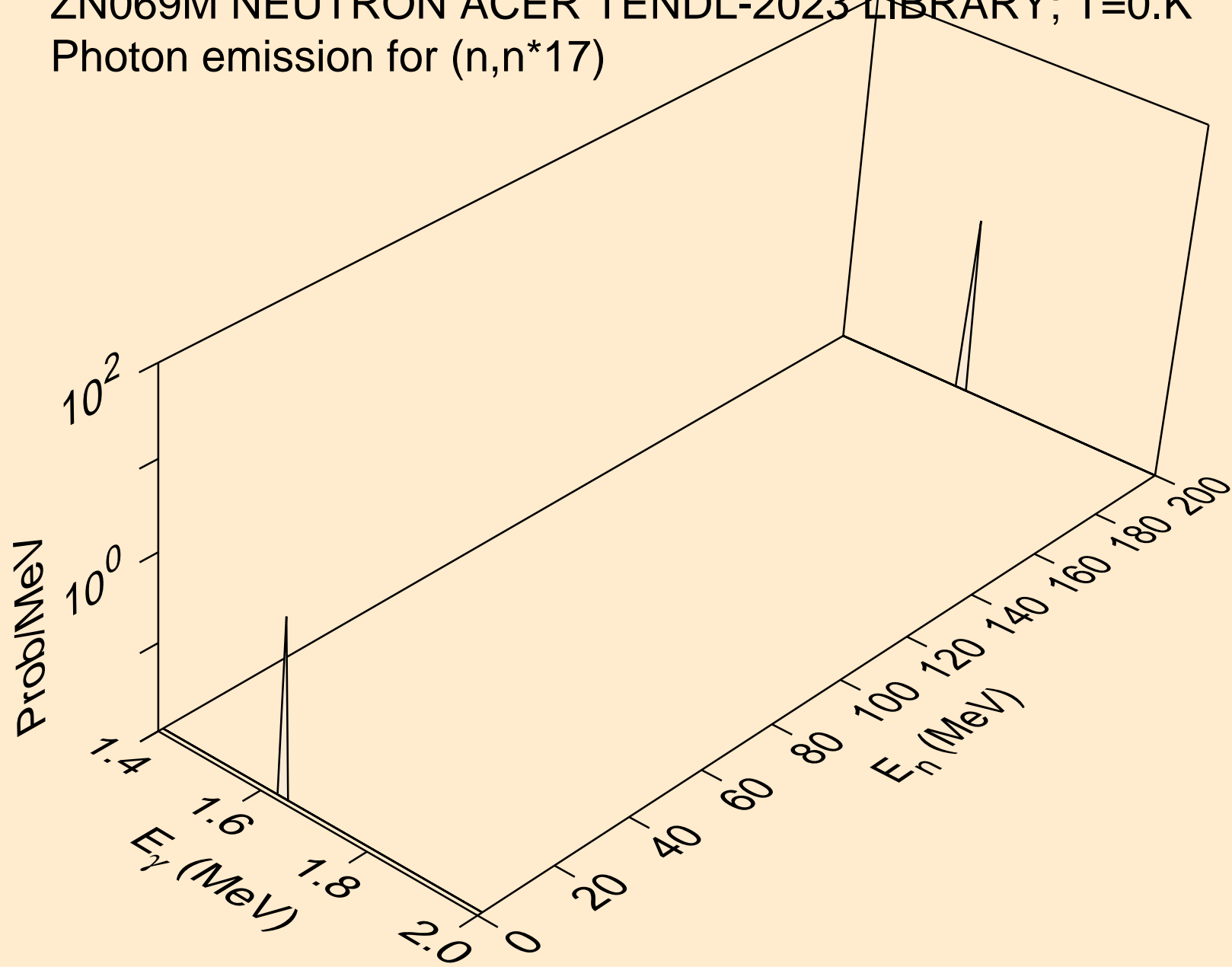

ZN069M NEUTRON ACER TENDL-2023 LIBRARY; T=0.K  
Photon emission for (n,n\*18)

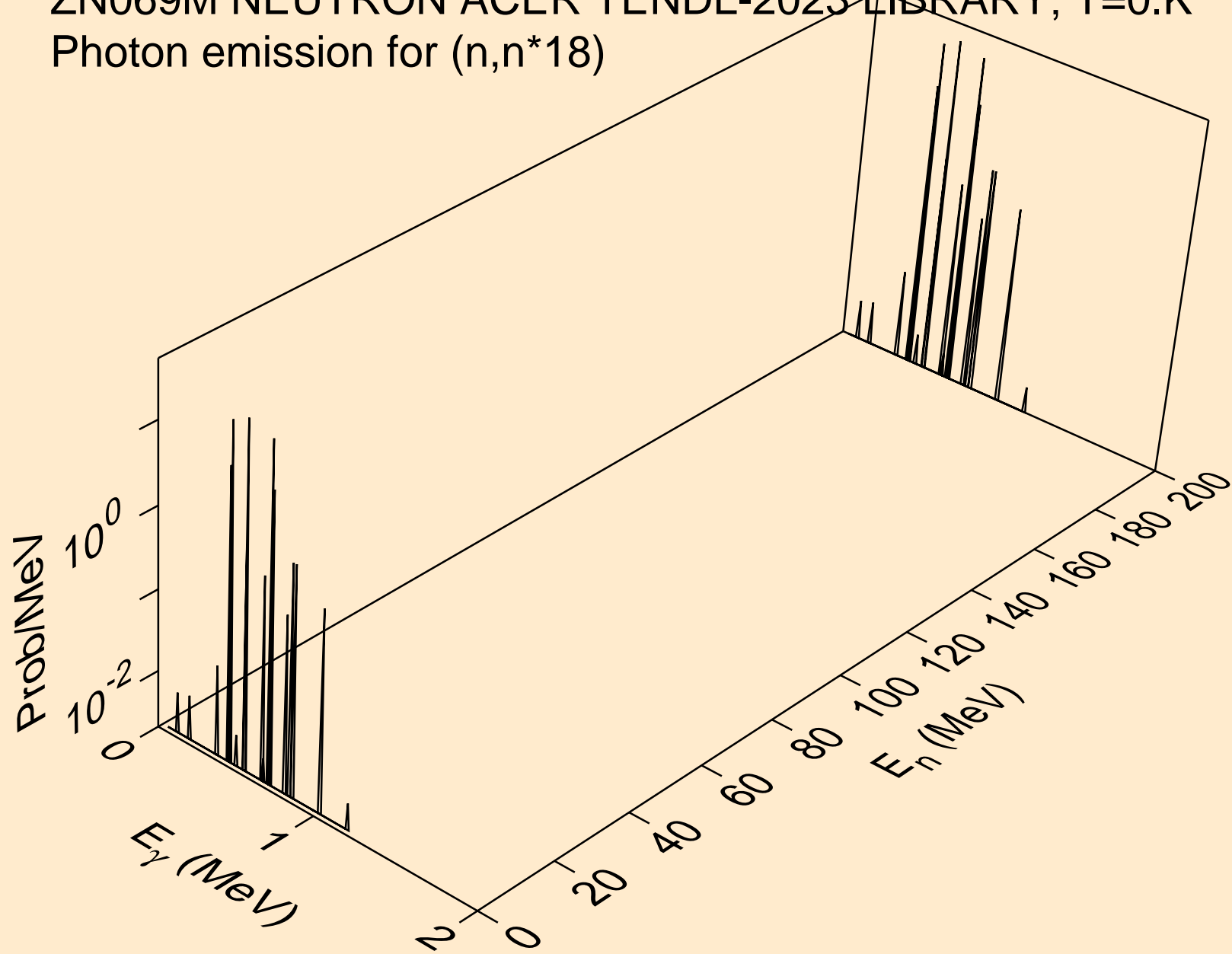

ZN069M NEUTRON ACER TENDL-2023 LIBRARY; T=0.K  
Photon emission for (n,n\*19)

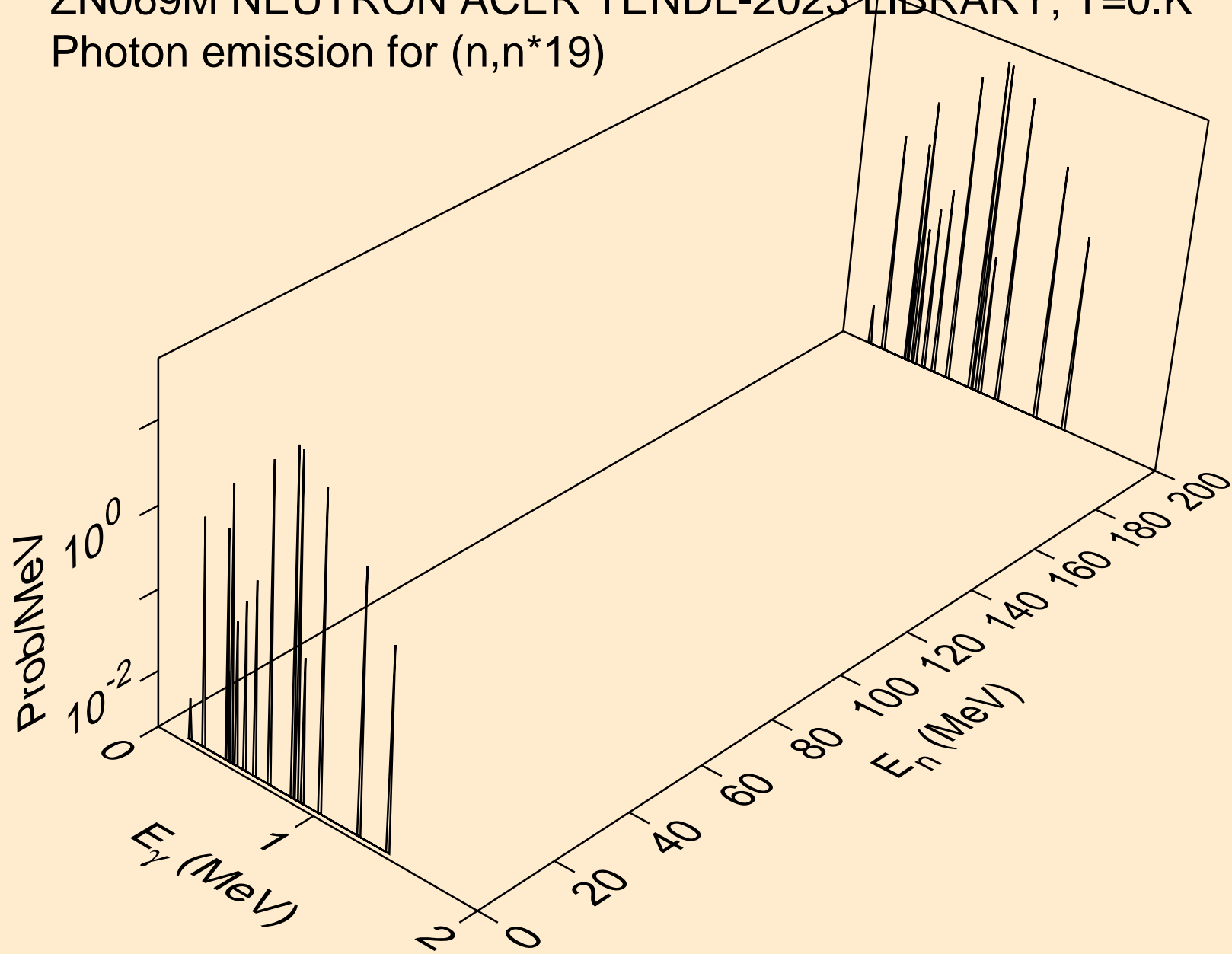

ZN069M NEUTRON ACER TENDL-2023 LIBRARY; T=0.K  
Photon emission for (n,n\*20)

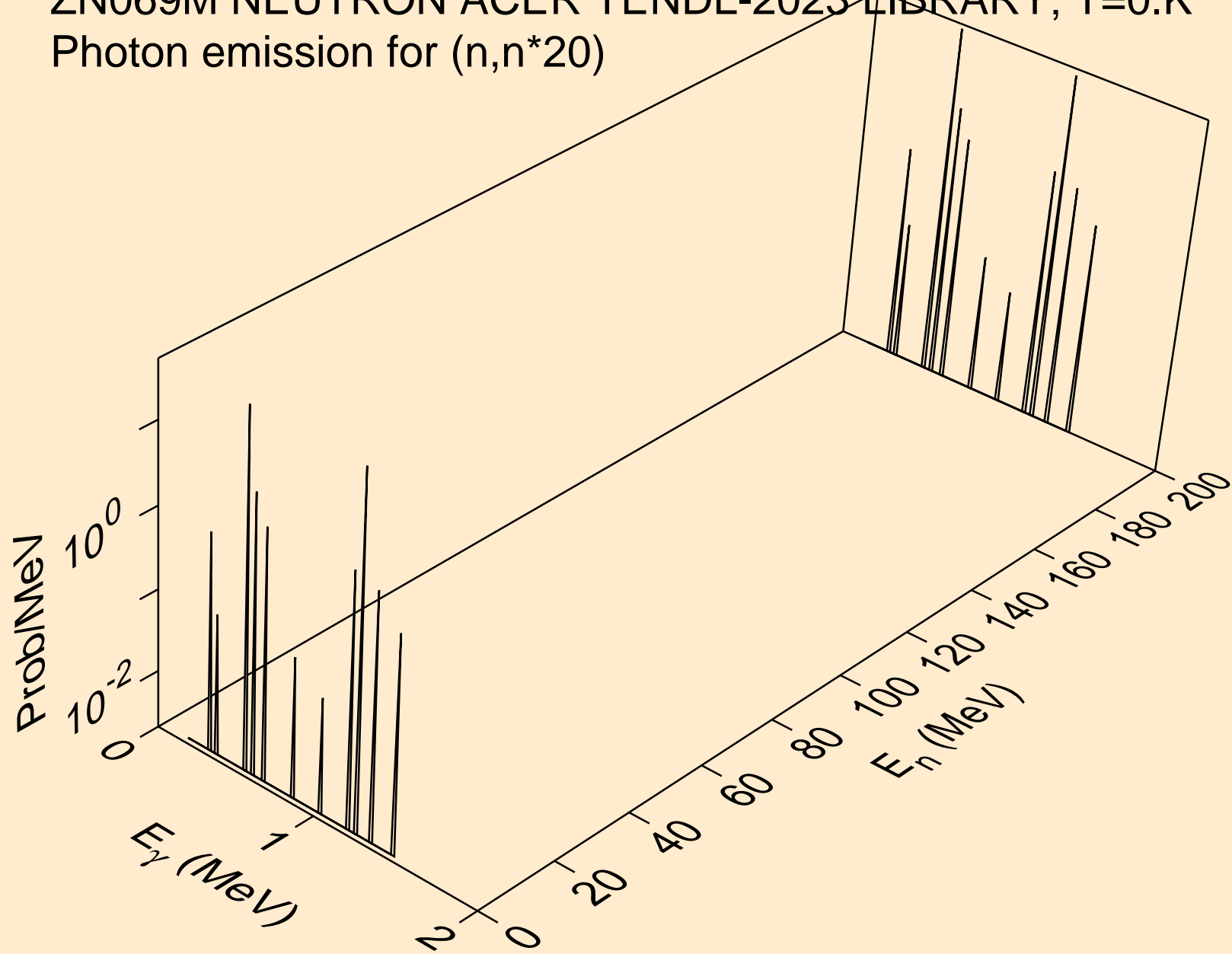

ZN069M NEUTRON ACER TENDL-2023 LIBRARY; T=0.K  
Photon emission for (n,n\*21)

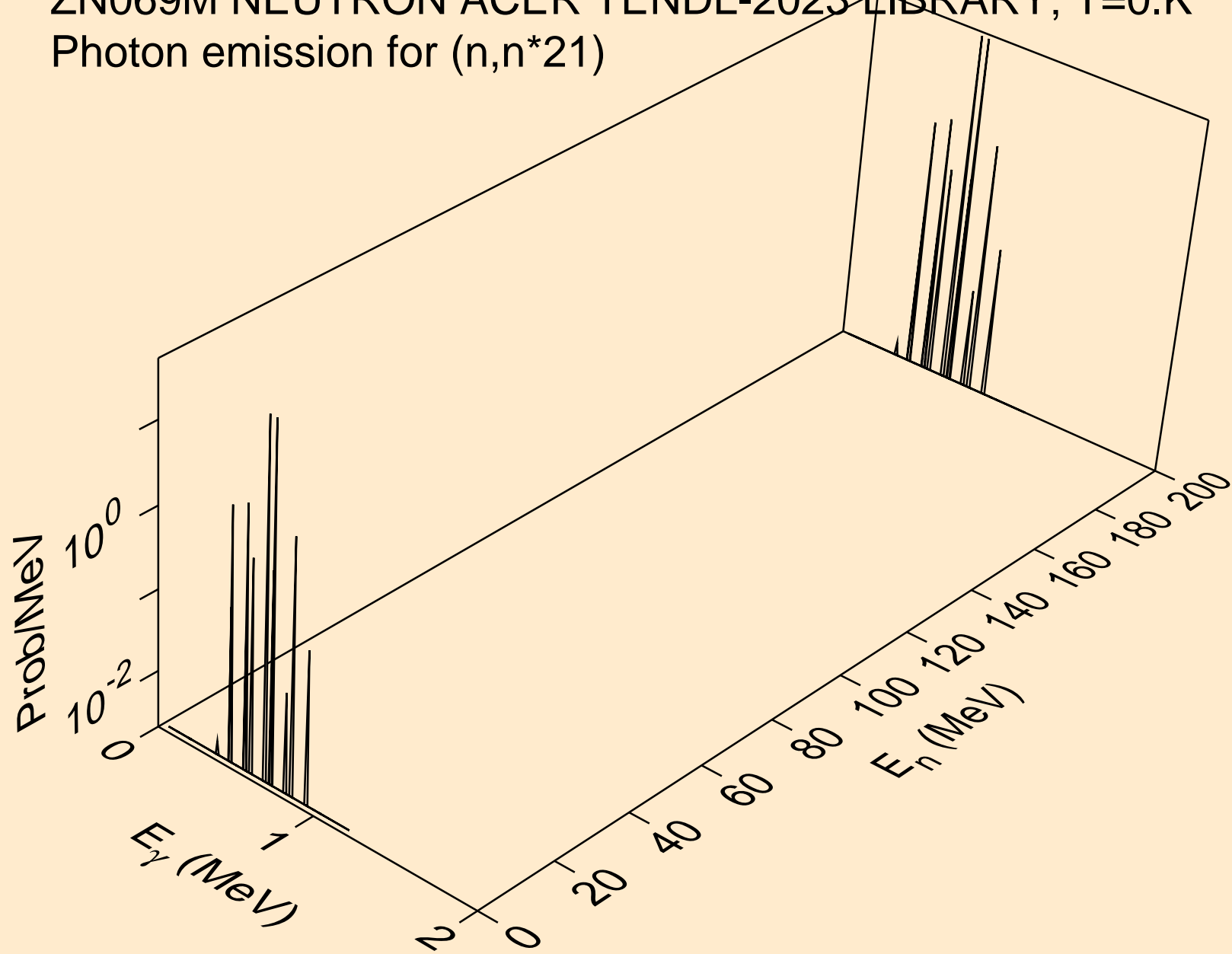

ZN069M NEUTRON ACER TENDL-2023 LIBRARY; T=0.K  
Photon emission for (n,n\*22)

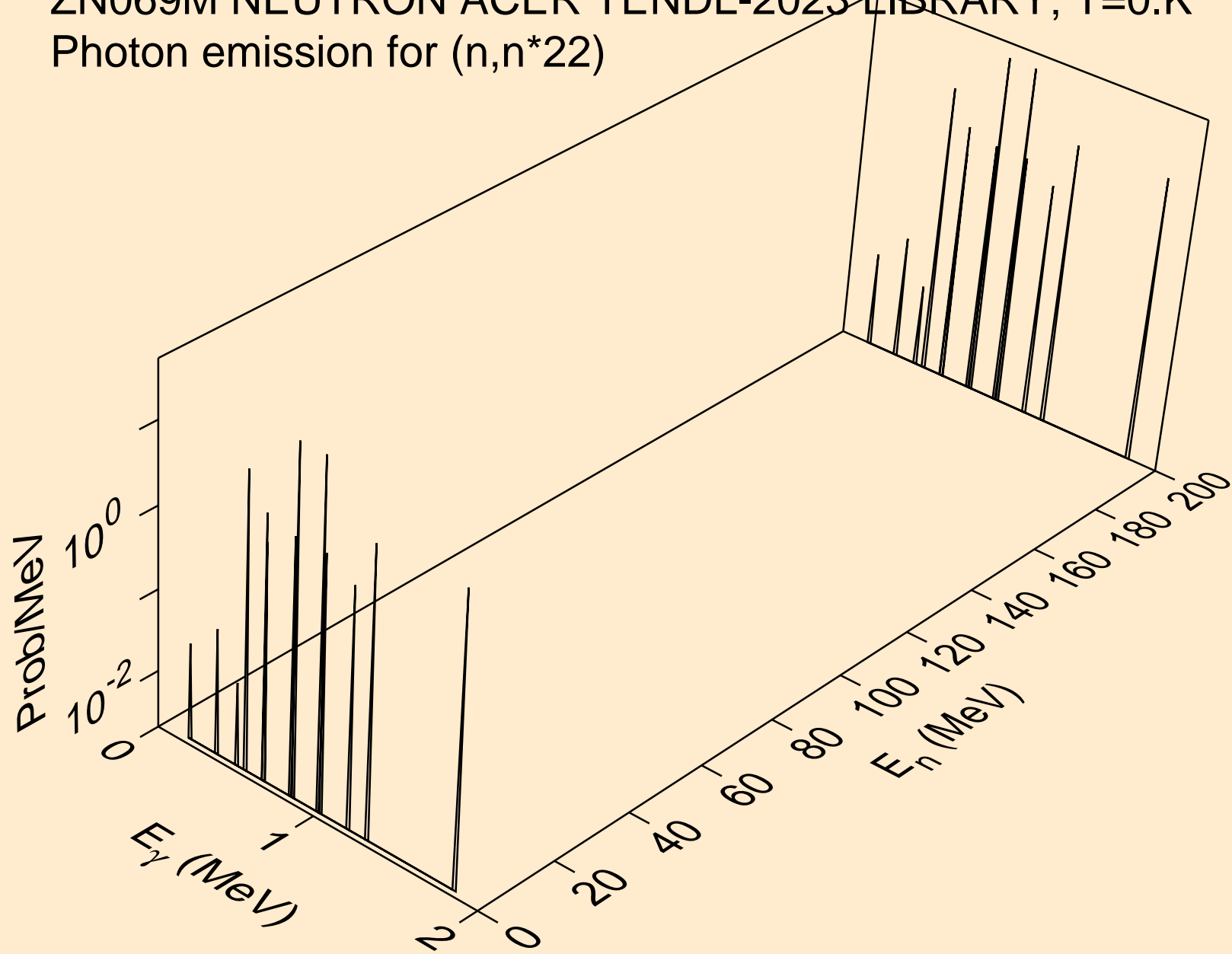

ZN069M NEUTRON ACER TENDL-2023 LIBRARY; T=0.K  
Photon emission for (n,n\*23)

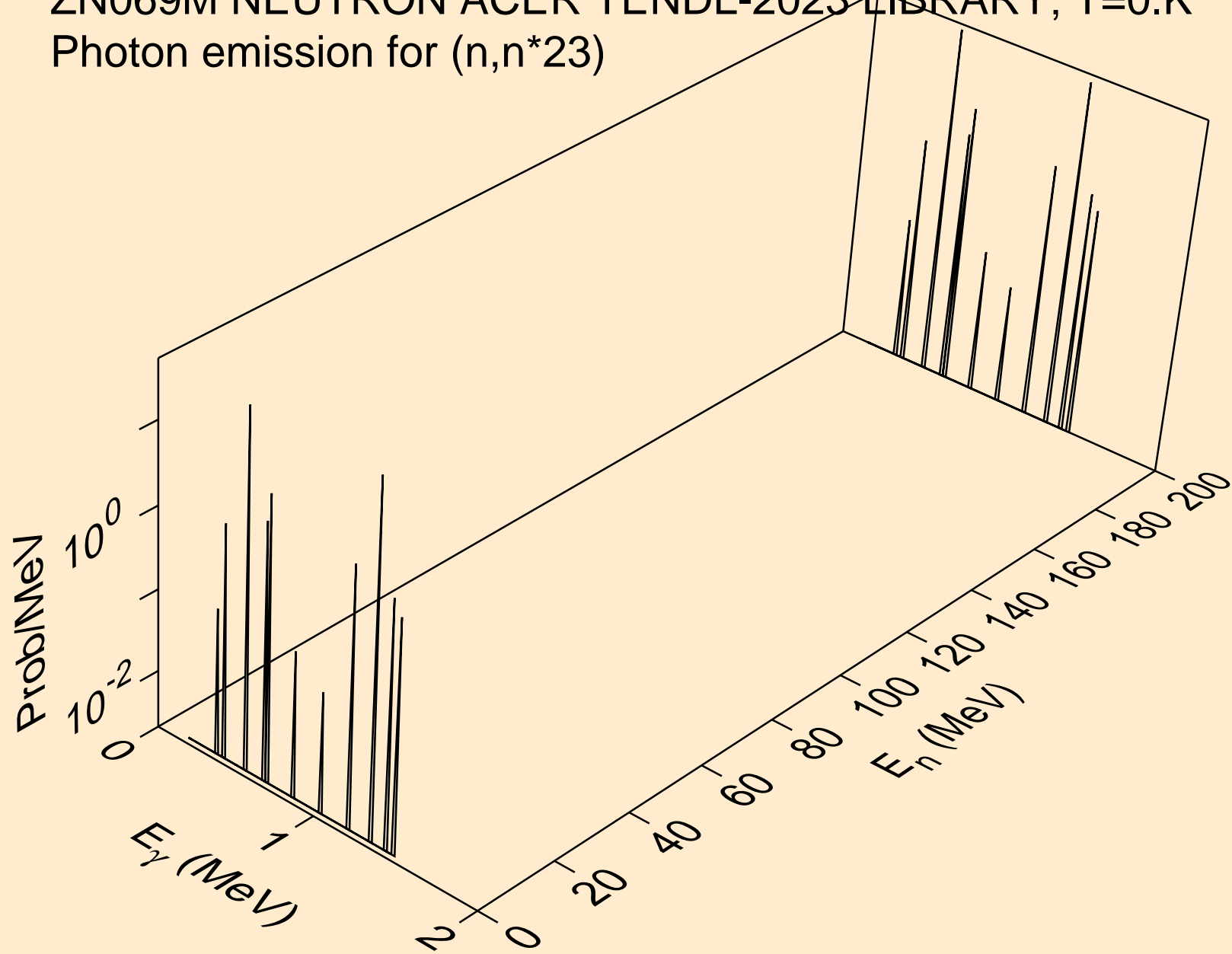



ZN069M NEUTRON ACER TENDL-2023 LIBRARY; T=0.K  
Photon emission for (n,n\*24)

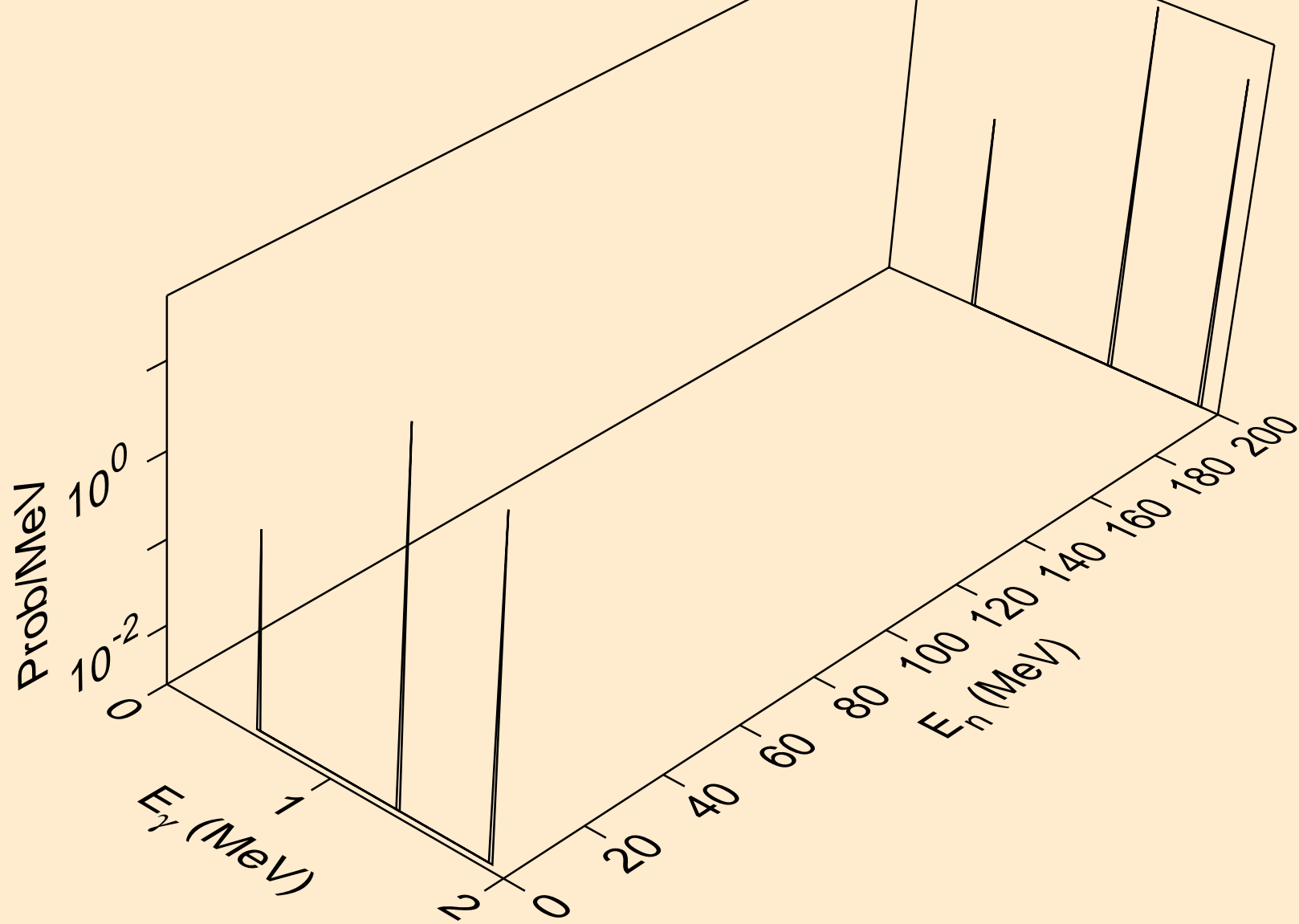

ZN069M NEUTRON ACER TENDL-2023 LIBRARY; T=0.K  
Photon emission for (n,n\*25)

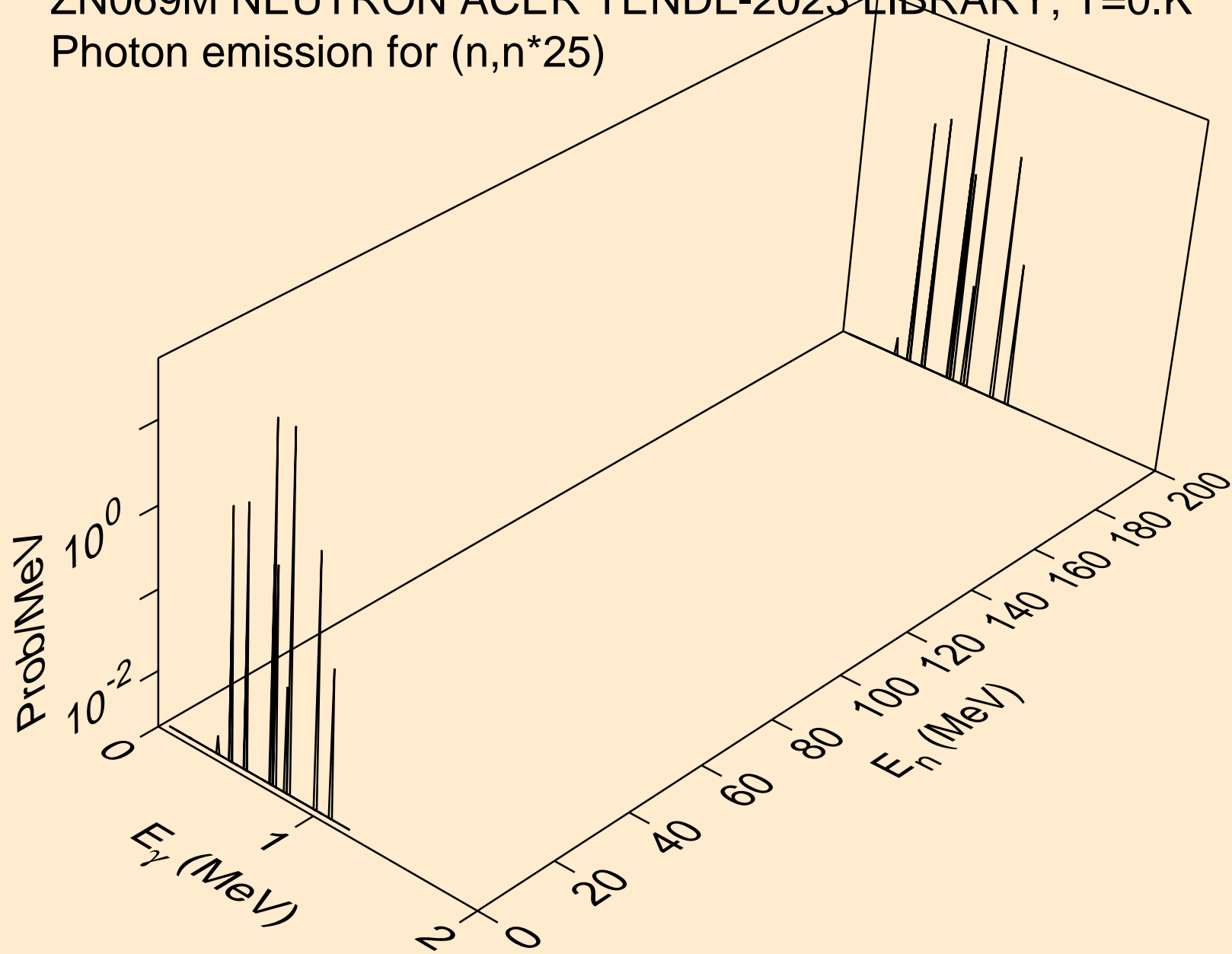

ZN069M NEUTRON ACER TENDL-2023 LIBRARY; T=0.K  
Photon emission for (n,n\*c)

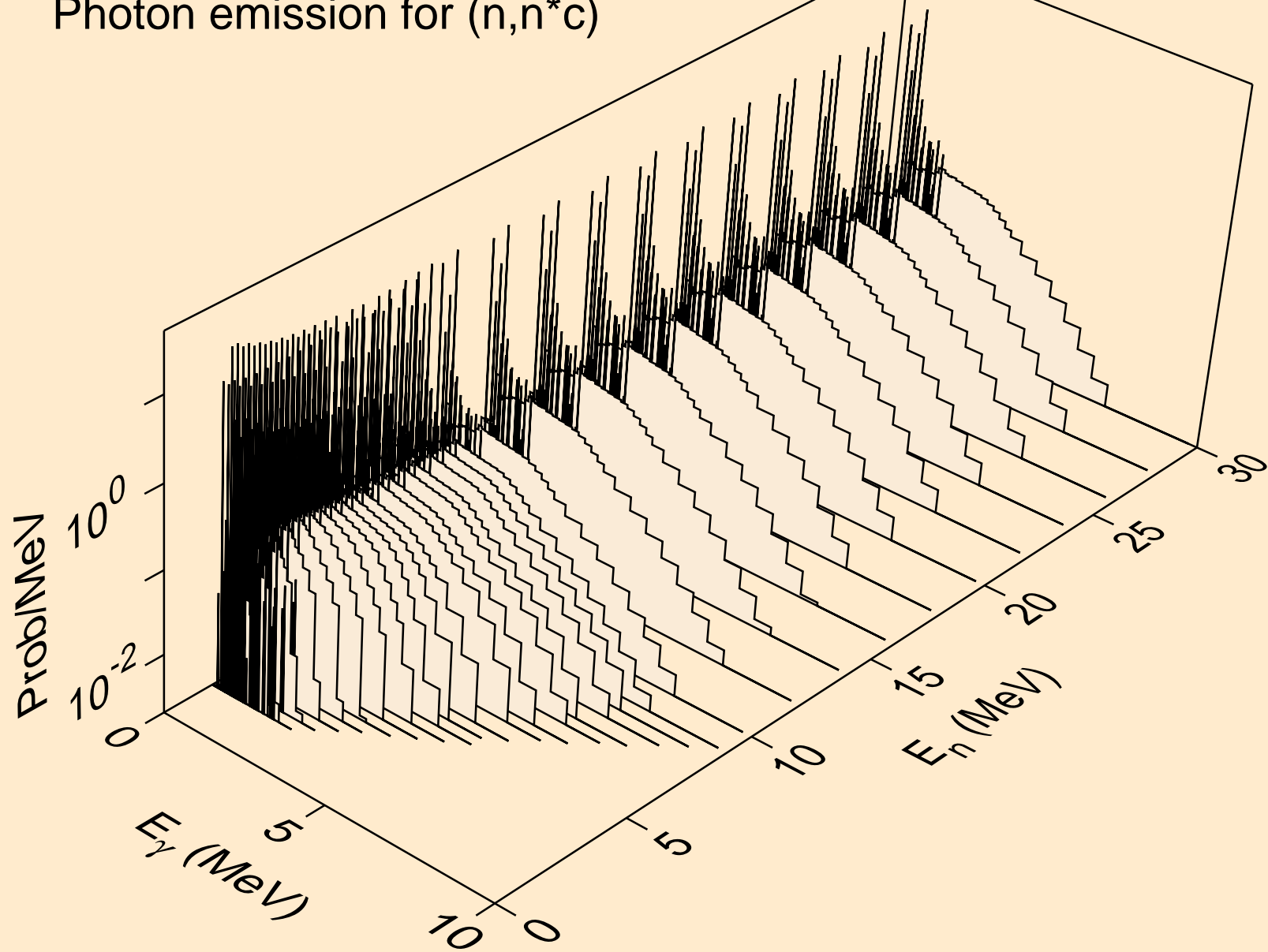

ZN069M NEUTRON ACER TENDL-2023 LIBRARY; T=0.K  
Photon emission for (n,gma)

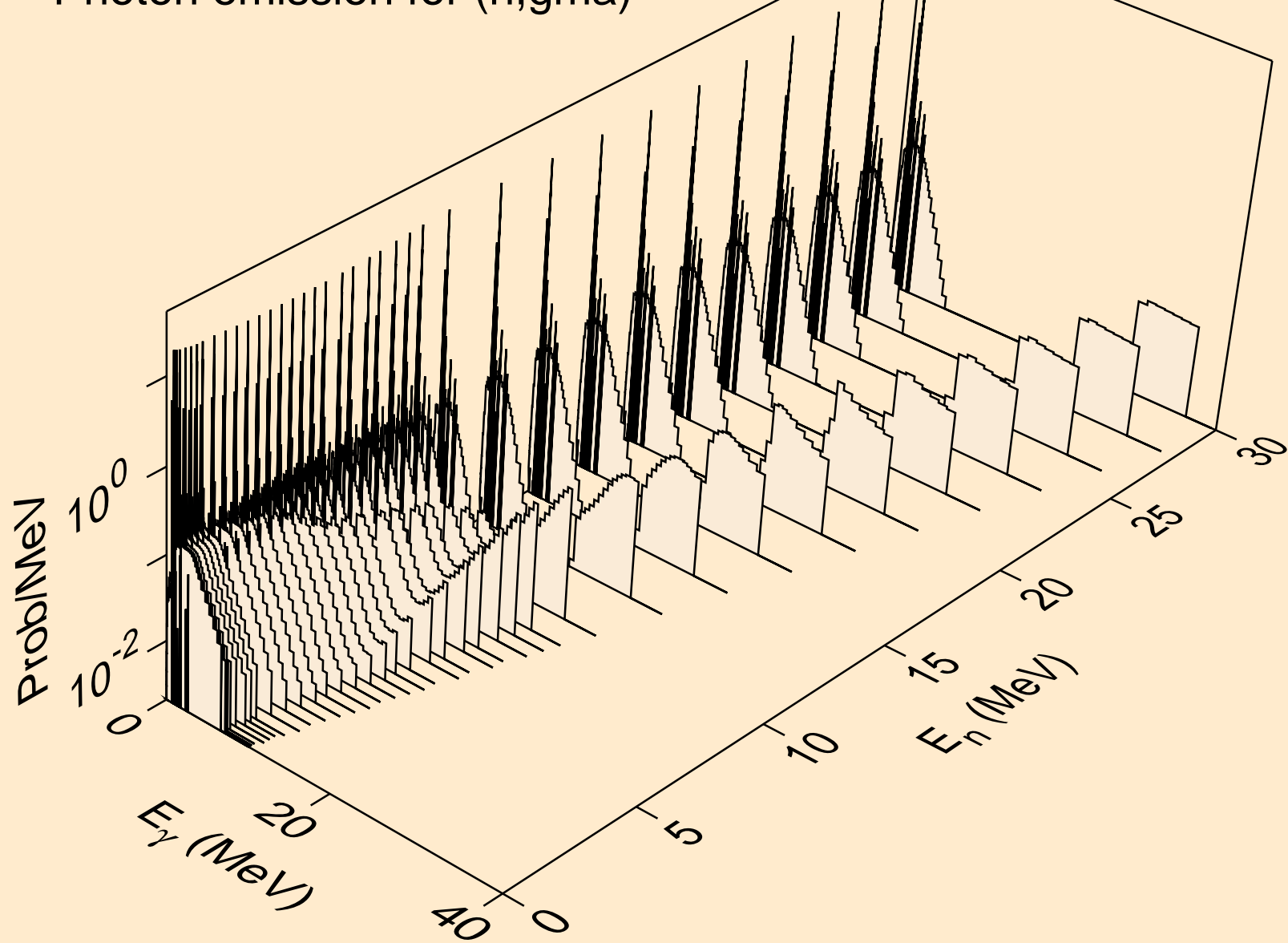

ZN069M NEUTRON ACER TENDL-2023 LIBRARY; T=0.K  
Photon emission for (n,p)

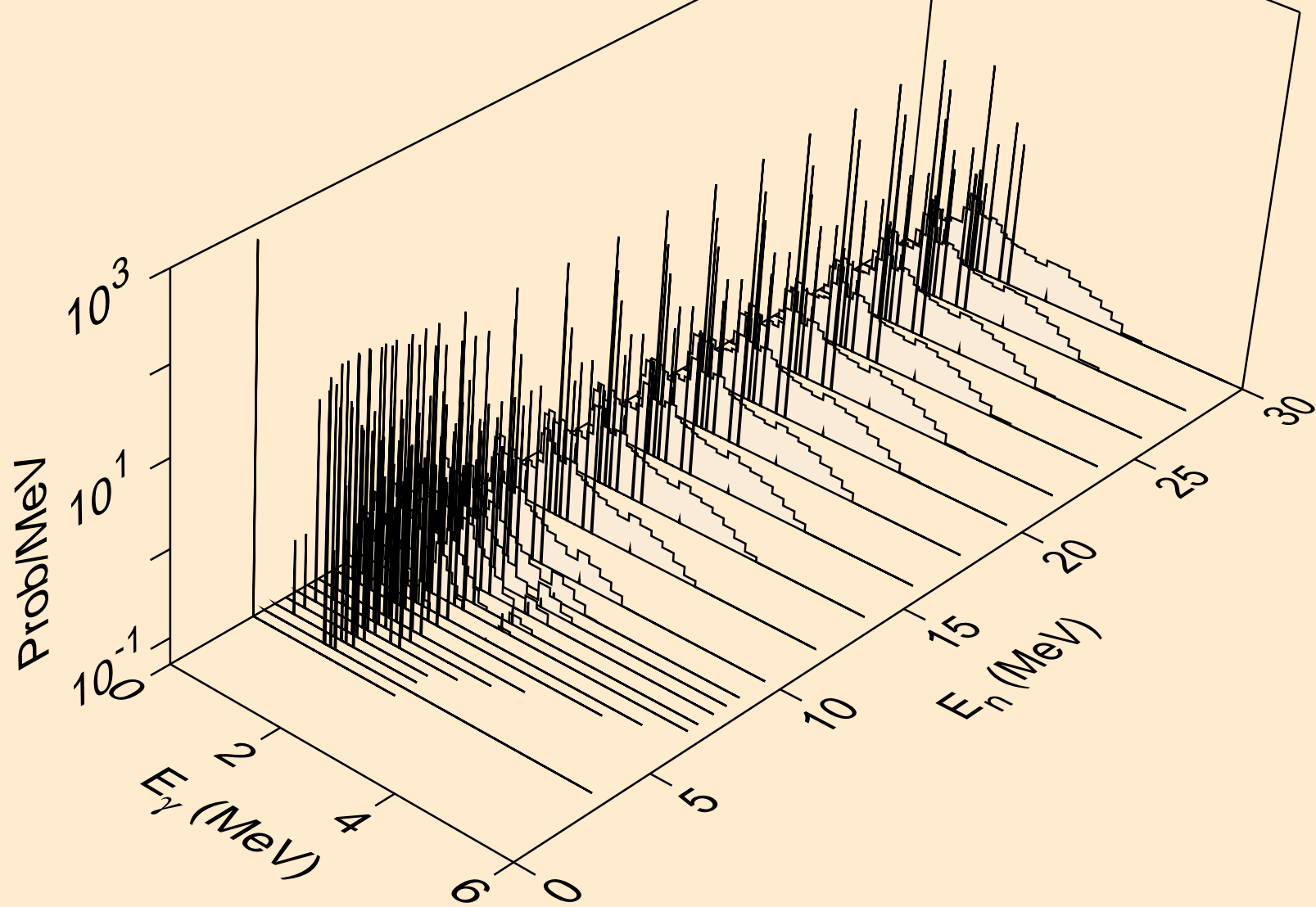

ZN069M NEUTRON ACER TENDL-2023 LIBRARY; T=0.K  
Photon emission for (n,d)

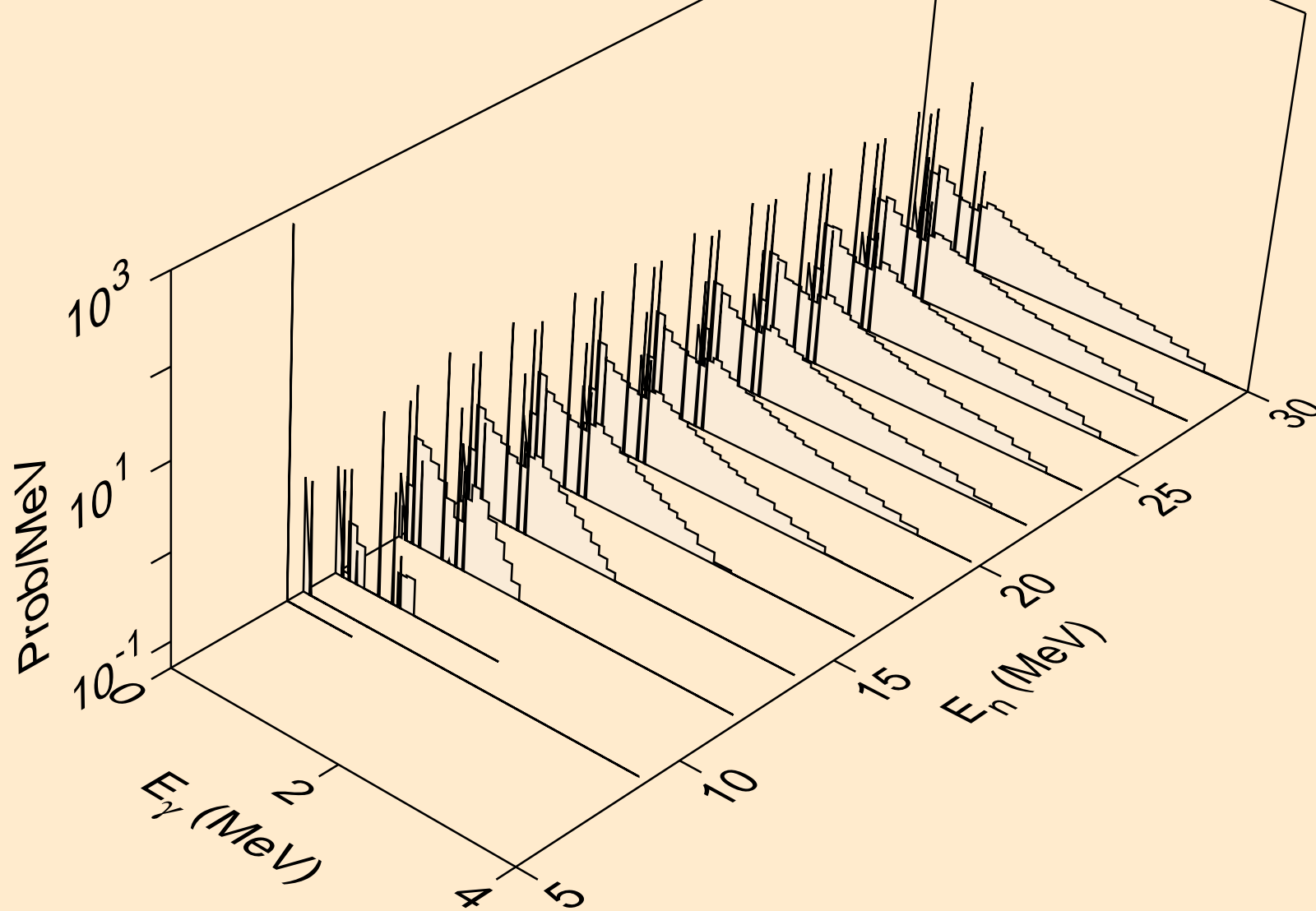

ZN069M NEUTRON ACER TENDL-2023 LIBRARY; T=0.K  
Photon emission for (n,t)

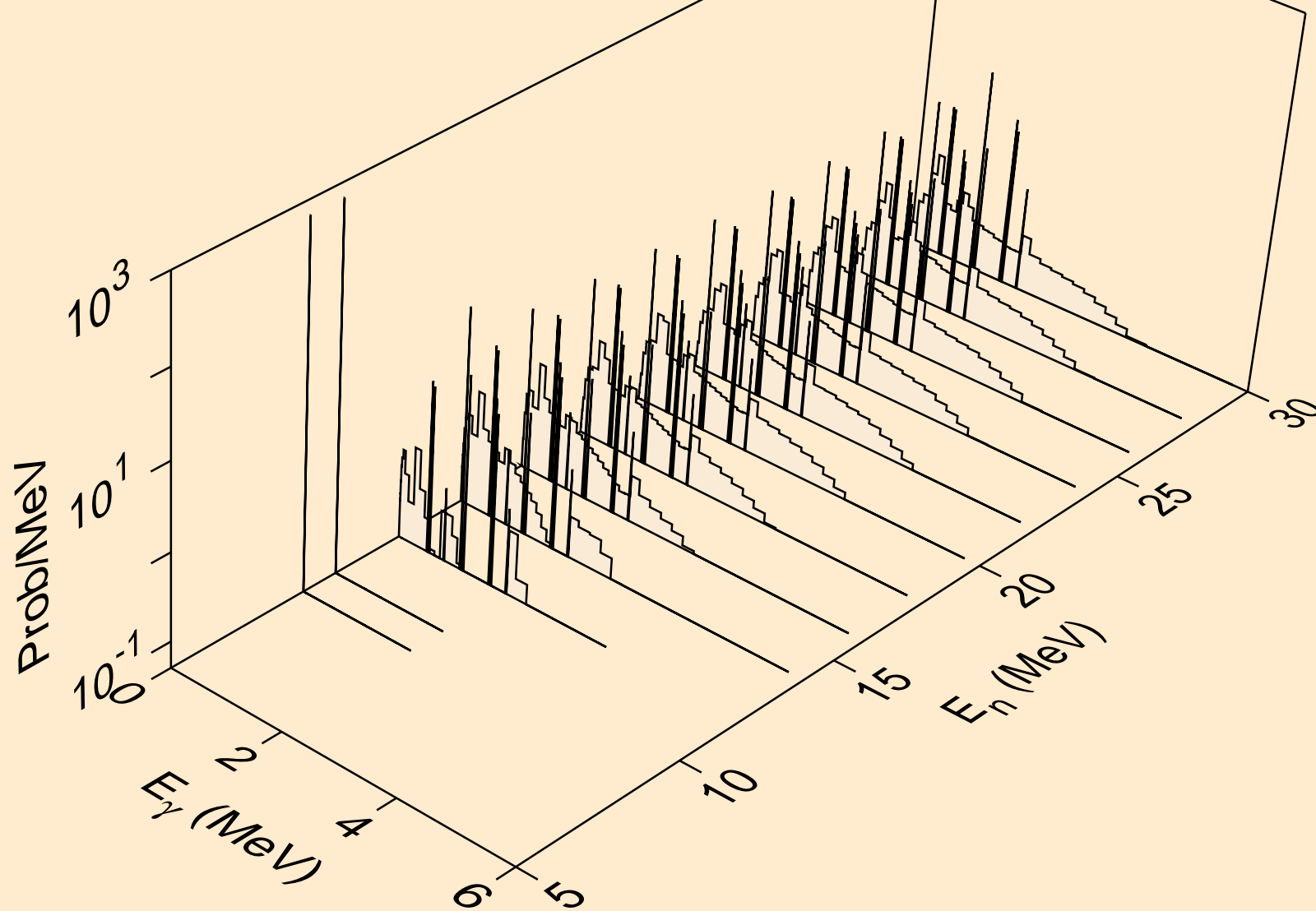

ZN069M NEUTRON ACER TENDL-2023 LIBRARY; T=0.K  
Photon emission for (n,he3)

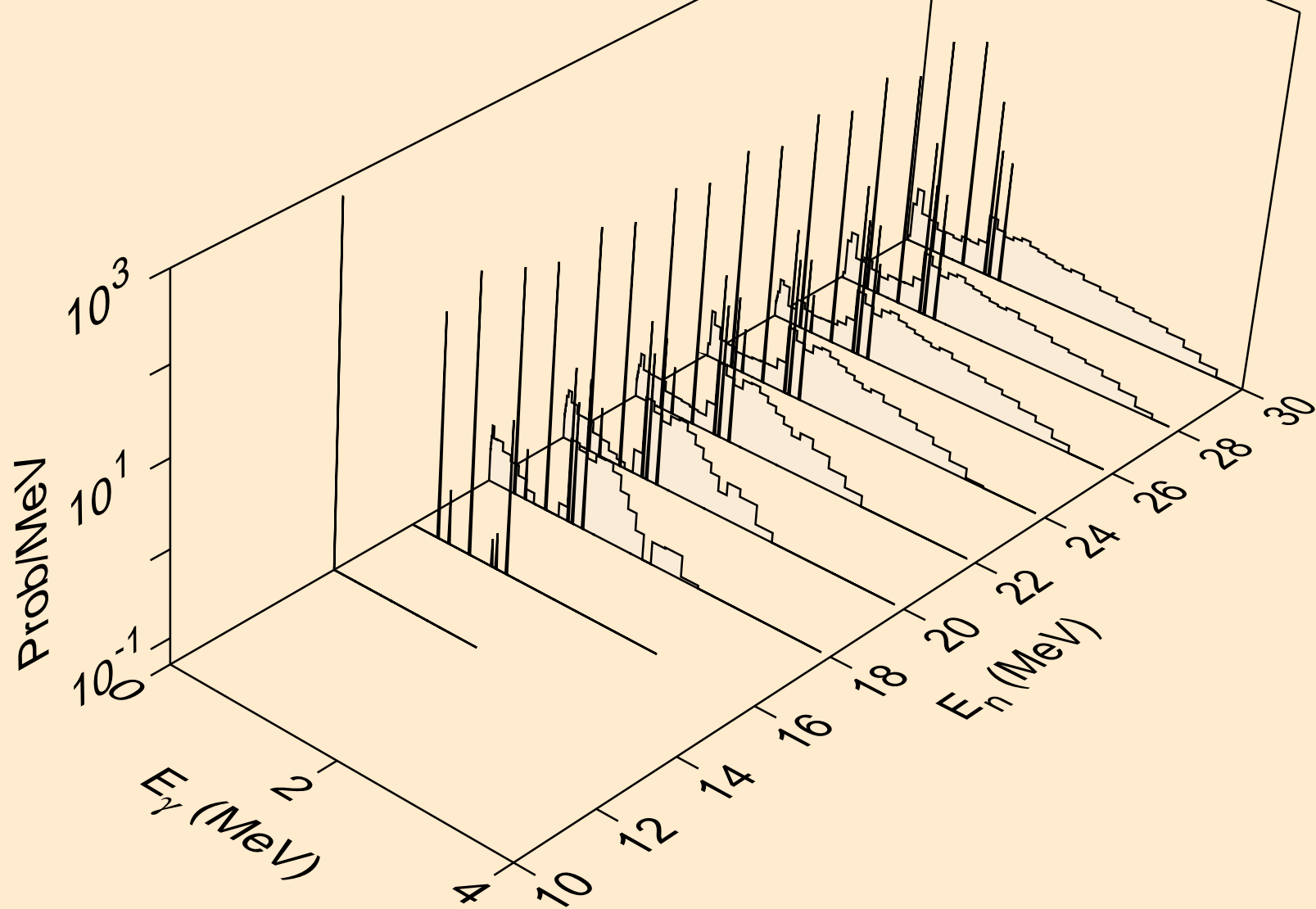



ZN069M NEUTRON ACER TENDL-2023 LIBRARY; T=0.K  
Photon emission for (n,a)

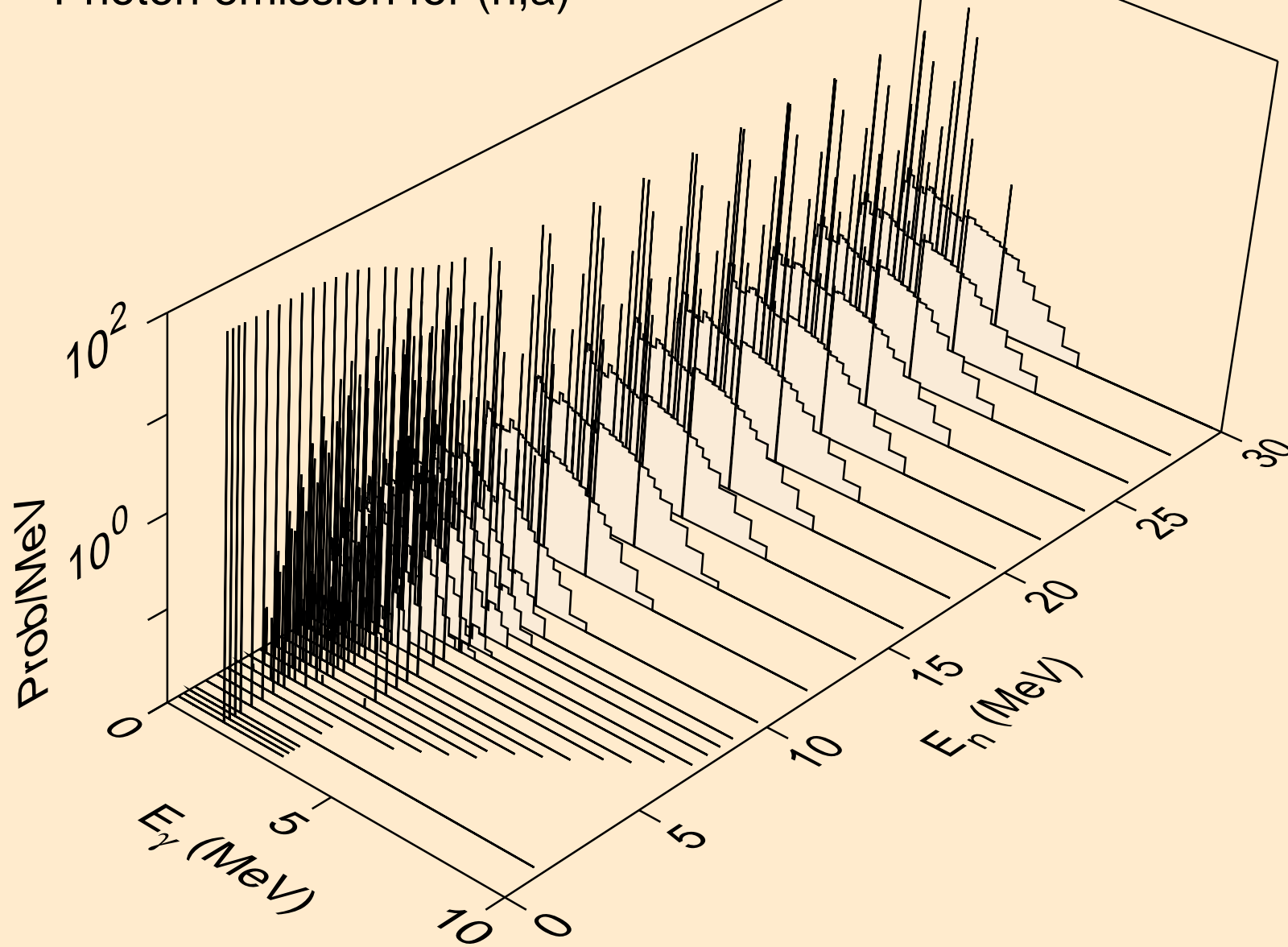

ZN069M NEUTRON ACER TENDL-2023 LIBRARY; T=0.K  
Photon emission for (n,2a)

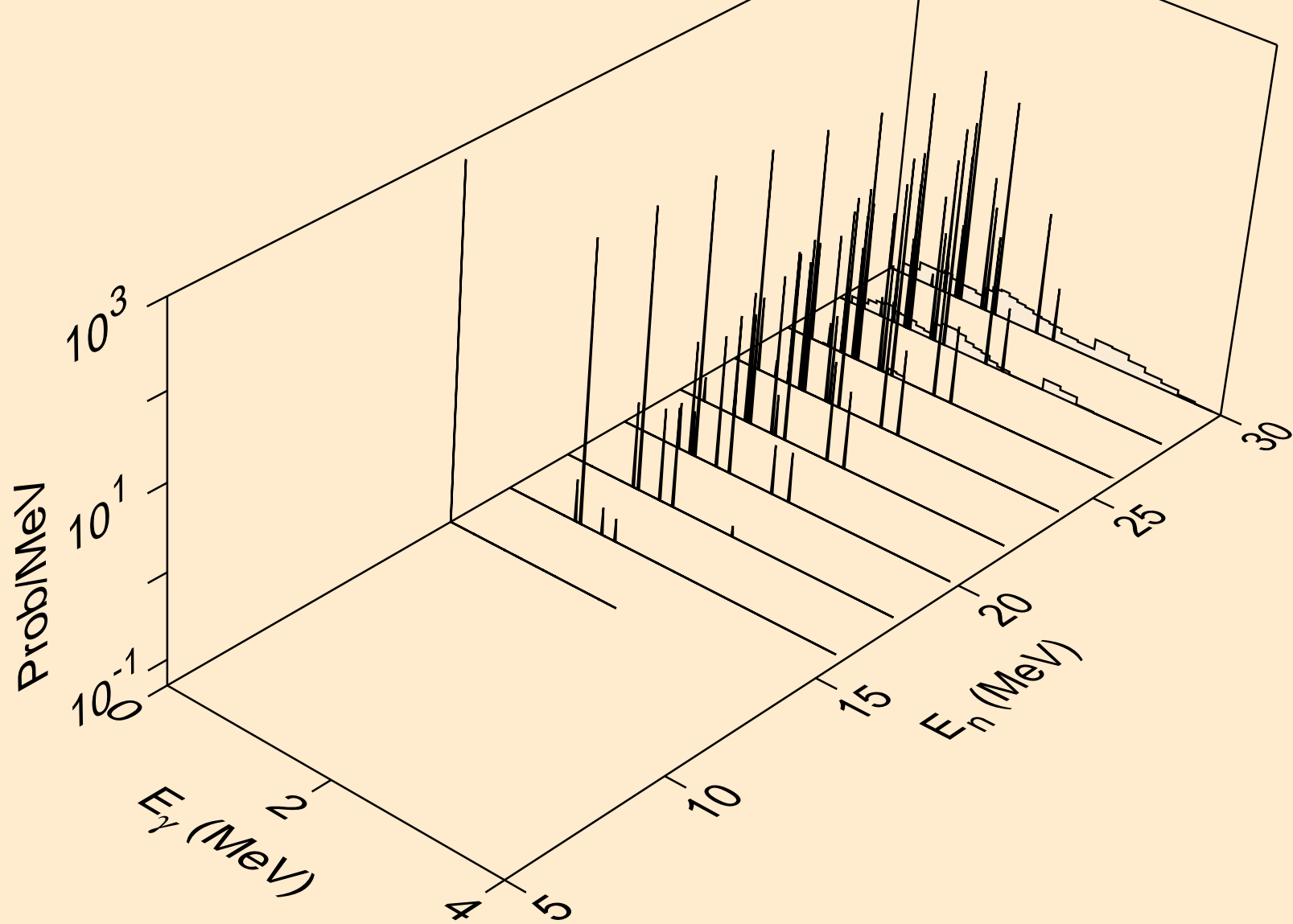

ZN069M NEUTRON ACER TENDL-2023 LIBRARY; T=0.K  
Photon emission for (n,2p)

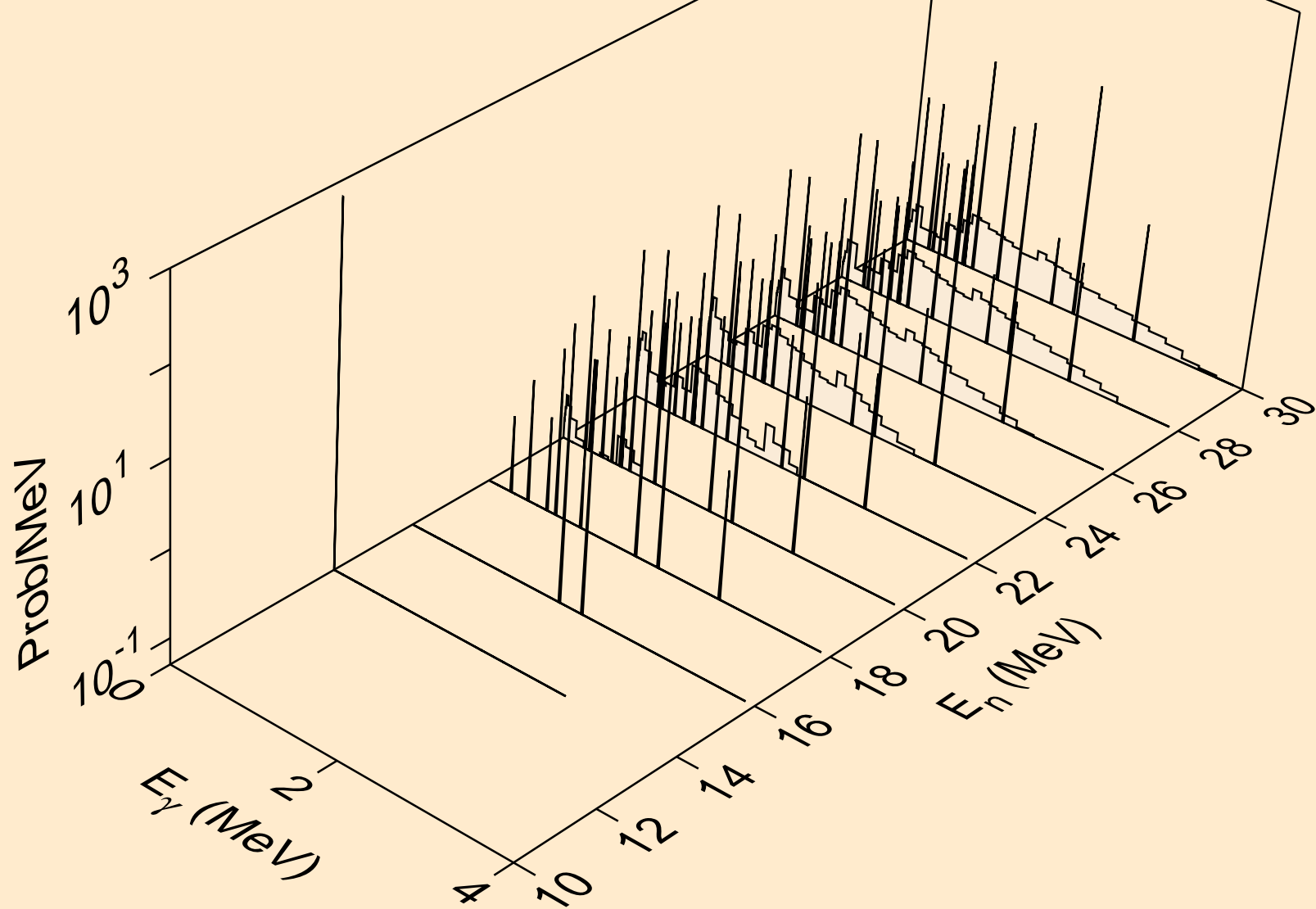

ZN069M NEUTRON ACER TENDL-2023 LIBRARY; T=0.K  
Photon emission for (n,p $\alpha$ )

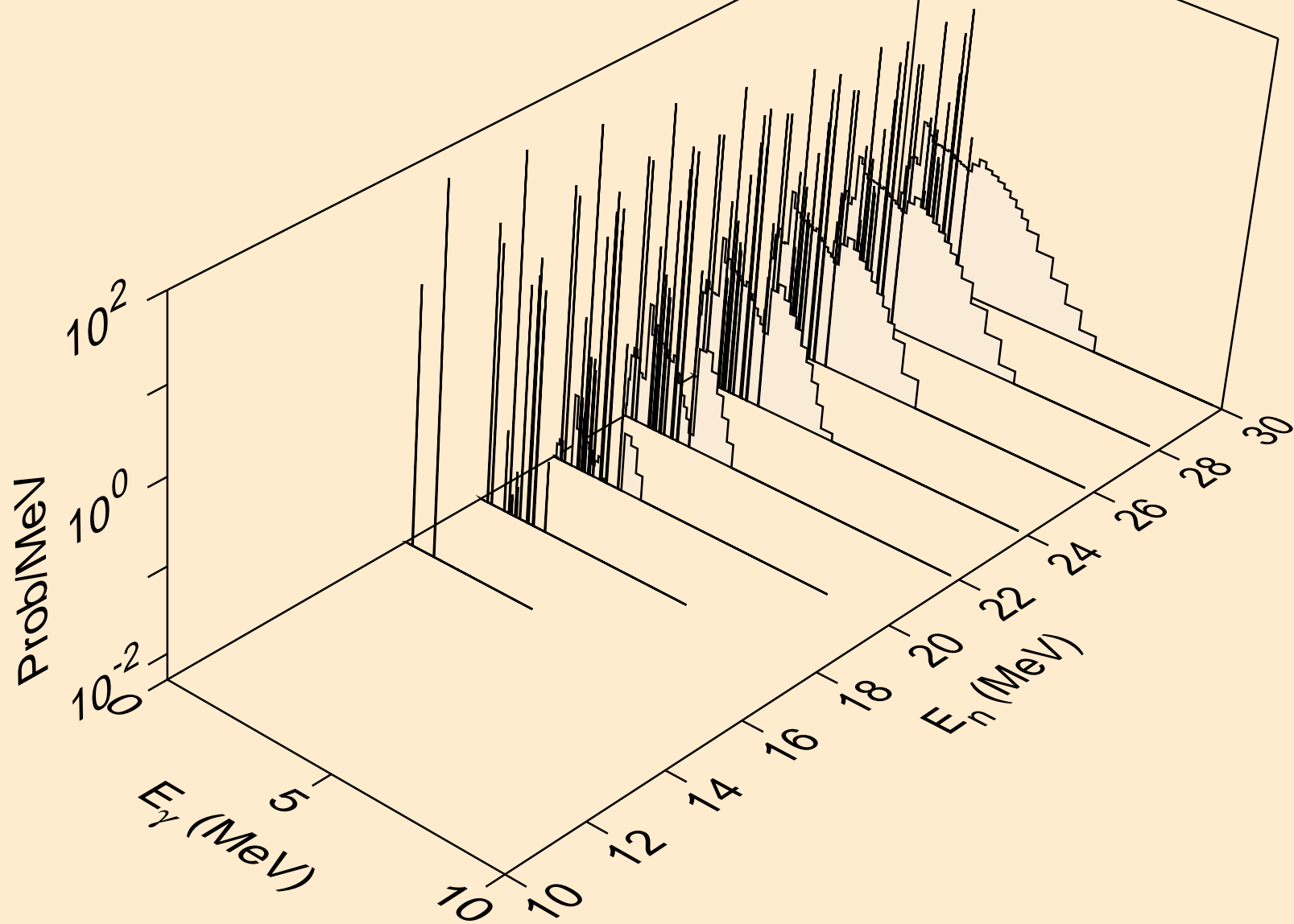

ZN069M NEUTRON ACER TENDL-2023 LIBRARY; T=0.K  
Photon emission for (n,pd)

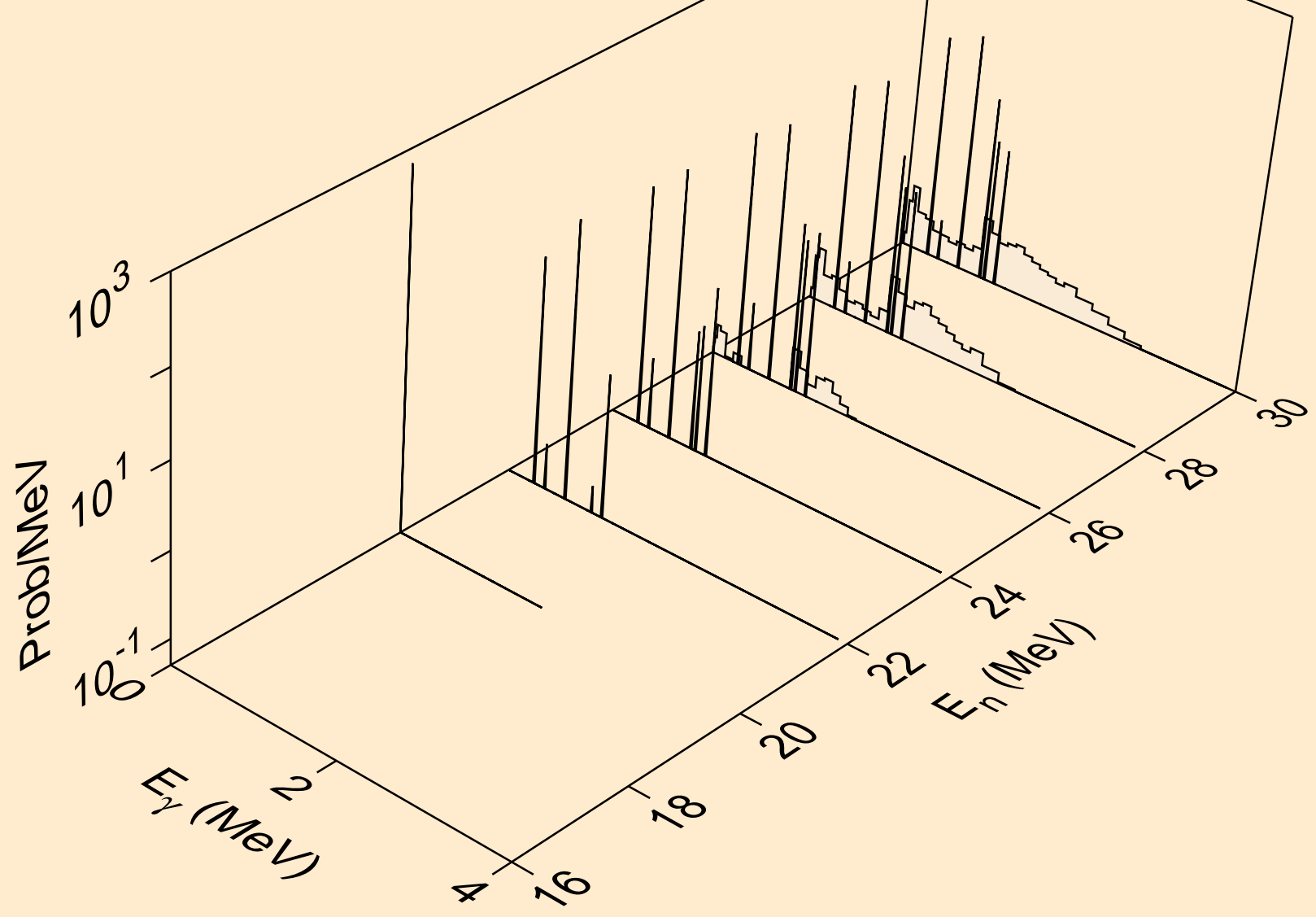

ZN069M NEUTRON ACER TENDL-2023 LIBRARY; T=0.K  
Photon emission for (n,pt)

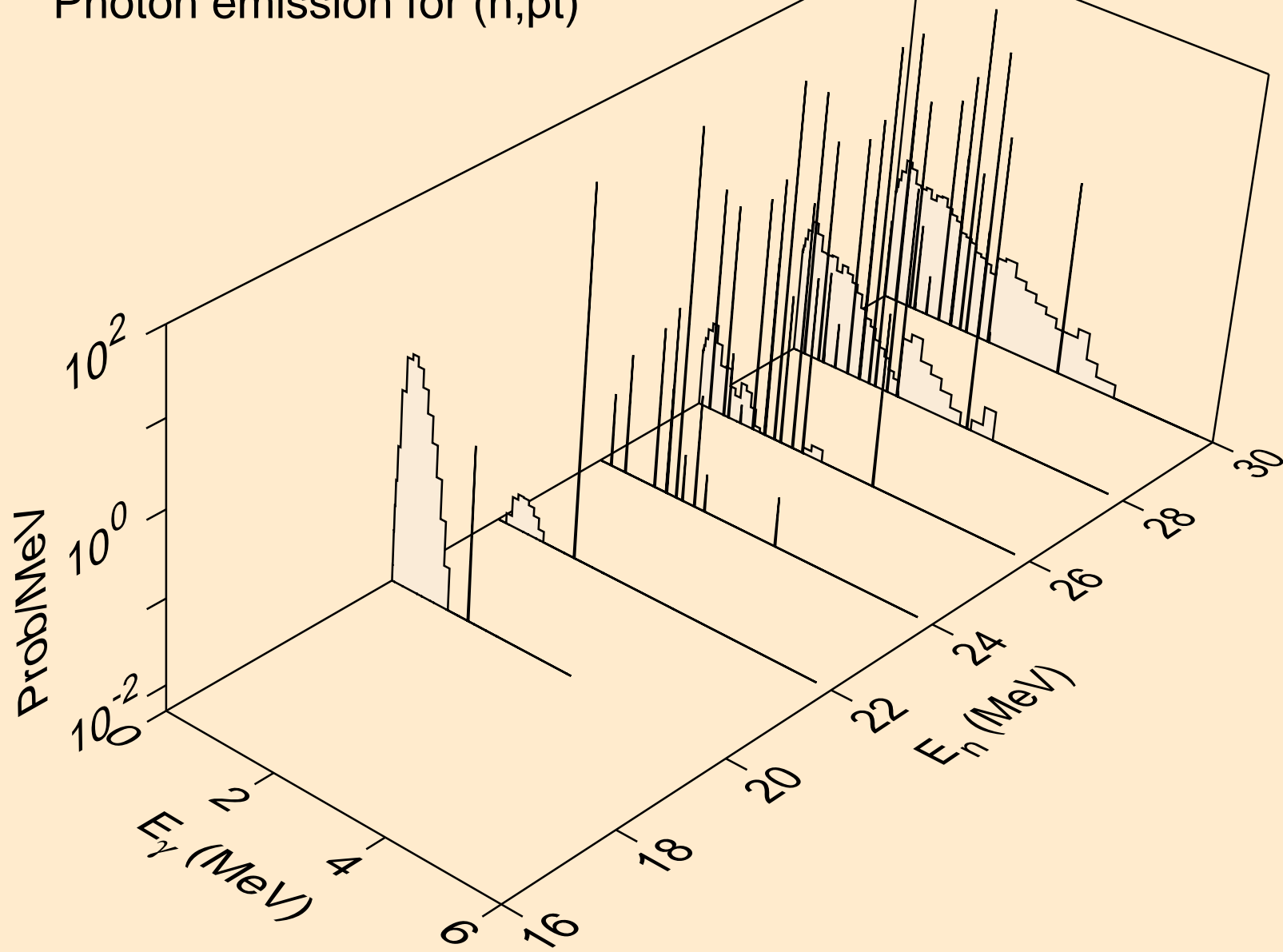

ZN069M NEUTRON ACER TENDL-2023 LIBRARY; T=0.K  
Photon emission for (n,da)

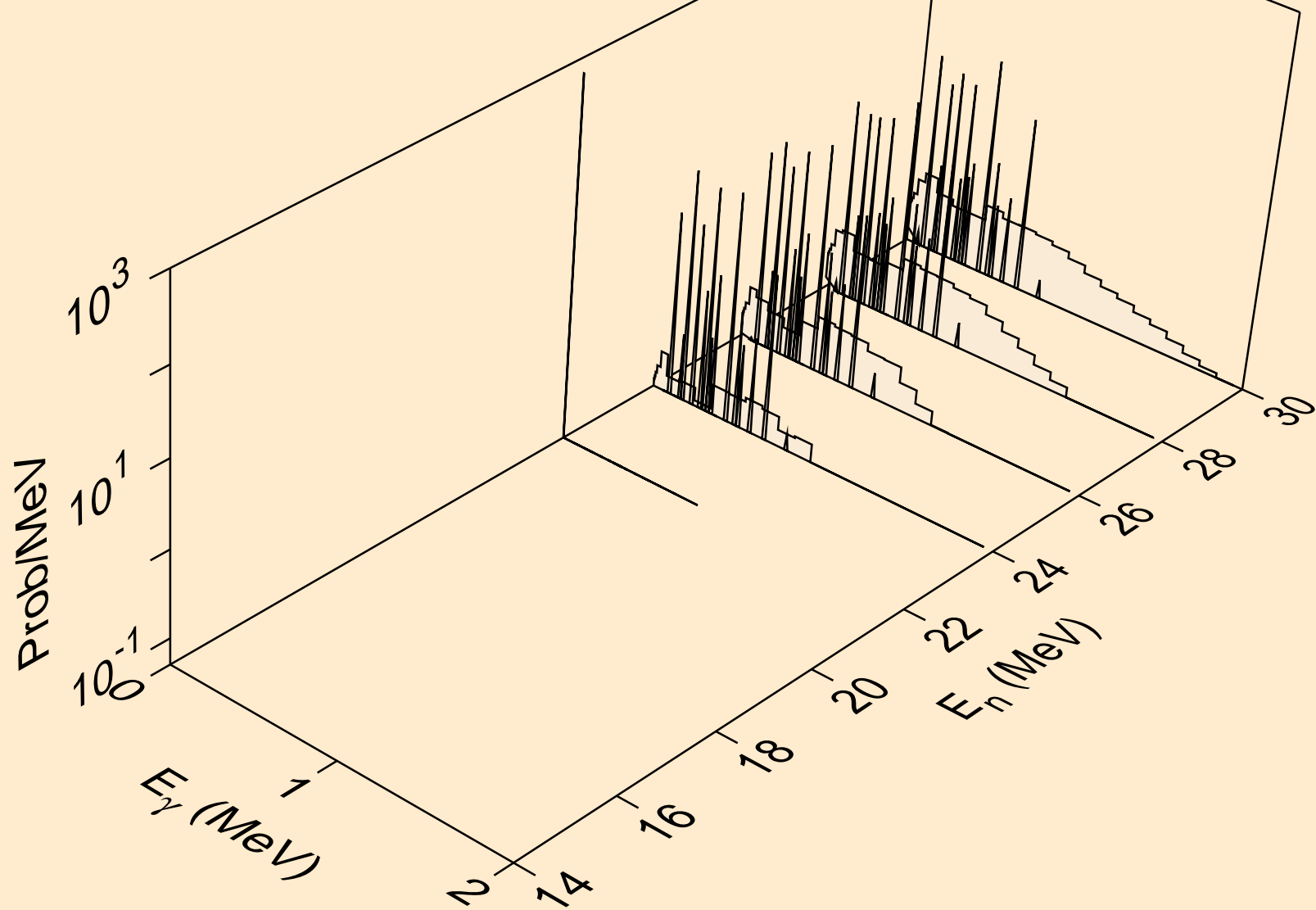

ZN069M NEUTRON ACER TENDL-2023 LIBRARY; T=0.K  
thermal capture photon spectrum

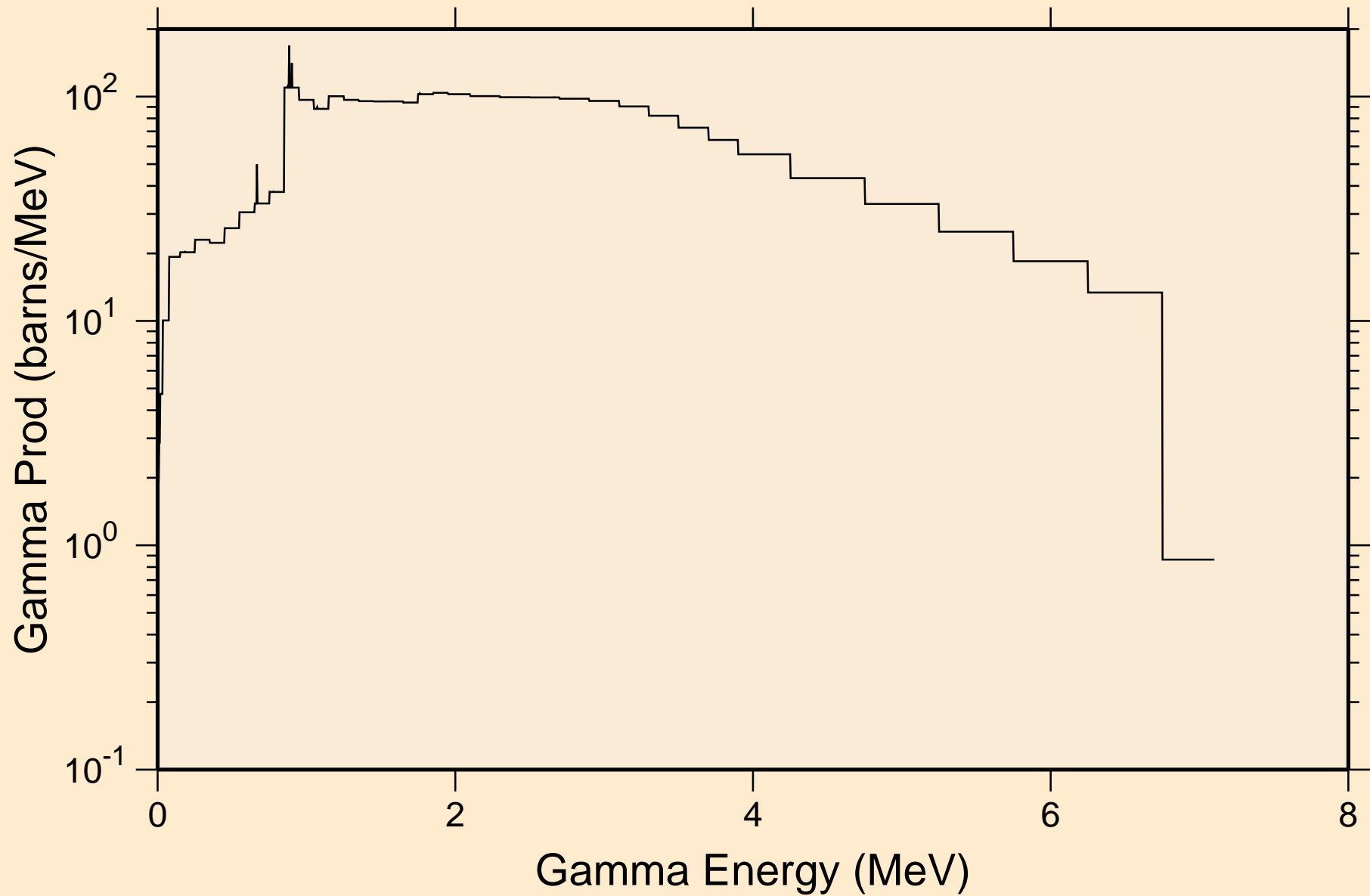



ZN069M NEUTRON ACER TENDL-2023 LIBRARY; T=0.K  
14 MeV photon spectrum

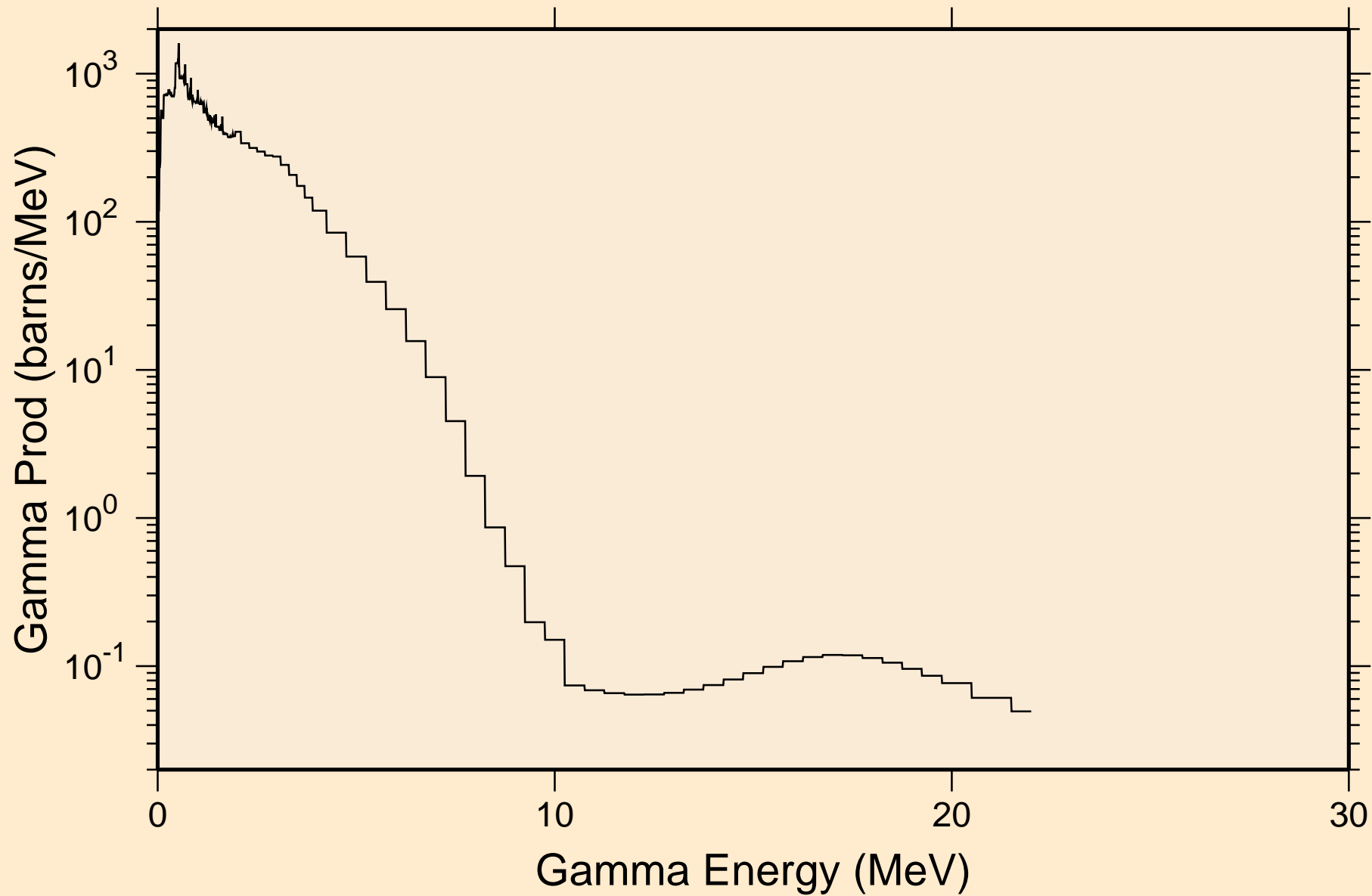

# ZN069M NEUTRON ACER TENDL-2023 LIBRARY; T=0.K

## Particle heating contributions

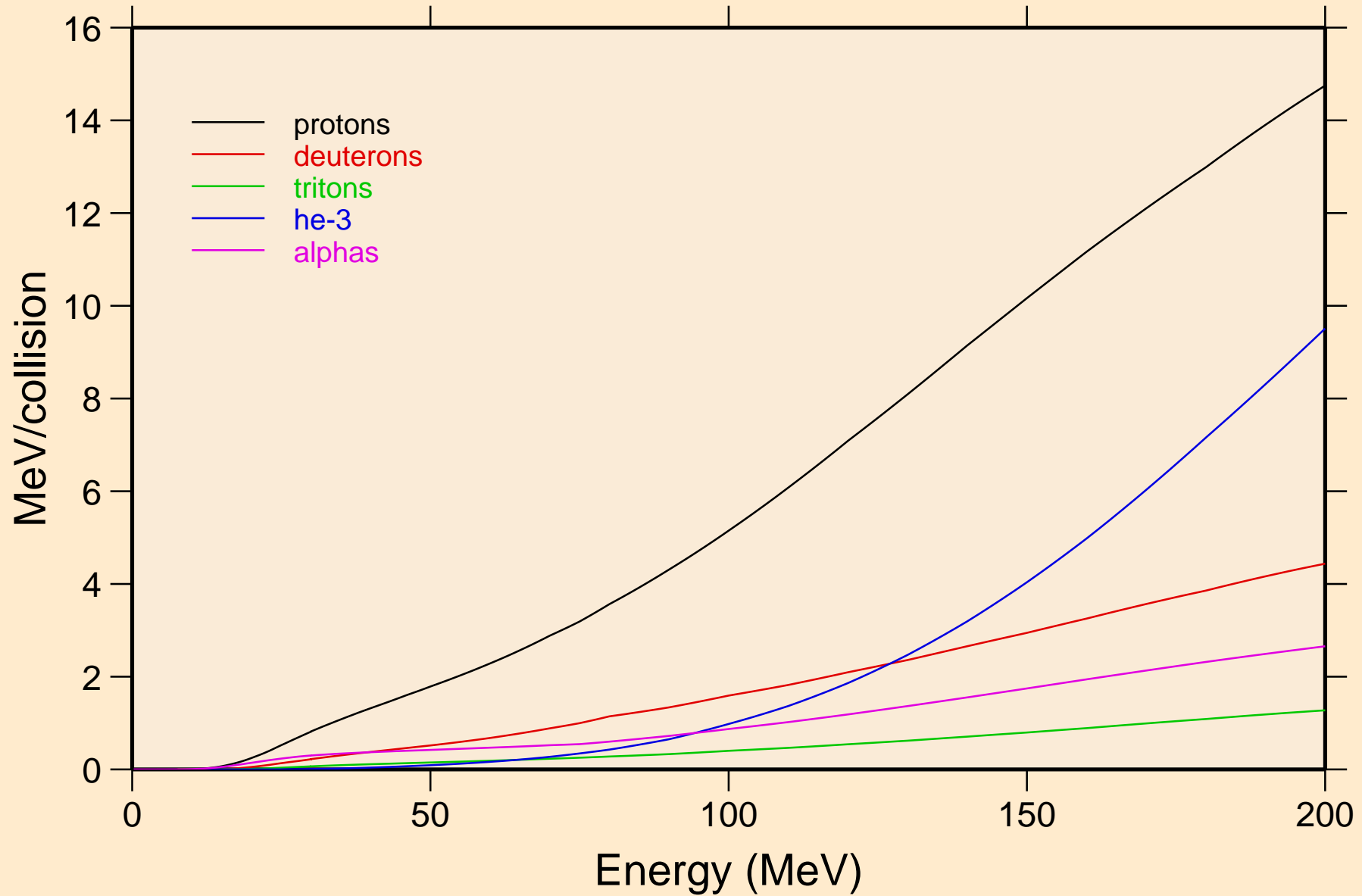

ZN069M NEUTRON ACER TENDL-2023 LIBRARY; T=0.K  
Recoil Heating

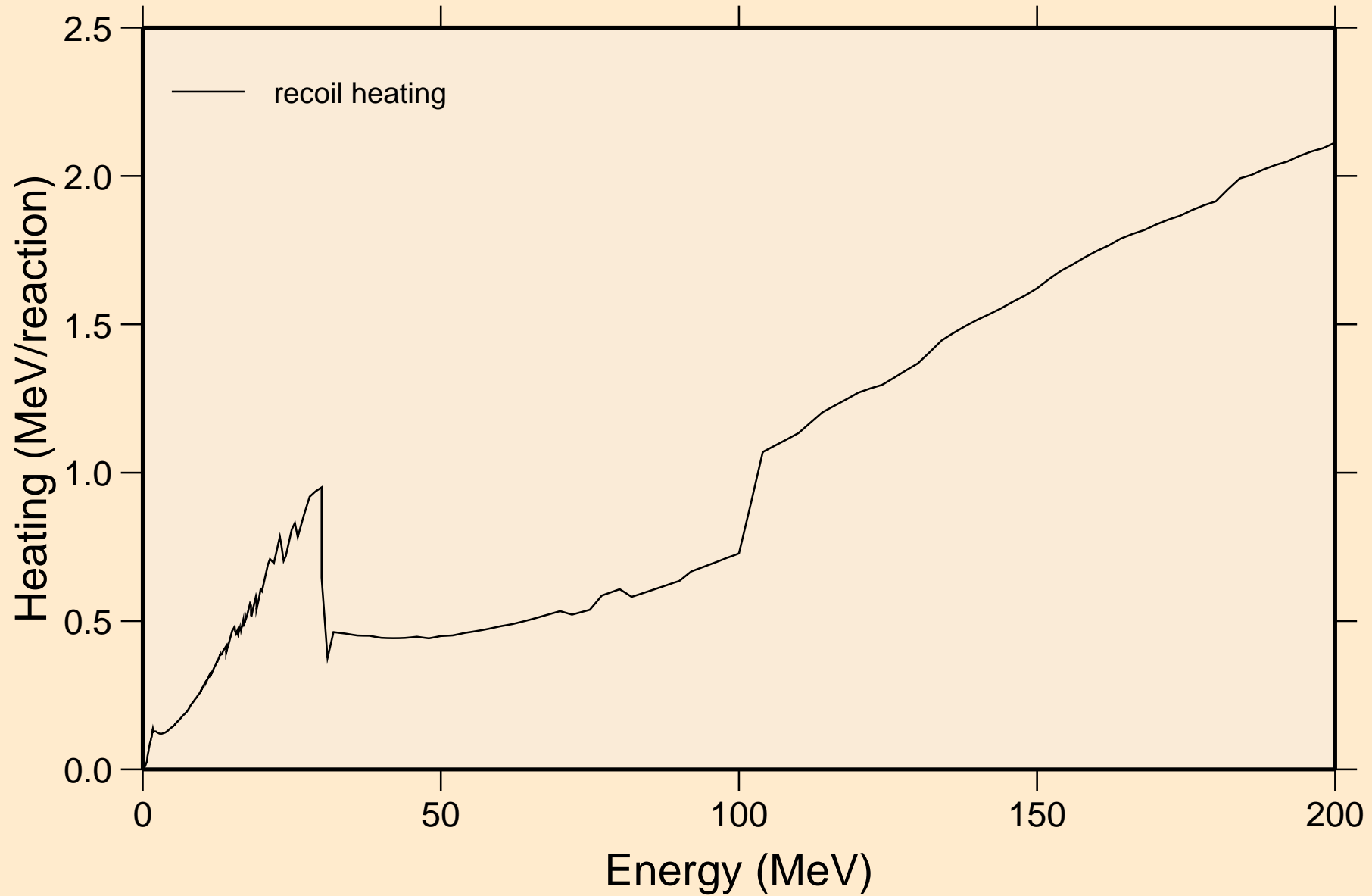

# ZN069M NEUTRON ACER TENDL-2023 LIBRARY; T=0.K

## Particle production cross sections

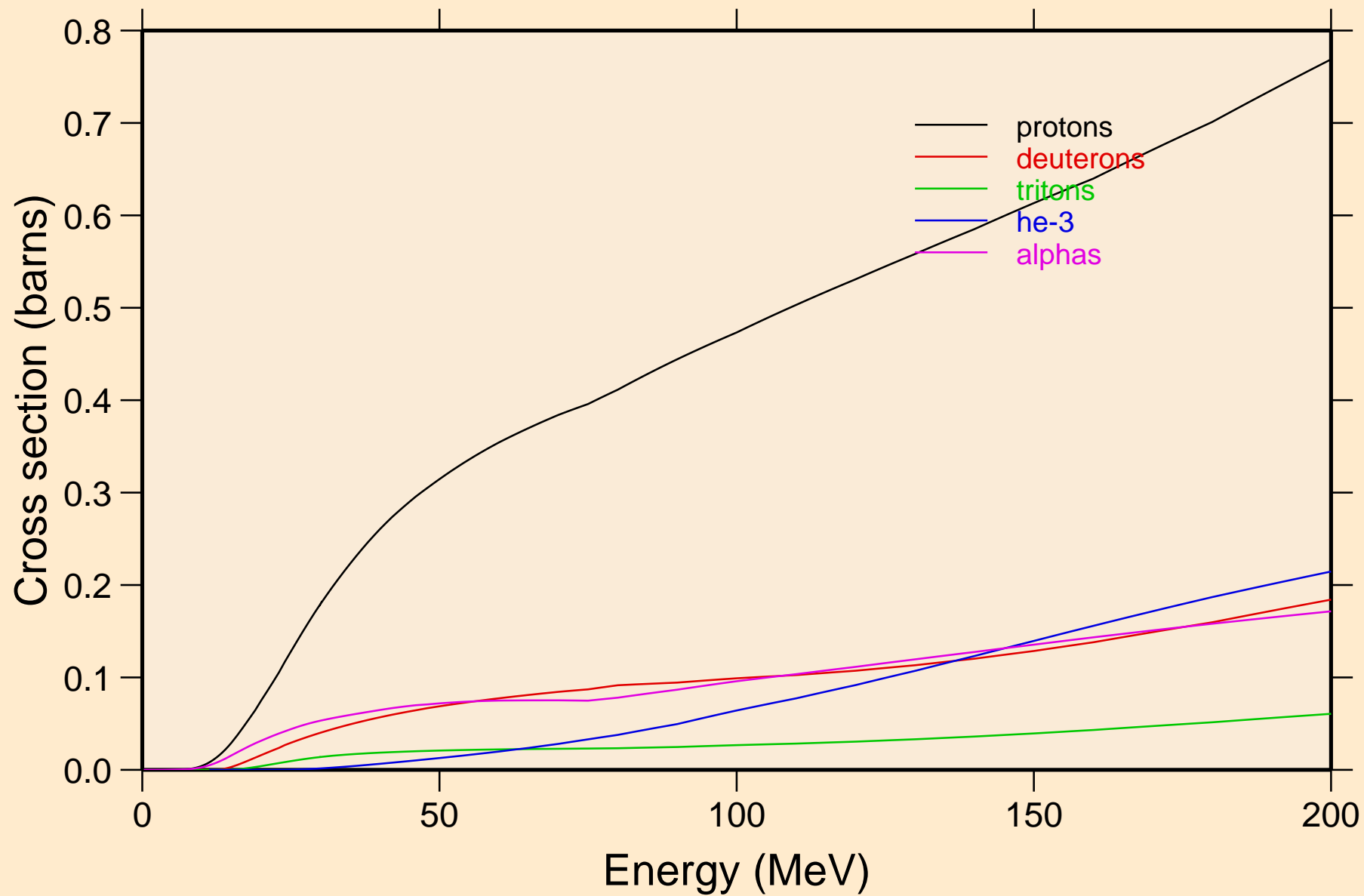

ZN069M NEUTRON ACER TENDL-2023 LIBRARY; T=0.K  
protons from (n,x)

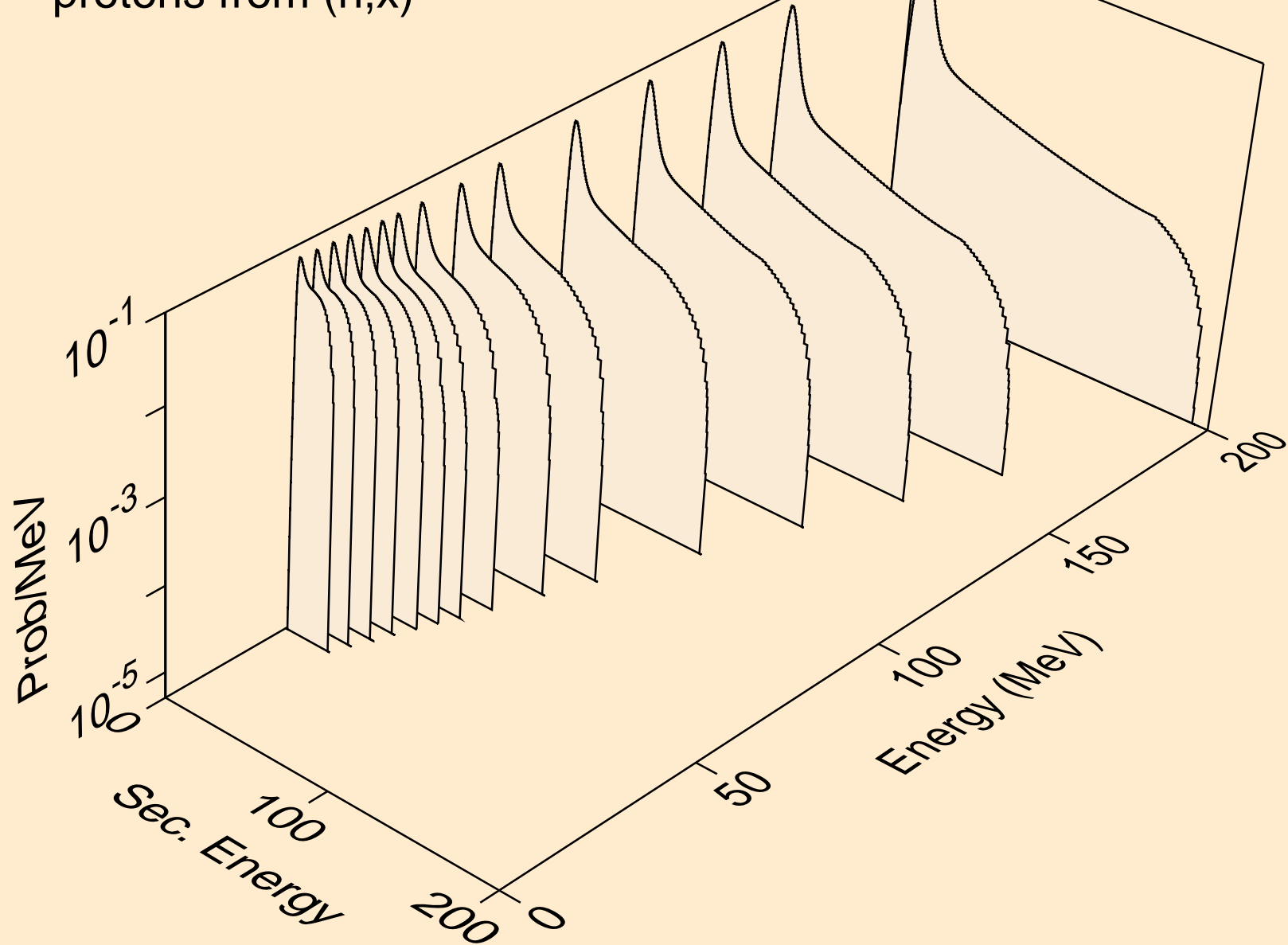

ZN069M NEUTRON ACER TENDL-2023 LIBRARY; T=0.K  
protons from (n,n\*)p

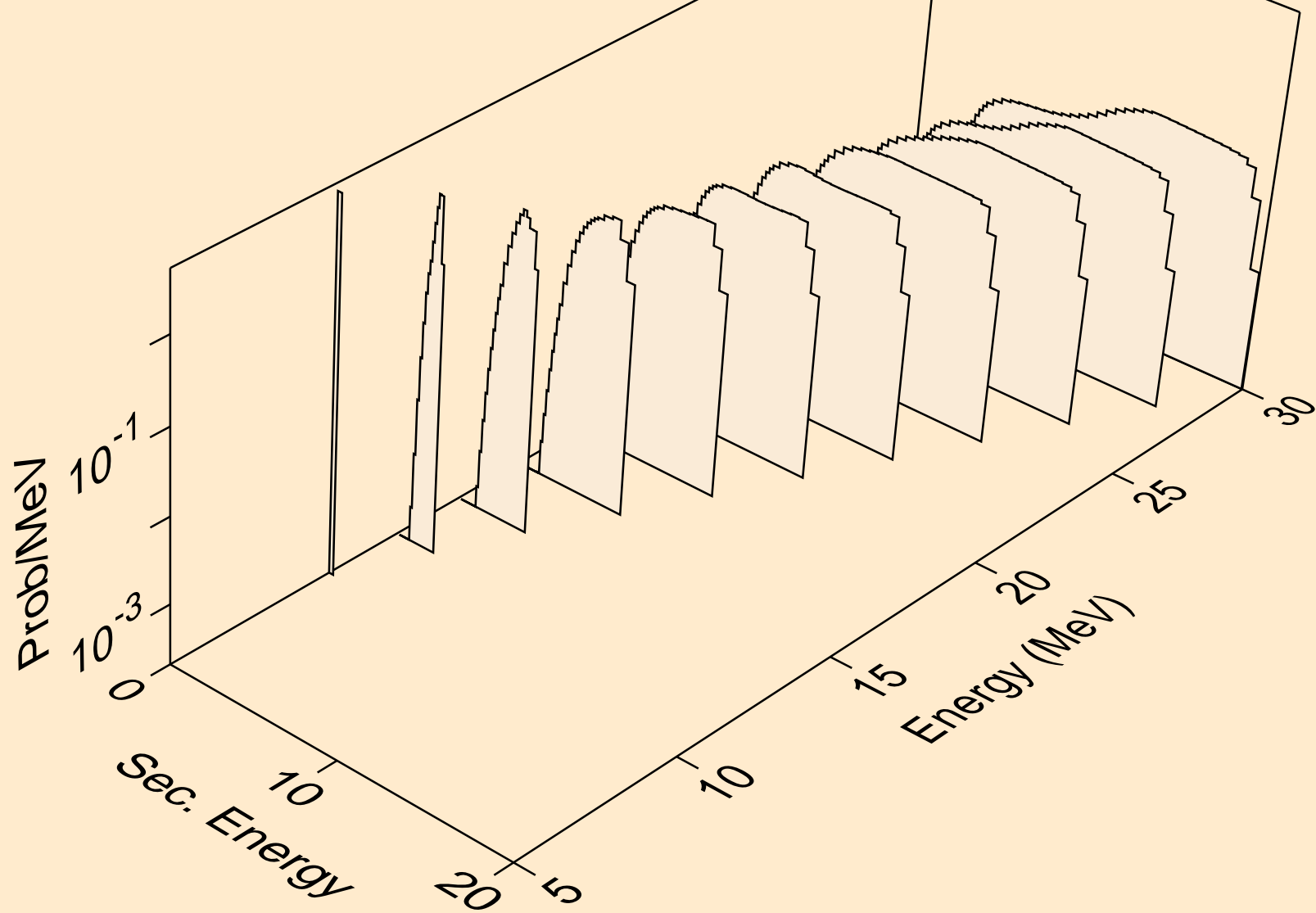

ZN069M NEUTRON ACER TENDL-2023 LIBRARY; T=0.K  
protons from (n,2np)

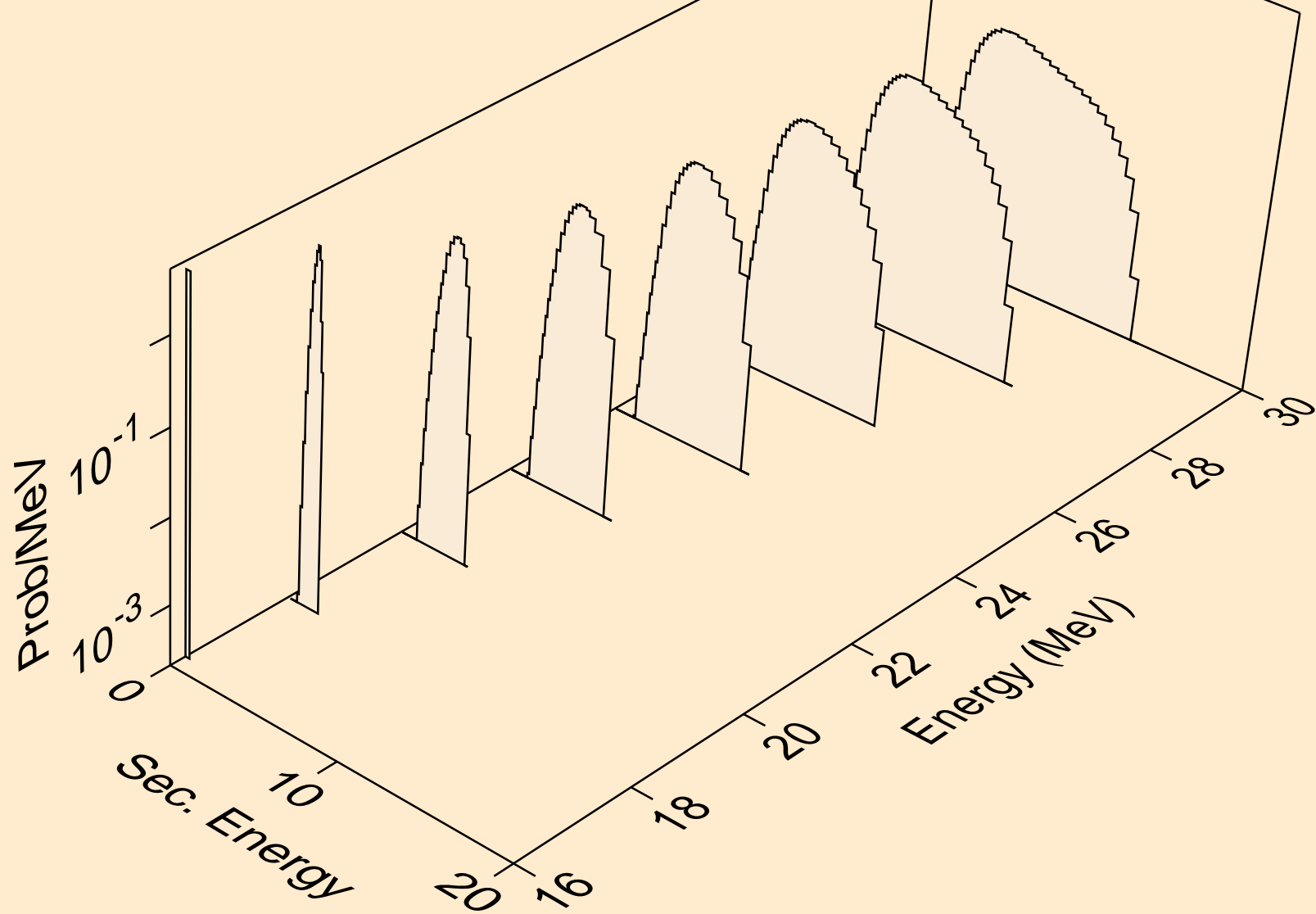

ZN069M NEUTRON ACER TENDL-2023 LIBRARY; T=0.K  
protons from (n,3np)

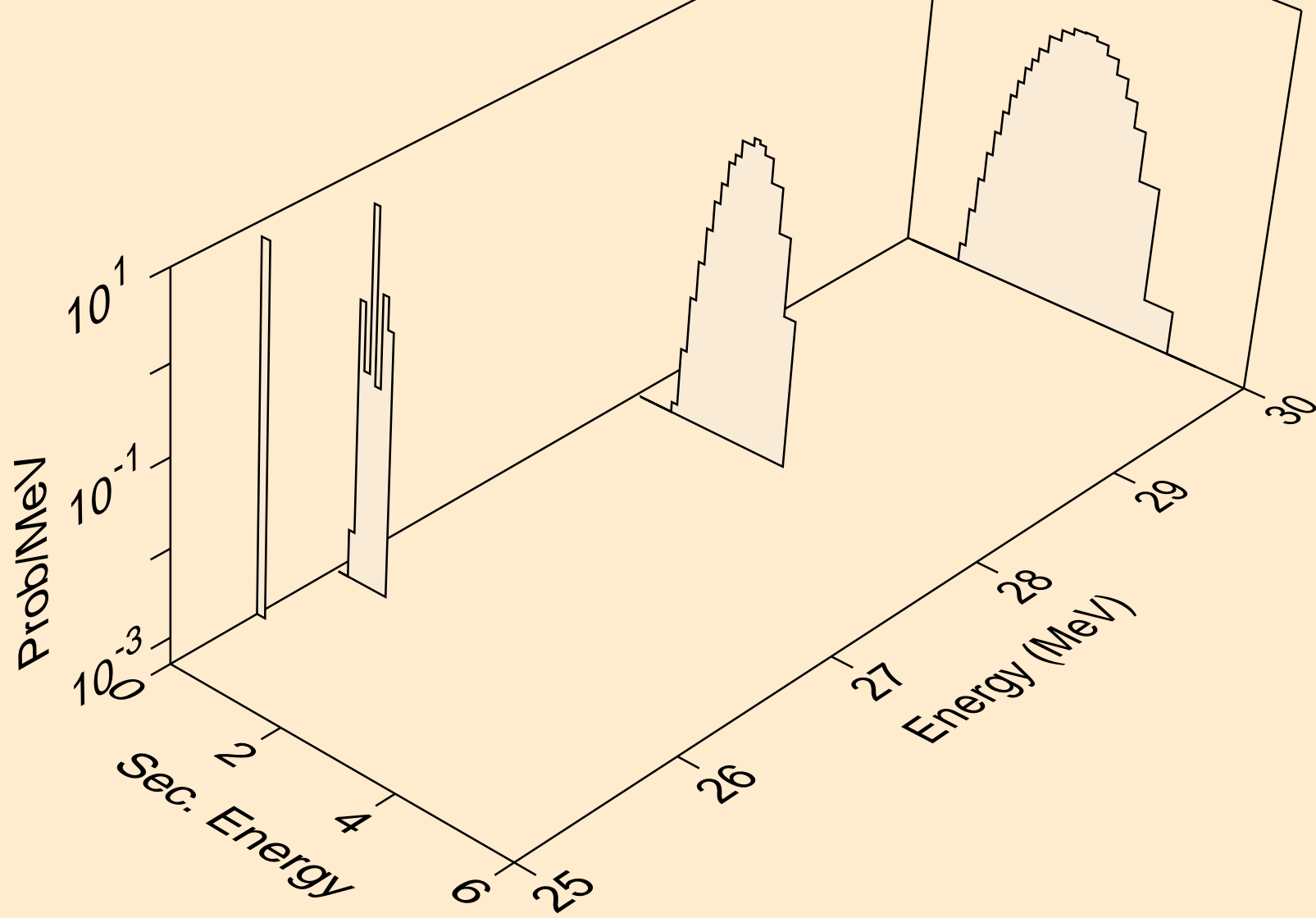



ZN069M NEUTRON ACER TENDL-2023 LIBRARY; T=0.K  
protons from (n,n2p)

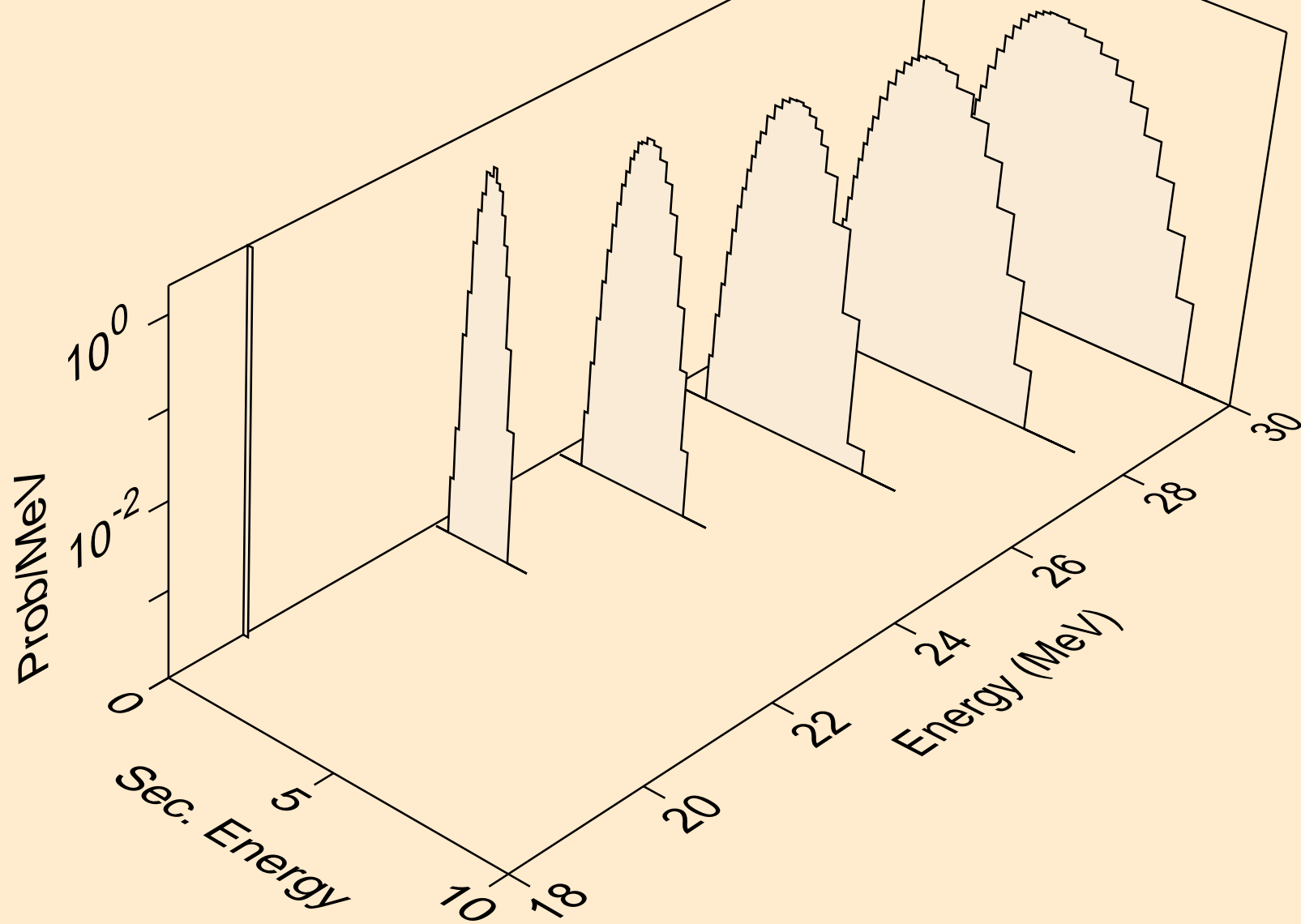

ZN069M NEUTRON ACER TENDL-2023 LIBRARY; T=0.K  
protons from (n,npa)

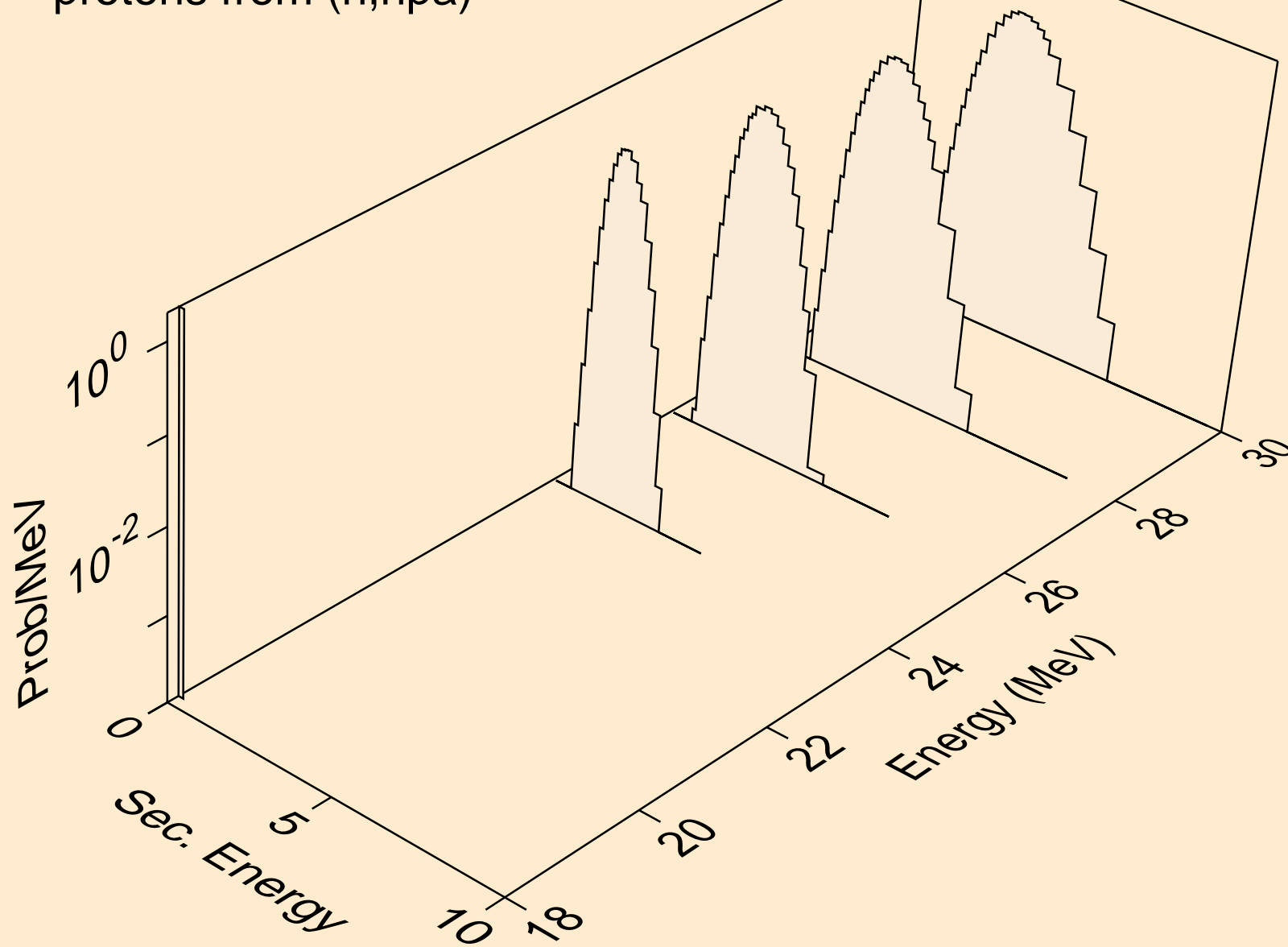

ZN069M NEUTRON ACER TENDL-2023 LIBRARY; T=0.K  
protons from (n,p)

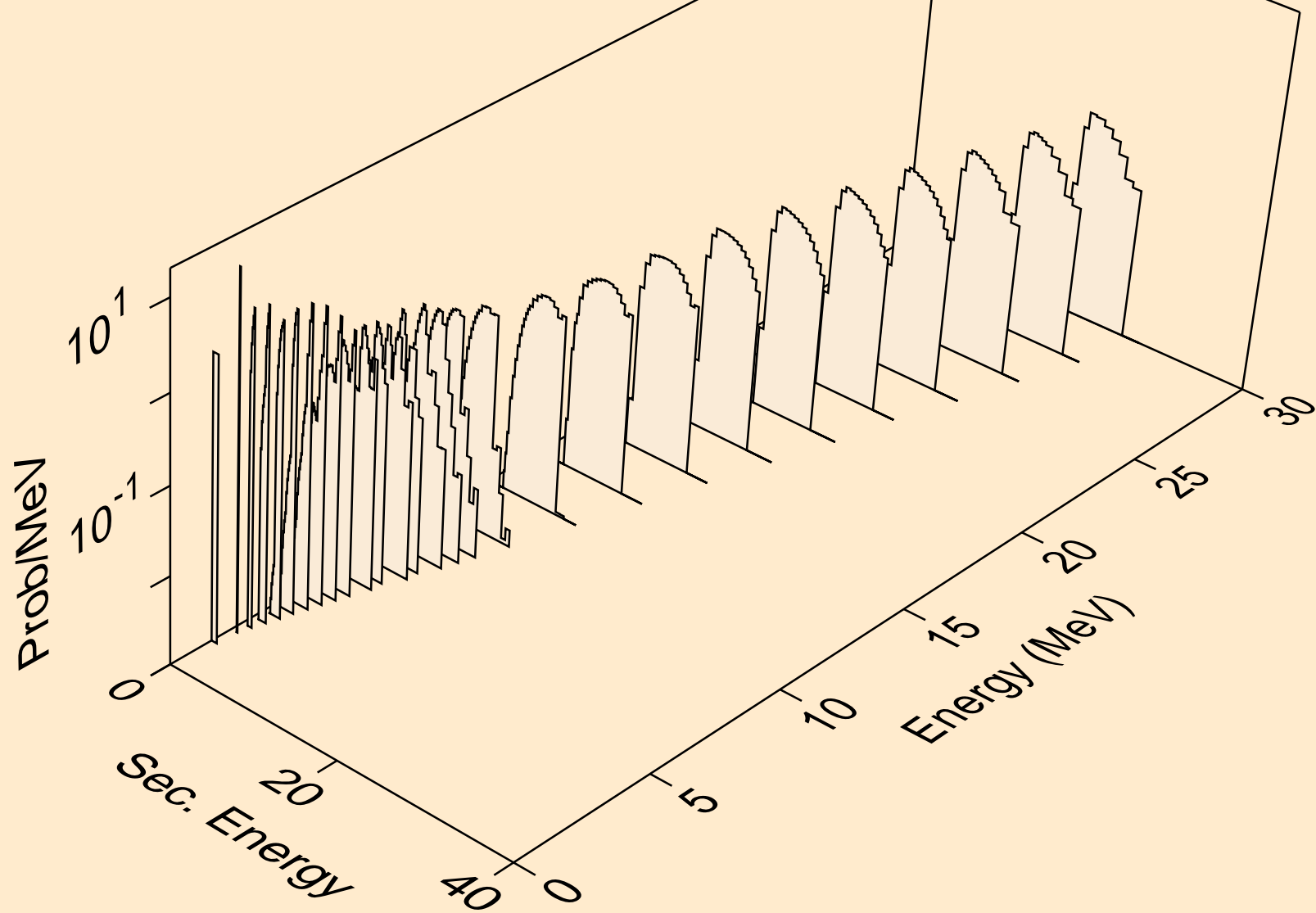

ZN069M NEUTRON ACER TENDL-2023 LIBRARY; T=0.K  
protons from (n,2p)

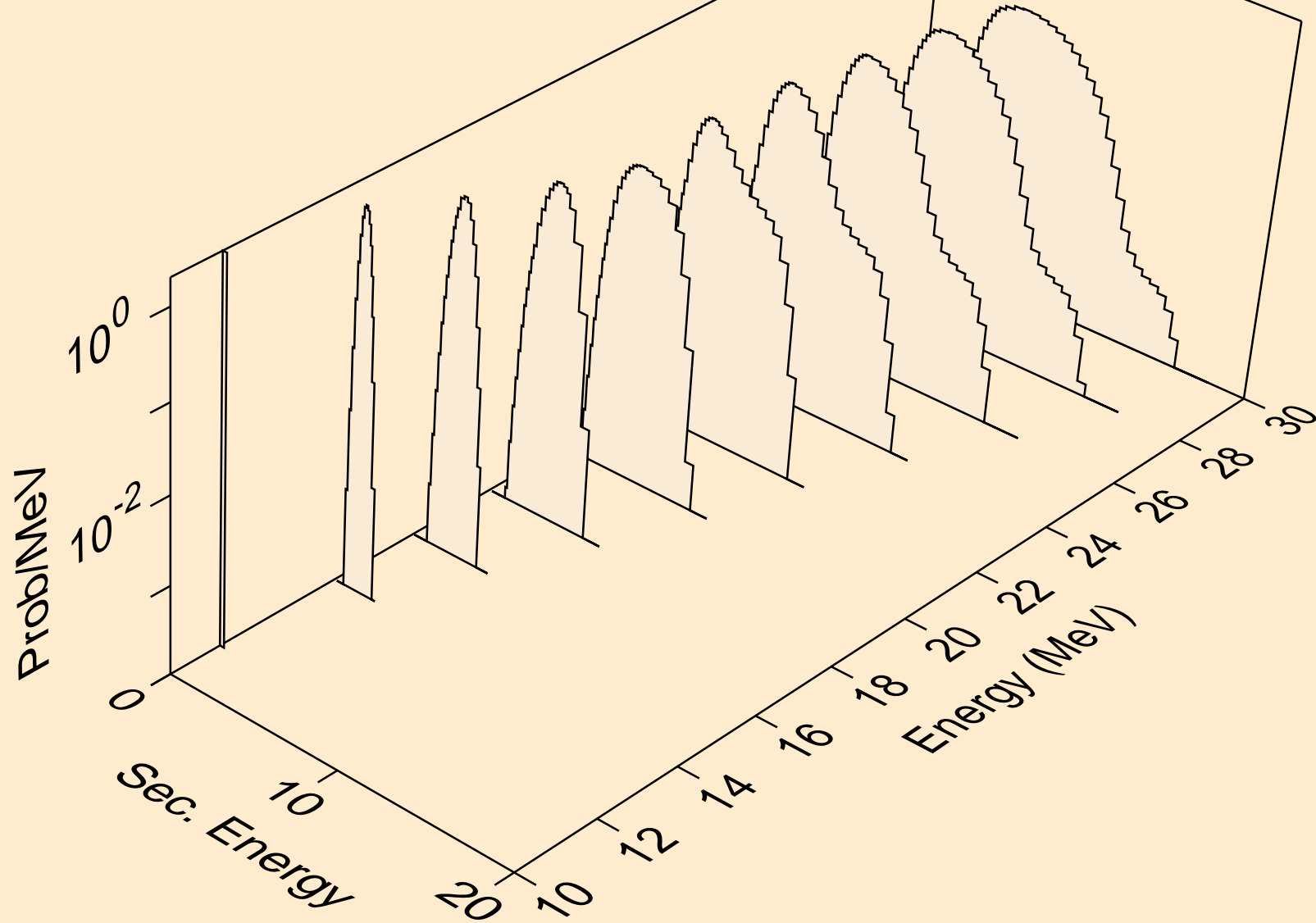

ZN069M NEUTRON ACER TENDL-2023 LIBRARY; T=0.K  
protons from (n,p)

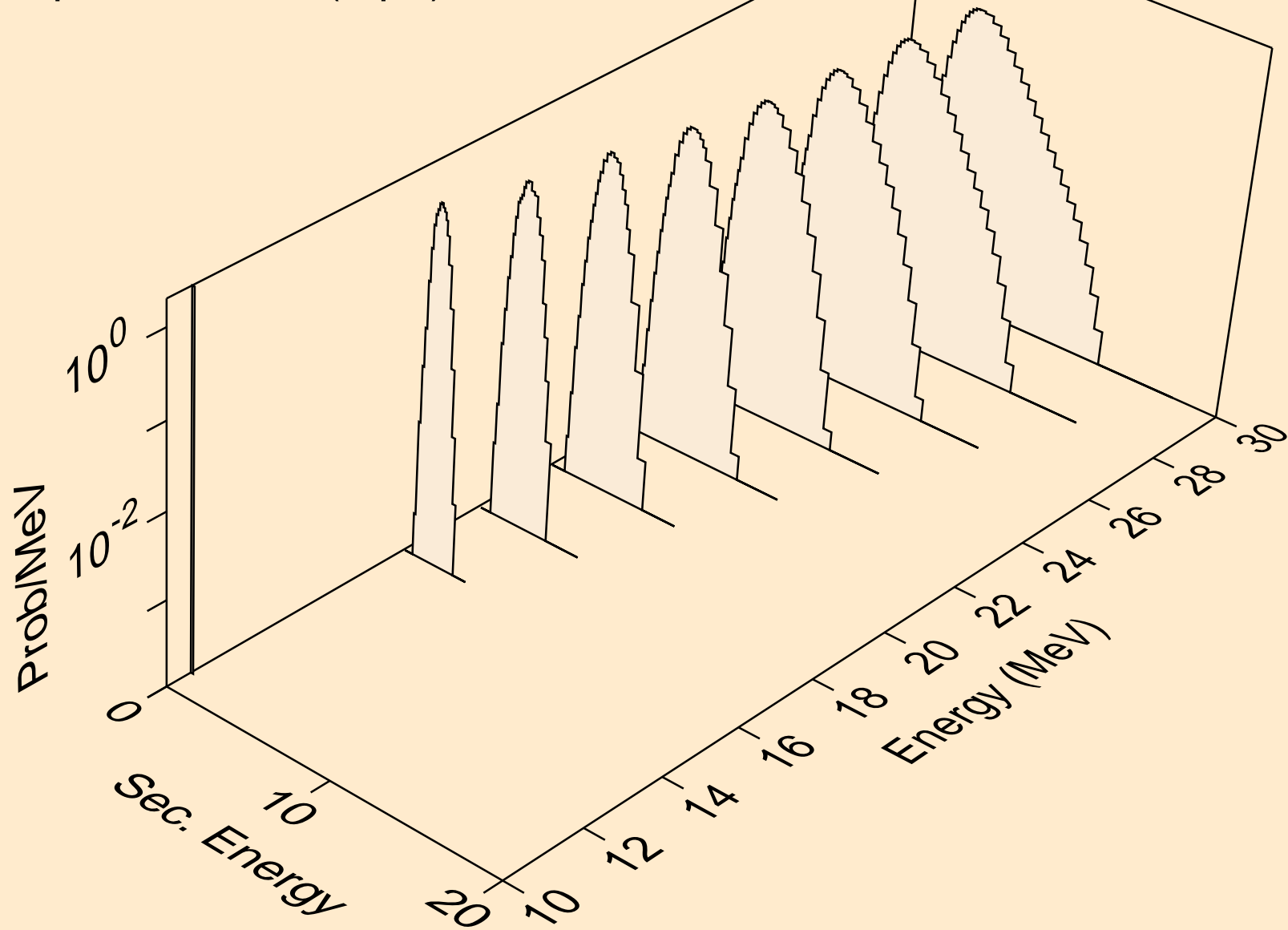

ZN069M NEUTRON ACER TENDL-2023 LIBRARY; T=0.K  
protons from (n,pd)

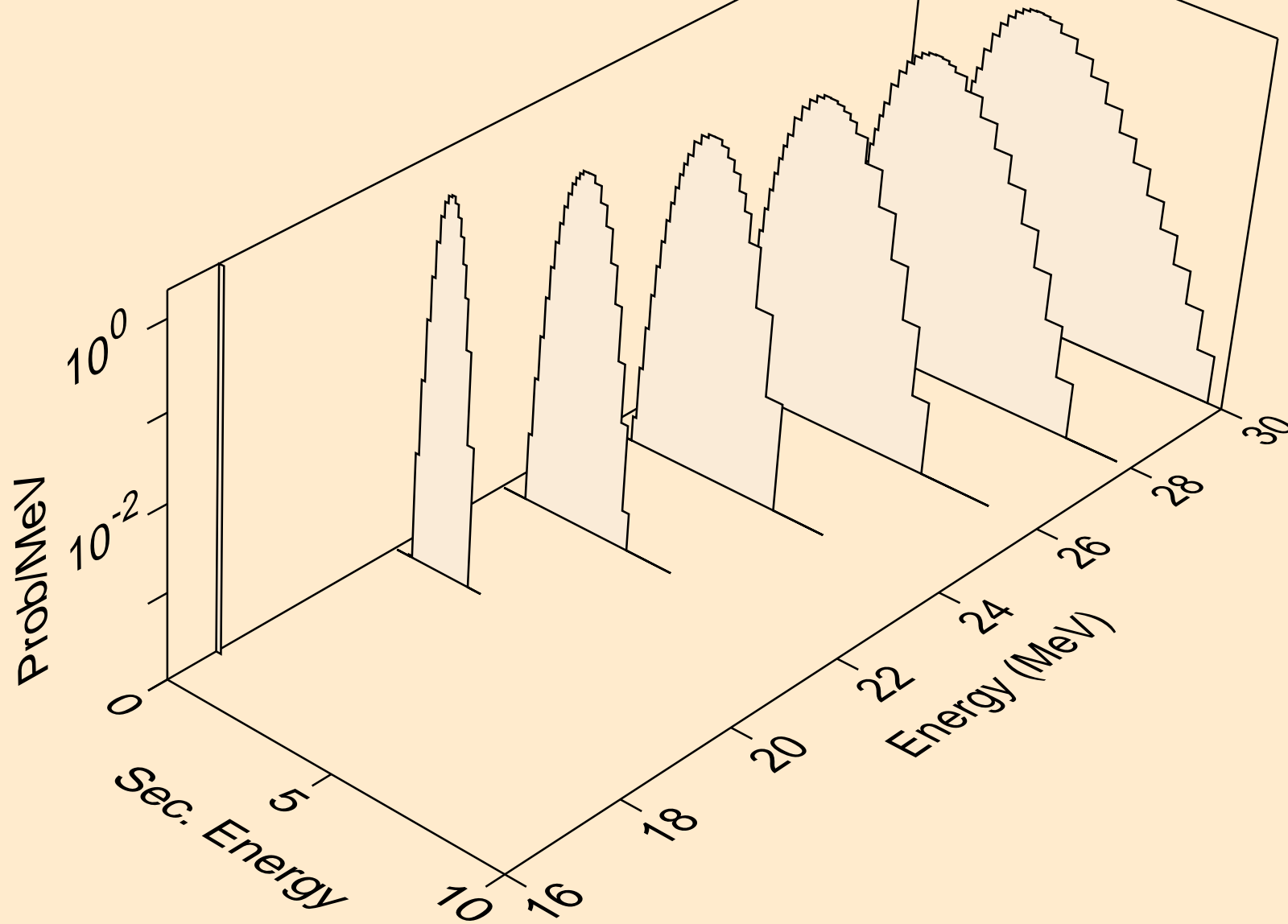

ZN069M NEUTRON ACER TENDL-2023 LIBRARY; T=0.K  
protons from (n,pt)

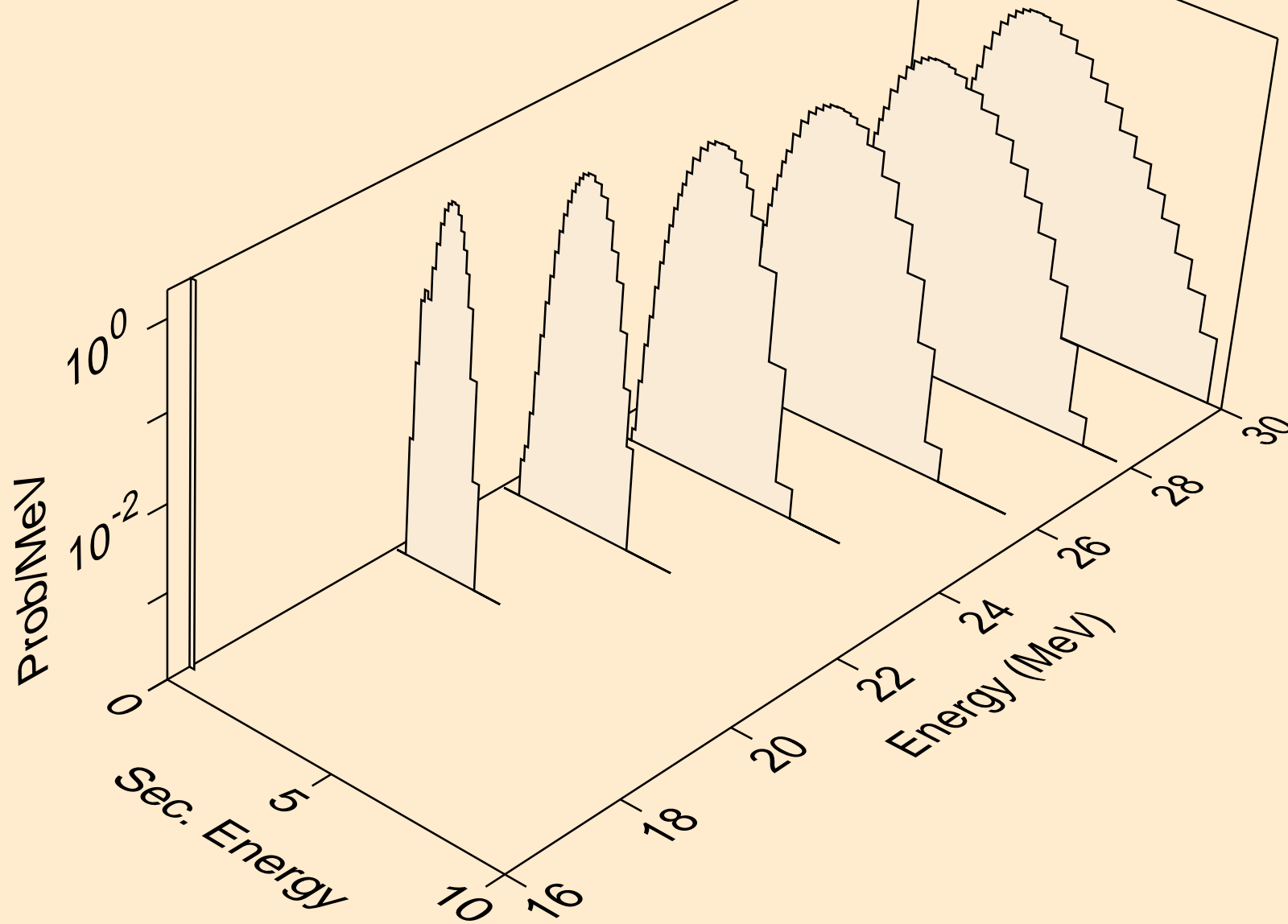

ZN069M NEUTRON ACER TENDL-2023 LIBRARY; T=0.K  
deuterons from (n,x)

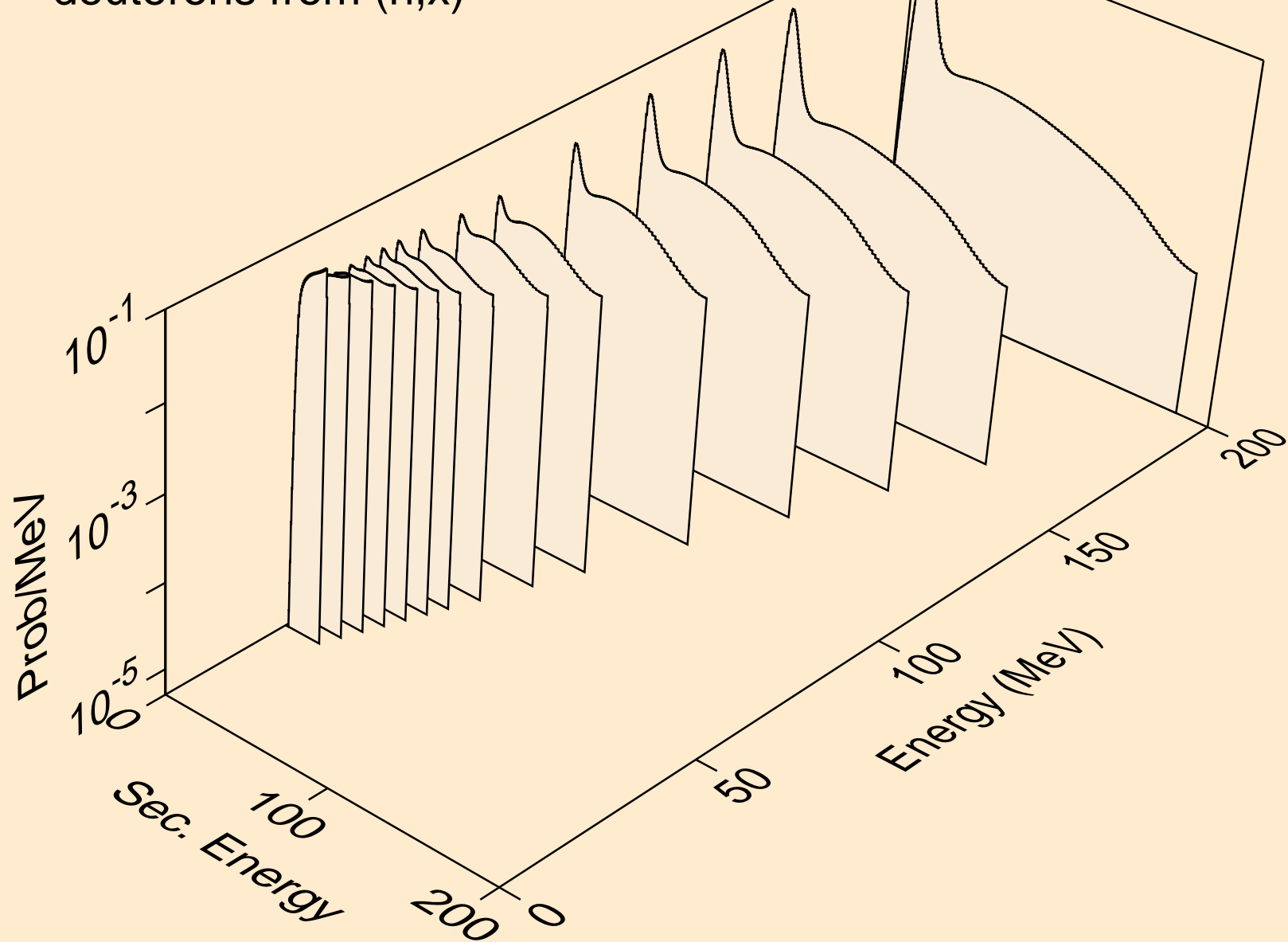



ZN069M NEUTRON ACER TENDL-2023 LIBRARY; T=0.K  
deuterons from (n,2nd)

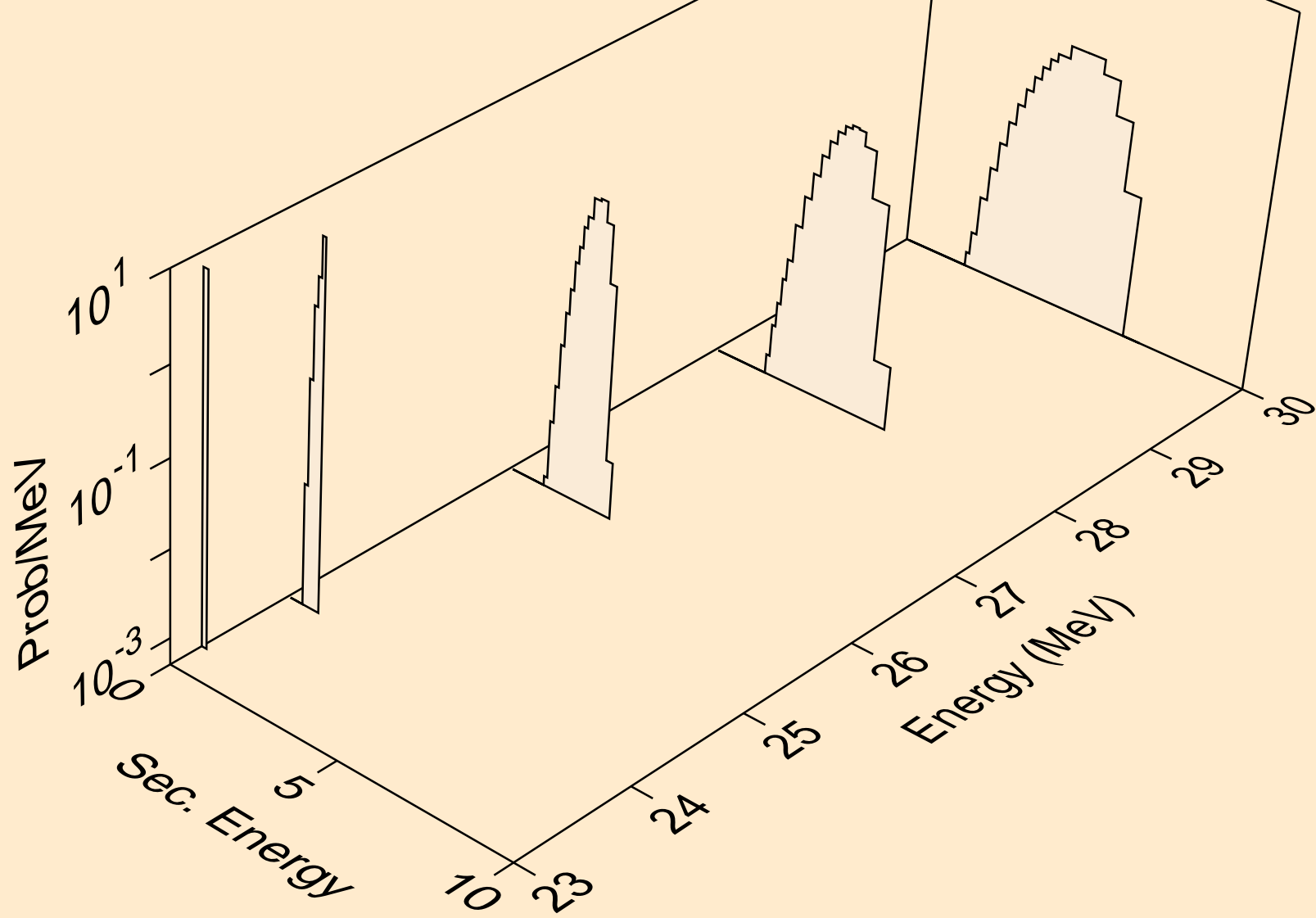

ZN069M NEUTRON ACER TENDL-2023 LIBRARY; T=0.K  
deuterons from (n,n\*)d

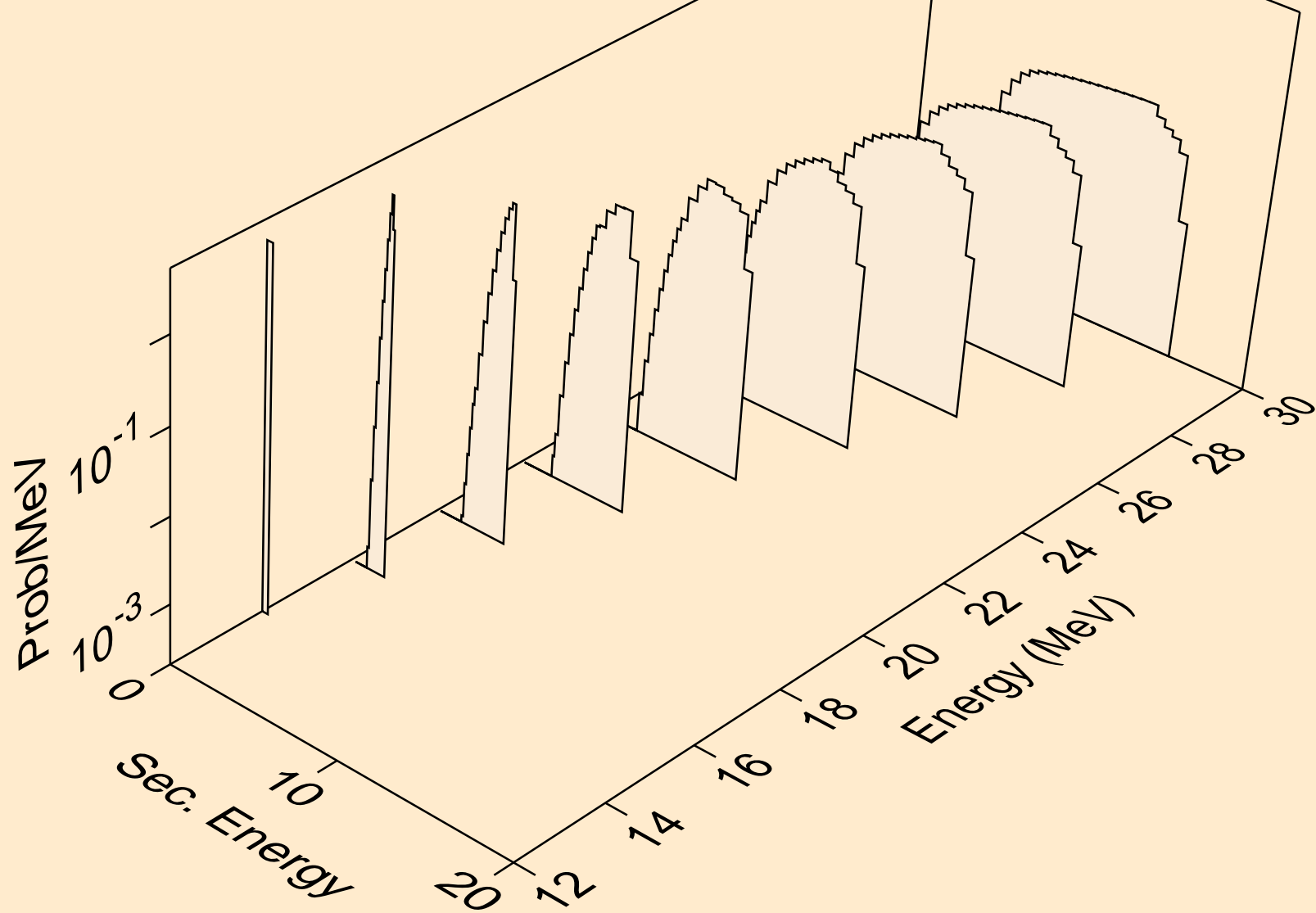

ZN069M NEUTRON ACER TENDL-2023 LIBRARY; T=0.K  
deuterons from (n,d)

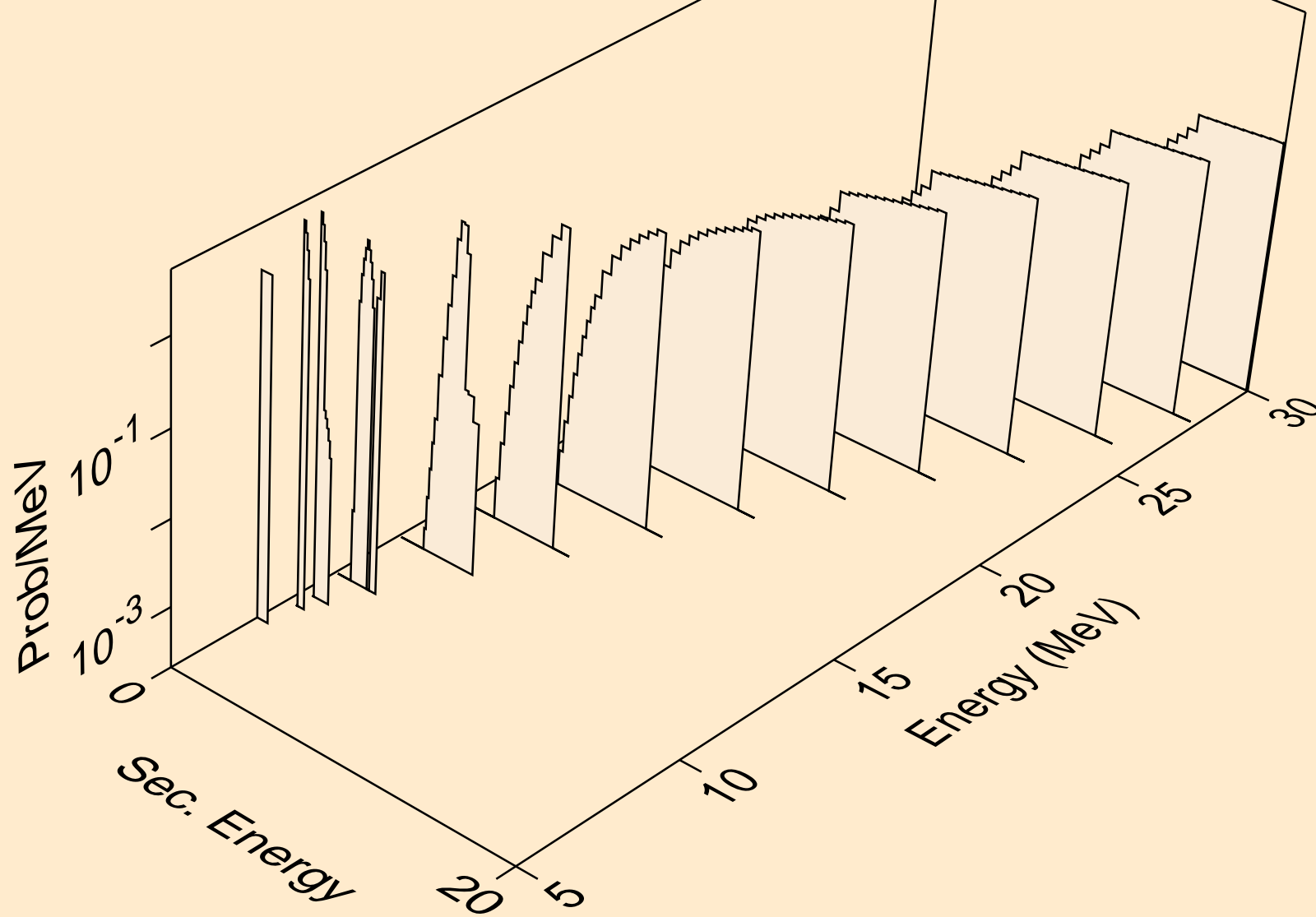

ZN069M NEUTRON ACER TENDL-2023 LIBRARY; T=0.K  
deuterons from (n,pd)

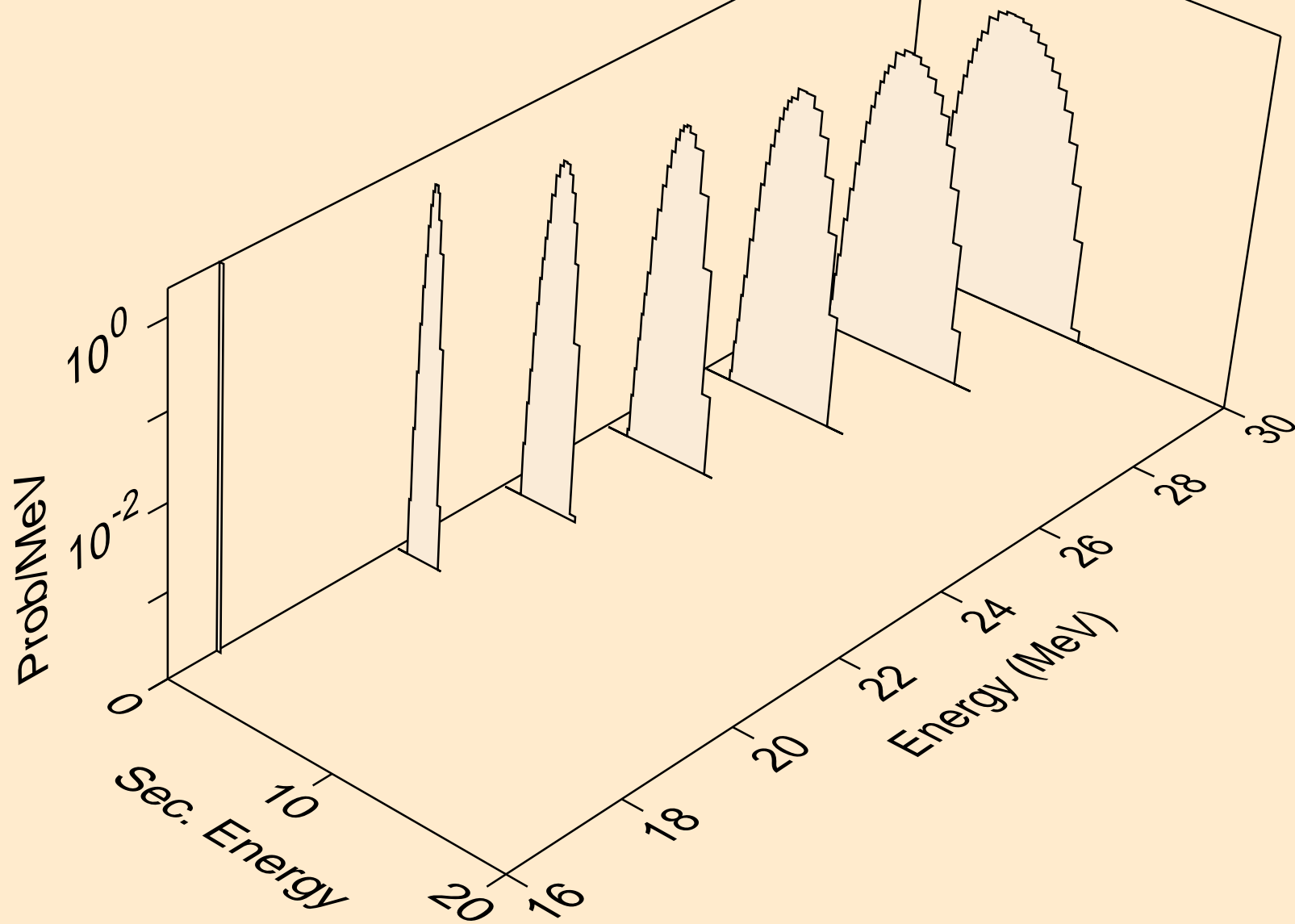

ZN069M NEUTRON ACER TENDL-2023 LIBRARY; T=0.K  
deuterons from (n,da)

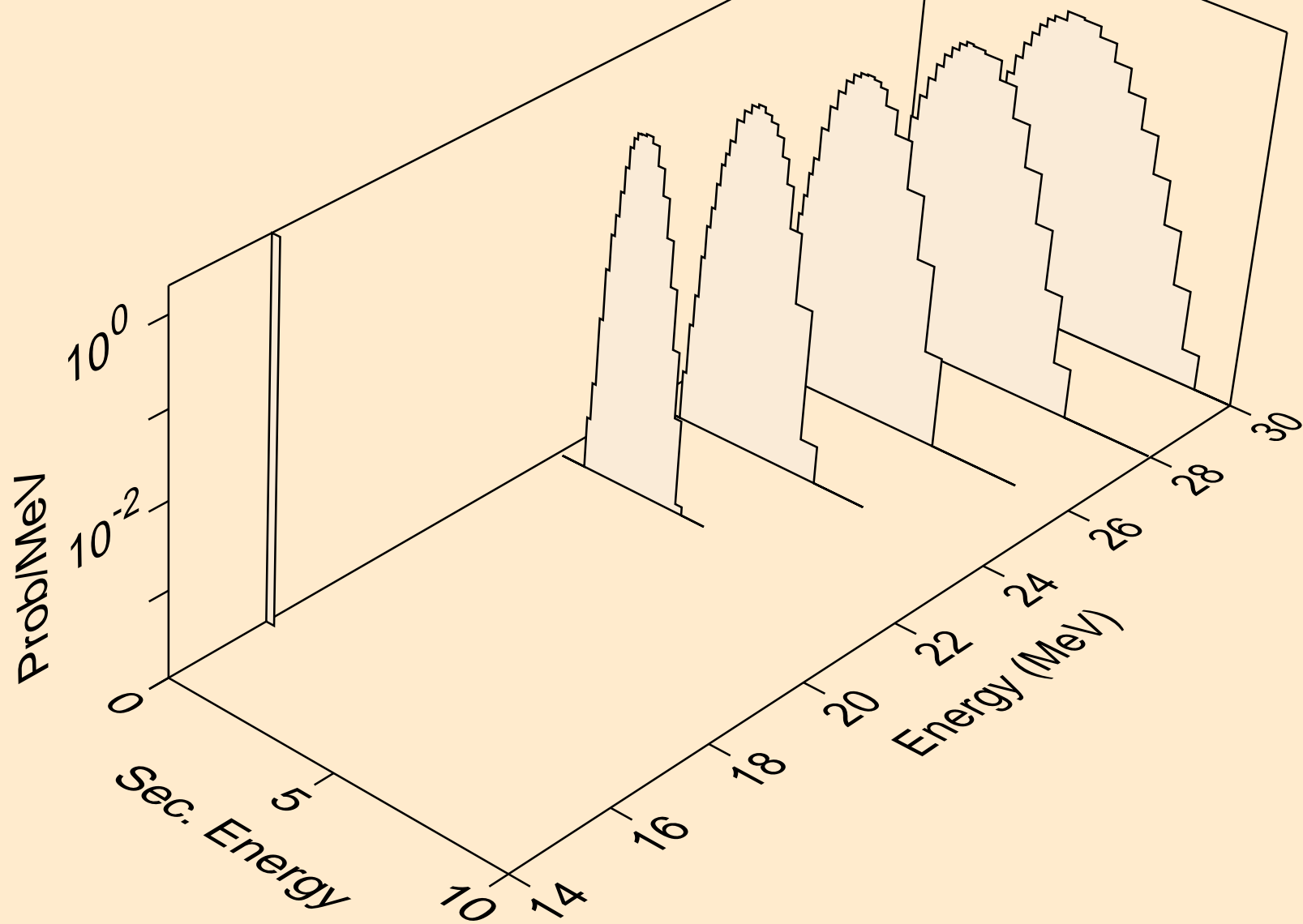

ZN069M NEUTRON ACER TENDL-2023 LIBRARY; T=0.K  
tritons from (n,x)

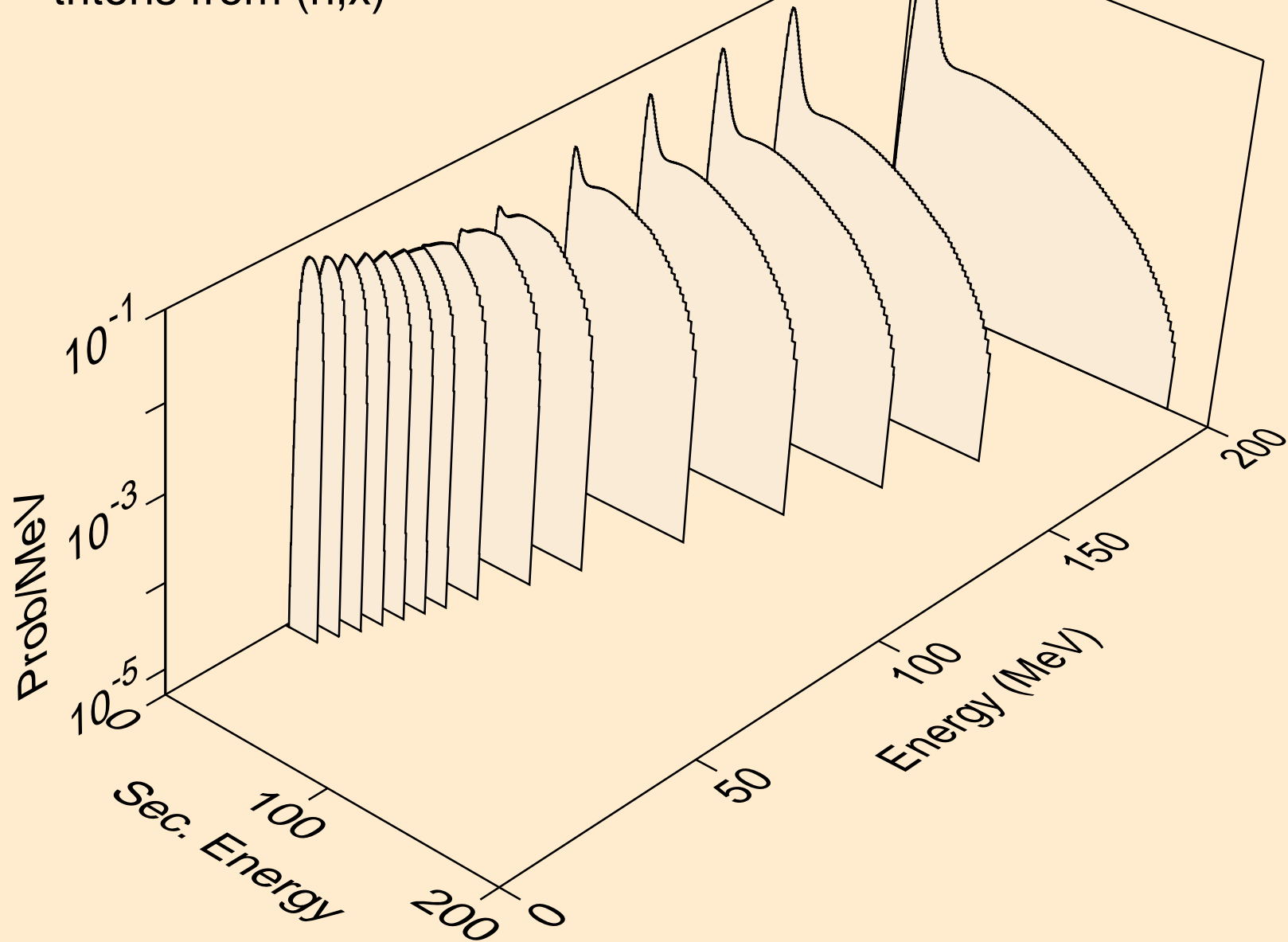

ZN069M NEUTRON ACER TENDL-2023 LIBRARY; T=0.K  
tritons from (n,n\*)t

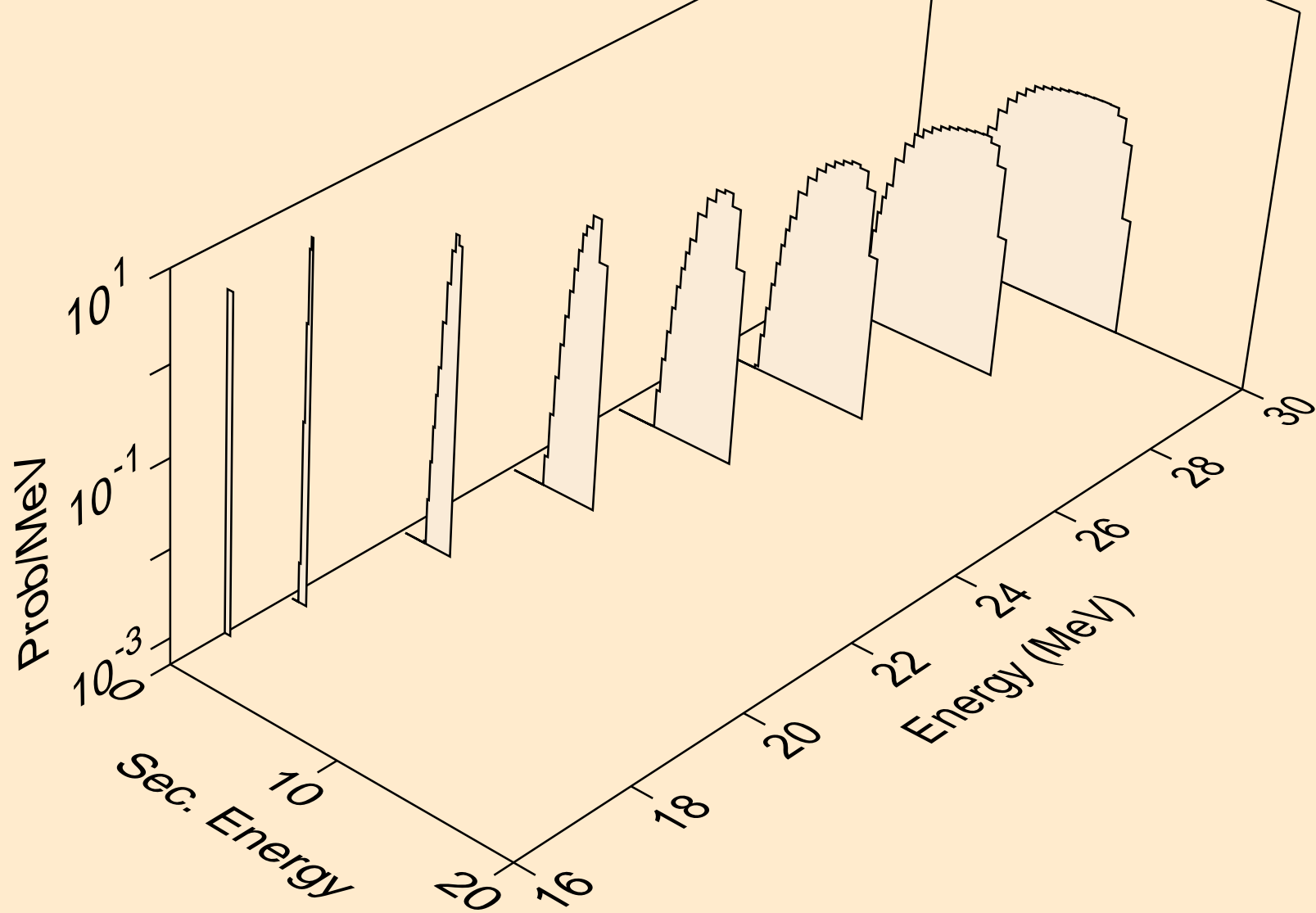

ZN069M NEUTRON ACER TENDL-2023 LIBRARY; T=0.K  
tritons from (n,t)

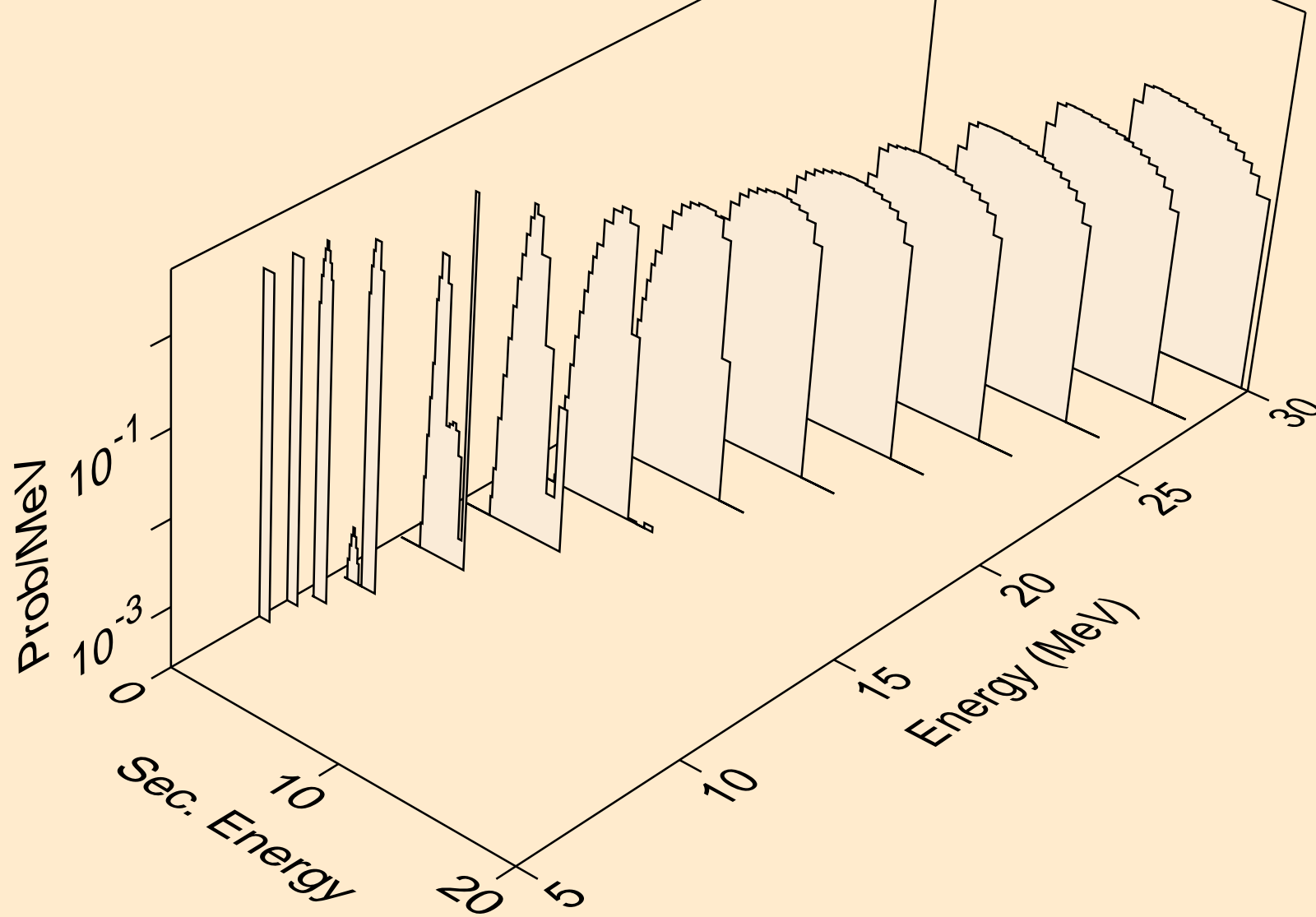



ZN069M NEUTRON ACER TENDL-2023 LIBRARY; T=0.K  
tritons from (n,pt)

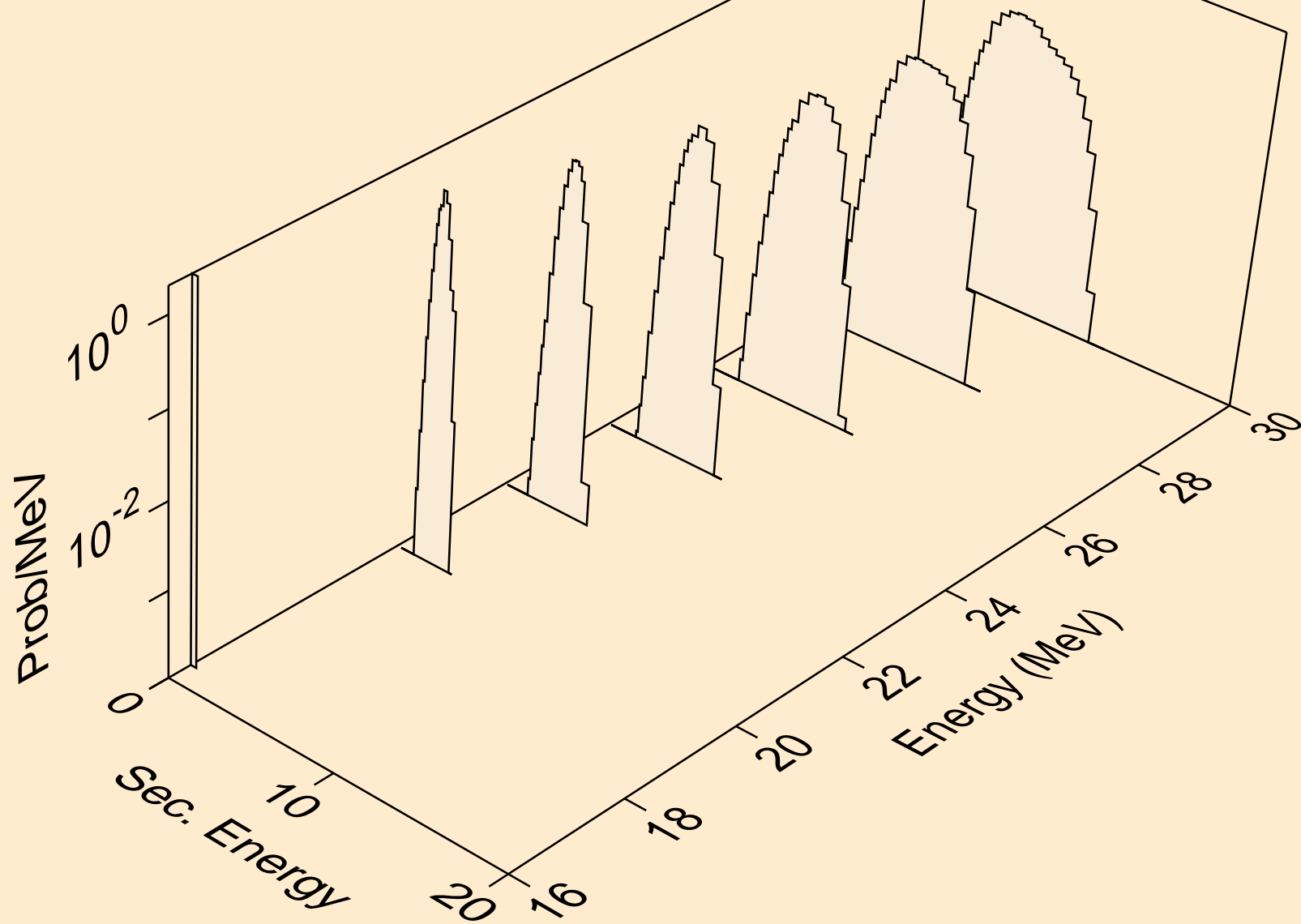

ZN069M NEUTRON ACER TENDL-2023 LIBRARY; T=0.K  
he3s from (n,x)

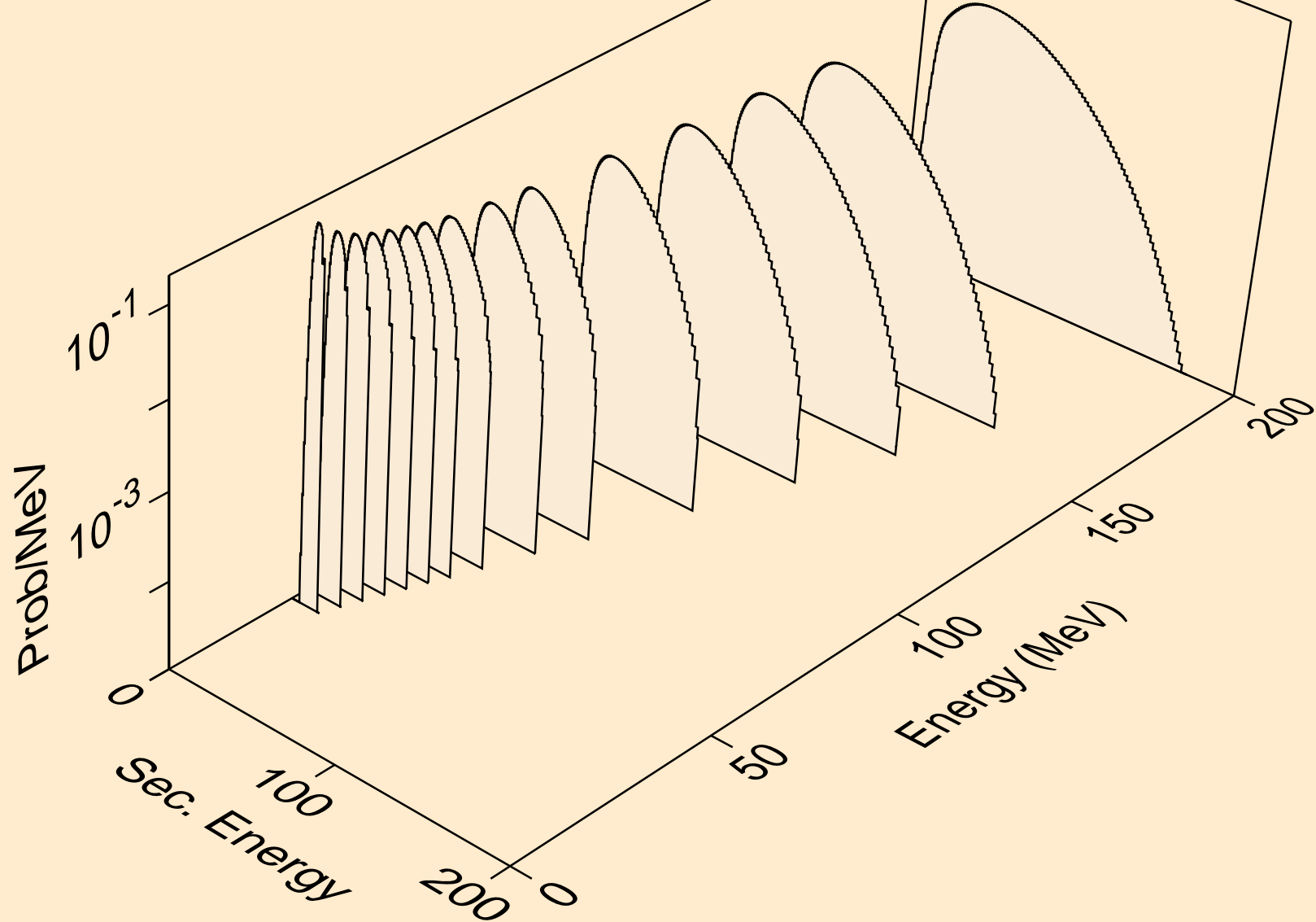

ZN069M NEUTRON ACER TENDL-2023 LIBRARY; T=0.K  
he3s from (n,n\*)he3

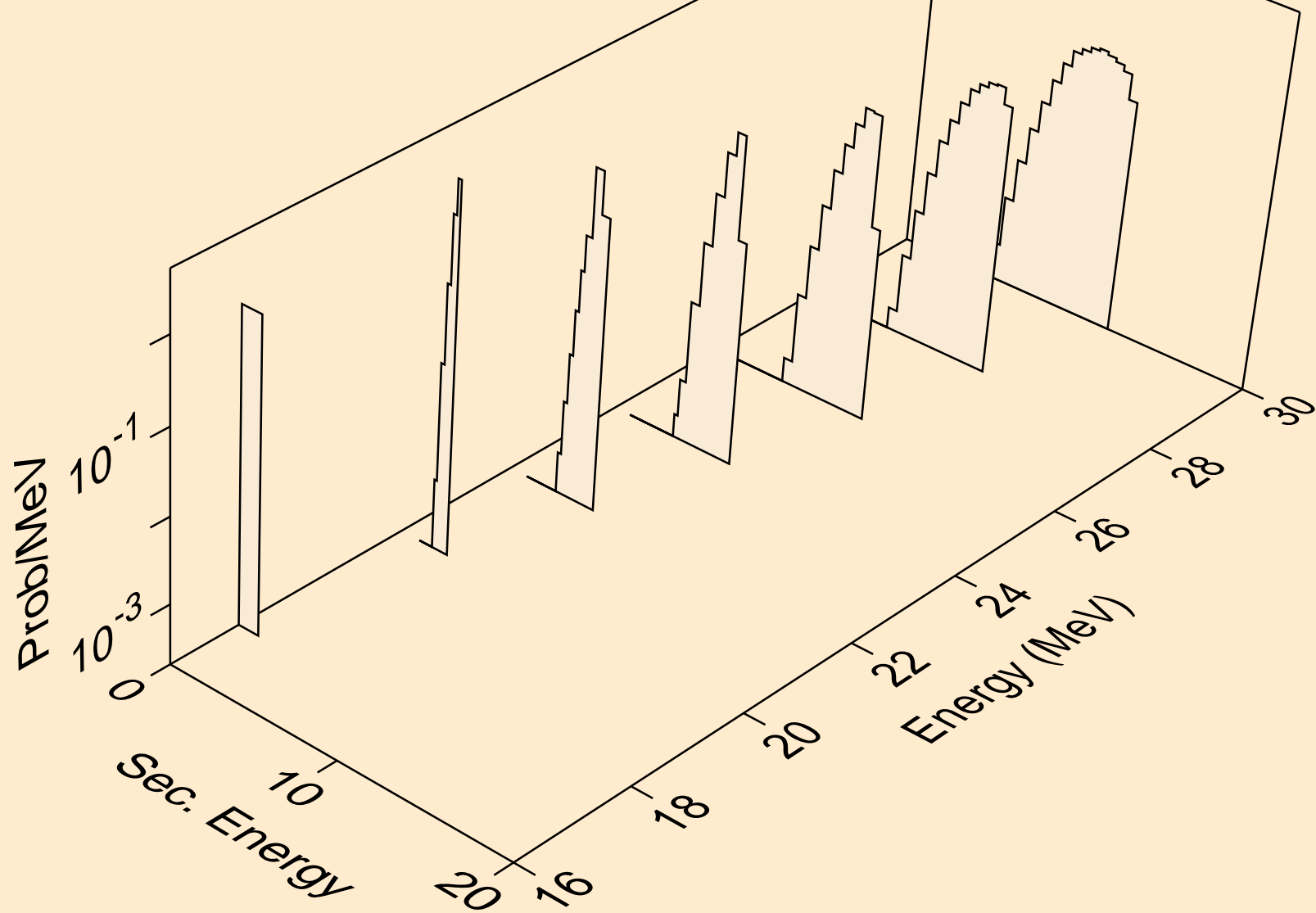

ZN069M NEUTRON ACER TENDL-2023 LIBRARY; T=0.K  
he3s from (n,he3)

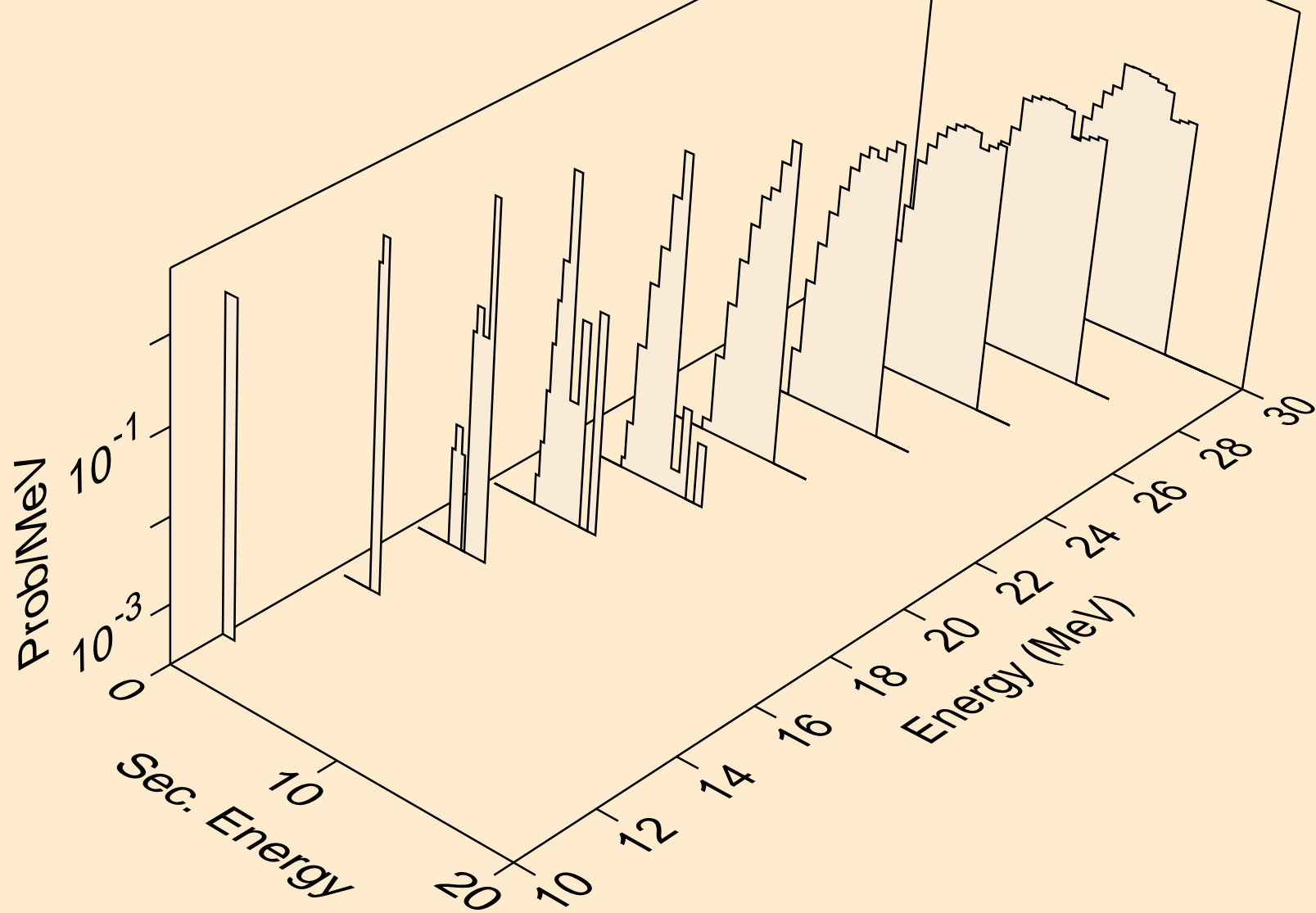

ZN069M NEUTRON ACER TENDL-2023 LIBRARY; T=0.K  
alphas from (n,x)

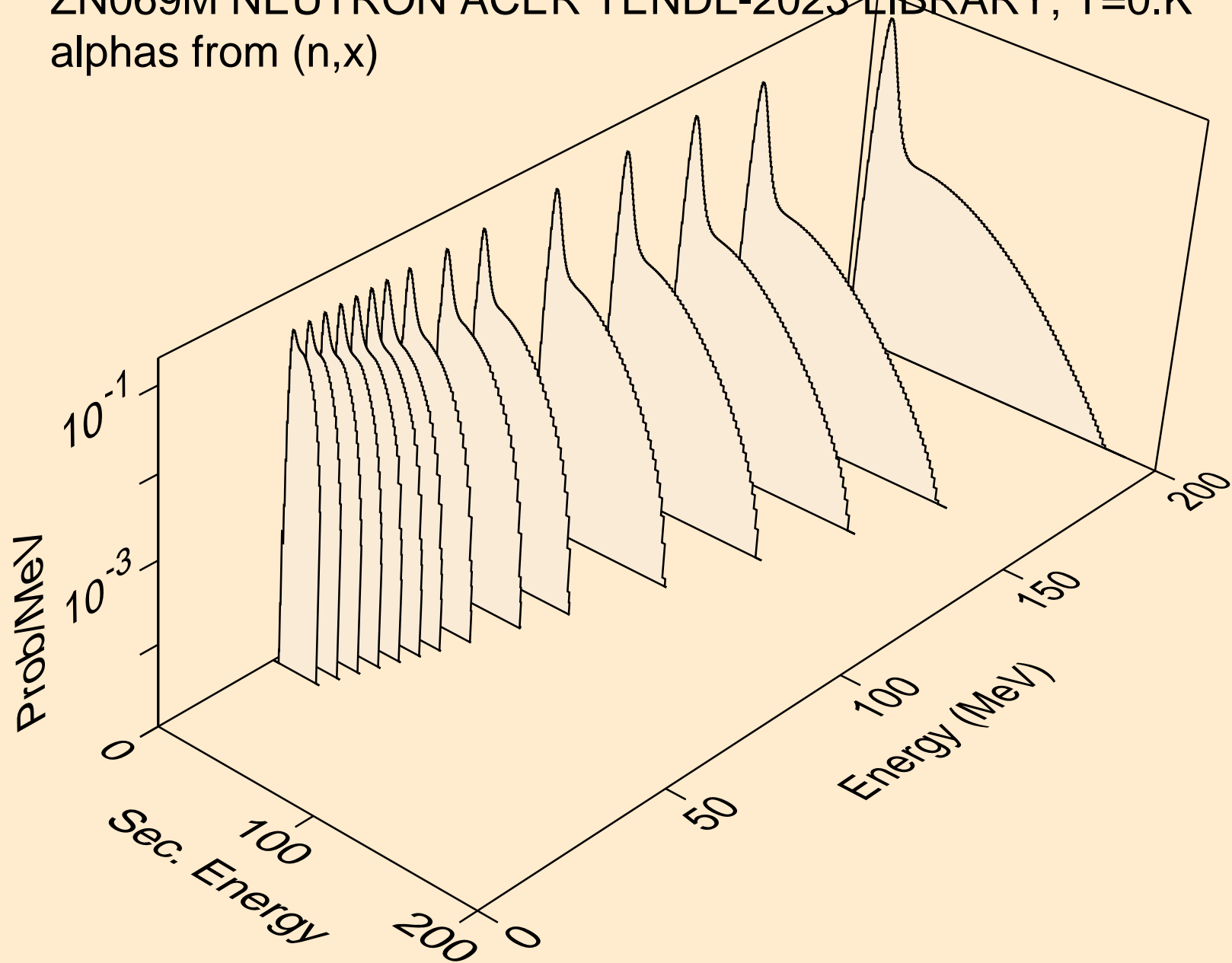

ZN069M NEUTRON ACER TENDL-2023 LIBRARY; T=0.K  
alphas from (n,n\*)a

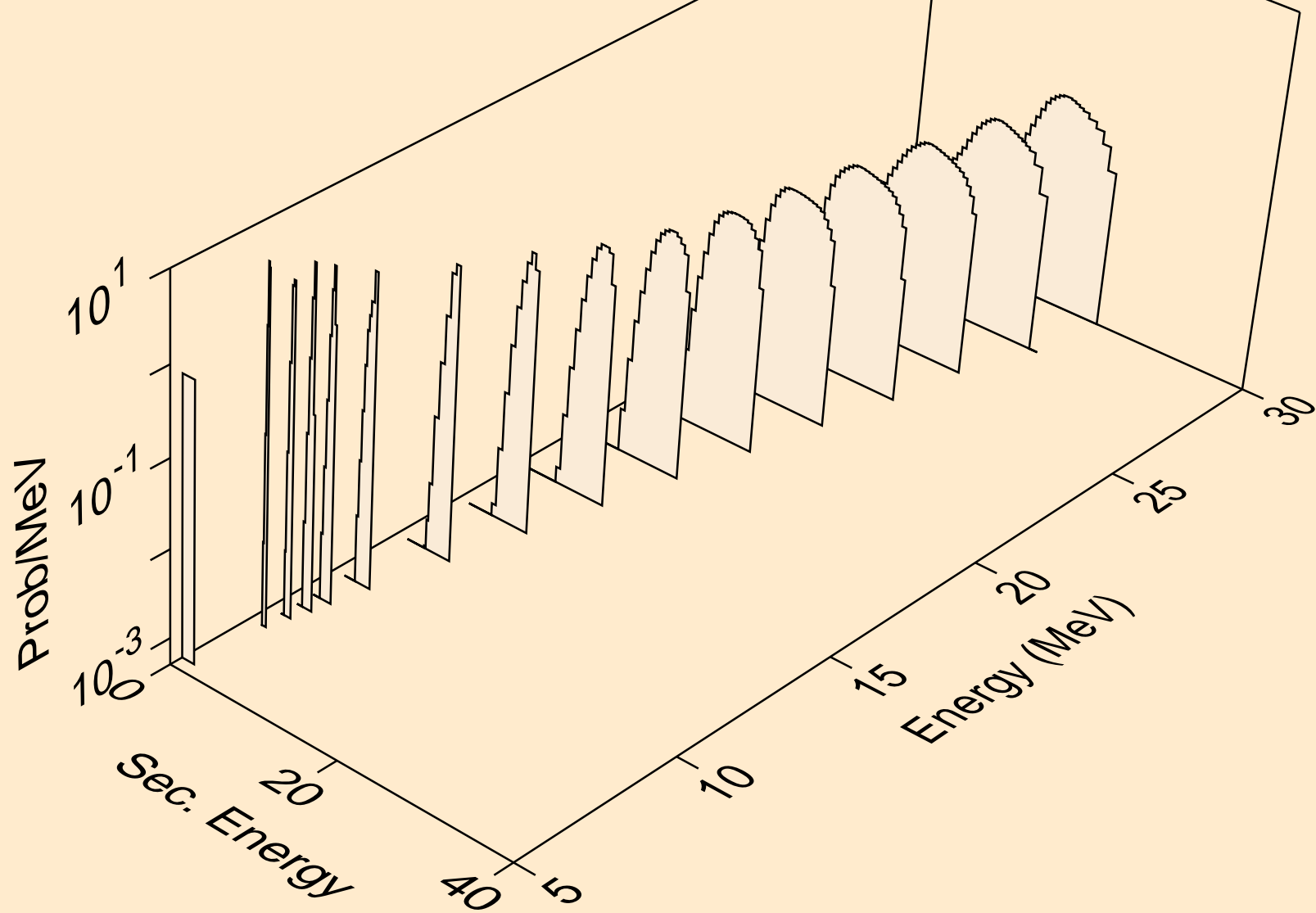

ZN069M NEUTRON ACER TENDL-2023 LIBRARY; T=0.K  
alphas from (n,2n)a

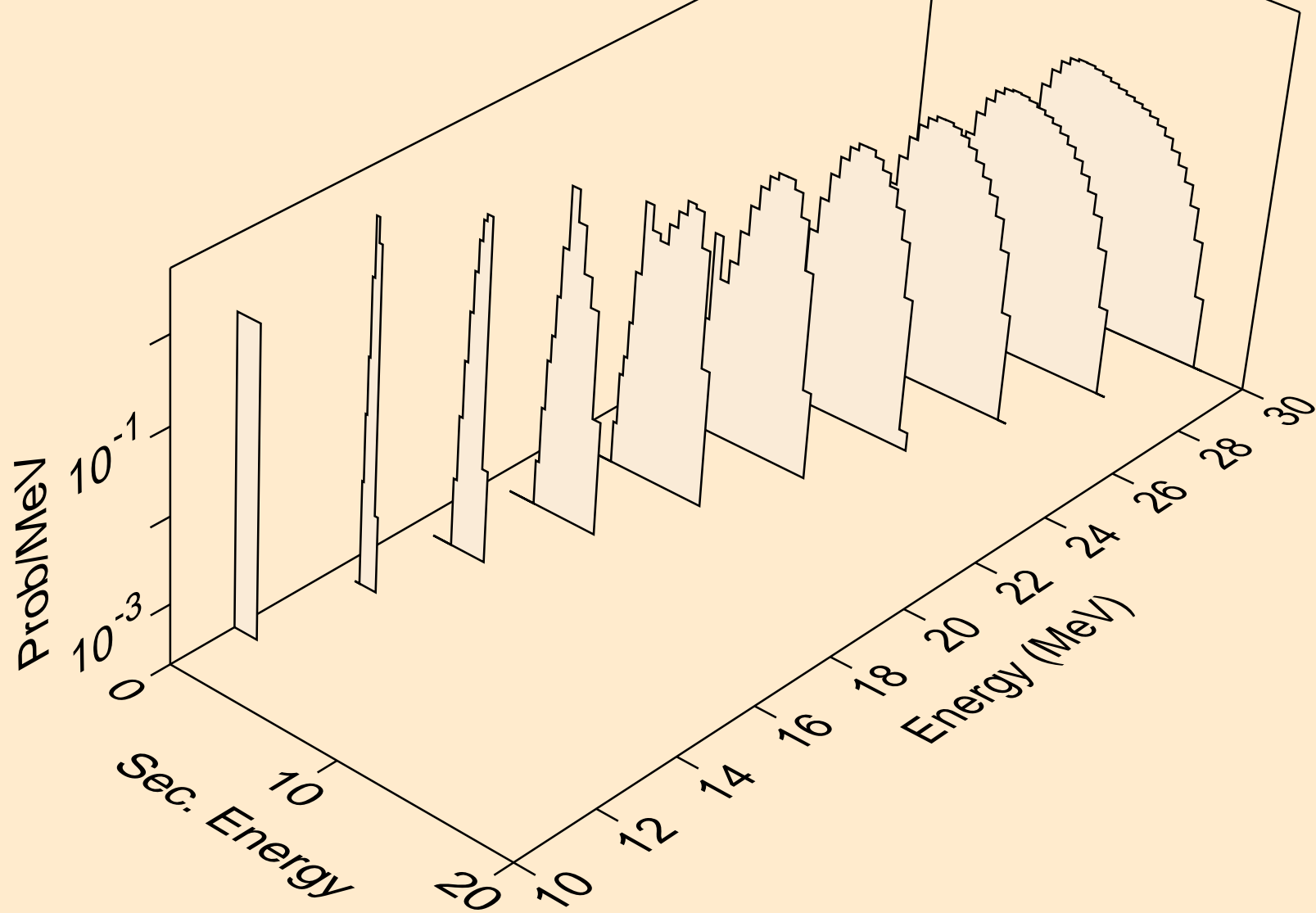

ZN069M NEUTRON ACER TENDL-2023 LIBRARY; T=0.K  
alphas from (n,3n)a

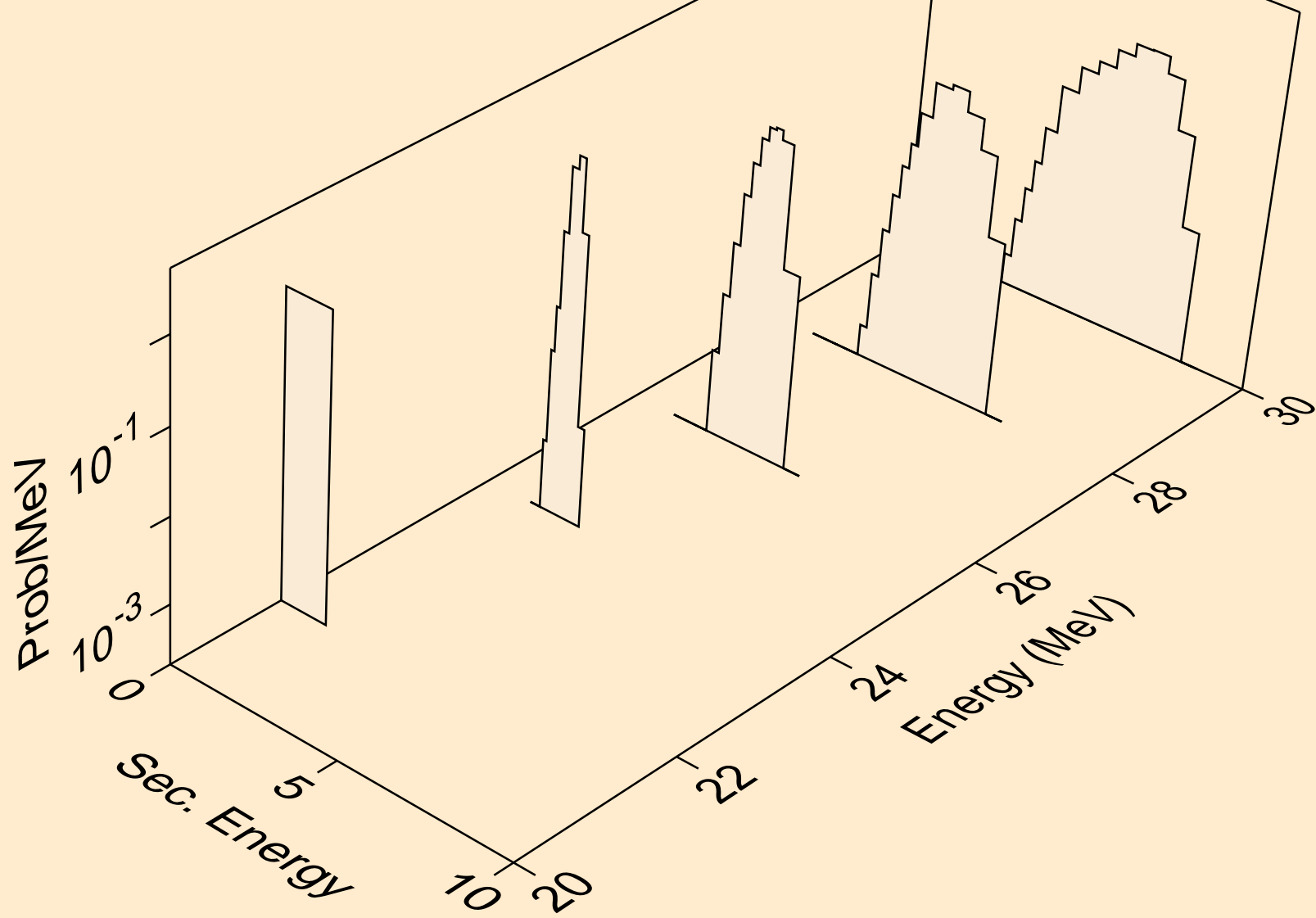



ZN069M NEUTRON ACER TENDL-2023 LIBRARY; T=0.K  
alphas from (n,n\*)2a

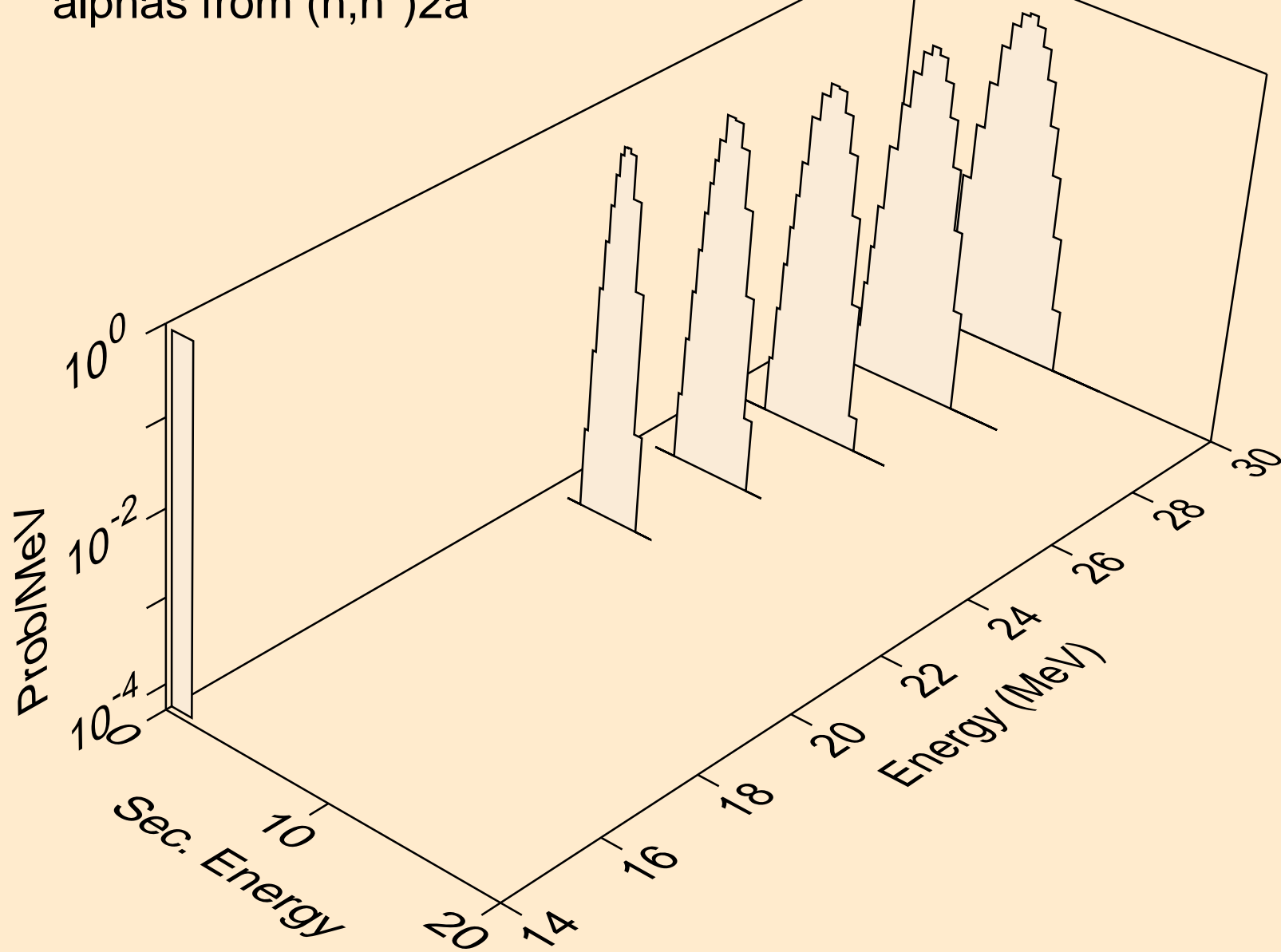

ZN069M NEUTRON ACER TENDL-2023 LIBRARY; T=0.K  
alphas from (n,npa)

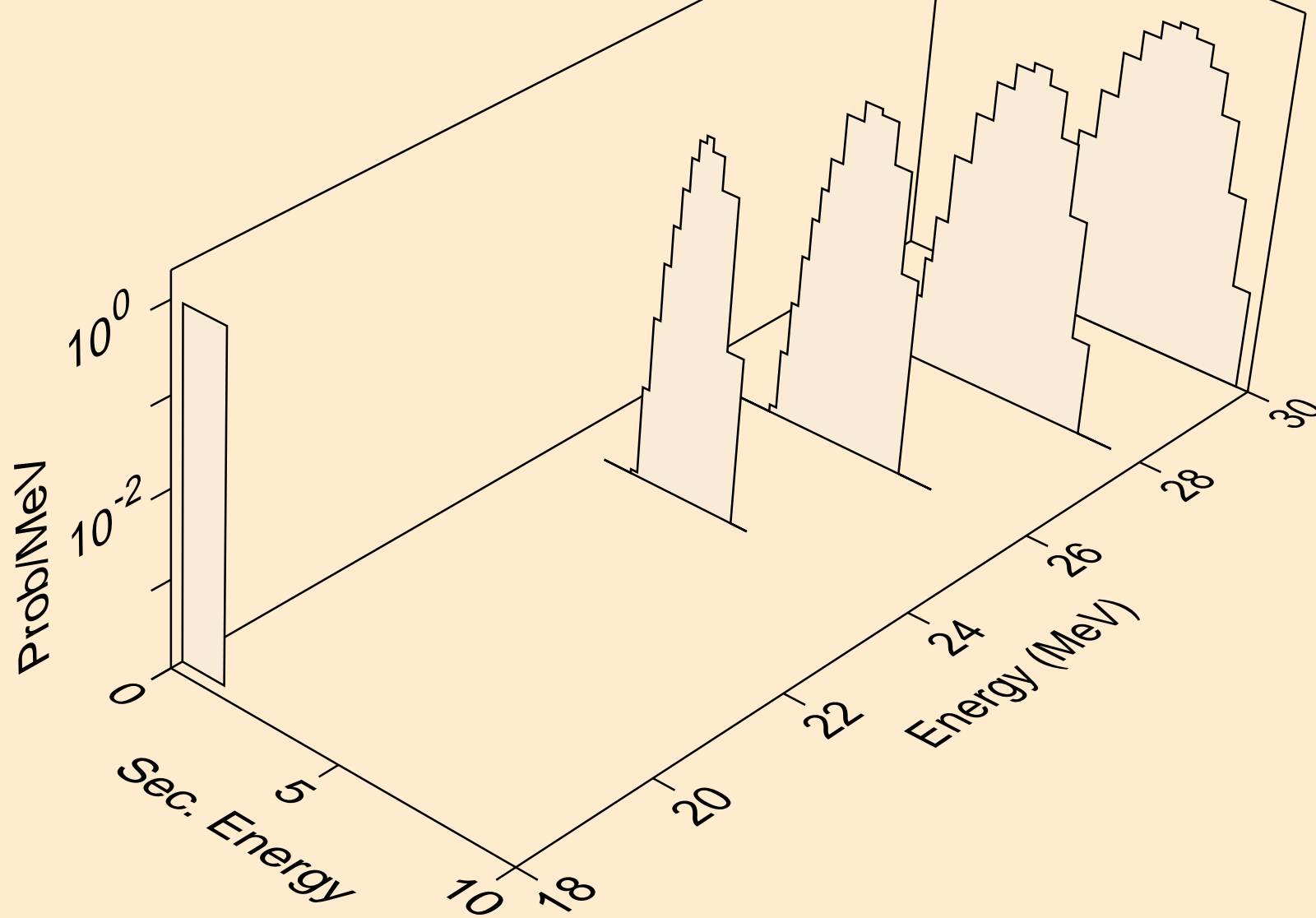

ZN069M NEUTRON ACER TENDL-2023 LIBRARY; T=0.K  
alphas from (n,a)

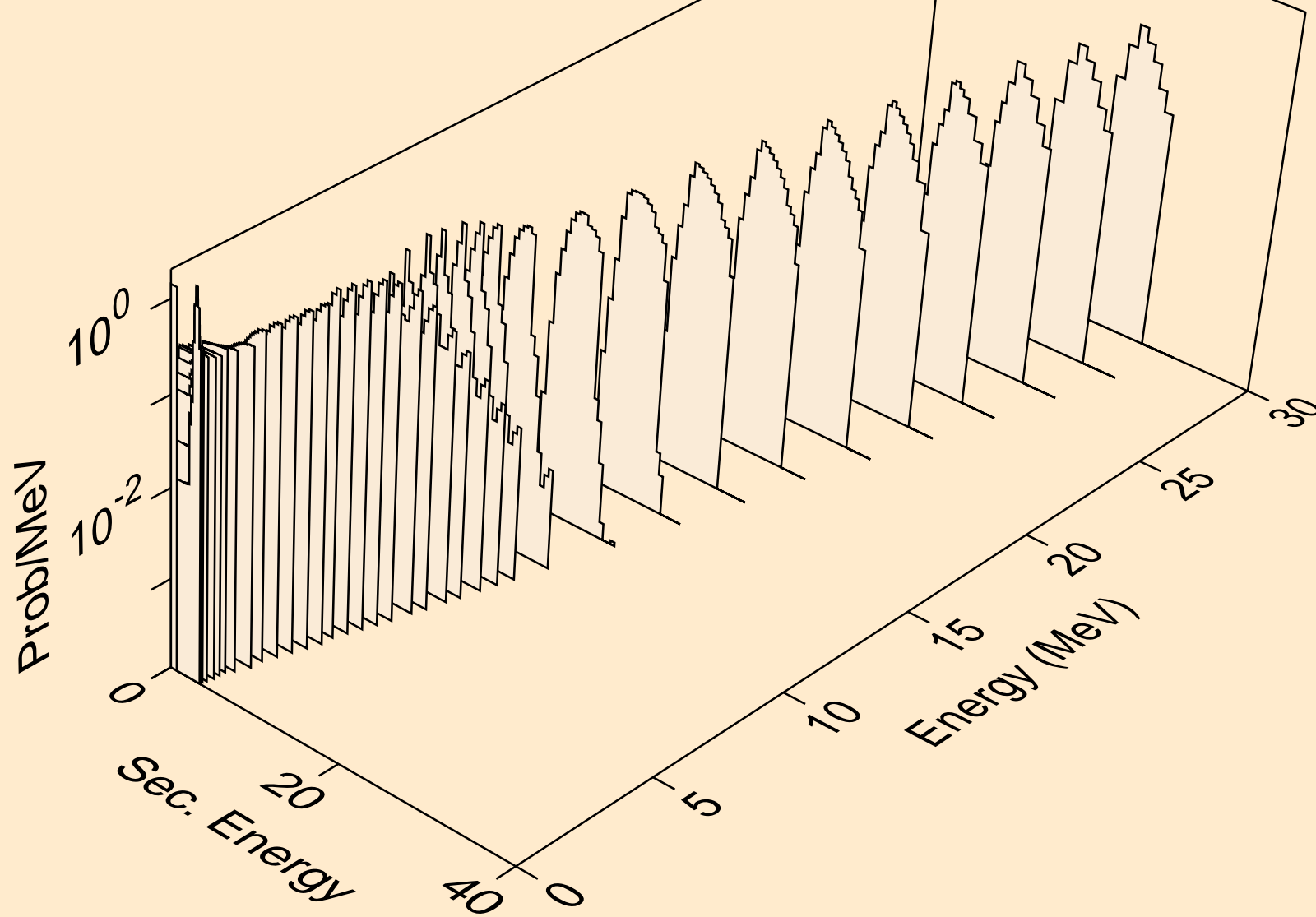

ZN069M NEUTRON ACER TENDL-2023 LIBRARY; T=0.K  
alphas from (n,2a)

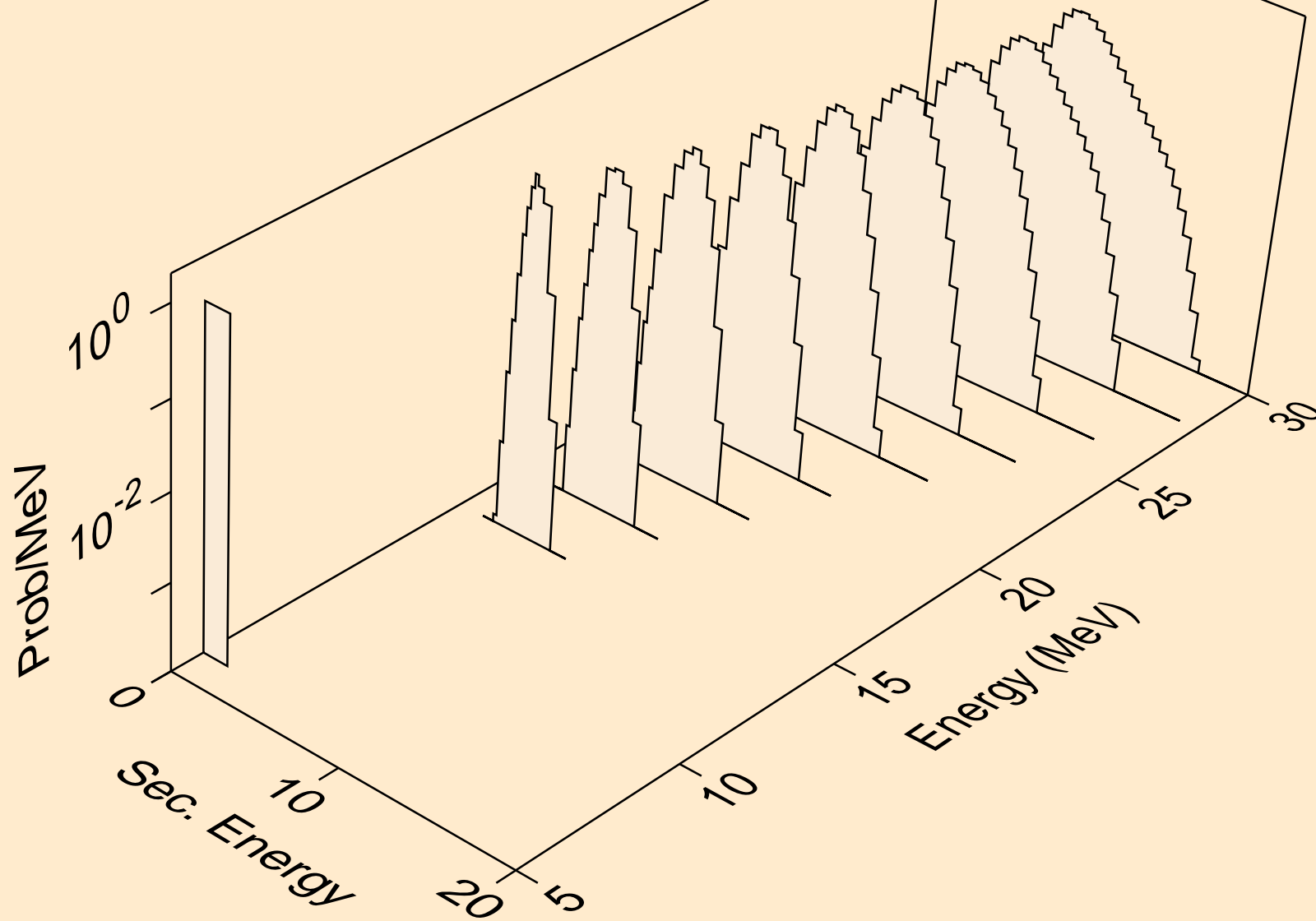

ZN069M NEUTRON ACER TENDL-2023 LIBRARY; T=0.K  
alphas from (n,pa)

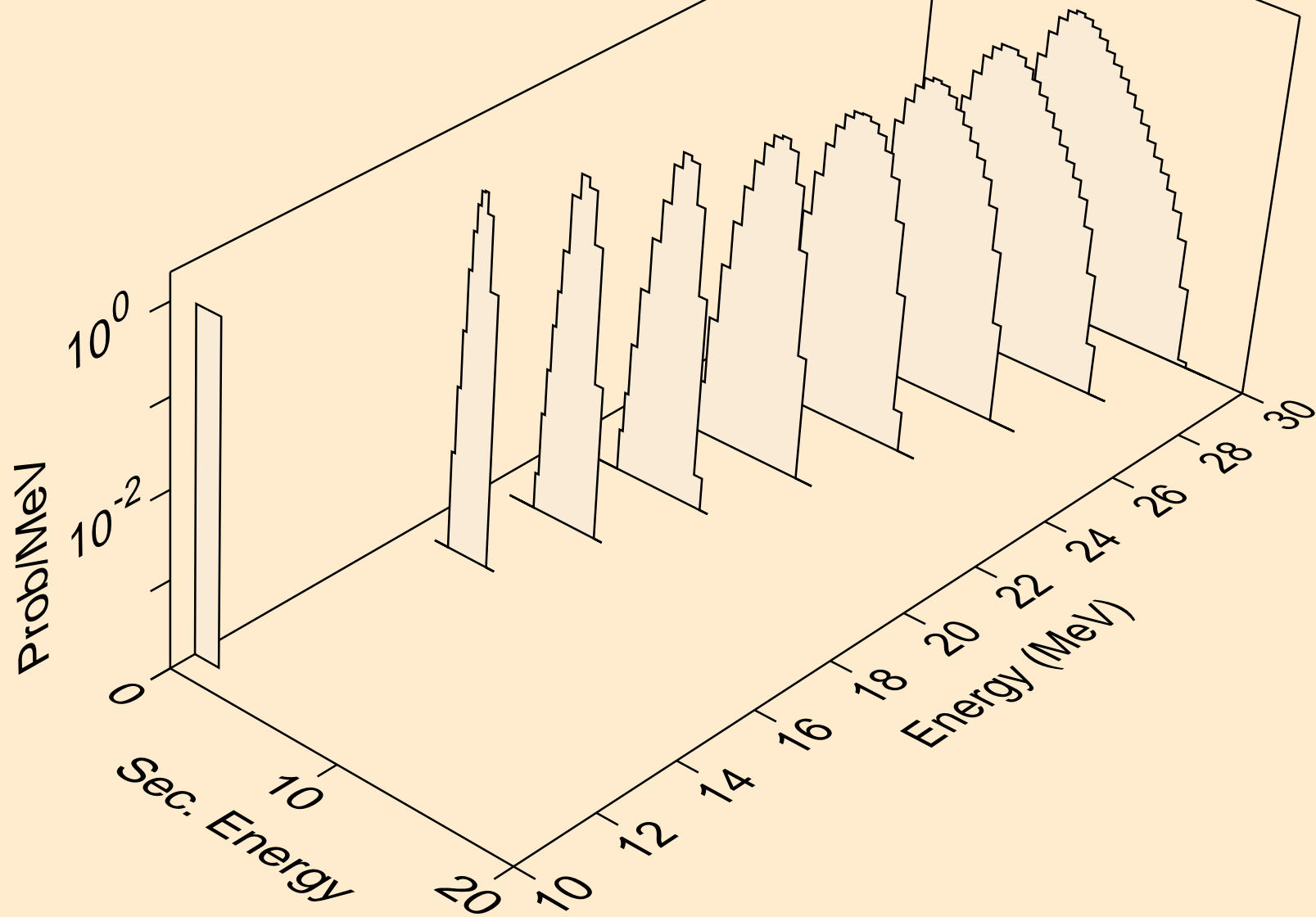

ZN069M NEUTRON ACER TENDL-2023 LIBRARY; T=0.K  
alphas from (n,da)

