

# BH268 NEUTRON ACER TENDL-2024 LIBRARY; T=0.K

## Principal cross sections

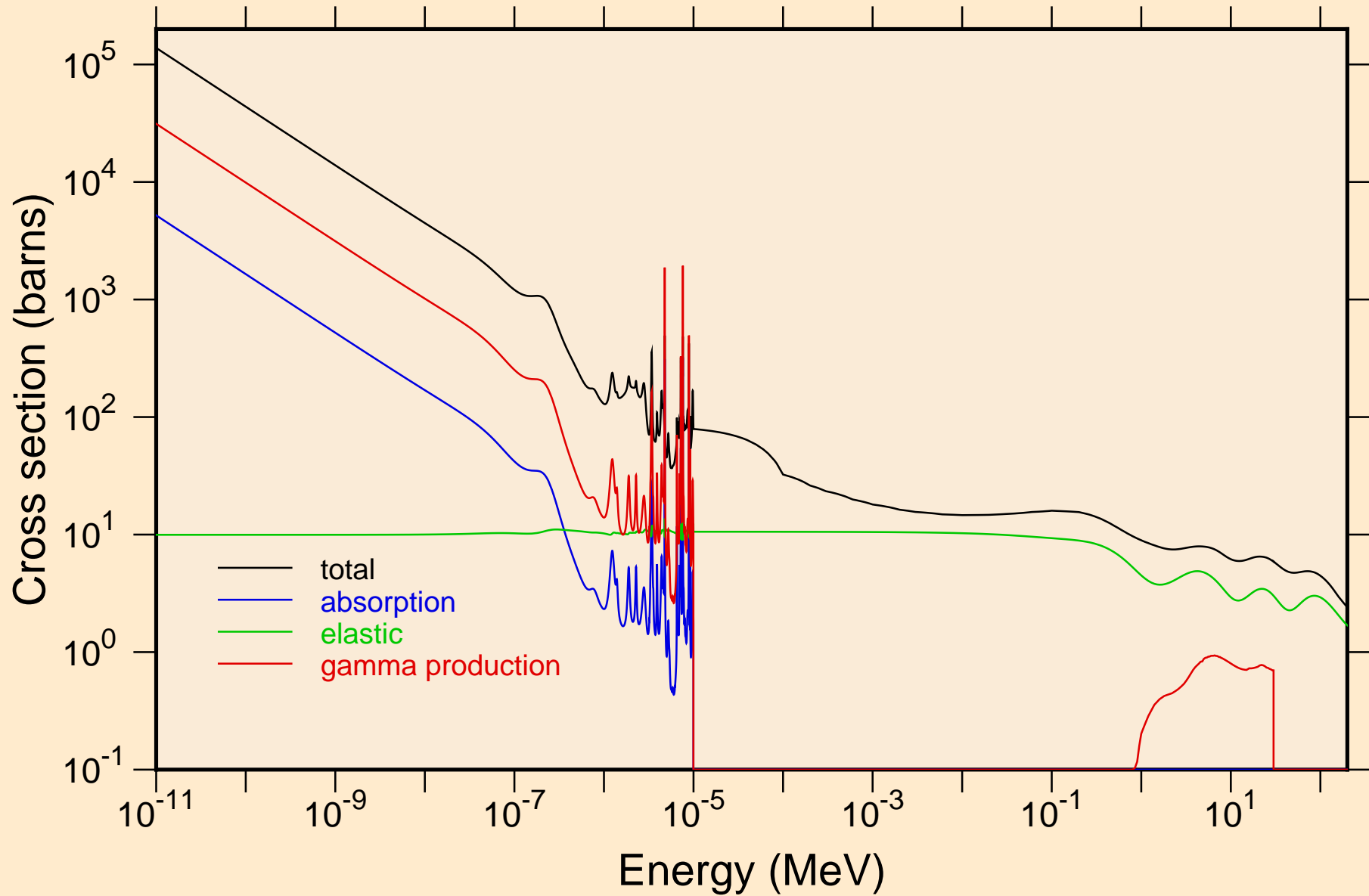

BH268 NEUTRON ACER TENDL-2024 LIBRARY; T=0.K  
resonance total cross section

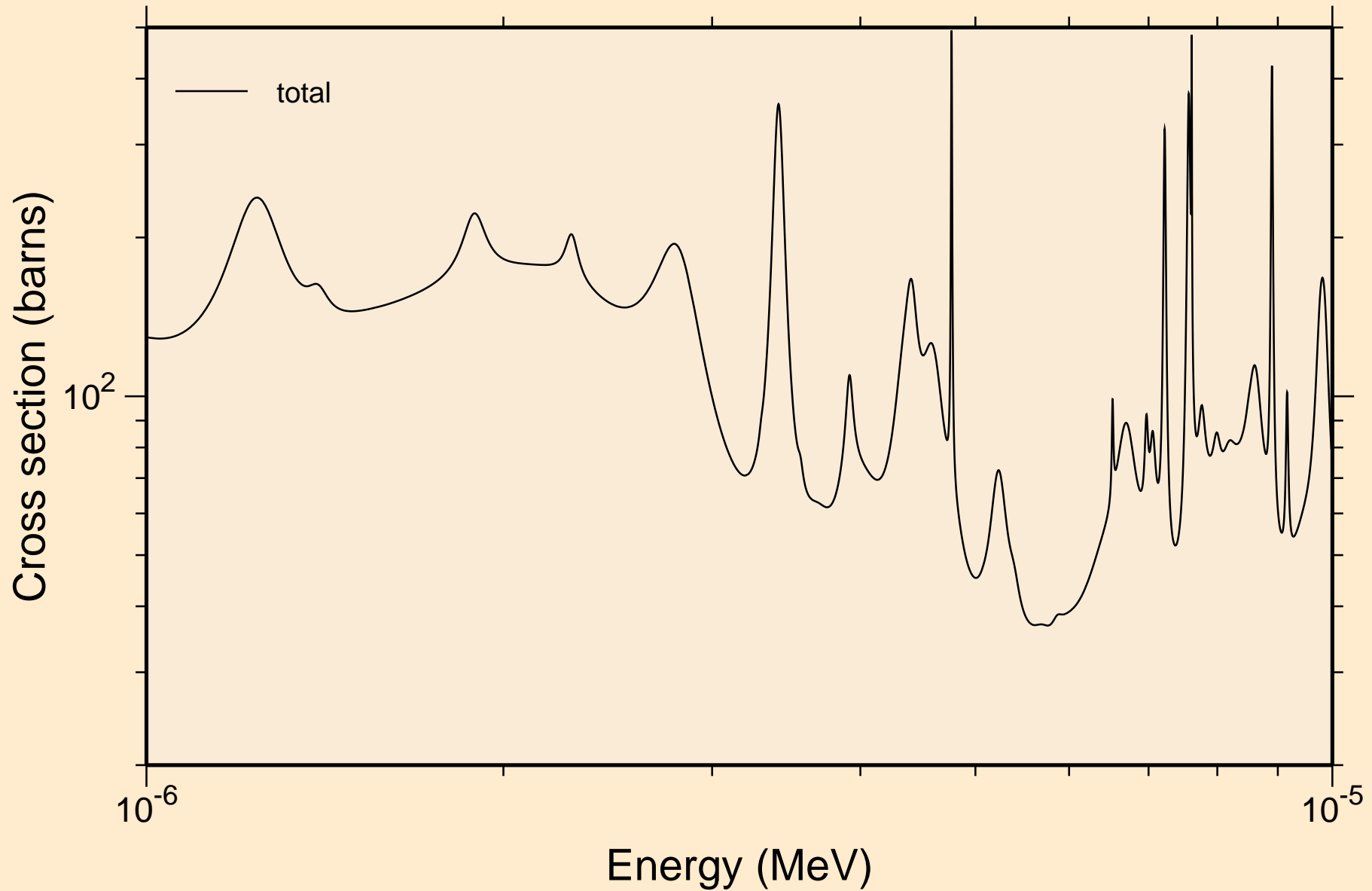

BH268 NEUTRON ACER TENDL-2024 LIBRARY; T=0.K  
resonance total cross section

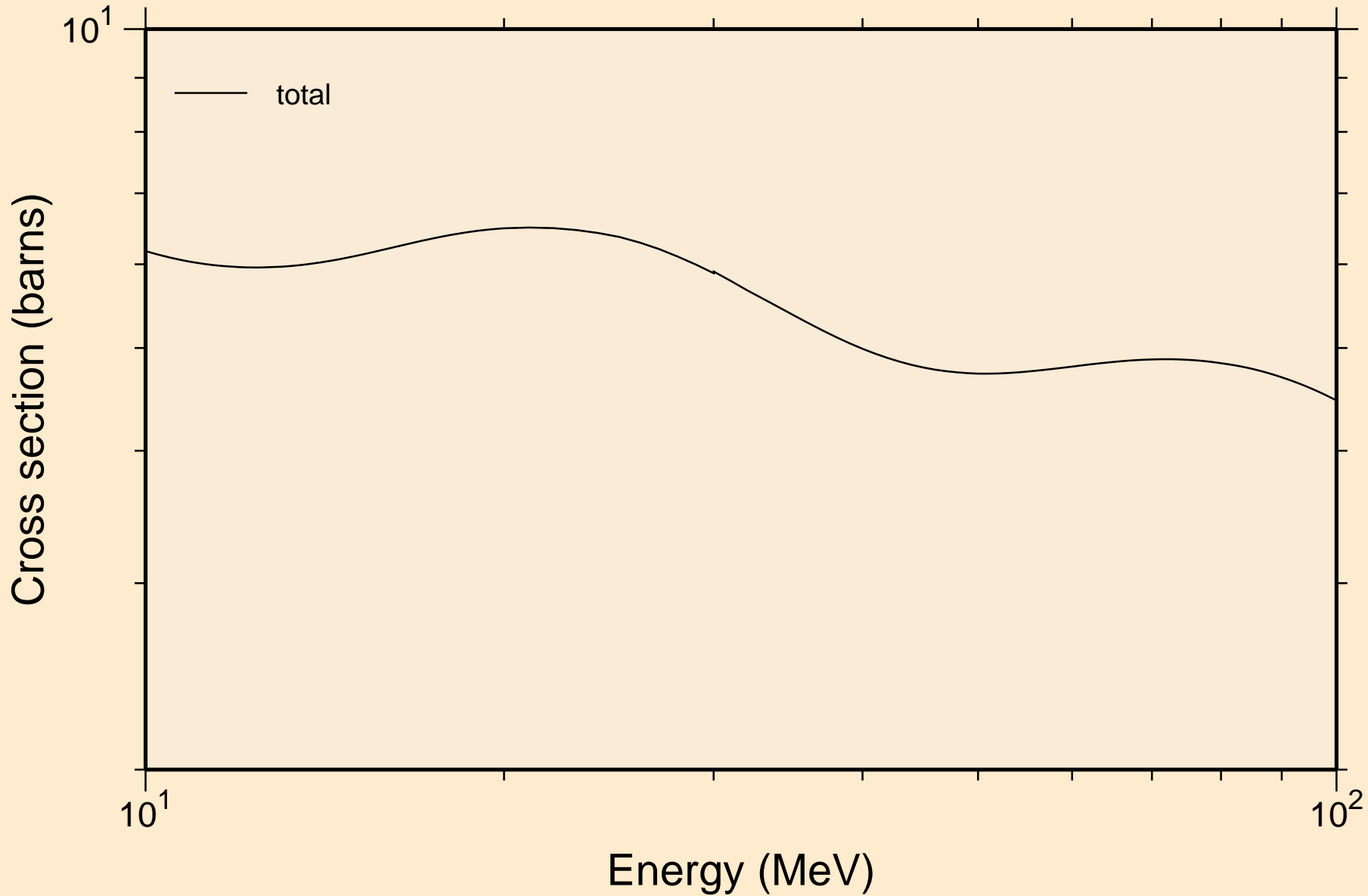

BH268 NEUTRON ACER TENDL-2024 LIBRARY; T=0.K  
resonance absorption cross sections

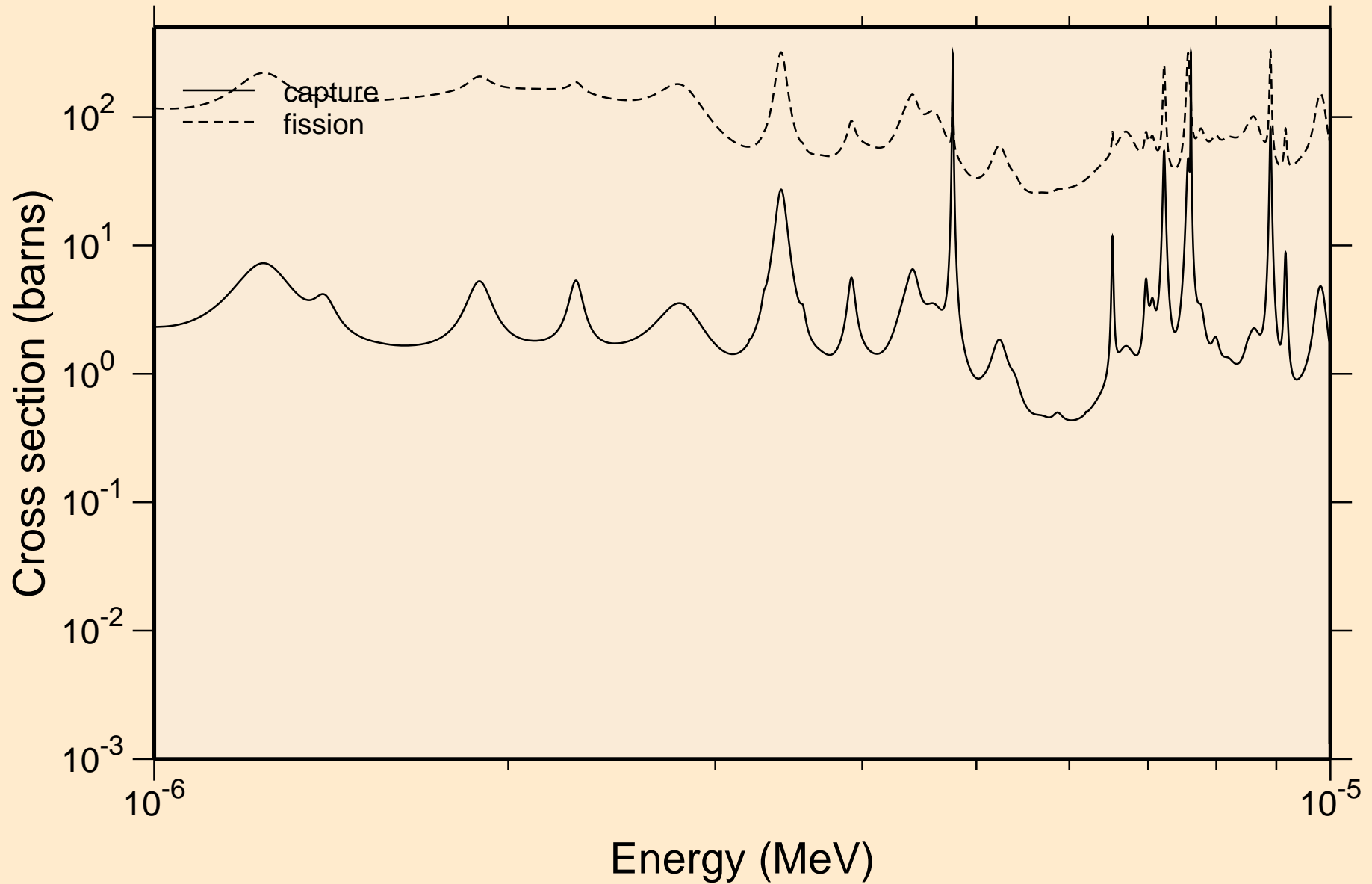

BH268 NEUTRON ACER TENDL-2024 LIBRARY; T=0.K  
resonance absorption cross sections

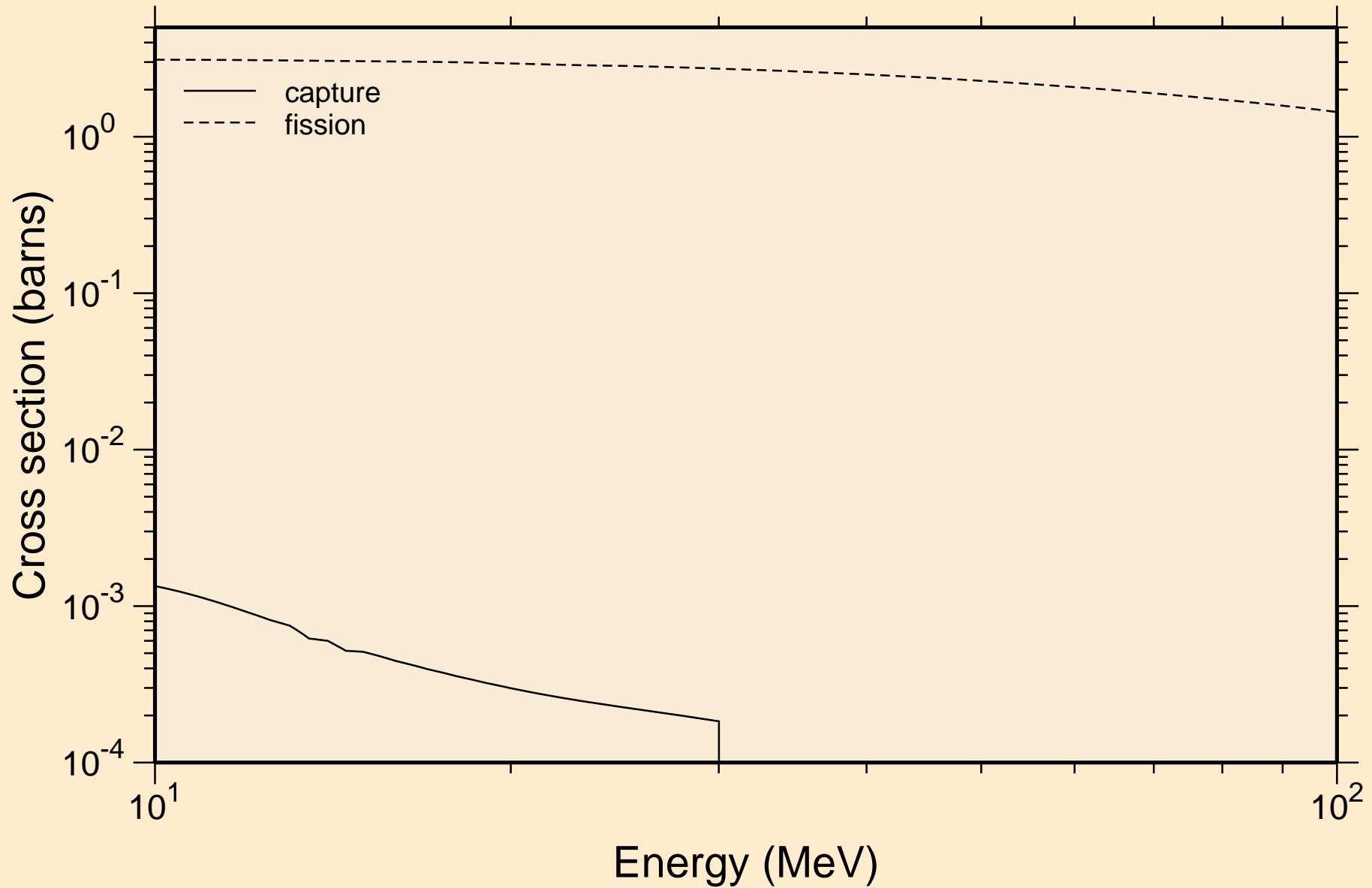

# BH268 NEUTRON ACER TENDL-2024 LIBRARY; T=0.K

## Heating

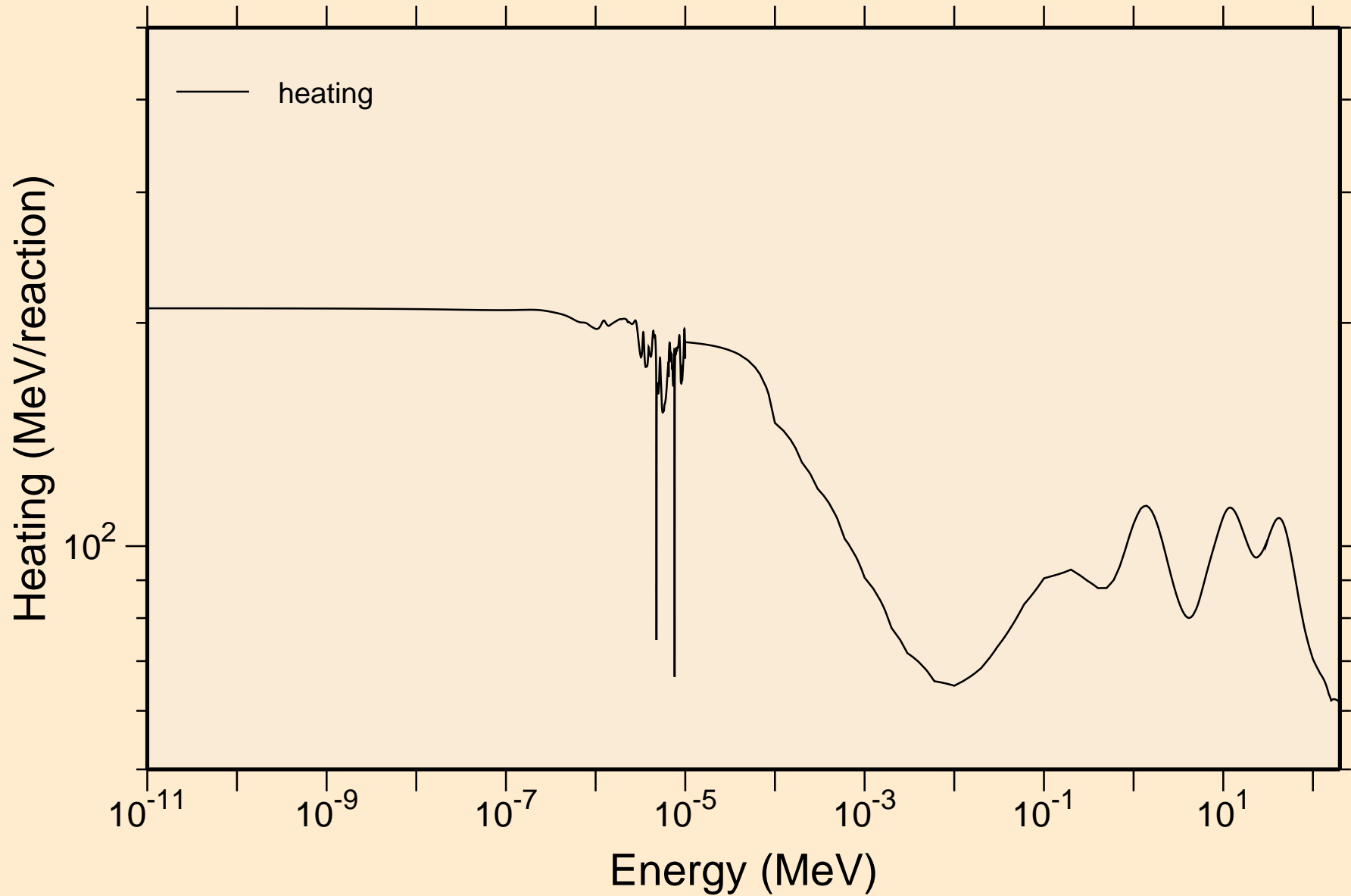

BH268 NEUTRON ACER TENDL-2024 LIBRARY; T=0.K  
Damage

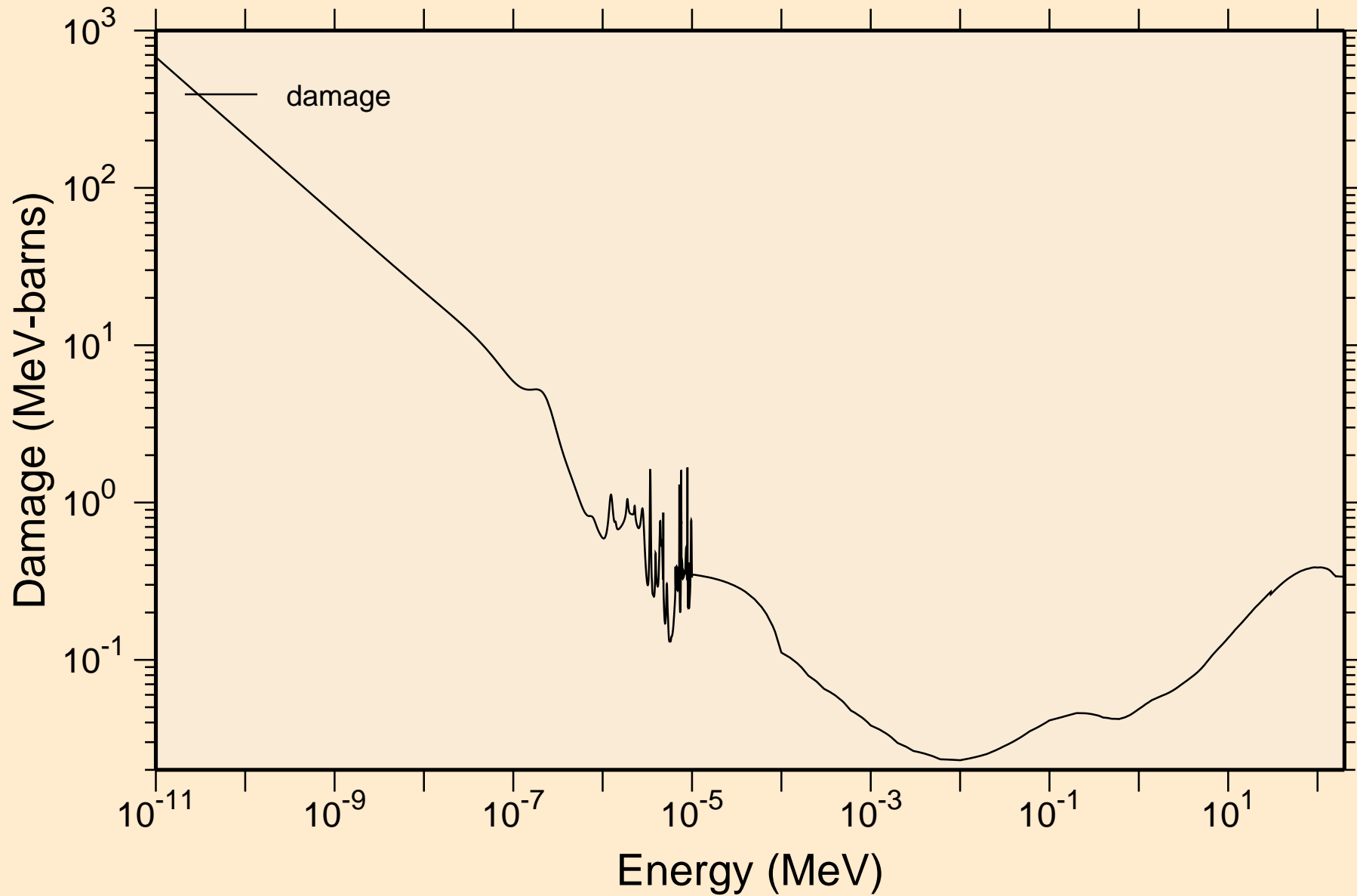

# BH268 NEUTRON ACER TENDL-2024 LIBRARY; T=0.K

## Non-threshold reactions

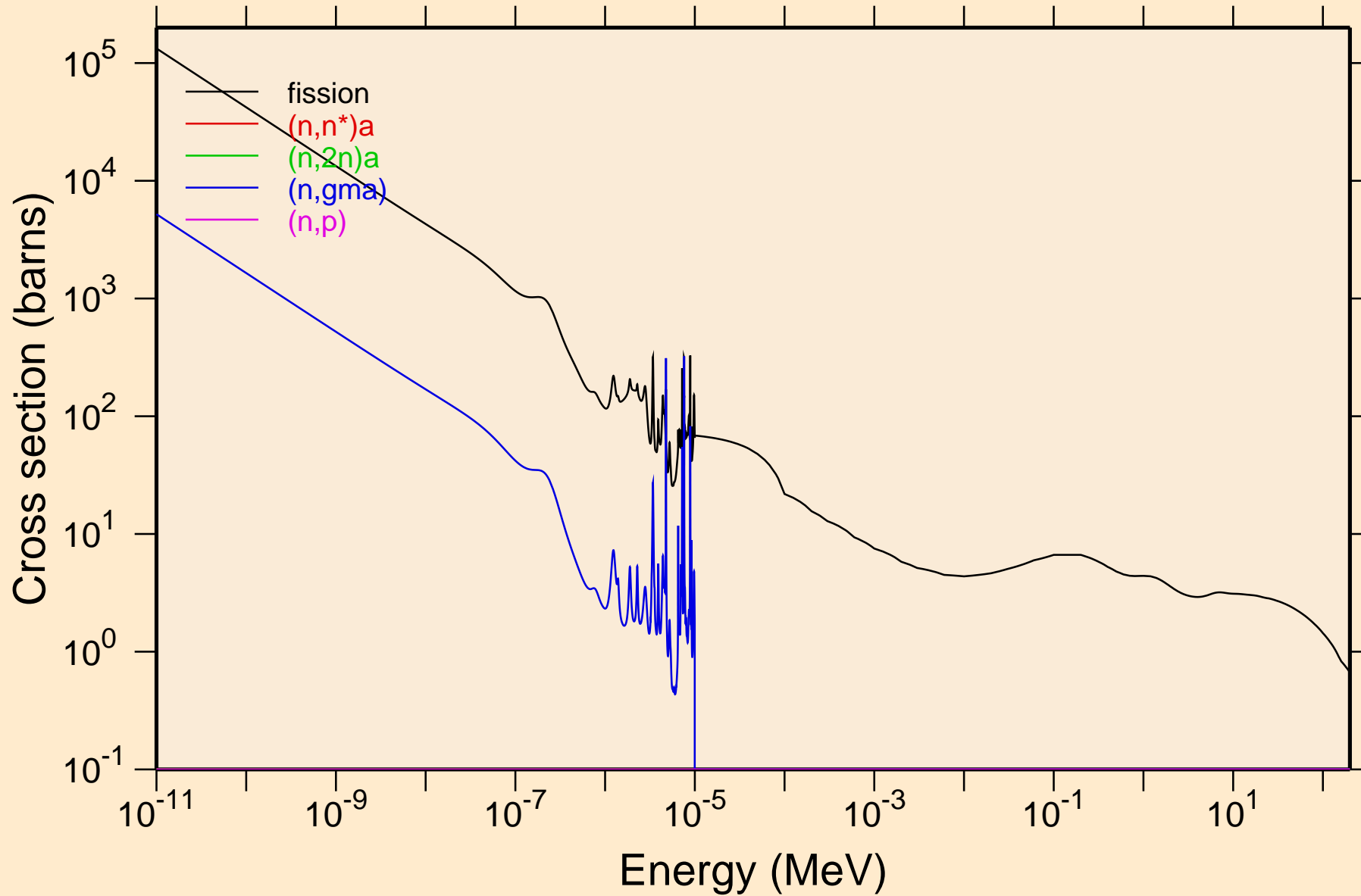



# BH268 NEUTRON ACER TENDL-2024 LIBRARY; T=0.K

## Non-threshold reactions

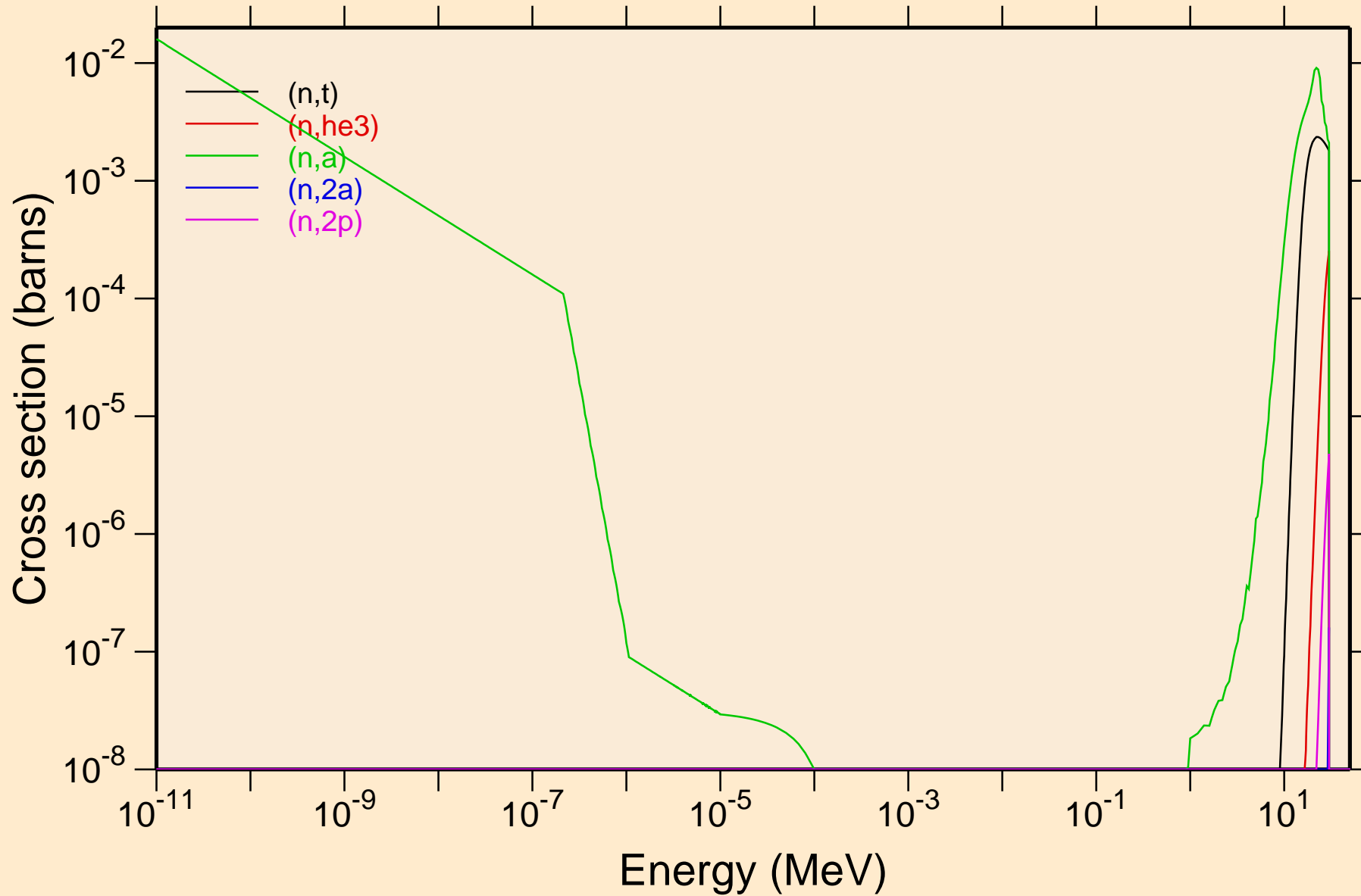

# BH268 NEUTRON ACER TENDL-2024 LIBRARY; T=0.K

## Non-threshold reactions

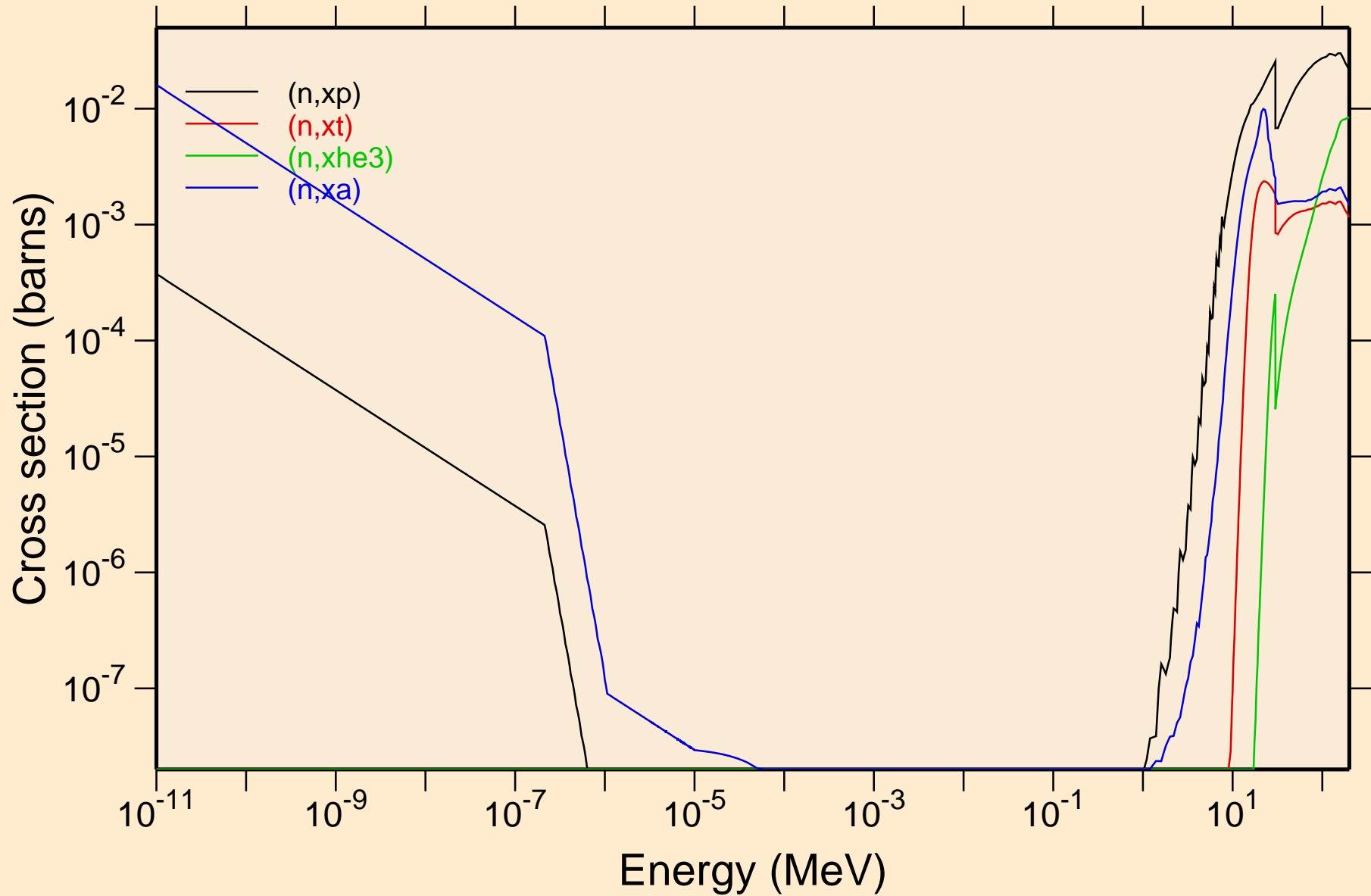

# BH268 NEUTRON ACER TENDL-2024 LIBRARY; T=0.K

## Principal cross sections

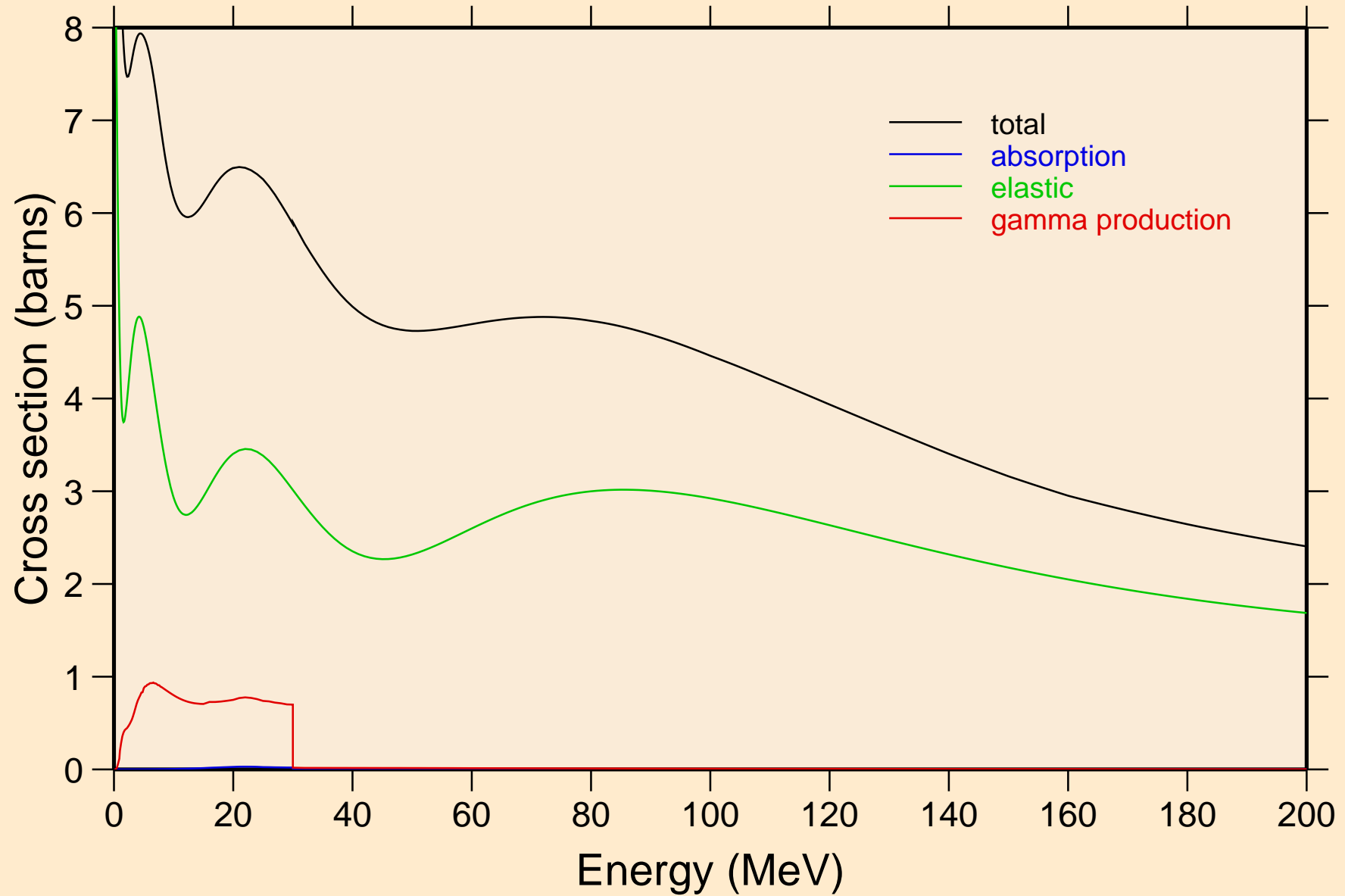

# BH268 NEUTRON ACER TENDL-2024 LIBRARY; T=0.K

## Heating

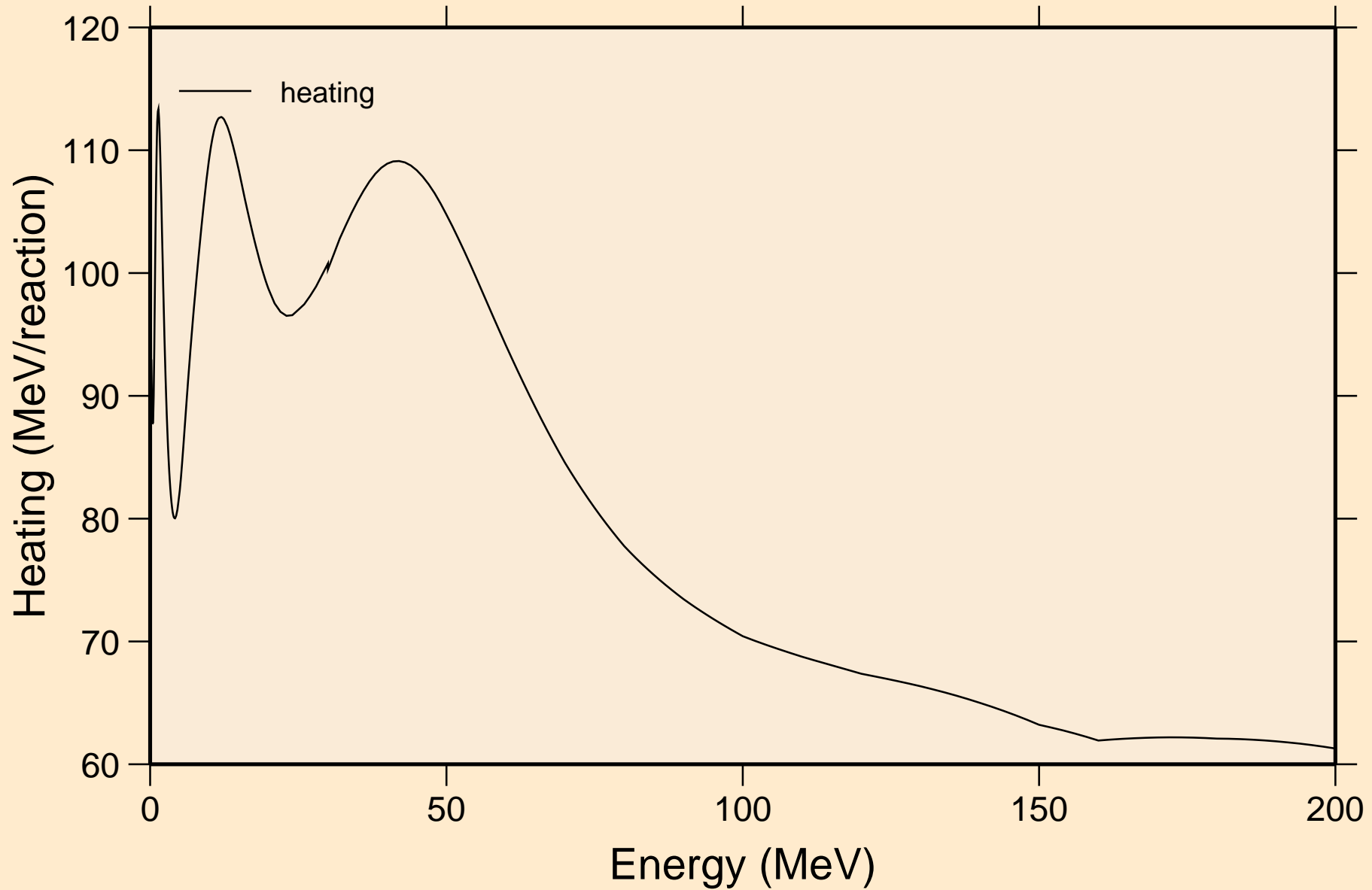

BH268 NEUTRON ACER TENDL-2024 LIBRARY; T=0.K  
Damage

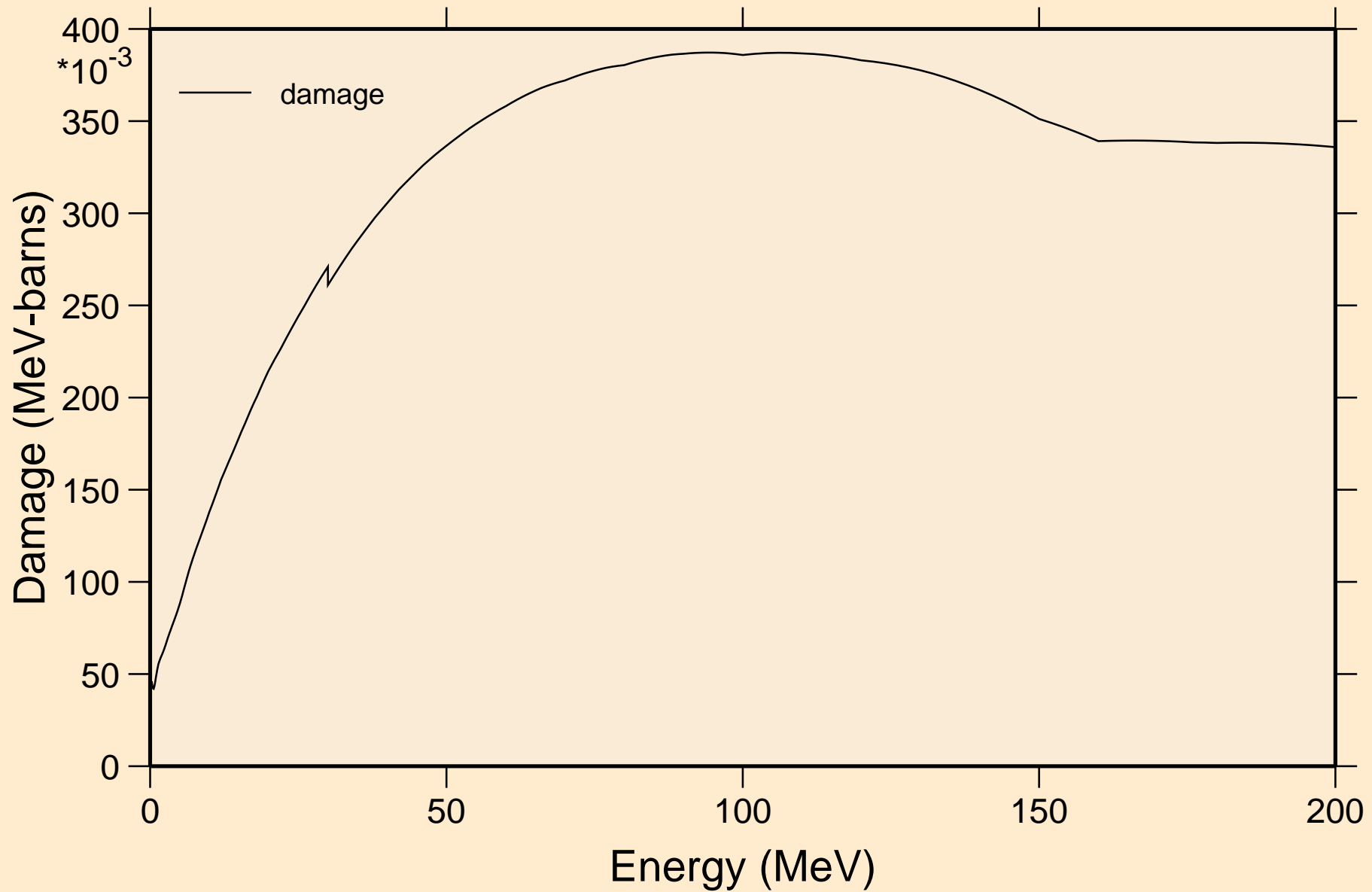

BH268 NEUTRON ACER TENDL-2024 LIBRARY; T=0.K  
Non-threshold reactions

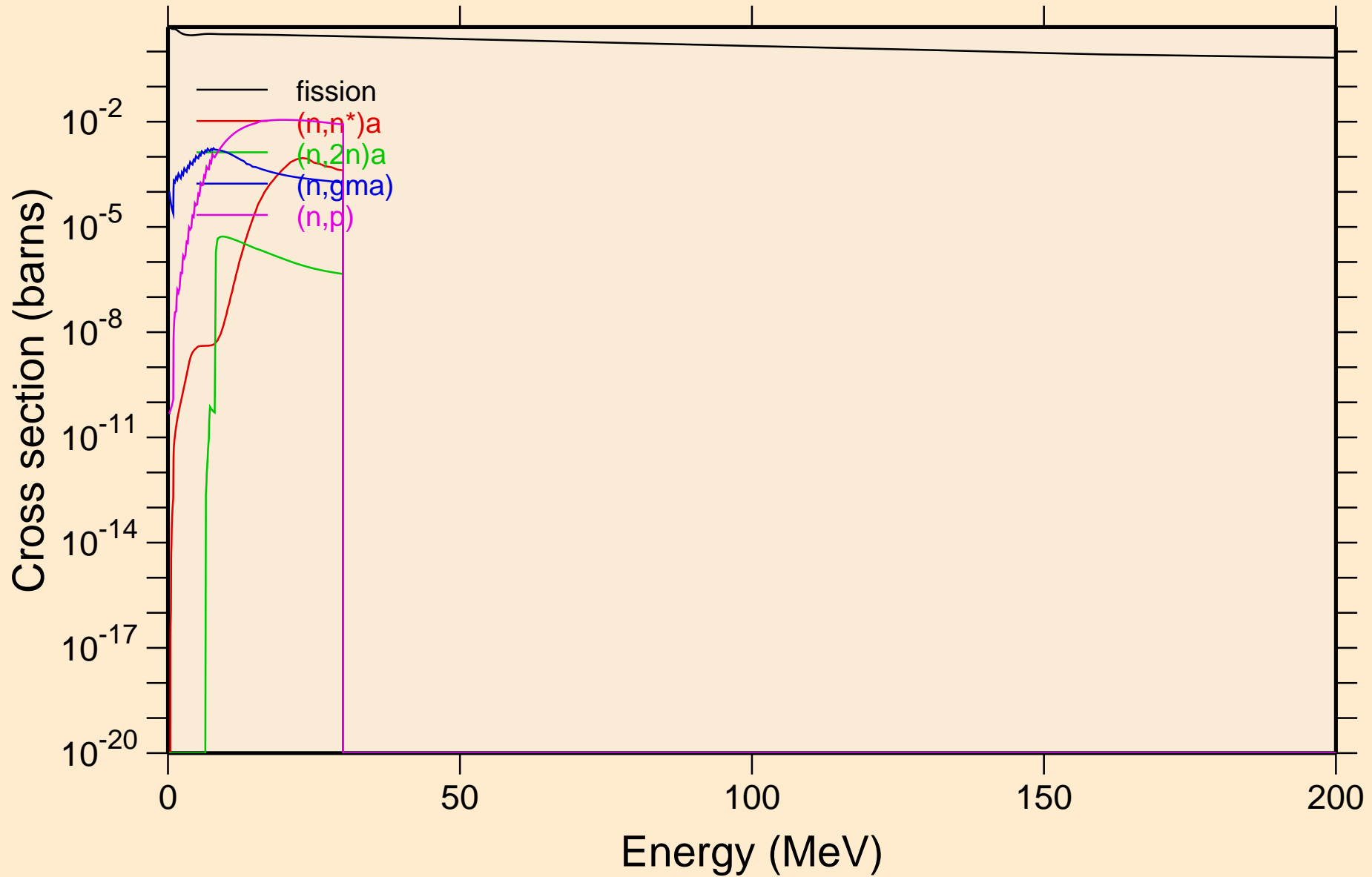

BH268 NEUTRON ACER TENDL-2024 LIBRARY; T=0.K  
Non-threshold reactions

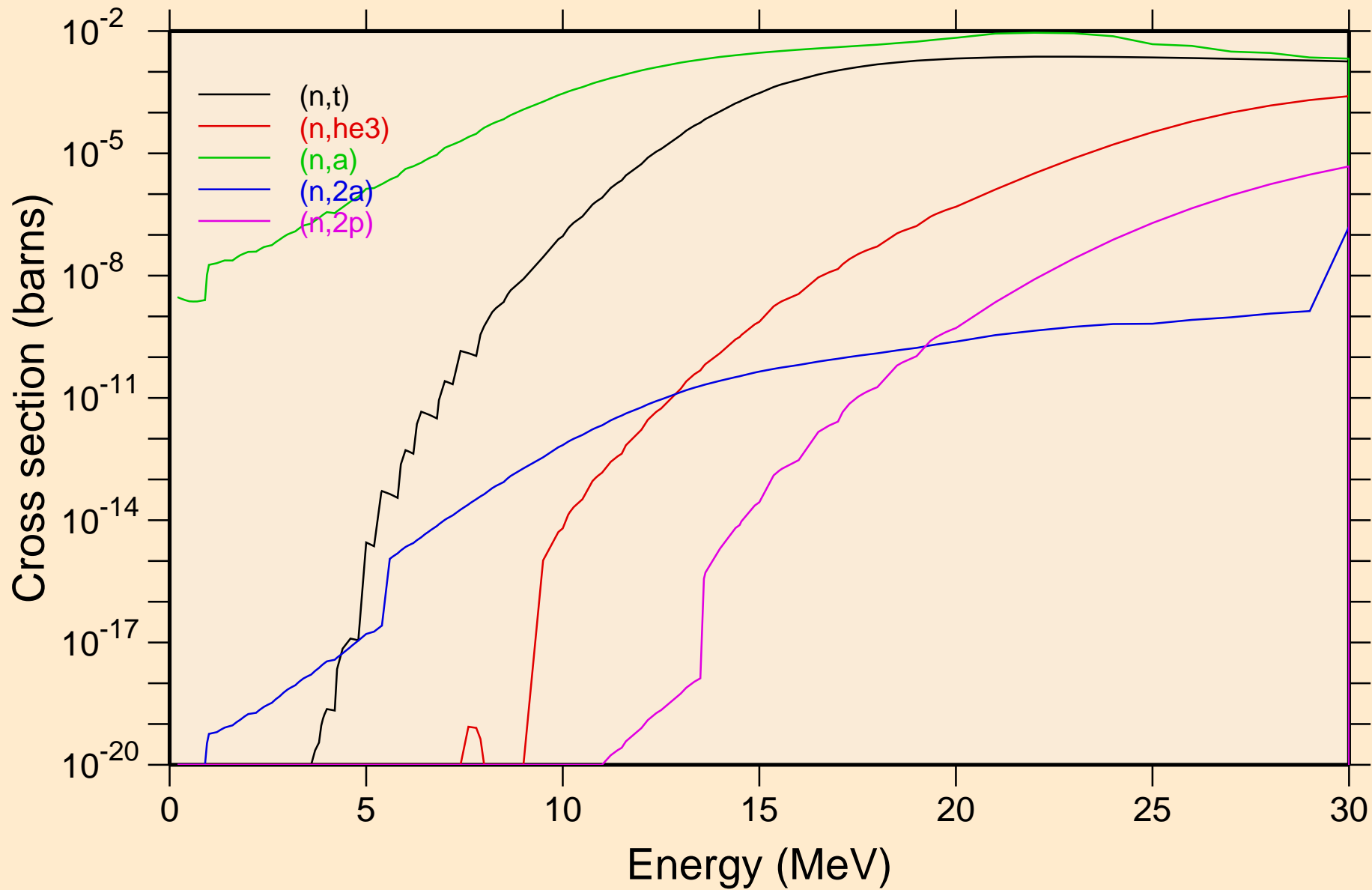

BH268 NEUTRON ACER TENDL-2024 LIBRARY; T=0.K  
Non-threshold reactions

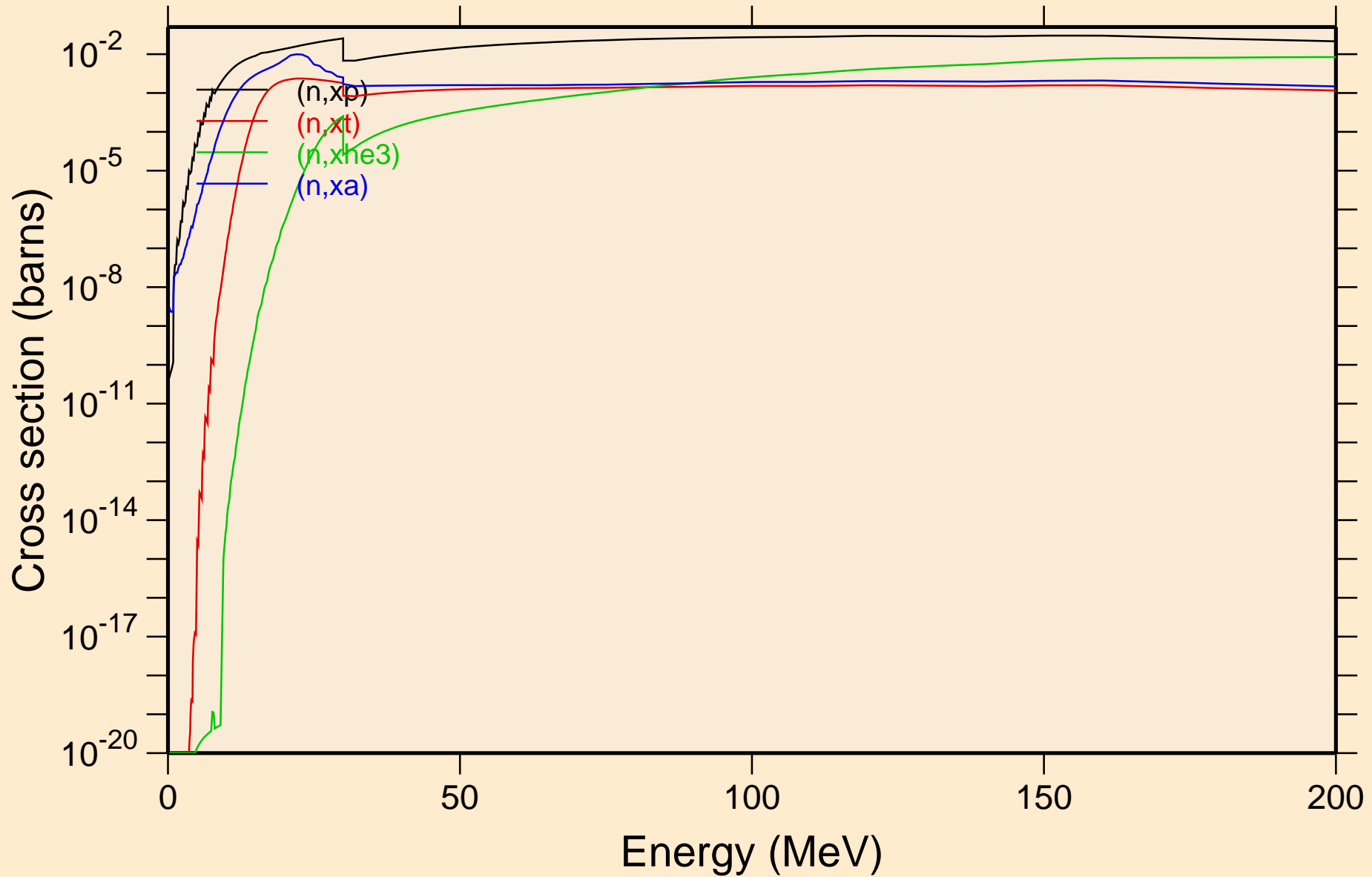



BH268 NEUTRON ACER TENDL-2024 LIBRARY; T=0.K  
Inelastic levels

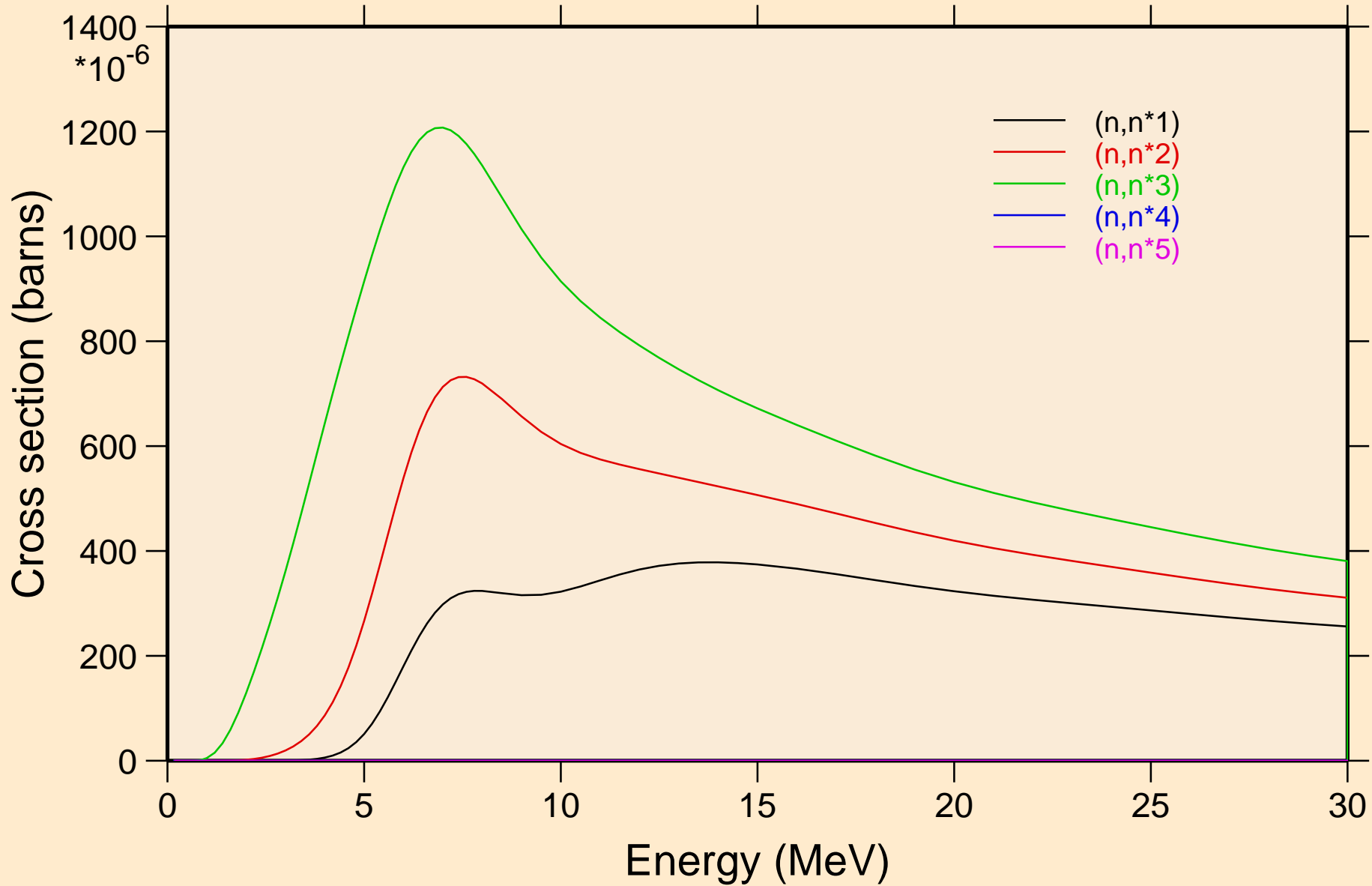

BH268 NEUTRON ACER TENDL-2024 LIBRARY; T=0.K  
Inelastic levels

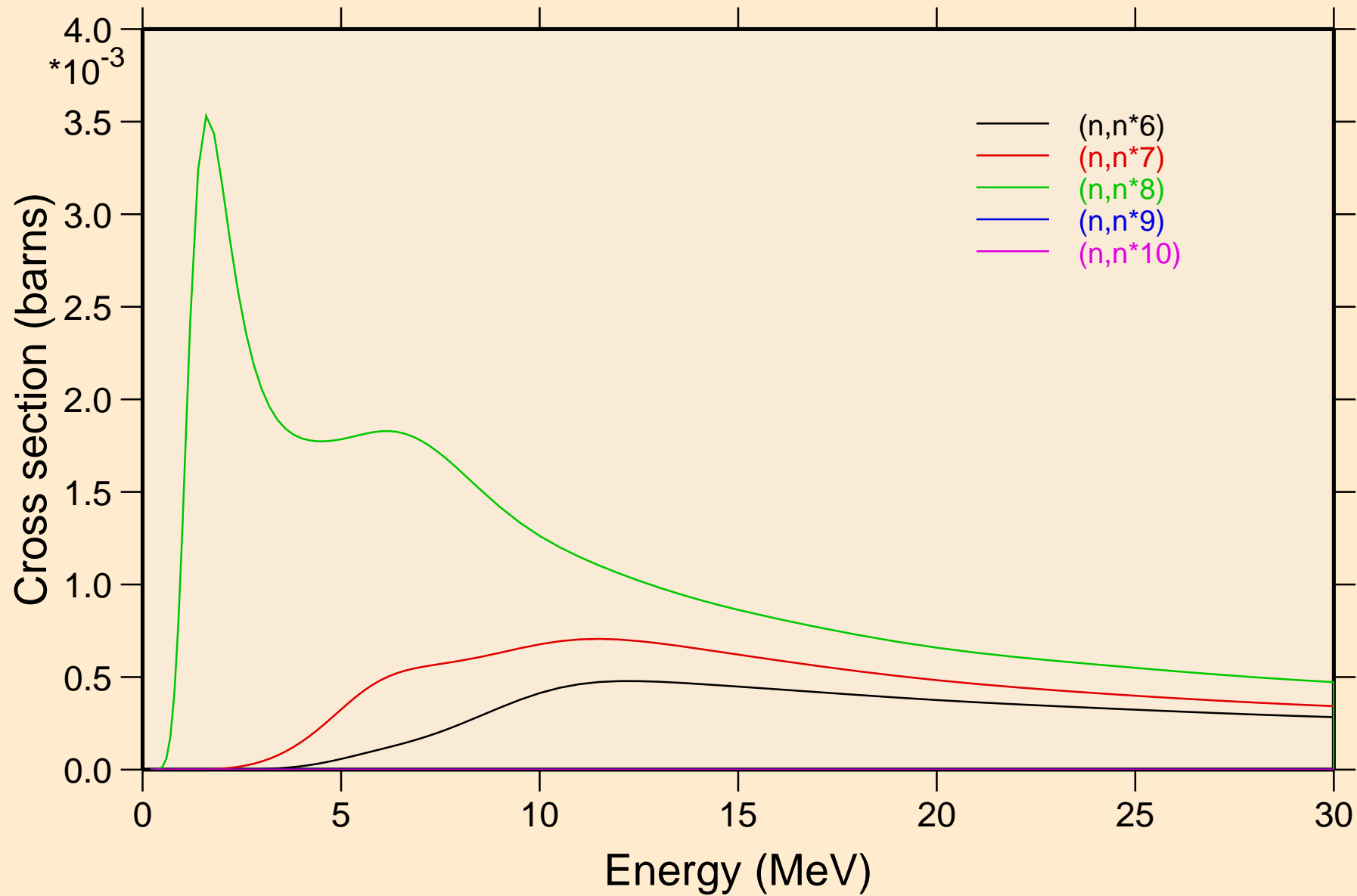

BH268 NEUTRON ACER TENDL-2024 LIBRARY; T=0.K  
Inelastic levels

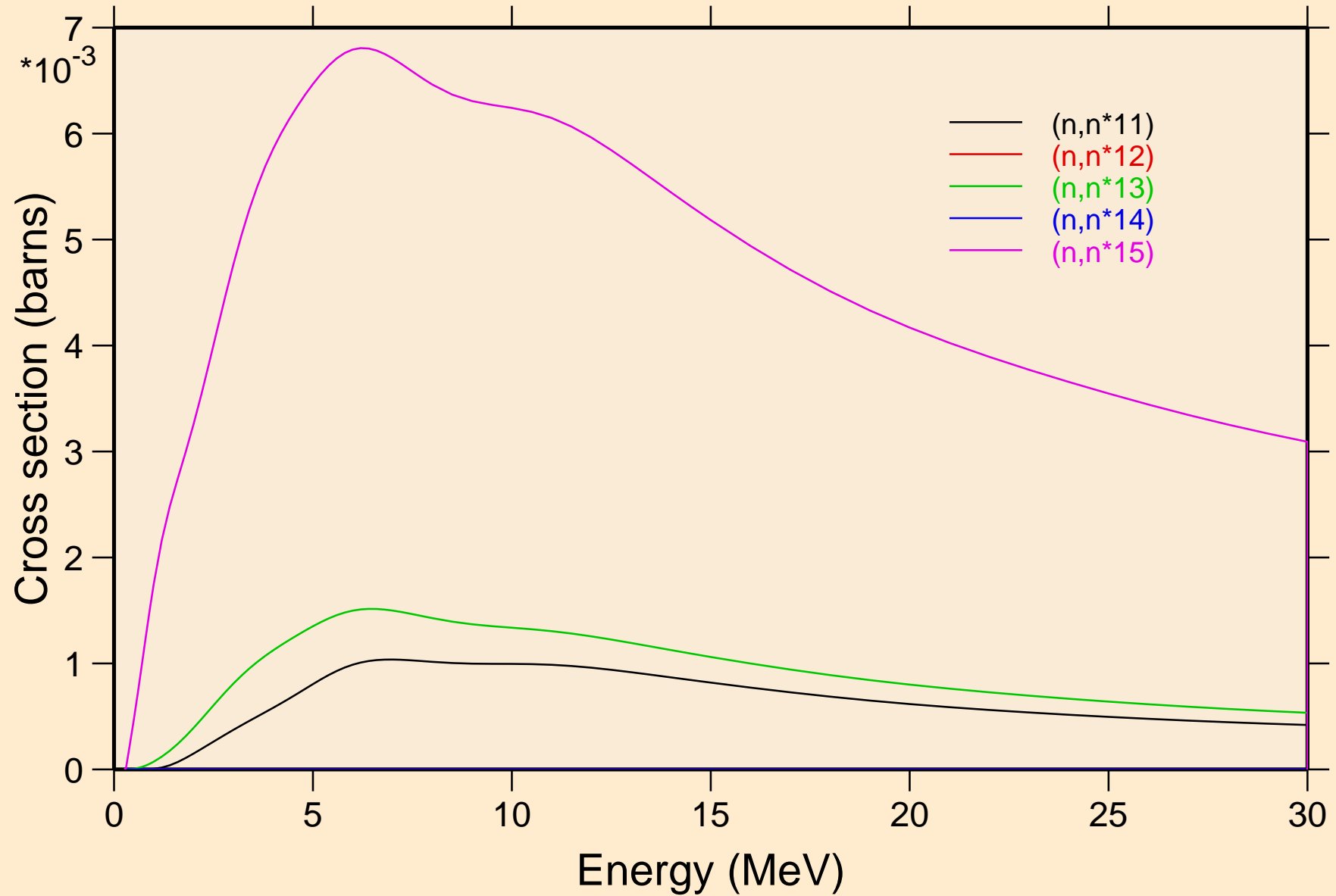

BH268 NEUTRON ACER TENDL-2024 LIBRARY; T=0.K  
Inelastic levels

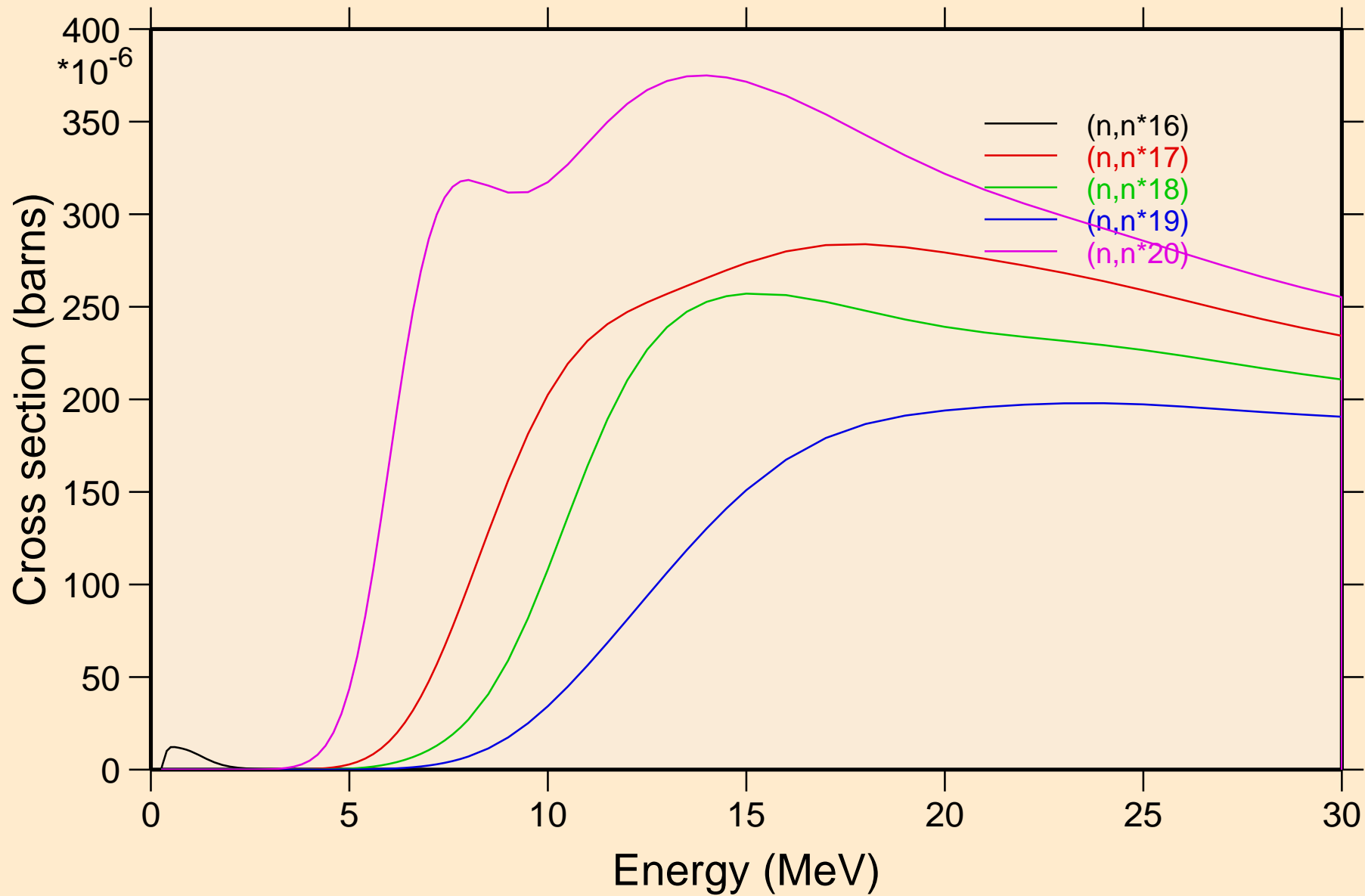

BH268 NEUTRON ACER TENDL-2024 LIBRARY; T=0.K  
Inelastic levels

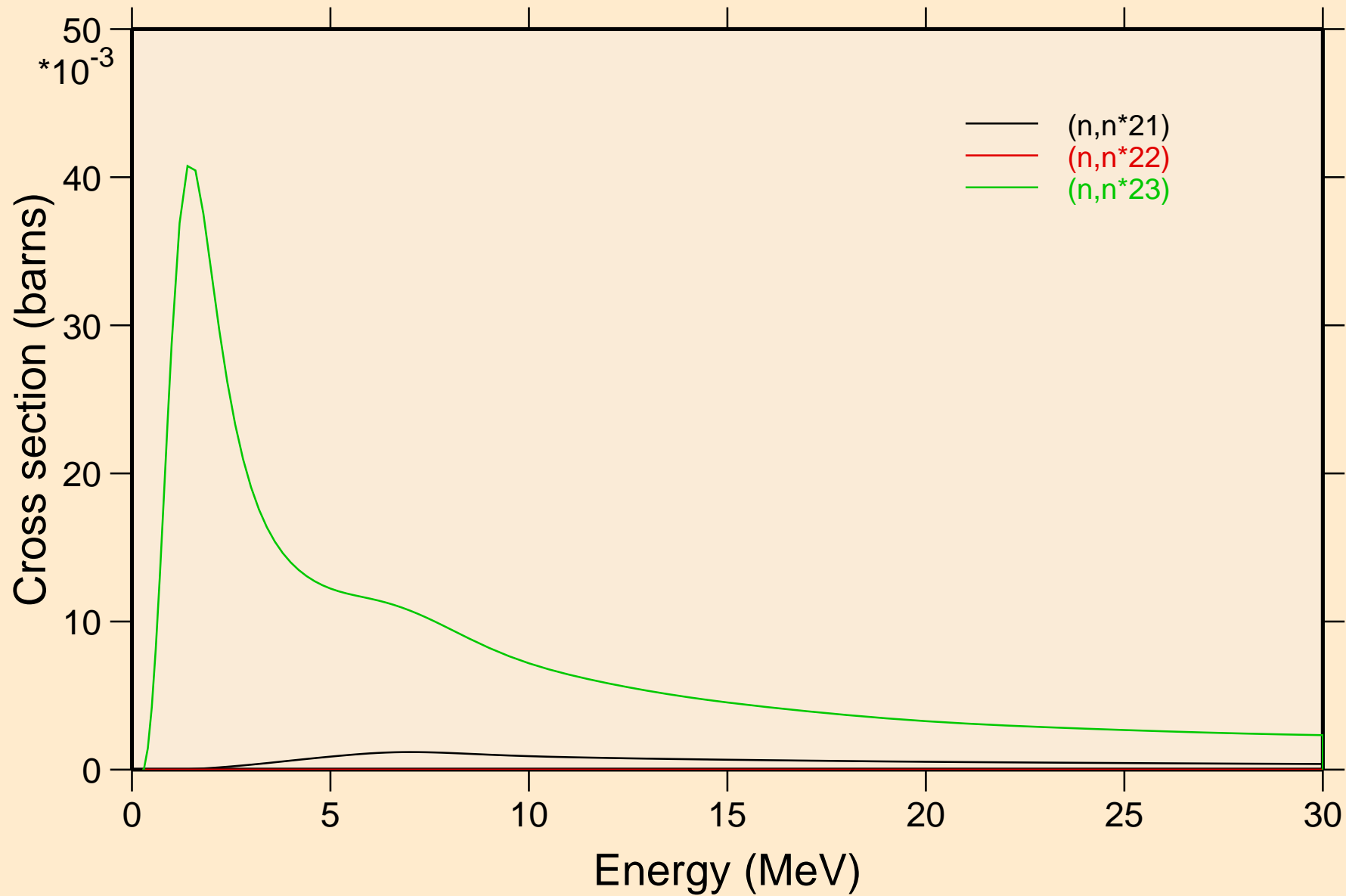

BH268 NEUTRON ACER TENDL-2024 LIBRARY; T=0.K  
Threshold reactions

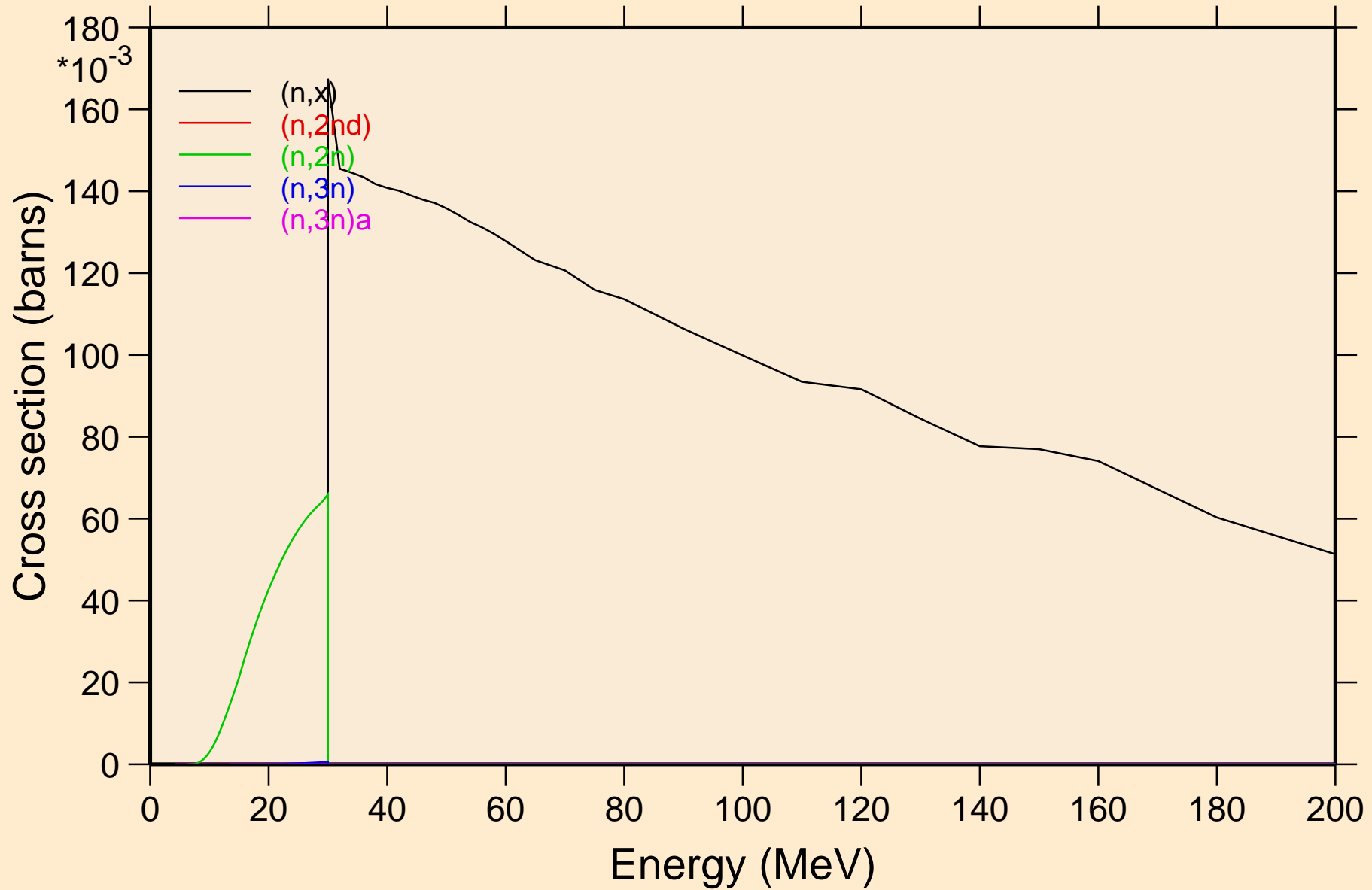

BH268 NEUTRON ACER TENDL-2024 LIBRARY; T=0.K  
Threshold reactions

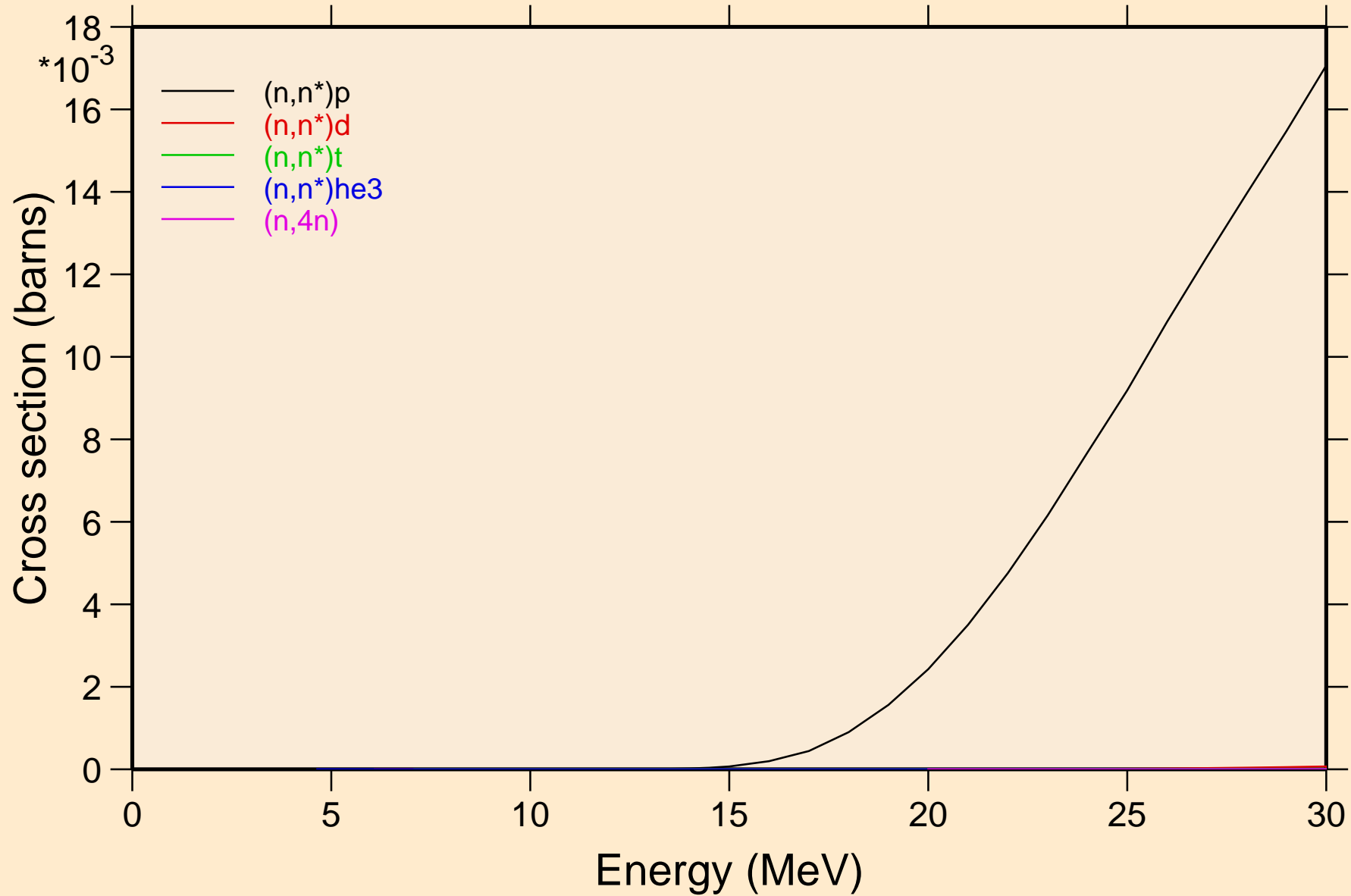

BH268 NEUTRON ACER TENDL-2024 LIBRARY; T=0.K  
Threshold reactions

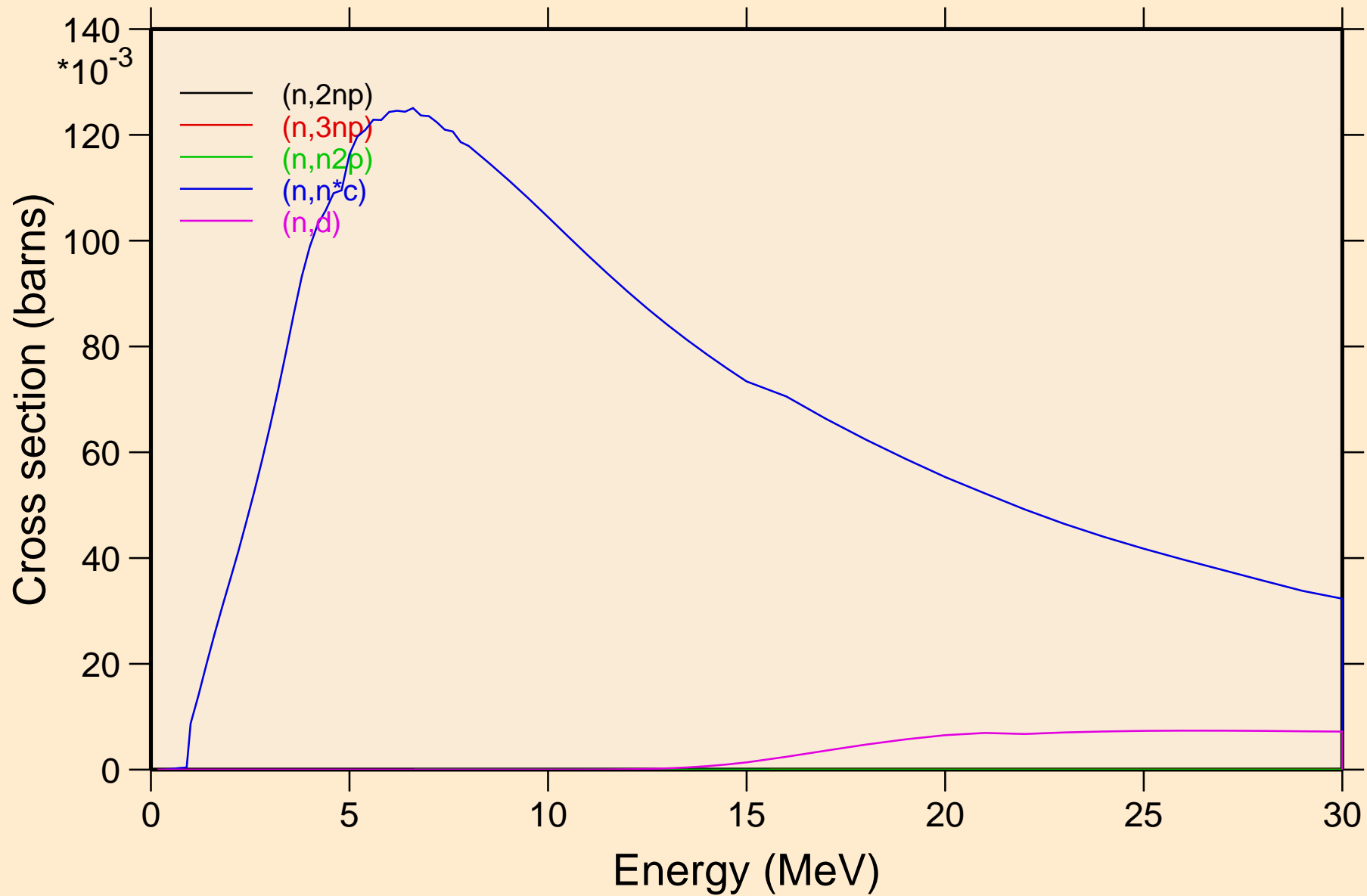



BH268 NEUTRON ACER TENDL-2024 LIBRARY; T=0.K  
Threshold reactions

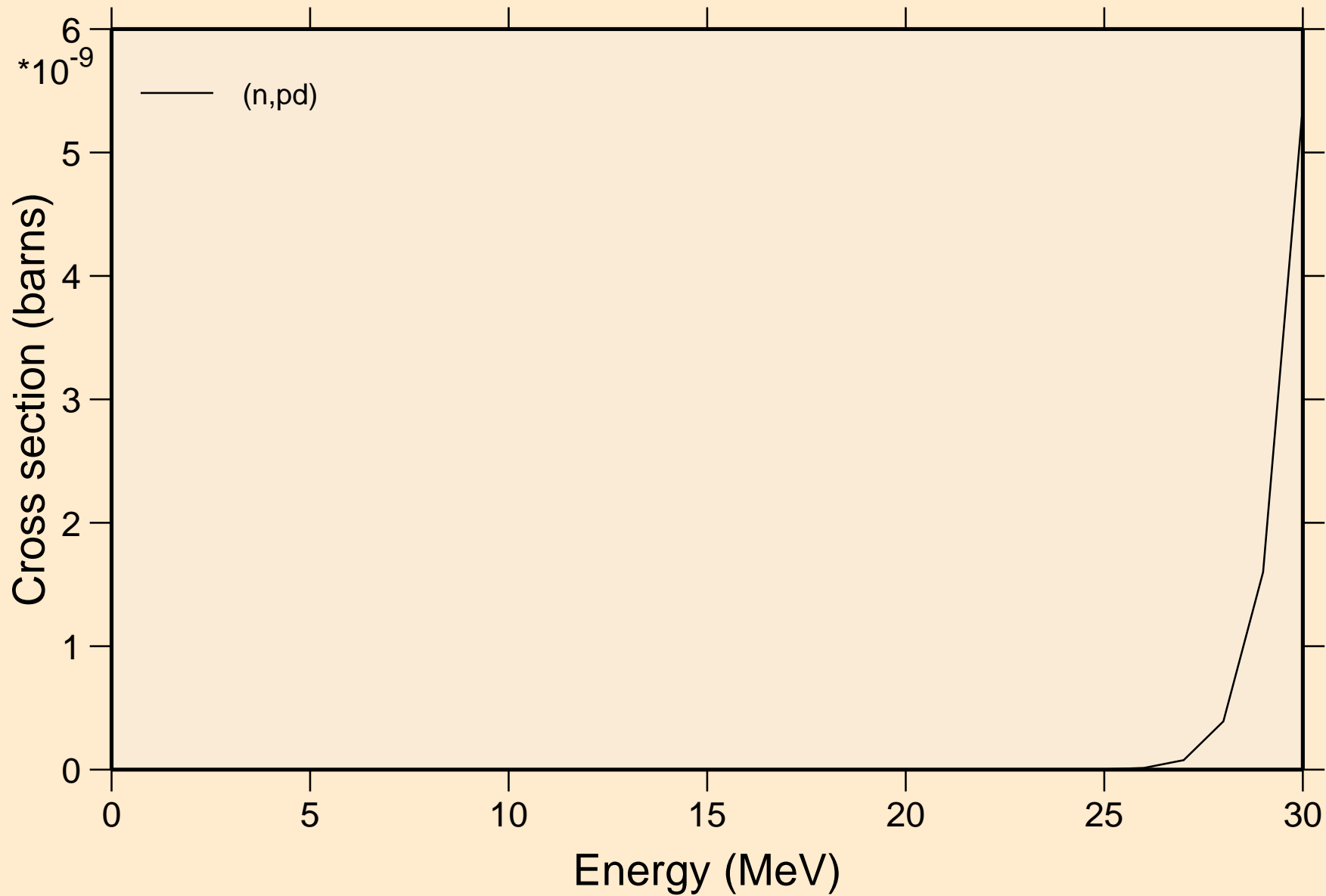

BH268 NEUTRON ACER TENDL-2024 LIBRARY; T=0.K  
Threshold reactions

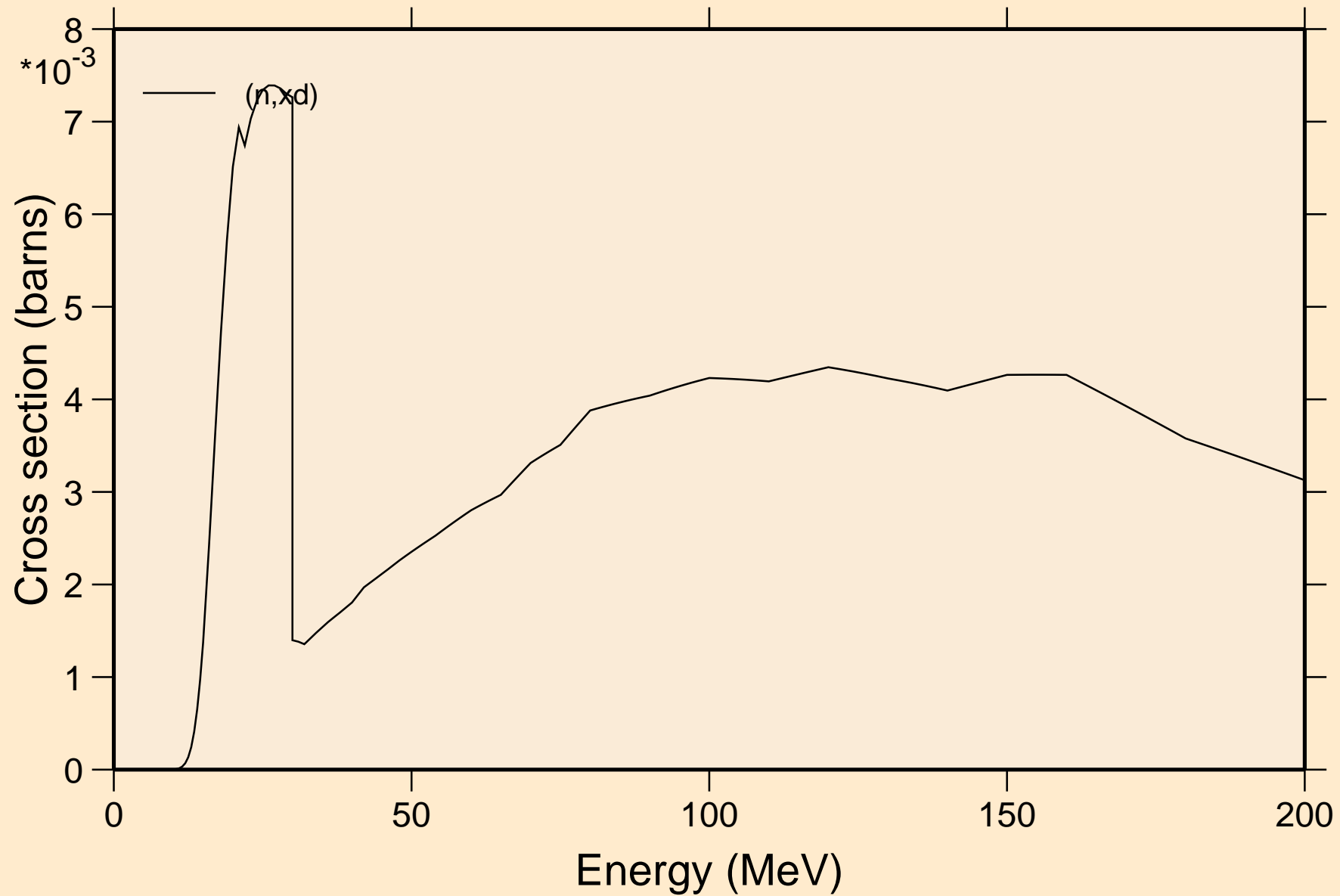

BH268 NEUTRON ACER TENDL-2024 LIBRARY; T=0.K  
angular distribution for elastic

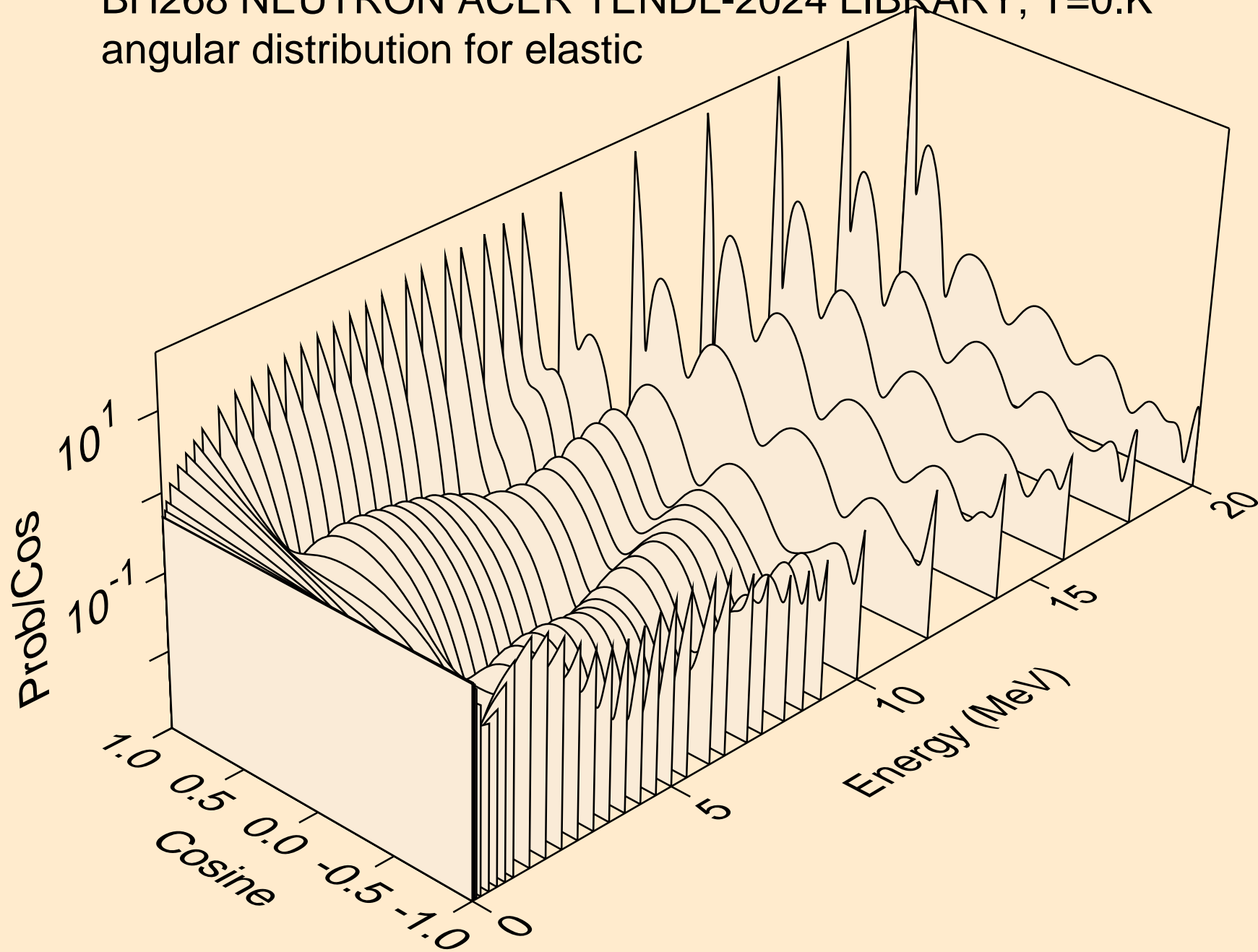

BH268 NEUTRON ACER TENDL-2024 LIBRARY; T=0.K  
angular distribution for elastic

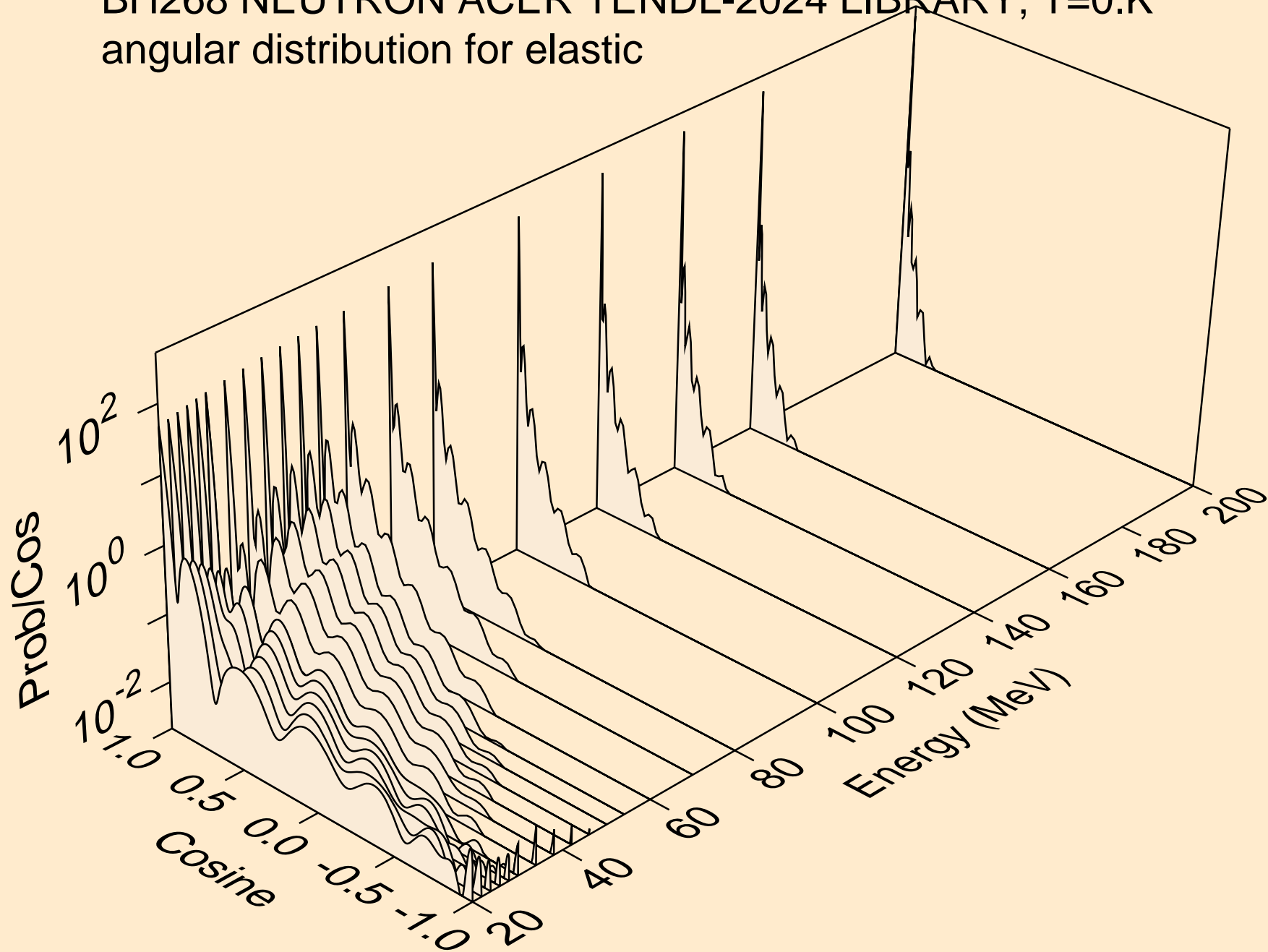

BH268 NEUTRON ACER TENDL-2024 LIBRARY; T=0.K  
angular distribution for (n,n\*1)

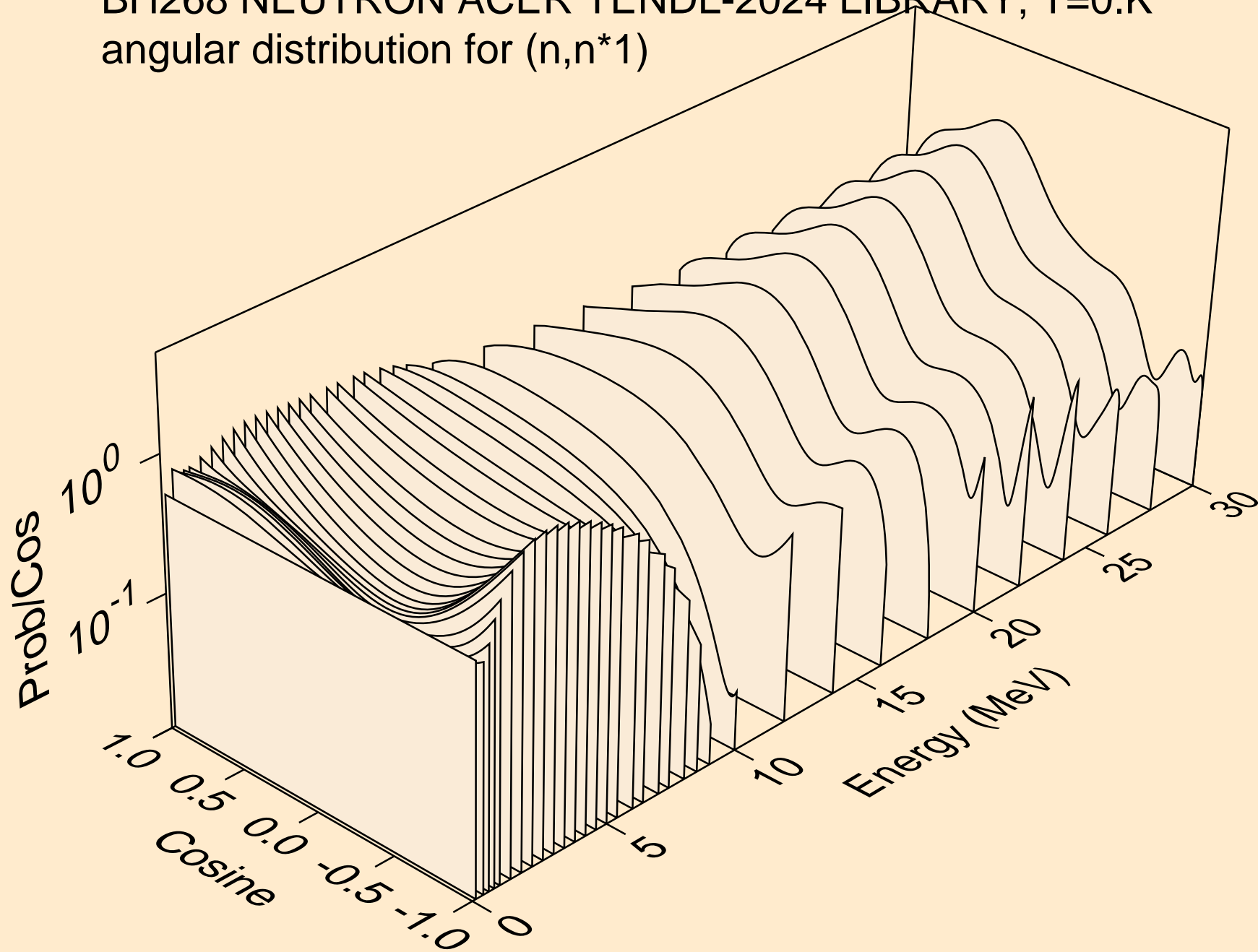

BH268 NEUTRON ACER TENDL-2024 LIBRARY; T=0.K  
angular distribution for (n,n\*2)

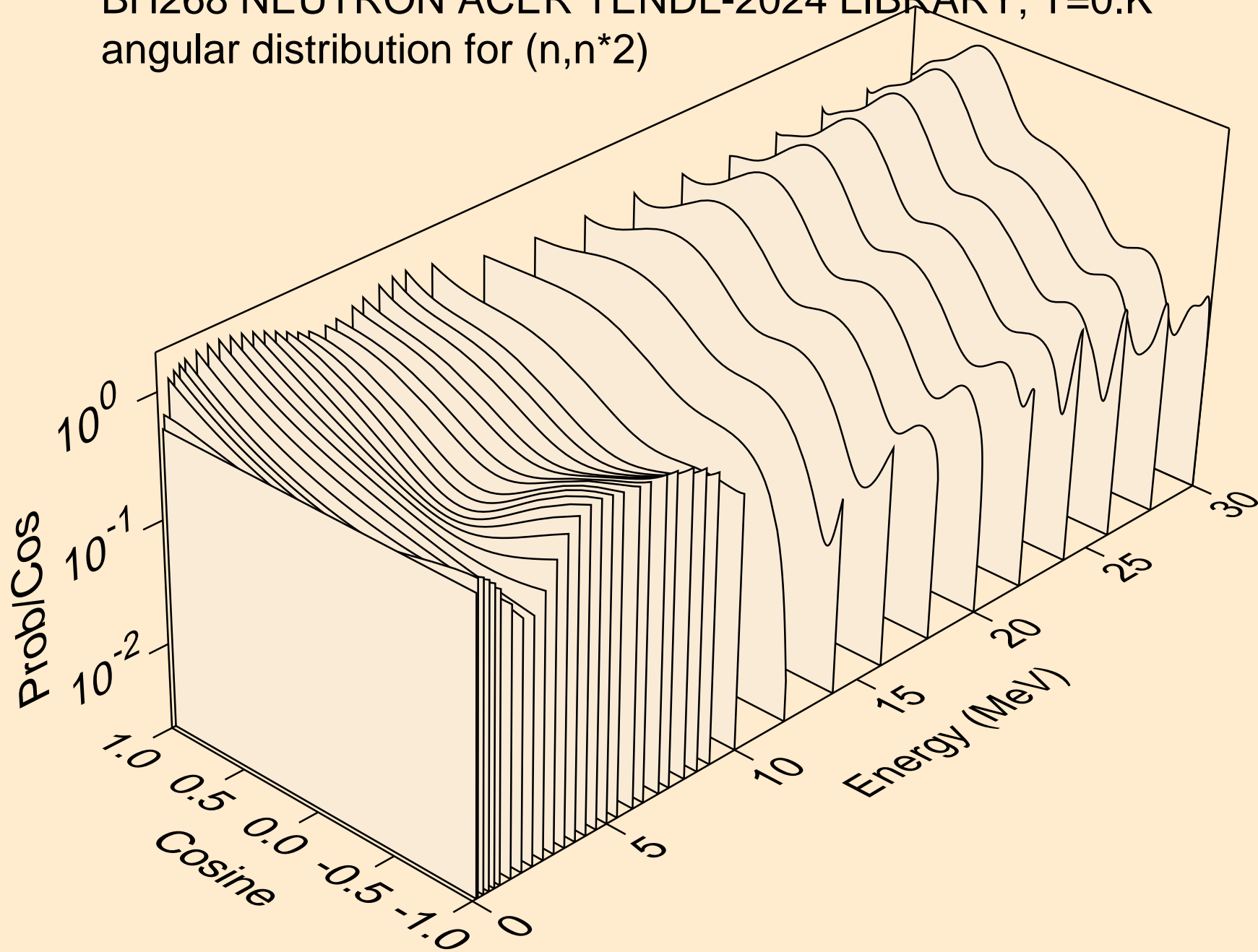

BH268 NEUTRON ACER TENDL-2024 LIBRARY; T=0.K  
angular distribution for (n,n\*3)

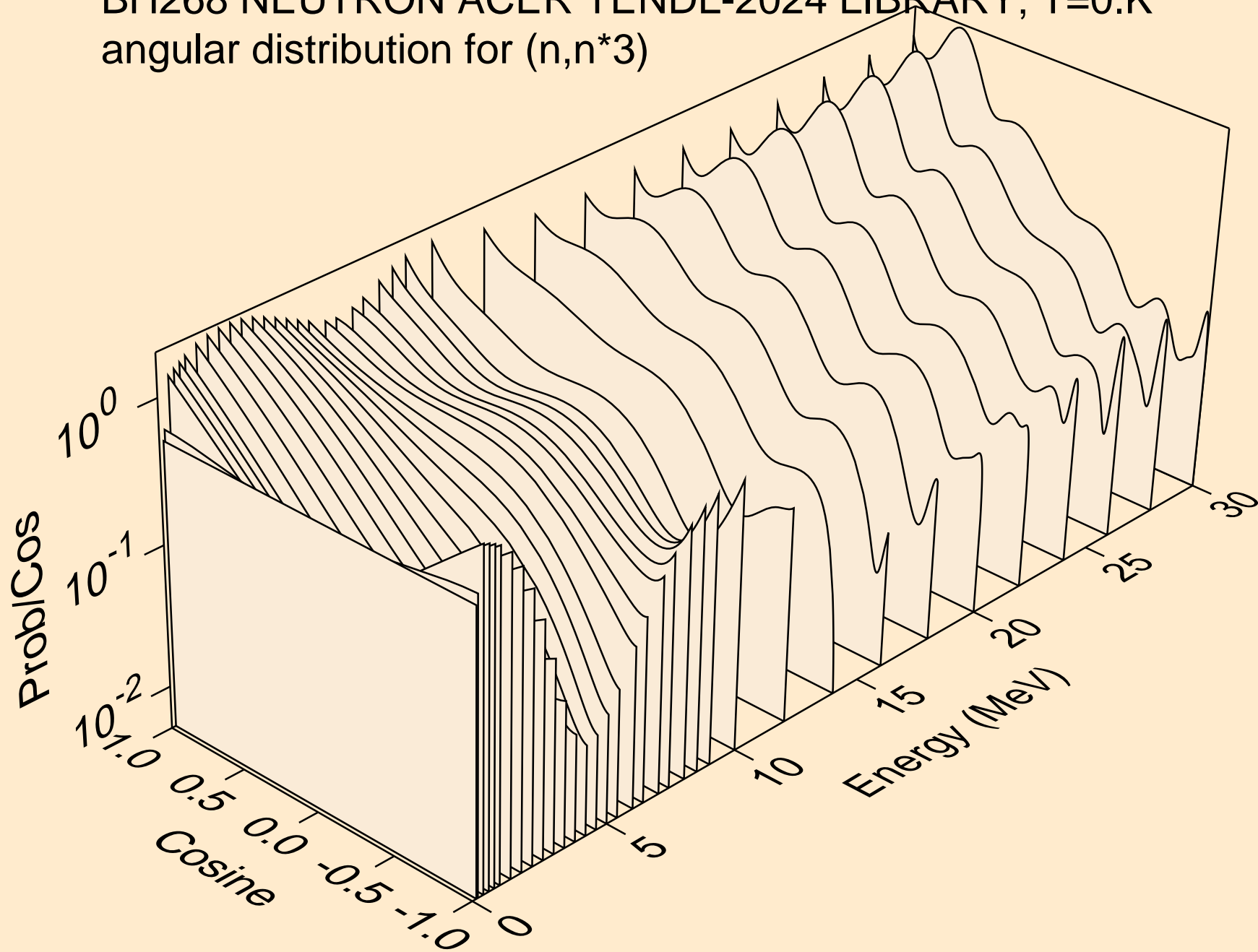

BH268 NEUTRON ACER TENDL-2024 LIBRARY; T=0.K  
angular distribution for (n,n\*4)

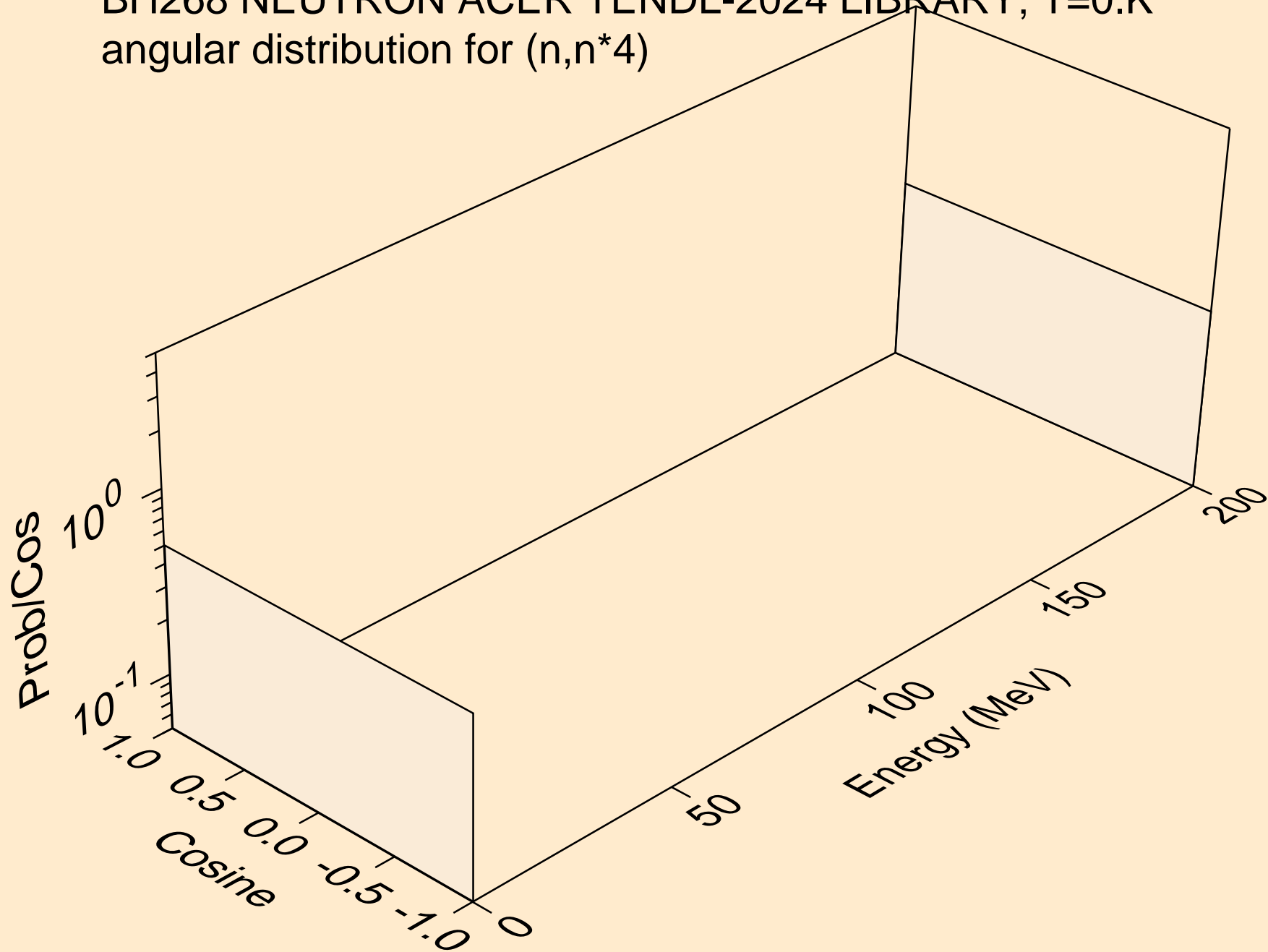



BH268 NEUTRON ACER TENDL-2024 LIBRARY; T=0.K  
angular distribution for (n,n\*5)

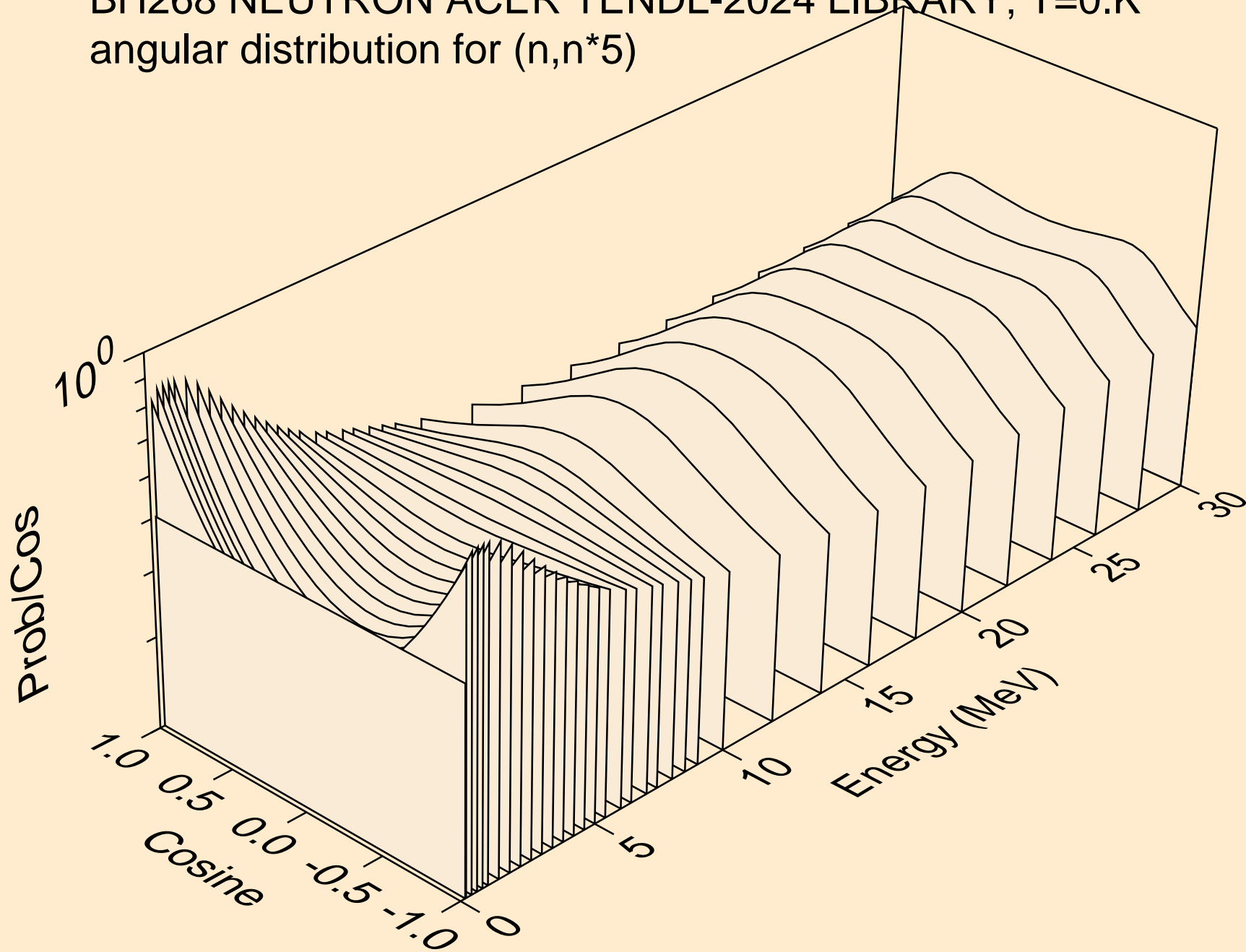

BH268 NEUTRON ACER TENDL-2024 LIBRARY; T=0.K  
angular distribution for (n,n\*6)

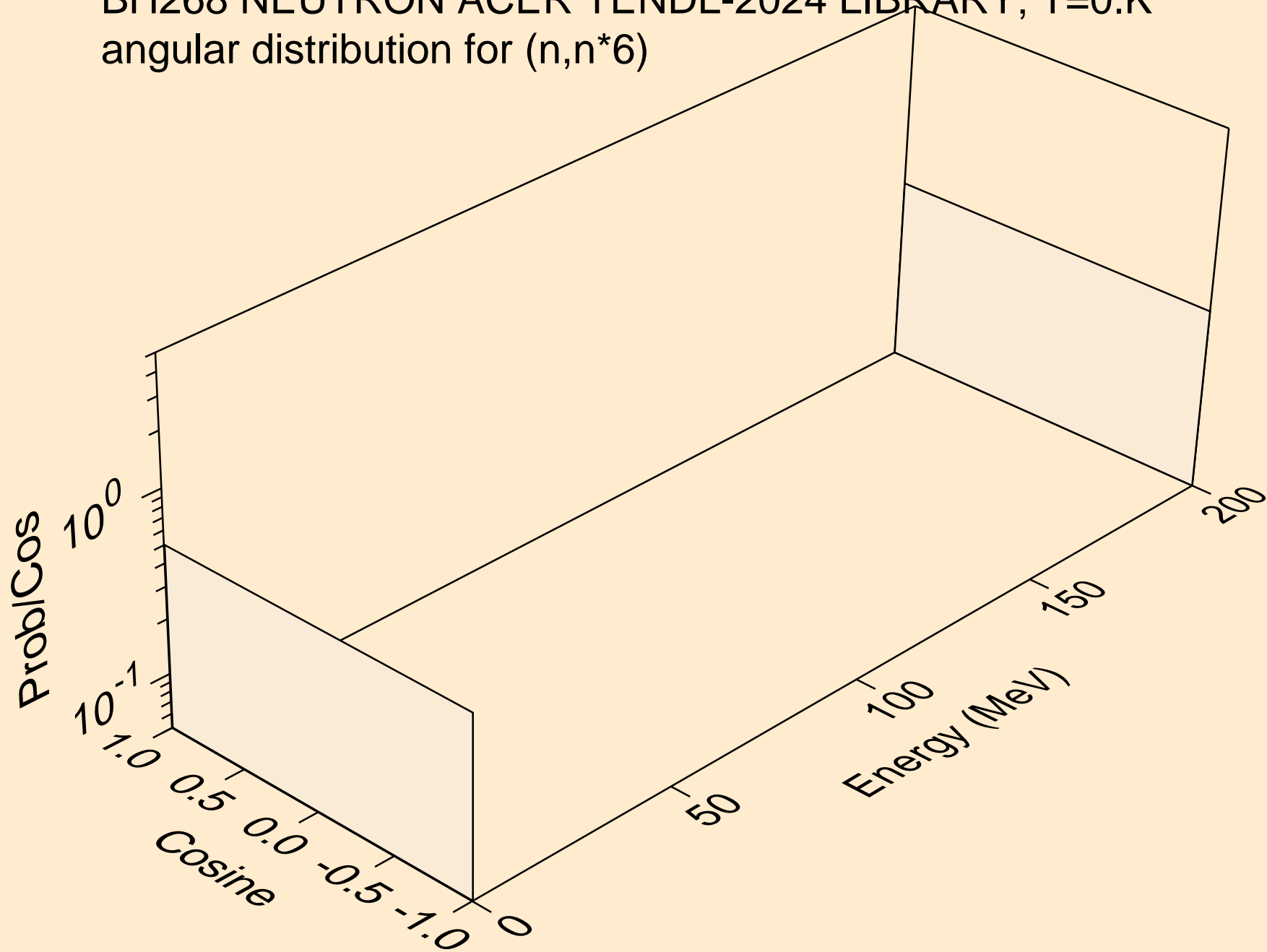

BH268 NEUTRON ACER TENDL-2024 LIBRARY; T=0.K  
angular distribution for (n,n\*7)

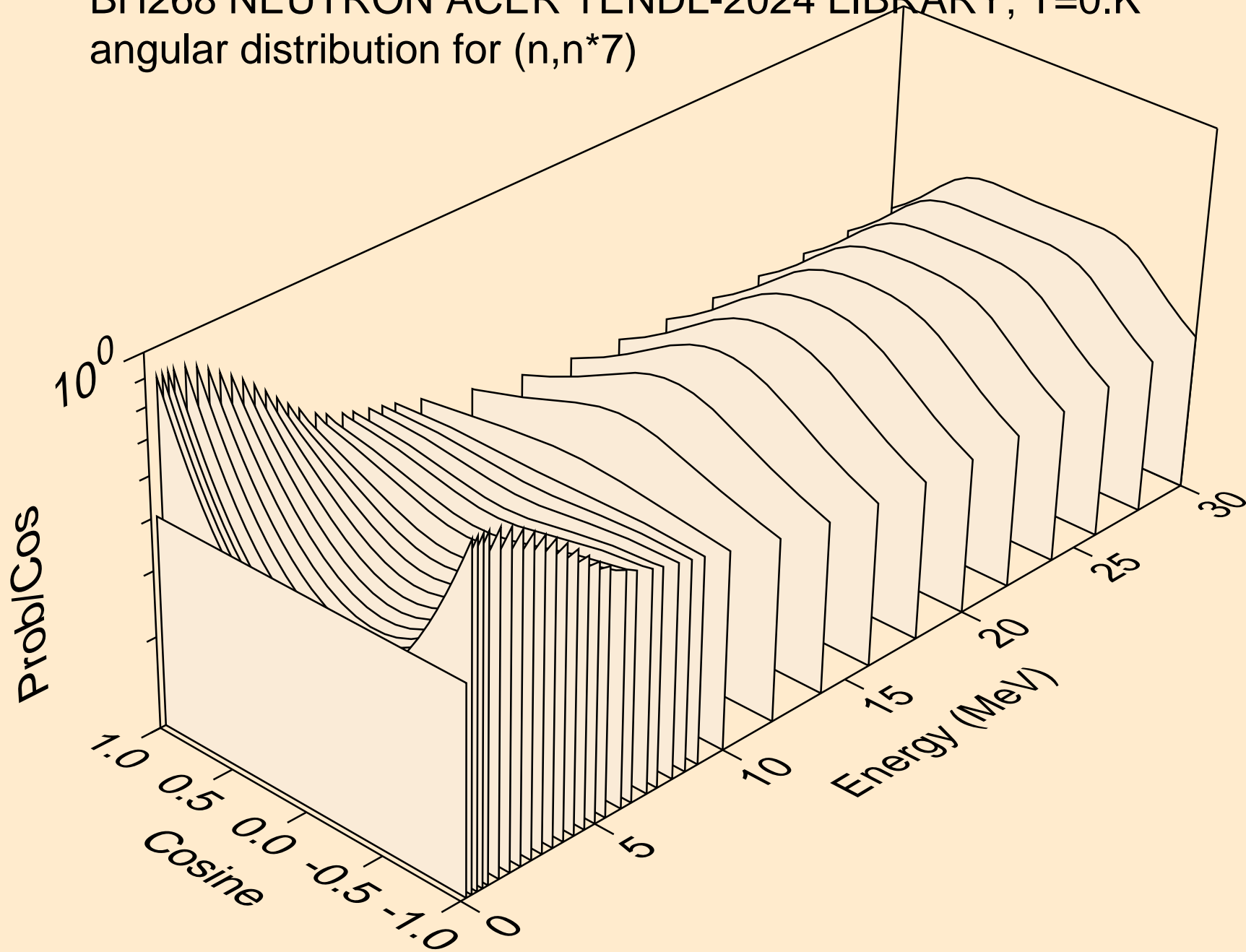

BH268 NEUTRON ACER TENDL-2024 LIBRARY; T=0.K  
angular distribution for (n,n\*8)

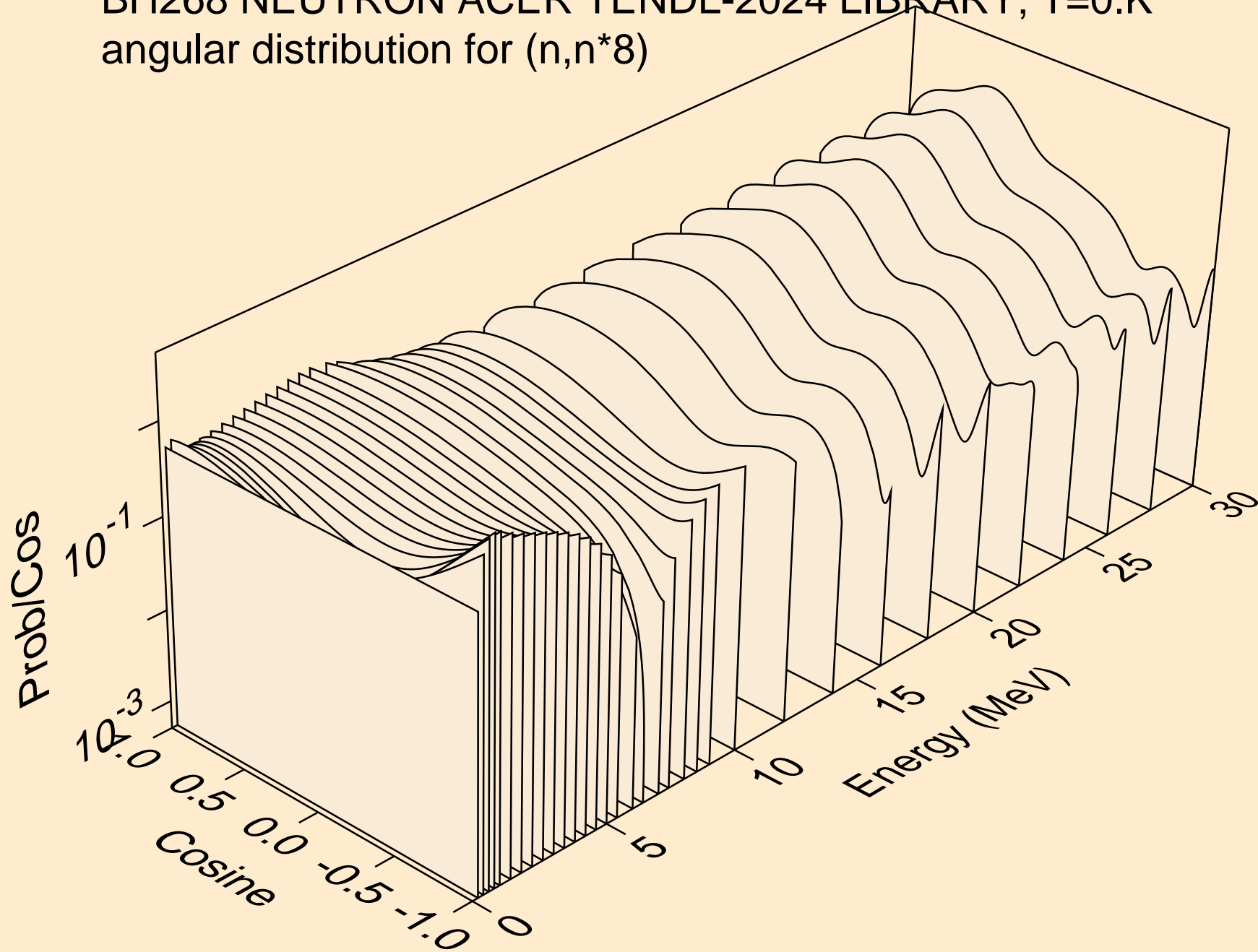

BH268 NEUTRON ACER TENDL-2024 LIBRARY; T=0.K  
angular distribution for (n,n\*9)

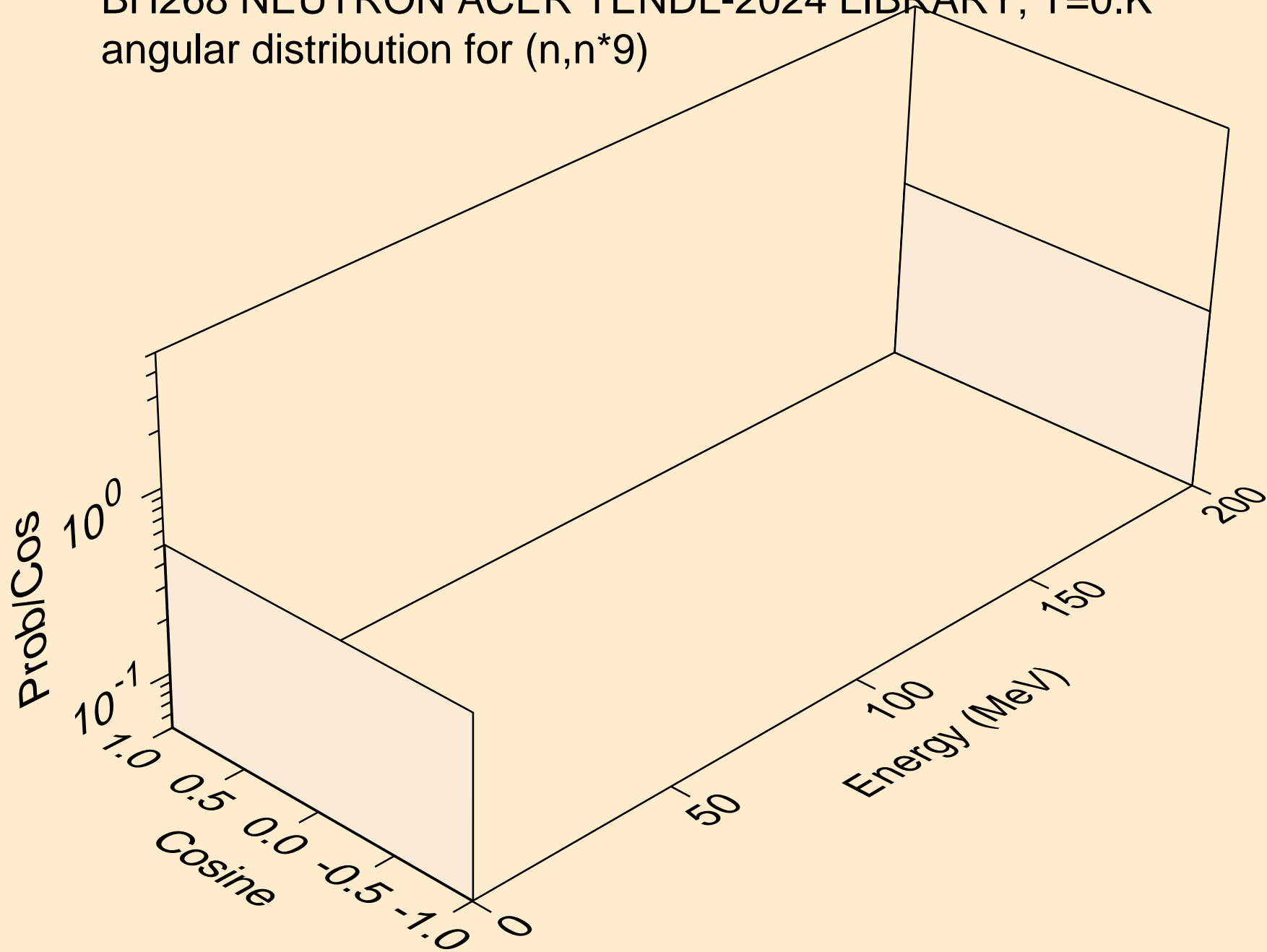

BH268 NEUTRON ACER TENDL-2024 LIBRARY; T=0.K  
angular distribution for (n,n\*10)

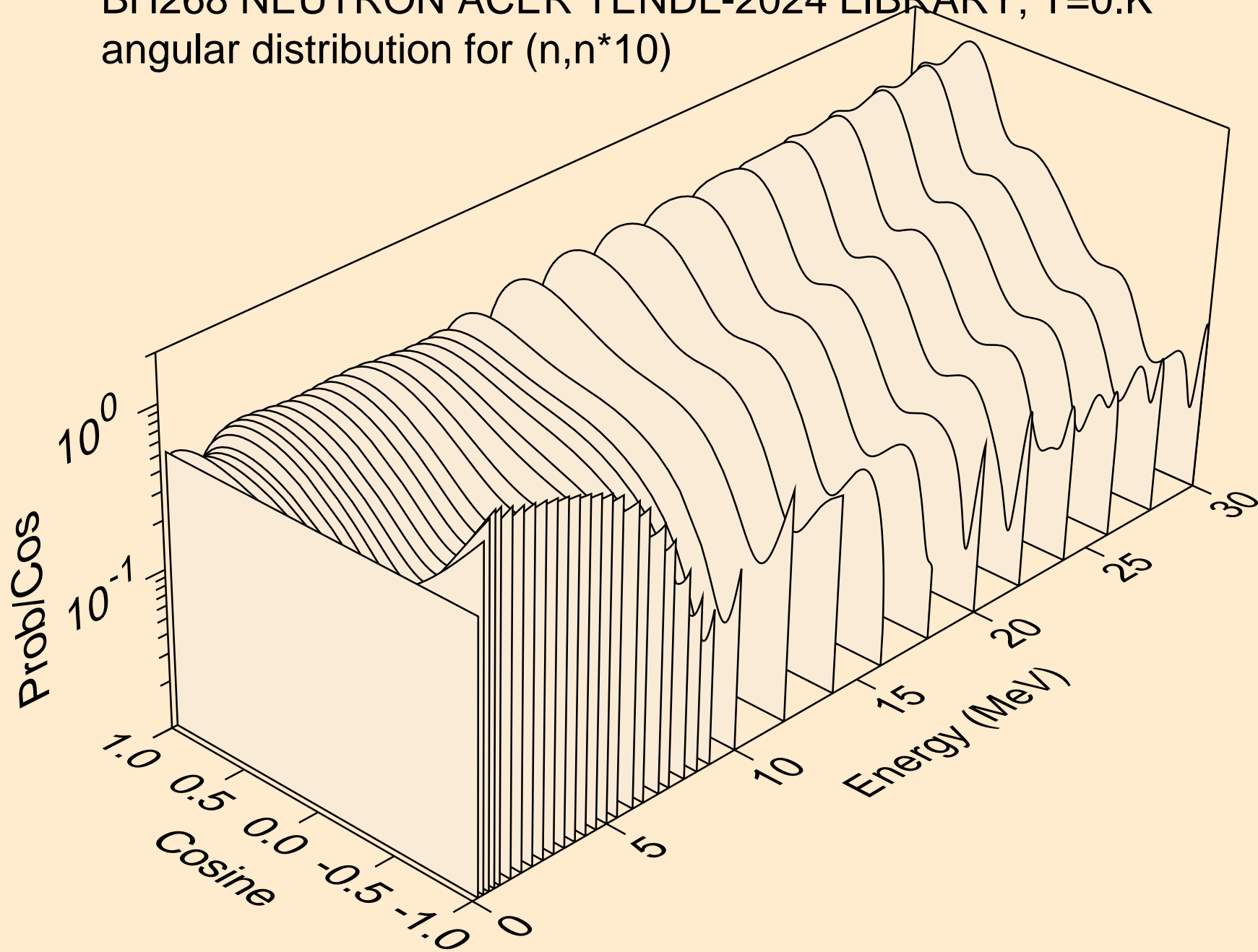

BH268 NEUTRON ACER TENDL-2024 LIBRARY; T=0.K  
angular distribution for (n,n\*11)

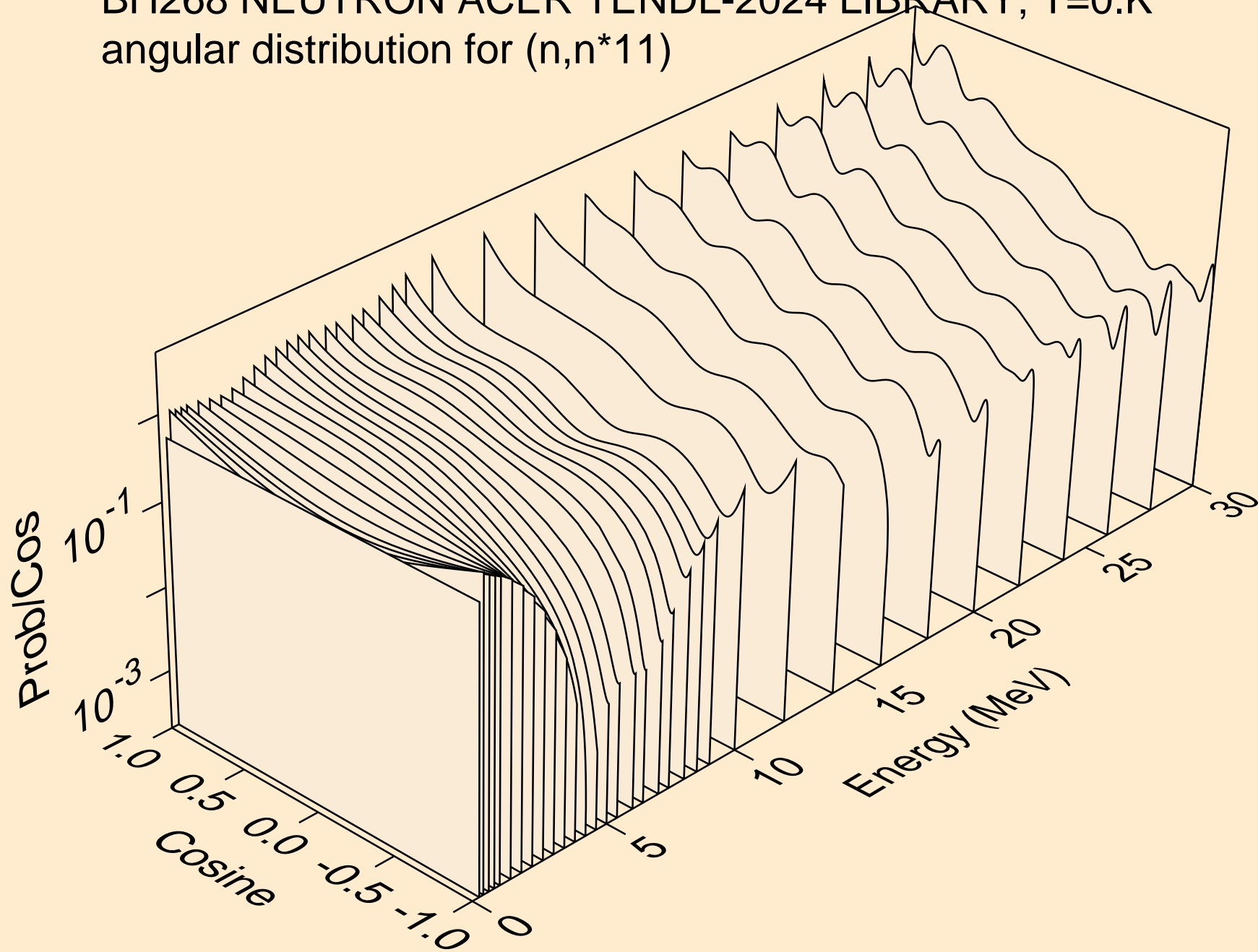

BH268 NEUTRON ACER TENDL-2024 LIBRARY; T=0.K  
angular distribution for (n,n\*12)

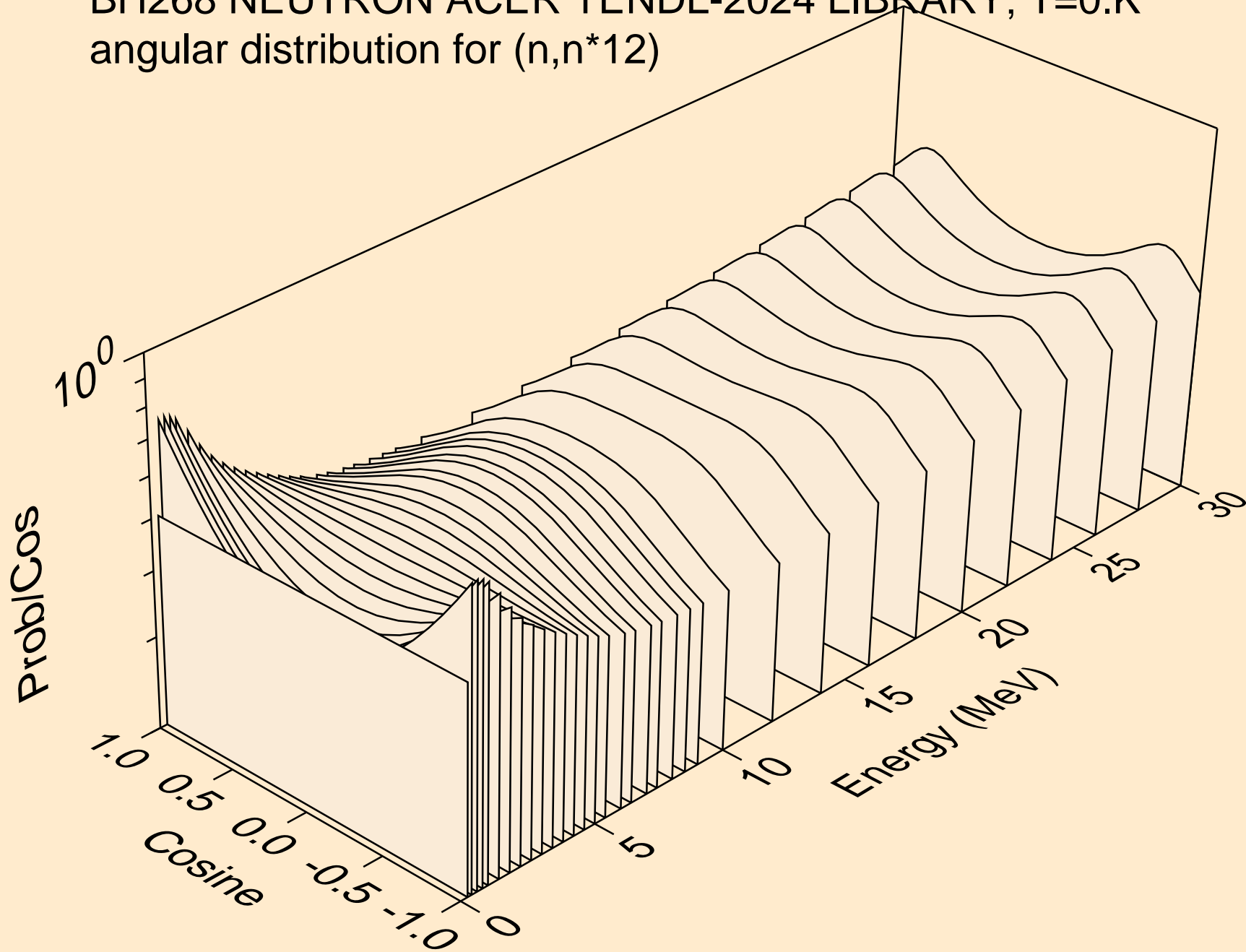



BH268 NEUTRON ACER TENDL-2024 LIBRARY; T=0.K  
angular distribution for (n,n\*13)

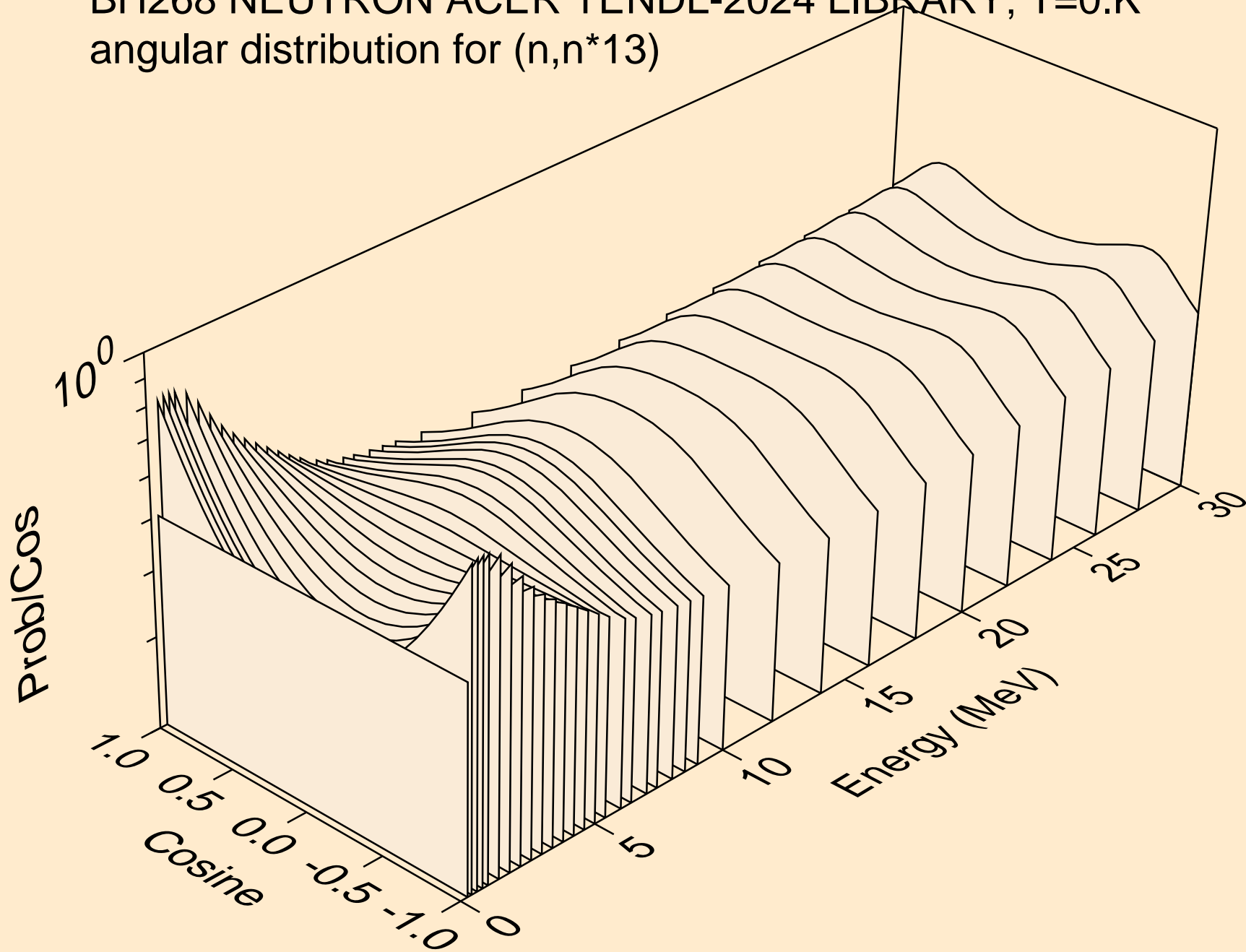

BH268 NEUTRON ACER TENDL-2024 LIBRARY; T=0.K  
angular distribution for (n,n\*14)

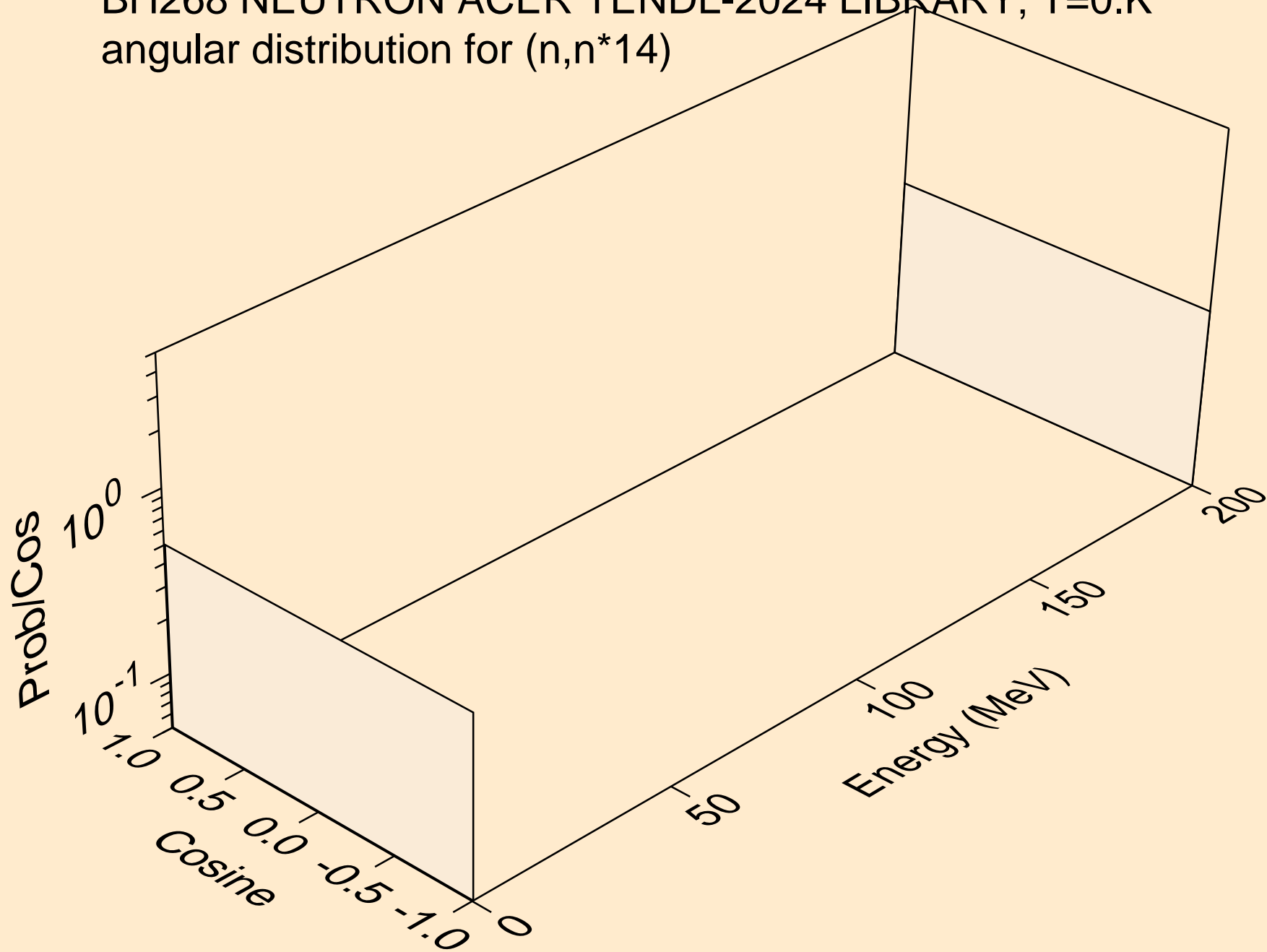

BH268 NEUTRON ACER TENDL-2024 LIBRARY; T=0.K  
angular distribution for (n,n\*15)

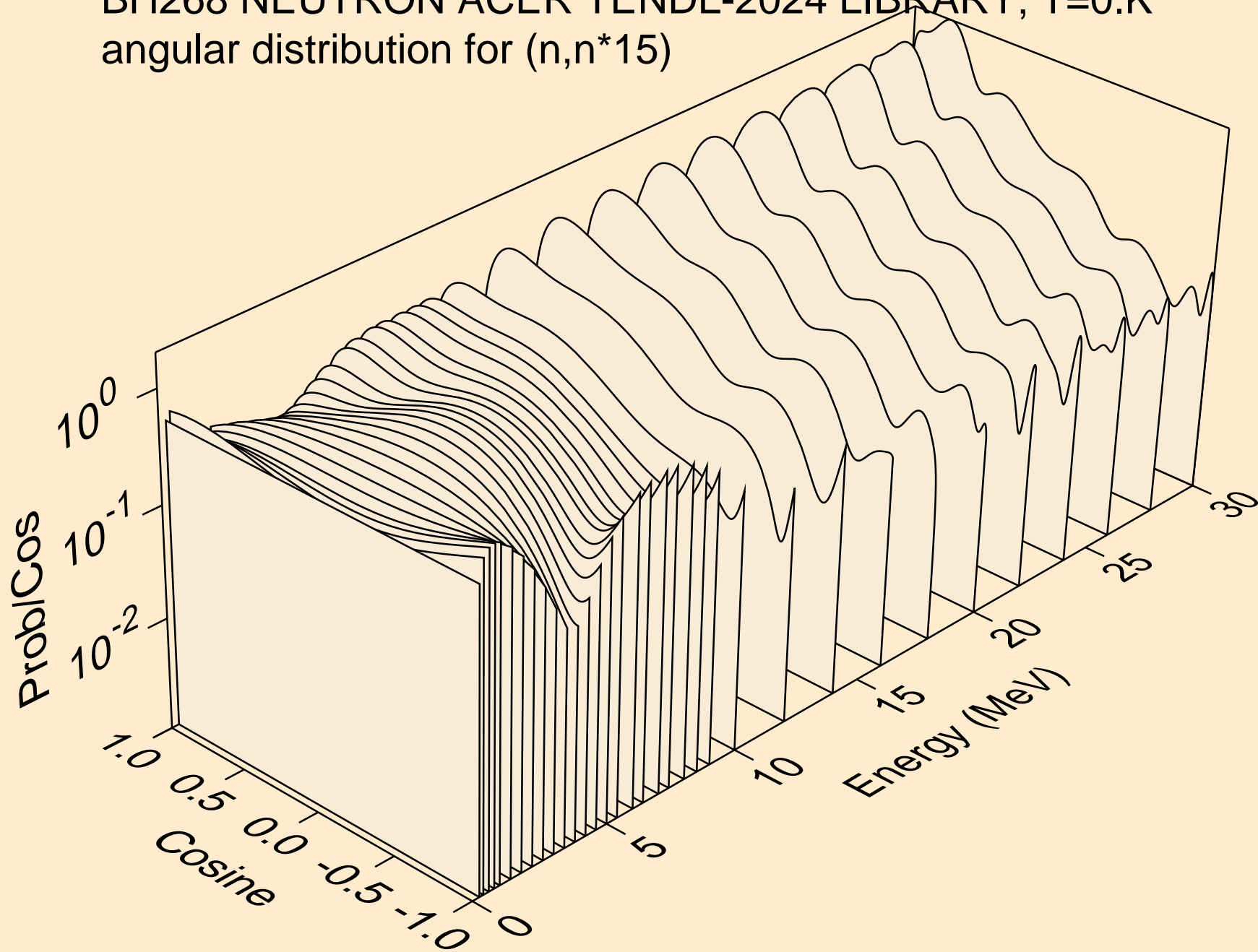

BH268 NEUTRON ACER TENDL-2024 LIBRARY; T=0.K  
angular distribution for (n,n\*16)

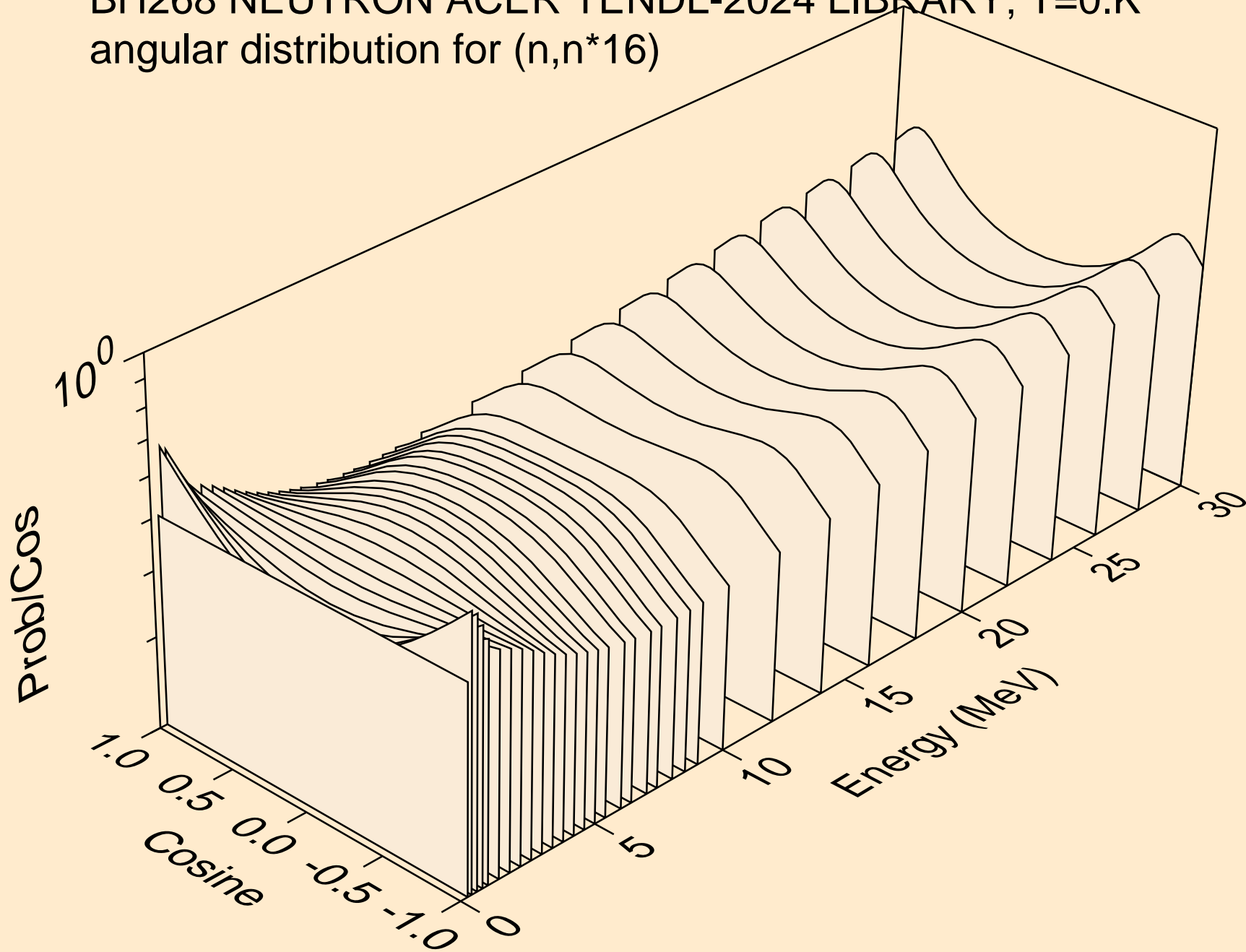

BH268 NEUTRON ACER TENDL-2024 LIBRARY; T=0.K  
angular distribution for (n,n\*17)

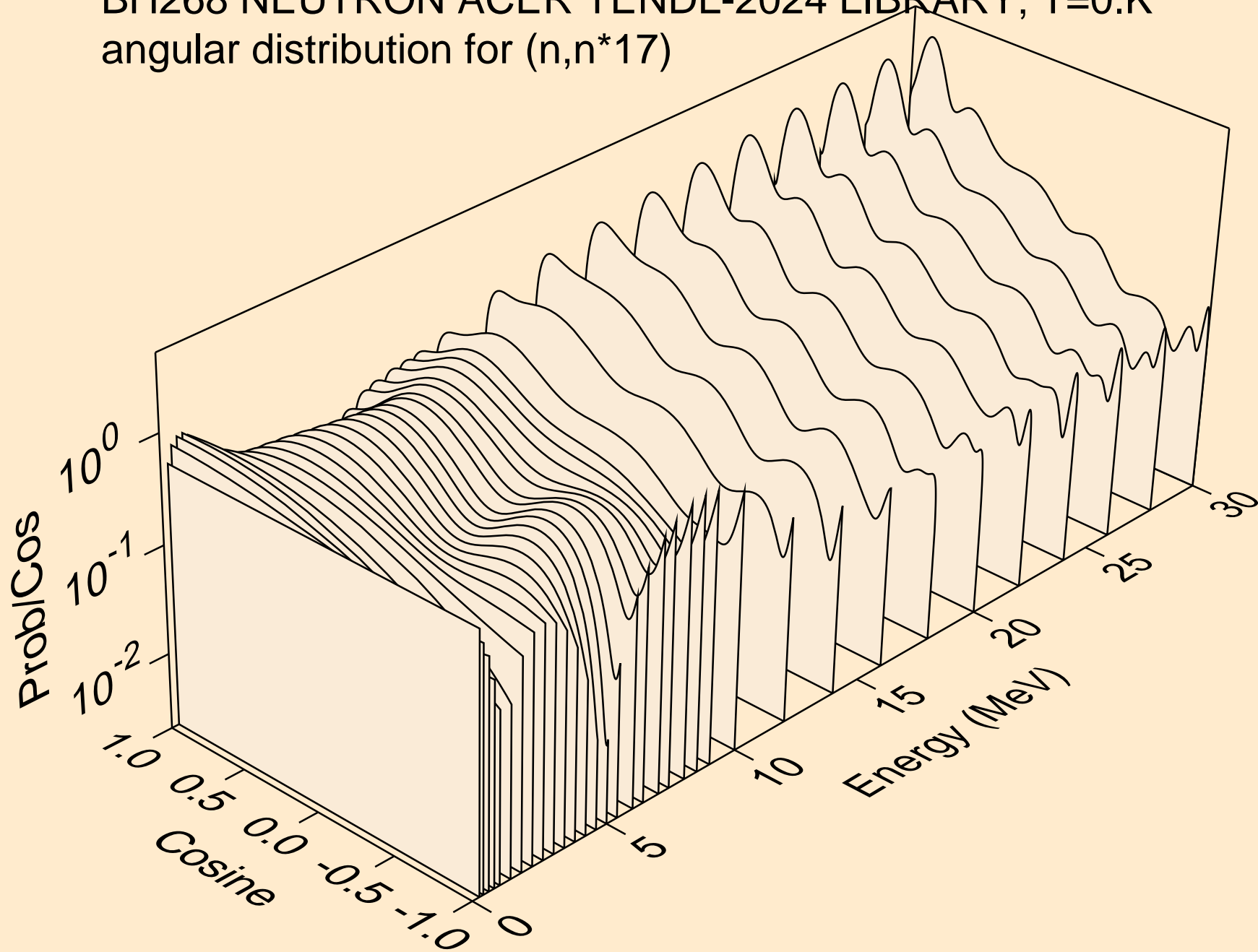

BH268 NEUTRON ACER TENDL-2024 LIBRARY; T=0.K  
angular distribution for (n,n\*18)

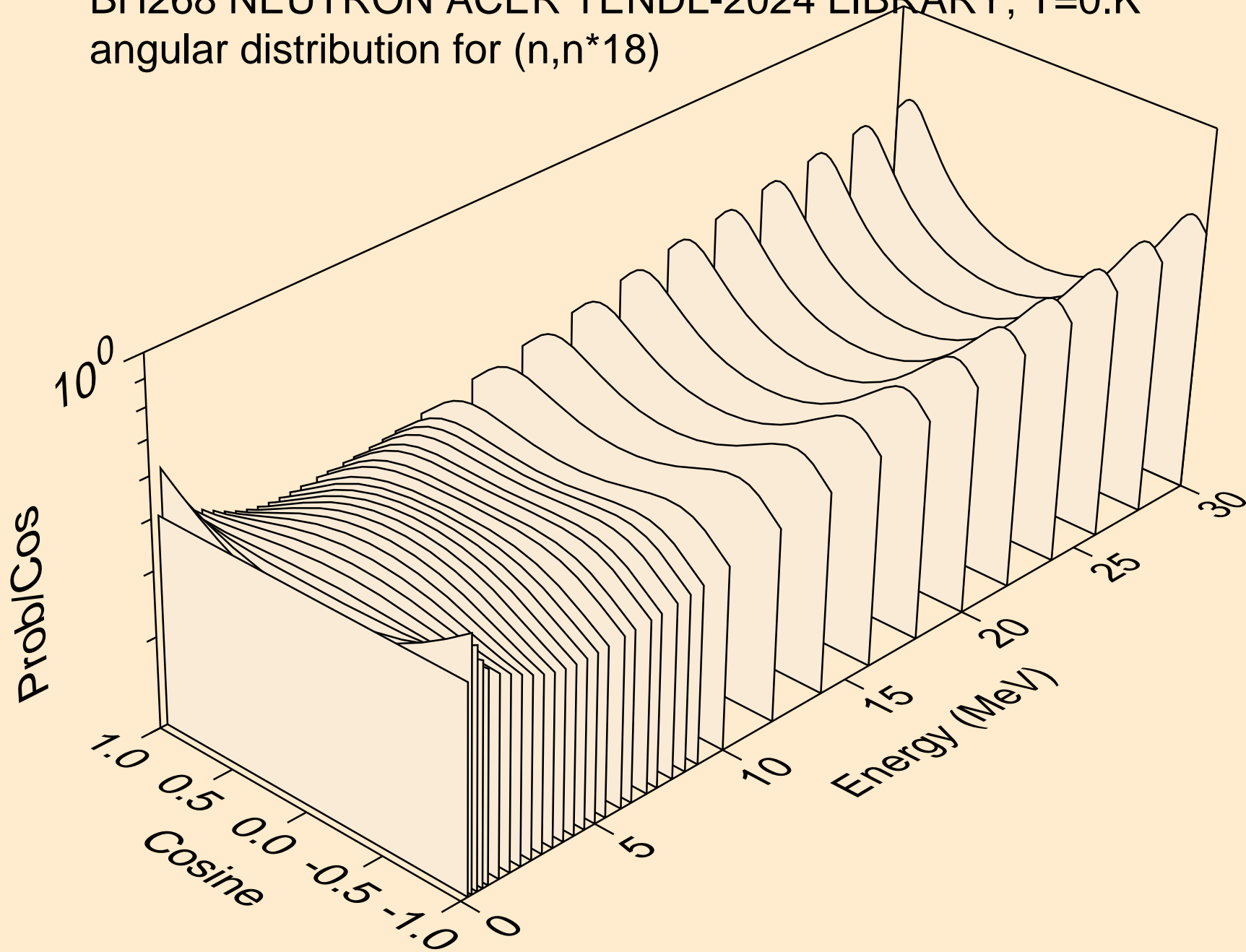

BH268 NEUTRON ACER TENDL-2024 LIBRARY; T=0.K  
angular distribution for (n,n\*19)

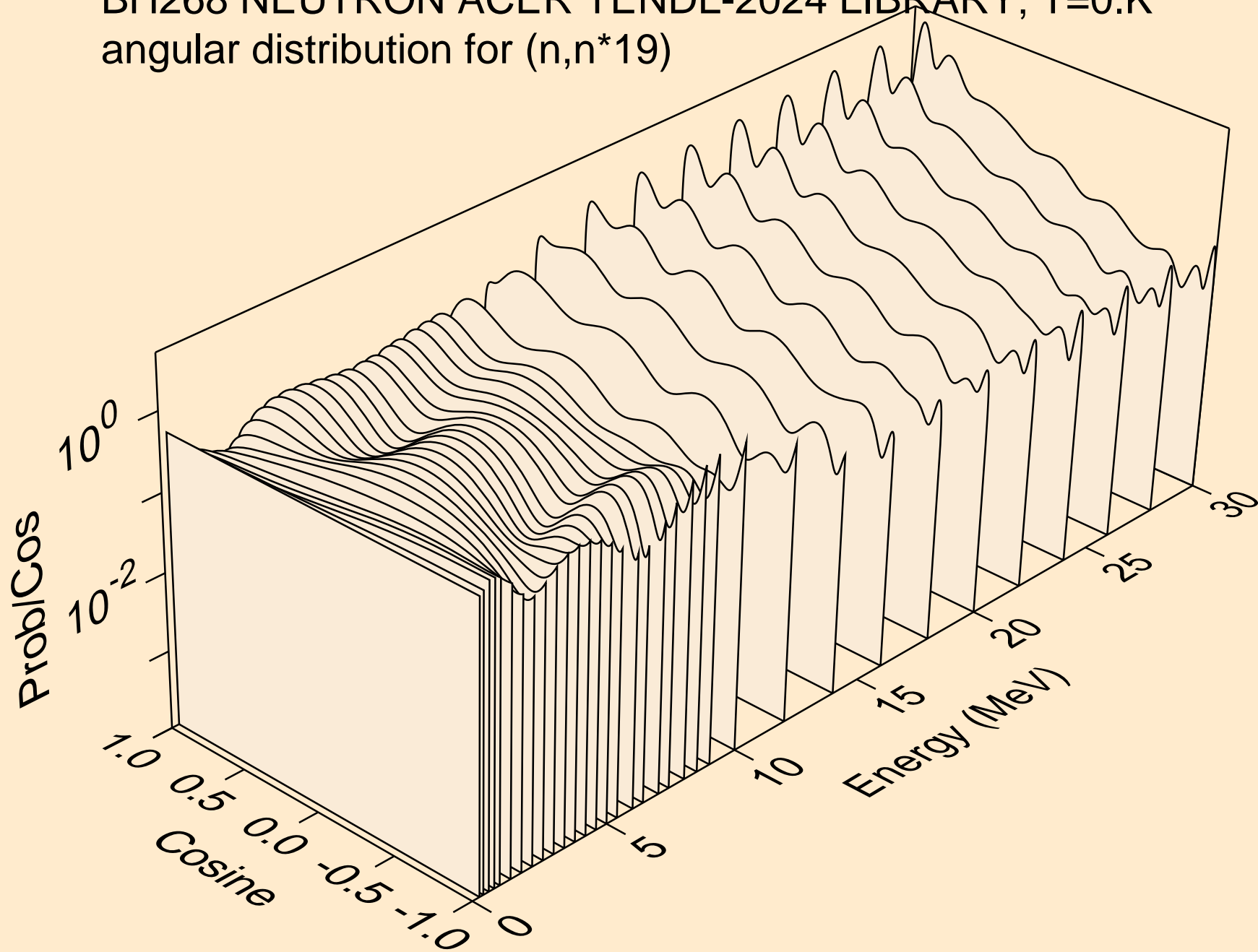

BH268 NEUTRON ACER TENDL-2024 LIBRARY; T=0.K  
angular distribution for (n,n\*20)

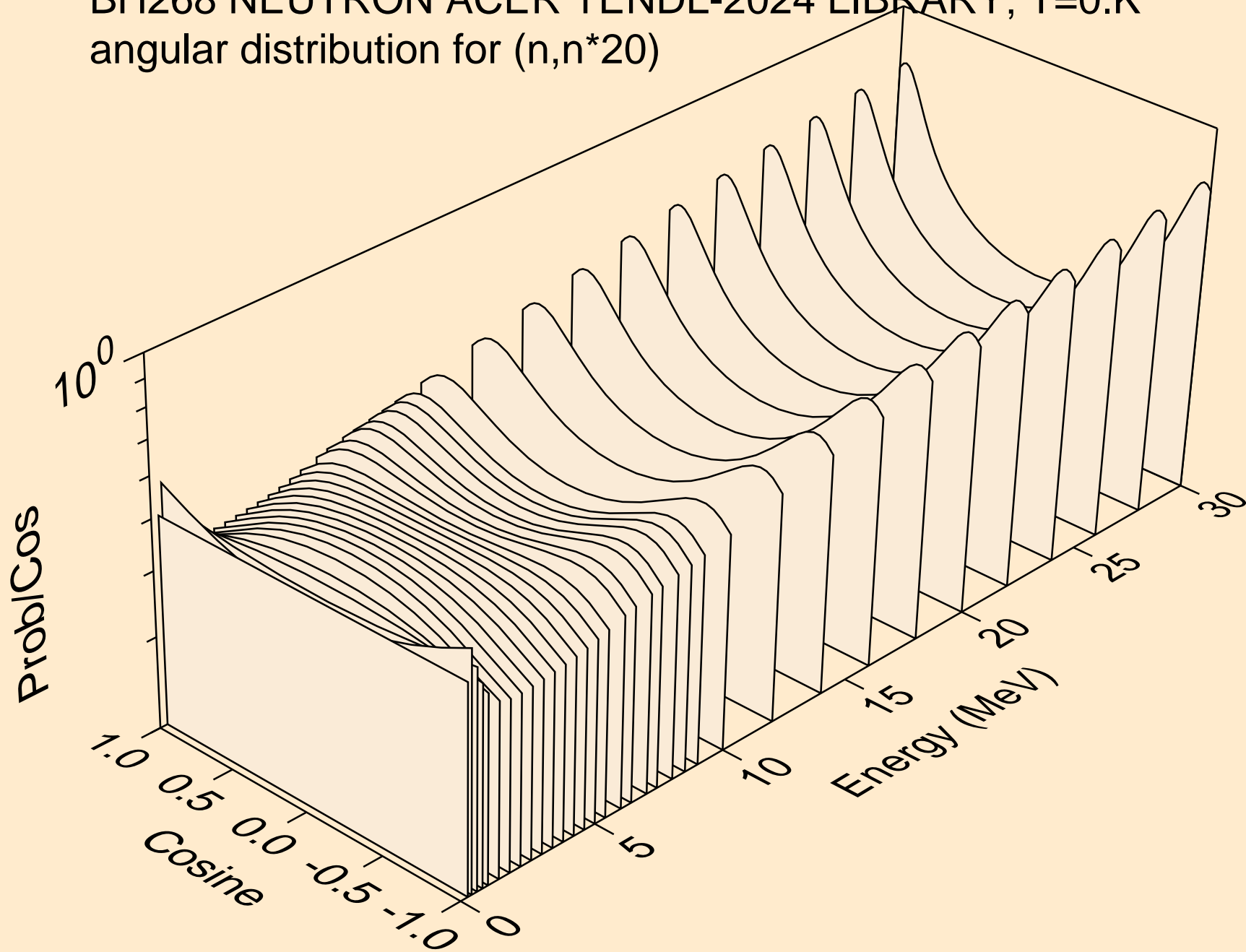



BH268 NEUTRON ACER TENDL-2024 LIBRARY; T=0.K  
angular distribution for (n,n\*21)

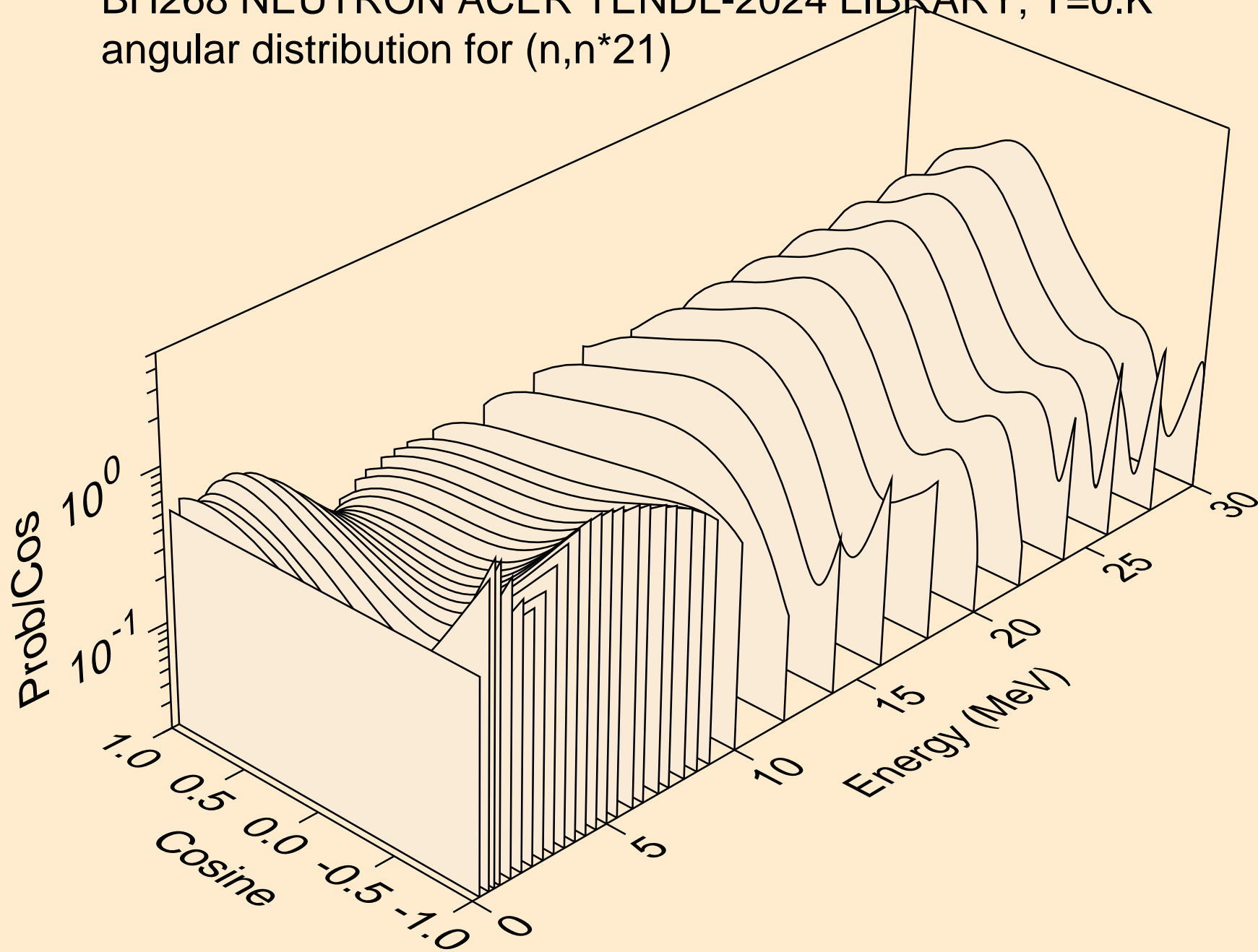

BH268 NEUTRON ACER TENDL-2024 LIBRARY; T=0.K  
angular distribution for (n,n\*22)

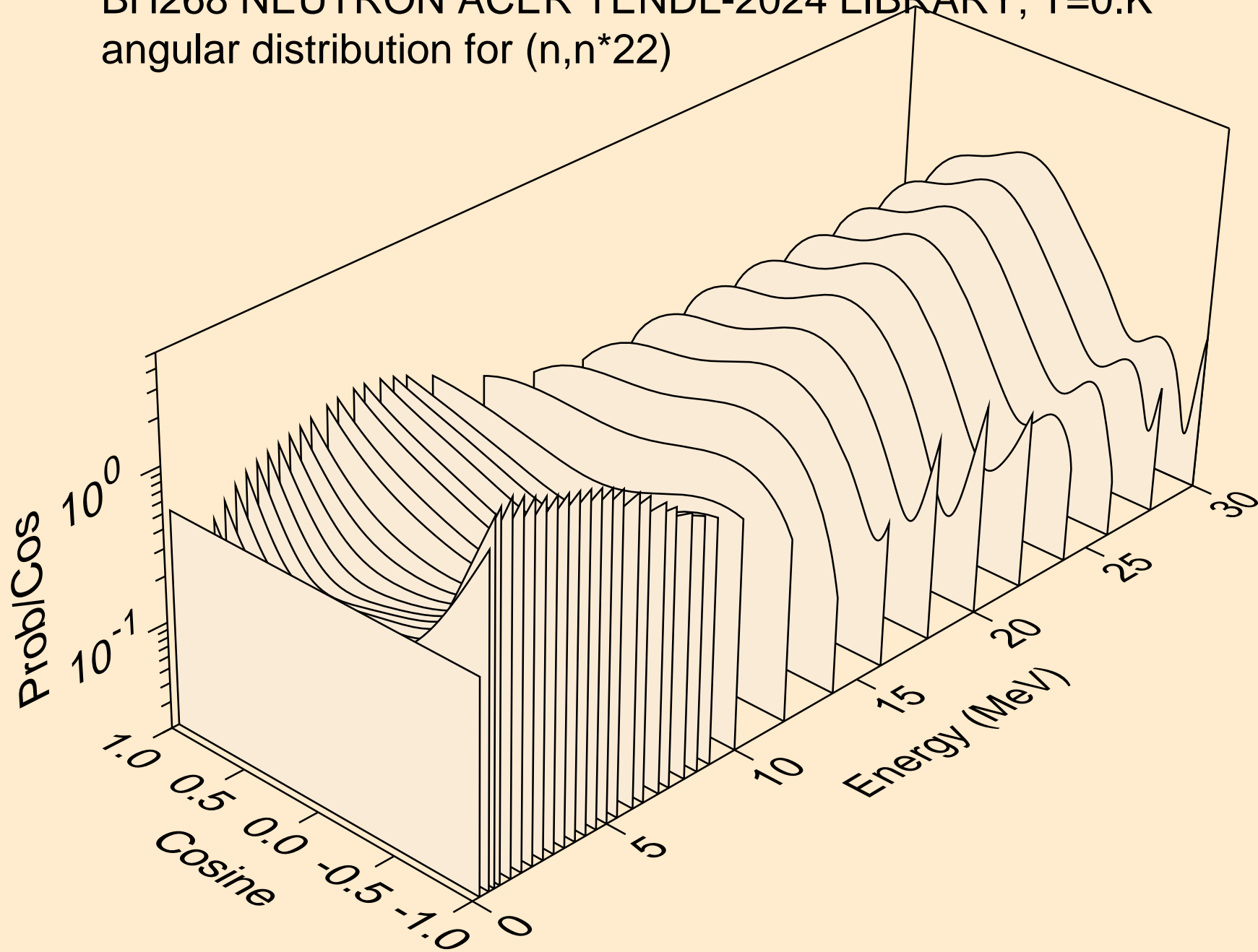

BH268 NEUTRON ACER TENDL-2024 LIBRARY; T=0.K  
angular distribution for (n,n\*23)

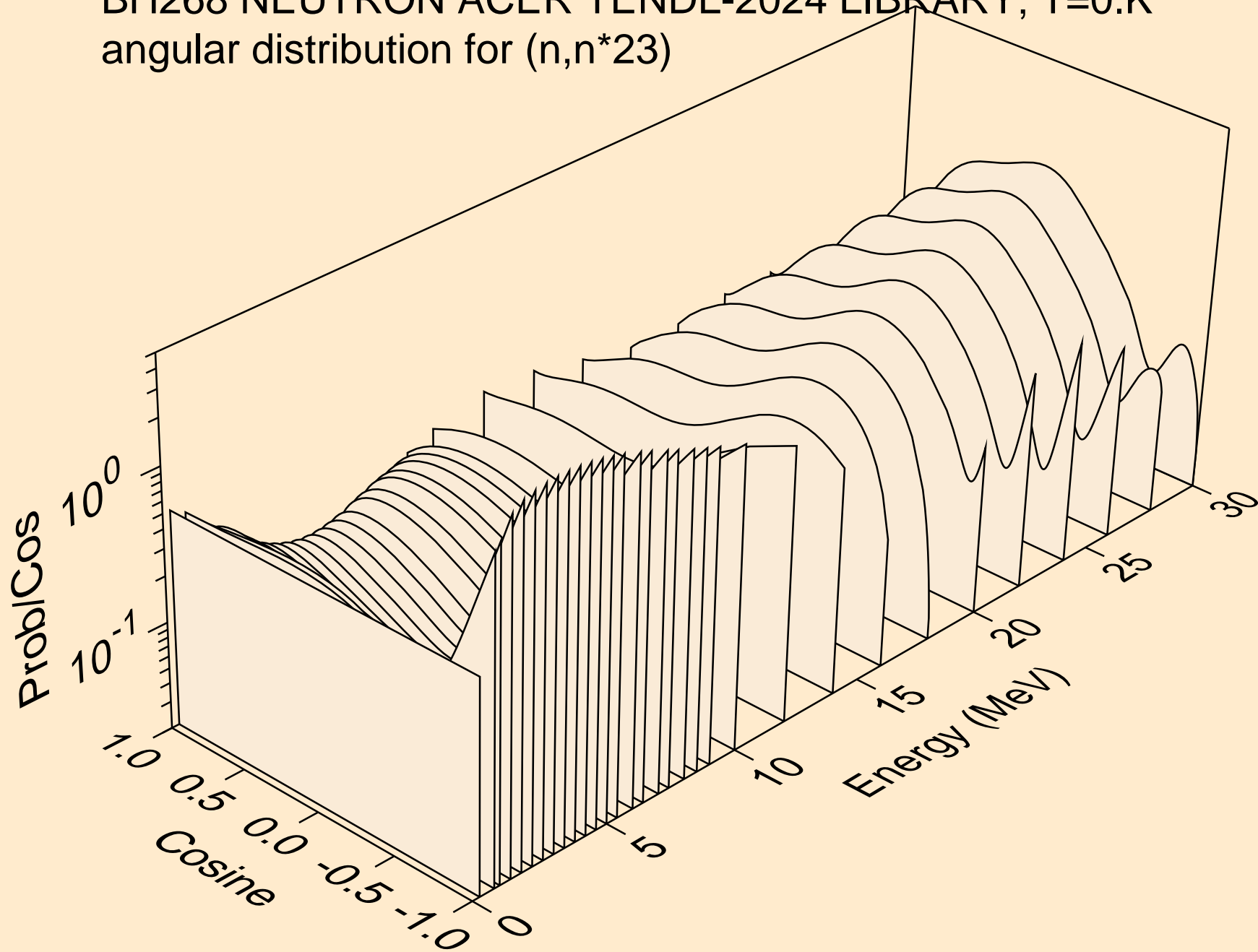

# BH268 NEUTRON ACER TENDL-2024 LIBRARY; T=0.K

## Total fission nubar

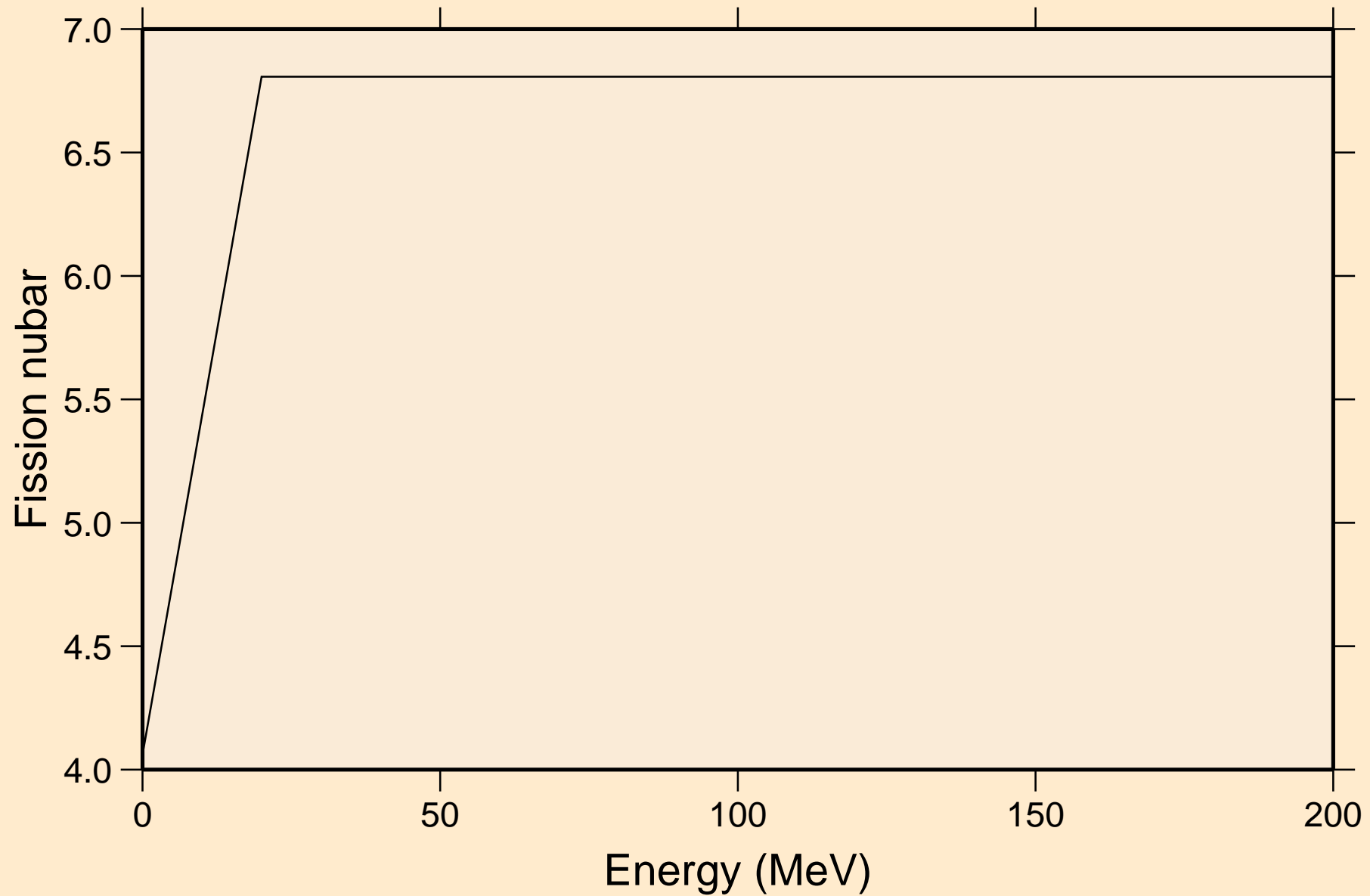

BH268 NEUTRON ACER TENDL-2024 LIBRARY; T=0.K  
Neutron emission for (n,x)

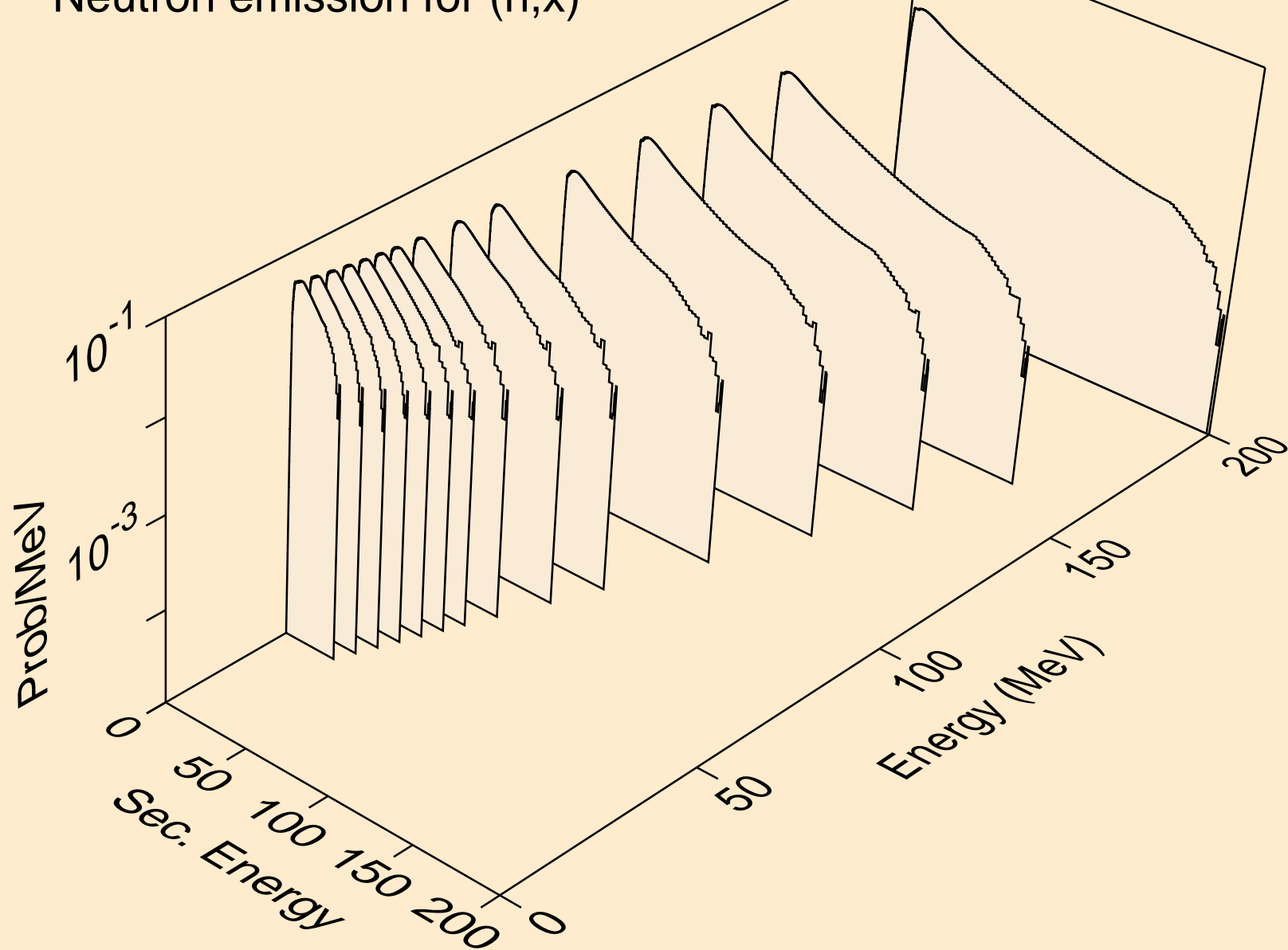

BH268 NEUTRON ACER TENDL-2024 LIBRARY; T=0.K  
Neutron emission for (n,2nd)

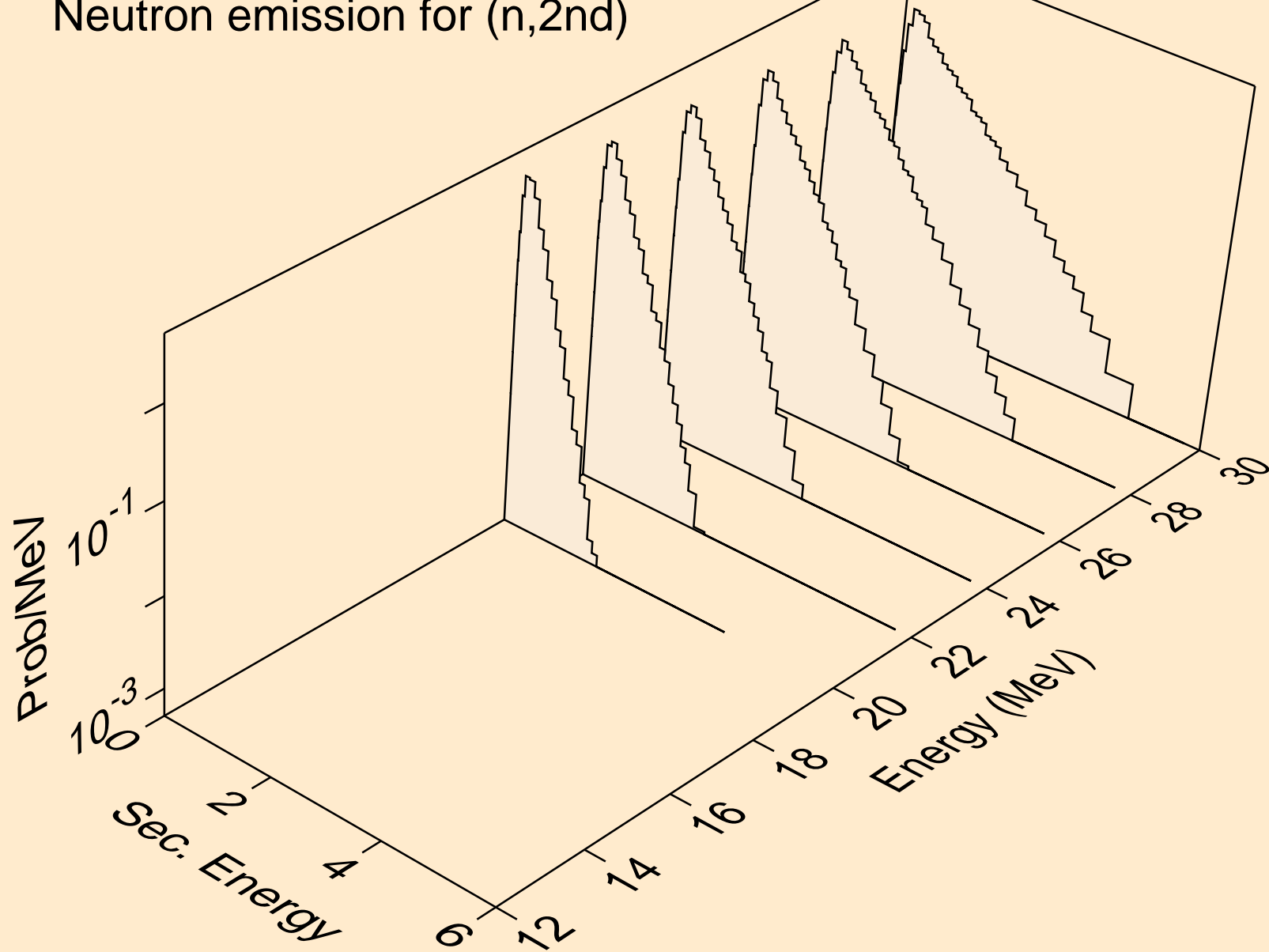

BH268 NEUTRON ACER TENDL-2024 LIBRARY; T=0.K  
Neutron emission for (n,2n)

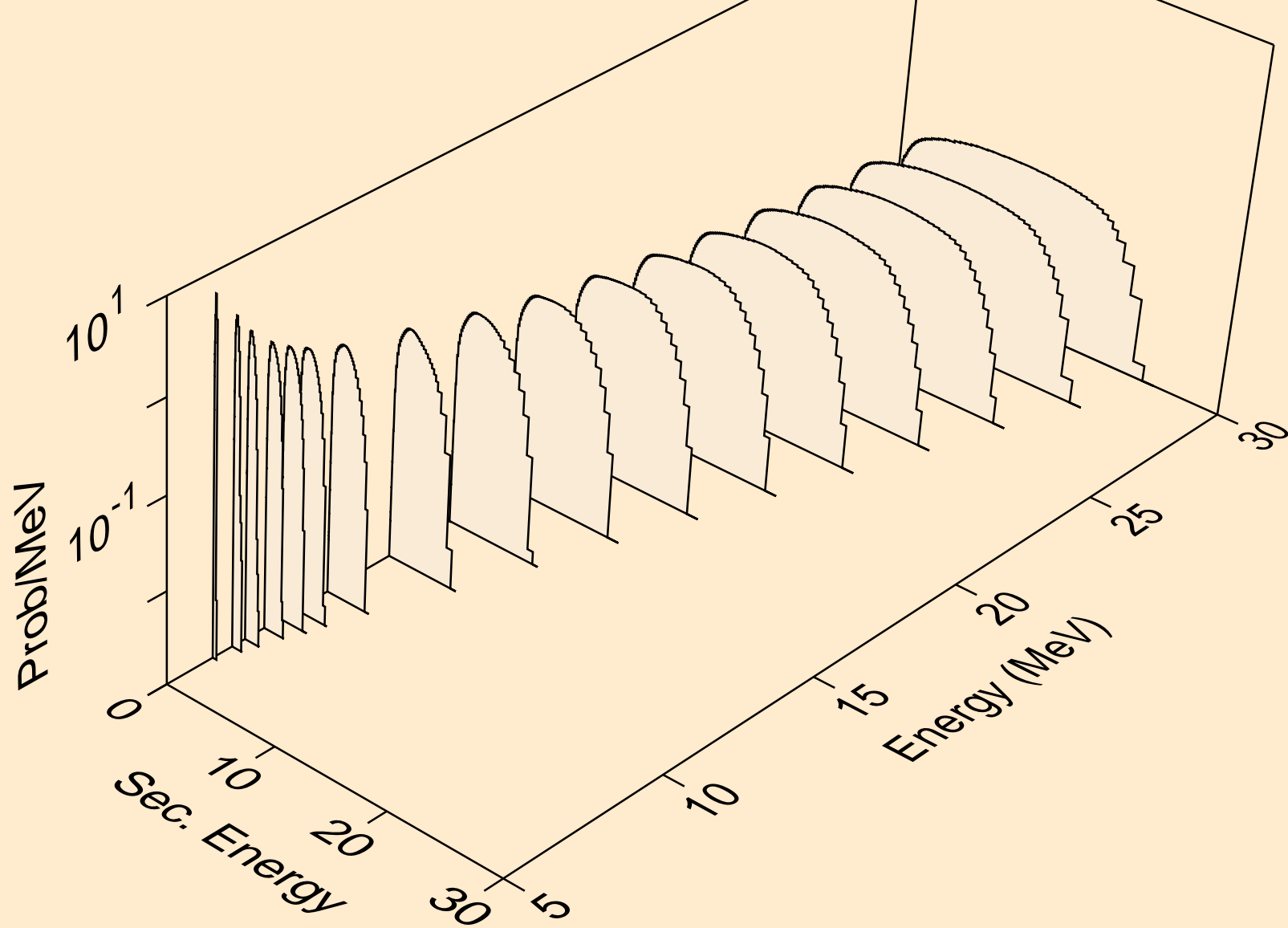

BH268 NEUTRON ACER TENDL-2024 LIBRARY; T=0.K  
Neutron emission for (n,3n)

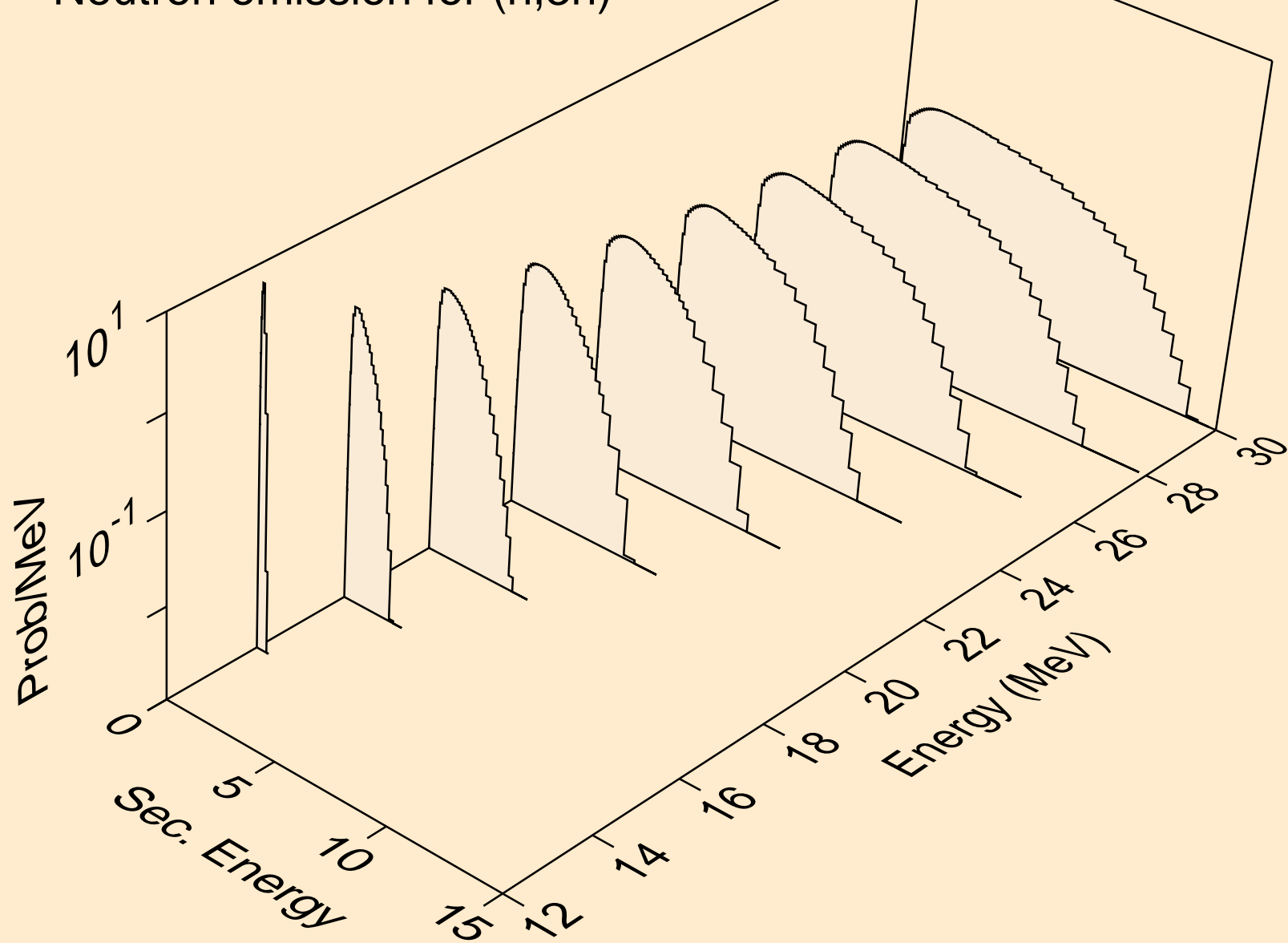



BH268 NEUTRON ACER TENDL-2024 LIBRARY; T=0.K  
Neutron emission for fission

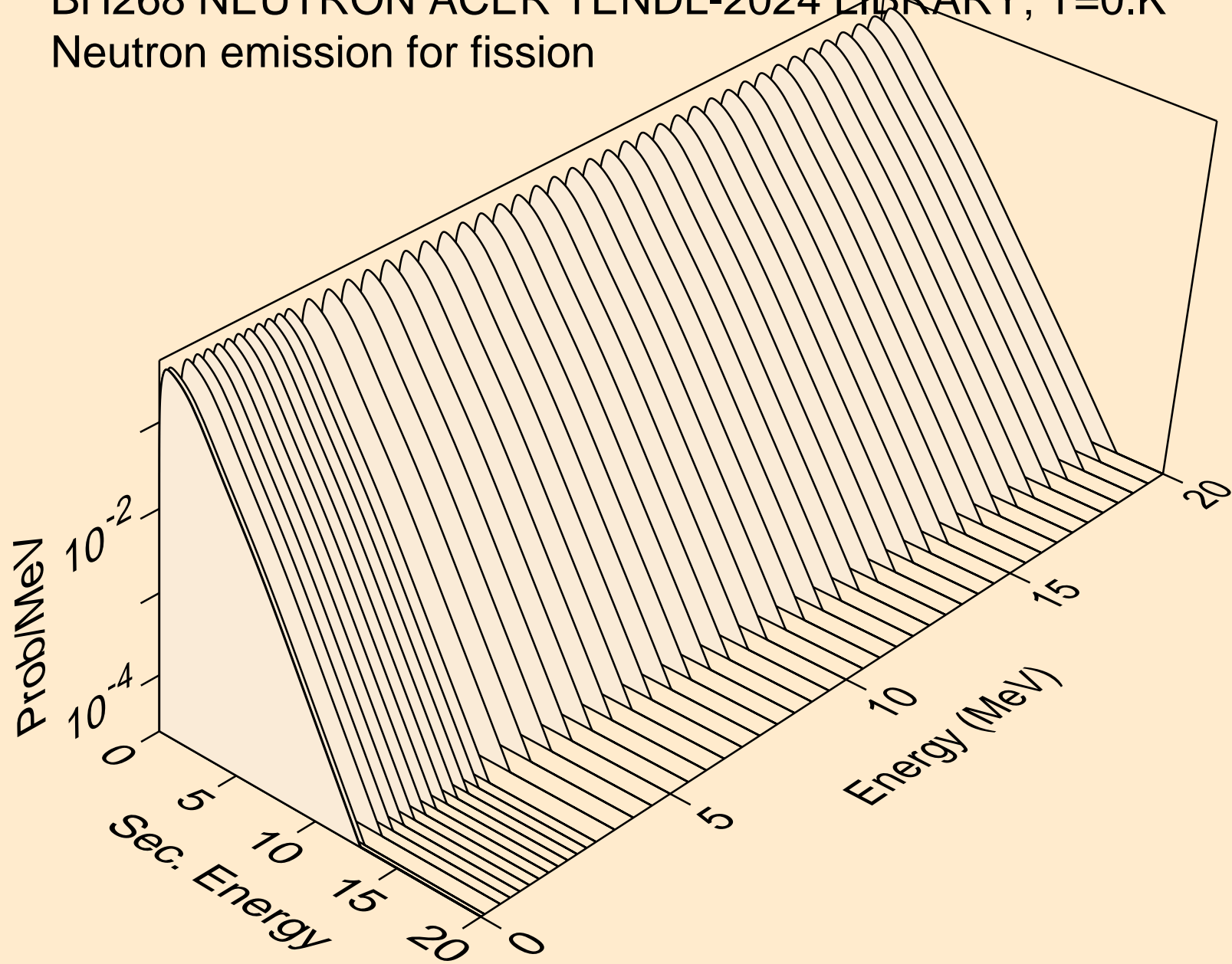

BH268 NEUTRON ACER TENDL-2024 LIBRARY; T=0.K  
Neutron emission for (n,n\*)a

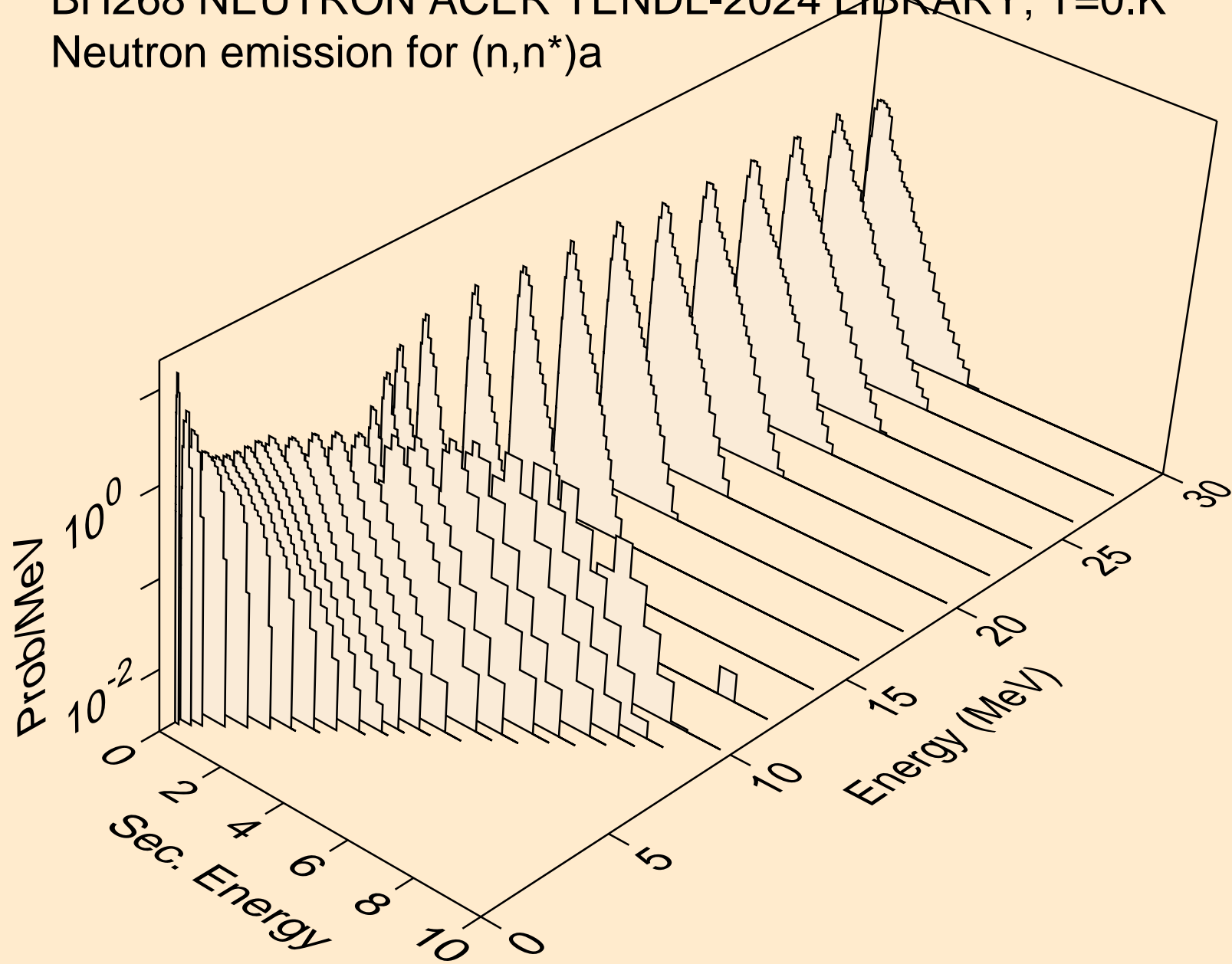

BH268 NEUTRON ACER TENDL-2024 LIBRARY; T=0.K  
Neutron emission for (n,2n)a

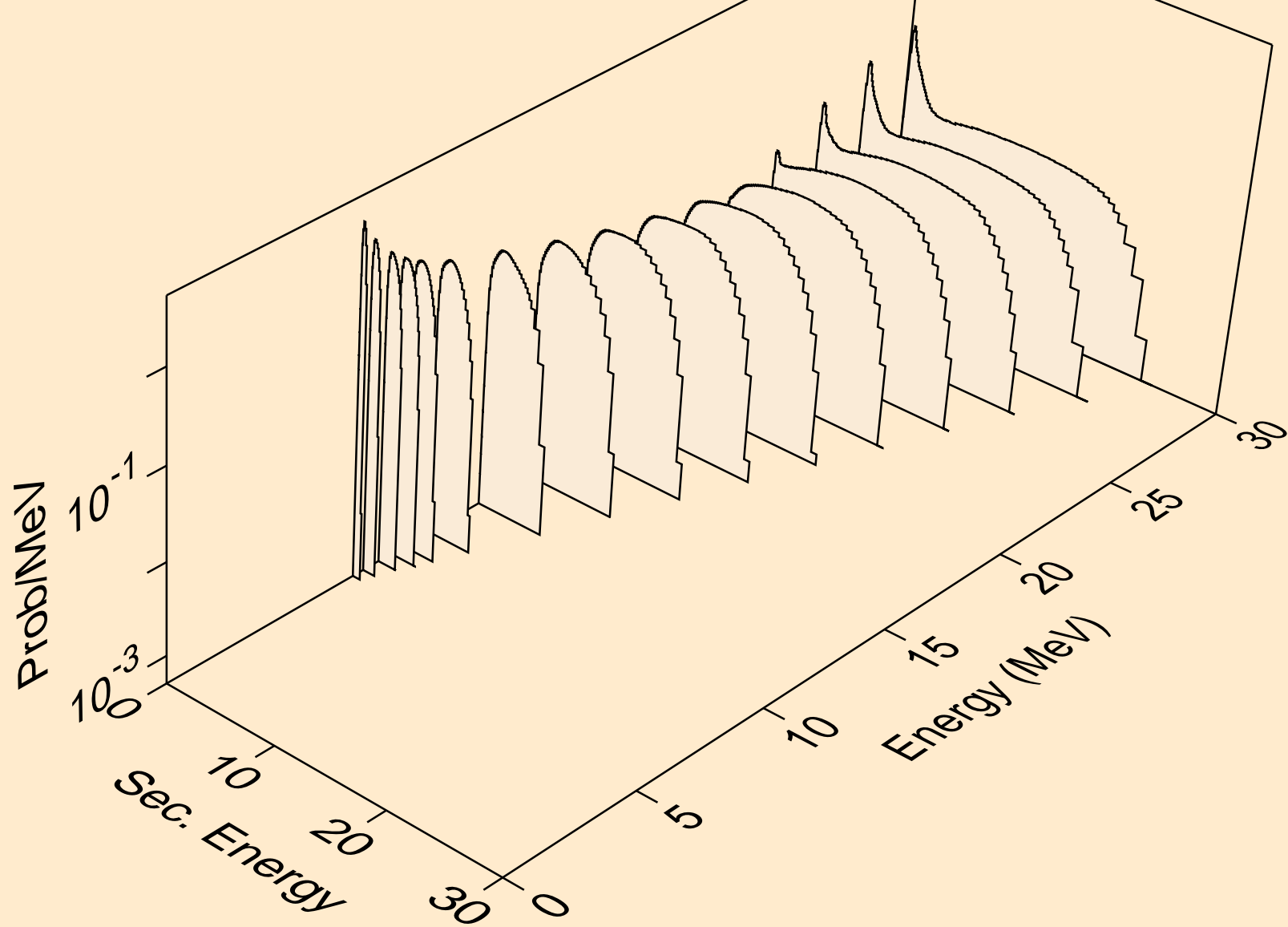

BH268 NEUTRON ACER TENDL-2024 LIBRARY; T=0.K  
Neutron emission for (n,3n)a

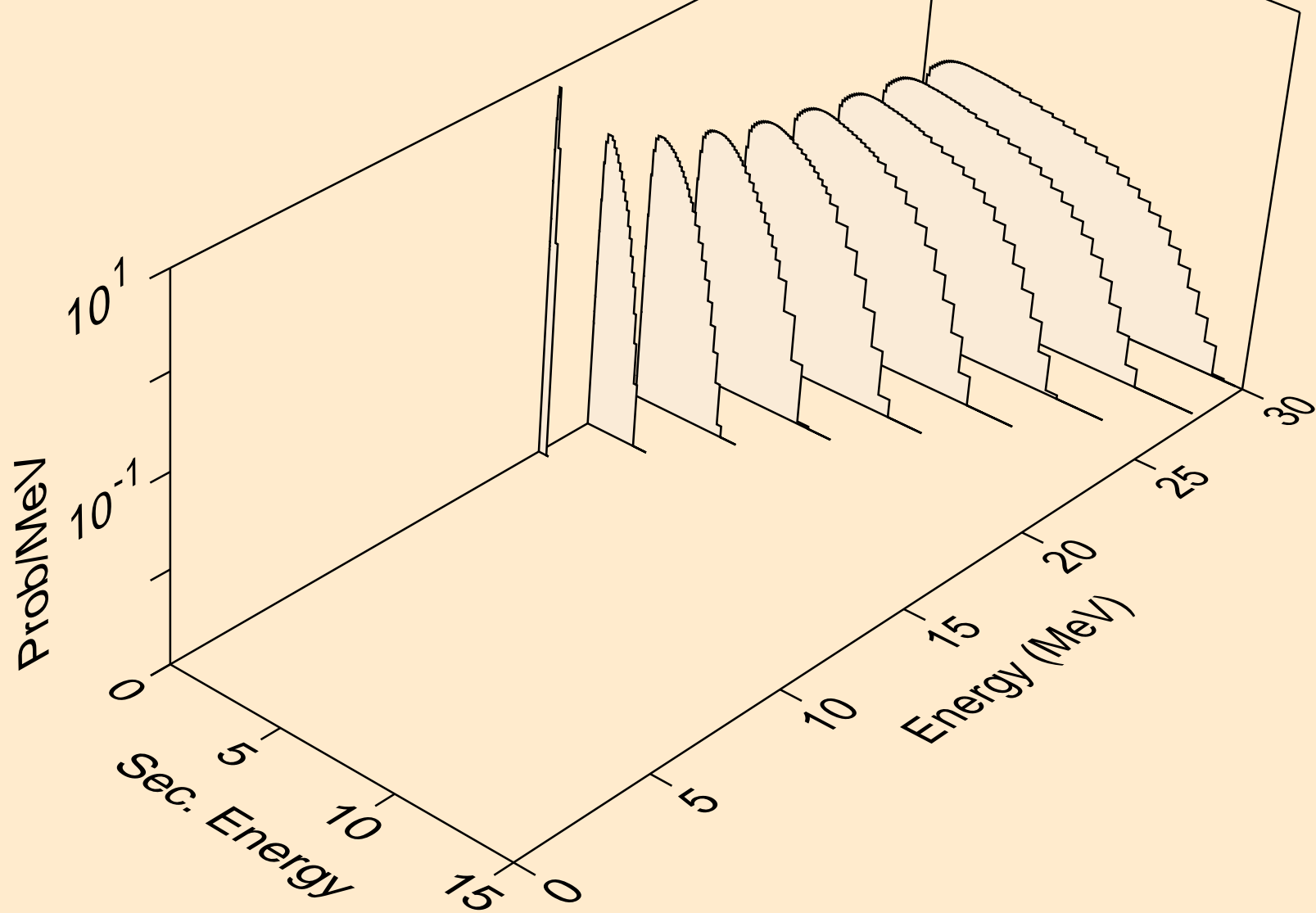

BH268 NEUTRON ACER TENDL-2024 LIBRARY; T=0.K  
Neutron emission for (n,n\*)p

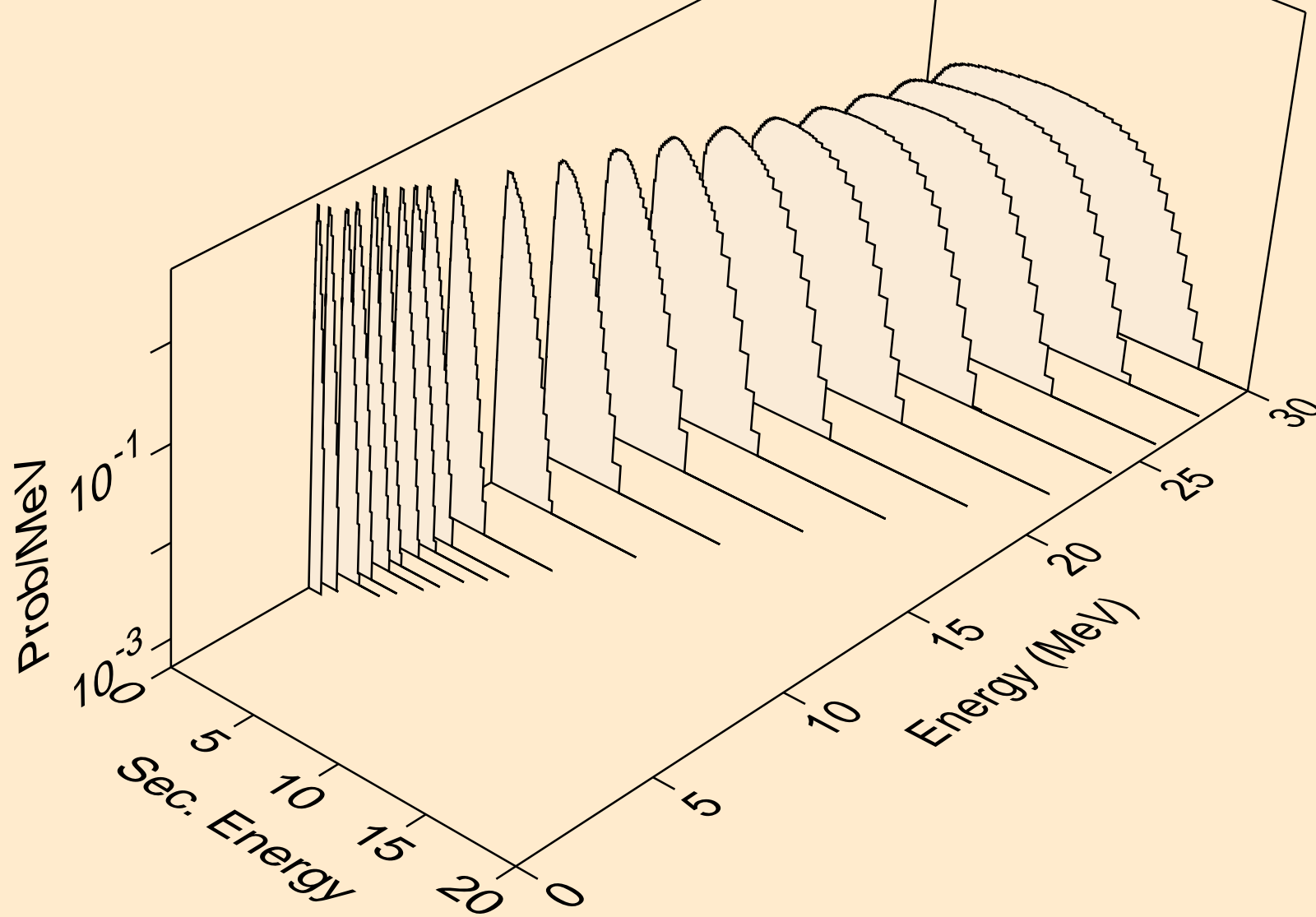

BH268 NEUTRON ACER TENDL-2024 LIBRARY; T=0.K  
Neutron emission for (n,n\*)d

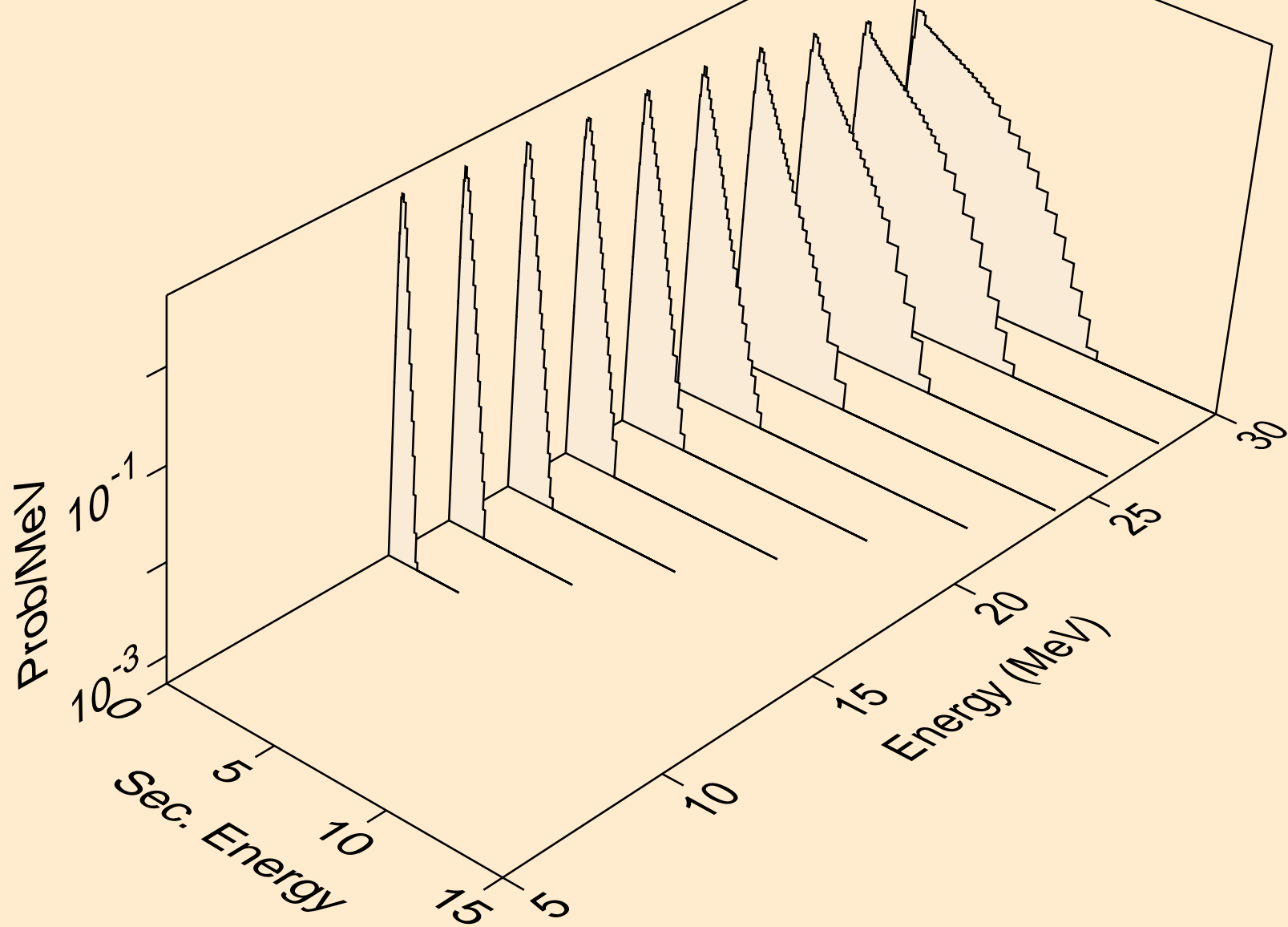

BH268 NEUTRON ACER TENDL-2024 LIBRARY; T=0.K  
Neutron emission for (n,n\*)t

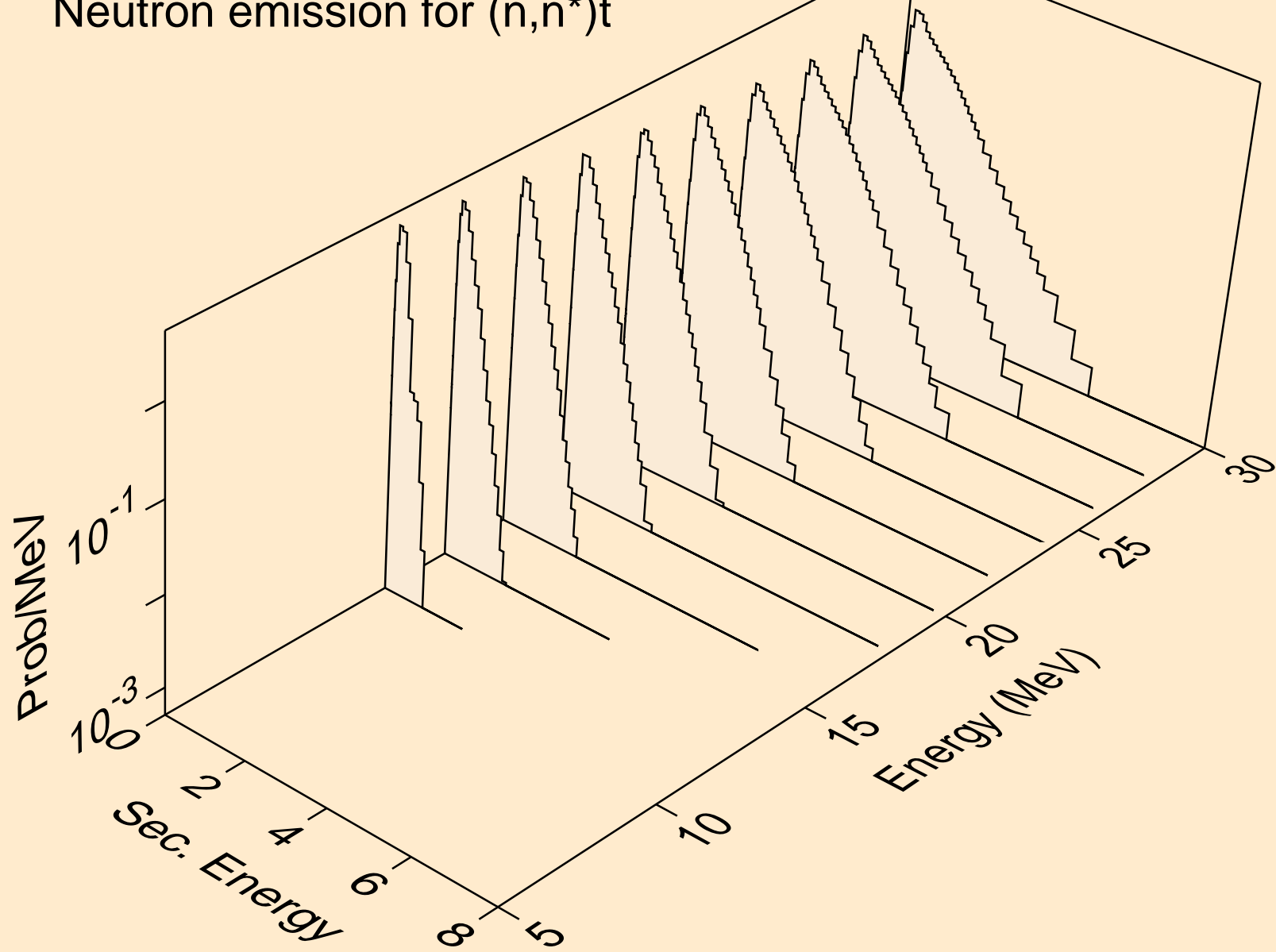

BH268 NEUTRON ACER TENDL-2024 LIBRARY; T=0.K  
Neutron emission for (n,n\*)he3

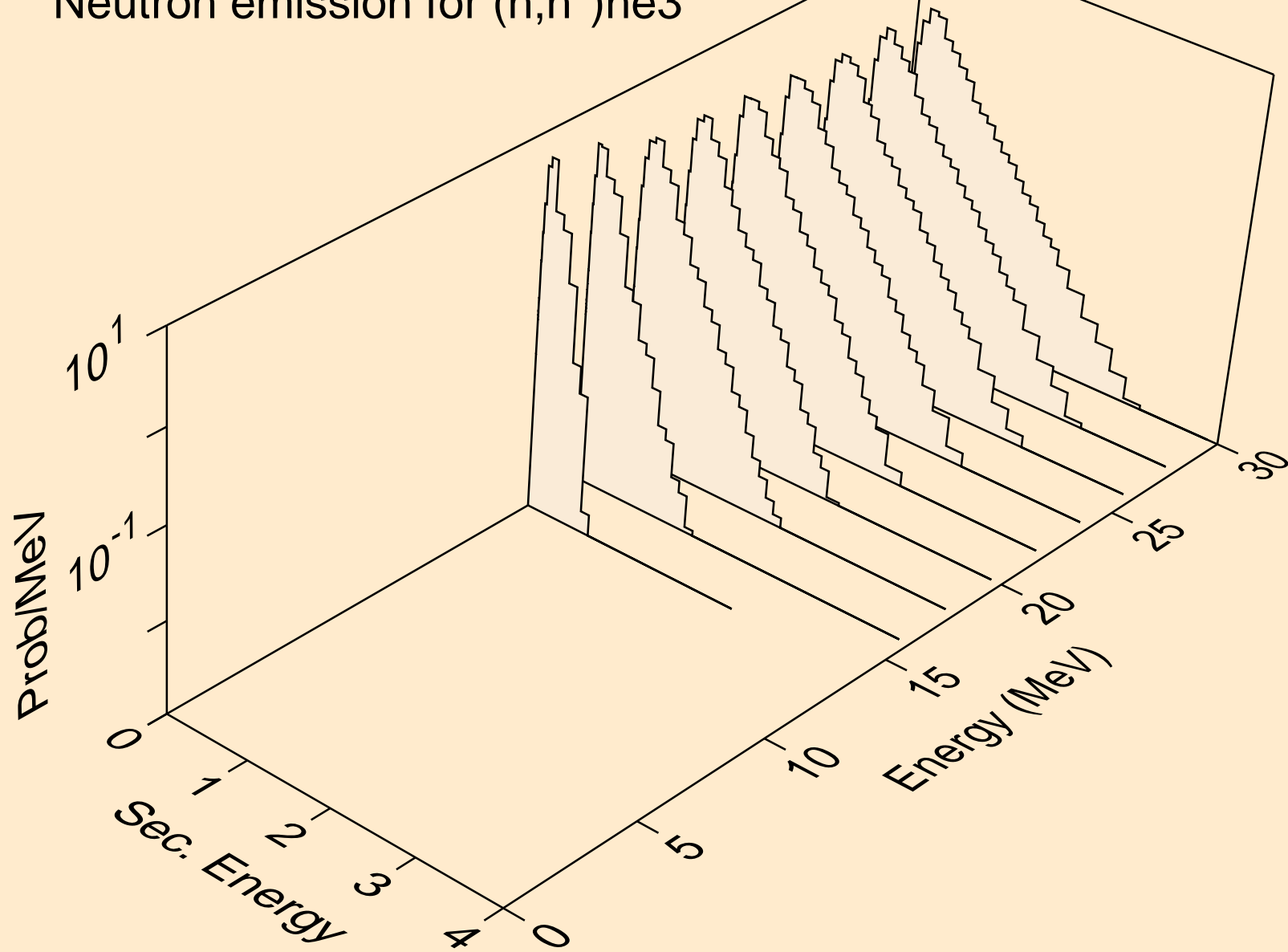



BH268 NEUTRON ACER TENDL-2024 LIBRARY; T=0.K  
Neutron emission for (n,4n)

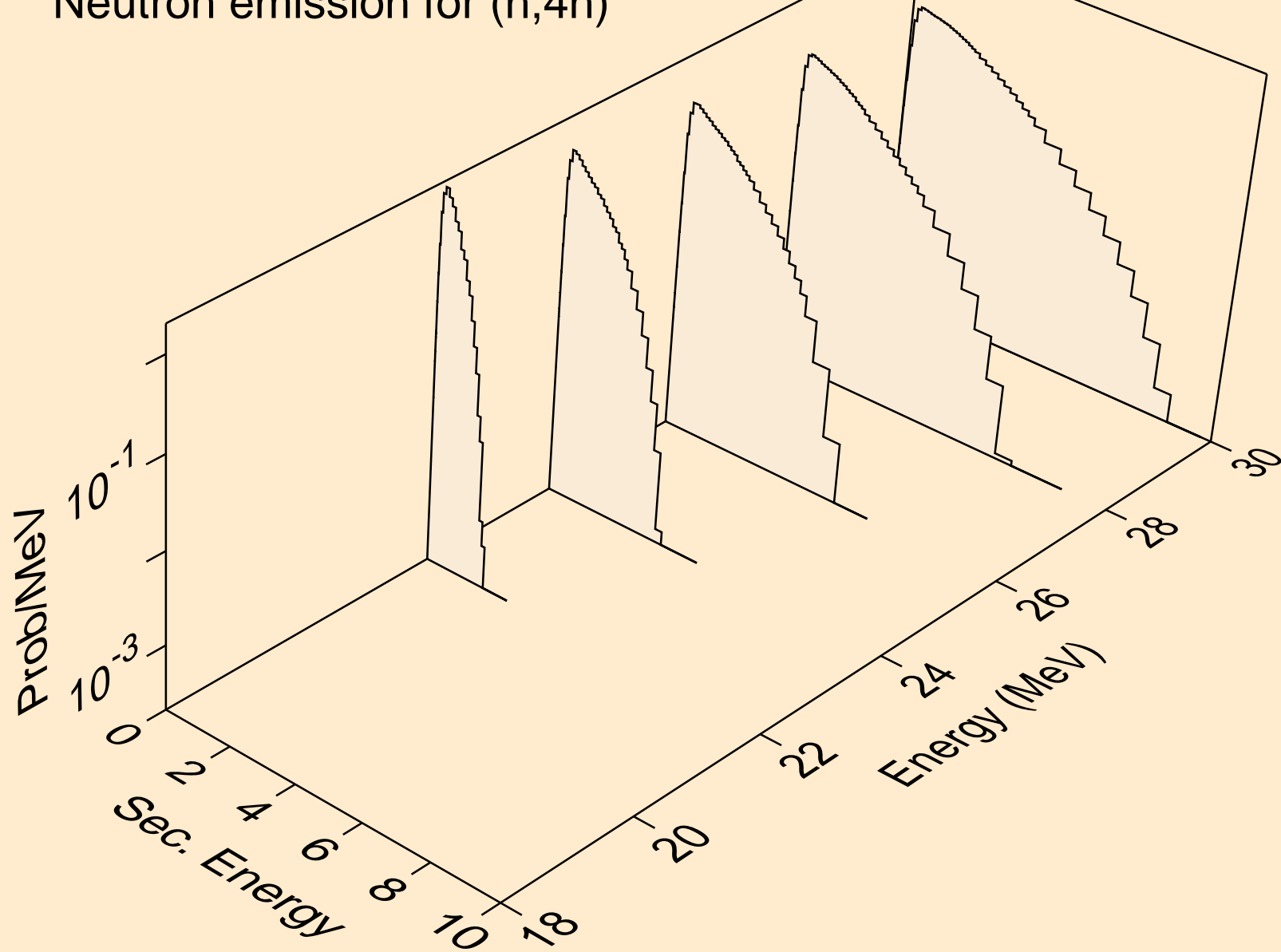

BH268 NEUTRON ACER TENDL-2024 LIBRARY; T=0.K  
Neutron emission for (n,2np)

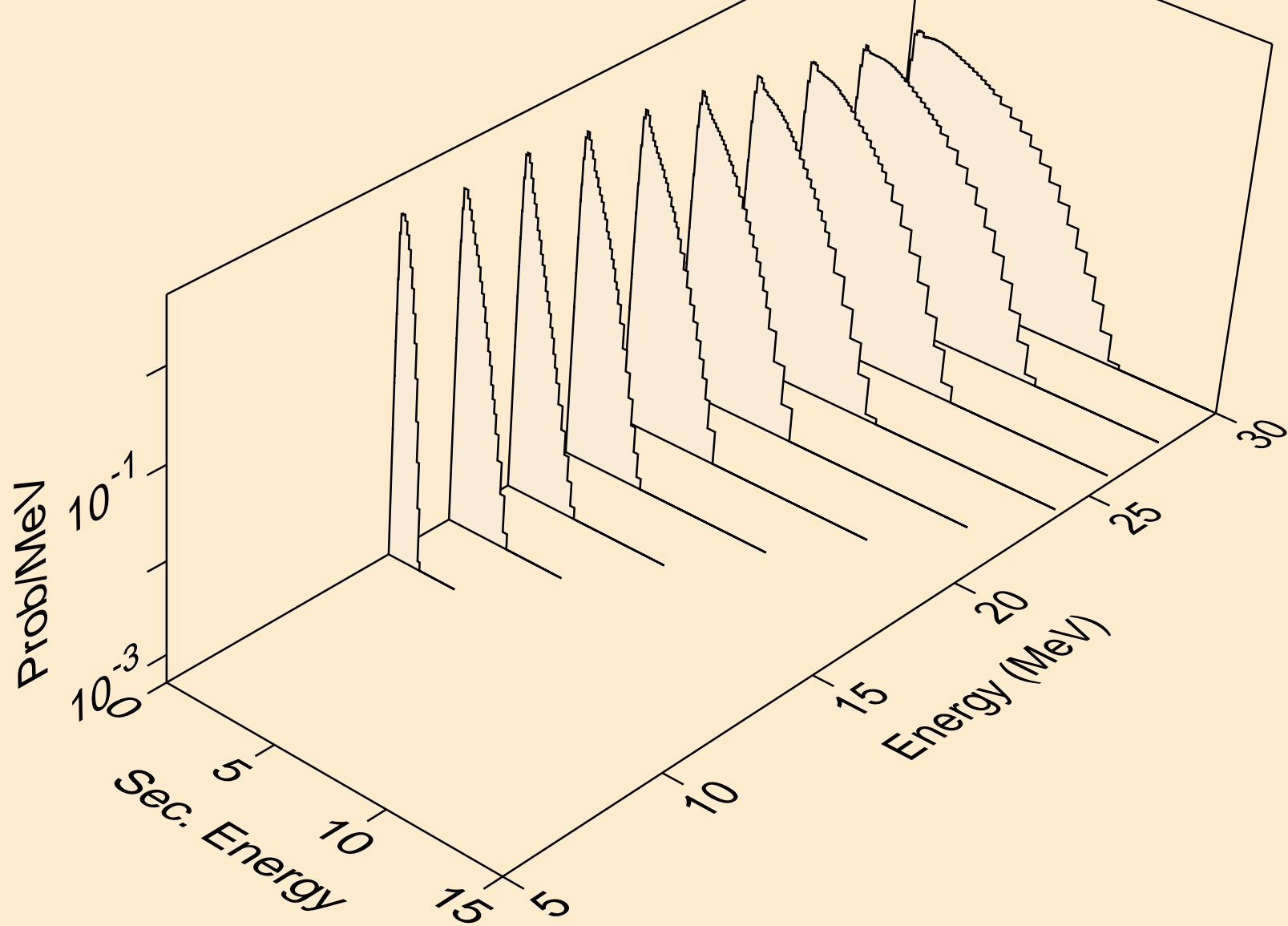

BH268 NEUTRON ACER TENDL-2024 LIBRARY; T=0.K  
Neutron emission for (n,3np)

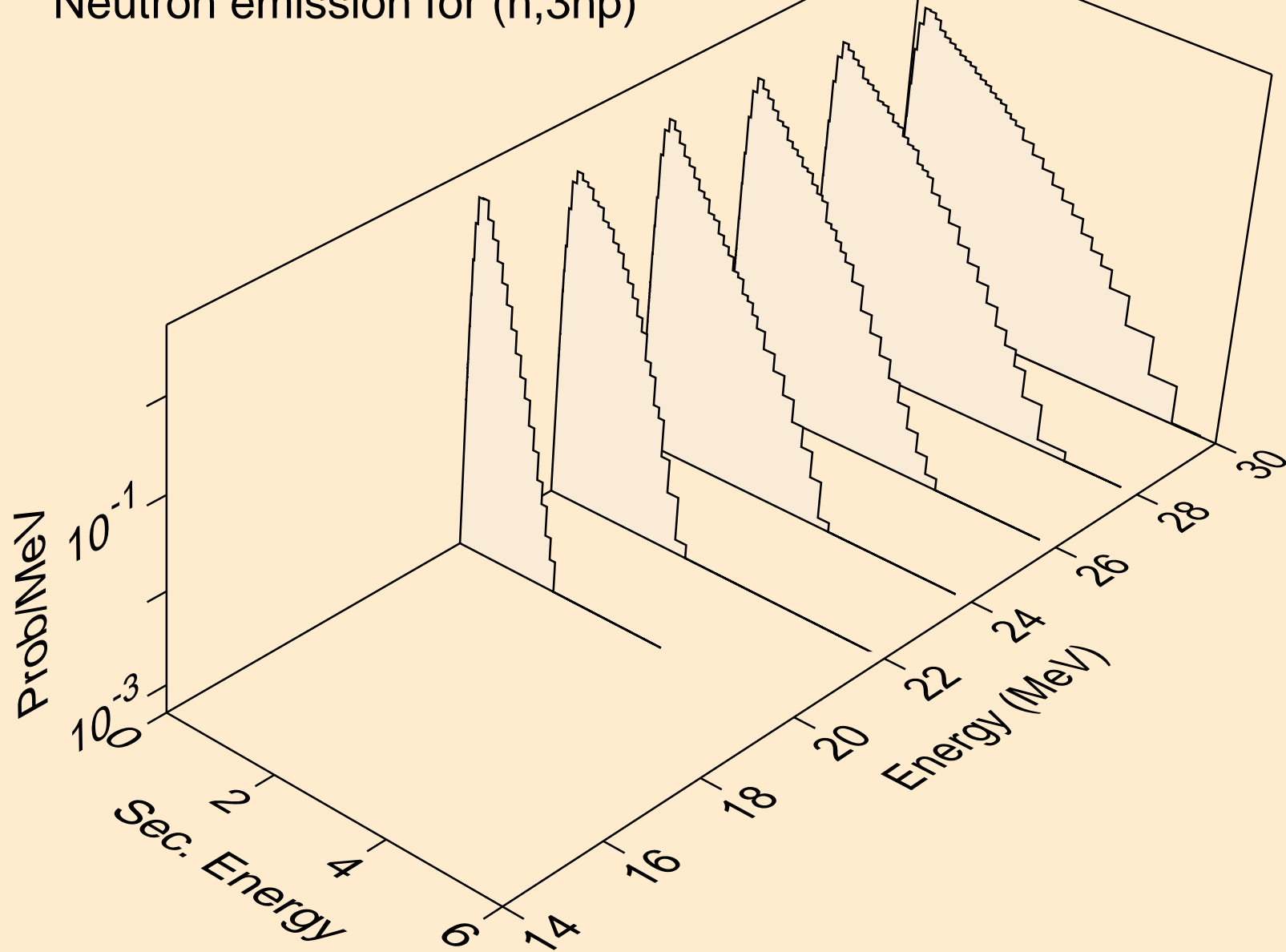

BH268 NEUTRON ACER TENDL-2024 LIBRARY; T=0.K  
Neutron emission for (n,n2p)

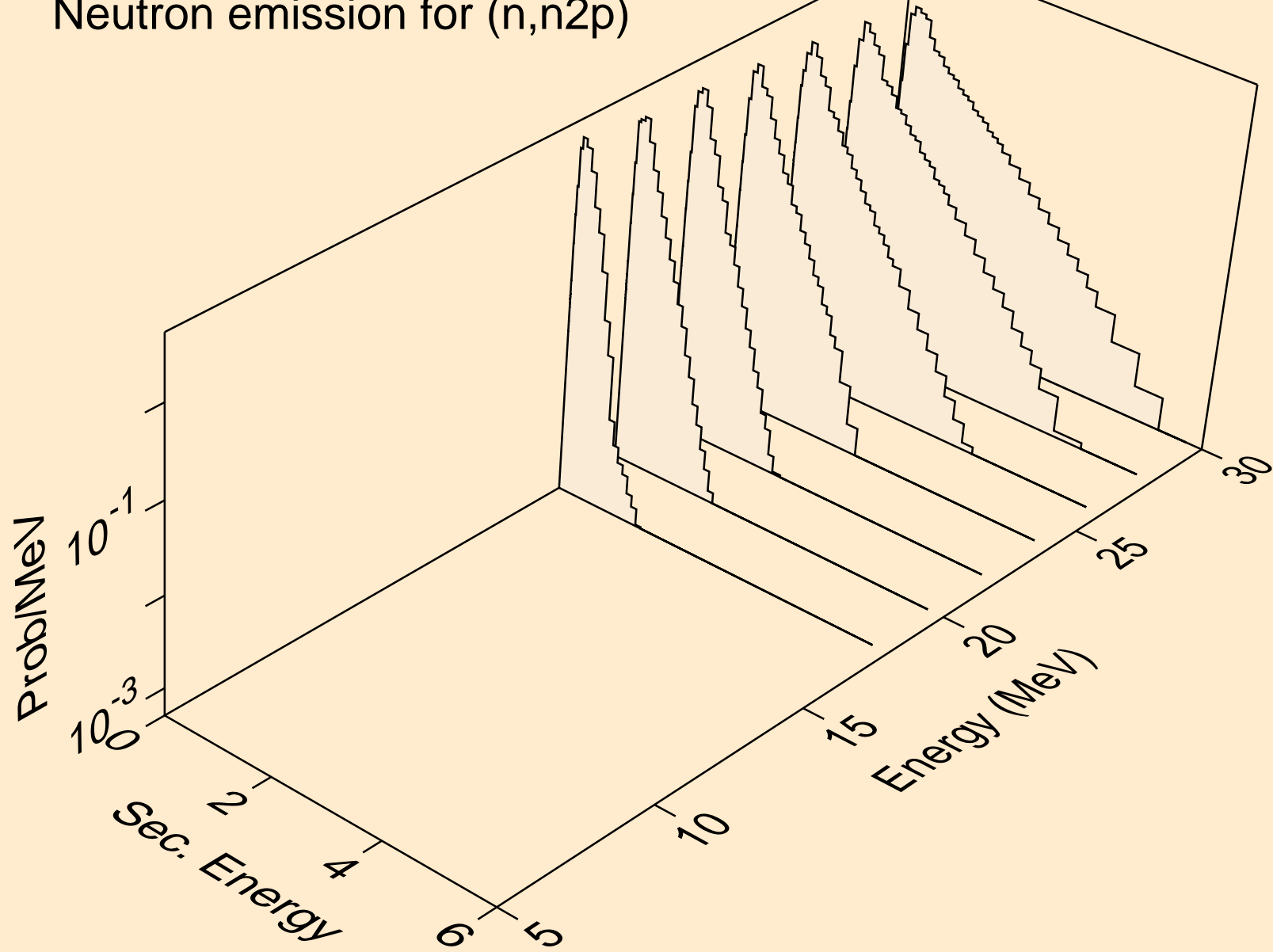

BH268 NEUTRON ACER TENDL-2024 LIBRARY; T=0.K  
Neutron emission for (n,n\*c)

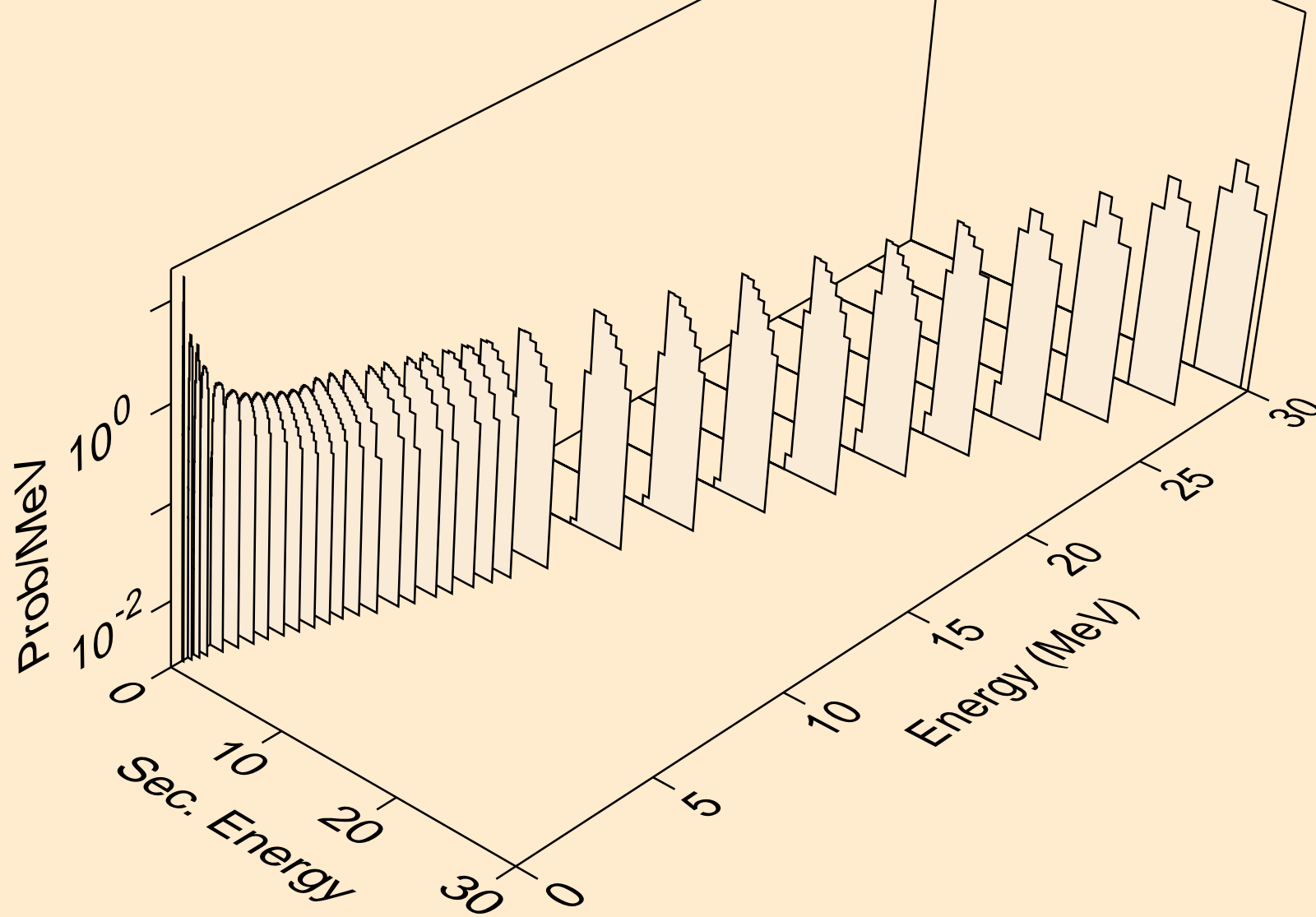

# BH268 NEUTRON ACER TENDL-2024 LIBRARY; T=0.K

## Delayed nubar

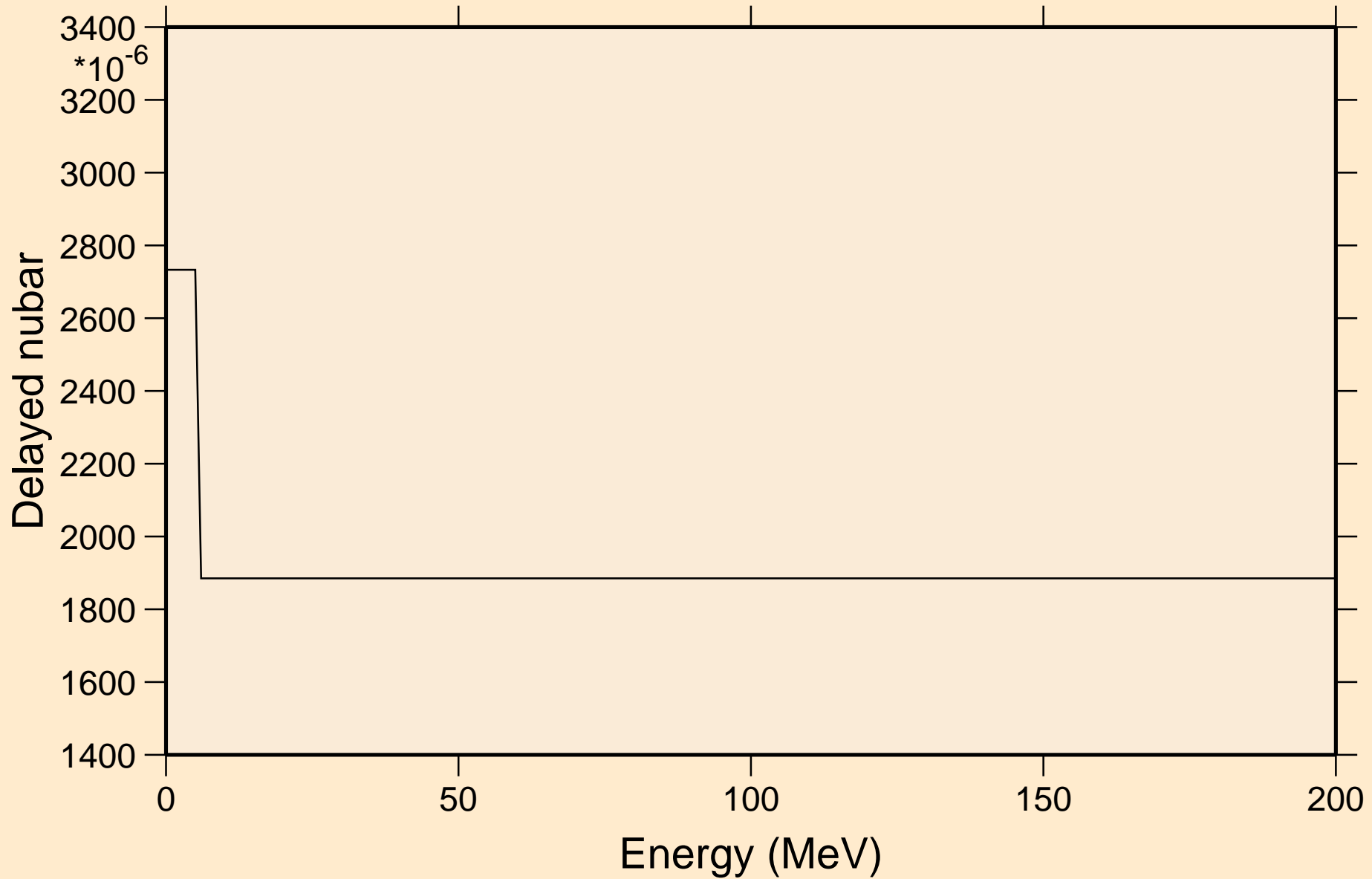

# BH268 NEUTRON ACER TENDL-2024 LIBRARY; T=0.K

## Delayed neutron spectra

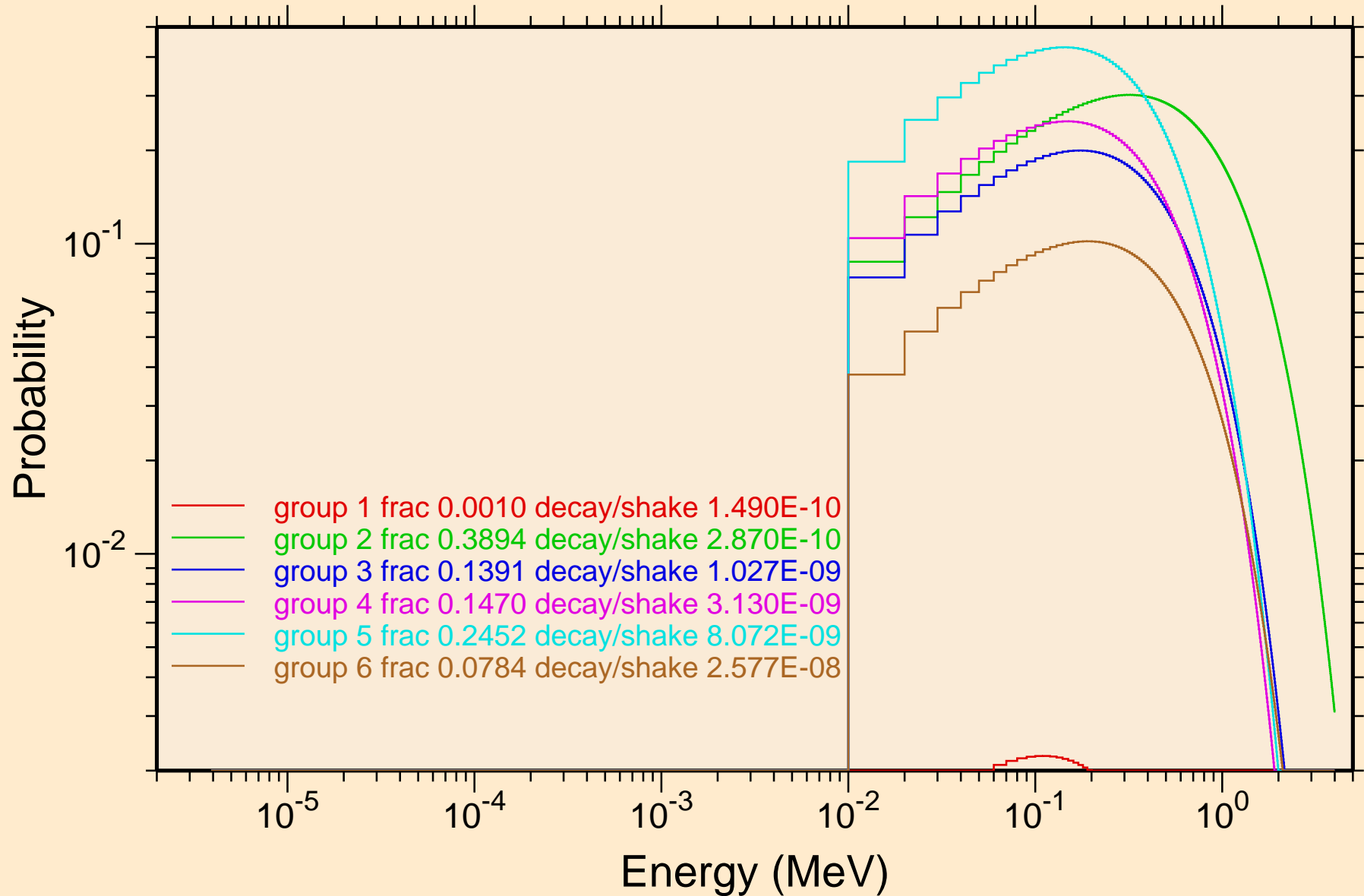

BH268 NEUTRON ACER TENDL-2024 LIBRARY; T=0.K  
Photon emission for (n,x)

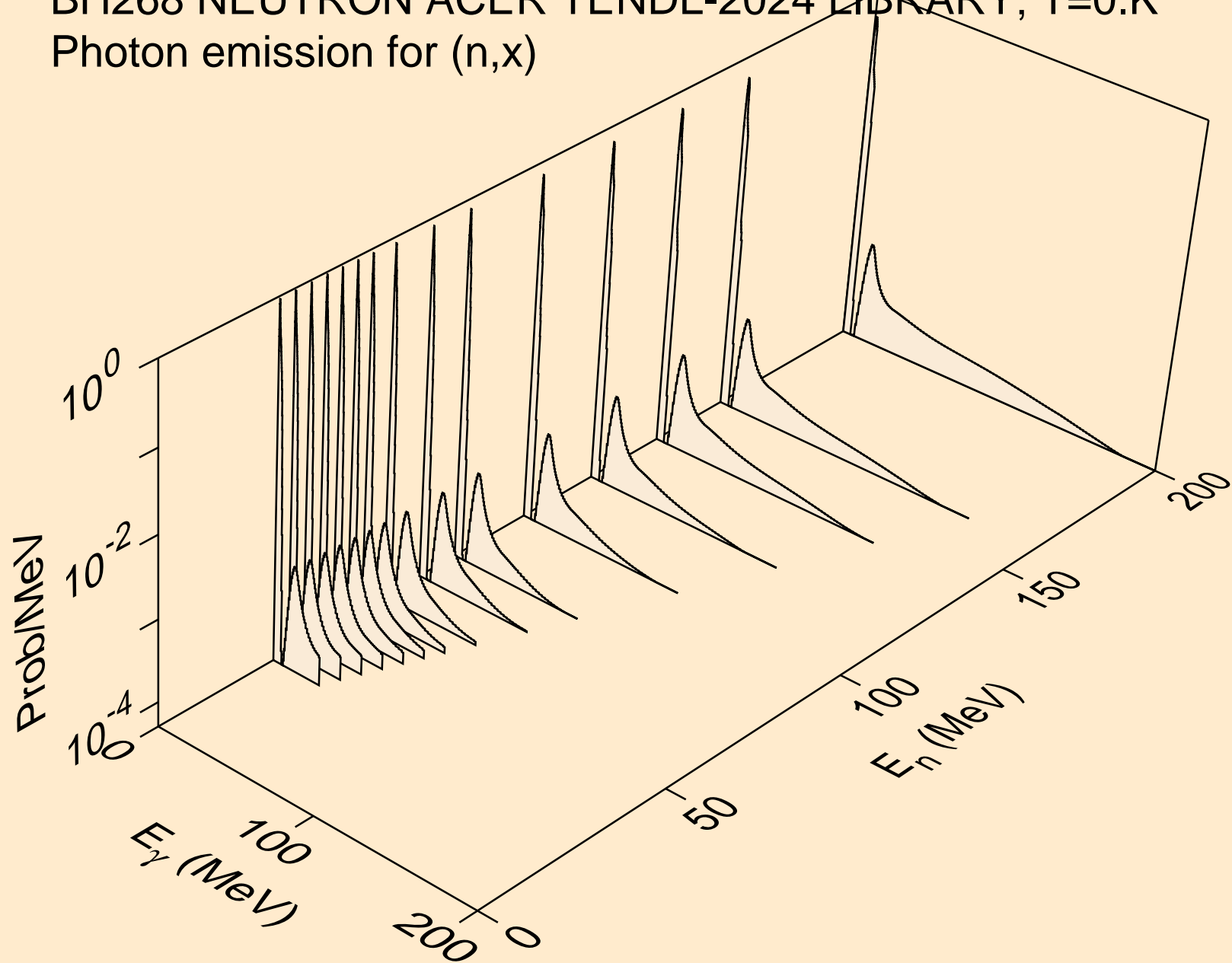



BH268 NEUTRON ACER TENDL-2024 LIBRARY; T=0.K  
Photon emission for (n,2nd)

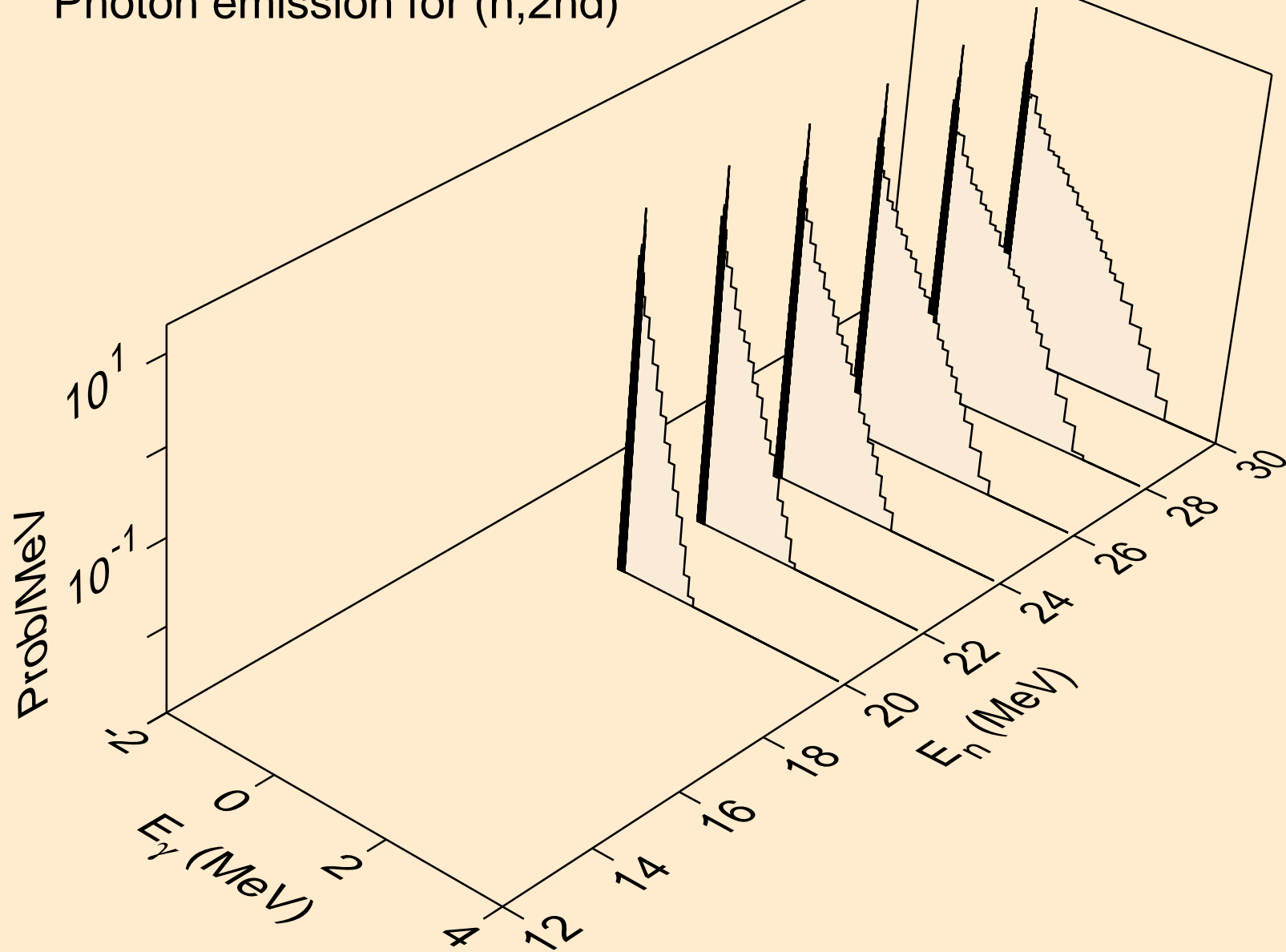

BH268 NEUTRON ACER TENDL-2024 LIBRARY; T=0.K  
Photon emission for (n,2n)

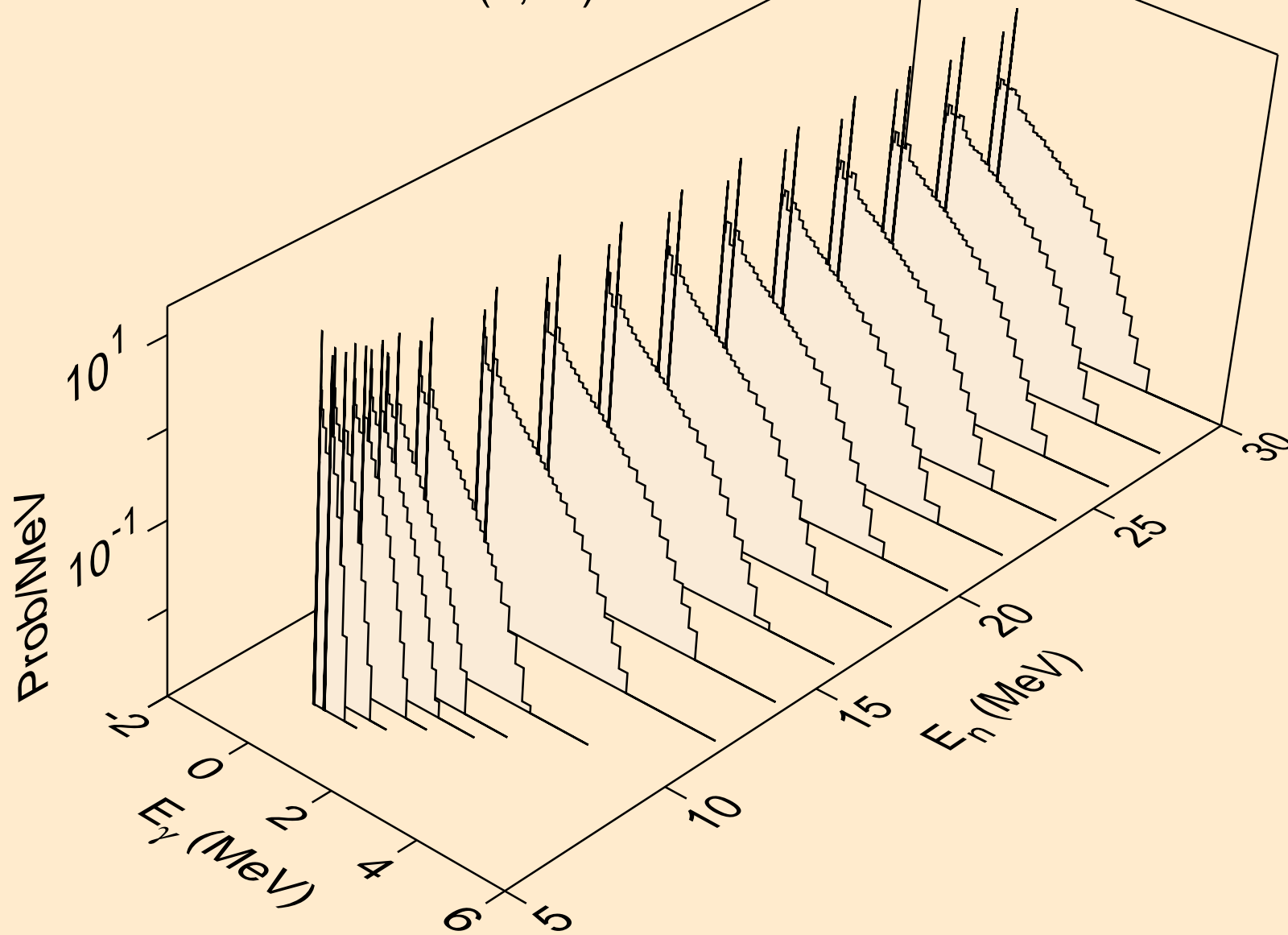

BH268 NEUTRON ACER TENDL-2024 LIBRARY; T=0.K  
Photon emission for (n,3n)

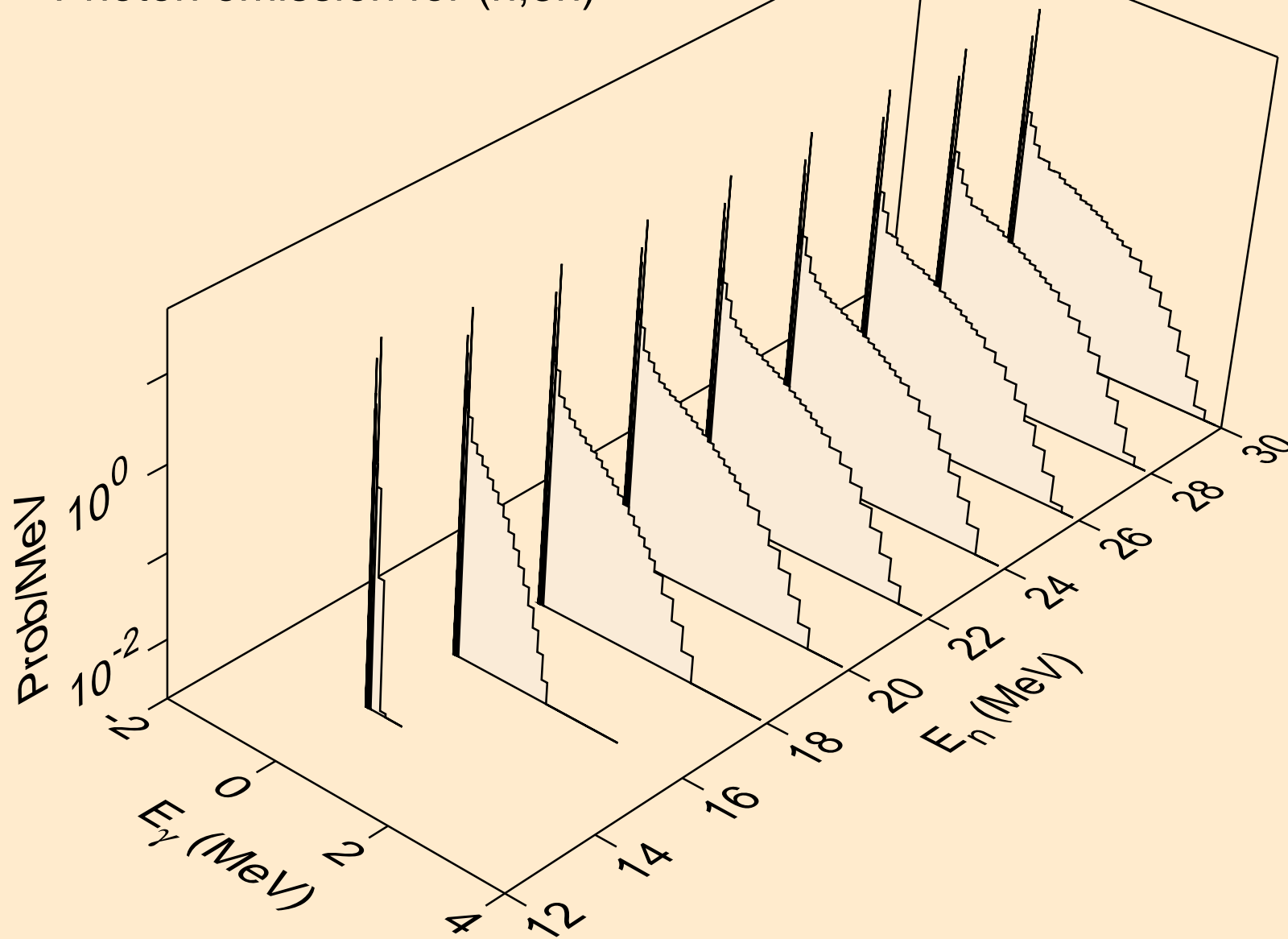

BH268 NEUTRON ACER TENDL-2024 LIBRARY; T=0.K  
Photon emission for (n,n\*)a

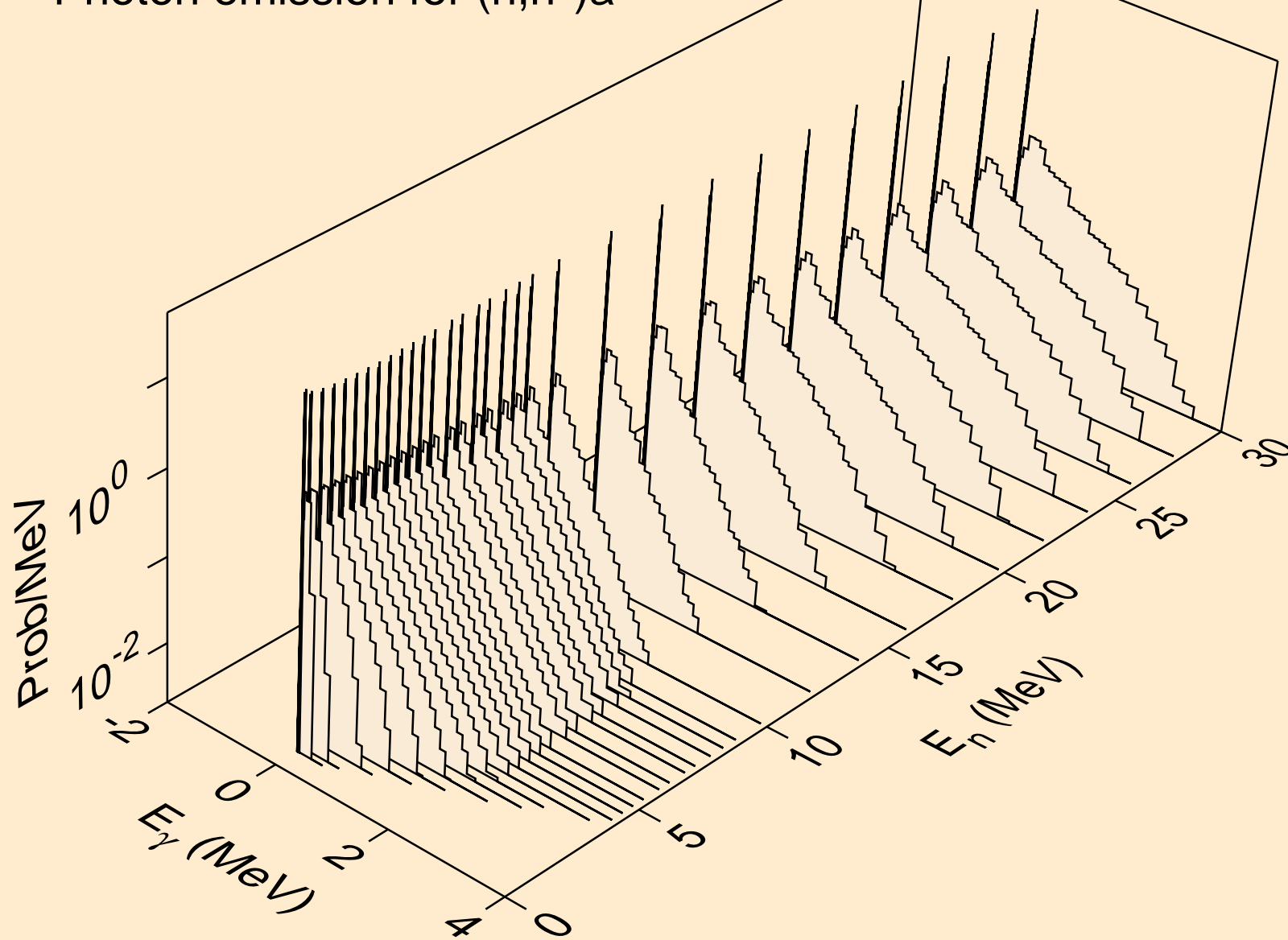

BH268 NEUTRON ACER TENDL-2024 LIBRARY; T=0.K  
Photon emission for (n,2n)a

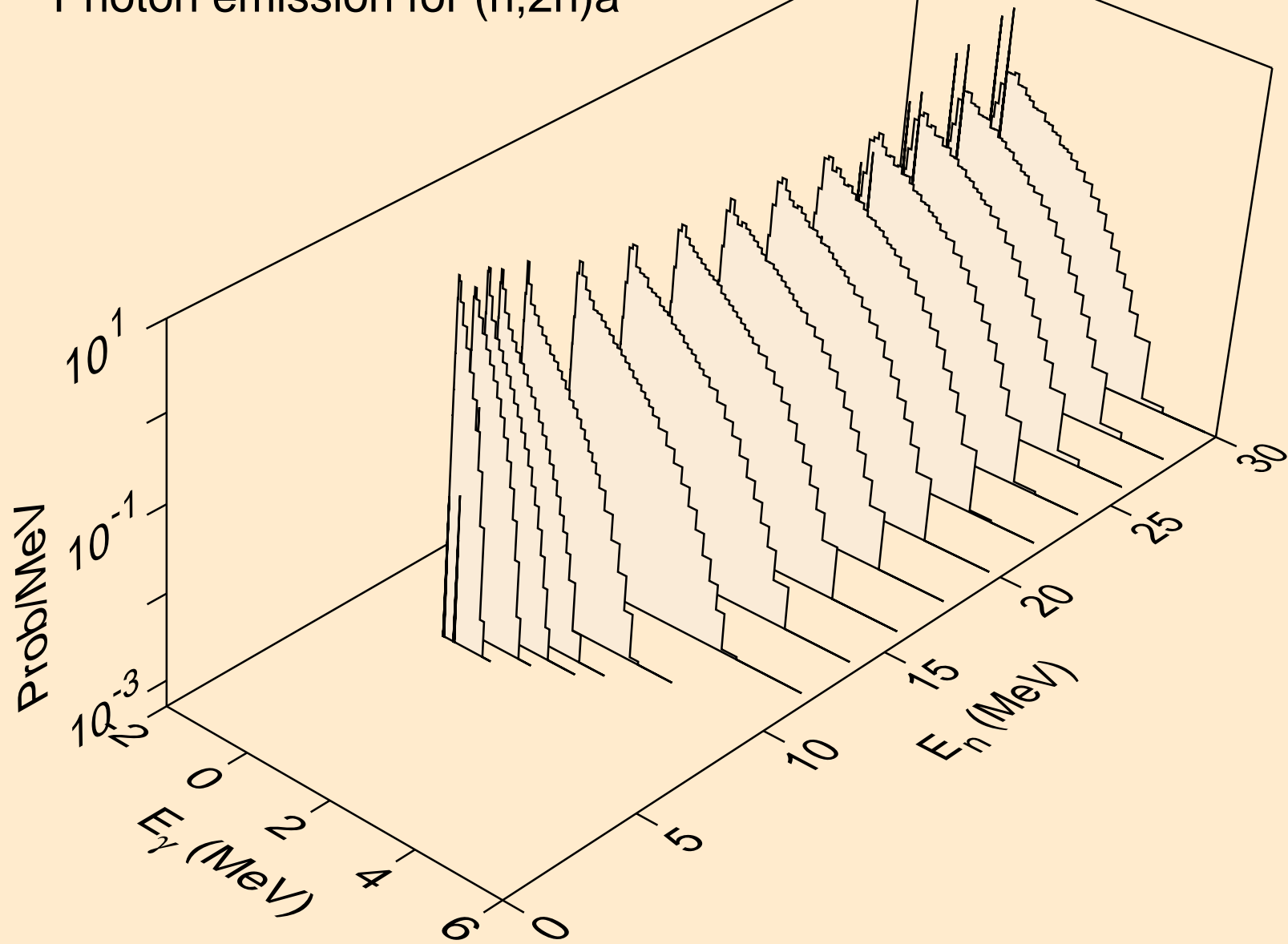

BH268 NEUTRON ACER TENDL-2024 LIBRARY; T=0.K  
Photon emission for (n,3n)a

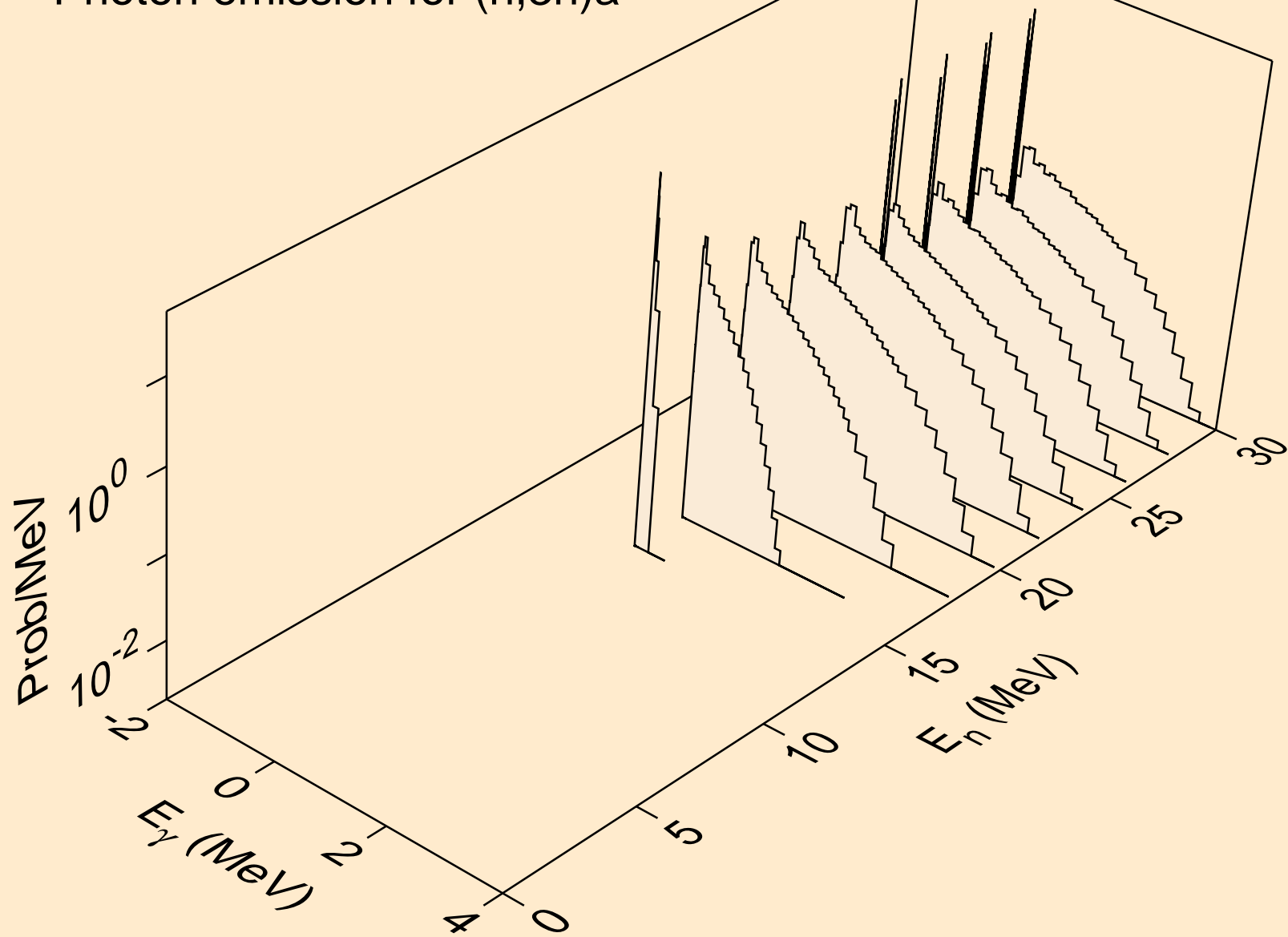

BH268 NEUTRON ACER TENDL-2024 LIBRARY; T=0.K  
Photon emission for (n,n\*)p

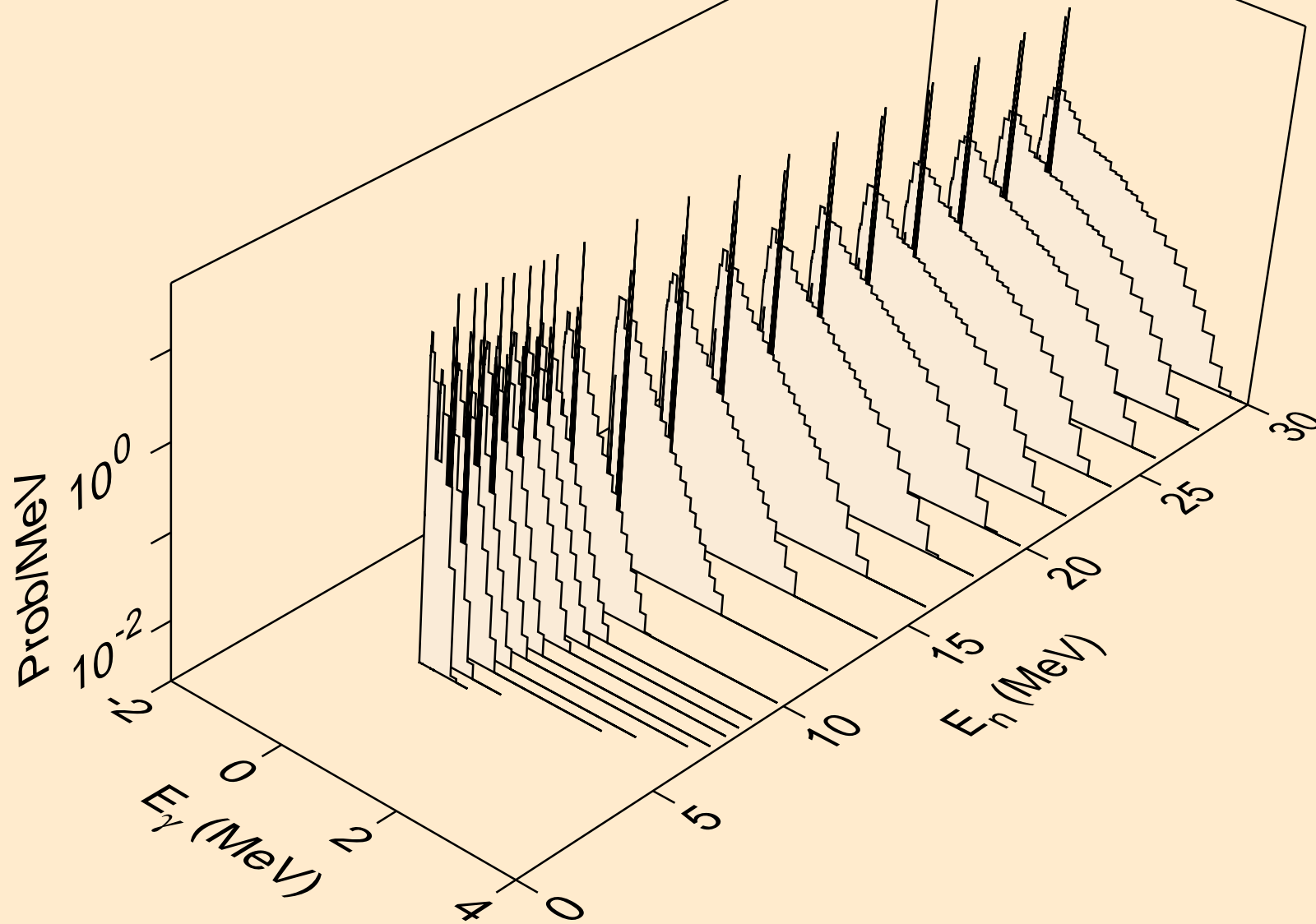

BH268 NEUTRON ACER TENDL-2024 LIBRARY; T=0.K  
Photon emission for (n,n\*)d

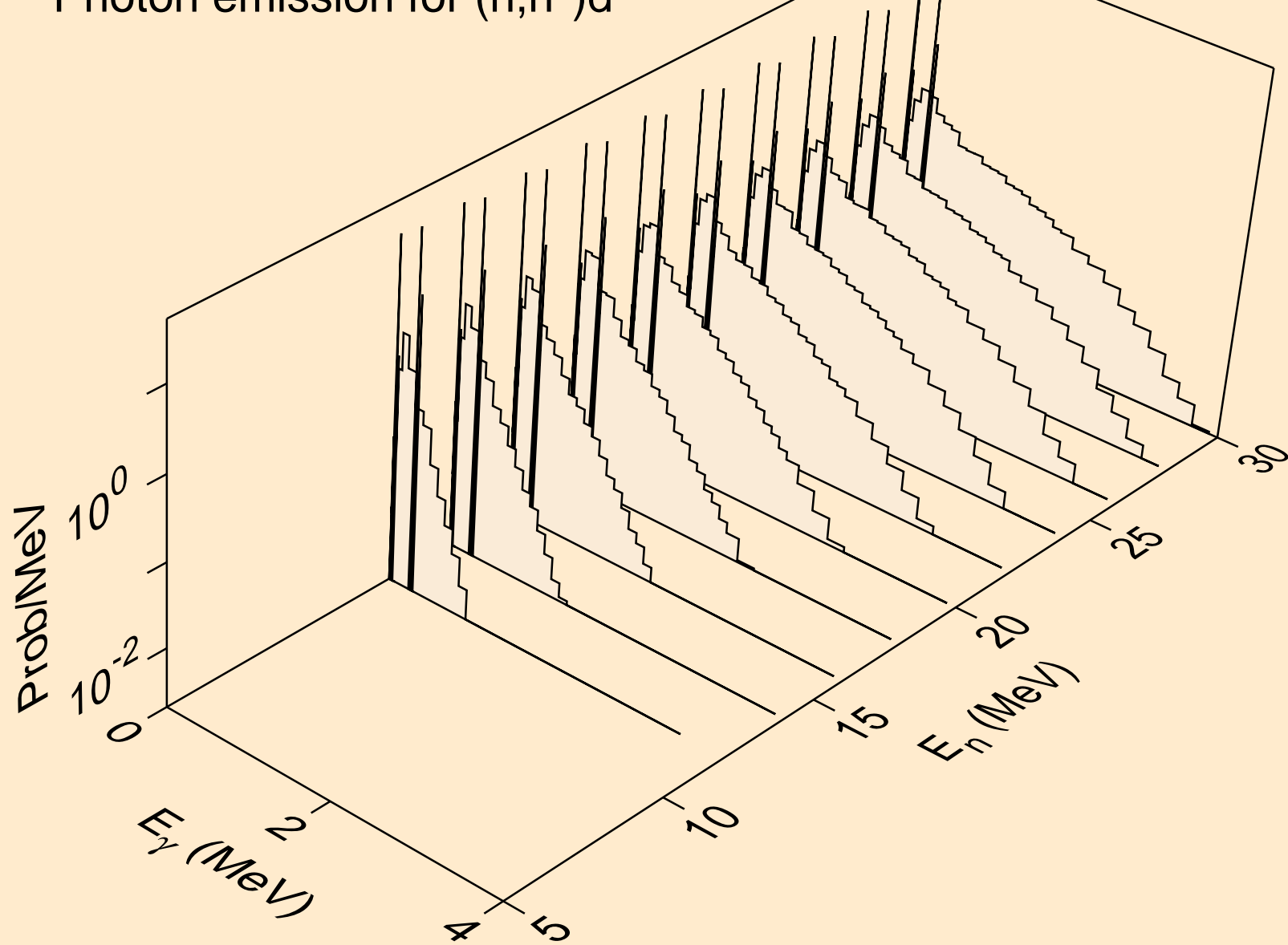



BH268 NEUTRON ACER TENDL-2024 LIBRARY; T=0.K  
Photon emission for (n,n\*)t

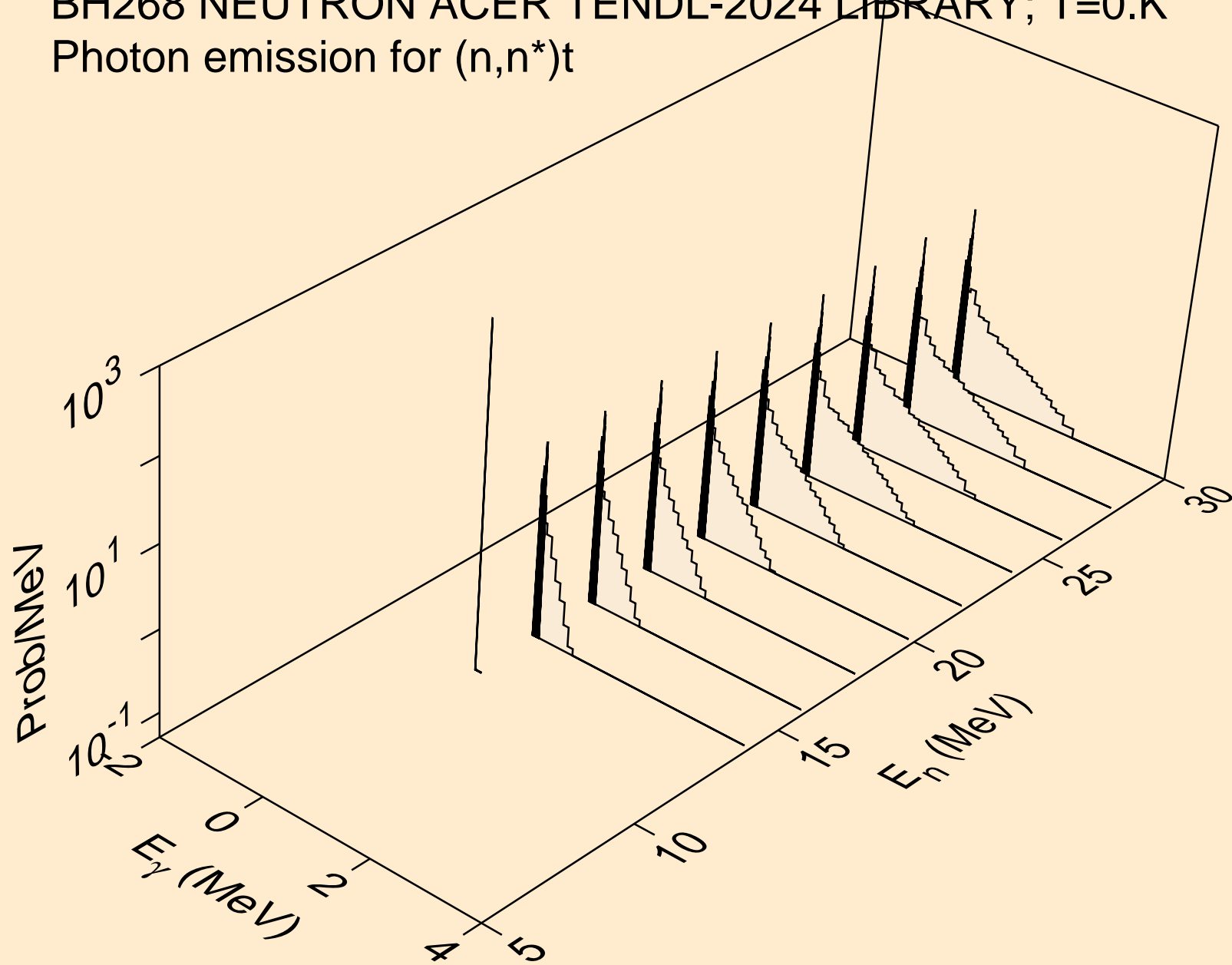

BH268 NEUTRON ACER TENDL-2024 LIBRARY; T=0.K  
Photon emission for (n,n\*)he3

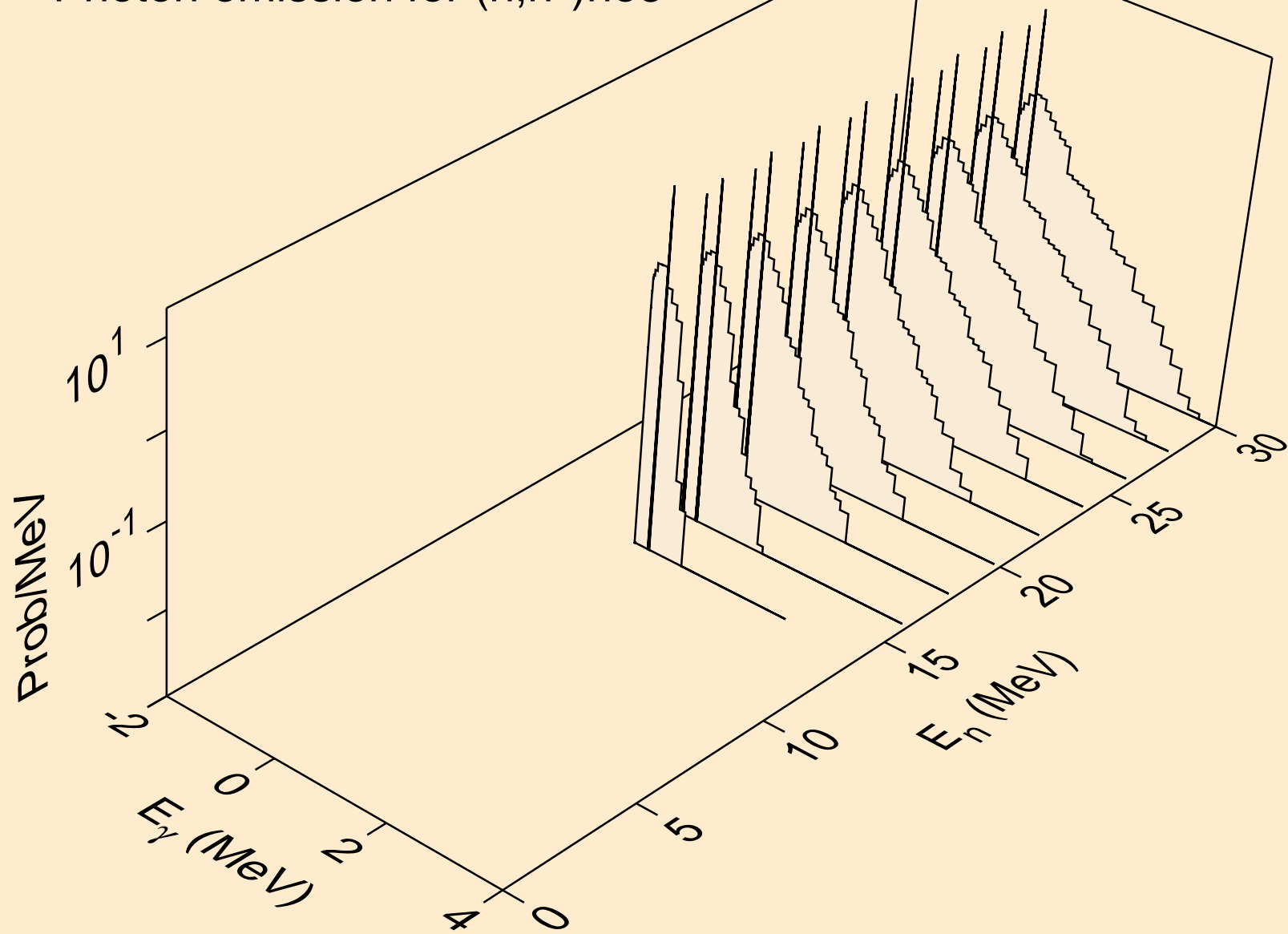

BH268 NEUTRON ACER TENDL-2024 LIBRARY; T=0.K  
Photon emission for (n,4n)

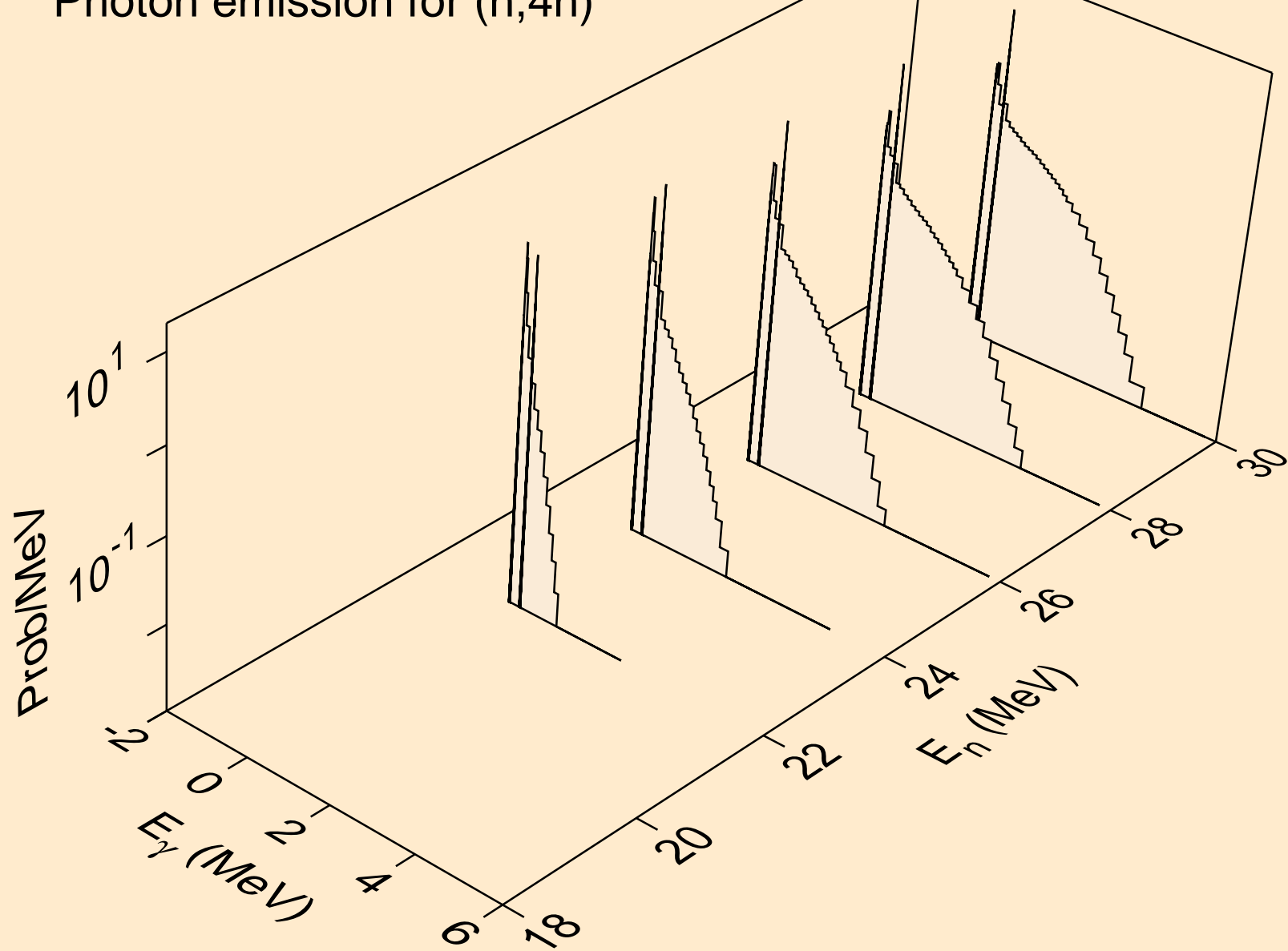

BH268 NEUTRON ACER TENDL-2024 LIBRARY; T=0.K  
Photon emission for (n,2np)

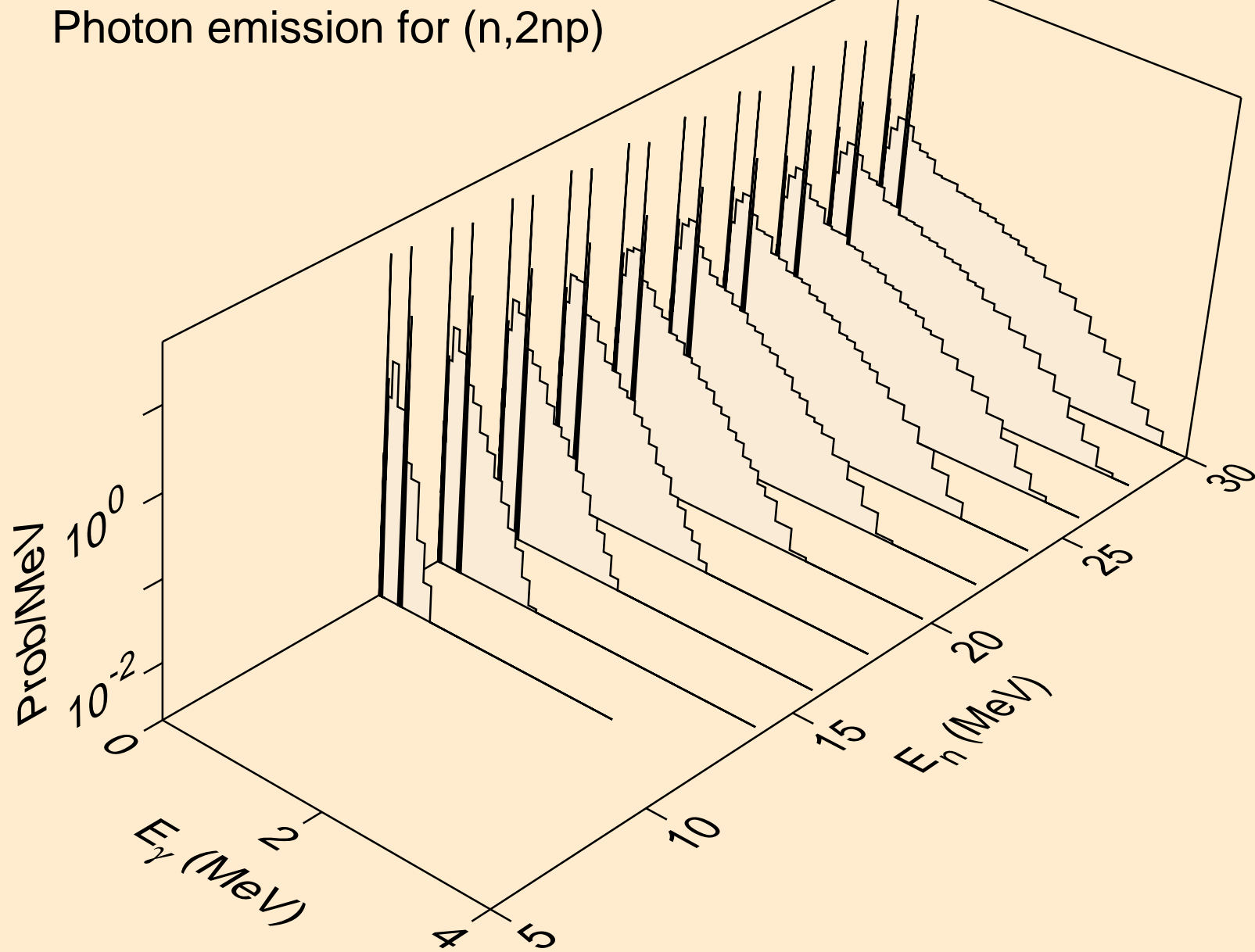

BH268 NEUTRON ACER TENDL-2024 LIBRARY; T=0.K  
Photon emission for (n,3np)

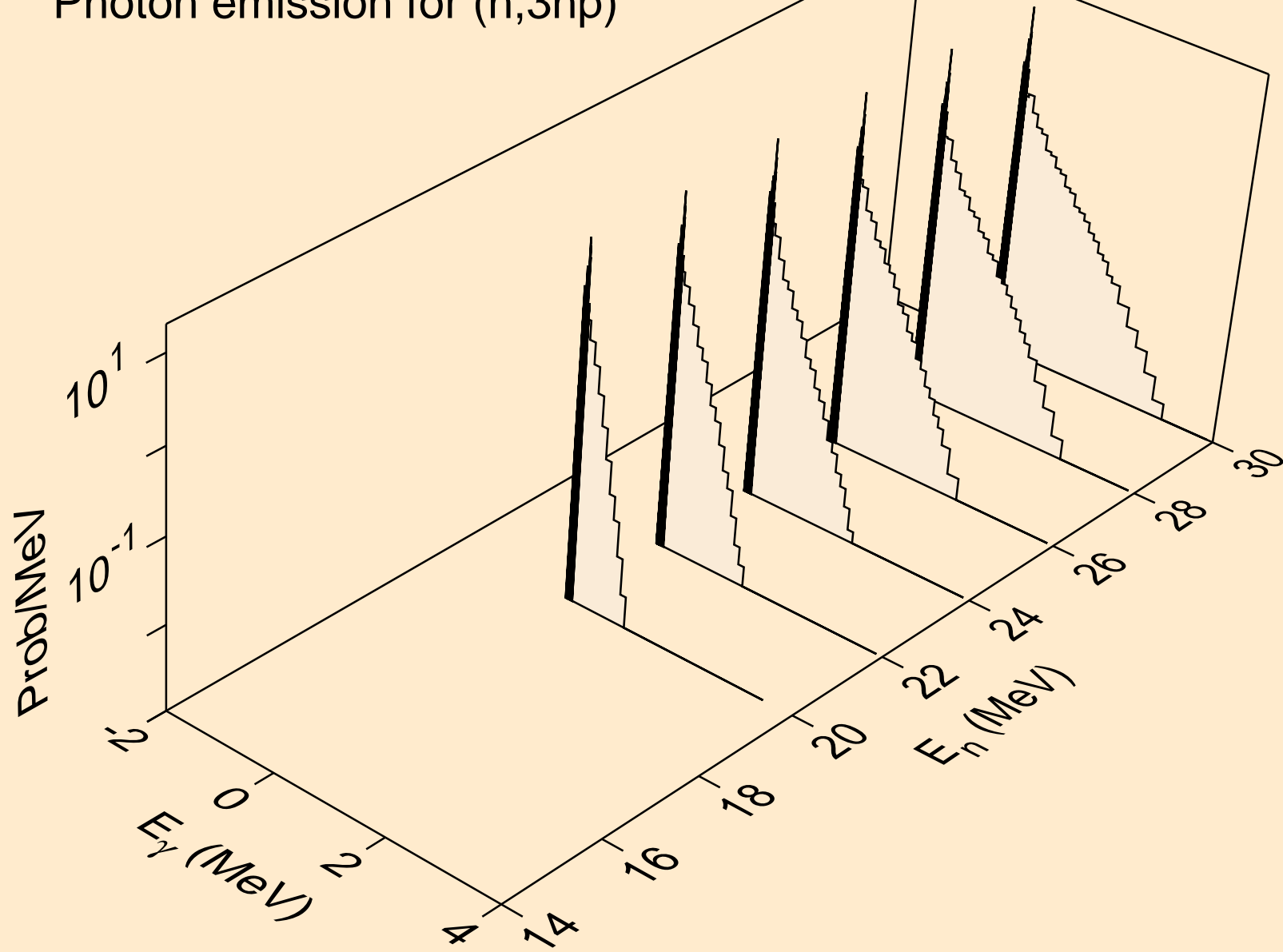

BH268 NEUTRON ACER TENDL-2024 LIBRARY; T=0.K  
Photon emission for (n,n2p)

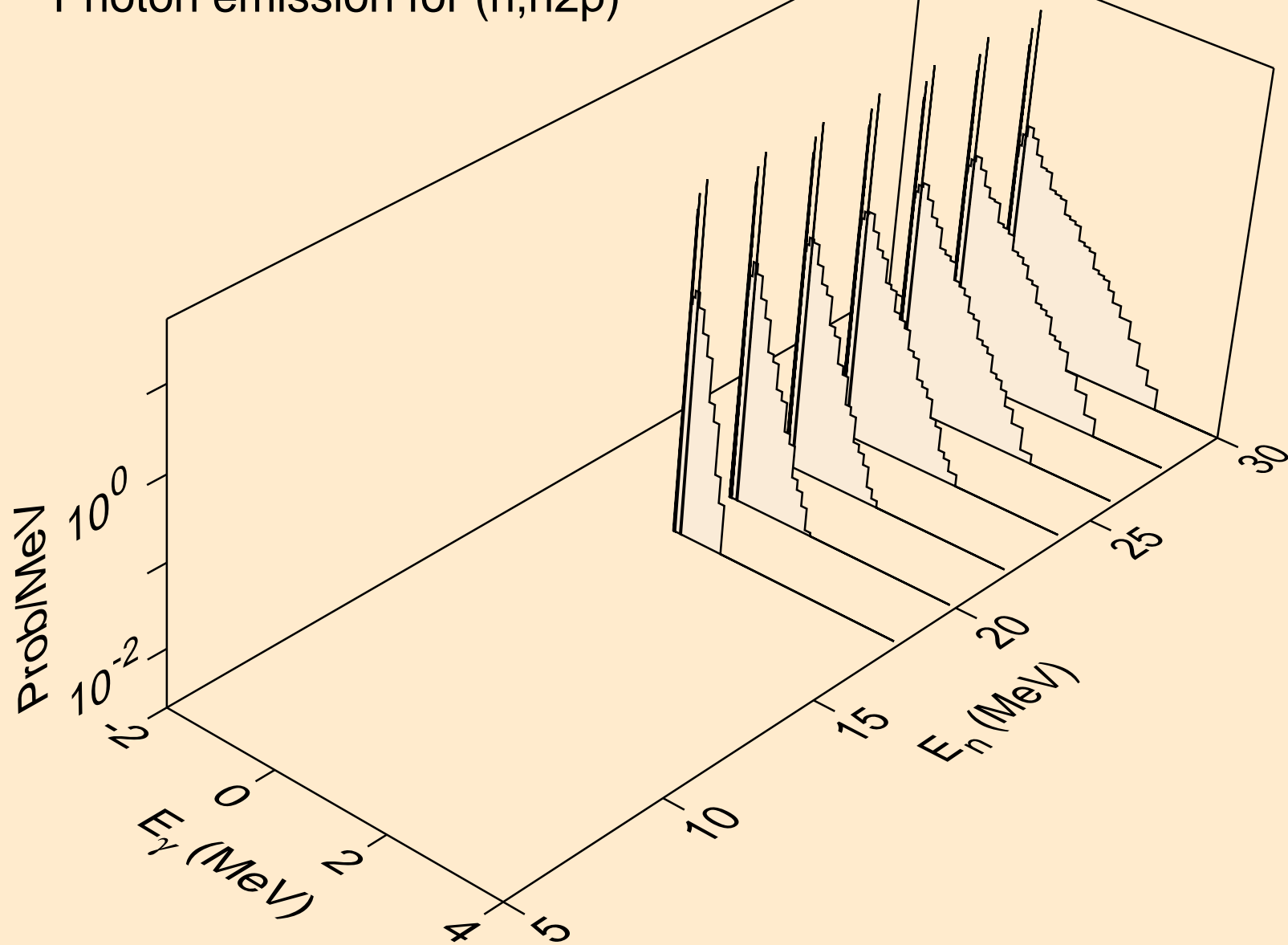

BH268 NEUTRON ACER TENDL-2024 LIBRARY; T=0.K  
Photon emission for (n,n\*c)

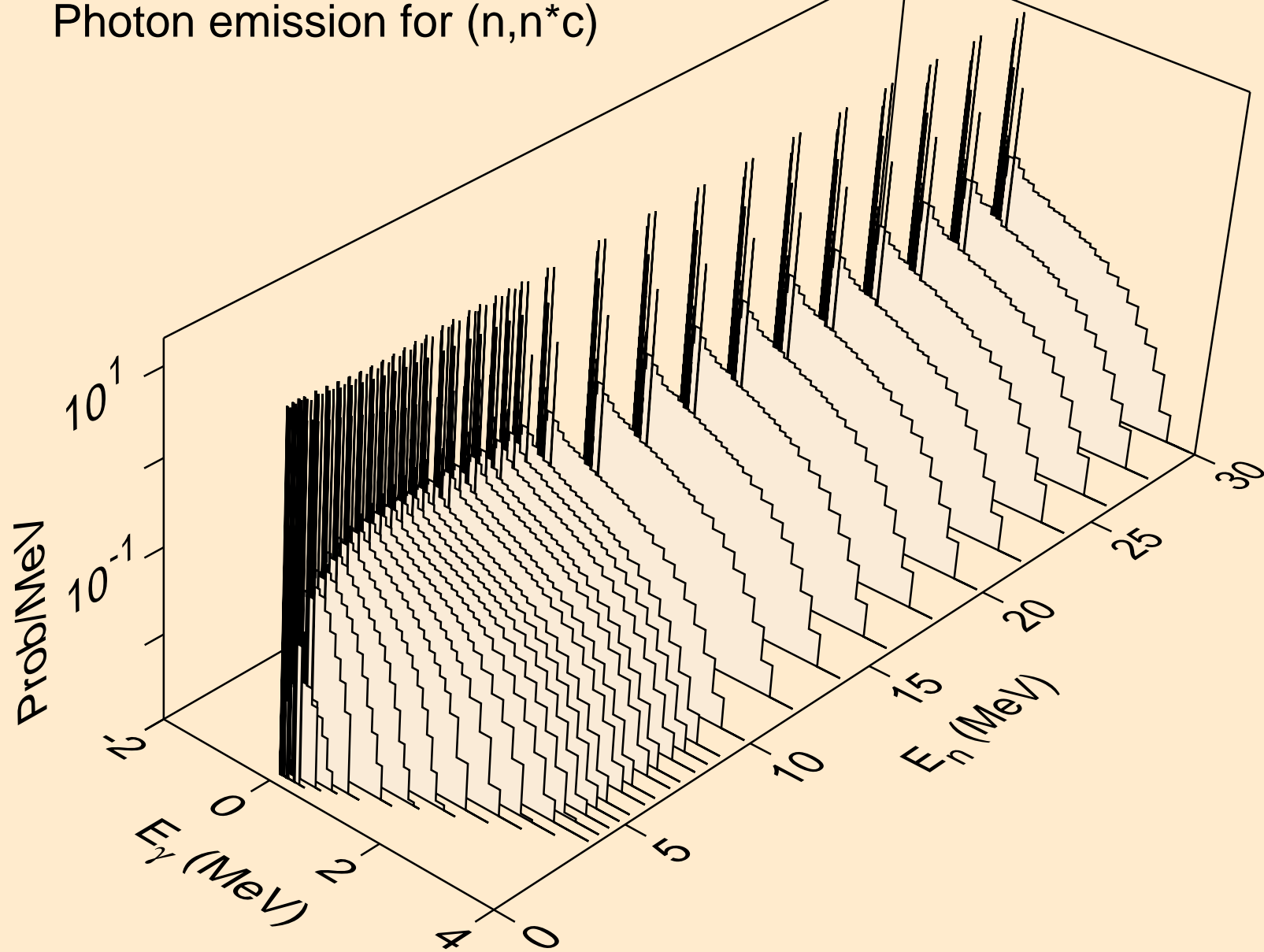

BH268 NEUTRON ACER TENDL-2024 LIBRARY; T=0.K  
Photon emission for (n,gma)

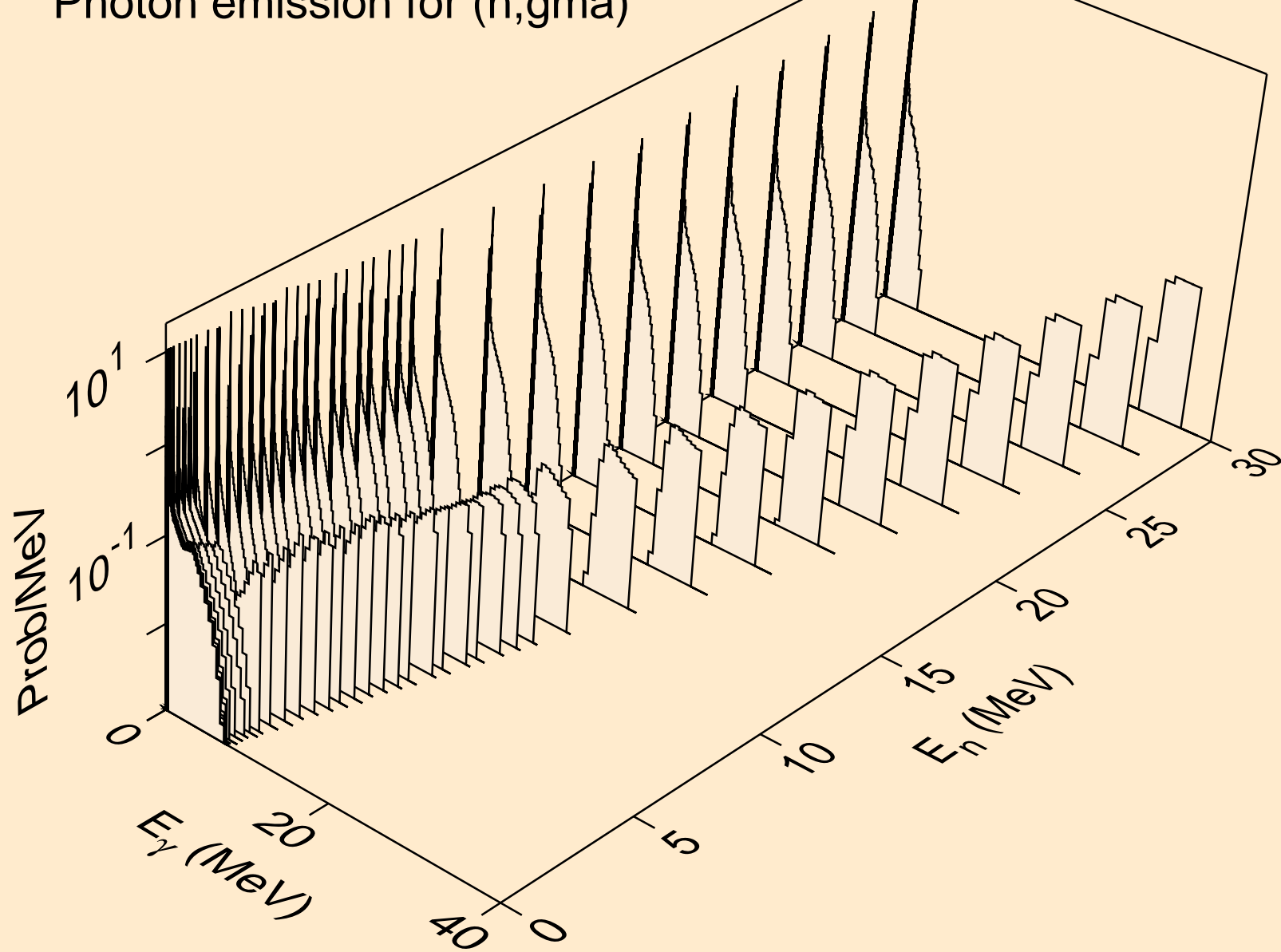



BH268 NEUTRON ACER TENDL-2024 LIBRARY; T=0.K  
Photon emission for (n,p)

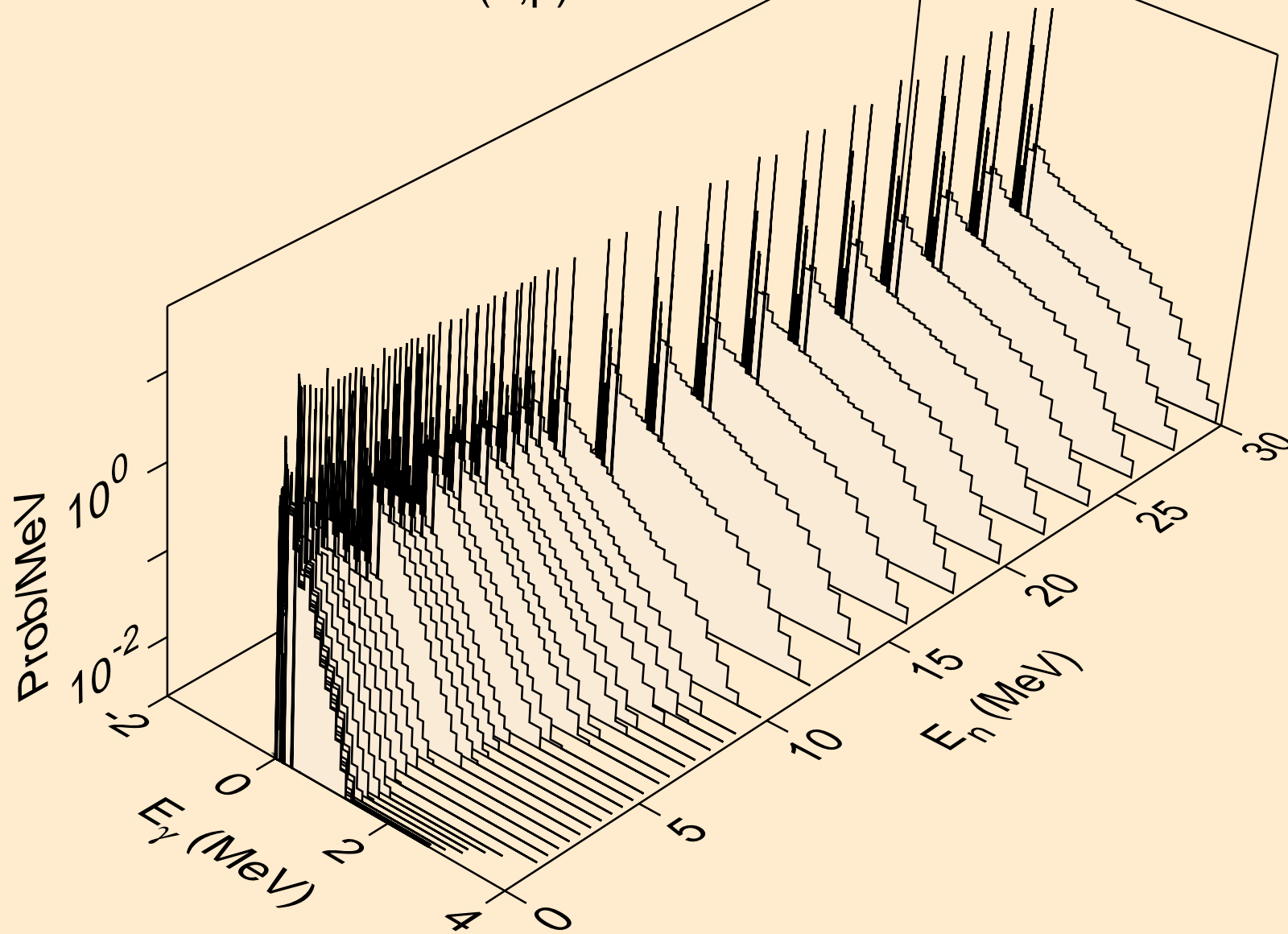

BH268 NEUTRON ACER TENDL-2024 LIBRARY; T=0.K  
Photon emission for (n,d)

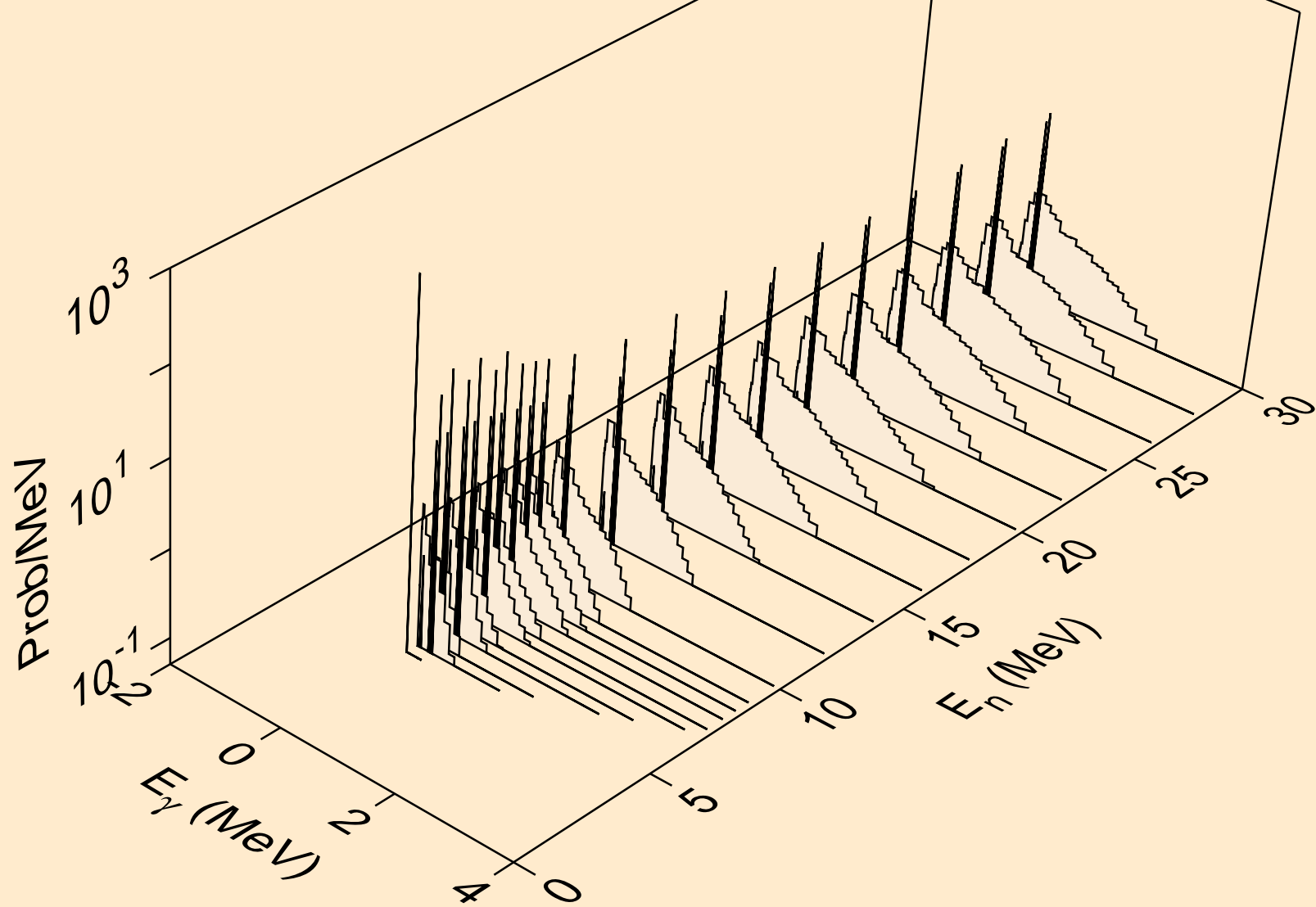

BH268 NEUTRON ACER TENDL-2024 LIBRARY; T=0.K  
Photon emission for (n,t)

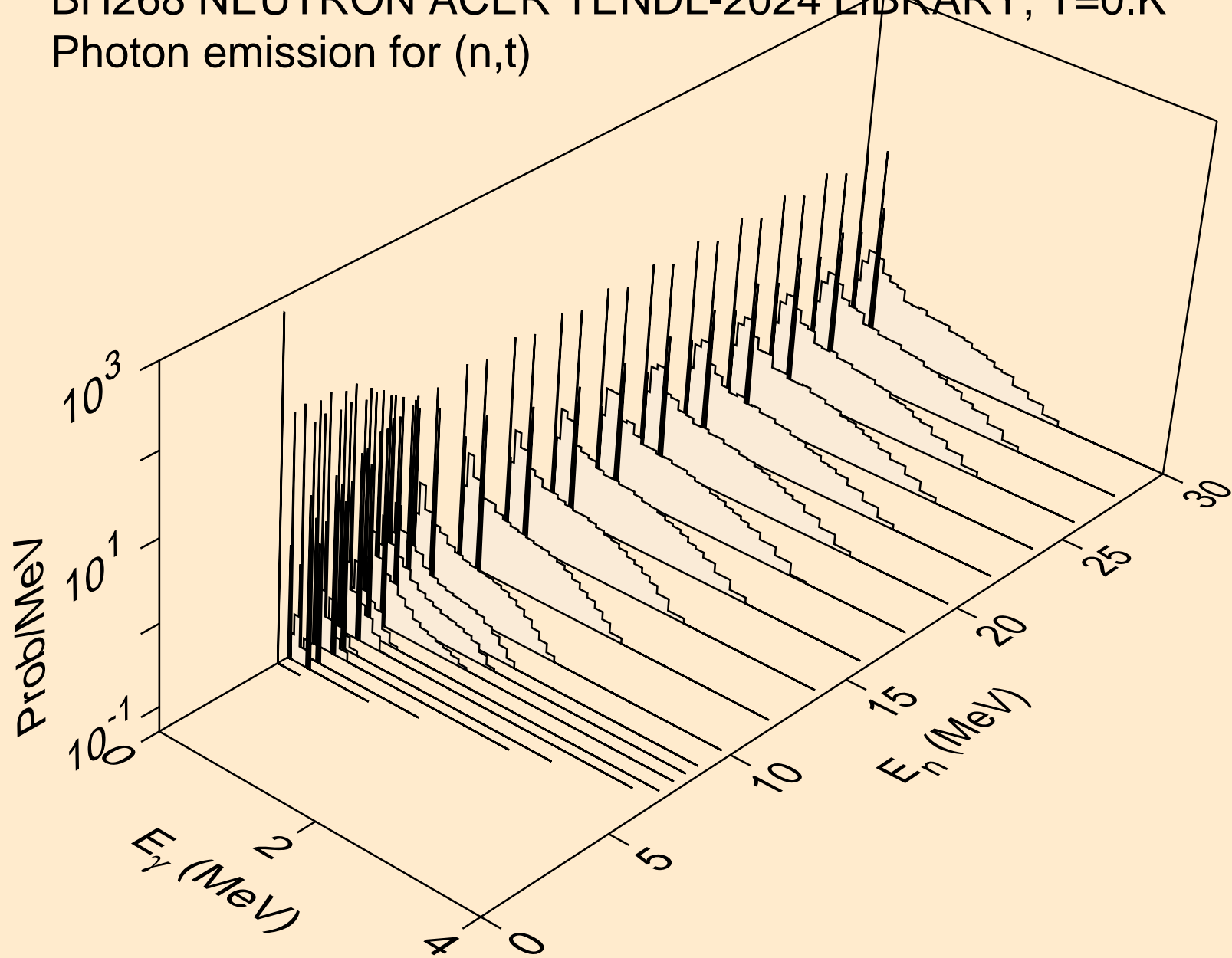

BH268 NEUTRON ACER TENDL-2024 LIBRARY; T=0.K  
Photon emission for (n,he3)

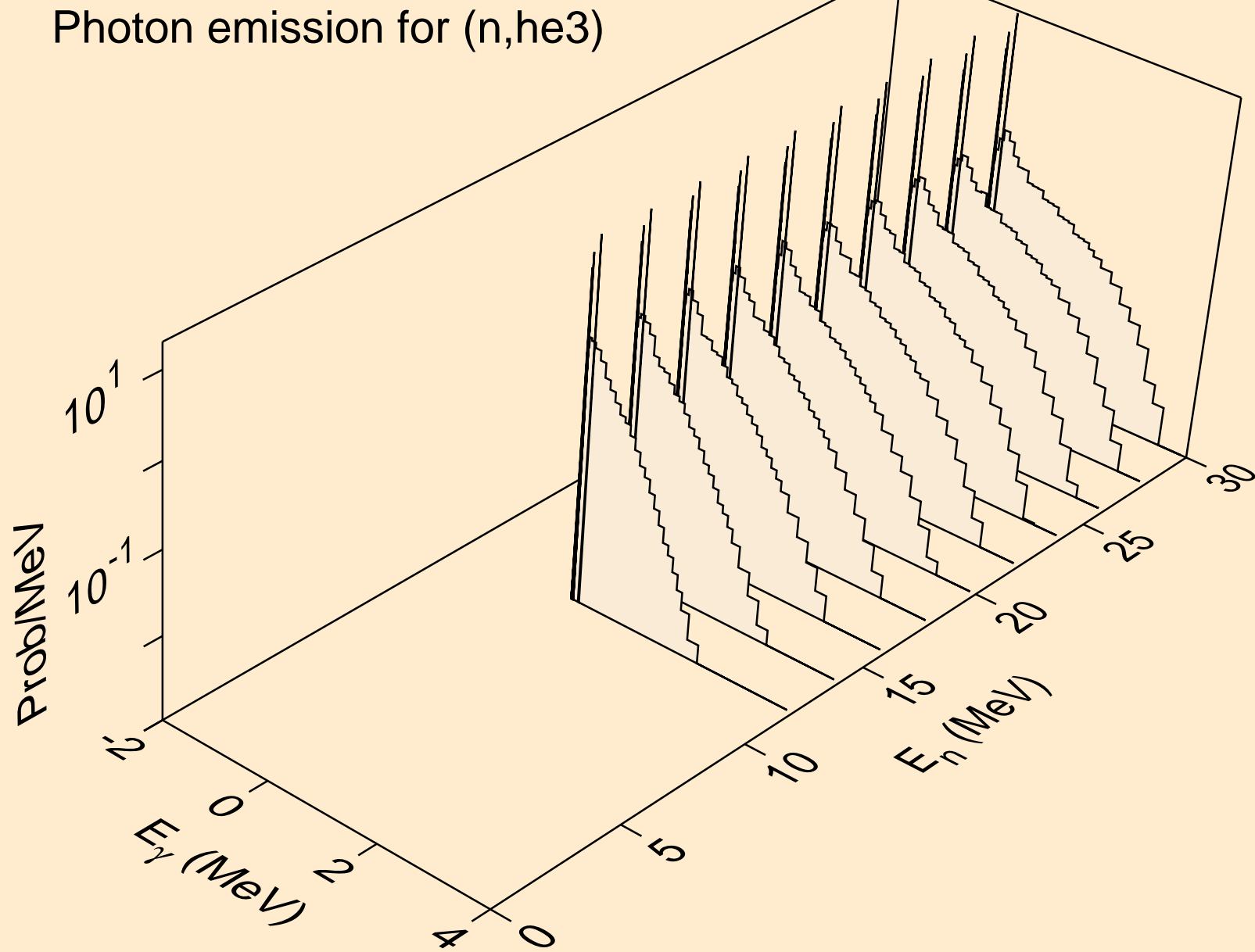

BH268 NEUTRON ACER TENDL-2024 LIBRARY; T=0.K  
Photon emission for (n,a)

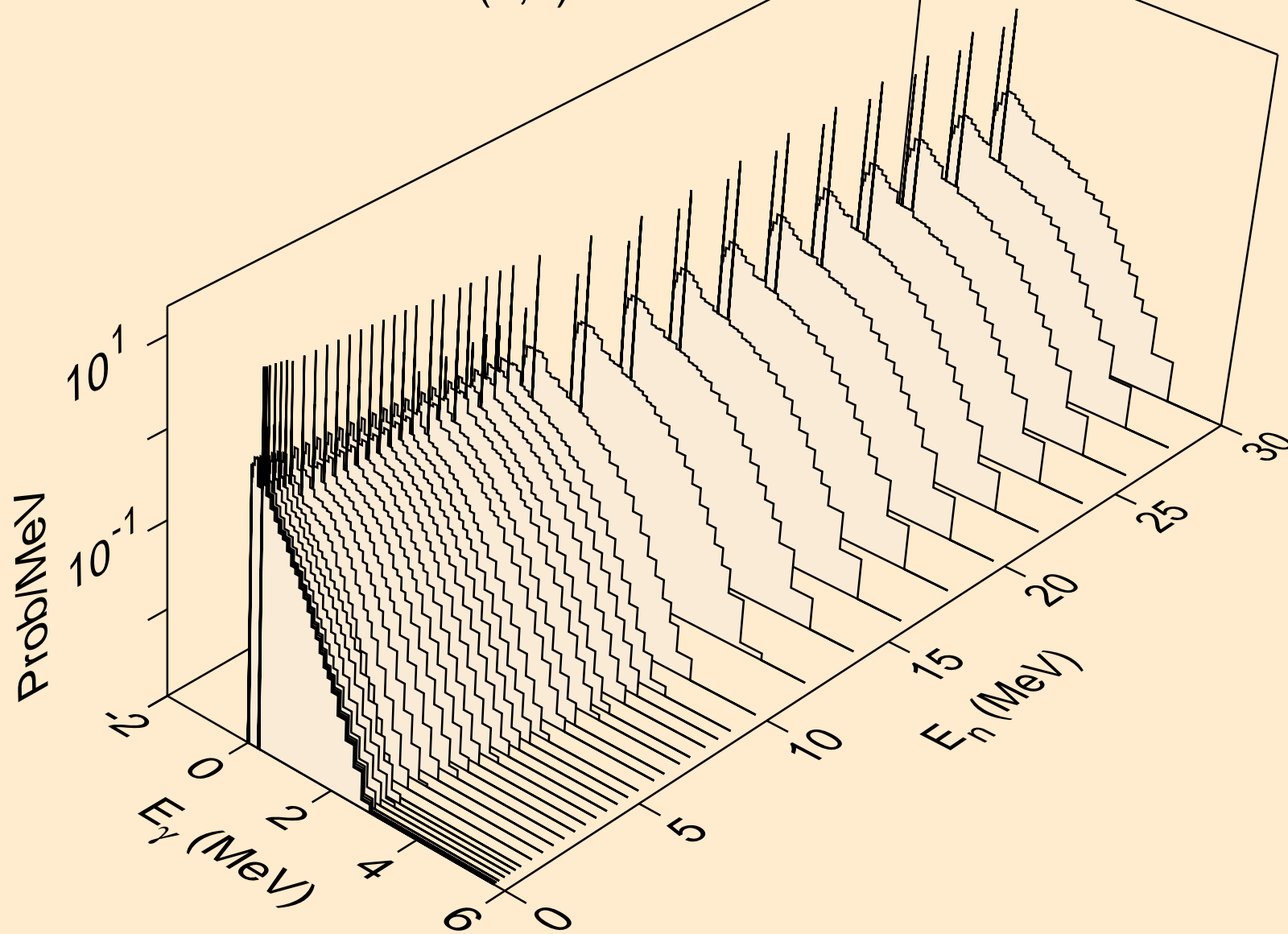

BH268 NEUTRON ACER TENDL-2024 LIBRARY; T=0.K  
Photon emission for (n,2a)

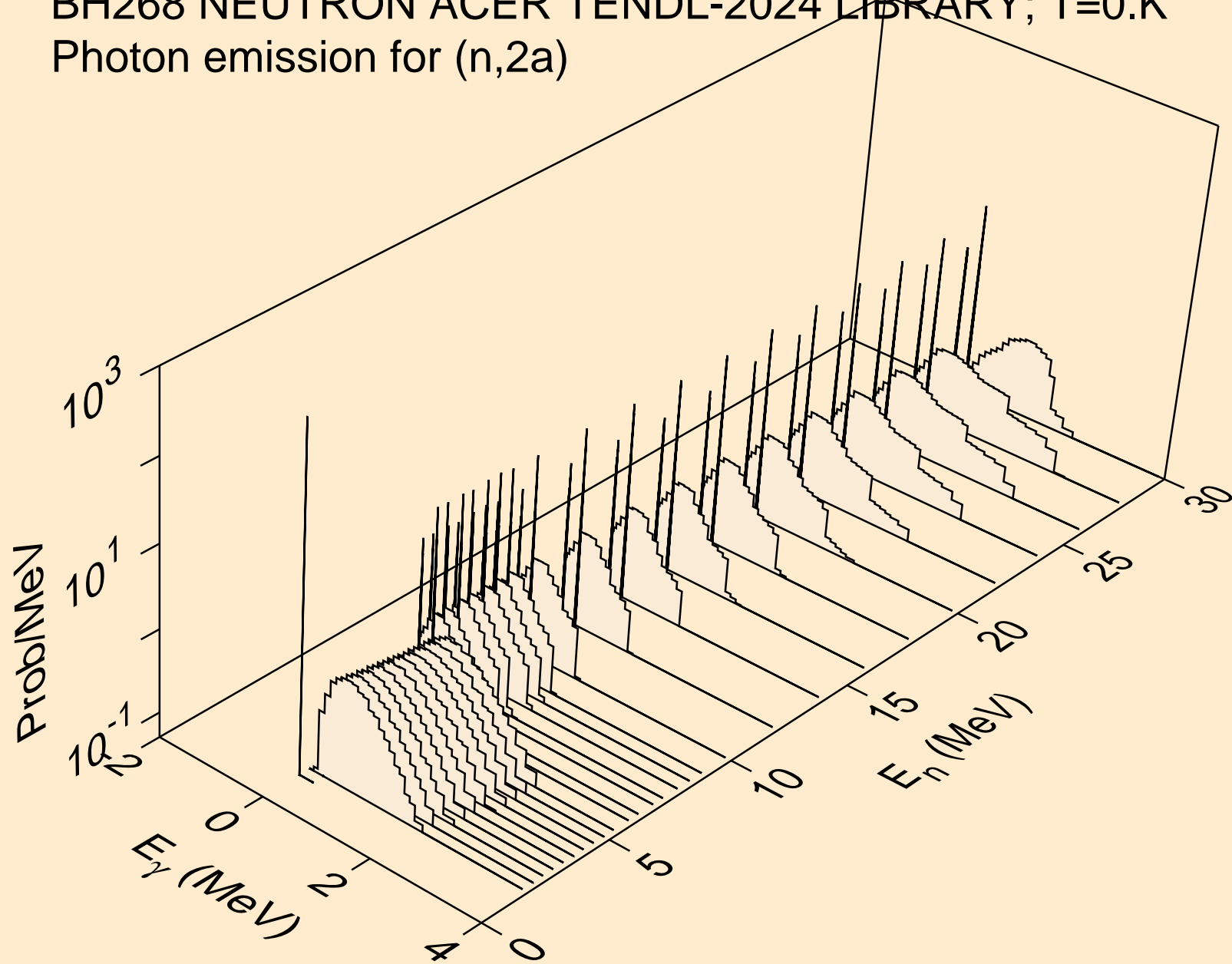

BH268 NEUTRON ACER TENDL-2024 LIBRARY; T=0.K  
Photon emission for (n,2p)

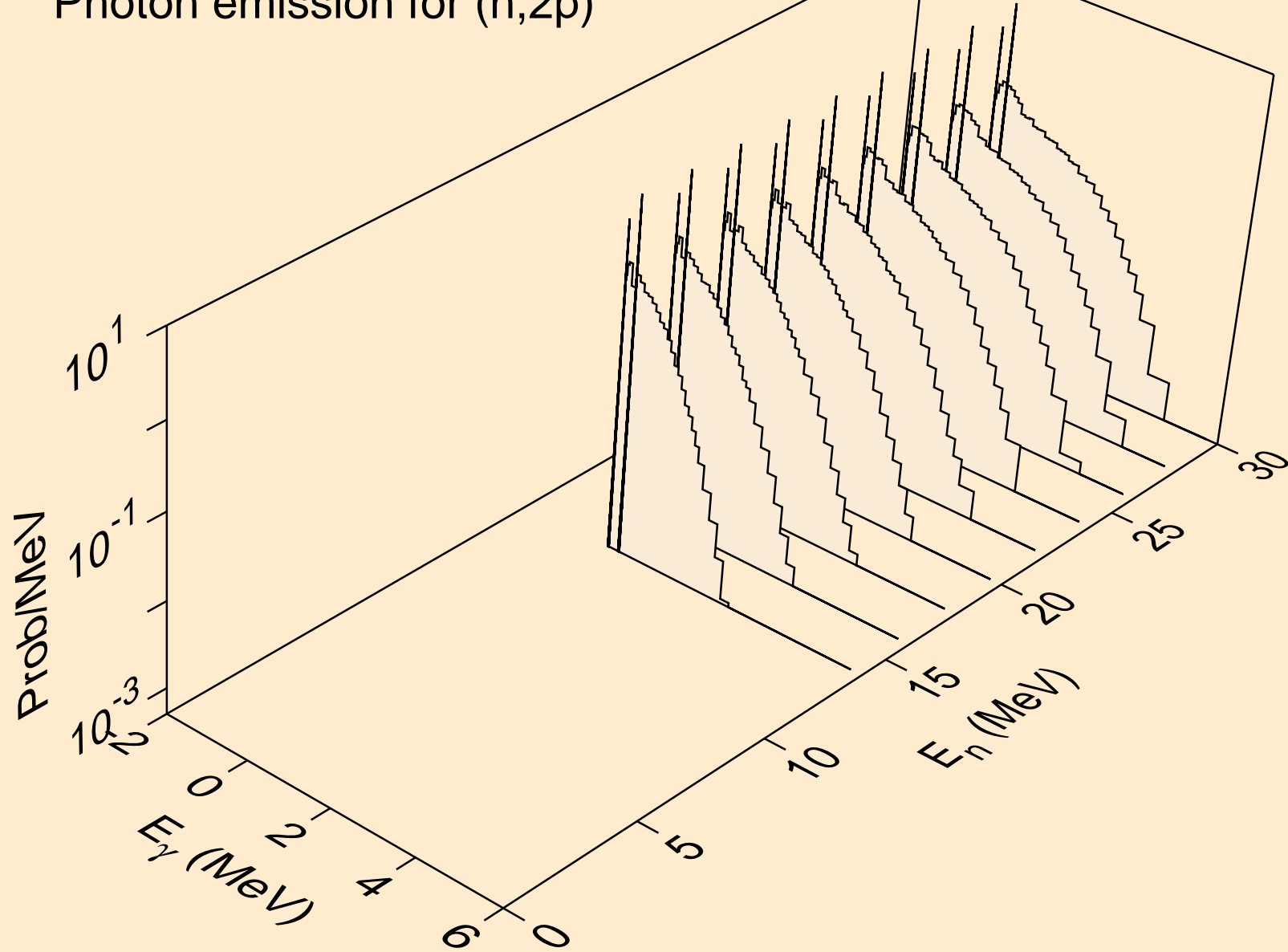

BH268 NEUTRON ACER TENDL-2024 LIBRARY; T=0.K  
Photon emission for (n,pd)

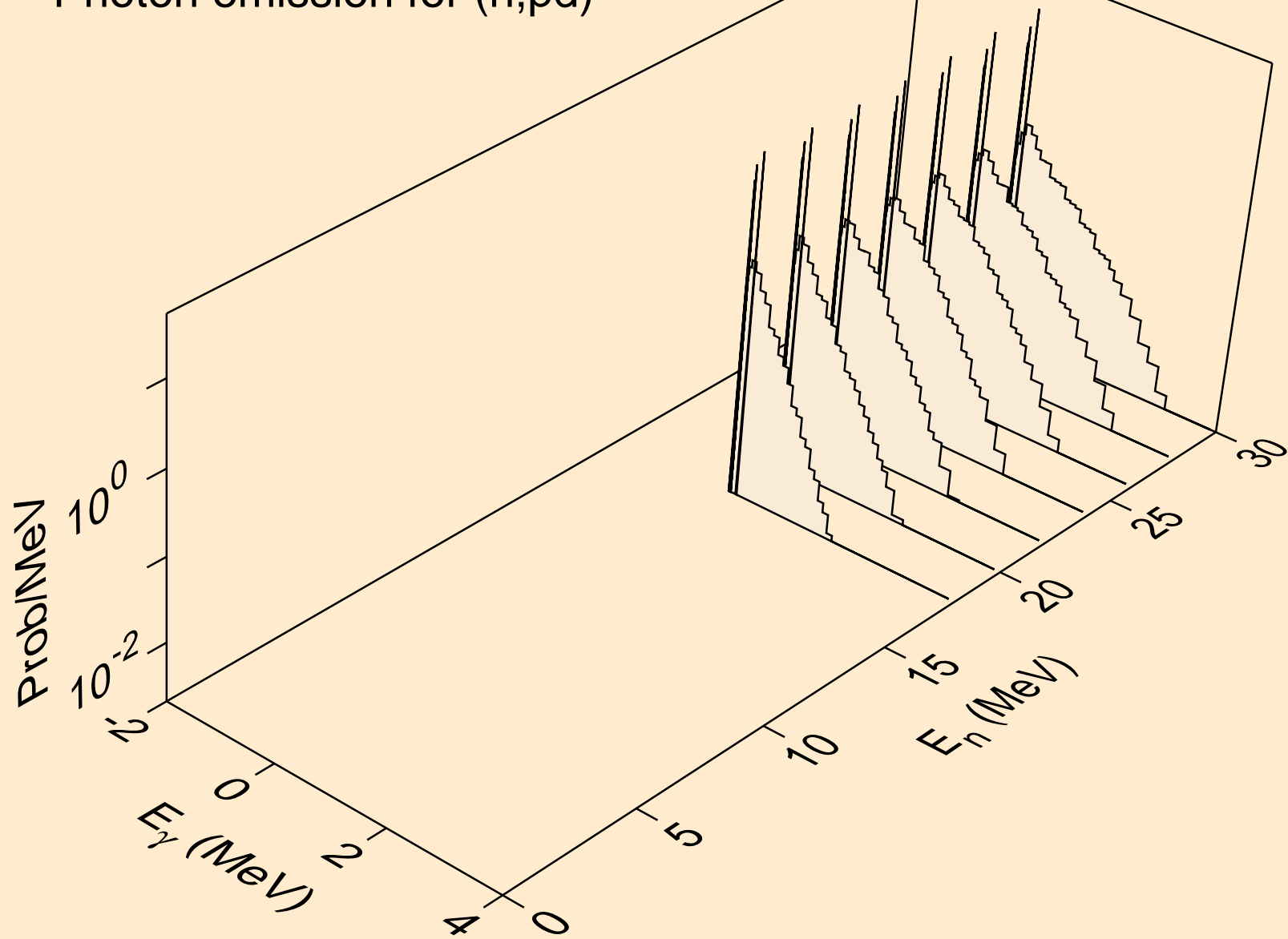



BH268 NEUTRON ACER TENDL-2024 LIBRARY; T=0.K  
thermal capture photon spectrum

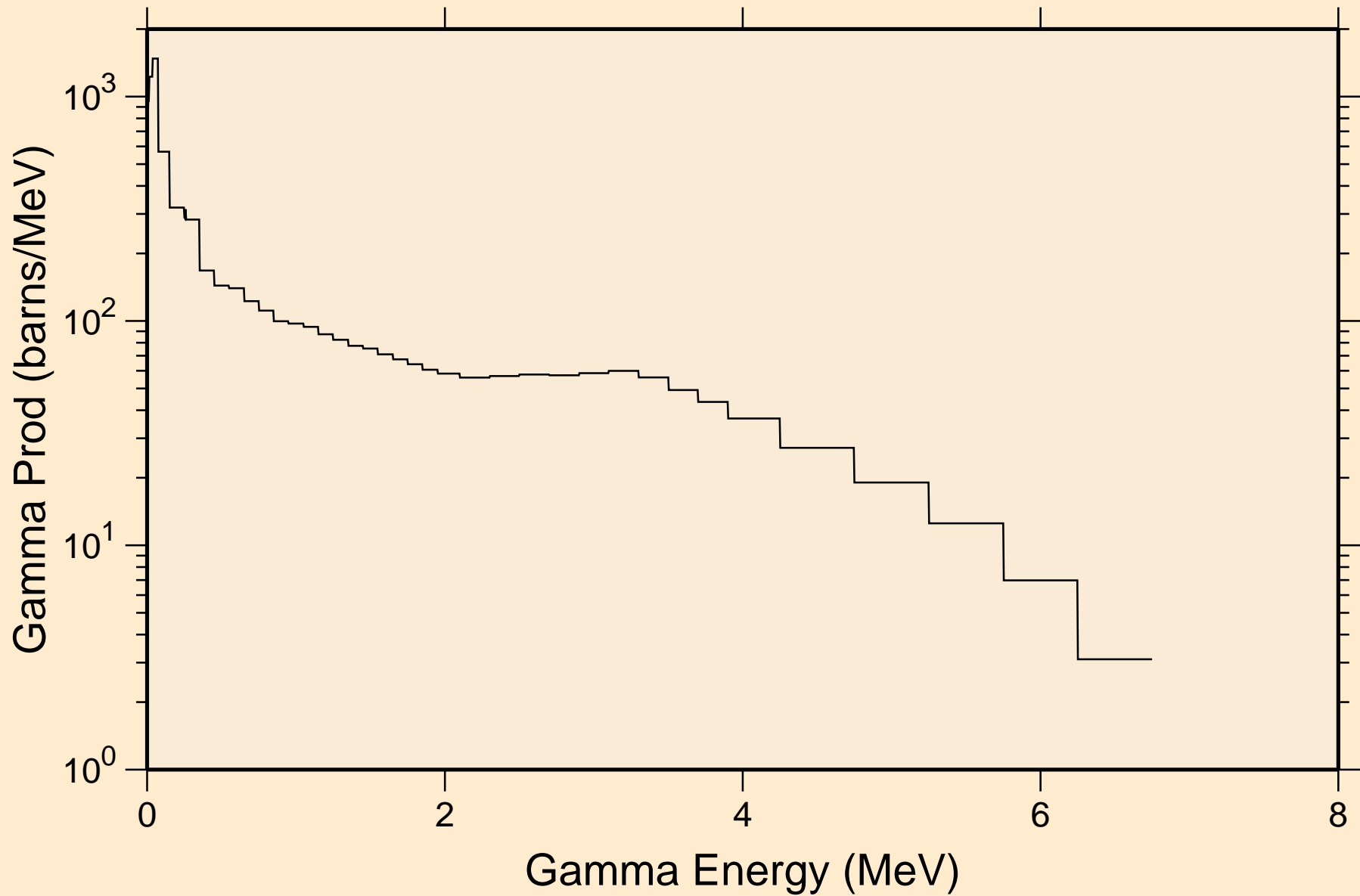

BH268 NEUTRON ACER TENDL-2024 LIBRARY; T=0.K  
14 MeV photon spectrum

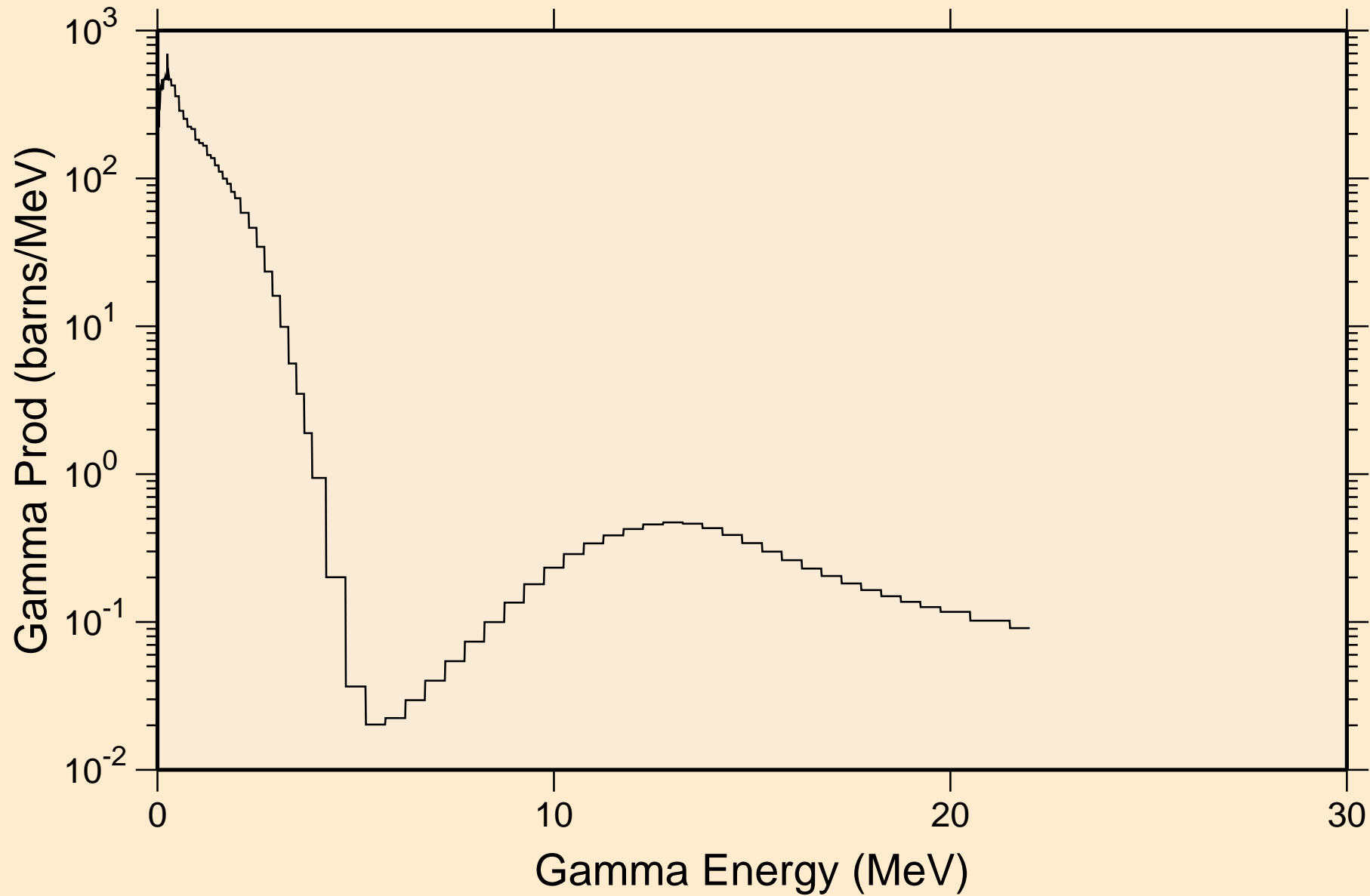

# BH268 NEUTRON ACER TENDL-2024 LIBRARY; T=0.K

## Particle heating contributions

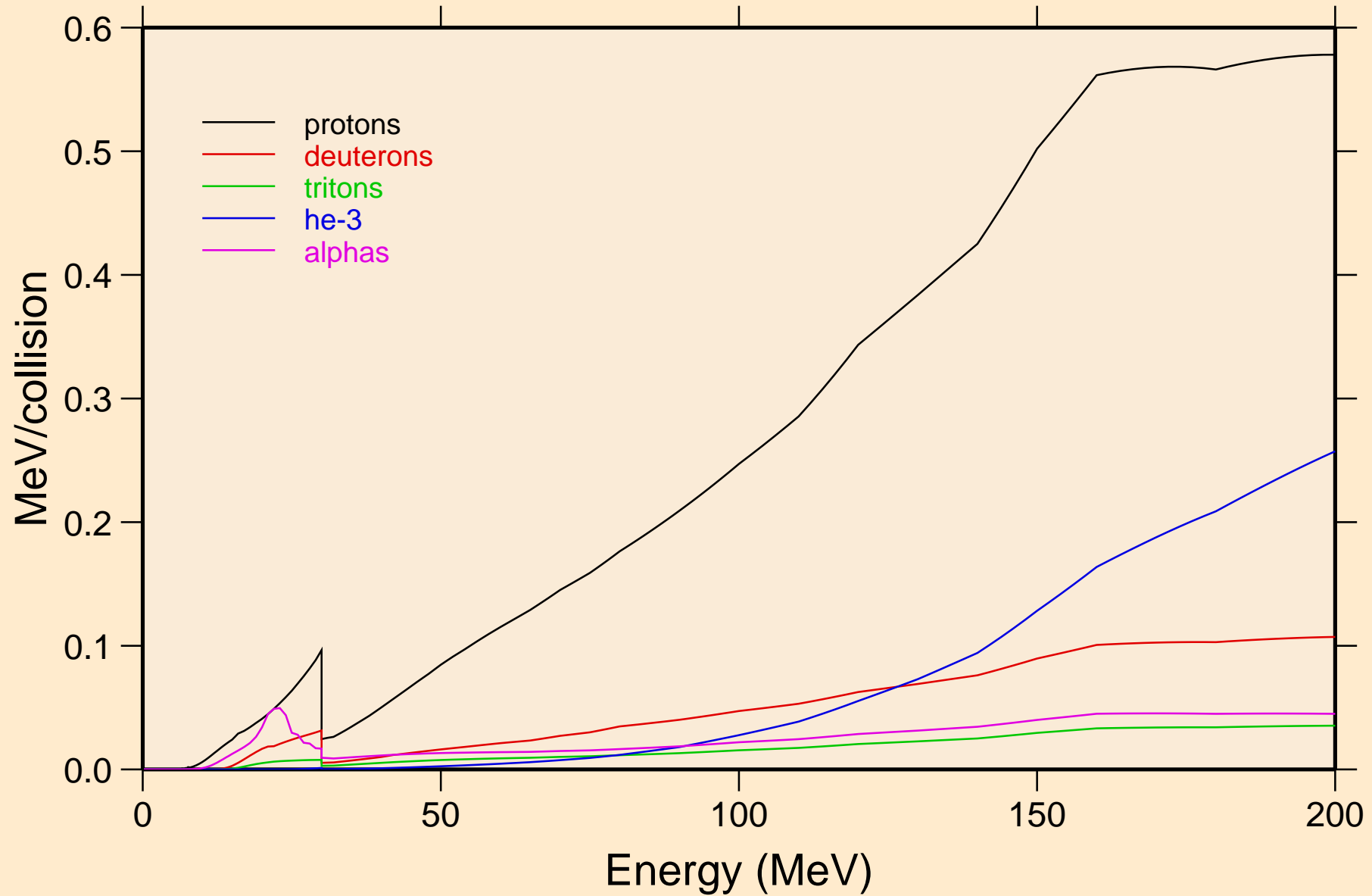

BH268 NEUTRON ACER TENDL-2024 LIBRARY; T=0.K  
Recoil Heating

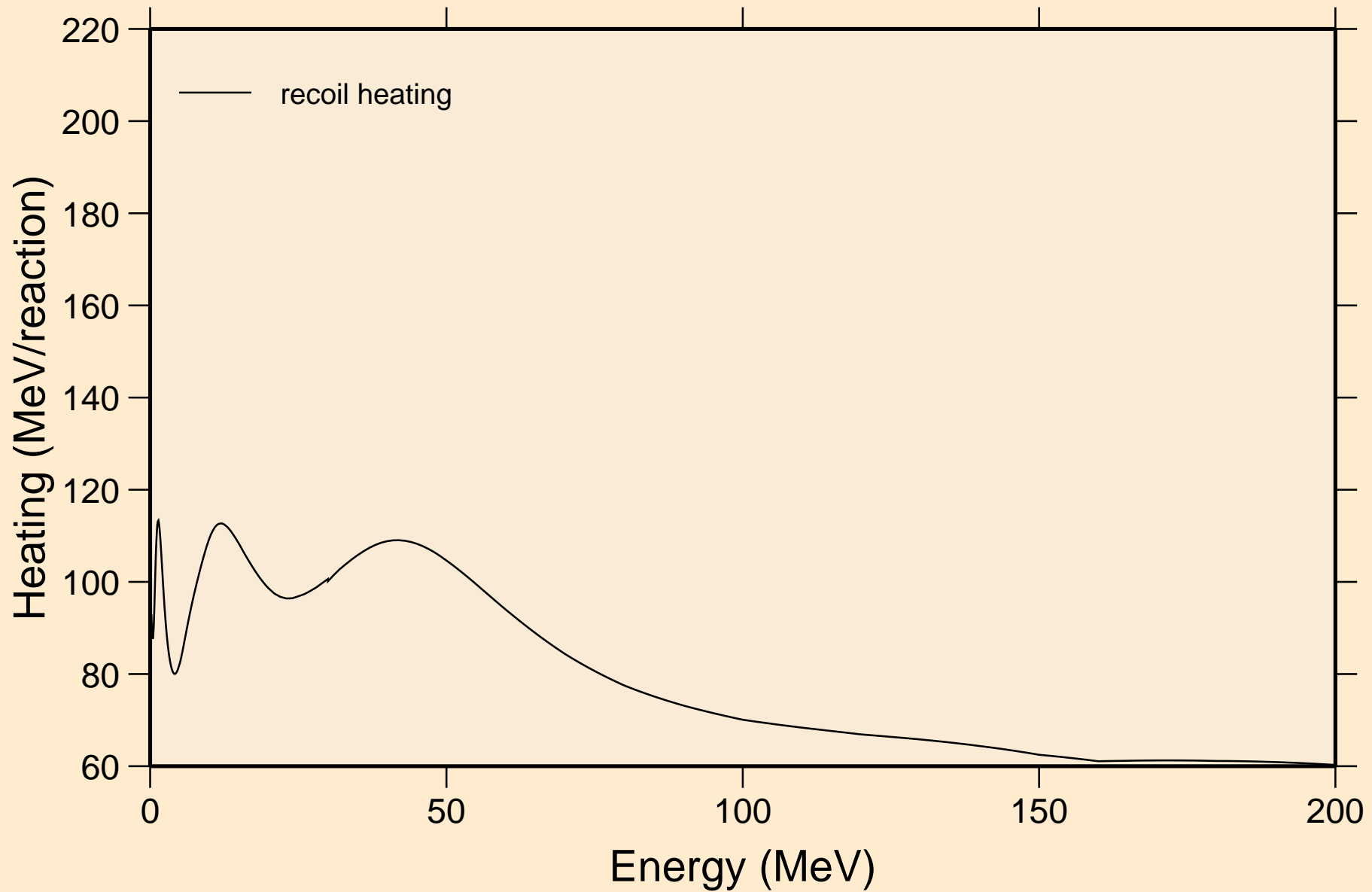

# BH268 NEUTRON ACER TENDL-2024 LIBRARY; T=0.K

## Particle production cross sections

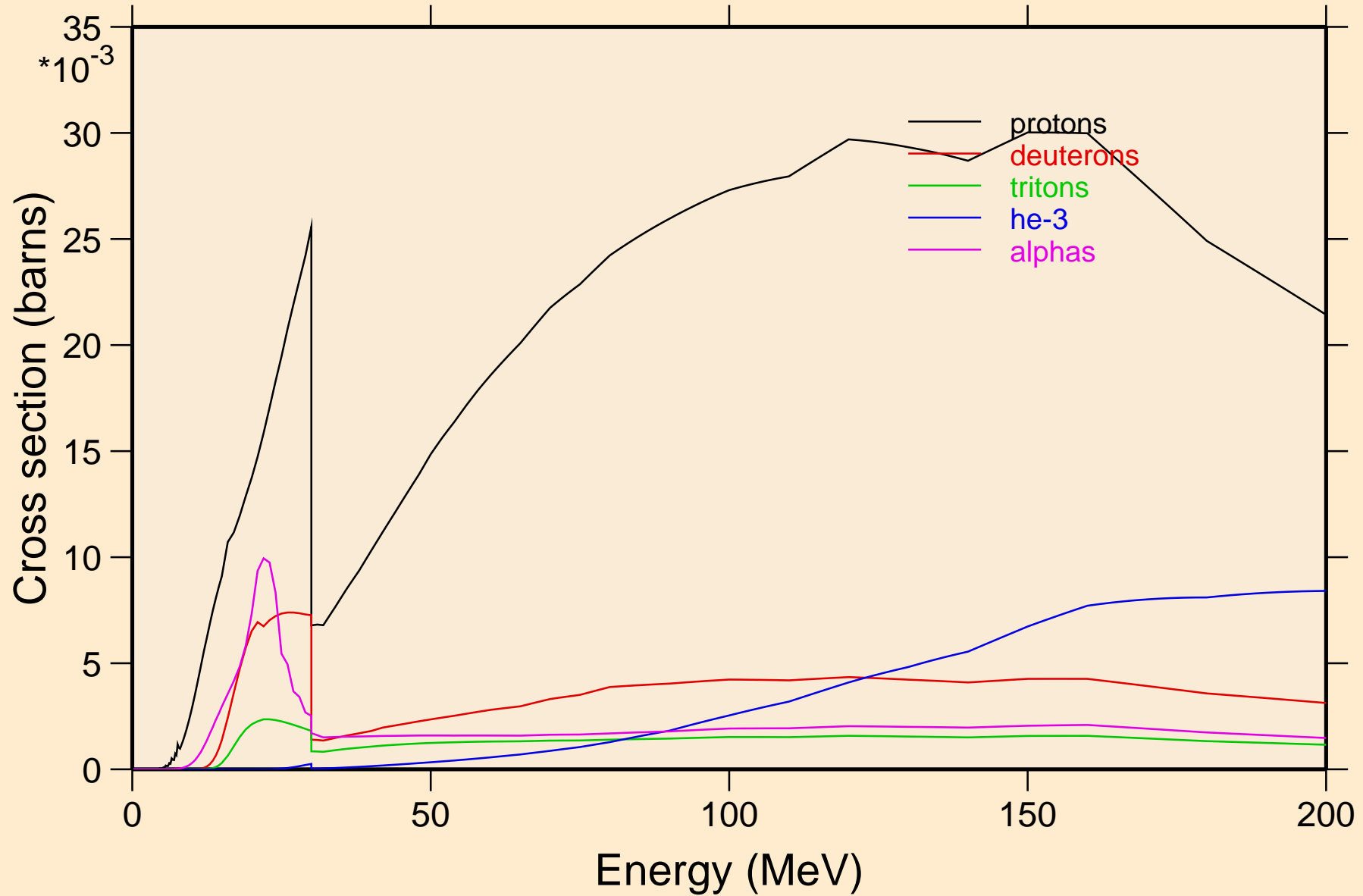

BH268 NEUTRON ACER TENDL-2024 LIBRARY; T=0.K  
protons from (n,x)

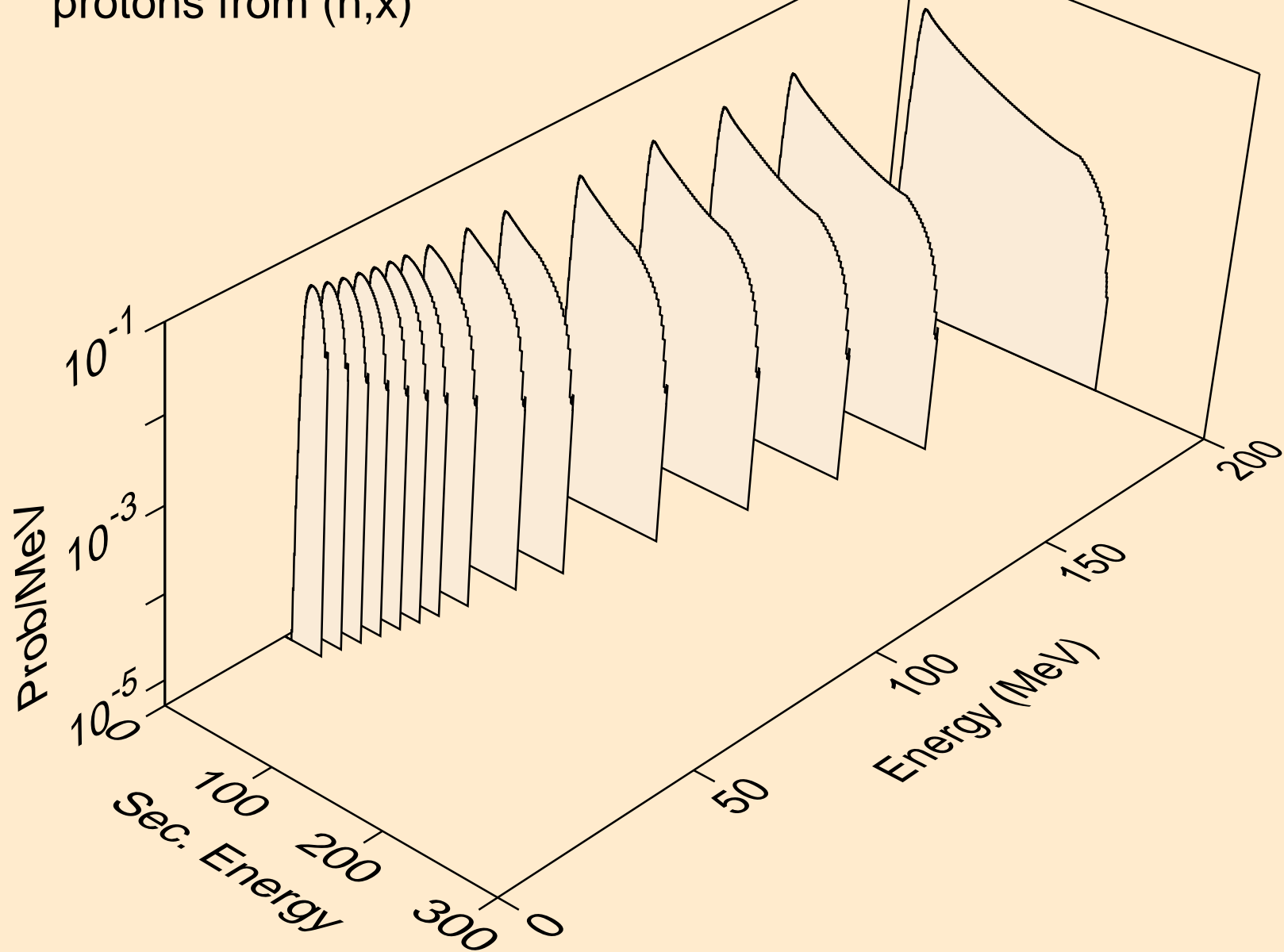

BH268 NEUTRON ACER TENDL-2024 LIBRARY; T=0.K  
protons from (n,n\*)p

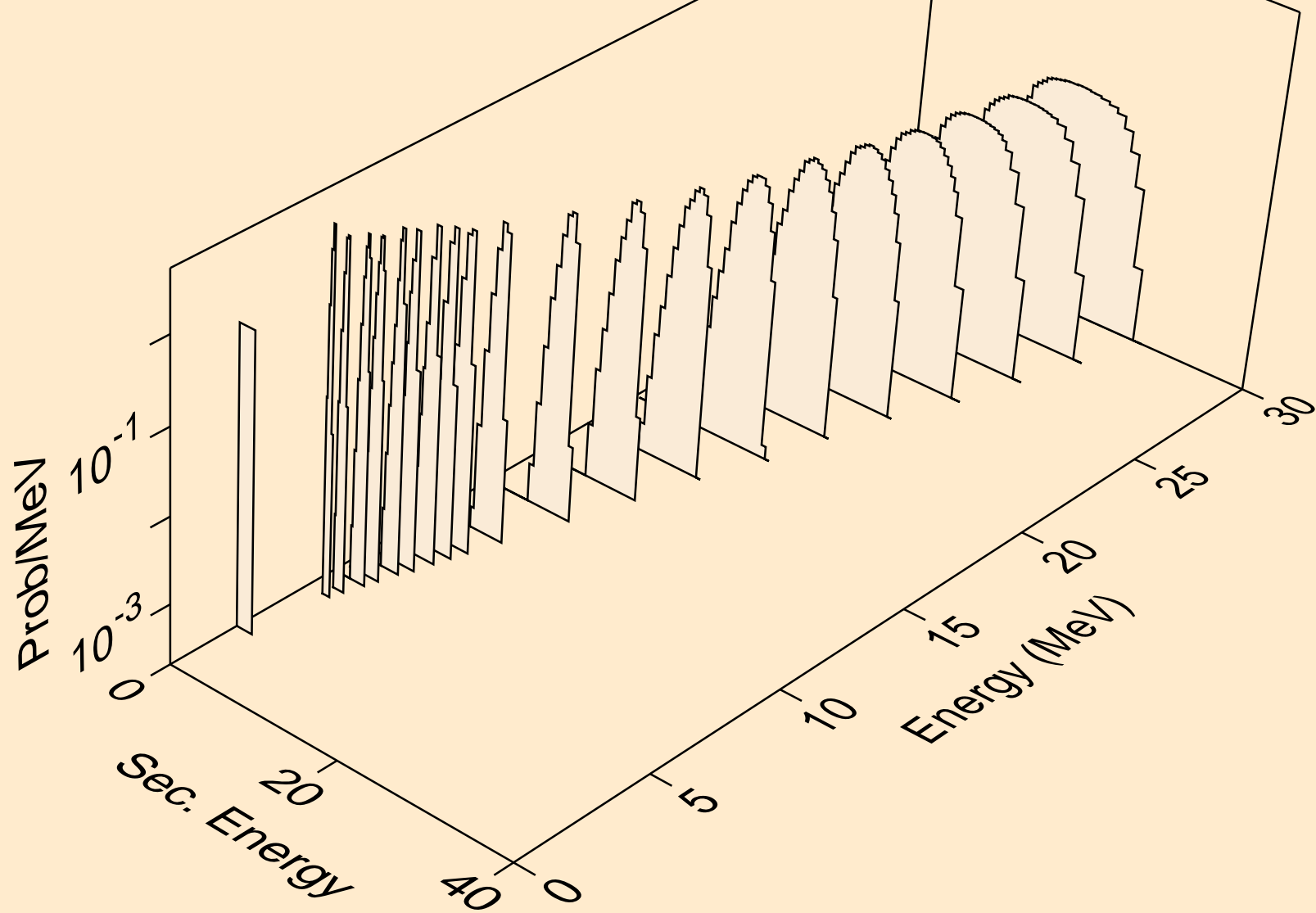

BH268 NEUTRON ACER TENDL-2024 LIBRARY; T=0.K  
protons from (n,2np)

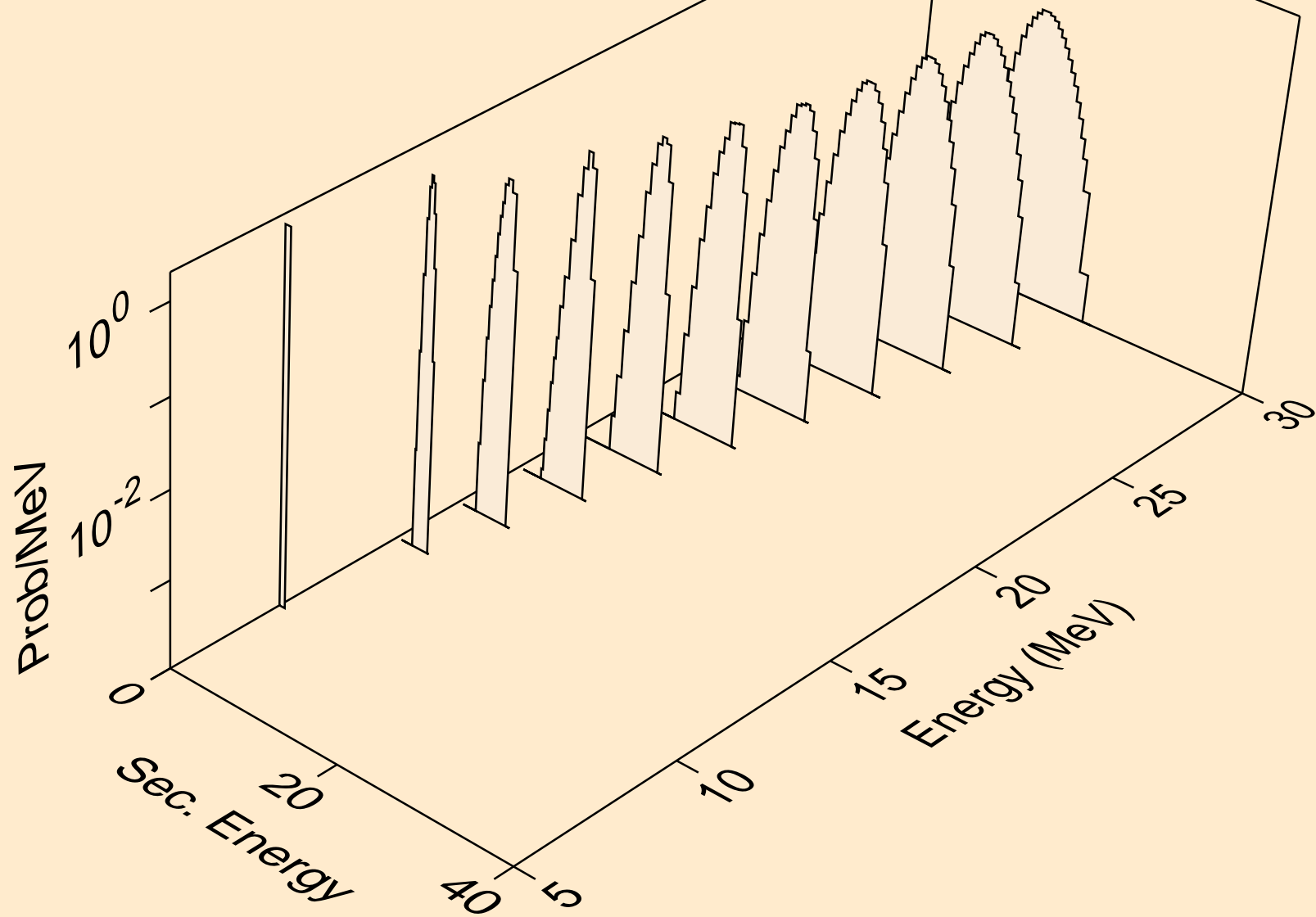



BH268 NEUTRON ACER TENDL-2024 LIBRARY; T=0.K  
protons from (n,3np)

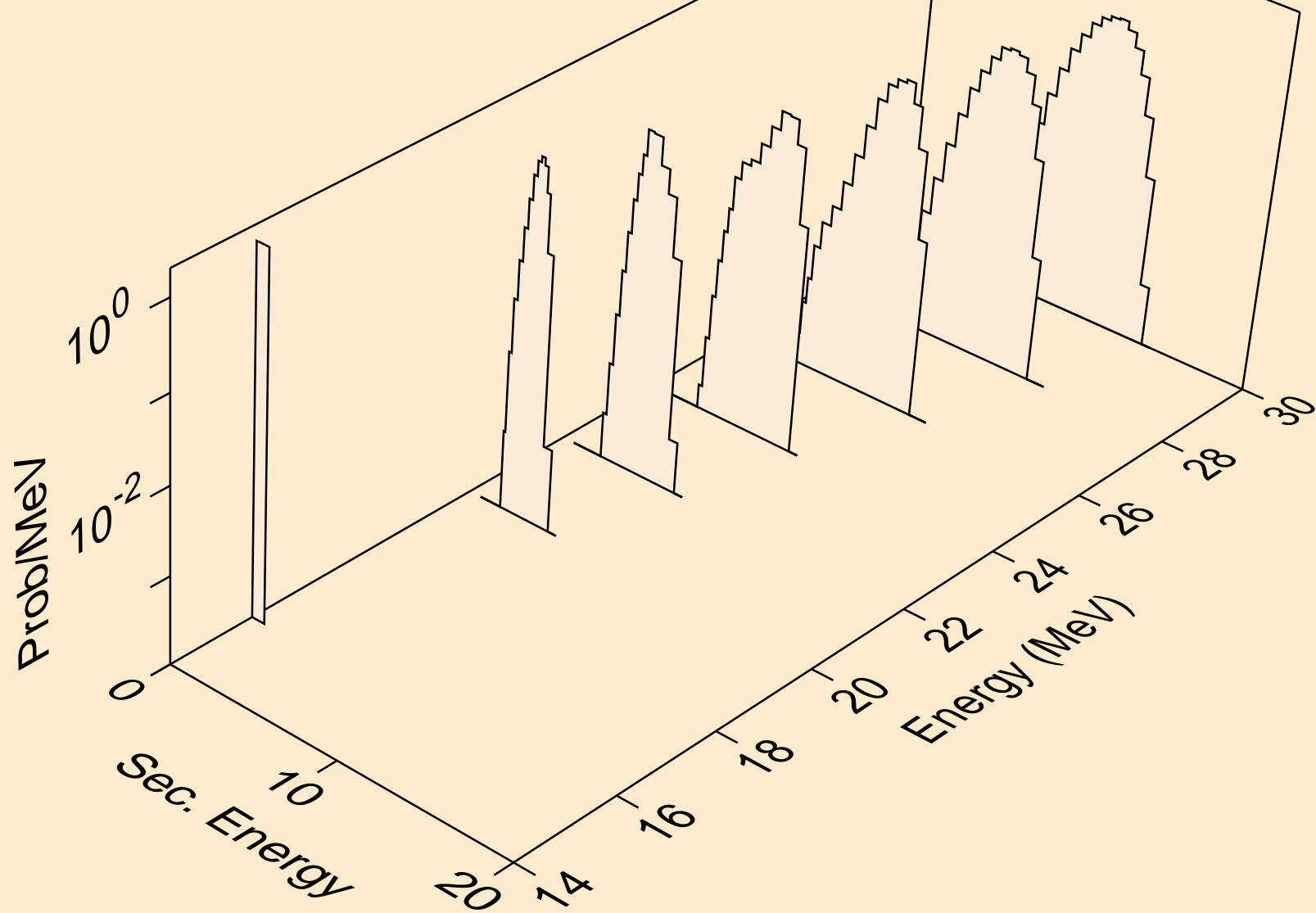

BH268 NEUTRON ACER TENDL-2024 LIBRARY; T=0.K  
protons from (n,n2p)

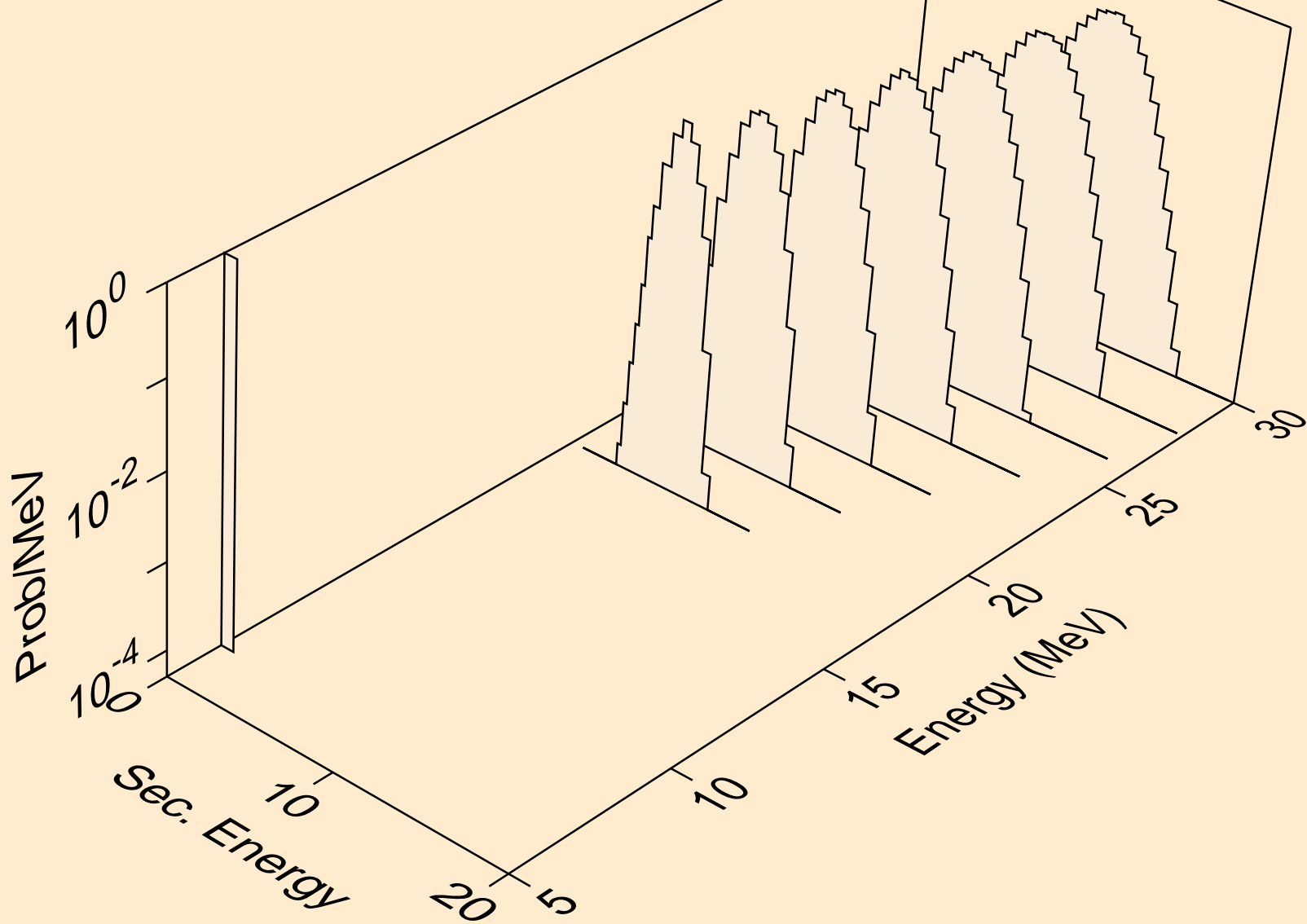

BH268 NEUTRON ACER TENDL-2024 LIBRARY; T=0.K  
protons from (n,p)

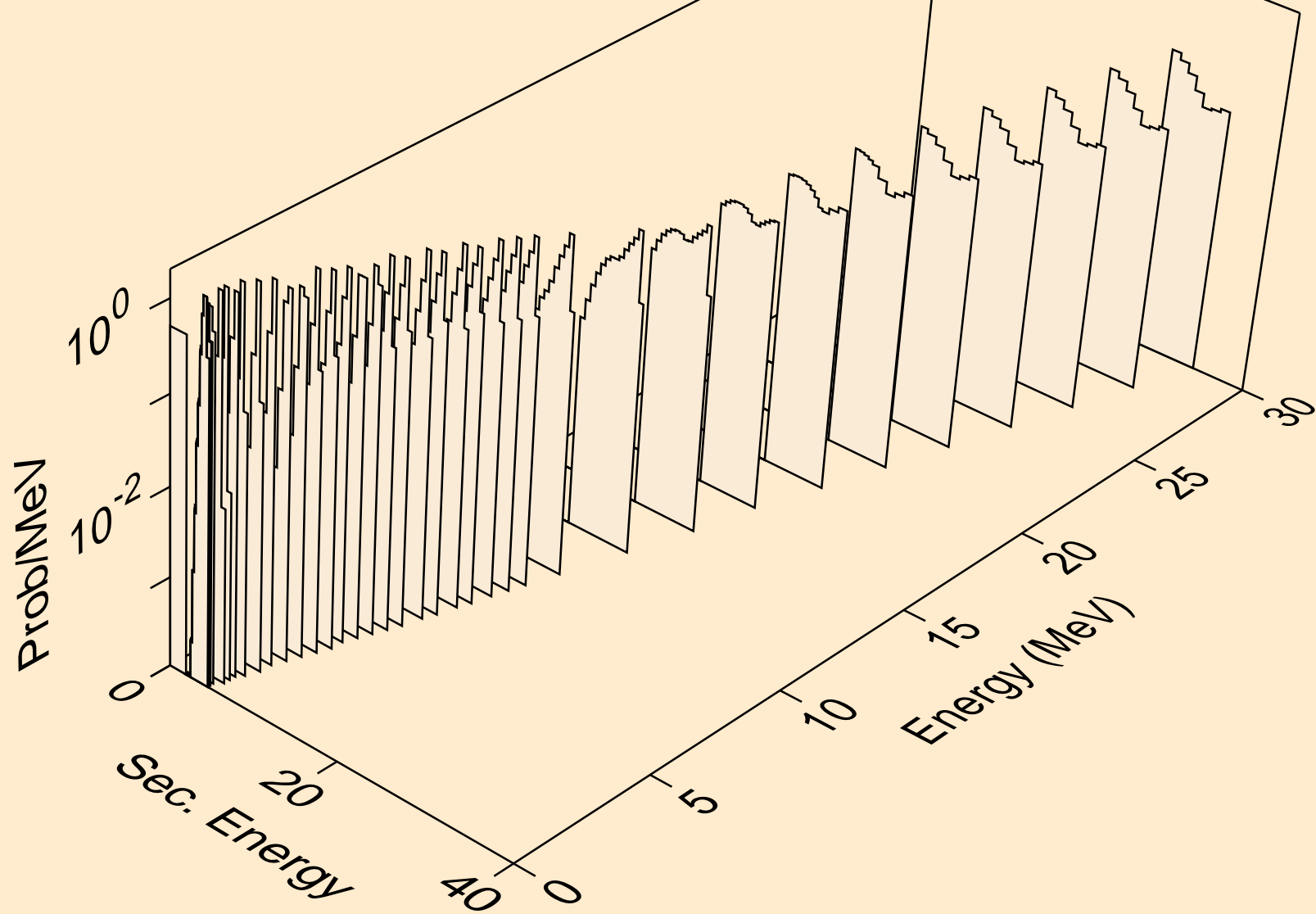

BH268 NEUTRON ACER TENDL-2024 LIBRARY; T=0.K  
protons from (n,2p)

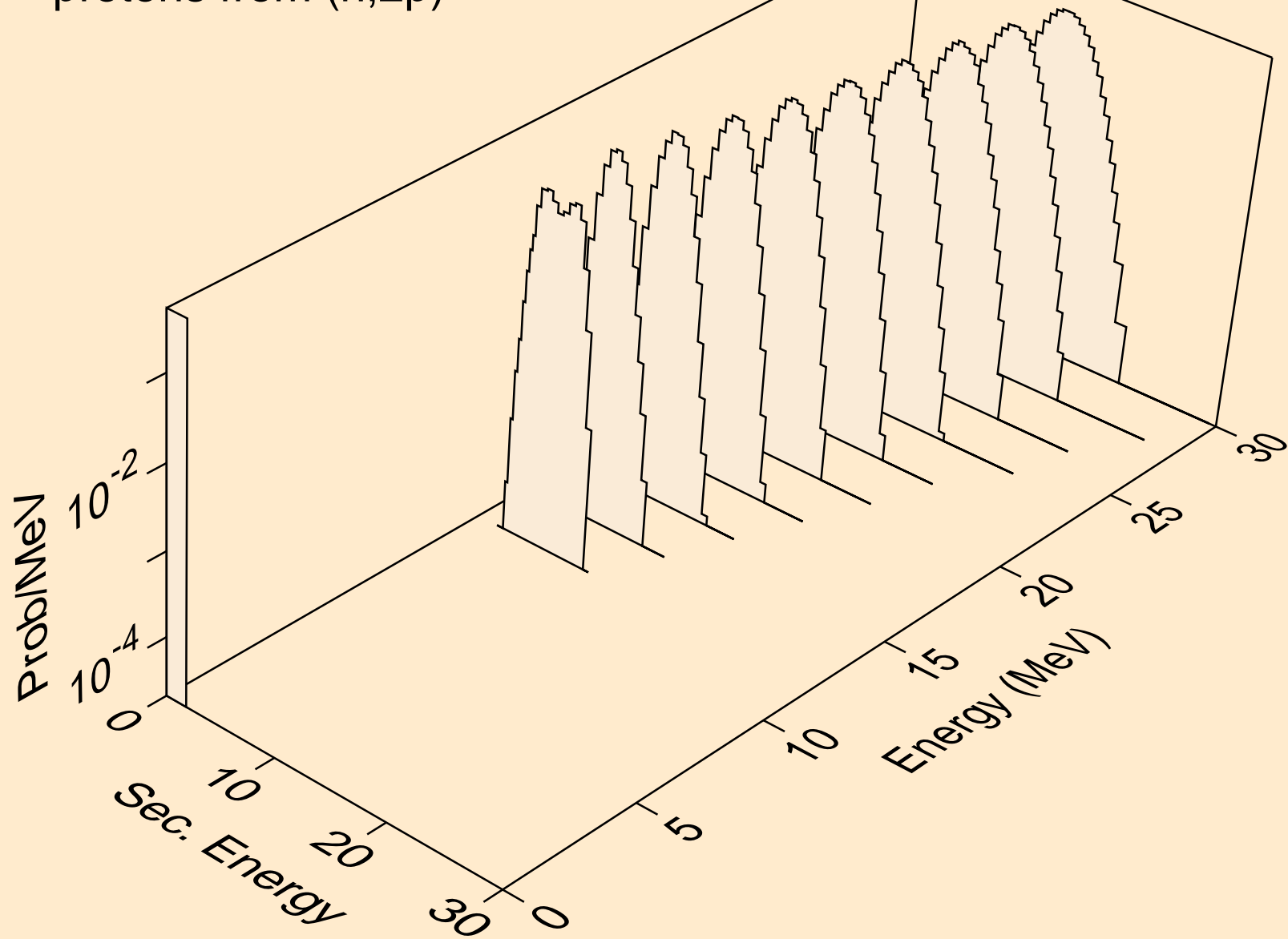

BH268 NEUTRON ACER TENDL-2024 LIBRARY; T=0.K  
protons from (n,pd)

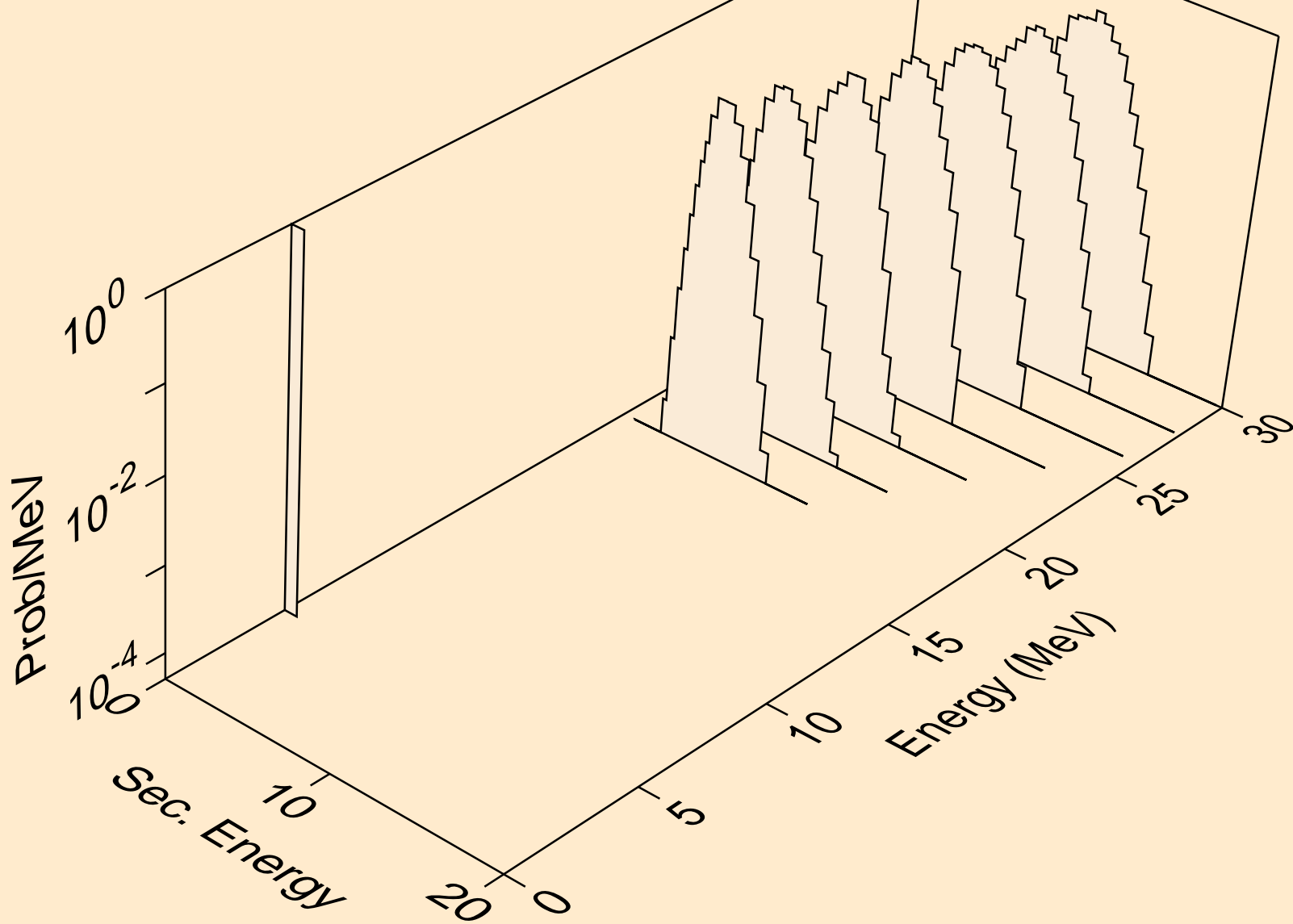

BH268 NEUTRON ACER TENDL-2024 LIBRARY; T=0.K  
deuterons from (n,x)

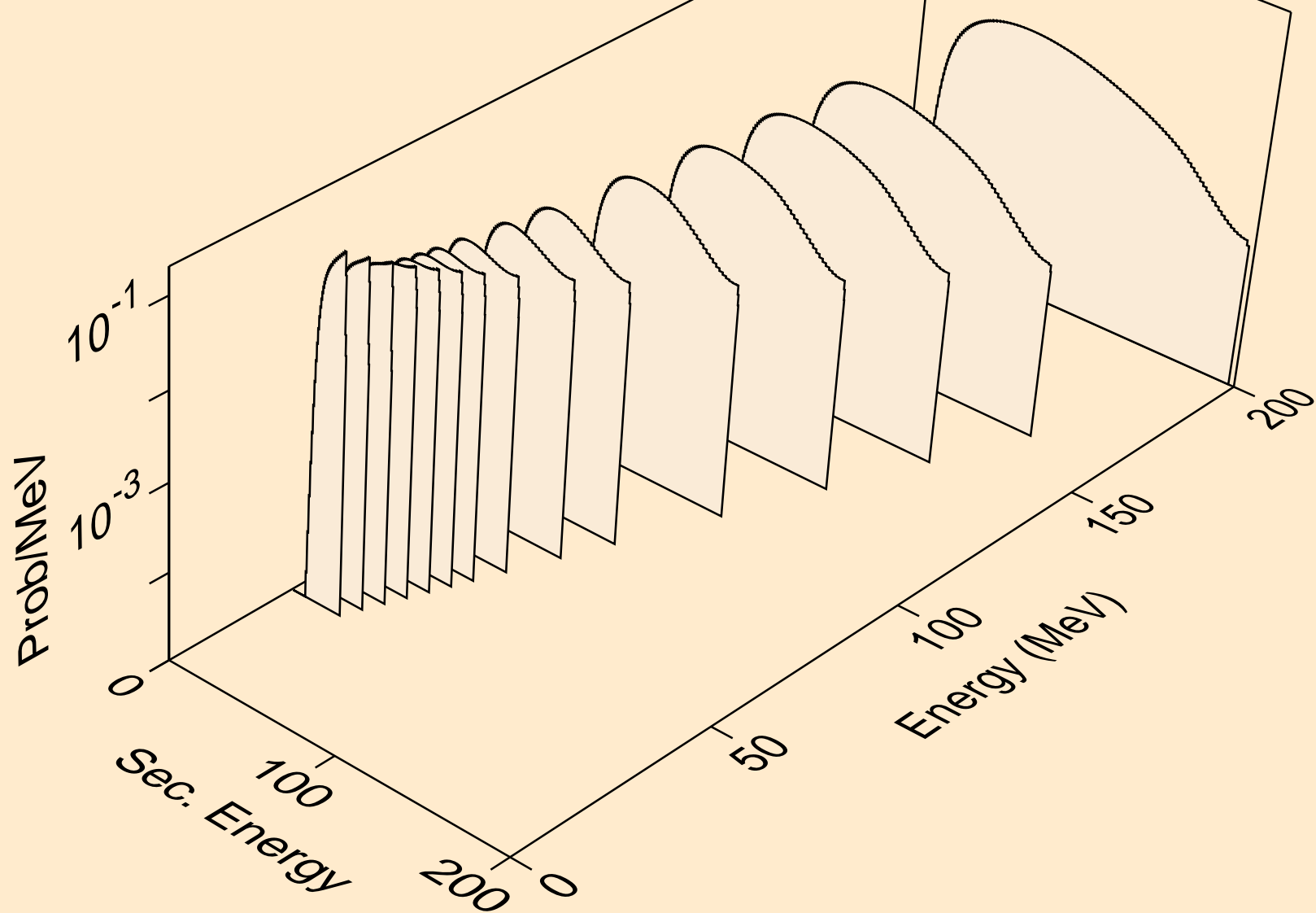

BH268 NEUTRON ACER TENDL-2024 LIBRARY; T=0.K  
deuterons from (n,2nd)

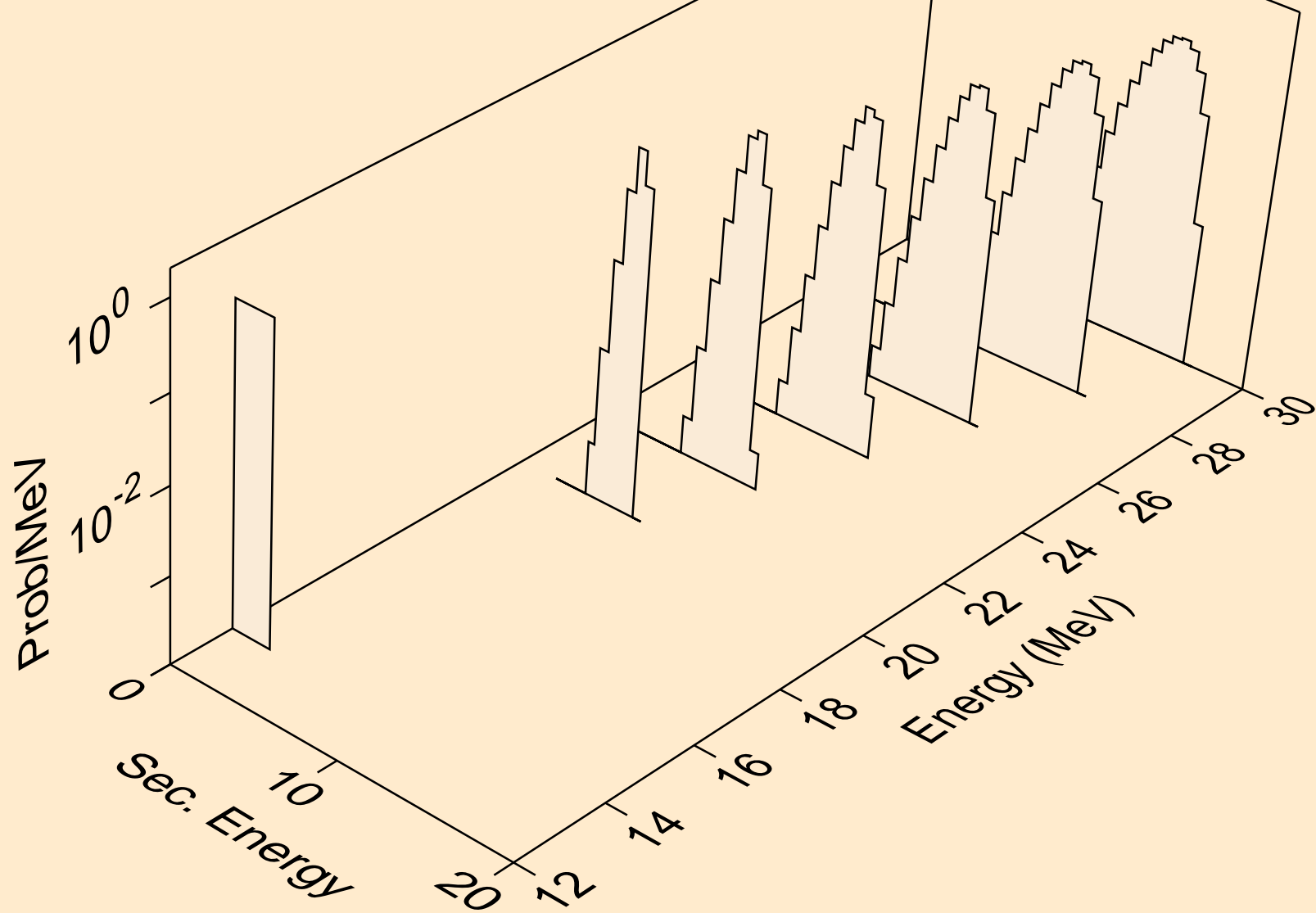

BH268 NEUTRON ACER TENDL-2024 LIBRARY; T=0.K  
deuterons from (n,n\*)d

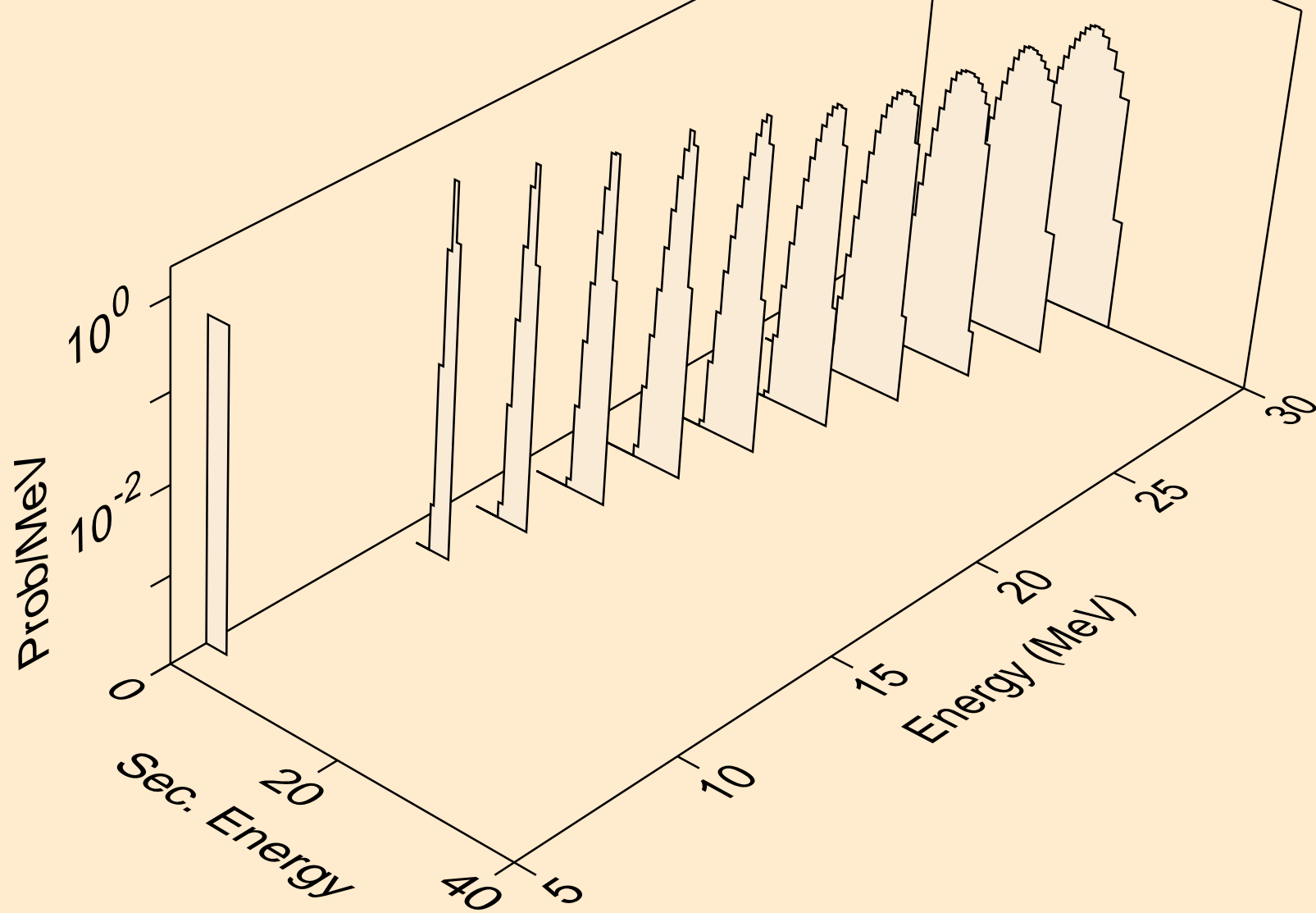



BH268 NEUTRON ACER TENDL-2024 LIBRARY; T=0.K  
deuterons from (n,d)

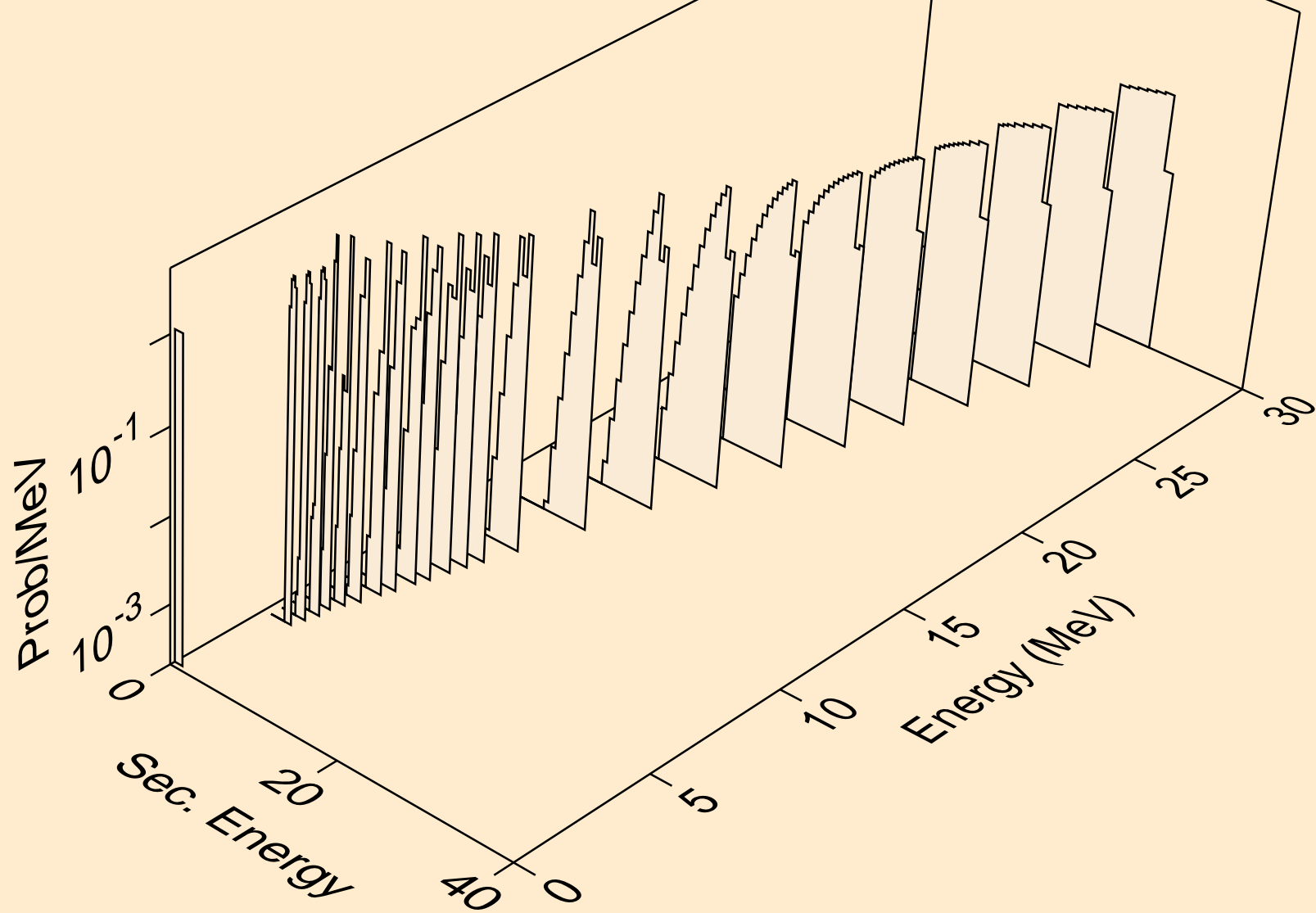

BH268 NEUTRON ACER TENDL-2024 LIBRARY; T=0.K  
deuterons from (n,pd)

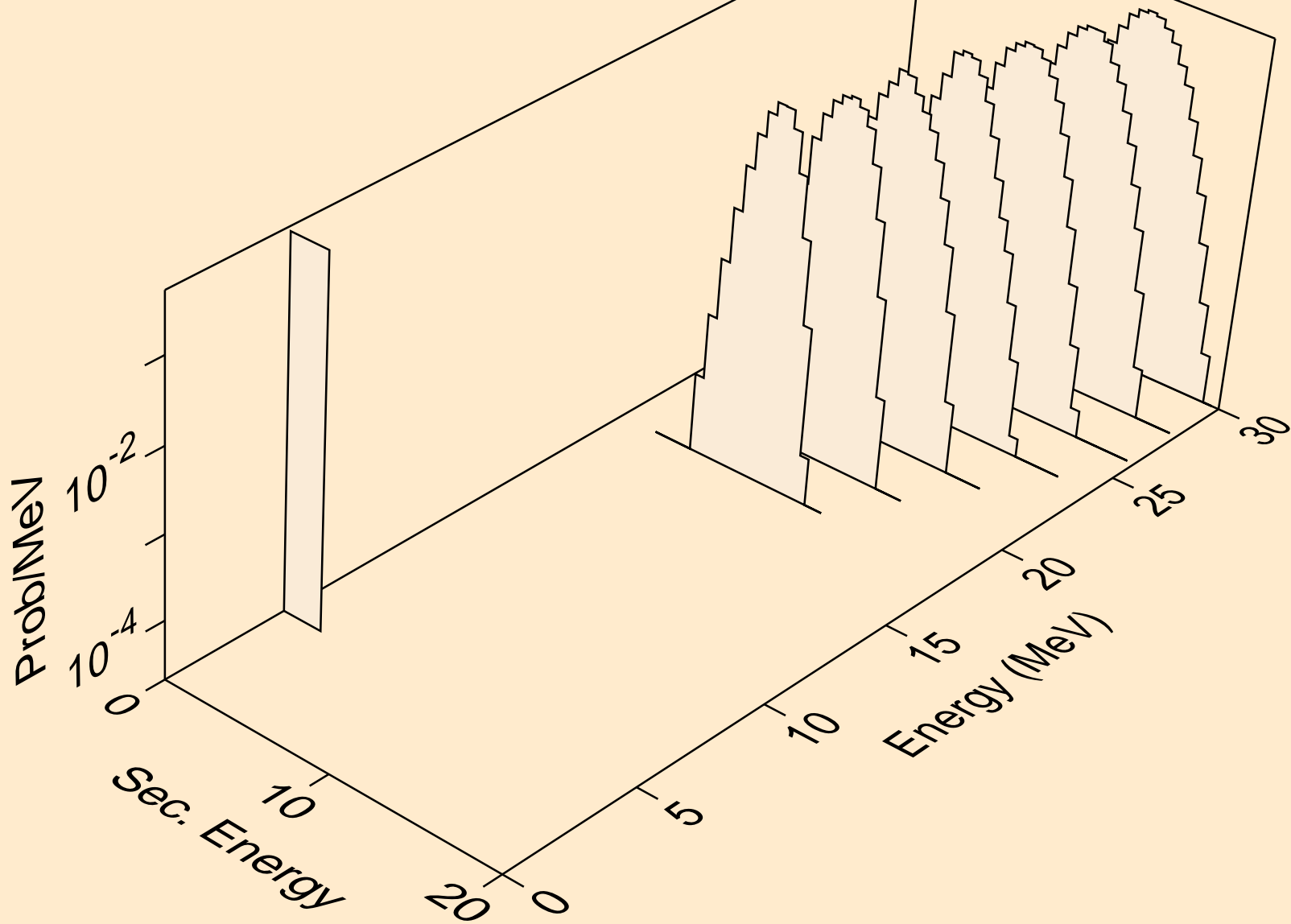

BH268 NEUTRON ACER TENDL-2024 LIBRARY; T=0.K  
tritons from (n,x)

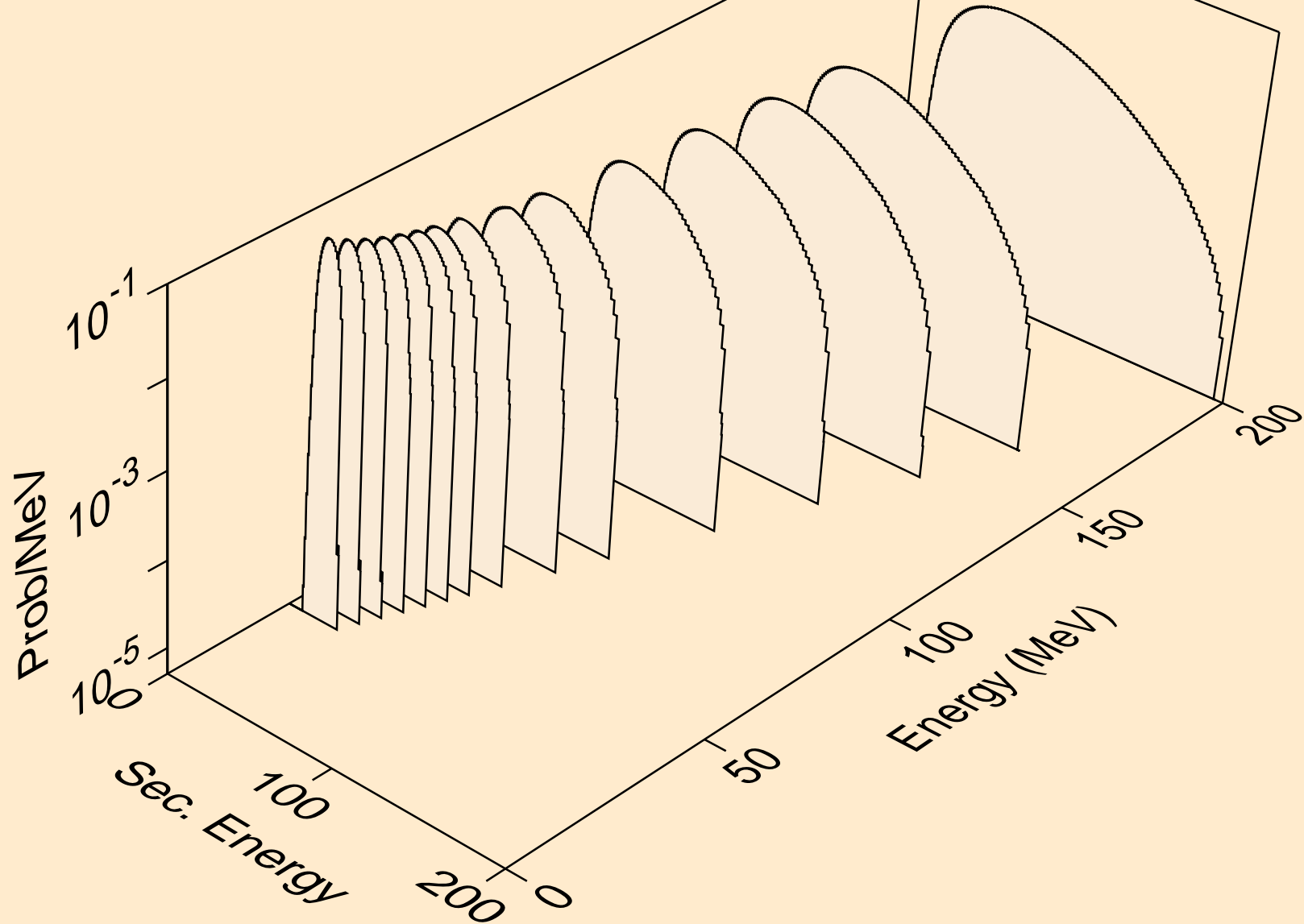

BH268 NEUTRON ACER TENDL-2024 LIBRARY; T=0.K  
tritons from (n,n\*)t

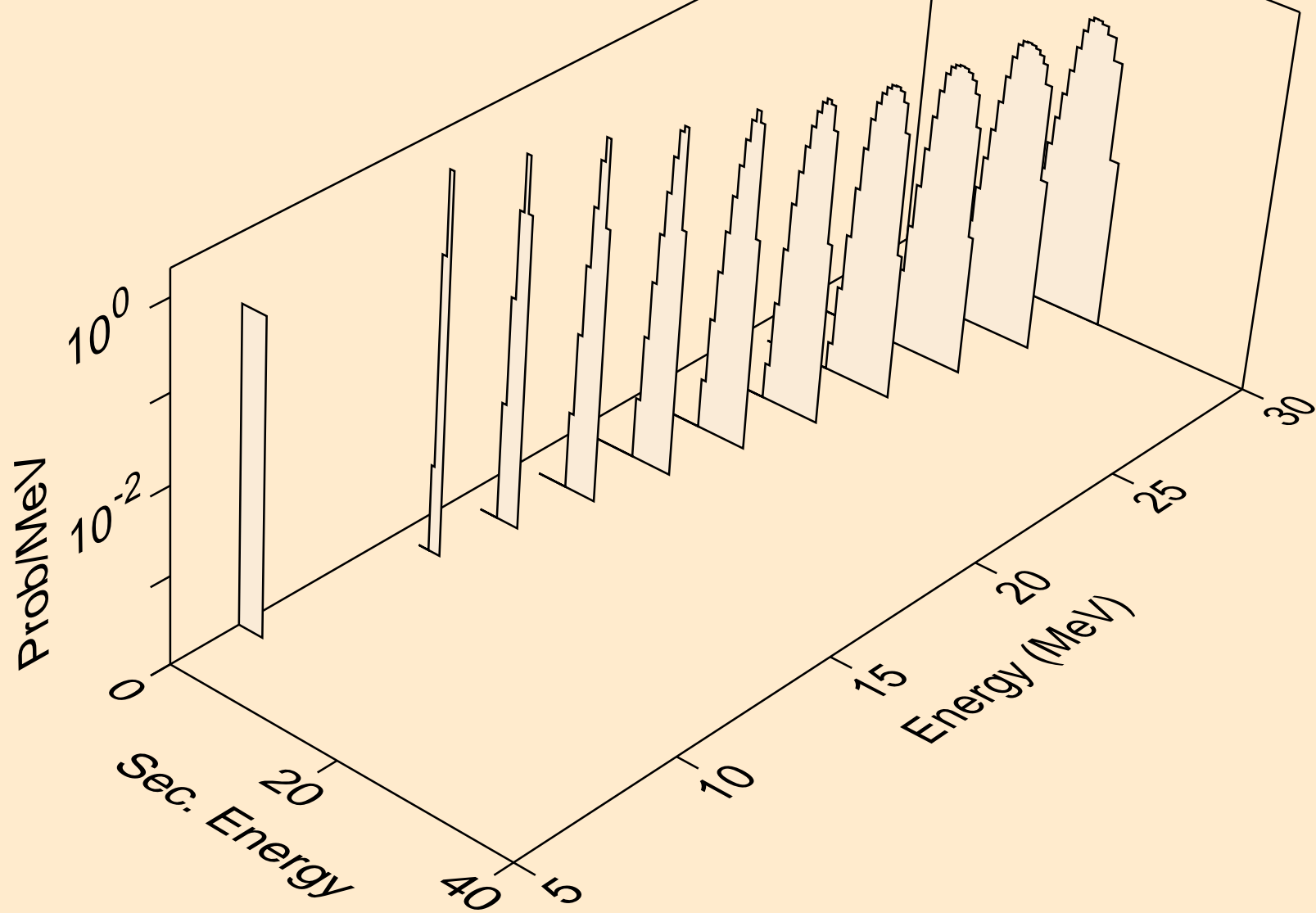

BH268 NEUTRON ACER TENDL-2024 LIBRARY; T=0.K  
tritons from (n,t)

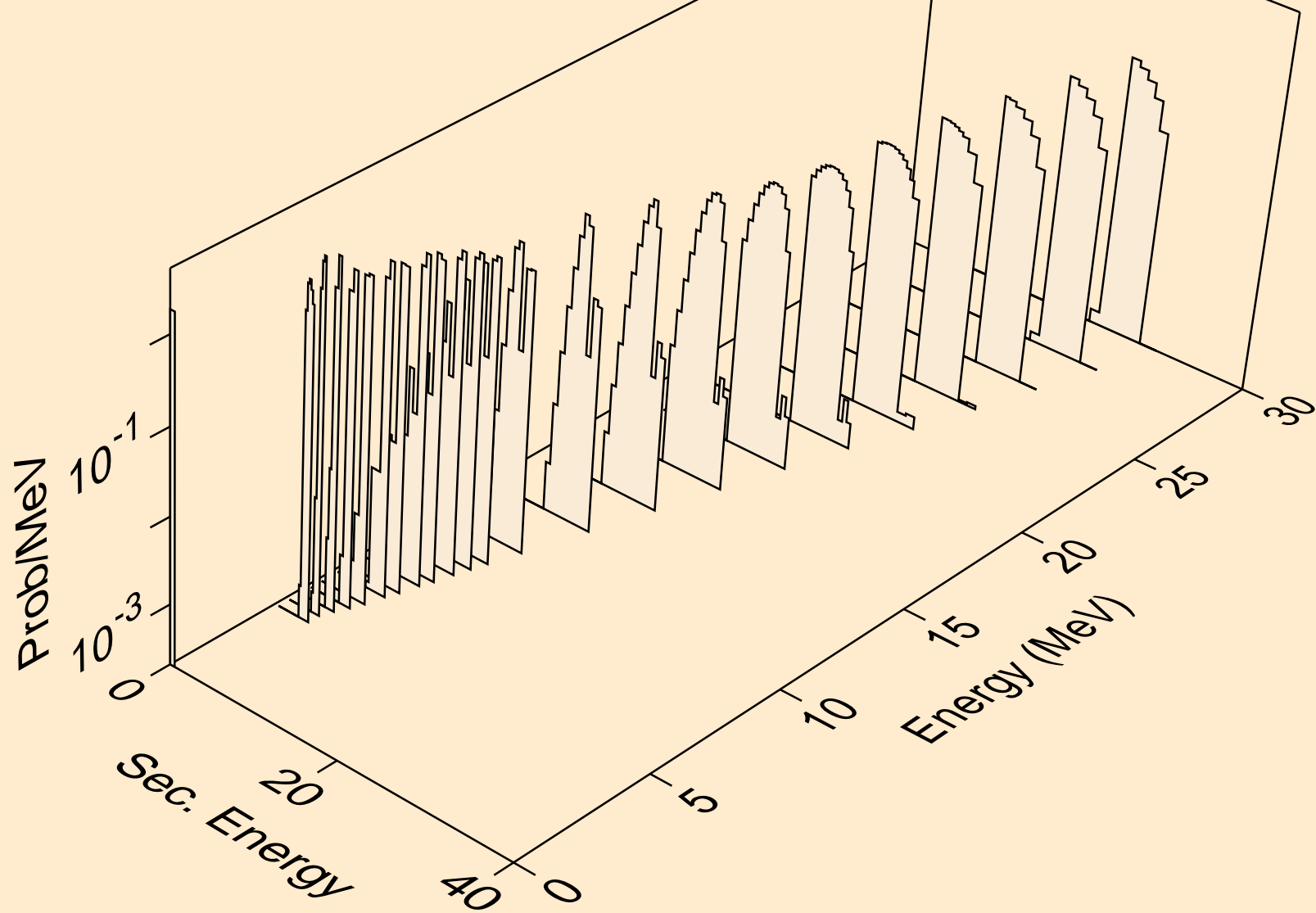

BH268 NEUTRON ACER TENDL-2024 LIBRARY; T=0.K  
he3s from (n,x)

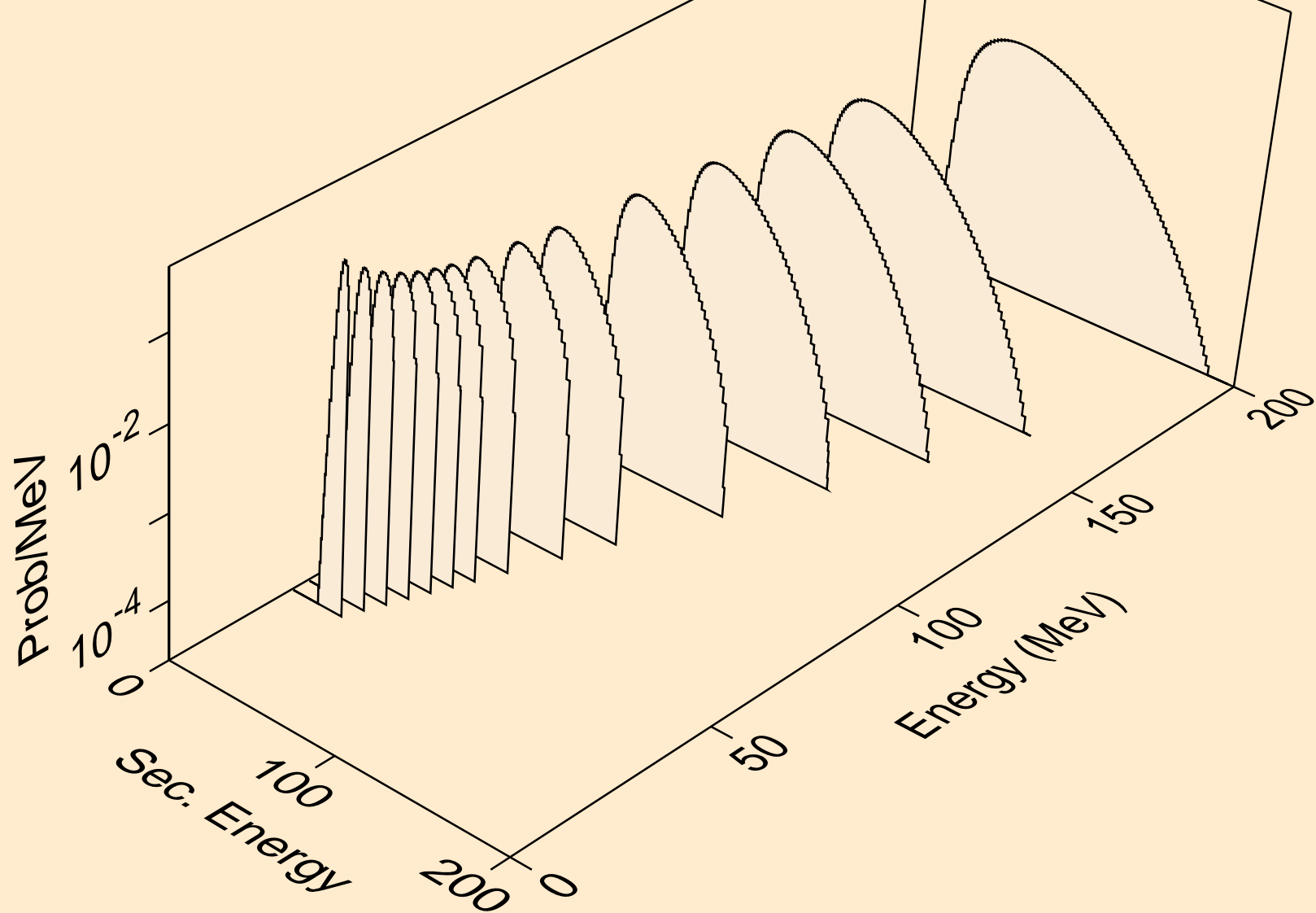

BH268 NEUTRON ACER TENDL-2024 LIBRARY; T=0.K  
he3s from (n,n\*)he3

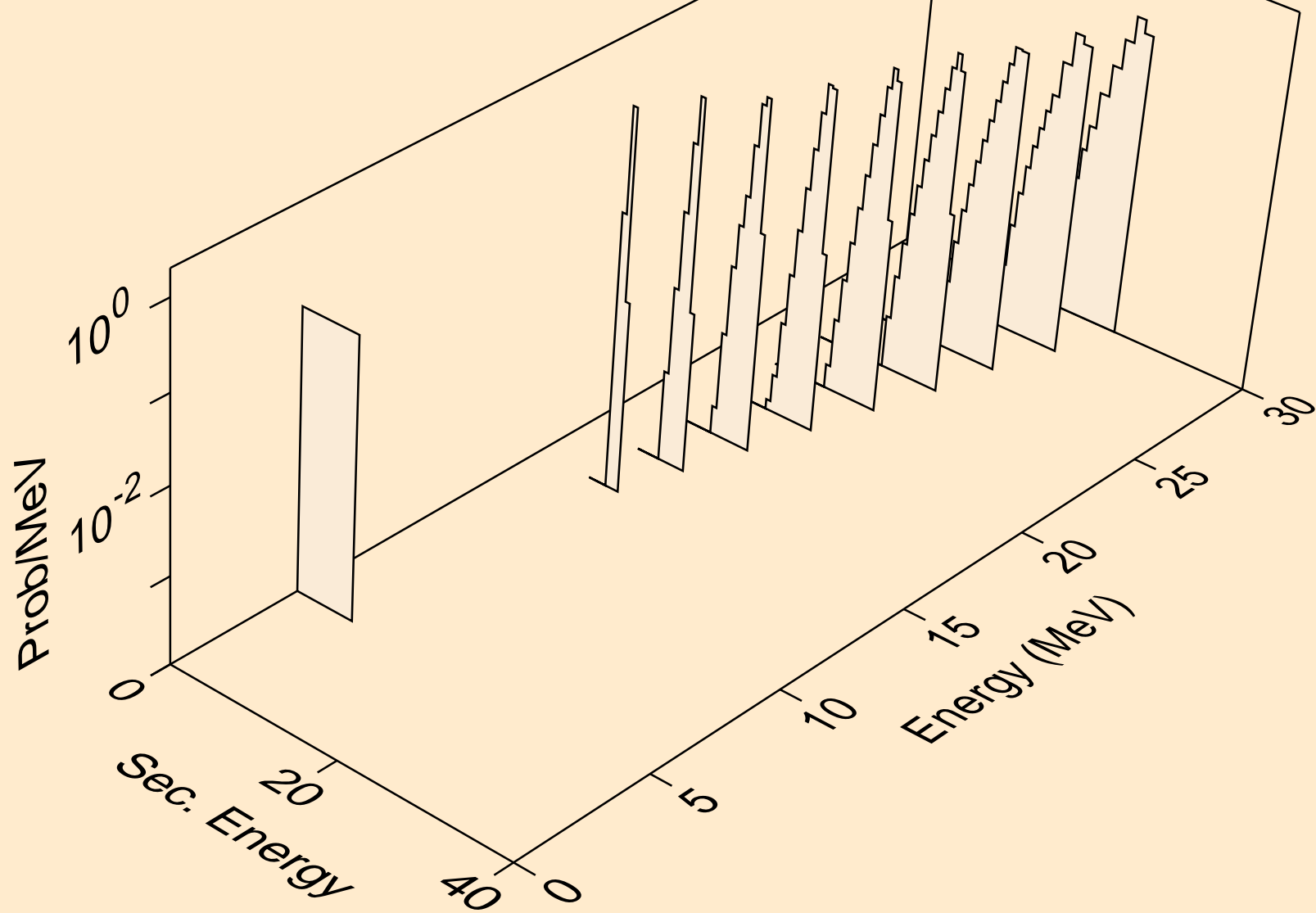

BH268 NEUTRON ACER TENDL-2024 LIBRARY; T=0.K  
he3s from (n,he3)

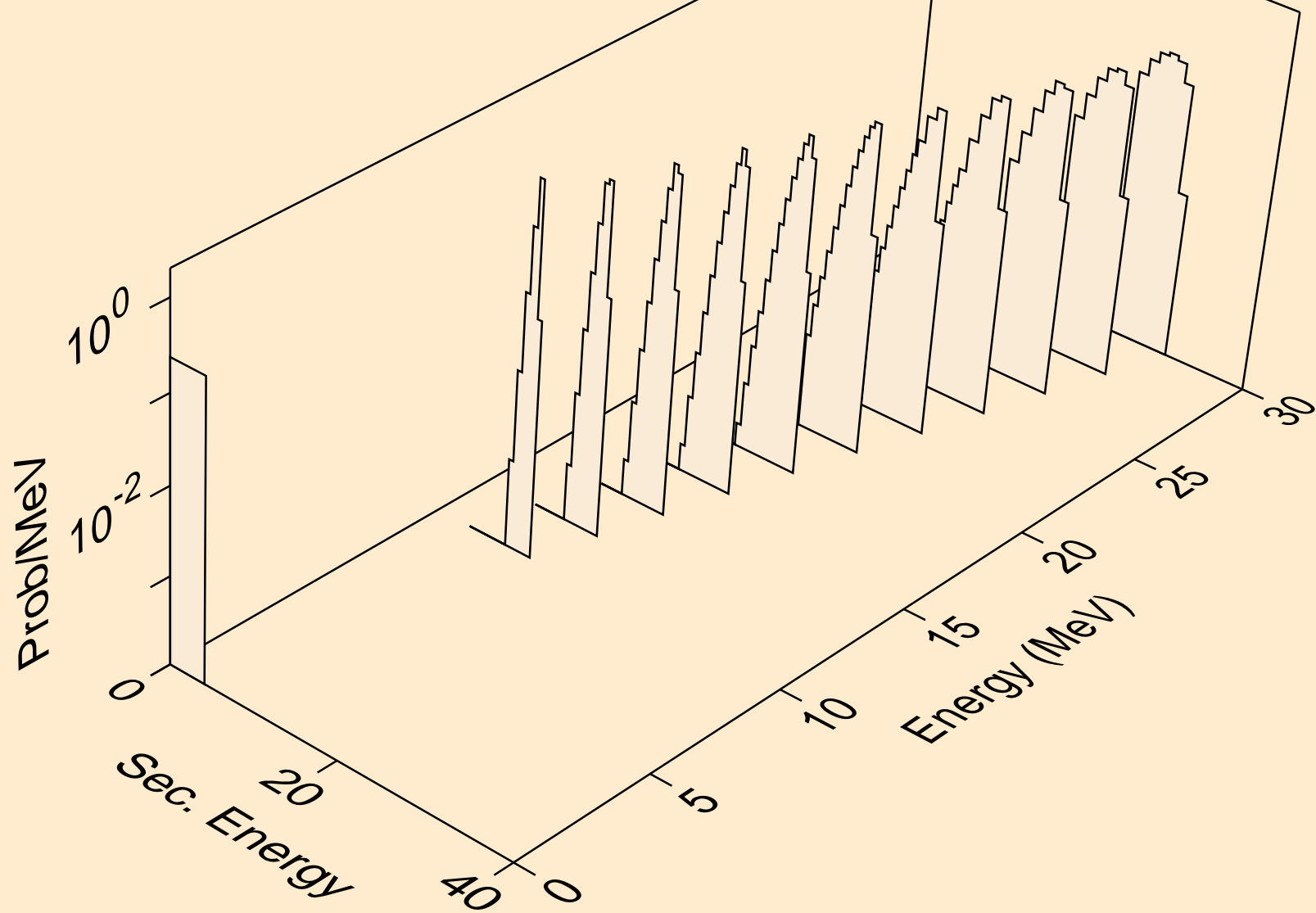



BH268 NEUTRON ACER TENDL-2024 LIBRARY; T=0.K  
alphas from (n,x)

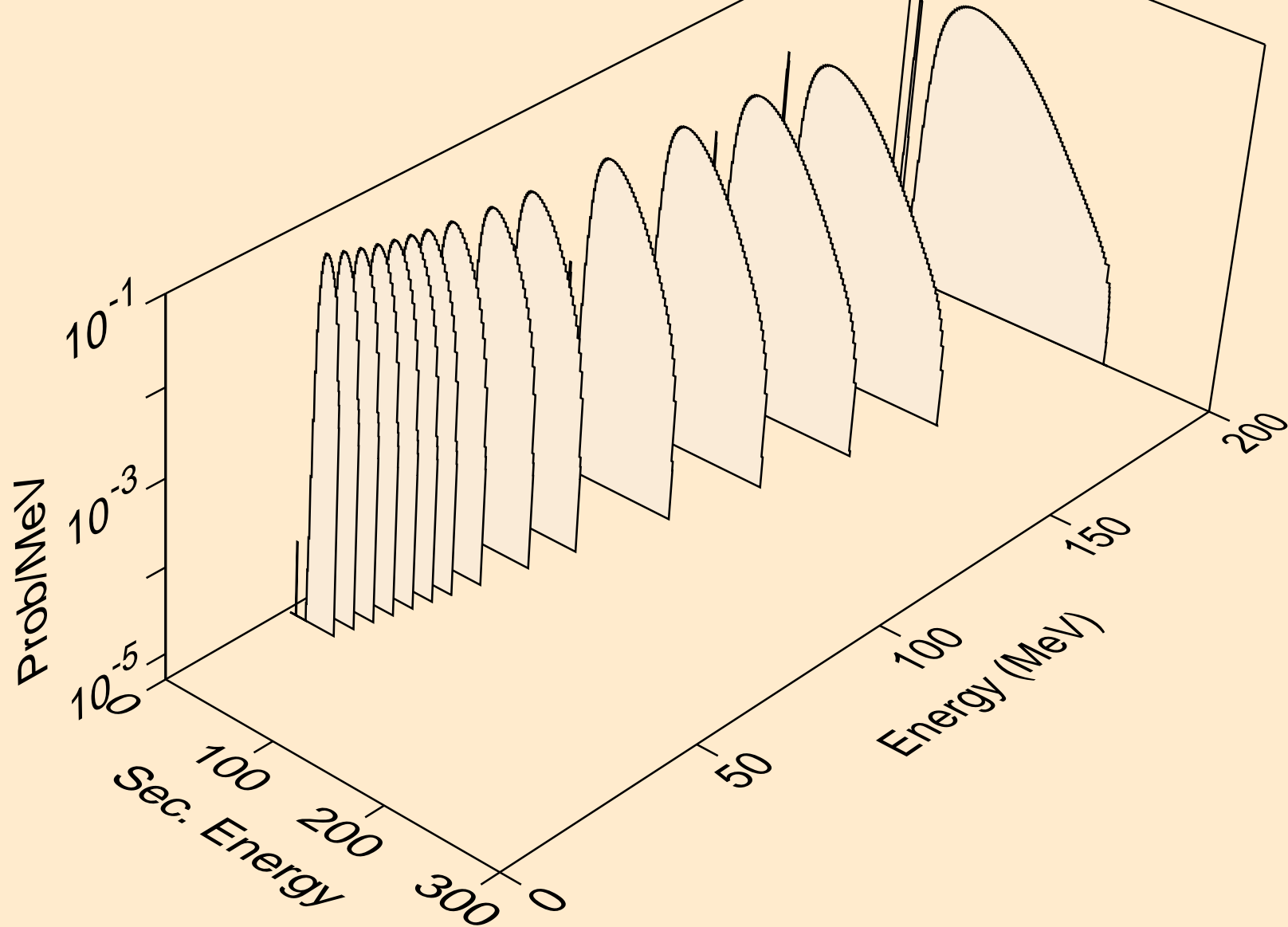

BH268 NEUTRON ACER TENDL-2024 LIBRARY; T=0.K  
alphas from (n,n\*)a

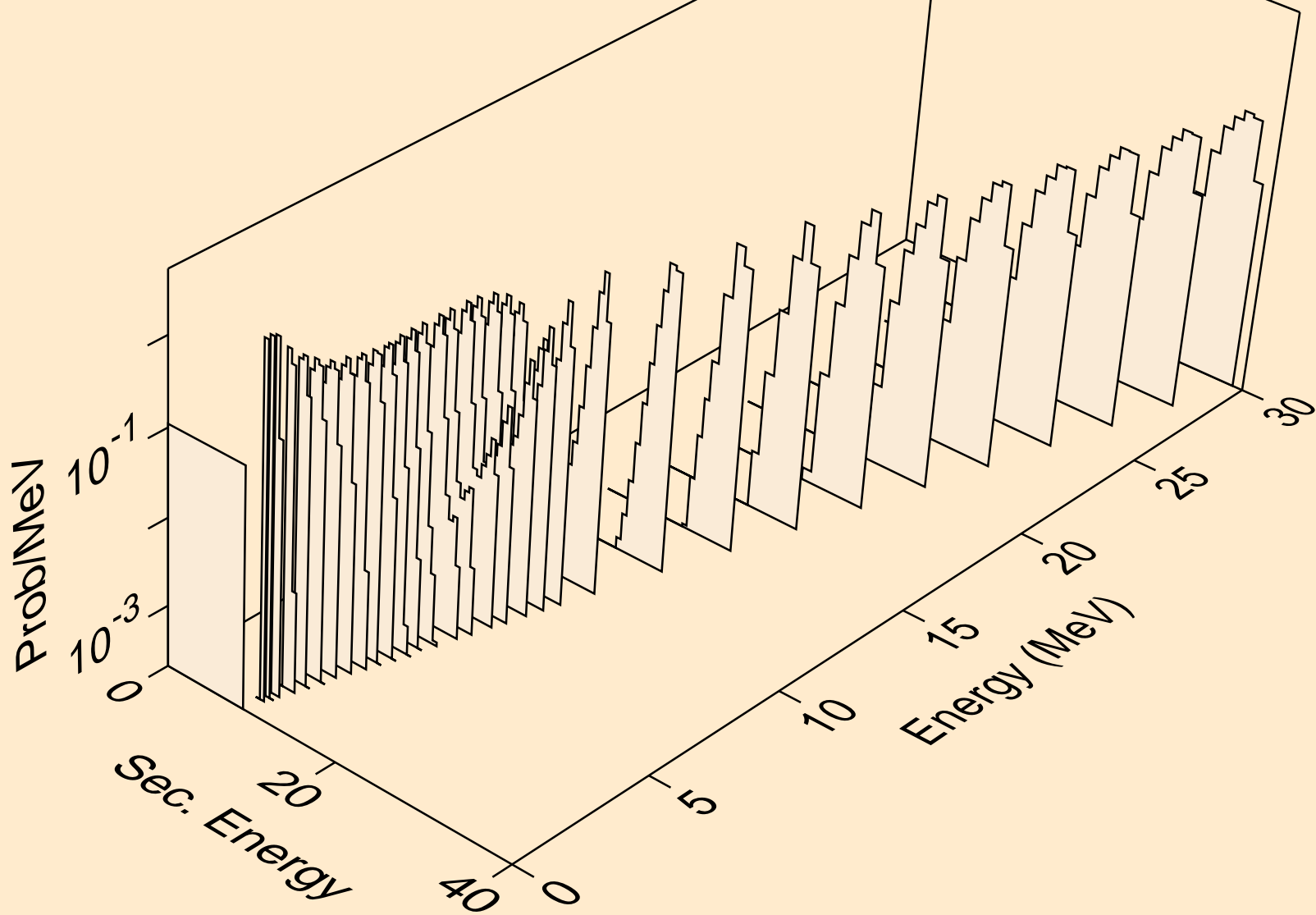

BH268 NEUTRON ACER TENDL-2024 LIBRARY; T=0.K  
alphas from (n,2n)a

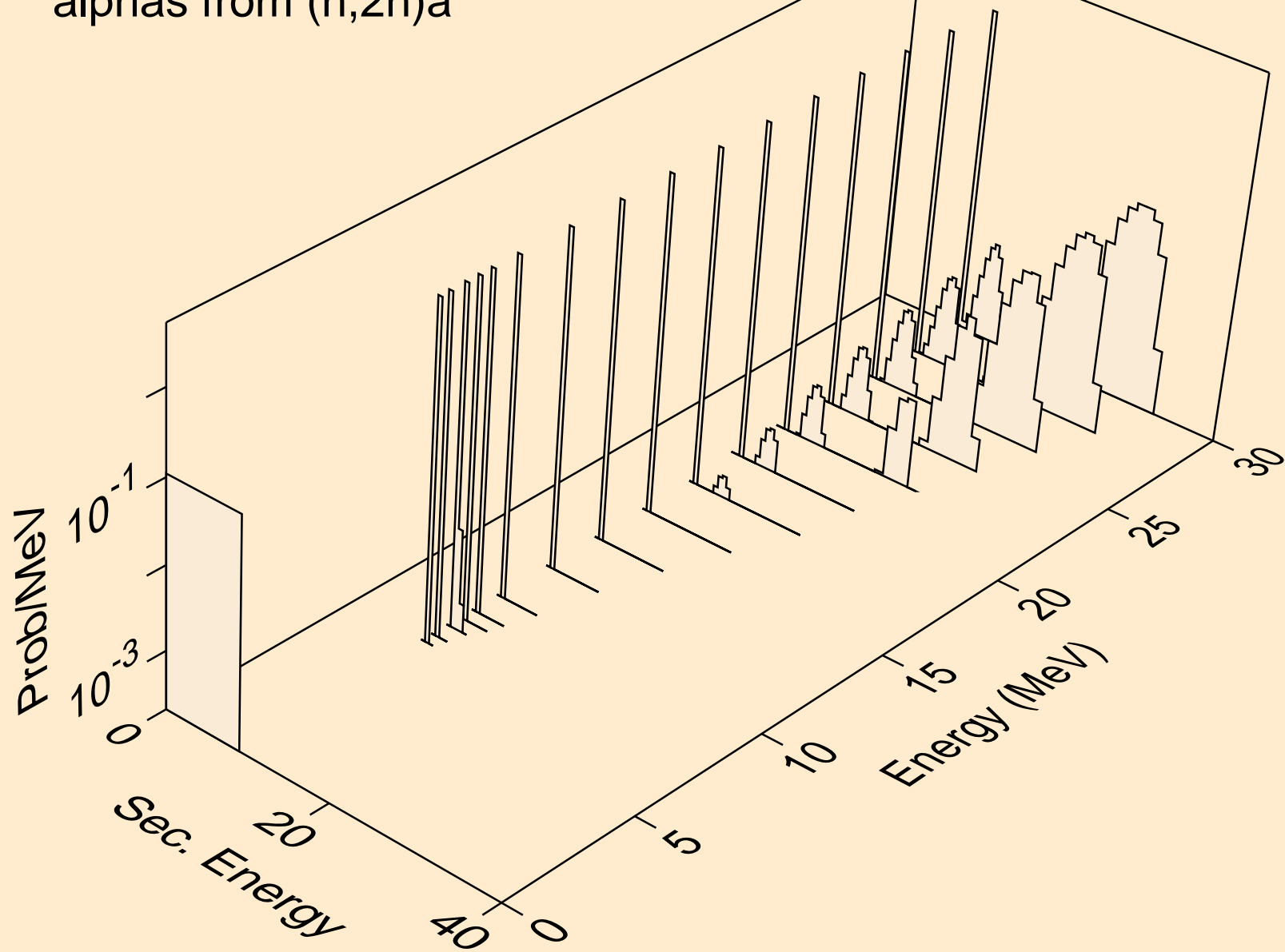

BH268 NEUTRON ACER TENDL-2024 LIBRARY; T=0.K  
alphas from (n,3n)a

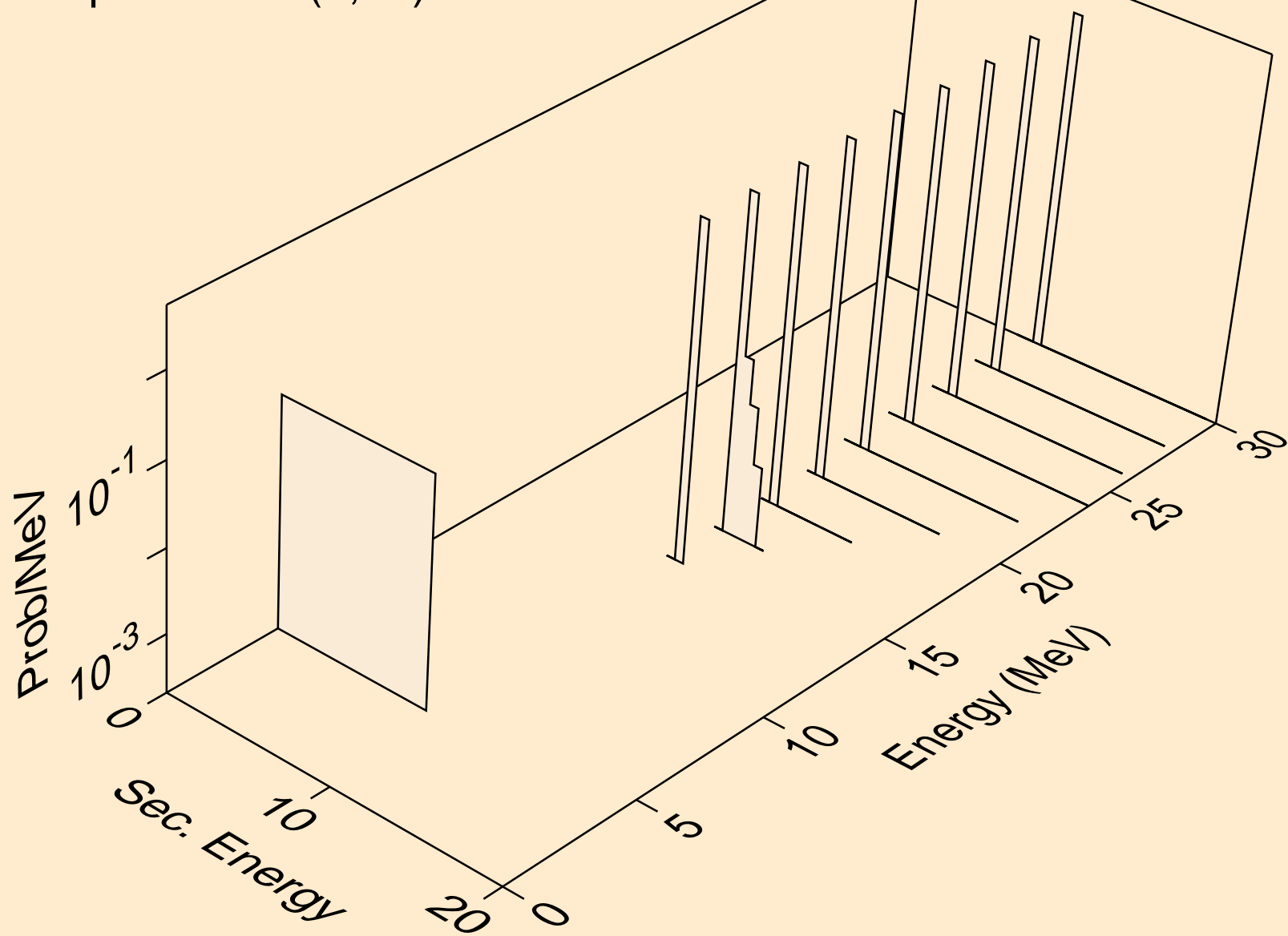

BH268 NEUTRON ACER TENDL-2024 LIBRARY; T=0.K  
alphas from (n,a)

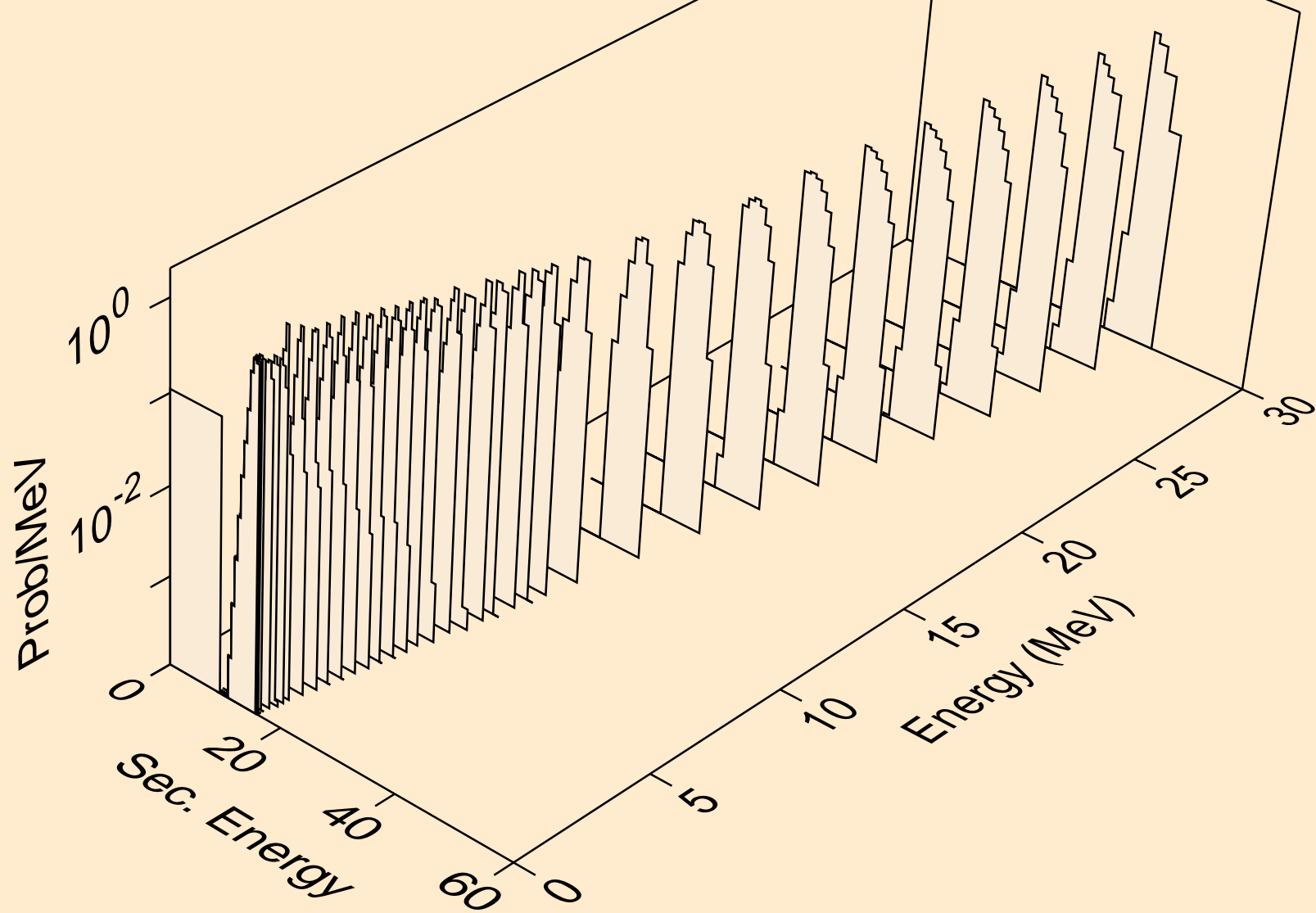

BH268 NEUTRON ACER TENDL-2024 LIBRARY; T=0.K  
alphas from (n,2a)

