

C014 NEUTRON ACER TENDL-2024 LIBRARY; T=0.K

Principal cross sections

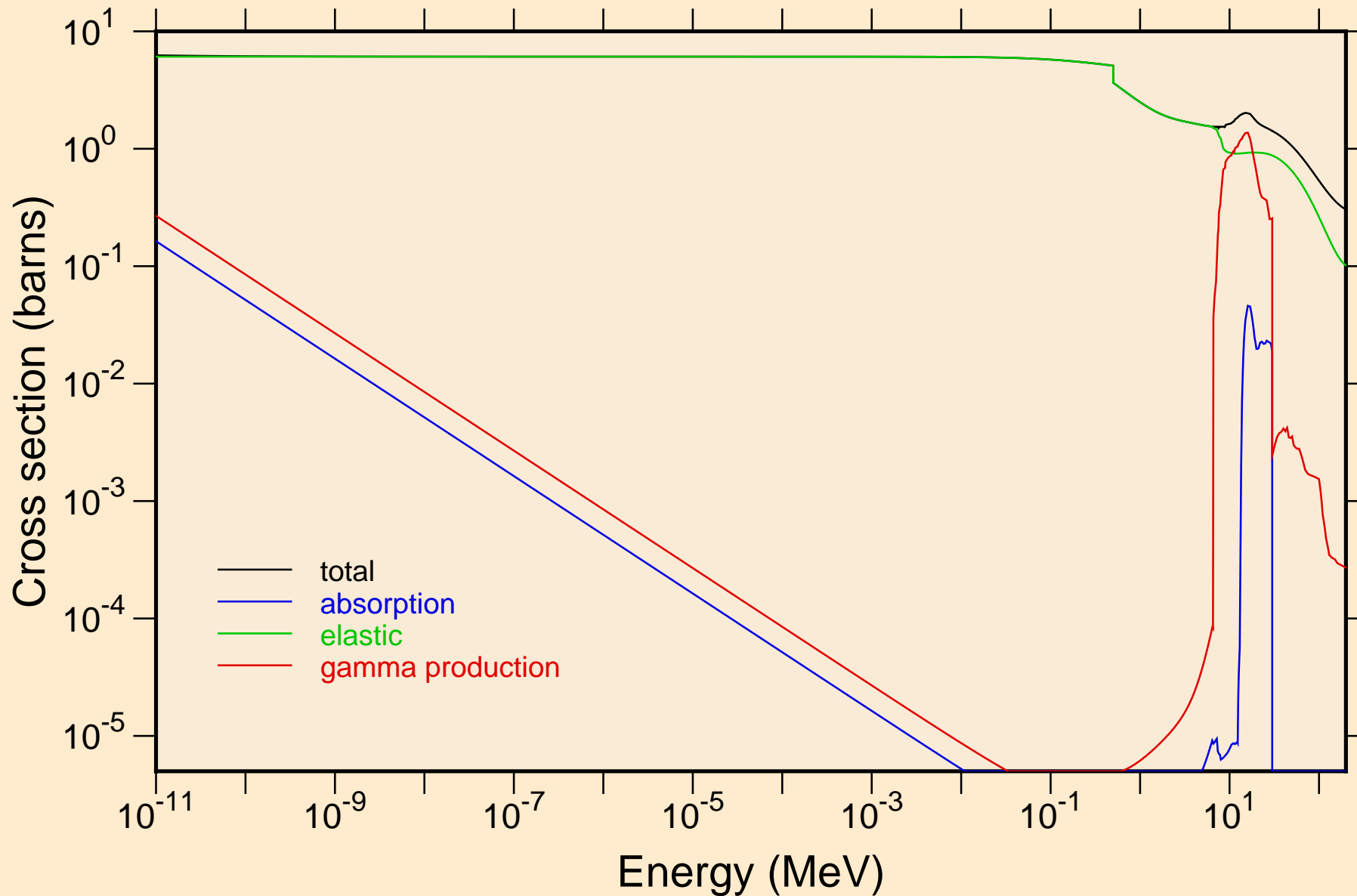

C014 NEUTRON ACER TENDL-2024 LIBRARY; T=0.K

Heating

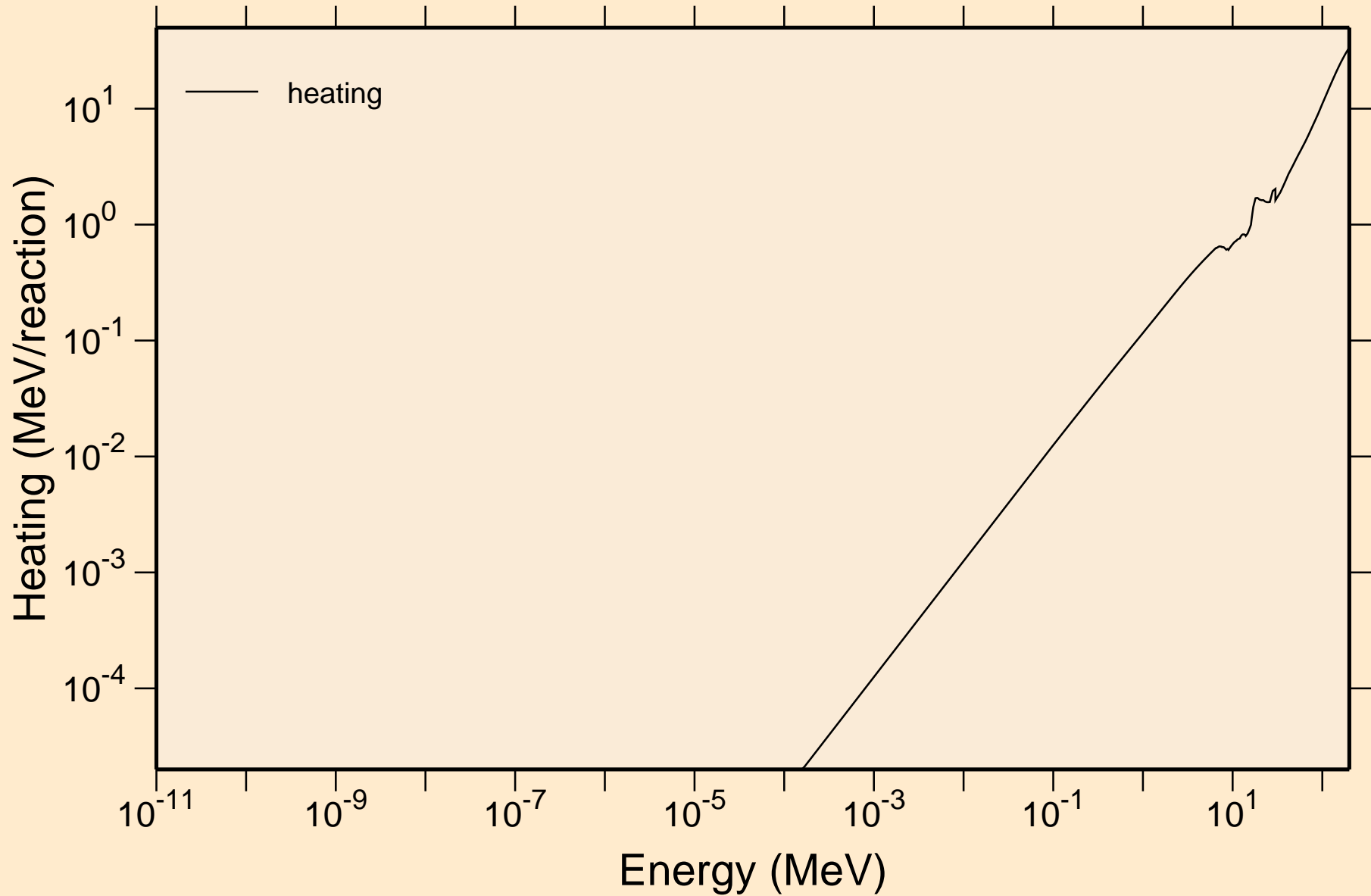

C014 NEUTRON ACER TENDL-2024 LIBRARY; T=0.K

Damage

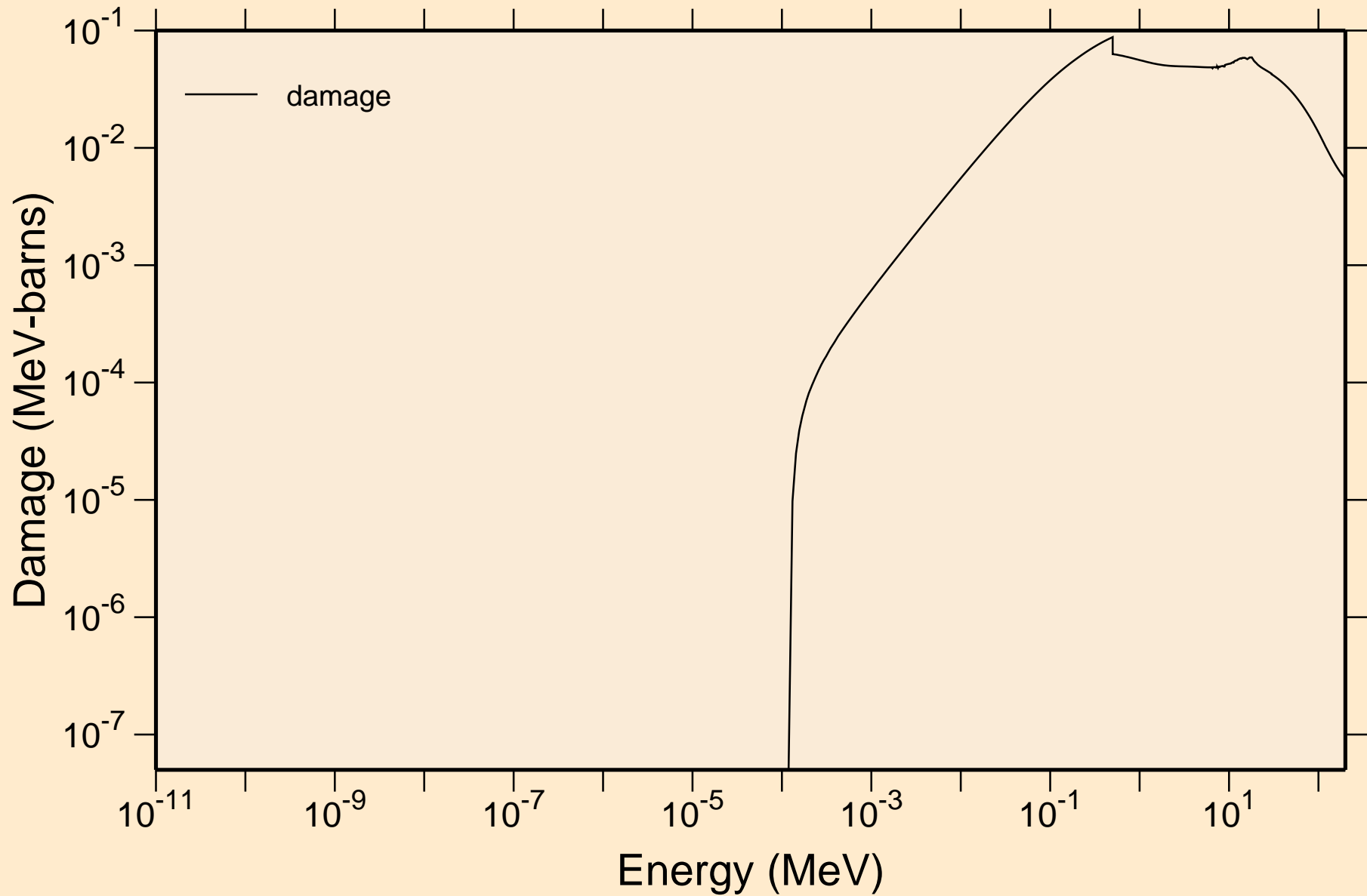

C014 NEUTRON ACER TENDL-2024 LIBRARY; T=0.K
Non-threshold reactions

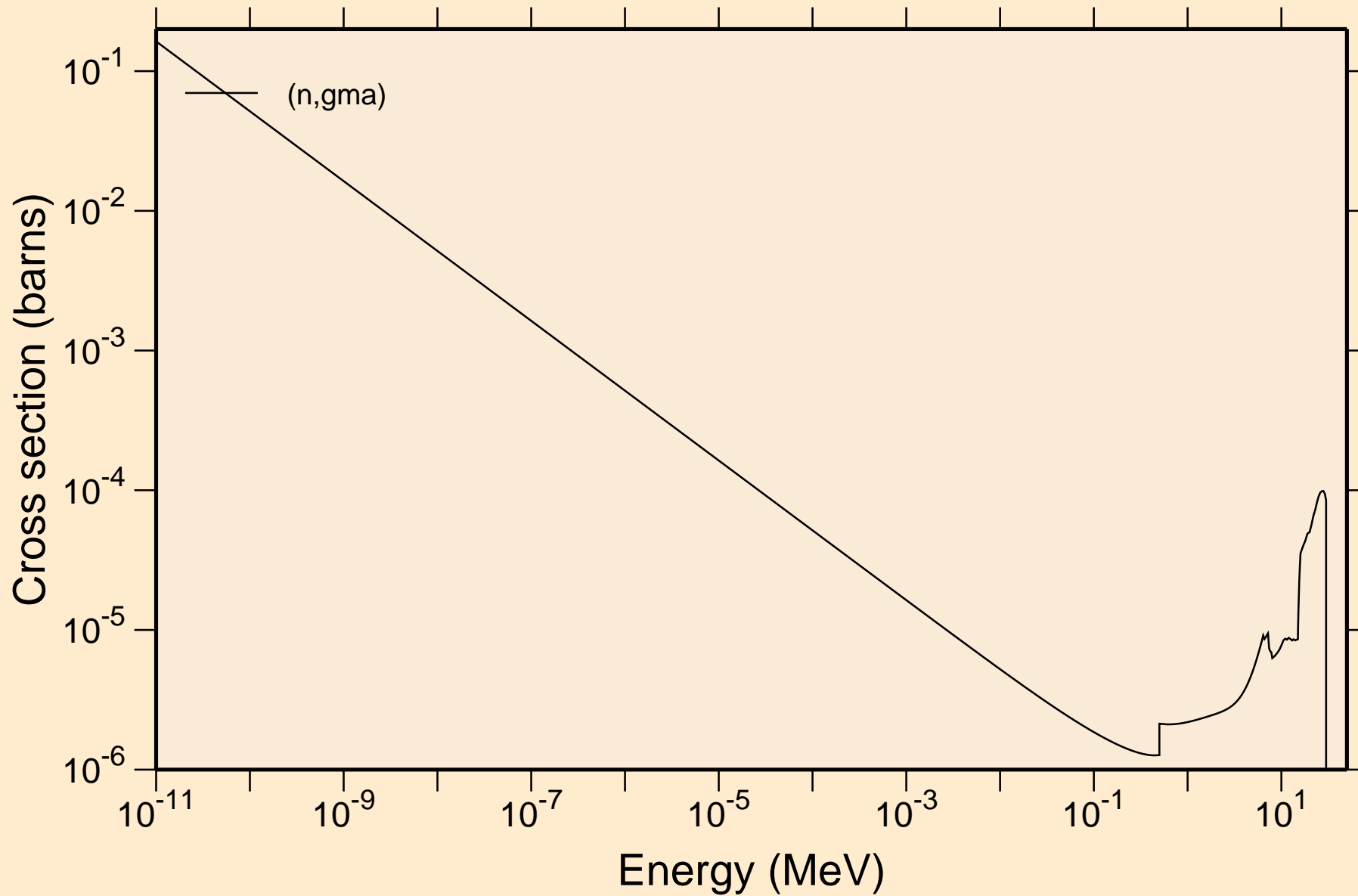

C014 NEUTRON ACER TENDL-2024 LIBRARY; T=0.K

Principal cross sections

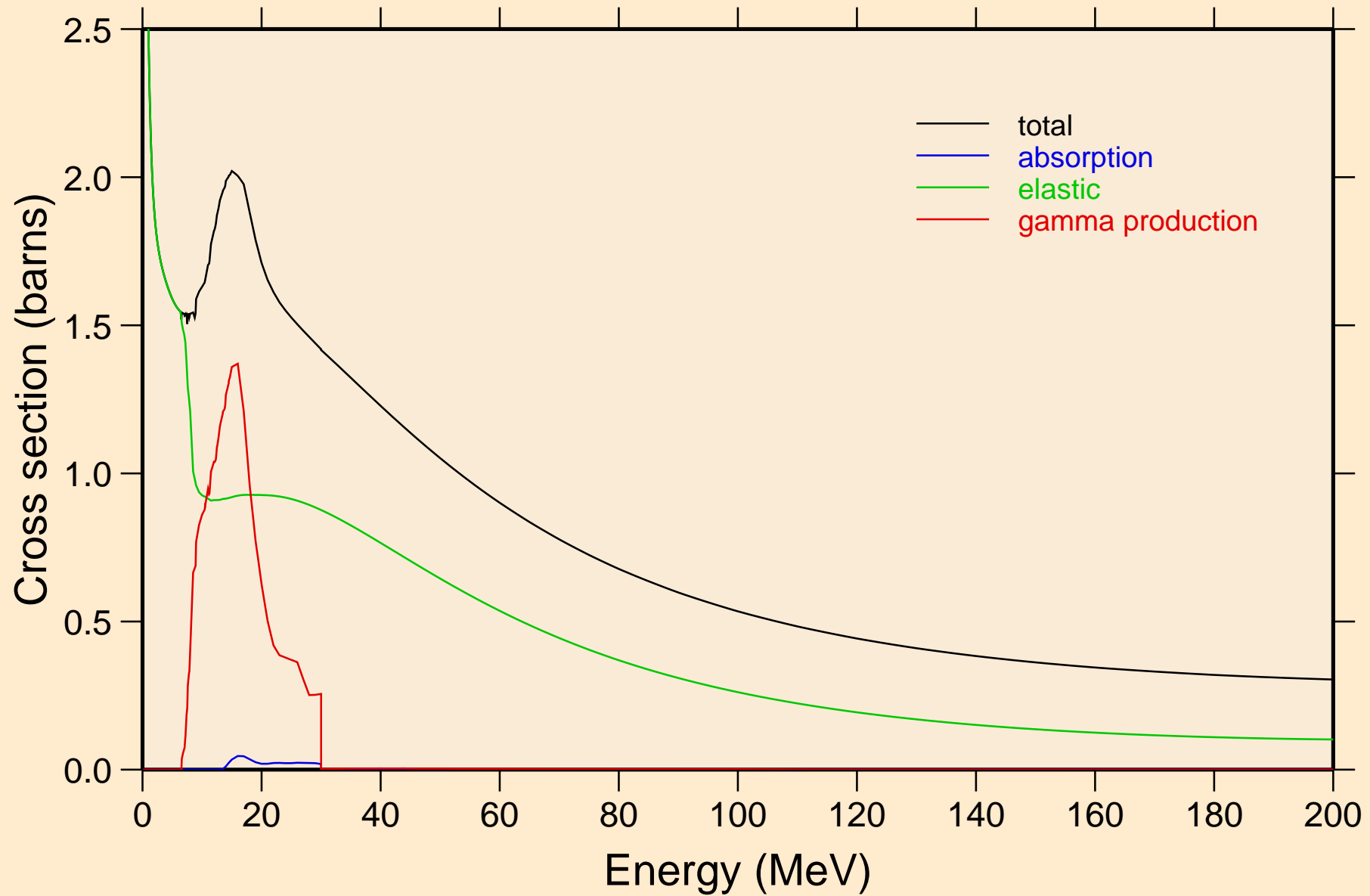

C014 NEUTRON ACER TENDL-2024 LIBRARY; T=0.K

Heating

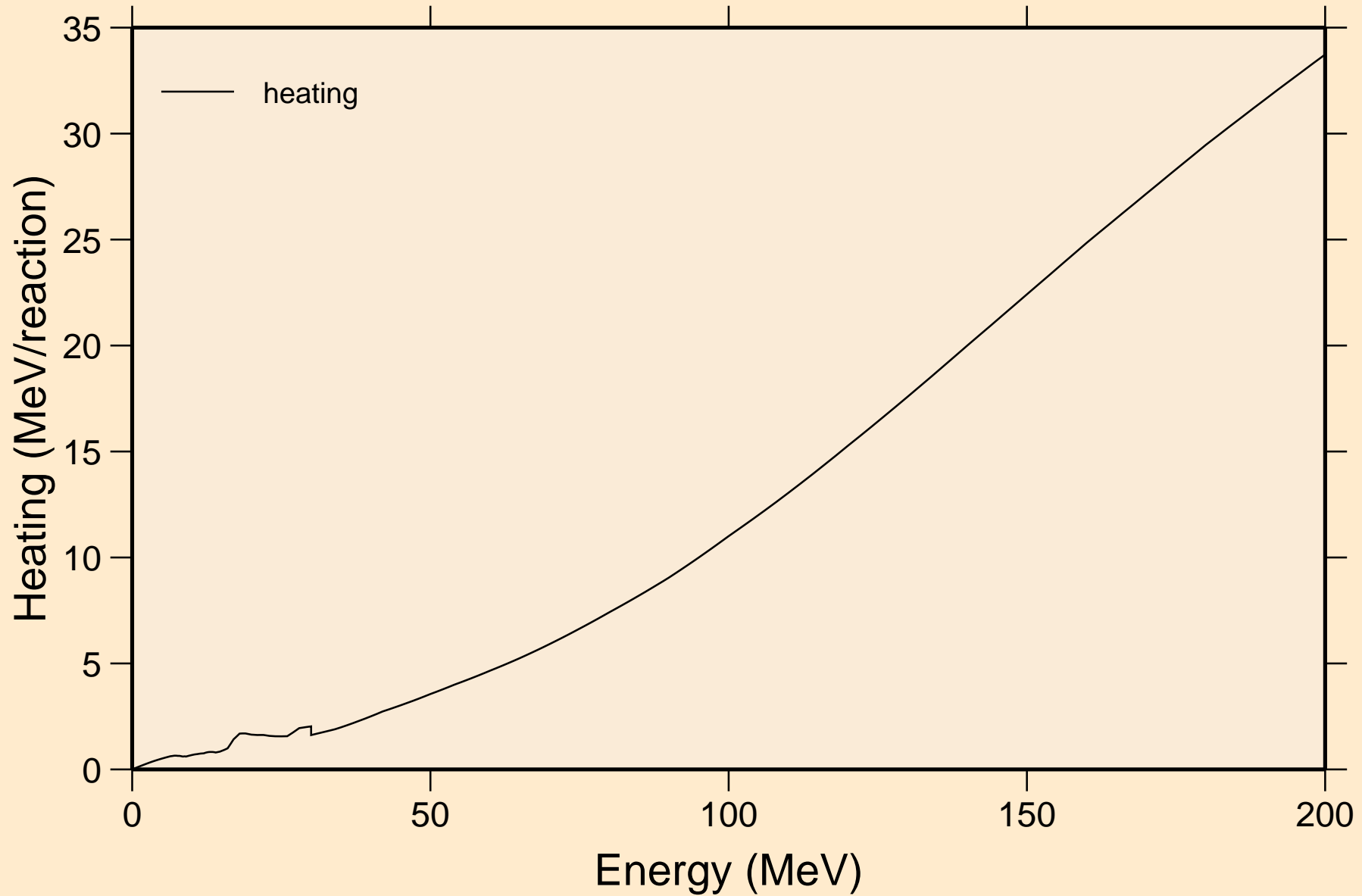

C014 NEUTRON ACER TENDL-2024 LIBRARY; T=0.K

Damage

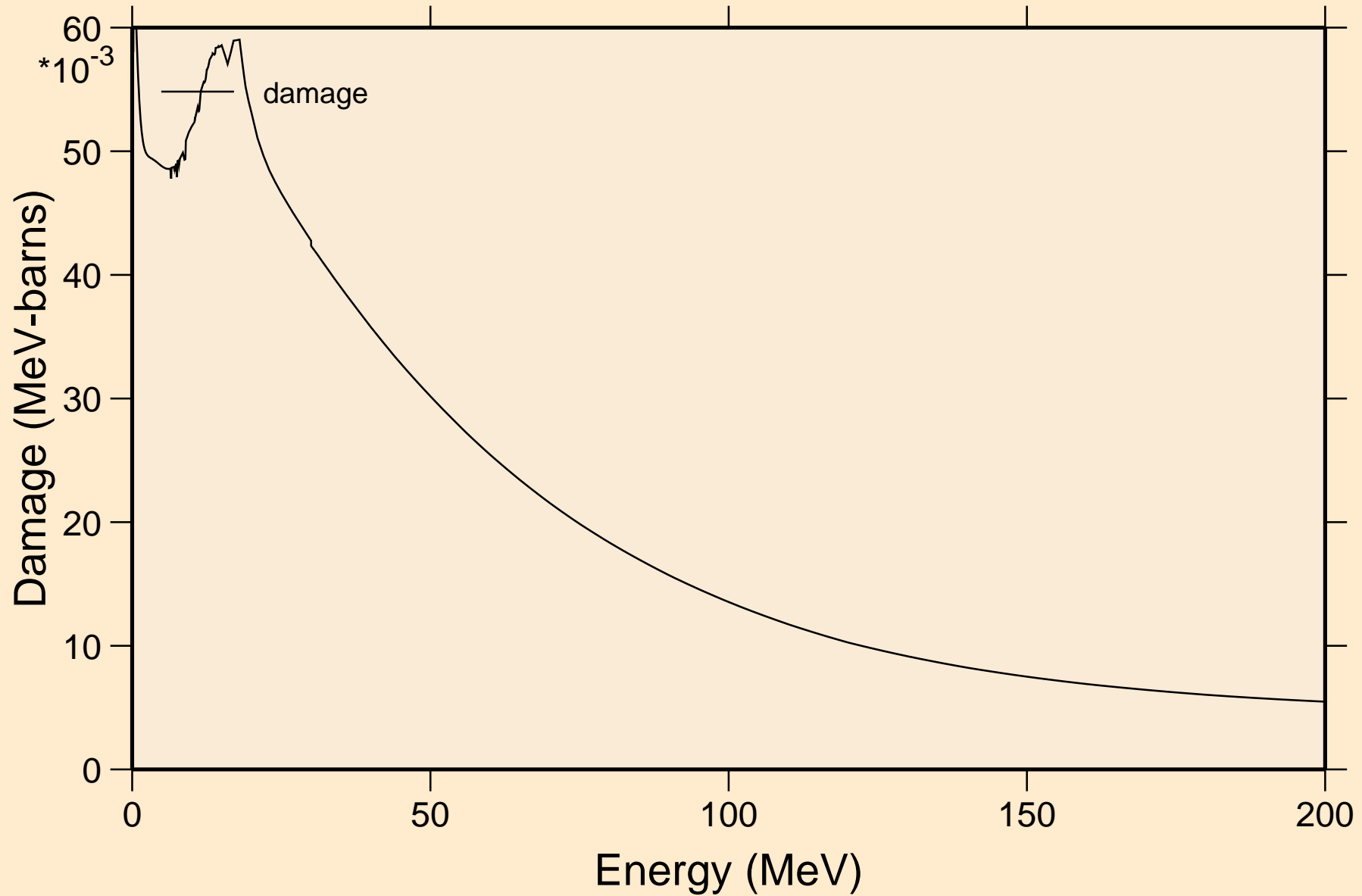

C014 NEUTRON ACER TENDL-2024 LIBRARY; T=0.K
Non-threshold reactions

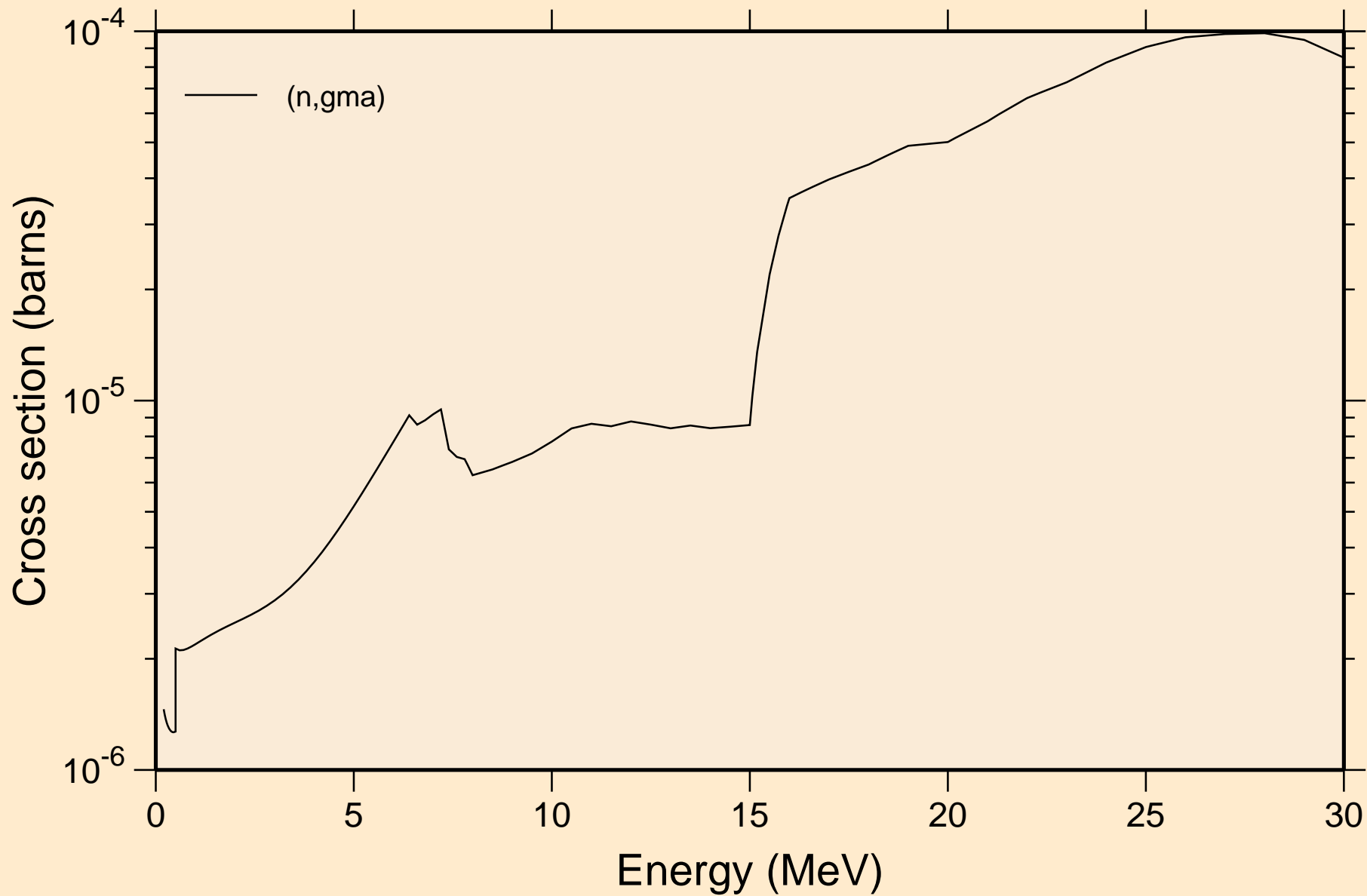

C014 NEUTRON ACER TENDL-2024 LIBRARY; T=0.K

Inelastic levels

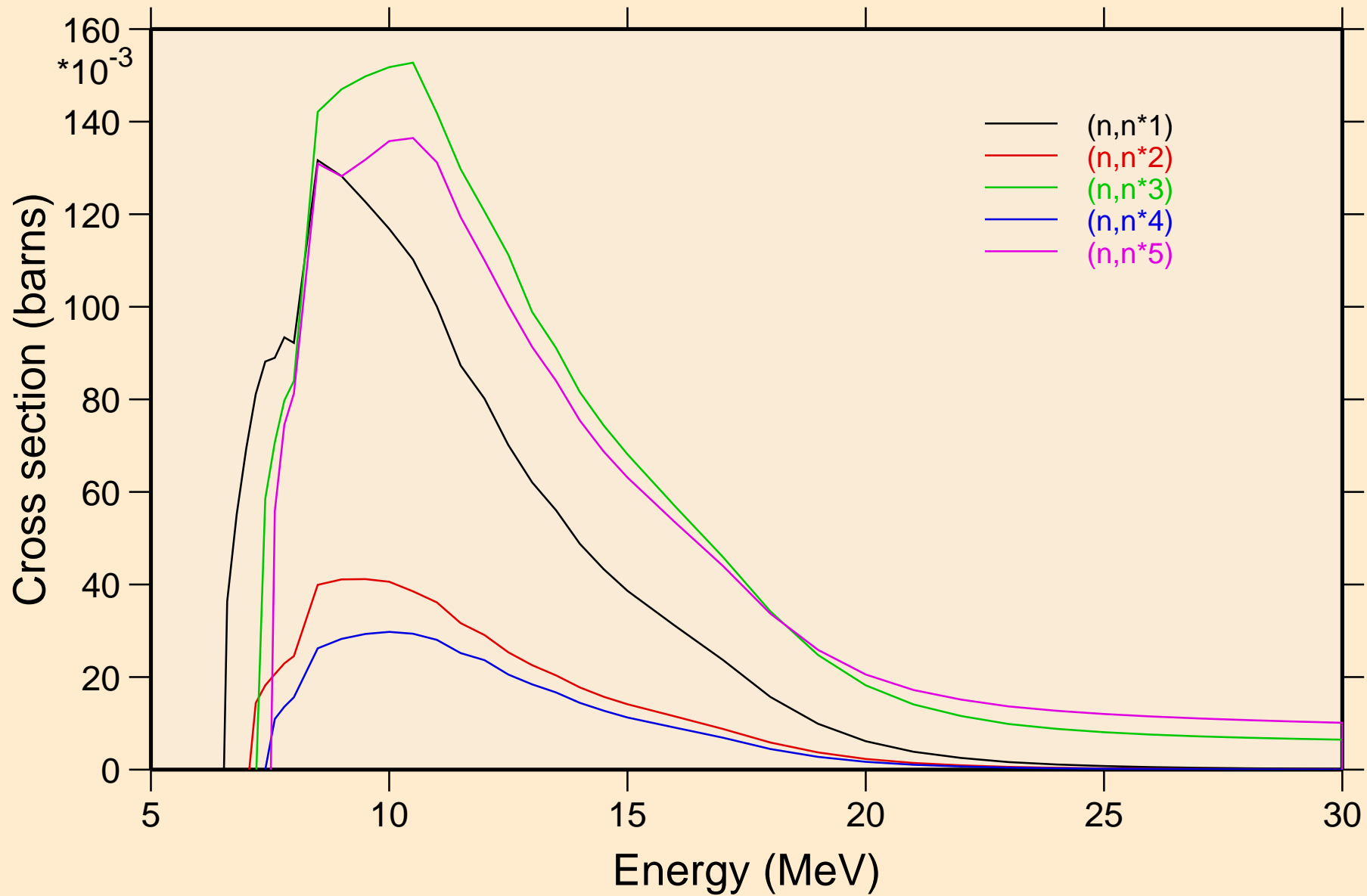

C014 NEUTRON ACER TENDL-2024 LIBRARY; T=0.K
Inelastic levels

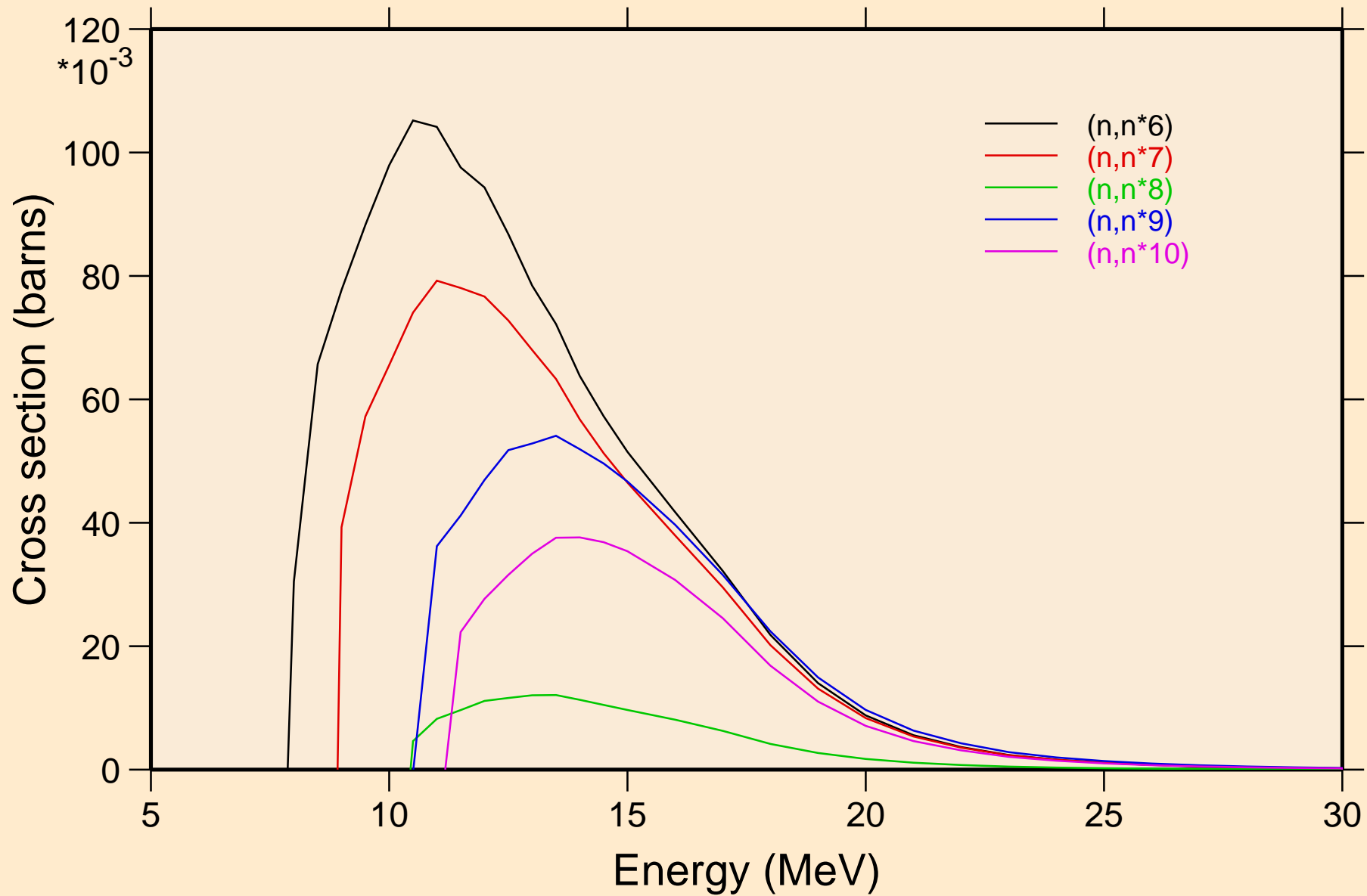

C014 NEUTRON ACER TENDL-2024 LIBRARY; T=0.K
Inelastic levels

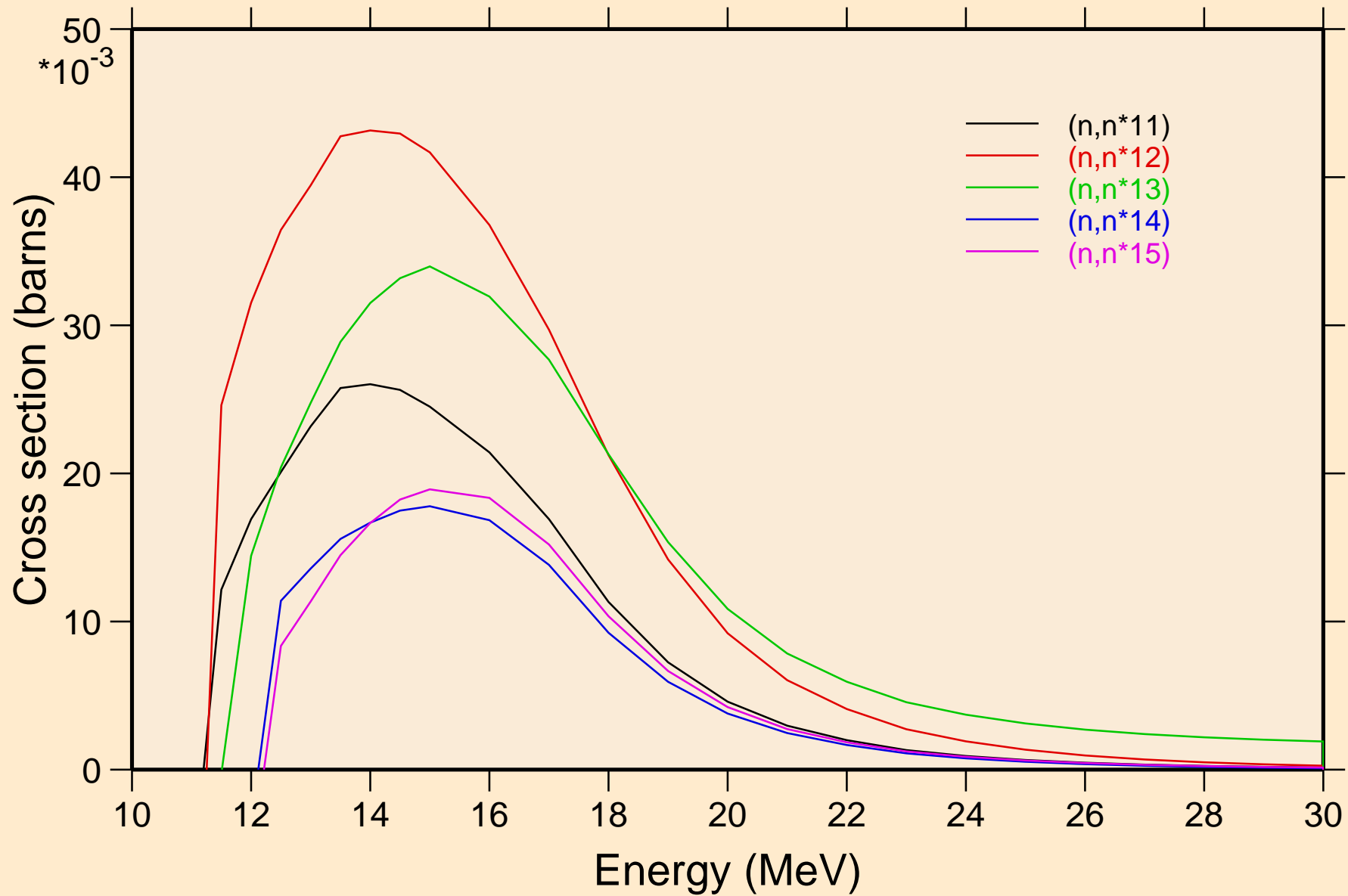

C014 NEUTRON ACER TENDL-2024 LIBRARY; T=0.K
Inelastic levels

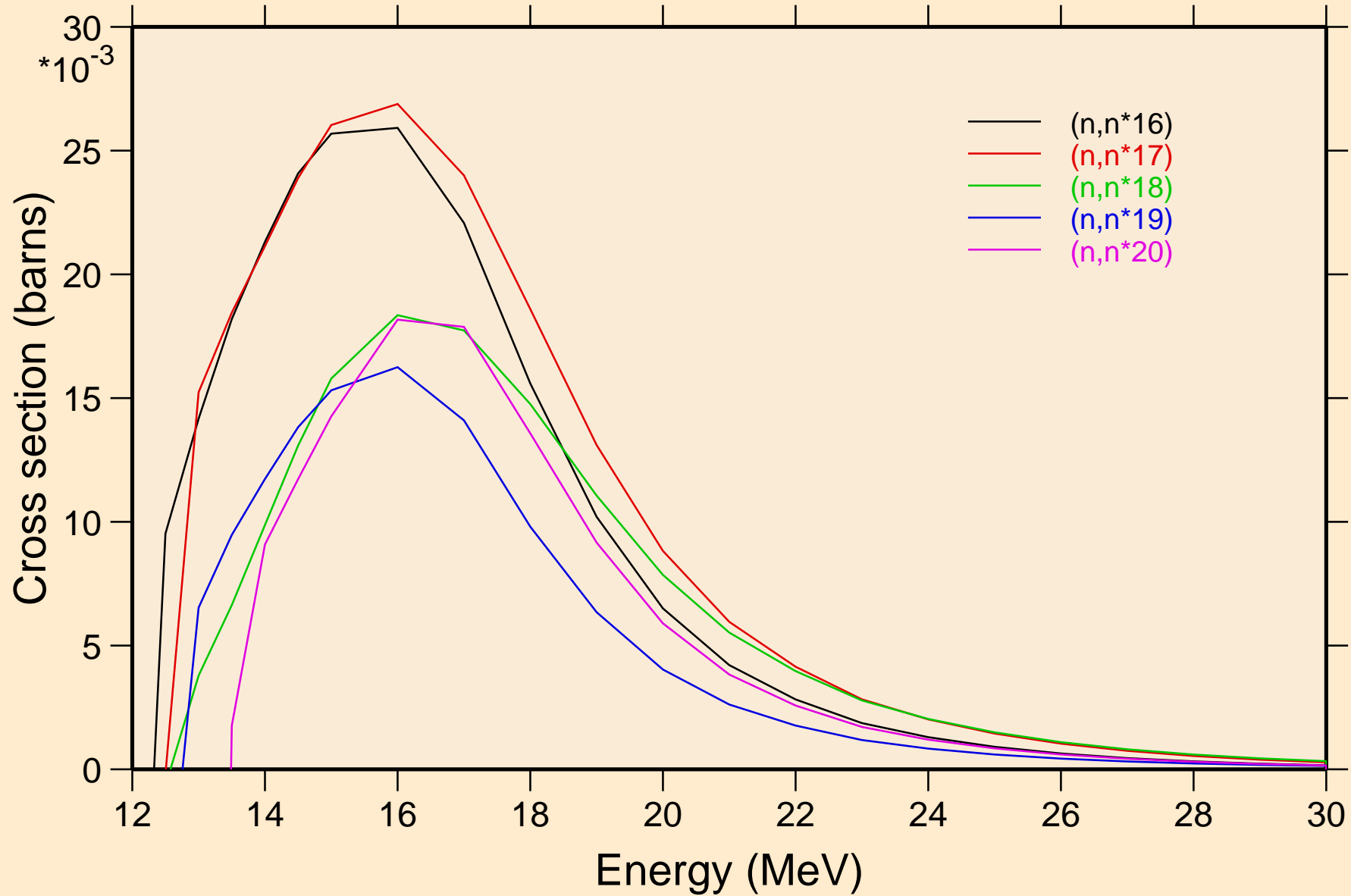

C014 NEUTRON ACER TENDL-2024 LIBRARY; T=0.K
Inelastic levels

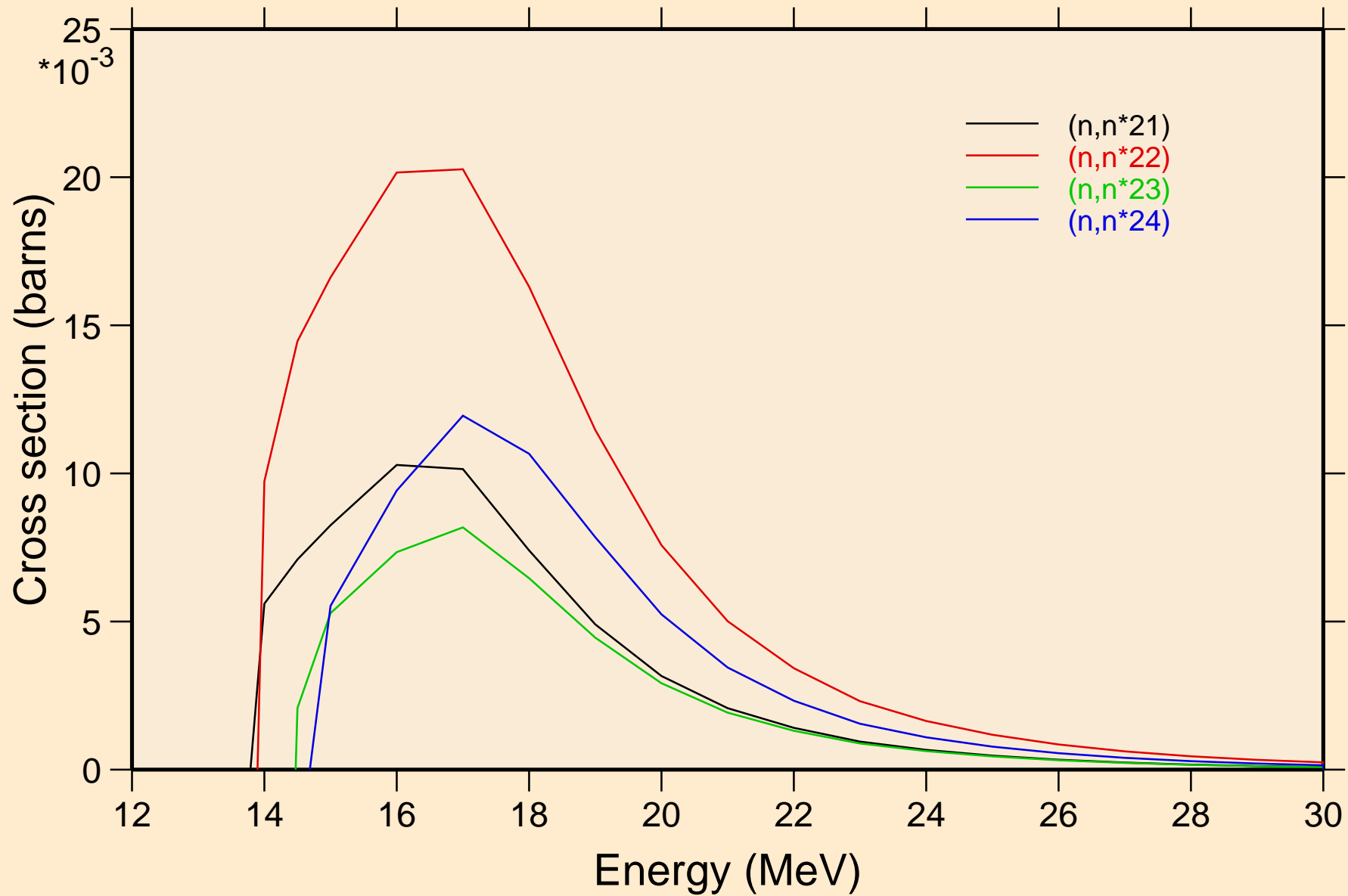

C014 NEUTRON ACER TENDL-2024 LIBRARY; T=0.K
Threshold reactions

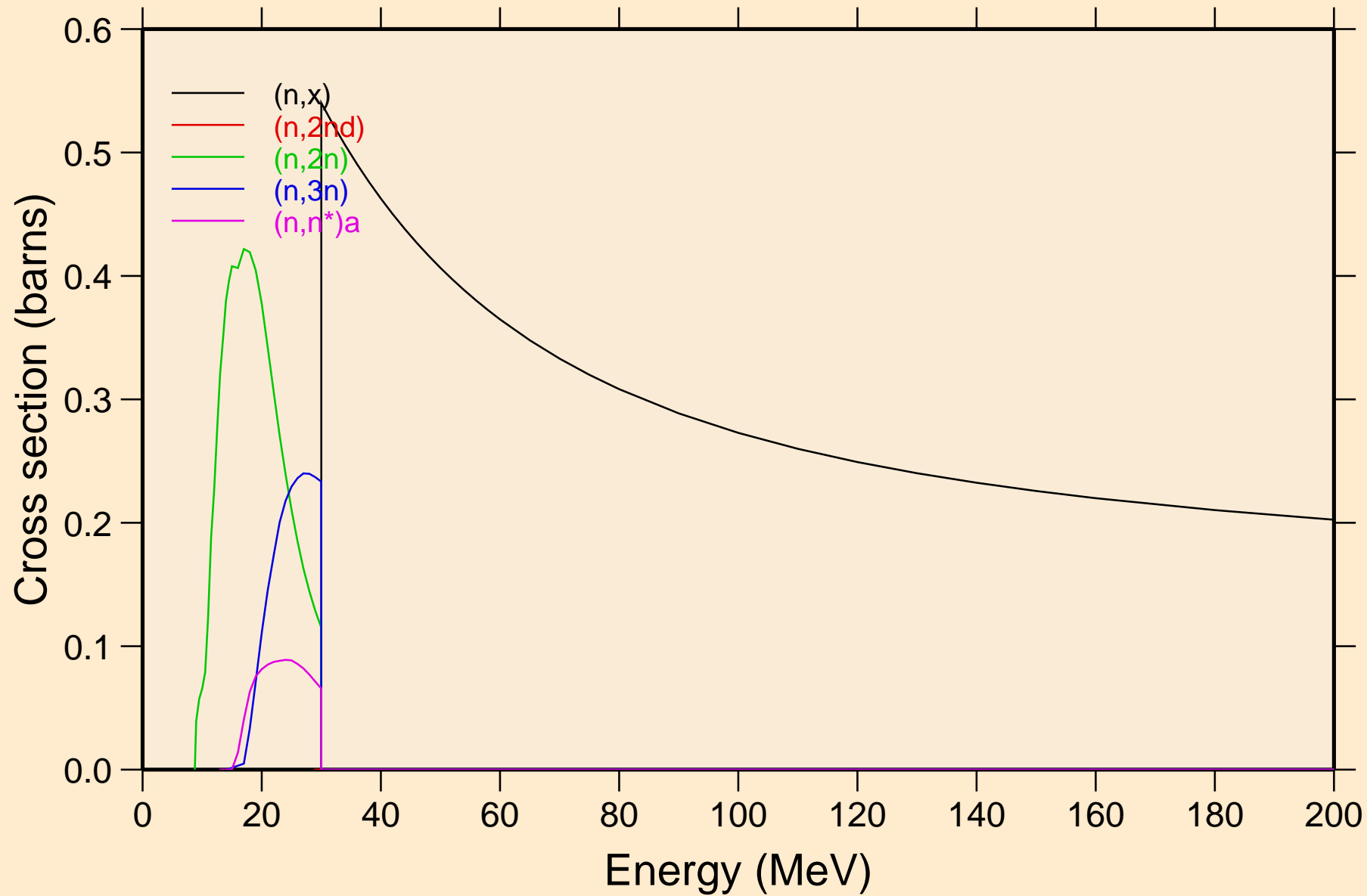

C014 NEUTRON ACER TENDL-2024 LIBRARY; T=0.K

Threshold reactions

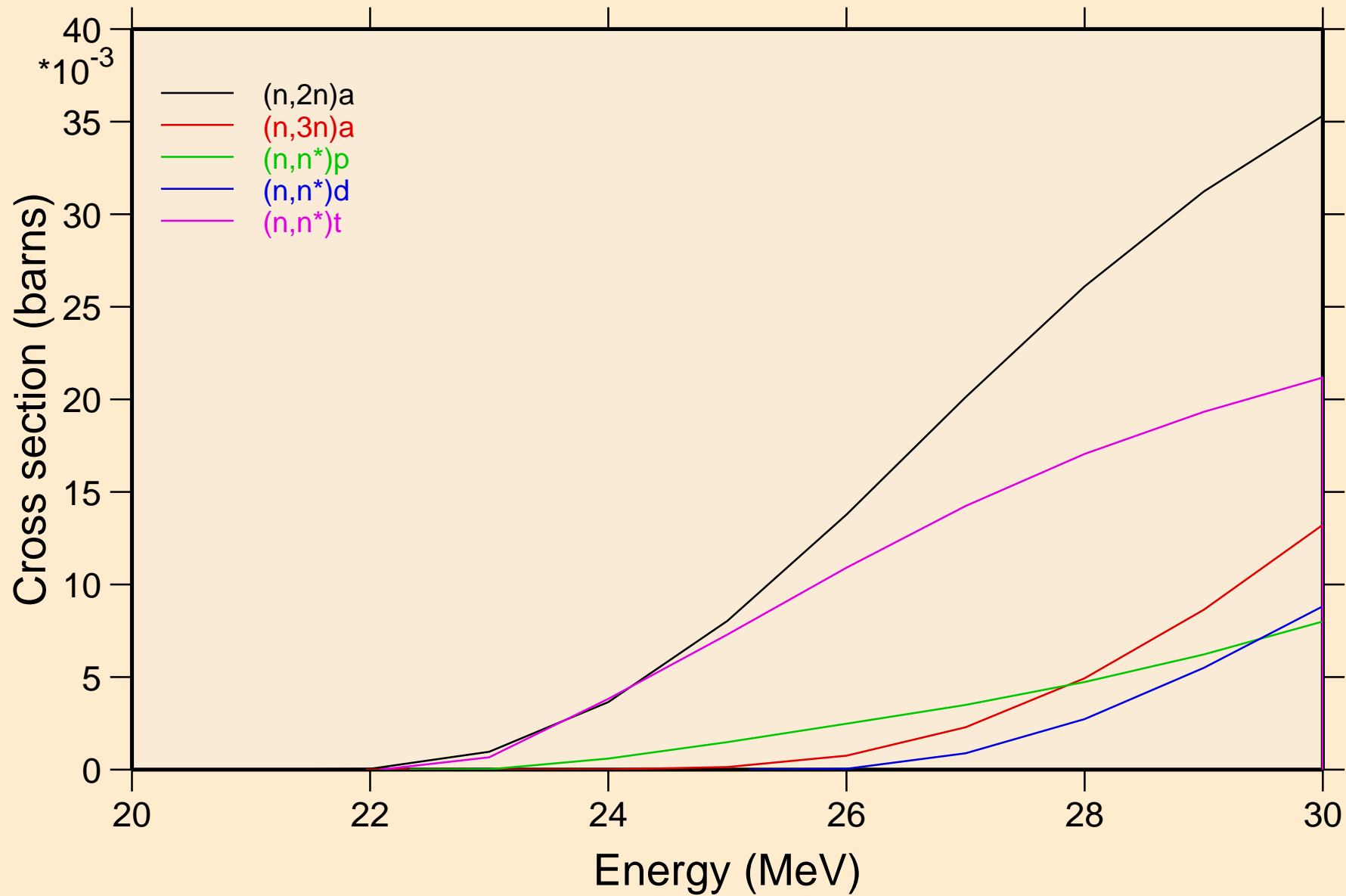

C014 NEUTRON ACER TENDL-2024 LIBRARY; T=0.K

Threshold reactions

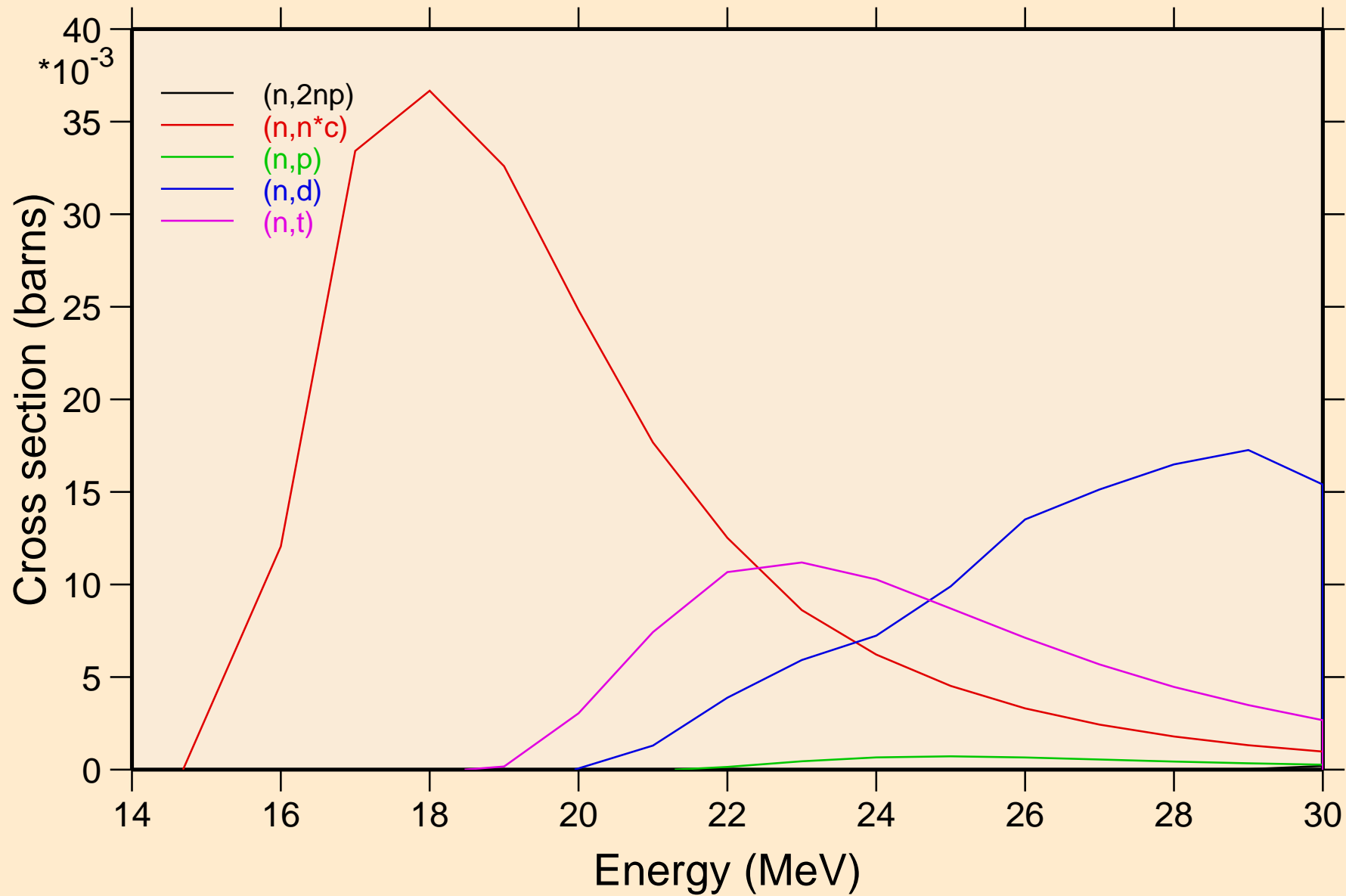

C014 NEUTRON ACER TENDL-2024 LIBRARY; T=0.K
Threshold reactions

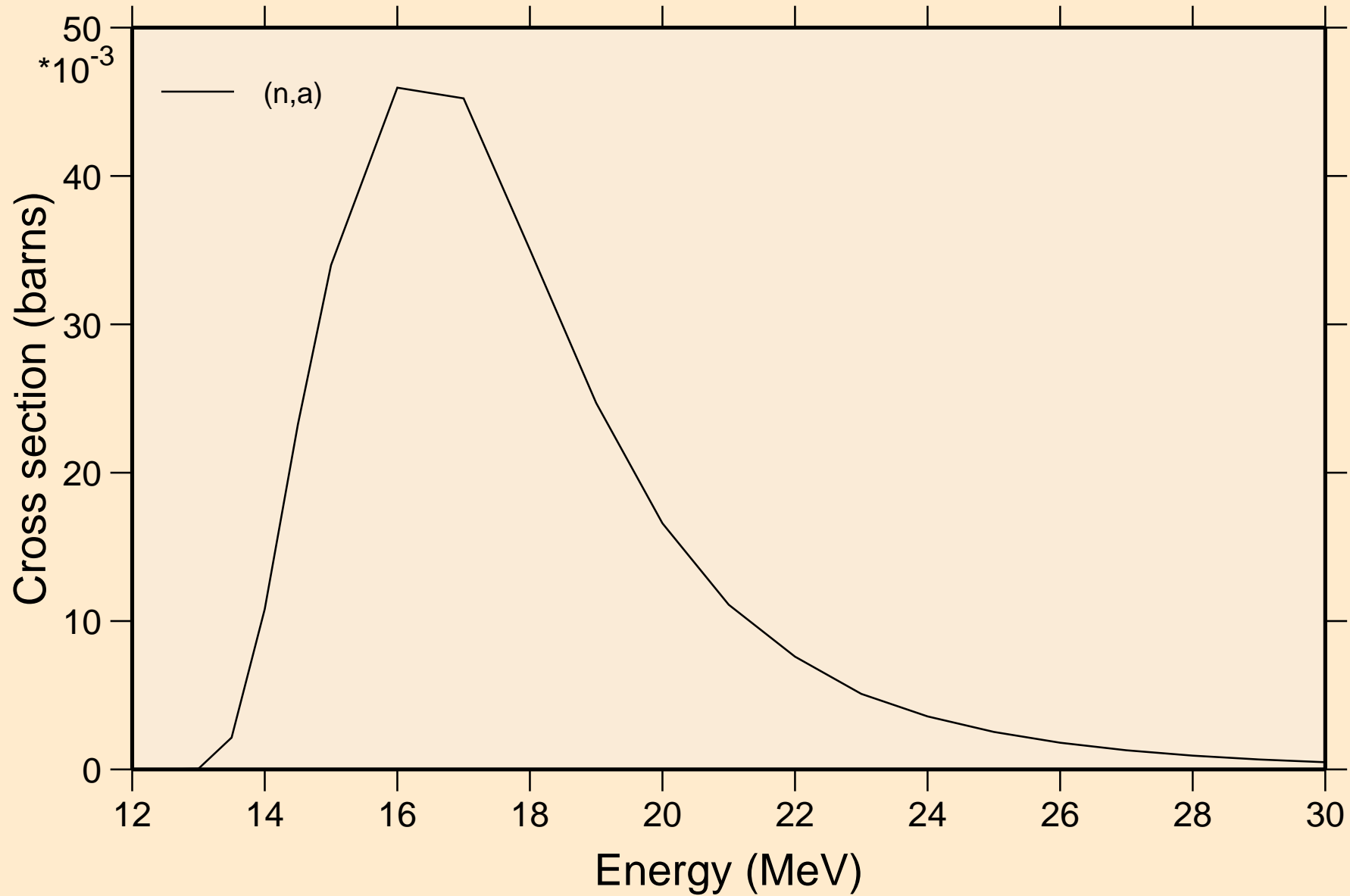

C014 NEUTRON ACER TENDL-2024 LIBRARY; T=0.K

Threshold reactions

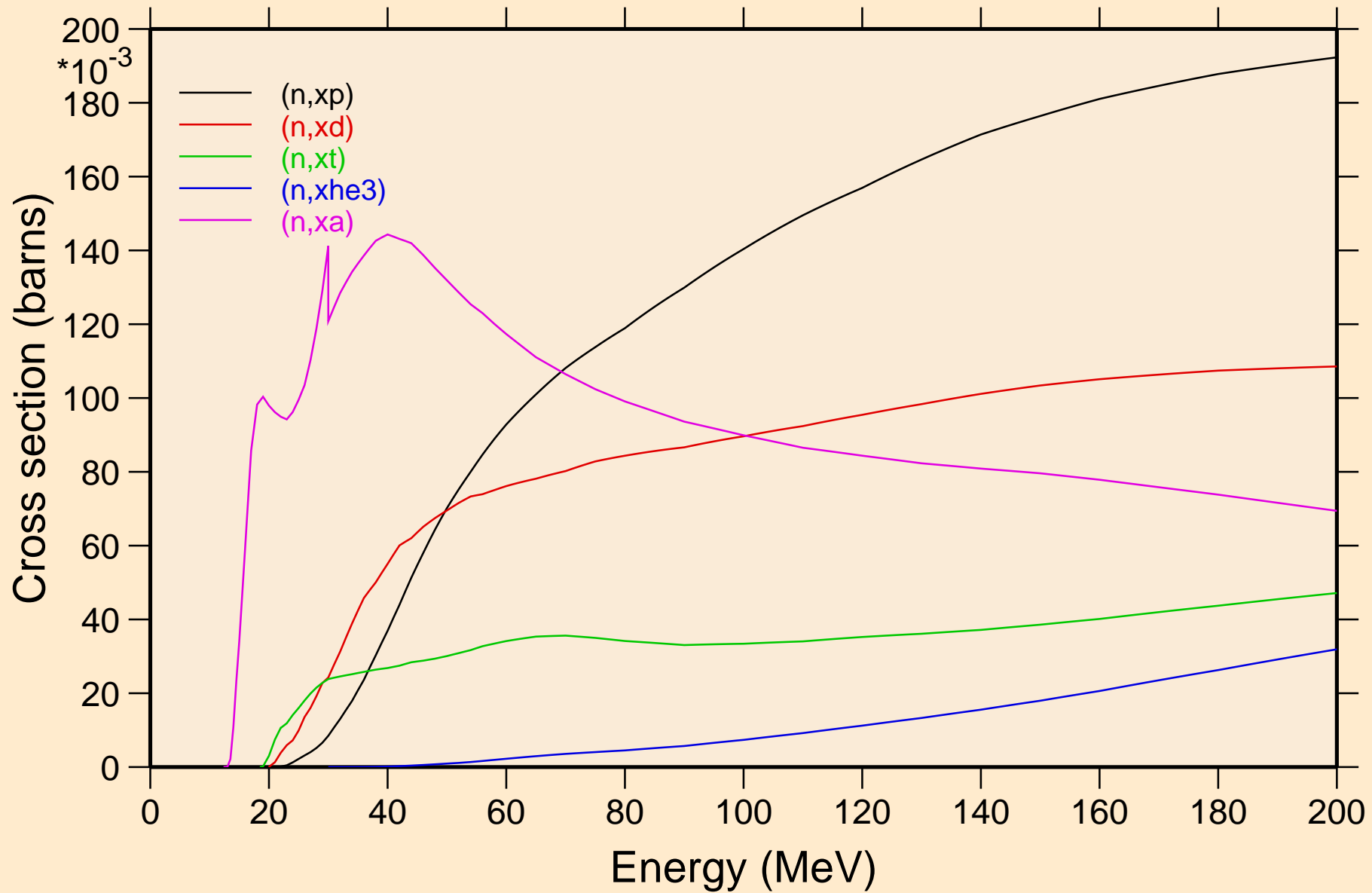

C014 NEUTRON ACER TENDL-2024 LIBRARY; T=0.K
angular distribution for elastic

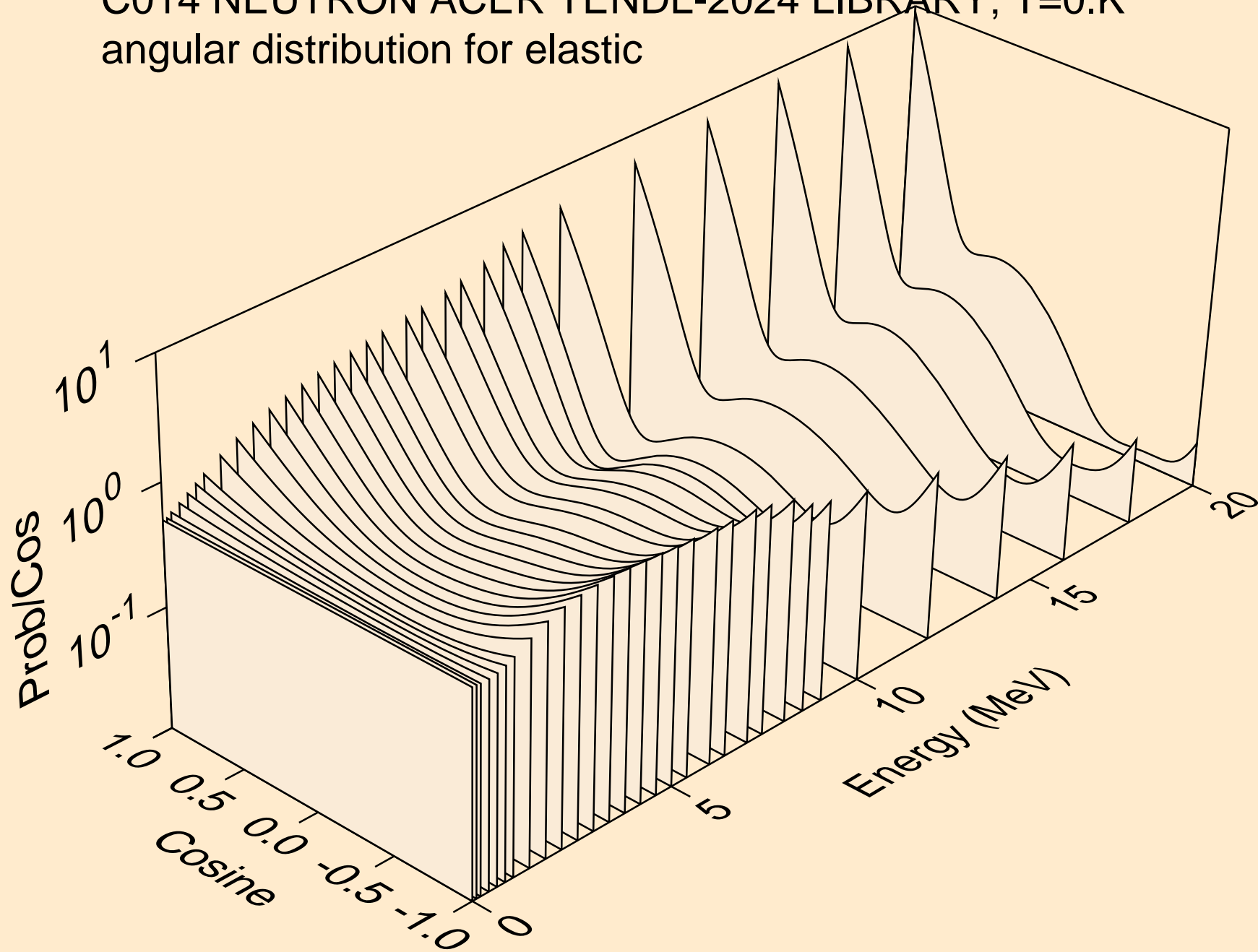

C014 NEUTRON ACER TENDL-2024 LIBRARY; T=0.K
angular distribution for elastic

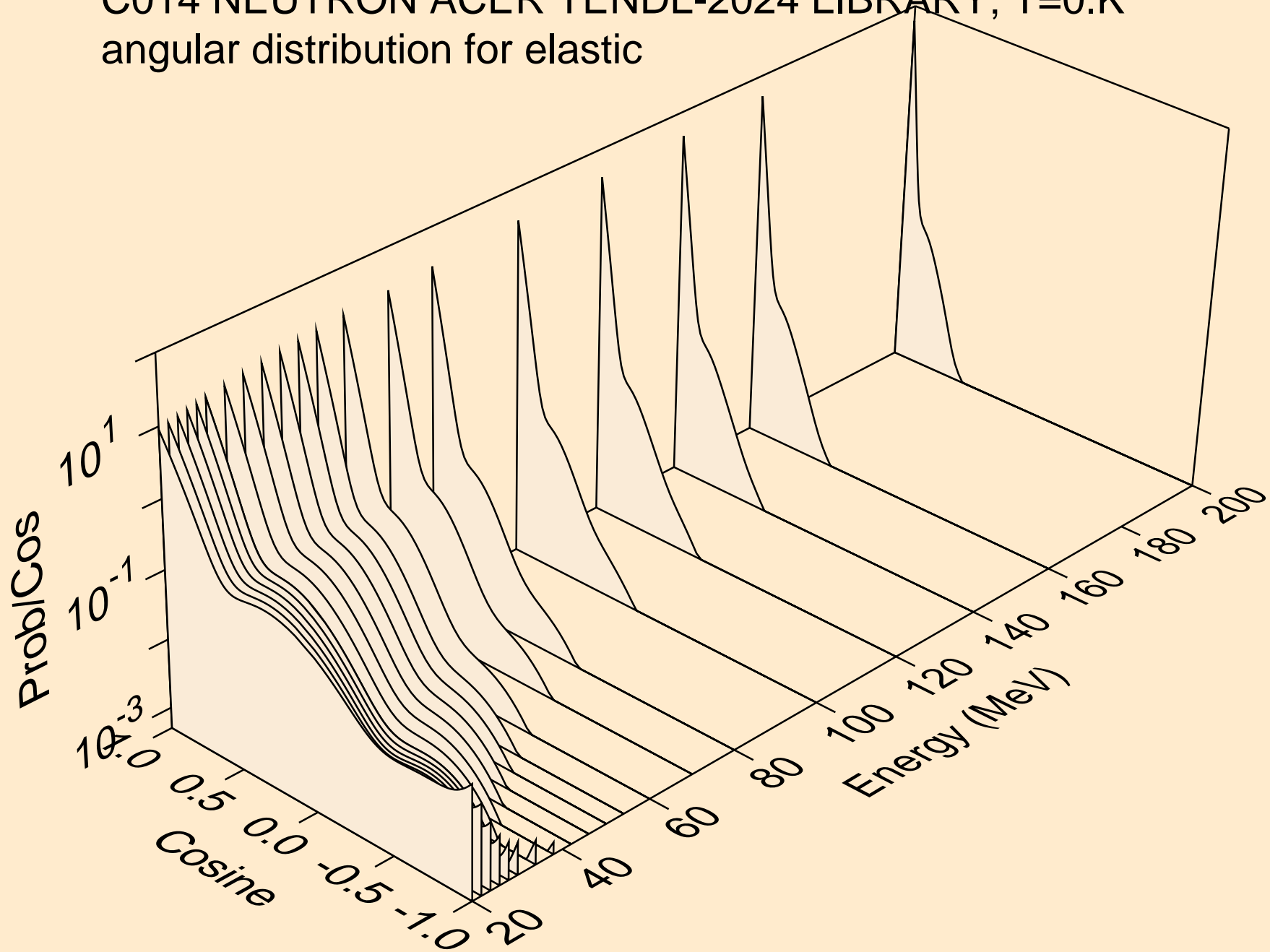

C014 NEUTRON ACER TENDL-2024 LIBRARY; T=0.K
angular distribution for (n,n*1)

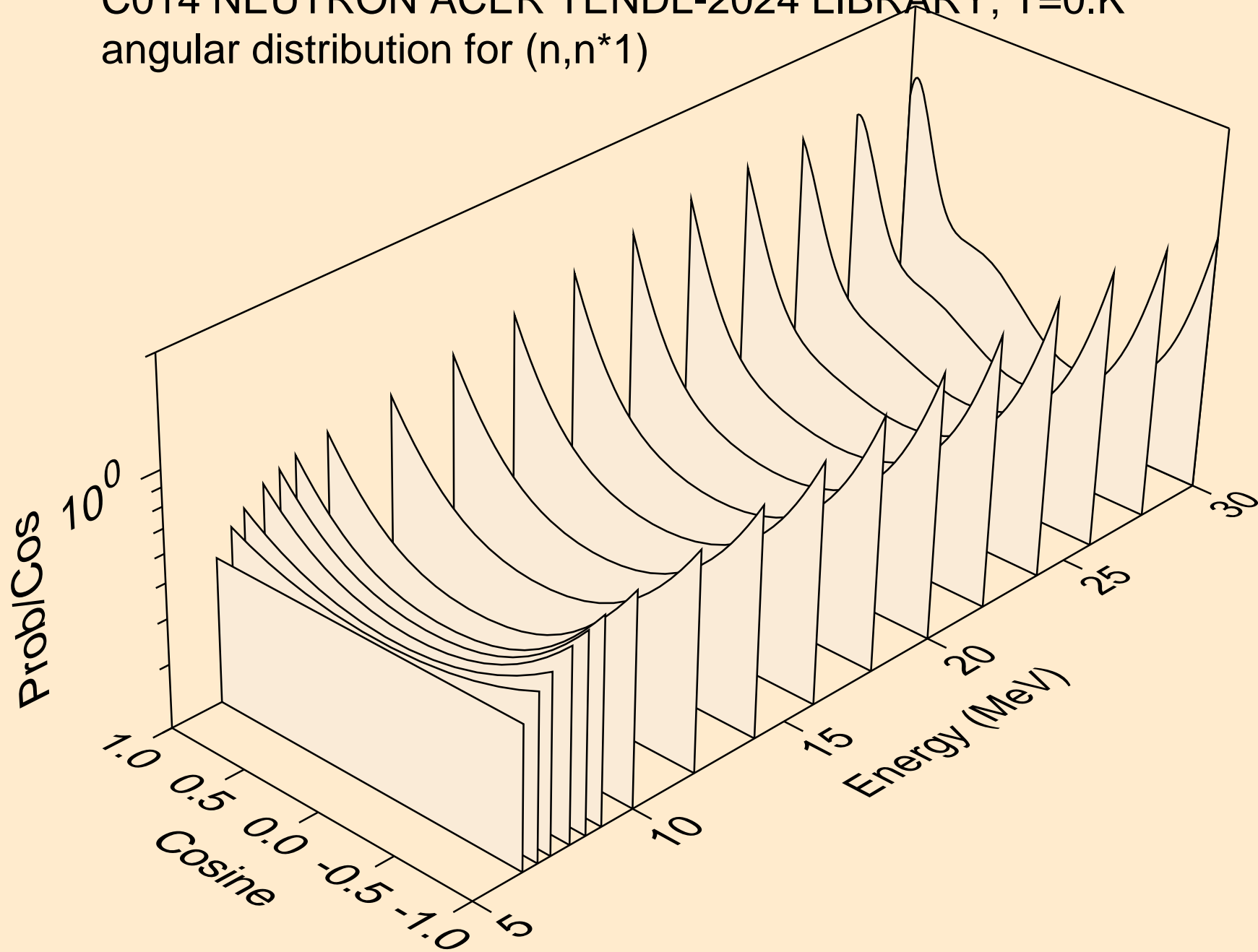

C014 NEUTRON ACER TENDL-2024 LIBRARY; T=0.K
angular distribution for (n,n*2)

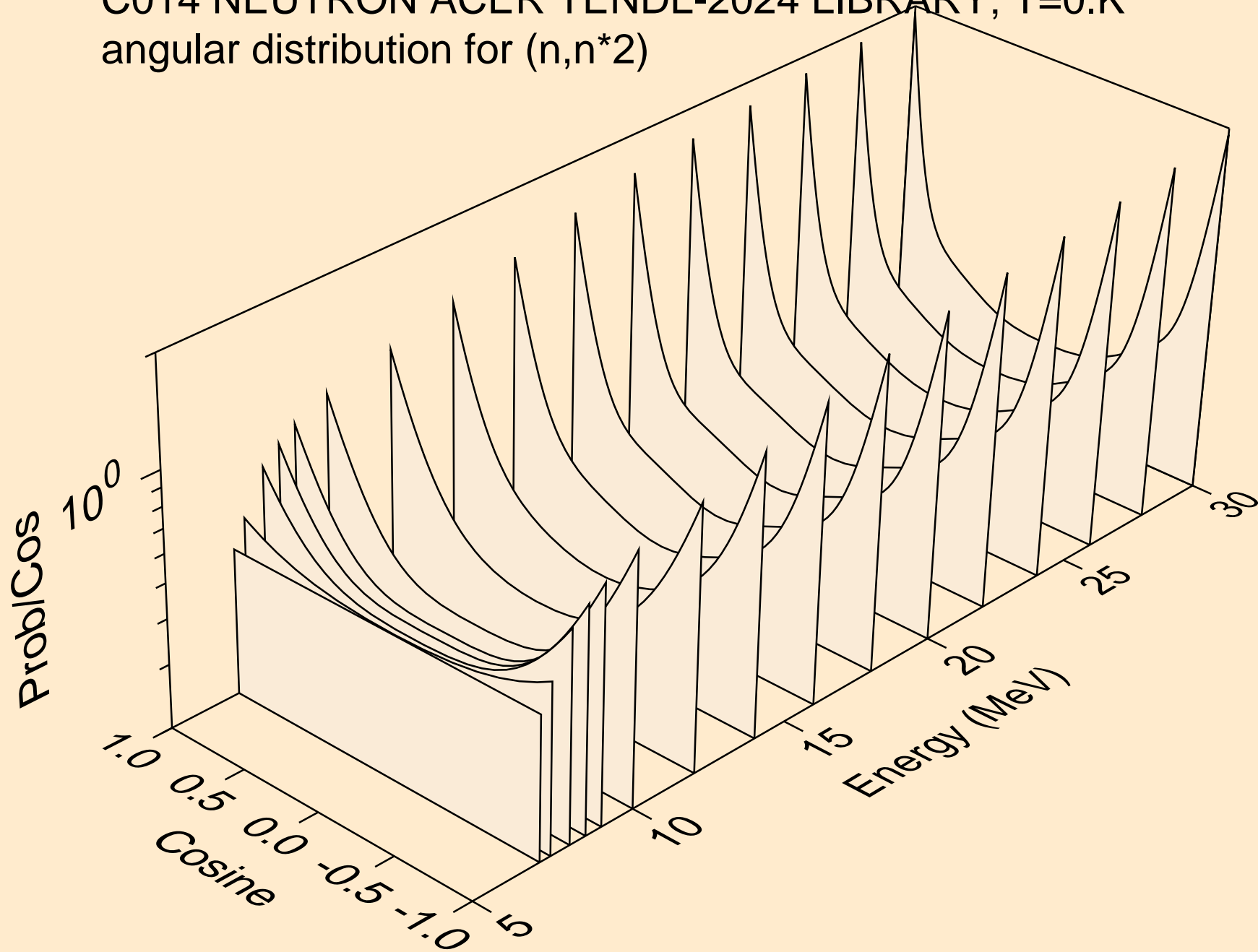

C014 NEUTRON ACER TENDL-2024 LIBRARY; T=0.K
angular distribution for (n,n*3)

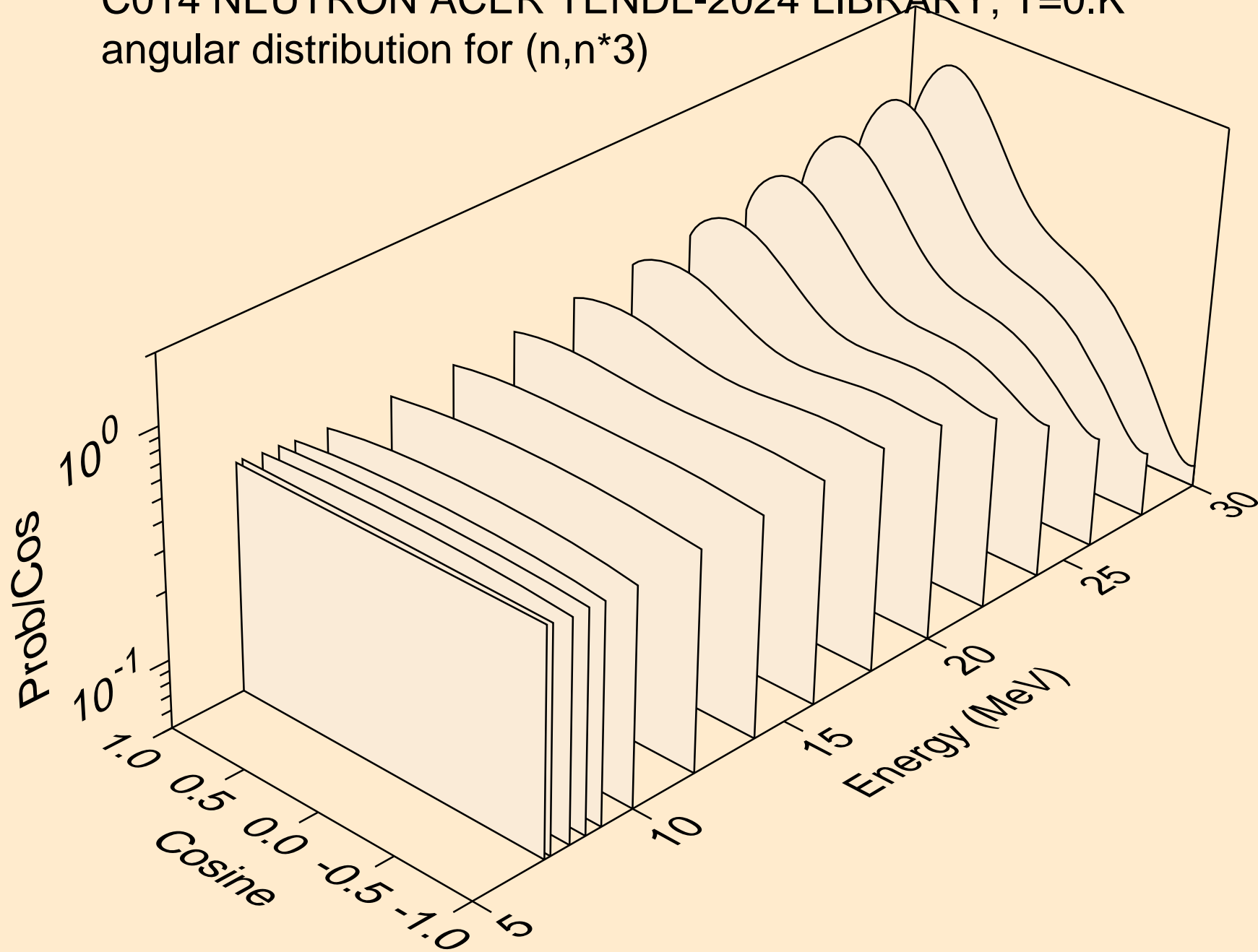

C014 NEUTRON ACER TENDL-2024 LIBRARY; T=0.K
angular distribution for (n,n*4)

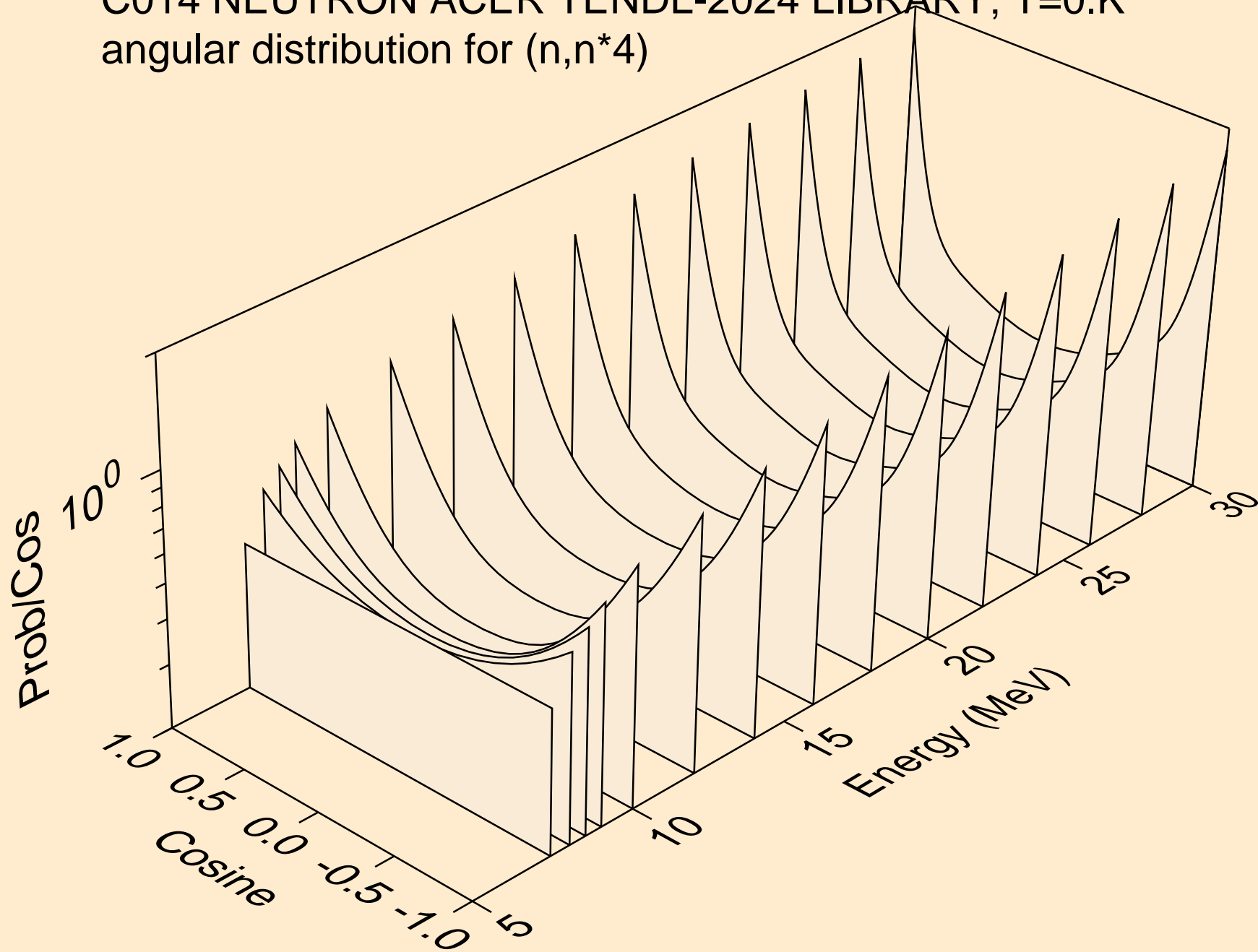

C014 NEUTRON ACER TENDL-2024 LIBRARY; T=0.K
angular distribution for (n,n*5)

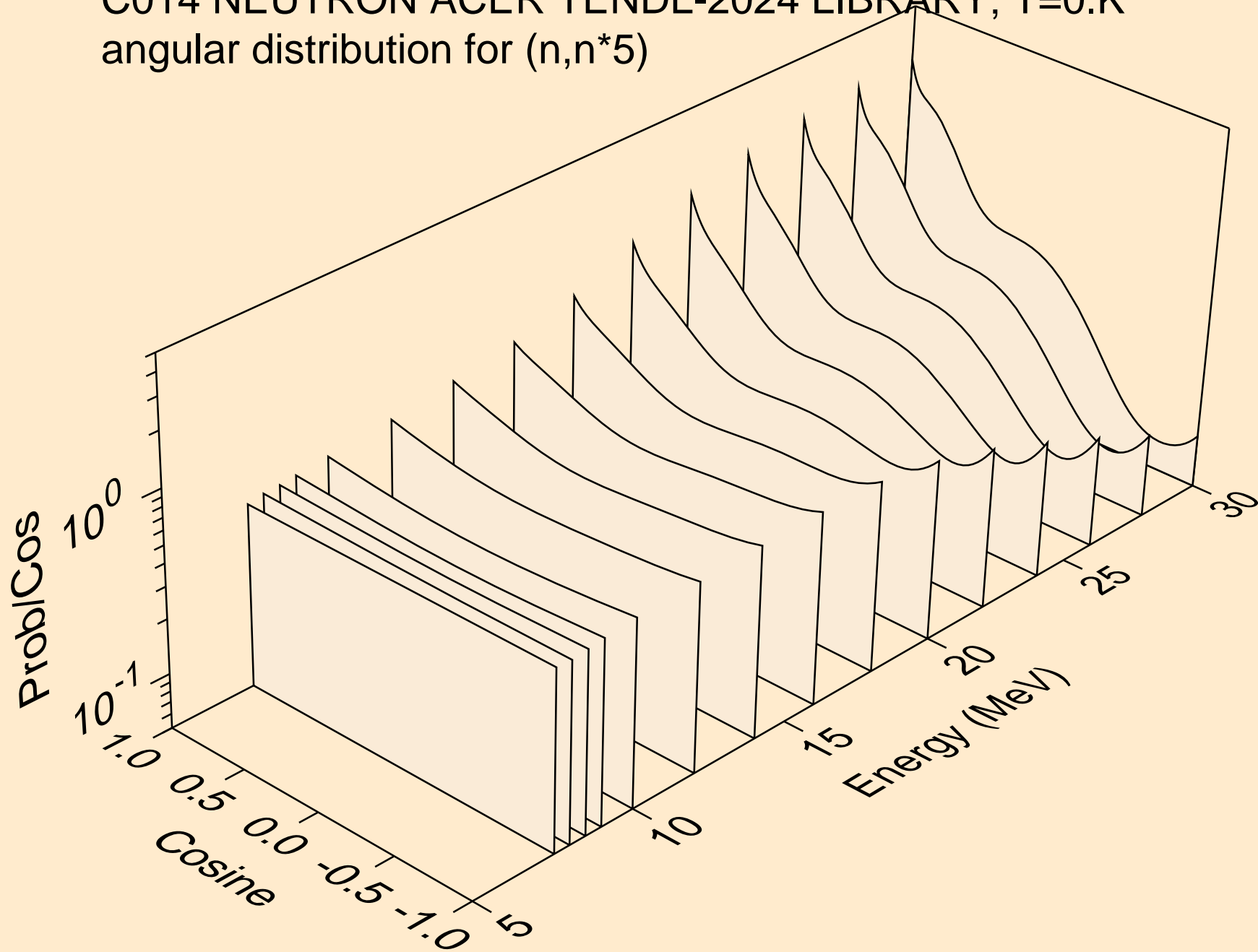

C014 NEUTRON ACER TENDL-2024 LIBRARY; T=0.K
angular distribution for (n,n*6)

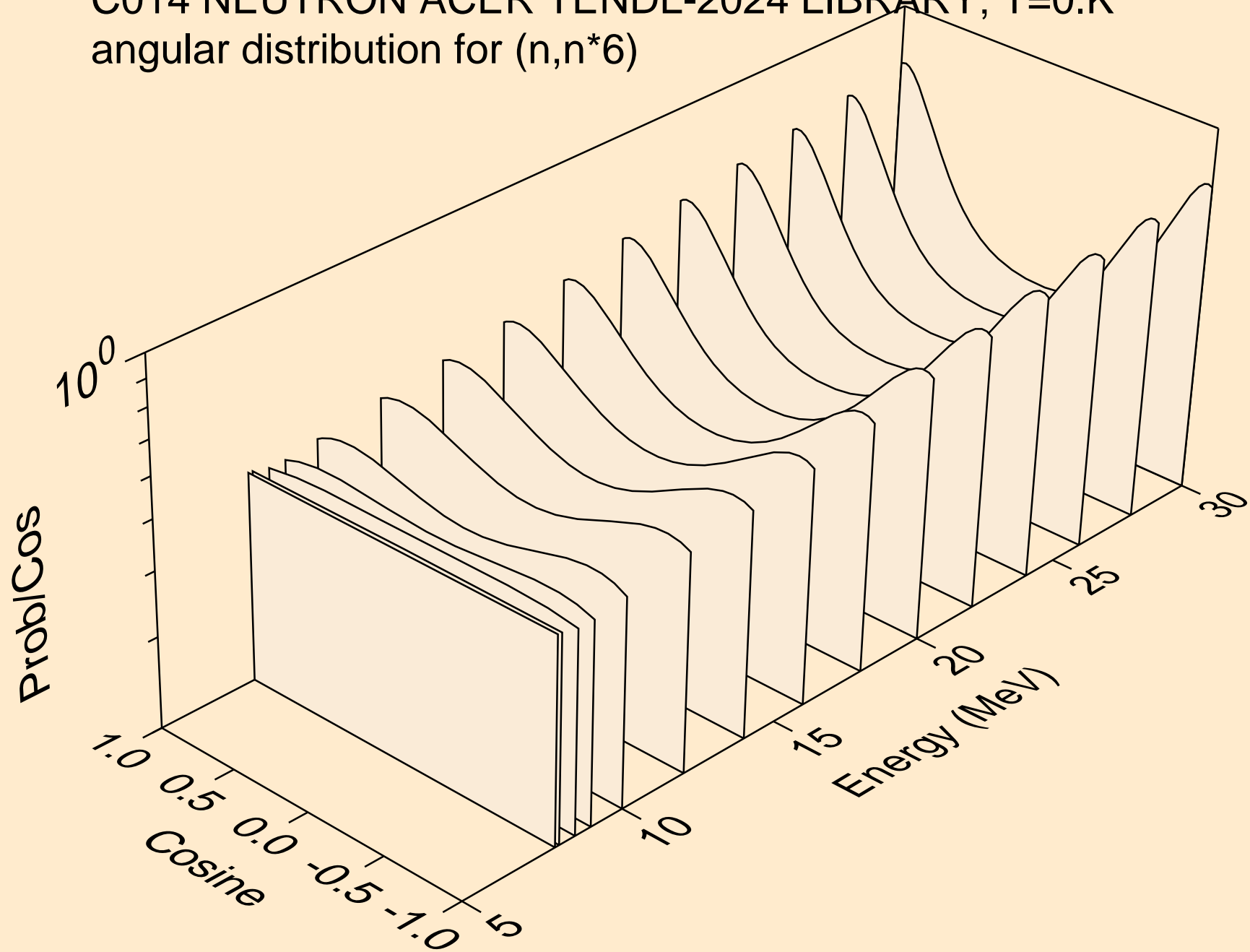

C014 NEUTRON ACER TENDL-2024 LIBRARY; T=0.K
angular distribution for (n,n*7)

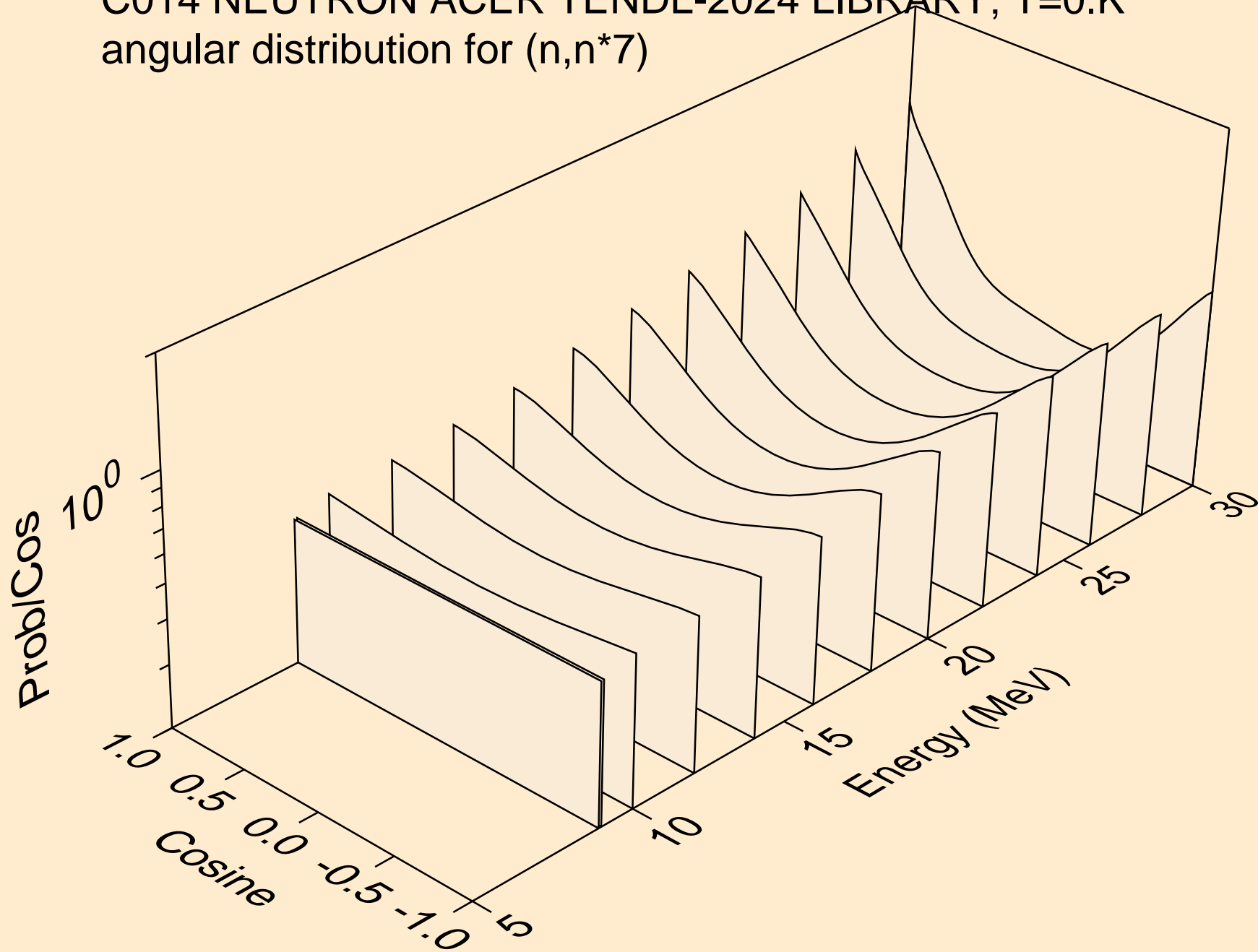

C014 NEUTRON ACER TENDL-2024 LIBRARY; T=0.K
angular distribution for (n,n*8)

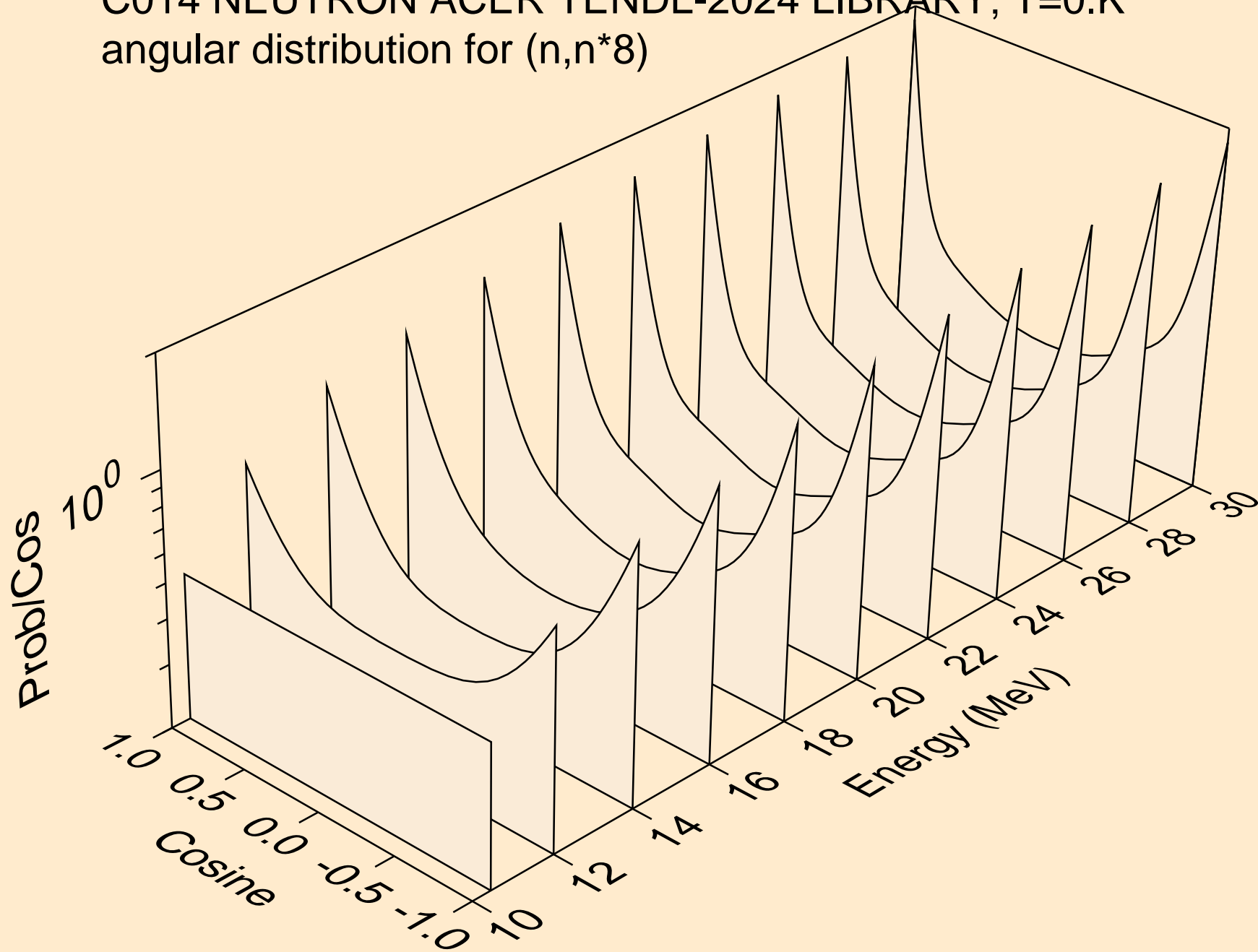

C014 NEUTRON ACER TENDL-2024 LIBRARY; T=0.K
angular distribution for (n,n*9)

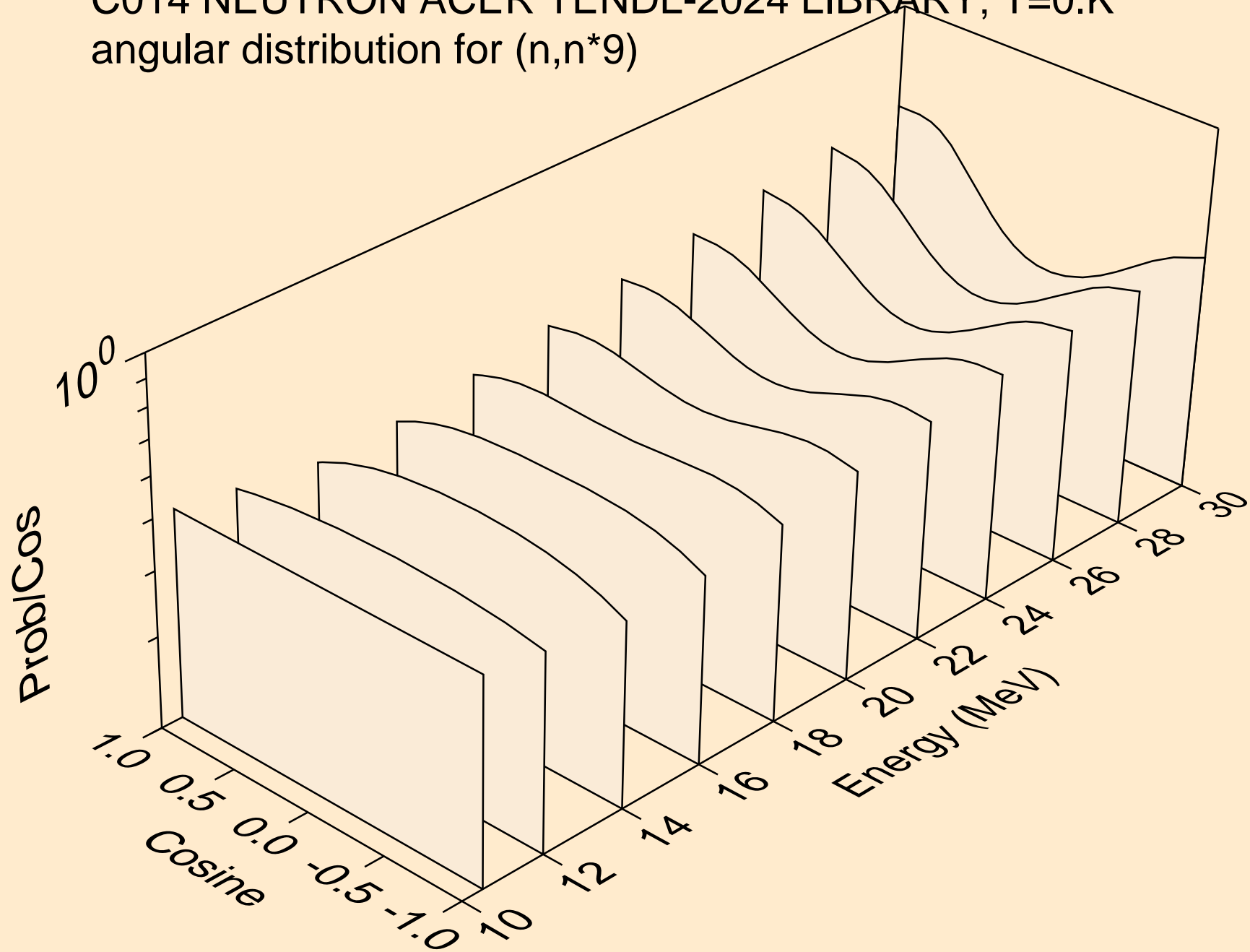

C014 NEUTRON ACER TENDL-2024 LIBRARY; T=0.K
angular distribution for (n,n*10)

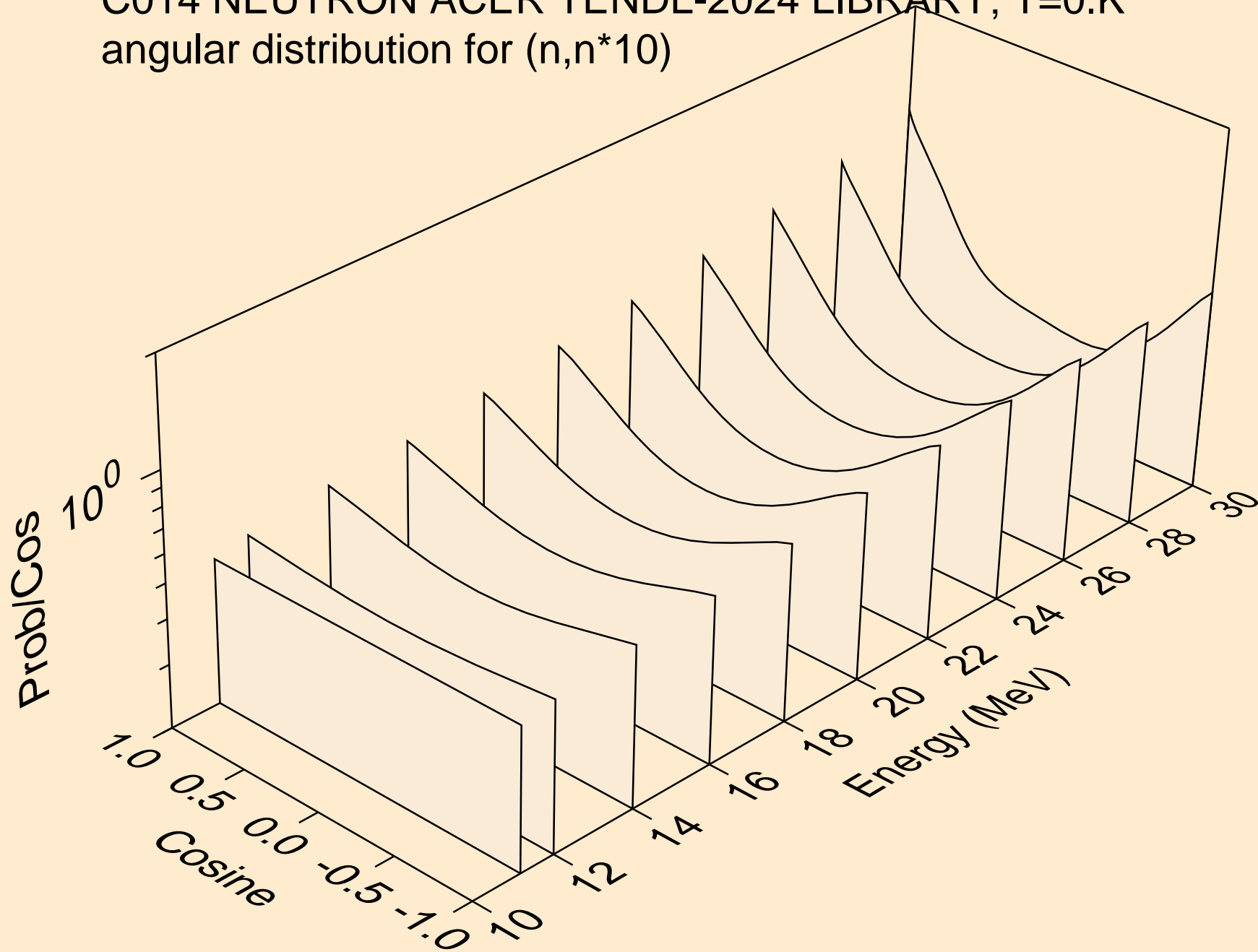

C014 NEUTRON ACER TENDL-2024 LIBRARY; T=0.K
angular distribution for (n,n*11)

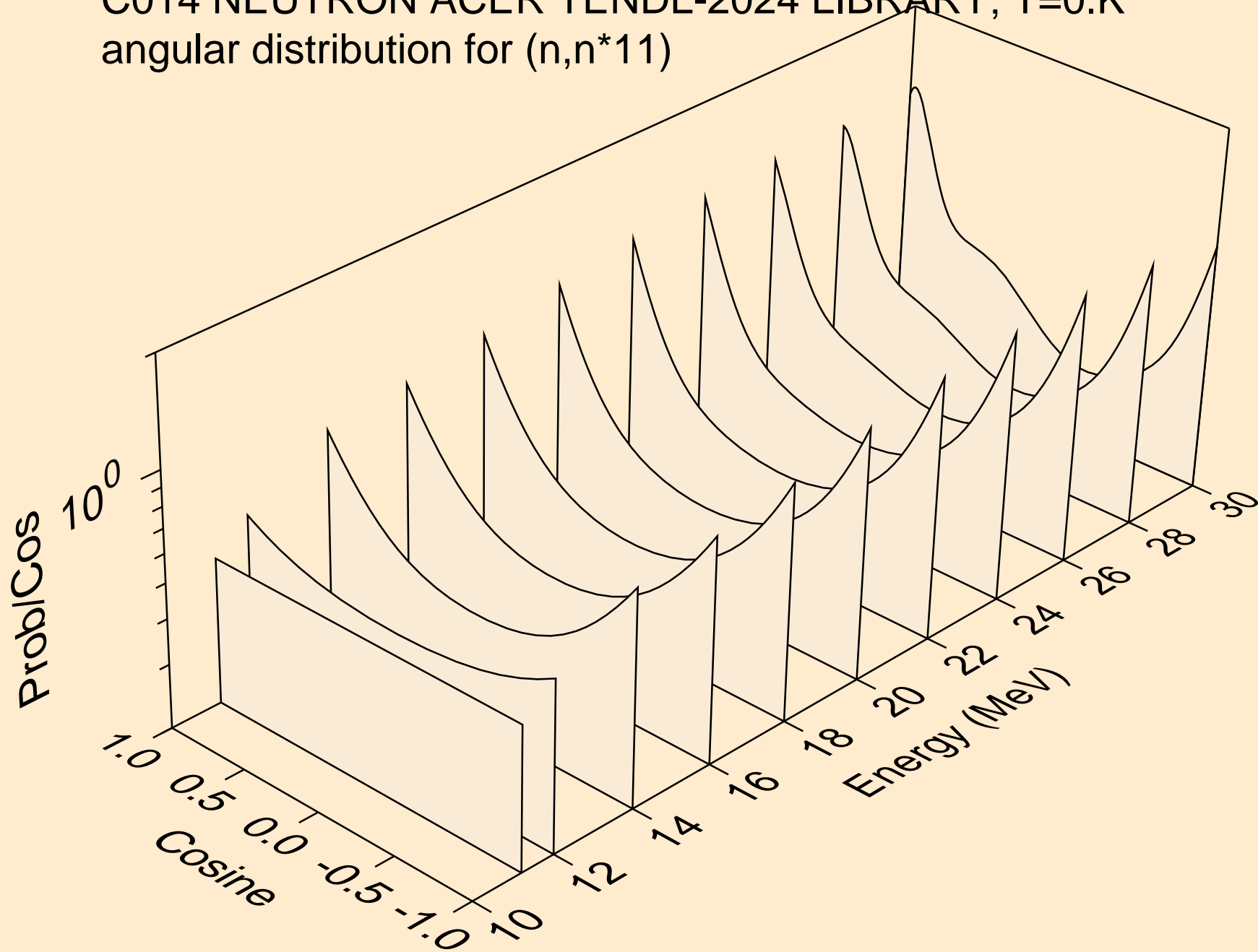

C014 NEUTRON ACER TENDL-2024 LIBRARY; T=0.K
angular distribution for (n,n*12)

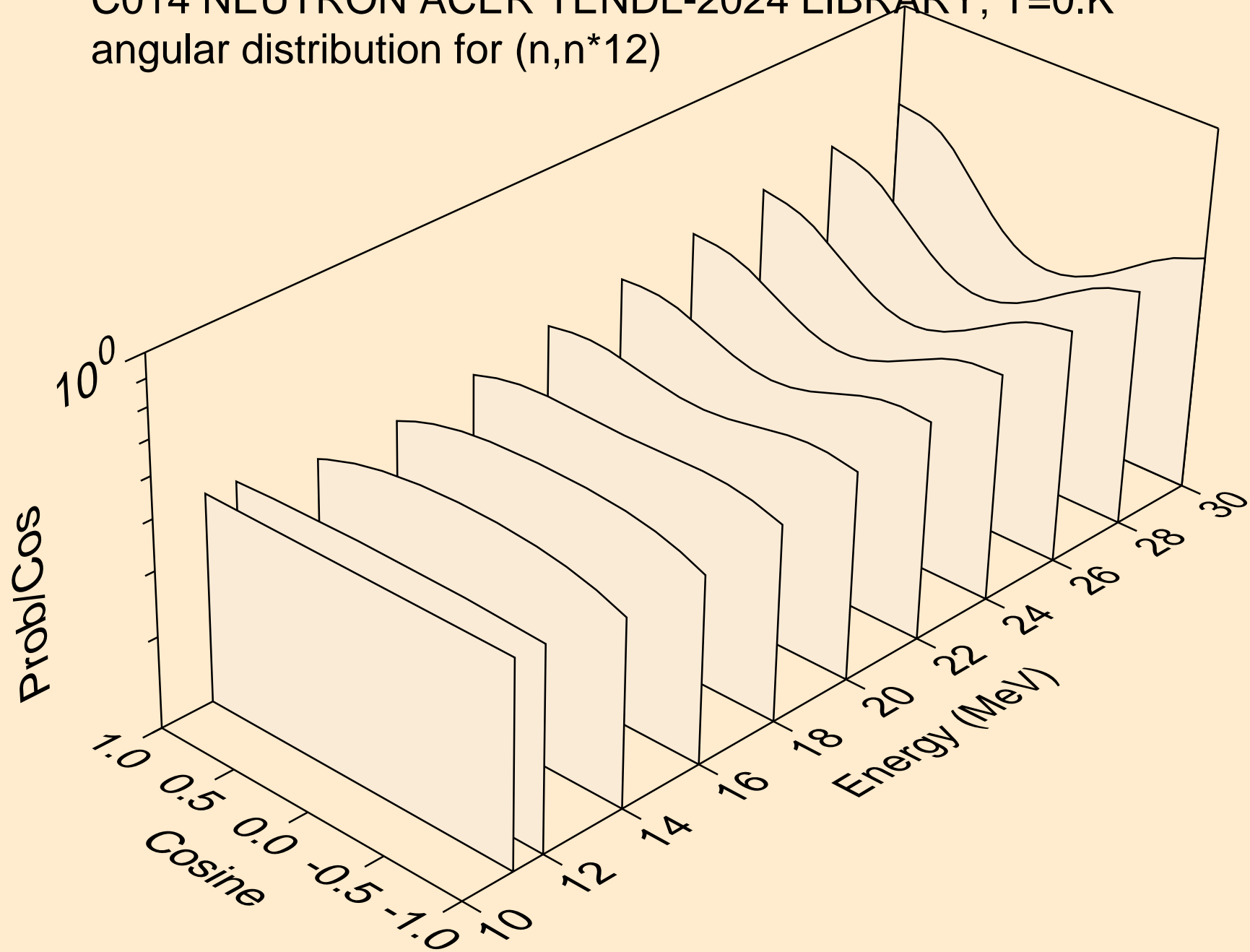

C014 NEUTRON ACER TENDL-2024 LIBRARY; T=0.K
angular distribution for (n,n*13)

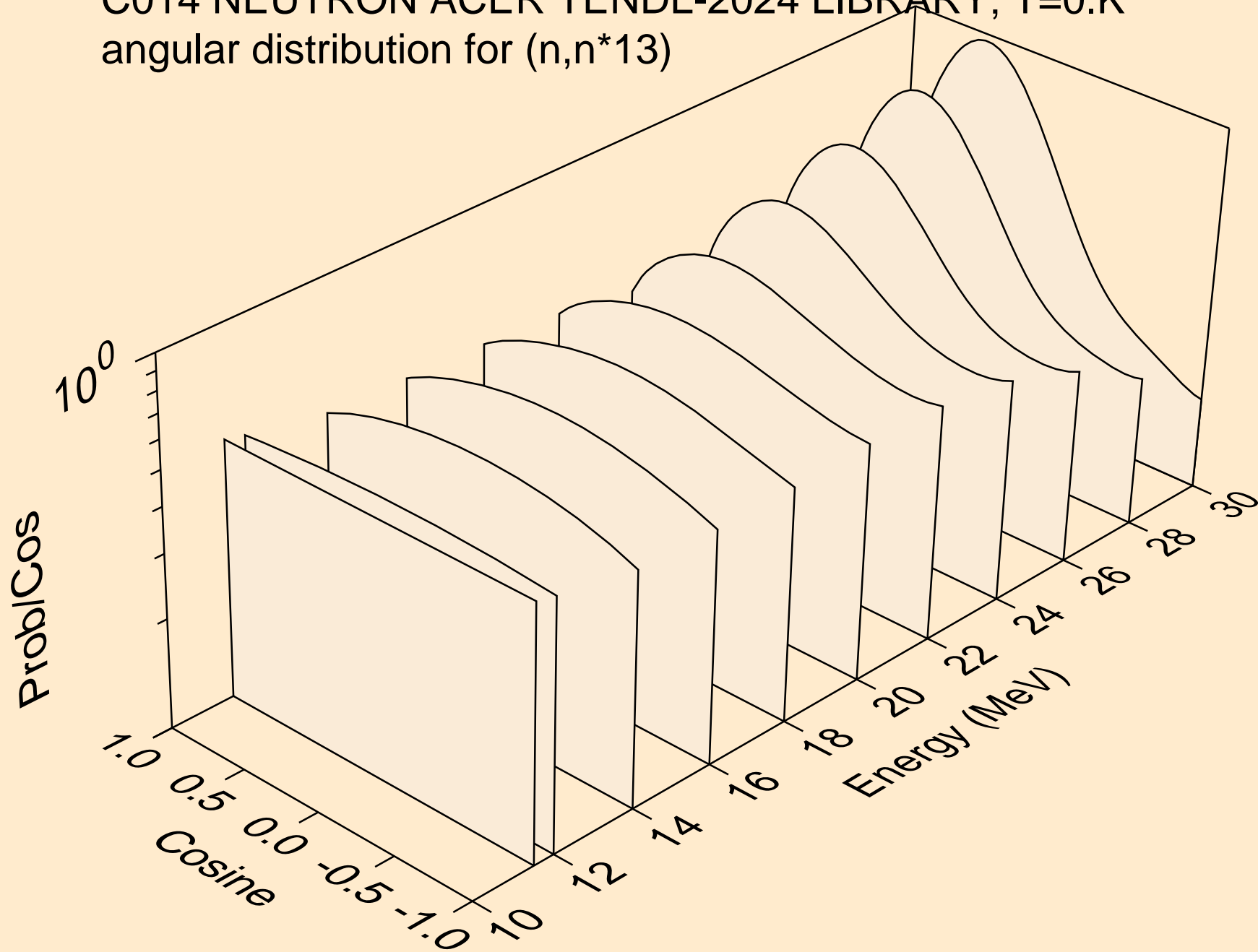

C014 NEUTRON ACER TENDL-2024 LIBRARY; T=0.K
angular distribution for (n,n*14)

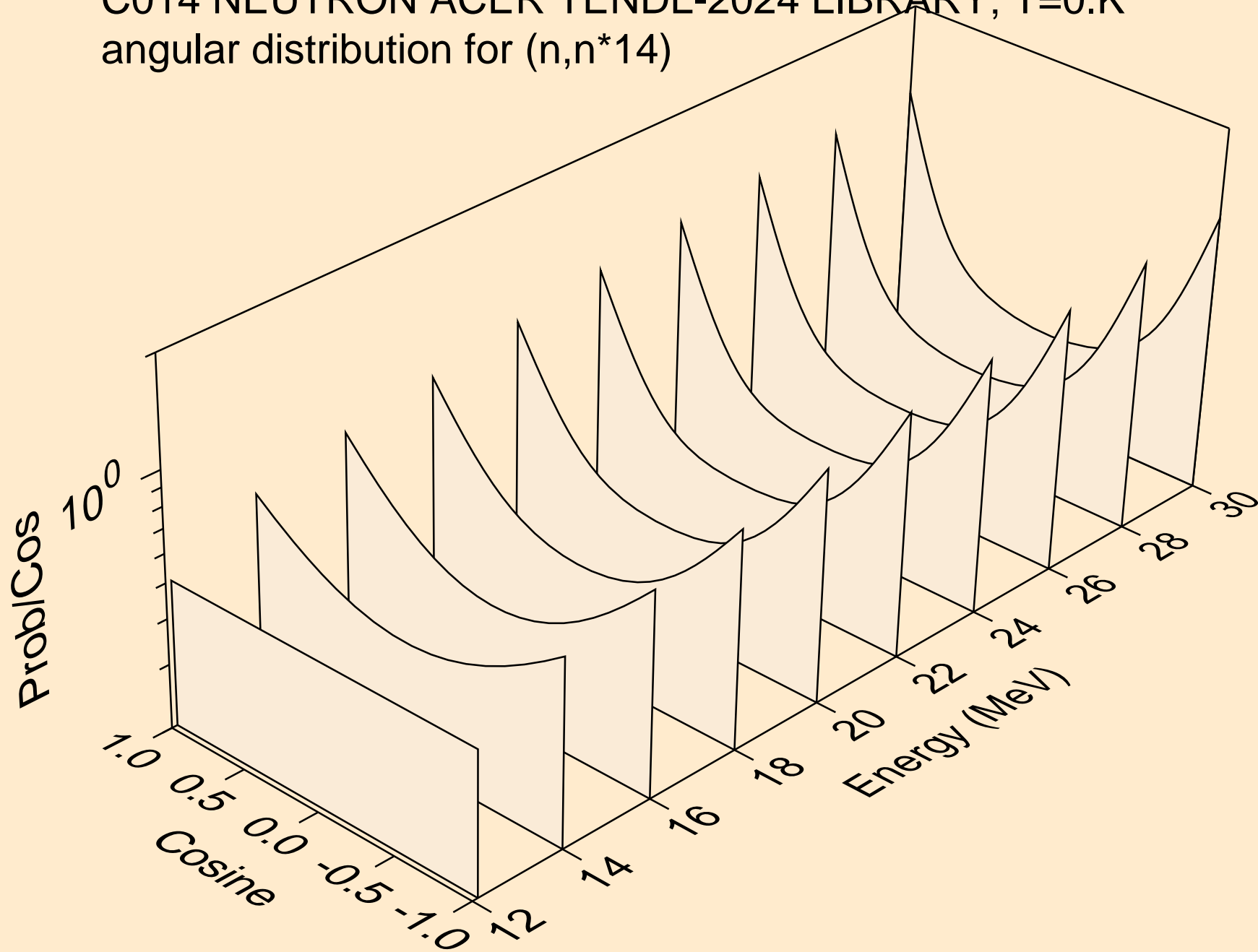

C014 NEUTRON ACER TENDL-2024 LIBRARY; T=0.K
angular distribution for (n,n*15)

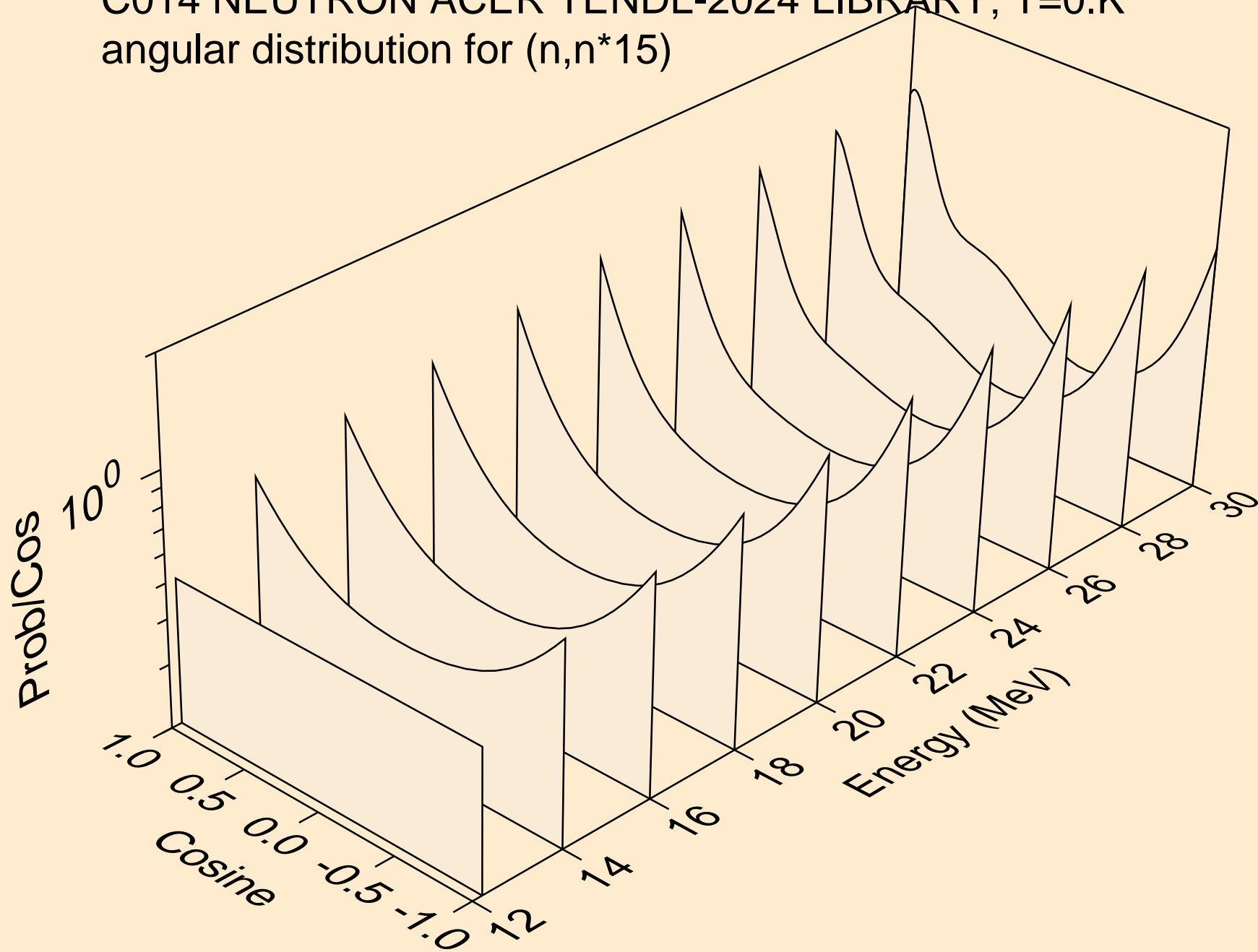

C014 NEUTRON ACER TENDL-2024 LIBRARY; T=0.K
angular distribution for (n,n*16)

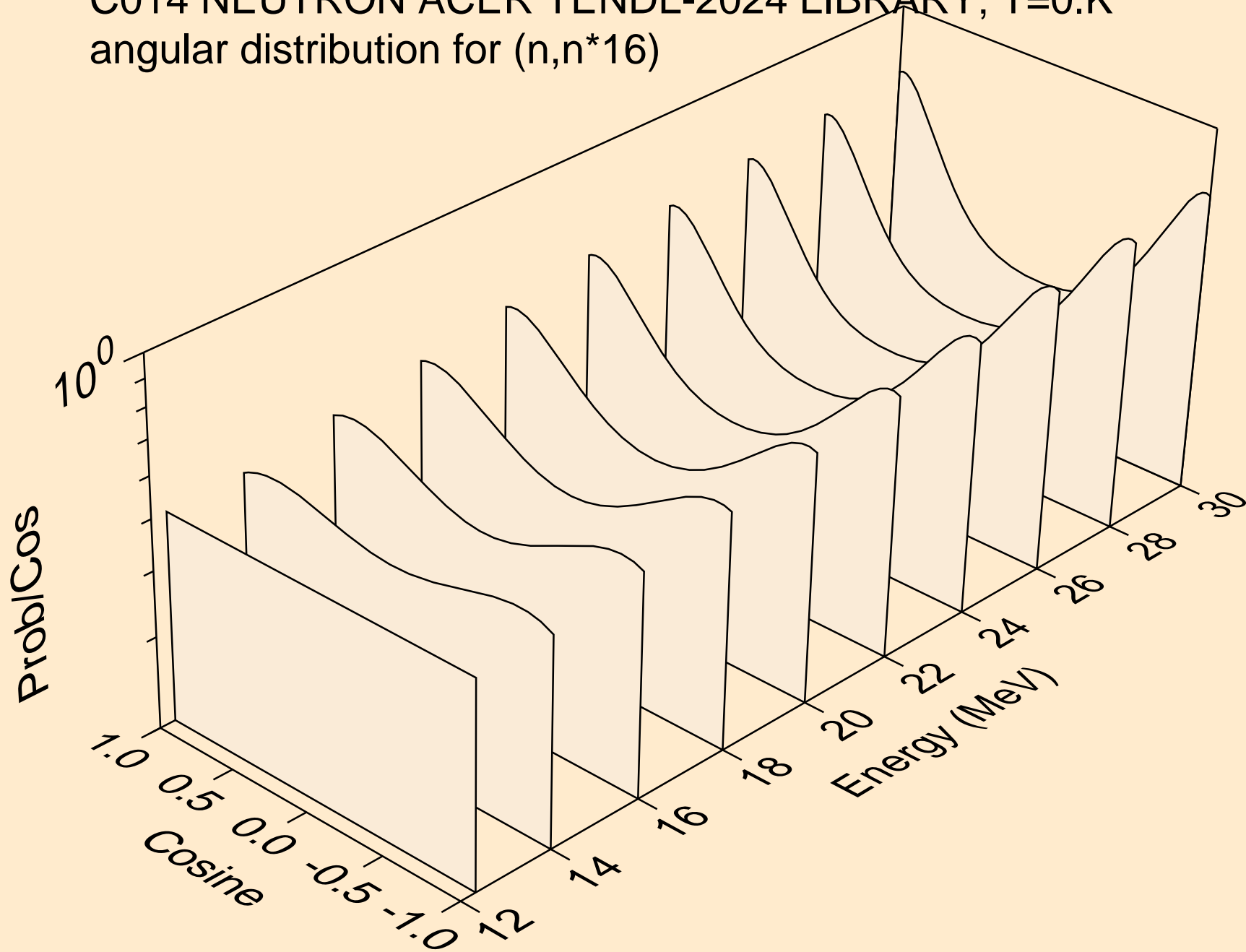

C014 NEUTRON ACER TENDL-2024 LIBRARY; T=0.K
angular distribution for (n,n*17)

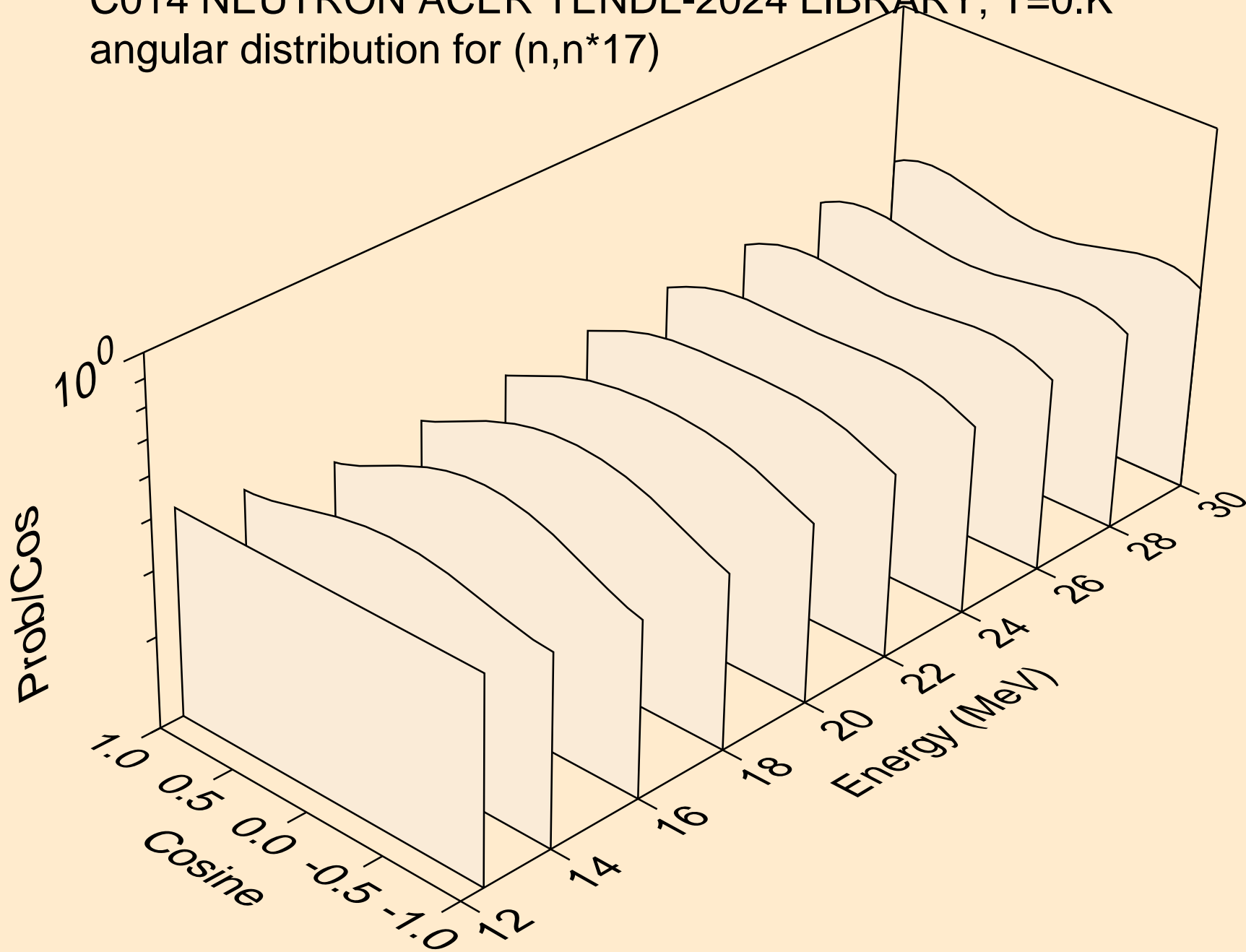

C014 NEUTRON ACER TENDL-2024 LIBRARY; T=0.K
angular distribution for (n,n*18)

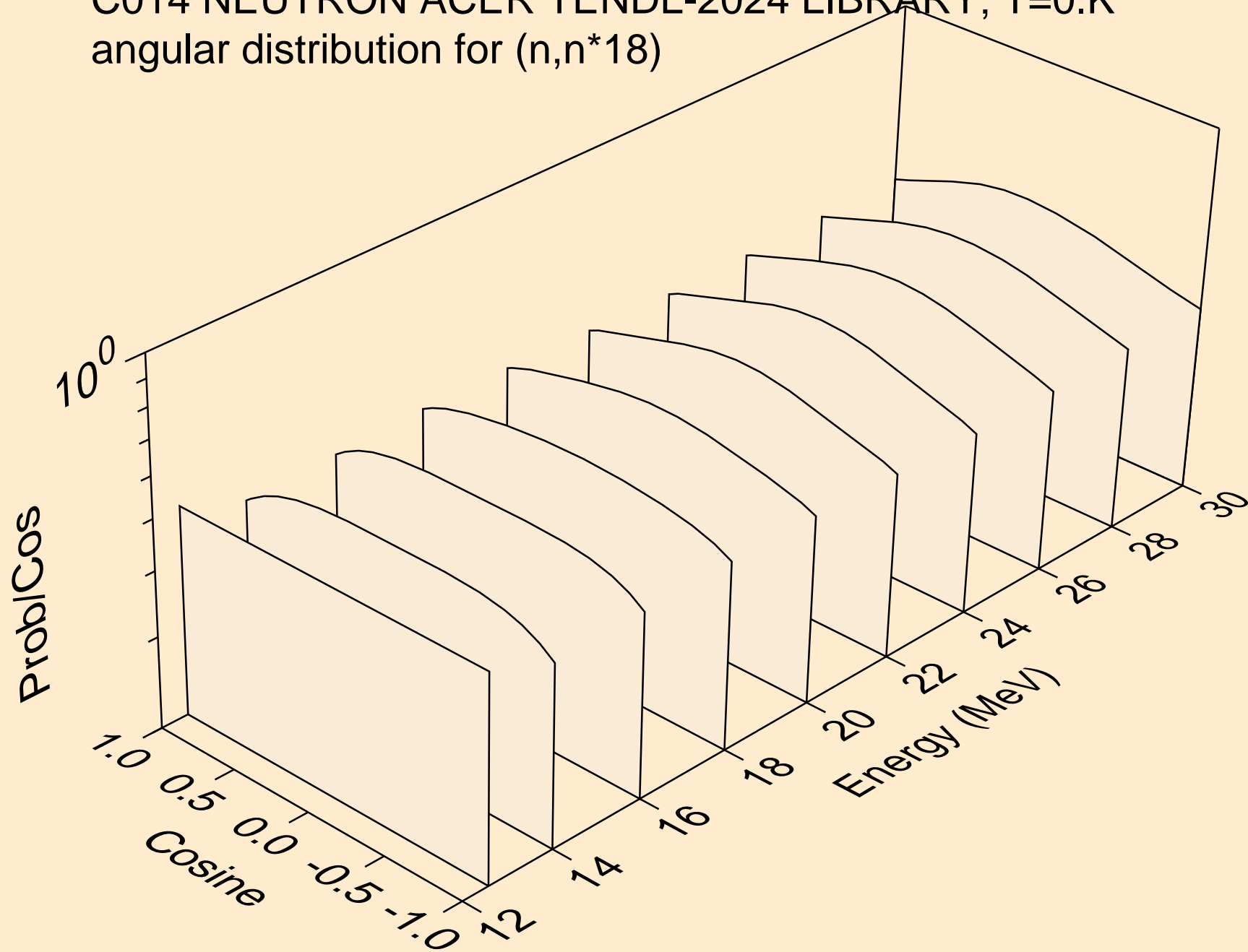

C014 NEUTRON ACER TENDL-2024 LIBRARY; T=0.K
angular distribution for (n,n*19)

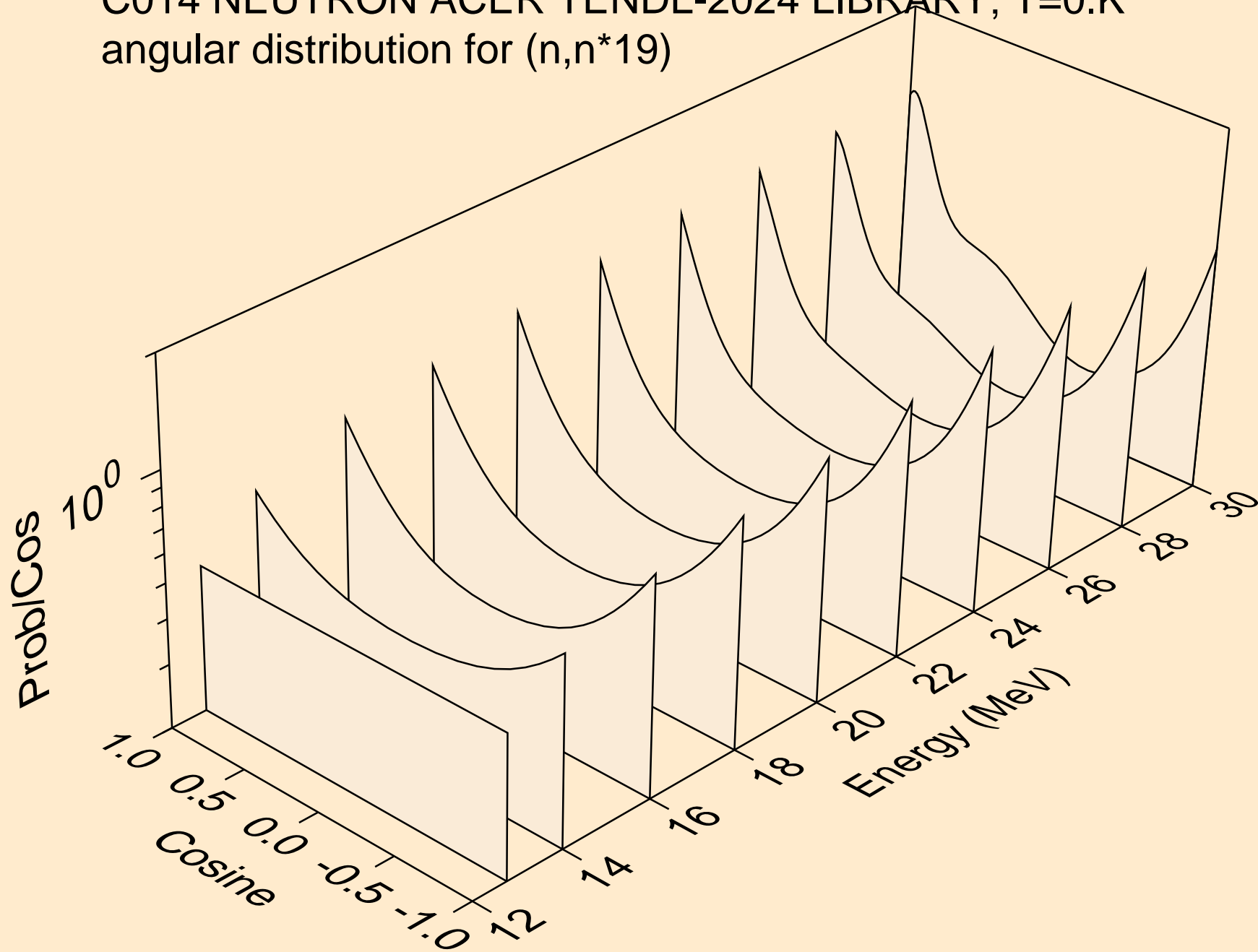

C014 NEUTRON ACER TENDL-2024 LIBRARY; T=0.K
angular distribution for (n,n*20)

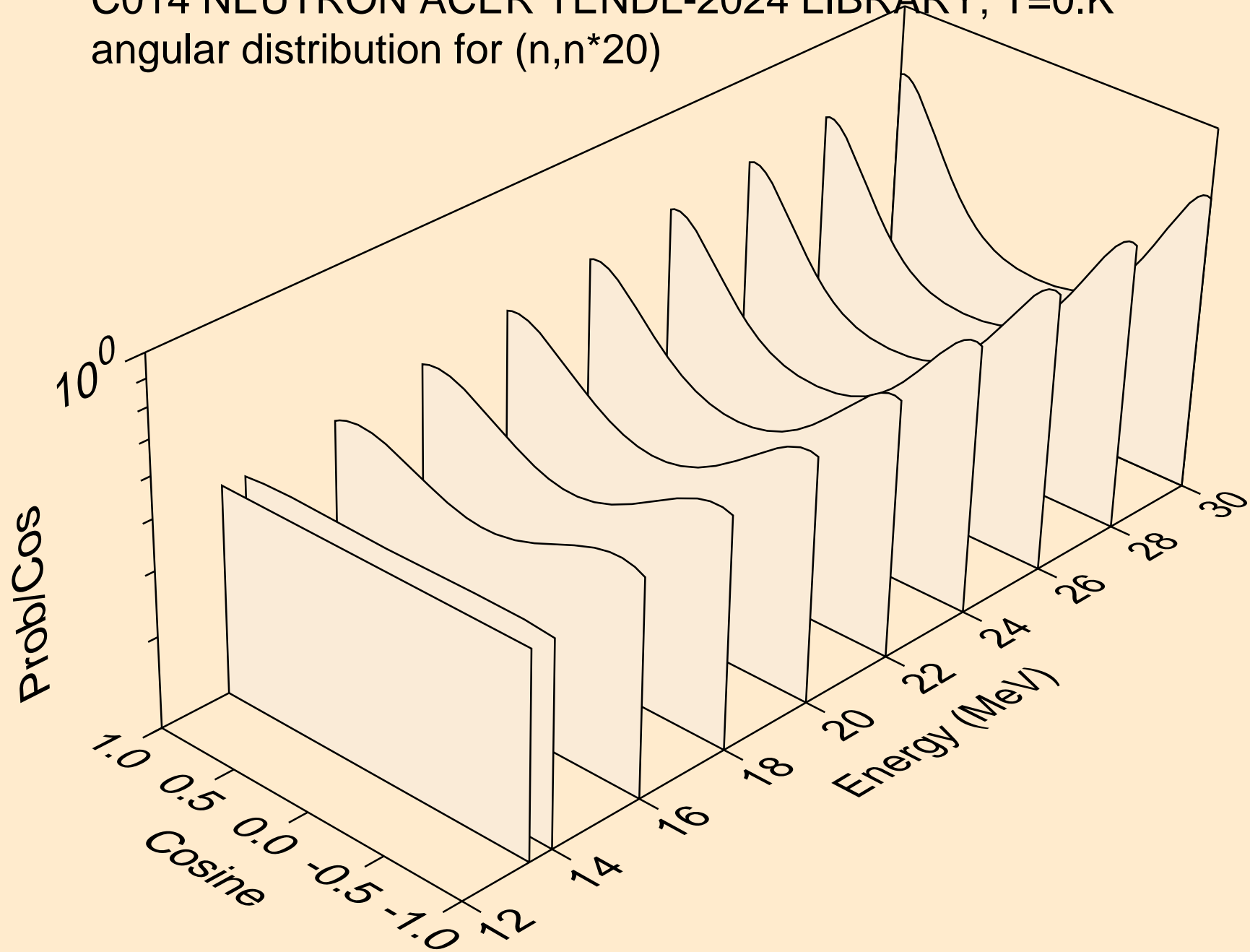

C014 NEUTRON ACER TENDL-2024 LIBRARY; T=0.K
angular distribution for (n,n*21)

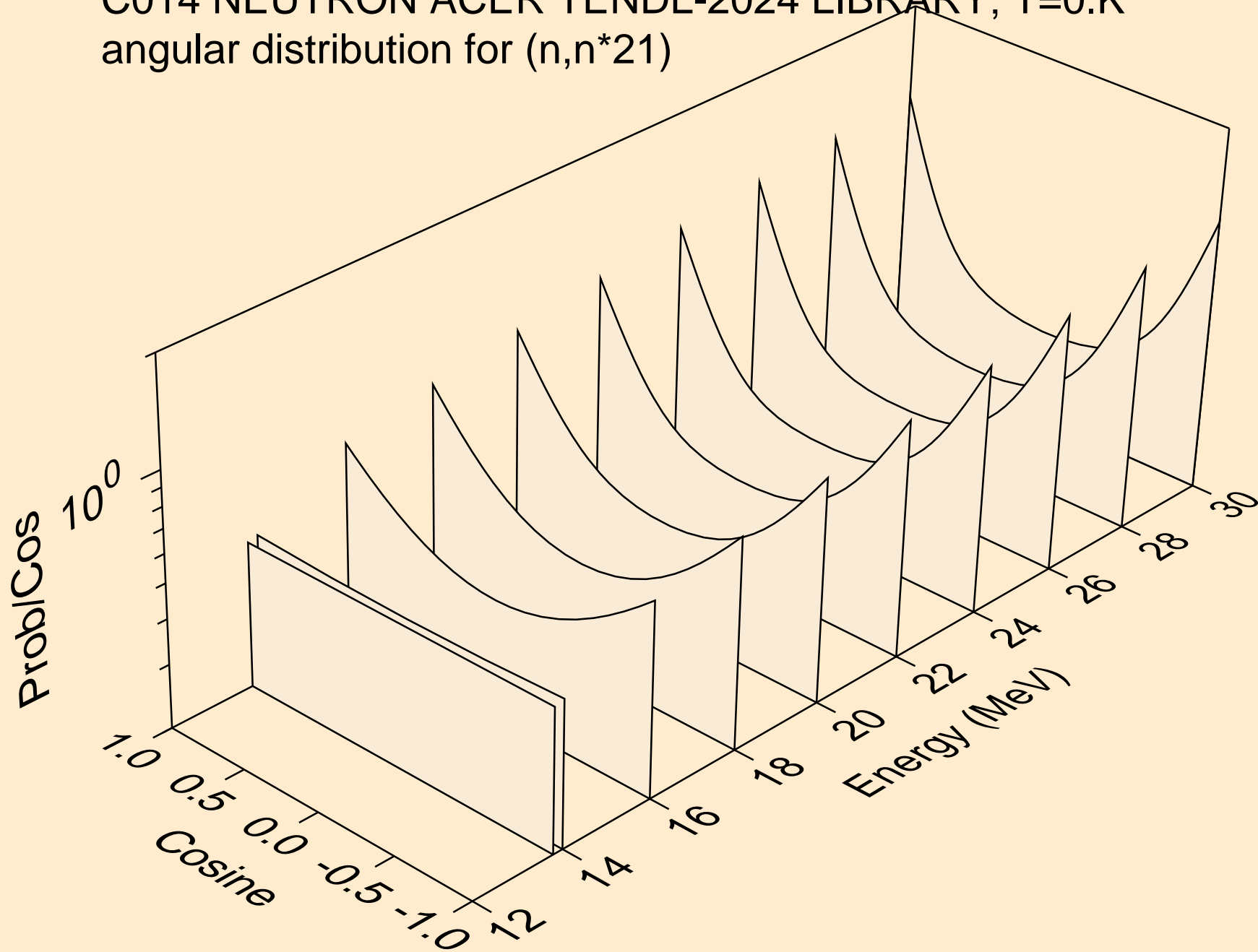

C014 NEUTRON ACER TENDL-2024 LIBRARY; T=0.K
angular distribution for (n,n*22)

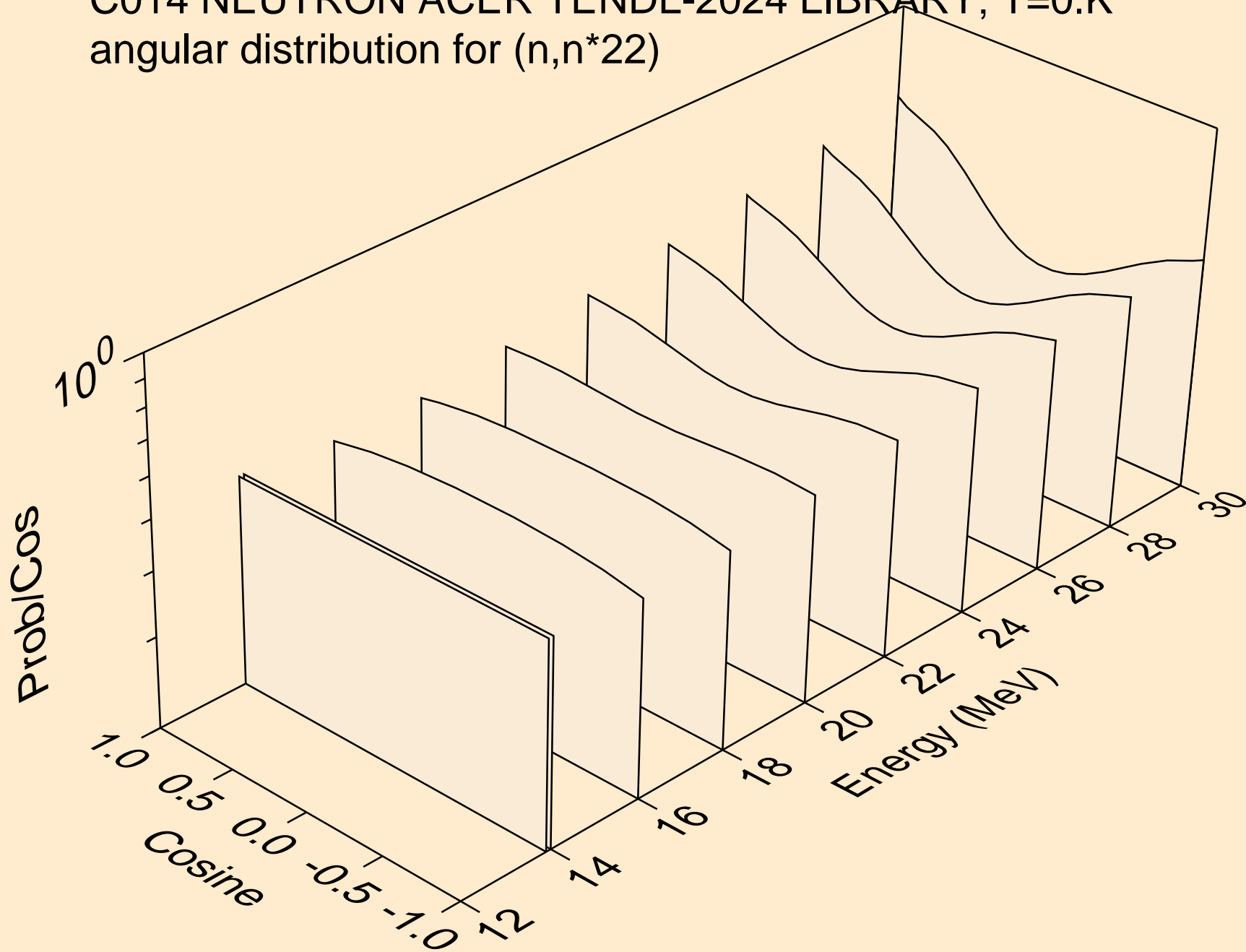

C014 NEUTRON ACER TENDL-2024 LIBRARY; T=0.K
angular distribution for (n,n*23)

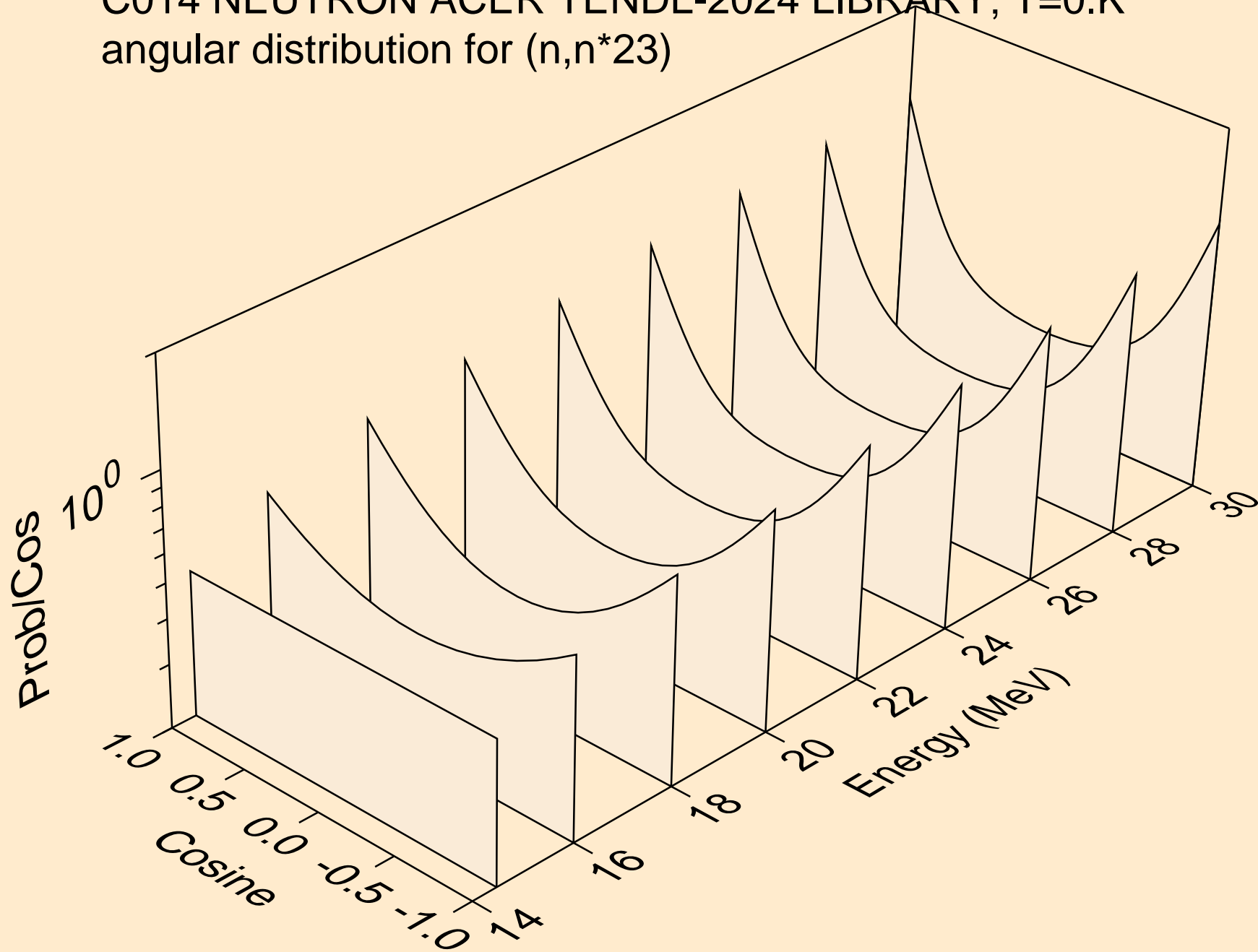

C014 NEUTRON ACER TENDL-2024 LIBRARY; T=0.K
angular distribution for (n,n*24)

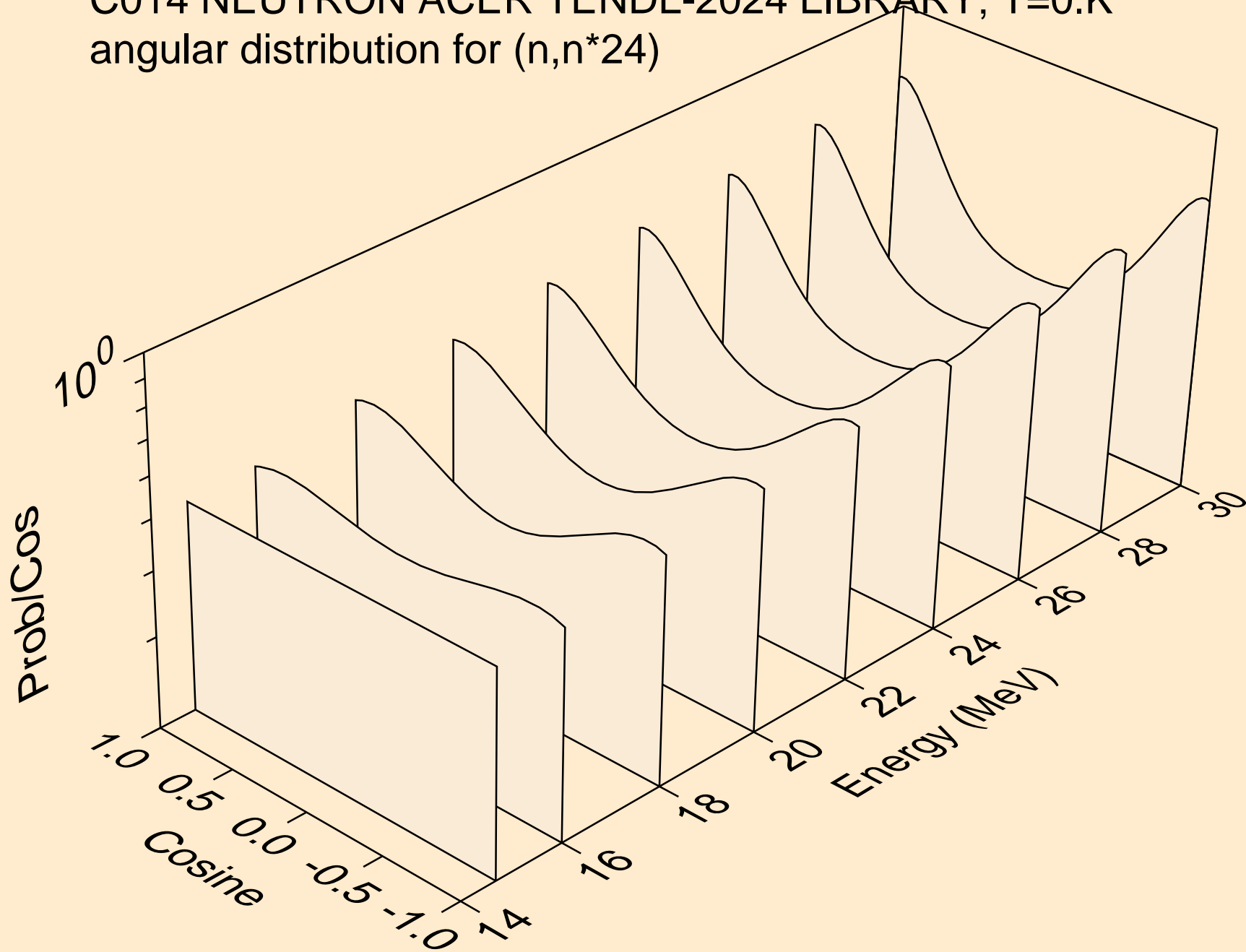

C014 NEUTRON ACER TENDL-2024 LIBRARY; T=0.K
Neutron emission for (n,x)

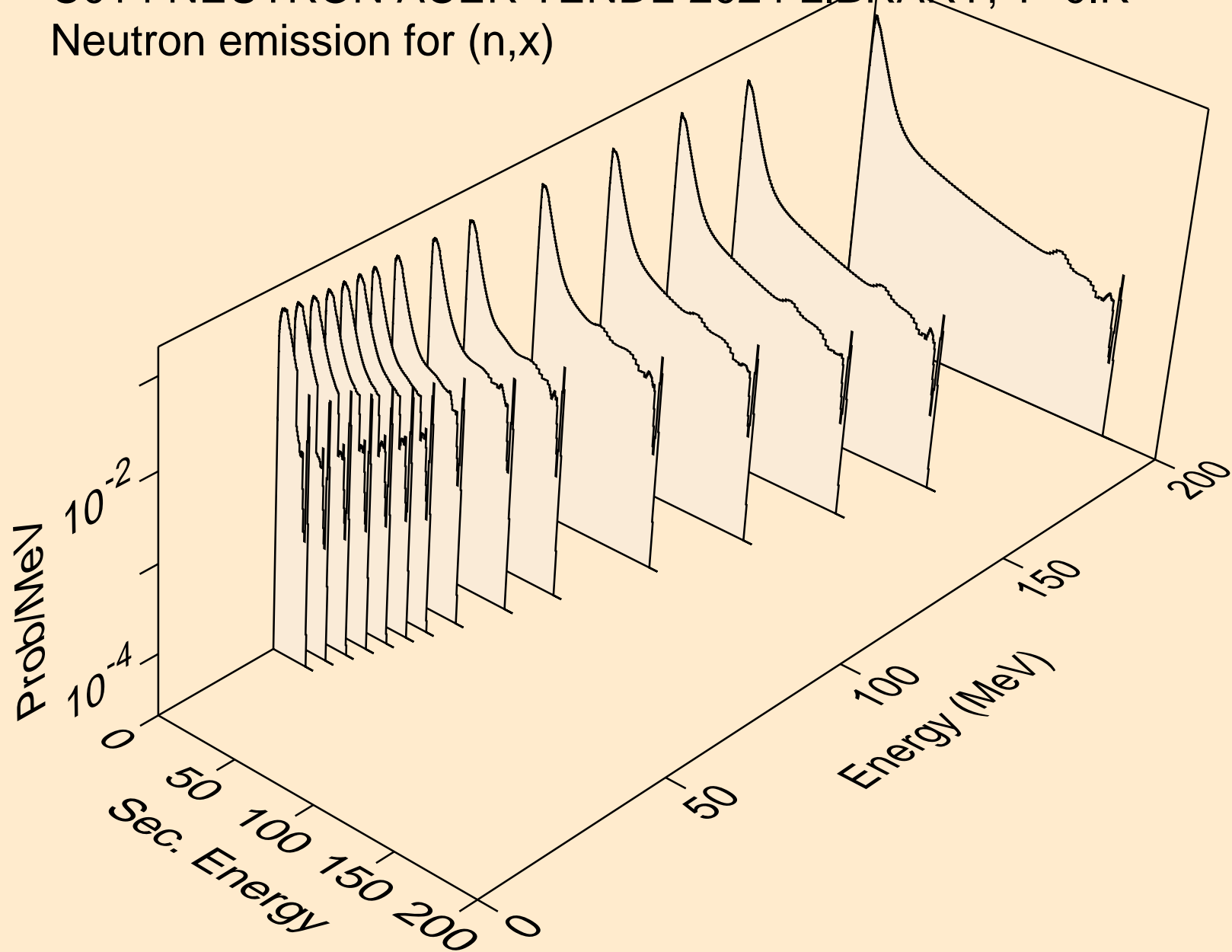

C014 NEUTRON ACER TENDL-2024 LIBRARY; T=0.K
Neutron emission for (n,2nd)

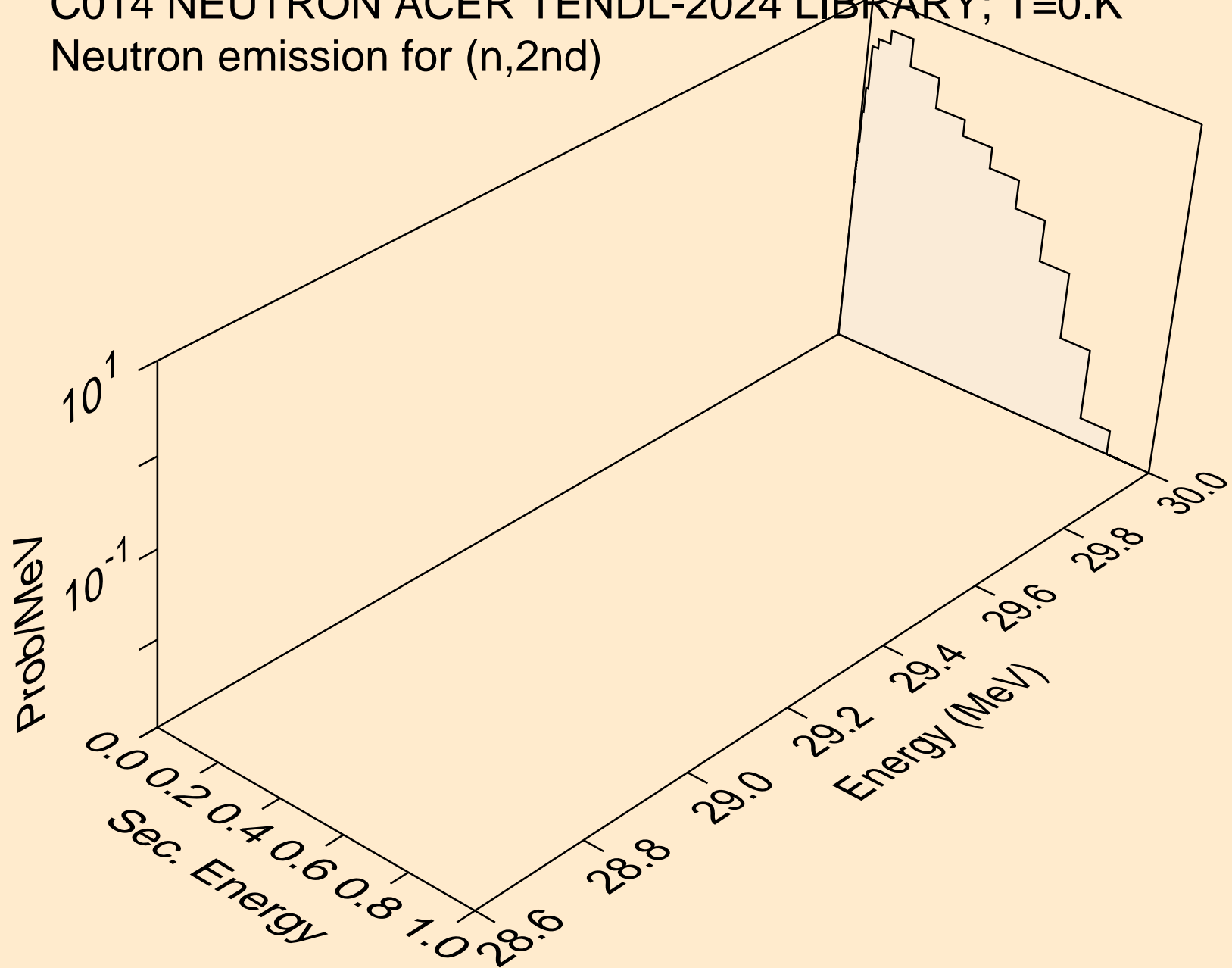

C014 NEUTRON ACER TENDL-2024 LIBRARY; T=0.K
Neutron emission for (n,2n)

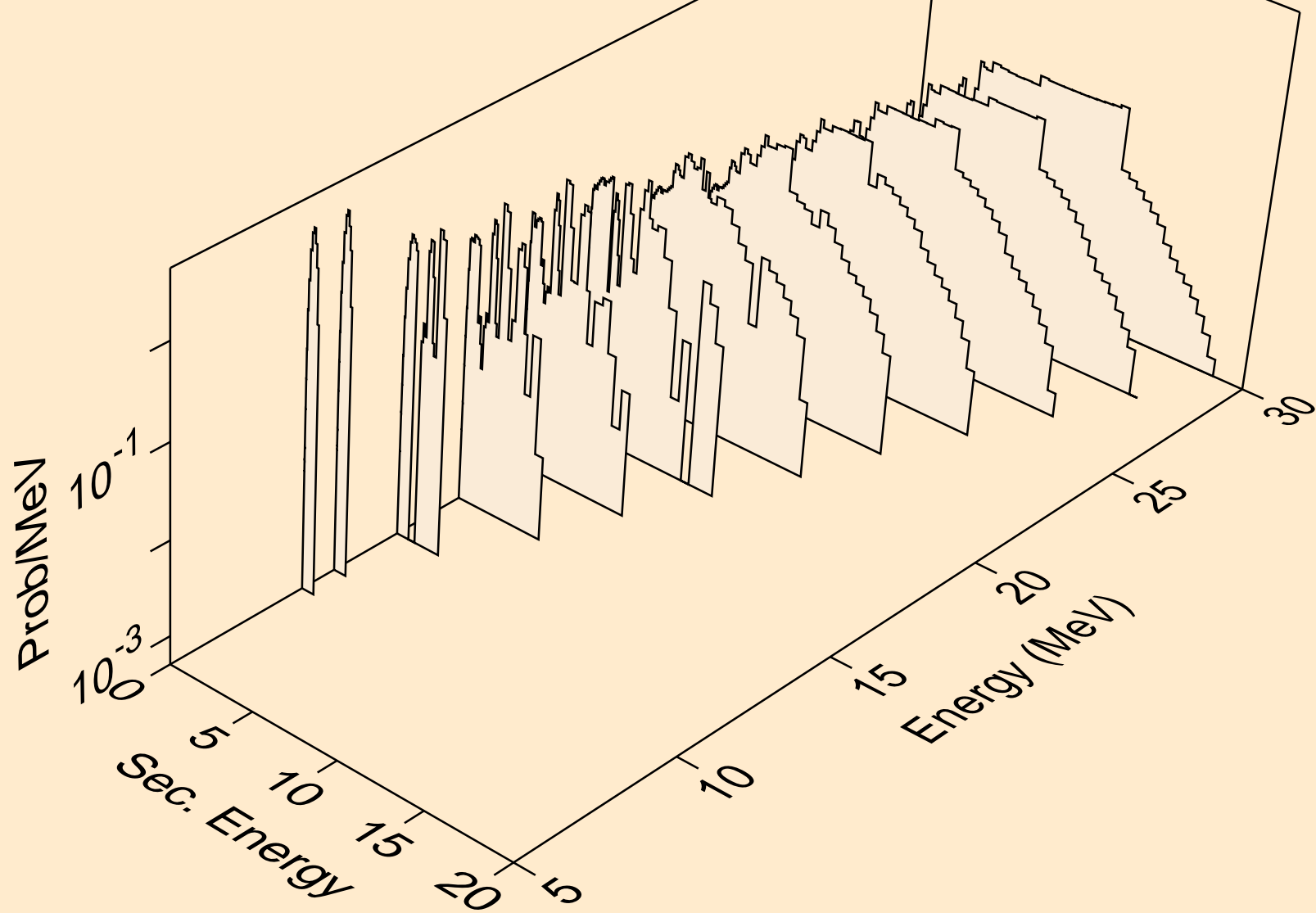

C014 NEUTRON ACER TENDL-2024 LIBRARY; T=0.K
Neutron emission for (n,3n)

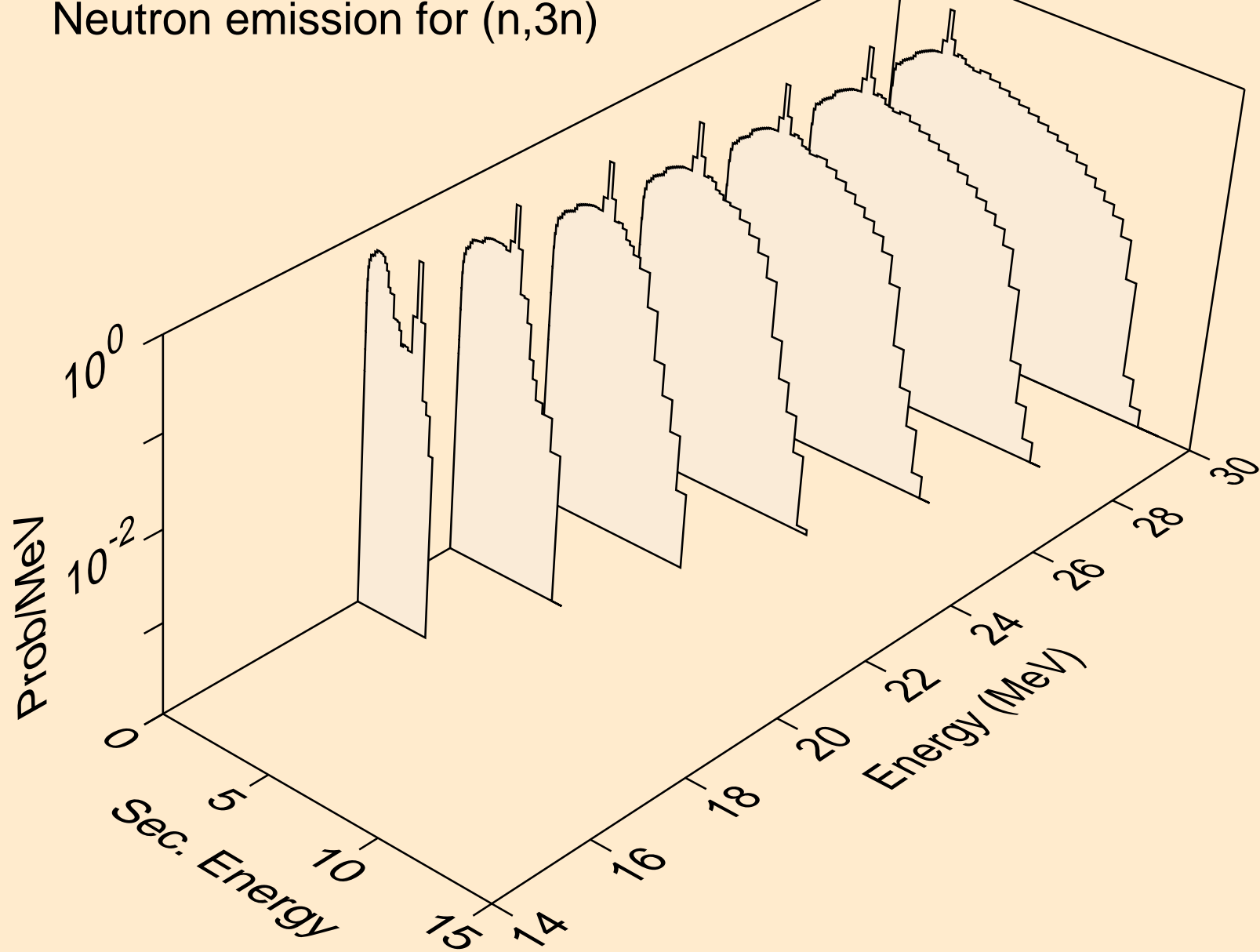

C014 NEUTRON ACER TENDL-2024 LIBRARY; T=0.K
Neutron emission for (n,n*)a



C014 NEUTRON ACER TENDL-2024 LIBRARY; T=0.K
Neutron emission for (n,2n)a

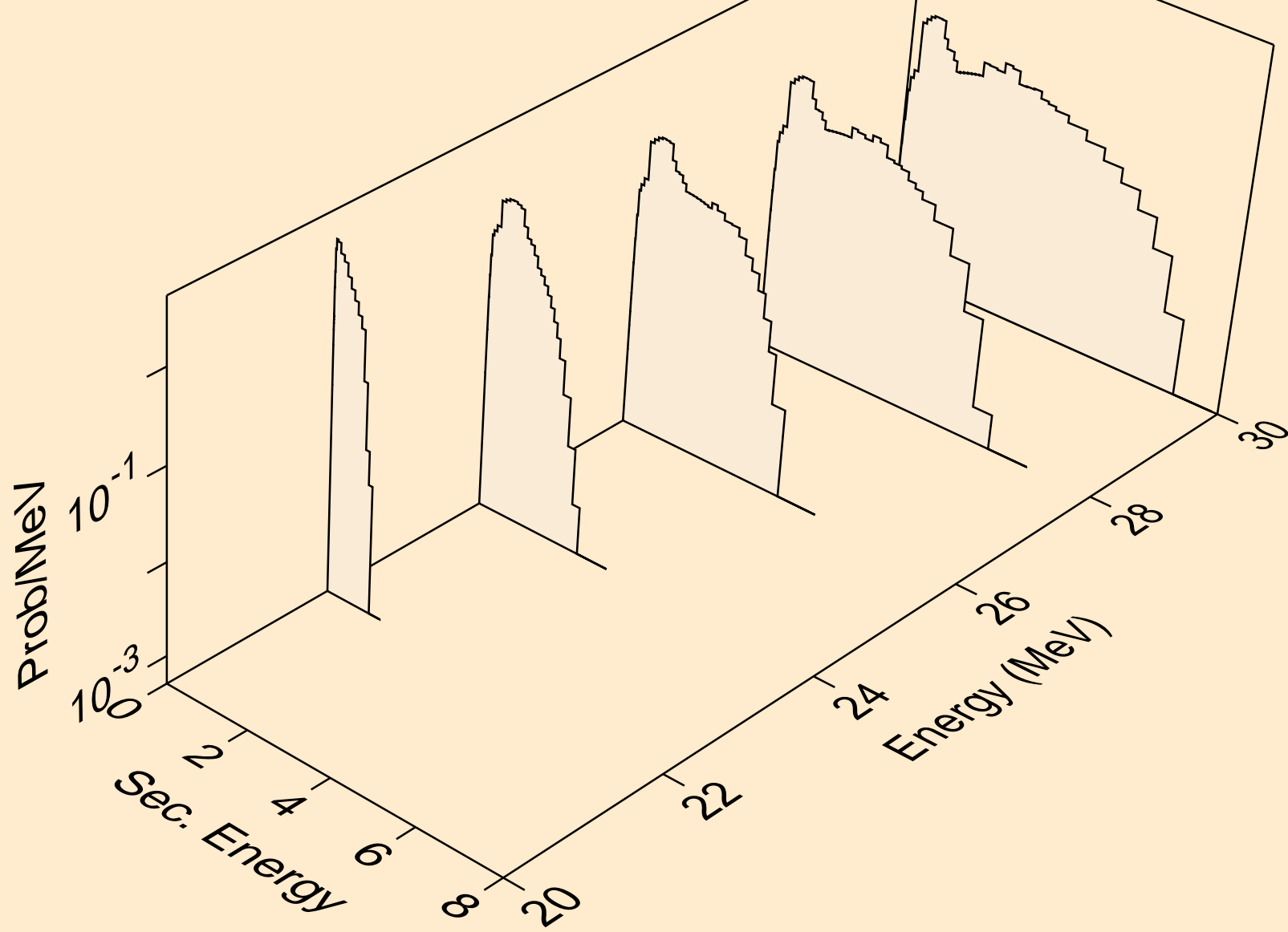

C014 NEUTRON ACER TENDL-2024 LIBRARY; T=0.K
Neutron emission for (n,3n)a

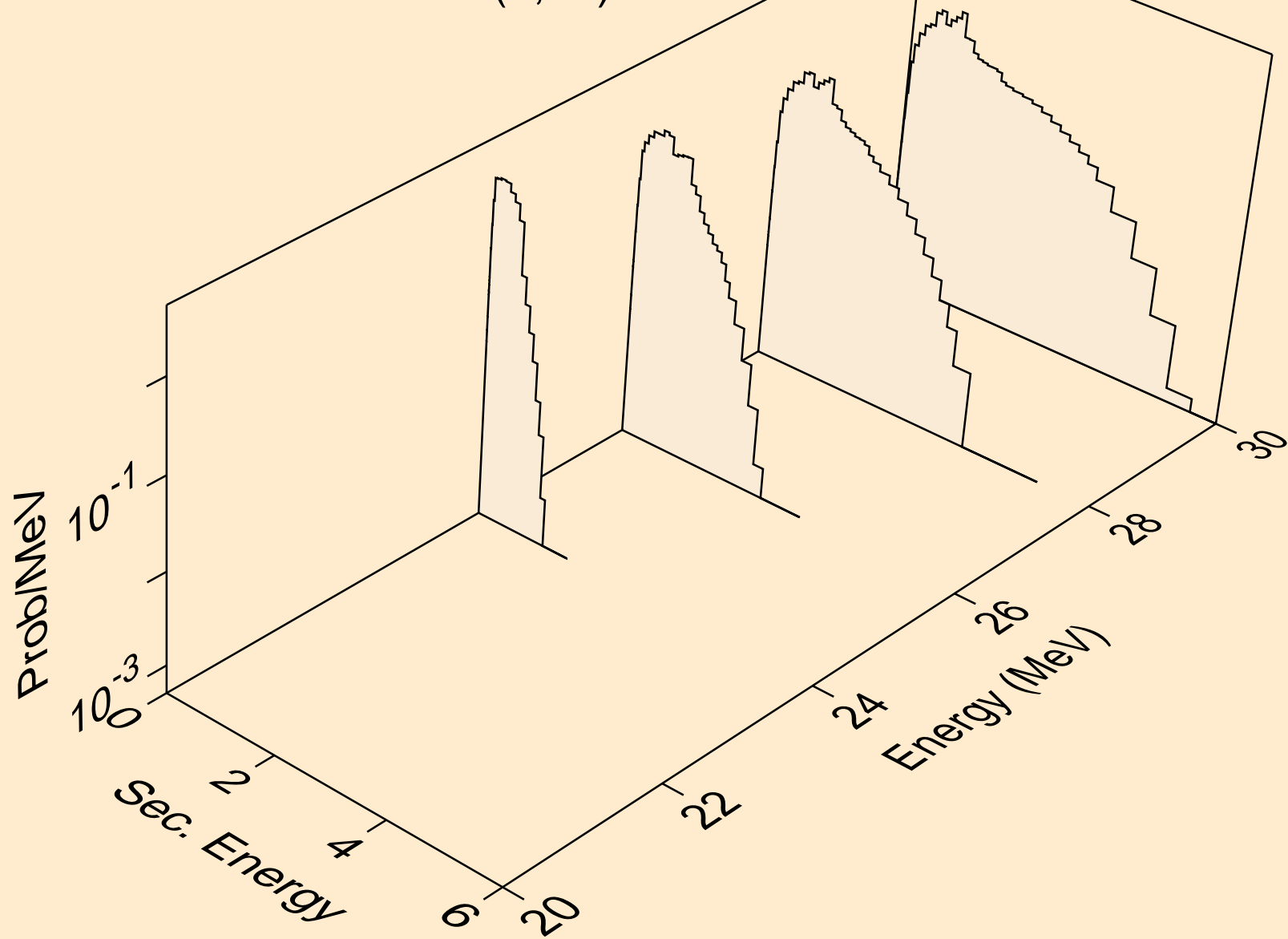

C014 NEUTRON ACER TENDL-2024 LIBRARY; T=0.K
Neutron emission for (n,n*)p

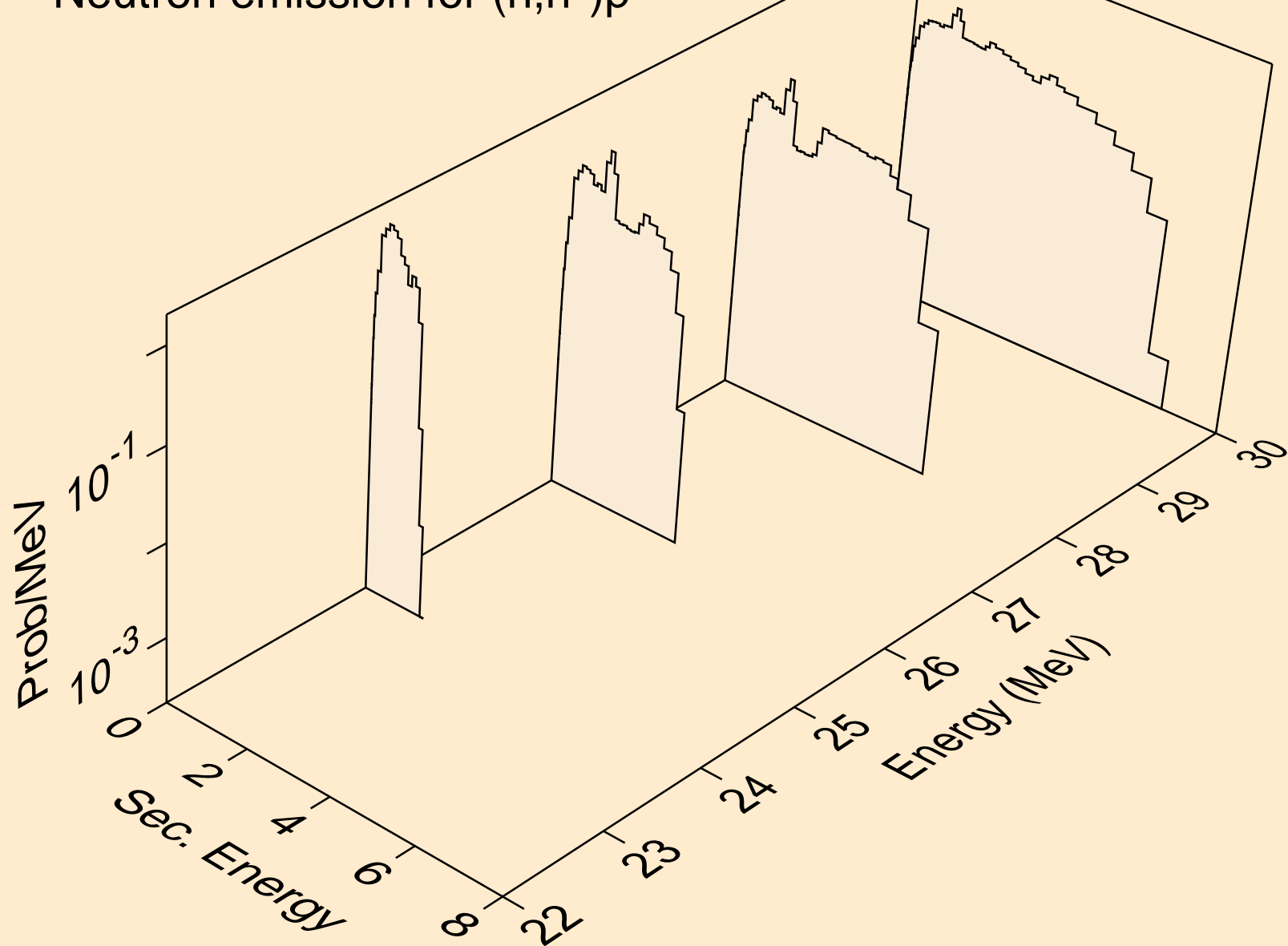

C014 NEUTRON ACER TENDL-2024 LIBRARY; T=0.K
Neutron emission for (n,n*)d

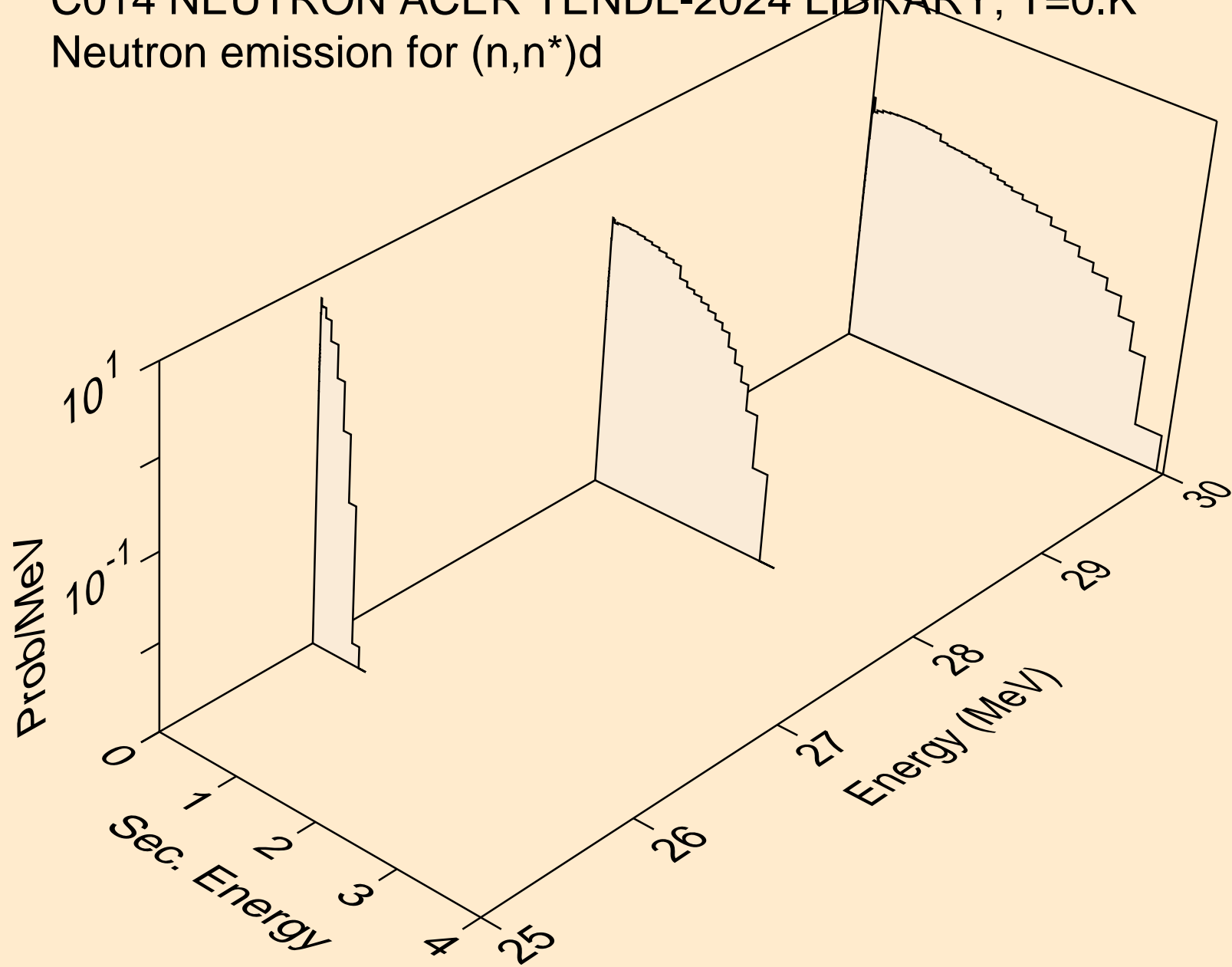

C014 NEUTRON ACER TENDL-2024 LIBRARY; T=0.K
Neutron emission for (n,n*)t

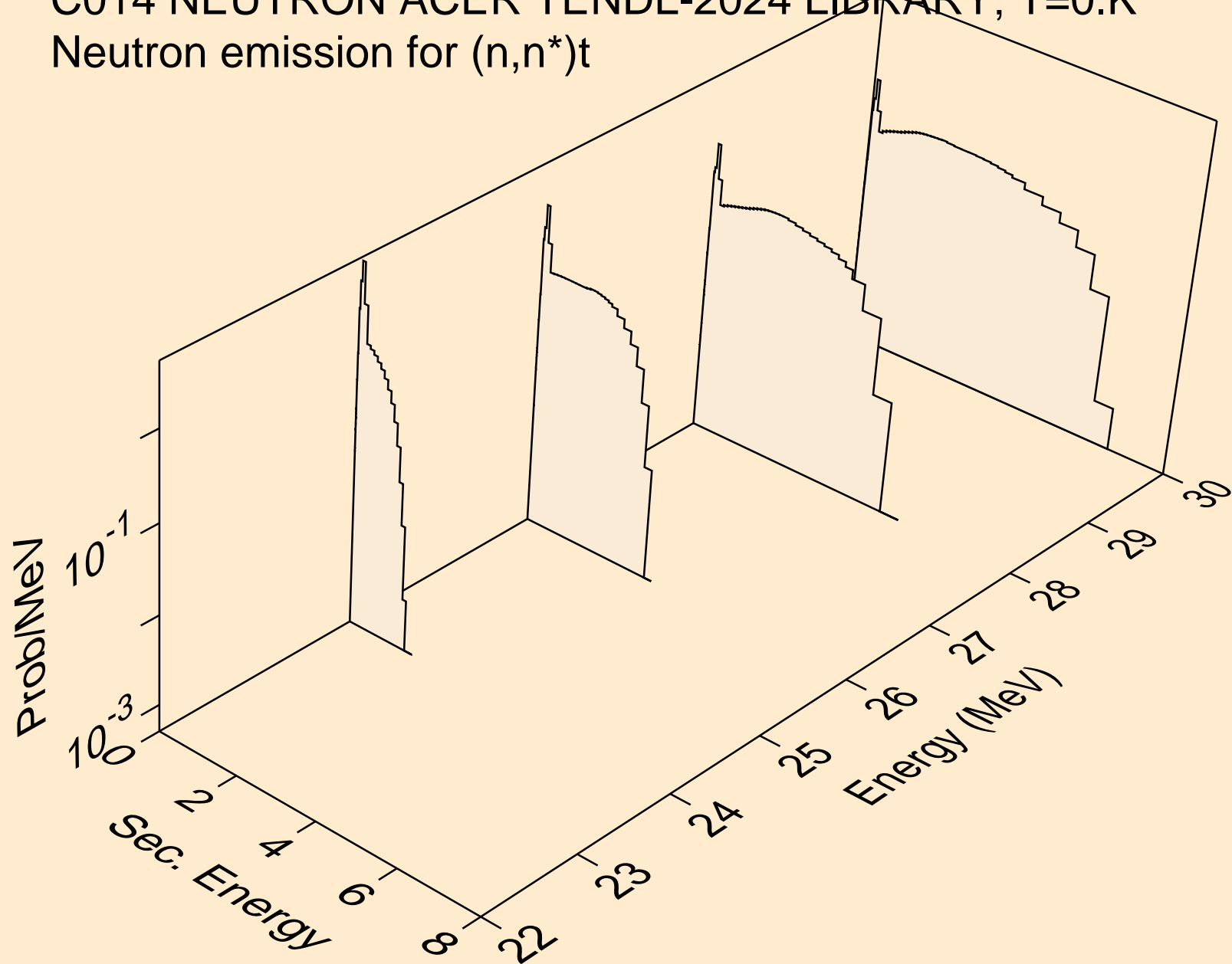

C014 NEUTRON ACER TENDL-2024 LIBRARY; T=0.K
Neutron emission for (n,2np)

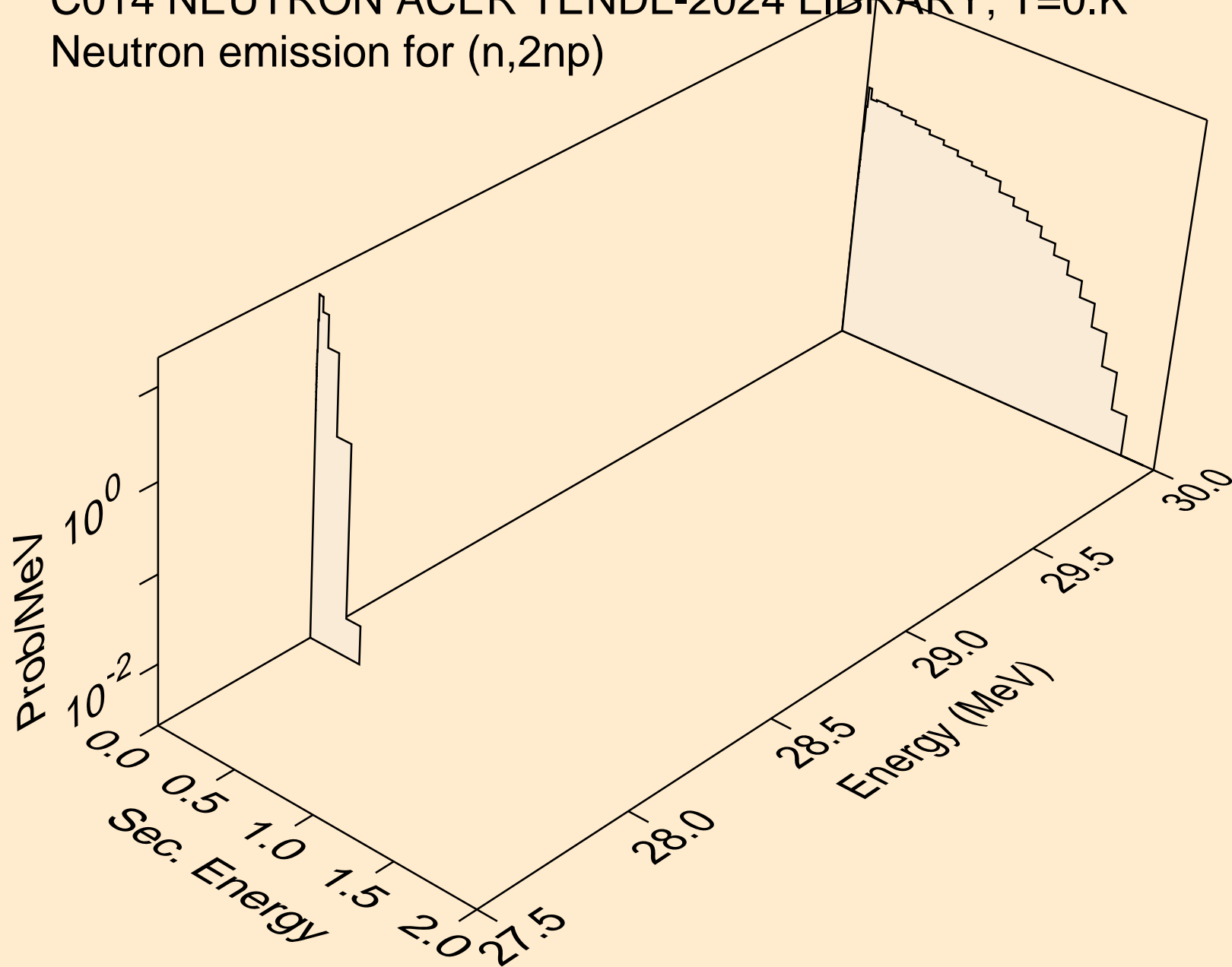

C014 NEUTRON ACER TENDL-2024 LIBRARY; T=0.K
Photon emission for (n,x)

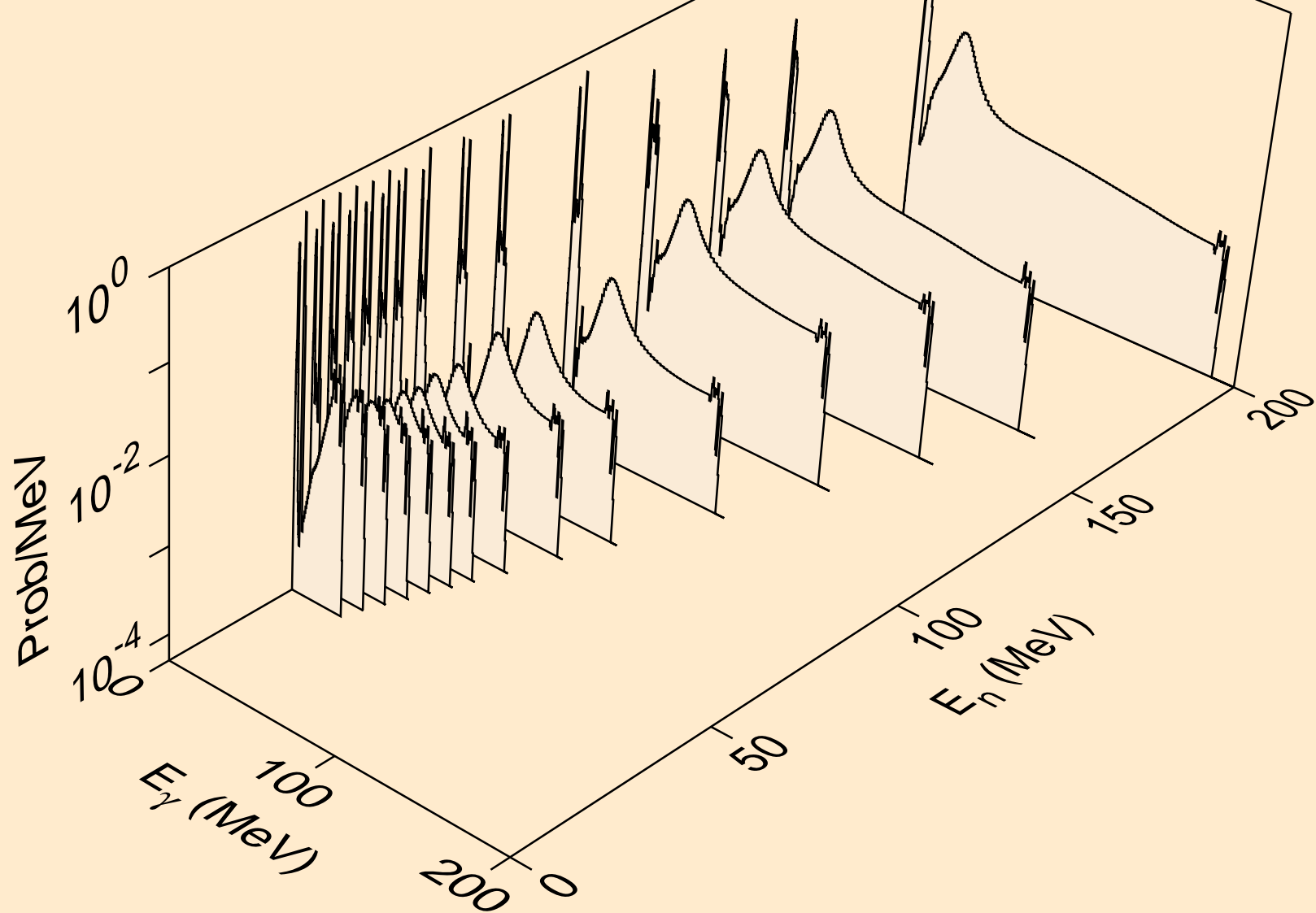

C014 NEUTRON ACER TENDL-2024 LIBRARY; T=0.K
Photon emission for (n,2nd)

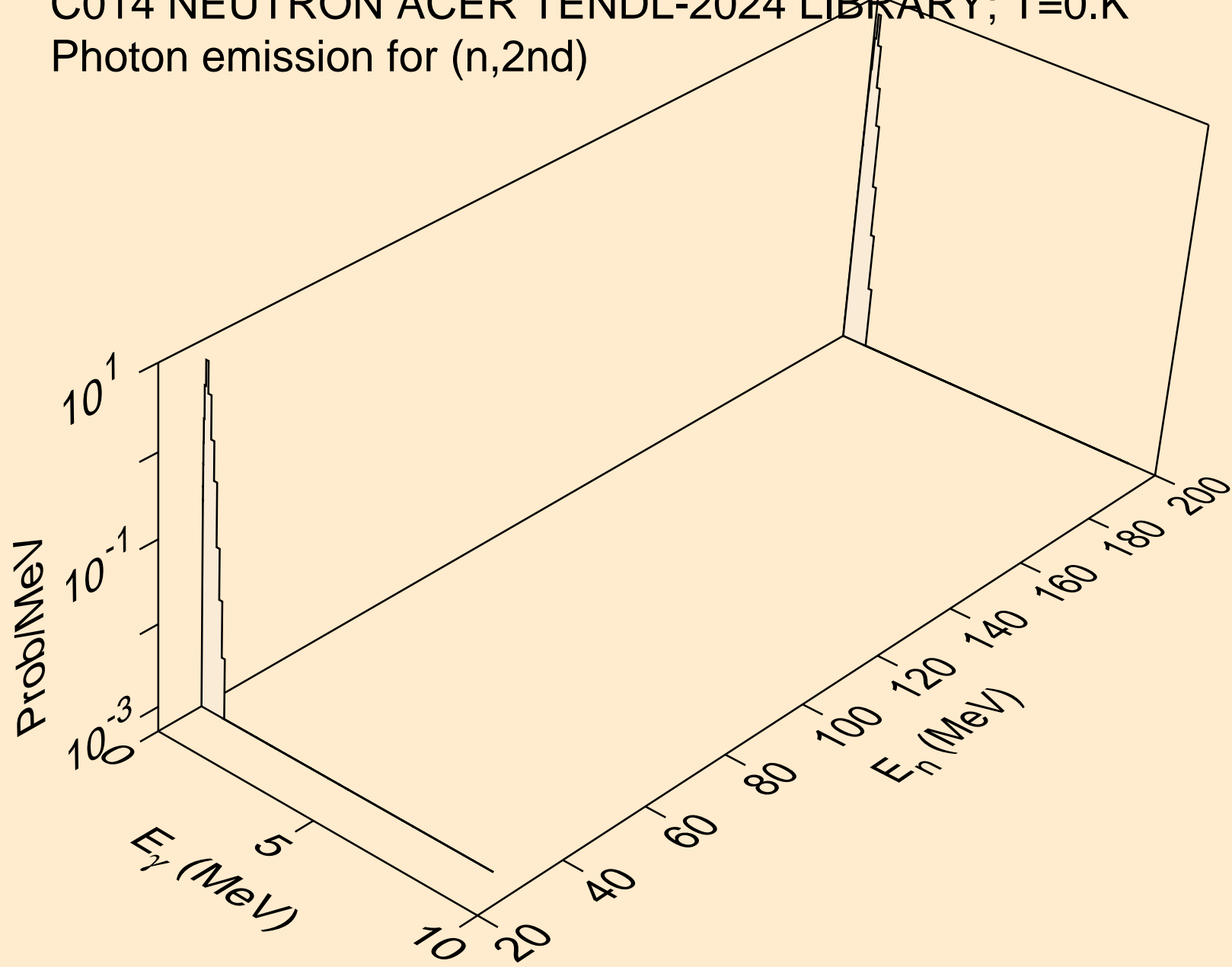

C014 NEUTRON ACER TENDL-2024 LIBRARY; T=0.K
Photon emission for (n,2n)

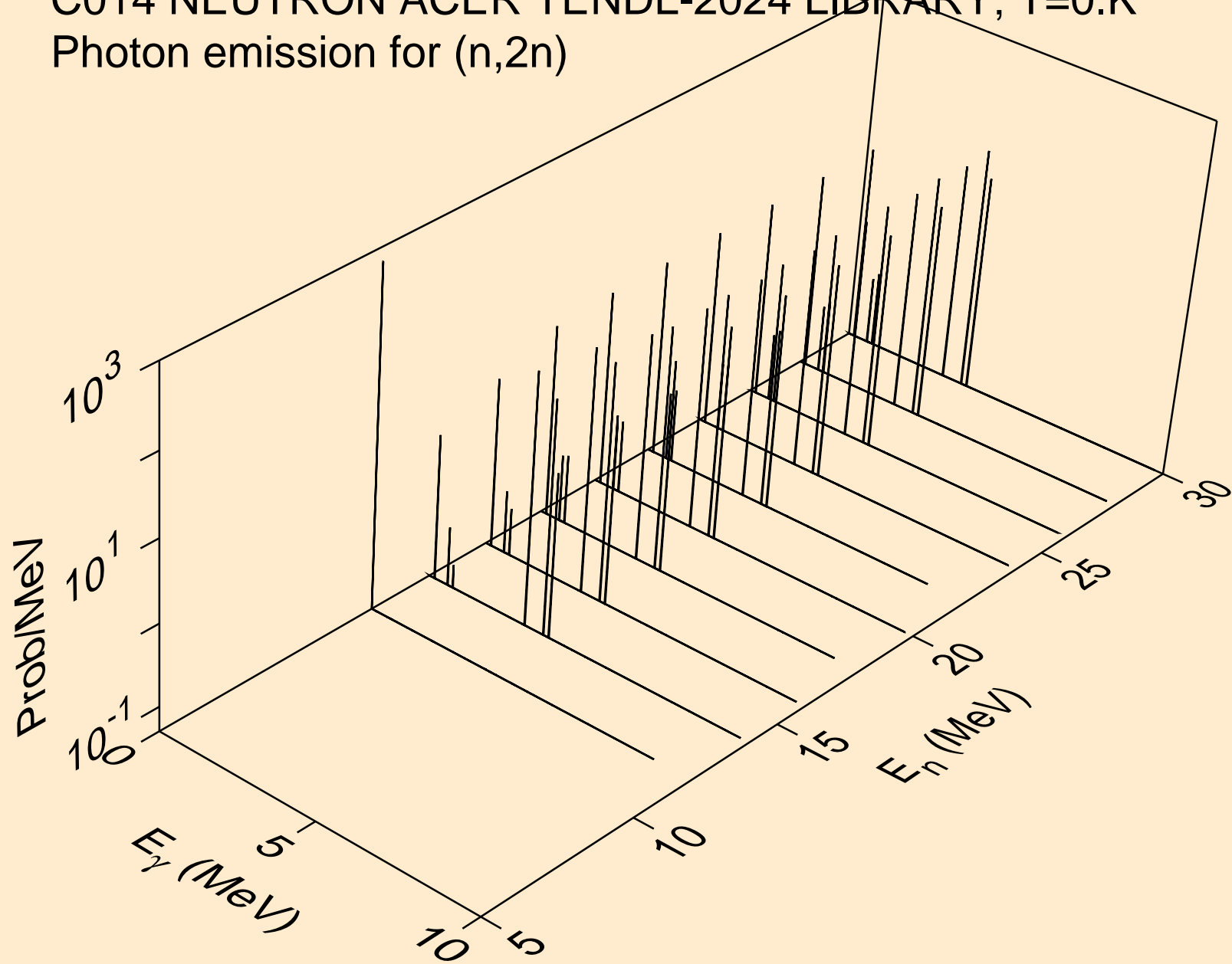

C014 NEUTRON ACER TENDL-2024 LIBRARY; T=0.K
Photon emission for (n,3n)

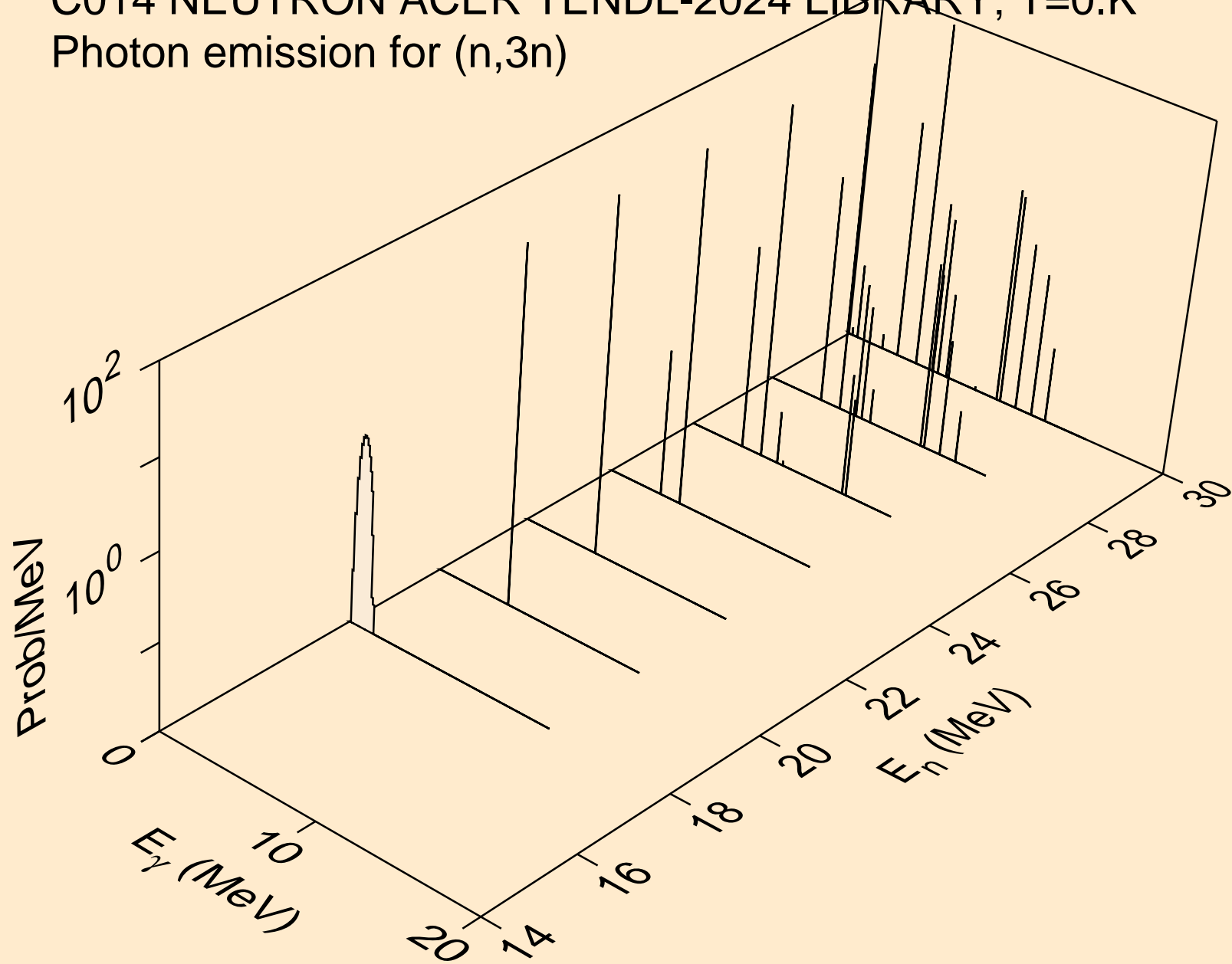

C014 NEUTRON ACER TENDL-2024 LIBRARY; T=0.K
Photon emission for (n,n*)a

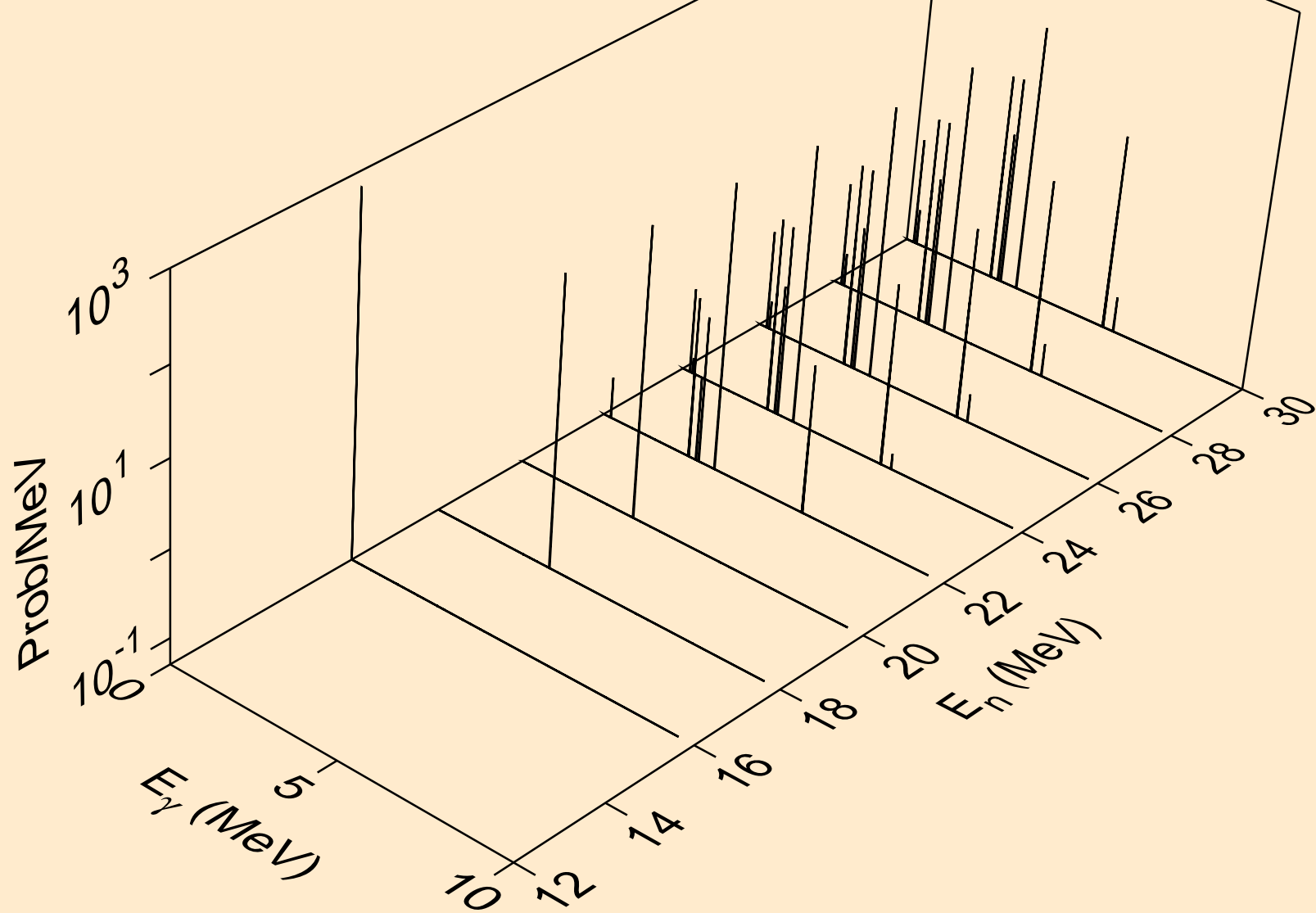

C014 NEUTRON ACER TENDL-2024 LIBRARY; T=0.K
Photon emission for (n,2n)a

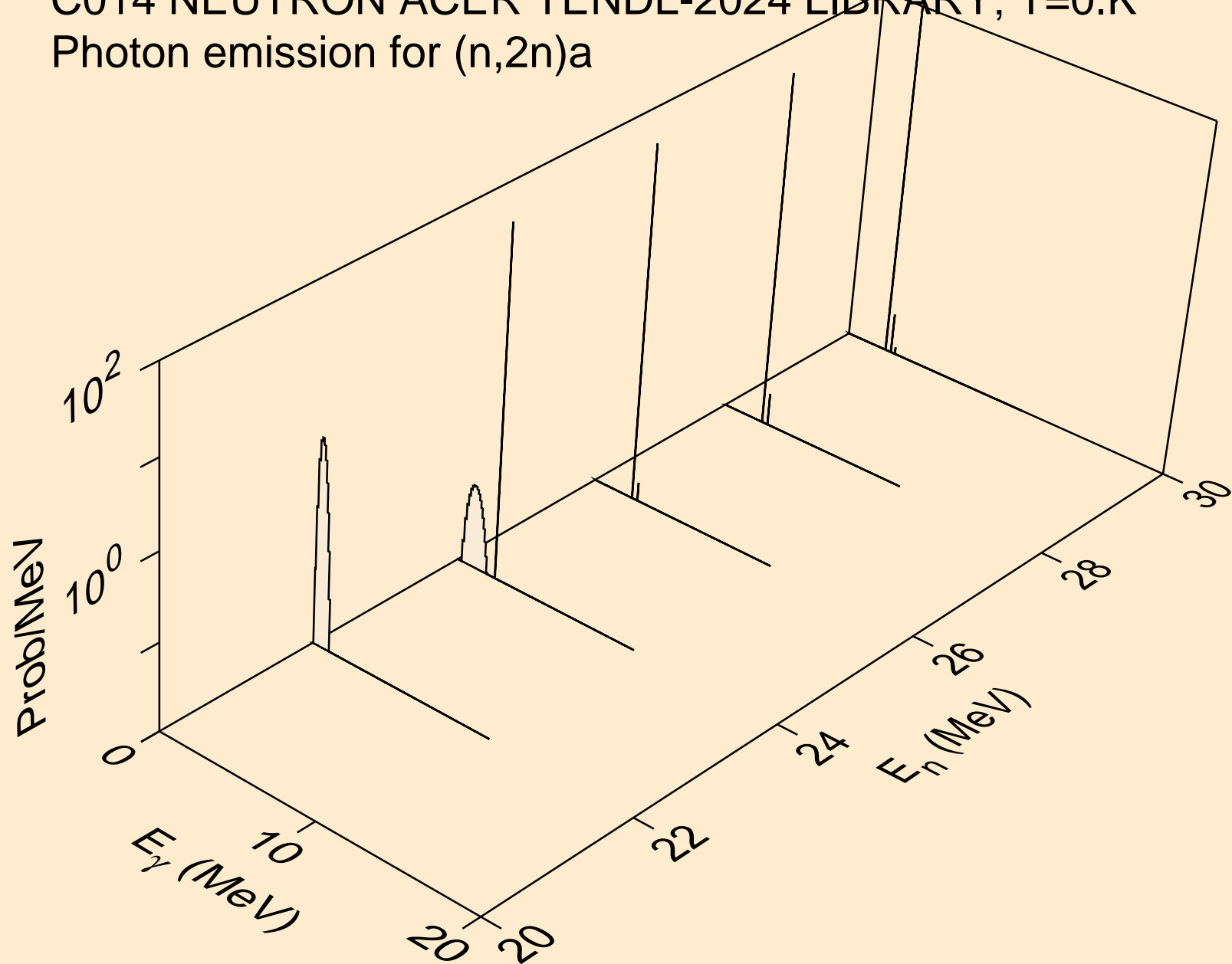

C014 NEUTRON ACER TENDL-2024 LIBRARY; T=0.K
Photon emission for (n,3n)a

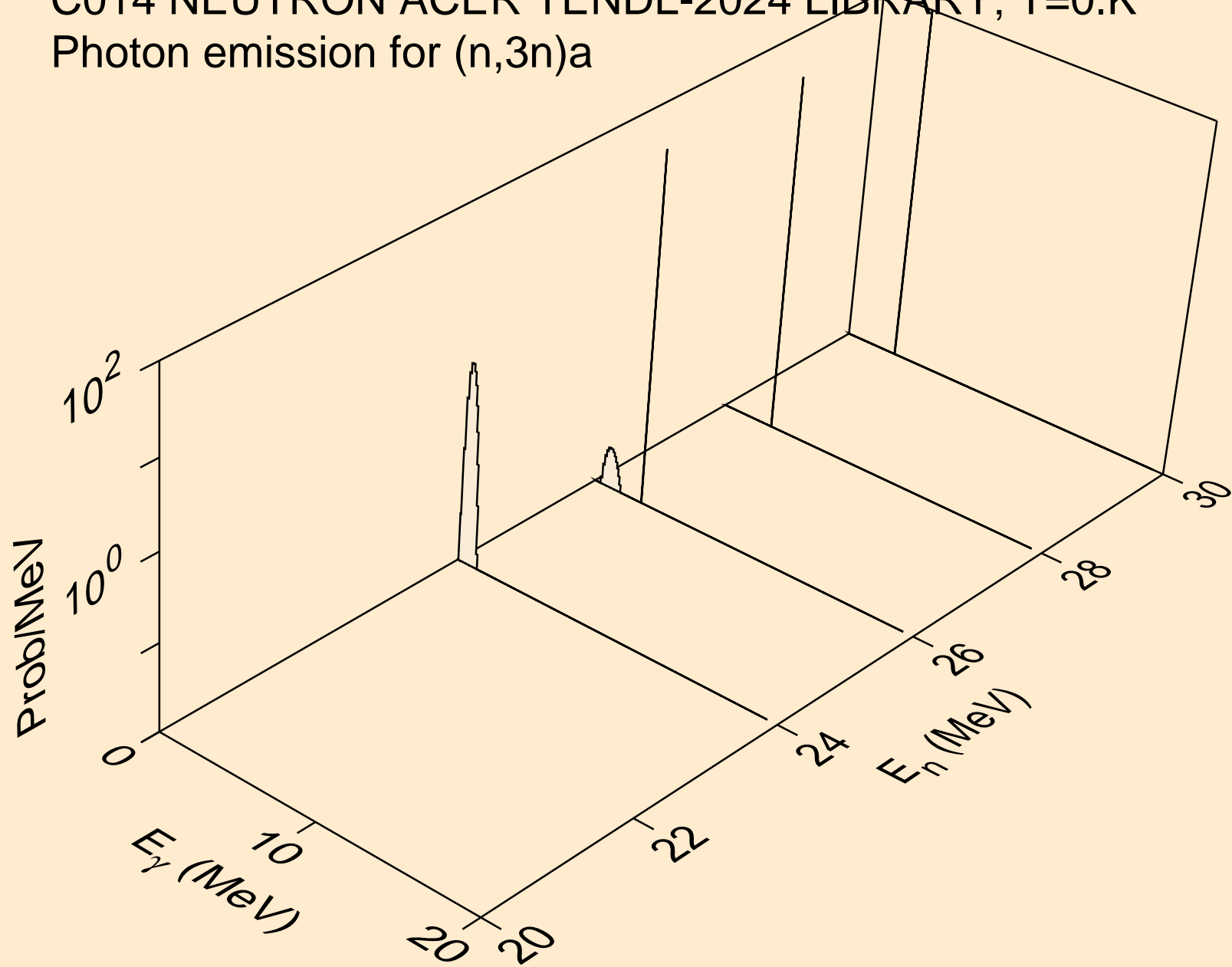

C014 NEUTRON ACER TENDL-2024 LIBRARY; T=0.K
Photon emission for (n,n*)p

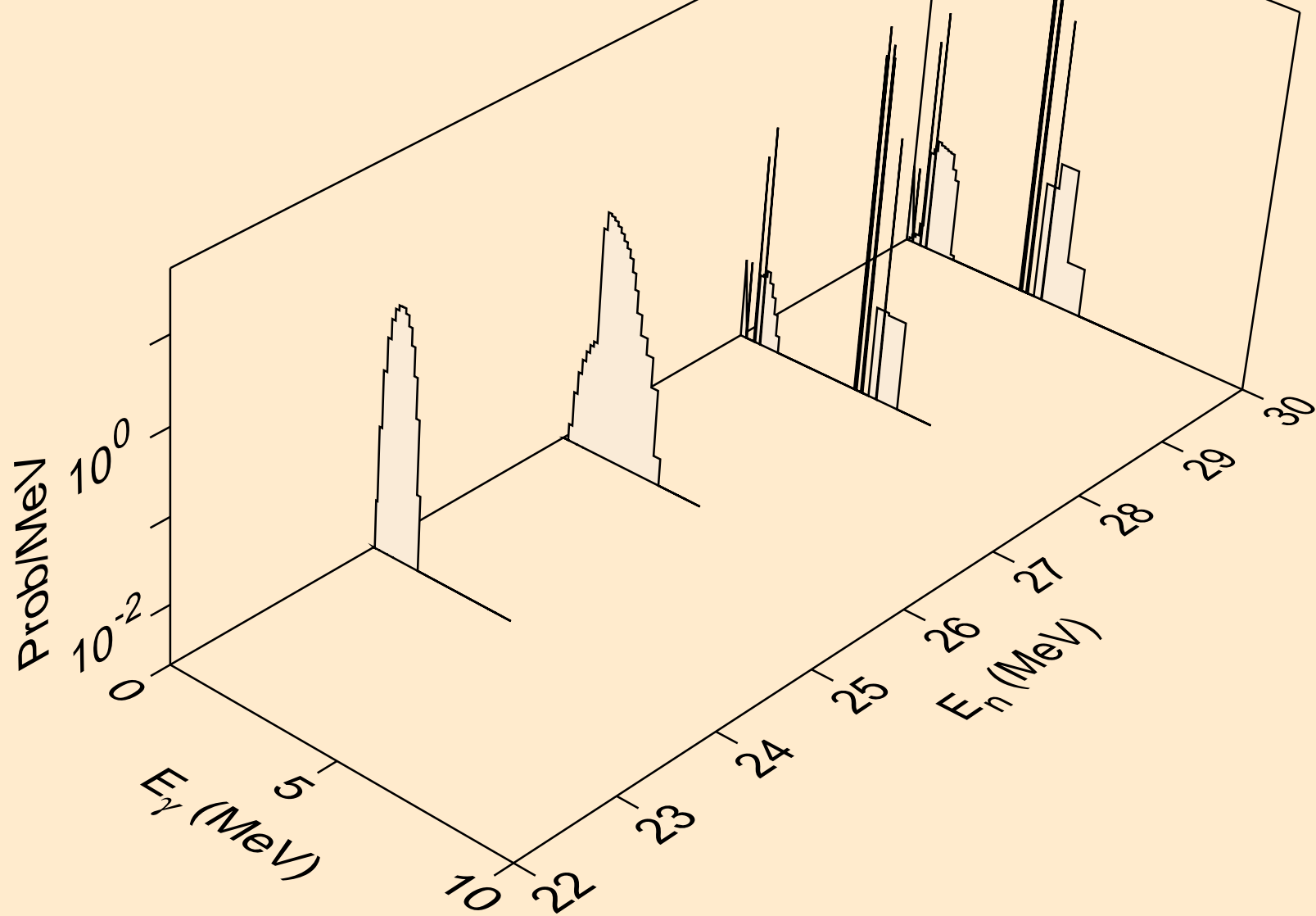

C014 NEUTRON ACER TENDL-2024 LIBRARY; T=0.K
Photon emission for (n,n*)d

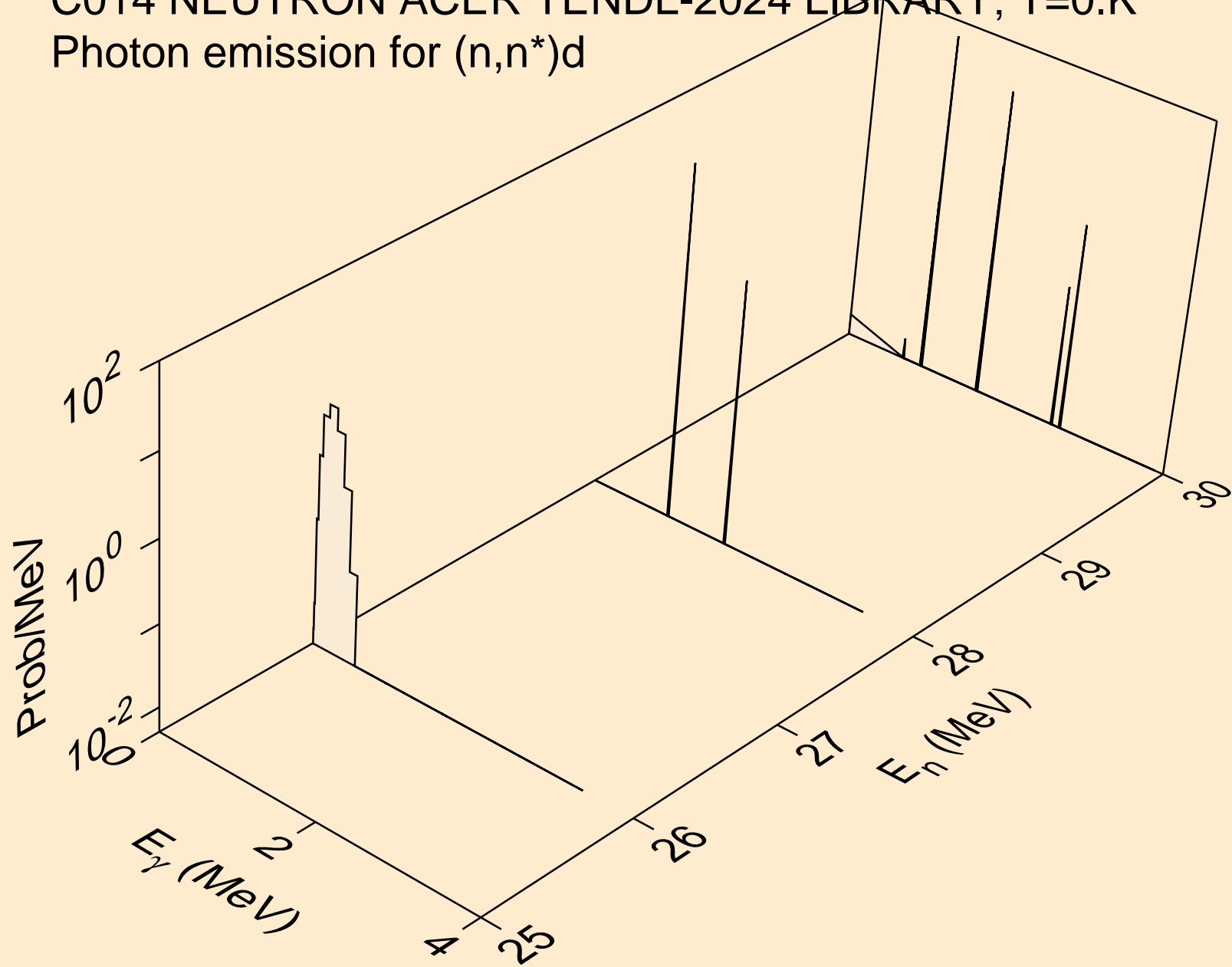

C014 NEUTRON ACER TENDL-2024 LIBRARY; T=0.K
Photon emission for (n,n*)t

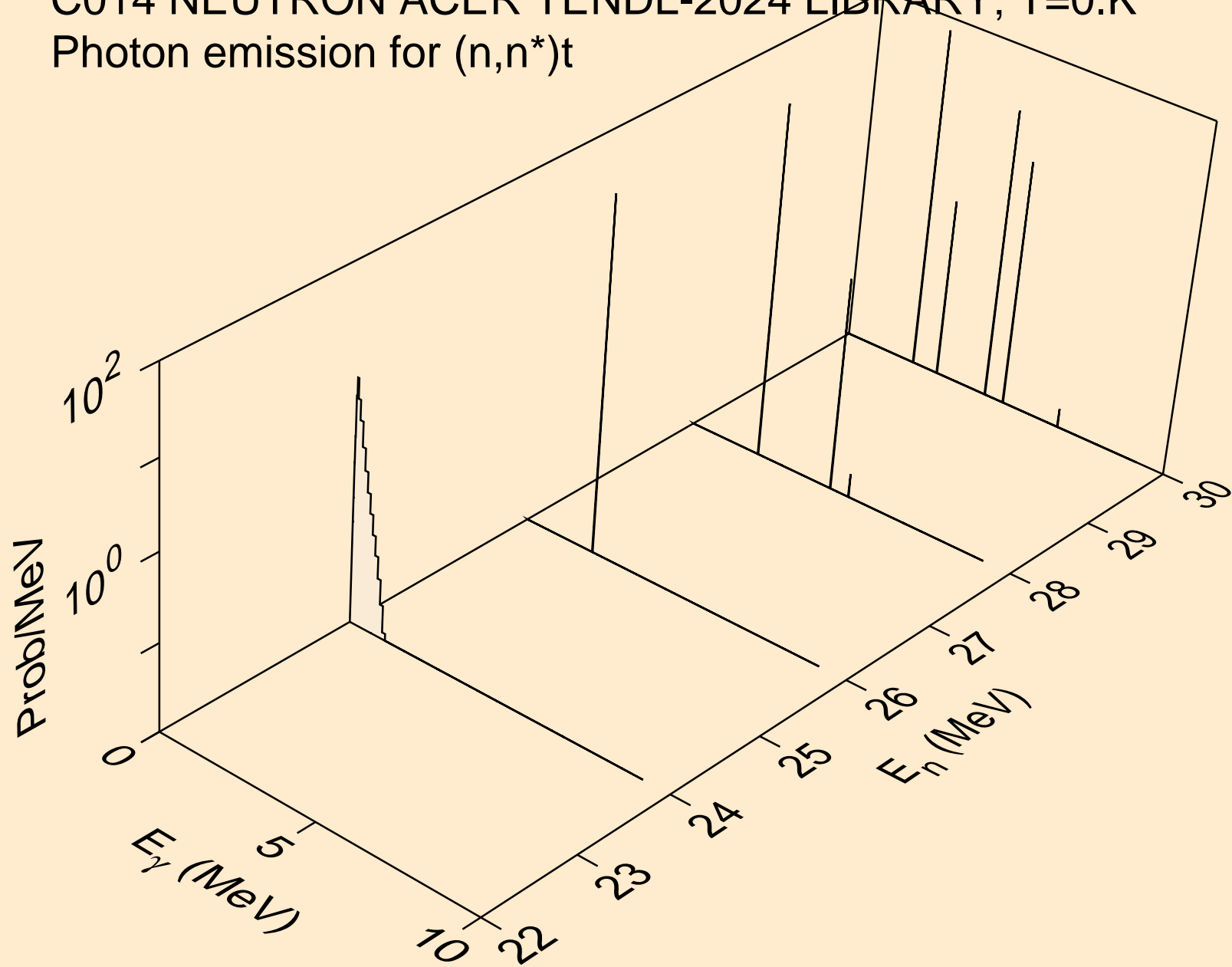

C014 NEUTRON ACER TENDL-2024 LIBRARY; T=0.K
Photon emission for (n,2np)

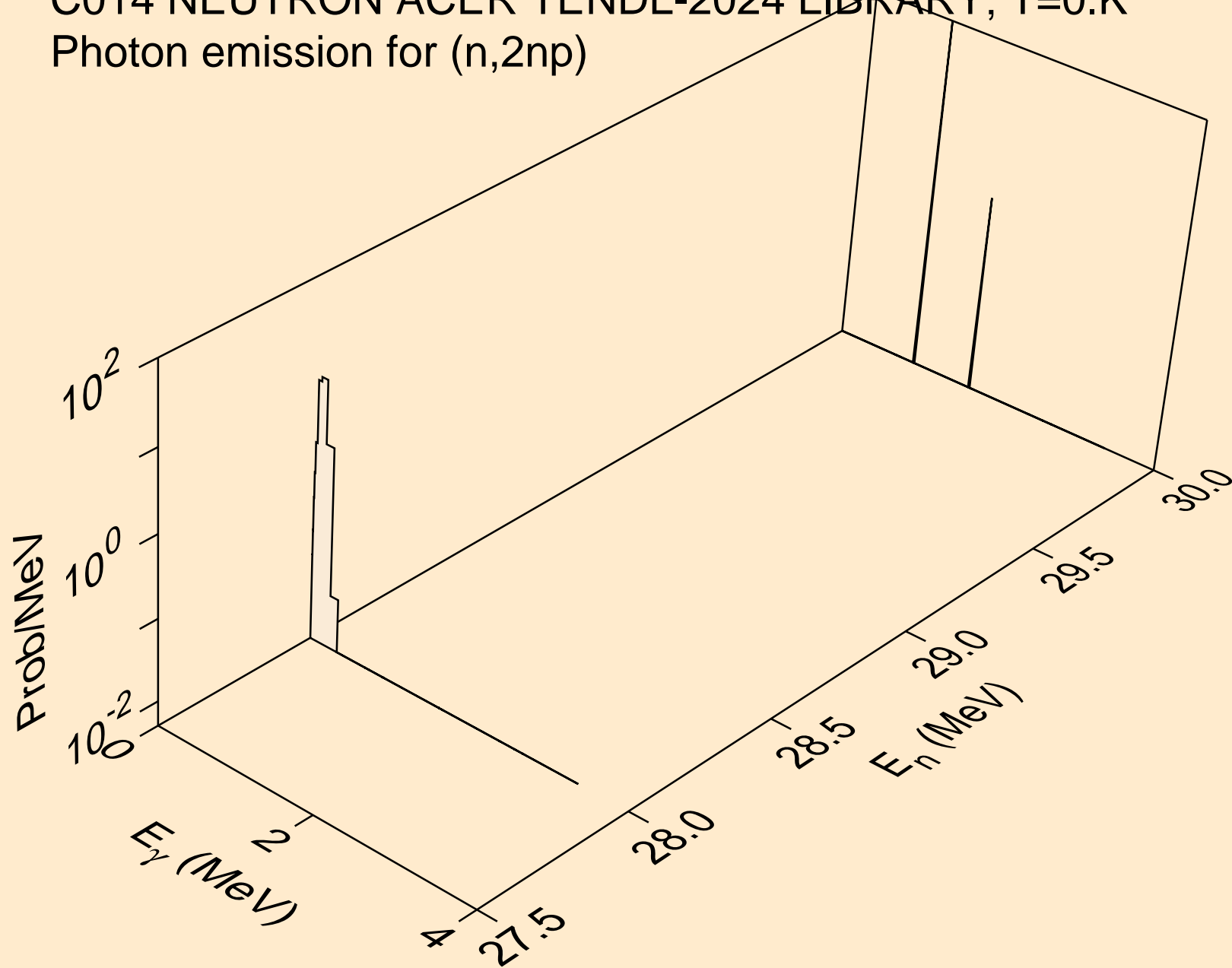

C014 NEUTRON ACER TENDL-2024 LIBRARY; T=0.K
Photon emission for (n,n*c)

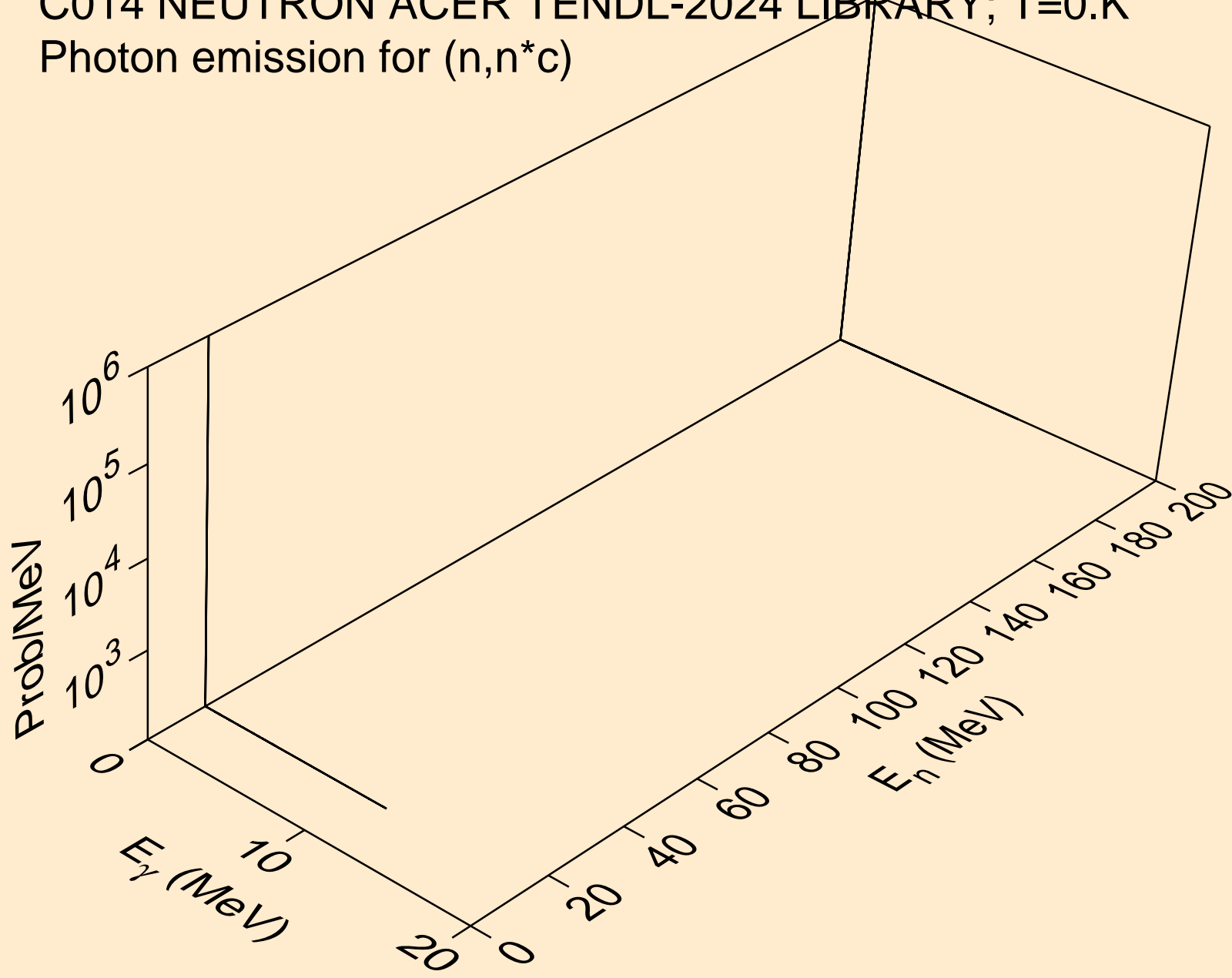

C014 NEUTRON ACER TENDL-2024 LIBRARY; T=0.K
Photon emission for (n,gma)

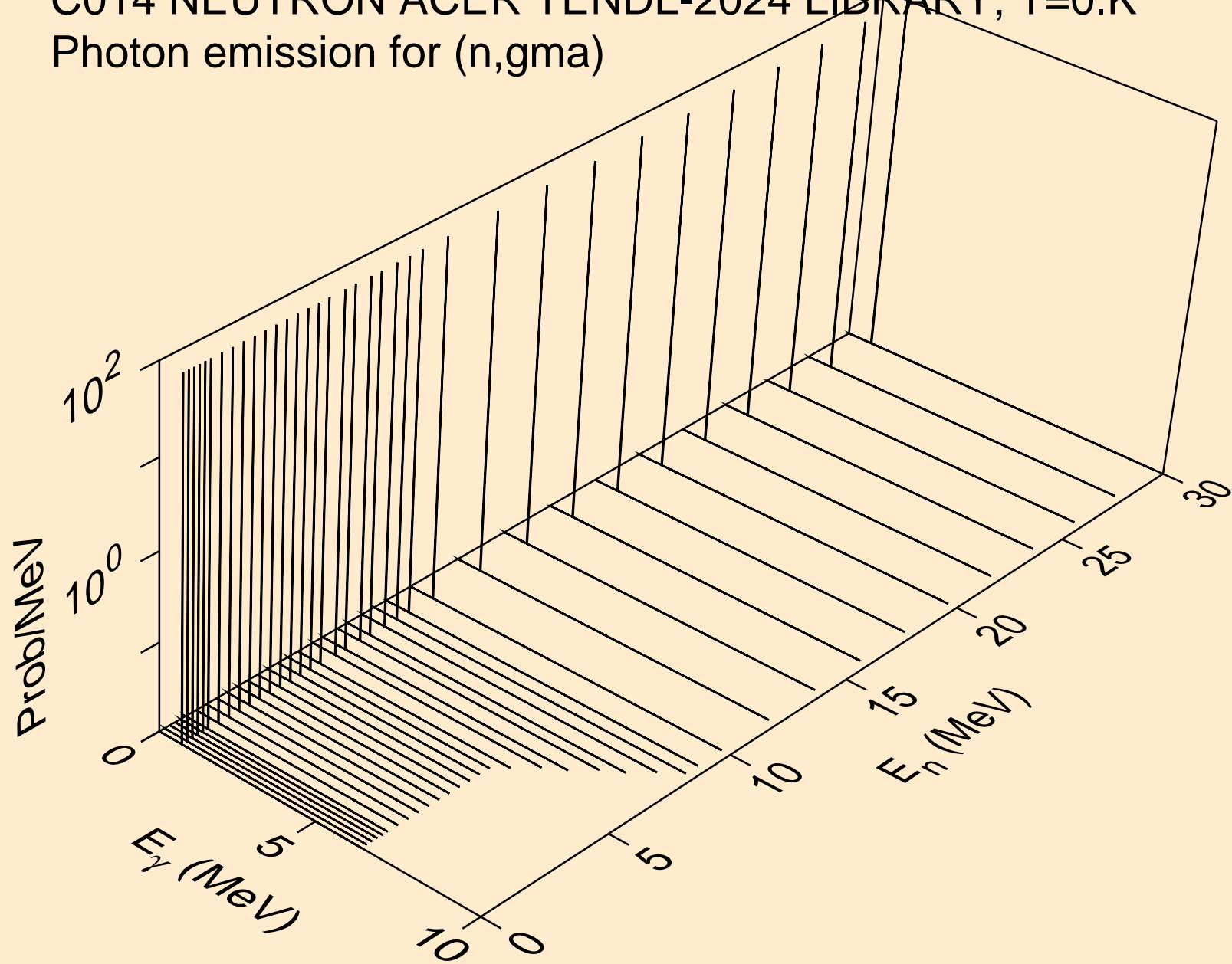

C014 NEUTRON ACER TENDL-2024 LIBRARY; T=0.K
Photon emission for (n,p)

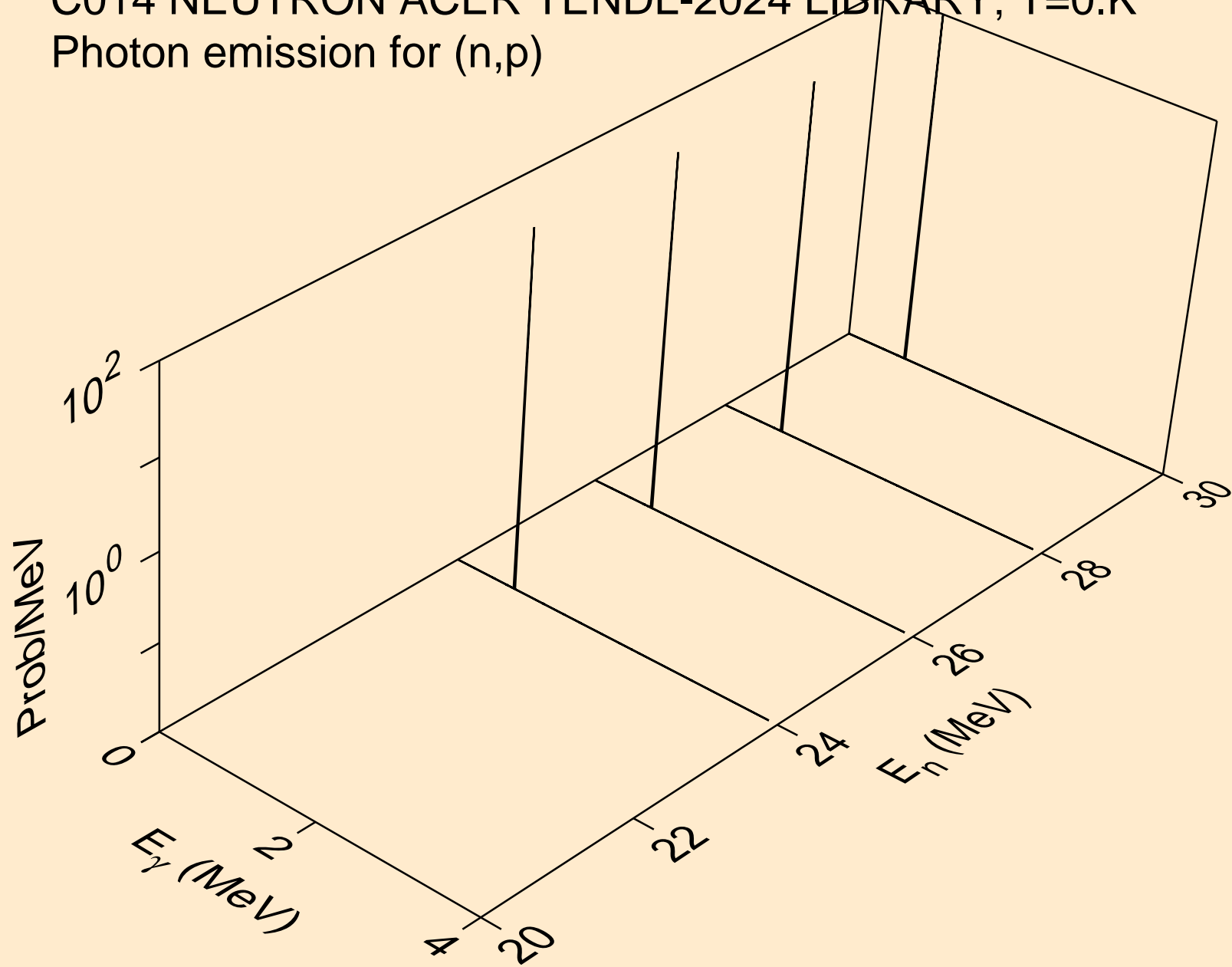

C014 NEUTRON ACER TENDL-2024 LIBRARY; T=0.K
Photon emission for (n,d)

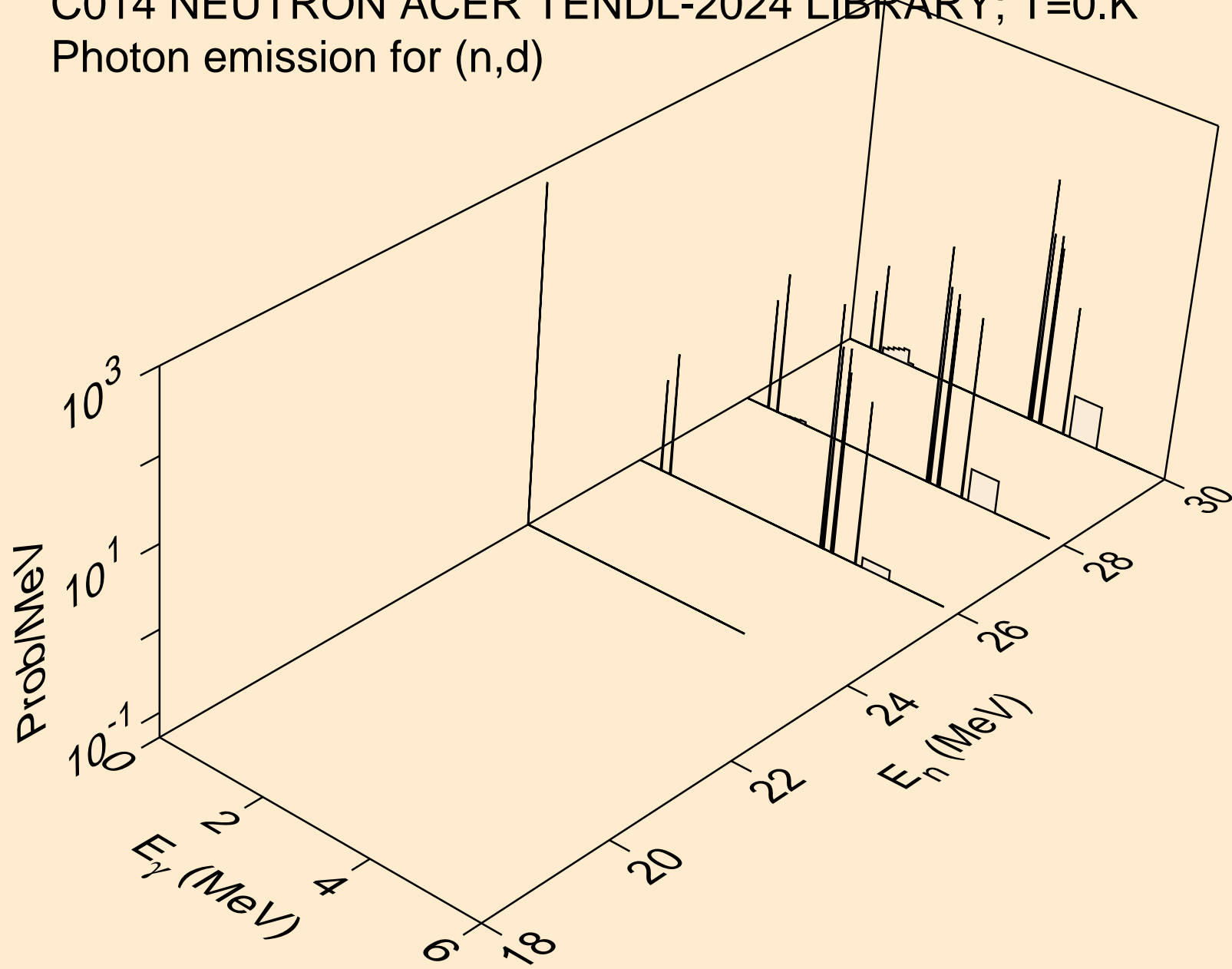

C014 NEUTRON ACER TENDL-2024 LIBRARY; T=0.K
Photon emission for (n,t)

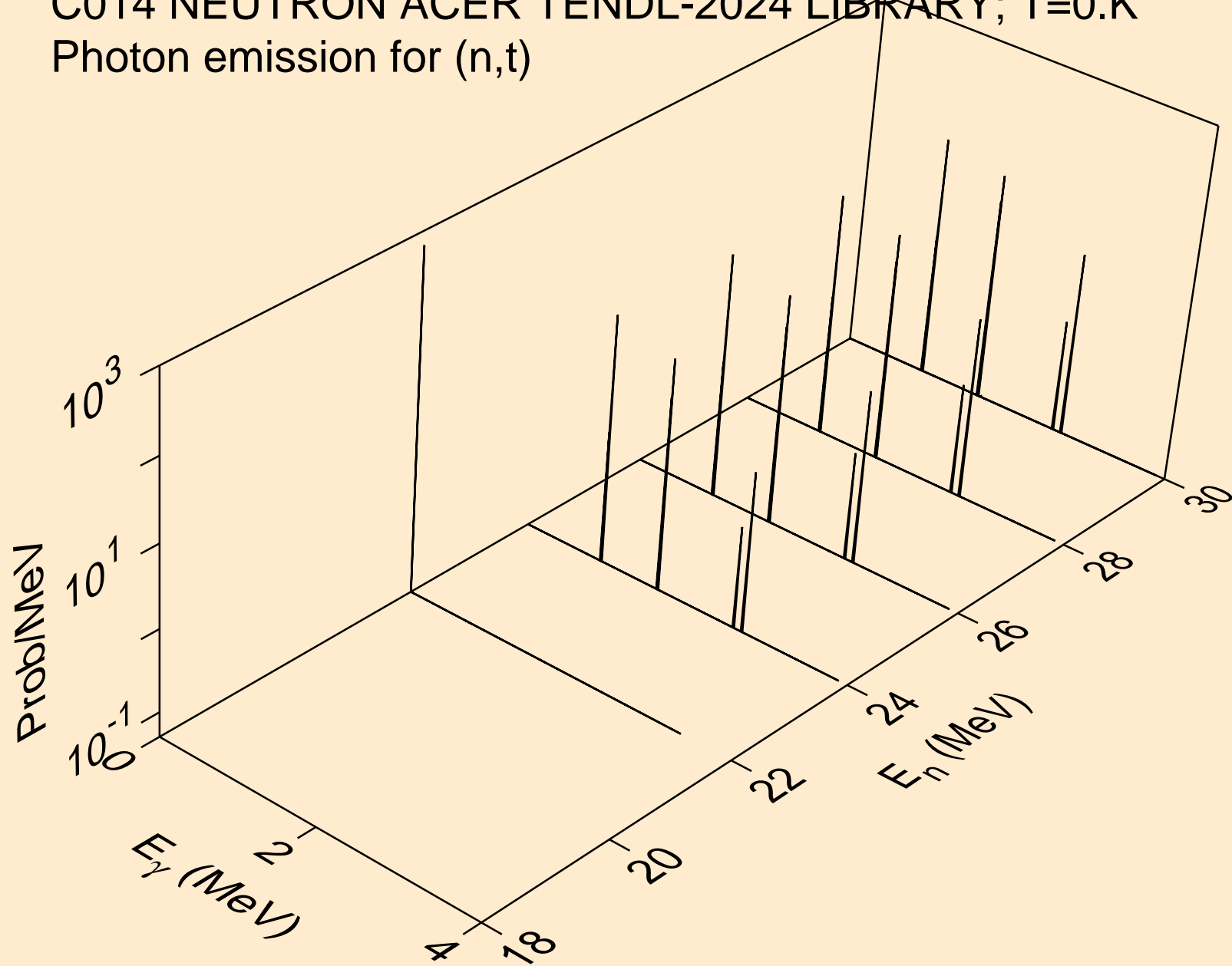

C014 NEUTRON ACER TENDL-2024 LIBRARY; T=0.K
Photon emission for (n,a)

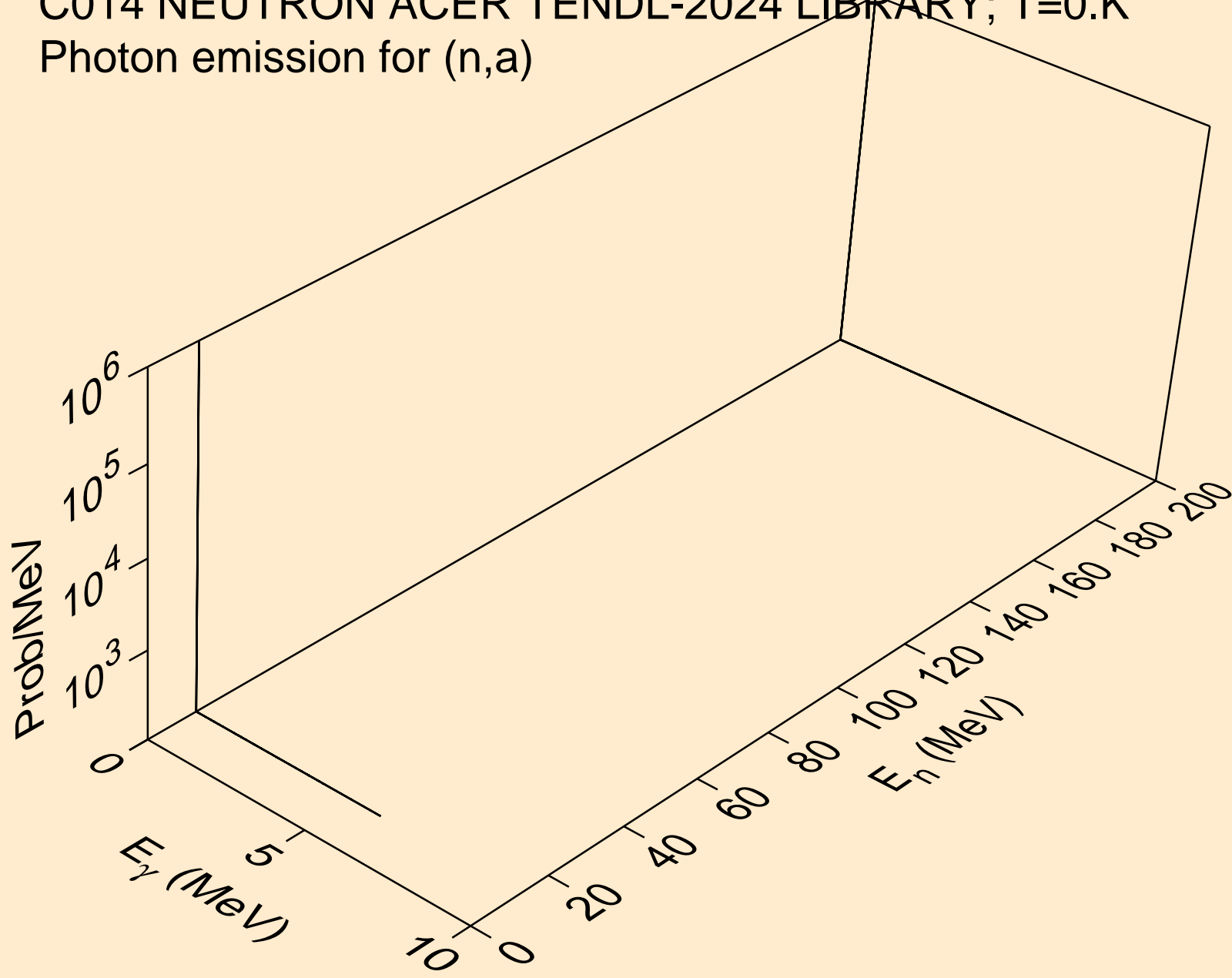

C014 NEUTRON ACER TENDL-2024 LIBRARY; T=0.K
thermal capture photon spectrum

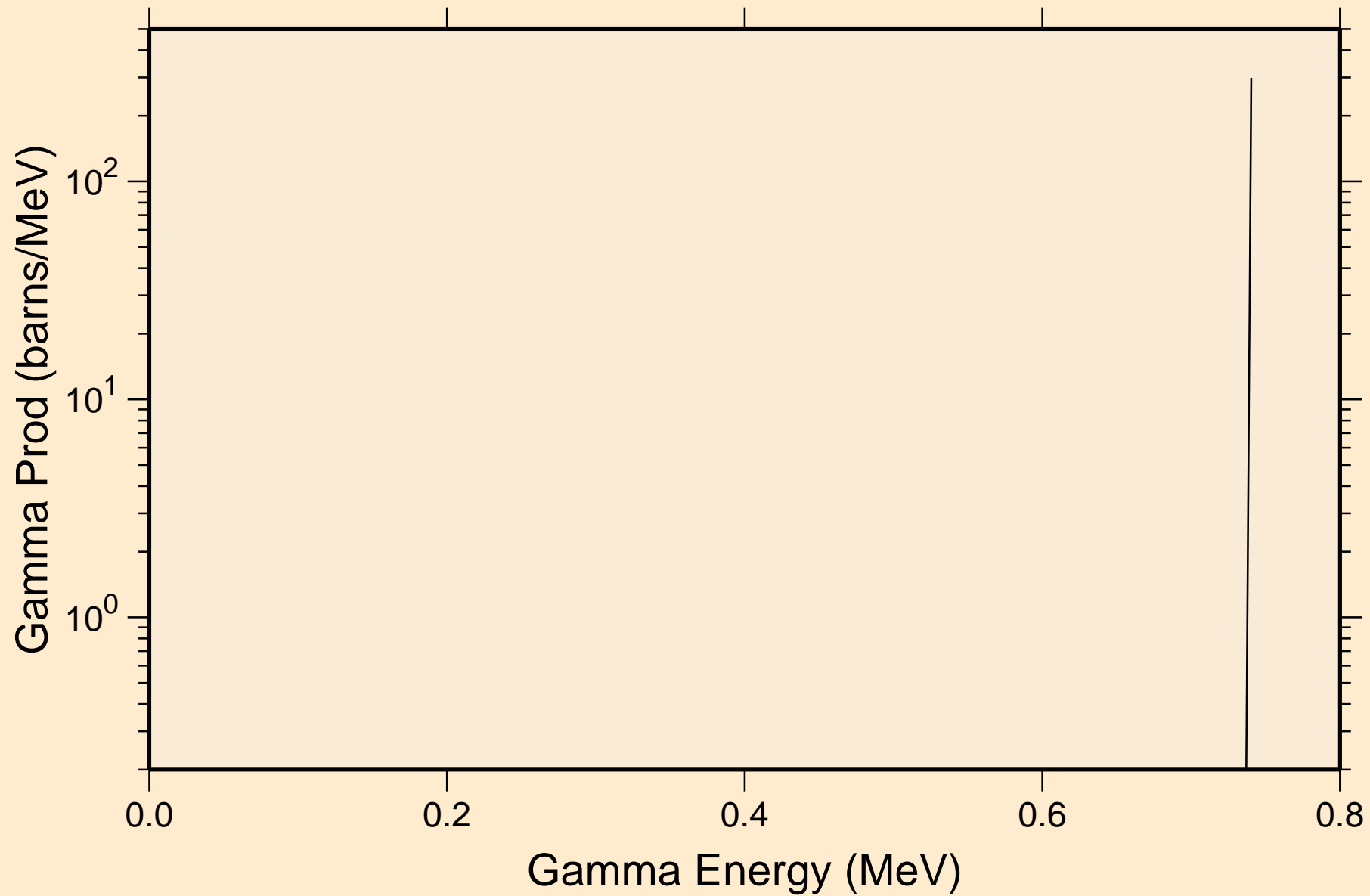

C014 NEUTRON ACER TENDL-2024 LIBRARY; T=0.K
14 MeV photon spectrum

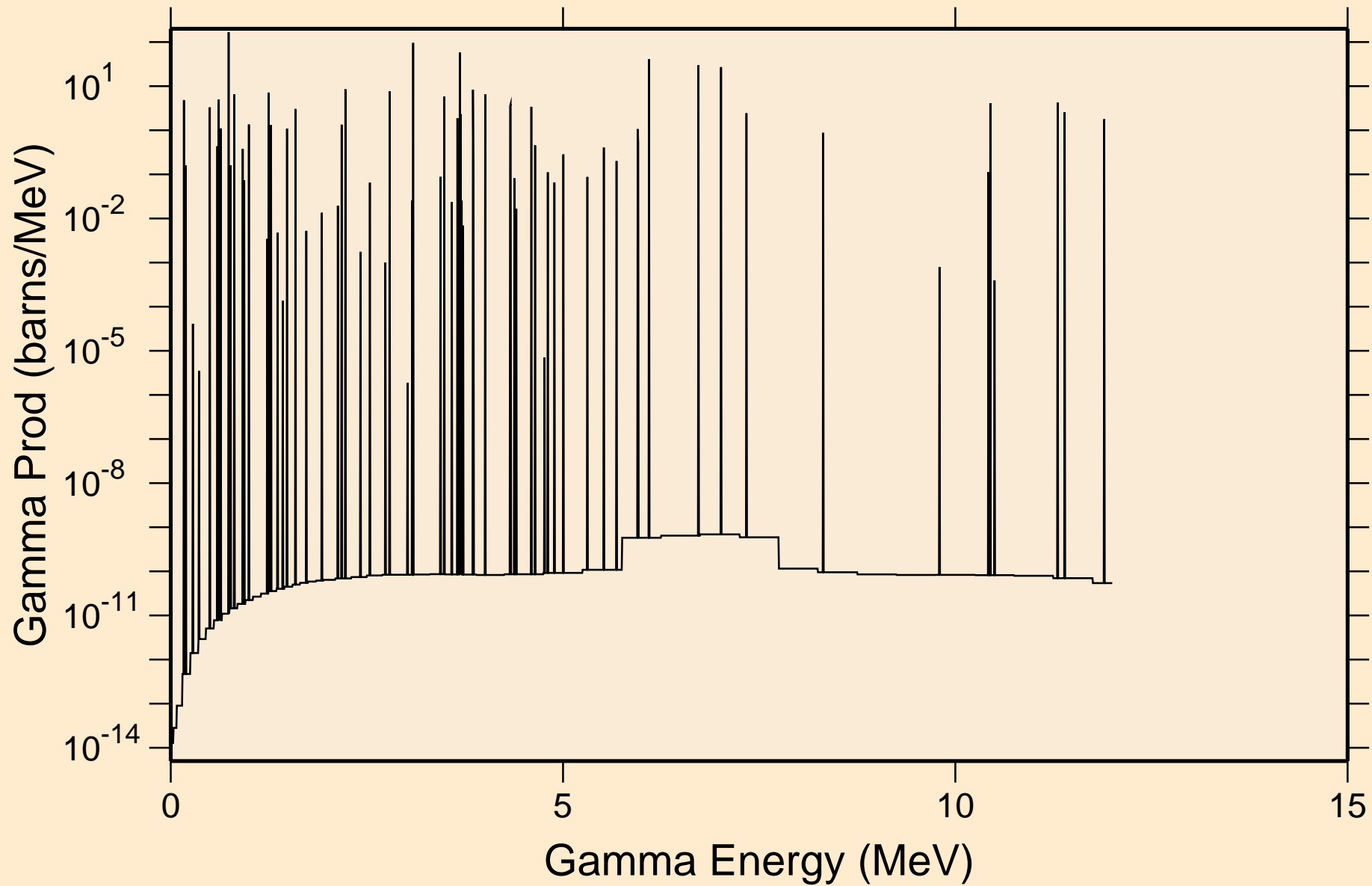

C014 NEUTRON ACER TENDL-2024 LIBRARY; T=0.K
Particle heating contributions

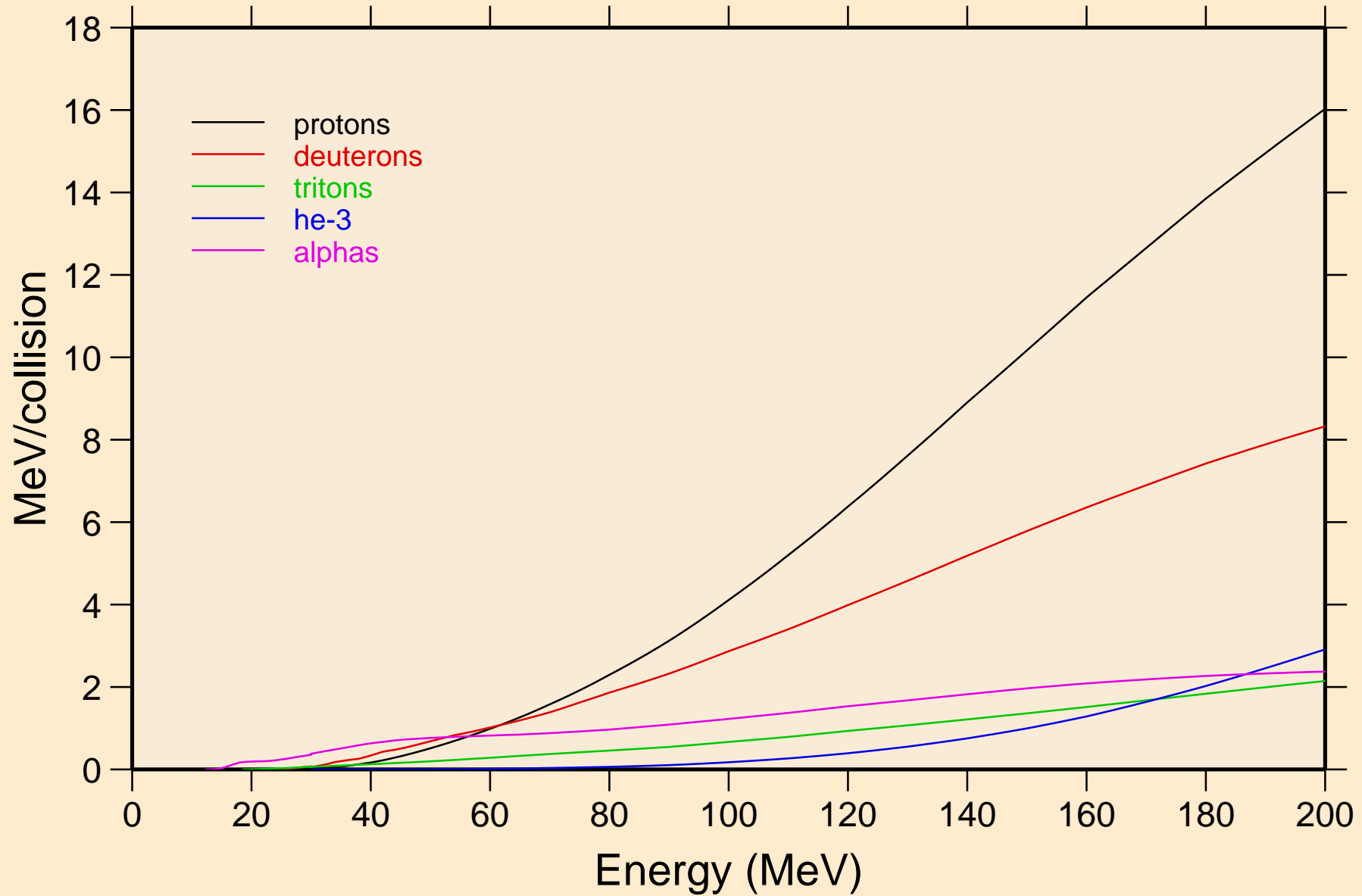

C014 NEUTRON ACER TENDL-2024 LIBRARY; T=0.K
Recoil Heating

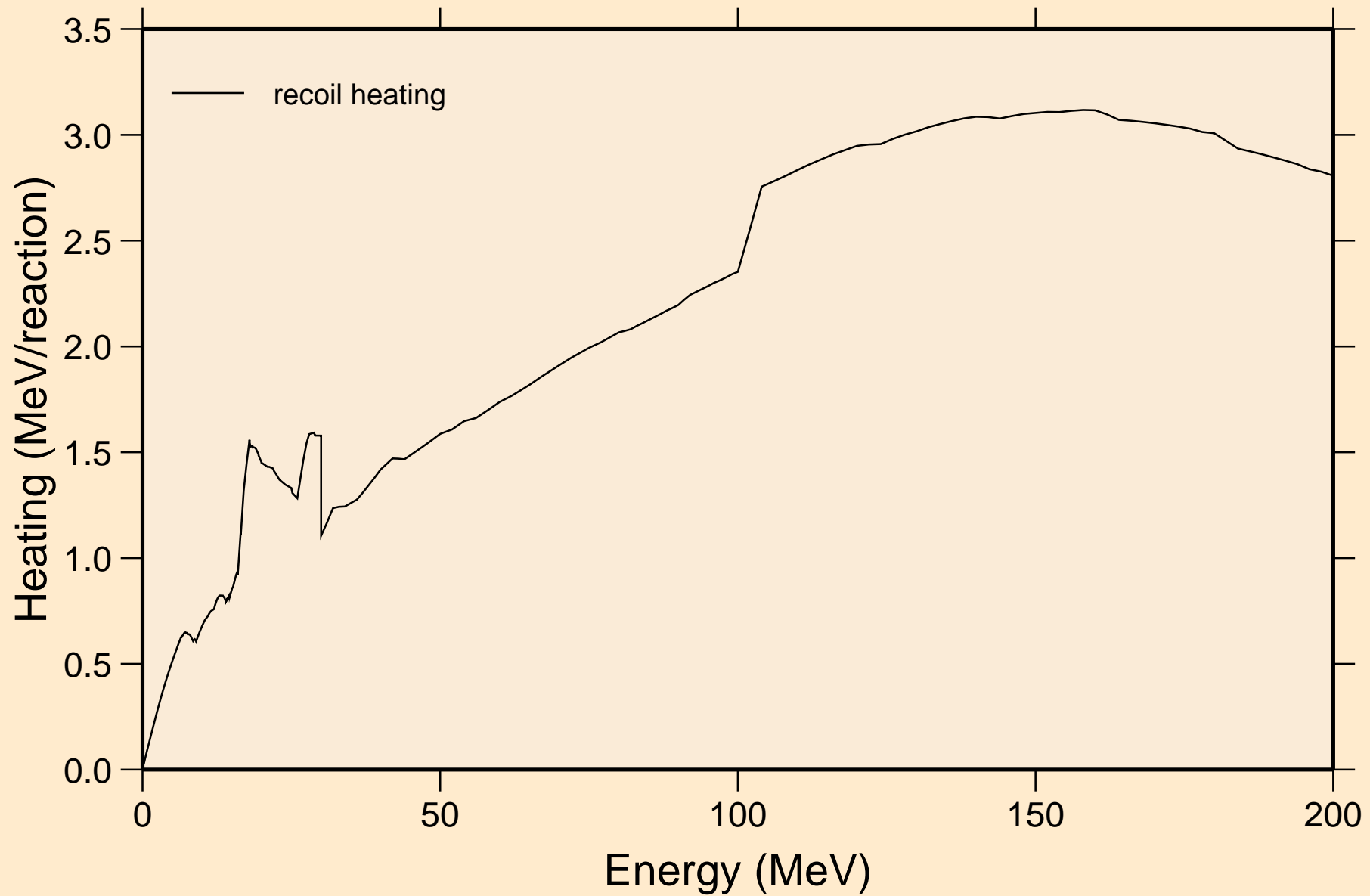

C014 NEUTRON ACER TENDL-2024 LIBRARY; T=0.K

Particle production cross sections

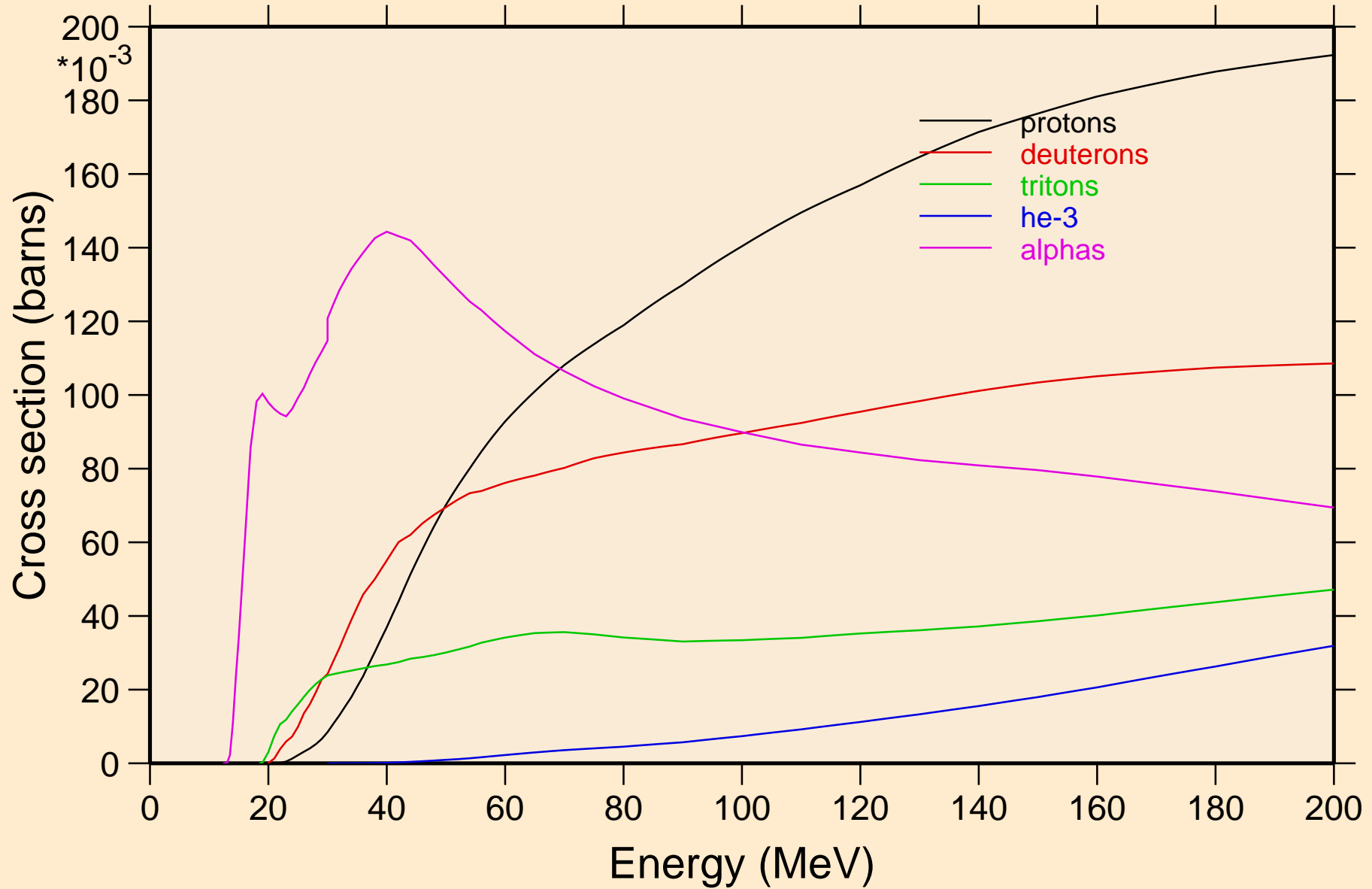

C014 NEUTRON ACER TENDL-2024 LIBRARY; T=0.K
protons from (n,x)

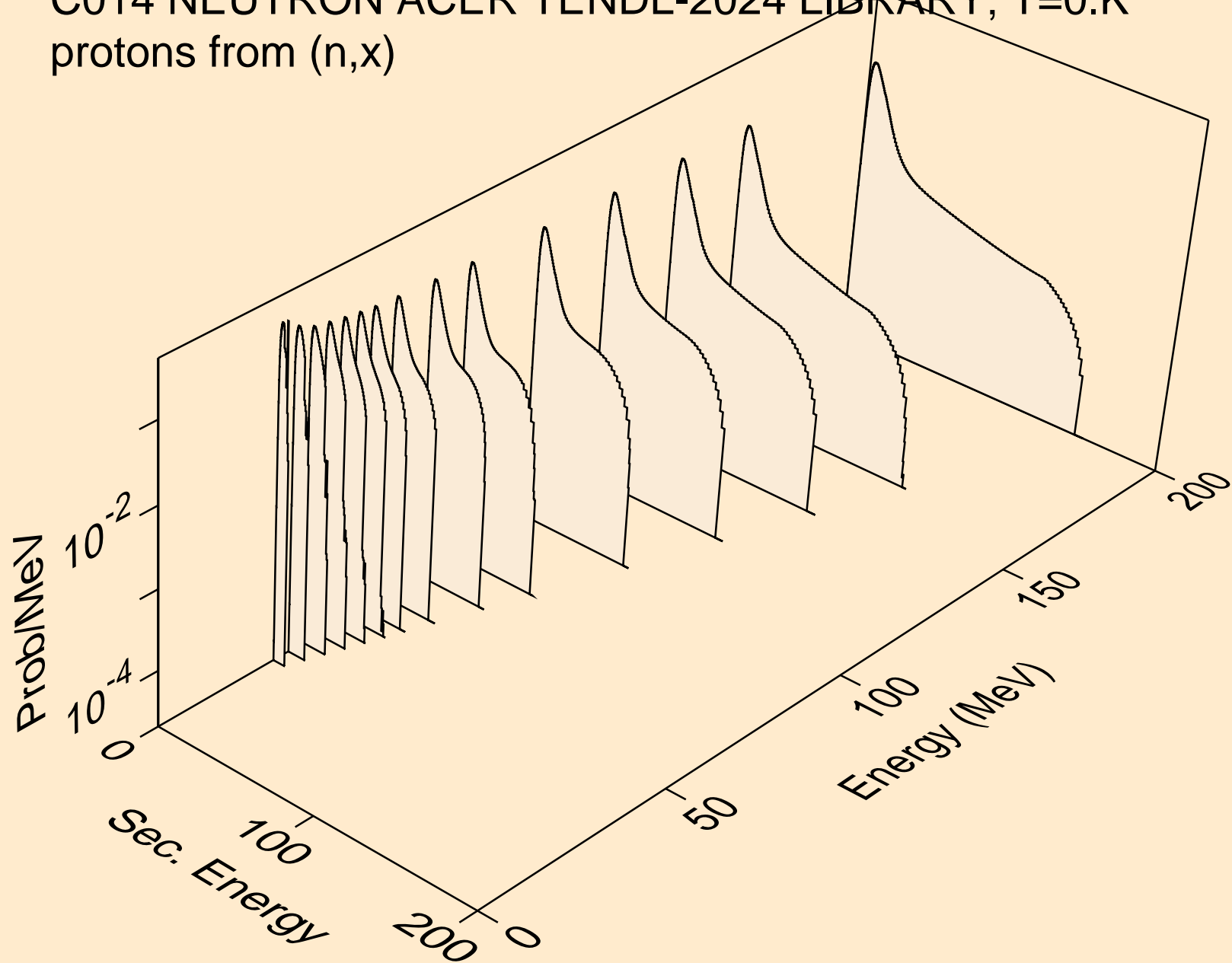

C014 NEUTRON ACER TENDL-2024 LIBRARY; T=0.K
protons from (n,n*)p

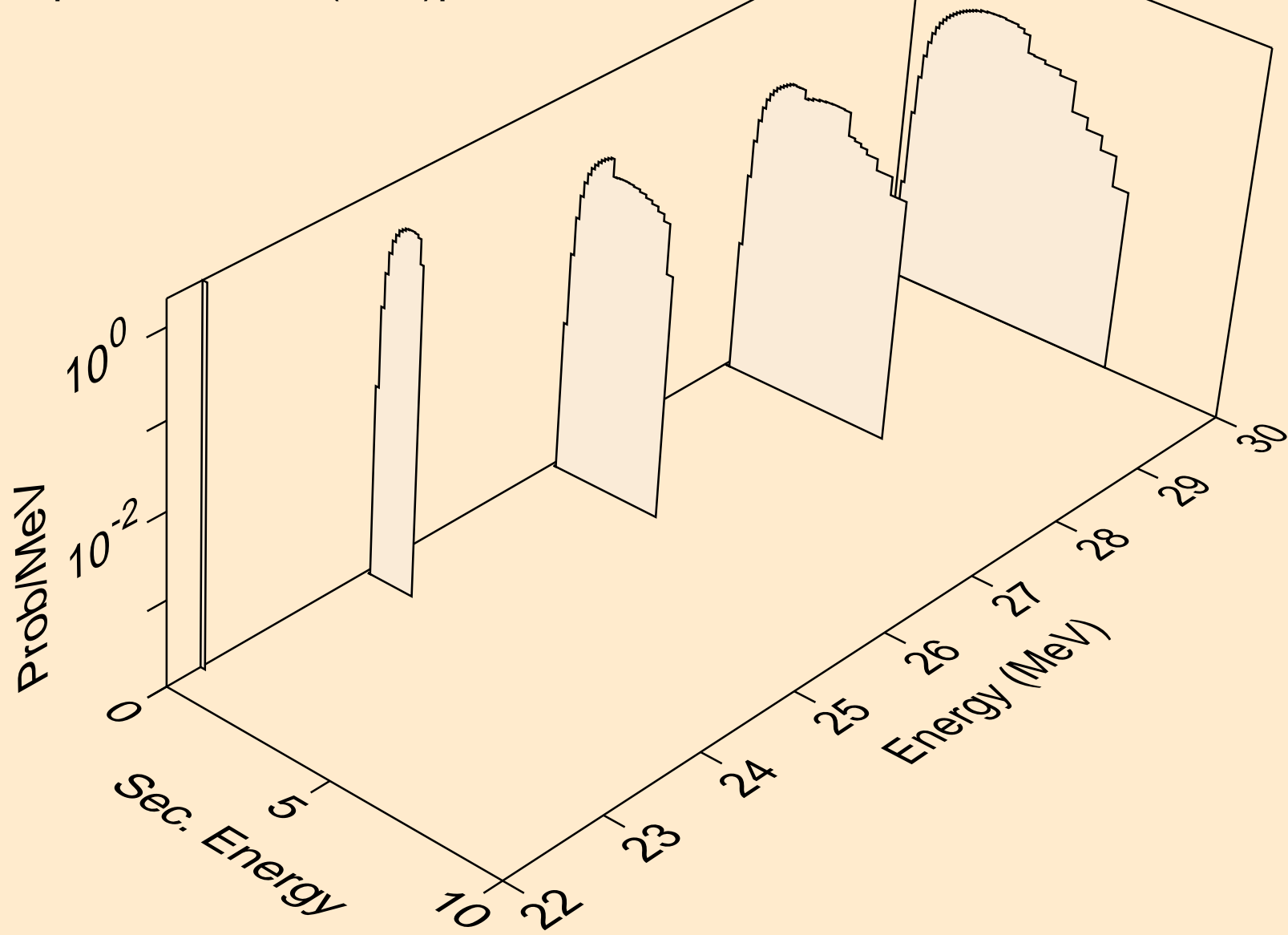

C014 NEUTRON ACER TENDL-2024 LIBRARY; T=0.K
protons from (n,2np)

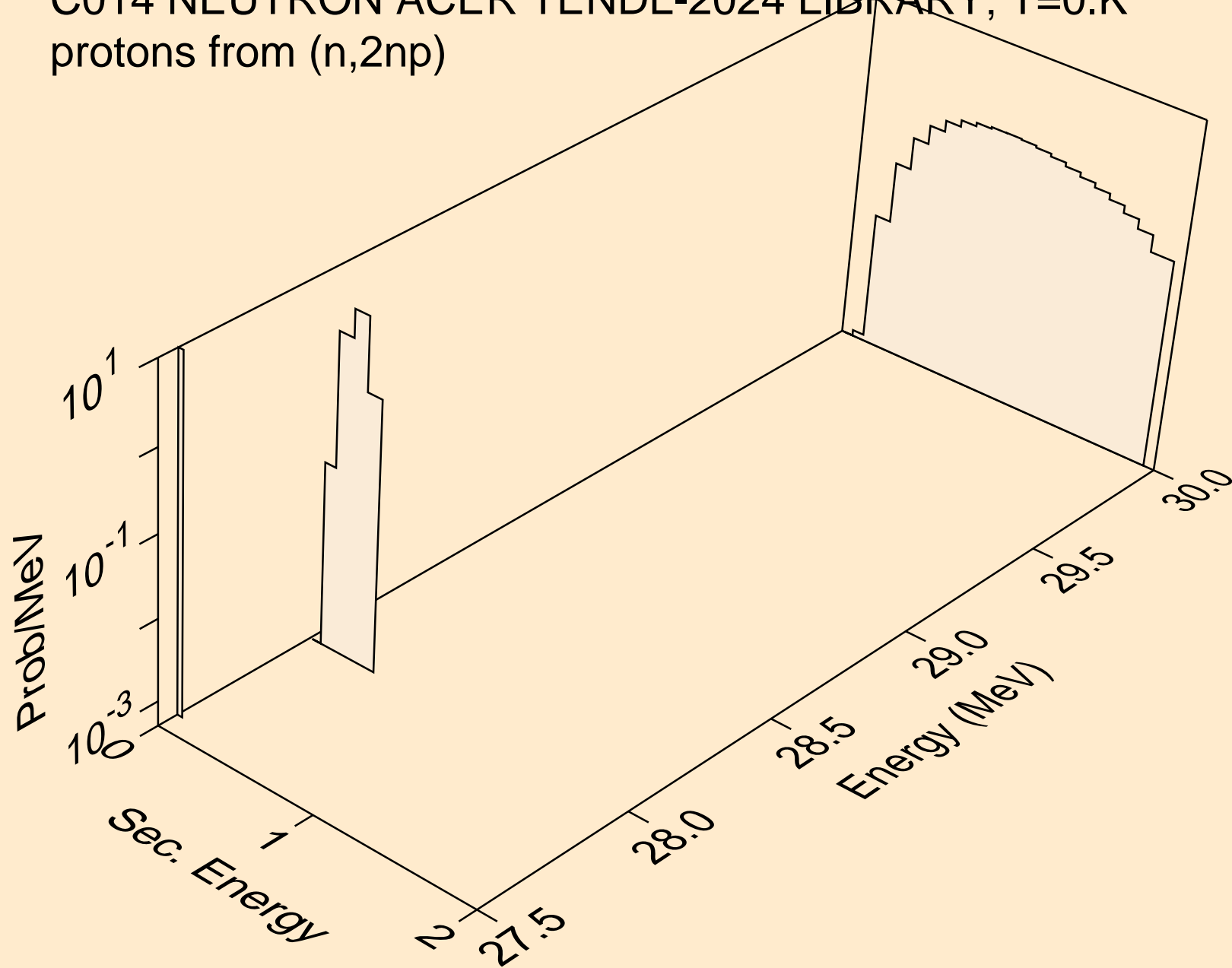

C014 NEUTRON ACER TENDL-2024 LIBRARY; T=0.K
protons from (n,p)

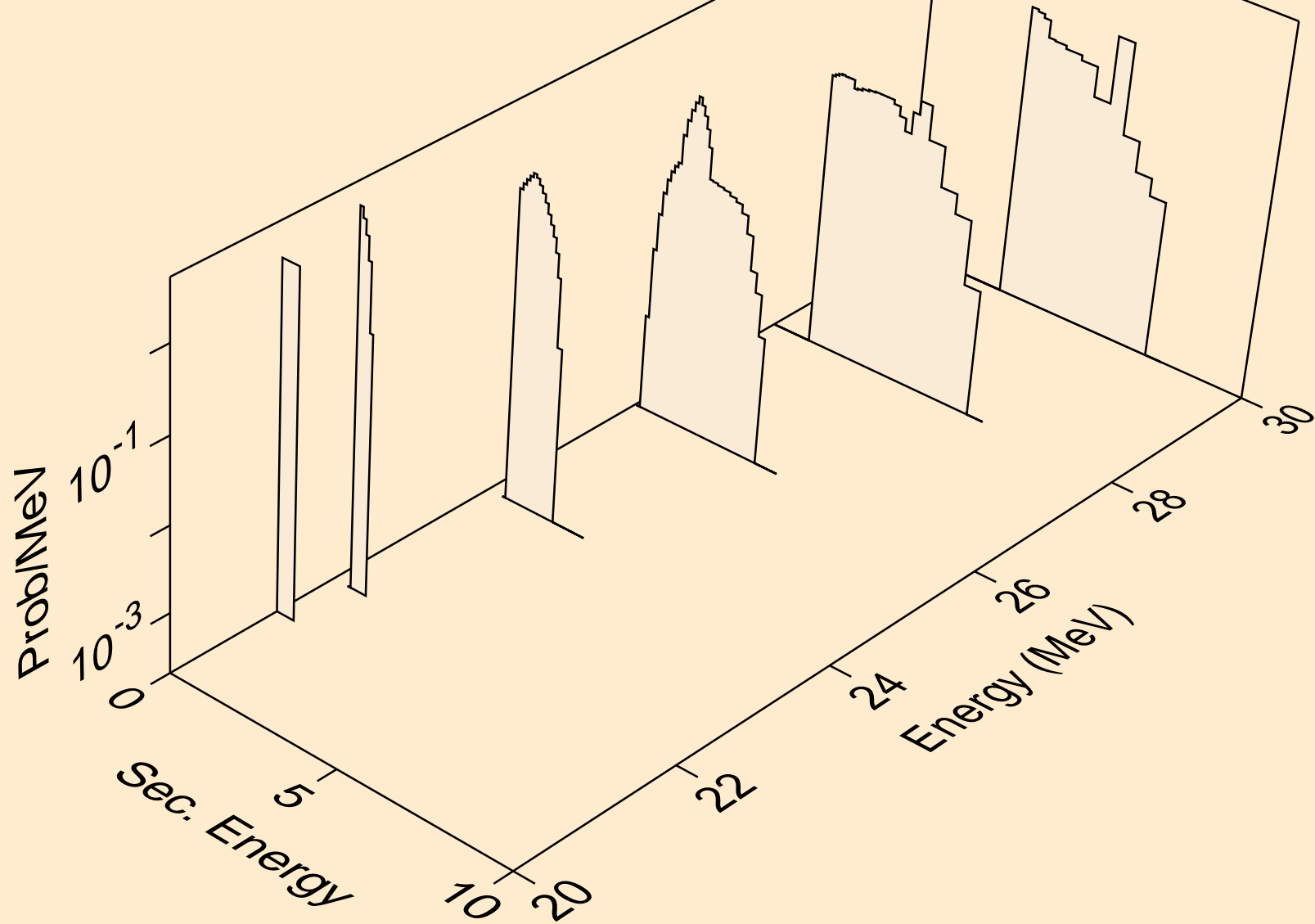

C014 NEUTRON ACER TENDL-2024 LIBRARY; T=0.K
deuterons from (n,x)

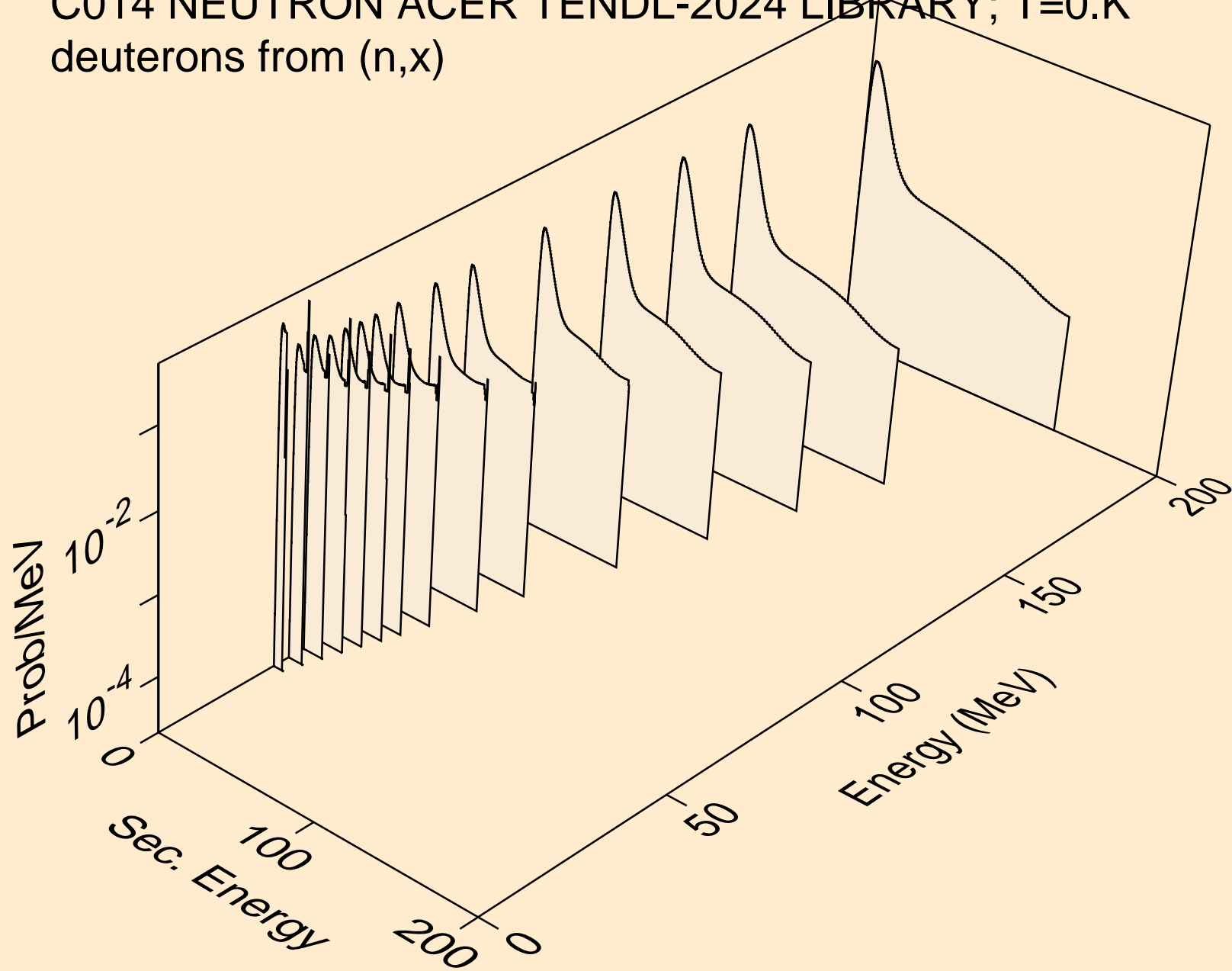

C014 NEUTRON ACER TENDL-2024 LIBRARY; T=0.K
deuterons from (n,2nd)

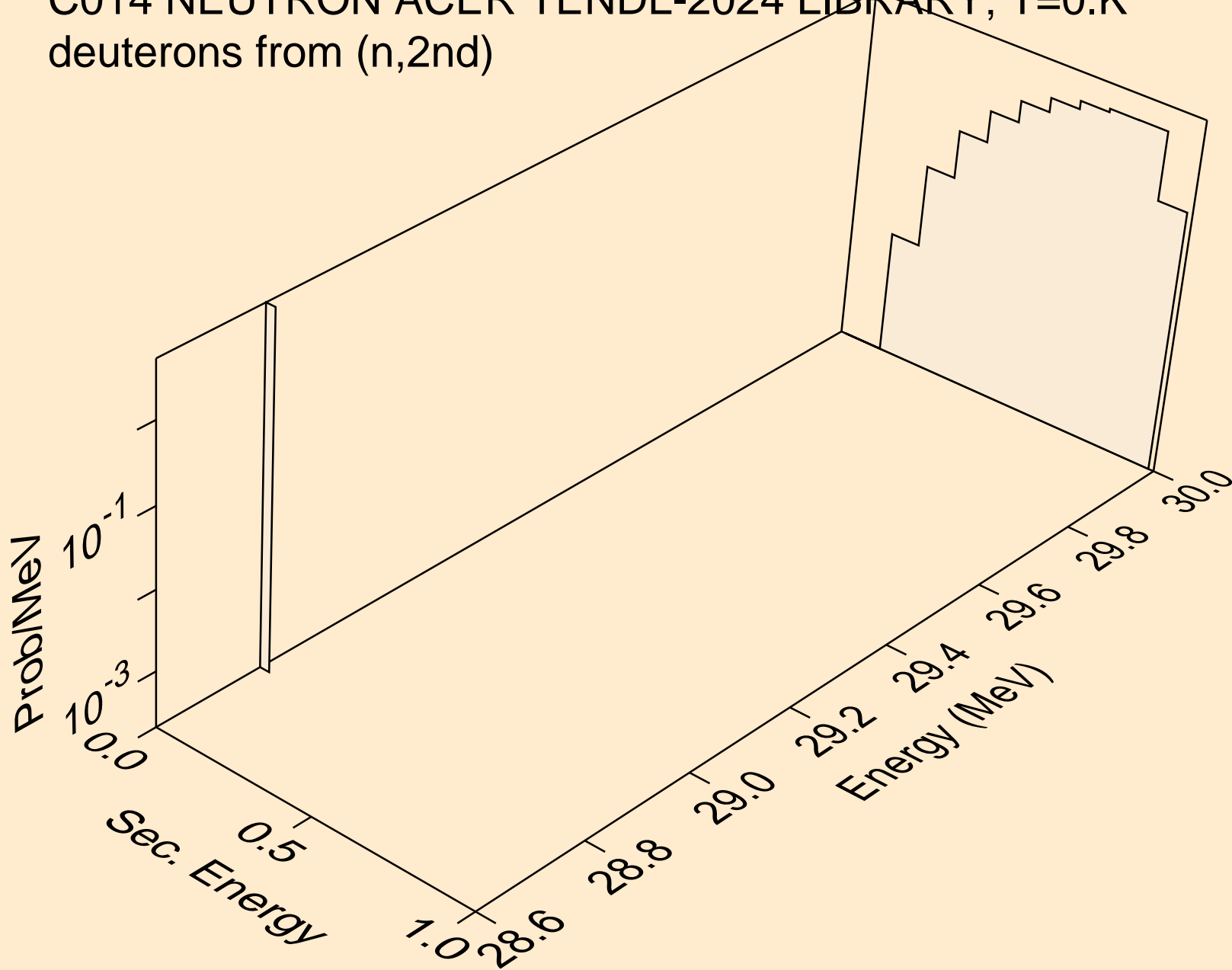

C014 NEUTRON ACER TENDL-2024 LIBRARY; T=0.K
deuterons from (n,n*)d

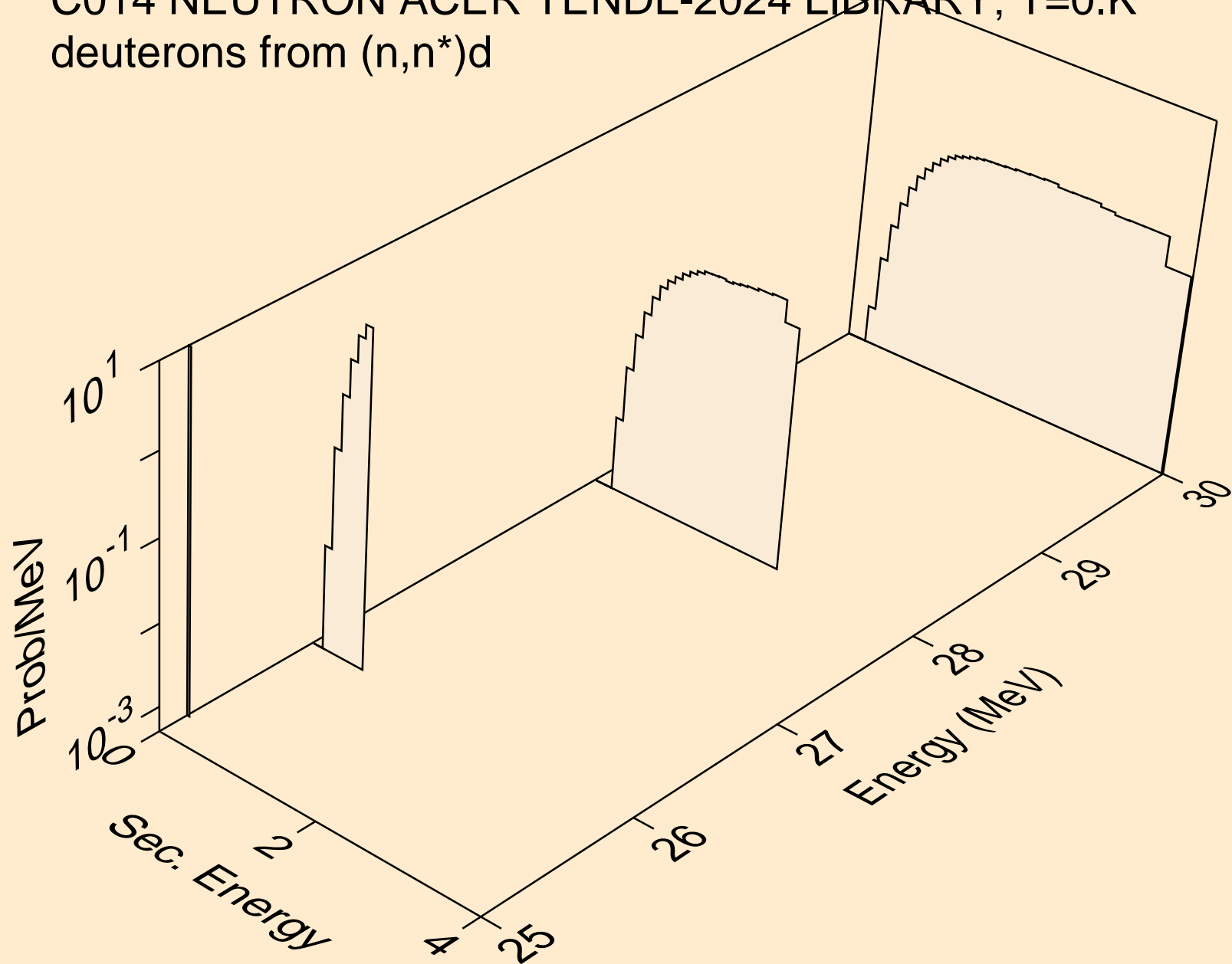

C014 NEUTRON ACER TENDL-2024 LIBRARY; T=0.K
deuterons from (n,d)

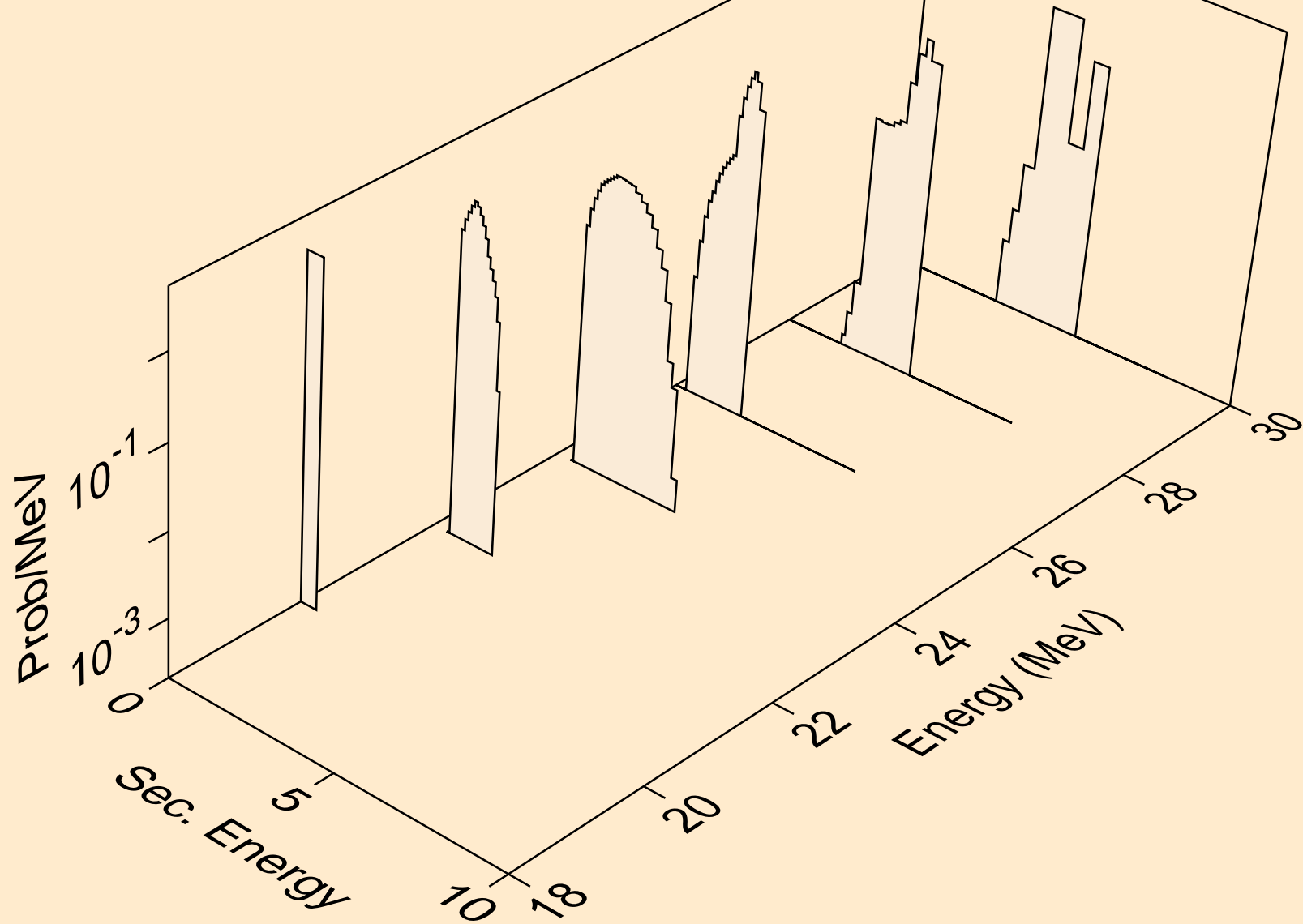

C014 NEUTRON ACER TENDL-2024 LIBRARY; T=0.K
tritons from (n,x)

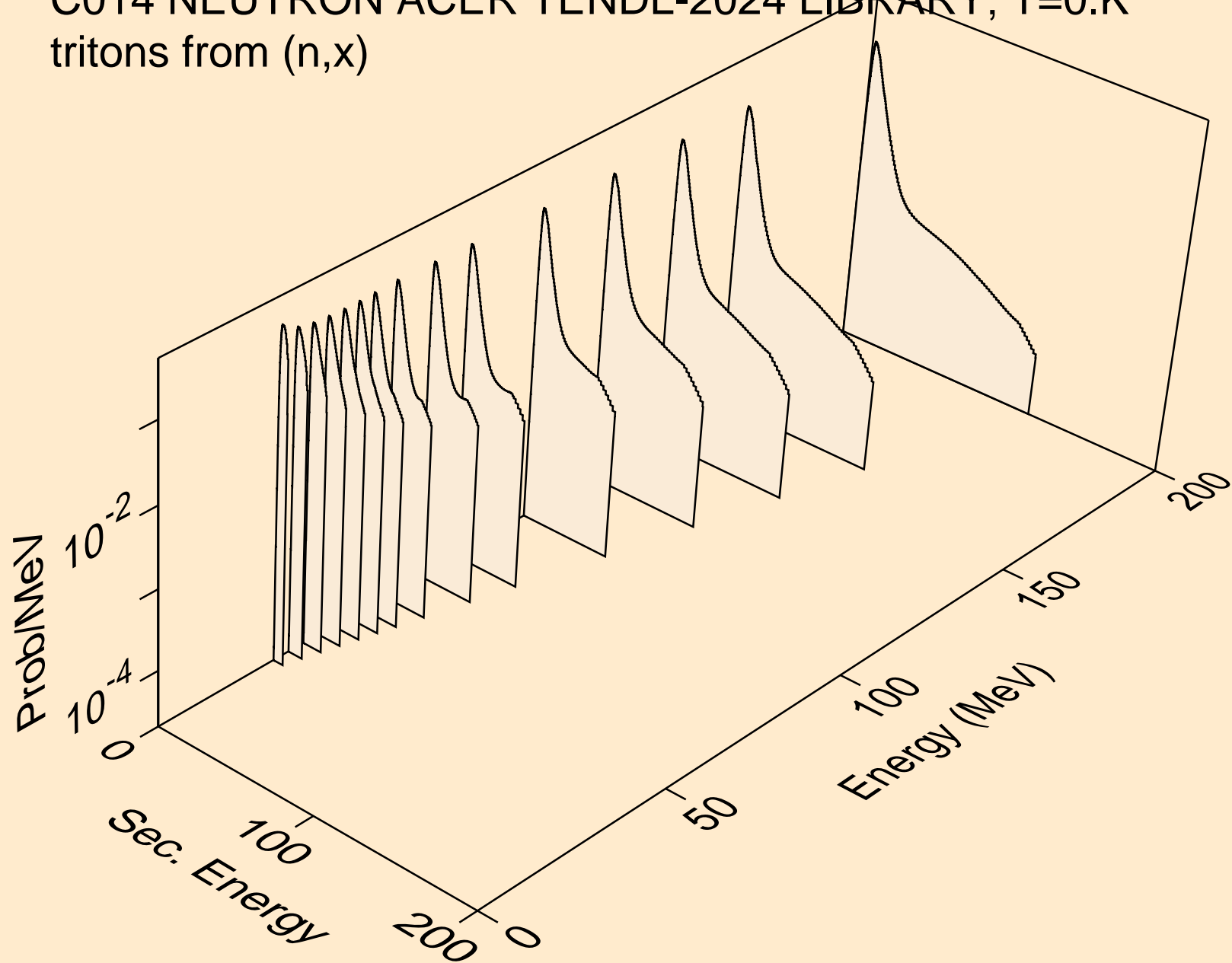

C014 NEUTRON ACER TENDL-2024 LIBRARY; T=0.K
tritons from (n,n*)t

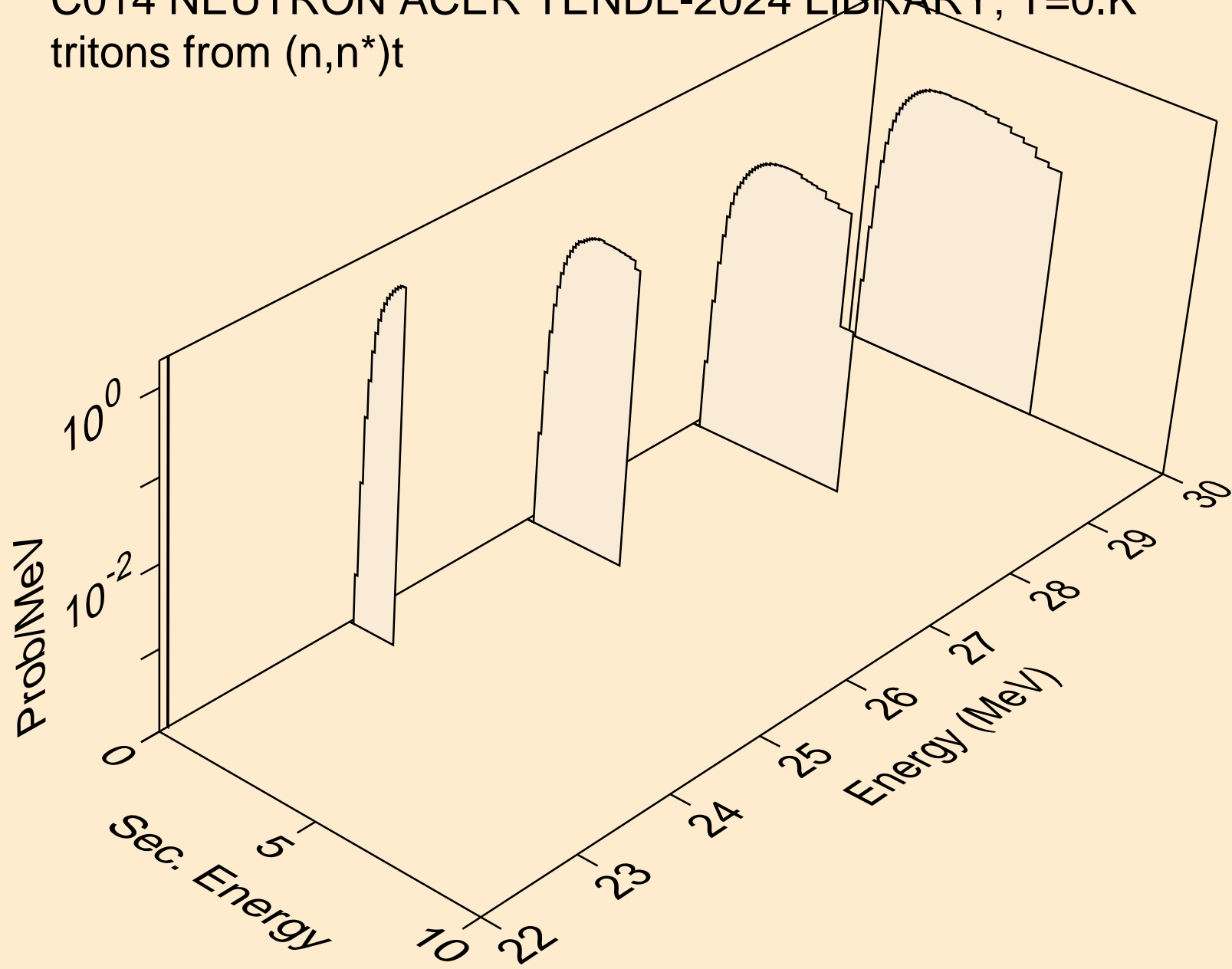

C014 NEUTRON ACER TENDL-2024 LIBRARY; T=0.K
tritons from (n,t)

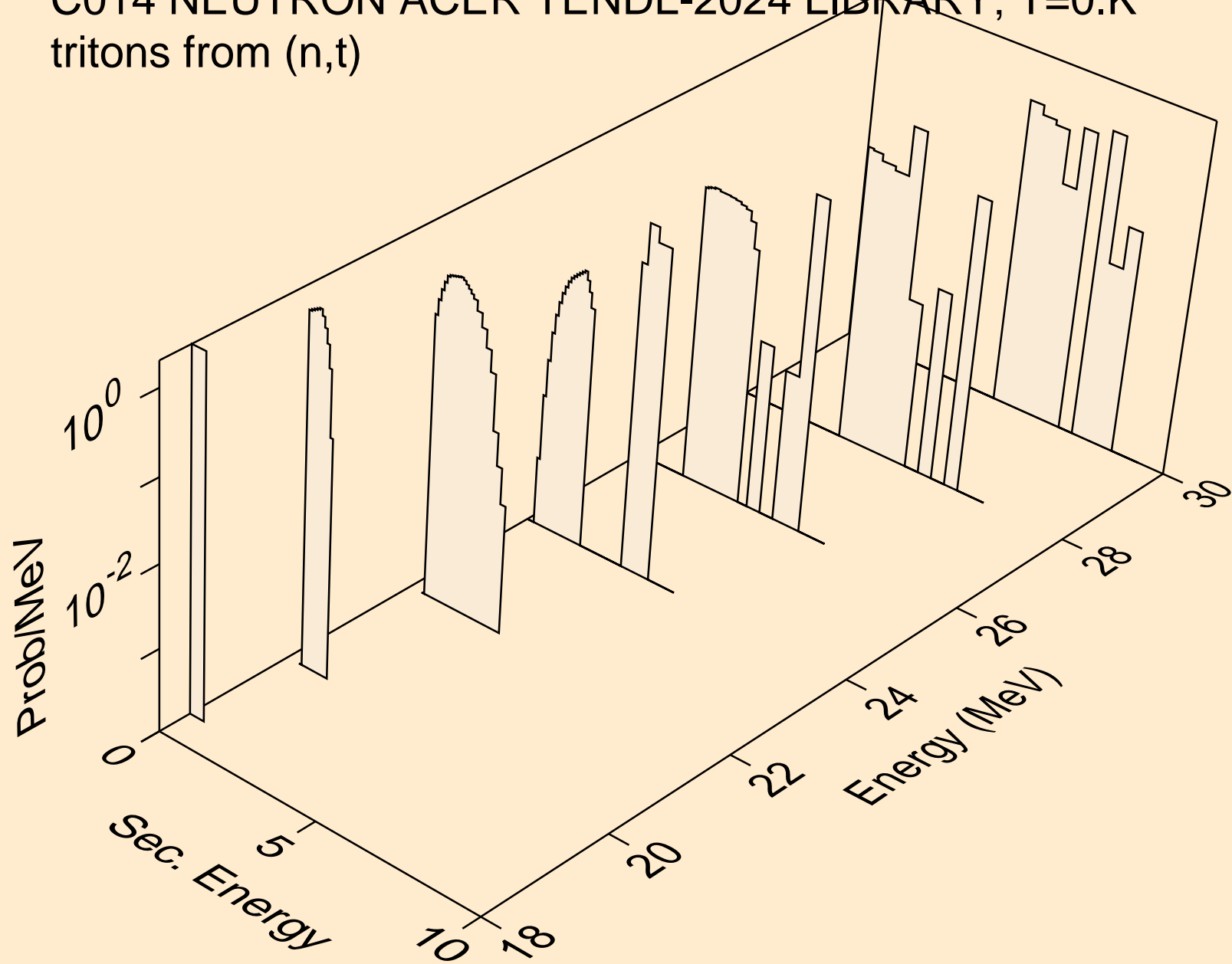

C014 NEUTRON ACER TENDL-2024 LIBRARY; T=0.K
he3s from (n,x)

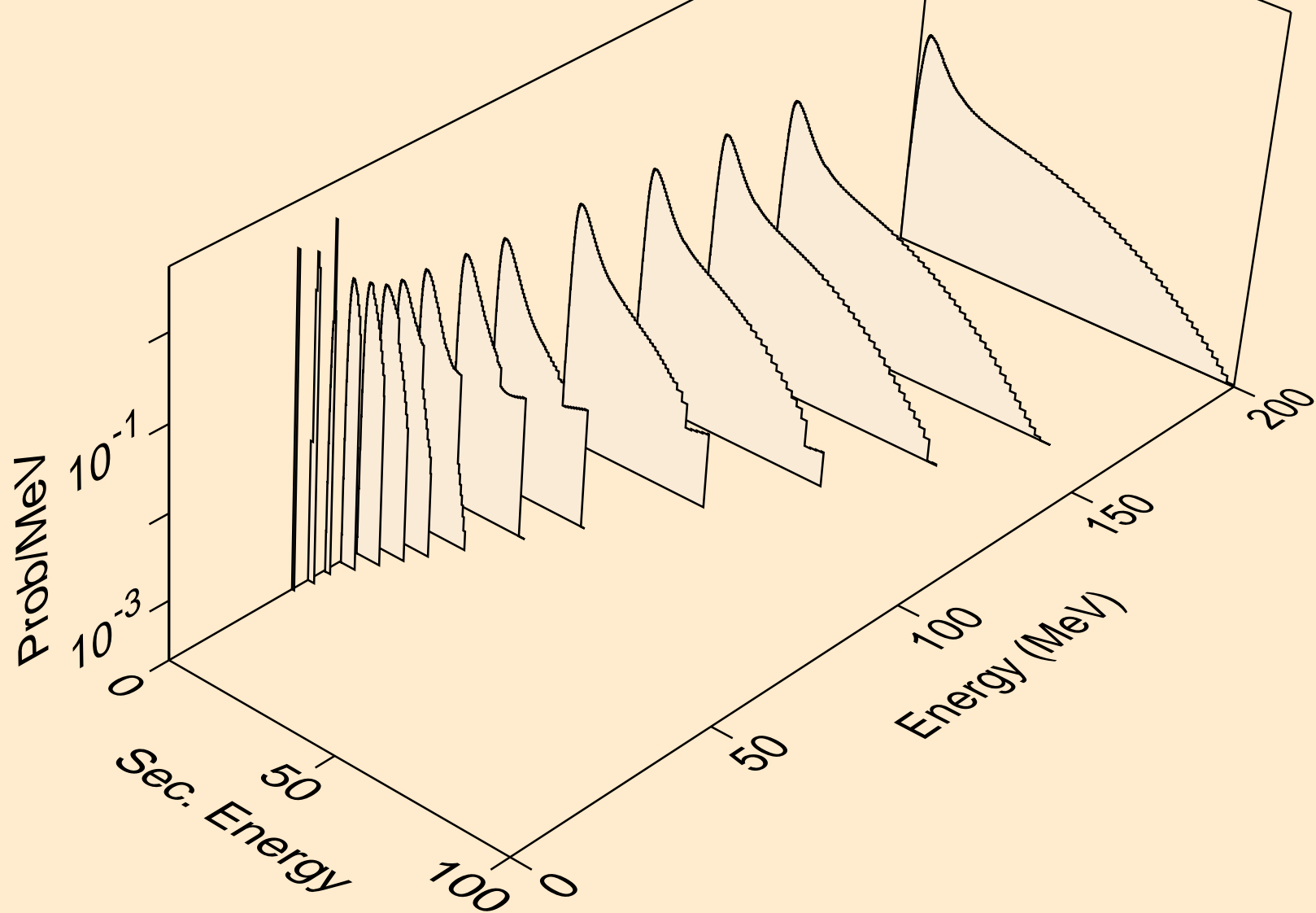

C014 NEUTRON ACER TENDL-2024 LIBRARY; T=0.K
alphas from (n,x)

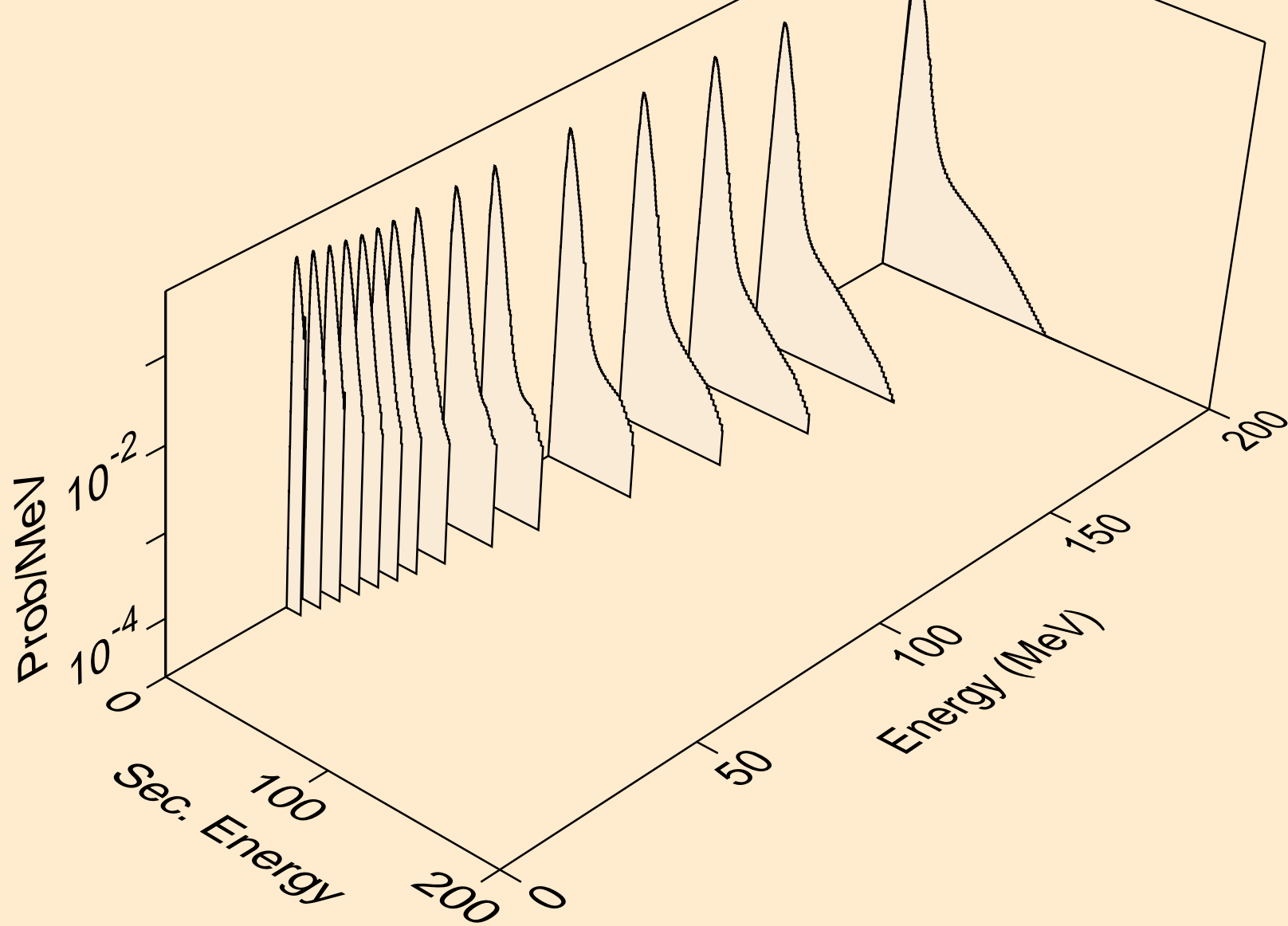

C014 NEUTRON ACER TENDL-2024 LIBRARY; T=0.K
alphas from (n,n*)a

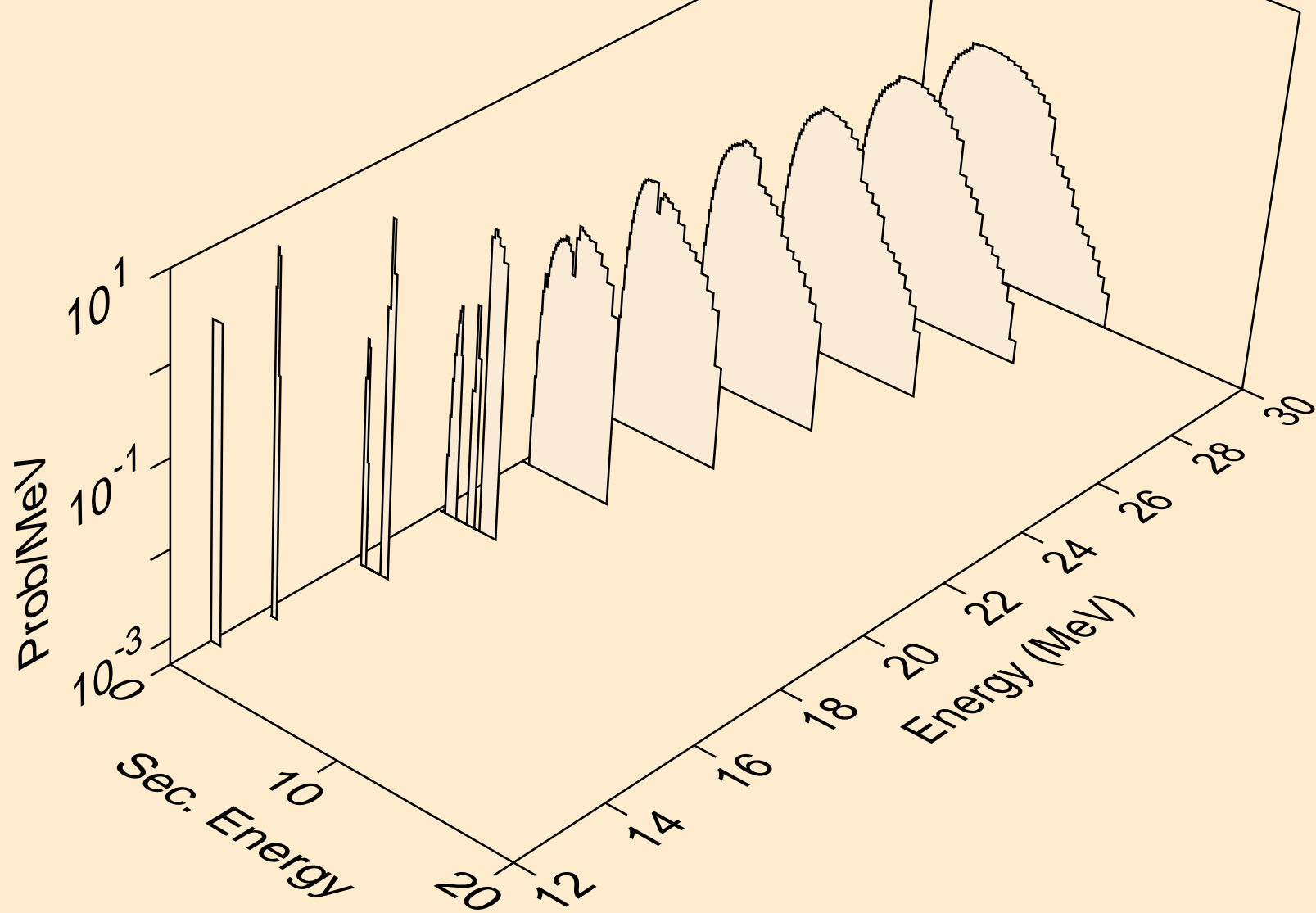

C014 NEUTRON ACER TENDL-2024 LIBRARY; T=0.K
alphas from (n,2n)a

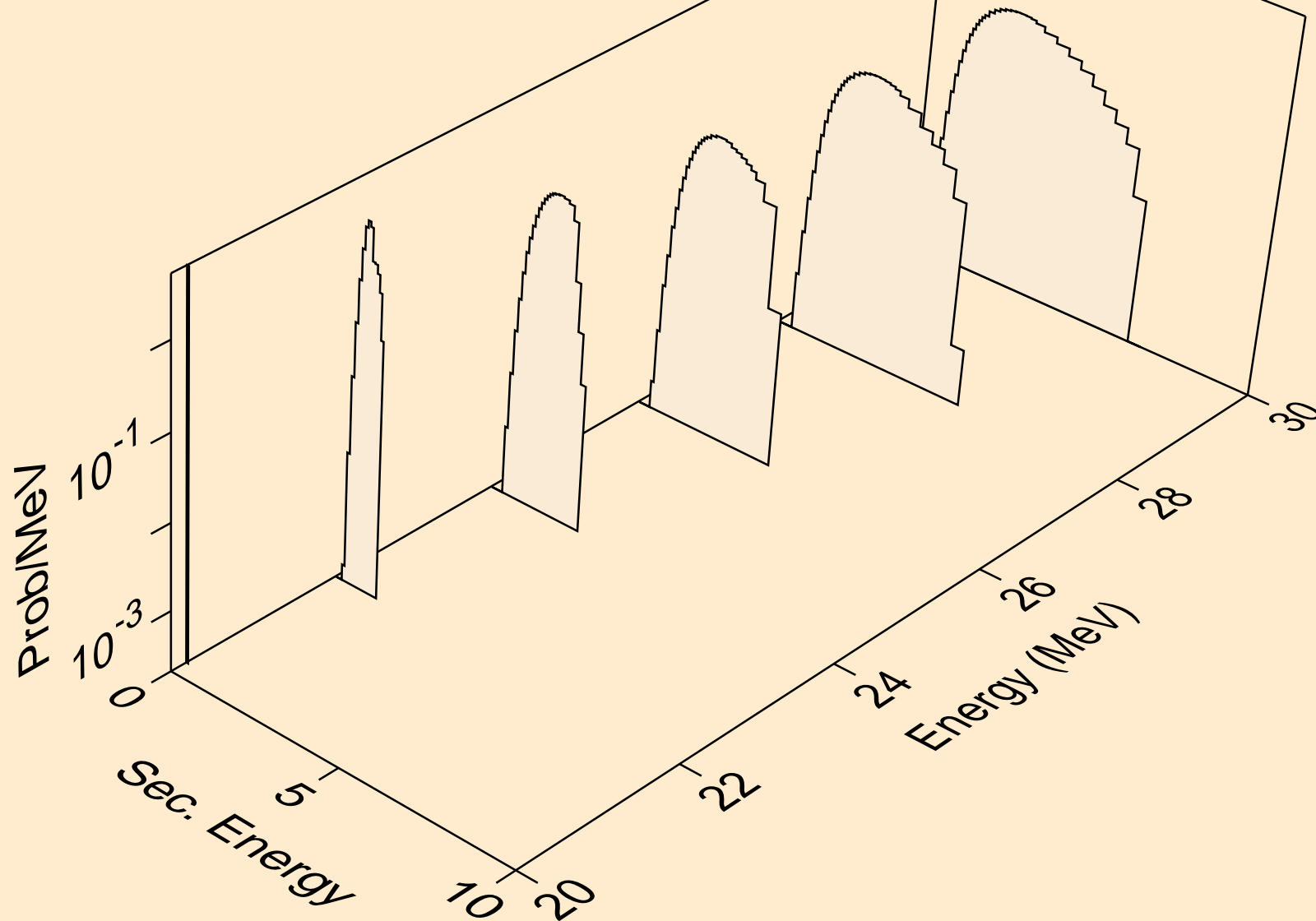

C014 NEUTRON ACER TENDL-2024 LIBRARY; T=0.K
alphas from (n,3n)a

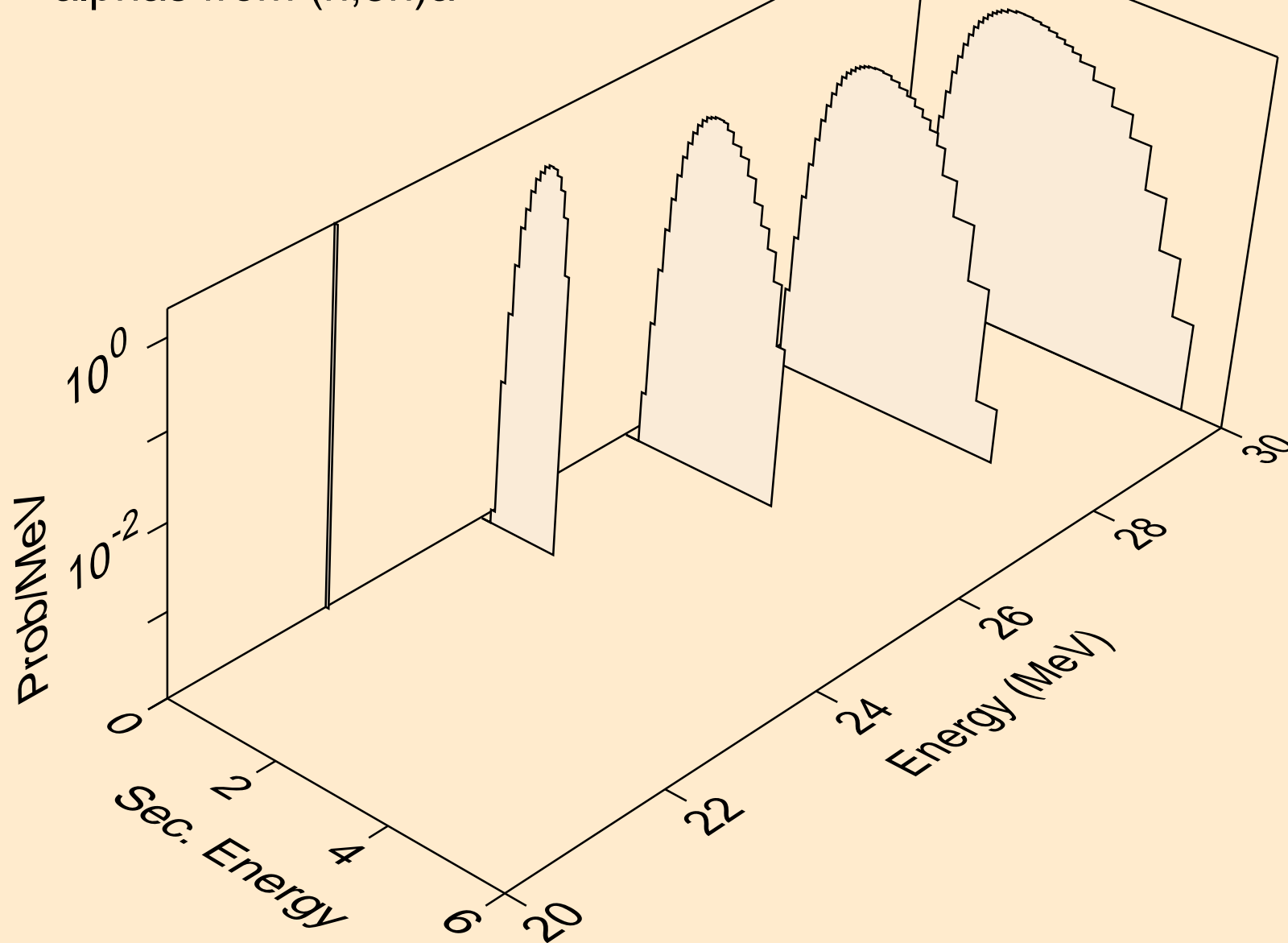

C014 NEUTRON ACER TENDL-2024 LIBRARY; T=0.K
alphas from (n,a)

