

CR054 NEUTRON ACER TENDL-2024 LIBRARY; T=0.K

Principal cross sections

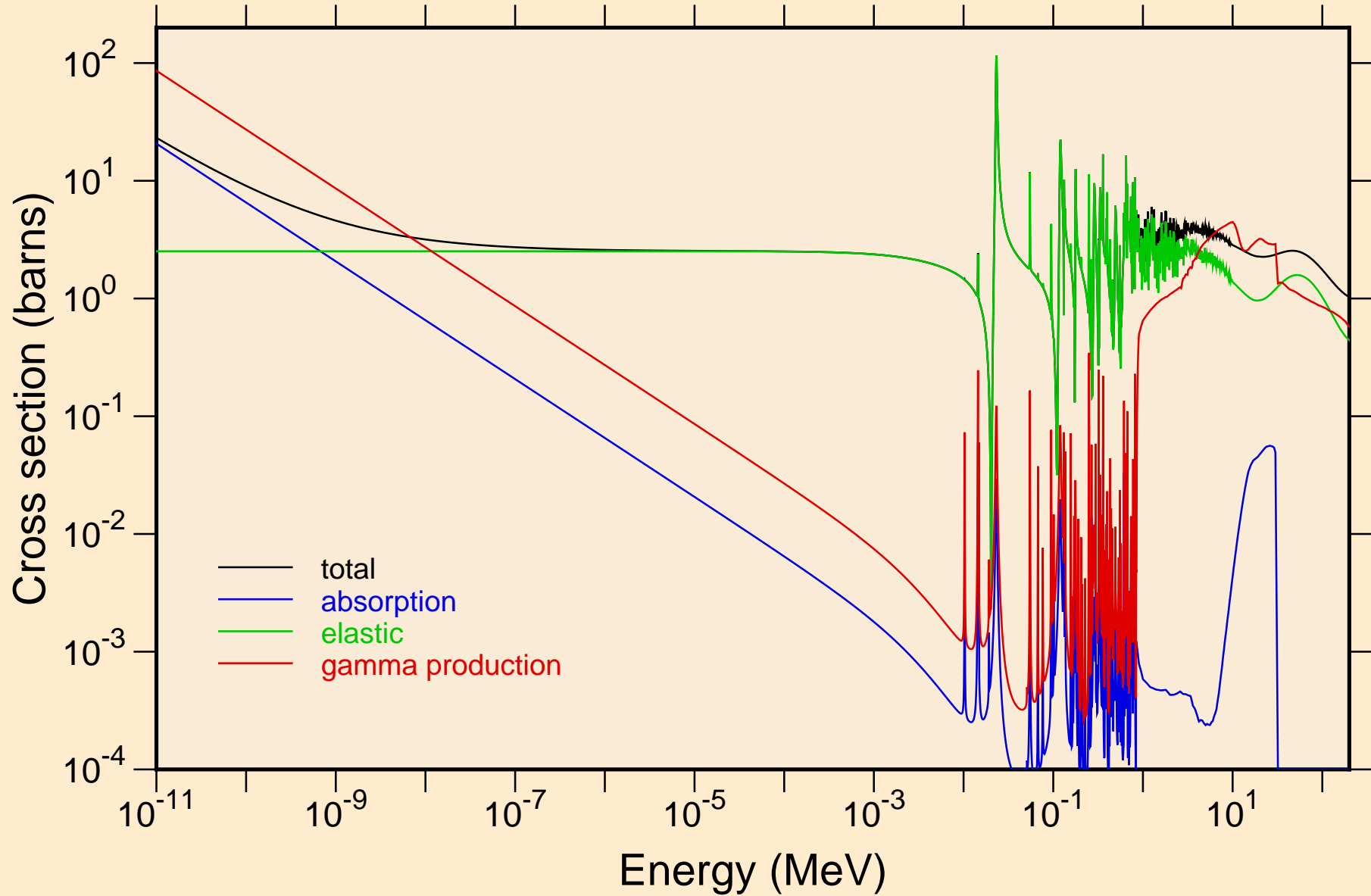

CR054 NEUTRON ACER TENDL-2024 LIBRARY; T=0.K
resonance total cross section

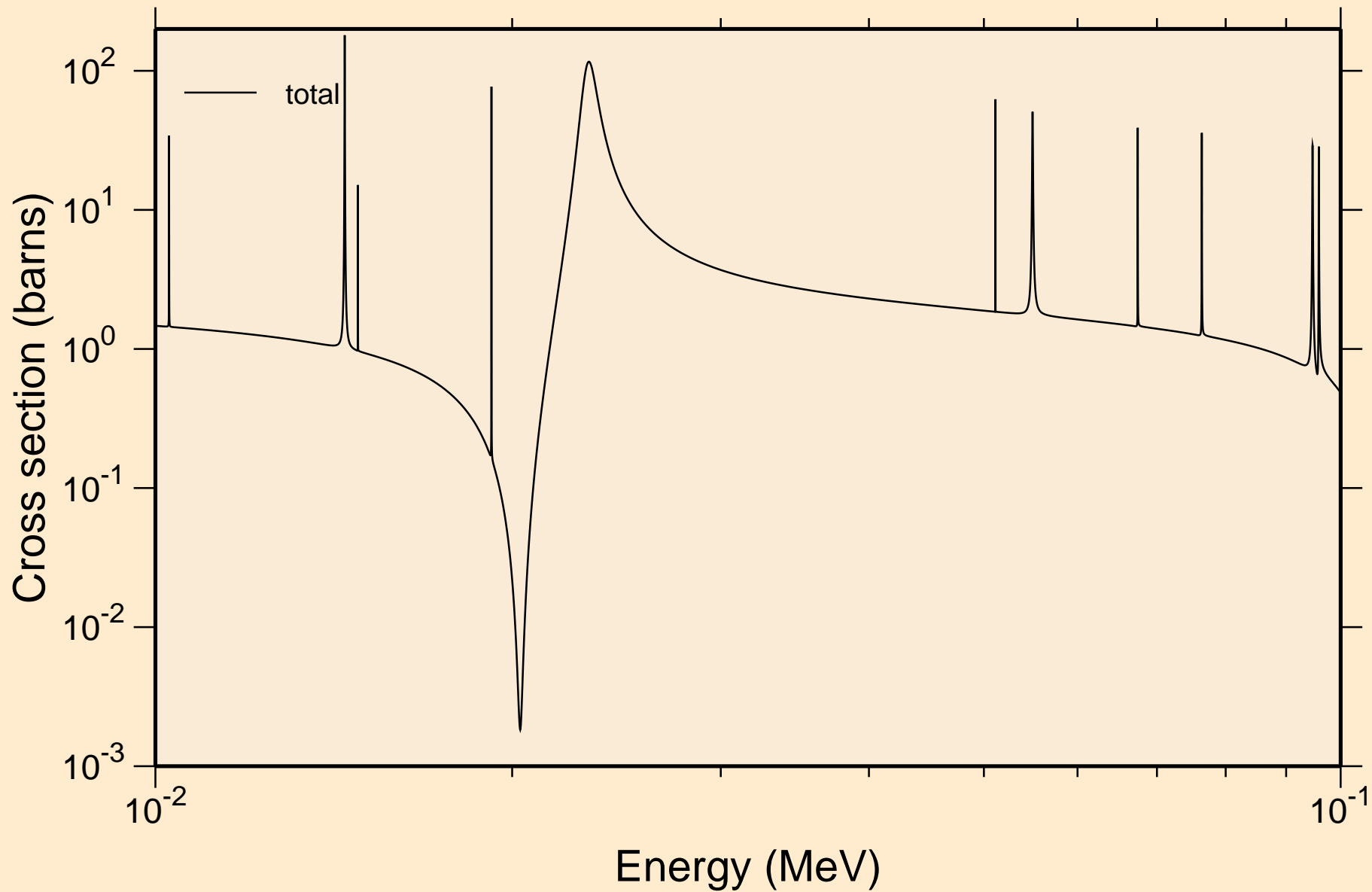

CR054 NEUTRON ACER TENDL-2024 LIBRARY; T=0.K
resonance total cross section

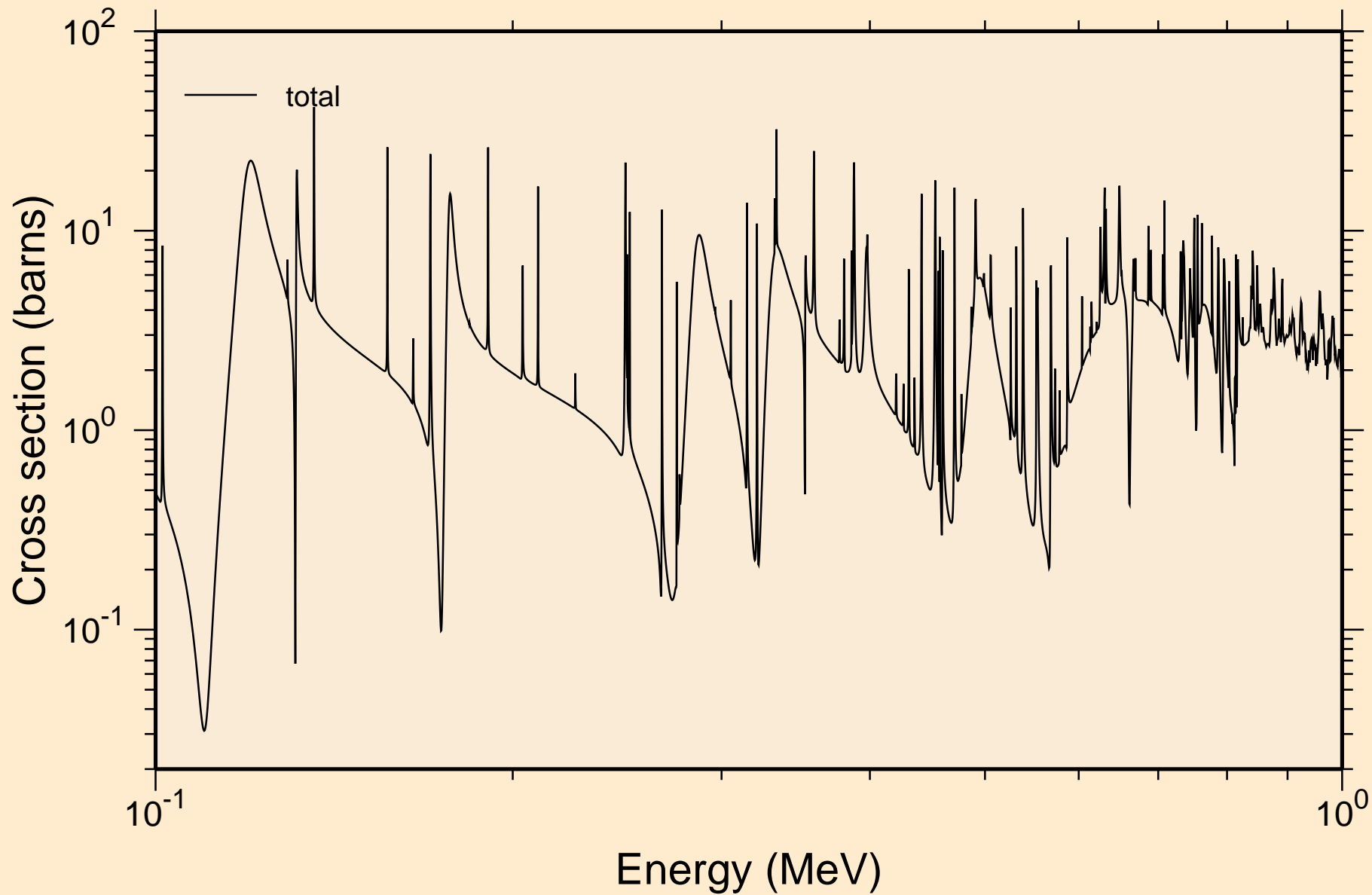

CR054 NEUTRON ACER TENDL-2024 LIBRARY; T=0.K
resonance total cross section

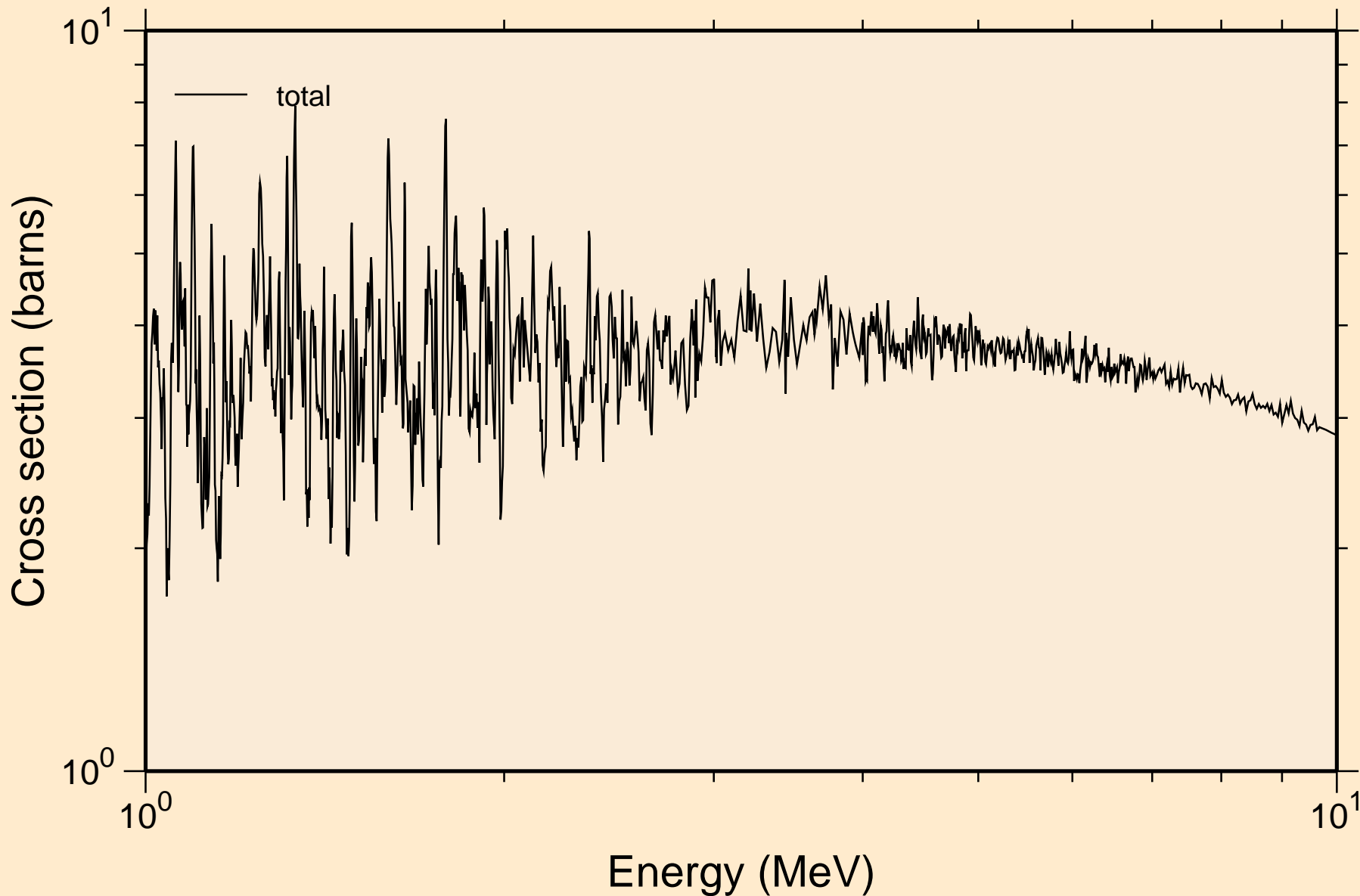

CR054 NEUTRON ACER TENDL-2024 LIBRARY; T=0.K
resonance absorption cross sections

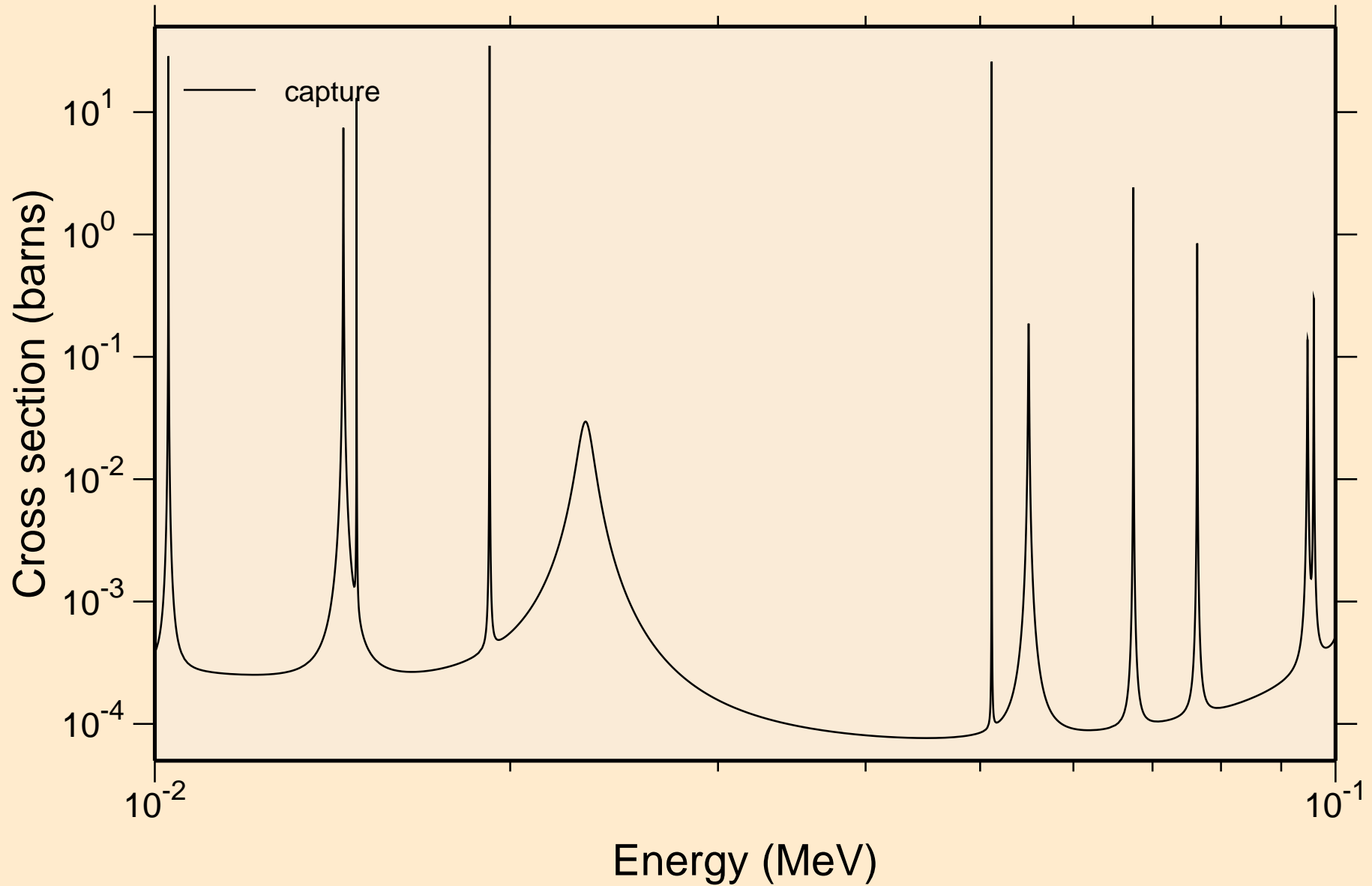

CR054 NEUTRON ACER TENDL-2024 LIBRARY; T=0.K
resonance absorption cross sections

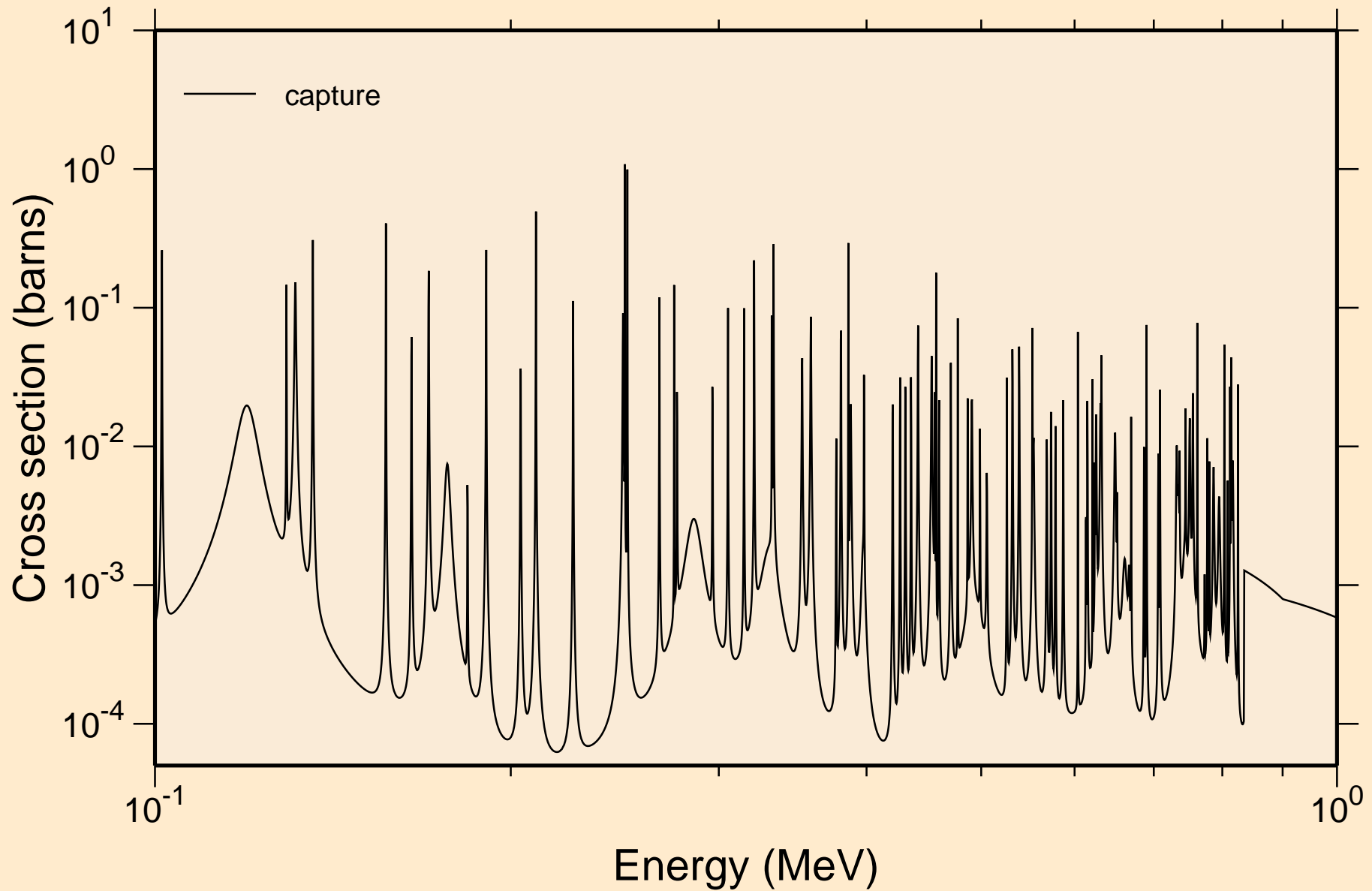

CR054 NEUTRON ACER TENDL-2024 LIBRARY; T=0.K
resonance absorption cross sections

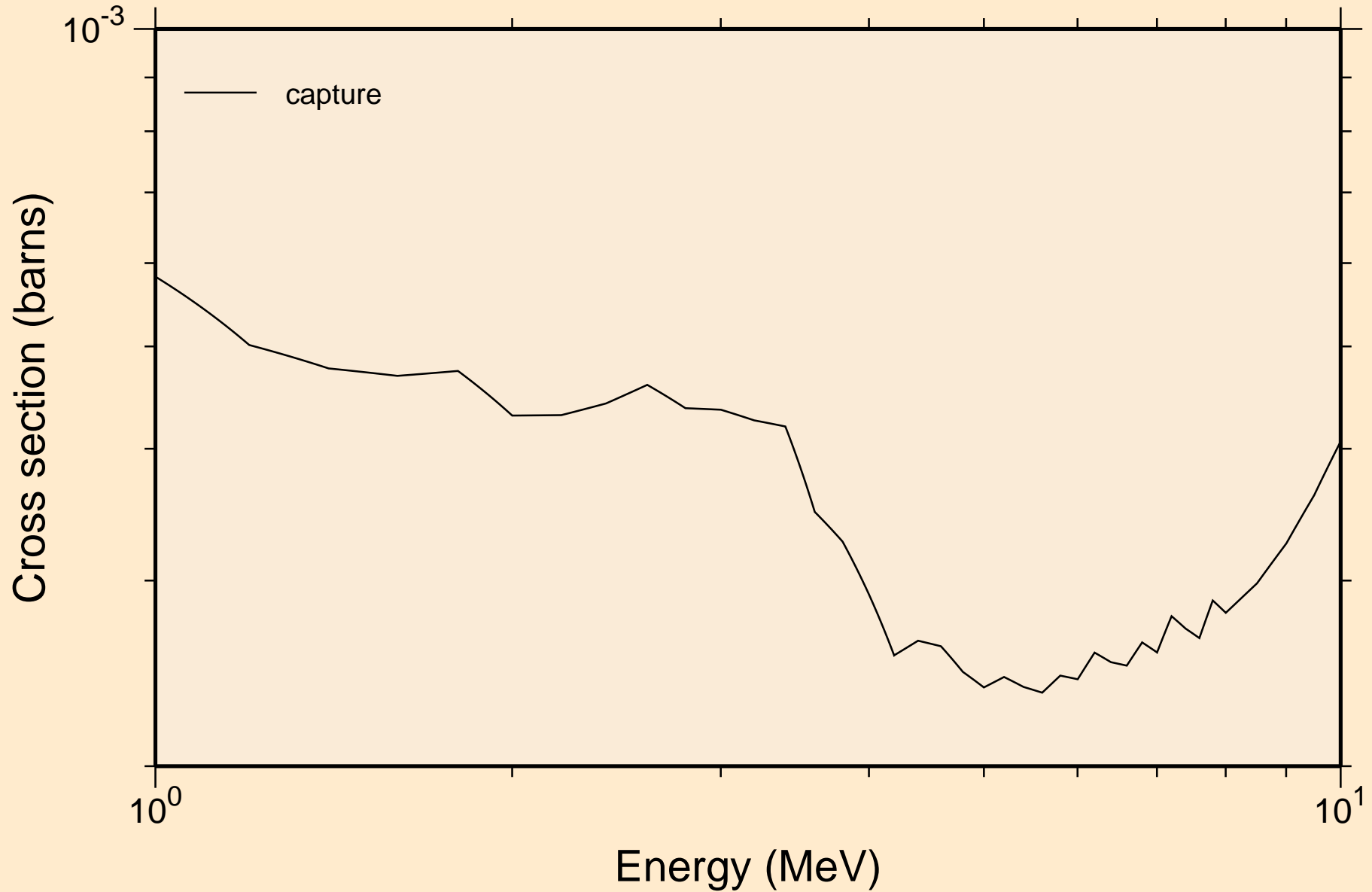

CR054 NEUTRON ACER TENDL-2024 LIBRARY; T=0.K
Heating

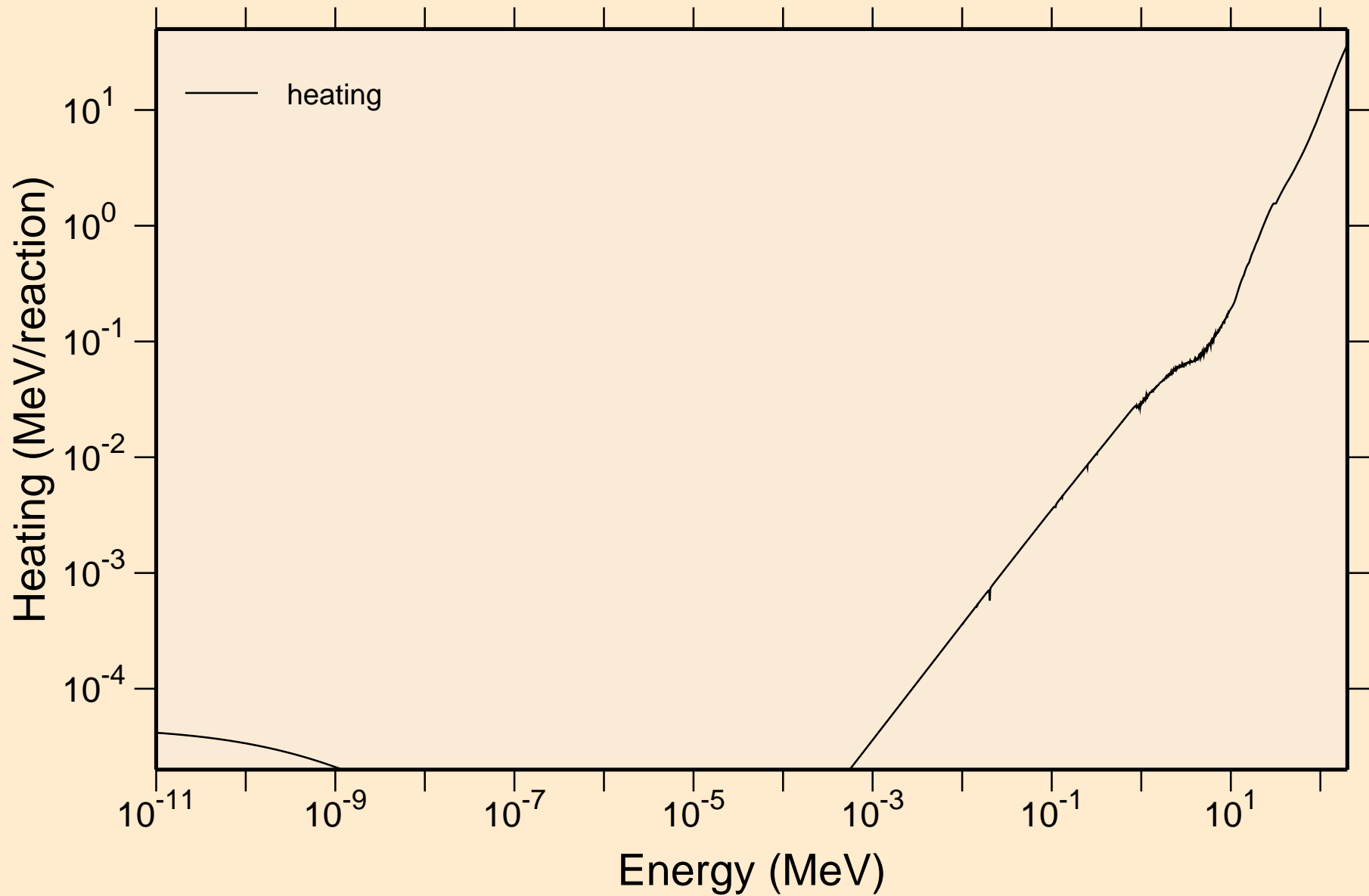

CR054 NEUTRON ACER TENDL-2024 LIBRARY; T=0.K

Damage

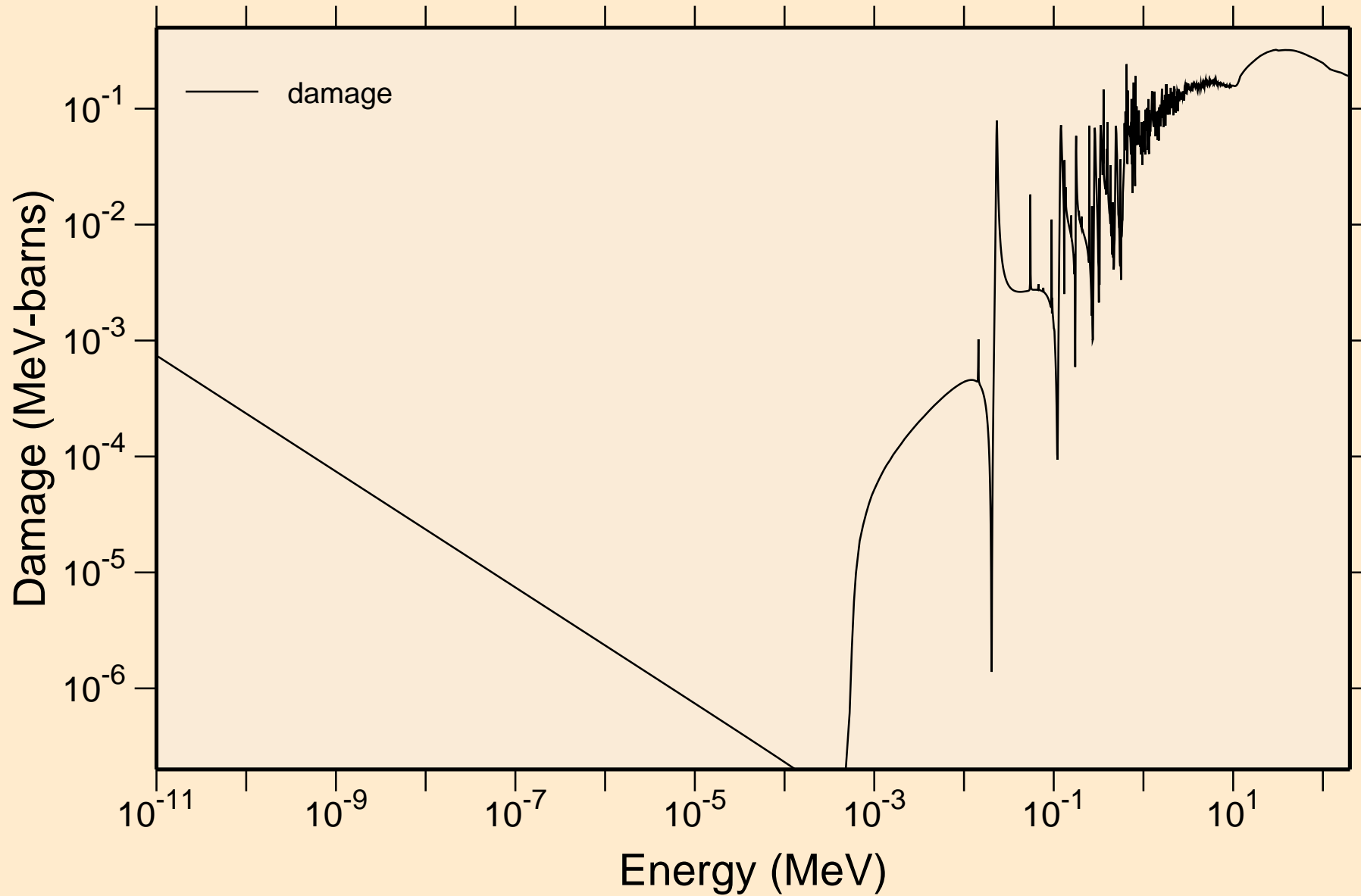

CR054 NEUTRON ACER TENDL-2024 LIBRARY; T=0.K
Non-threshold reactions

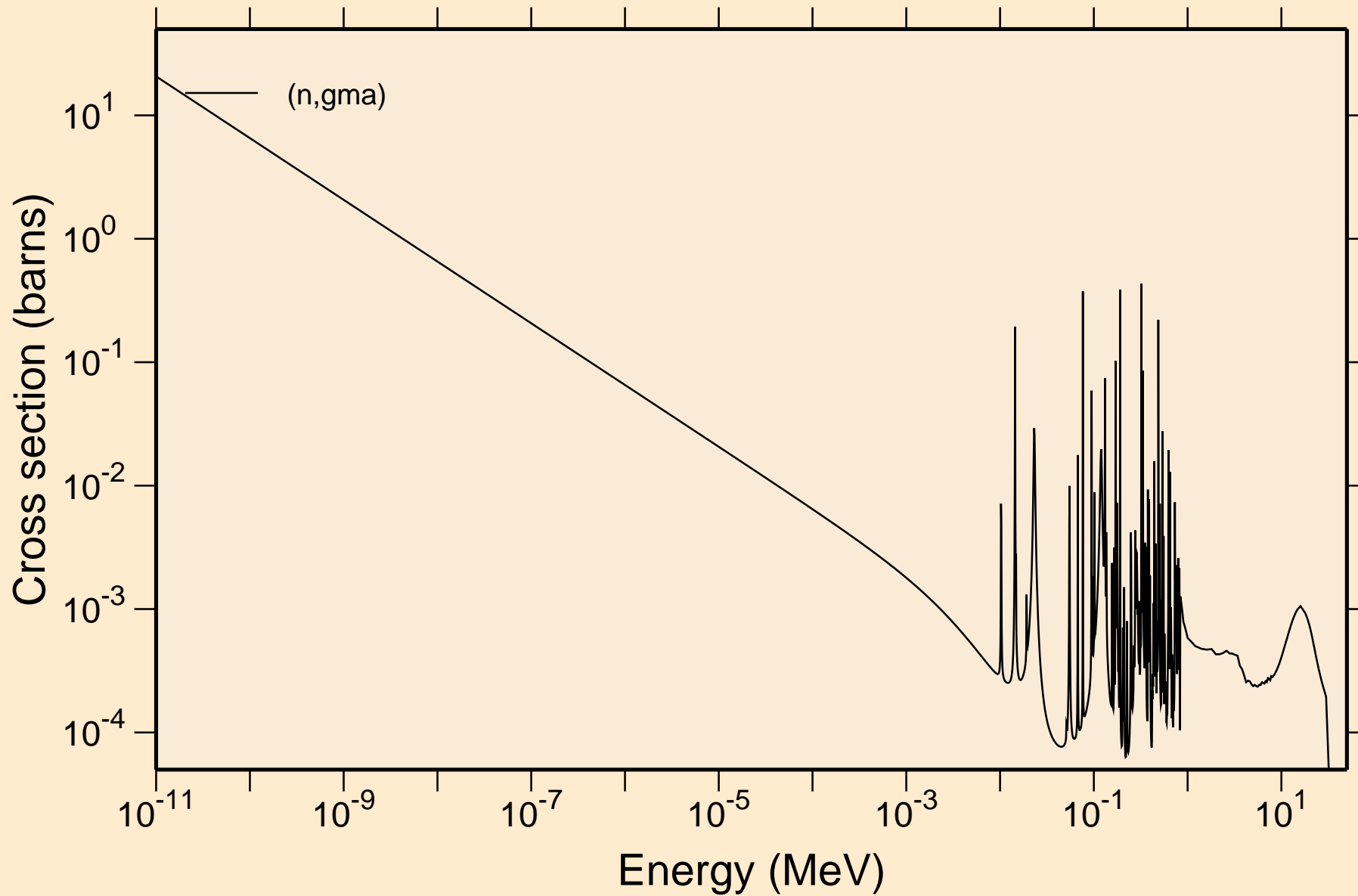

CR054 NEUTRON ACER TENDL-2024 LIBRARY; T=0.K

Principal cross sections

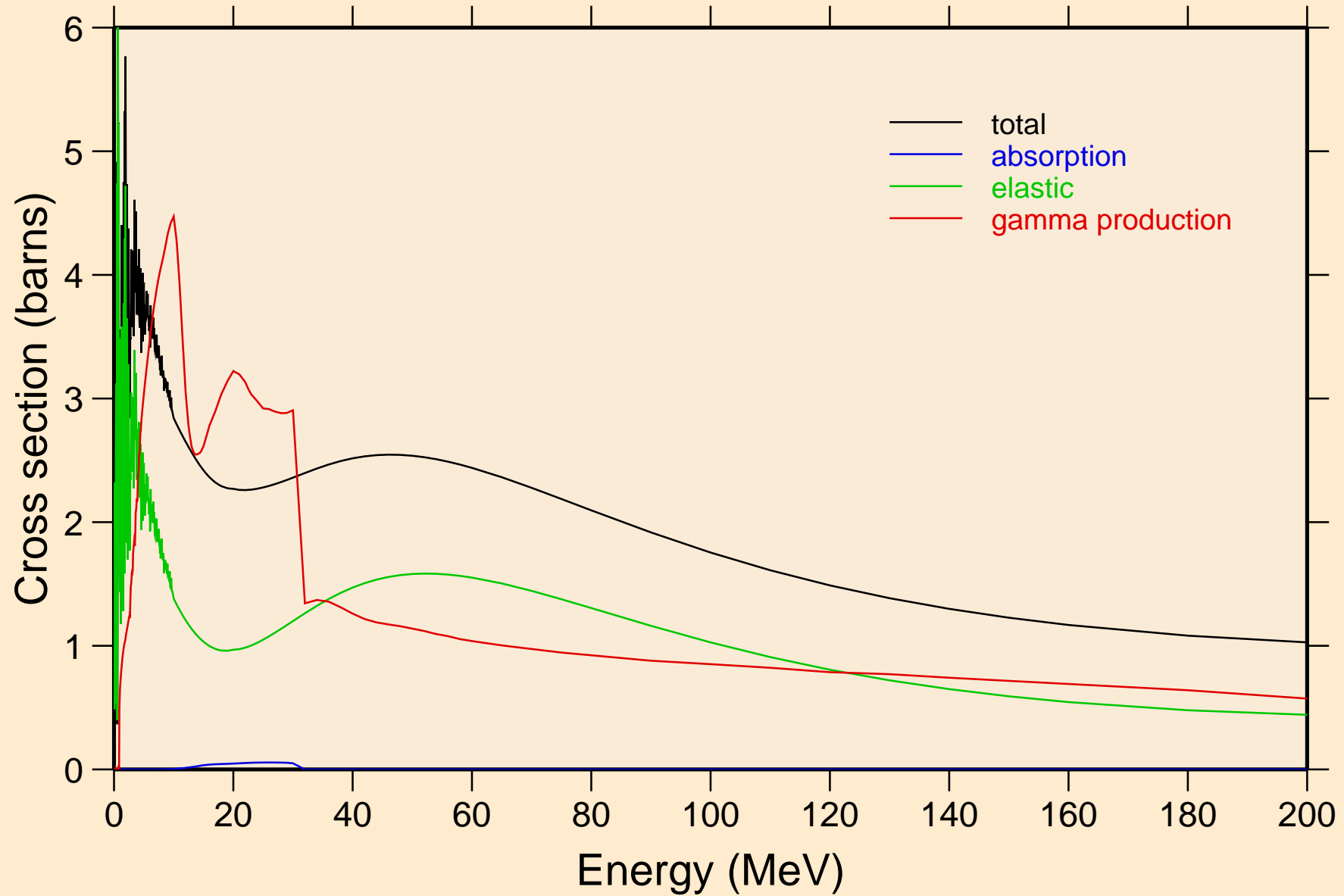

CR054 NEUTRON ACER TENDL-2024 LIBRARY; T=0.K

Heating

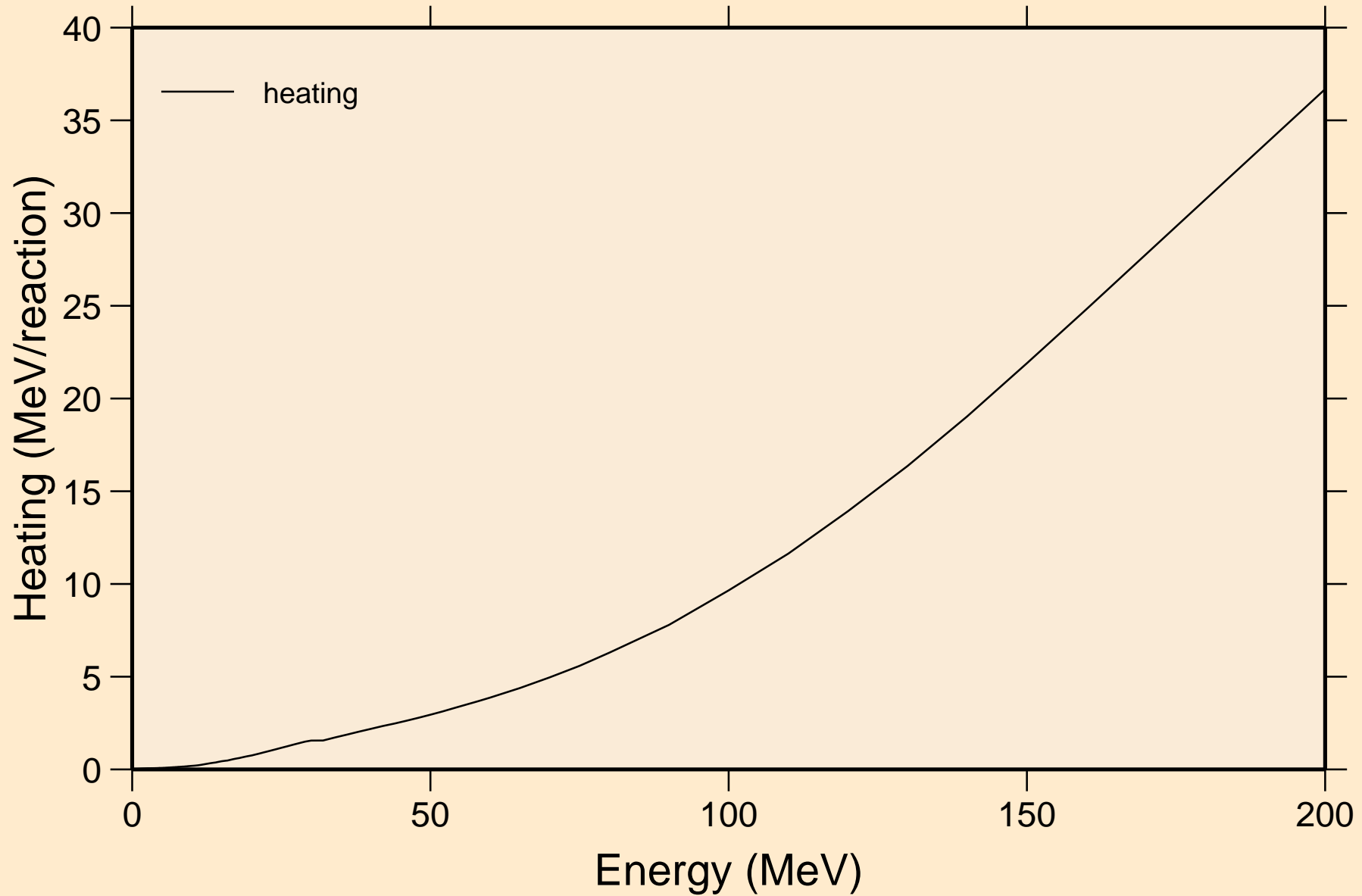

CR054 NEUTRON ACER TENDL-2024 LIBRARY; T=0.K

Damage

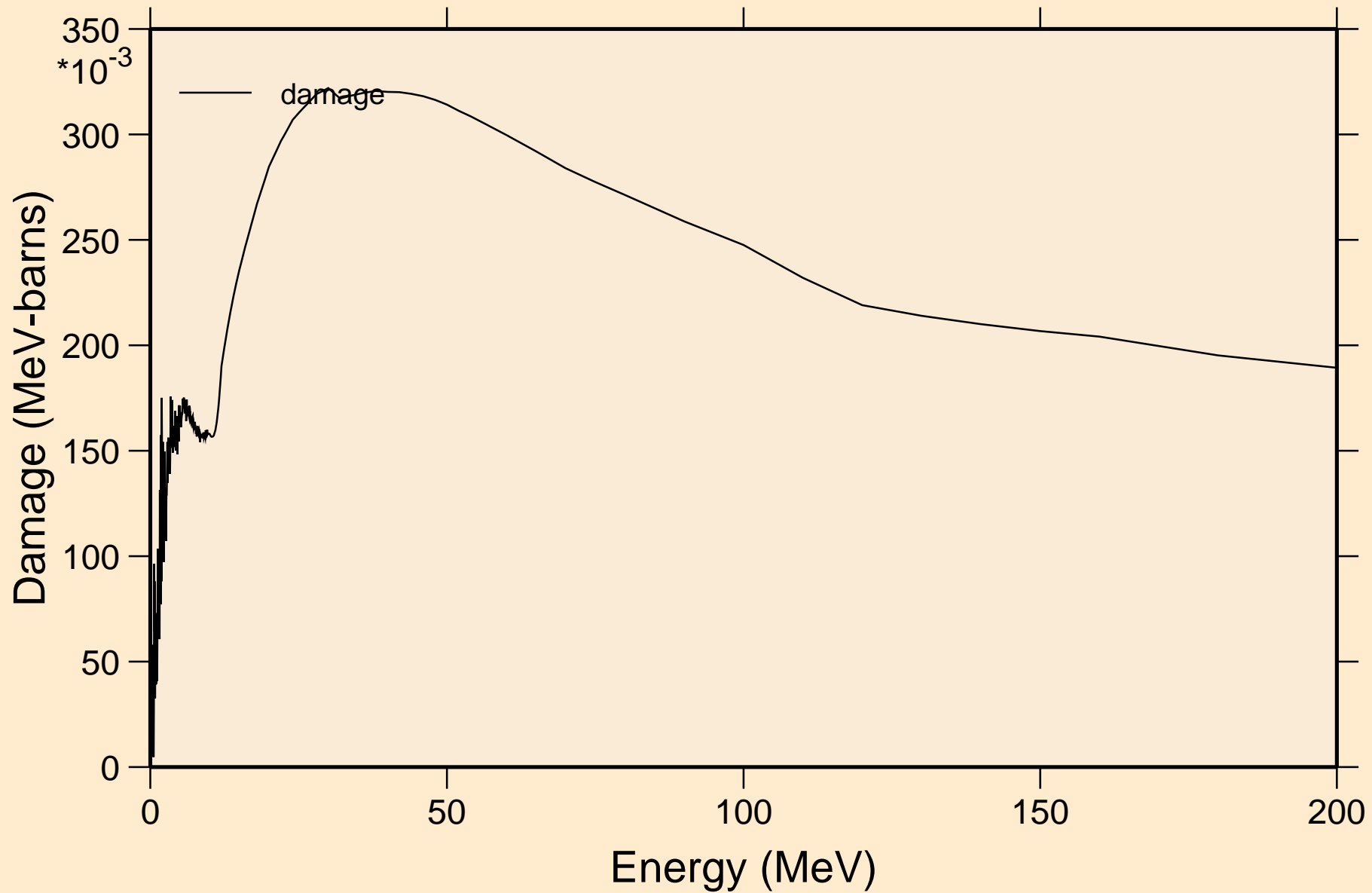

CR054 NEUTRON ACER TENDL-2024 LIBRARY; T=0.K
Non-threshold reactions

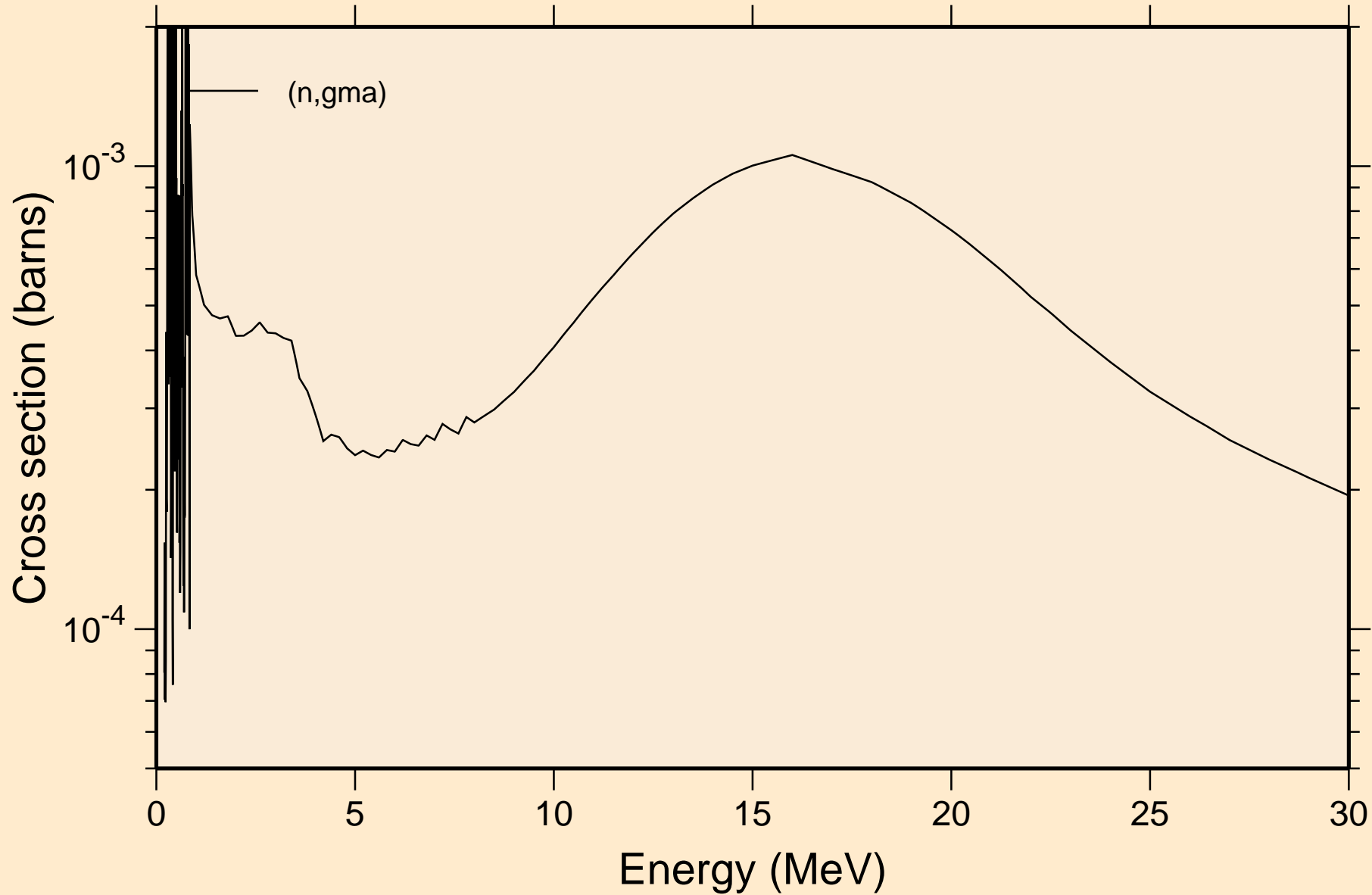

CR054 NEUTRON ACER TENDL-2024 LIBRARY; T=0.K
Inelastic levels

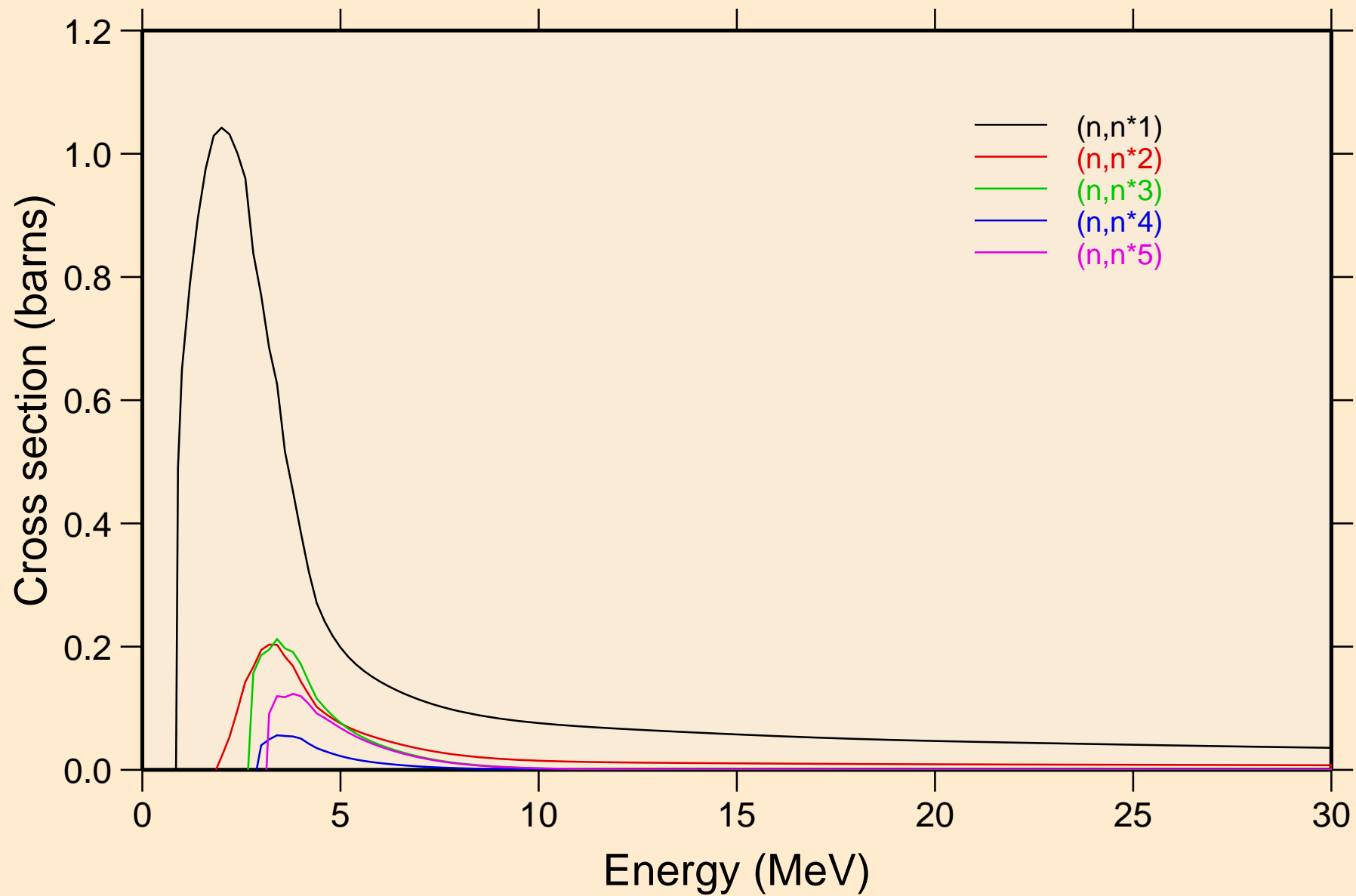

CR054 NEUTRON ACER TENDL-2024 LIBRARY; T=0.K

Inelastic levels

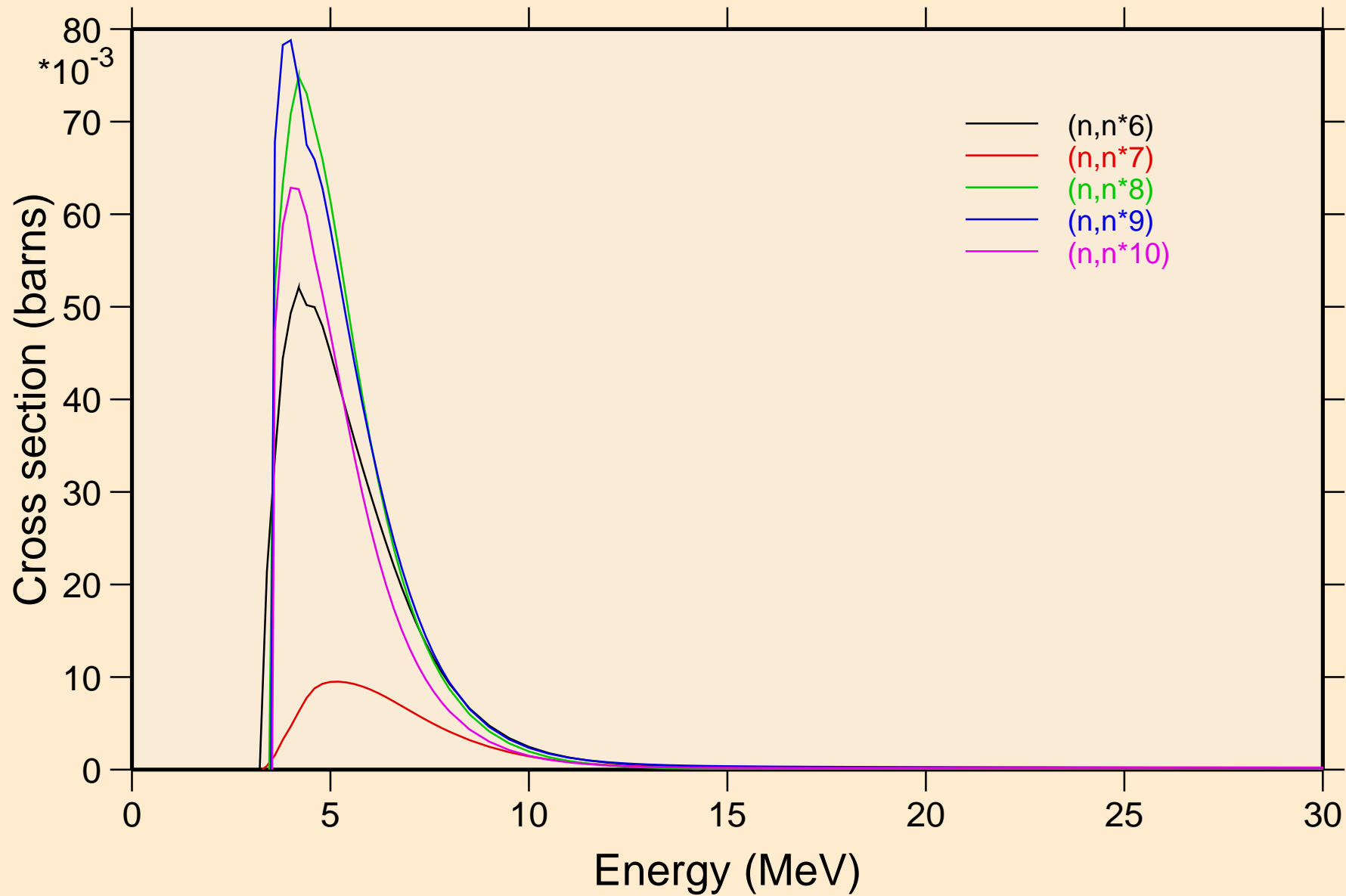

CR054 NEUTRON ACER TENDL-2024 LIBRARY; T=0.K
Inelastic levels

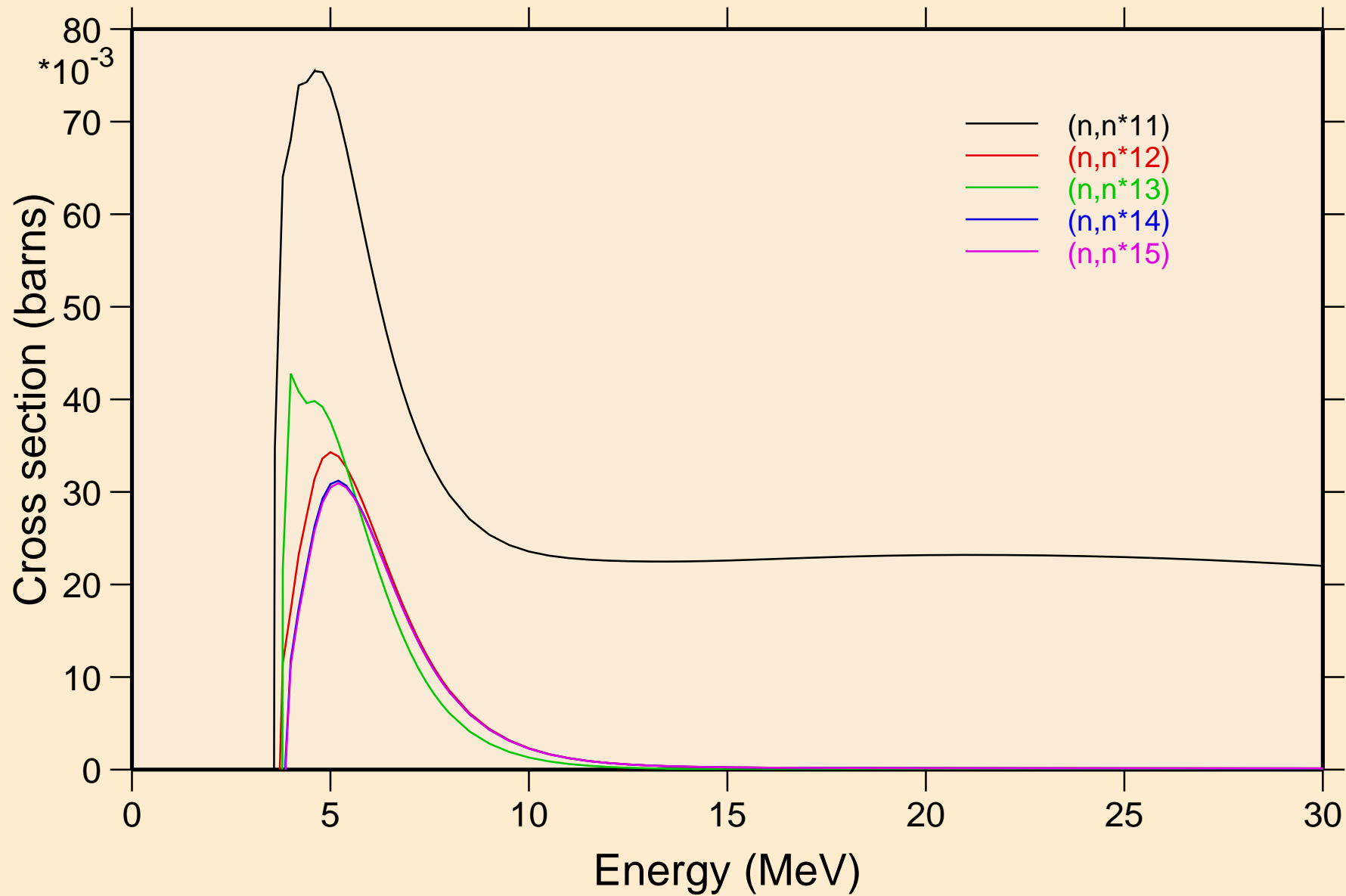

CR054 NEUTRON ACER TENDL-2024 LIBRARY; T=0.K
Inelastic levels

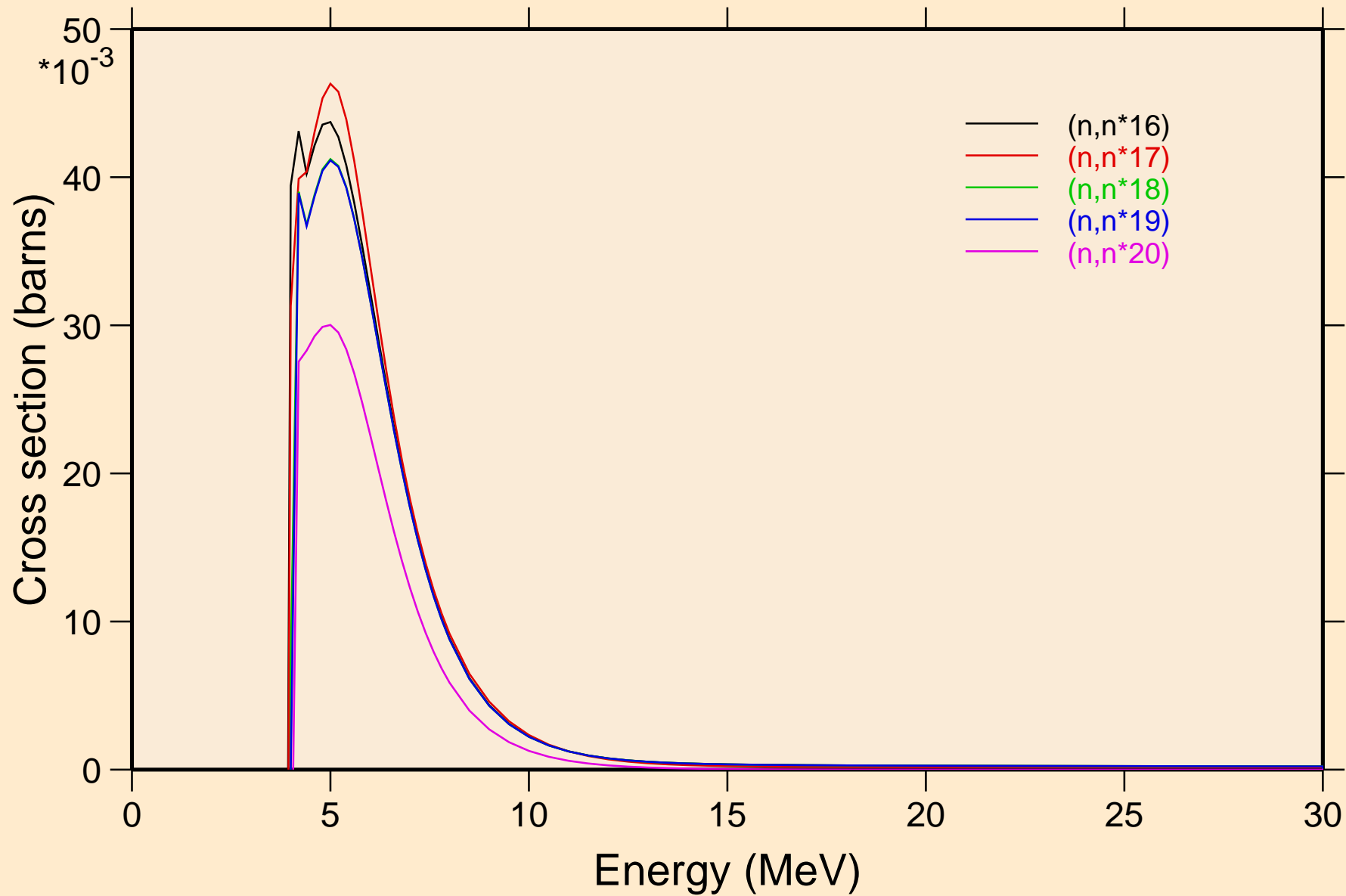

CR054 NEUTRON ACER TENDL-2024 LIBRARY; T=0.K
Inelastic levels

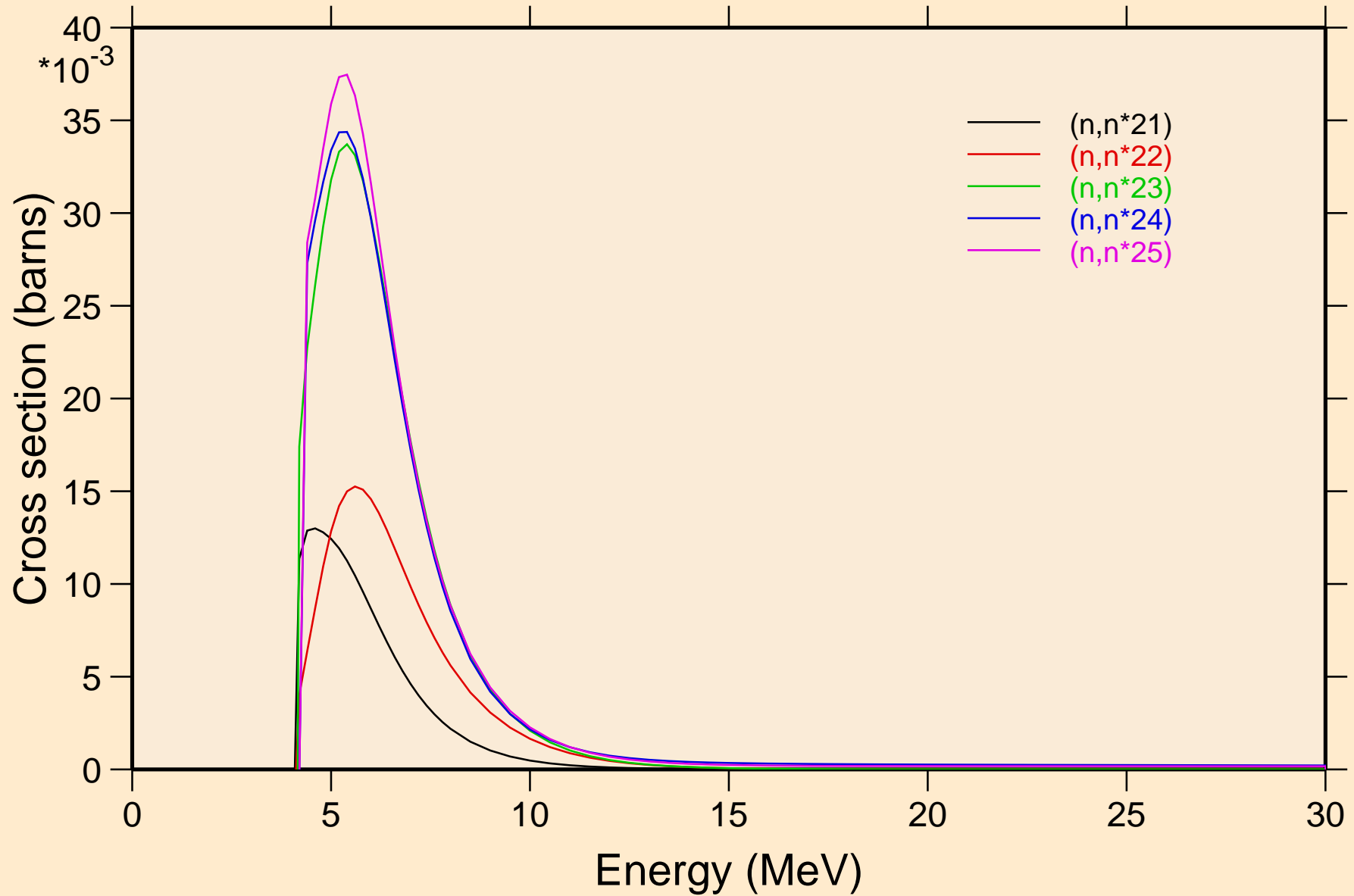

CR054 NEUTRON ACER TENDL-2024 LIBRARY; T=0.K
Inelastic levels

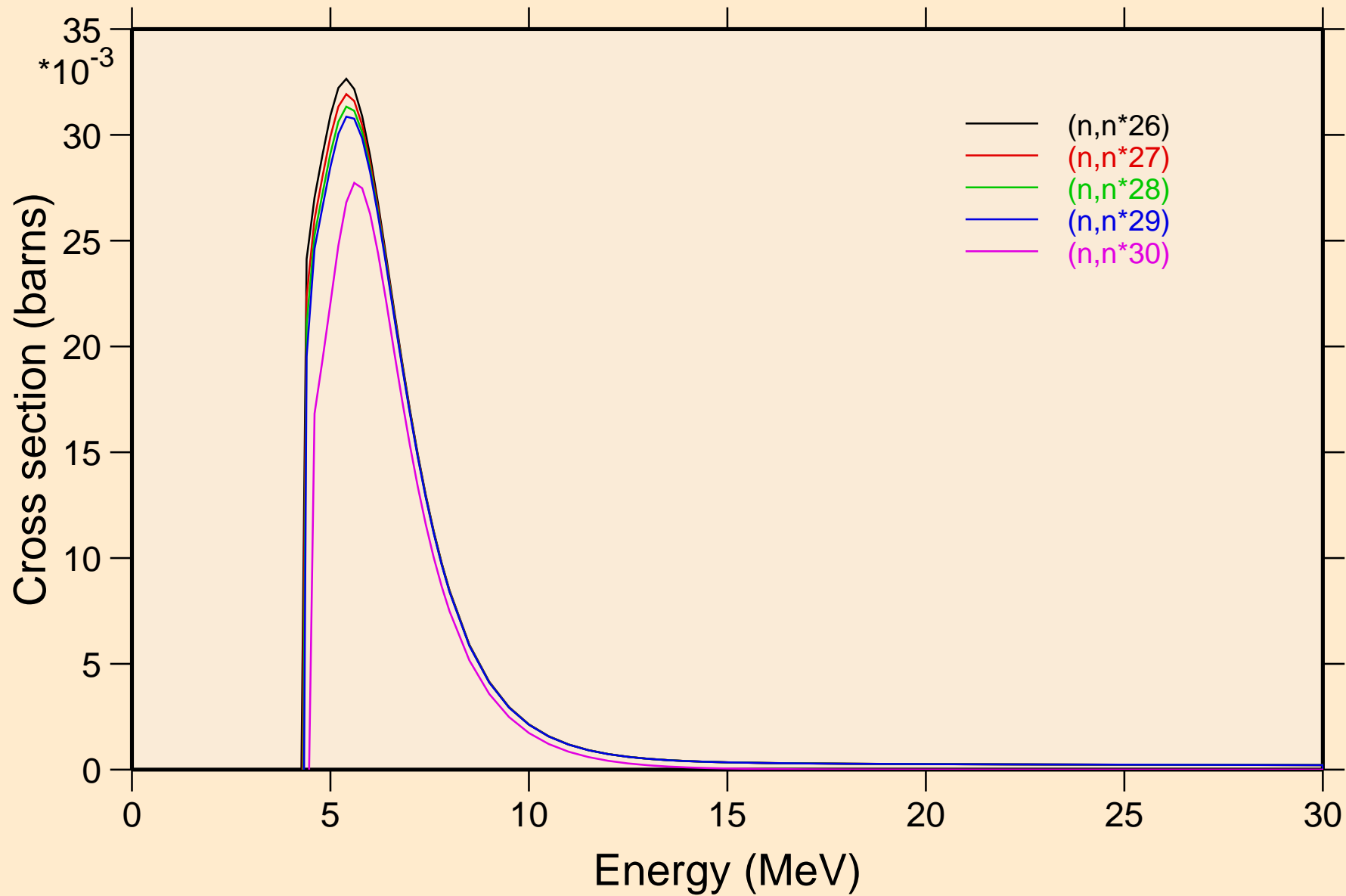

CR054 NEUTRON ACER TENDL-2024 LIBRARY; T=0.K
Threshold reactions

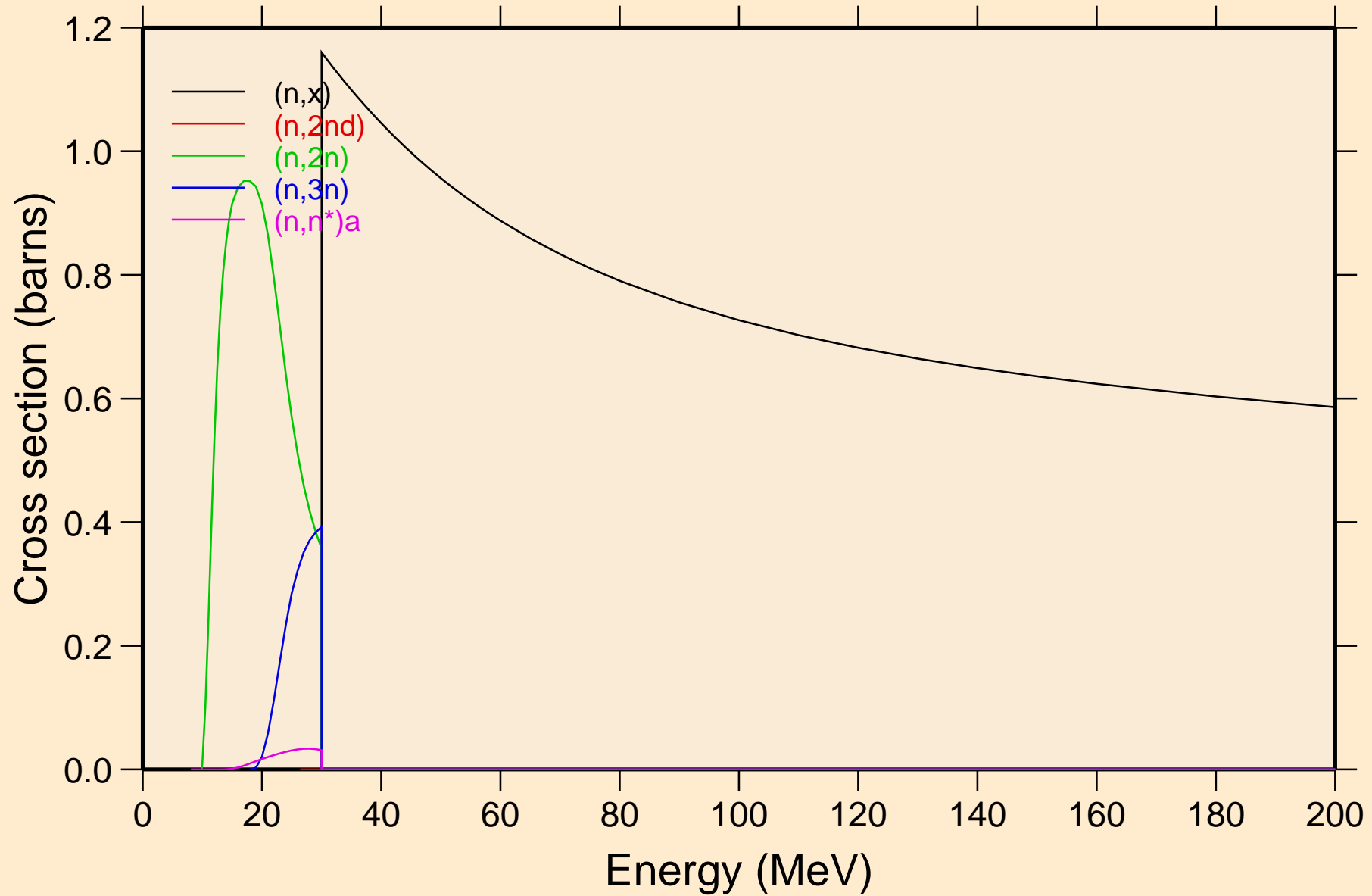

CR054 NEUTRON ACER TENDL-2024 LIBRARY; T=0.K

Threshold reactions

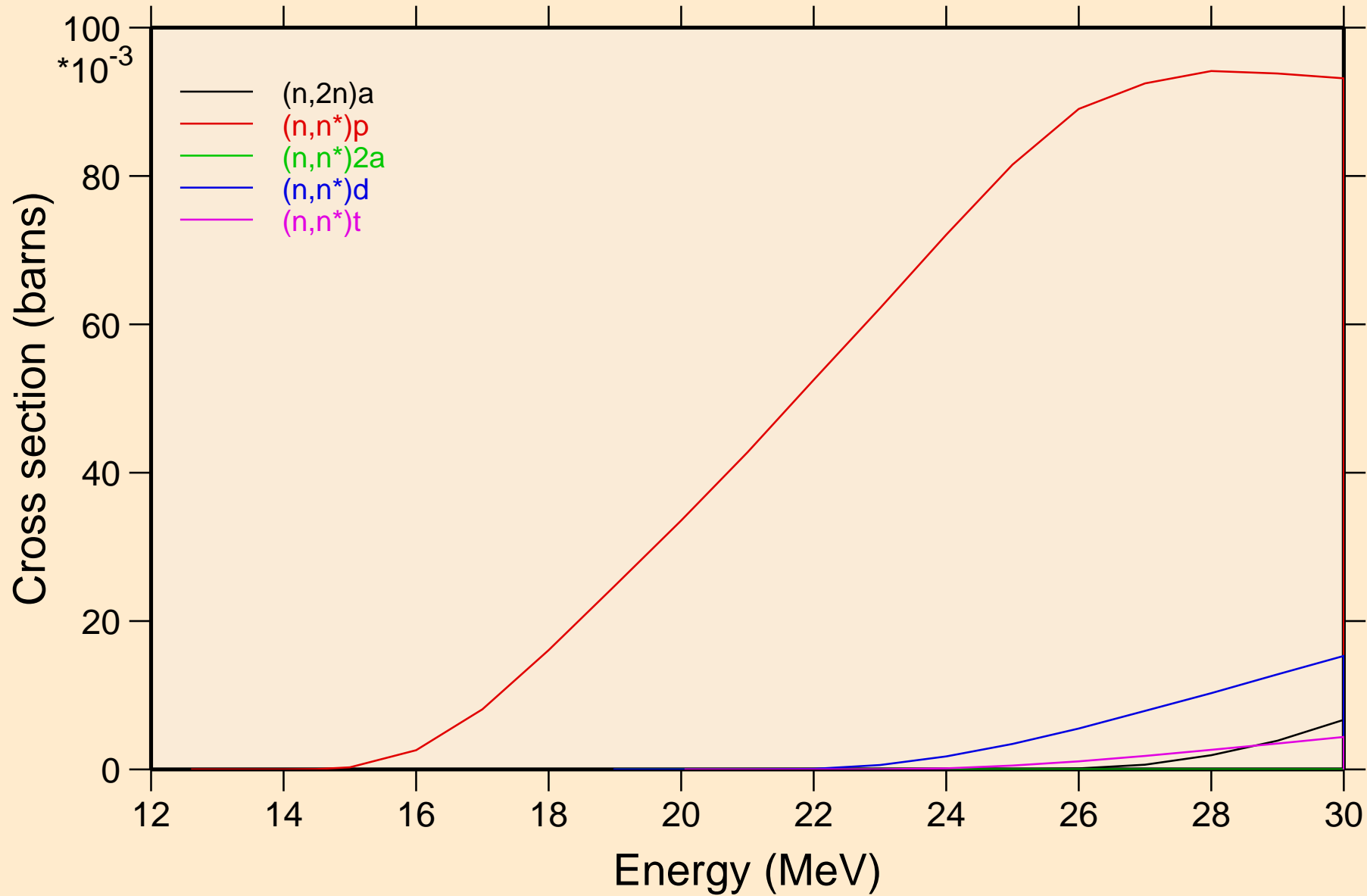

CR054 NEUTRON ACER TENDL-2024 LIBRARY; T=0.K
Threshold reactions

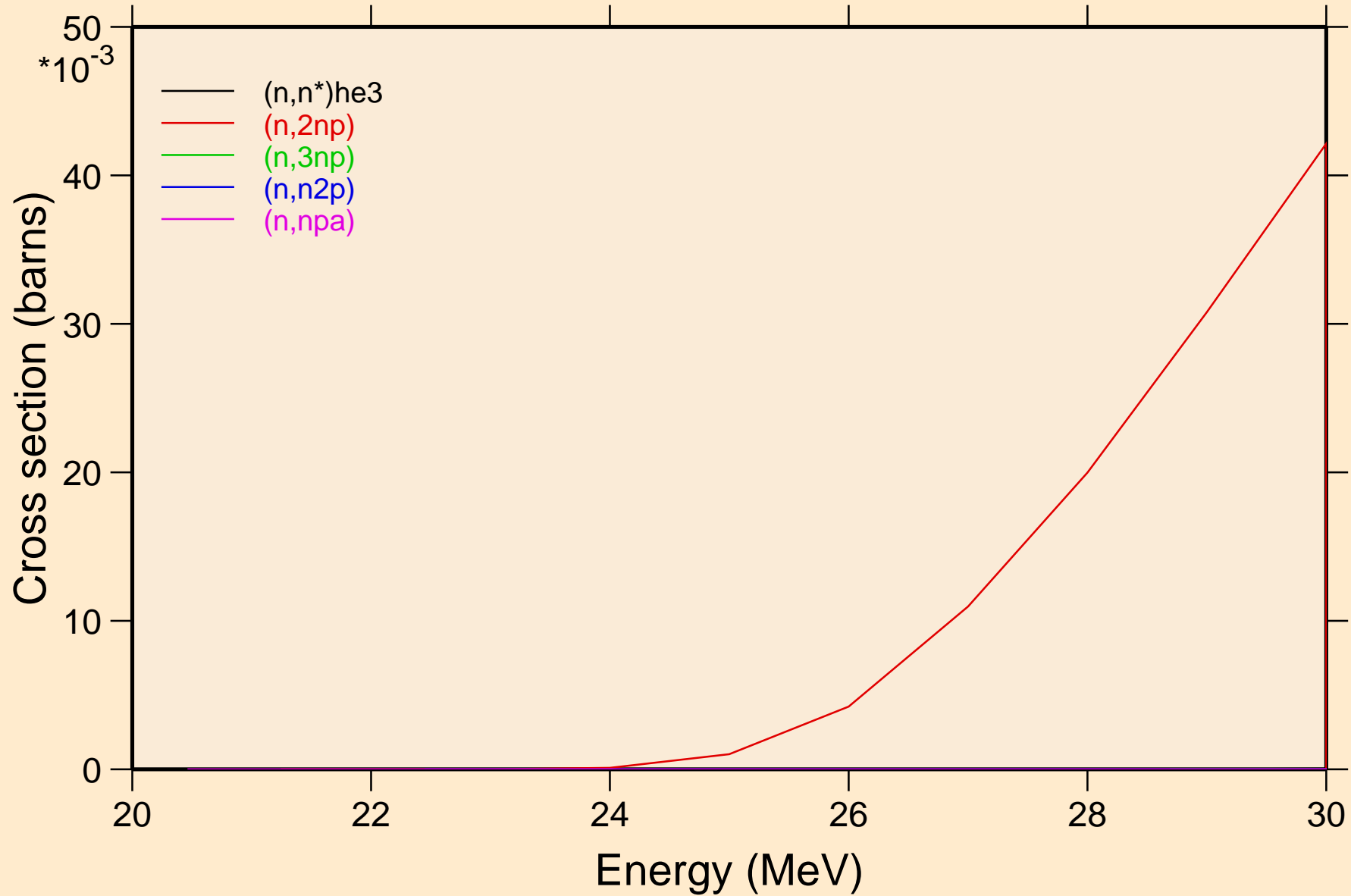

CR054 NEUTRON ACER TENDL-2024 LIBRARY; T=0.K

Threshold reactions

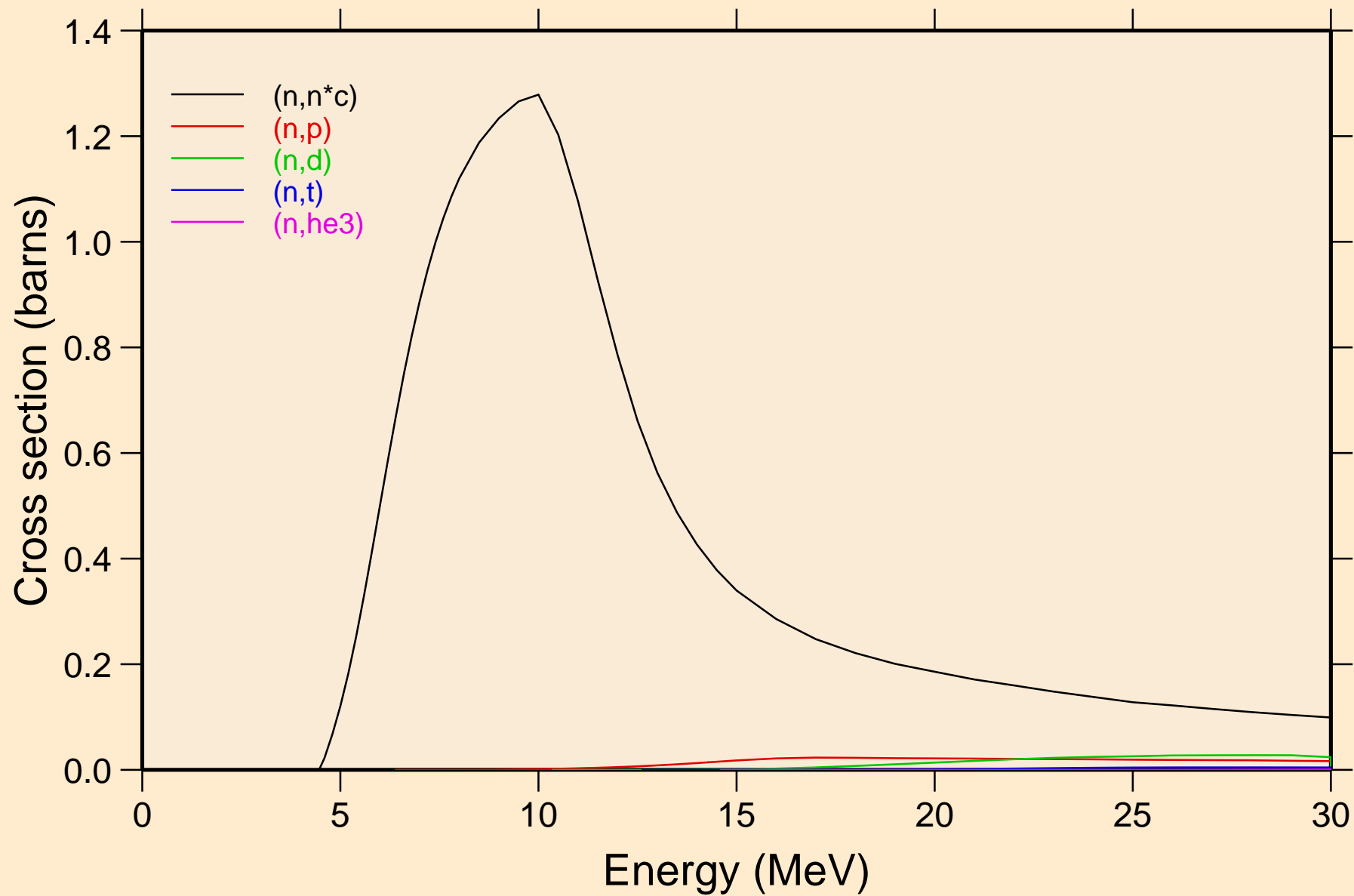

CR054 NEUTRON ACER TENDL-2024 LIBRARY; T=0.K

Threshold reactions

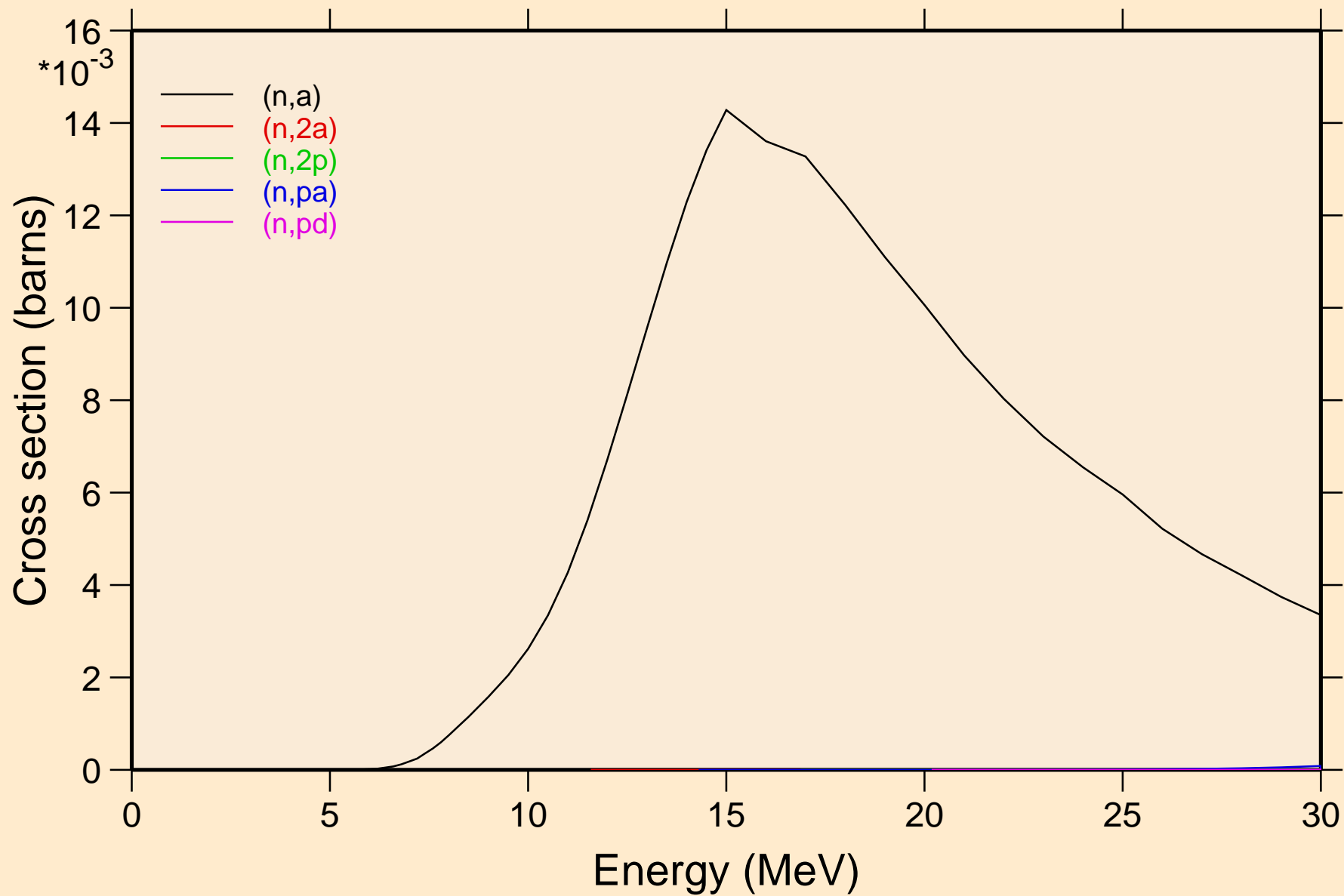

CR054 NEUTRON ACER TENDL-2024 LIBRARY; T=0.K

Threshold reactions

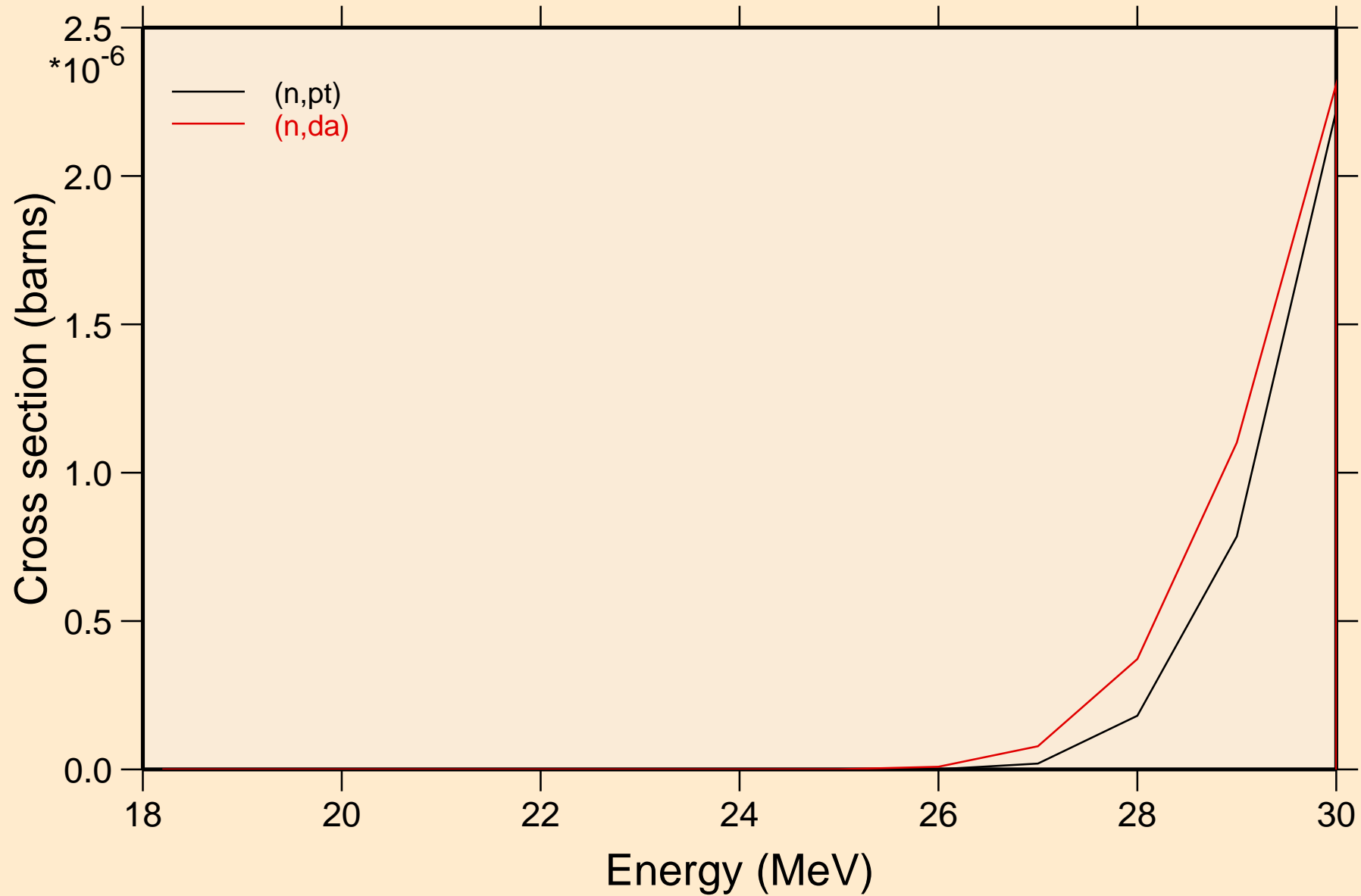

CR054 NEUTRON ACER TENDL-2024 LIBRARY; T=0.K

Threshold reactions

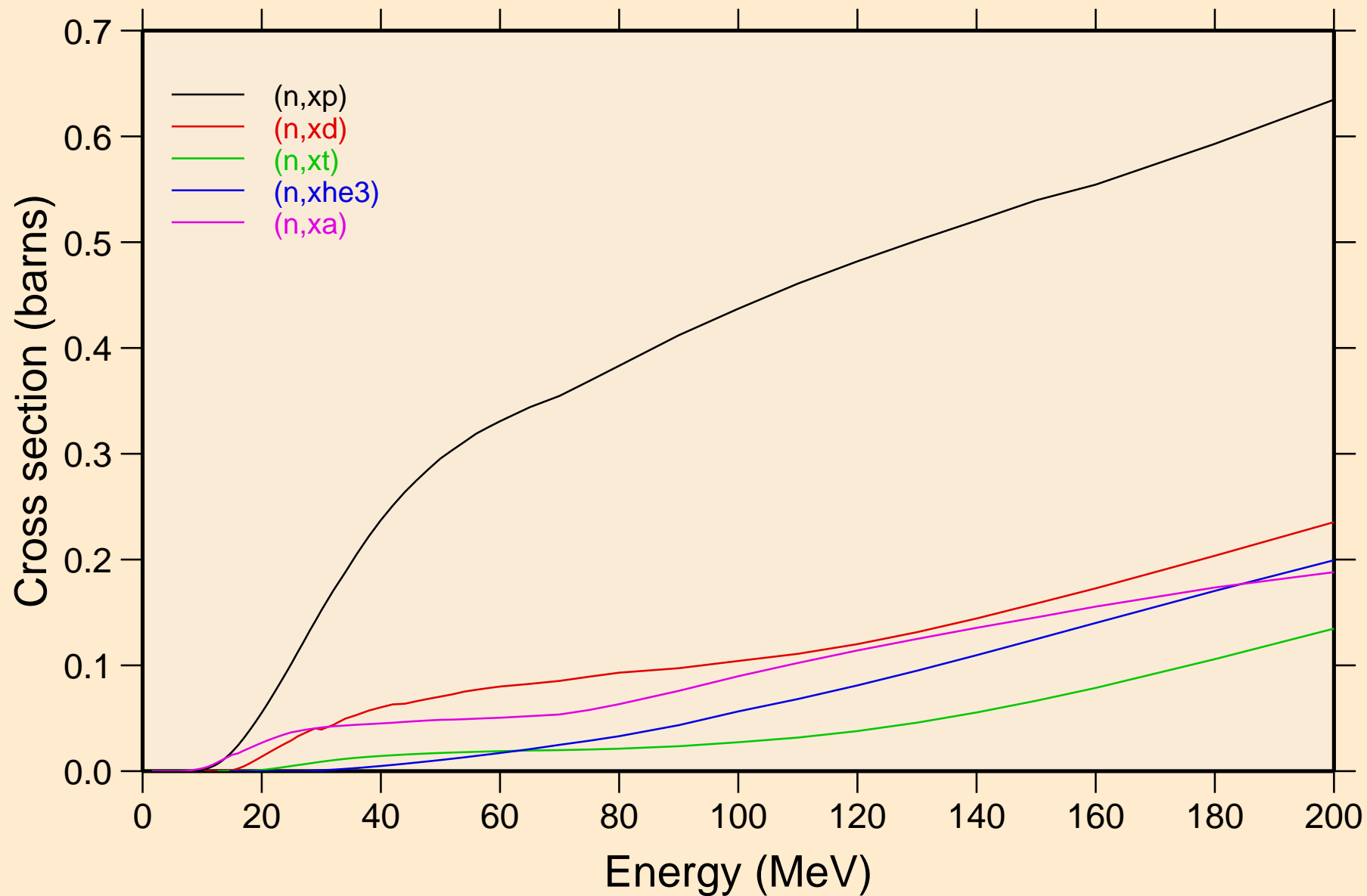

CR054 NEUTRON ACER TENDL-2024 LIBRARY; T=0.K
angular distribution for elastic

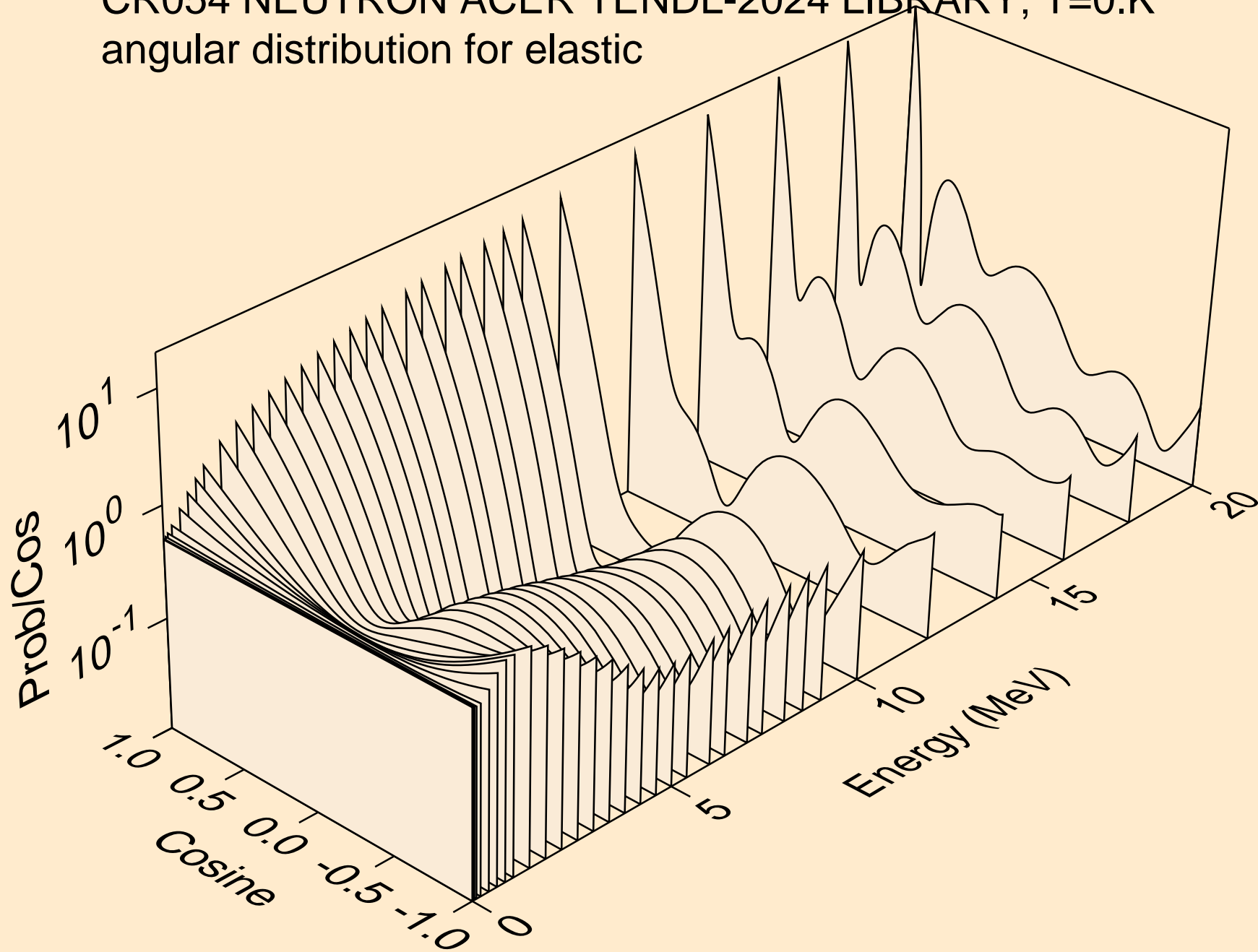

CR054 NEUTRON ACER TENDL-2024 LIBRARY; T=0.K
angular distribution for elastic

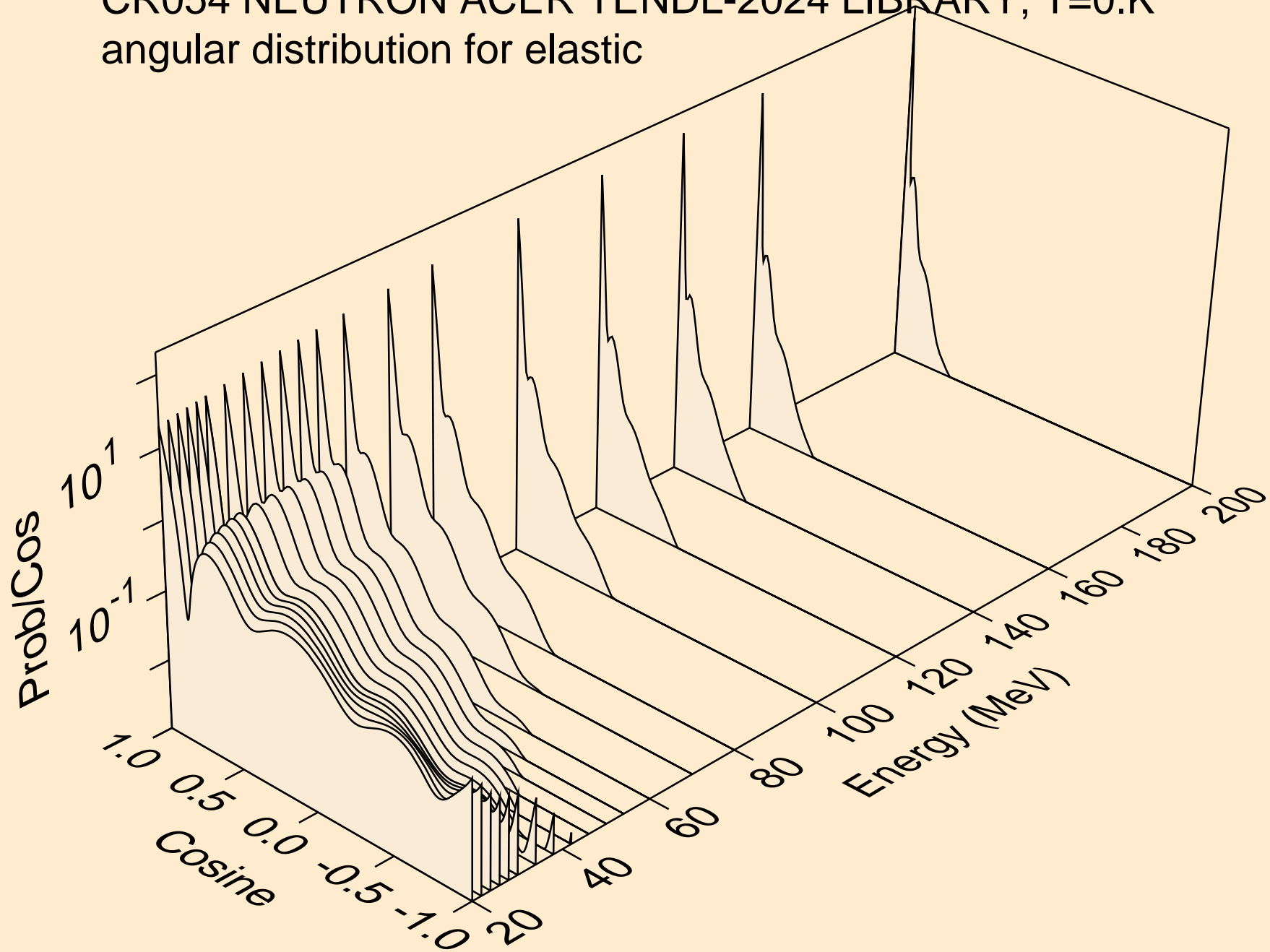

CR054 NEUTRON ACER TENDL-2024 LIBRARY; T=0.K
angular distribution for (n,n*1)

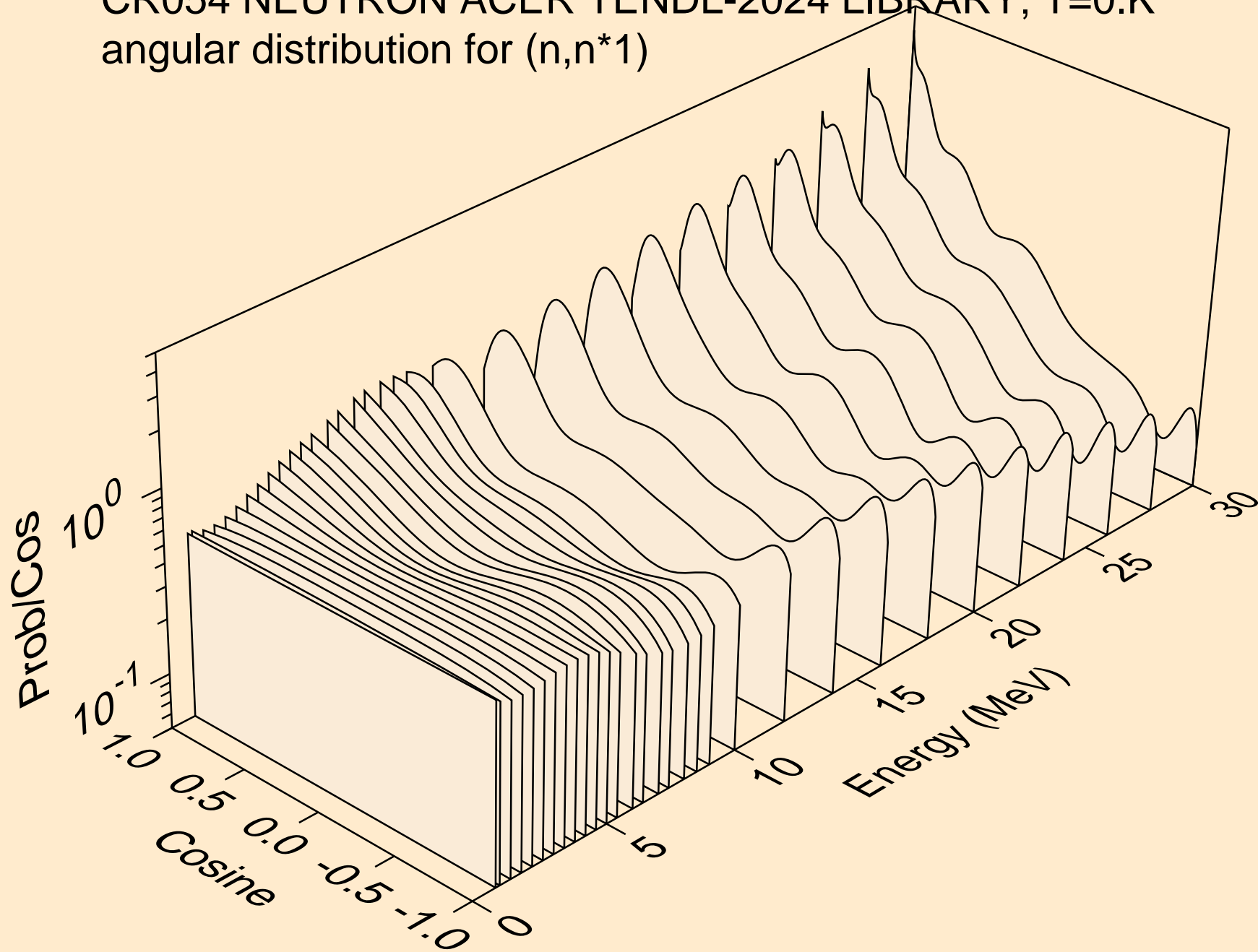

CR054 NEUTRON ACER TENDL-2024 LIBRARY; T=0.K
angular distribution for (n,n*2)

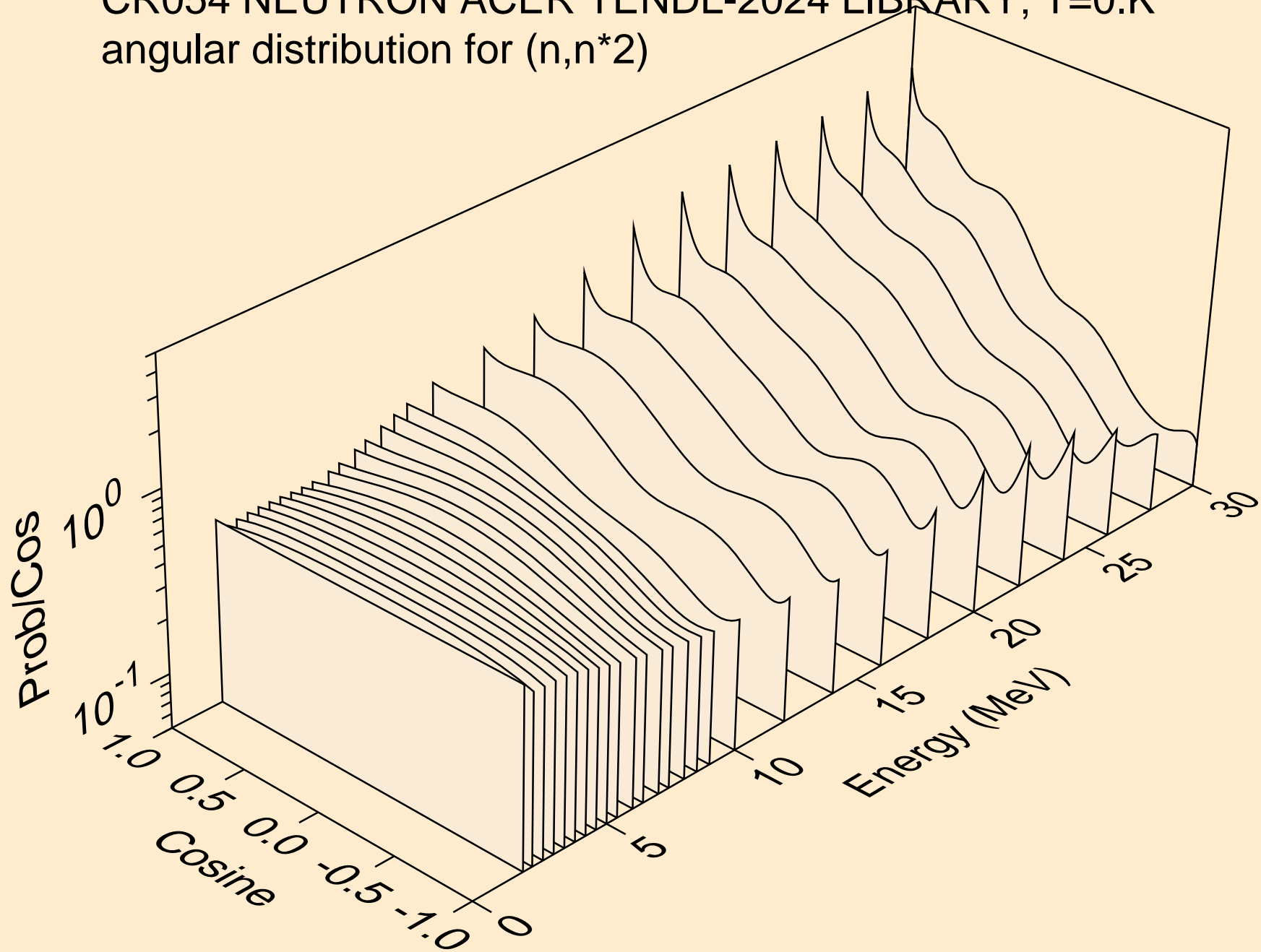

CR054 NEUTRON ACER TENDL-2024 LIBRARY; T=0.K
angular distribution for (n,n*3)

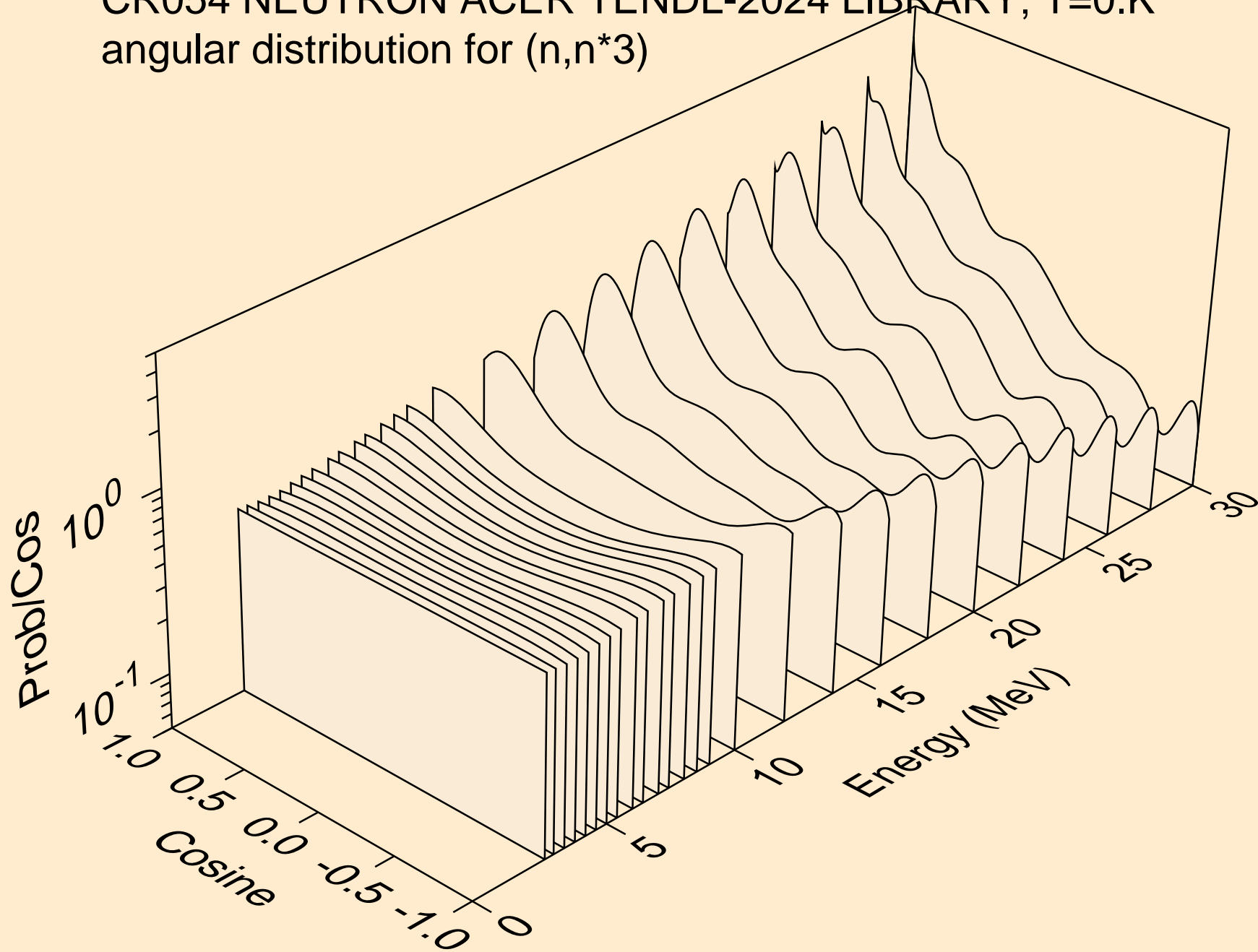

CR054 NEUTRON ACER TENDL-2024 LIBRARY; T=0.K
angular distribution for (n,n*4)

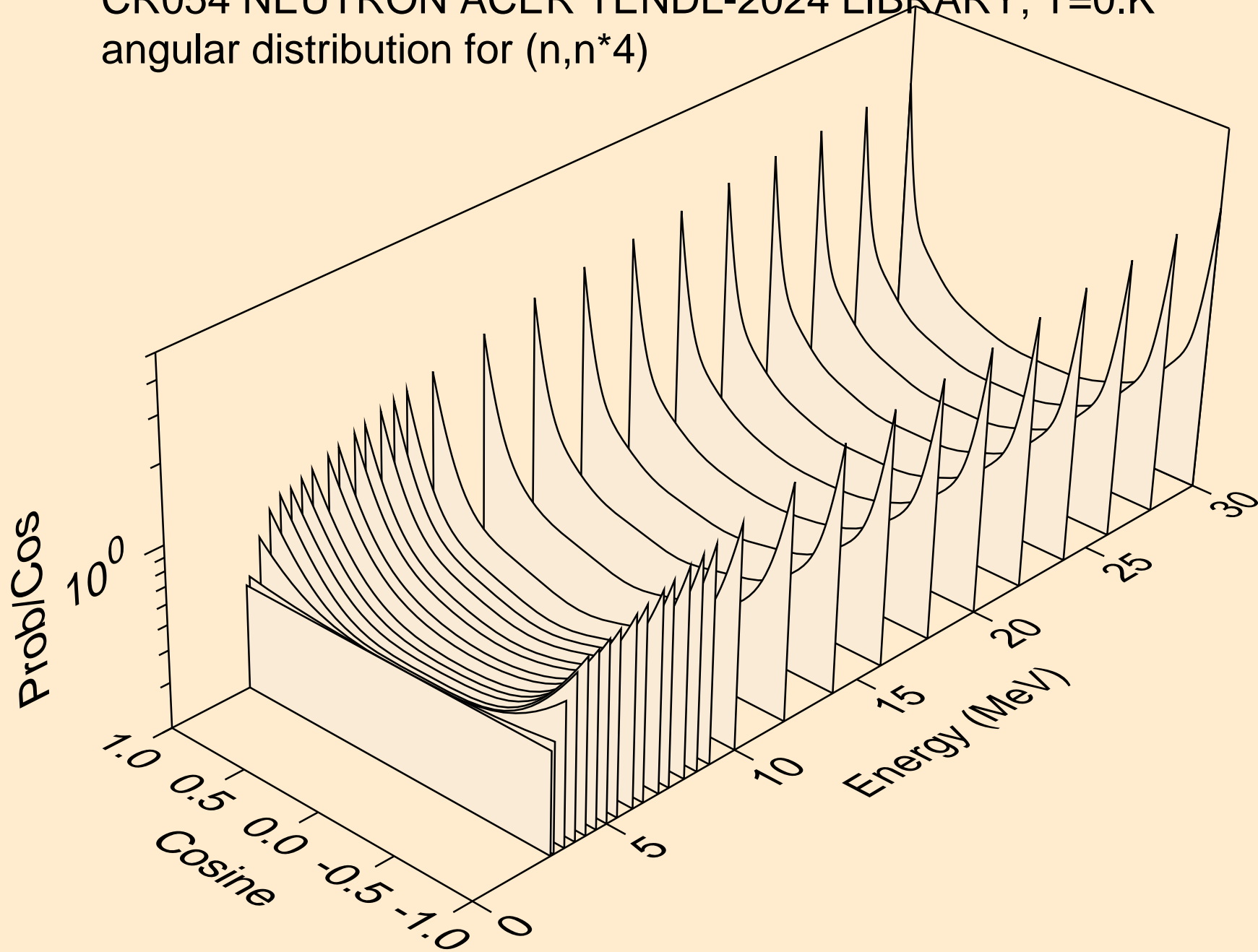

CR054 NEUTRON ACER TENDL-2024 LIBRARY; T=0.K
angular distribution for (n,n*5)

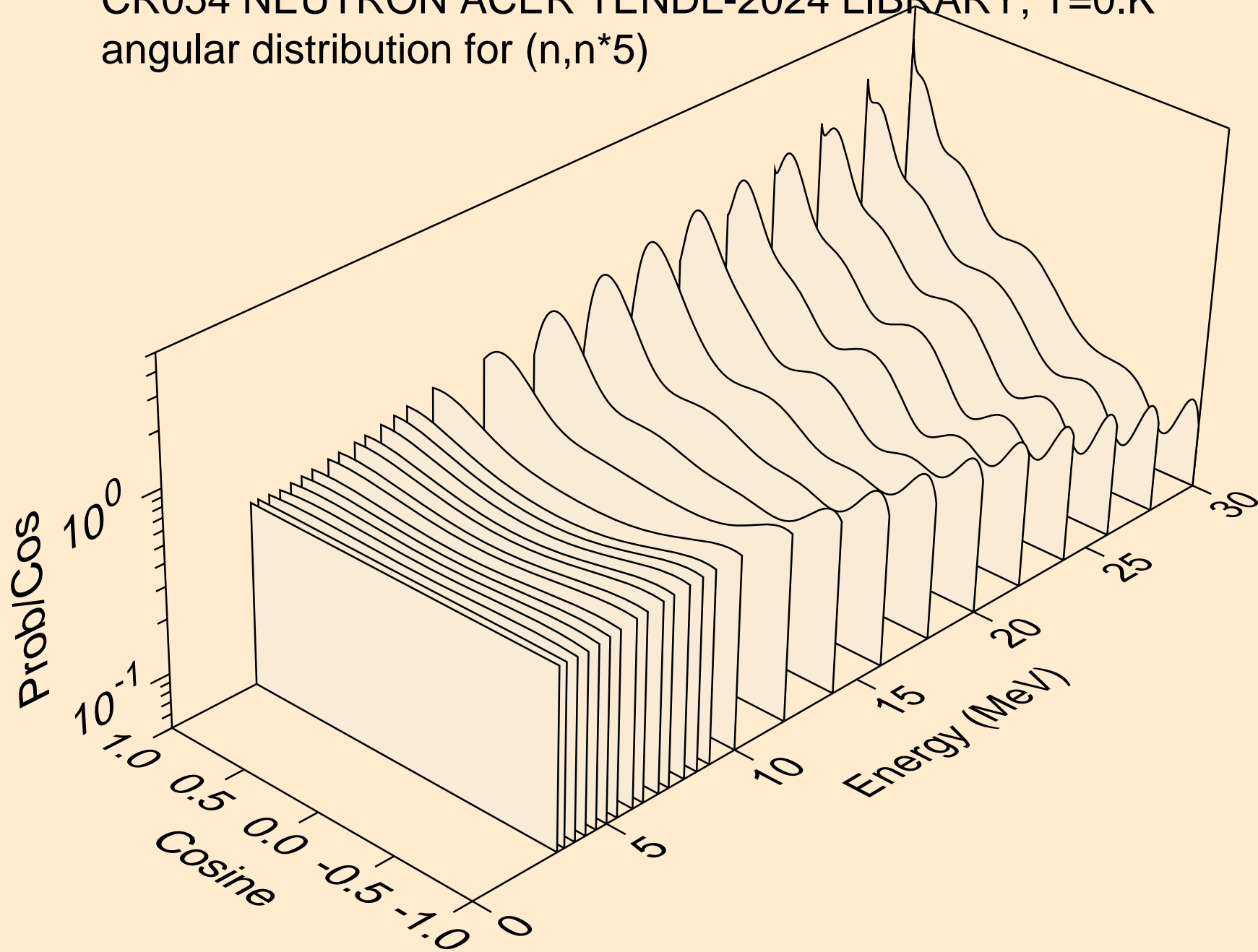

CR054 NEUTRON ACER TENDL-2024 LIBRARY; T=0.K
angular distribution for (n,n*6)

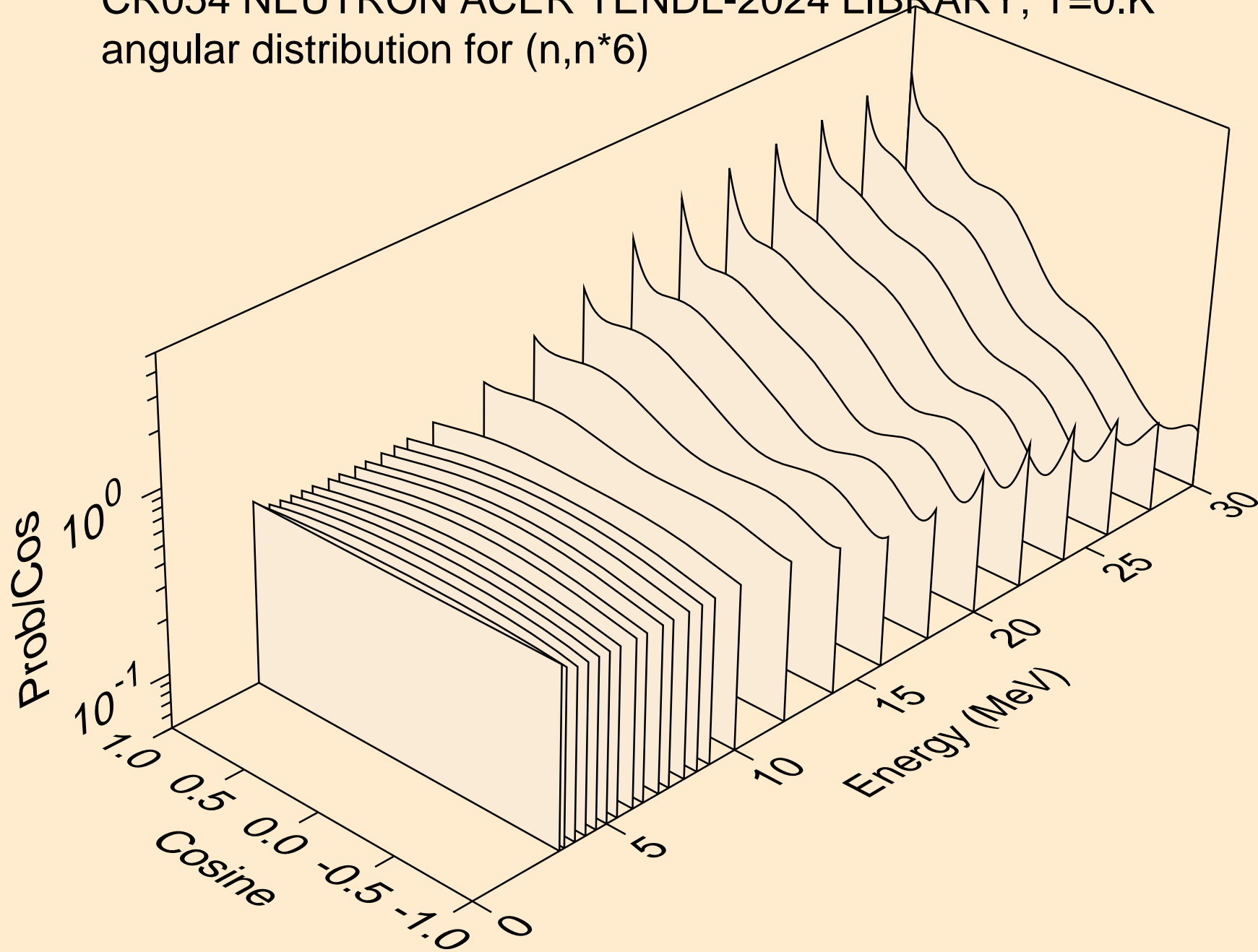

CR054 NEUTRON ACER TENDL-2024 LIBRARY; T=0.K
angular distribution for (n,n*7)

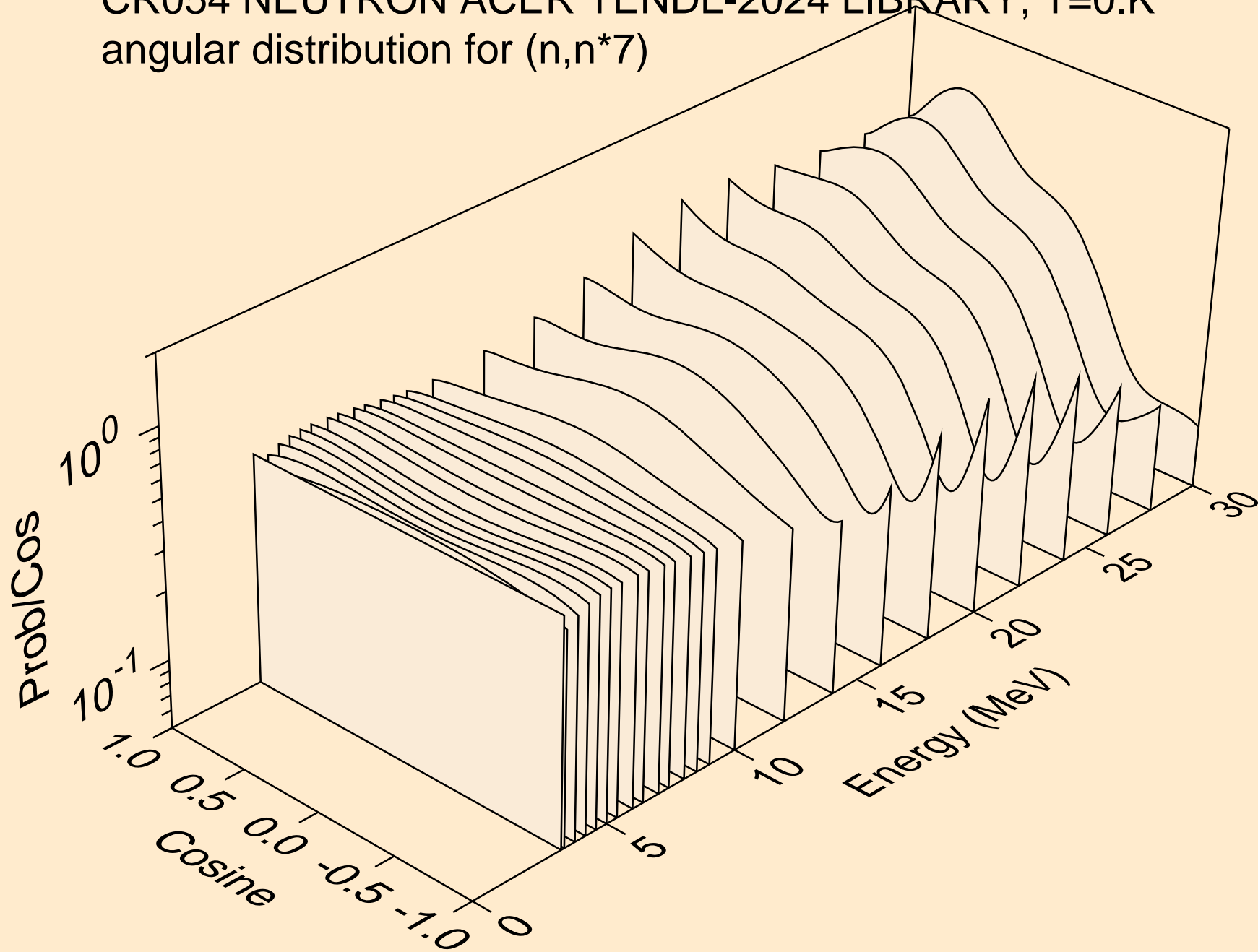

CR054 NEUTRON ACER TENDL-2024 LIBRARY; T=0.K
angular distribution for (n,n*8)

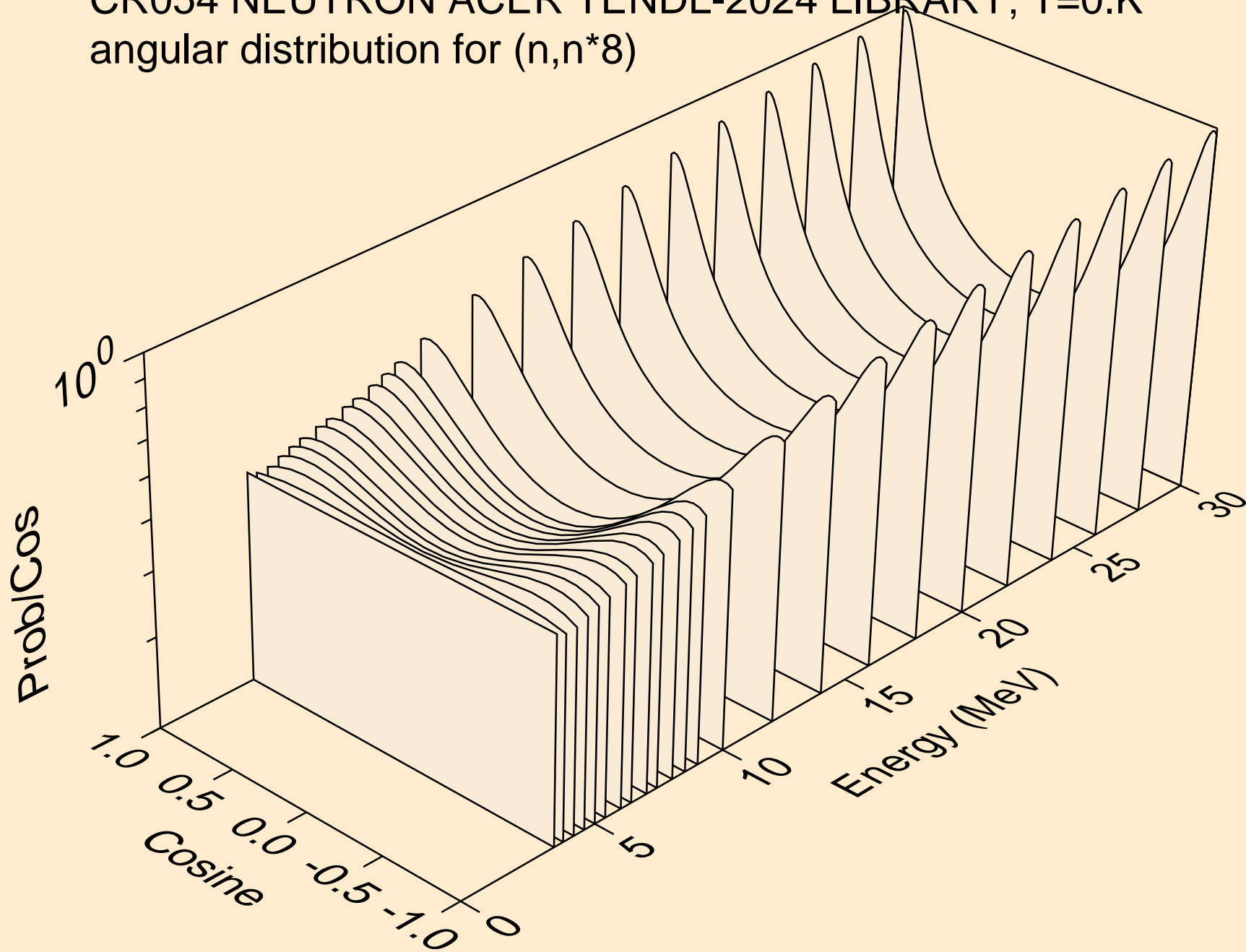

CR054 NEUTRON ACER TENDL-2024 LIBRARY; T=0.K
angular distribution for (n,n*9)

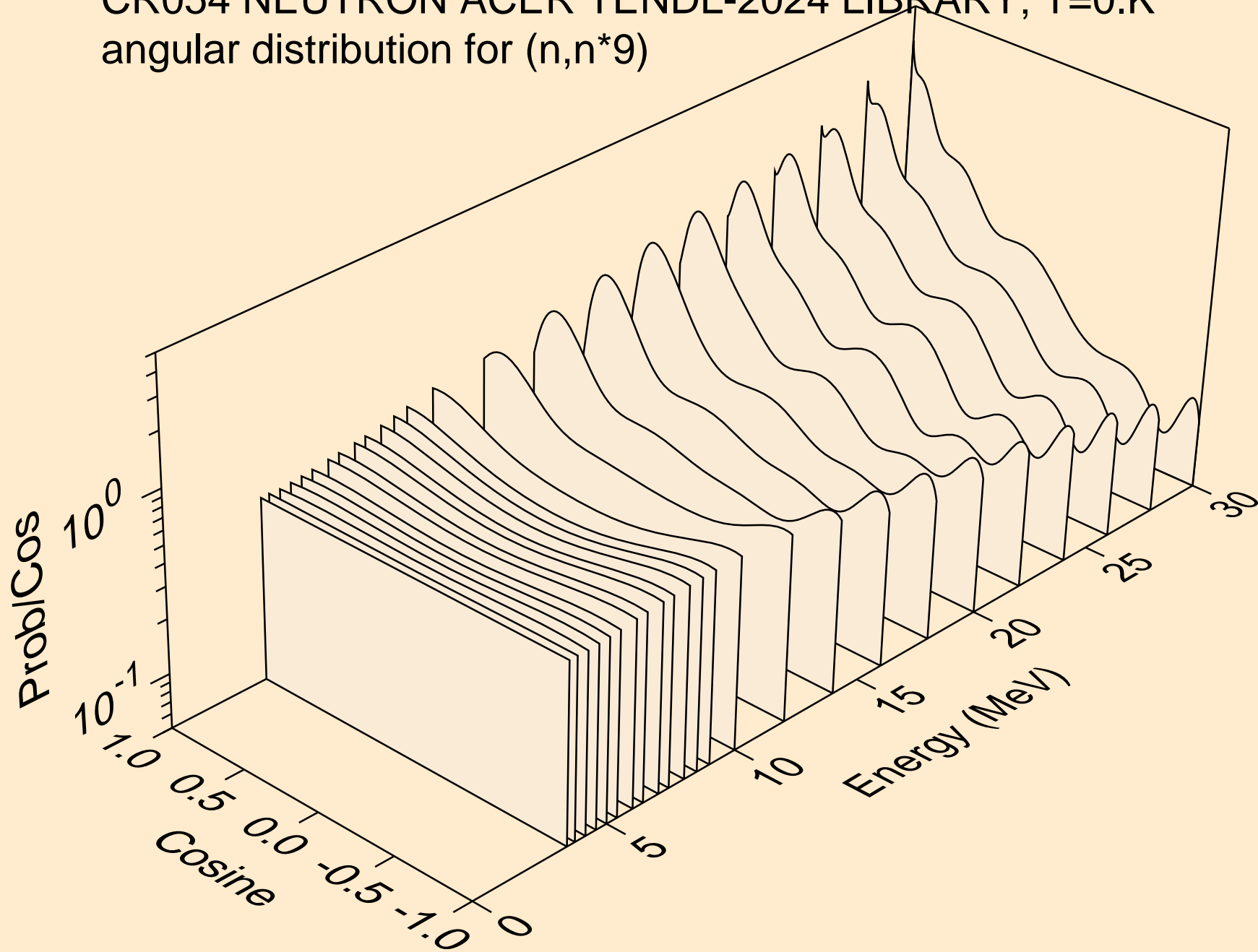

CR054 NEUTRON ACER TENDL-2024 LIBRARY; T=0.K
angular distribution for (n,n*10)

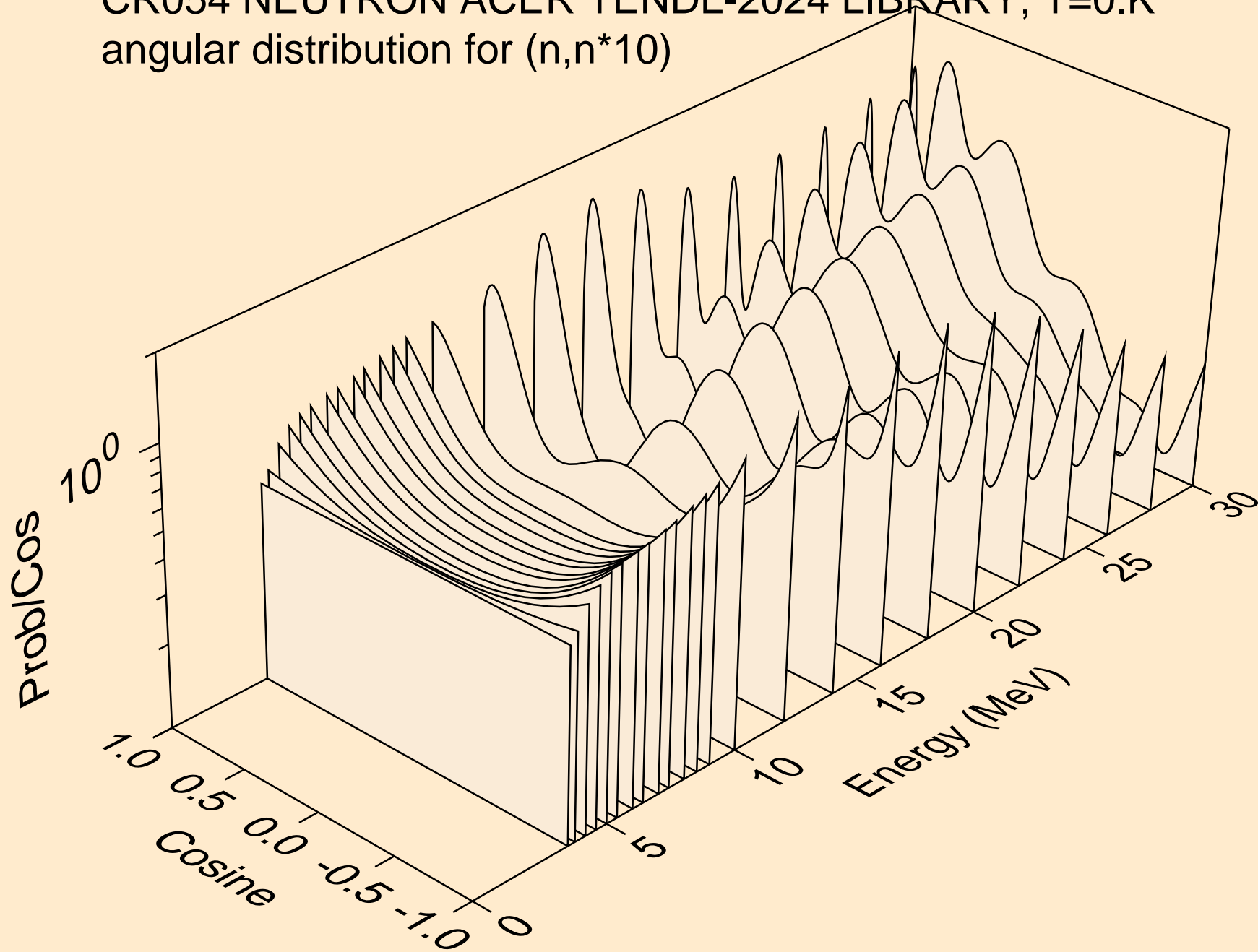

CR054 NEUTRON ACER TENDL-2024 LIBRARY; T=0.K
angular distribution for (n,n*11)

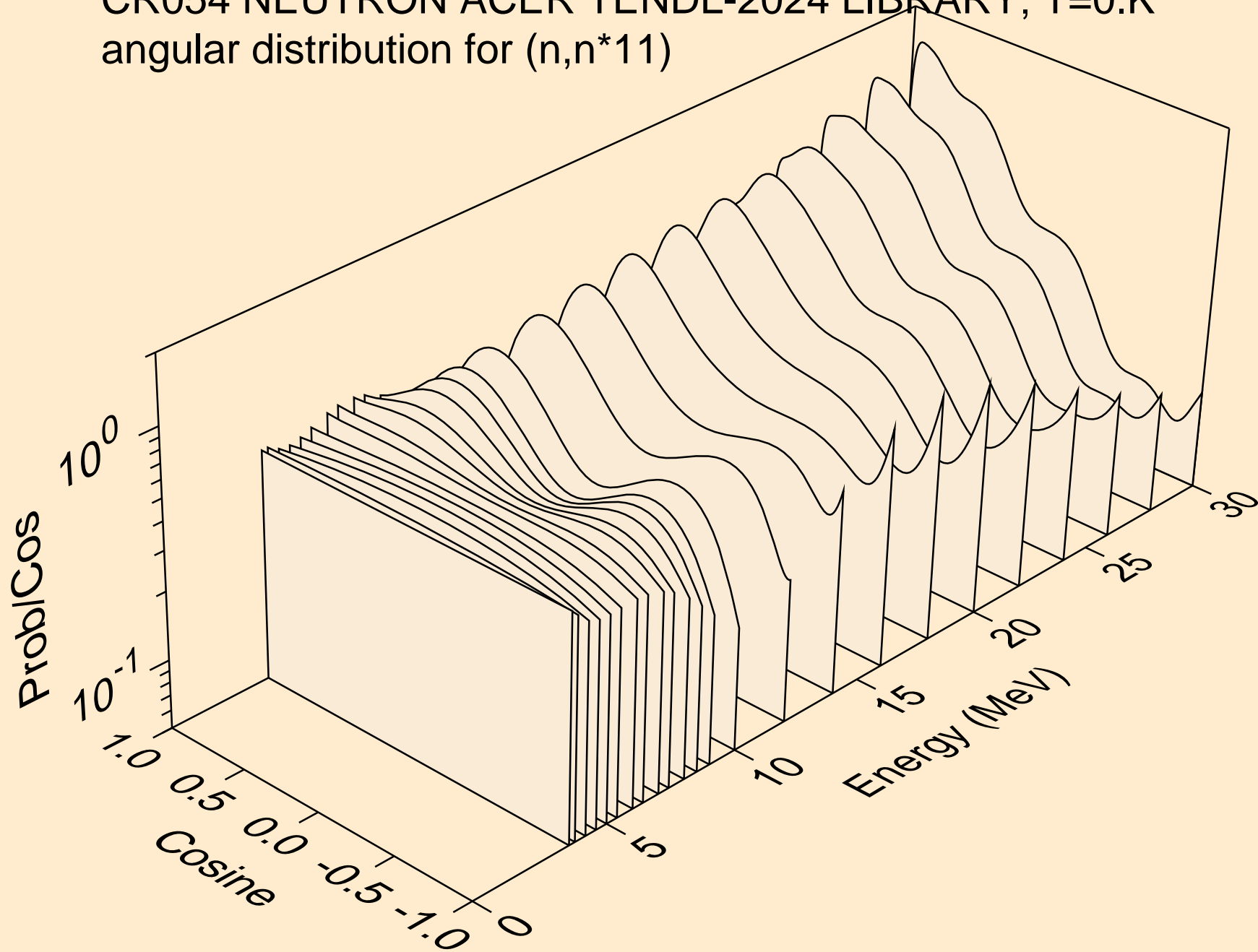

CR054 NEUTRON ACER TENDL-2024 LIBRARY; T=0.K
angular distribution for (n,n*12)

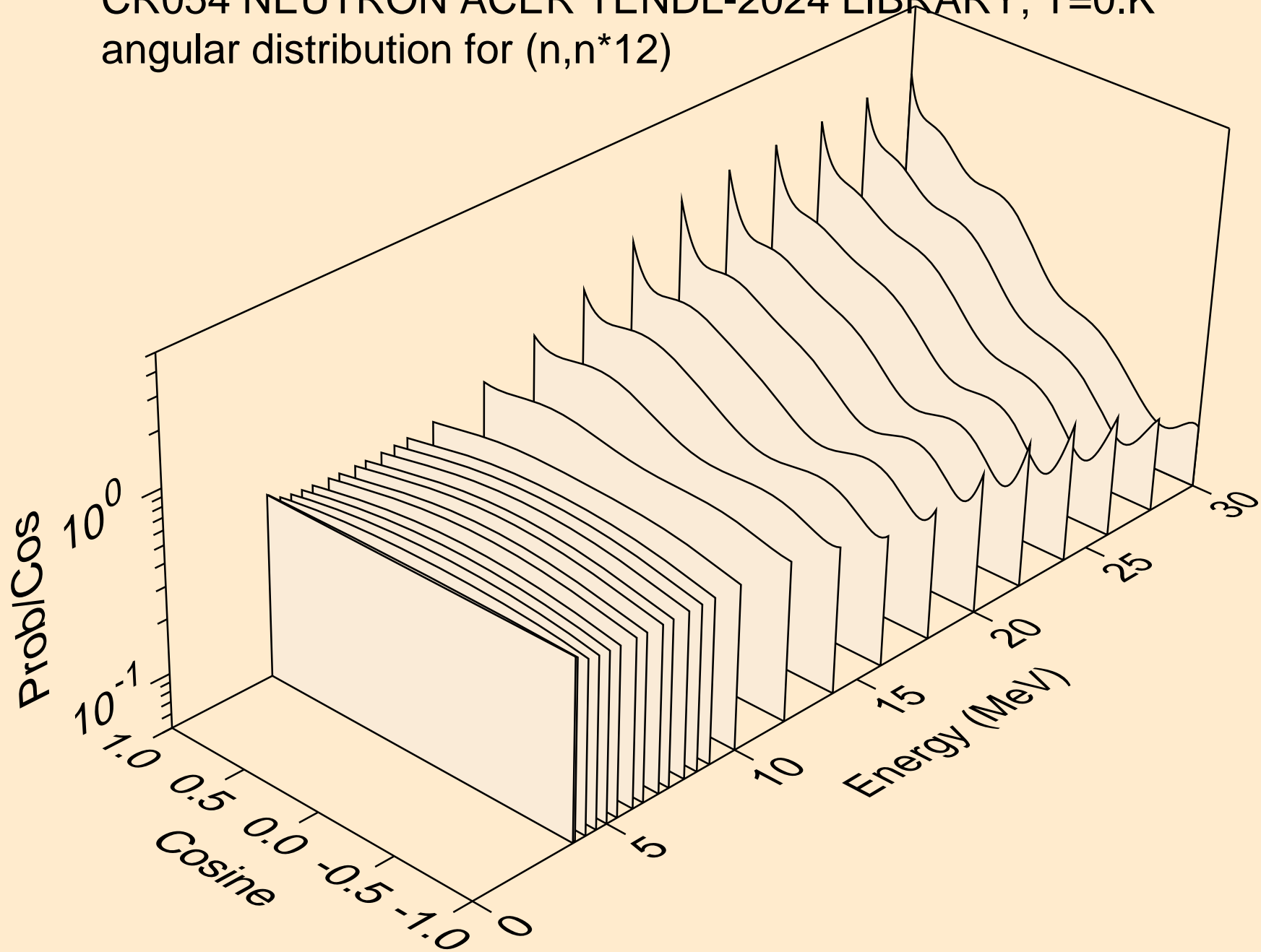

CR054 NEUTRON ACER TENDL-2024 LIBRARY; T=0.K
angular distribution for (n,n*13)

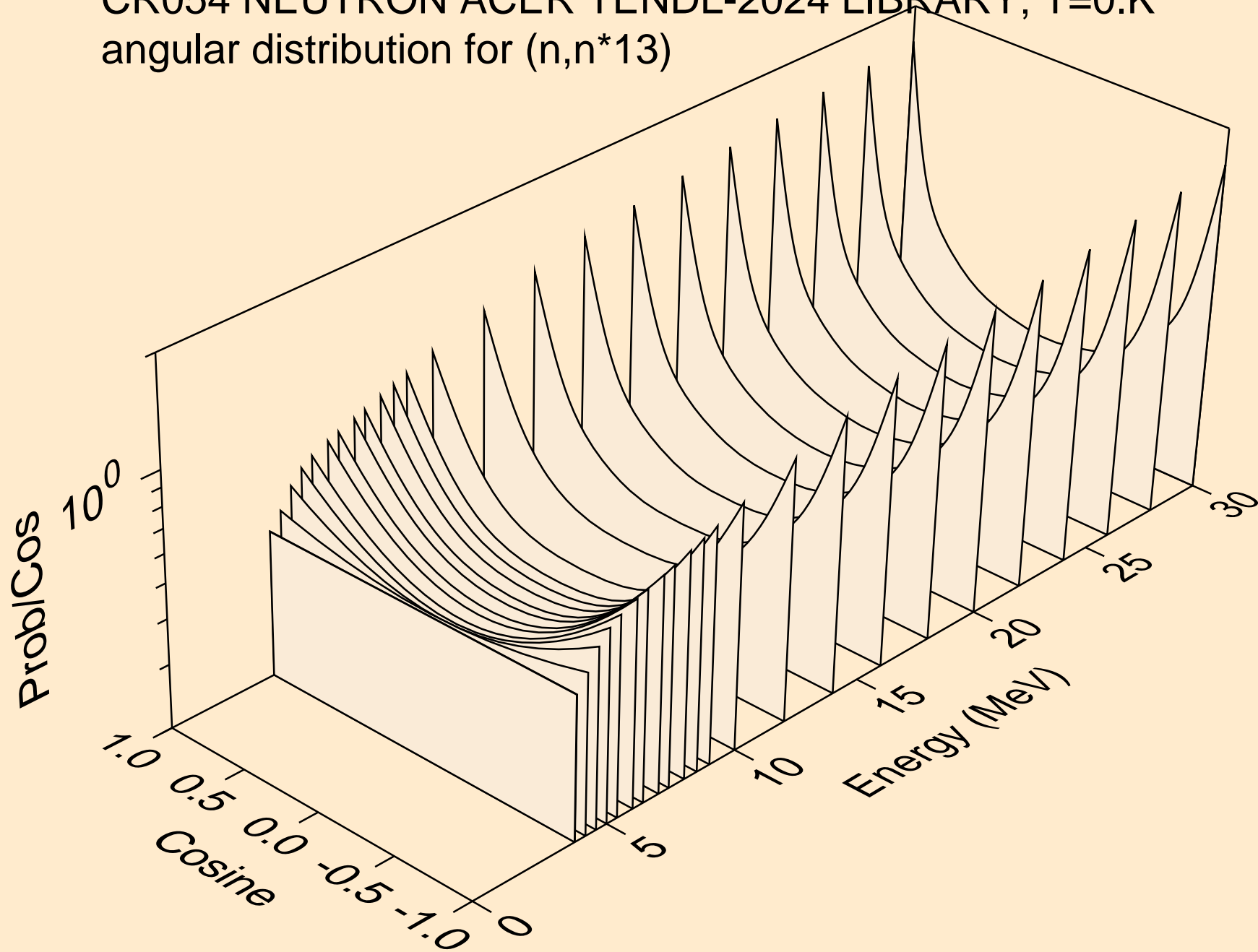

CR054 NEUTRON ACER TENDL-2024 LIBRARY; T=0.K
angular distribution for (n,n*14)

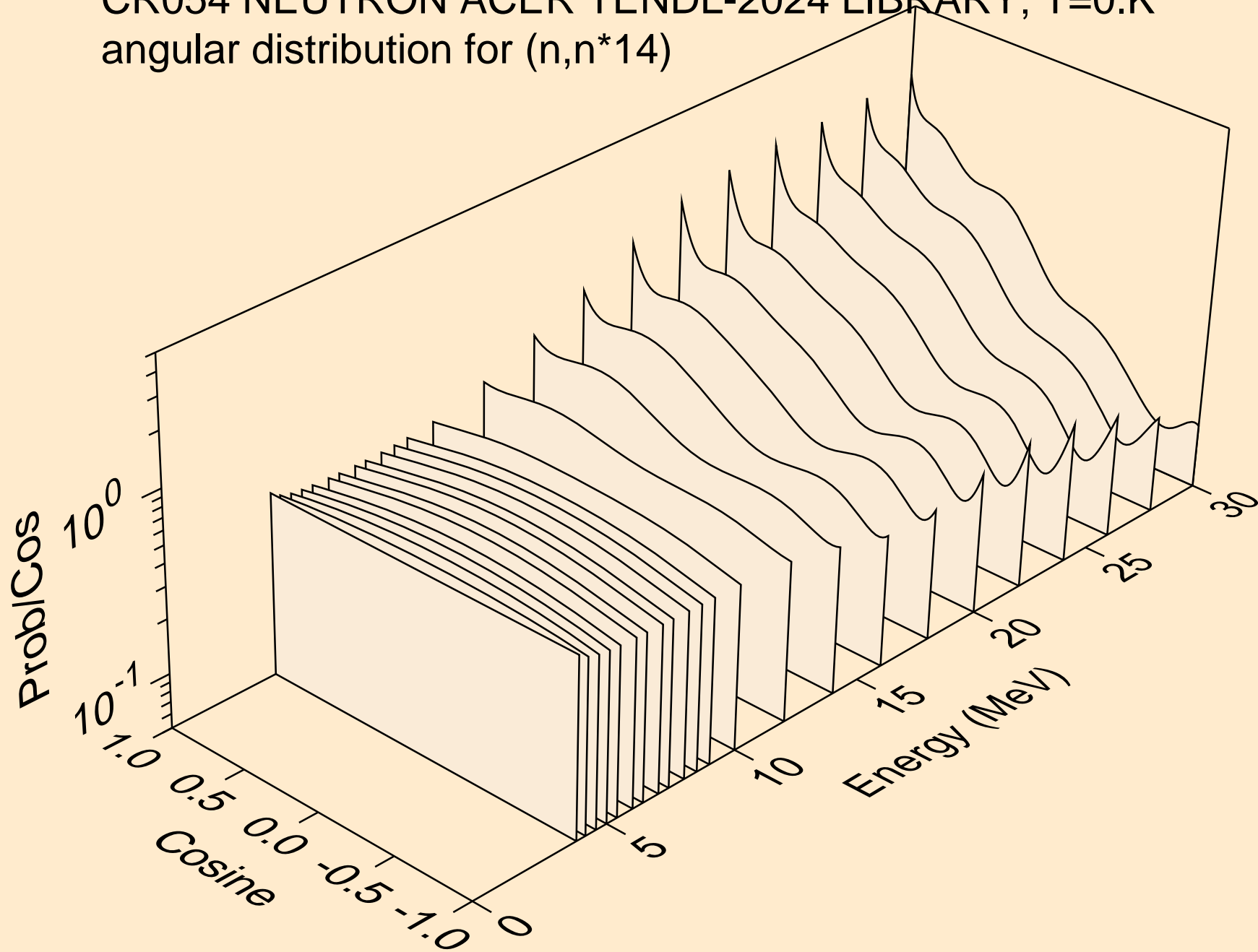

CR054 NEUTRON ACER TENDL-2024 LIBRARY; T=0.K
angular distribution for (n,n*15)

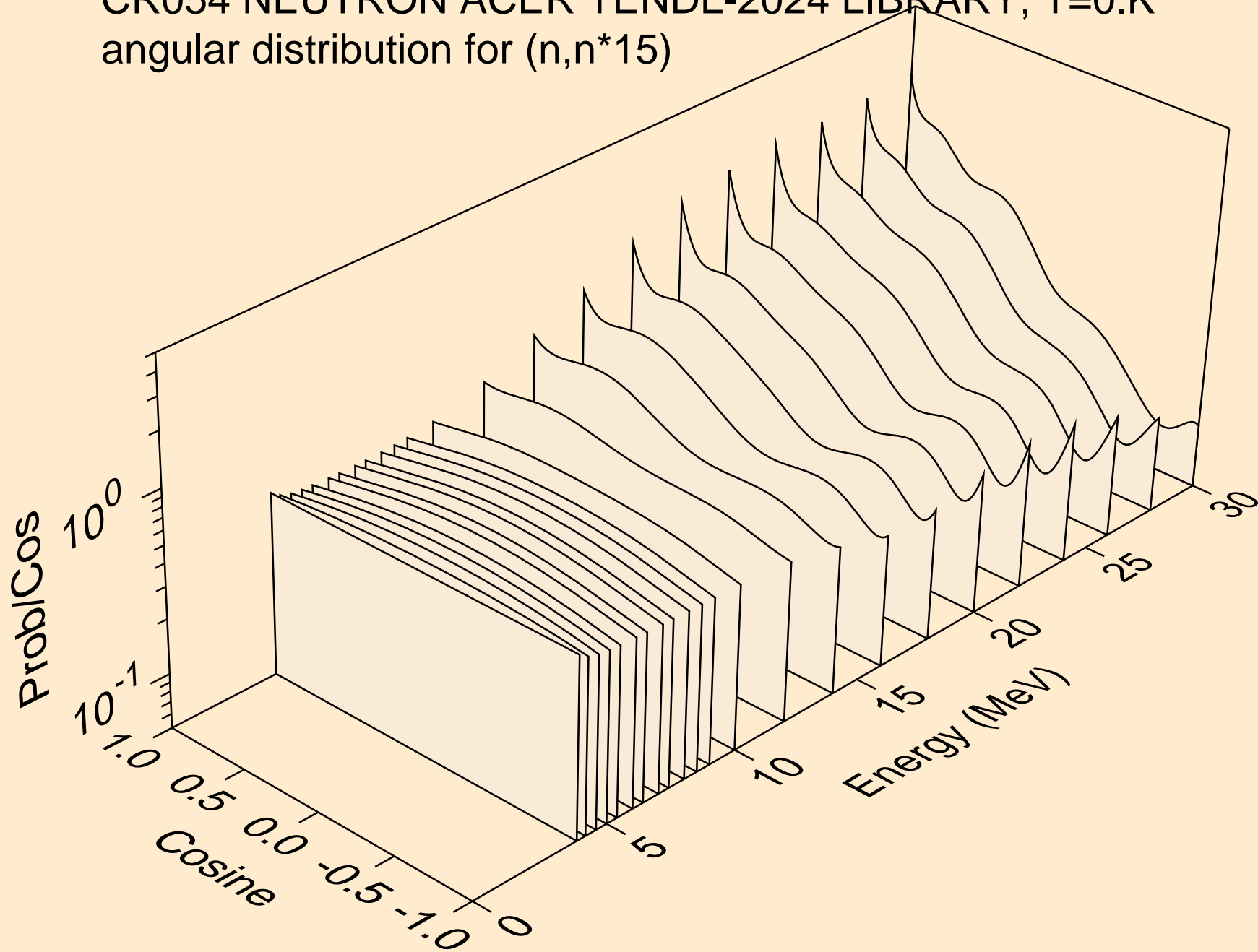

CR054 NEUTRON ACER TENDL-2024 LIBRARY; T=0.K
angular distribution for (n,n*16)

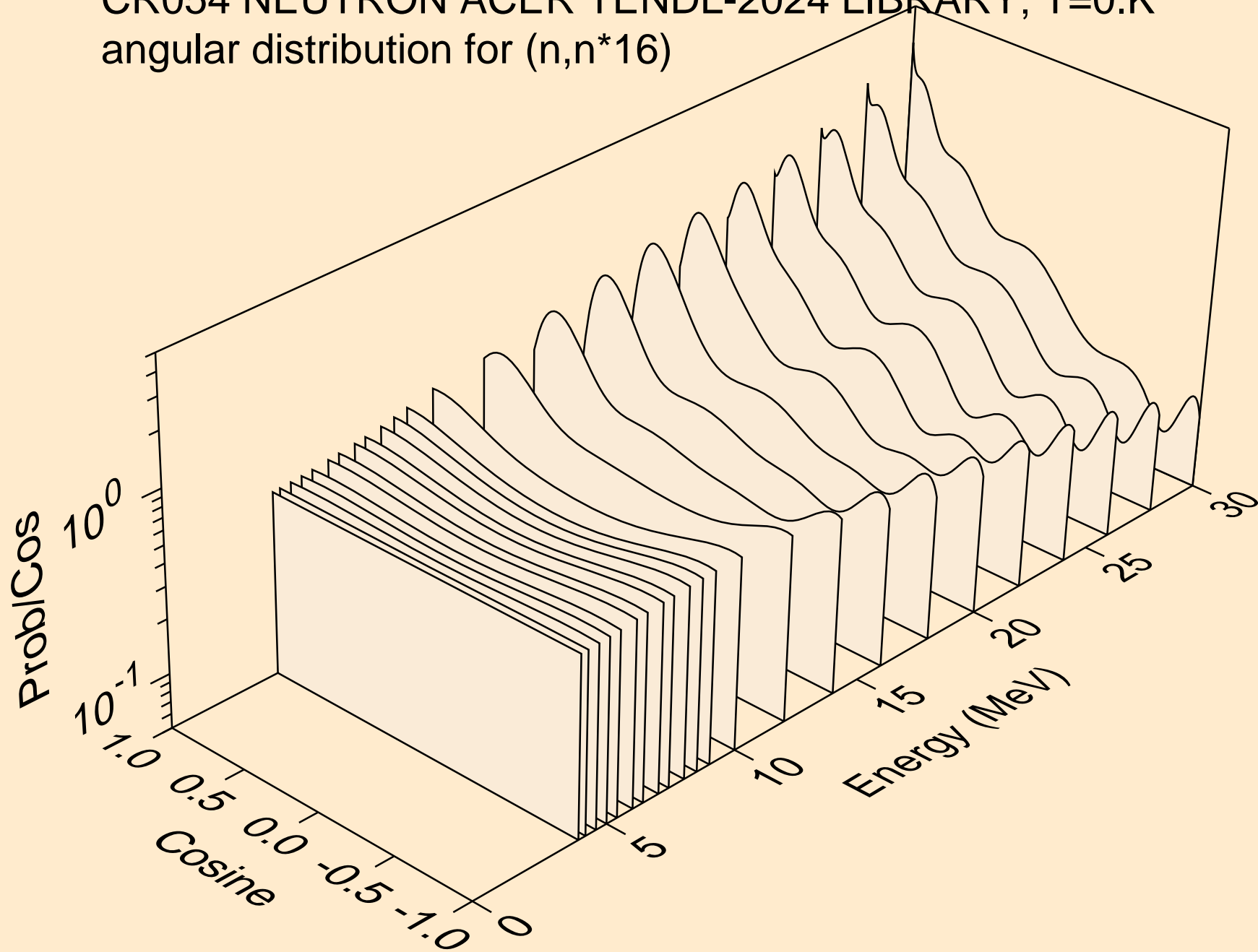

CR054 NEUTRON ACER TENDL-2024 LIBRARY; T=0.K
angular distribution for (n,n*17)

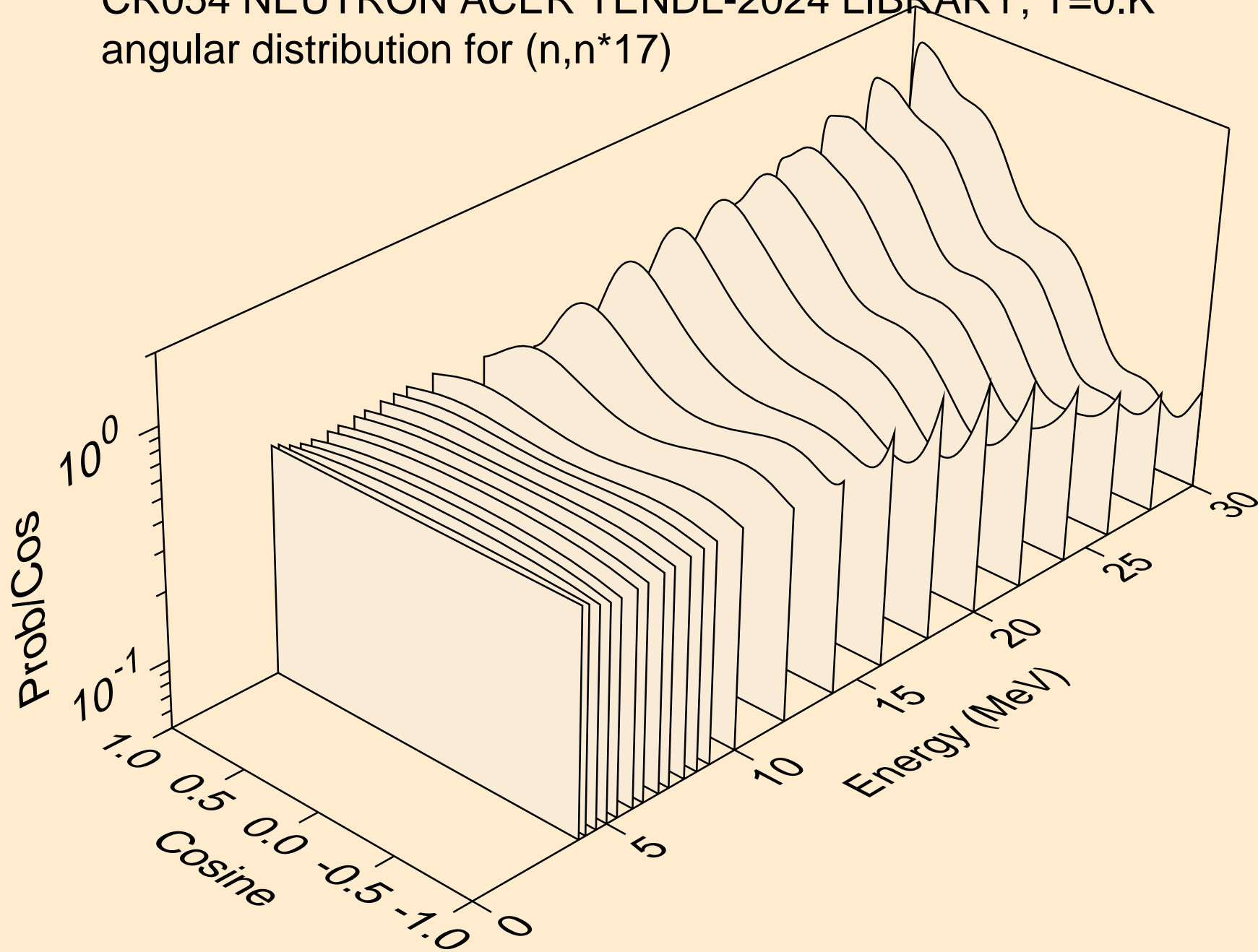

CR054 NEUTRON ACER TENDL-2024 LIBRARY; T=0.K
angular distribution for (n,n*18)

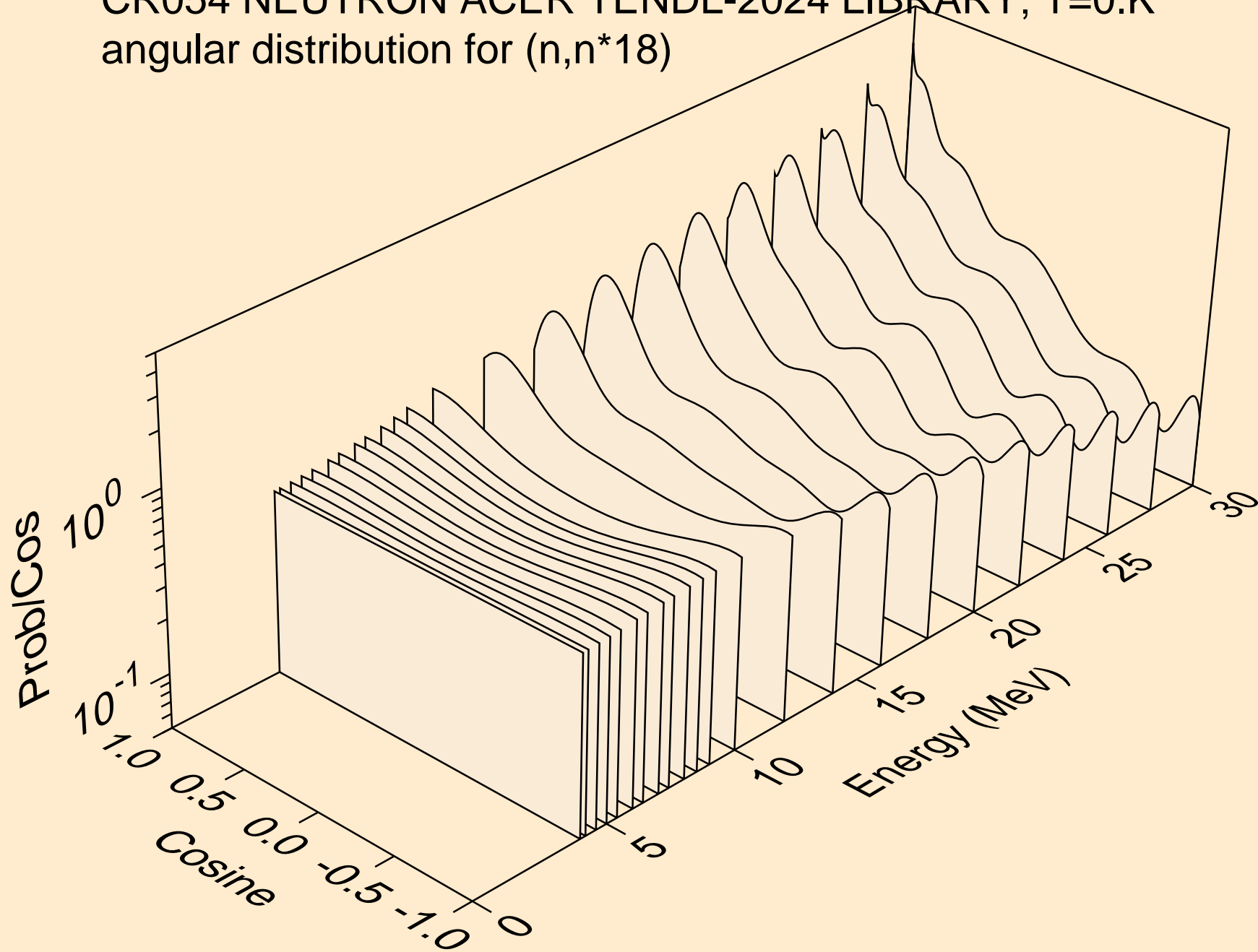

CR054 NEUTRON ACER TENDL-2024 LIBRARY; T=0.K
angular distribution for (n,n*19)

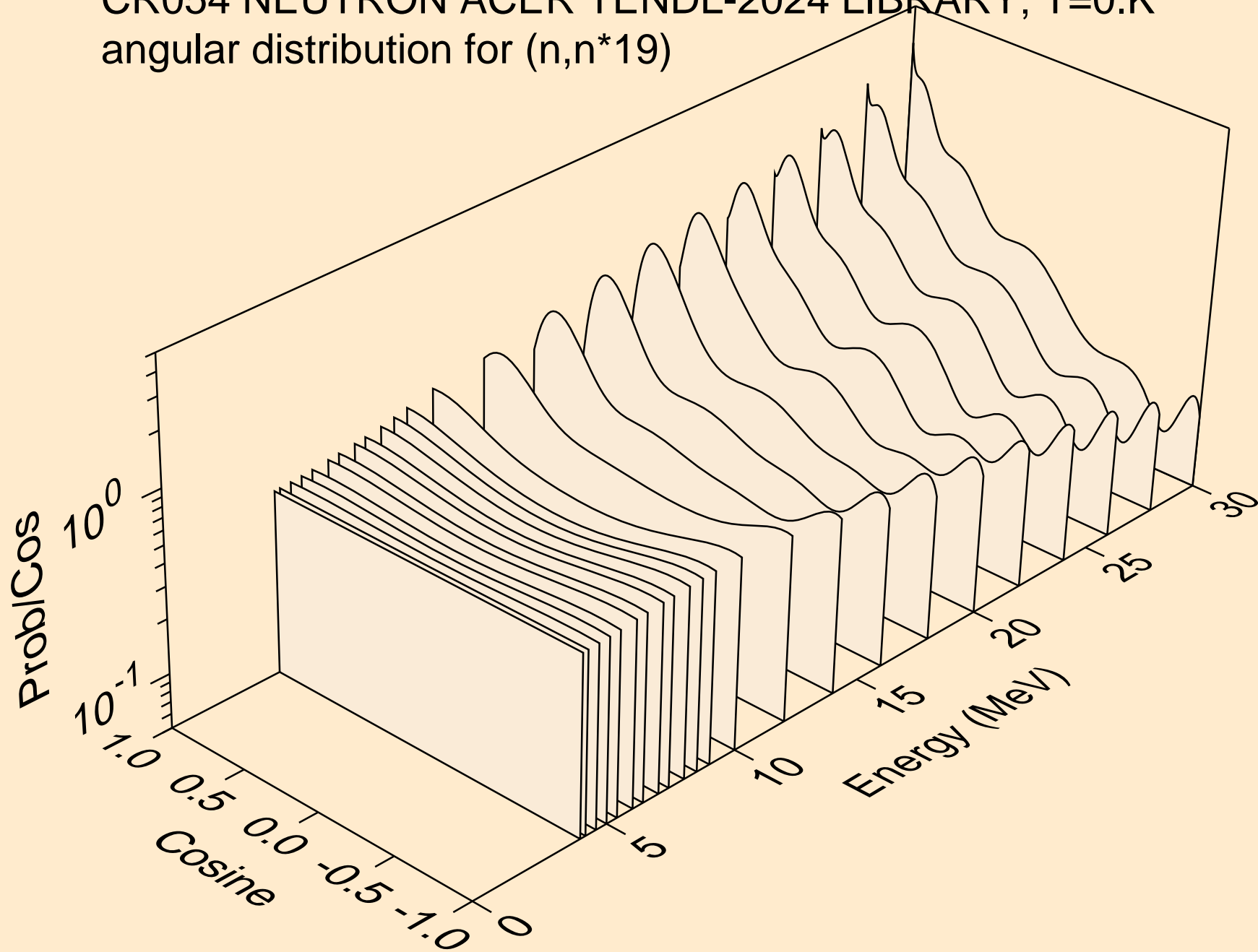

CR054 NEUTRON ACER TENDL-2024 LIBRARY; T=0.K
angular distribution for (n,n*20)

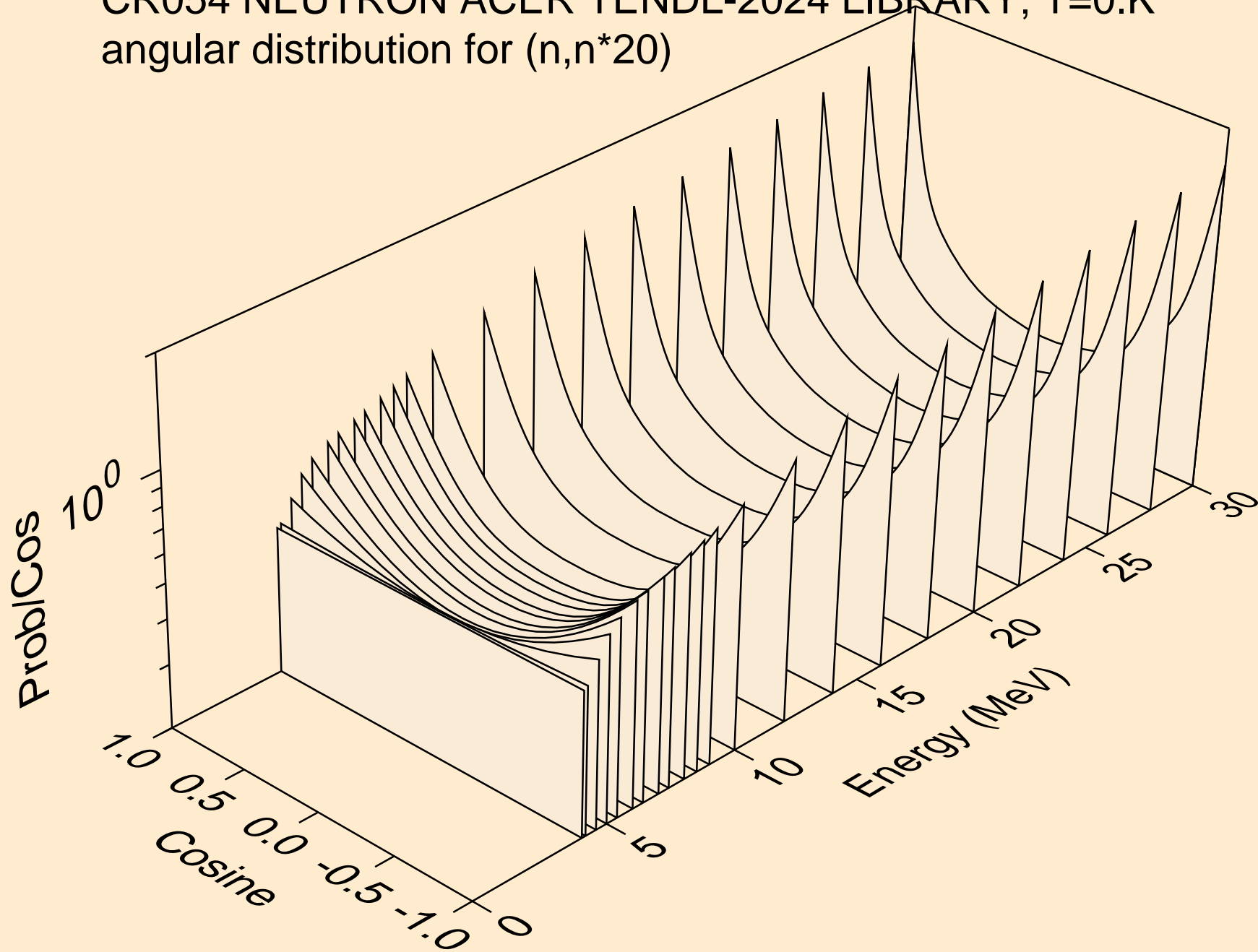

CR054 NEUTRON ACER TENDL-2024 LIBRARY; T=0.K
angular distribution for (n,n*21)

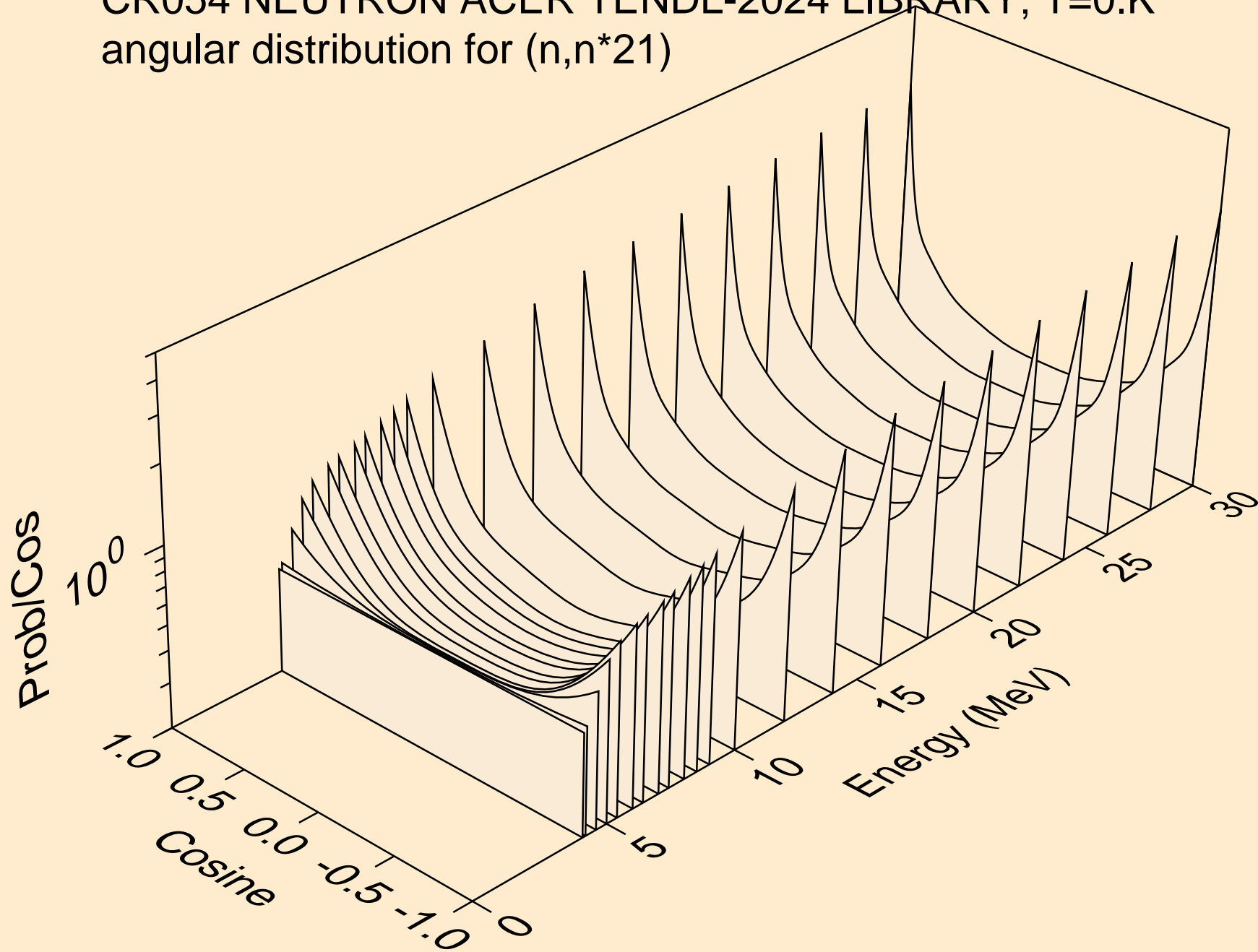

CR054 NEUTRON ACER TENDL-2024 LIBRARY; T=0.K
angular distribution for (n,n*22)

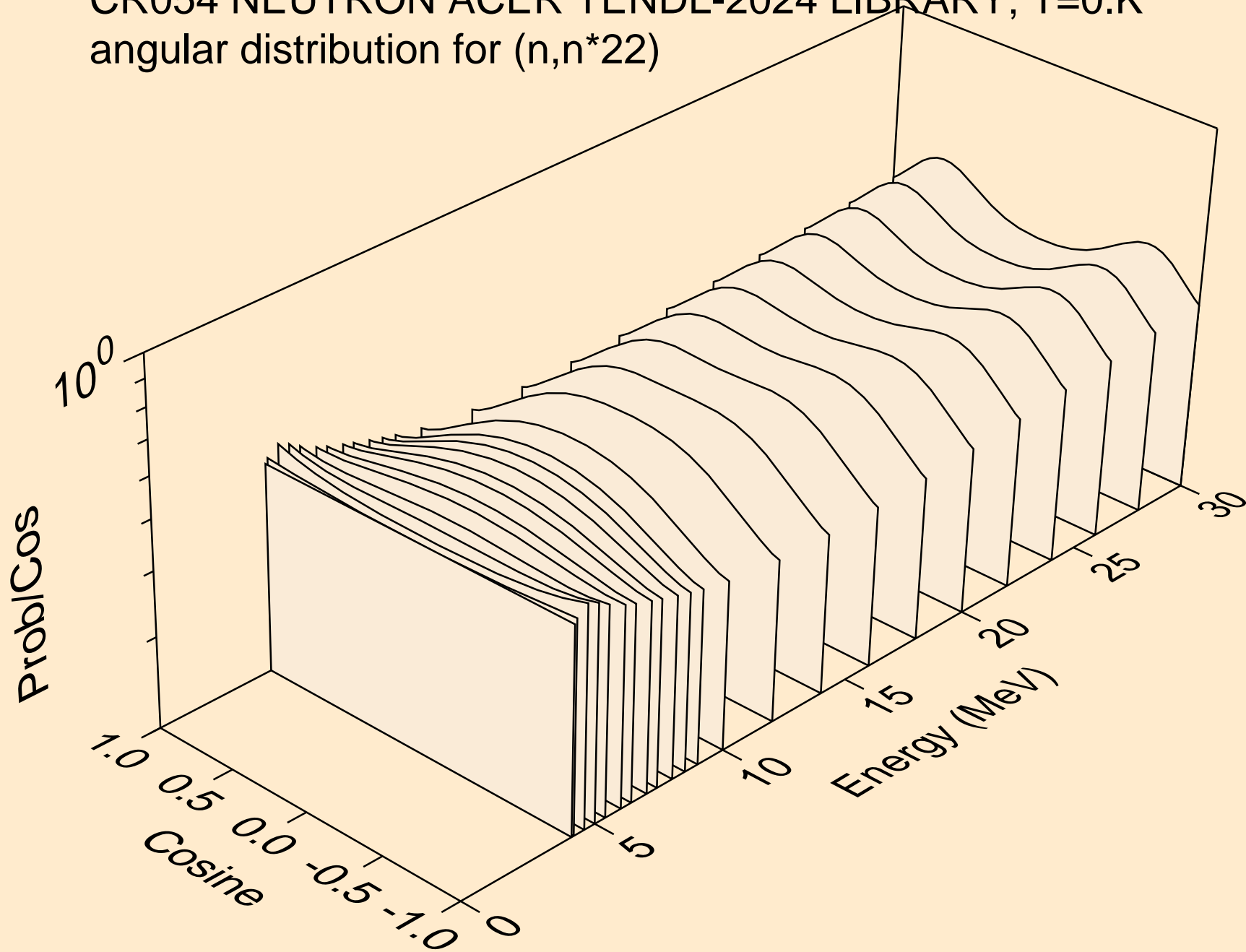

CR054 NEUTRON ACER TENDL-2024 LIBRARY; T=0.K
angular distribution for (n,n*23)

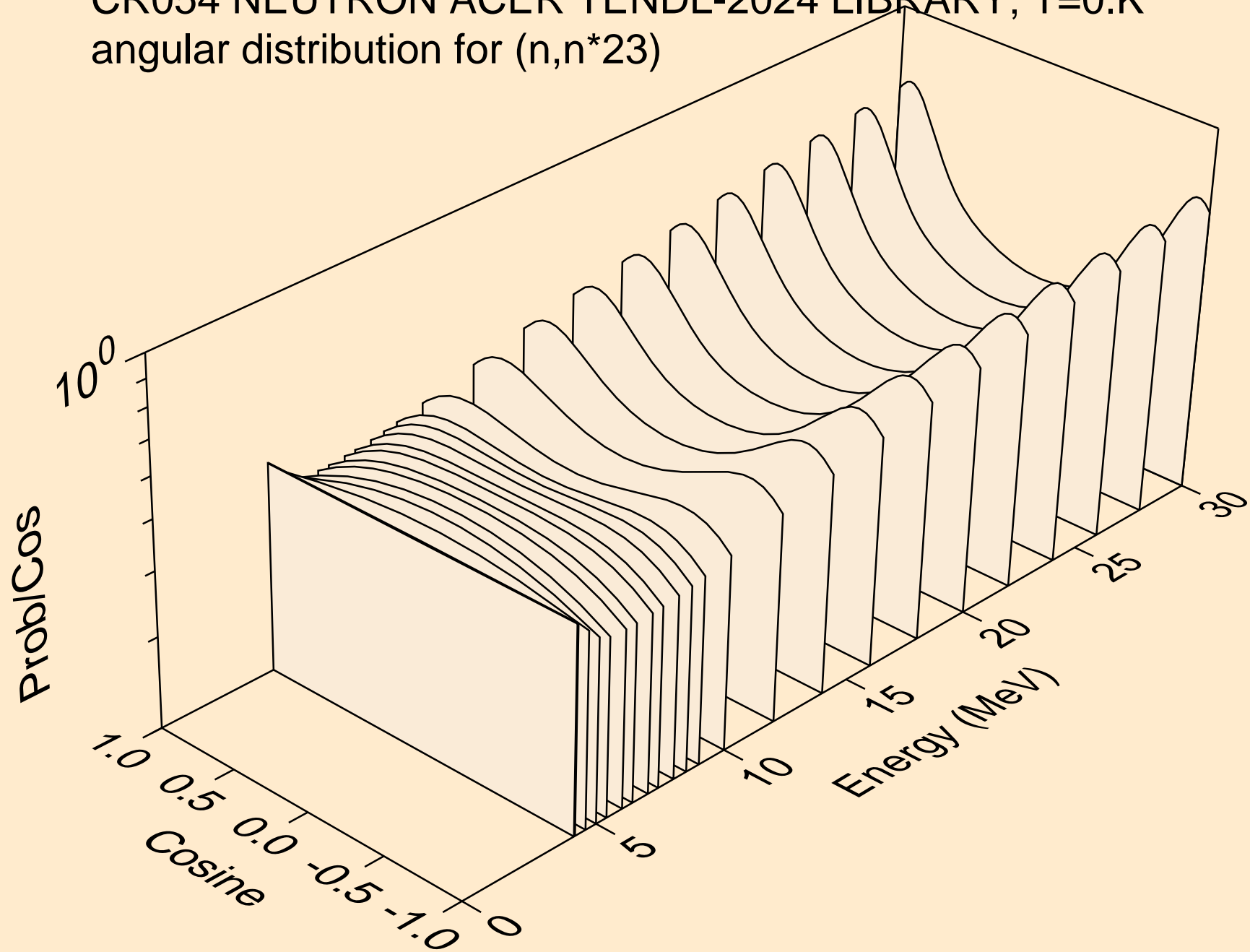

CR054 NEUTRON ACER TENDL-2024 LIBRARY; T=0.K
angular distribution for (n,n*24)

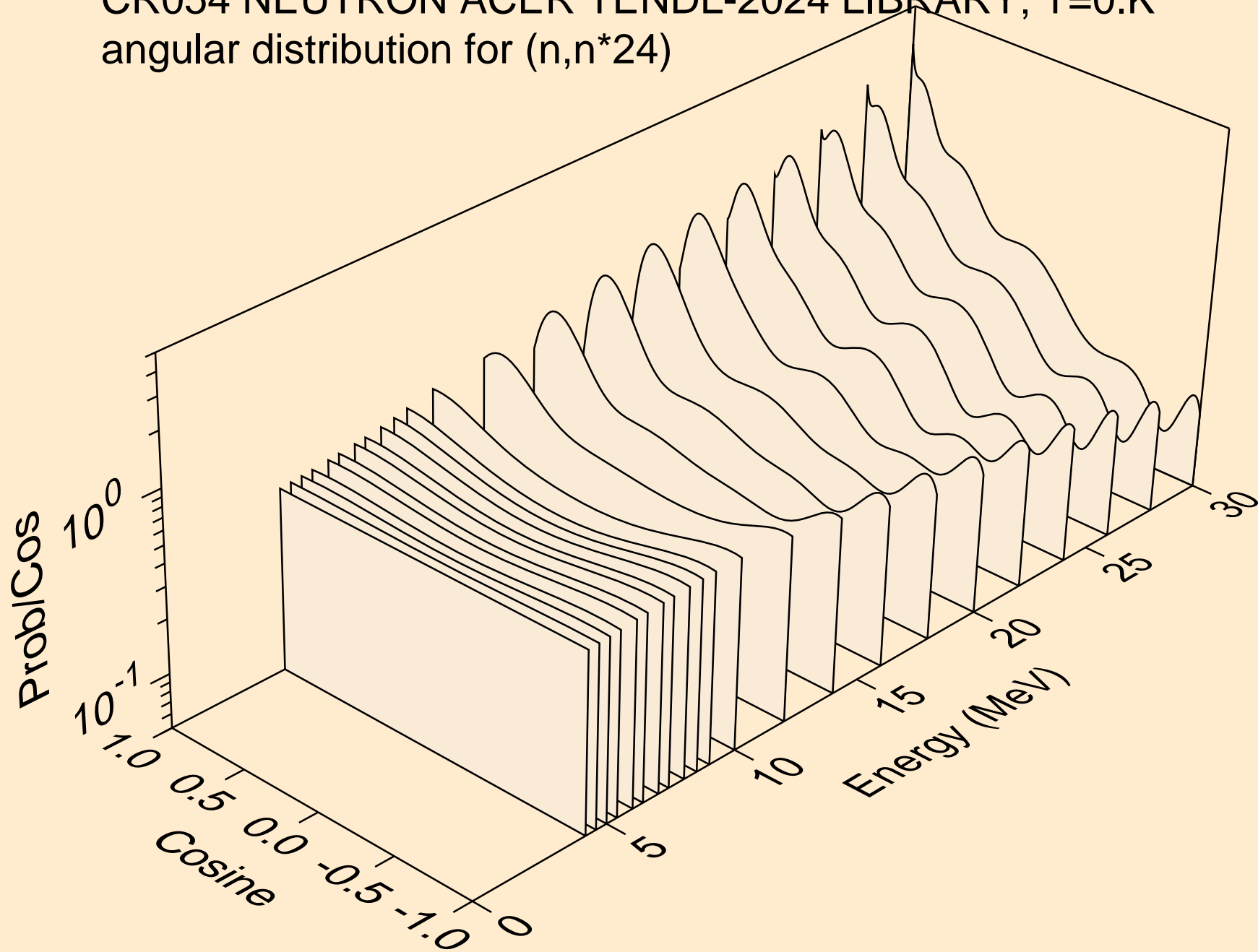

CR054 NEUTRON ACER TENDL-2024 LIBRARY; T=0.K
angular distribution for (n,n*25)

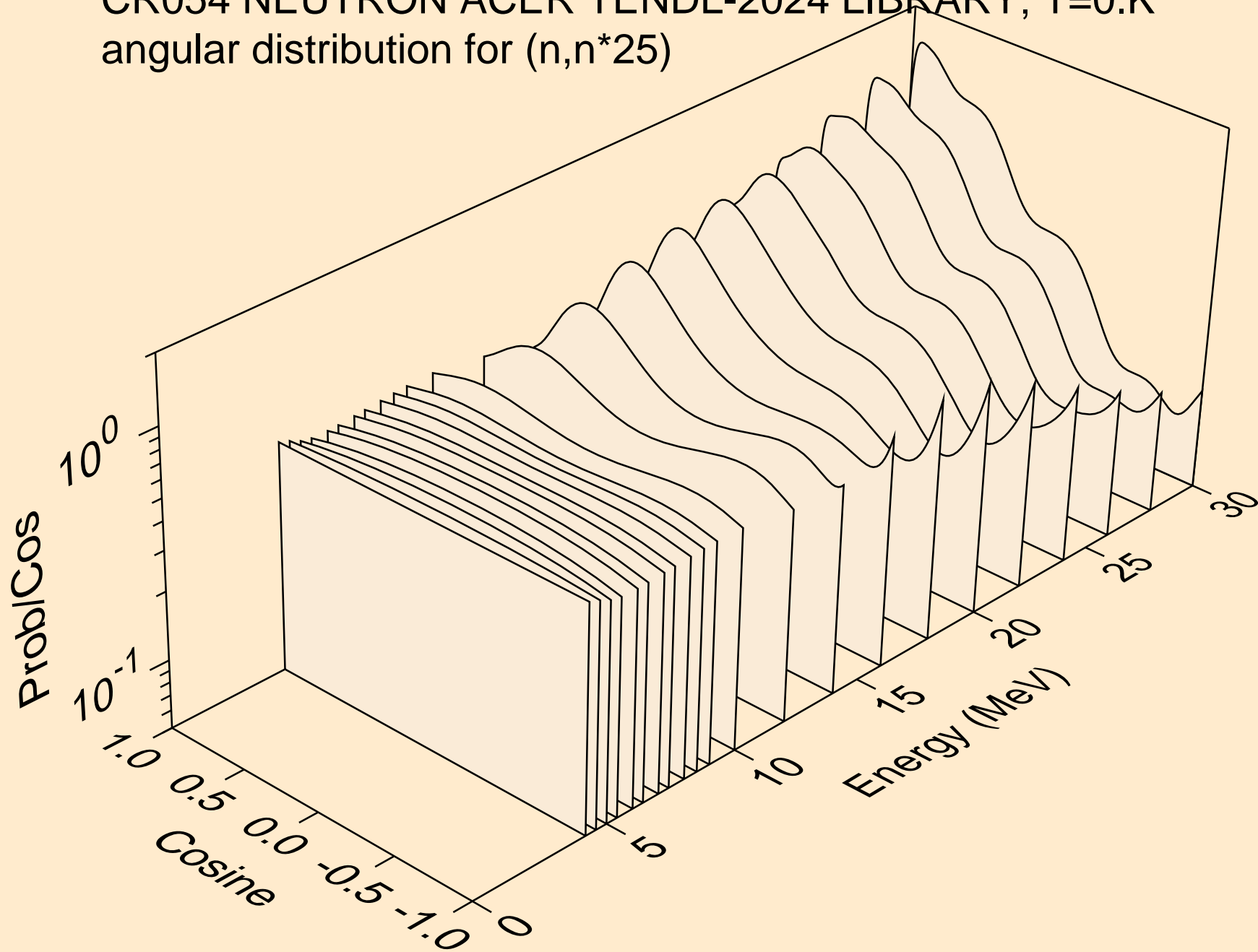

CR054 NEUTRON ACER TENDL-2024 LIBRARY; T=0.K
angular distribution for (n,n*26)

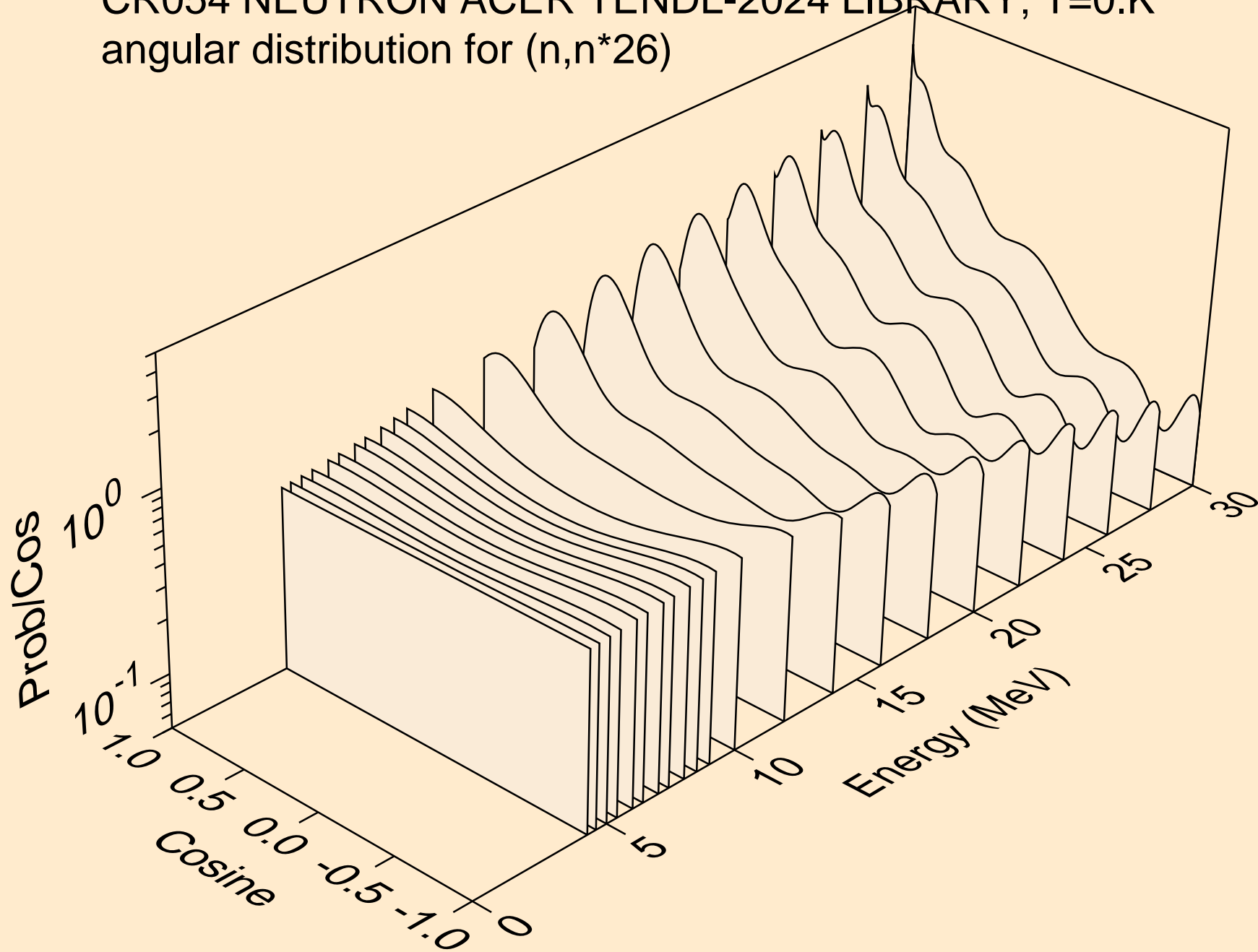

CR054 NEUTRON ACER TENDL-2024 LIBRARY; T=0.K
angular distribution for (n,n*27)

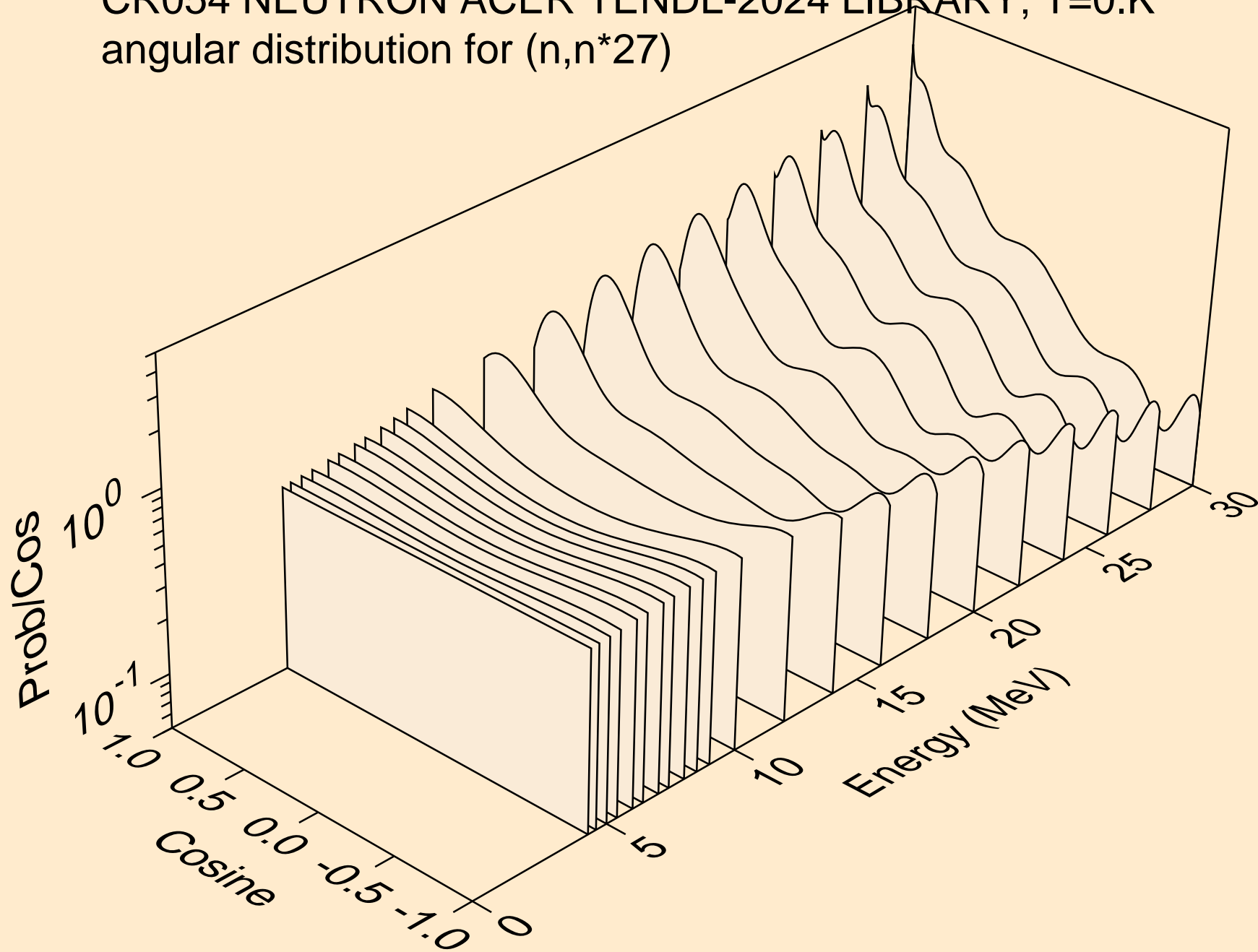

CR054 NEUTRON ACER TENDL-2024 LIBRARY; T=0.K
angular distribution for (n,n*28)

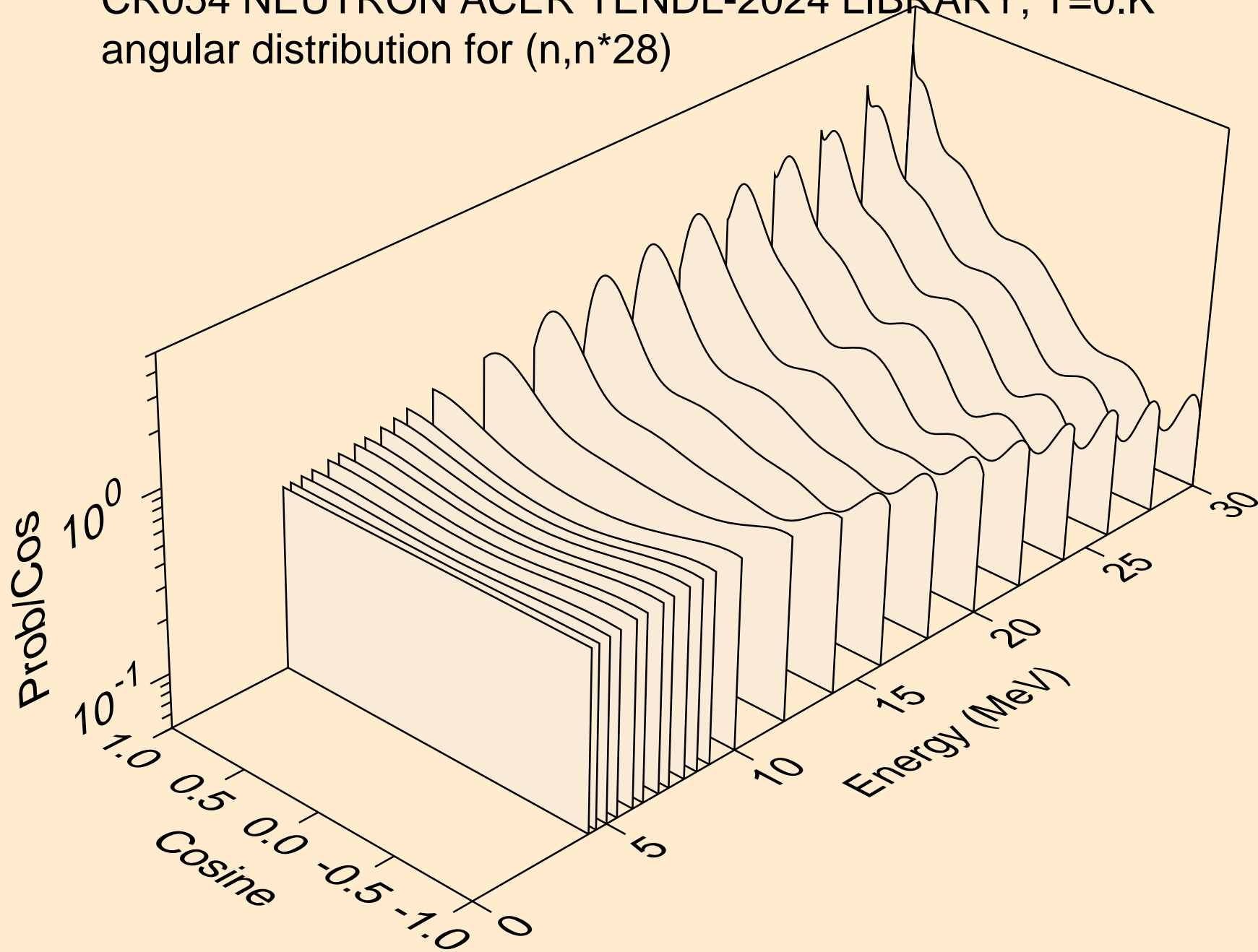

CR054 NEUTRON ACER TENDL-2024 LIBRARY; T=0.K
angular distribution for (n,n*29)

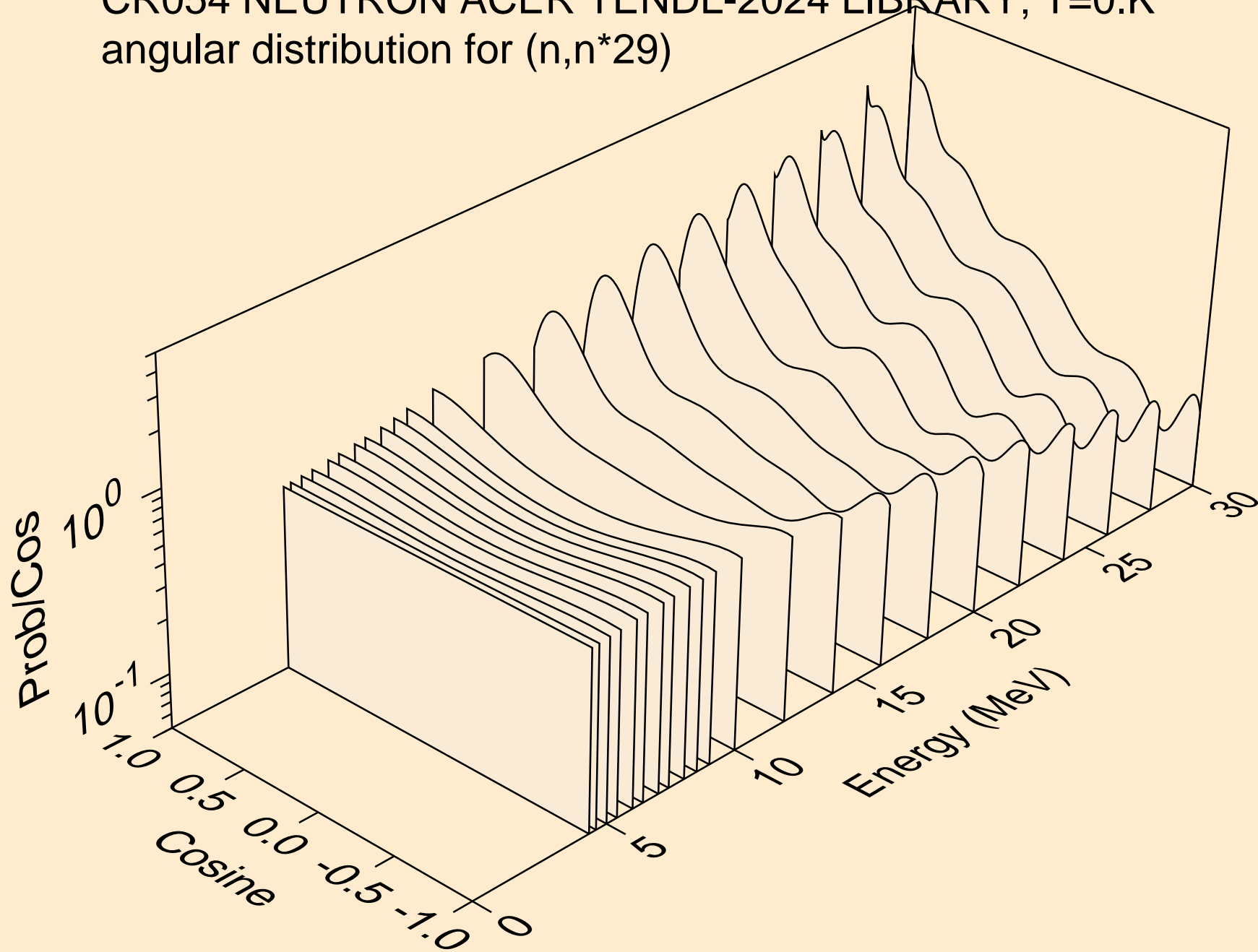

CR054 NEUTRON ACER TENDL-2024 LIBRARY; T=0.K
angular distribution for (n,n*30)

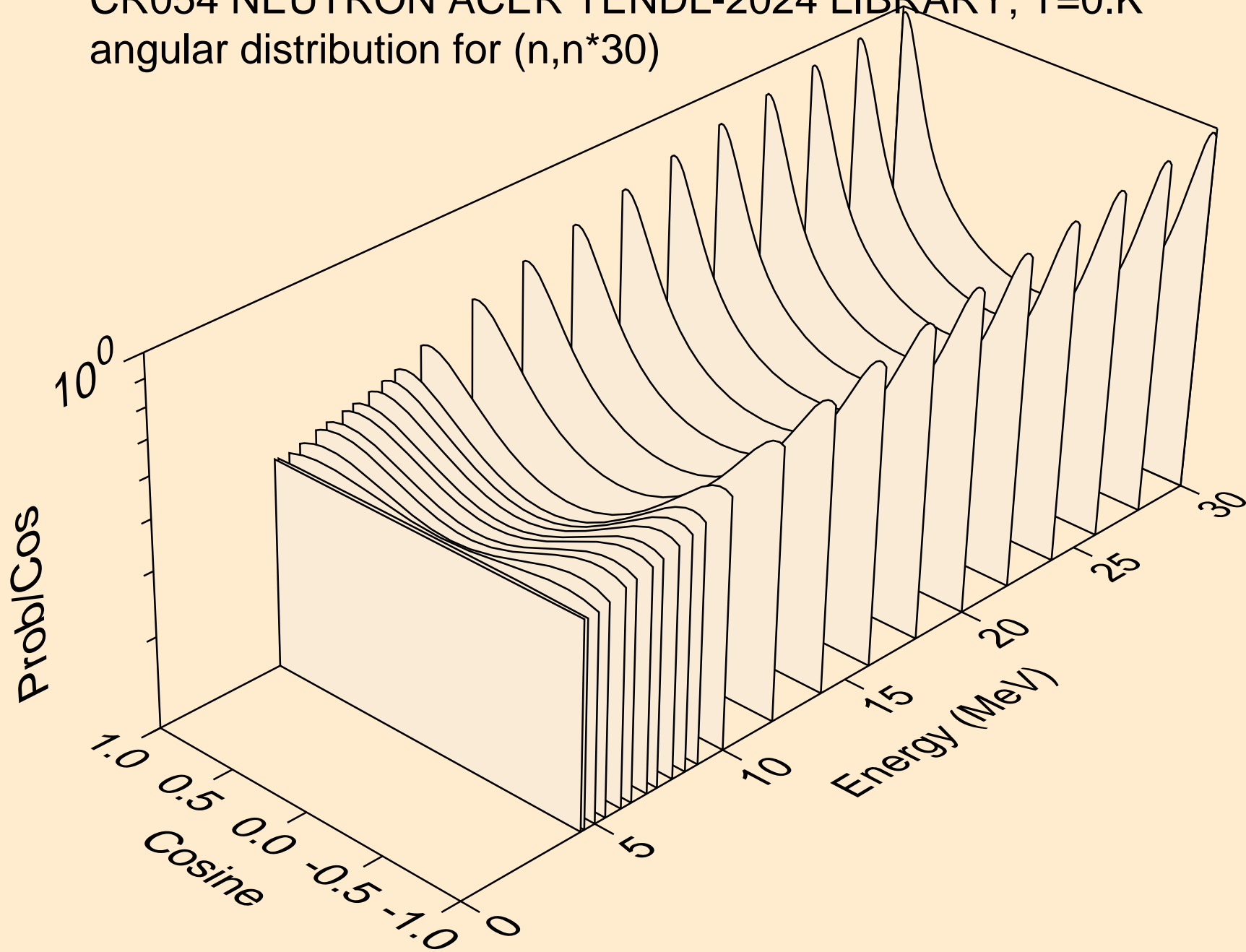

CR054 NEUTRON ACER TENDL-2024 LIBRARY; T=0.K
Neutron emission for (n,x)

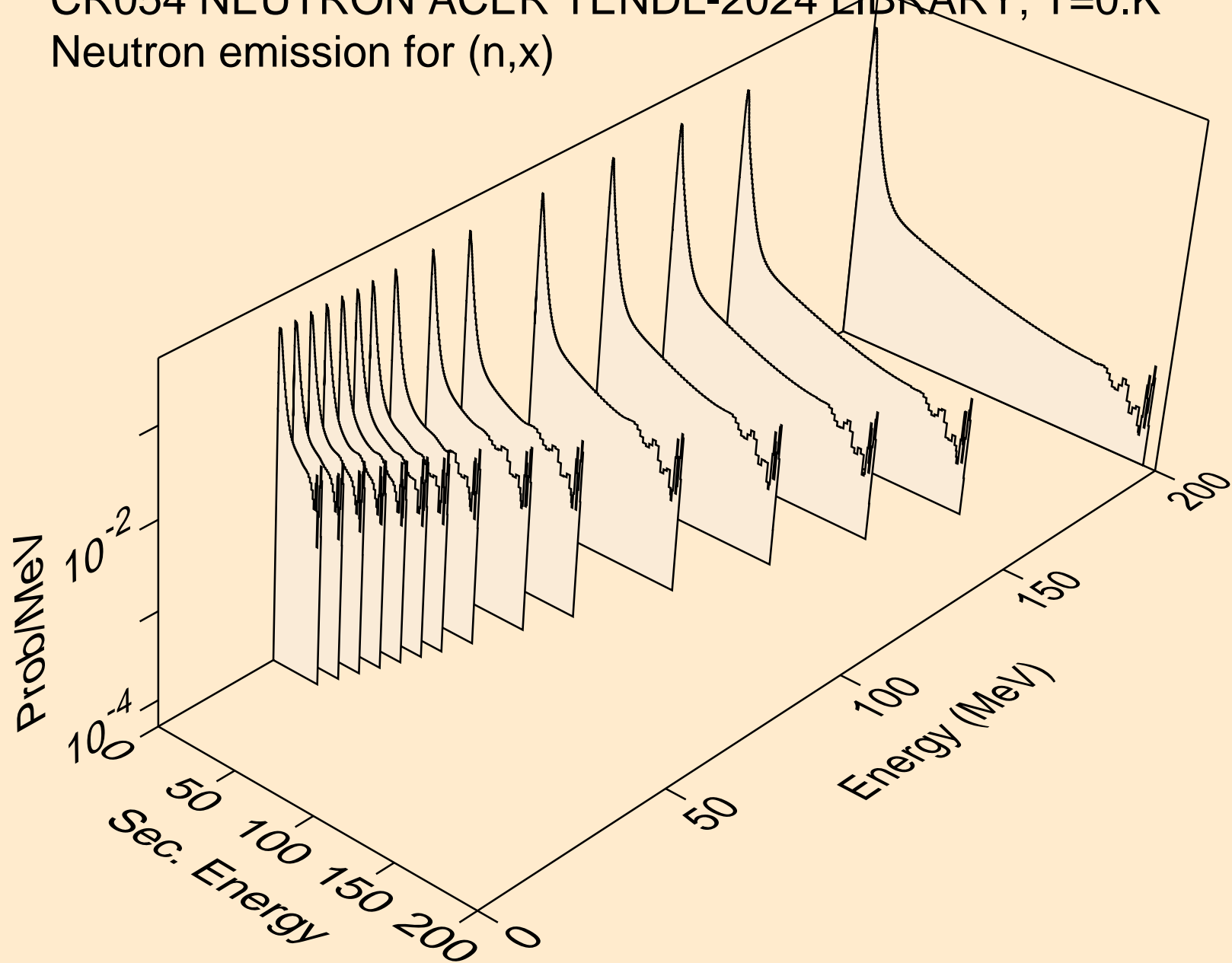

CR054 NEUTRON ACER TENDL-2024 LIBRARY; T=0.K
Neutron emission for (n,2nd)

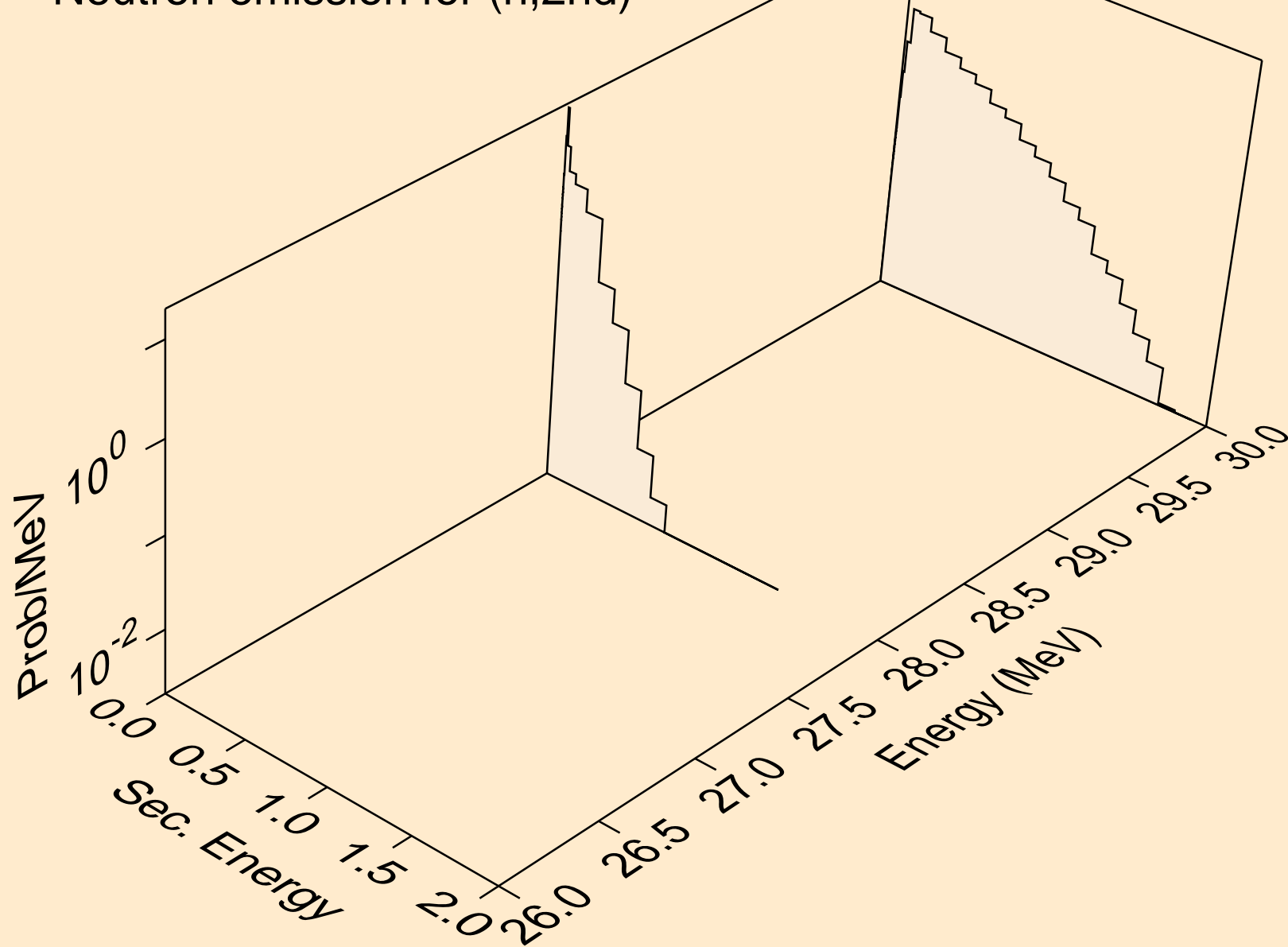

CR054 NEUTRON ACER TENDL-2024 LIBRARY; T=0.K
Neutron emission for (n,2n)

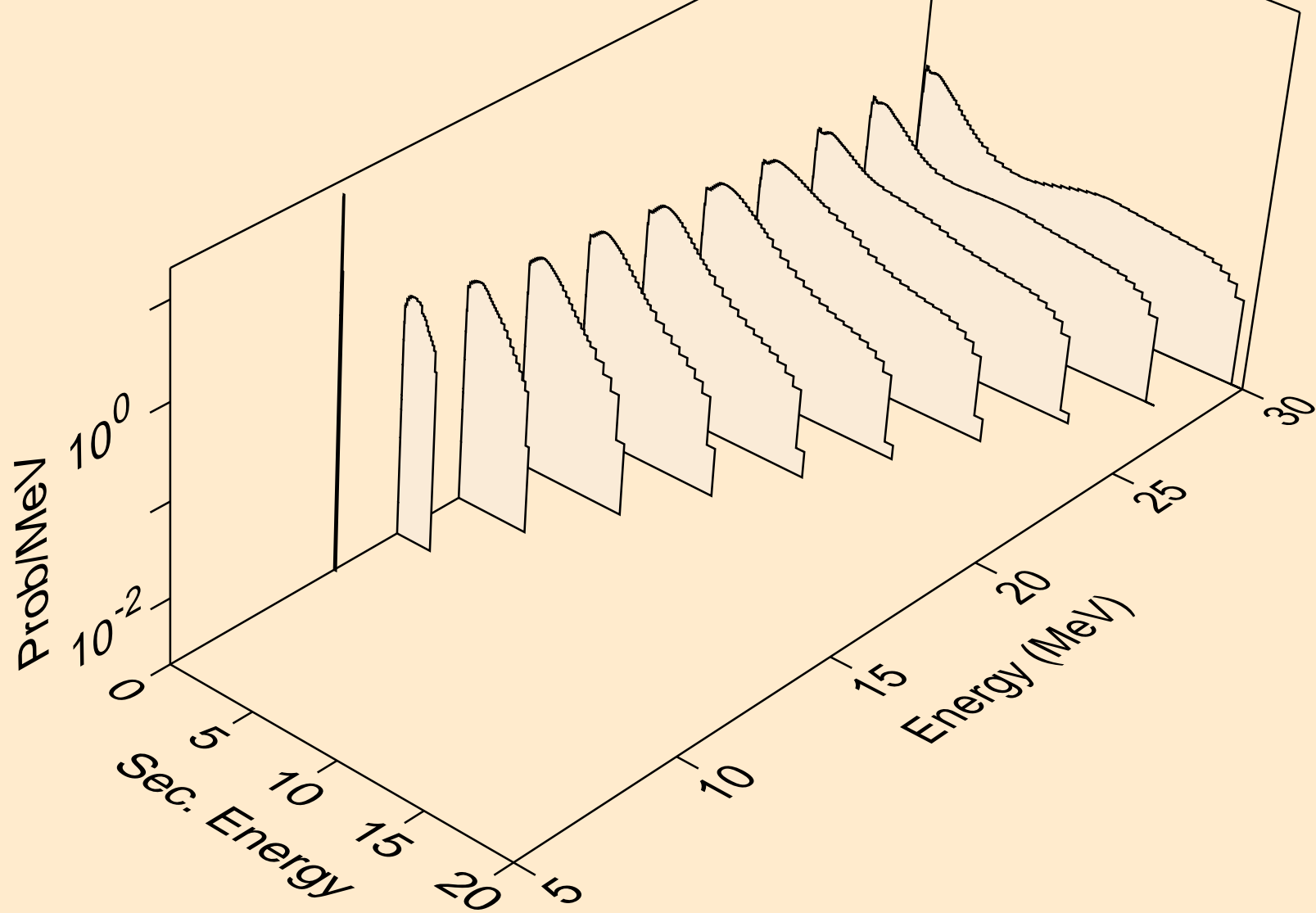

CR054 NEUTRON ACER TENDL-2024 LIBRARY; T=0.K
Neutron emission for (n,3n)

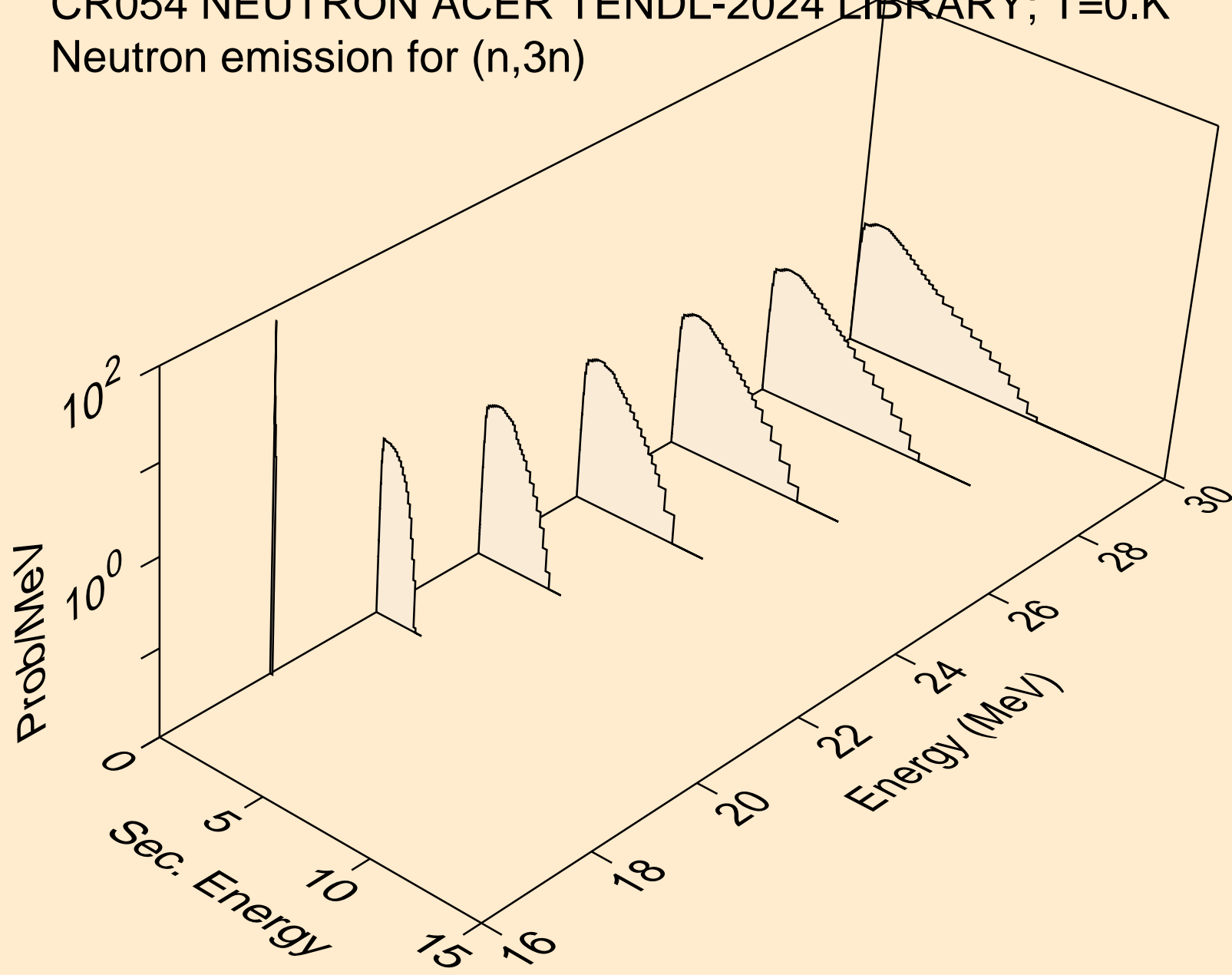

CR054 NEUTRON ACER TENDL-2024 LIBRARY; T=0.K
Neutron emission for (n,n*)a

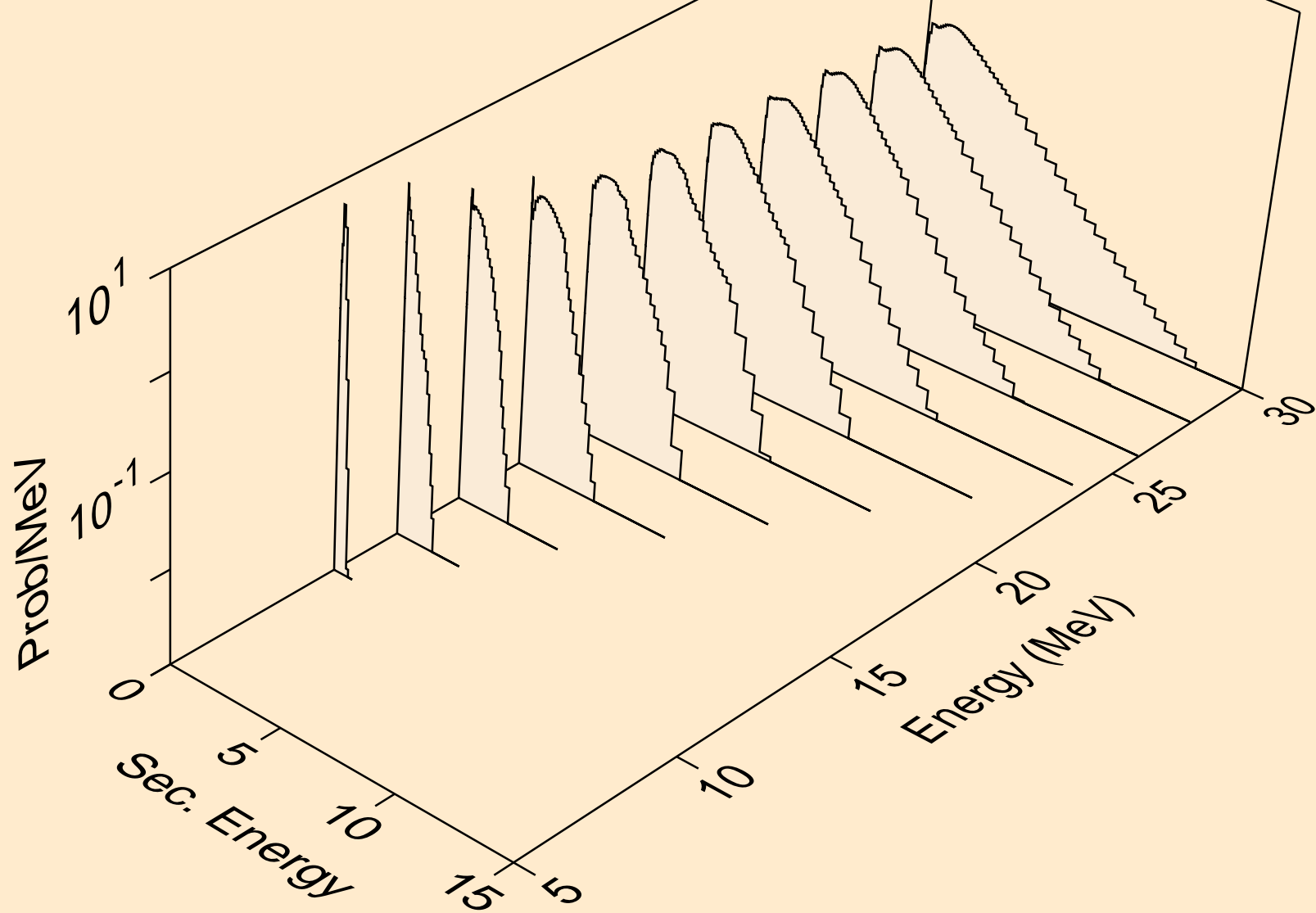

CR054 NEUTRON ACER TENDL-2024 LIBRARY; T=0.K
Neutron emission for (n,2n)a

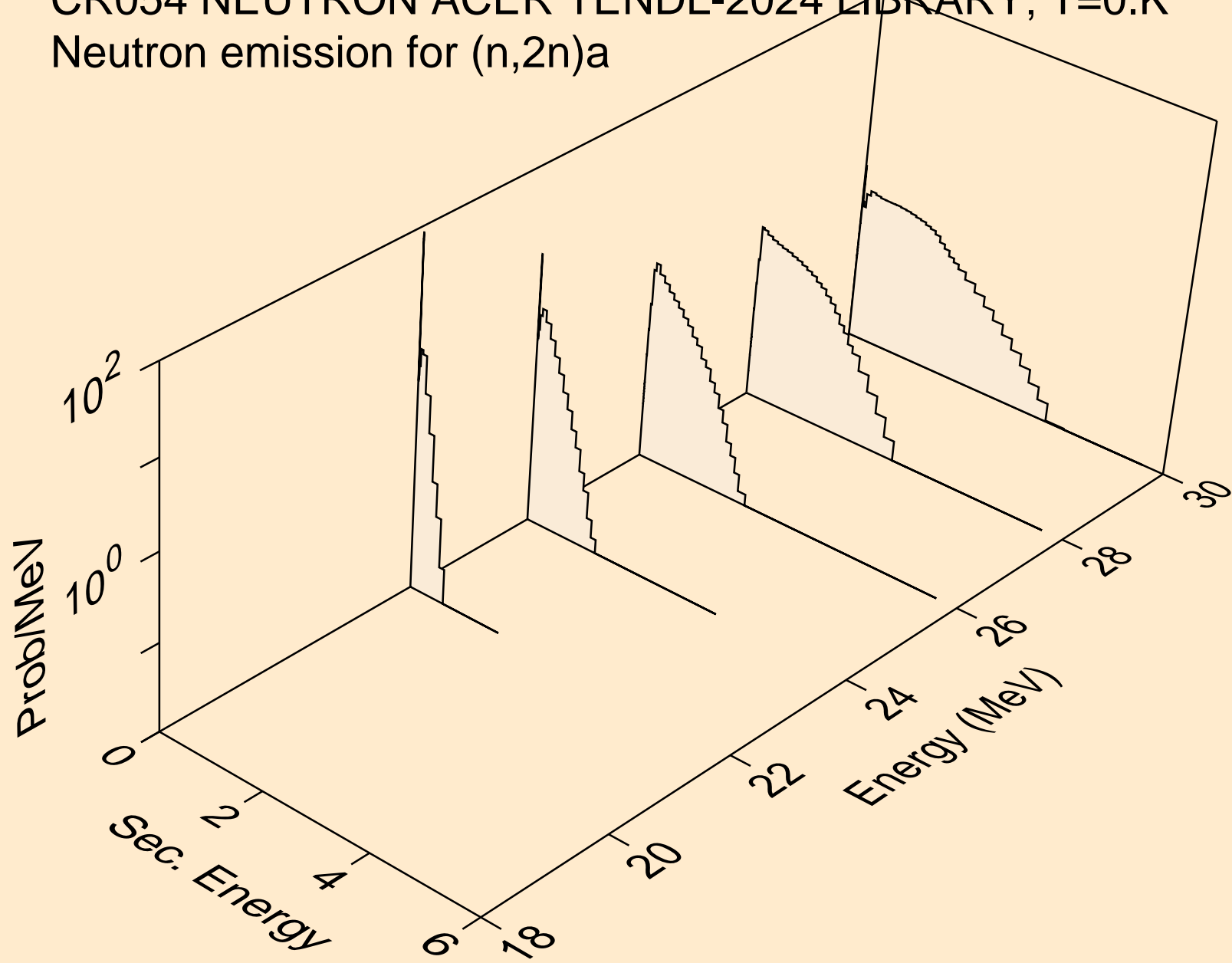

CR054 NEUTRON ACER TENDL-2024 LIBRARY; T=0.K
Neutron emission for (n,n*)p

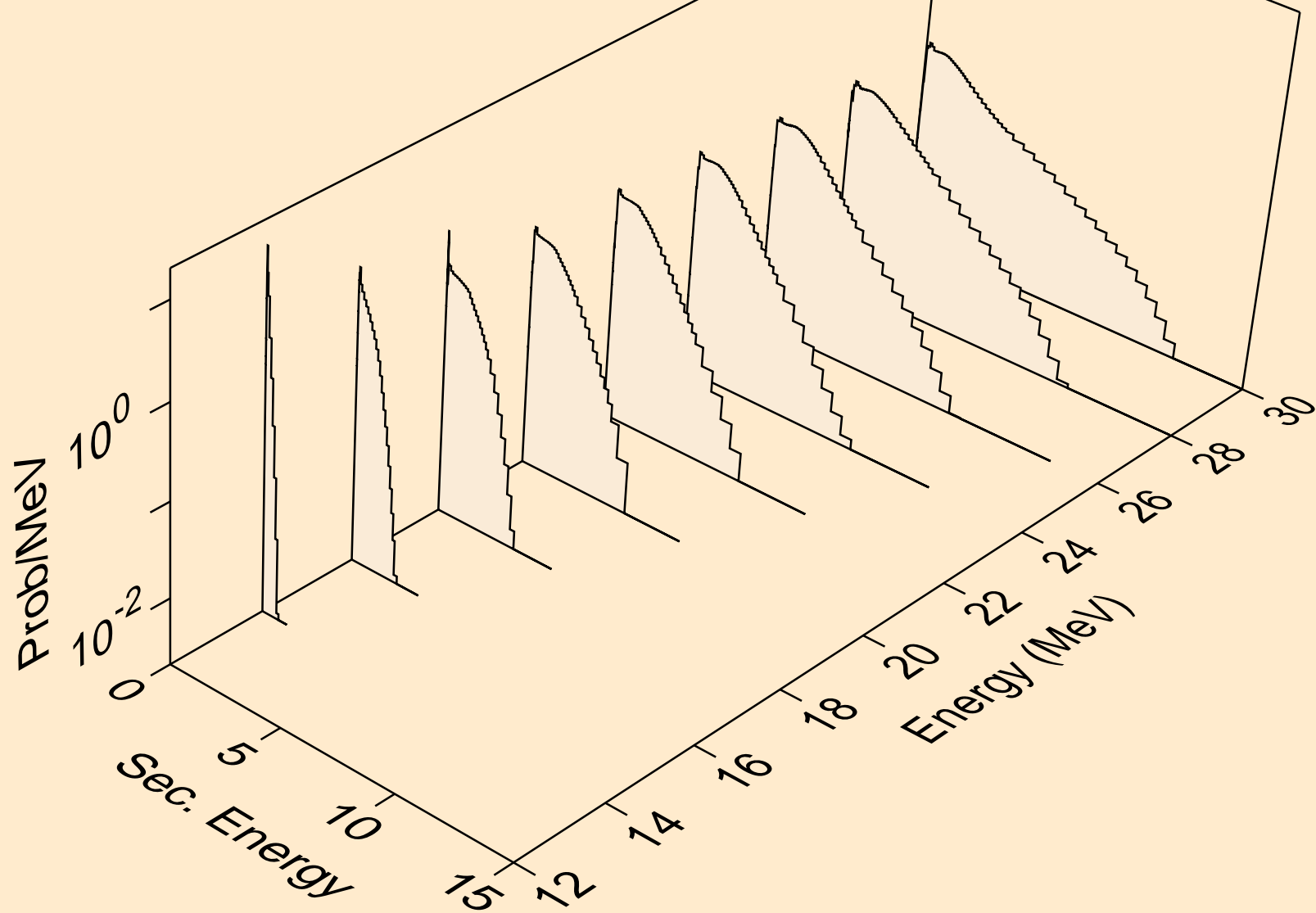

CR054 NEUTRON ACER TENDL-2024 LIBRARY; T=0.K
Neutron emission for (n,n*)2a

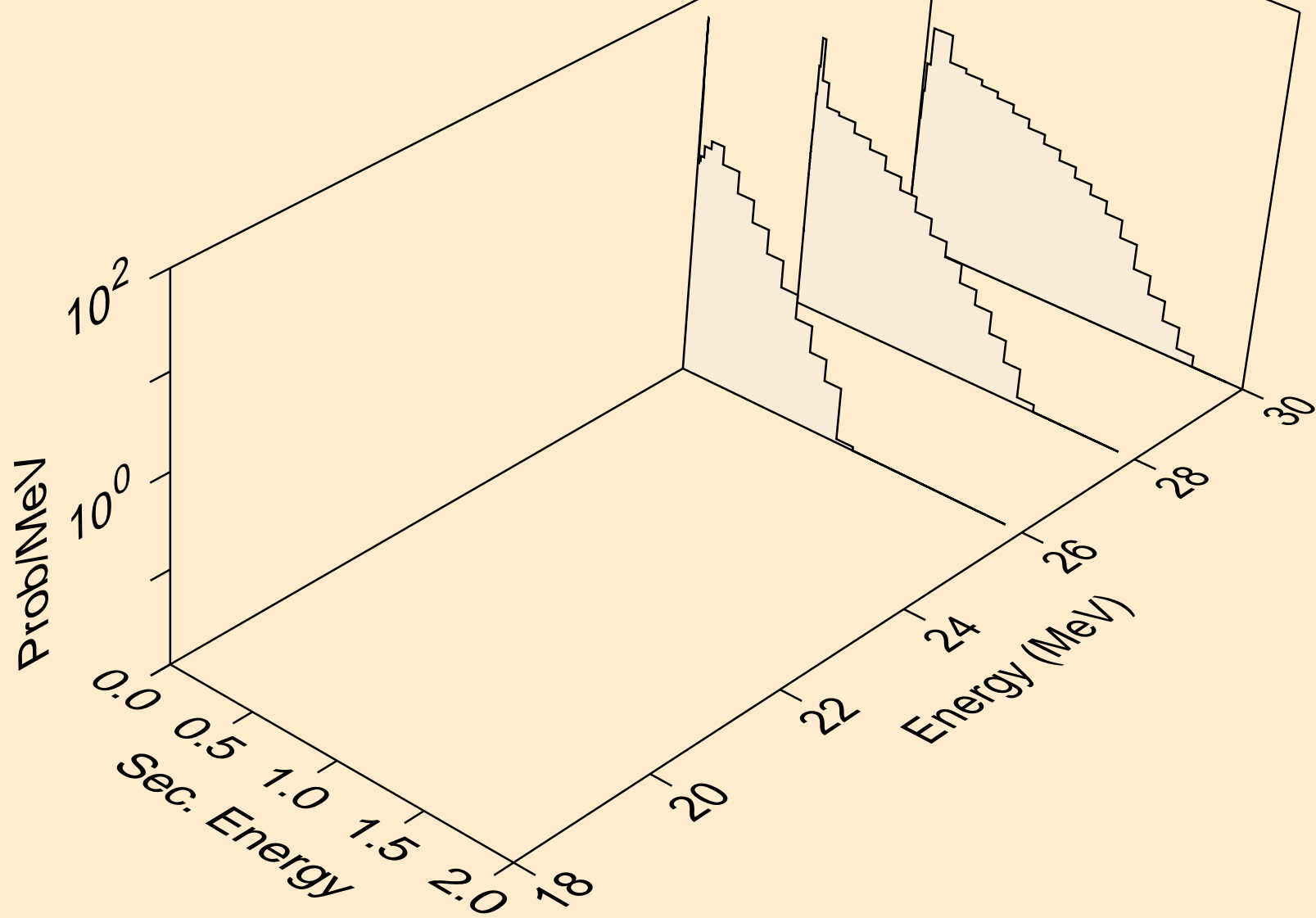

CR054 NEUTRON ACER TENDL-2024 LIBRARY; T=0.K
Neutron emission for (n,n*)d

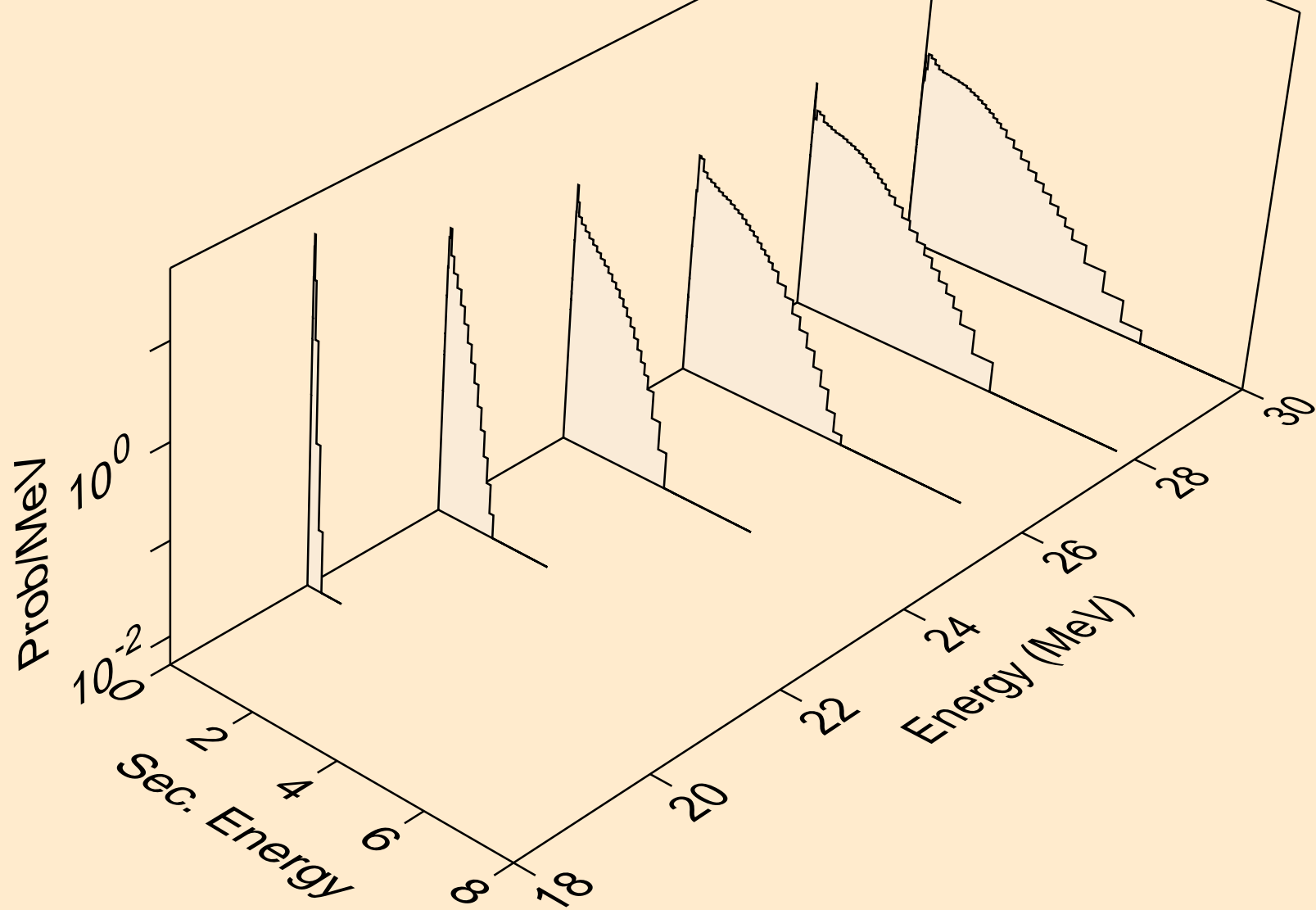

CR054 NEUTRON ACER TENDL-2024 LIBRARY; T=0.K
Neutron emission for (n,n*)t

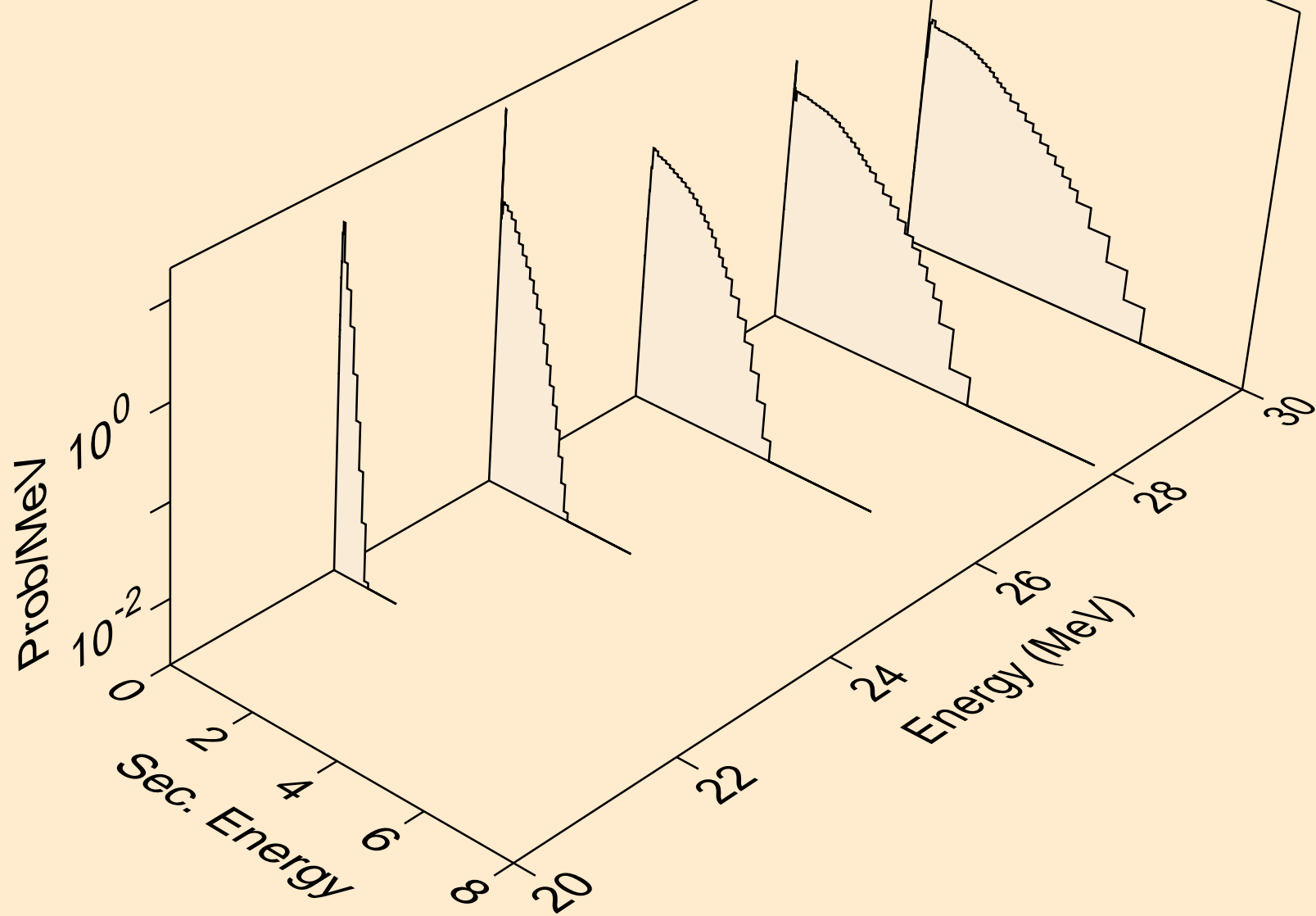

CR054 NEUTRON ACER TENDL-2024 LIBRARY; T=0.K
Neutron emission for (n,n*)he3

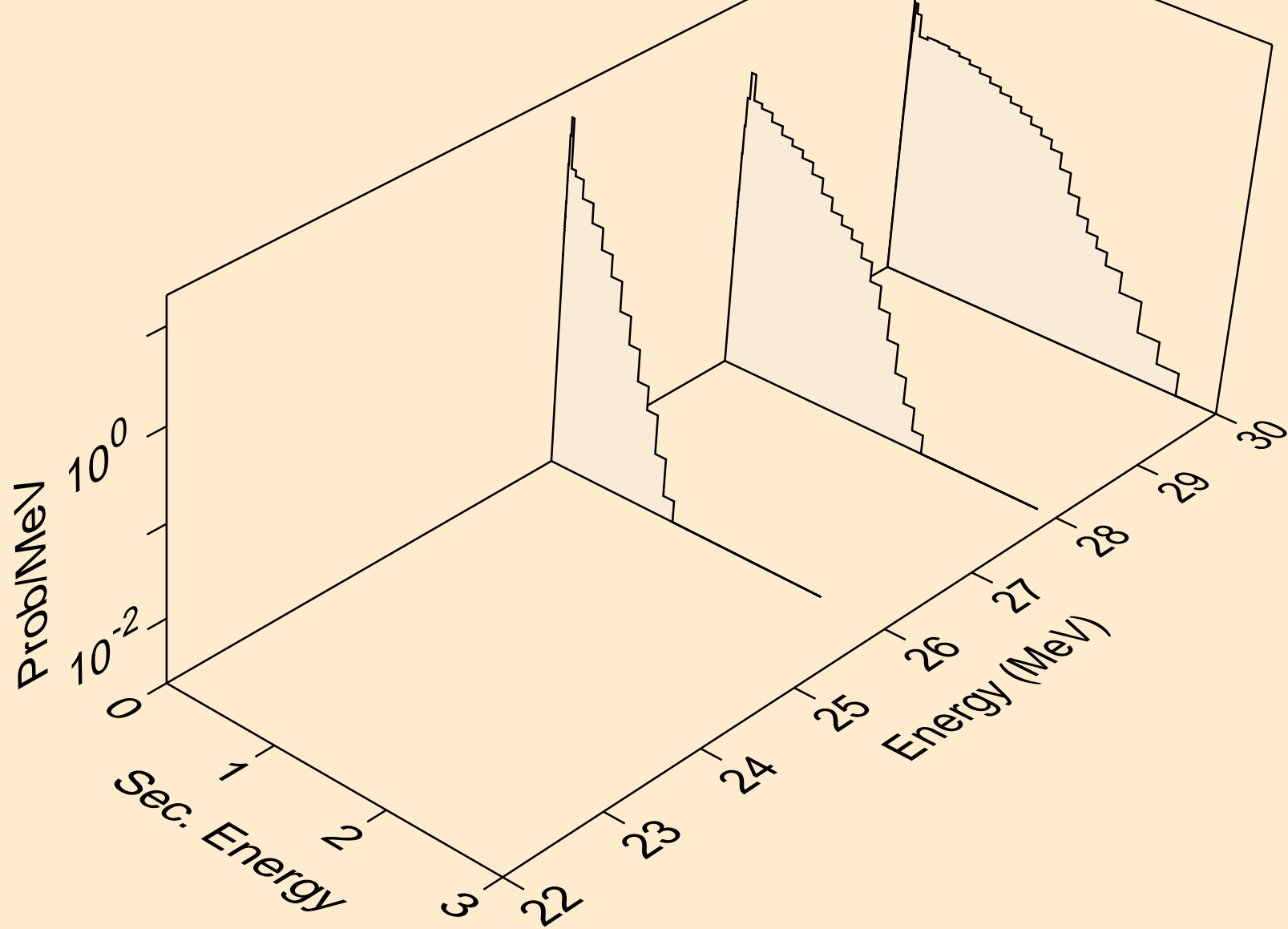

CR054 NEUTRON ACER TENDL-2024 LIBRARY; T=0.K
Neutron emission for (n,2np)

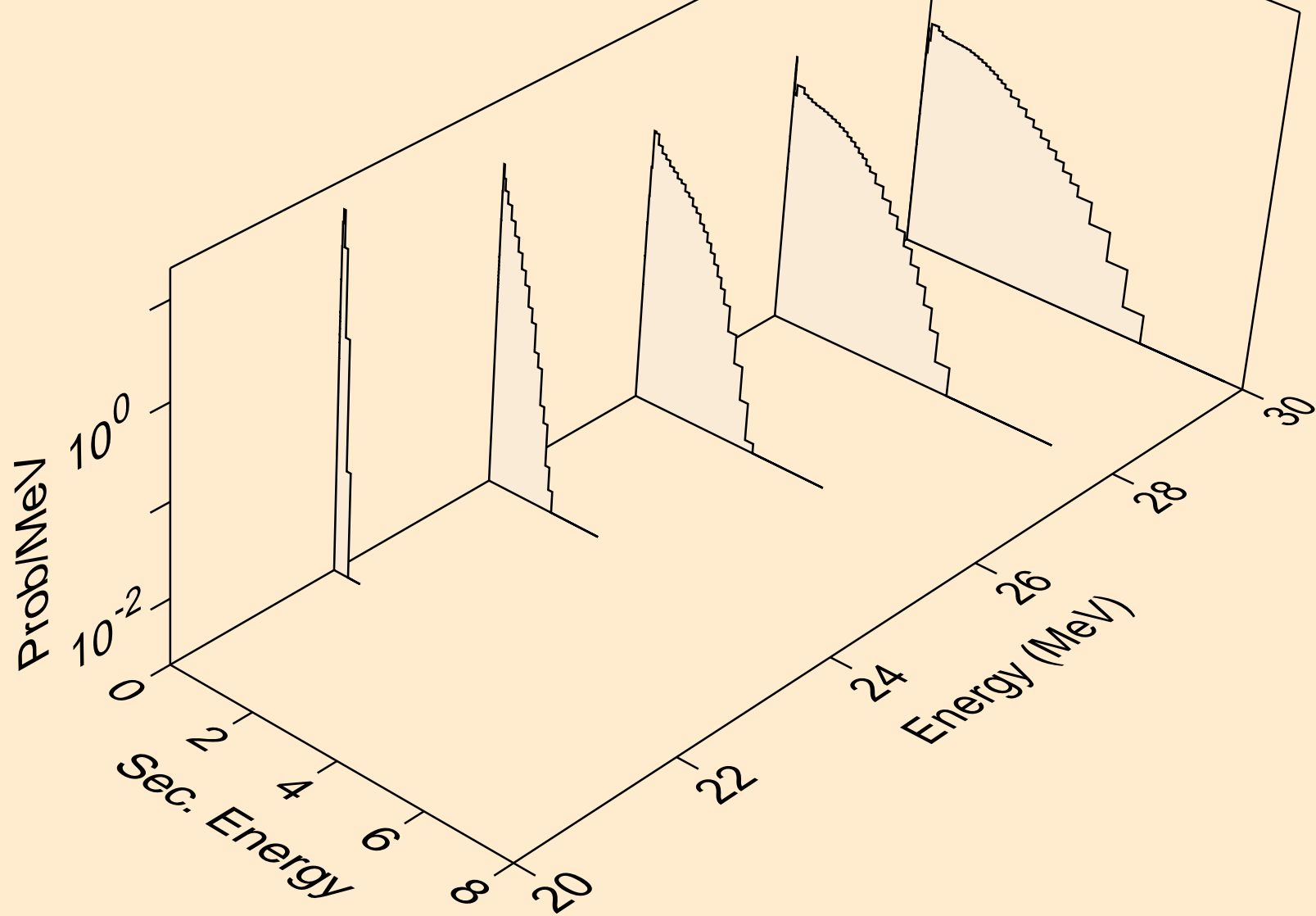

CR054 NEUTRON ACER TENDL-2024 LIBRARY; T=0.K
Neutron emission for (n,3np)

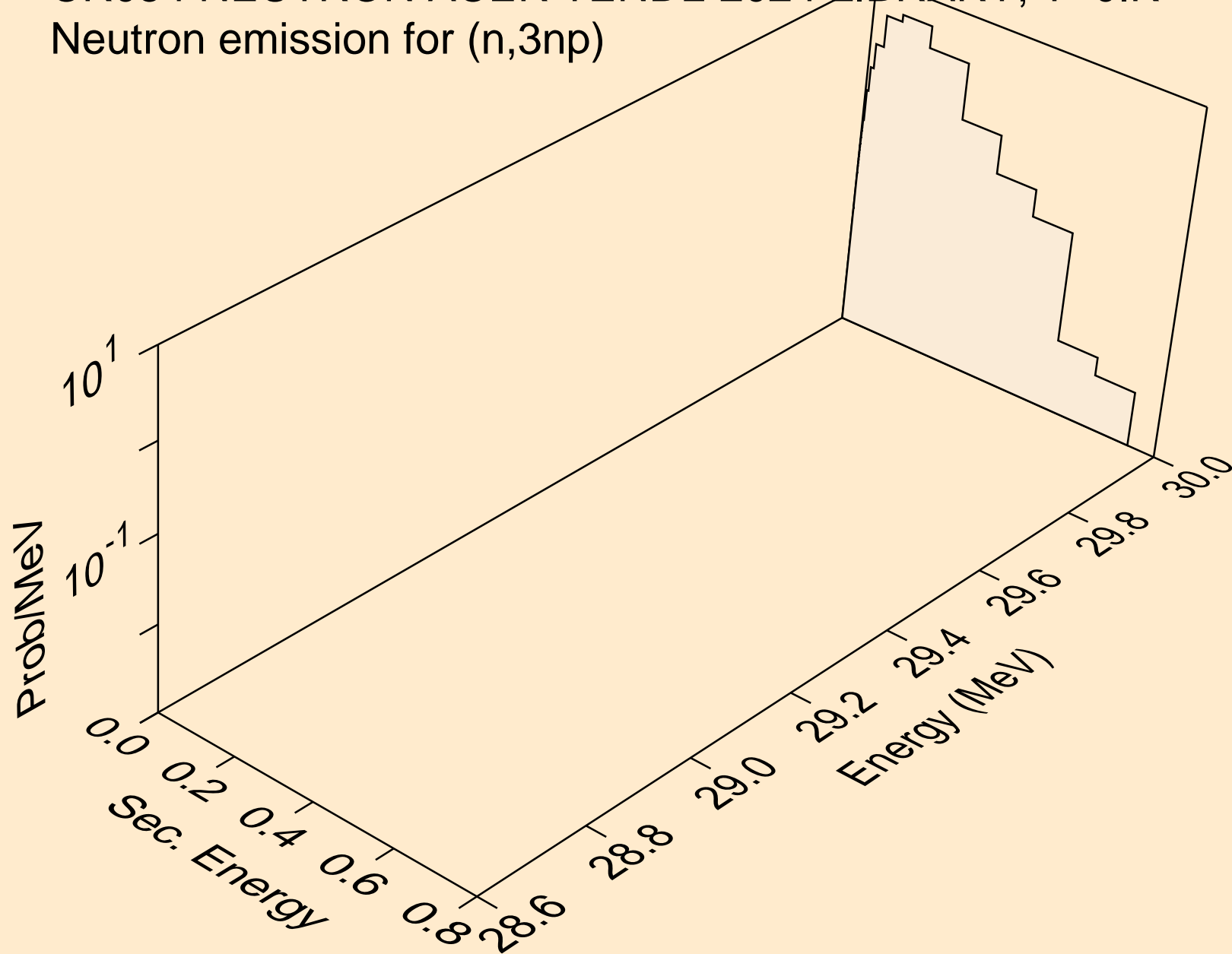

CR054 NEUTRON ACER TENDL-2024 LIBRARY; T=0.K
Neutron emission for (n,n2p)

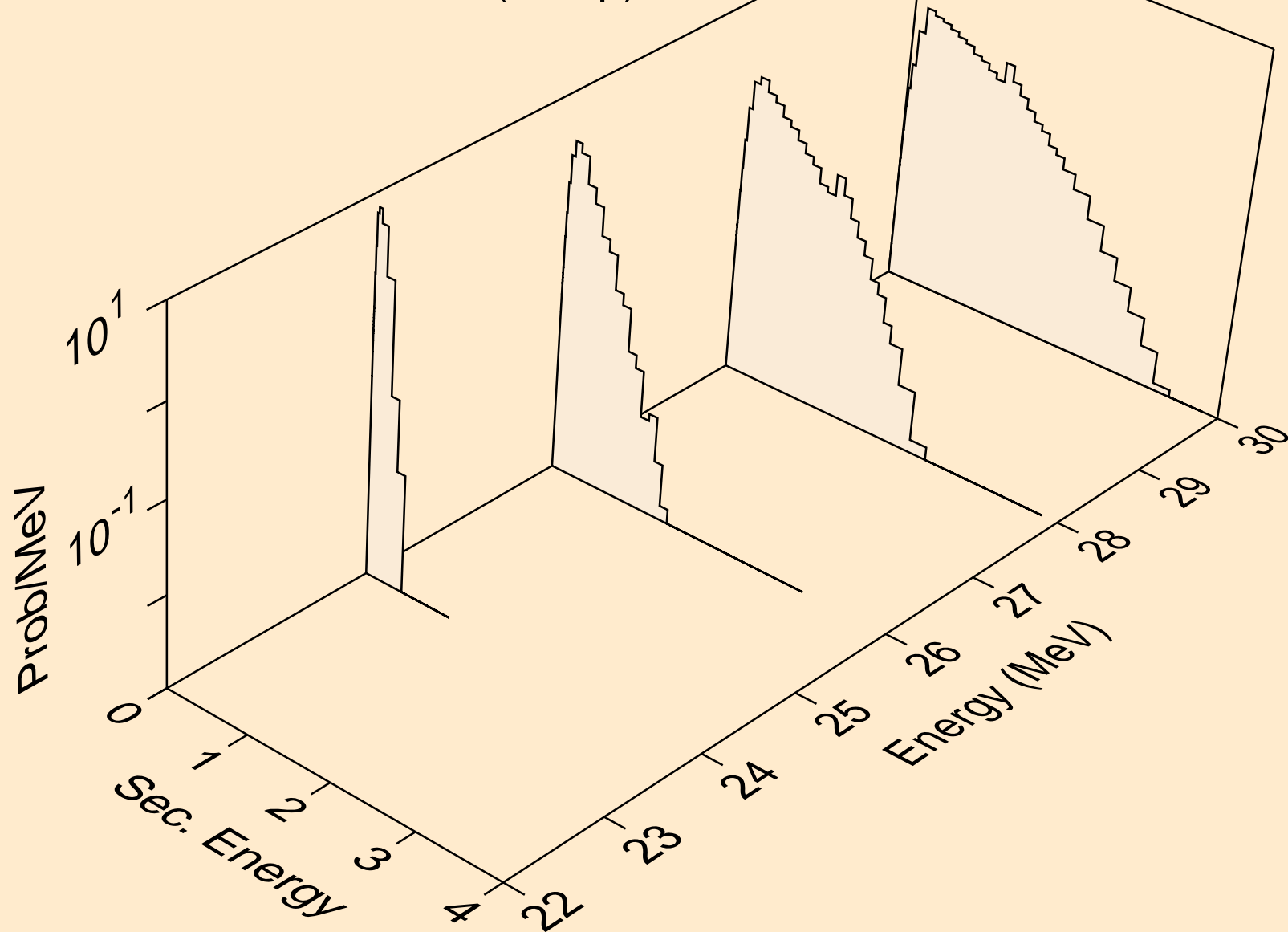

CR054 NEUTRON ACER TENDL-2024 LIBRARY; T=0.K
Neutron emission for (n,npa)

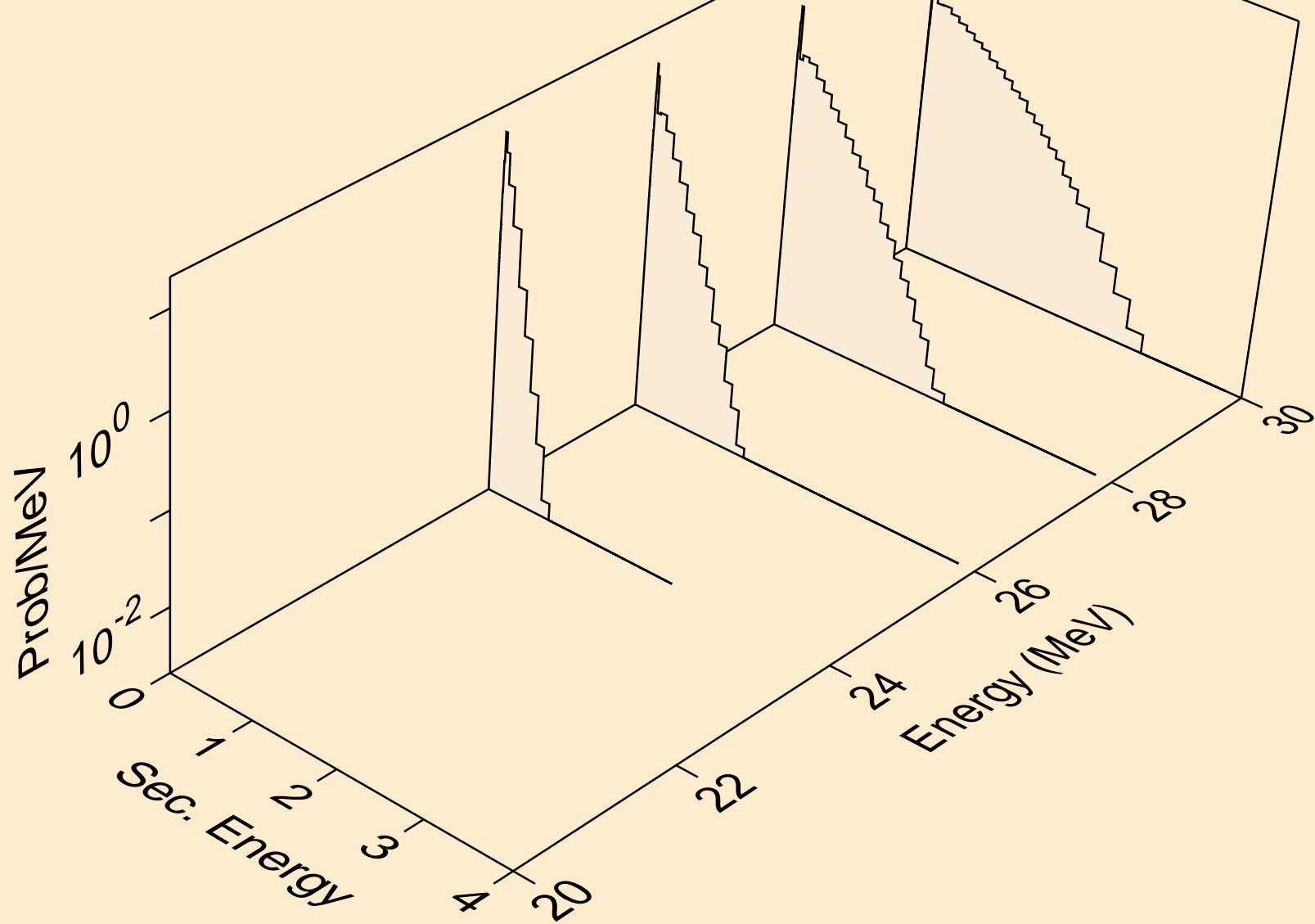

CR054 NEUTRON ACER TENDL-2024 LIBRARY; T=0.K
Neutron emission for (n,n*c)

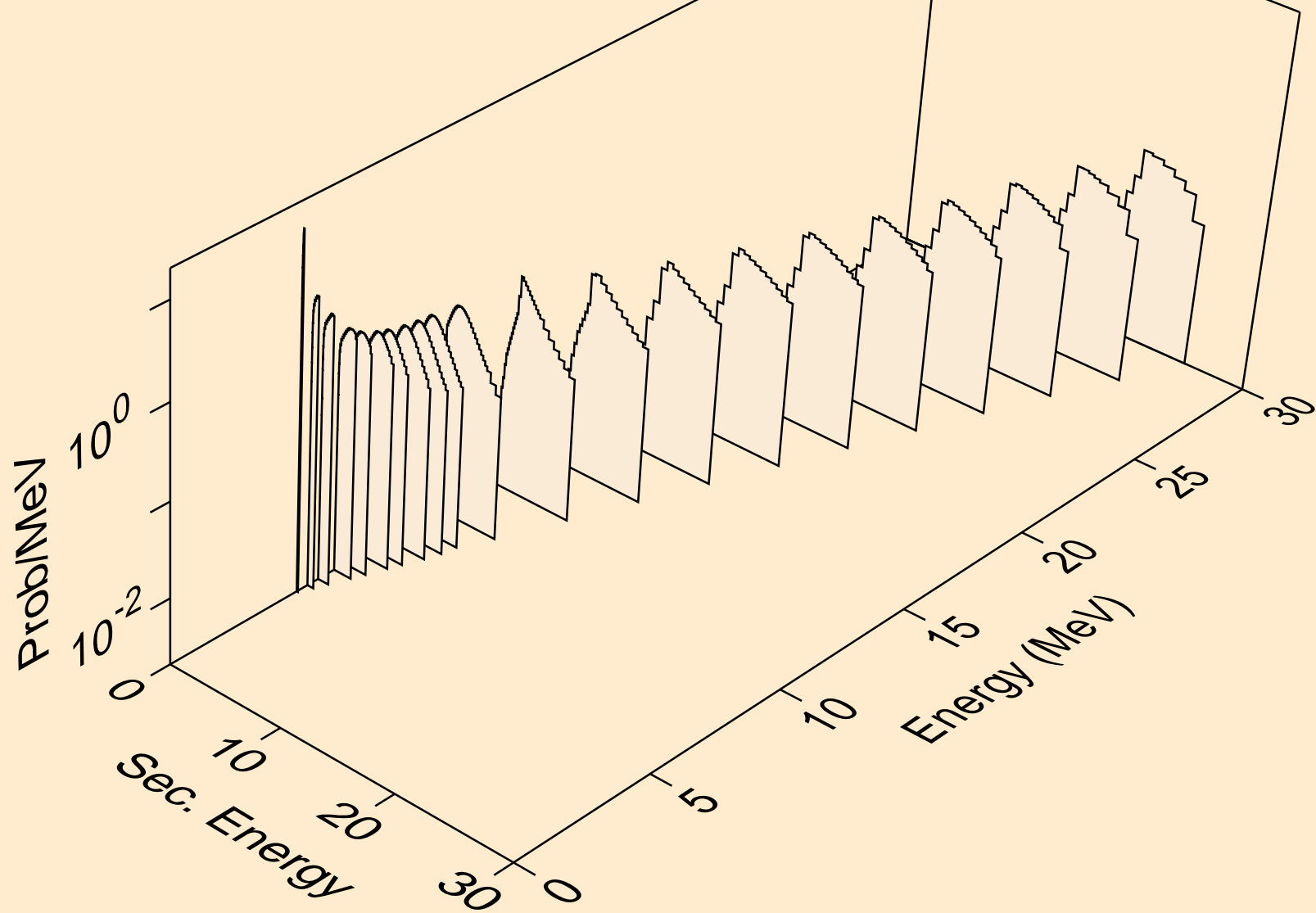

CR054 NEUTRON ACER TENDL-2024 LIBRARY; T=0.K
Photon emission for (n,x)

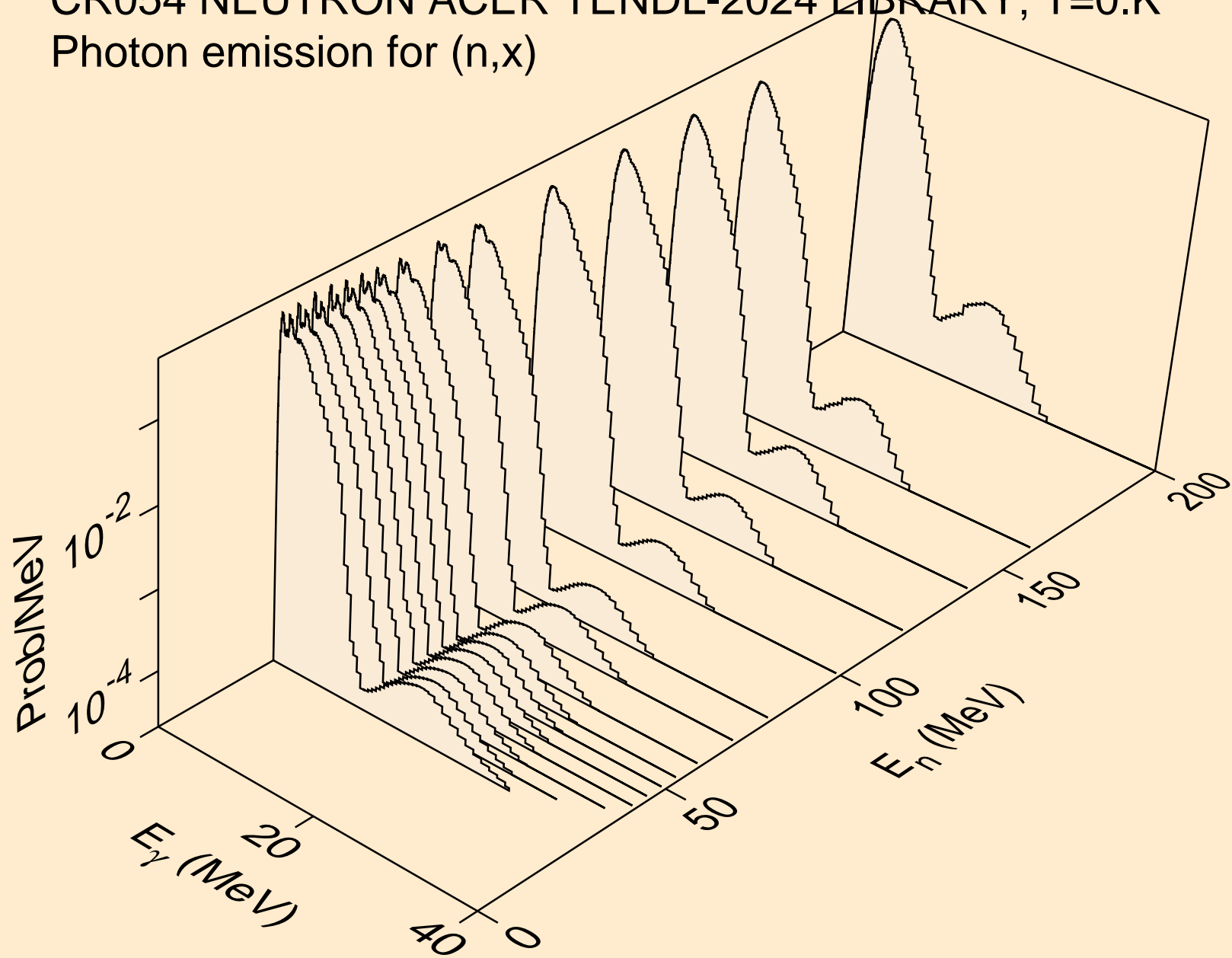

CR054 NEUTRON ACER TENDL-2024 LIBRARY; T=0.K
Photon emission for (n,2nd)

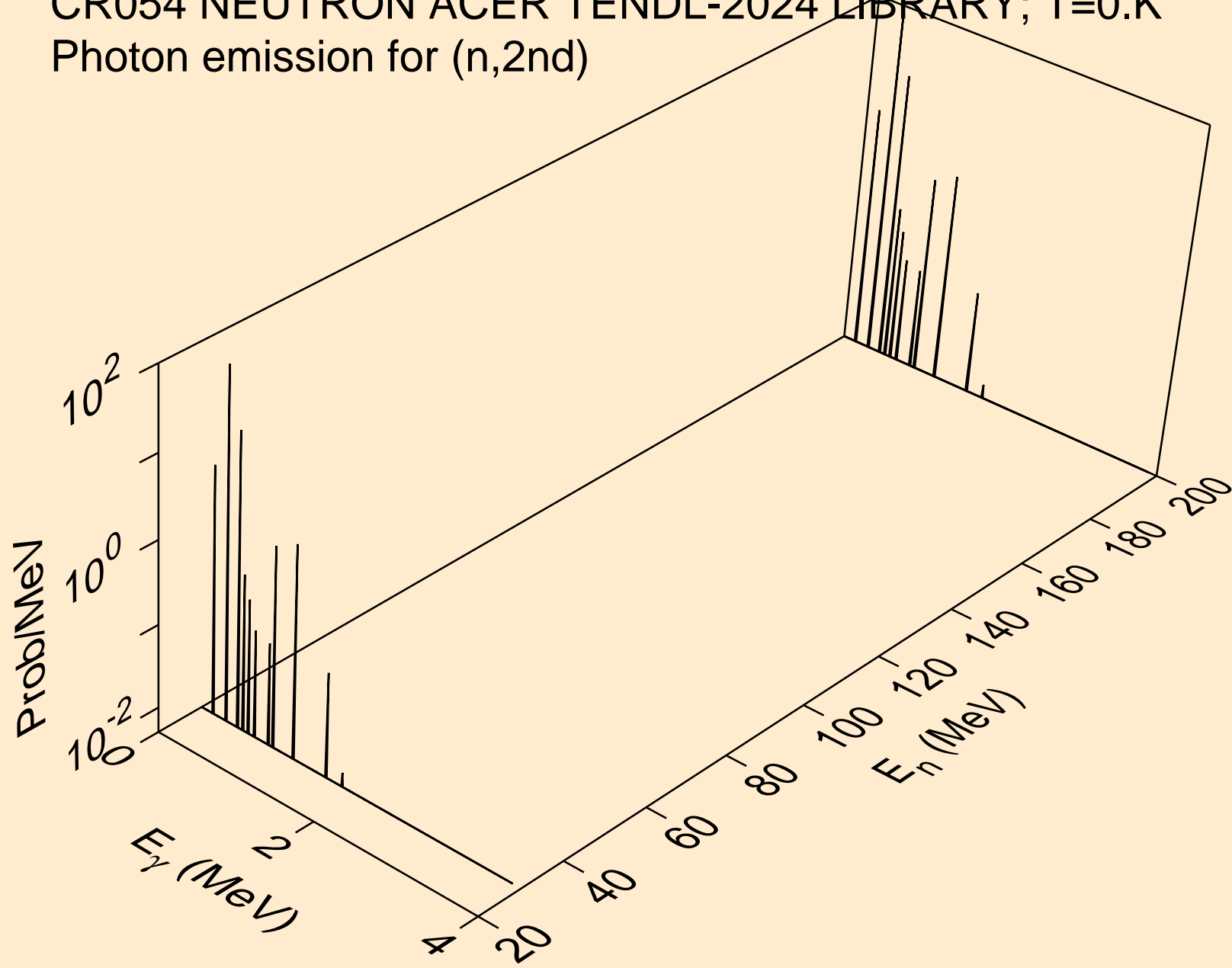

CR054 NEUTRON ACER TENDL-2024 LIBRARY; T=0.K
Photon emission for (n,2n)

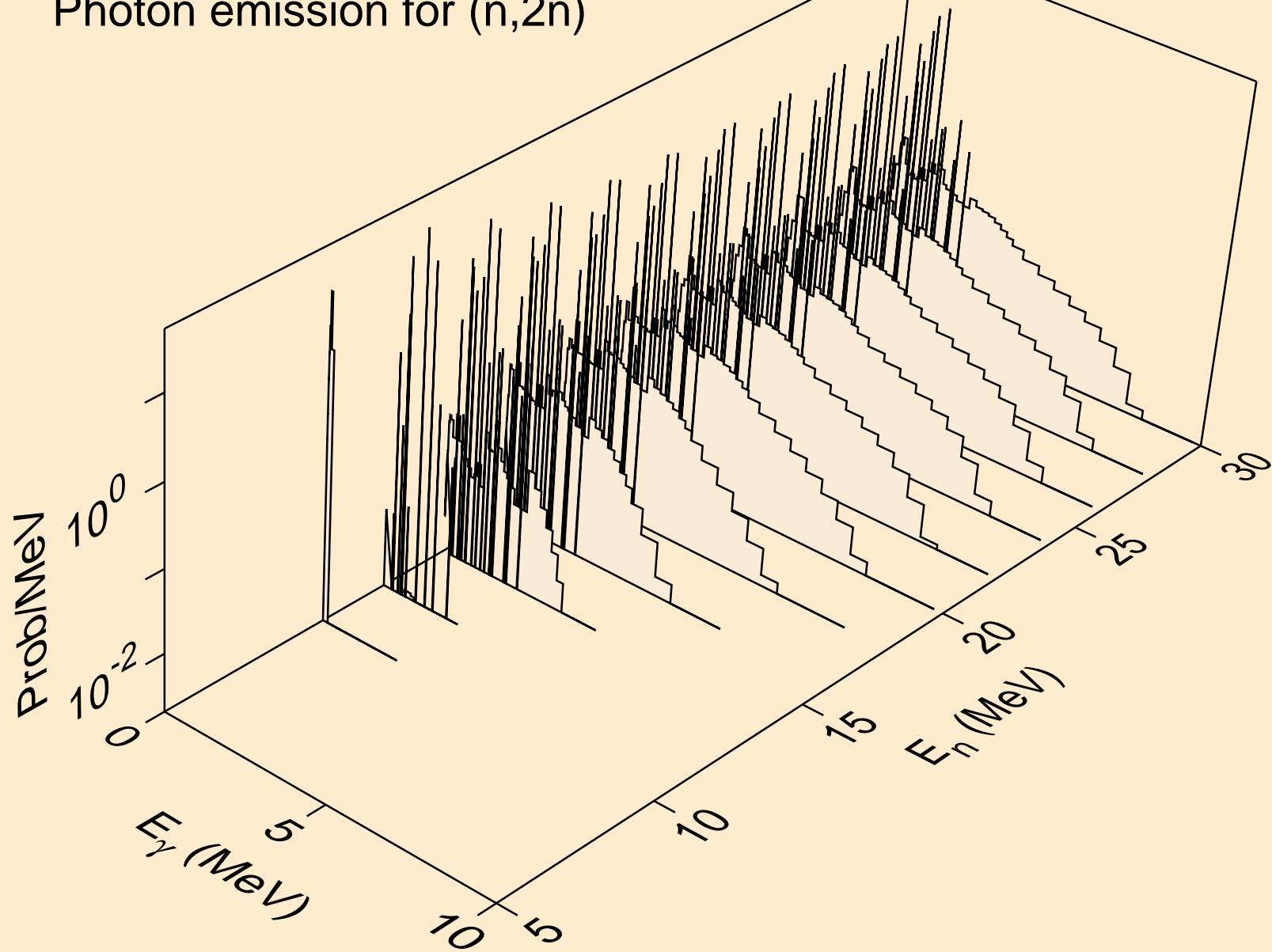

CR054 NEUTRON ACER TENDL-2024 LIBRARY; T=0.K
Photon emission for (n,3n)

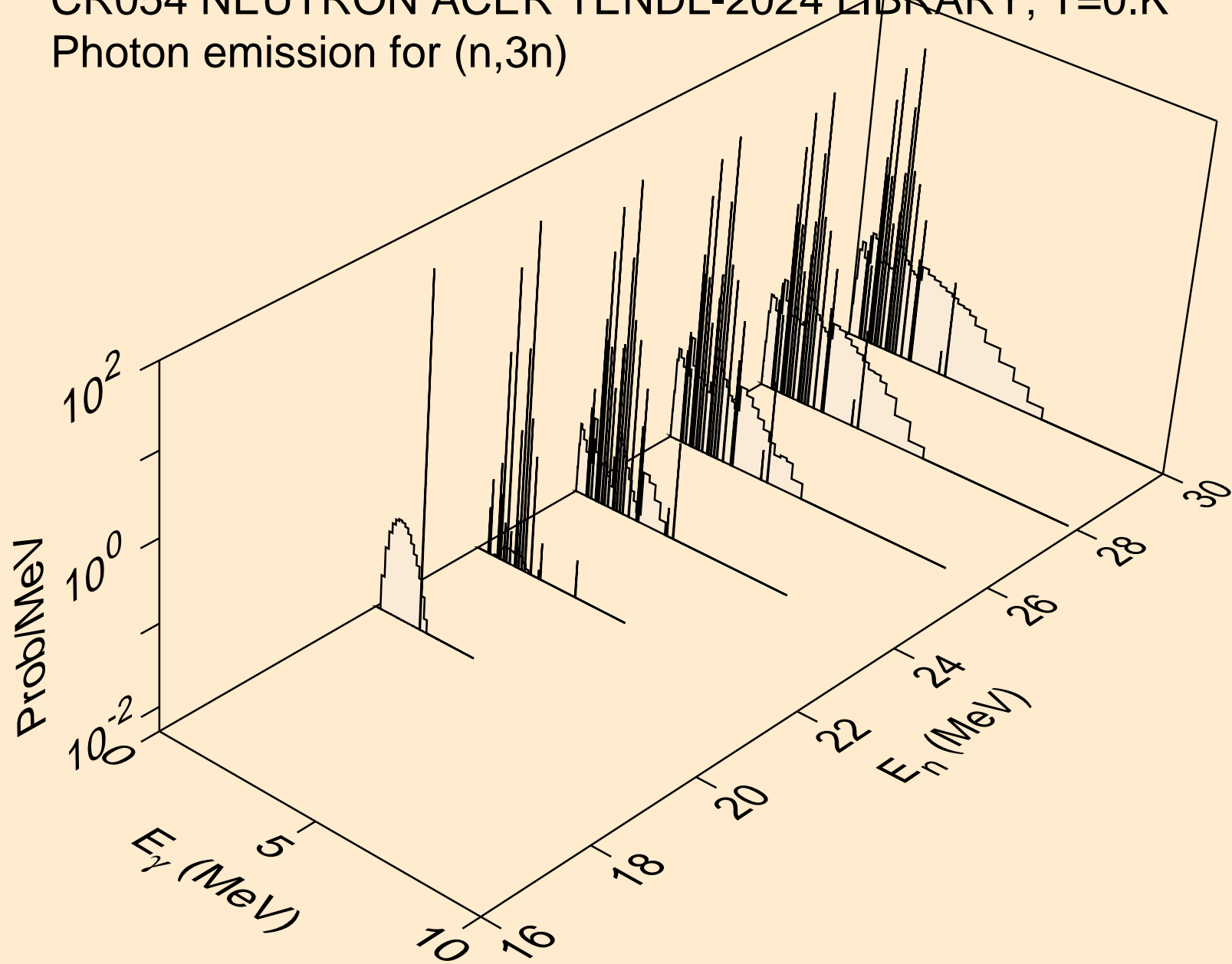

CR054 NEUTRON ACER TENDL-2024 LIBRARY; T=0.K
Photon emission for (n,n*)a

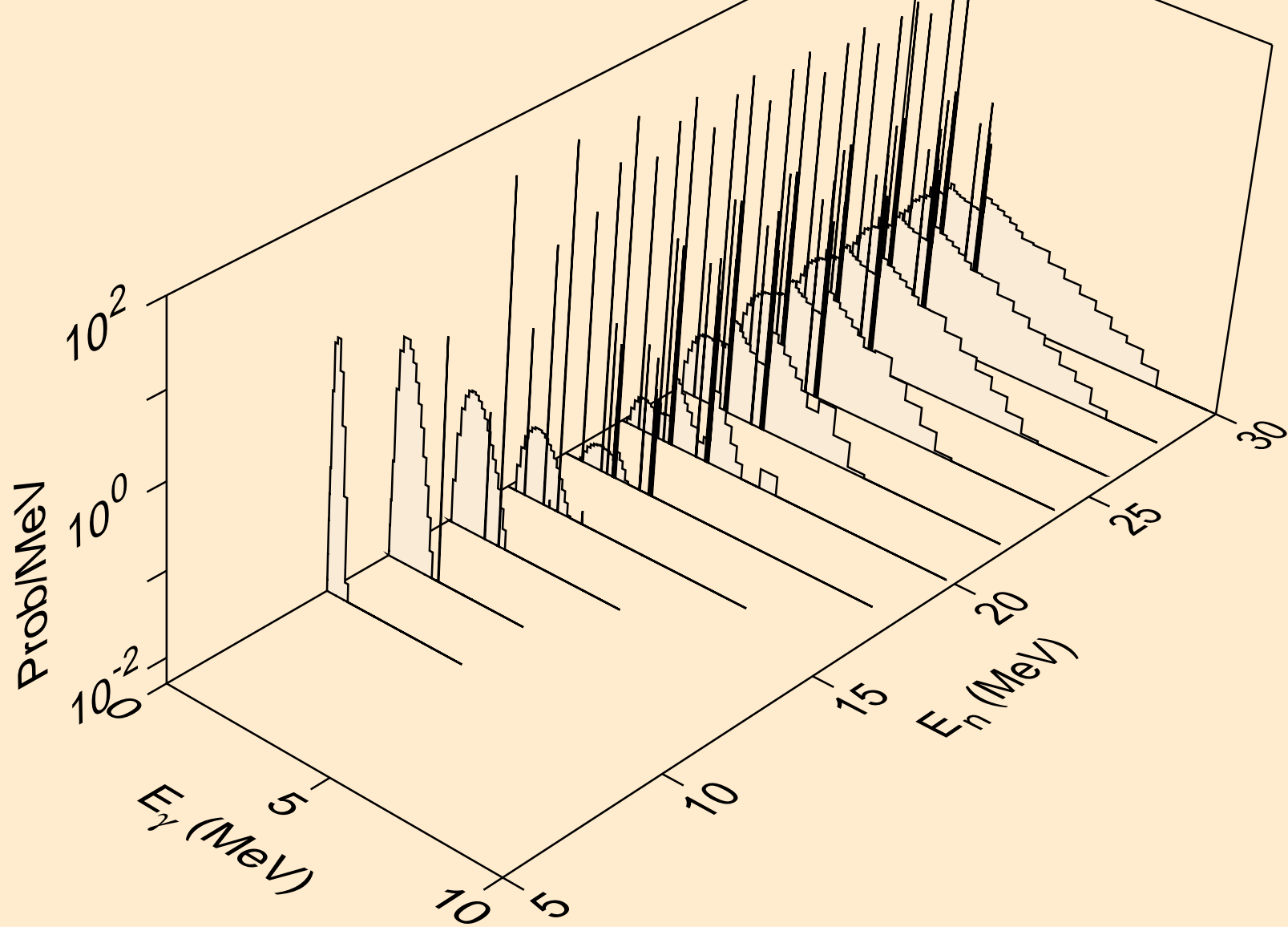

CR054 NEUTRON ACER TENDL-2024 LIBRARY; T=0.K
Photon emission for (n,2n)a

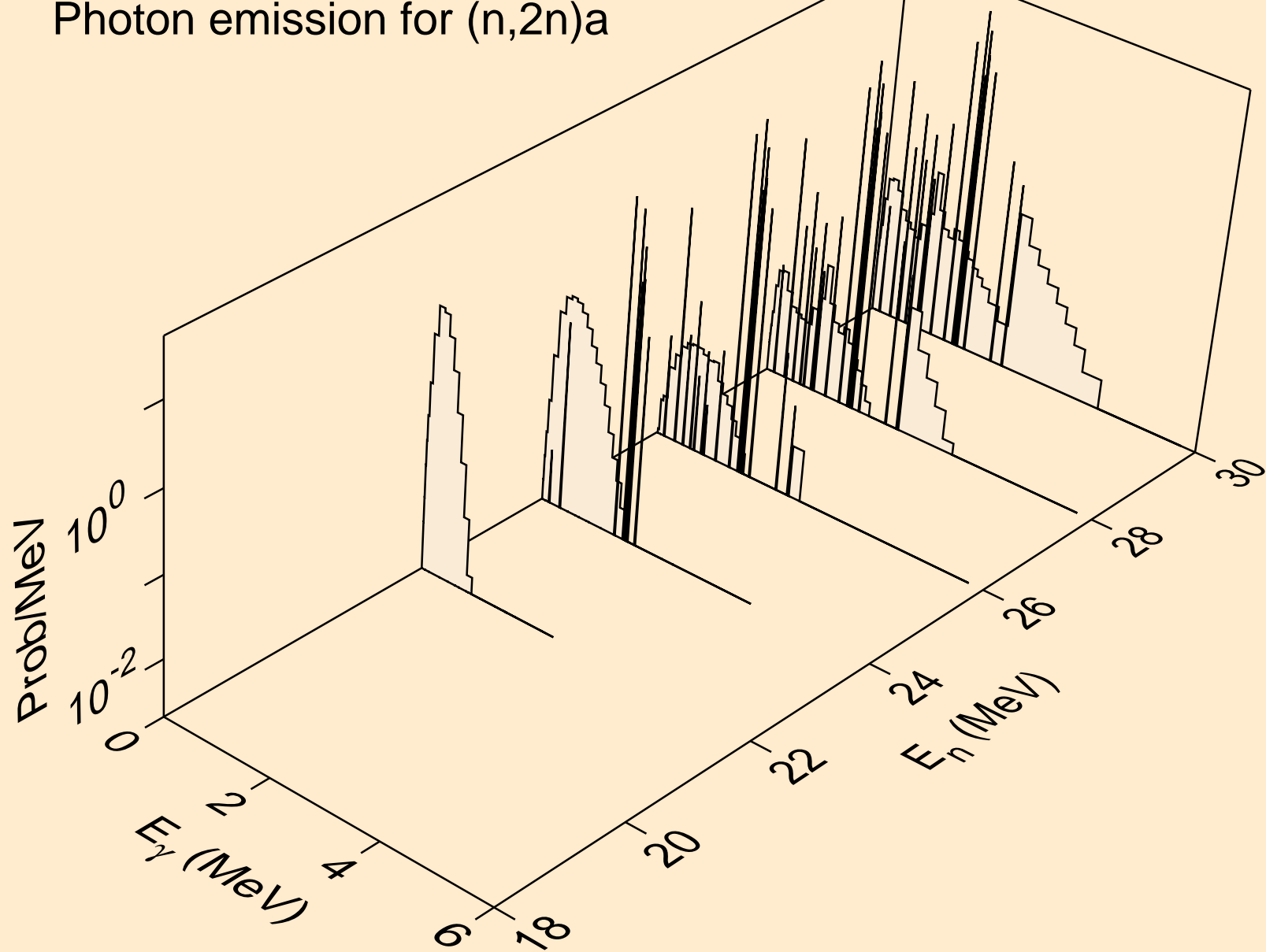

CR054 NEUTRON ACER TENDL-2024 LIBRARY; T=0.K
Photon emission for (n,n*)p

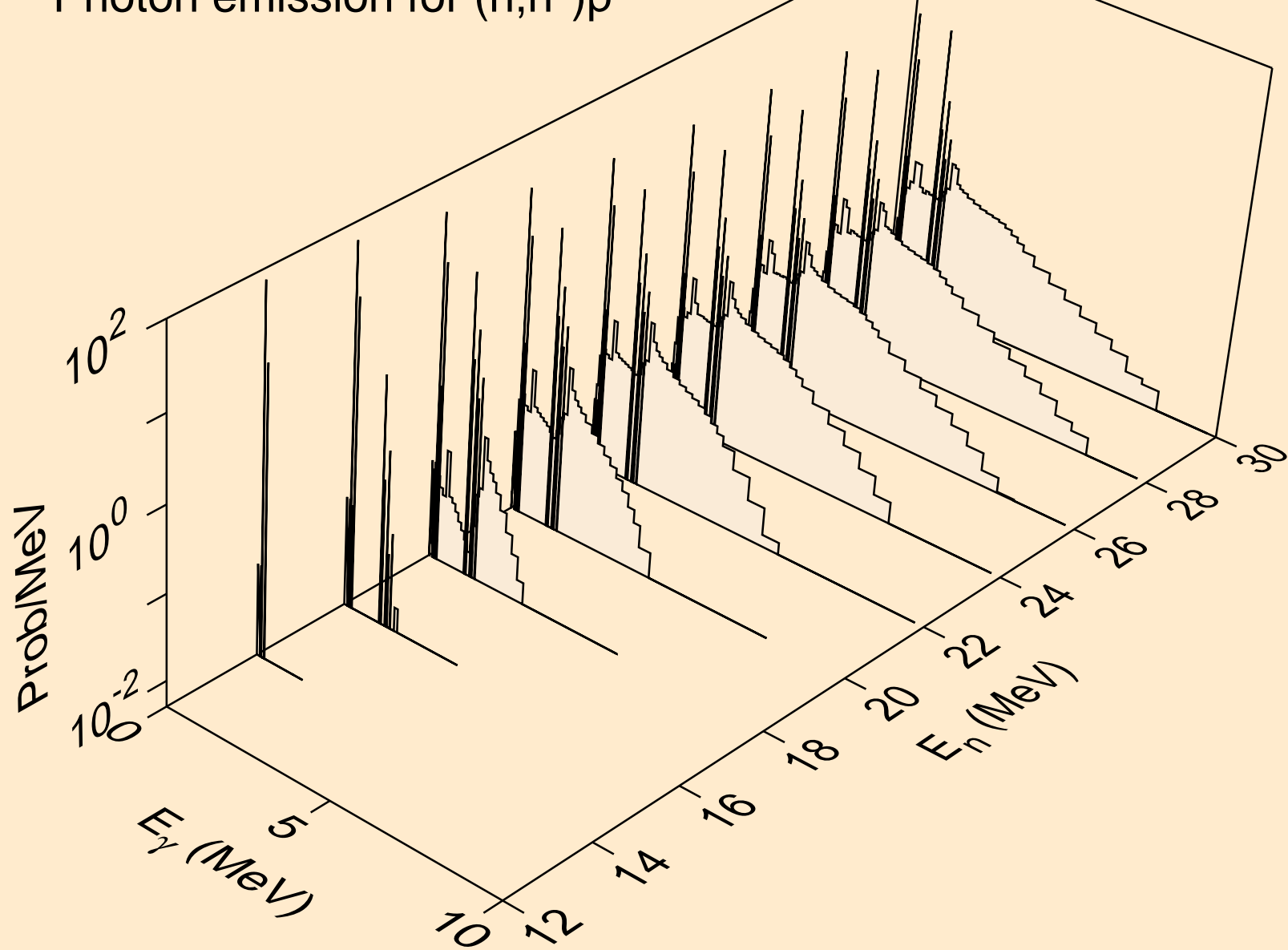

CR054 NEUTRON ACER TENDL-2024 LIBRARY; T=0.K
Photon emission for (n,n*)2a

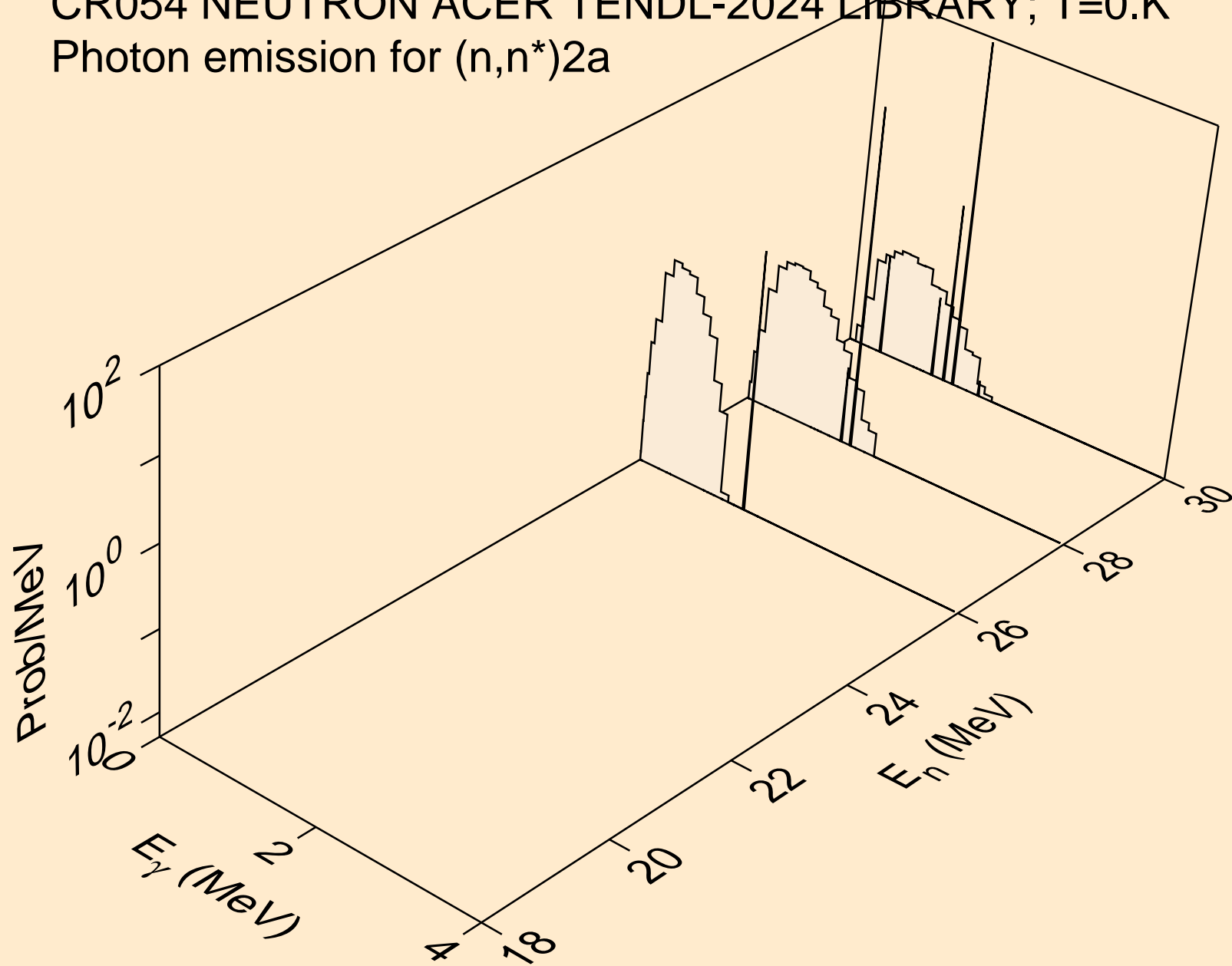

CR054 NEUTRON ACER TENDL-2024 LIBRARY; T=0.K
Photon emission for (n,n*)d

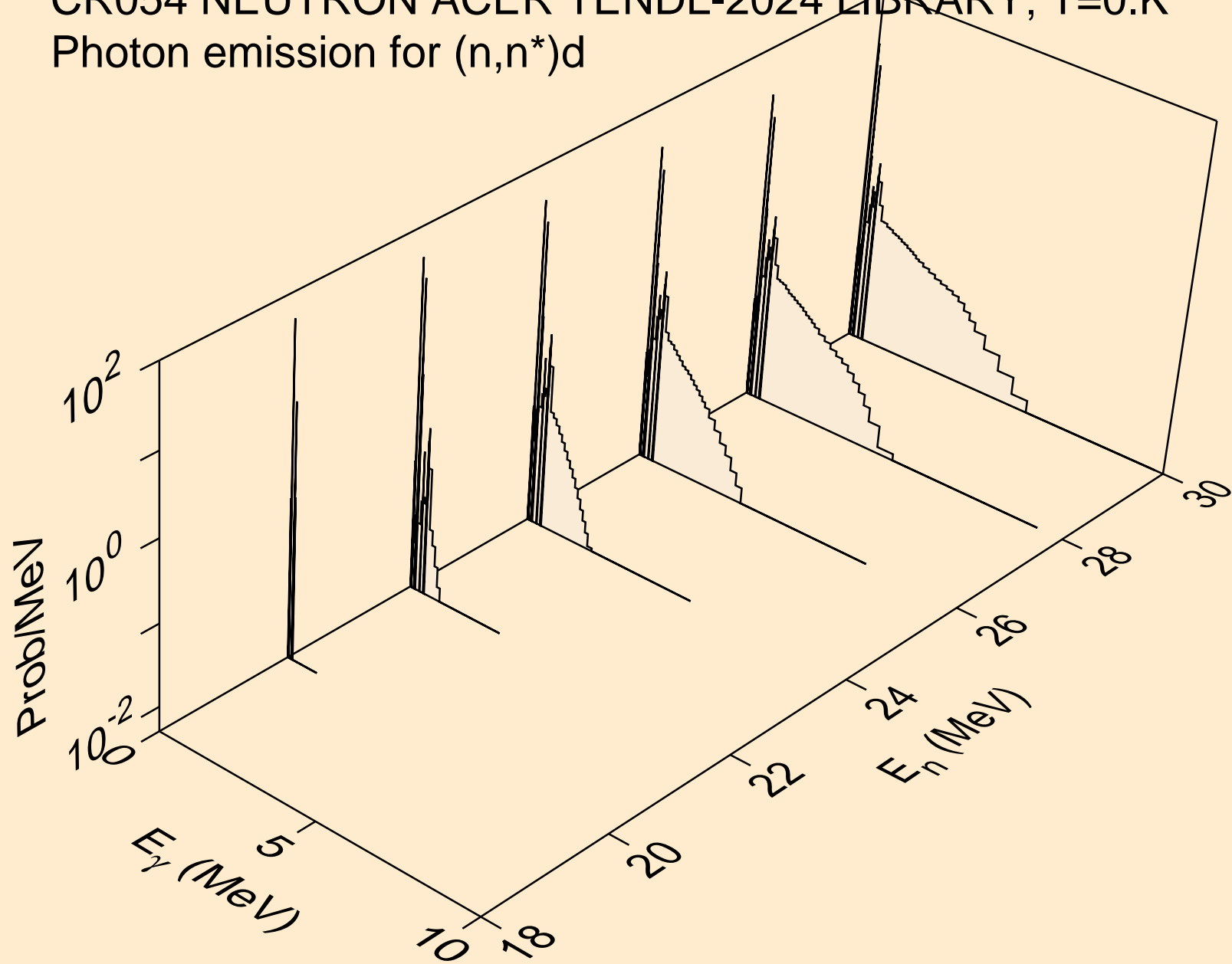

CR054 NEUTRON ACER TENDL-2024 LIBRARY; T=0.K
Photon emission for (n,n*)t

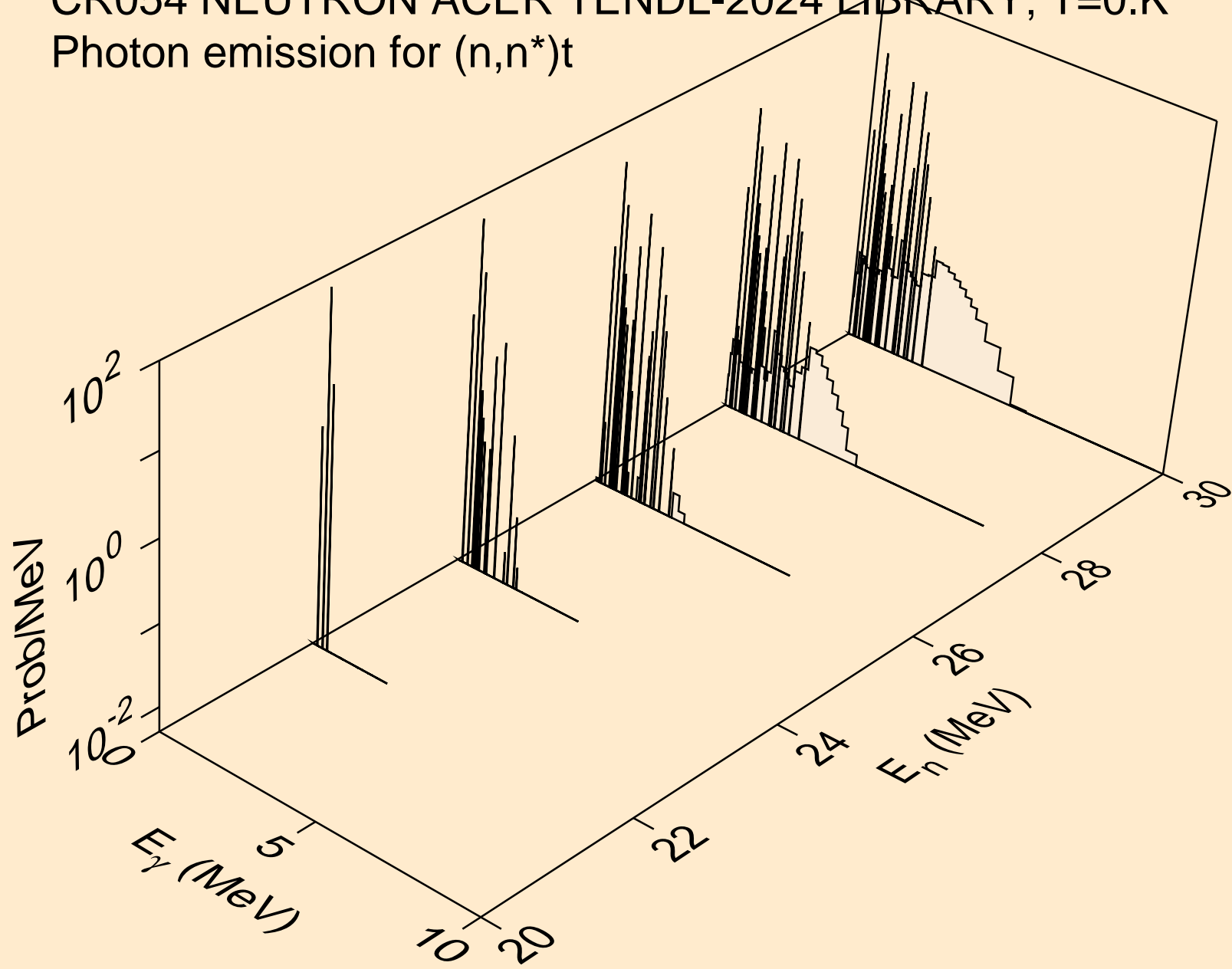

CR054 NEUTRON ACER TENDL-2024 LIBRARY; T=0.K
Photon emission for (n,n*)he3

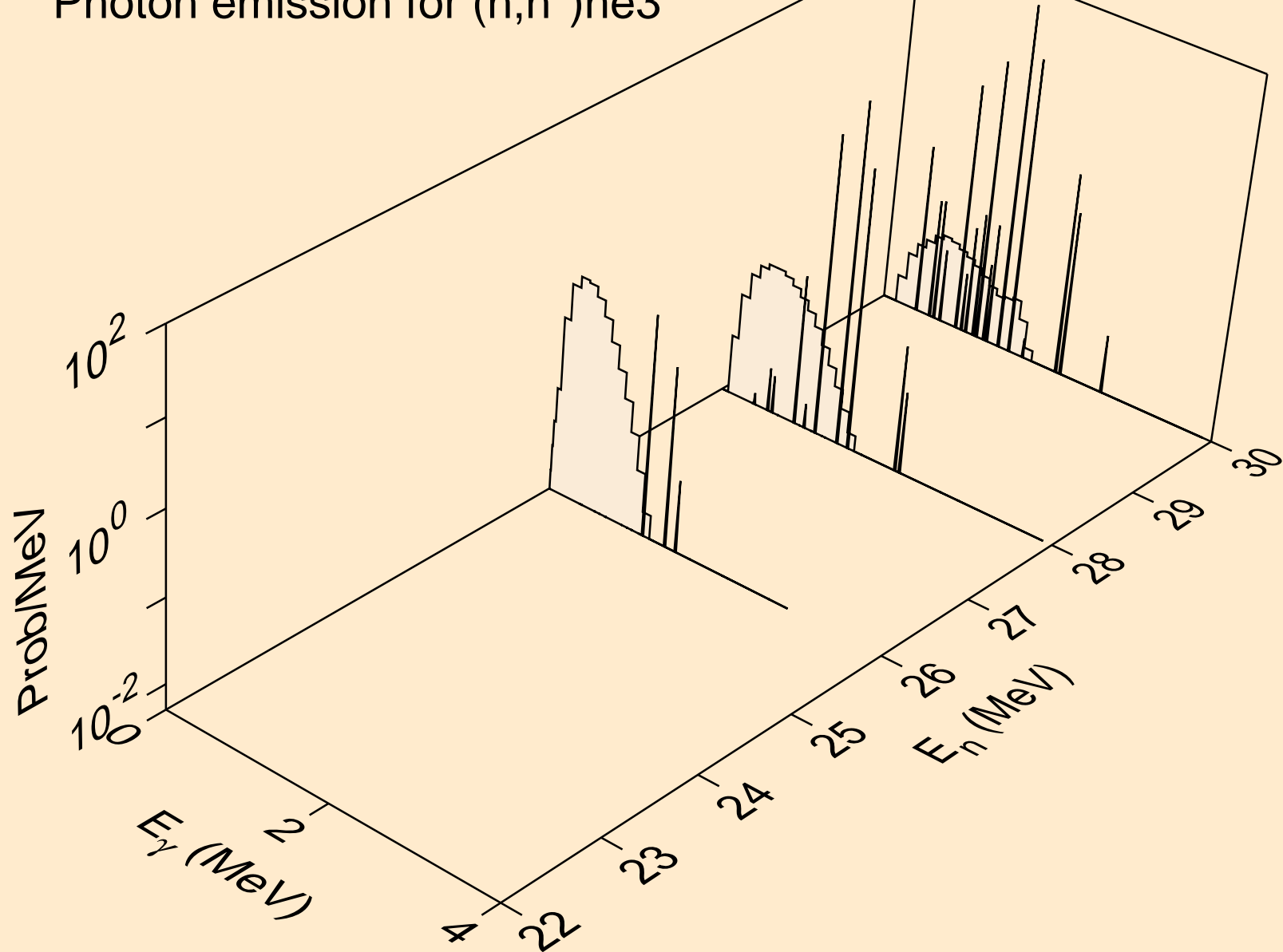

CR054 NEUTRON ACER TENDL-2024 LIBRARY; T=0.K
Photon emission for (n,2np)

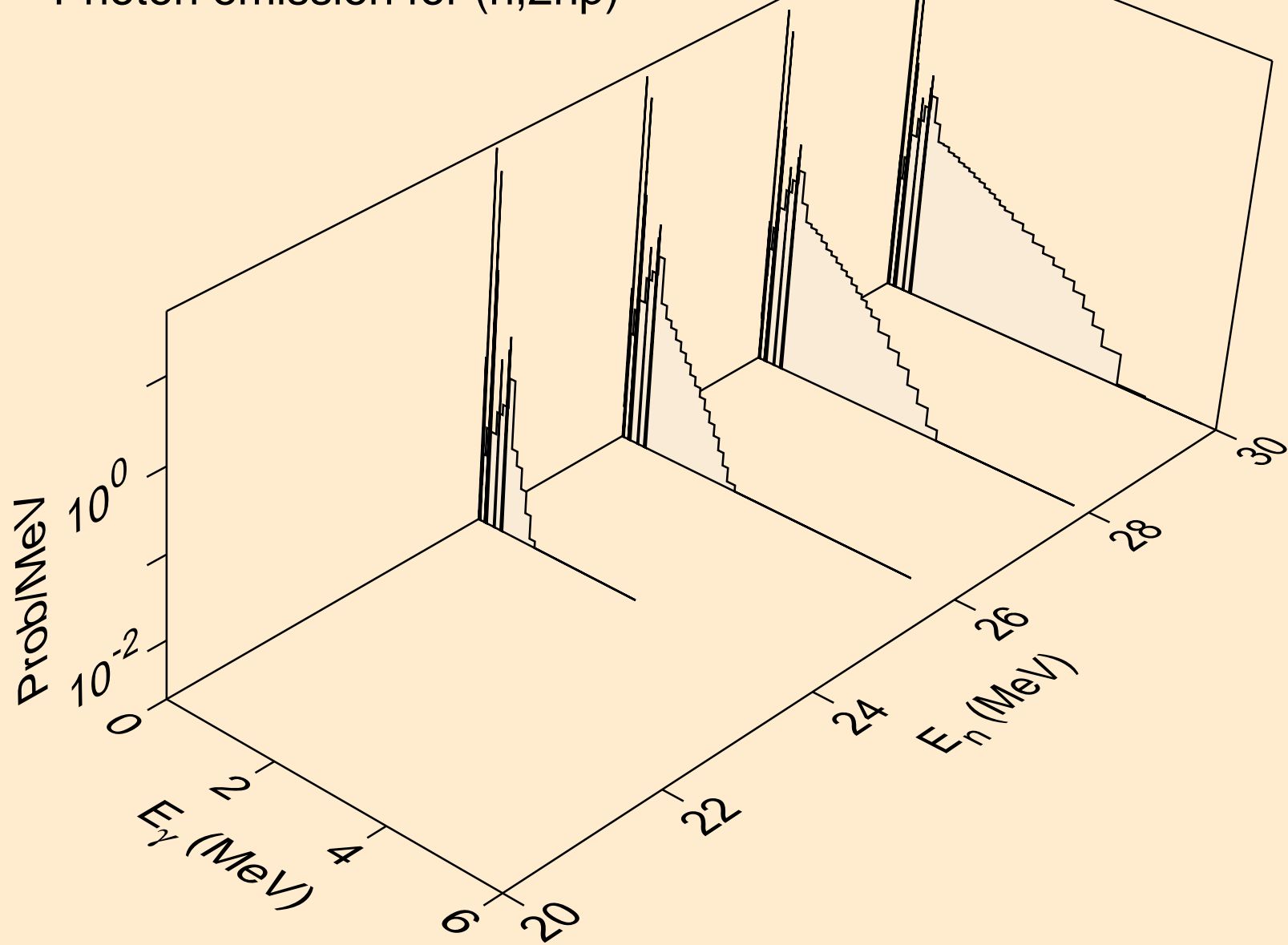

CR054 NEUTRON ACER TENDL-2024 LIBRARY; T=0.K
Photon emission for (n,3np)

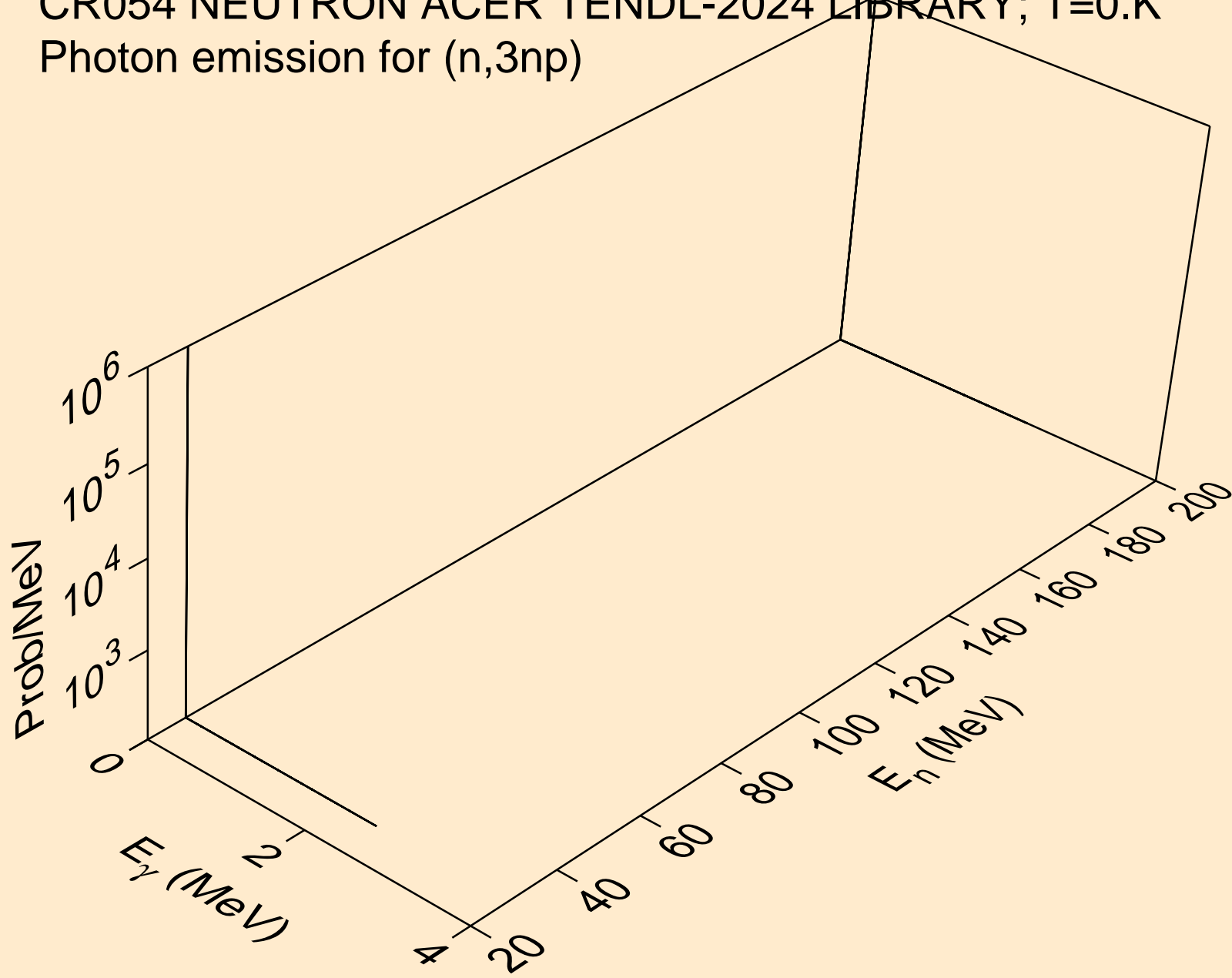

CR054 NEUTRON ACER TENDL-2024 LIBRARY; T=0.K
Photon emission for (n,n2p)

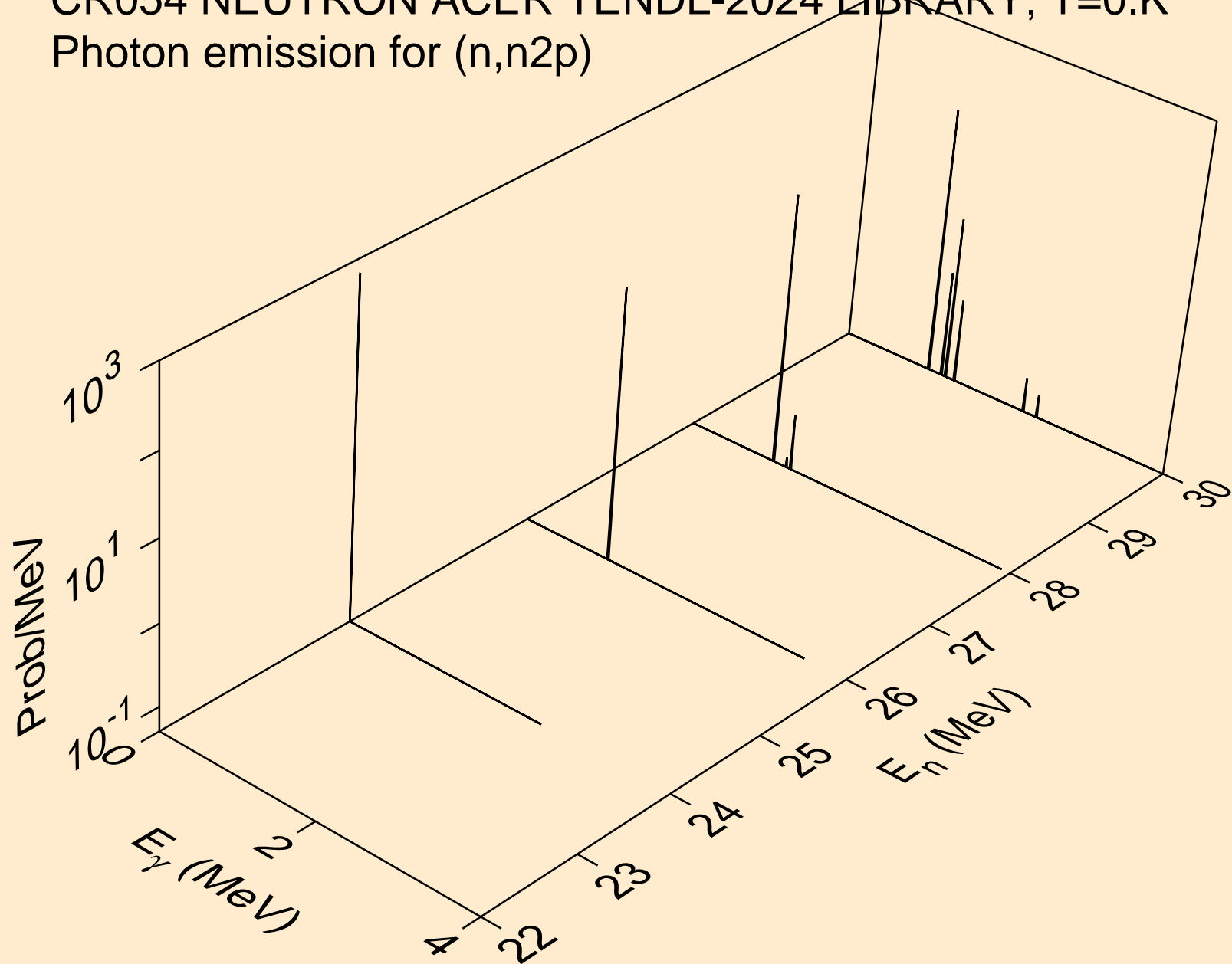

CR054 NEUTRON ACER TENDL-2024 LIBRARY; T=0.K
Photon emission for (n,npa)

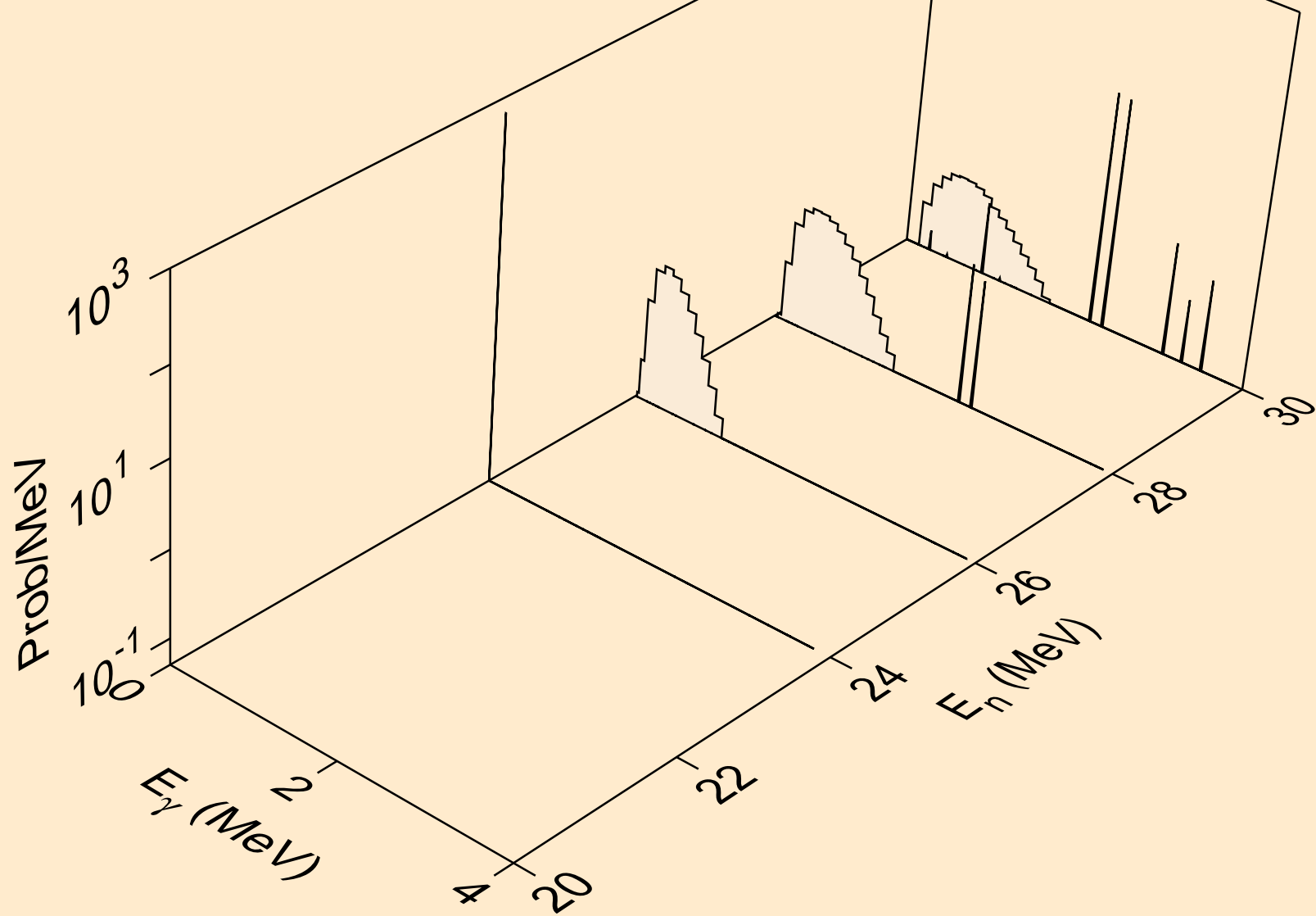

CR054 NEUTRON ACER TENDL-2024 LIBRARY; T=0.K
Photon emission for (n,n*c)

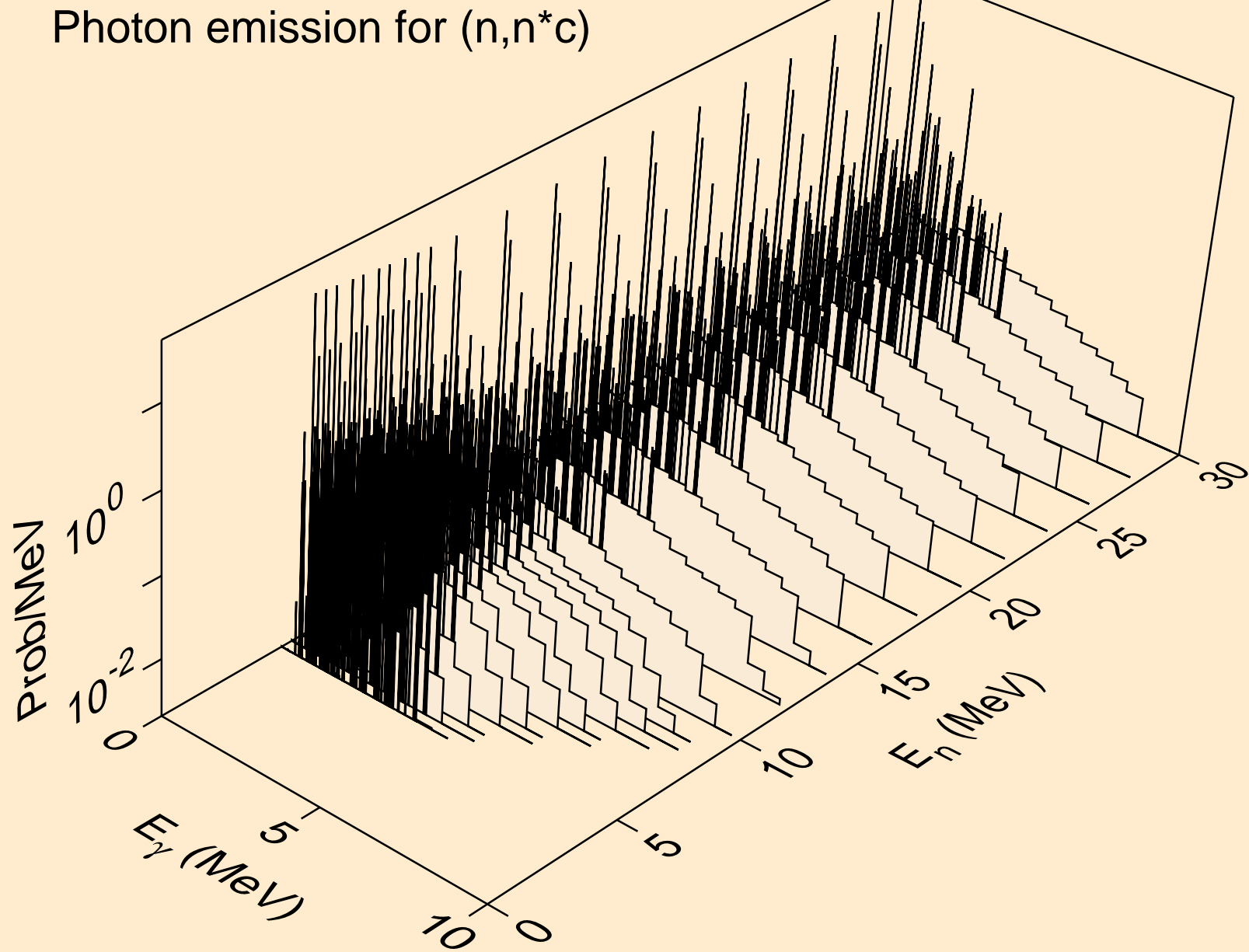

CR054 NEUTRON ACER TENDL-2024 LIBRARY; T=0.K
Photon emission for (n,gma)

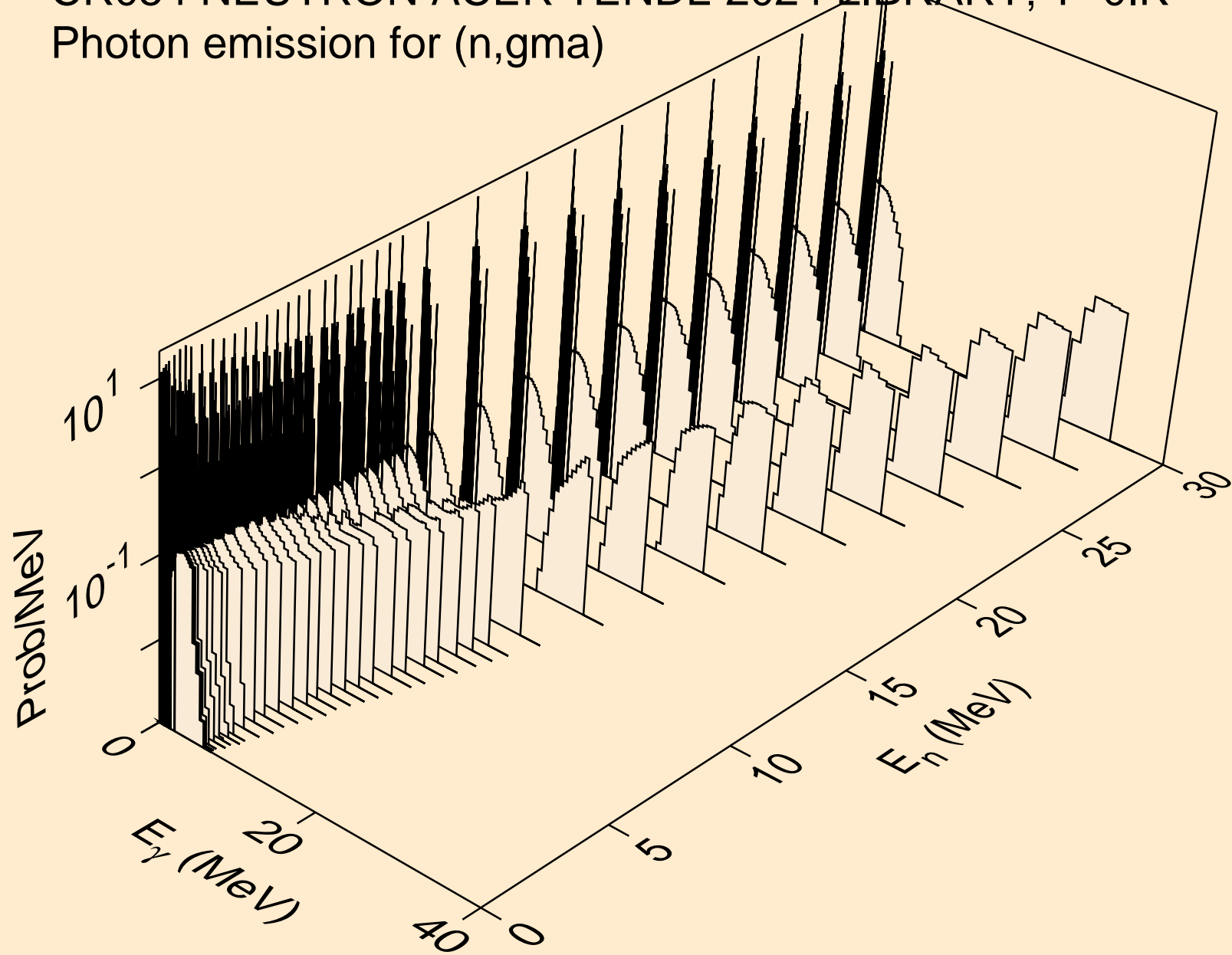

CR054 NEUTRON ACER TENDL-2024 LIBRARY; T=0.K
Photon emission for (n,p)

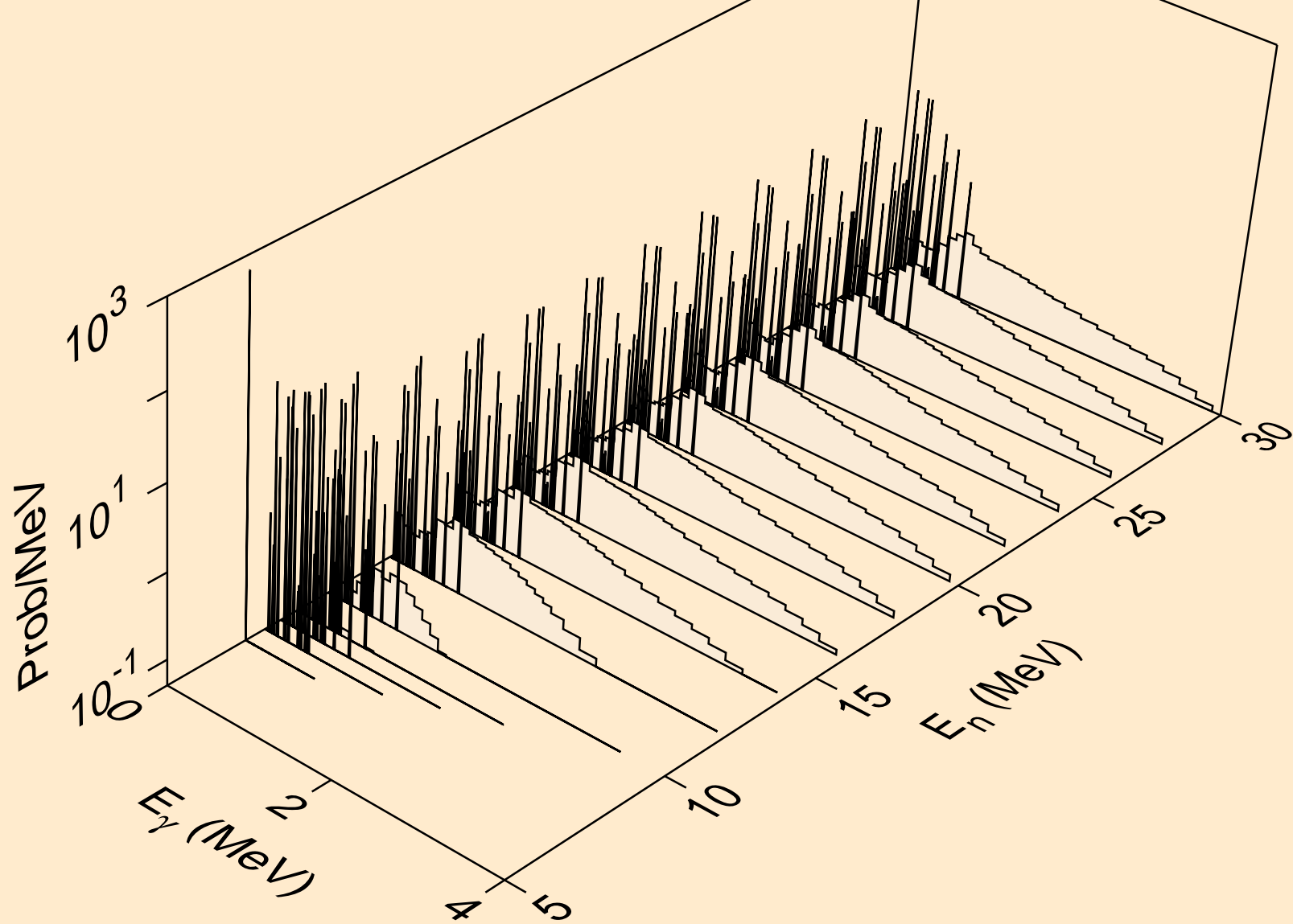

CR054 NEUTRON ACER TENDL-2024 LIBRARY; T=0.K
Photon emission for (n,d)

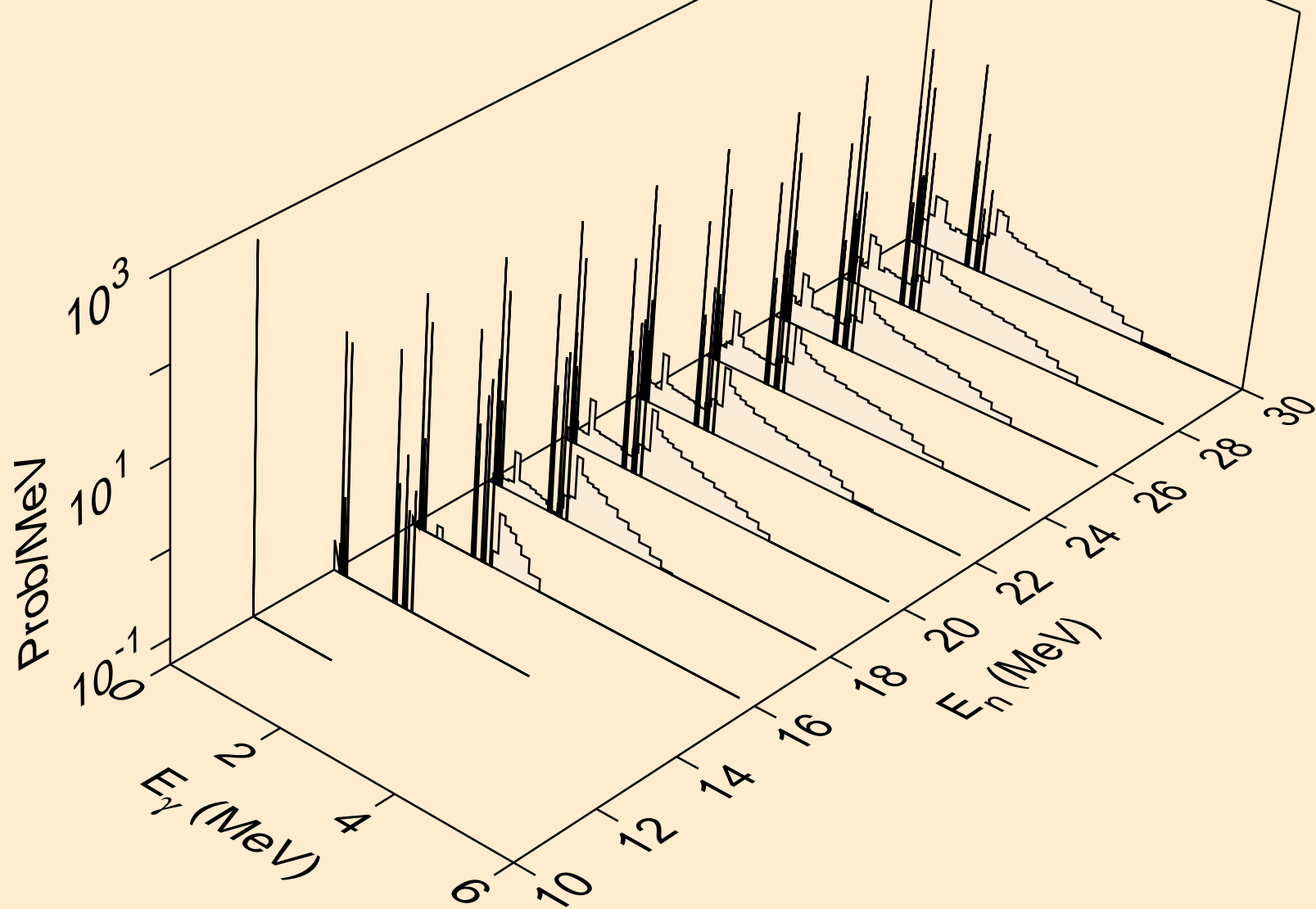

CR054 NEUTRON ACER TENDL-2024 LIBRARY; T=0.K
Photon emission for (n,t)

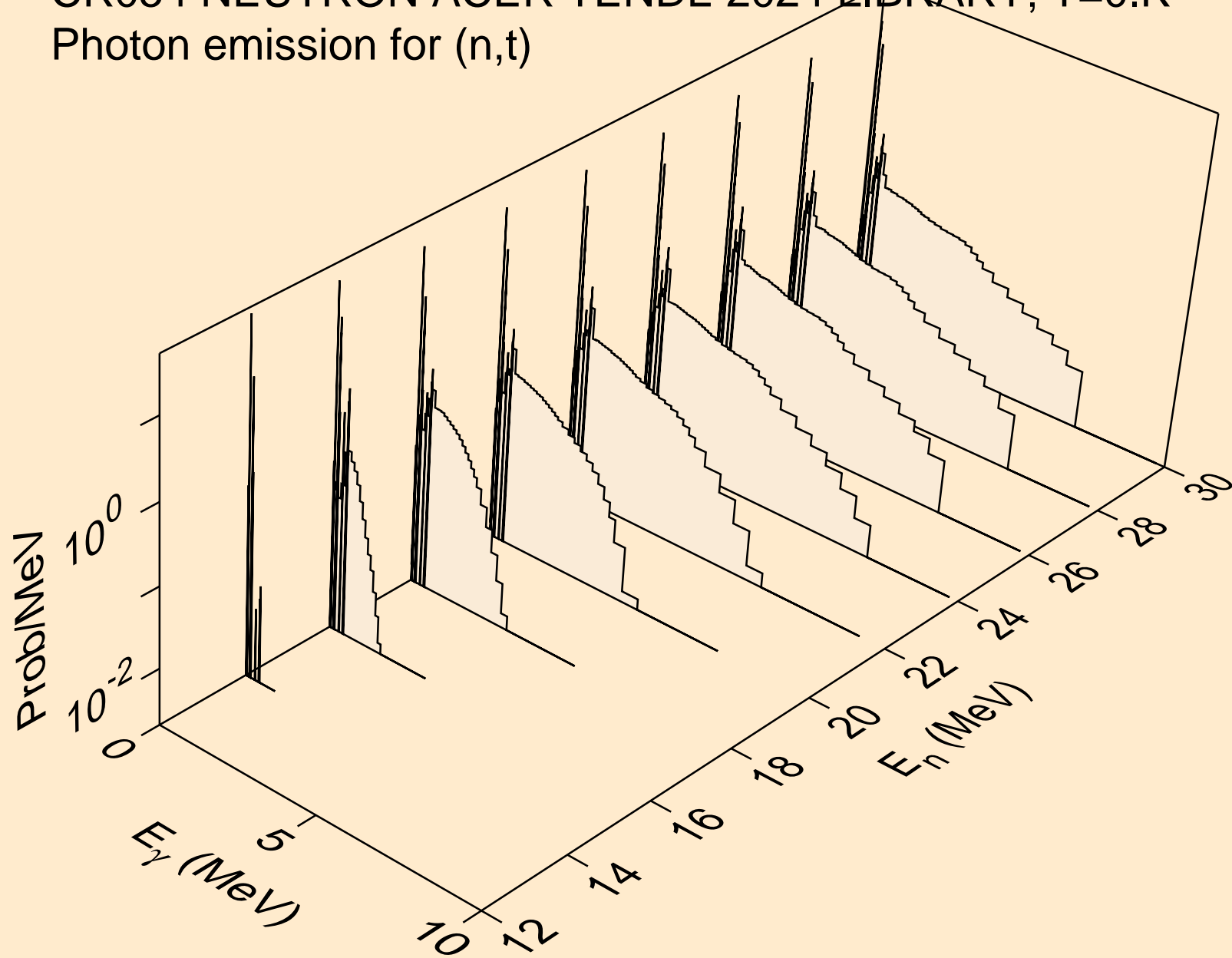

CR054 NEUTRON ACER TENDL-2024 LIBRARY; T=0.K
Photon emission for (n,he3)

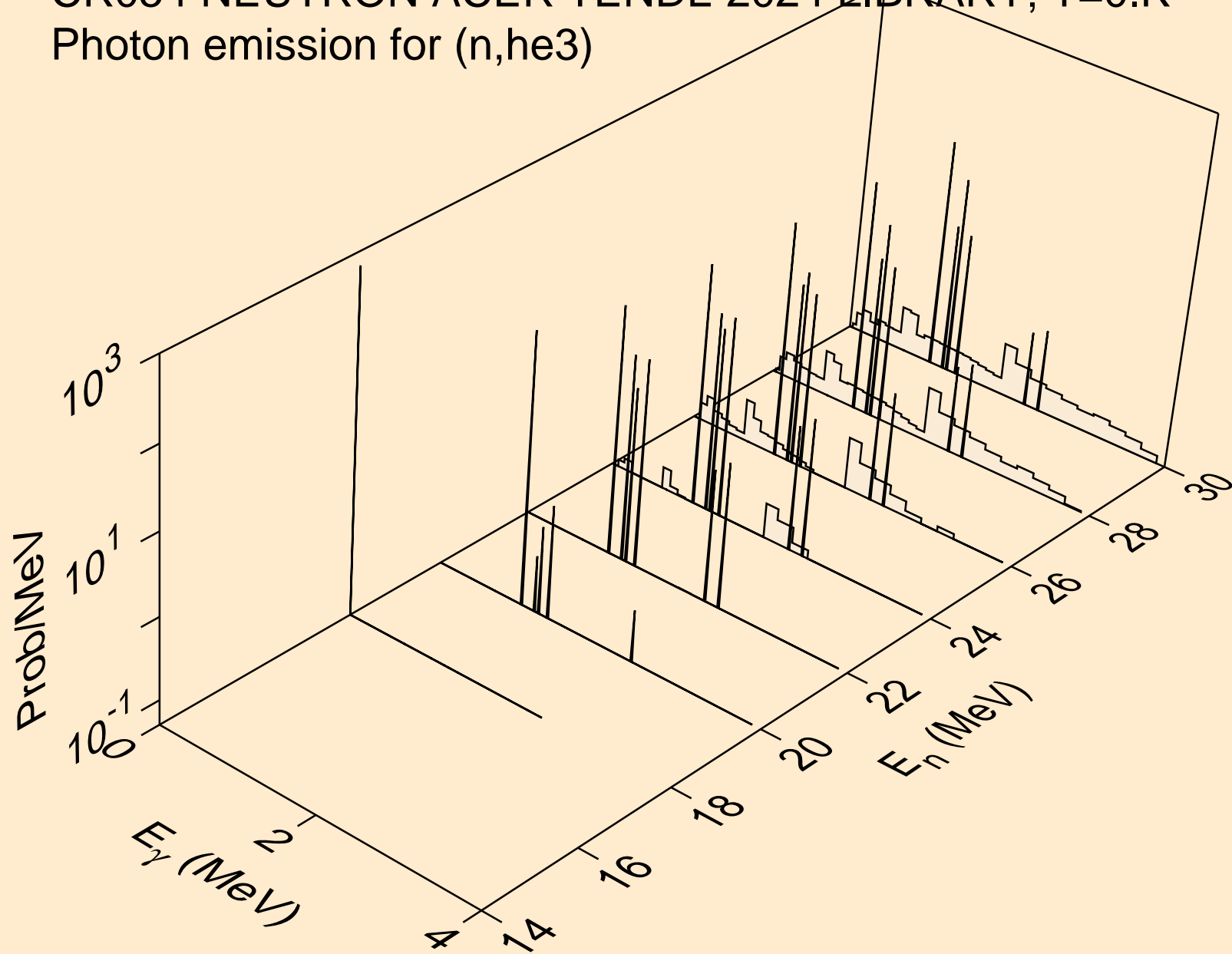

CR054 NEUTRON ACER TENDL-2024 LIBRARY; T=0.K
Photon emission for (n,a)

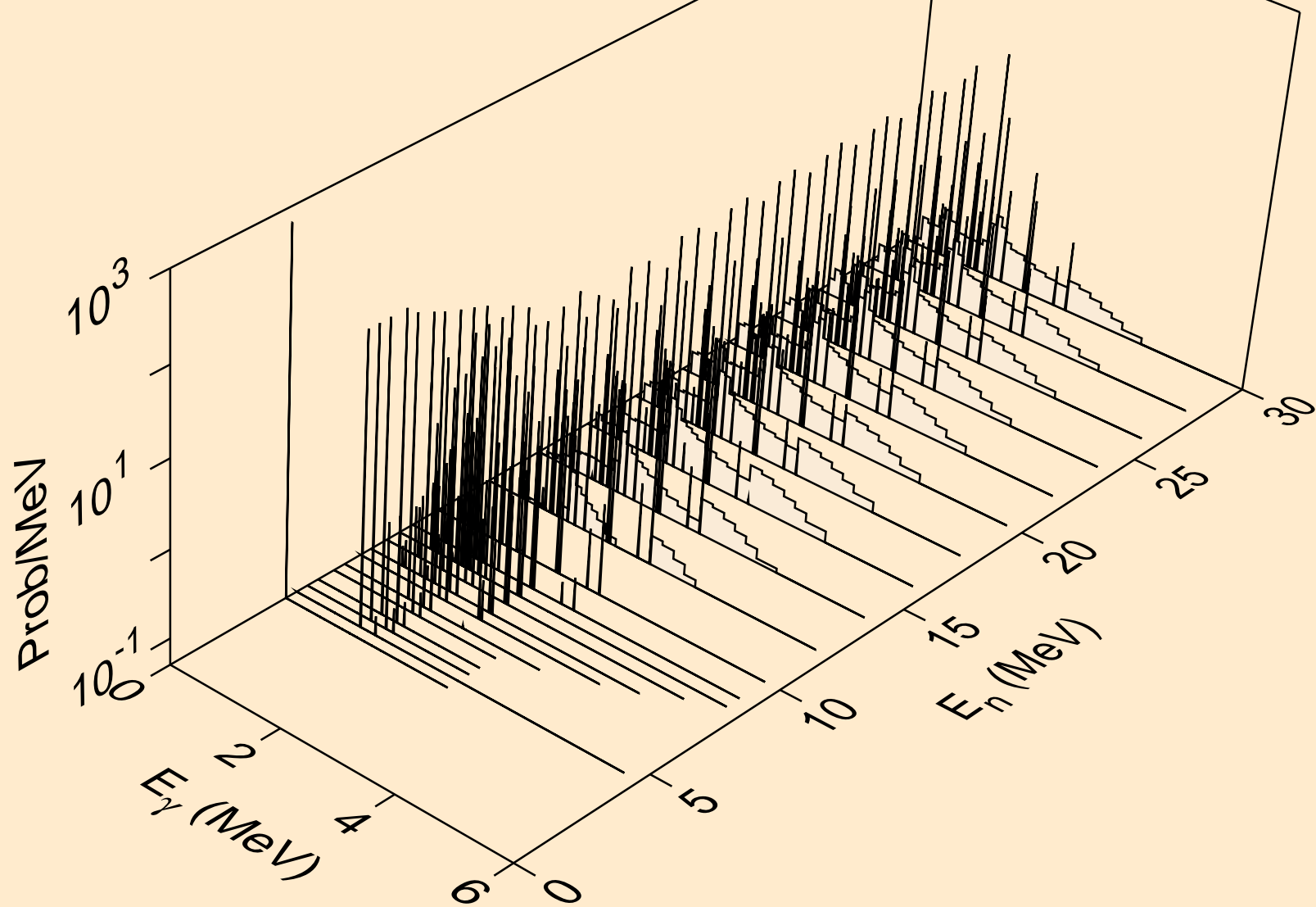

CR054 NEUTRON ACER TENDL-2024 LIBRARY; T=0.K
Photon emission for (n,2a)

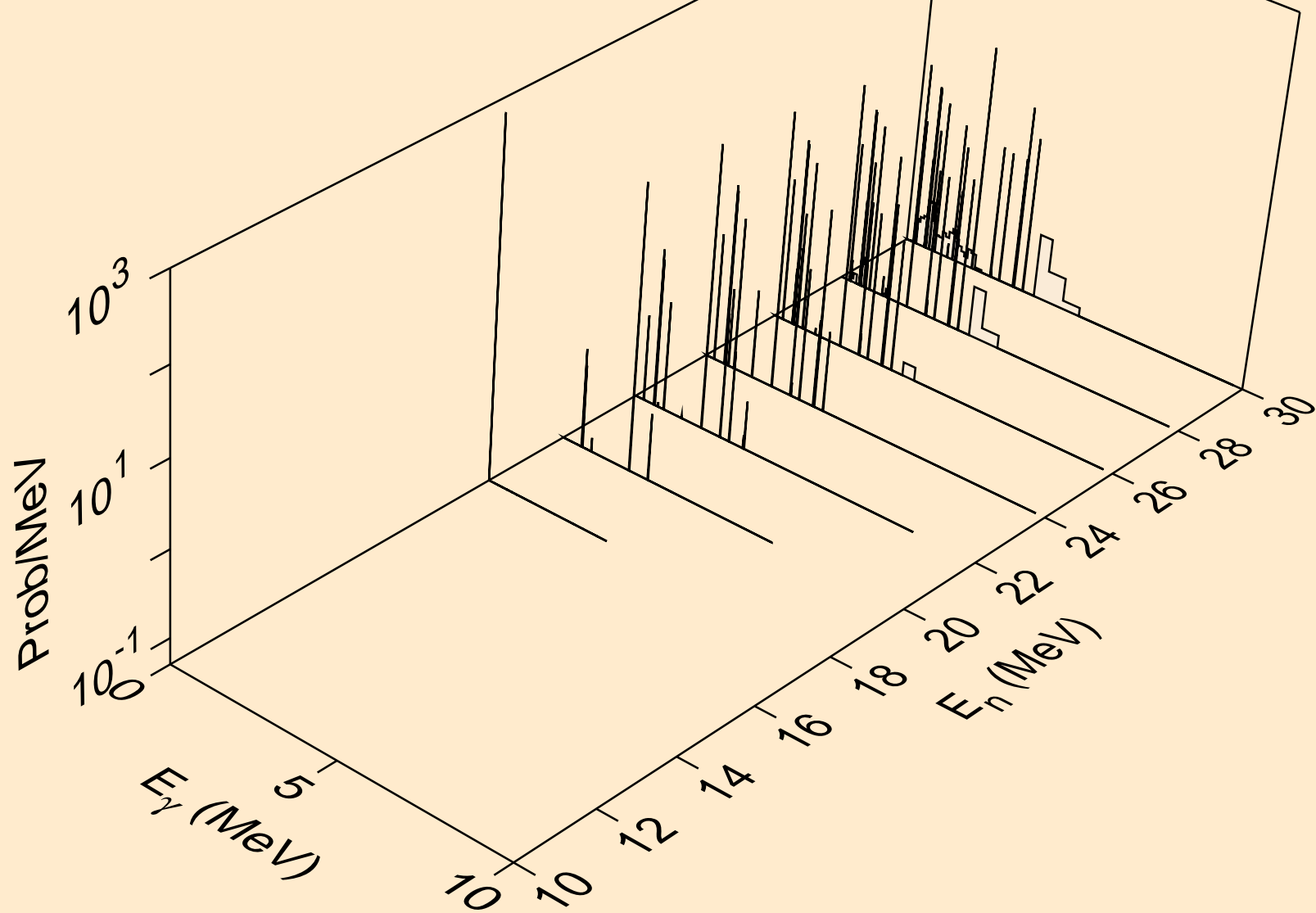

CR054 NEUTRON ACER TENDL-2024 LIBRARY; T=0.K
Photon emission for (n,2p)

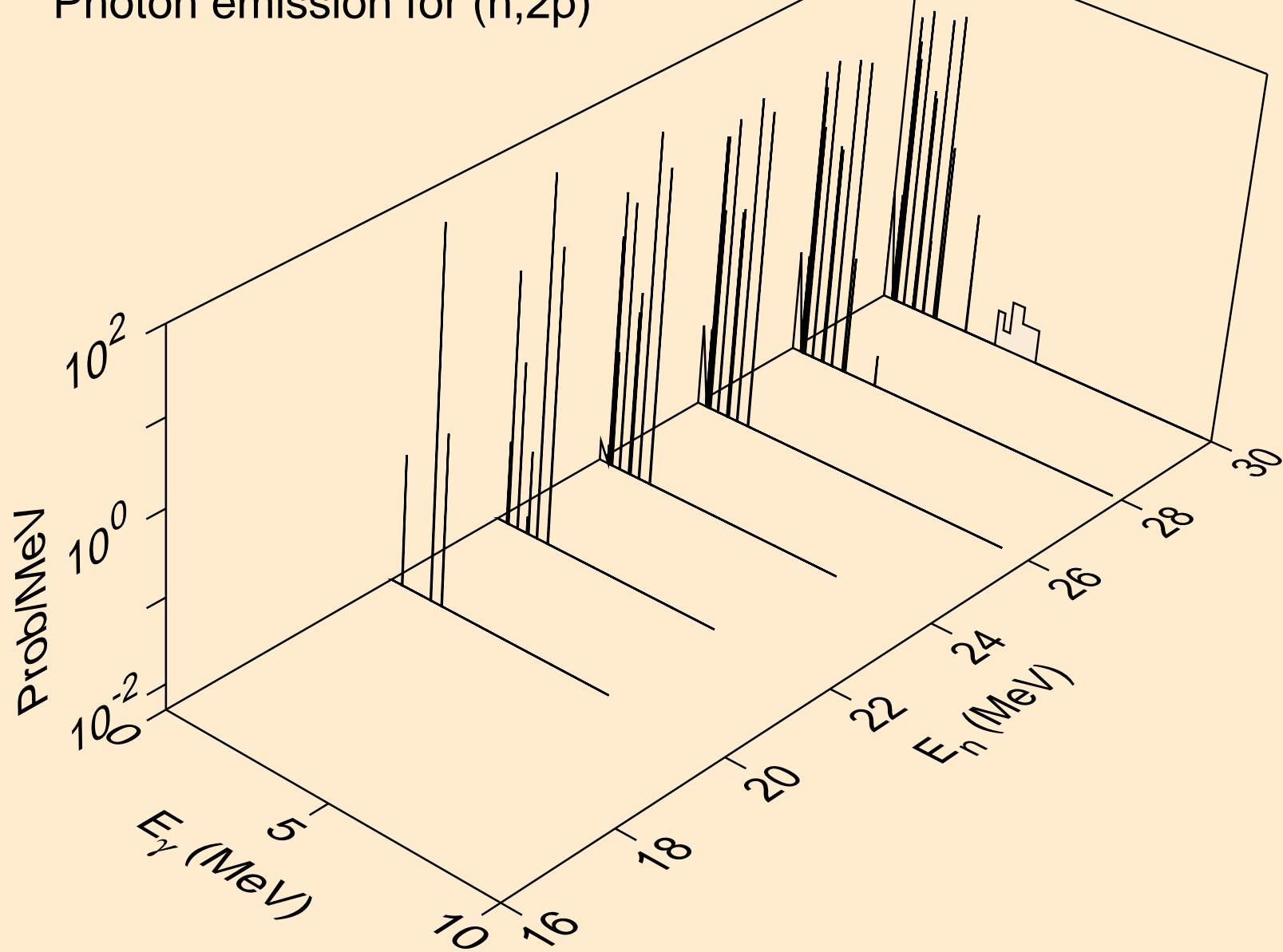

CR054 NEUTRON ACER TENDL-2024 LIBRARY; T=0.K
Photon emission for (n,p α)

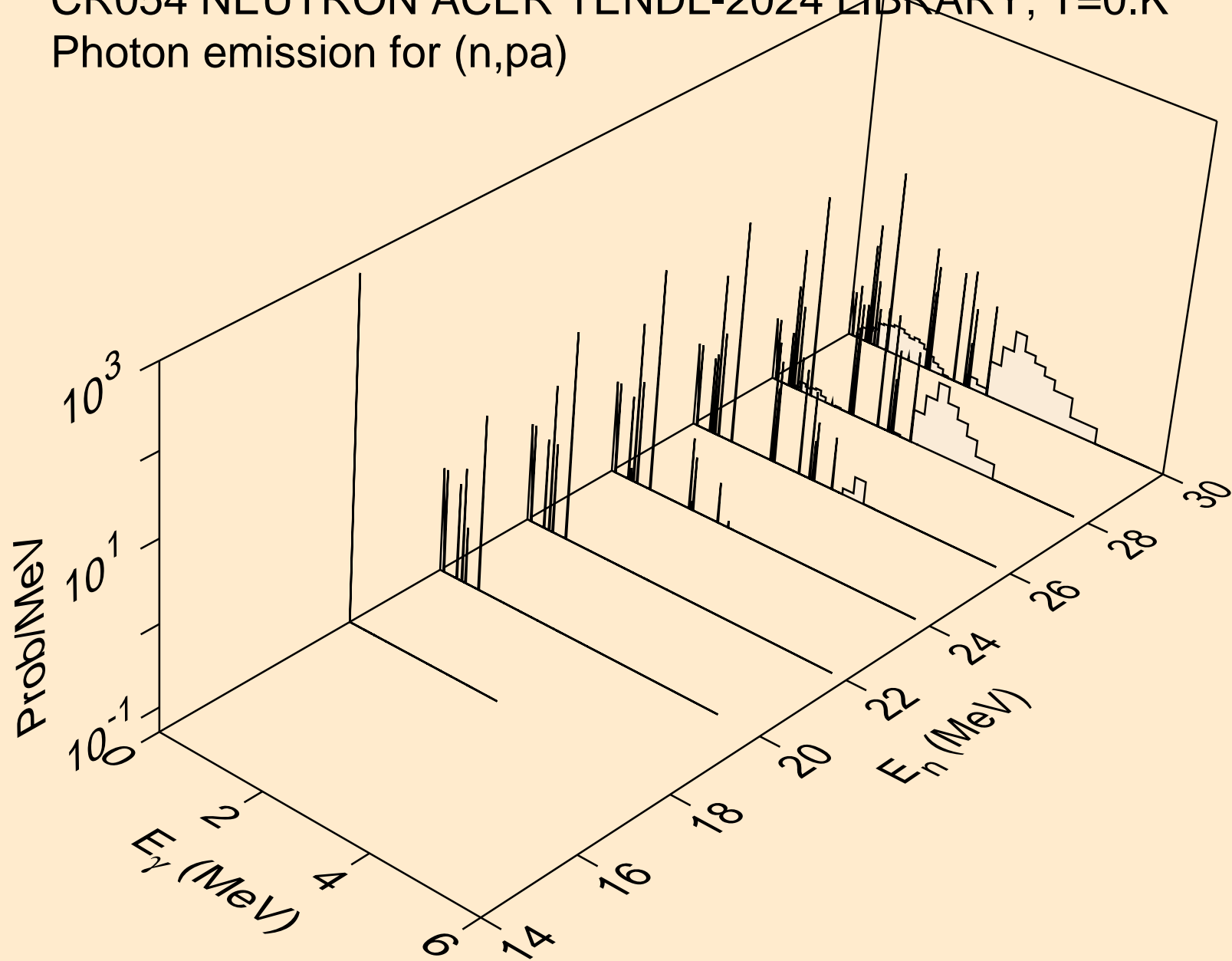

CR054 NEUTRON ACER TENDL-2024 LIBRARY; T=0.K
Photon emission for (n,pd)

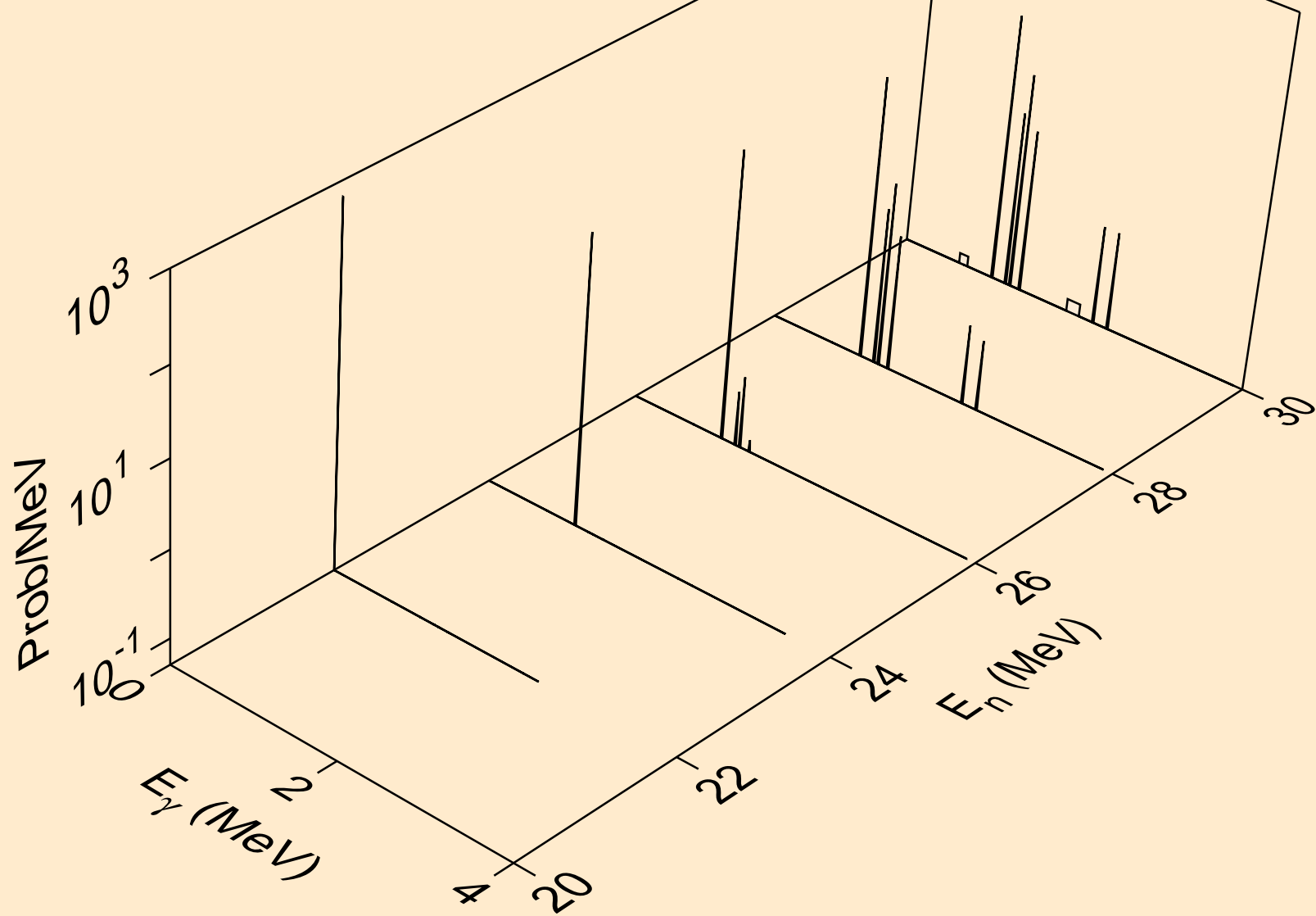

CR054 NEUTRON ACER TENDL-2024 LIBRARY; T=0.K
Photon emission for (n,pt)

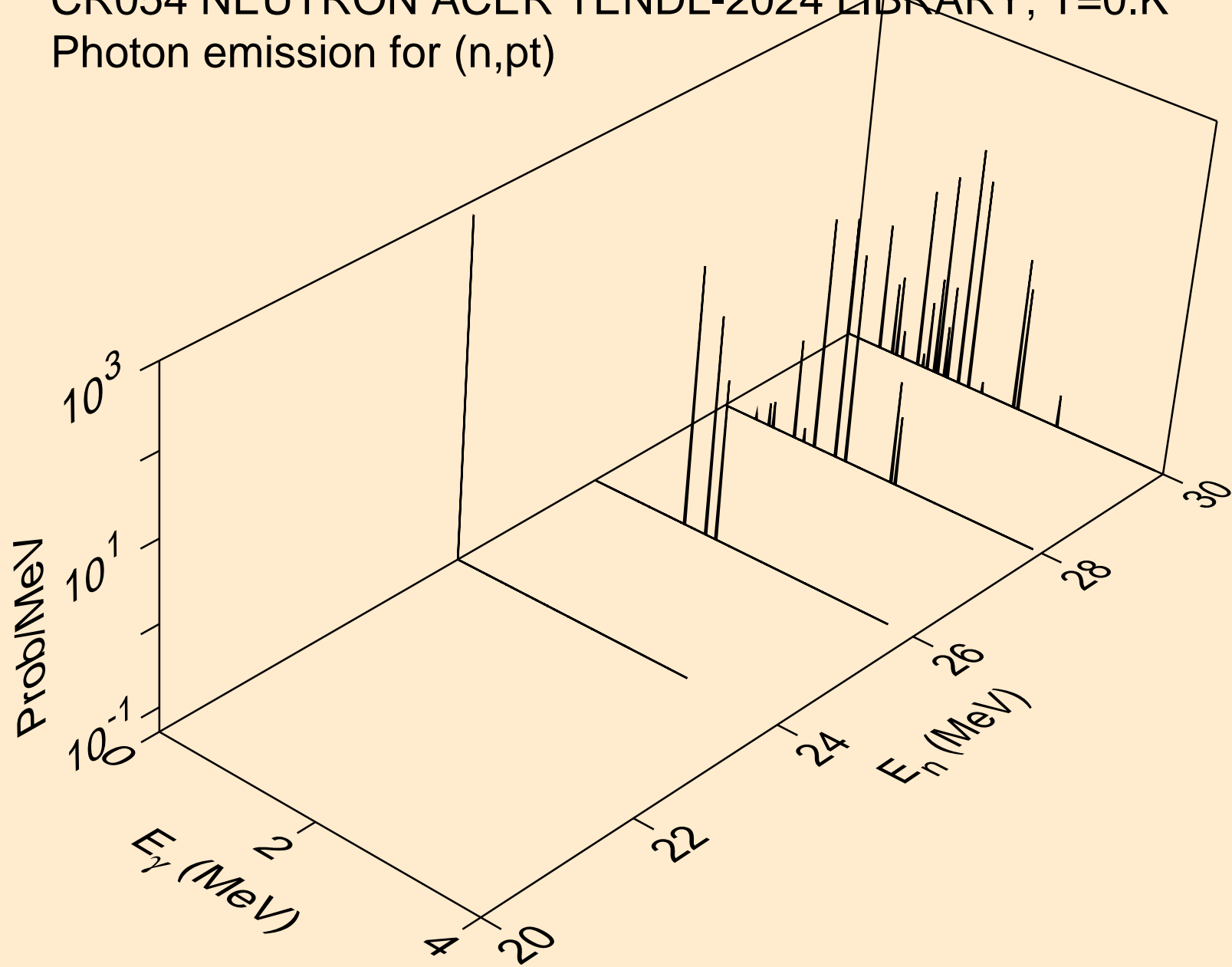

CR054 NEUTRON ACER TENDL-2024 LIBRARY; T=0.K
Photon emission for (n,da)

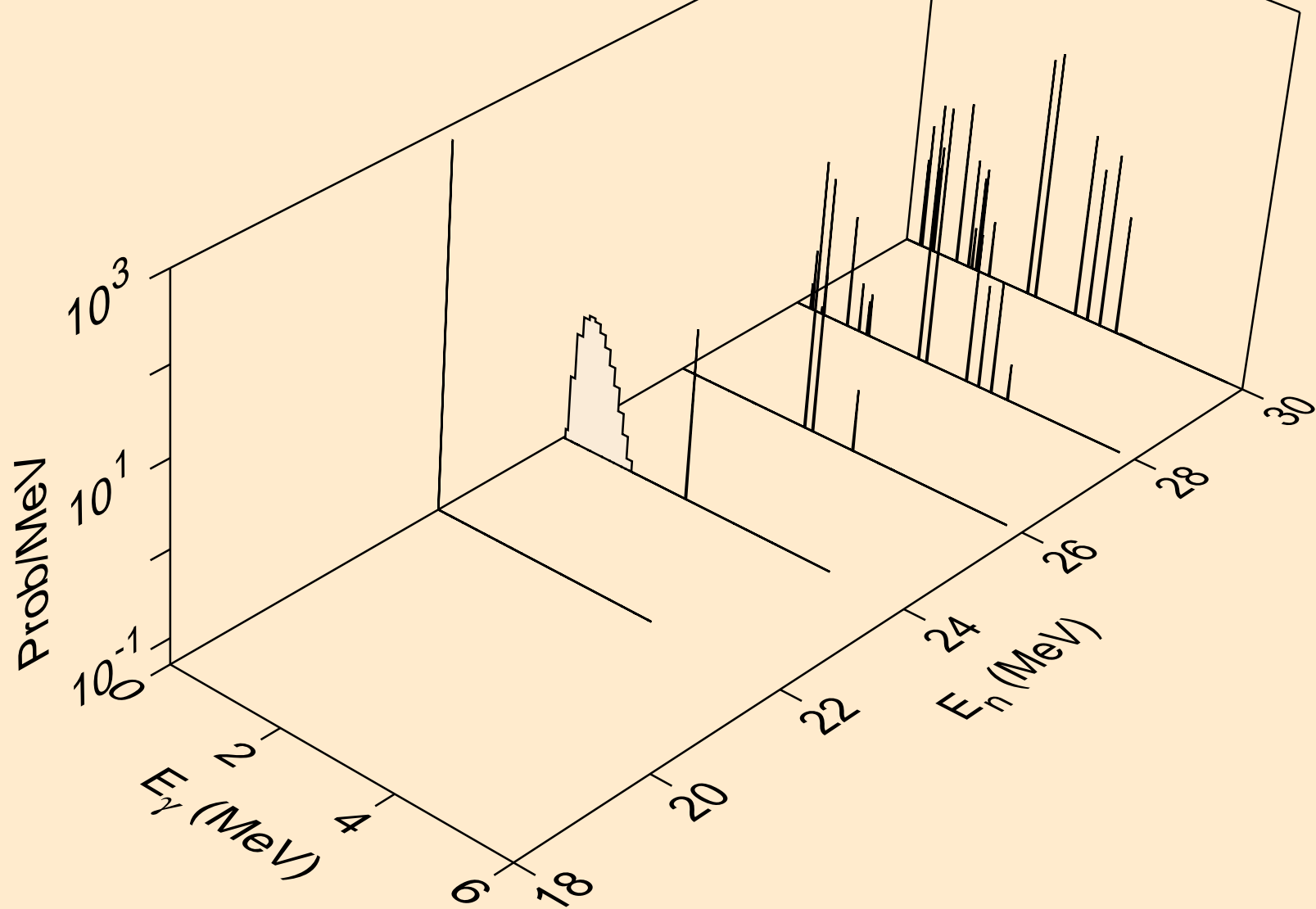

CR054 NEUTRON ACER TENDL-2024 LIBRARY; T=0.K
thermal capture photon spectrum

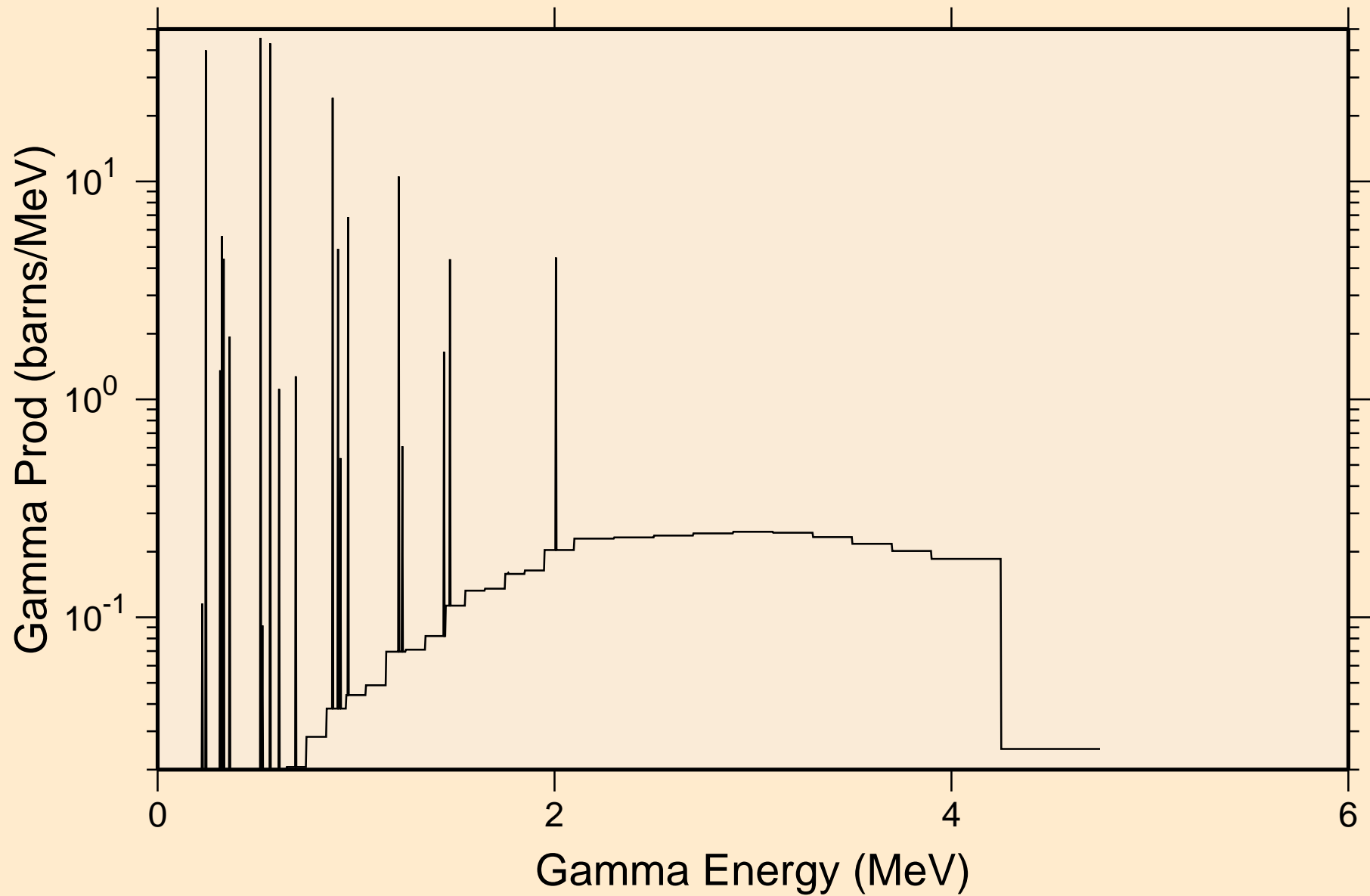

CR054 NEUTRON ACER TENDL-2024 LIBRARY; T=0.K
14 MeV photon spectrum

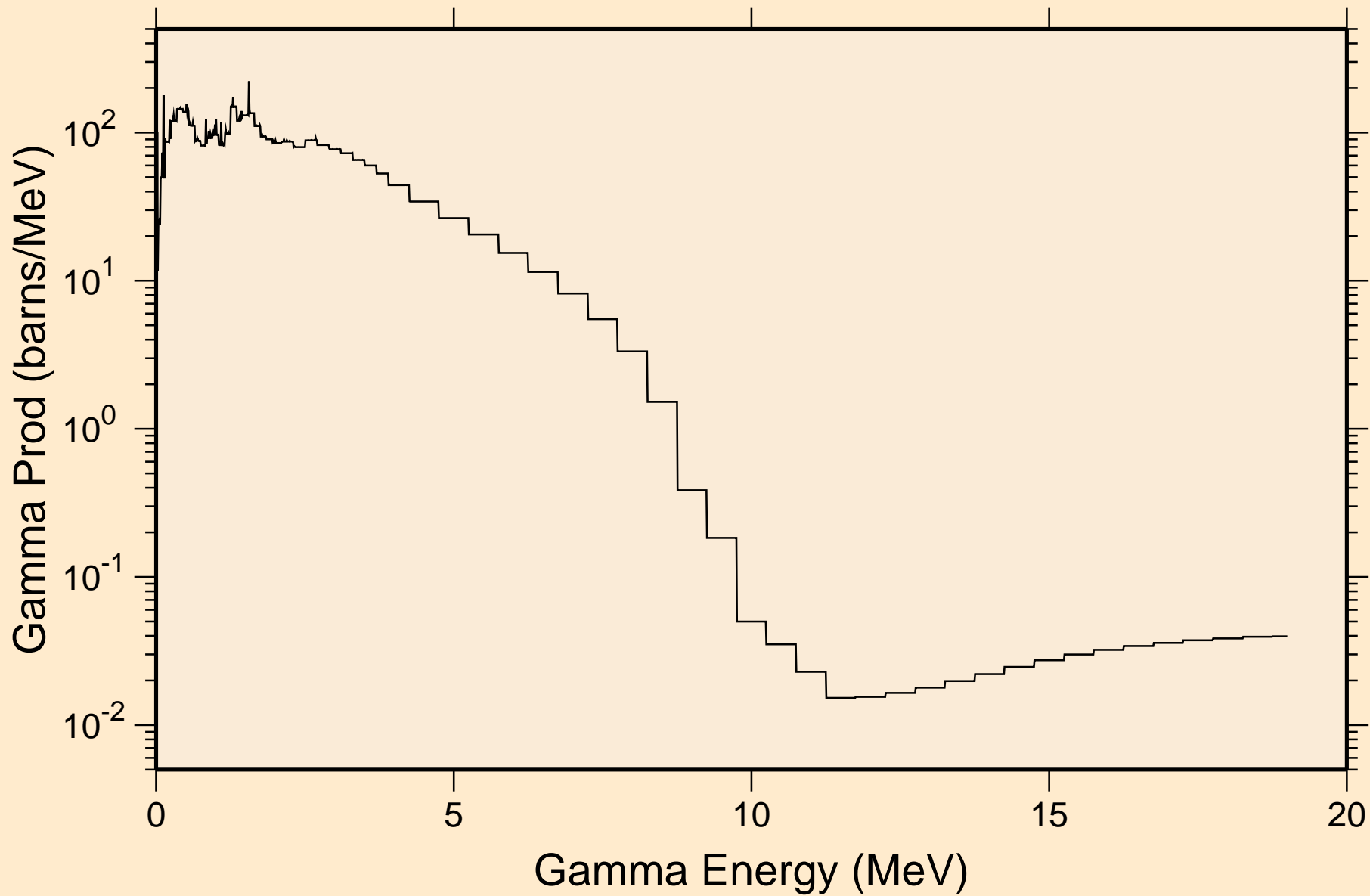

CR054 NEUTRON ACER TENDL-2024 LIBRARY; T=0.K

Particle heating contributions

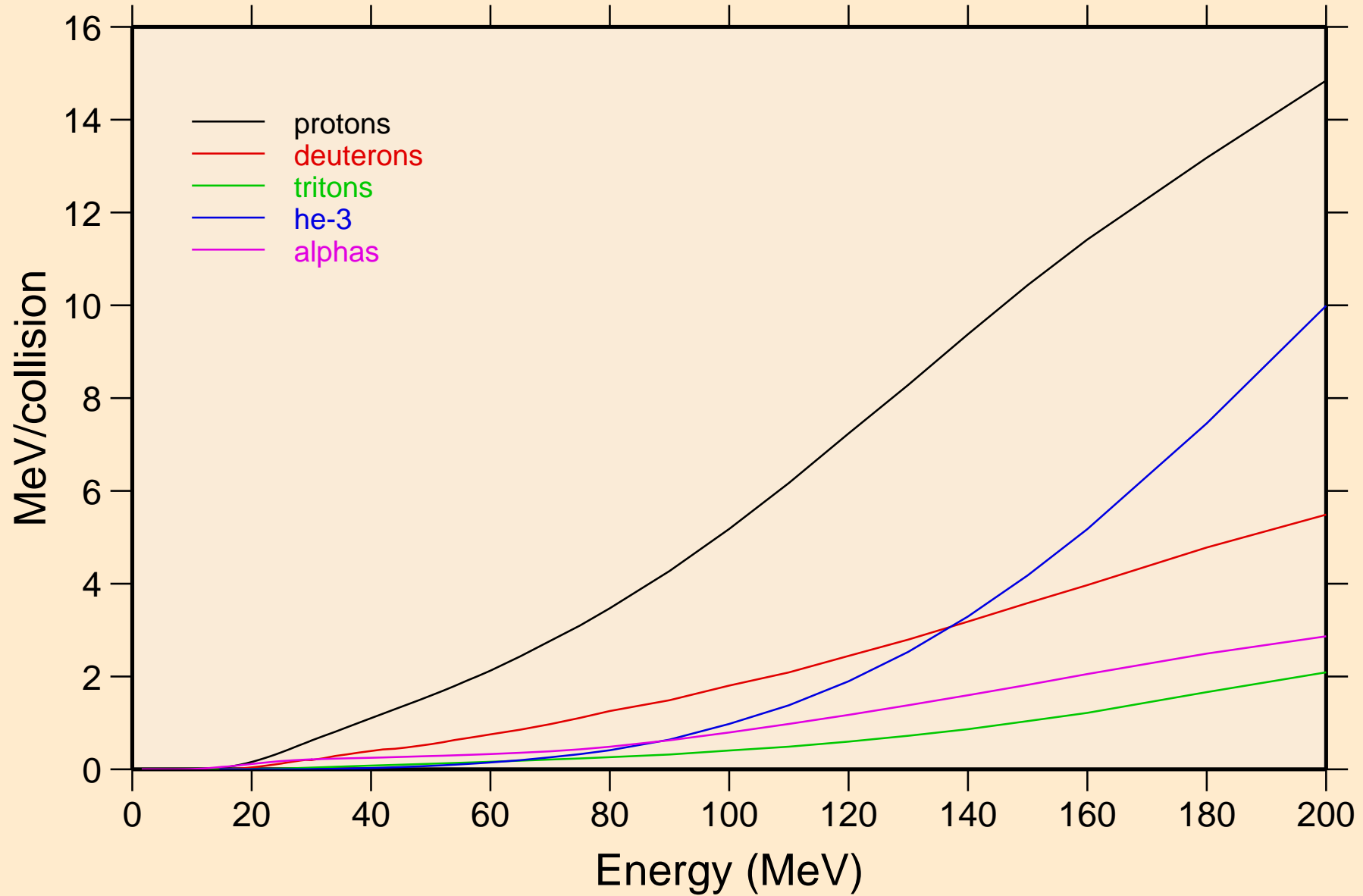

CR054 NEUTRON ACER TENDL-2024 LIBRARY; T=0.K
Recoil Heating

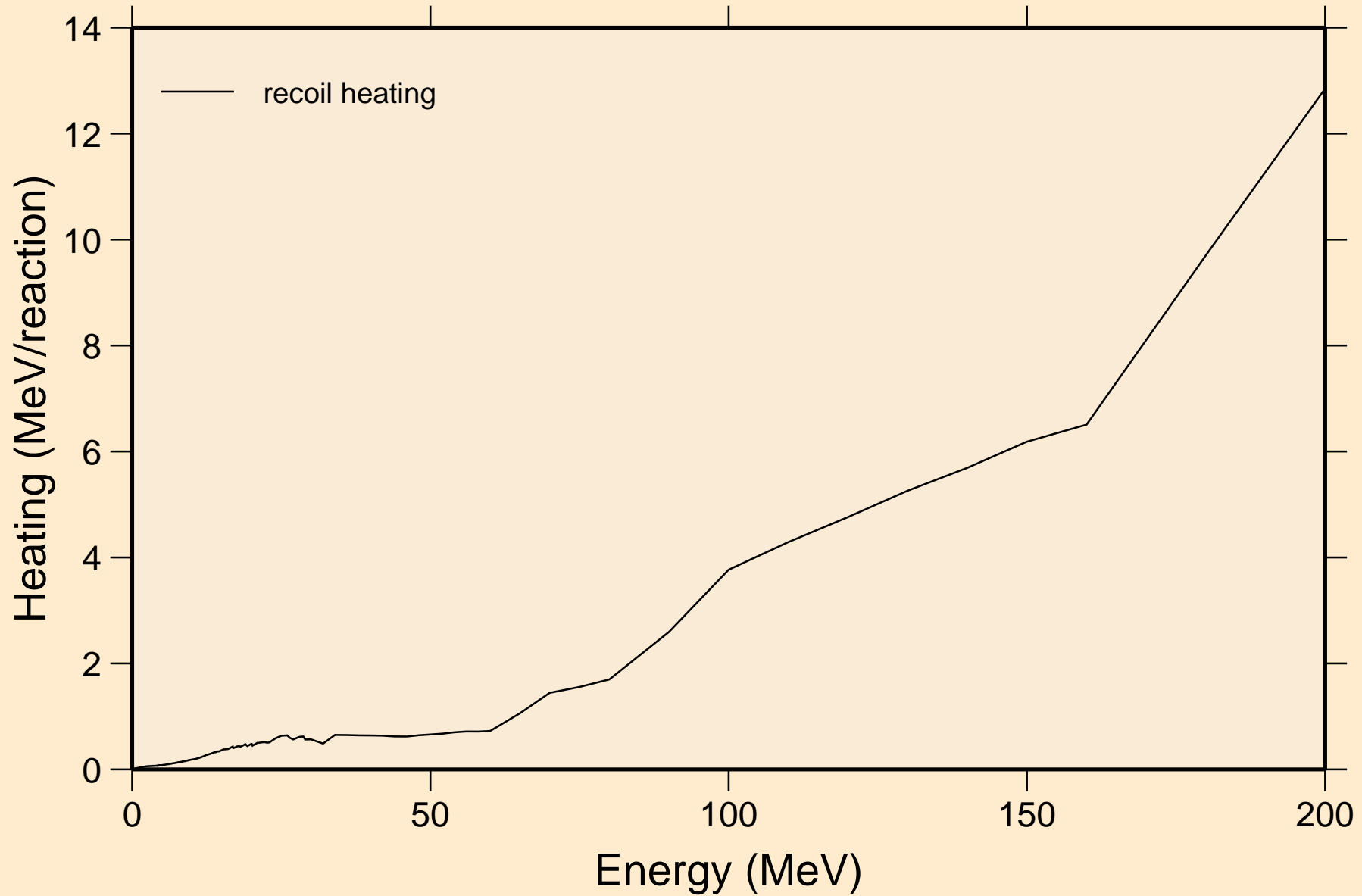

CR054 NEUTRON ACER TENDL-2024 LIBRARY; T=0.K
Particle production cross sections

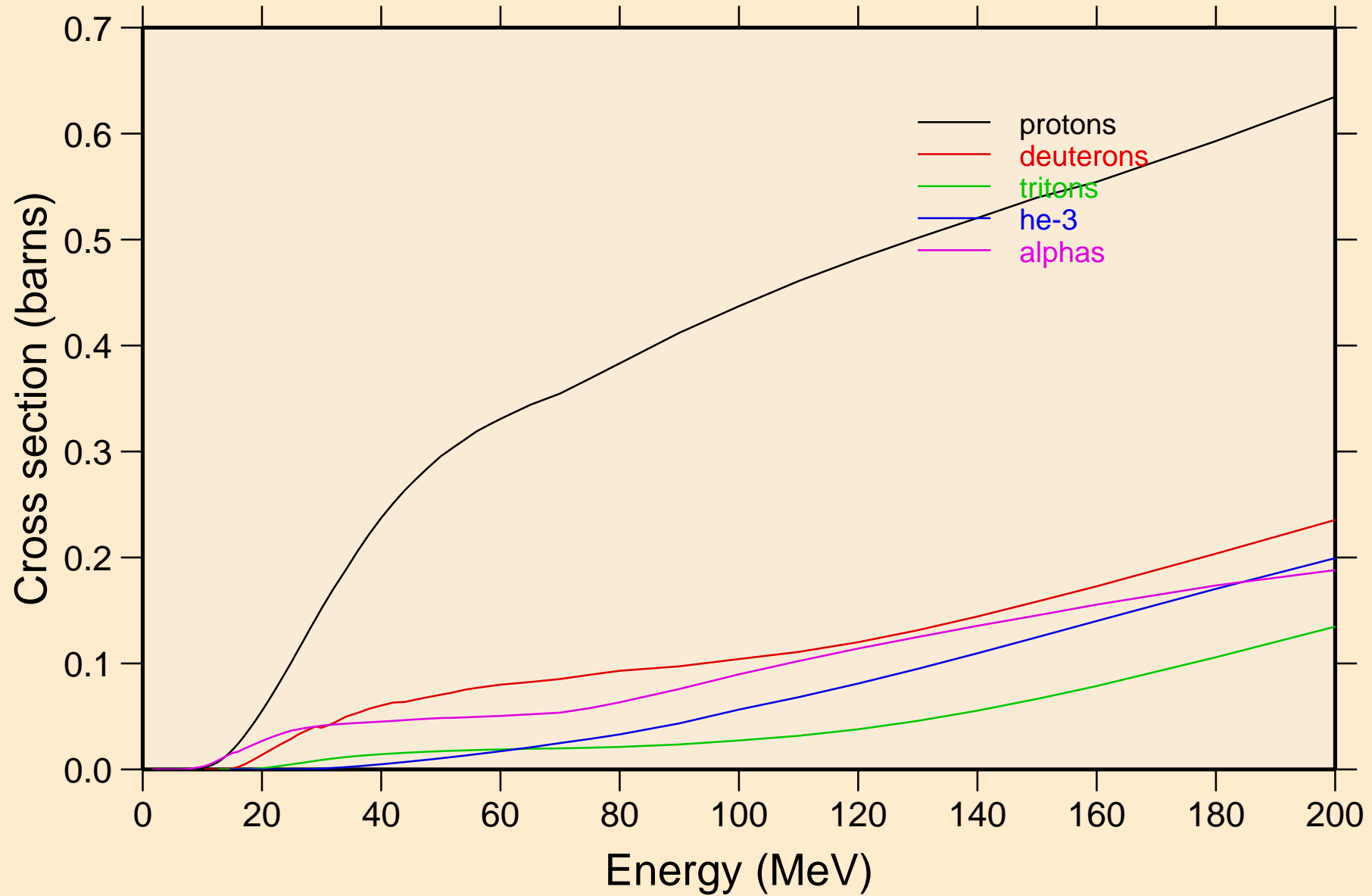

CR054 NEUTRON ACER TENDL-2024 LIBRARY; T=0.K
protons from (n,x)

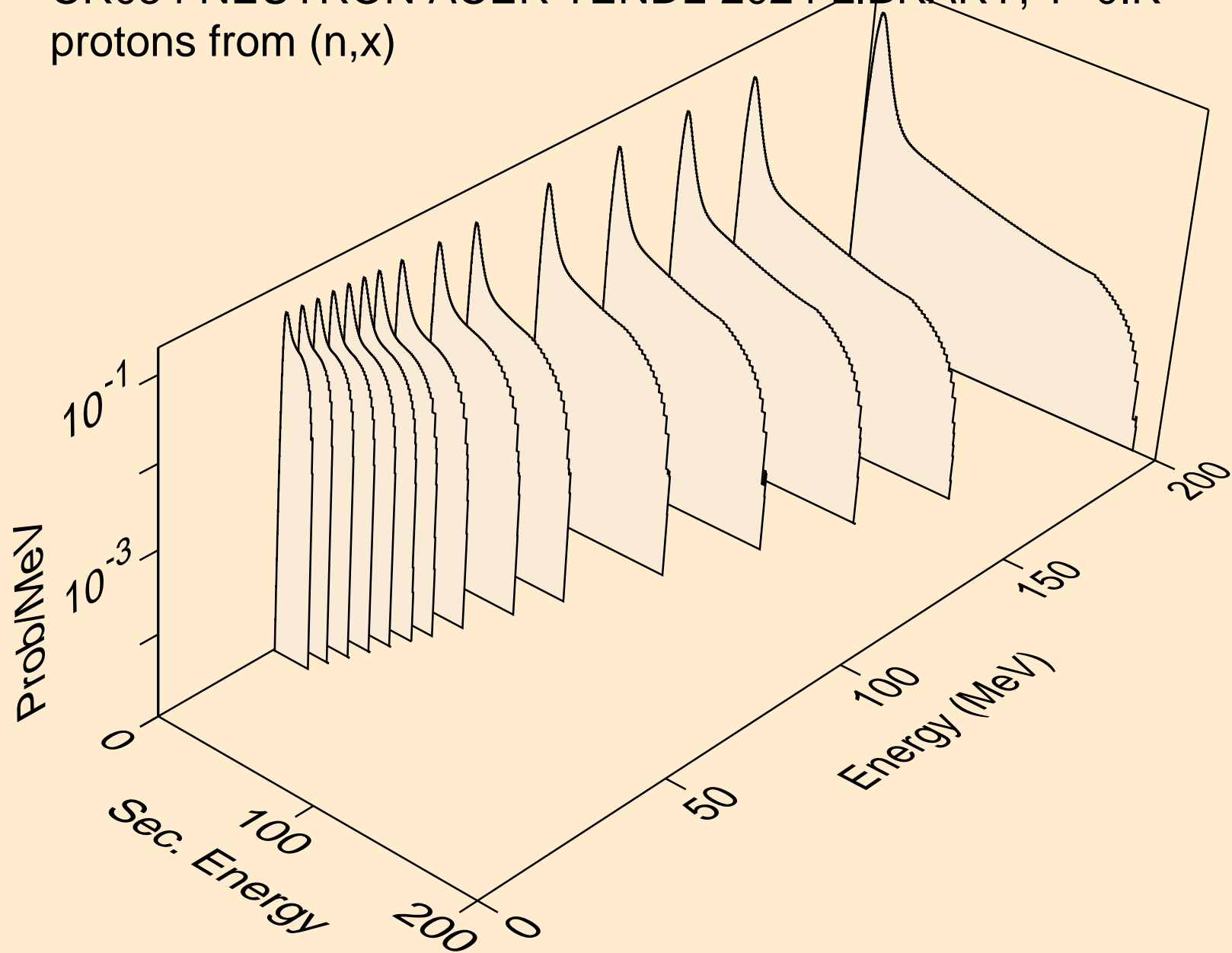

CR054 NEUTRON ACER TENDL-2024 LIBRARY; T=0.K
protons from (n,n*)p

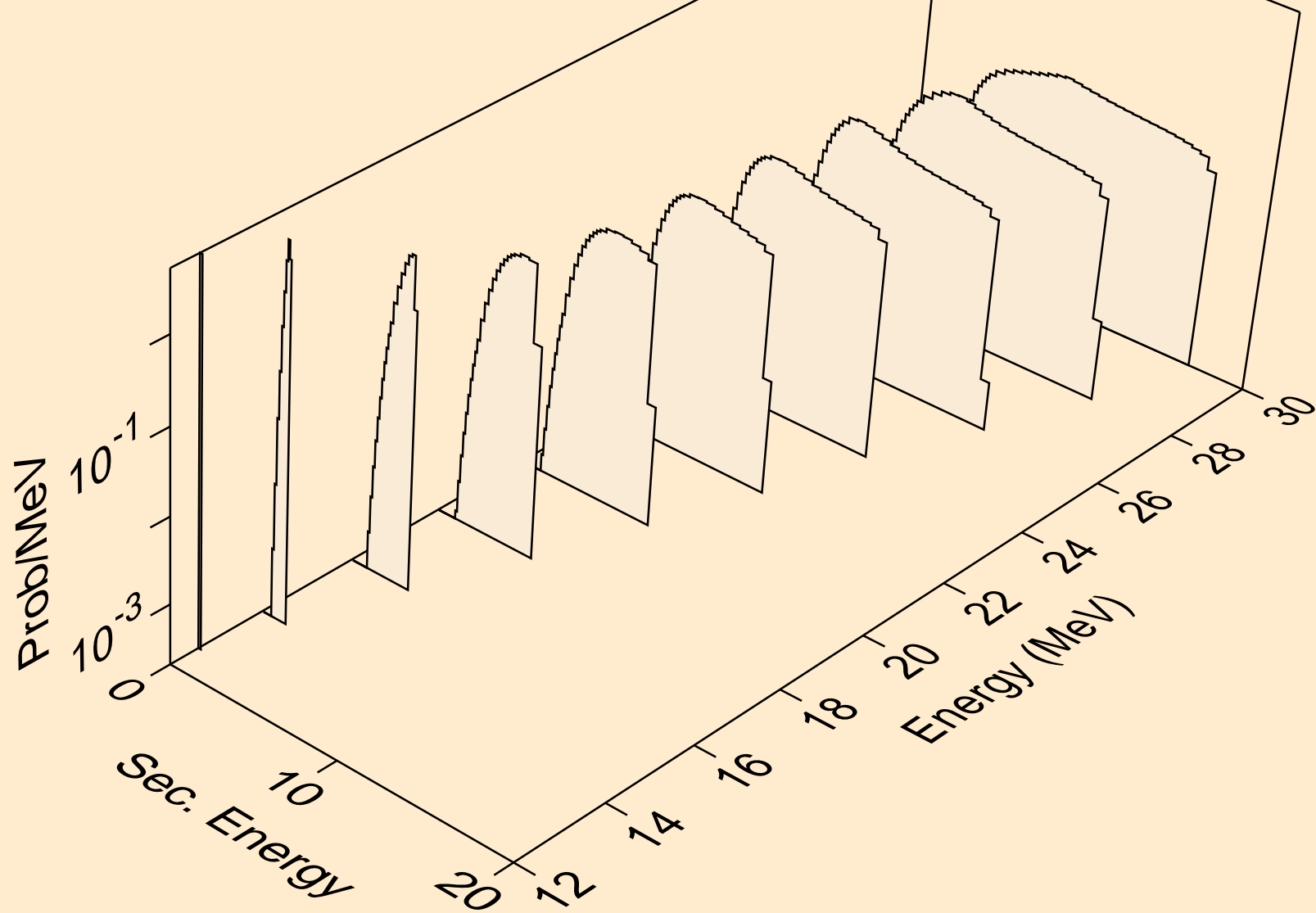

CR054 NEUTRON ACER TENDL-2024 LIBRARY; T=0.K
protons from (n,2np)

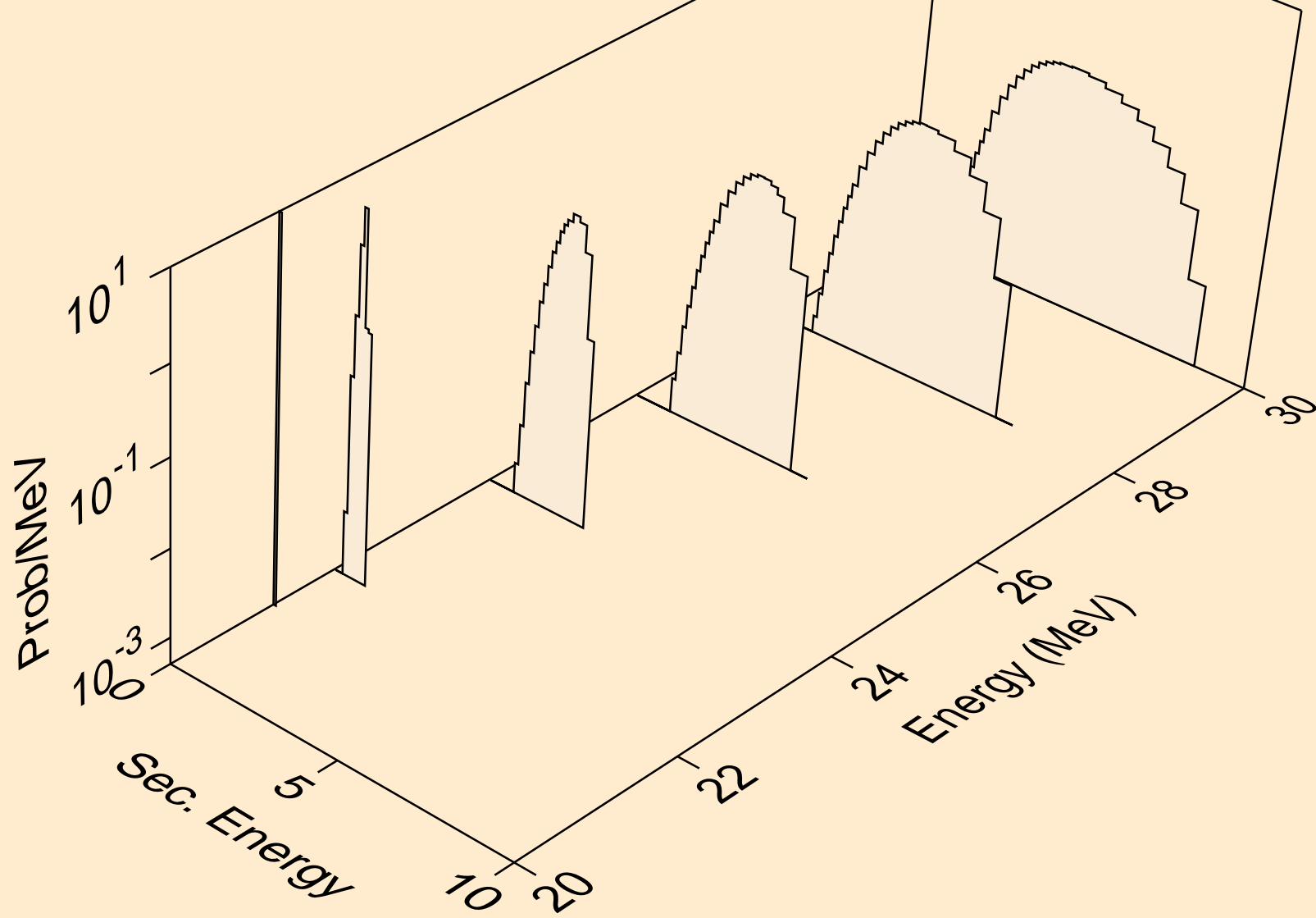

CR054 NEUTRON ACER TENDL-2024 LIBRARY; T=0.K
protons from (n,3np)

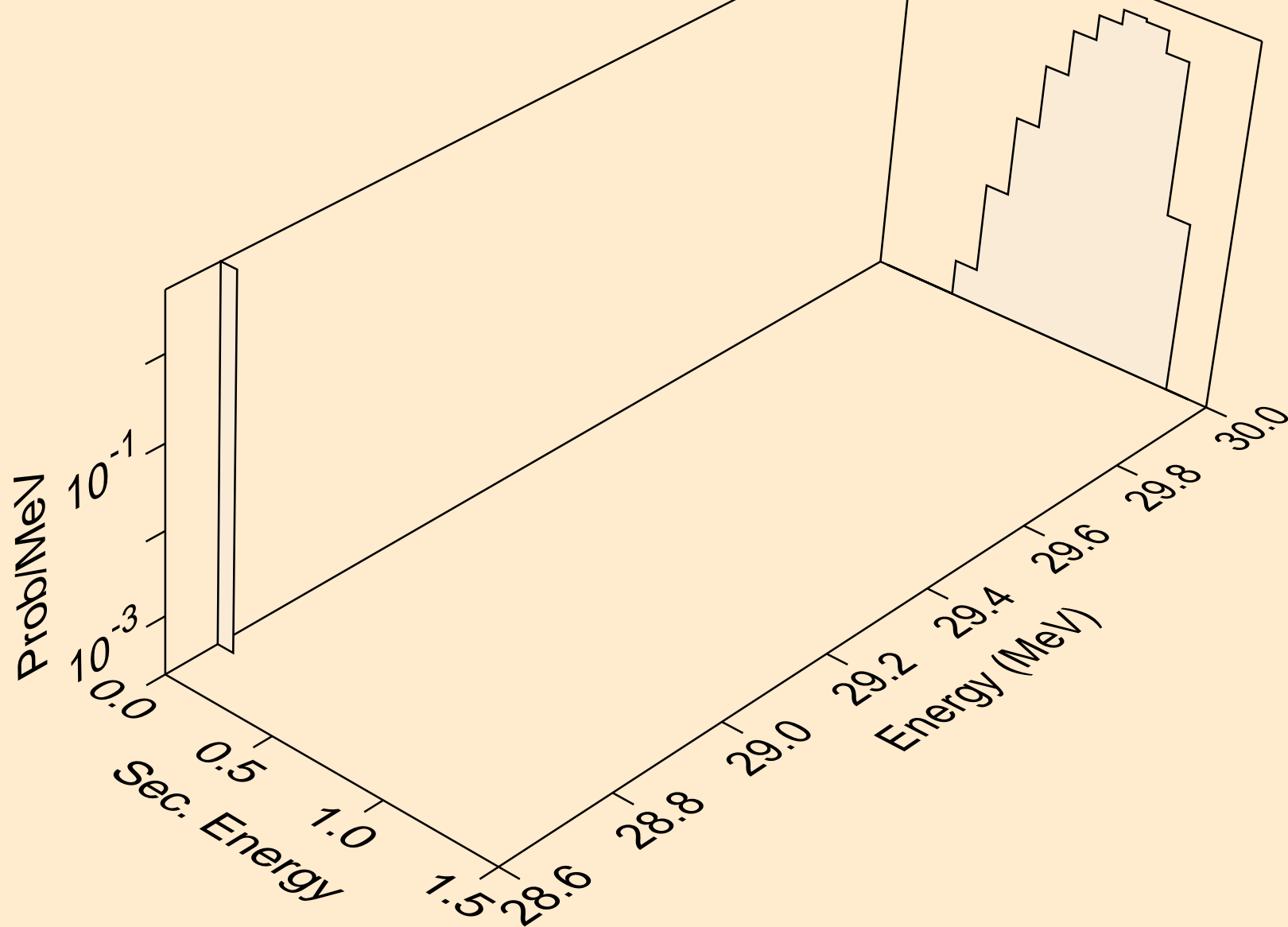

CR054 NEUTRON ACER TENDL-2024 LIBRARY; T=0.K
protons from (n,n2p)

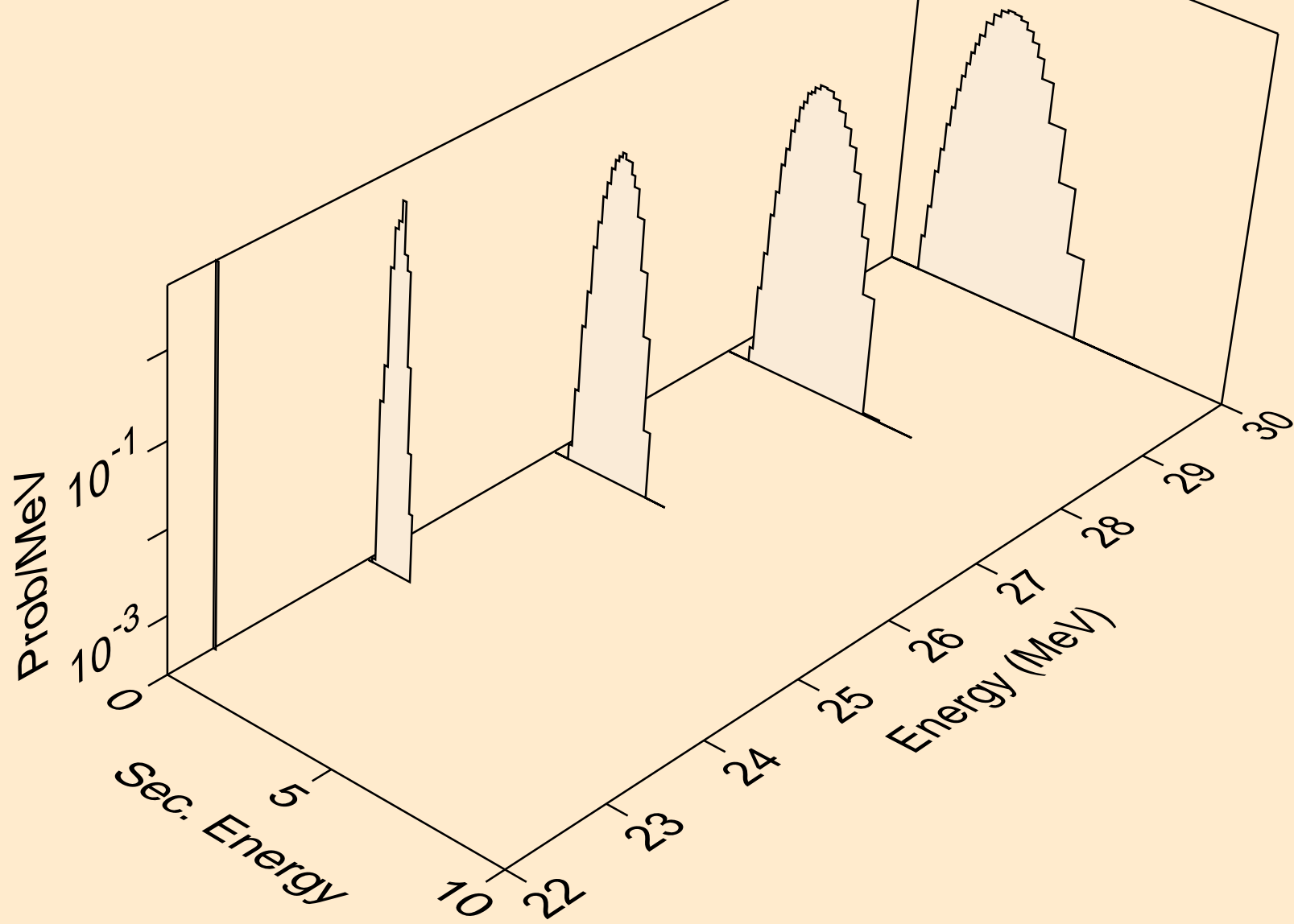

CR054 NEUTRON ACER TENDL-2024 LIBRARY; T=0.K
protons from (n,npa)

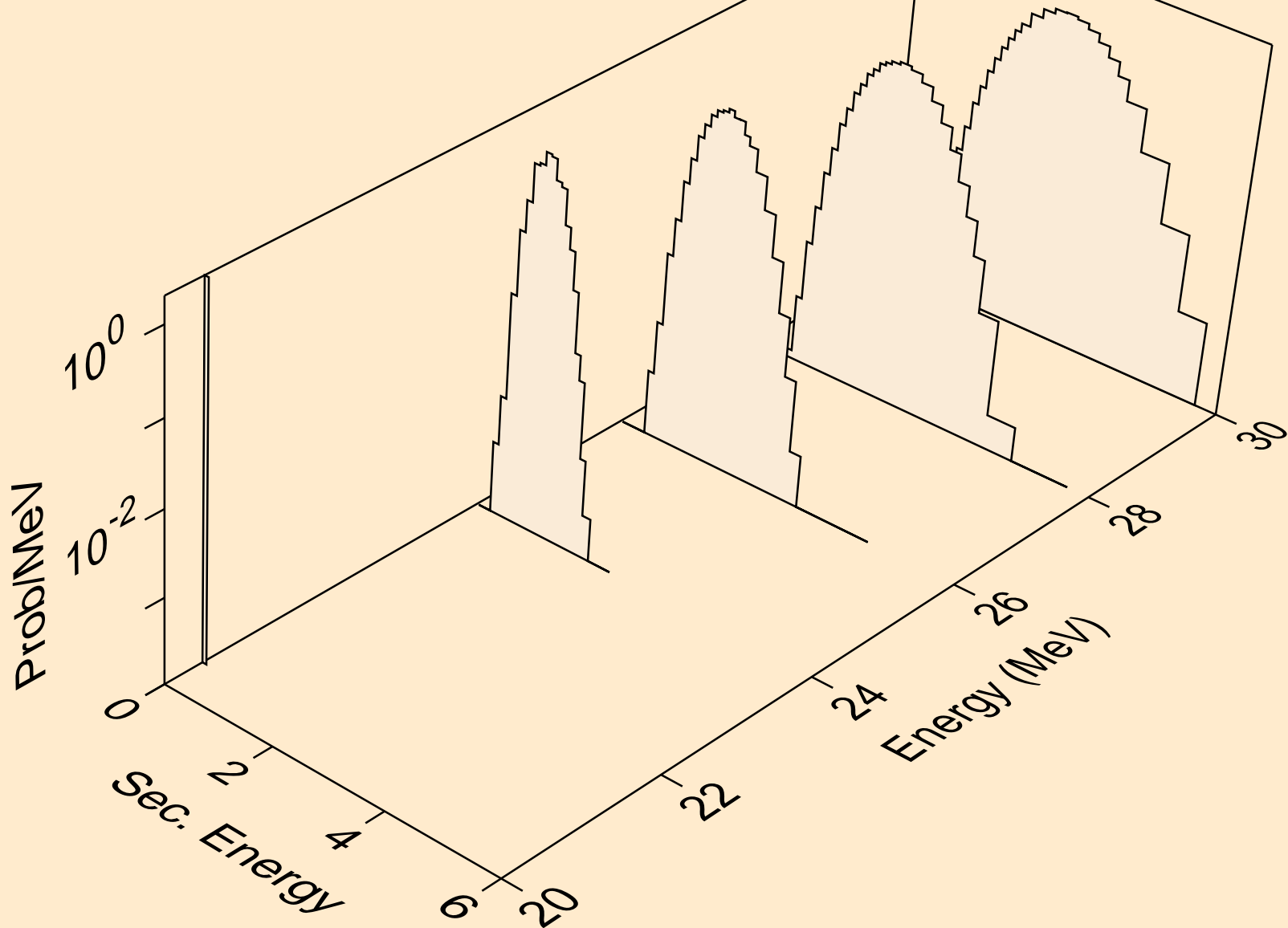

CR054 NEUTRON ACER TENDL-2024 LIBRARY; T=0.K
protons from (n,p)

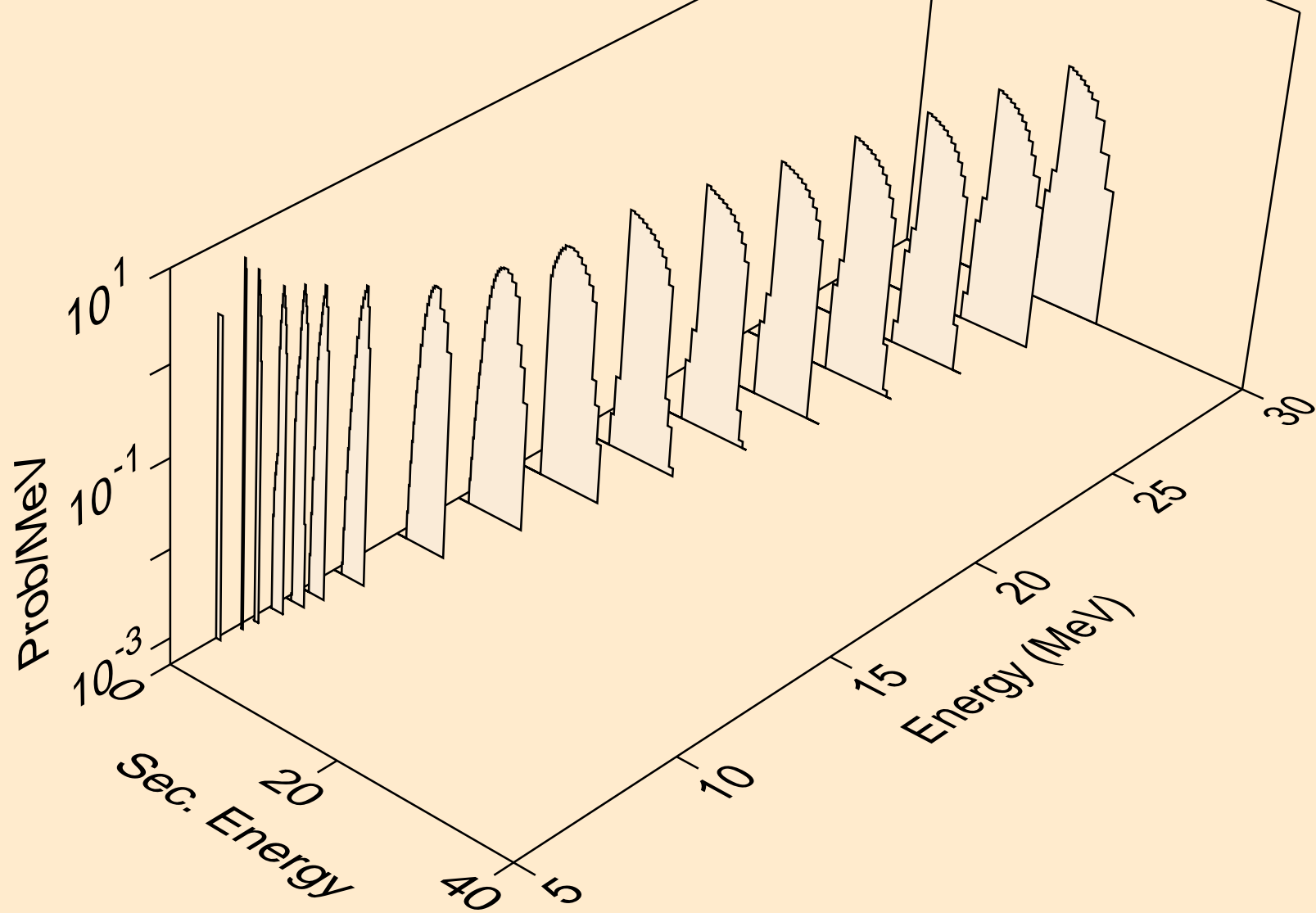

CR054 NEUTRON ACER TENDL-2024 LIBRARY; T=0.K
protons from (n,2p)

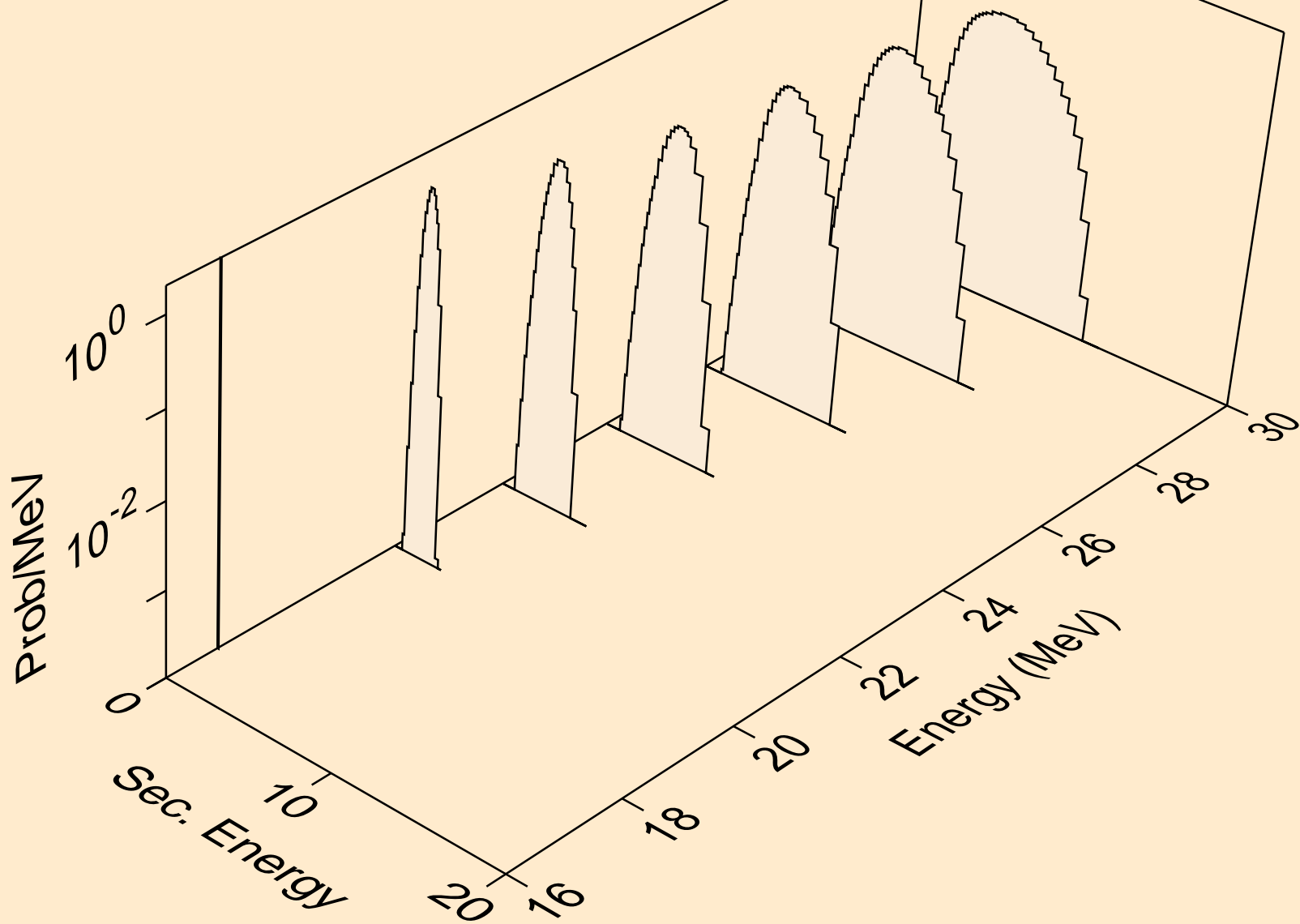

CR054 NEUTRON ACER TENDL-2024 LIBRARY; T=0.K
protons from (n,p)

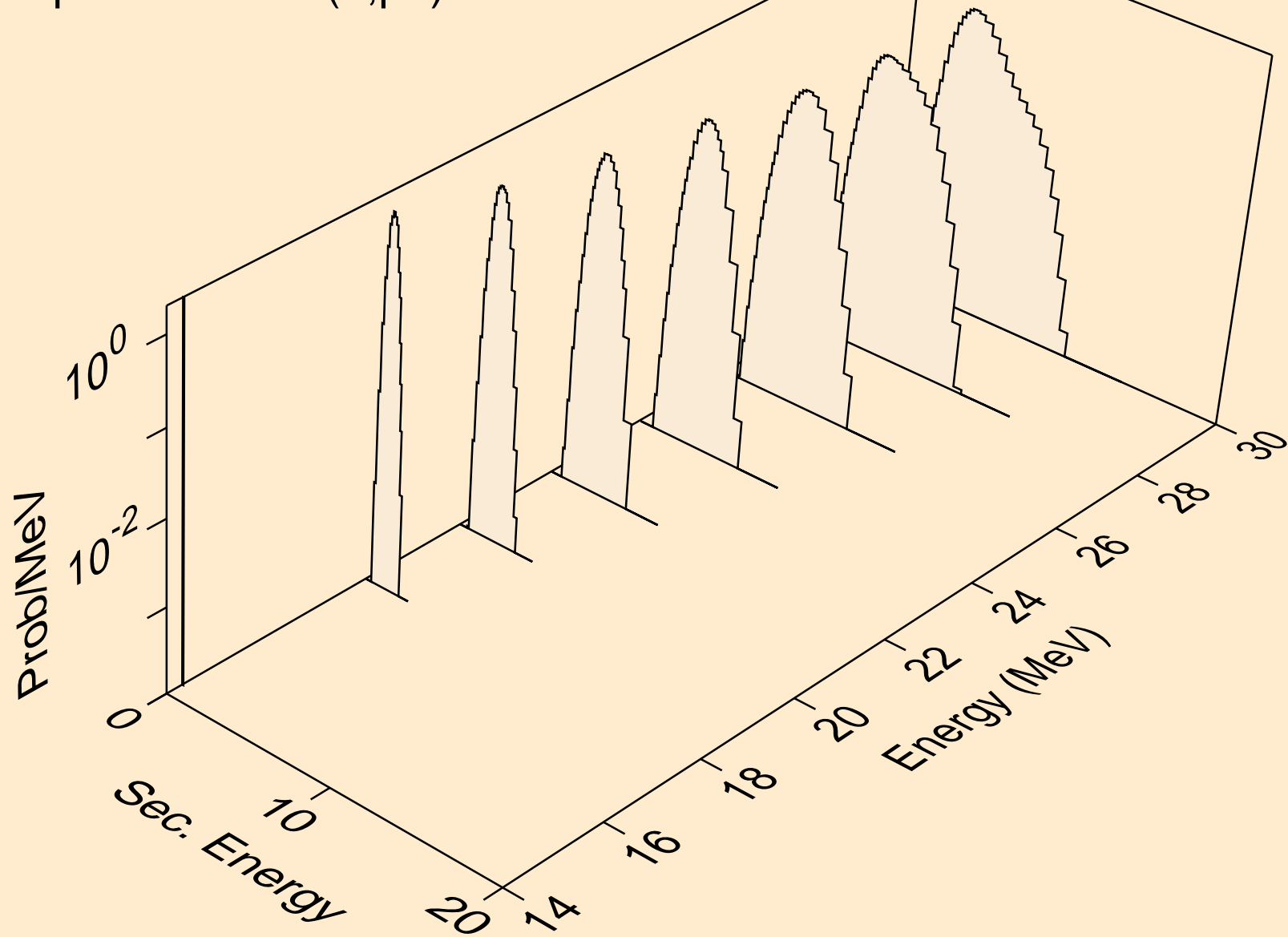

CR054 NEUTRON ACER TENDL-2024 LIBRARY; T=0.K
protons from (n,pd)

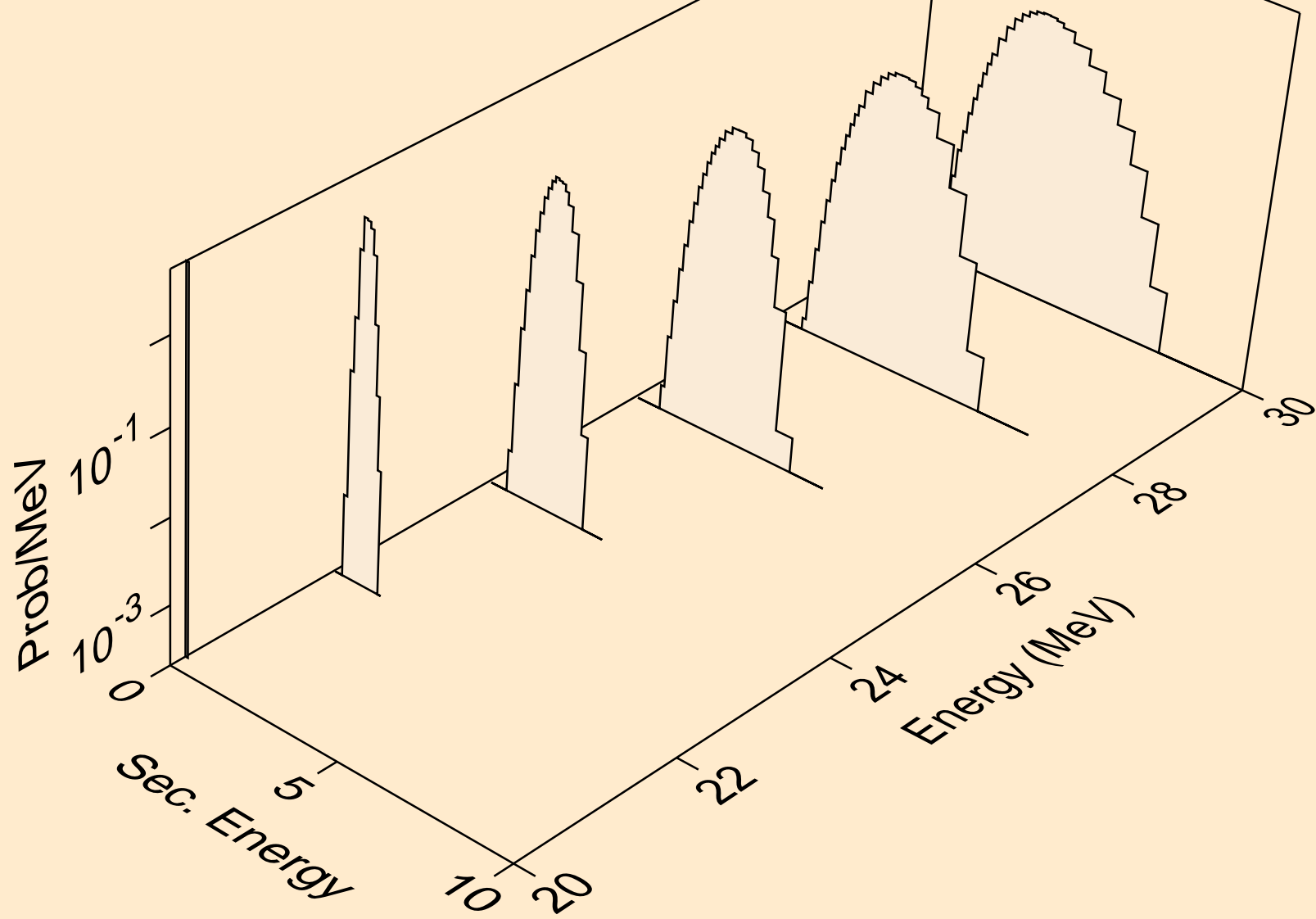

CR054 NEUTRON ACER TENDL-2024 LIBRARY; T=0.K
protons from (n,pt)

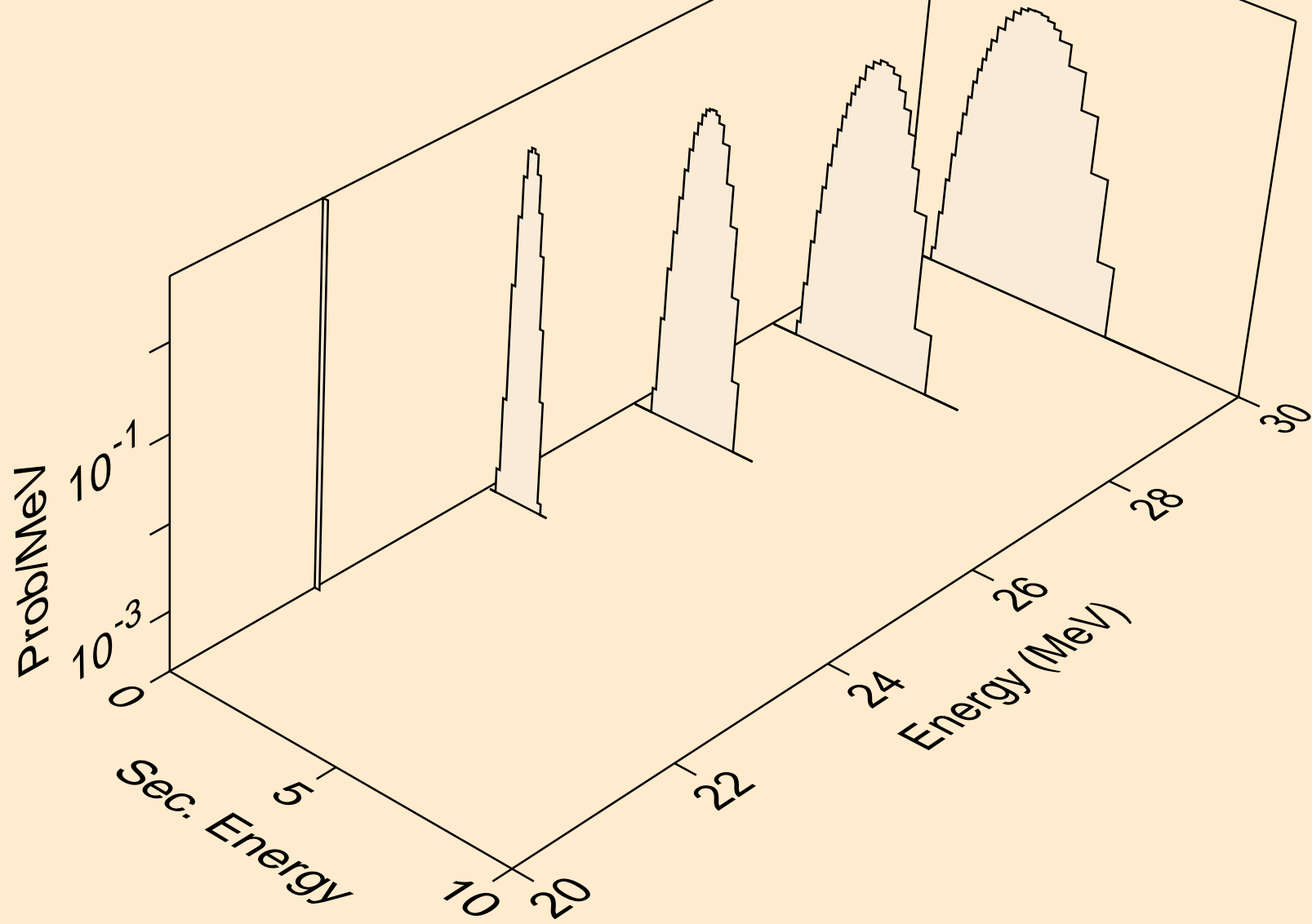

CR054 NEUTRON ACER TENDL-2024 LIBRARY; T=0.K
deuterons from (n,x)

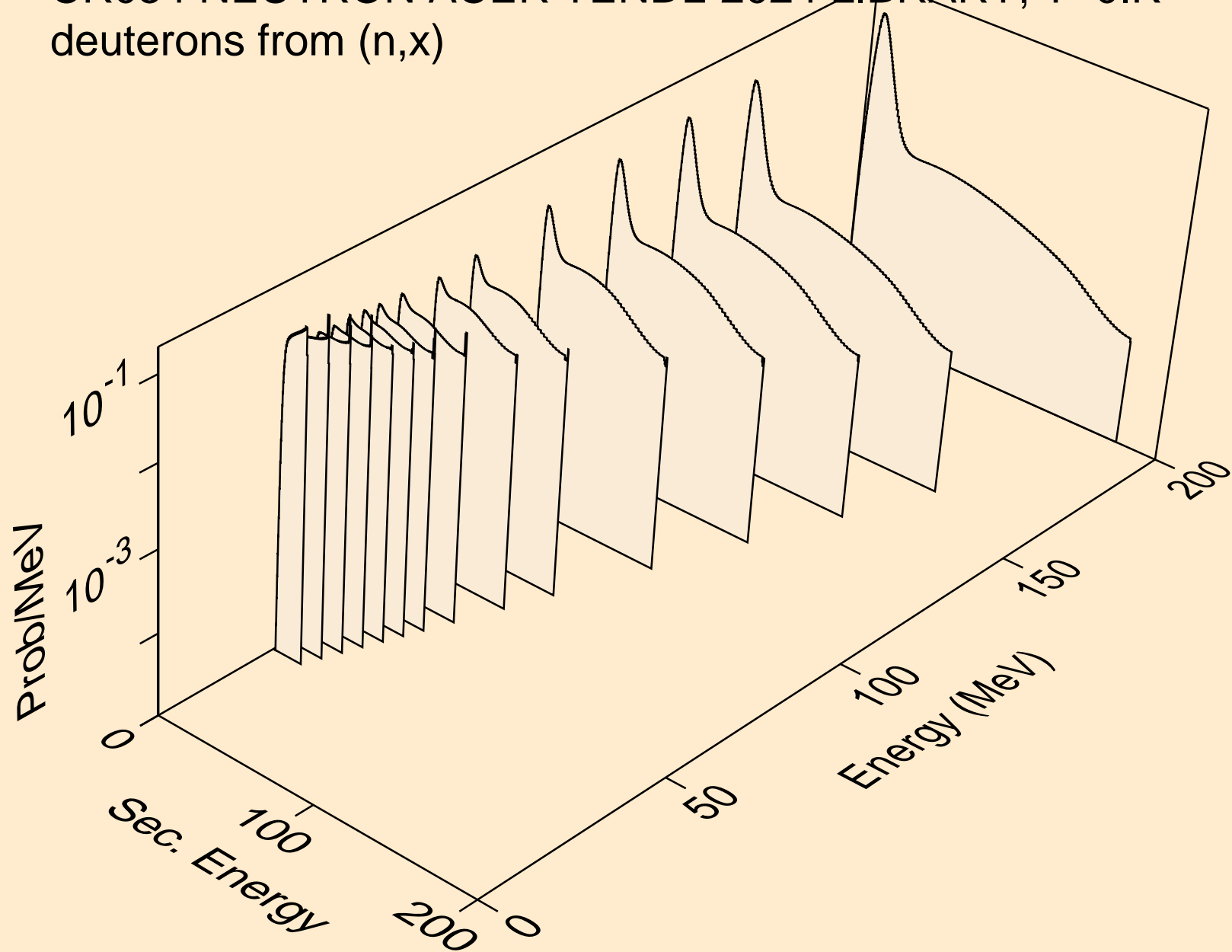

CR054 NEUTRON ACER TENDL-2024 LIBRARY; T=0.K
deuterons from (n,2nd)

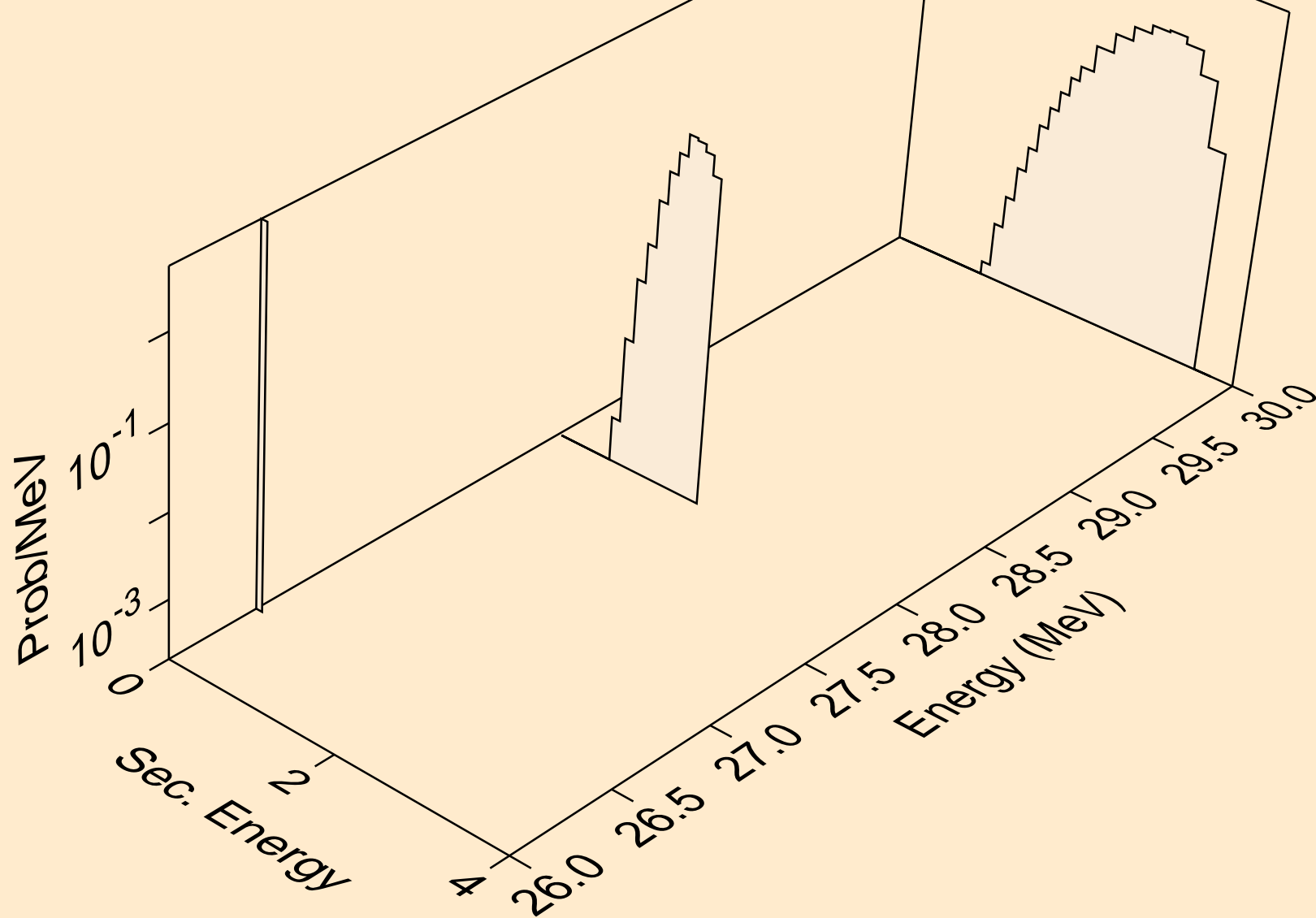

CR054 NEUTRON ACER TENDL-2024 LIBRARY; T=0.K
deuterons from (n,n*)d

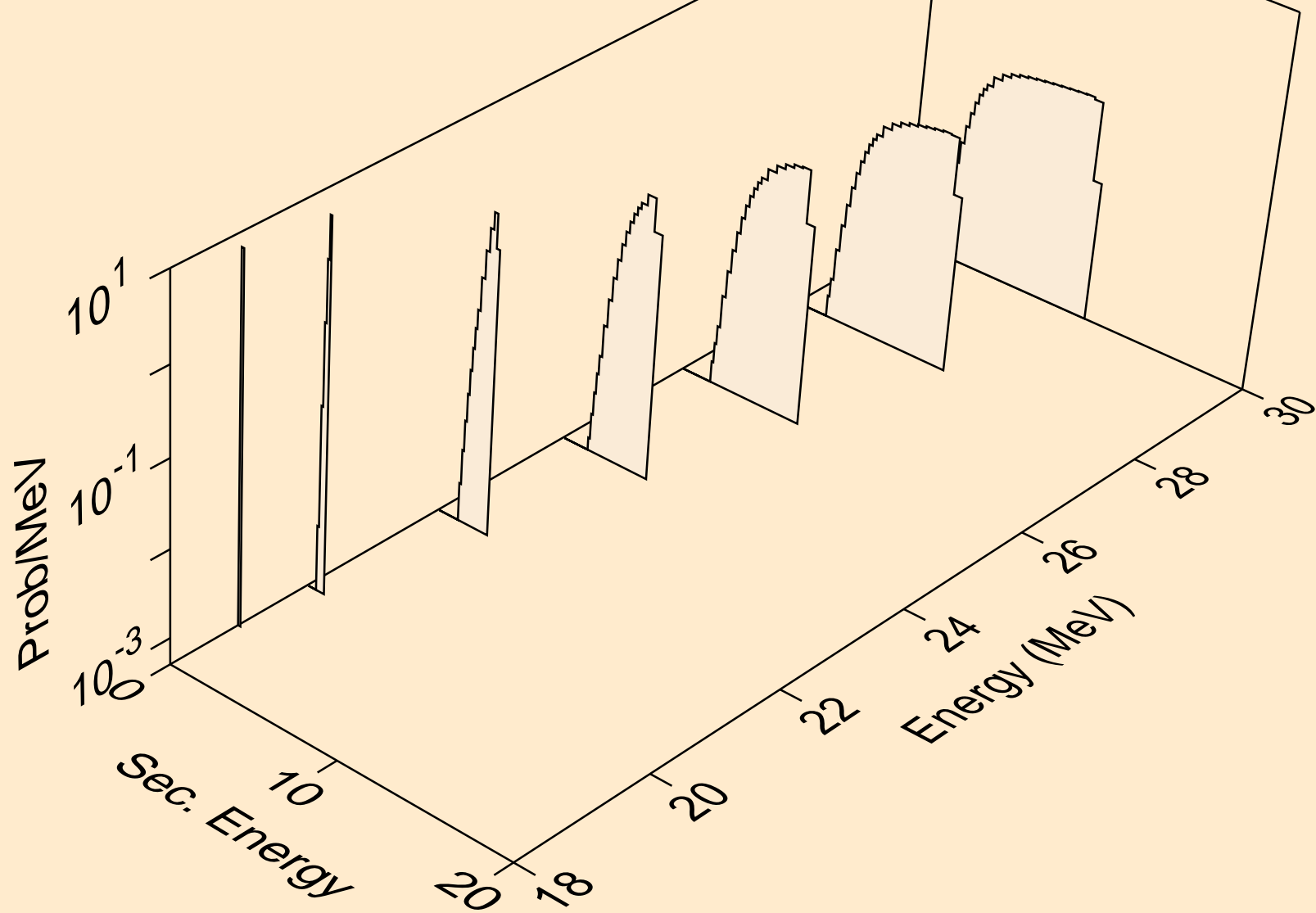

CR054 NEUTRON ACER TENDL-2024 LIBRARY; T=0.K
deuterons from (n,d)

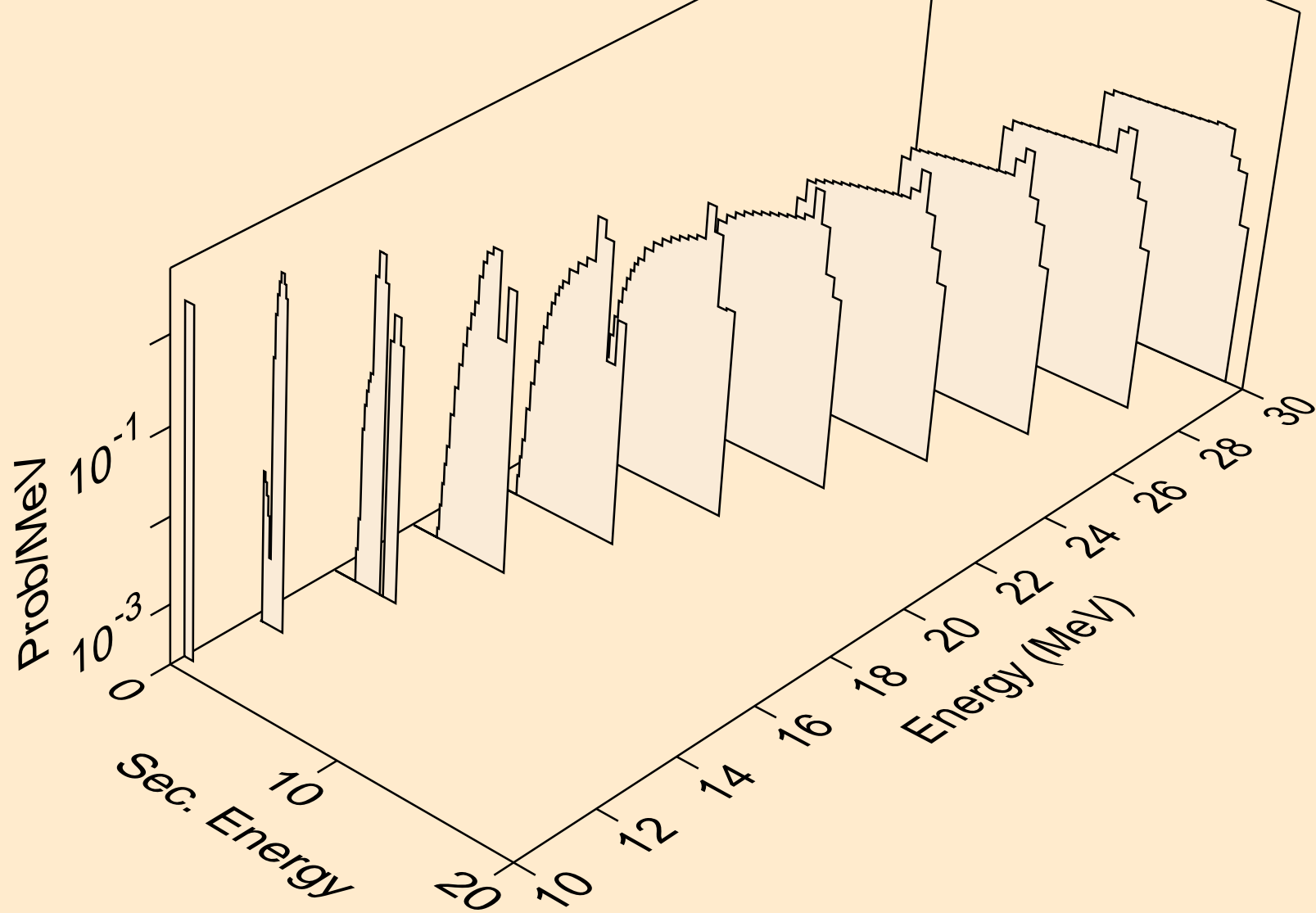

CR054 NEUTRON ACER TENDL-2024 LIBRARY; T=0.K
deuterons from (n,pd)

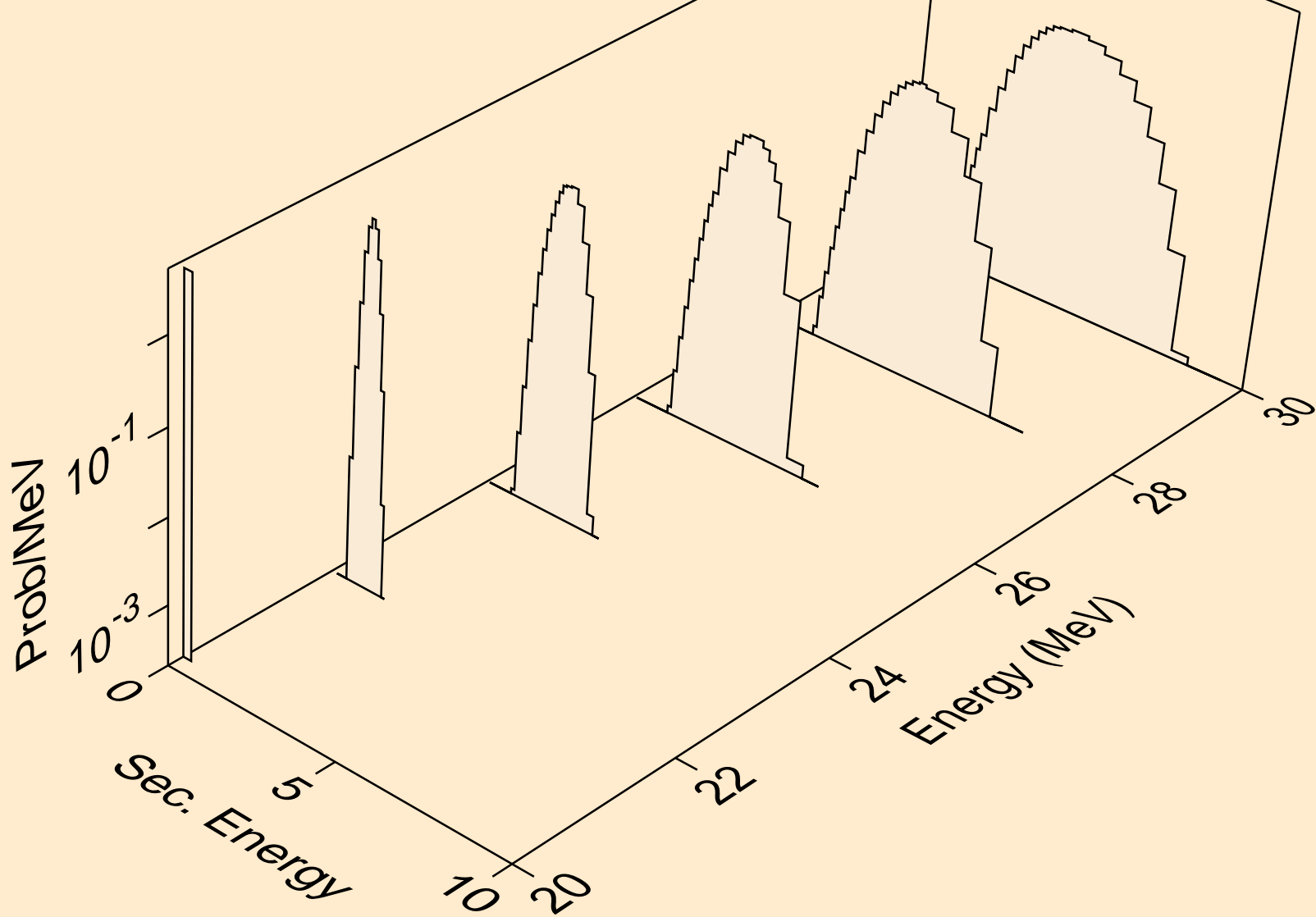

CR054 NEUTRON ACER TENDL-2024 LIBRARY; T=0.K
deuterons from (n,da)

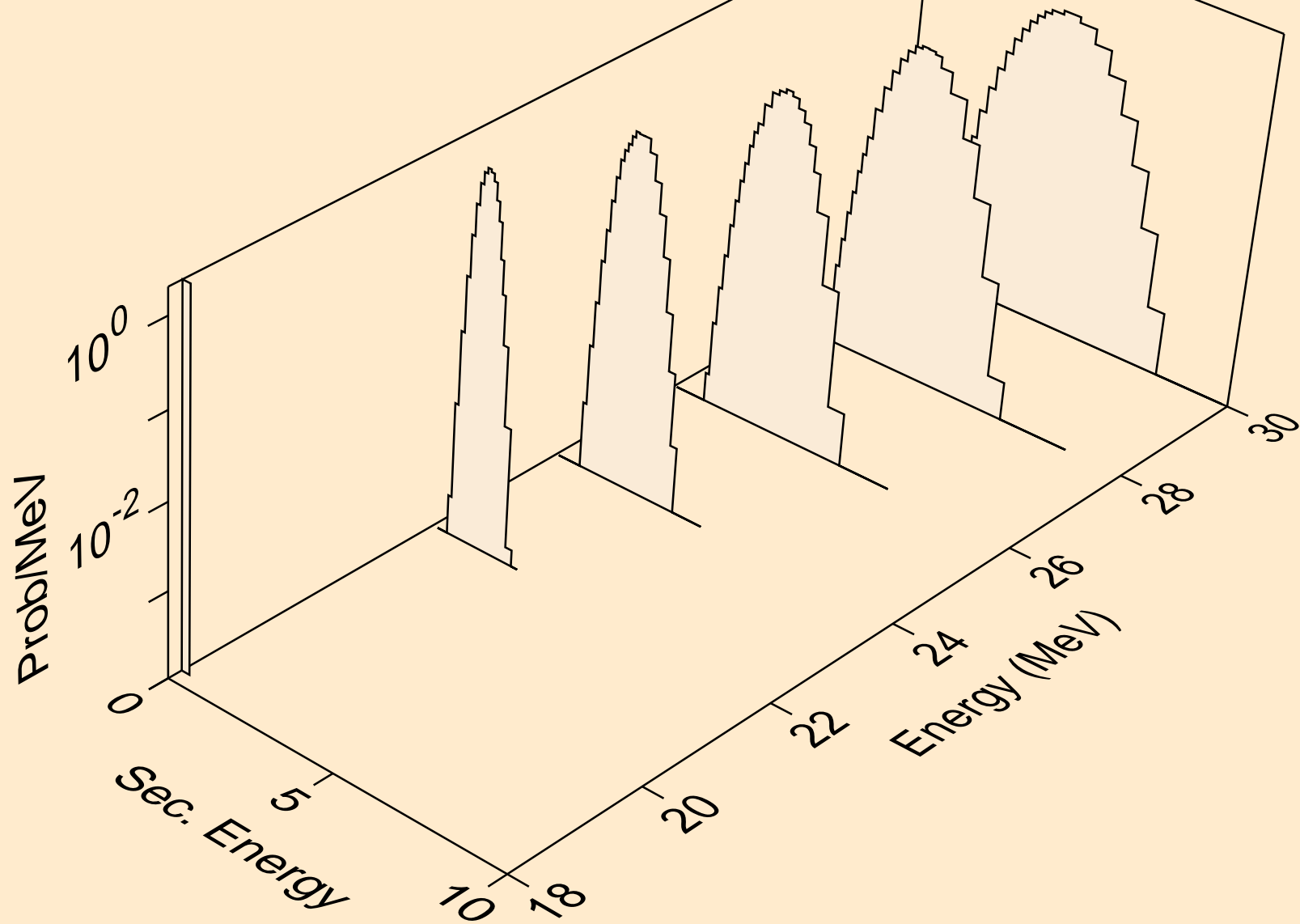

CR054 NEUTRON ACER TENDL-2024 LIBRARY; T=0.K
tritons from (n,x)

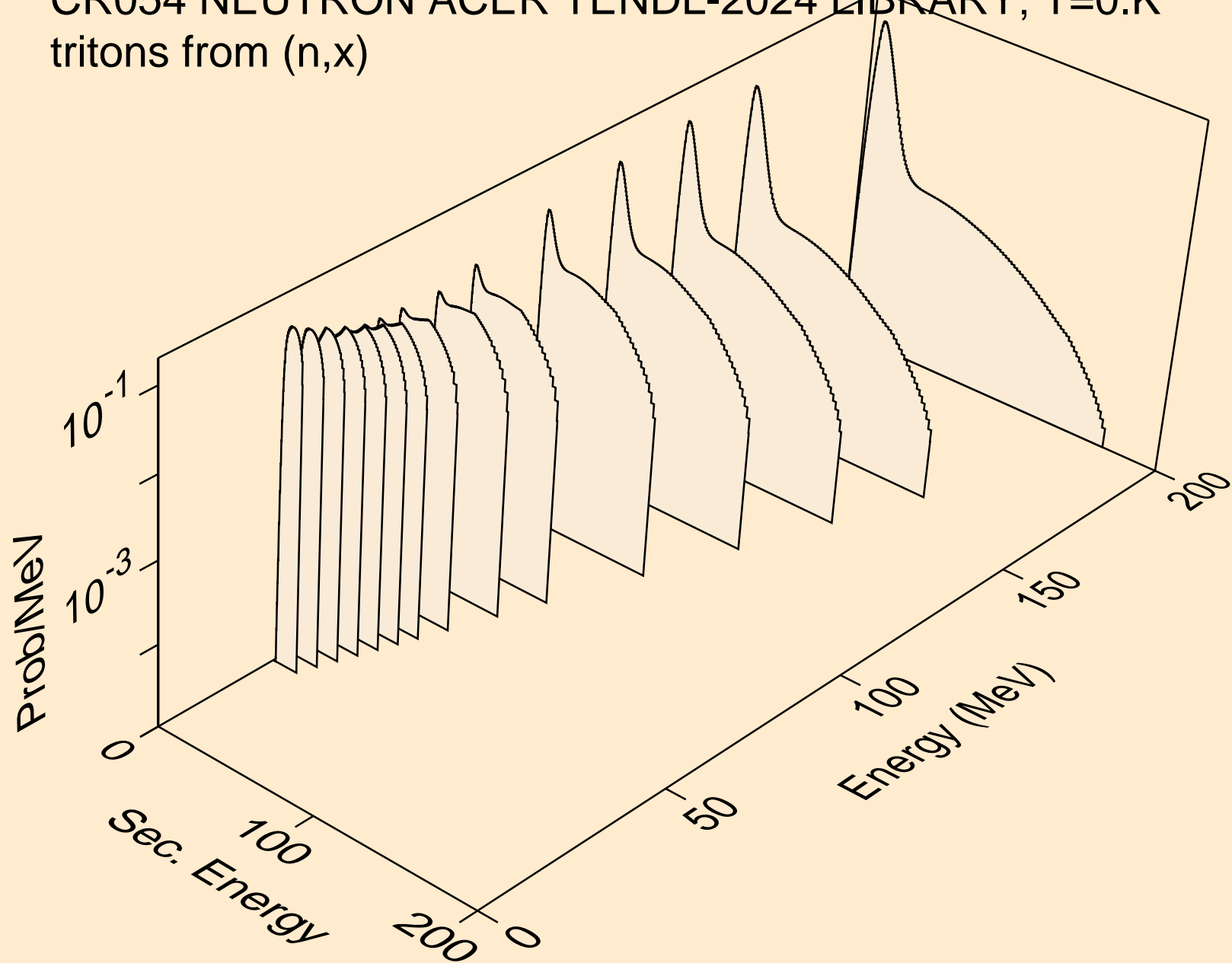

CR054 NEUTRON ACER TENDL-2024 LIBRARY; T=0.K
tritons from (n,n*)t

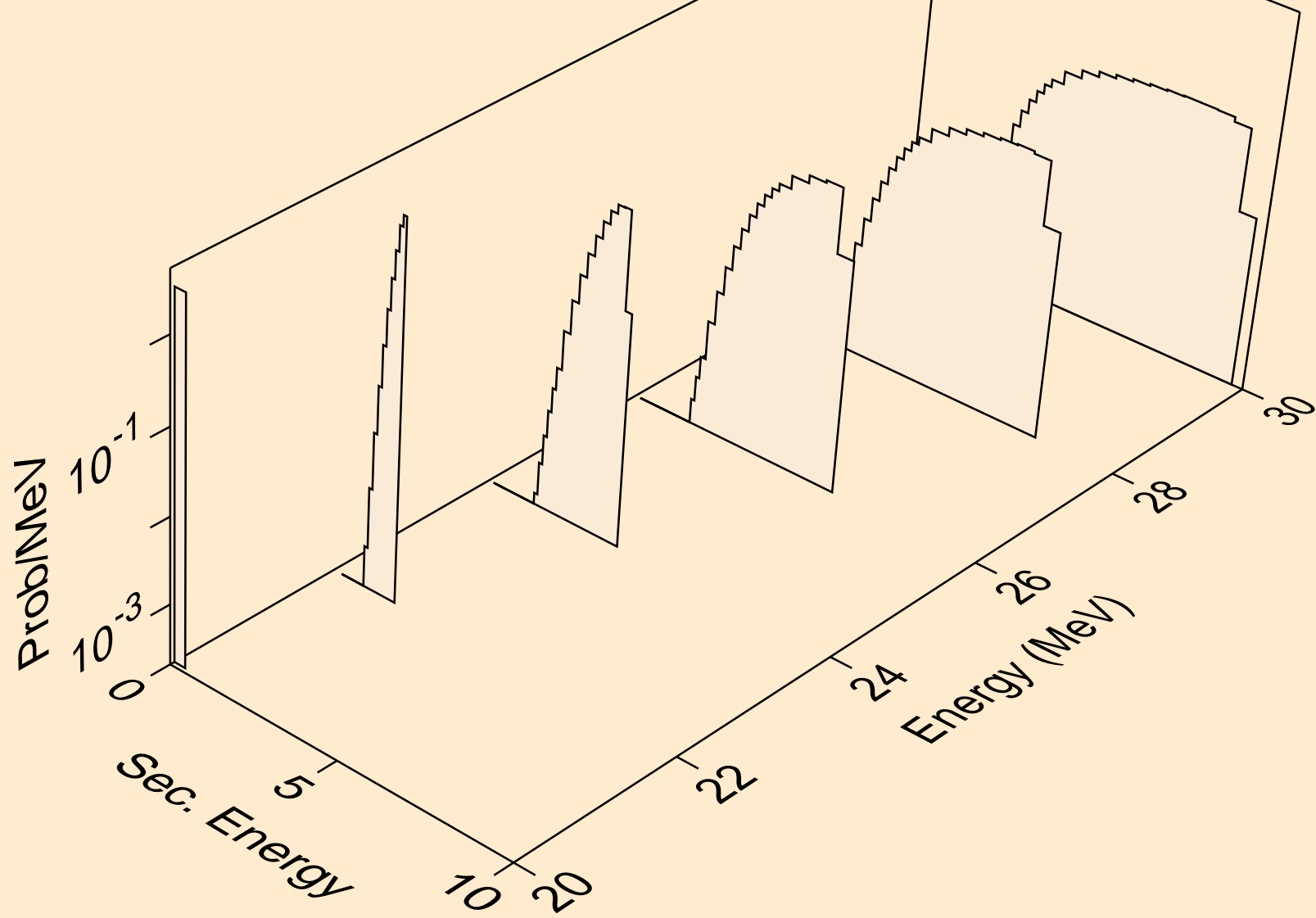

CR054 NEUTRON ACER TENDL-2024 LIBRARY; T=0.K
tritons from (n,t)

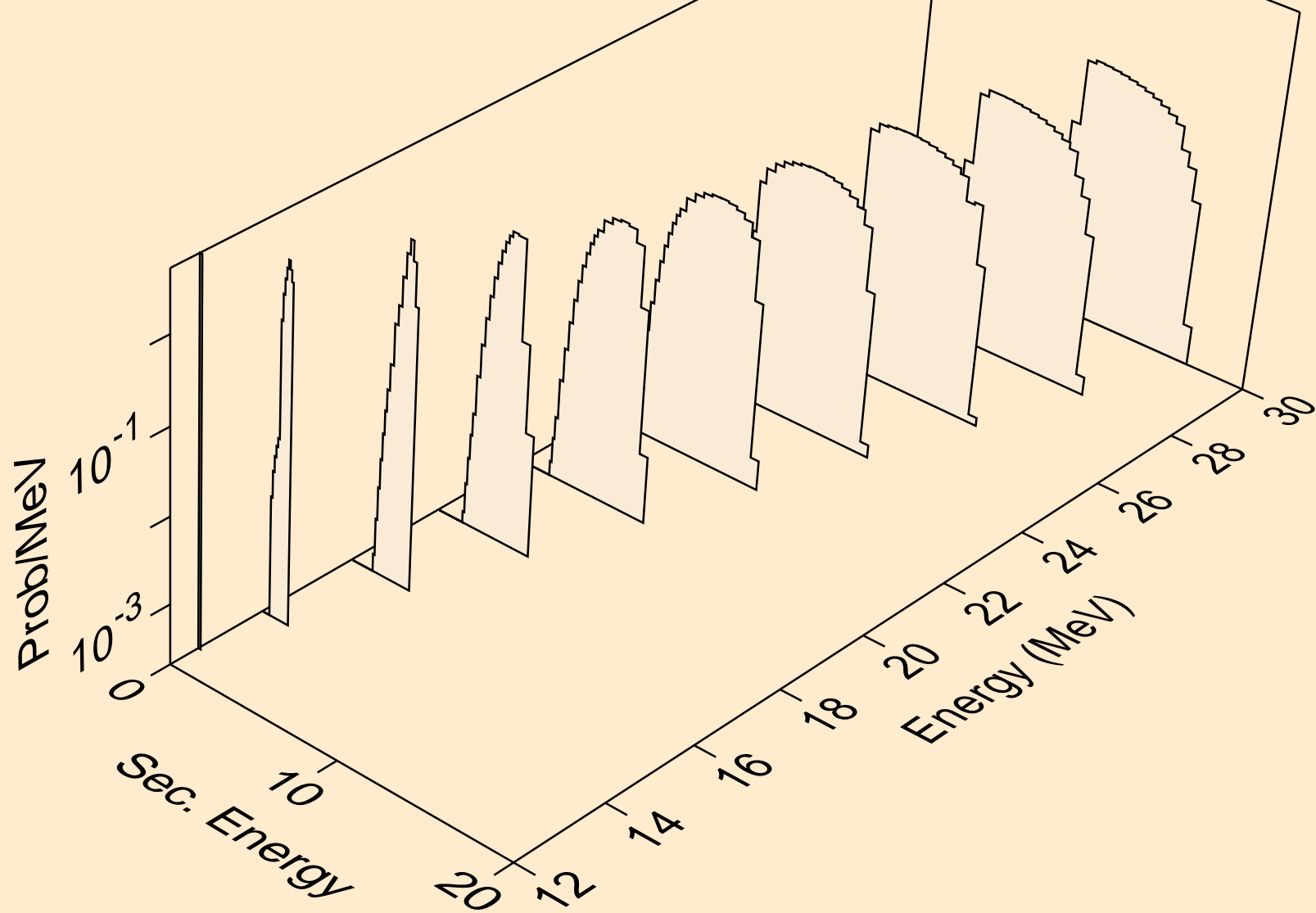

CR054 NEUTRON ACER TENDL-2024 LIBRARY; T=0.K
tritons from (n,pt)

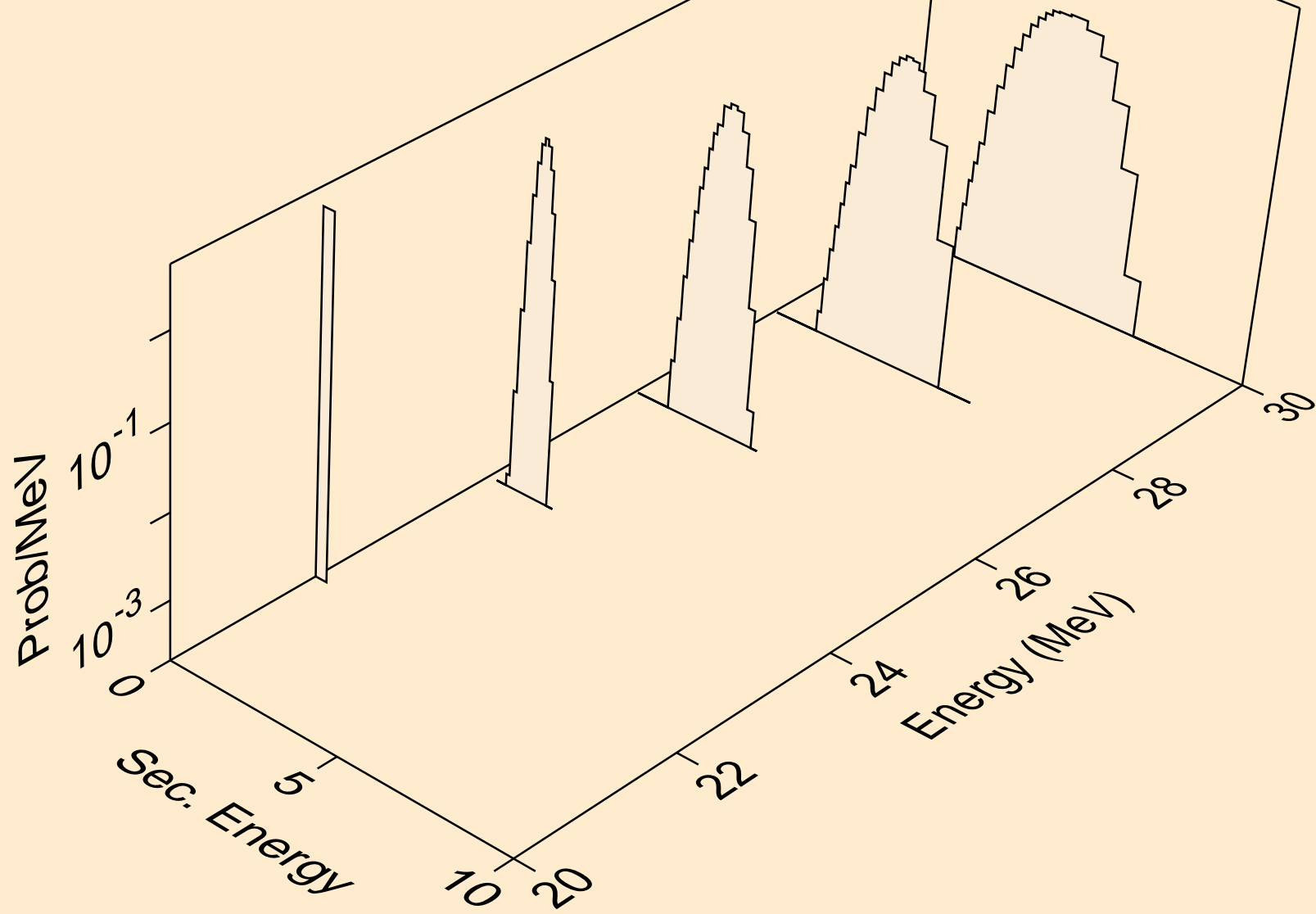

CR054 NEUTRON ACER TENDL-2024 LIBRARY; T=0.K
he3s from (n,x)

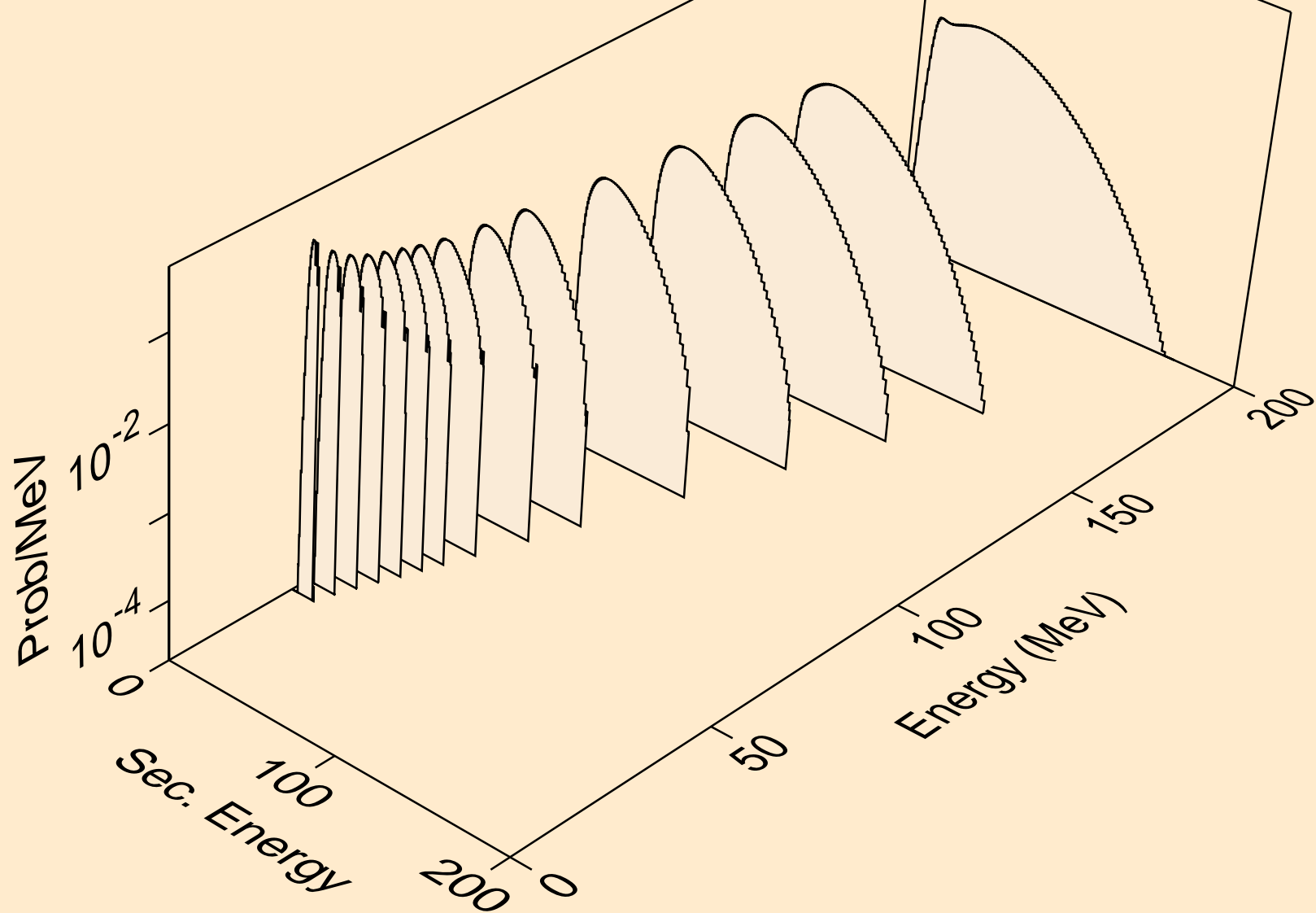

CR054 NEUTRON ACER TENDL-2024 LIBRARY; T=0.K
he3s from (n,n*)he3

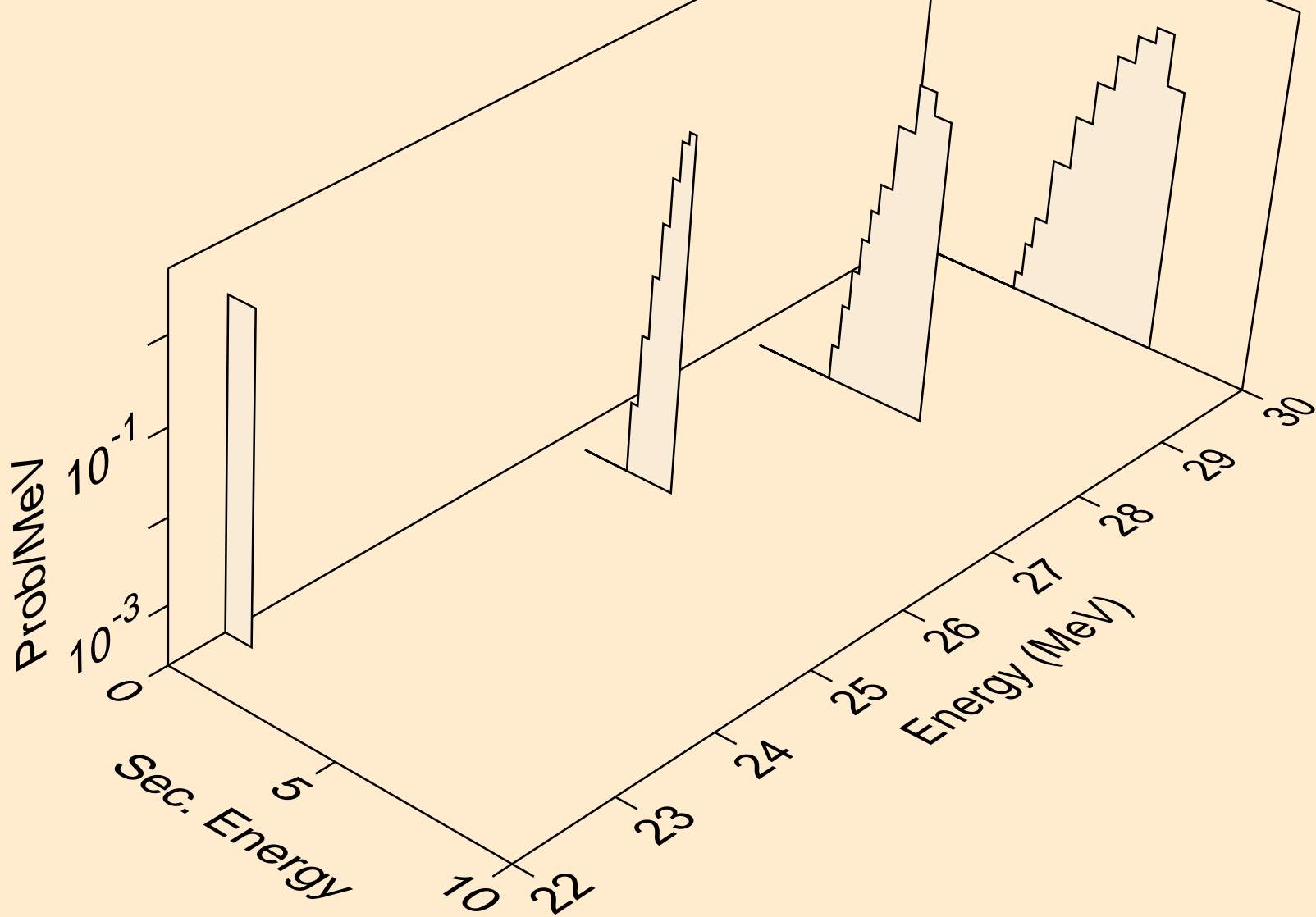

CR054 NEUTRON ACER TENDL-2024 LIBRARY; T=0.K
he3s from (n,he3)

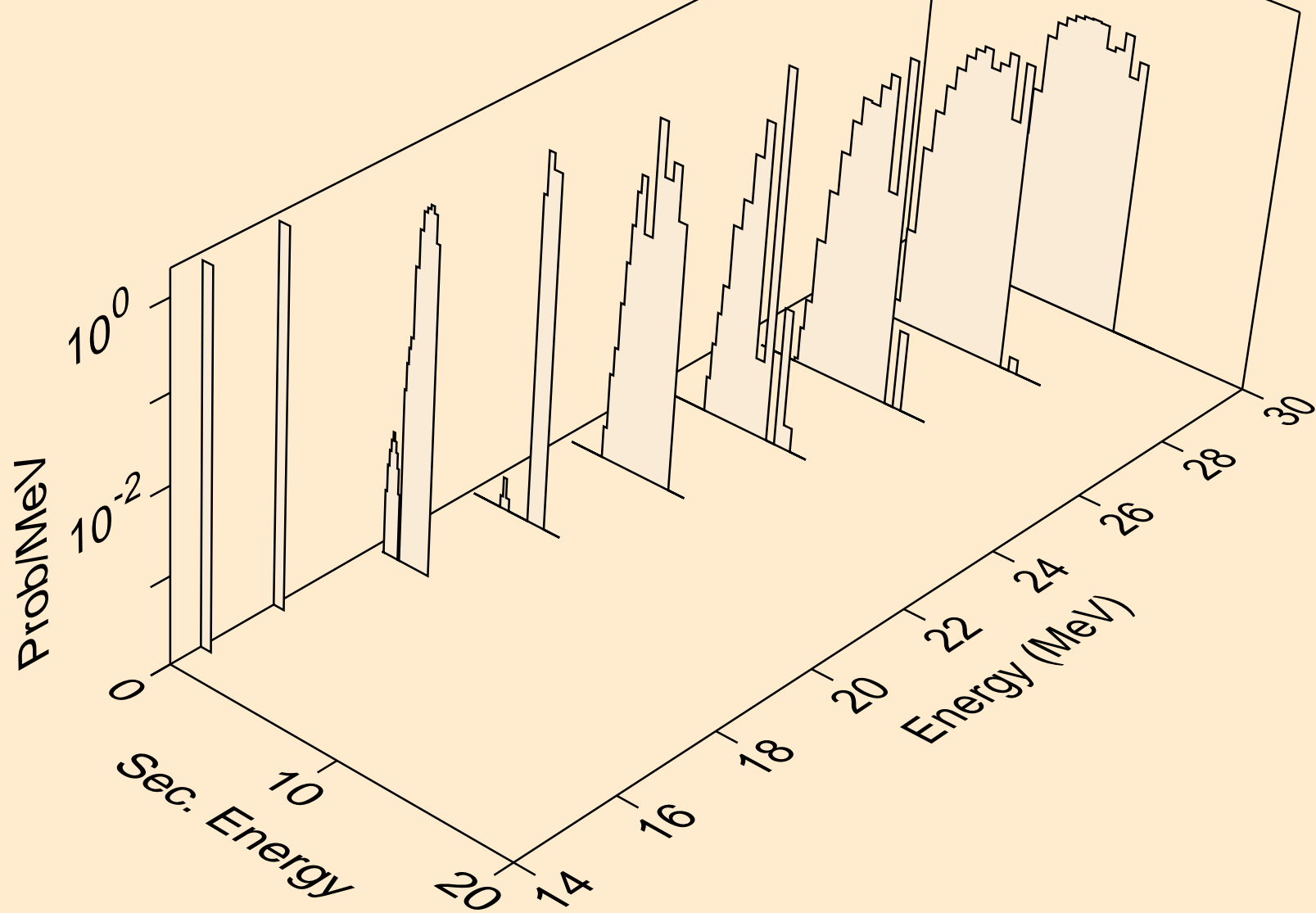

CR054 NEUTRON ACER TENDL-2024 LIBRARY; T=0.K
alphas from (n,x)

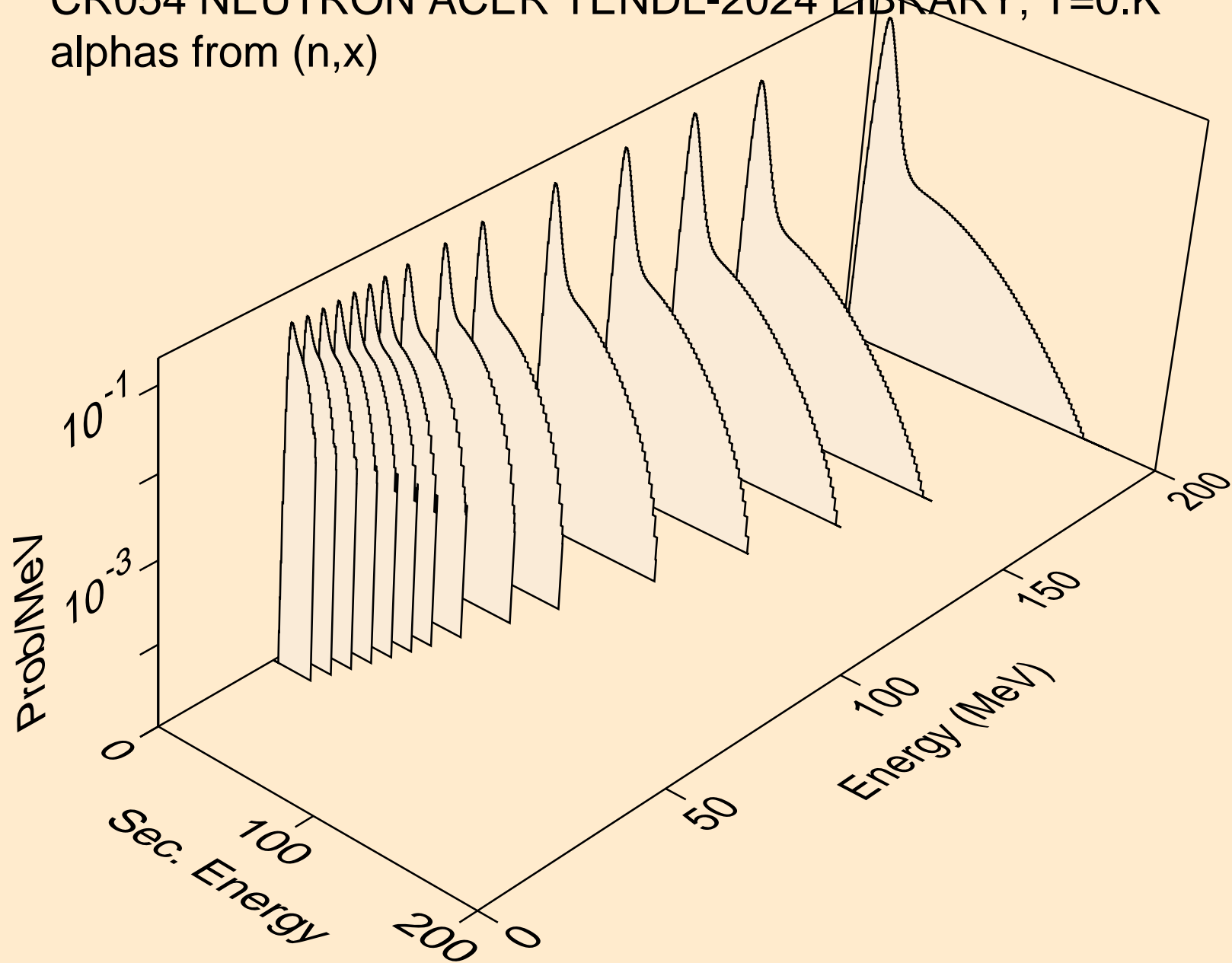

CR054 NEUTRON ACER TENDL-2024 LIBRARY; T=0.K
alphas from (n,n*)a

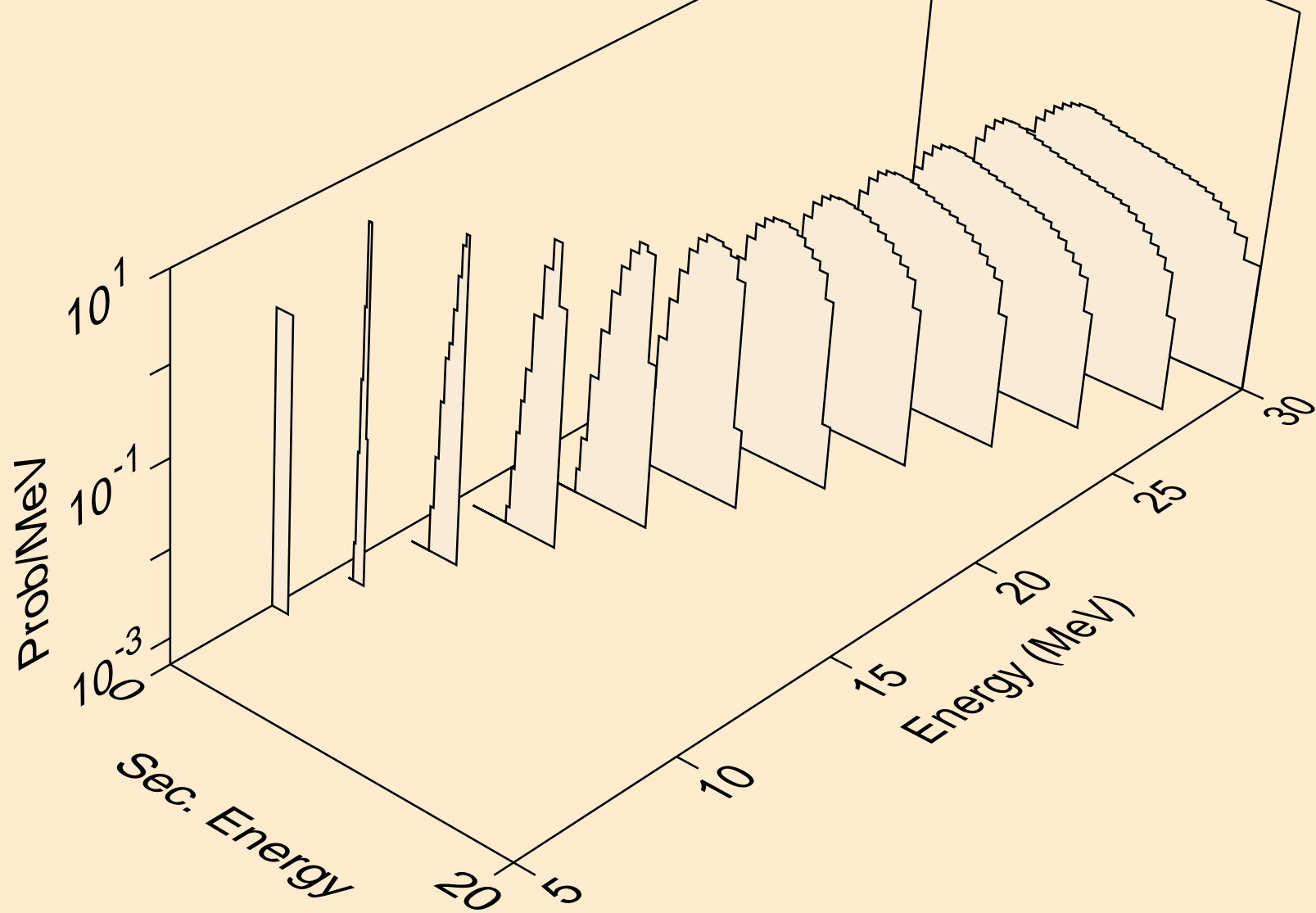

CR054 NEUTRON ACER TENDL-2024 LIBRARY; T=0.K
alphas from (n,2n)a

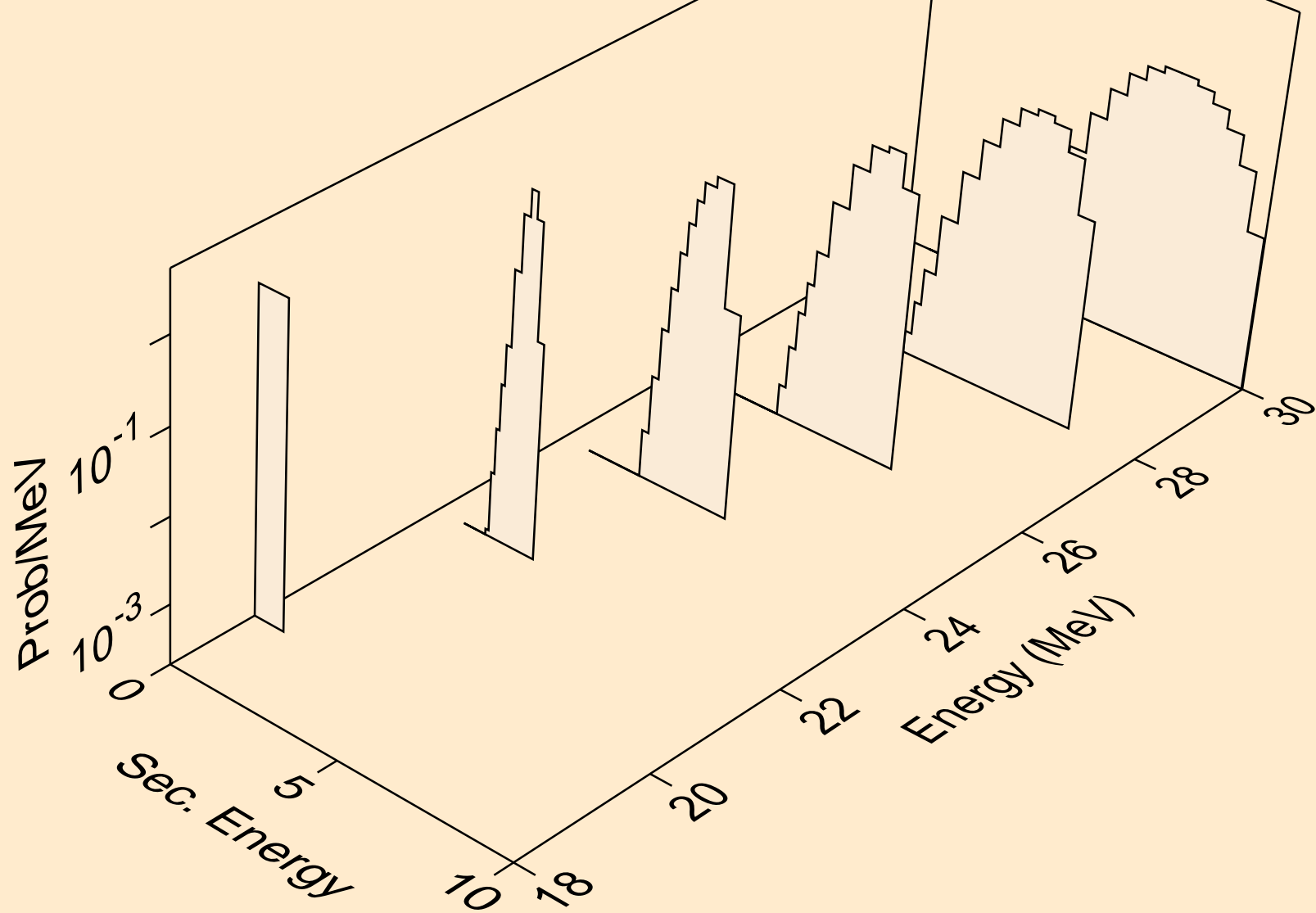

CR054 NEUTRON ACER TENDL-2024 LIBRARY; T=0.K
alphas from (n,n*)2a

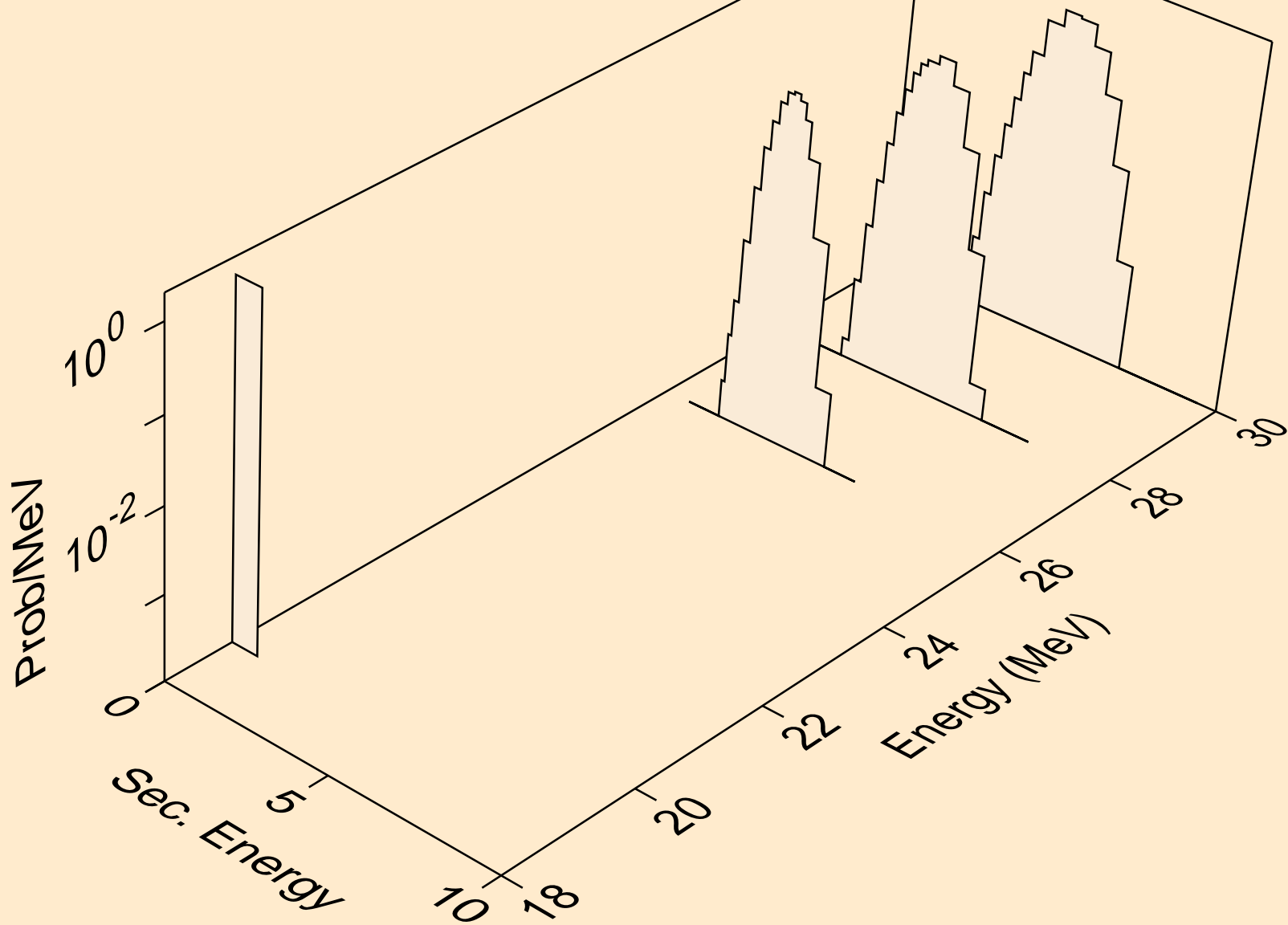

CR054 NEUTRON ACER TENDL-2024 LIBRARY; T=0.K
alphas from (n,npa)

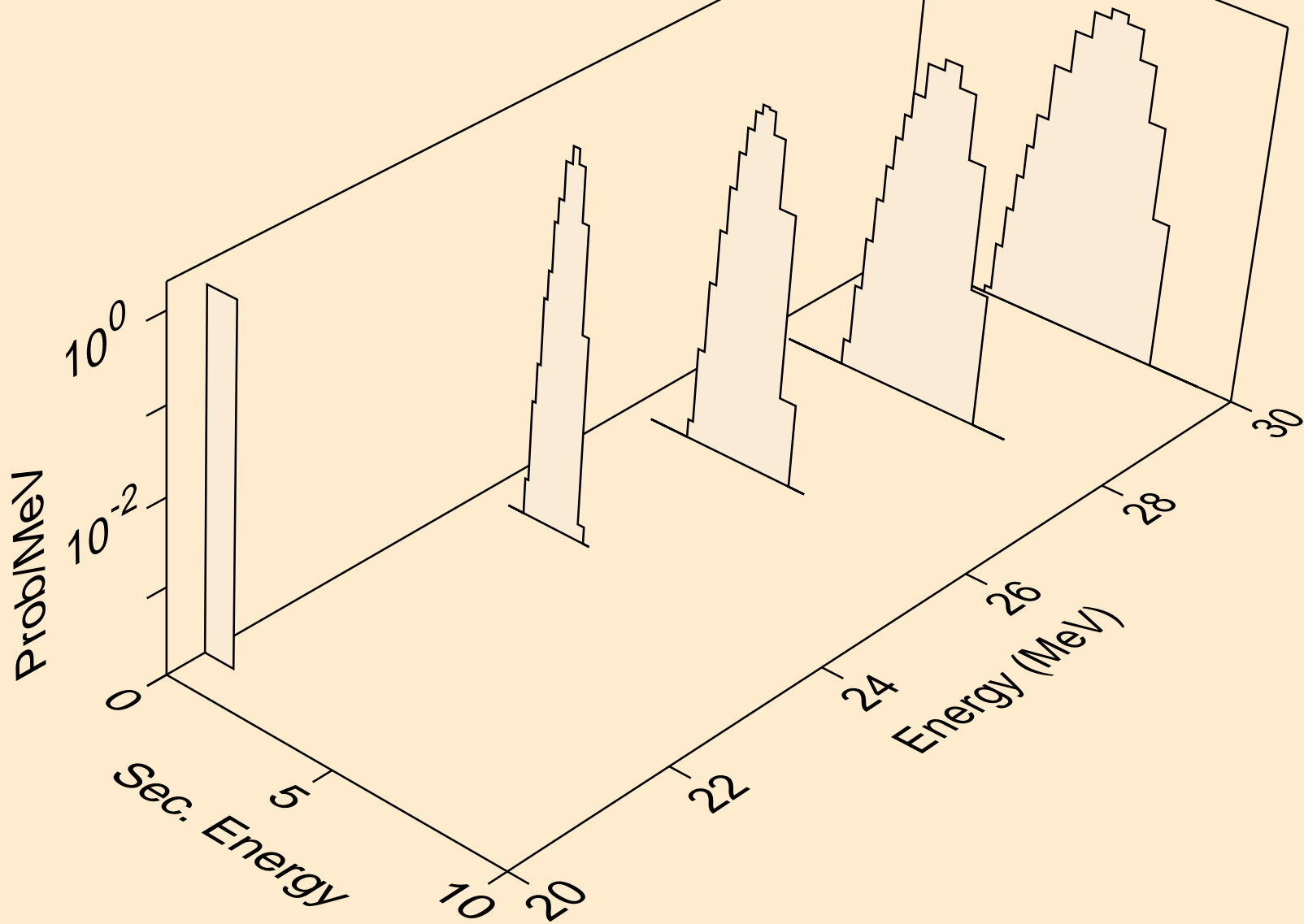

CR054 NEUTRON ACER TENDL-2024 LIBRARY; T=0.K
alphas from (n,a)

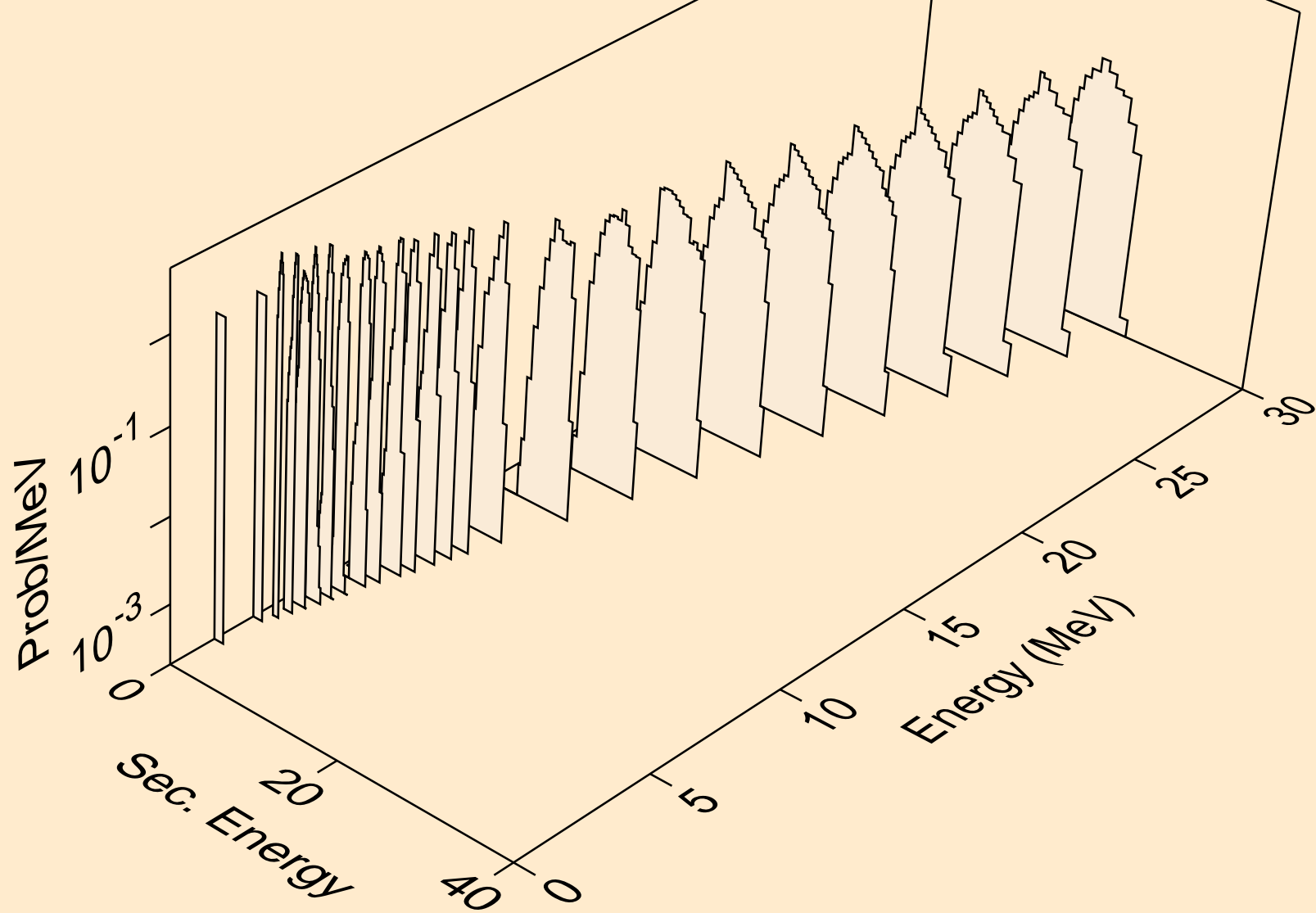

CR054 NEUTRON ACER TENDL-2024 LIBRARY; T=0.K
alphas from (n,2a)

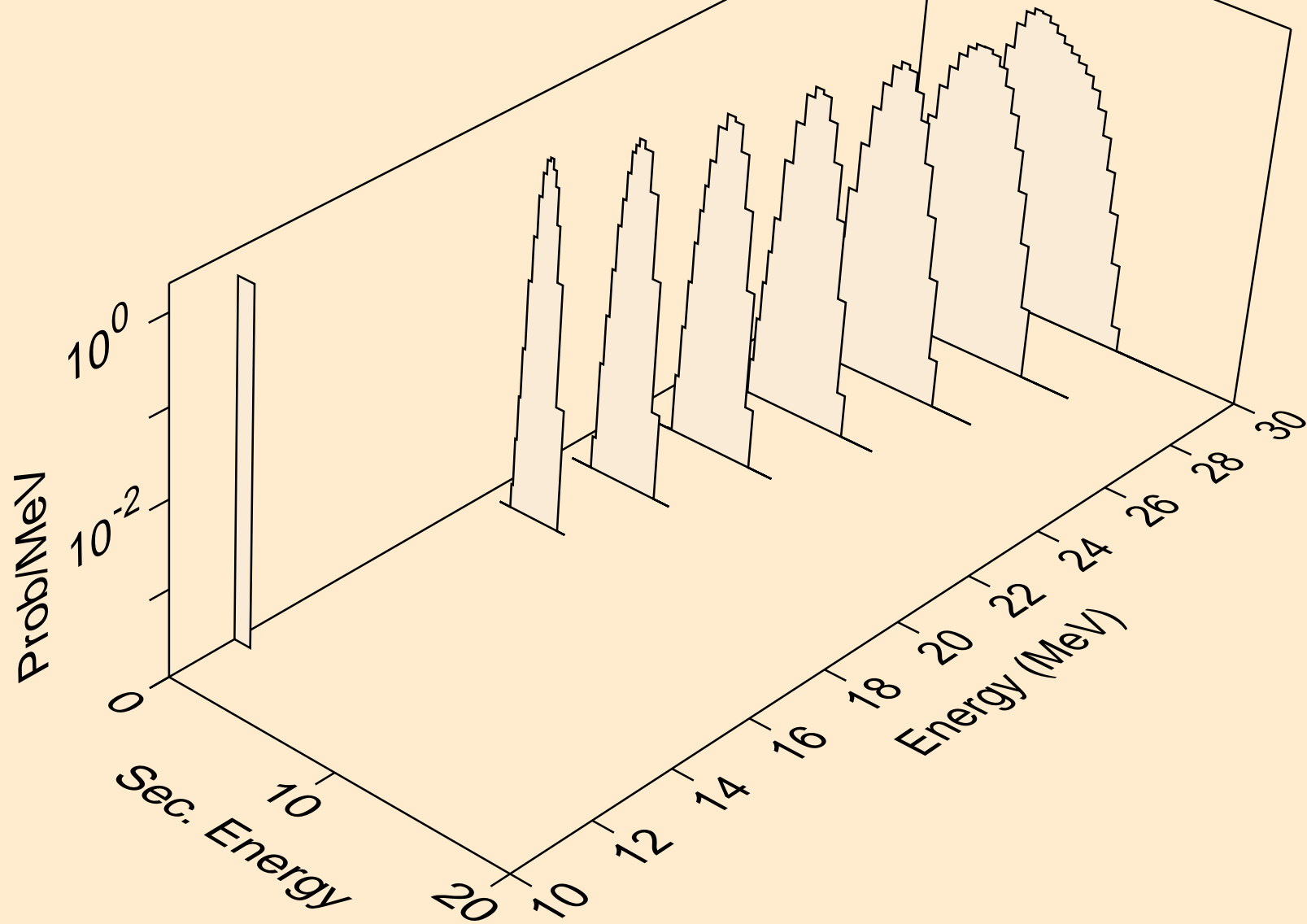

CR054 NEUTRON ACER TENDL-2024 LIBRARY; T=0.K
alphas from (n,pa)

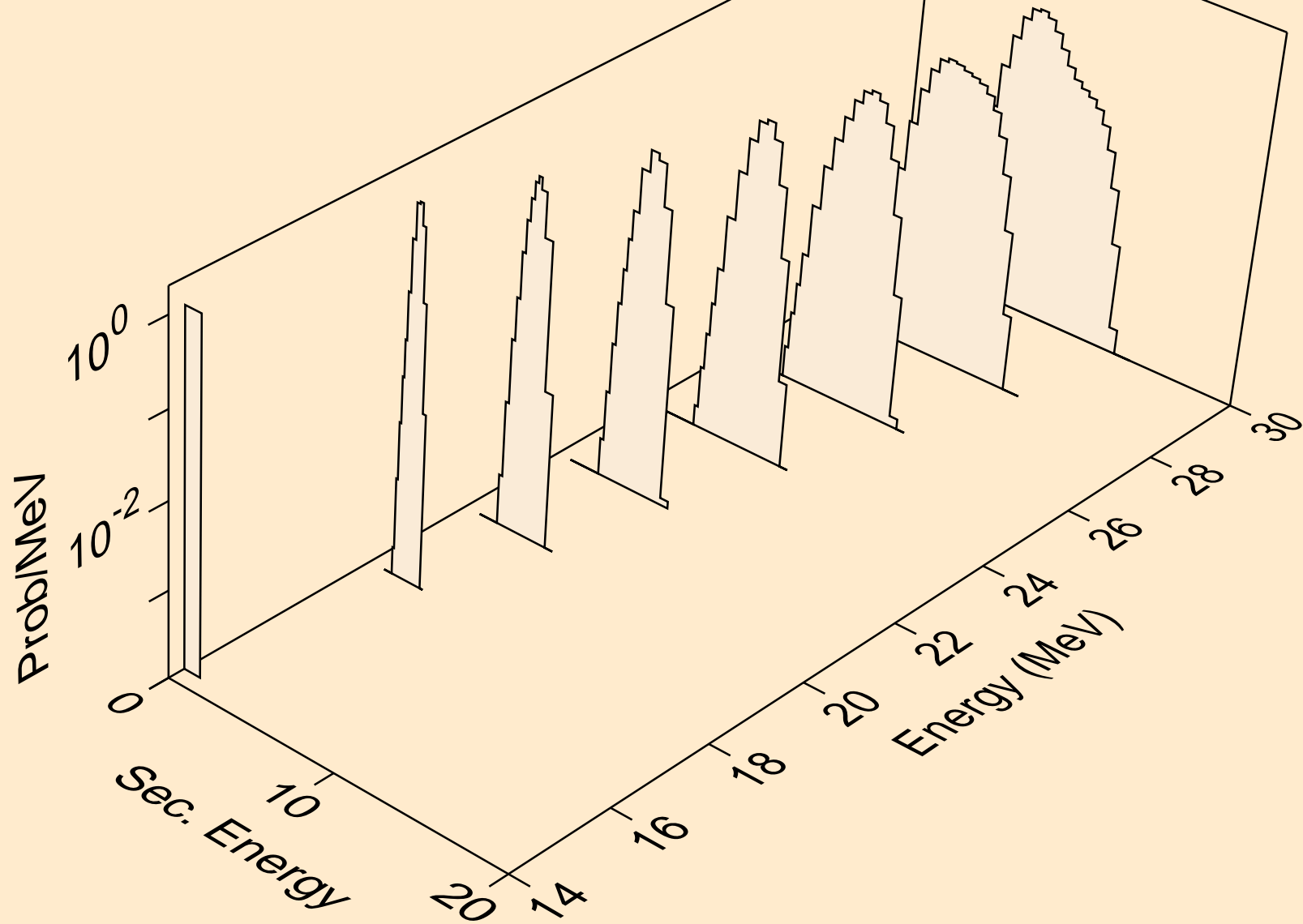

CR054 NEUTRON ACER TENDL-2024 LIBRARY; T=0.K
alphas from (n,da)

