

CS116M NEUTRON ACER TENDL-2024 LIBRARY; T=0.K

Principal cross sections

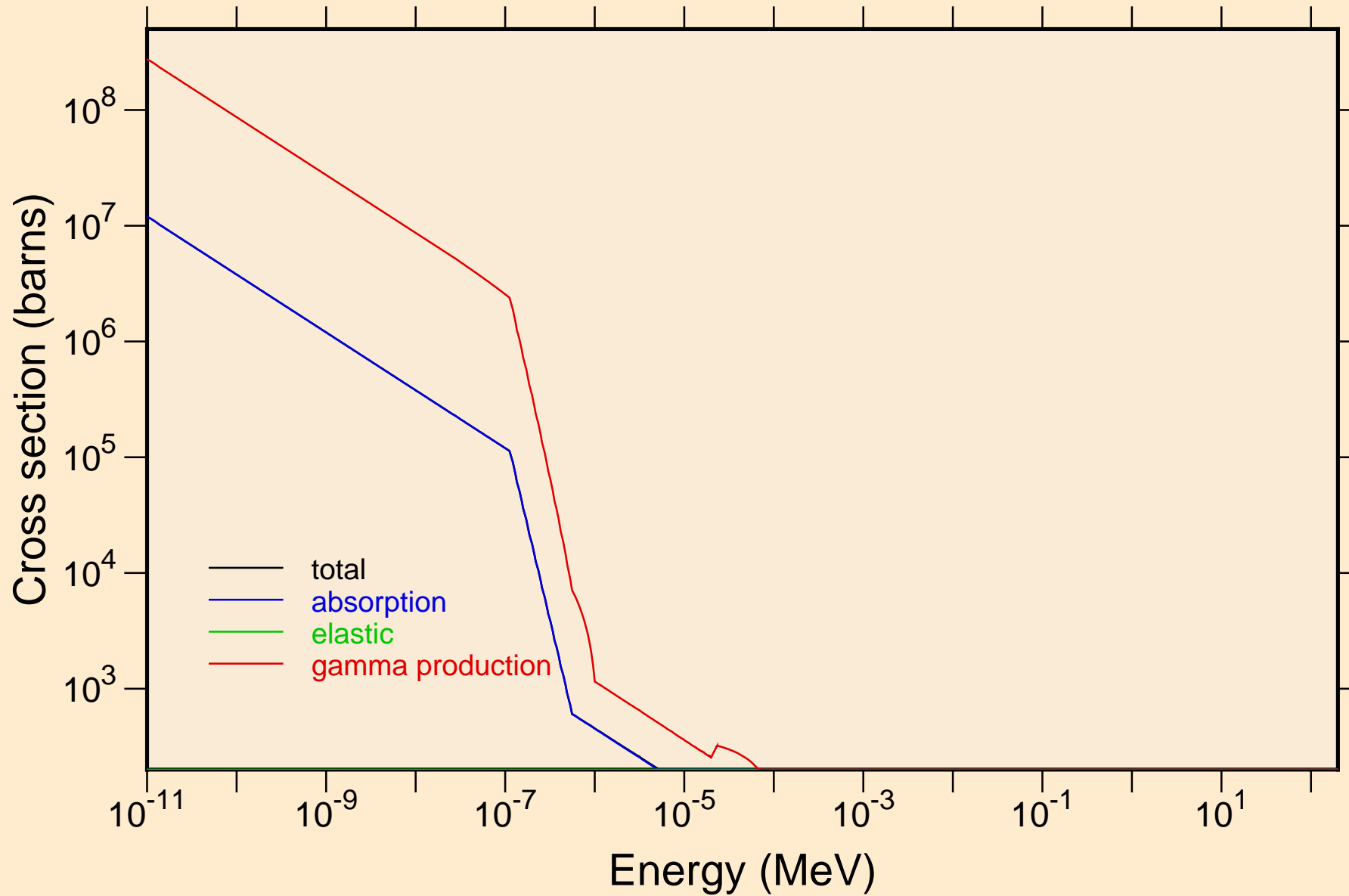

CS116M NEUTRON ACER TENDL-2024 LIBRARY; T=0.K
resonance total cross section

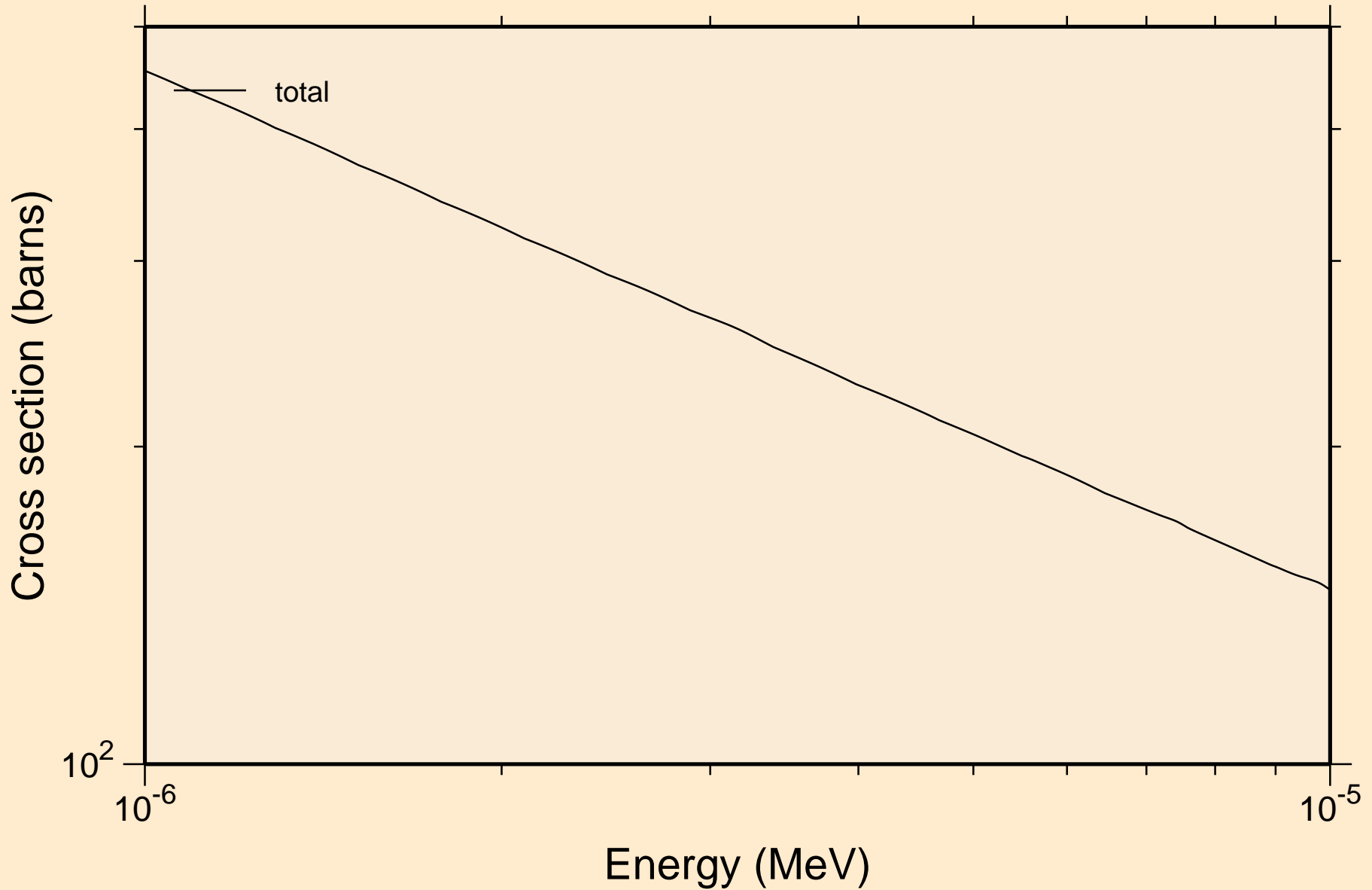

CS116M NEUTRON ACER TENDL-2024 LIBRARY; T=0.K
resonance total cross section

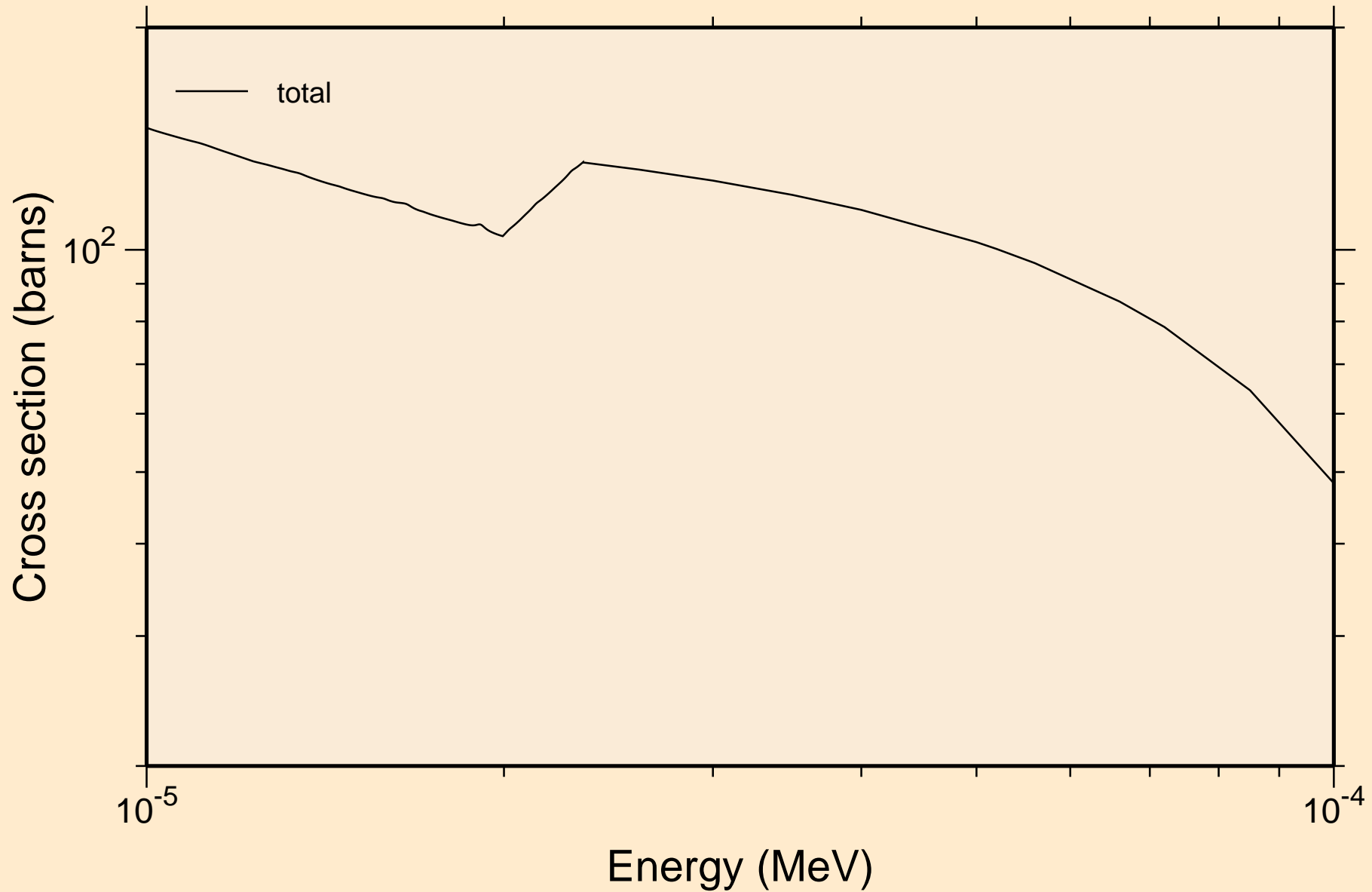

C¹¹⁶M NEUTRON ACER TENDL-2024 LIBRARY; T=0.K
resonance total cross section

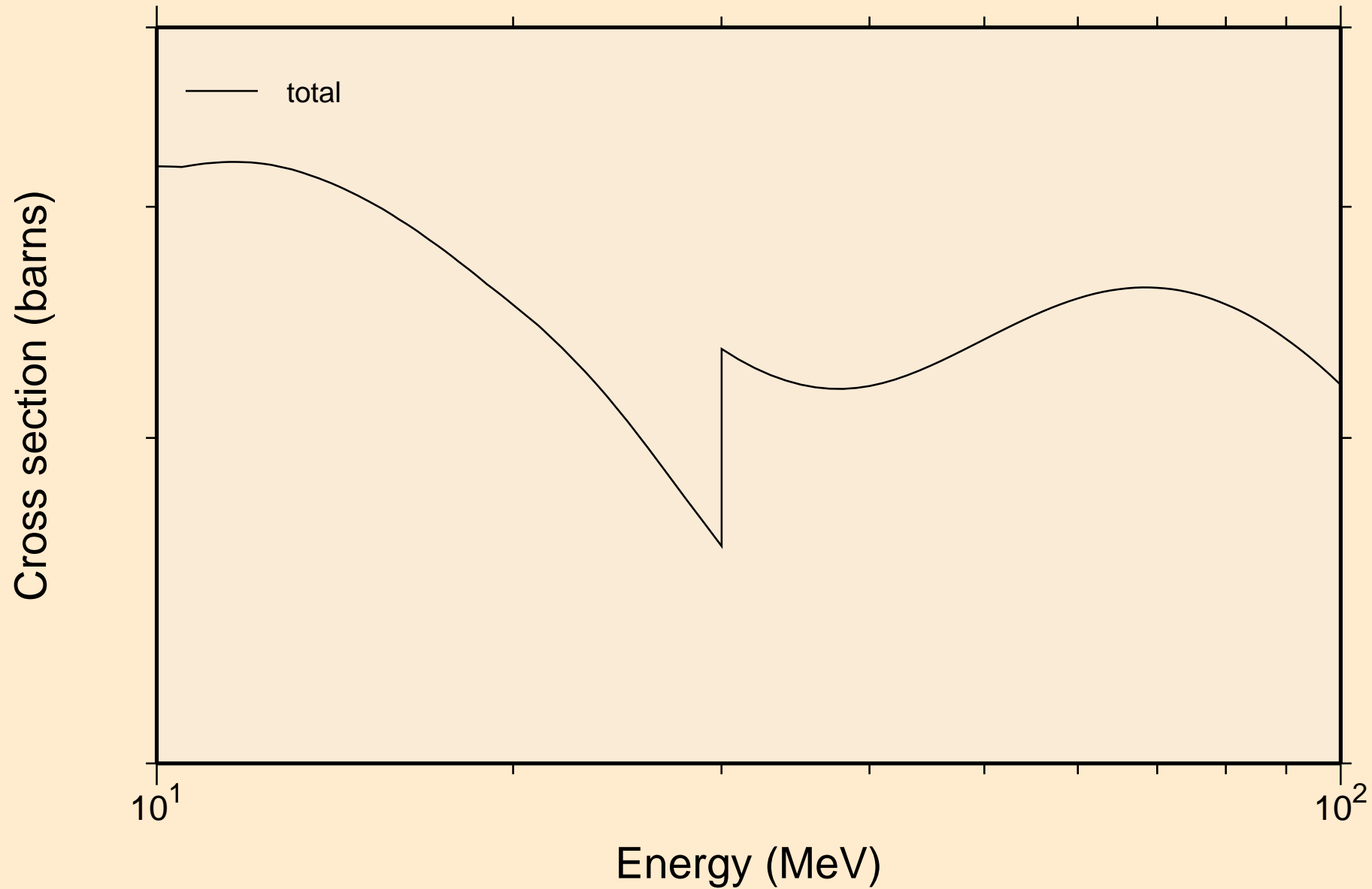

CS116M NEUTRON ACER TENDL-2024 LIBRARY; T=0.K
resonance absorption cross sections

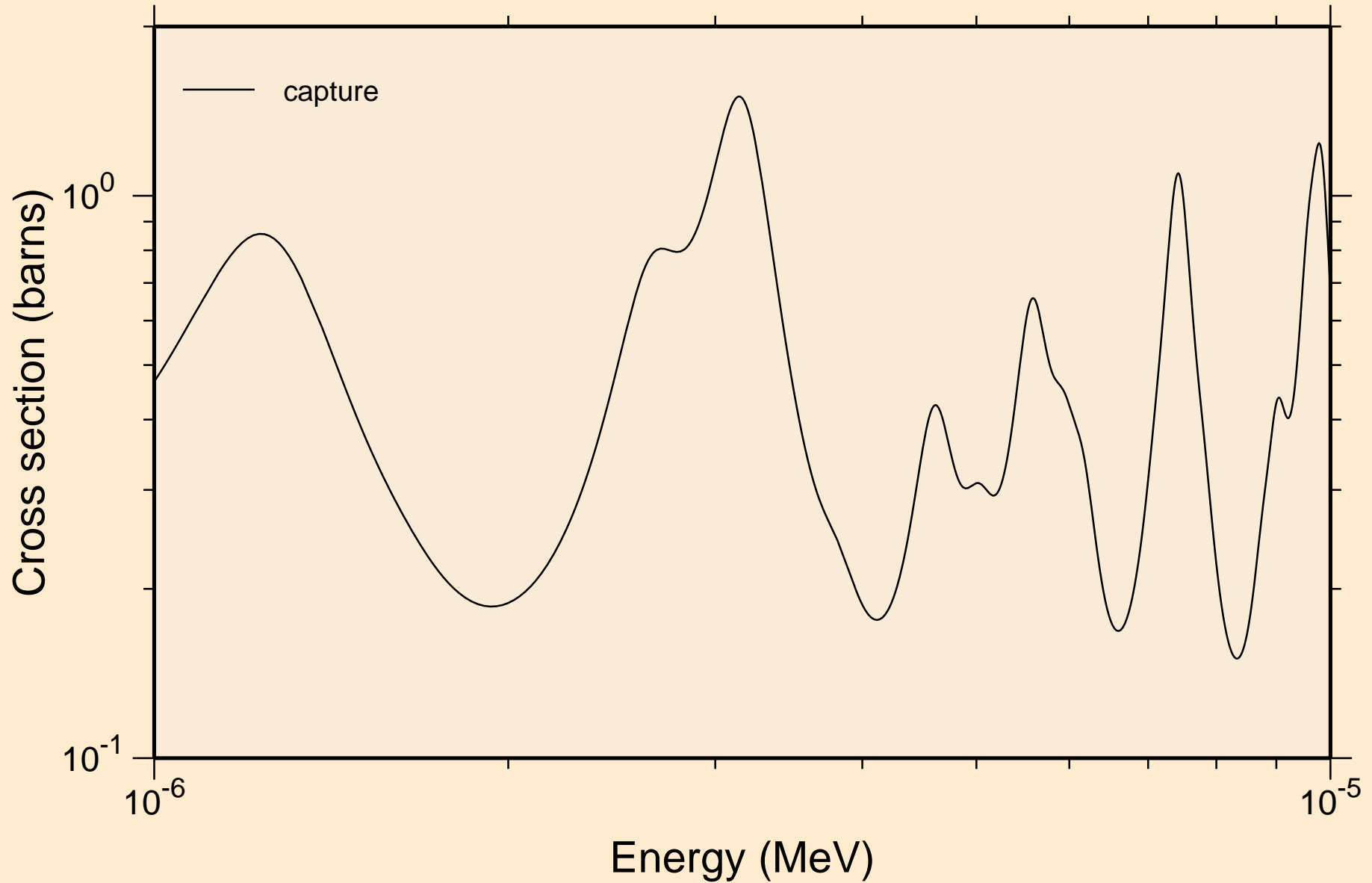

CS116M NEUTRON ACER TENDL-2024 LIBRARY; T=0.K
resonance absorption cross sections

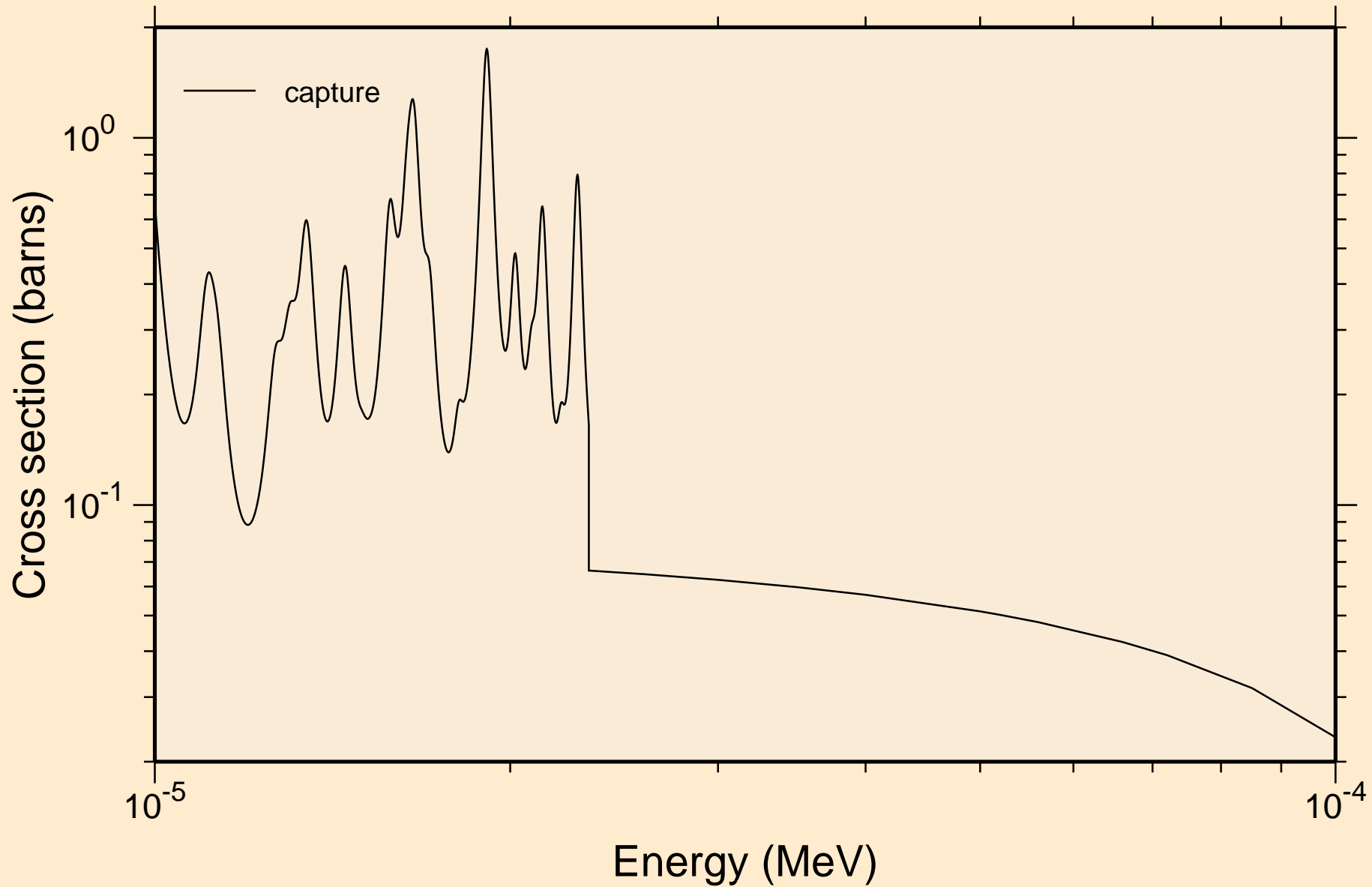

CS116M NEUTRON ACER TENDL-2024 LIBRARY; T=0.K
resonance absorption cross sections

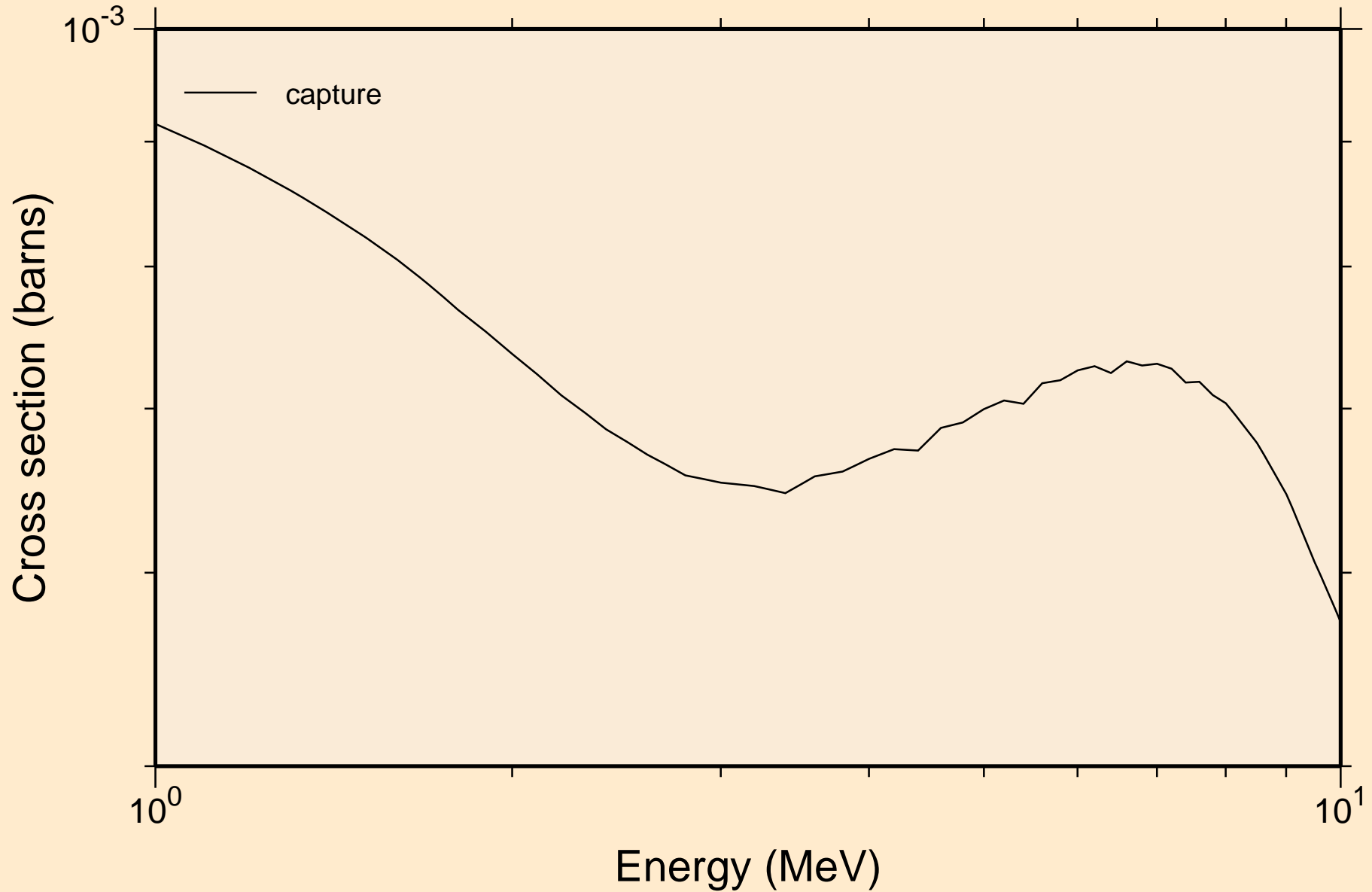

CS116M NEUTRON ACER TENDL-2024 LIBRARY; T=0.K

Heating

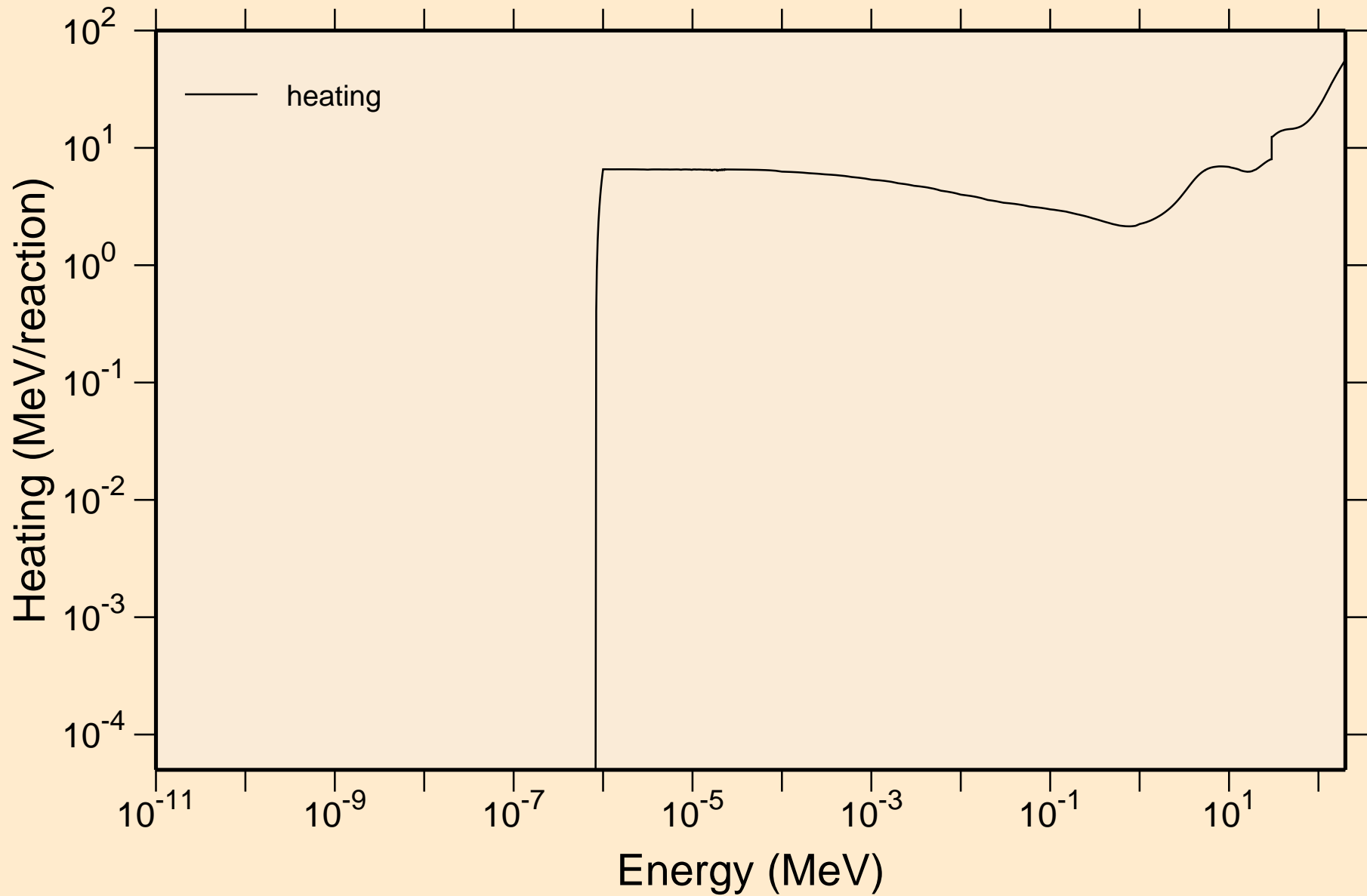

CS116M NEUTRON ACER TENDL-2024 LIBRARY; T=0.K

Damage

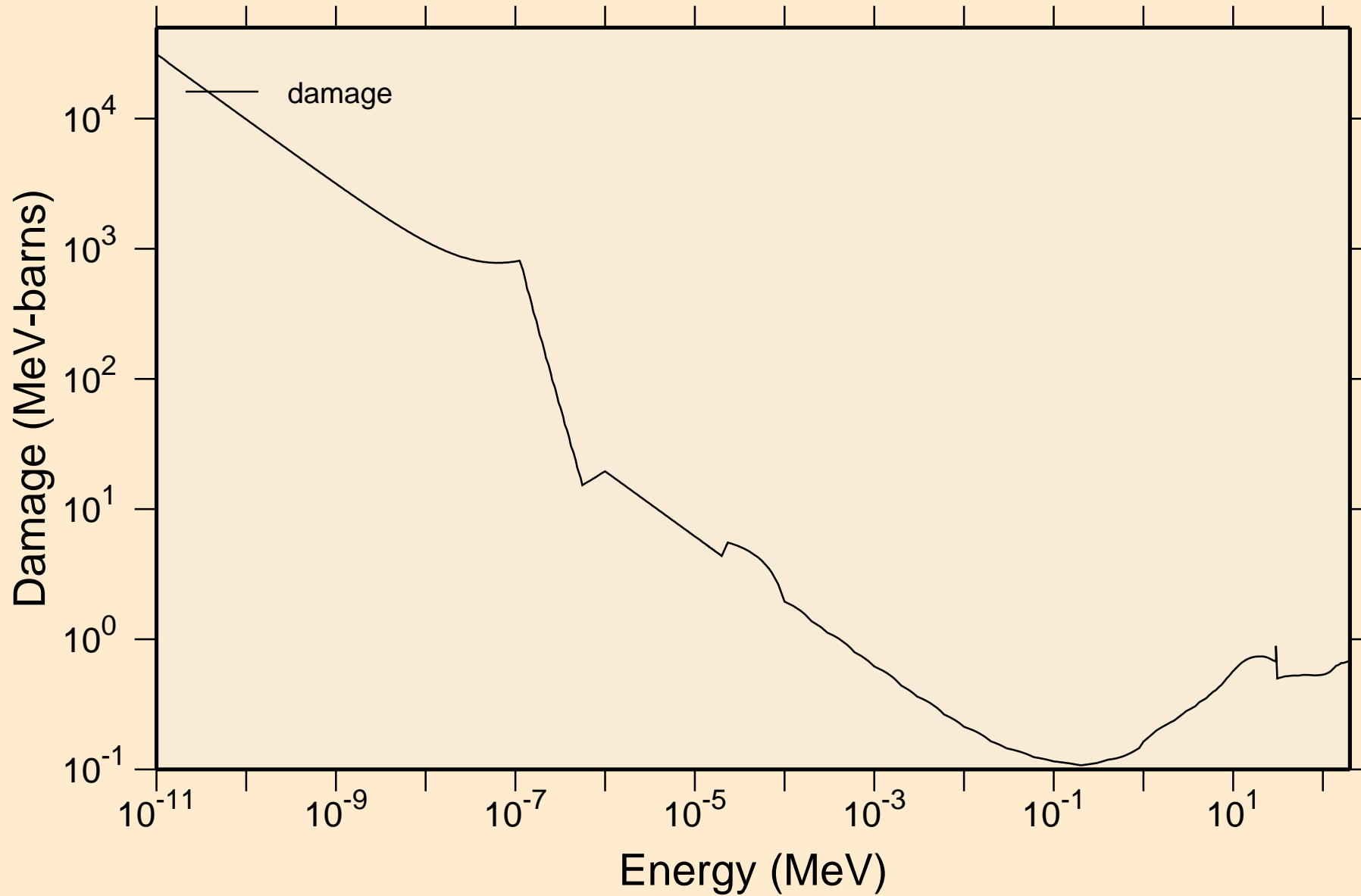

CS116M NEUTRON ACER TENDL-2024 LIBRARY; T=0.K

Non-threshold reactions

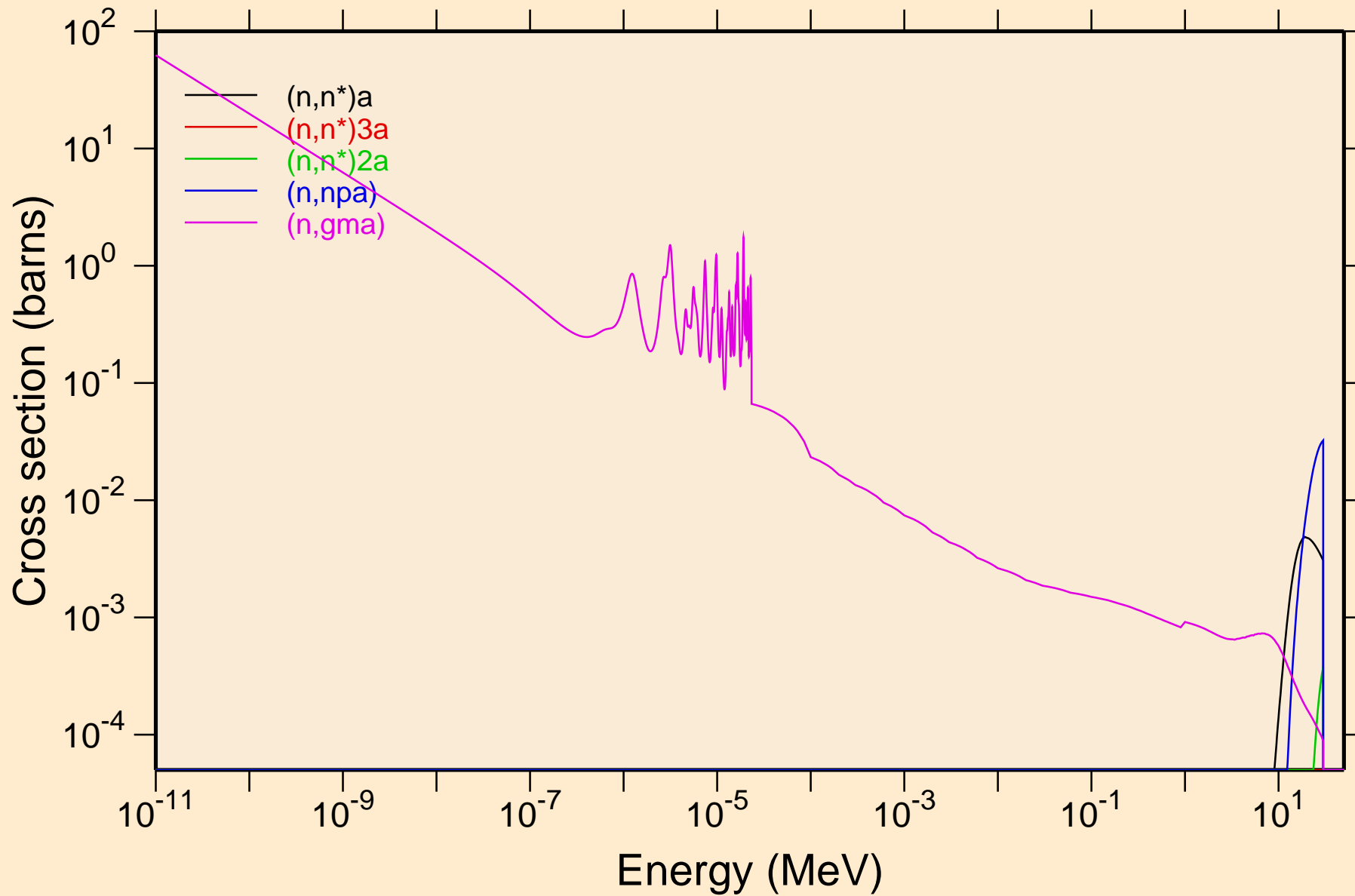

CS116M NEUTRON ACER TENDL-2024 LIBRARY; T=0.K

Non-threshold reactions

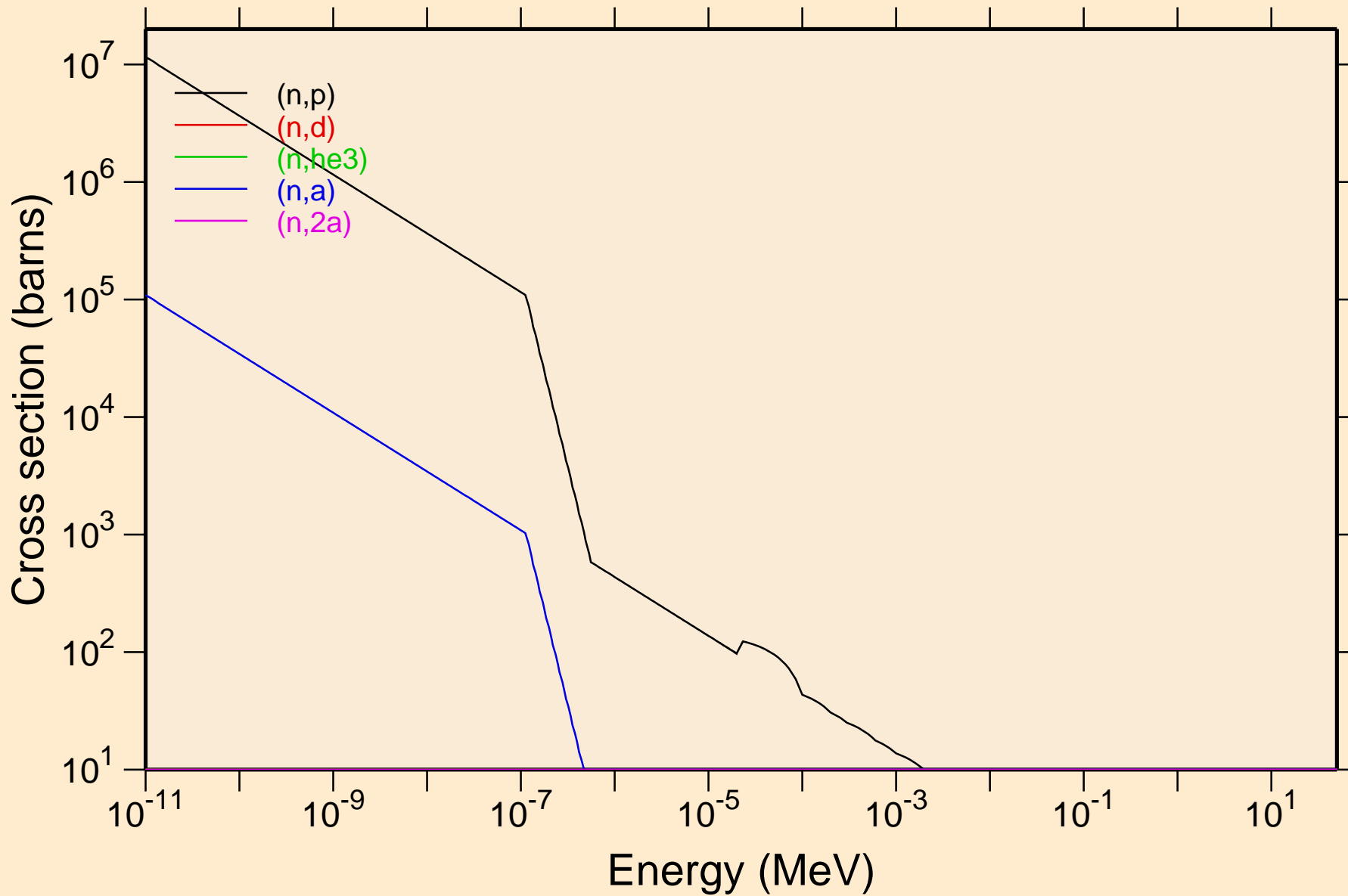

CS116M NEUTRON ACER TENDL-2024 LIBRARY; T=0.K

Non-threshold reactions

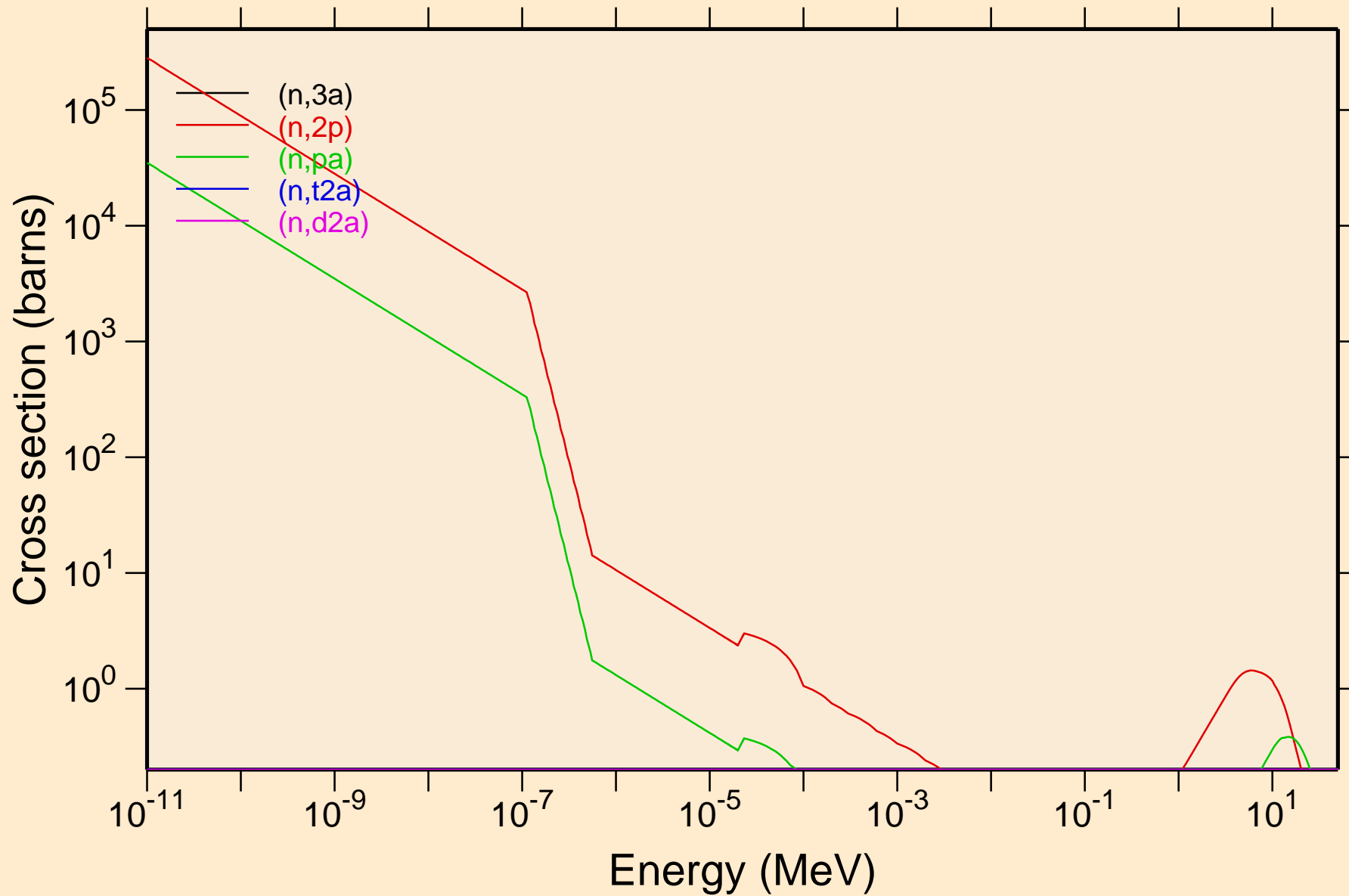

CS116M NEUTRON ACER TENDL-2024 LIBRARY; T=0.K

Non-threshold reactions

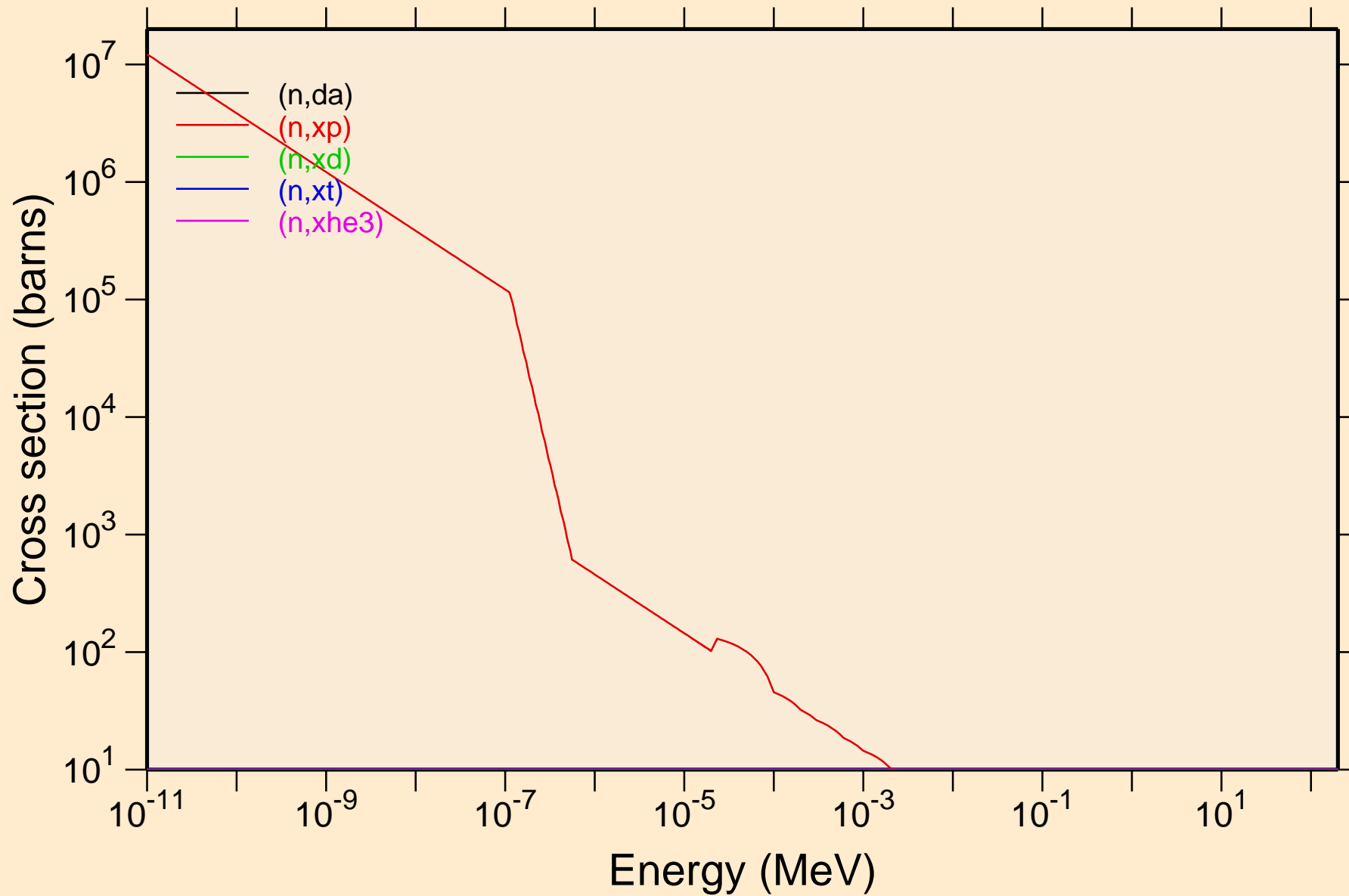

CS116M NEUTRON ACER TENDL-2024 LIBRARY; T=0.K
Non-threshold reactions

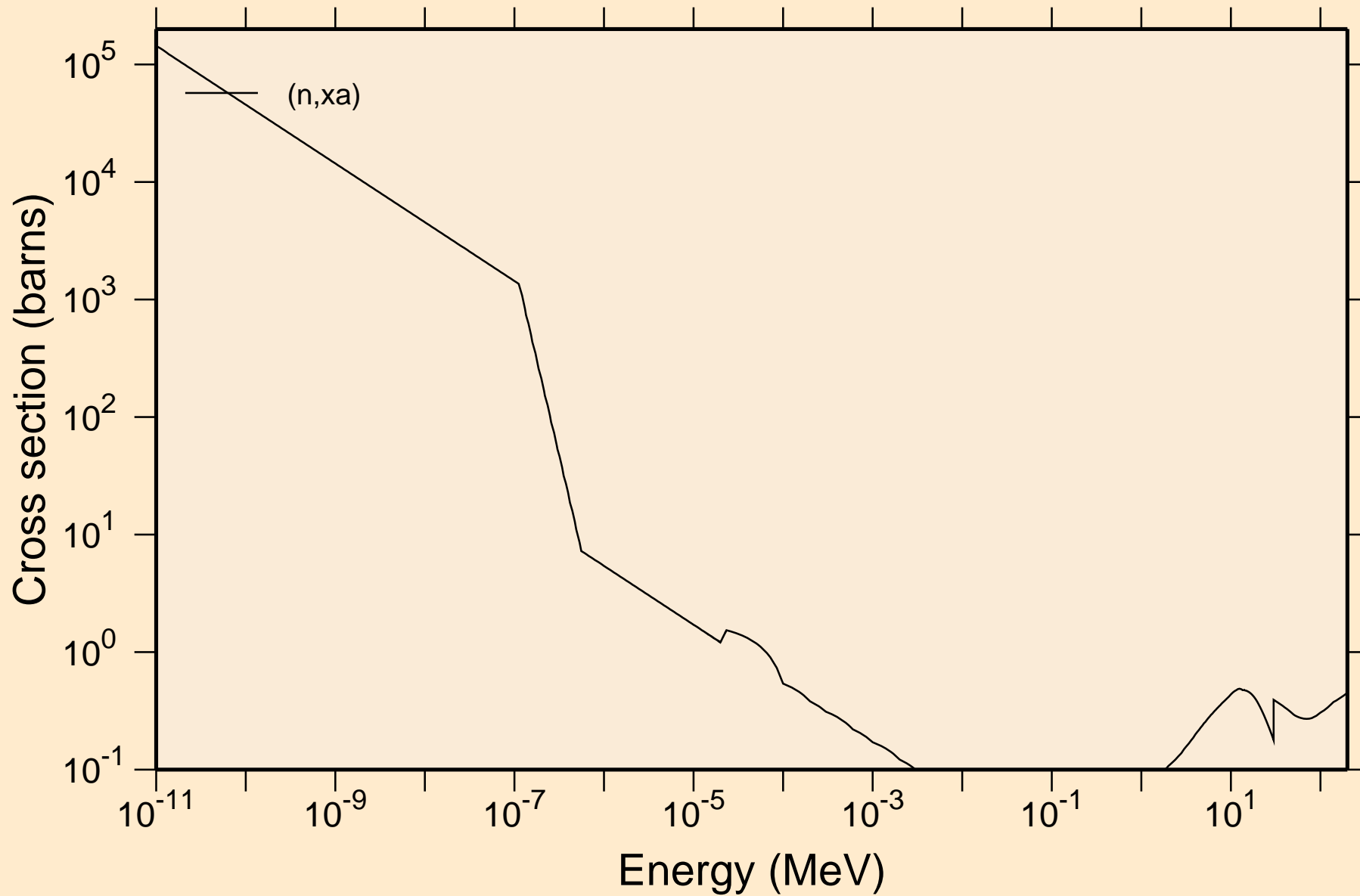

CS116M NEUTRON ACER TENDL-2024 LIBRARY; T=0.K

Principal cross sections

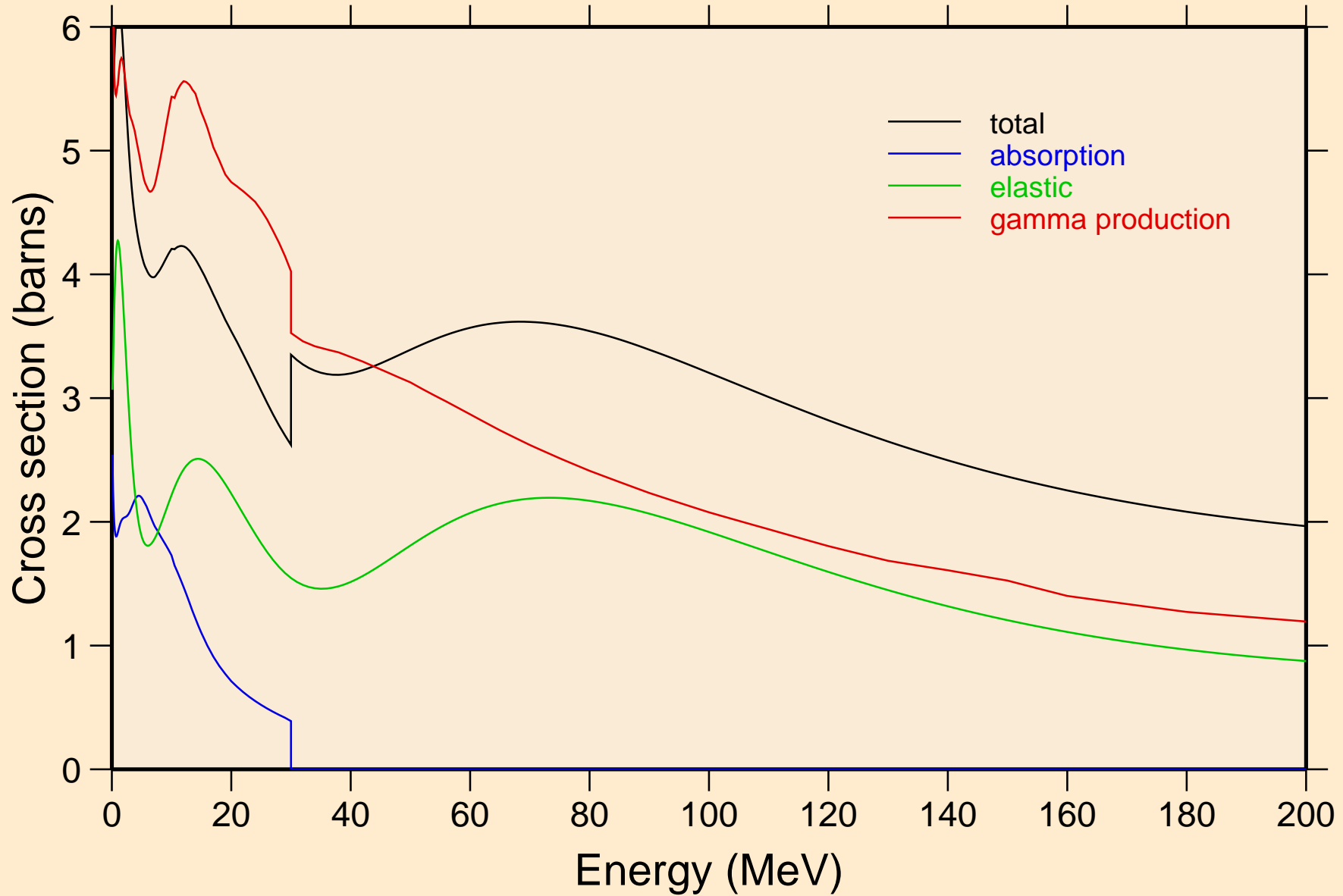

CS116M NEUTRON ACER TENDL-2024 LIBRARY; T=0.K
Heating

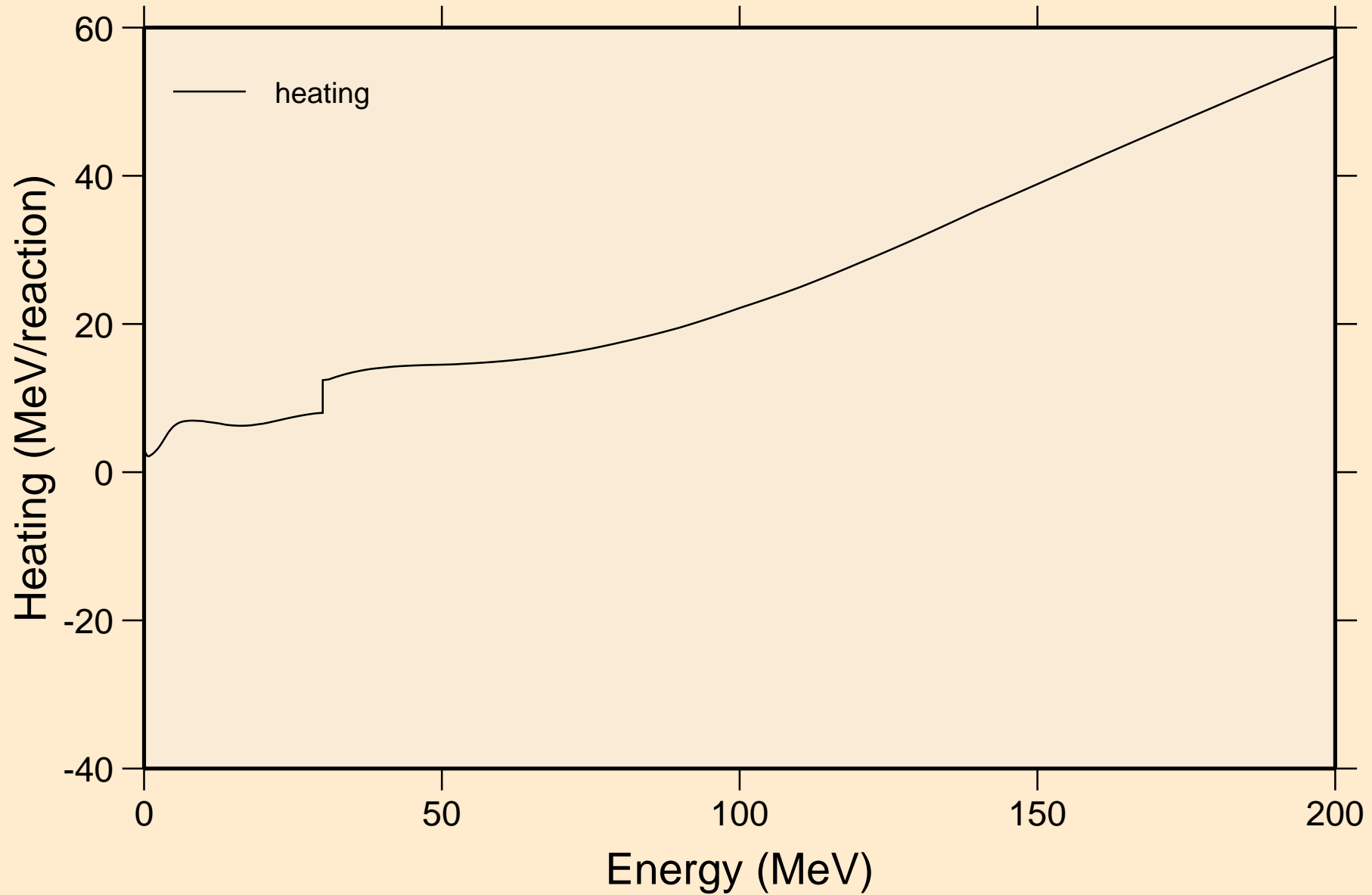

CS116M NEUTRON ACER TENDL-2024 LIBRARY; T=0.K

Damage

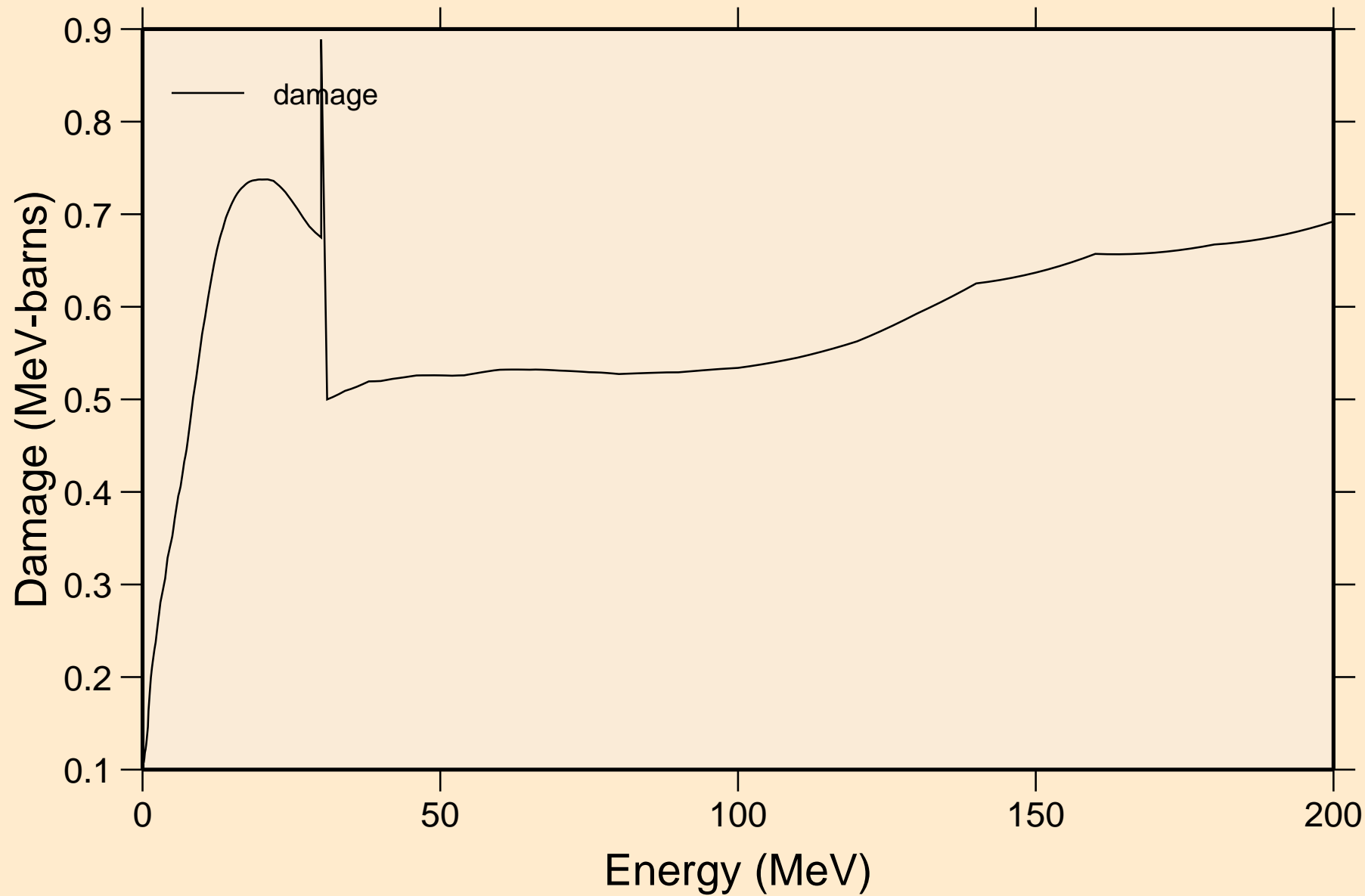

CS116M NEUTRON ACER TENDL-2024 LIBRARY; T=0.K

Non-threshold reactions

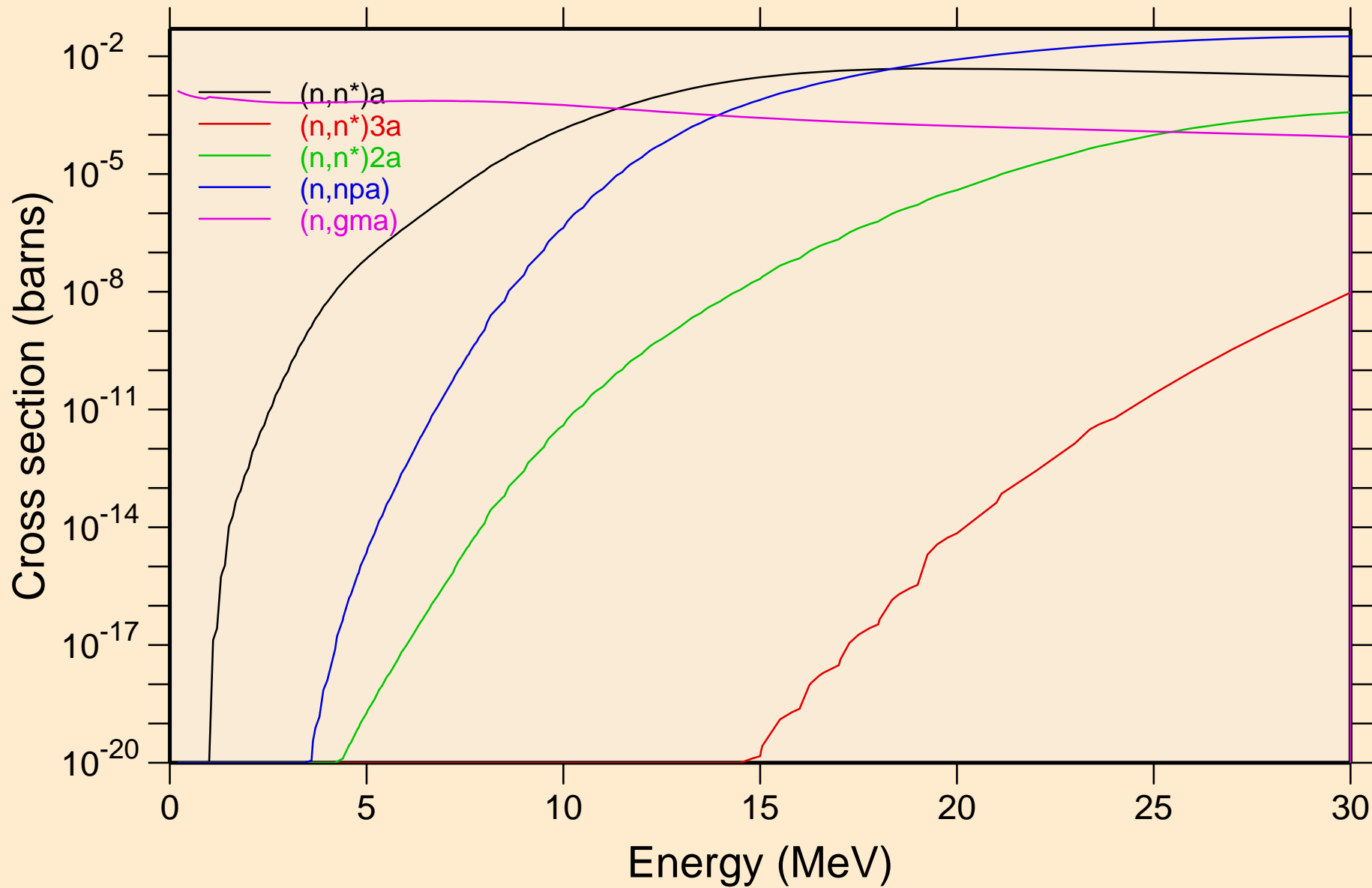

CS116M NEUTRON ACER TENDL-2024 LIBRARY; T=0.K

Non-threshold reactions

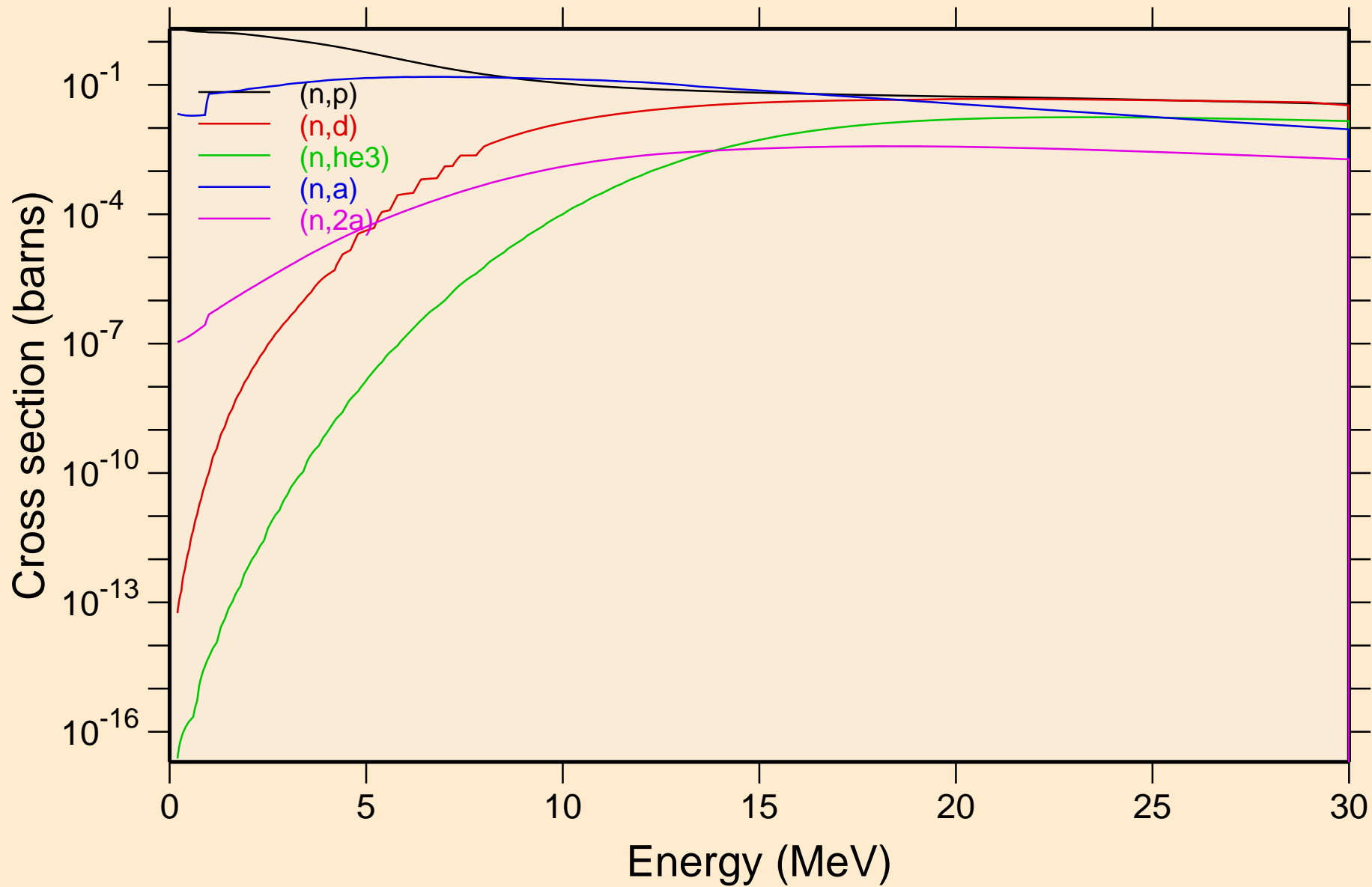

CS116M NEUTRON ACER TENDL-2024 LIBRARY; T=0.K

Non-threshold reactions

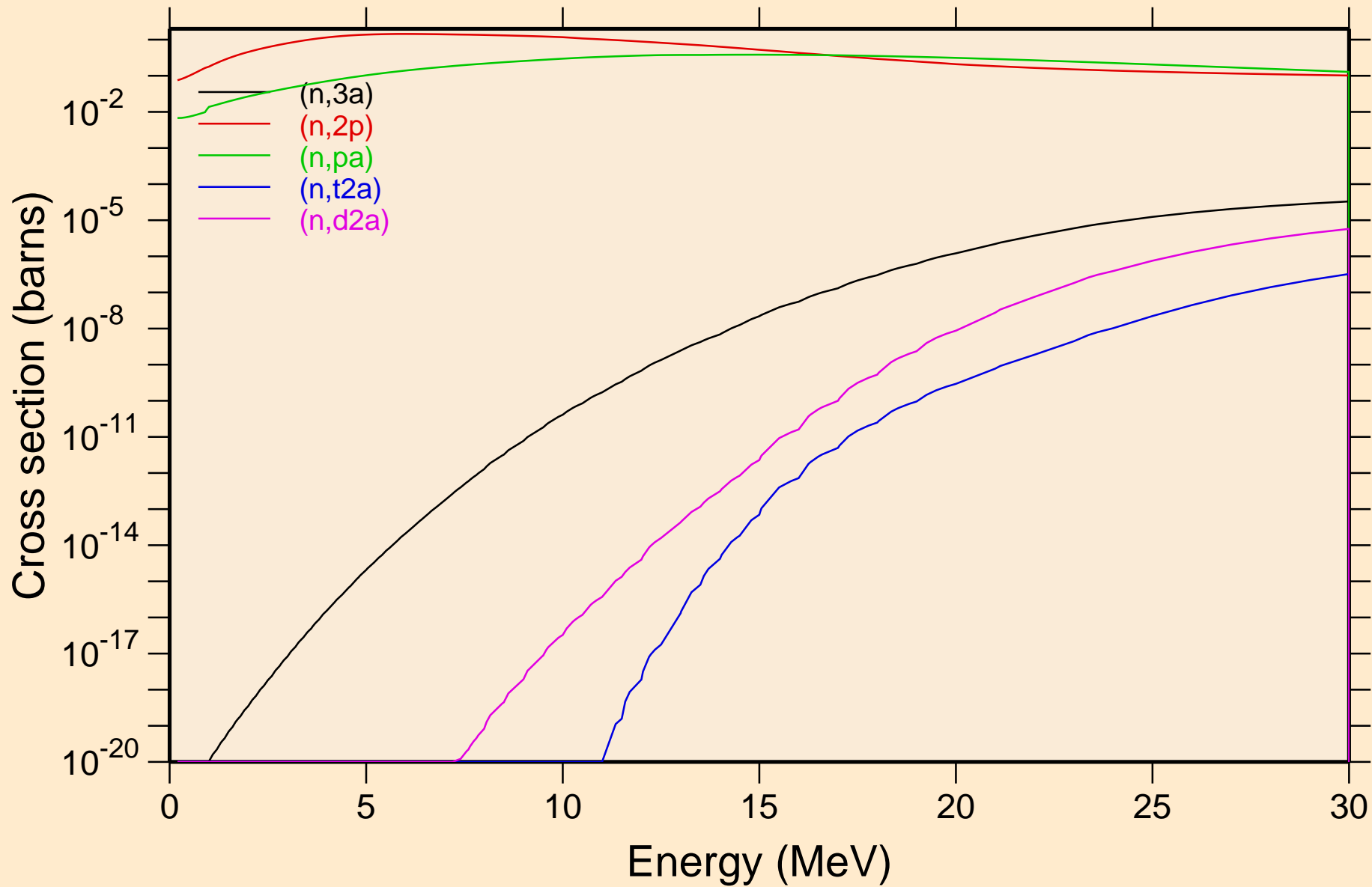

CS116M NEUTRON ACER TENDL-2024 LIBRARY; T=0.K
Non-threshold reactions

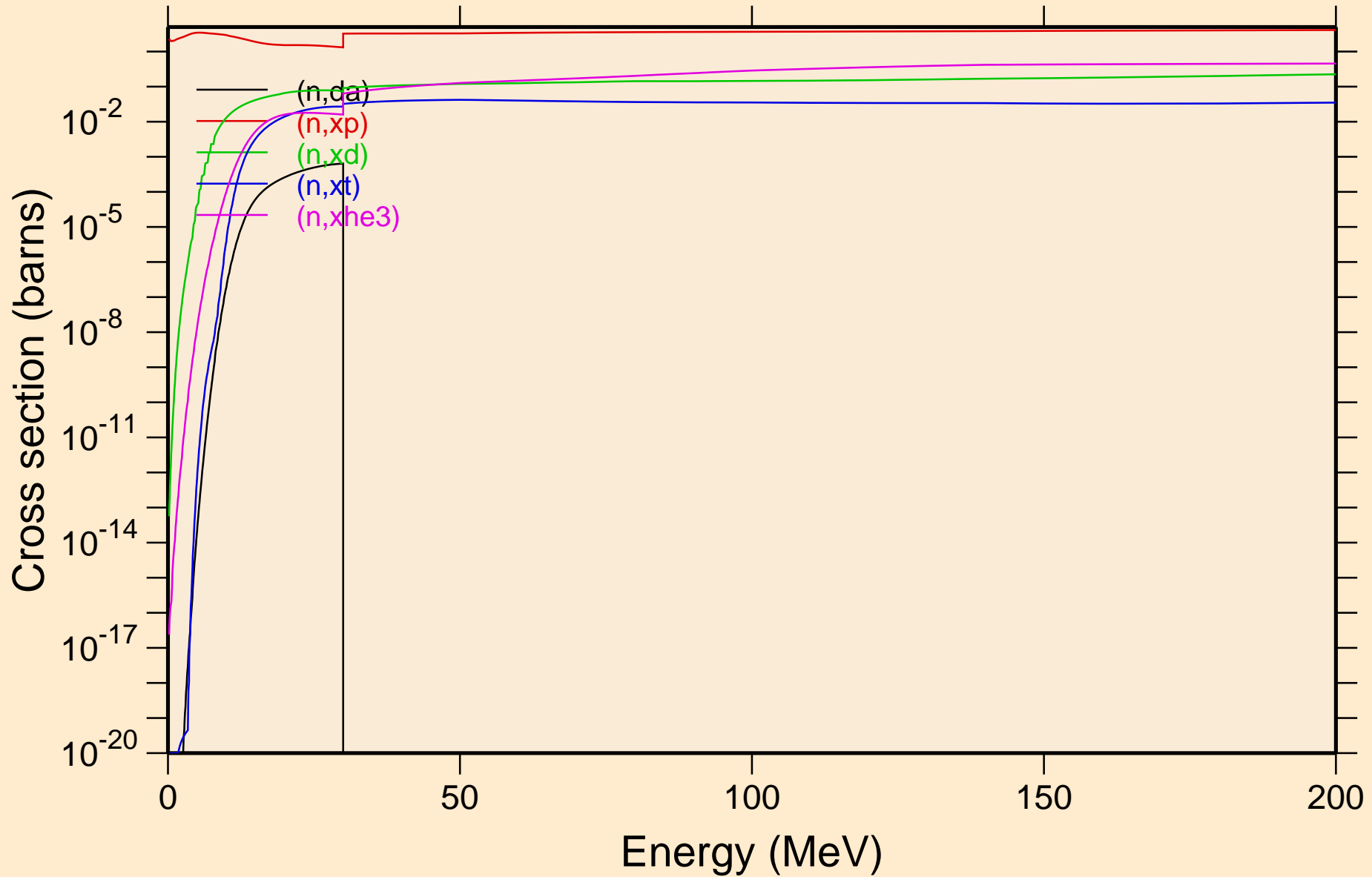

CS116M NEUTRON ACER TENDL-2024 LIBRARY; T=0.K
Non-threshold reactions

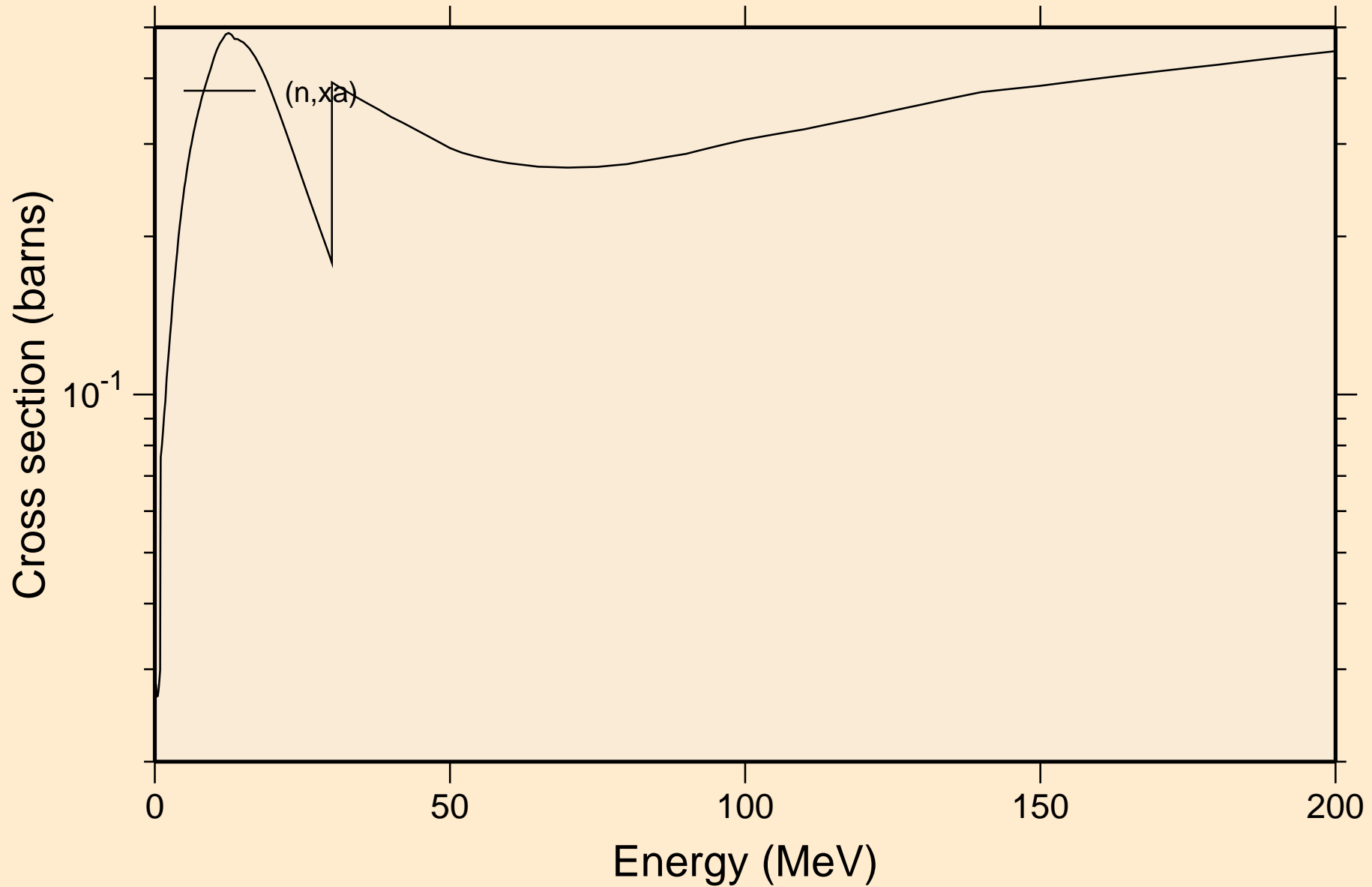

CS116M NEUTRON ACER TENDL-2024 LIBRARY; T=0.K
Inelastic levels

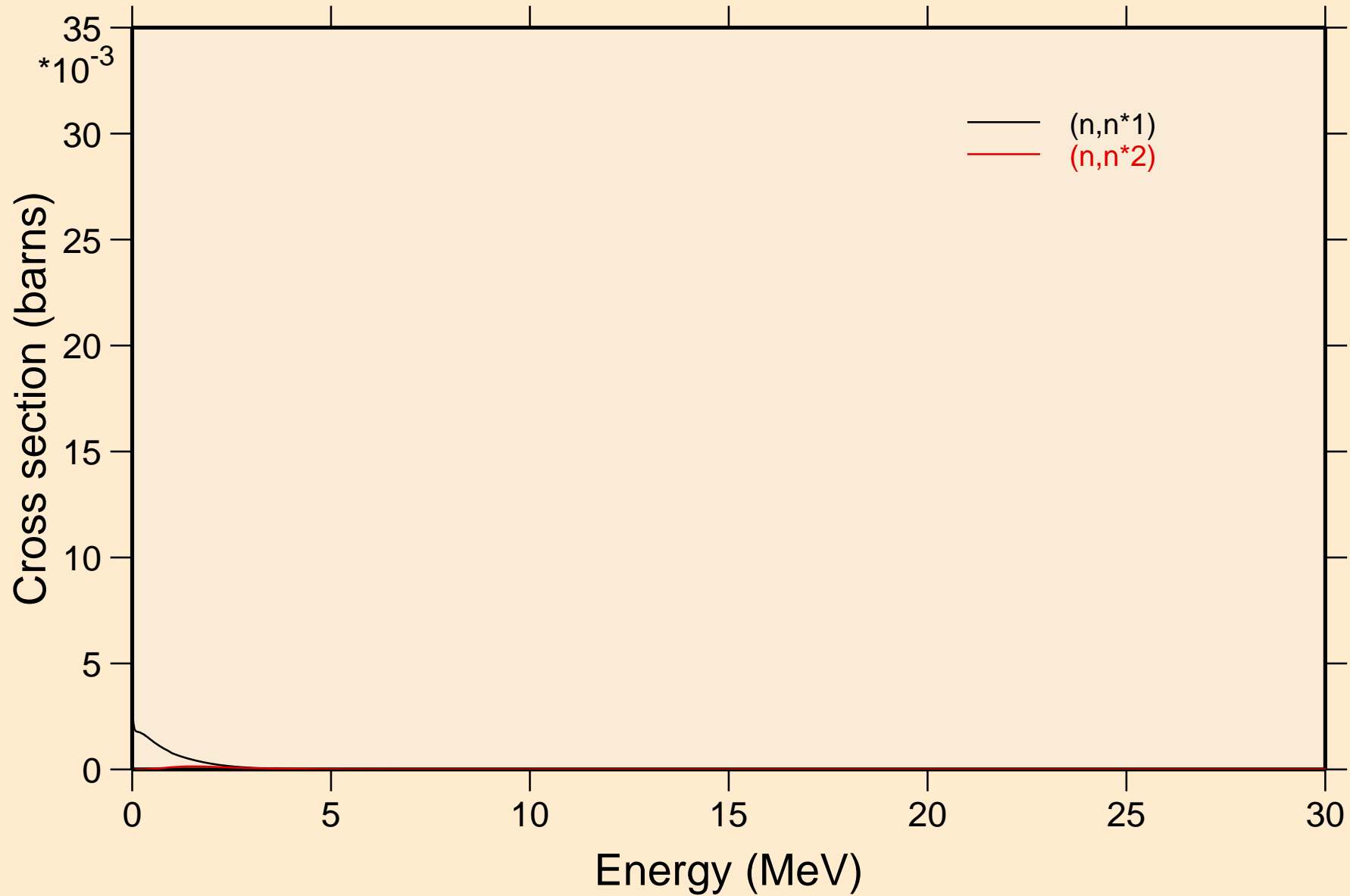

CS116M NEUTRON ACER TENDL-2024 LIBRARY; T=0.K

Threshold reactions

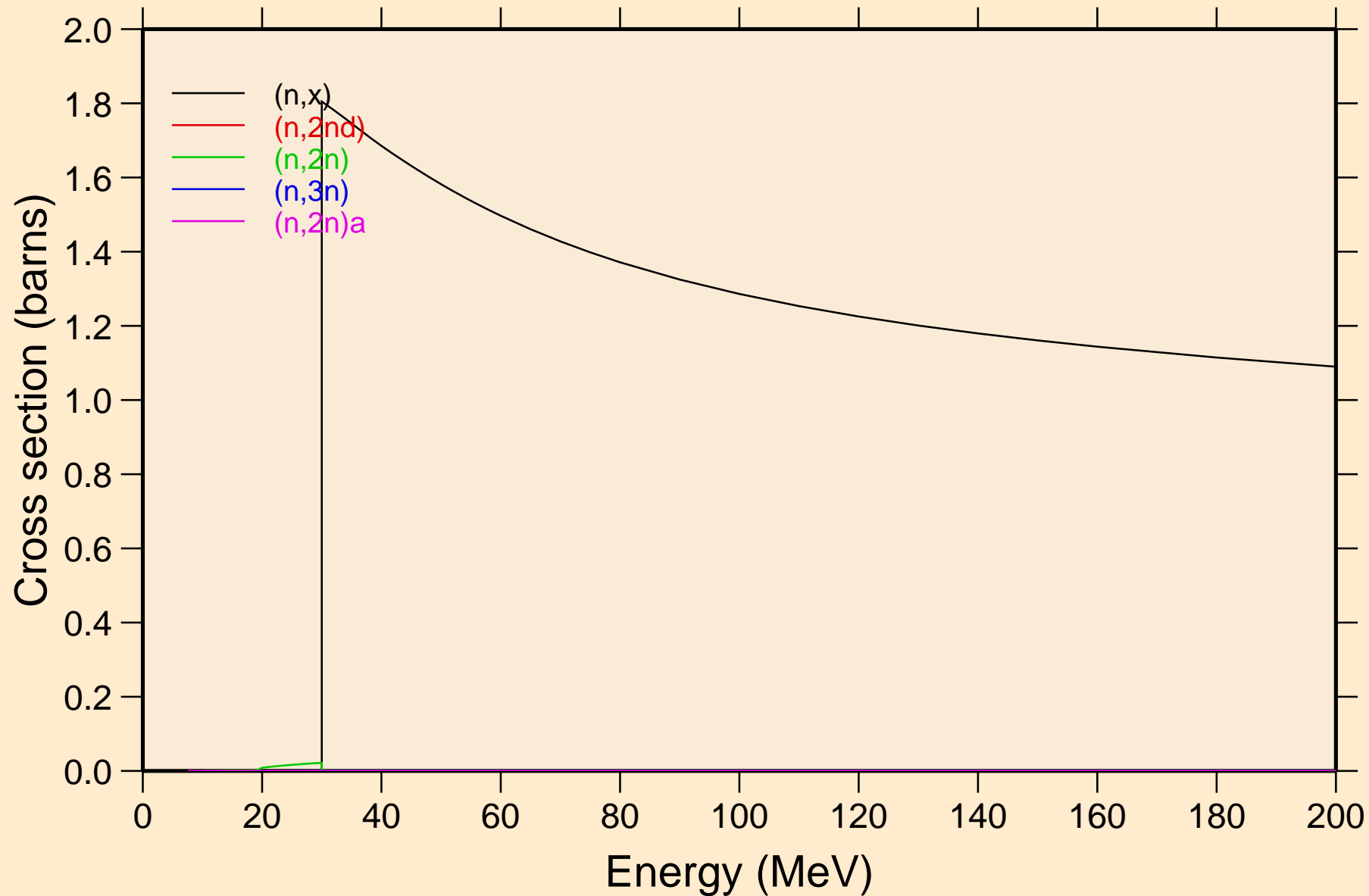

CS116M NEUTRON ACER TENDL-2024 LIBRARY; T=0.K

Threshold reactions

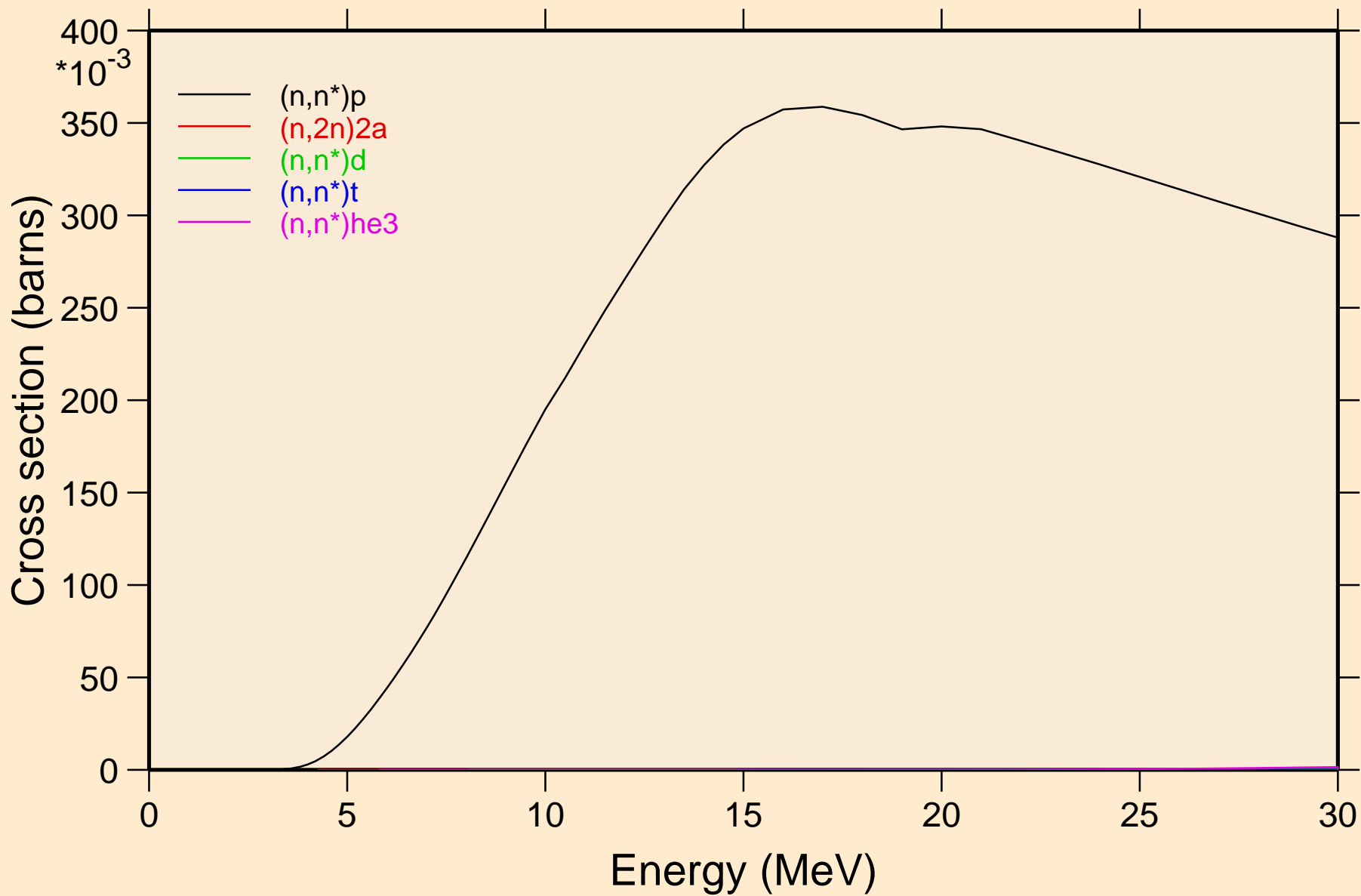

CS116M NEUTRON ACER TENDL-2024 LIBRARY; T=0.K

Threshold reactions

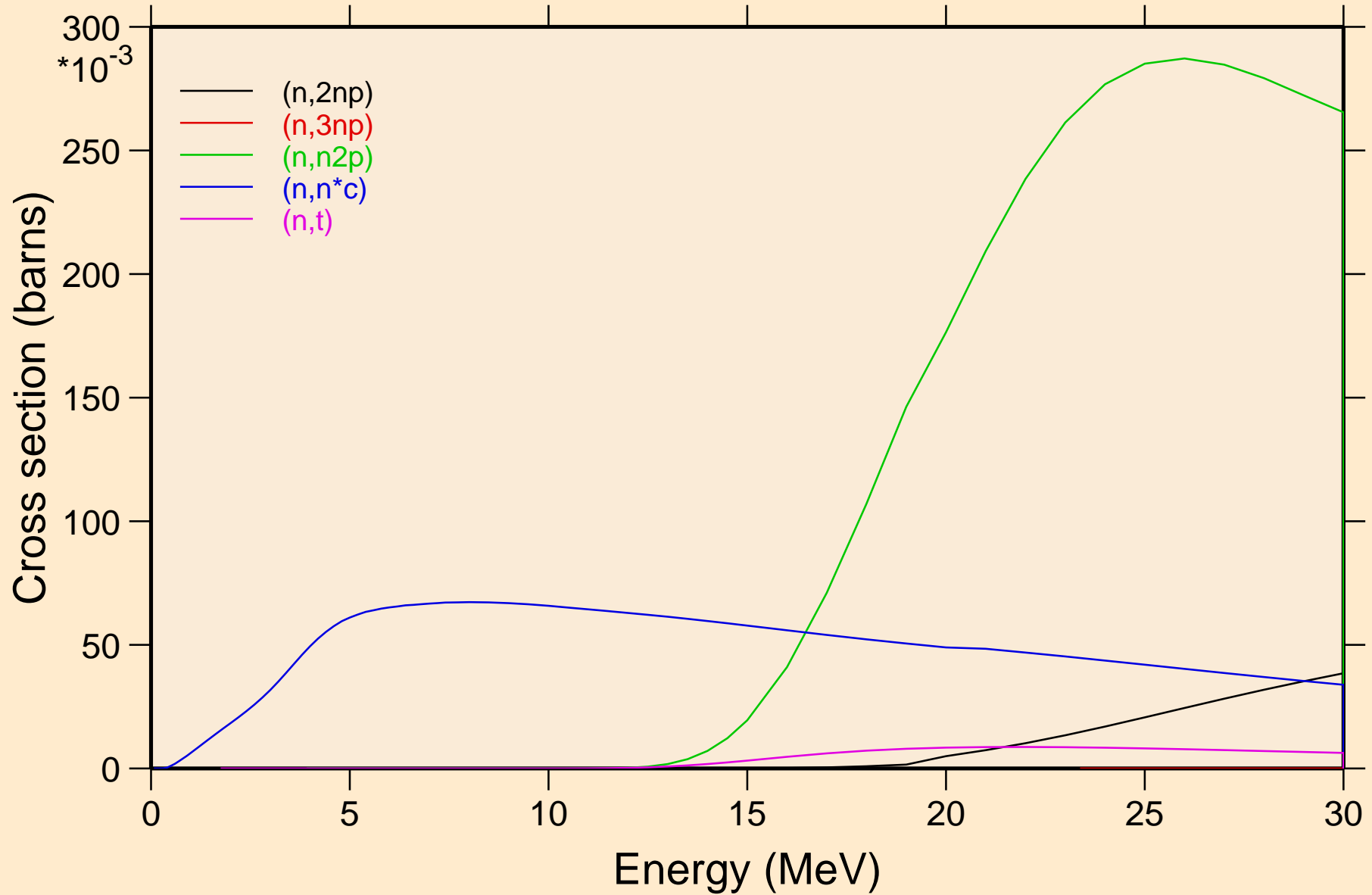

CS116M NEUTRON ACER TENDL-2024 LIBRARY; T=0.K

Threshold reactions

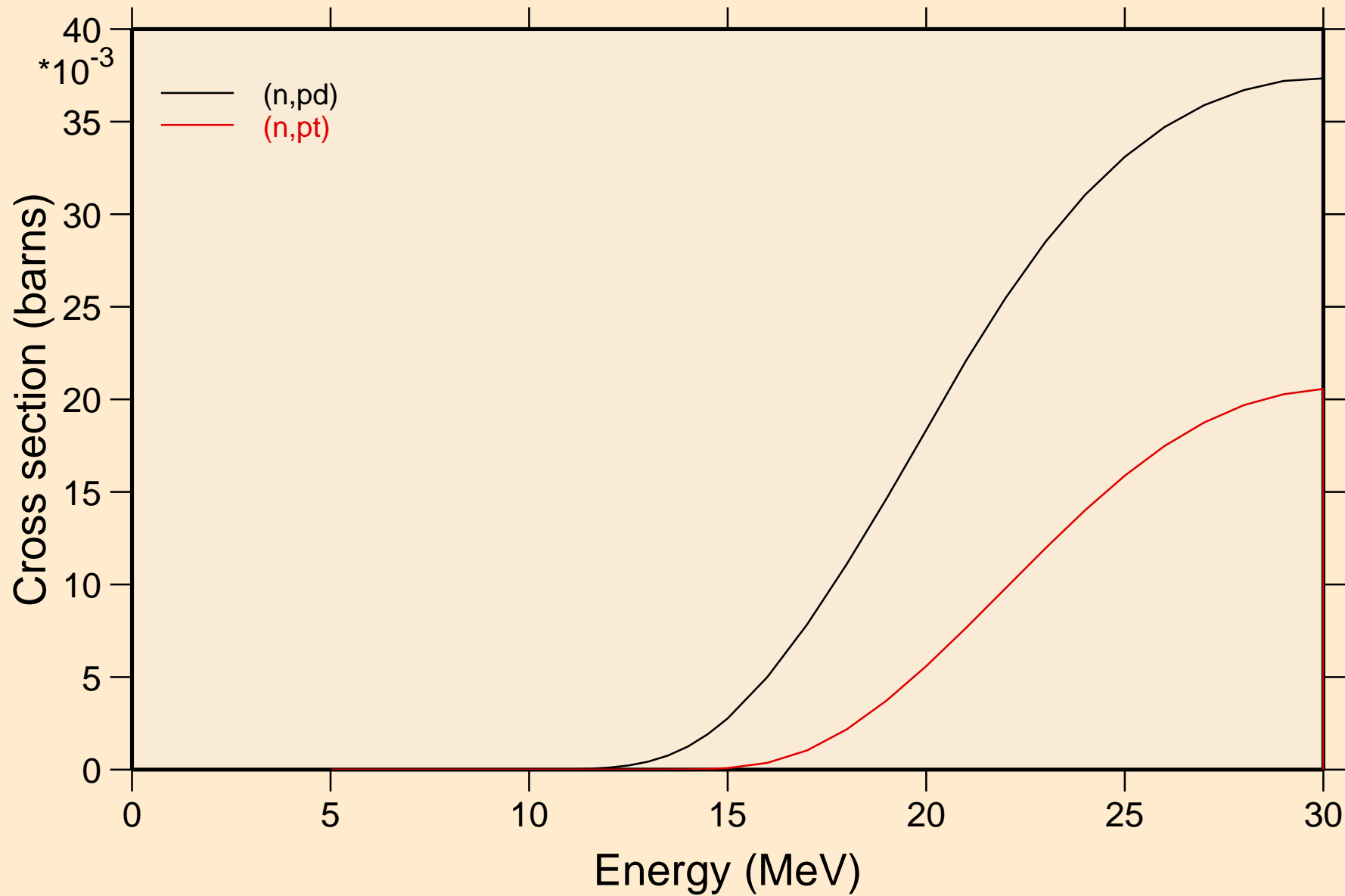

CS116M NEUTRON ACER TENDL-2024 LIBRARY; T=0.K
angular distribution for elastic

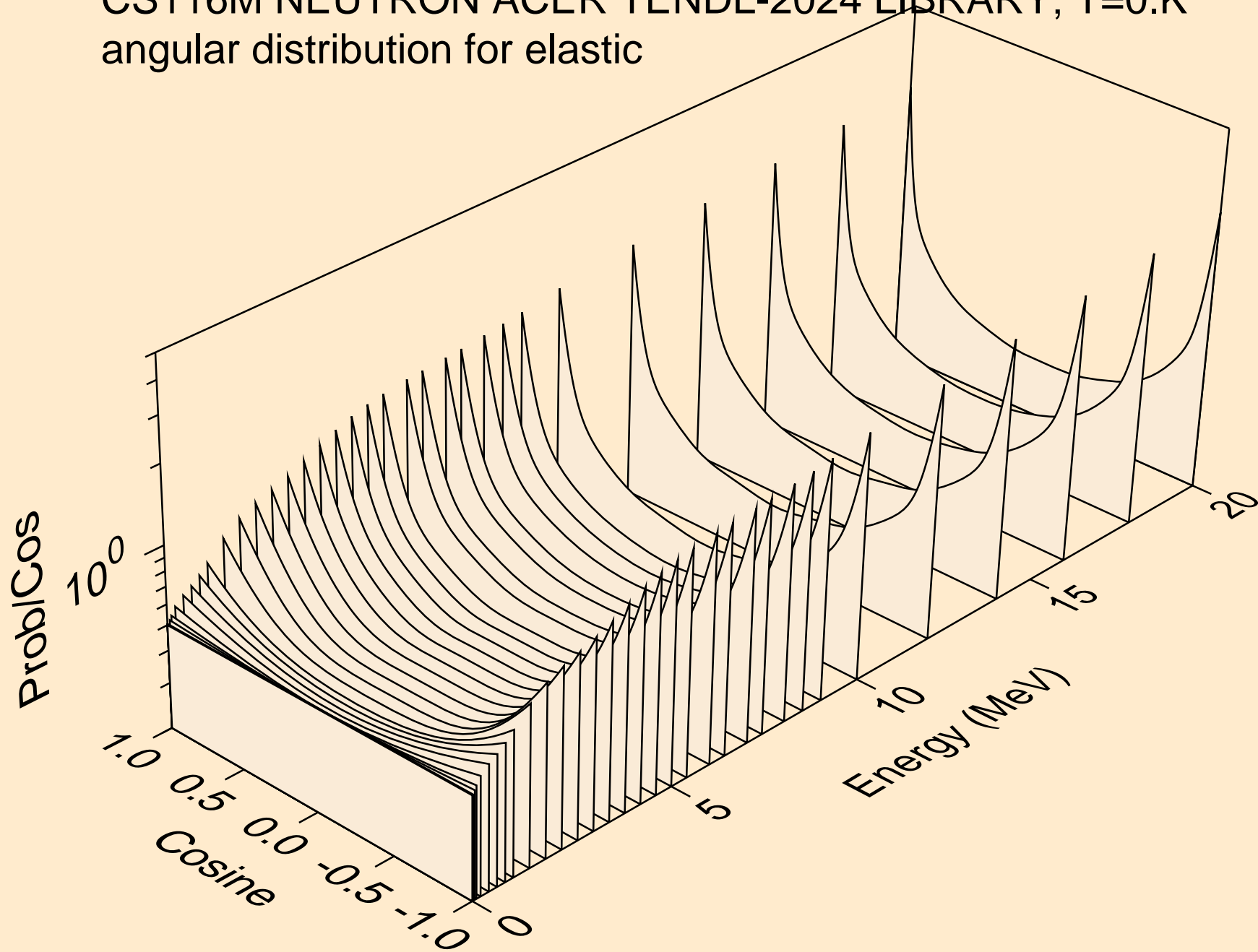

CS116M NEUTRON ACER TENDL-2024 LIBRARY; T=0.K
angular distribution for elastic

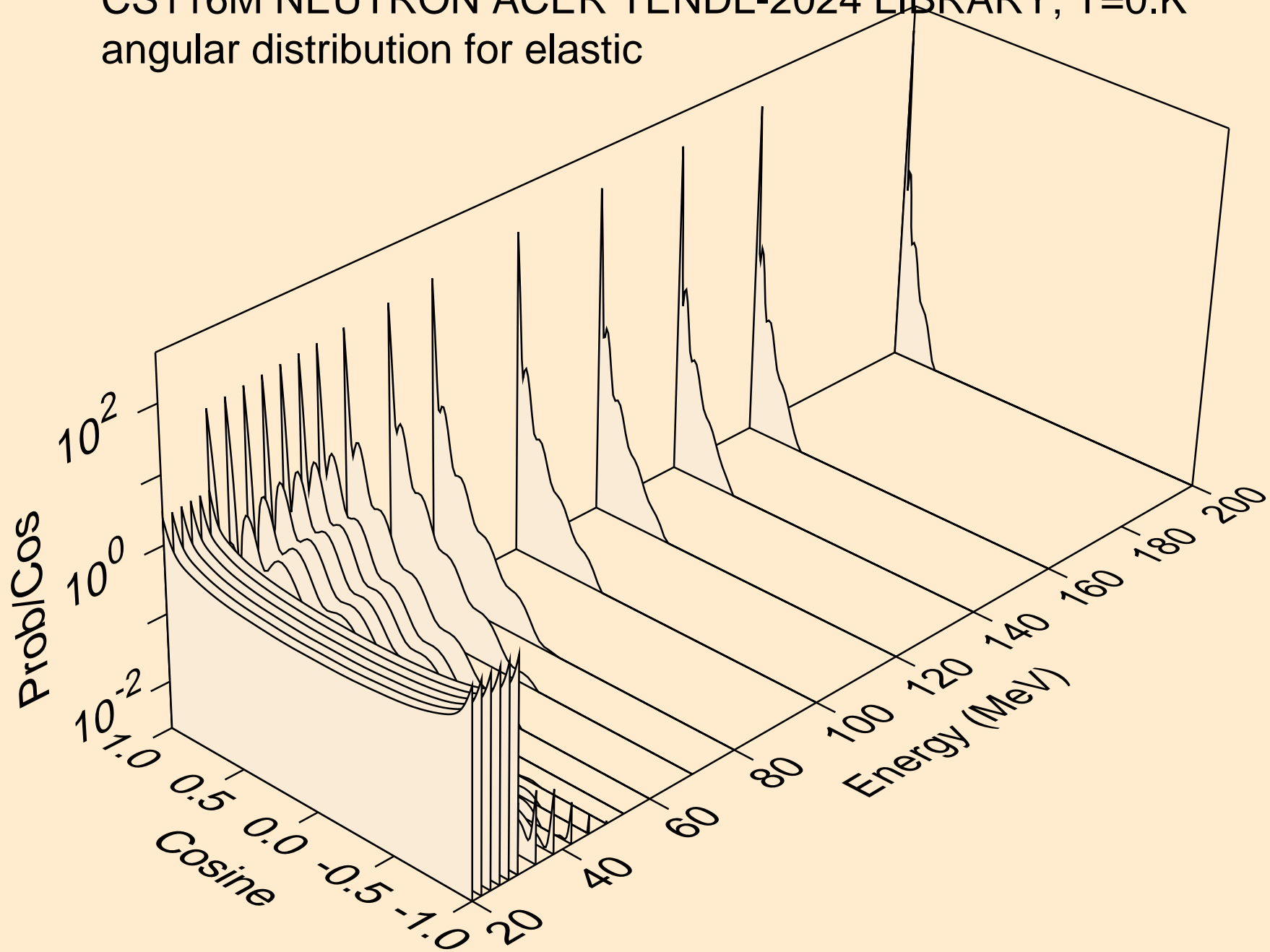

CS116M NEUTRON ACER TENDL-2024 LIBRARY; T=0.K
angular distribution for (n,n*1)

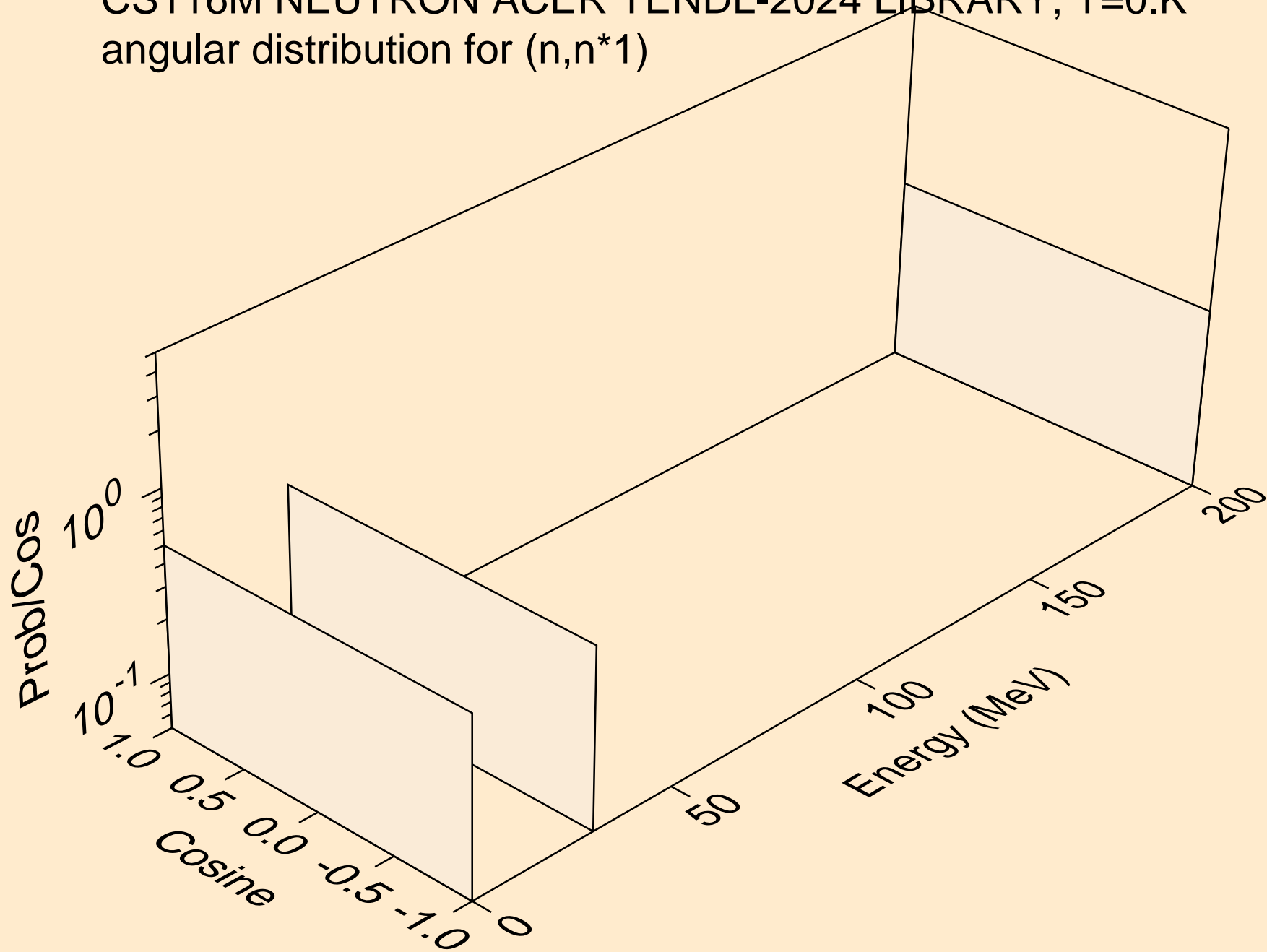

CS116M NEUTRON ACER TENDL-2024 LIBRARY; T=0.K
angular distribution for (n,n*2)

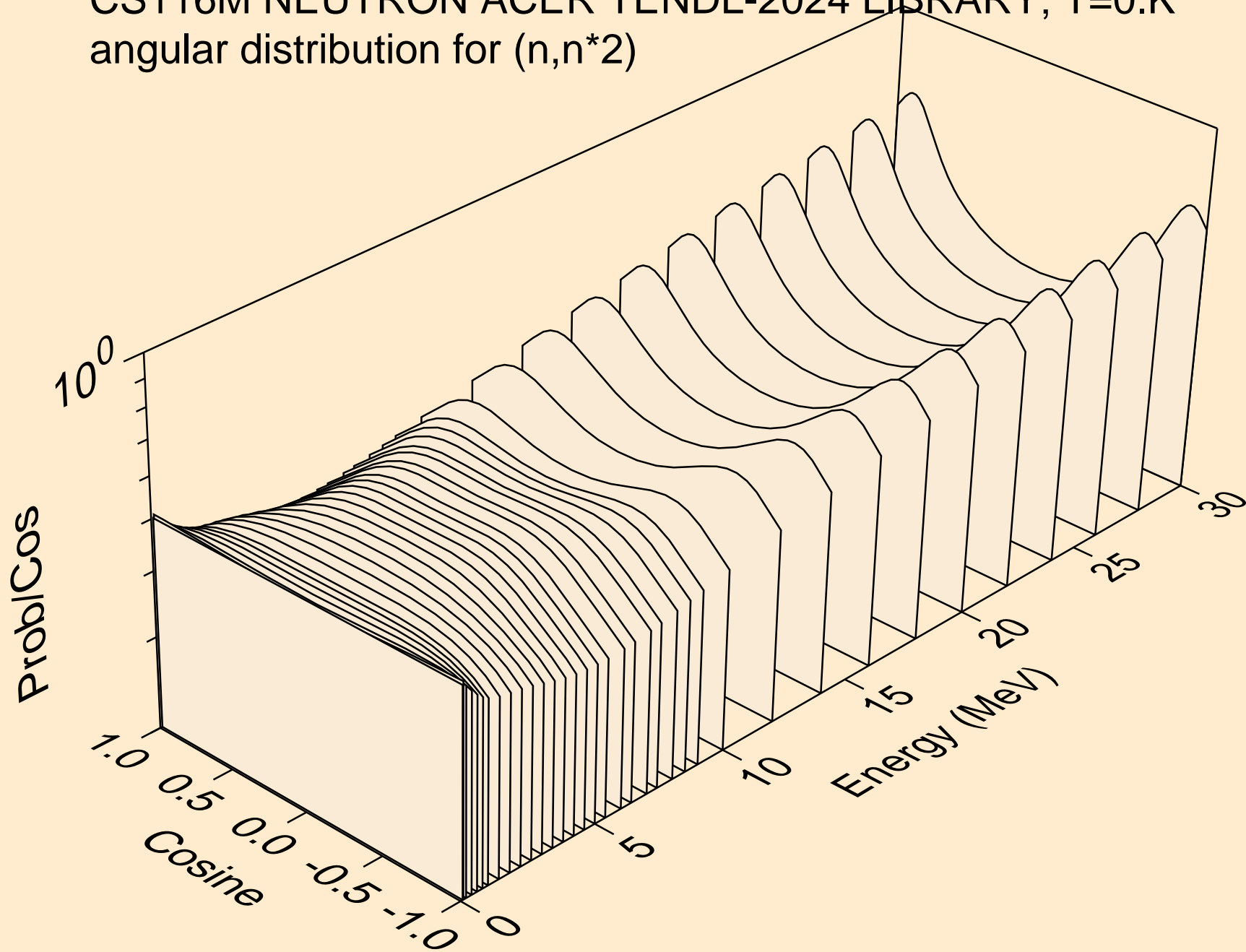

CS116M NEUTRON ACER TENDL-2024 LIBRARY; T=0.K
Neutron emission for (n,x)

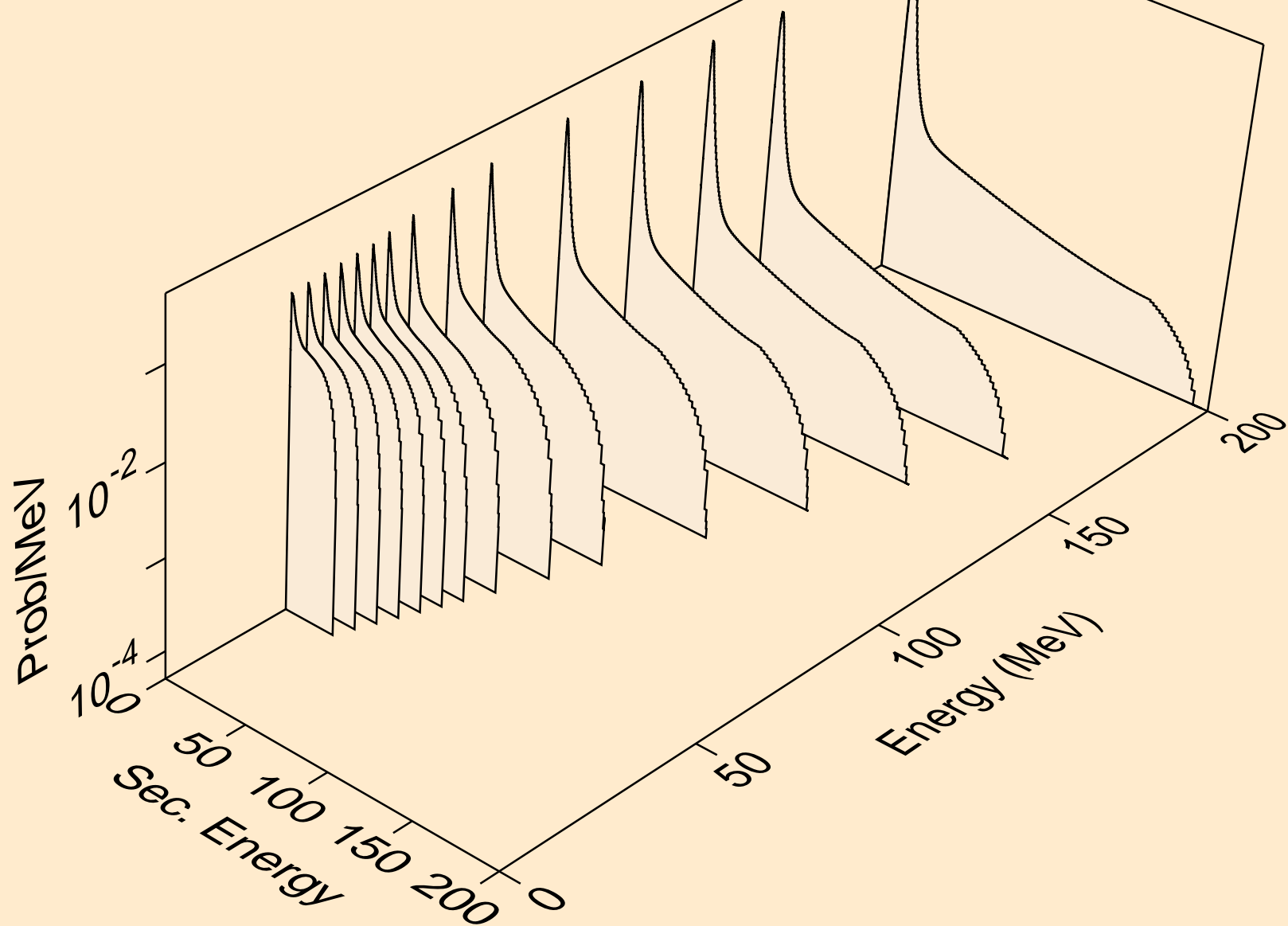

CS116M NEUTRON ACER TENDL-2024 LIBRARY; T=0.K
Neutron emission for (n,2nd)

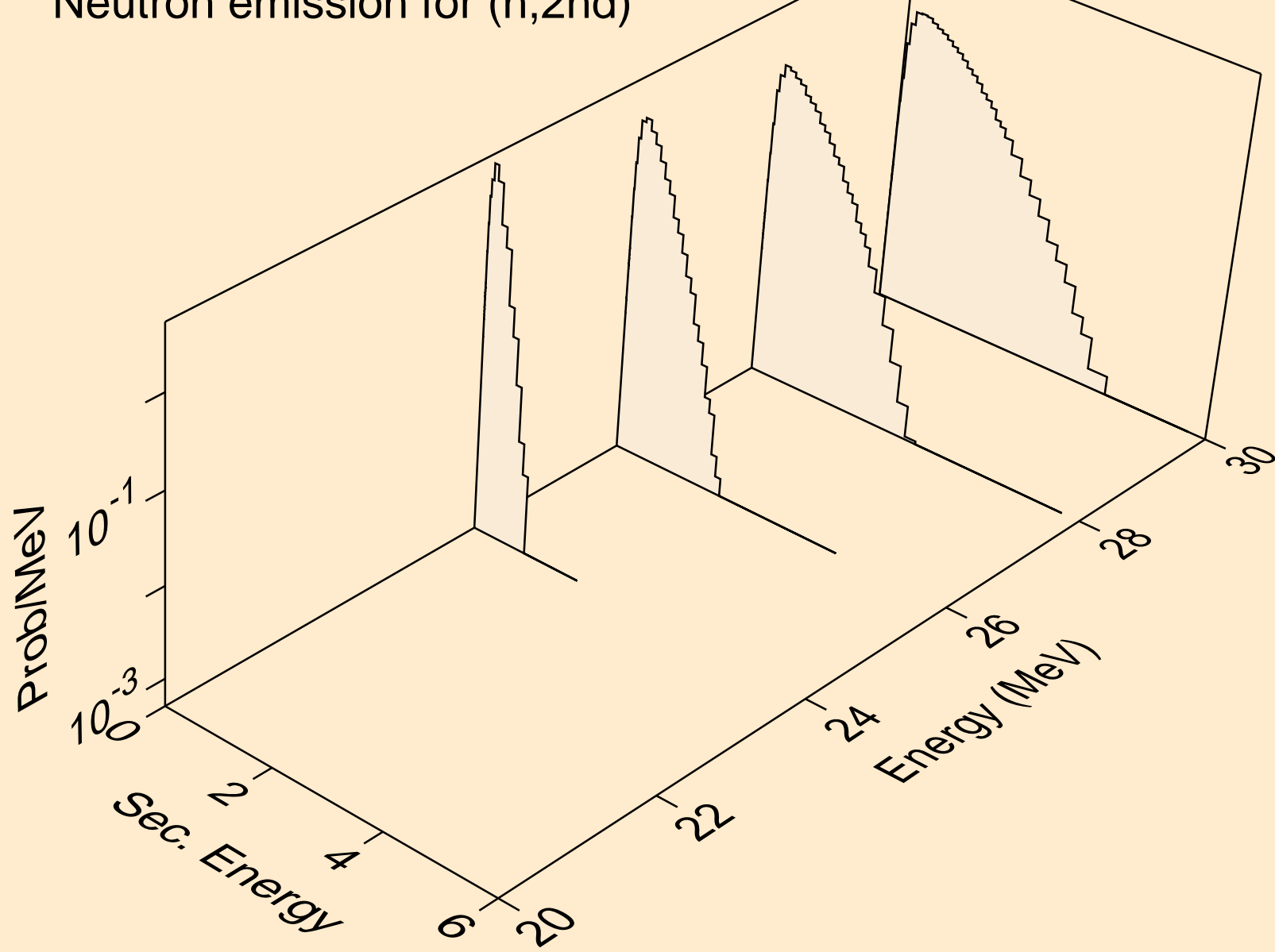

CS116M NEUTRON ACER TENDL-2024 LIBRARY; T=0.K
Neutron emission for (n,2n)

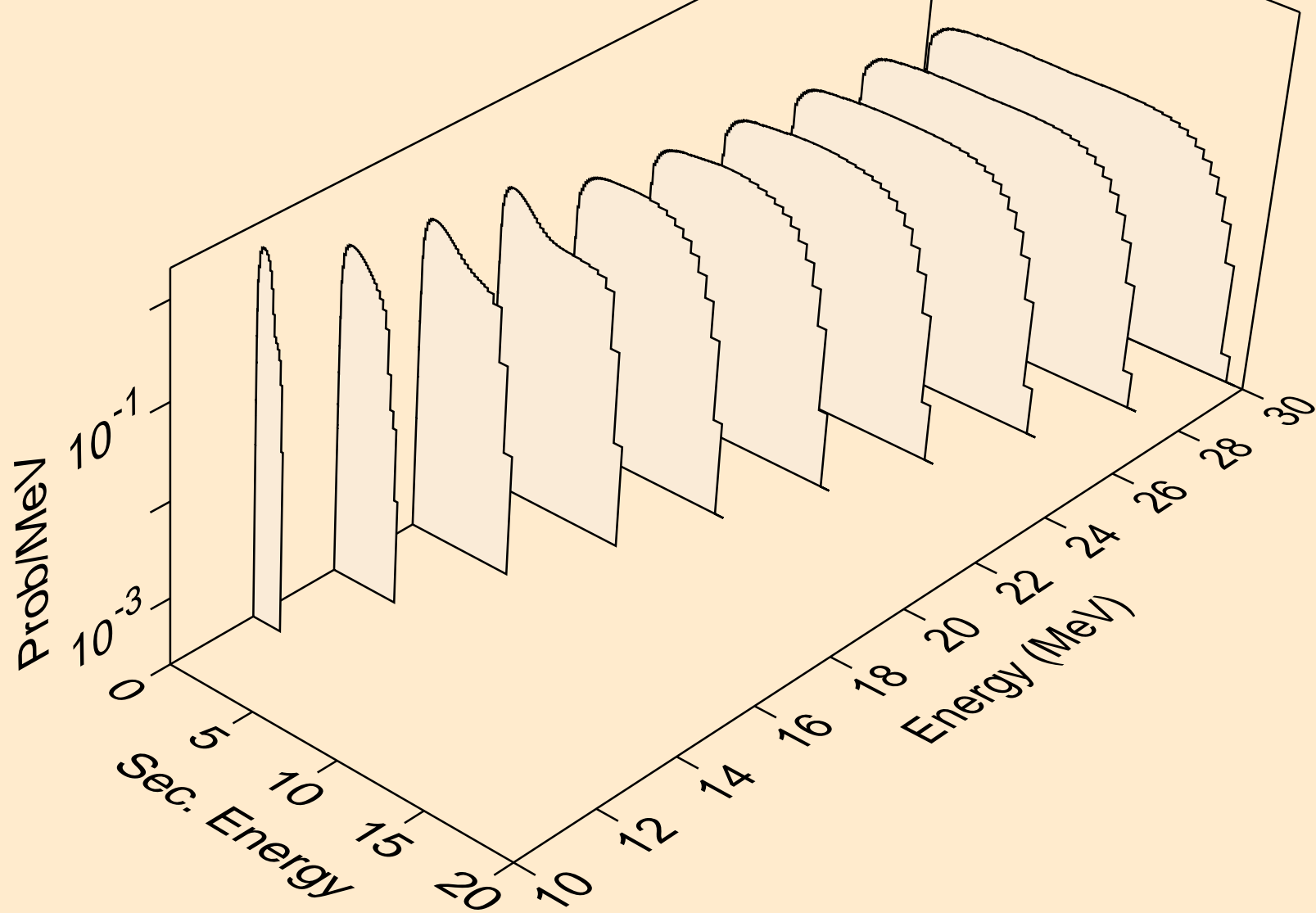

CS116M NEUTRON ACER TENDL-2024 LIBRARY; T=0.K
Neutron emission for (n,3n)

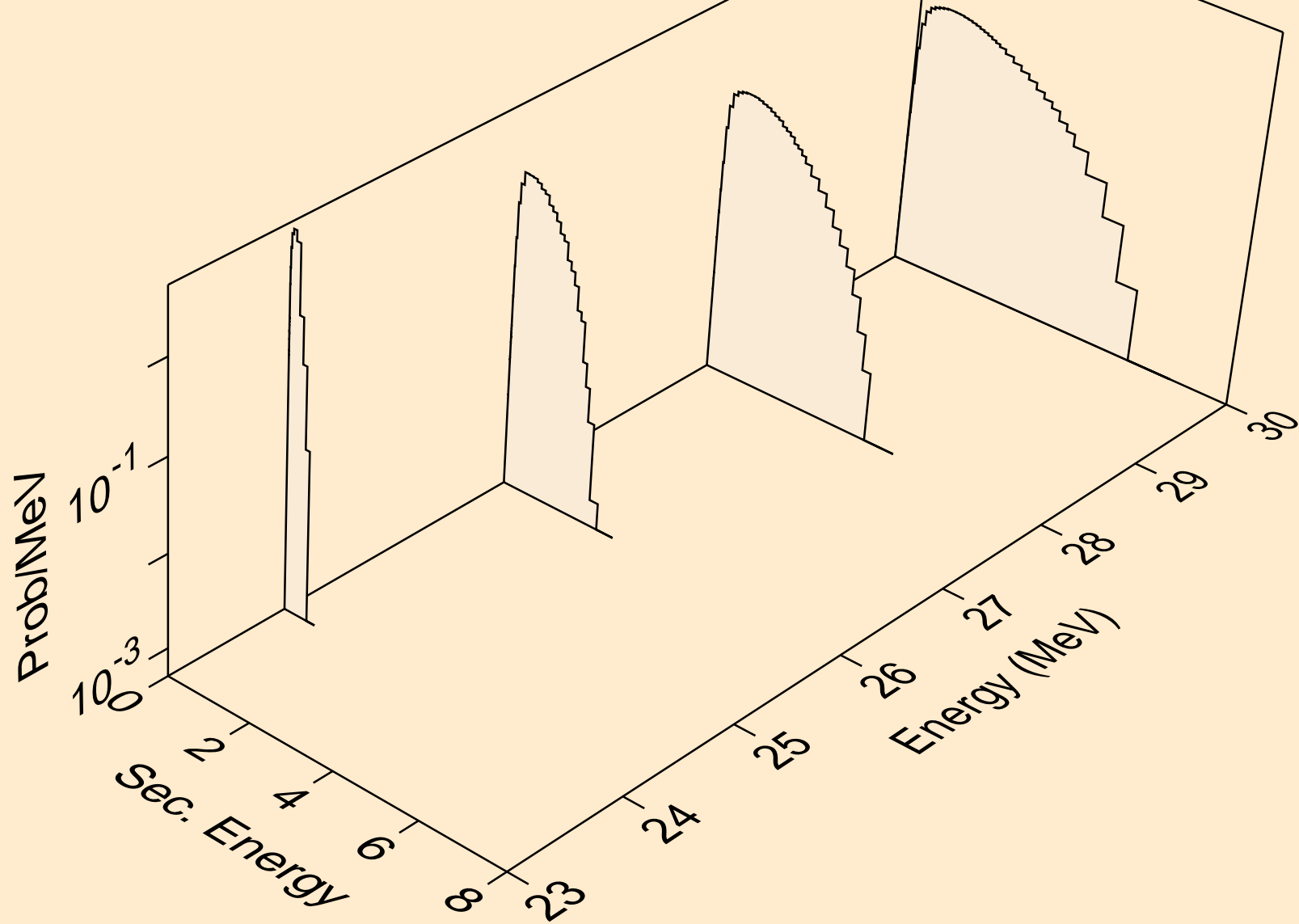

CS116M NEUTRON ACER TENDL-2024 LIBRARY; T=0.K
Neutron emission for (n,n*)a

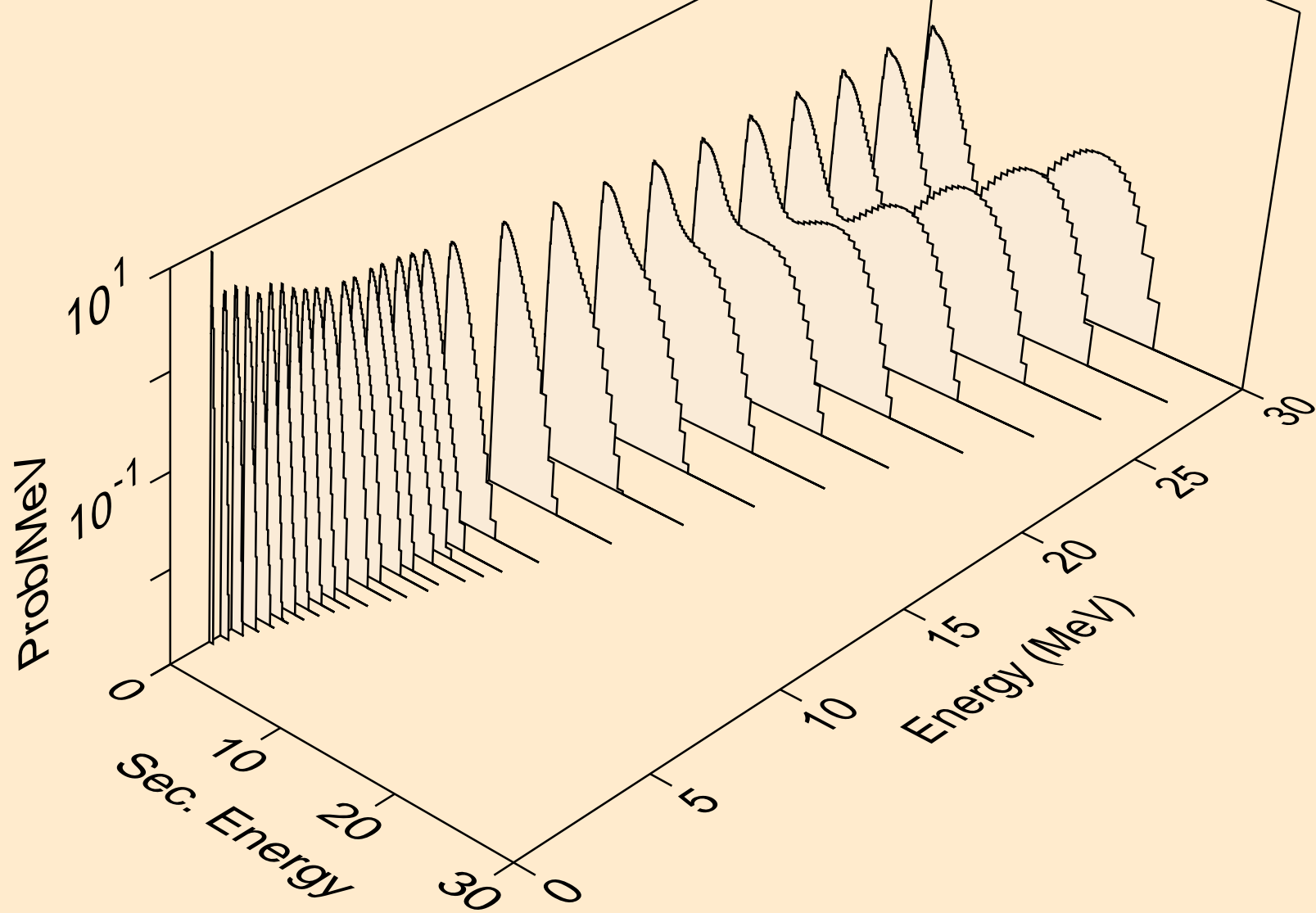

CS116M NEUTRON ACER TENDL-2024 LIBRARY; T=0.K
Neutron emission for (n,n*)3a

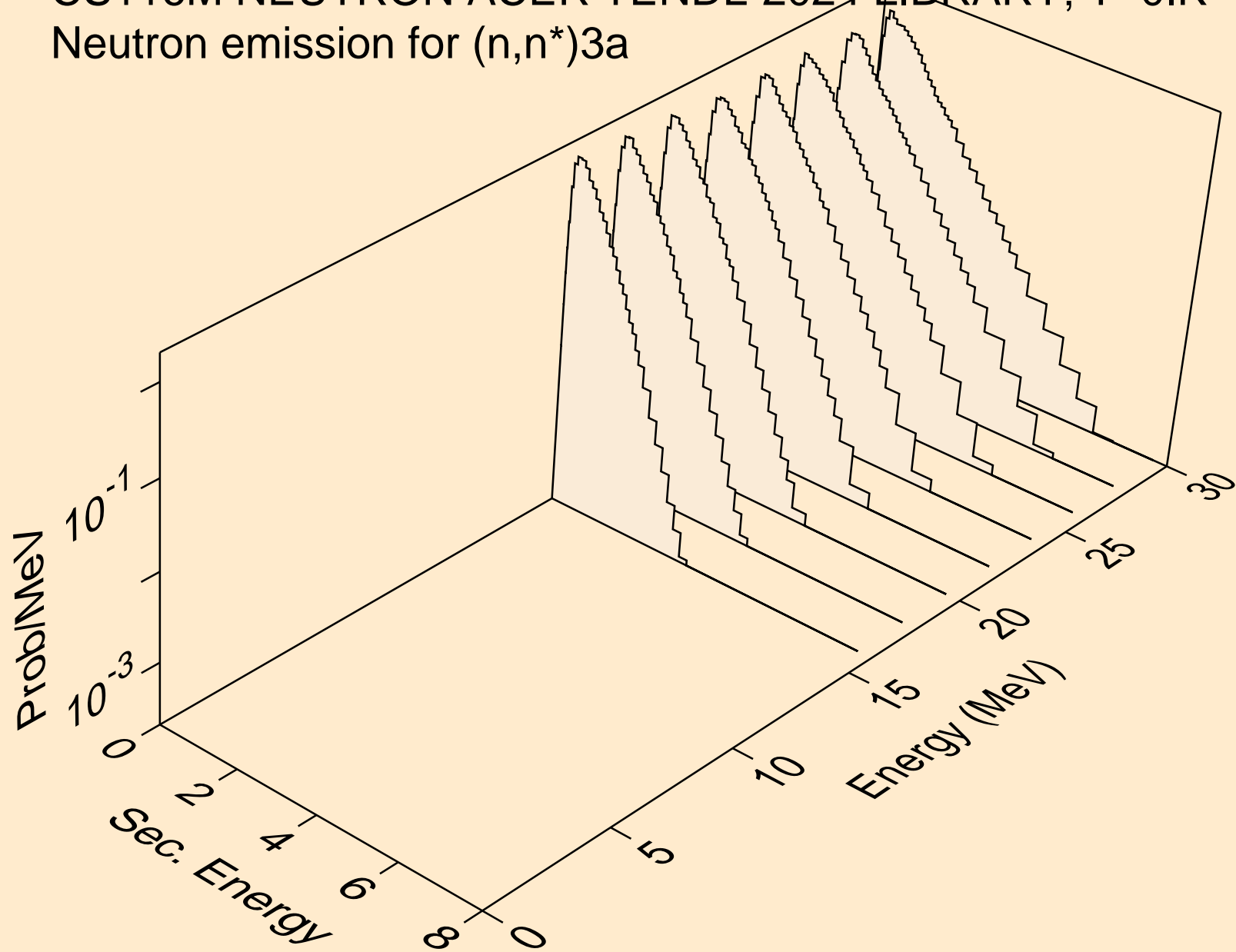

CS116M NEUTRON ACER TENDL-2024 LIBRARY; T=0.K
Neutron emission for (n,2n)a

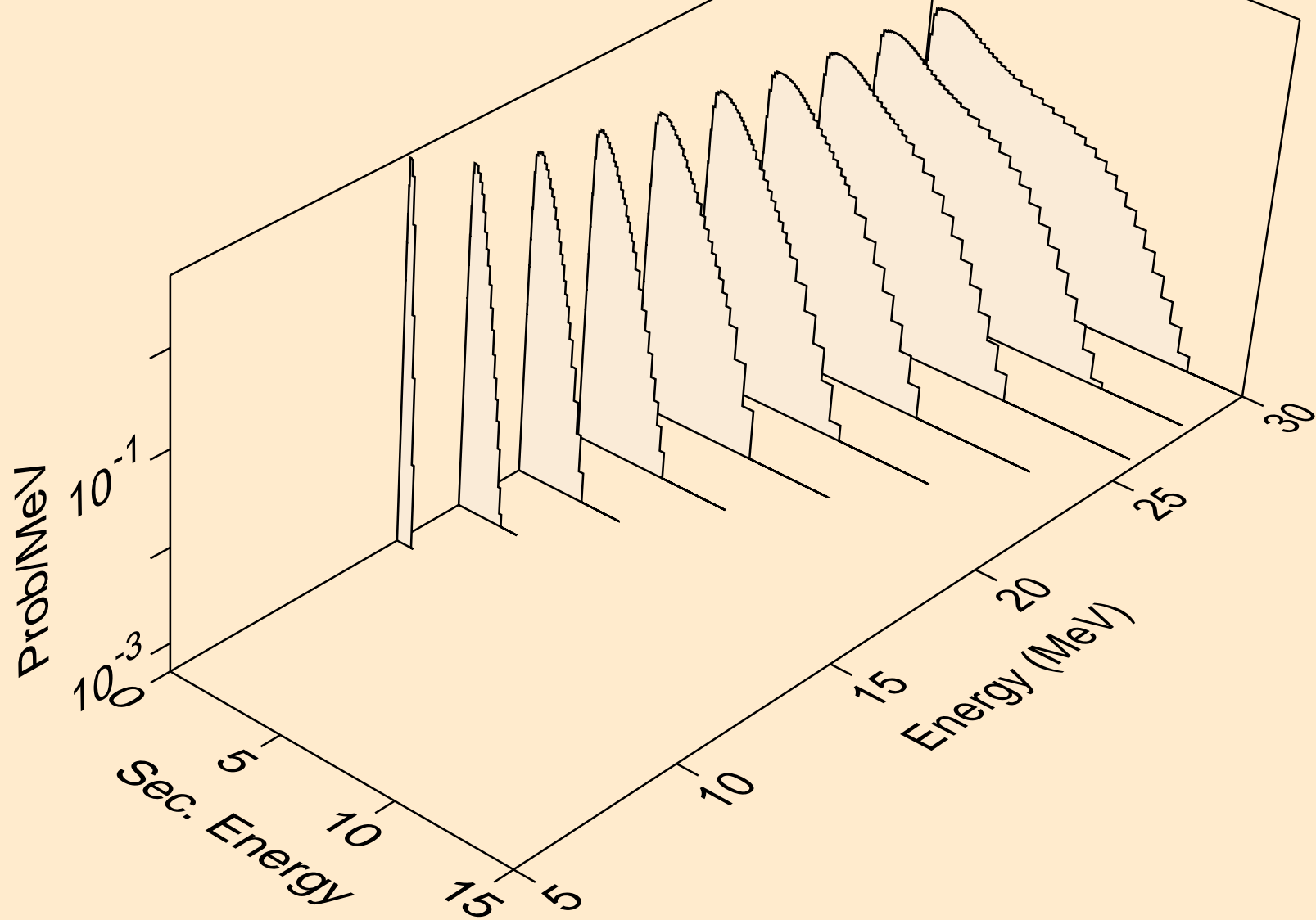

CS116M NEUTRON ACER TENDL-2024 LIBRARY; T=0.K
Neutron emission for (n,n*)p

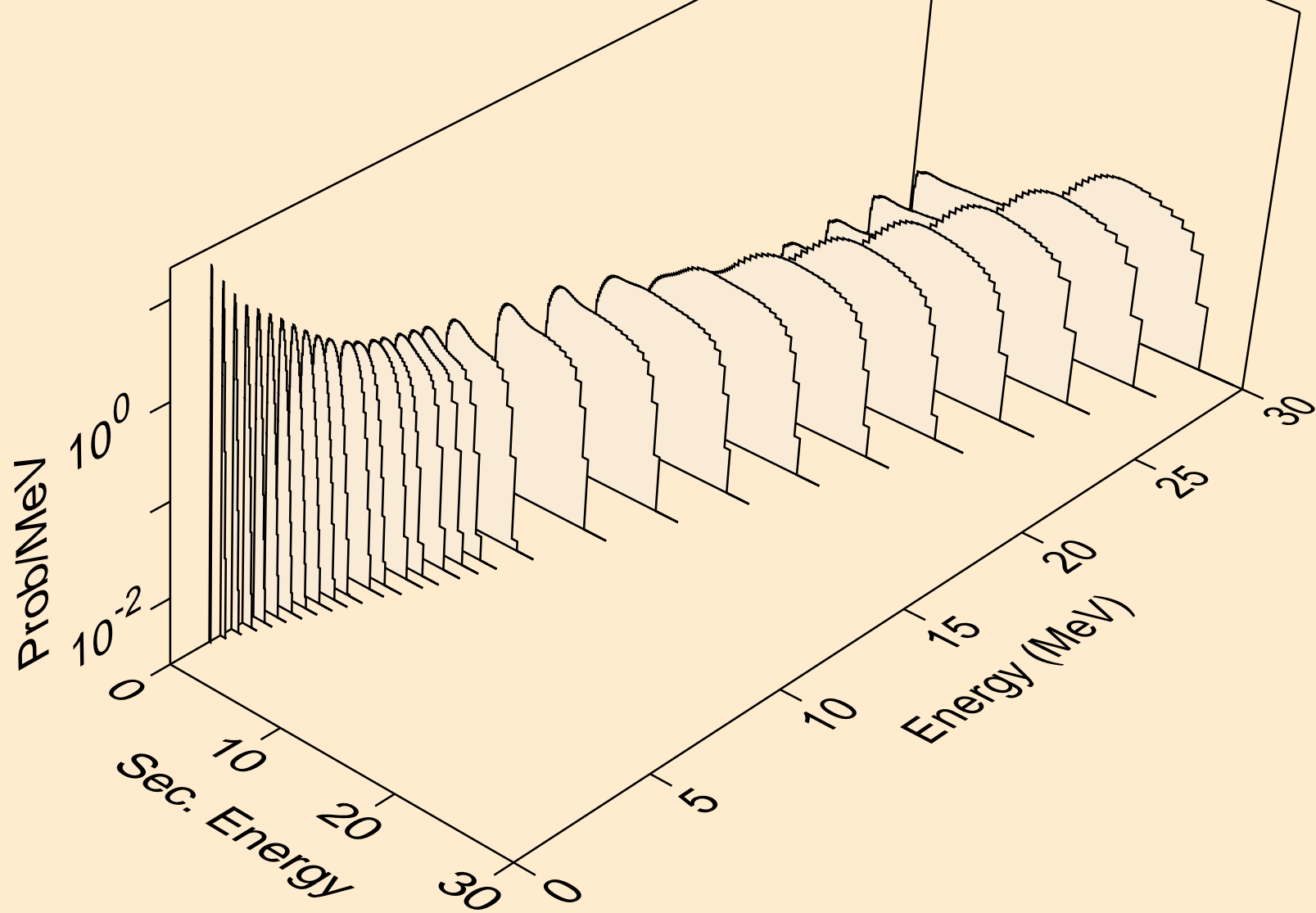

CS116M NEUTRON ACER TENDL-2024 LIBRARY; T=0.K
Neutron emission for (n,n*)2a

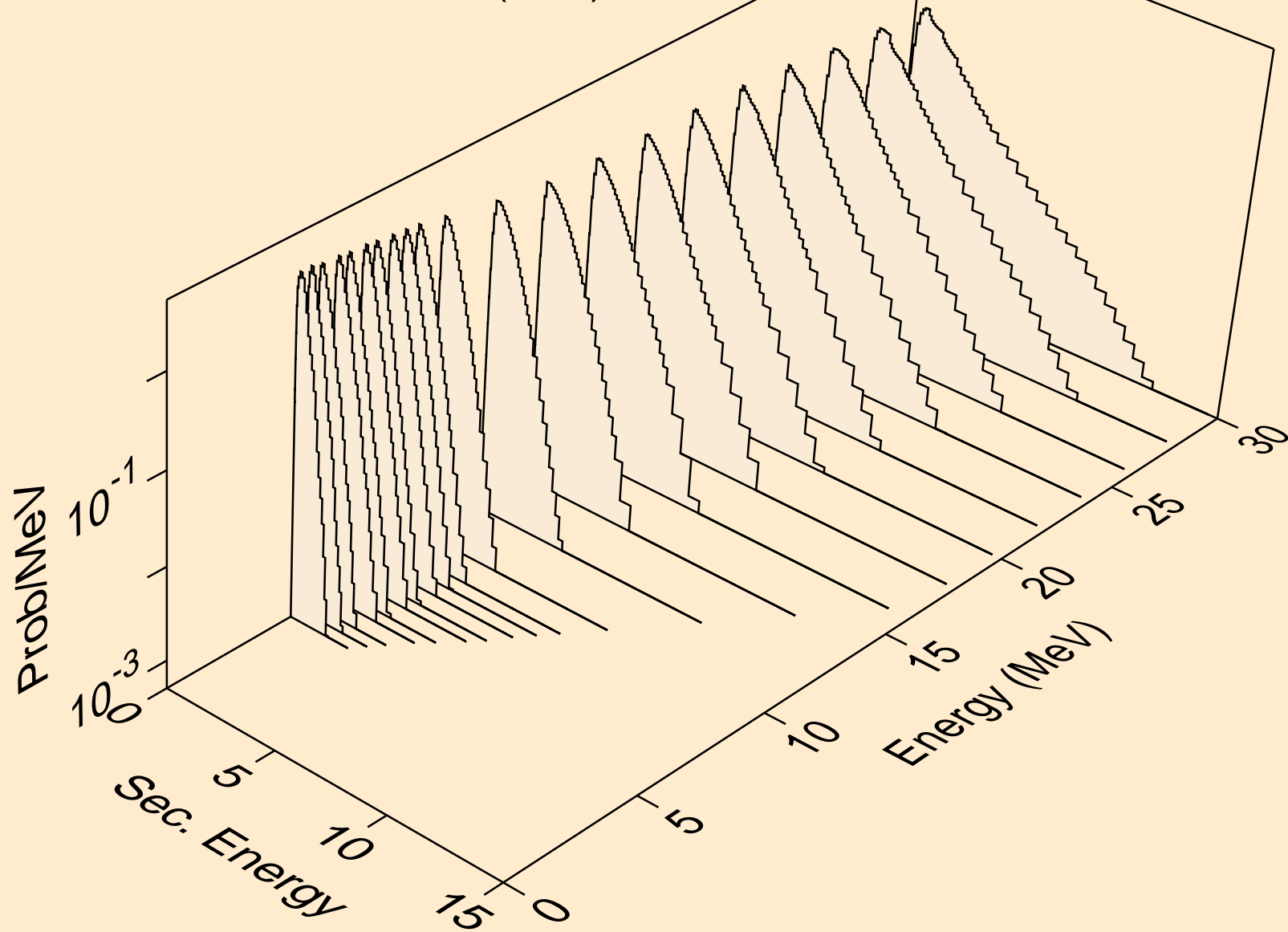

CS116M NEUTRON ACER TENDL-2024 LIBRARY; T=0.K
Neutron emission for (n,2n)2a

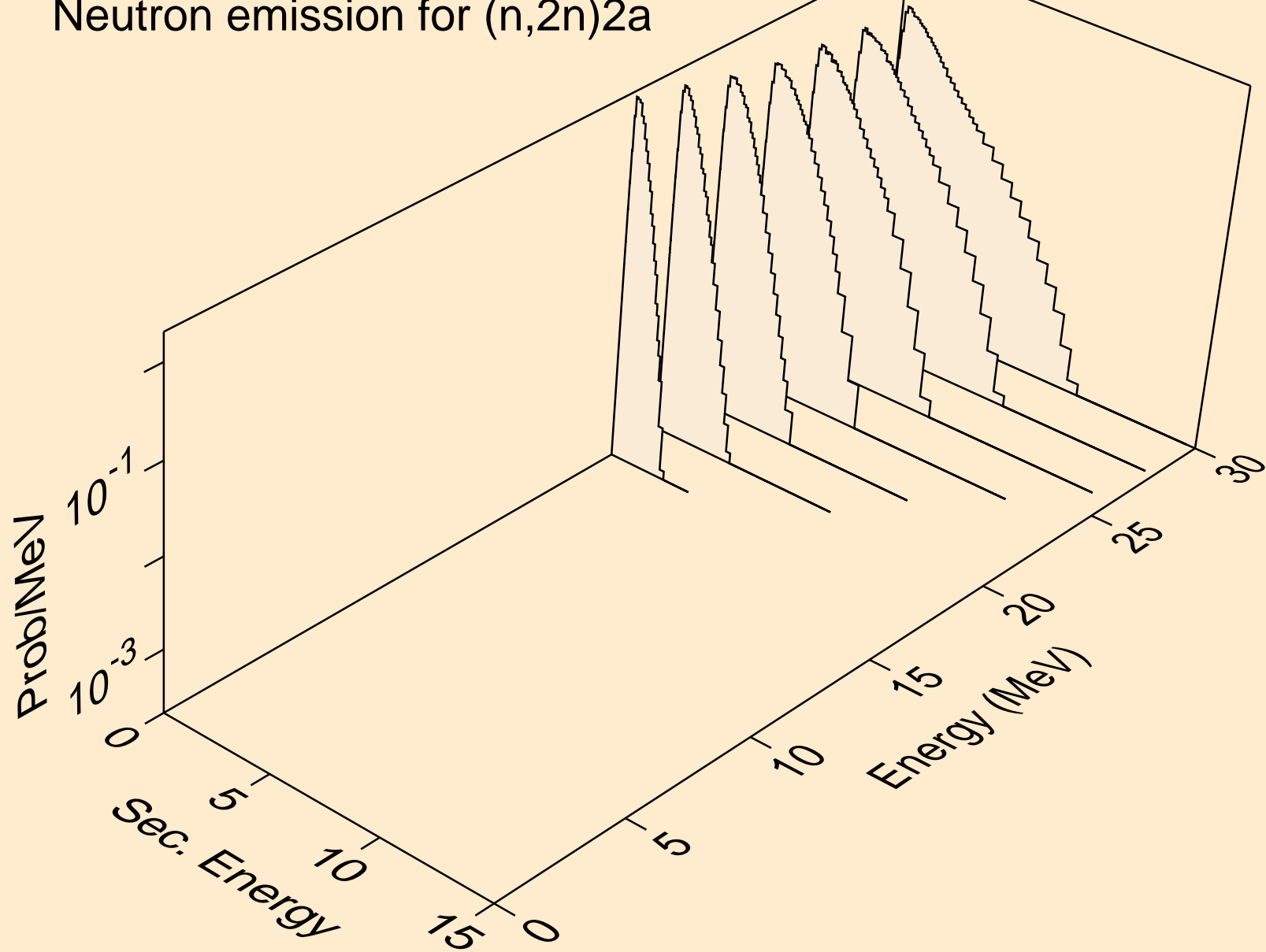

CS116M NEUTRON ACER TENDL-2024 LIBRARY; T=0.K
Neutron emission for (n,n*)d

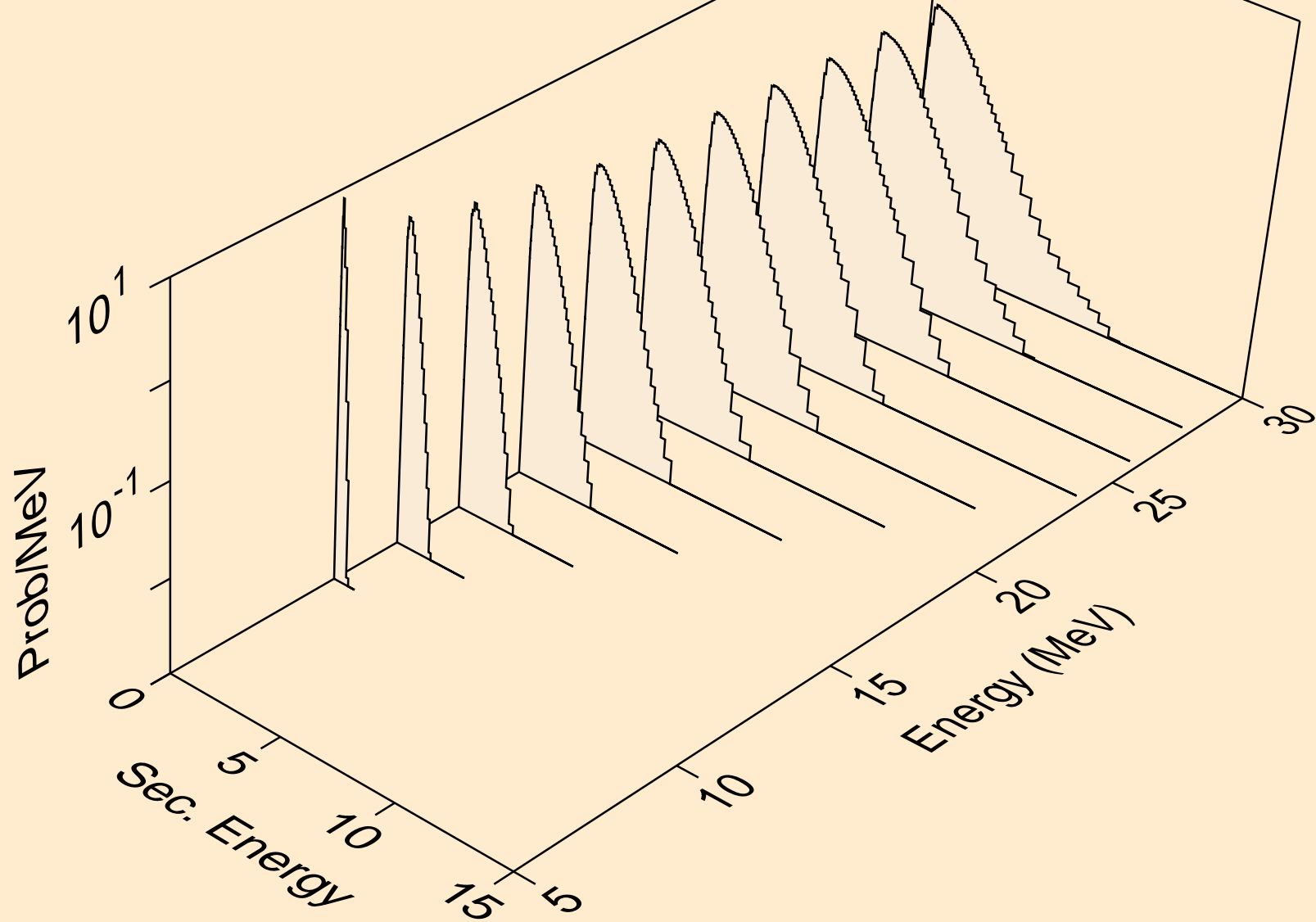

CS116M NEUTRON ACER TENDL-2024 LIBRARY; T=0.K
Neutron emission for (n,n*)t

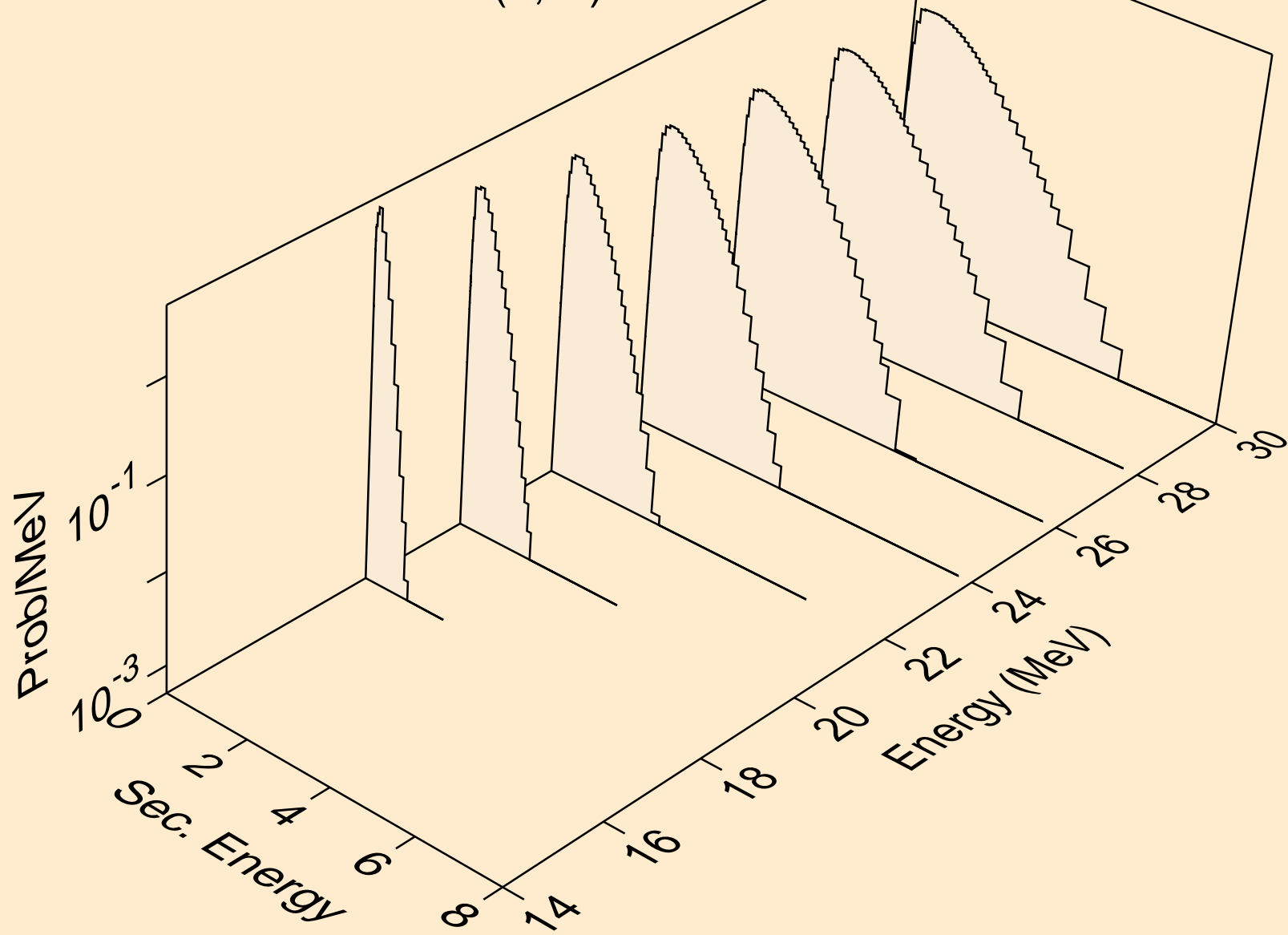

CS116M NEUTRON ACER TENDL-2024 LIBRARY; T=0.K
Neutron emission for (n,n*)he3

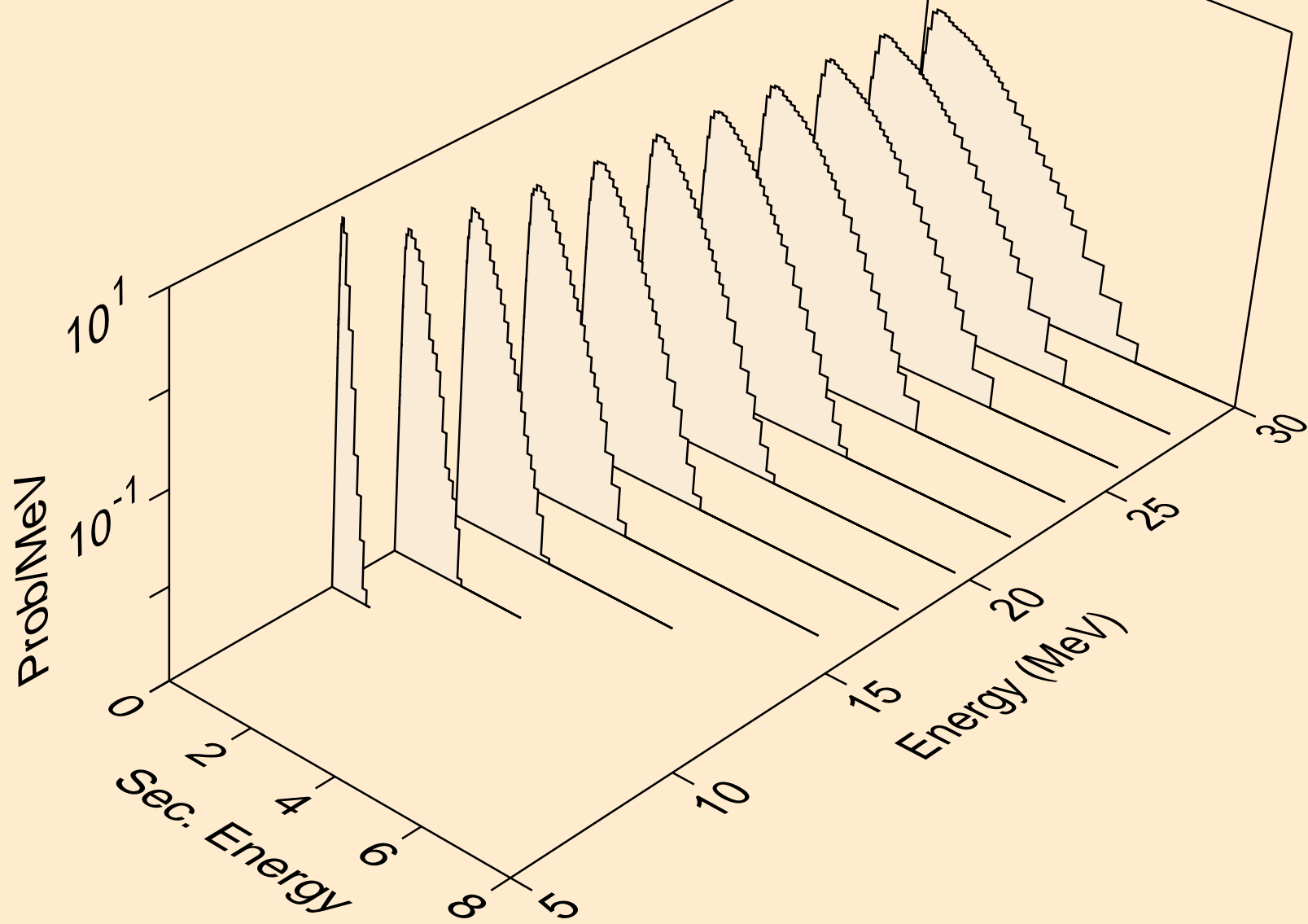

CS116M NEUTRON ACER TENDL-2024 LIBRARY; T=0.K
Neutron emission for (n,2np)

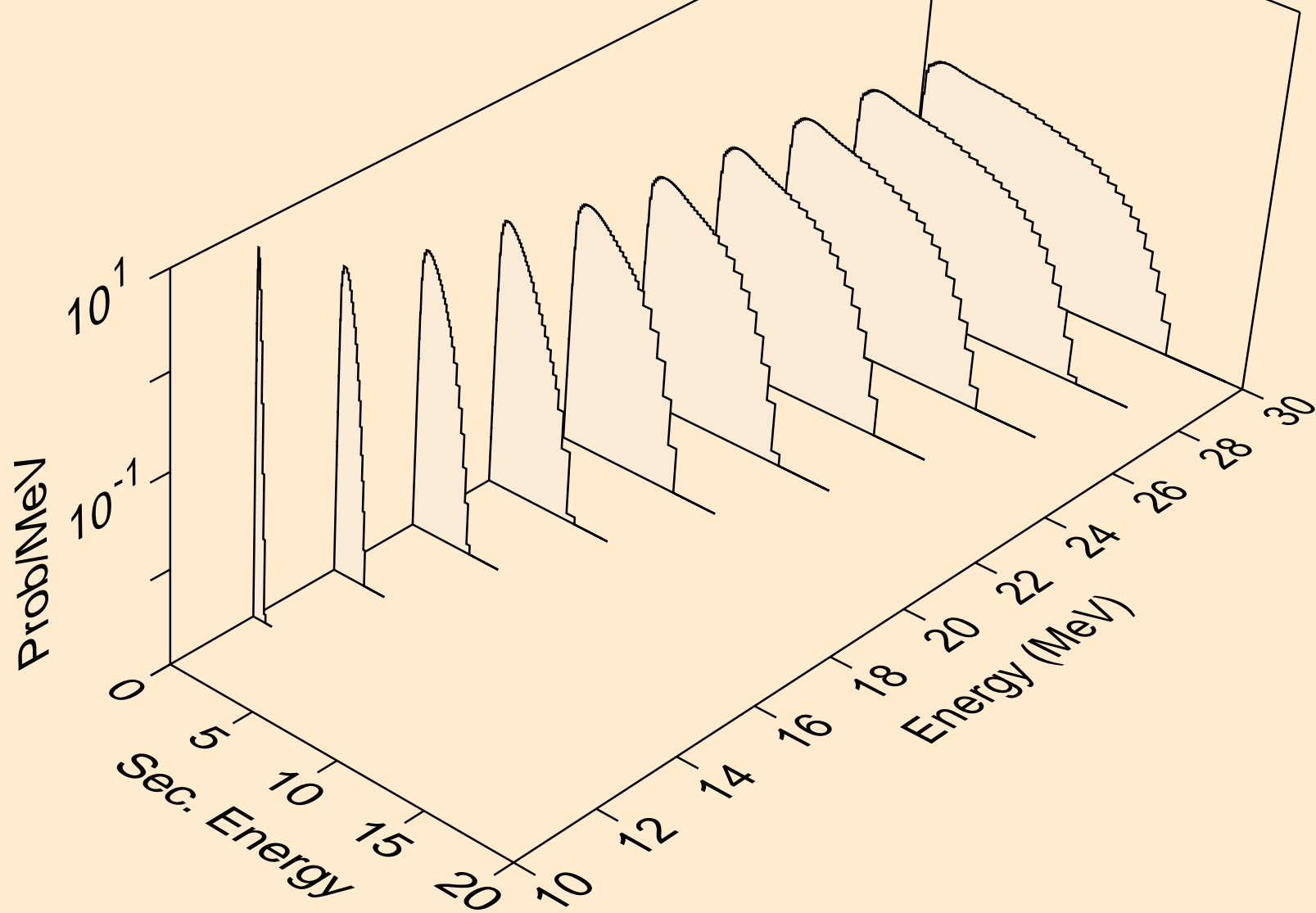

CS116M NEUTRON ACER TENDL-2024 LIBRARY; T=0.K
Neutron emission for (n,3np)

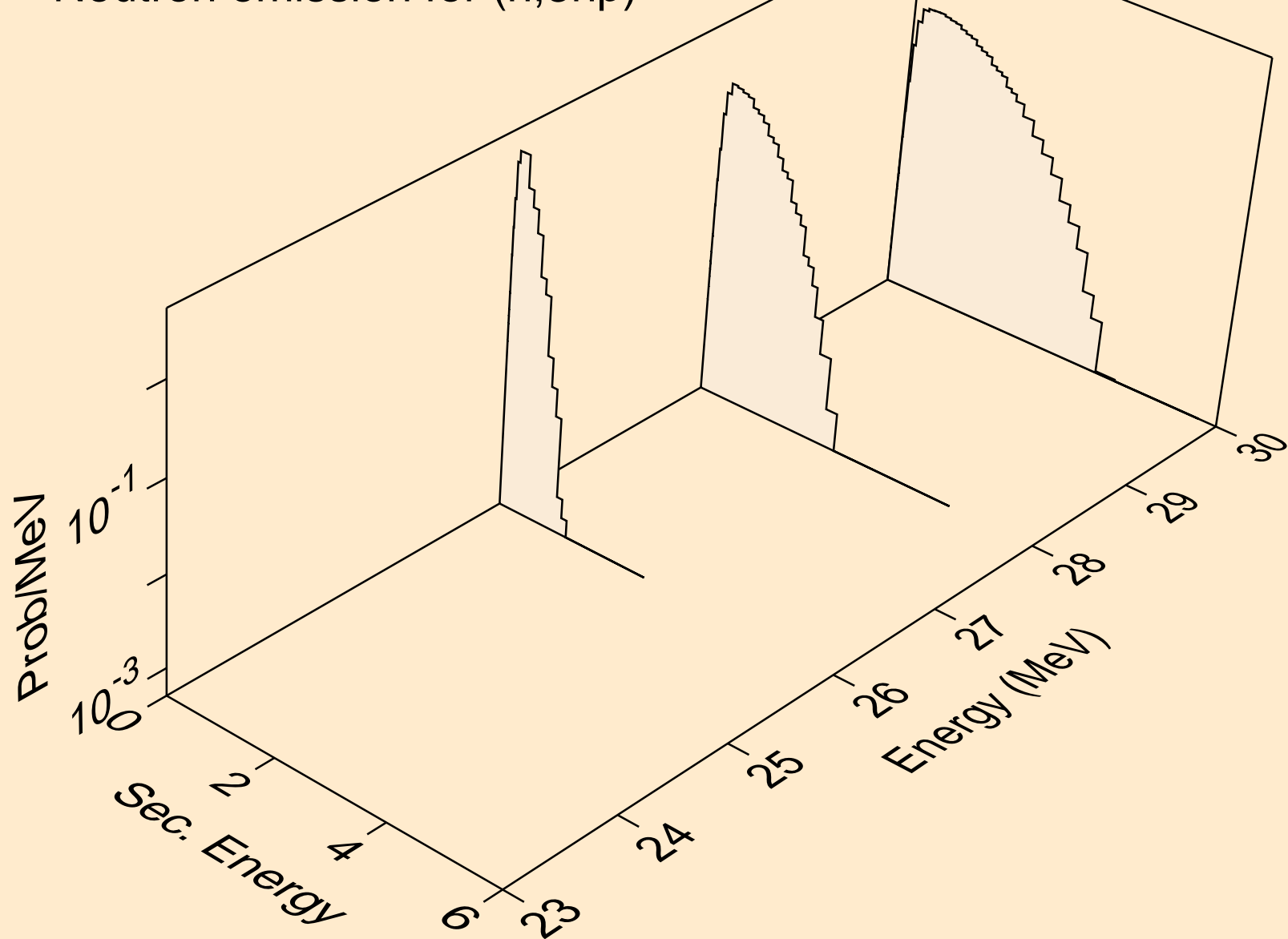

CS116M NEUTRON ACER TENDL-2024 LIBRARY; T=0.K
Neutron emission for (n,n2p)

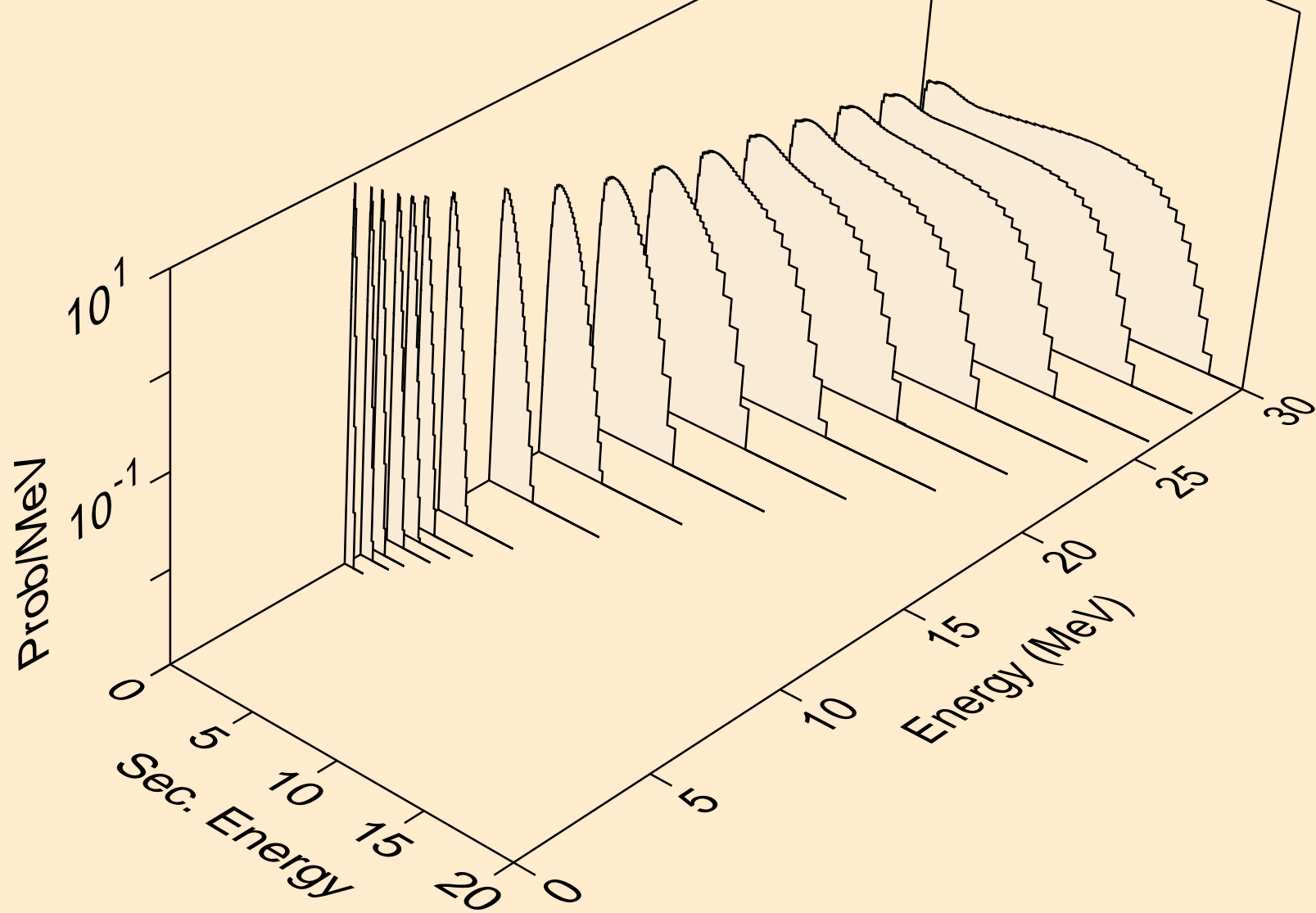

CS116M NEUTRON ACER TENDL-2024 LIBRARY; T=0.K
Neutron emission for (n,npa)

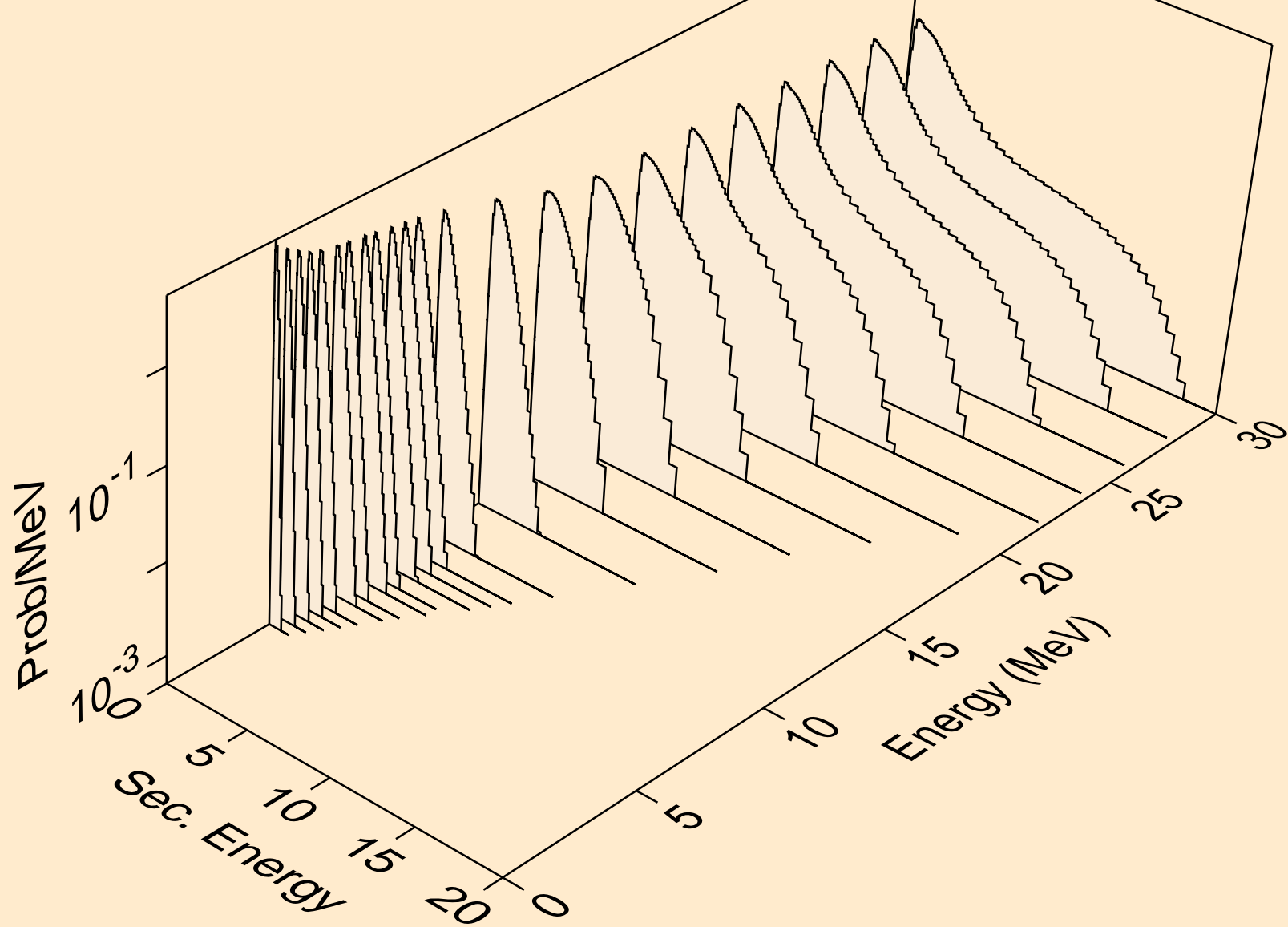

CS116M NEUTRON ACER TENDL-2024 LIBRARY; T=0.K
Neutron emission for (n,n*c)

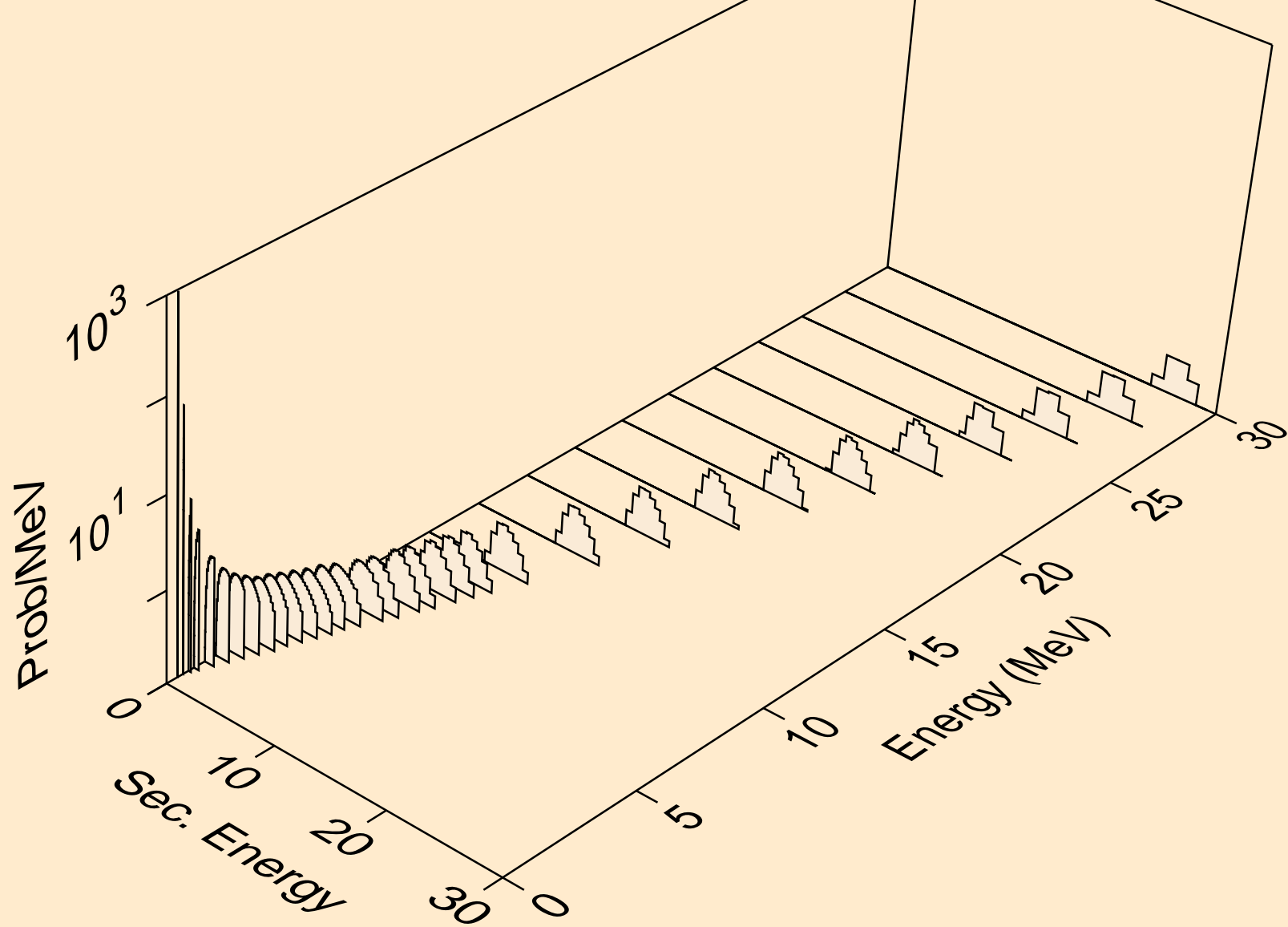

CS116M NEUTRON ACER TENDL-2024 LIBRARY; T=0.K
Photon emission for (n,x)

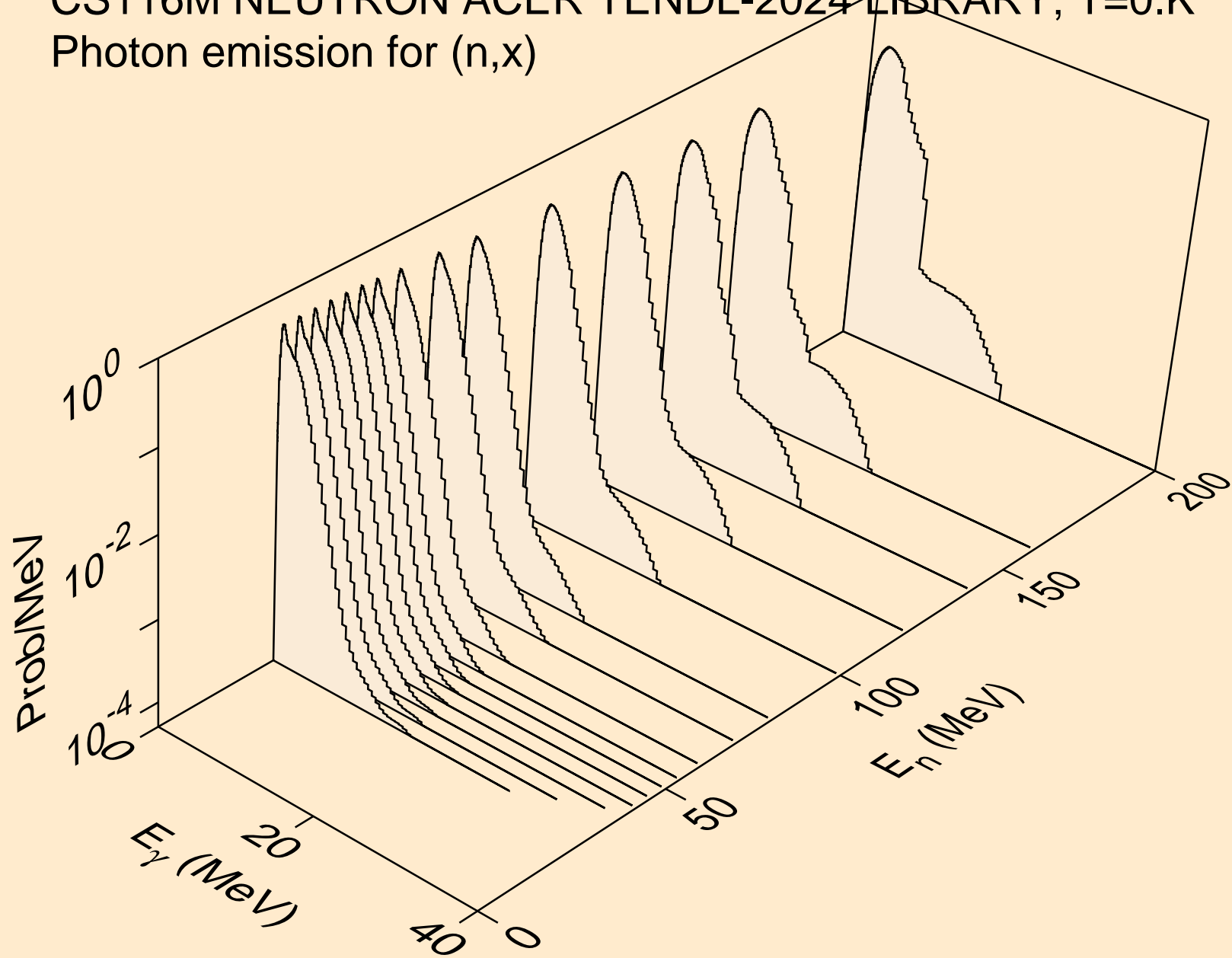

CS116M NEUTRON ACER TENDL-2024 LIBRARY; T=0.K
Photon emission for (n,2nd)

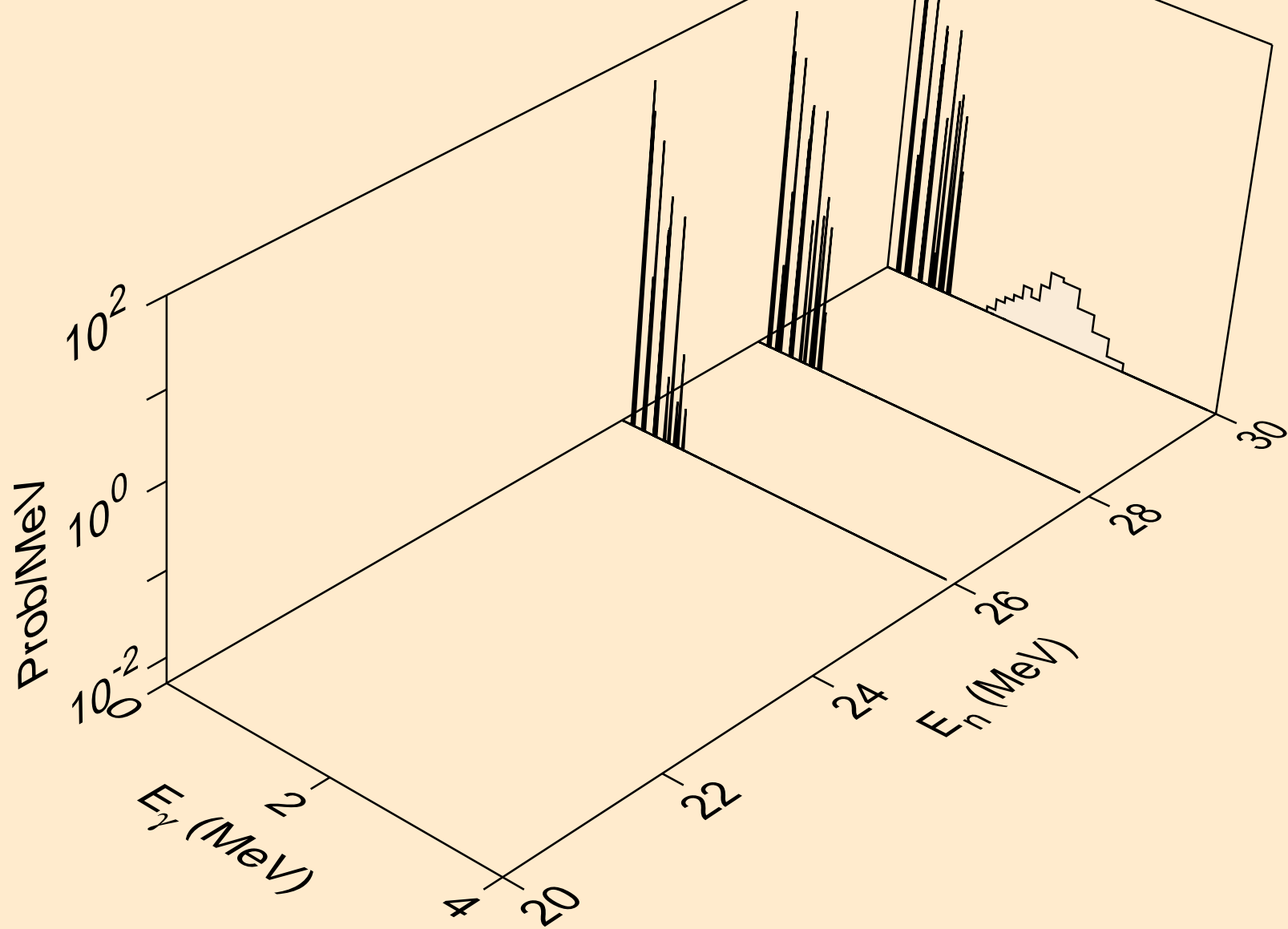

CS116M NEUTRON ACER TENDL-2024 LIBRARY; T=0.K
Photon emission for (n,2n)

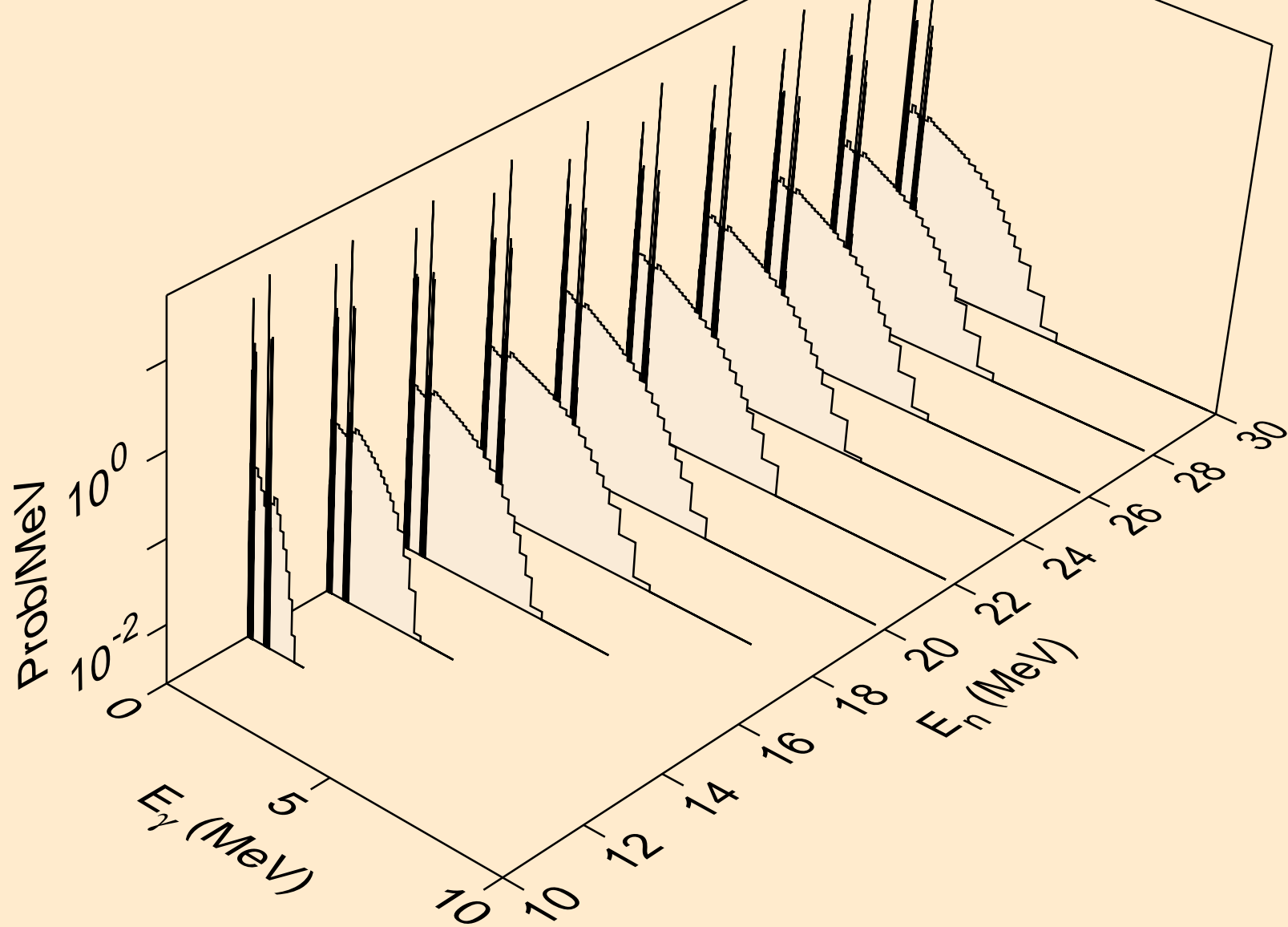

CS116M NEUTRON ACER TENDL-2024 LIBRARY; T=0.K
Photon emission for (n,3n)

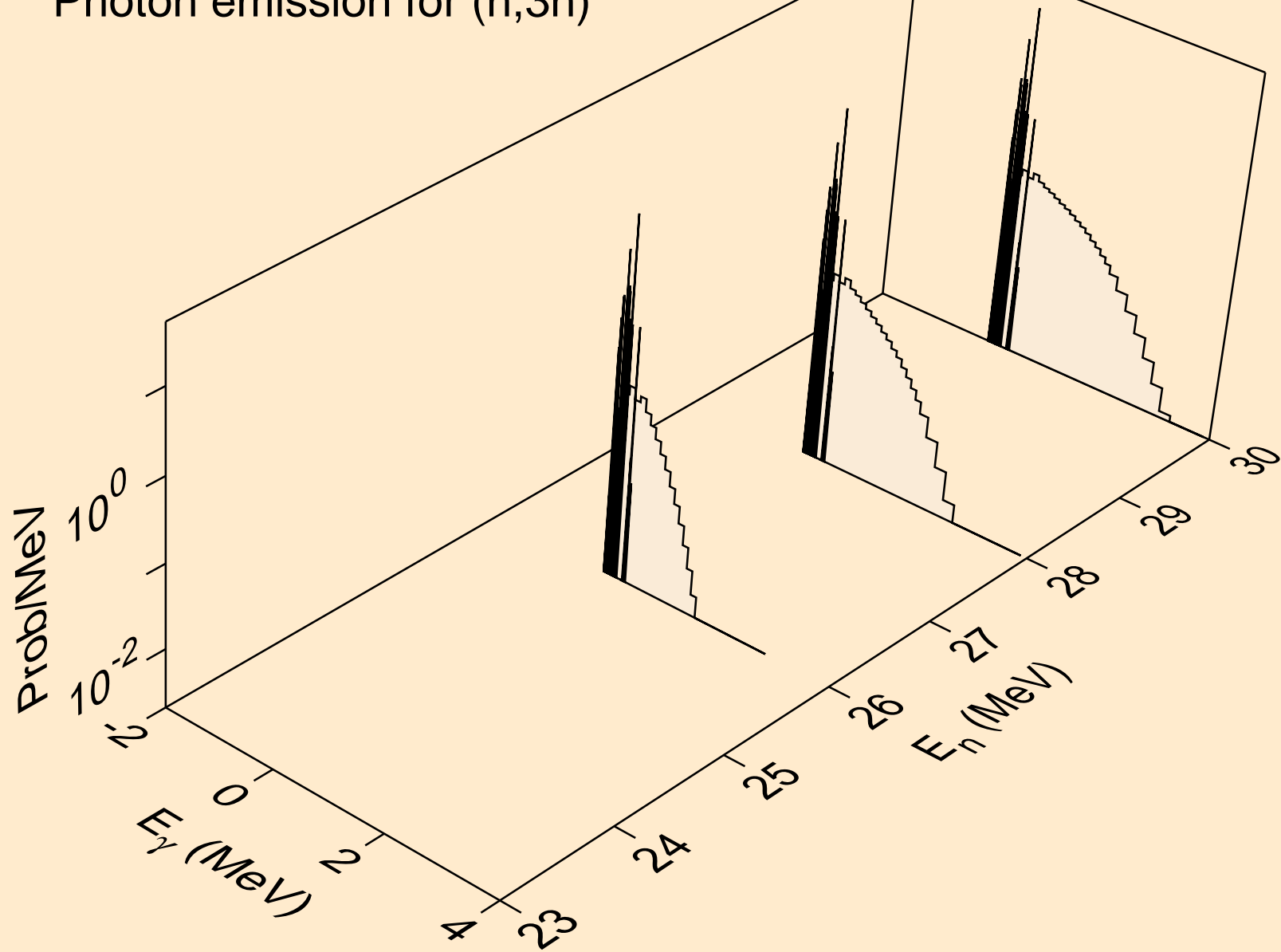

CS116M NEUTRON ACER TENDL-2024 LIBRARY; T=0.K
Photon emission for (n,n*)a

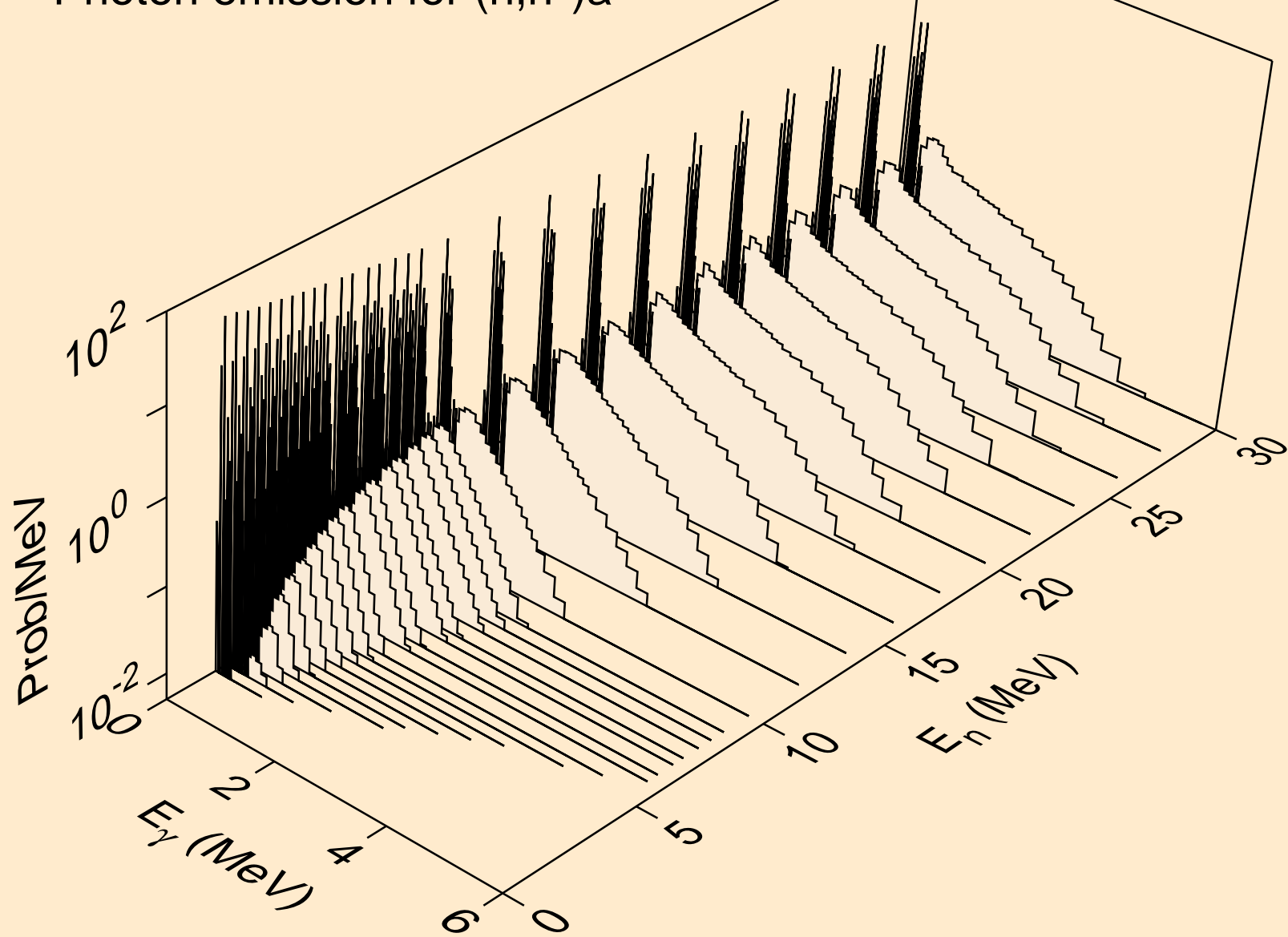

CS116M NEUTRON ACER TENDL-2024 LIBRARY; T=0.K
Photon emission for (n,n*)3a

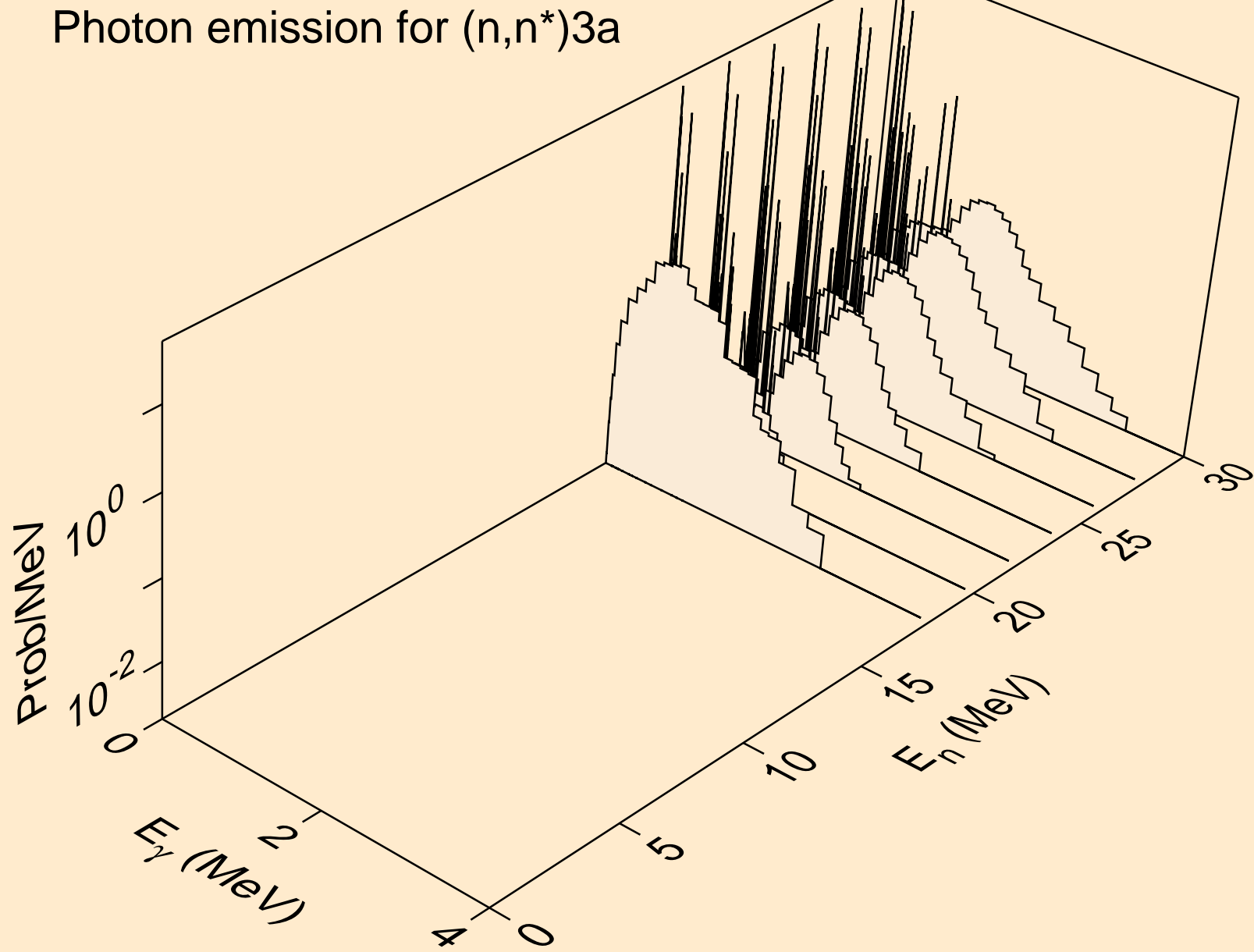

CS116M NEUTRON ACER TENDL-2024 LIBRARY; T=0.K
Photon emission for (n,2n)a

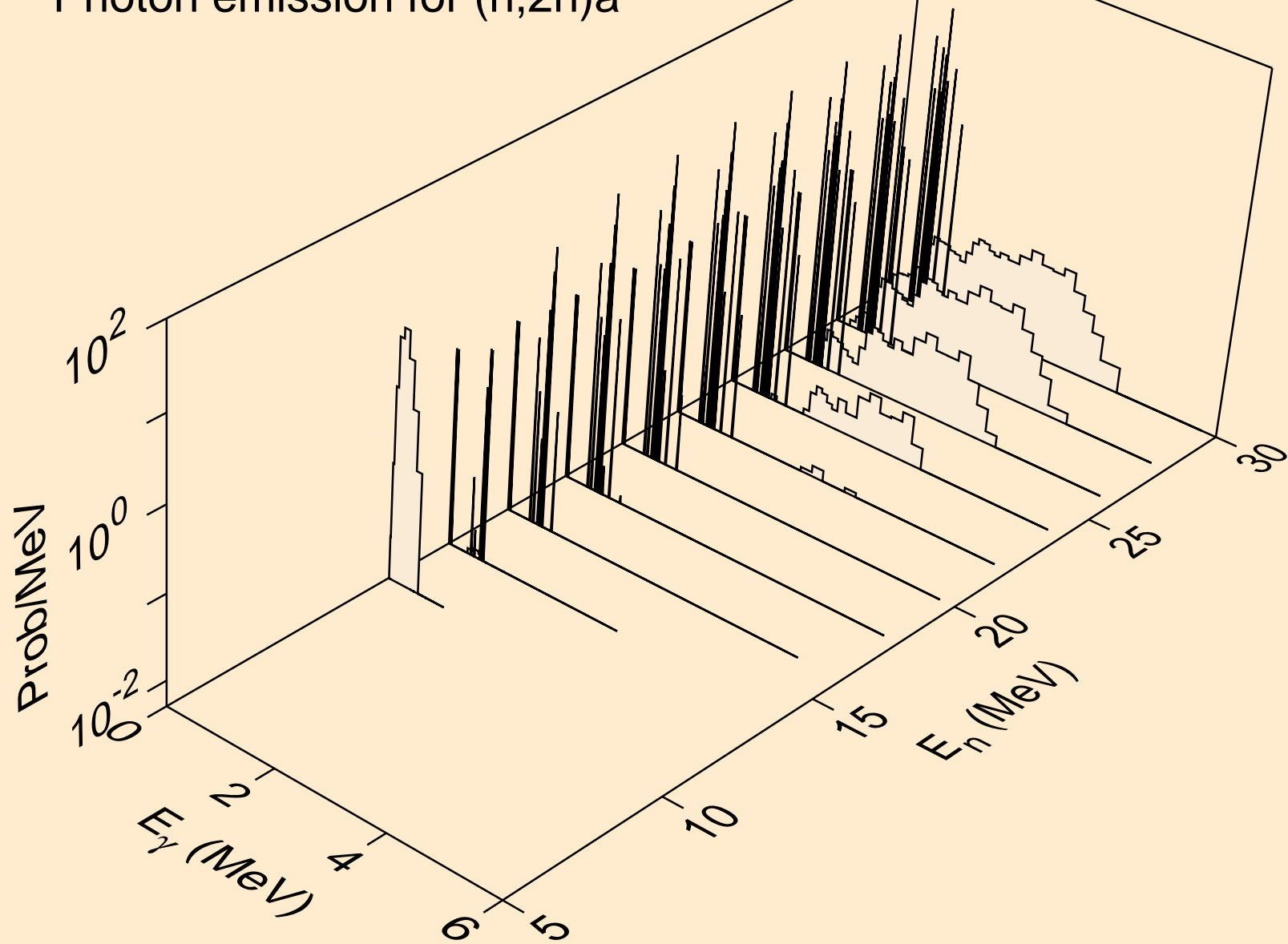

CS116M NEUTRON ACER TENDL-2024 LIBRARY; T=0.K
Photon emission for (n,n*)p

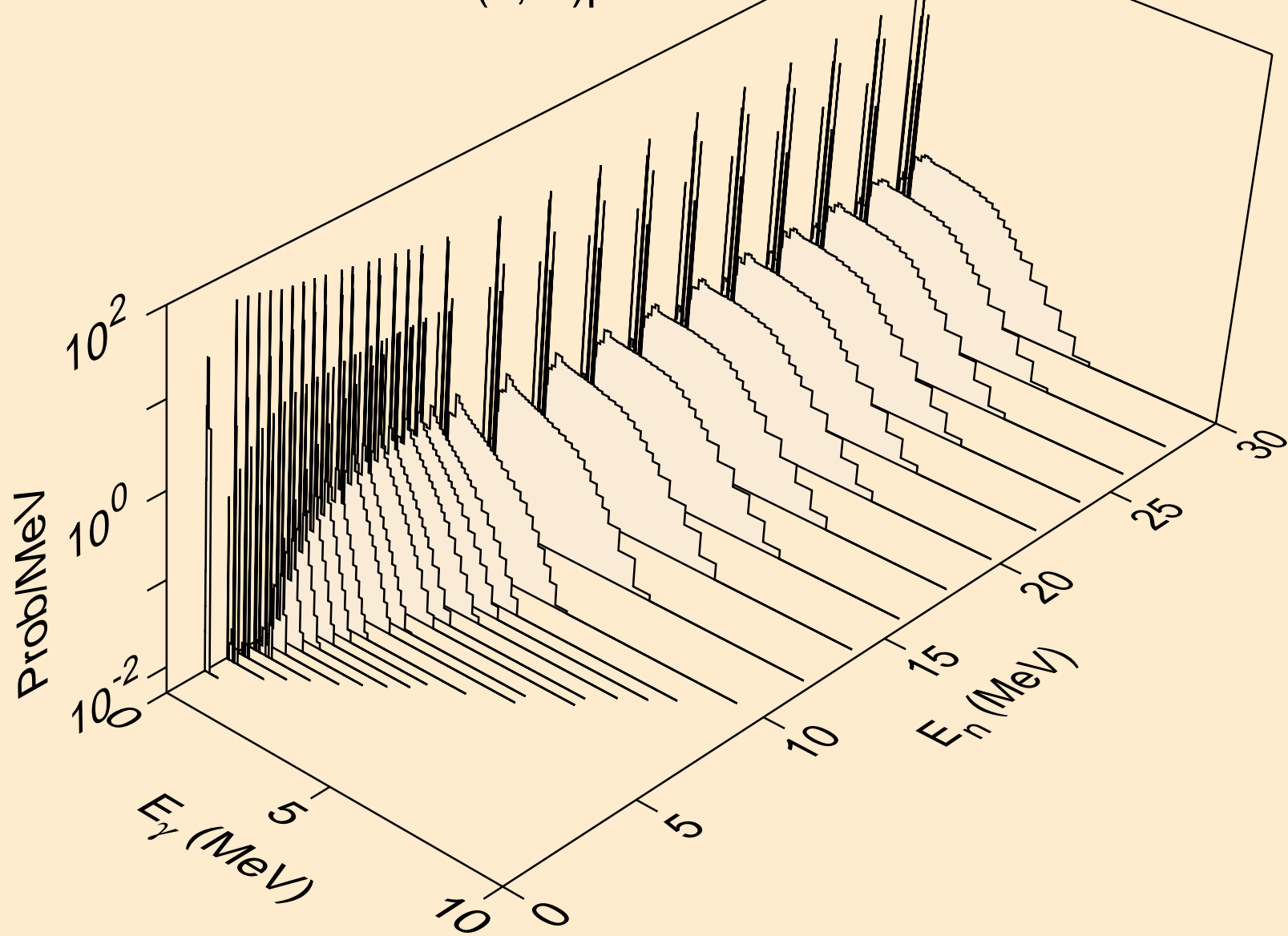

CS116M NEUTRON ACER TENDL-2024 LIBRARY; T=0.K
Photon emission for (n,n*)2a

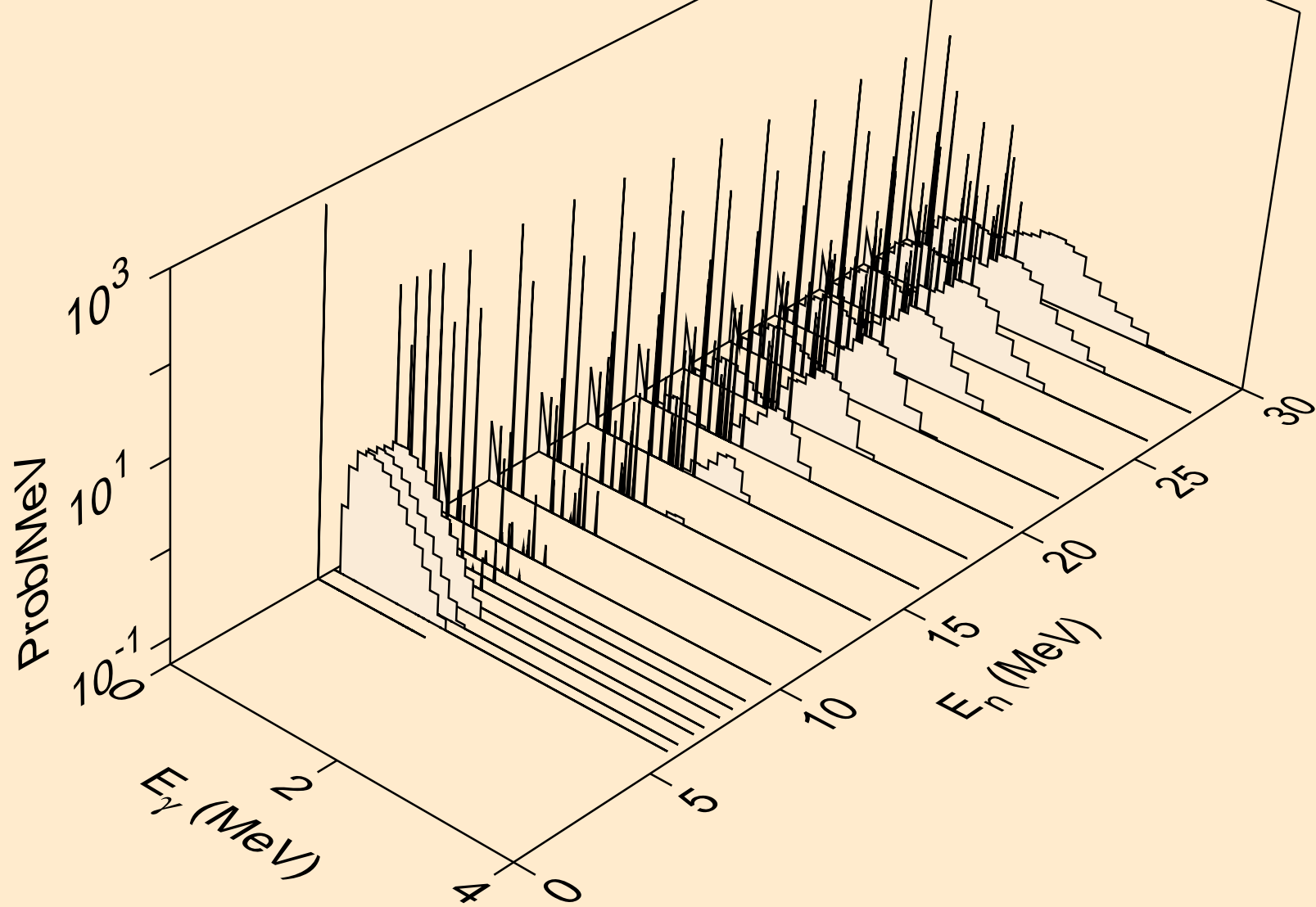

CS116M NEUTRON ACER TENDL-2024 LIBRARY; T=0.K
Photon emission for (n,2n)2a

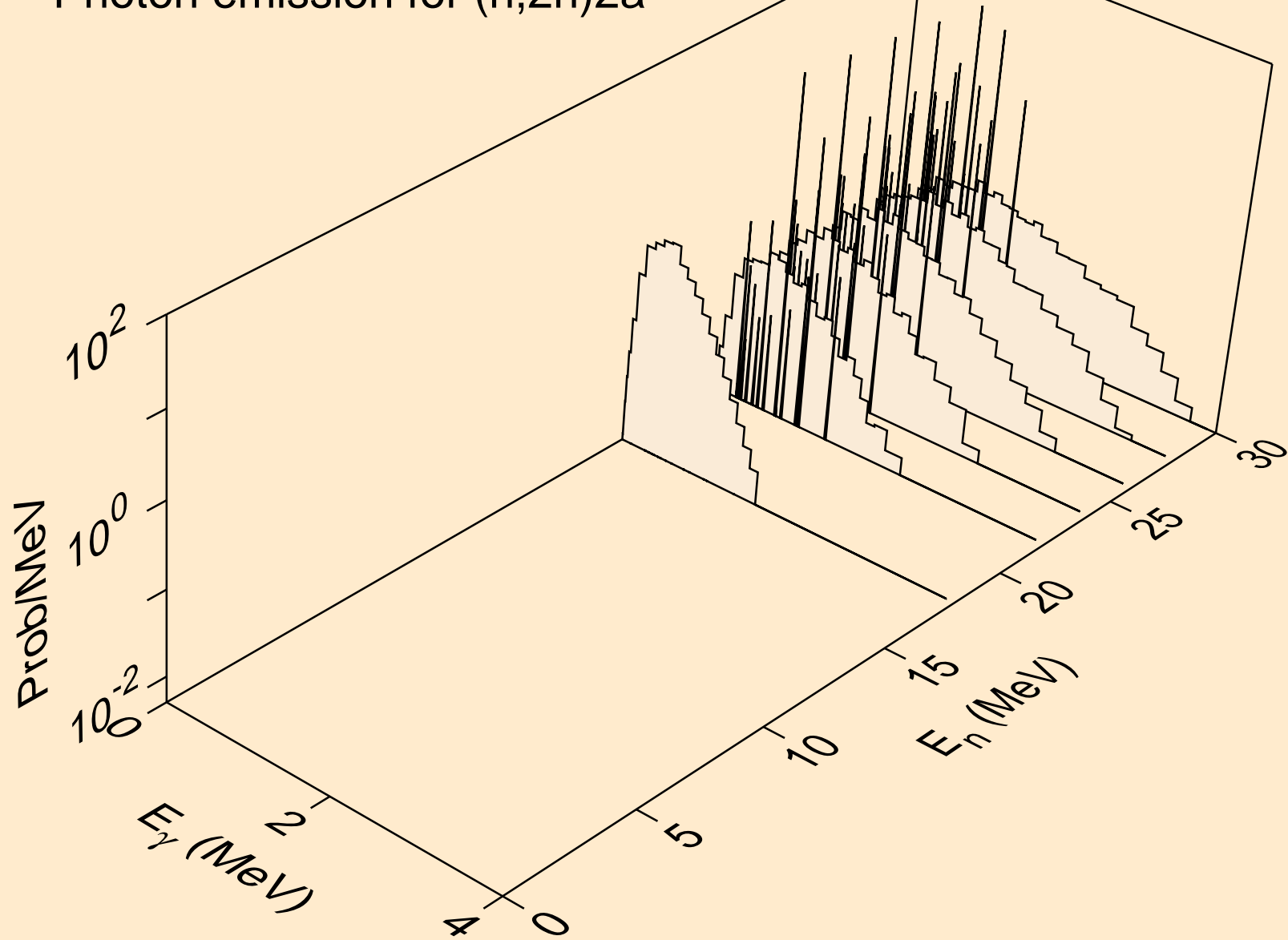

CS116M NEUTRON ACER TENDL-2024 LIBRARY; T=0.K
Photon emission for (n,n*)d

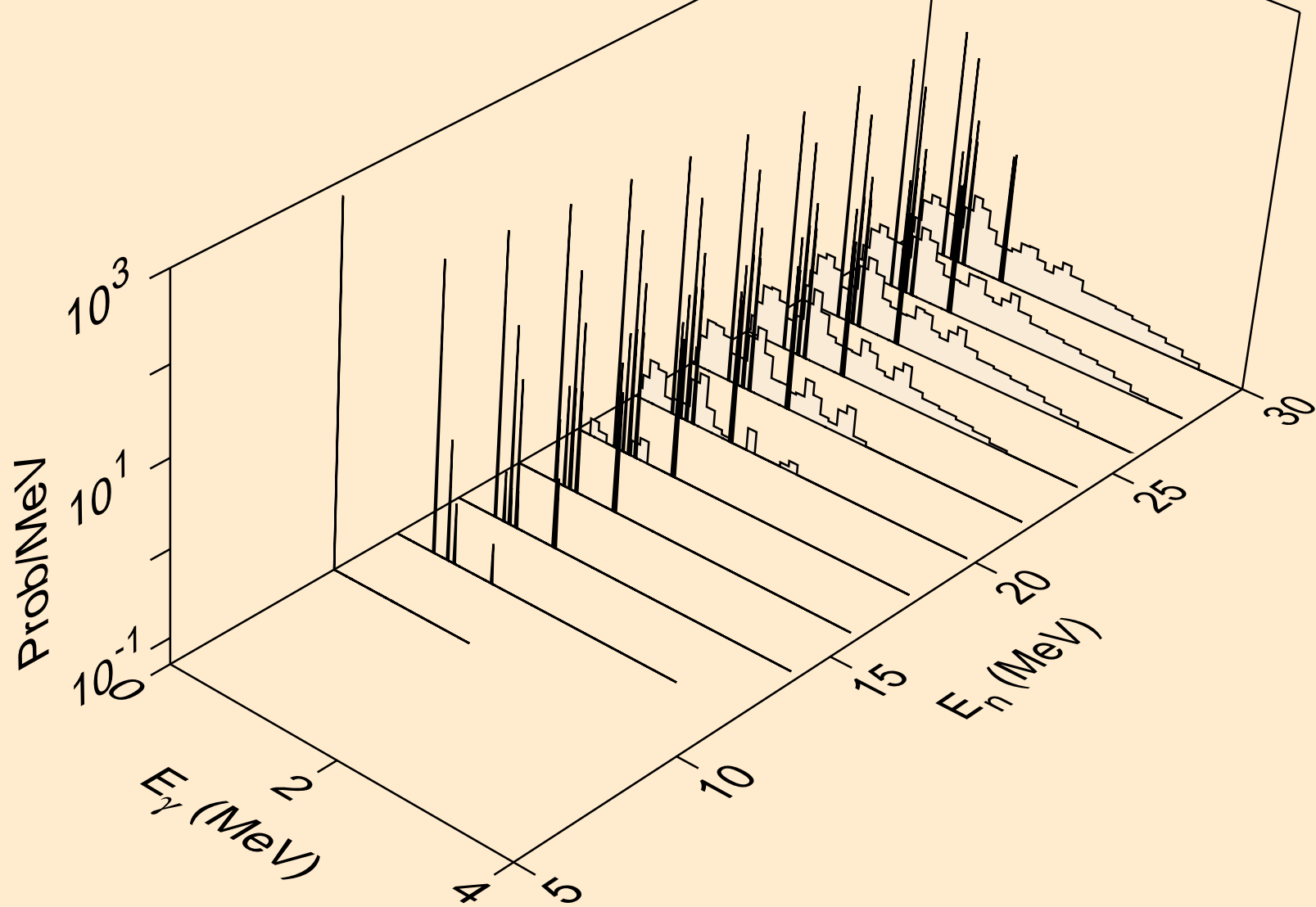

CS116M NEUTRON ACER TENDL-2024 LIBRARY; T=0.K
Photon emission for (n,n*)t

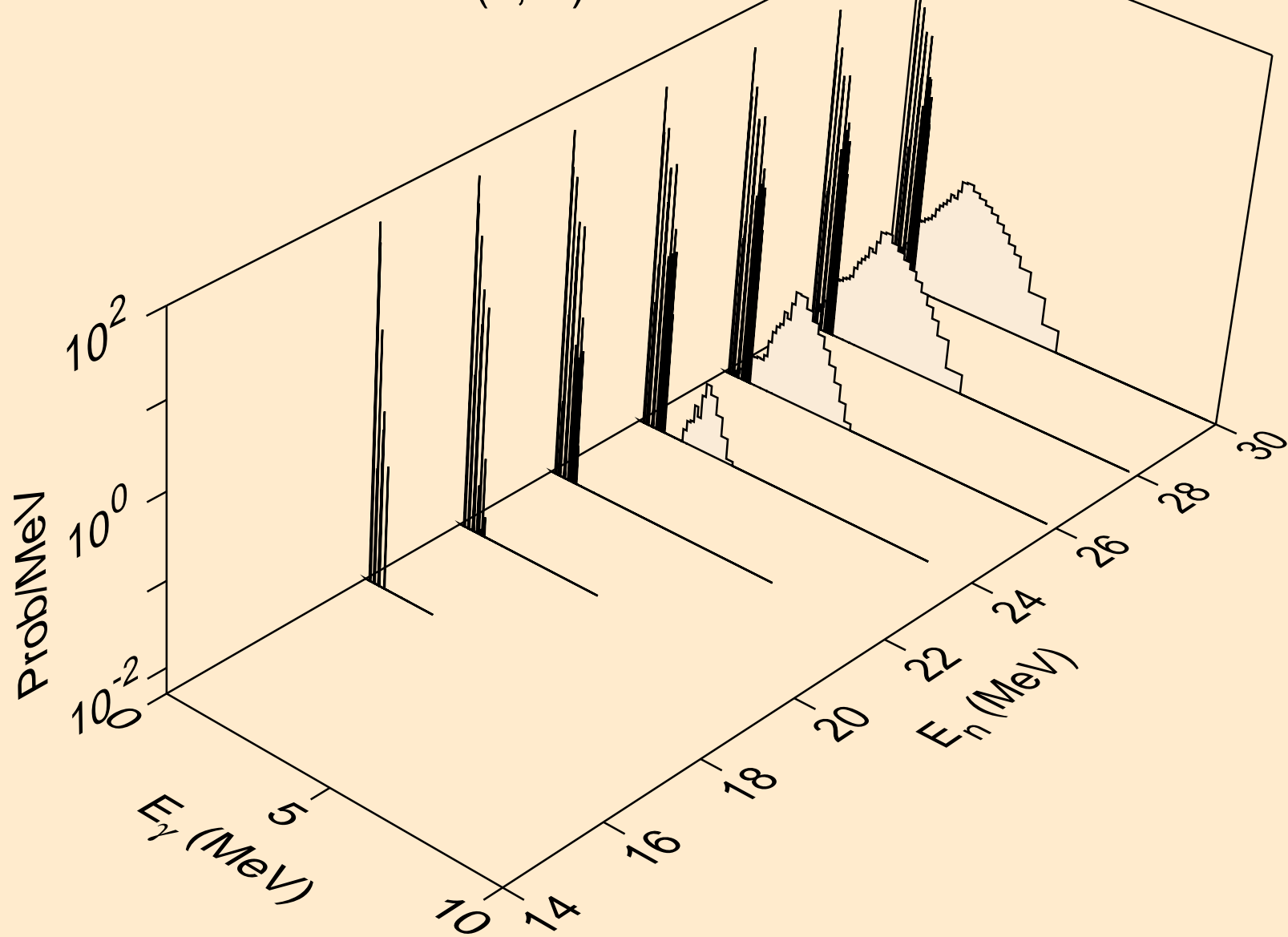

CS116M NEUTRON ACER TENDL-2024 LIBRARY; T=0.K
Photon emission for (n,n*)he3

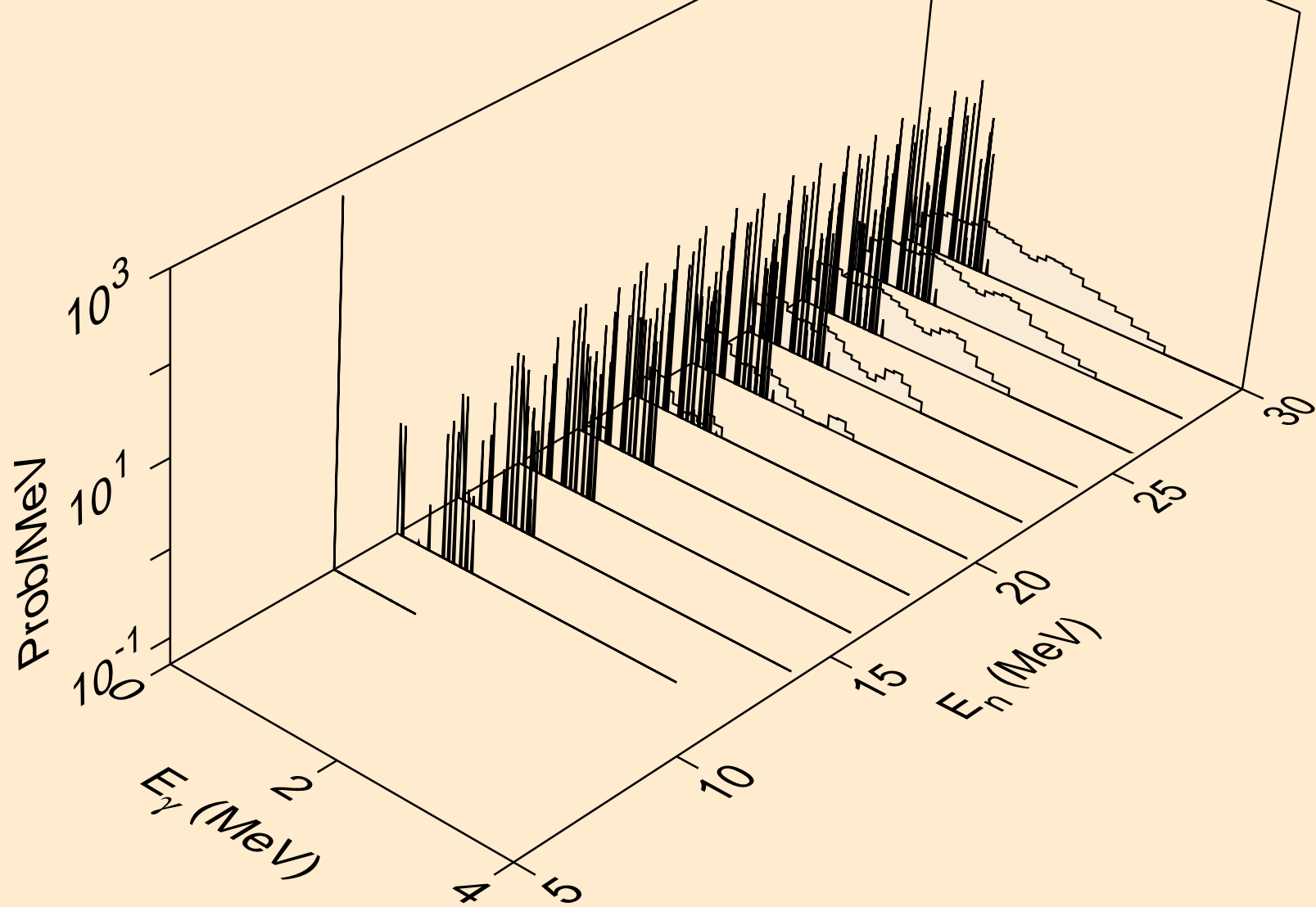

CS116M NEUTRON ACER TENDL-2024 LIBRARY; T=0.K
Photon emission for (n,2np)

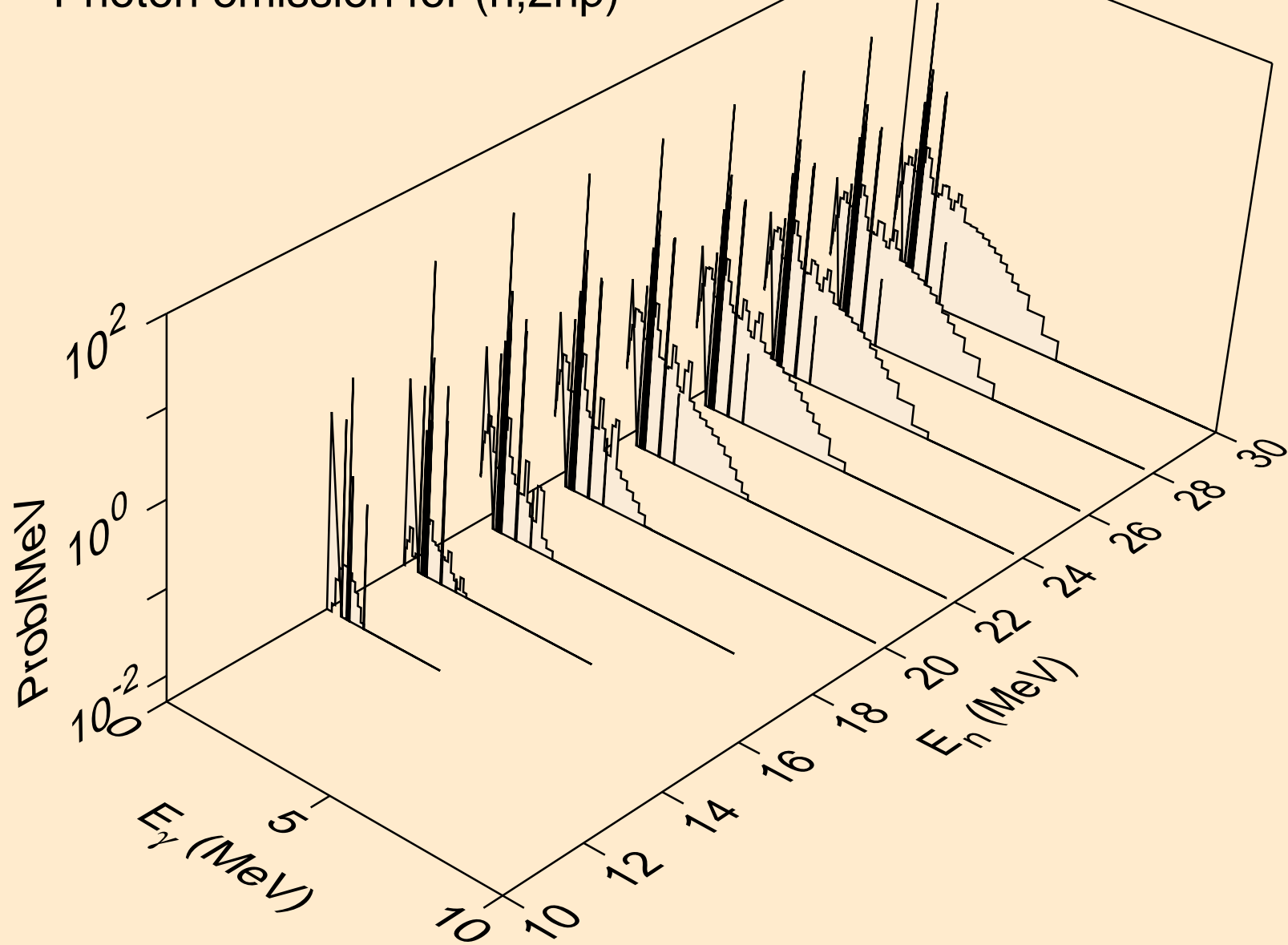

CS116M NEUTRON ACER TENDL-2024 LIBRARY; T=0.K
Photon emission for (n,3np)

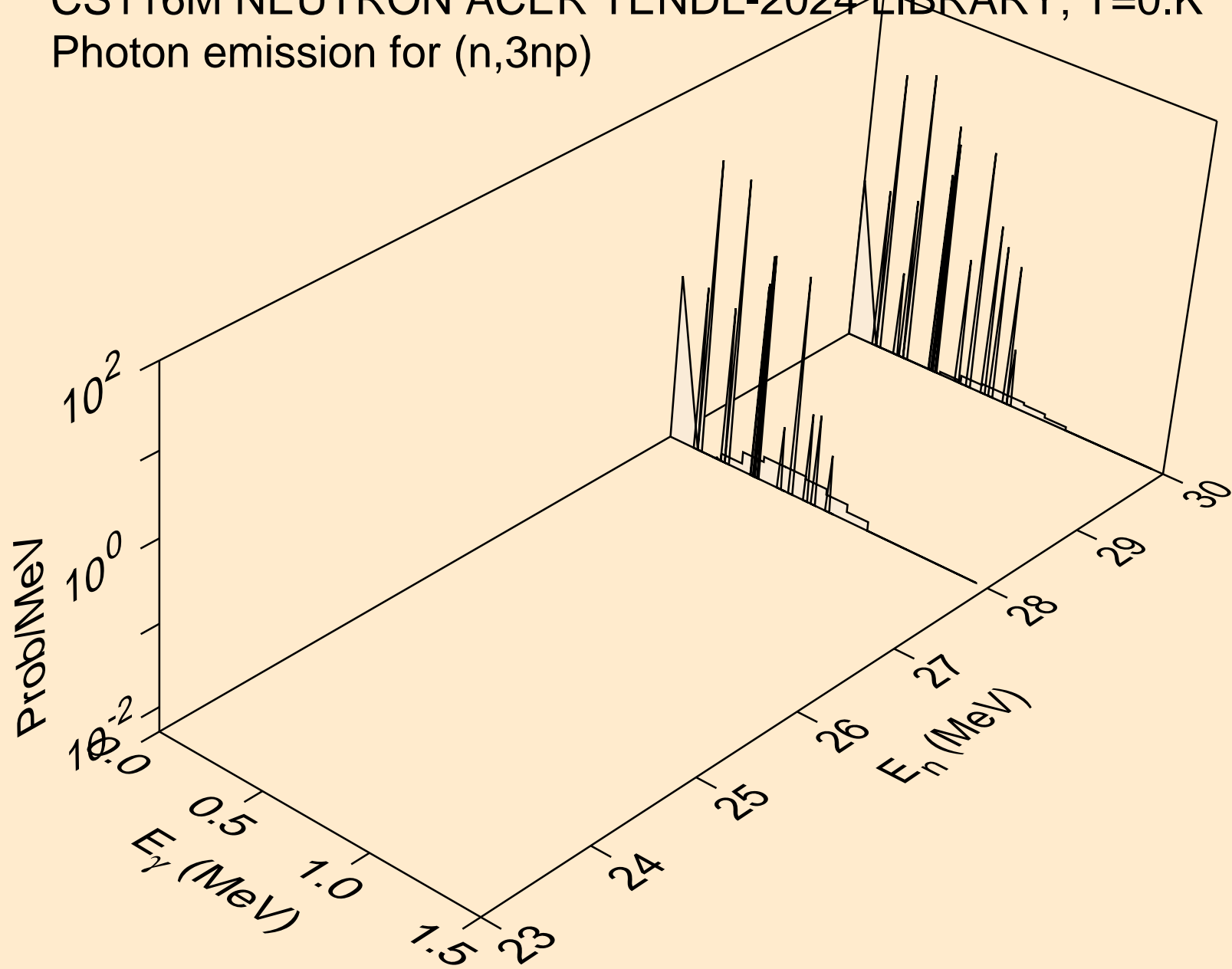

CS116M NEUTRON ACER TENDL-2024 LIBRARY; T=0.K
Photon emission for (n,n2p)

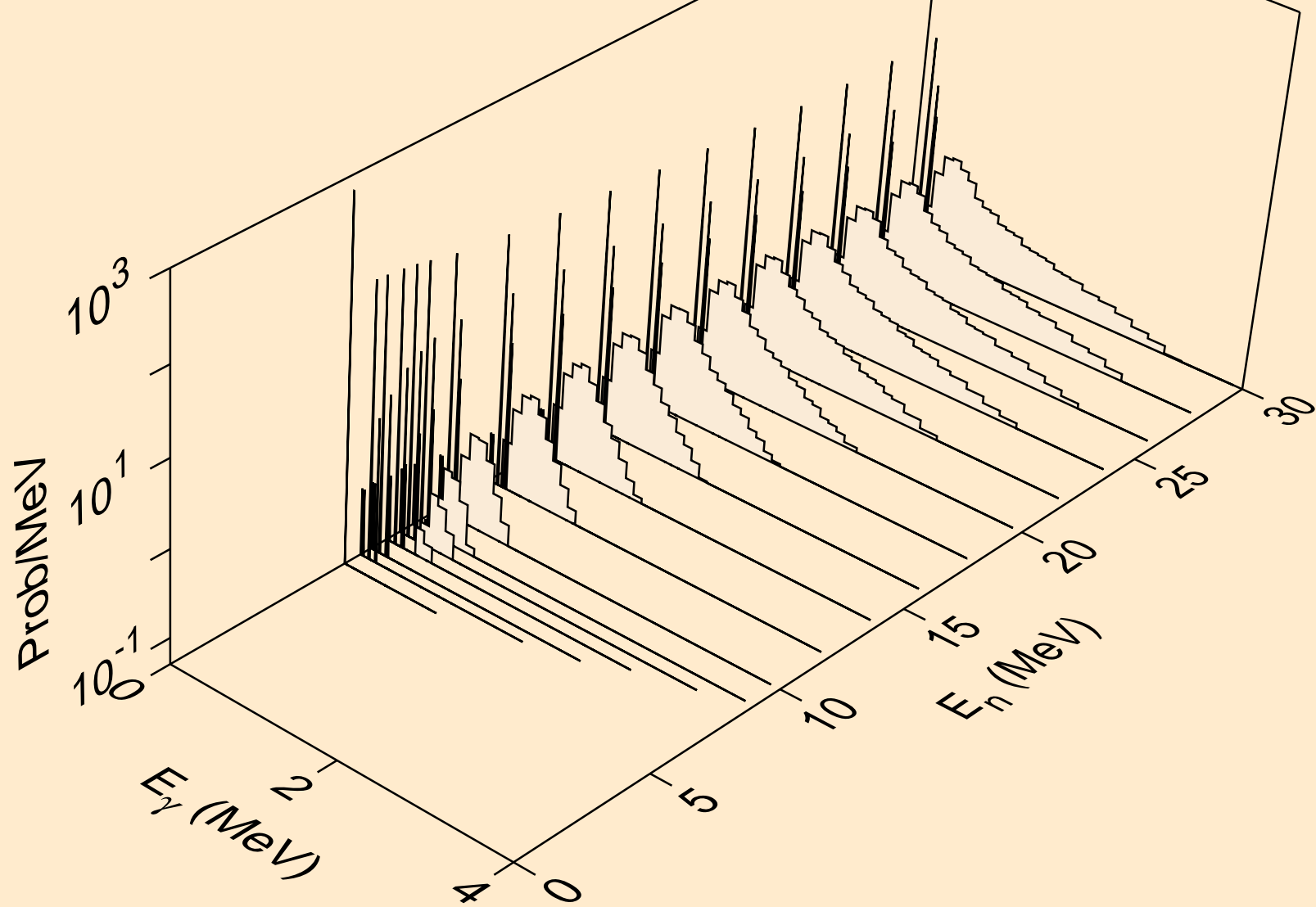

CS116M NEUTRON ACER TENDL-2024 LIBRARY; T=0.K
Photon emission for (n,npa)

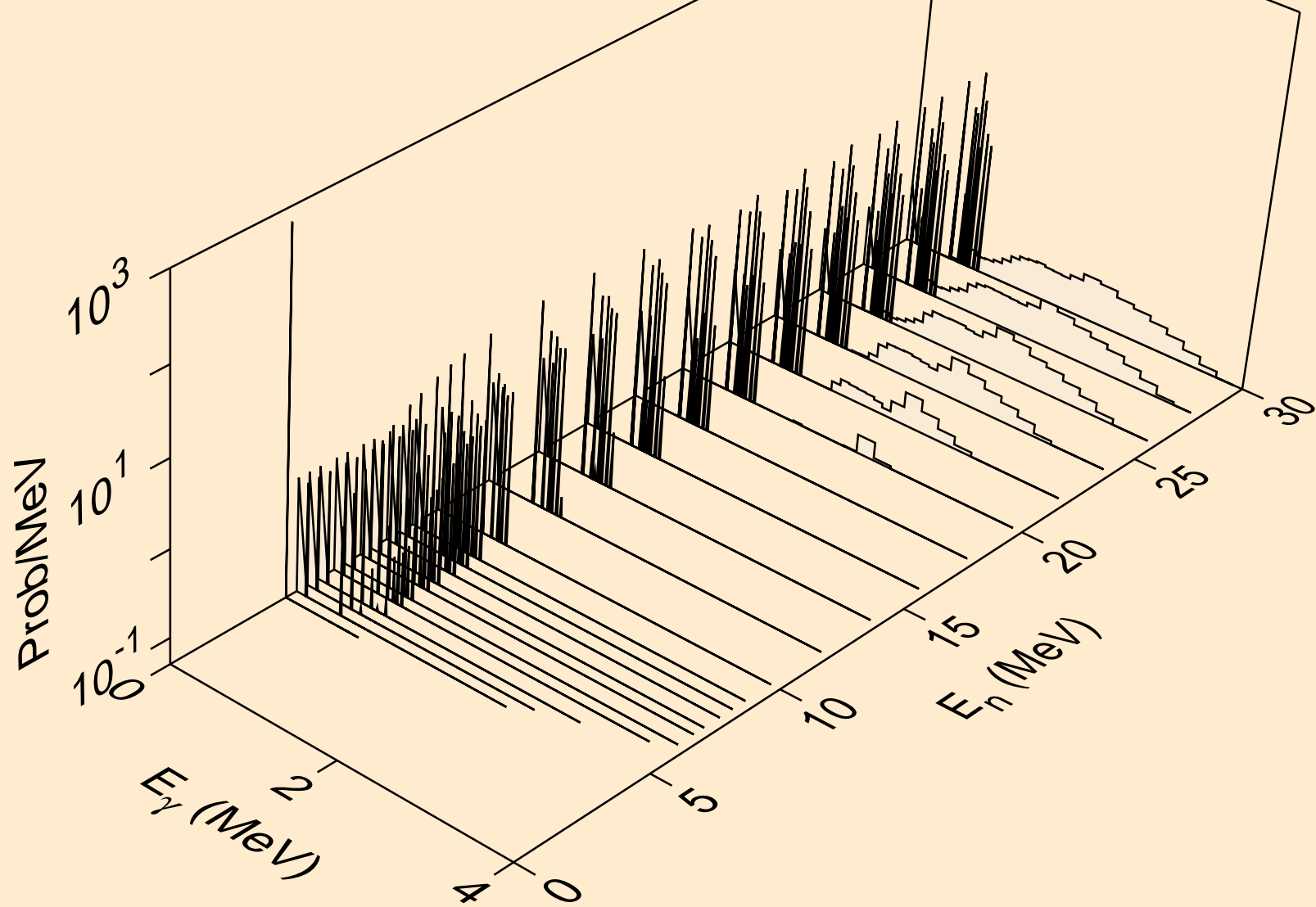

CS116M NEUTRON ACER TENDL-2024 LIBRARY; T=0.K
Photon emission for (n,n*2)

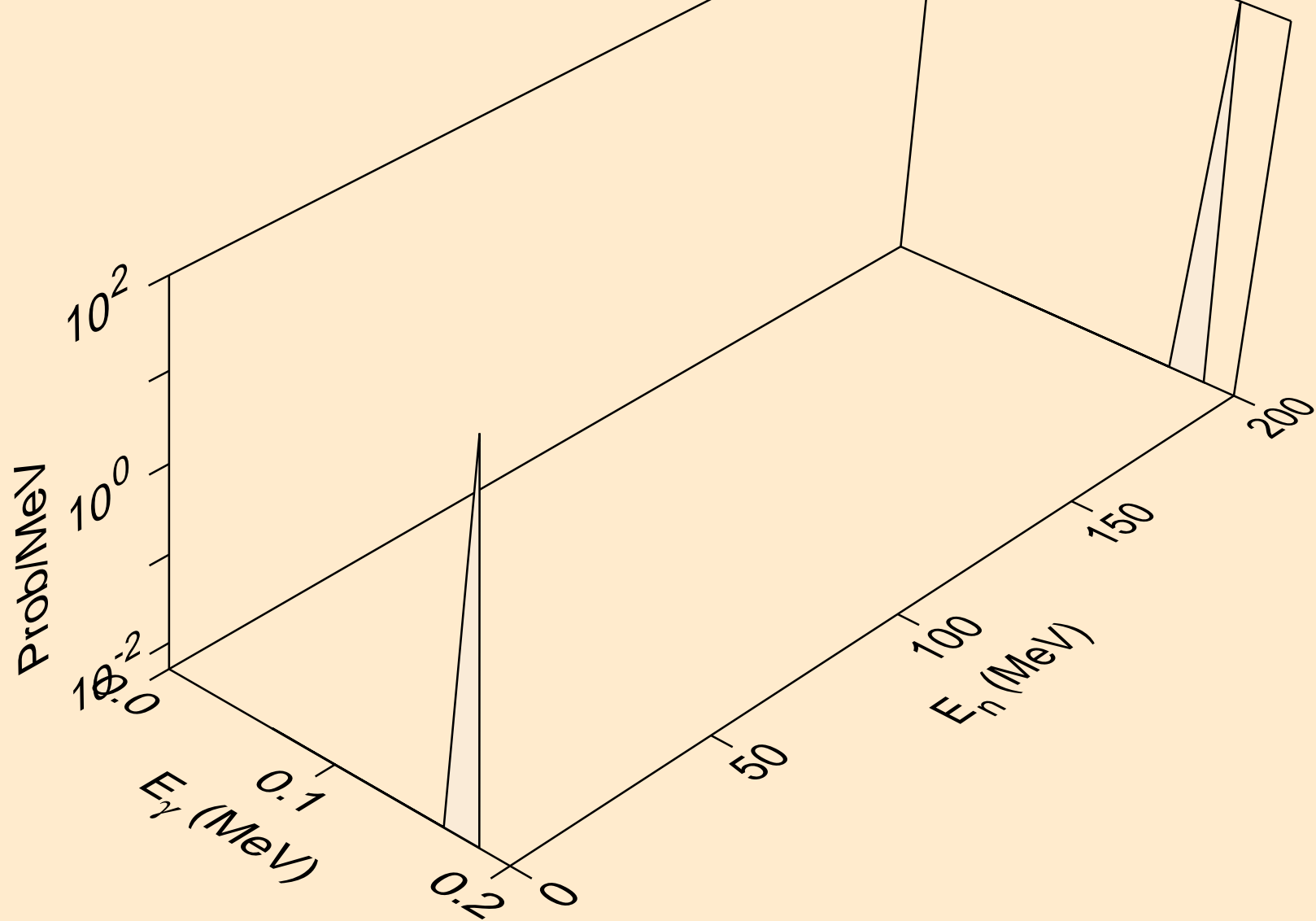

CS116M NEUTRON ACER TENDL-2024 LIBRARY; T=0.K
Photon emission for (n,n*c)

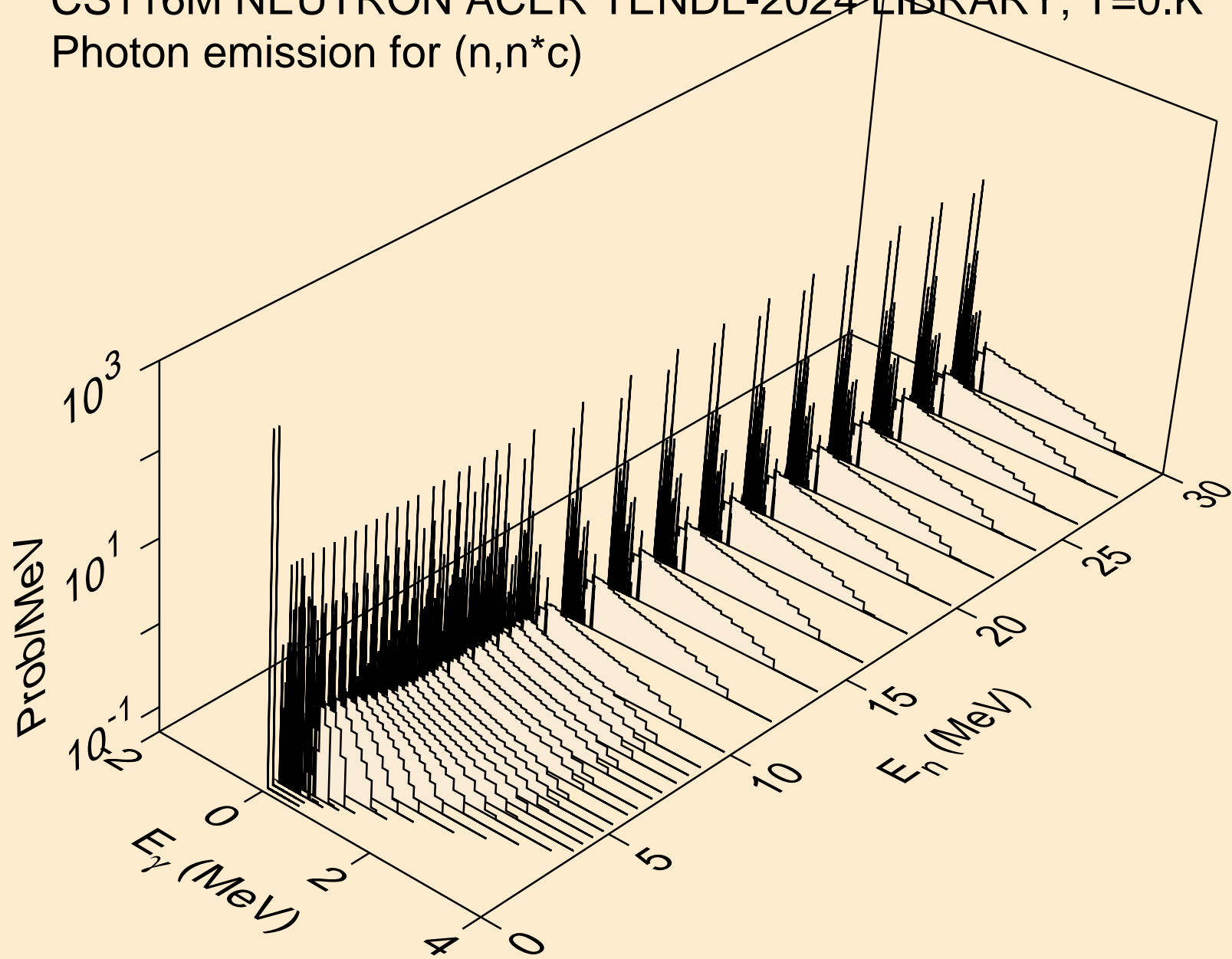

CS116M NEUTRON ACER TENDL-2024 LIBRARY; T=0.K
Photon emission for (n,gma)

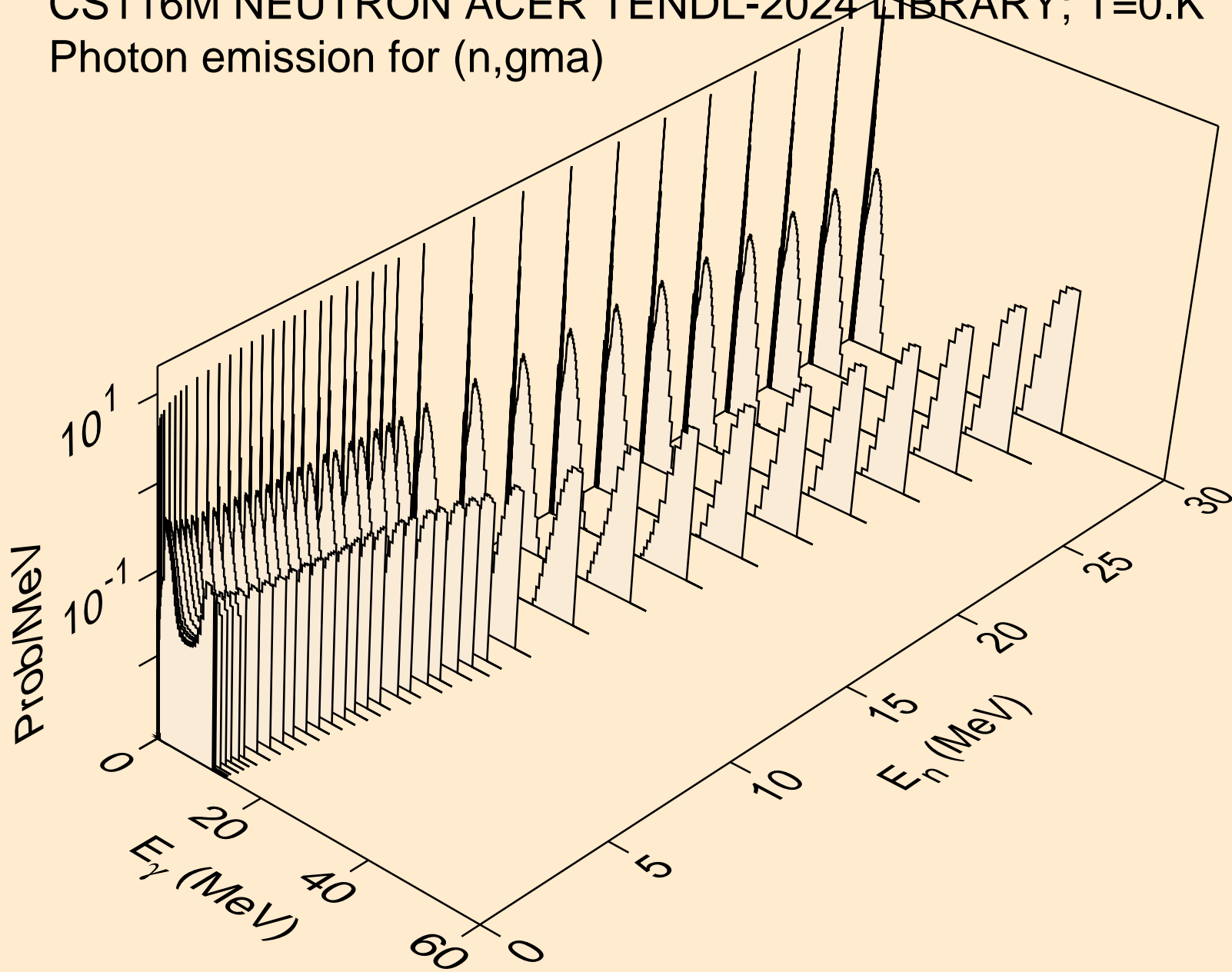

CS116M NEUTRON ACER TENDL-2024 LIBRARY; T=0.K
Photon emission for (n,p)

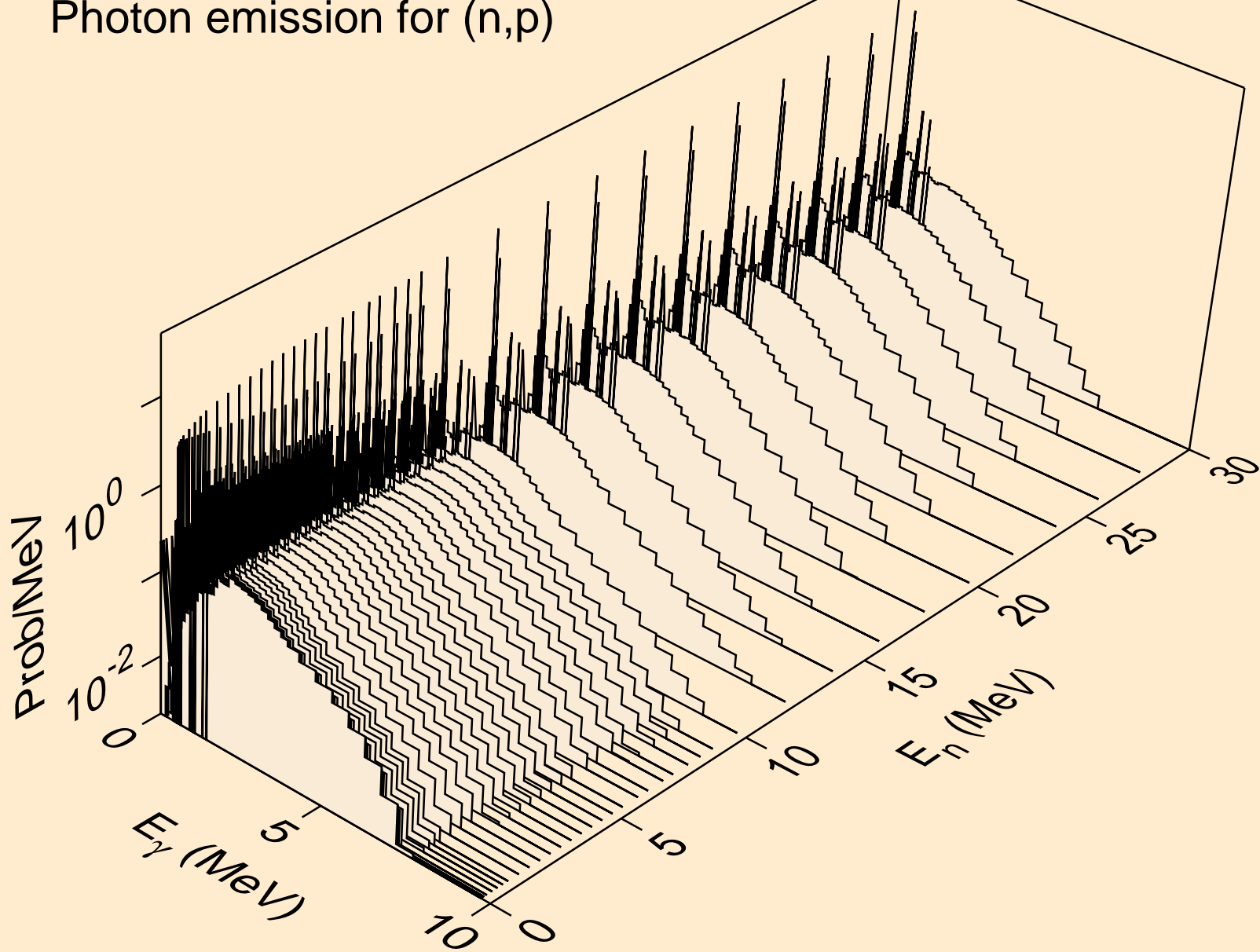

CS116M NEUTRON ACER TENDL-2024 LIBRARY; T=0.K
Photon emission for (n,d)

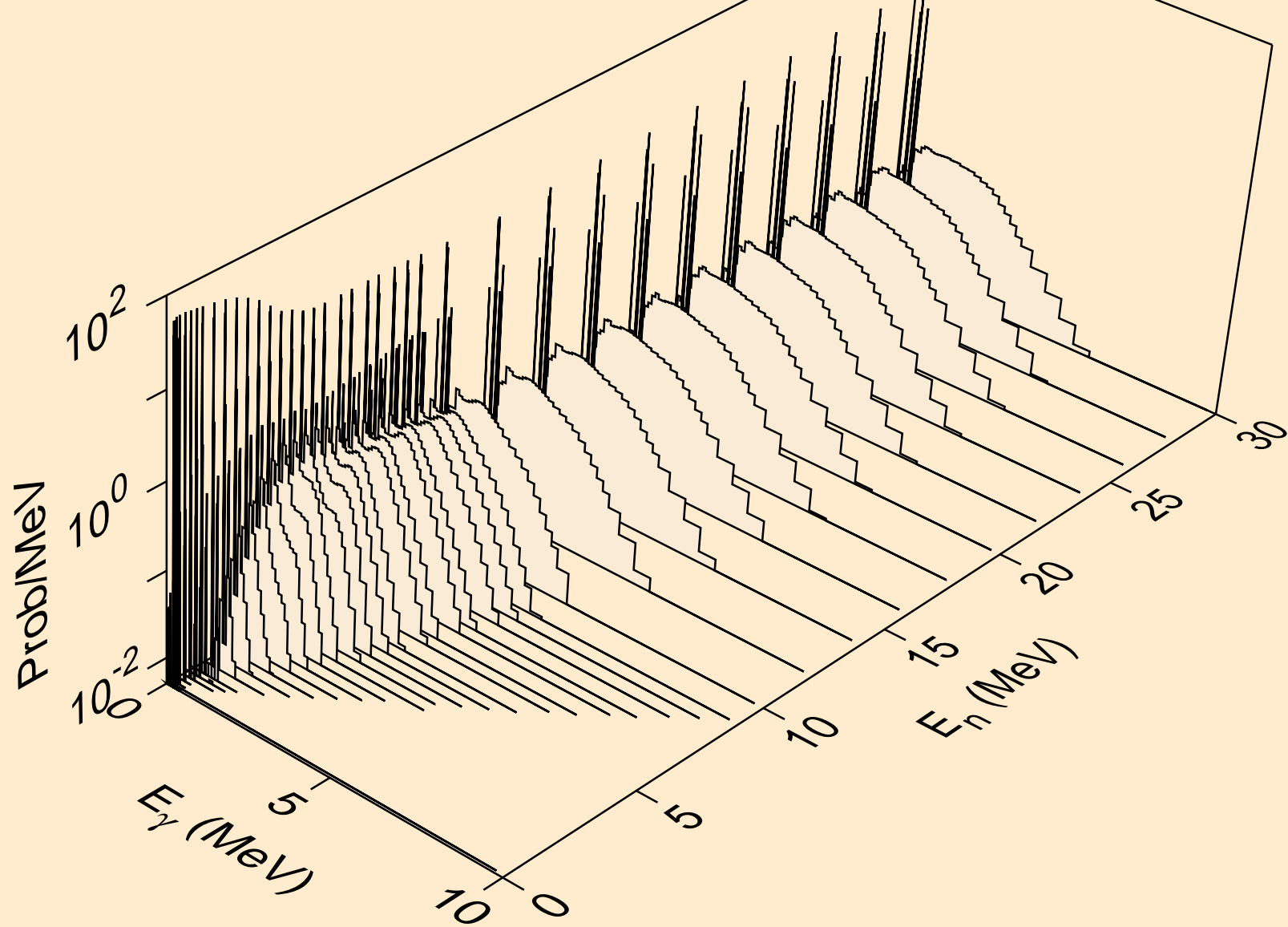

CS116M NEUTRON ACER TENDL-2024 LIBRARY; T=0.K
Photon emission for (n,t)

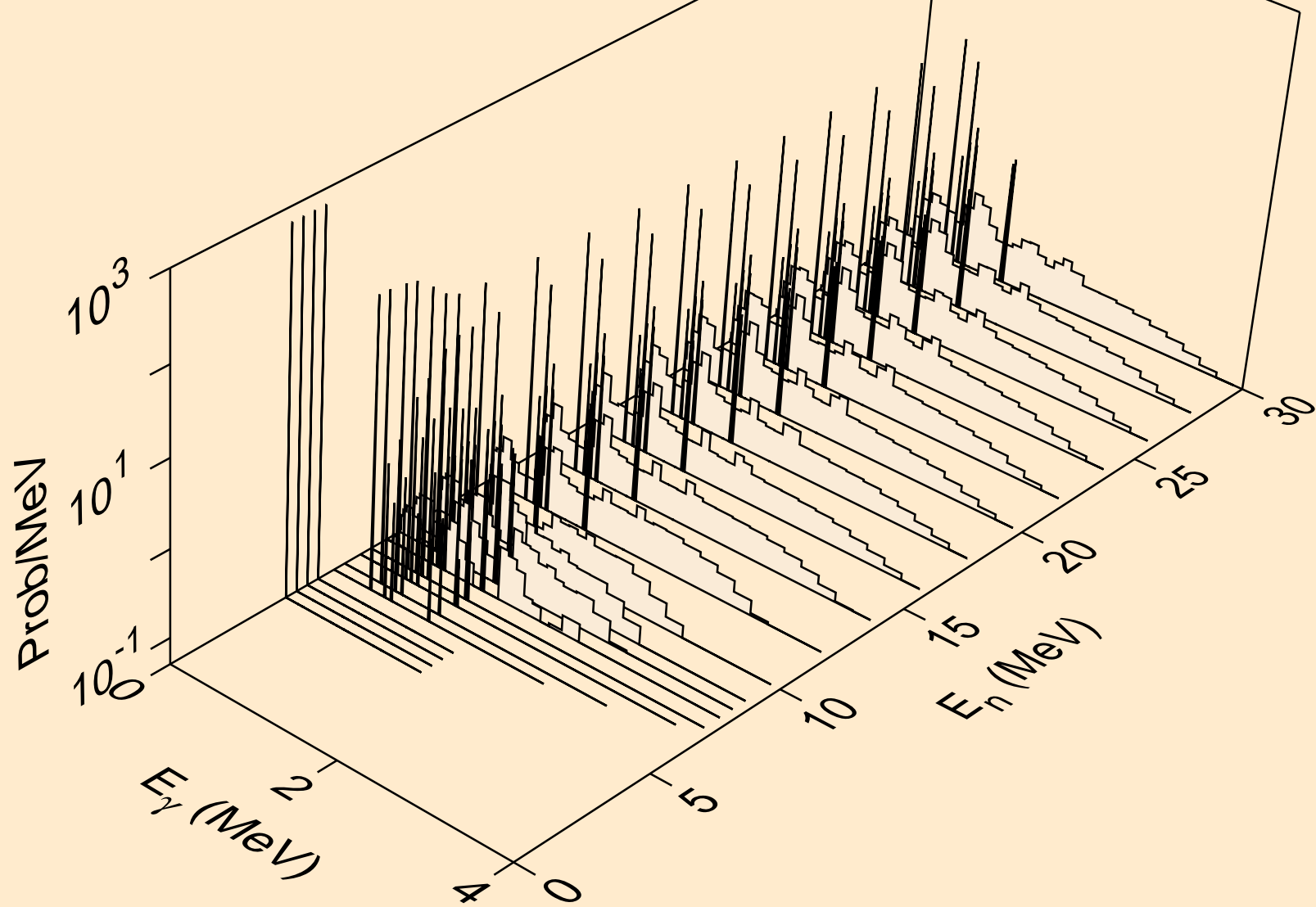

CS116M NEUTRON ACER TENDL-2024 LIBRARY; T=0.K
Photon emission for (n,he3)

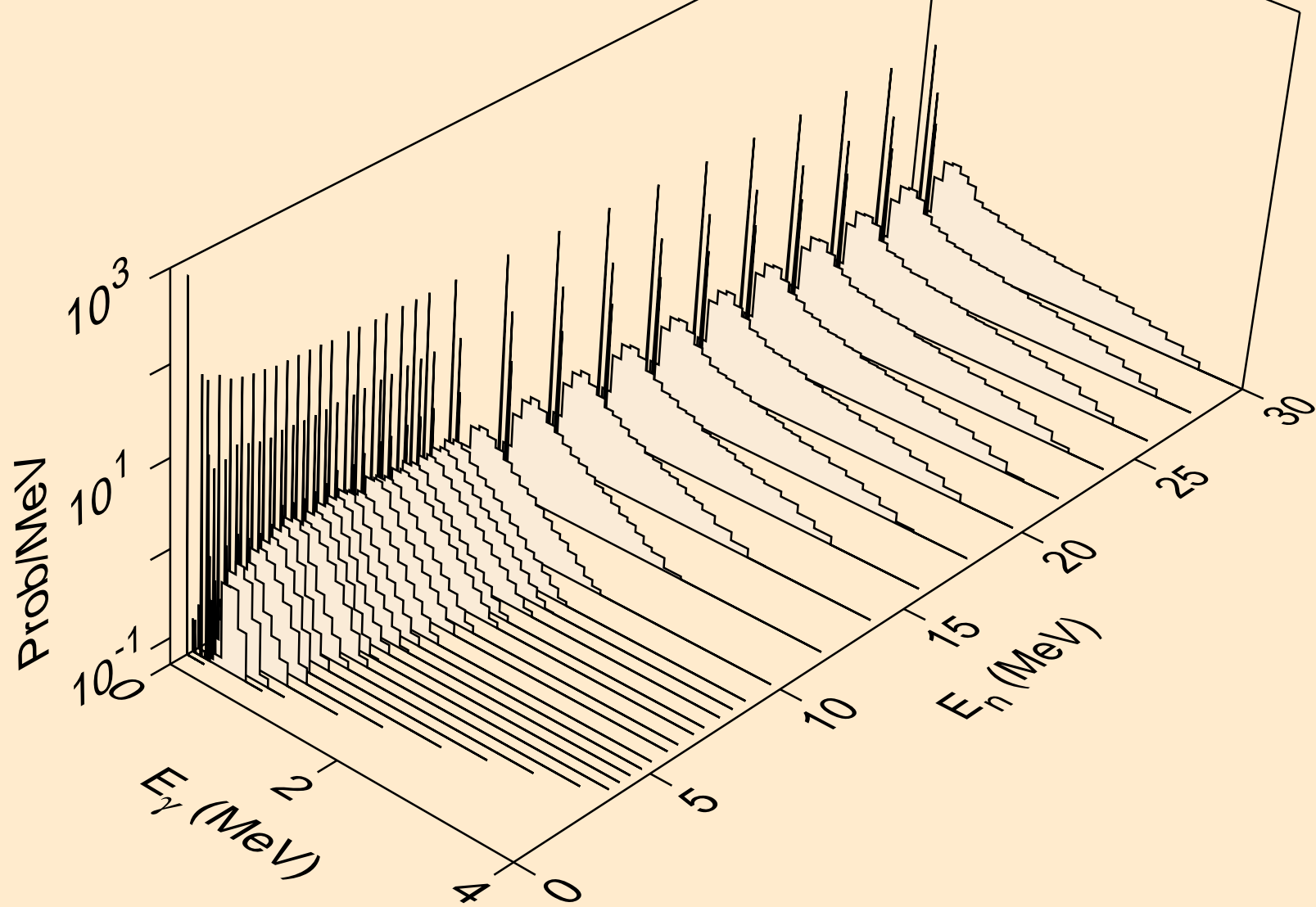

CS116M NEUTRON ACER TENDL-2024 LIBRARY; T=0.K
Photon emission for (n,a)

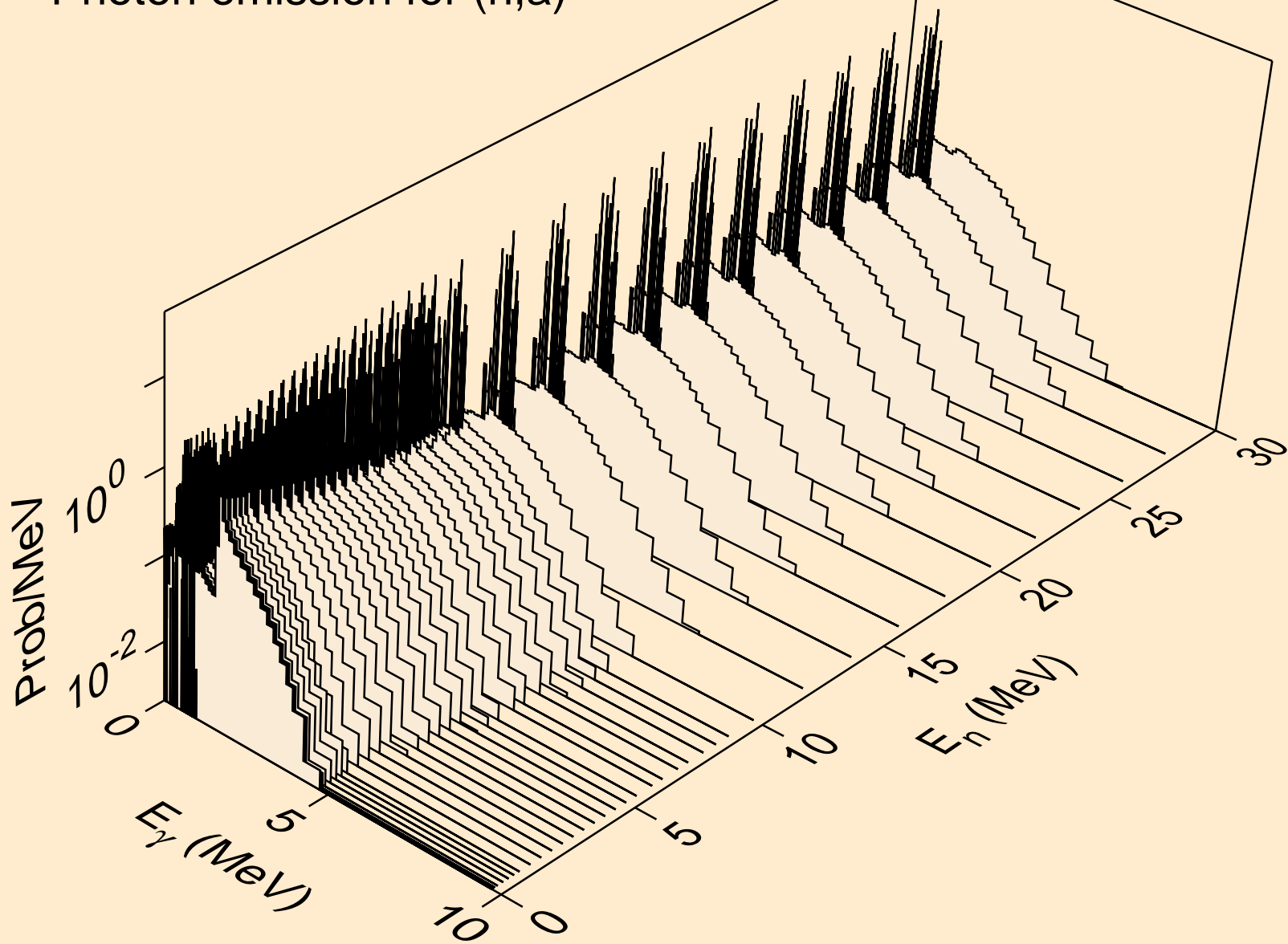

CS116M NEUTRON ACER TENDL-2024 LIBRARY; T=0.K
Photon emission for (n,2a)

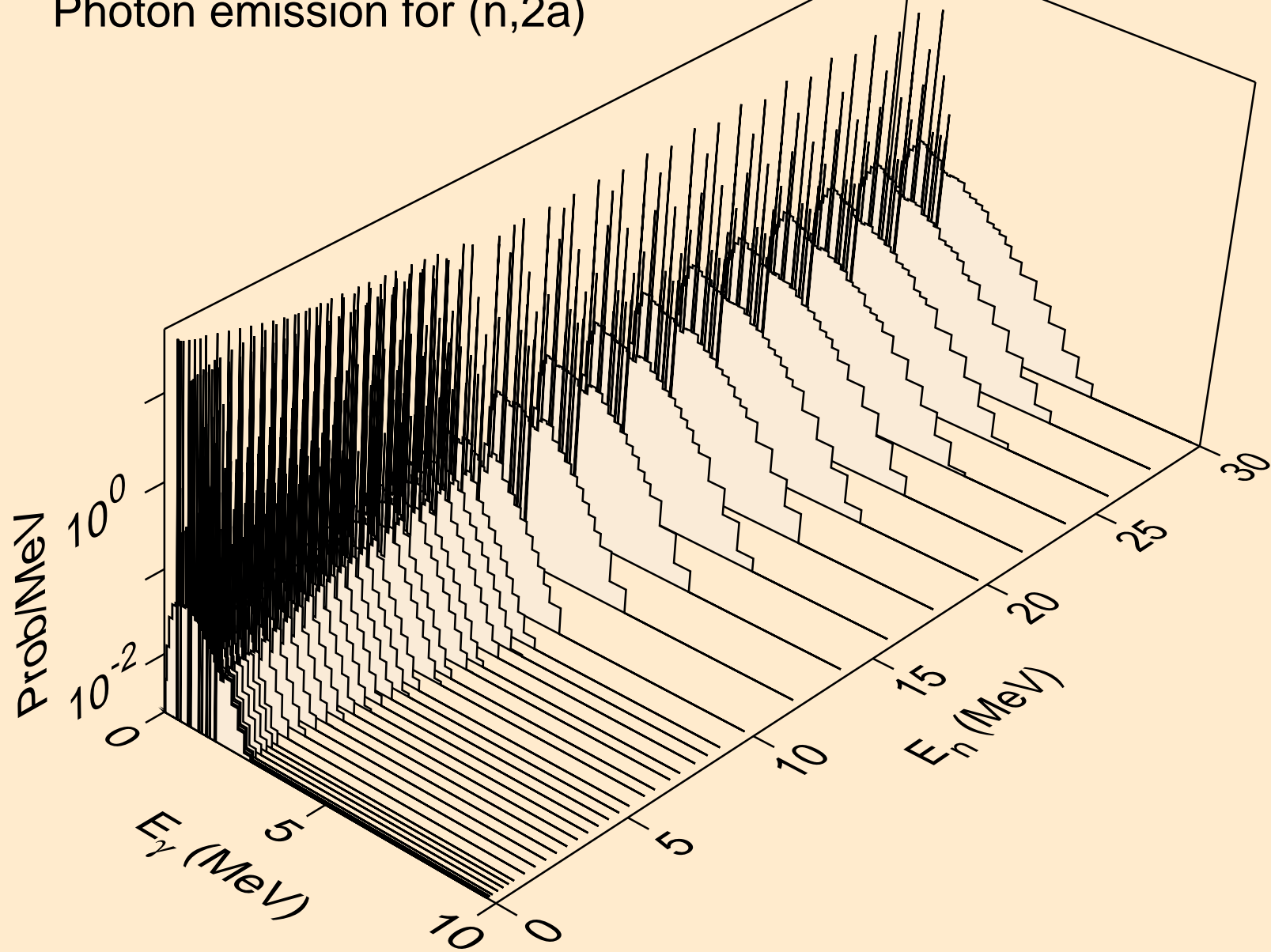

CS116M NEUTRON ACER TENDL-2024 LIBRARY; T=0.K
Photon emission for (n,3a)

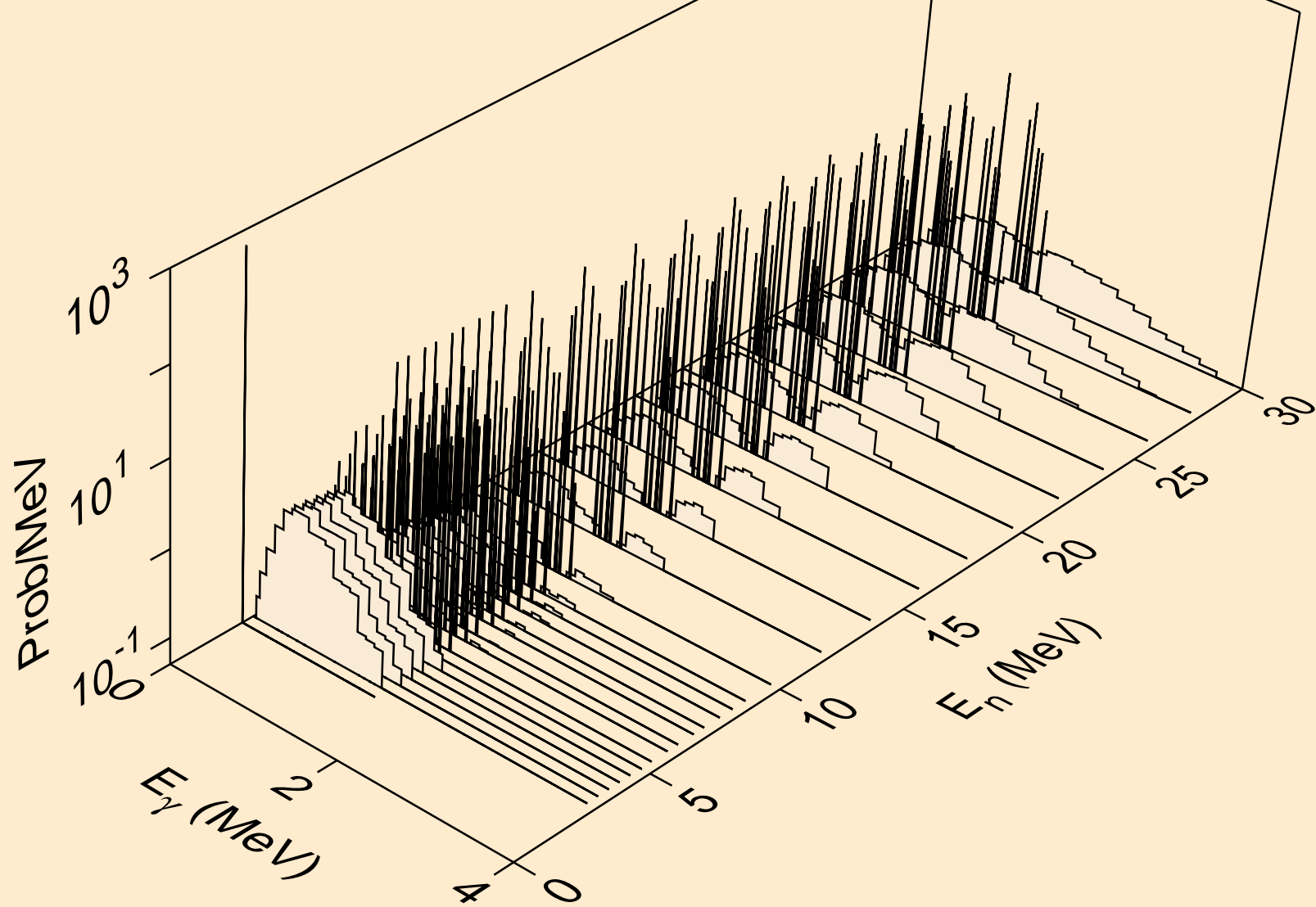

CS116M NEUTRON ACER TENDL-2024 LIBRARY; T=0.K
Photon emission for (n,2p)

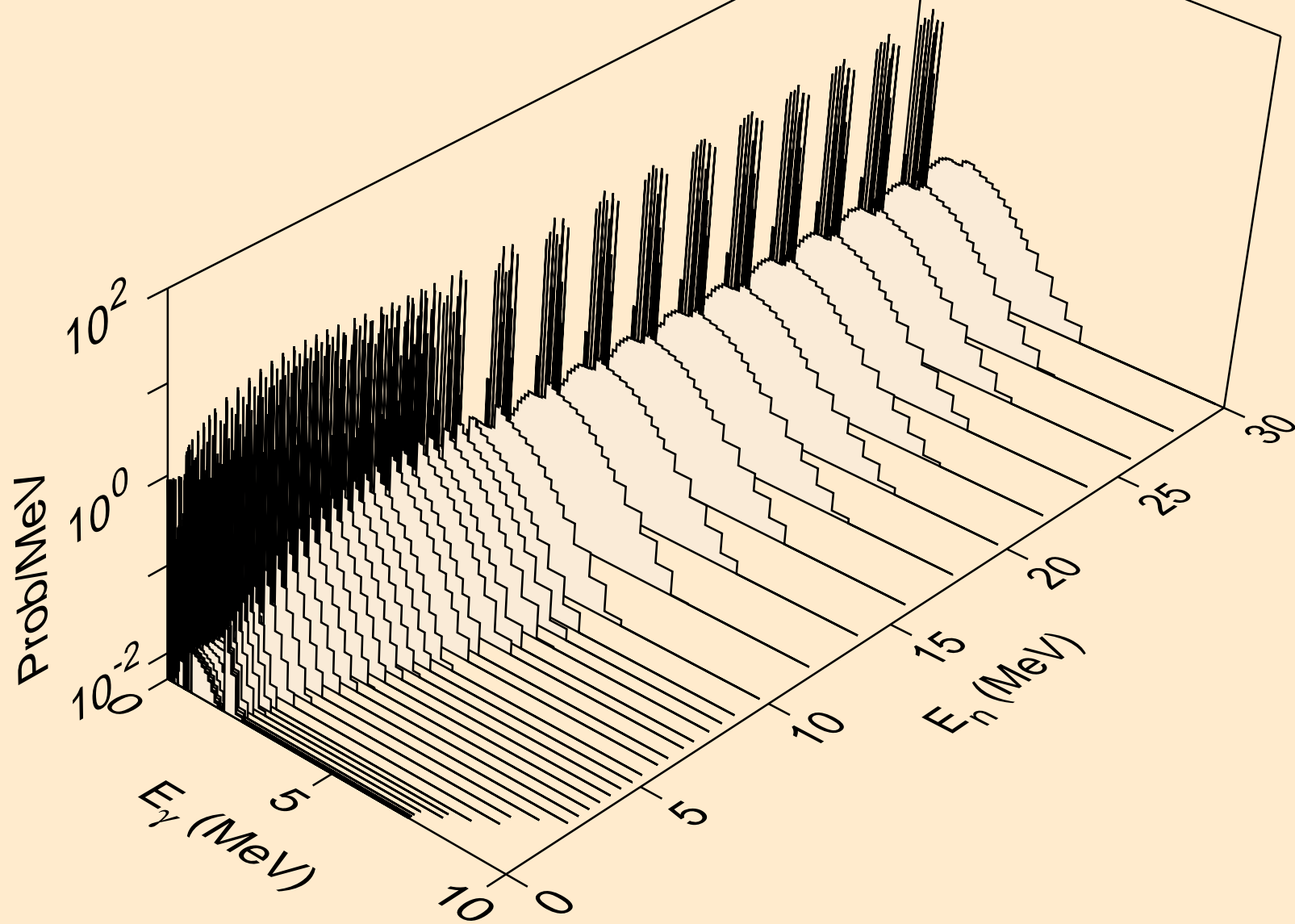

CS116M NEUTRON ACER TENDL-2024 LIBRARY; T=0.K
Photon emission for (n,p α)

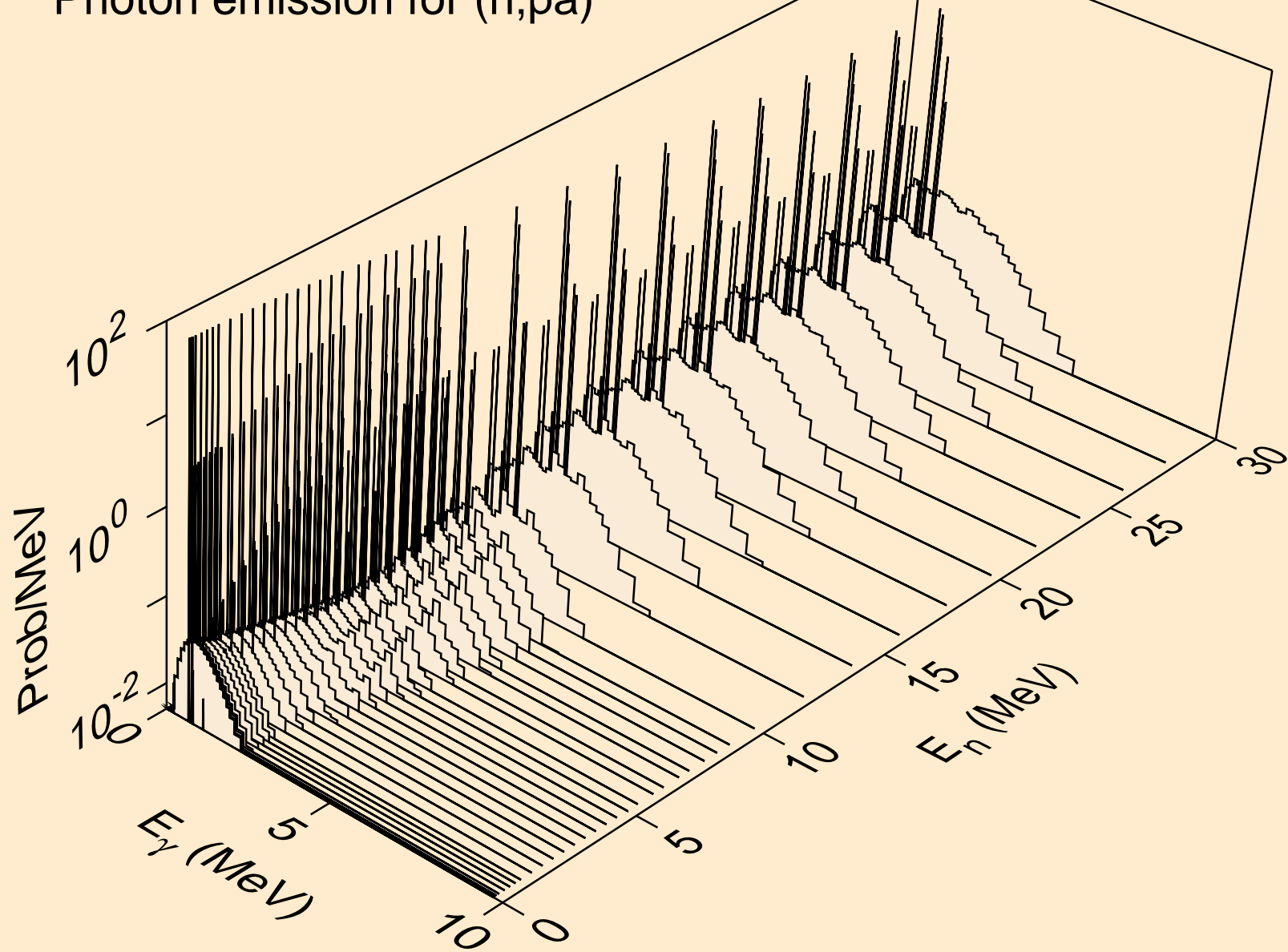

CS116M NEUTRON ACER TENDL-2024 LIBRARY; T=0.K
Photon emission for (n,t2a)

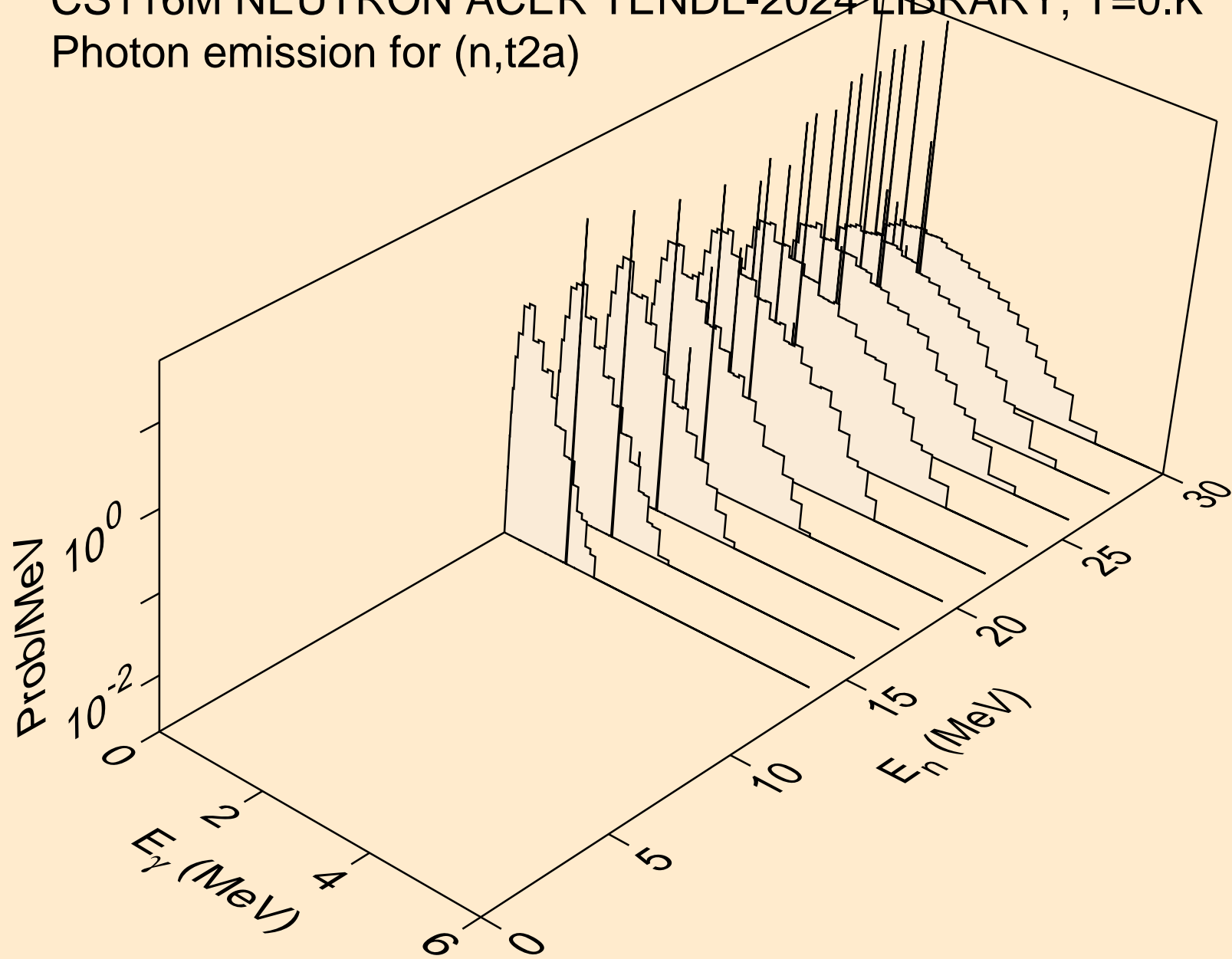

CS116M NEUTRON ACER TENDL-2024 LIBRARY; T=0.K
Photon emission for (n,d2a)

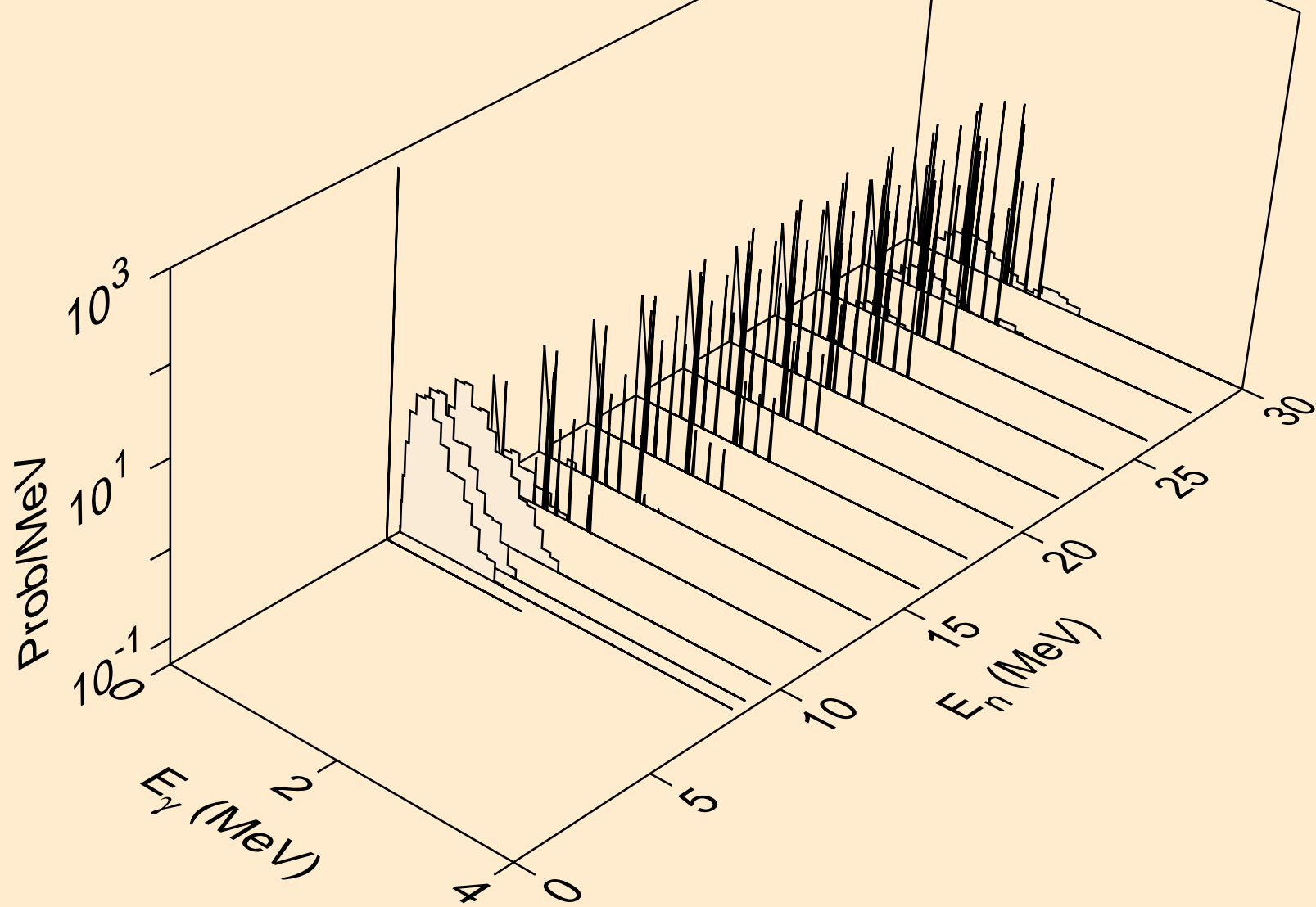

CS116M NEUTRON ACER TENDL-2024 LIBRARY; T=0.K
Photon emission for (n,pd)

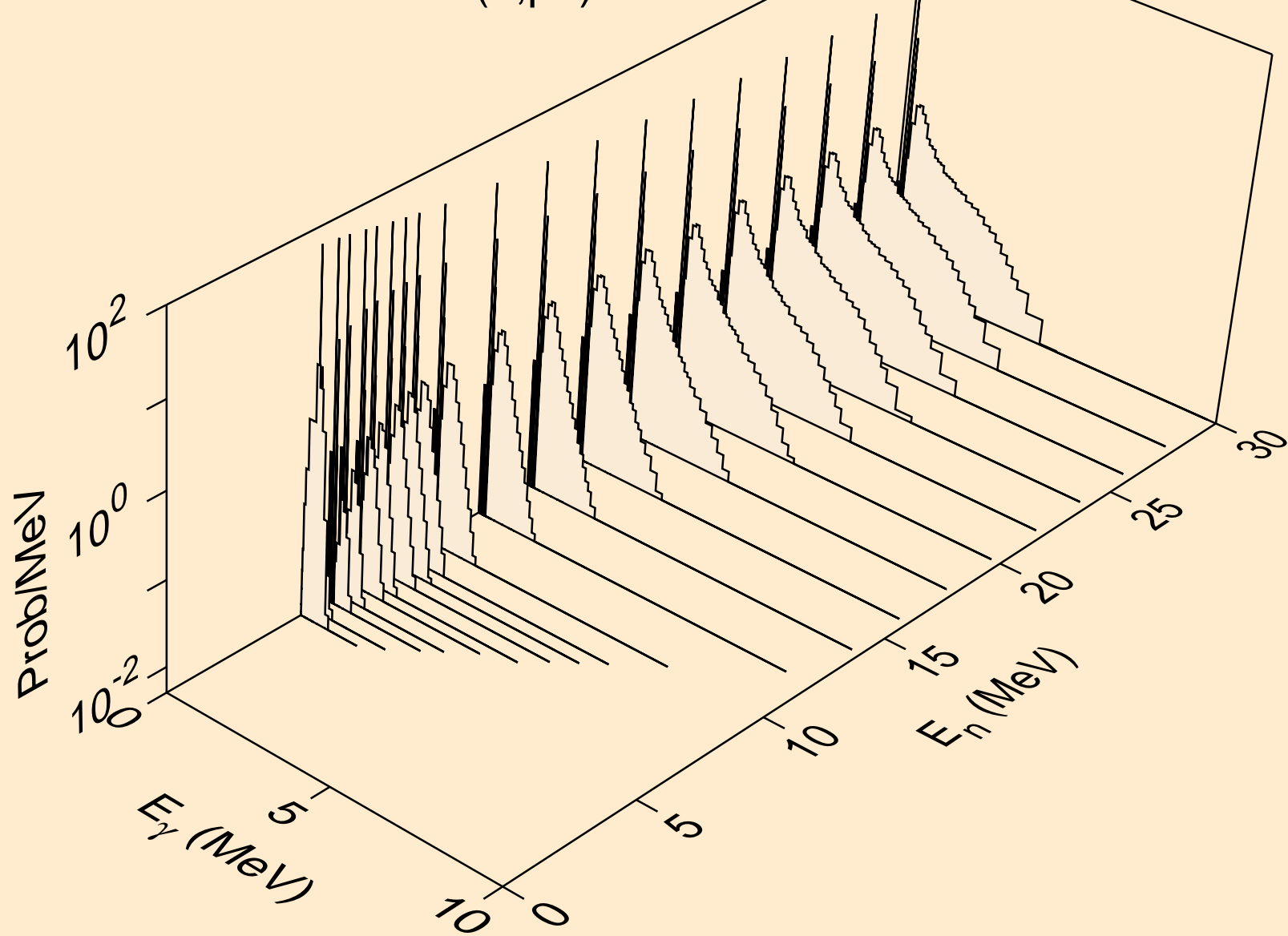

CS116M NEUTRON ACER TENDL-2024 LIBRARY; T=0.K
Photon emission for (n,pt)

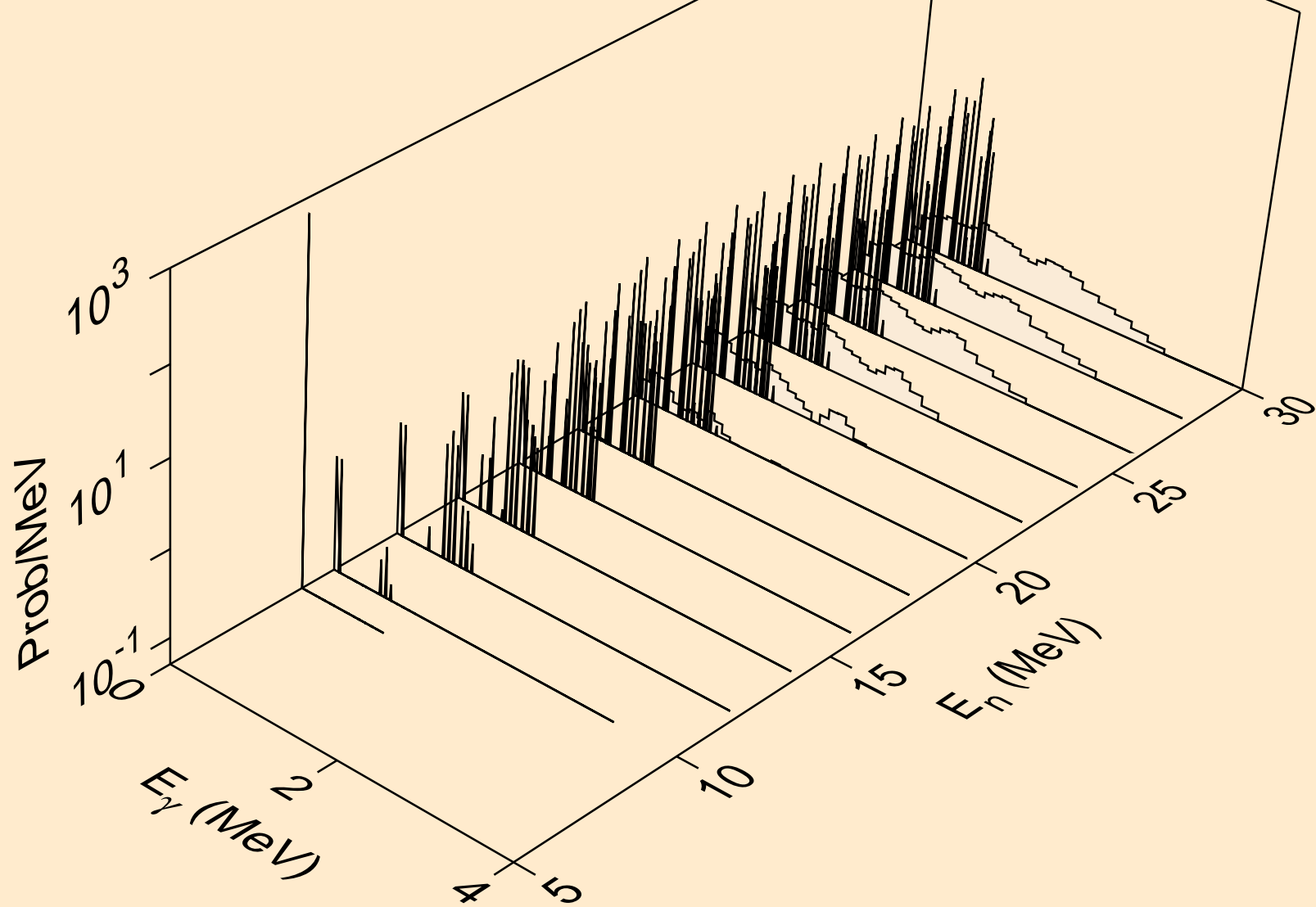

CS116M NEUTRON ACER TENDL-2024 LIBRARY; T=0.K
Photon emission for (n,da)

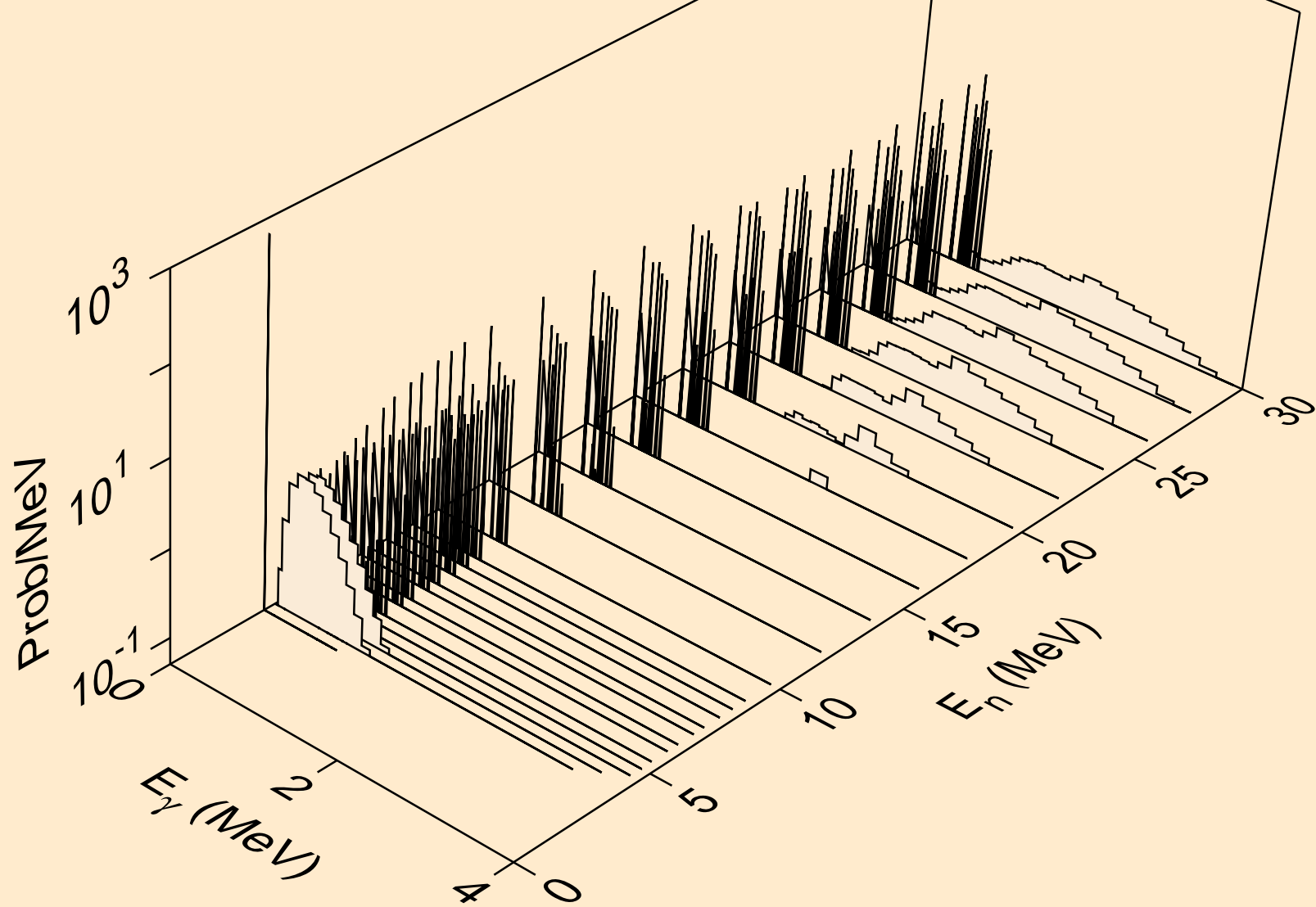

CS116M NEUTRON ACER TENDL-2024 LIBRARY; T=0.K
thermal capture photon spectrum

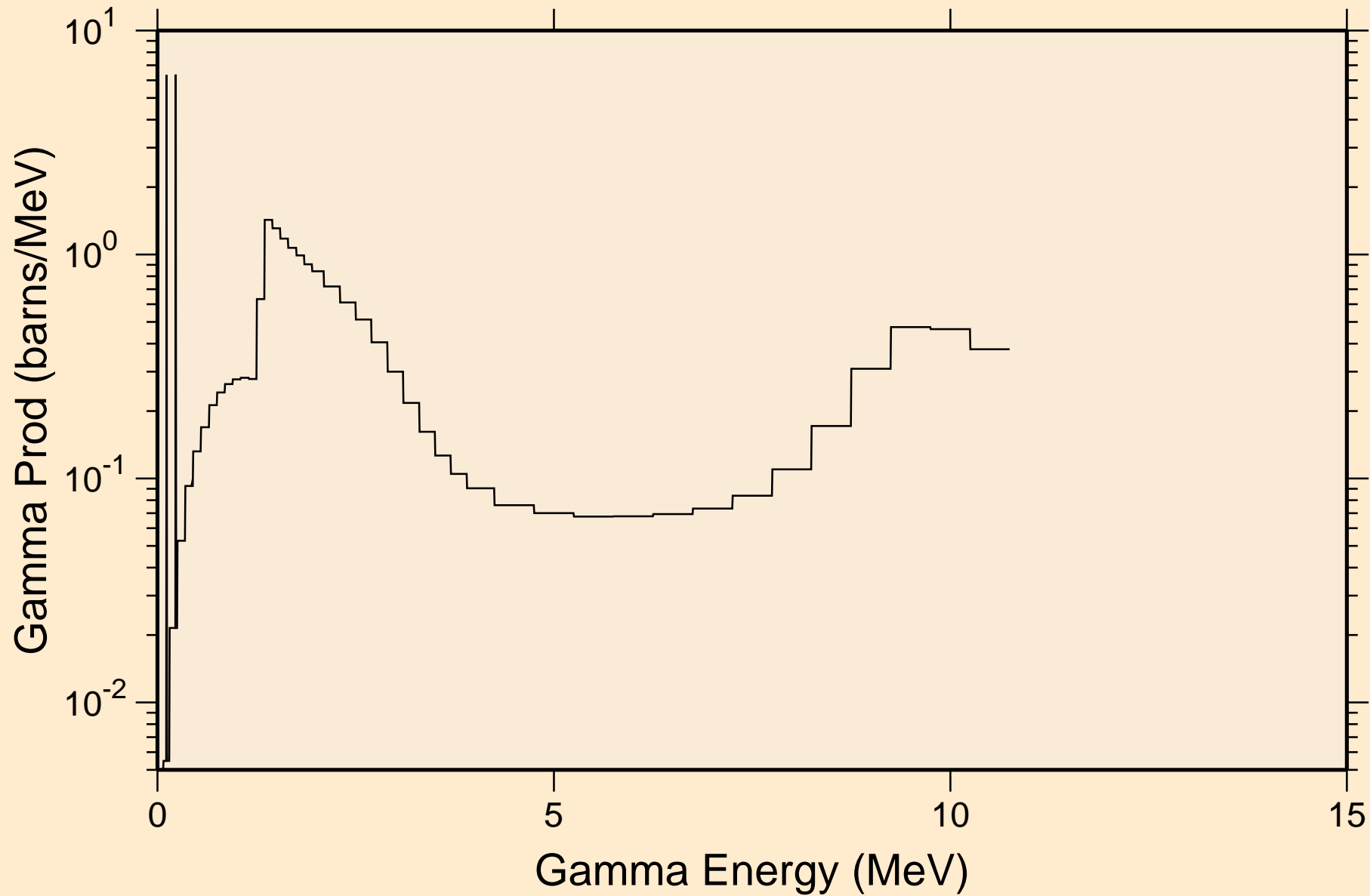

CS116M NEUTRON ACER TENDL-2024 LIBRARY; T=0.K
14 MeV photon spectrum

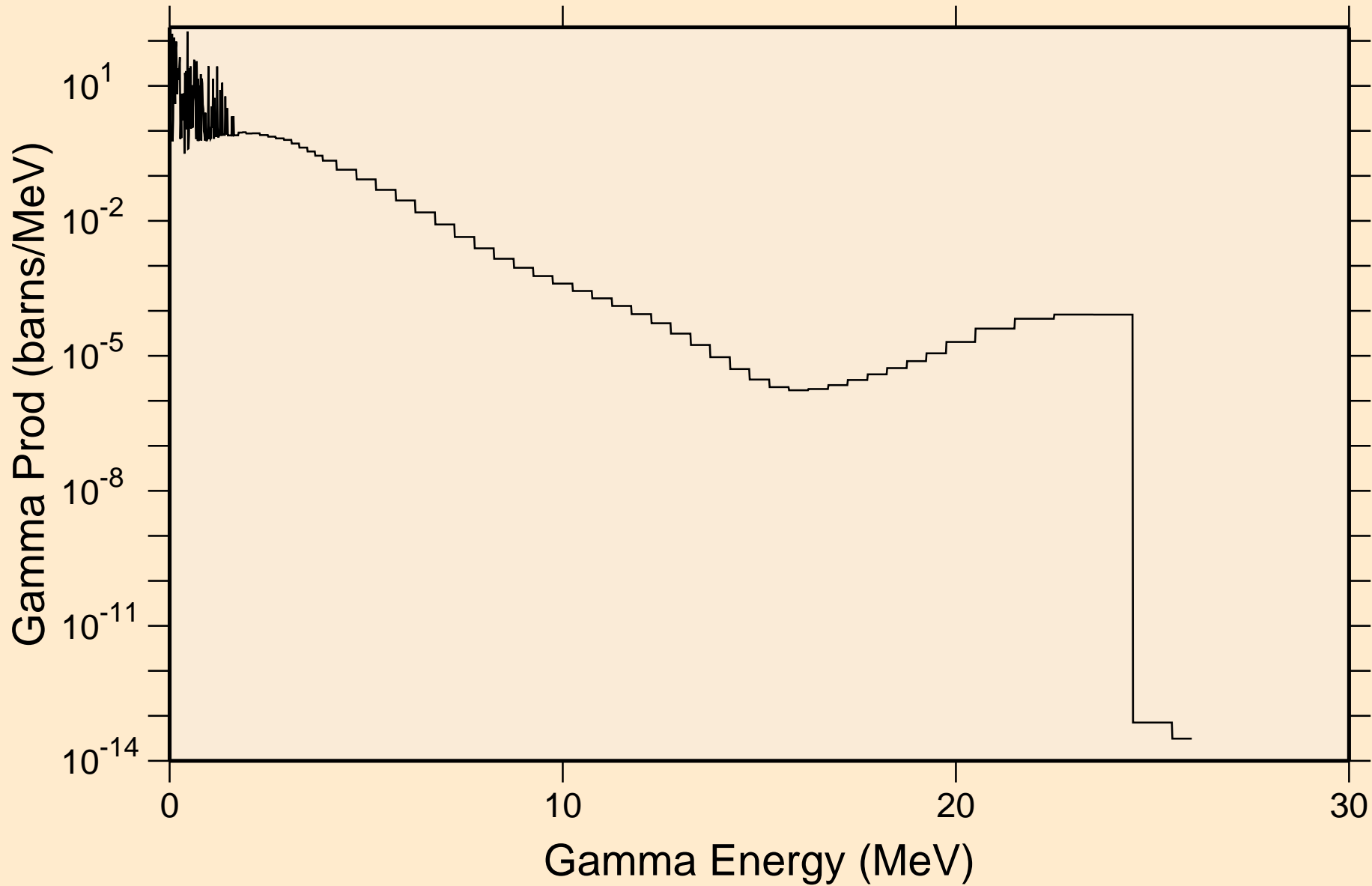

CS116M NEUTRON ACER TENDL-2024 LIBRARY; T=0.K

Particle heating contributions

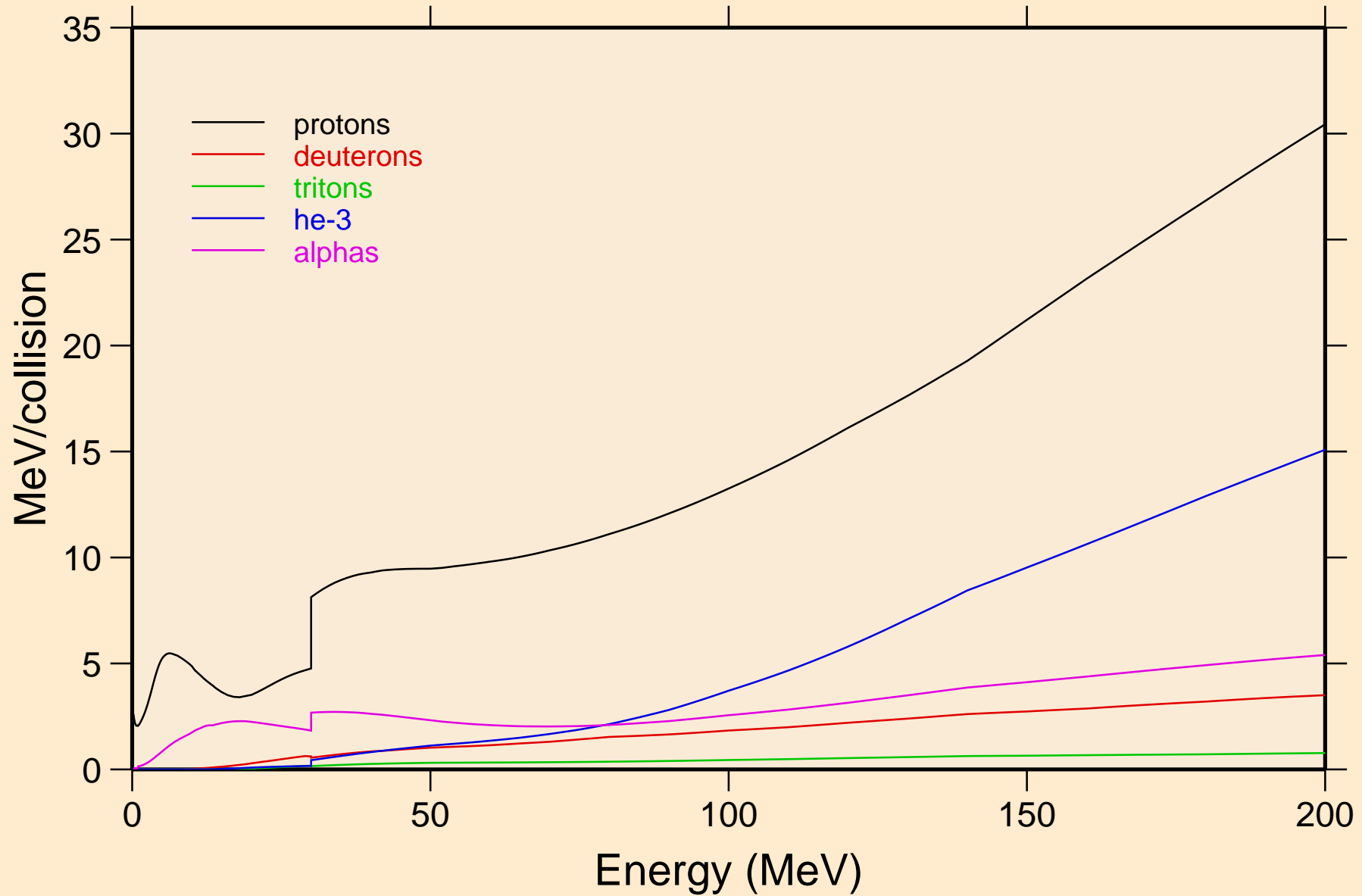

CS116M NEUTRON ACER TENDL-2024 LIBRARY; T=0.K
Recoil Heating

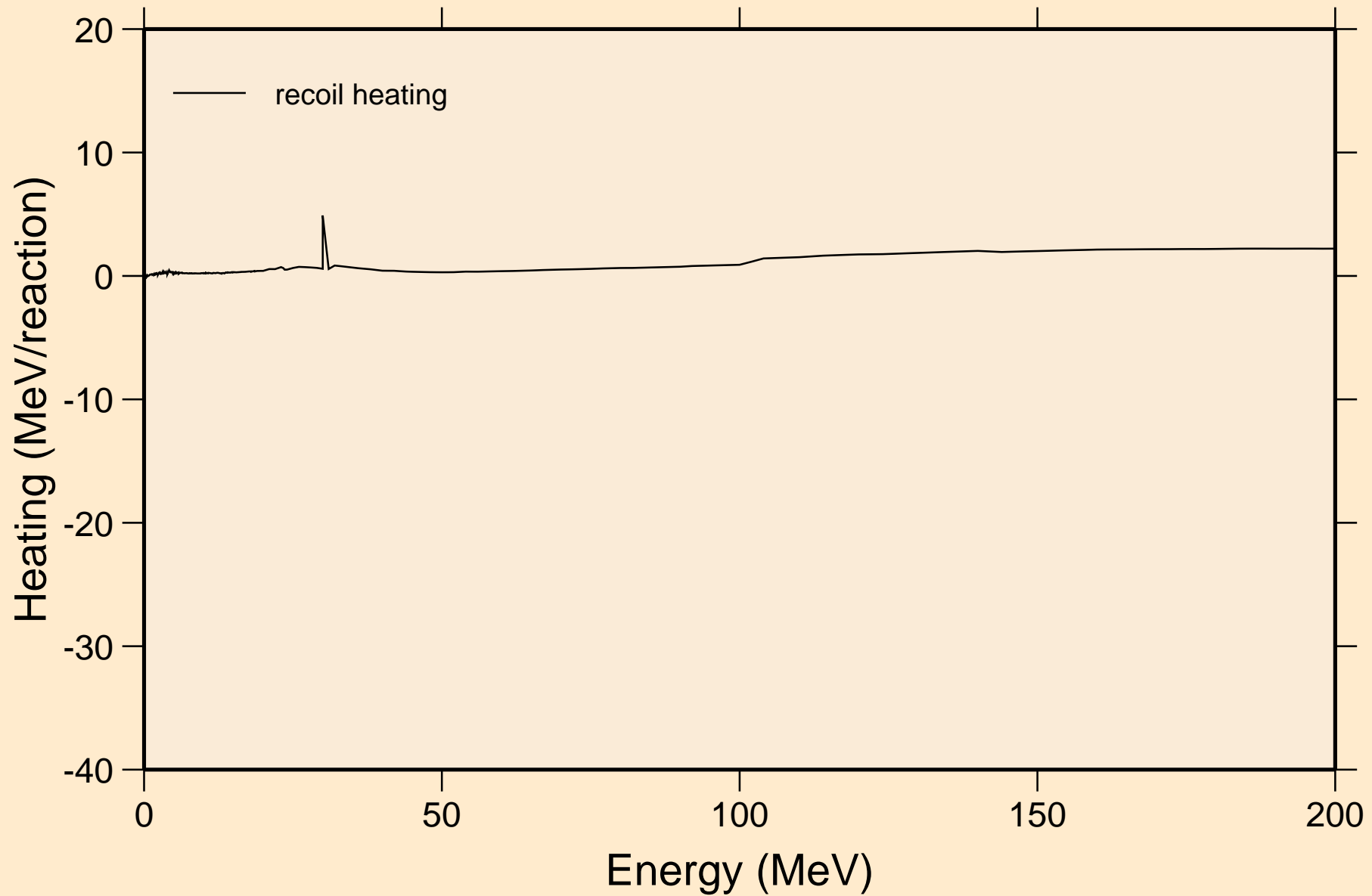

CS116M NEUTRON ACER TENDL-2024 LIBRARY; T=0.K

Particle production cross sections

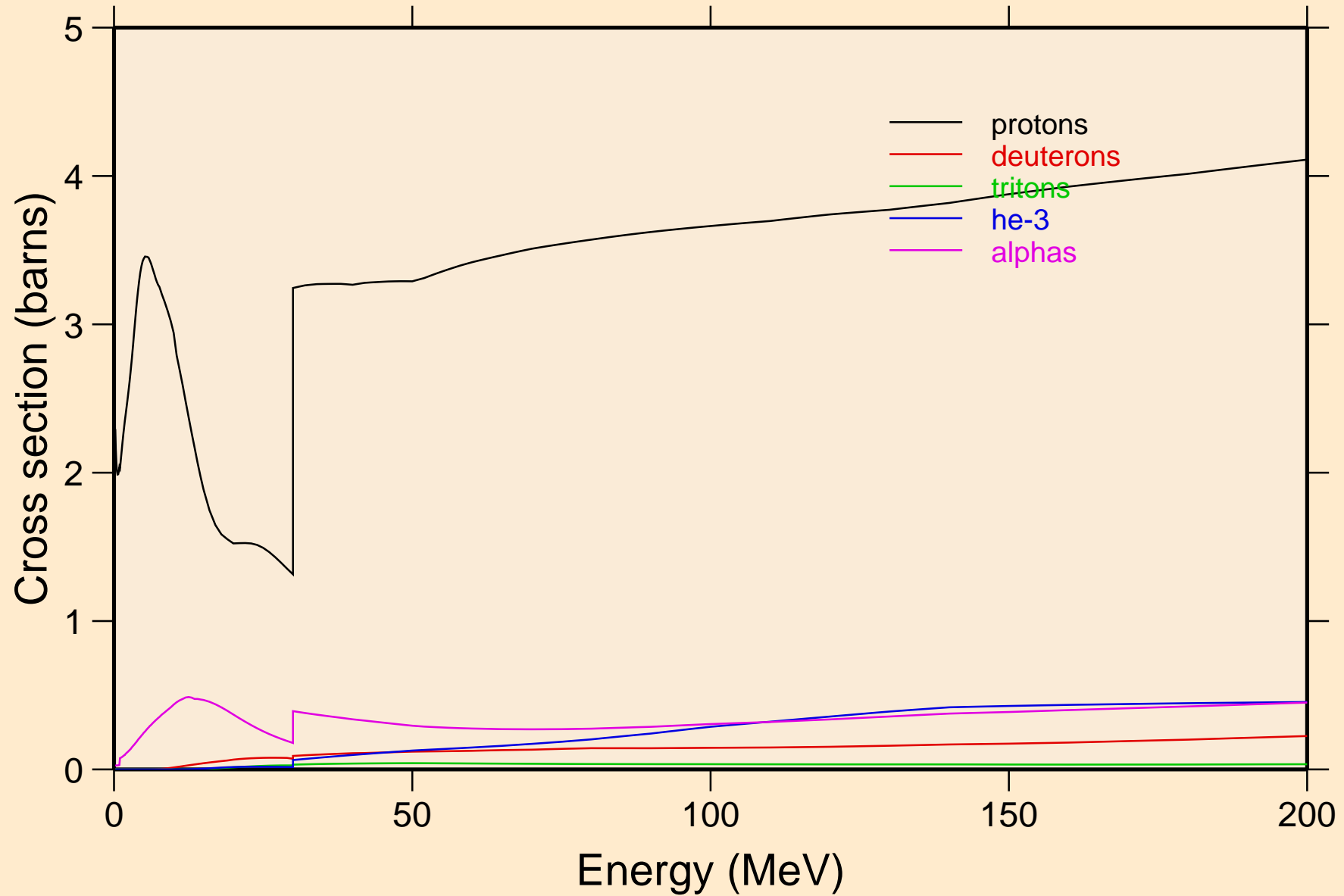

CS116M NEUTRON ACER TENDL-2024 LIBRARY; T=0.K
protons from (n,x)

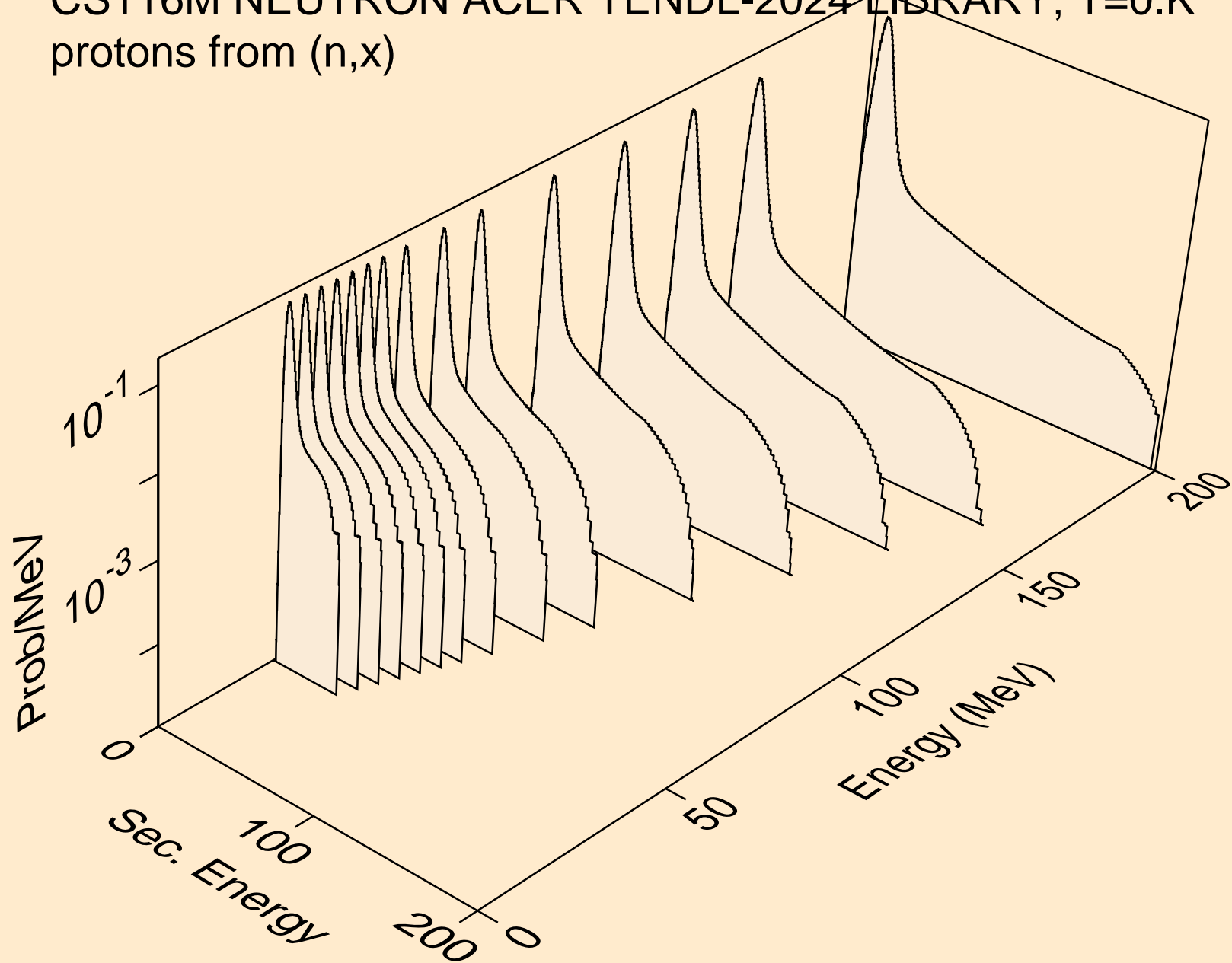

CS116M NEUTRON ACER TENDL-2024 LIBRARY; T=0.K
protons from (n,n*)p

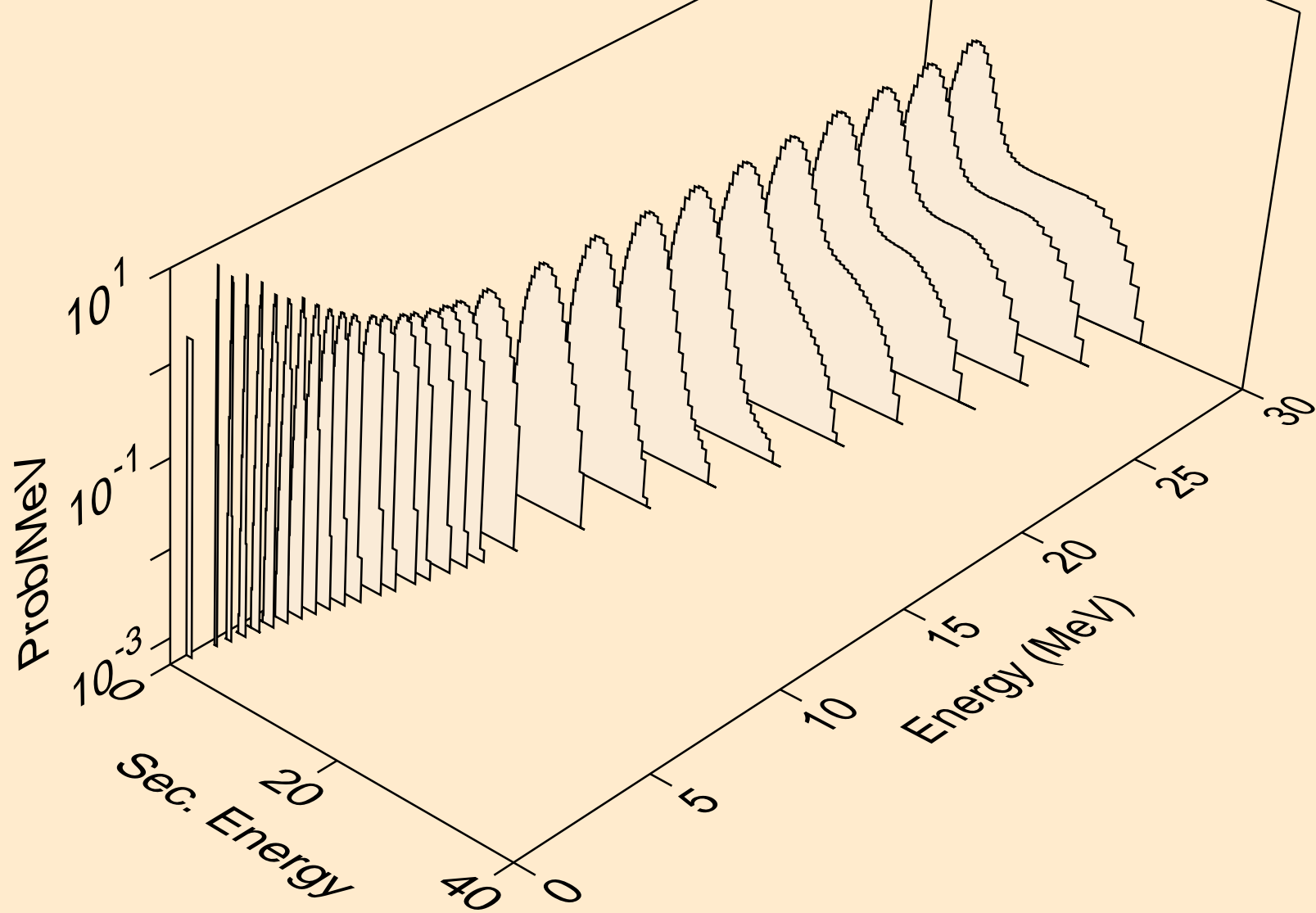

CS116M NEUTRON ACER TENDL-2024 LIBRARY; T=0.K
protons from (n,2np)

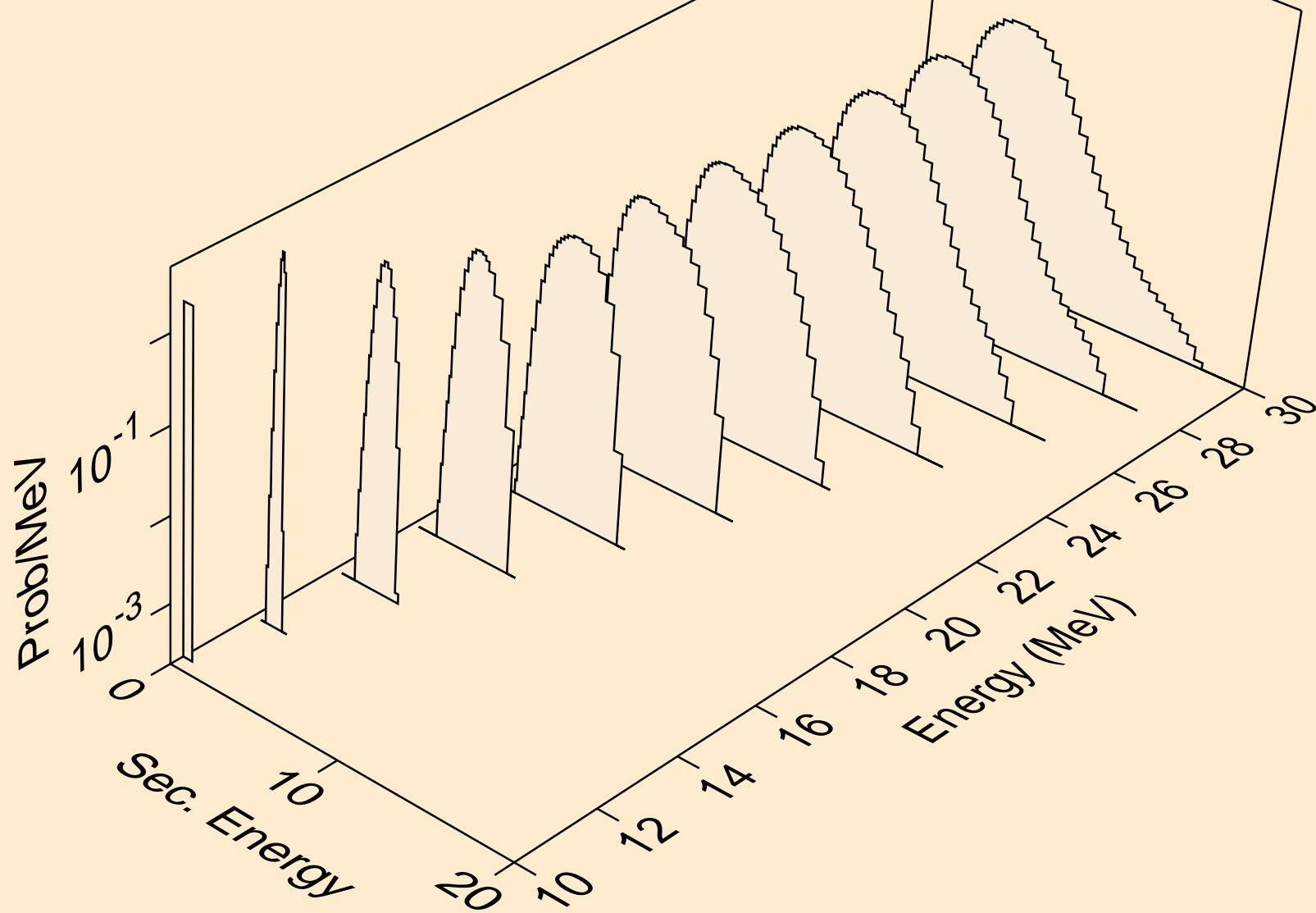

CS116M NEUTRON ACER TENDL-2024 LIBRARY; T=0.K
protons from (n,3np)

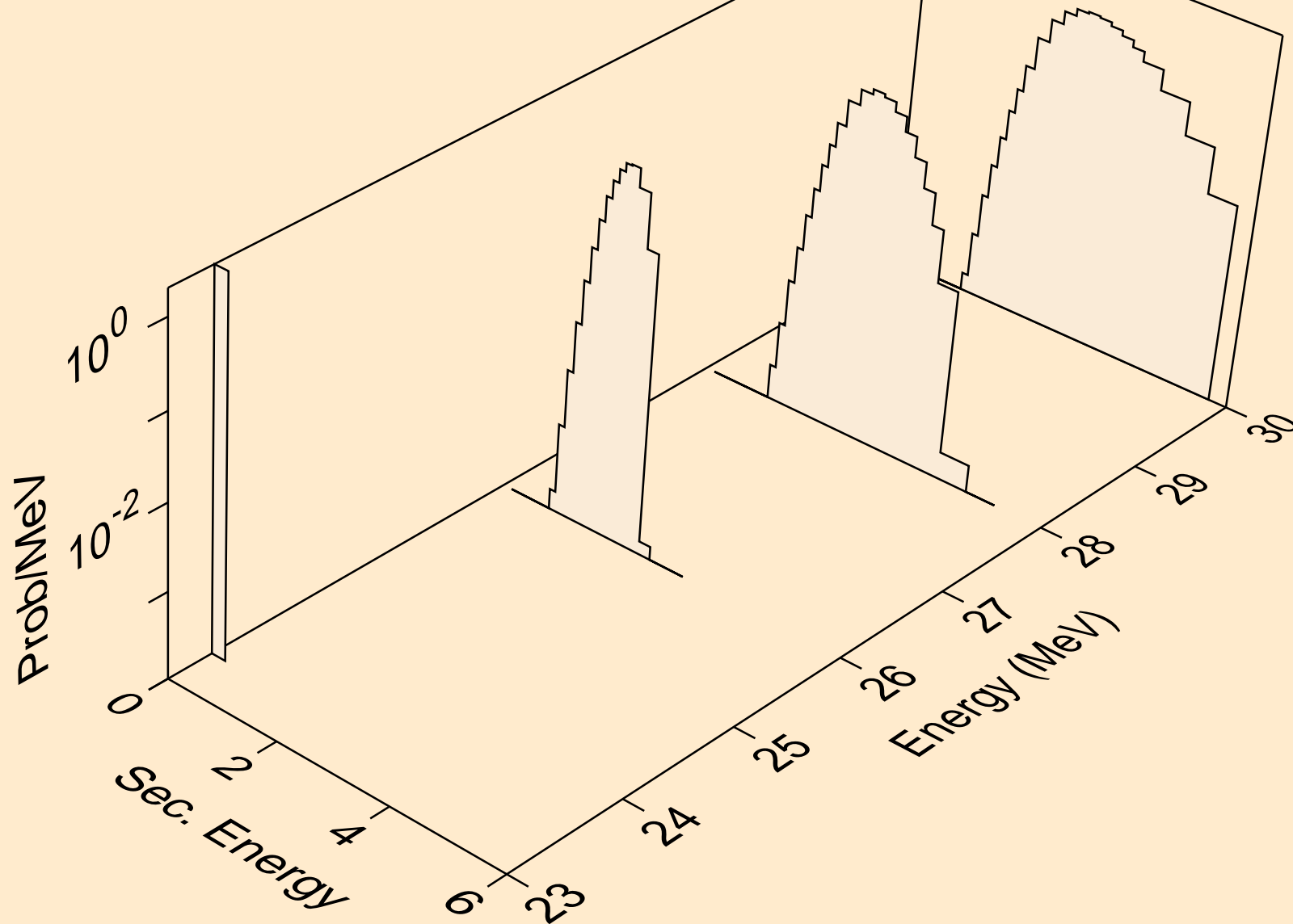

CS116M NEUTRON ACER TENDL-2024 LIBRARY; T=0.K
protons from (n,n2p)

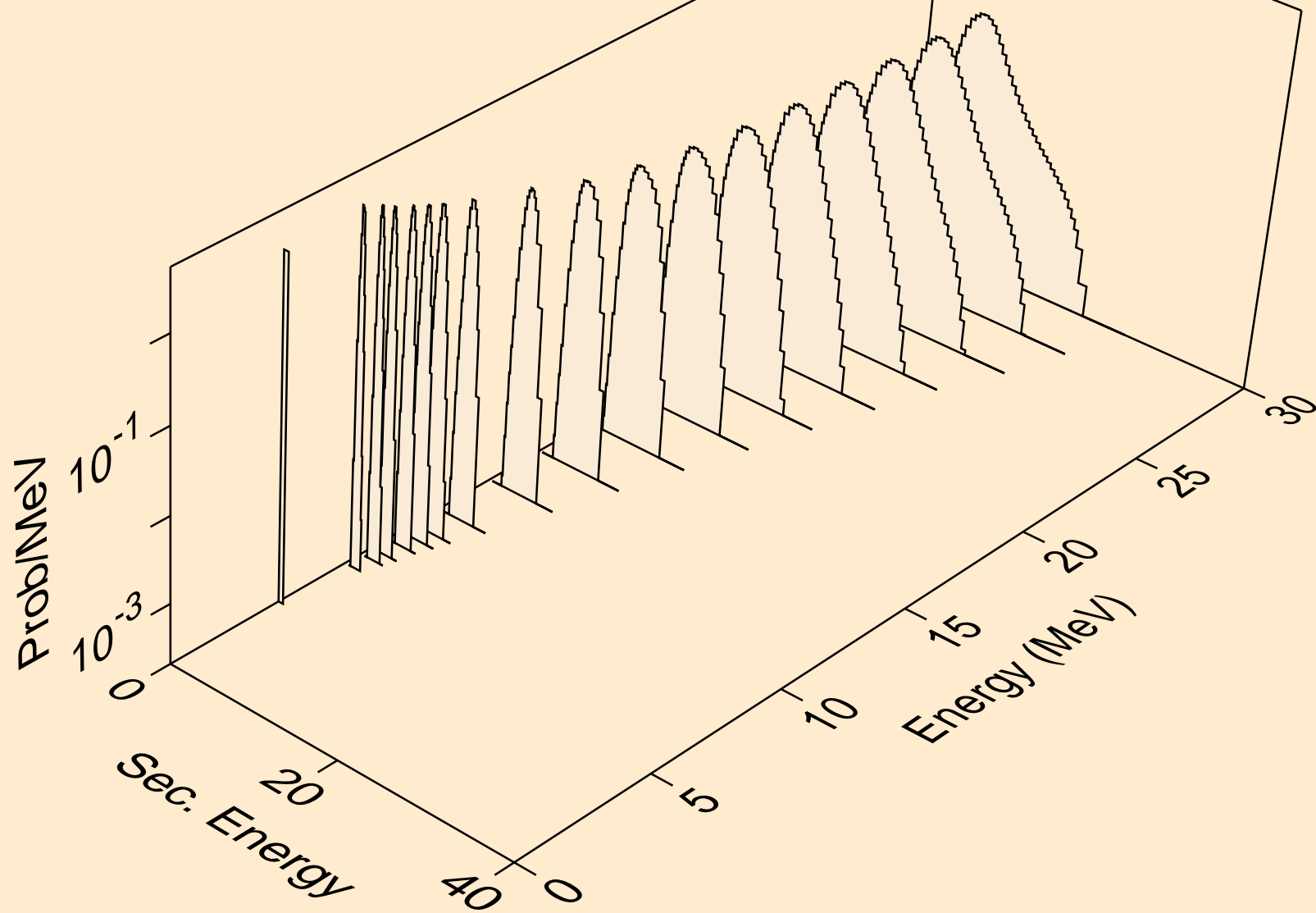

CS116M NEUTRON ACER TENDL-2024 LIBRARY; T=0.K
protons from (n,npa)

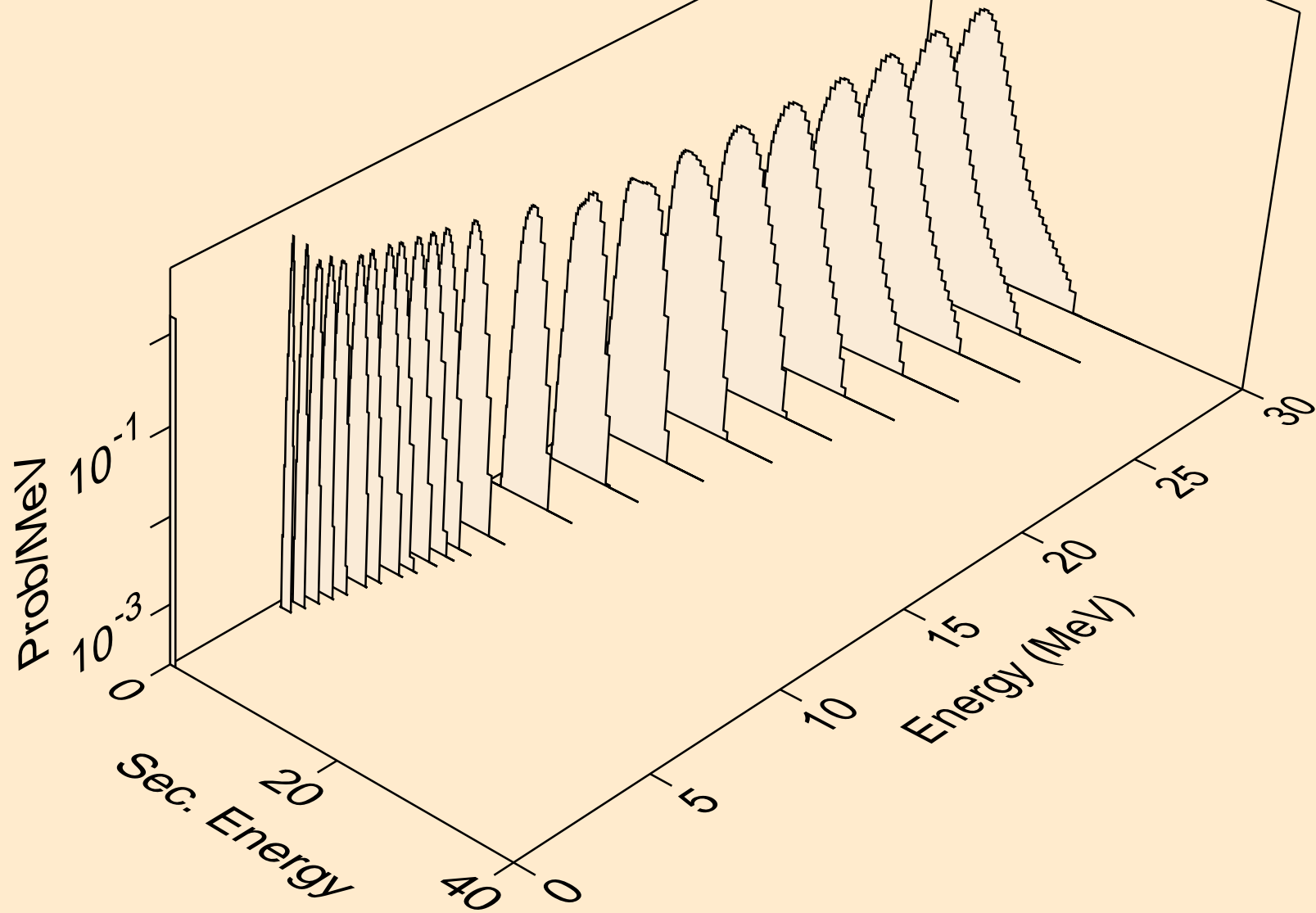

CS116M NEUTRON ACER TENDL-2024 LIBRARY; T=0.K
protons from (n,p)

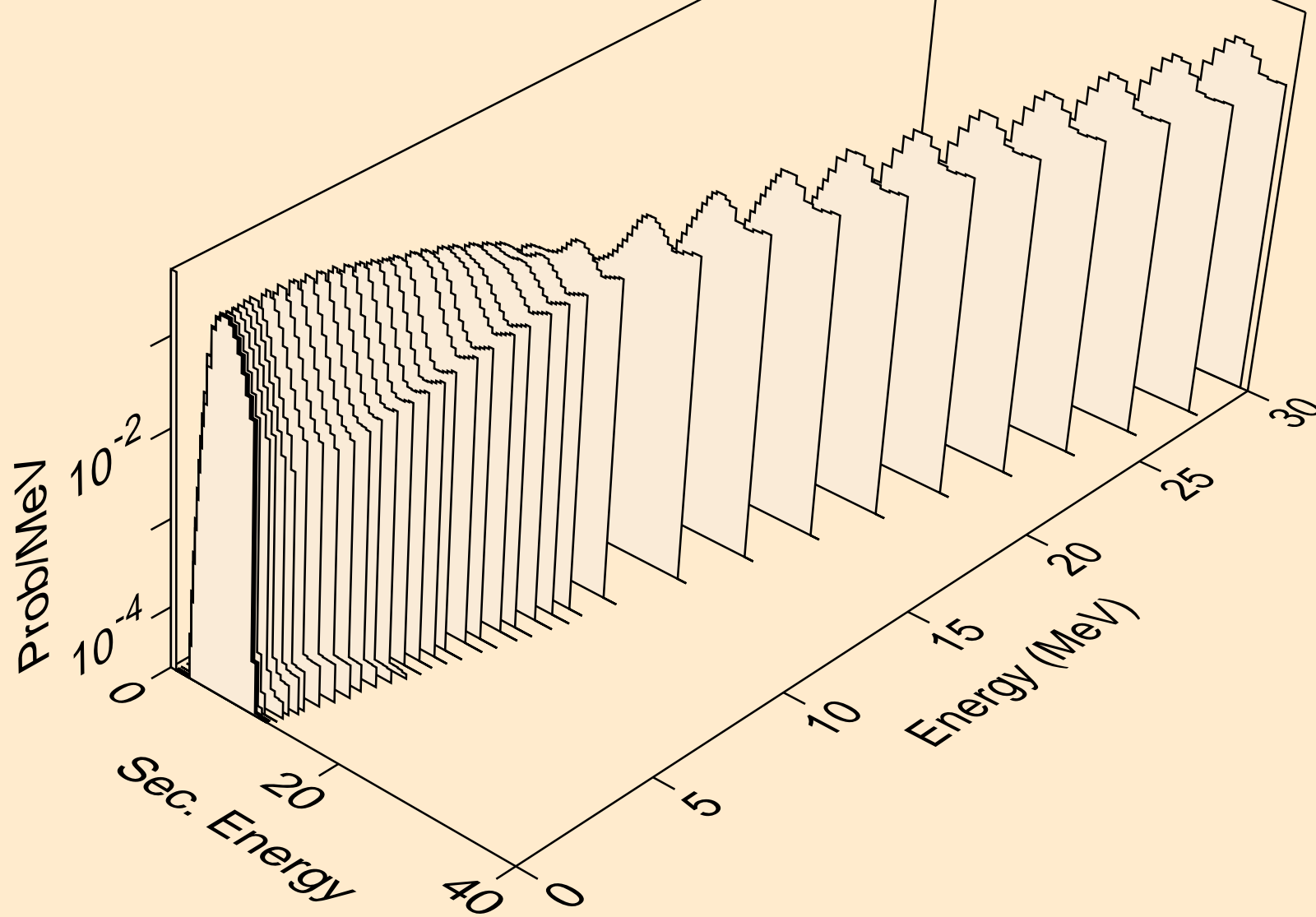

CS116M NEUTRON ACER TENDL-2024 LIBRARY; T=0.K
protons from (n,2p)

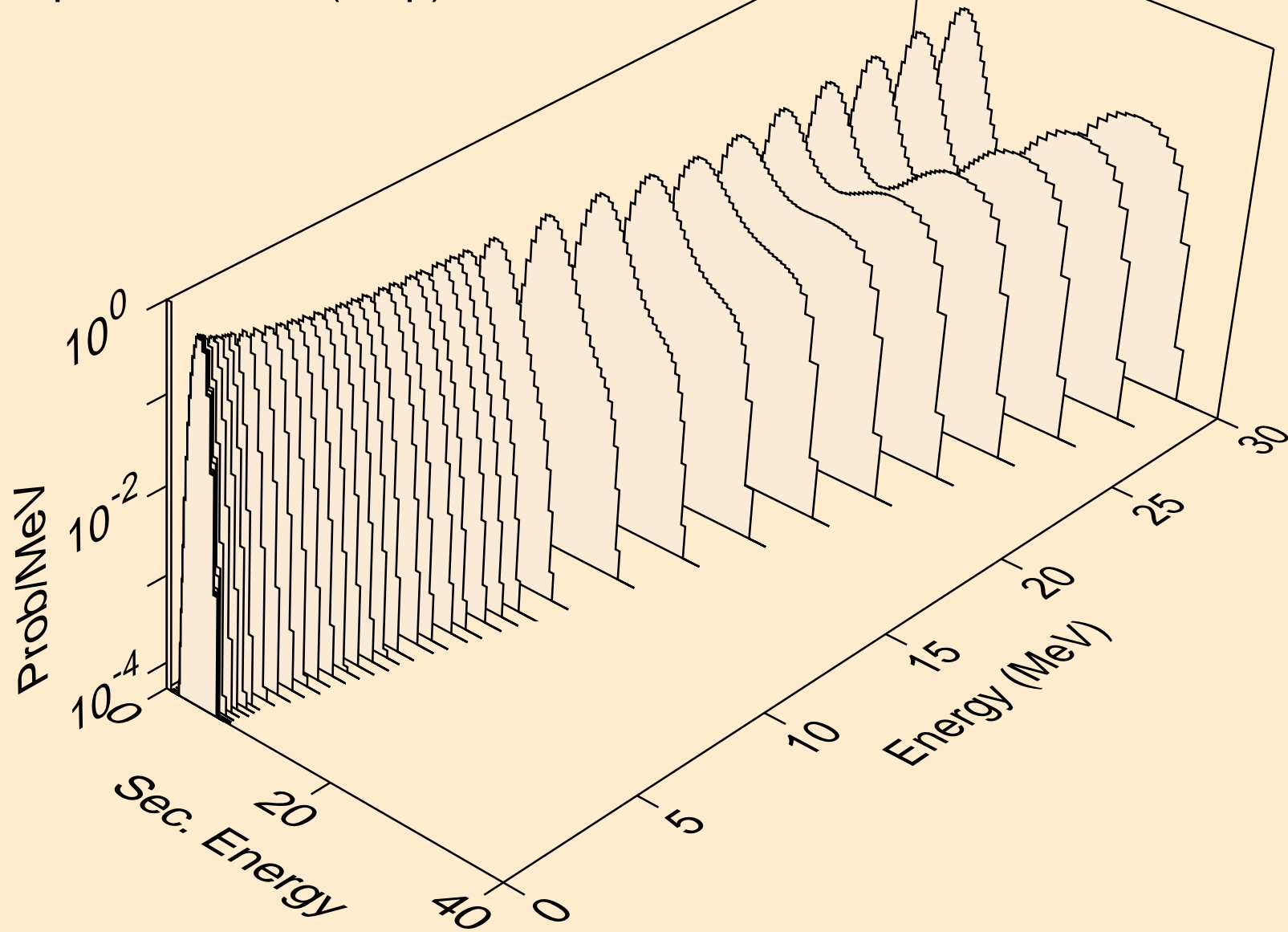

CS116M NEUTRON ACER TENDL-2024 LIBRARY; T=0.K
protons from (n,p)

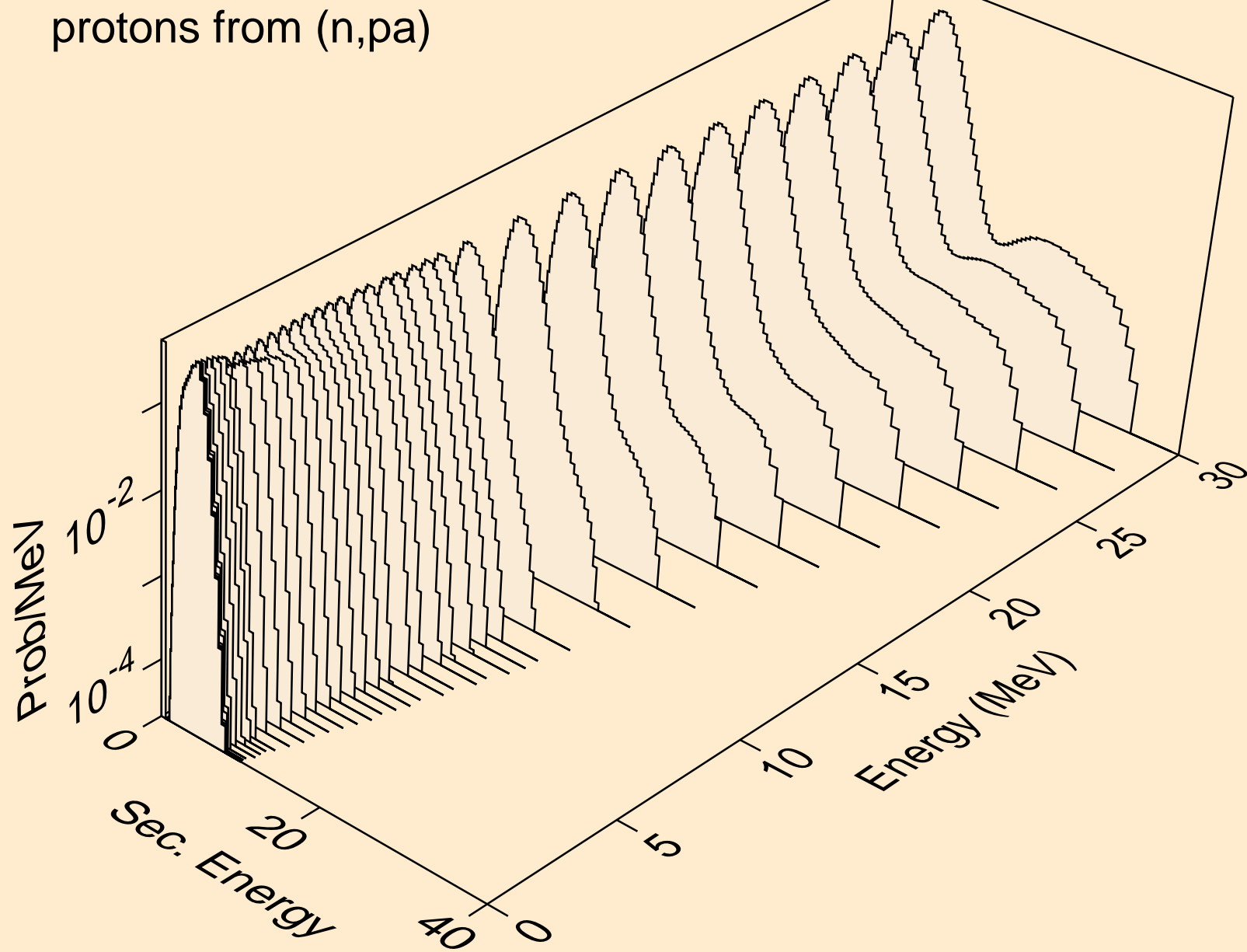

CS116M NEUTRON ACER TENDL-2024 LIBRARY; T=0.K
protons from (n,pd)

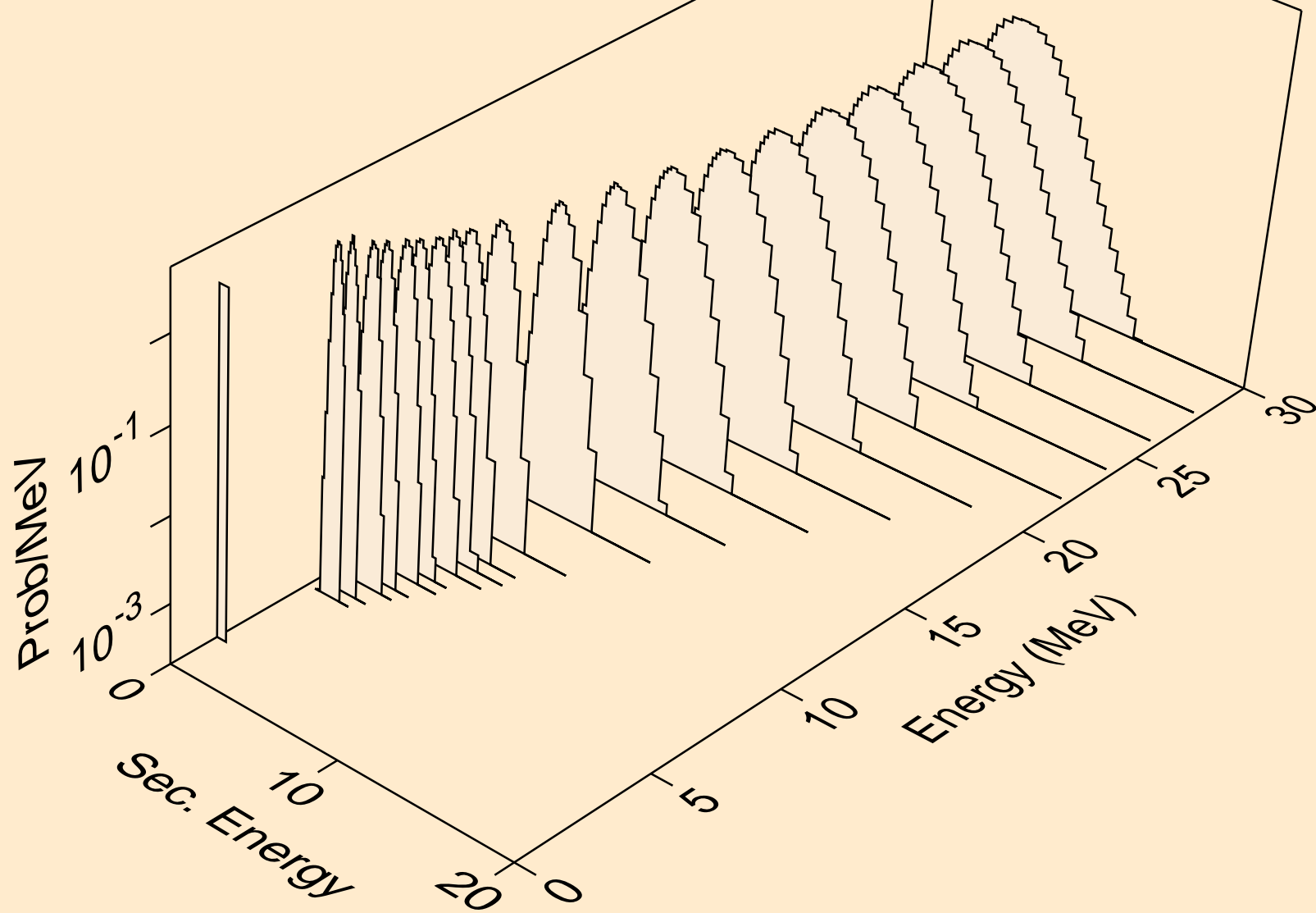

CS116M NEUTRON ACER TENDL-2024 LIBRARY; T=0.K
protons from (n,pt)

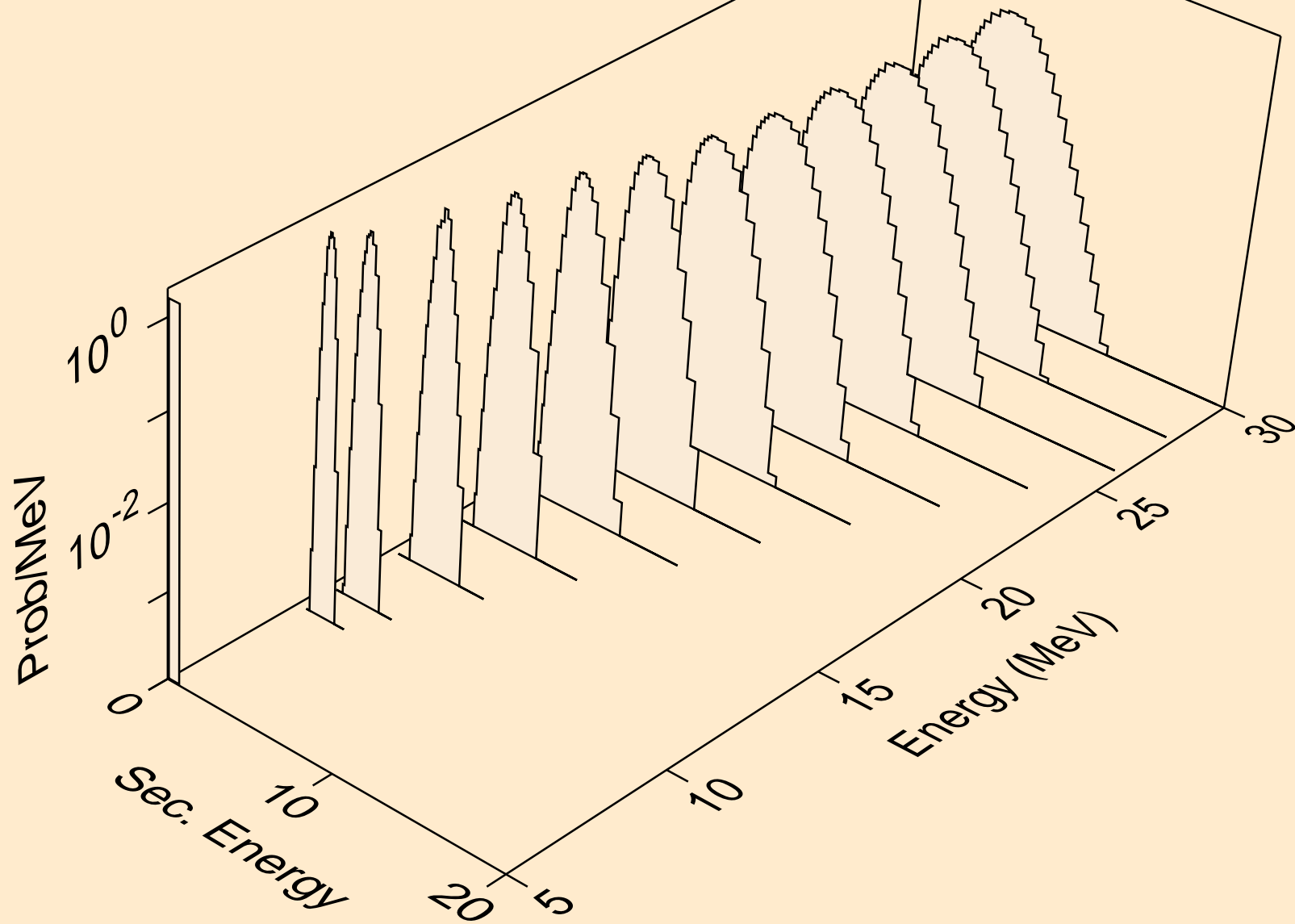

CS116M NEUTRON ACER TENDL-2024 LIBRARY; T=0.K
deuterons from (n,x)

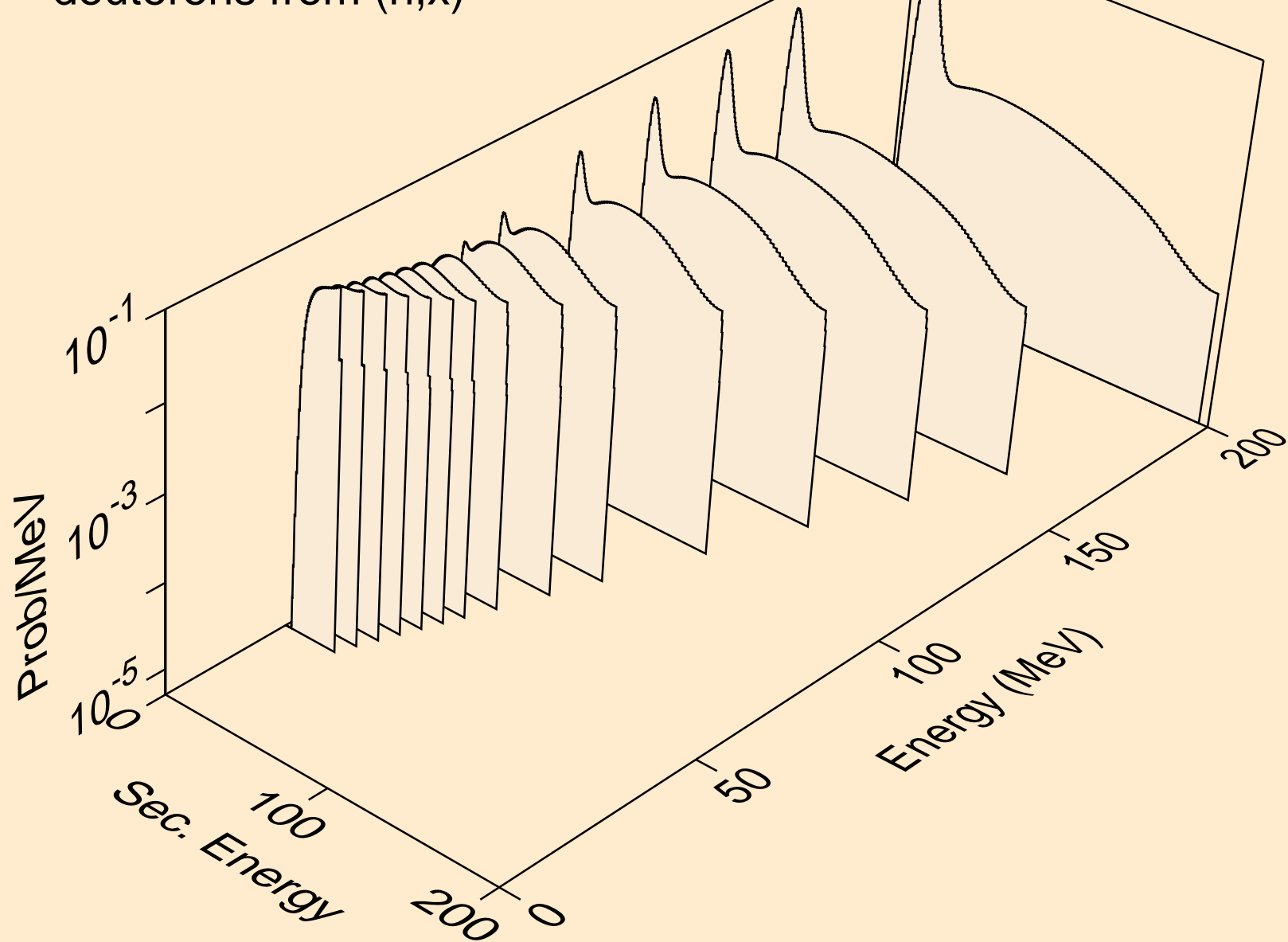

CS116M NEUTRON ACER TENDL-2024 LIBRARY; T=0.K
deuterons from (n,2nd)

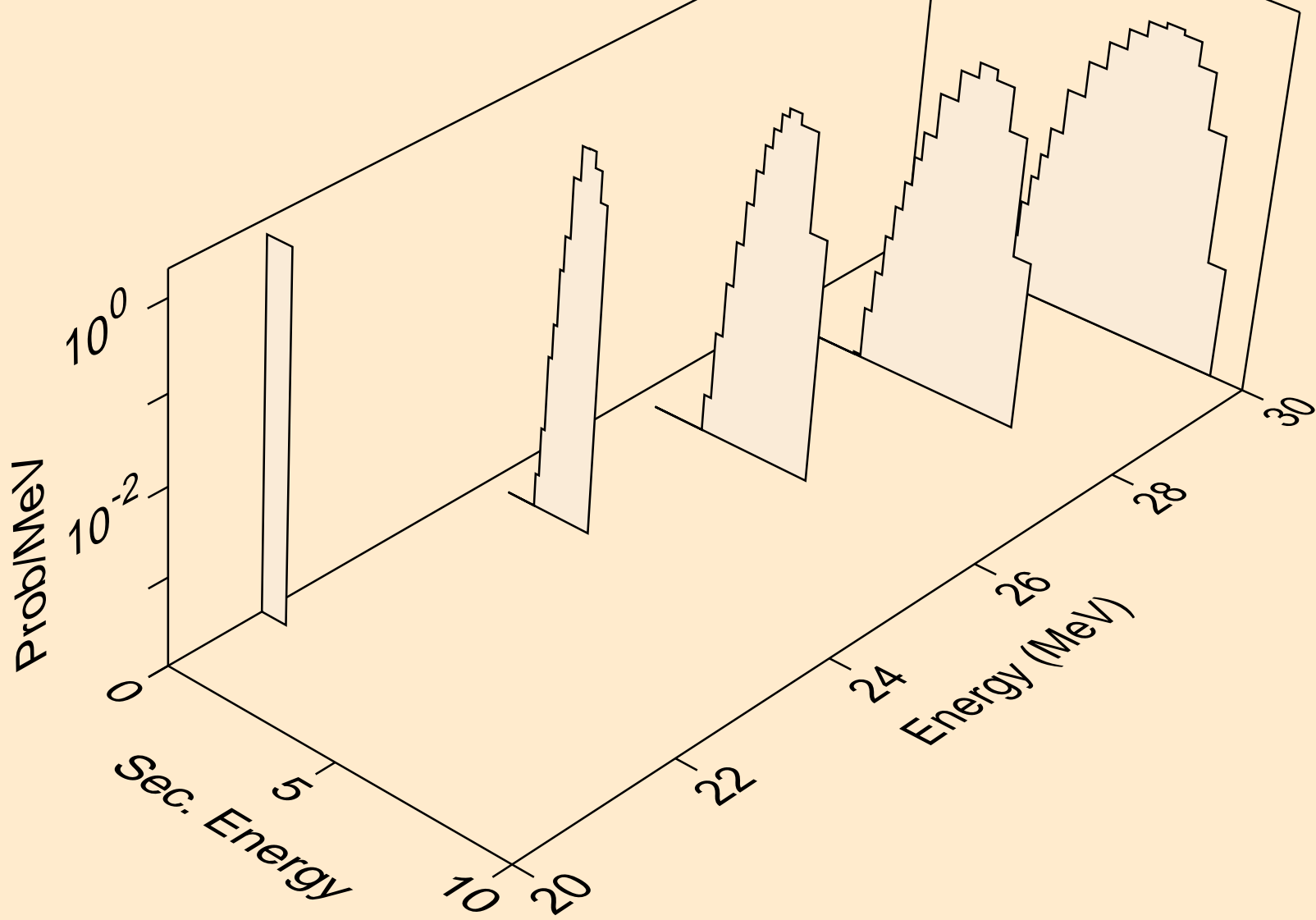

CS116M NEUTRON ACER TENDL-2024 LIBRARY; T=0.K
deuterons from (n,n*)d

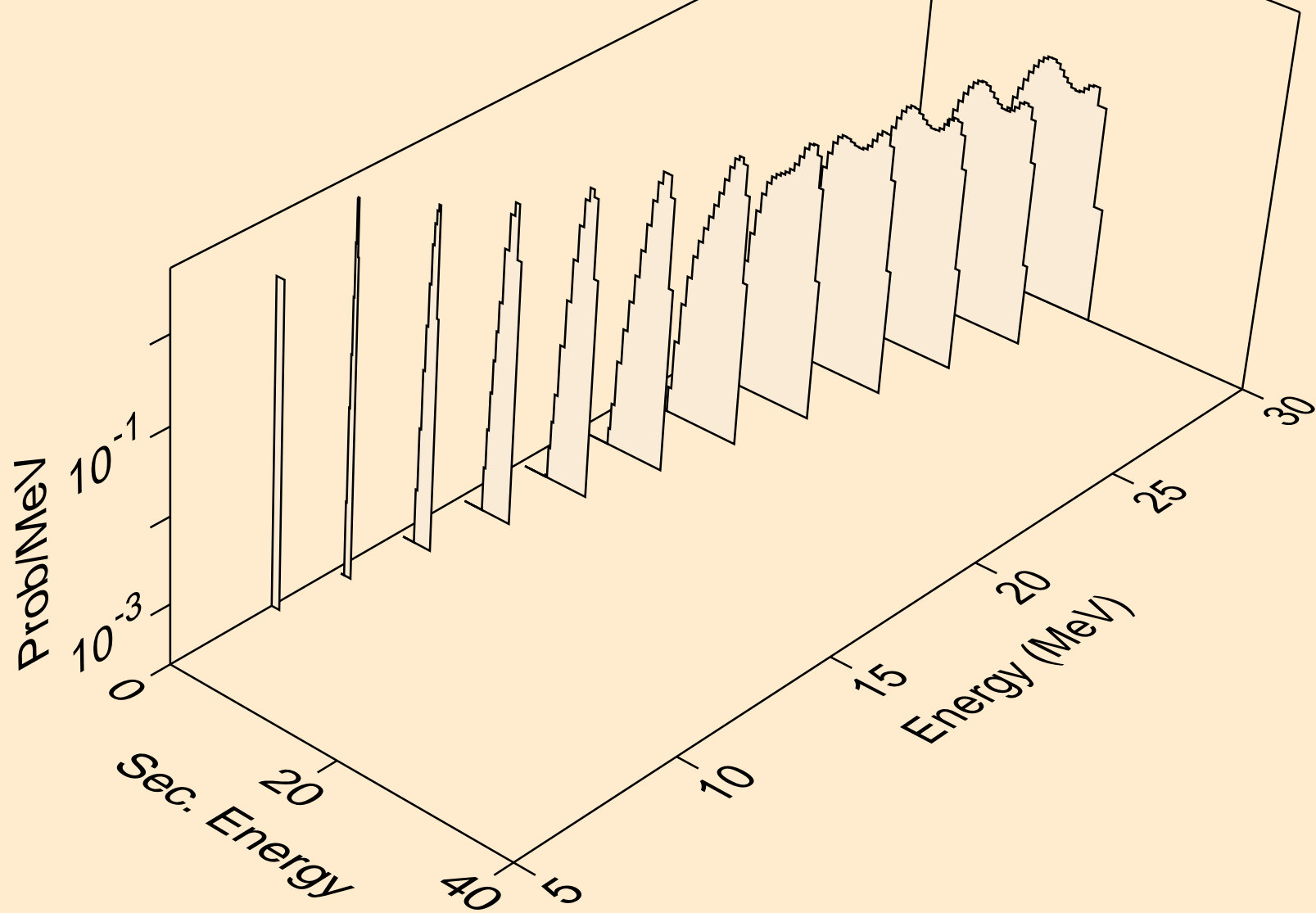

CS116M NEUTRON ACER TENDL-2024 LIBRARY; T=0.K
deuterons from (n,d)

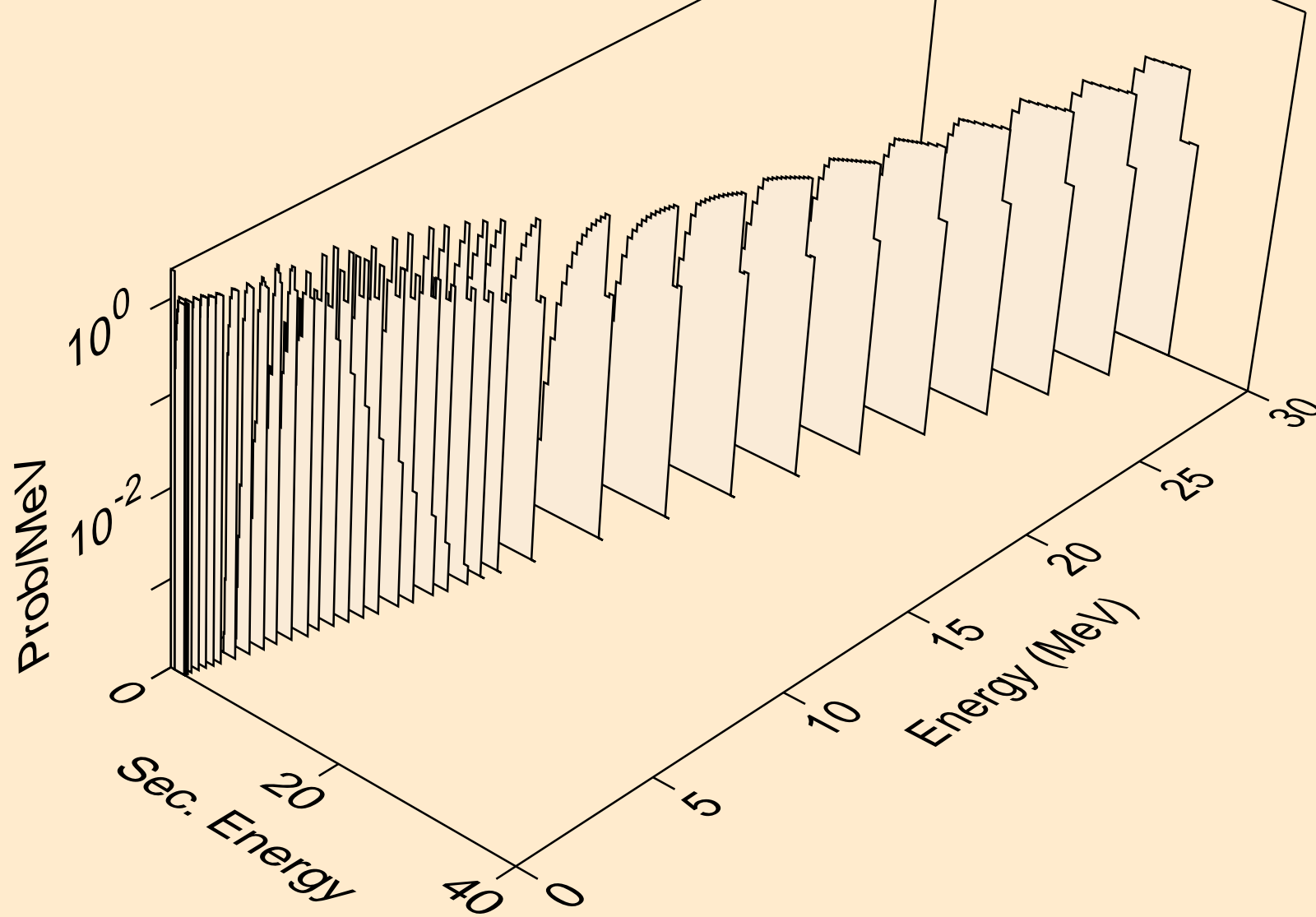

CS116M NEUTRON ACER TENDL-2024 LIBRARY; T=0.K
deuterons from (n,d2a)

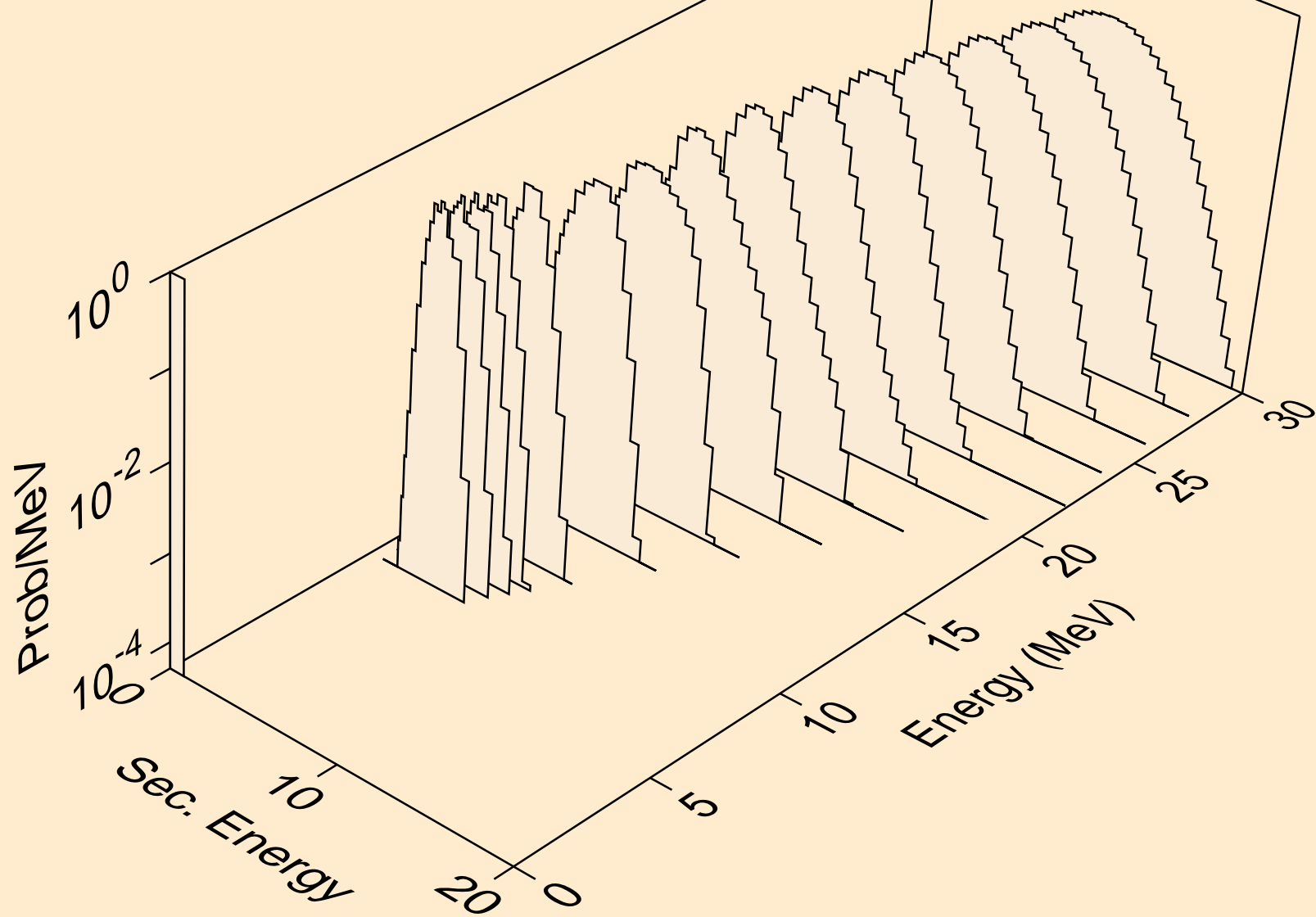

CS116M NEUTRON ACER TENDL-2024 LIBRARY; T=0.K
deuterons from (n,pd)

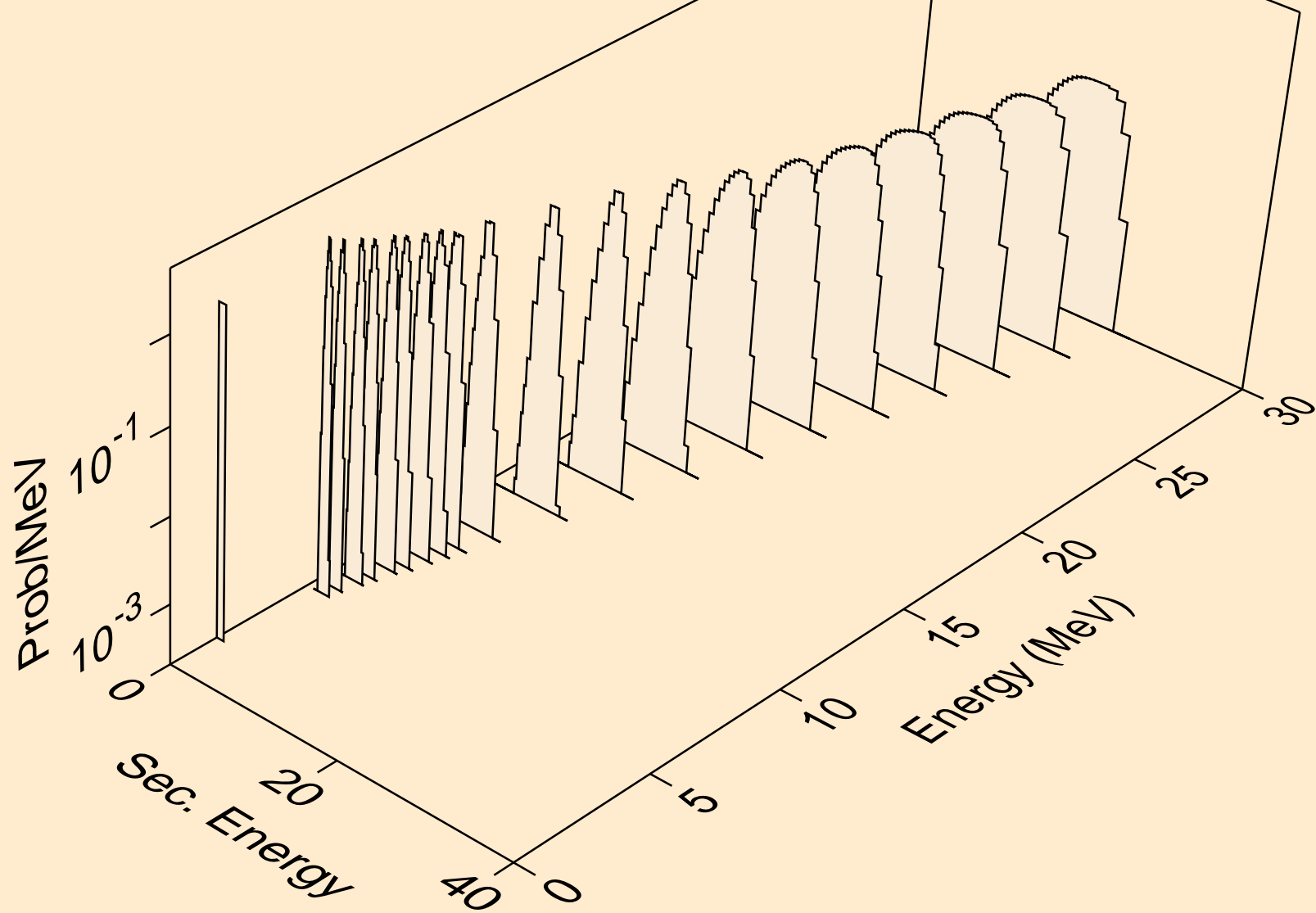

CS116M NEUTRON ACER TENDL-2024 LIBRARY; T=0.K
deuterons from (n,da)

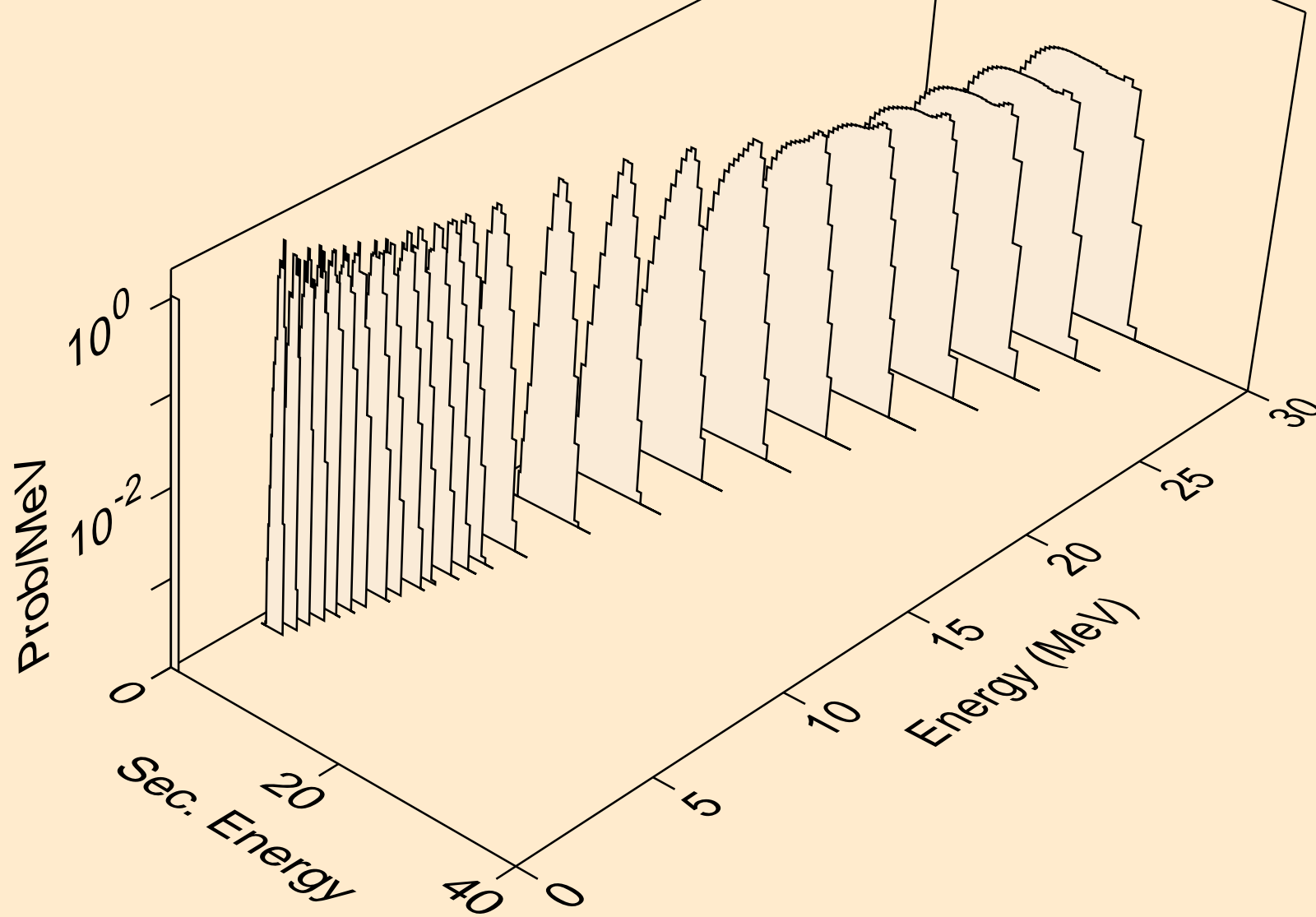

CS116M NEUTRON ACER TENDL-2024 LIBRARY; T=0.K
tritons from (n,x)

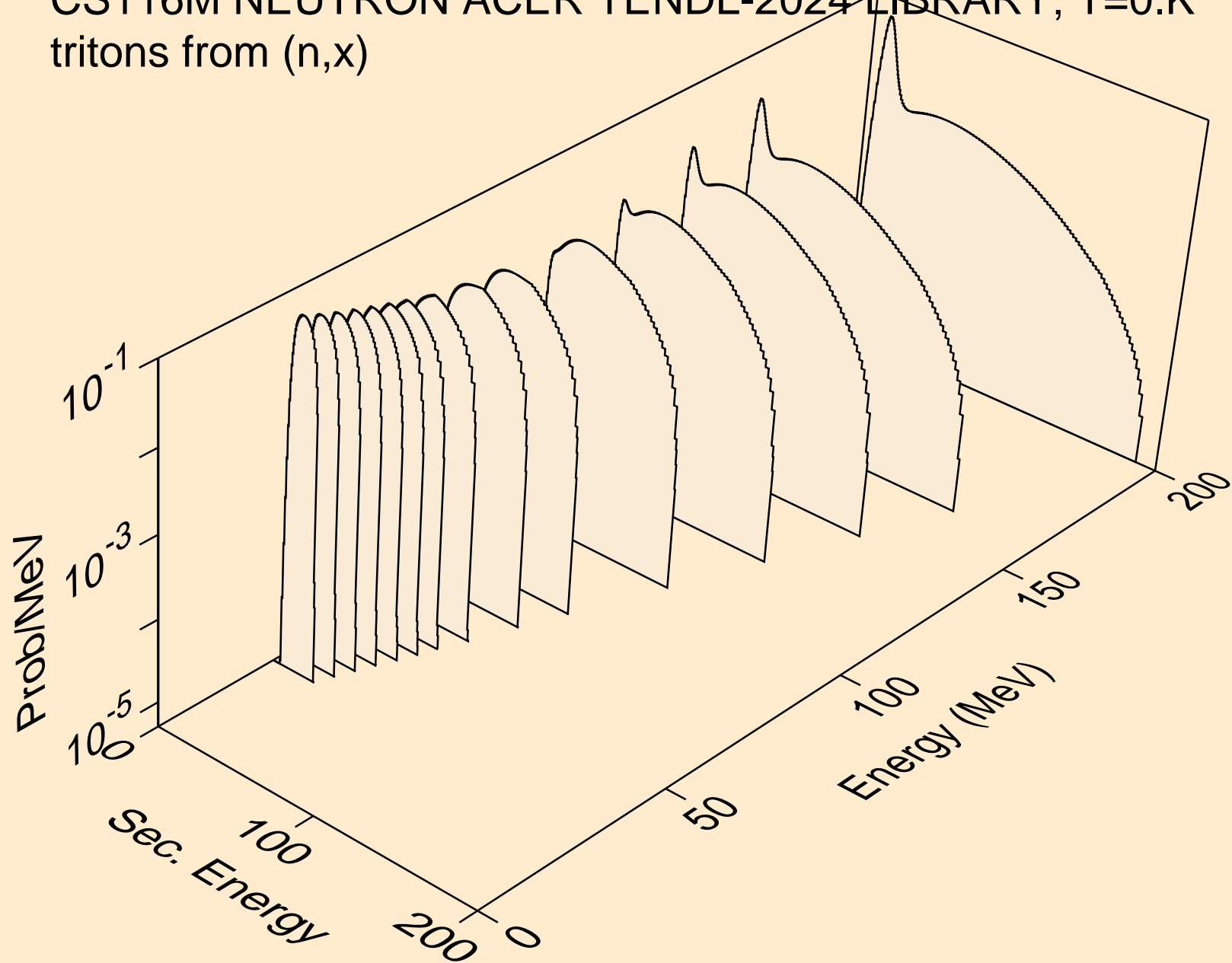

CS116M NEUTRON ACER TENDL-2024 LIBRARY; T=0.K
tritons from (n,n*)t

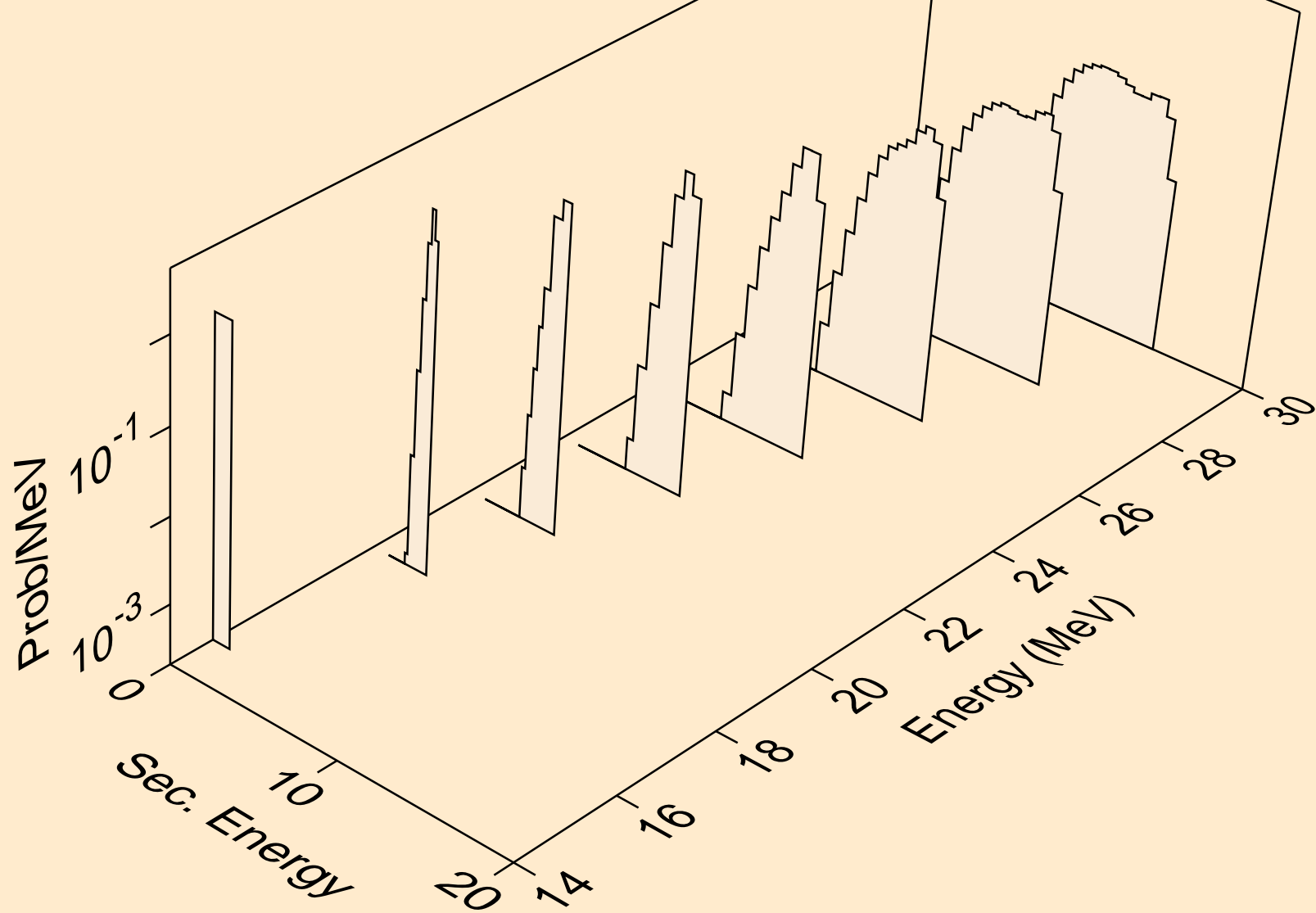

CS116M NEUTRON ACER TENDL-2024 LIBRARY; T=0.K
tritons from (n,t)

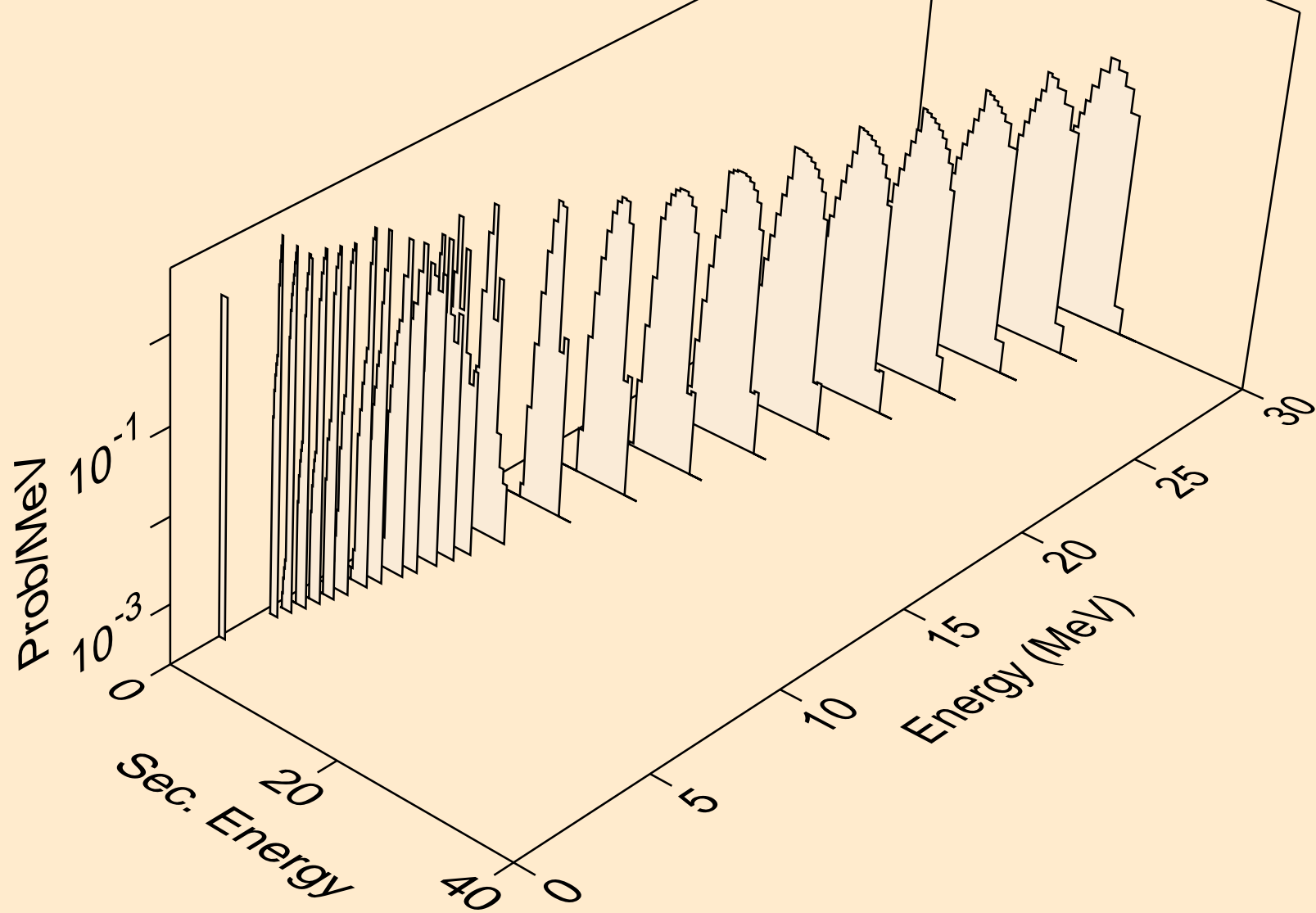

CS116M NEUTRON ACER TENDL-2024 LIBRARY; T=0.K
tritons from (n,t2a)

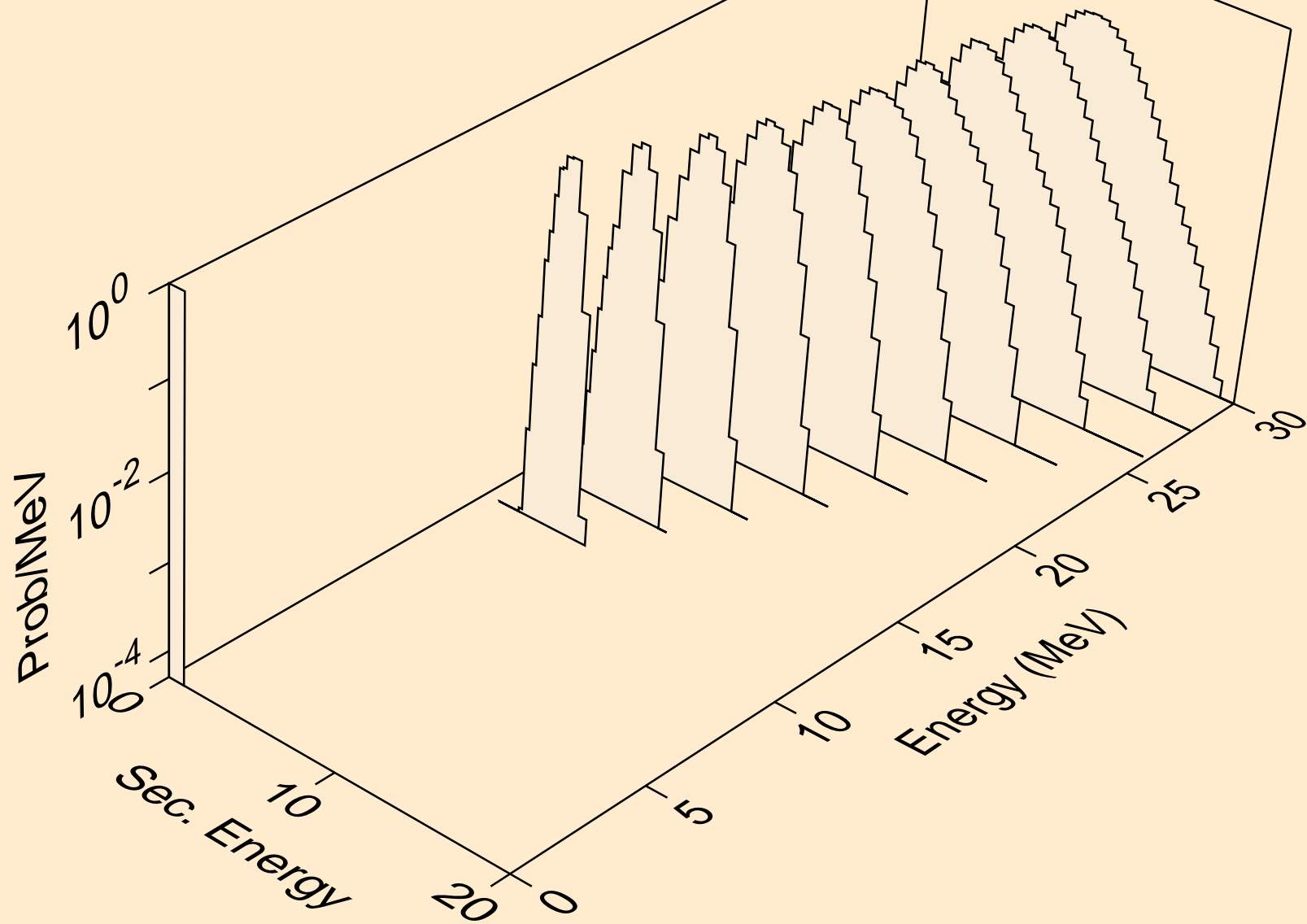

CS116M NEUTRON ACER TENDL-2024 LIBRARY; T=0.K
tritons from (n,pt)

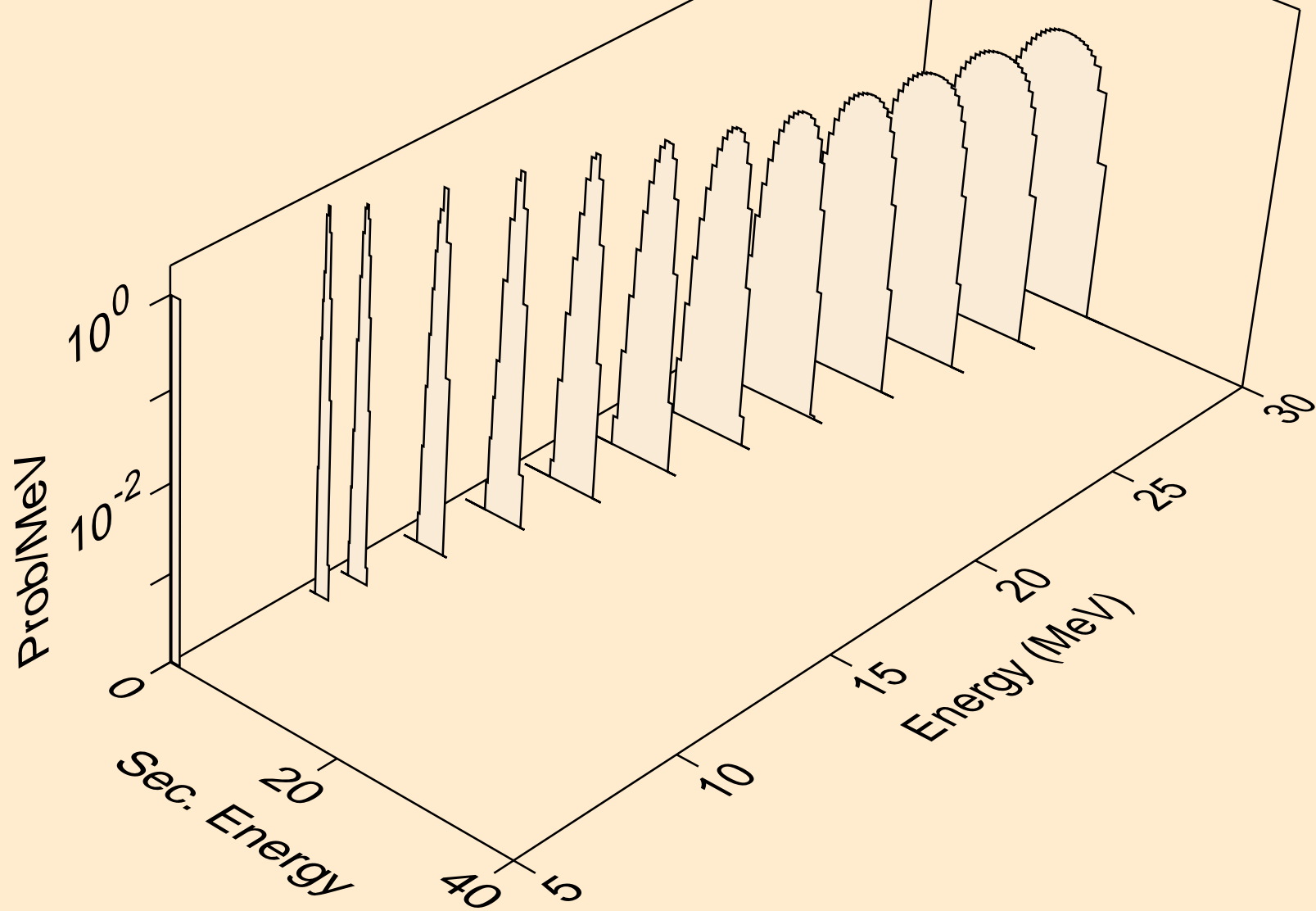

CS116M NEUTRON ACER TENDL-2024 LIBRARY; T=0.K
he3s from (n,x)

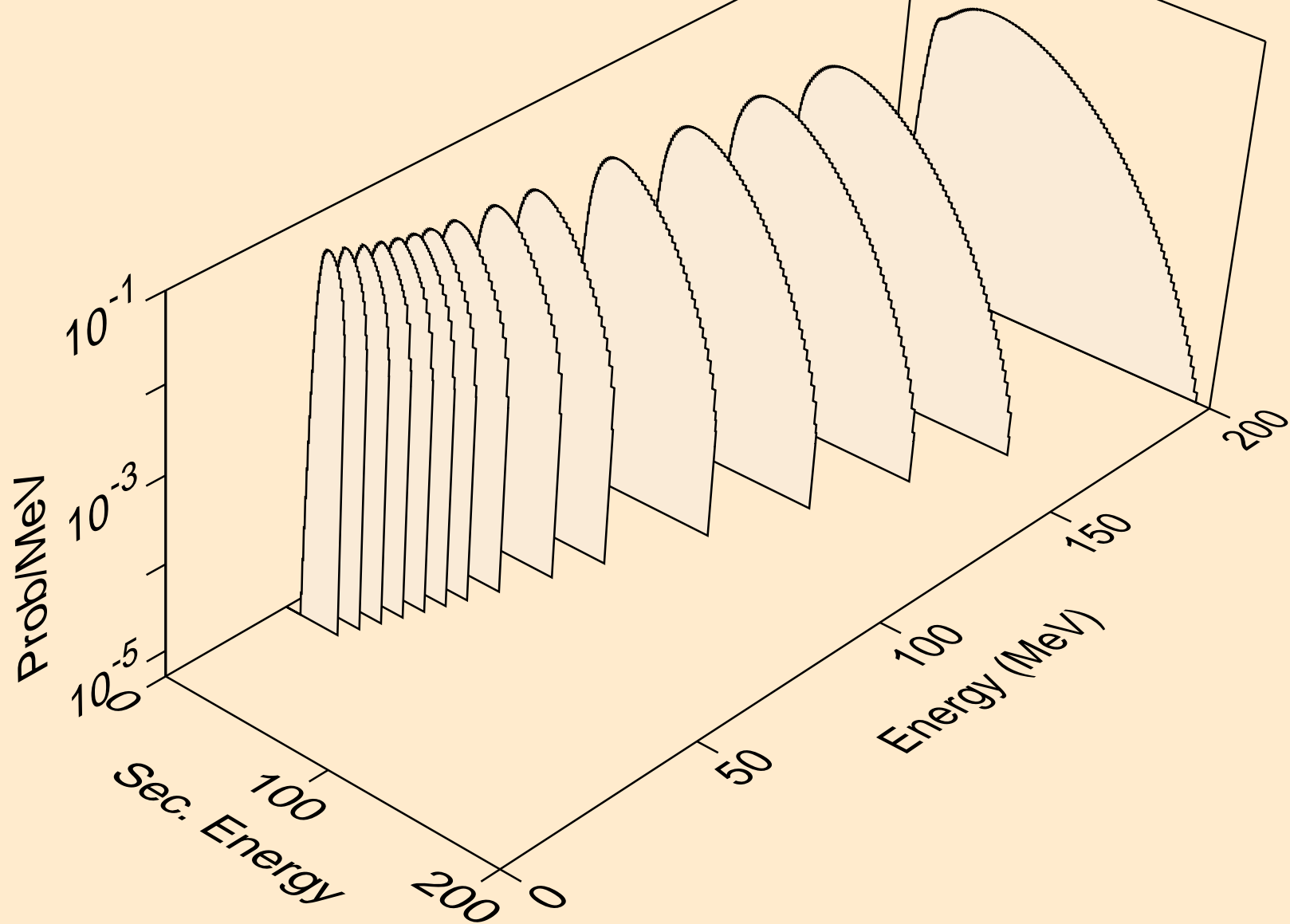

CS116M NEUTRON ACER TENDL-2024 LIBRARY; T=0.K
he3s from (n,n*)he3

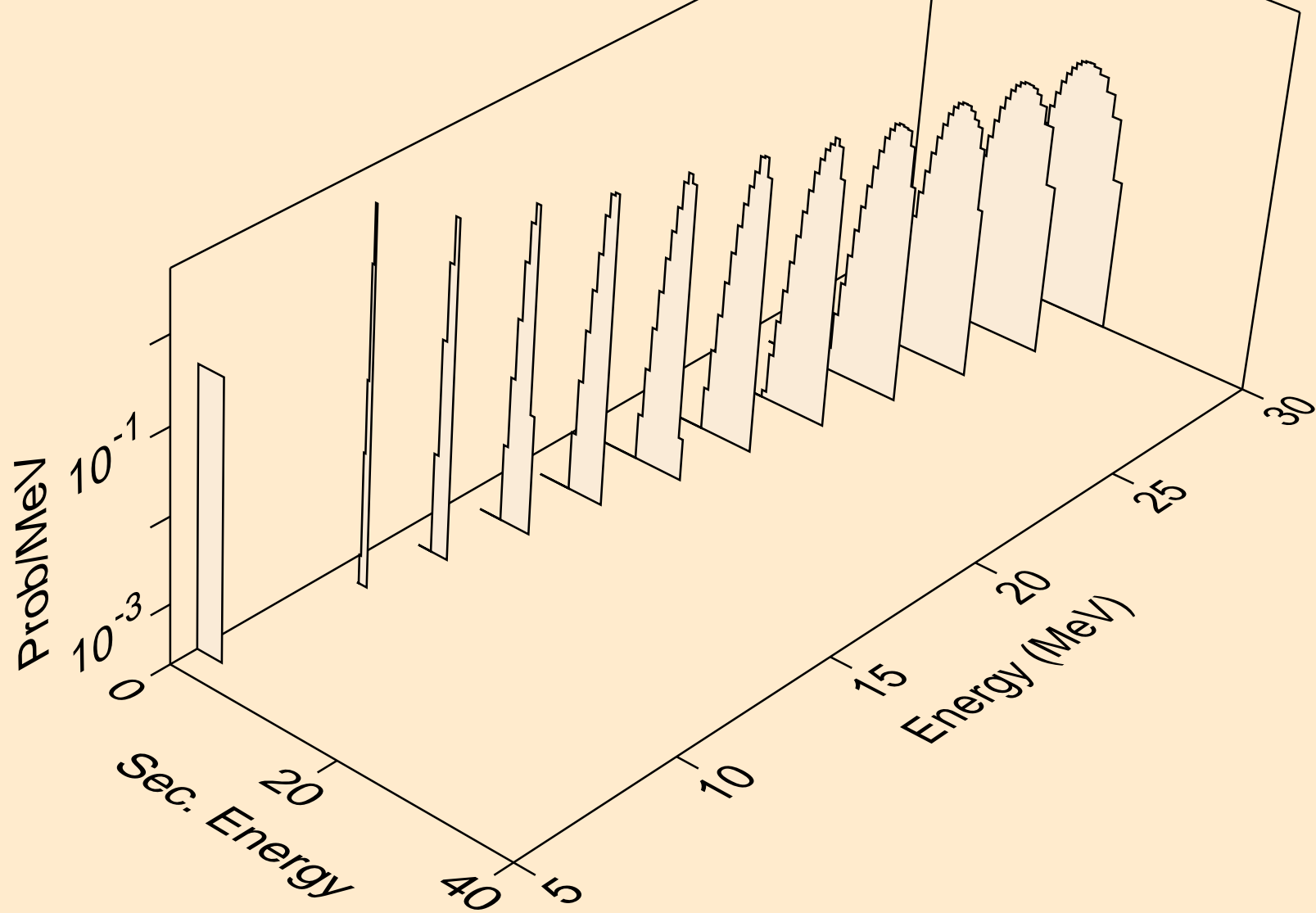

CS116M NEUTRON ACER TENDL-2024 LIBRARY; T=0.K
he3s from (n,he3)

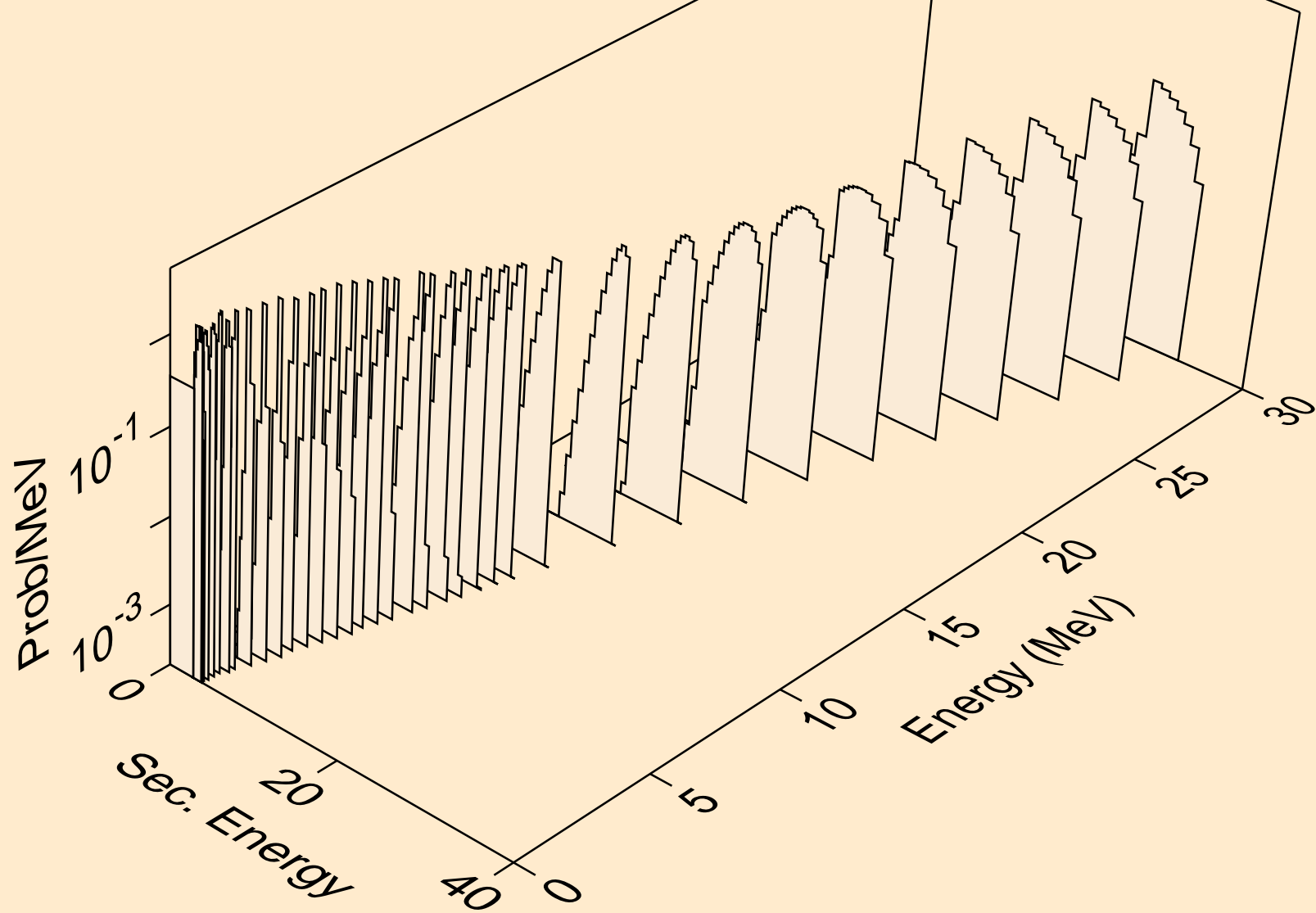

CS116M NEUTRON ACER TENDL-2024 LIBRARY; T=0.K
alphas from (n,x)

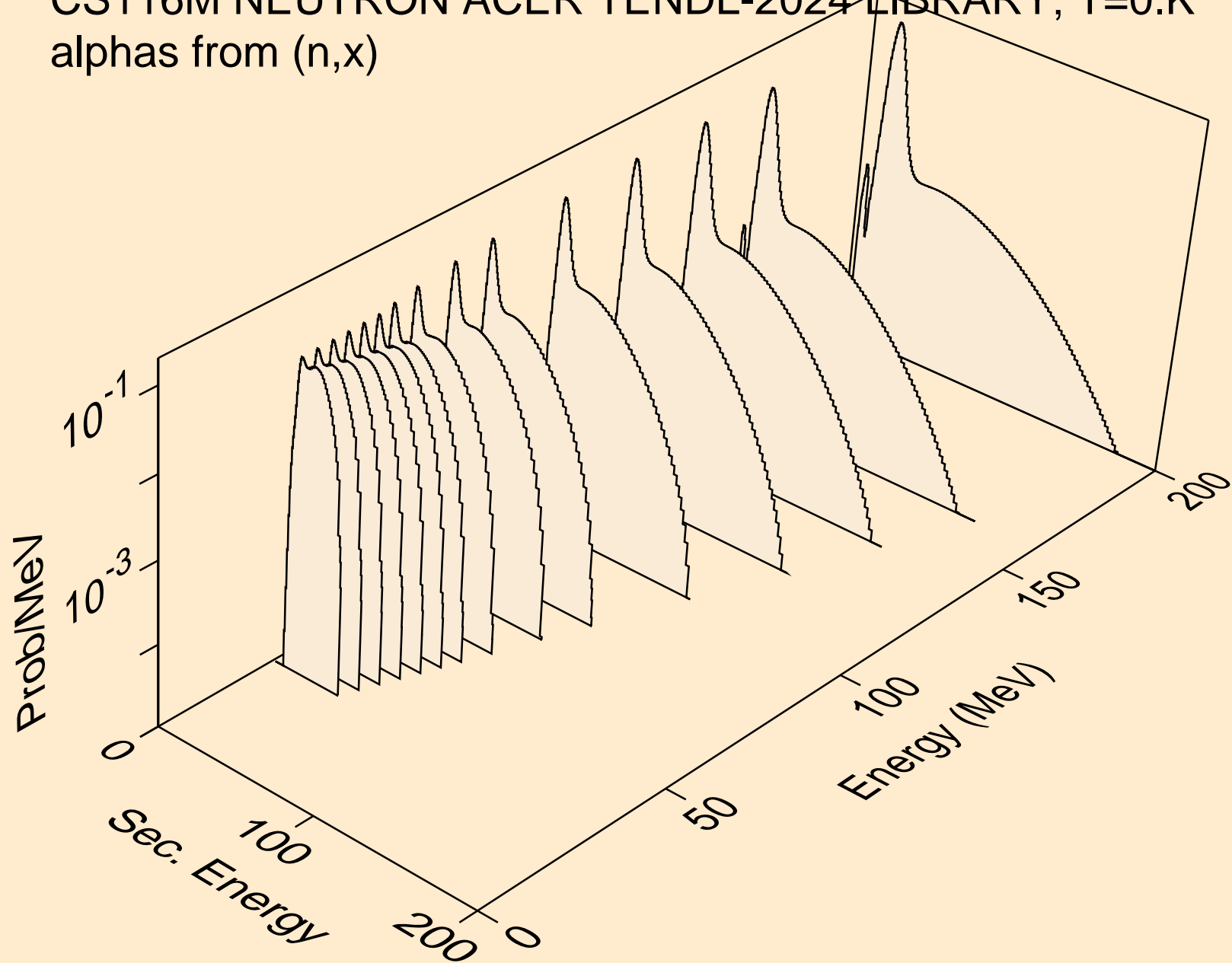

CS116M NEUTRON ACER TENDL-2024 LIBRARY; T=0.K
alphas from (n,n*)a

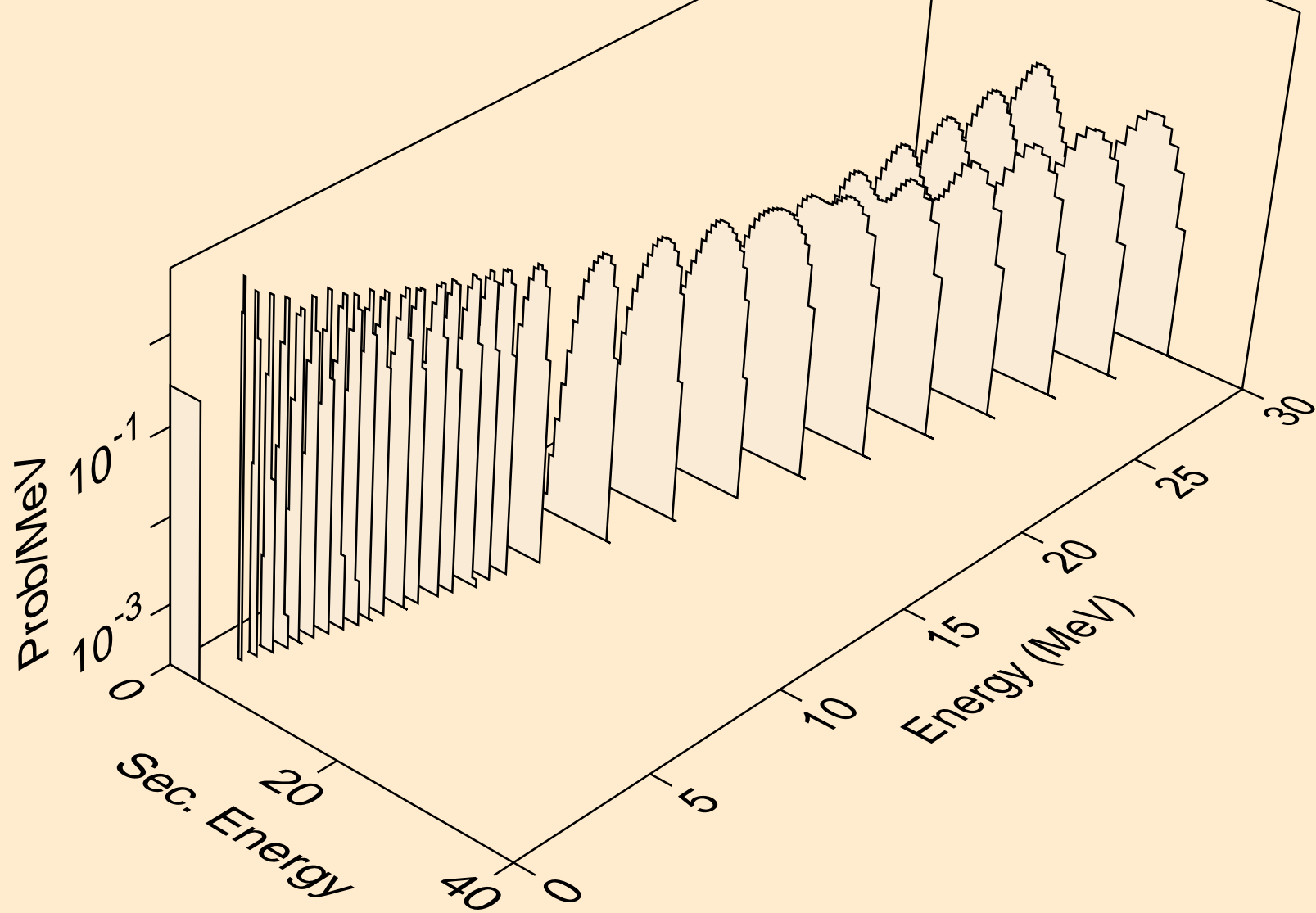

CS116M NEUTRON ACER TENDL-2024 LIBRARY; T=0.K
alphas from (n,n*)3a

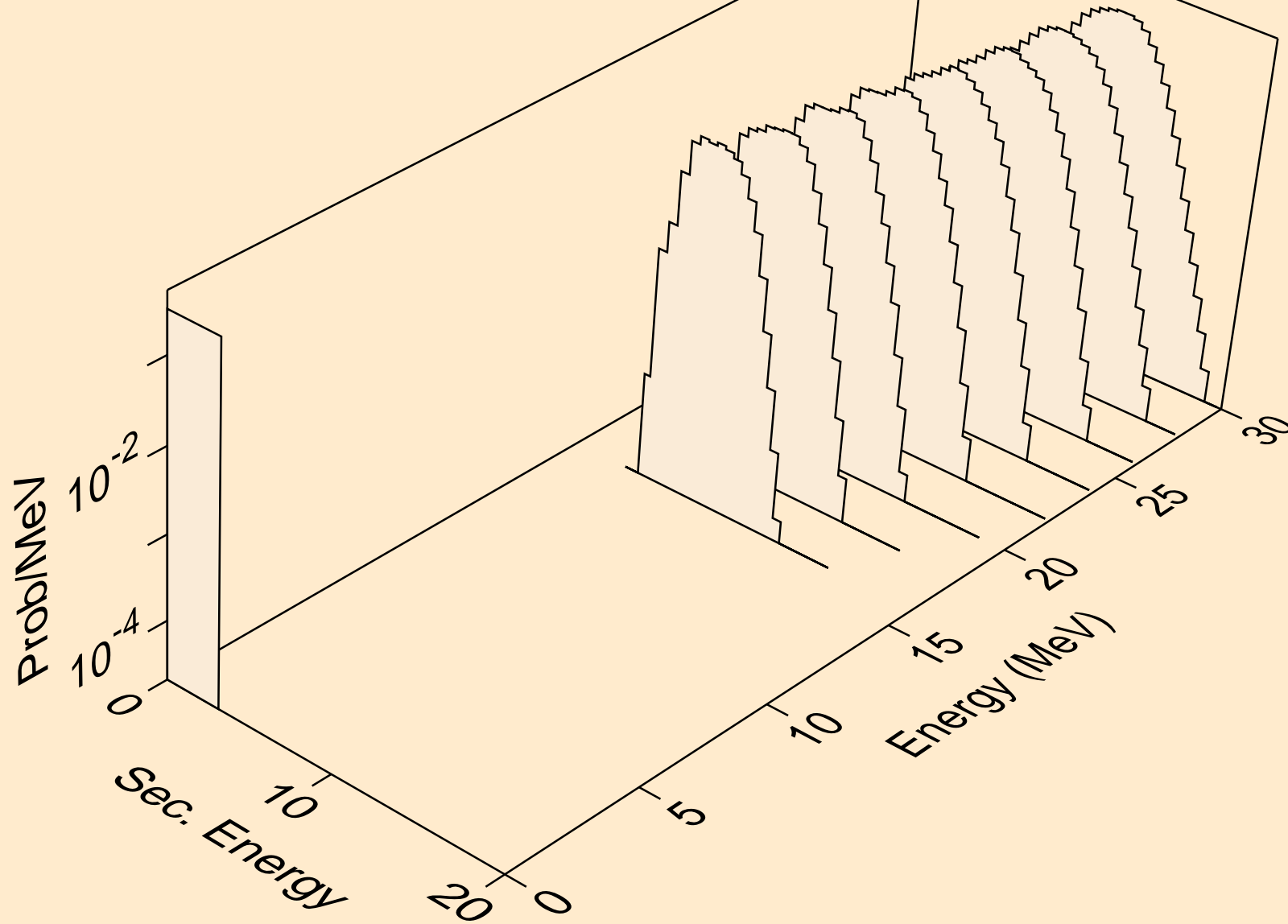

CS116M NEUTRON ACER TENDL-2024 LIBRARY; T=0.K
alphas from (n,2n)a

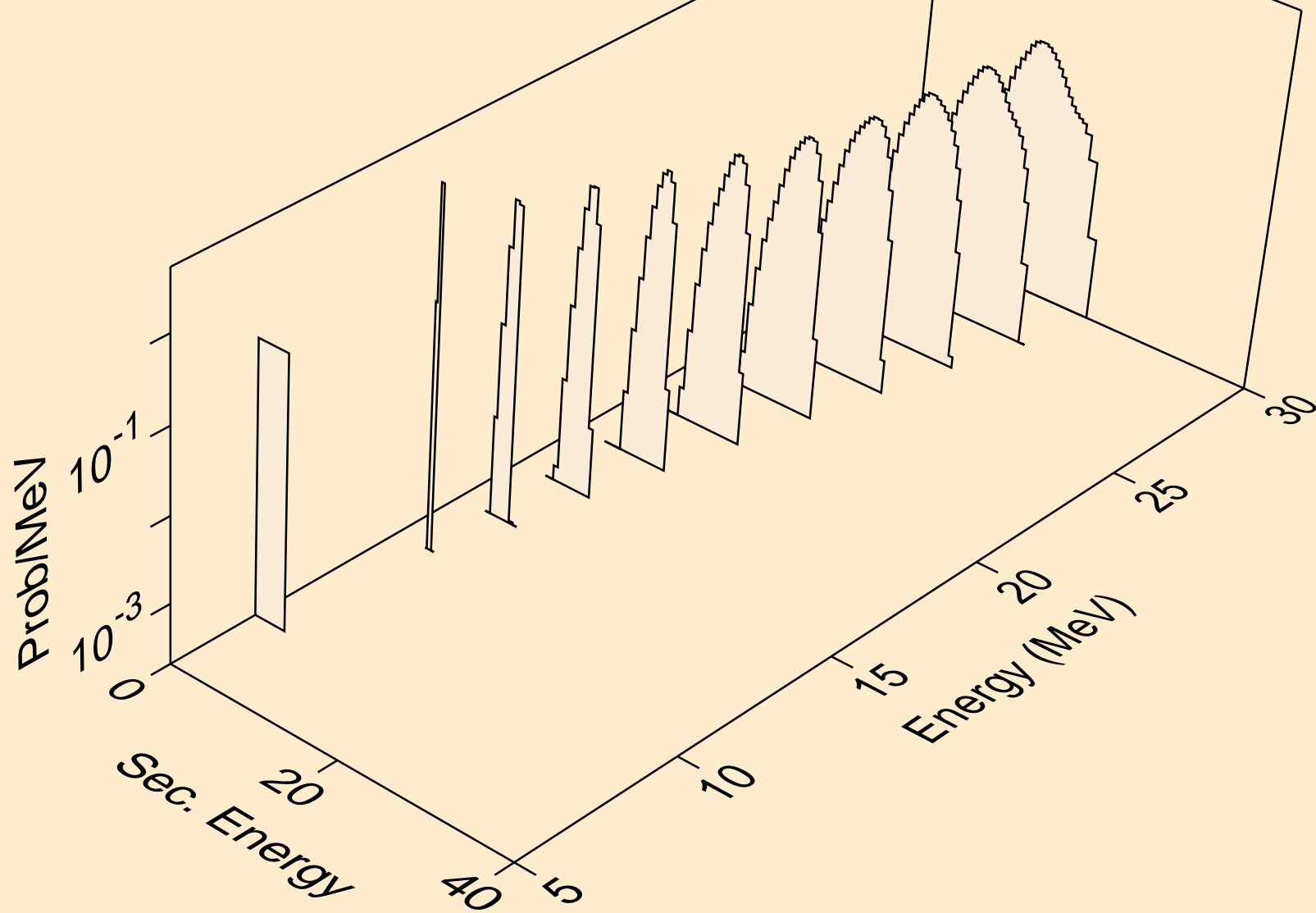

CS116M NEUTRON ACER TENDL-2024 LIBRARY; T=0.K
alphas from (n,n*)2a

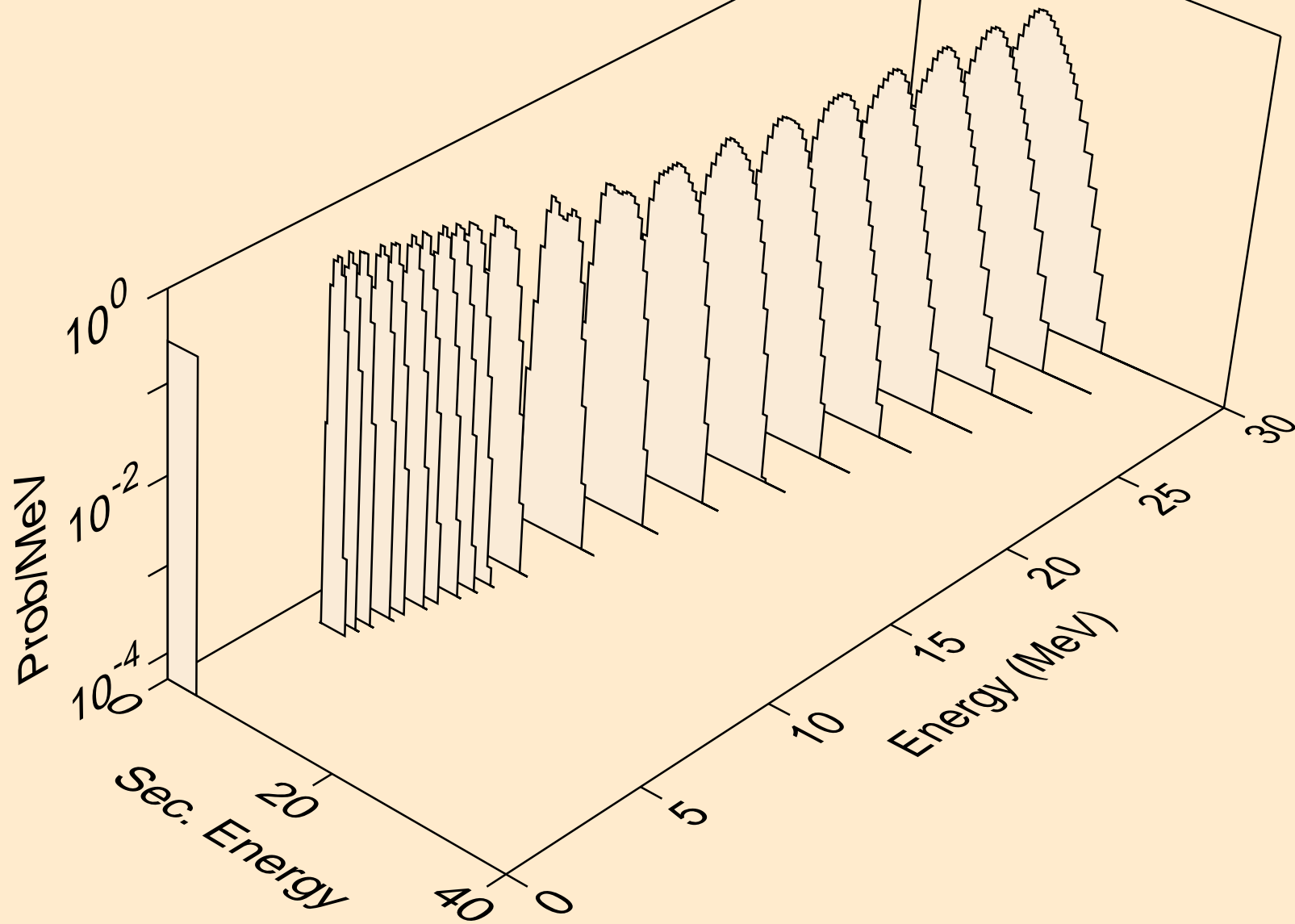

CS116M NEUTRON ACER TENDL-2024 LIBRARY; T=0.K
alphas from (n,2n)2a

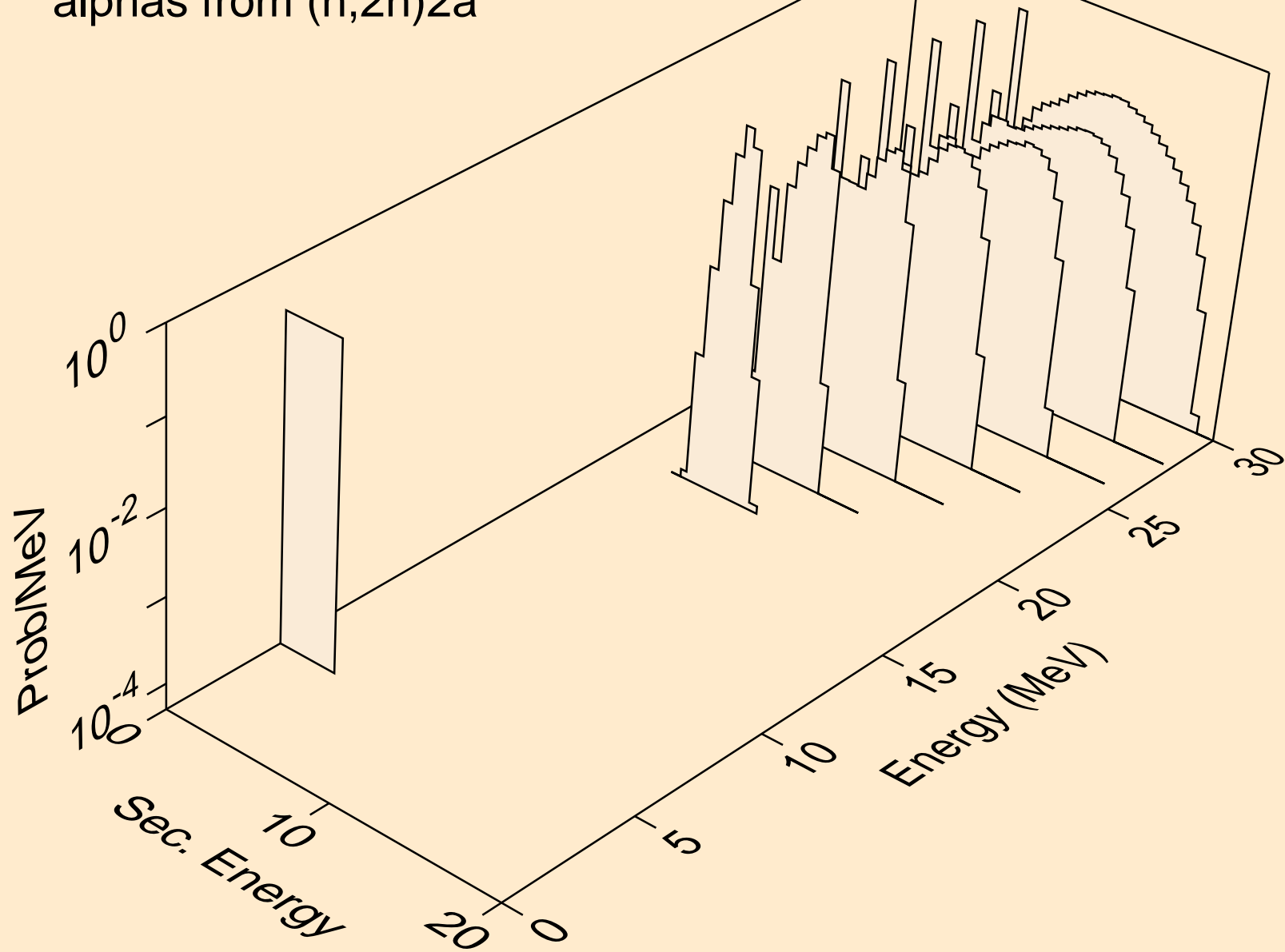

CS116M NEUTRON ACER TENDL-2024 LIBRARY; T=0.K
alphas from (n,npa)

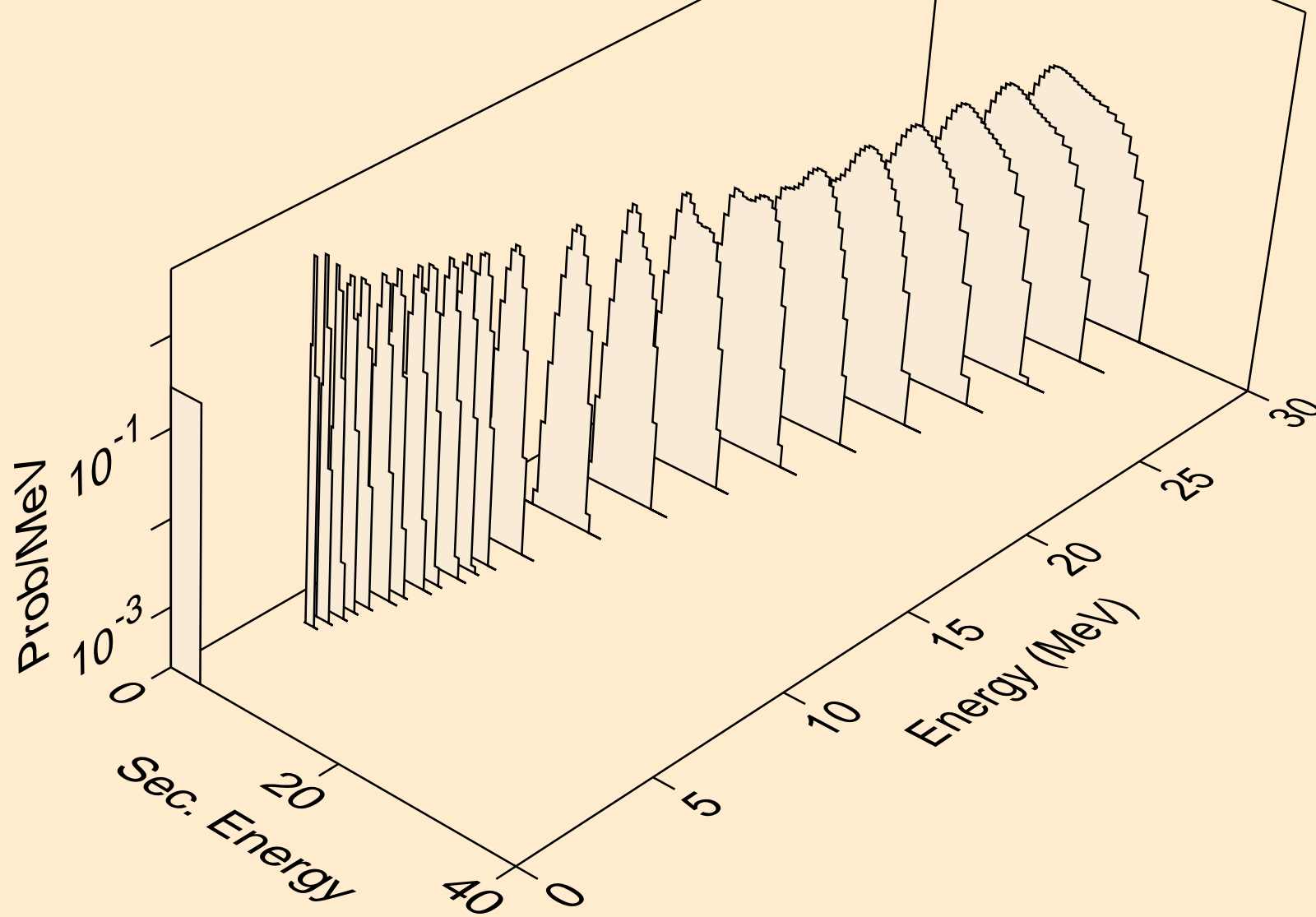

CS116M NEUTRON ACER TENDL-2024 LIBRARY; T=0.K
alphas from (n,a)

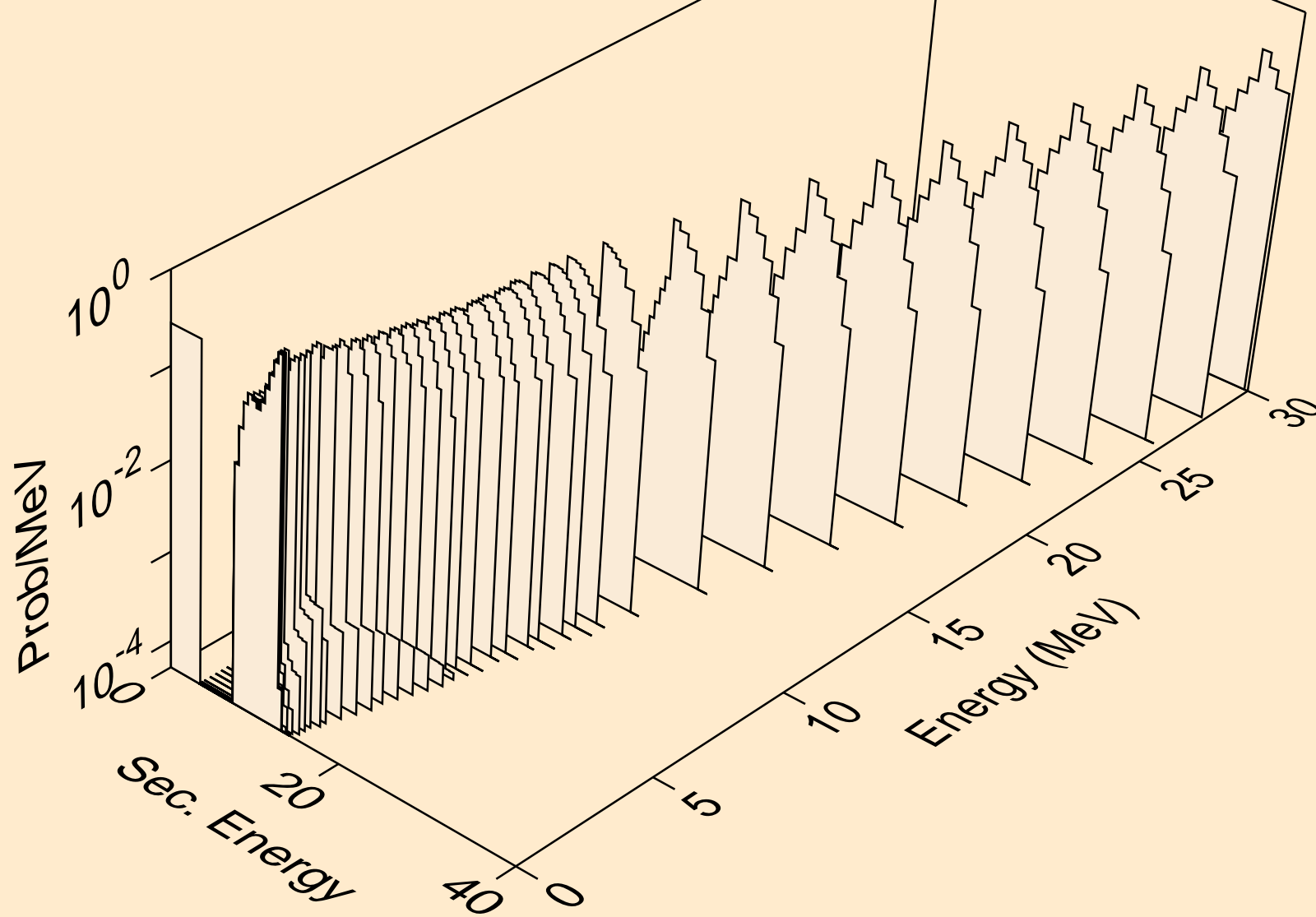

CS116M NEUTRON ACER TENDL-2024 LIBRARY; T=0.K
alphas from (n,2a)

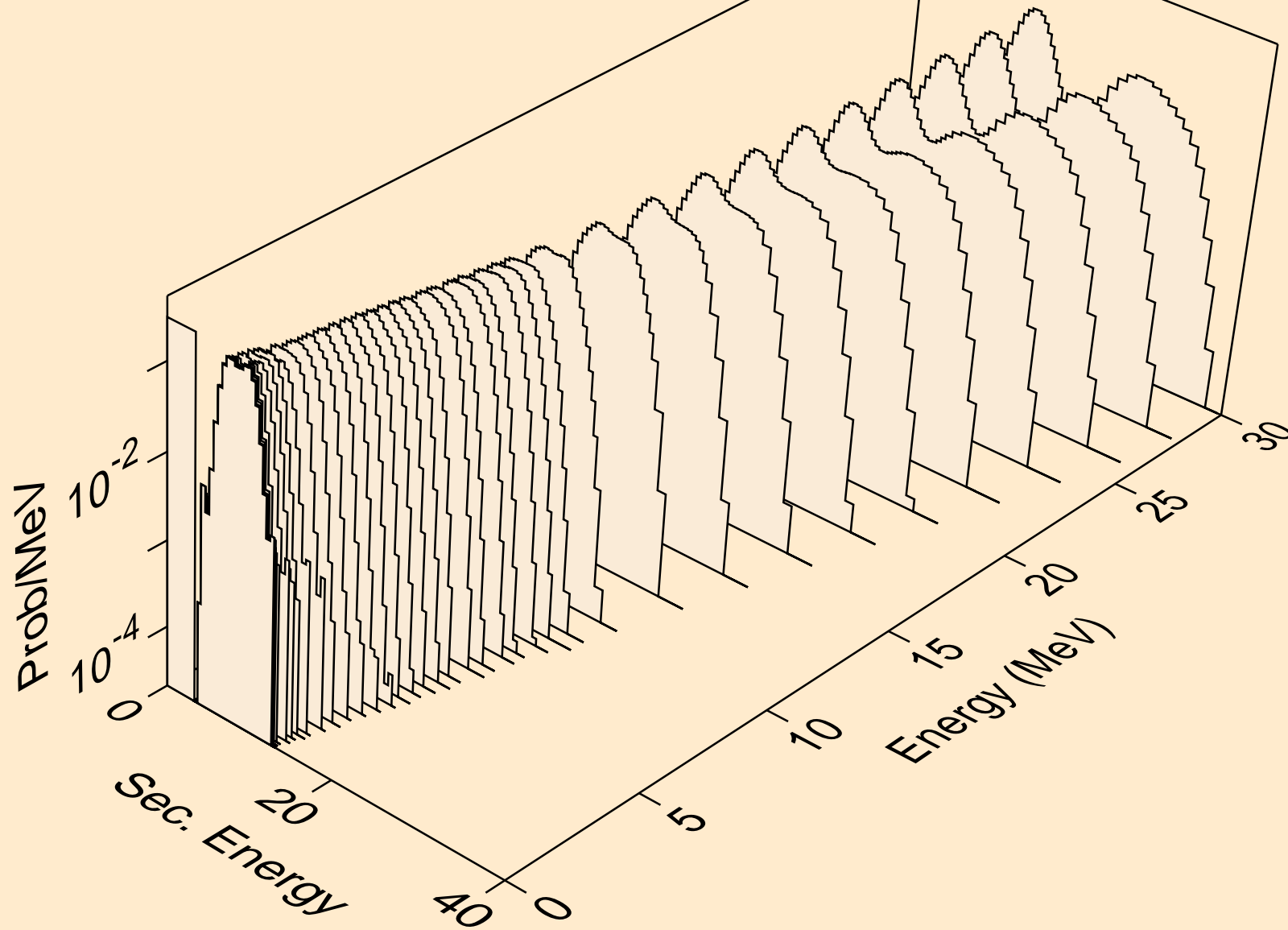

CS116M NEUTRON ACER TENDL-2024 LIBRARY; T=0.K
alphas from (n,3a)

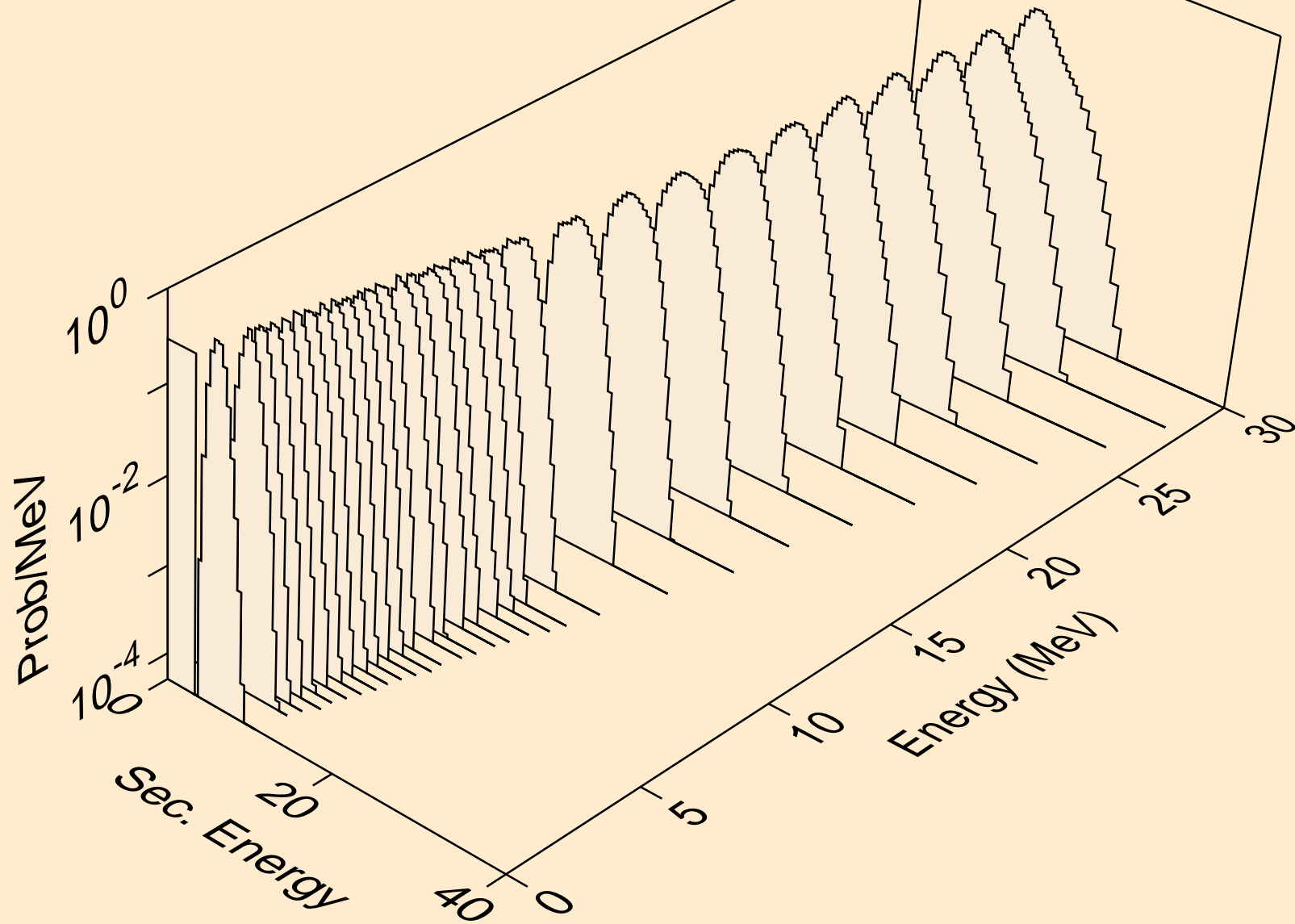

CS116M NEUTRON ACER TENDL-2024 LIBRARY; T=0.K
alphas from (n,pa)

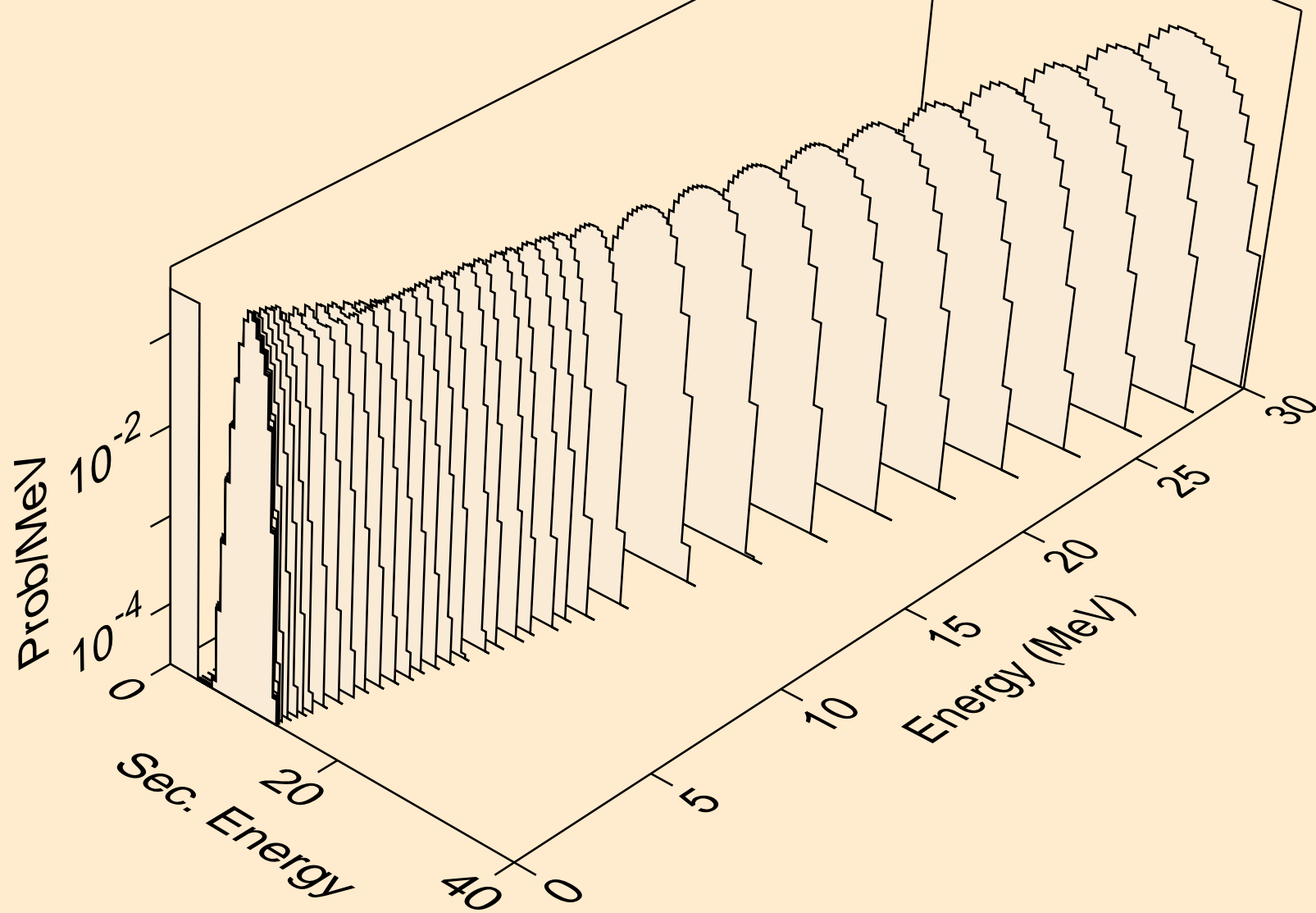

CS116M NEUTRON ACER TENDL-2024 LIBRARY; T=0.K
alphas from (n,t2a)

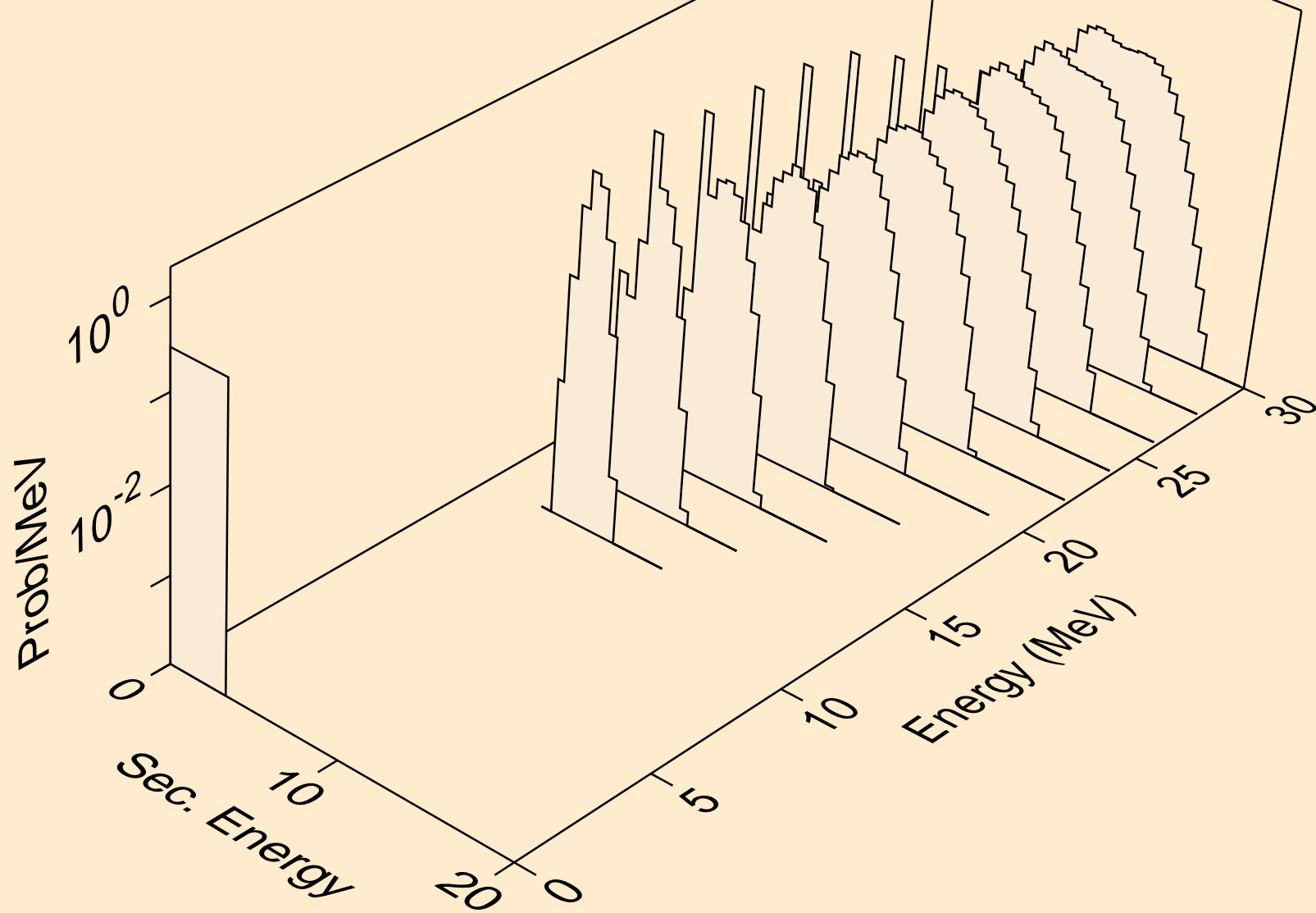

CS116M NEUTRON ACER TENDL-2024 LIBRARY; T=0.K
alphas from (n,d2a)

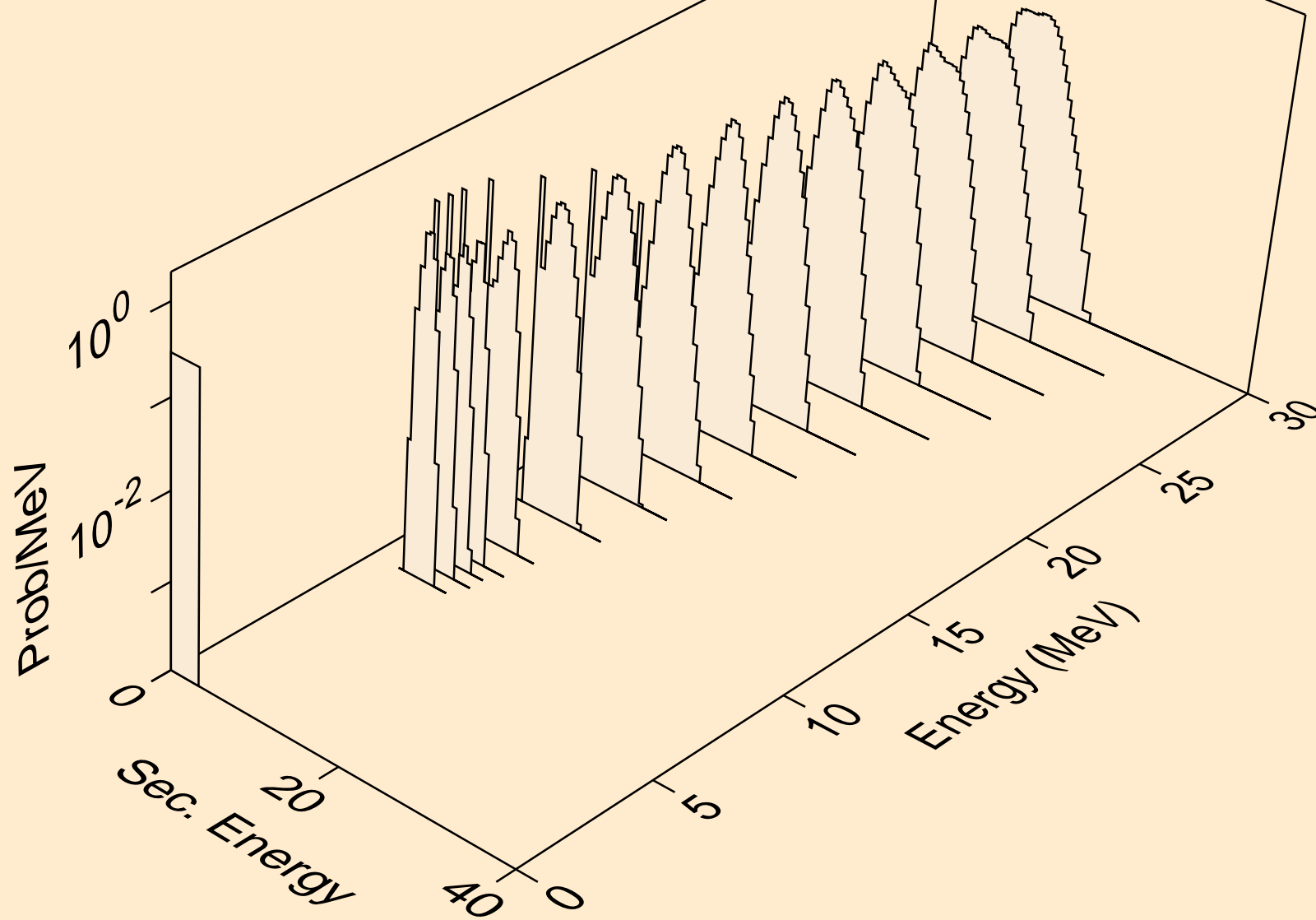

CS116M NEUTRON ACER TENDL-2024 LIBRARY; T=0.K
alphas from (n,da)

