

# ER163 NEUTRON ACER TENDL-2024 LIBRARY; T=0.K

## Principal cross sections

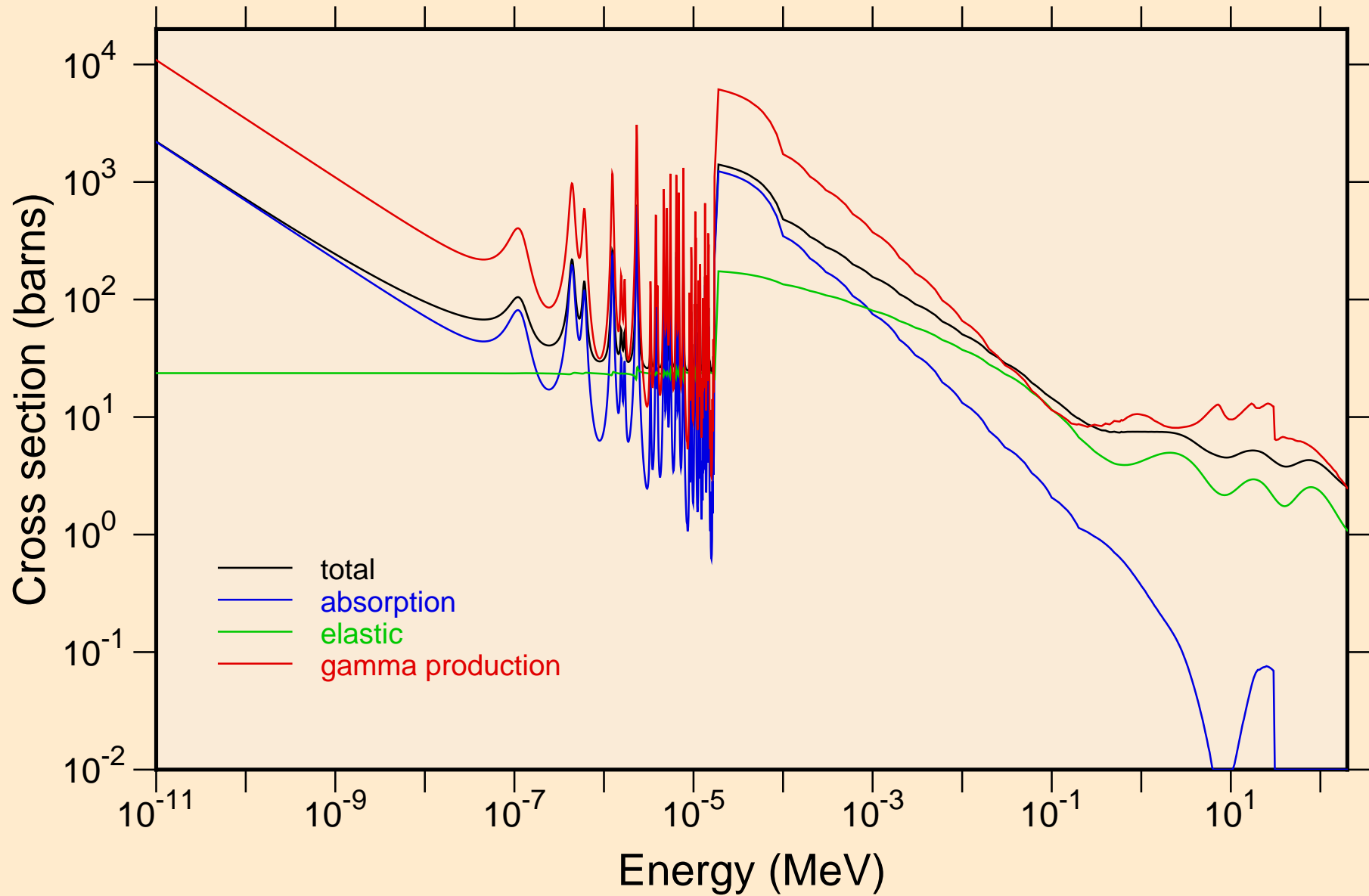

ER163 NEUTRON ACER TENDL-2024 LIBRARY; T=0.K  
resonance total cross section

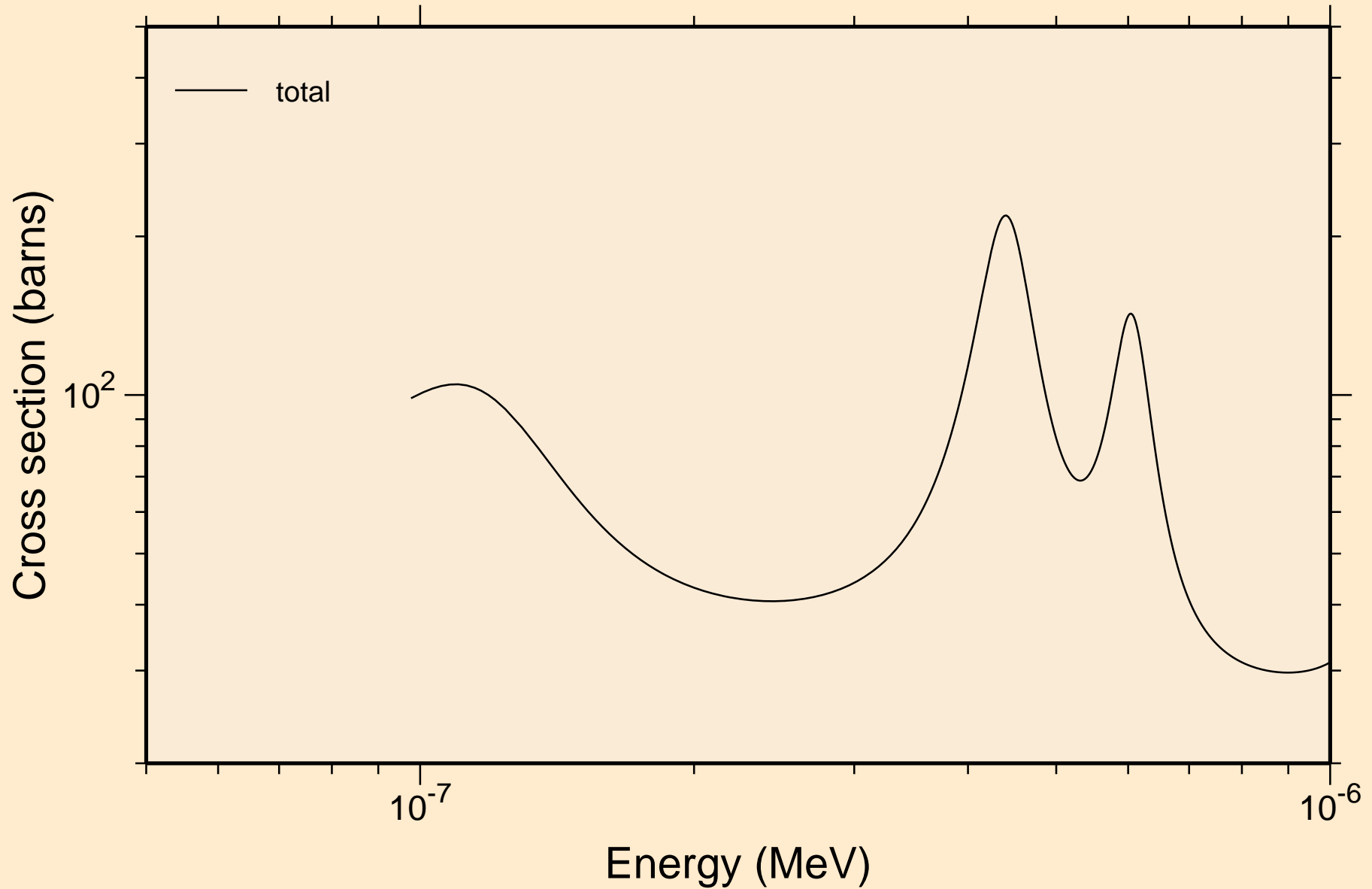

ER163 NEUTRON ACER TENDL-2024 LIBRARY; T=0.K  
resonance total cross section

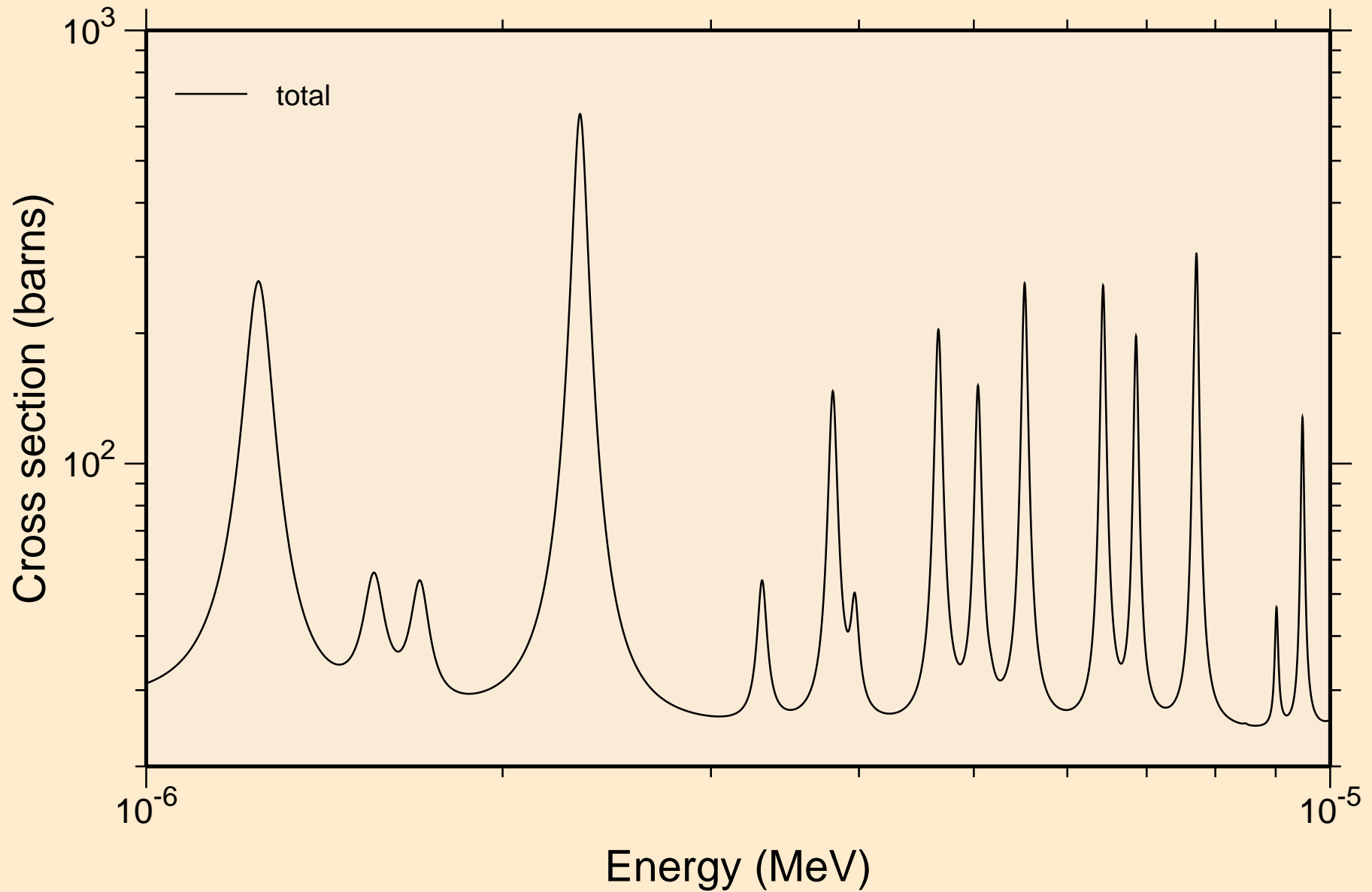

ER163 NEUTRON ACER TENDL-2024 LIBRARY; T=0.K  
resonance total cross section

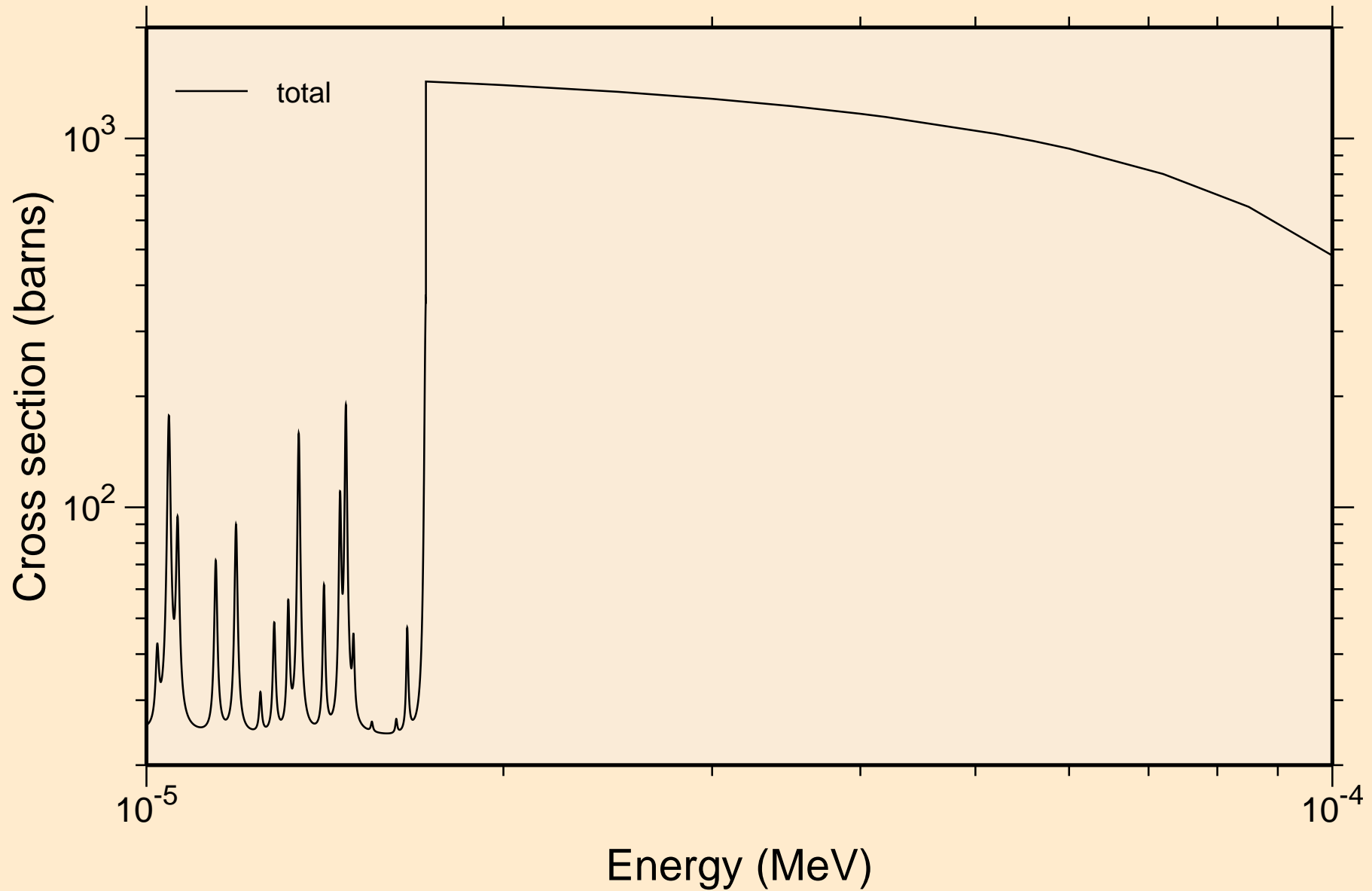

ER163 NEUTRON ACER TENDL-2024 LIBRARY; T=0.K  
resonance total cross section

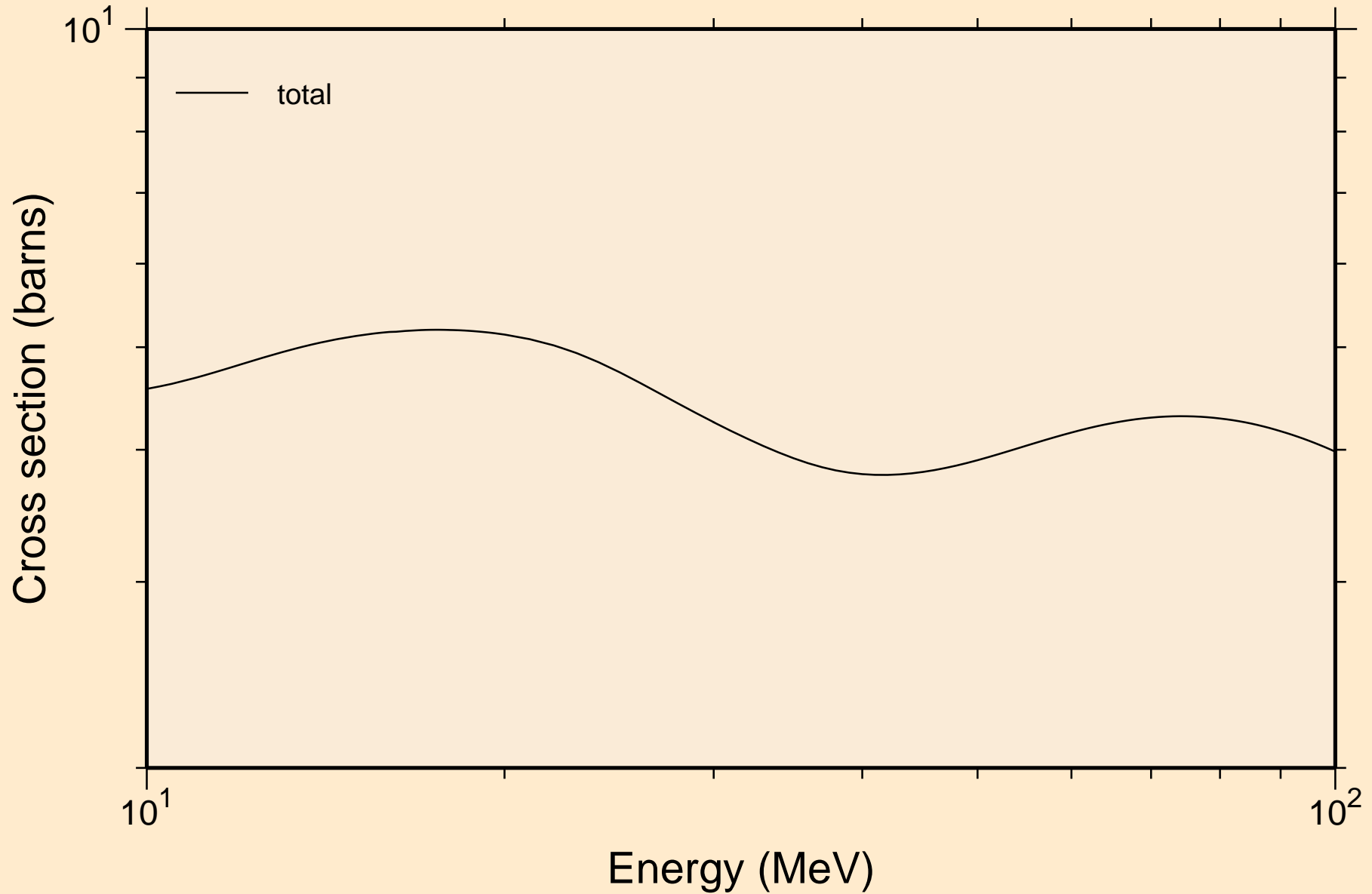

ER163 NEUTRON ACER TENDL-2024 LIBRARY; T=0.K  
resonance absorption cross sections

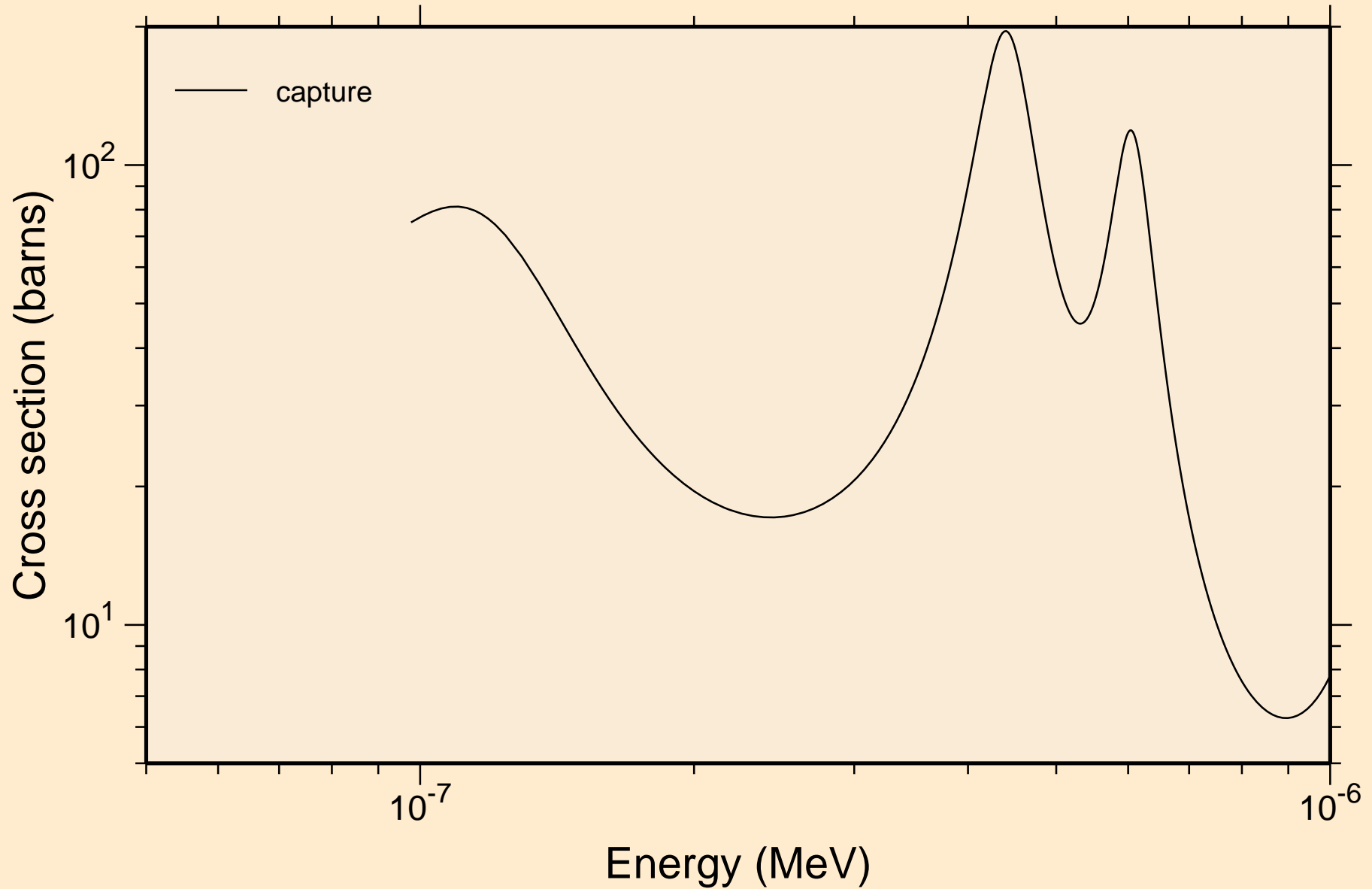

ER163 NEUTRON ACER TENDL-2024 LIBRARY; T=0.K  
resonance absorption cross sections

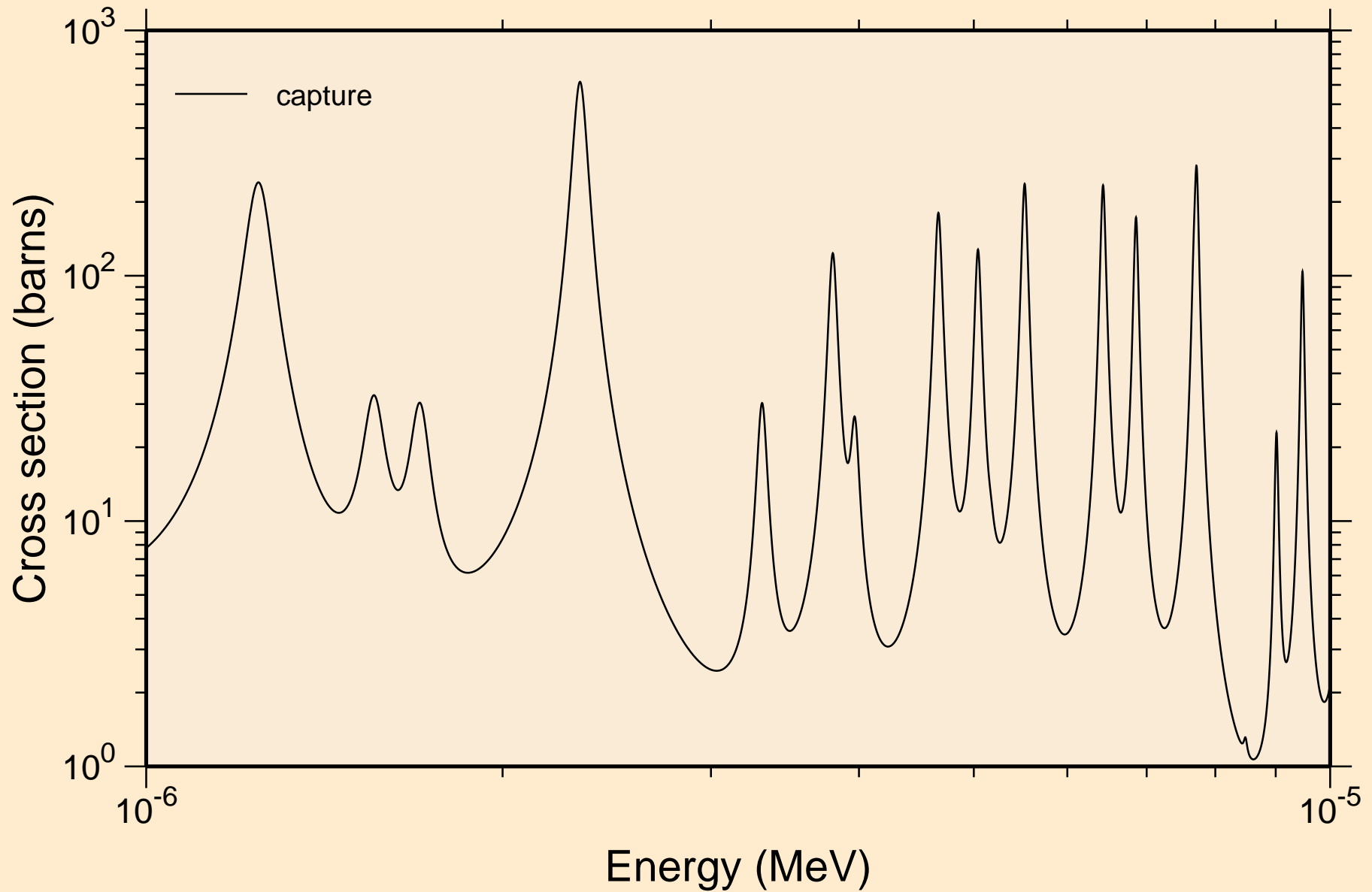

ER163 NEUTRON ACER TENDL-2024 LIBRARY; T=0.K  
resonance absorption cross sections

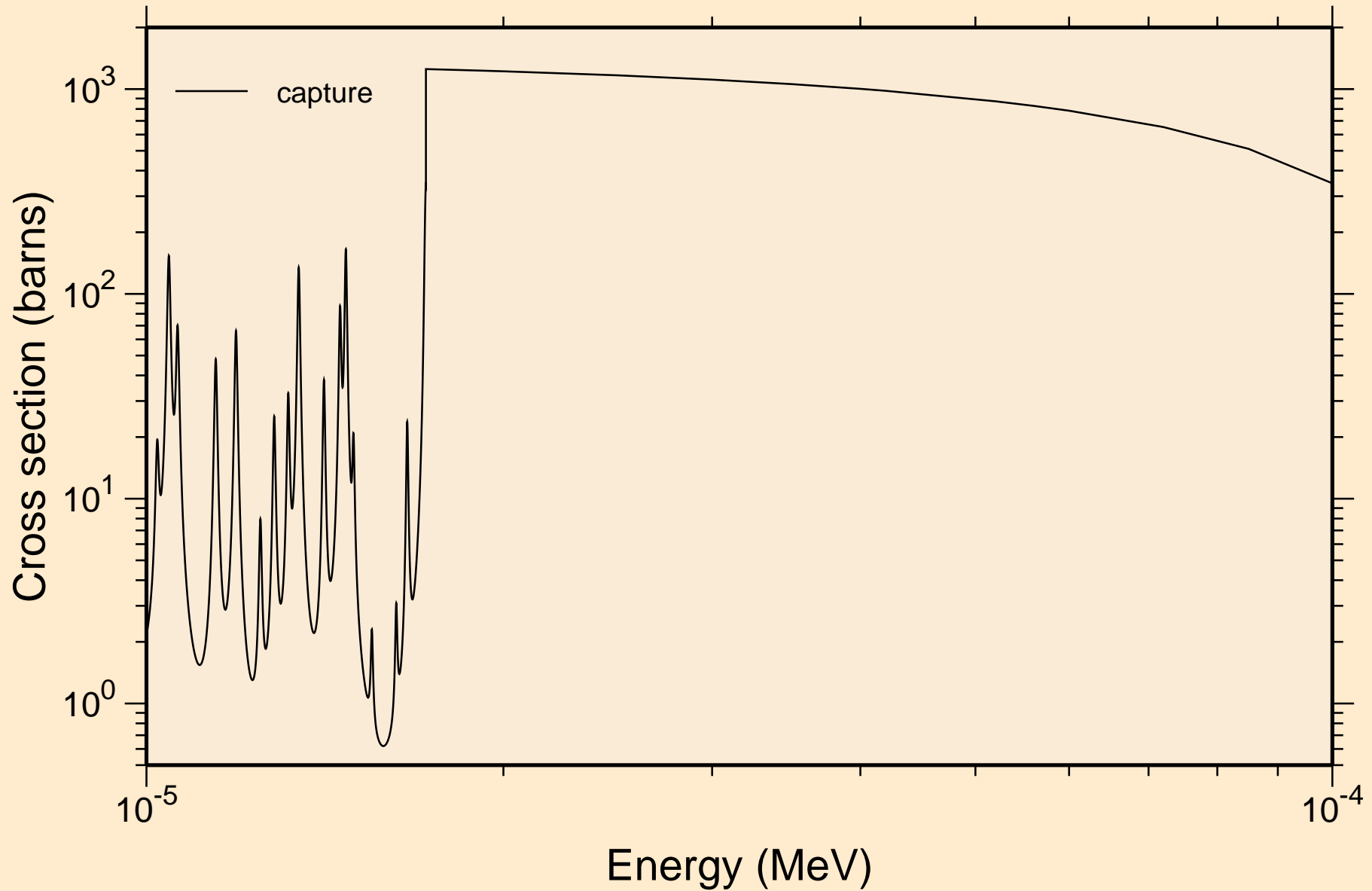



ER163 NEUTRON ACER TENDL-2024 LIBRARY; T=0.K  
resonance absorption cross sections

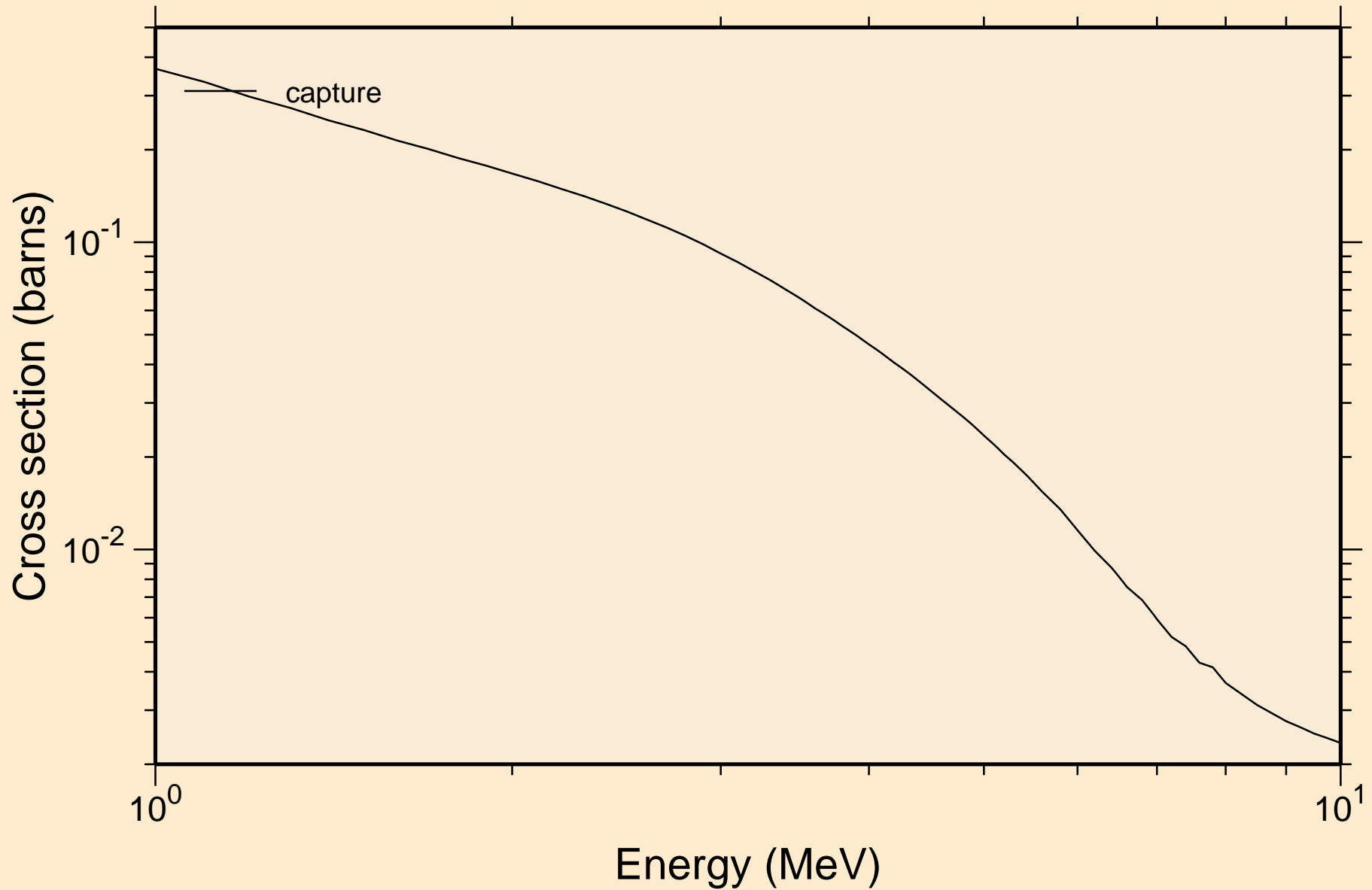

# ER163 NEUTRON ACER TENDL-2024 LIBRARY; T=0.K

## Heating

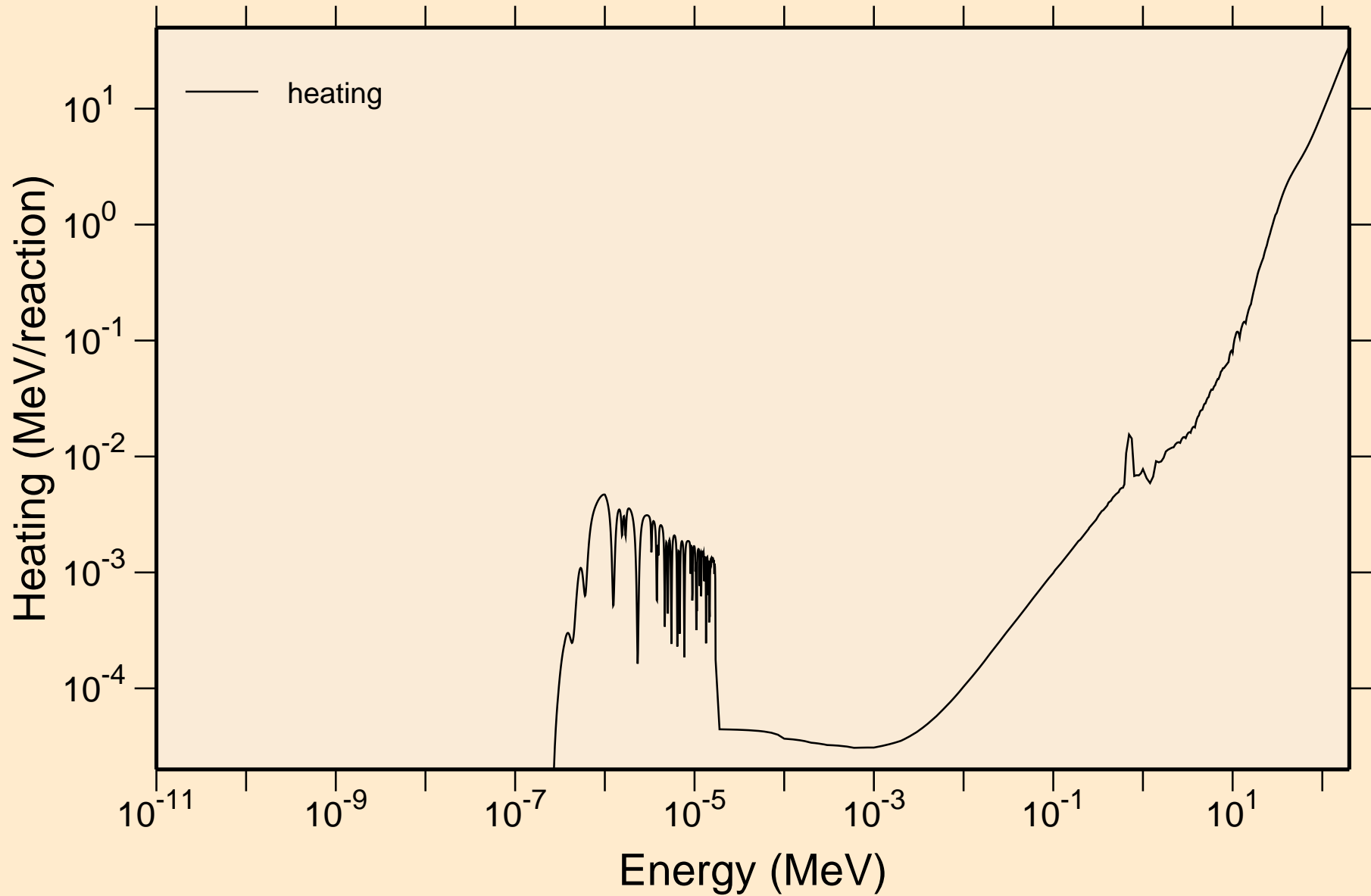

# ER163 NEUTRON ACER TENDL-2024 LIBRARY; T=0.K

## Damage

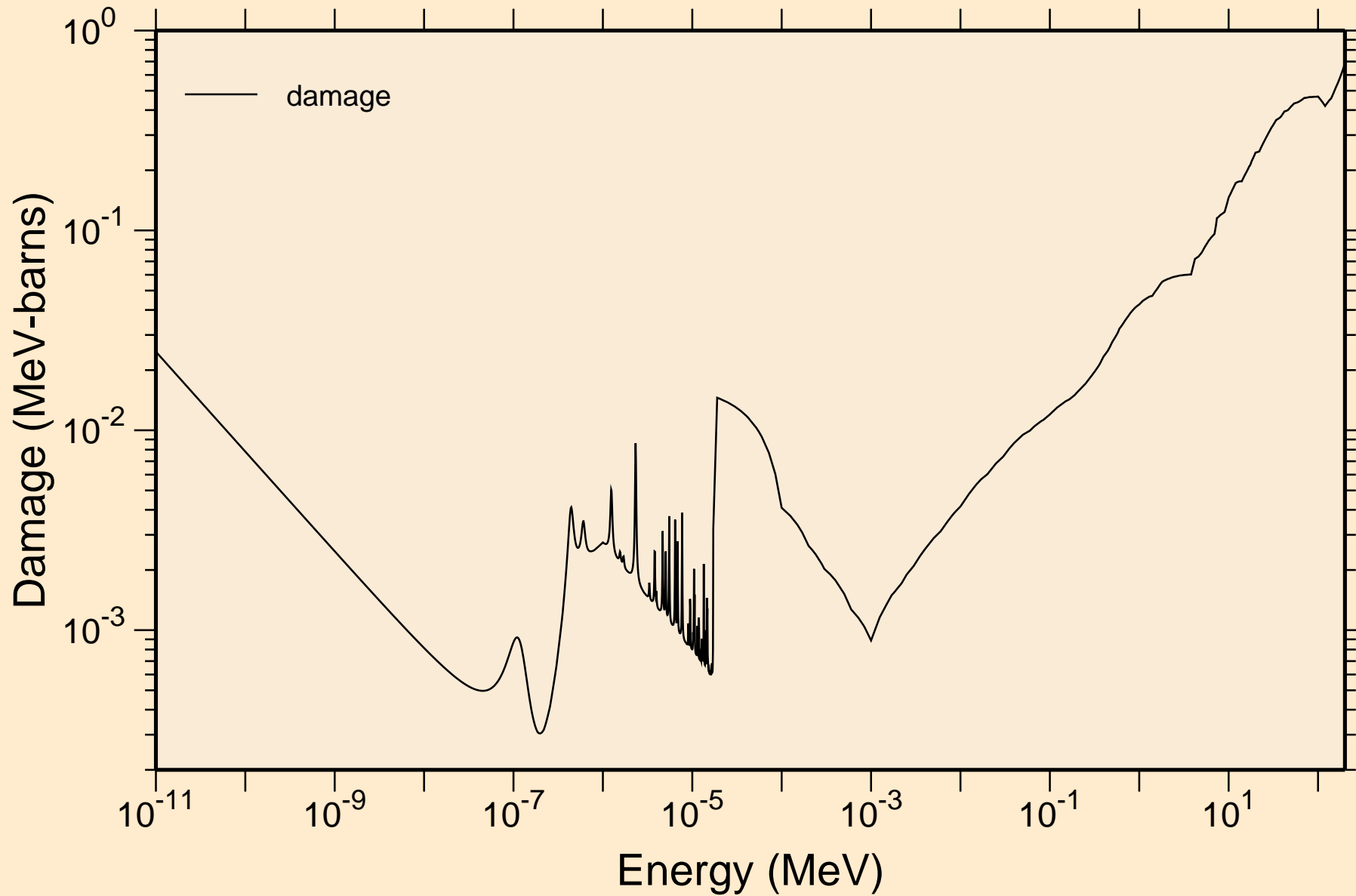

# ER163 NEUTRON ACER TENDL-2024 LIBRARY; T=0.K

## Non-threshold reactions

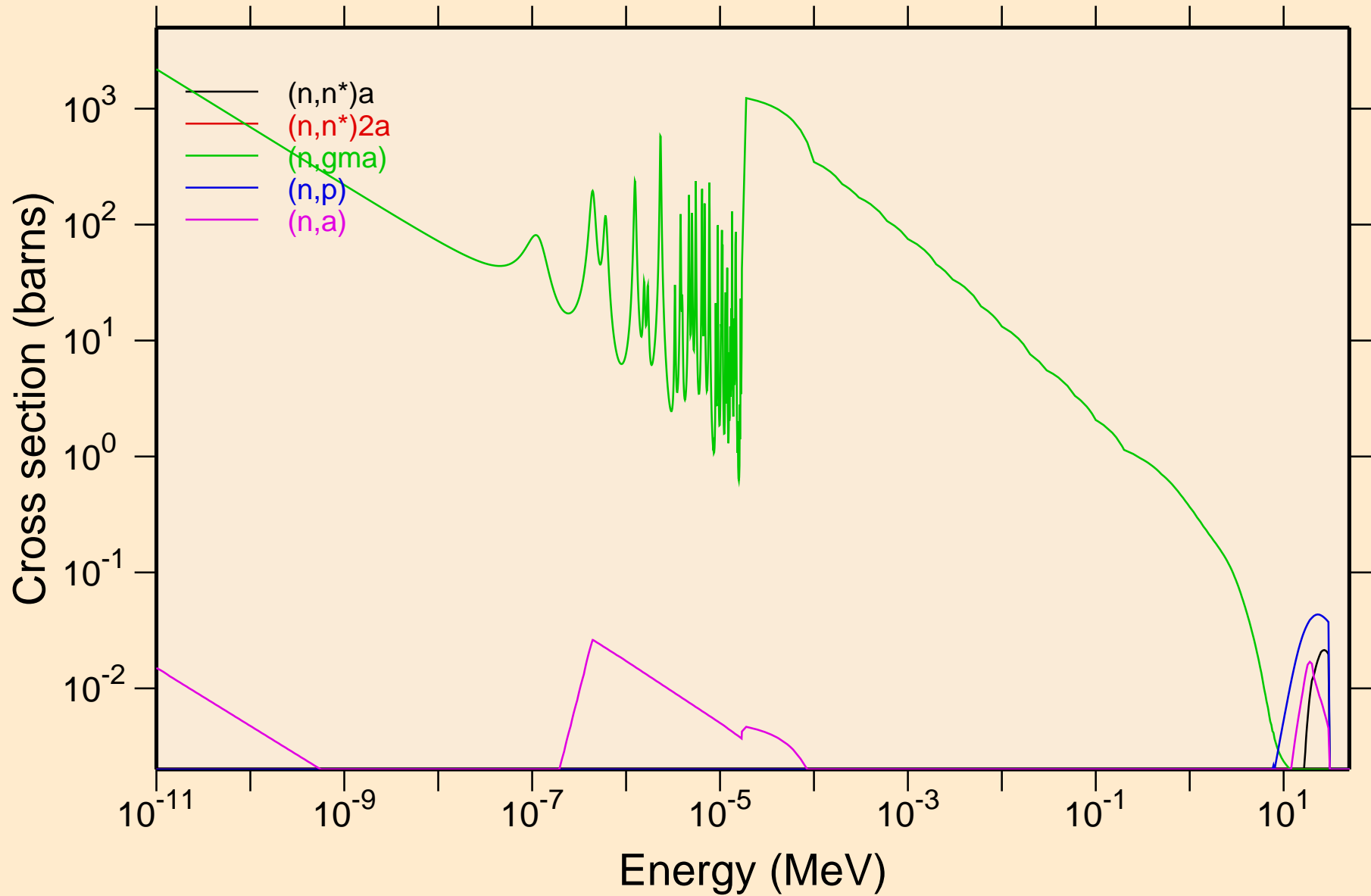

# ER163 NEUTRON ACER TENDL-2024 LIBRARY; T=0.K

## Non-threshold reactions

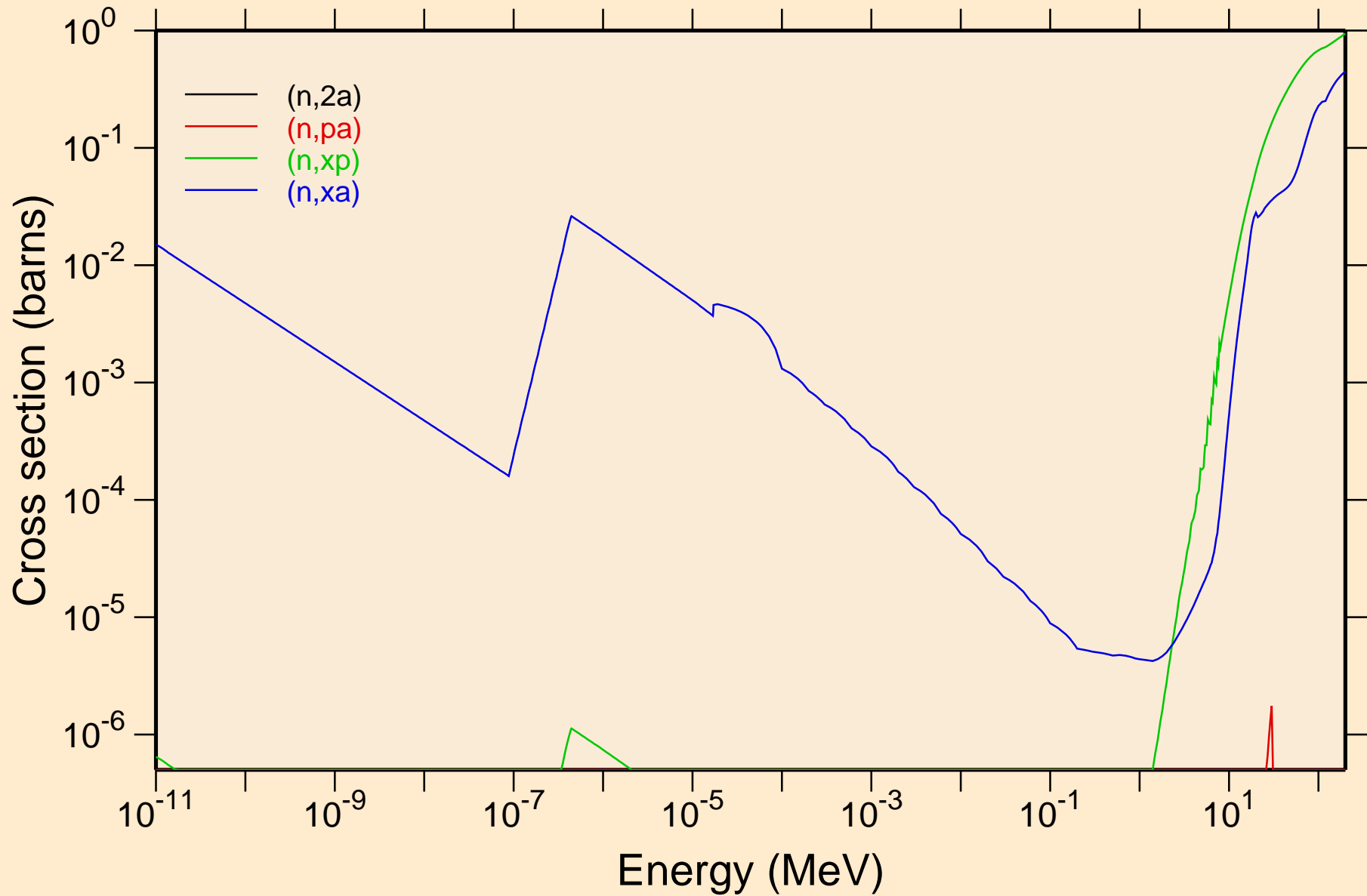

# ER163 NEUTRON ACER TENDL-2024 LIBRARY; T=0.K

## Principal cross sections

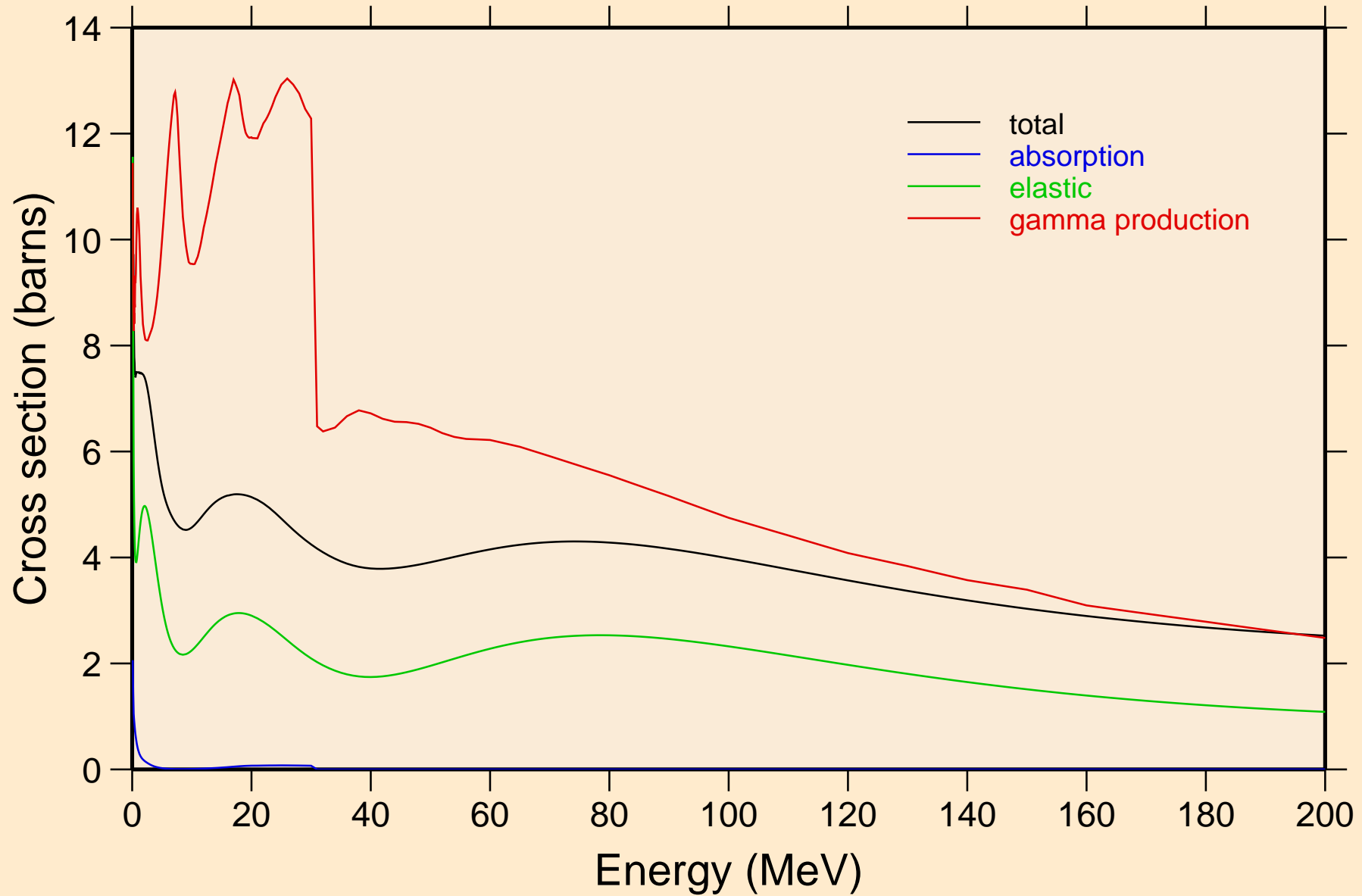

# ER163 NEUTRON ACER TENDL-2024 LIBRARY; T=0.K

## Heating

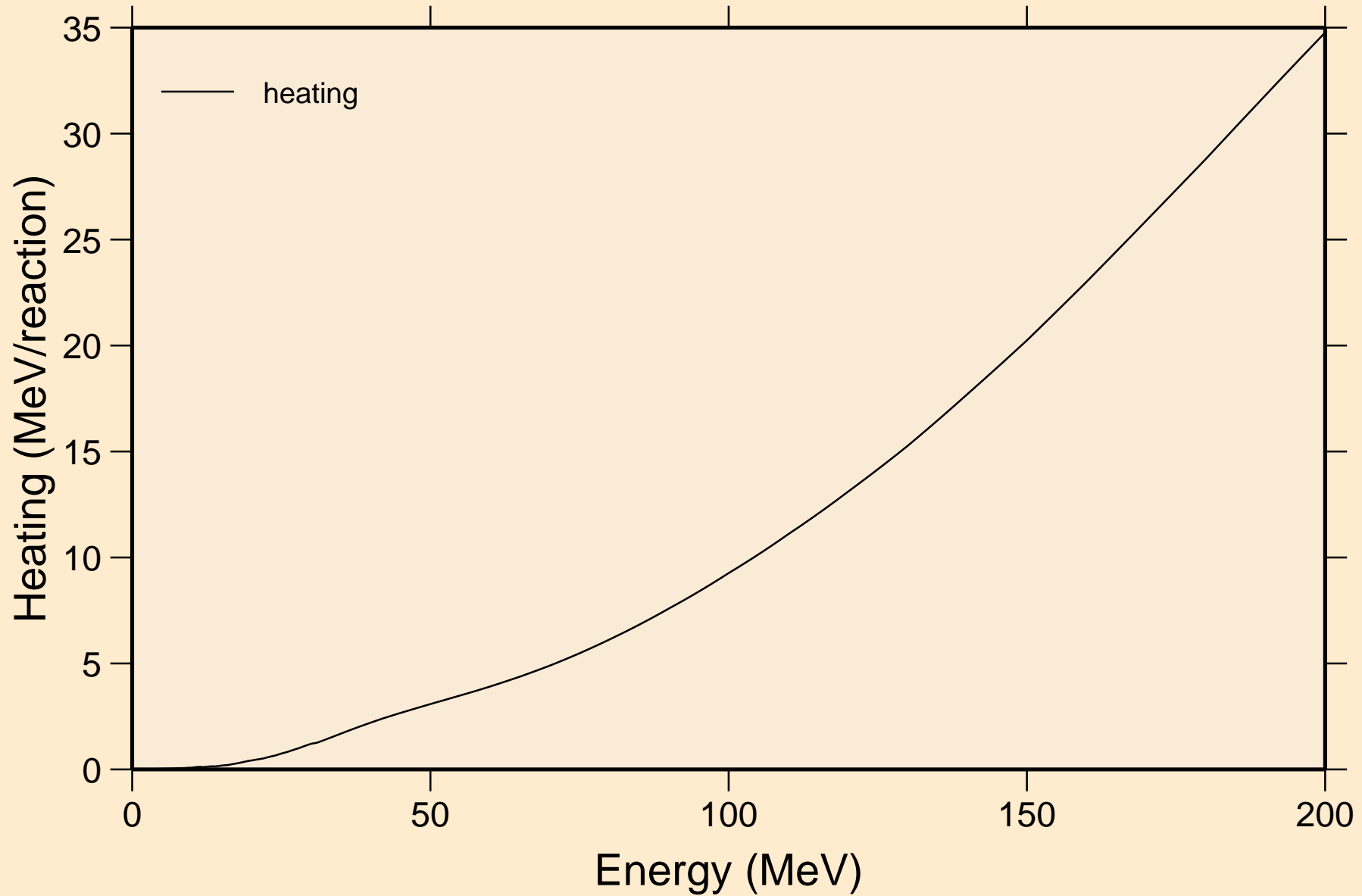

# ER163 NEUTRON ACER TENDL-2024 LIBRARY; T=0.K

## Damage

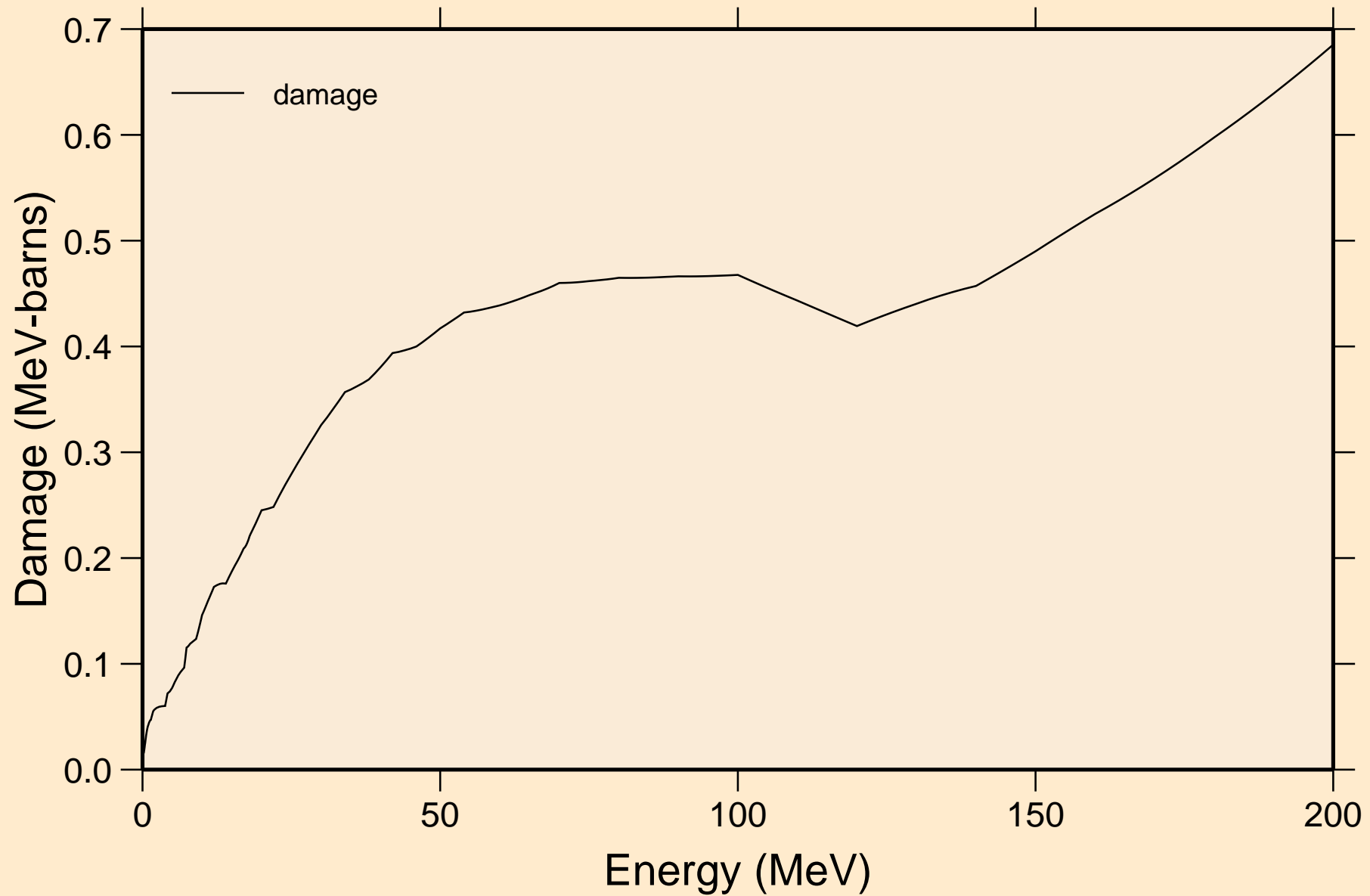



ER163 NEUTRON ACER TENDL-2024 LIBRARY; T=0.K  
Non-threshold reactions

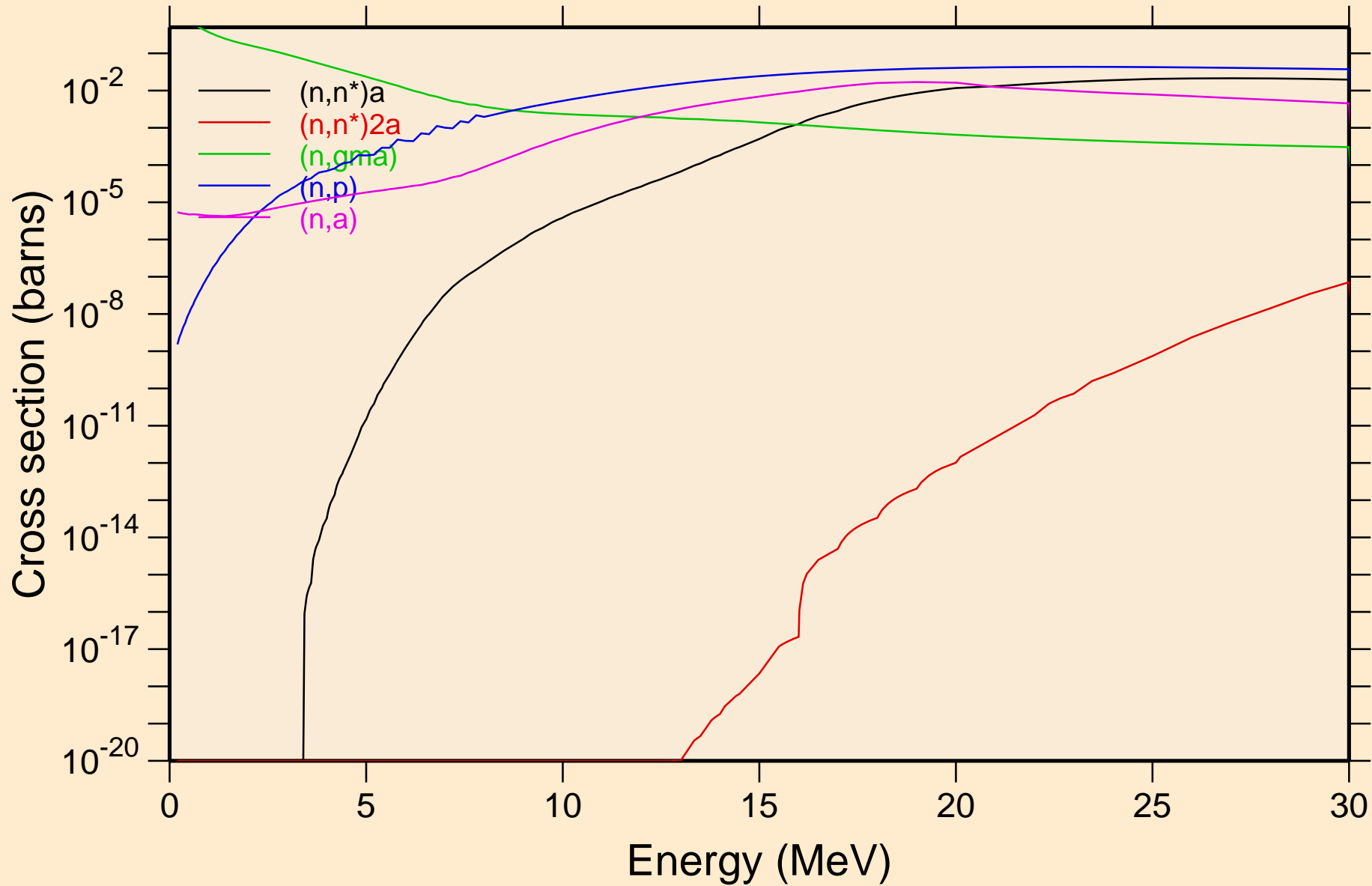

# ER163 NEUTRON ACER TENDL-2024 LIBRARY; T=0.K

## Non-threshold reactions

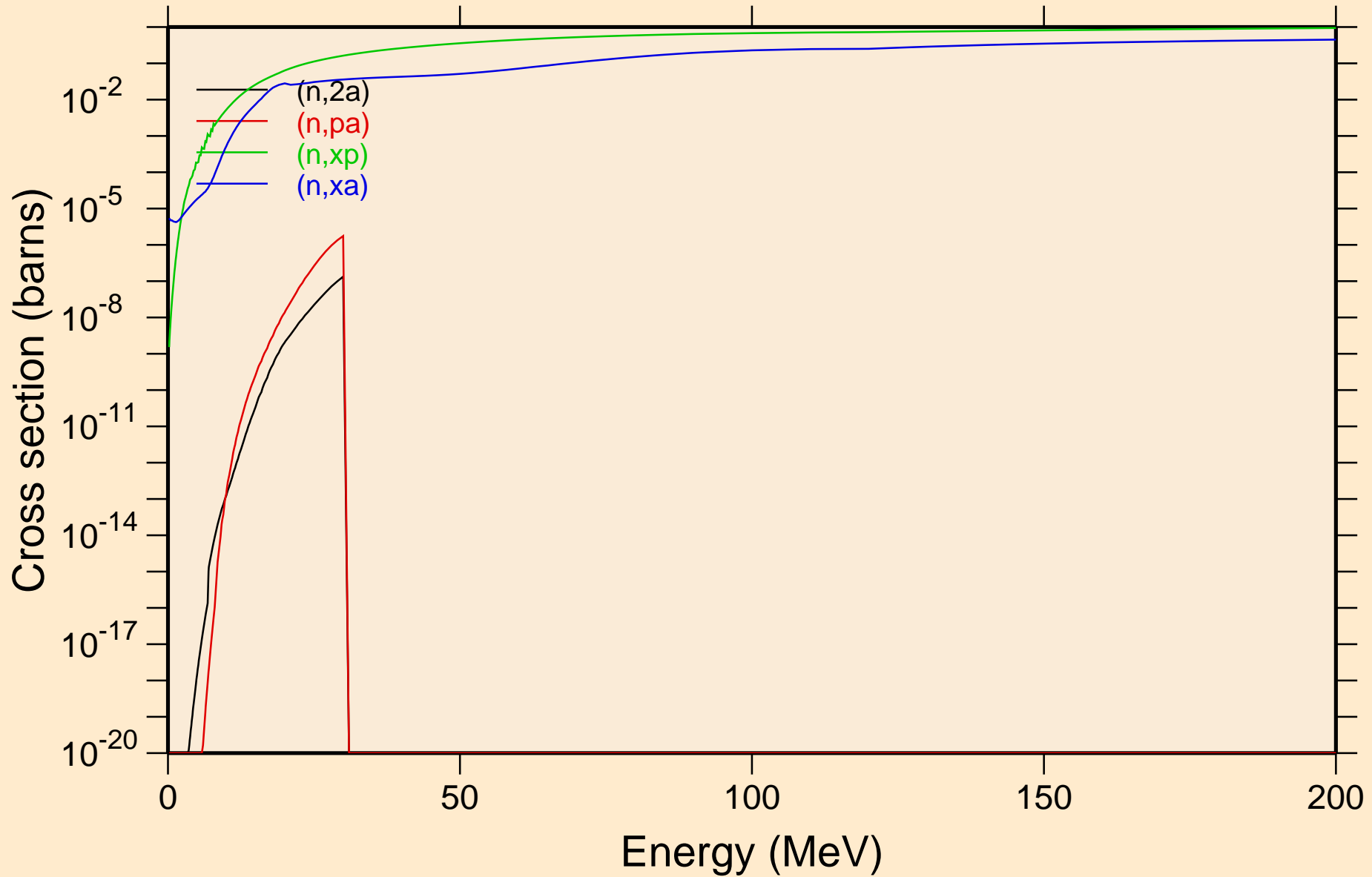

ER163 NEUTRON ACER TENDL-2024 LIBRARY; T=0.K  
Inelastic levels

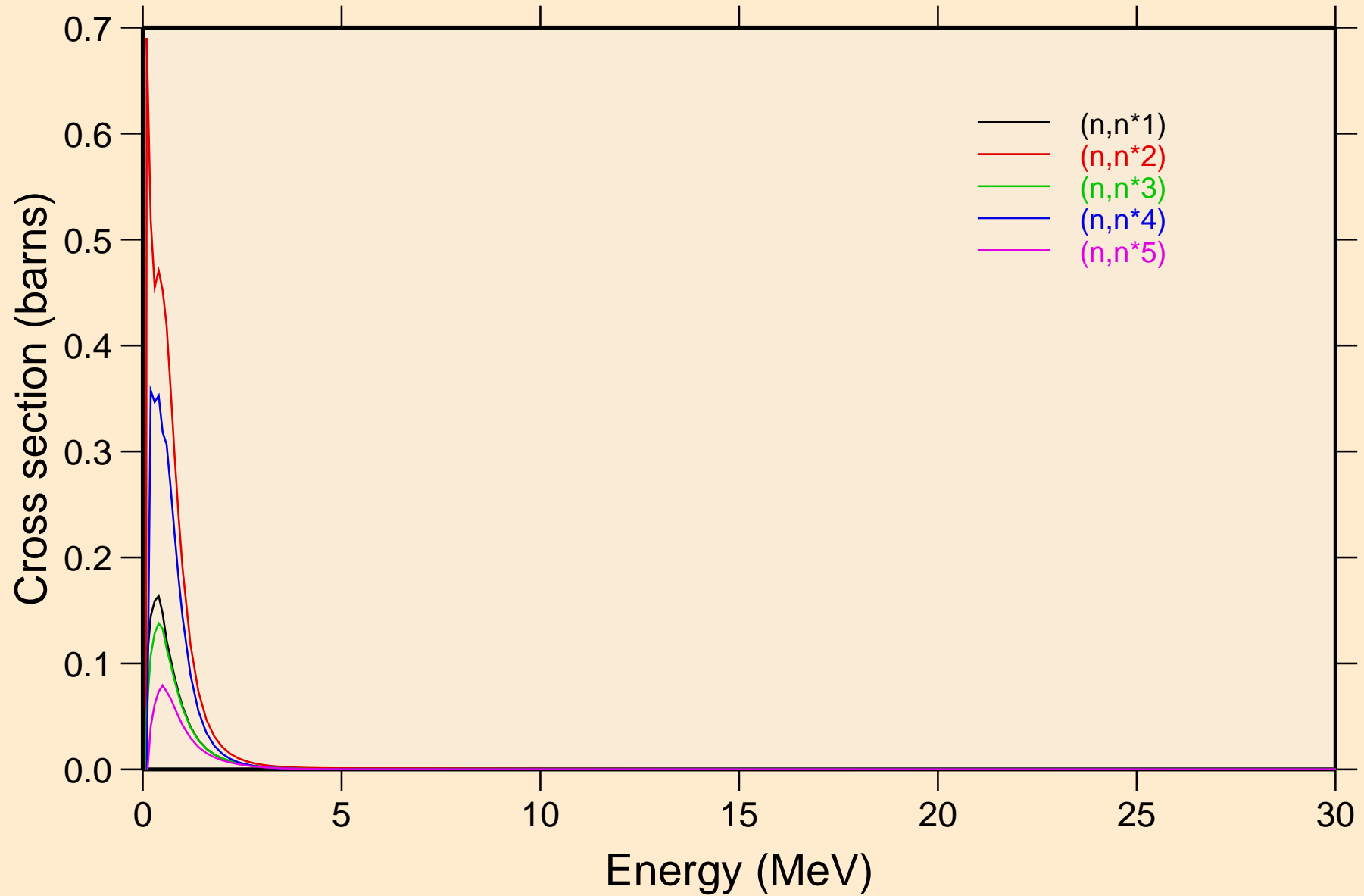

ER163 NEUTRON ACER TENDL-2024 LIBRARY; T=0.K  
Inelastic levels

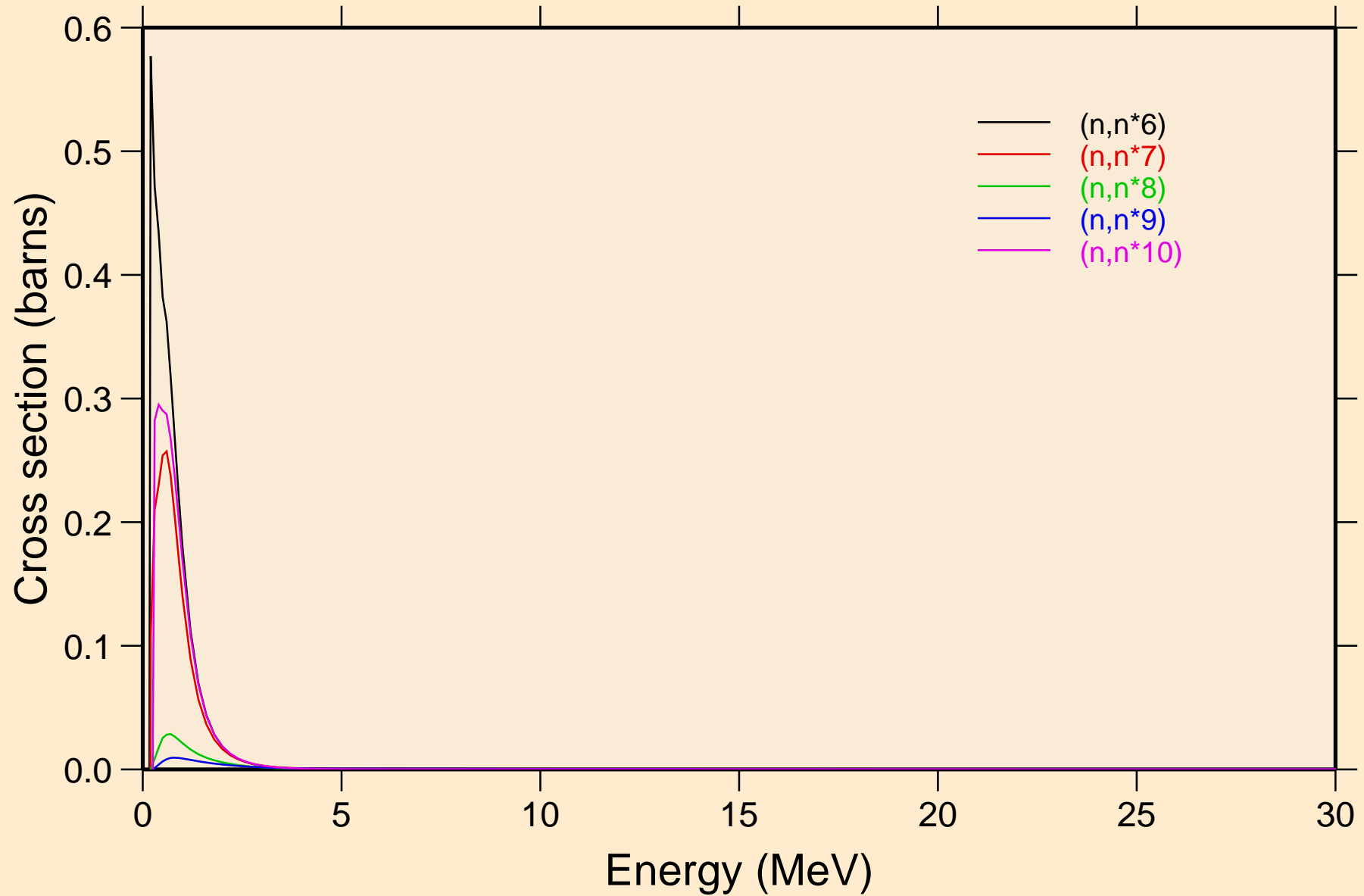

ER163 NEUTRON ACER TENDL-2024 LIBRARY; T=0.K  
Inelastic levels

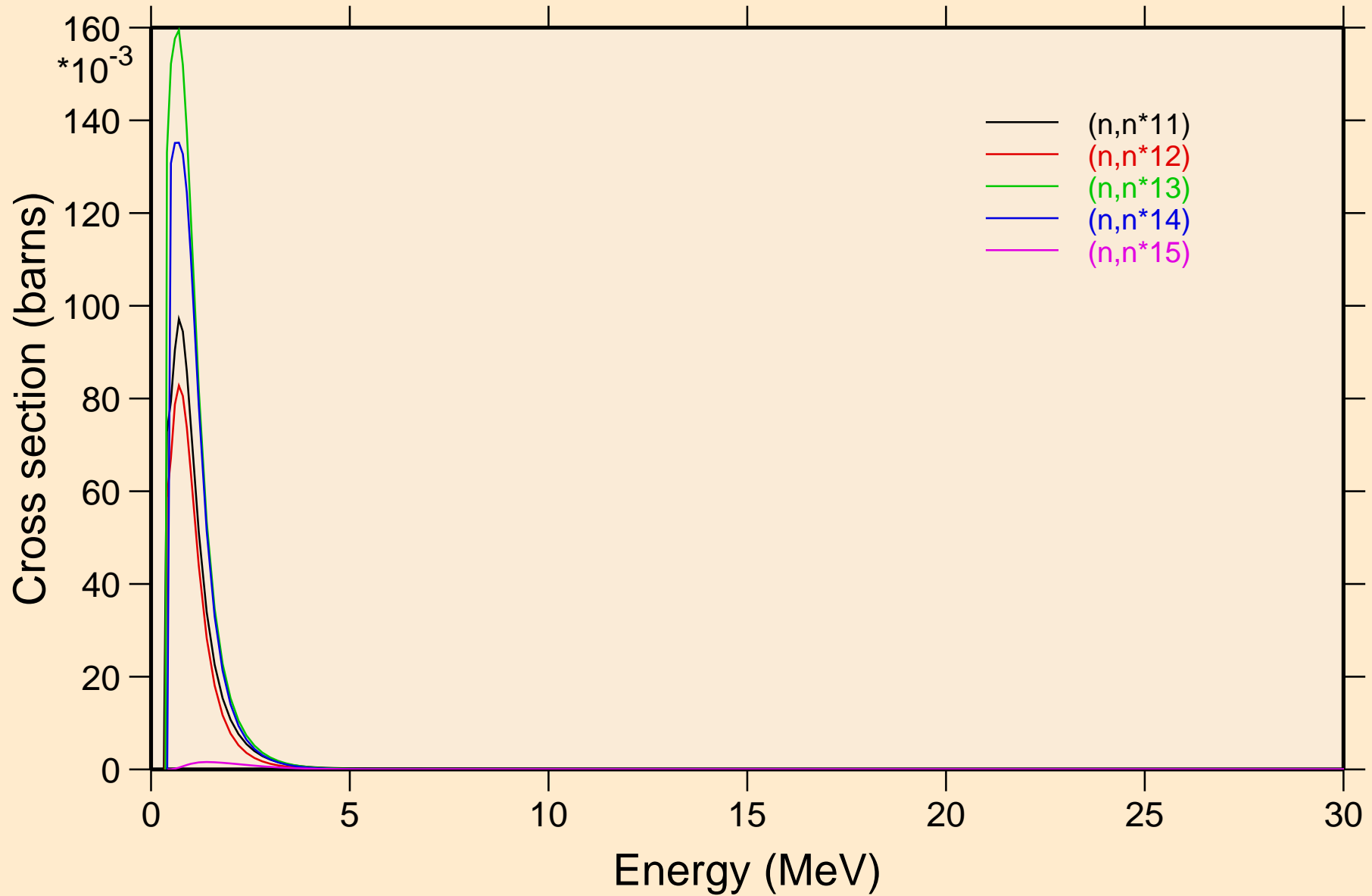

# ER163 NEUTRON ACER TENDL-2024 LIBRARY; T=0.K

## Inelastic levels

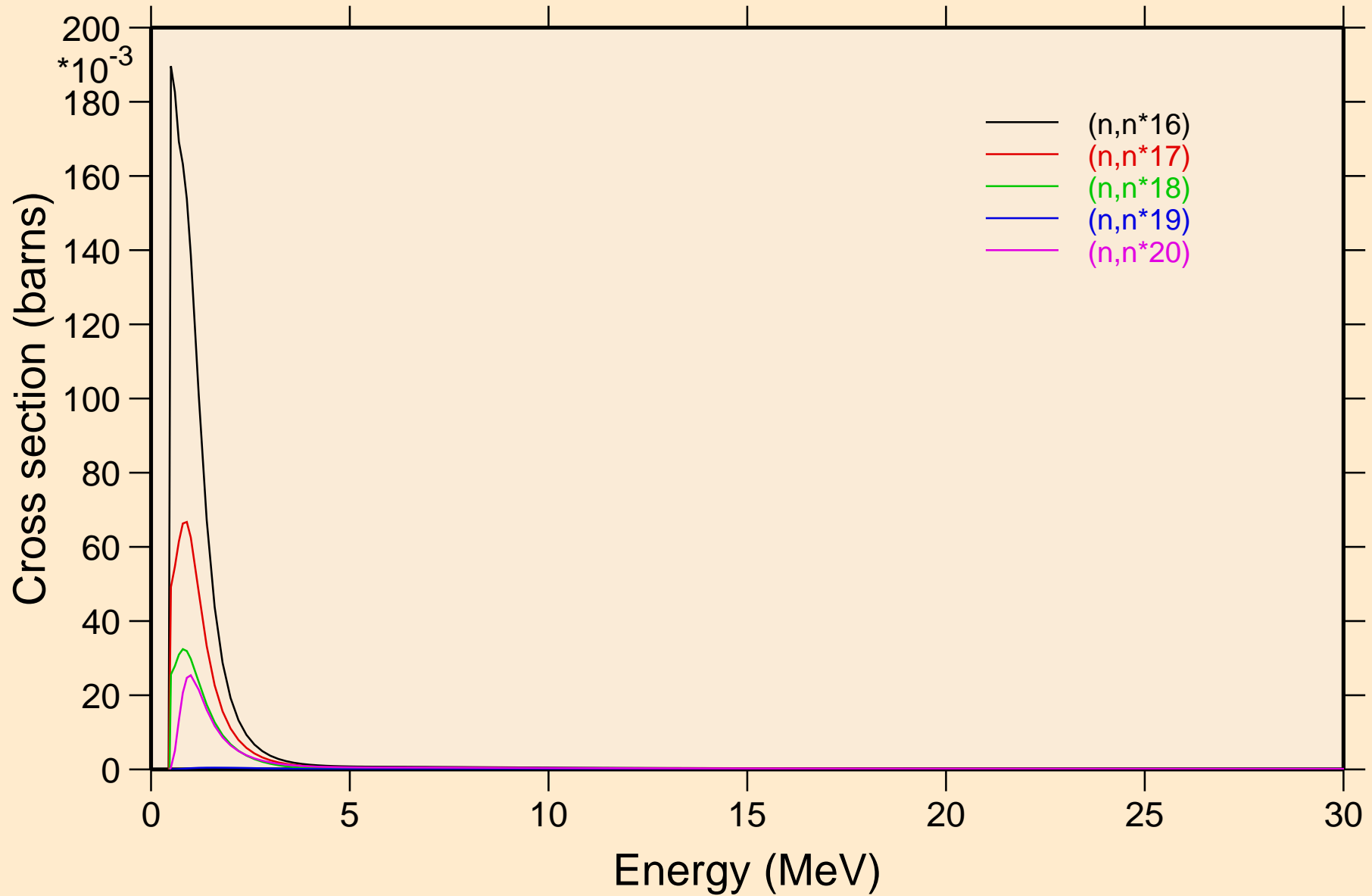

ER163 NEUTRON ACER TENDL-2024 LIBRARY; T=0.K  
Inelastic levels

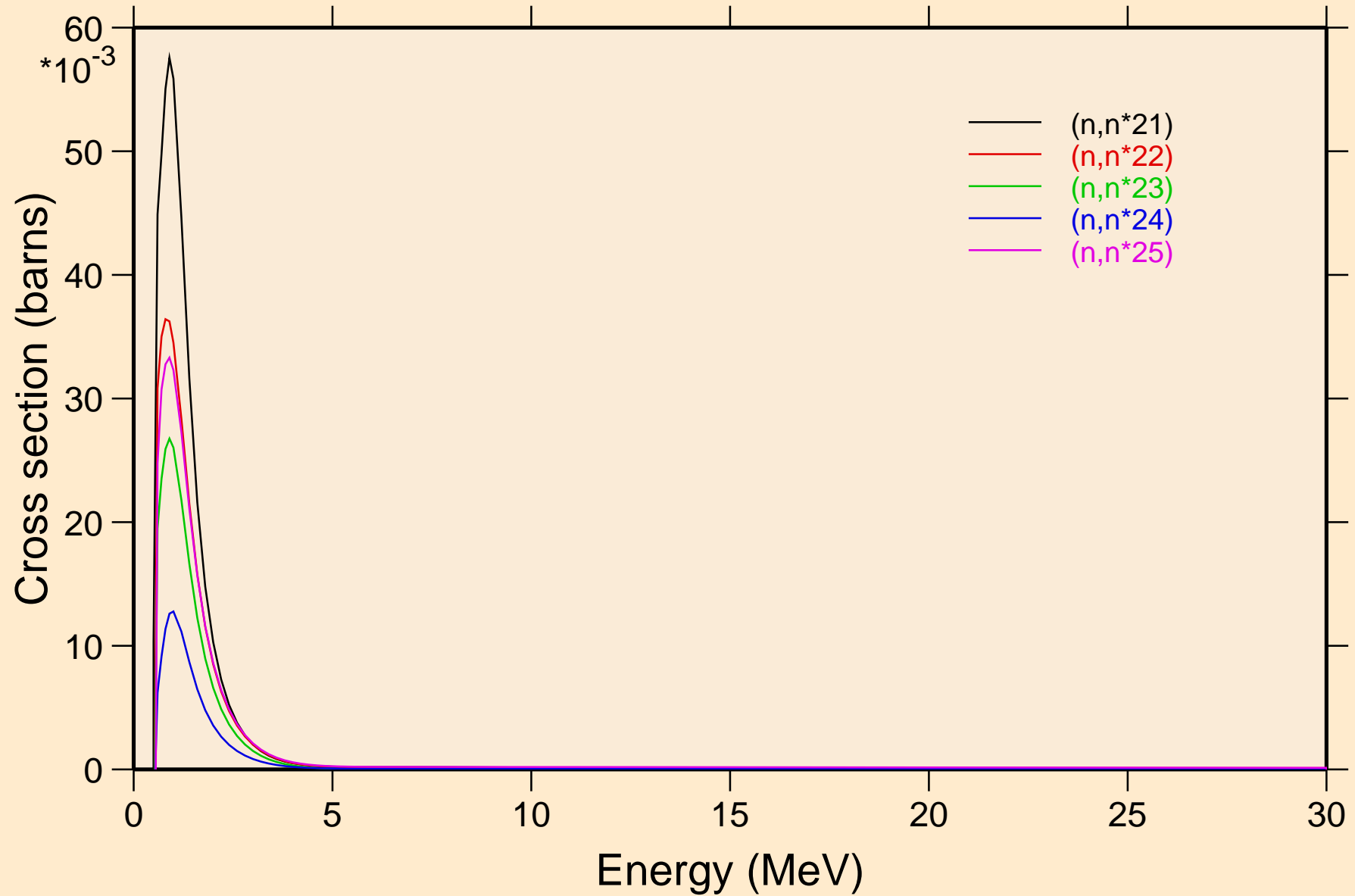

ER163 NEUTRON ACER TENDL-2024 LIBRARY; T=0.K  
Inelastic levels

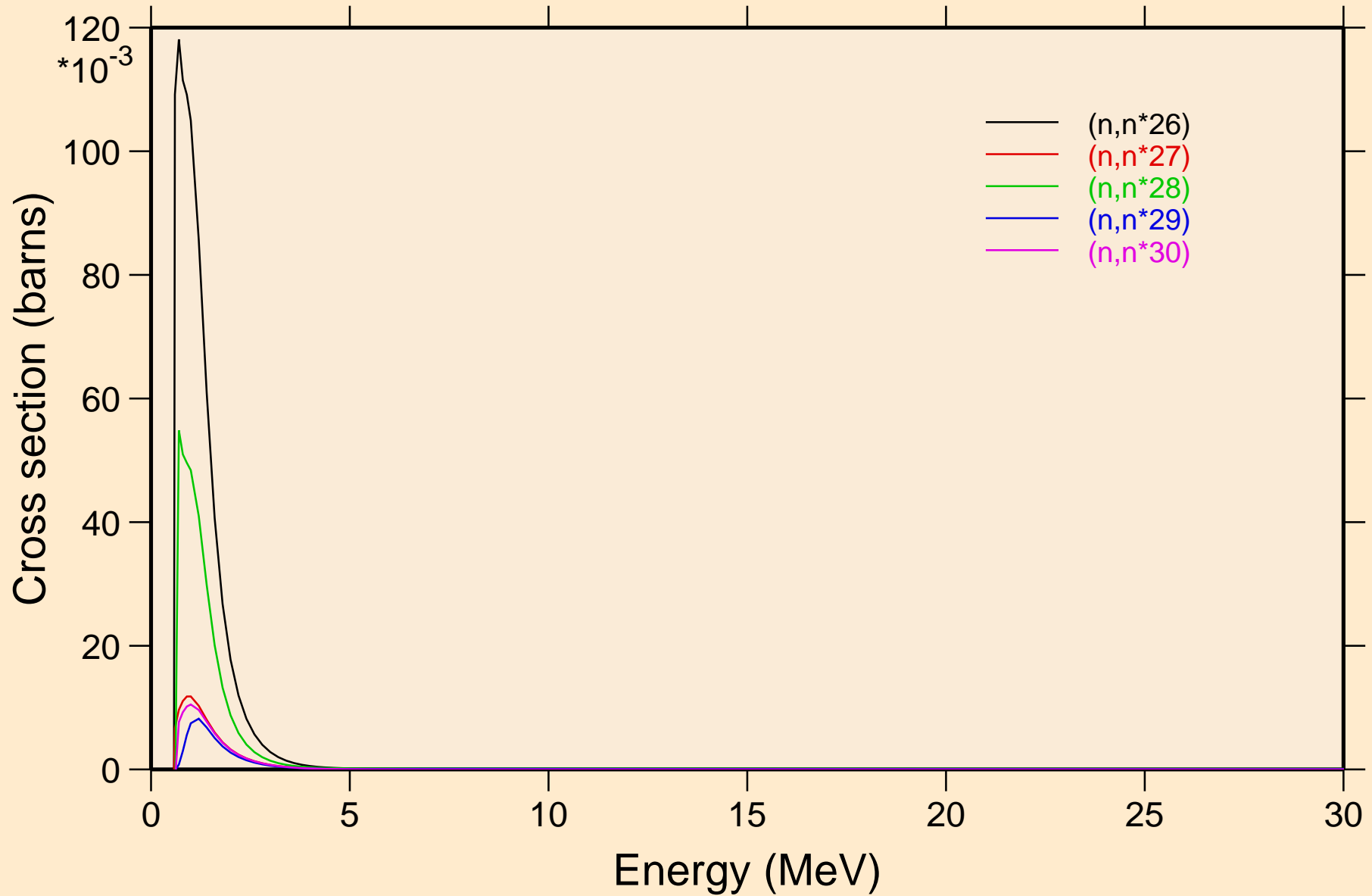



ER163 NEUTRON ACER TENDL-2024 LIBRARY; T=0.K  
Threshold reactions

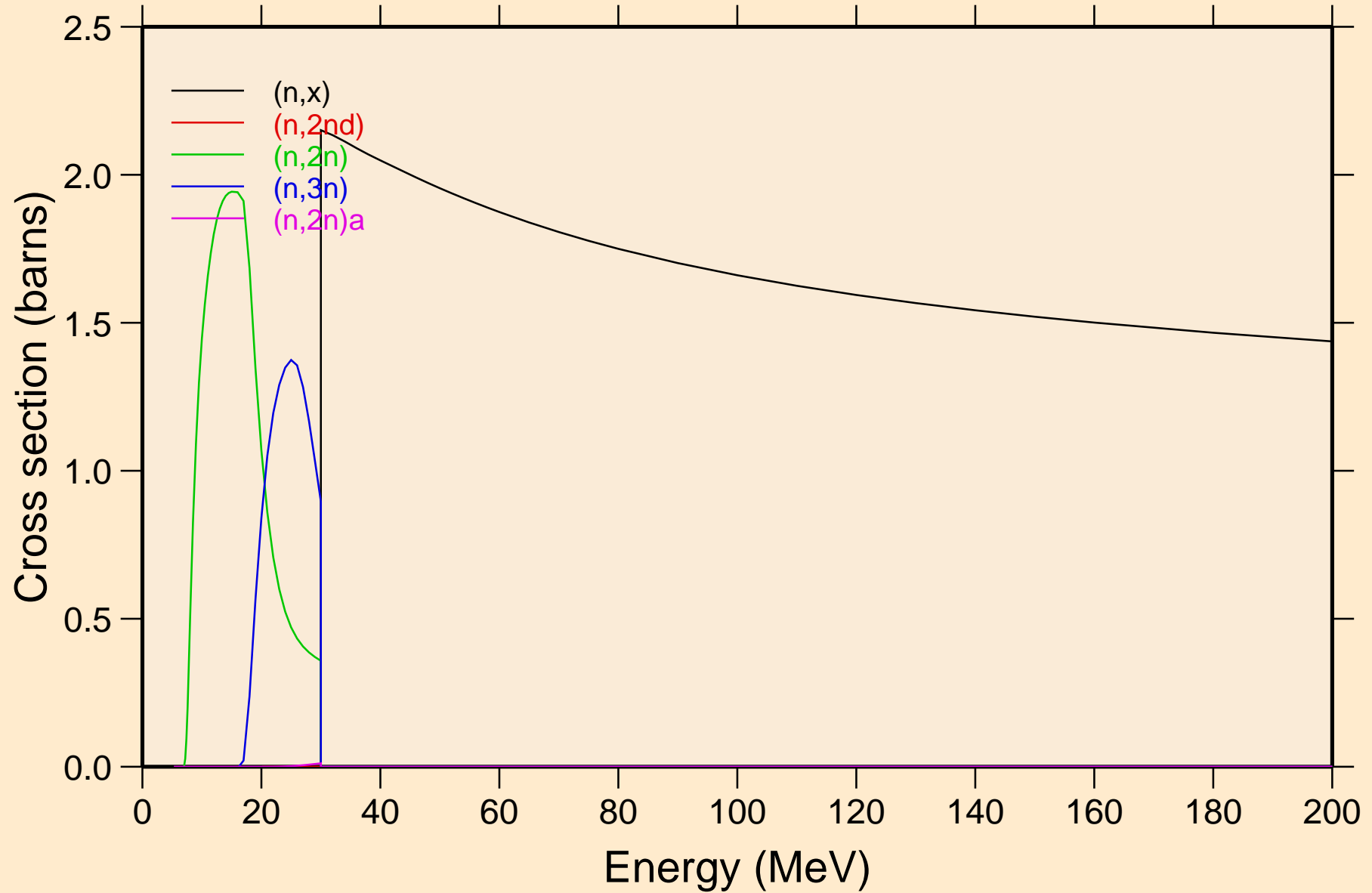

# ER163 NEUTRON ACER TENDL-2024 LIBRARY; T=0.K

## Threshold reactions

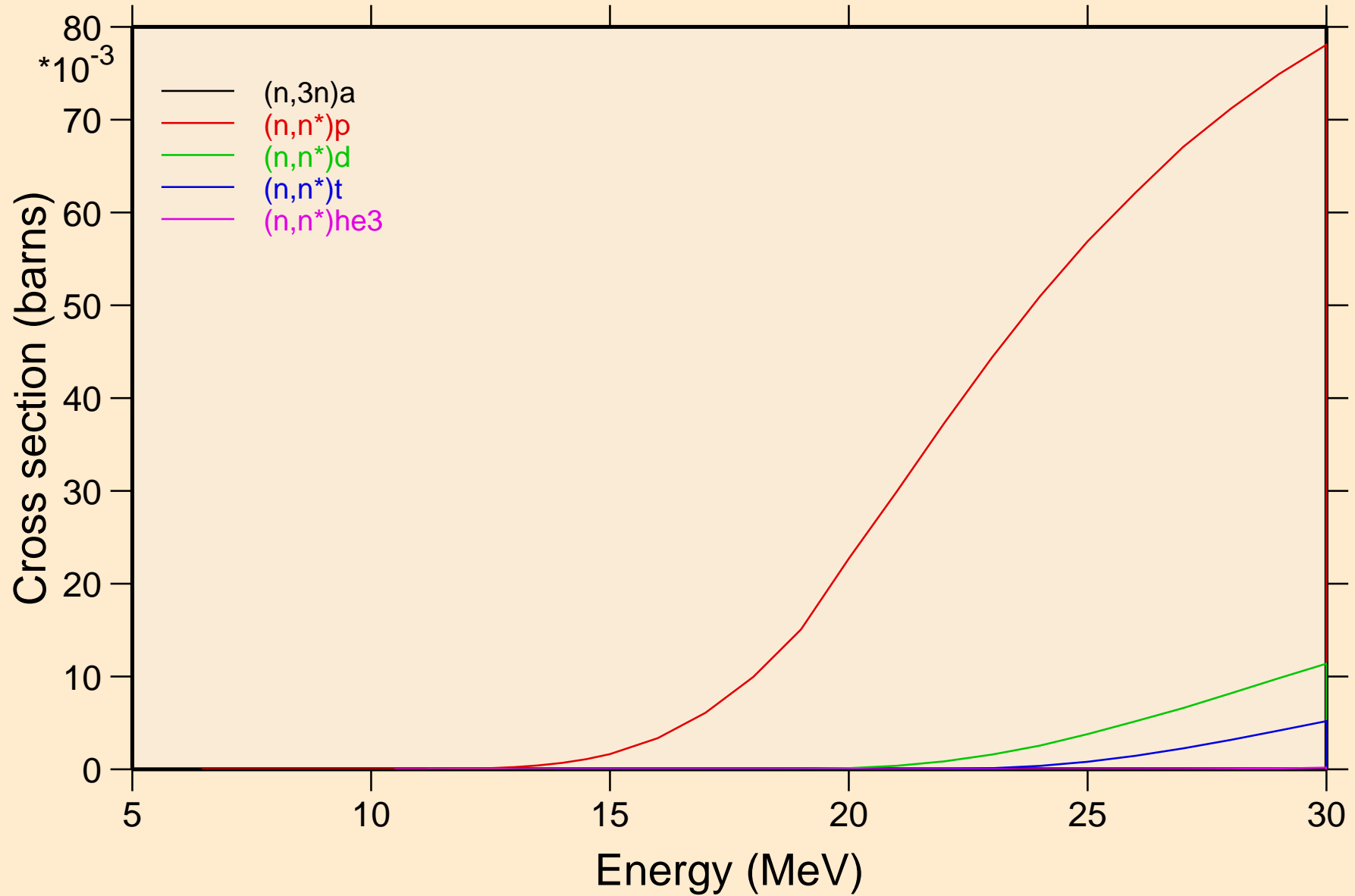

# ER163 NEUTRON ACER TENDL-2024 LIBRARY; T=0.K

## Threshold reactions

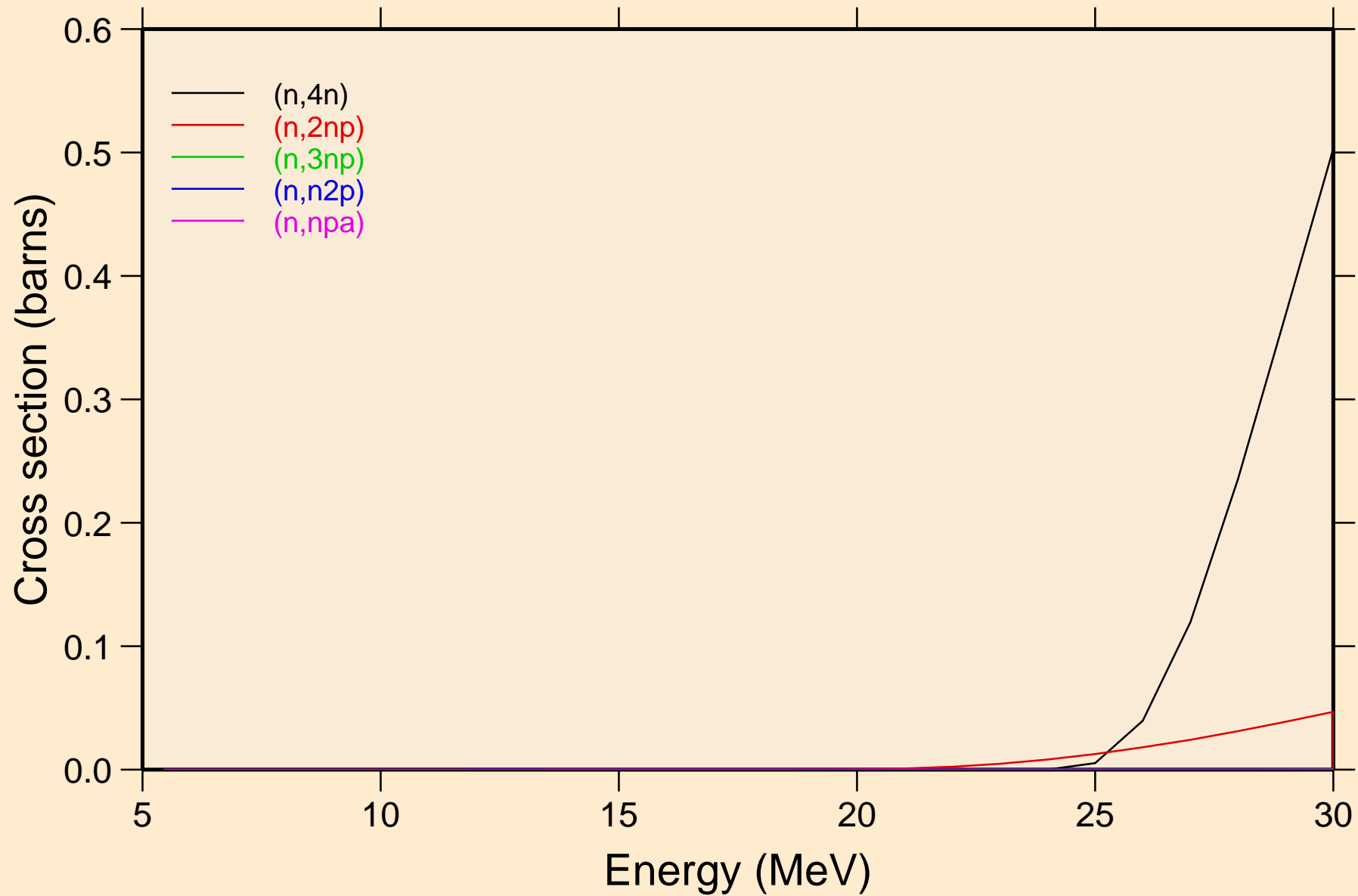

# ER163 NEUTRON ACER TENDL-2024 LIBRARY; T=0.K

## Threshold reactions

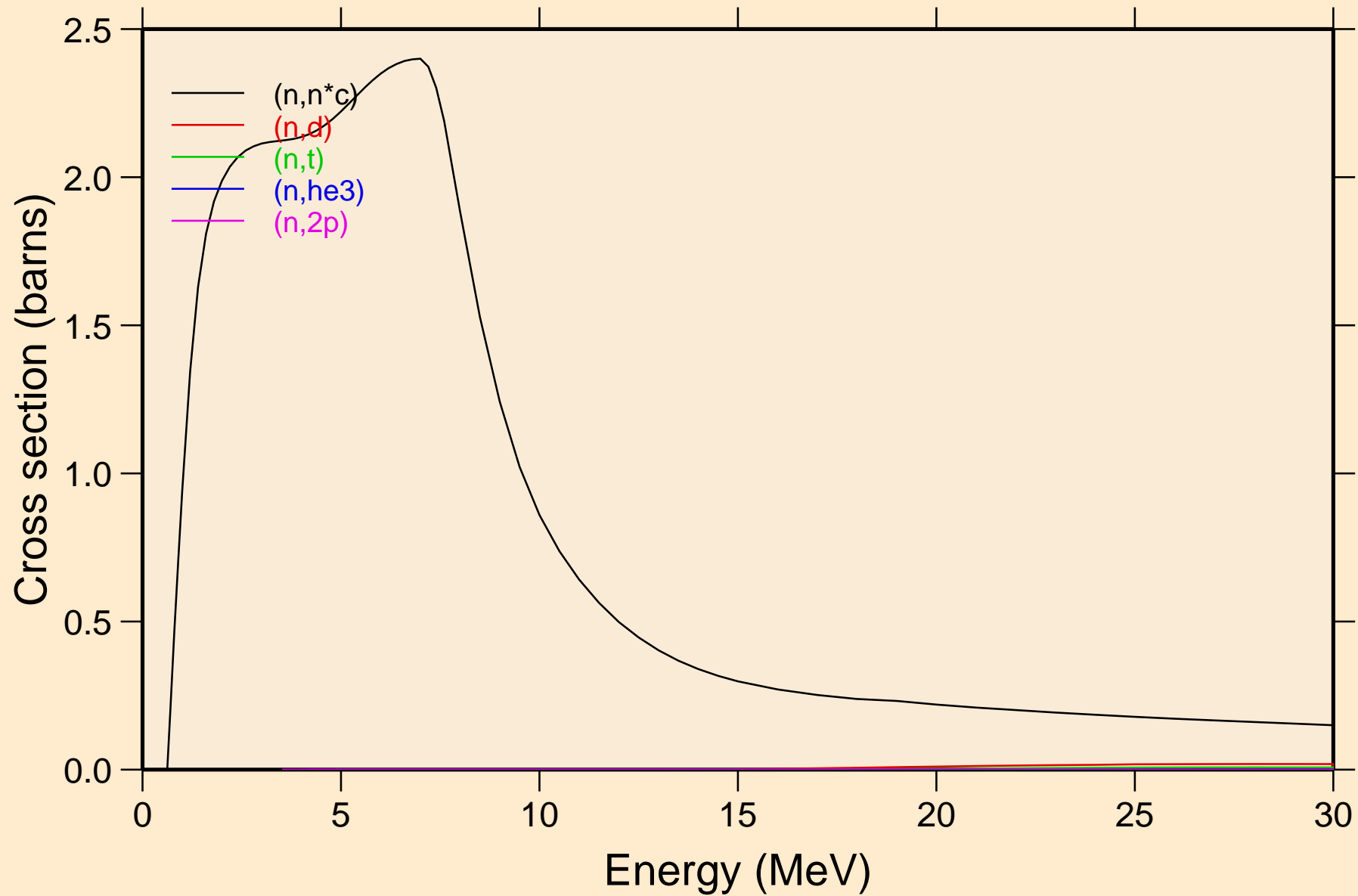

# ER163 NEUTRON ACER TENDL-2024 LIBRARY; T=0.K

## Threshold reactions

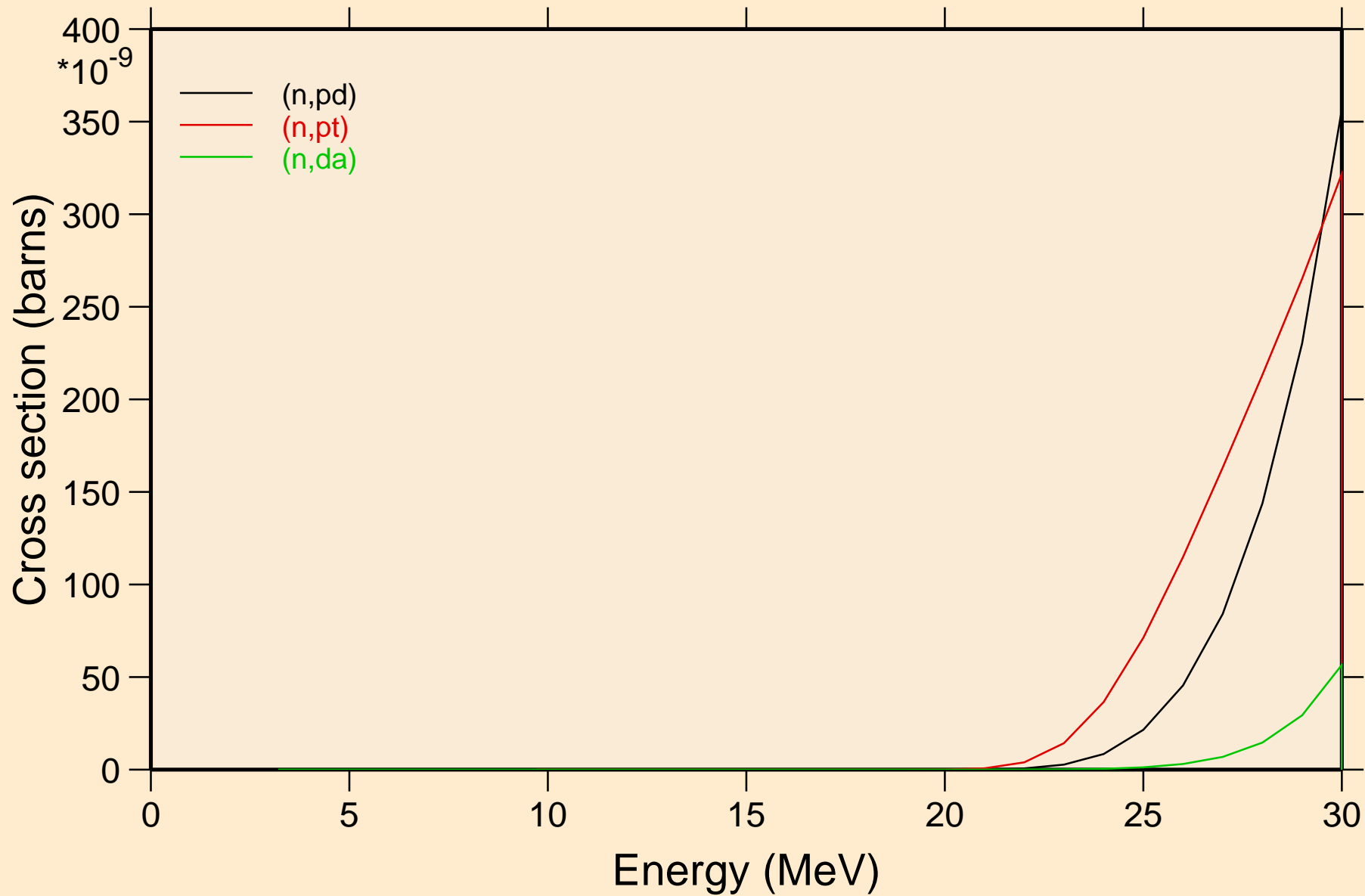

# ER163 NEUTRON ACER TENDL-2024 LIBRARY; T=0.K

## Threshold reactions

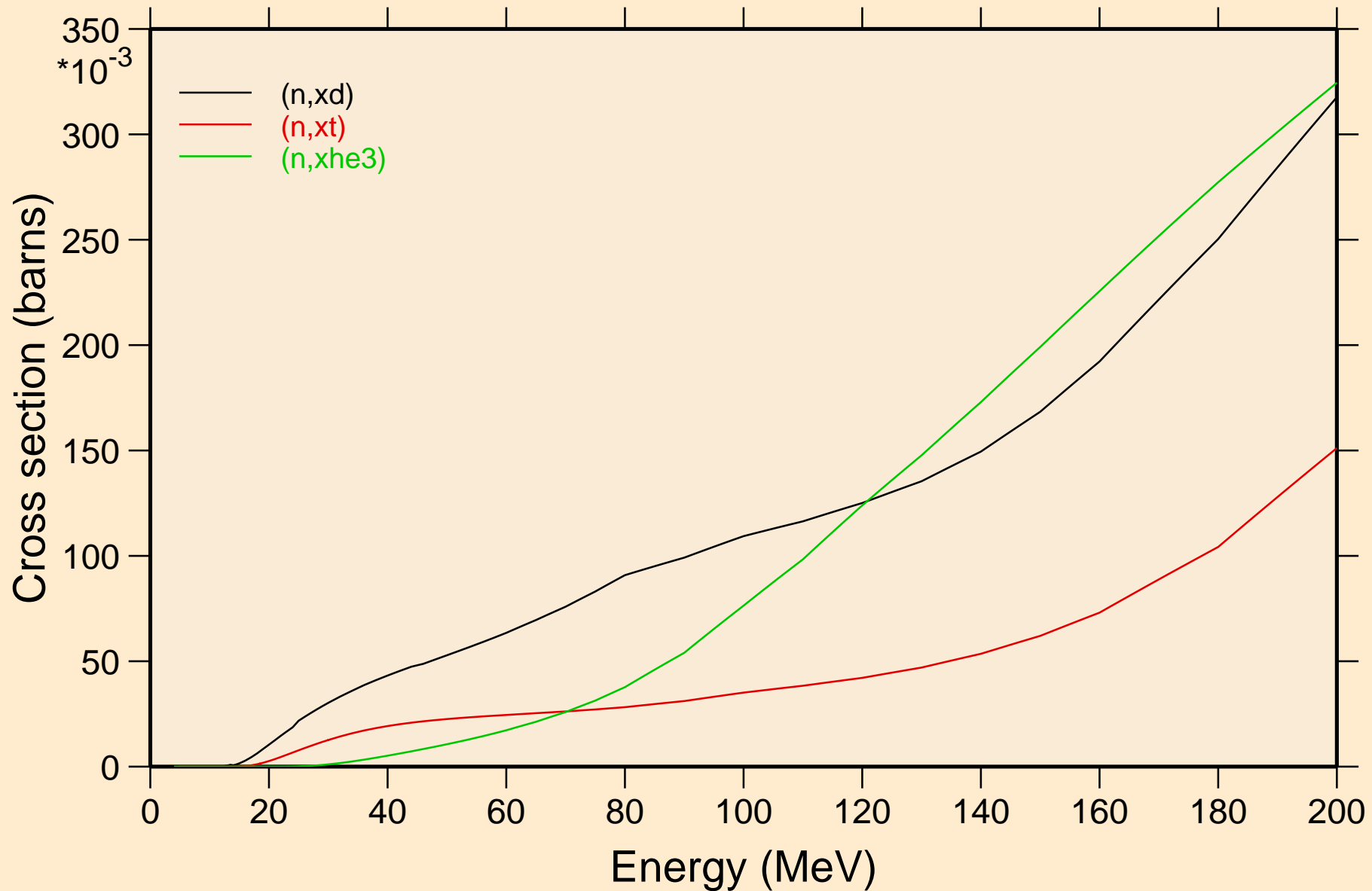

ER163 NEUTRON ACER TENDL-2024 LIBRARY; T=0.K  
angular distribution for elastic

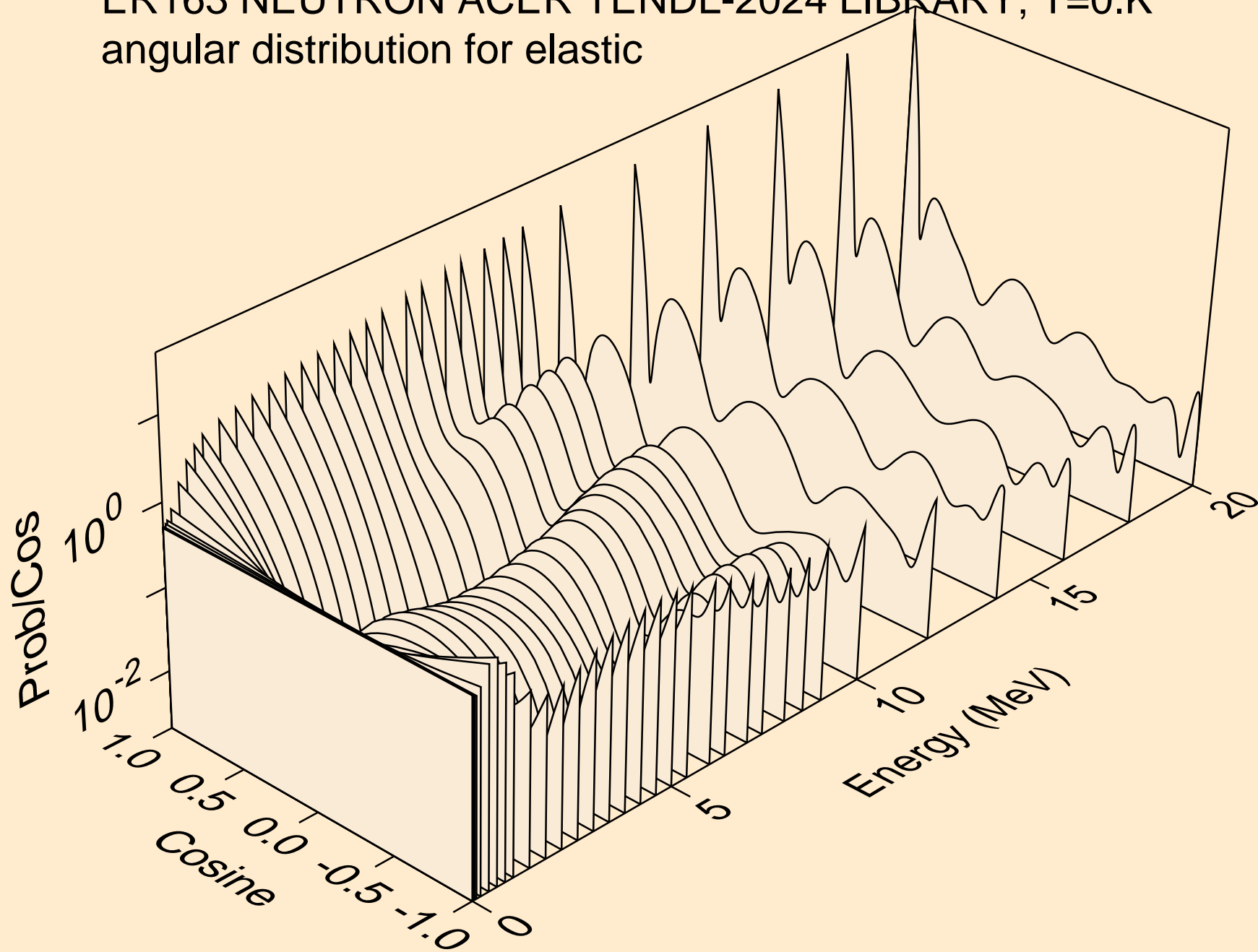

ER163 NEUTRON ACER TENDL-2024 LIBRARY; T=0.K  
angular distribution for elastic

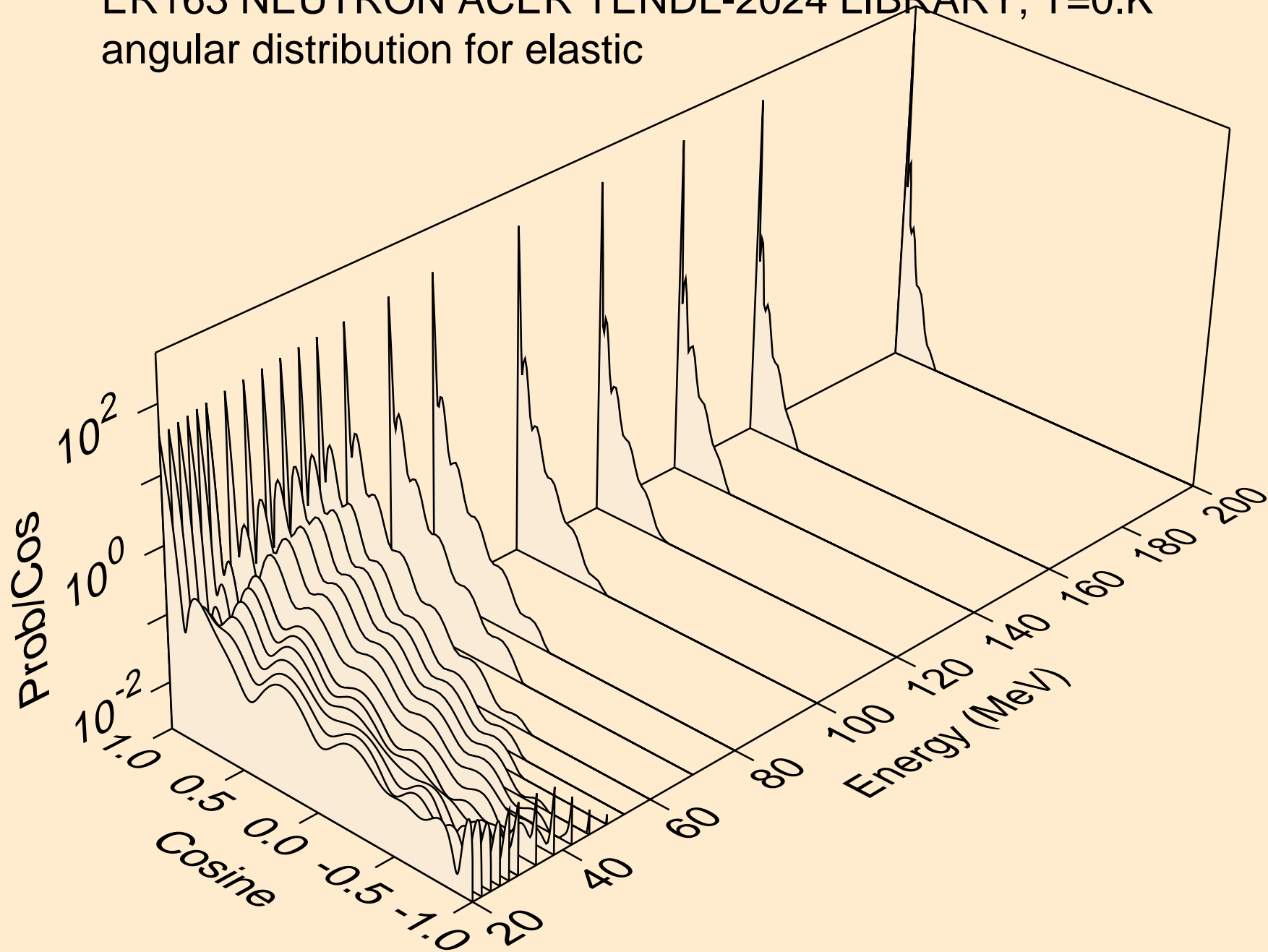



ER163 NEUTRON ACER TENDL-2024 LIBRARY; T=0.K  
angular distribution for (n,n\*1)

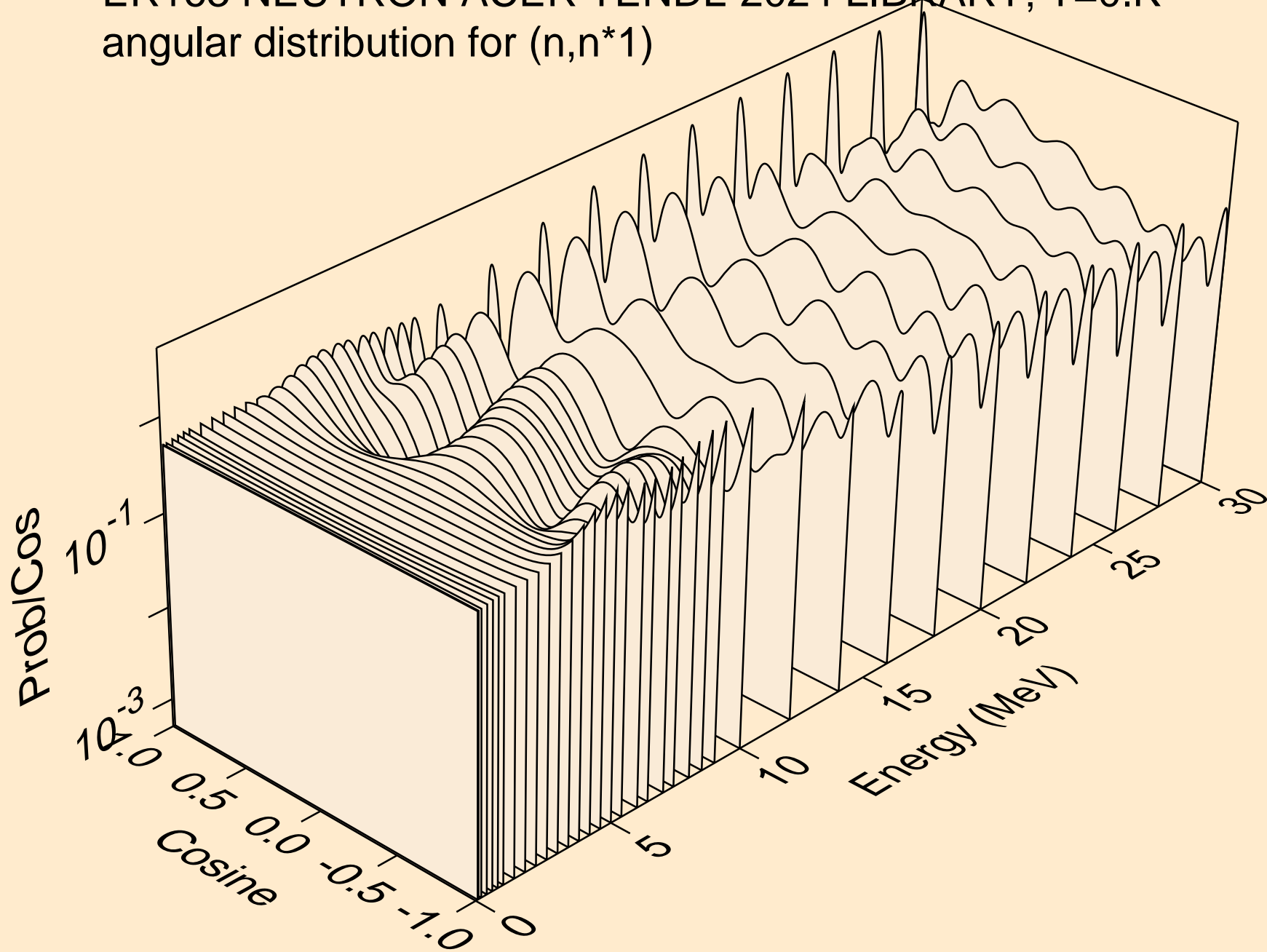

ER163 NEUTRON ACER TENDL-2024 LIBRARY; T=0.K  
angular distribution for (n,n\*2)

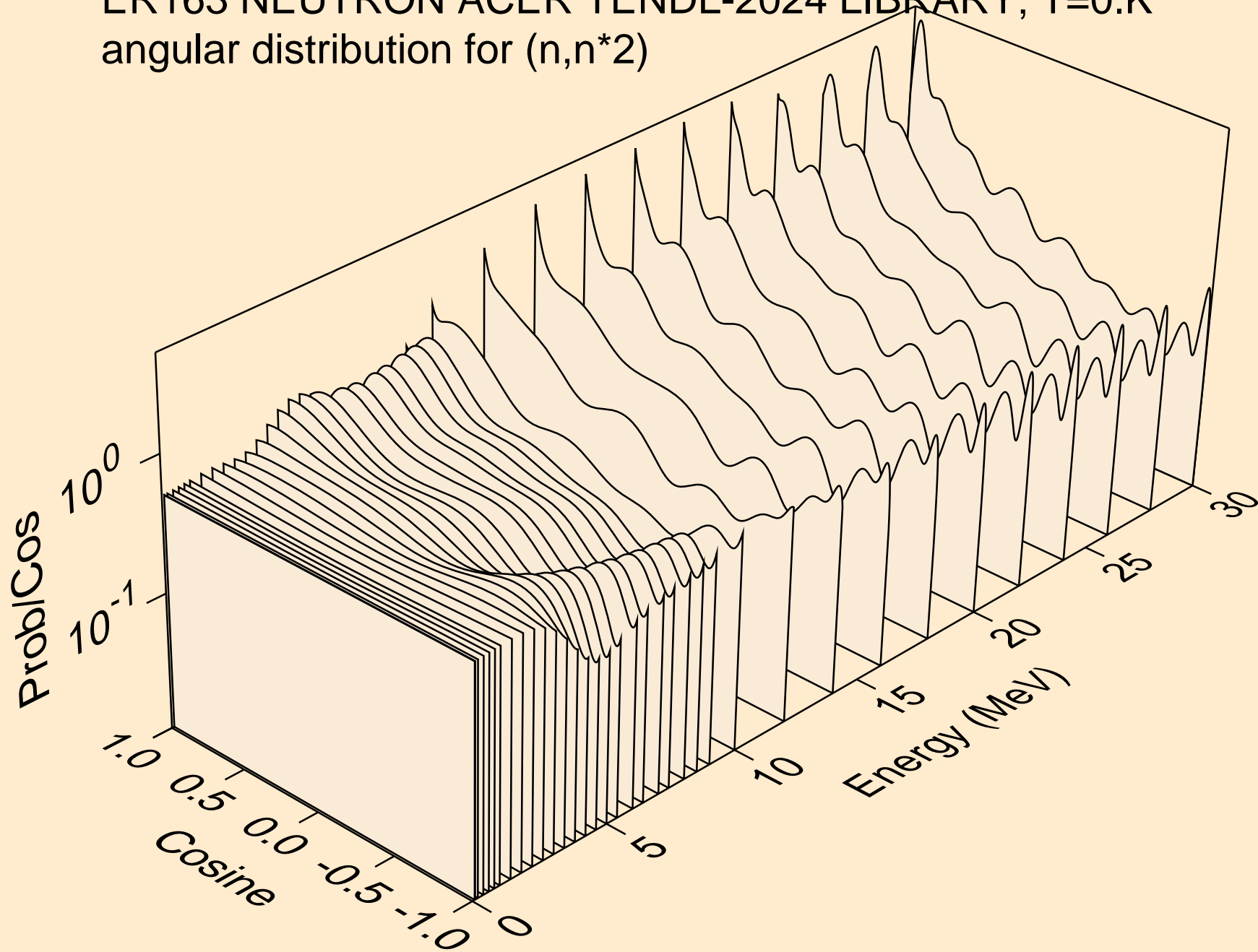

ER163 NEUTRON ACER TENDL-2024 LIBRARY; T=0.K  
angular distribution for (n,n\*3)

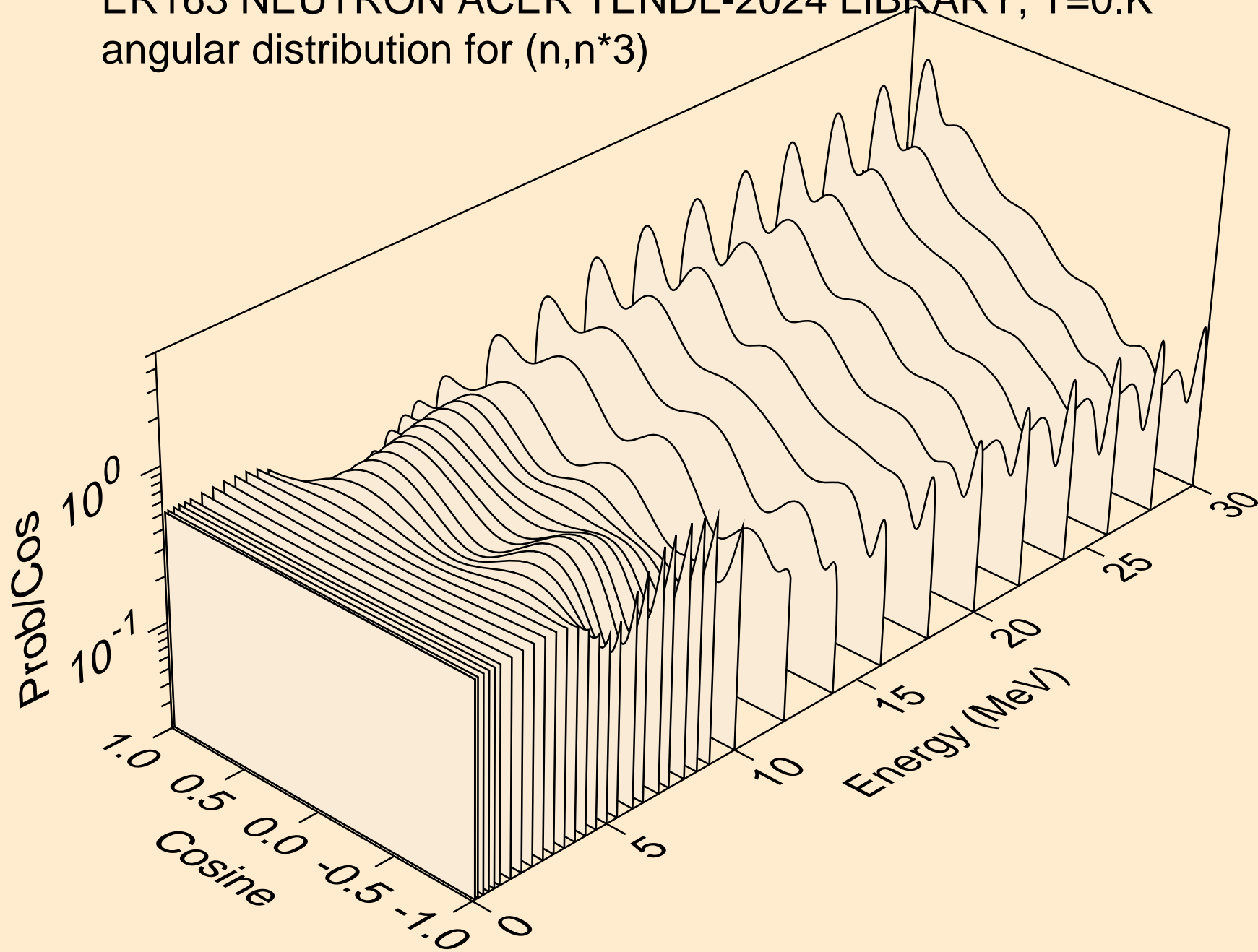

ER163 NEUTRON ACER TENDL-2024 LIBRARY; T=0.K  
angular distribution for (n,n\*4)

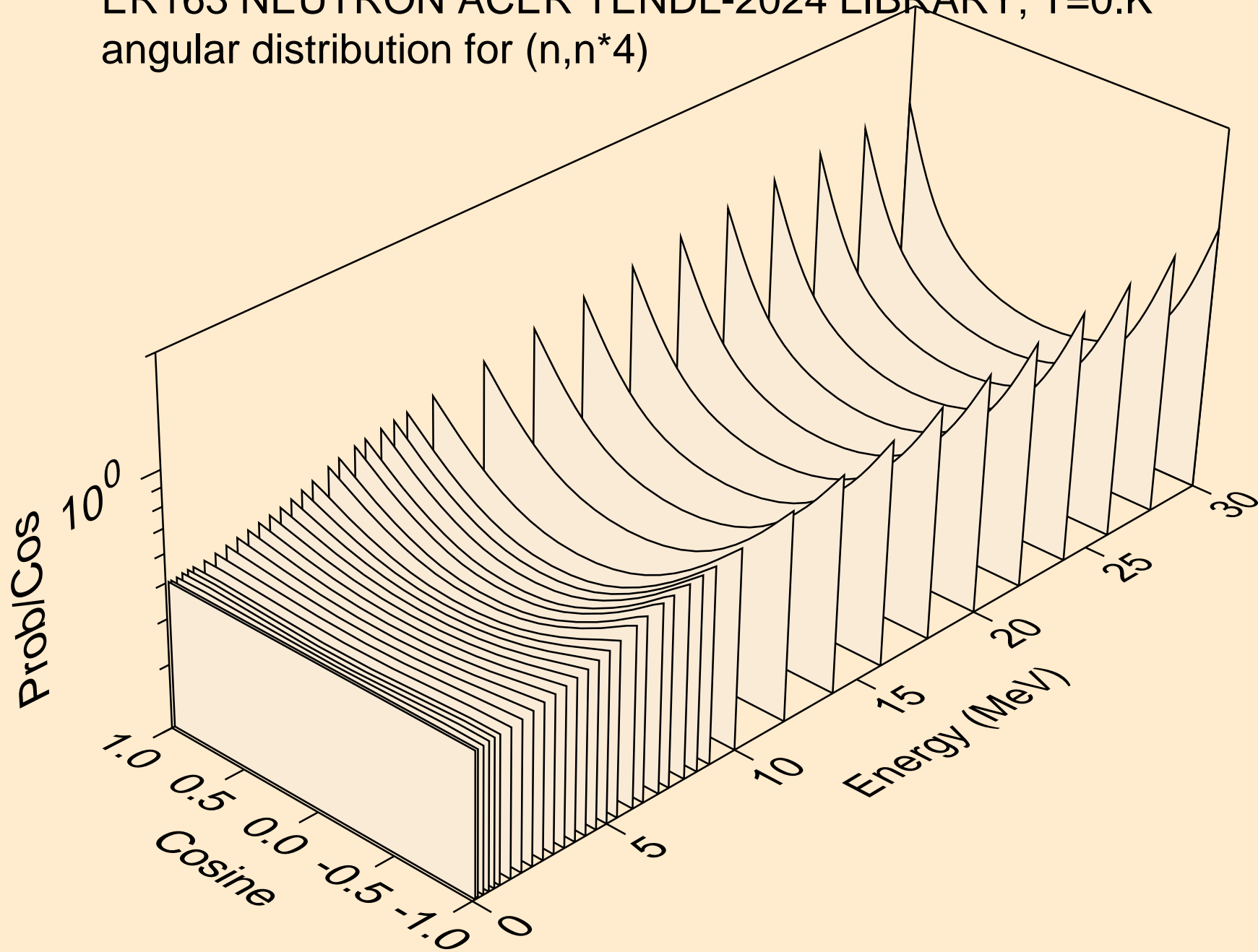

ER163 NEUTRON ACER TENDL-2024 LIBRARY; T=0.K  
angular distribution for (n,n\*5)

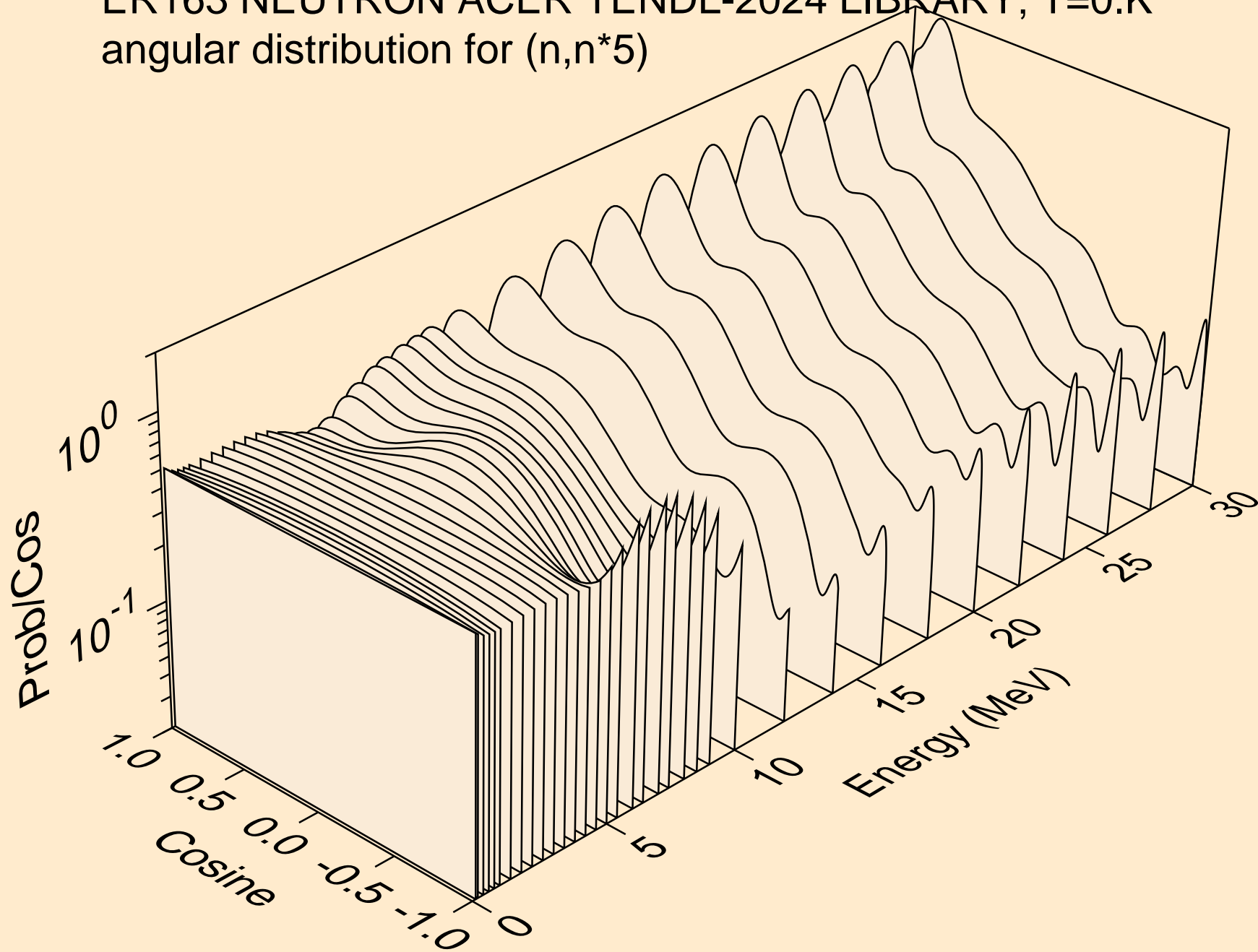

ER163 NEUTRON ACER TENDL-2024 LIBRARY; T=0.K  
angular distribution for (n,n\*6)

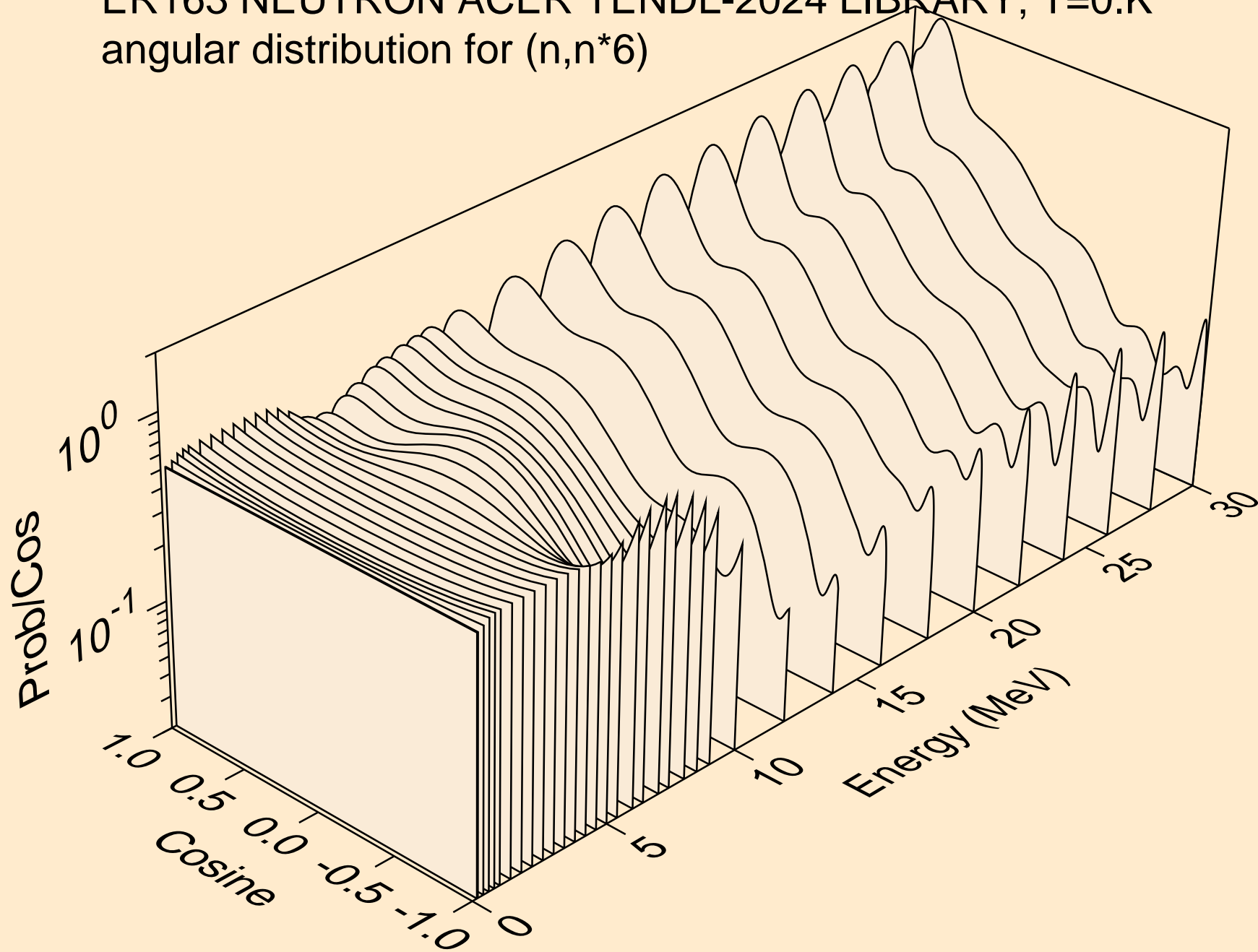

ER163 NEUTRON ACER TENDL-2024 LIBRARY; T=0.K  
angular distribution for (n,n\*7)

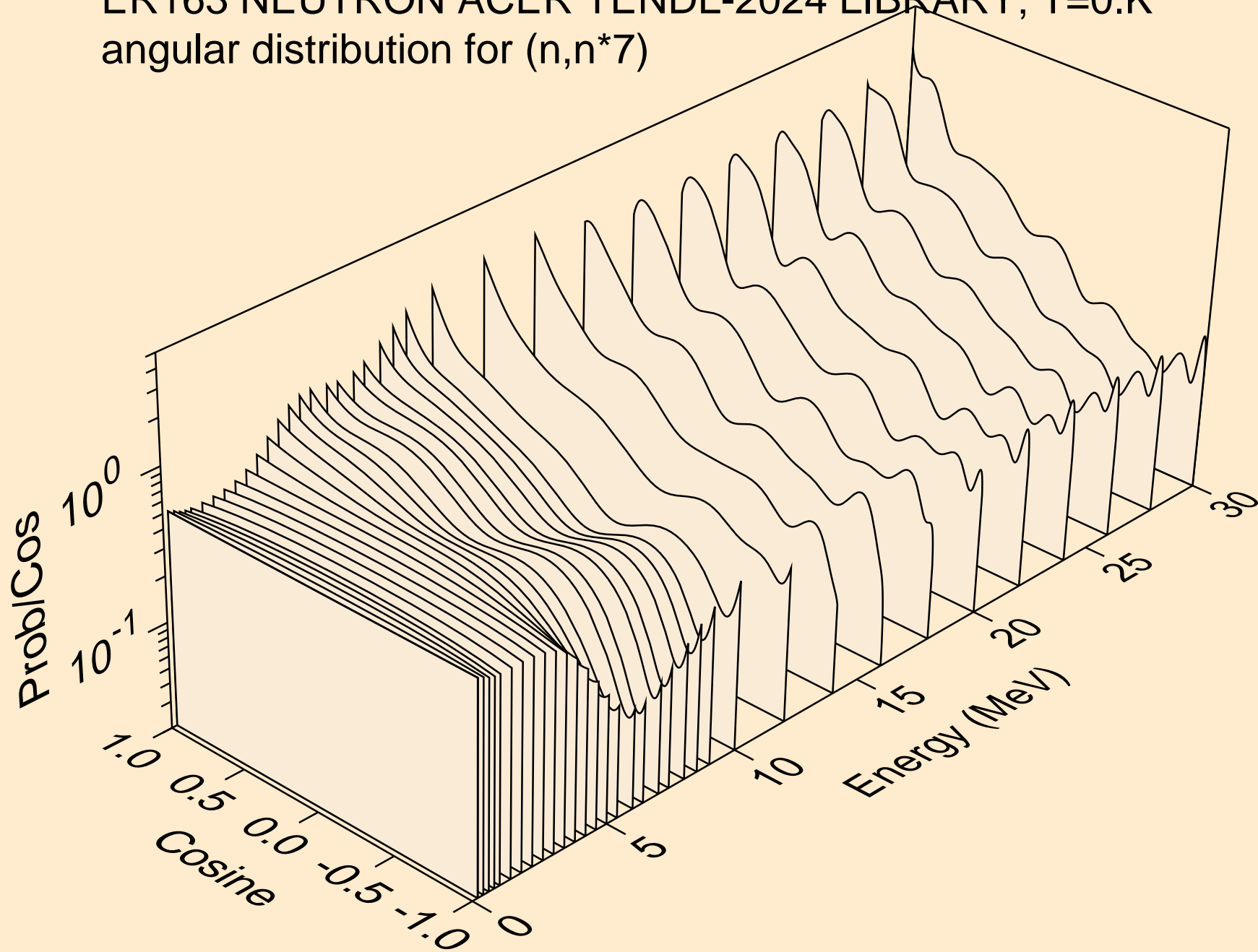

ER163 NEUTRON ACER TENDL-2024 LIBRARY; T=0.K  
angular distribution for (n,n\*8)

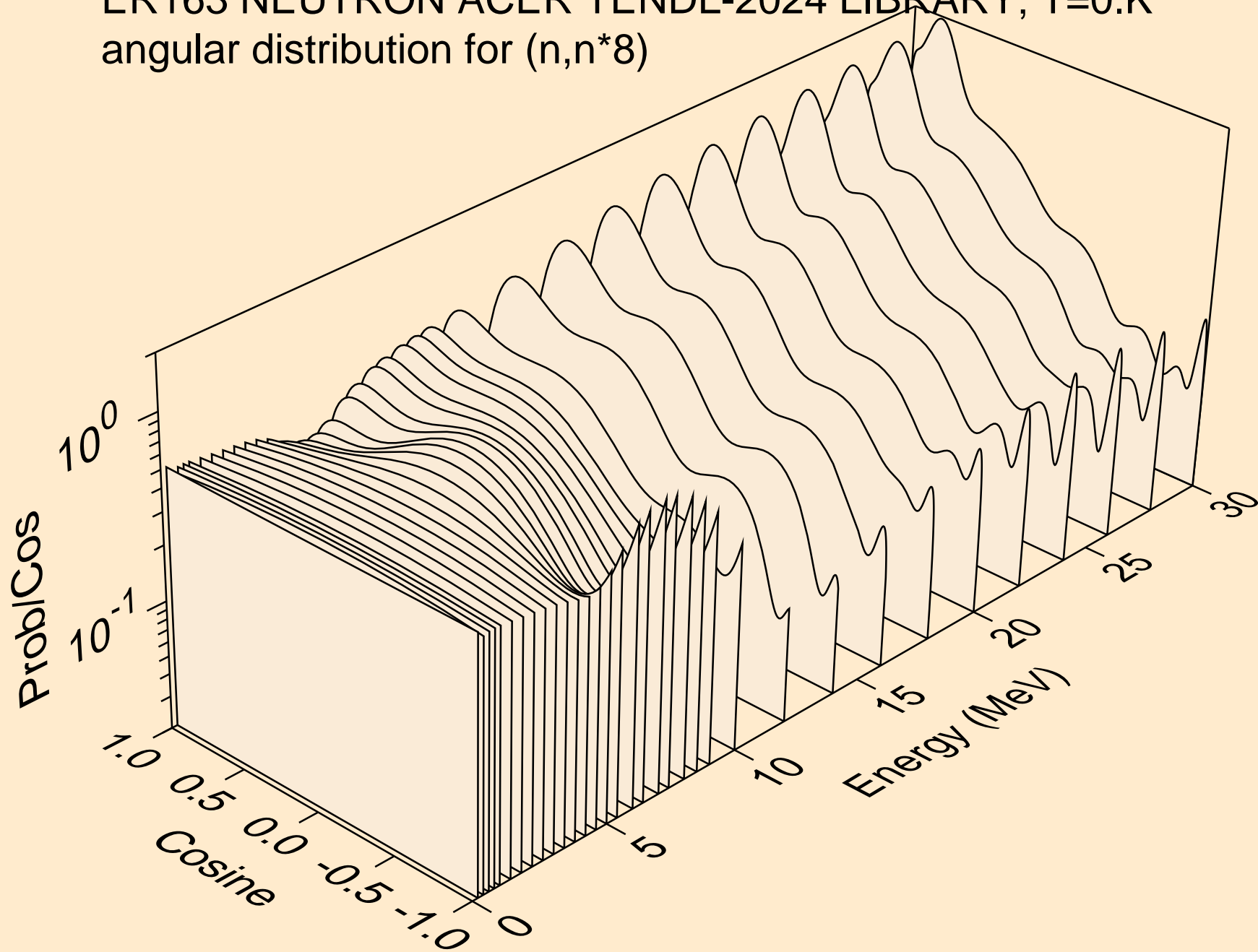



ER163 NEUTRON ACER TENDL-2024 LIBRARY; T=0.K  
angular distribution for (n,n\*9)

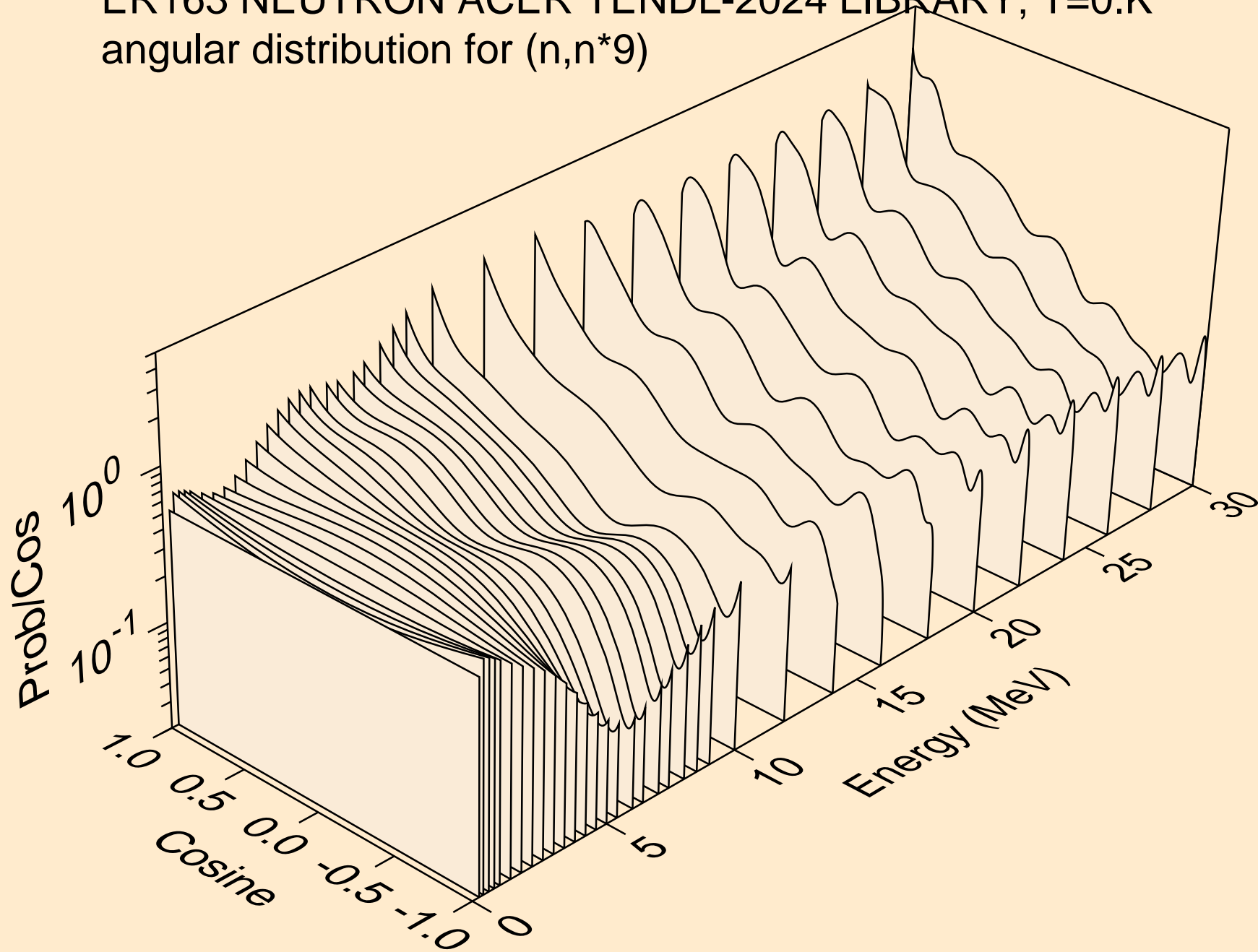

ER163 NEUTRON ACER TENDL-2024 LIBRARY; T=0.K  
angular distribution for (n,n\*10)

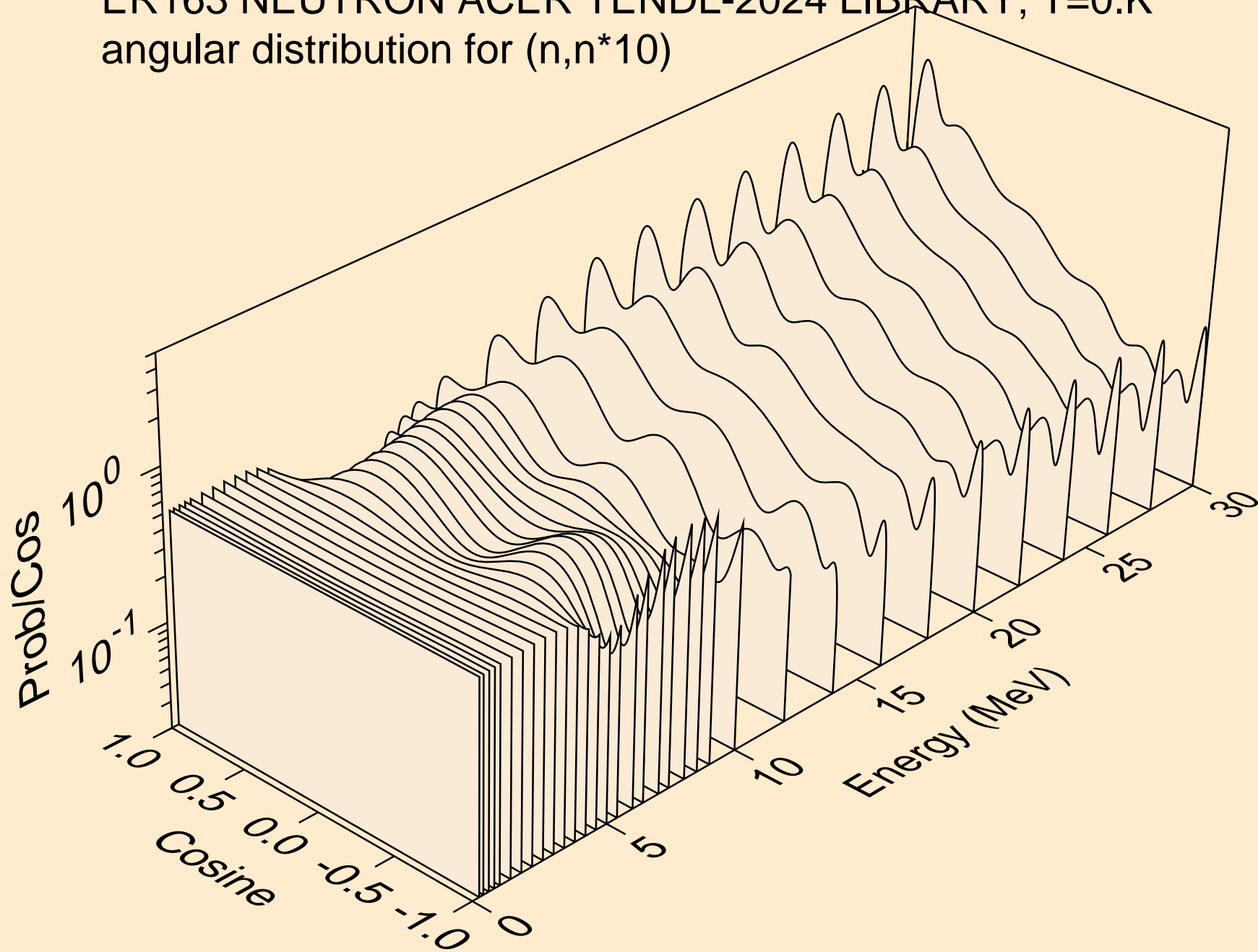

ER163 NEUTRON ACER TENDL-2024 LIBRARY; T=0.K  
angular distribution for (n,n\*11)

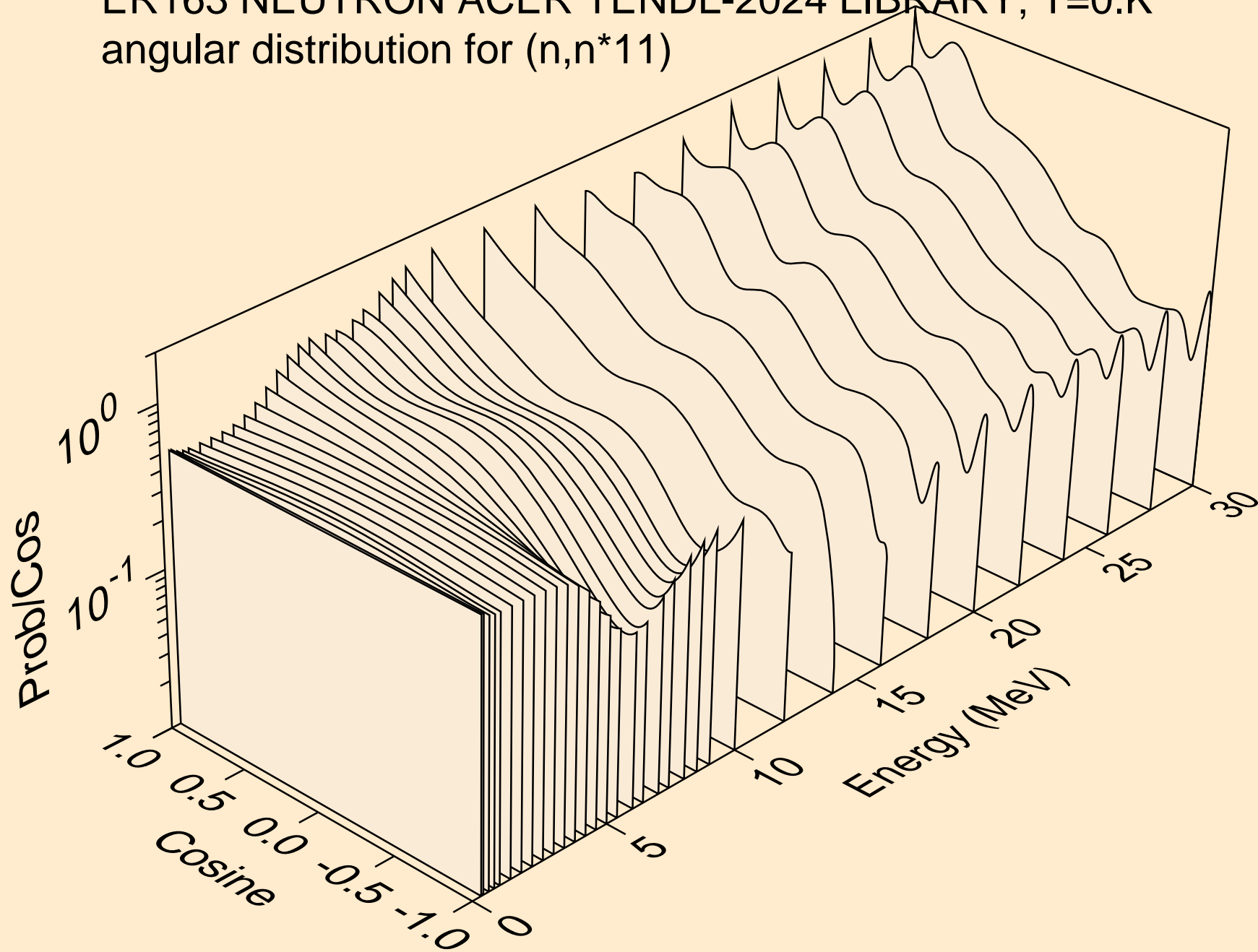

ER163 NEUTRON ACER TENDL-2024 LIBRARY; T=0.K  
angular distribution for (n,n\*12)

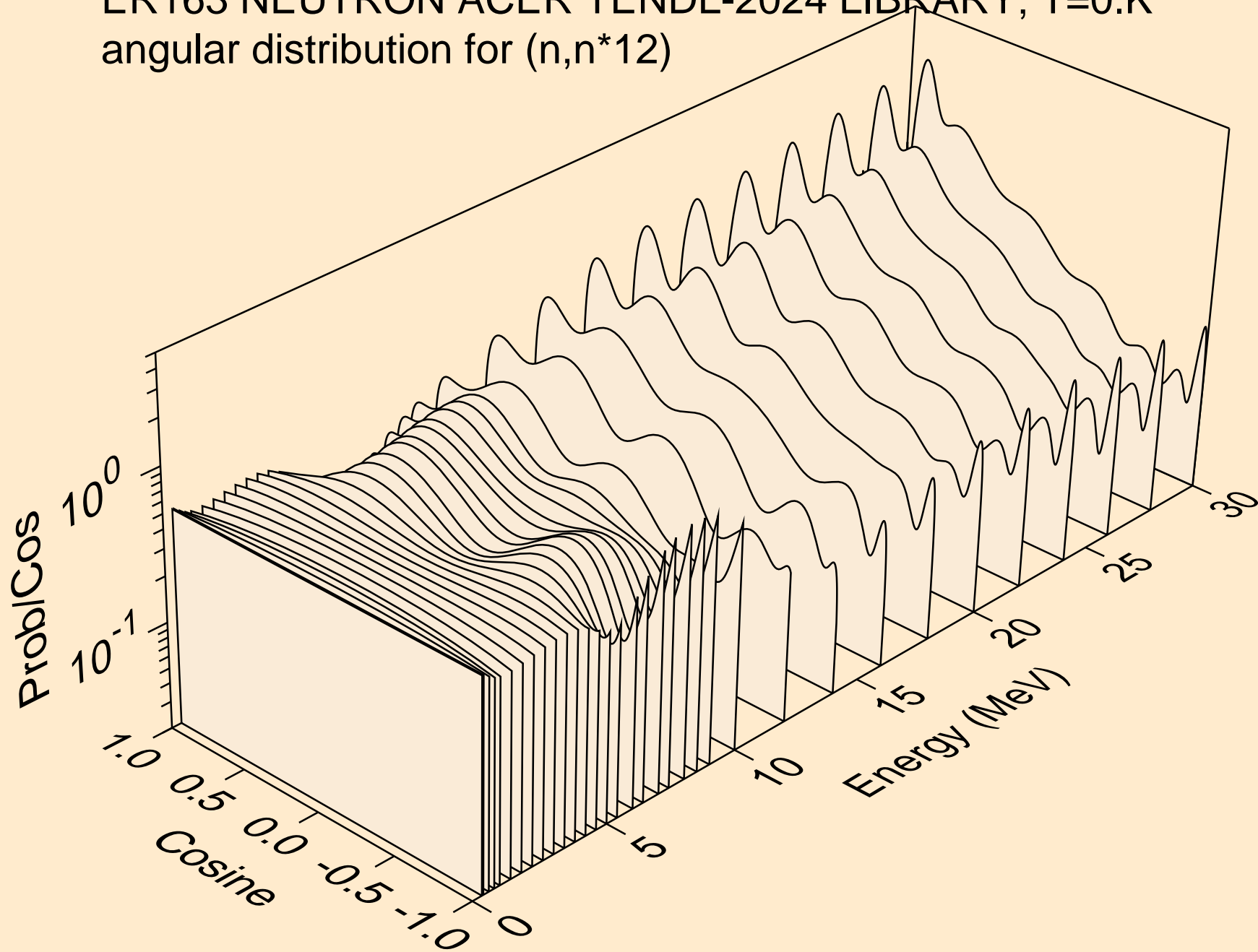

ER163 NEUTRON ACER TENDL-2024 LIBRARY; T=0.K  
angular distribution for (n,n\*13)

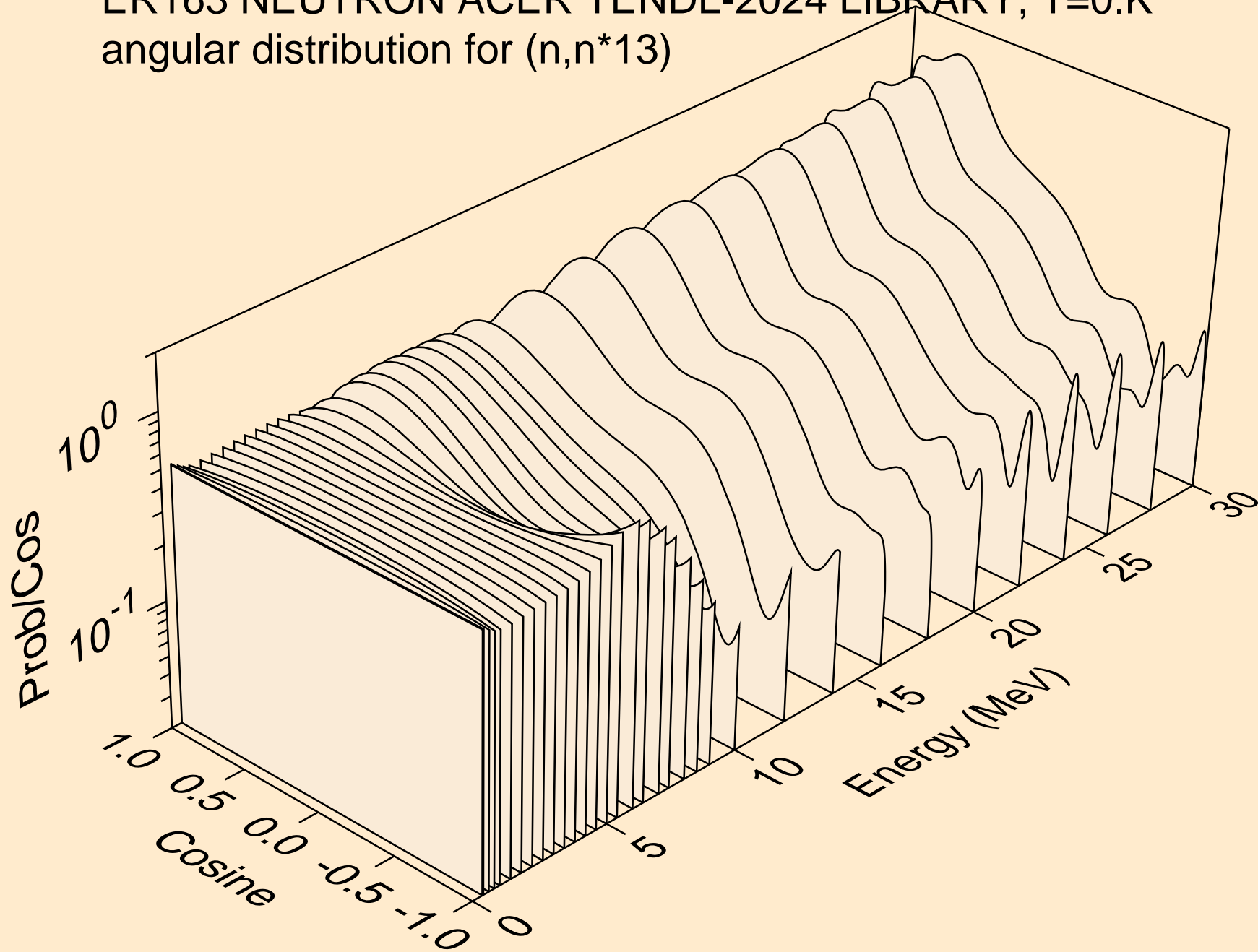

ER163 NEUTRON ACER TENDL-2024 LIBRARY; T=0.K  
angular distribution for (n,n\*14)

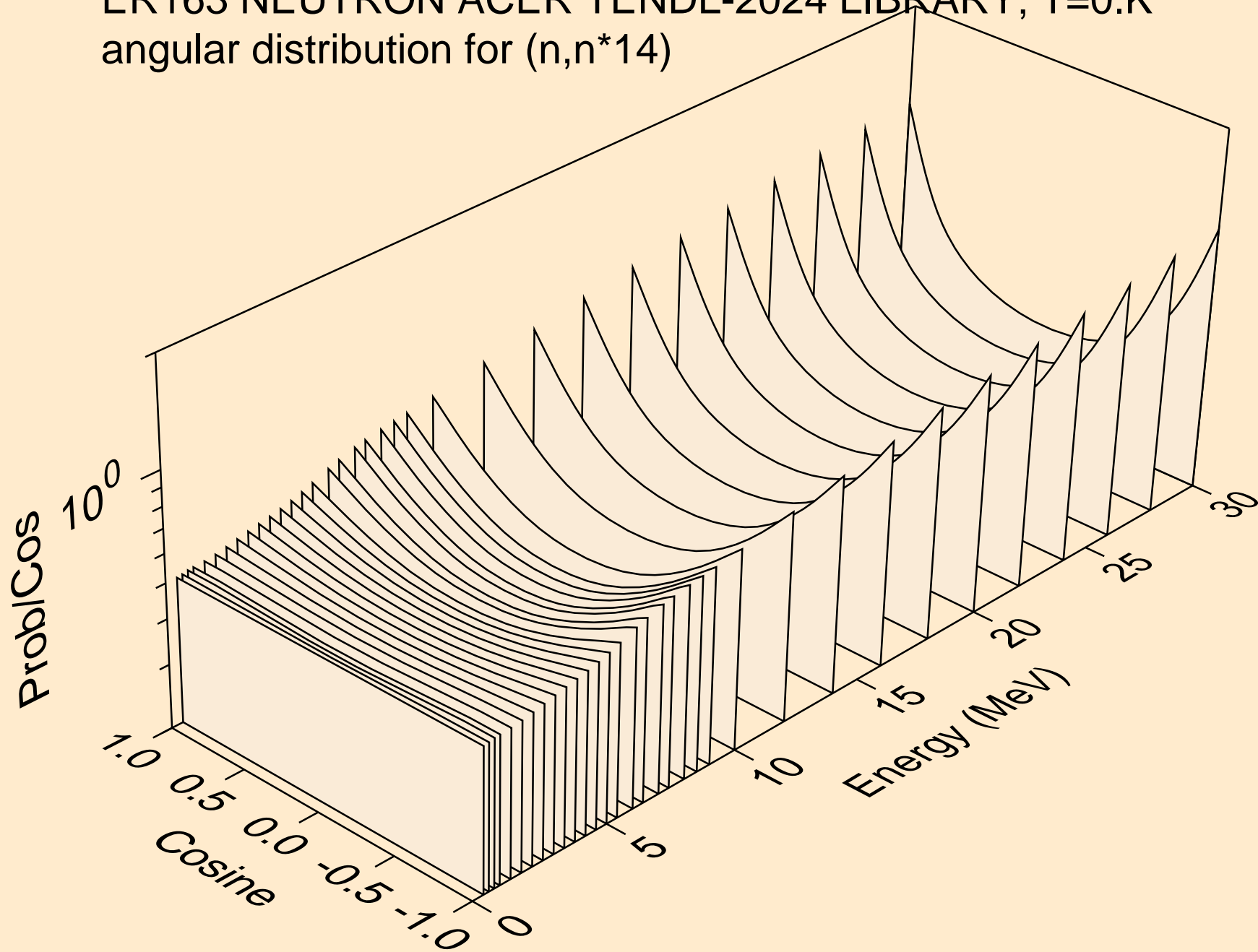

ER163 NEUTRON ACER TENDL-2024 LIBRARY; T=0.K  
angular distribution for (n,n\*15)

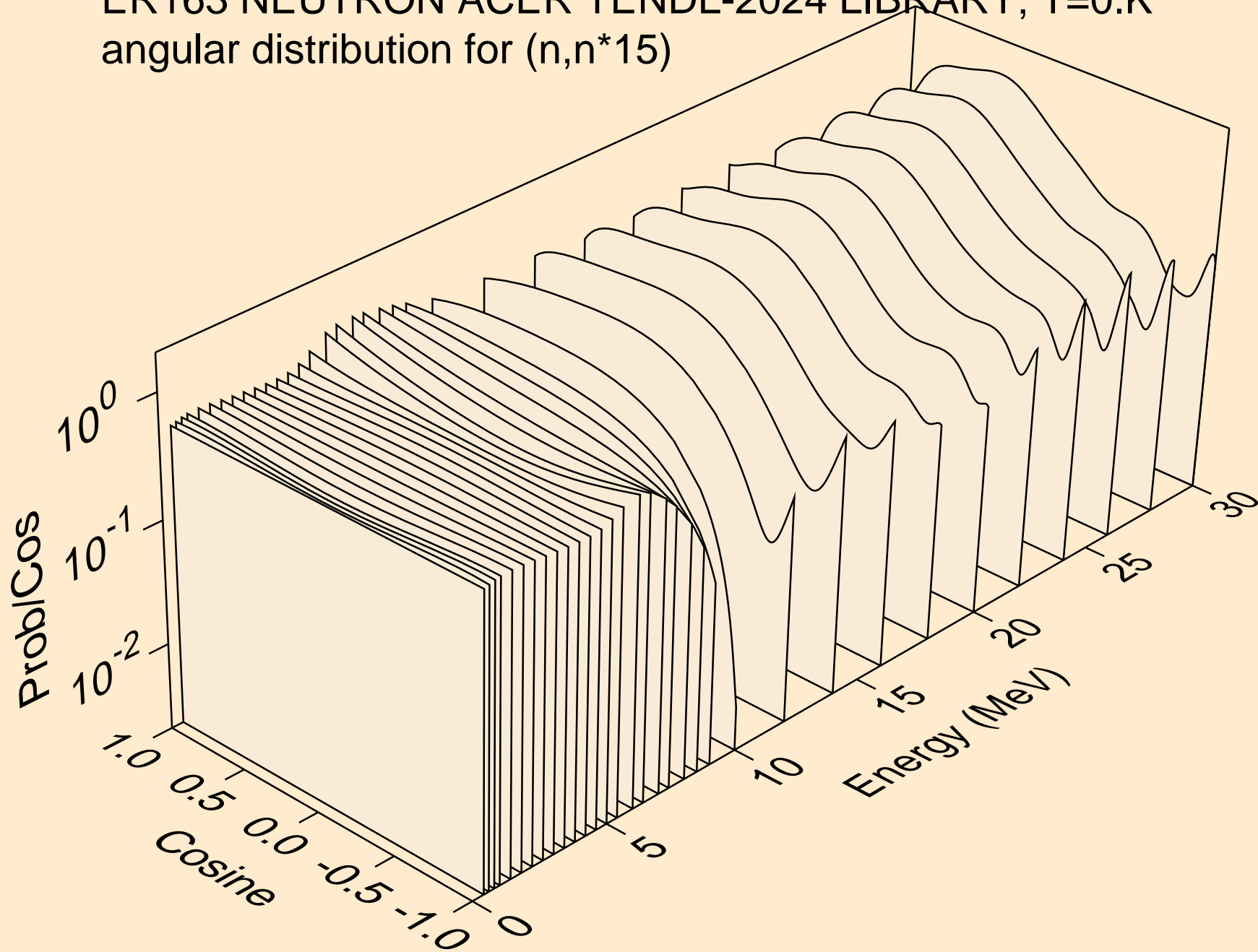

ER163 NEUTRON ACER TENDL-2024 LIBRARY; T=0.K  
angular distribution for (n,n\*16)

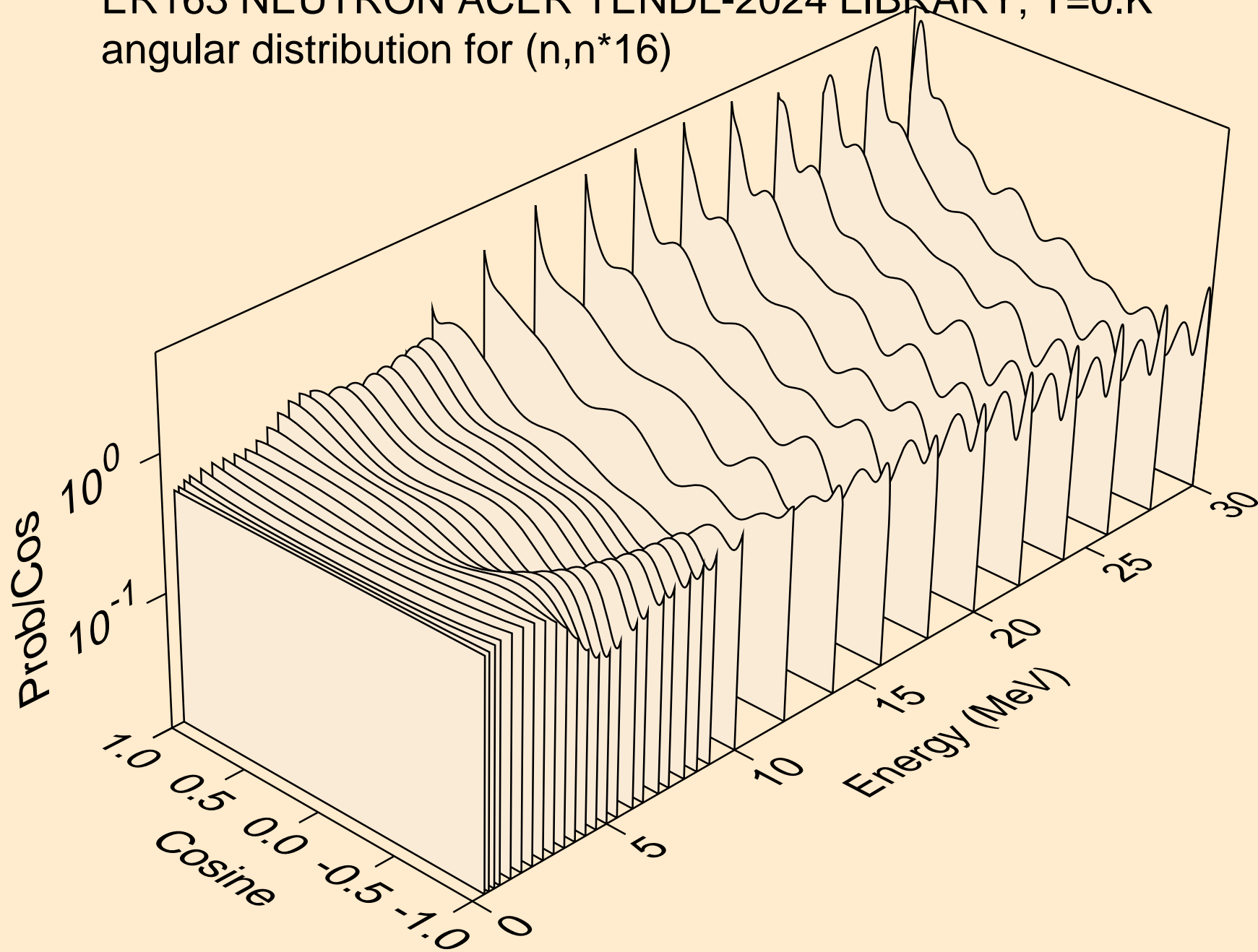



ER163 NEUTRON ACER TENDL-2024 LIBRARY; T=0.K  
angular distribution for (n,n\*17)

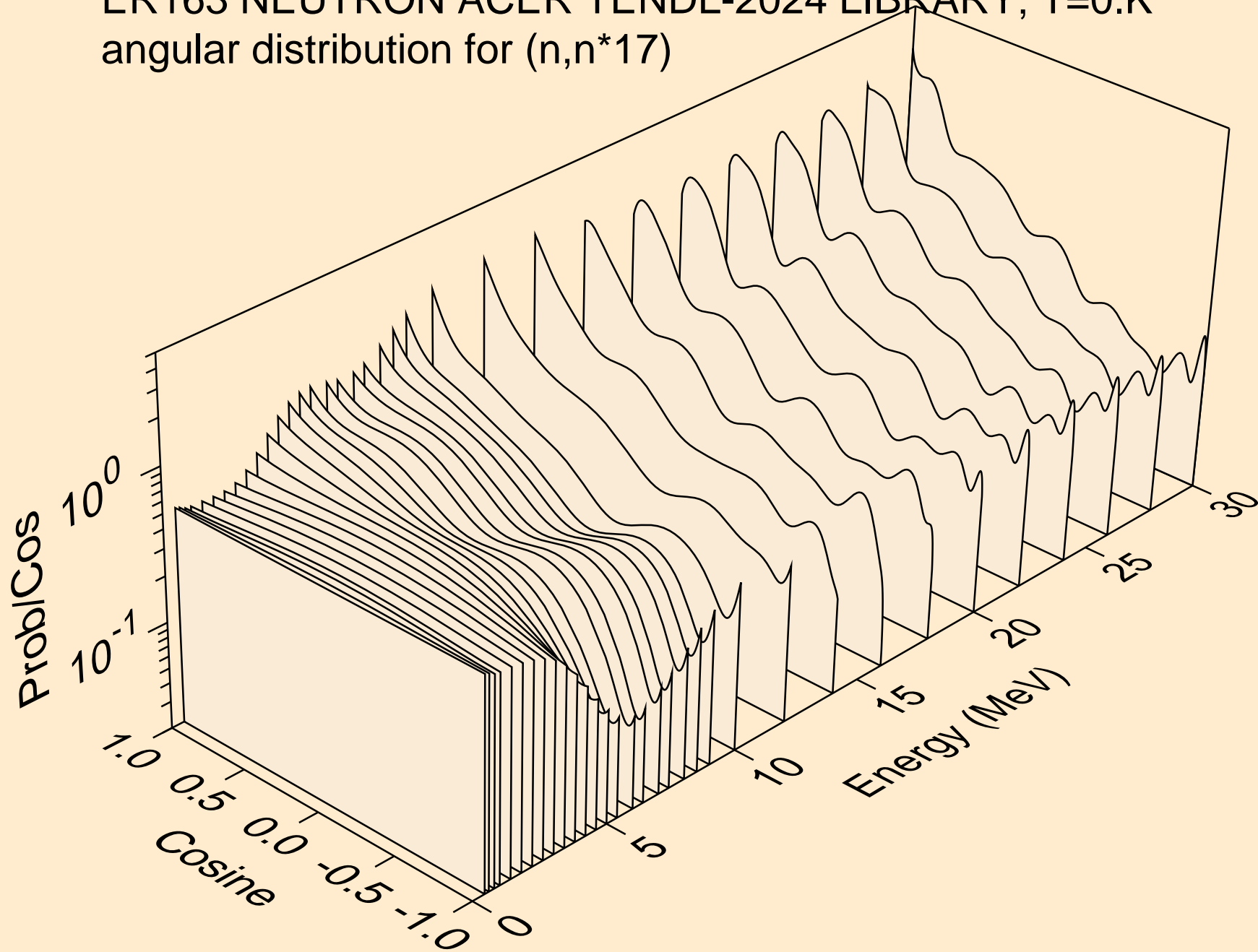

ER163 NEUTRON ACER TENDL-2024 LIBRARY; T=0.K  
angular distribution for (n,n\*18)

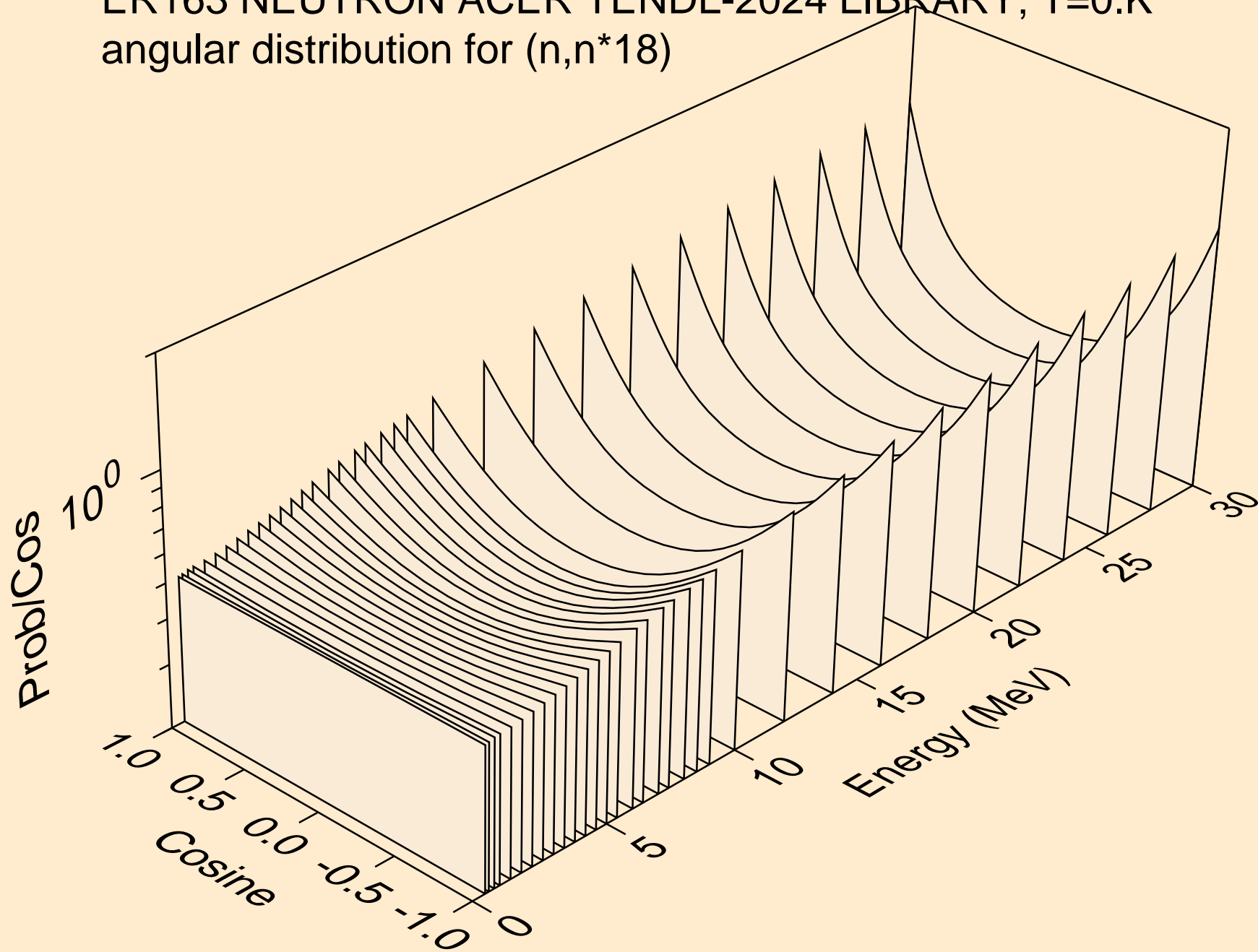

ER163 NEUTRON ACER TENDL-2024 LIBRARY; T=0.K  
angular distribution for (n,n\*19)

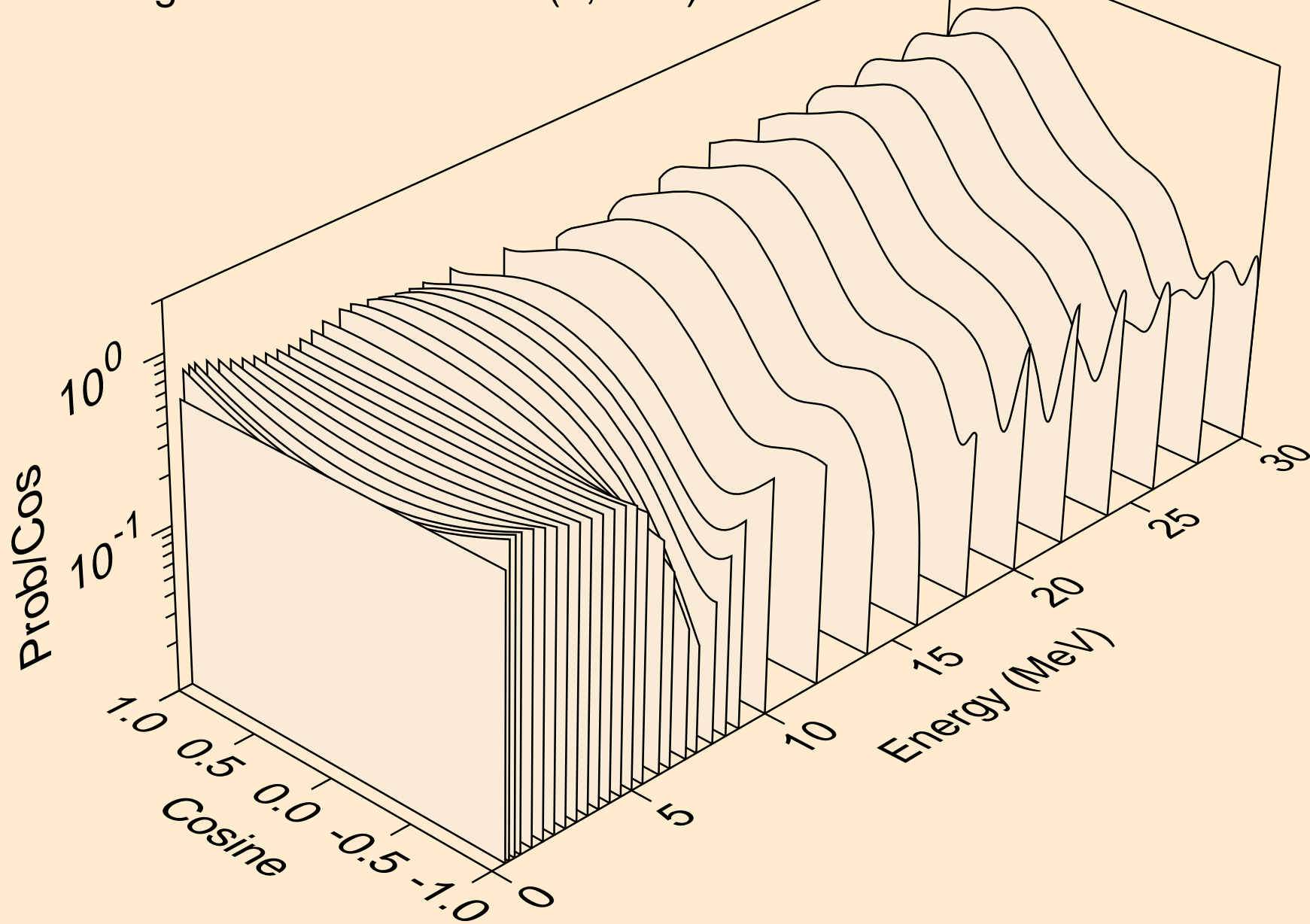

ER163 NEUTRON ACER TENDL-2024 LIBRARY; T=0.K  
angular distribution for (n,n\*20)

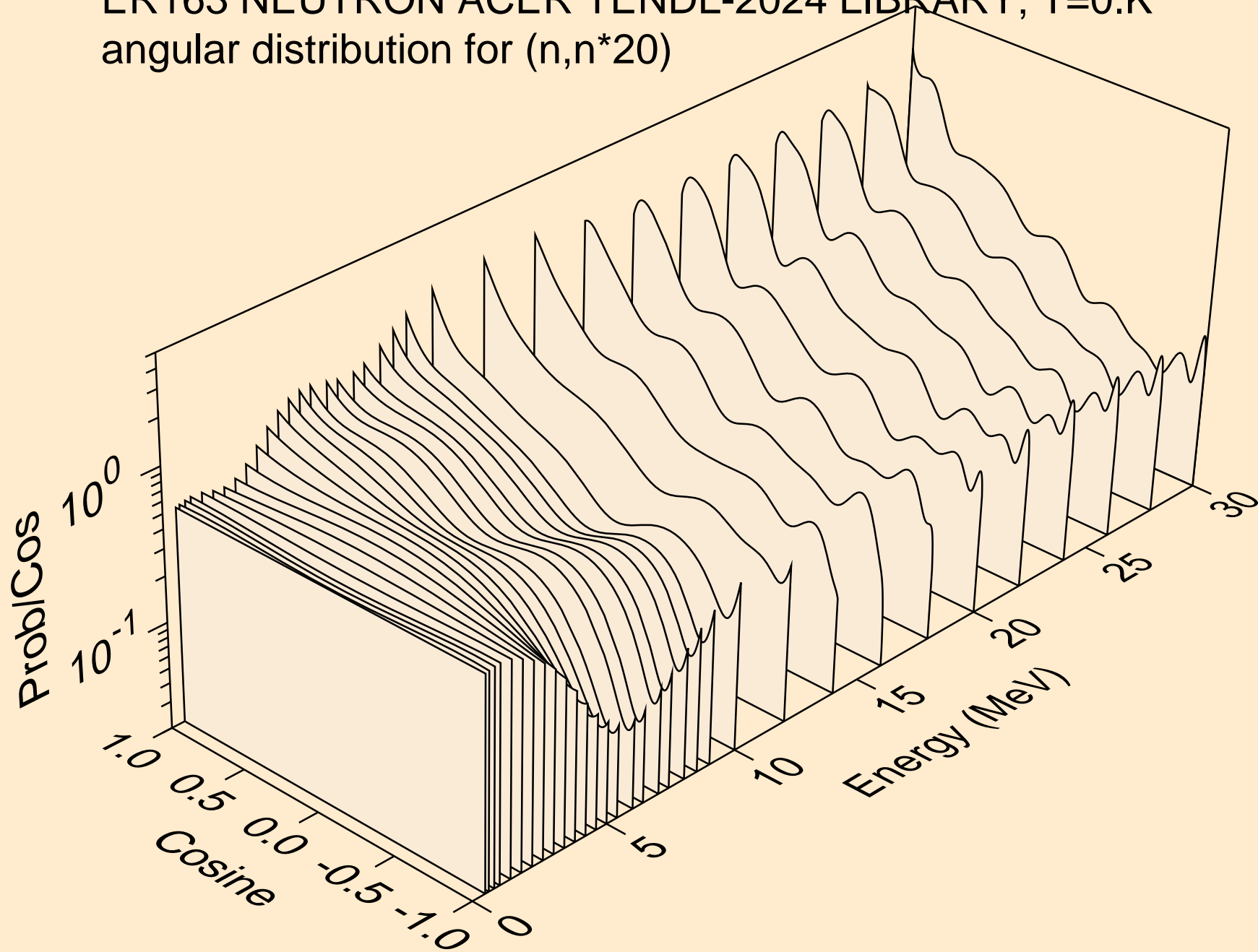

ER163 NEUTRON ACER TENDL-2024 LIBRARY; T=0.K  
angular distribution for (n,n\*21)

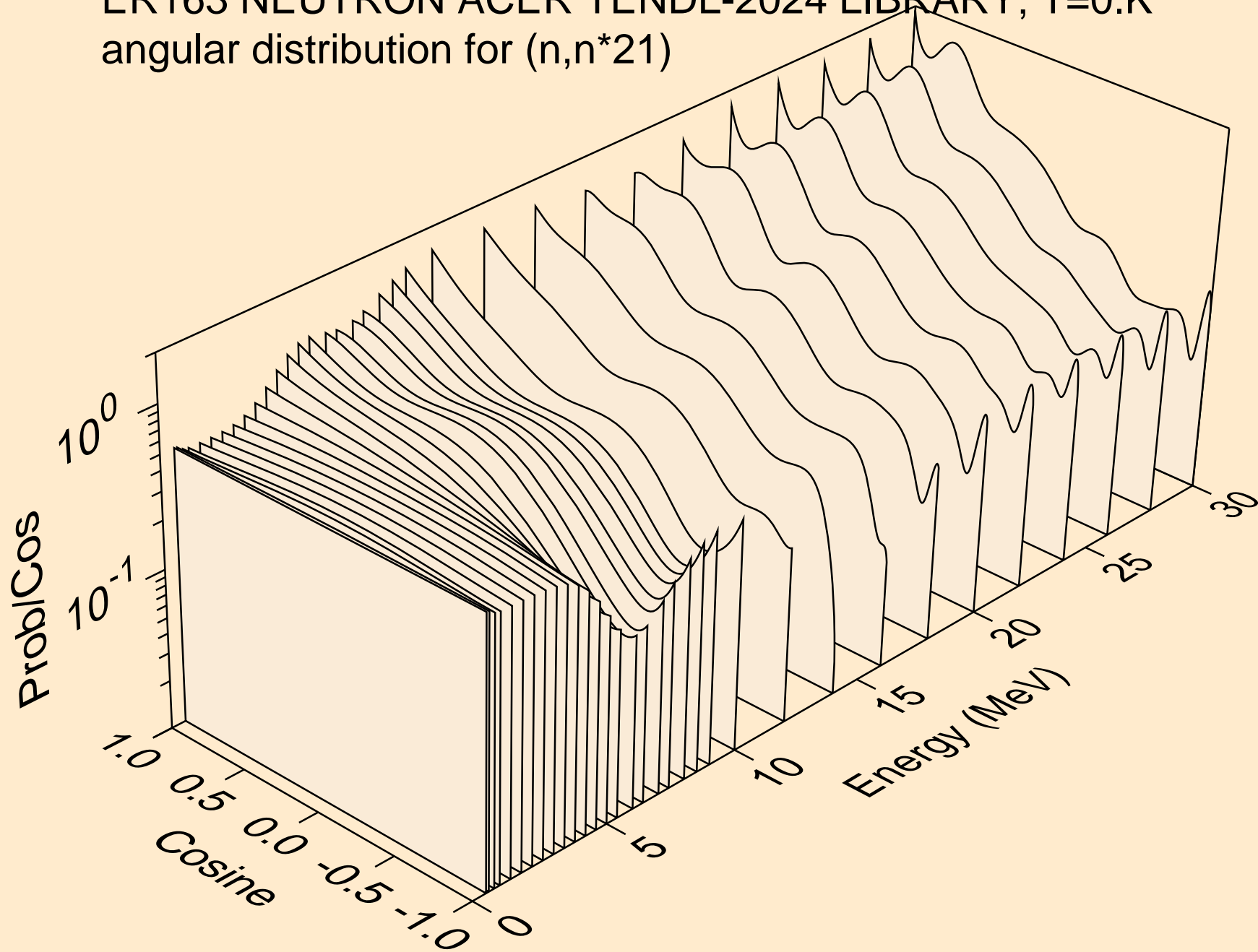

ER163 NEUTRON ACER TENDL-2024 LIBRARY; T=0.K  
angular distribution for (n,n\*22)

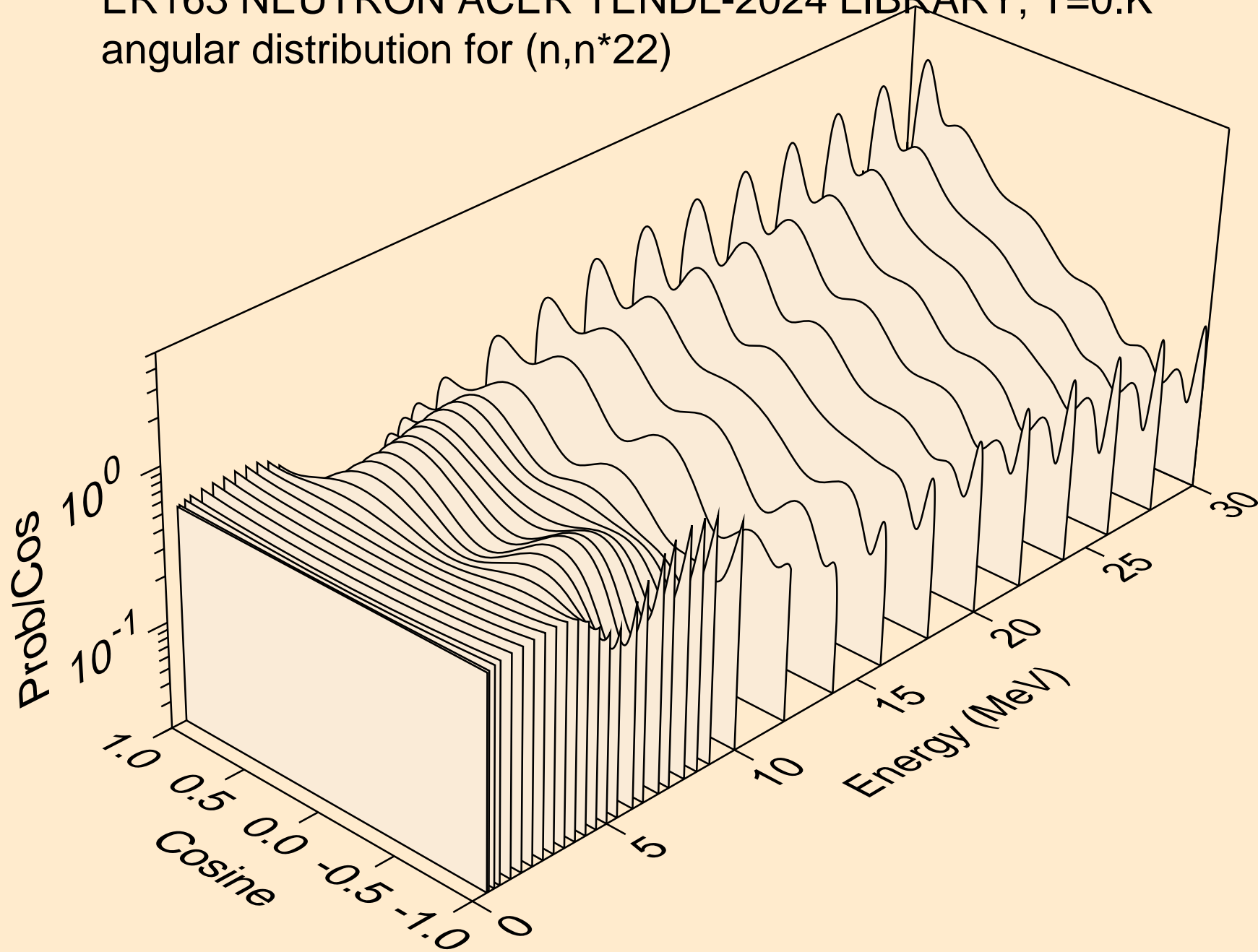

ER163 NEUTRON ACER TENDL-2024 LIBRARY; T=0.K  
angular distribution for (n,n\*23)

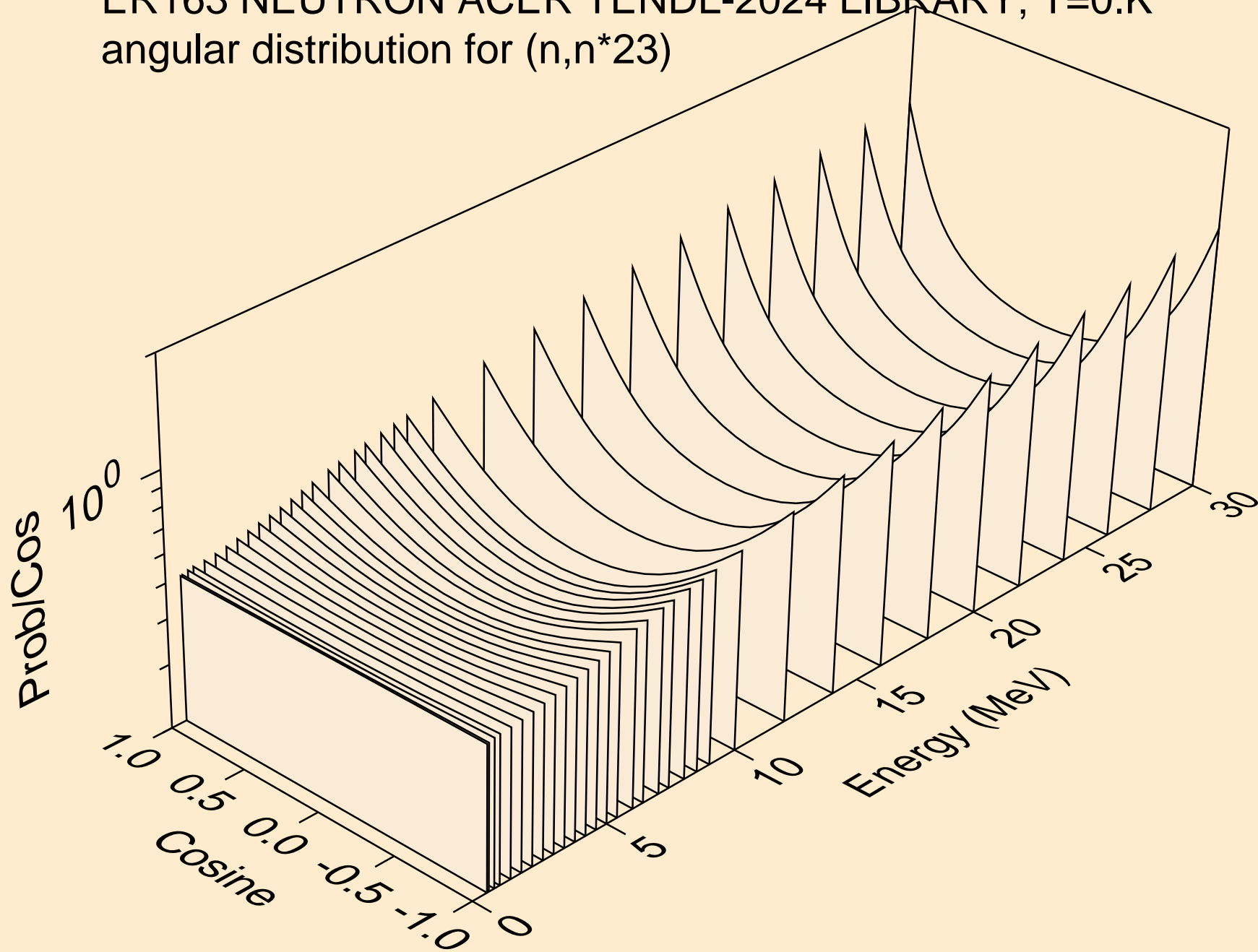

ER163 NEUTRON ACER TENDL-2024 LIBRARY; T=0.K  
angular distribution for (n,n\*24)

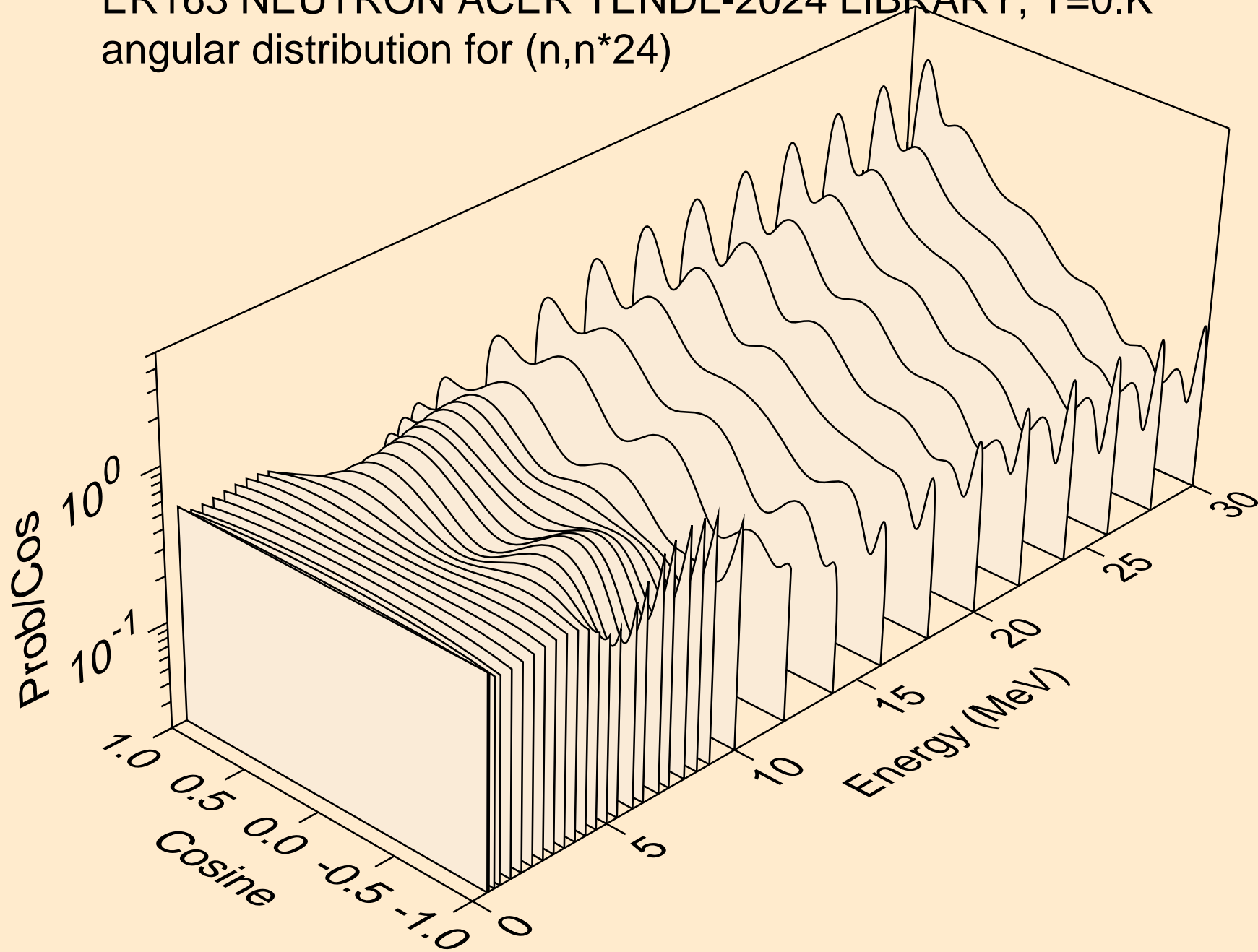



ER163 NEUTRON ACER TENDL-2024 LIBRARY; T=0.K  
angular distribution for (n,n\*25)

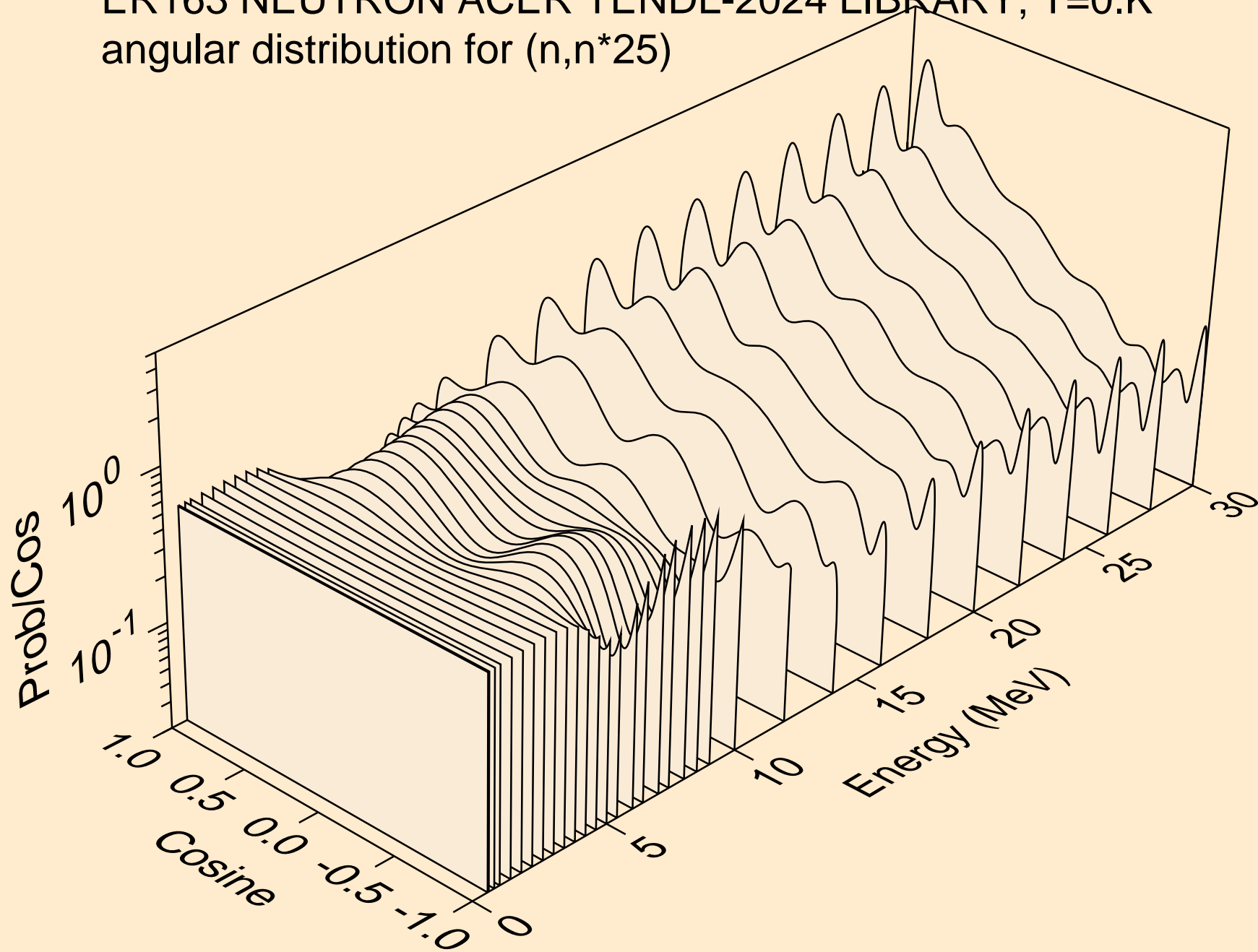

ER163 NEUTRON ACER TENDL-2024 LIBRARY; T=0.K  
angular distribution for (n,n\*26)

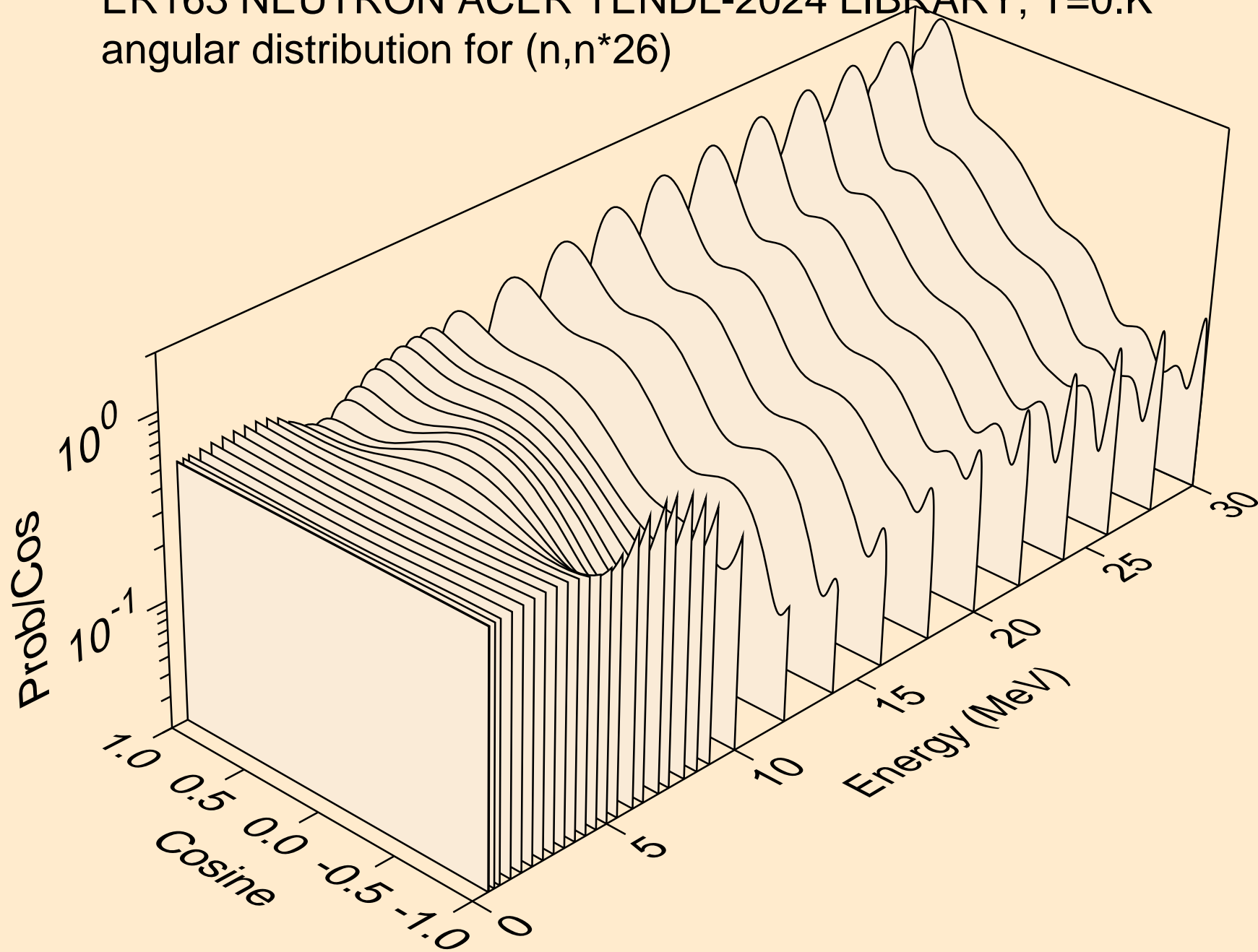

ER163 NEUTRON ACER TENDL-2024 LIBRARY; T=0.K  
angular distribution for (n,n\*27)

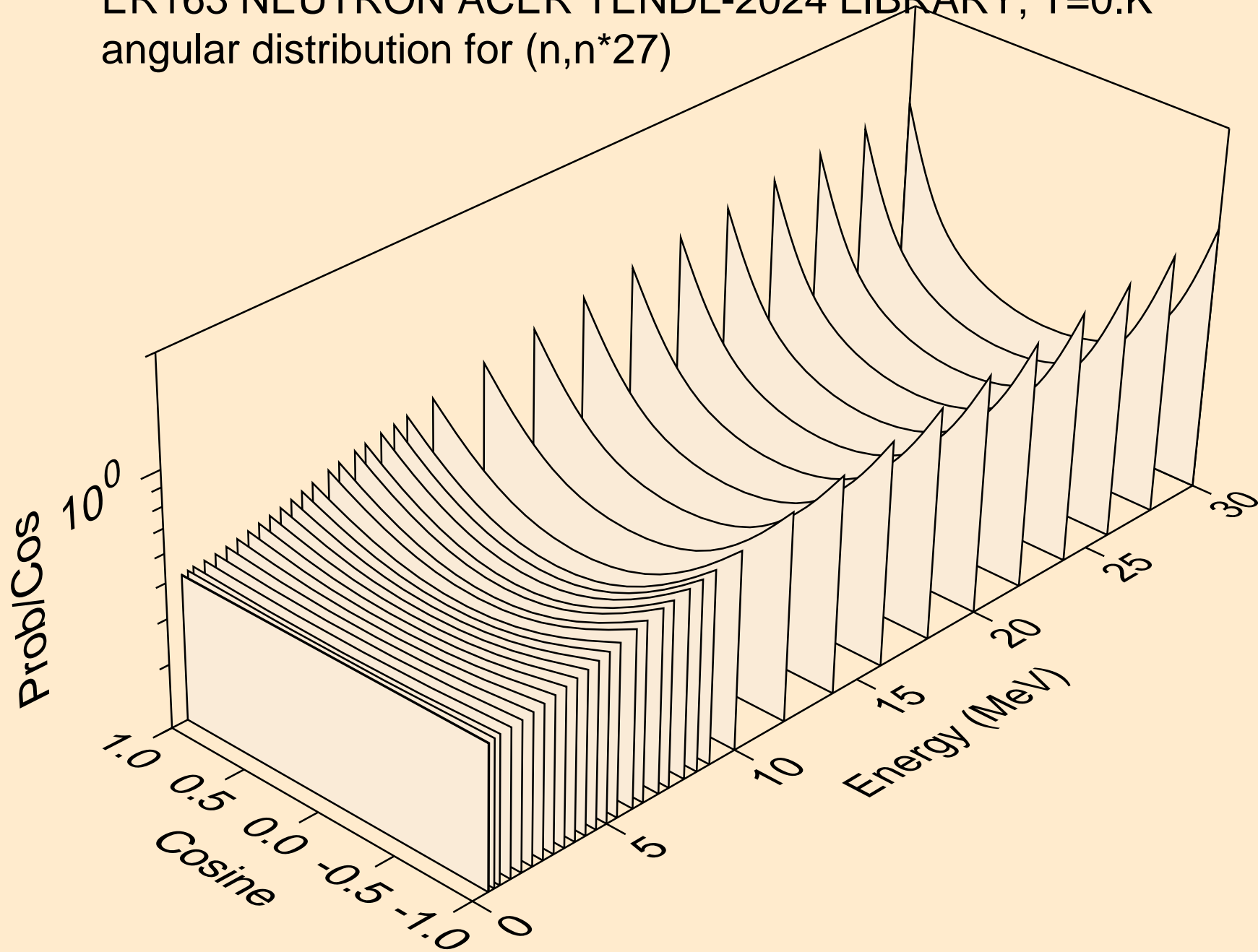

ER163 NEUTRON ACER TENDL-2024 LIBRARY; T=0.K  
angular distribution for (n,n\*28)

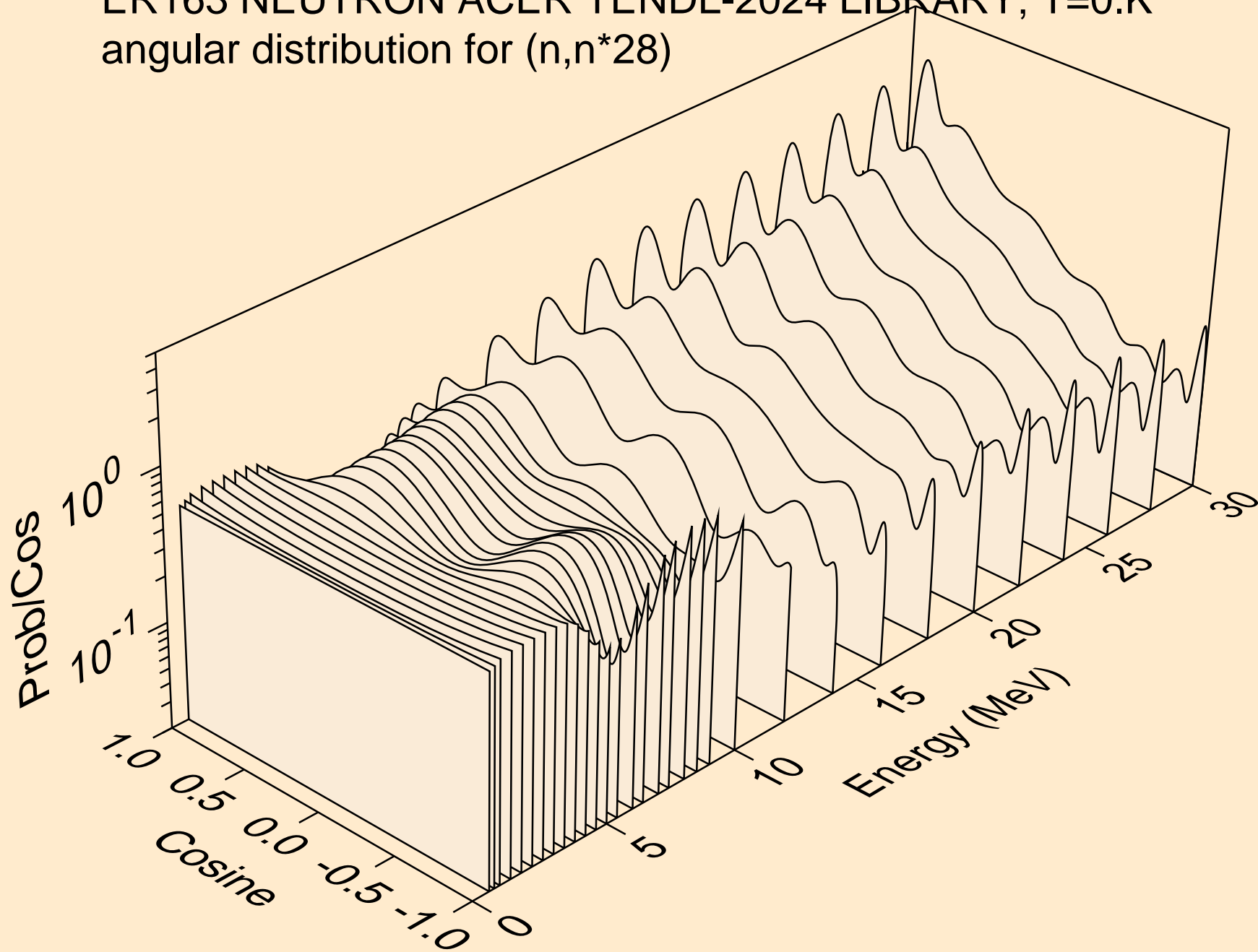

ER163 NEUTRON ACER TENDL-2024 LIBRARY; T=0.K  
angular distribution for (n,n\*29)

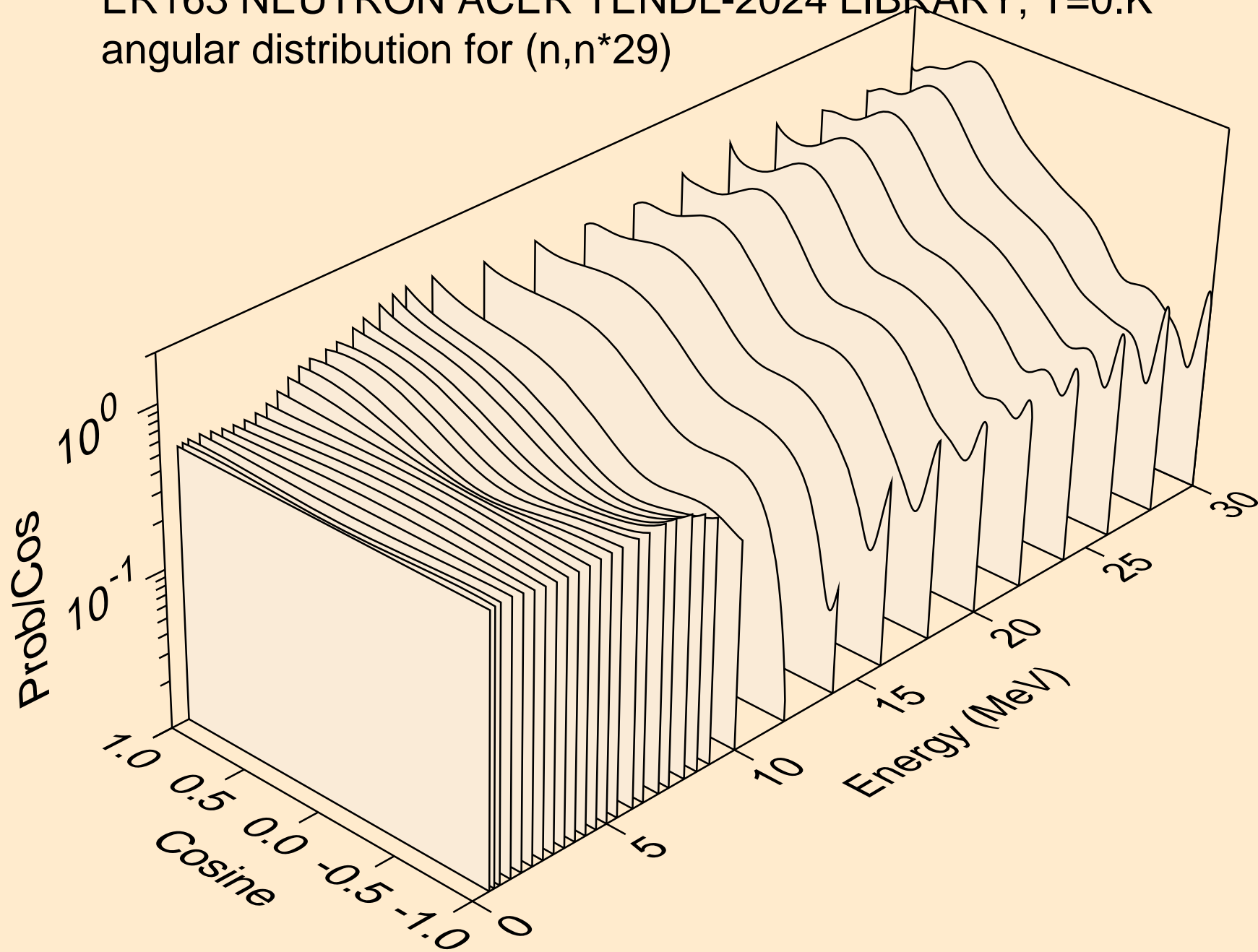

ER163 NEUTRON ACER TENDL-2024 LIBRARY; T=0.K  
angular distribution for (n,n\*30)

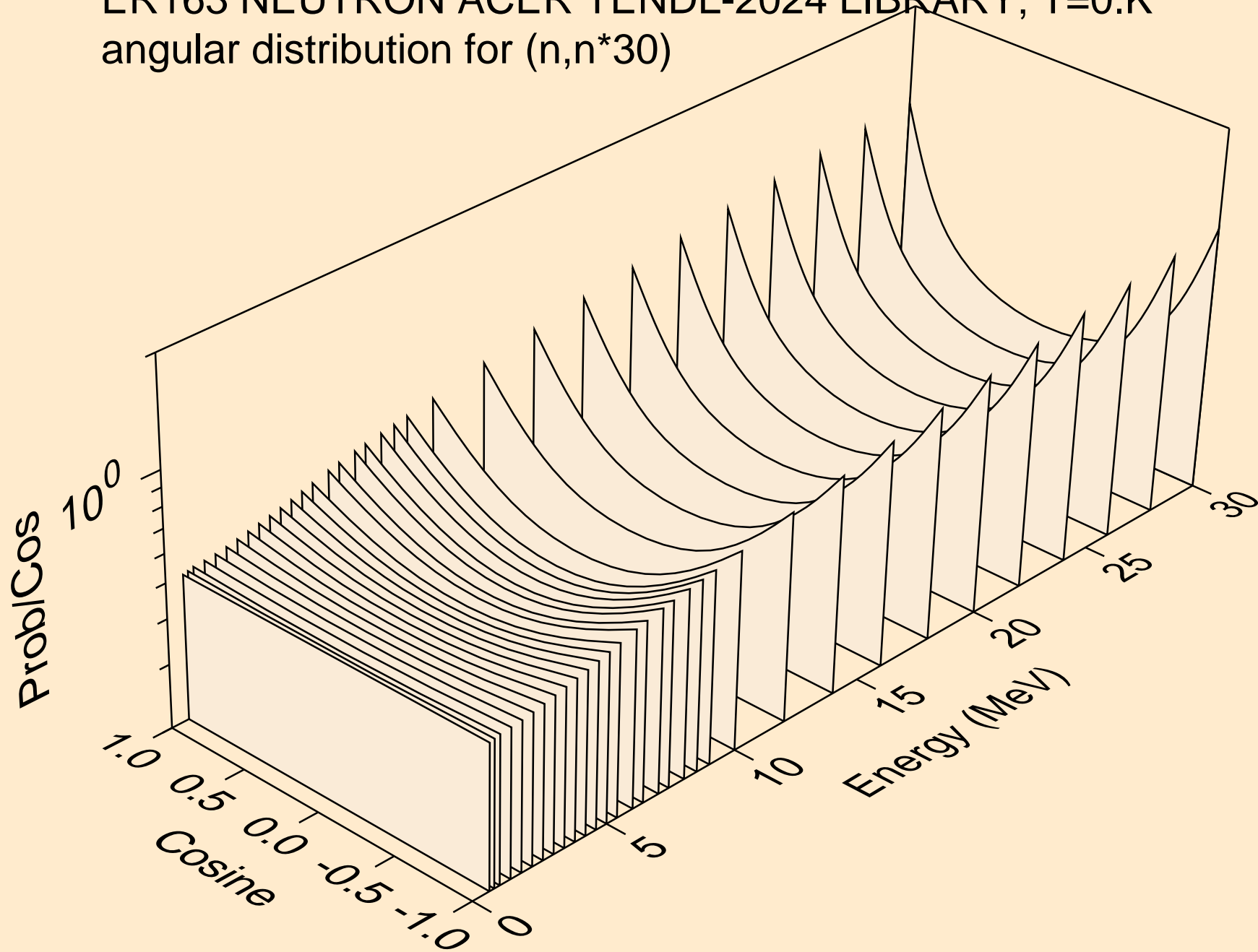

ER163 NEUTRON ACER TENDL-2024 LIBRARY; T=0.K  
Neutron emission for (n,x)

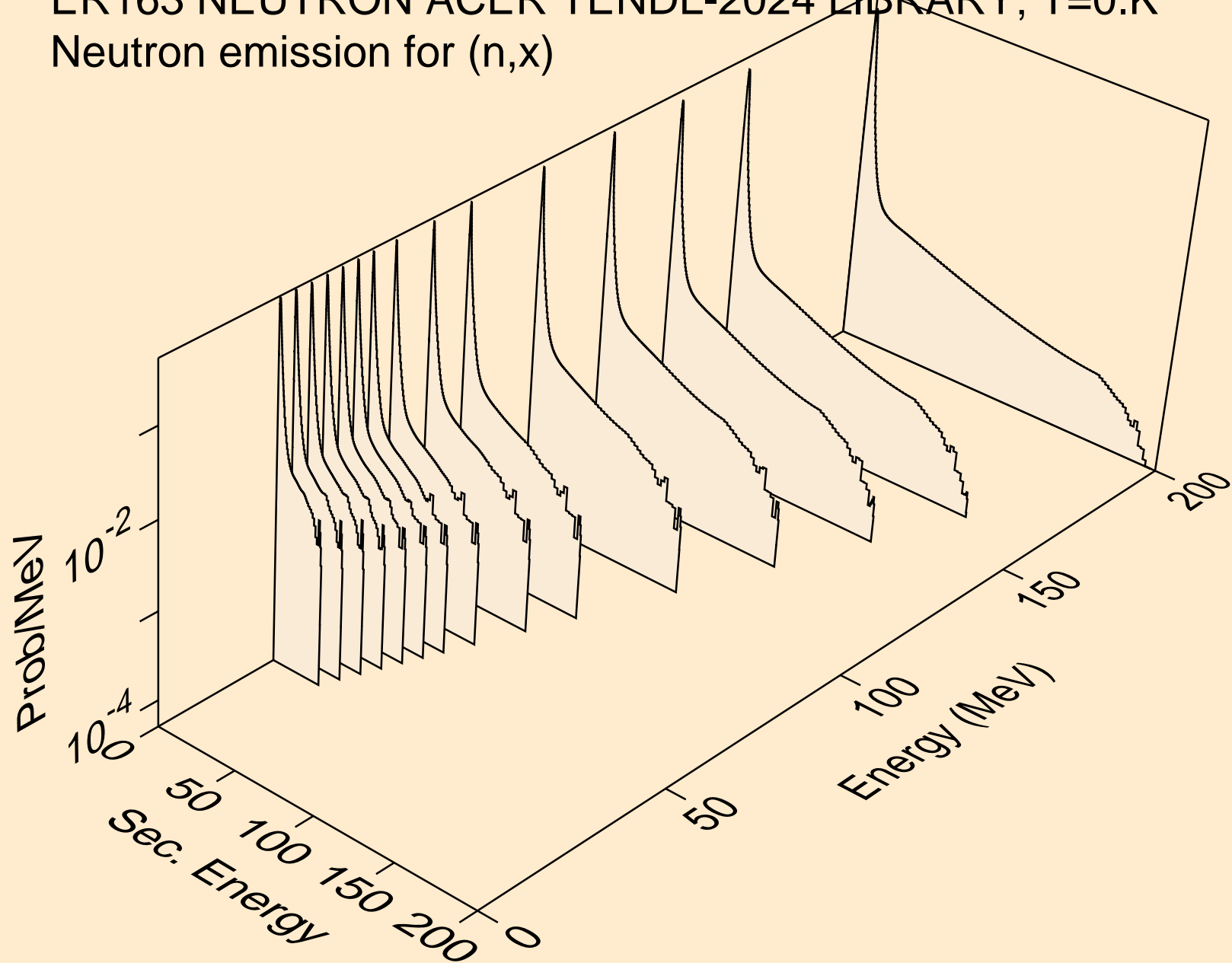

ER163 NEUTRON ACER TENDL-2024 LIBRARY; T=0.K  
Neutron emission for (n,2nd)

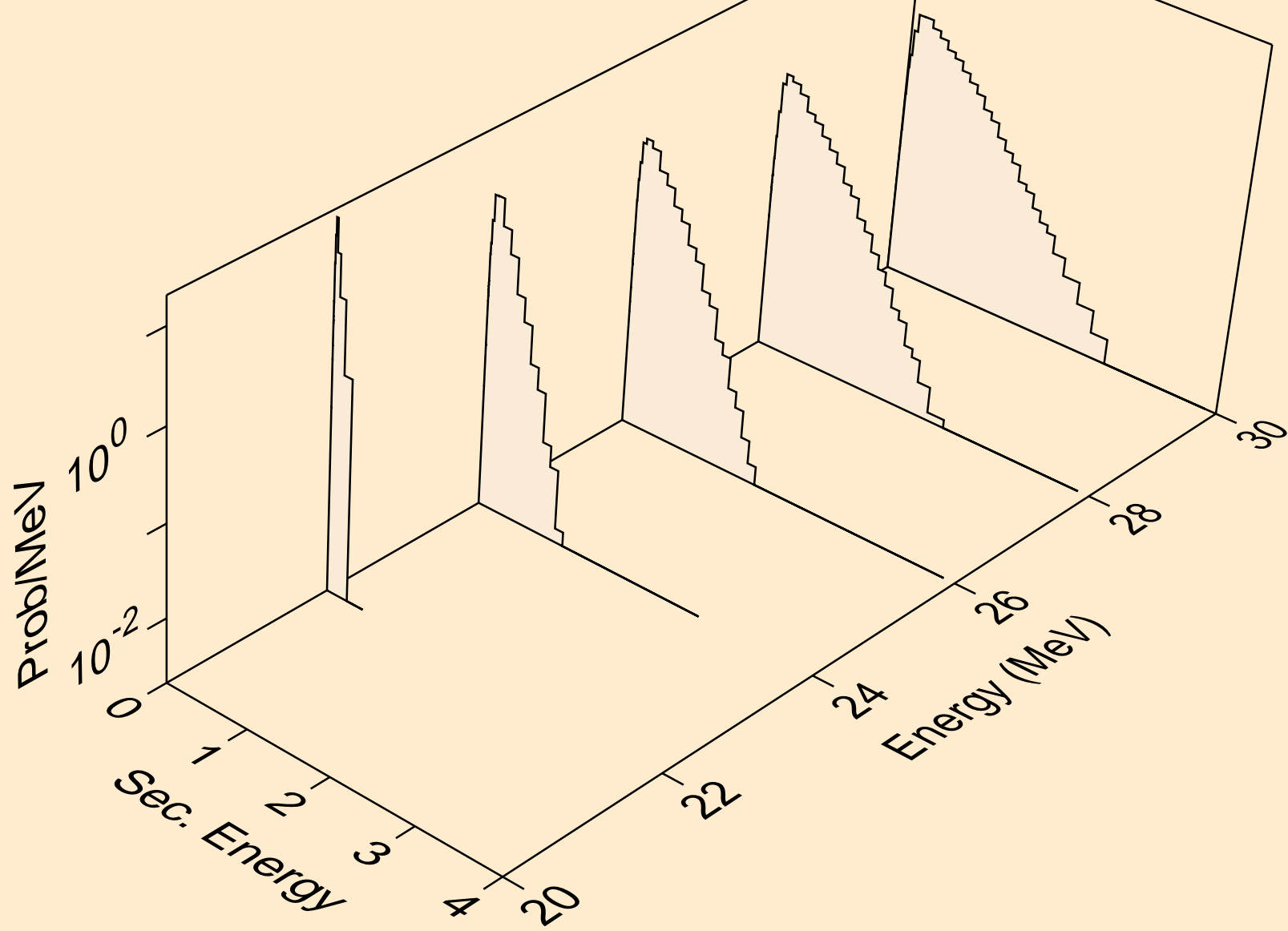



ER163 NEUTRON ACER TENDL-2024 LIBRARY; T=0.K  
Neutron emission for (n,2n)

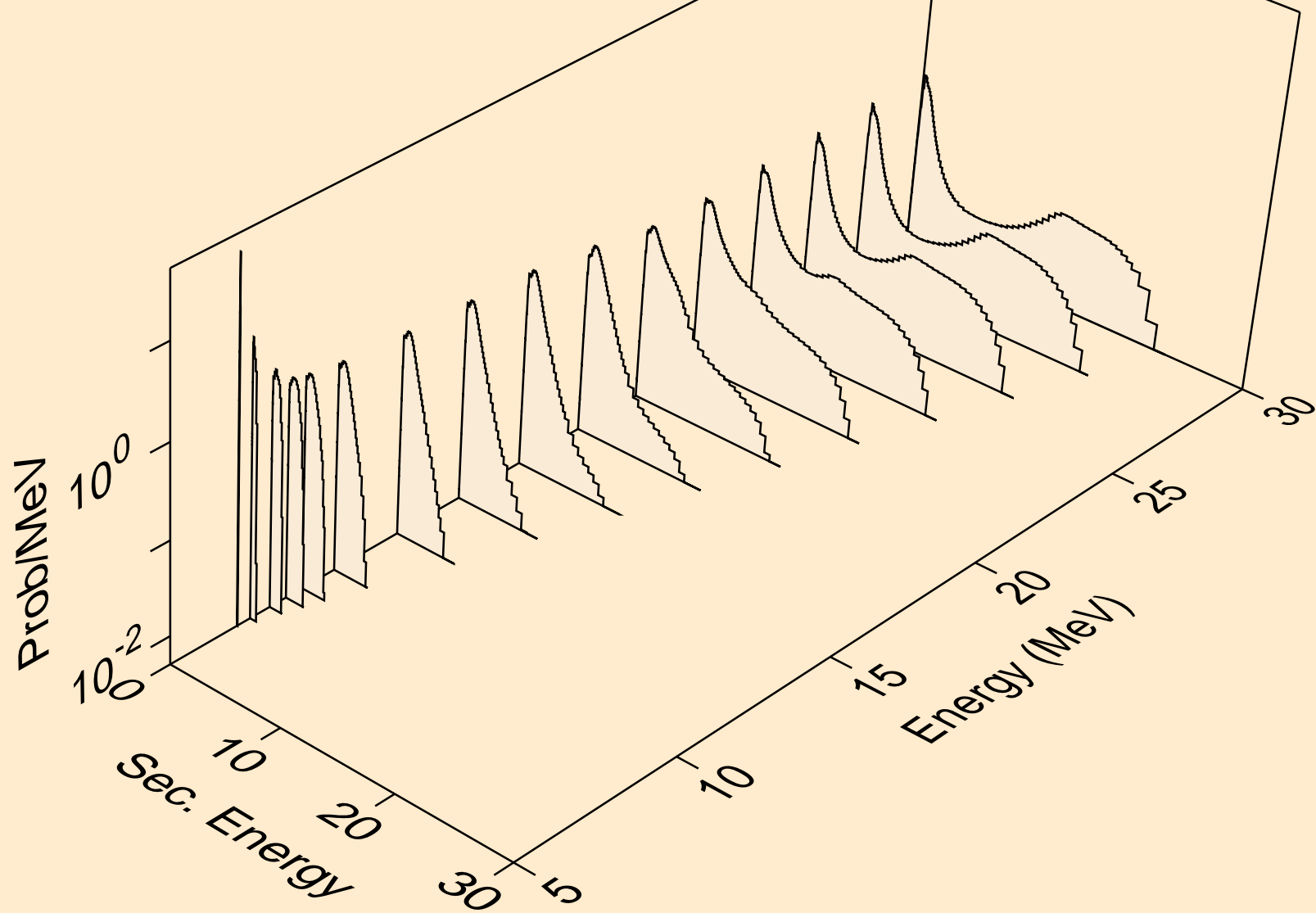

ER163 NEUTRON ACER TENDL-2024 LIBRARY; T=0.K  
Neutron emission for (n,3n)

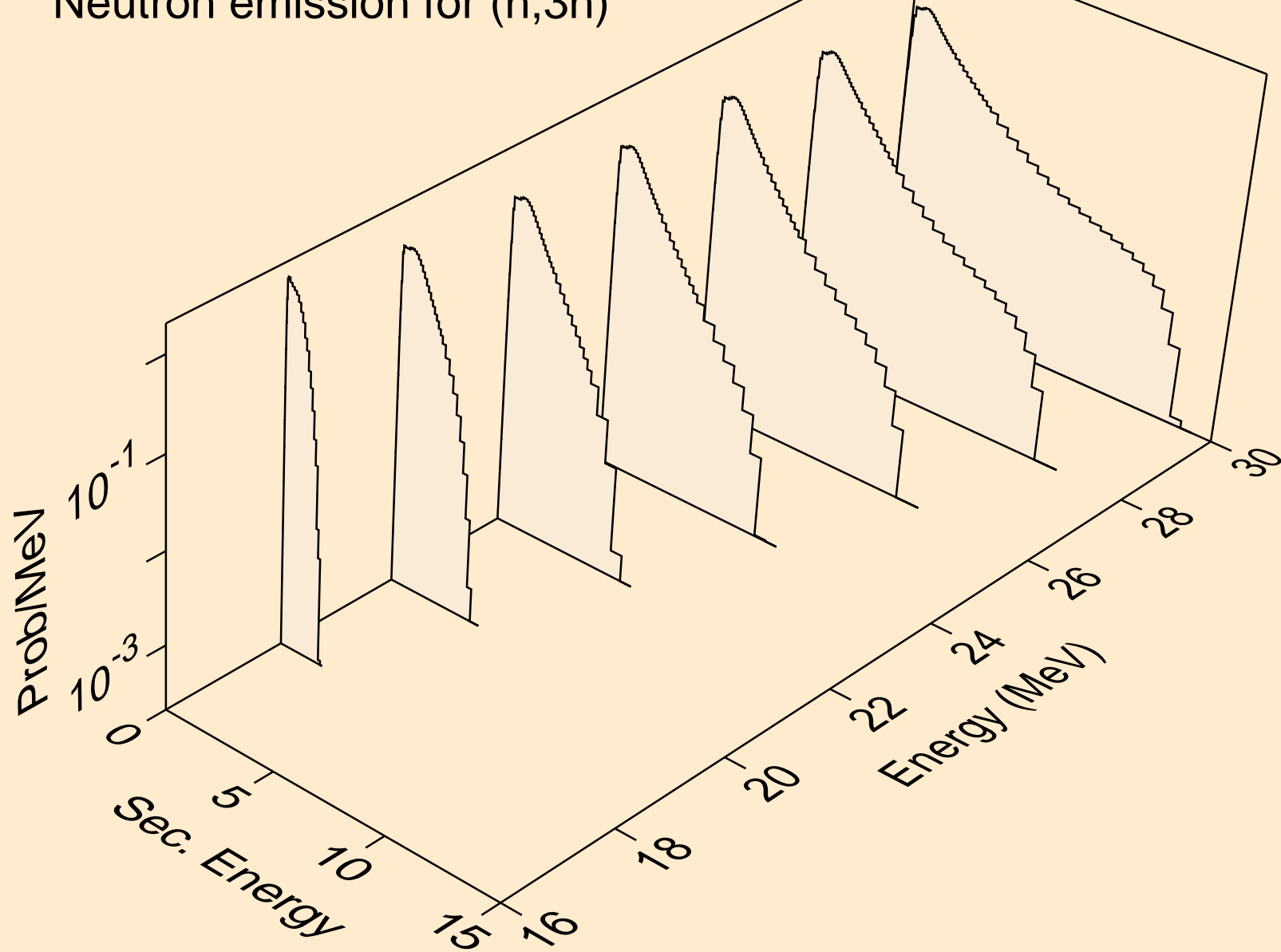

ER163 NEUTRON ACER TENDL-2024 LIBRARY; T=0.K  
Neutron emission for (n,n\*)a

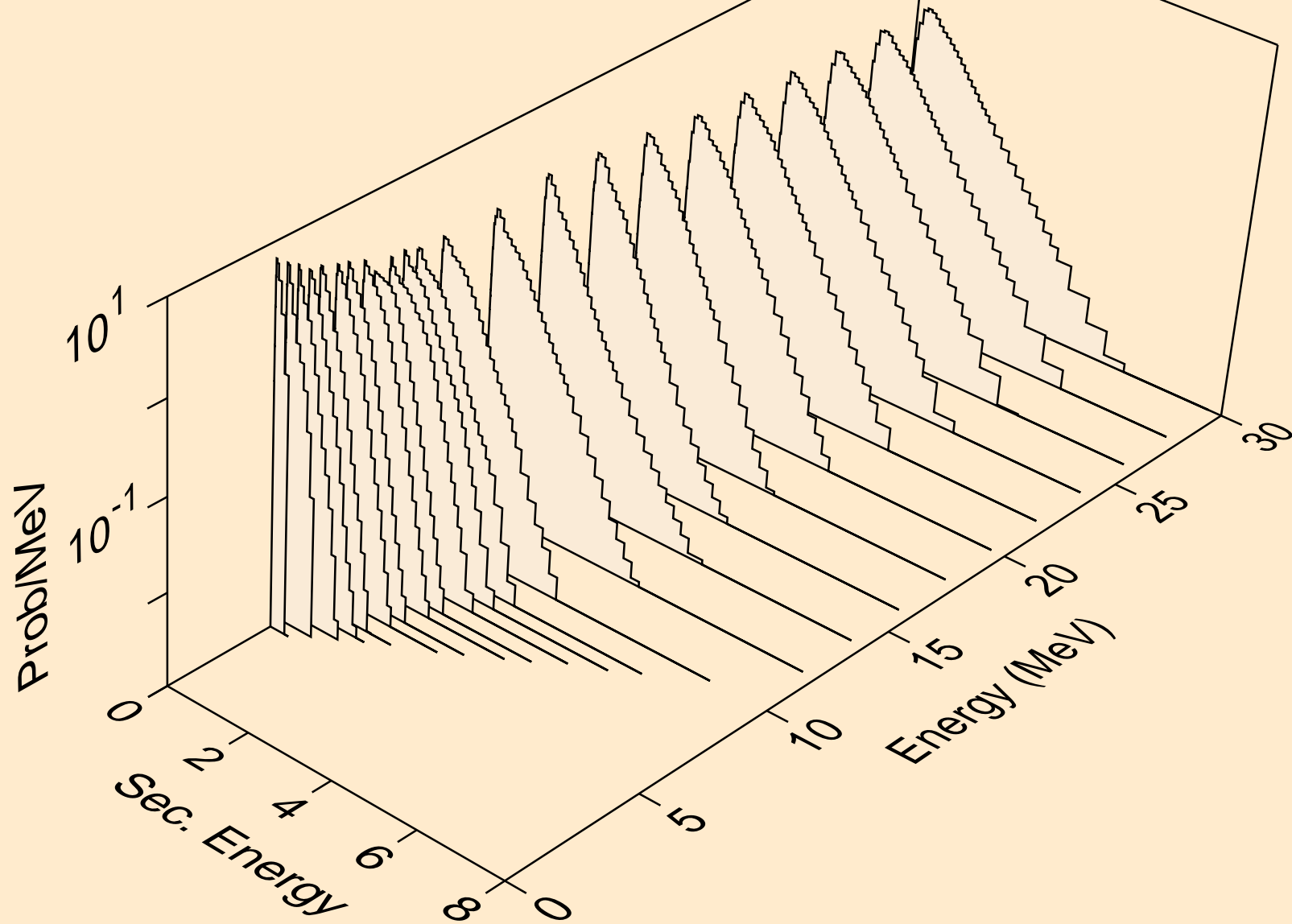

ER163 NEUTRON ACER TENDL-2024 LIBRARY; T=0.K  
Neutron emission for (n,2n)a

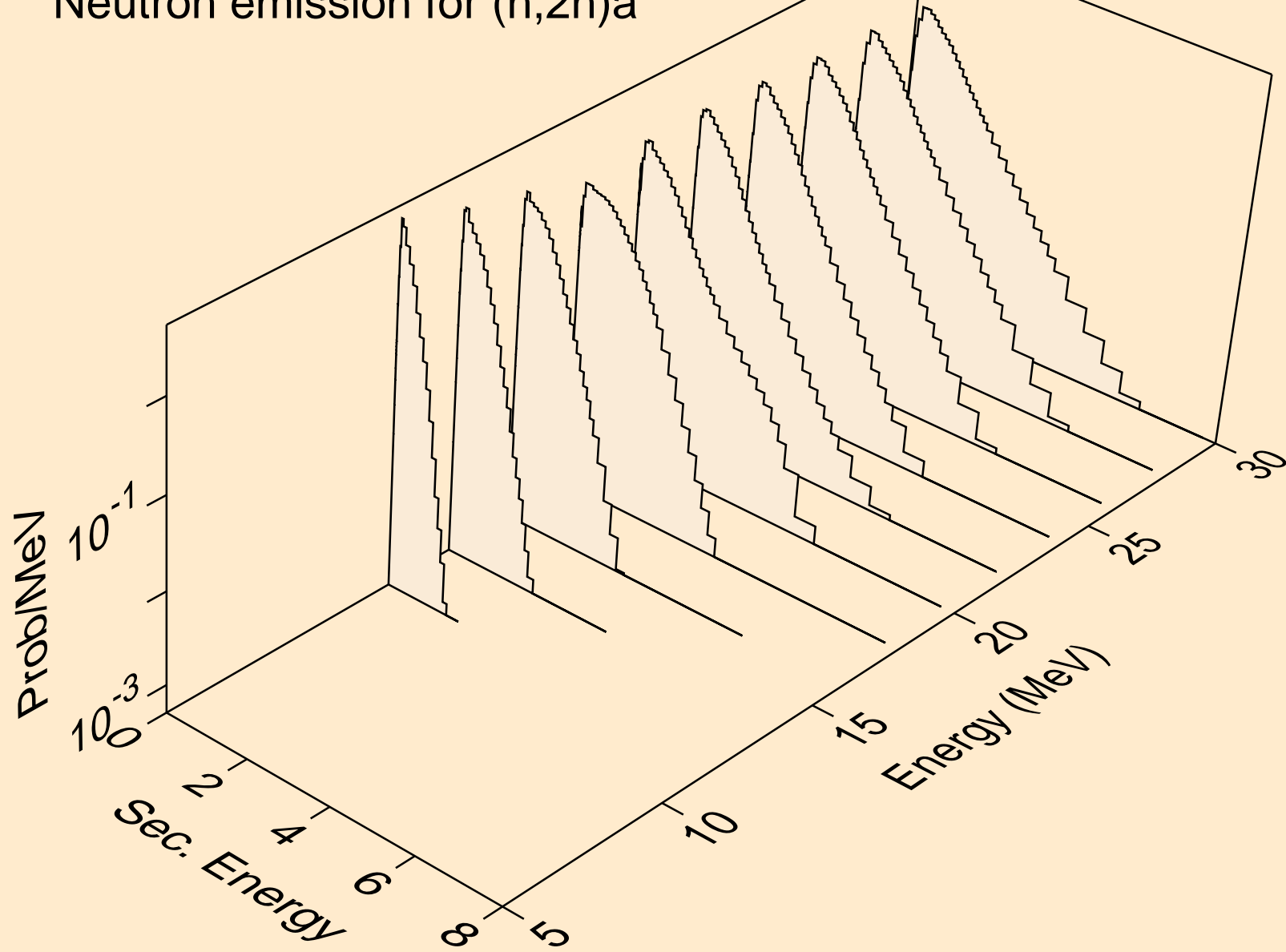

ER163 NEUTRON ACER TENDL-2024 LIBRARY; T=0.K  
Neutron emission for (n,3n)a

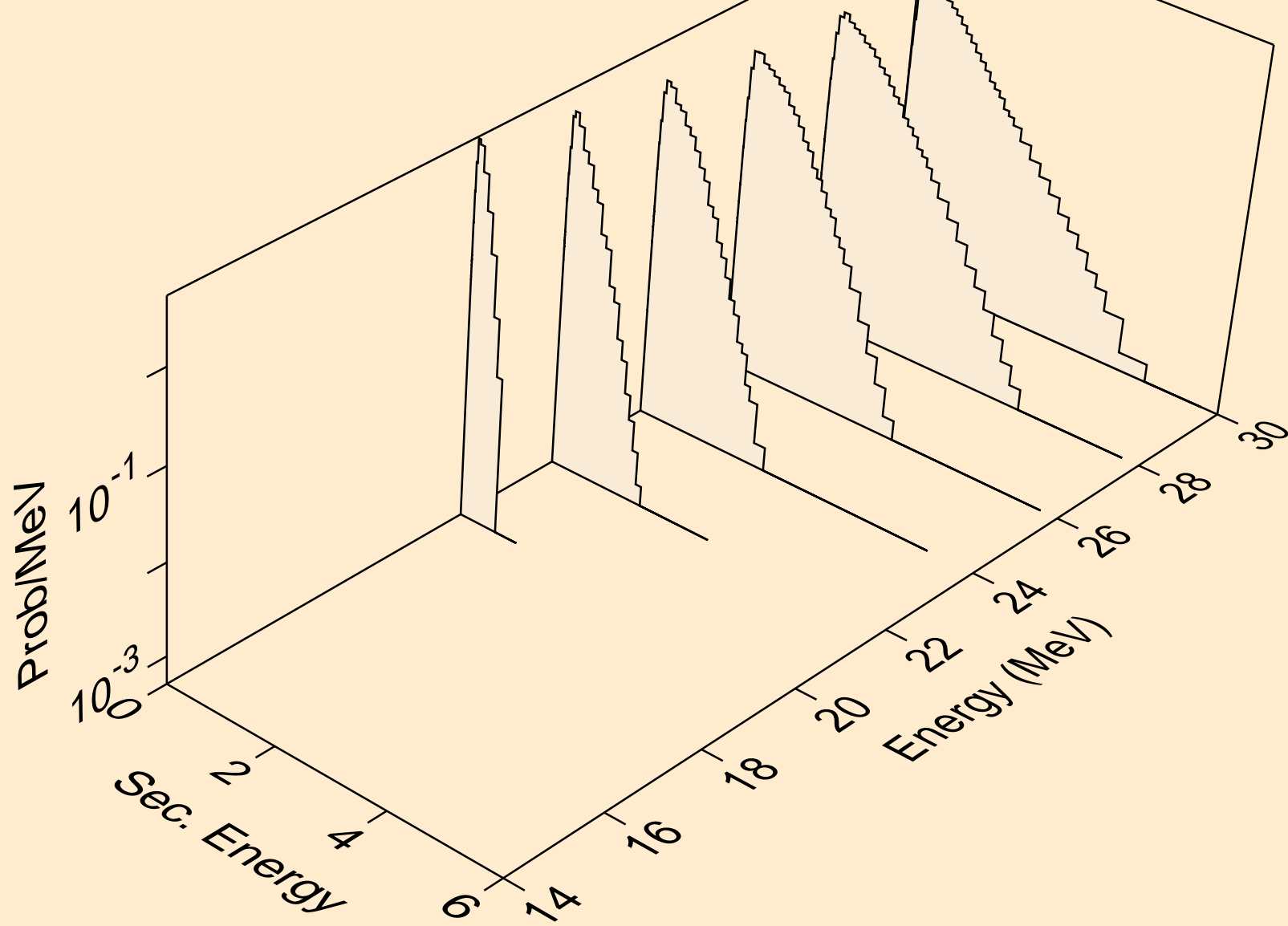

ER163 NEUTRON ACER TENDL-2024 LIBRARY; T=0.K  
Neutron emission for (n,n\*)p

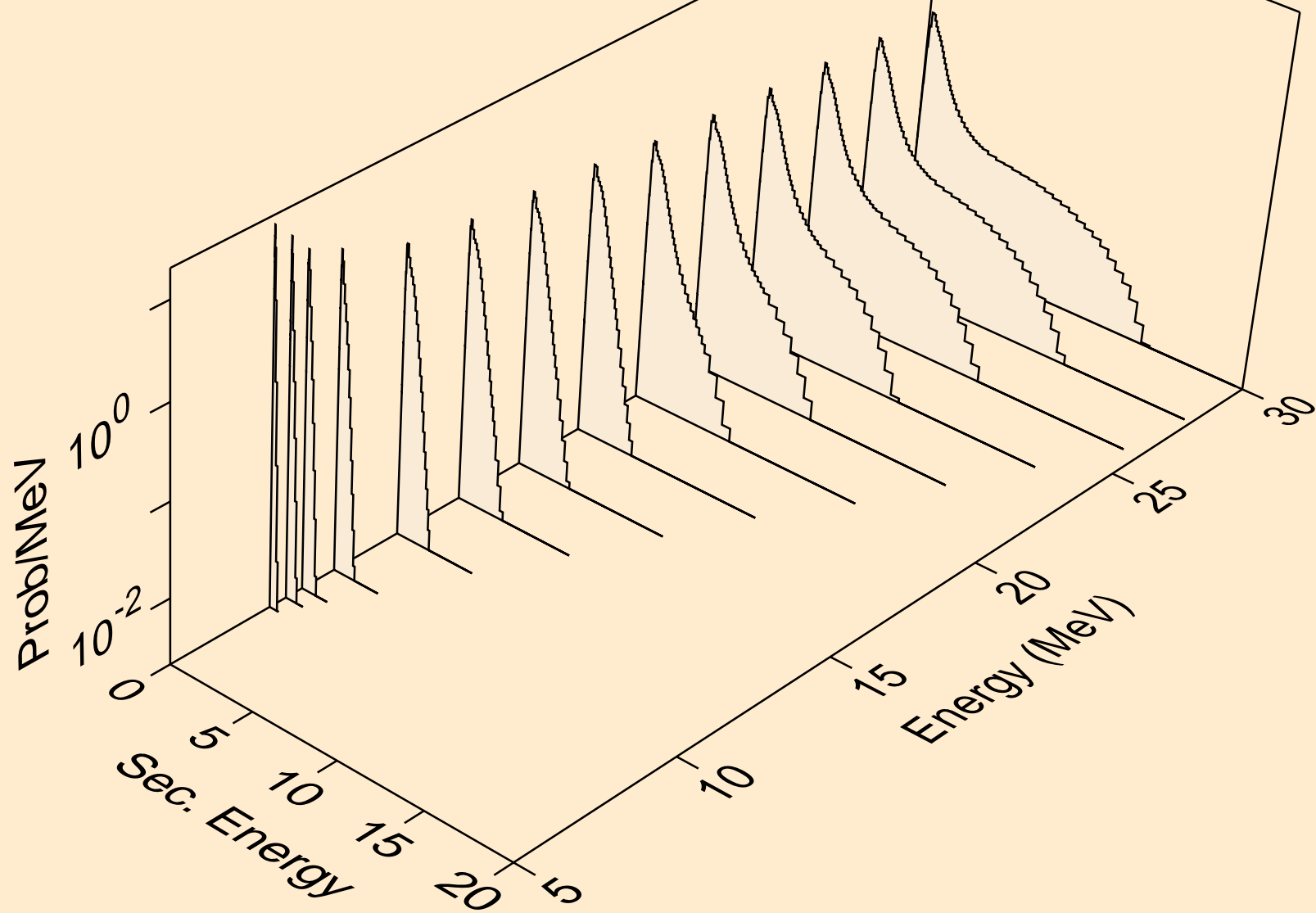

ER163 NEUTRON ACER TENDL-2024 LIBRARY; T=0.K  
Neutron emission for (n,n\*)2a

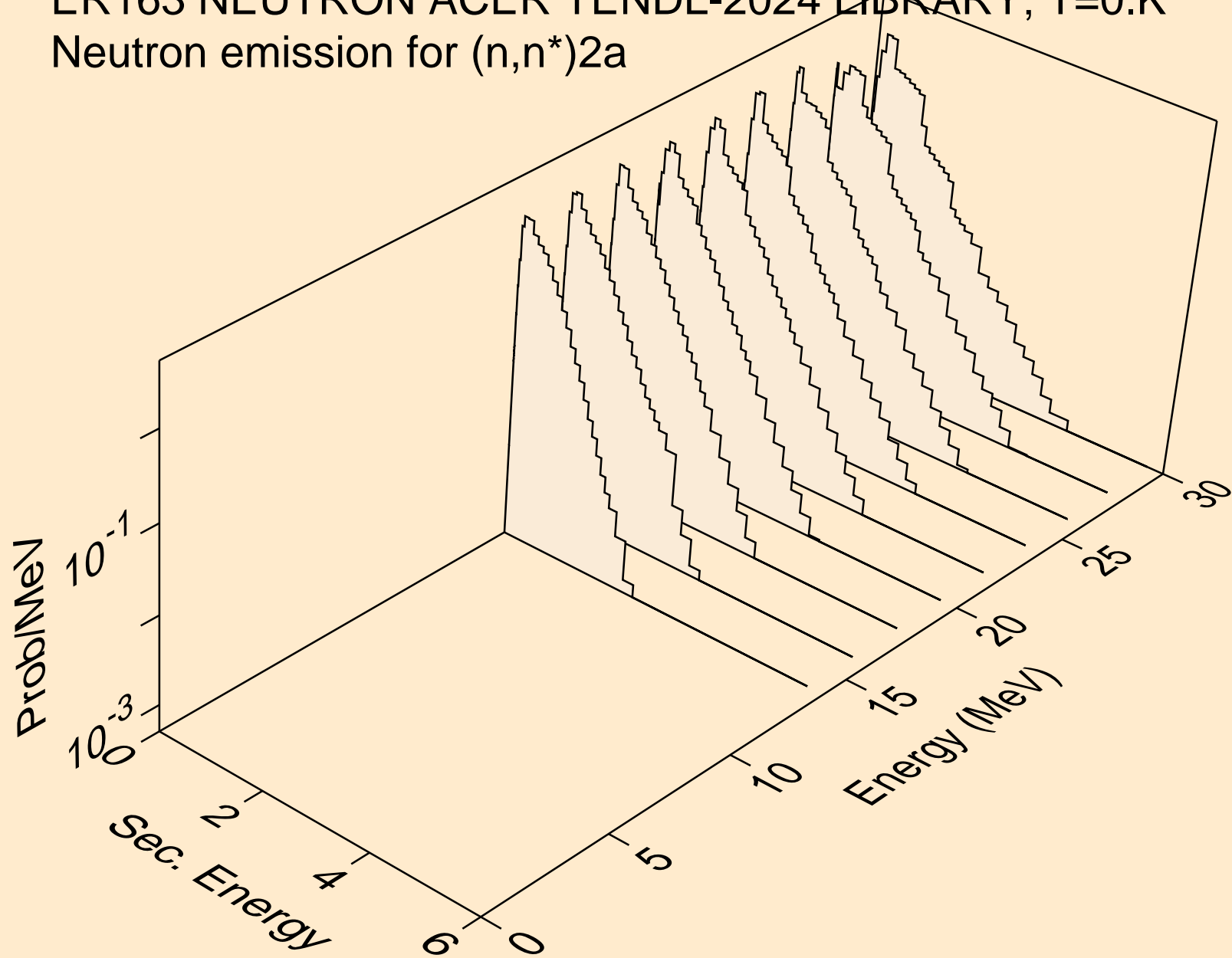

ER163 NEUTRON ACER TENDL-2024 LIBRARY; T=0.K  
Neutron emission for (n,n\*)d

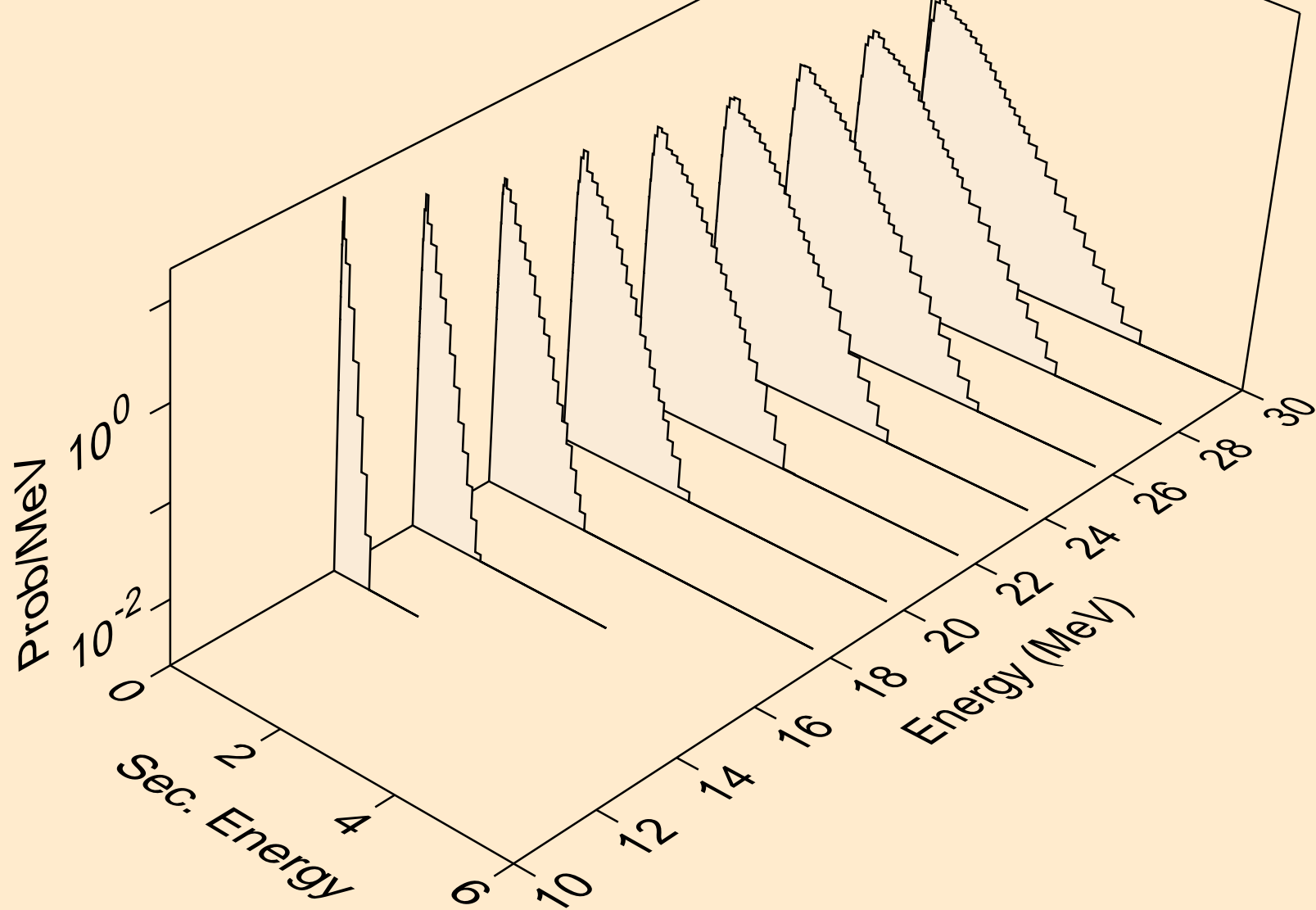



ER163 NEUTRON ACER TENDL-2024 LIBRARY; T=0.K  
Neutron emission for (n,n\*)t

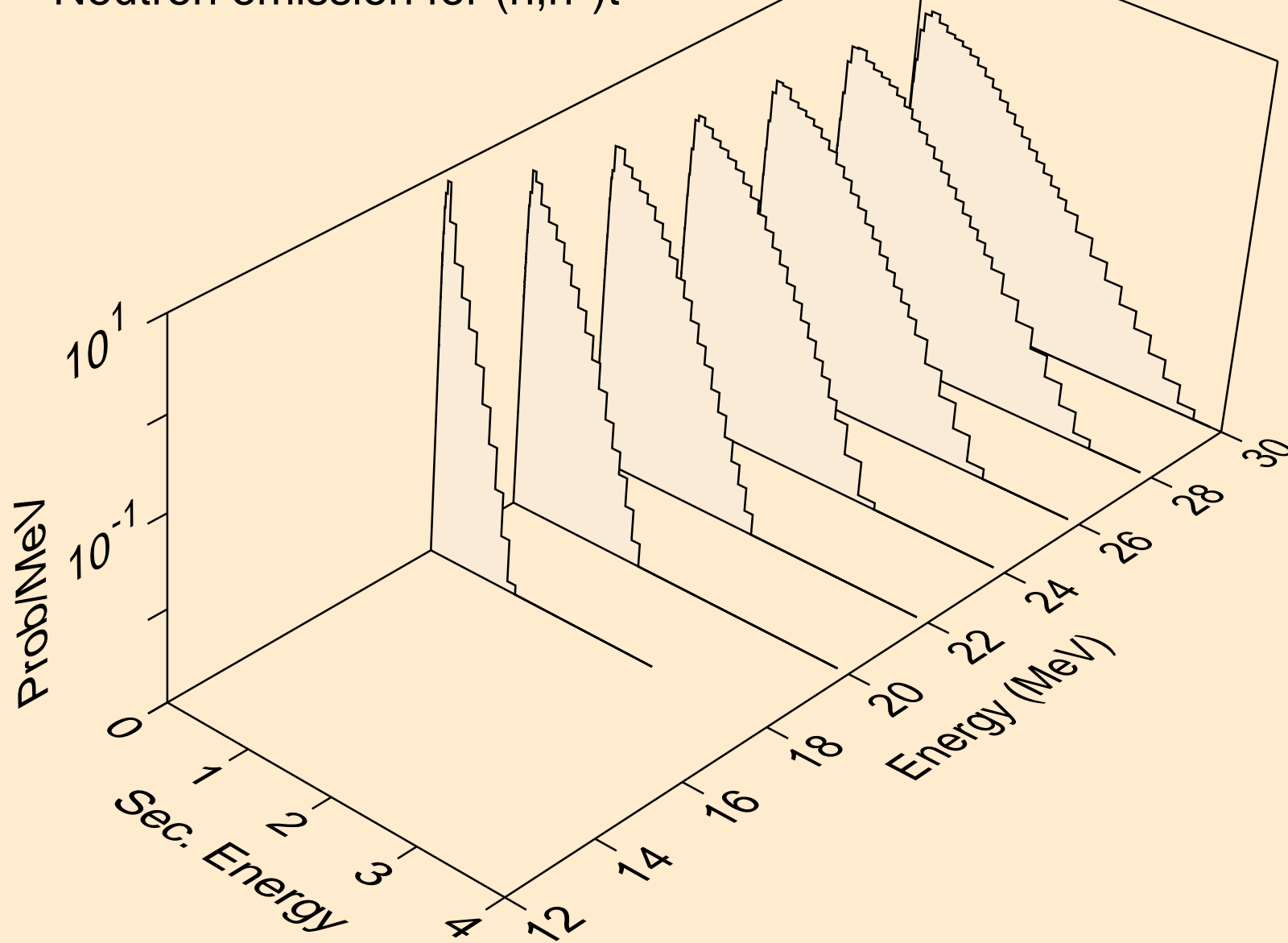

ER163 NEUTRON ACER TENDL-2024 LIBRARY; T=0.K  
Neutron emission for (n,n\*)he3

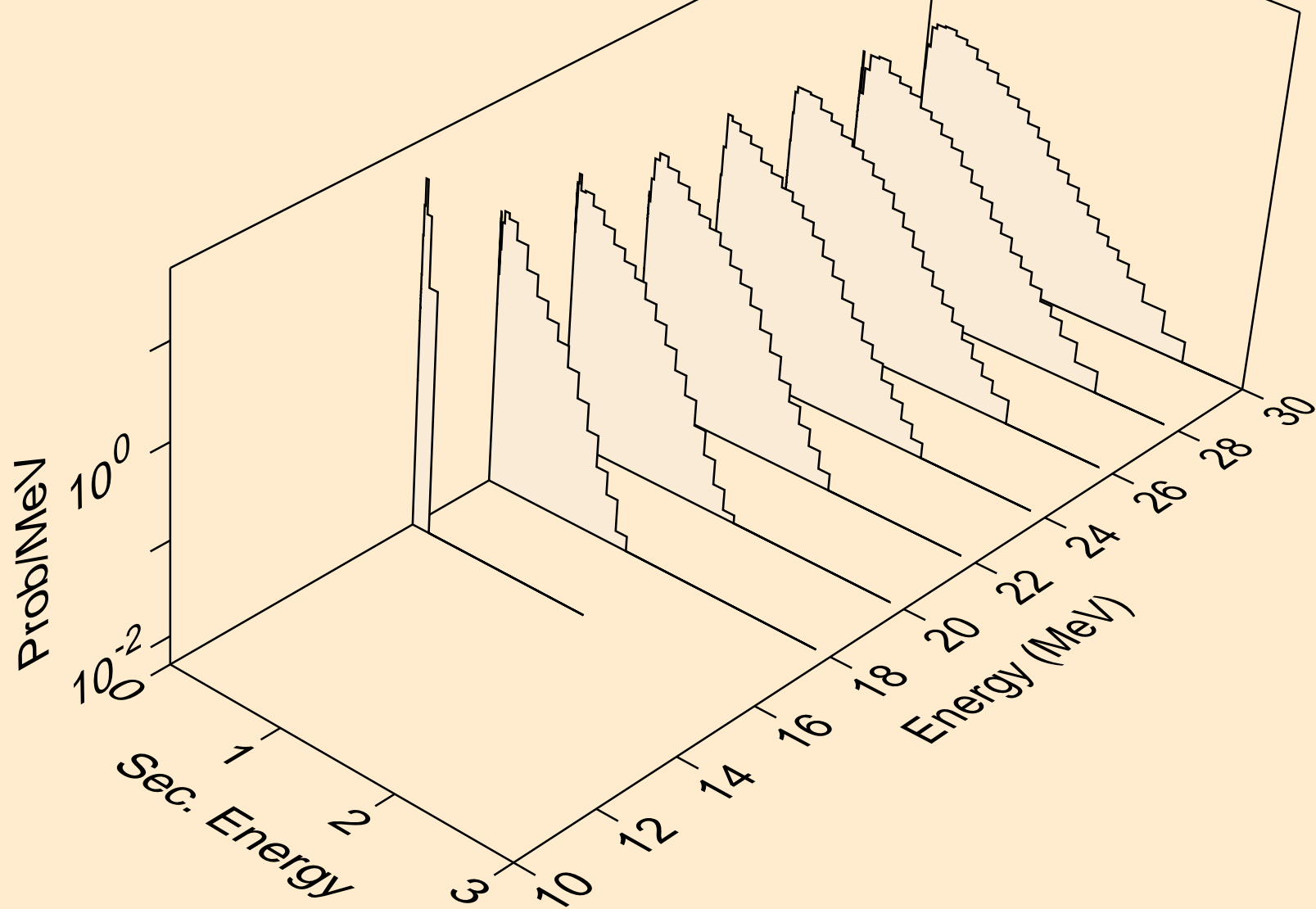

ER163 NEUTRON ACER TENDL-2024 LIBRARY; T=0.K  
Neutron emission for (n,4n)

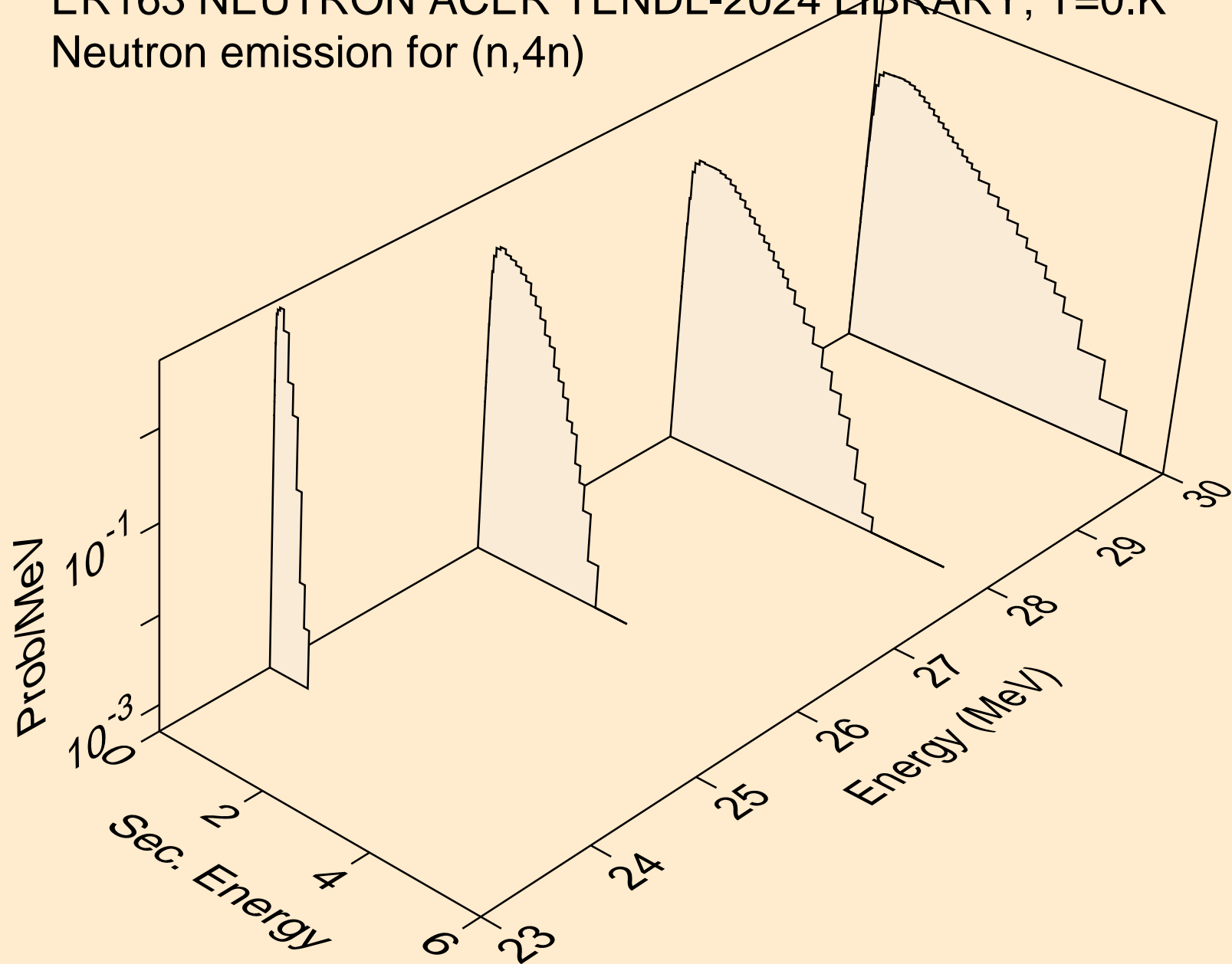

ER163 NEUTRON ACER TENDL-2024 LIBRARY; T=0.K  
Neutron emission for (n,2np)

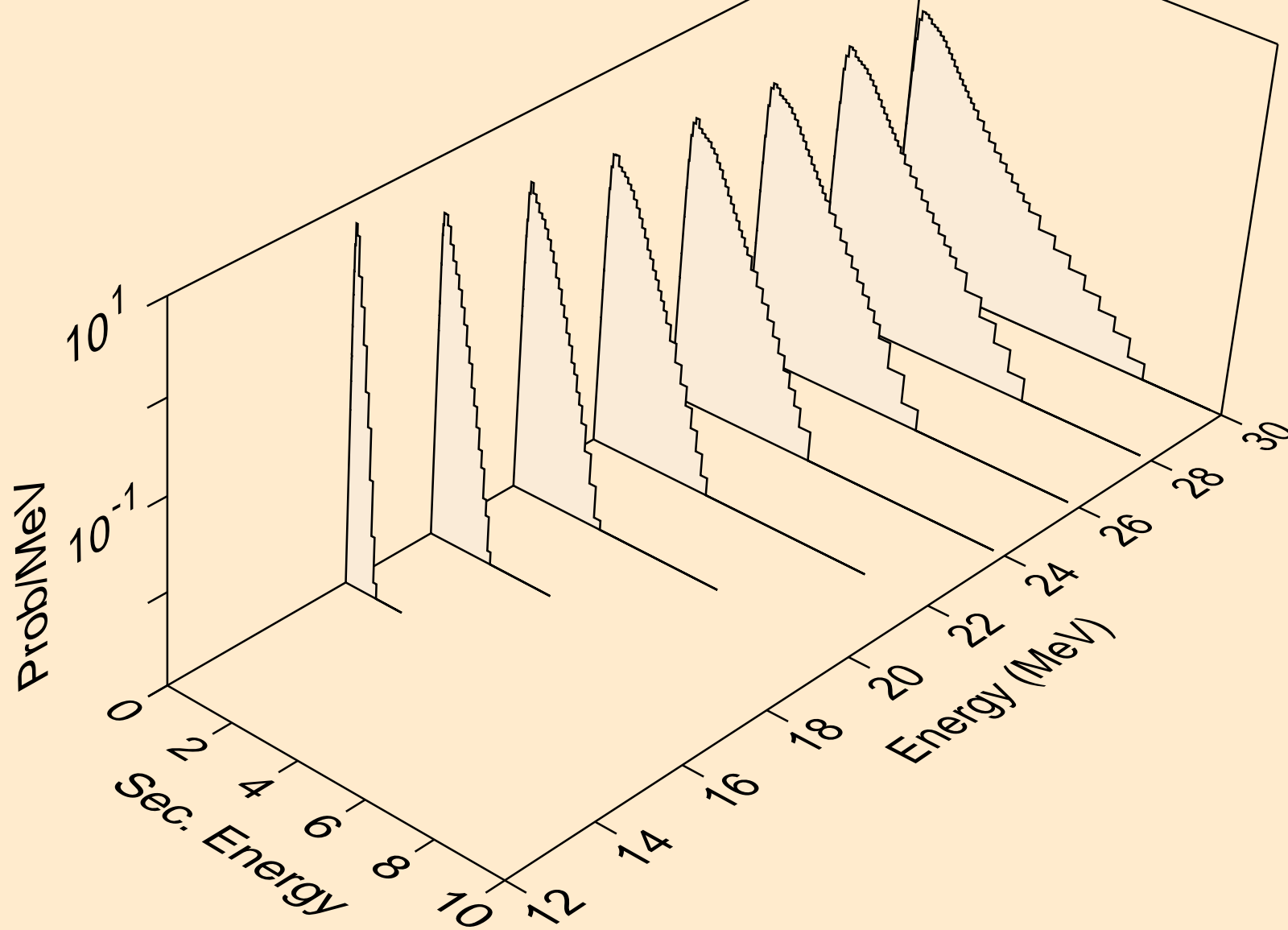

ER163 NEUTRON ACER TENDL-2024 LIBRARY; T=0.K  
Neutron emission for (n,3np)

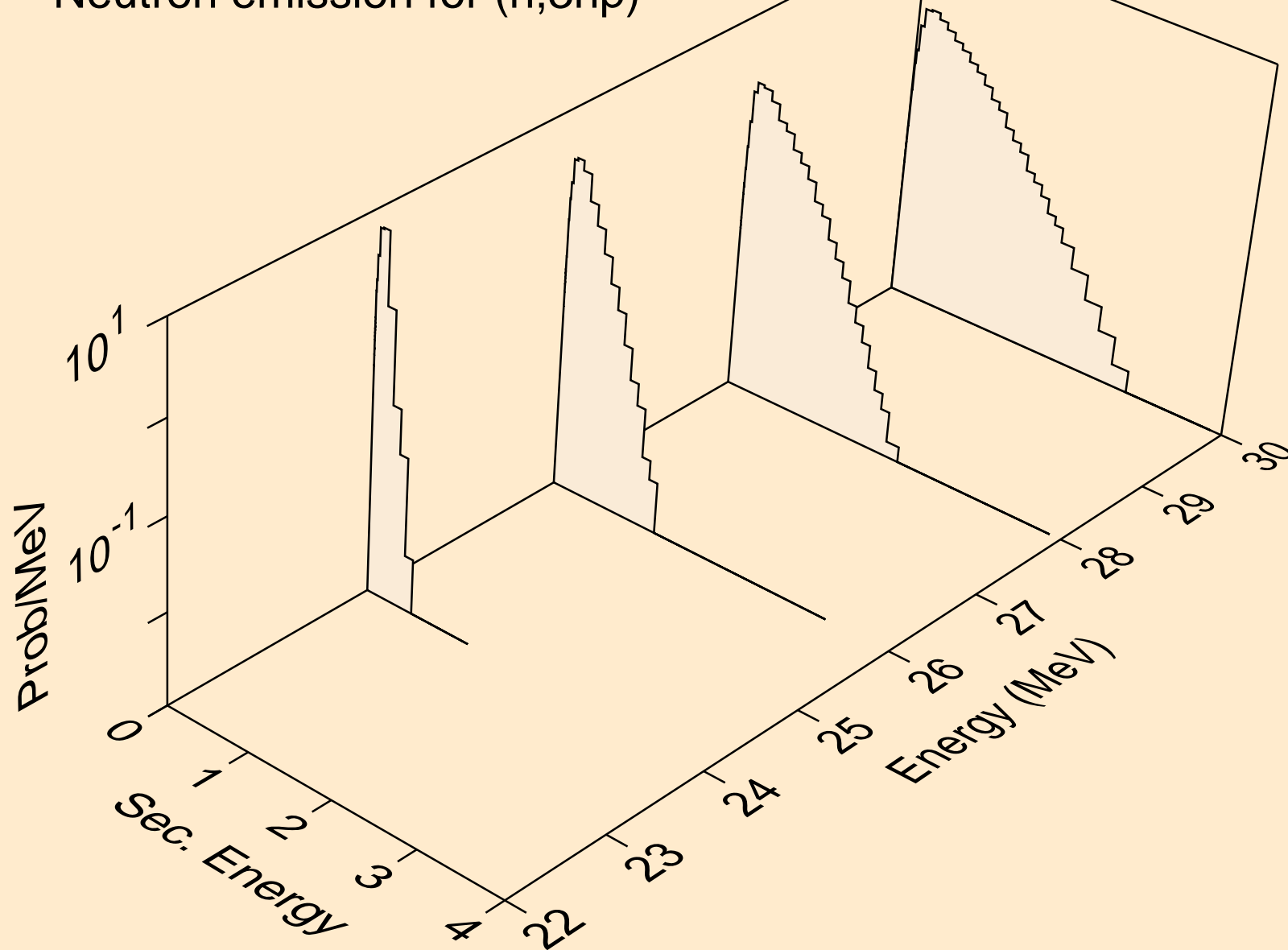

ER163 NEUTRON ACER TENDL-2024 LIBRARY; T=0.K  
Neutron emission for (n,n2p)

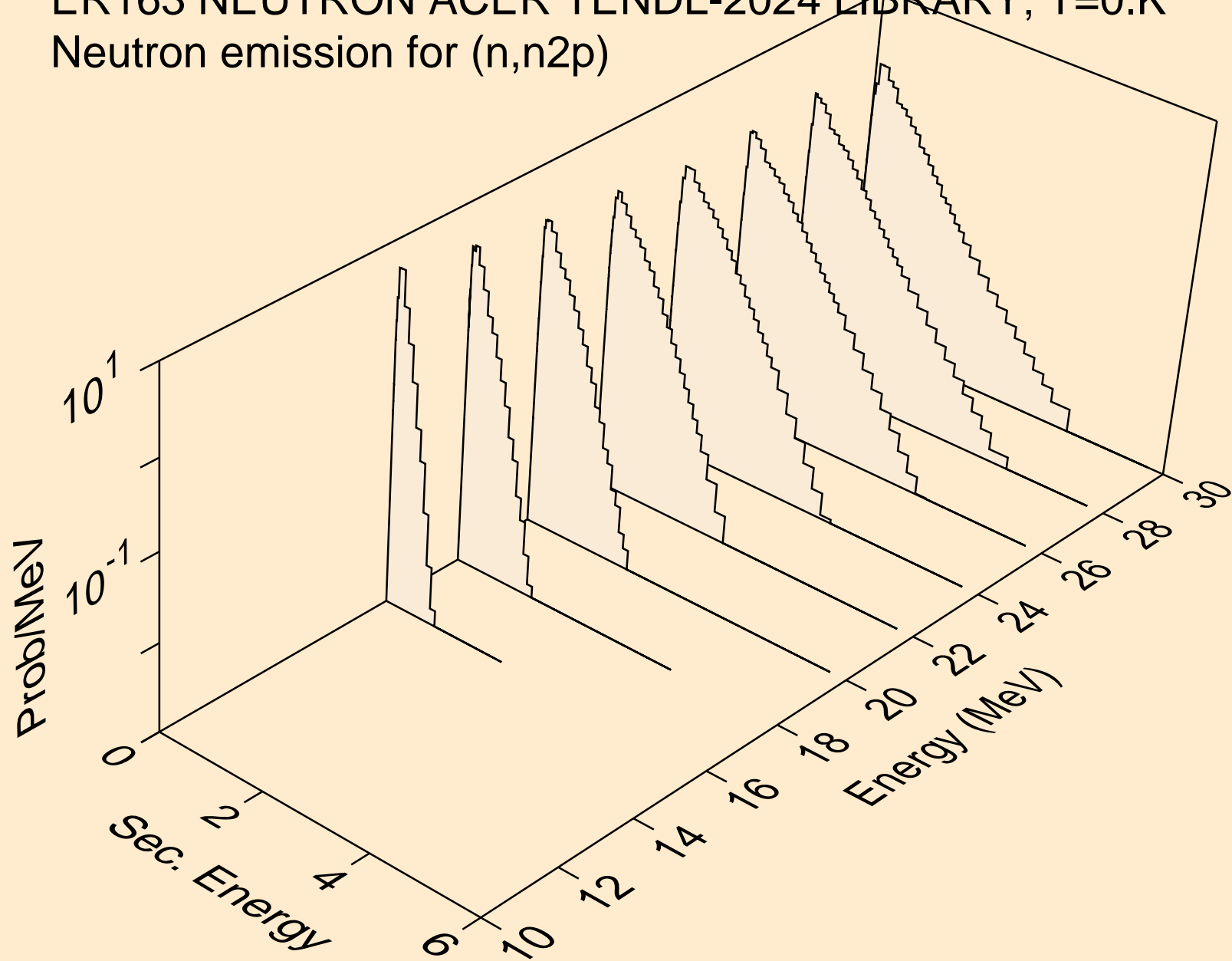

ER163 NEUTRON ACER TENDL-2024 LIBRARY; T=0.K  
Neutron emission for (n,npa)

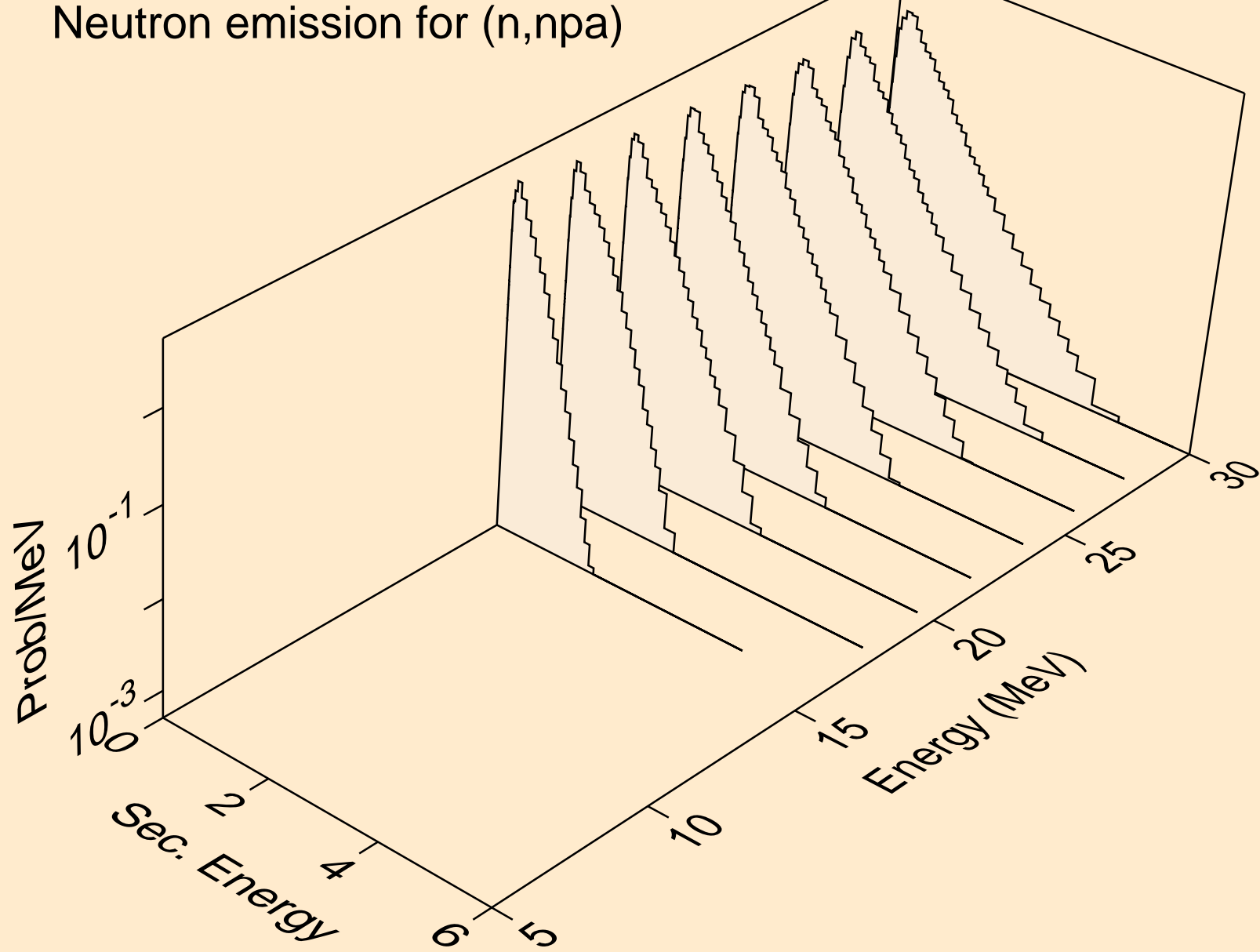

ER163 NEUTRON ACER TENDL-2024 LIBRARY; T=0.K  
Neutron emission for (n,n\*c)

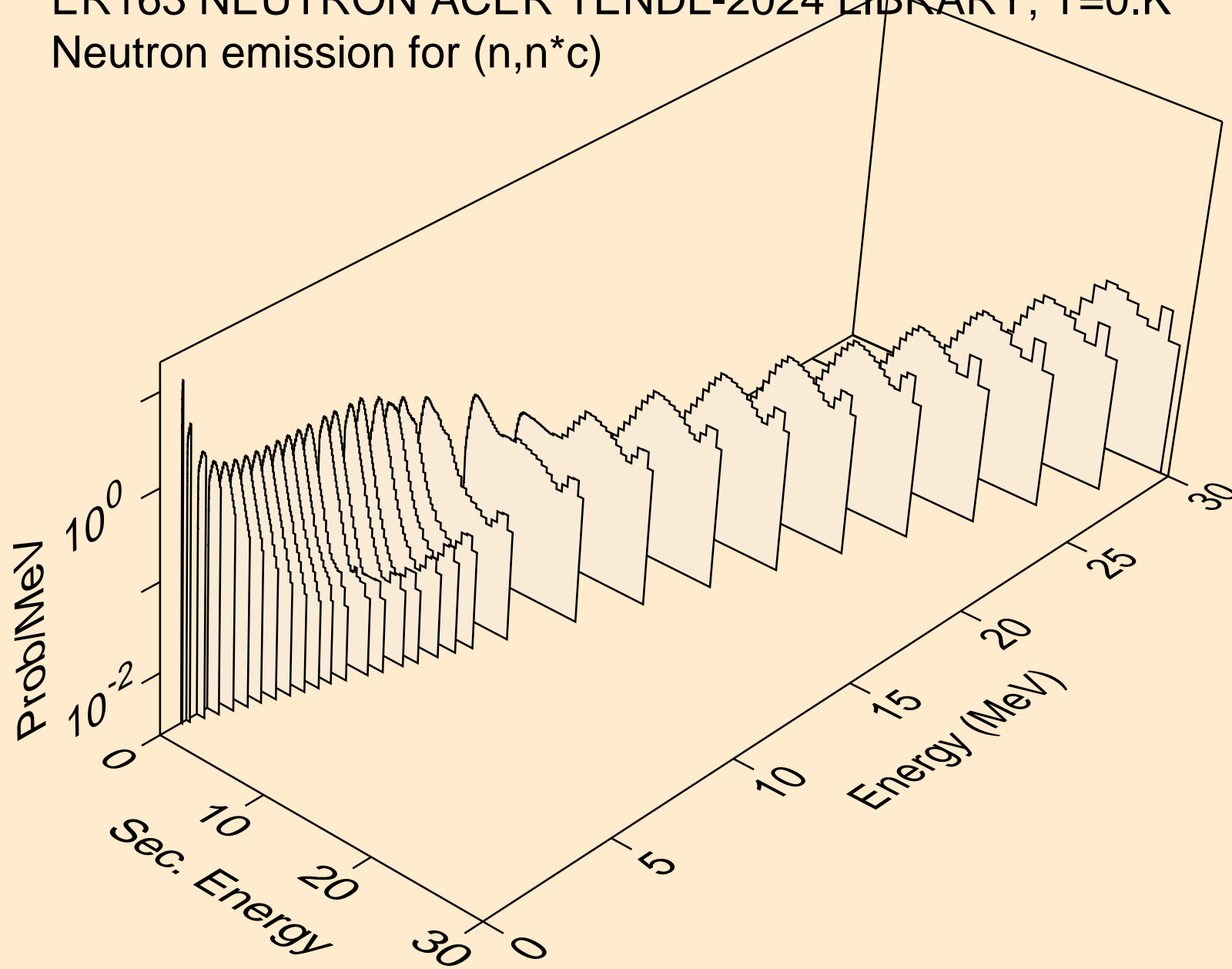



ER163 NEUTRON ACER TENDL-2024 LIBRARY; T=0.K  
Photon emission for (n,x)

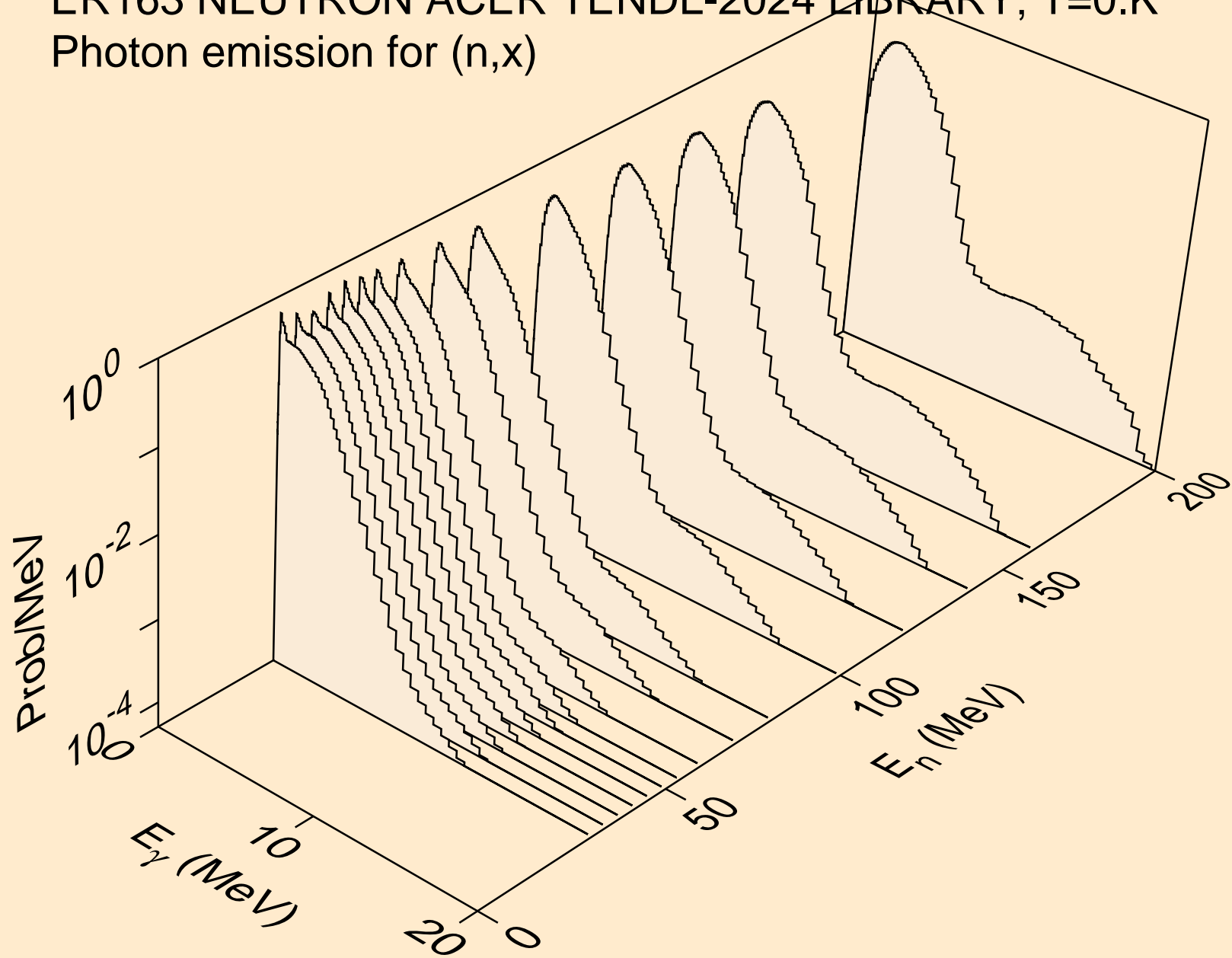

ER163 NEUTRON ACER TENDL-2024 LIBRARY; T=0.K  
Photon emission for (n,2nd)

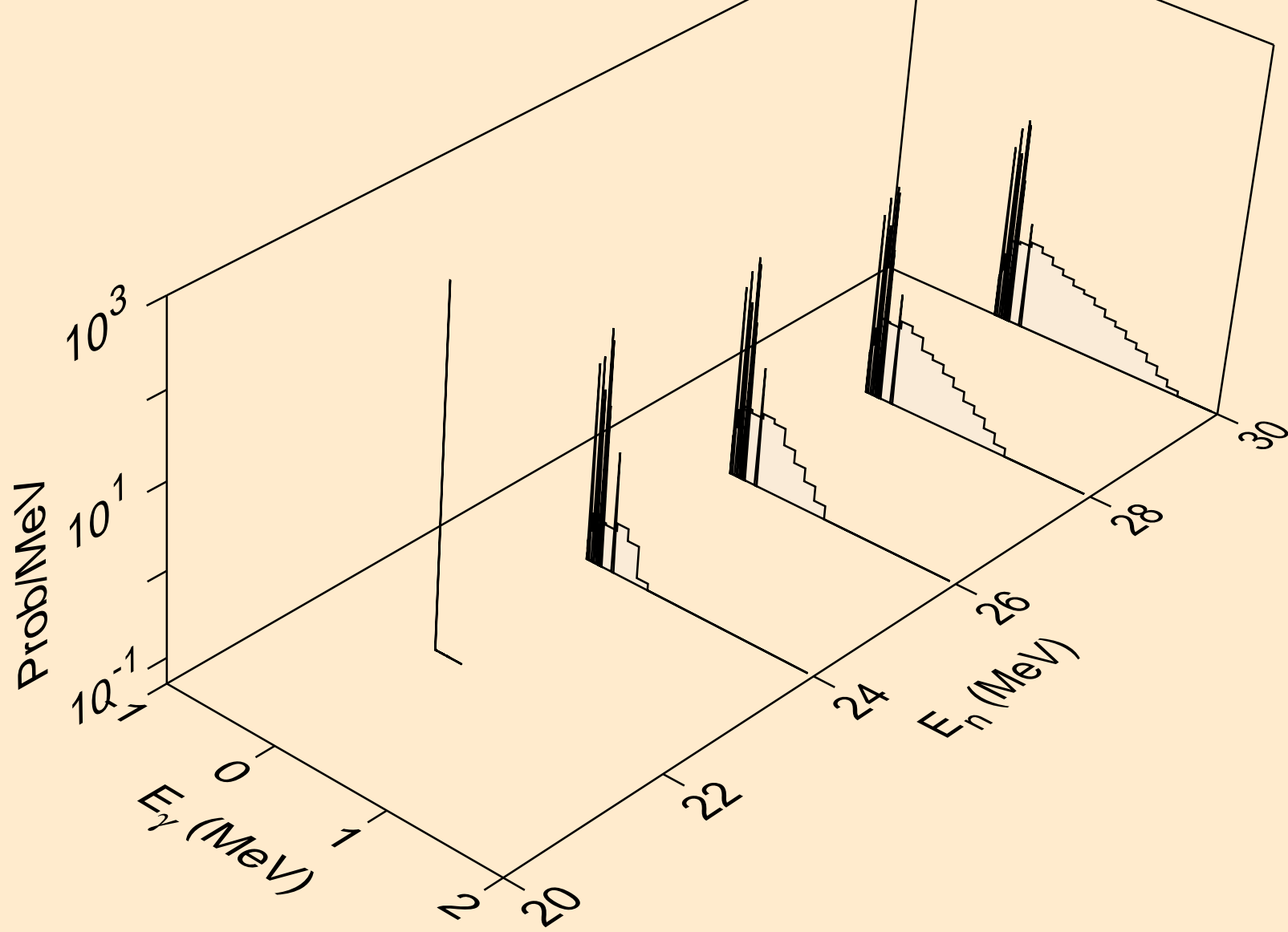

ER163 NEUTRON ACER TENDL-2024 LIBRARY; T=0.K  
Photon emission for (n,2n)

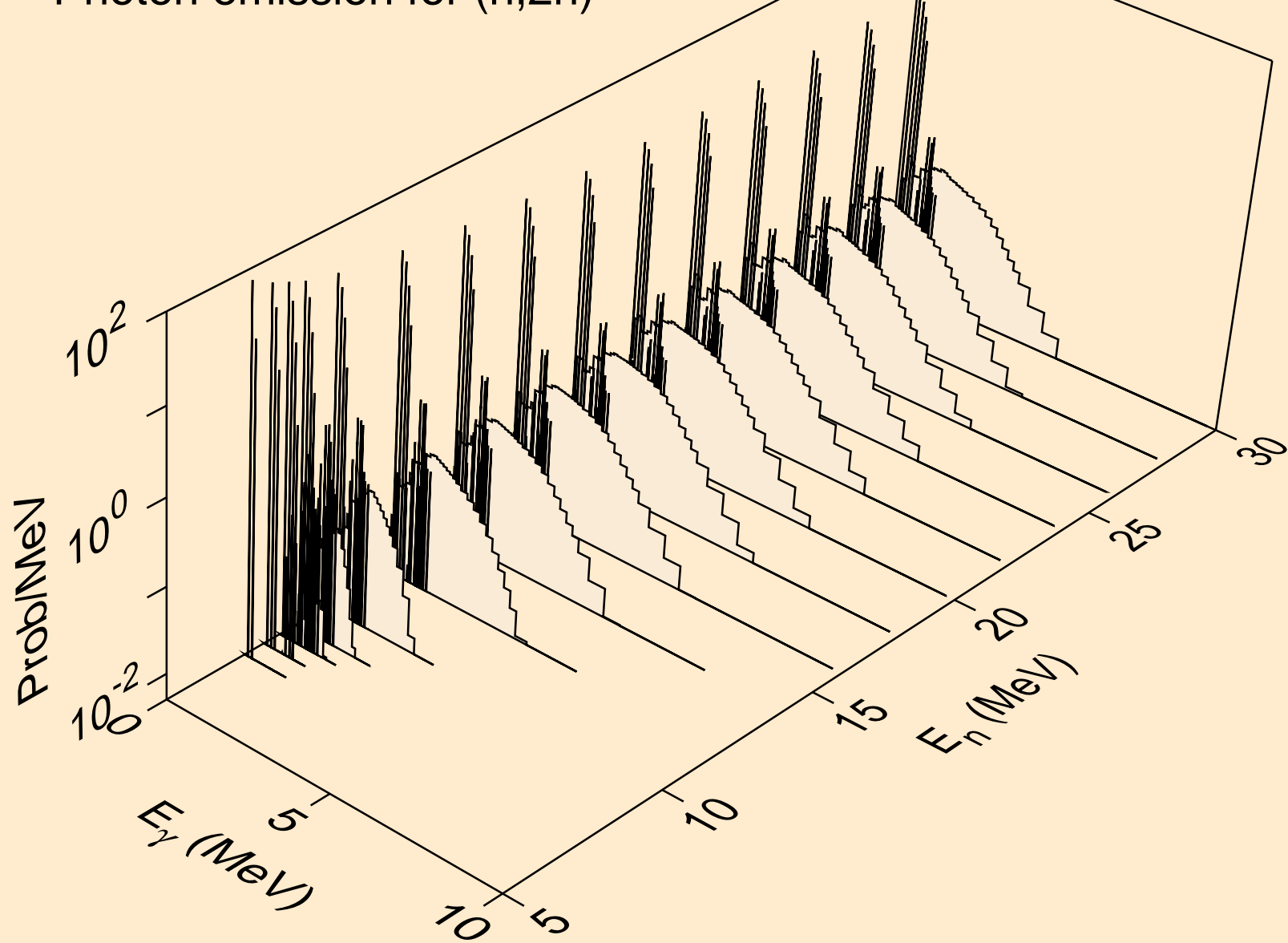

ER163 NEUTRON ACER TENDL-2024 LIBRARY; T=0.K  
Photon emission for (n,3n)

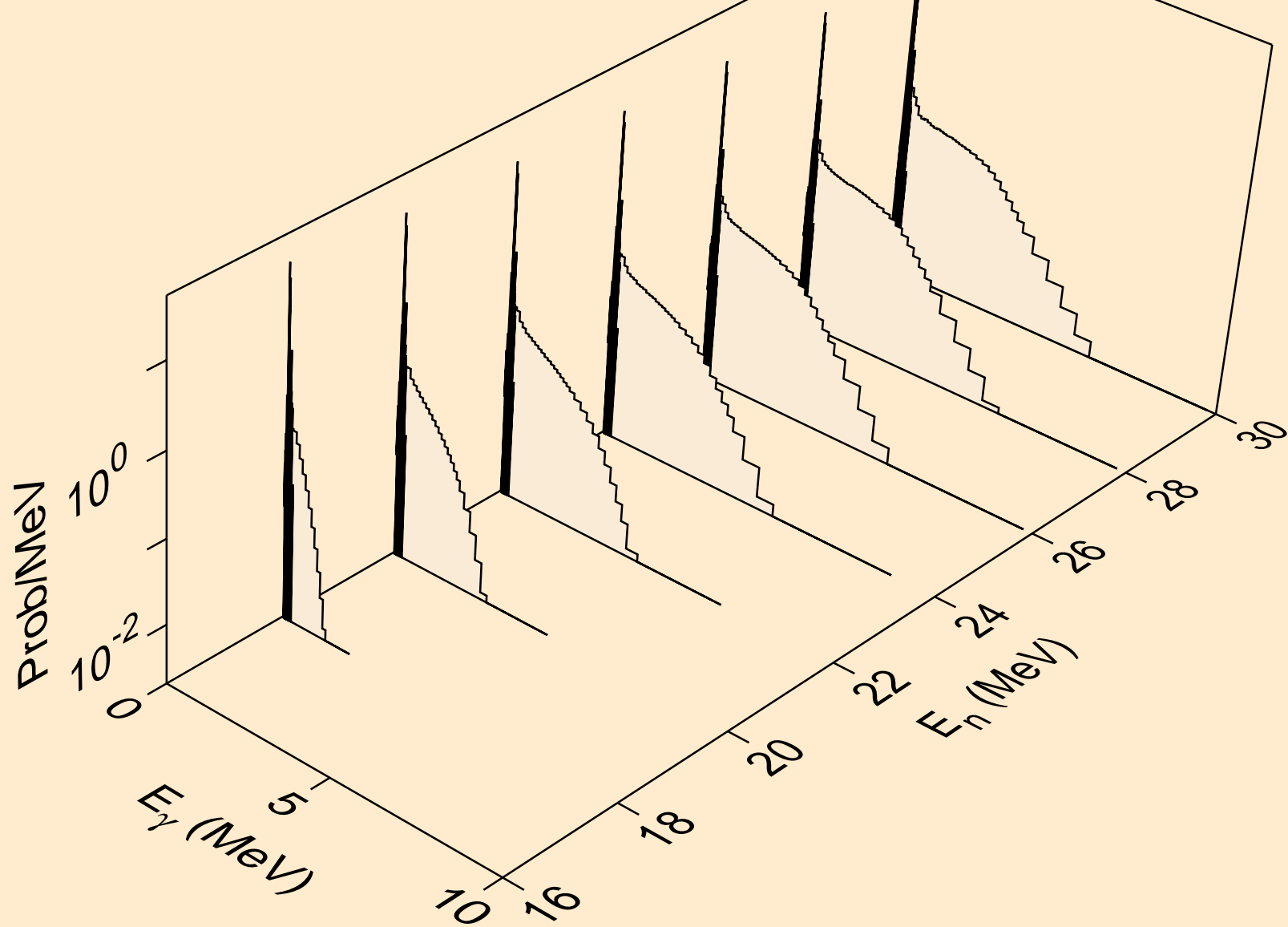

ER163 NEUTRON ACER TENDL-2024 LIBRARY; T=0.K  
Photon emission for (n,n\*)a

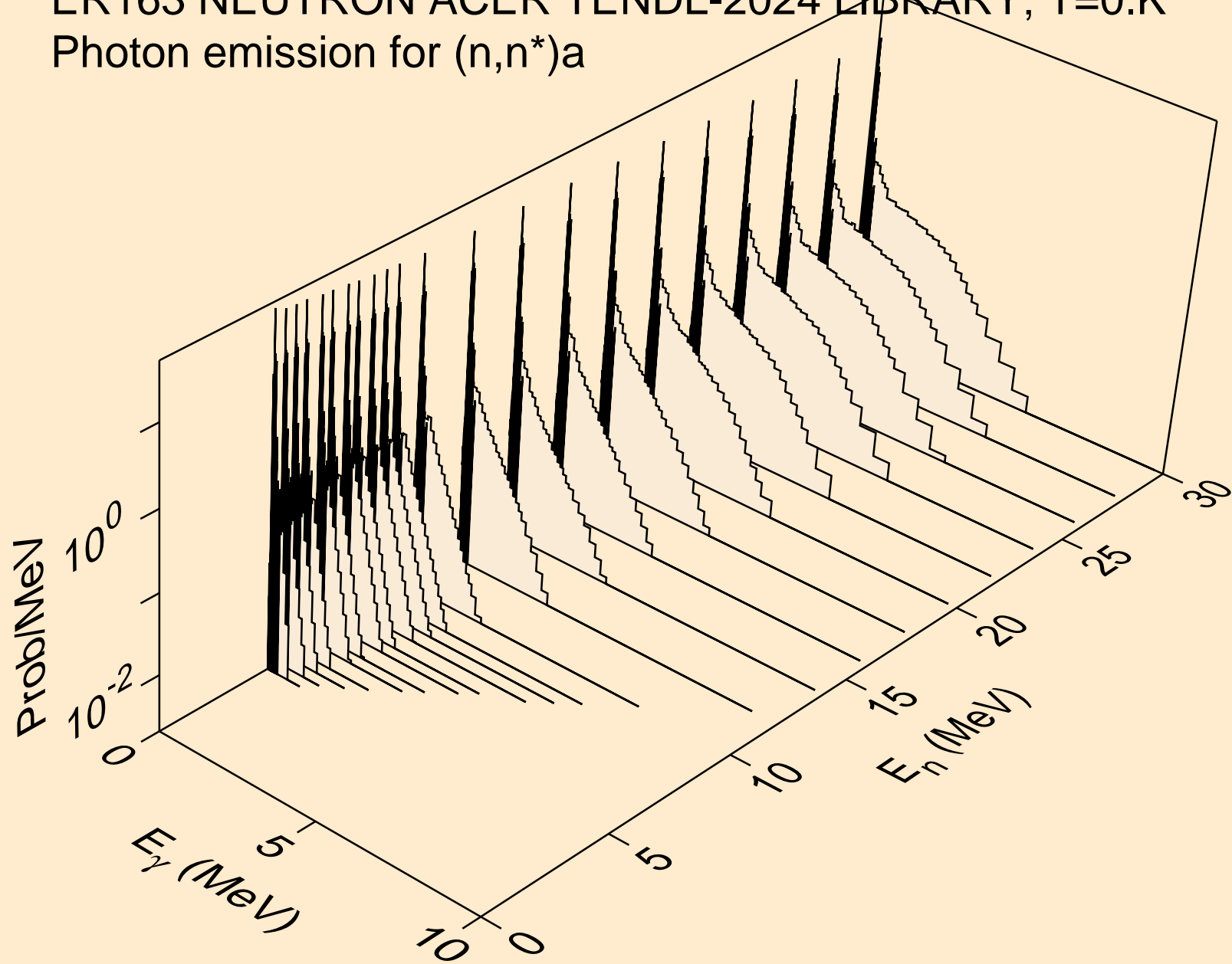

ER163 NEUTRON ACER TENDL-2024 LIBRARY; T=0.K  
Photon emission for (n,2n)a

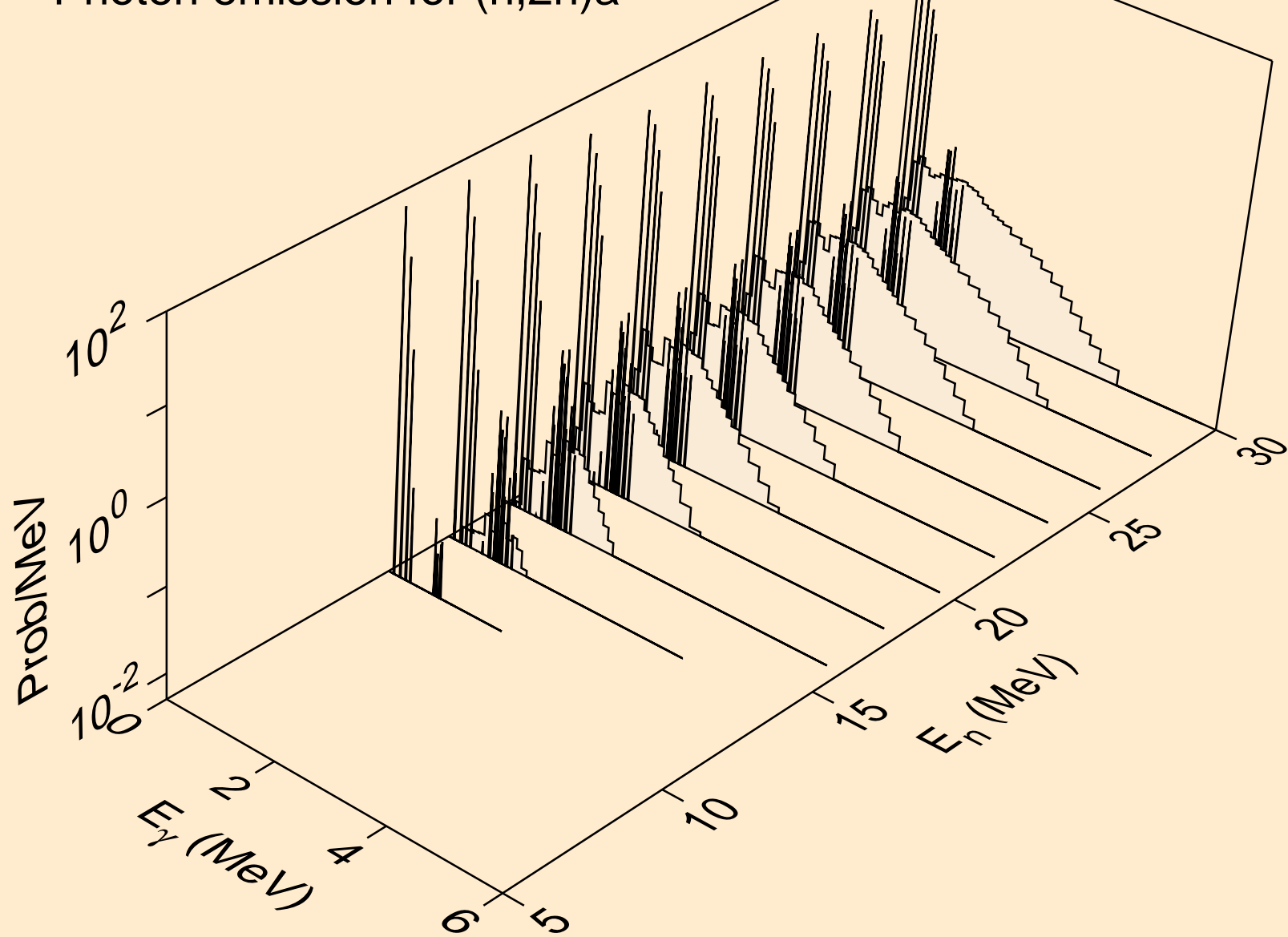

ER163 NEUTRON ACER TENDL-2024 LIBRARY; T=0.K  
Photon emission for (n,3n)a

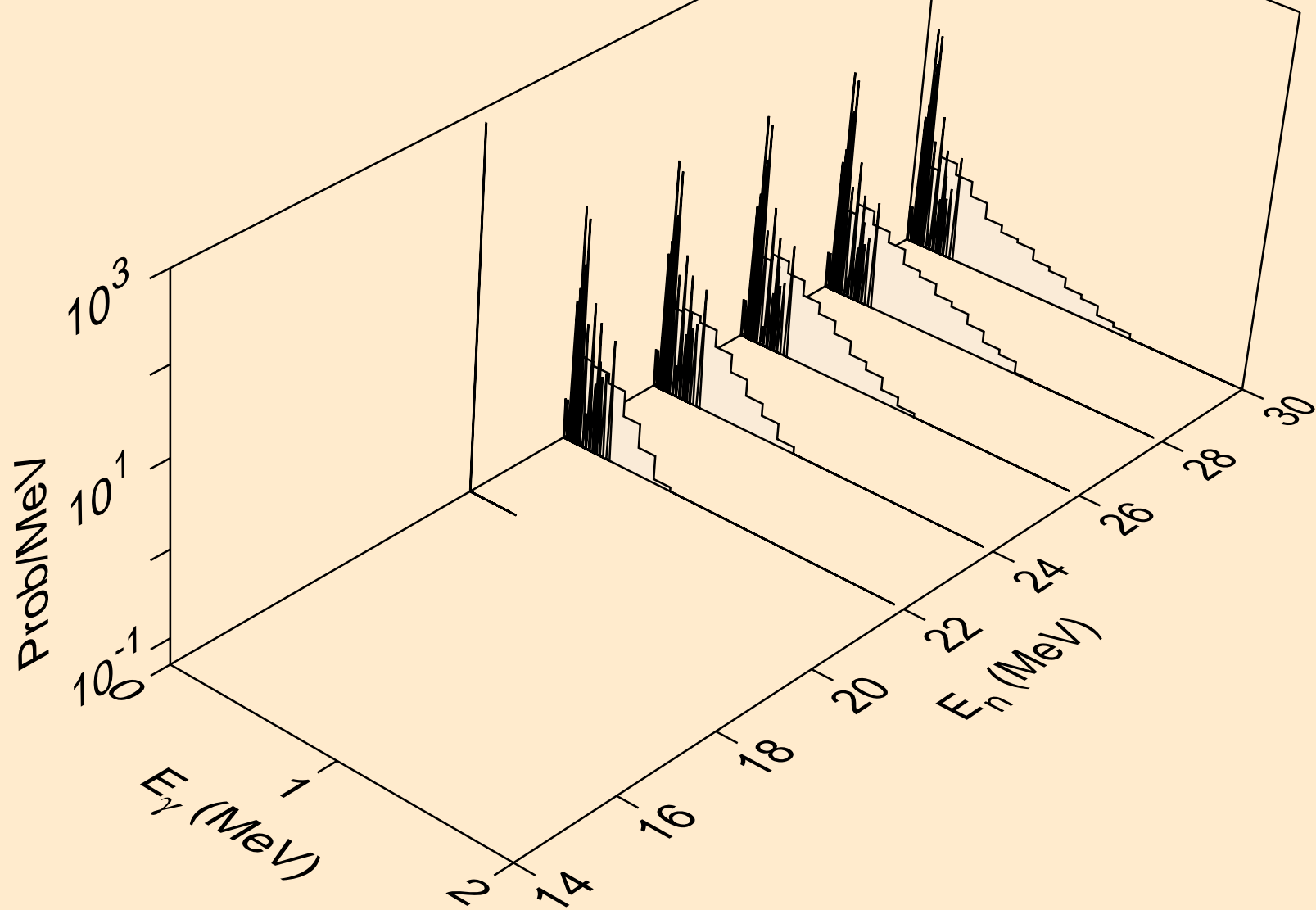

ER163 NEUTRON ACER TENDL-2024 LIBRARY; T=0.K  
Photon emission for (n,n\*)p

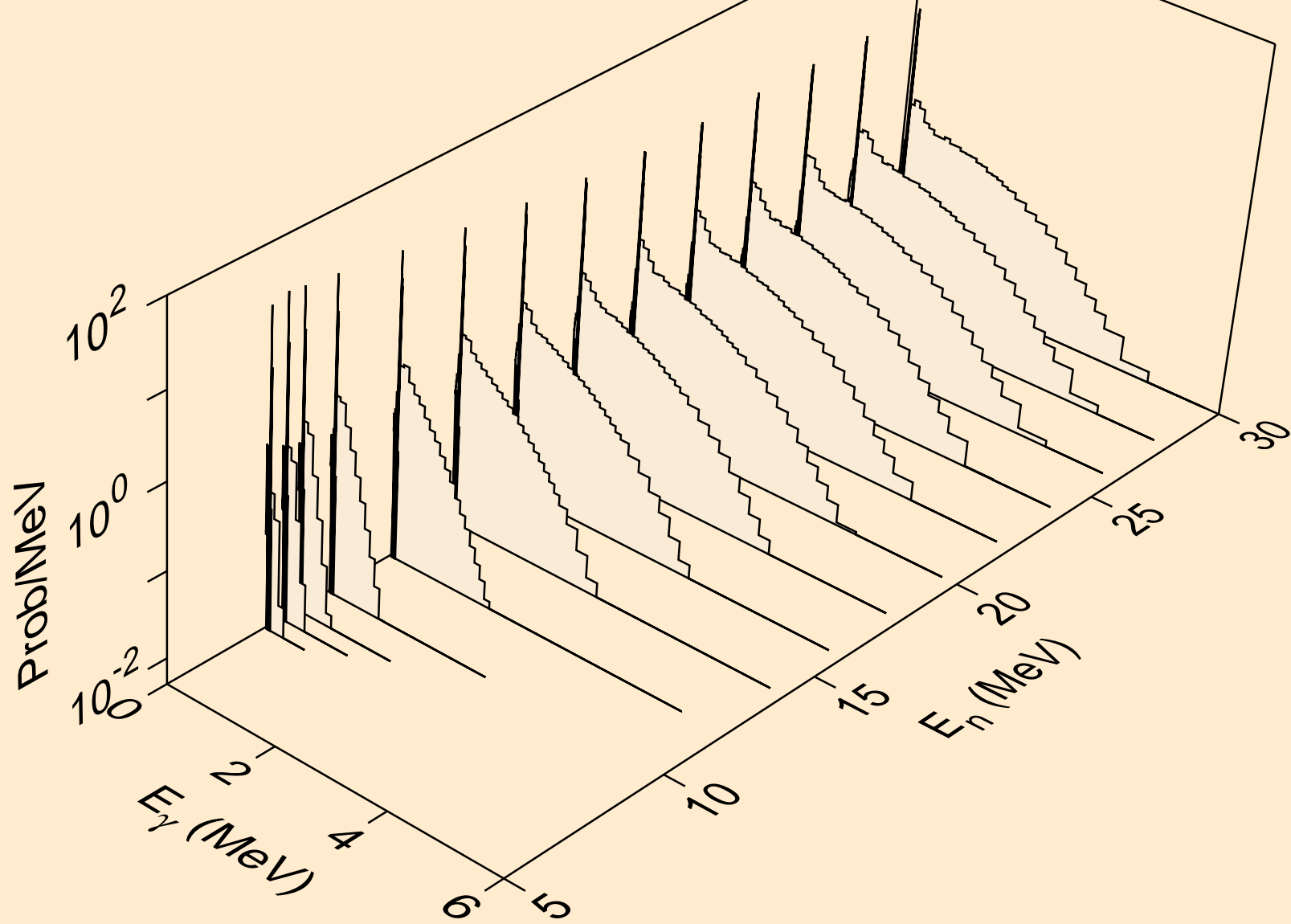



ER163 NEUTRON ACER TENDL-2024 LIBRARY; T=0.K  
Photon emission for (n,n\*)2a

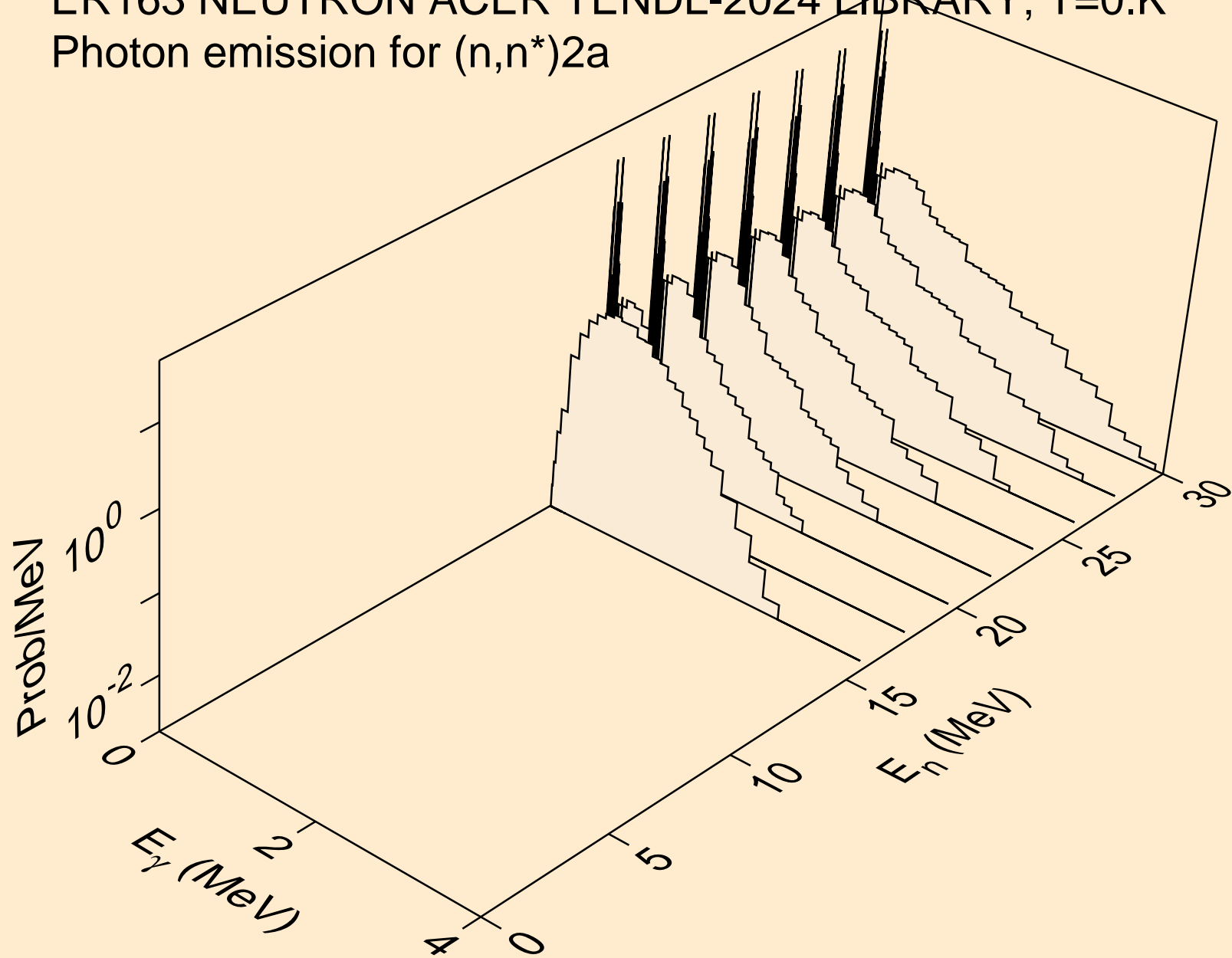

ER163 NEUTRON ACER TENDL-2024 LIBRARY; T=0.K  
Photon emission for (n,n\*)d

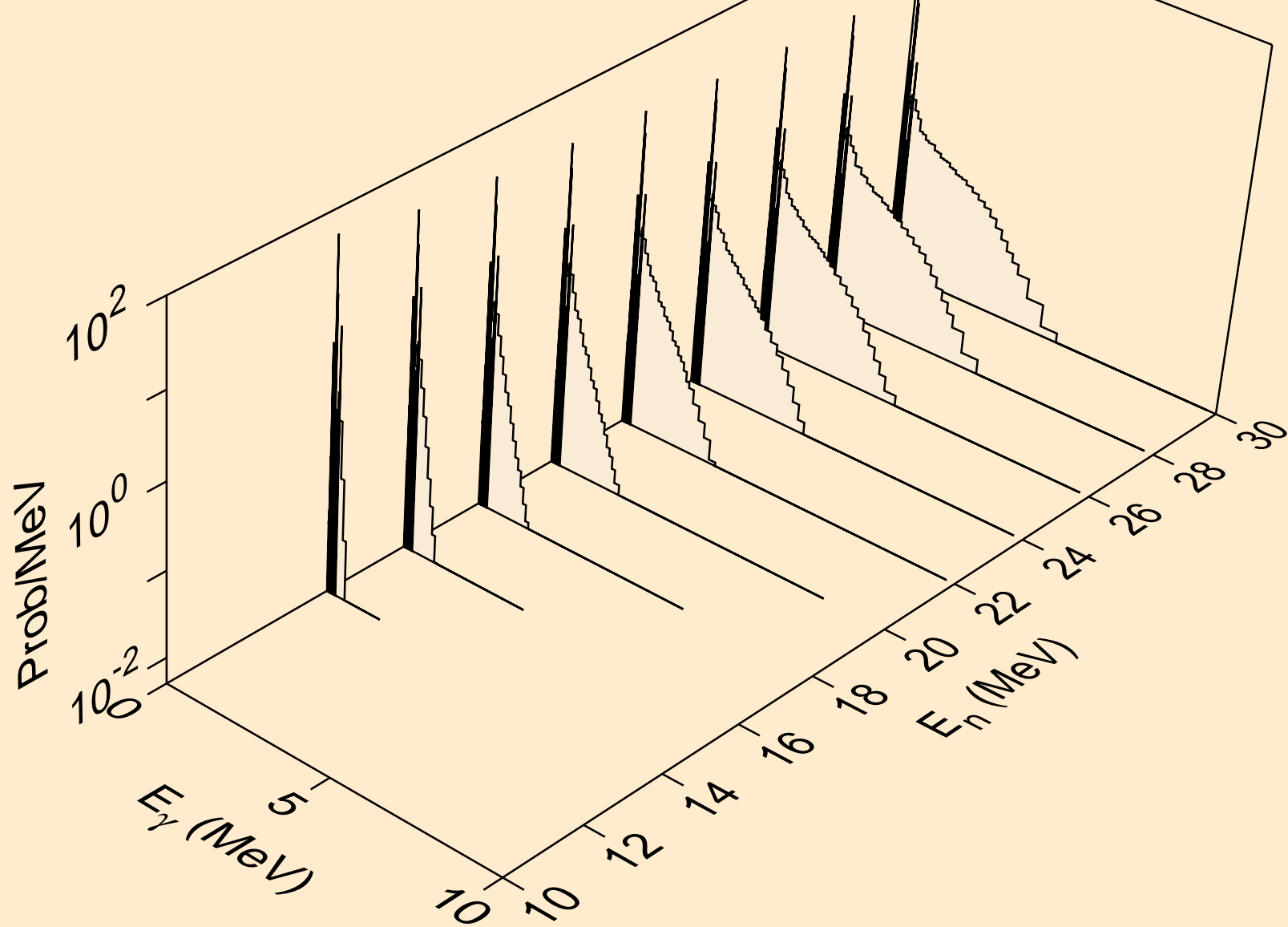

ER163 NEUTRON ACER TENDL-2024 LIBRARY; T=0.K  
Photon emission for (n,n\*)t

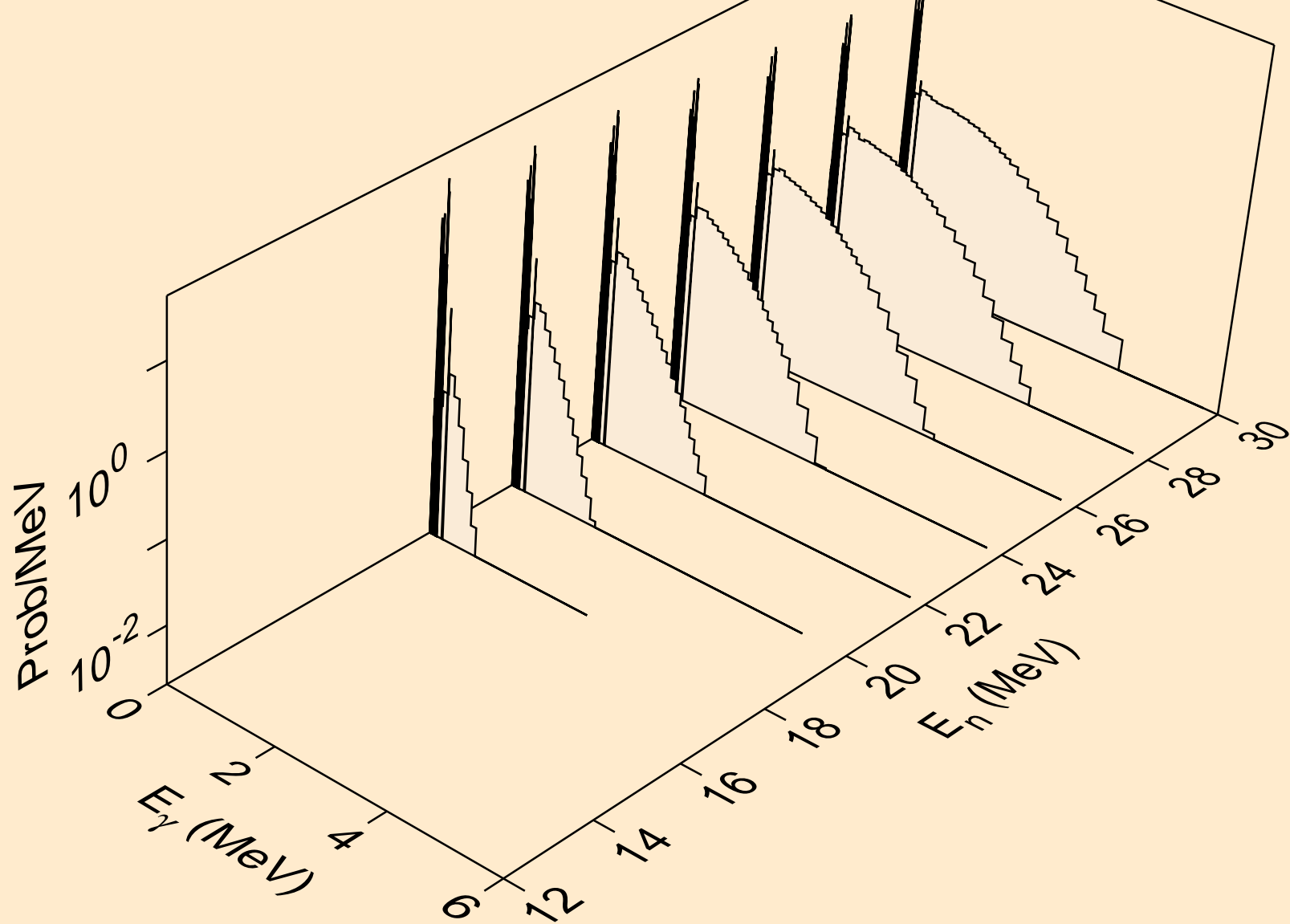

ER163 NEUTRON ACER TENDL-2024 LIBRARY; T=0.K  
Photon emission for (n,n\*)he3

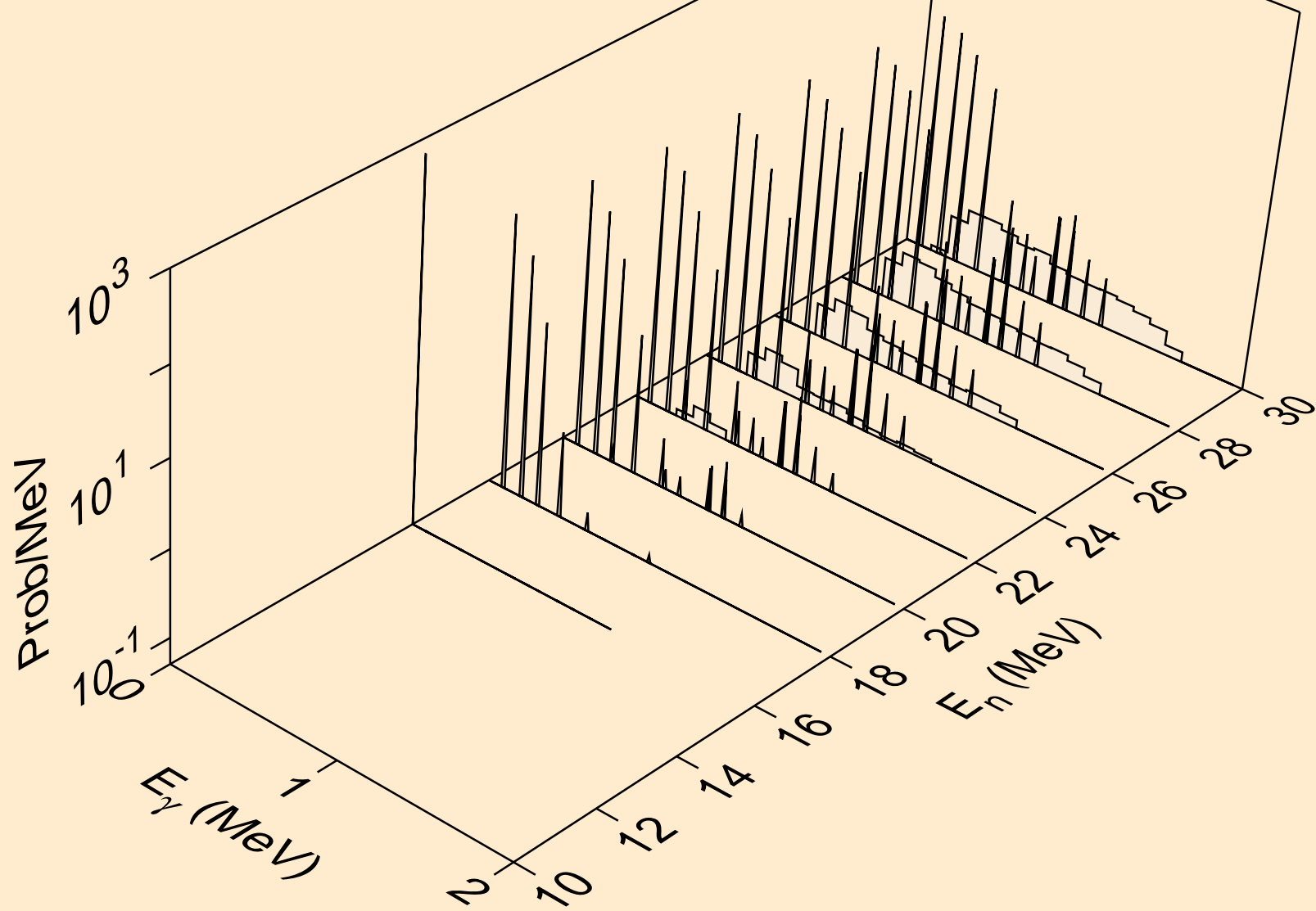

ER163 NEUTRON ACER TENDL-2024 LIBRARY; T=0.K  
Photon emission for (n,4n)

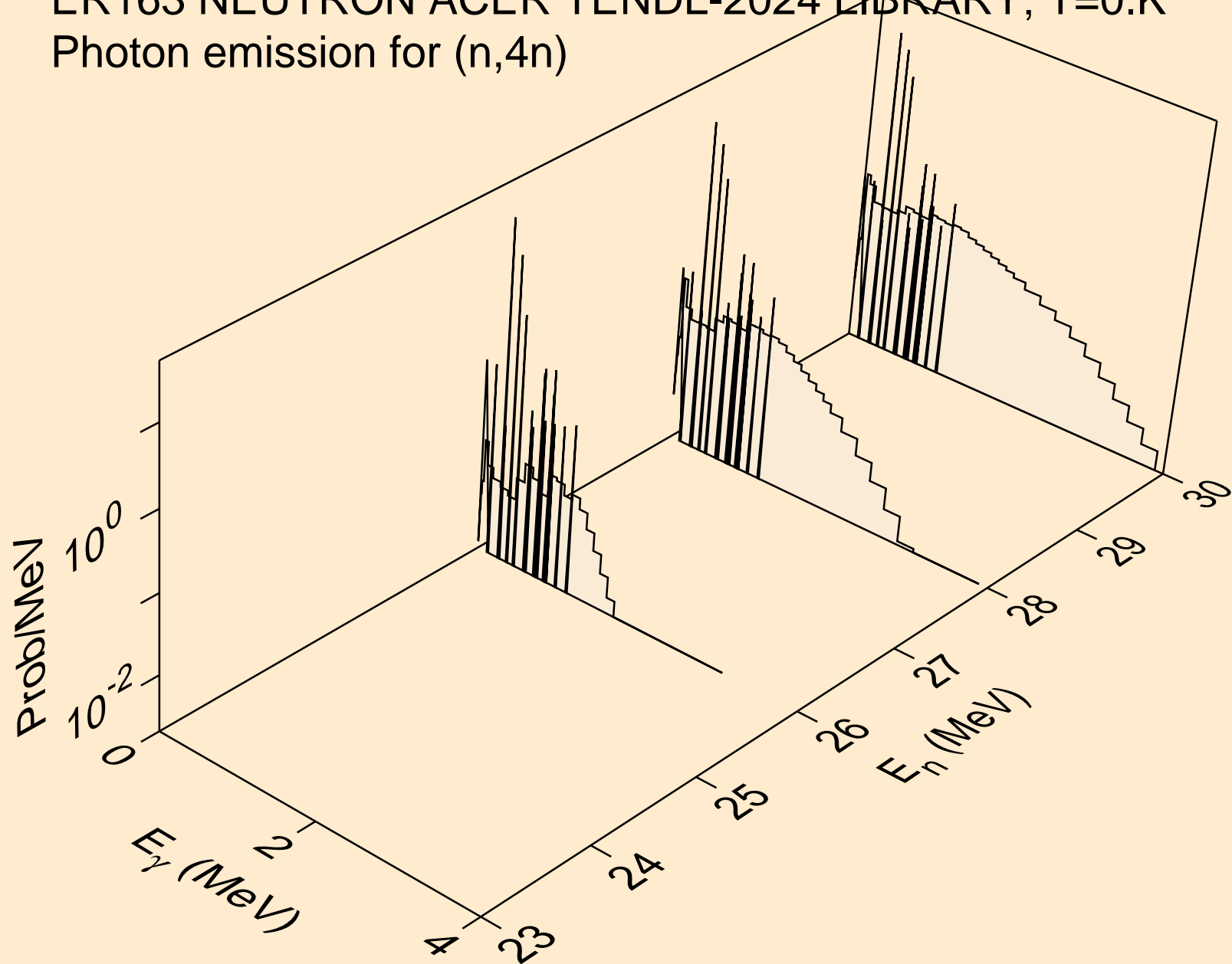

ER163 NEUTRON ACER TENDL-2024 LIBRARY; T=0.K  
Photon emission for (n,2np)

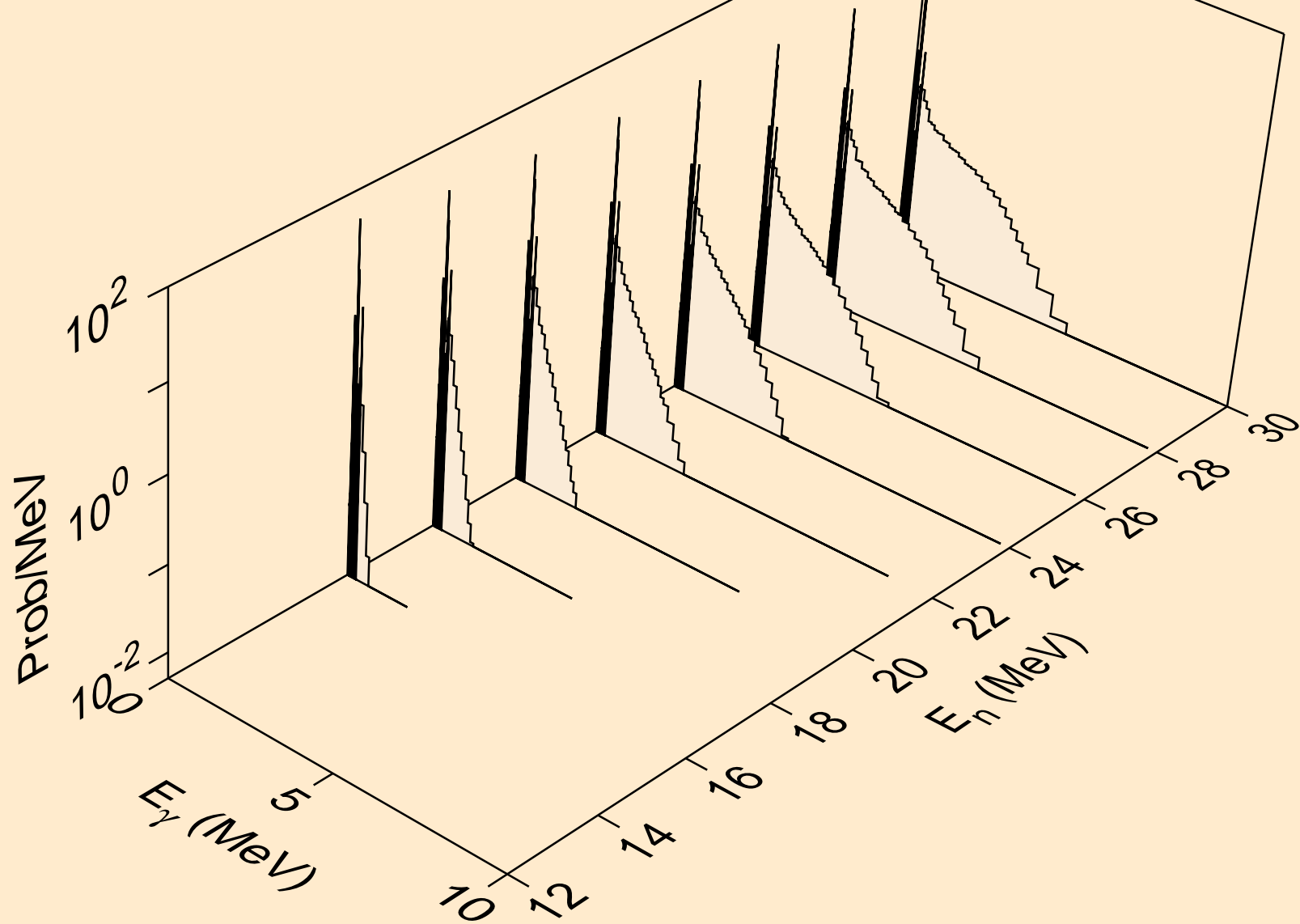

ER163 NEUTRON ACER TENDL-2024 LIBRARY; T=0.K  
Photon emission for (n,3np)

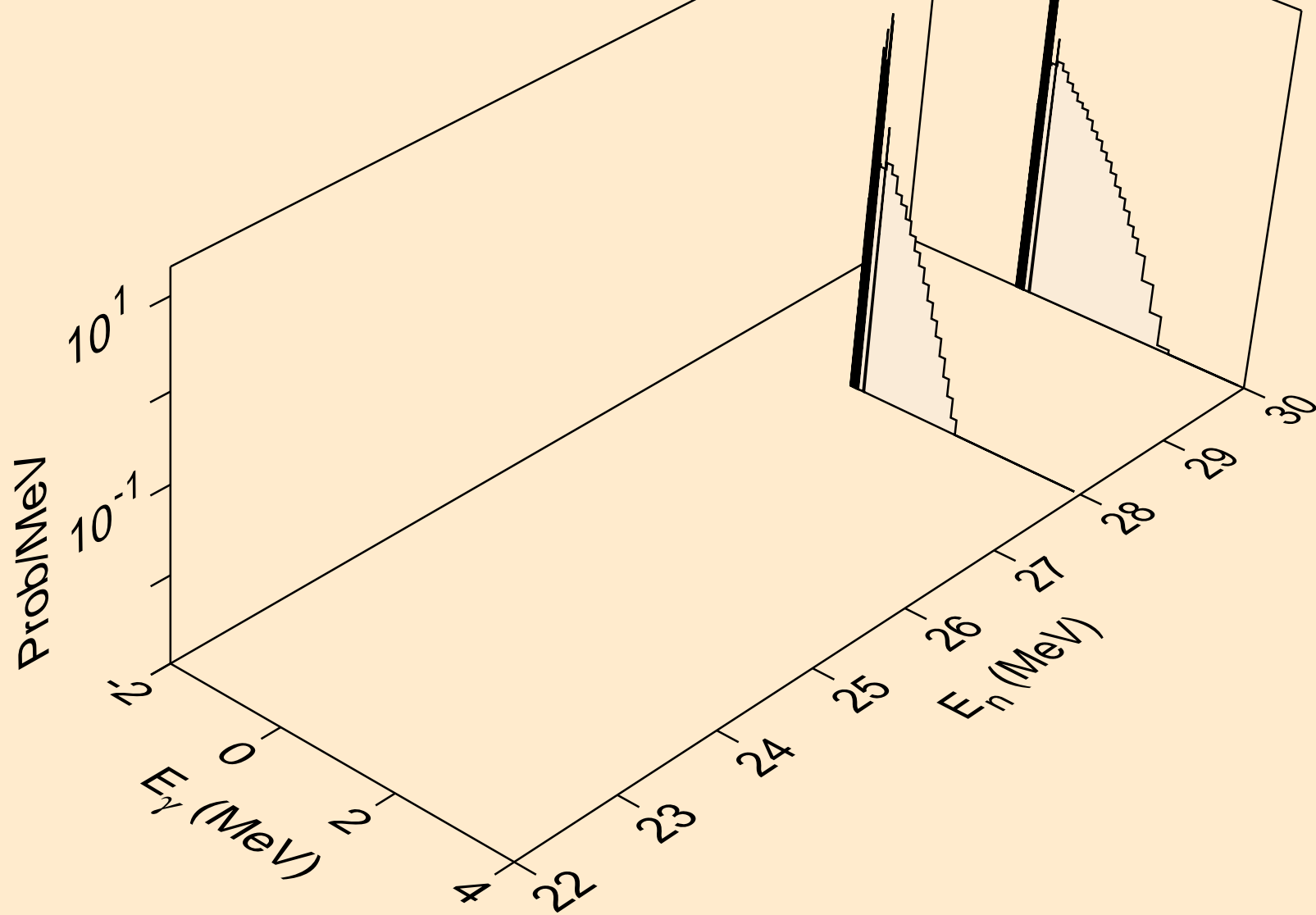

ER163 NEUTRON ACER TENDL-2024 LIBRARY; T=0.K  
Photon emission for (n,n2p)

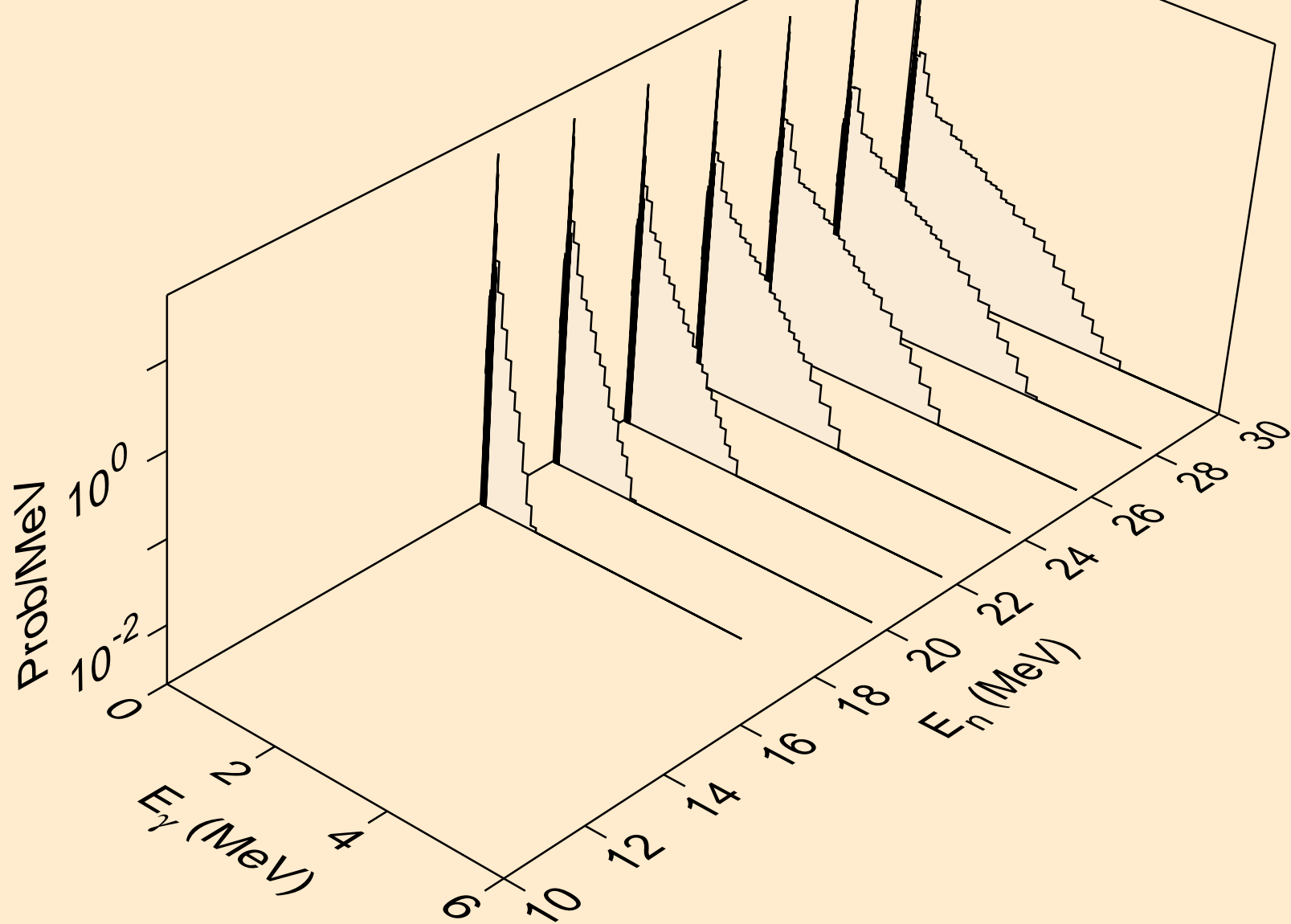



ER163 NEUTRON ACER TENDL-2024 LIBRARY; T=0.K  
Photon emission for (n,npa)

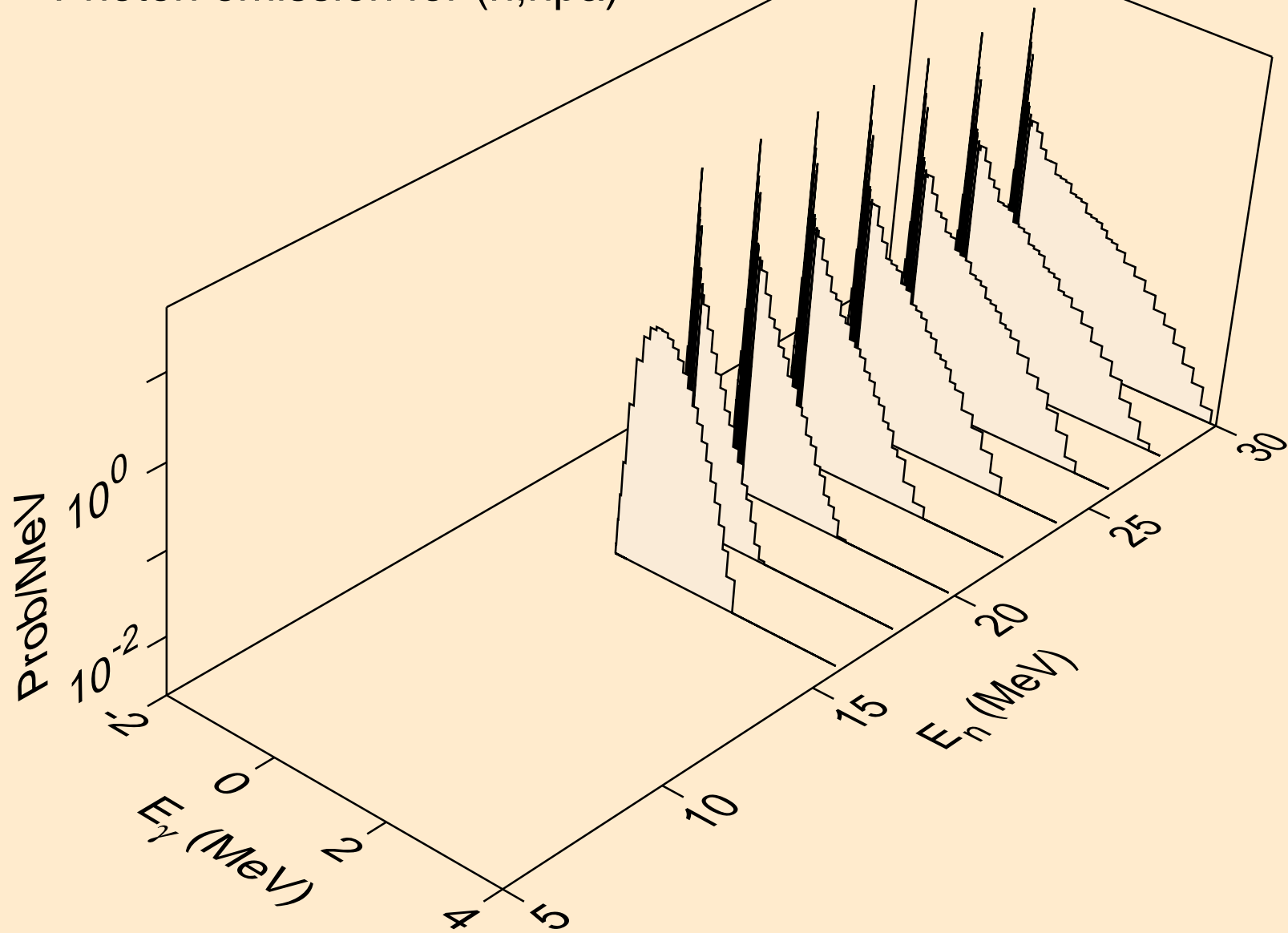

ER163 NEUTRON ACER TENDL-2024 LIBRARY; T=0.K  
Photon emission for (n,n\*c)

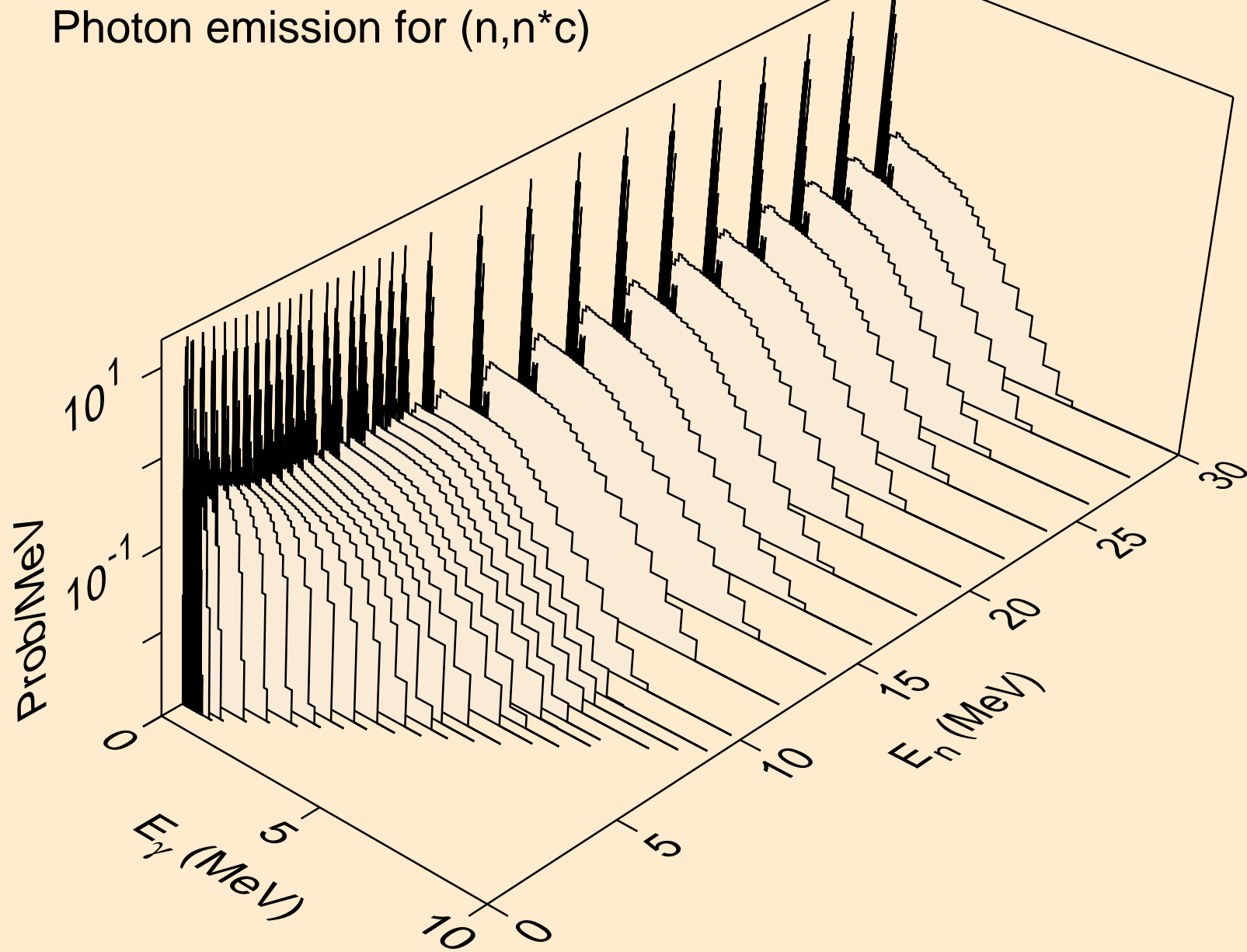

ER163 NEUTRON ACER TENDL-2024 LIBRARY; T=0.K  
Photon emission for (n,gma)

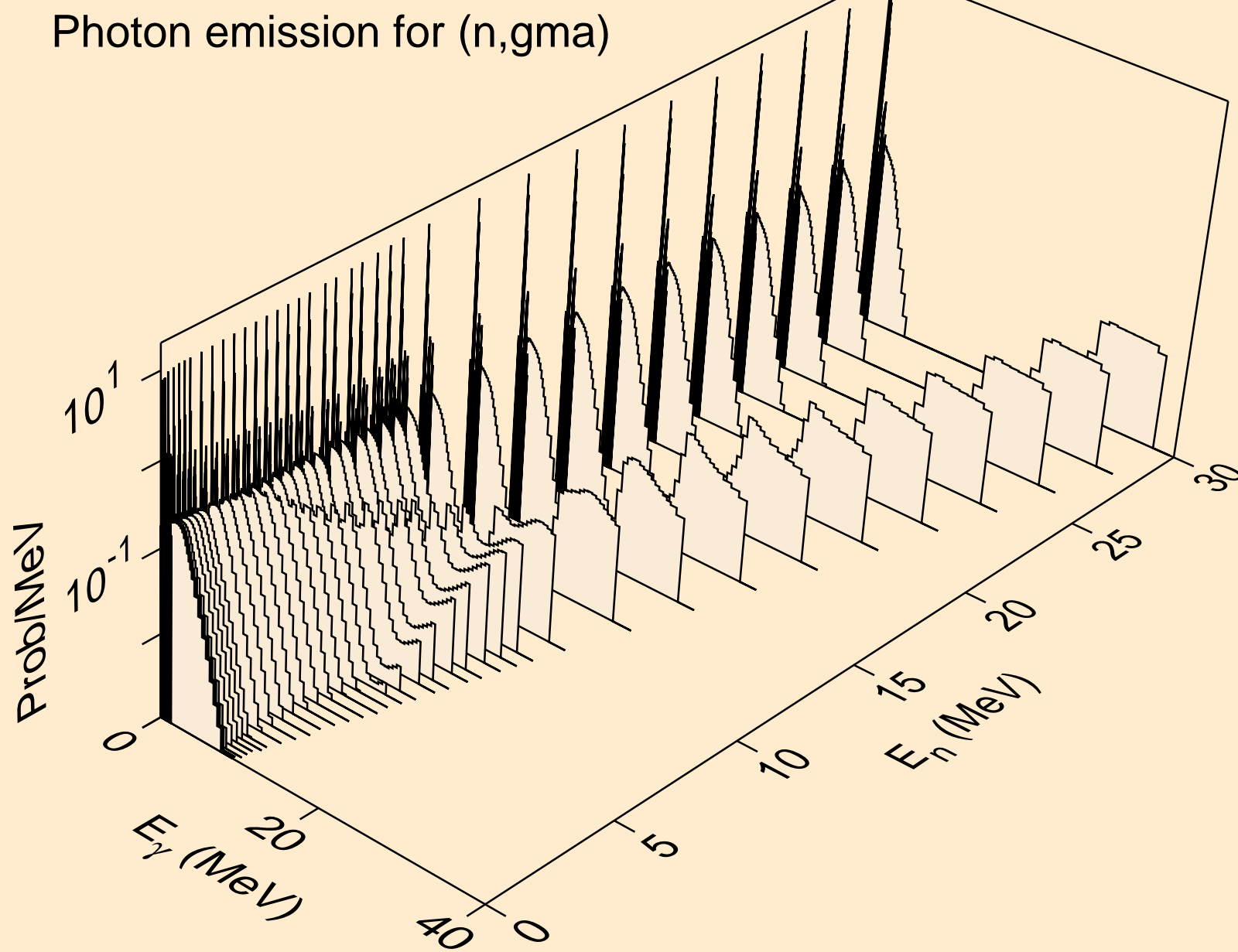

ER163 NEUTRON ACER TENDL-2024 LIBRARY; T=0.K  
Photon emission for (n,p)

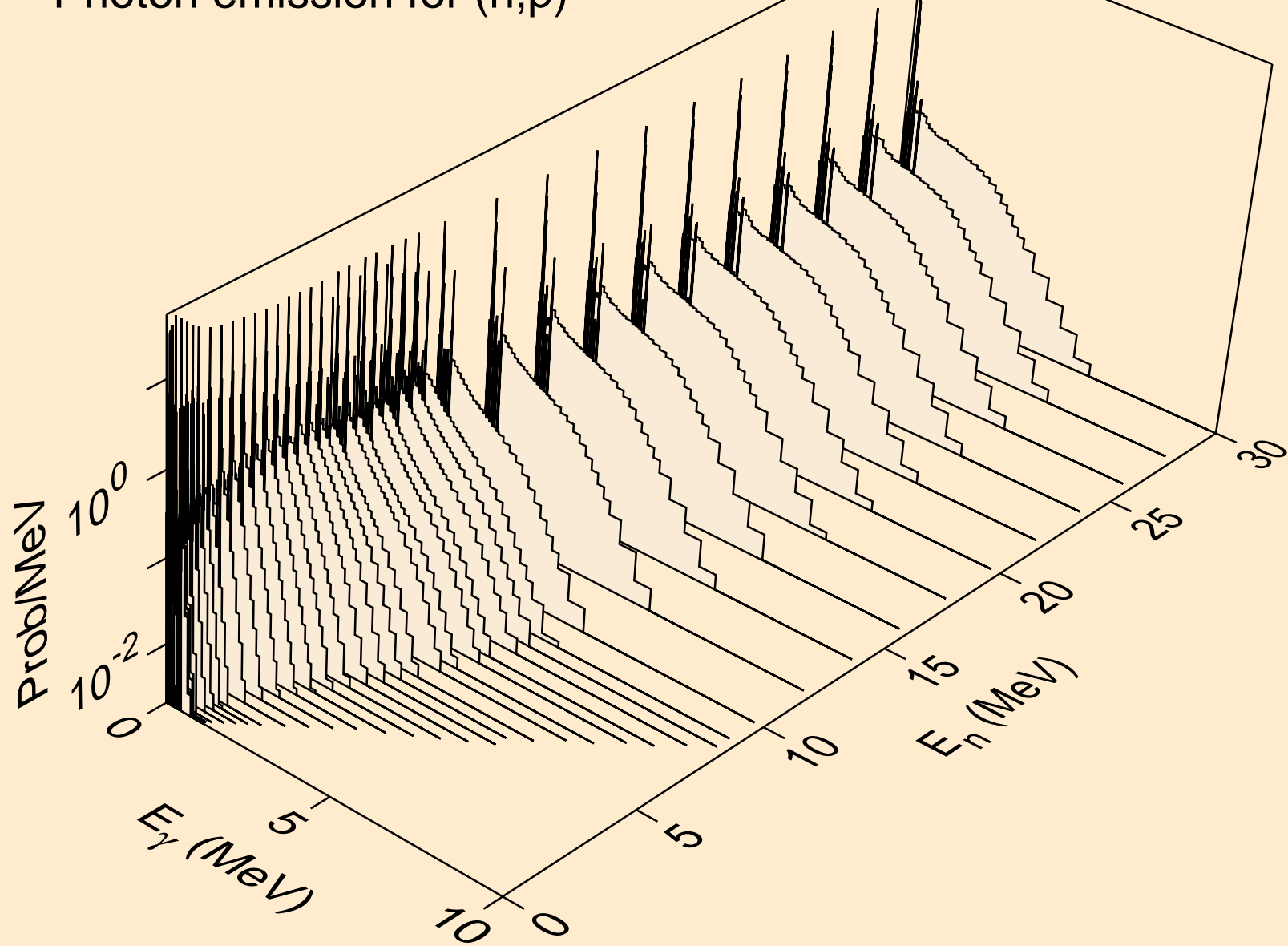

ER163 NEUTRON ACER TENDL-2024 LIBRARY; T=0.K  
Photon emission for (n,d)

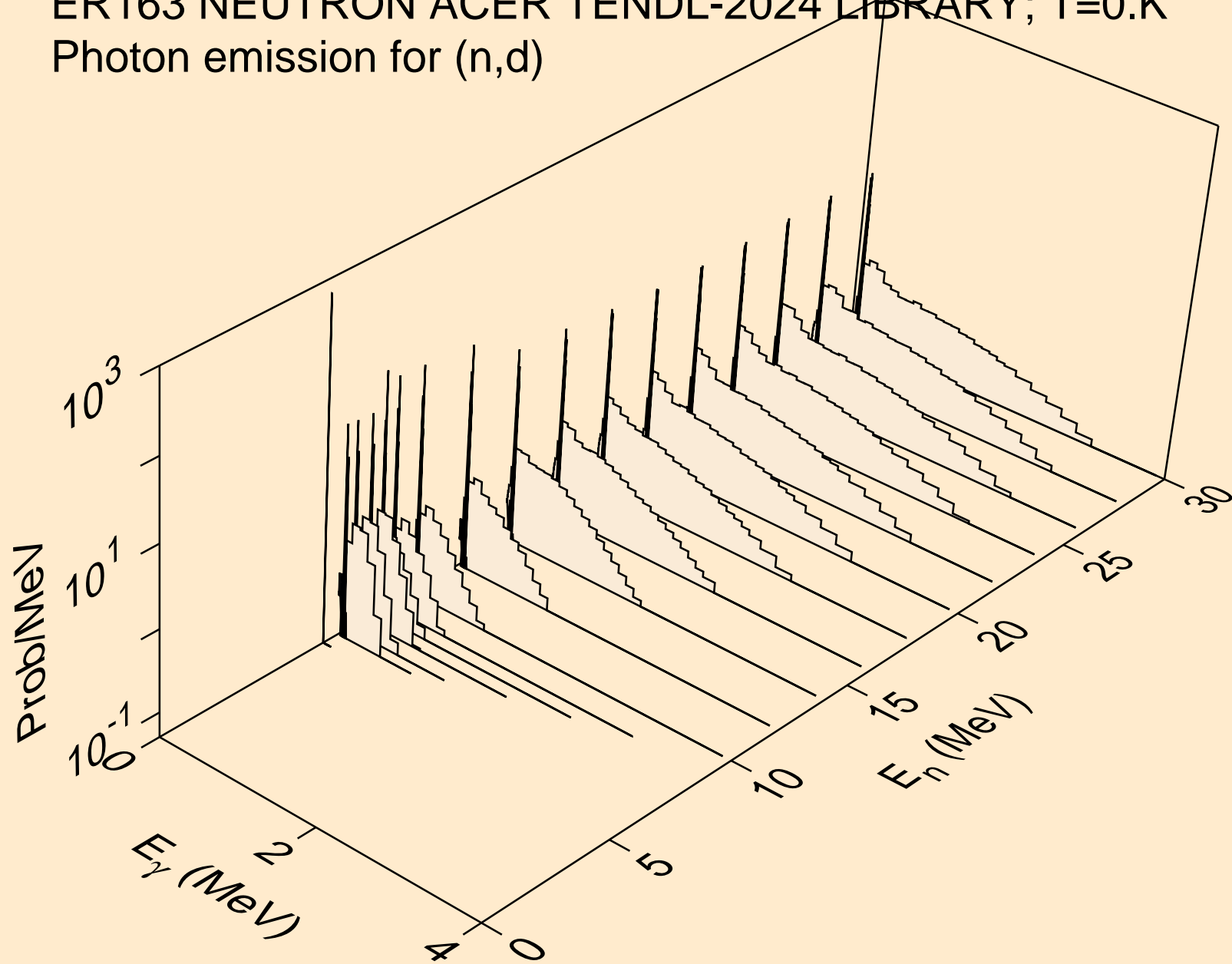

ER163 NEUTRON ACER TENDL-2024 LIBRARY; T=0.K  
Photon emission for (n,t)

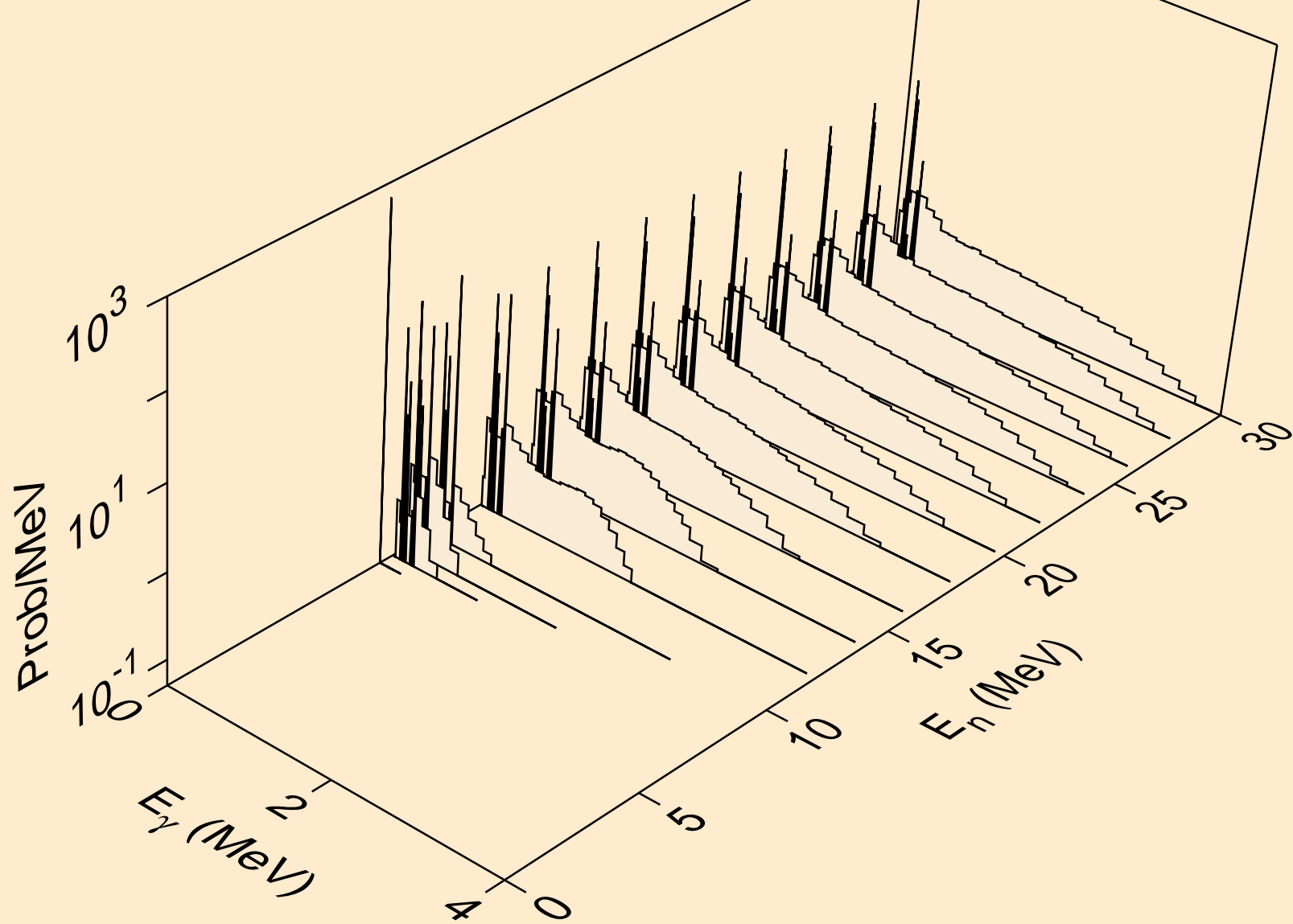

ER163 NEUTRON ACER TENDL-2024 LIBRARY; T=0.K  
Photon emission for (n,he3)

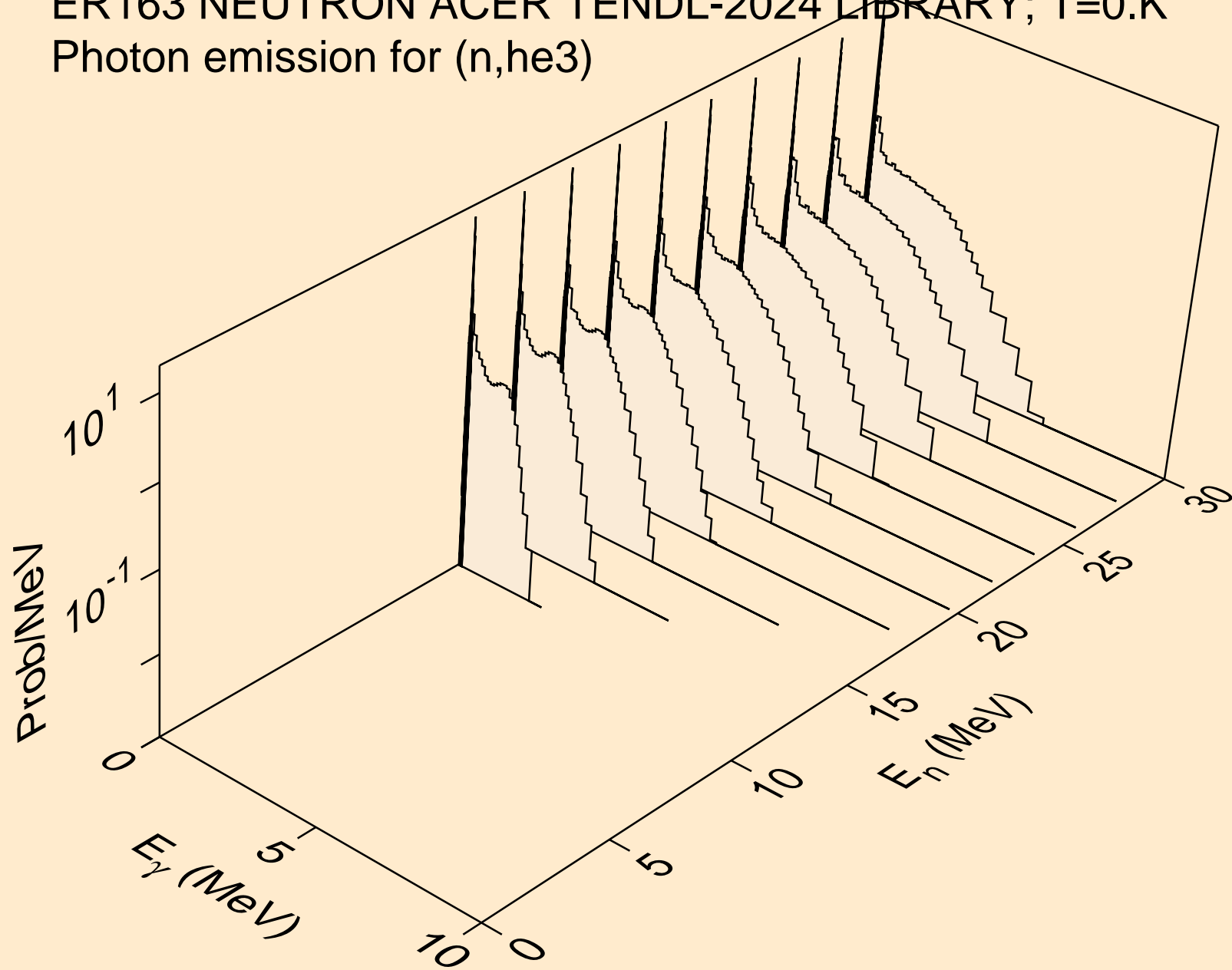

ER163 NEUTRON ACER TENDL-2024 LIBRARY; T=0.K  
Photon emission for (n,a)

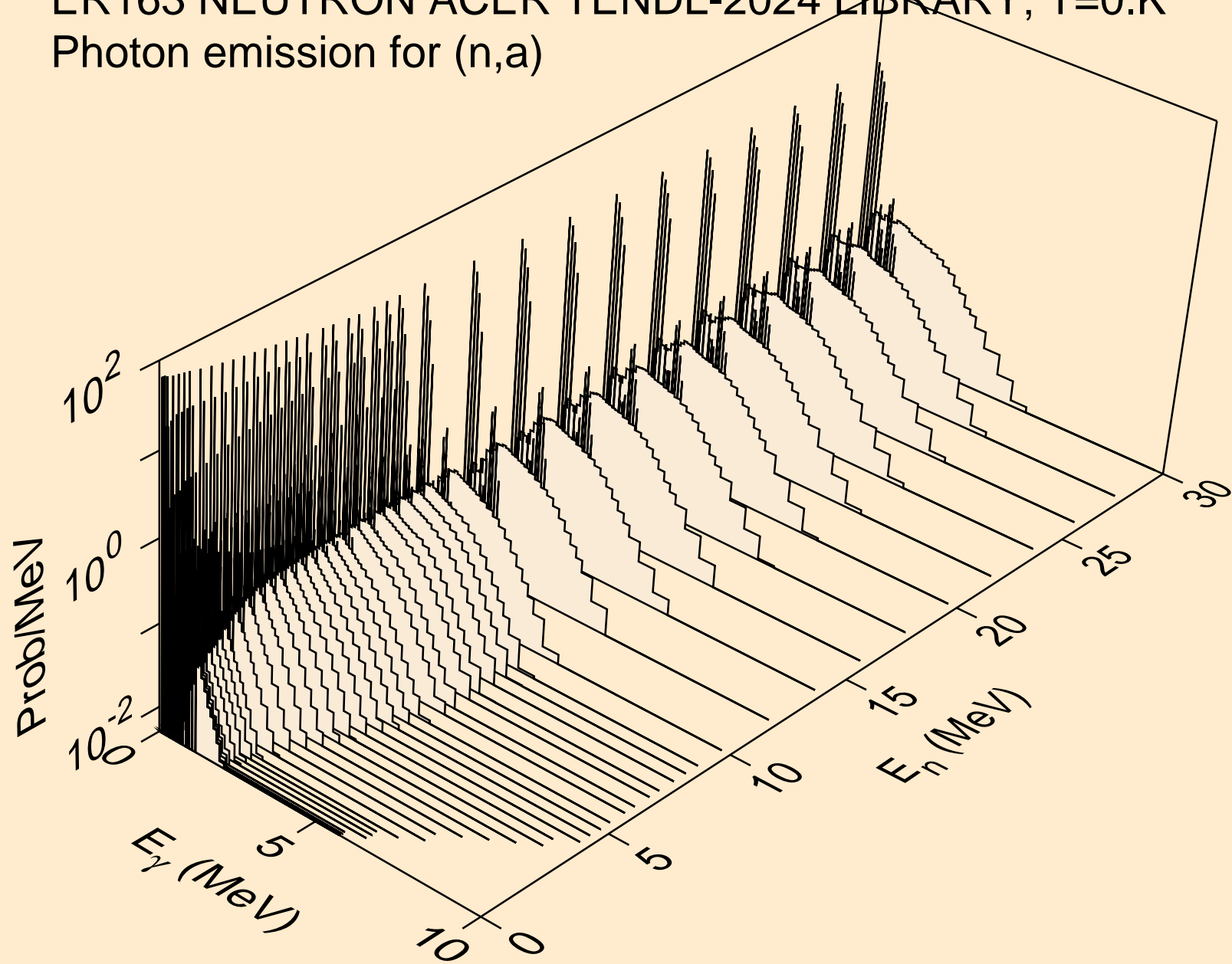



ER163 NEUTRON ACER TENDL-2024 LIBRARY; T=0.K  
Photon emission for (n,2a)

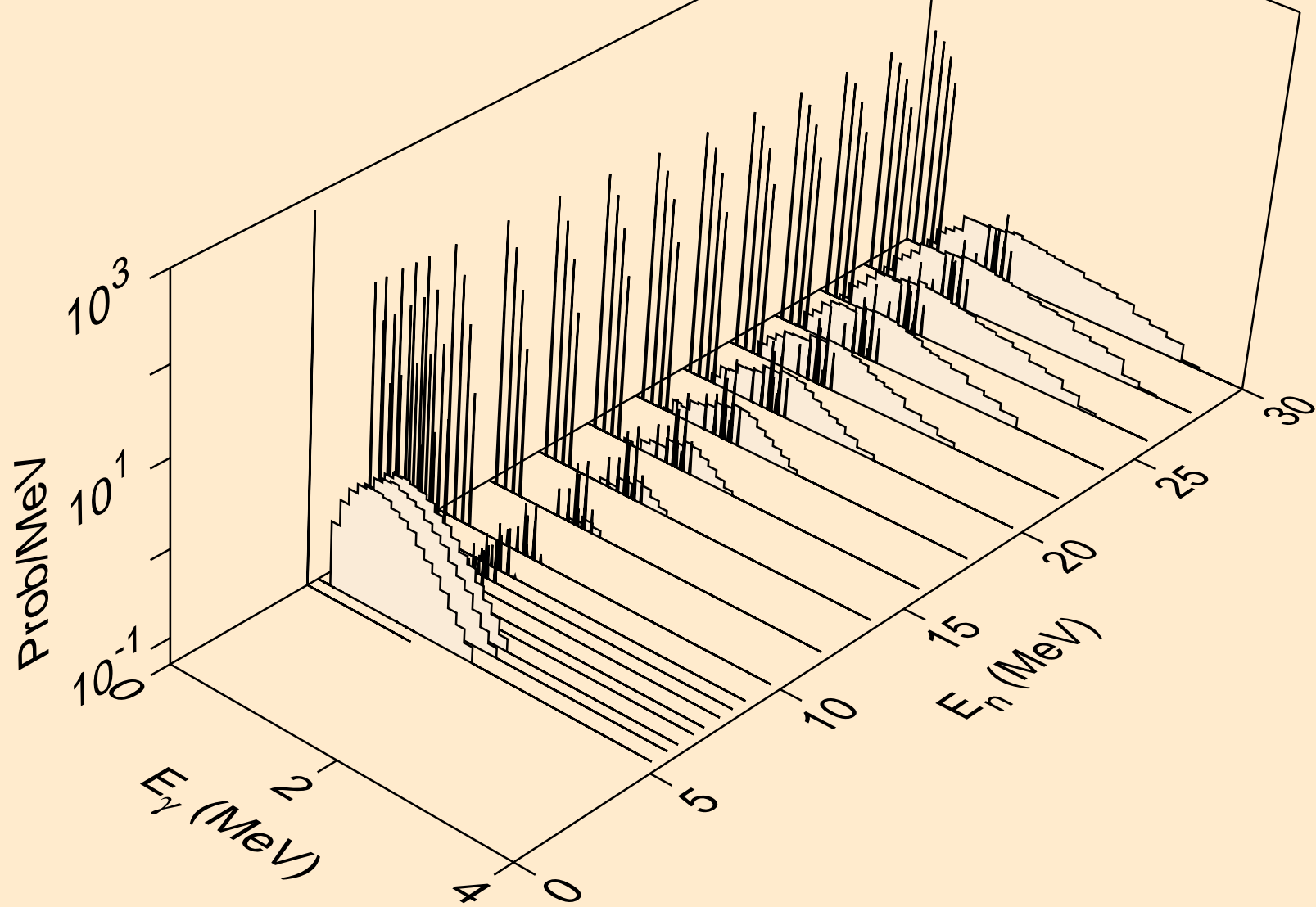

ER163 NEUTRON ACER TENDL-2024 LIBRARY; T=0.K  
Photon emission for (n,2p)

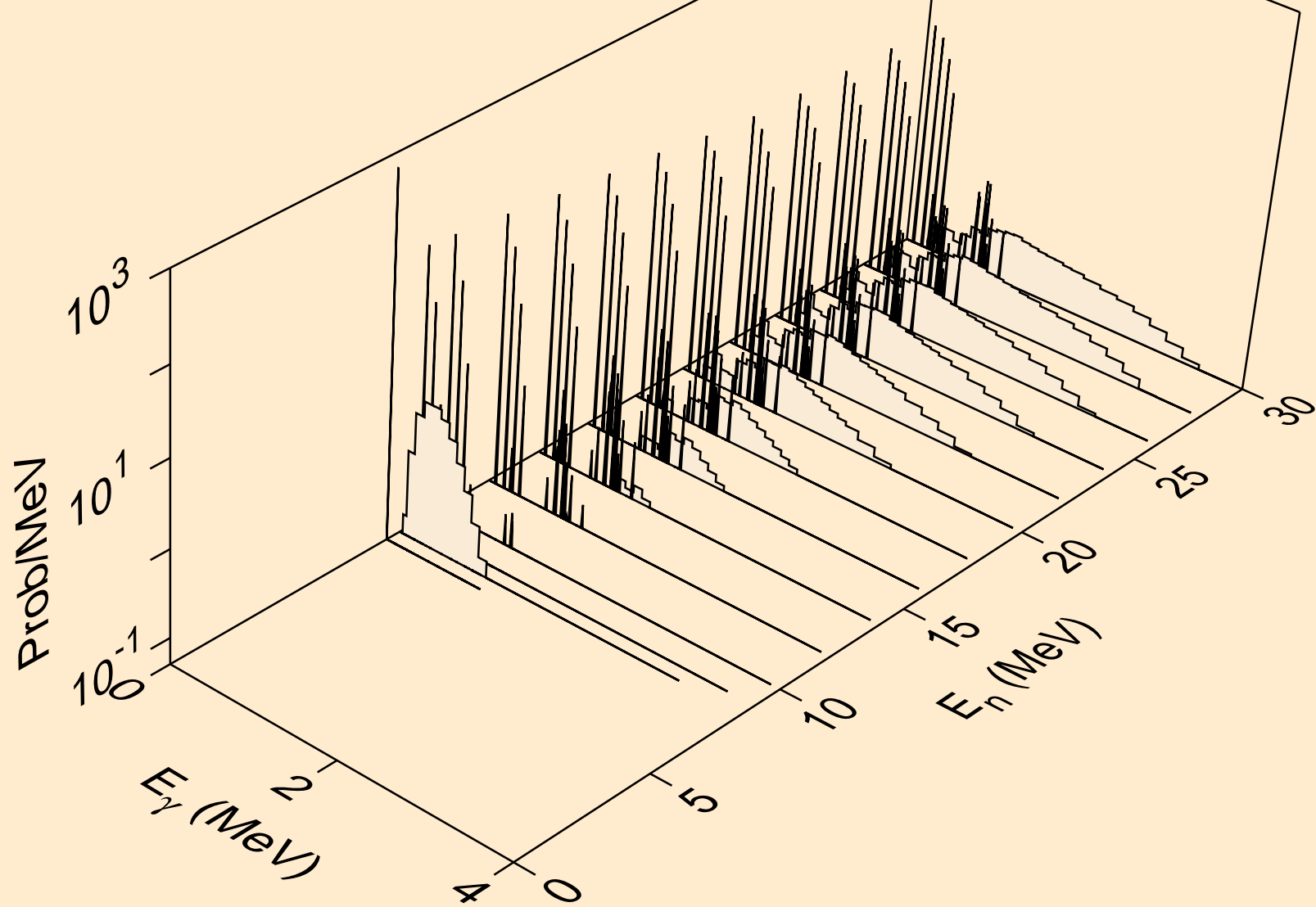

ER163 NEUTRON ACER TENDL-2024 LIBRARY; T=0.K  
Photon emission for (n,p $\alpha$ )

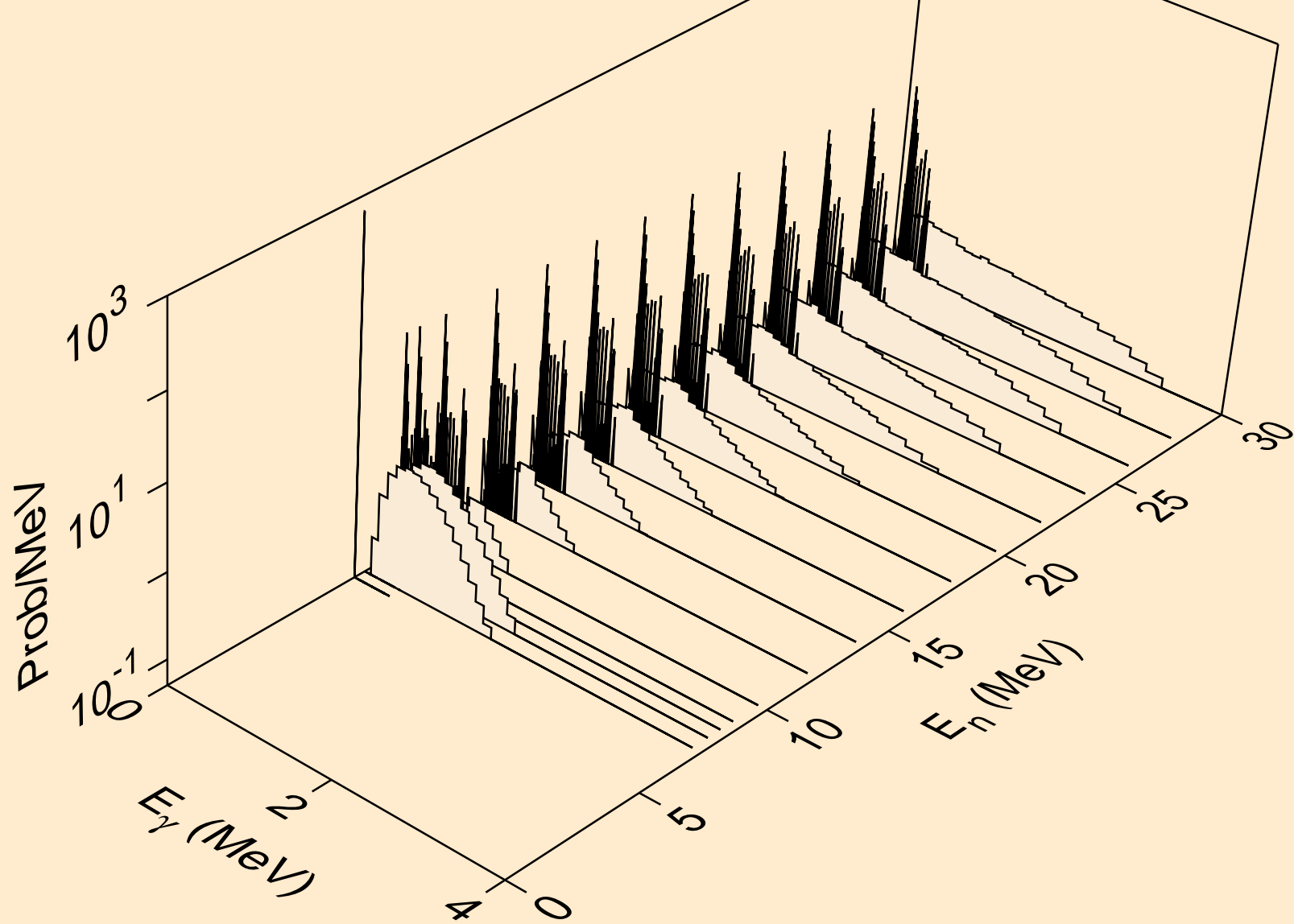

ER163 NEUTRON ACER TENDL-2024 LIBRARY; T=0.K  
Photon emission for (n,pd)

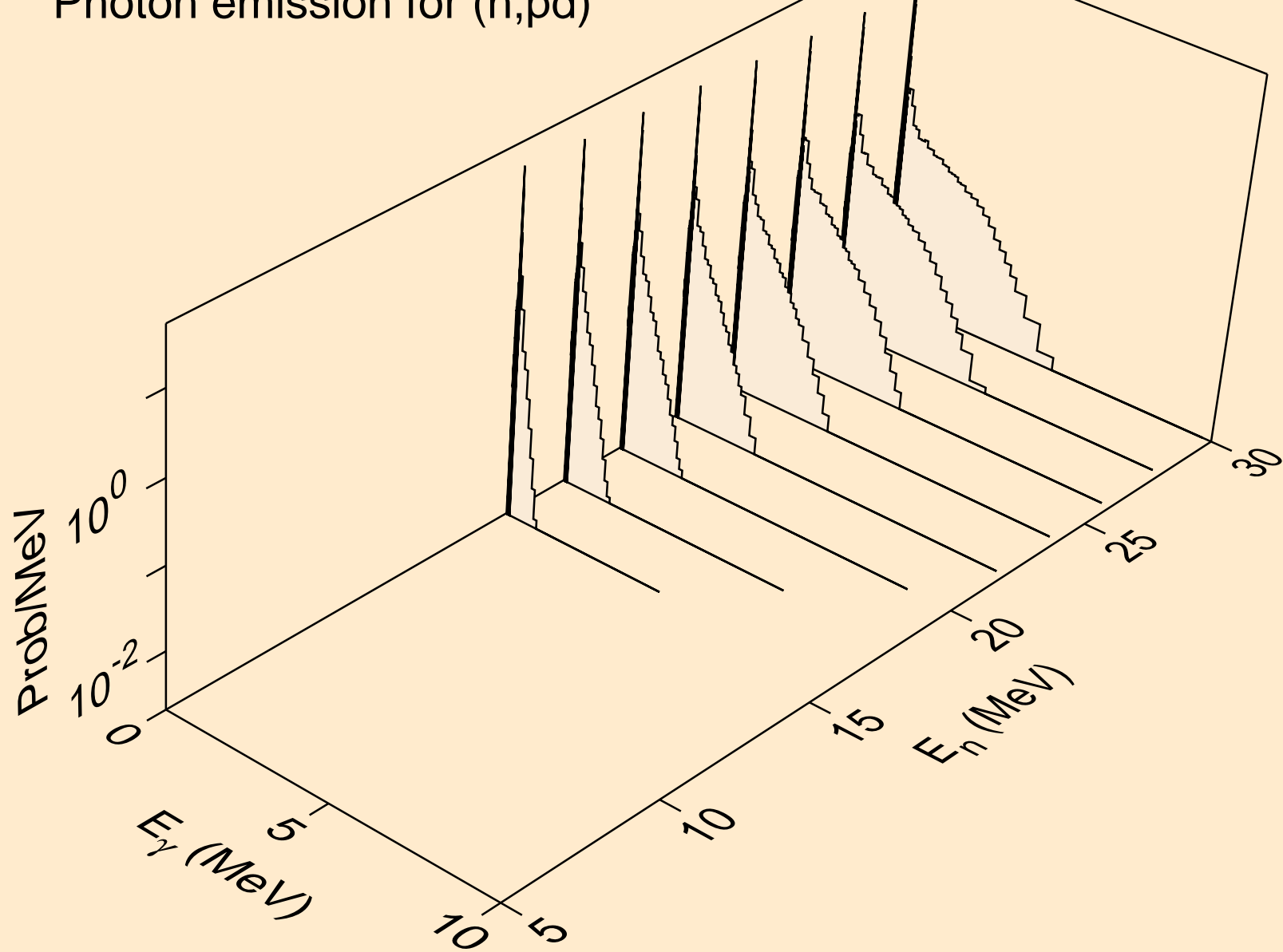

ER163 NEUTRON ACER TENDL-2024 LIBRARY; T=0.K  
Photon emission for (n,pt)

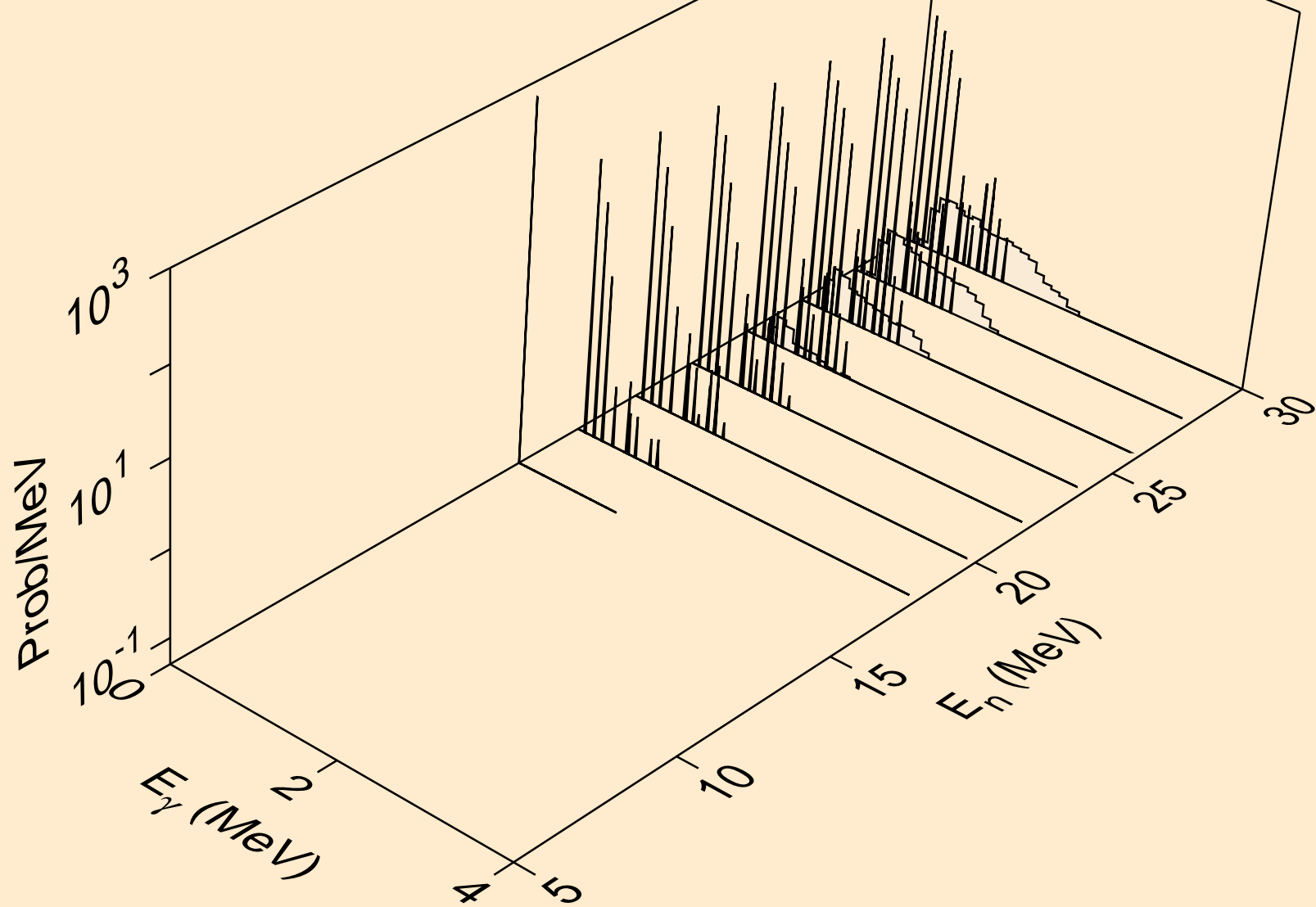

ER163 NEUTRON ACER TENDL-2024 LIBRARY; T=0.K  
Photon emission for (n,da)

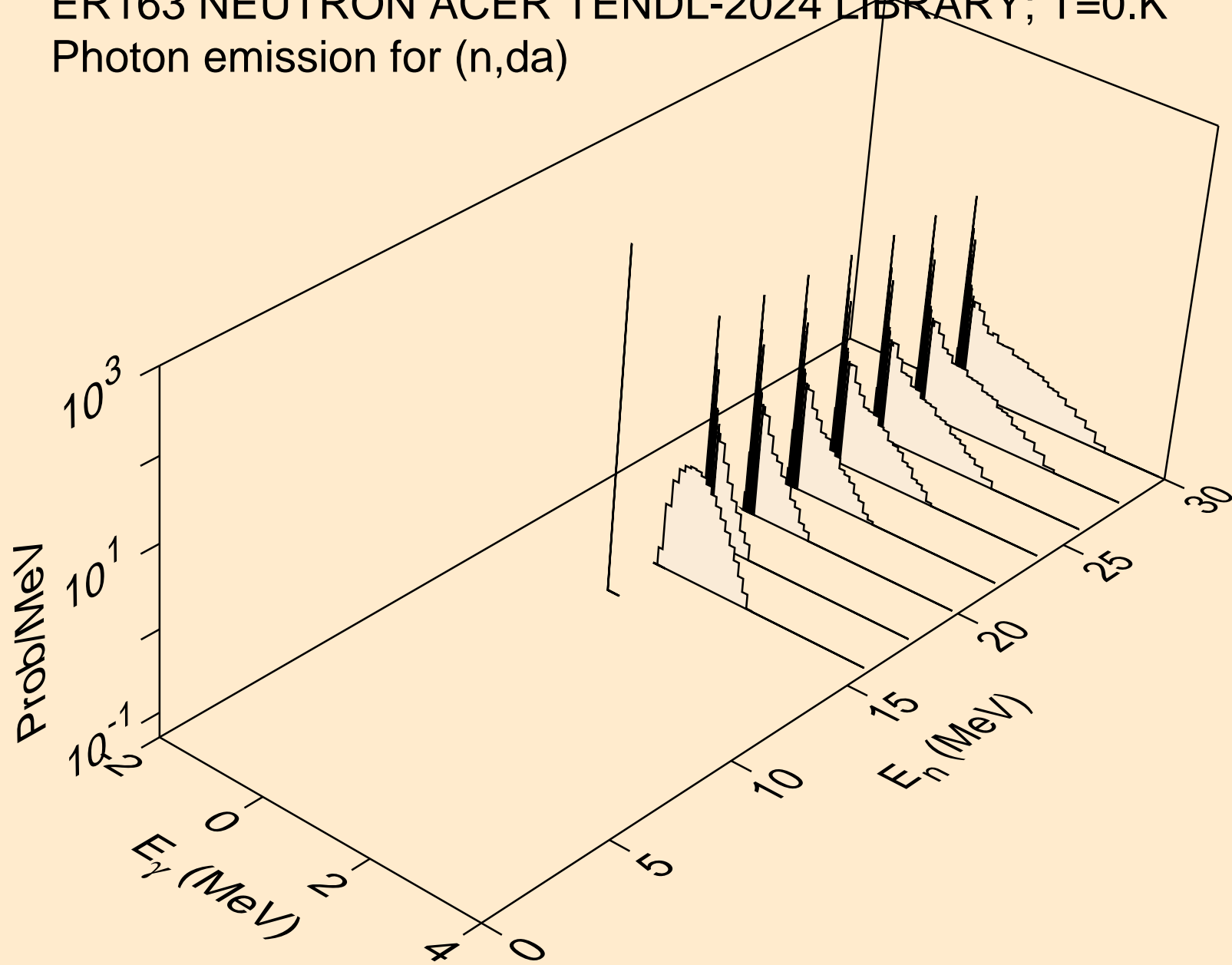

ER163 NEUTRON ACER TENDL-2024 LIBRARY; T=0.K  
thermal capture photon spectrum

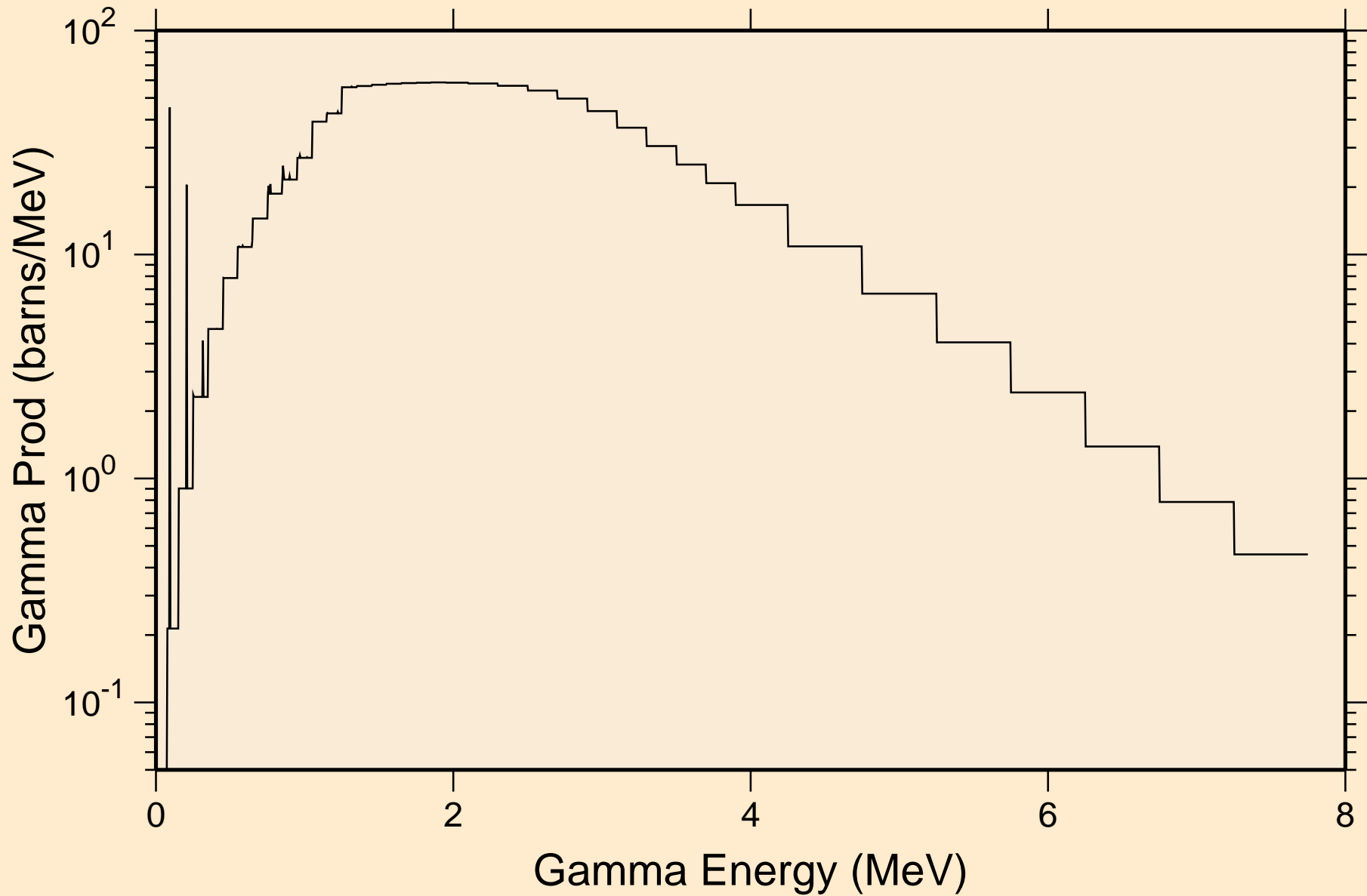

ER163 NEUTRON ACER TENDL-2024 LIBRARY; T=0.K  
14 MeV photon spectrum

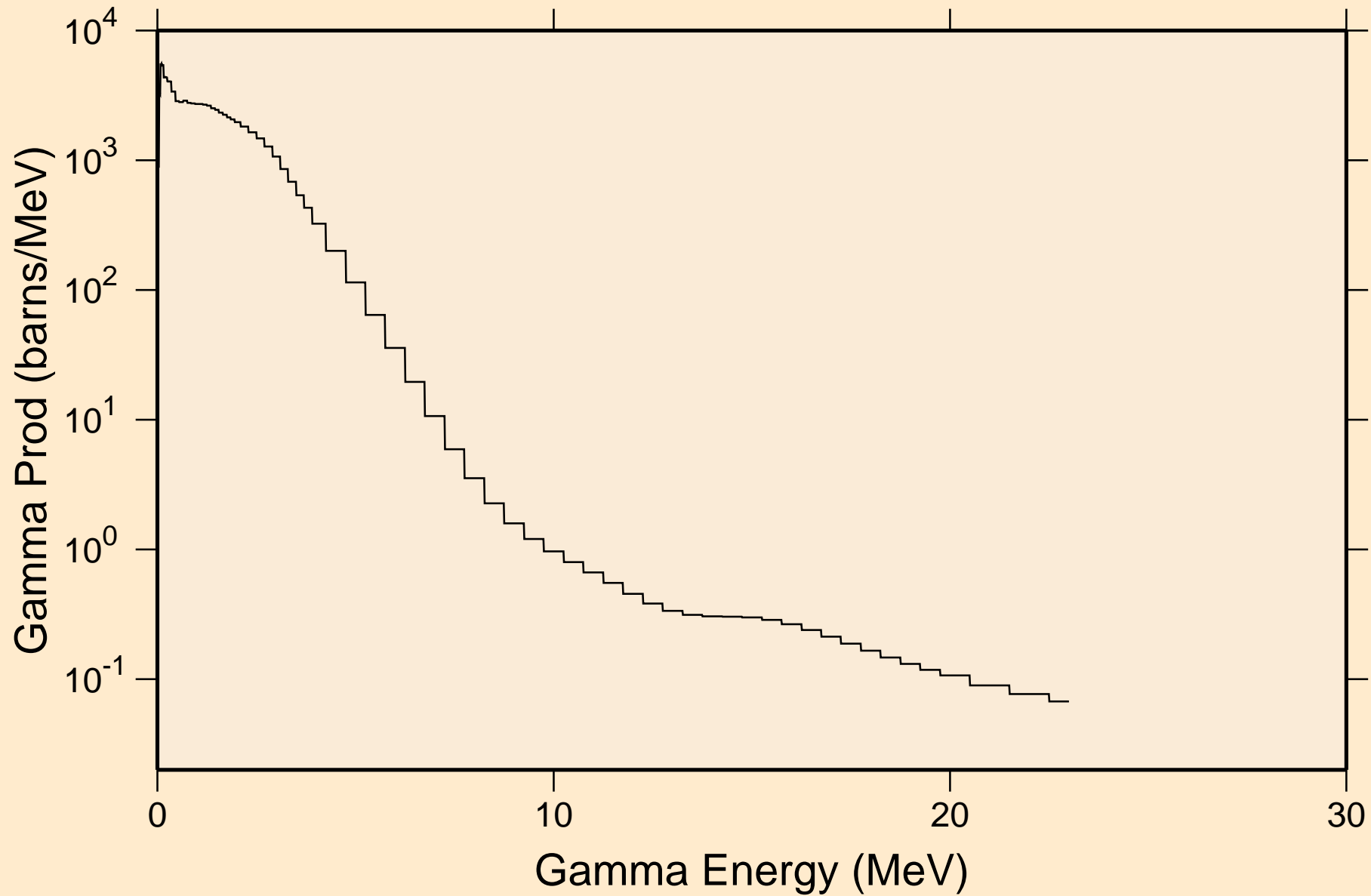



# ER163 NEUTRON ACER TENDL-2024 LIBRARY; T=0.K

## Particle heating contributions

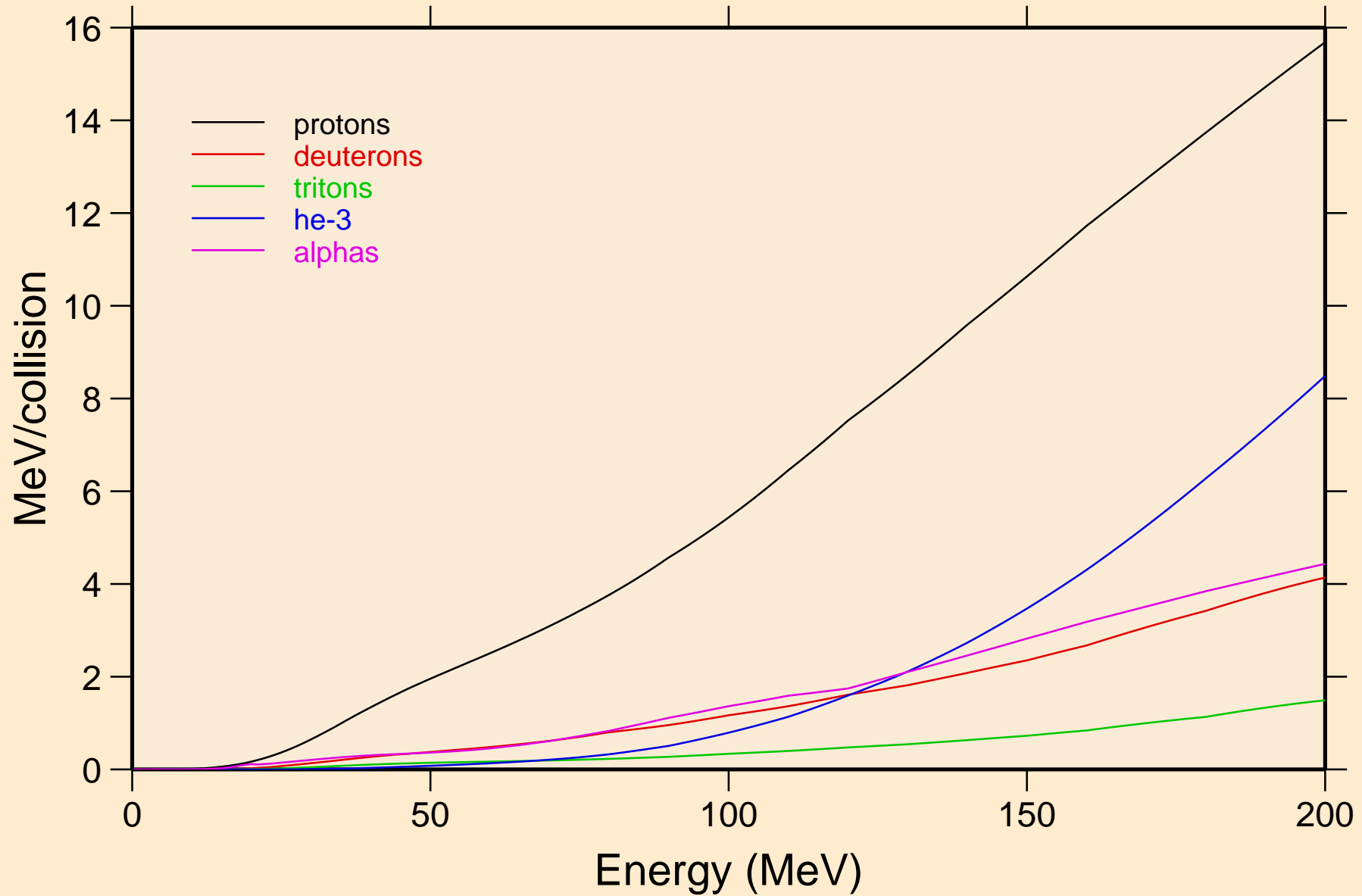

ER163 NEUTRON ACER TENDL-2024 LIBRARY; T=0.K  
Recoil Heating

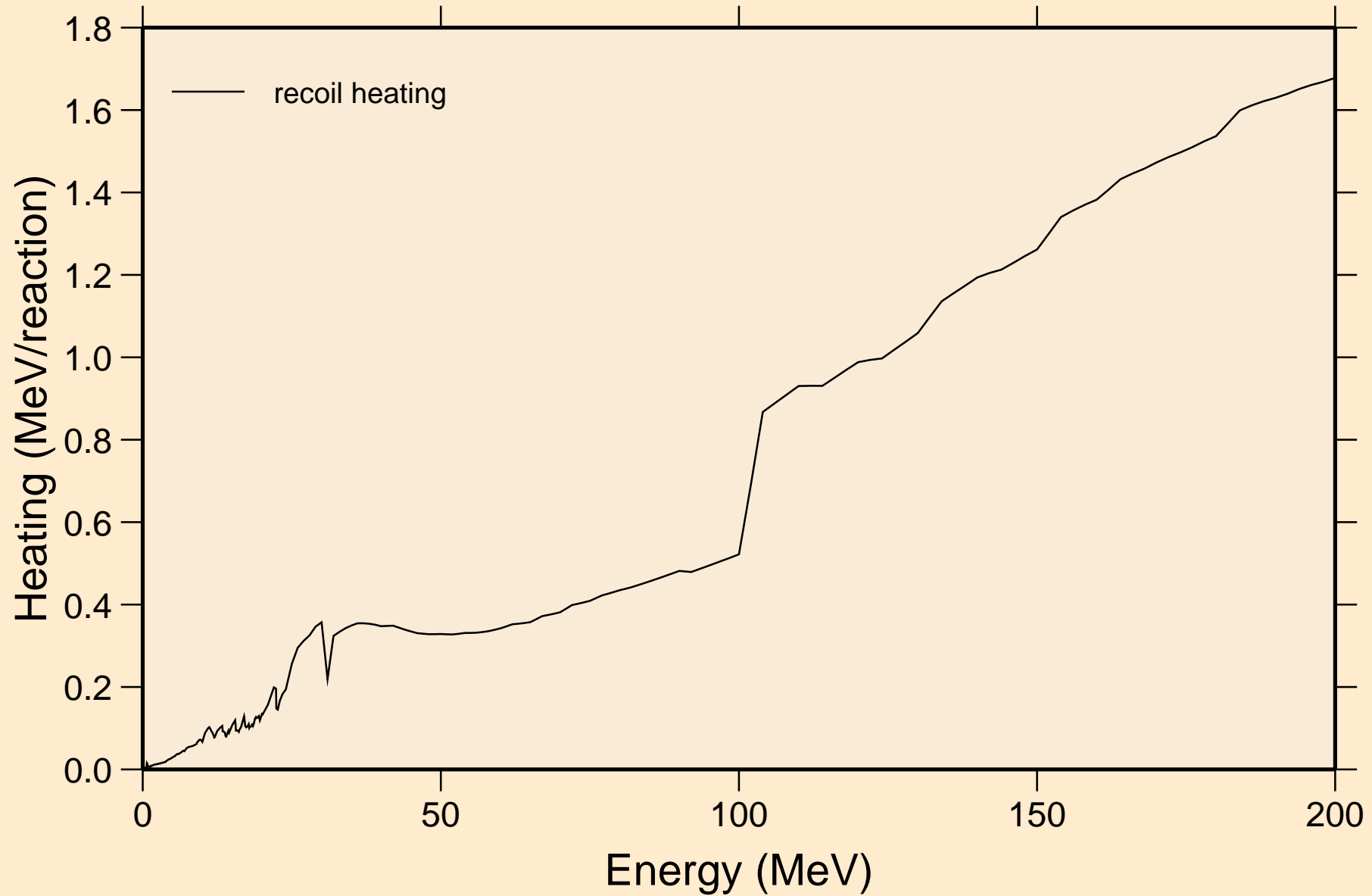

# ER163 NEUTRON ACER TENDL-2024 LIBRARY; T=0.K

## Particle production cross sections

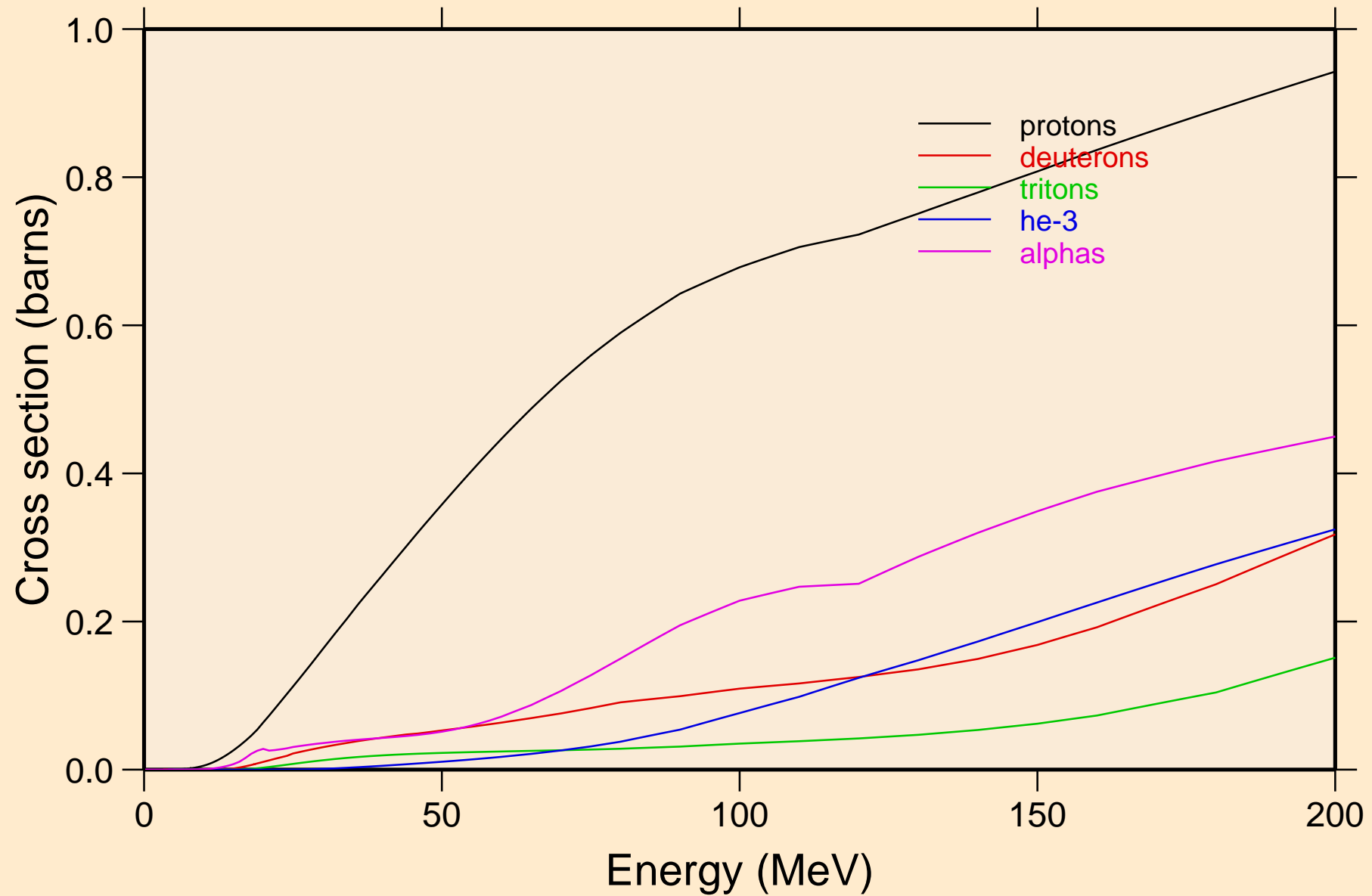

ER163 NEUTRON ACER TENDL-2024 LIBRARY; T=0.K  
protons from (n,x)

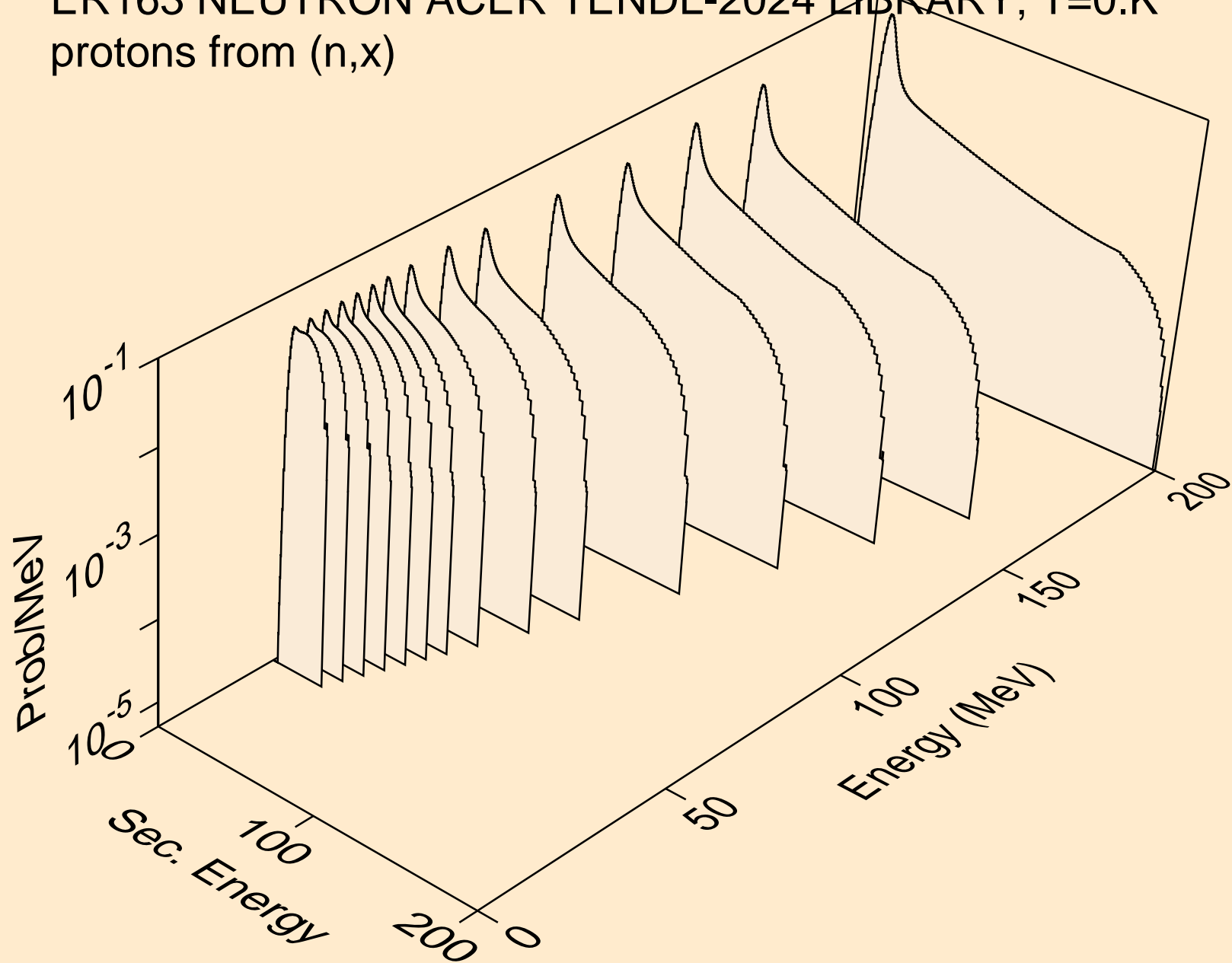

ER163 NEUTRON ACER TENDL-2024 LIBRARY; T=0.K  
protons from (n,n\*)p

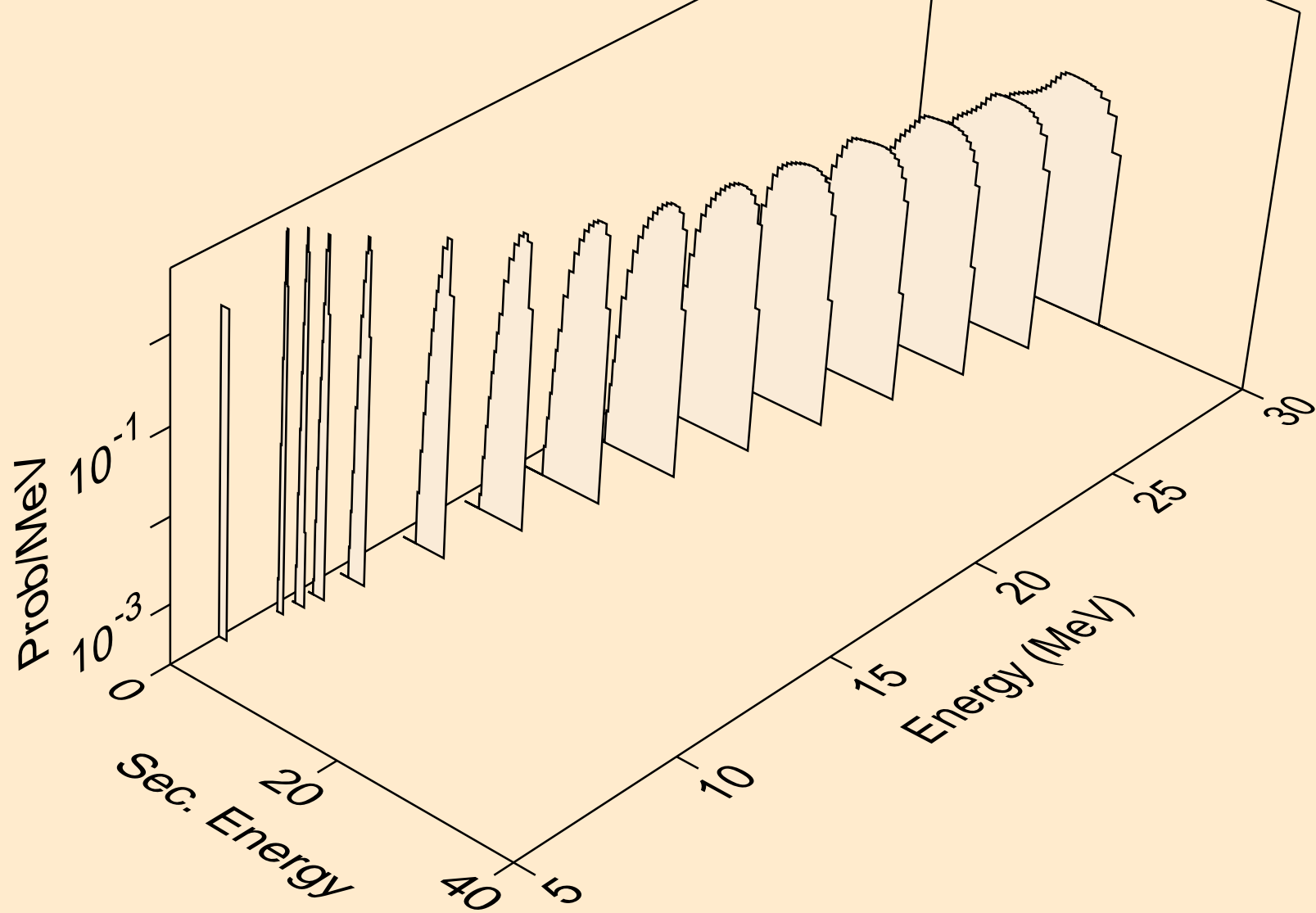

ER163 NEUTRON ACER TENDL-2024 LIBRARY; T=0.K  
protons from (n,2np)

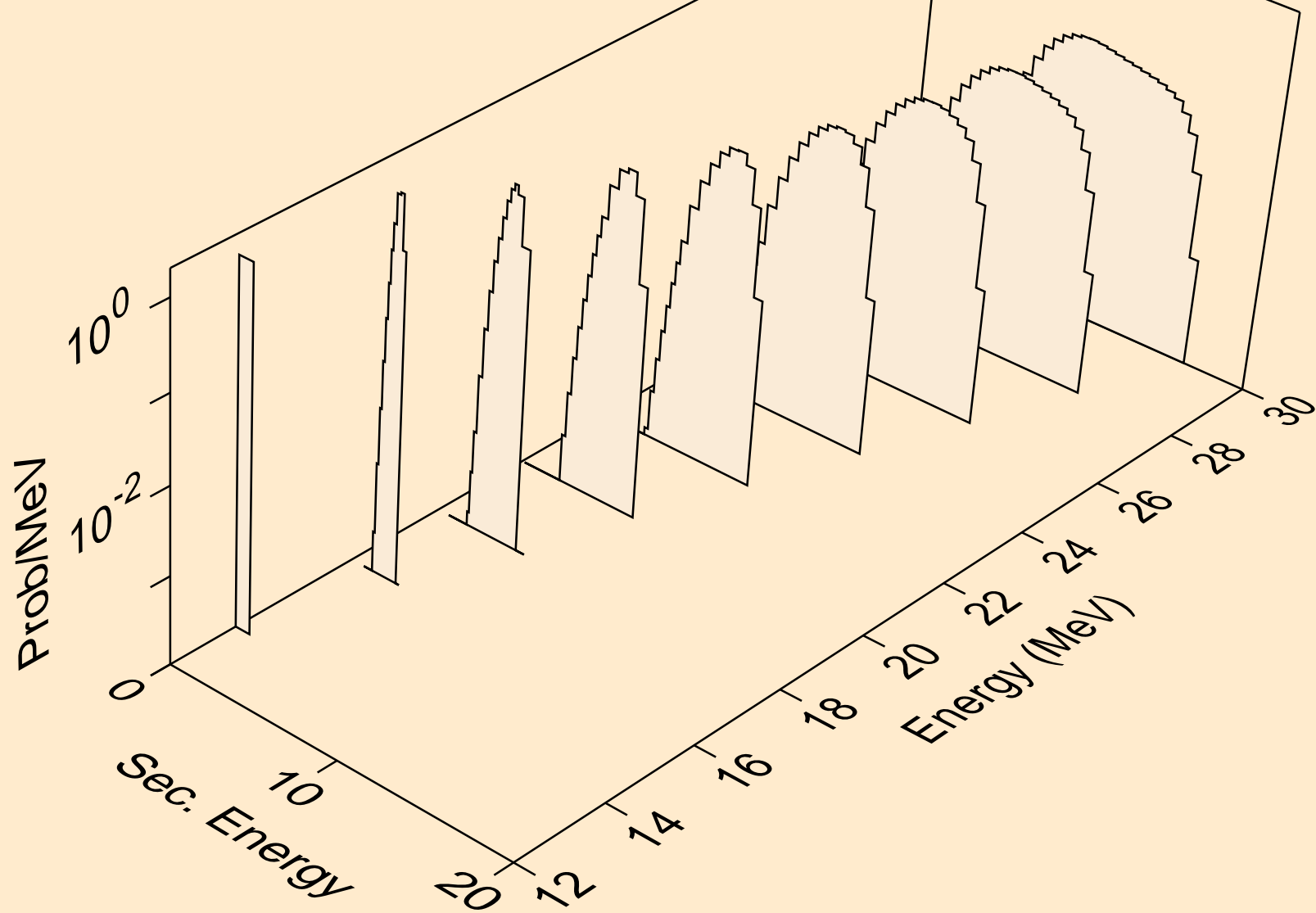

ER163 NEUTRON ACER TENDL-2024 LIBRARY; T=0.K  
protons from (n,3np)

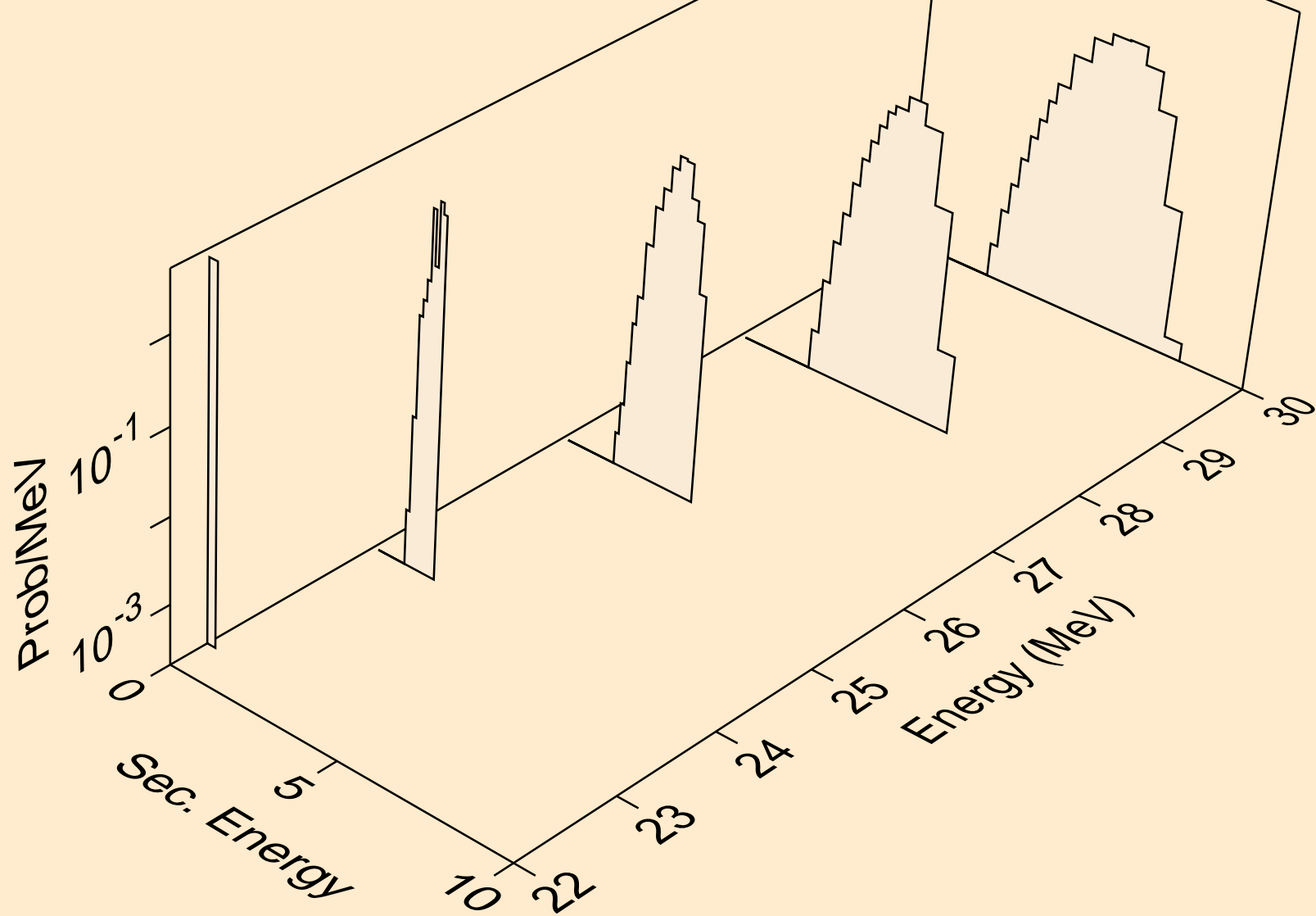

ER163 NEUTRON ACER TENDL-2024 LIBRARY; T=0.K  
protons from (n,n2p)

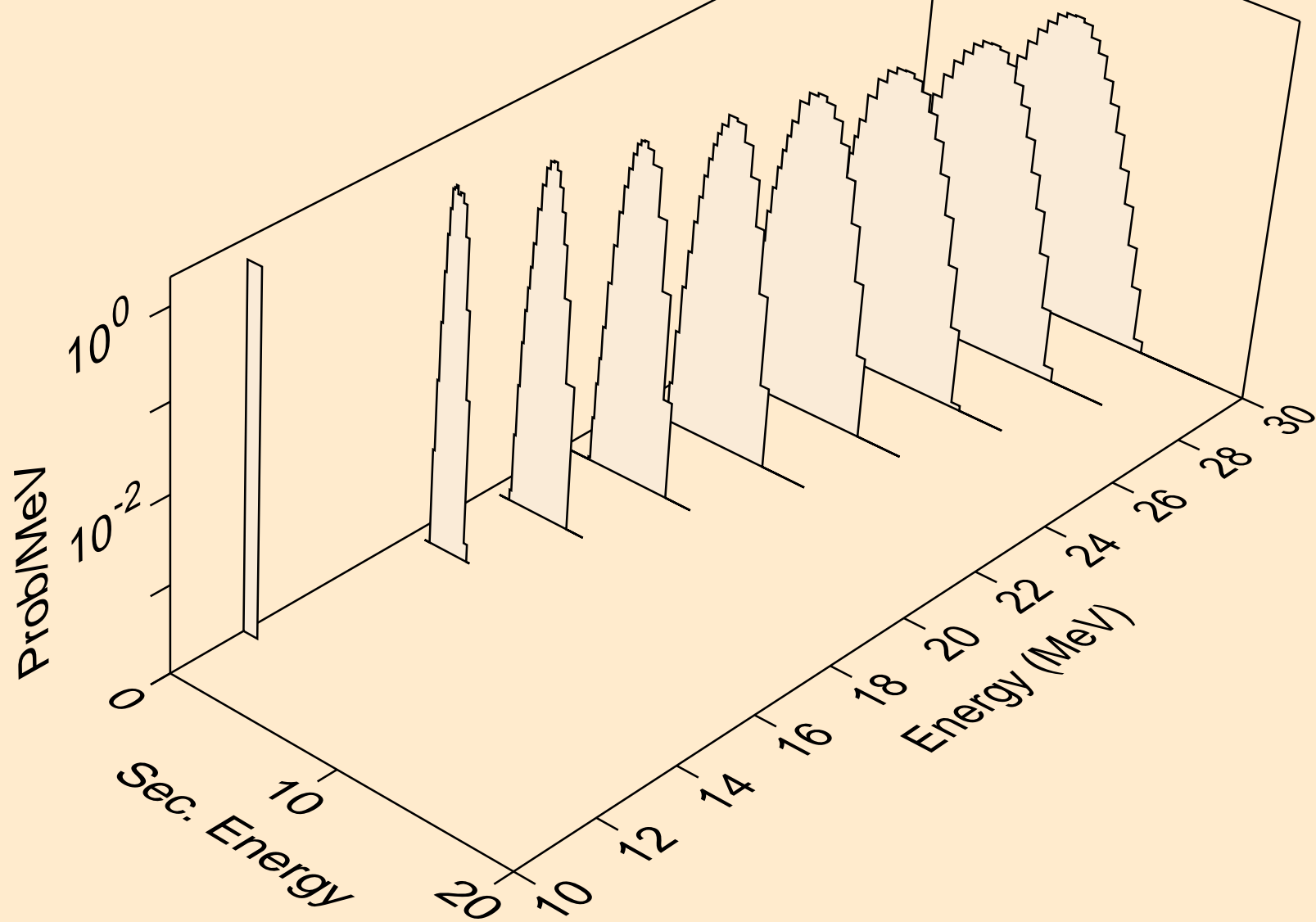



ER163 NEUTRON ACER TENDL-2024 LIBRARY; T=0.K  
protons from (n,npa)

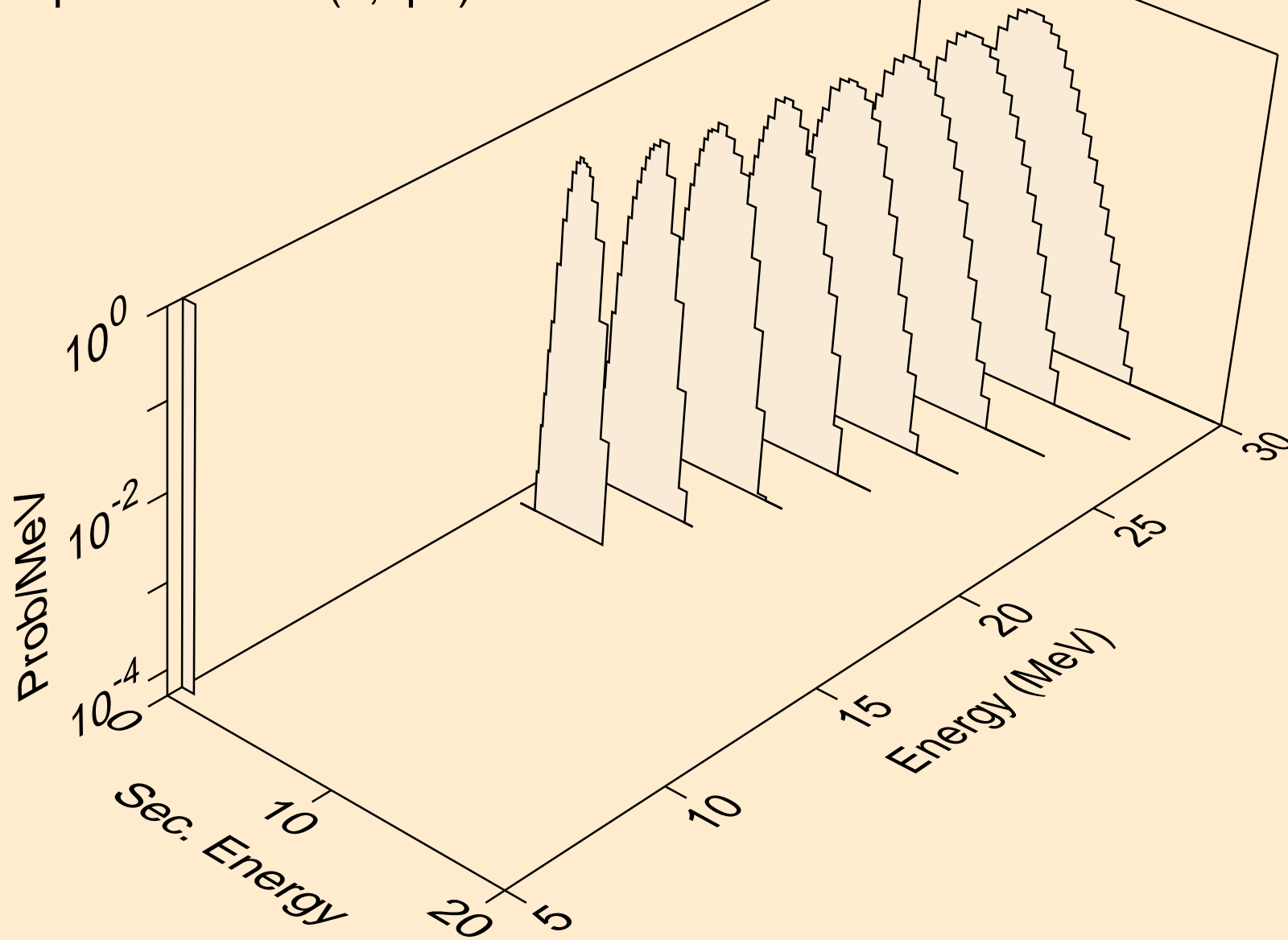

ER163 NEUTRON ACER TENDL-2024 LIBRARY; T=0.K  
protons from (n,p)

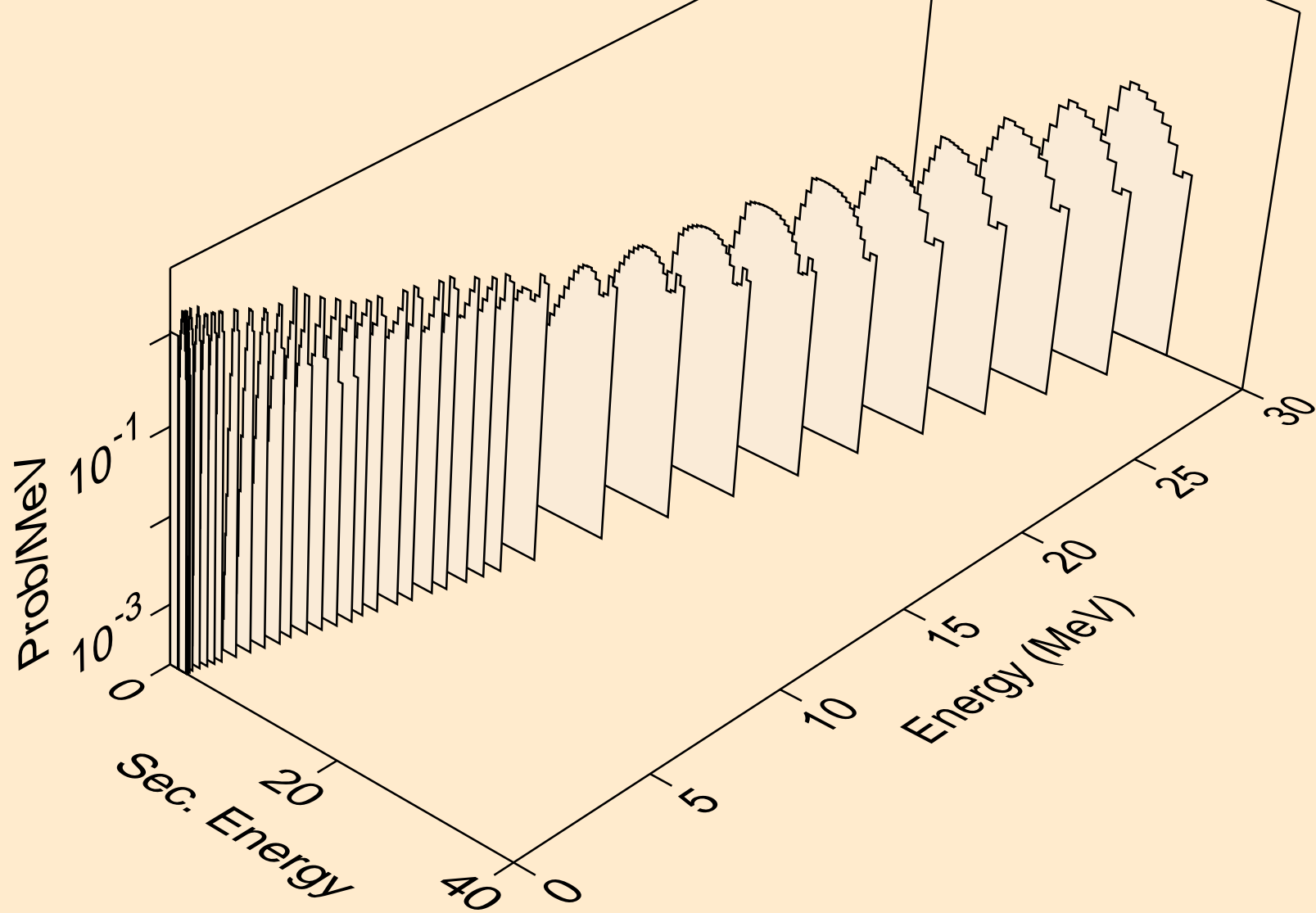

ER163 NEUTRON ACER TENDL-2024 LIBRARY; T=0.K  
protons from (n,2p)

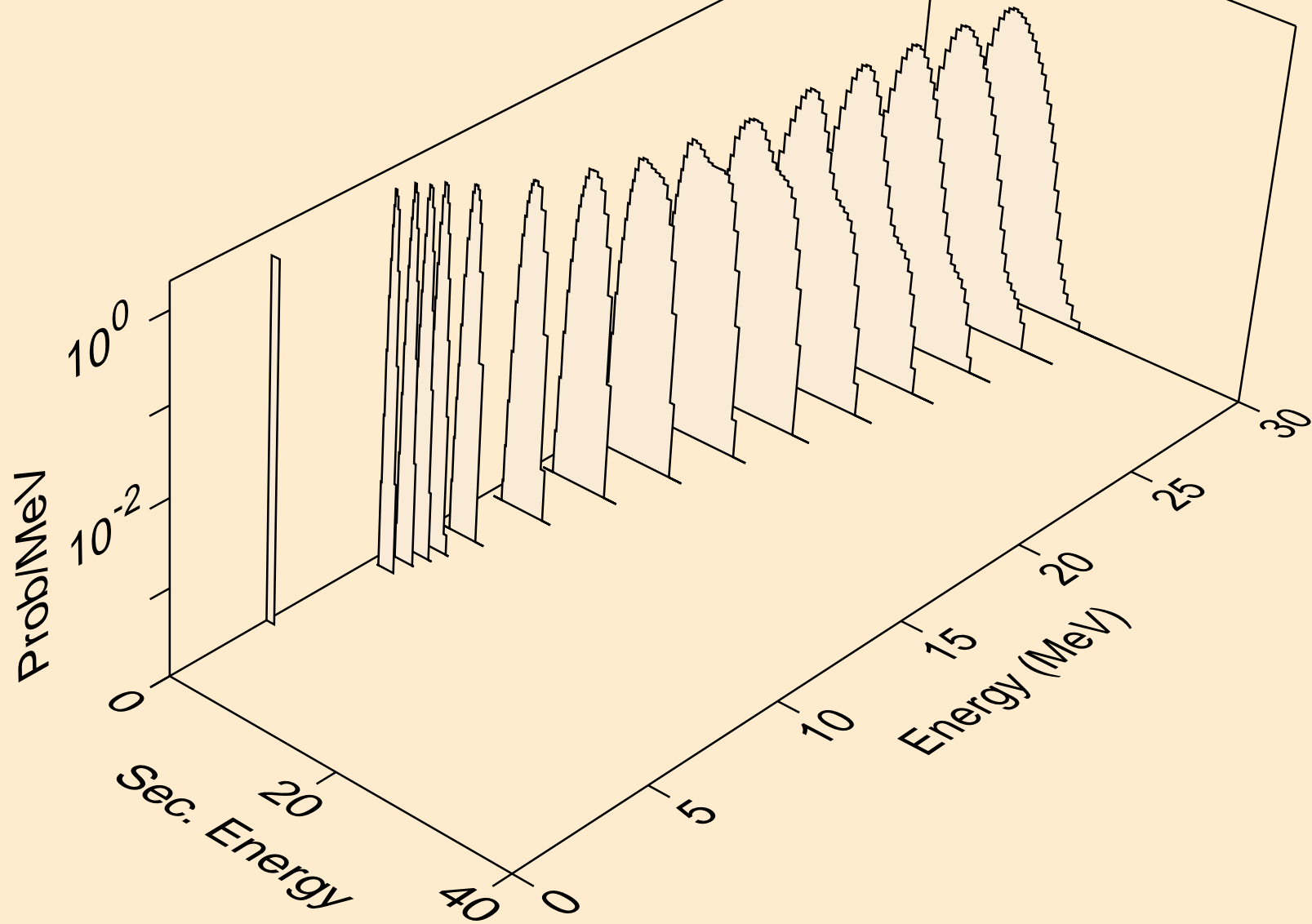

ER163 NEUTRON ACER TENDL-2024 LIBRARY; T=0.K  
protons from (n,pa)

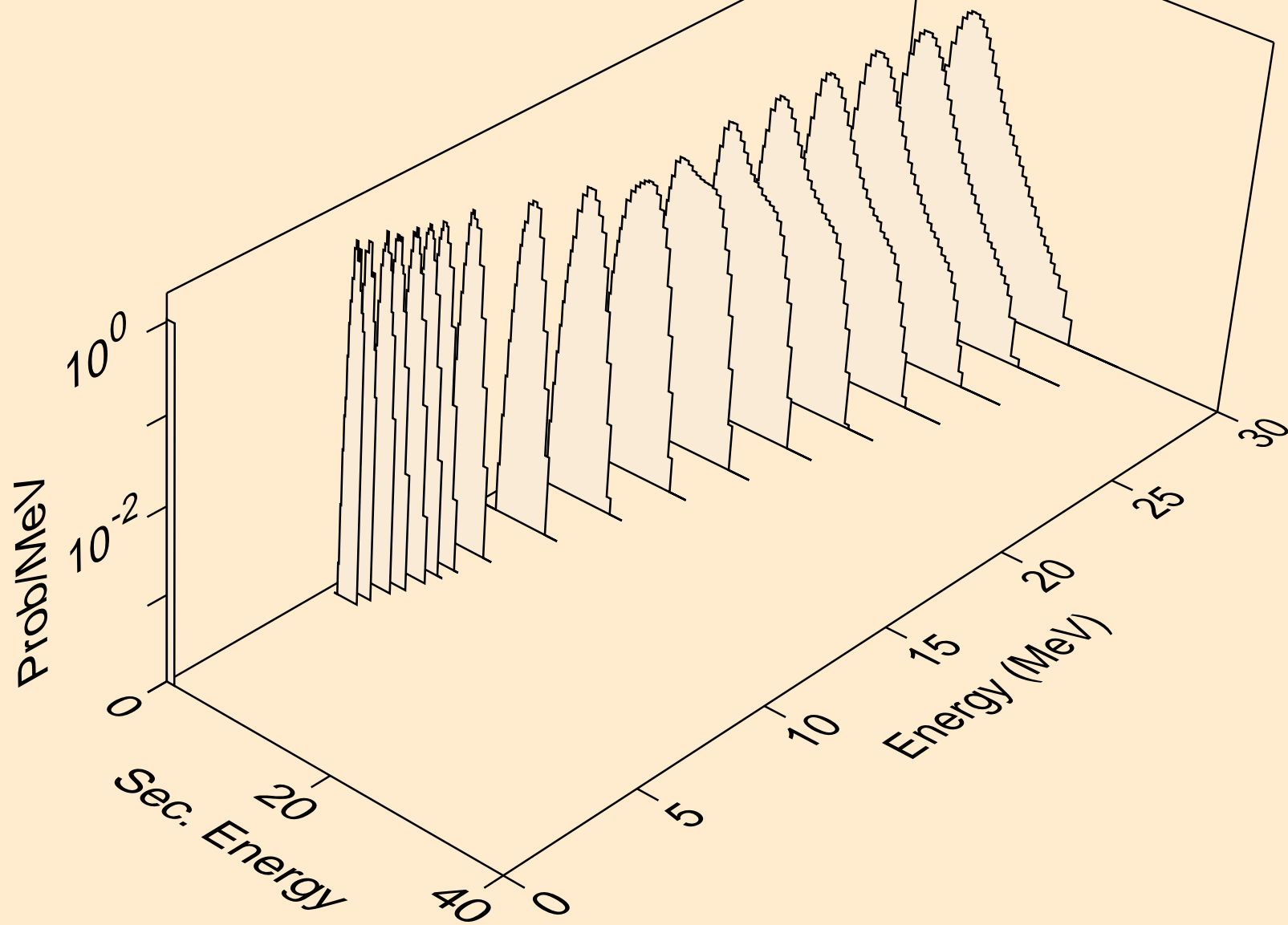

ER163 NEUTRON ACER TENDL-2024 LIBRARY; T=0.K  
protons from (n,pd)

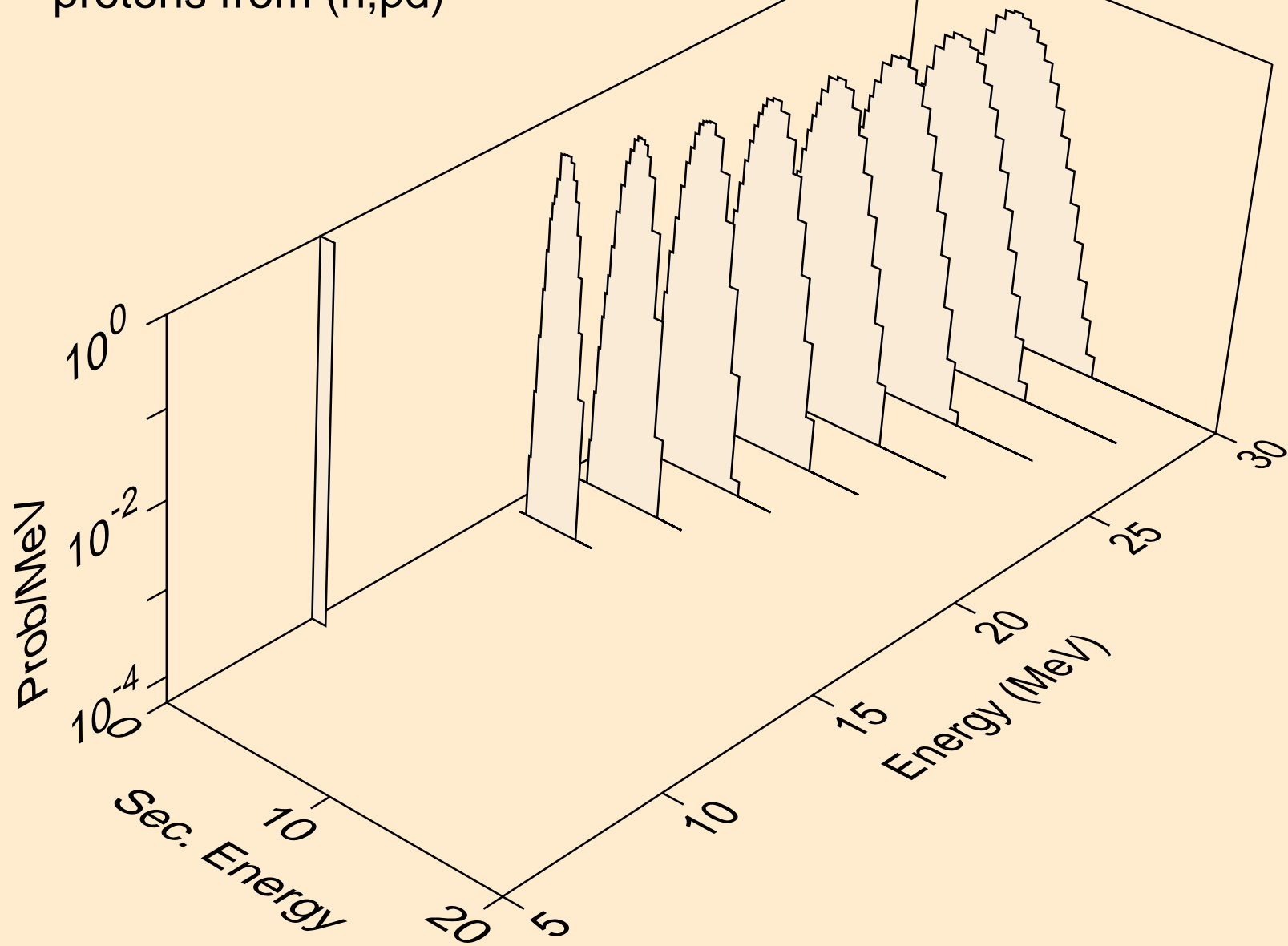

ER163 NEUTRON ACER TENDL-2024 LIBRARY; T=0.K  
protons from (n,pt)

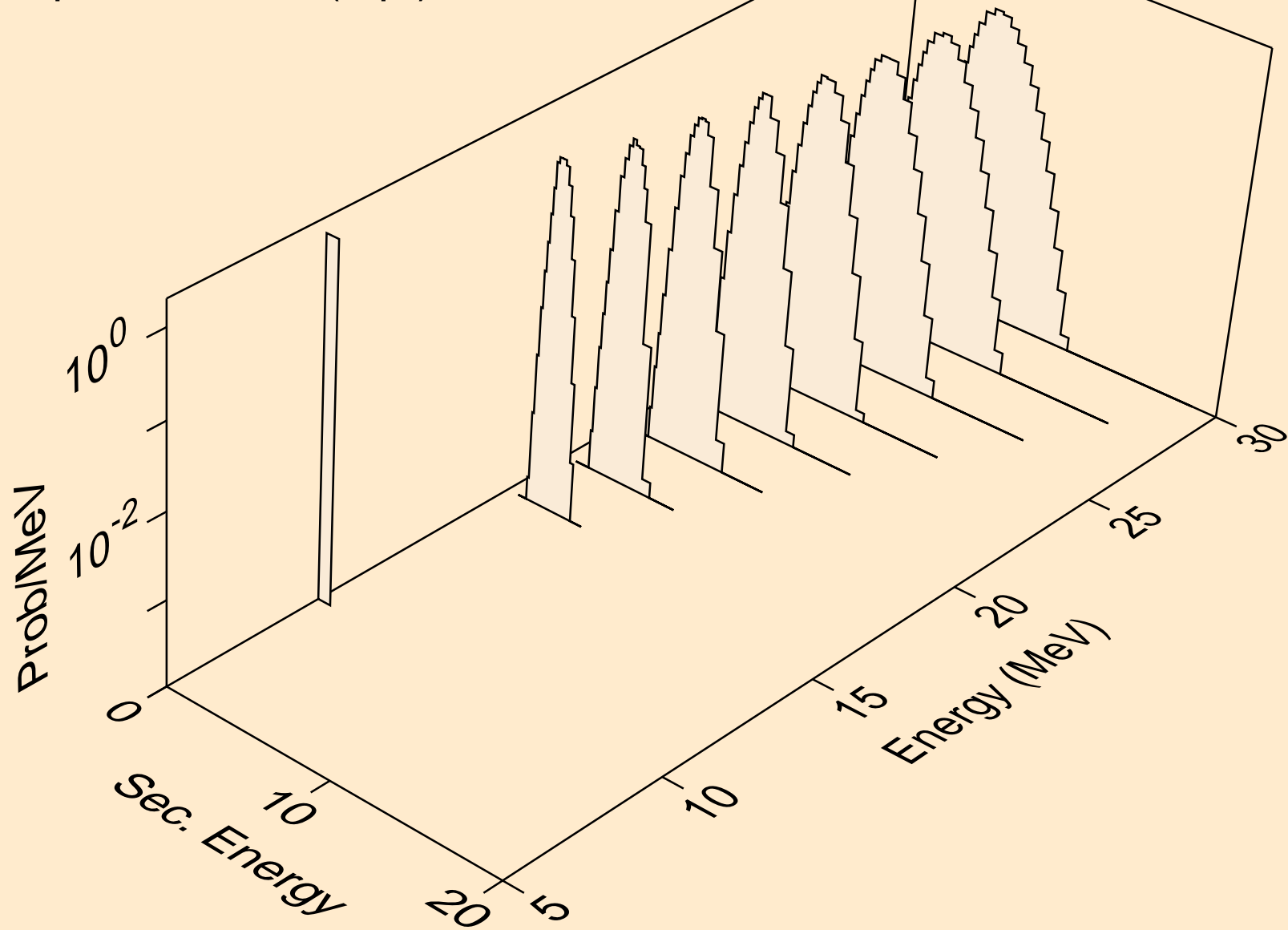

ER163 NEUTRON ACER TENDL-2024 LIBRARY; T=0.K  
deuterons from (n,x)

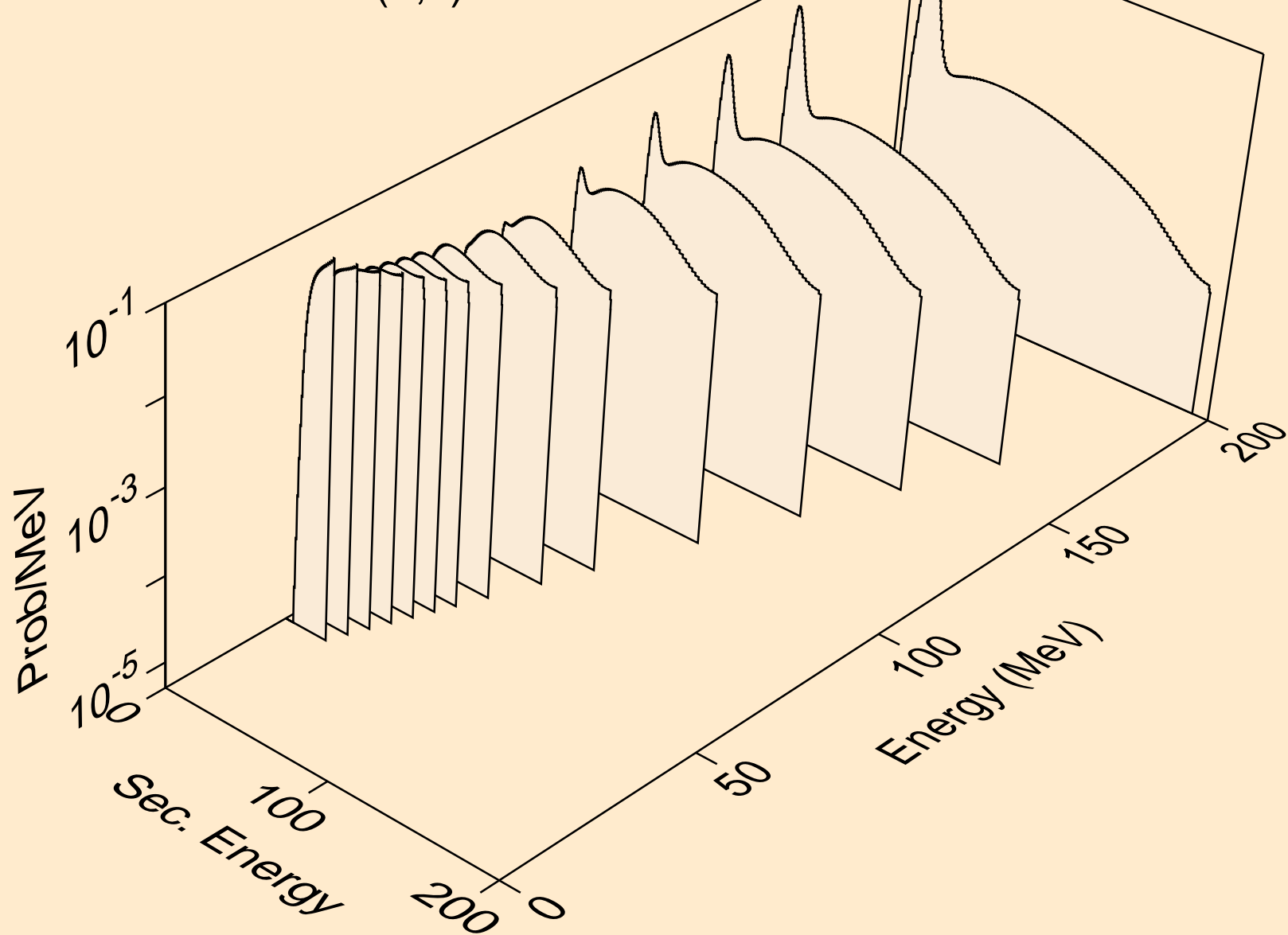

ER163 NEUTRON ACER TENDL-2024 LIBRARY; T=0.K  
deuterons from (n,2nd)

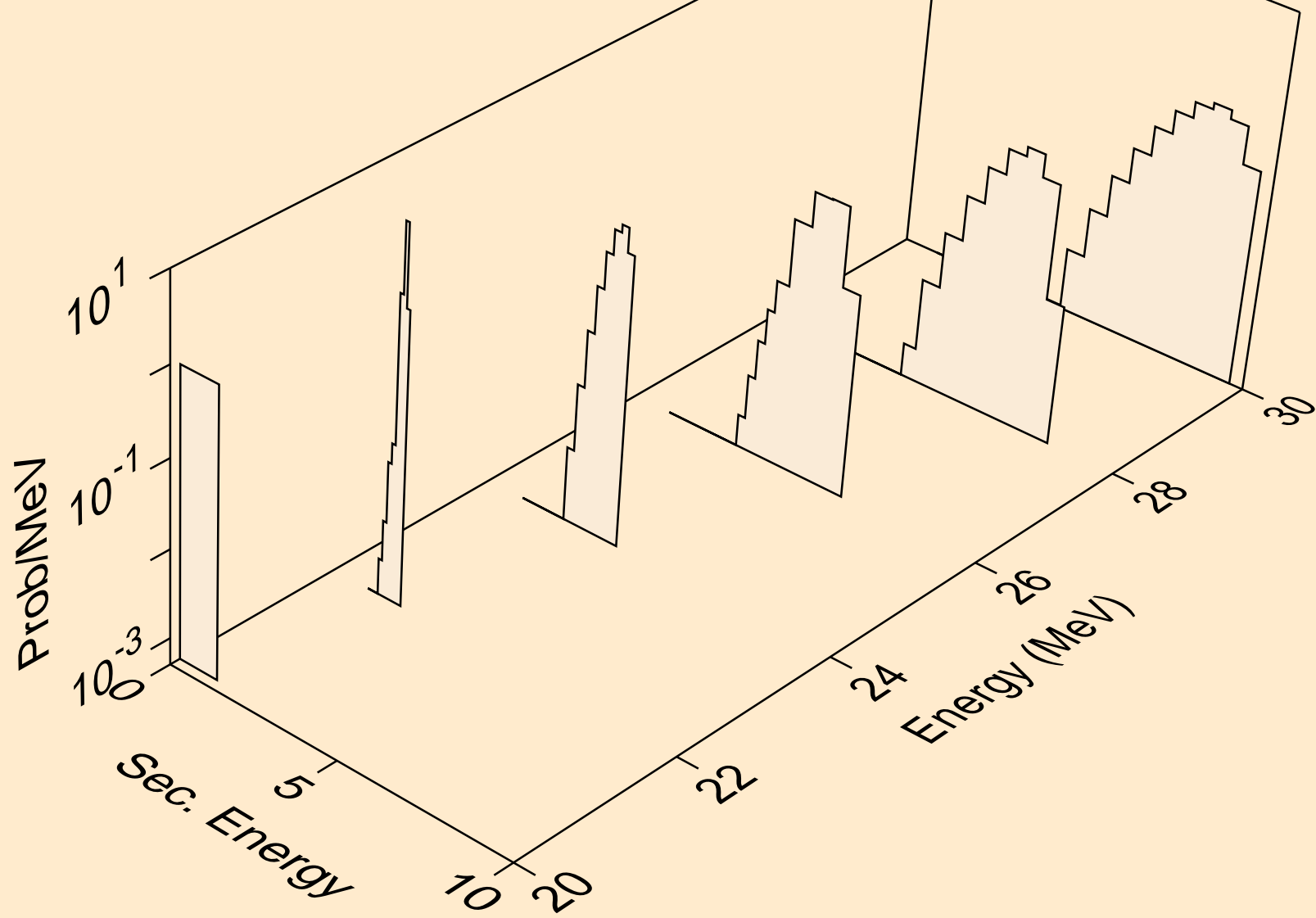



ER163 NEUTRON ACER TENDL-2024 LIBRARY; T=0.K  
deuterons from (n,n\*)d

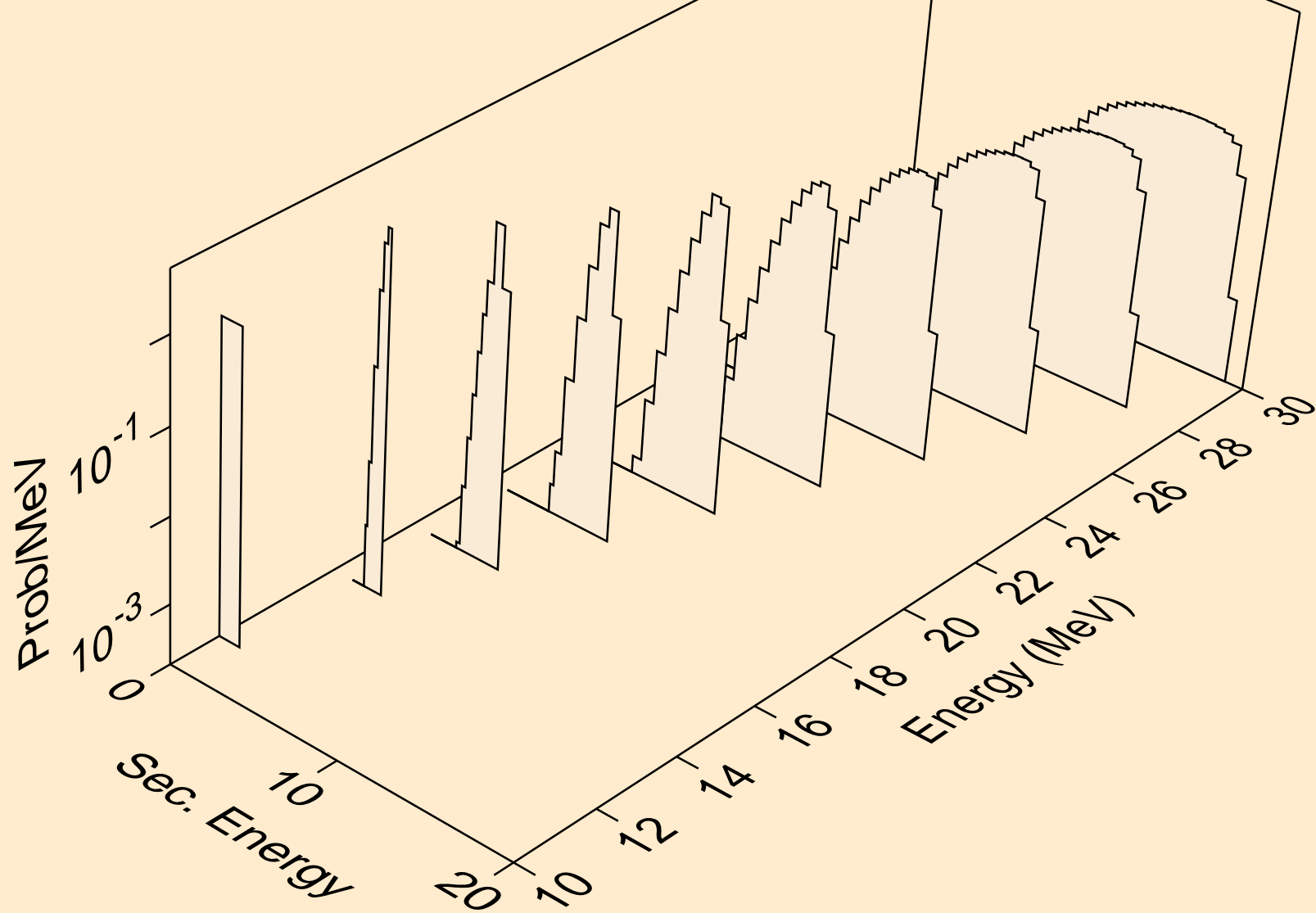

ER163 NEUTRON ACER TENDL-2024 LIBRARY; T=0.K  
deuterons from (n,d)

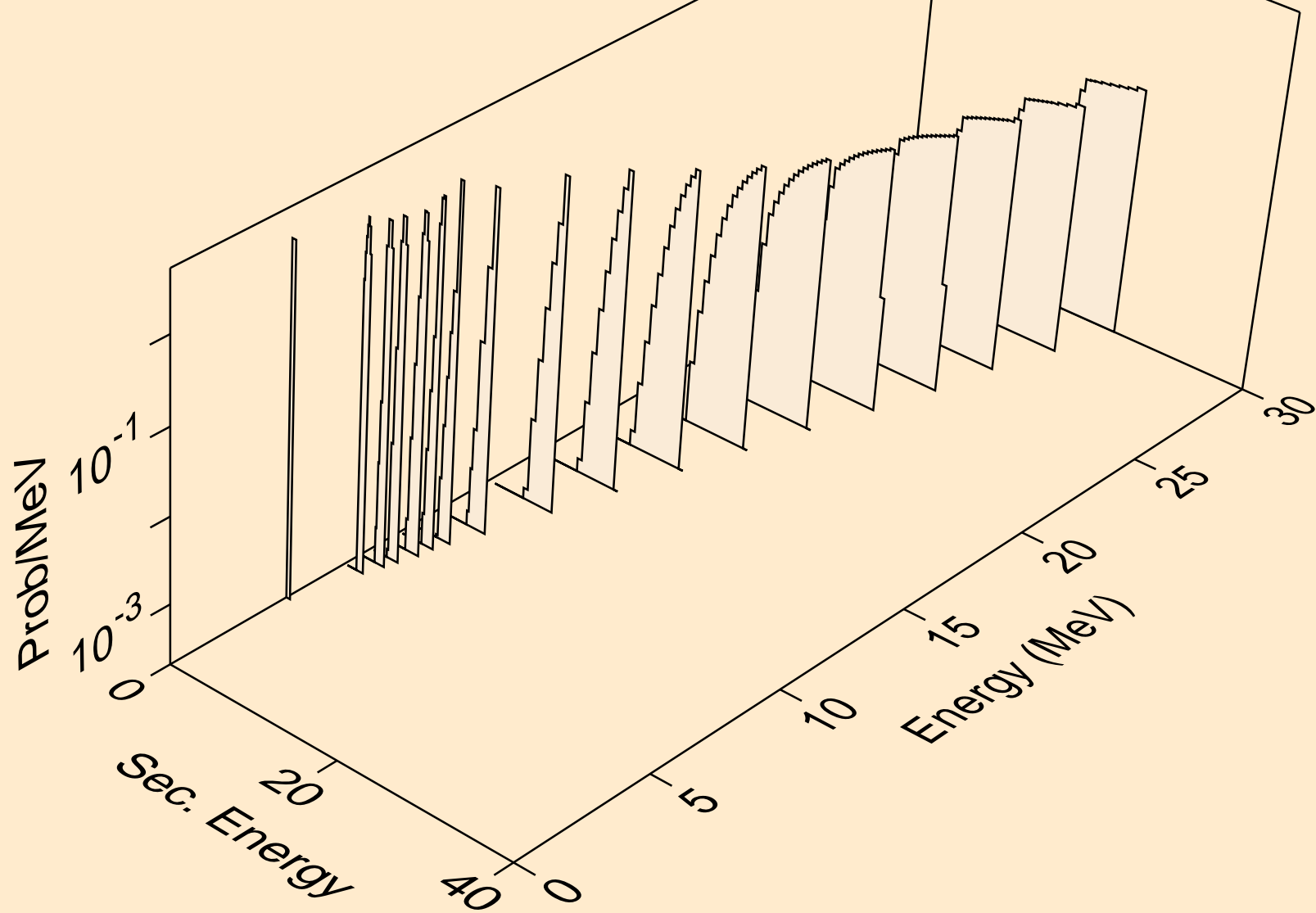

ER163 NEUTRON ACER TENDL-2024 LIBRARY; T=0.K  
deuterons from (n,pd)

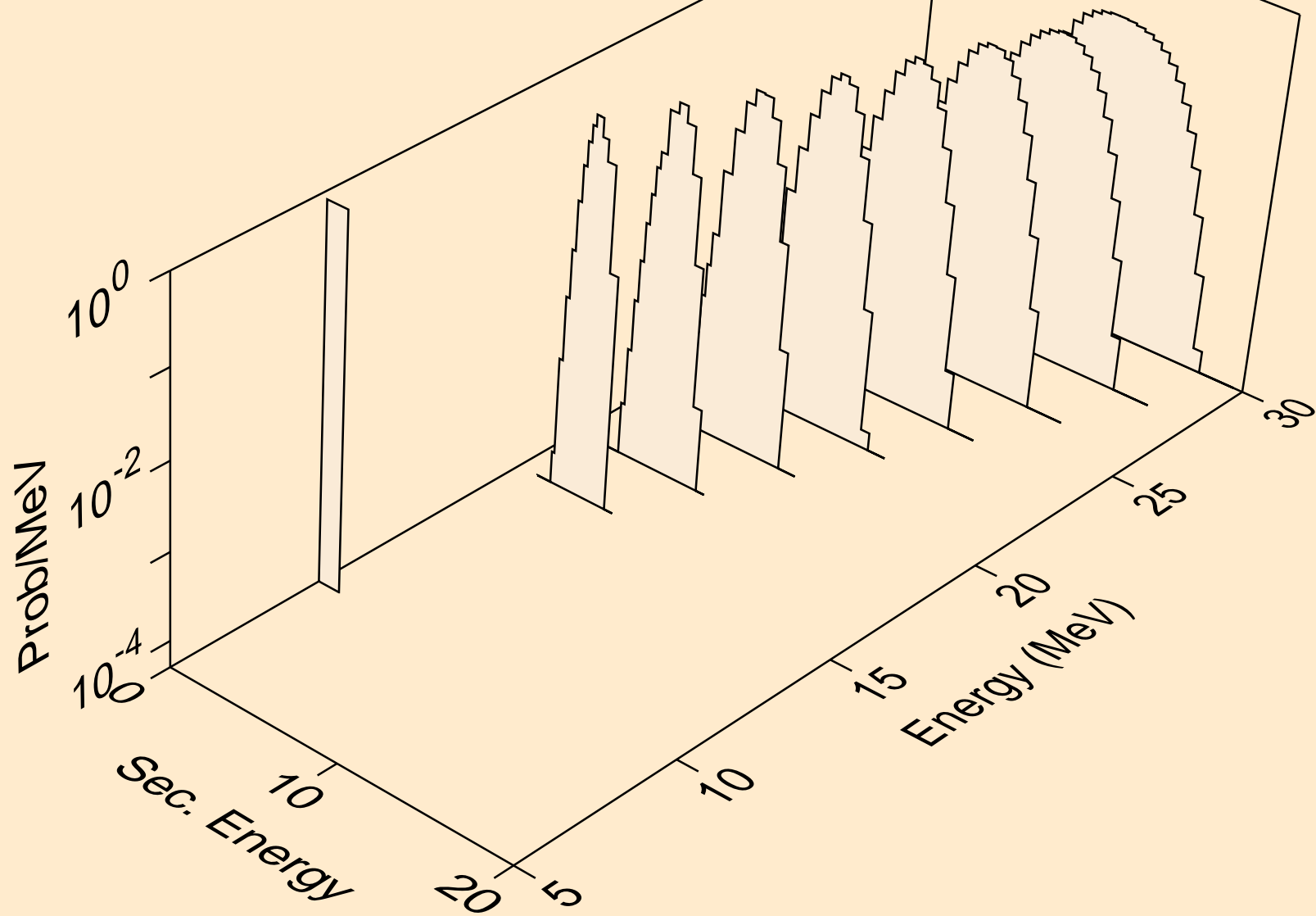

ER163 NEUTRON ACER TENDL-2024 LIBRARY; T=0.K  
deuterons from (n,da)

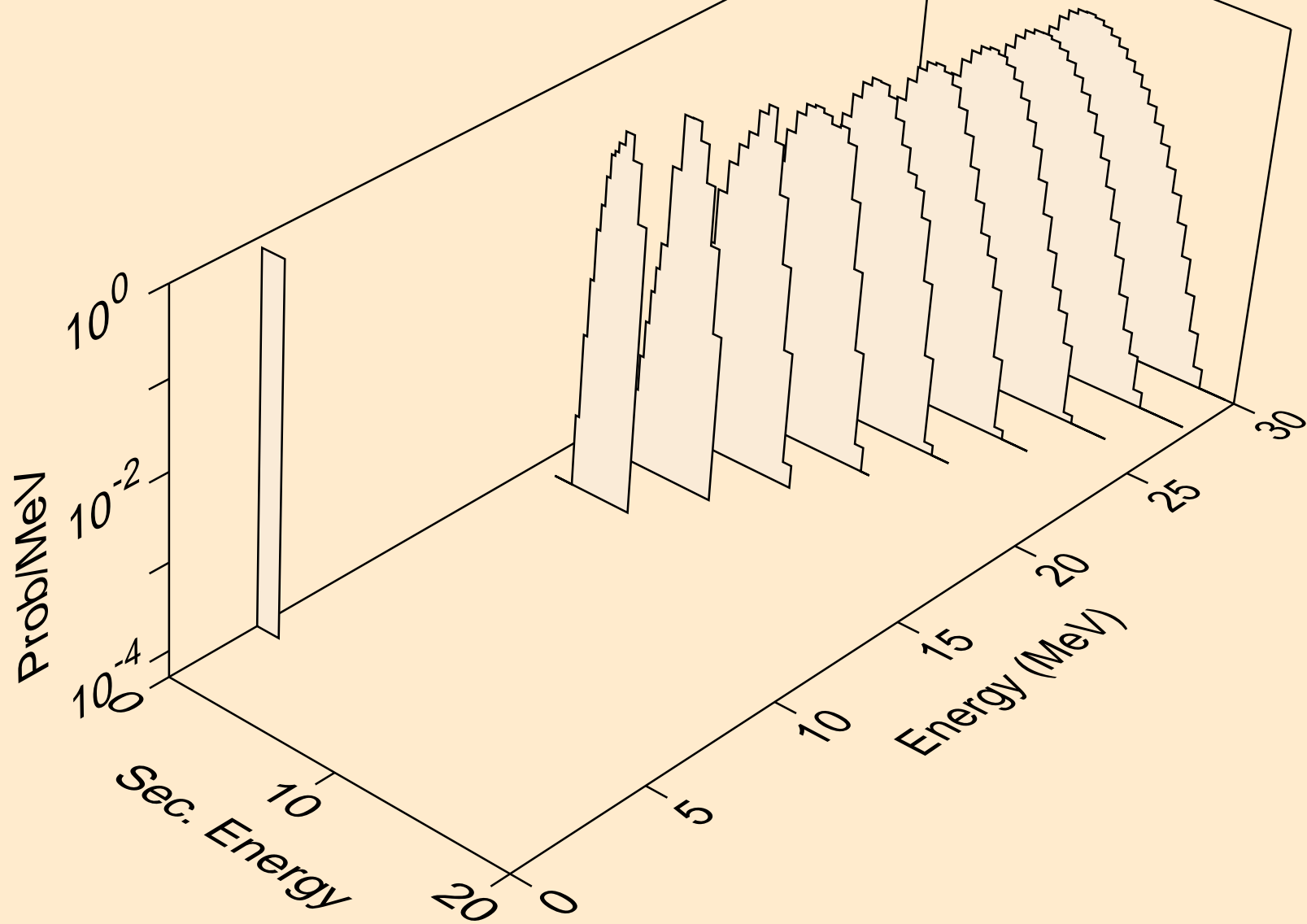

ER163 NEUTRON ACER TENDL-2024 LIBRARY; T=0.K  
tritons from (n,x)

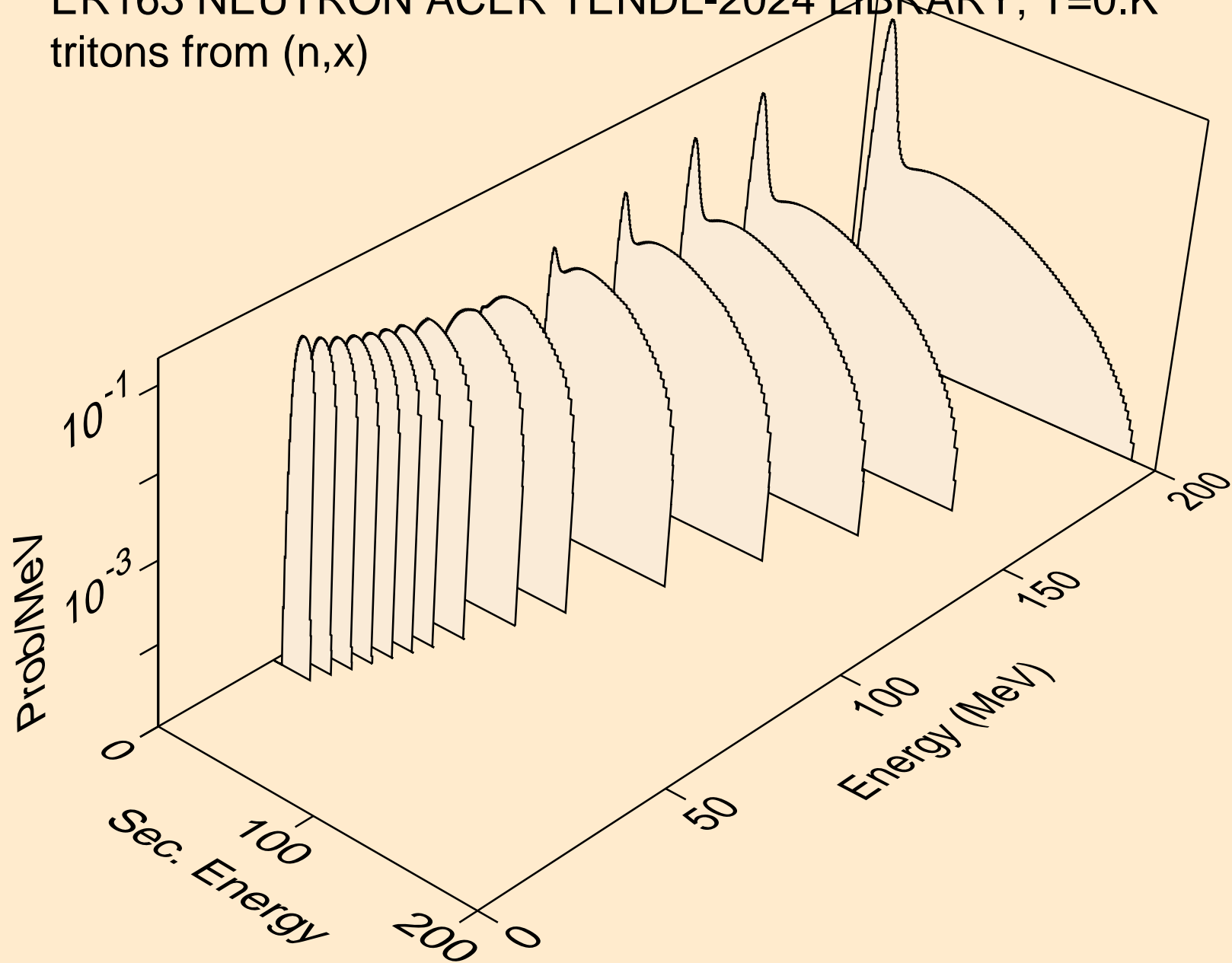

ER163 NEUTRON ACER TENDL-2024 LIBRARY; T=0.K  
tritons from (n,n\*)t

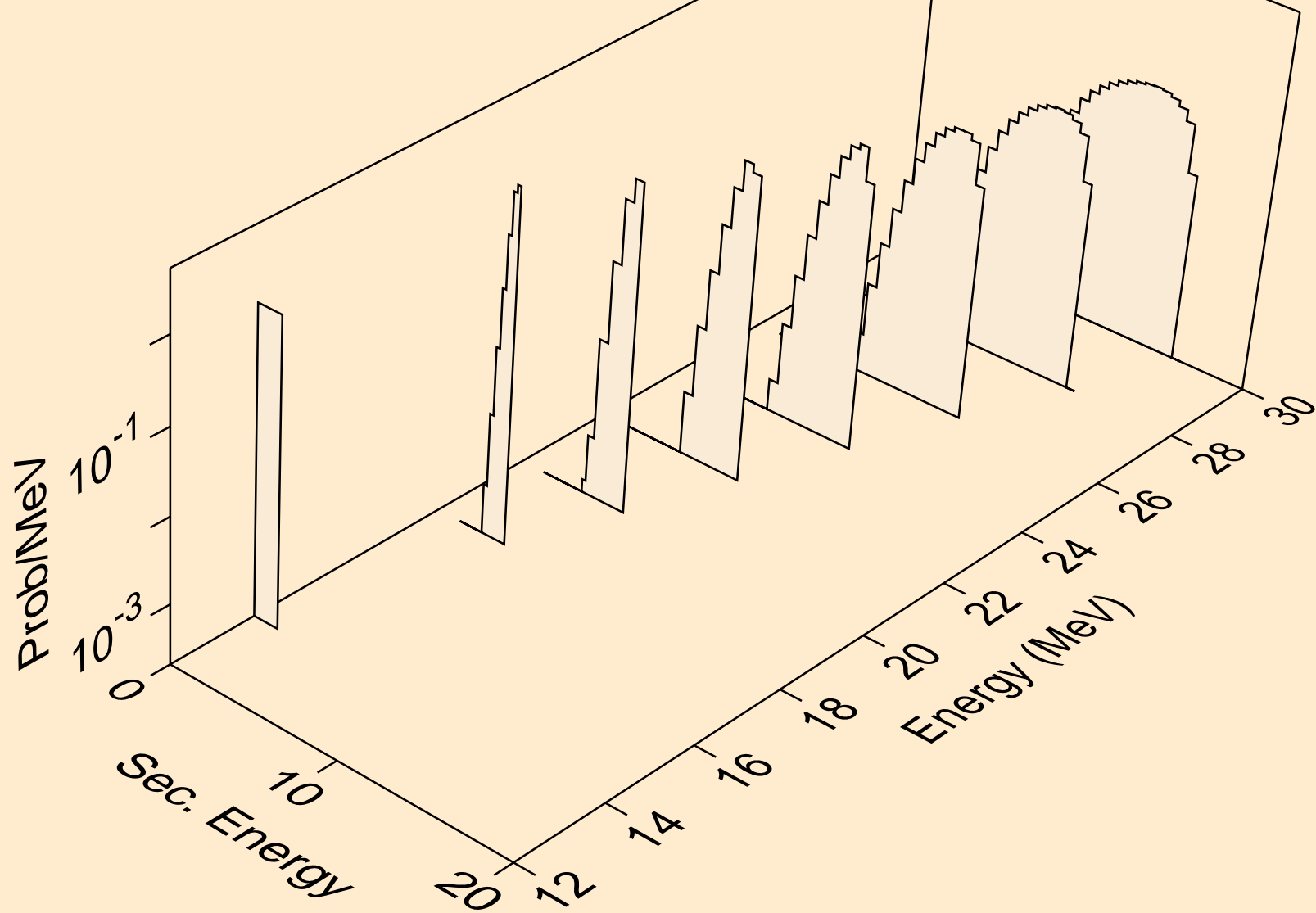

ER163 NEUTRON ACER TENDL-2024 LIBRARY; T=0.K  
tritons from (n,t)

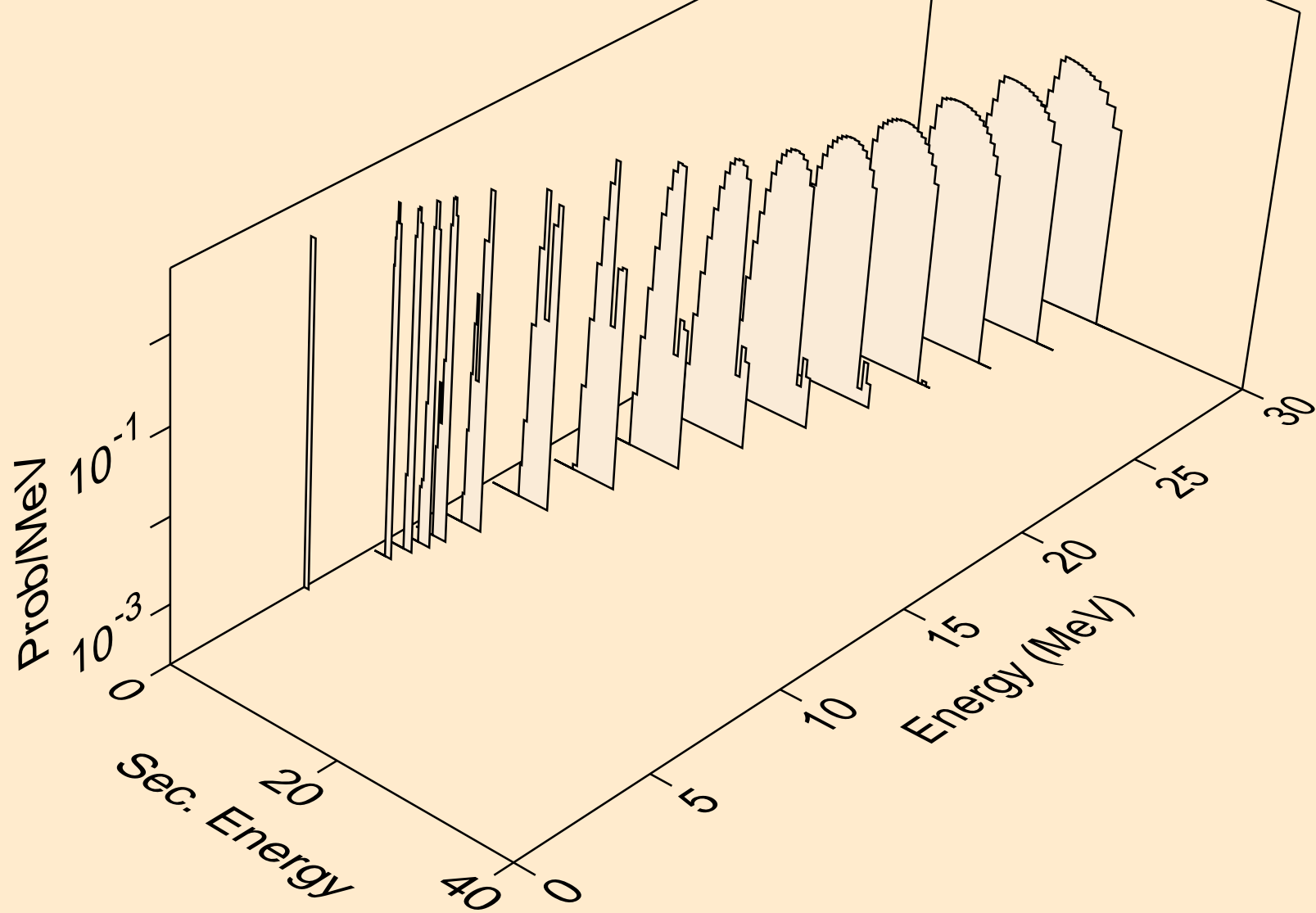

ER163 NEUTRON ACER TENDL-2024 LIBRARY; T=0.K  
tritons from (n,pt)

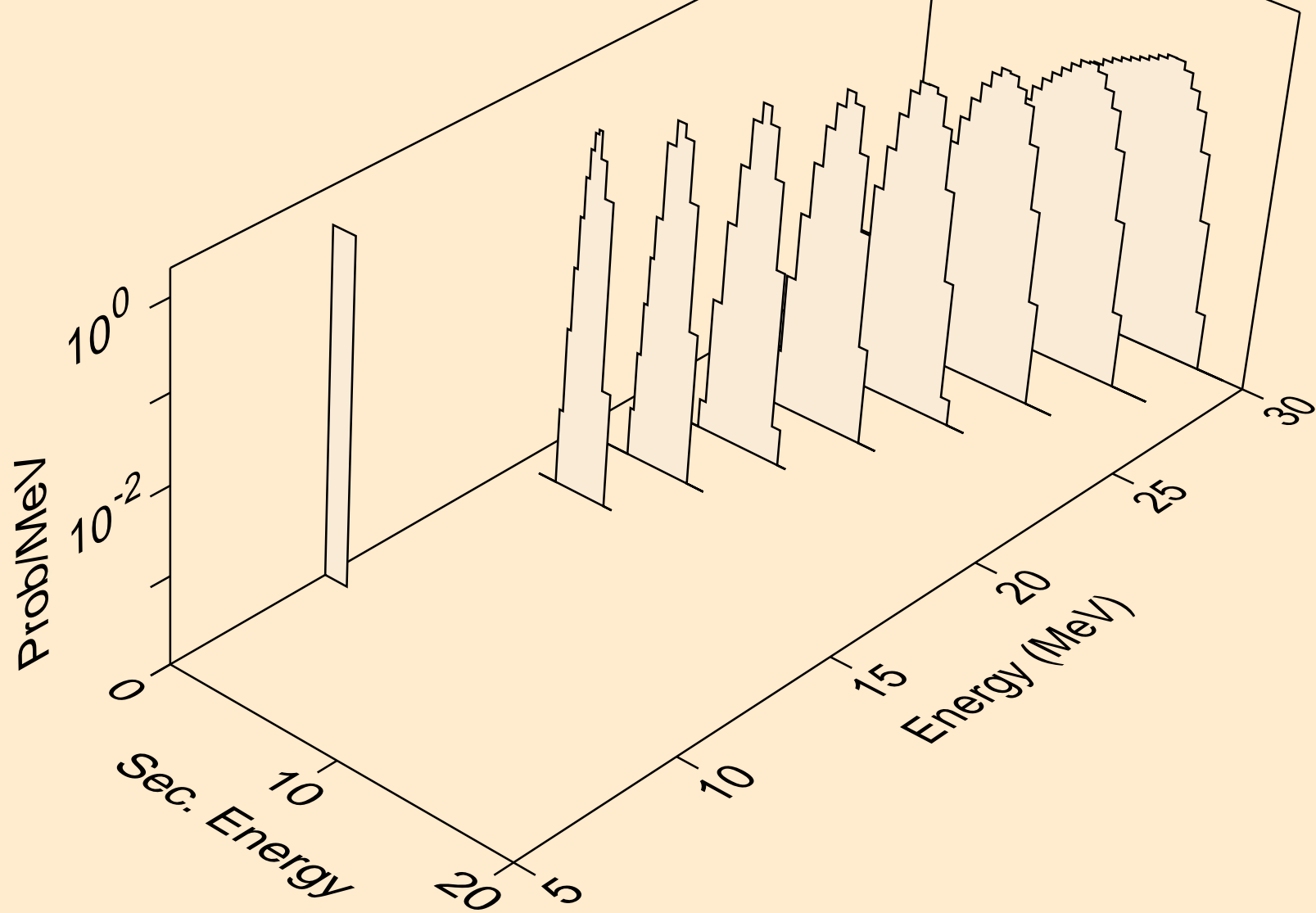



ER163 NEUTRON ACER TENDL-2024 LIBRARY; T=0.K  
he3s from (n,x)

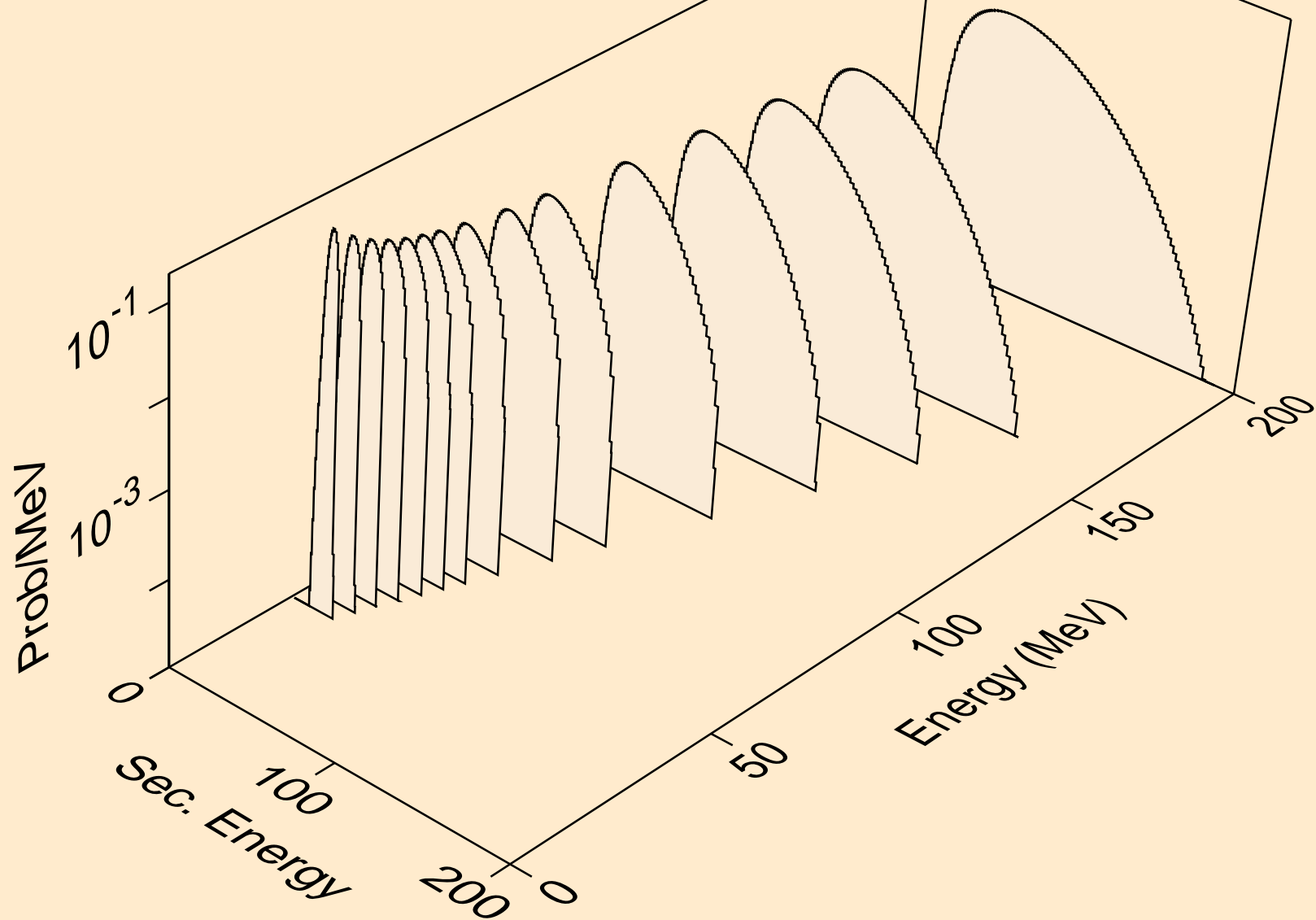

ER163 NEUTRON ACER TENDL-2024 LIBRARY; T=0.K  
he3s from (n,n\*)he3

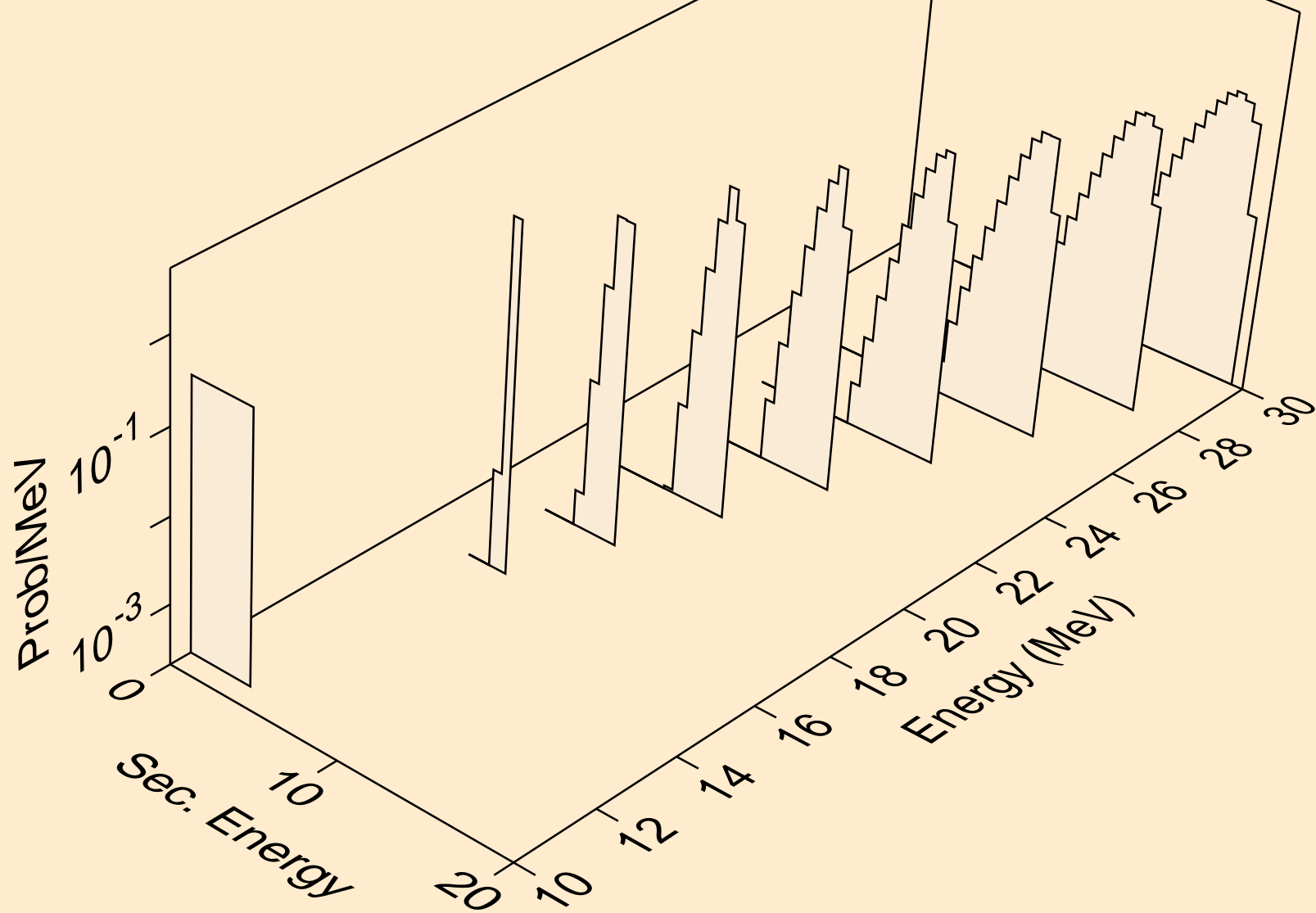

ER163 NEUTRON ACER TENDL-2024 LIBRARY; T=0.K  
he3s from (n,he3)

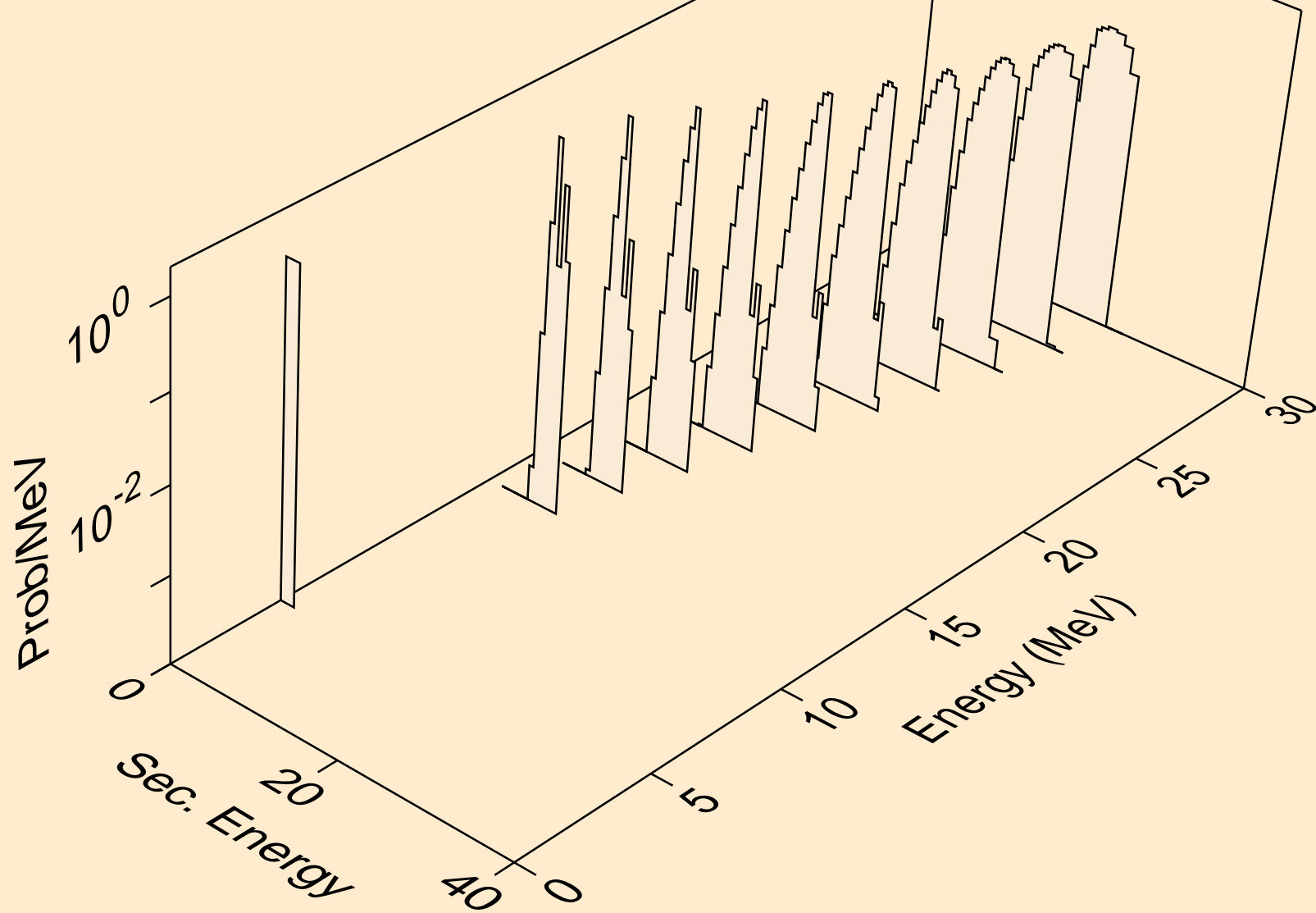

ER163 NEUTRON ACER TENDL-2024 LIBRARY; T=0.K  
alphas from (n,x)

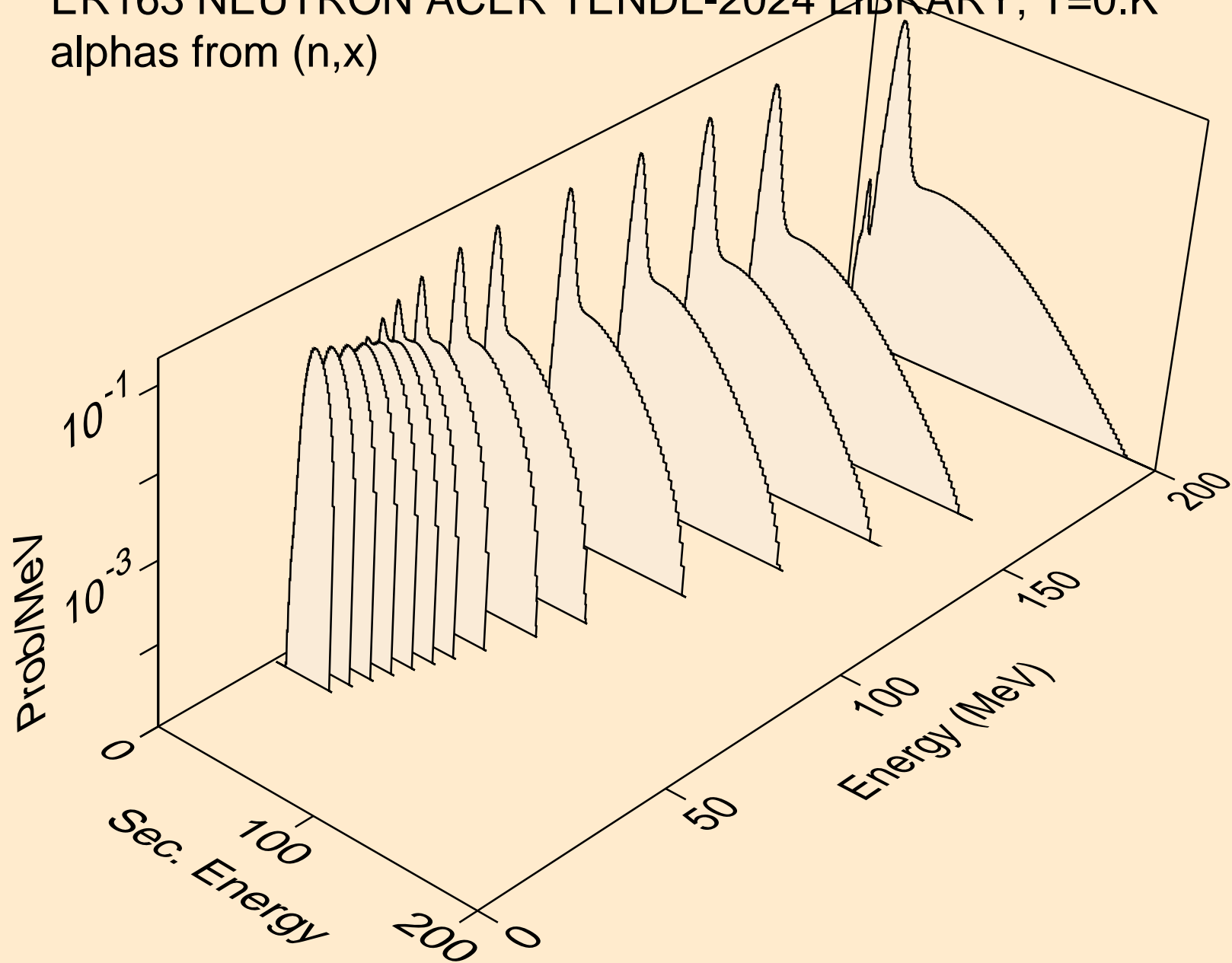

ER163 NEUTRON ACER TENDL-2024 LIBRARY; T=0.K  
alphas from (n,n\*)a

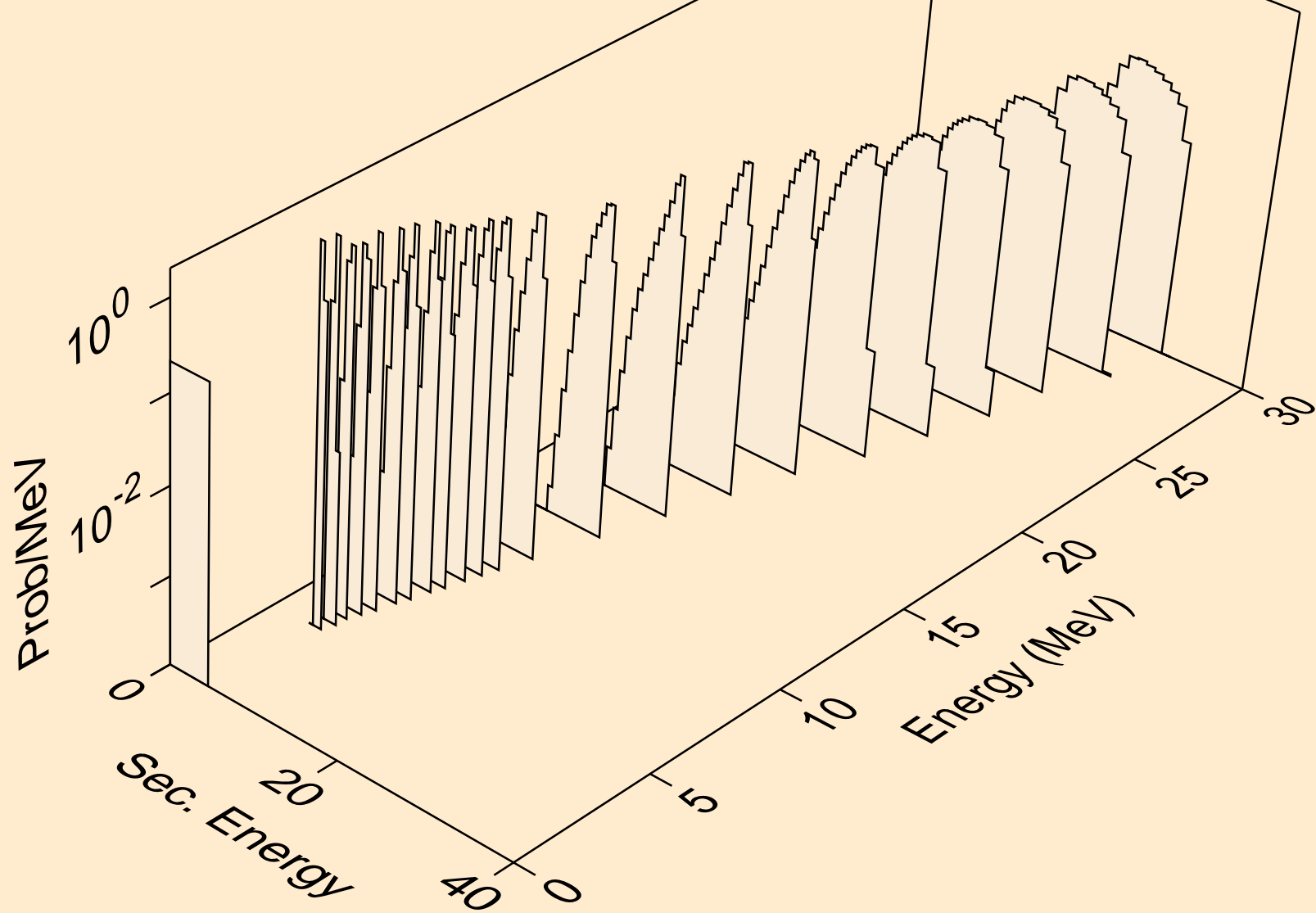

ER163 NEUTRON ACER TENDL-2024 LIBRARY; T=0.K  
alphas from (n,2n)a

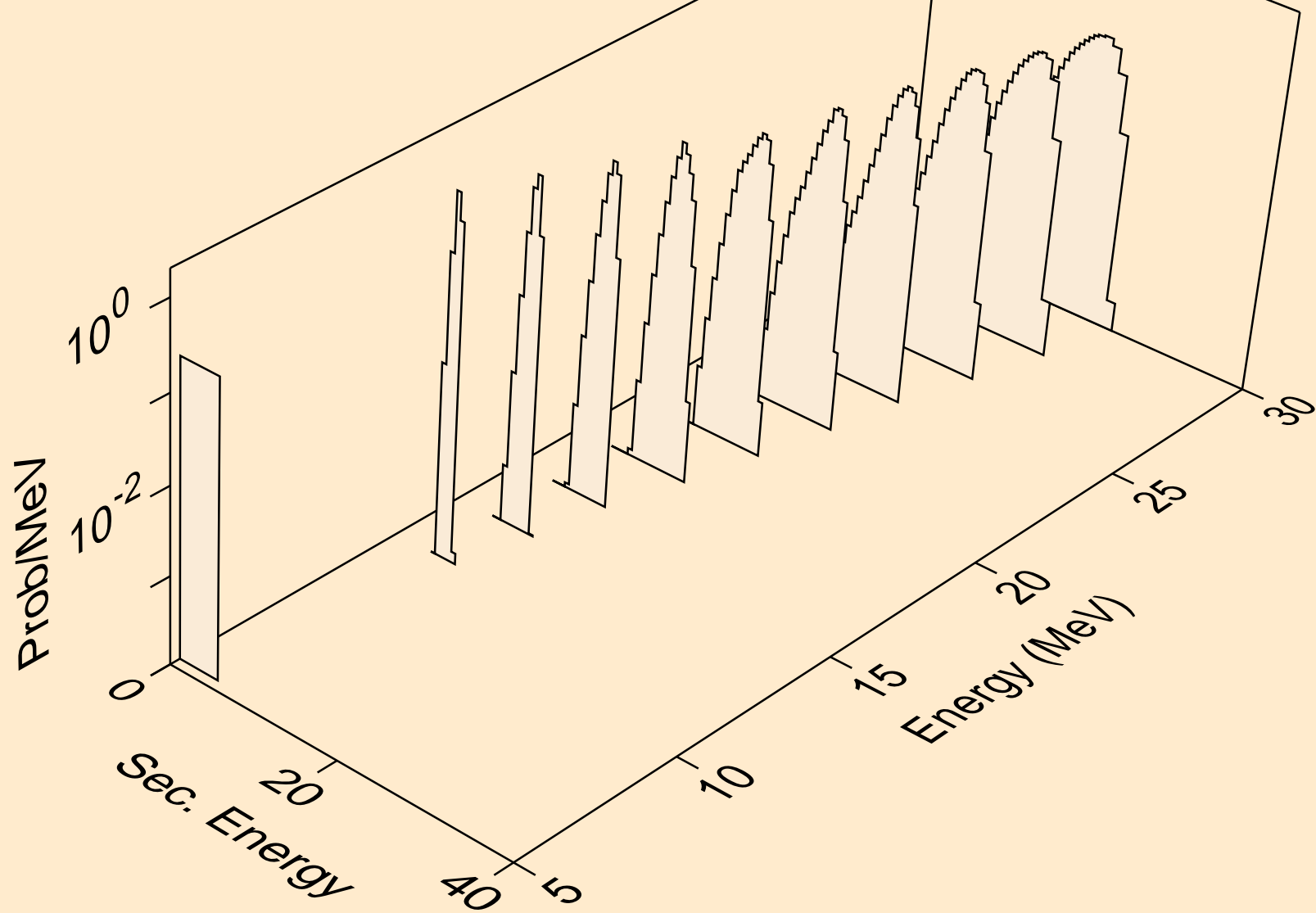

ER163 NEUTRON ACER TENDL-2024 LIBRARY; T=0.K  
alphas from (n,3n)a

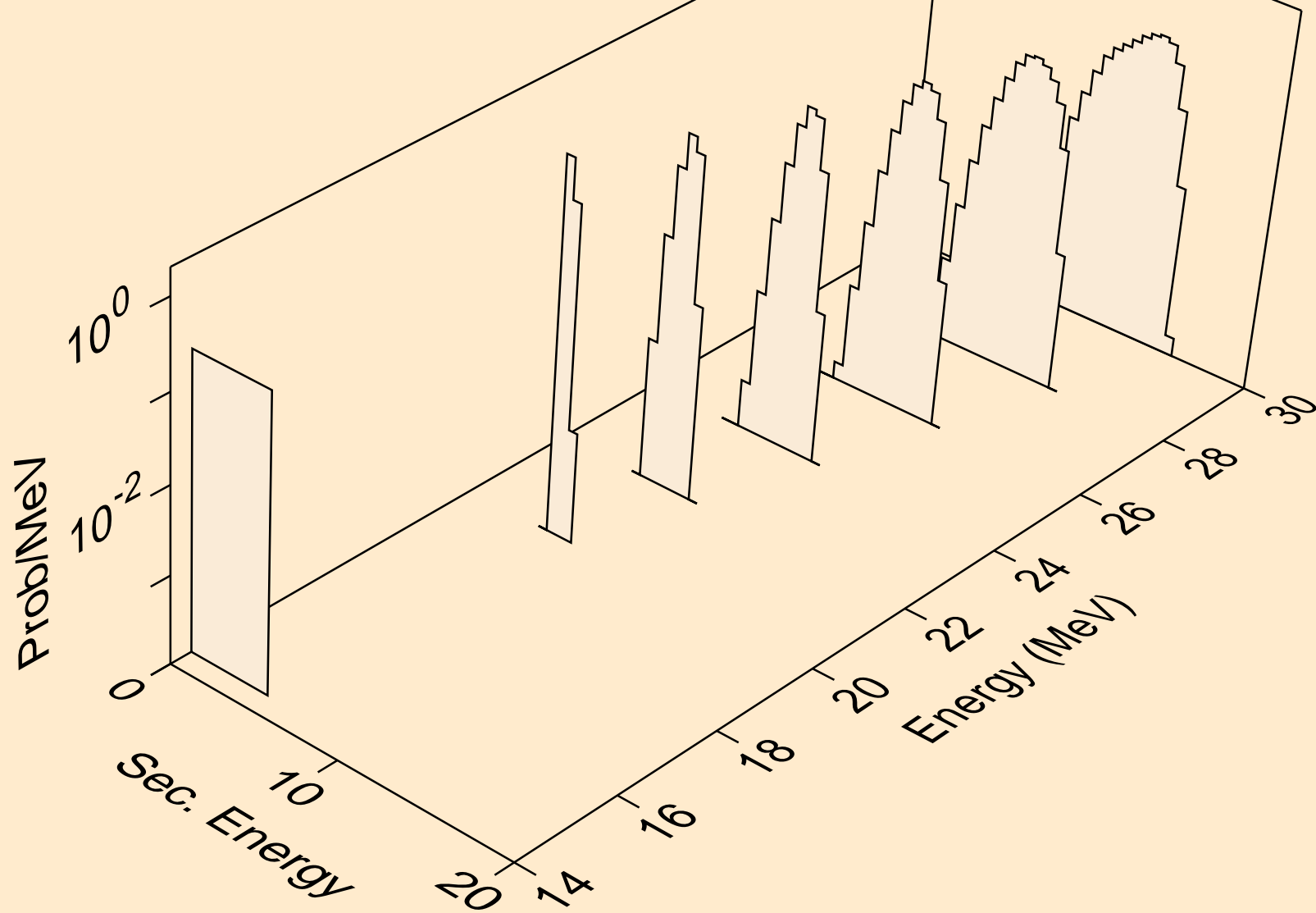

ER163 NEUTRON ACER TENDL-2024 LIBRARY; T=0.K  
alphas from (n,n\*)2a

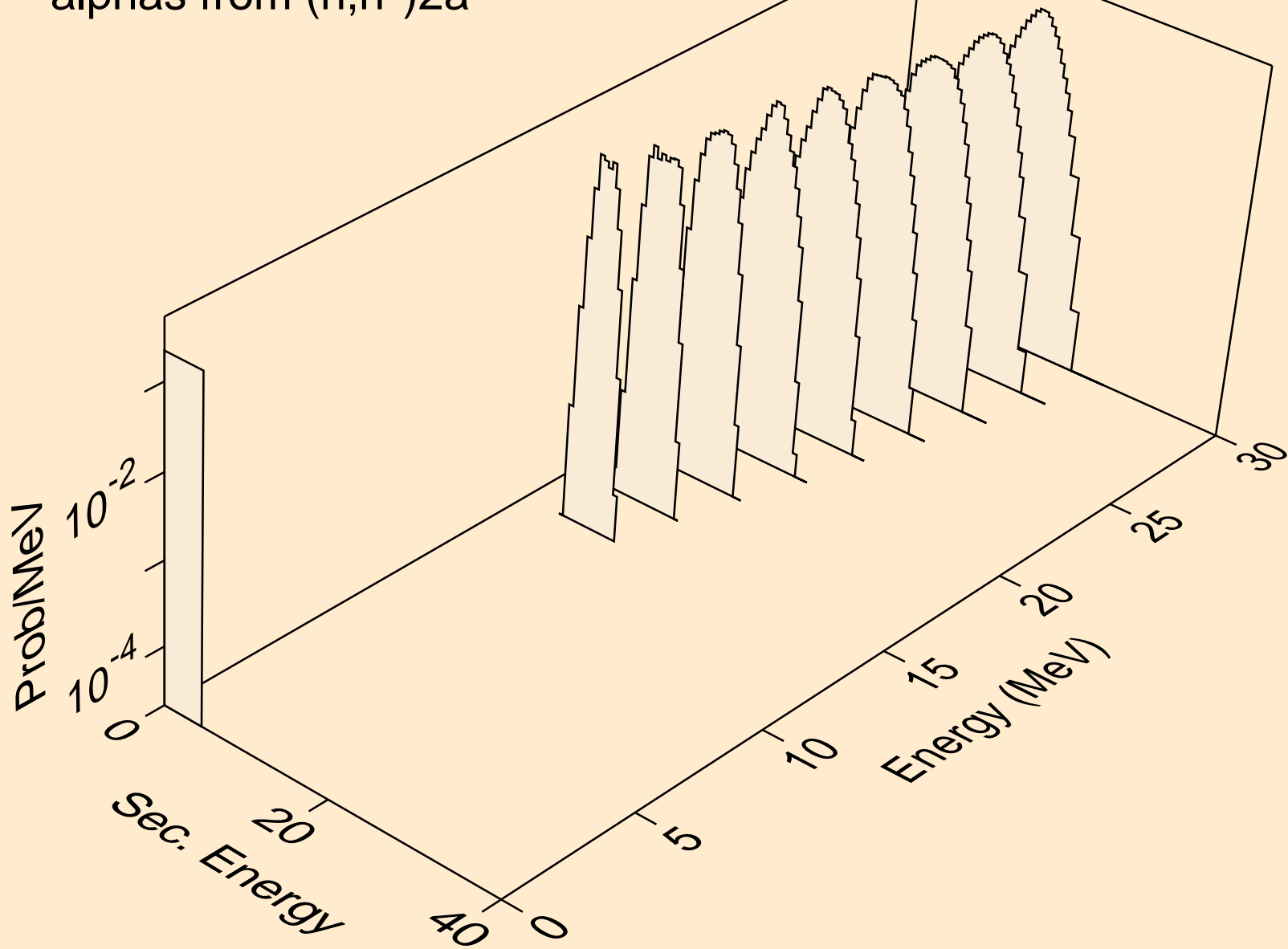



ER163 NEUTRON ACER TENDL-2024 LIBRARY; T=0.K  
alphas from (n,npa)

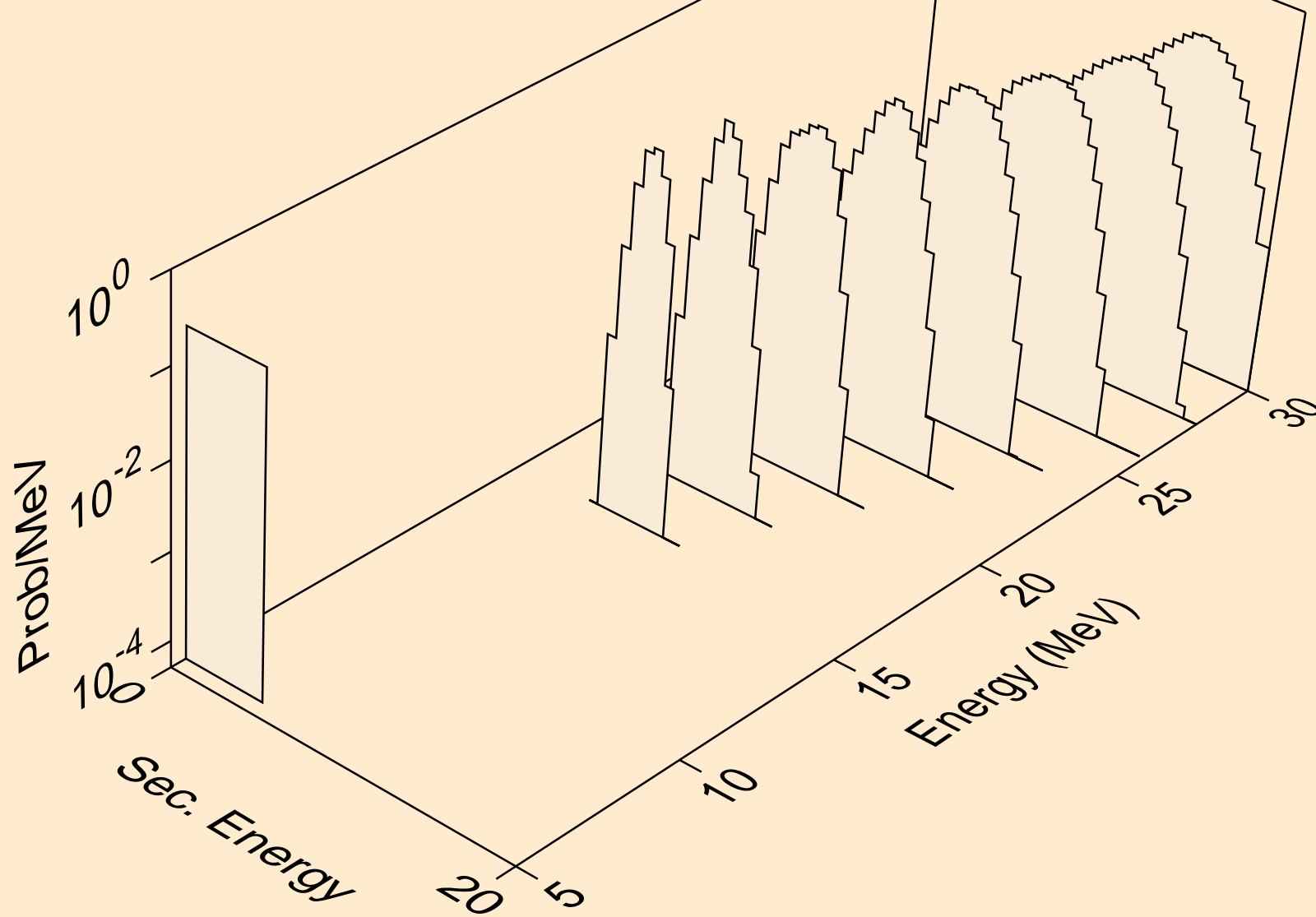

ER163 NEUTRON ACER TENDL-2024 LIBRARY; T=0.K  
alphas from (n,a)

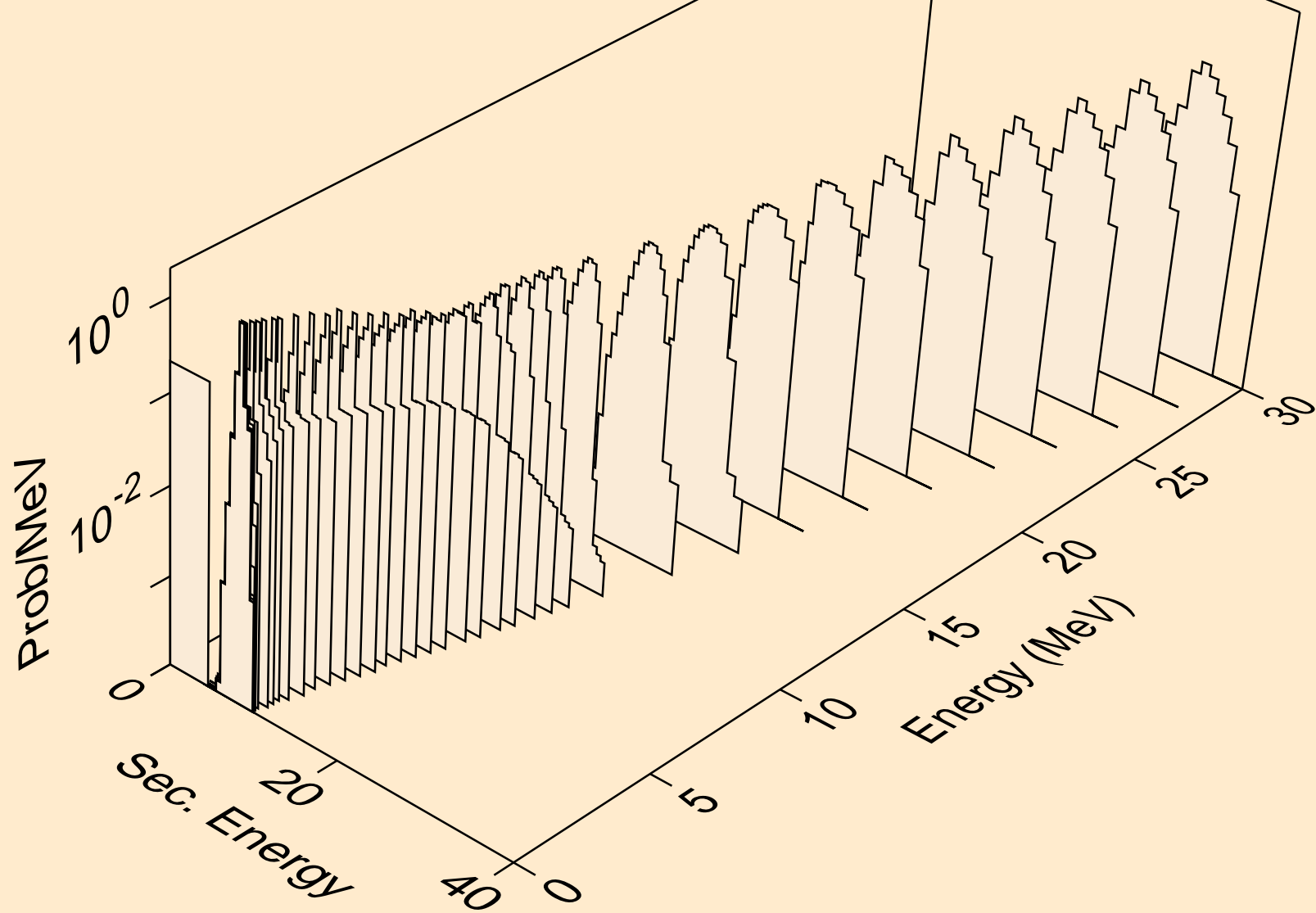

ER163 NEUTRON ACER TENDL-2024 LIBRARY; T=0.K  
alphas from (n,2a)

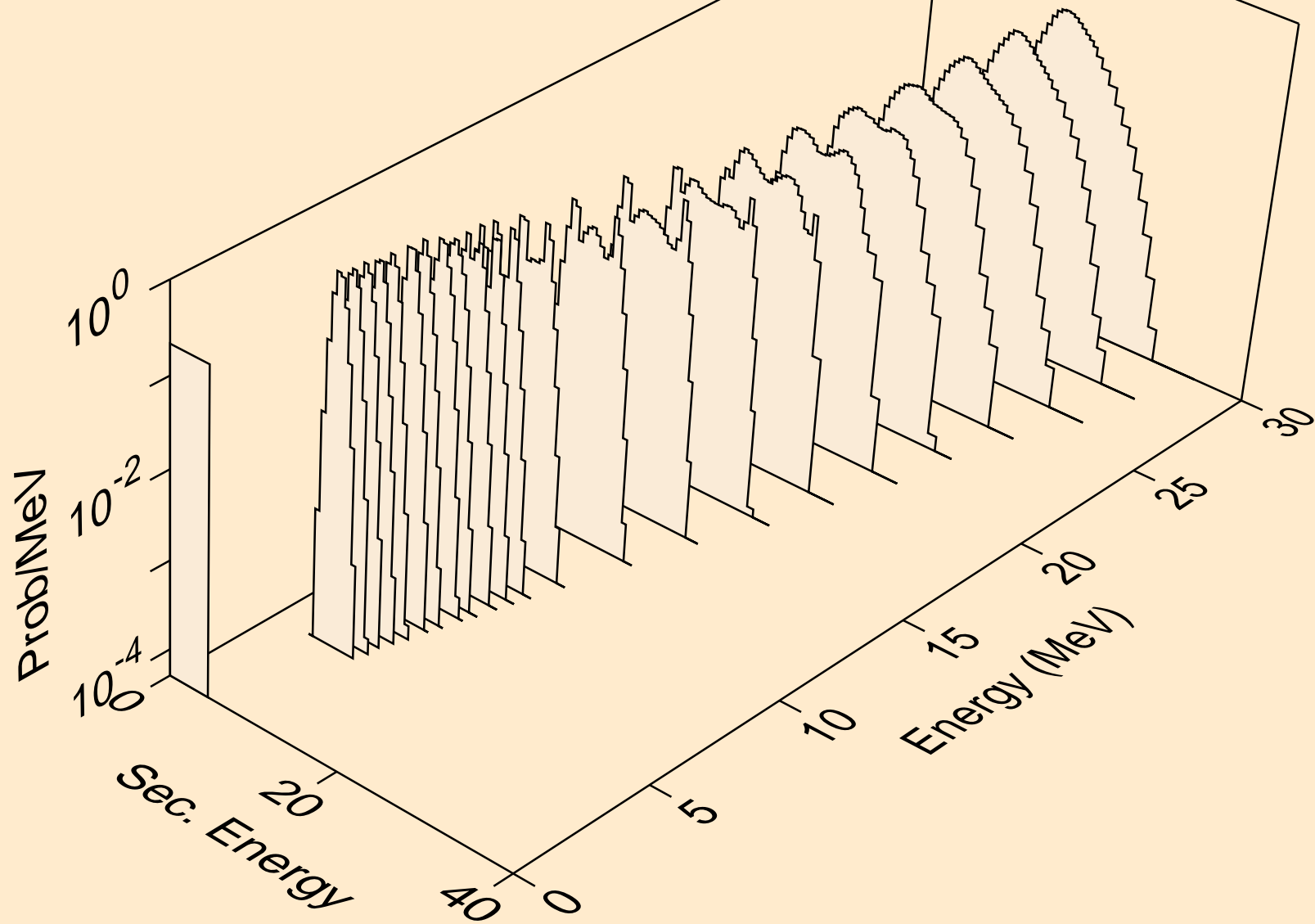

ER163 NEUTRON ACER TENDL-2024 LIBRARY; T=0.K  
alphas from (n,pa)

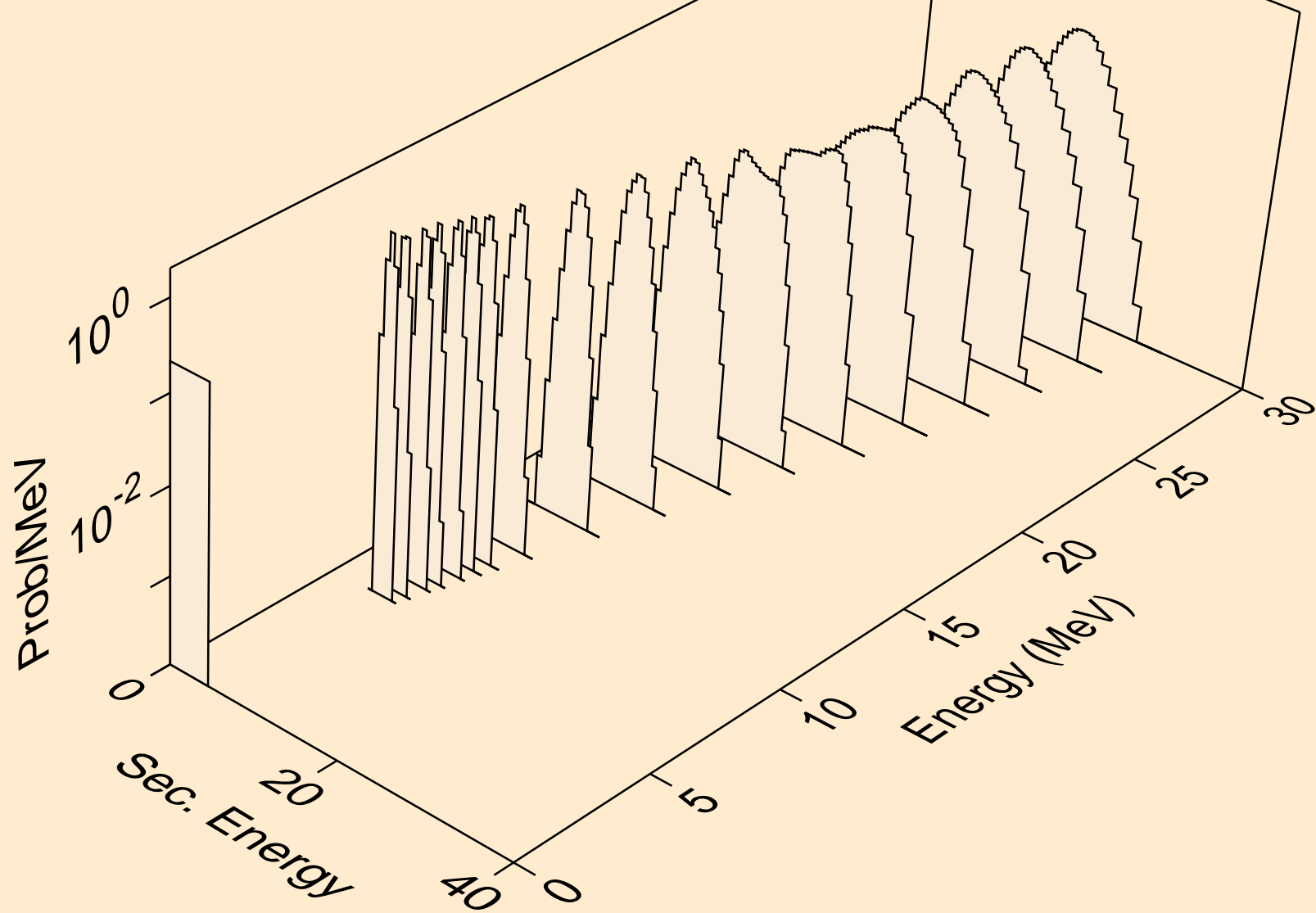

ER163 NEUTRON ACER TENDL-2024 LIBRARY; T=0.K  
alphas from (n,da)

