

FM250M NEUTRON ACER TENDL-2024 LIBRARY; T=0.K

Principal cross sections

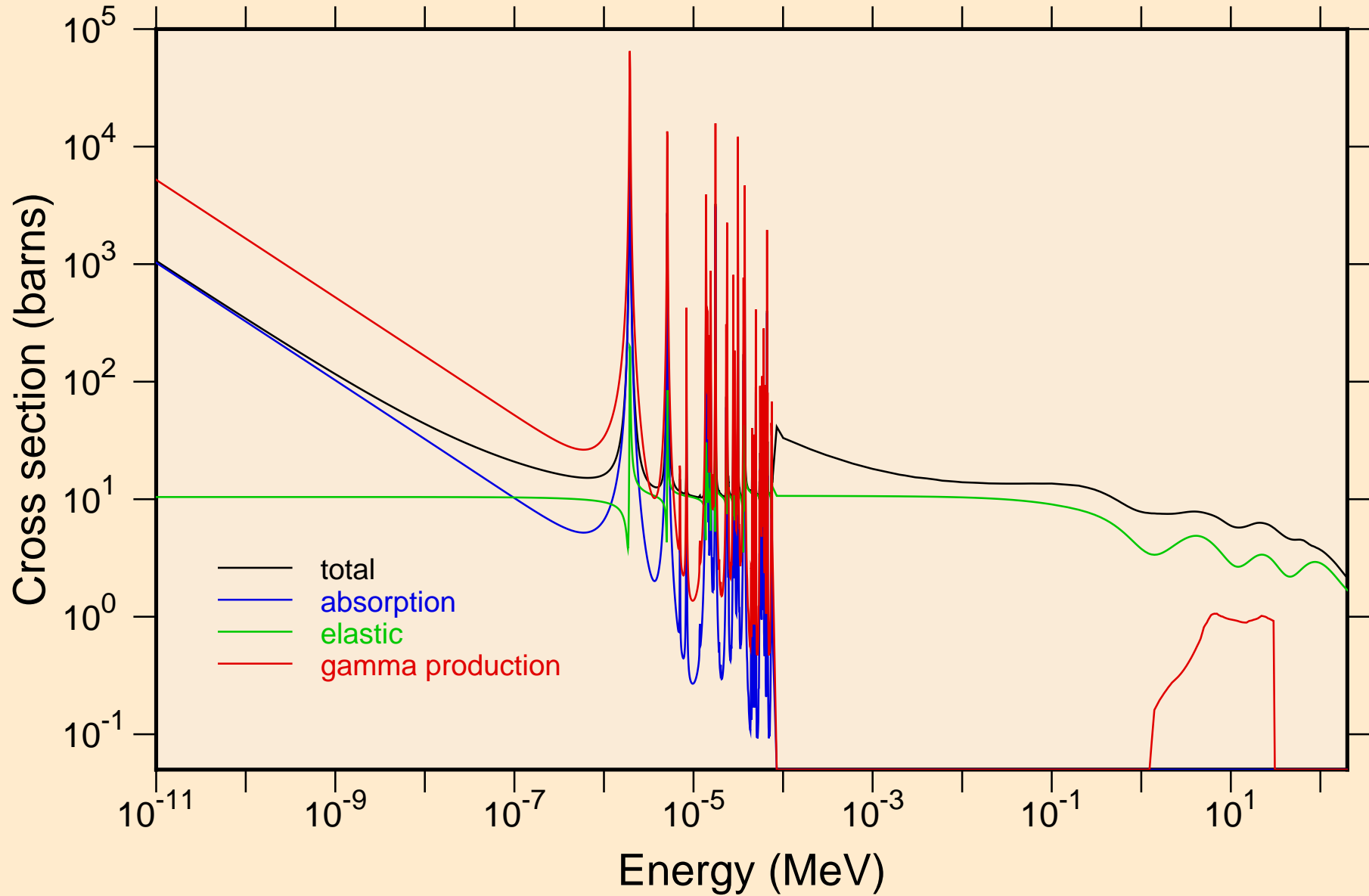

FM250M NEUTRON ACER TENDL-2024 LIBRARY; T=0.K
resonance total cross section

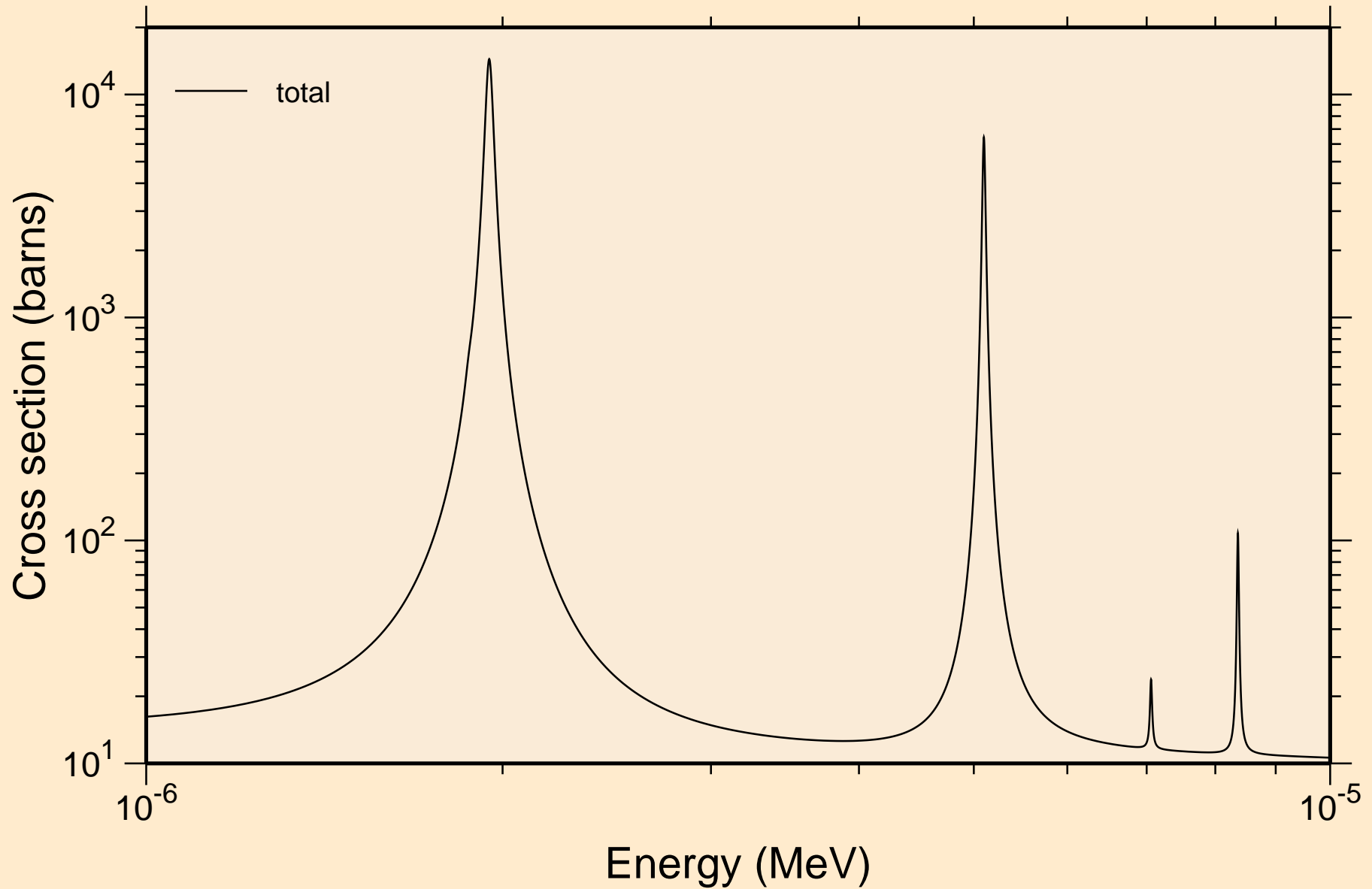

FM250M NEUTRON ACER TENDL-2024 LIBRARY; T=0.K
resonance total cross section

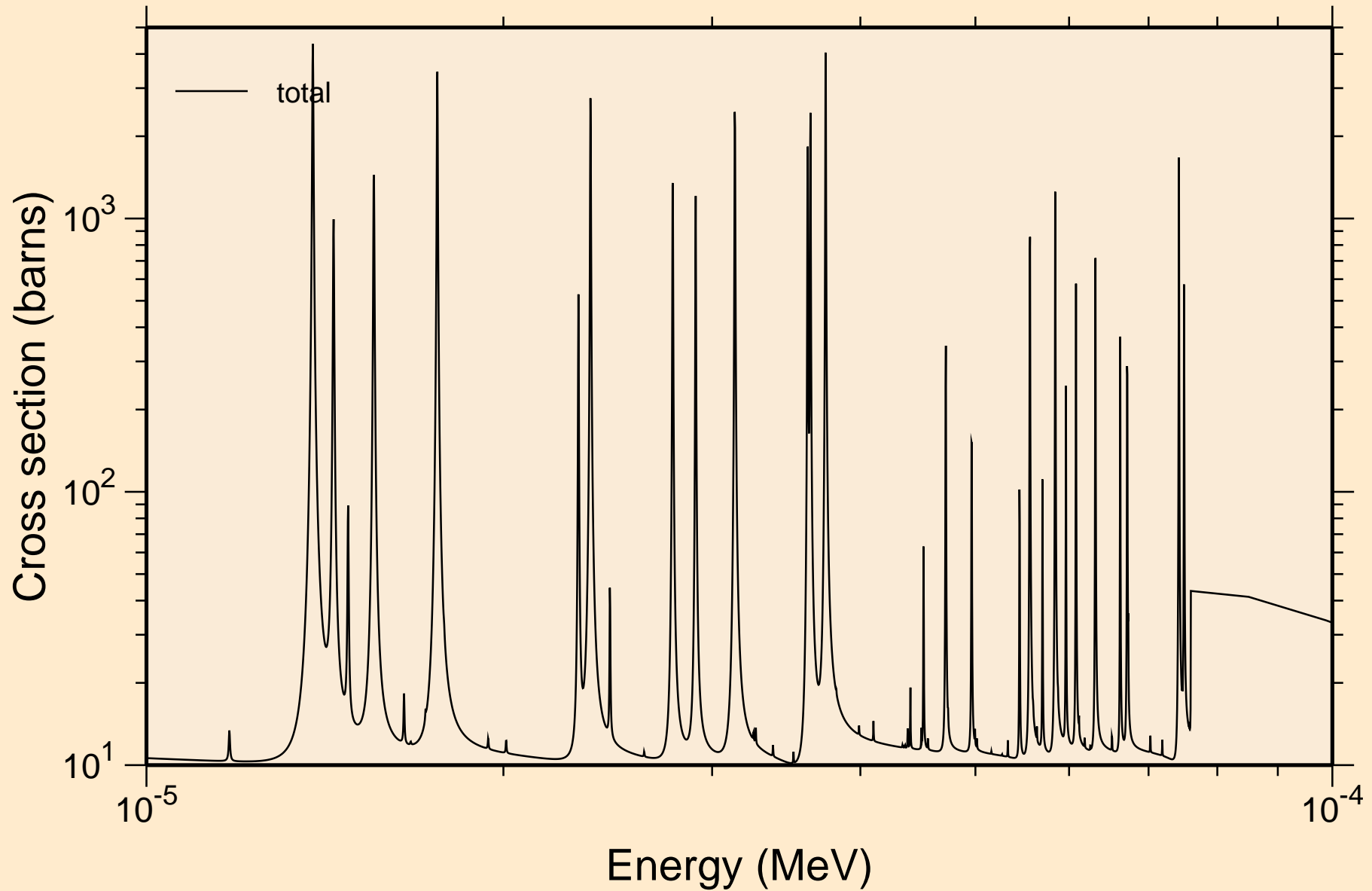

FM250M NEUTRON ACER TENDL-2024 LIBRARY; T=0.K
resonance total cross section

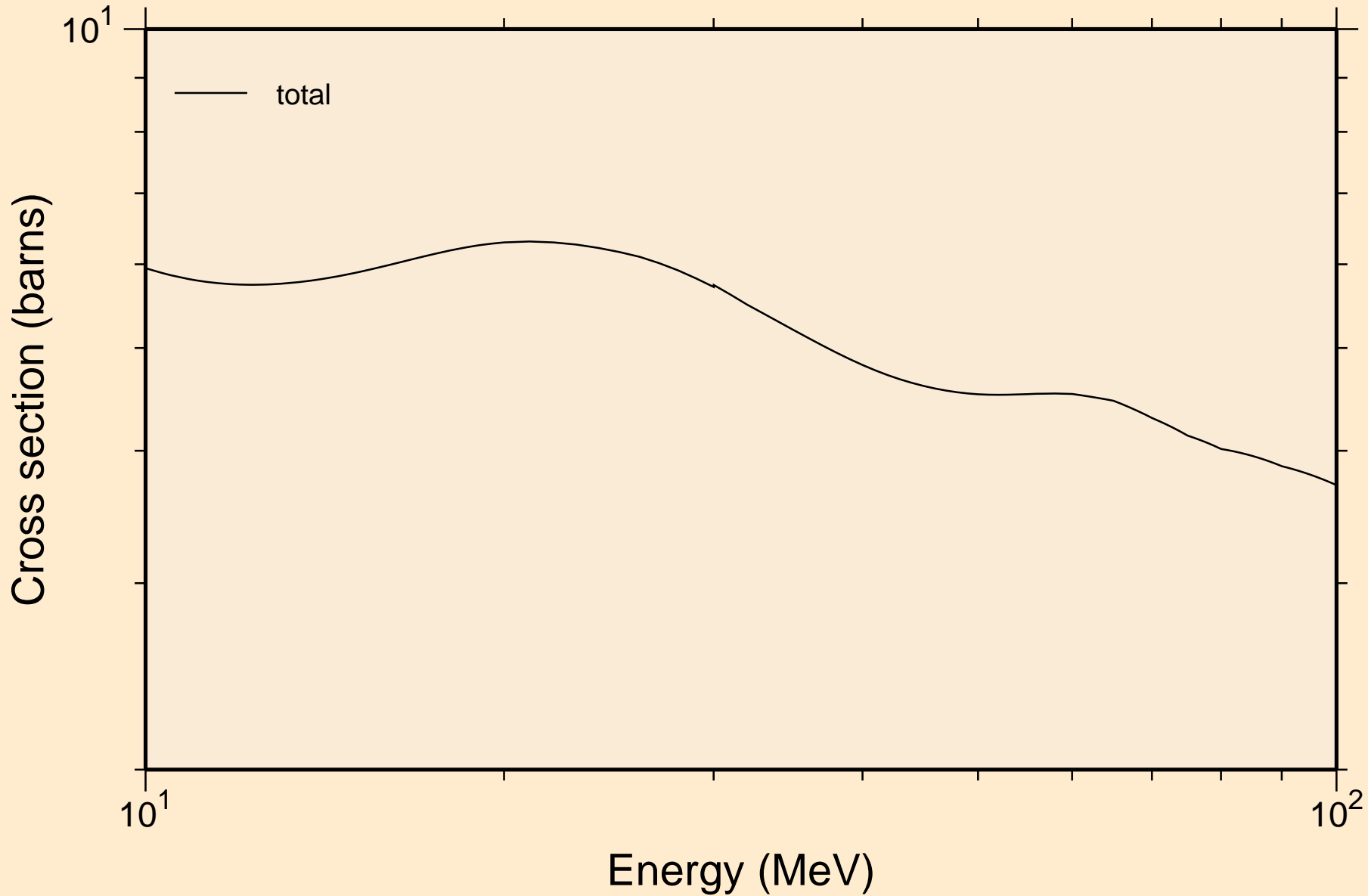

FM250M NEUTRON ACER TENDL-2024 LIBRARY; T=0.K
resonance absorption cross sections

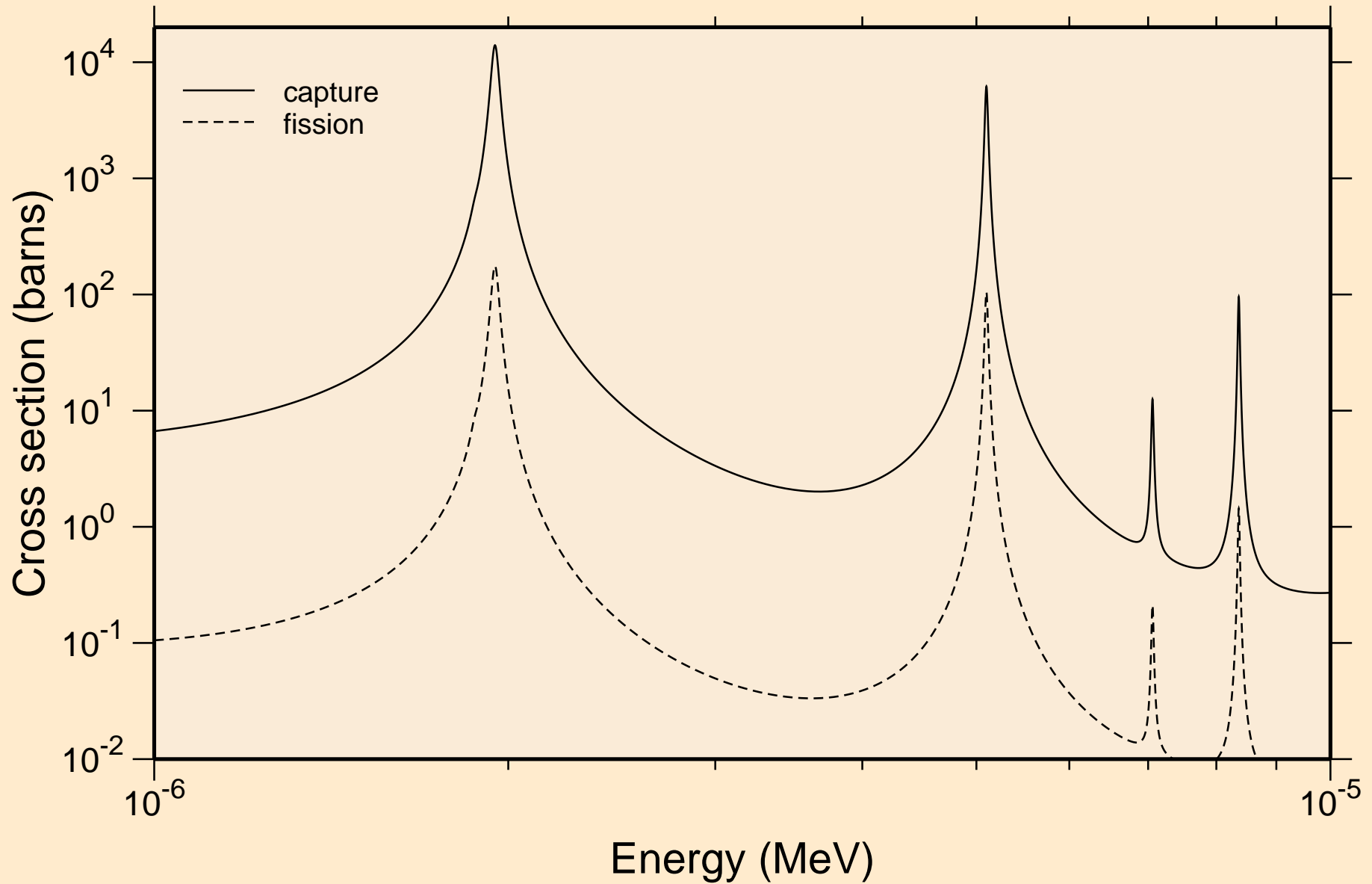

FM250M NEUTRON ACER TENDL-2024 LIBRARY; T=0.K
resonance absorption cross sections

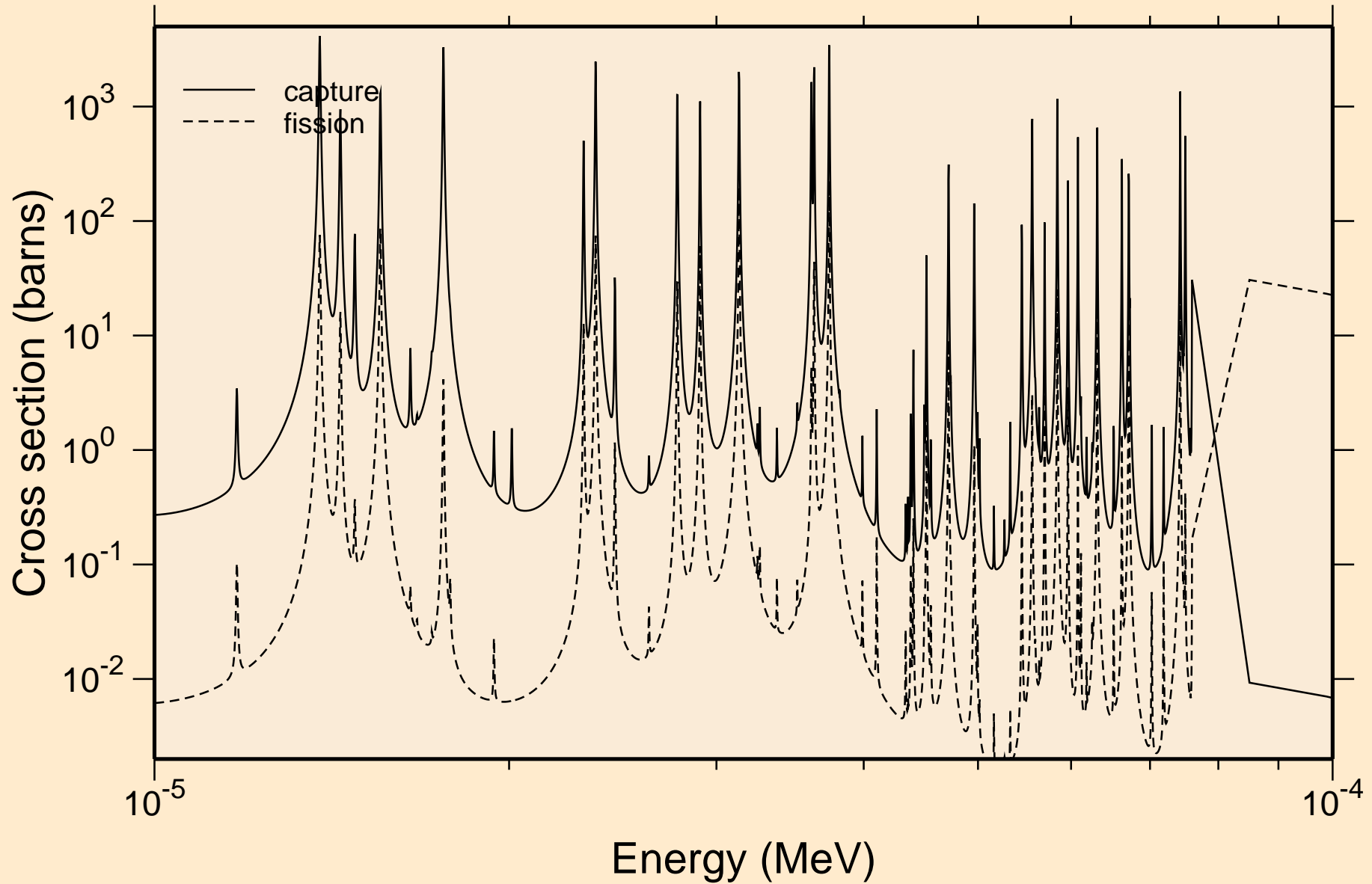

FM250M NEUTRON ACER TENDL-2024 LIBRARY; T=0.K
resonance absorption cross sections

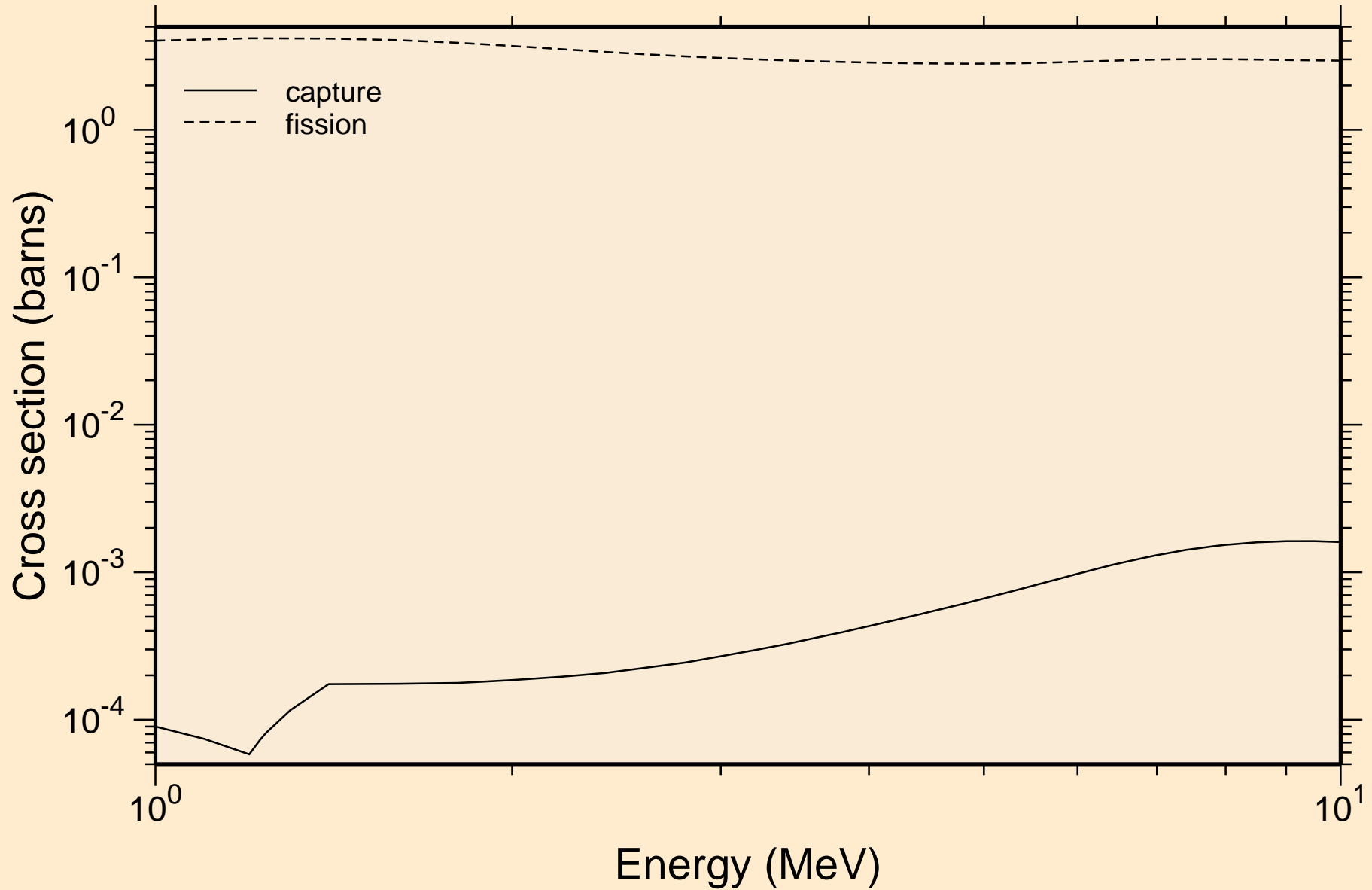

FM250M NEUTRON ACER TENDL-2024 LIBRARY; T=0.K

Heating

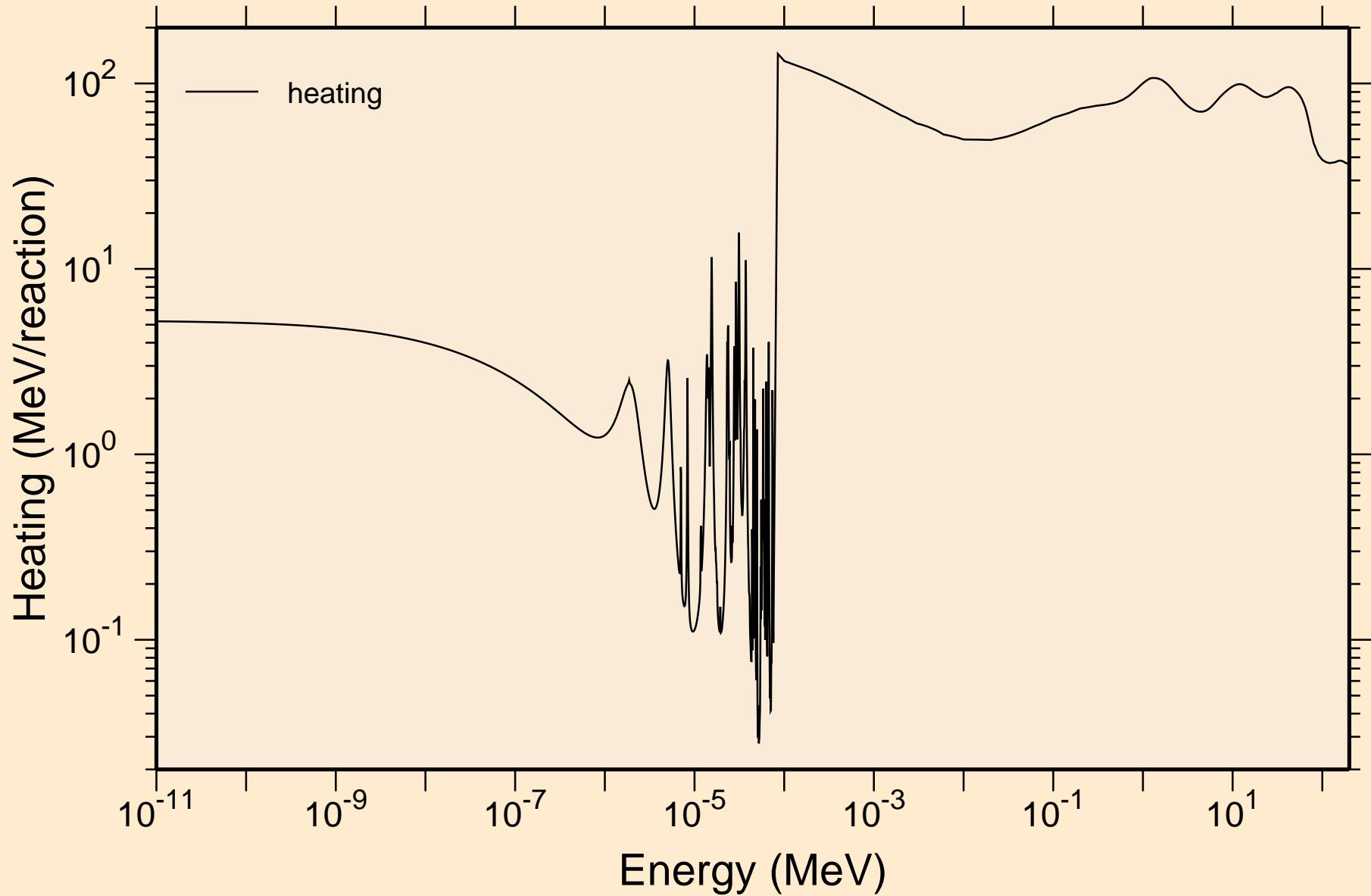

FM250M NEUTRON ACER TENDL-2024 LIBRARY; T=0.K
Damage

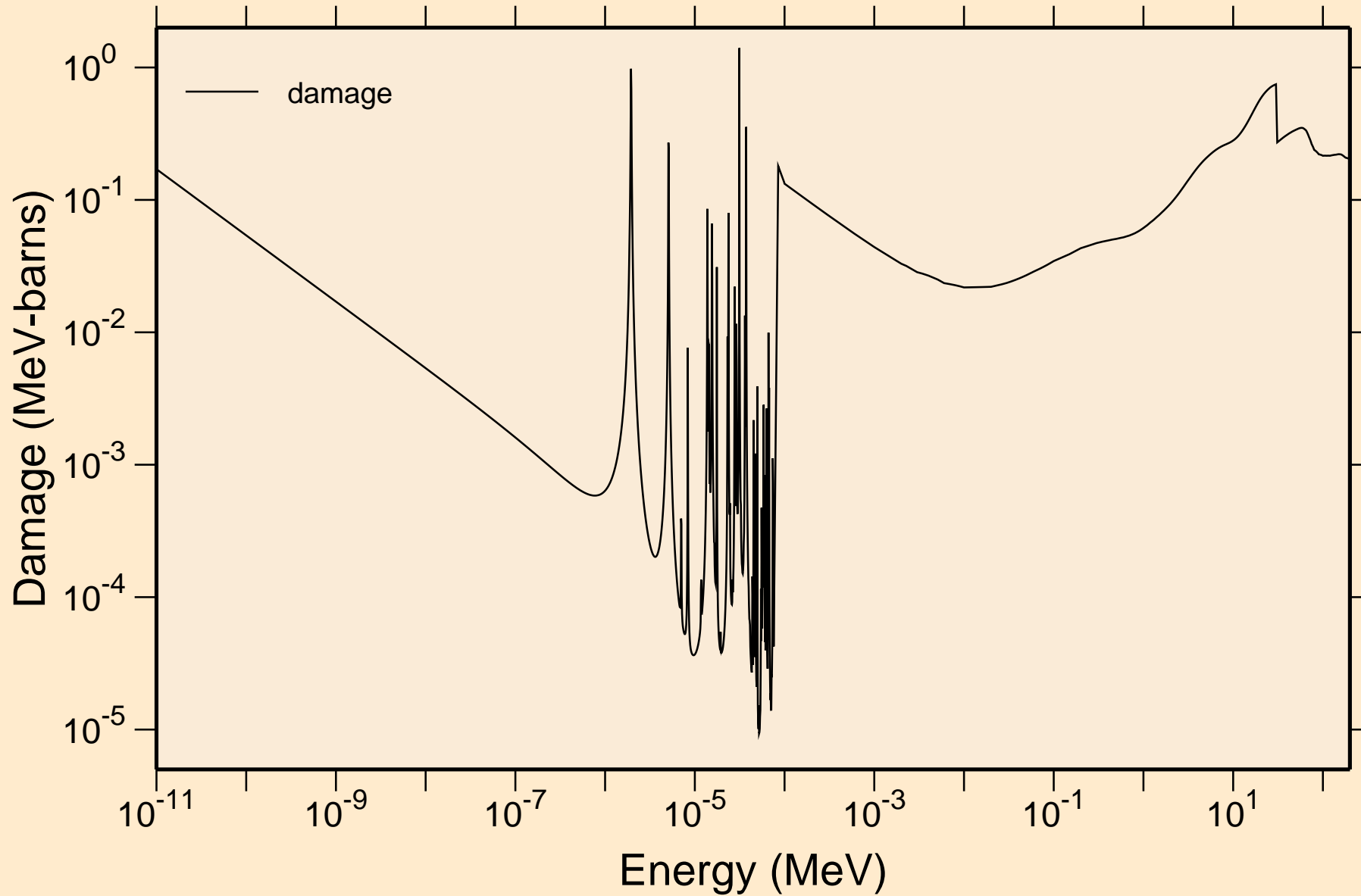

FM250M NEUTRON ACER TENDL-2024 LIBRARY; T=0.K

Non-threshold reactions

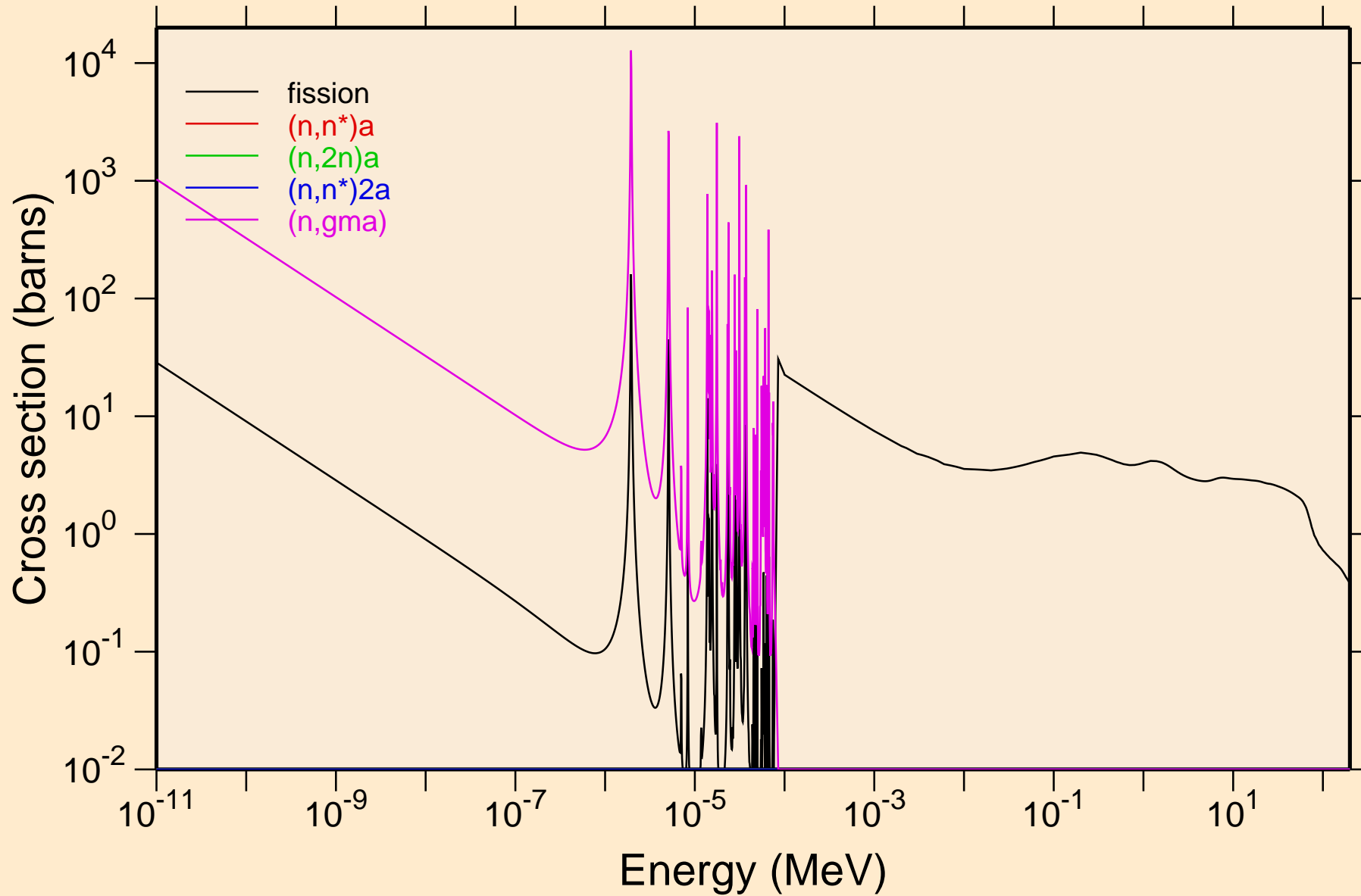

FM250M NEUTRON ACER TENDL-2024 LIBRARY; T=0.K

Non-threshold reactions

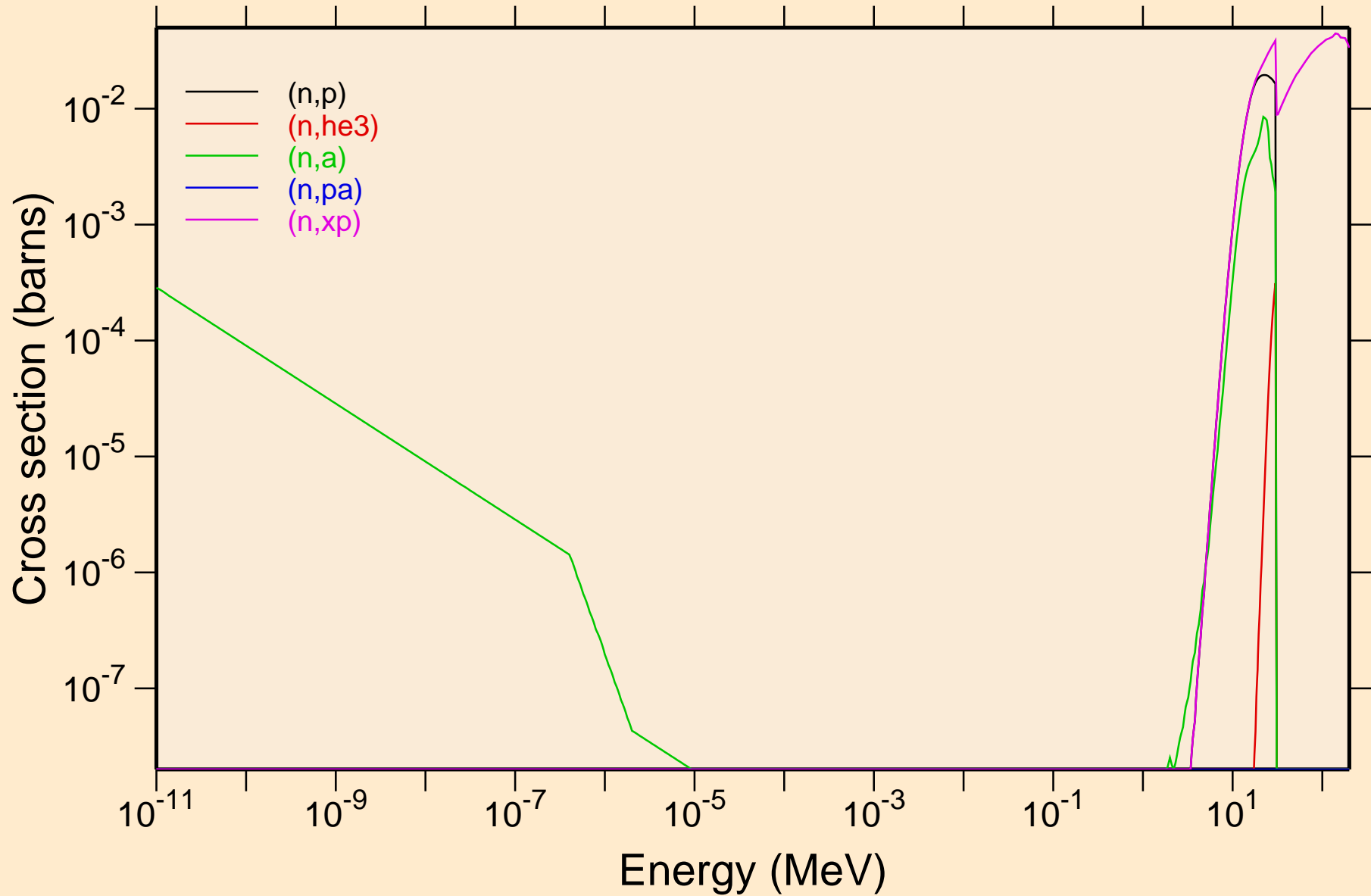

FM250M NEUTRON ACER TENDL-2024 LIBRARY; T=0.K
Non-threshold reactions

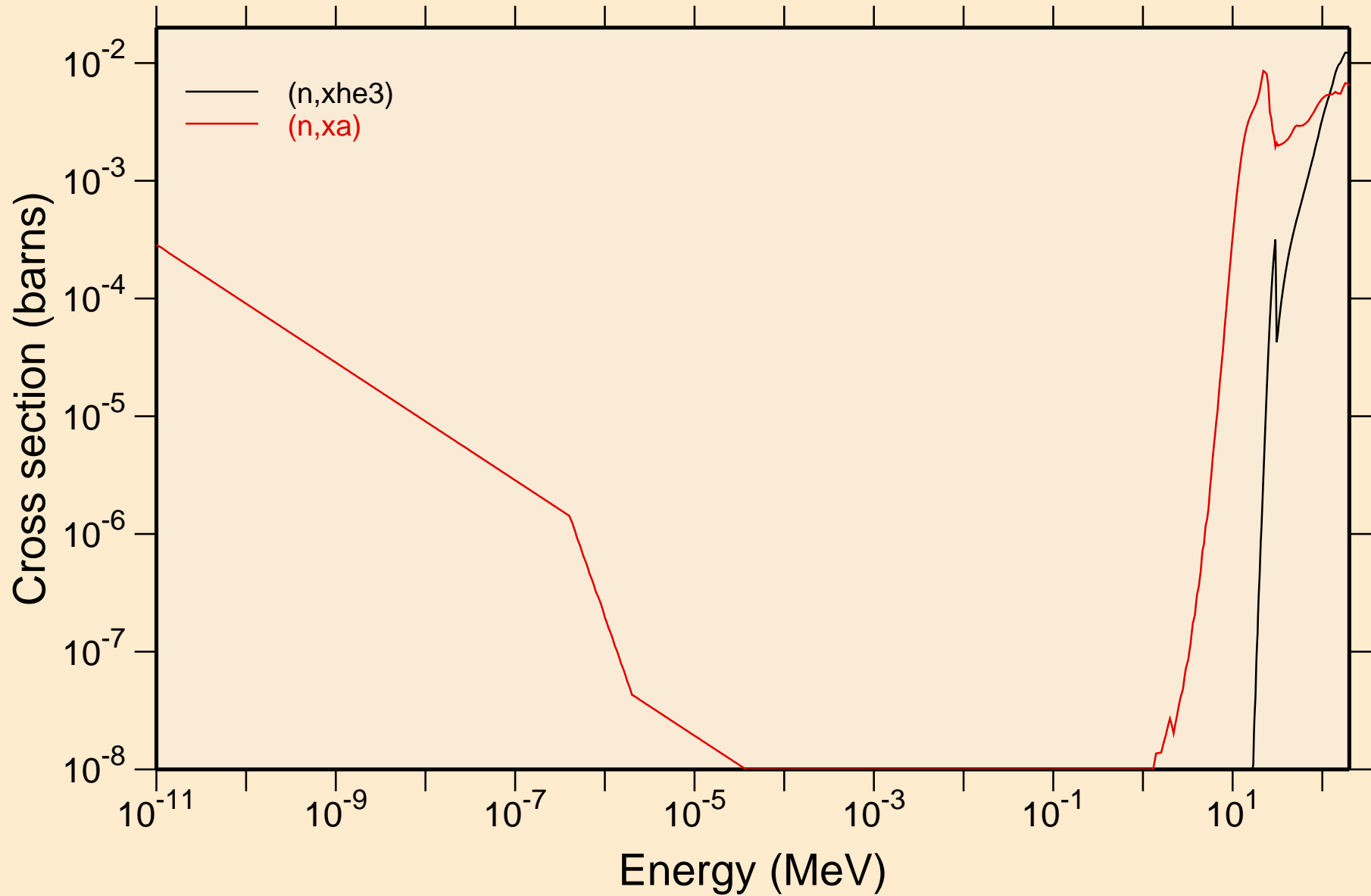

FM250M NEUTRON ACER TENDL-2024 LIBRARY; T=0.K

Principal cross sections

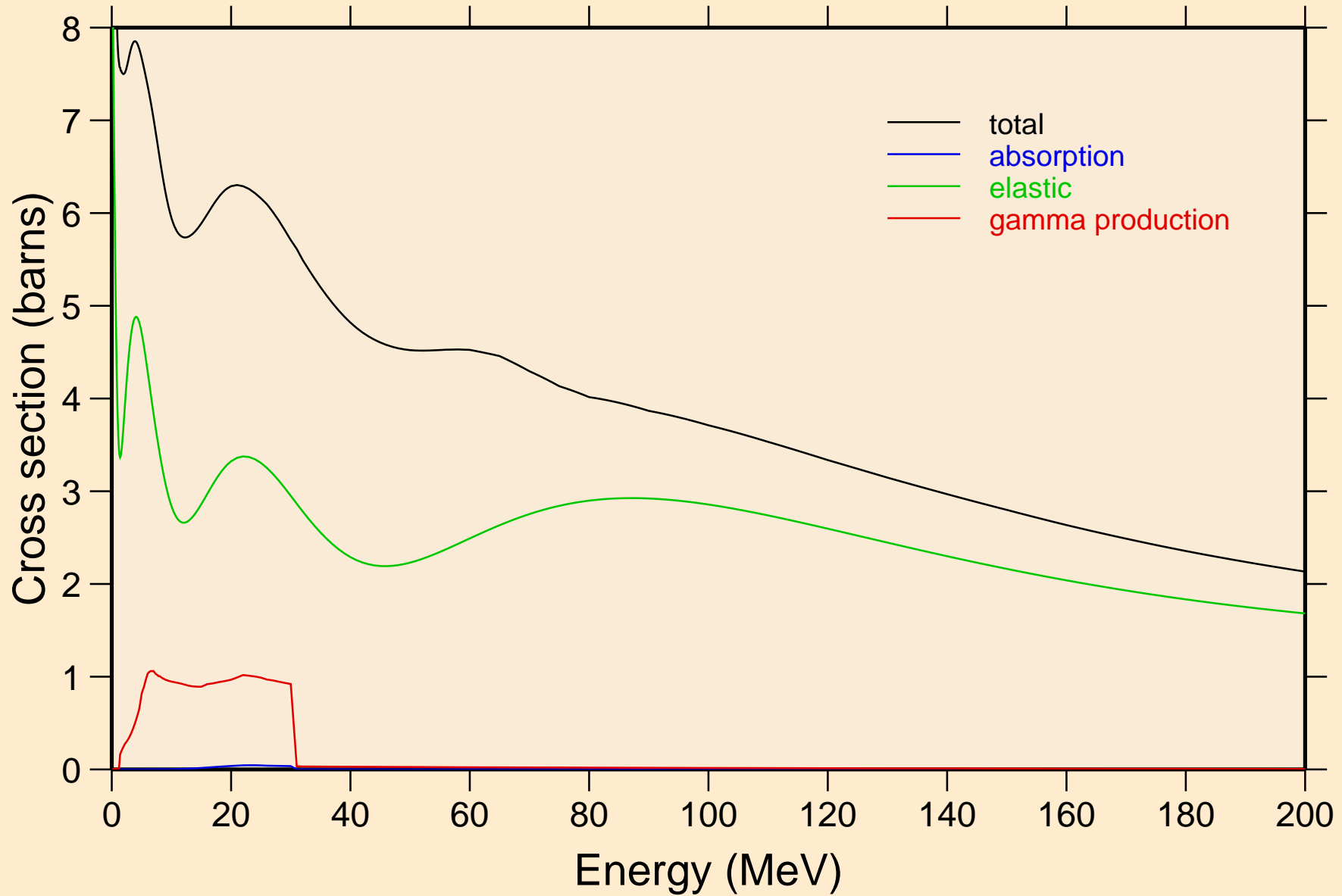

FM250M NEUTRON ACER TENDL-2024 LIBRARY; T=0.K
Heating

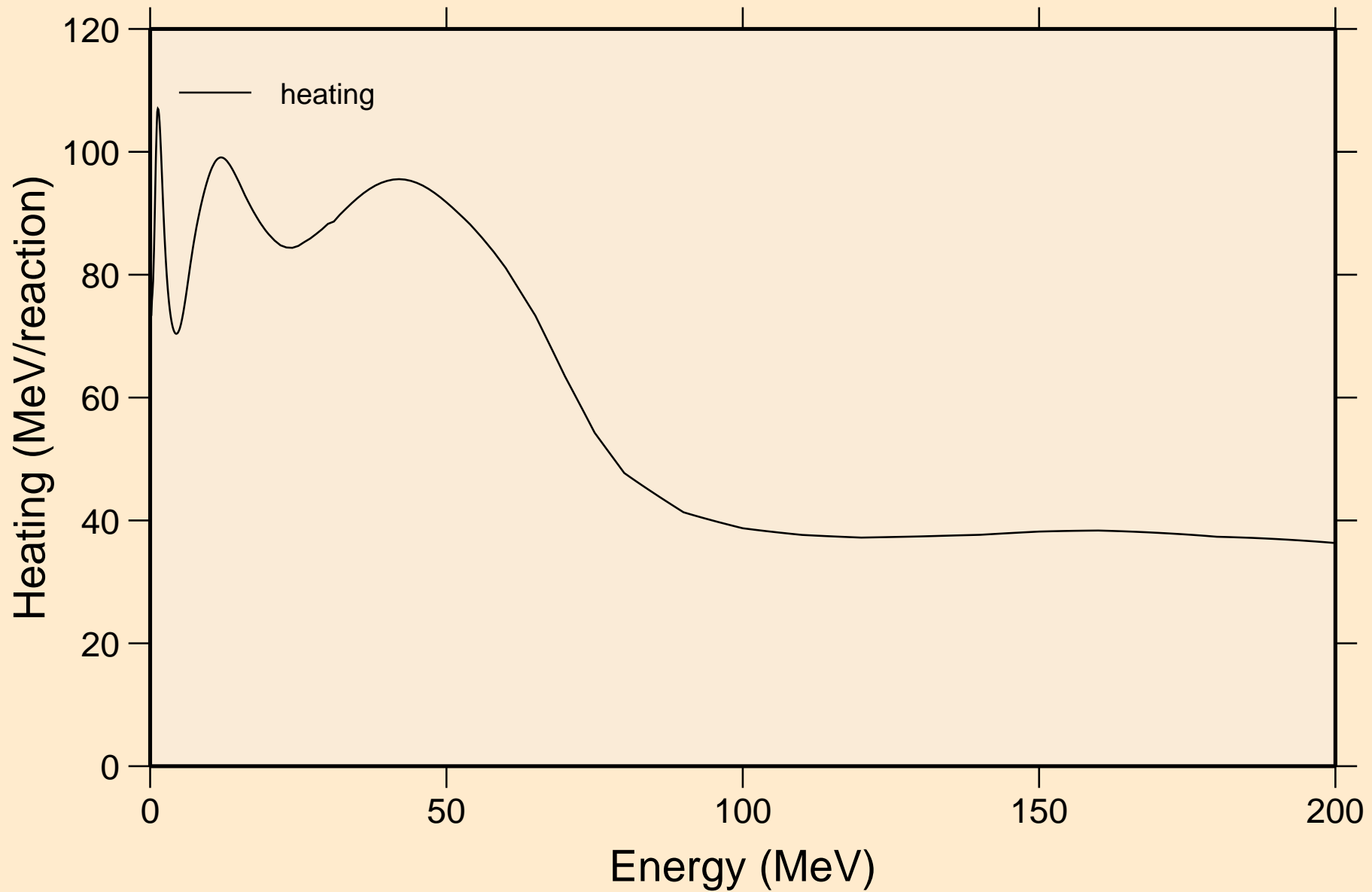

FM250M NEUTRON ACER TENDL-2024 LIBRARY; T=0.K

Damage

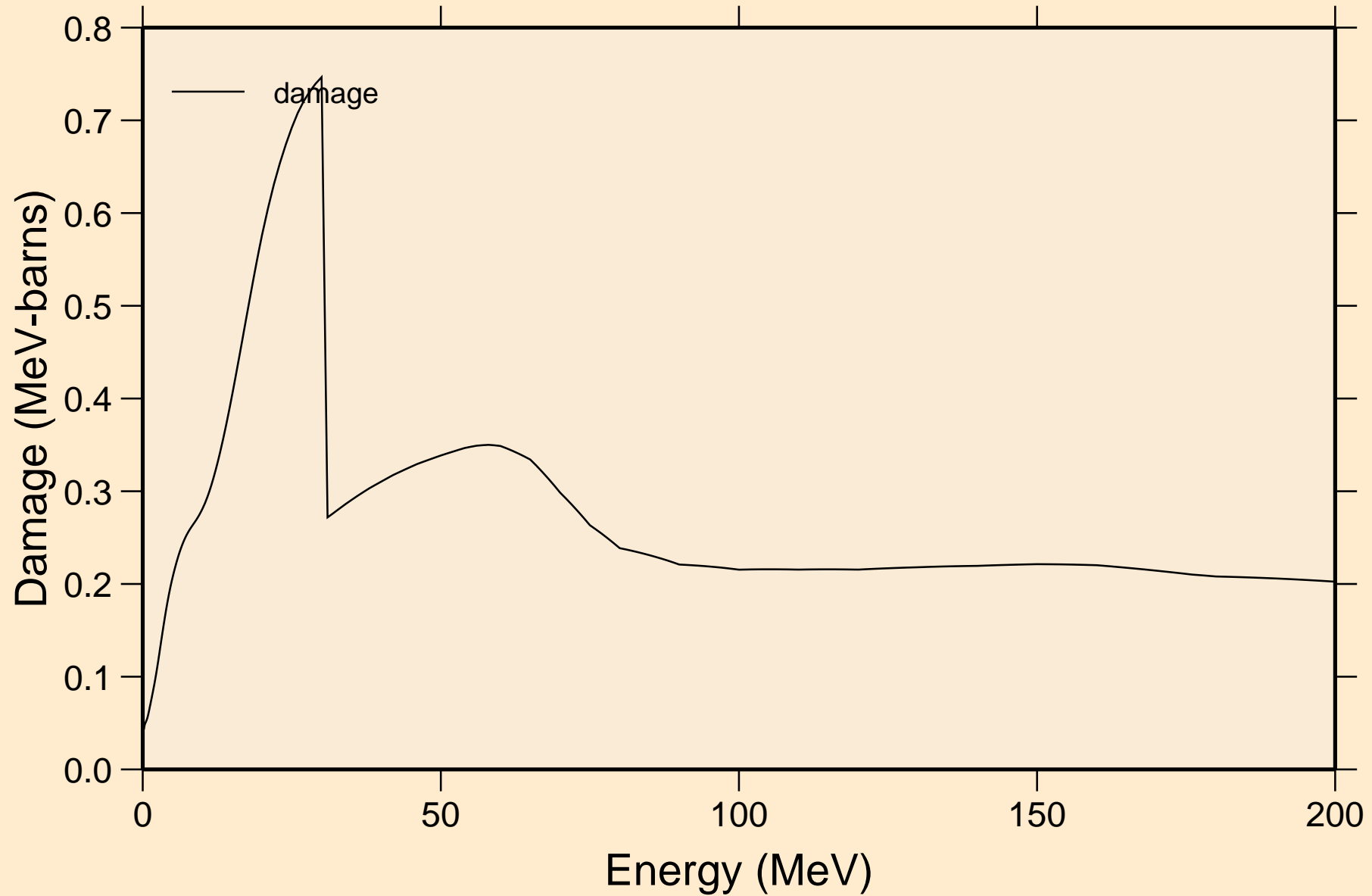

FM250M NEUTRON ACER TENDL-2024 LIBRARY; T=0.K

Non-threshold reactions

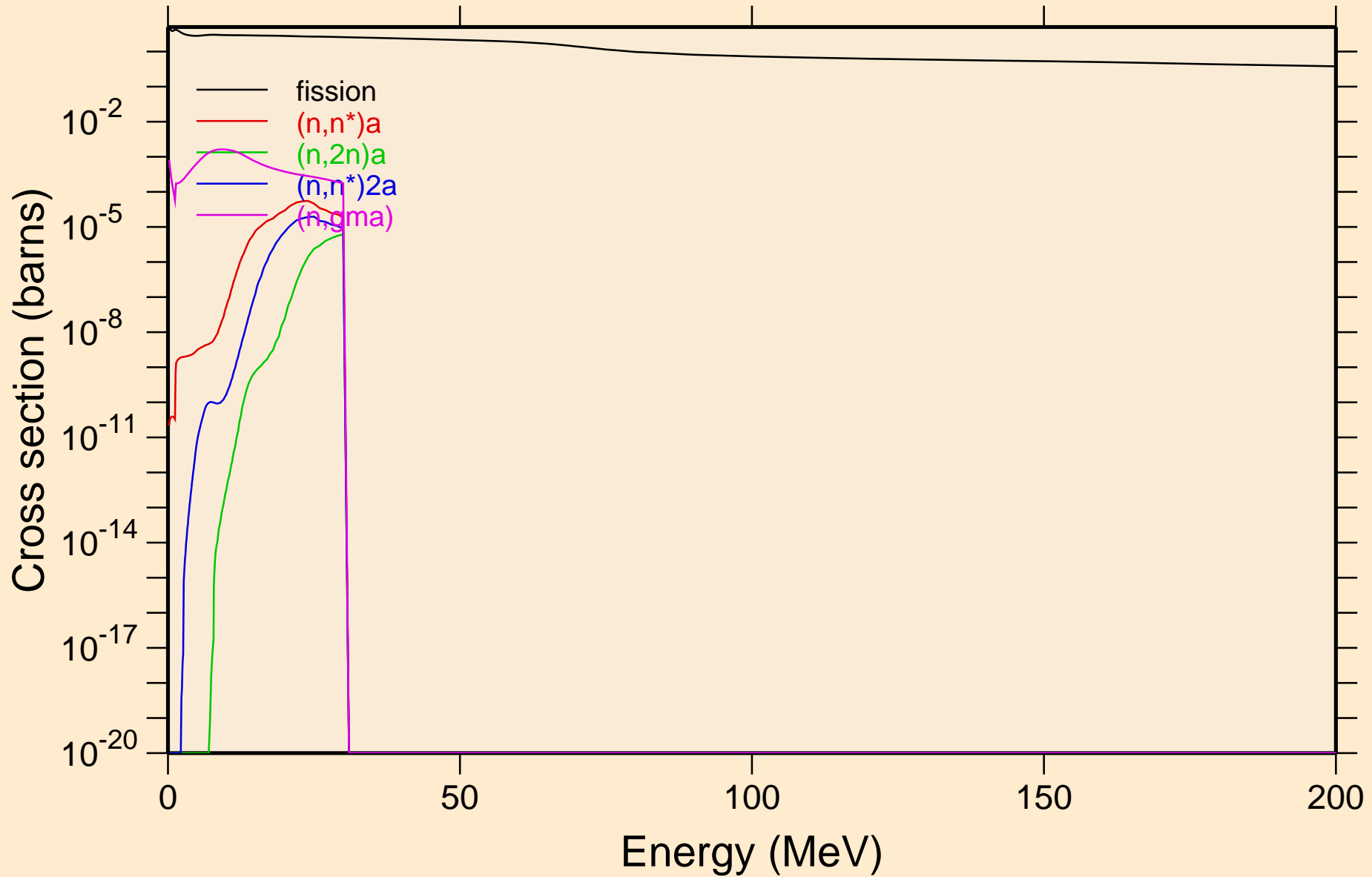

FM250M NEUTRON ACER TENDL-2024 LIBRARY; T=0.K

Non-threshold reactions

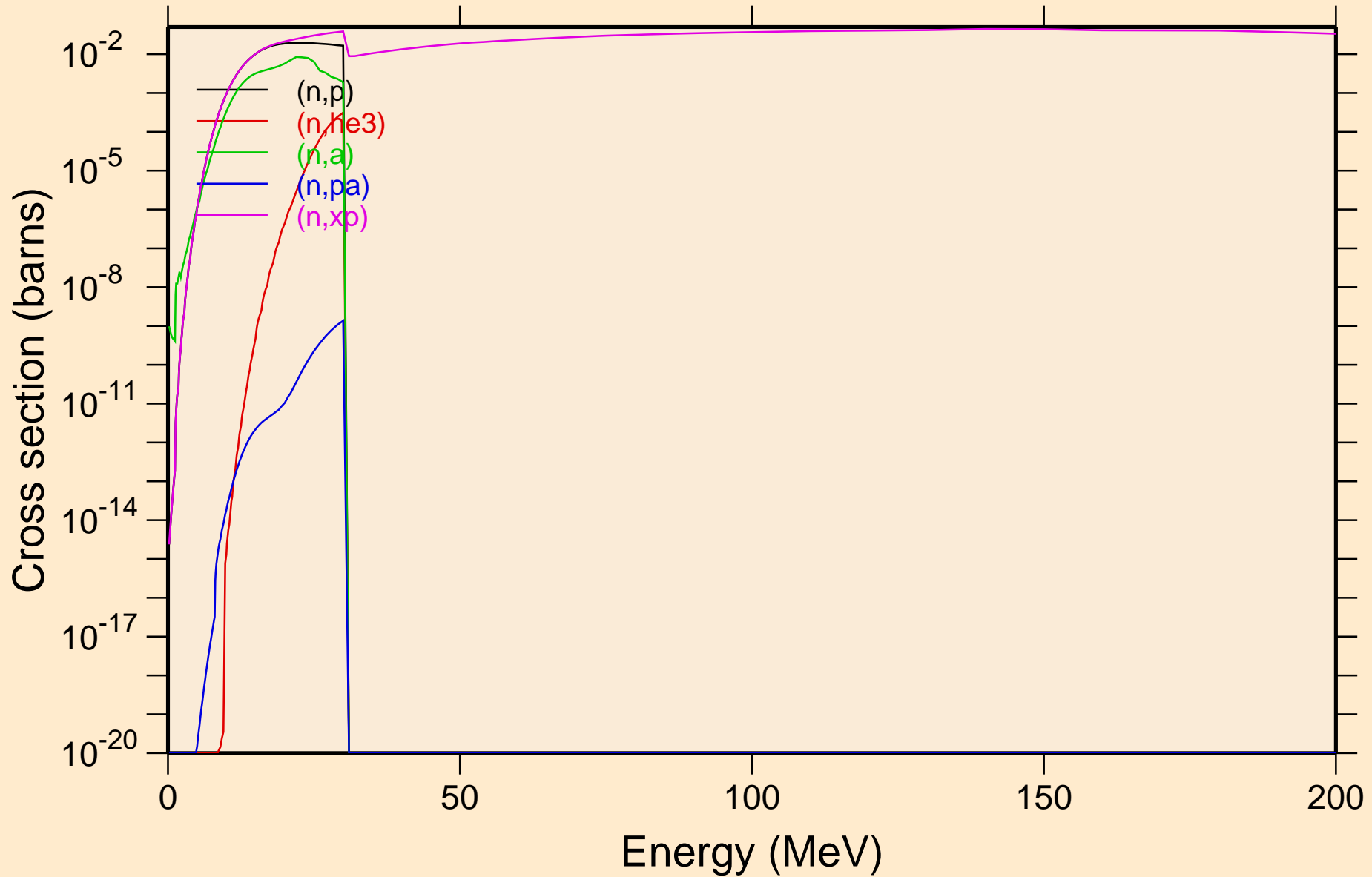

FM250M NEUTRON ACER TENDL-2024 LIBRARY; T=0.K
Non-threshold reactions

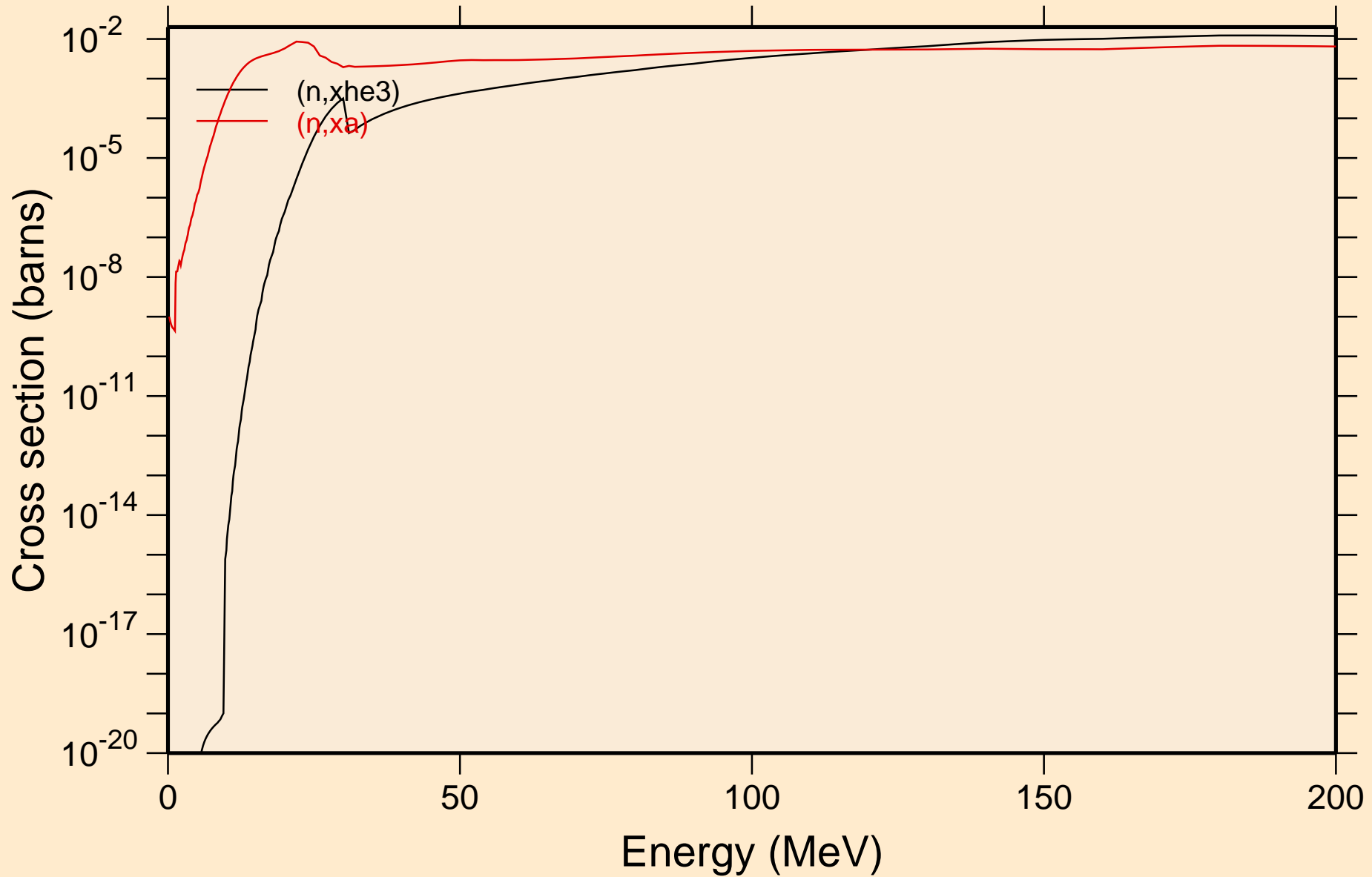

FM250M NEUTRON ACER TENDL-2024 LIBRARY; T=0.K
Inelastic levels

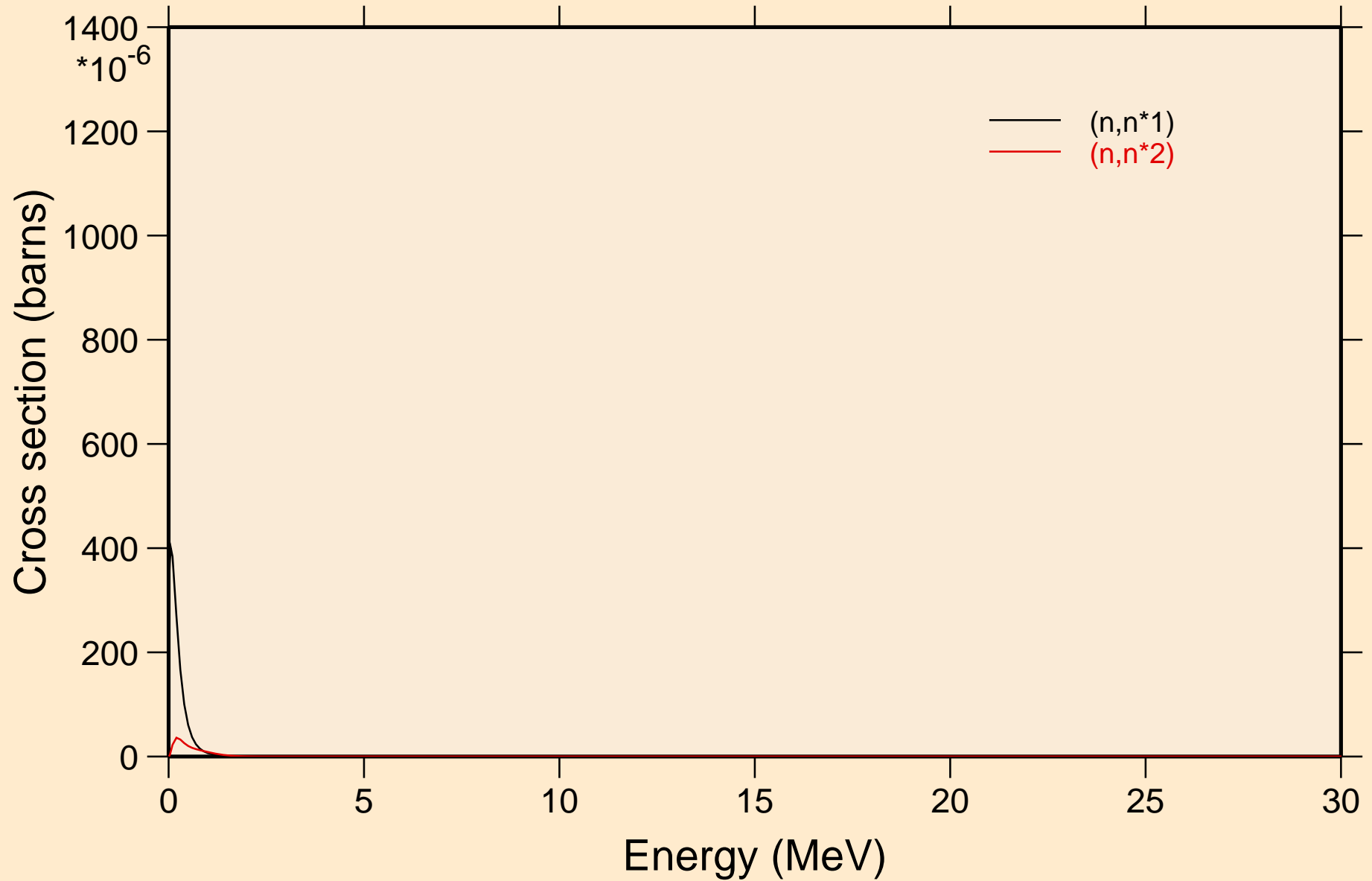

FM250M NEUTRON ACER TENDL-2024 LIBRARY; T=0.K

Threshold reactions

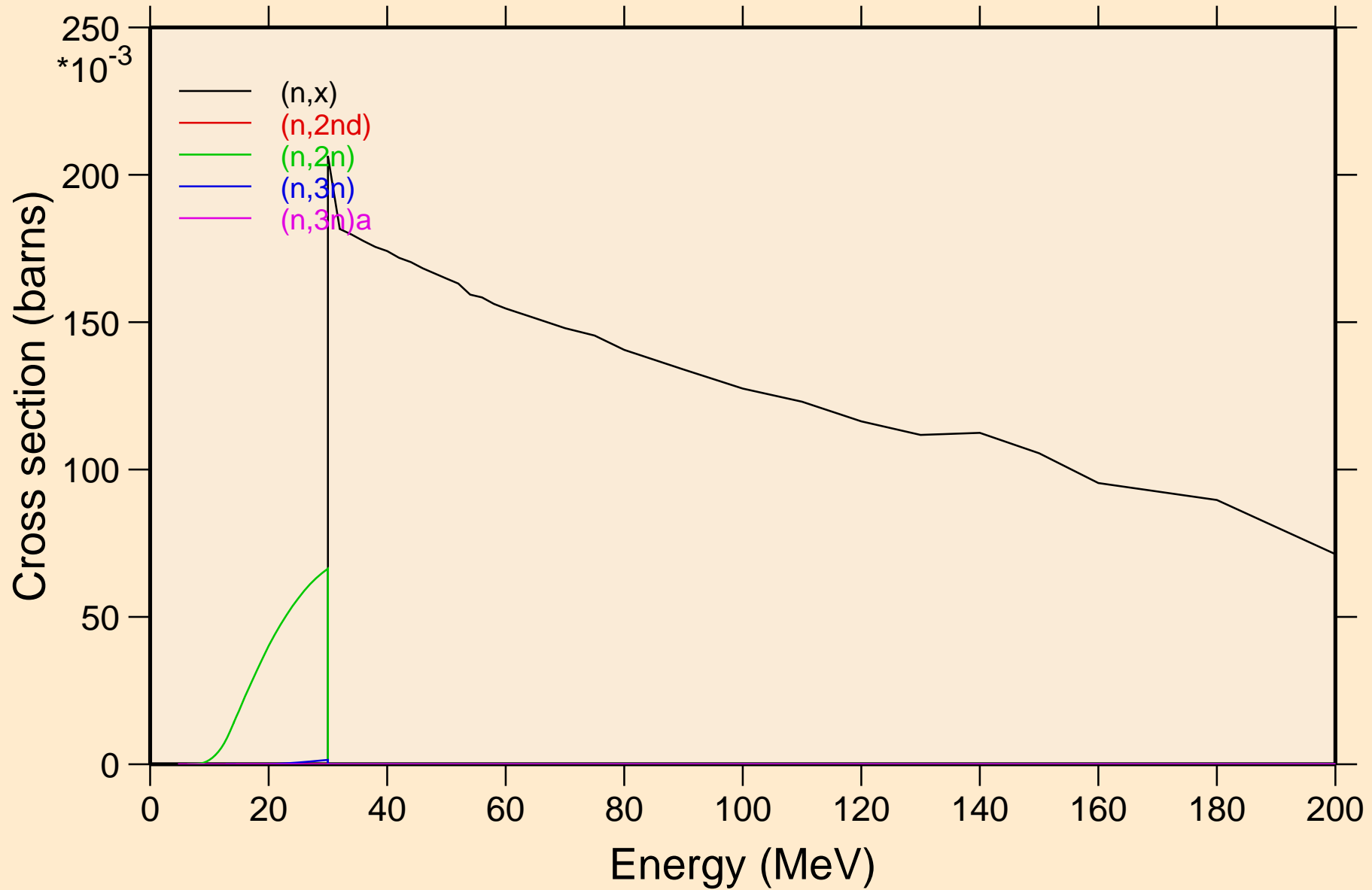

FM250M NEUTRON ACER TENDL-2024 LIBRARY; T=0.K
Threshold reactions

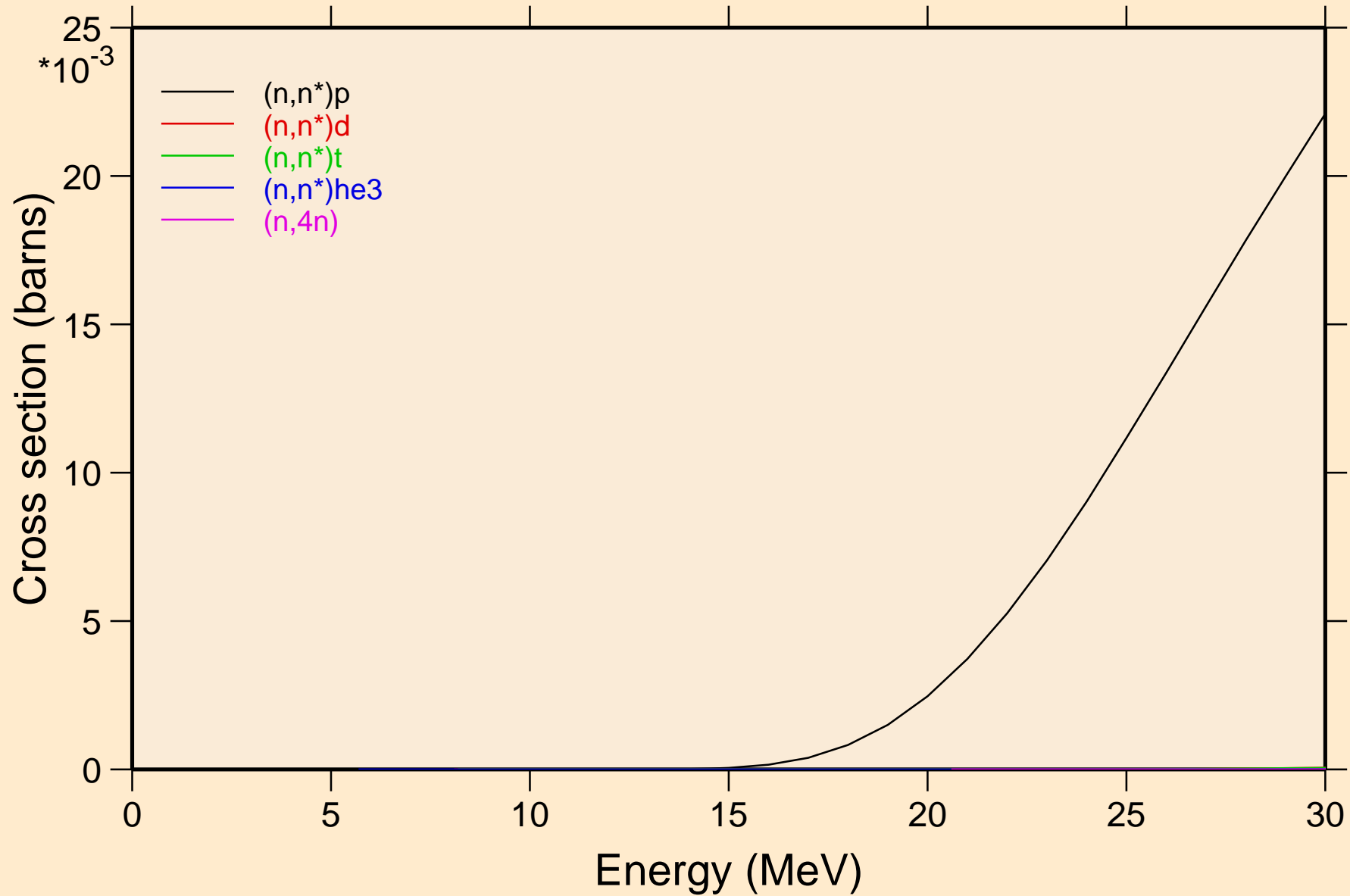

FM250M NEUTRON ACER TENDL-2024 LIBRARY; T=0.K

Threshold reactions

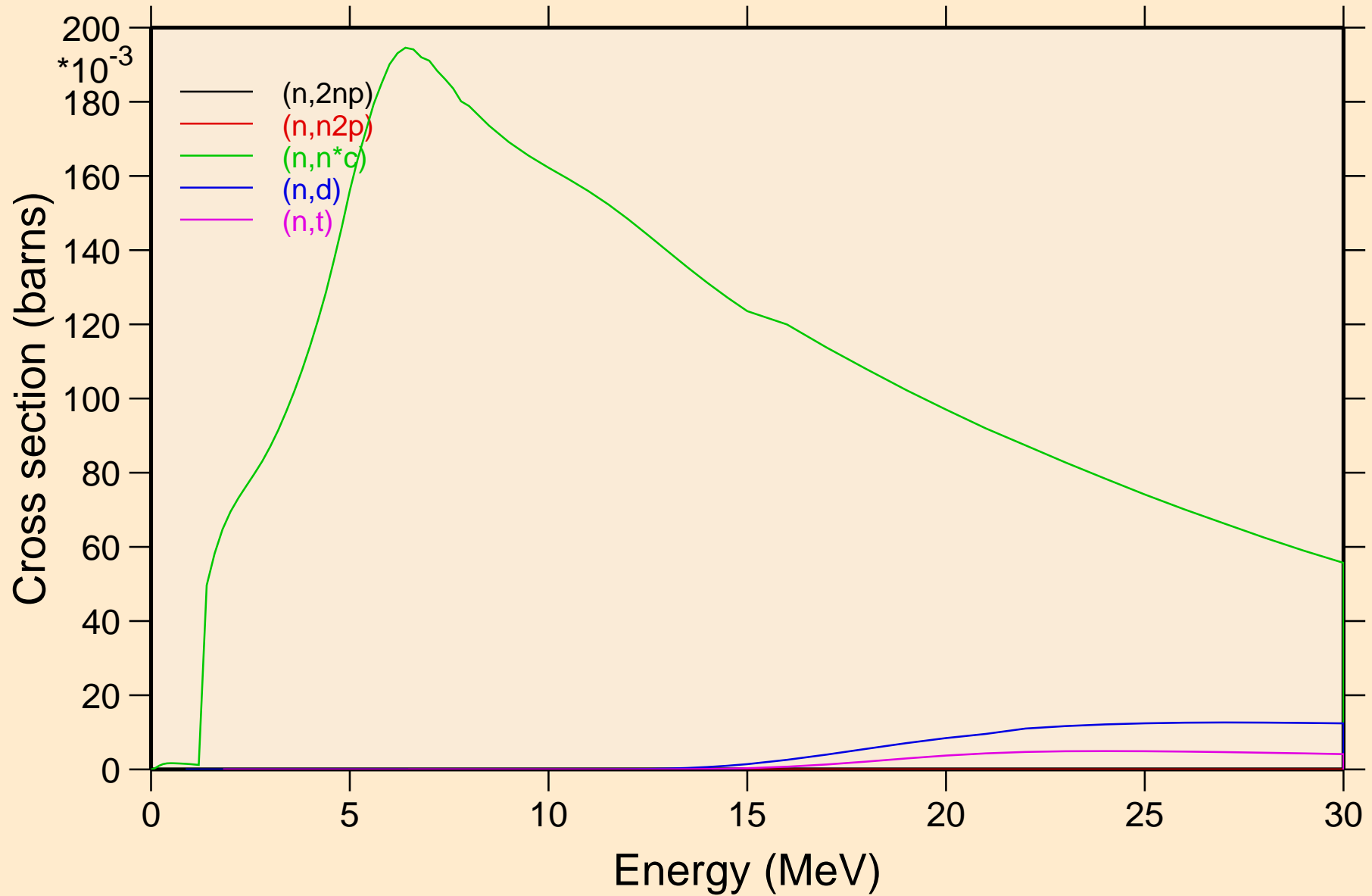

FM250M NEUTRON ACER TENDL-2024 LIBRARY; T=0.K
Threshold reactions

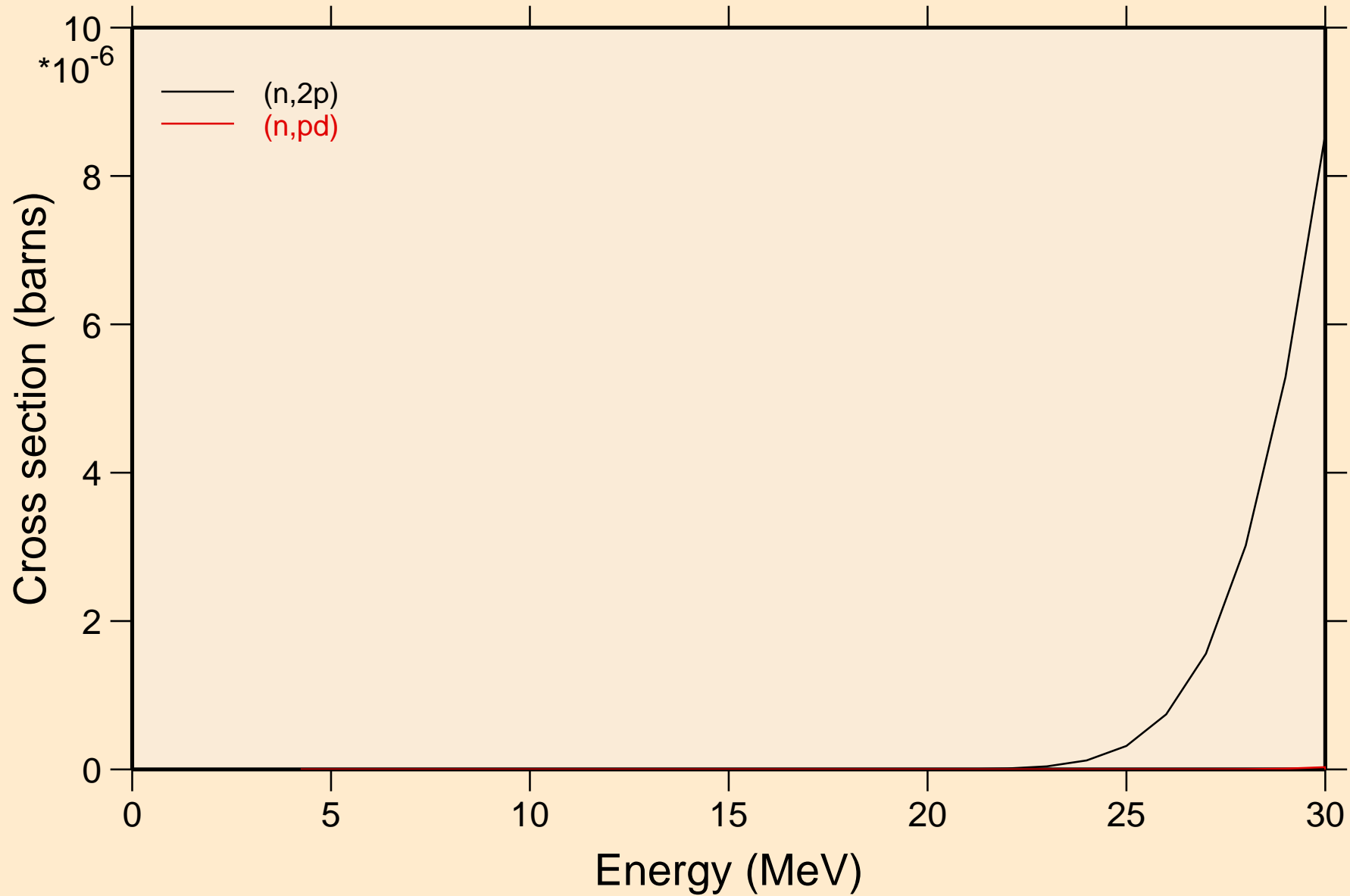

FM250M NEUTRON ACER TENDL-2024 LIBRARY; T=0.K

Threshold reactions

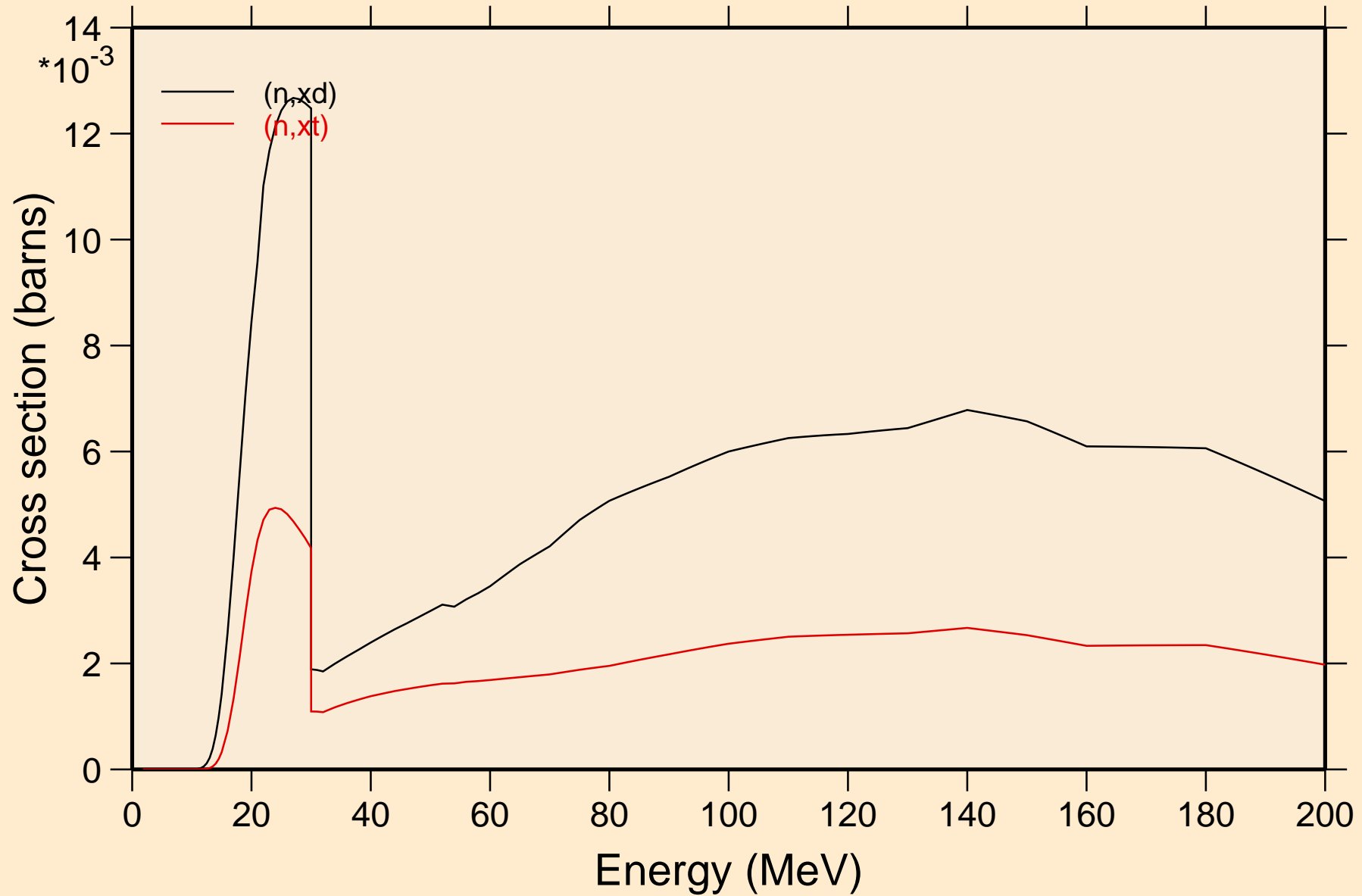

FM250M NEUTRON ACER TENDL-2024 LIBRARY; T=0.K
angular distribution for elastic

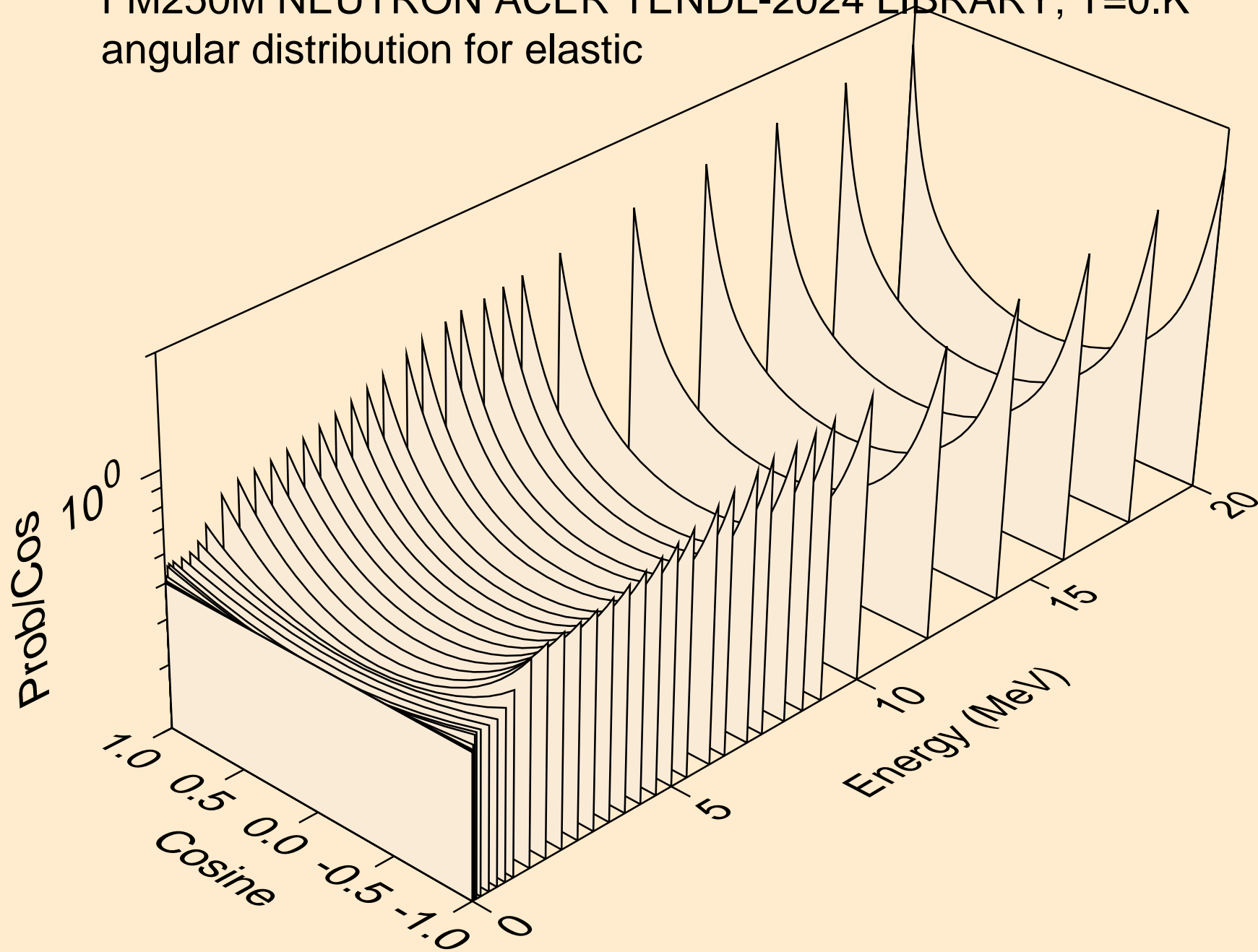

FM250M NEUTRON ACER TENDL-2024 LIBRARY; T=0.K
angular distribution for elastic

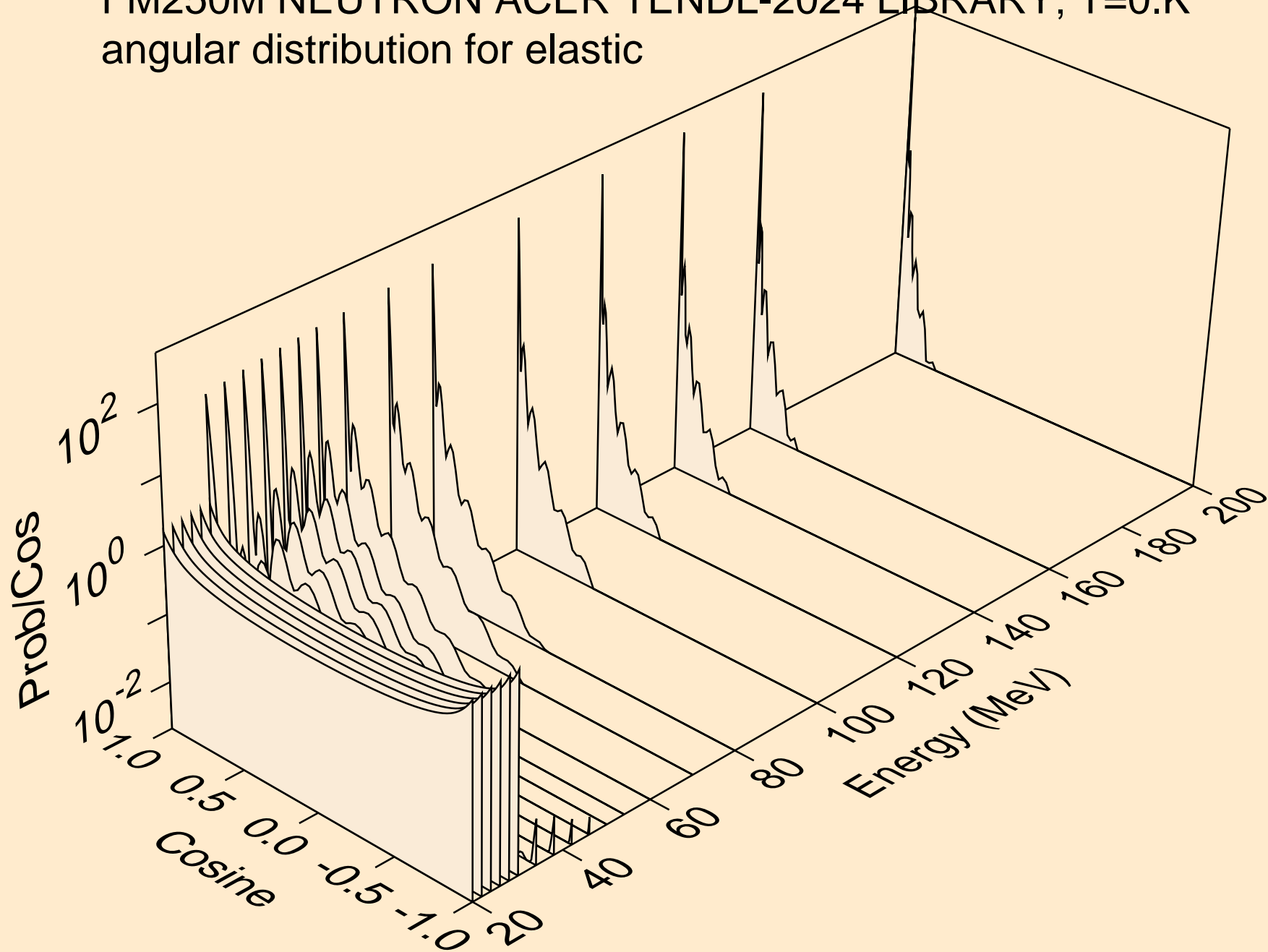

FM250M NEUTRON ACER TENDL-2024 LIBRARY; T=0.K
angular distribution for (n,n*1)

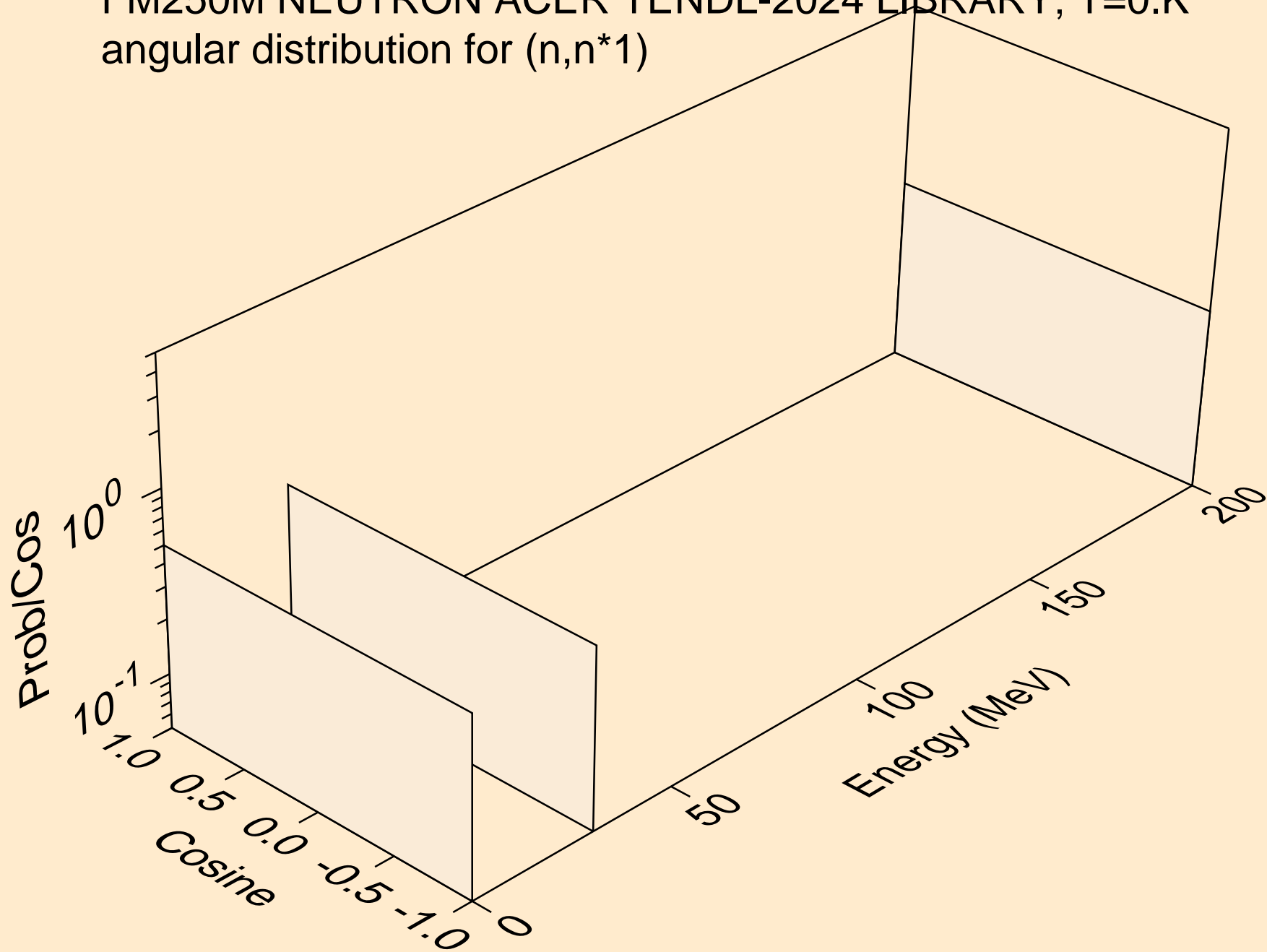

FM250M NEUTRON ACER TENDL-2024 LIBRARY; T=0.K
angular distribution for (n,n*2)

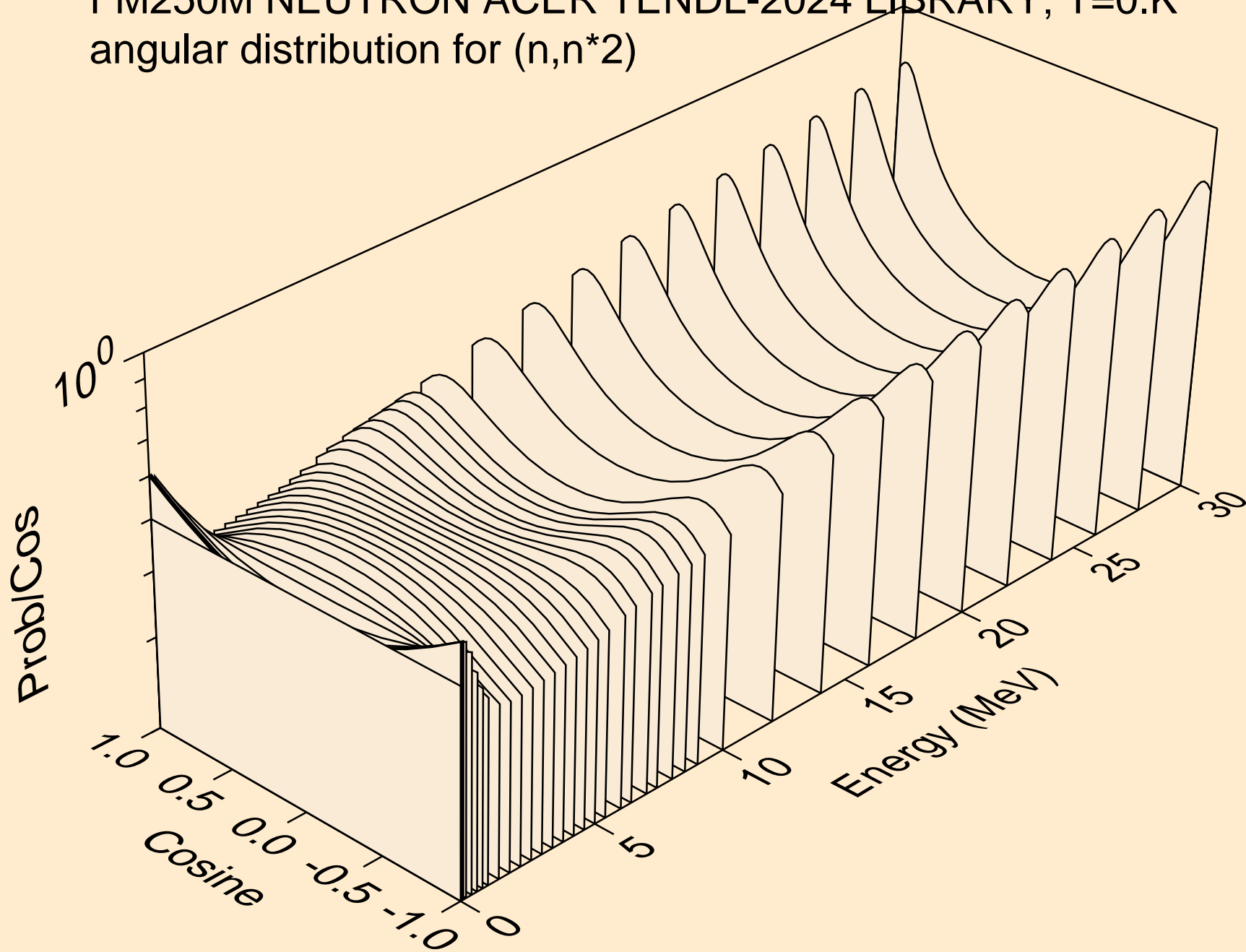

FM250M NEUTRON ACER TENDL-2024 LIBRARY; T=0.K
Total fission nubar

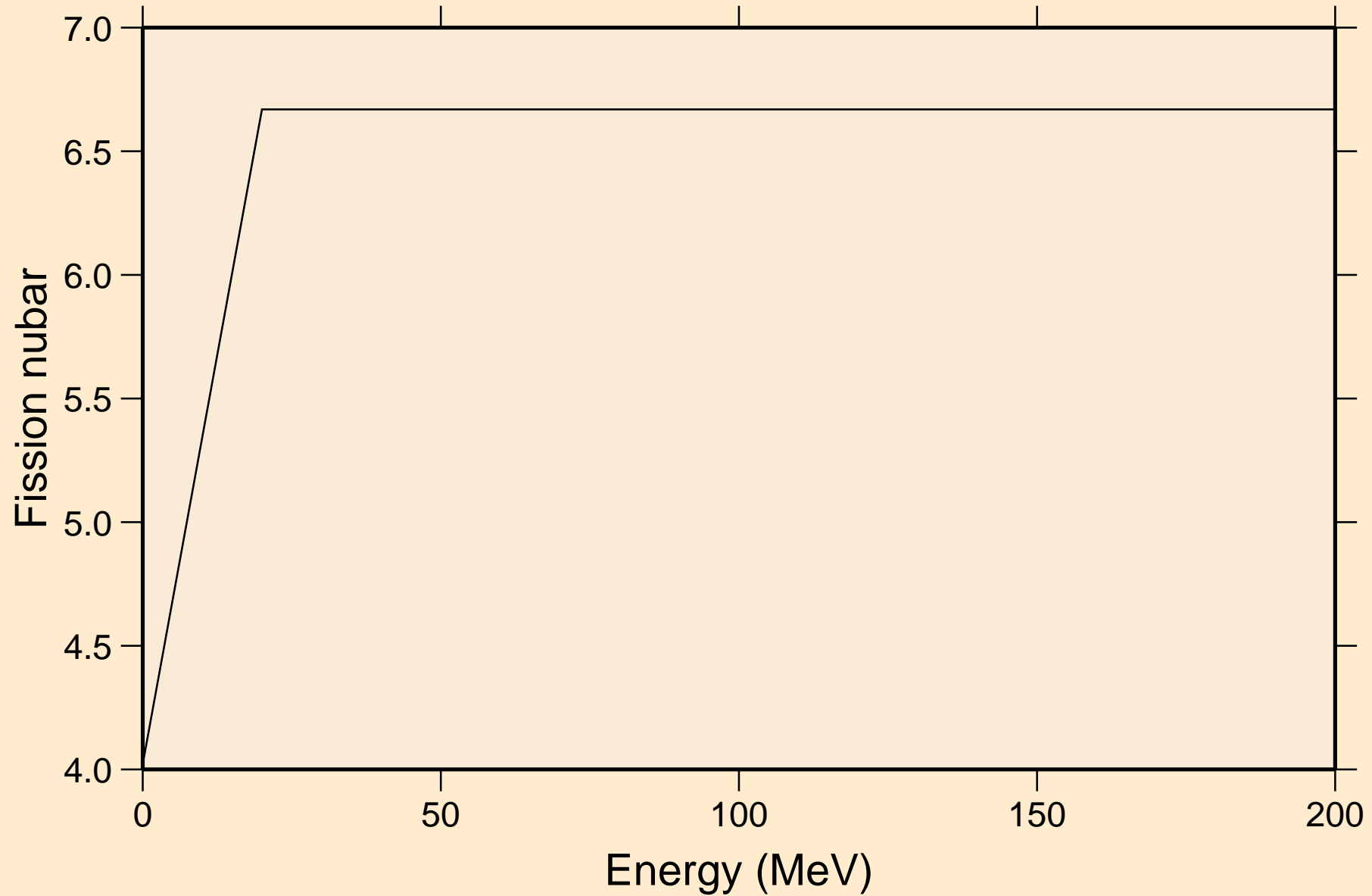

FM250M NEUTRON ACER TENDL-2024 LIBRARY; T=0.K
Neutron emission for (n,x)

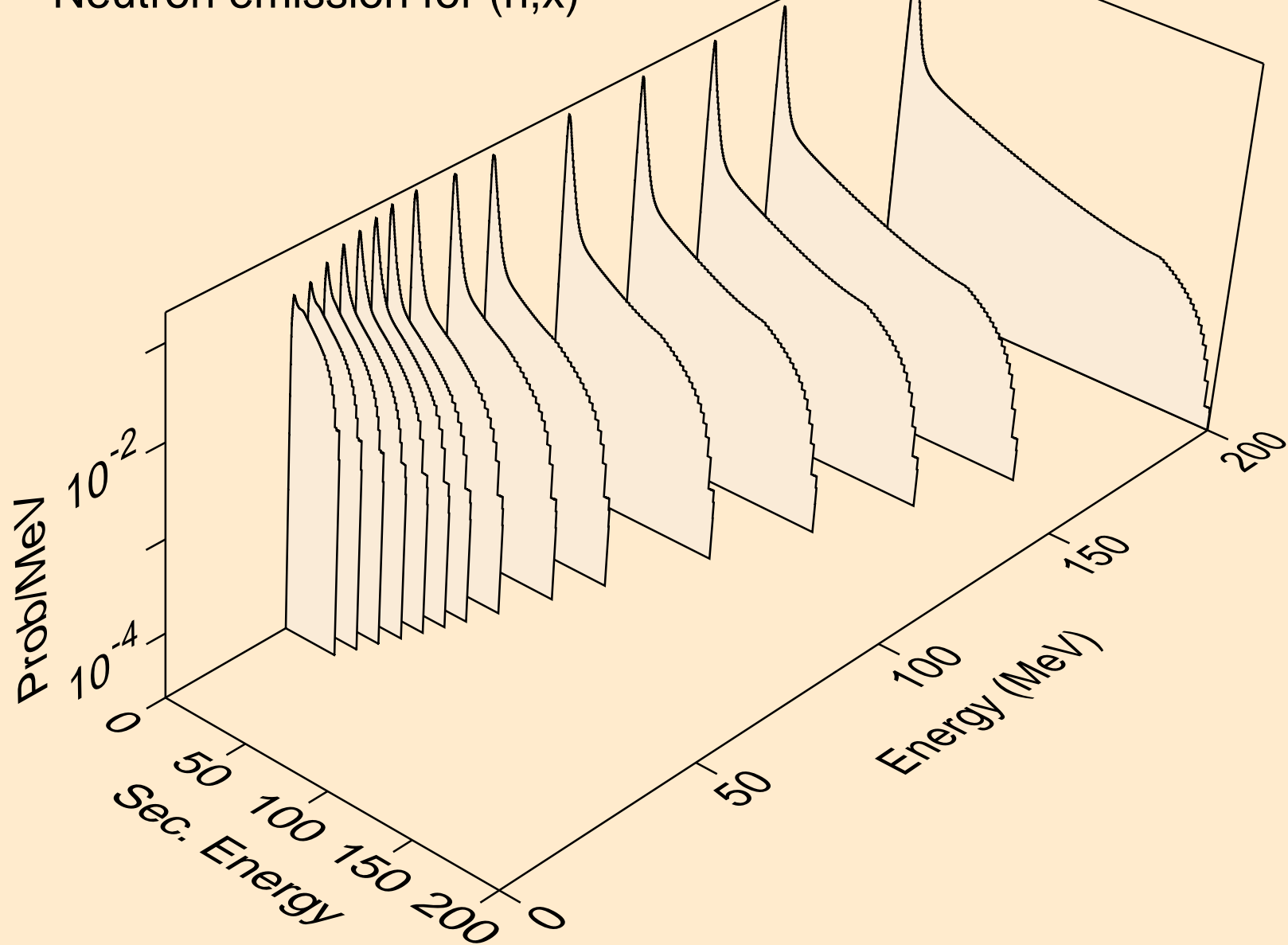

FM250M NEUTRON ACER TENDL-2024 LIBRARY; T=0.K
Neutron emission for (n,2nd)

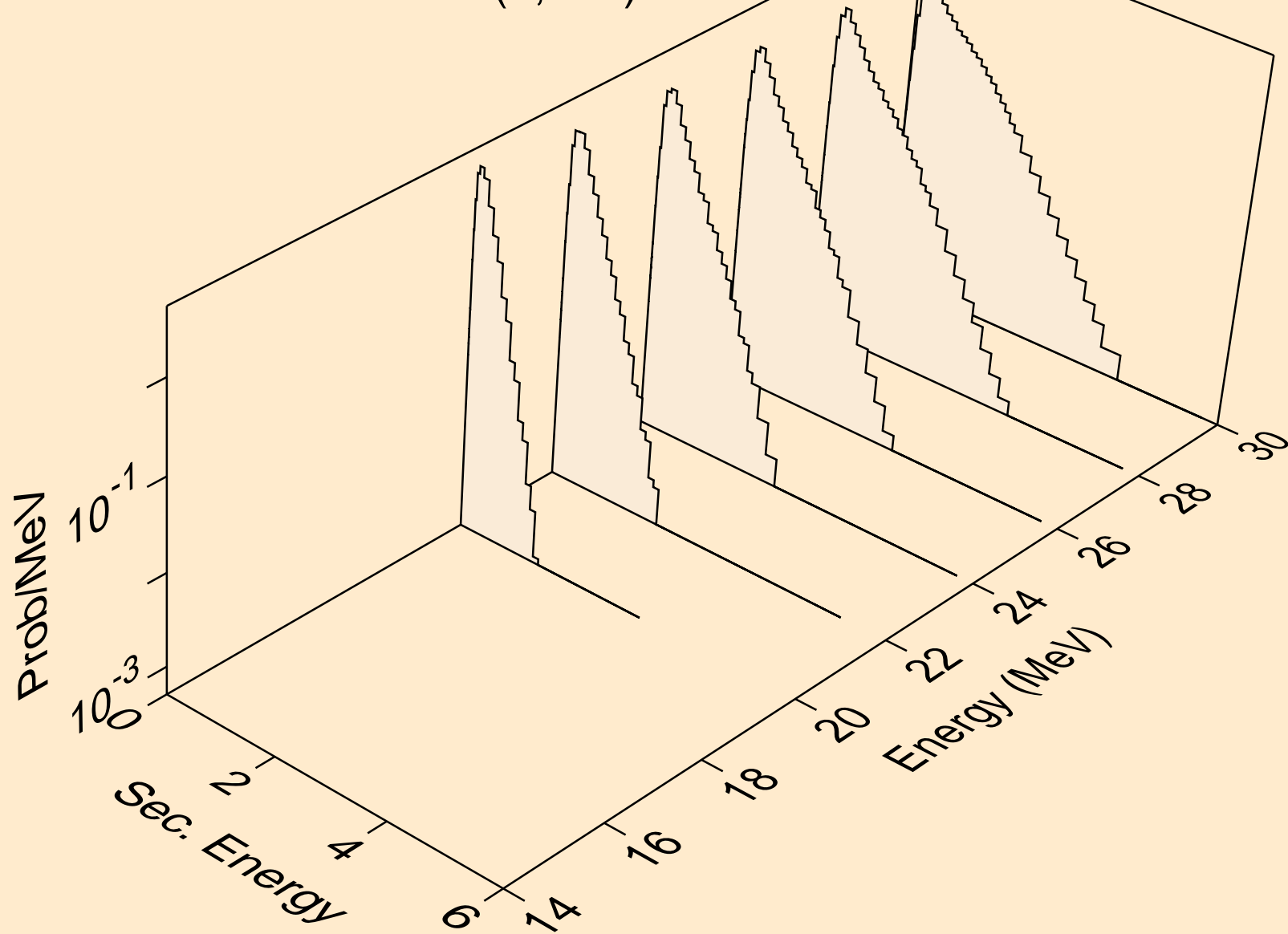

FM250M NEUTRON ACER TENDL-2024 LIBRARY; T=0.K
Neutron emission for (n,2n)

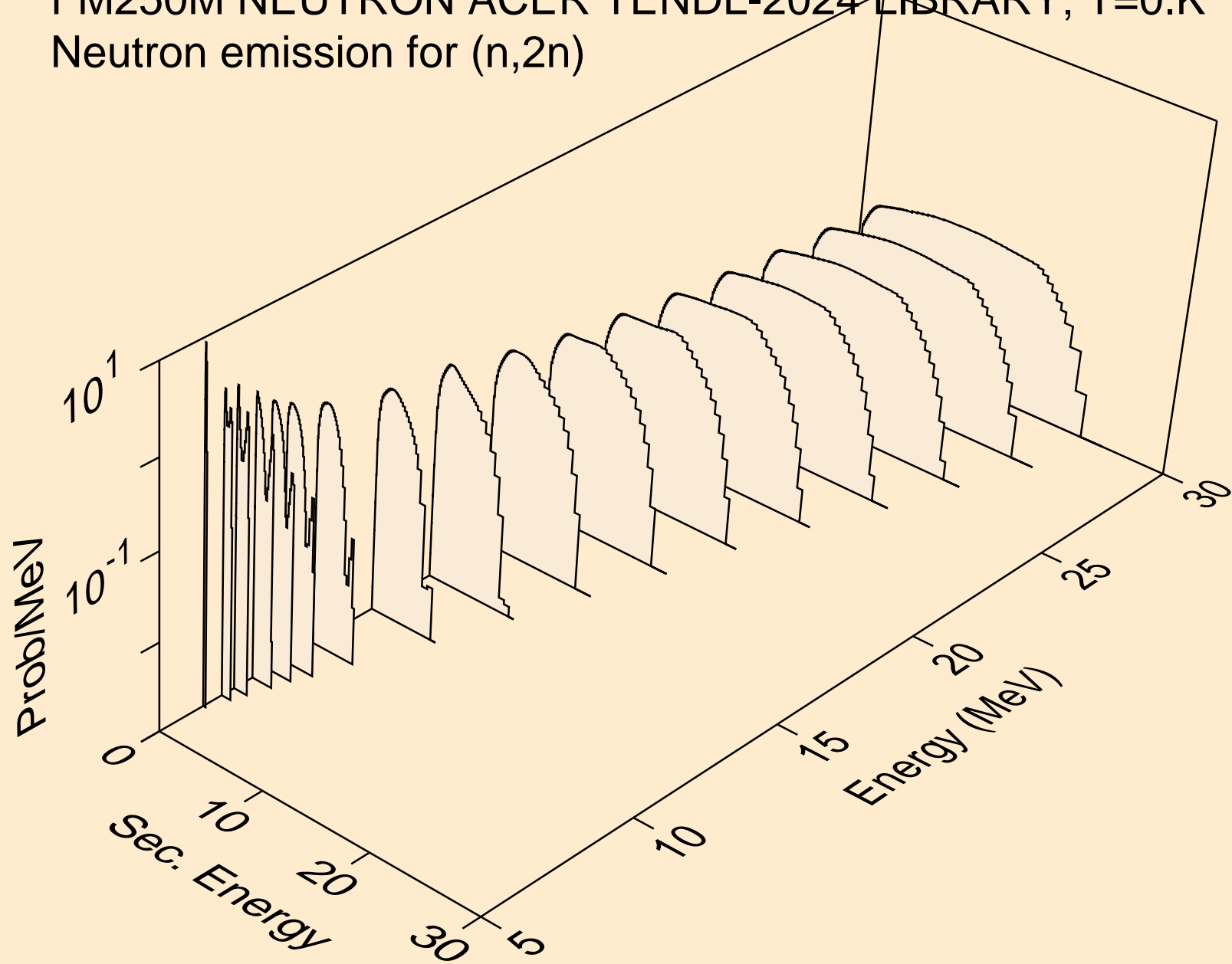

FM250M NEUTRON ACER TENDL-2024 LIBRARY; T=0.K
Neutron emission for (n,3n)

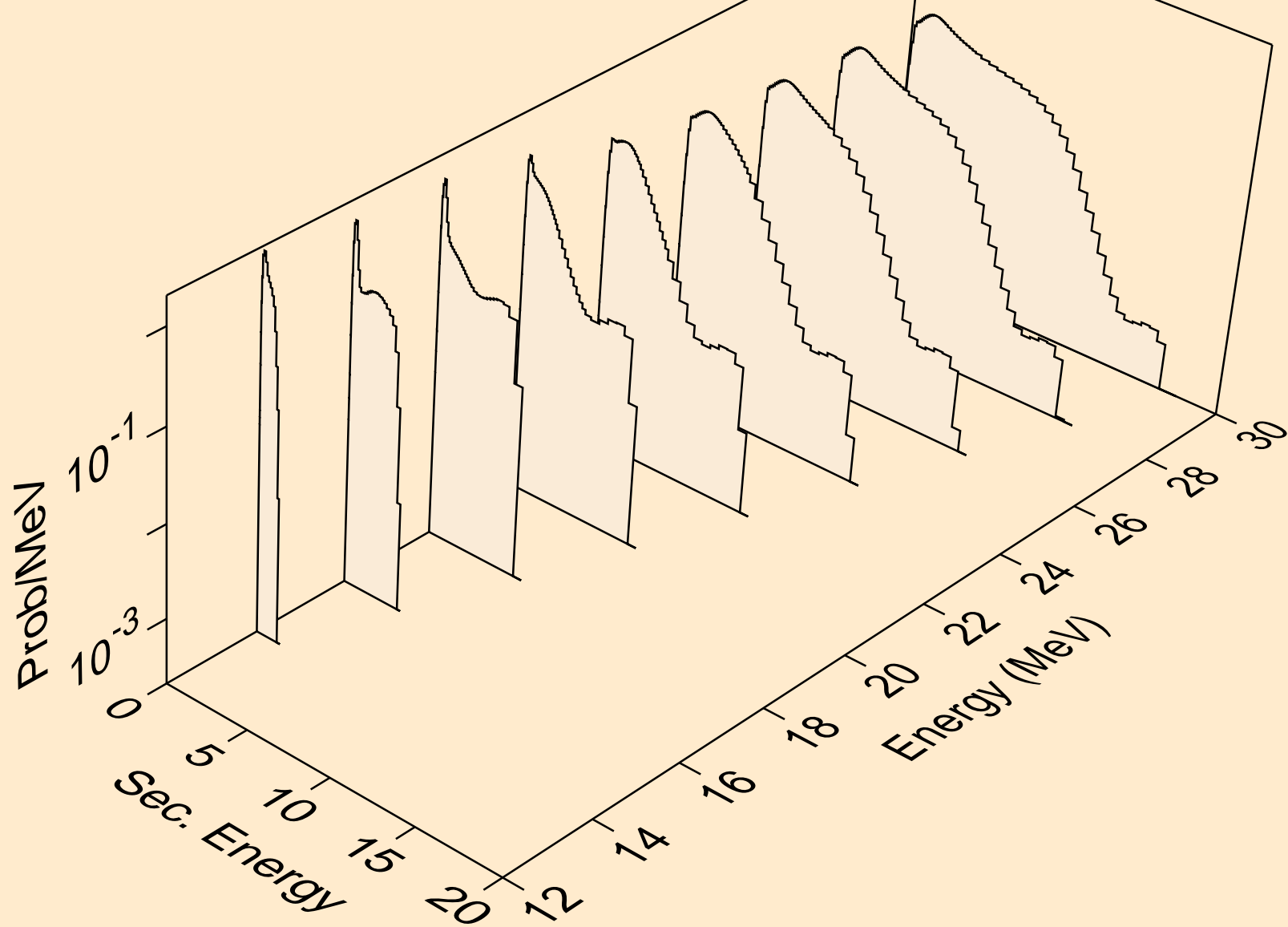

FM250M NEUTRON ACER TENDL-2024 LIBRARY; T=0.K
Neutron emission for fission

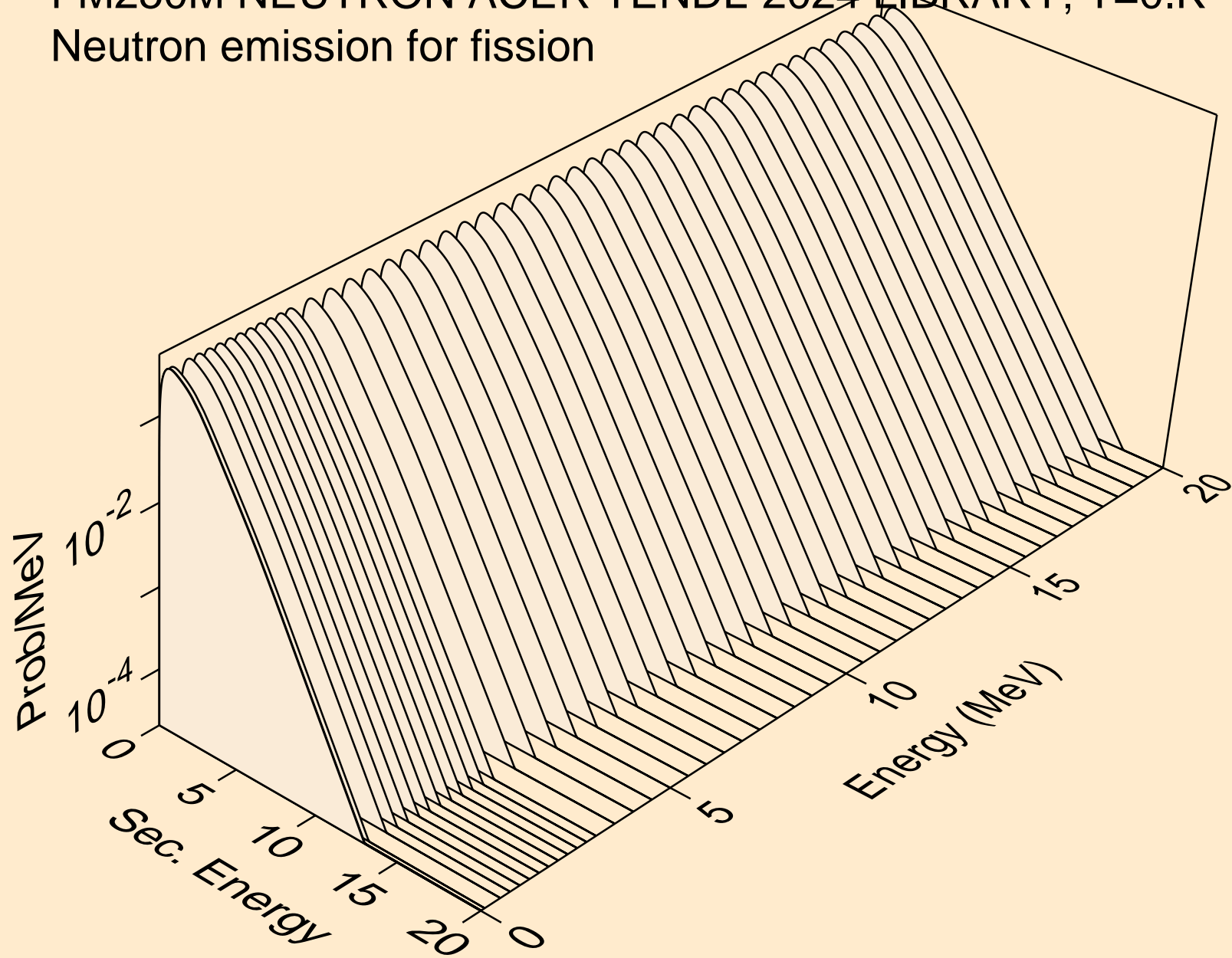

FM250M NEUTRON ACER TENDL-2024 LIBRARY; T=0.K
Neutron emission for (n,n*)a

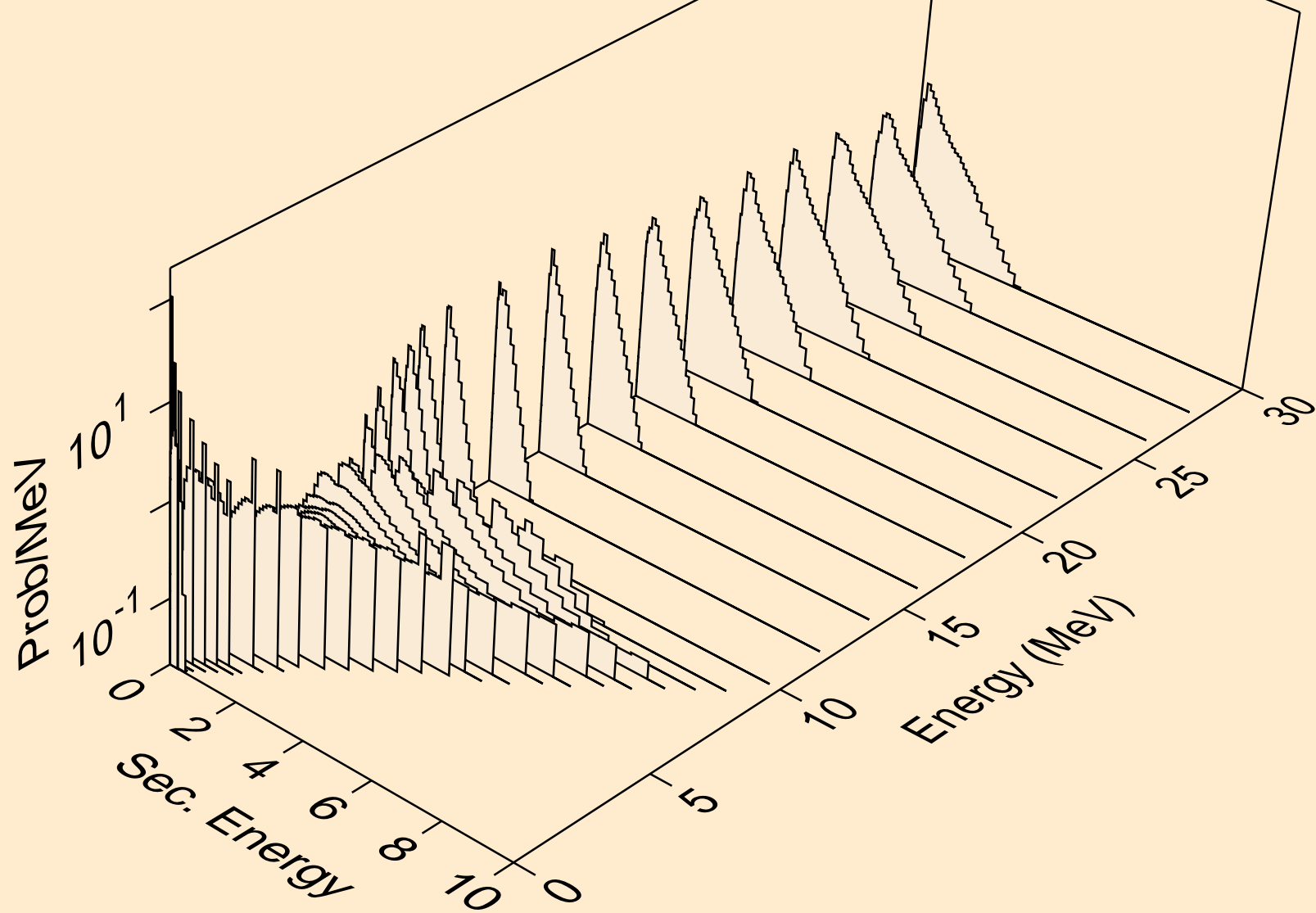

FM250M NEUTRON ACER TENDL-2024 LIBRARY; T=0.K
Neutron emission for (n,2n)a

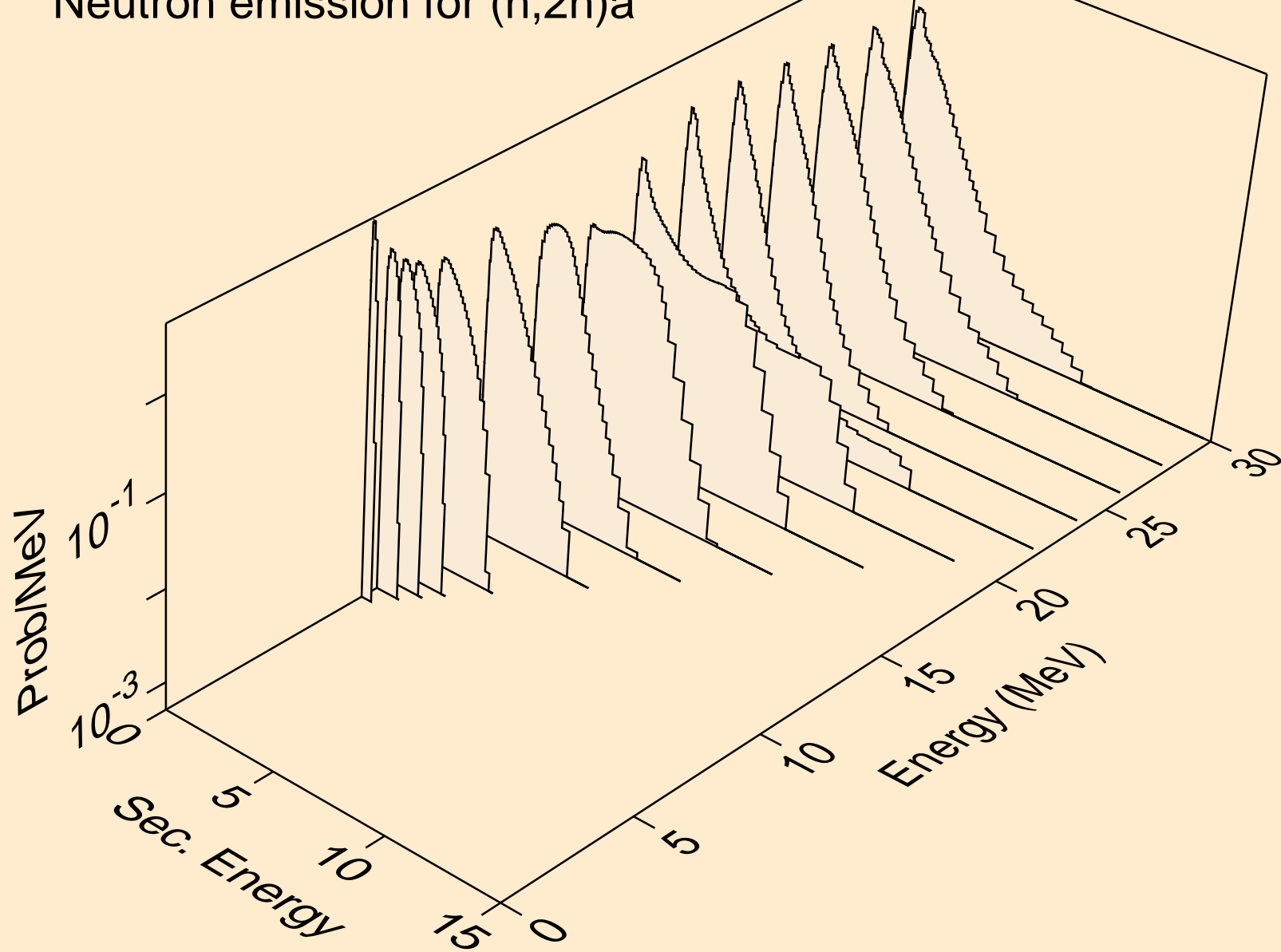

FM250M NEUTRON ACER TENDL-2024 LIBRARY; T=0.K
Neutron emission for (n,3n)a

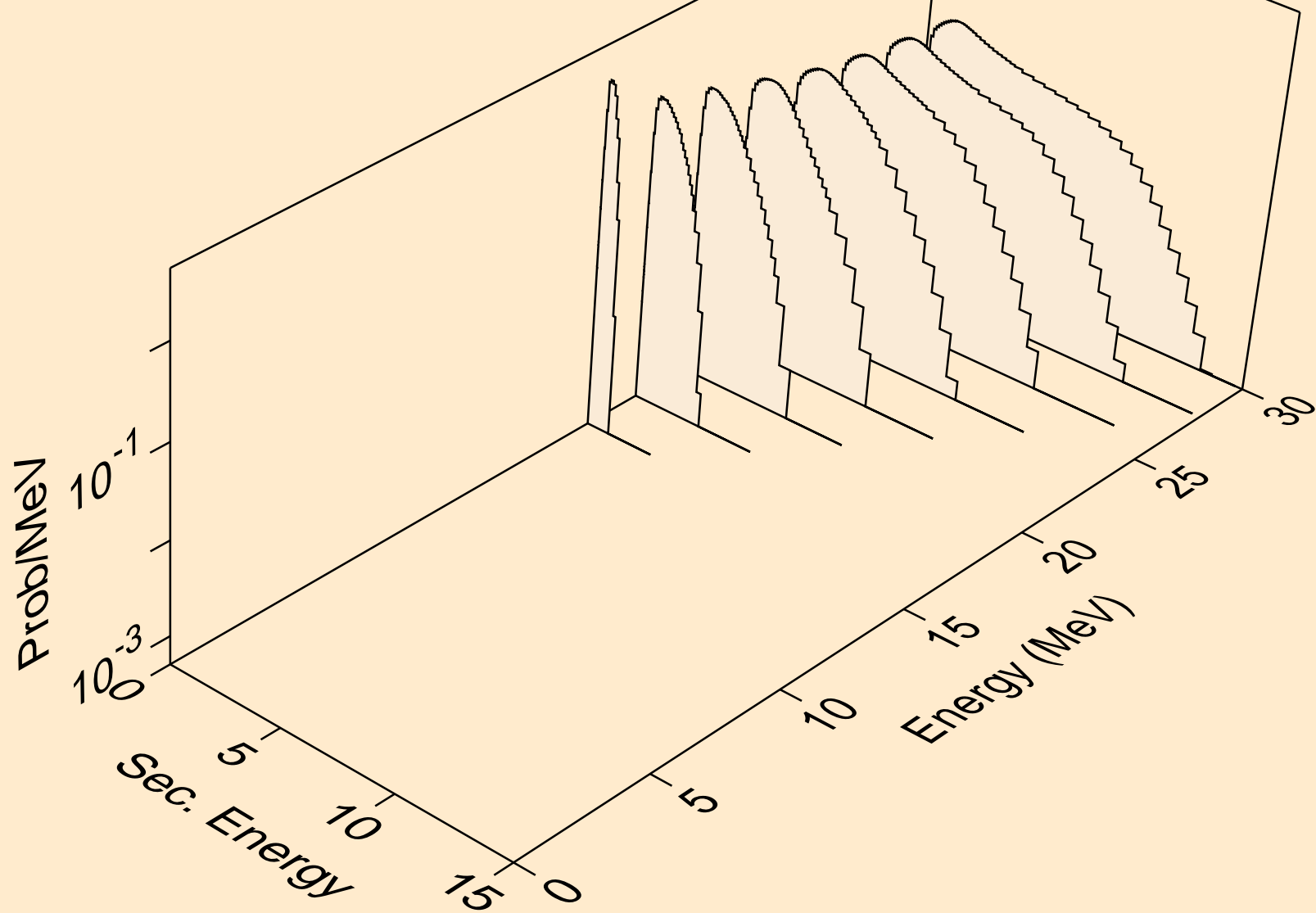

FM250M NEUTRON ACER TENDL-2024 LIBRARY; T=0.K
Neutron emission for (n,n*)p

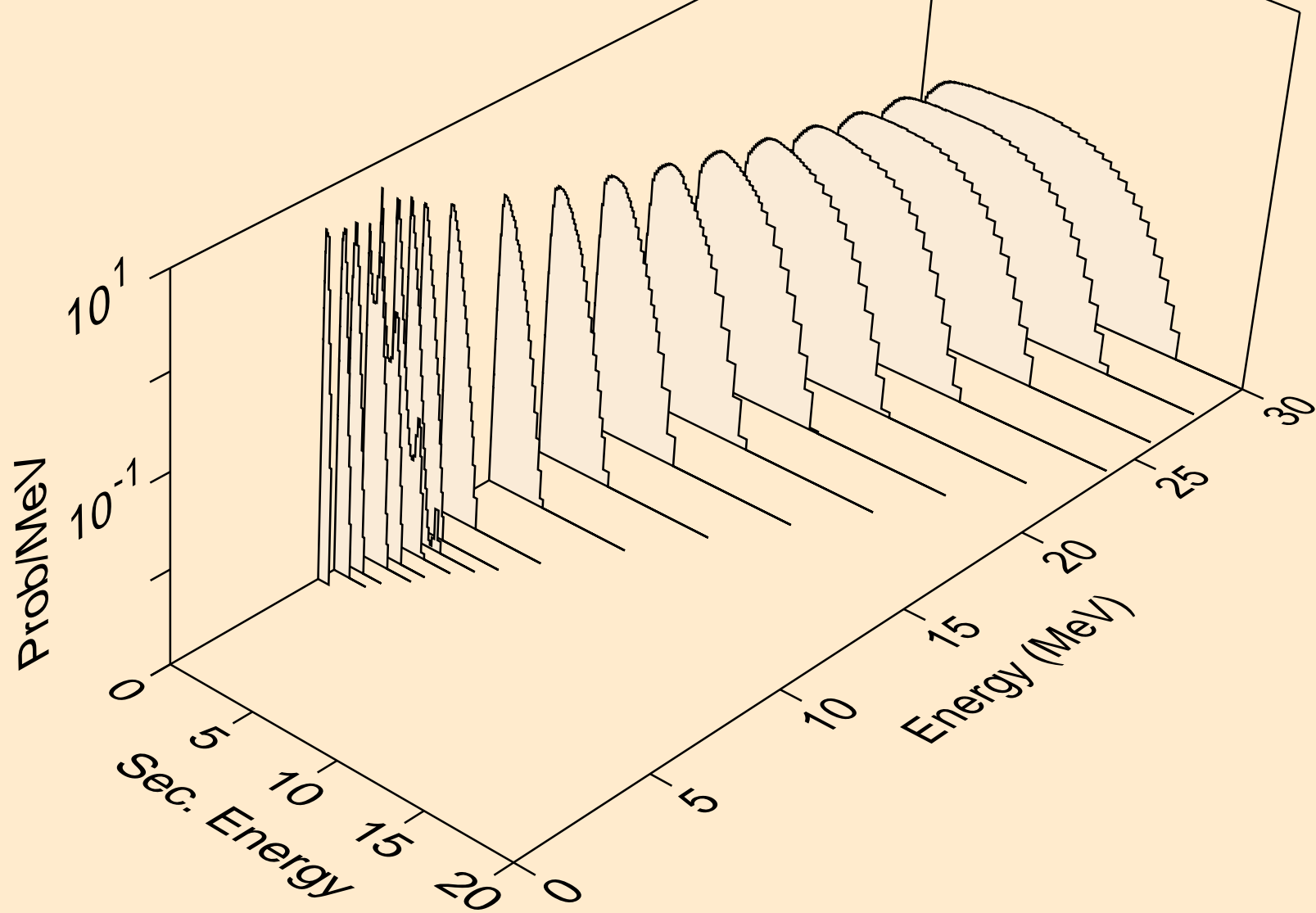

FM250M NEUTRON ACER TENDL-2024 LIBRARY; T=0.K
Neutron emission for (n,n*)2a

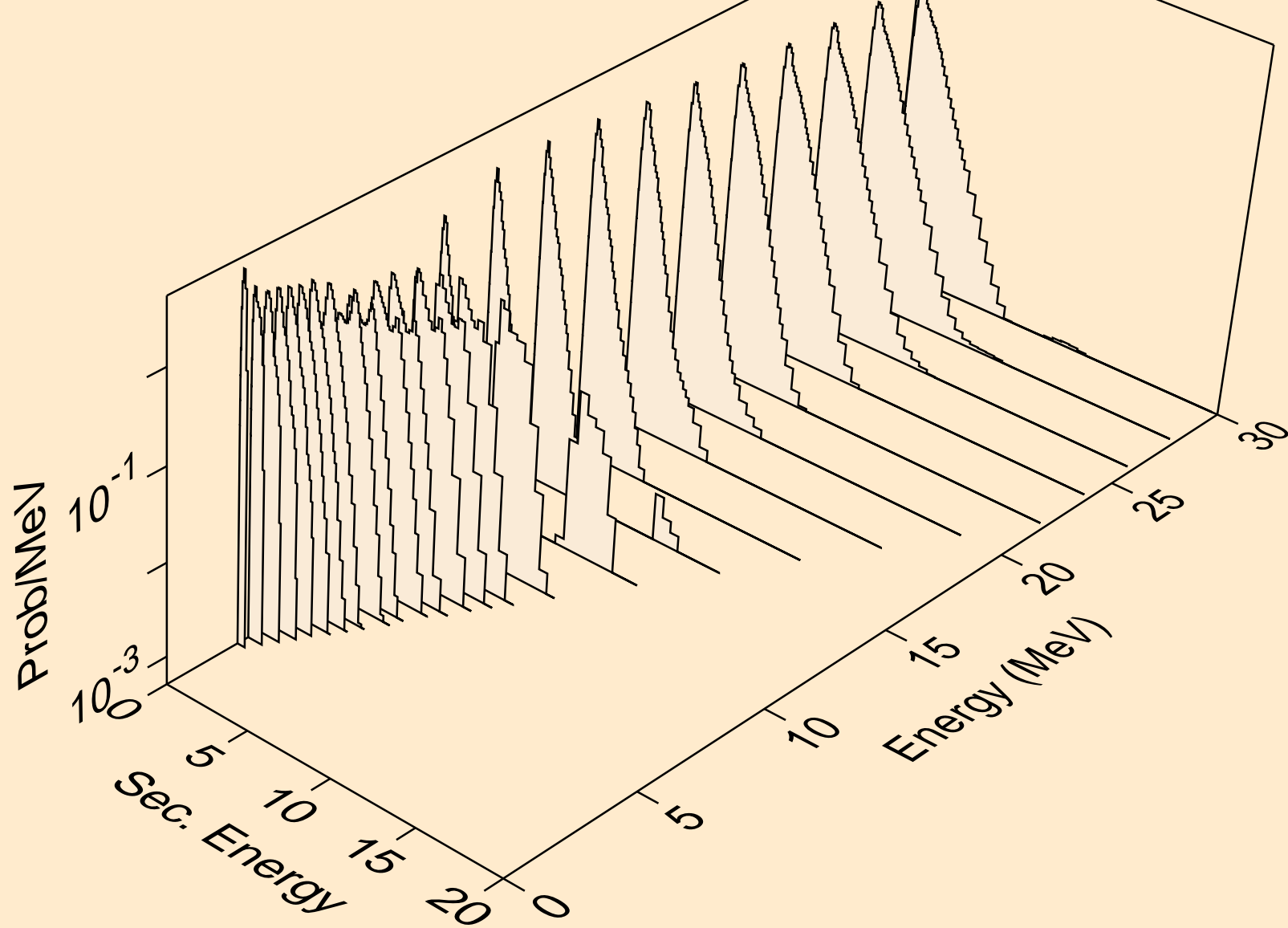

FM250M NEUTRON ACER TENDL-2024 LIBRARY; T=0.K
Neutron emission for (n,n*)d

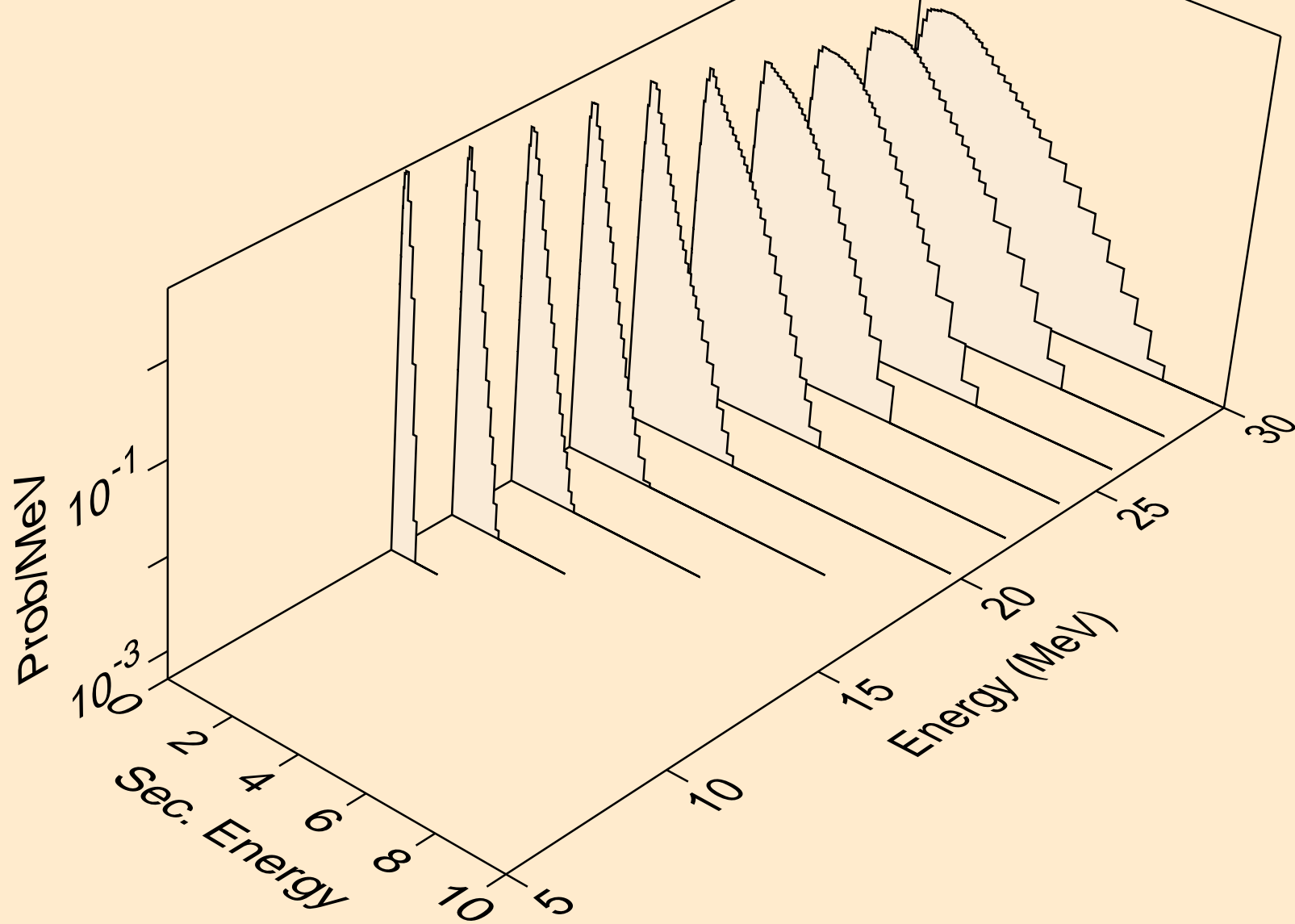

FM250M NEUTRON ACER TENDL-2024 LIBRARY; T=0.K
Neutron emission for (n,n*)t

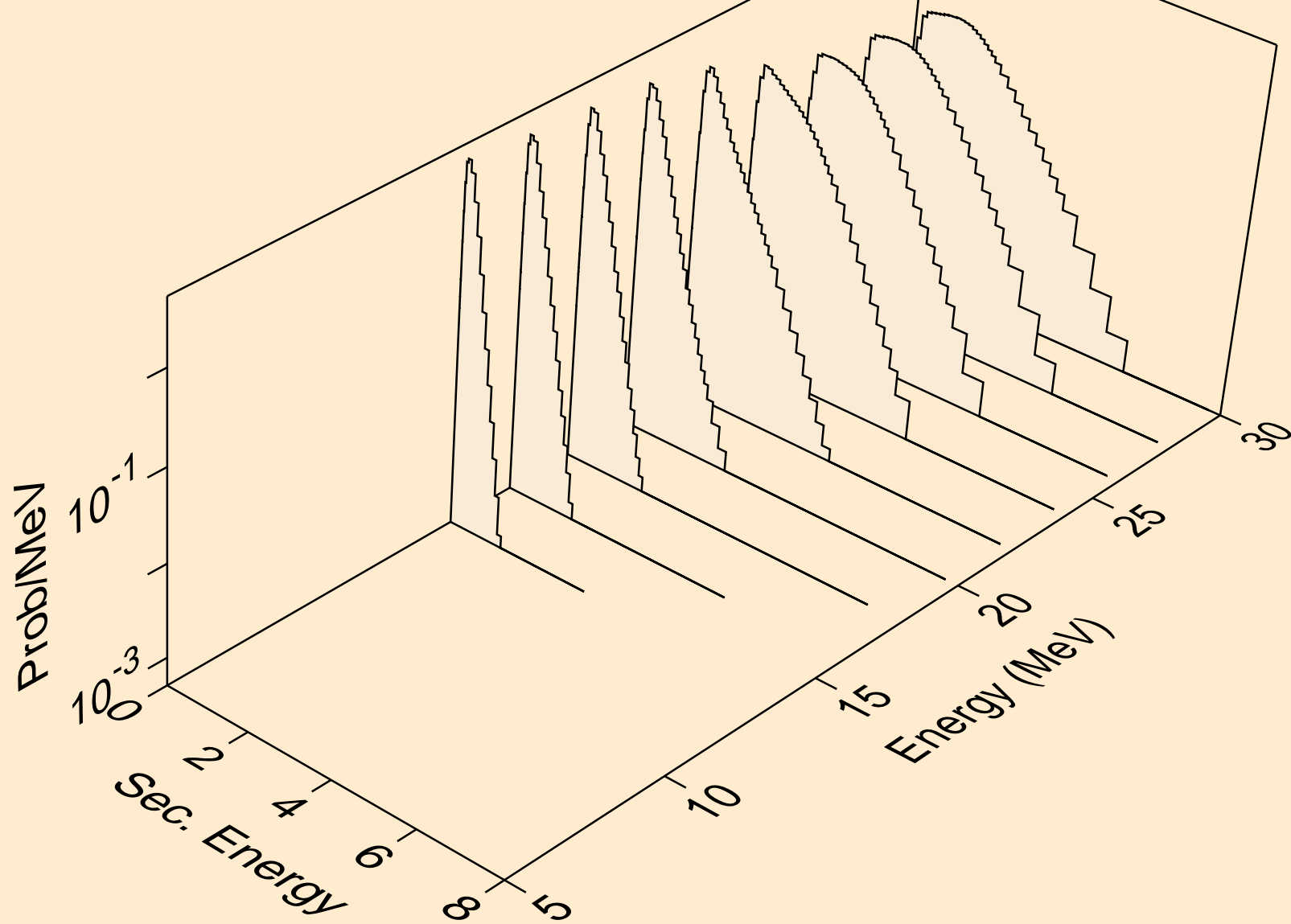

FM250M NEUTRON ACER TENDL-2024 LIBRARY; T=0.K
Neutron emission for (n,n*)he3

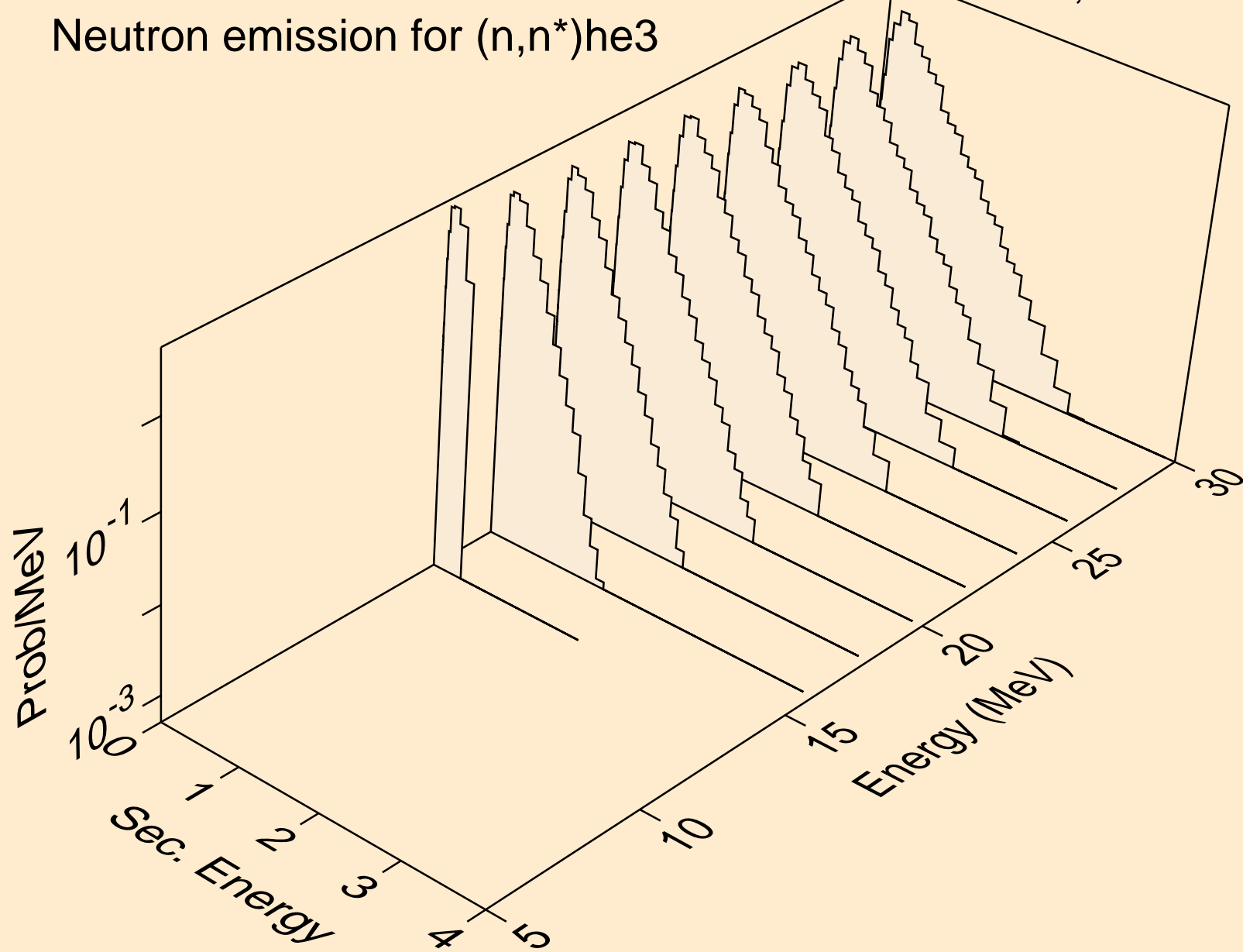

FM250M NEUTRON ACER TENDL-2024 LIBRARY; T=0.K
Neutron emission for (n,4n)

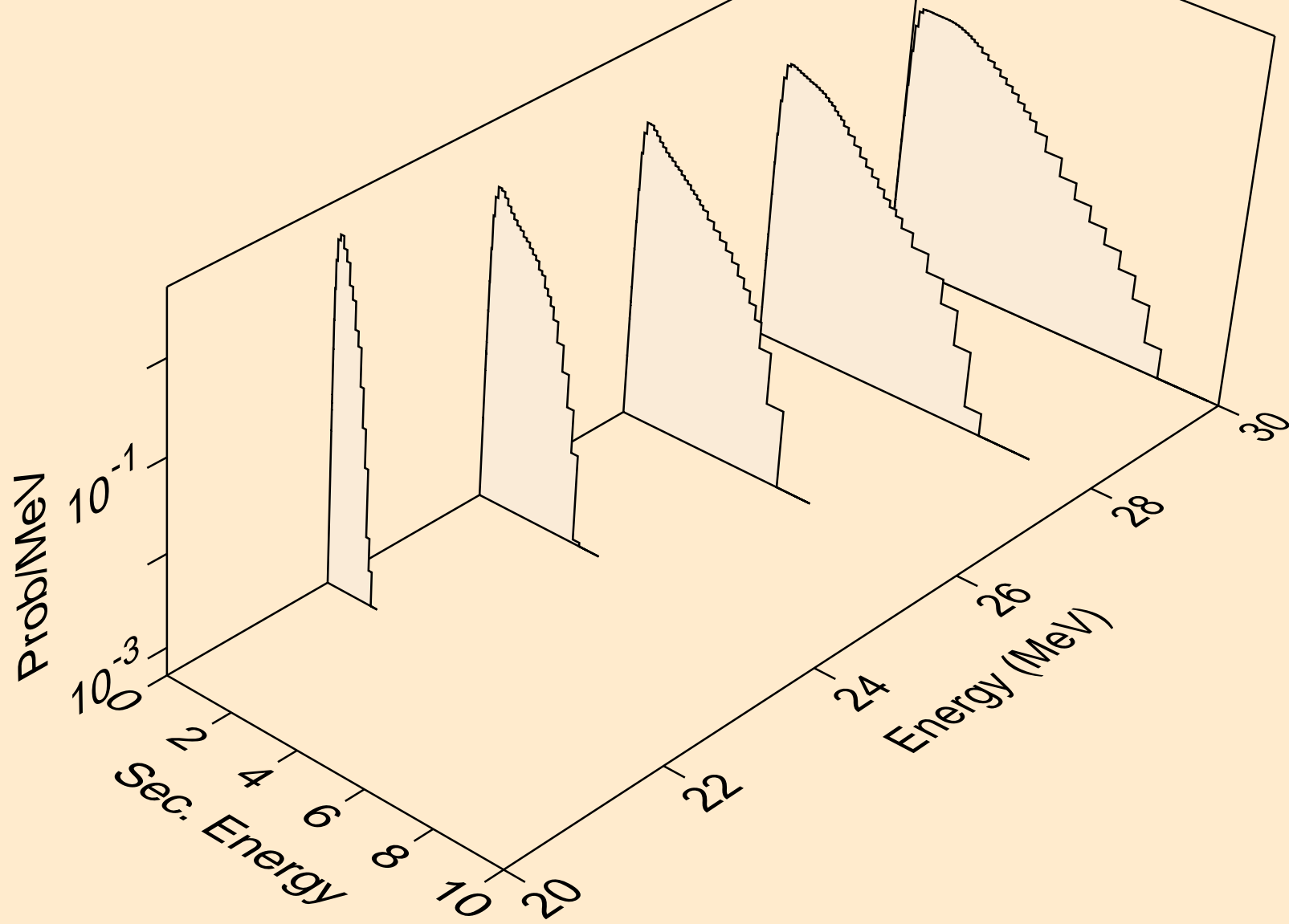

FM250M NEUTRON ACER TENDL-2024 LIBRARY; T=0.K
Neutron emission for (n,2np)

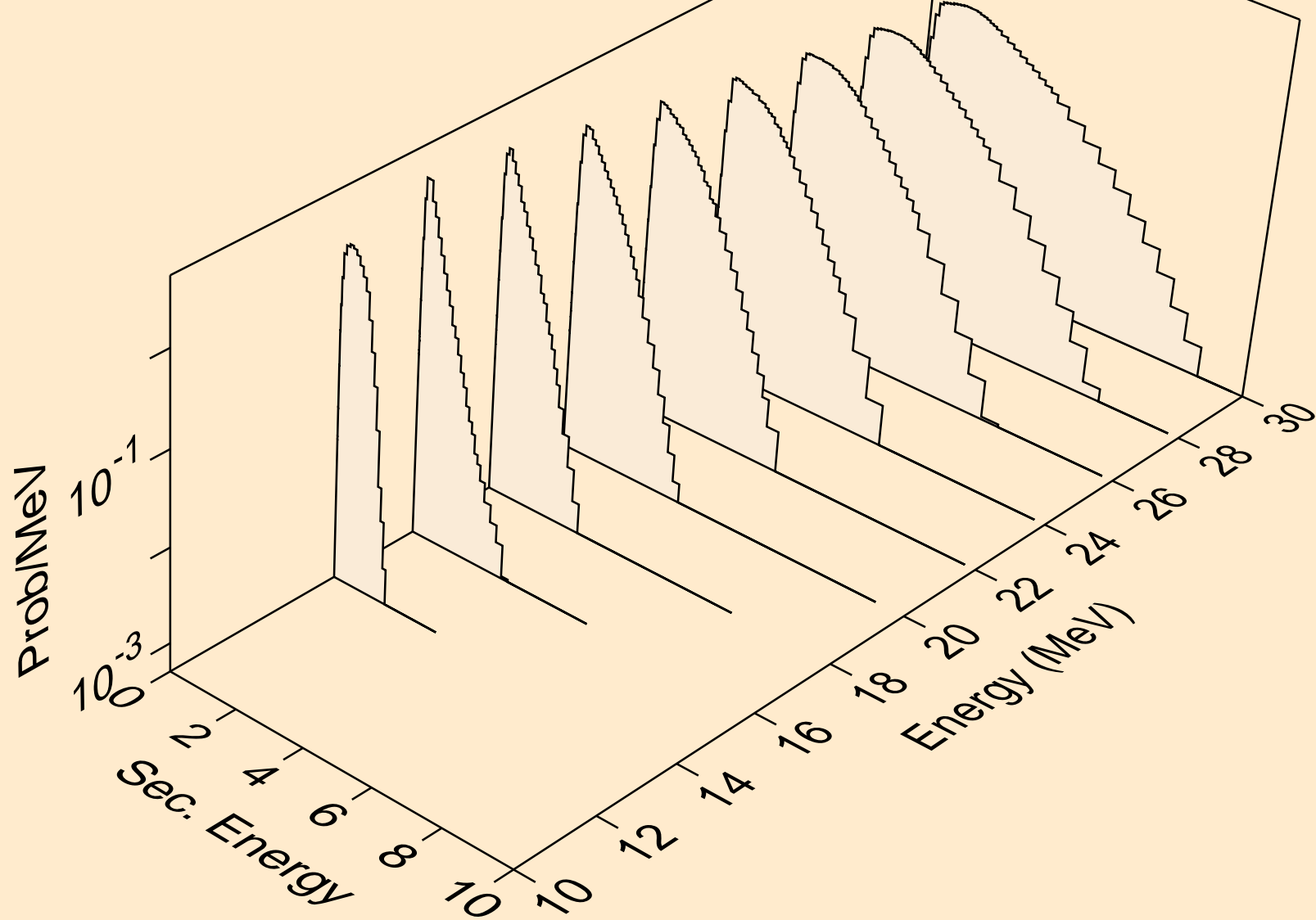

FM250M NEUTRON ACER TENDL-2024 LIBRARY; T=0.K
Neutron emission for (n,n2p)

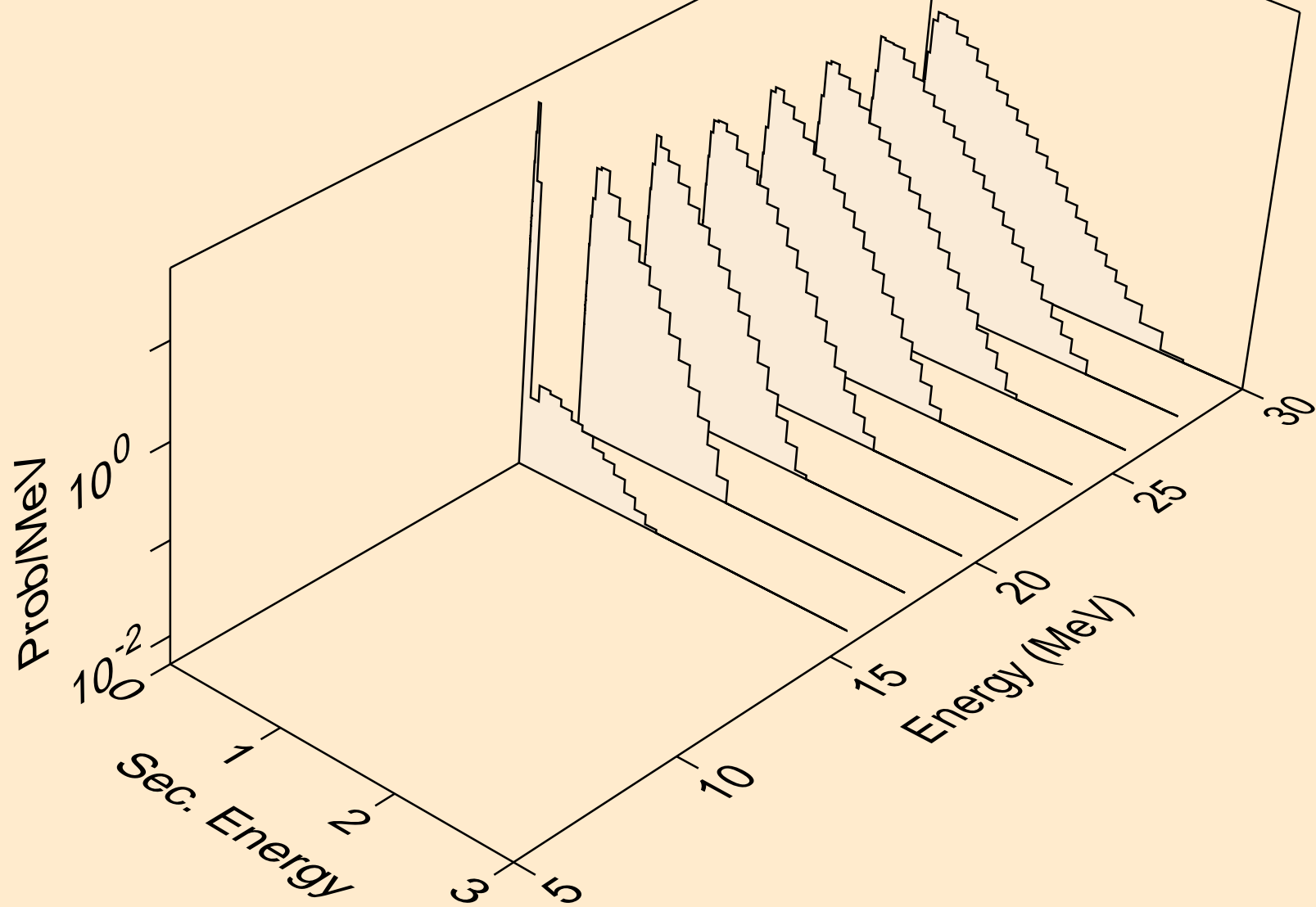

FM250M NEUTRON ACER TENDL-2024 LIBRARY; T=0.K
Neutron emission for (n,n*c)

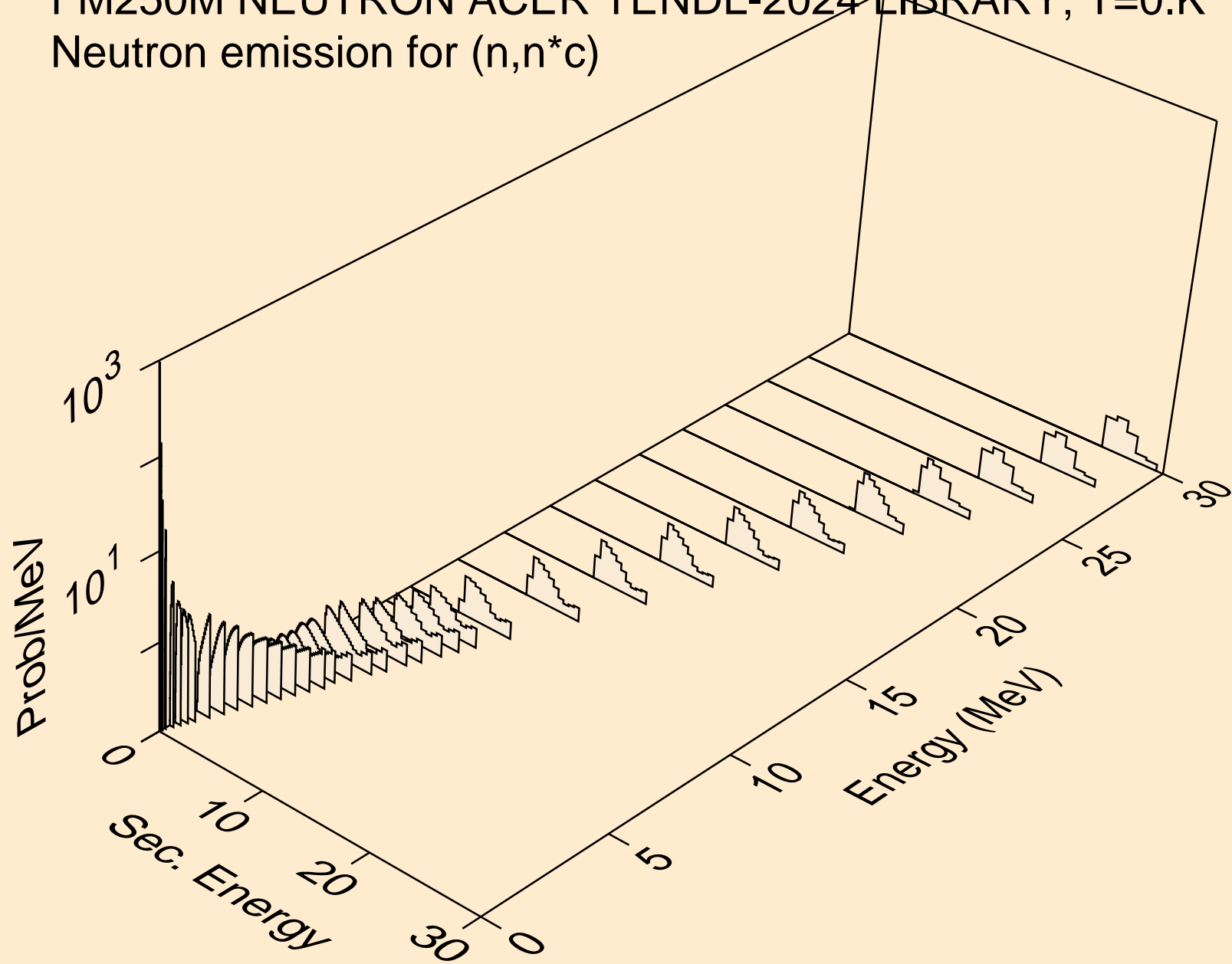

FM250M NEUTRON ACER TENDL-2024 LIBRARY; T=0.K

Delayed nubar

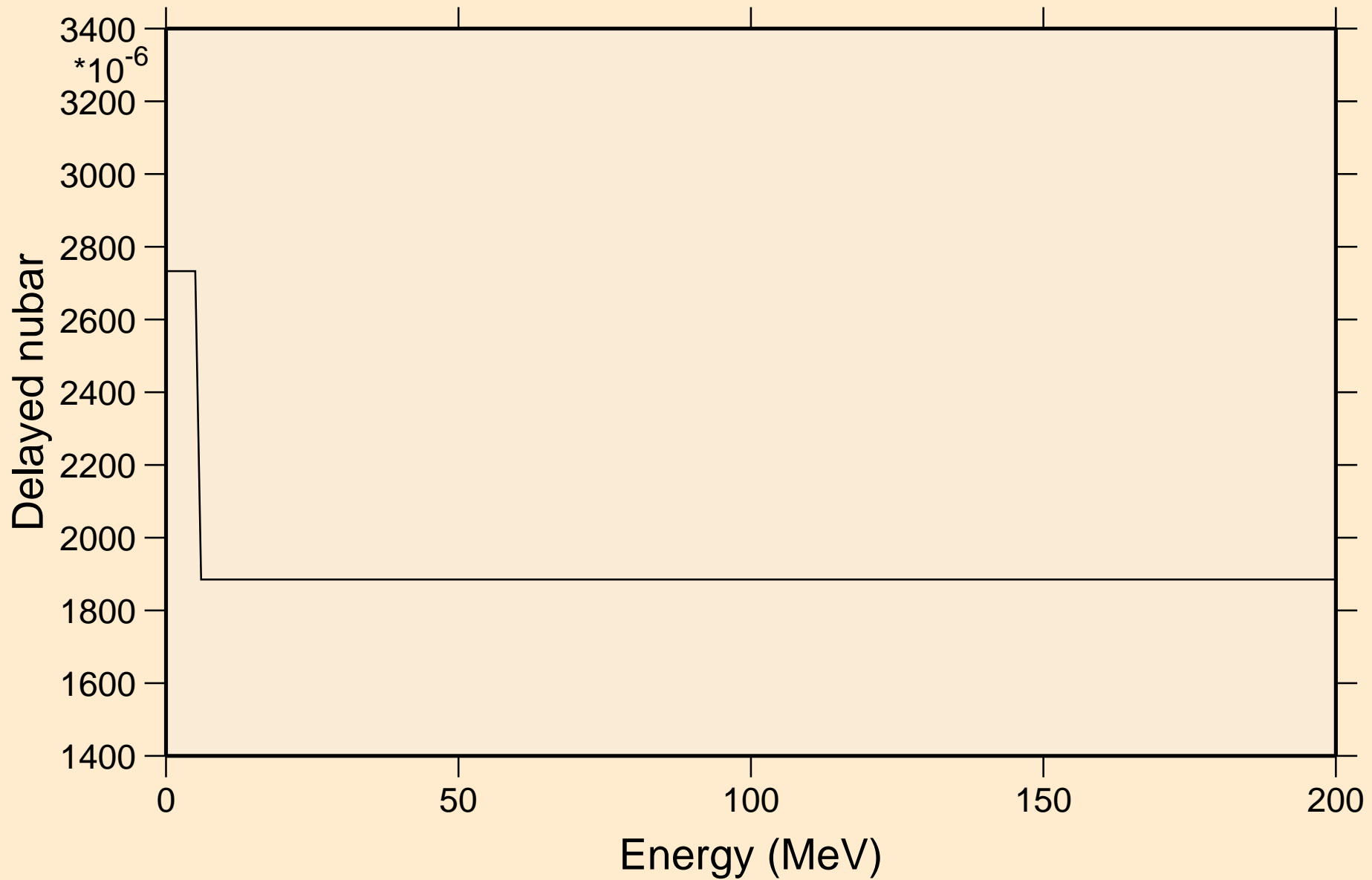

FM250M NEUTRON ACER TENDL-2024 LIBRARY; T=0.K

Delayed neutron spectra

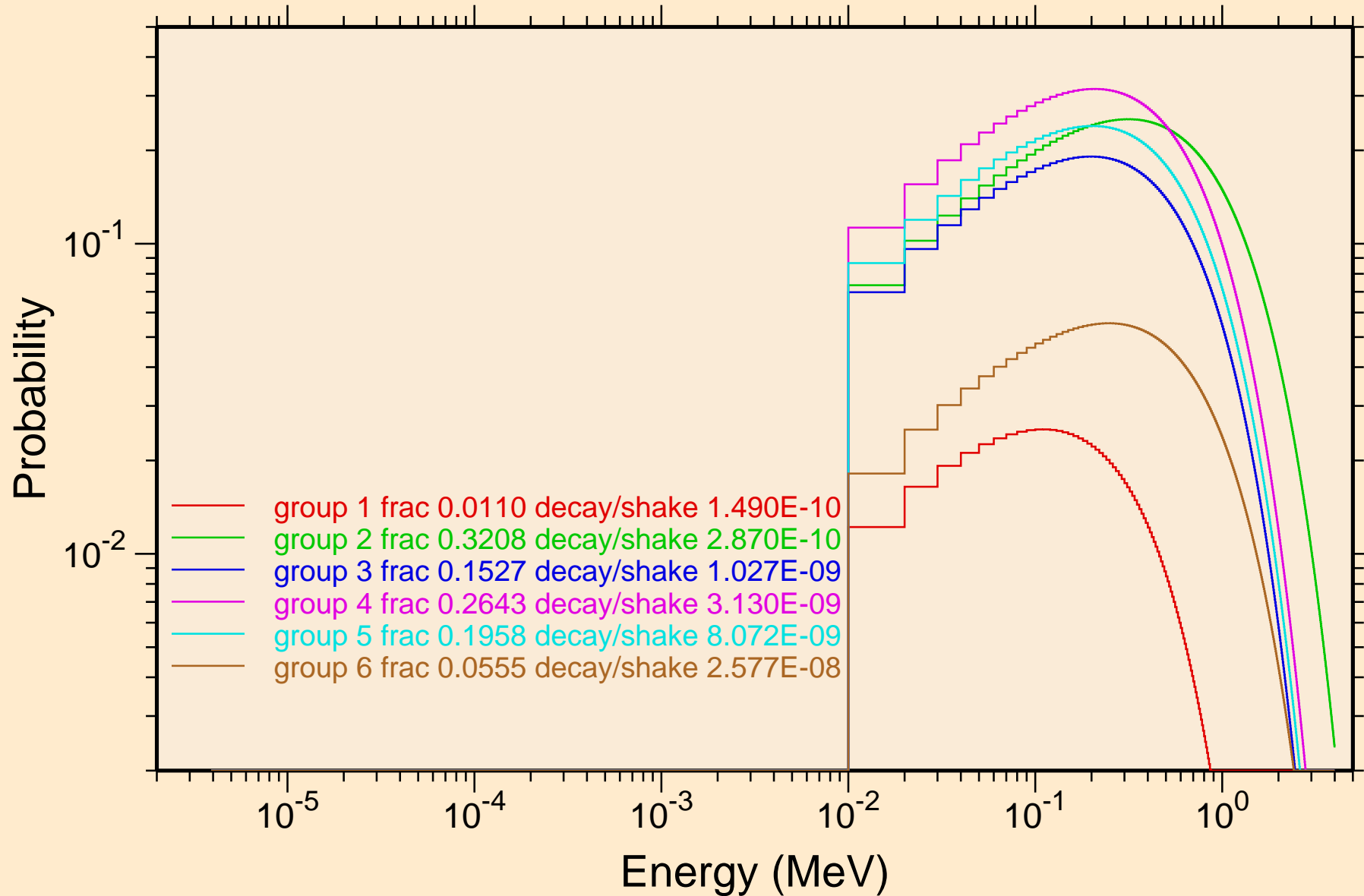

FM250M NEUTRON ACER TENDL-2024 LIBRARY; T=0.K
Photon emission for (n,x)

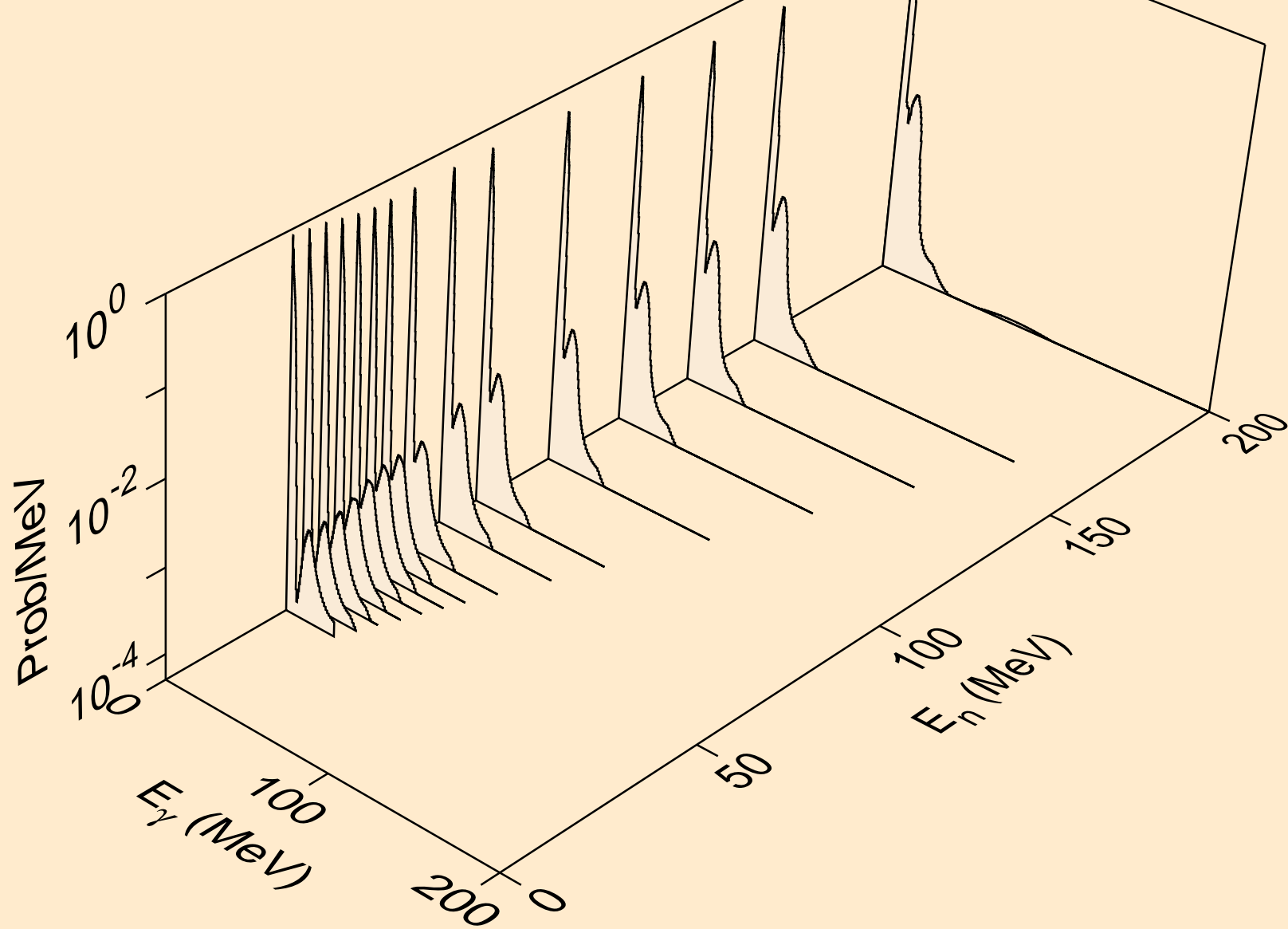

FM250M NEUTRON ACER TENDL-2024 LIBRARY; T=0.K
Photon emission for (n,2nd)

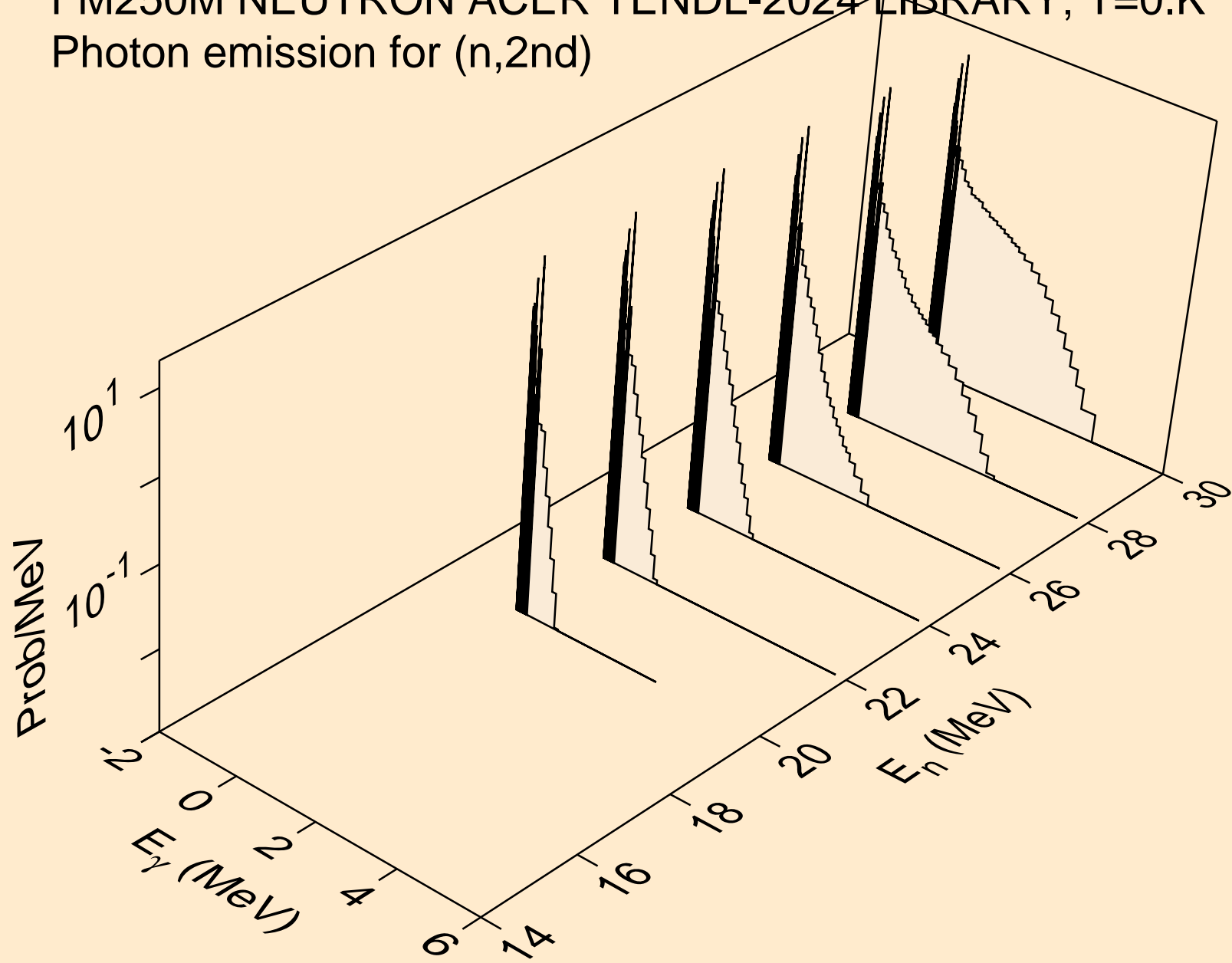

FM250M NEUTRON ACER TENDL-2024 LIBRARY; T=0.K
Photon emission for (n,2n)

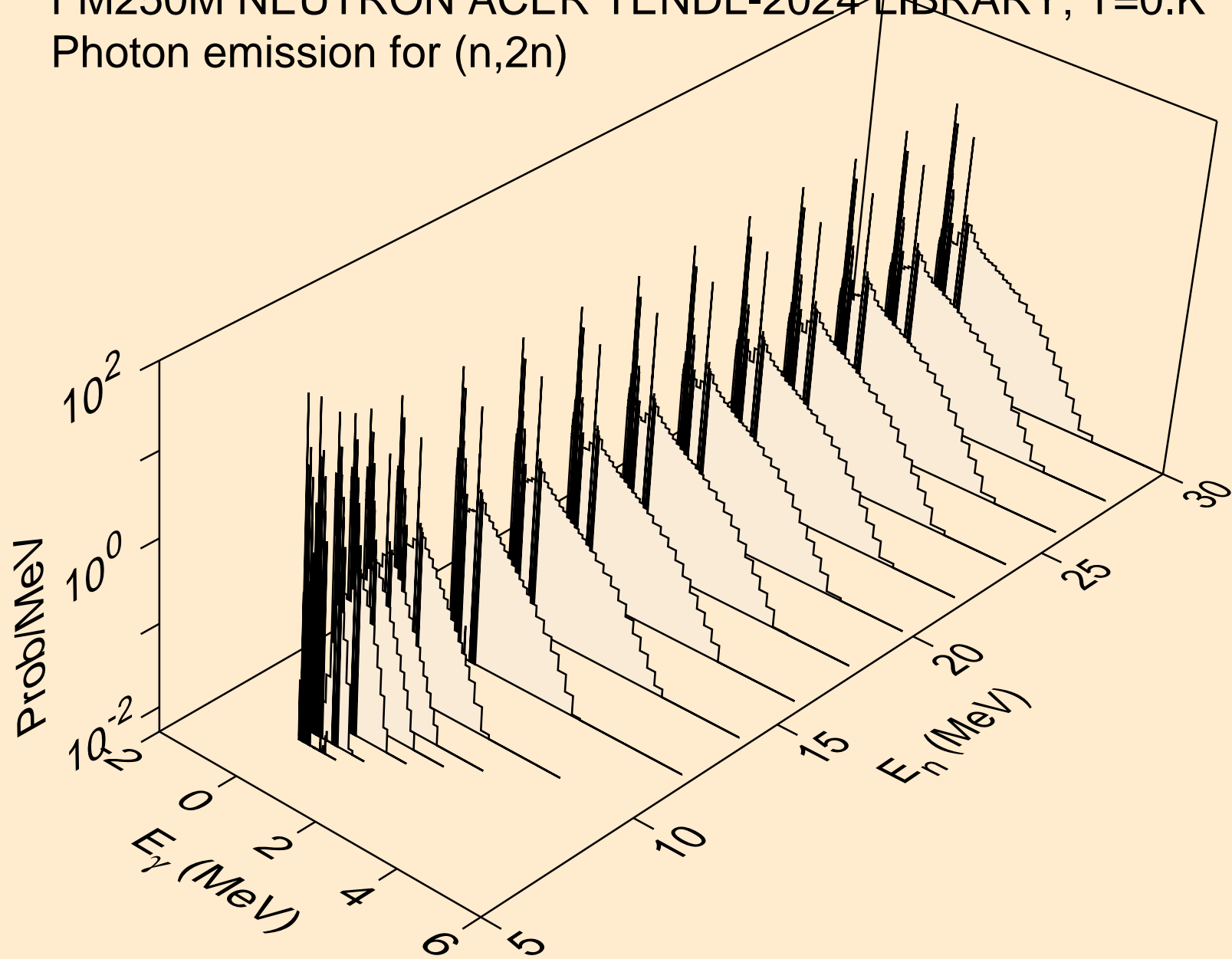

FM250M NEUTRON ACER TENDL-2024 LIBRARY; T=0.K
Photon emission for (n,3n)

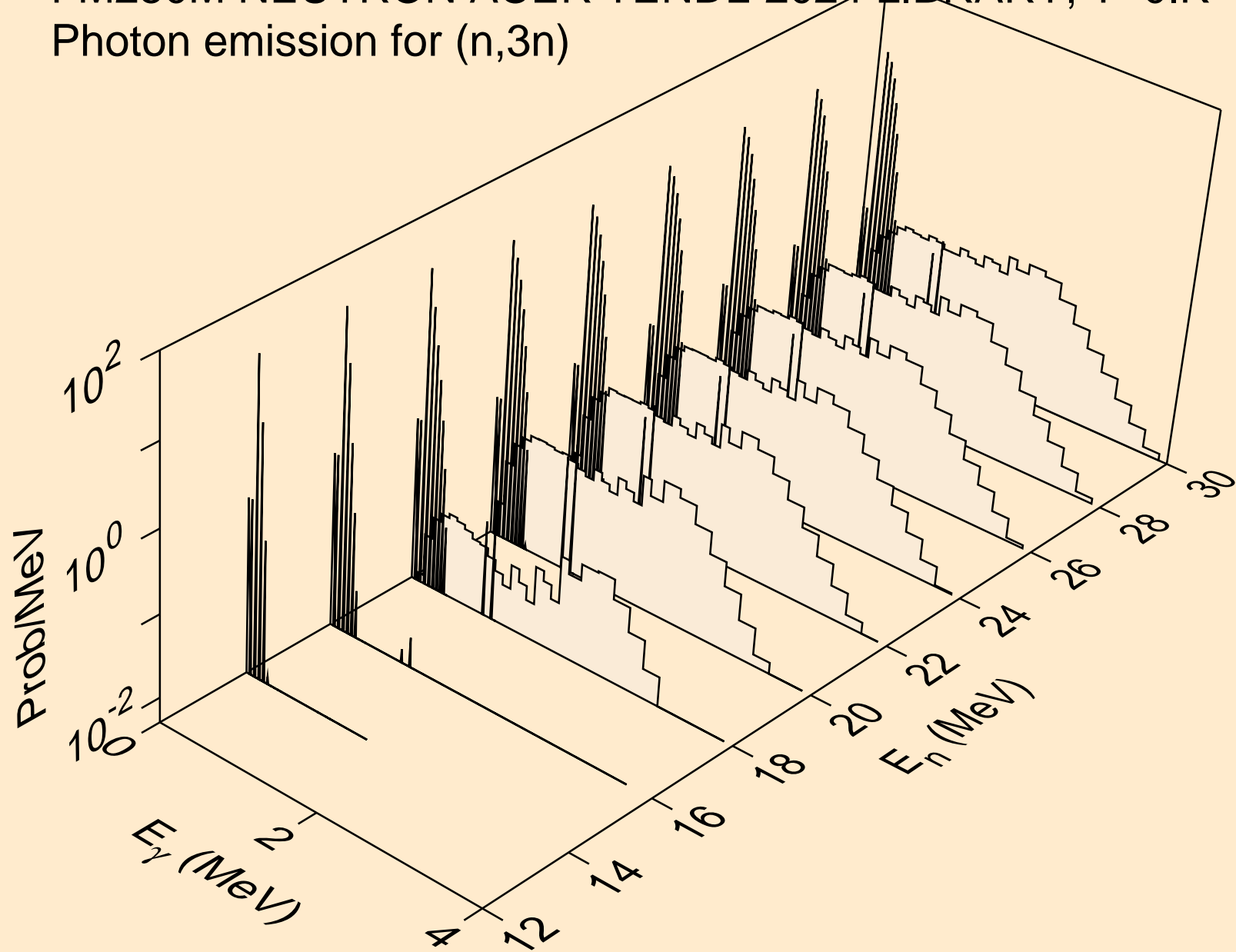

FM250M NEUTRON ACER TENDL-2024 LIBRARY; T=0.K
Photon emission for (n,n*)a

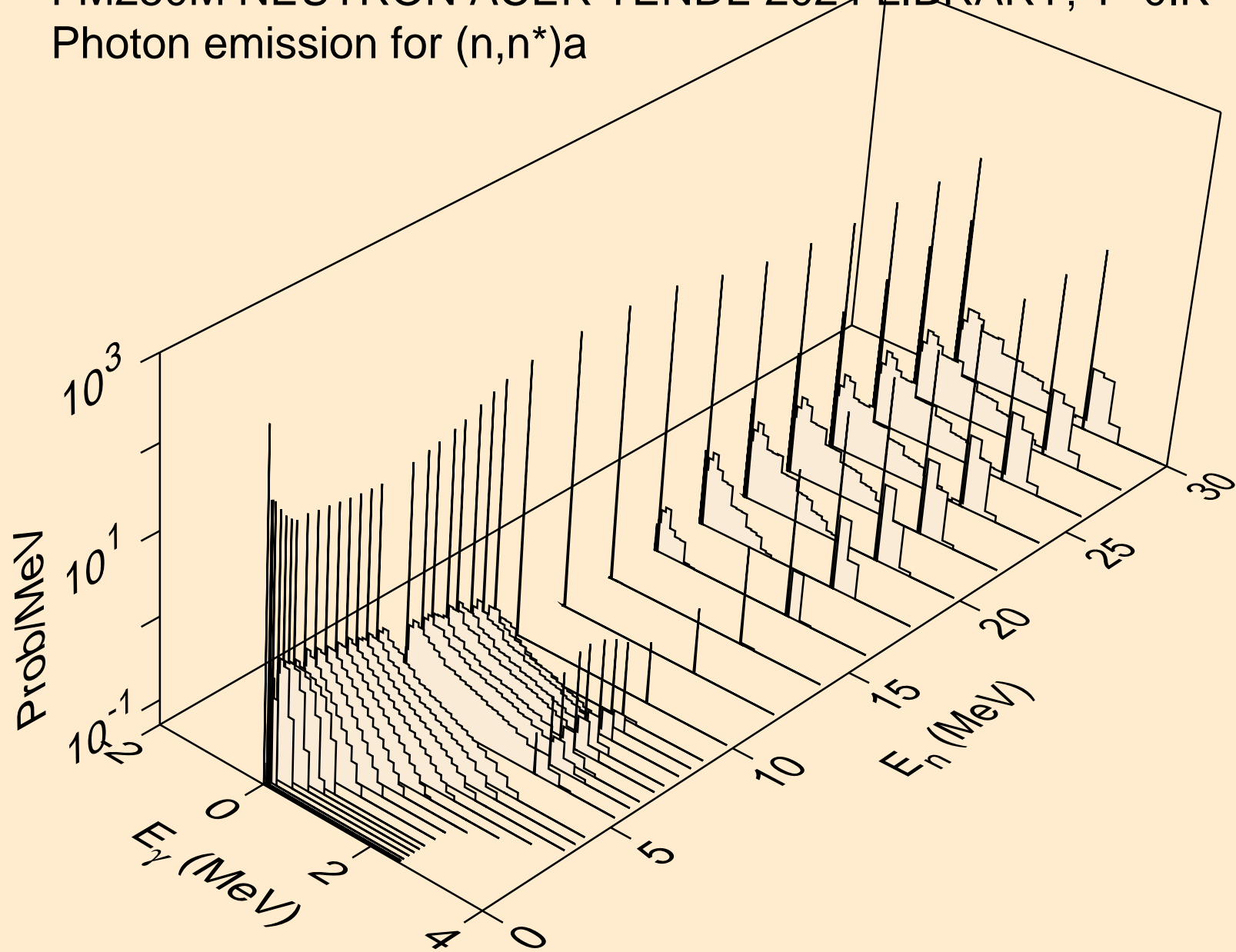

FM250M NEUTRON ACER TENDL-2024 LIBRARY; T=0.K
Photon emission for (n,2n)a

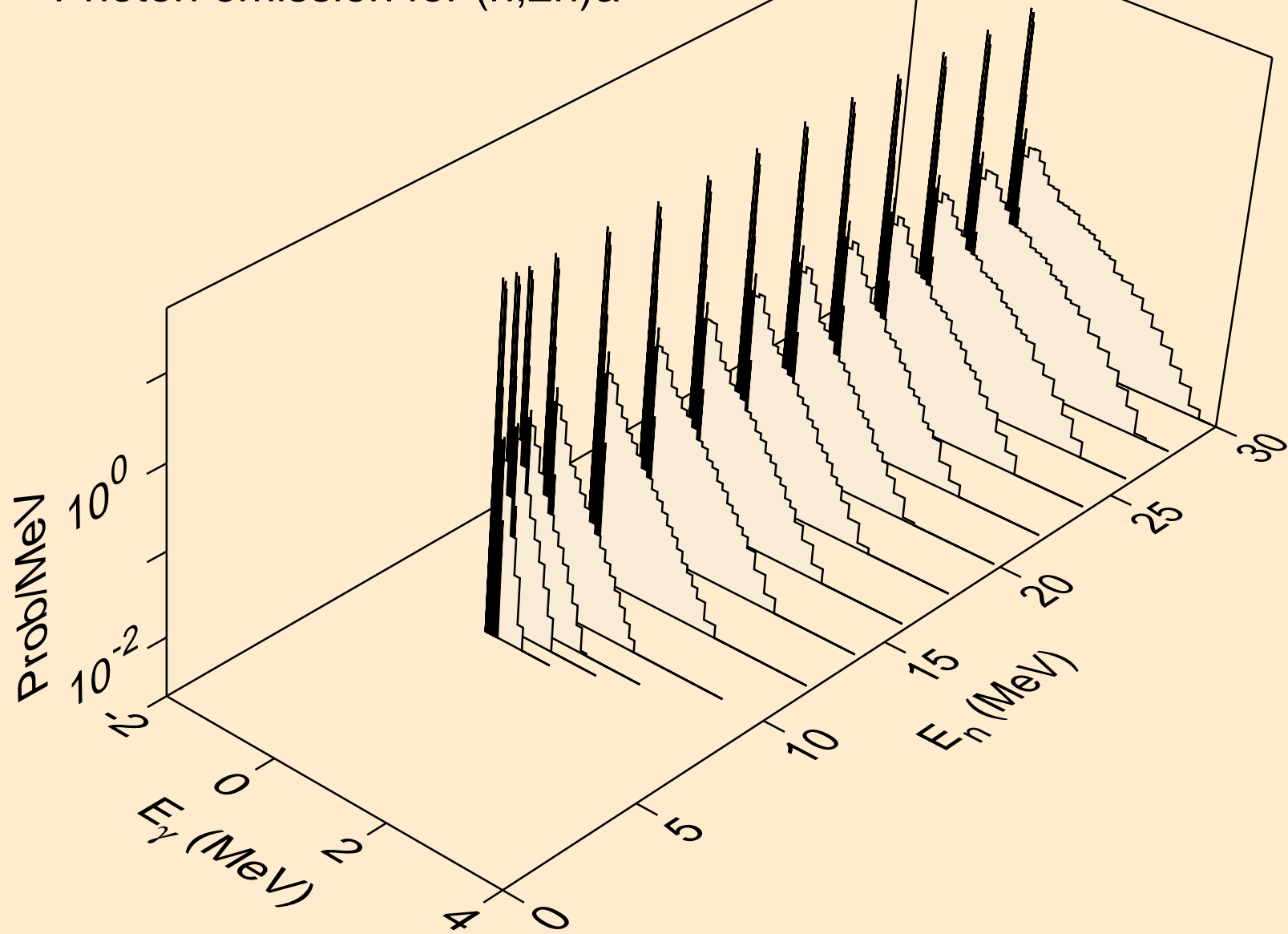

FM250M NEUTRON ACER TENDL-2024 LIBRARY; T=0.K
Photon emission for (n,3n)a

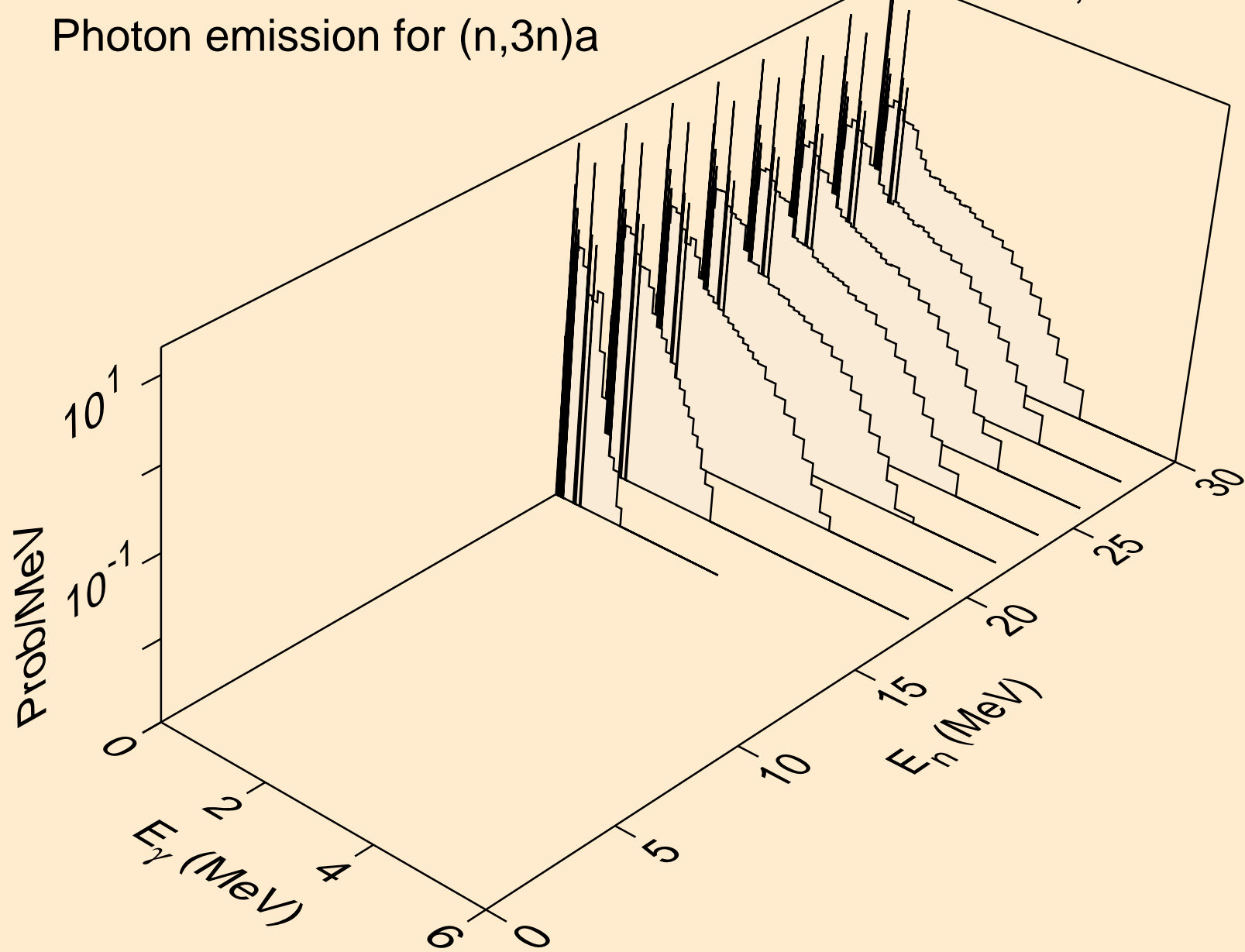

FM250M NEUTRON ACER TENDL-2024 LIBRARY; T=0.K
Photon emission for (n,n*)p

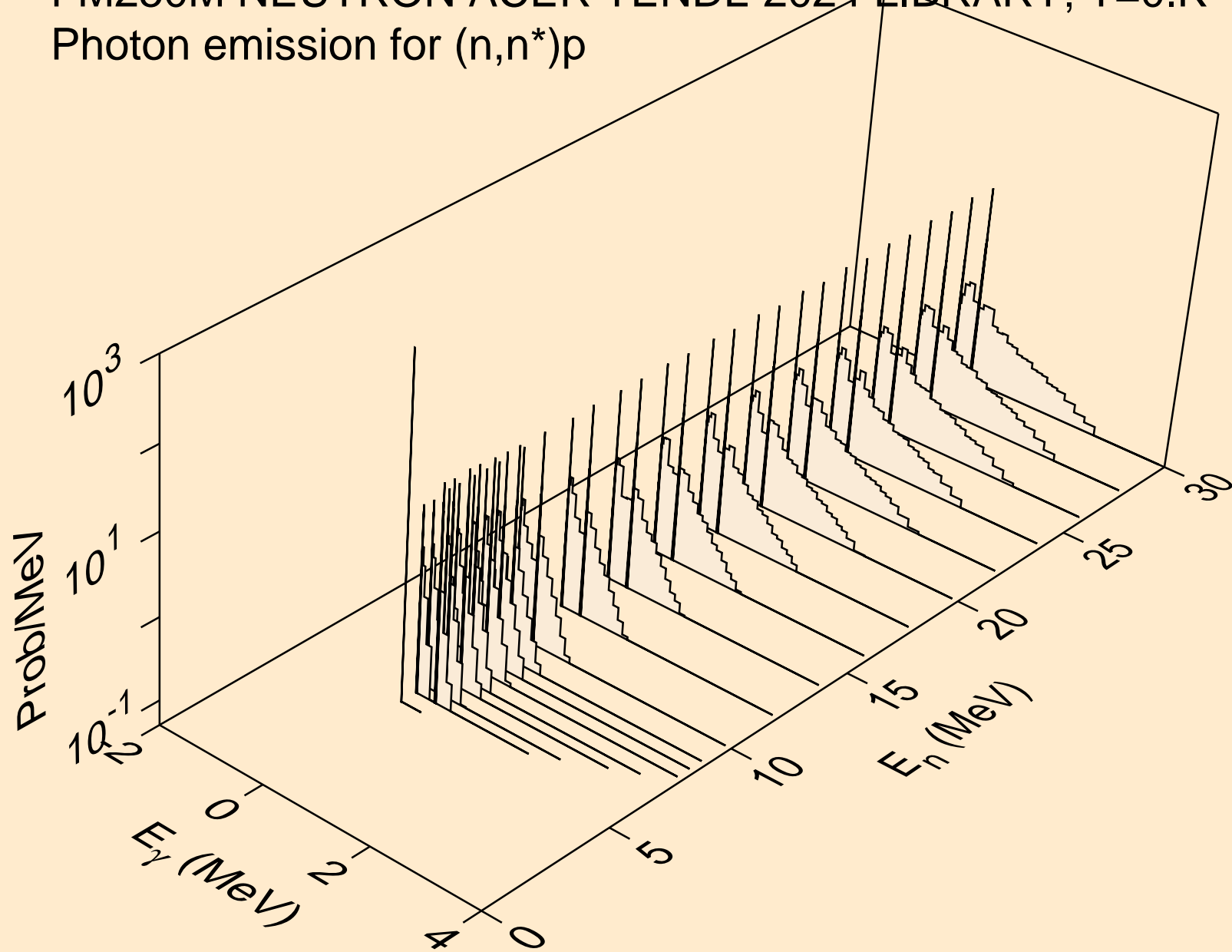

FM250M NEUTRON ACER TENDL-2024 LIBRARY; T=0.K
Photon emission for (n,n*)2a

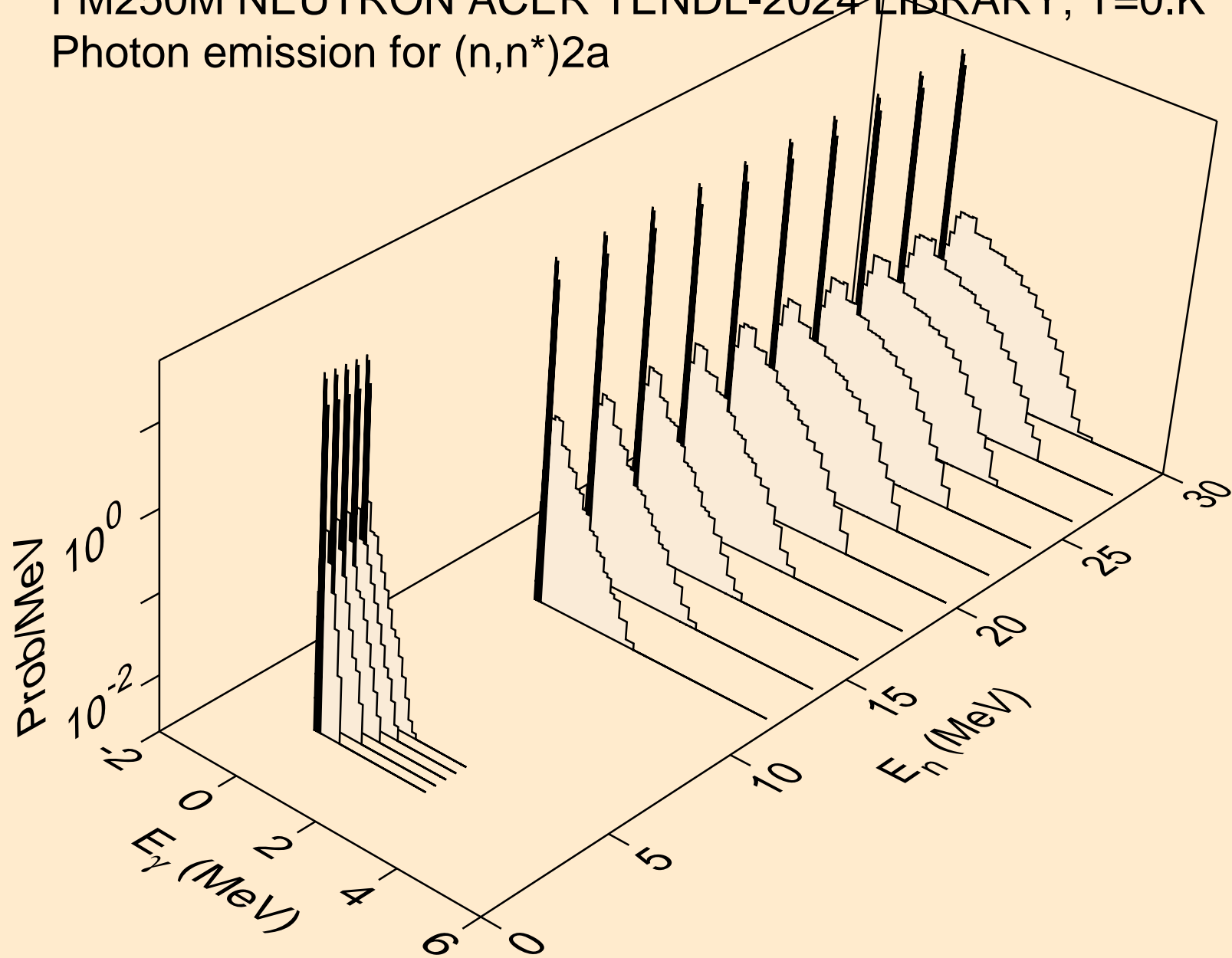

FM250M NEUTRON ACER TENDL-2024 LIBRARY; T=0.K
Photon emission for (n,n*)d

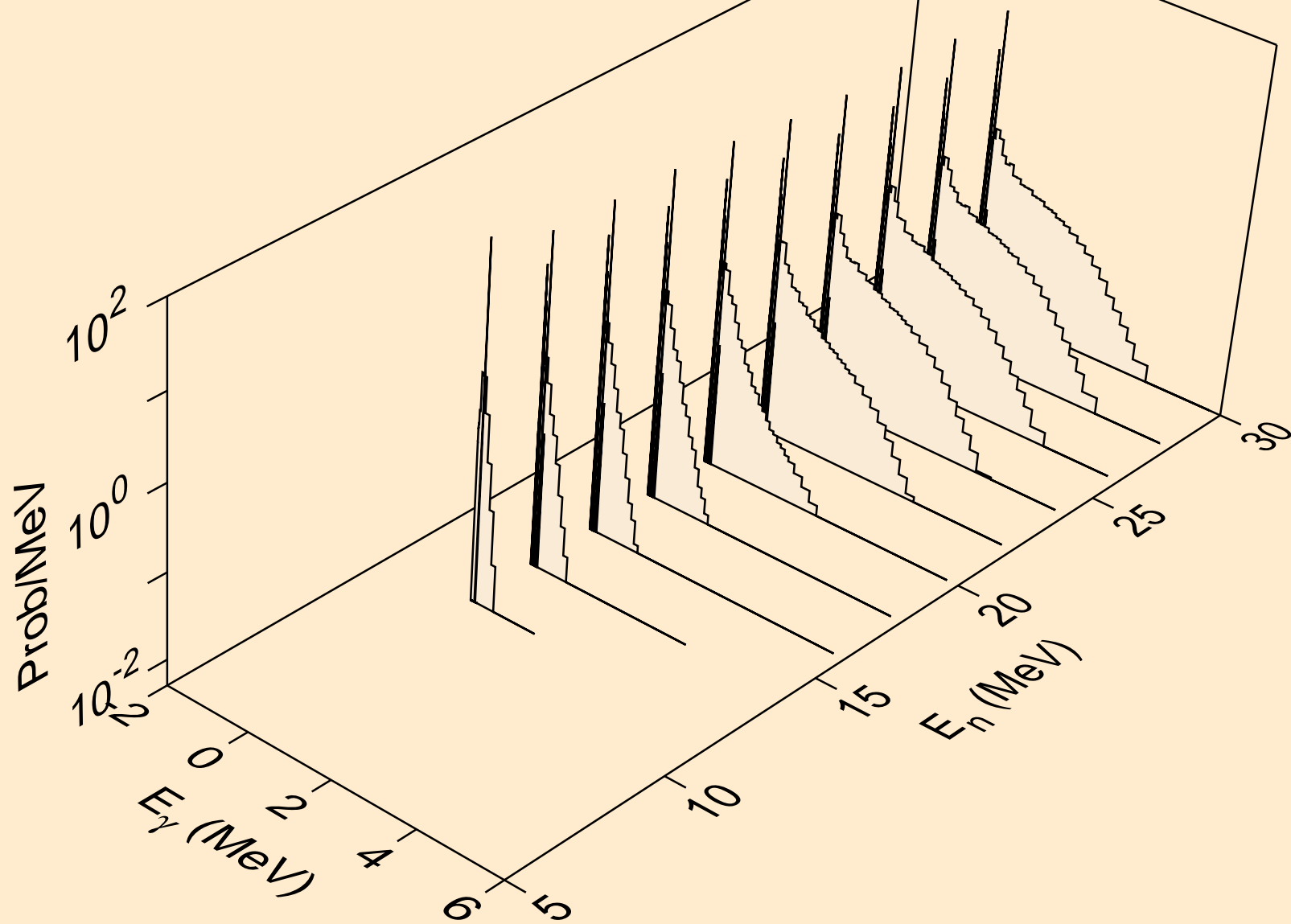

FM250M NEUTRON ACER TENDL-2024 LIBRARY; T=0.K
Photon emission for (n,n*)t

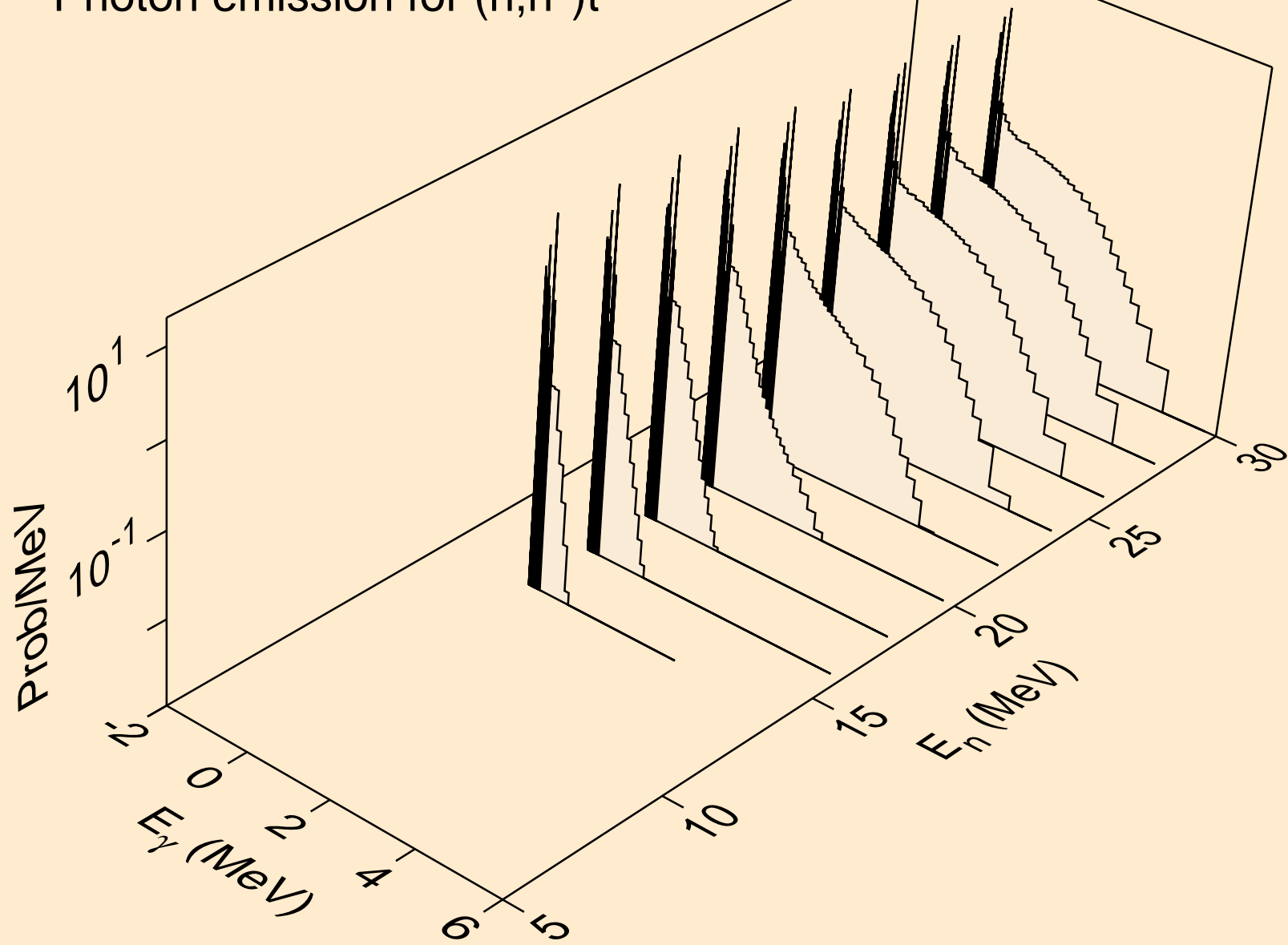

FM250M NEUTRON ACER TENDL-2024 LIBRARY; T=0.K
Photon emission for (n,n*)he3

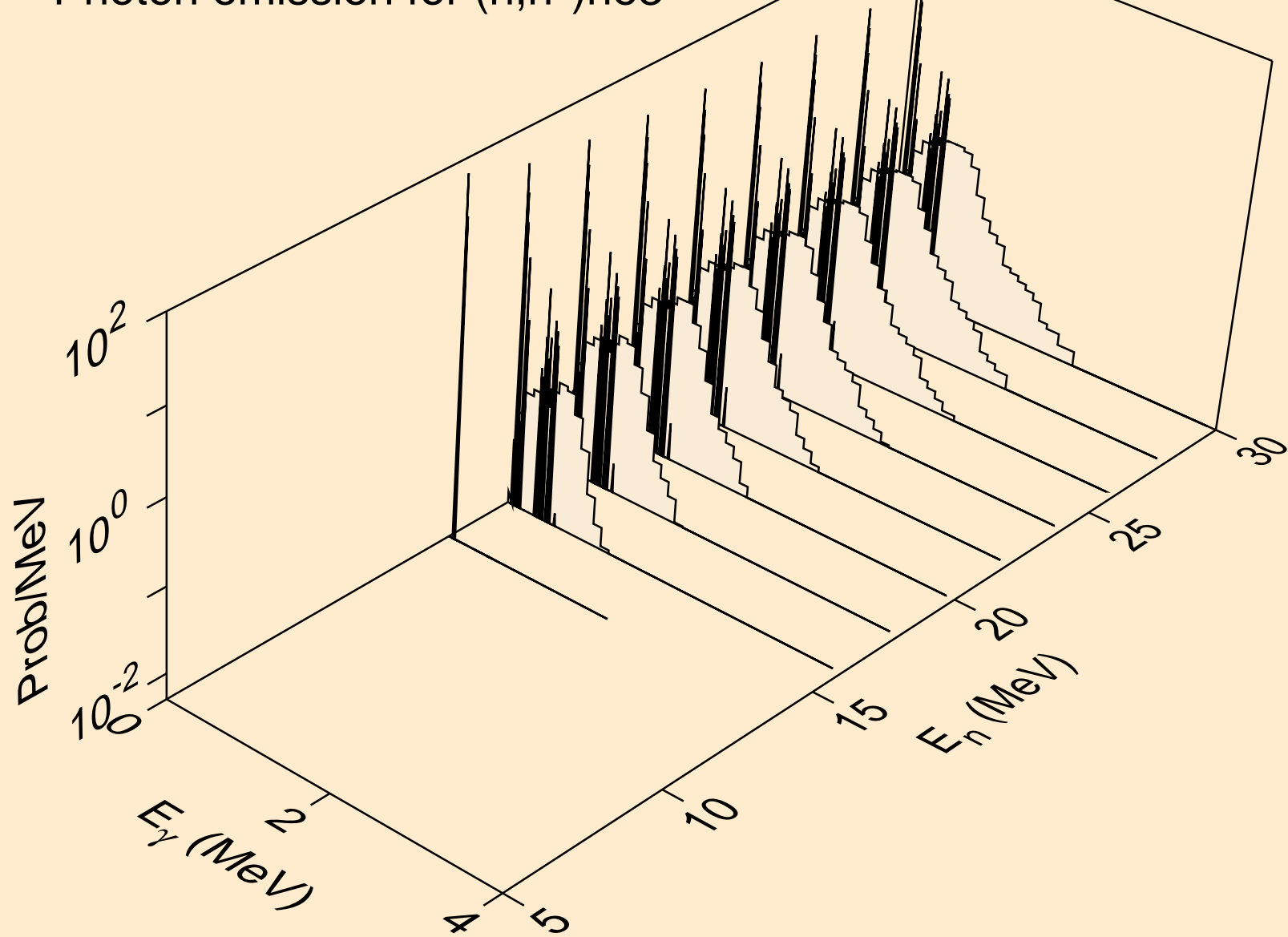

FM250M NEUTRON ACER TENDL-2024 LIBRARY; T=0.K
Photon emission for (n,4n)

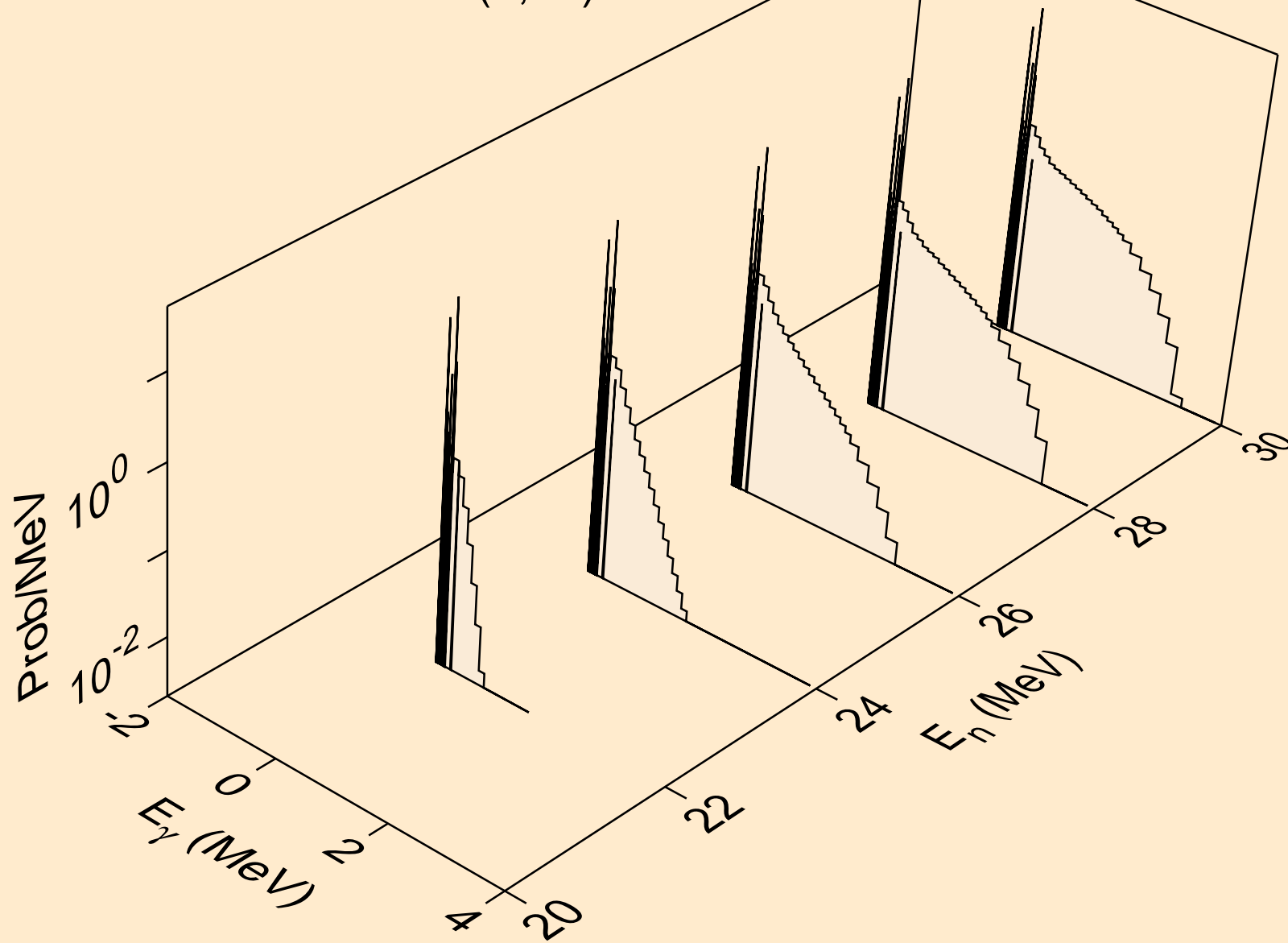

FM250M NEUTRON ACER TENDL-2024 LIBRARY; T=0.K
Photon emission for (n,2np)

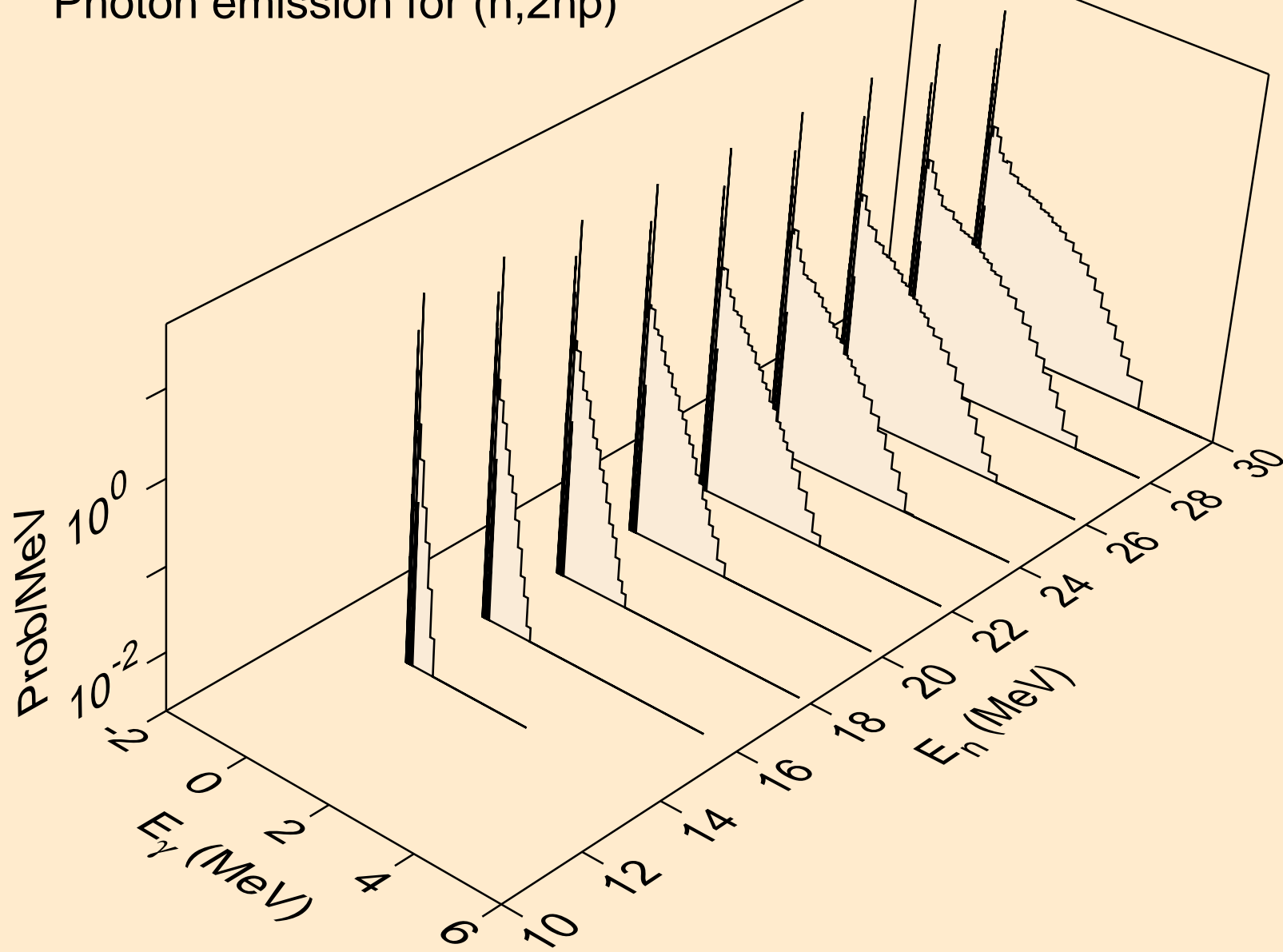

FM250M NEUTRON ACER TENDL-2024 LIBRARY; T=0.K
Photon emission for (n,n2p)

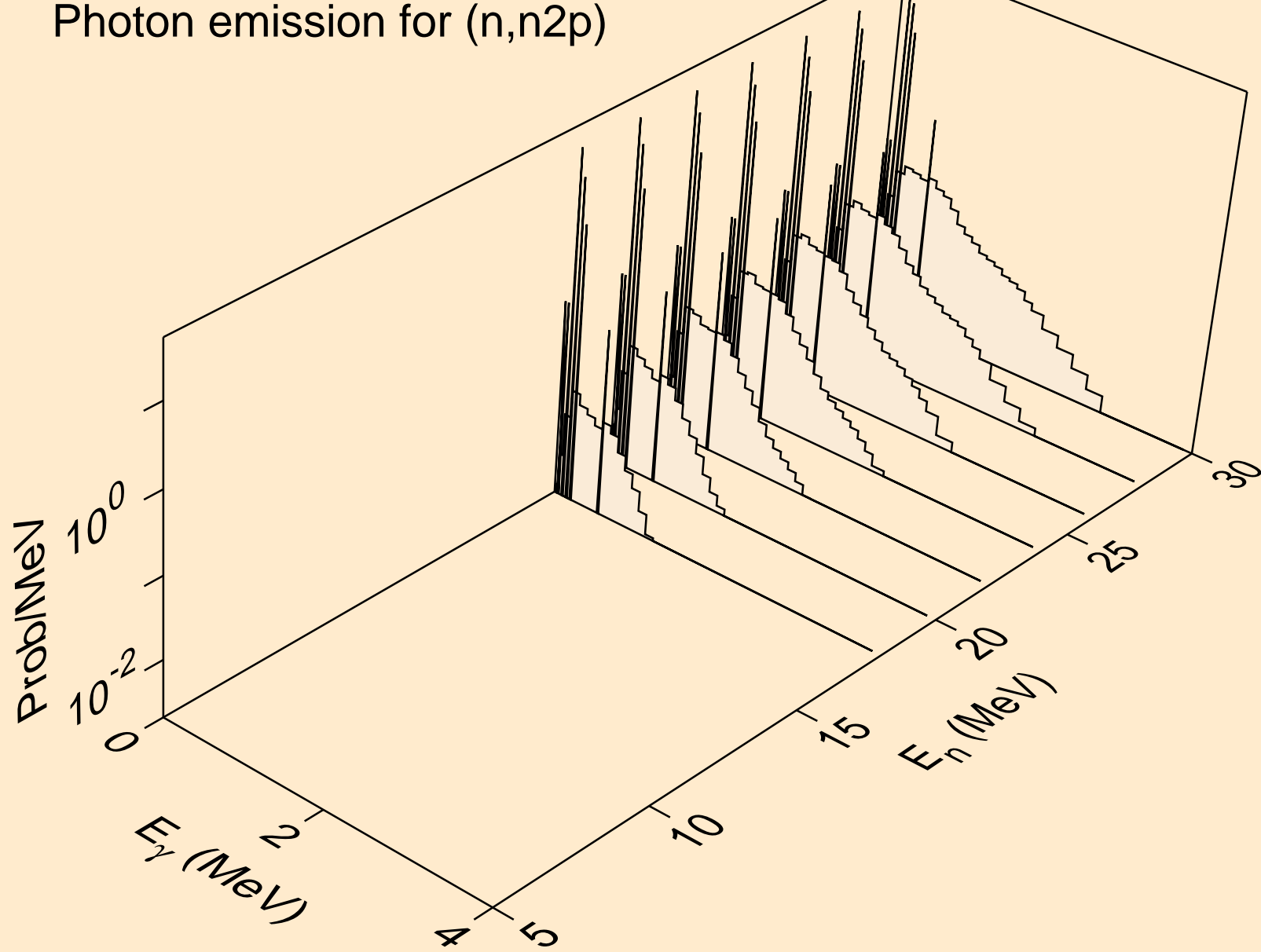

FM250M NEUTRON ACER TENDL-2024 LIBRARY; T=0.K
Photon emission for (n,n*2)

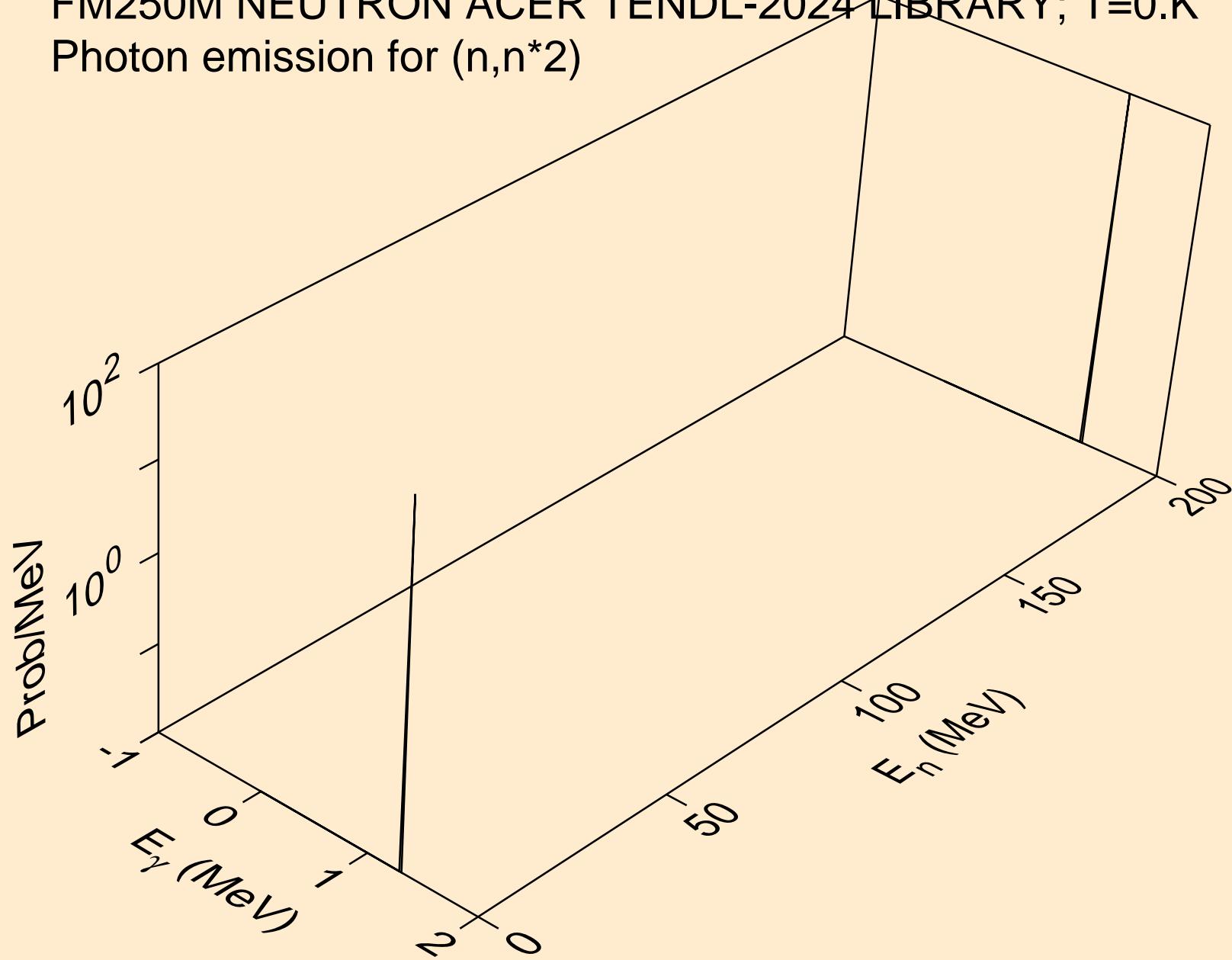

FM250M NEUTRON ACER TENDL-2024 LIBRARY; T=0.K
Photon emission for (n,n*c)

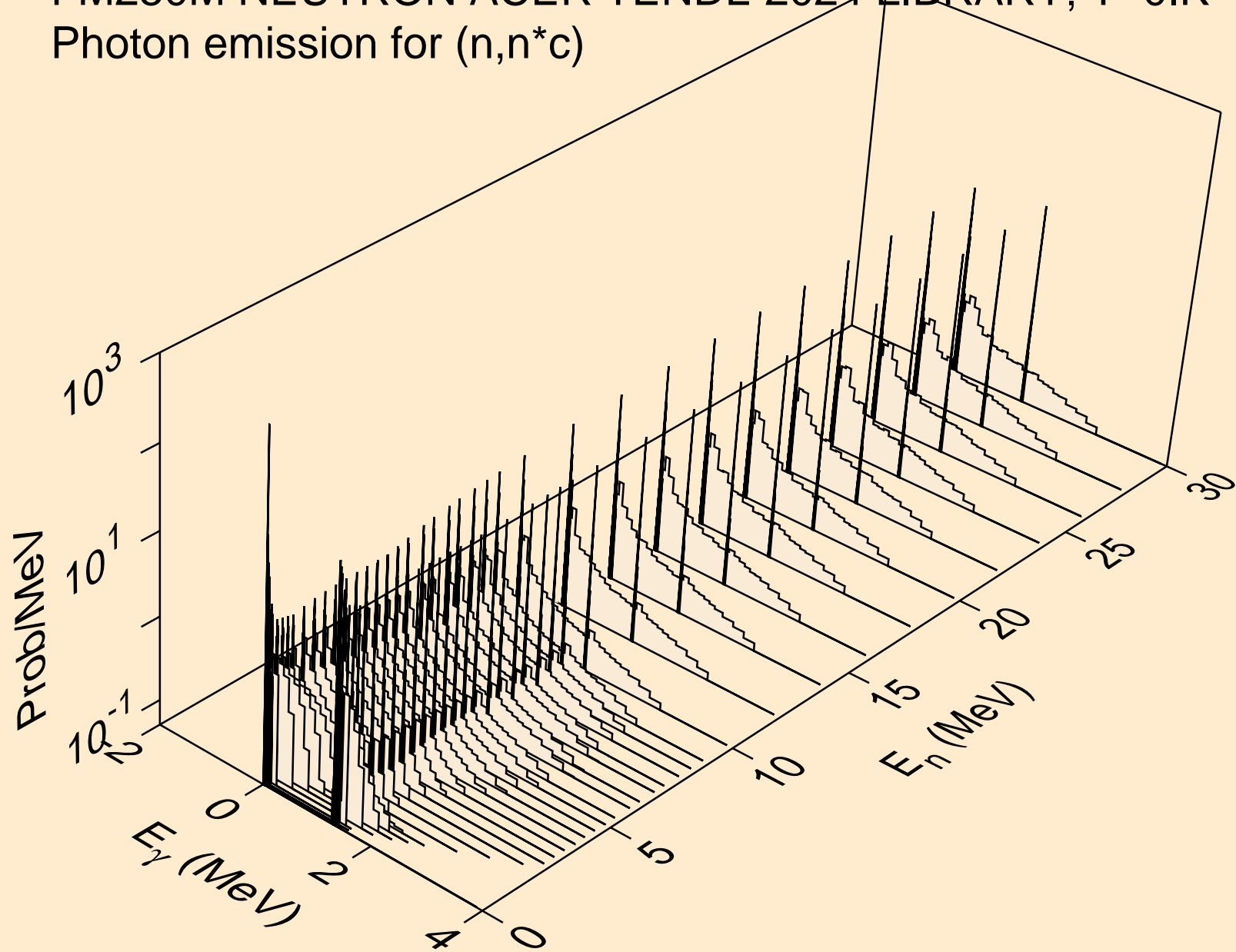

FM250M NEUTRON ACER TENDL-2024 LIBRARY; T=0.K
Photon emission for (n,gma)

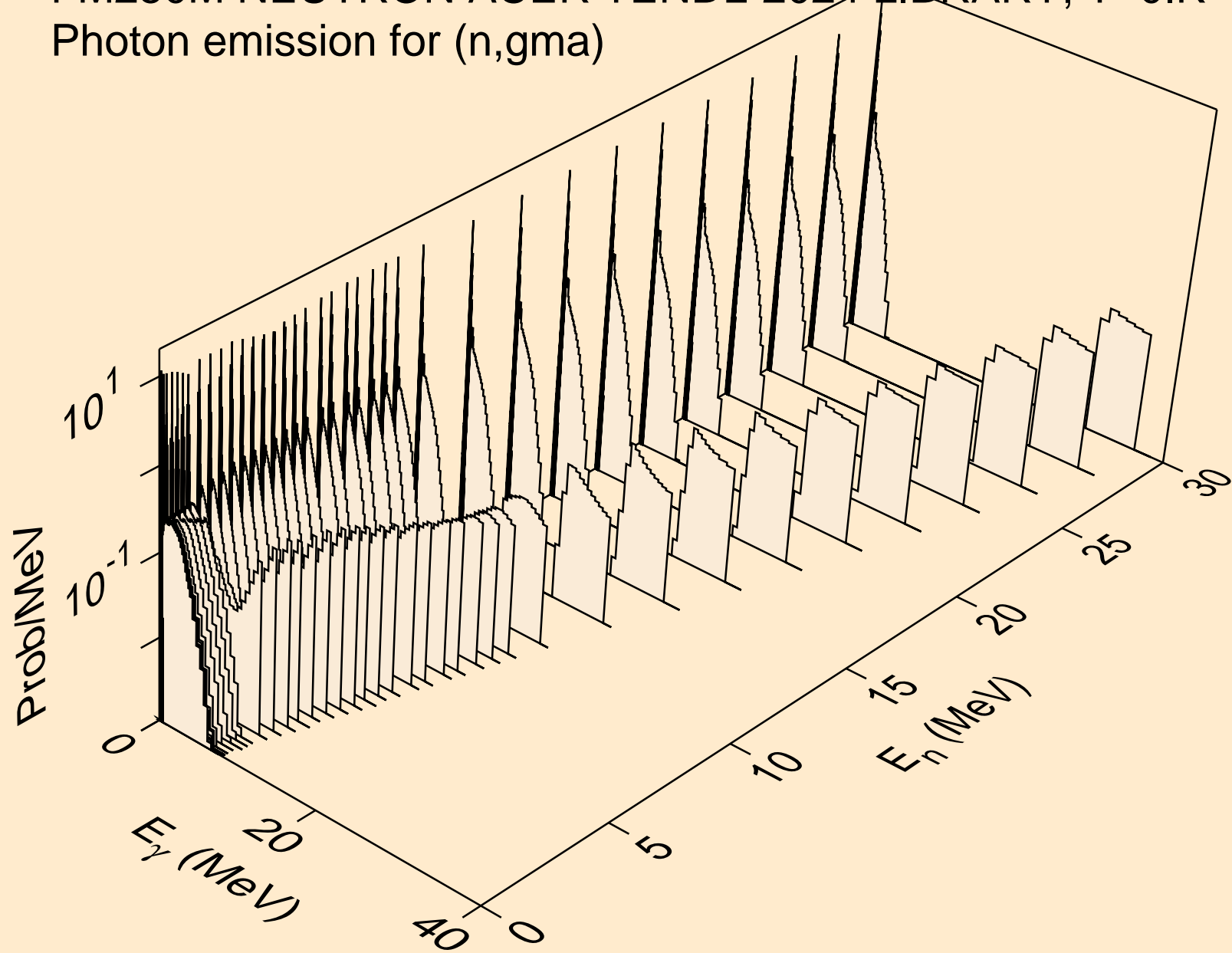

FM250M NEUTRON ACER TENDL-2024 LIBRARY; T=0.K
Photon emission for (n,p)

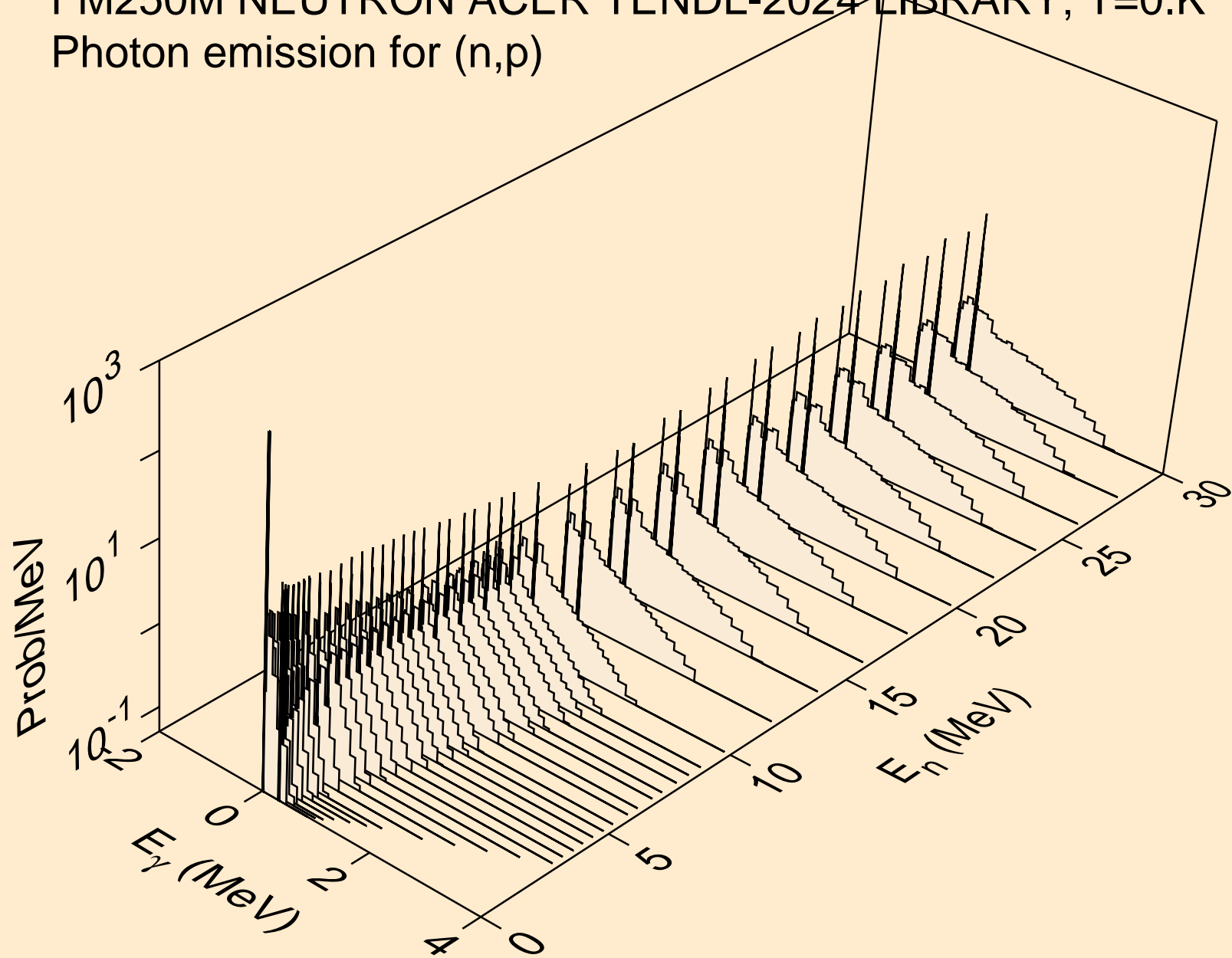

FM250M NEUTRON ACER TENDL-2024 LIBRARY; T=0.K
Photon emission for (n,d)

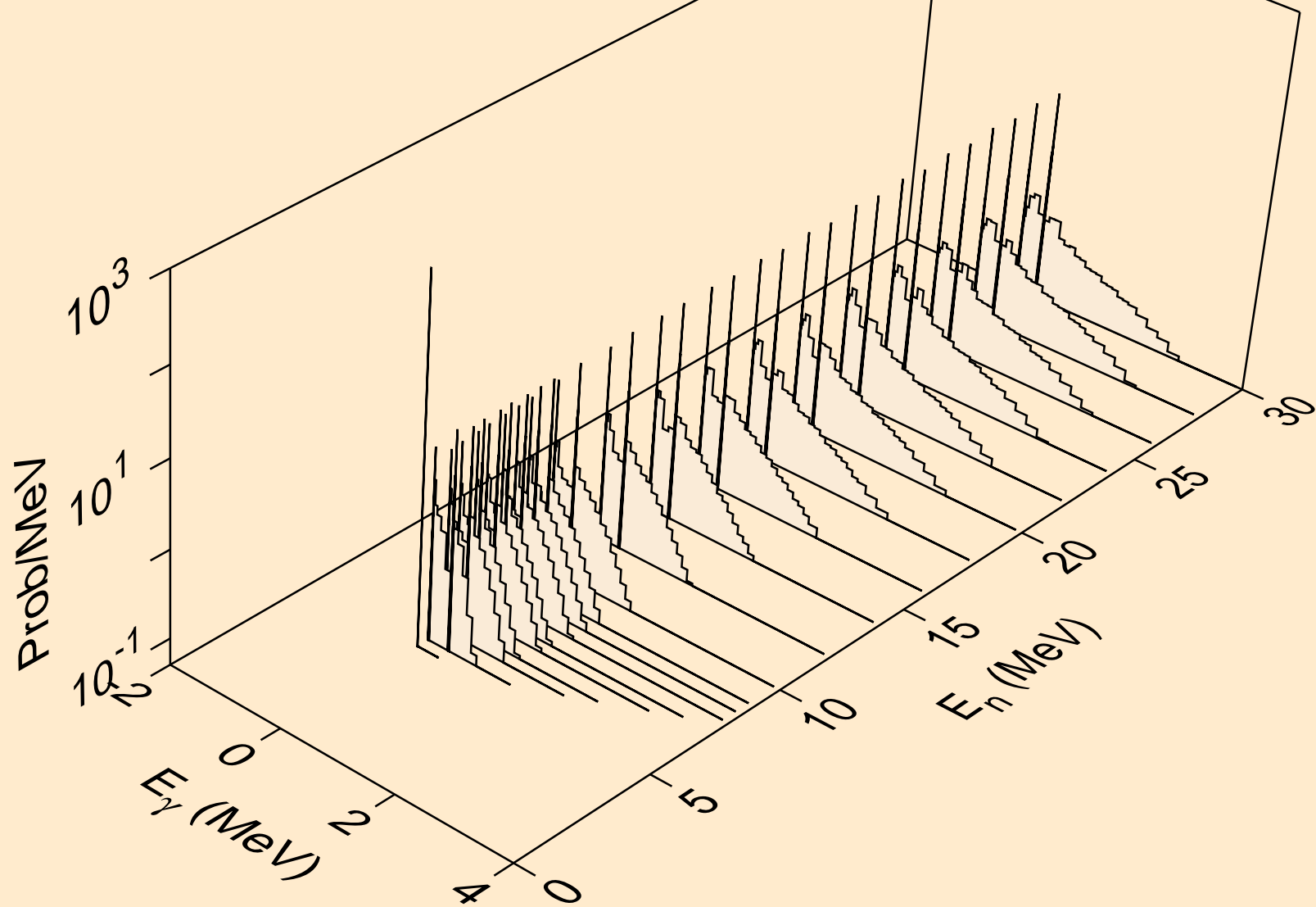

FM250M NEUTRON ACER TENDL-2024 LIBRARY; T=0.K
Photon emission for (n,t)

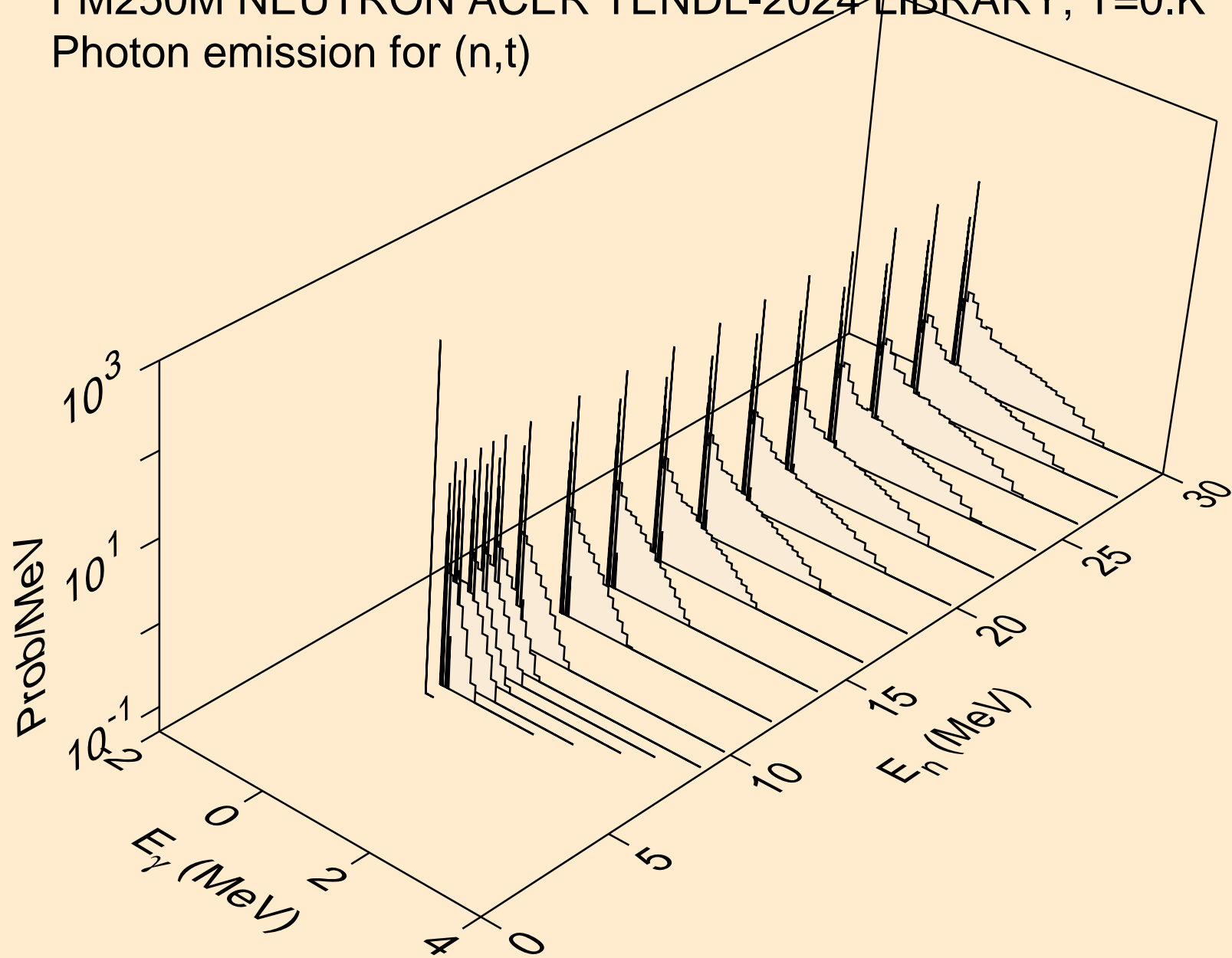

FM250M NEUTRON ACER TENDL-2024 LIBRARY; T=0.K
Photon emission for (n,he3)

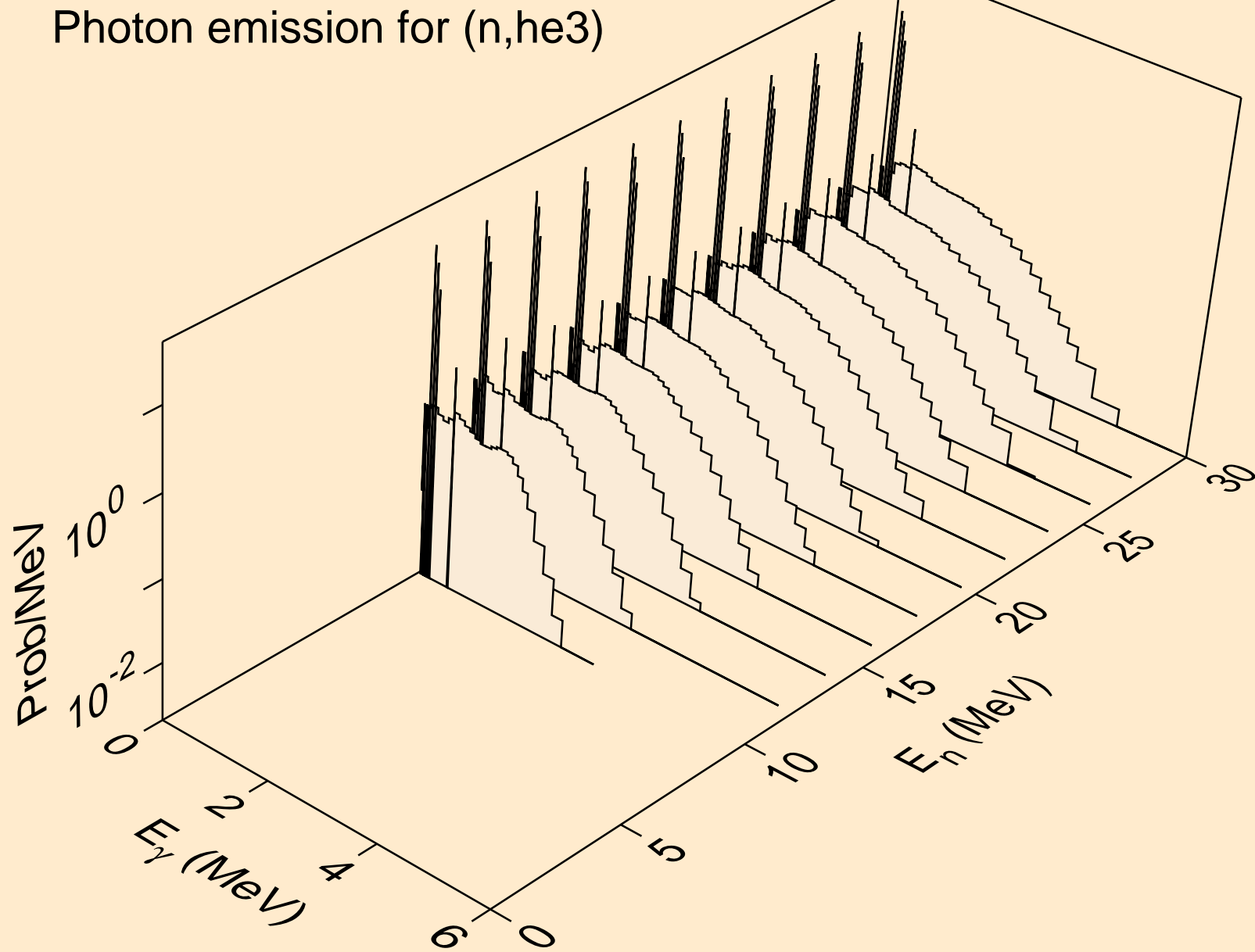

FM250M NEUTRON ACER TENDL-2024 LIBRARY; T=0.K
Photon emission for (n,a)

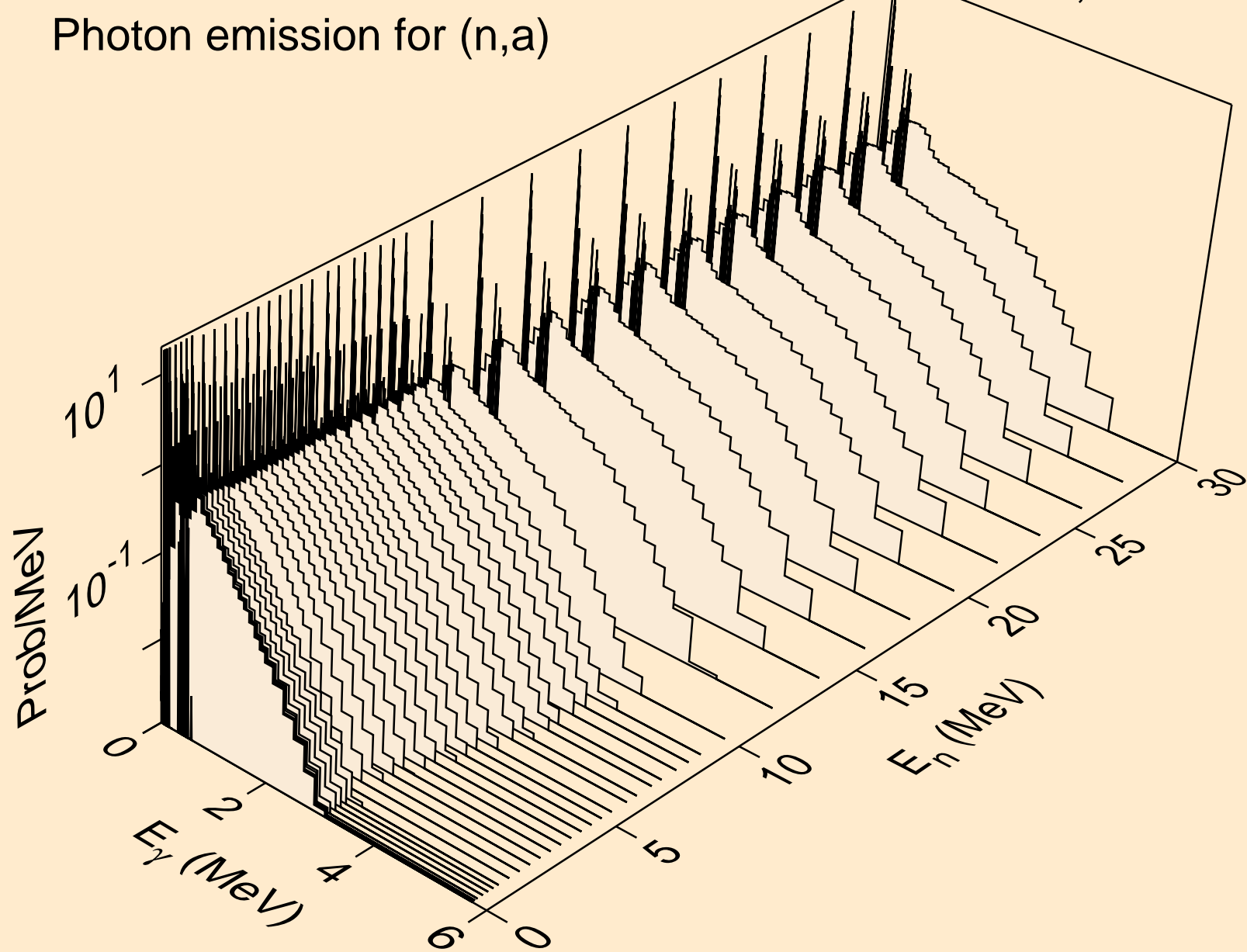

FM250M NEUTRON ACER TENDL-2024 LIBRARY; T=0.K
Photon emission for (n,2p)

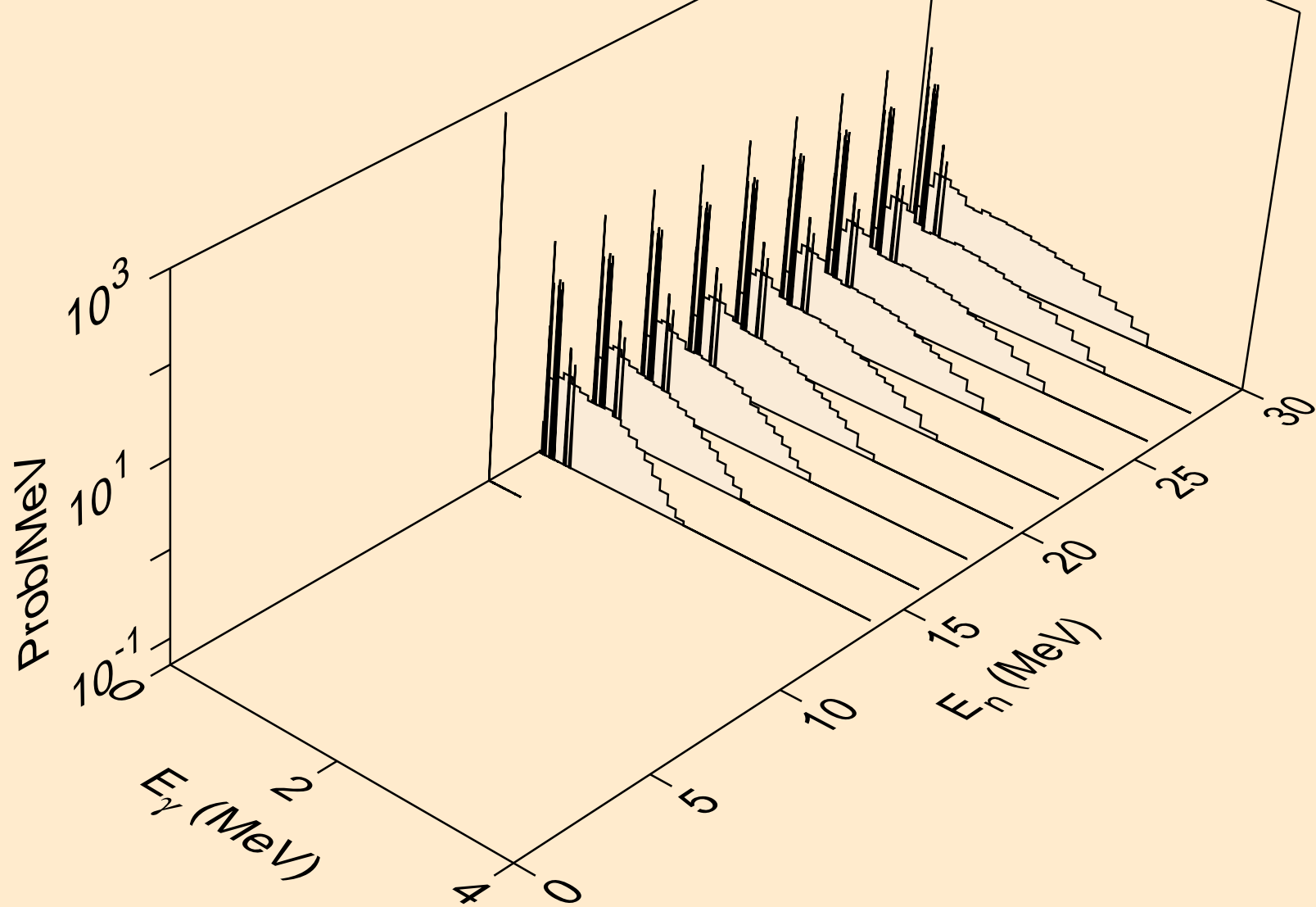

FM250M NEUTRON ACER TENDL-2024 LIBRARY; T=0.K
Photon emission for (n,p)

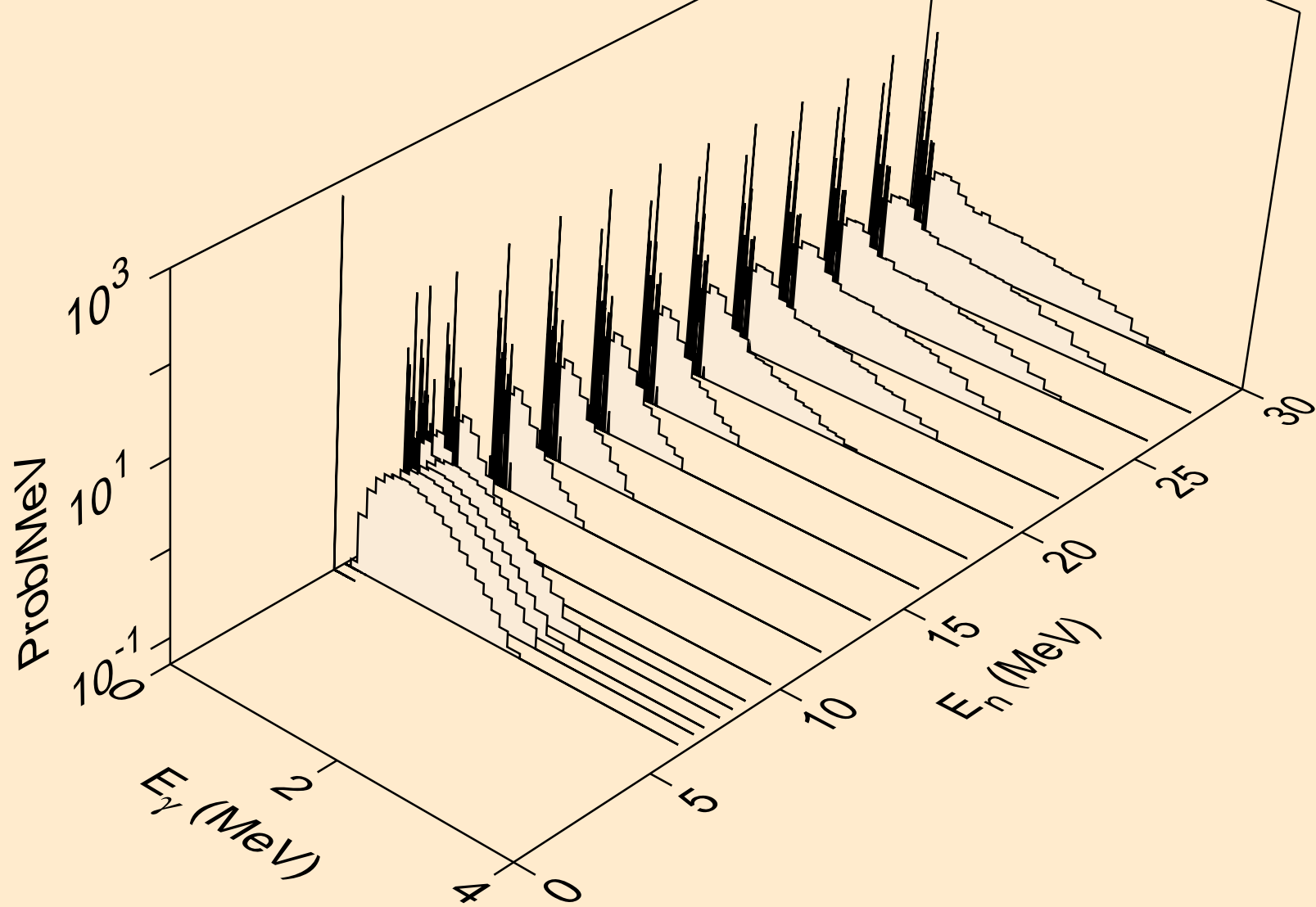

FM250M NEUTRON ACER TENDL-2024 LIBRARY; T=0.K
Photon emission for (n,pd)

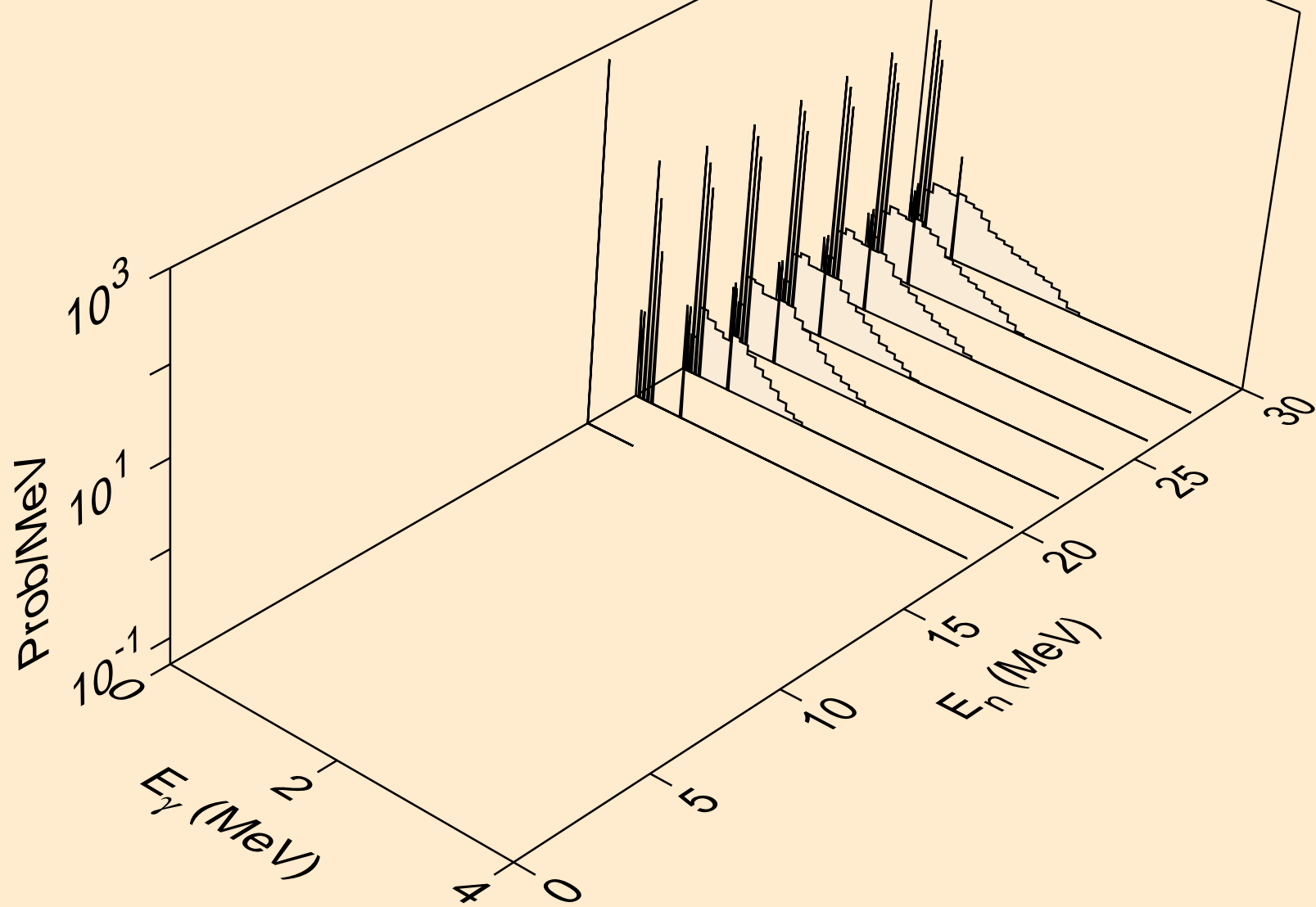

FM250M NEUTRON ACER TENDL-2024 LIBRARY; T=0.K
thermal capture photon spectrum

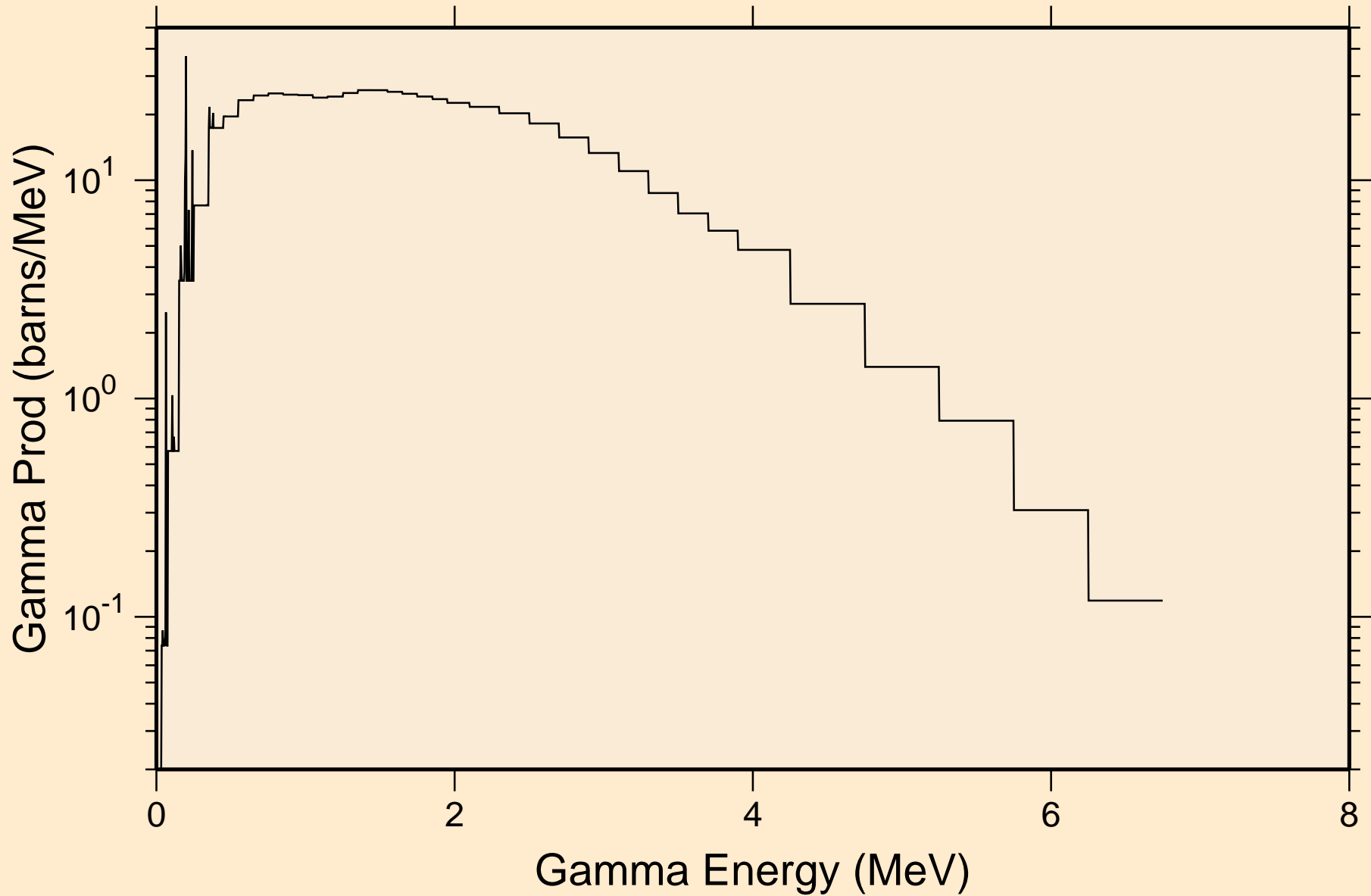

FM250M NEUTRON ACER TENDL-2024 LIBRARY; T=0.K
14 MeV photon spectrum

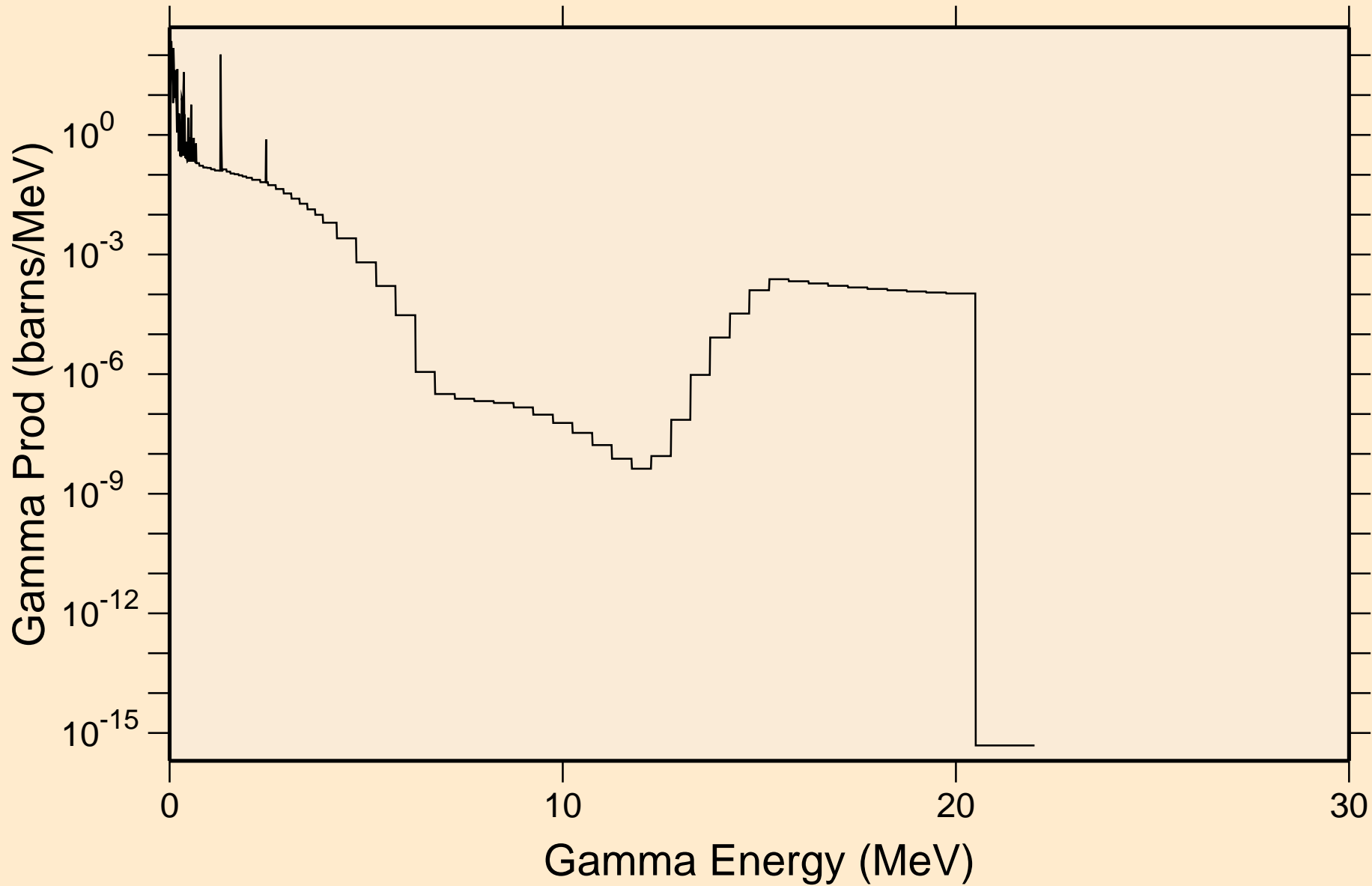

FM250M NEUTRON ACER TENDL-2024 LIBRARY; T=0.K

Particle heating contributions

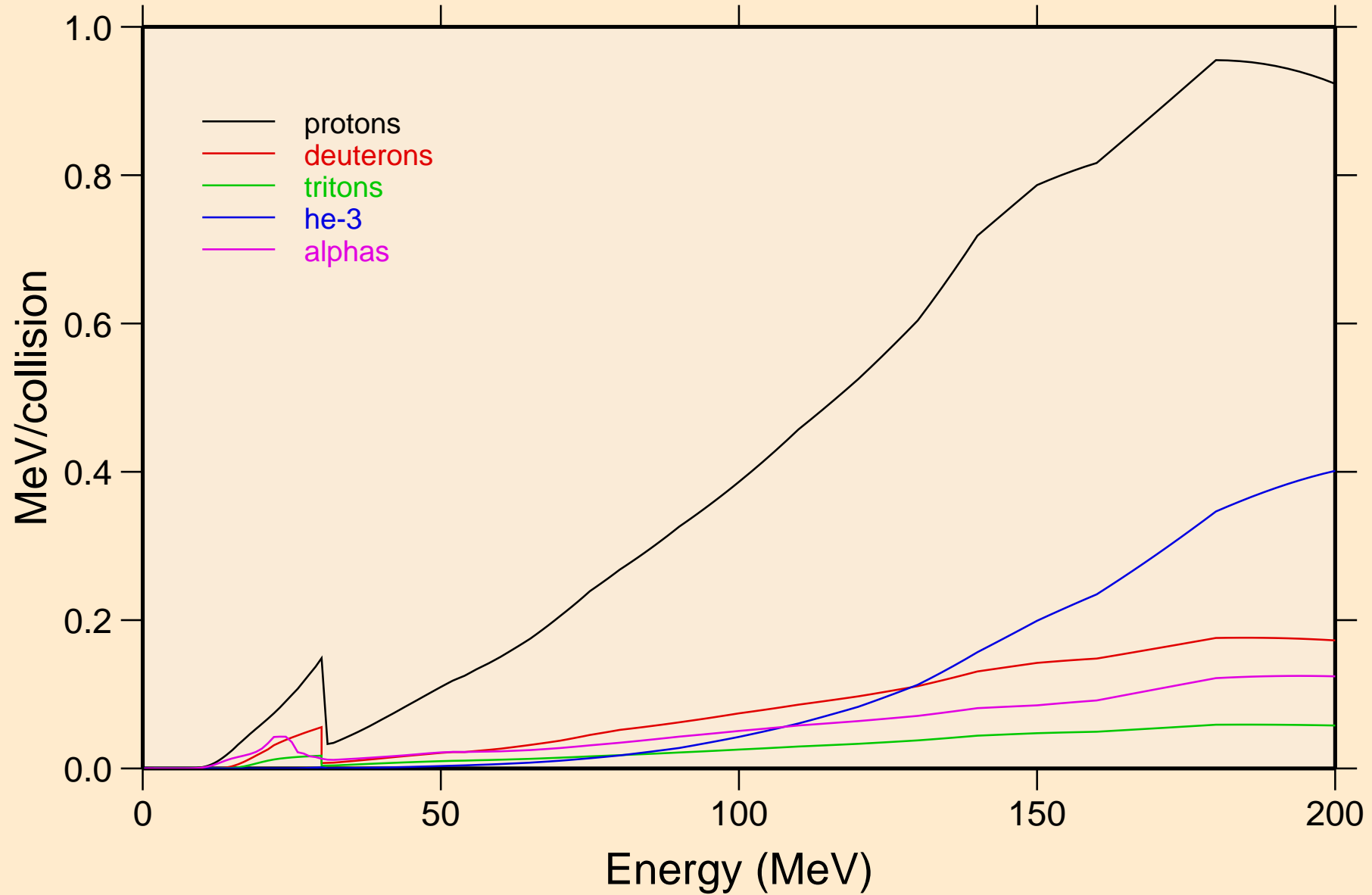

FM250M NEUTRON ACER TENDL-2024 LIBRARY; T=0.K
Recoil Heating

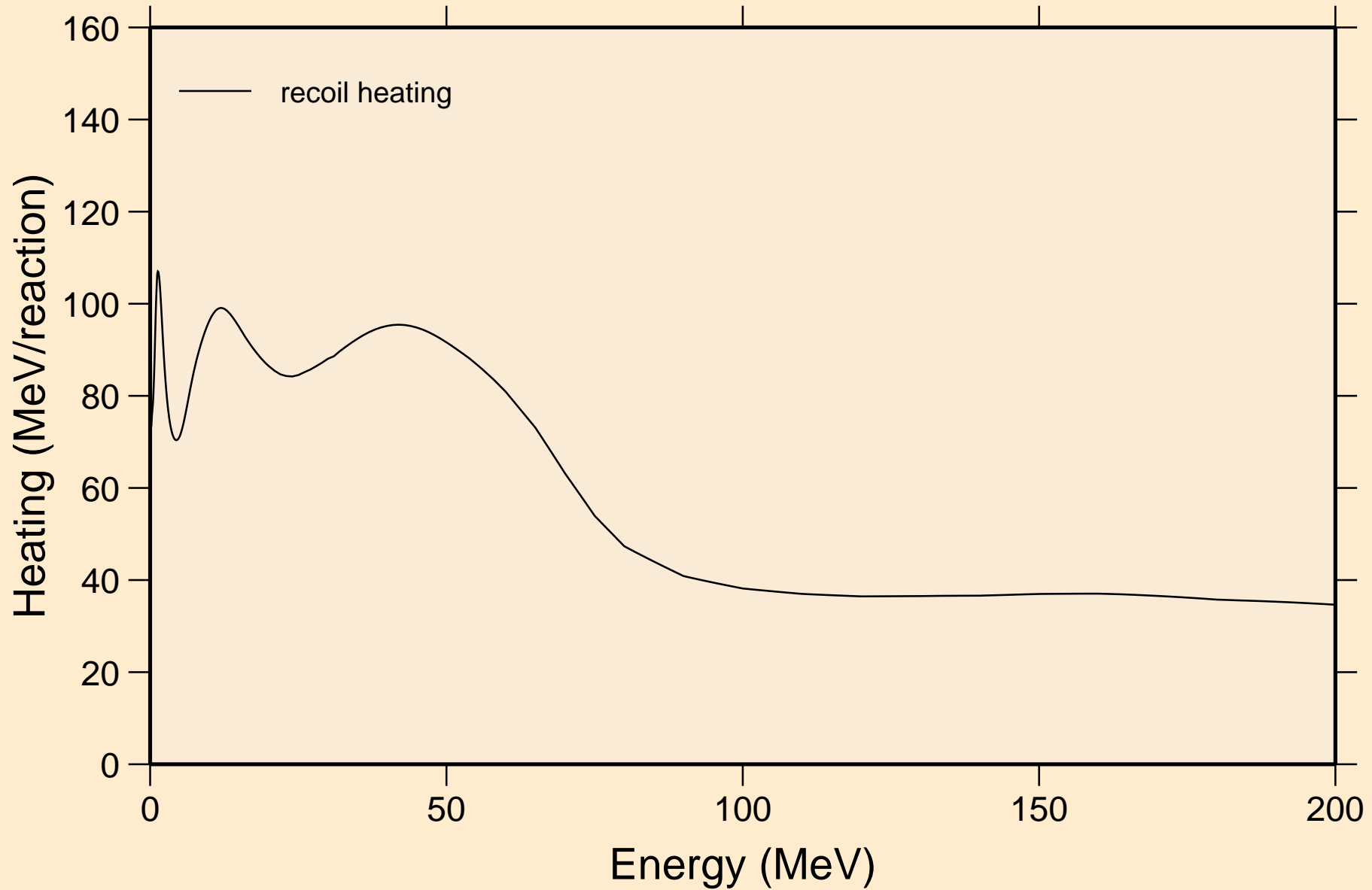

FM250M NEUTRON ACER TENDL-2024 LIBRARY; T=0.K

Particle production cross sections

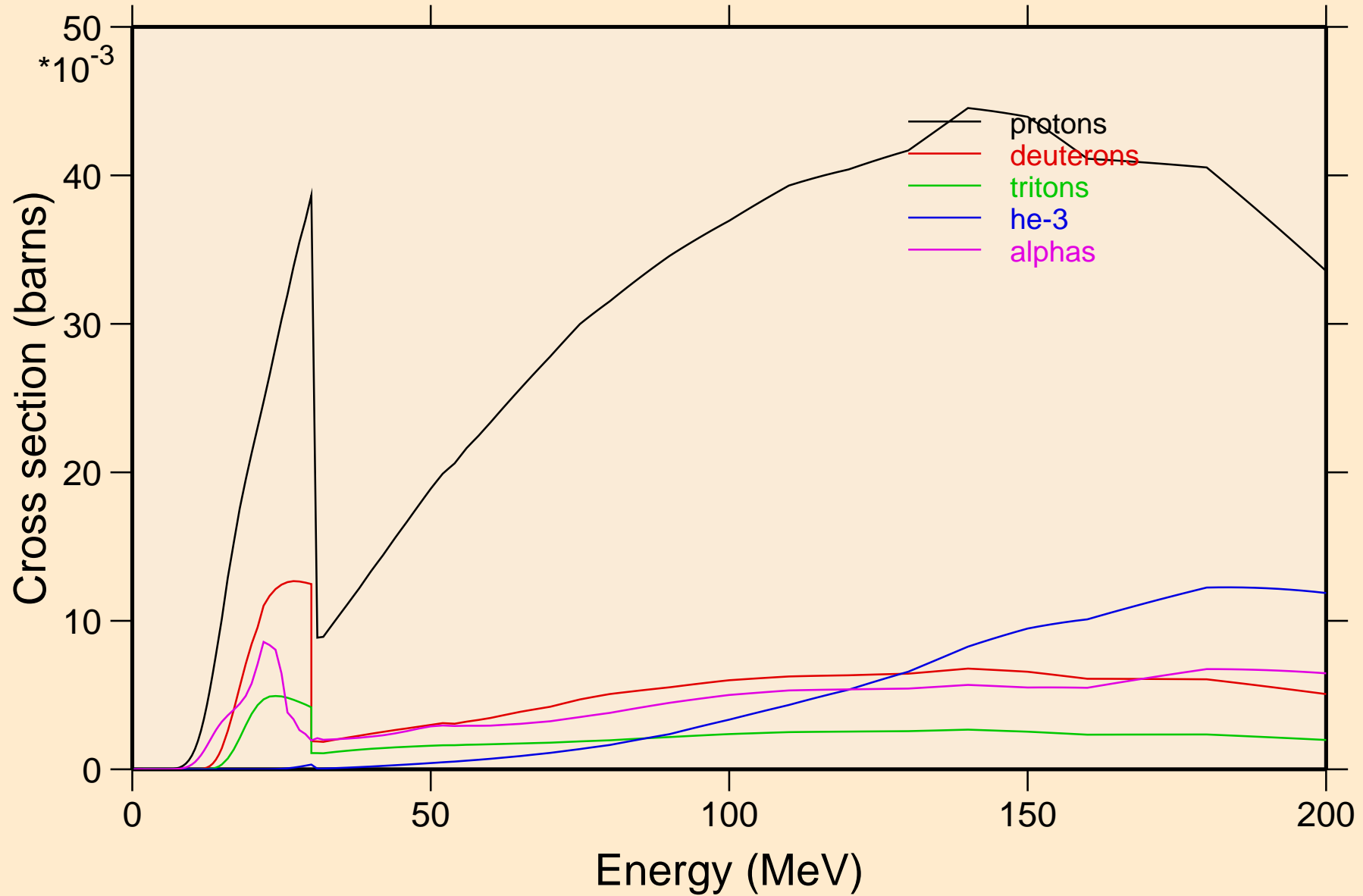

FM250M NEUTRON ACER TENDL-2024 LIBRARY; T=0.K
protons from (n,x)

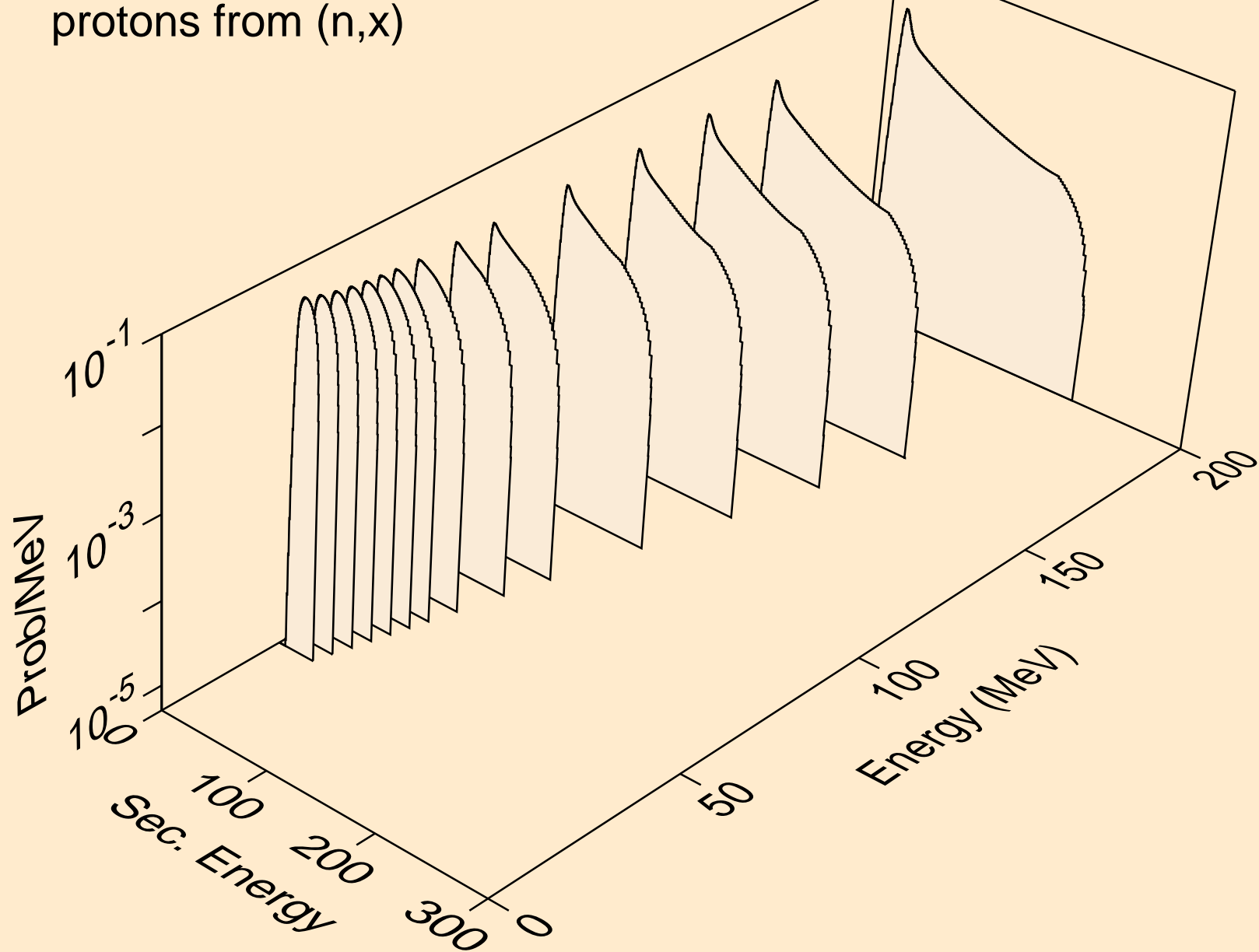

FM250M NEUTRON ACER TENDL-2024 LIBRARY; T=0.K
protons from (n,n*)p

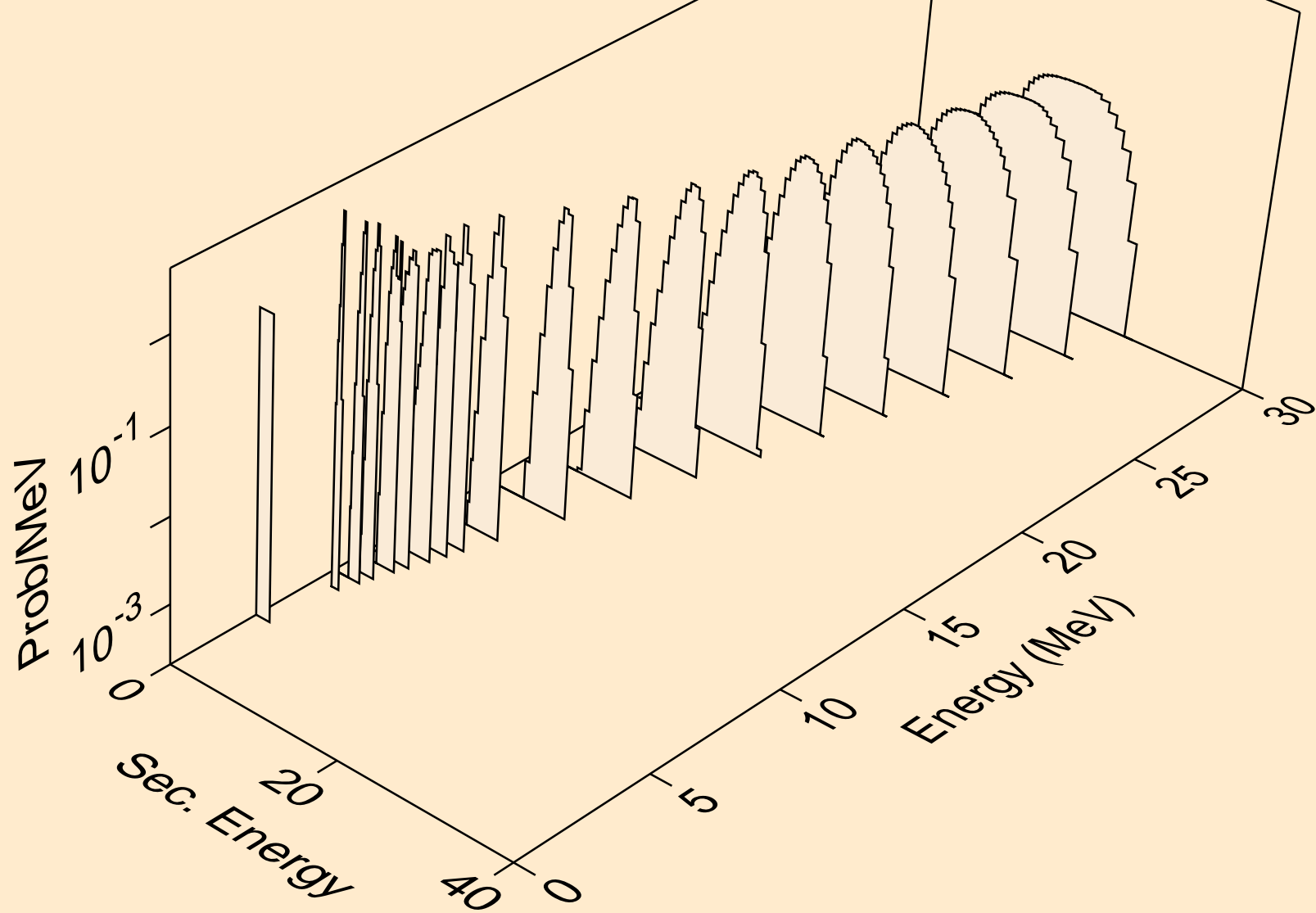

FM250M NEUTRON ACER TENDL-2024 LIBRARY; T=0.K
protons from (n,2np)

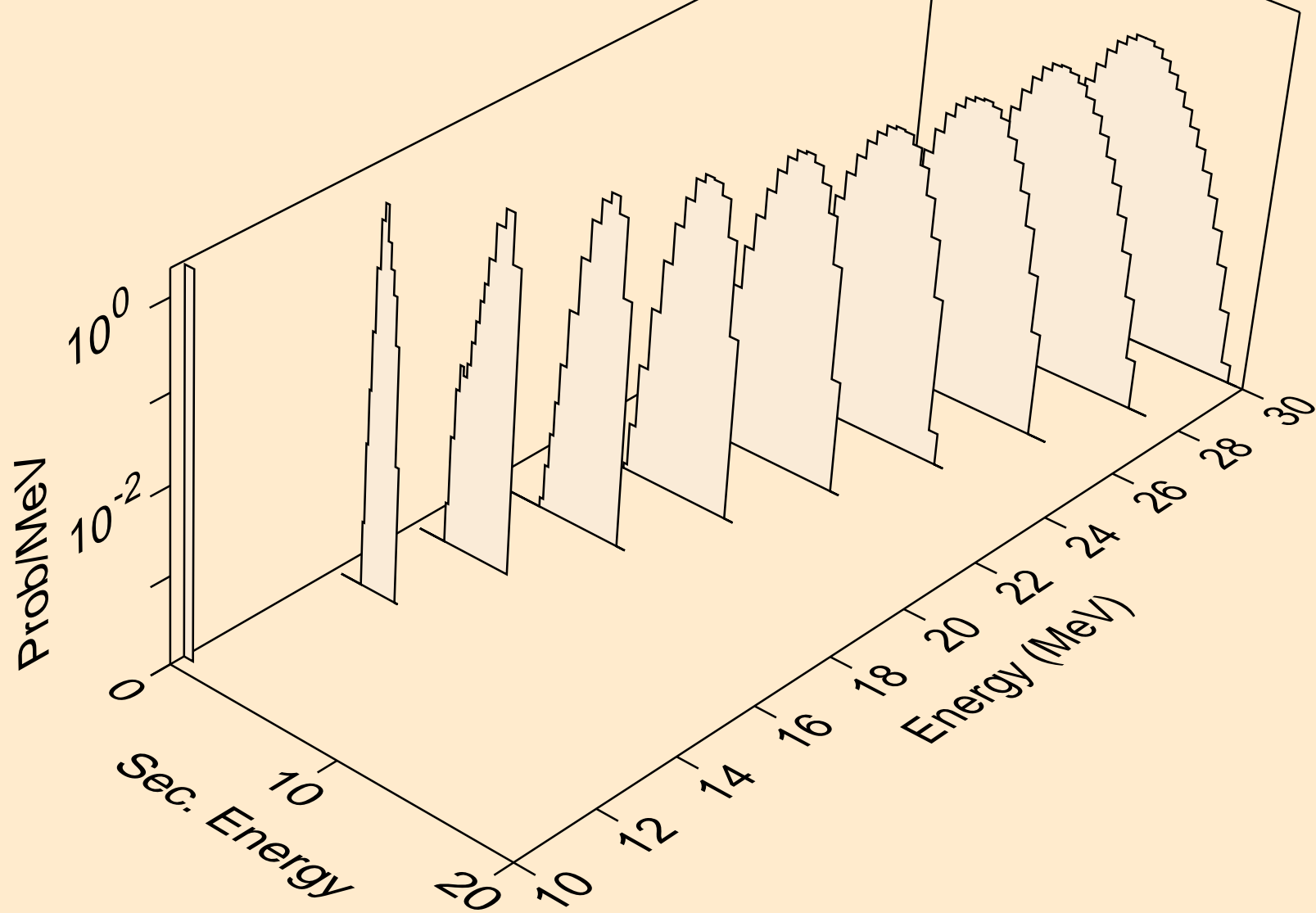

FM250M NEUTRON ACER TENDL-2024 LIBRARY; T=0.K
protons from (n,n2p)

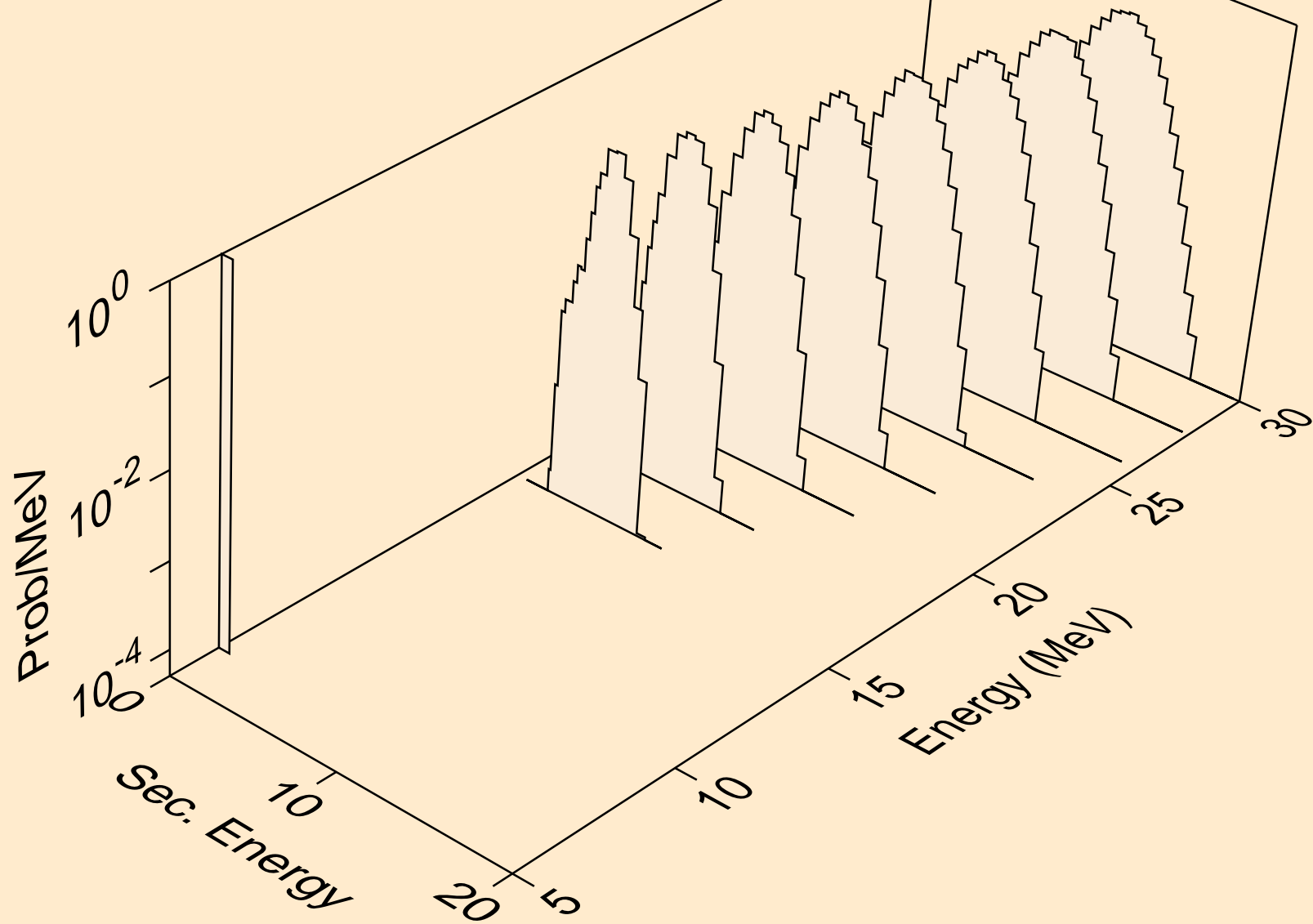

FM250M NEUTRON ACER TENDL-2024 LIBRARY; T=0.K
protons from (n,p)

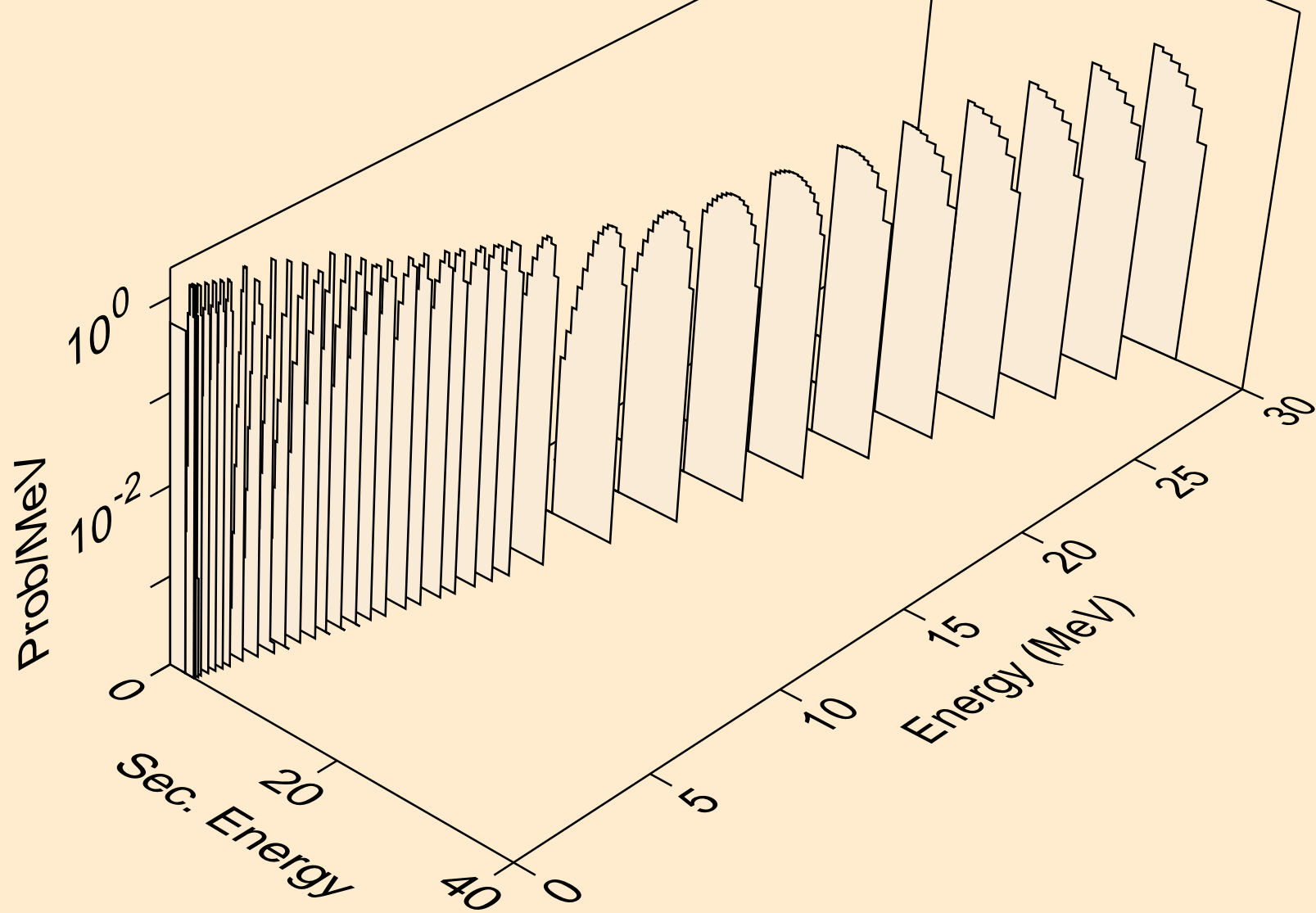

FM250M NEUTRON ACER TENDL-2024 LIBRARY; T=0.K
protons from (n,2p)

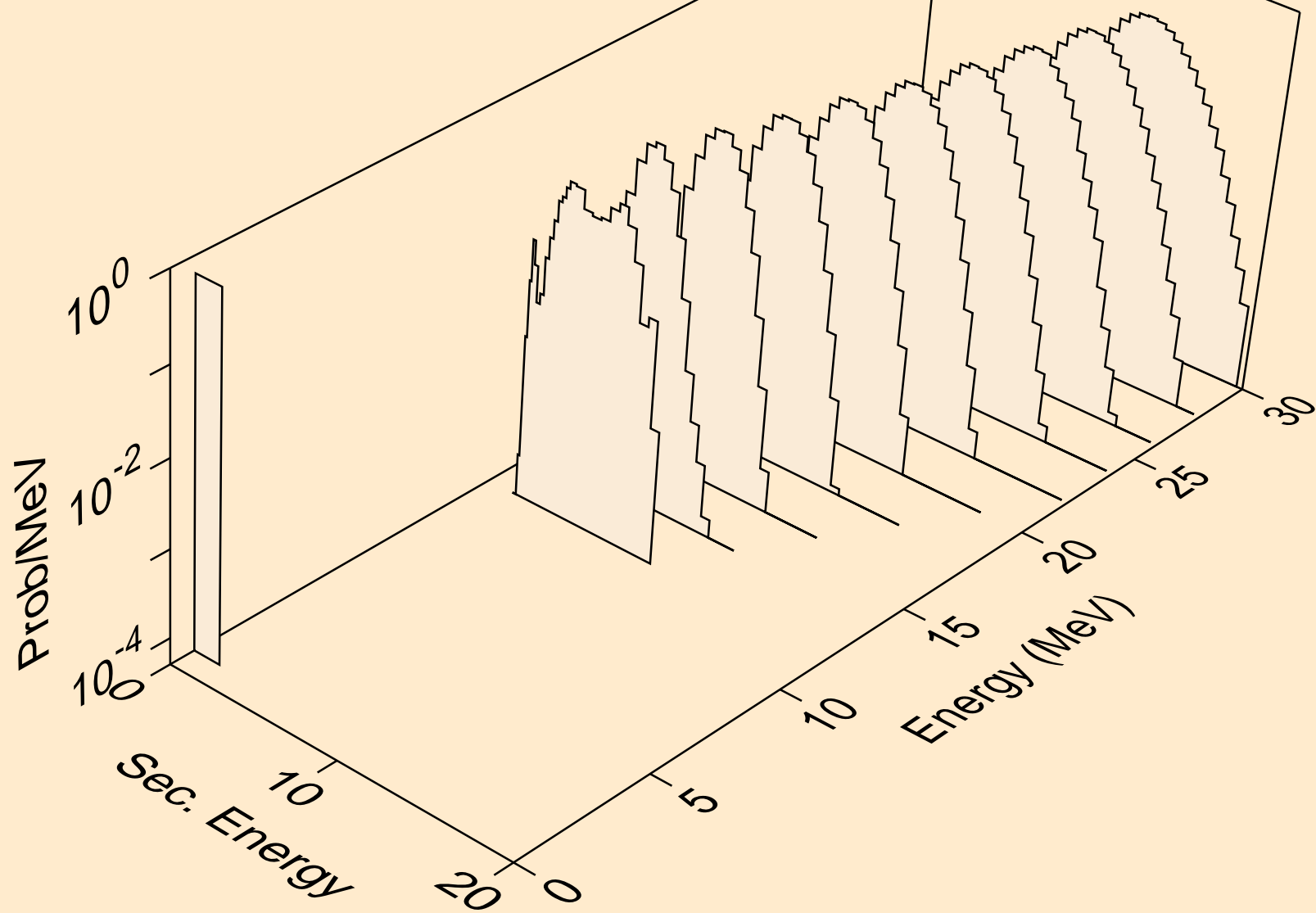

FM250M NEUTRON ACER TENDL-2024 LIBRARY; T=0.K
protons from (n,p)

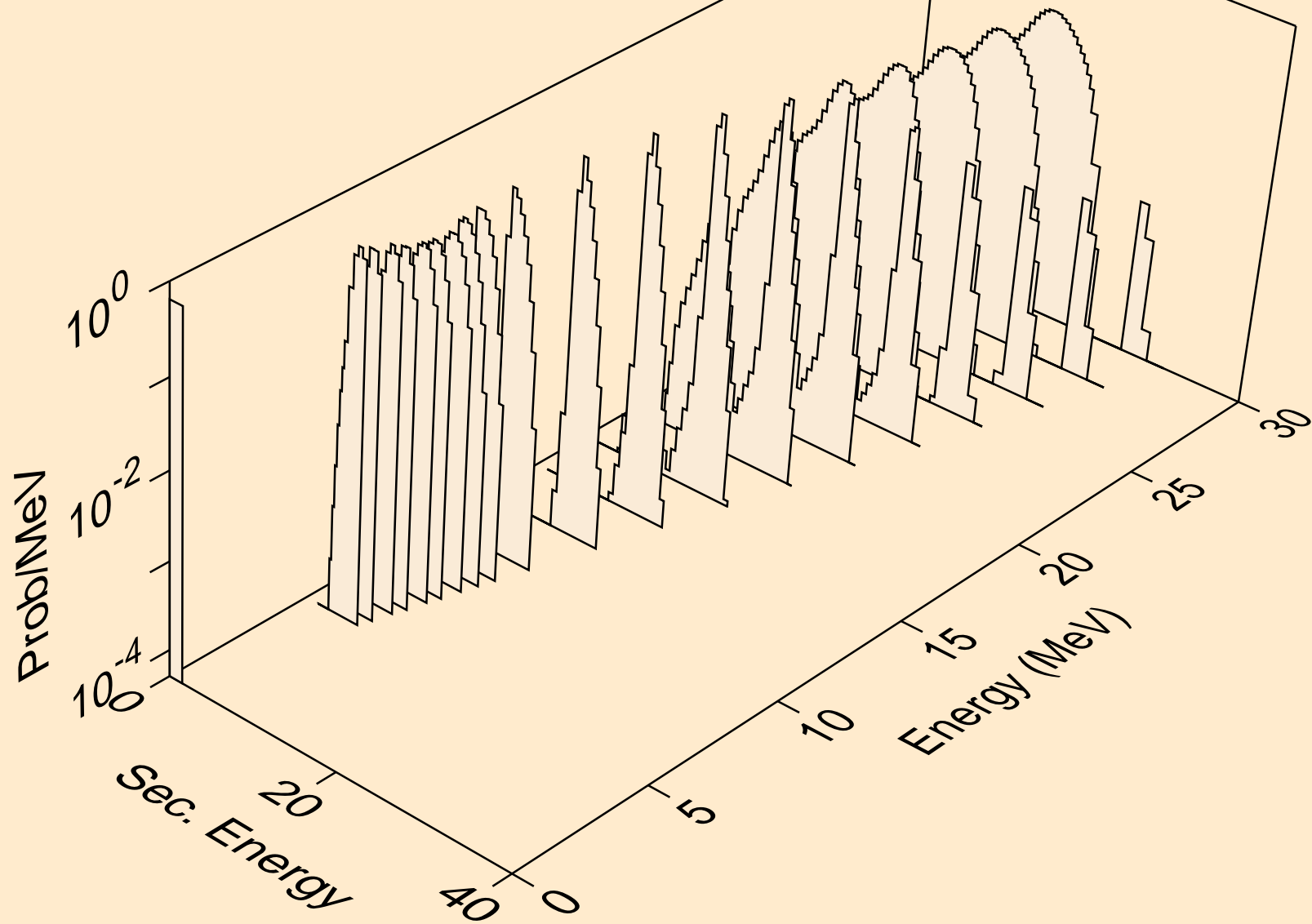

FM250M NEUTRON ACER TENDL-2024 LIBRARY; T=0.K
protons from (n,pd)

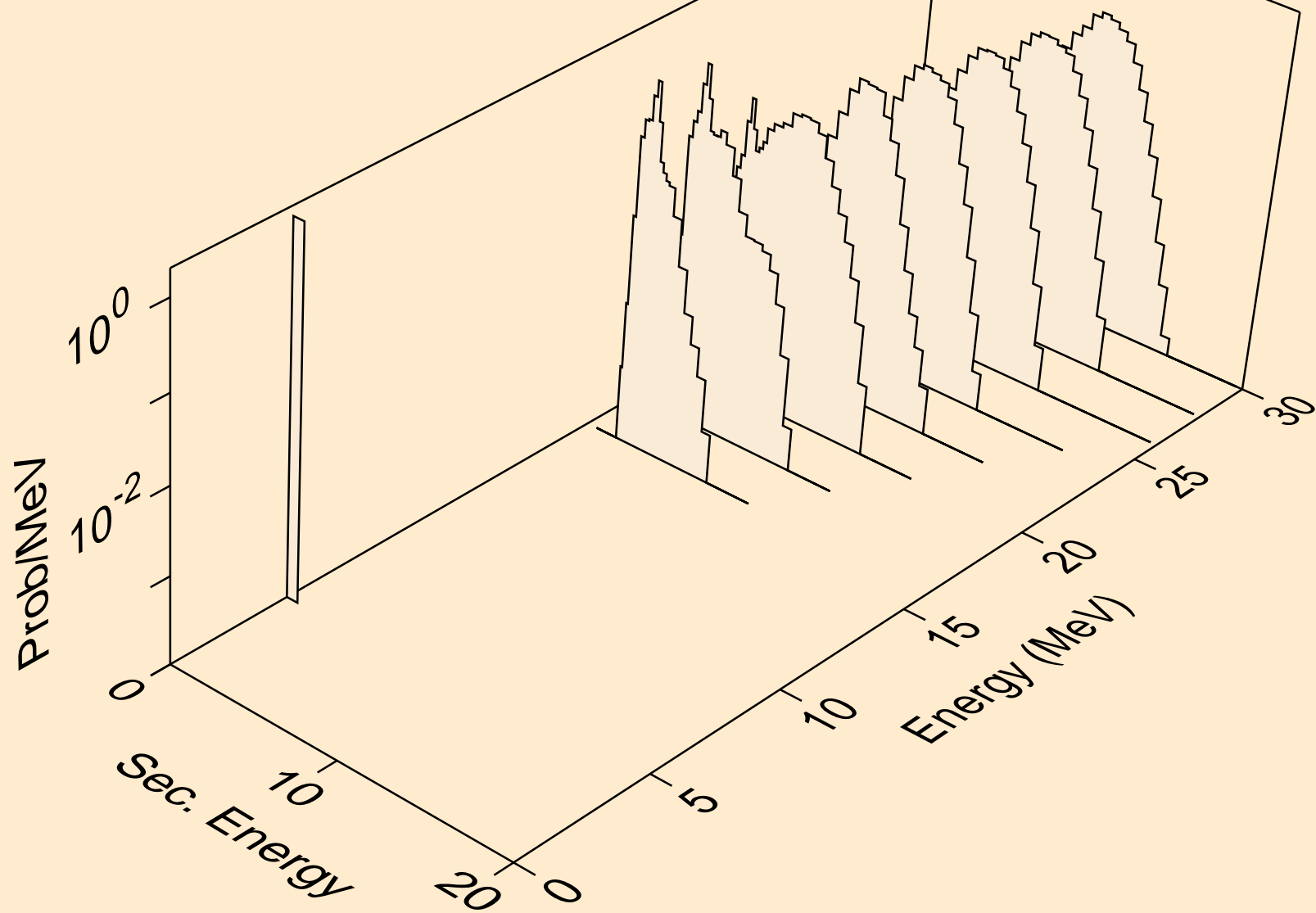

FM250M NEUTRON ACER TENDL-2024 LIBRARY; T=0.K
deuterons from (n,x)

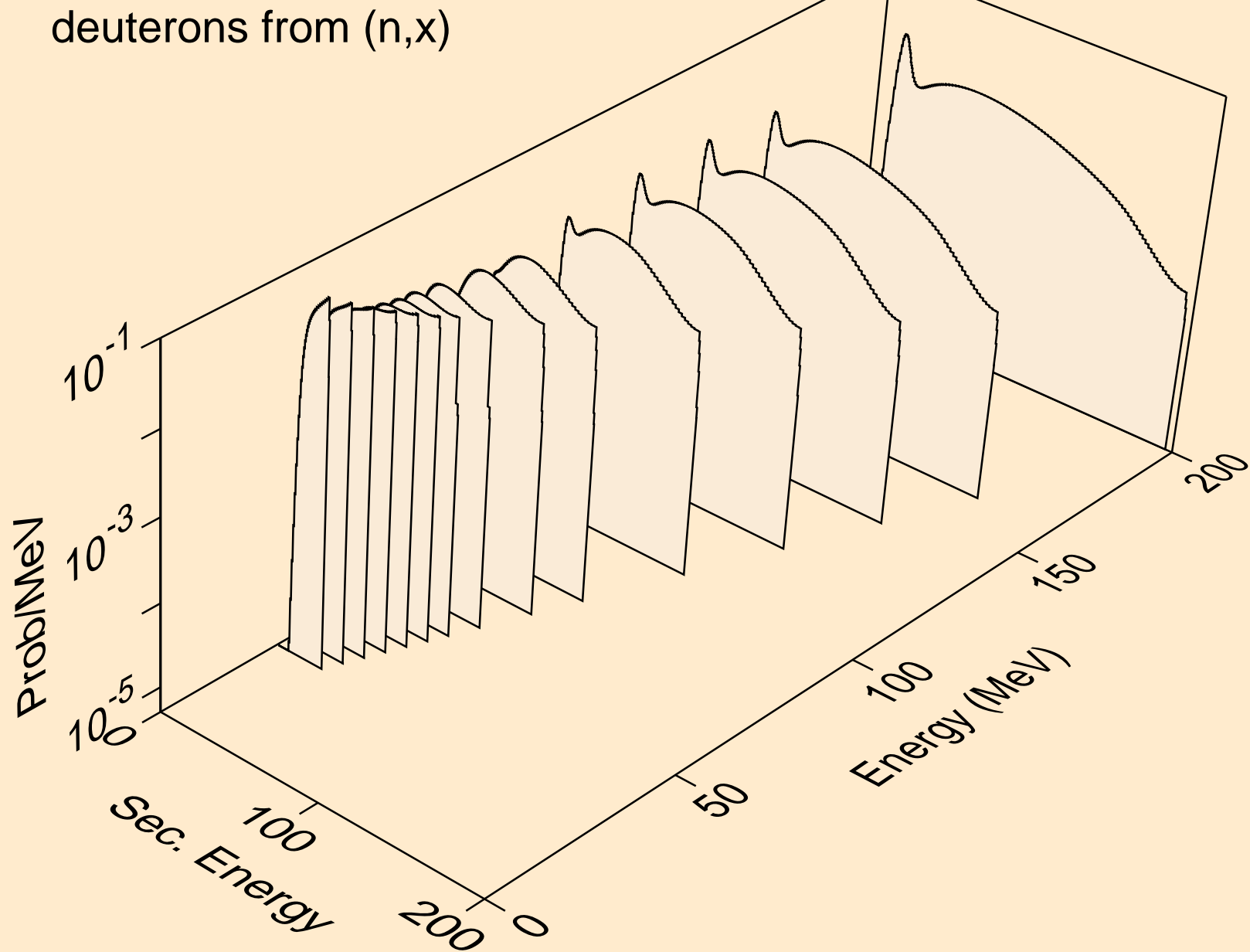

FM250M NEUTRON ACER TENDL-2024 LIBRARY; T=0.K
deuterons from (n,2nd)

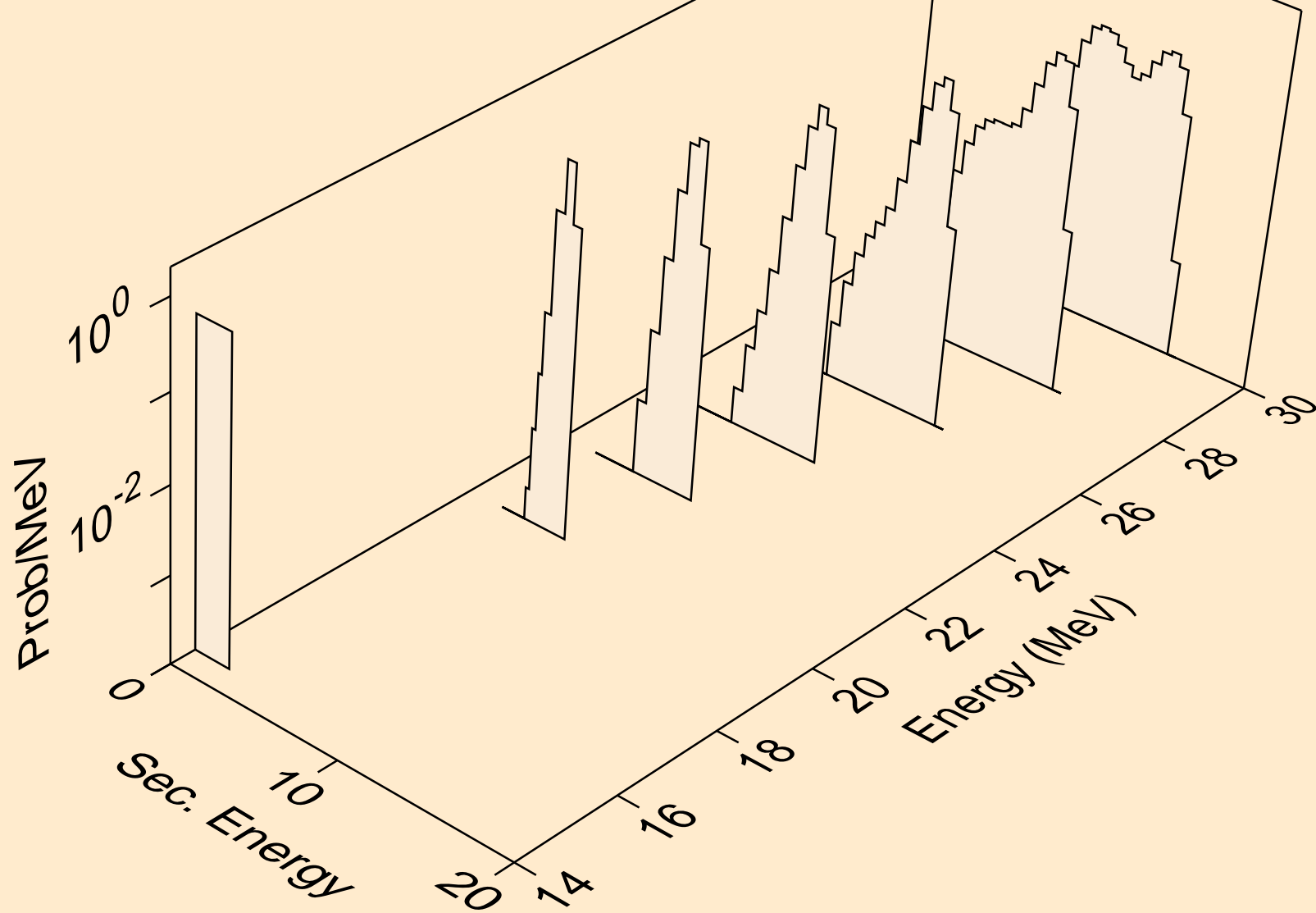

FM250M NEUTRON ACER TENDL-2024 LIBRARY; T=0.K
deuterons from (n,n*)d

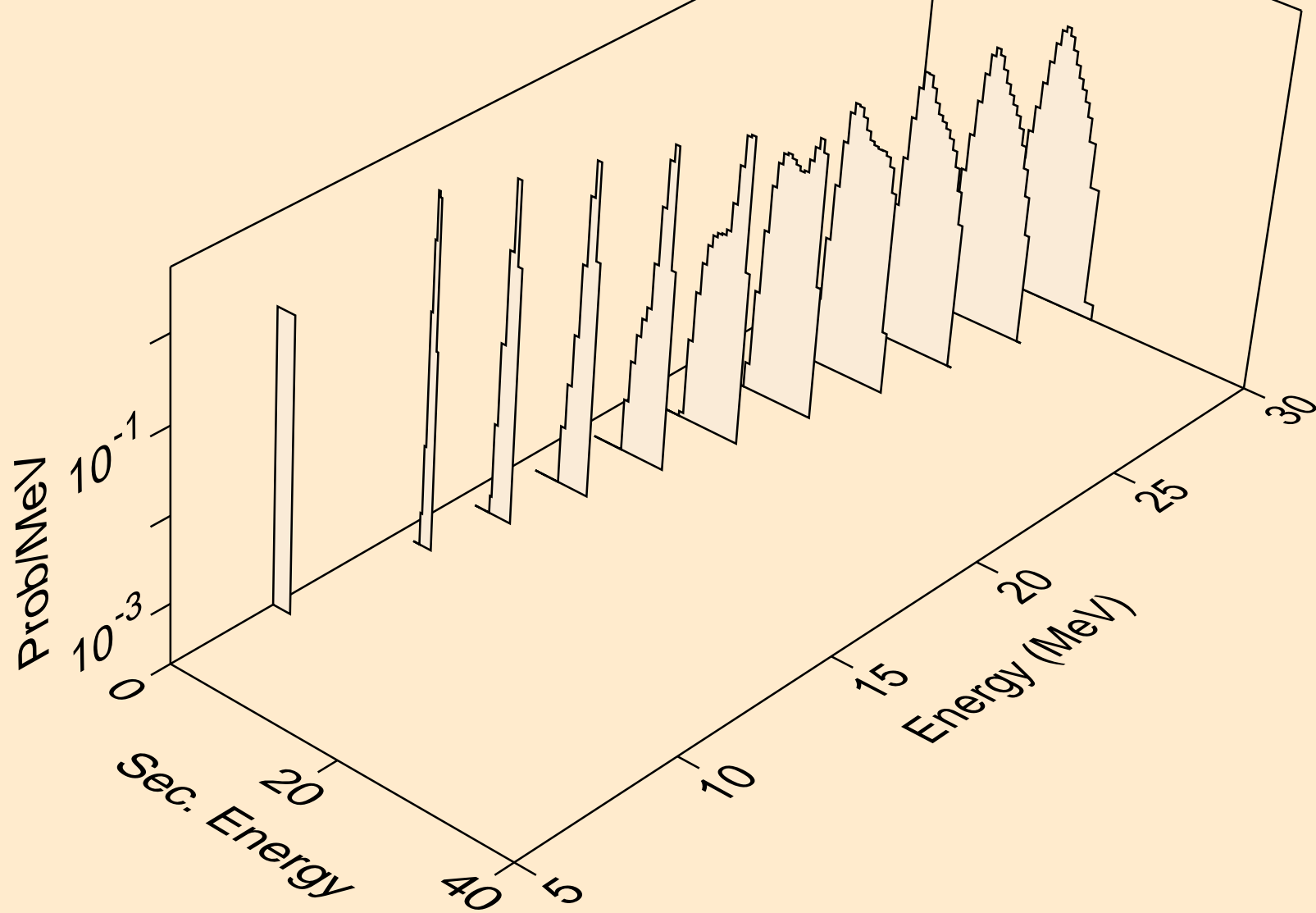

FM250M NEUTRON ACER TENDL-2024 LIBRARY; T=0.K
deuterons from (n,d)

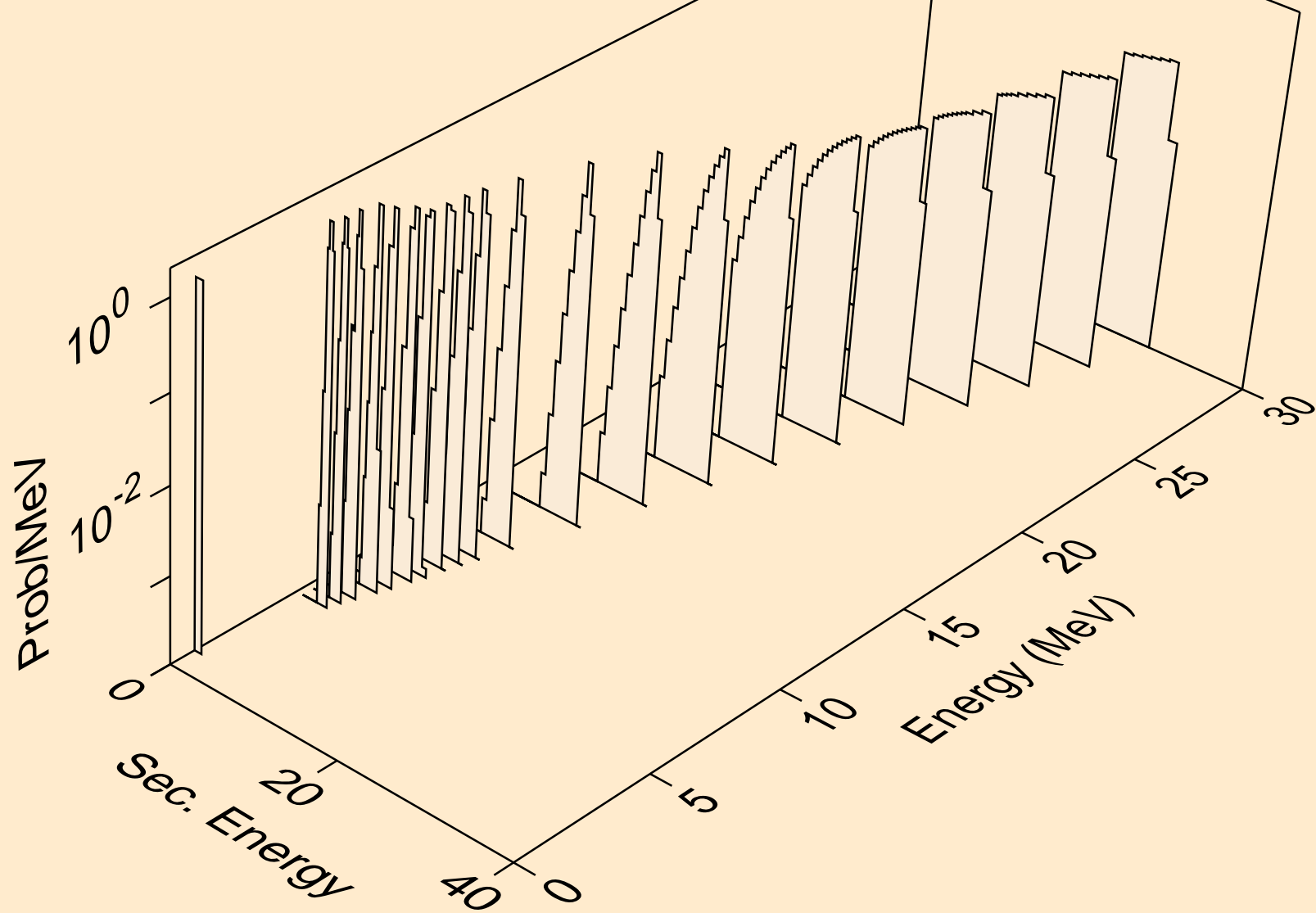

FM250M NEUTRON ACER TENDL-2024 LIBRARY; T=0.K
deuterons from (n,pd)

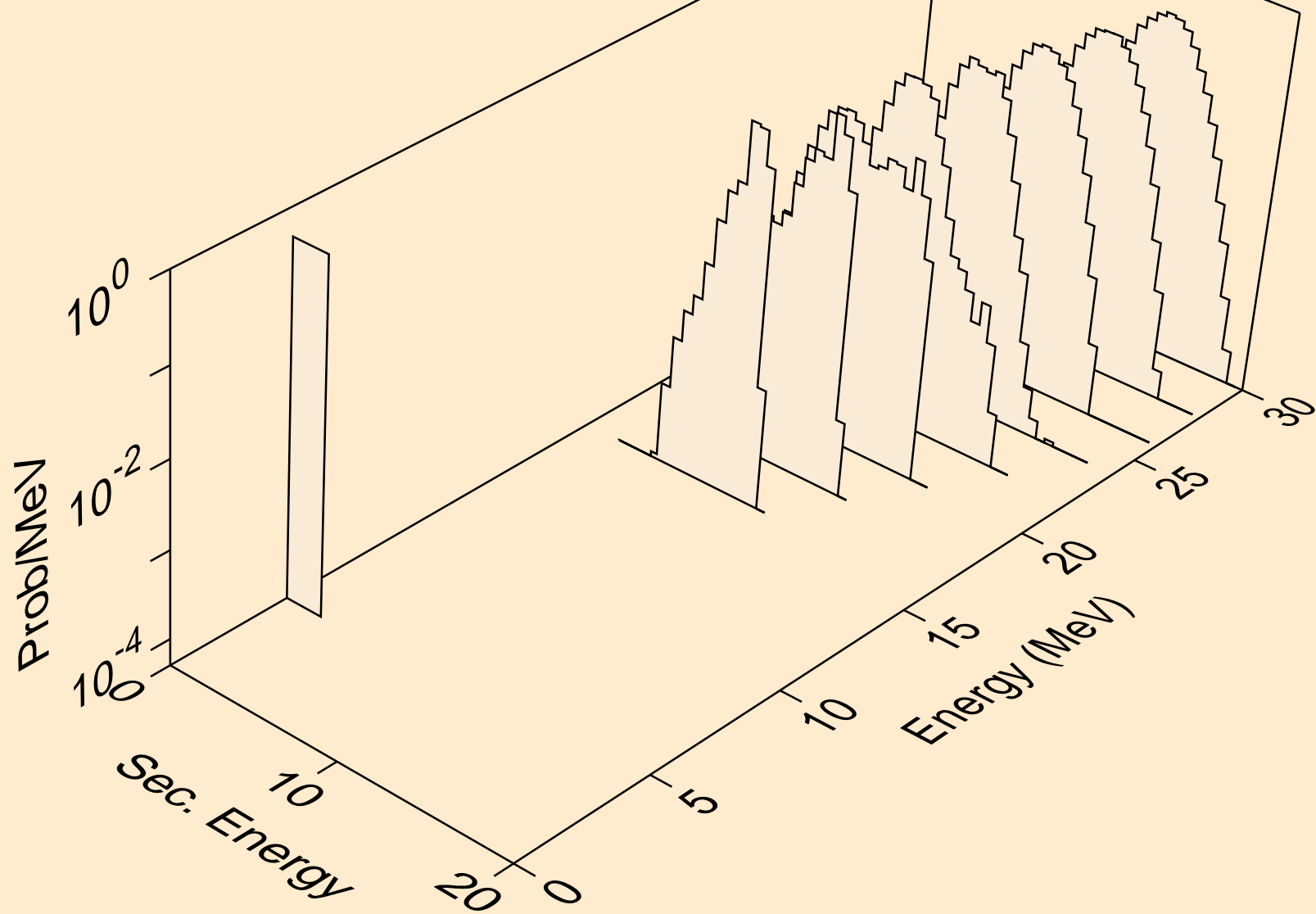

FM250M NEUTRON ACER TENDL-2024 LIBRARY; T=0.K
tritons from (n,x)

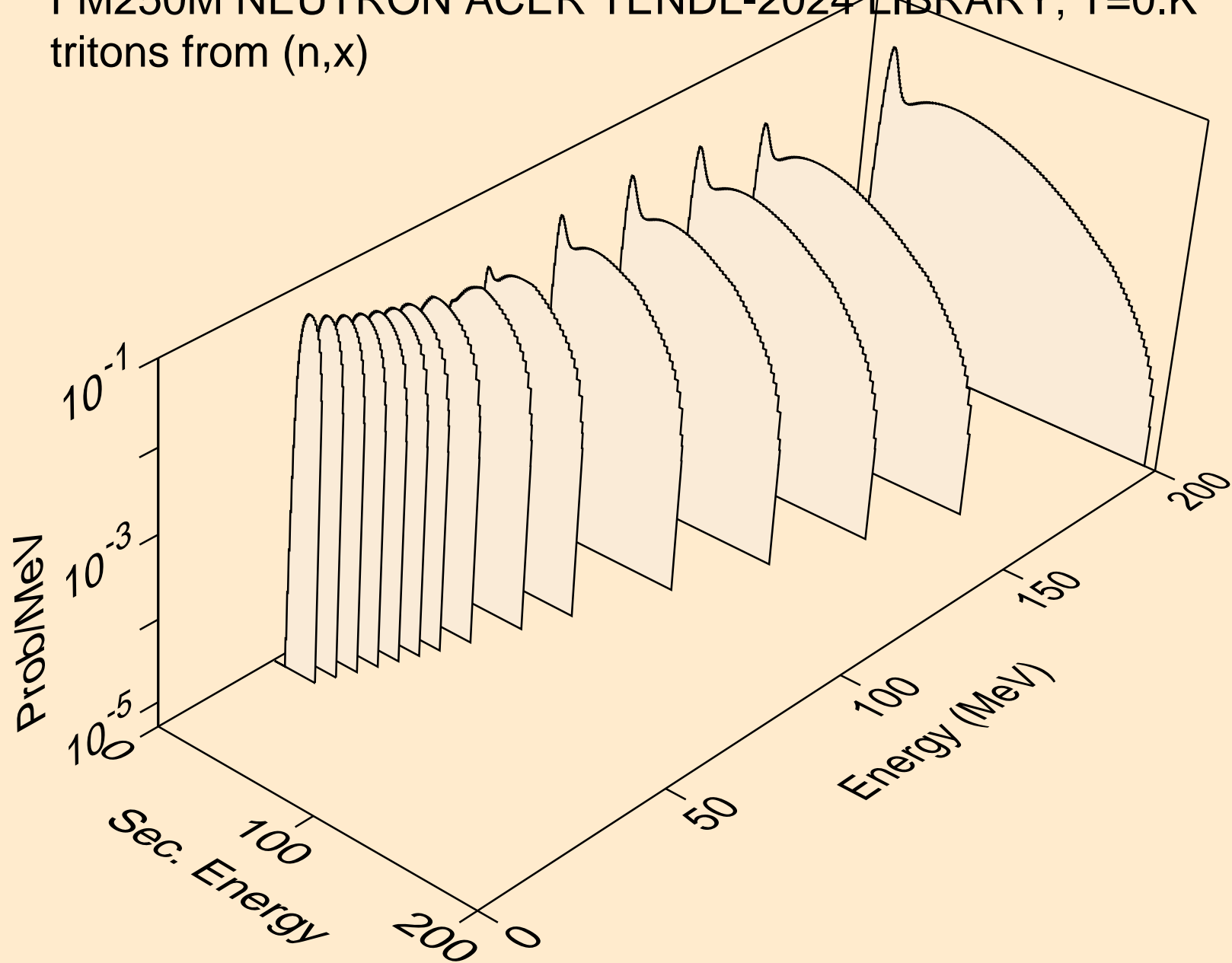

FM250M NEUTRON ACER TENDL-2024 LIBRARY; T=0.K
tritons from (n,n*)t

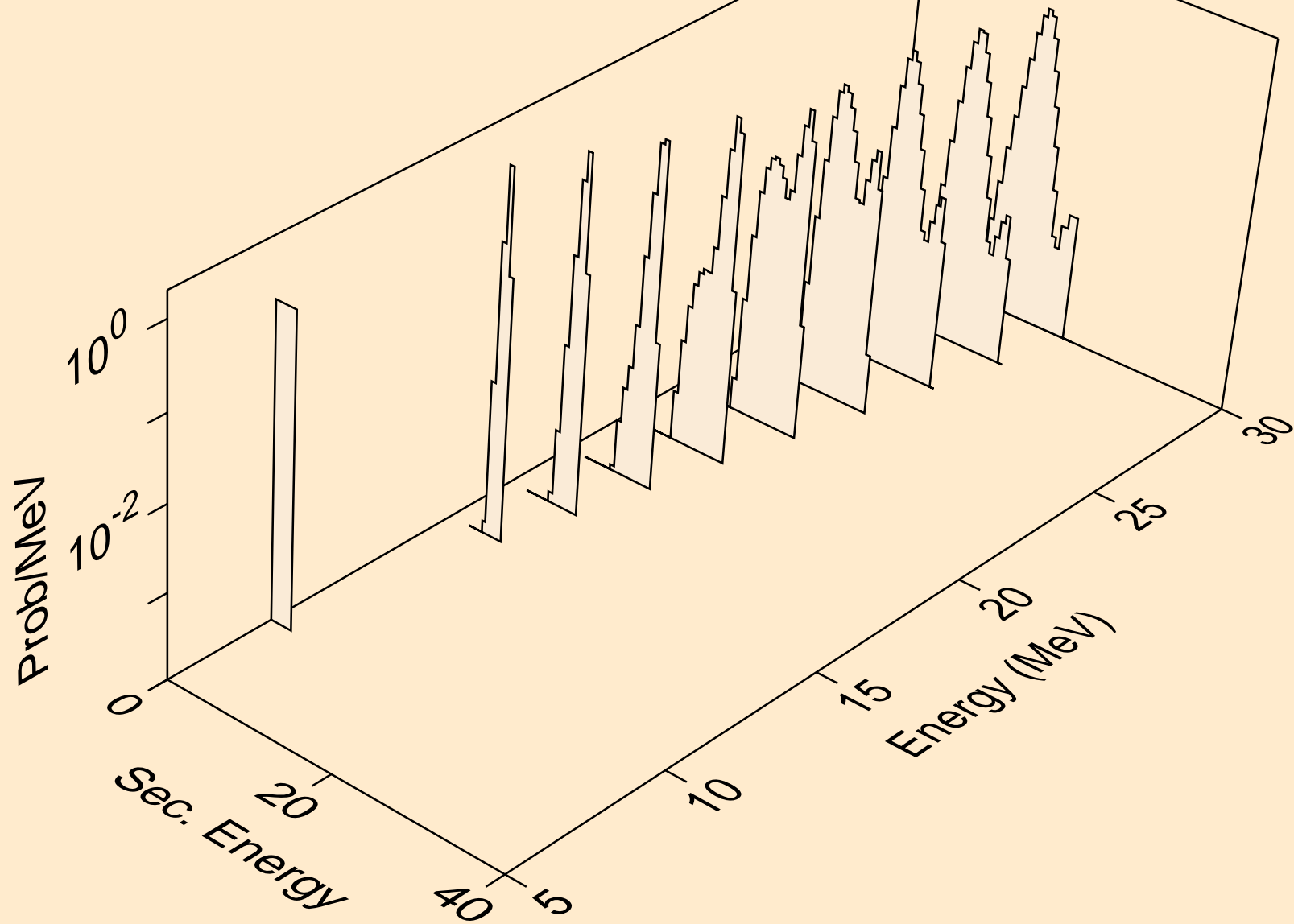

FM250M NEUTRON ACER TENDL-2024 LIBRARY; T=0.K
tritons from (n,t)

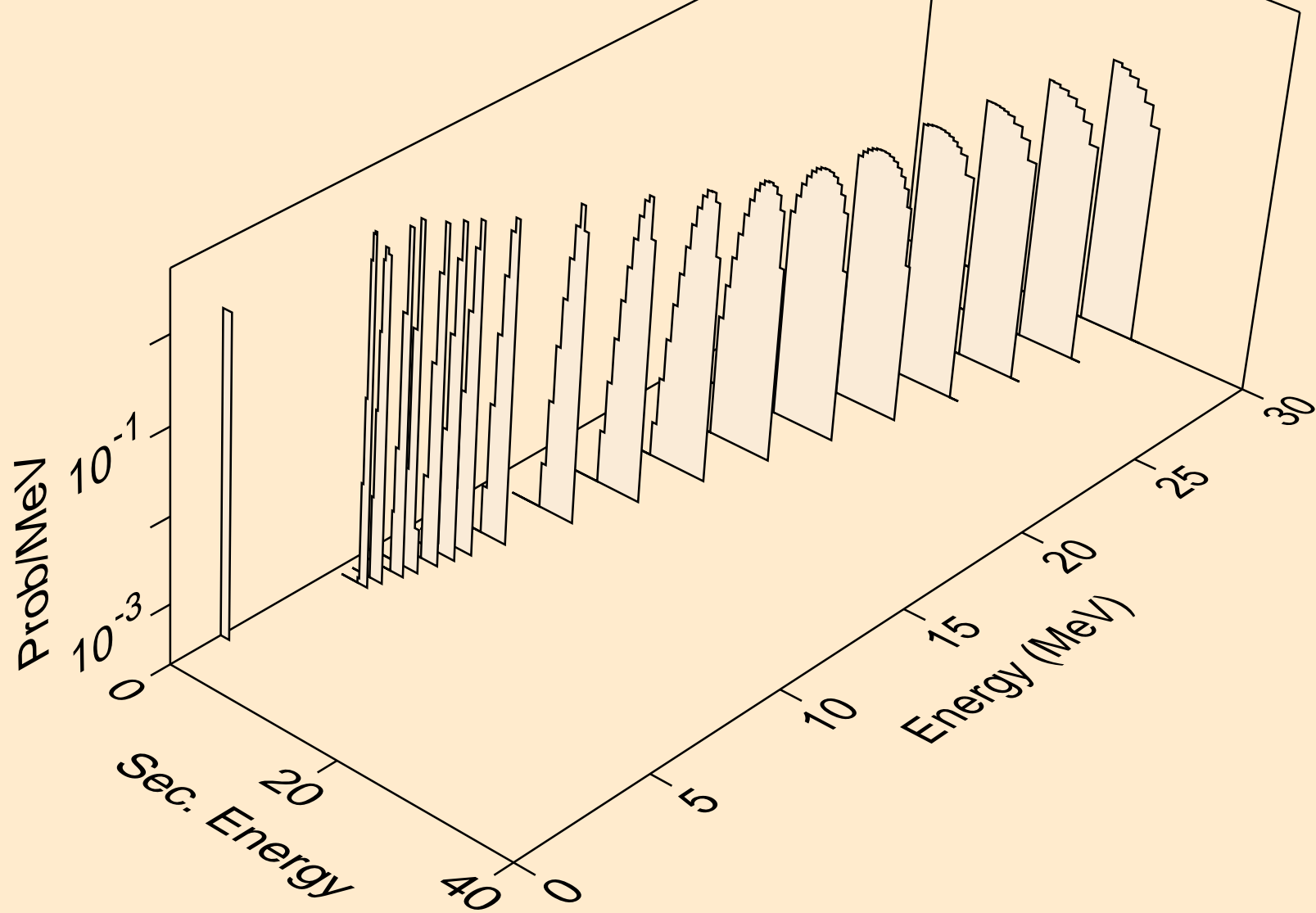

FM250M NEUTRON ACER TENDL-2024 LIBRARY; T=0.K
he3s from (n,x)

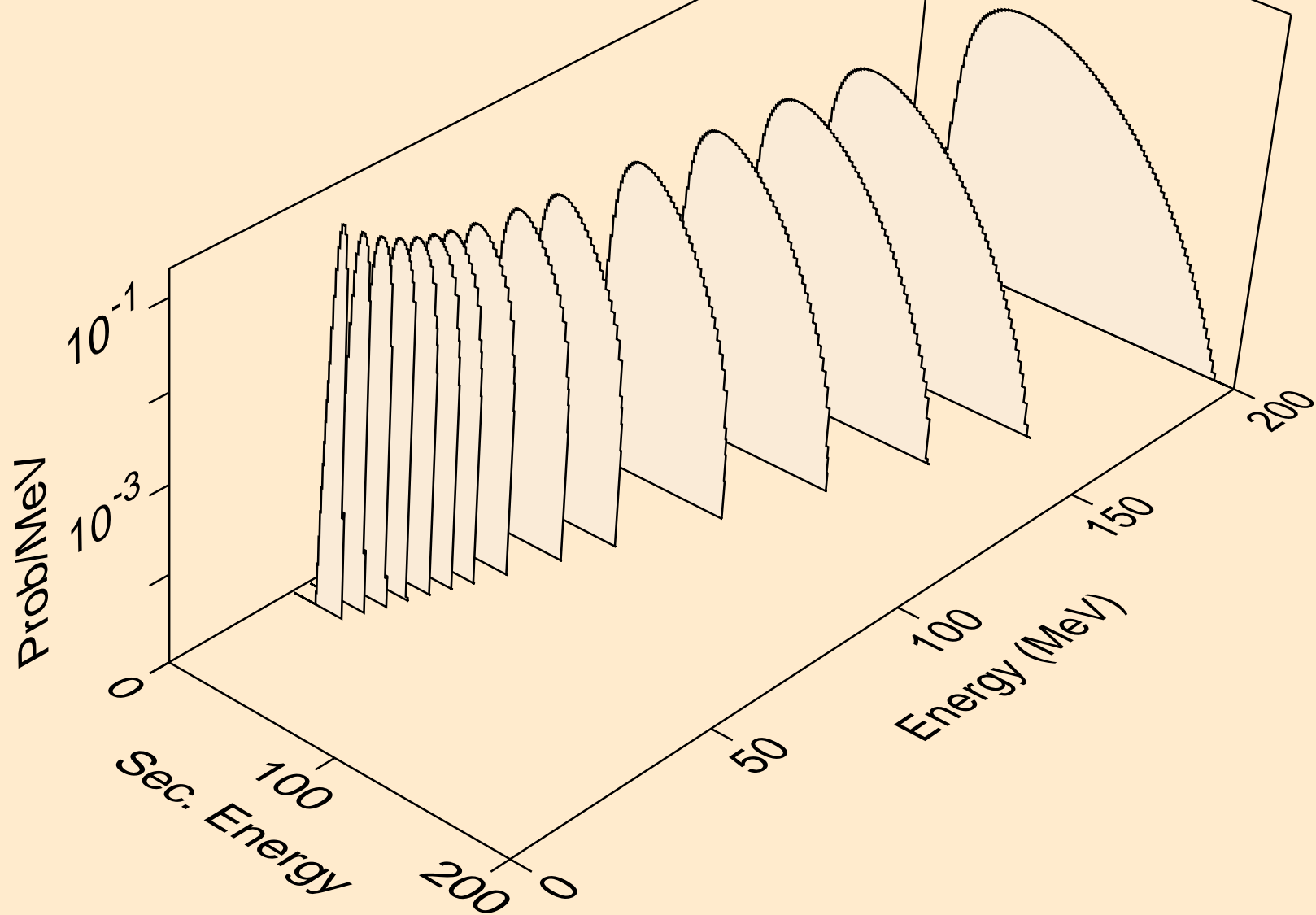

FM250M NEUTRON ACER TENDL-2024 LIBRARY; T=0.K
he3s from (n,n*)he3

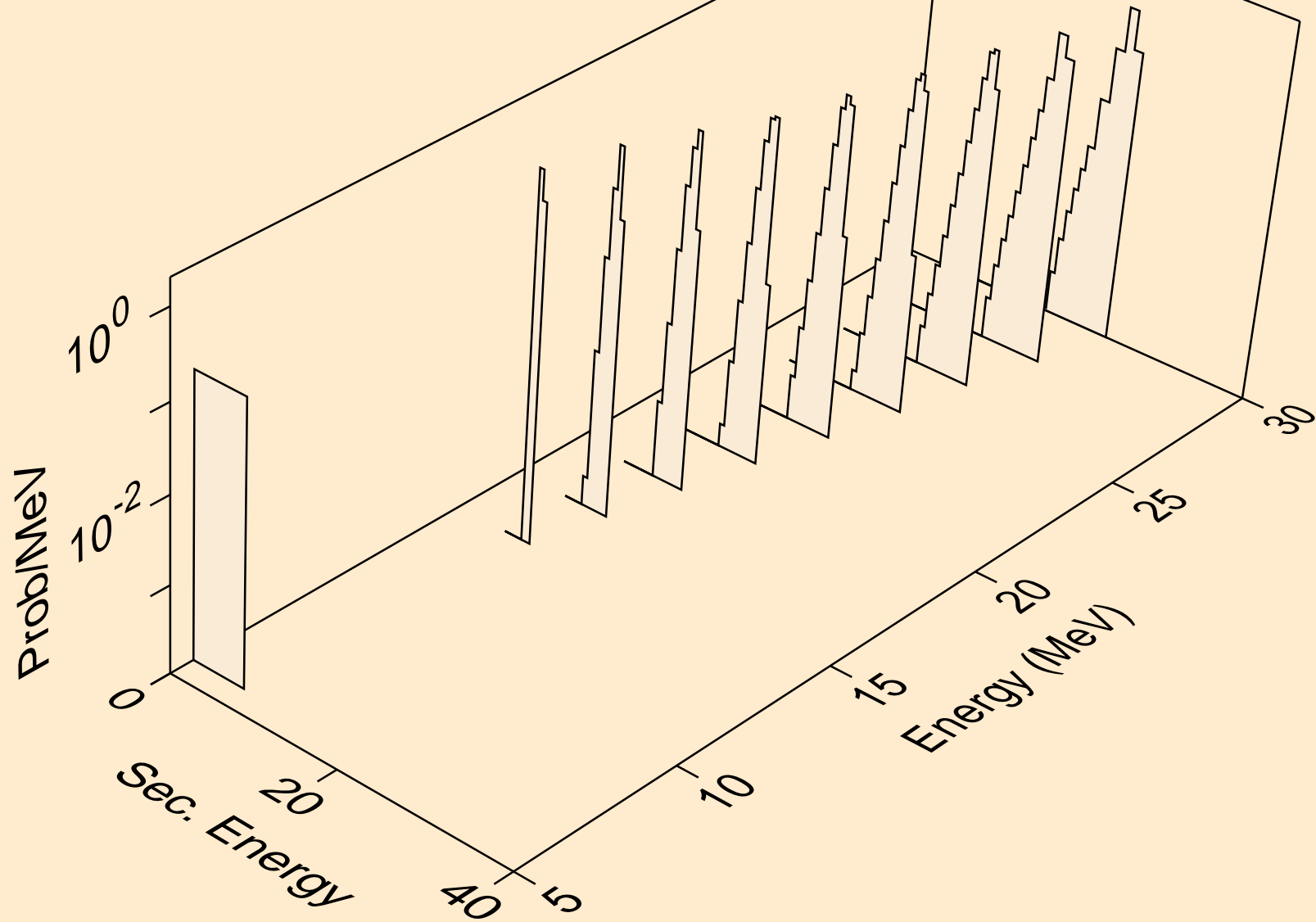

FM250M NEUTRON ACER TENDL-2024 LIBRARY; T=0.K
he3s from (n,he3)

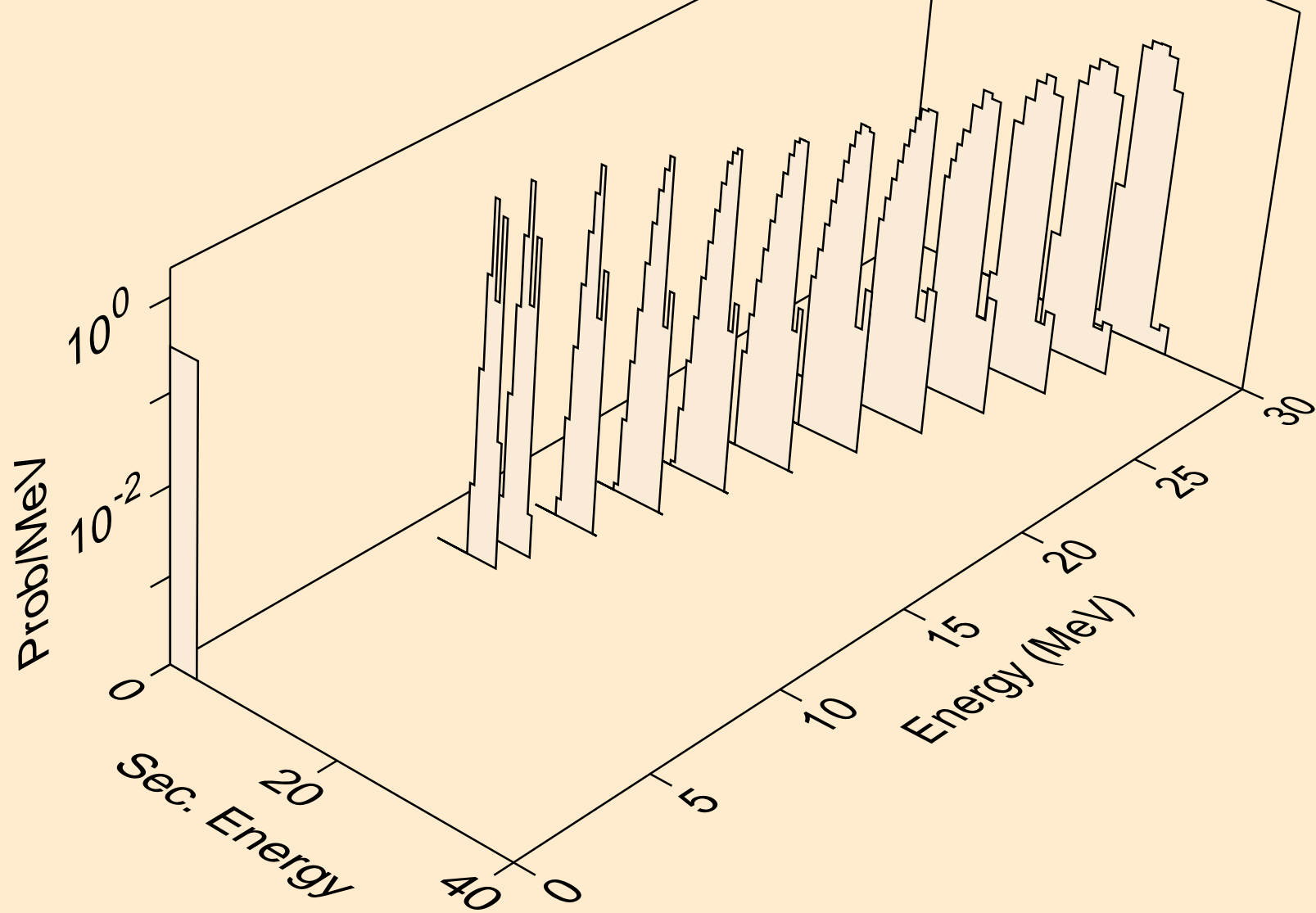

FM250M NEUTRON ACER TENDL-2024 LIBRARY; T=0.K
alphas from (n,x)

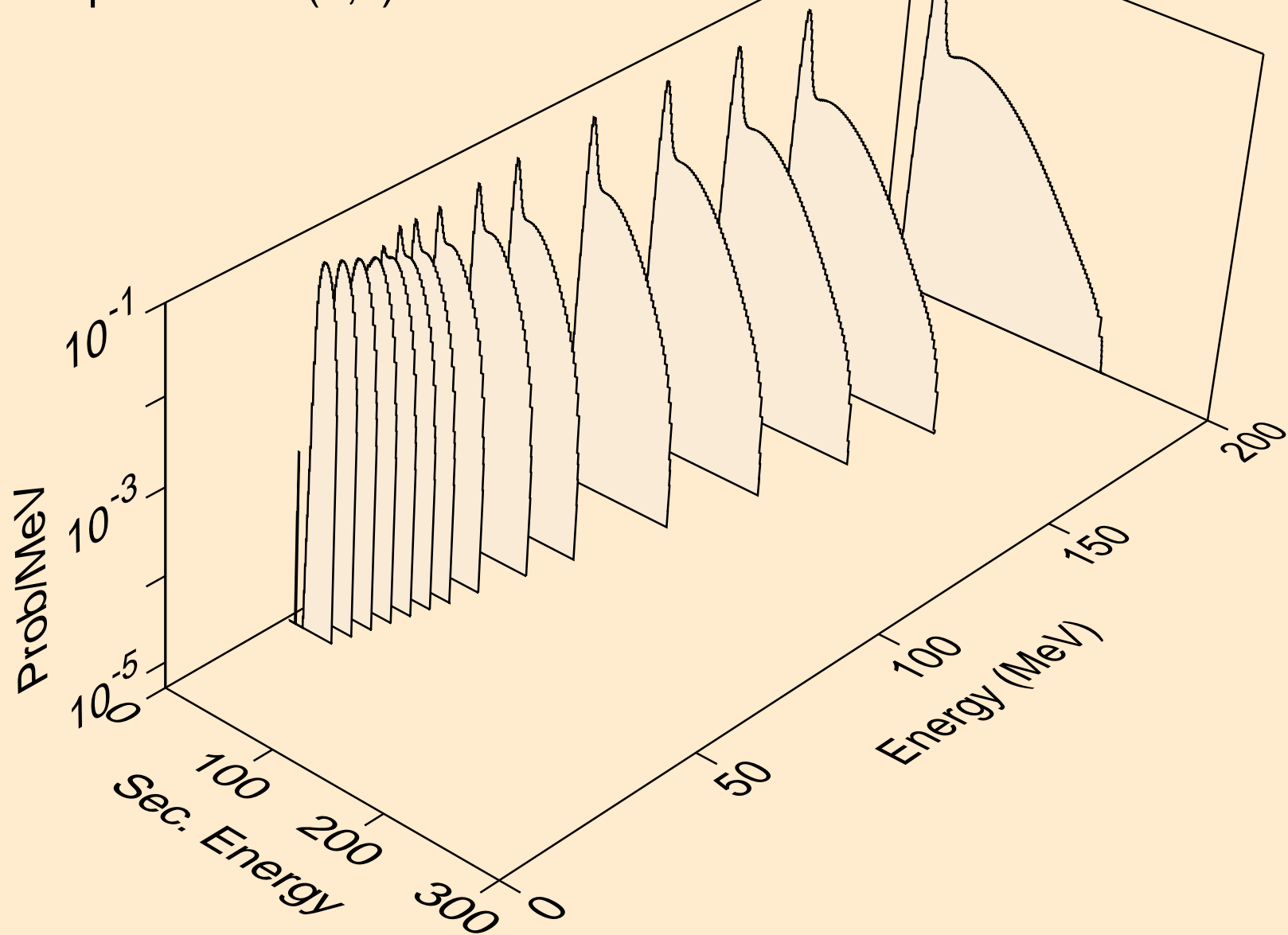

FM250M NEUTRON ACER TENDL-2024 LIBRARY; T=0.K
alphas from (n,n*)a

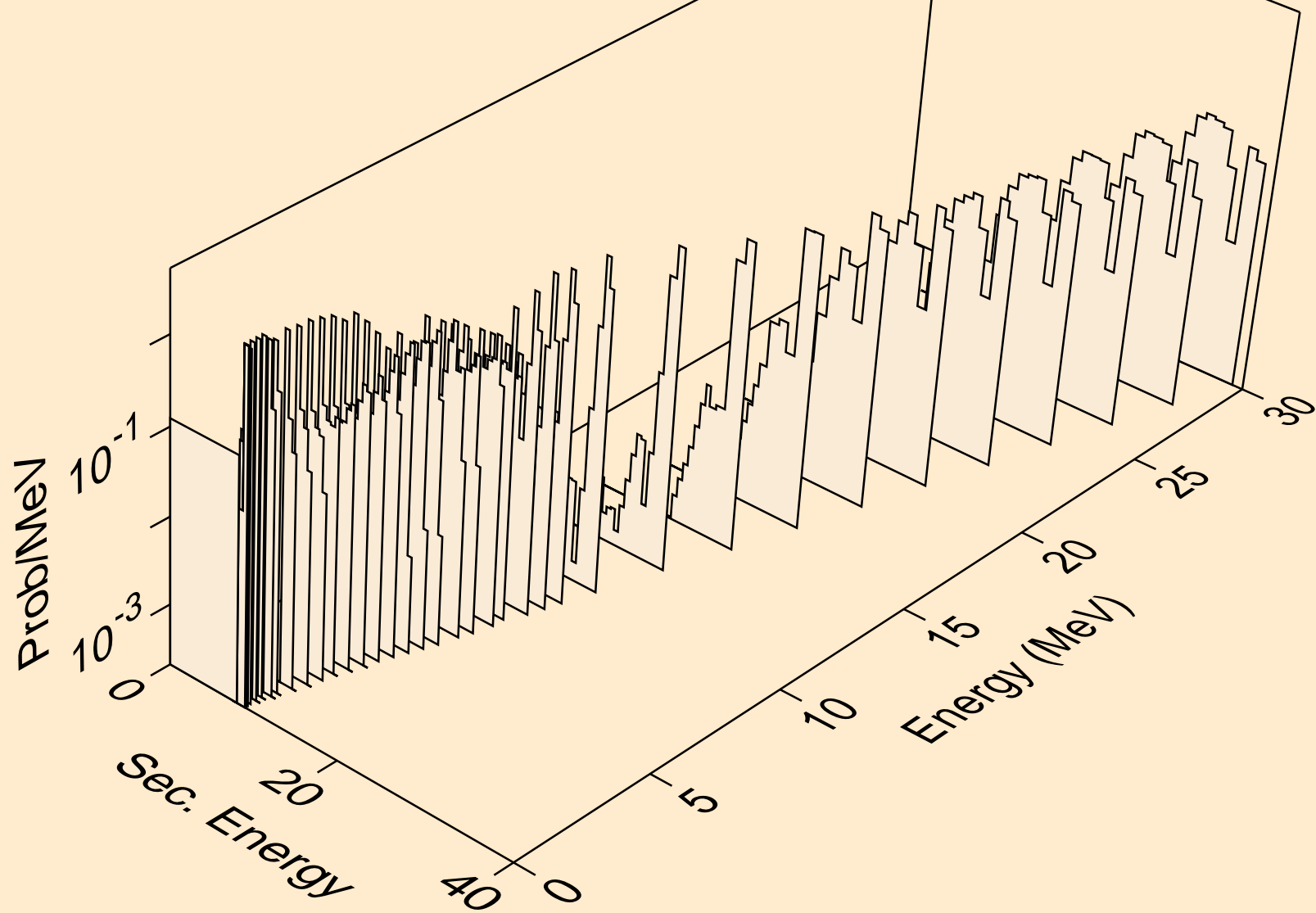

FM250M NEUTRON ACER TENDL-2024 LIBRARY; T=0.K
alphas from (n,2n)a

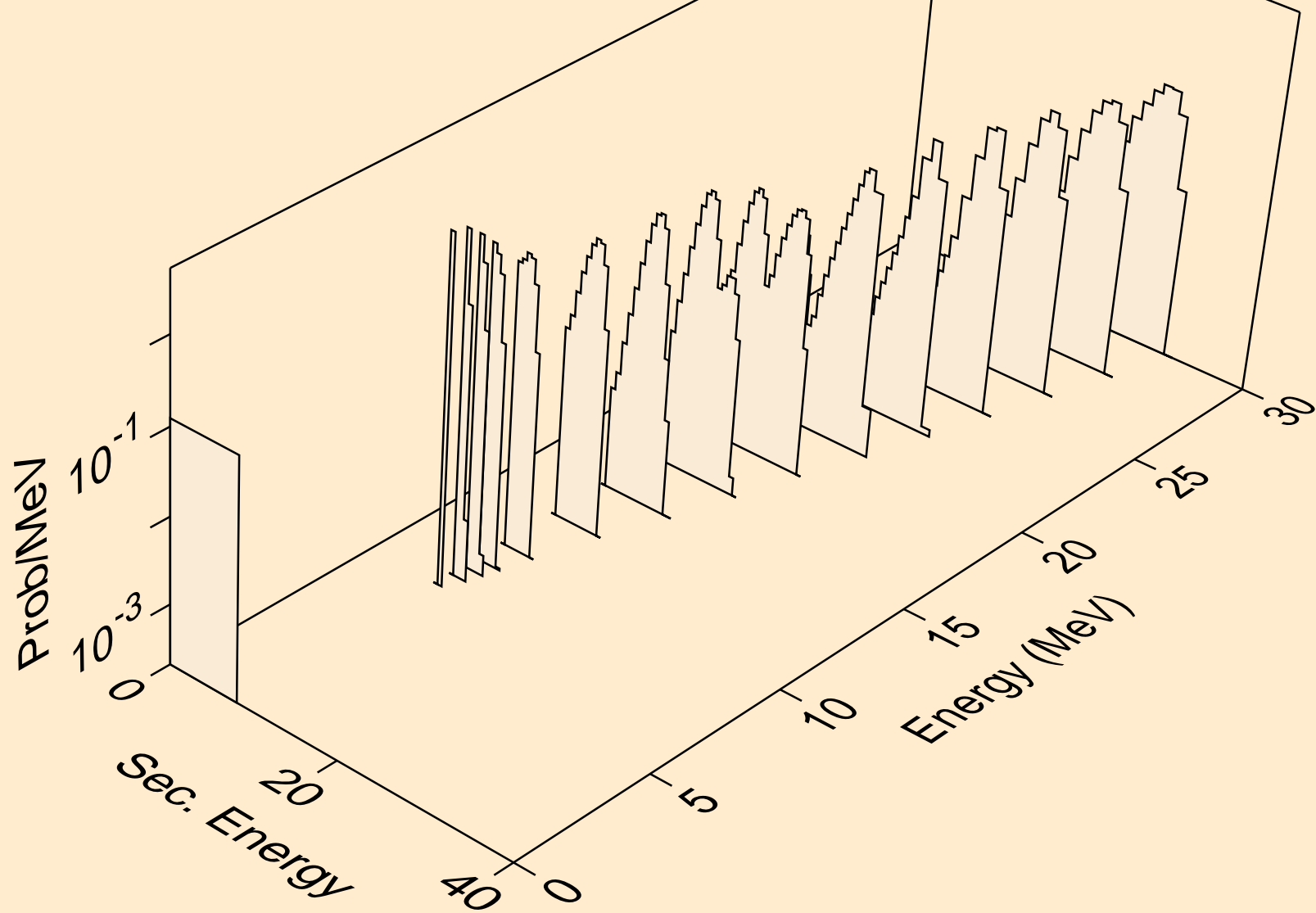

FM250M NEUTRON ACER TENDL-2024 LIBRARY; T=0.K
alphas from (n,3n)a

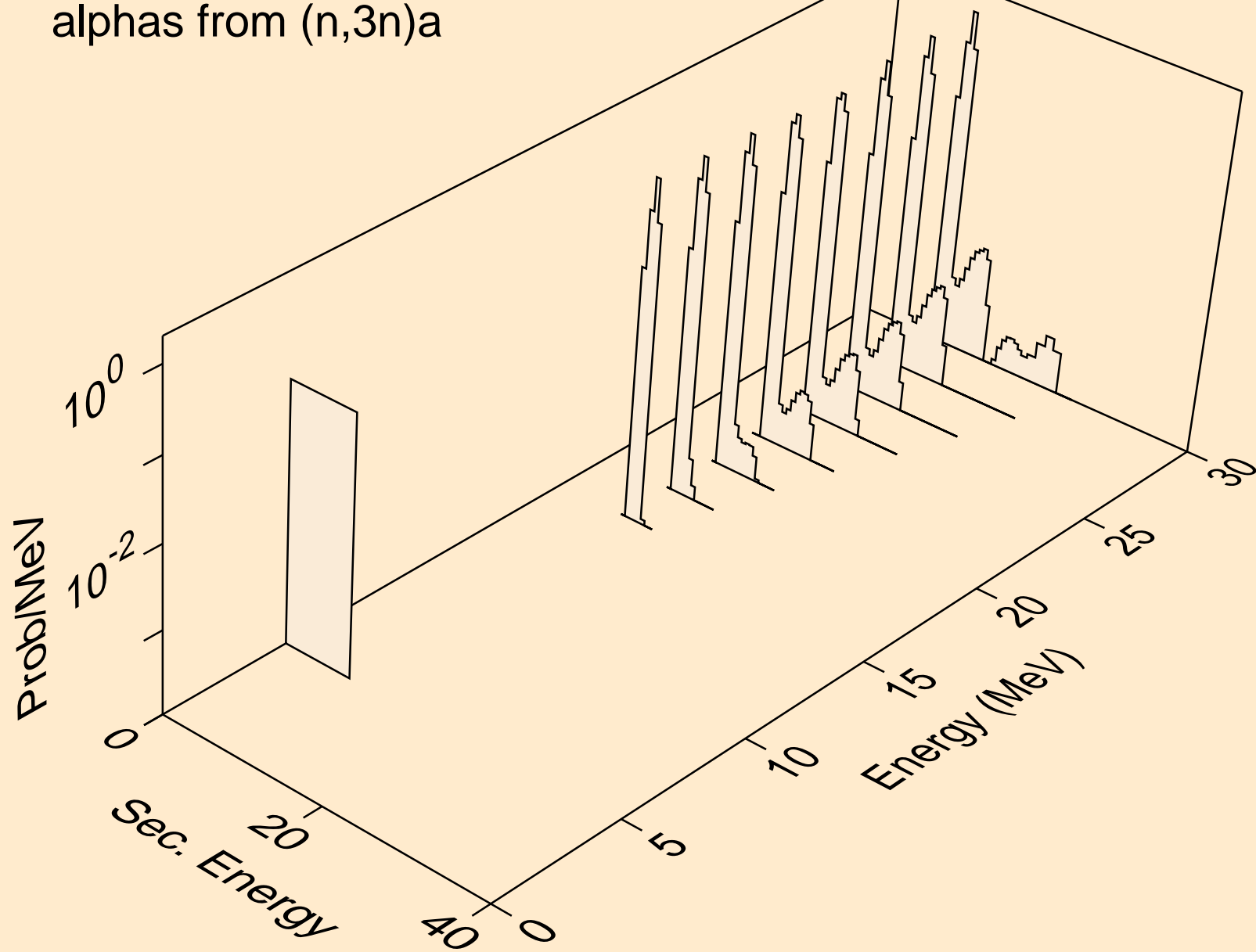

FM250M NEUTRON ACER TENDL-2024 LIBRARY; T=0.K
alphas from (n,n*)2a

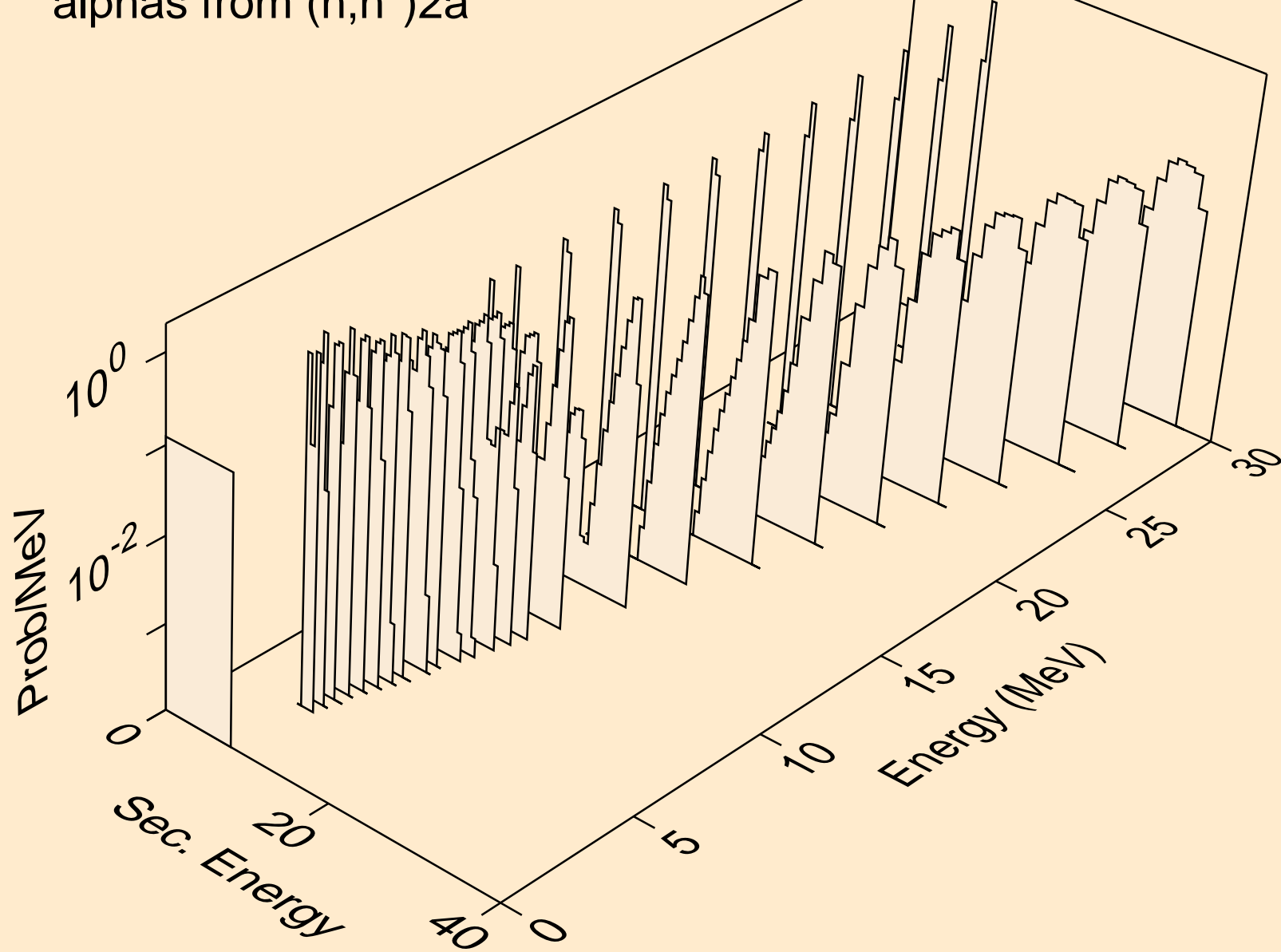

FM250M NEUTRON ACER TENDL-2024 LIBRARY; T=0.K
alphas from (n,a)

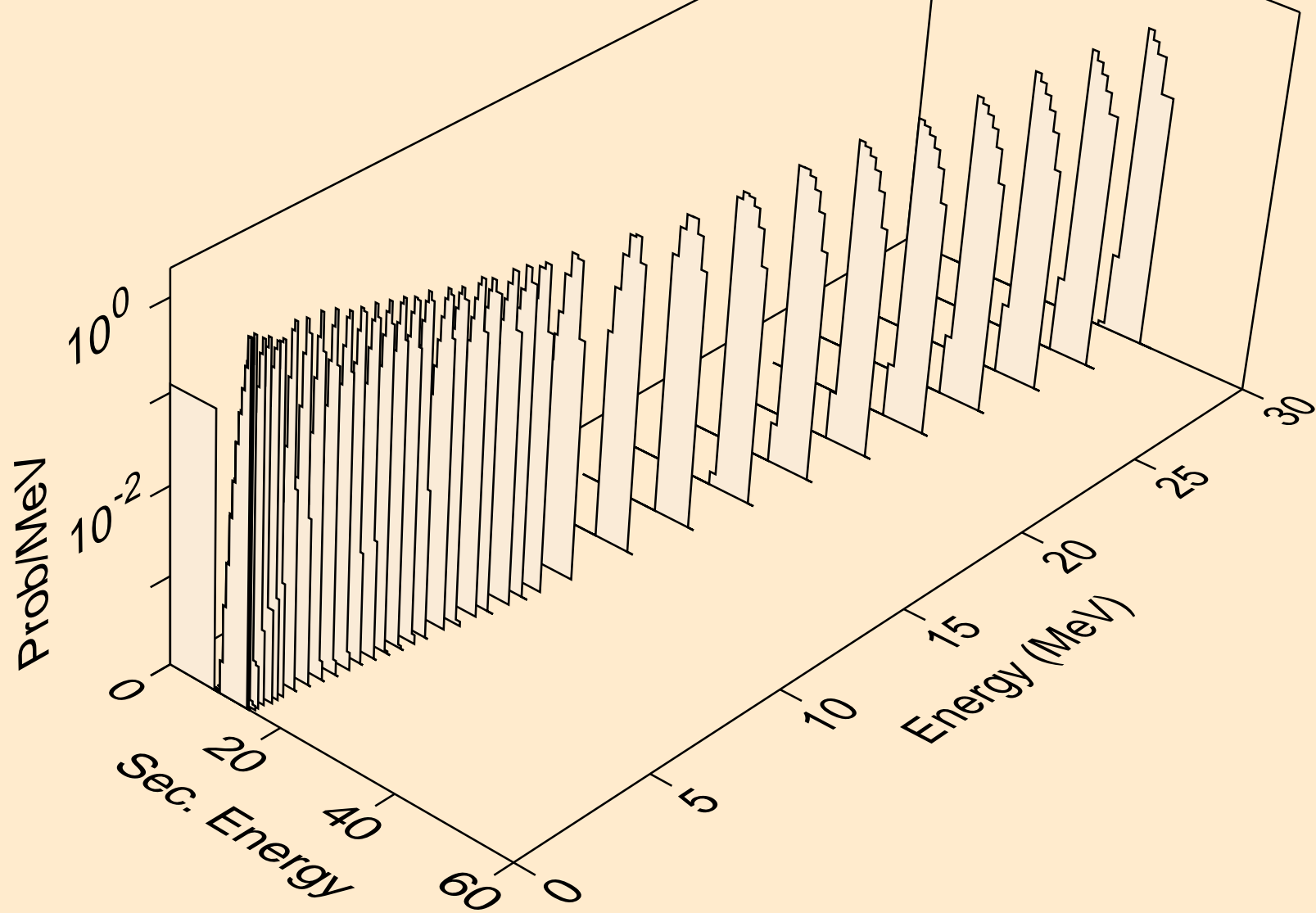

FM250M NEUTRON ACER TENDL-2024 LIBRARY; T=0.K
alphas from (n,pa)

