

FM259 NEUTRON ACER TENDL-2024 LIBRARY; T=0.K

Principal cross sections

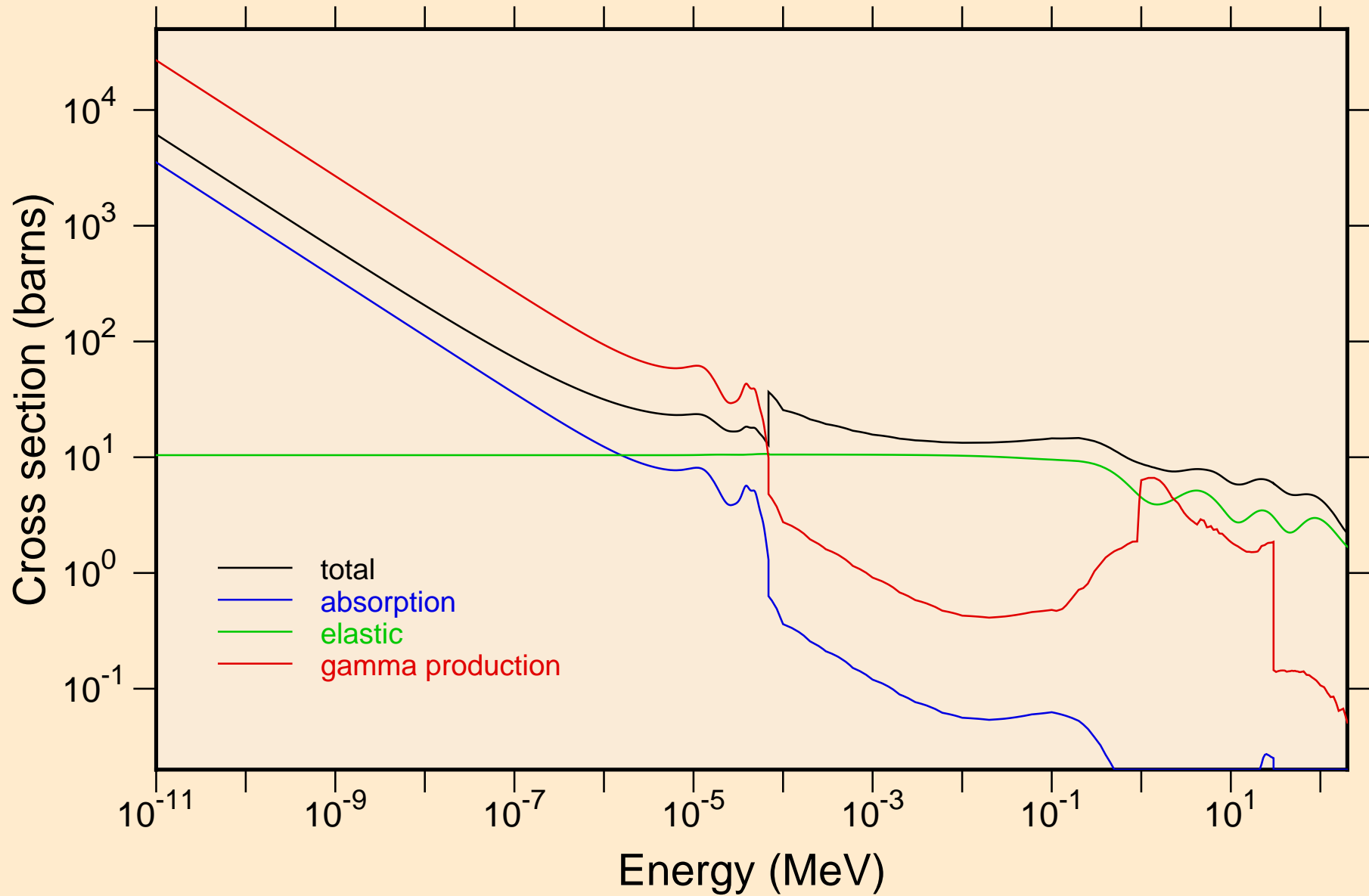

FM259 NEUTRON ACER TENDL-2024 LIBRARY; T=0.K

Heating

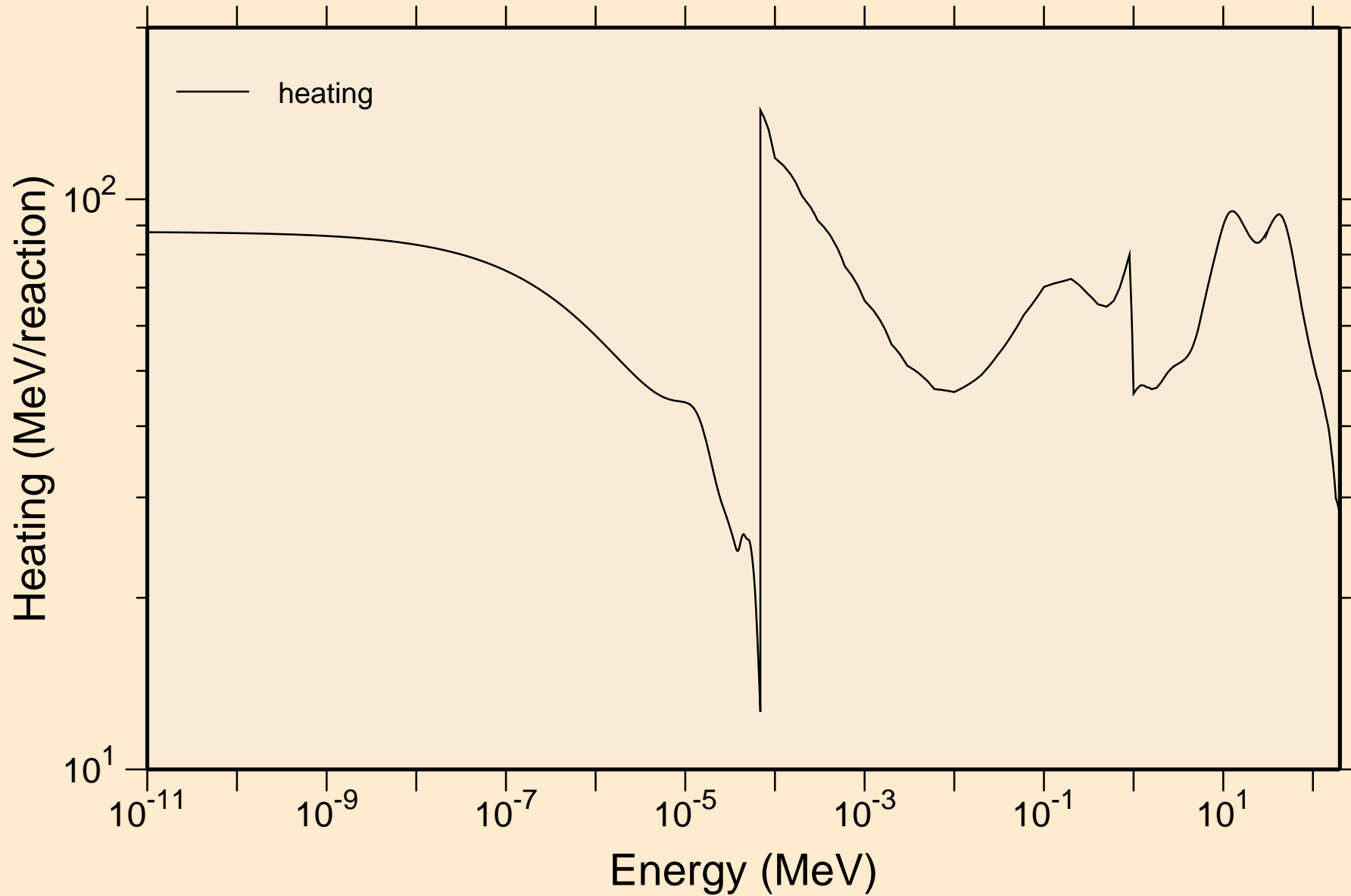

FM259 NEUTRON ACER TENDL-2024 LIBRARY; T=0.K
Damage

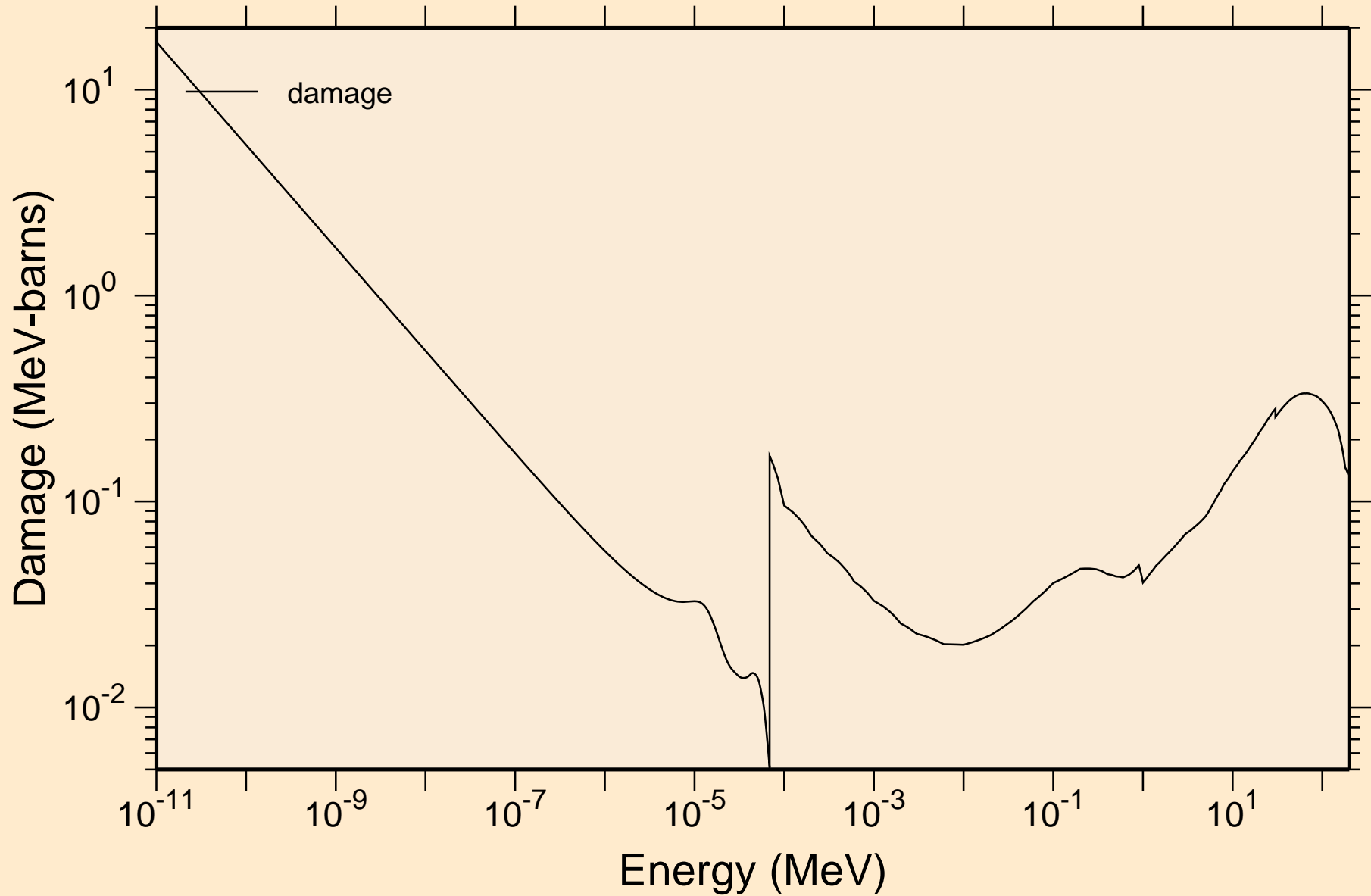

FM259 NEUTRON ACER TENDL-2024 LIBRARY; T=0.K

Non-threshold reactions

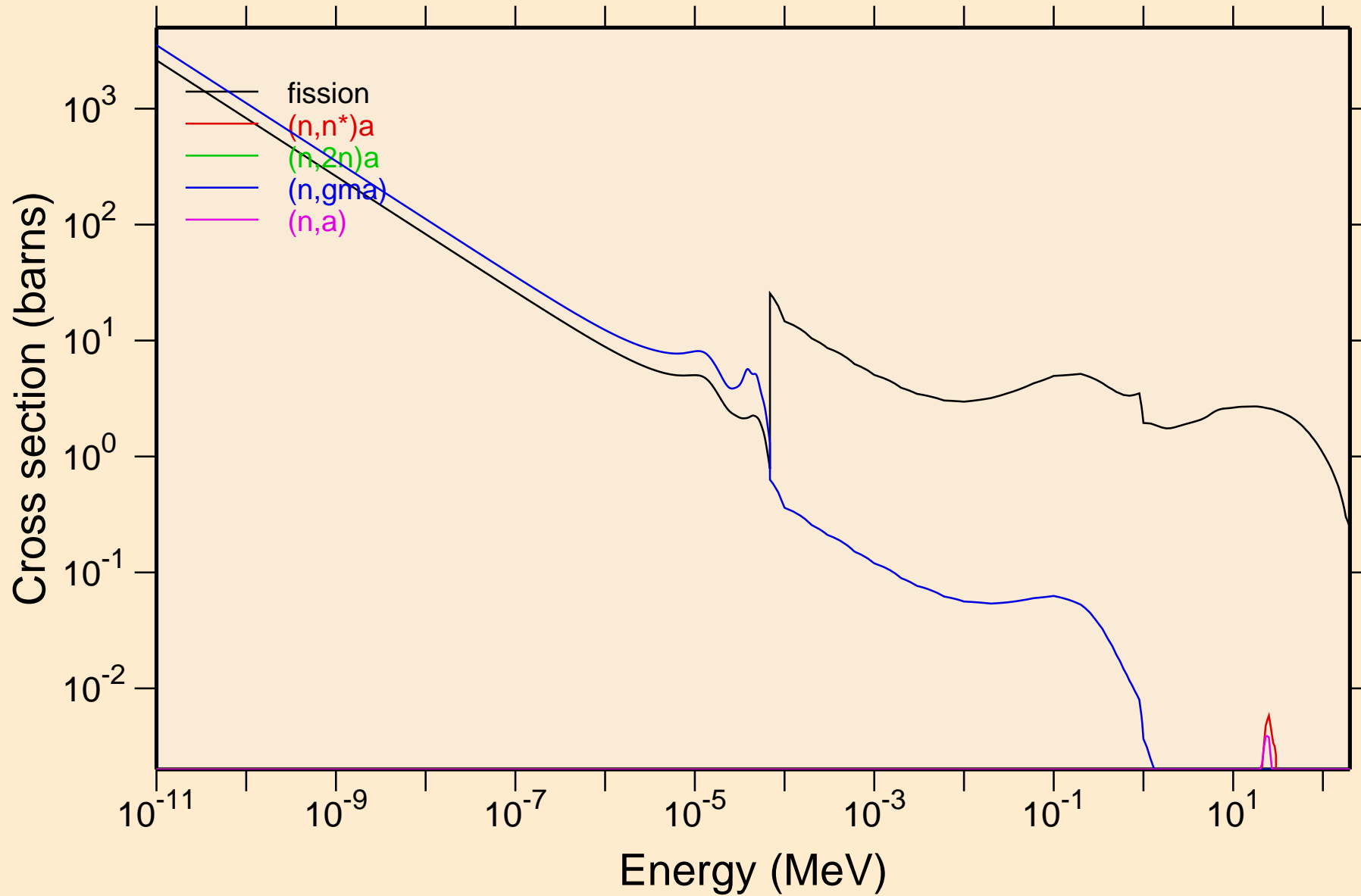

FM259 NEUTRON ACER TENDL-2024 LIBRARY; T=0.K
Non-threshold reactions

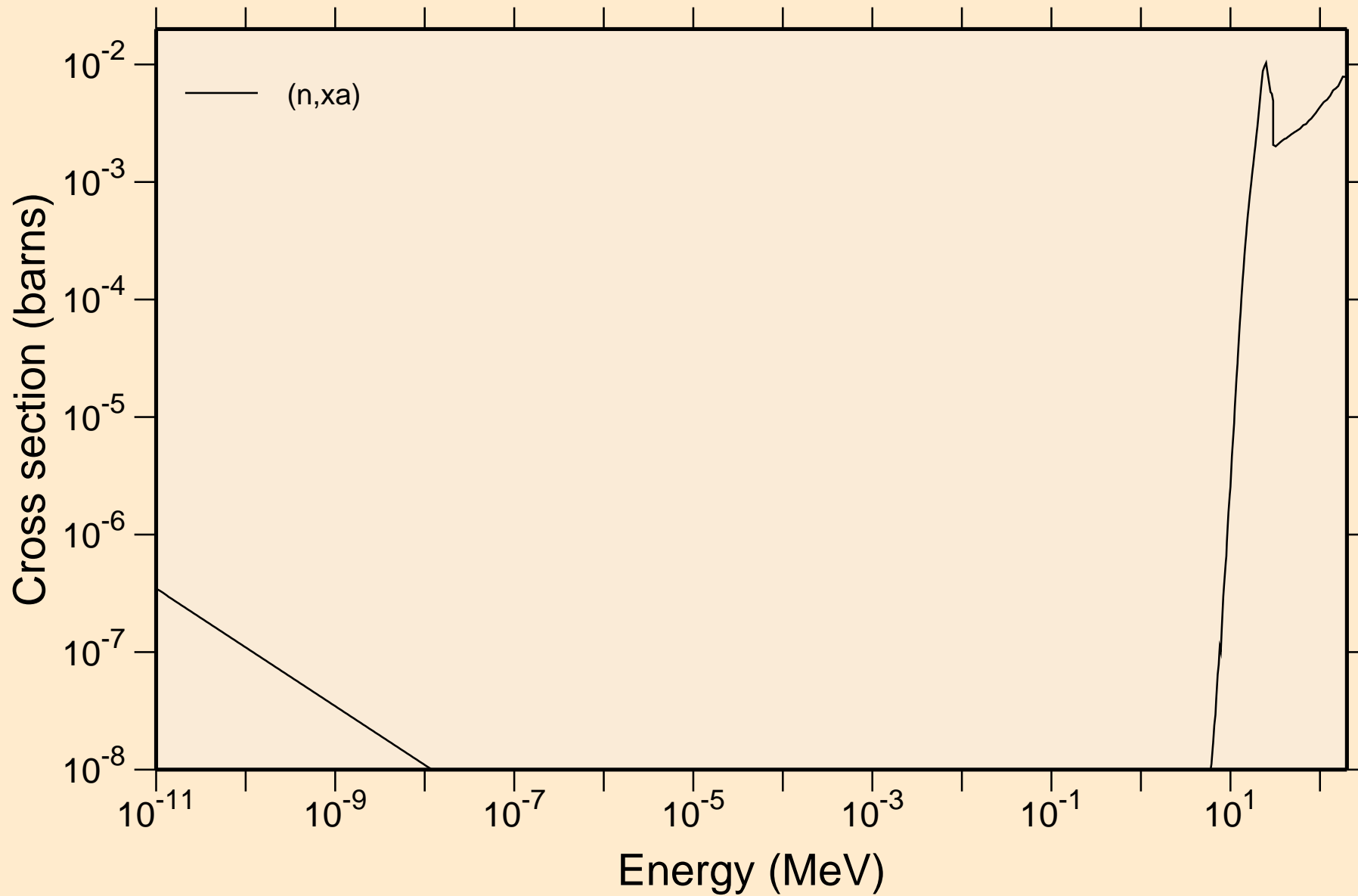

FM259 NEUTRON ACER TENDL-2024 LIBRARY; T=0.K

Principal cross sections

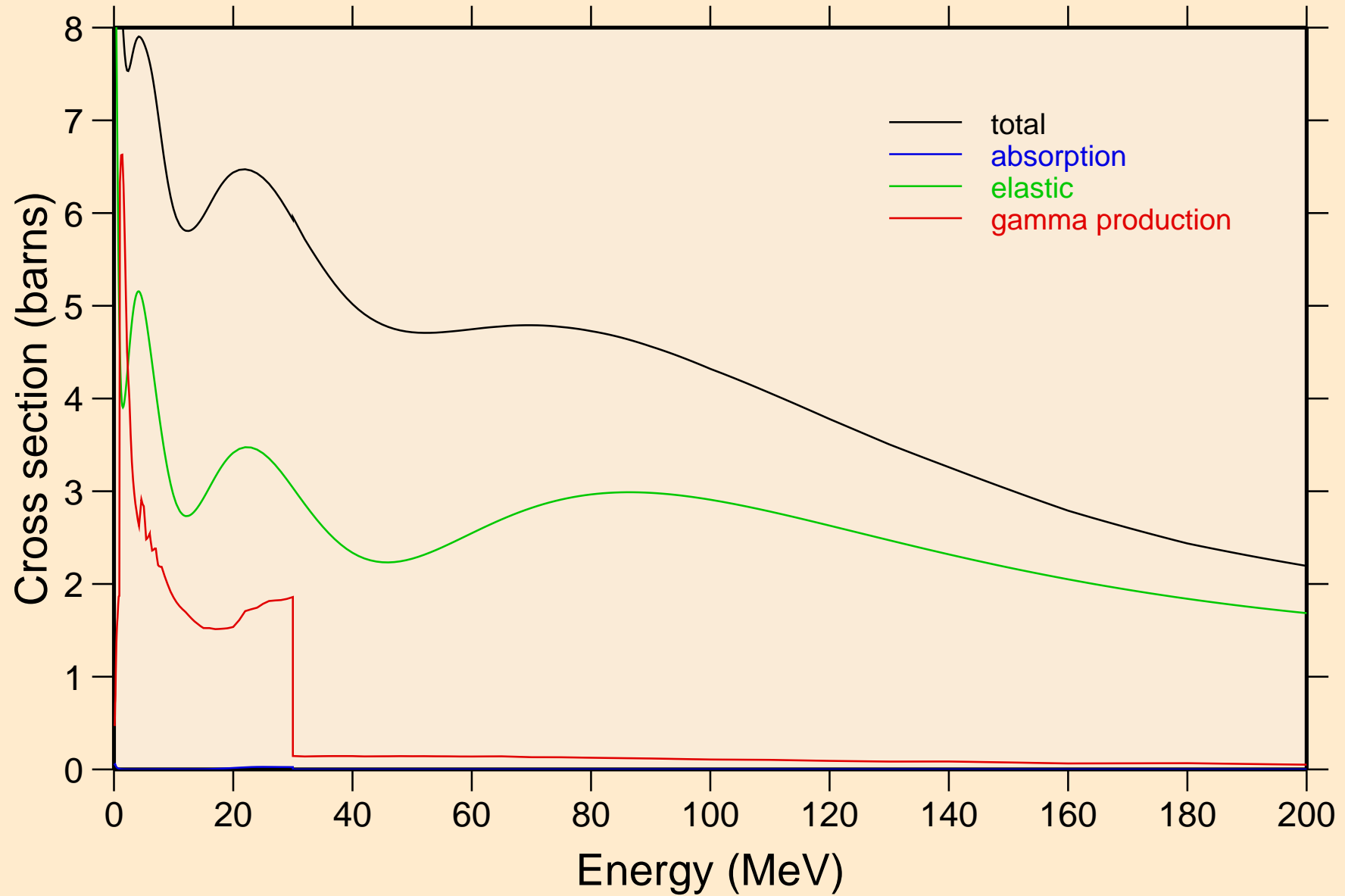

FM259 NEUTRON ACER TENDL-2024 LIBRARY; T=0.K
Heating

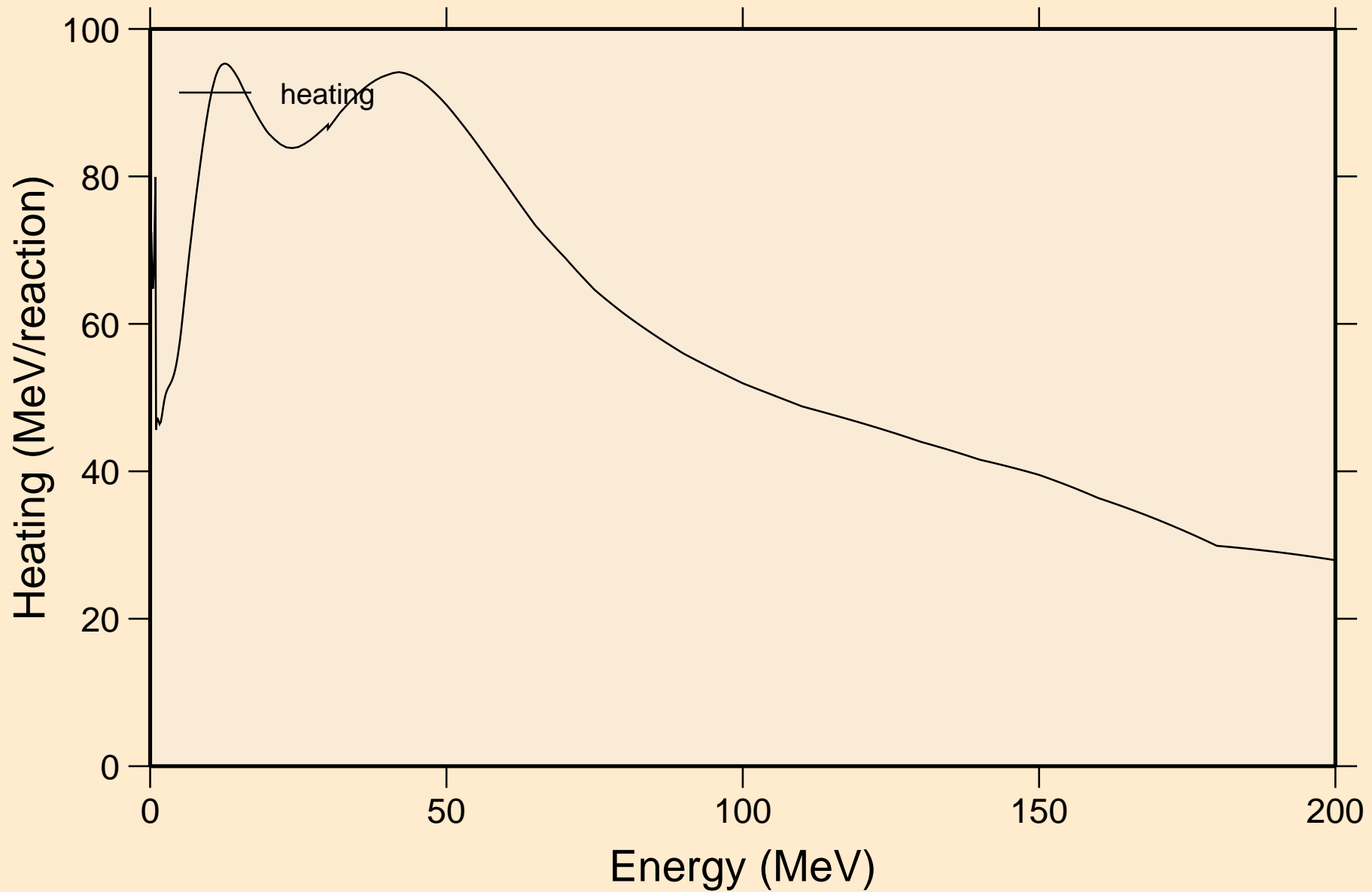

FM259 NEUTRON ACER TENDL-2024 LIBRARY; T=0.K

Damage

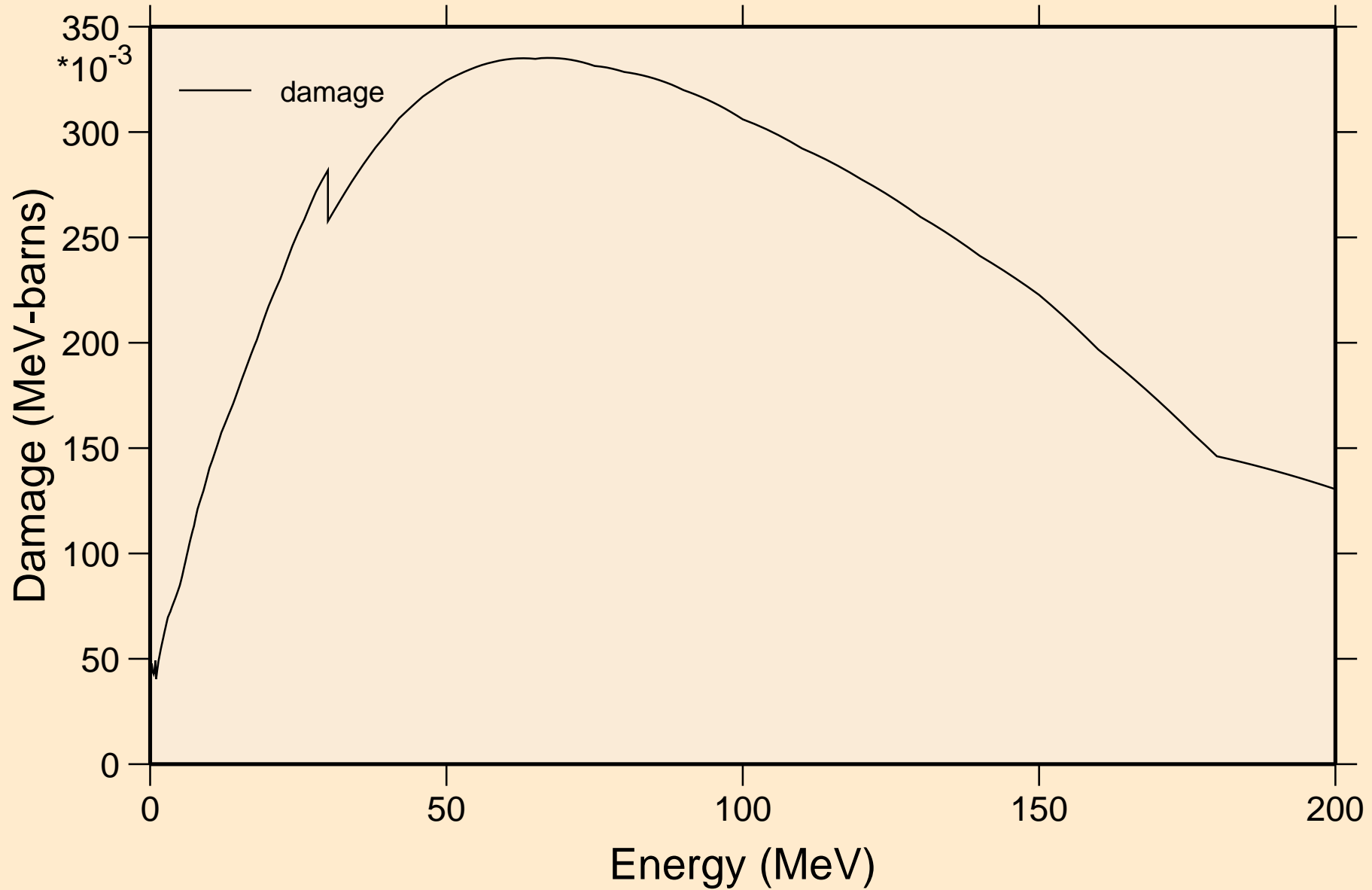

FM259 NEUTRON ACER TENDL-2024 LIBRARY; T=0.K

Non-threshold reactions

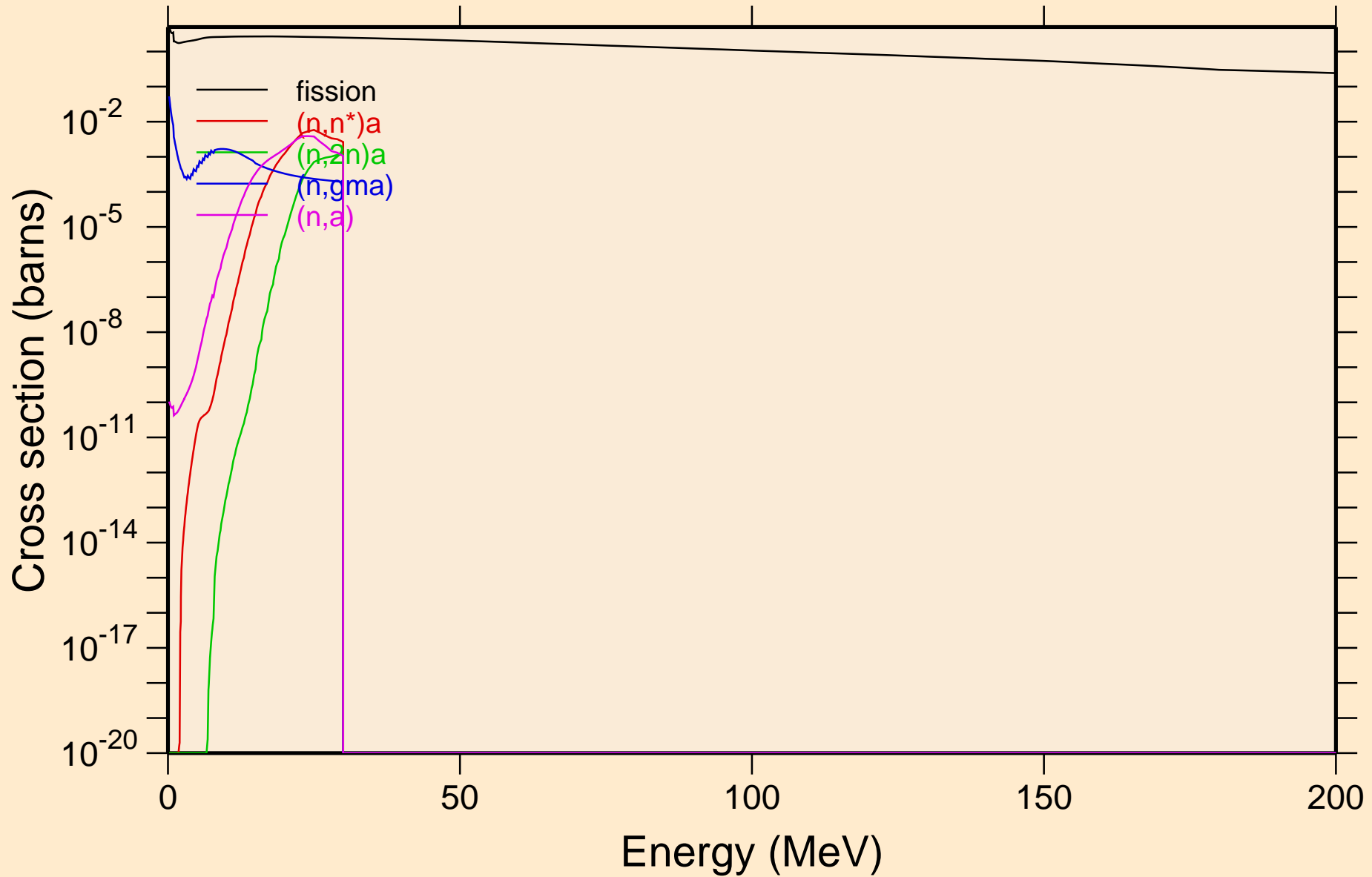

FM259 NEUTRON ACER TENDL-2024 LIBRARY; T=0.K
Non-threshold reactions

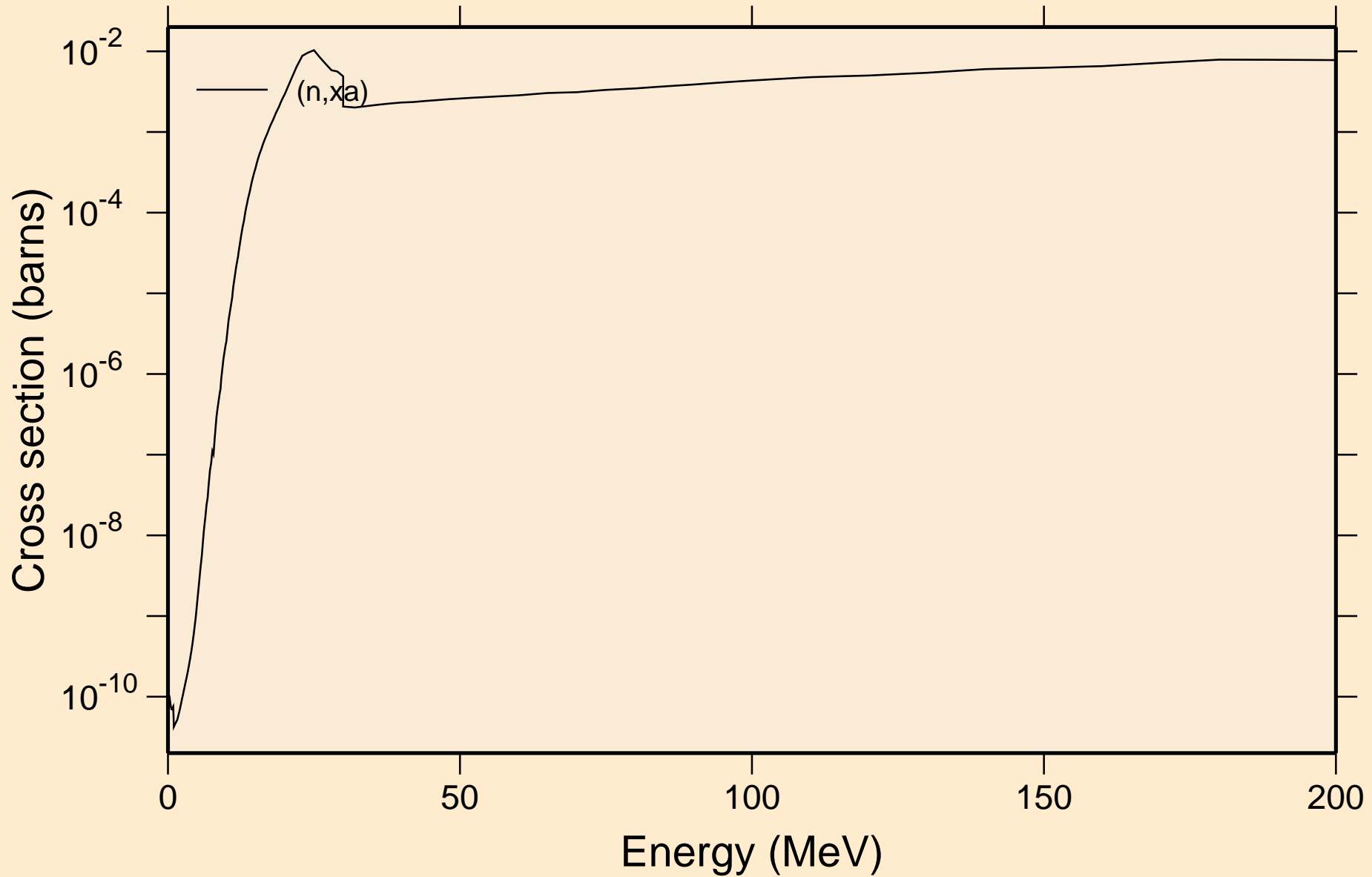

FM259 NEUTRON ACER TENDL-2024 LIBRARY; T=0.K
Inelastic levels

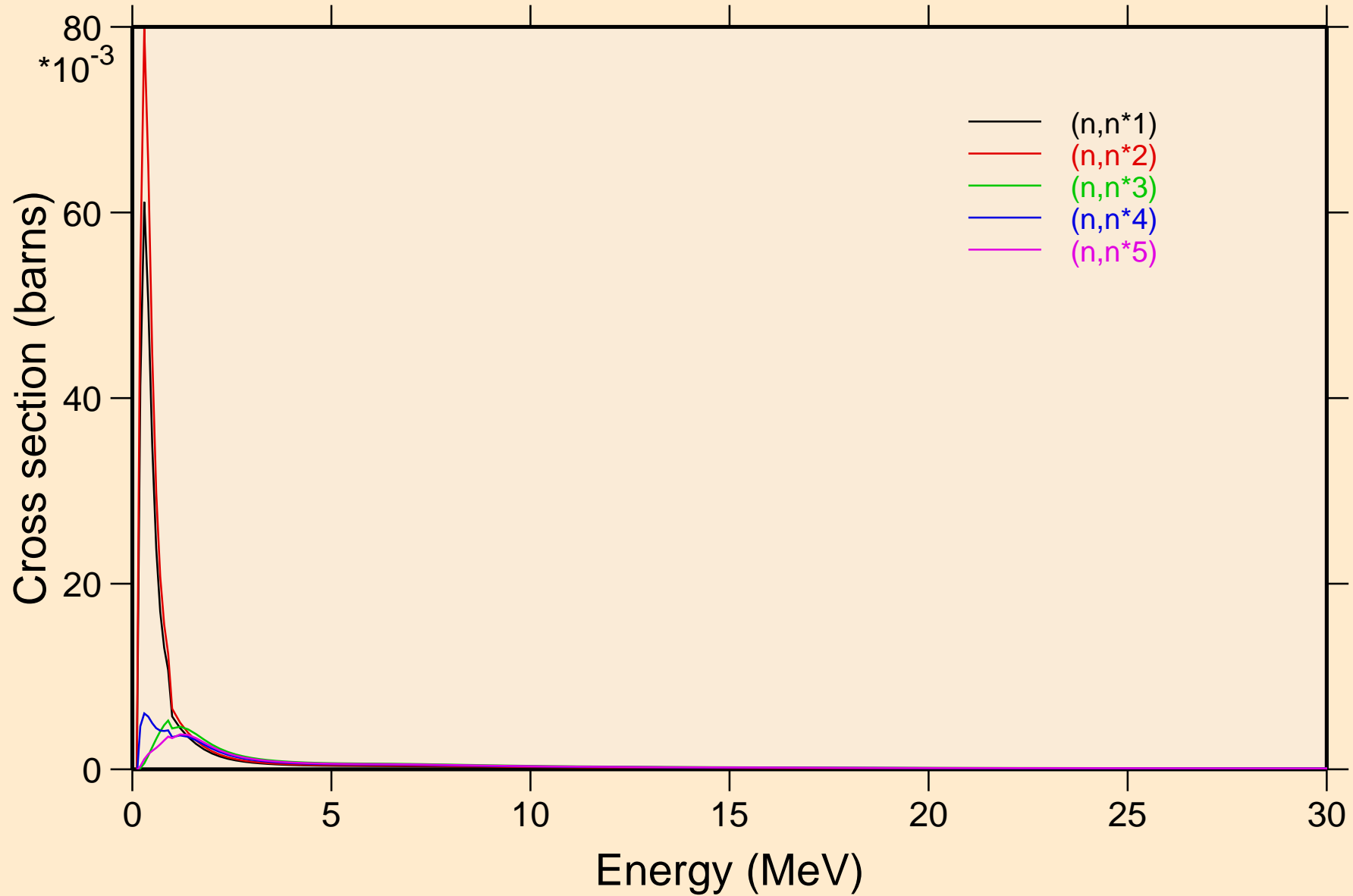

FM259 NEUTRON ACER TENDL-2024 LIBRARY; T=0.K
Inelastic levels

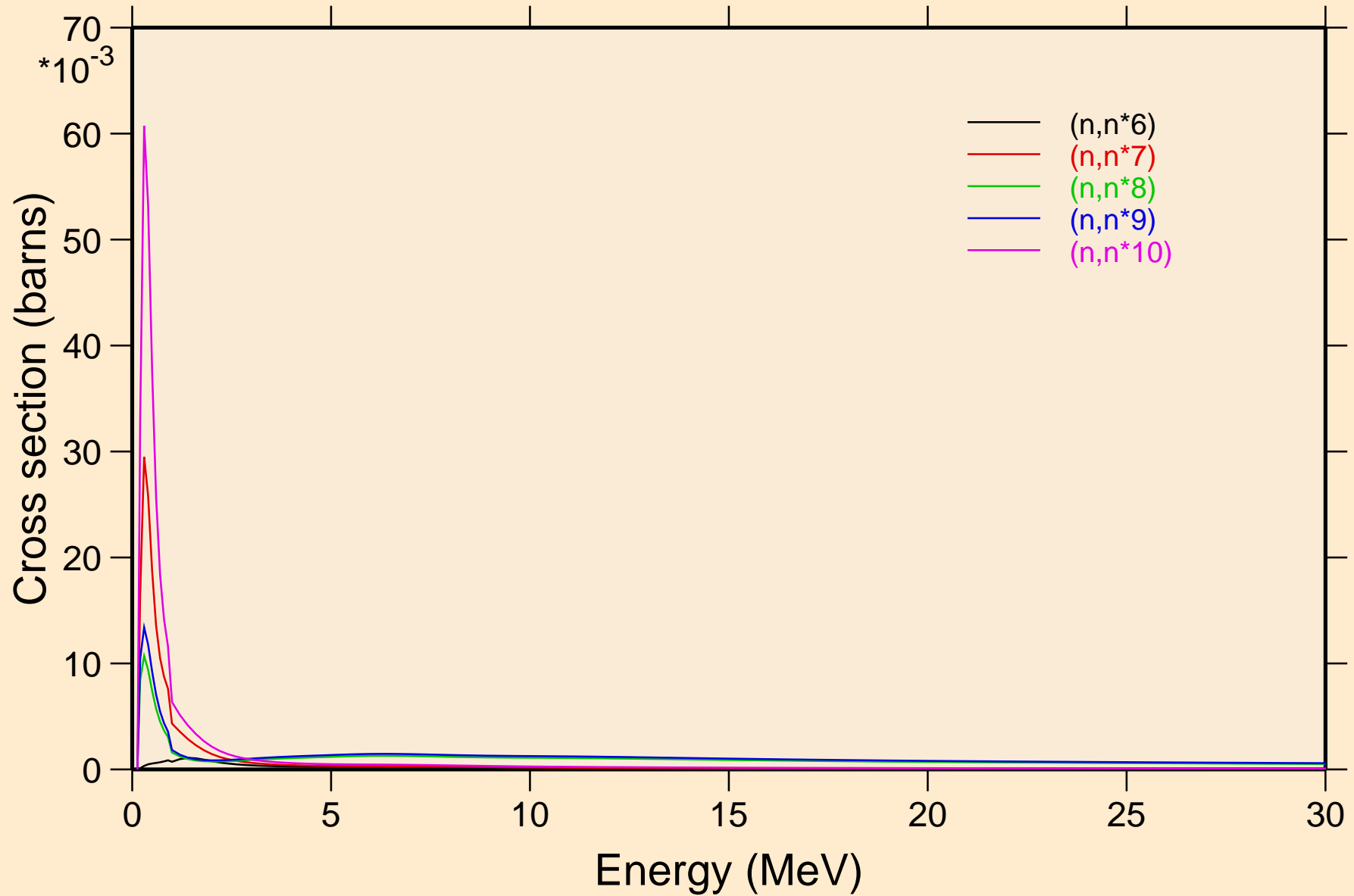

FM259 NEUTRON ACER TENDL-2024 LIBRARY; T=0.K
Inelastic levels

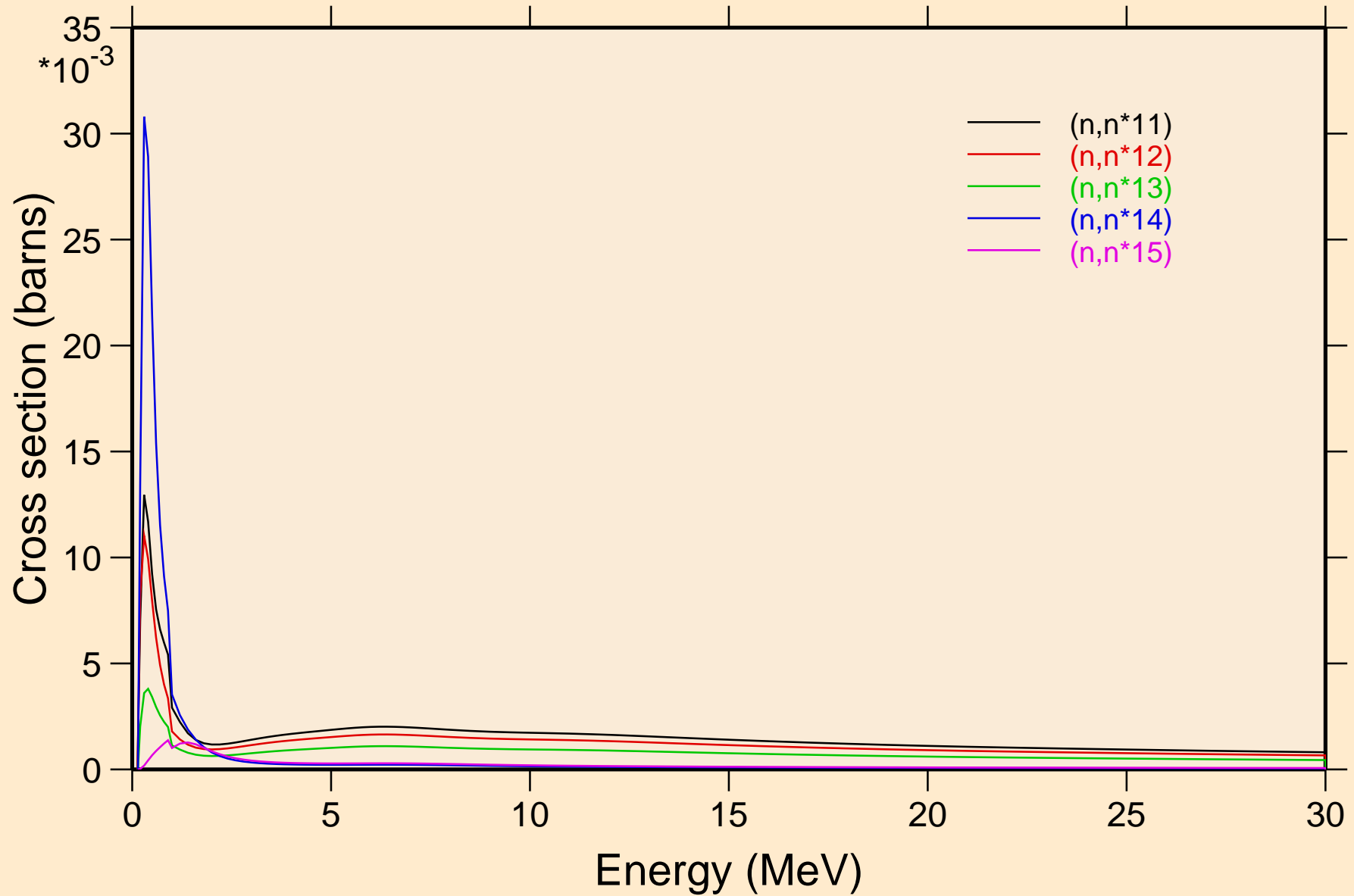

FM259 NEUTRON ACER TENDL-2024 LIBRARY; T=0.K
Inelastic levels

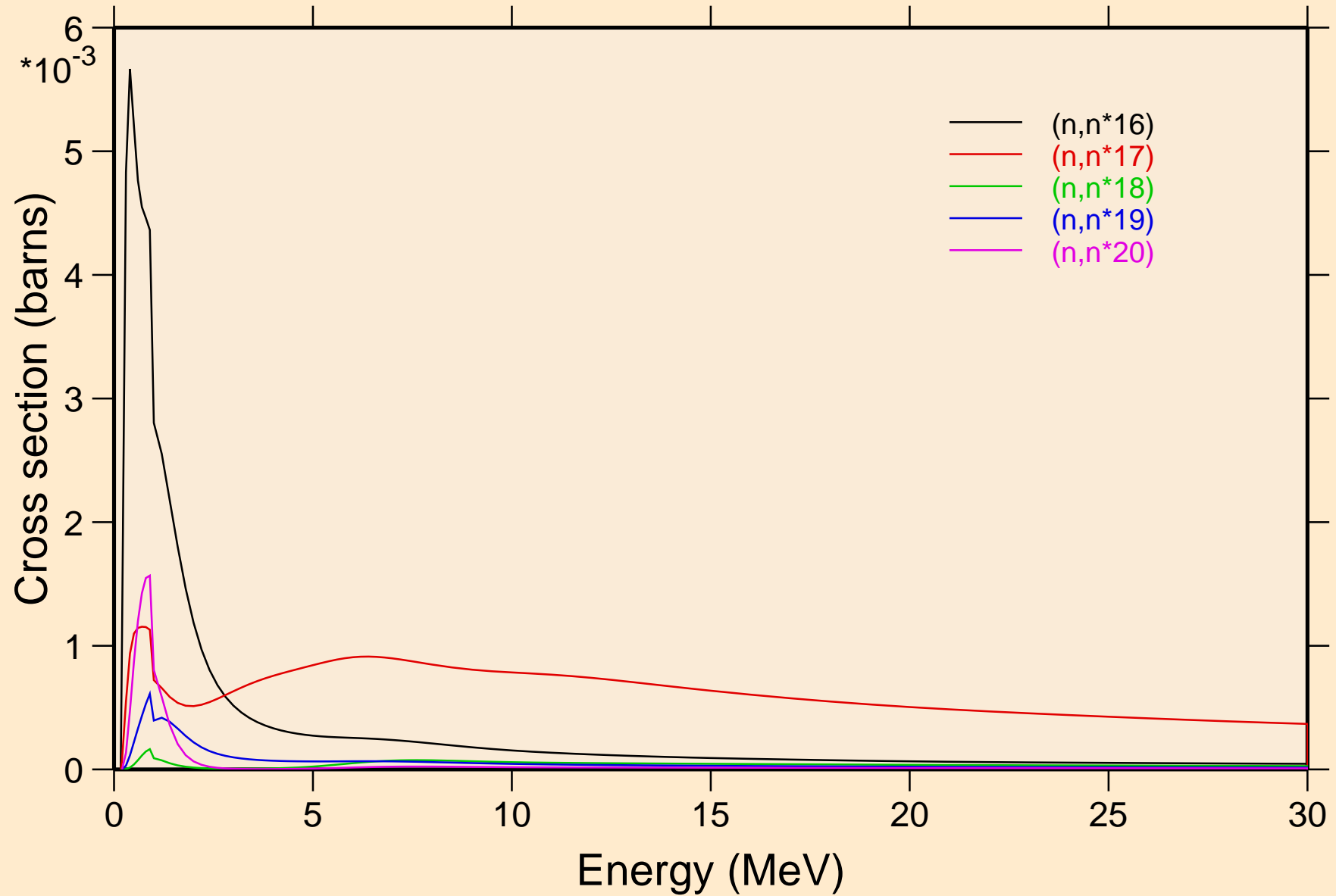

FM259 NEUTRON ACER TENDL-2024 LIBRARY; T=0.K

Inelastic levels

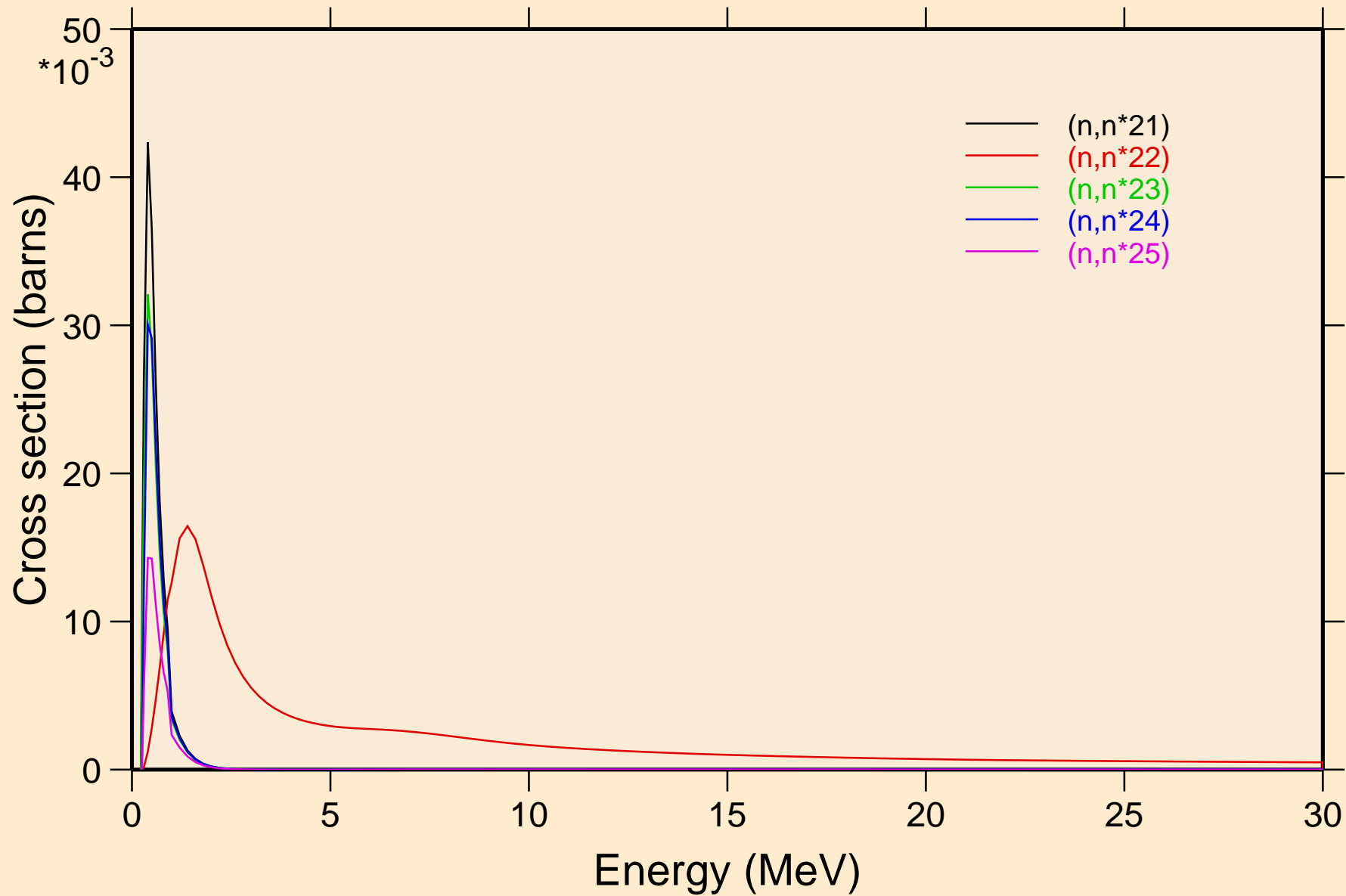

FM259 NEUTRON ACER TENDL-2024 LIBRARY; T=0.K
Inelastic levels

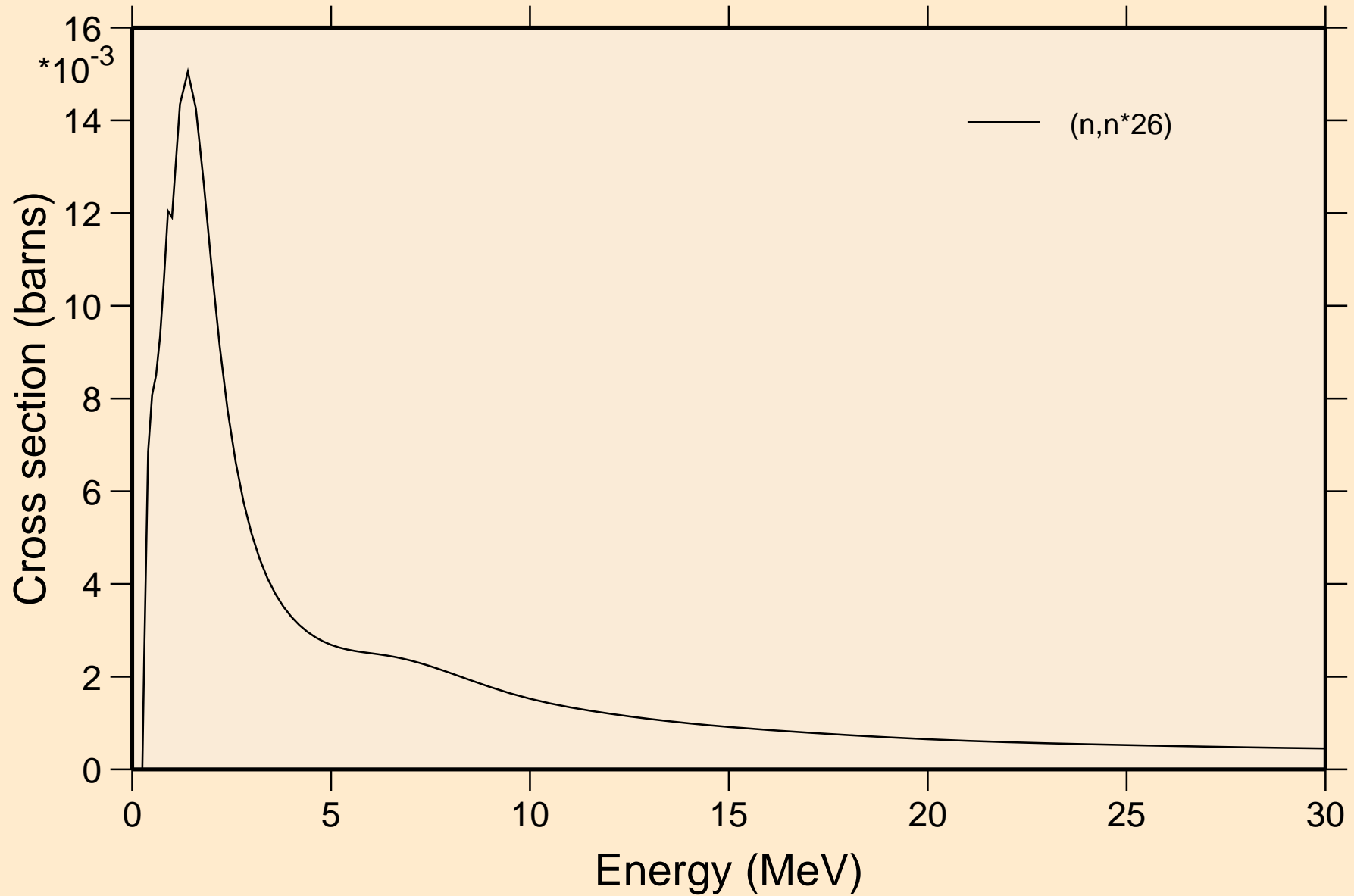

FM259 NEUTRON ACER TENDL-2024 LIBRARY; T=0.K
Threshold reactions

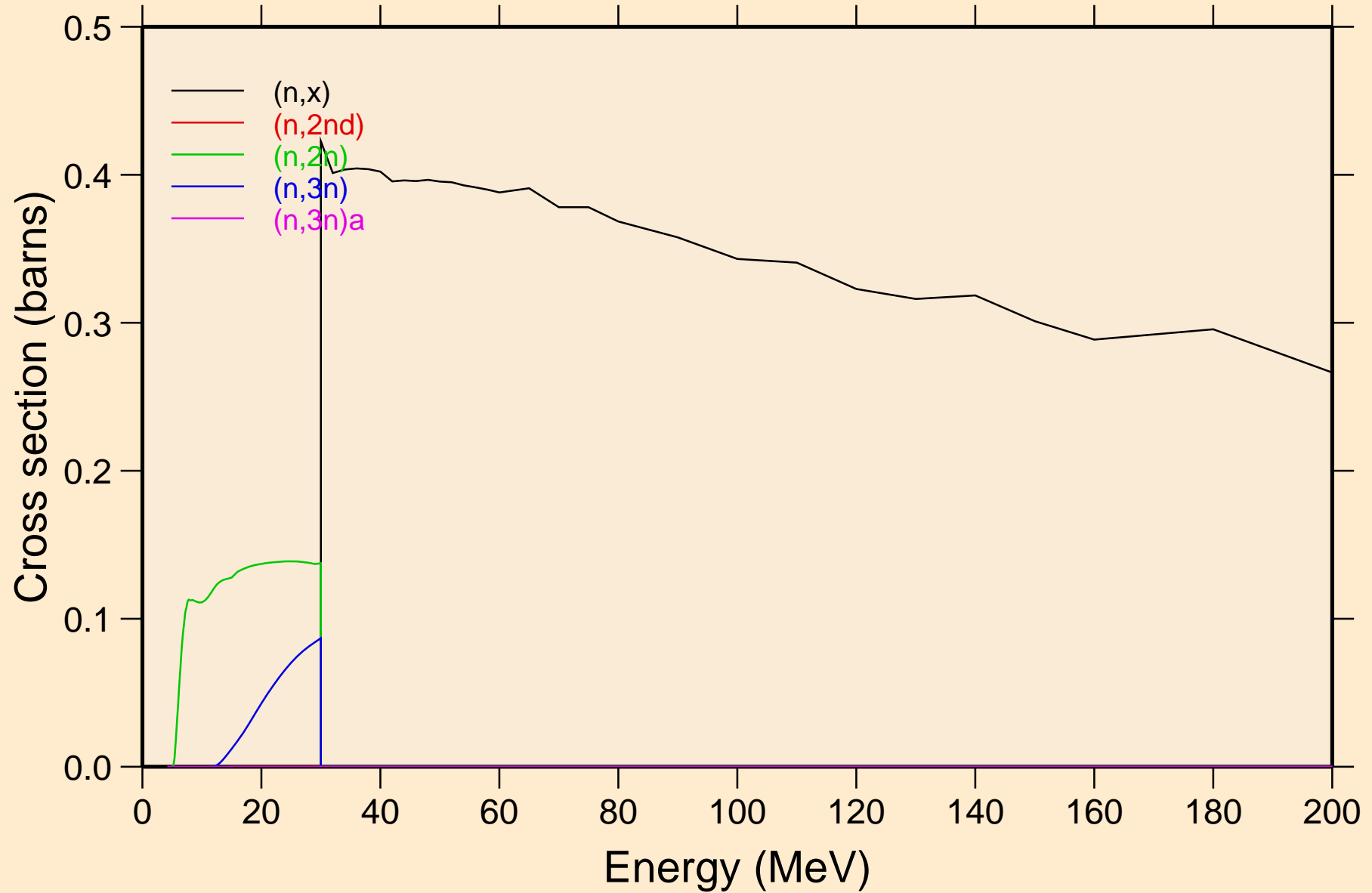

FM259 NEUTRON ACER TENDL-2024 LIBRARY; T=0.K
Threshold reactions

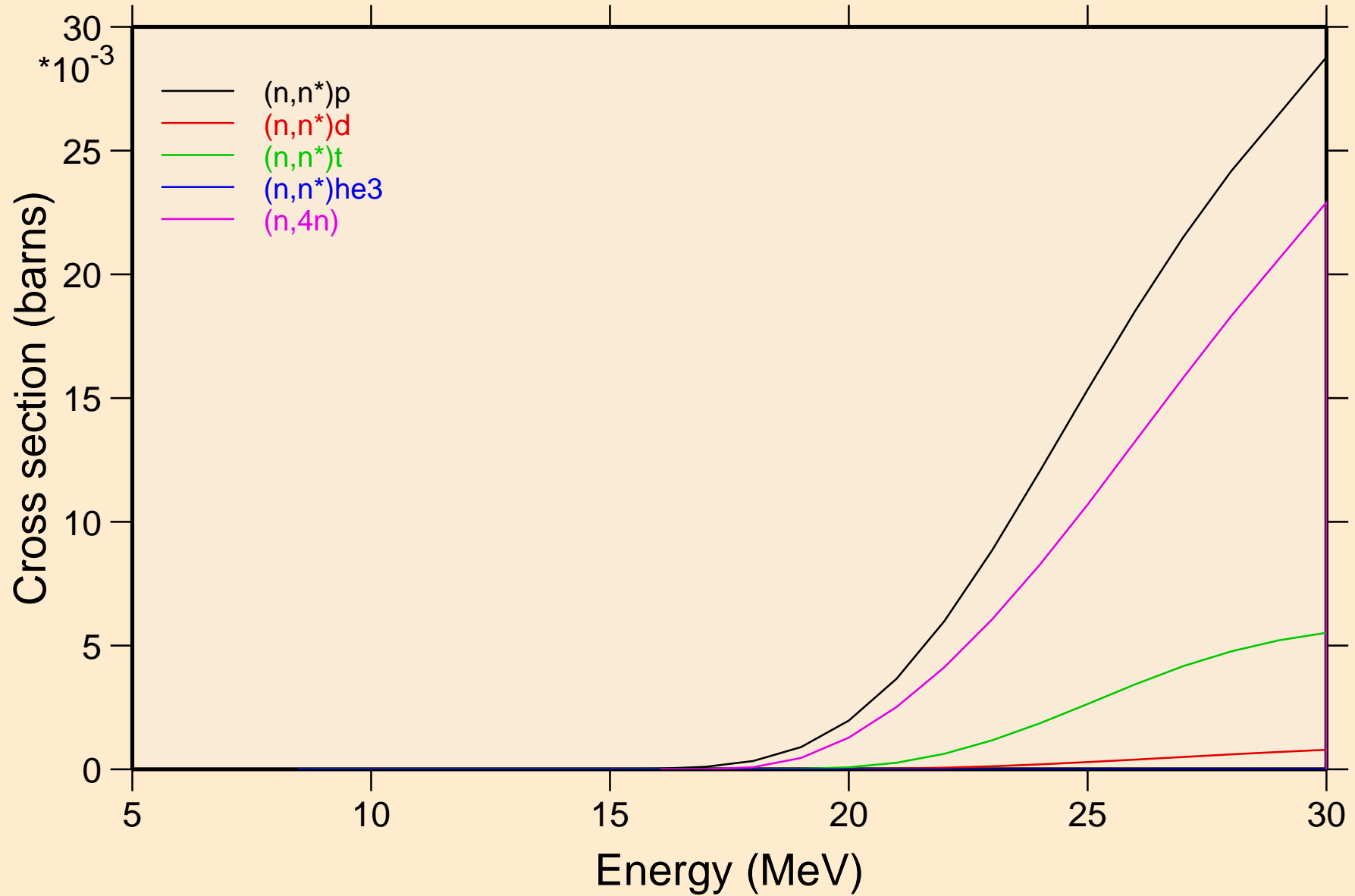

FM259 NEUTRON ACER TENDL-2024 LIBRARY; T=0.K
Threshold reactions

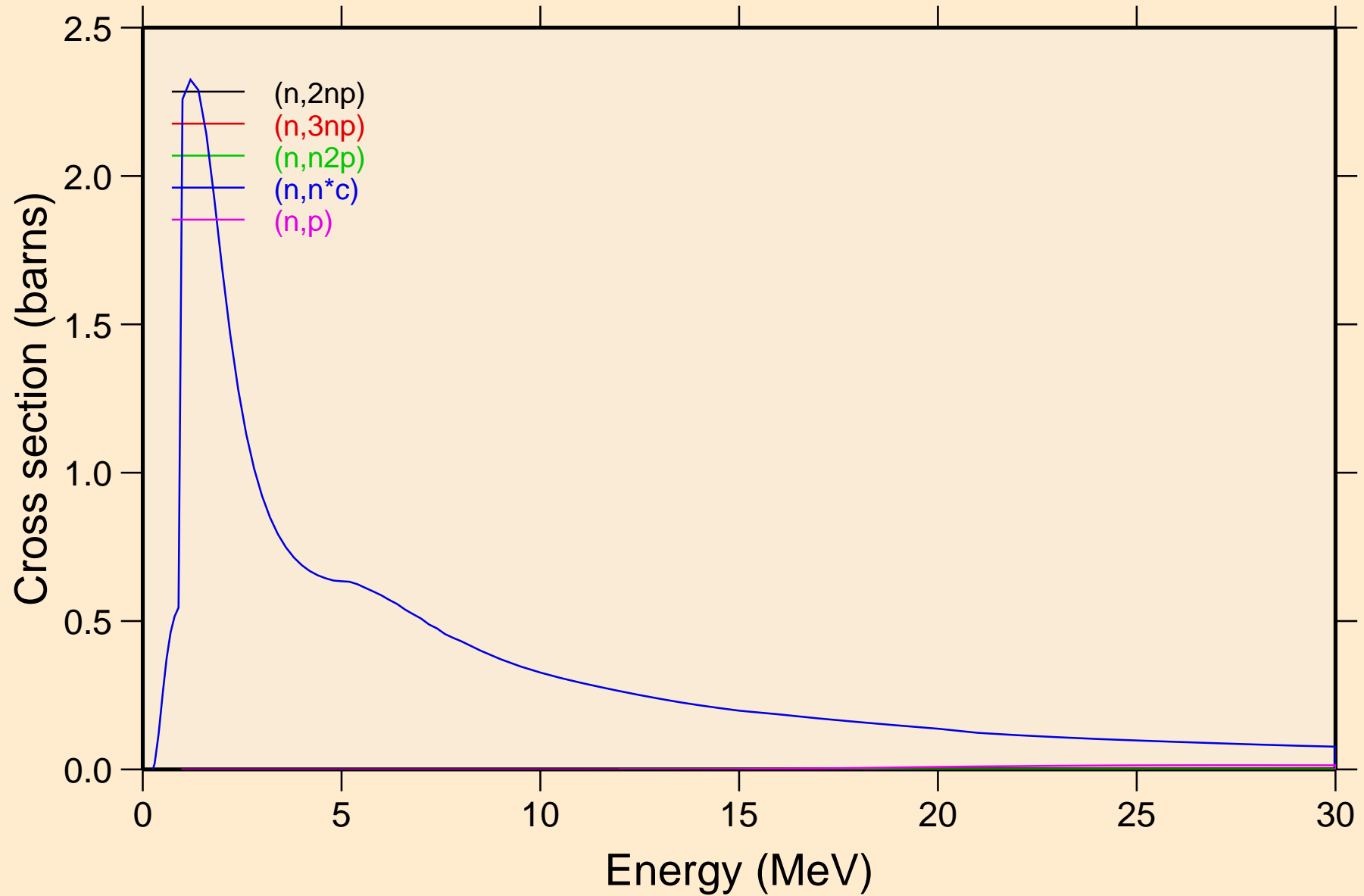

FM259 NEUTRON ACER TENDL-2024 LIBRARY; T=0.K
Threshold reactions

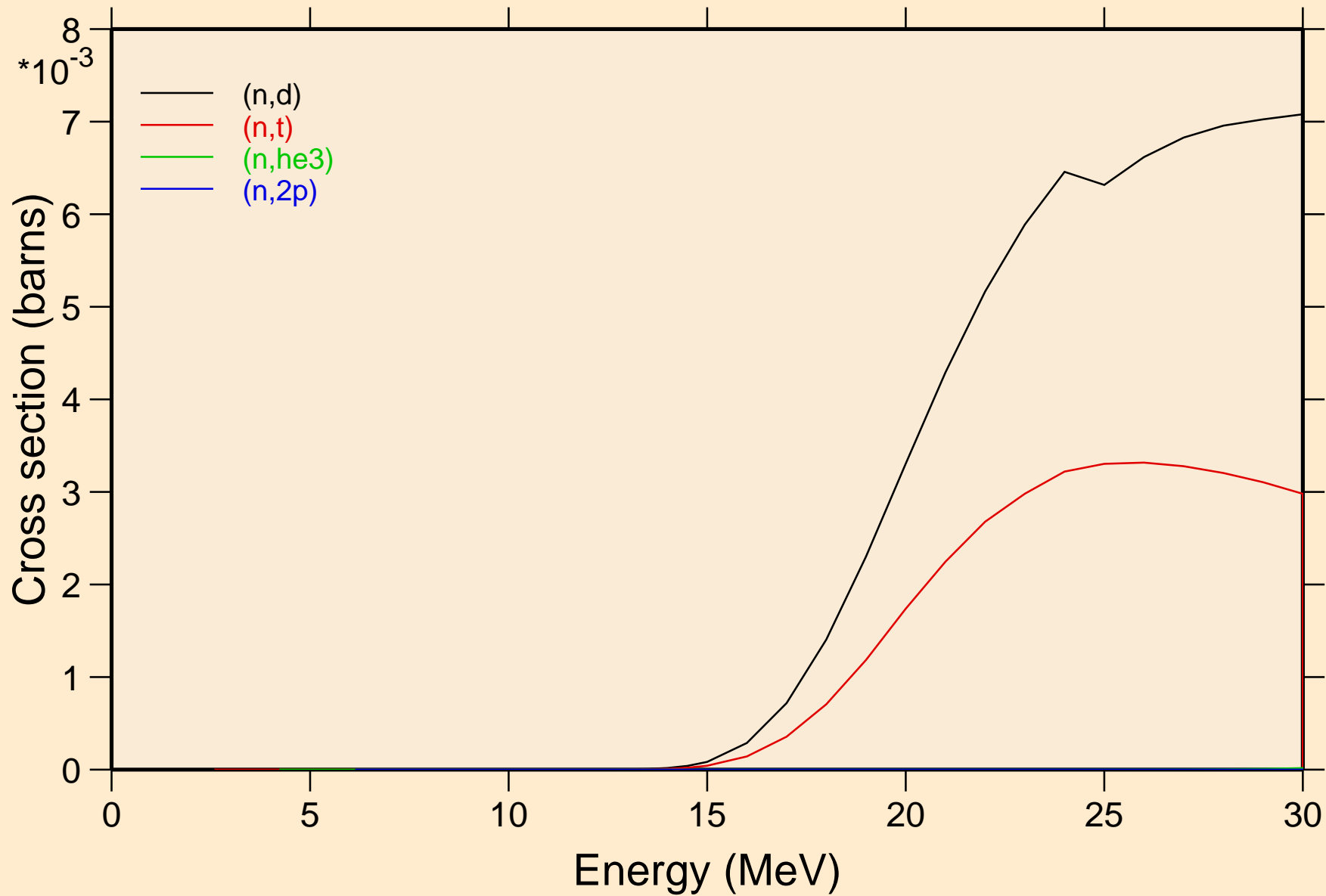

FM259 NEUTRON ACER TENDL-2024 LIBRARY; T=0.K

Threshold reactions

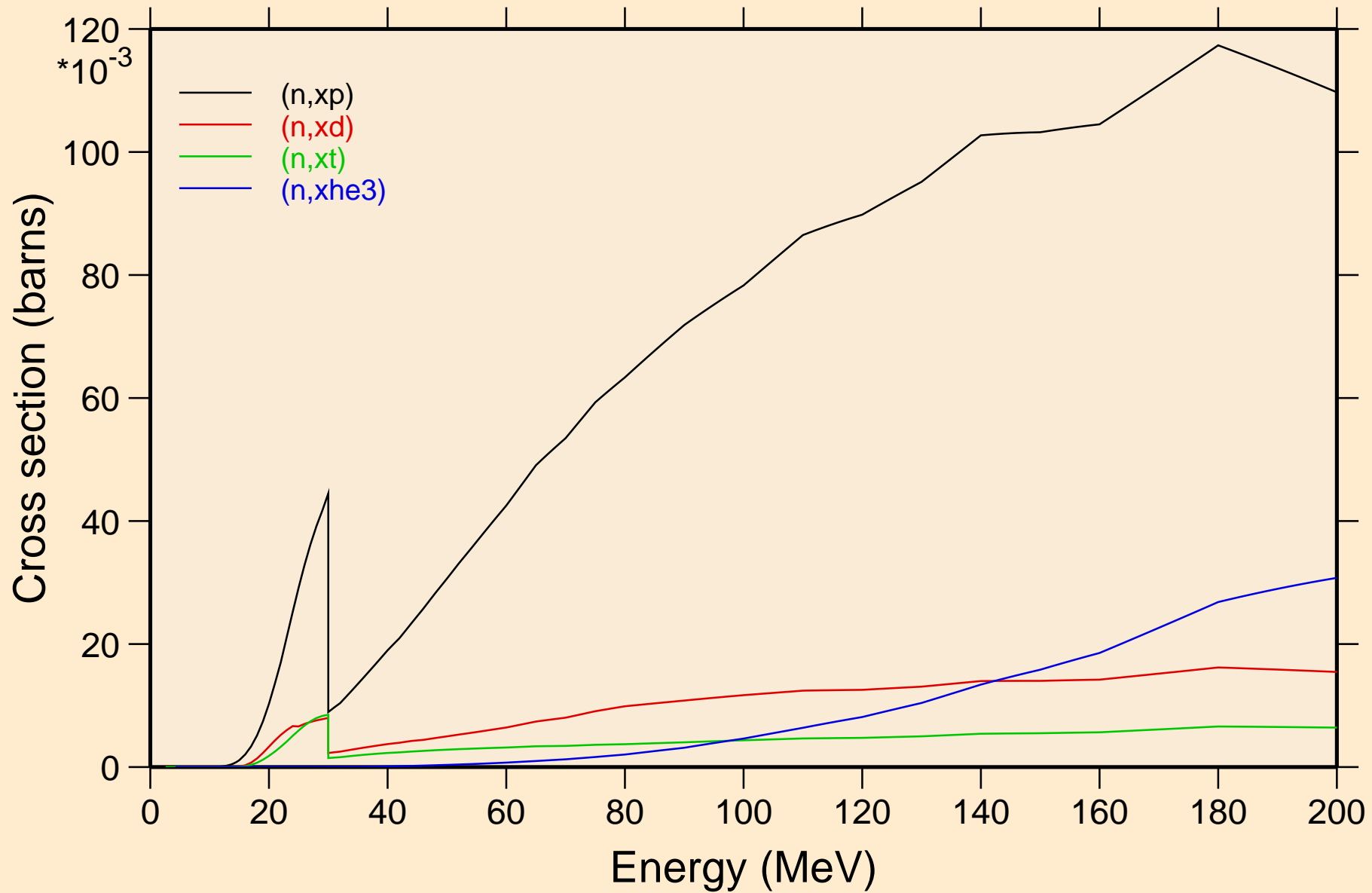

FM259 NEUTRON ACER TENDL-2024 LIBRARY; T=0.K
angular distribution for elastic

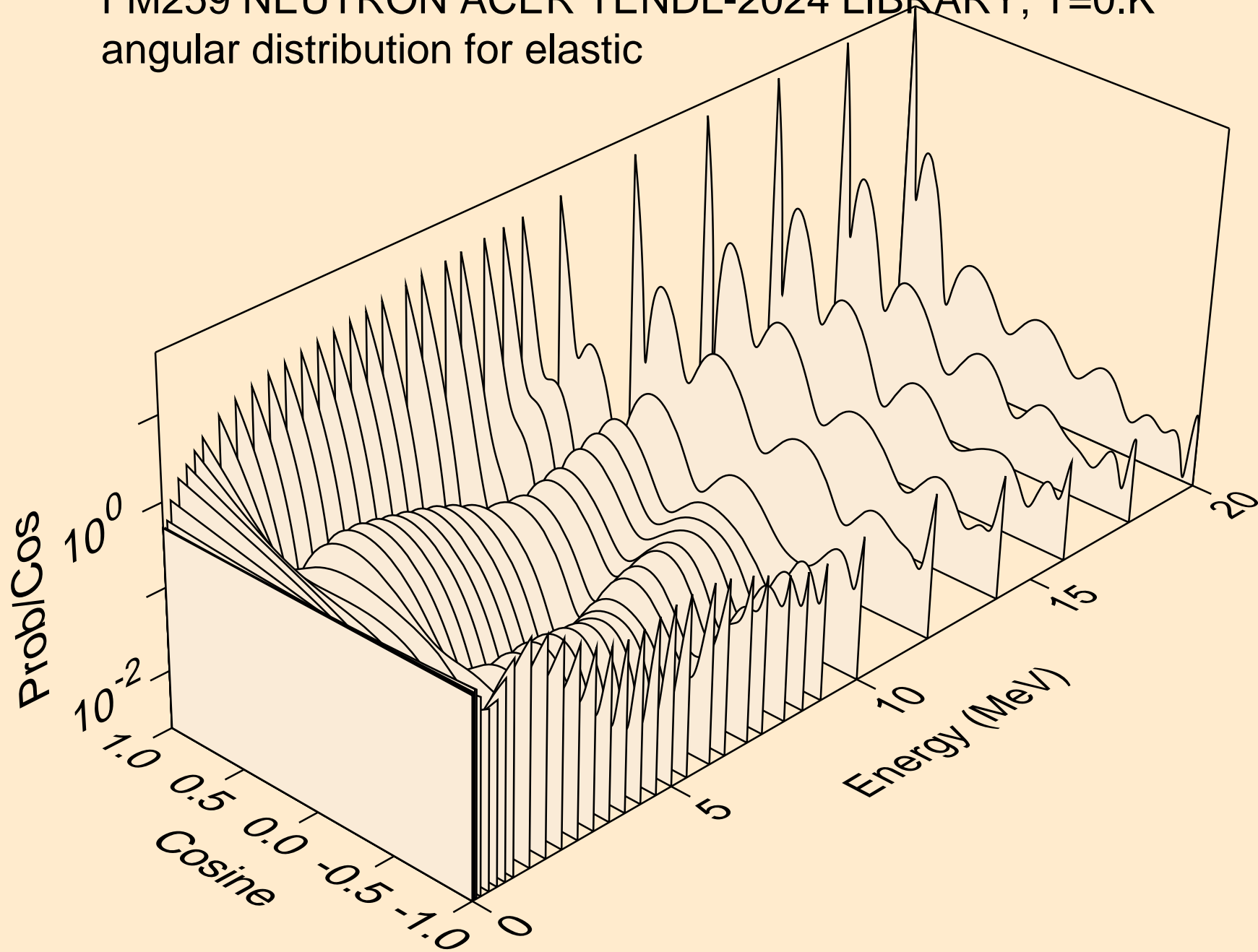

FM259 NEUTRON ACER TENDL-2024 LIBRARY; T=0.K
angular distribution for elastic

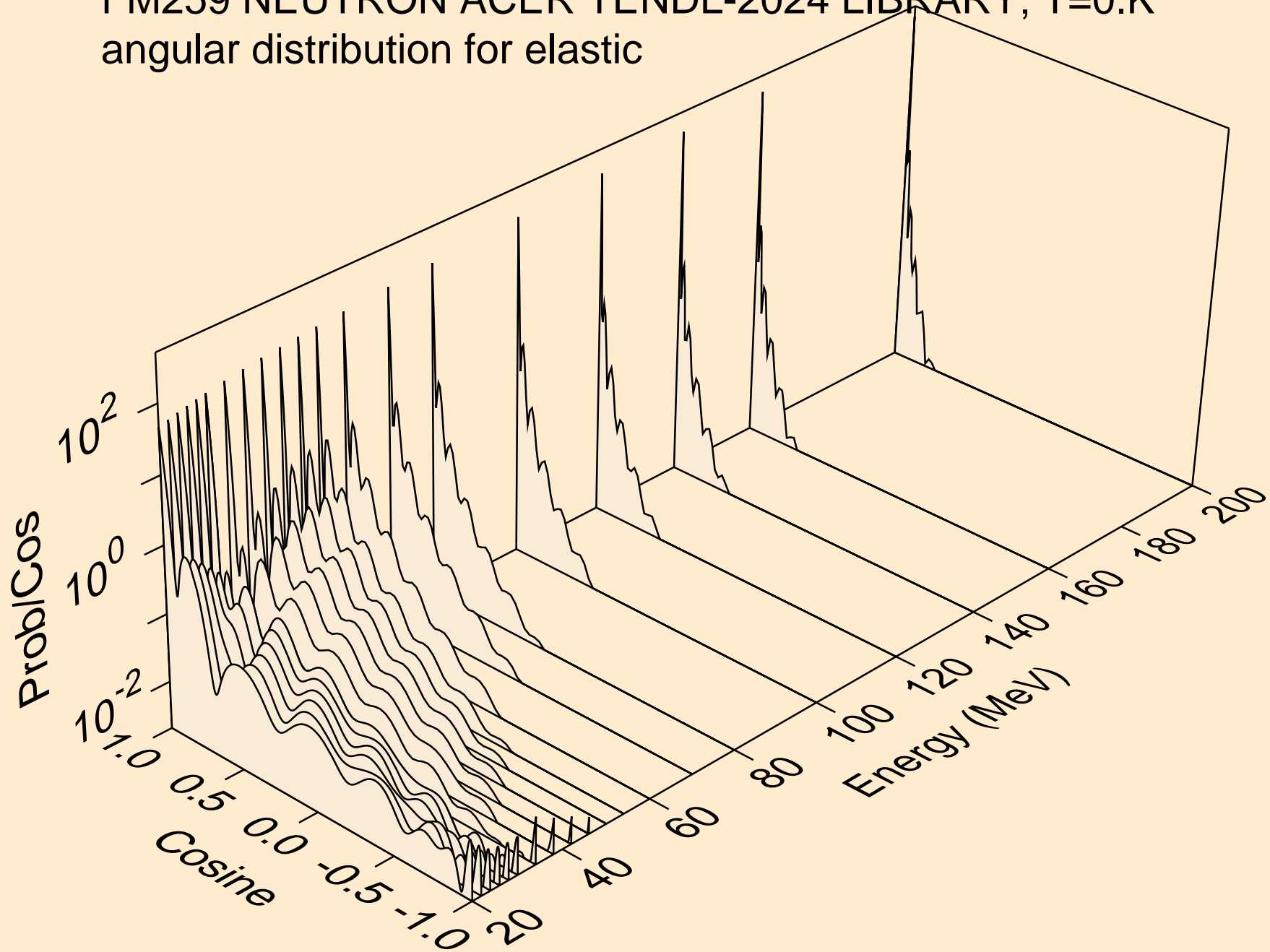

FM259 NEUTRON ACER TENDL-2024 LIBRARY; T=0.K
angular distribution for (n,n*1)

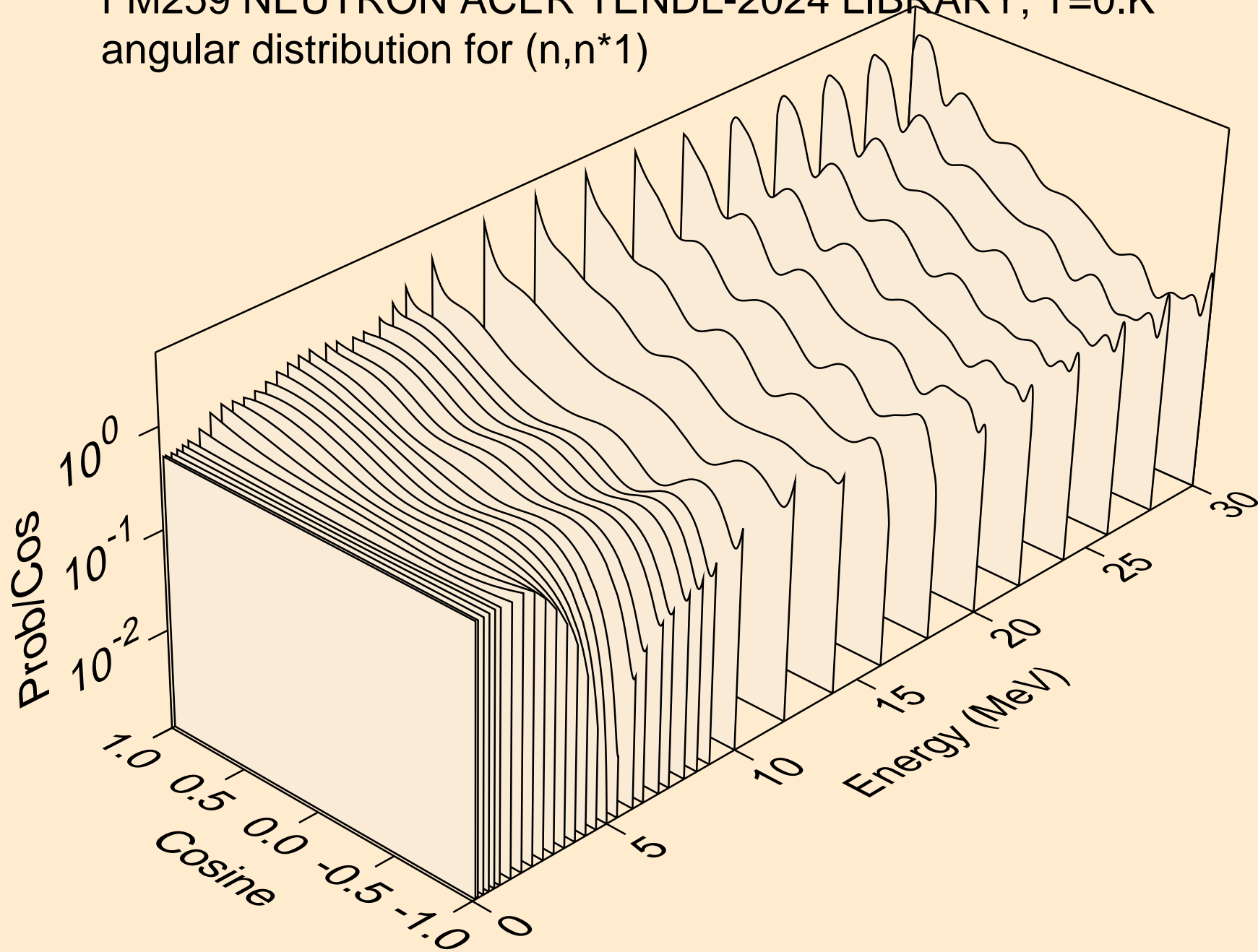

FM259 NEUTRON ACER TENDL-2024 LIBRARY; T=0.K
angular distribution for (n,n*2)

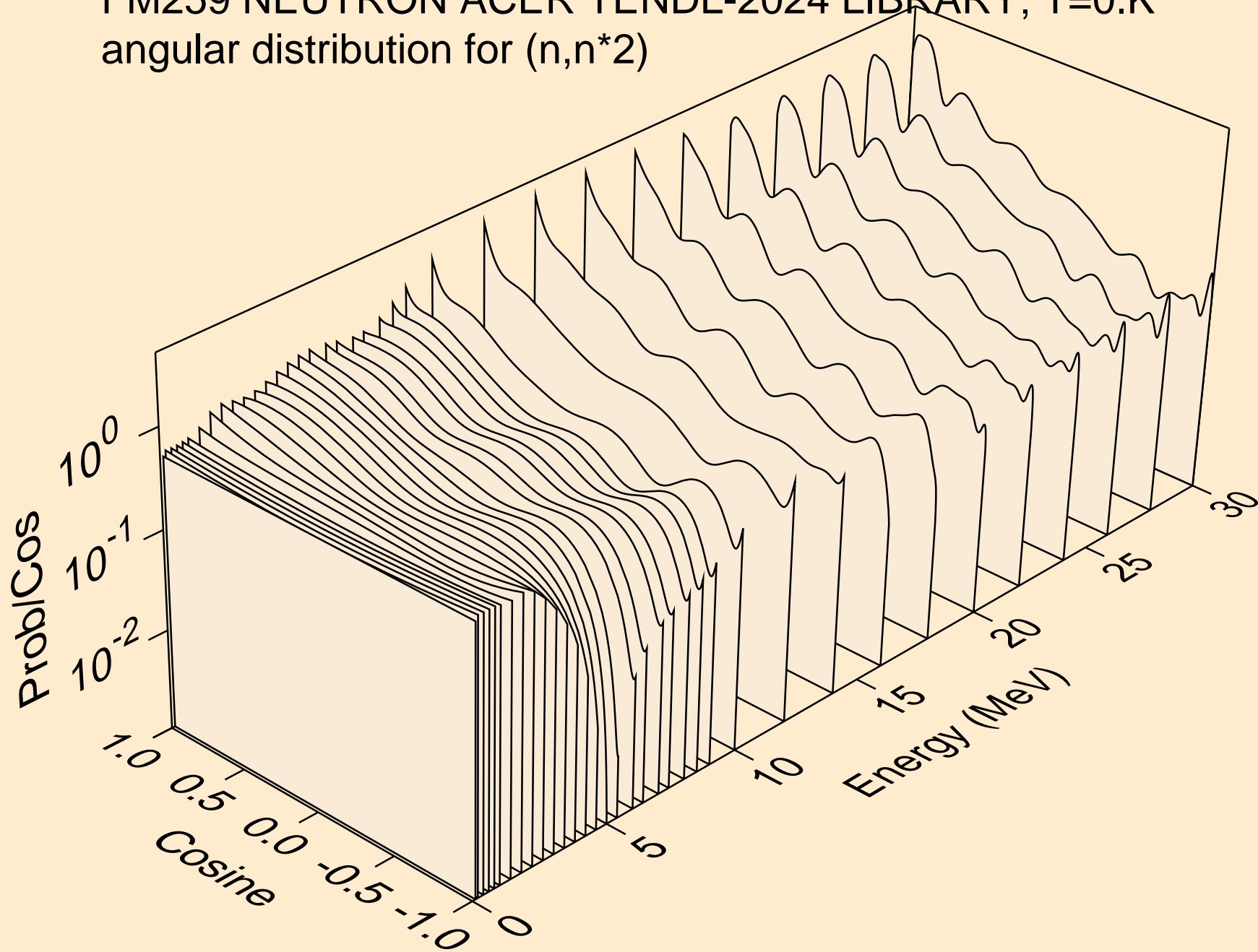

FM259 NEUTRON ACER TENDL-2024 LIBRARY; T=0.K
angular distribution for (n,n*3)

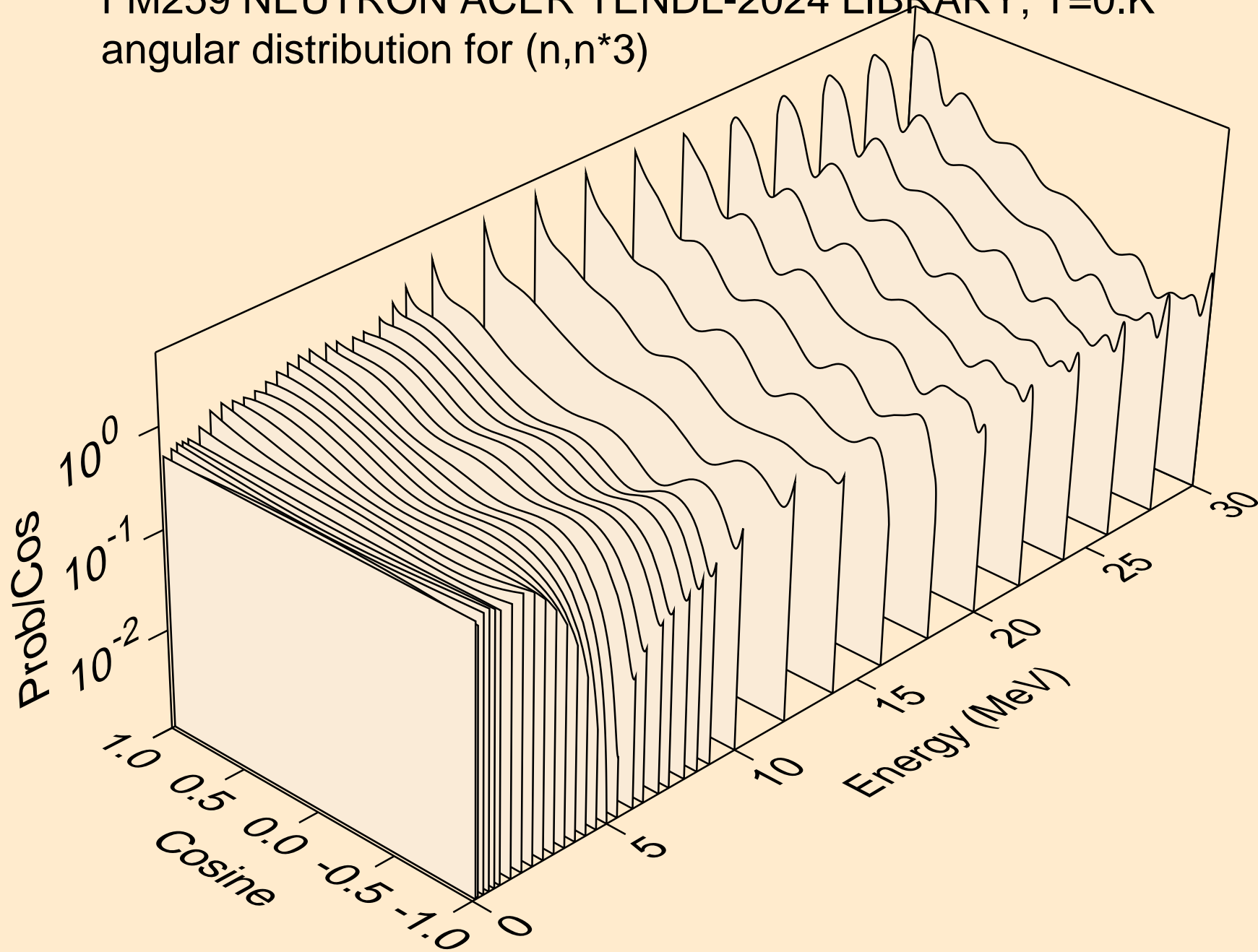

FM259 NEUTRON ACER TENDL-2024 LIBRARY; T=0.K
angular distribution for (n,n*4)

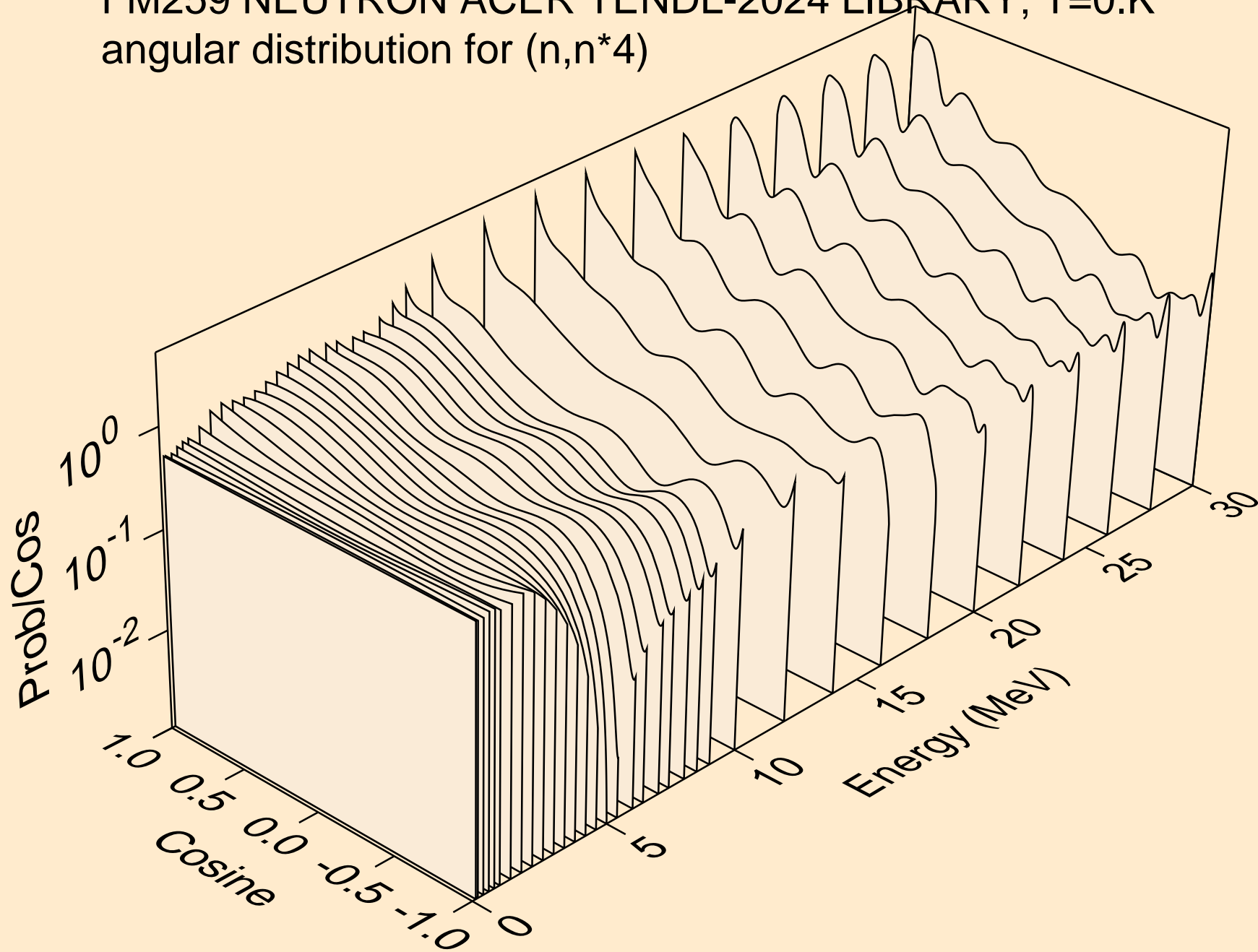

FM259 NEUTRON ACER TENDL-2024 LIBRARY; T=0.K
angular distribution for (n,n*5)

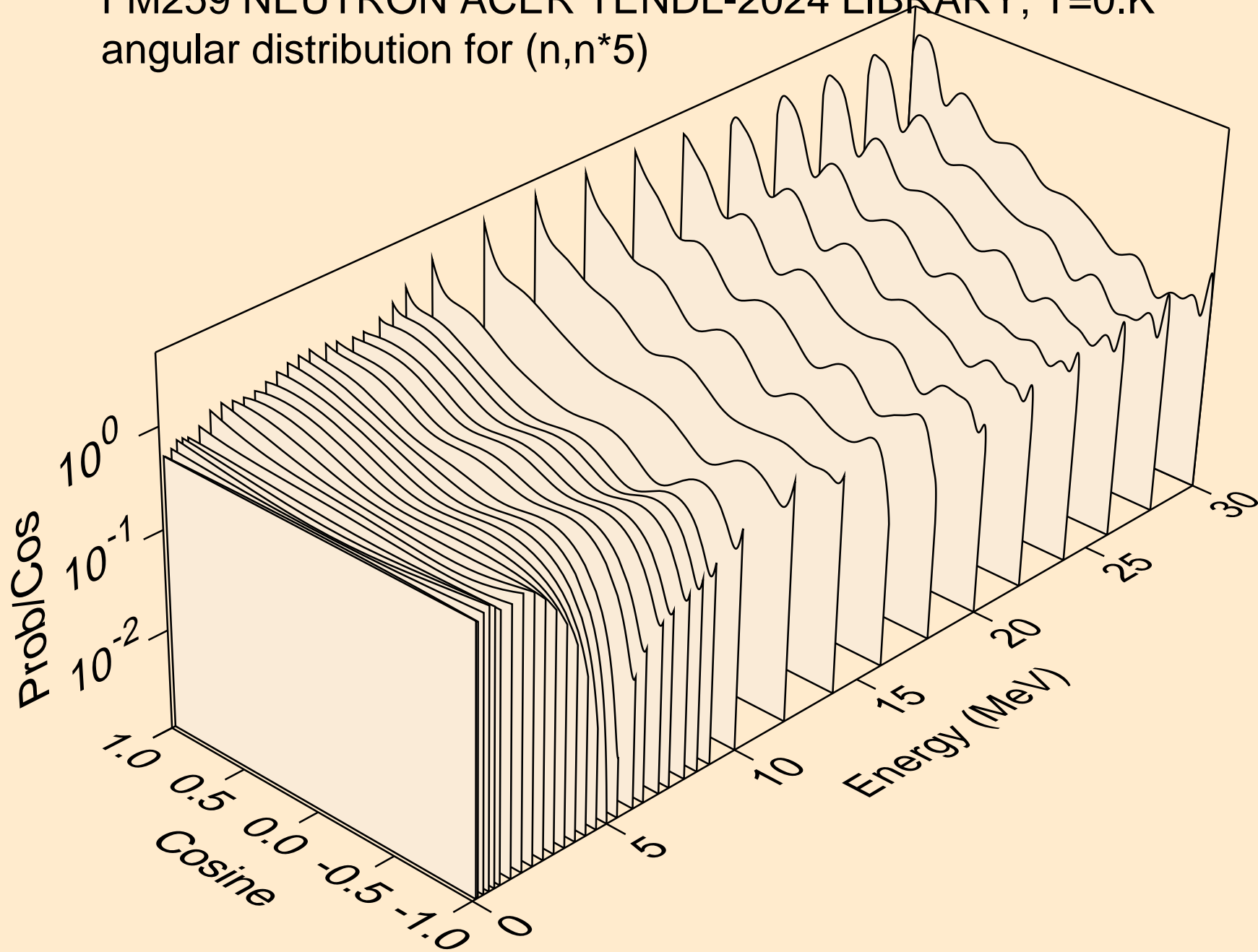

FM259 NEUTRON ACER TENDL-2024 LIBRARY; T=0.K
angular distribution for (n,n*6)

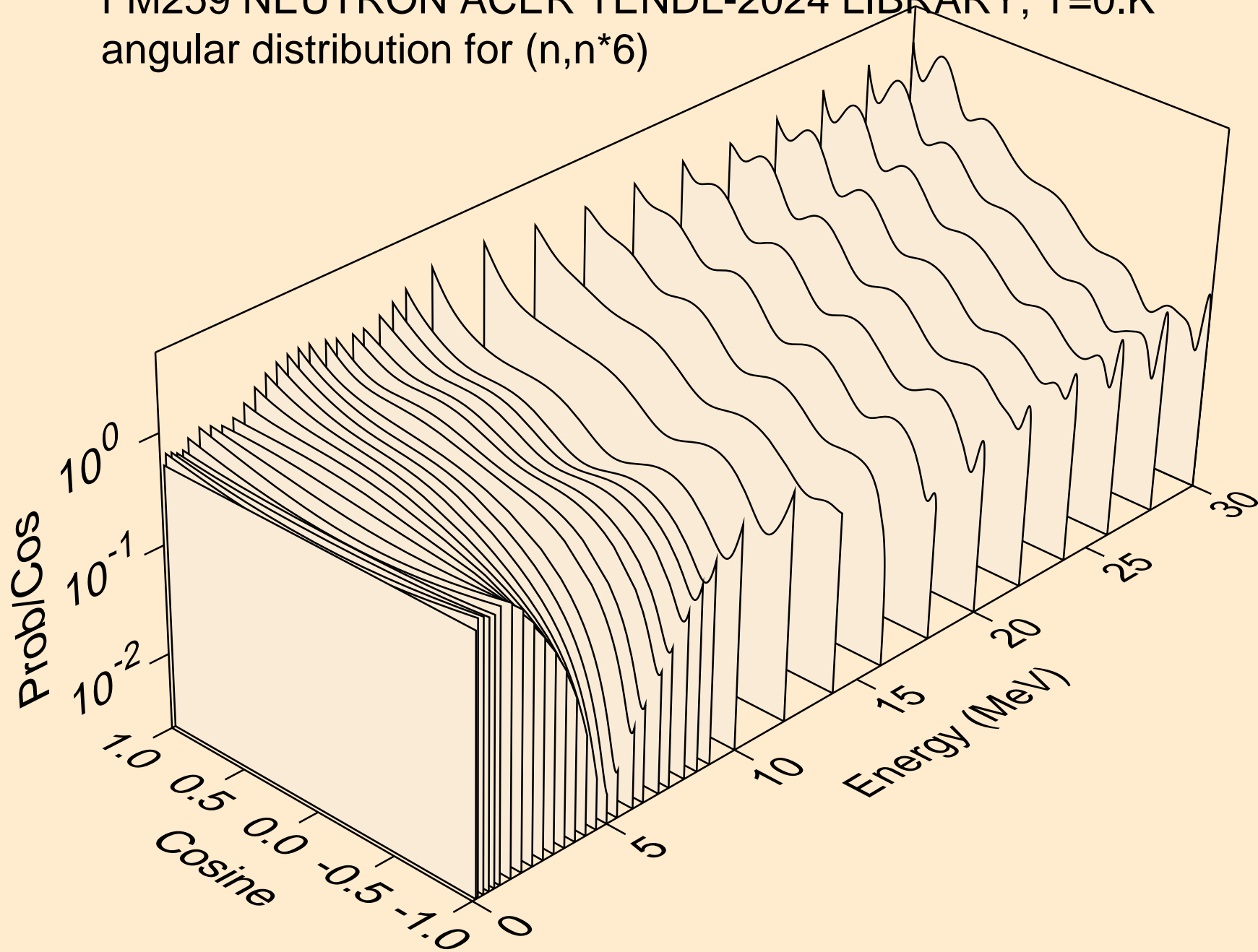

FM259 NEUTRON ACER TENDL-2024 LIBRARY; T=0.K
angular distribution for (n,n*7)

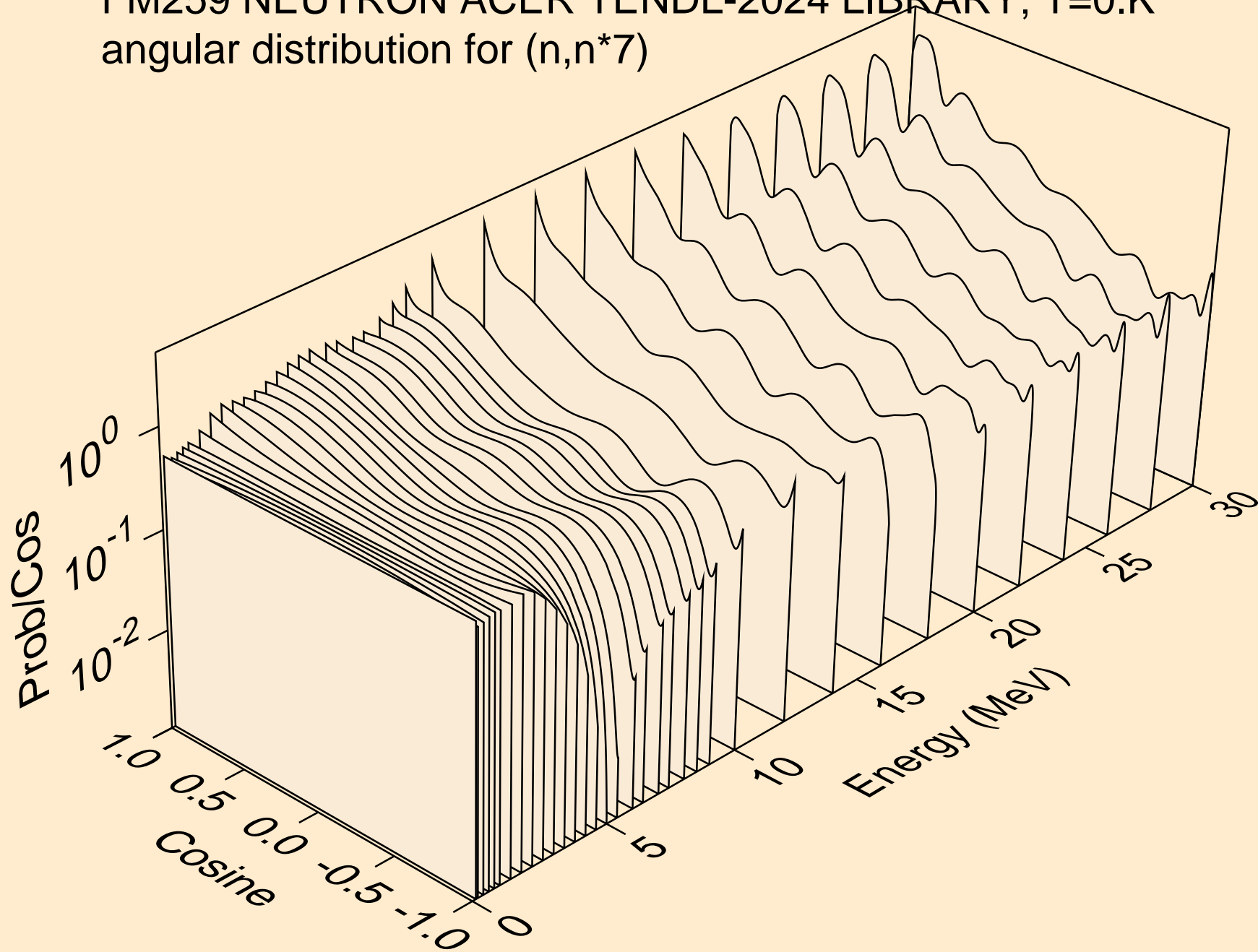

FM259 NEUTRON ACER TENDL-2024 LIBRARY; T=0.K
angular distribution for (n,n*8)

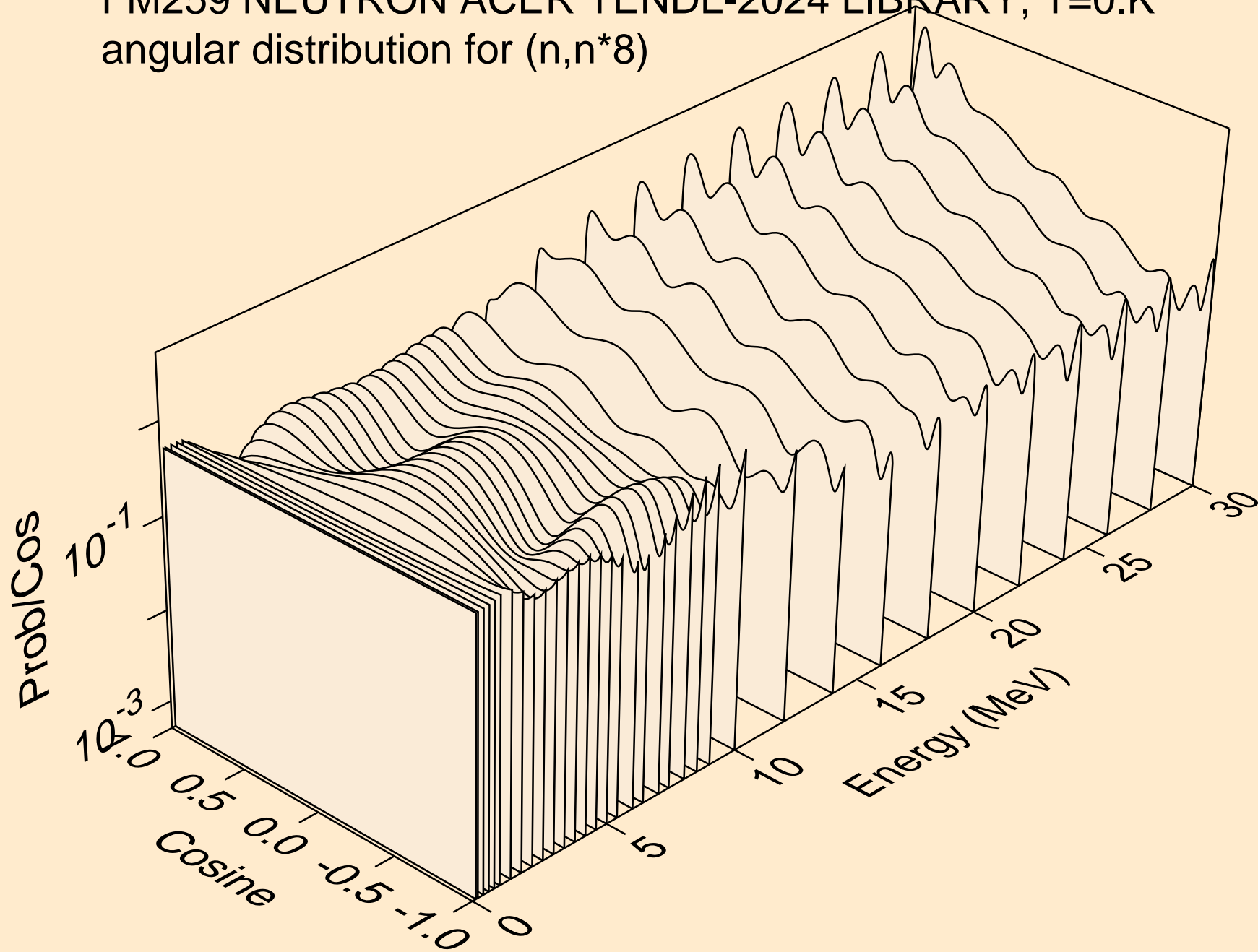

FM259 NEUTRON ACER TENDL-2024 LIBRARY; T=0.K
angular distribution for (n,n*9)

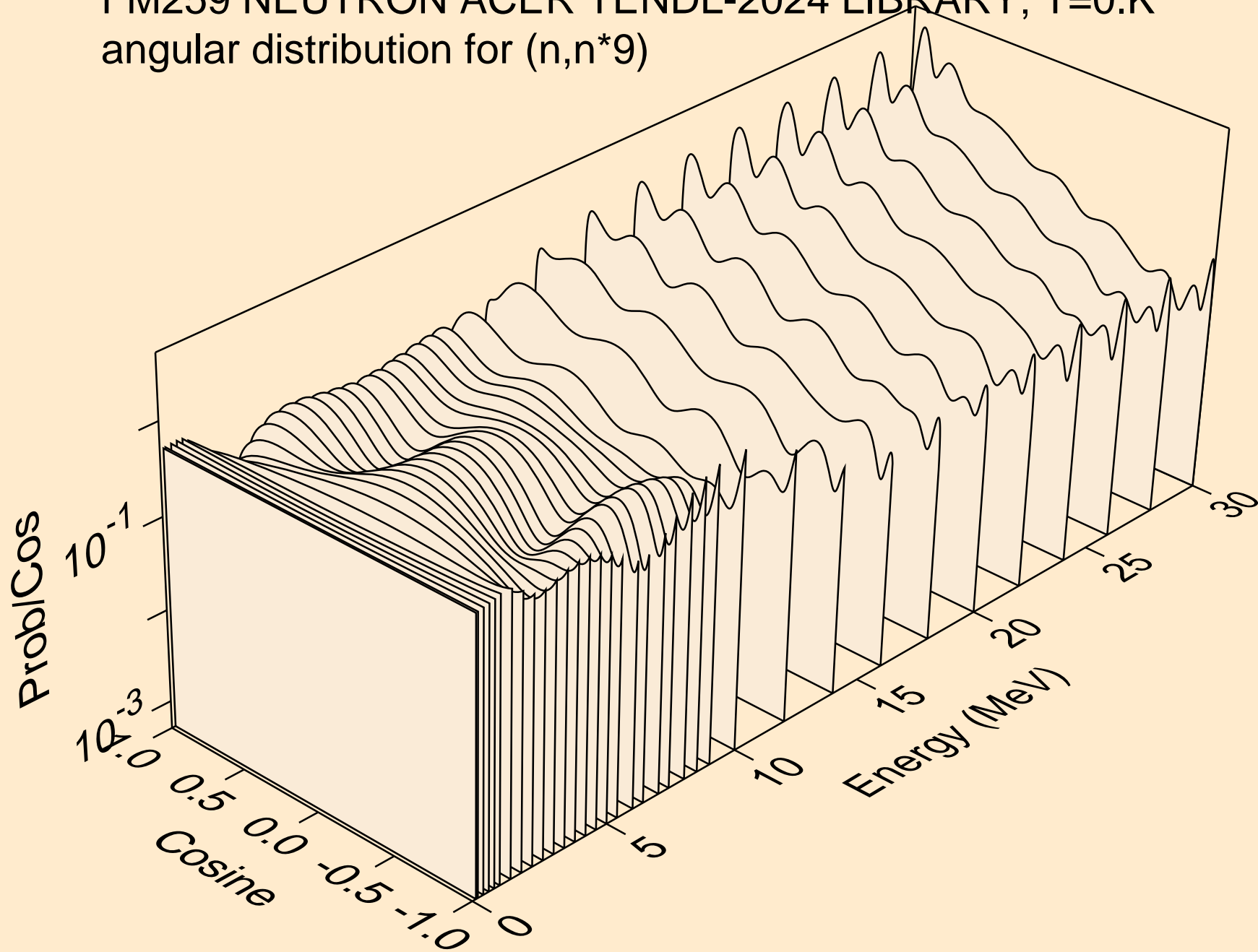

FM259 NEUTRON ACER TENDL-2024 LIBRARY; T=0.K
angular distribution for (n,n*10)

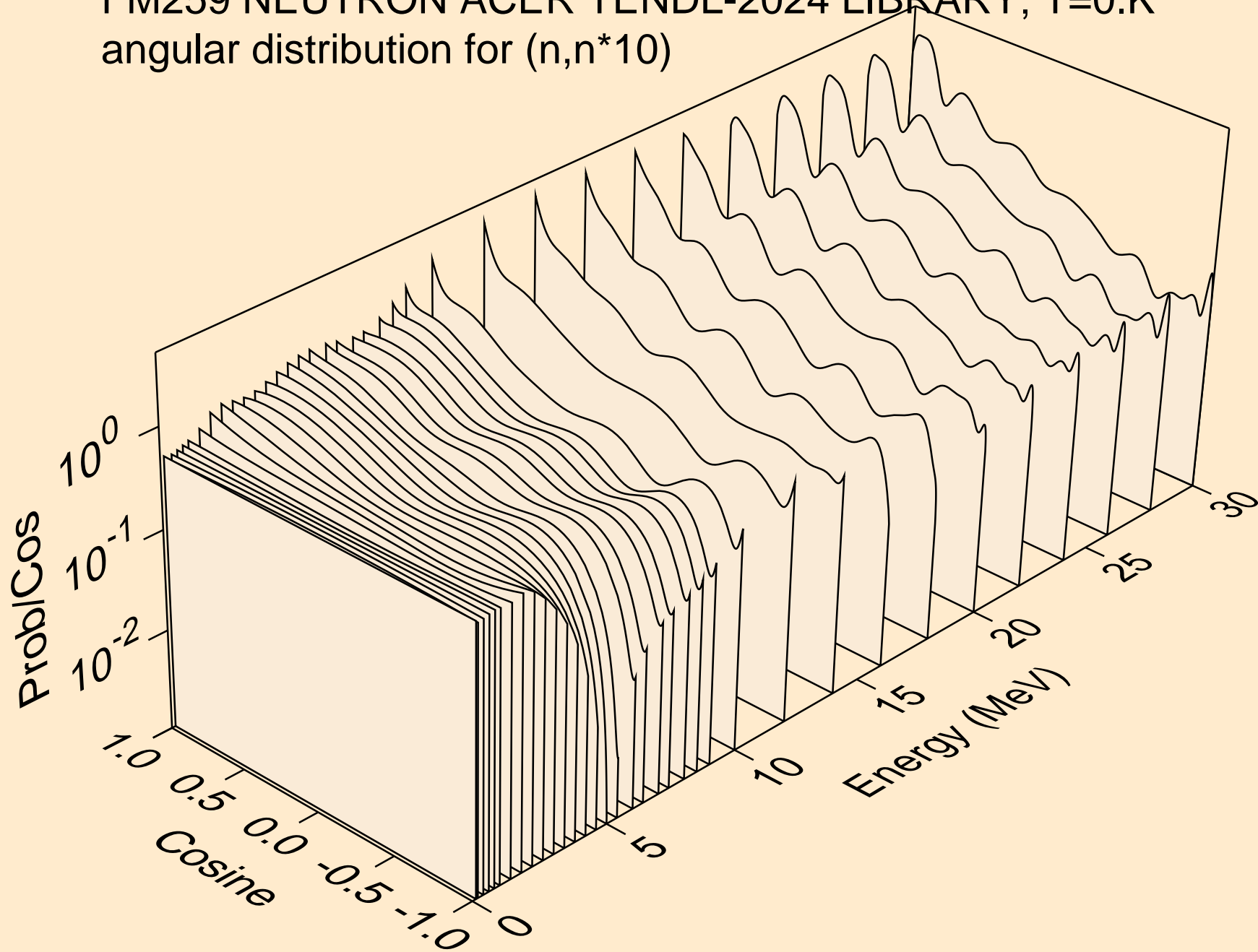

FM259 NEUTRON ACER TENDL-2024 LIBRARY; T=0.K
angular distribution for (n,n*11)

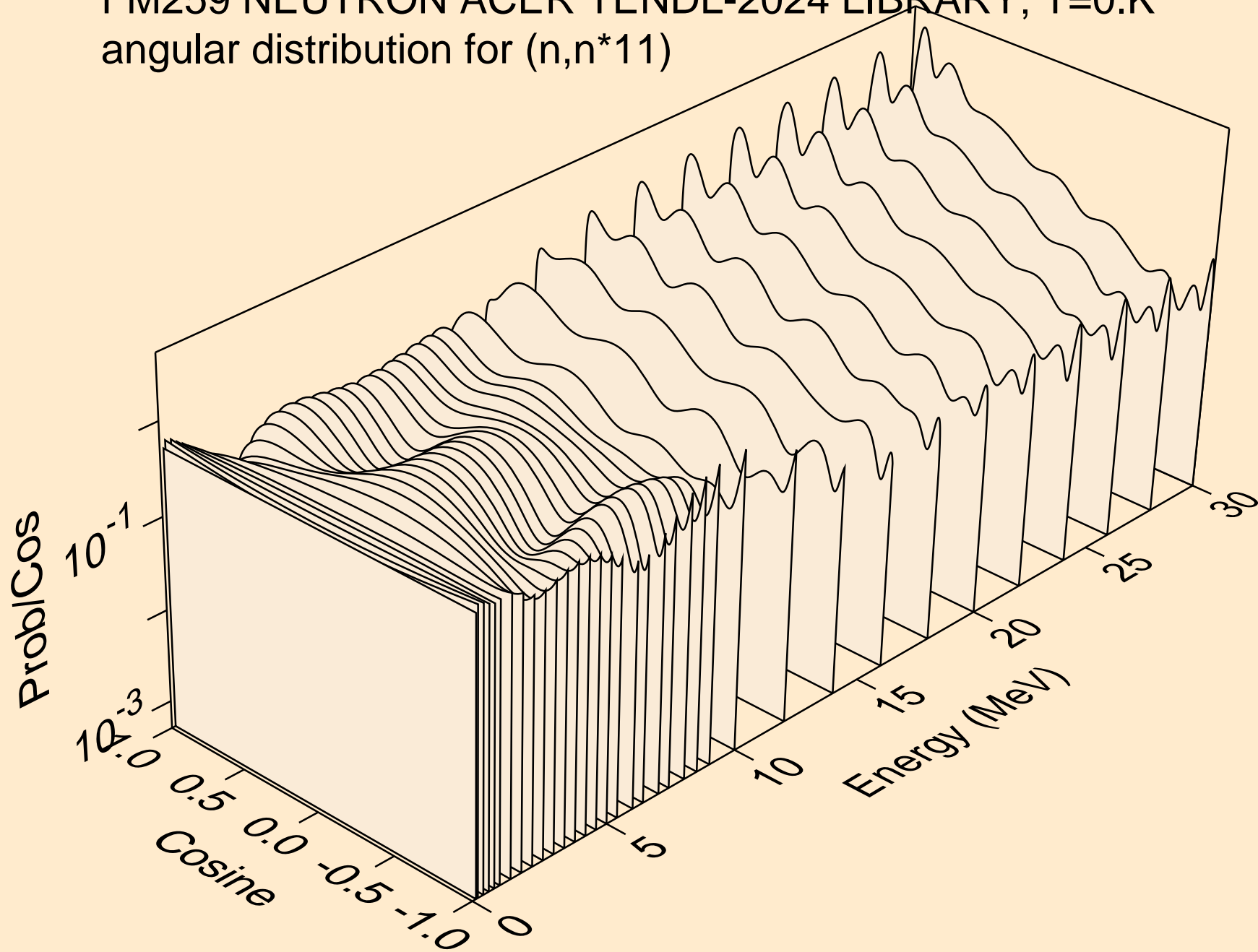

FM259 NEUTRON ACER TENDL-2024 LIBRARY; T=0.K
angular distribution for (n,n*12)

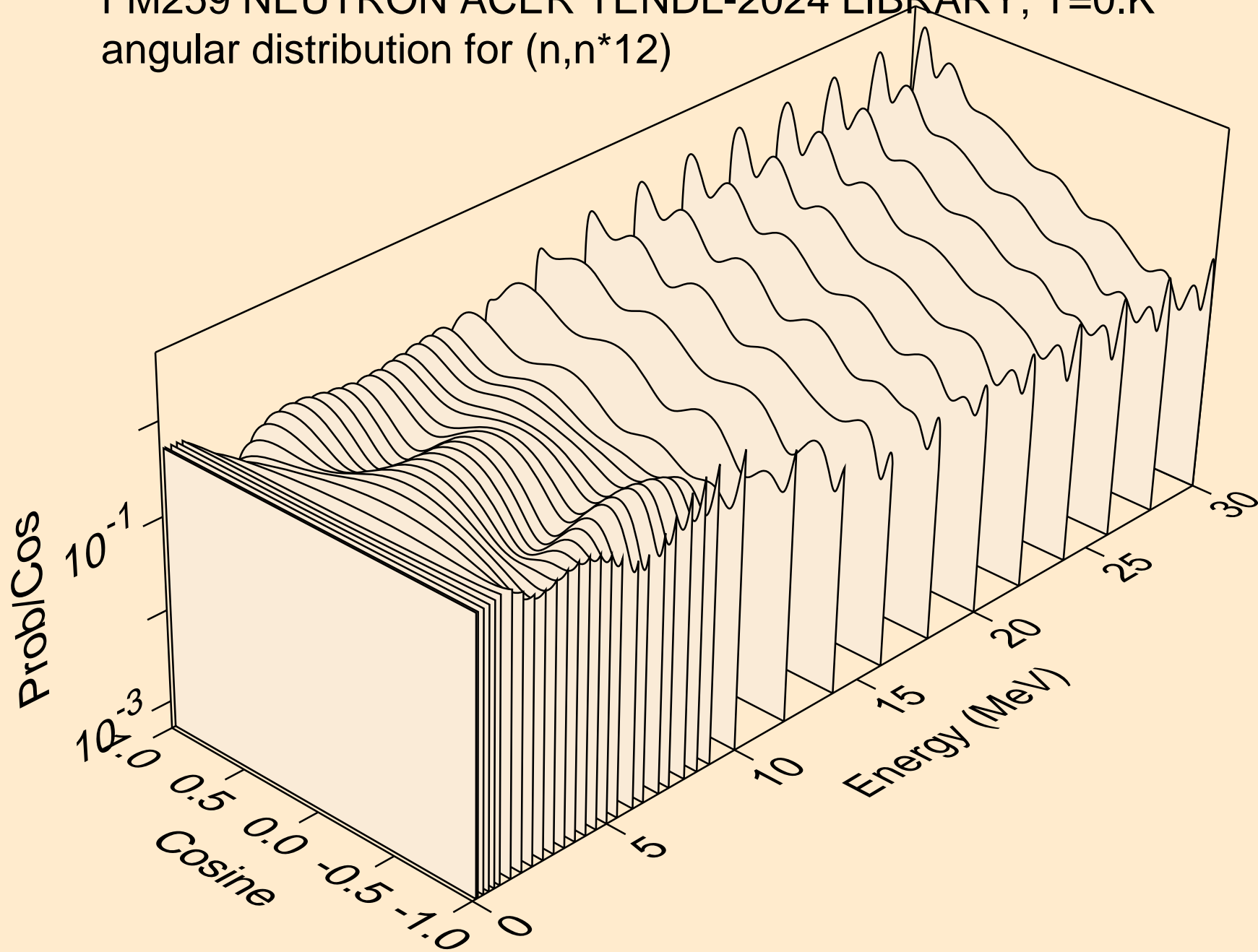

FM259 NEUTRON ACER TENDL-2024 LIBRARY; T=0.K
angular distribution for (n,n*13)

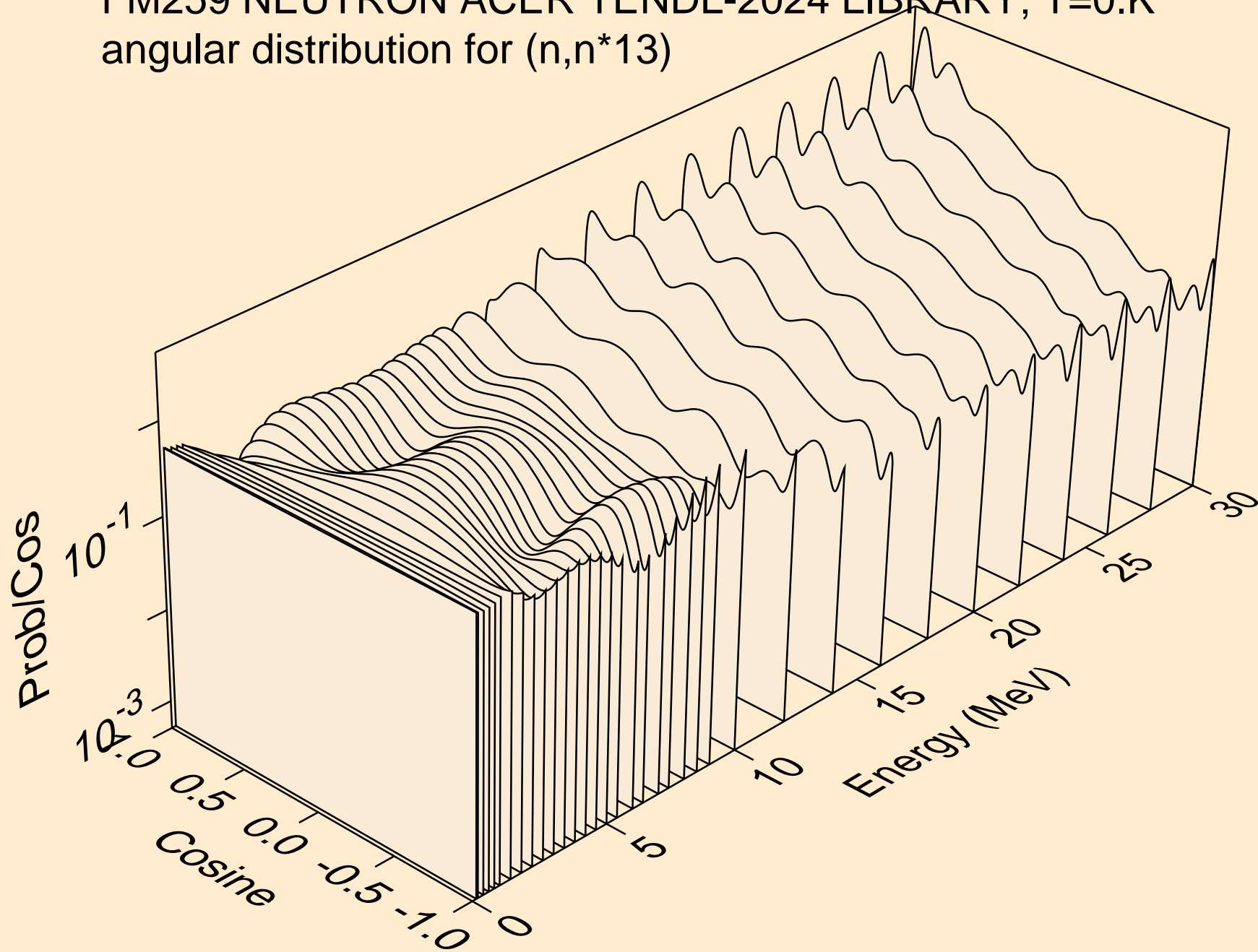

FM259 NEUTRON ACER TENDL-2024 LIBRARY; T=0.K
angular distribution for (n,n*14)

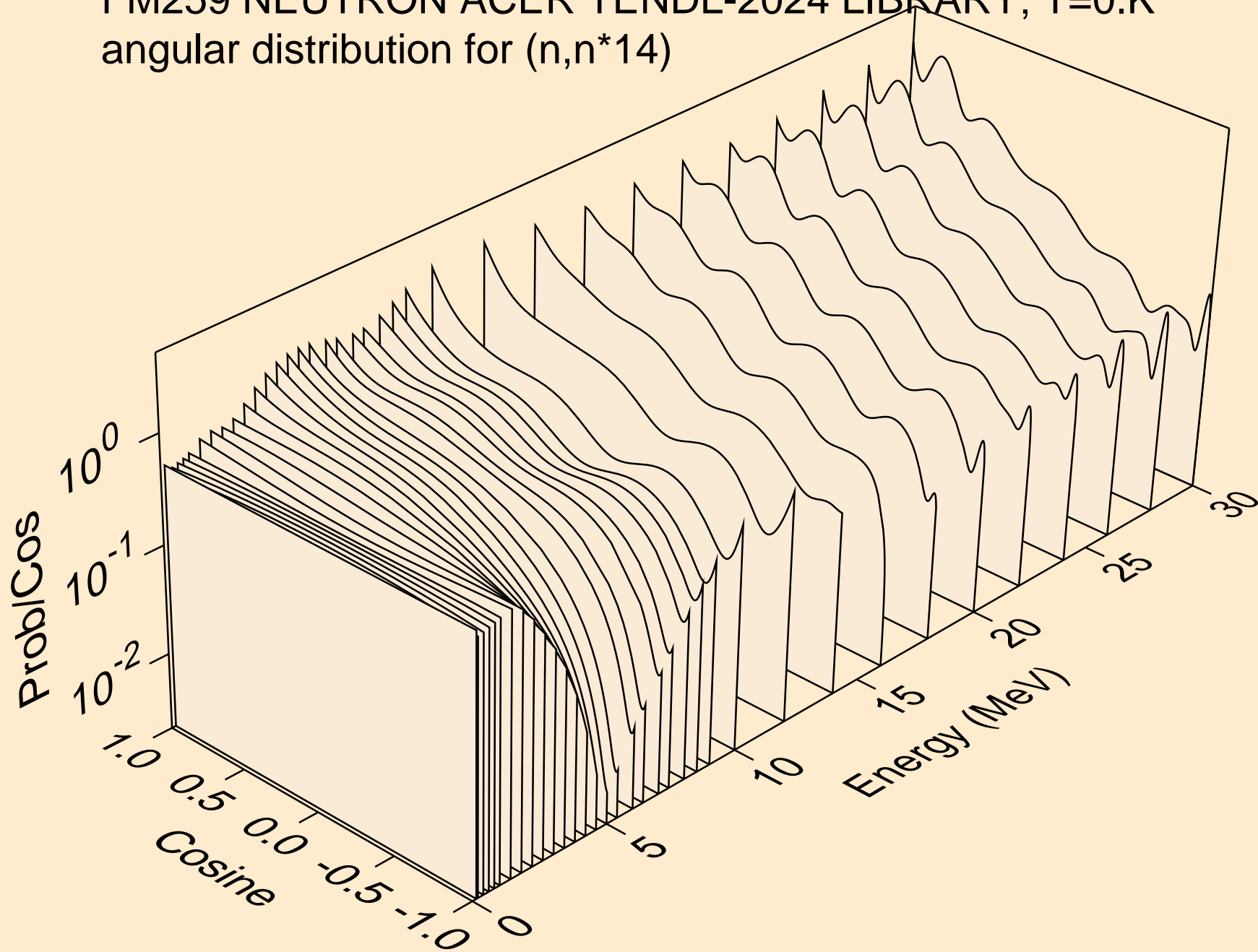

FM259 NEUTRON ACER TENDL-2024 LIBRARY; T=0.K
angular distribution for (n,n*15)

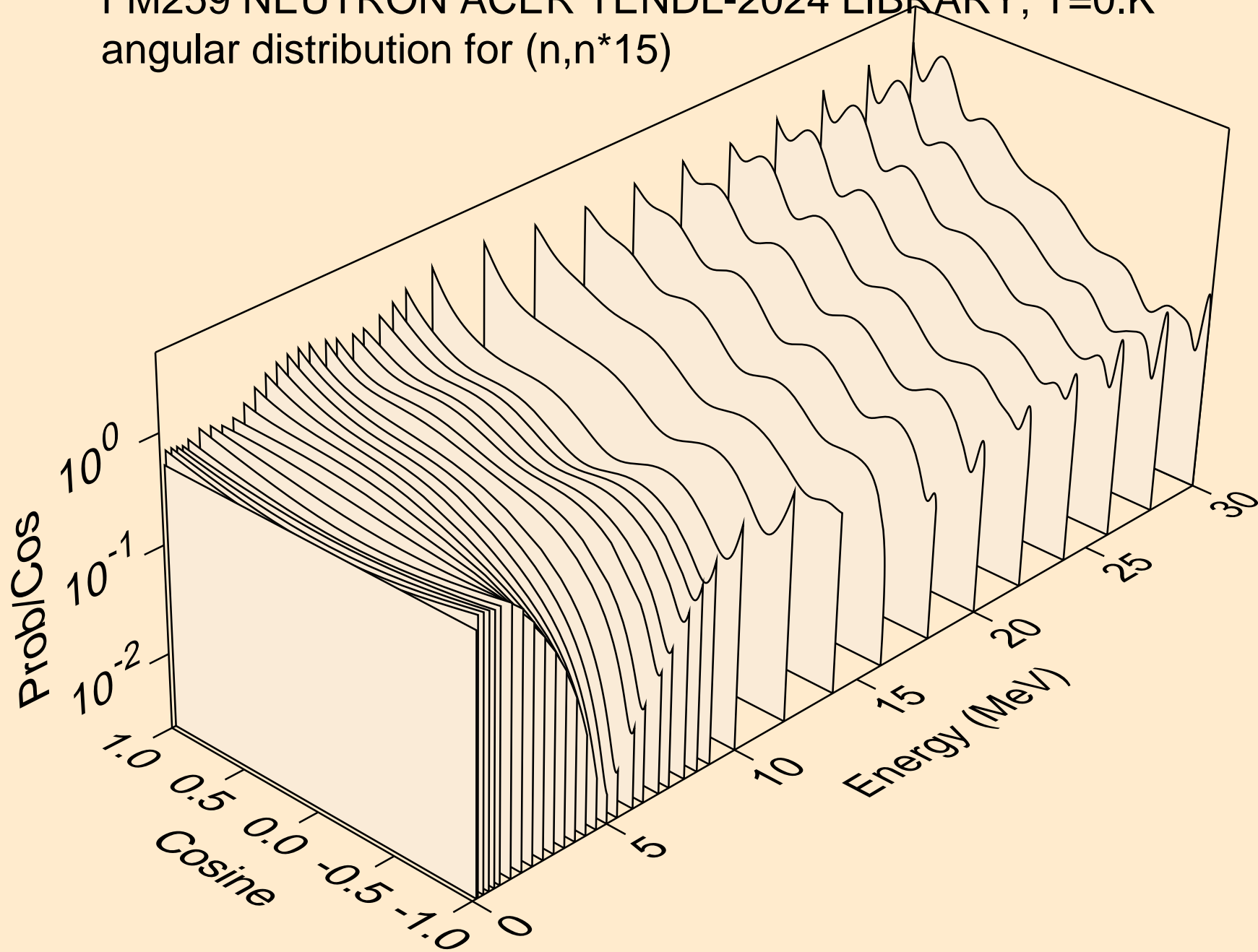

FM259 NEUTRON ACER TENDL-2024 LIBRARY; T=0.K
angular distribution for (n,n*16)

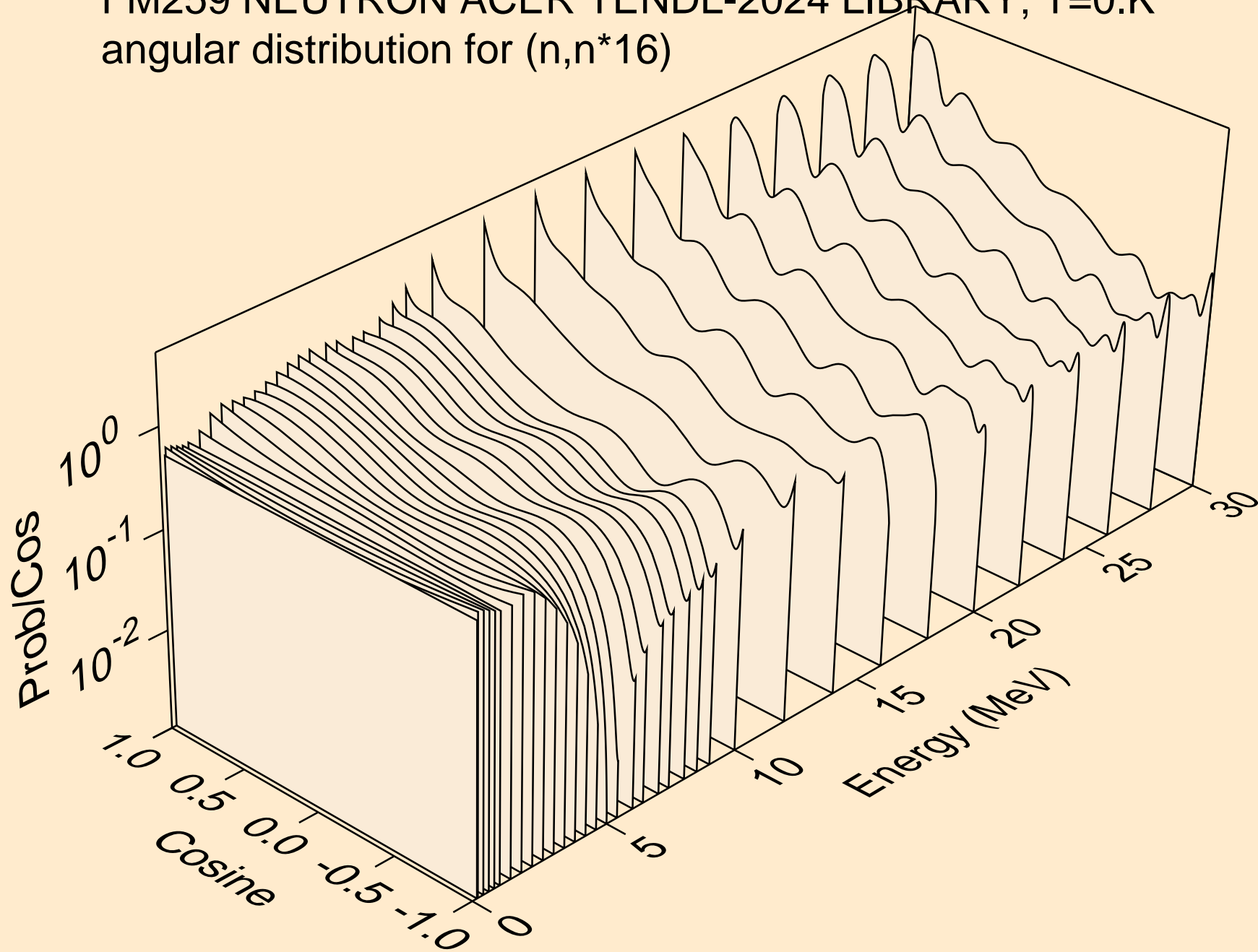

FM259 NEUTRON ACER TENDL-2024 LIBRARY; T=0.K
angular distribution for (n,n*17)

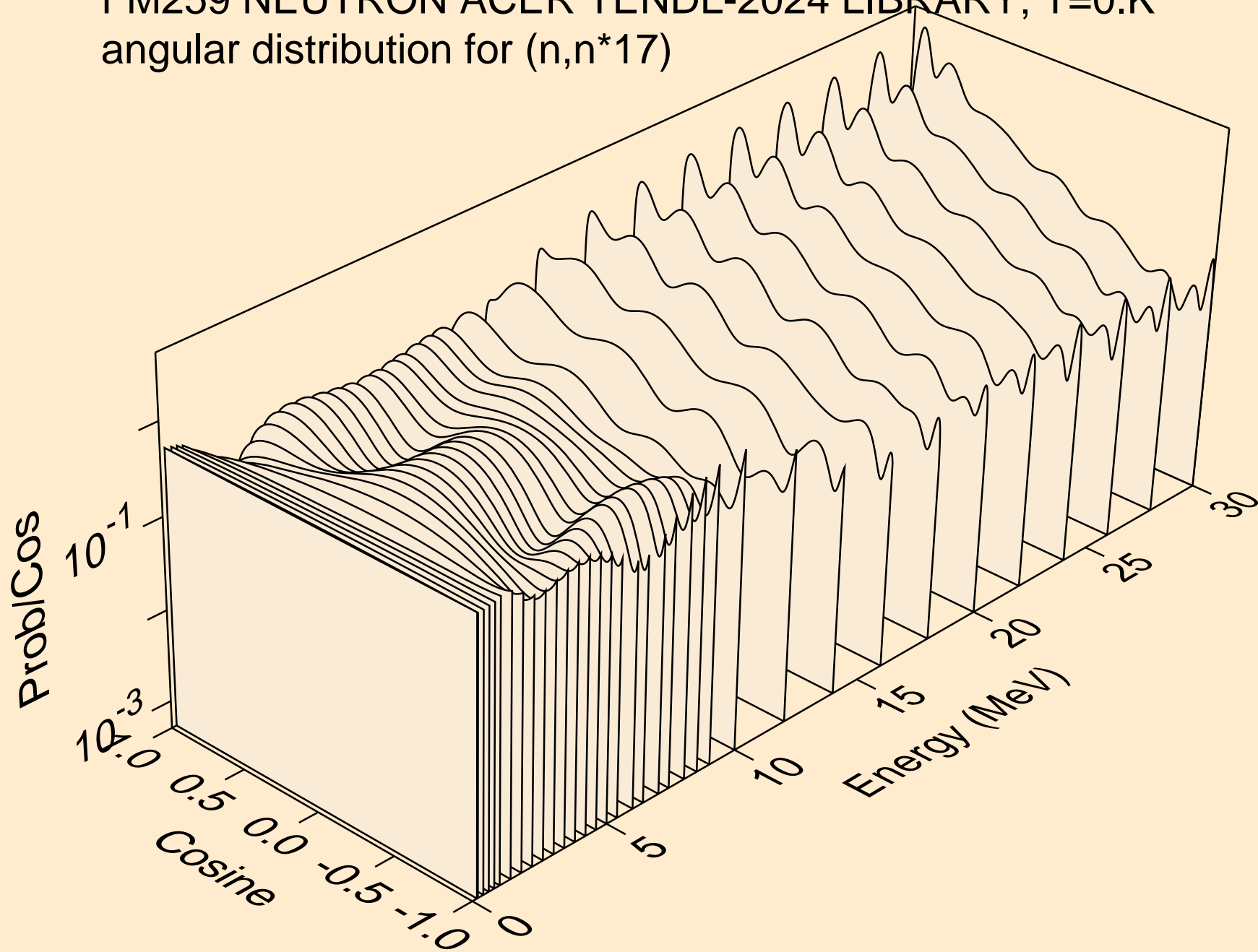

FM259 NEUTRON ACER TENDL-2024 LIBRARY; T=0.K
angular distribution for (n,n*18)

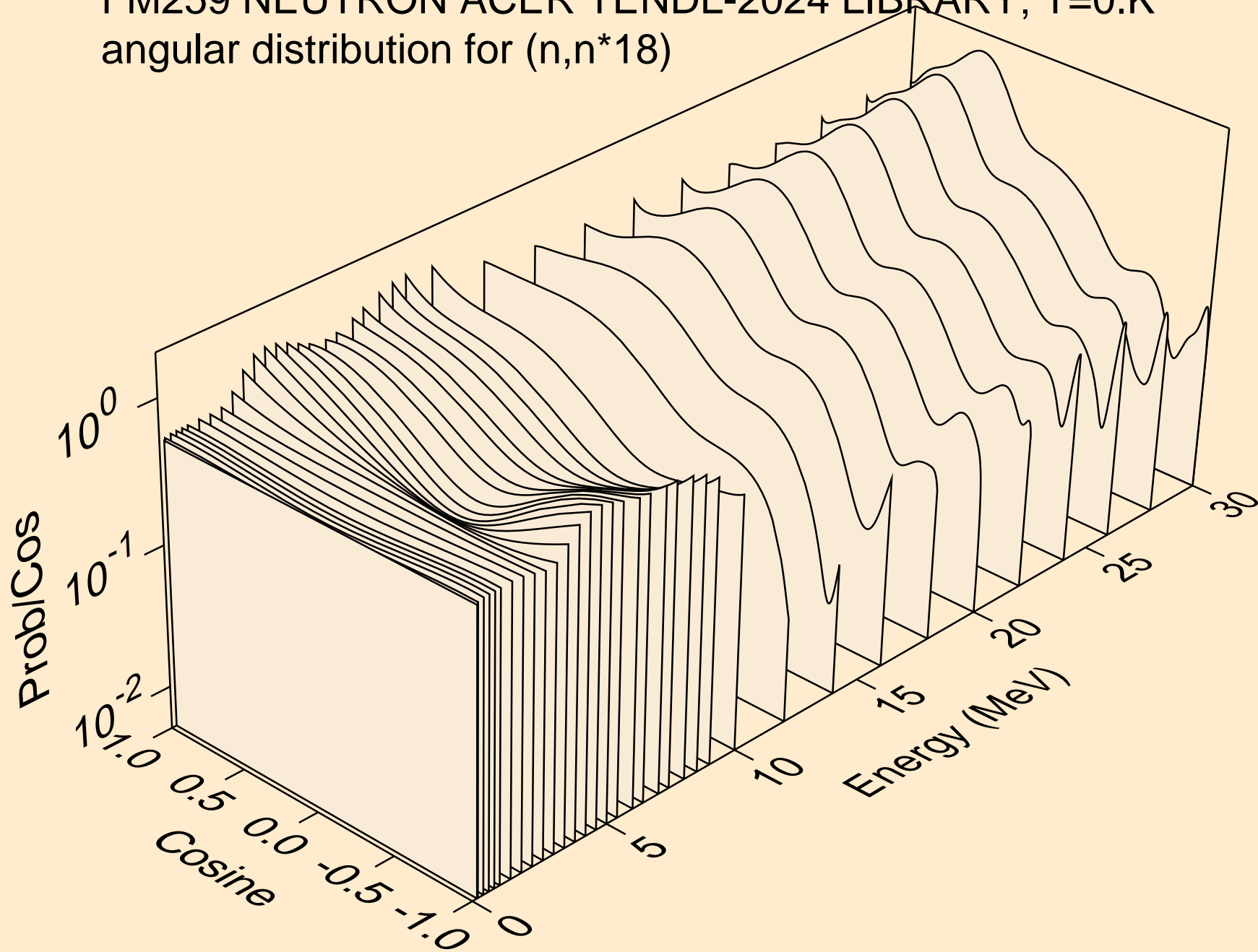

FM259 NEUTRON ACER TENDL-2024 LIBRARY; T=0.K
angular distribution for (n,n*19)

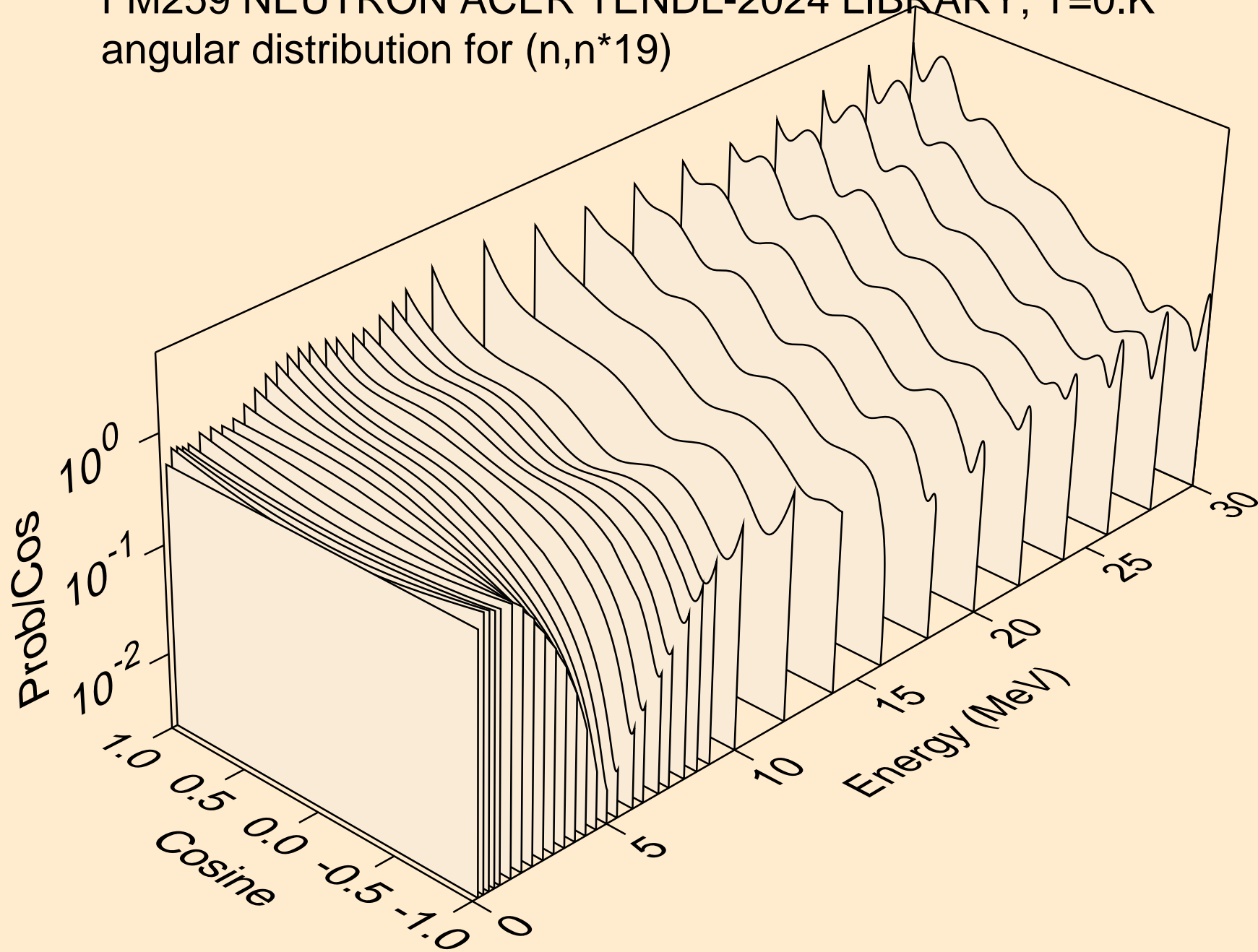

FM259 NEUTRON ACER TENDL-2024 LIBRARY; T=0.K
angular distribution for (n,n*20)

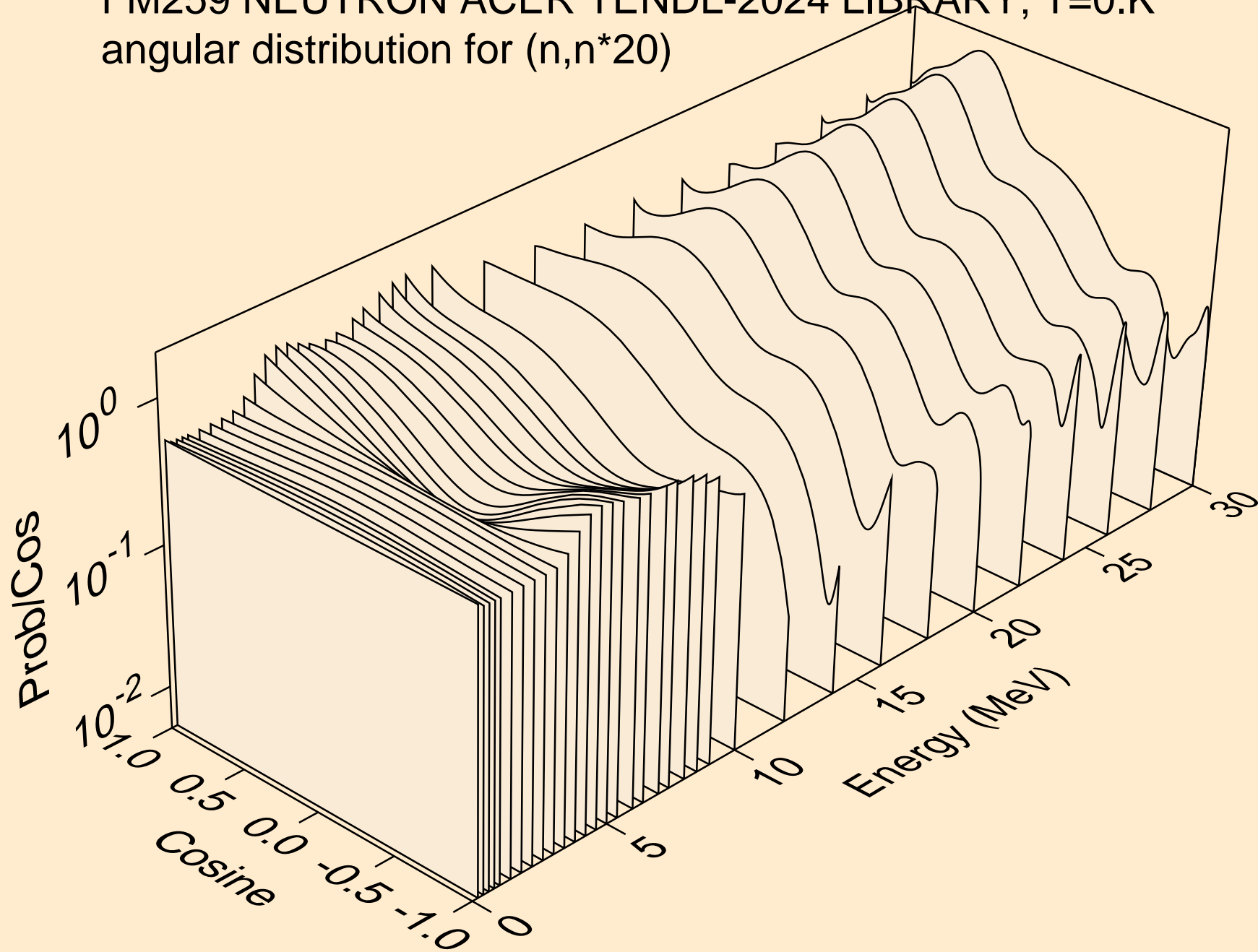

FM259 NEUTRON ACER TENDL-2024 LIBRARY; T=0.K
angular distribution for (n,n*21)

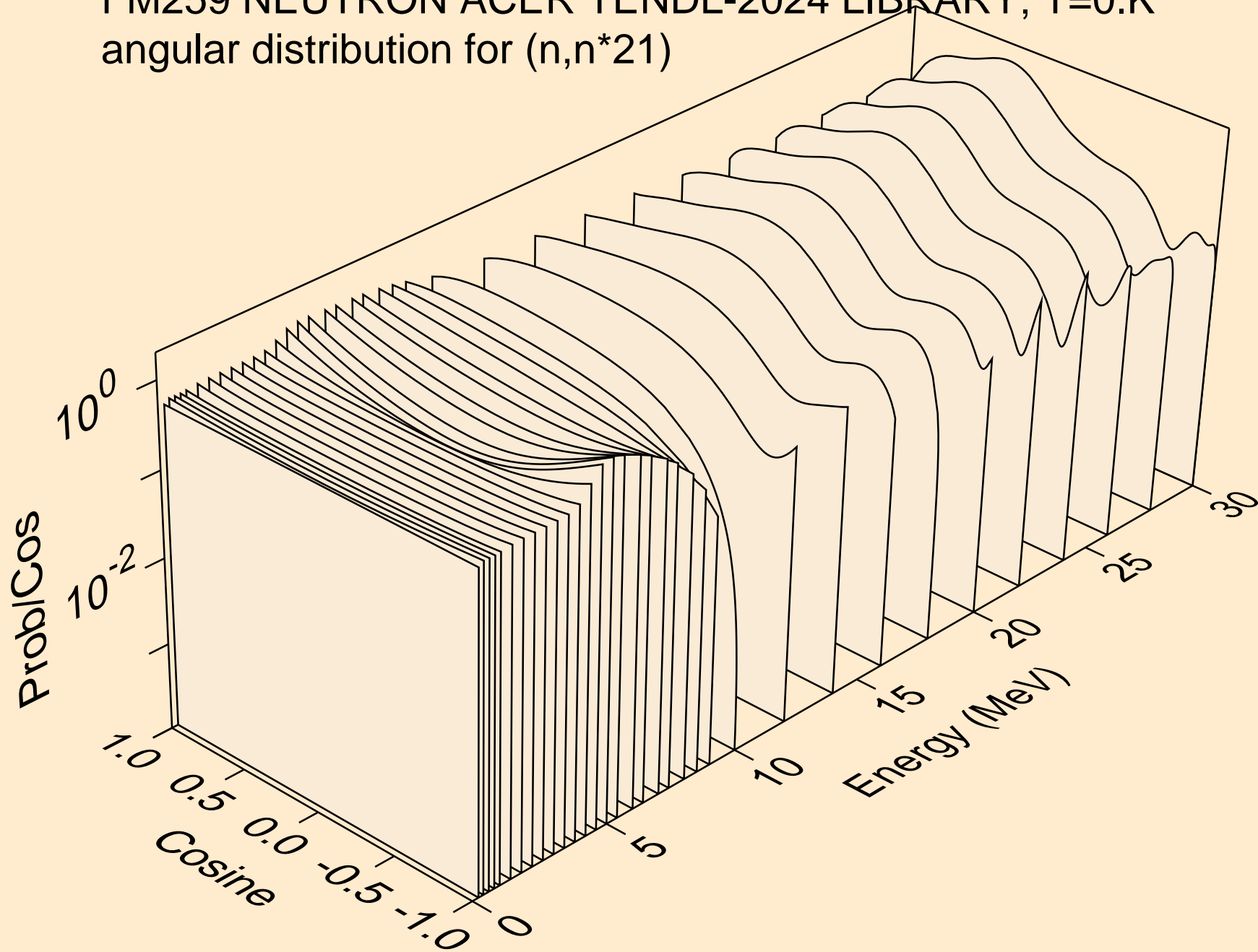

FM259 NEUTRON ACER TENDL-2024 LIBRARY; T=0.K
angular distribution for (n,n*22)

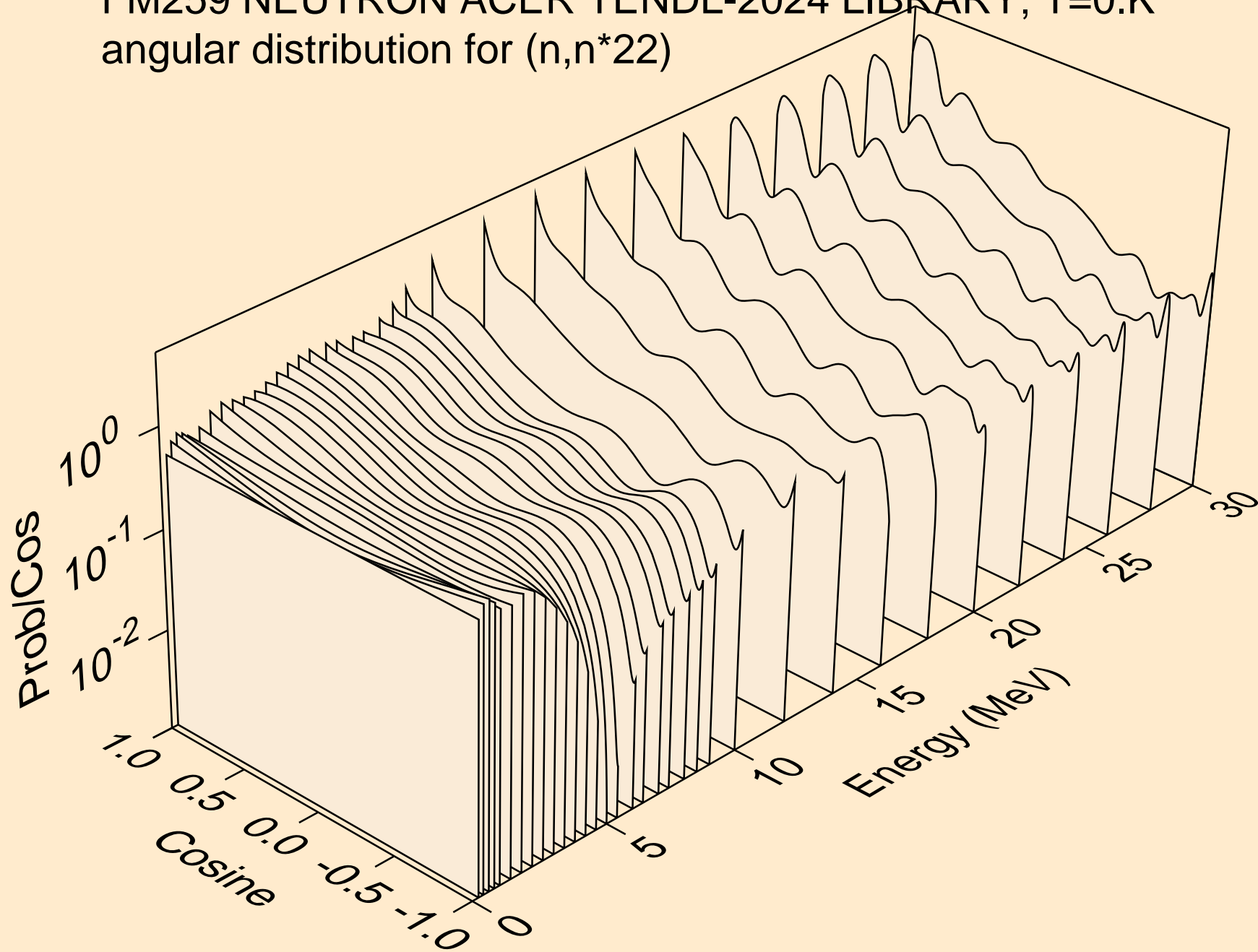

FM259 NEUTRON ACER TENDL-2024 LIBRARY; T=0.K
angular distribution for (n,n*23)

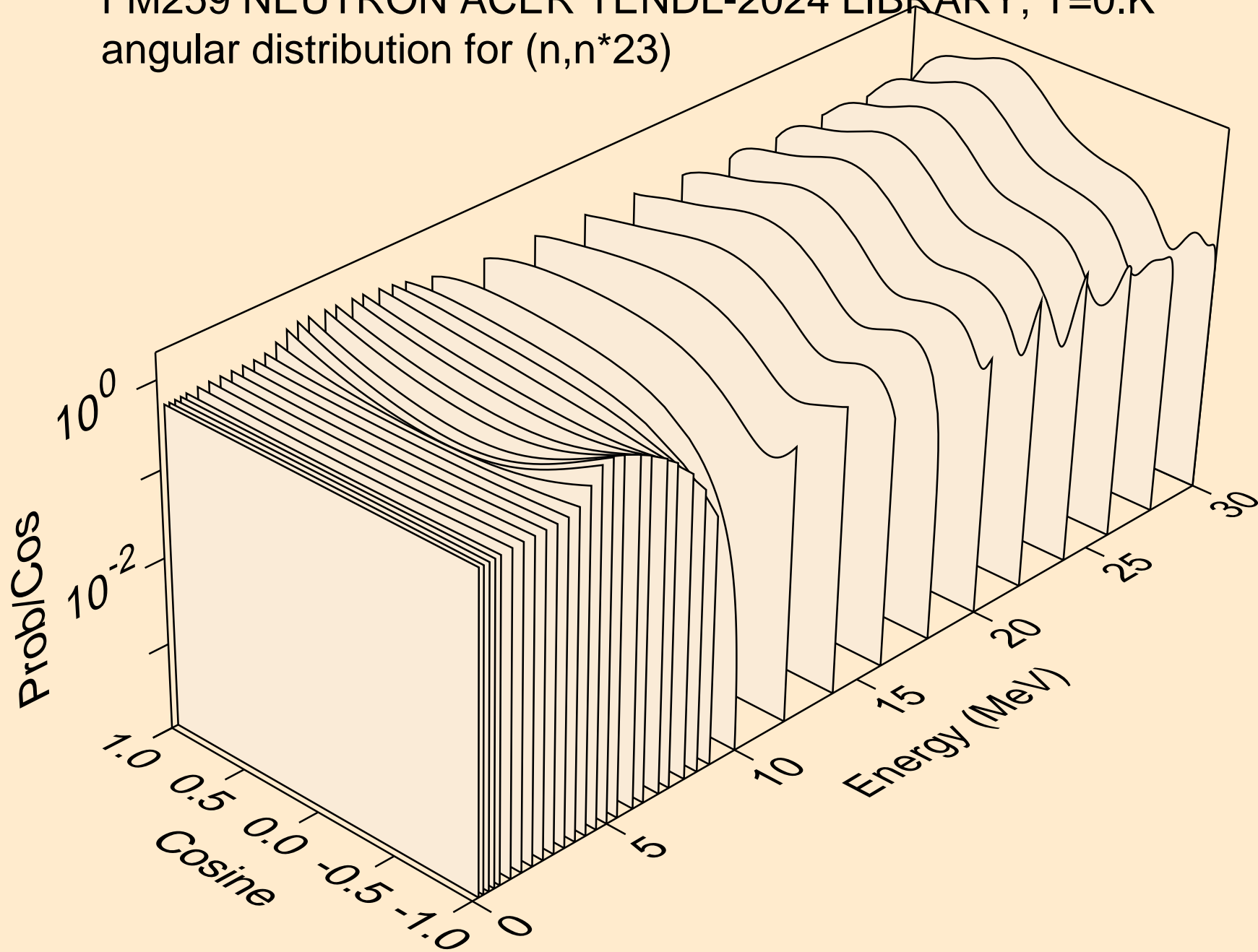

FM259 NEUTRON ACER TENDL-2024 LIBRARY; T=0.K
angular distribution for (n,n*24)

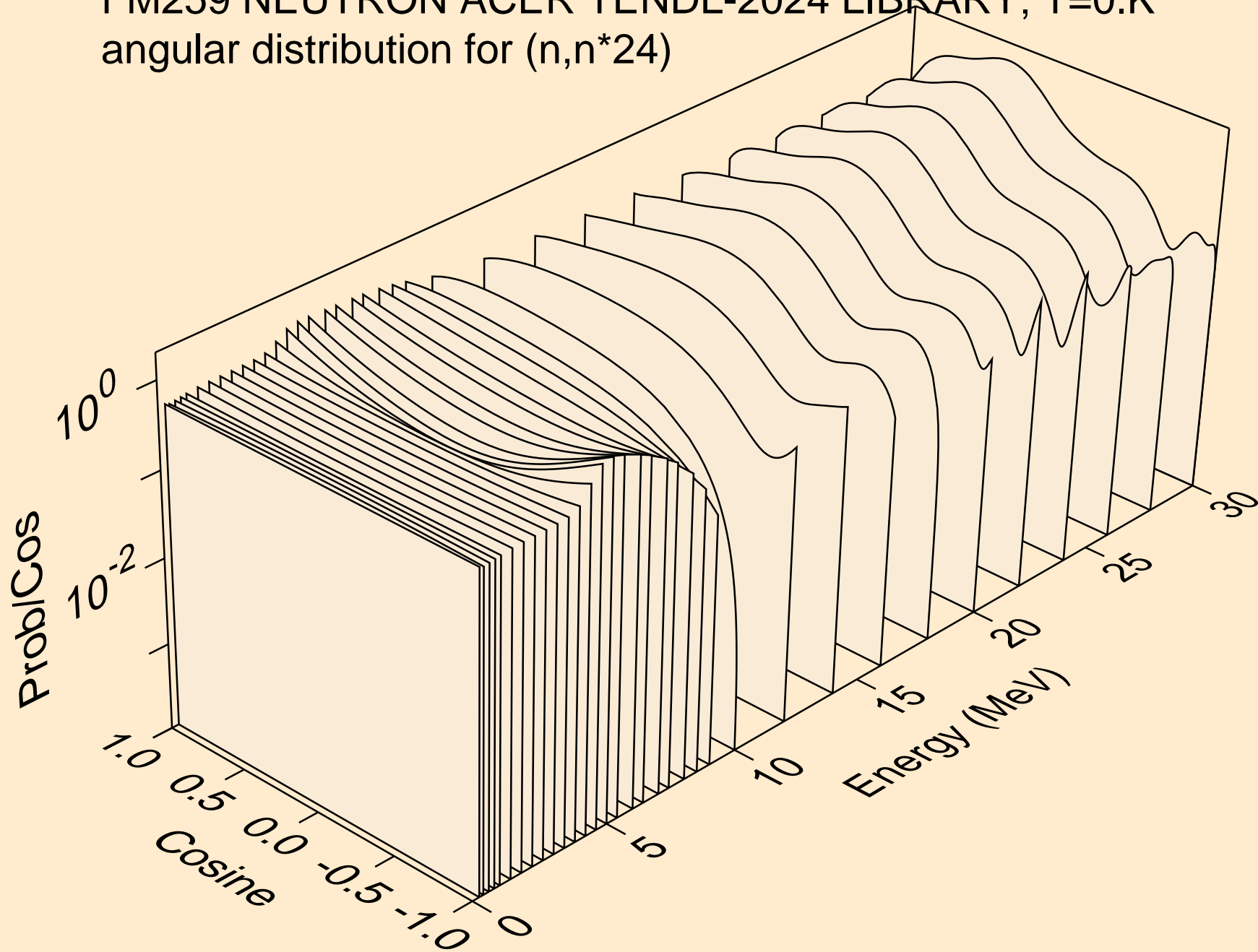

FM259 NEUTRON ACER TENDL-2024 LIBRARY; T=0.K
angular distribution for (n,n*25)

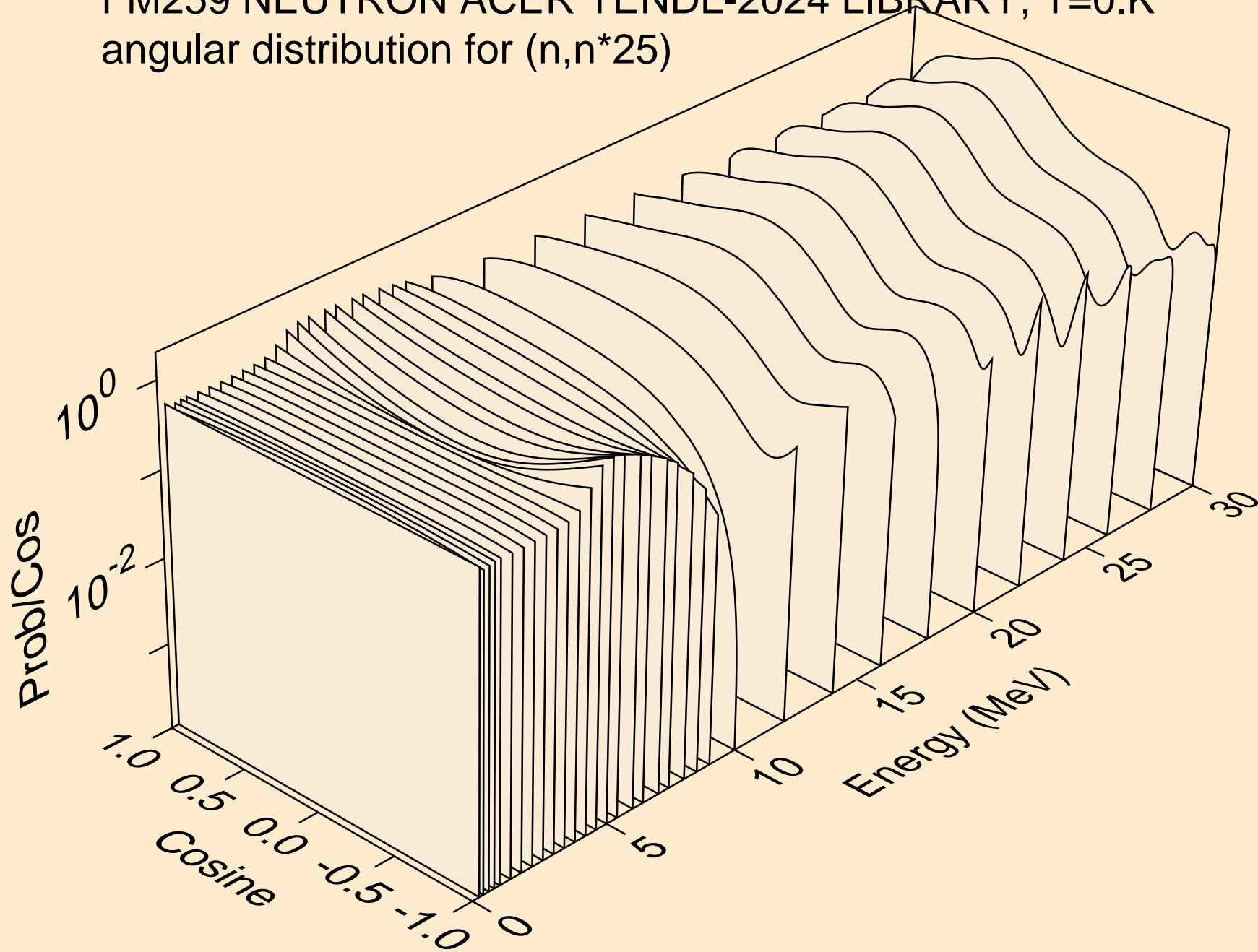

FM259 NEUTRON ACER TENDL-2024 LIBRARY; T=0.K
angular distribution for (n,n*26)

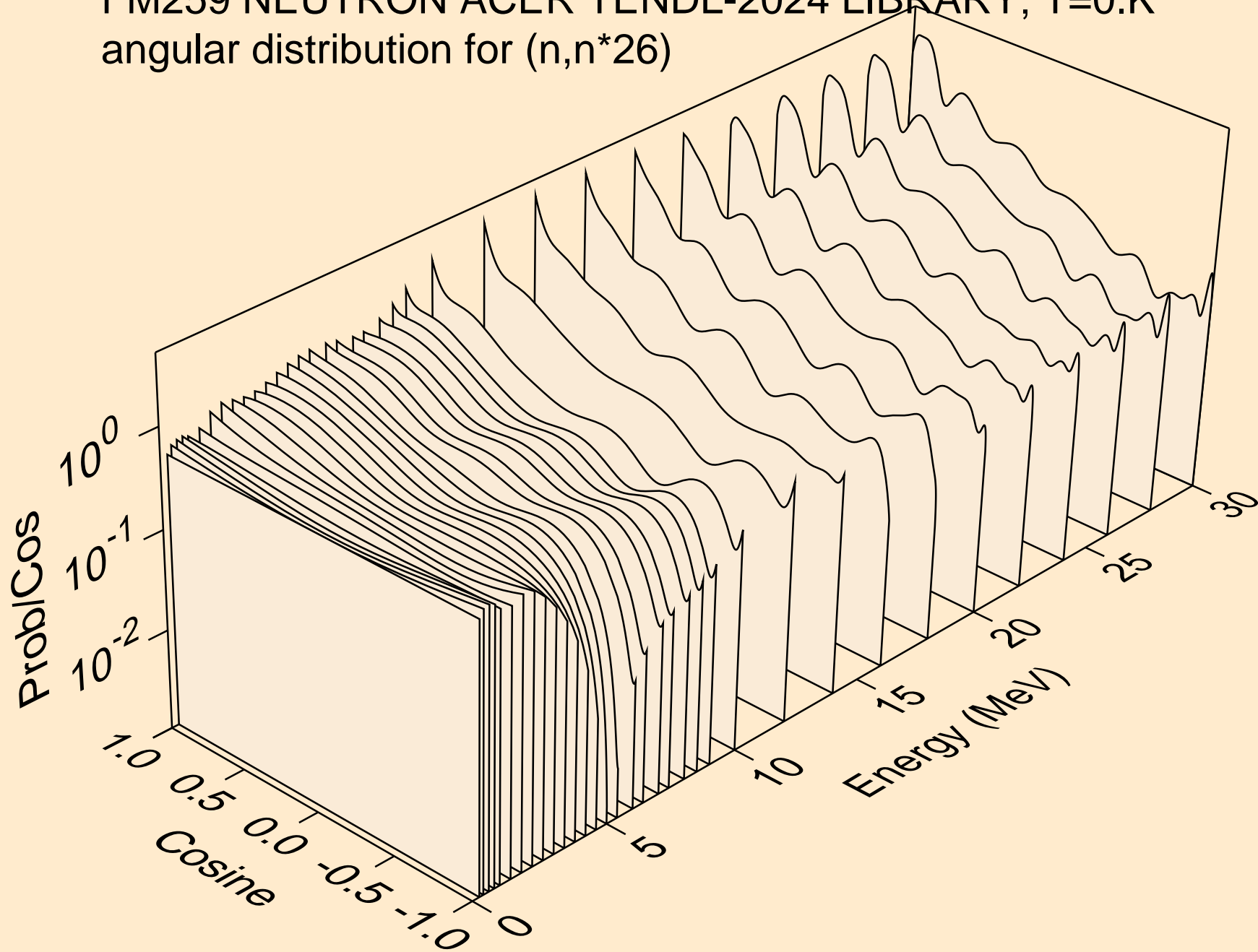

FM259 NEUTRON ACER TENDL-2024 LIBRARY; T=0.K
Total fission nubar

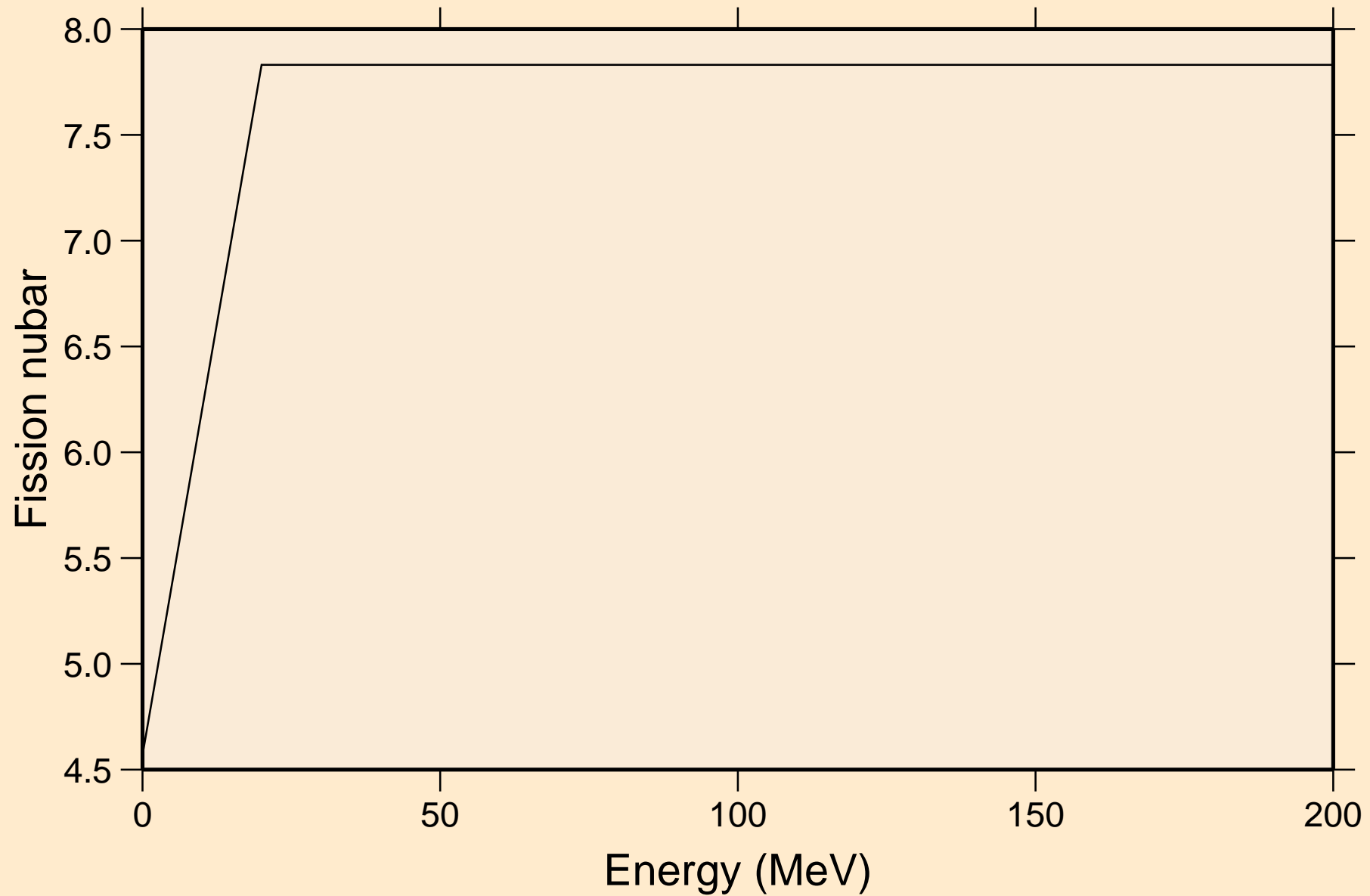

FM259 NEUTRON ACER TENDL-2024 LIBRARY; T=0.K
Neutron emission for (n,x)

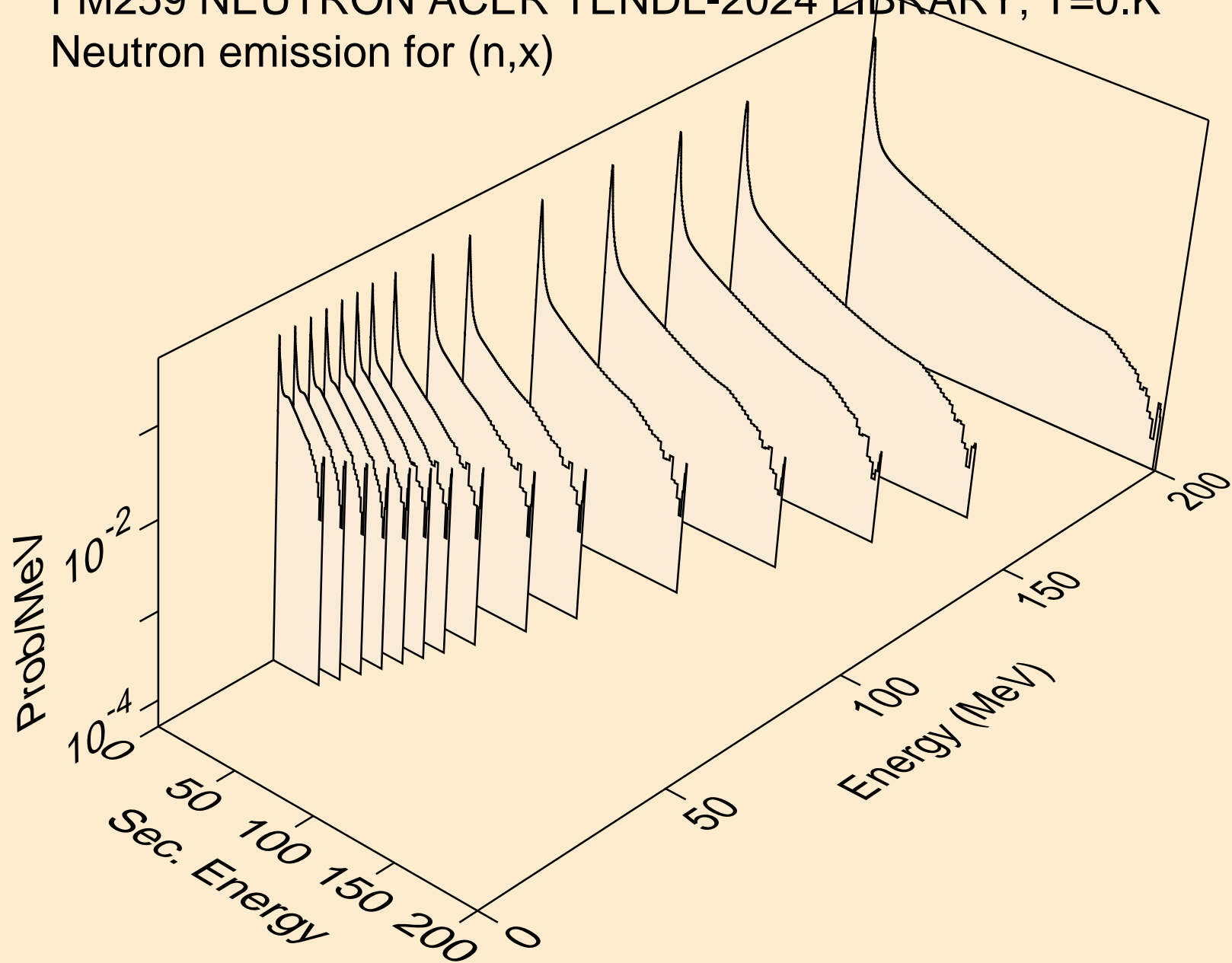

FM259 NEUTRON ACER TENDL-2024 LIBRARY; T=0.K
Neutron emission for (n,2nd)

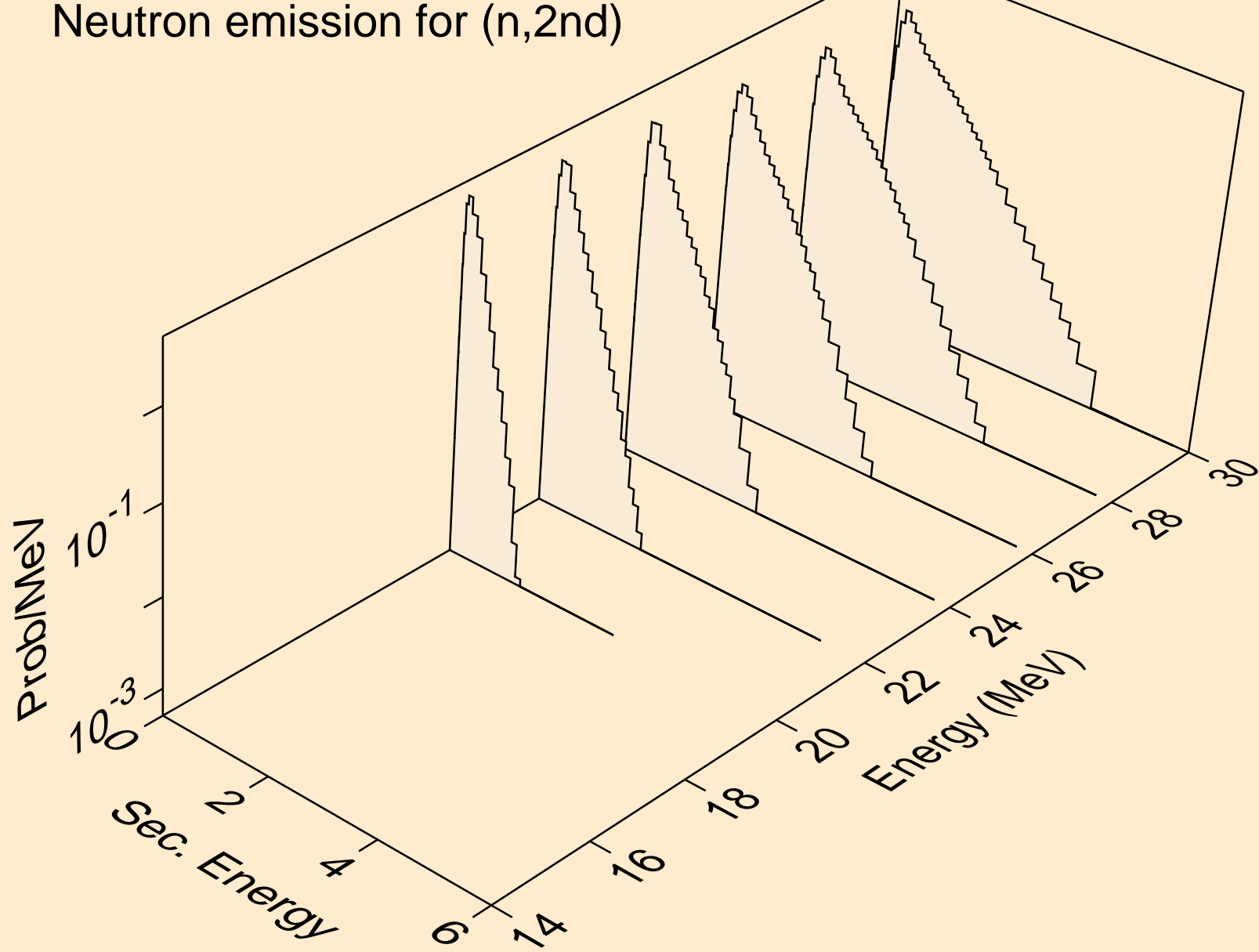

FM259 NEUTRON ACER TENDL-2024 LIBRARY; T=0.K
Neutron emission for (n,2n)

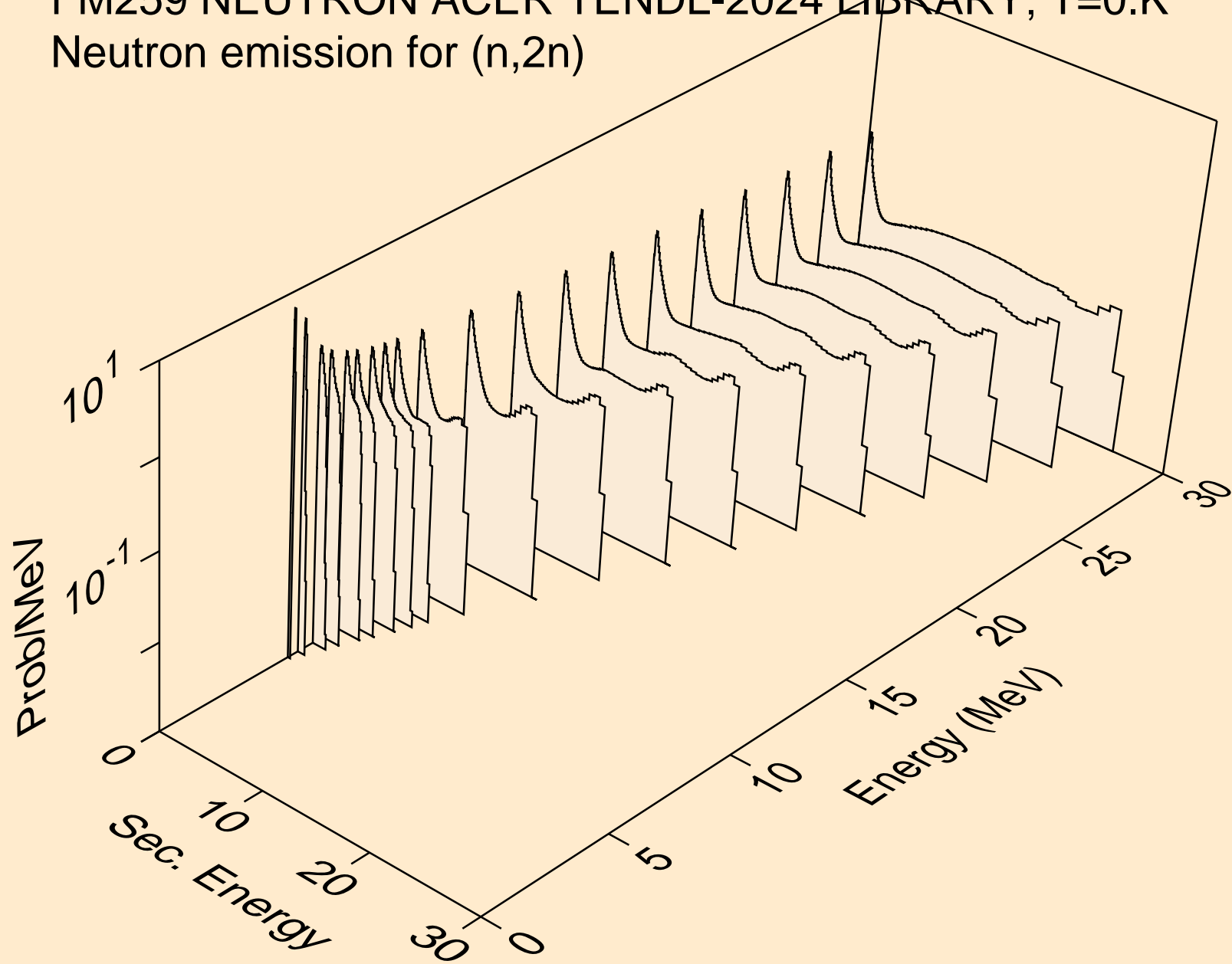

FM259 NEUTRON ACER TENDL-2024 LIBRARY; T=0.K
Neutron emission for (n,3n)

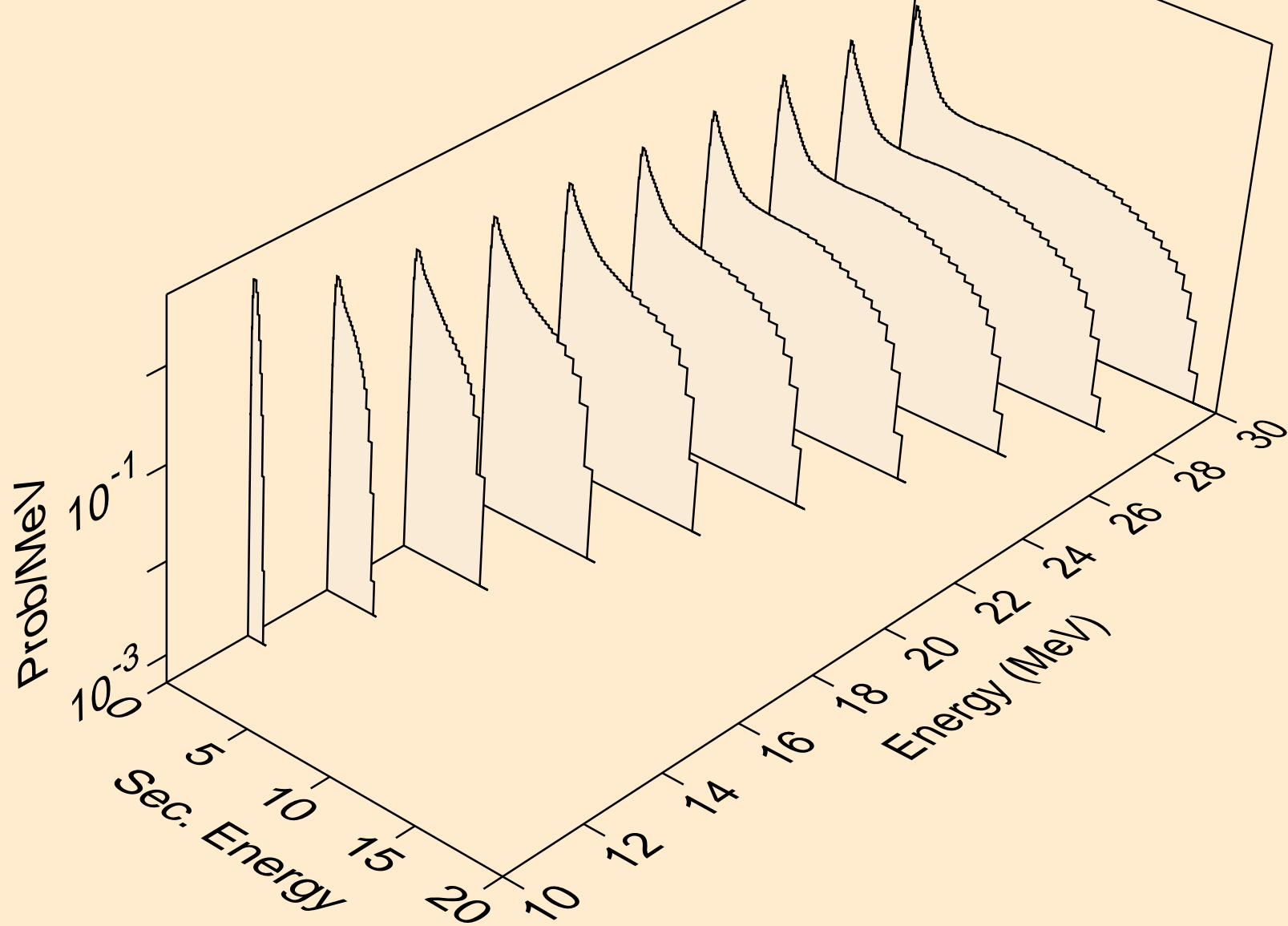

FM259 NEUTRON ACER TENDL-2024 LIBRARY; T=0.K
Neutron emission for fission

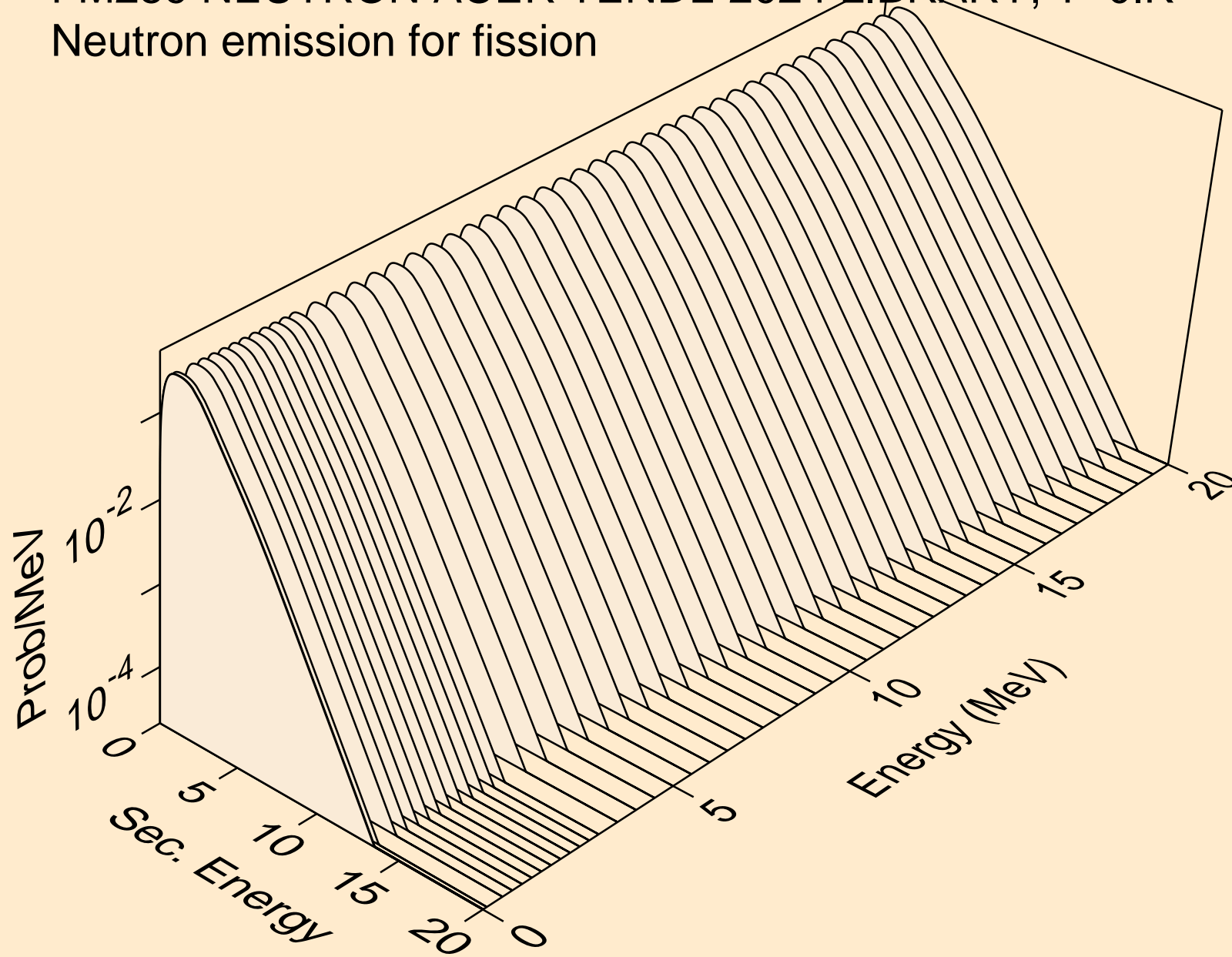

FM259 NEUTRON ACER TENDL-2024 LIBRARY; T=0.K
Neutron emission for (n,n*)a

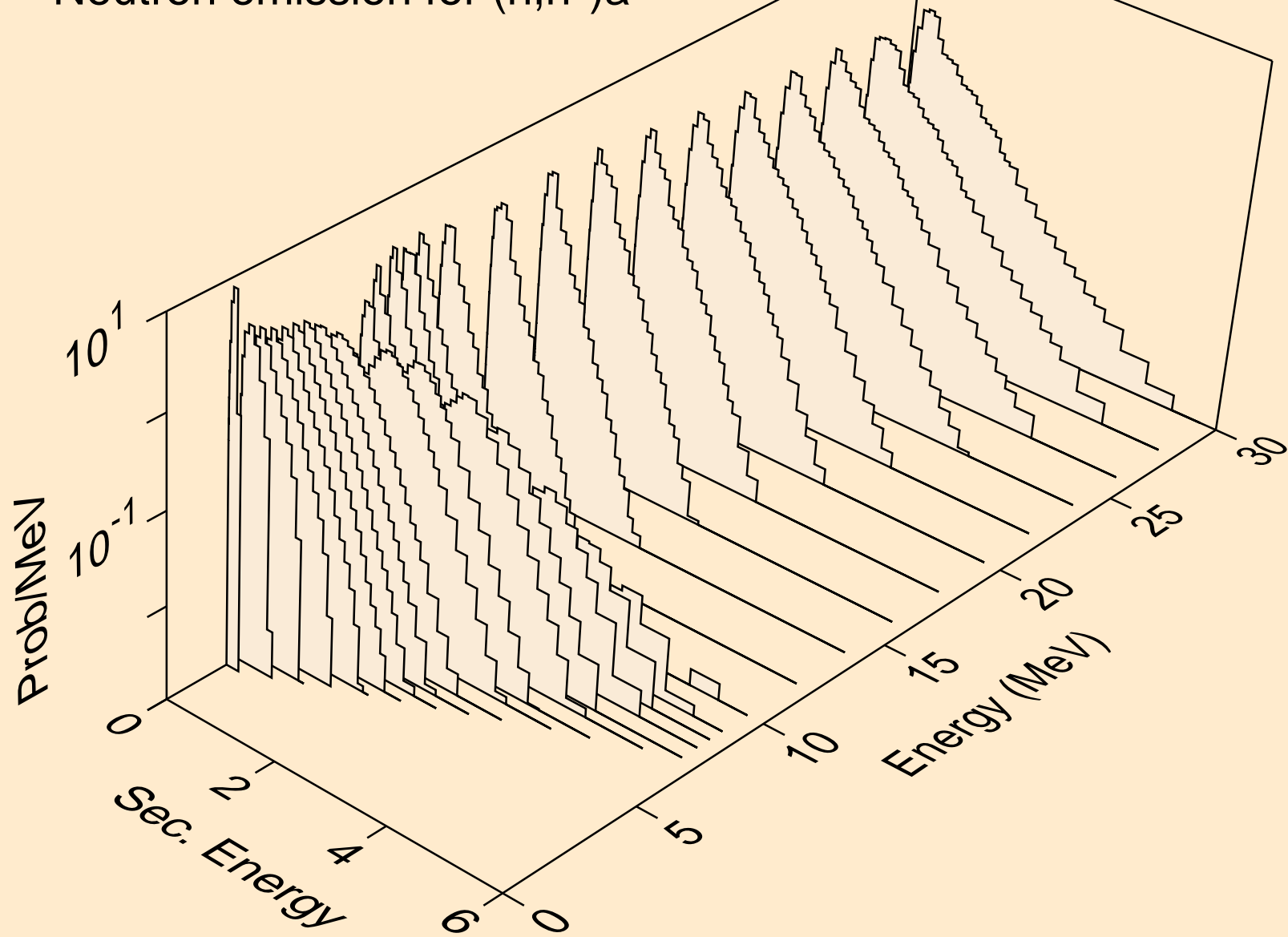

FM259 NEUTRON ACER TENDL-2024 LIBRARY; T=0.K
Neutron emission for (n,2n)a

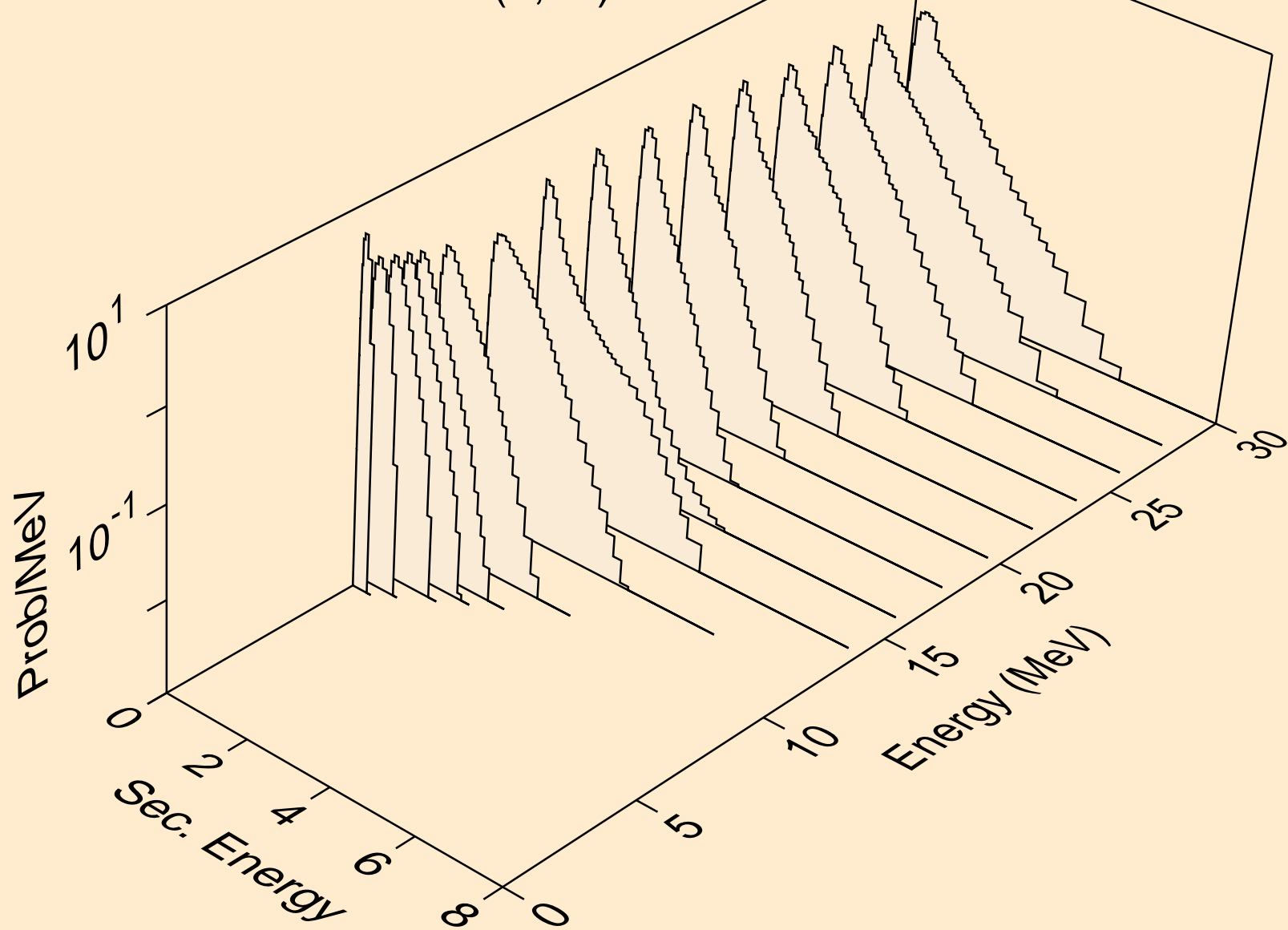

FM259 NEUTRON ACER TENDL-2024 LIBRARY; T=0.K
Neutron emission for (n,3n)a

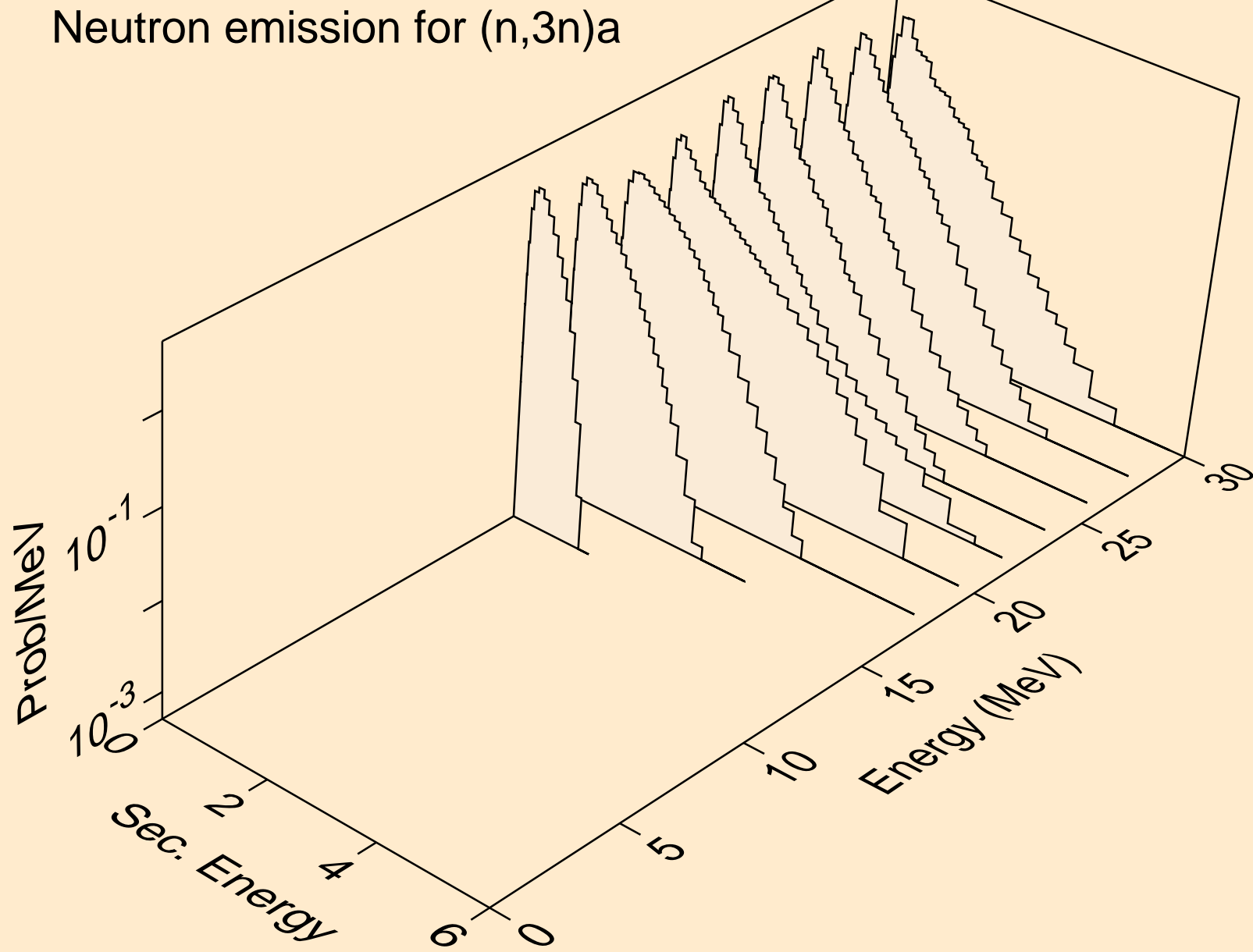

FM259 NEUTRON ACER TENDL-2024 LIBRARY; T=0.K
Neutron emission for (n,n*)p

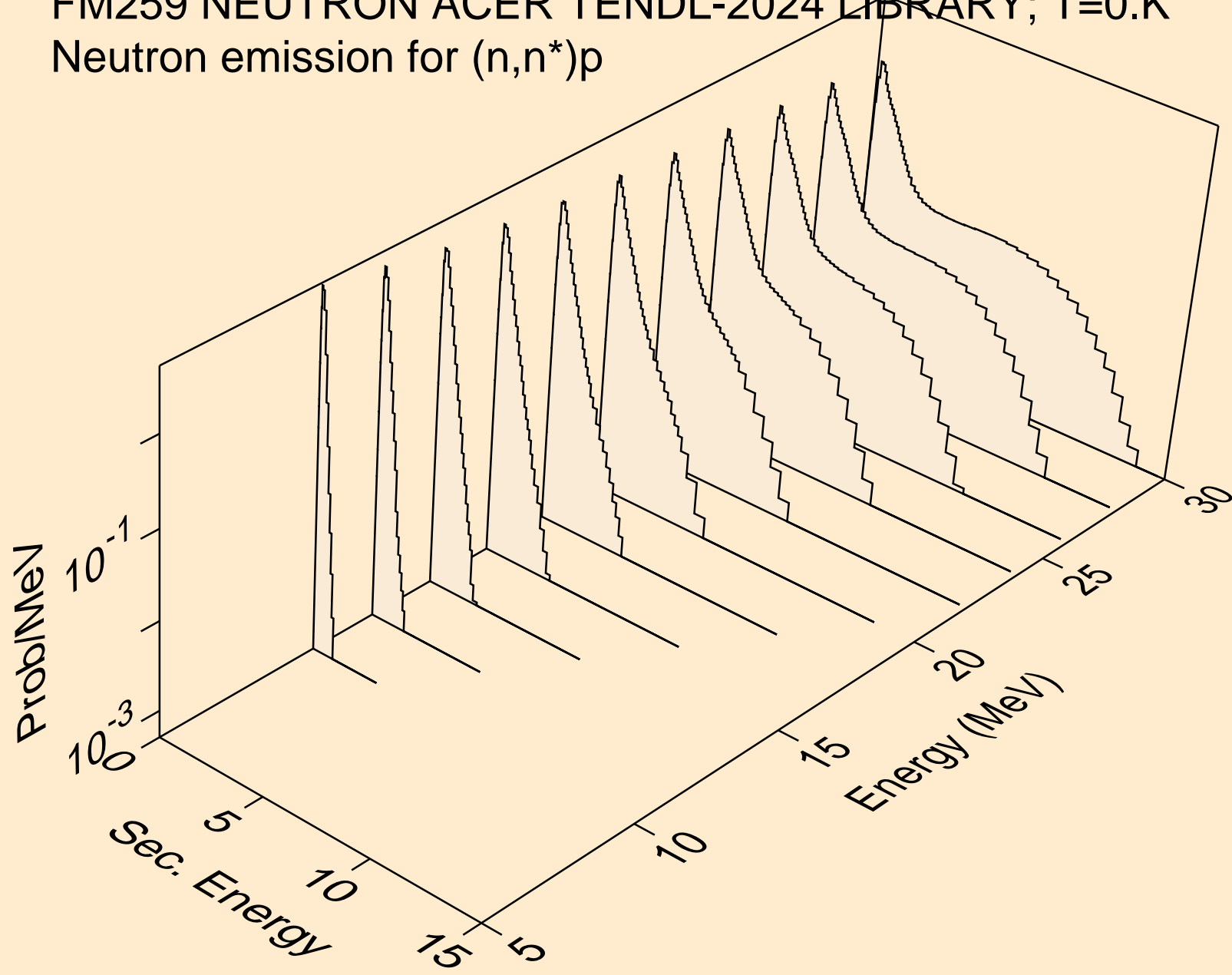

FM259 NEUTRON ACER TENDL-2024 LIBRARY; T=0.K
Neutron emission for (n,n*)d

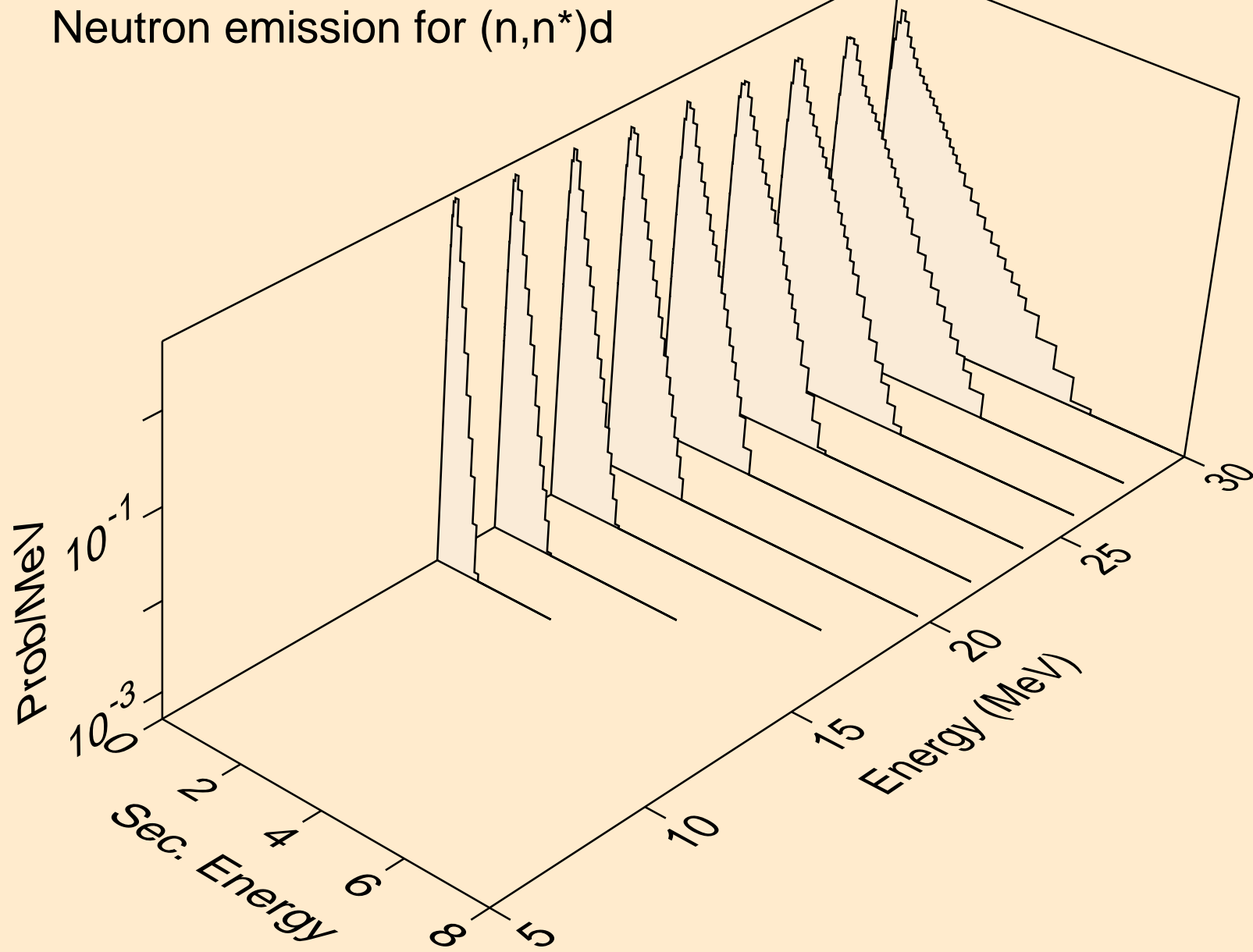

FM259 NEUTRON ACER TENDL-2024 LIBRARY; T=0.K
Neutron emission for (n,n*)t

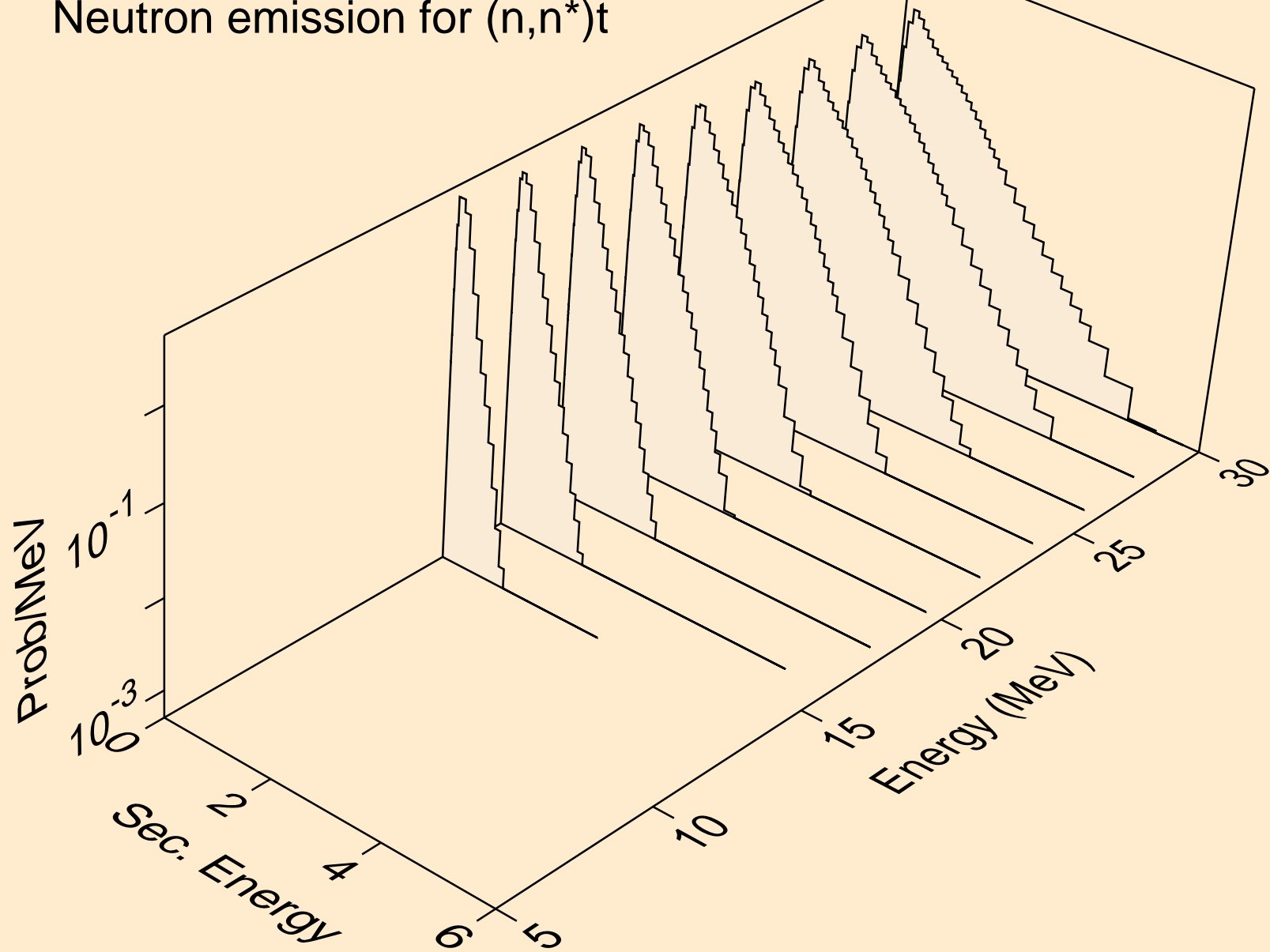

FM259 NEUTRON ACER TENDL-2024 LIBRARY; T=0.K
Neutron emission for (n,n*)he3

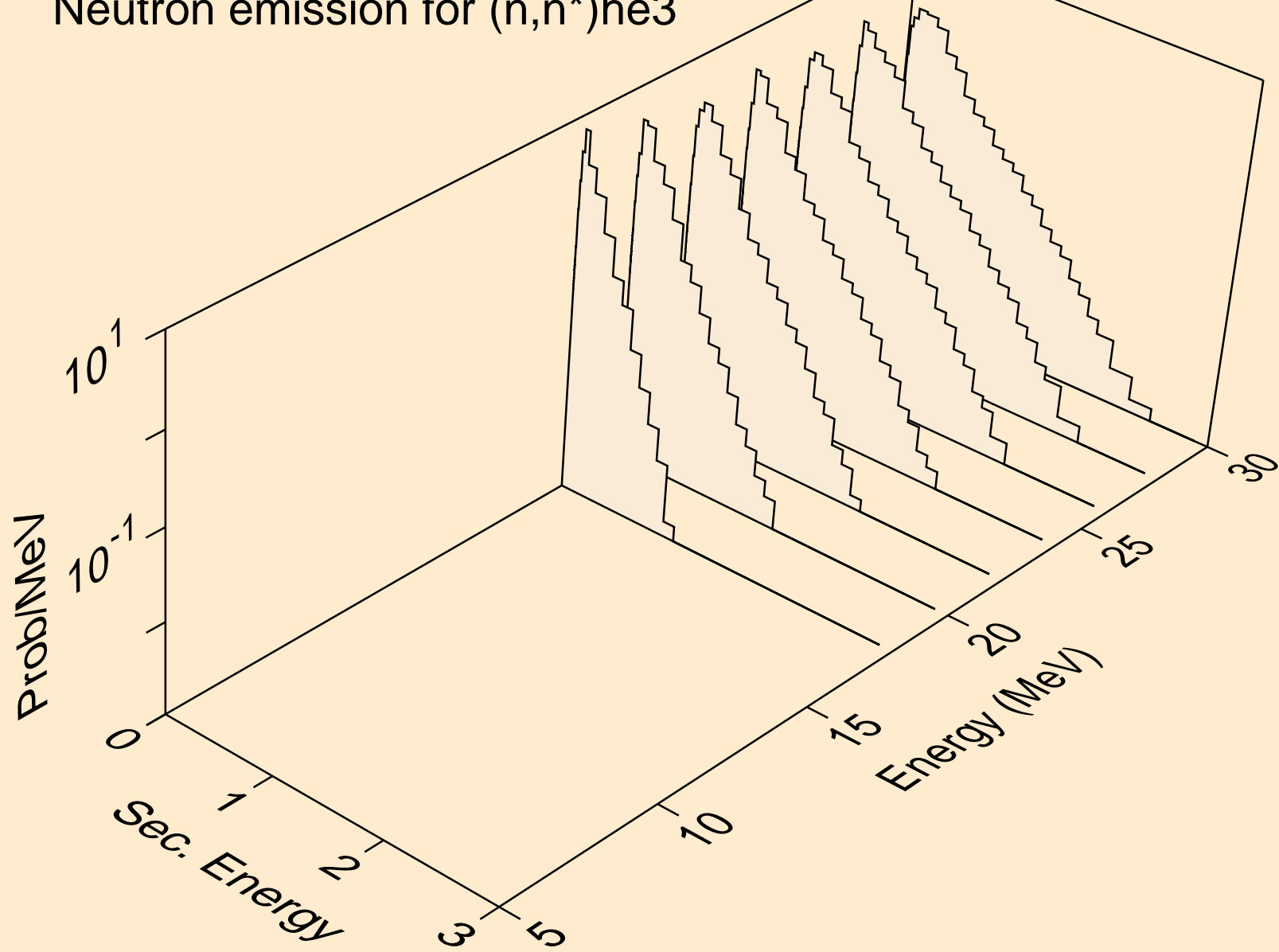

FM259 NEUTRON ACER TENDL-2024 LIBRARY; T=0.K
Neutron emission for (n,4n)

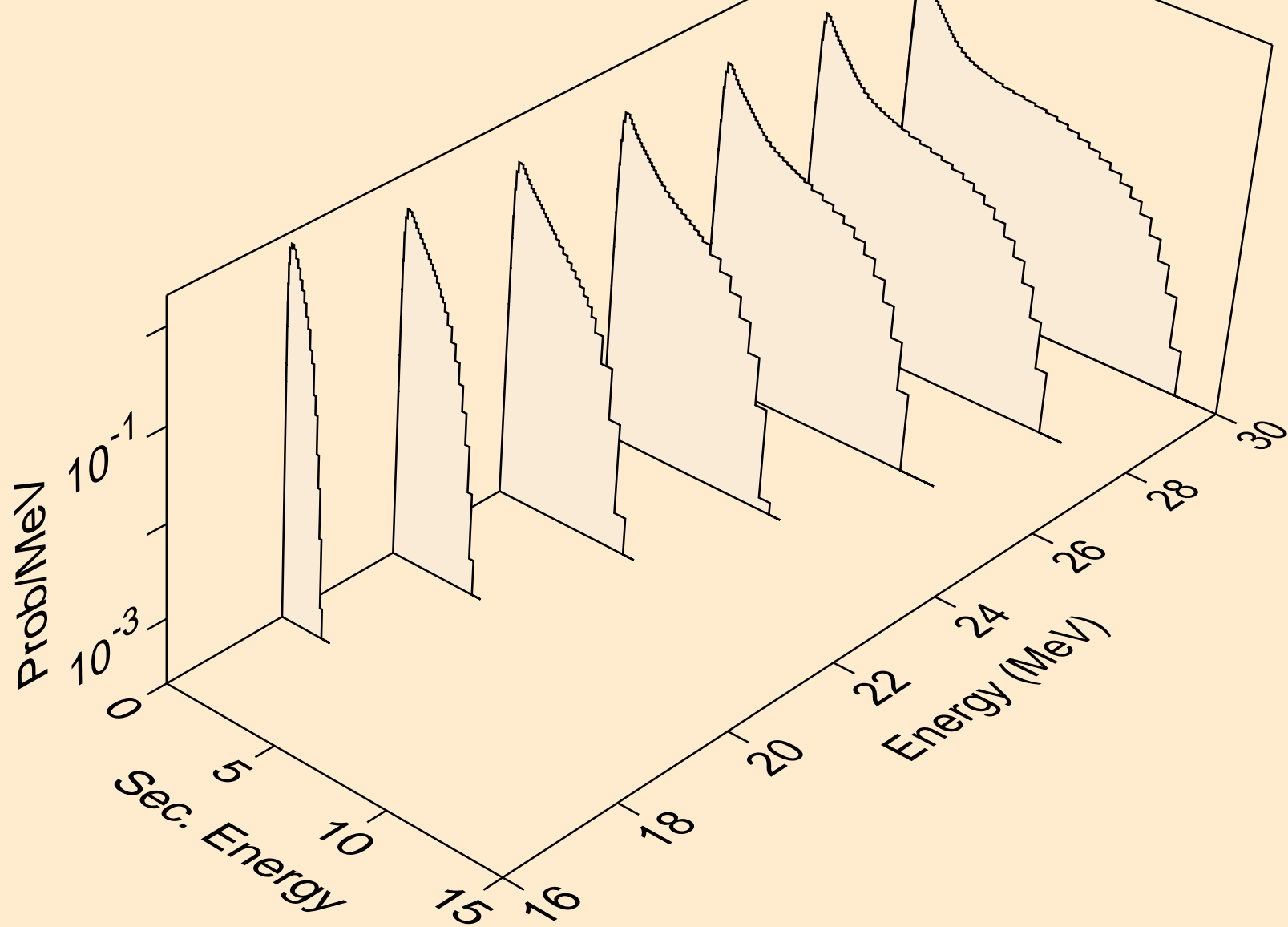

FM259 NEUTRON ACER TENDL-2024 LIBRARY; T=0.K
Neutron emission for (n,2np)

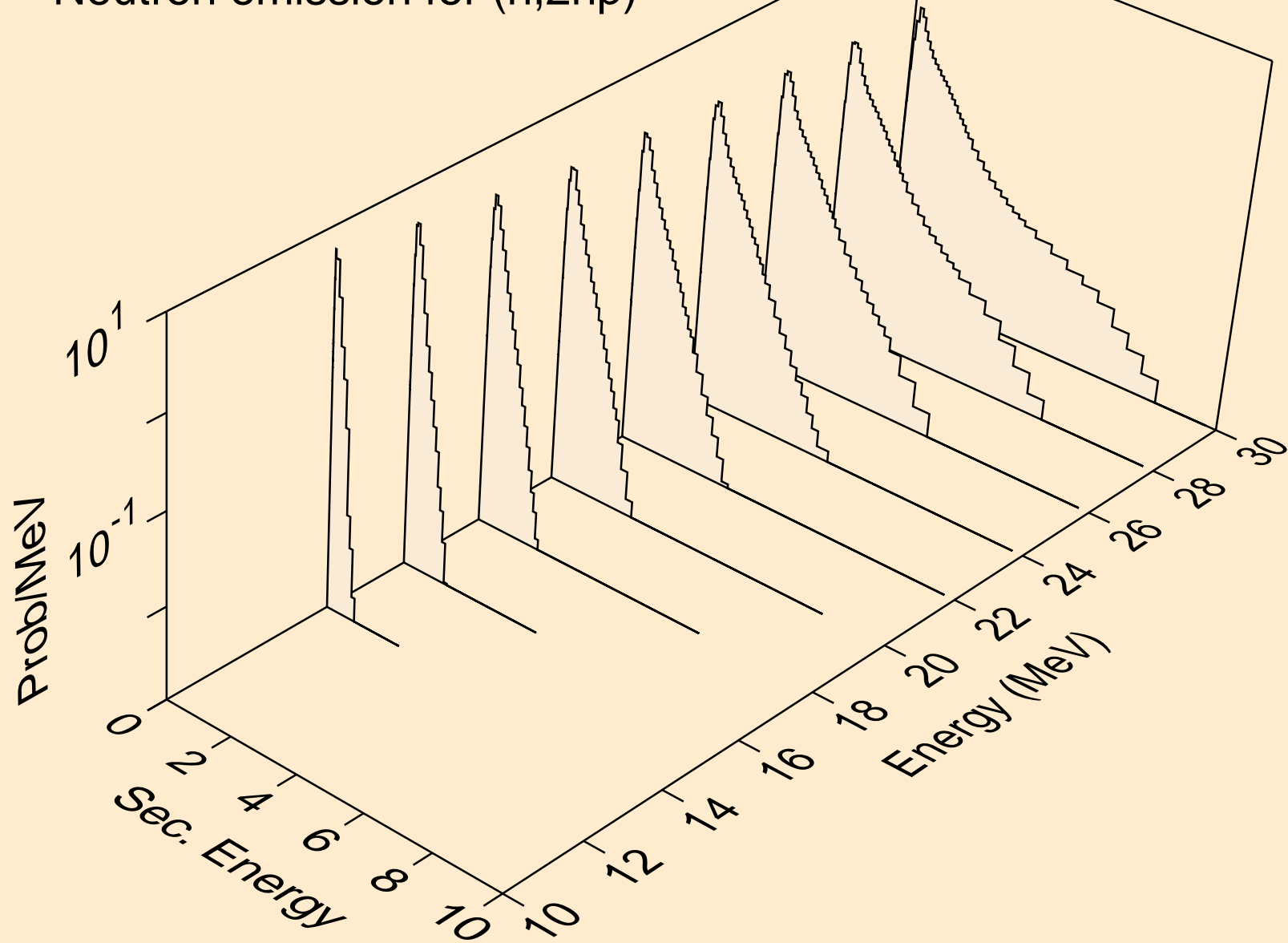

FM259 NEUTRON ACER TENDL-2024 LIBRARY; T=0.K
Neutron emission for (n,3np)

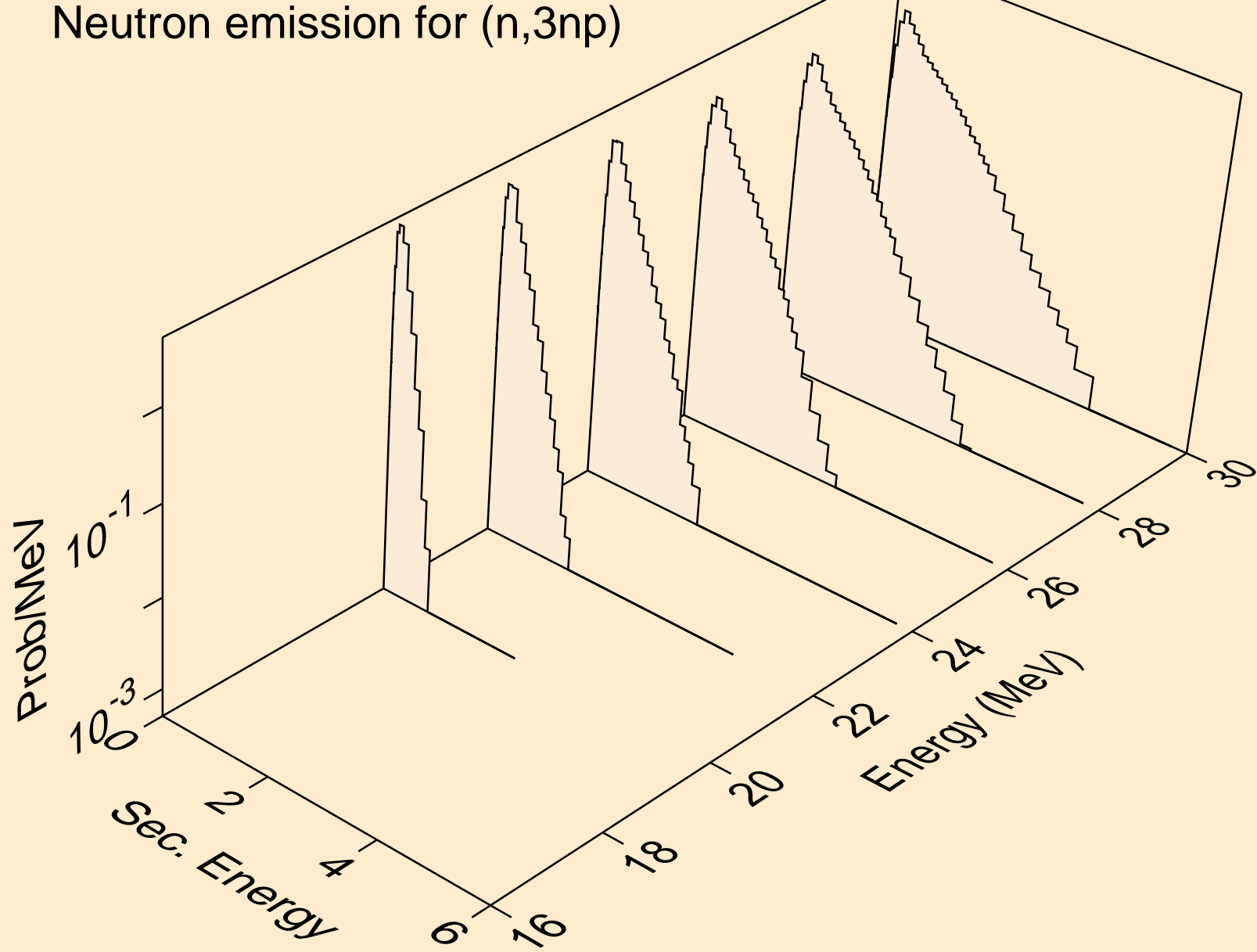

FM259 NEUTRON ACER TENDL-2024 LIBRARY; T=0.K
Neutron emission for (n,n2p)

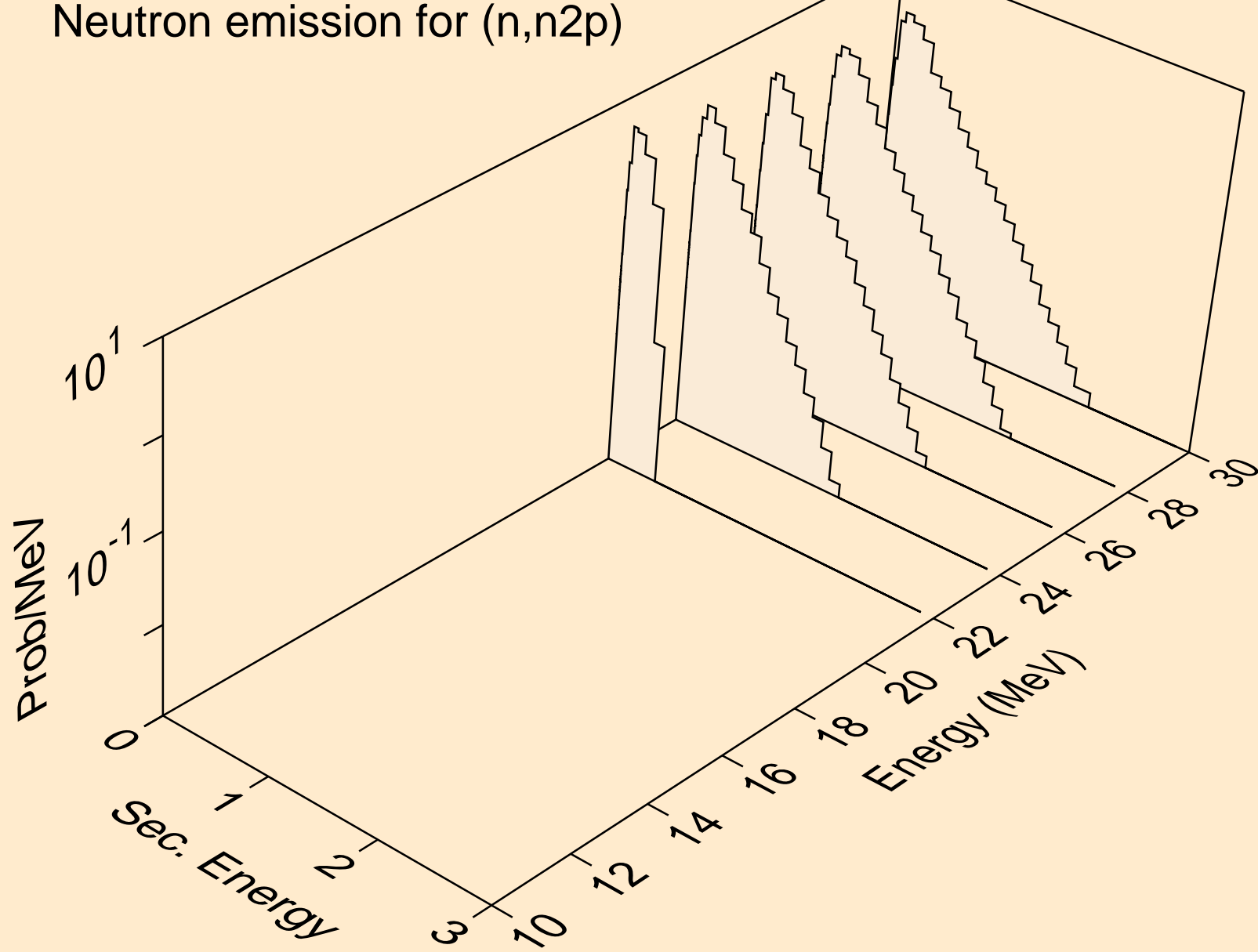

FM259 NEUTRON ACER TENDL-2024 LIBRARY; T=0.K
Neutron emission for (n,n*c)

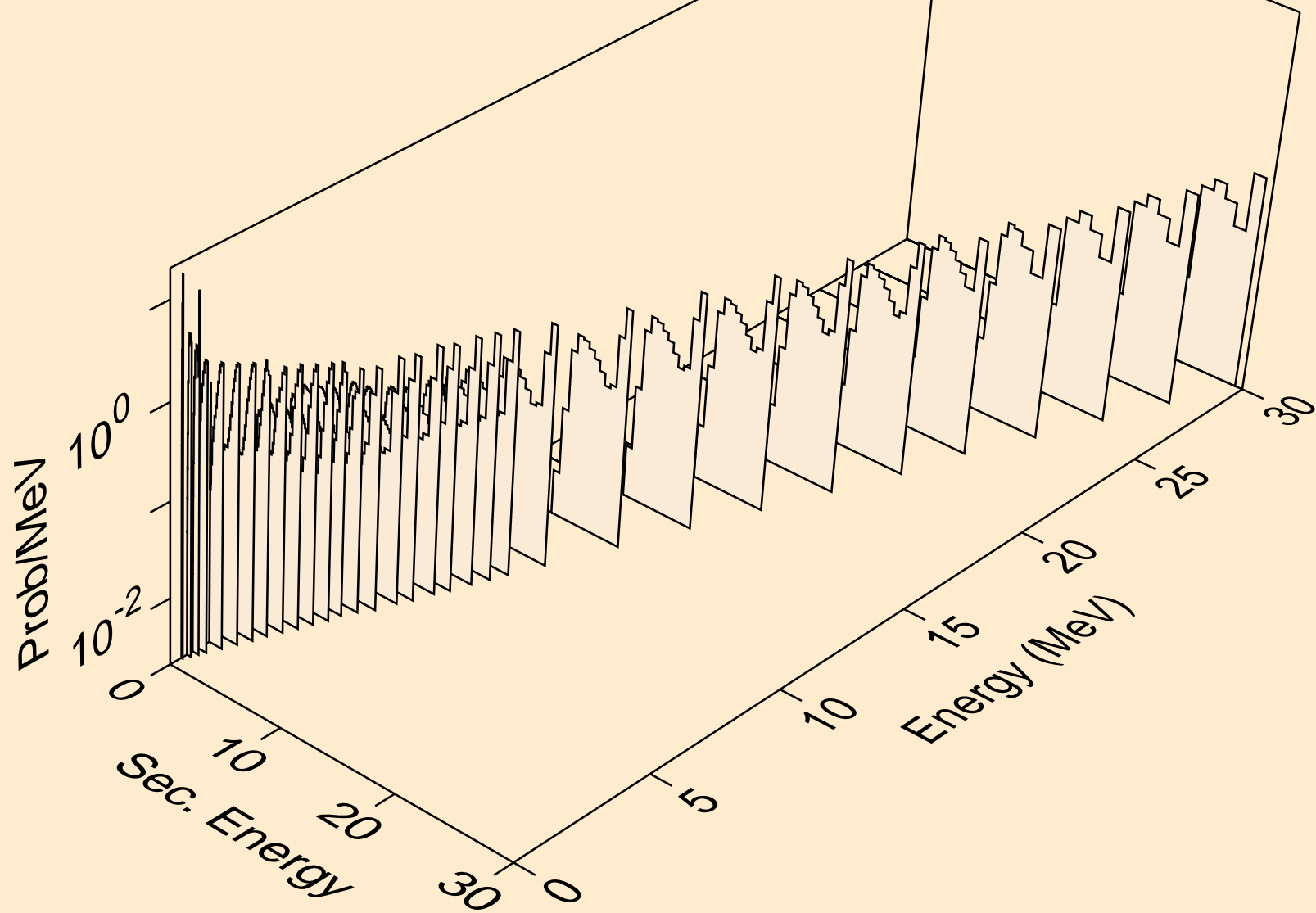

FM259 NEUTRON ACER TENDL-2024 LIBRARY; T=0.K

Delayed nubar

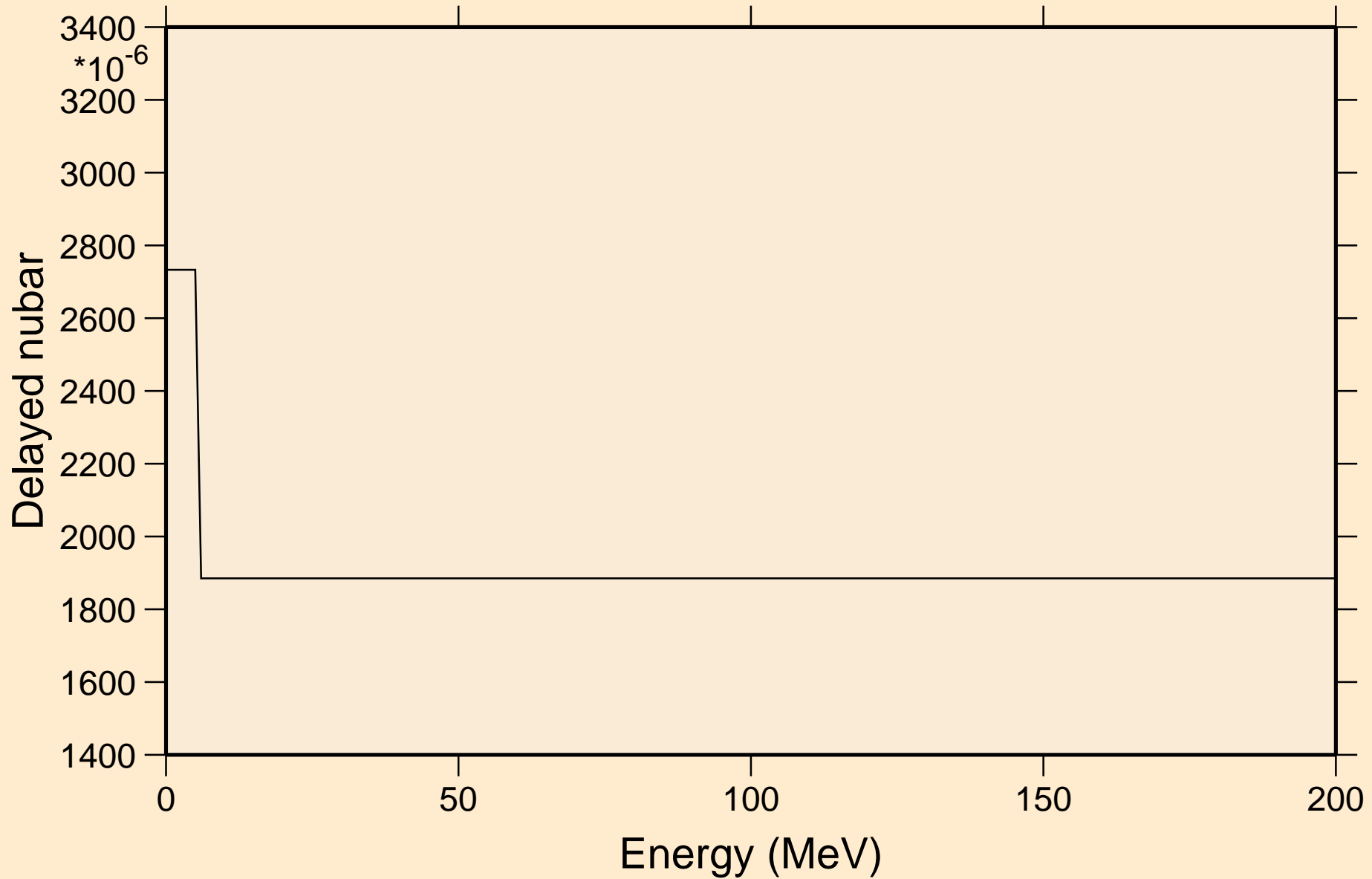

FM259 NEUTRON ACER TENDL-2024 LIBRARY; T=0.K

Delayed neutron spectra

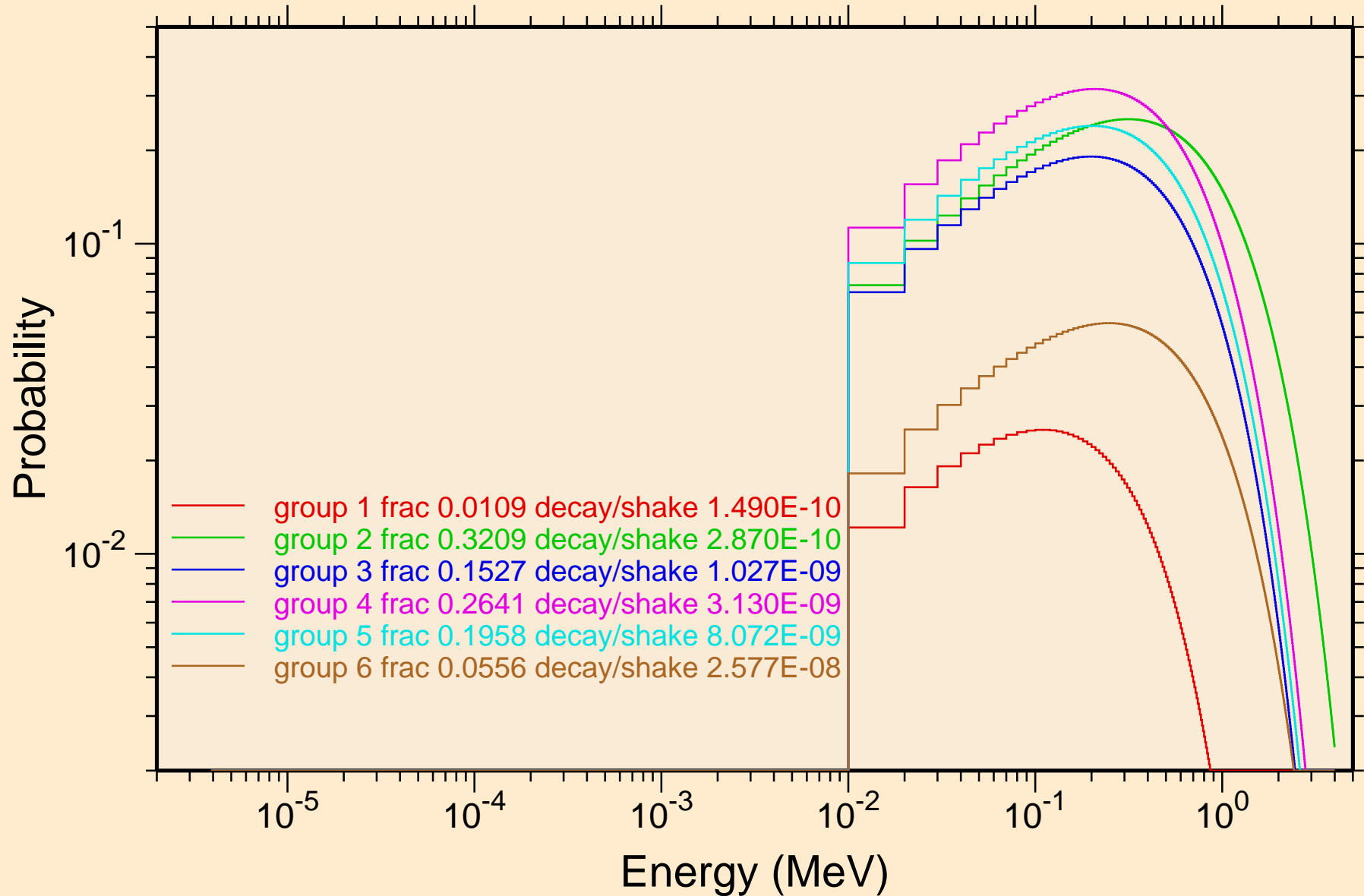

FM259 NEUTRON ACER TENDL-2024 LIBRARY; T=0.K
Photon emission for (n,x)

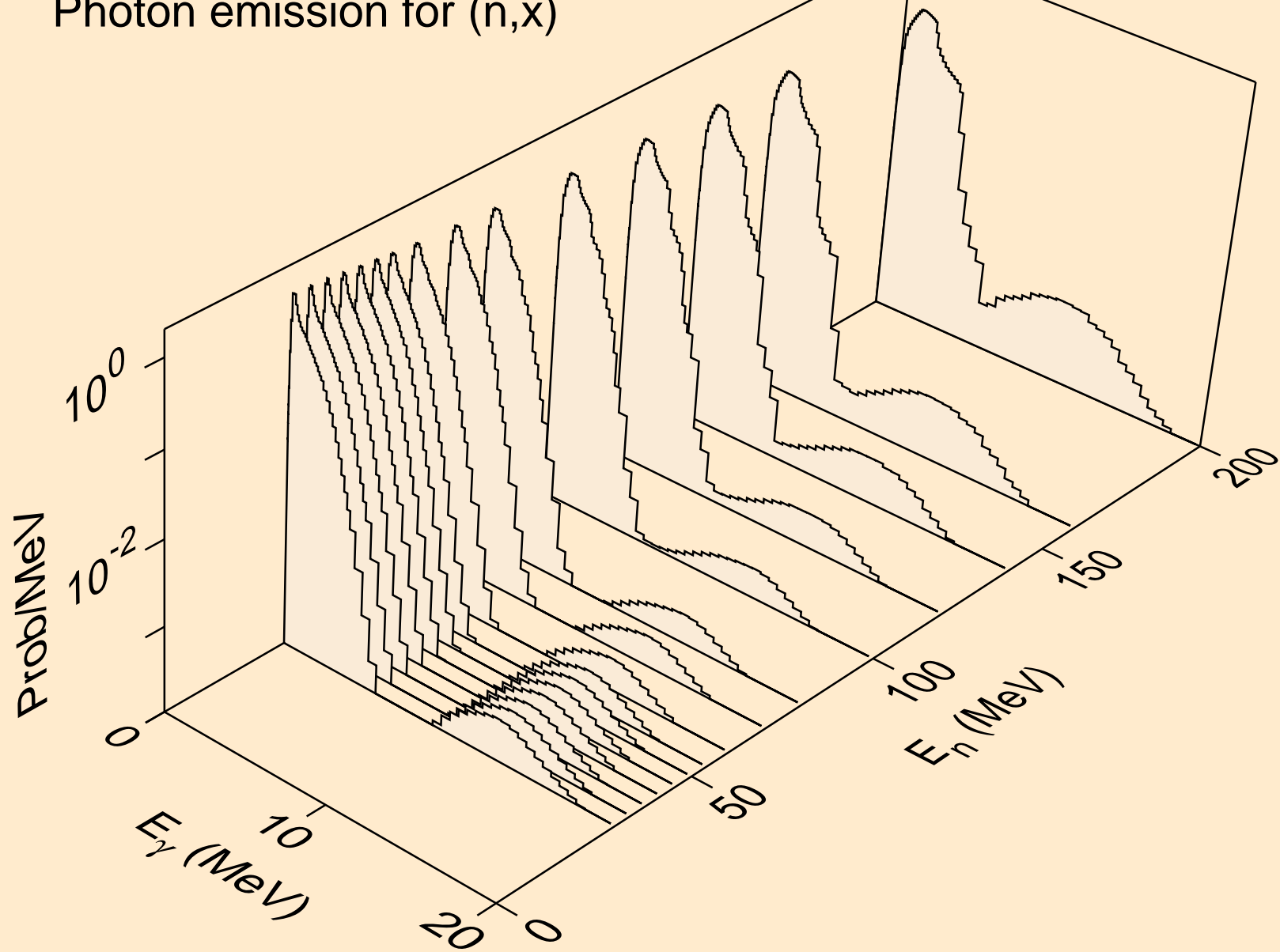

FM259 NEUTRON ACER TENDL-2024 LIBRARY; T=0.K
Photon emission for (n,2nd)

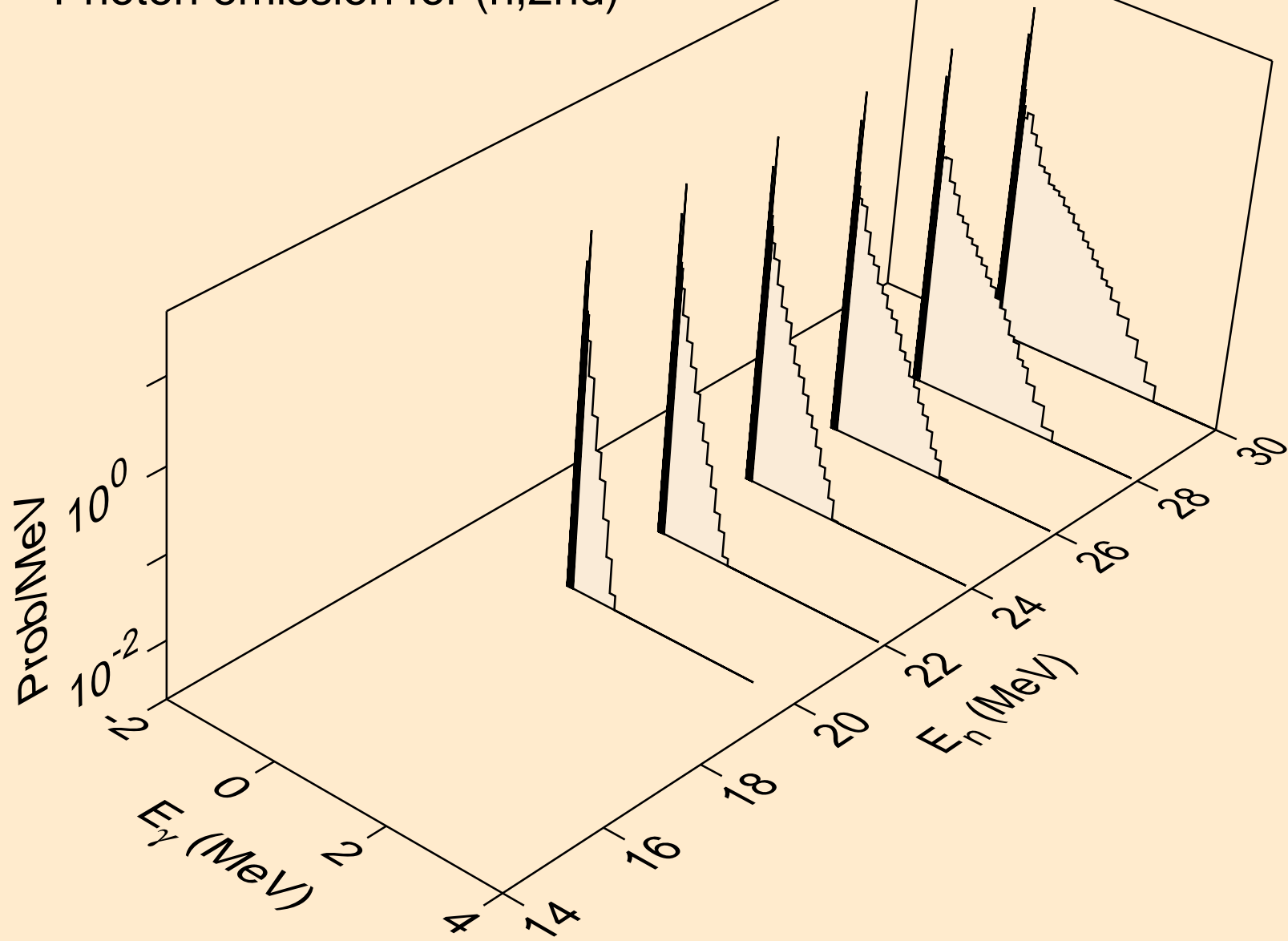

FM259 NEUTRON ACER TENDL-2024 LIBRARY; T=0.K
Photon emission for (n,2n)

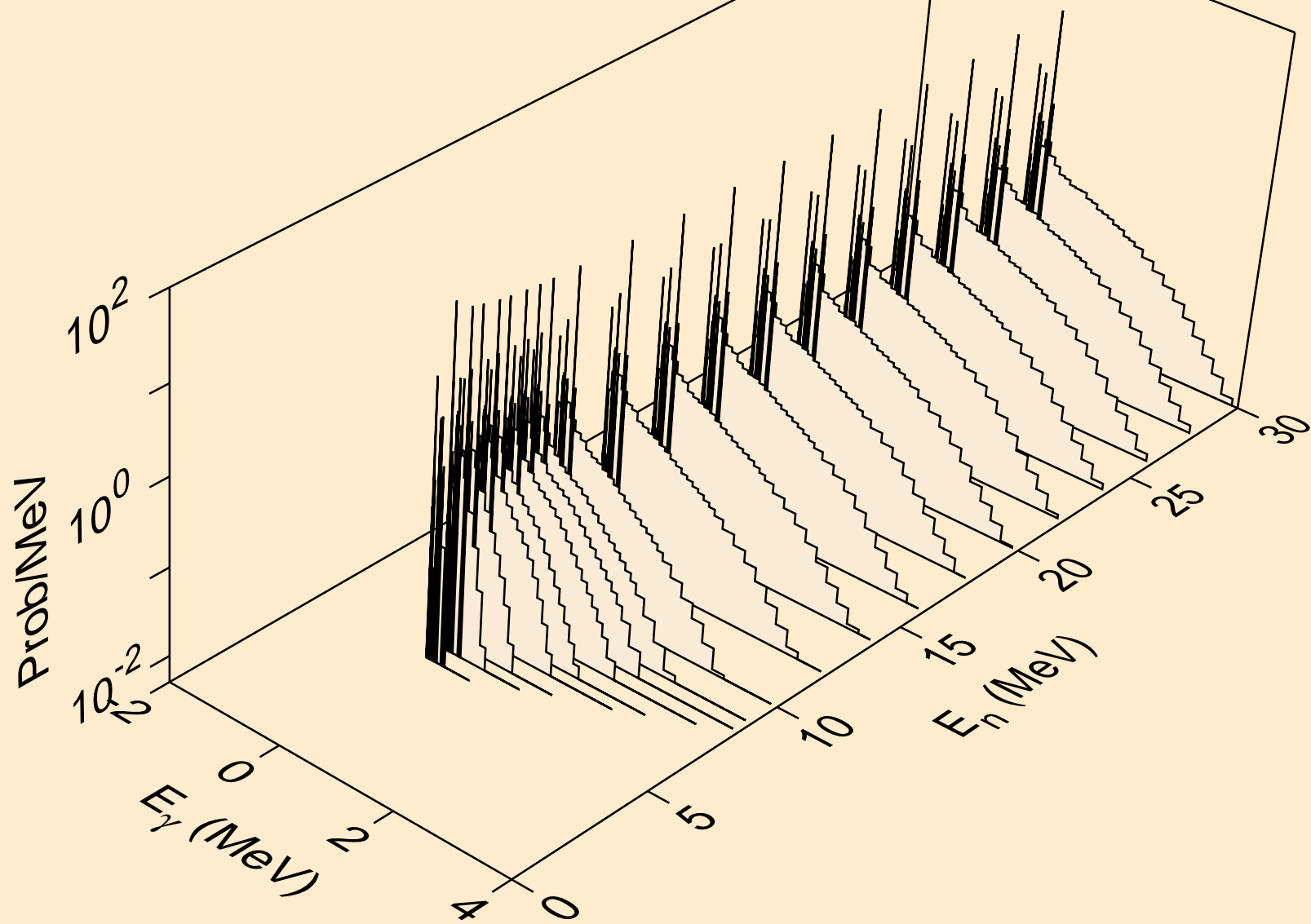

FM259 NEUTRON ACER TENDL-2024 LIBRARY; T=0.K
Photon emission for (n,3n)

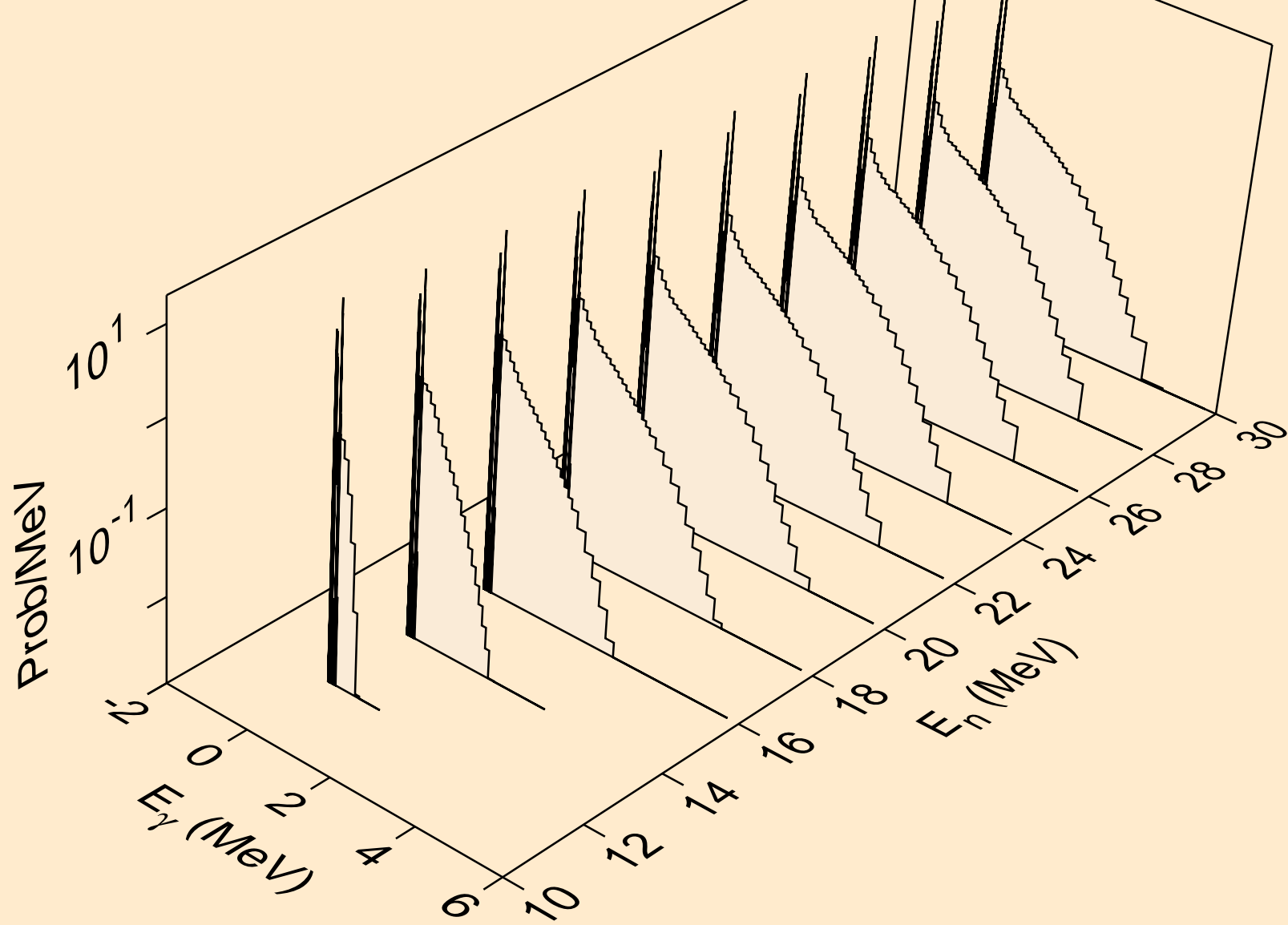

FM259 NEUTRON ACER TENDL-2024 LIBRARY; T=0.K
Photon emission for (n,n*)a

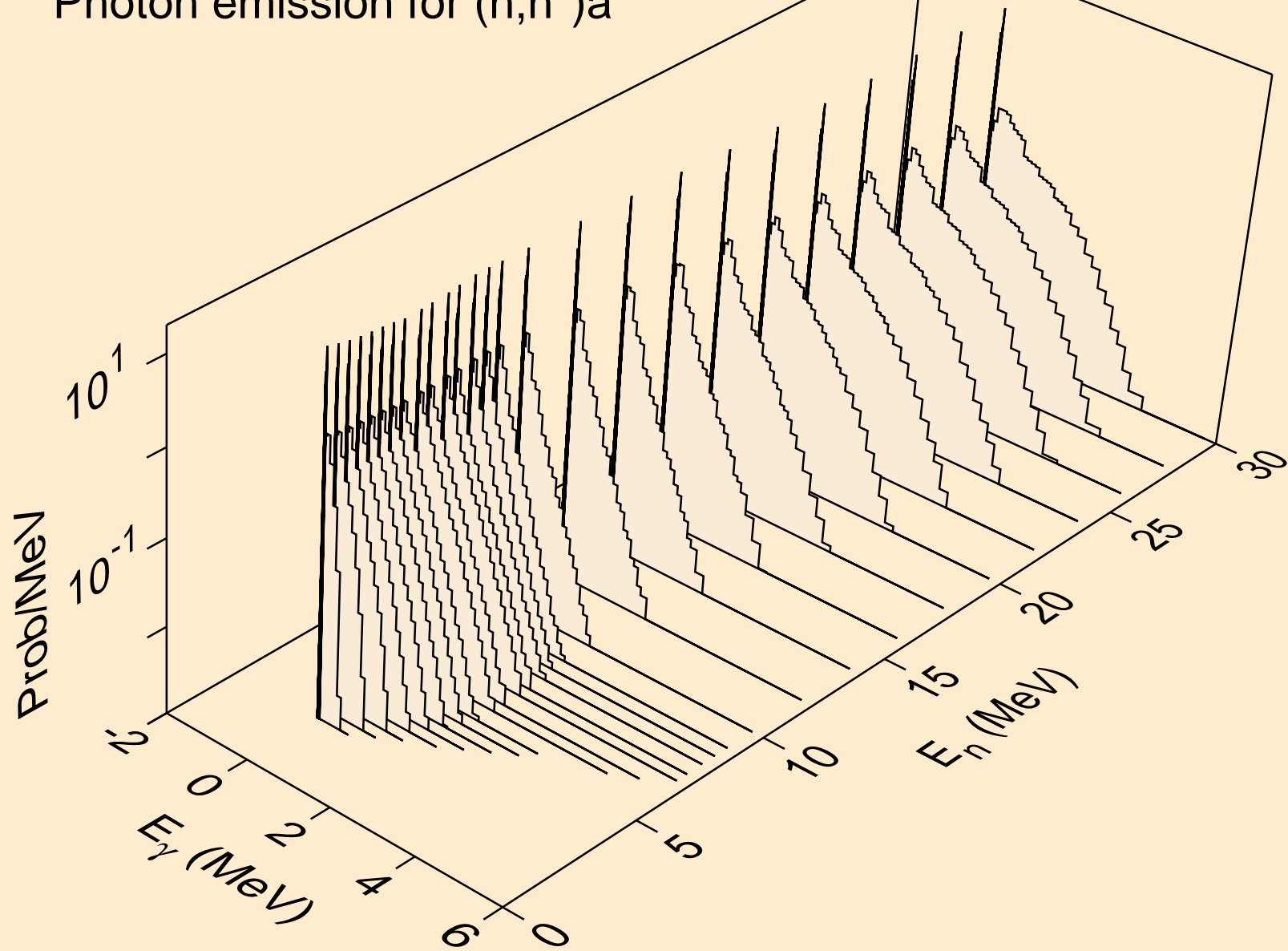

FM259 NEUTRON ACER TENDL-2024 LIBRARY; T=0.K
Photon emission for (n,2n)a

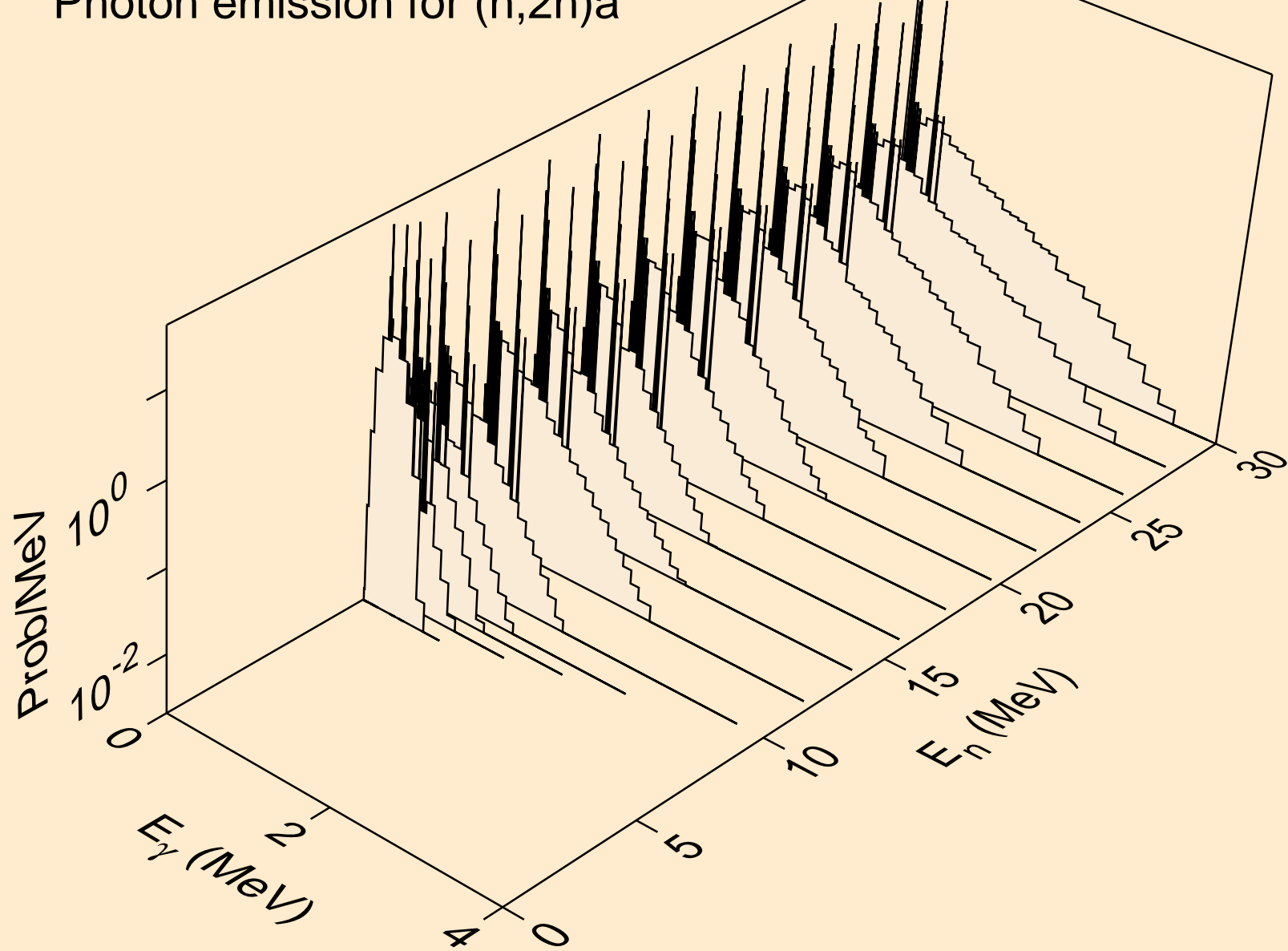

FM259 NEUTRON ACER TENDL-2024 LIBRARY; T=0.K
Photon emission for (n,3n)a

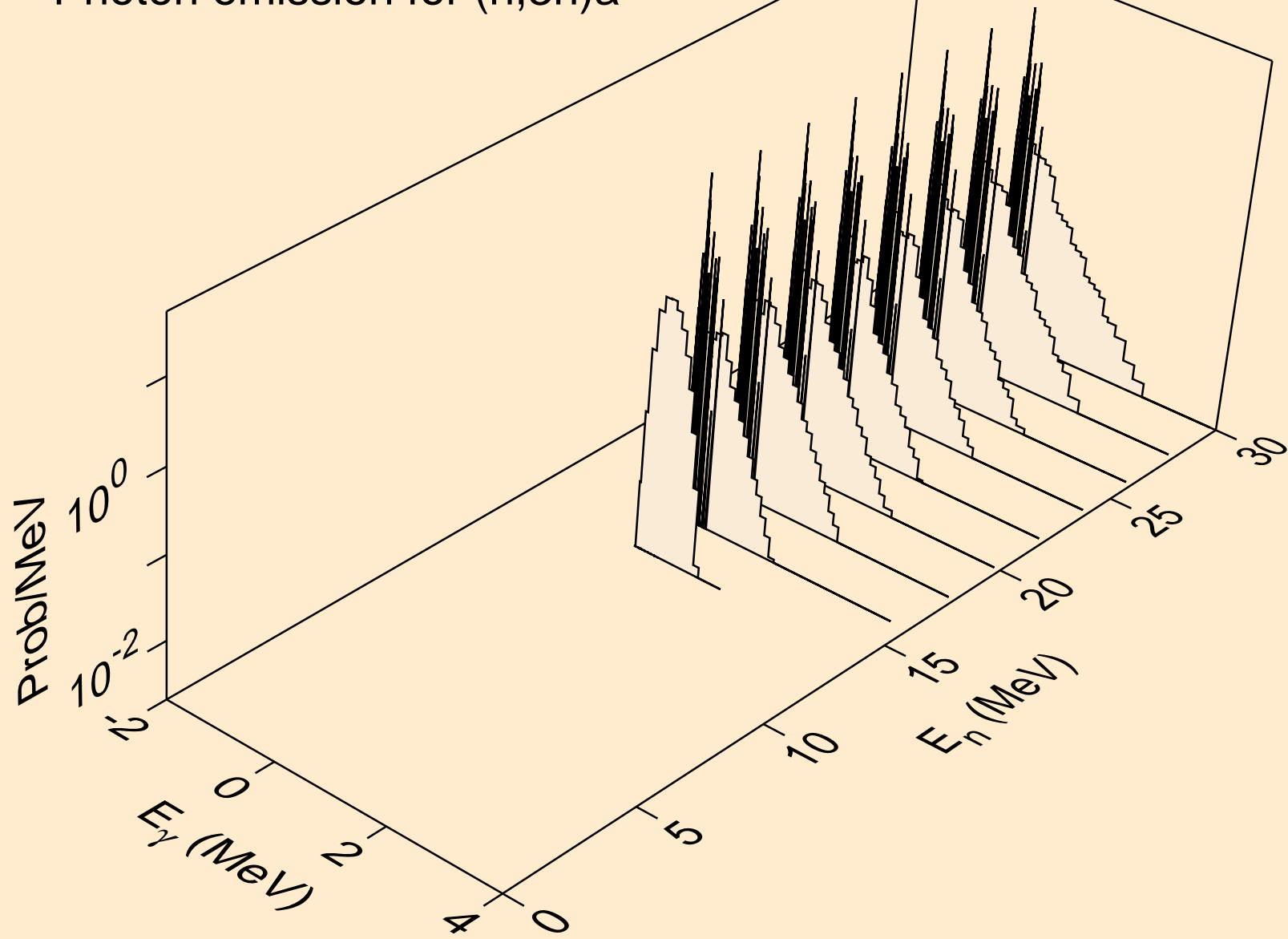

FM259 NEUTRON ACER TENDL-2024 LIBRARY; T=0.K
Photon emission for (n,n*)p

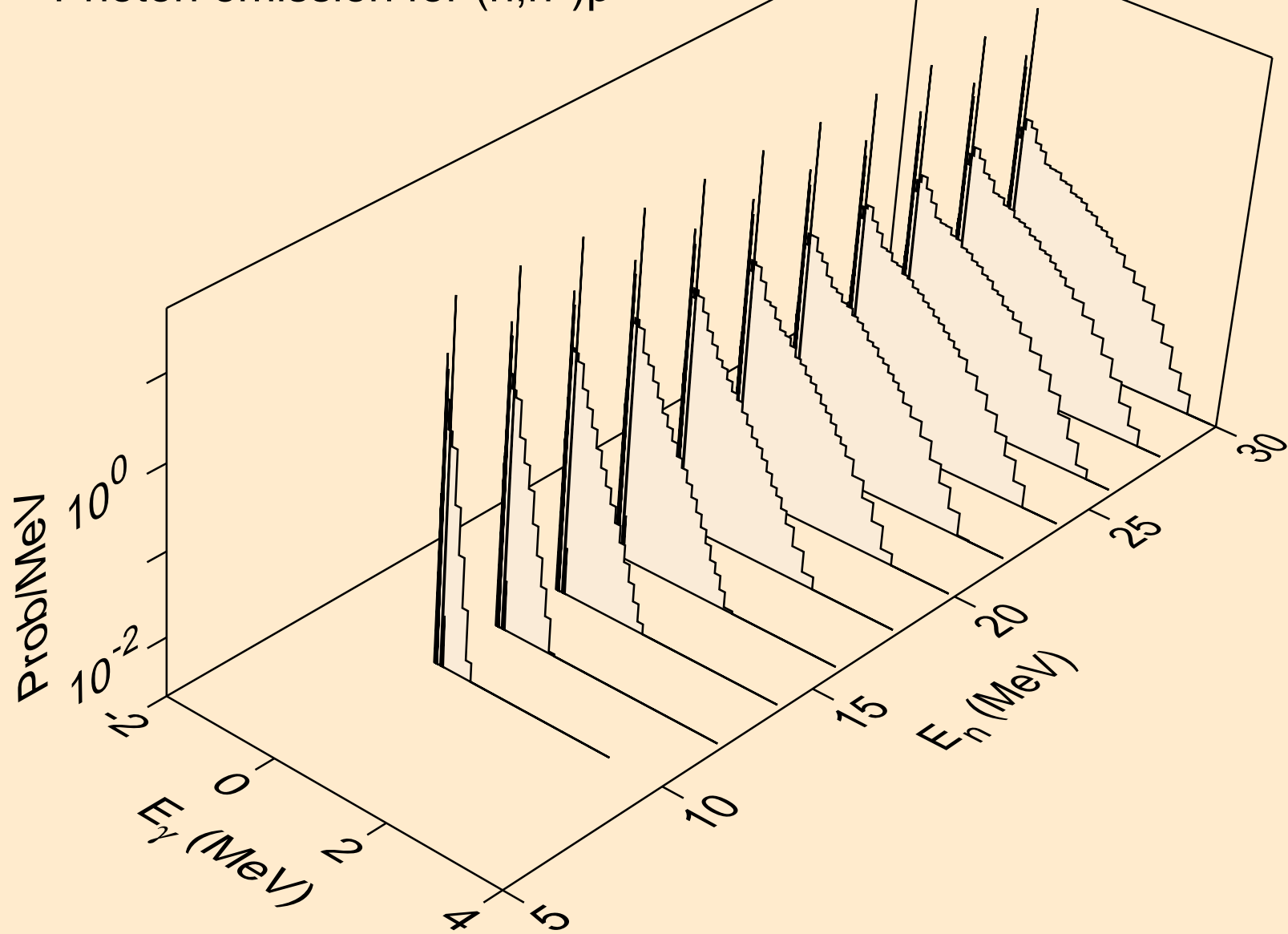

FM259 NEUTRON ACER TENDL-2024 LIBRARY; T=0.K
Photon emission for (n,n*)d

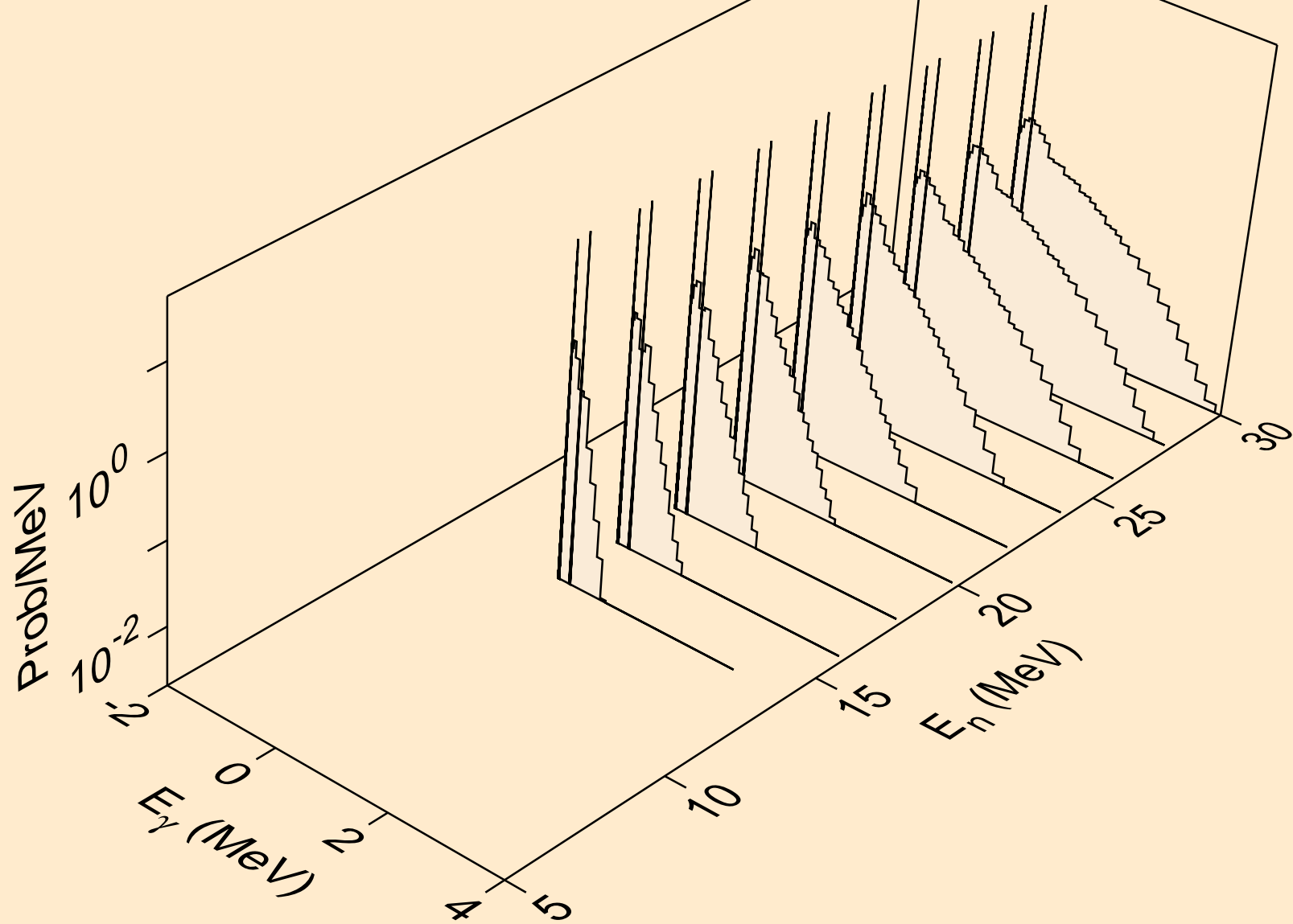

FM259 NEUTRON ACER TENDL-2024 LIBRARY; T=0.K
Photon emission for (n,n*)t

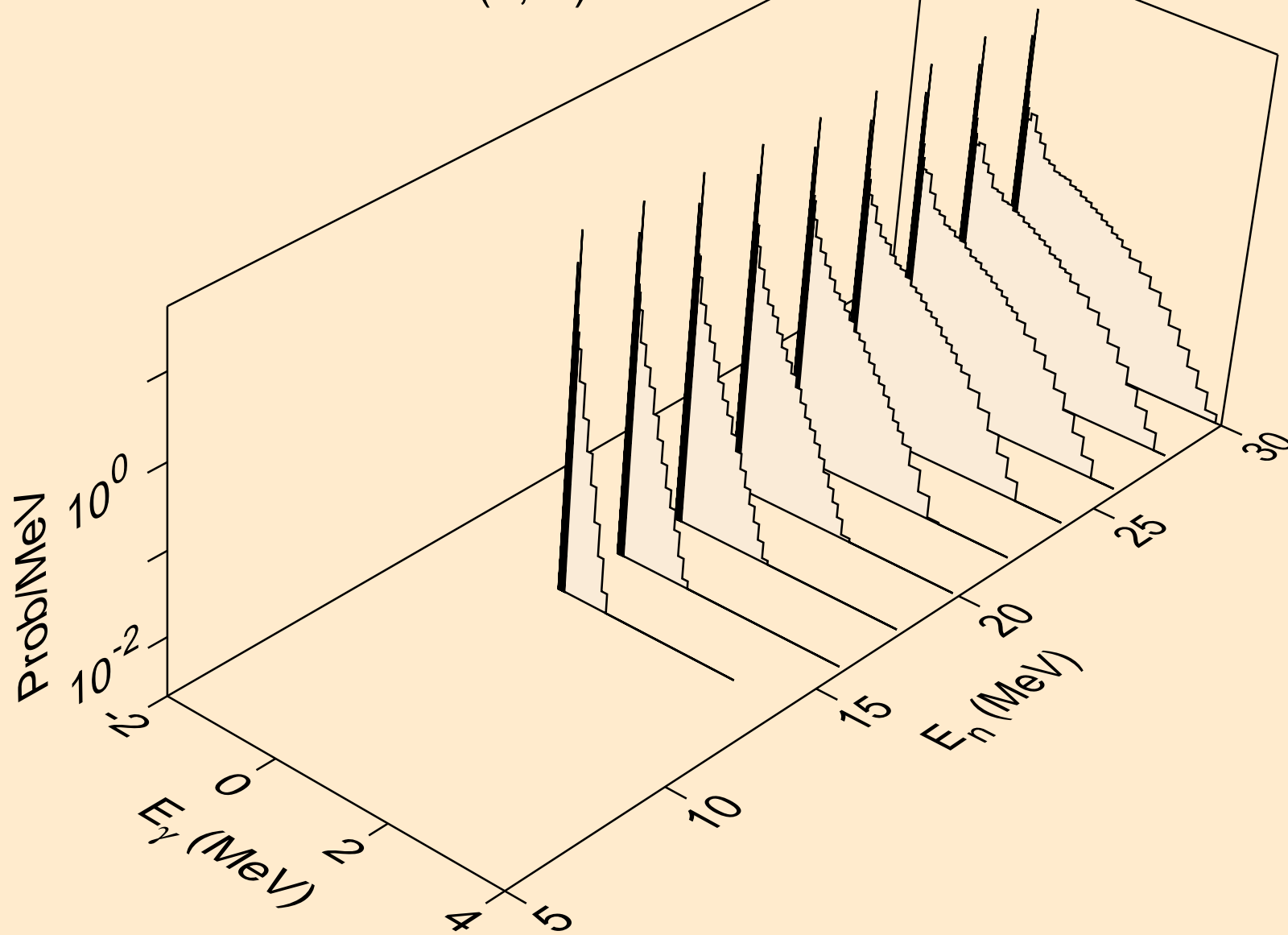

FM259 NEUTRON ACER TENDL-2024 LIBRARY; T=0.K
Photon emission for (n,n*)he3

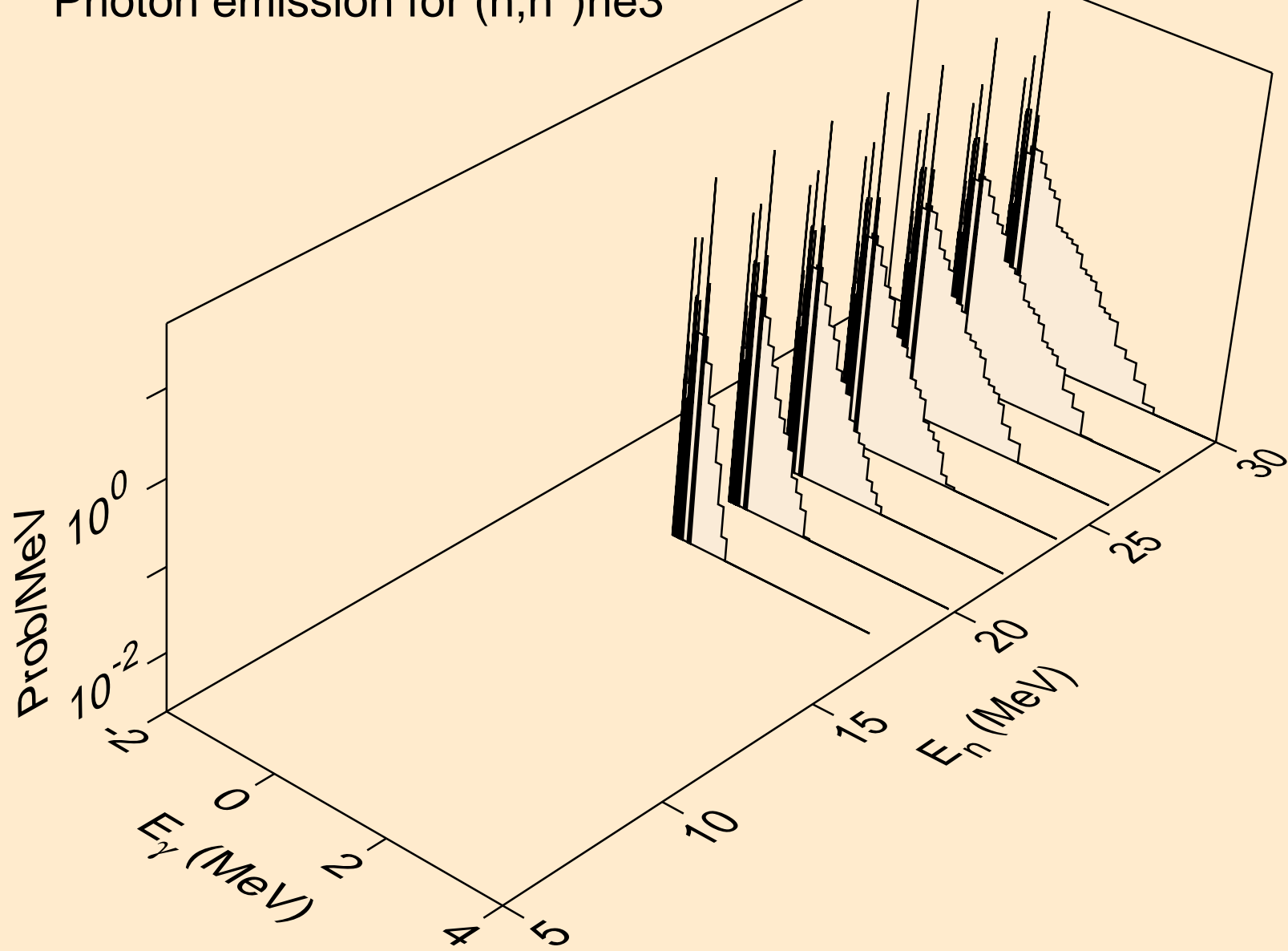

FM259 NEUTRON ACER TENDL-2024 LIBRARY; T=0.K
Photon emission for (n,4n)

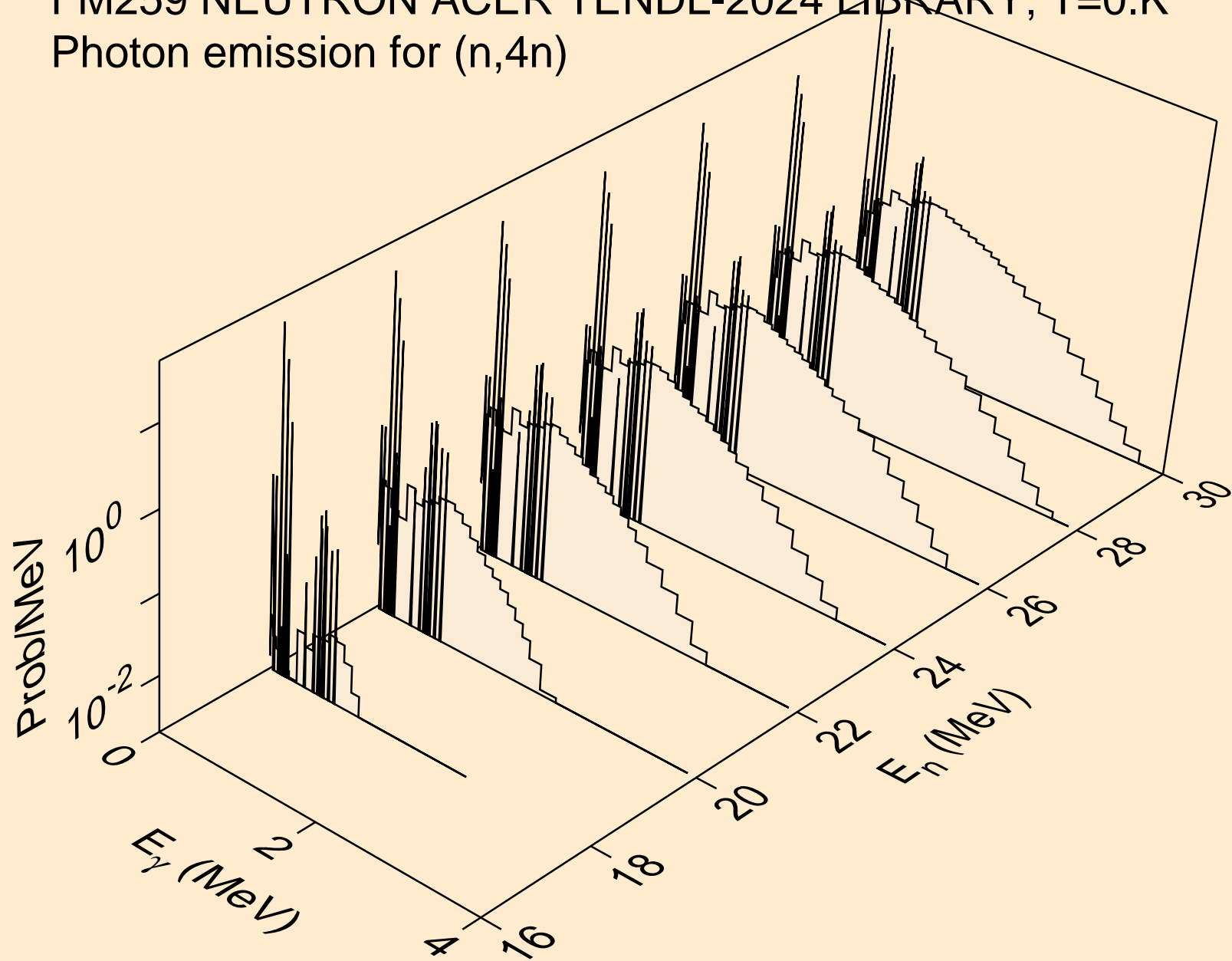

FM259 NEUTRON ACER TENDL-2024 LIBRARY; T=0.K
Photon emission for (n,2np)

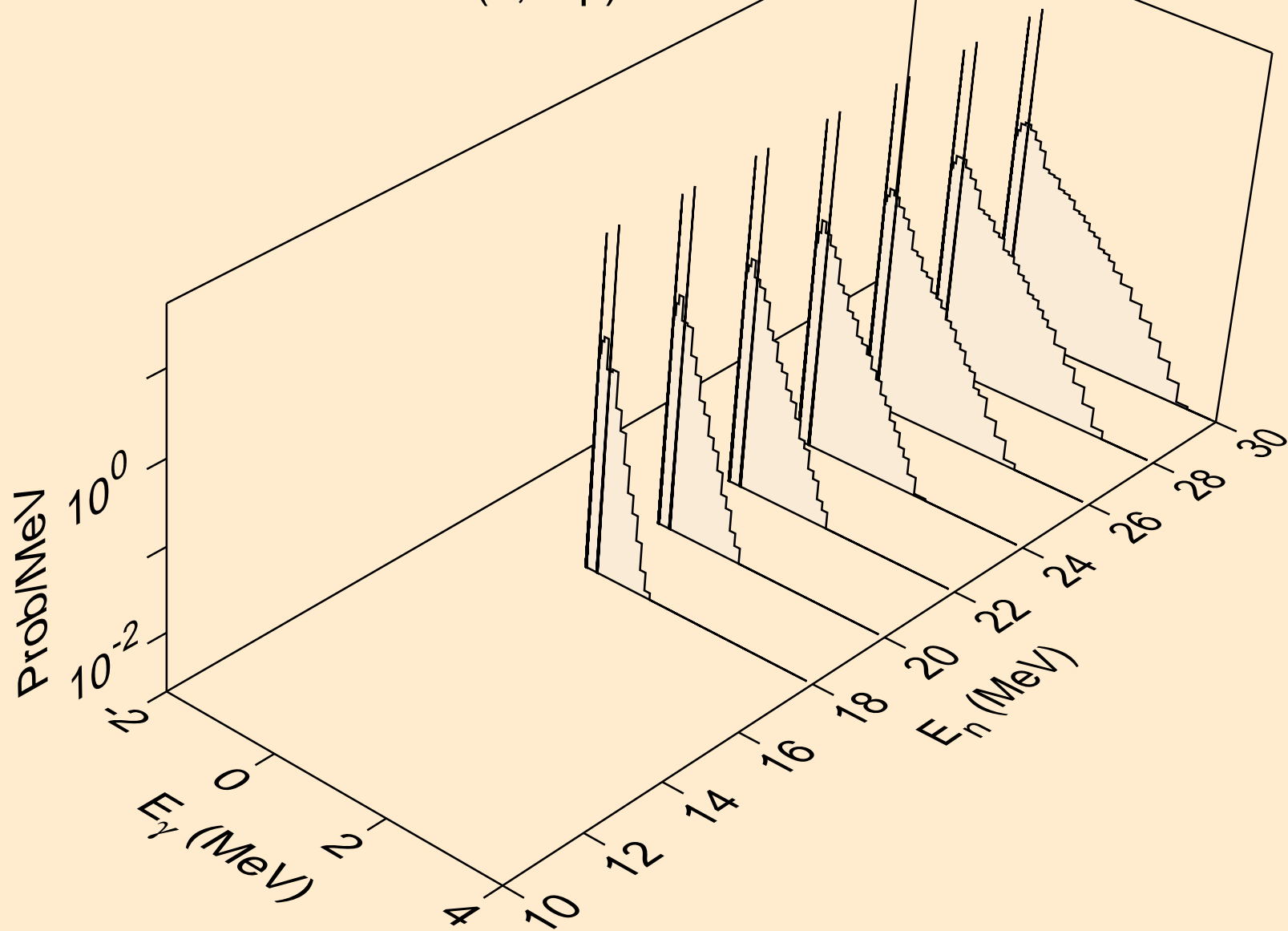

FM259 NEUTRON ACER TENDL-2024 LIBRARY; T=0.K
Photon emission for (n,3np)

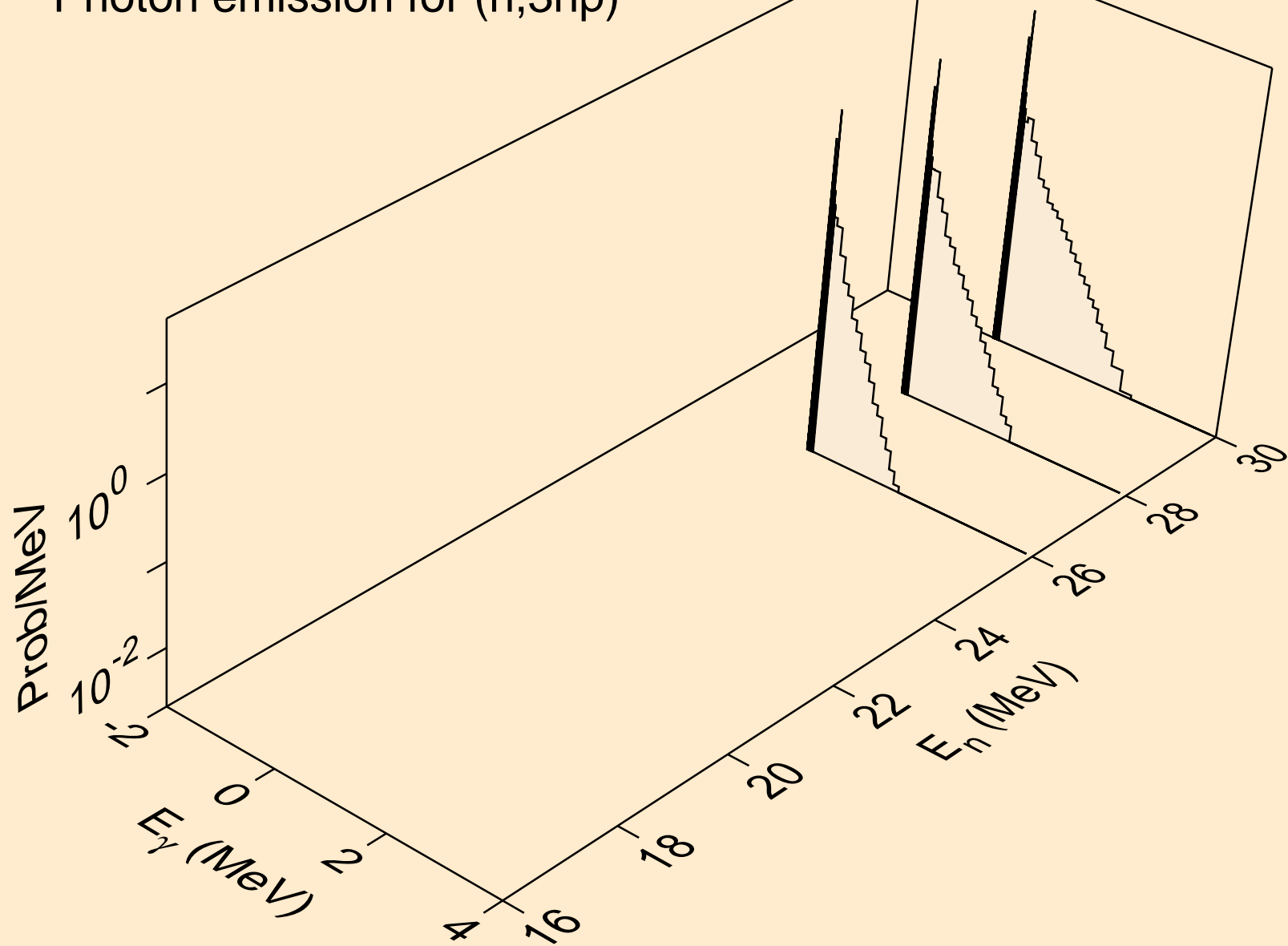

FM259 NEUTRON ACER TENDL-2024 LIBRARY; T=0.K
Photon emission for (n,n2p)

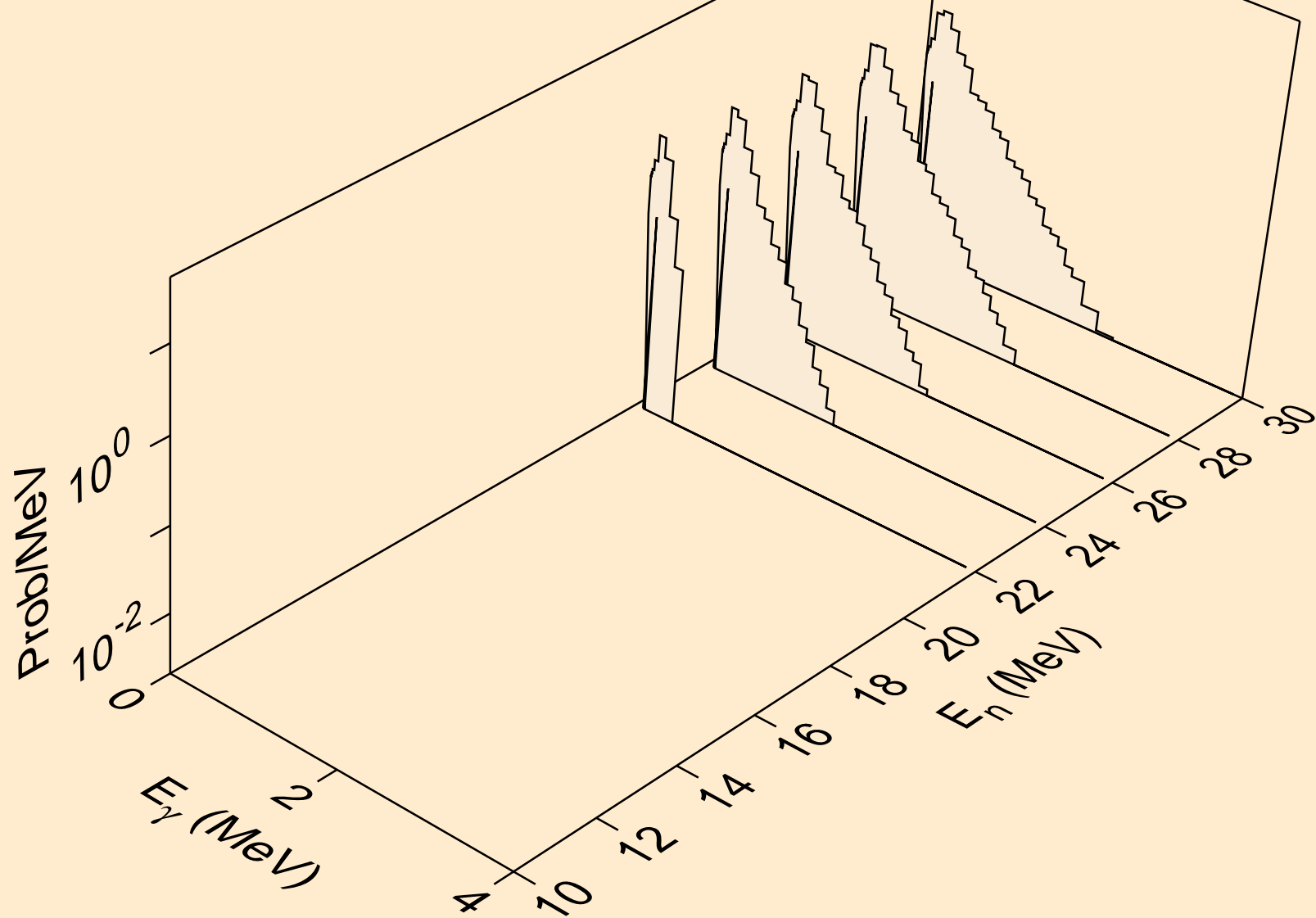

FM259 NEUTRON ACER TENDL-2024 LIBRARY; T=0.K
Photon emission for (n,n*c)

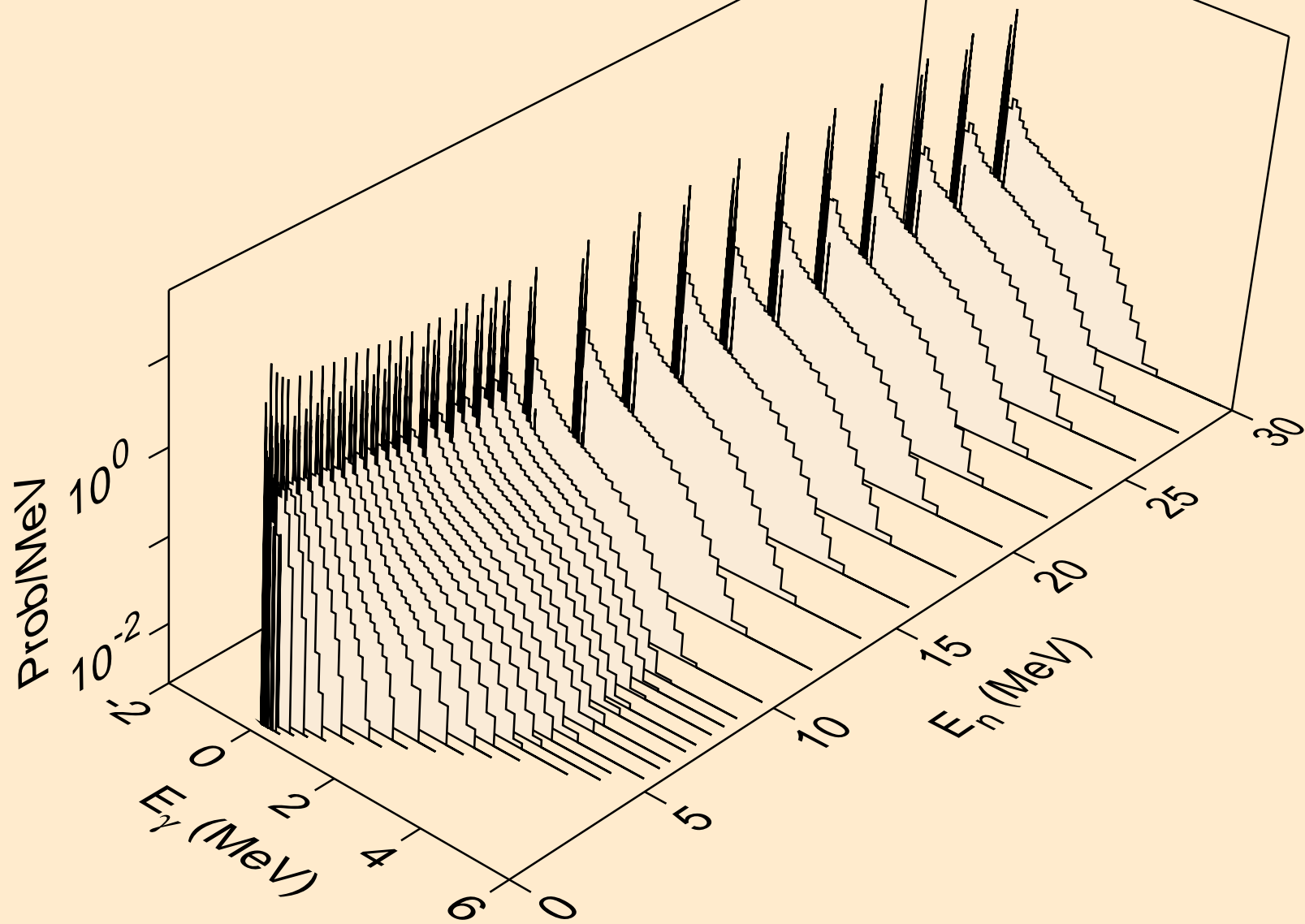

FM259 NEUTRON ACER TENDL-2024 LIBRARY; T=0.K
Photon emission for (n,gma)

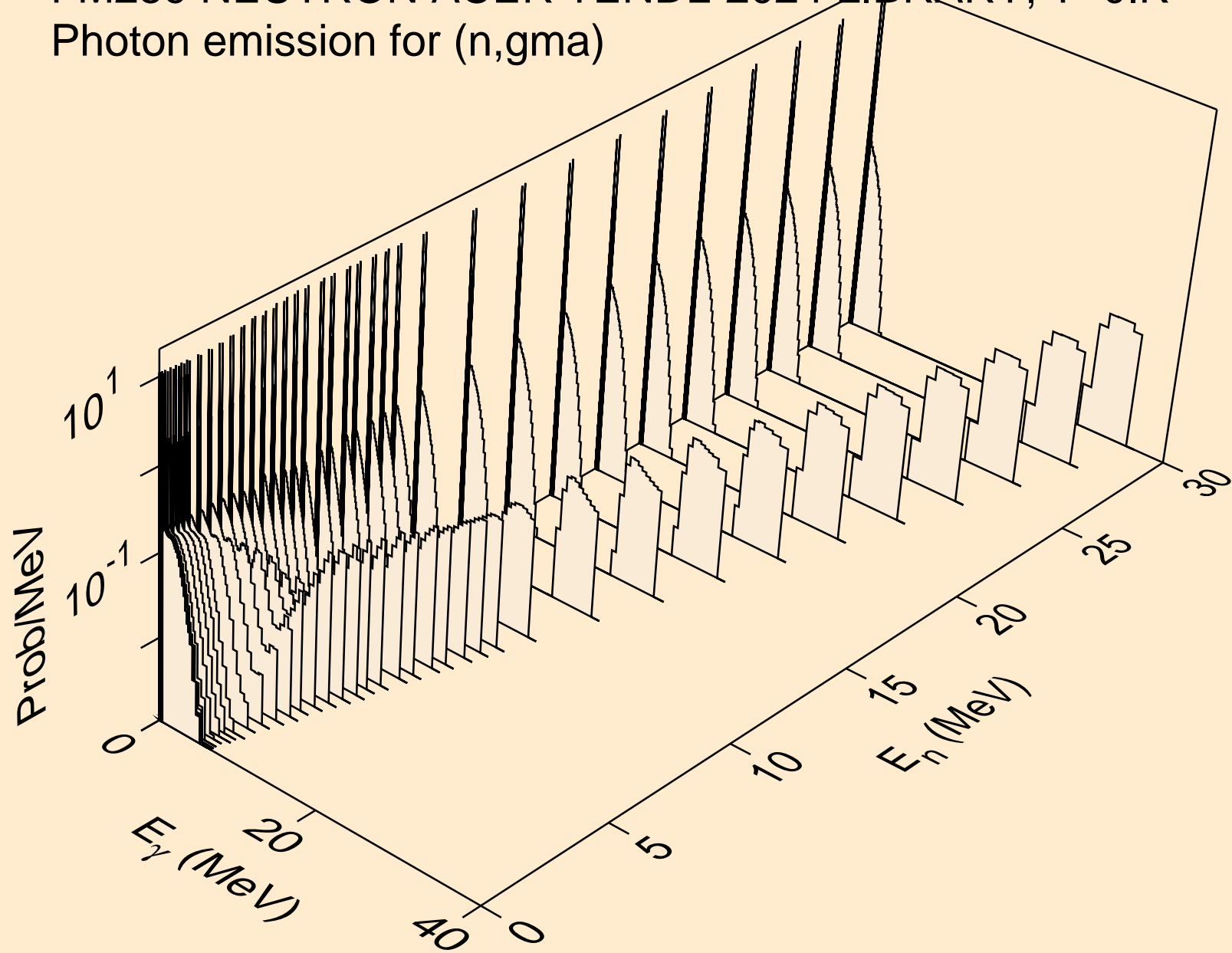

FM259 NEUTRON ACER TENDL-2024 LIBRARY; T=0.K
Photon emission for (n,p)

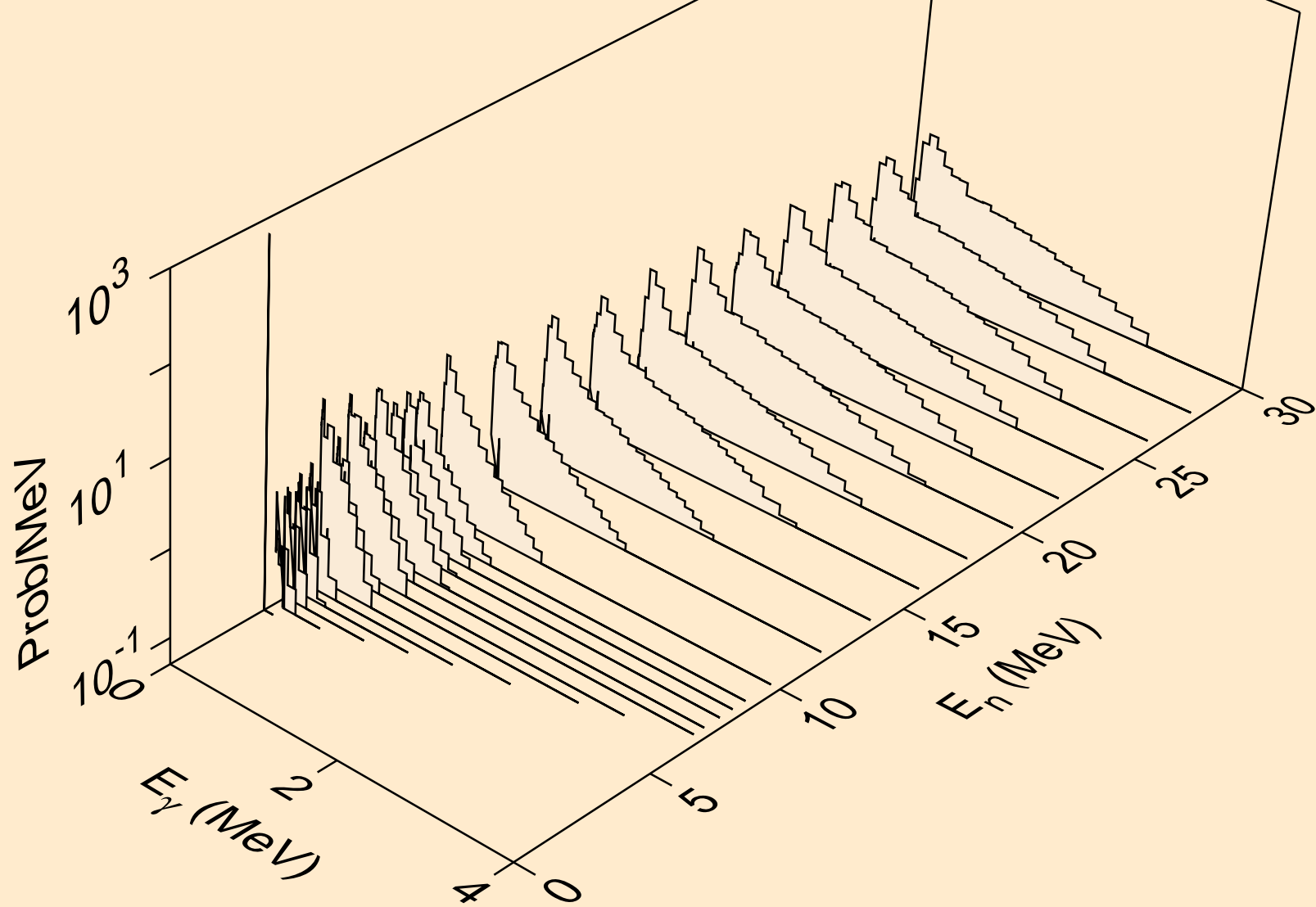

FM259 NEUTRON ACER TENDL-2024 LIBRARY; T=0.K
Photon emission for (n,d)

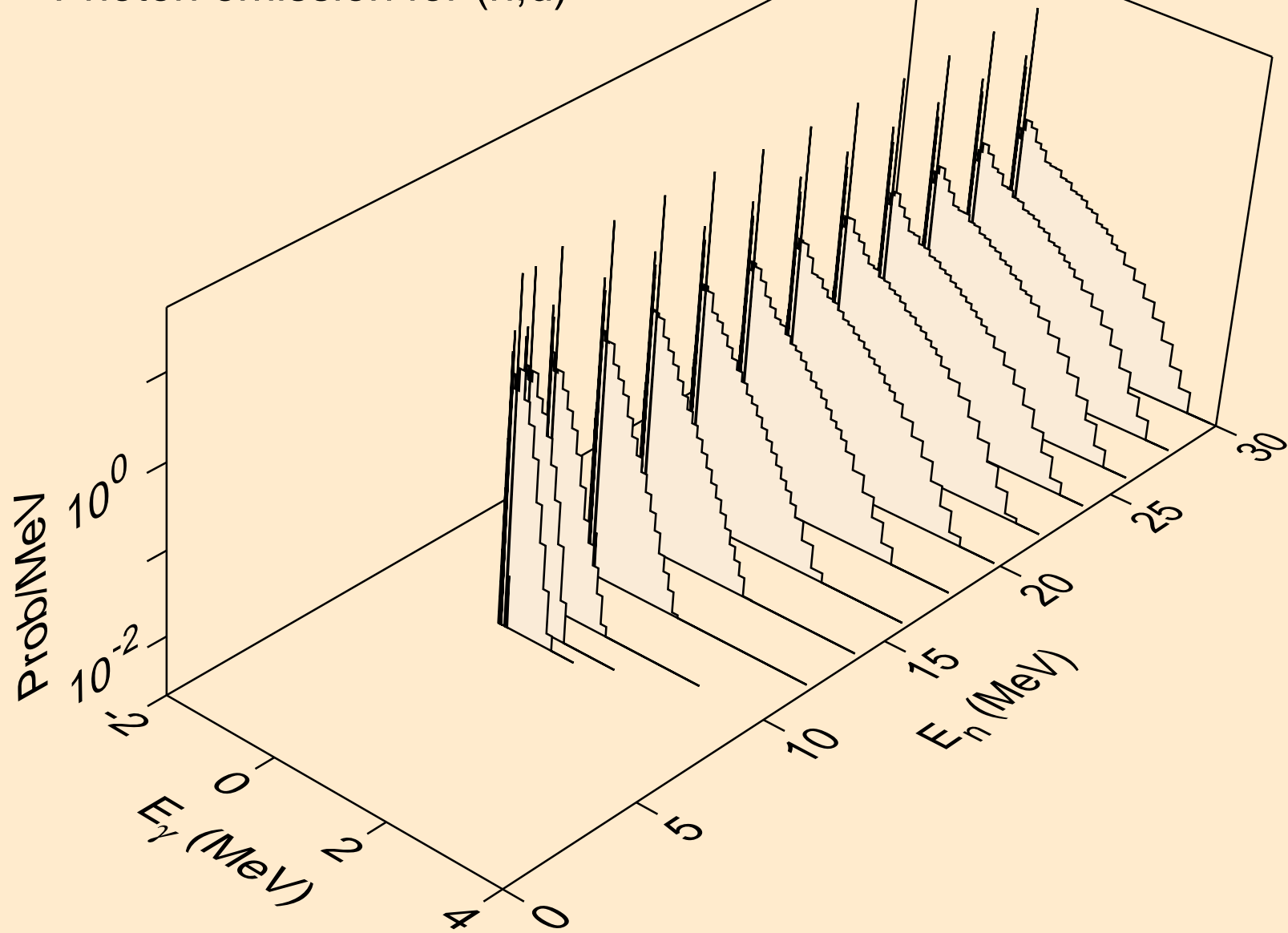

FM259 NEUTRON ACER TENDL-2024 LIBRARY; T=0.K
Photon emission for (n,t)

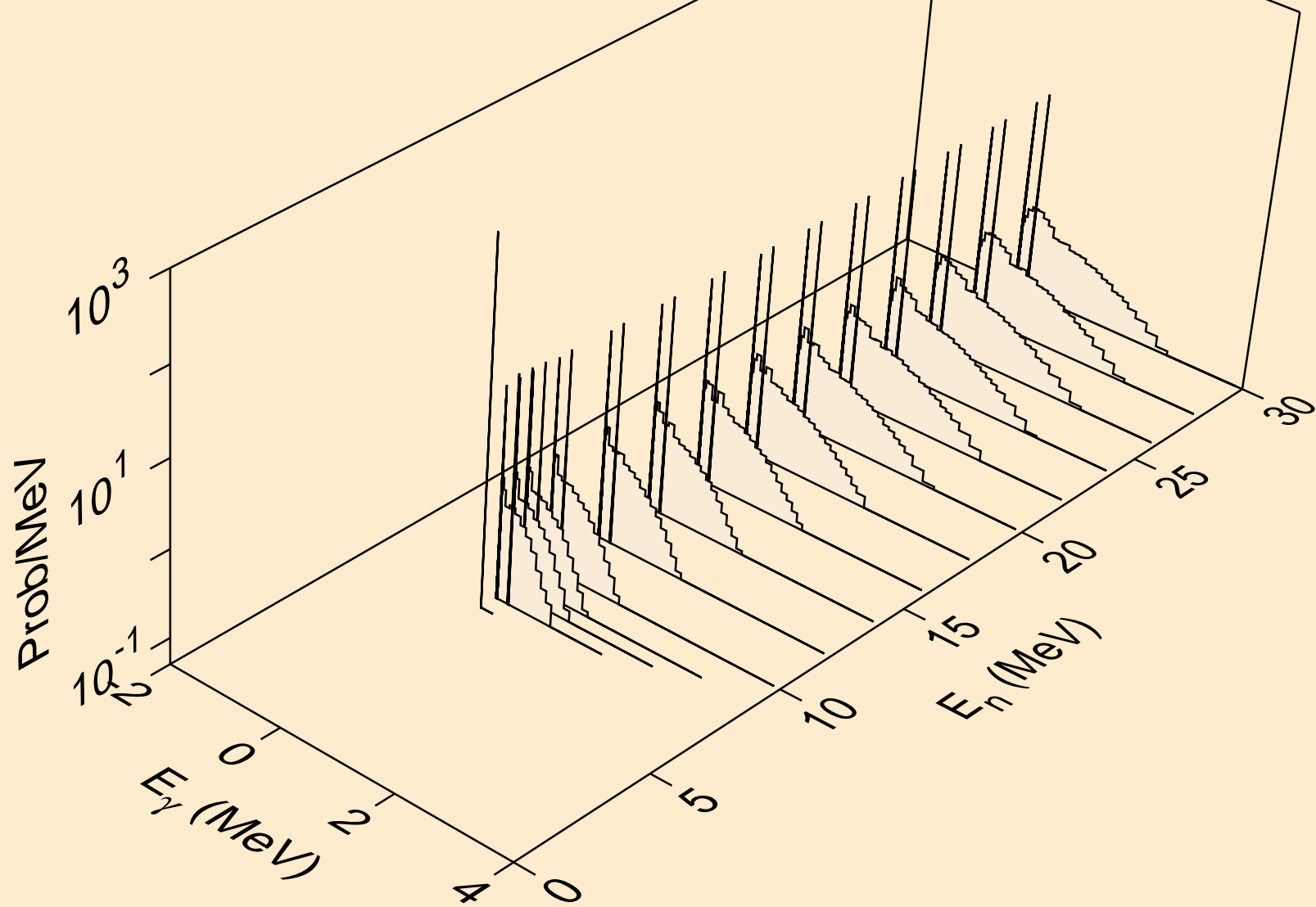

FM259 NEUTRON ACER TENDL-2024 LIBRARY; T=0.K
Photon emission for (n,he3)

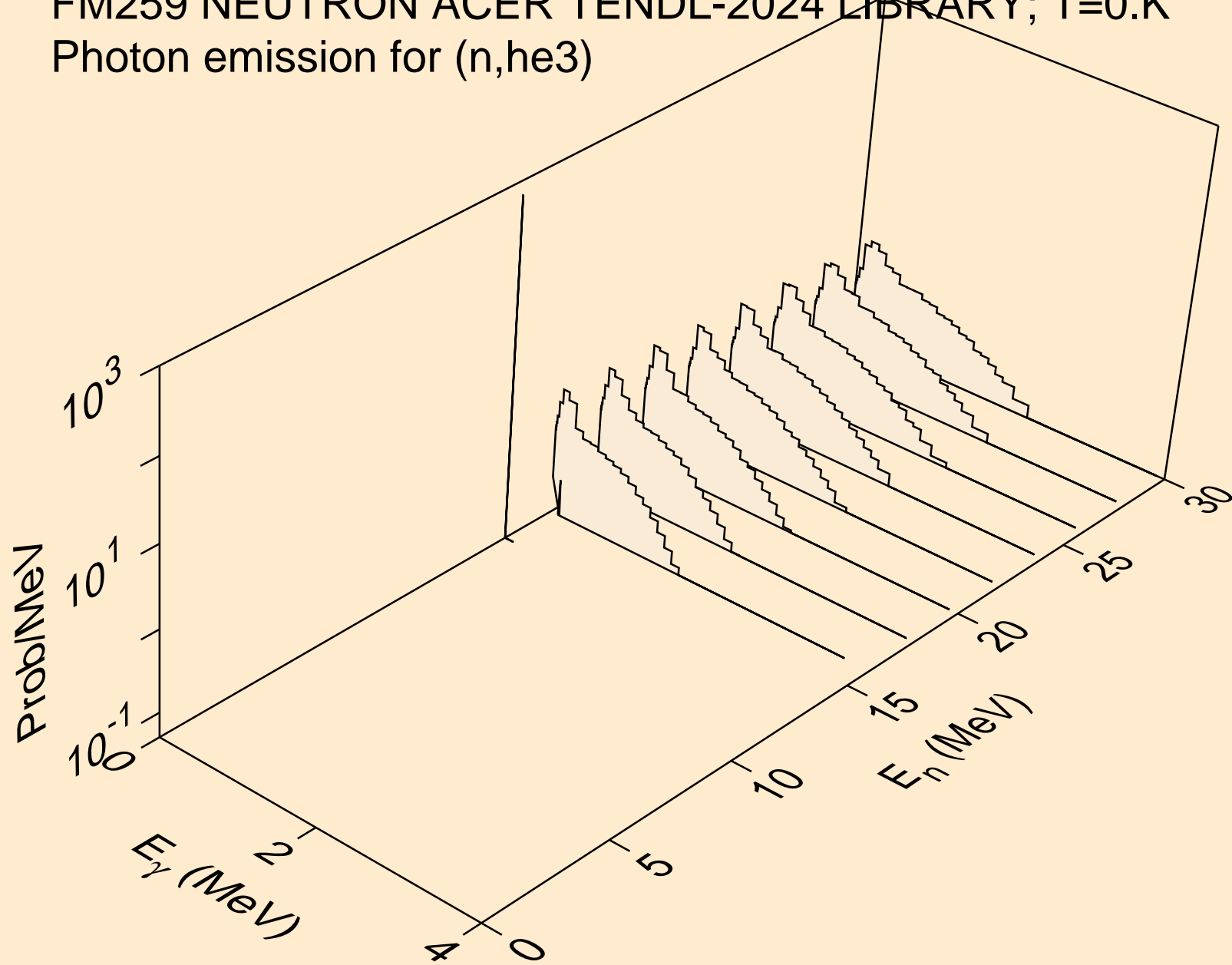

FM259 NEUTRON ACER TENDL-2024 LIBRARY; T=0.K
Photon emission for (n,a)

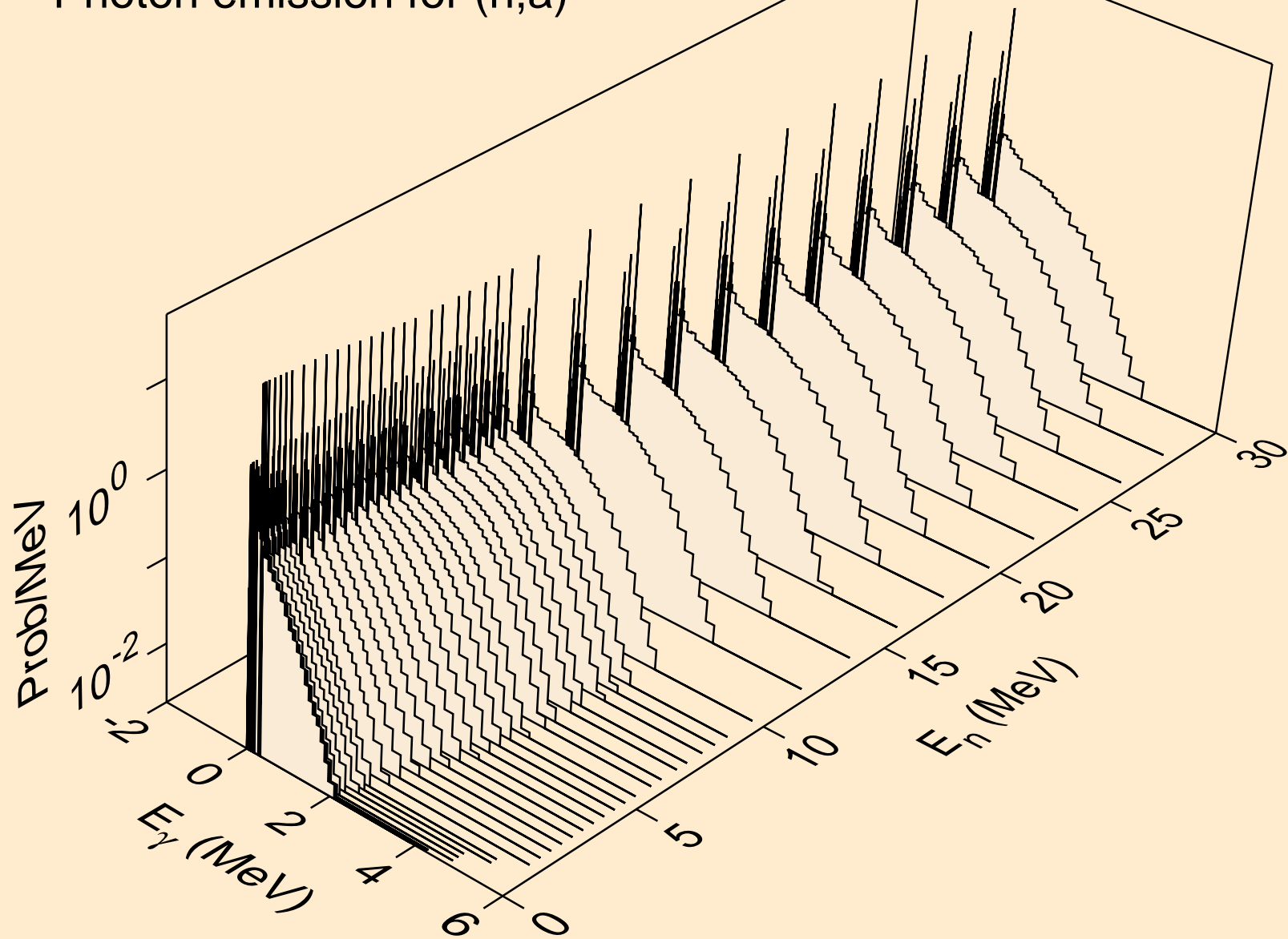

FM259 NEUTRON ACER TENDL-2024 LIBRARY; T=0.K
Photon emission for (n,2p)

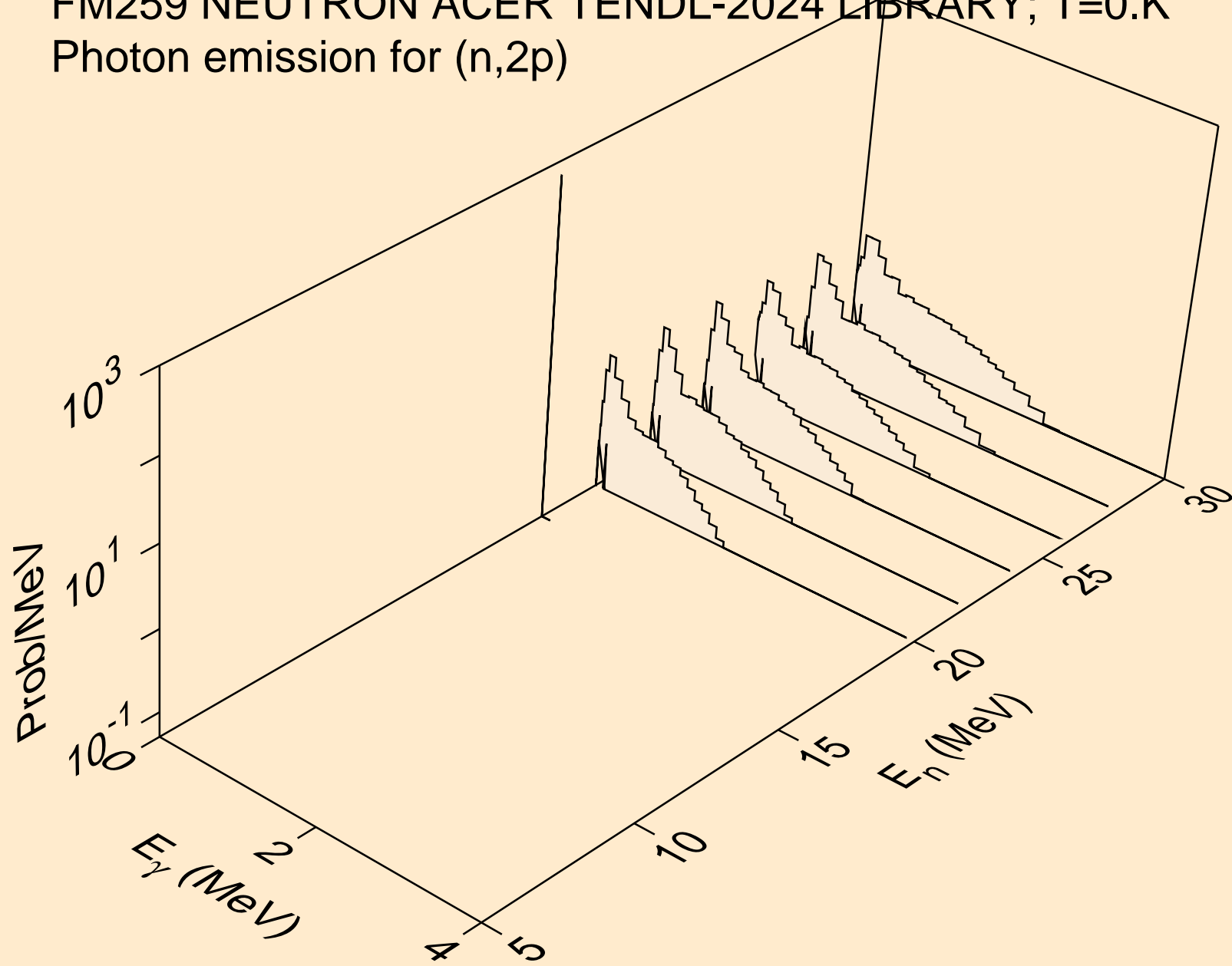

FM259 NEUTRON ACER TENDL-2024 LIBRARY; T=0.K
thermal capture photon spectrum

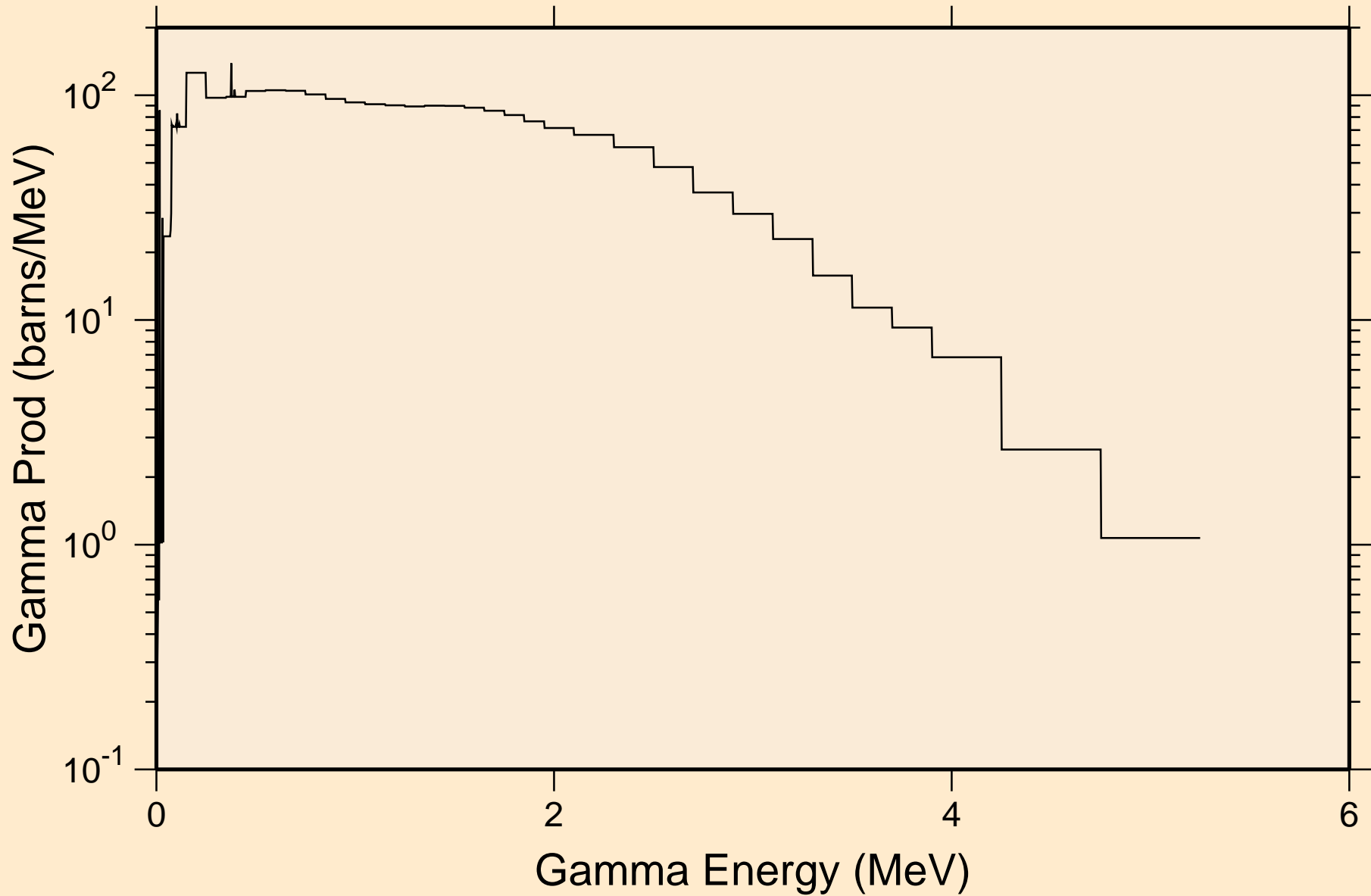

FM259 NEUTRON ACER TENDL-2024 LIBRARY; T=0.K
14 MeV photon spectrum

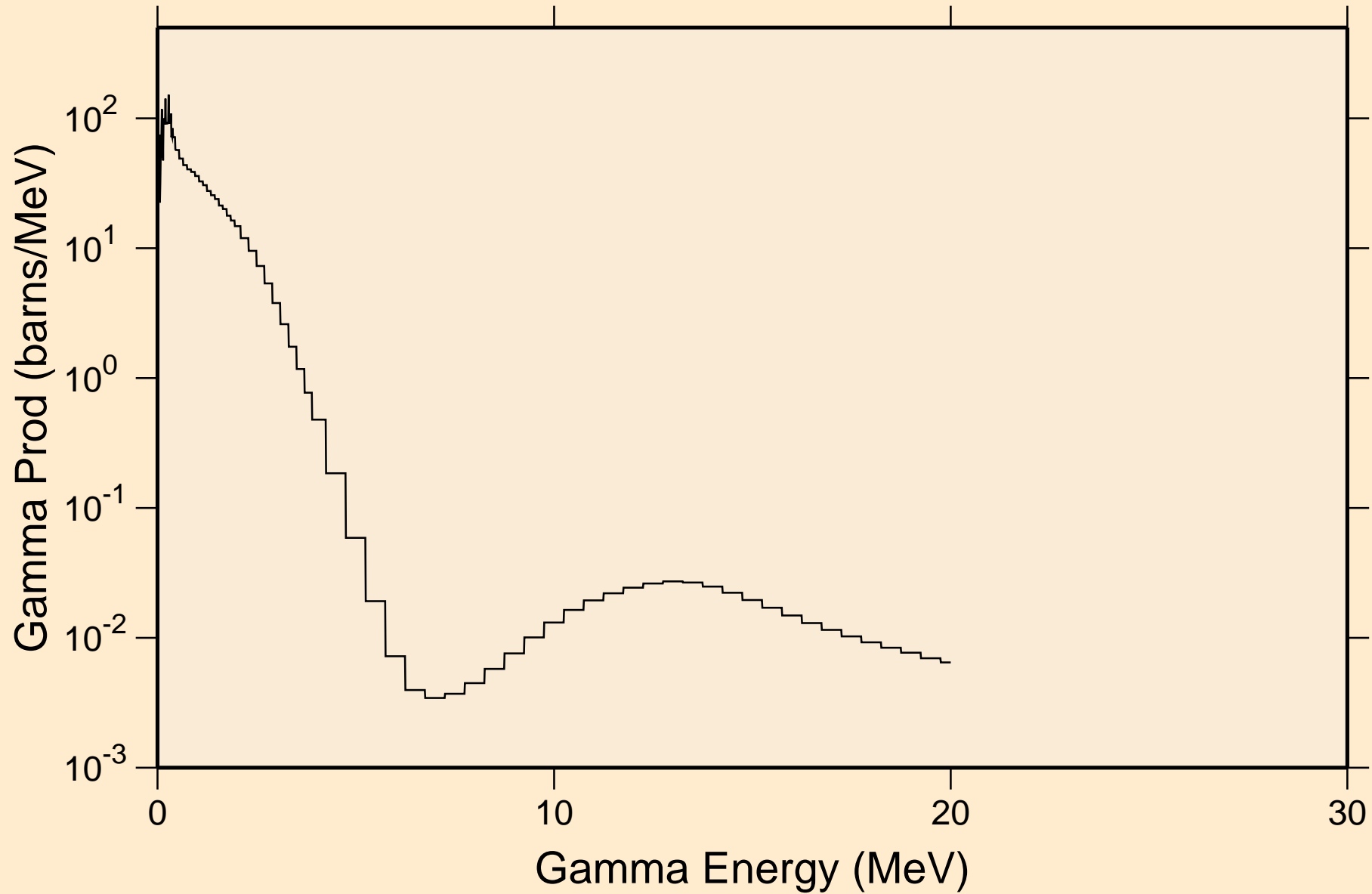

FM259 NEUTRON ACER TENDL-2024 LIBRARY; T=0.K

Particle heating contributions

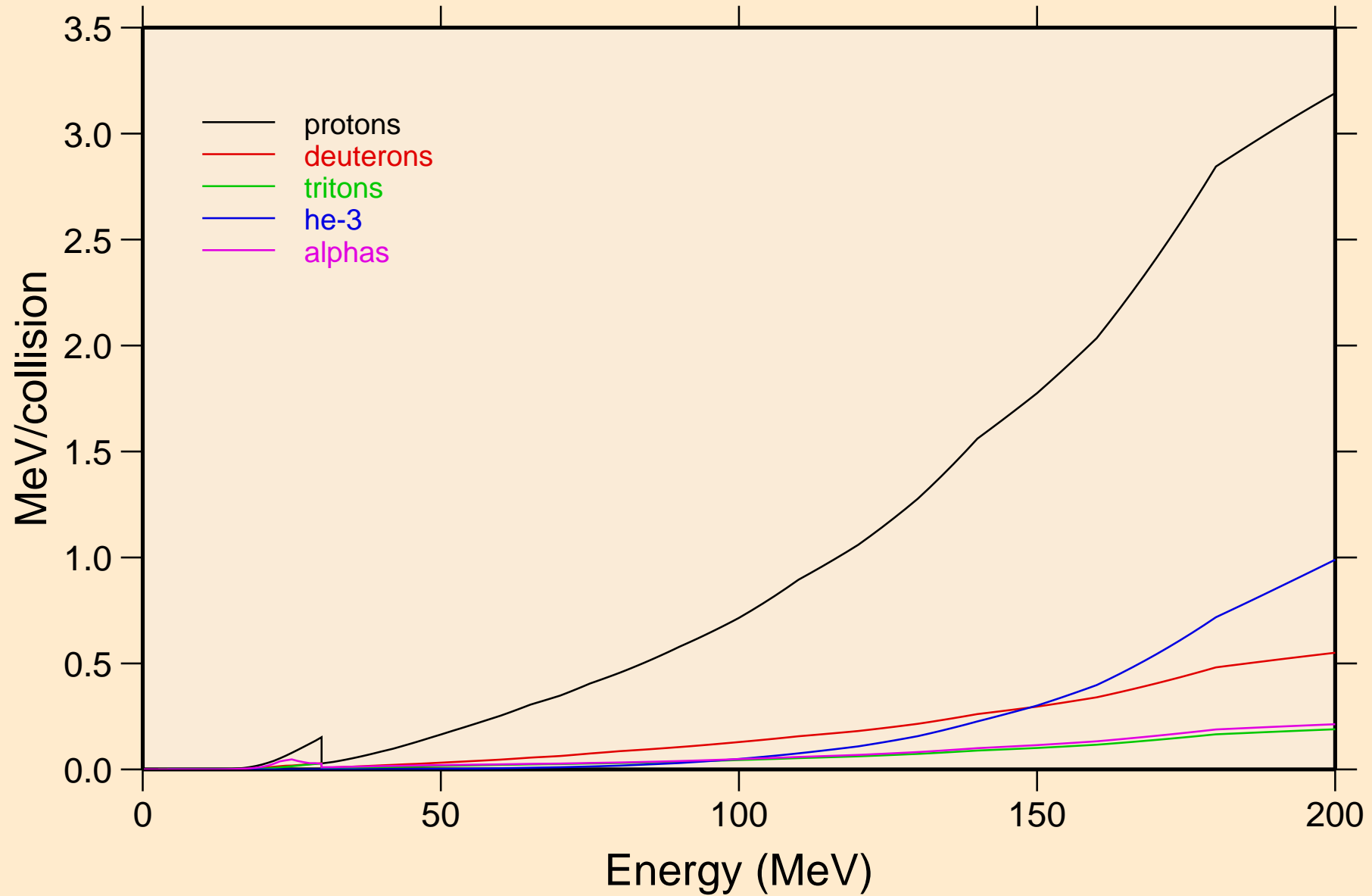

FM259 NEUTRON ACER TENDL-2024 LIBRARY; T=0.K
Recoil Heating

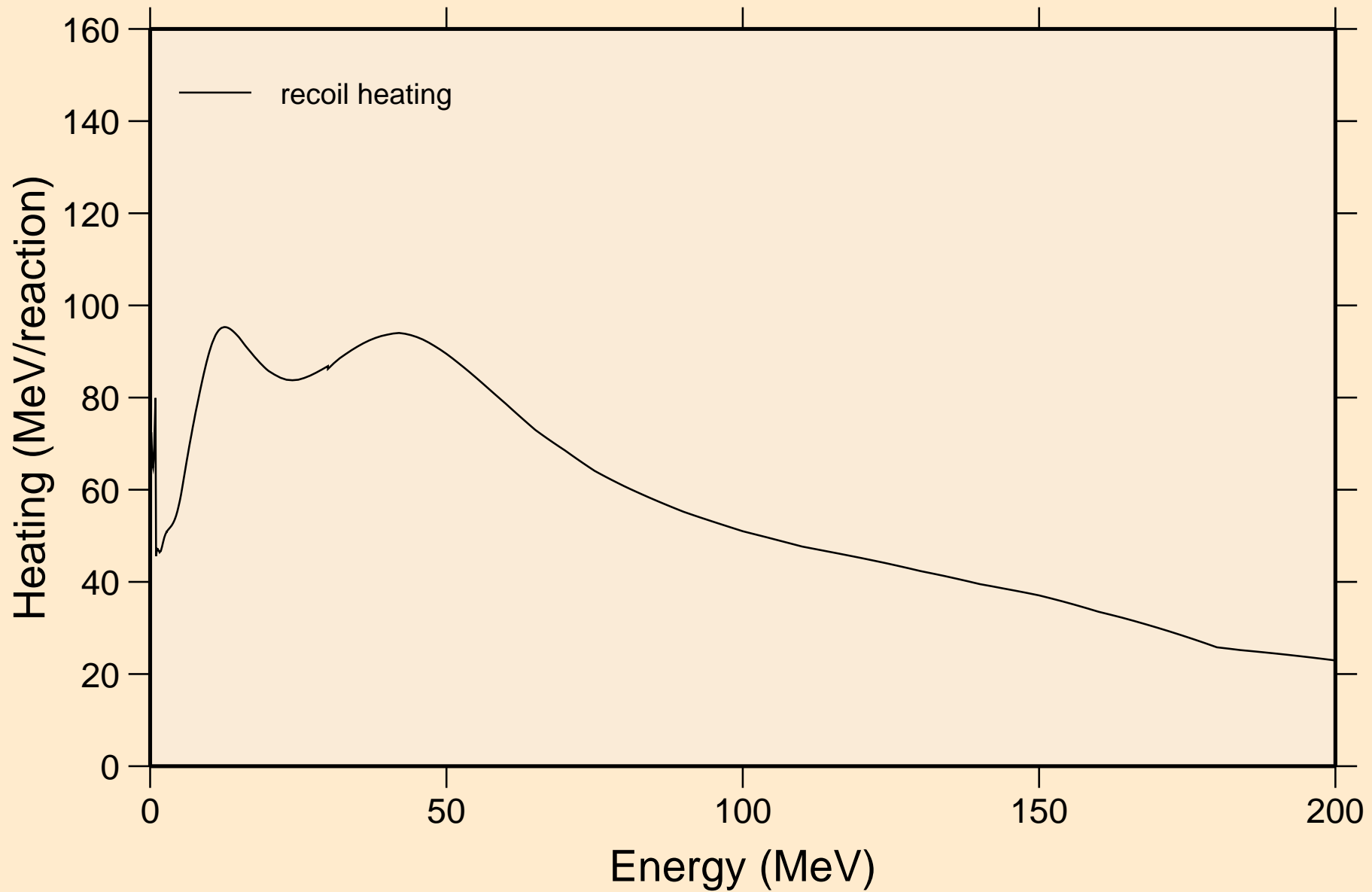

FM259 NEUTRON ACER TENDL-2024 LIBRARY; T=0.K

Particle production cross sections

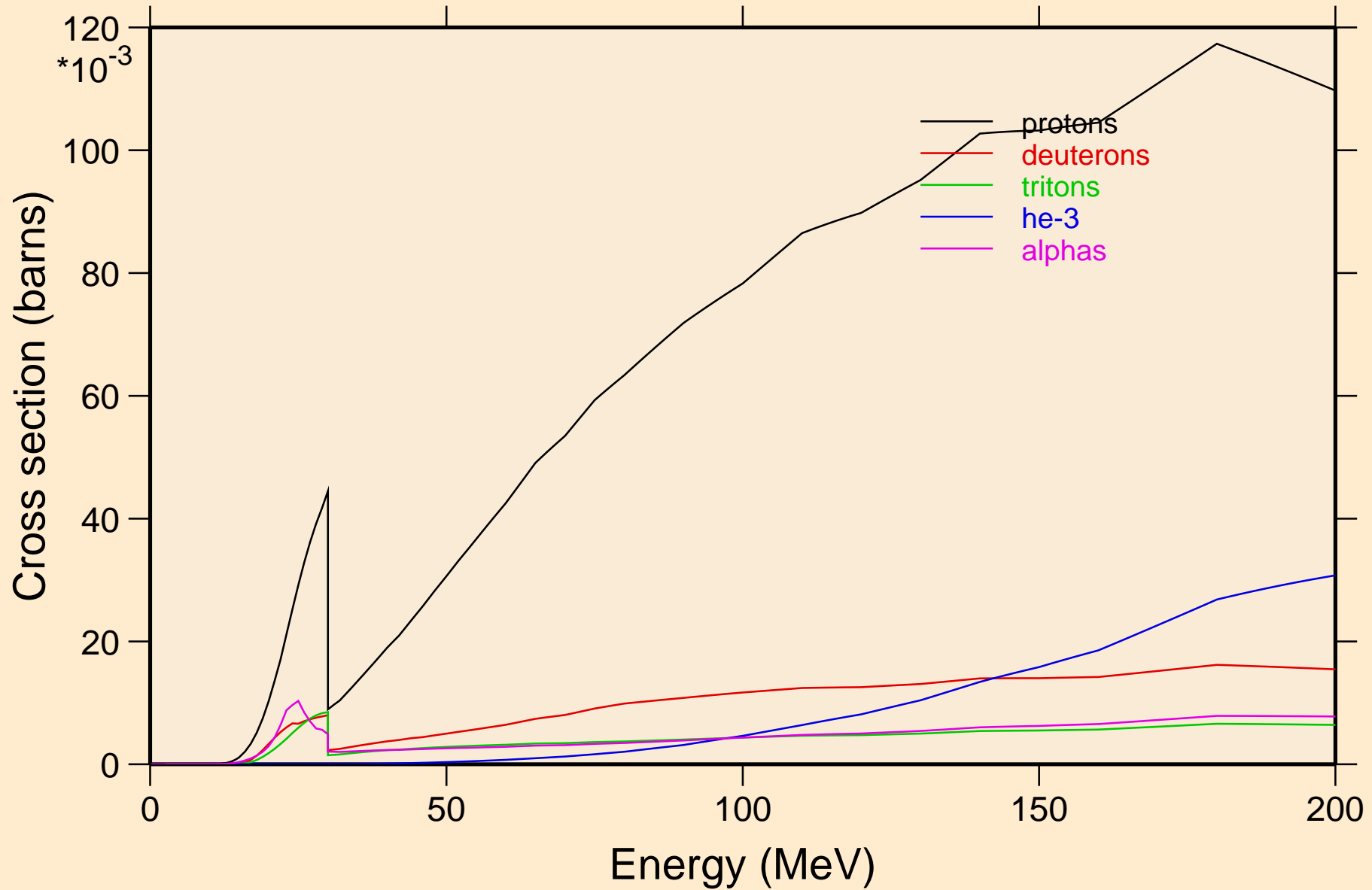

FM259 NEUTRON ACER TENDL-2024 LIBRARY; T=0.K
protons from (n,x)

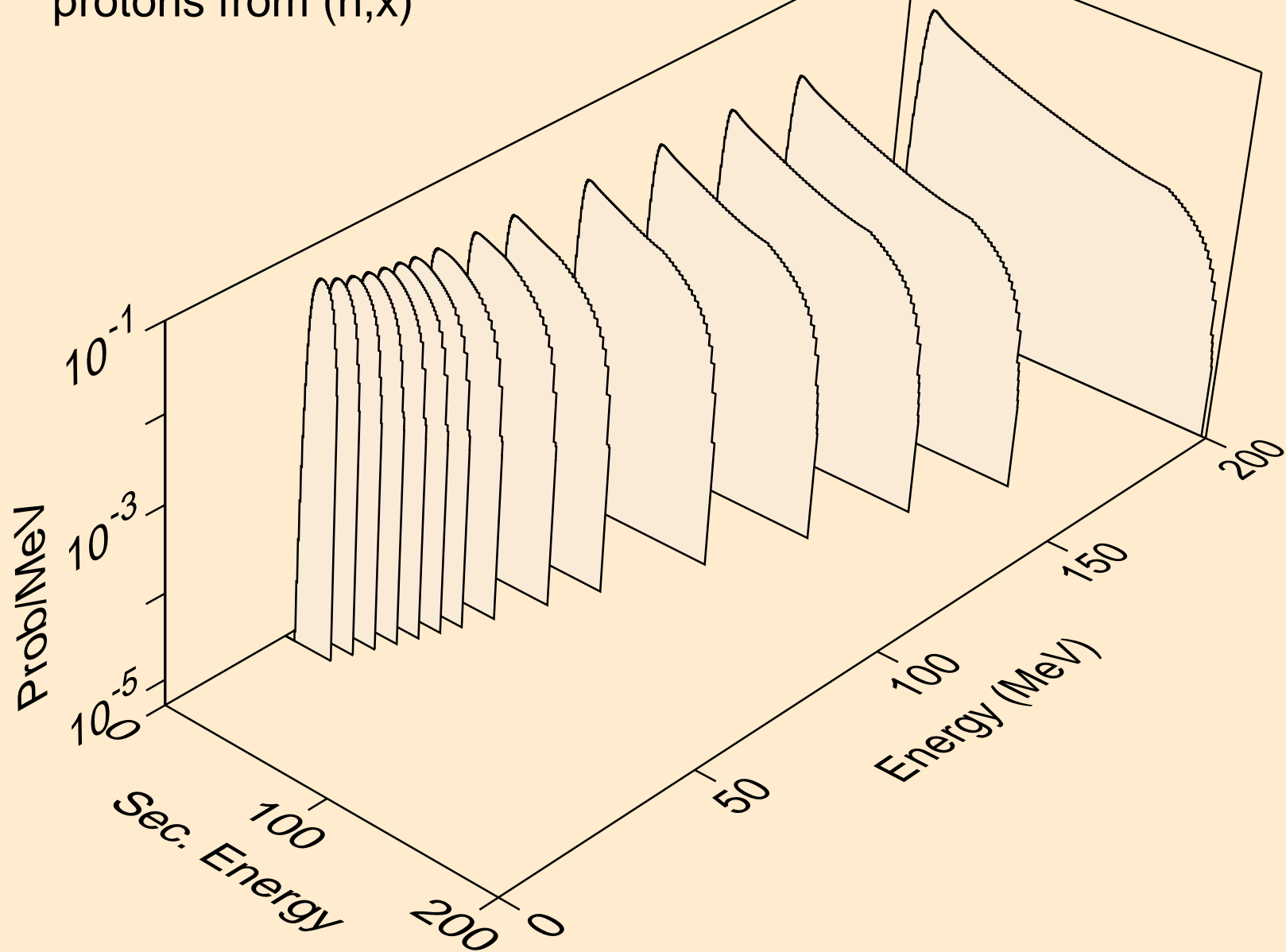

FM259 NEUTRON ACER TENDL-2024 LIBRARY; T=0.K
protons from (n,n*)p

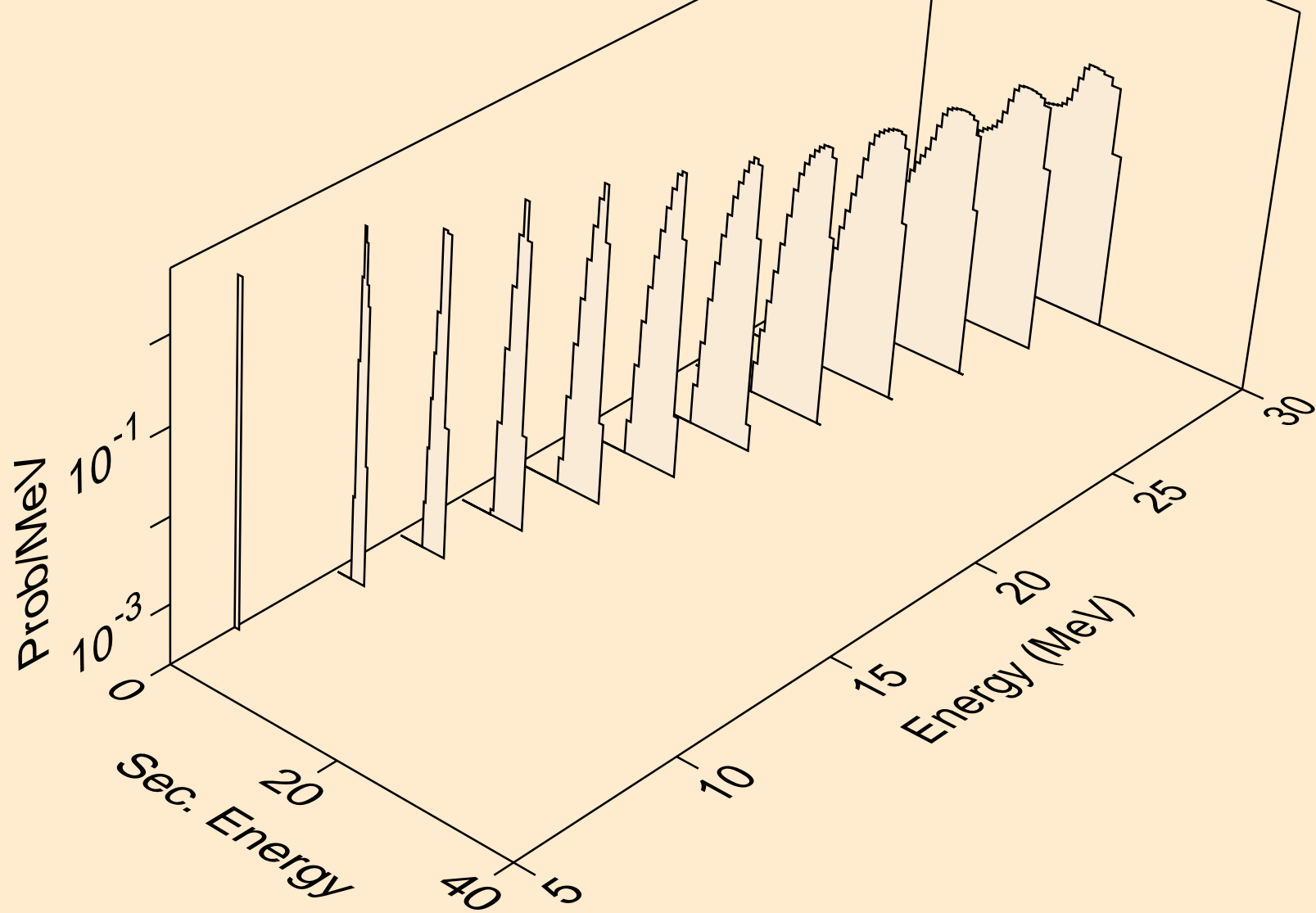

FM259 NEUTRON ACER TENDL-2024 LIBRARY; T=0.K
protons from (n,2np)

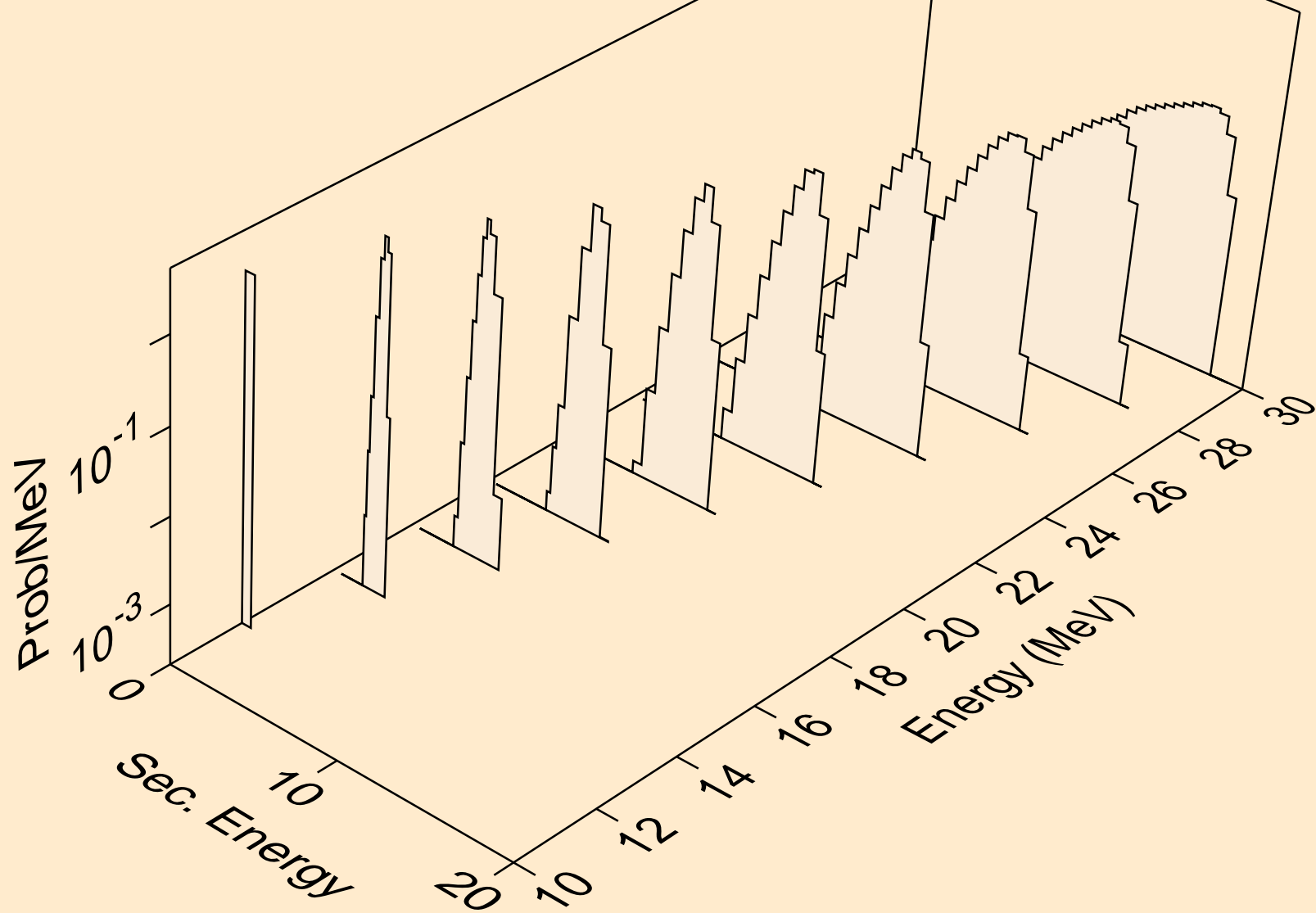

FM259 NEUTRON ACER TENDL-2024 LIBRARY; T=0.K
protons from (n,3np)

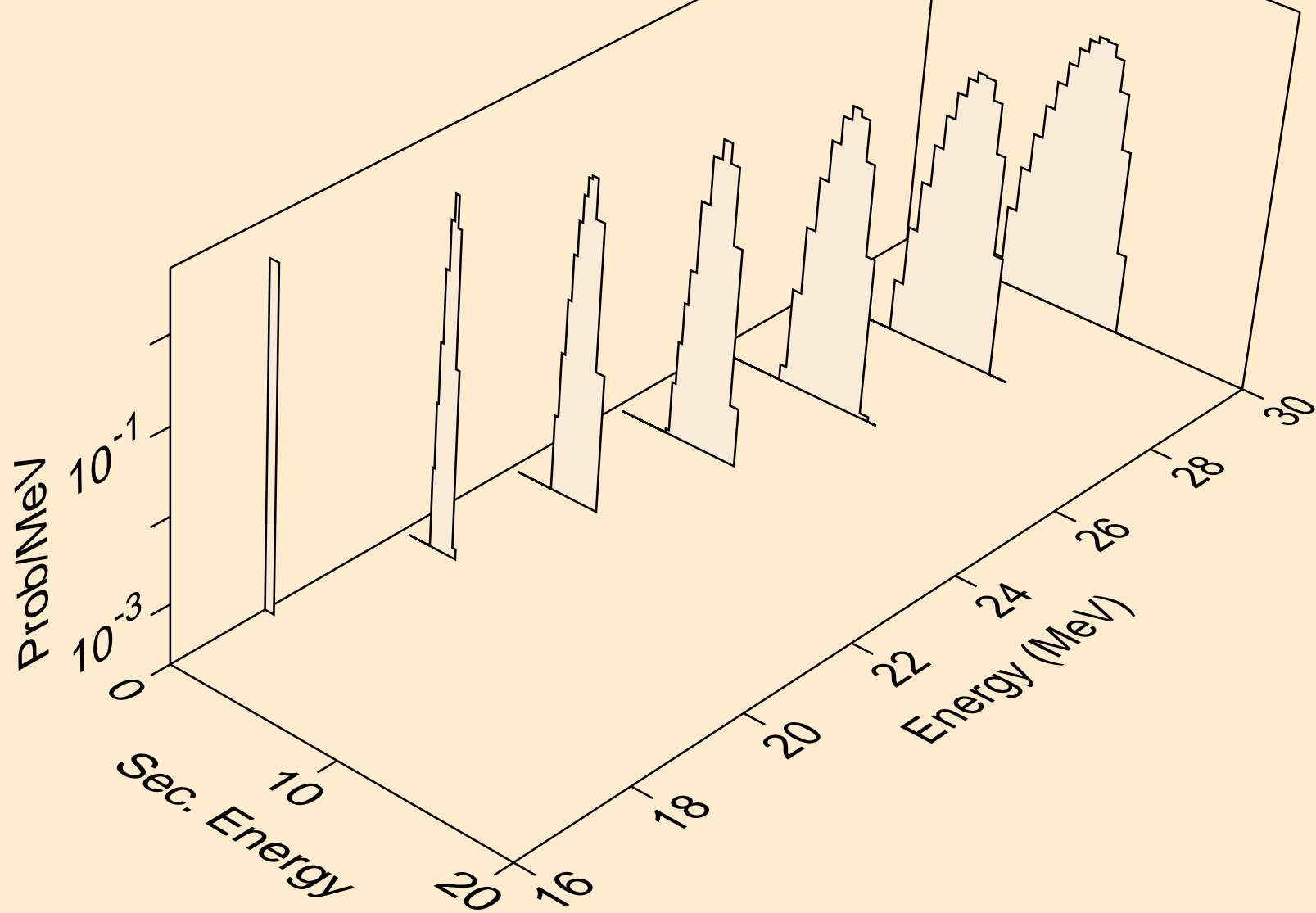

FM259 NEUTRON ACER TENDL-2024 LIBRARY; T=0.K
protons from (n,n2p)

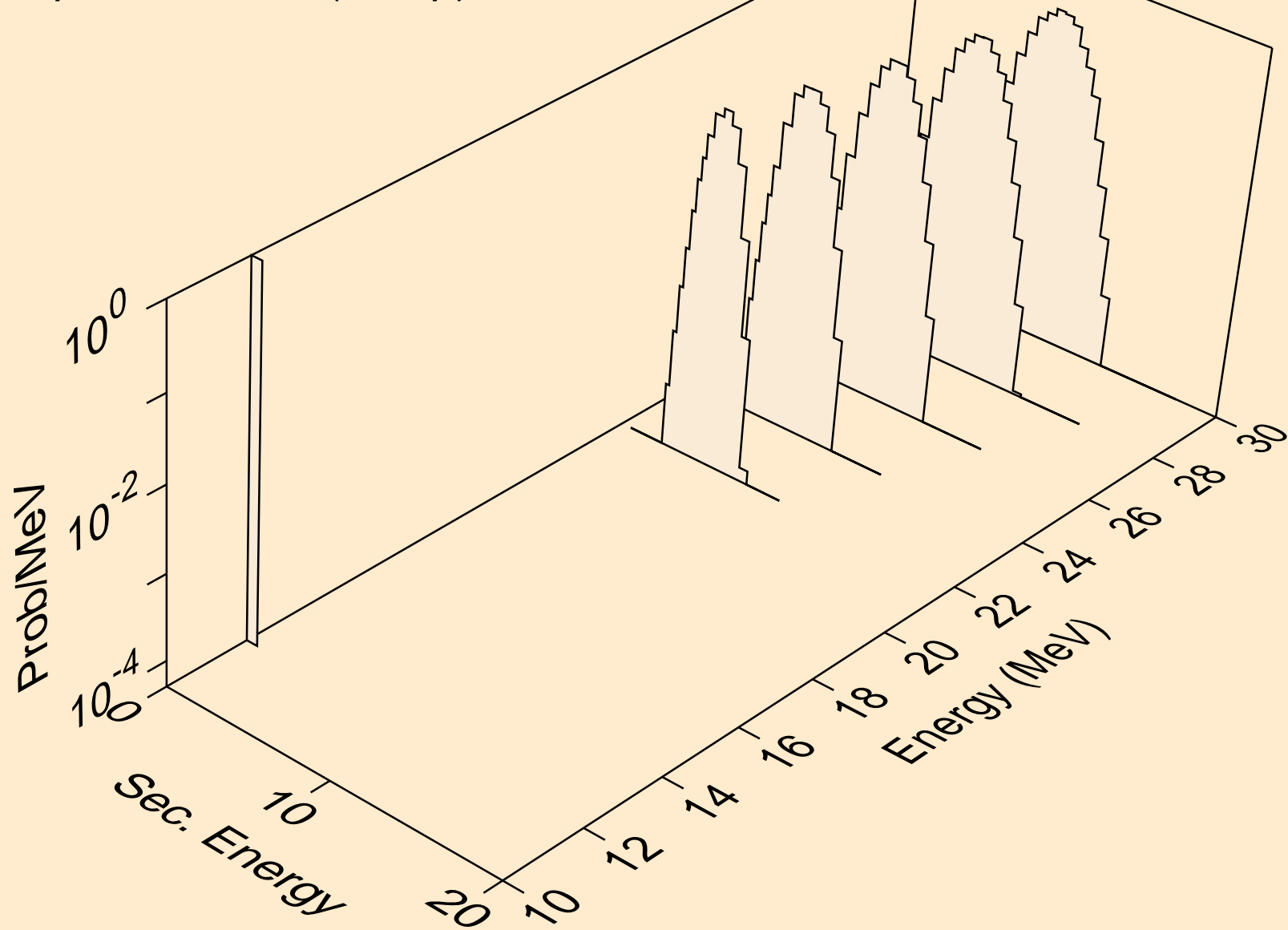

FM259 NEUTRON ACER TENDL-2024 LIBRARY; T=0.K
protons from (n,p)

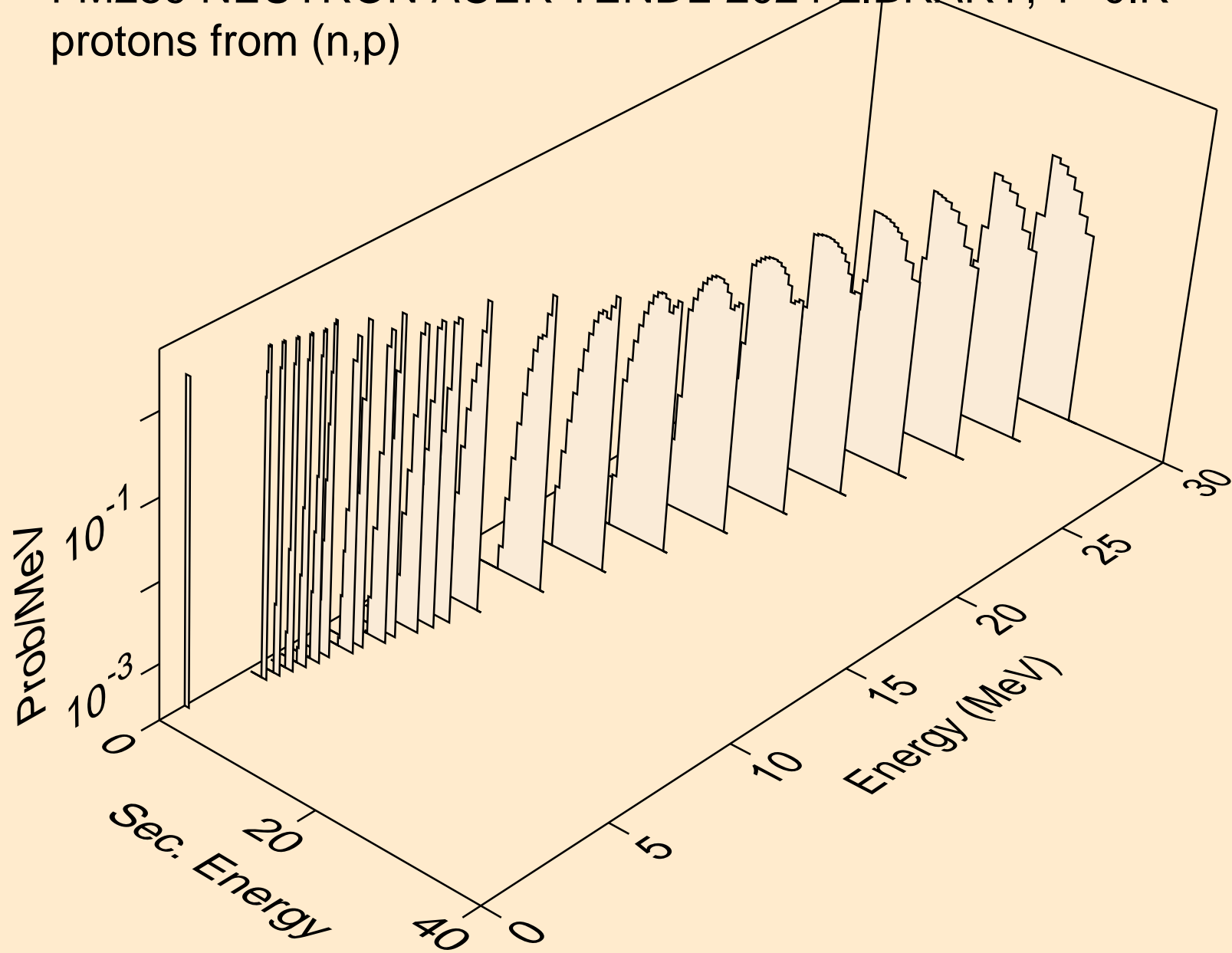

FM259 NEUTRON ACER TENDL-2024 LIBRARY; T=0.K
protons from (n,2p)

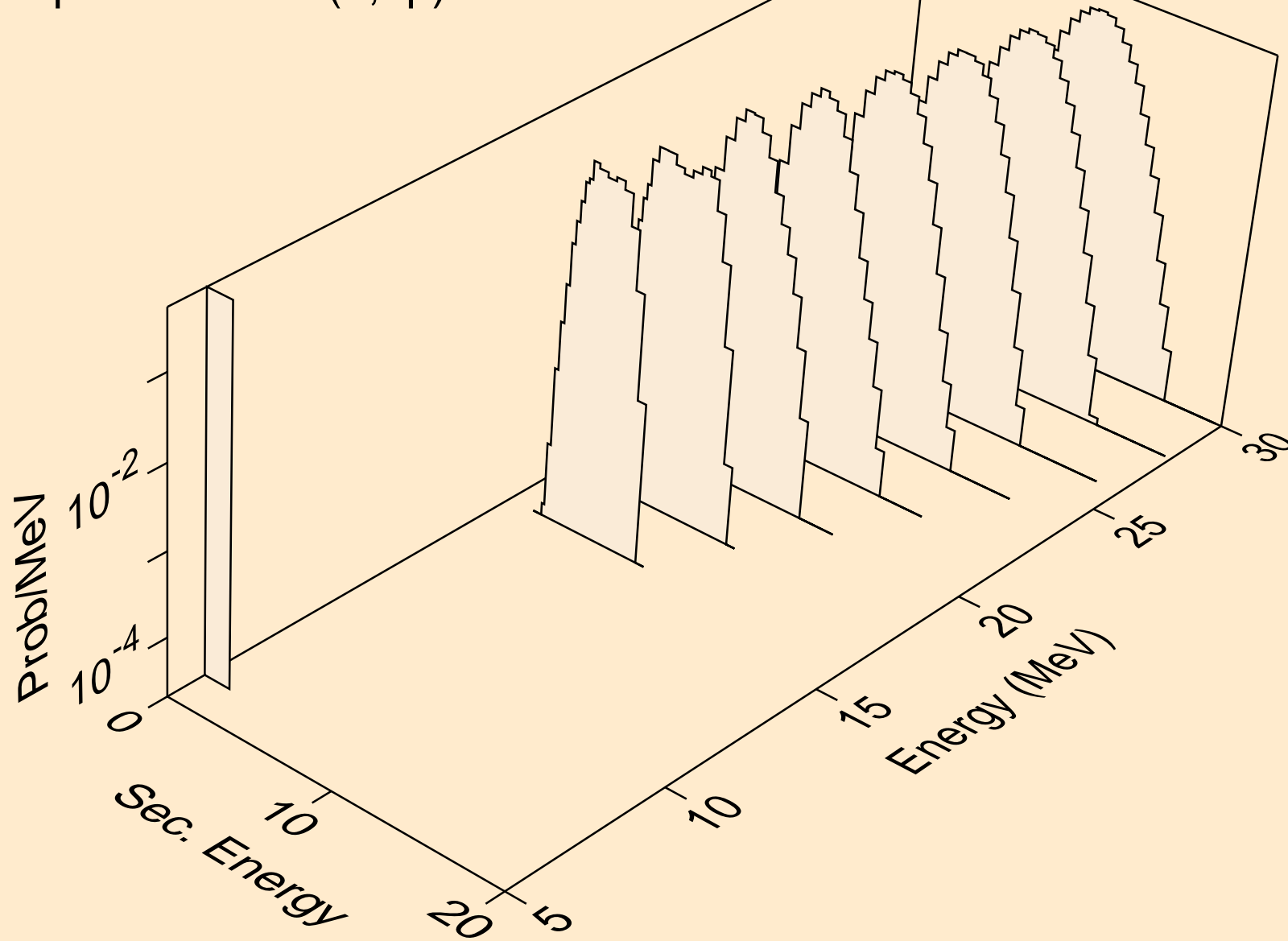

FM259 NEUTRON ACER TENDL-2024 LIBRARY; T=0.K
deuterons from (n,x)

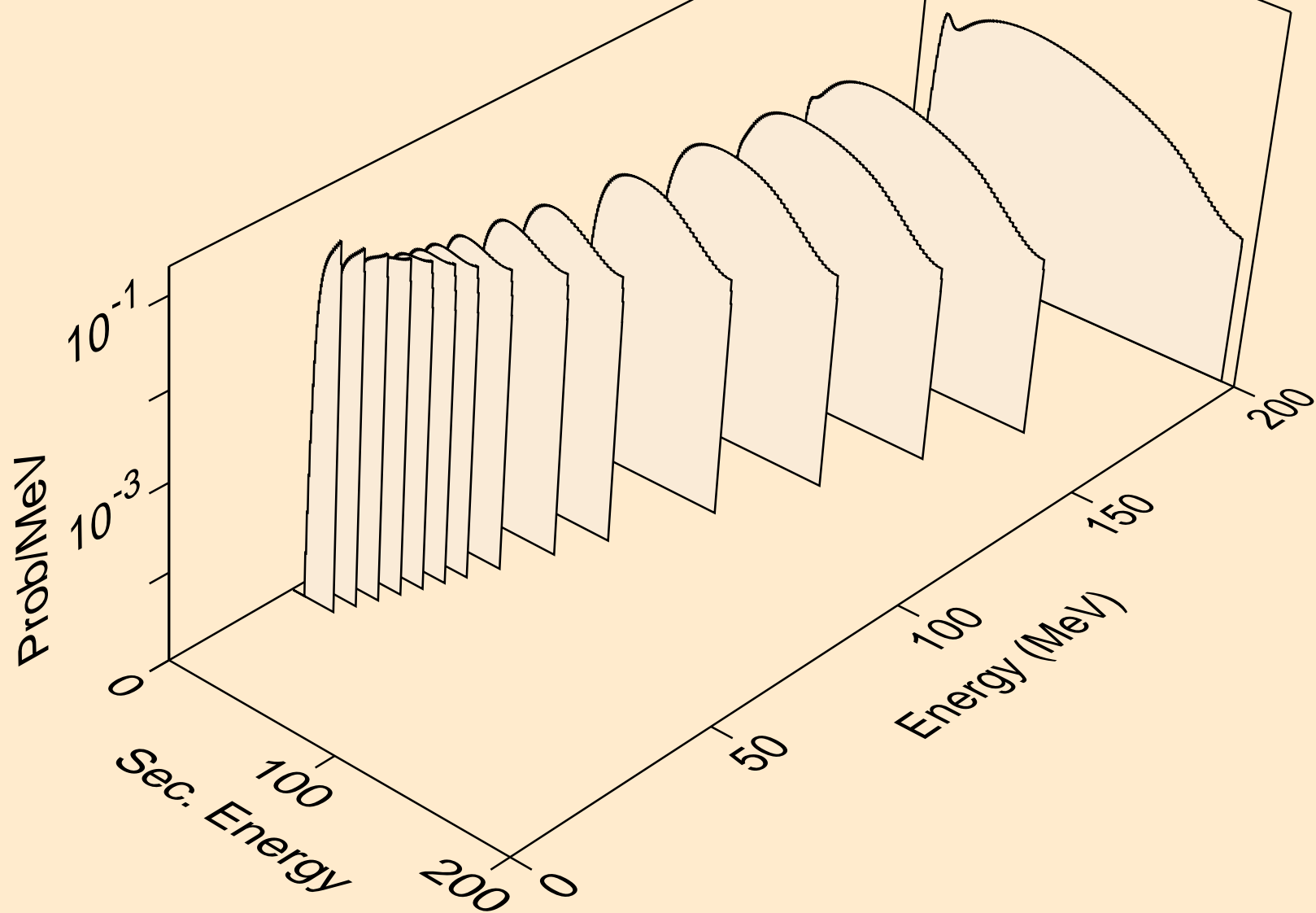

FM259 NEUTRON ACER TENDL-2024 LIBRARY; T=0.K
deuterons from (n,2nd)

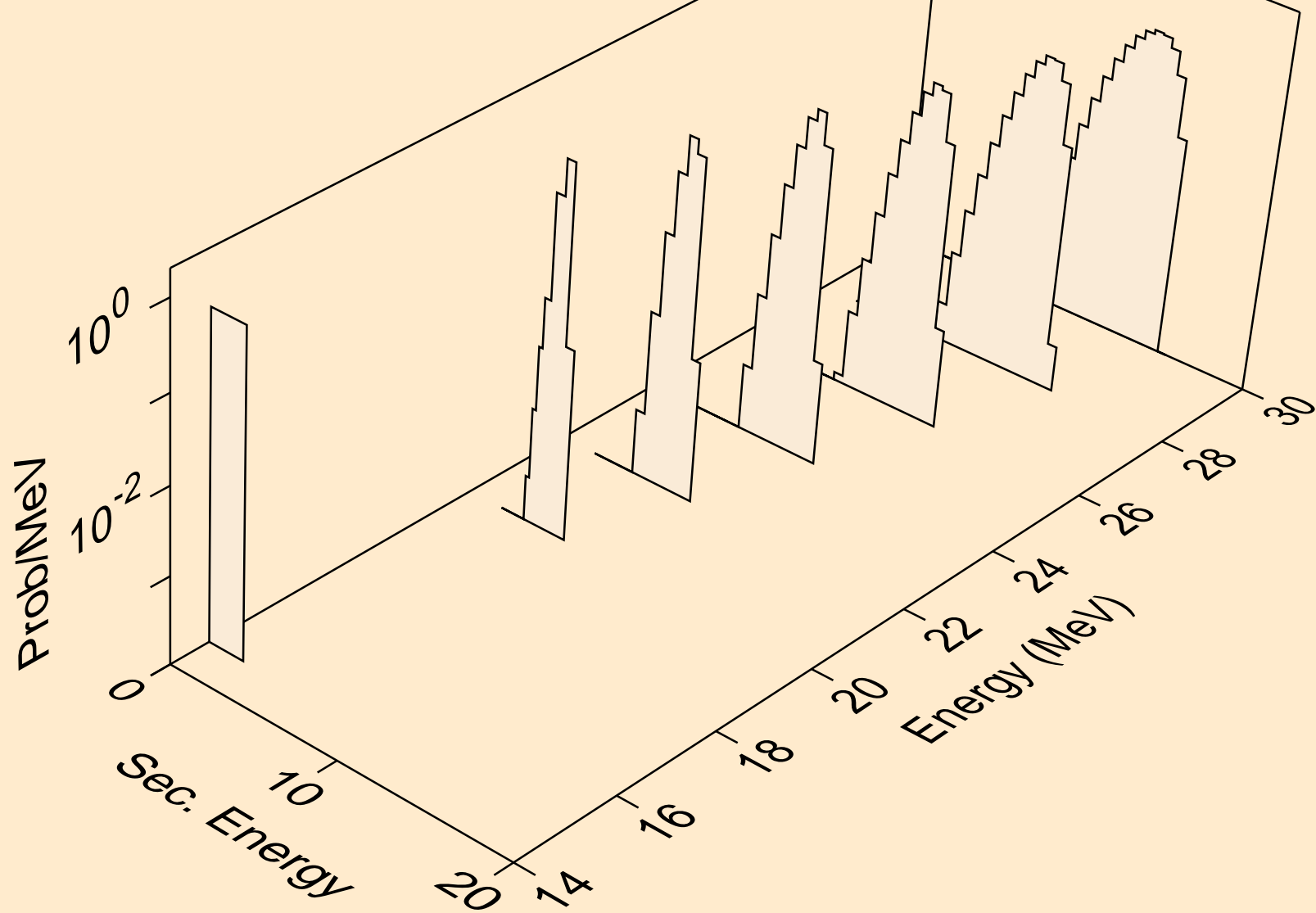

FM259 NEUTRON ACER TENDL-2024 LIBRARY; T=0.K
deuterons from (n,n*)d

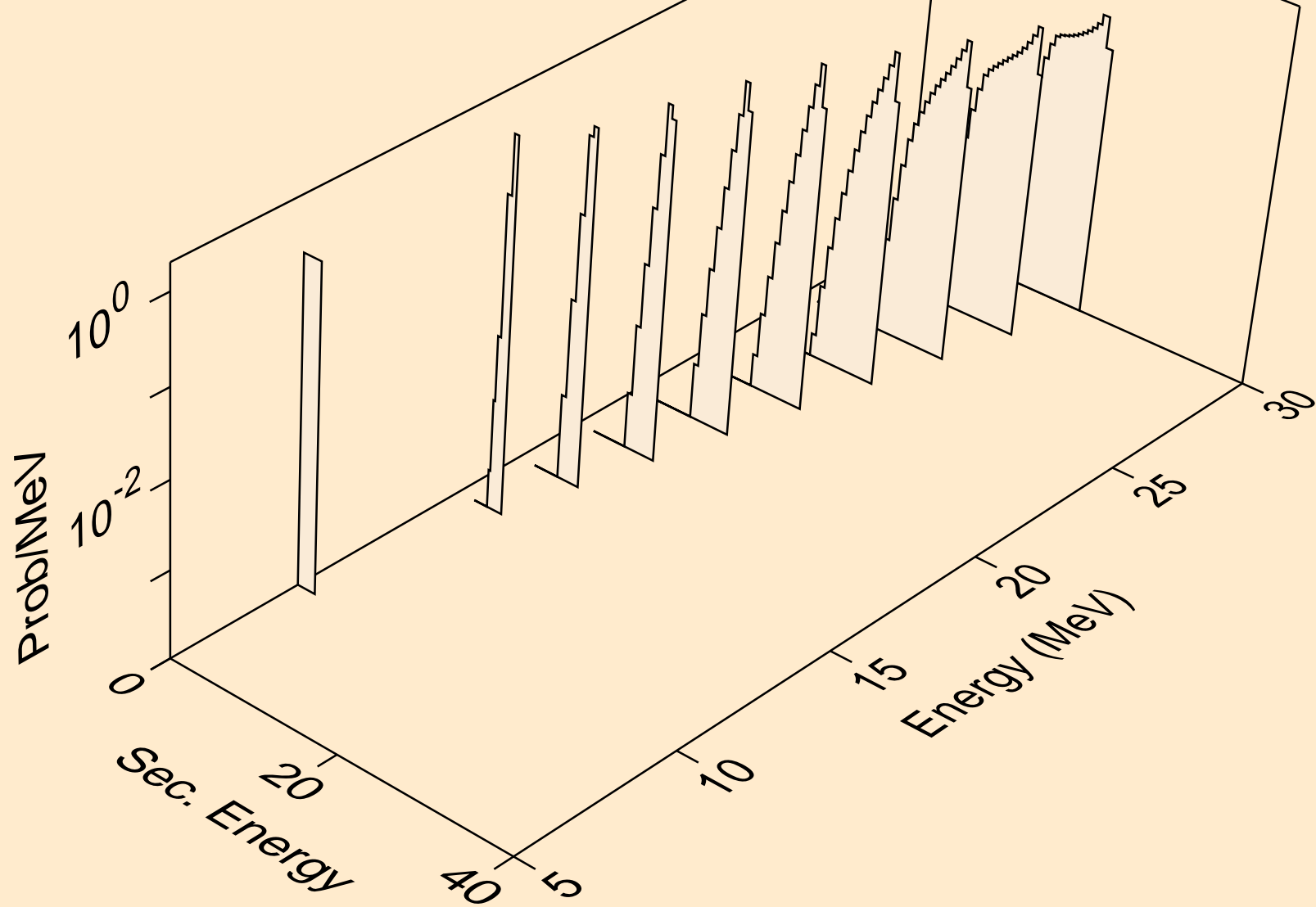

FM259 NEUTRON ACER TENDL-2024 LIBRARY; T=0.K
deuterons from (n,d)

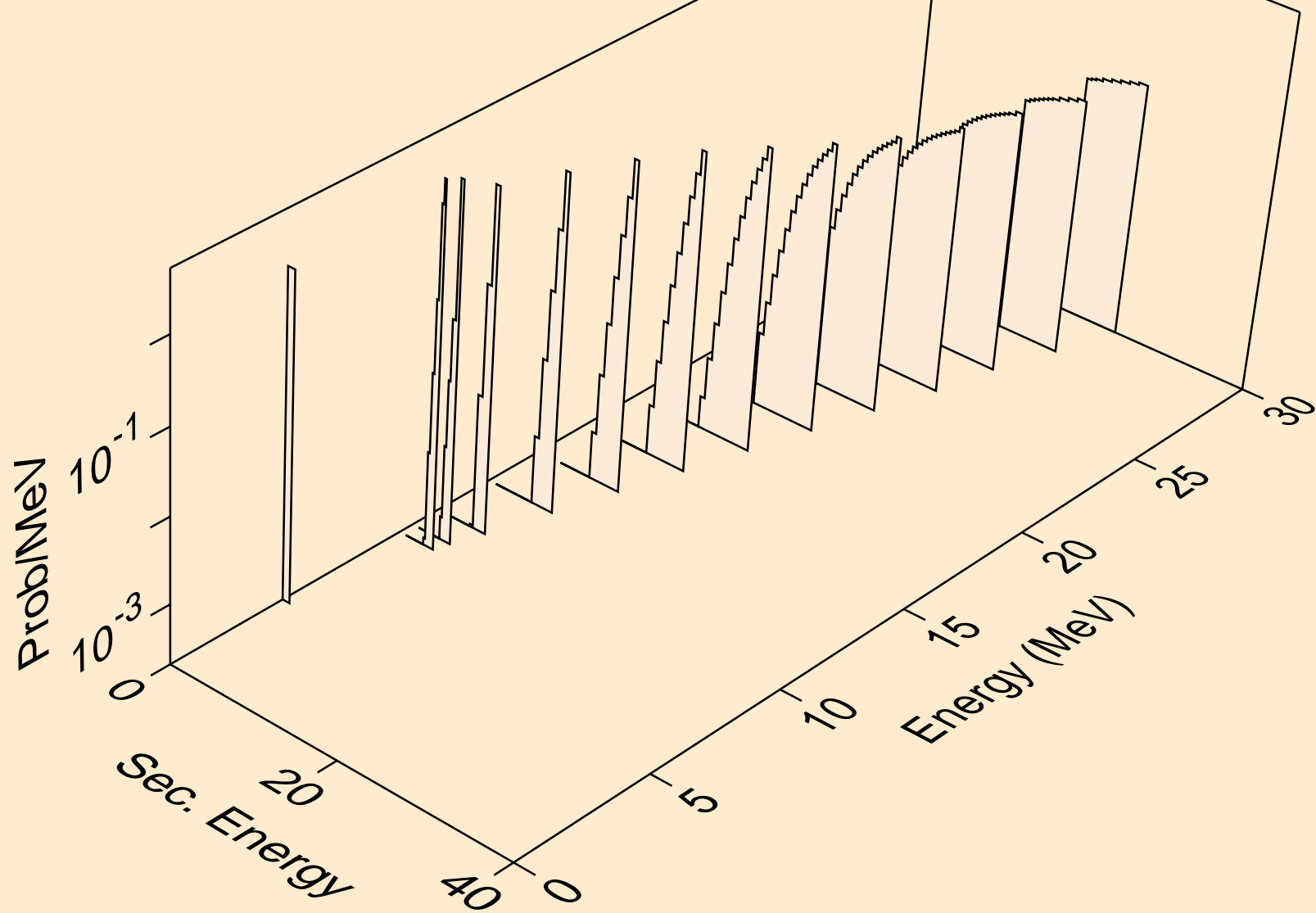

FM259 NEUTRON ACER TENDL-2024 LIBRARY; T=0.K
tritons from (n,x)

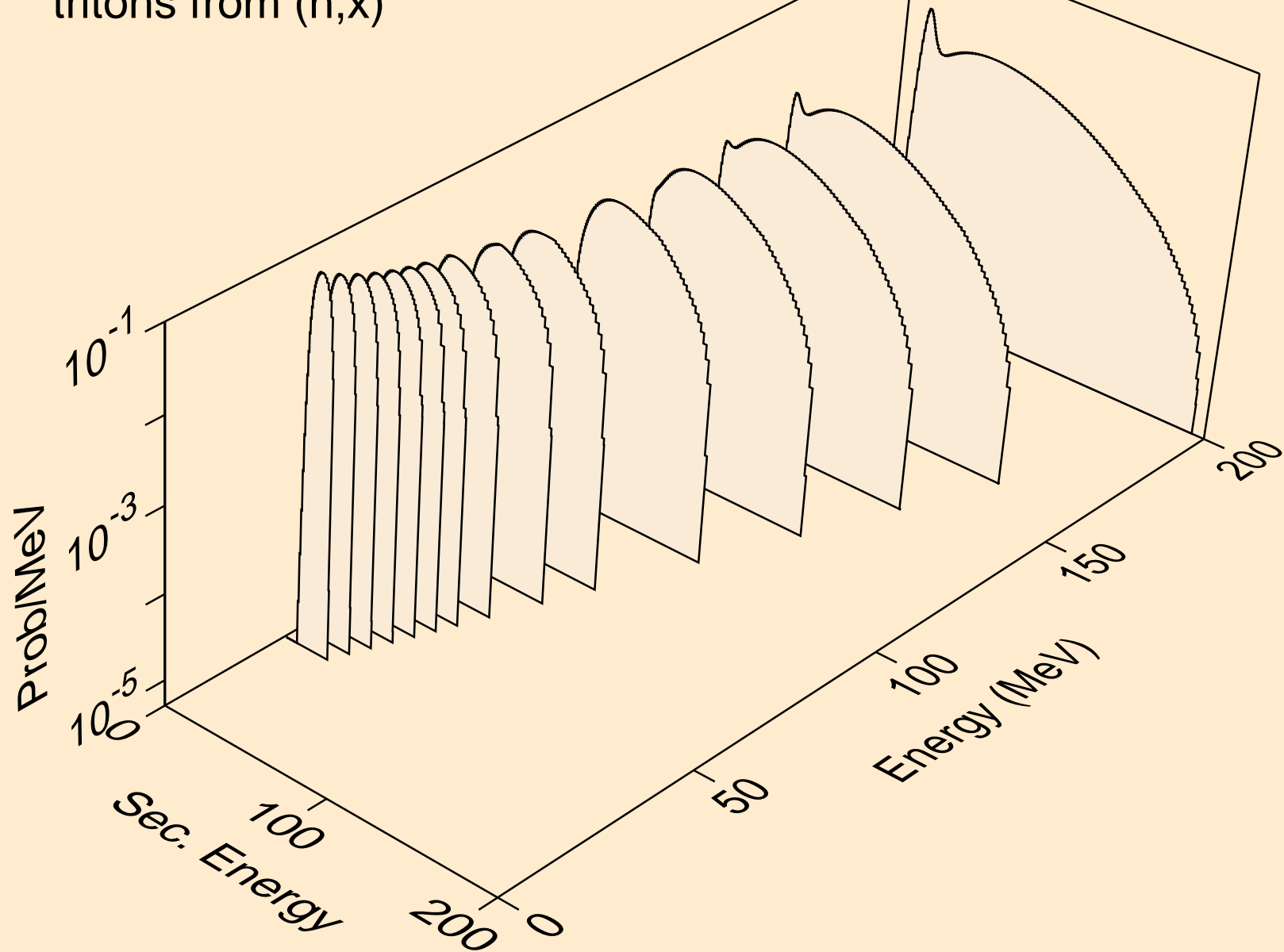

FM259 NEUTRON ACER TENDL-2024 LIBRARY; T=0.K
tritons from (n,n*)t

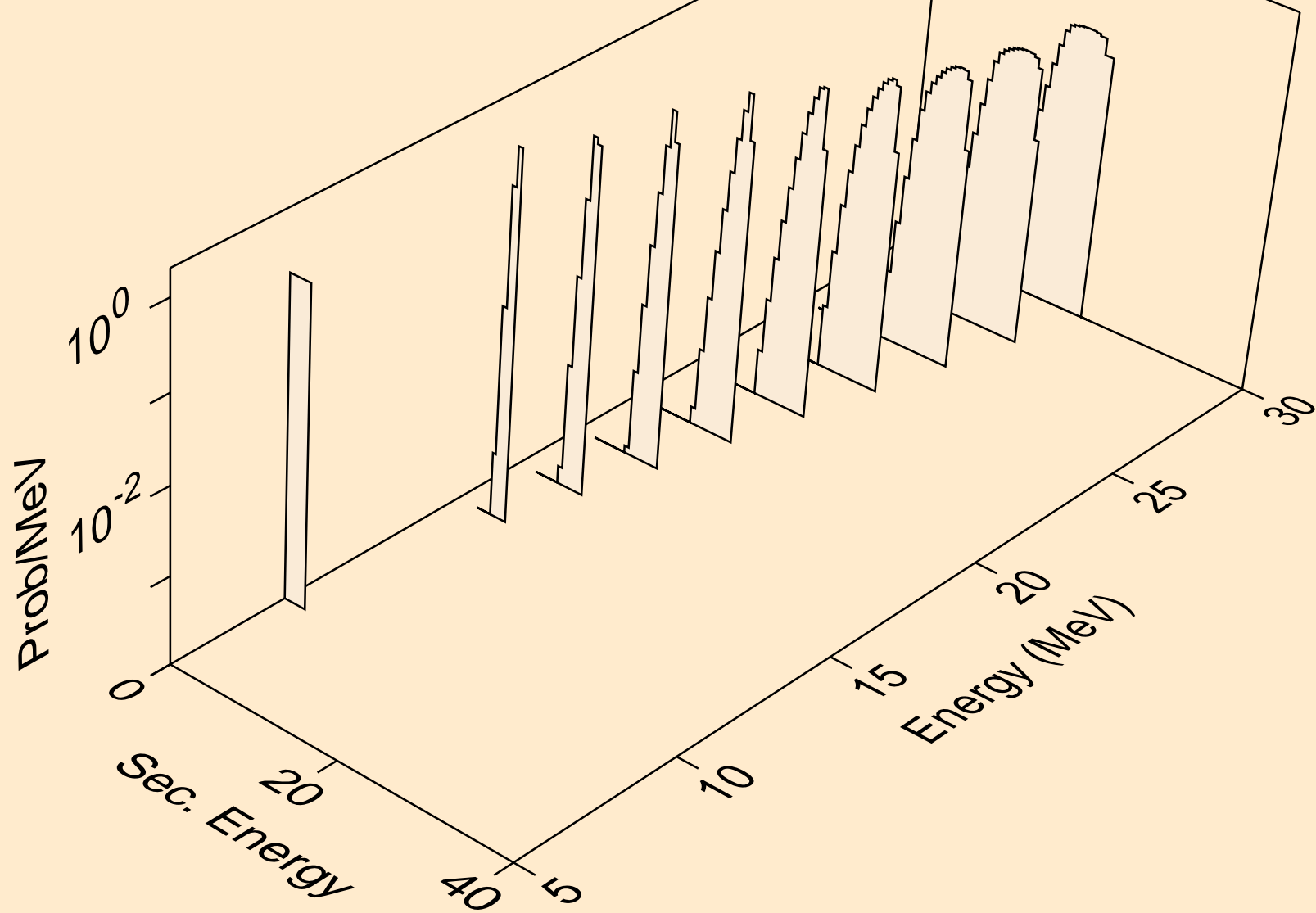

FM259 NEUTRON ACER TENDL-2024 LIBRARY; T=0.K
tritons from (n,t)

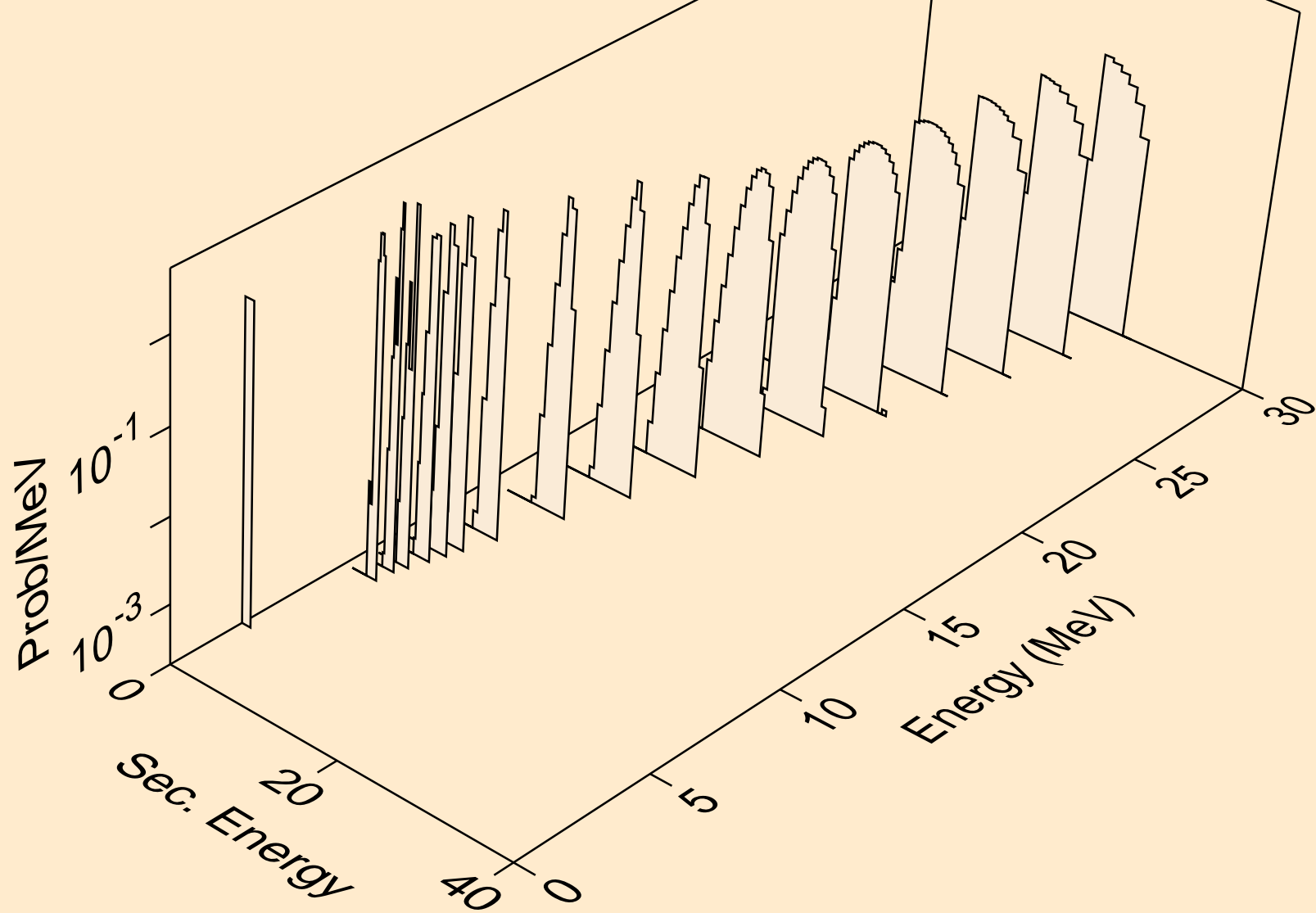

FM259 NEUTRON ACER TENDL-2024 LIBRARY; T=0.K
he3s from (n,x)

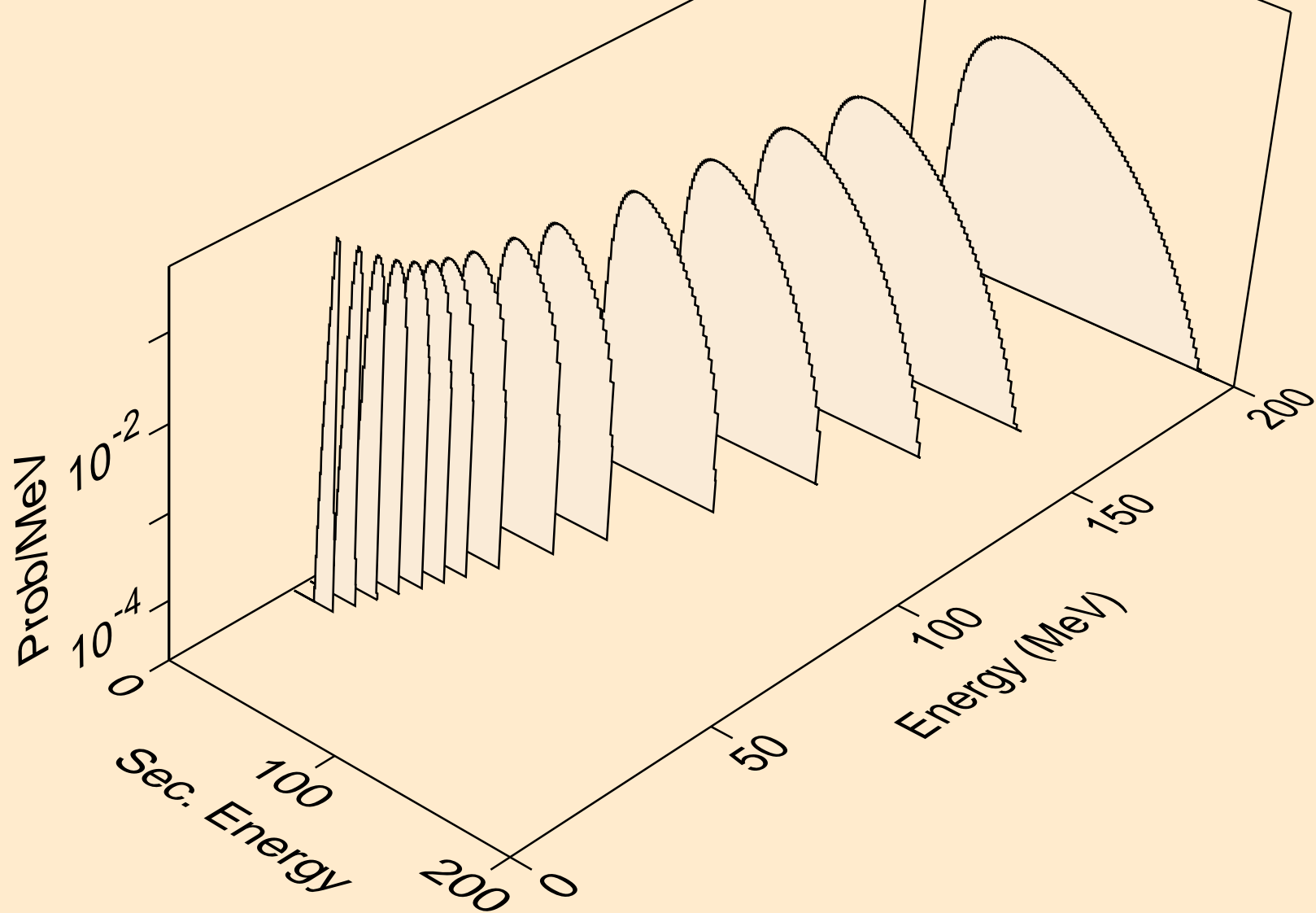

FM259 NEUTRON ACER TENDL-2024 LIBRARY; T=0.K
he3s from (n,n*)he3

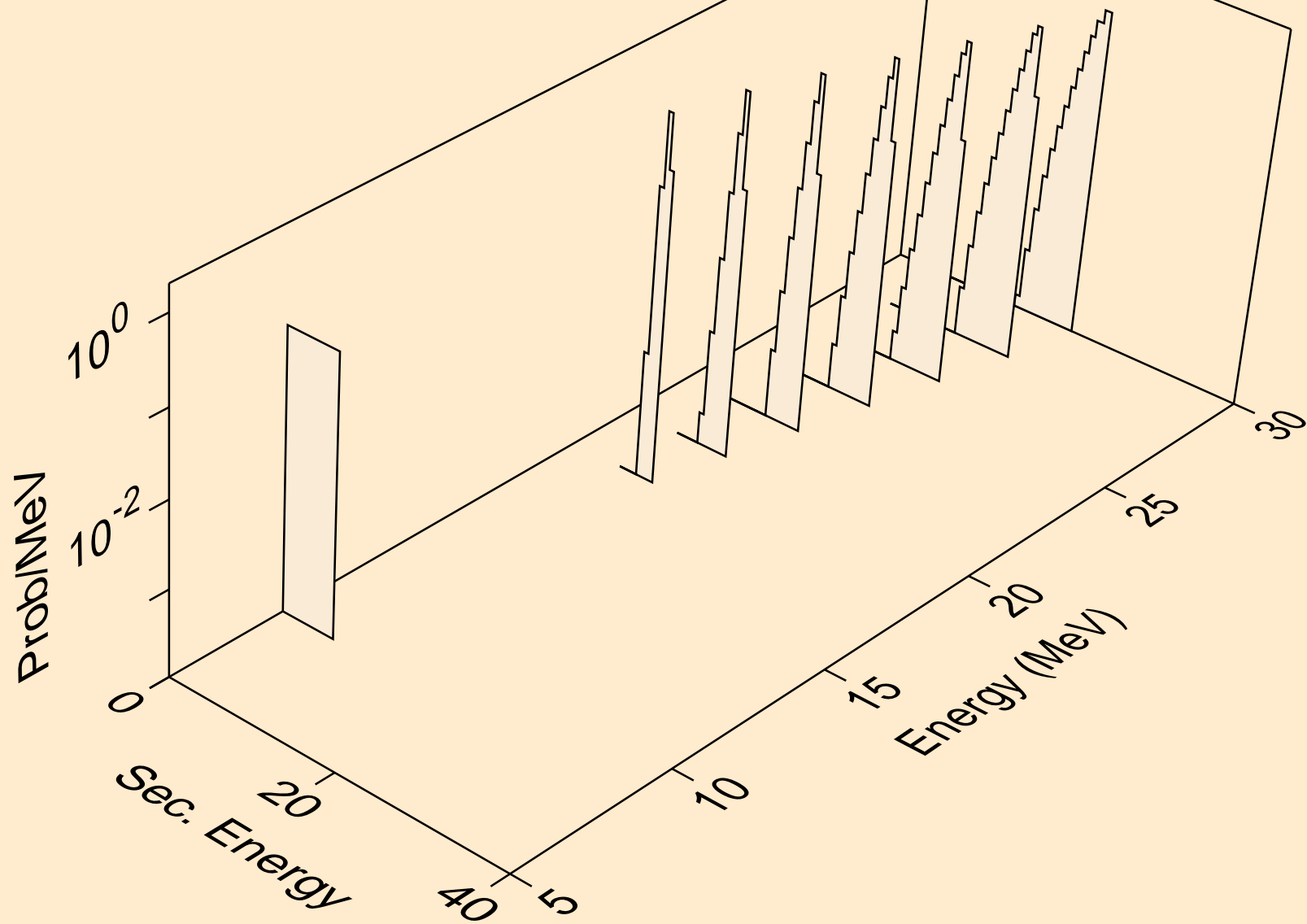

FM259 NEUTRON ACER TENDL-2024 LIBRARY; T=0.K
he3s from (n,he3)

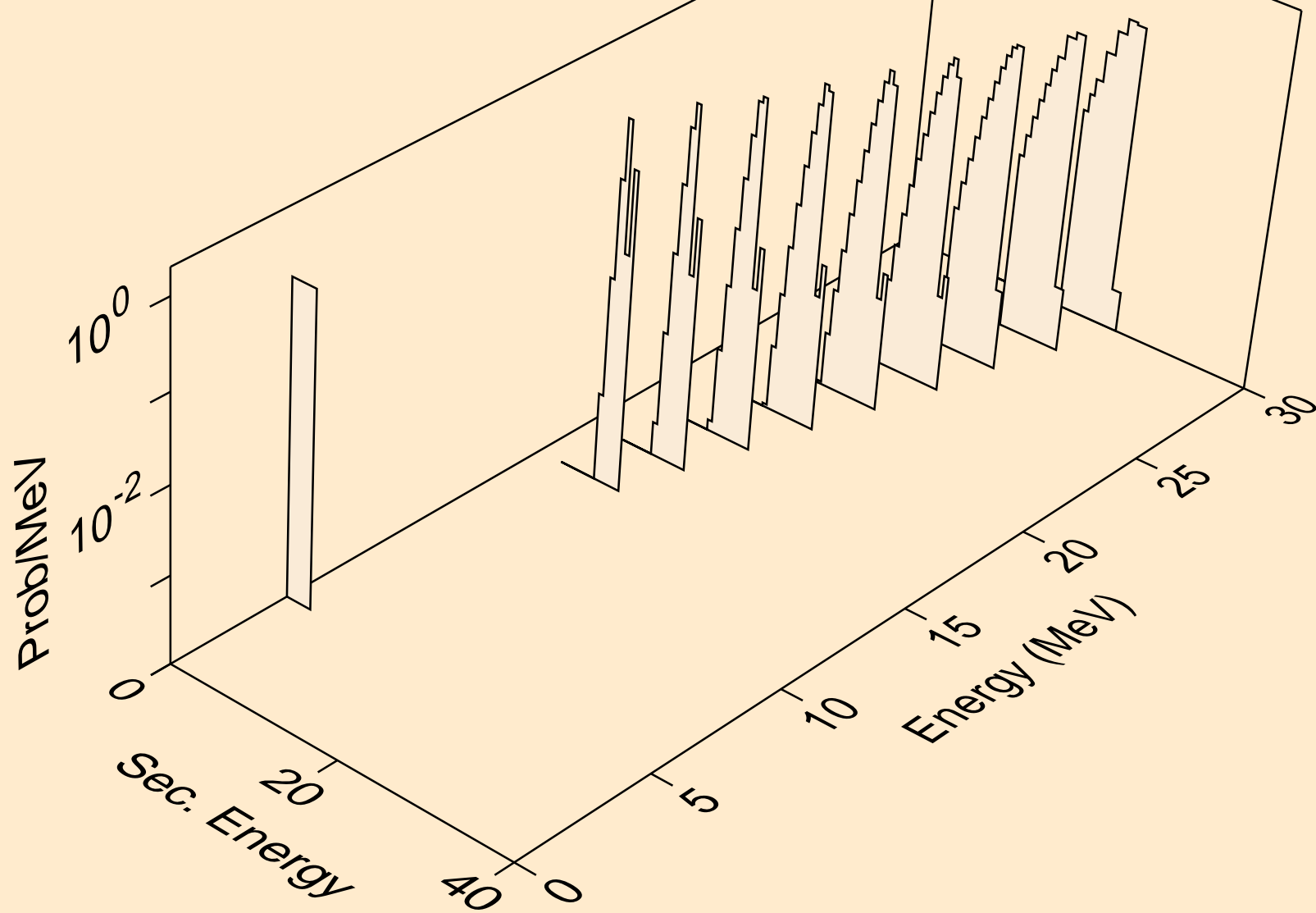

FM259 NEUTRON ACER TENDL-2024 LIBRARY; T=0.K
alphas from (n,x)

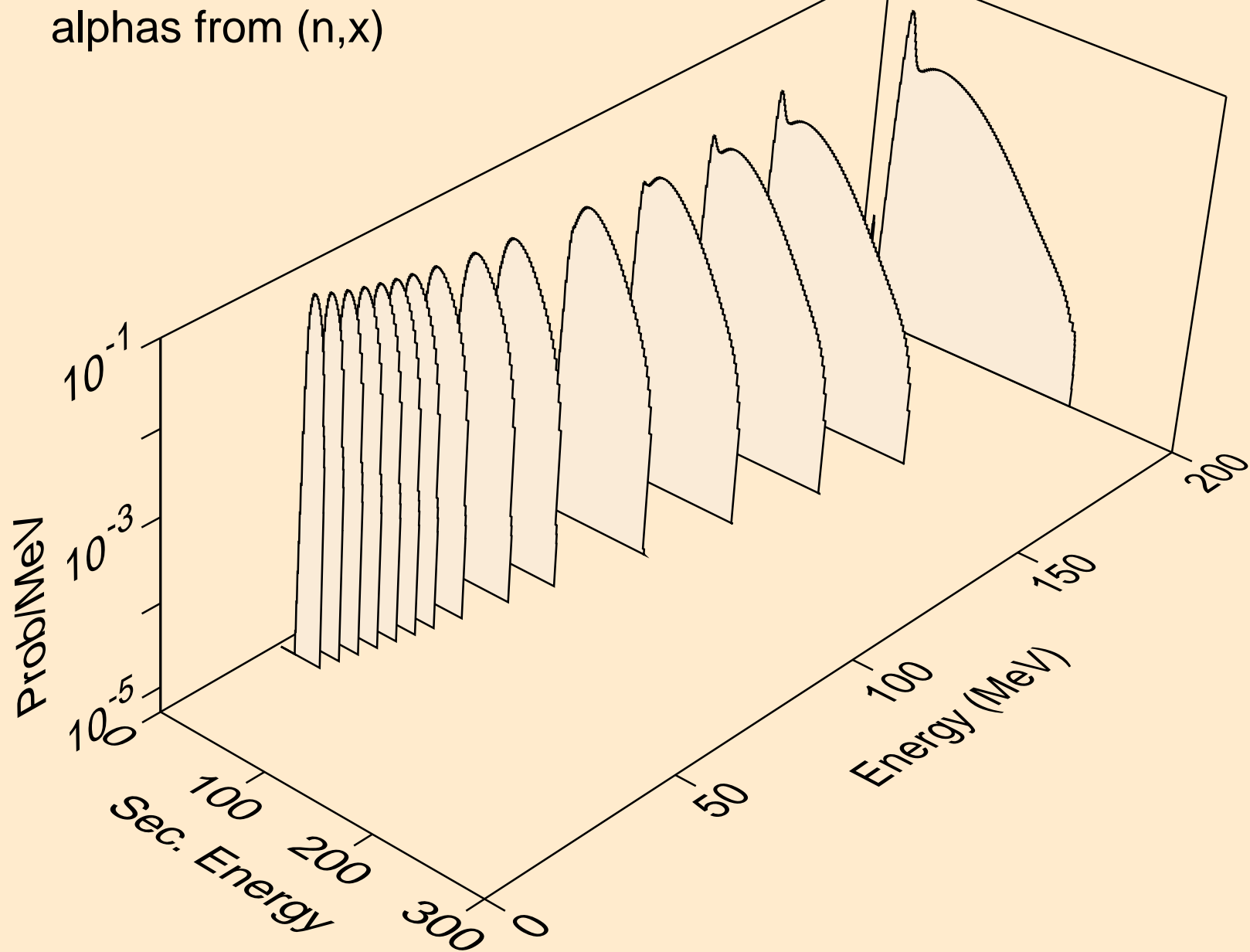

FM259 NEUTRON ACER TENDL-2024 LIBRARY; T=0.K
alphas from (n,n*)a

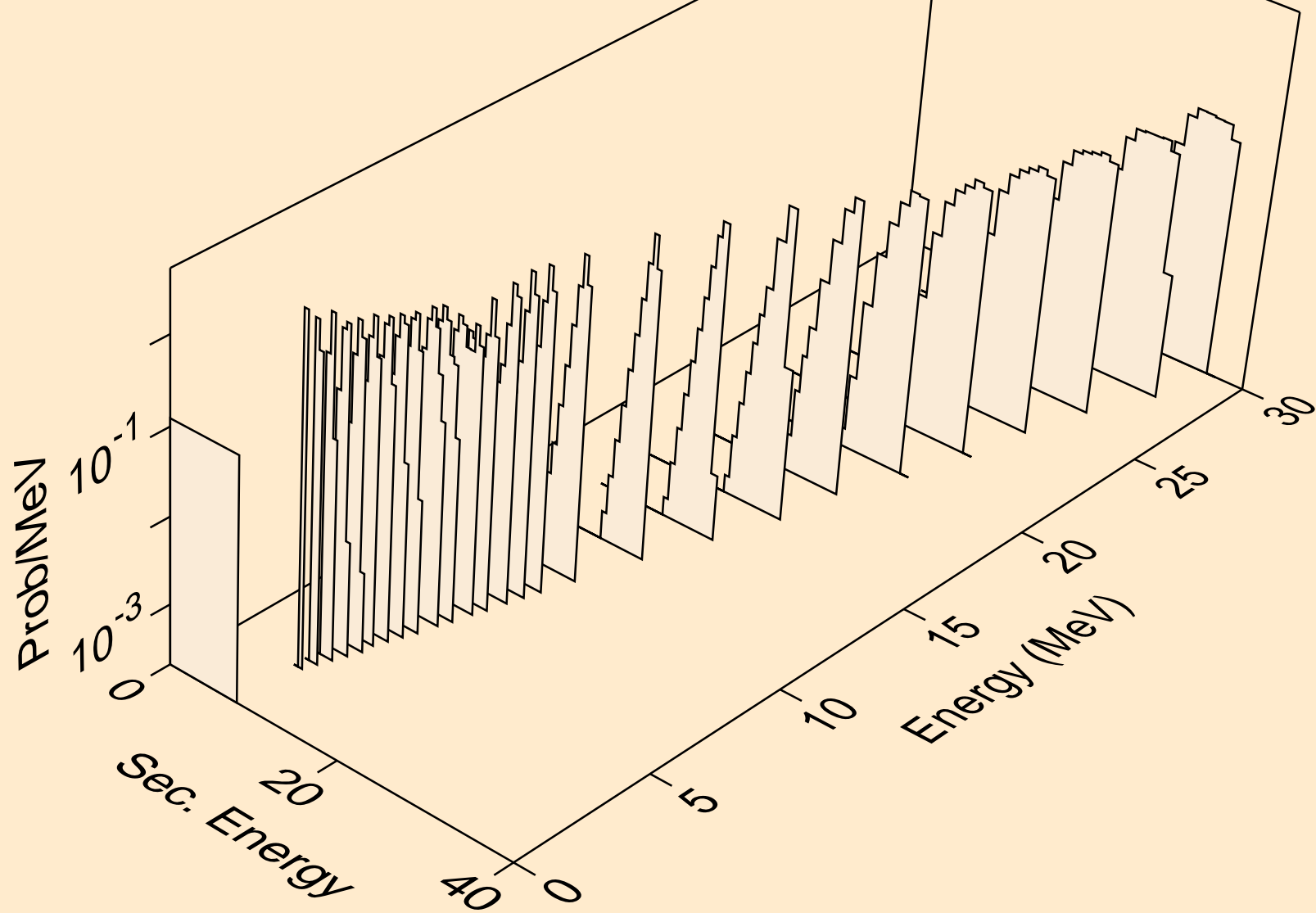

FM259 NEUTRON ACER TENDL-2024 LIBRARY; T=0.K
alphas from (n,2n)a

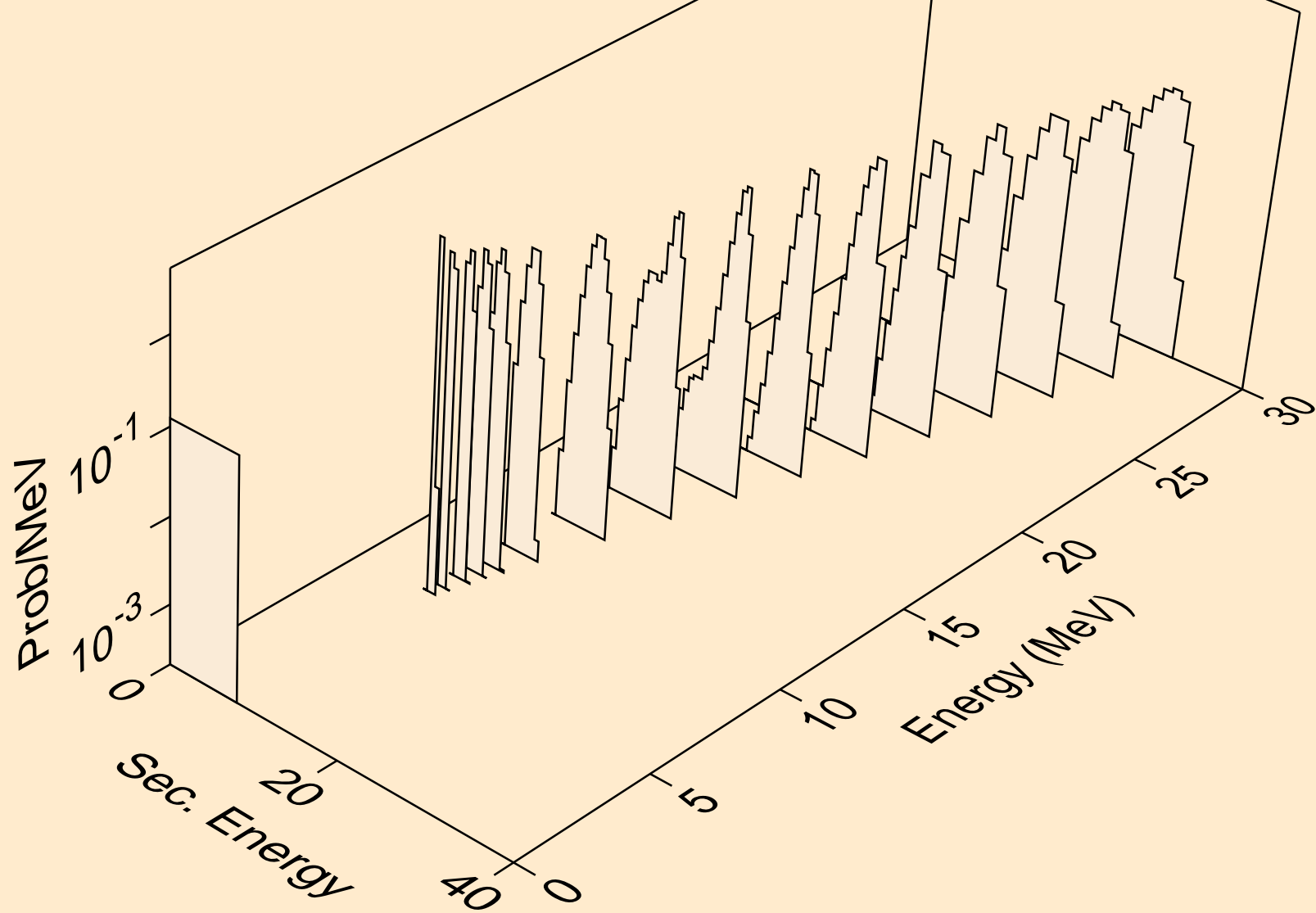

FM259 NEUTRON ACER TENDL-2024 LIBRARY; T=0.K
alphas from (n,3n)a

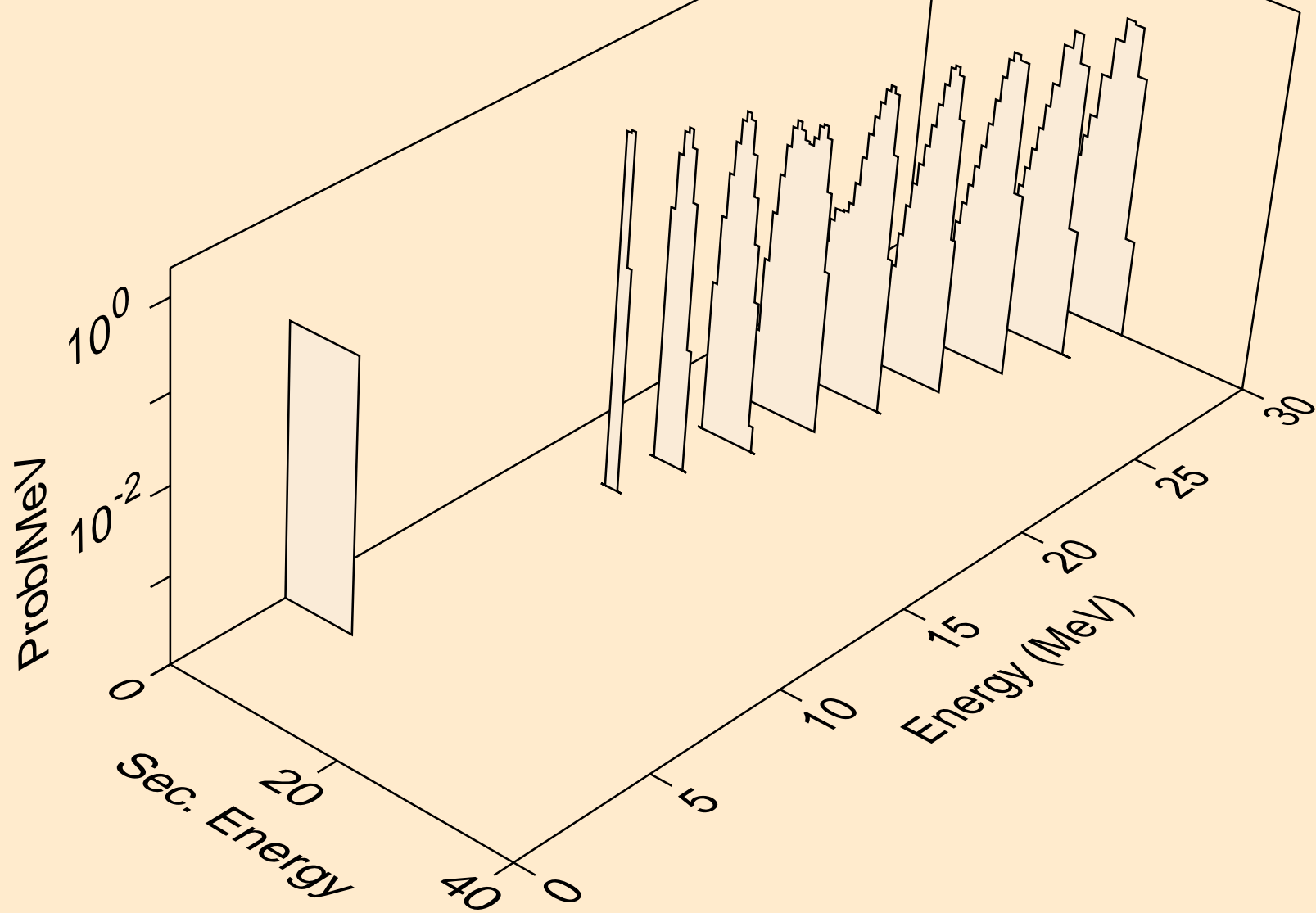

FM259 NEUTRON ACER TENDL-2024 LIBRARY; T=0.K
alphas from (n,a)

