

LR263 NEUTRON ACER TENDL-2024 LIBRARY; T=0.K

Principal cross sections

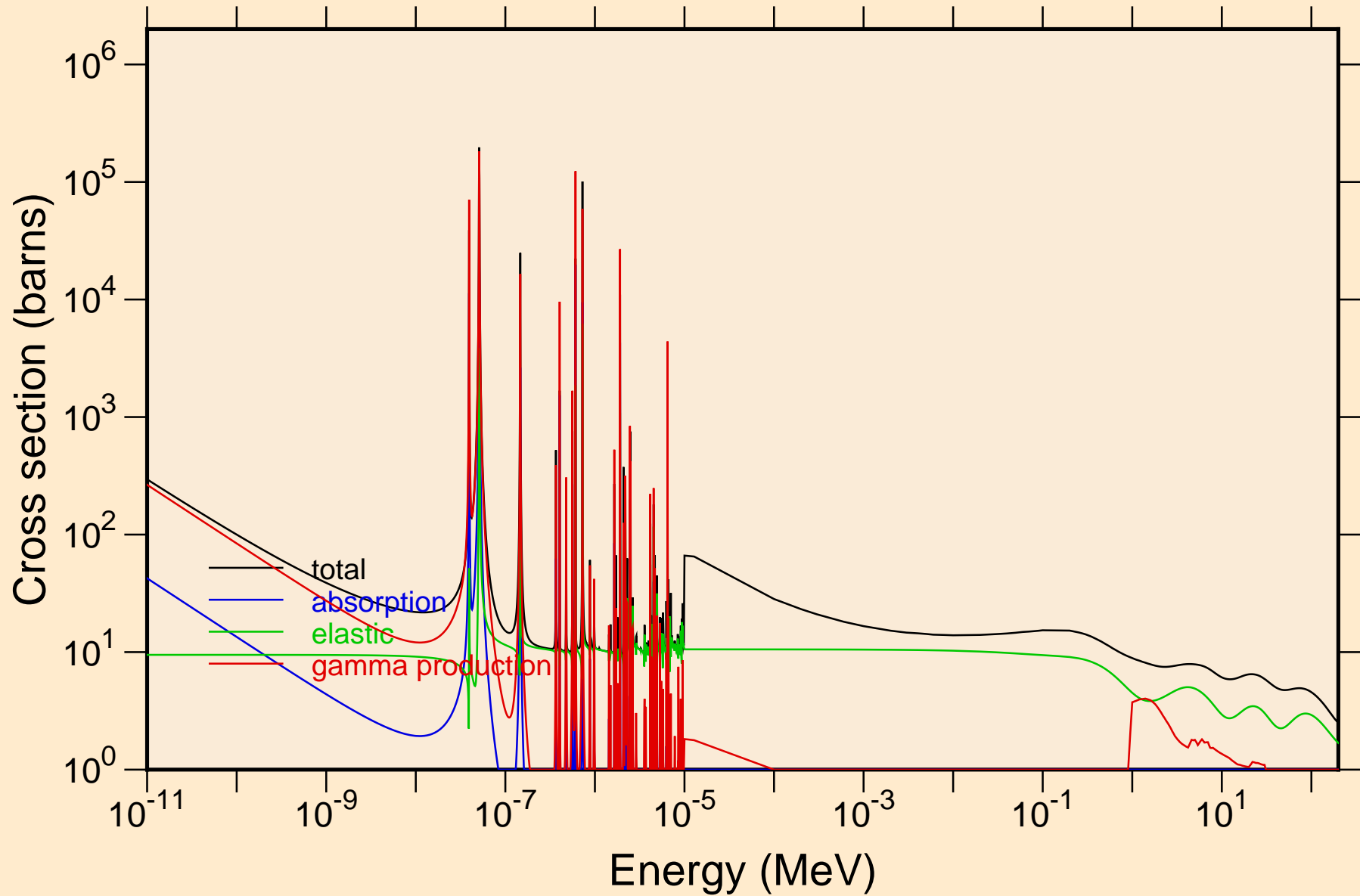

LR263 NEUTRON ACER TENDL-2024 LIBRARY; T=0.K
resonance total cross section

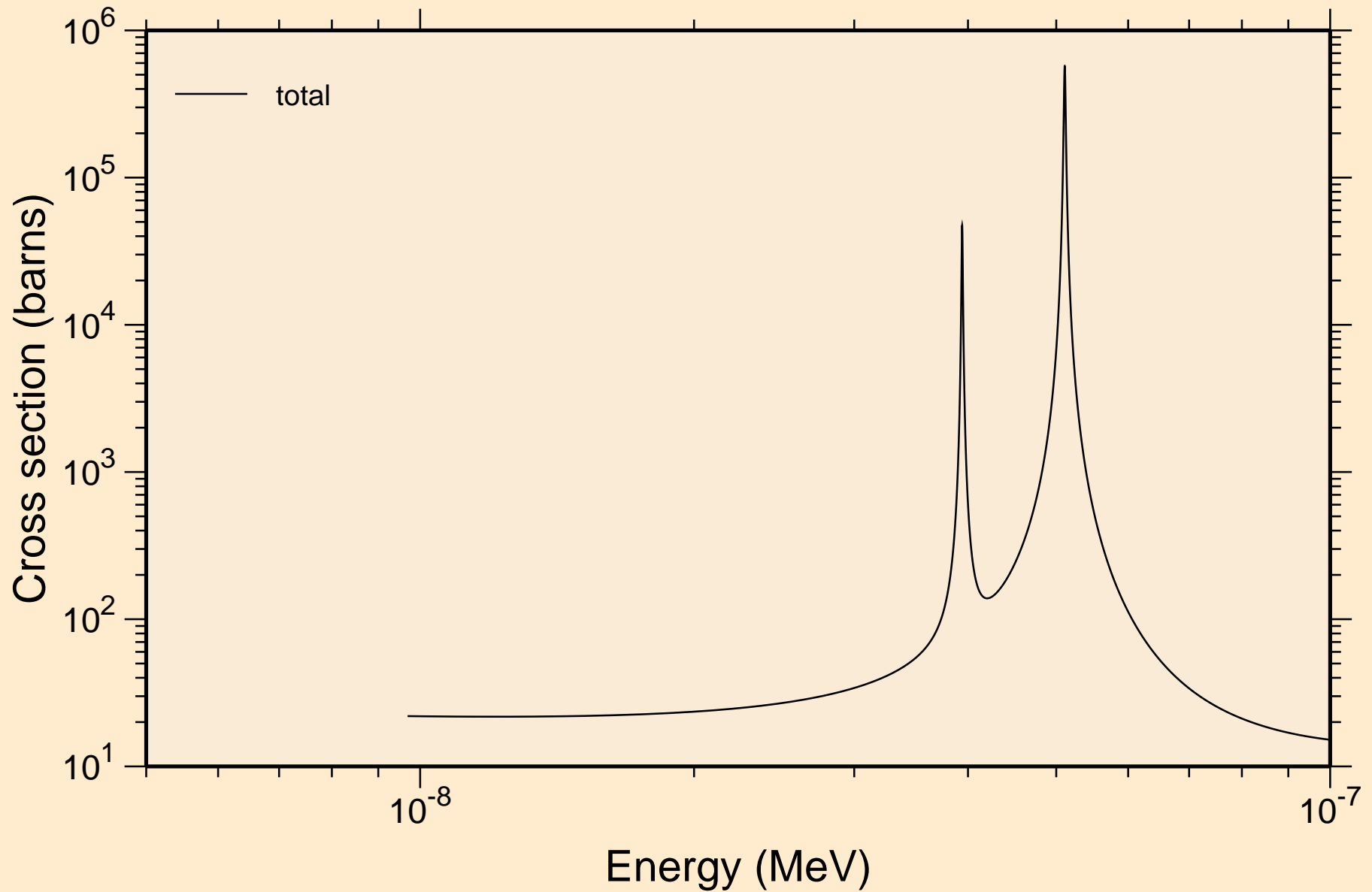

LR263 NEUTRON ACER TENDL-2024 LIBRARY; T=0.K
resonance total cross section

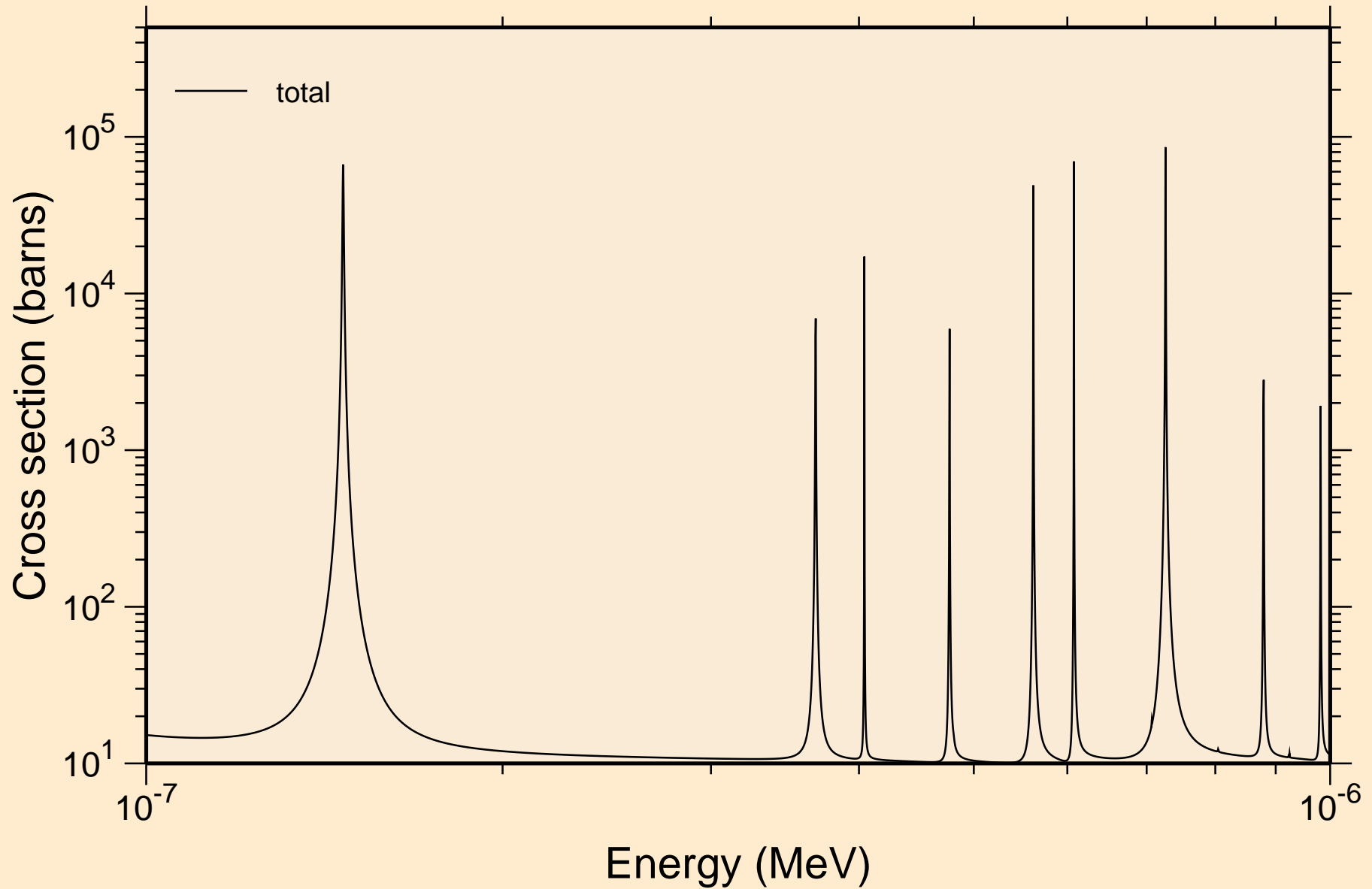

LR263 NEUTRON ACER TENDL-2024 LIBRARY; T=0.K
resonance total cross section

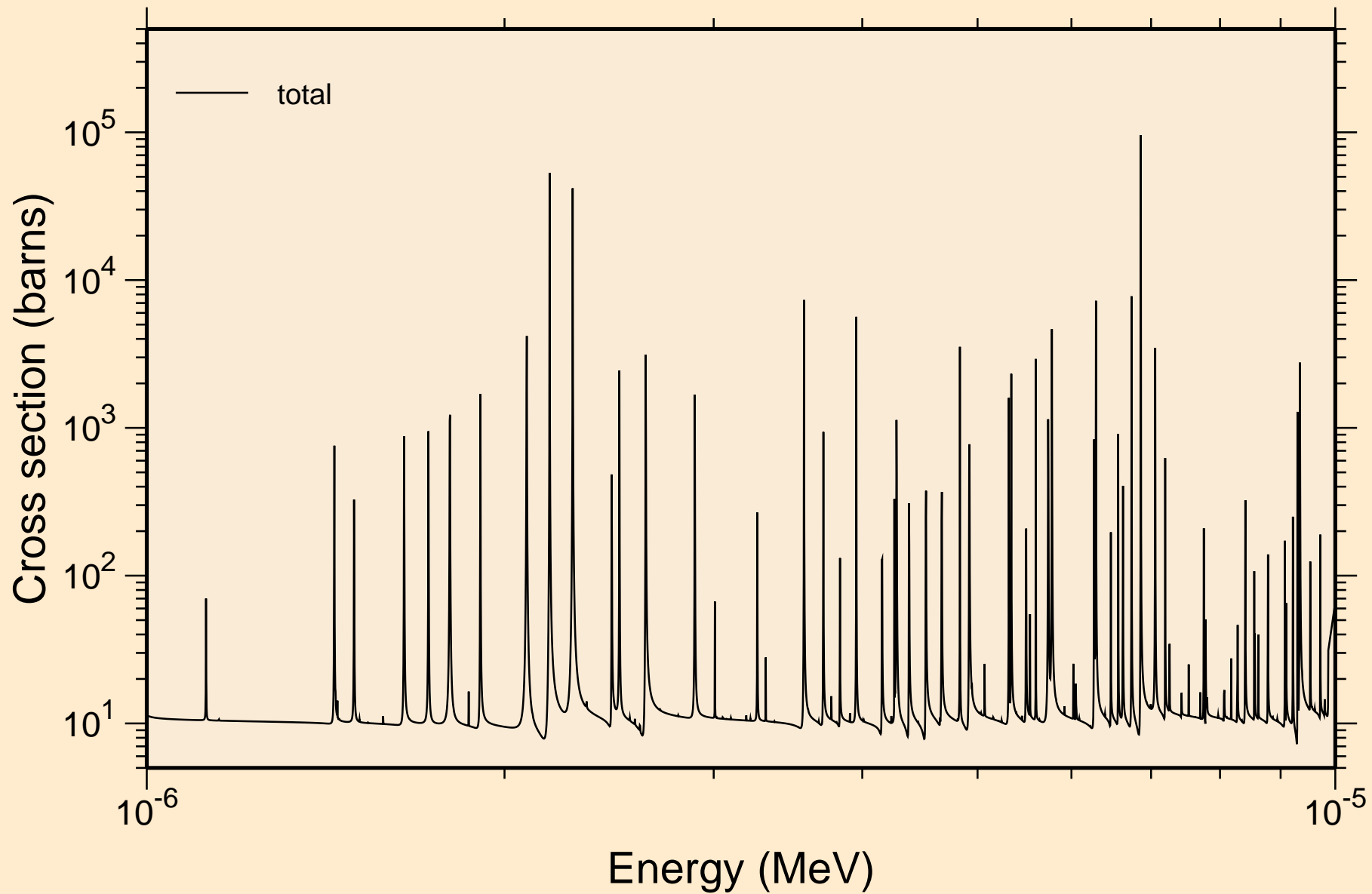

LR263 NEUTRON ACER TENDL-2024 LIBRARY; T=0.K
resonance total cross section

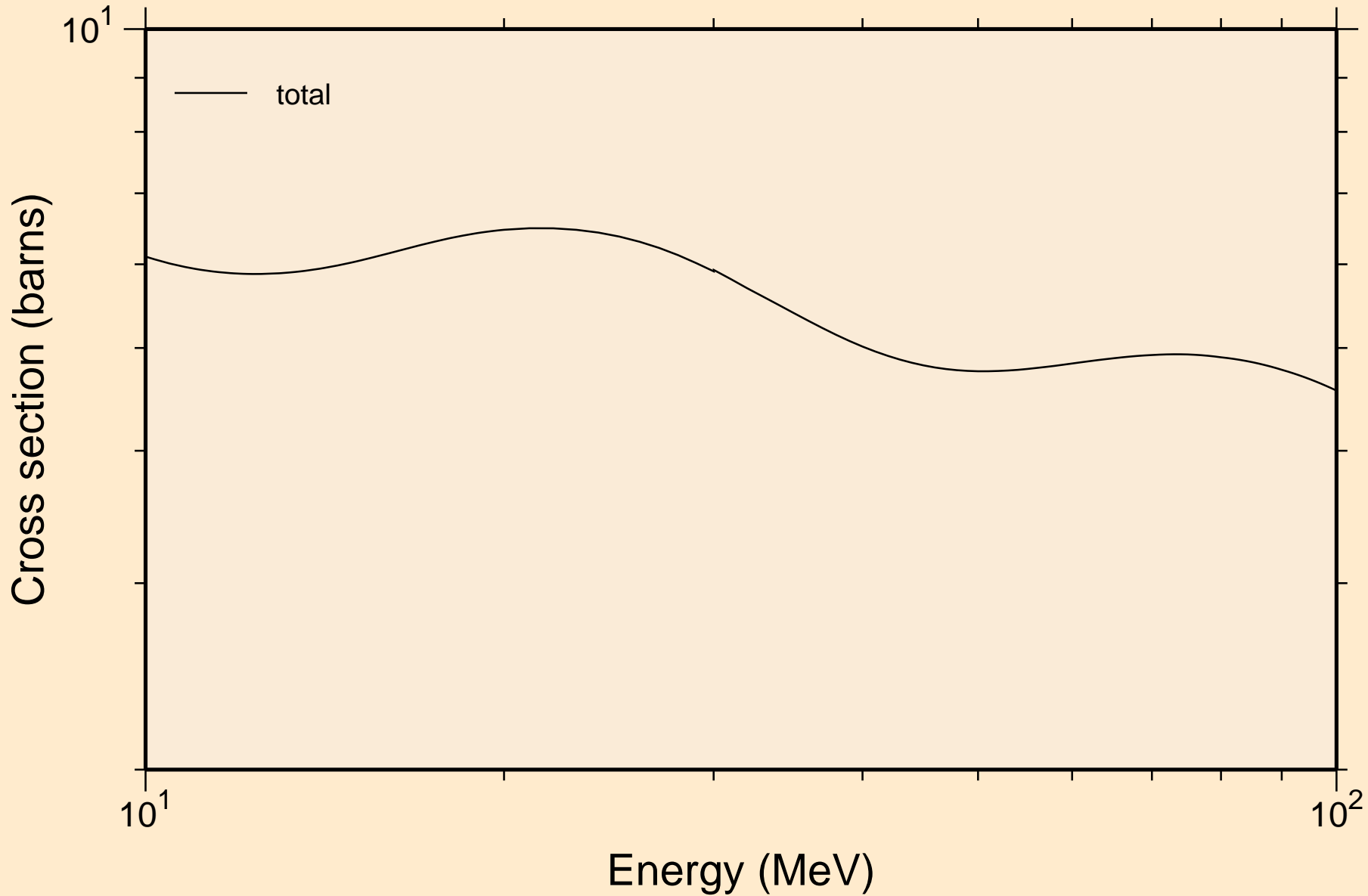

LR263 NEUTRON ACER TENDL-2024 LIBRARY; T=0.K
resonance absorption cross sections

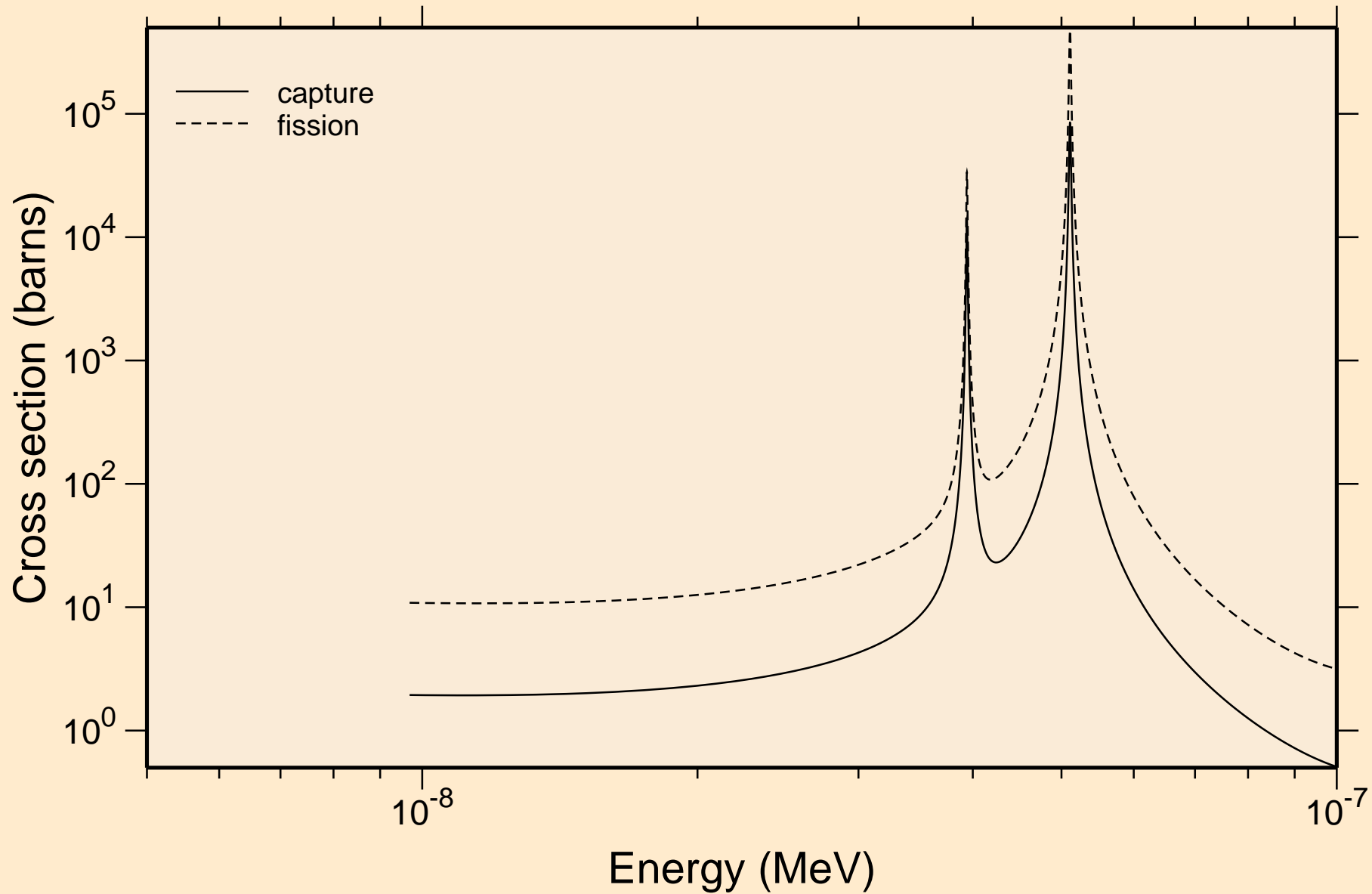

LR263 NEUTRON ACER TENDL-2024 LIBRARY; T=0.K
resonance absorption cross sections

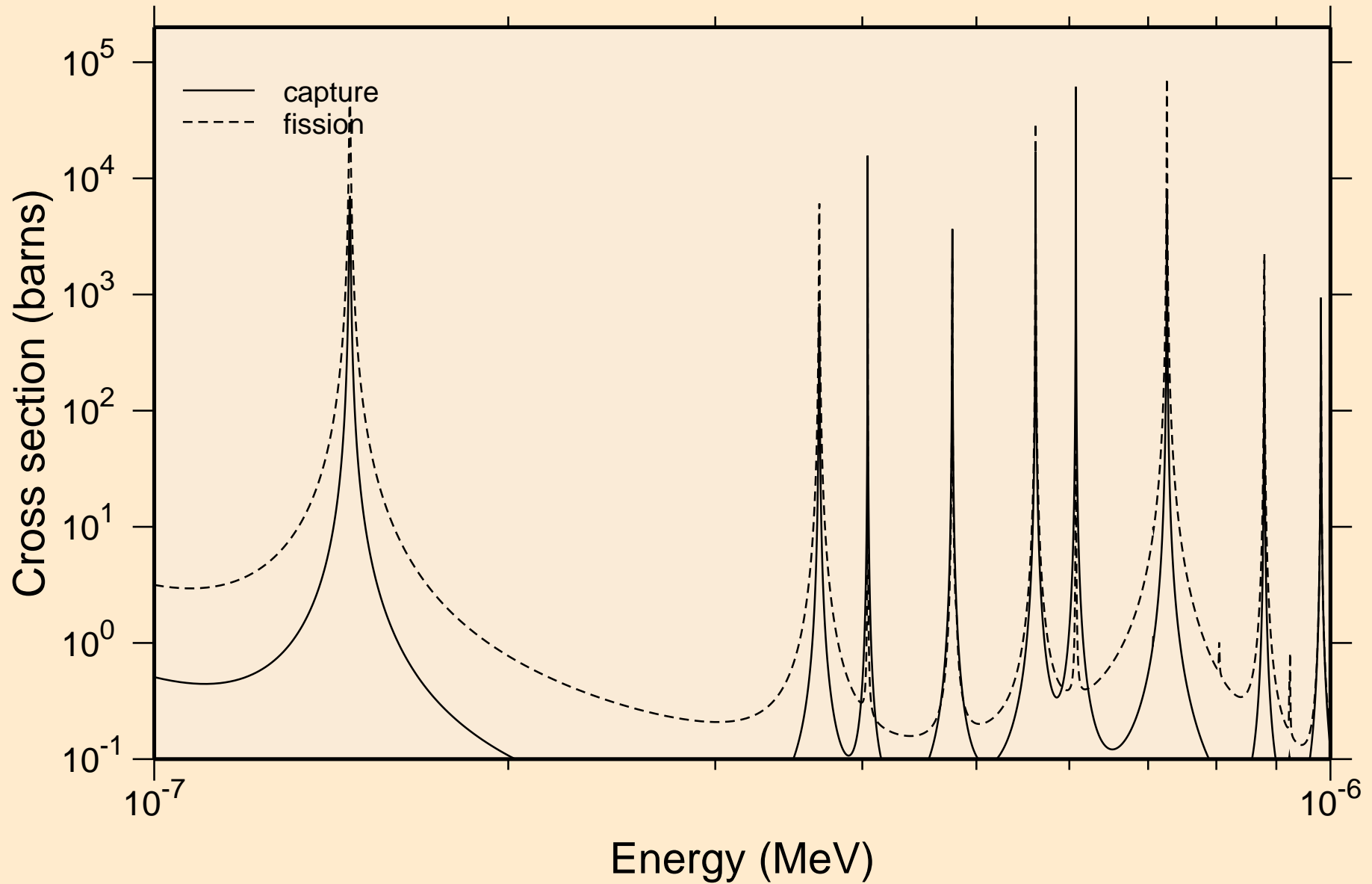

LR263 NEUTRON ACER TENDL-2024 LIBRARY; T=0.K
resonance absorption cross sections

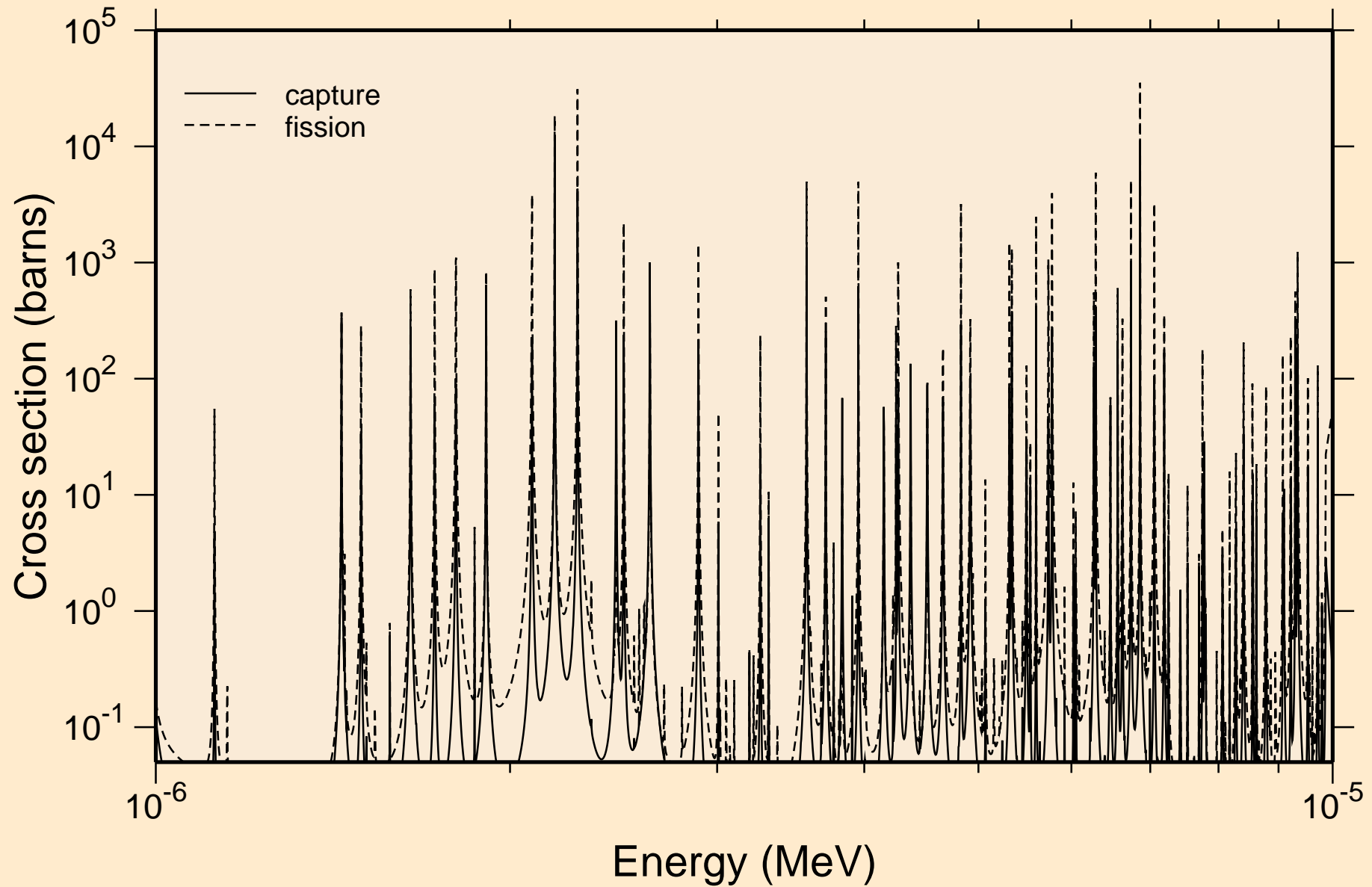

LR263 NEUTRON ACER TENDL-2024 LIBRARY; T=0.K
resonance absorption cross sections

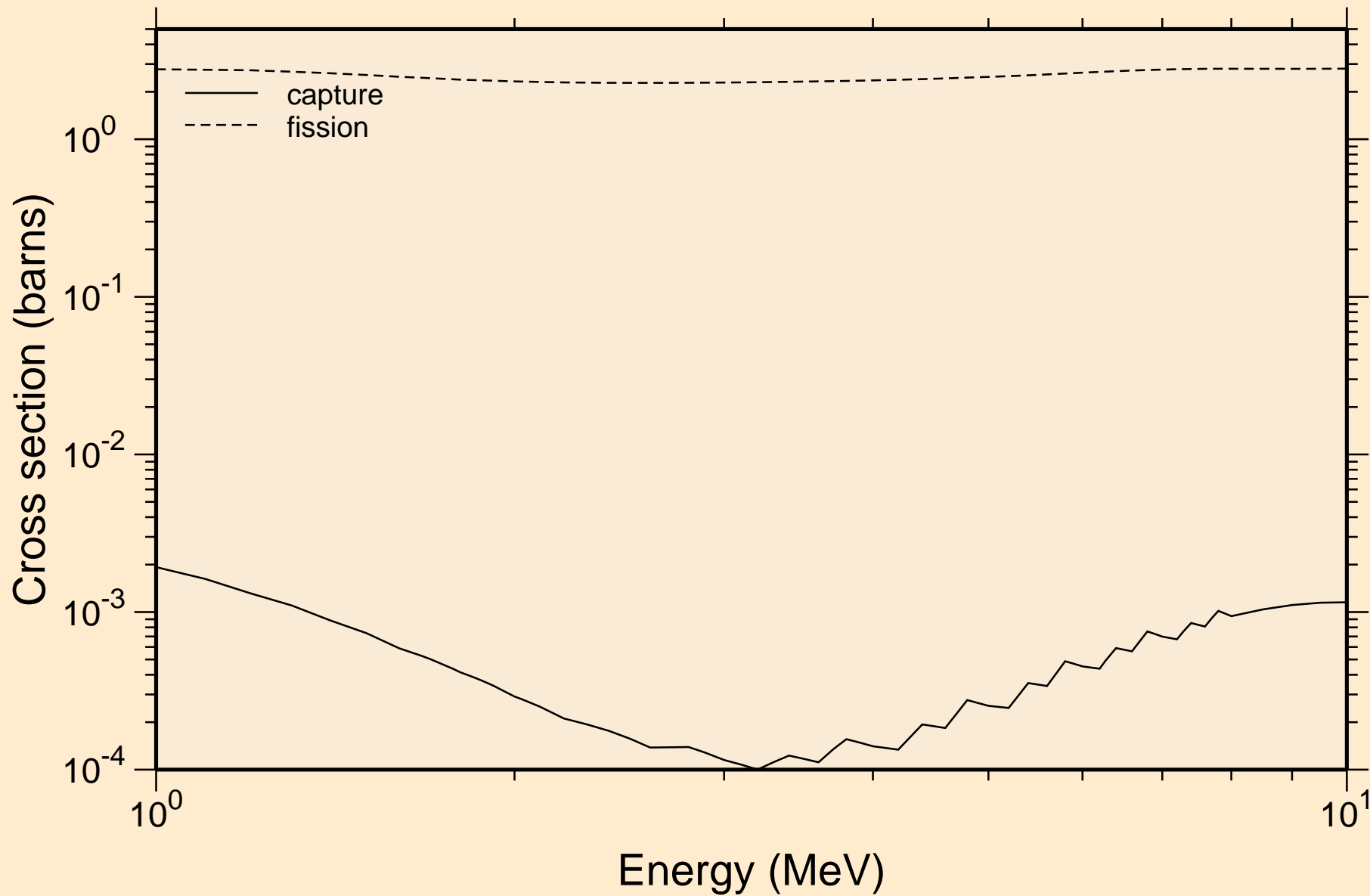

LR263 NEUTRON ACER TENDL-2024 LIBRARY; T=0.K
Heating

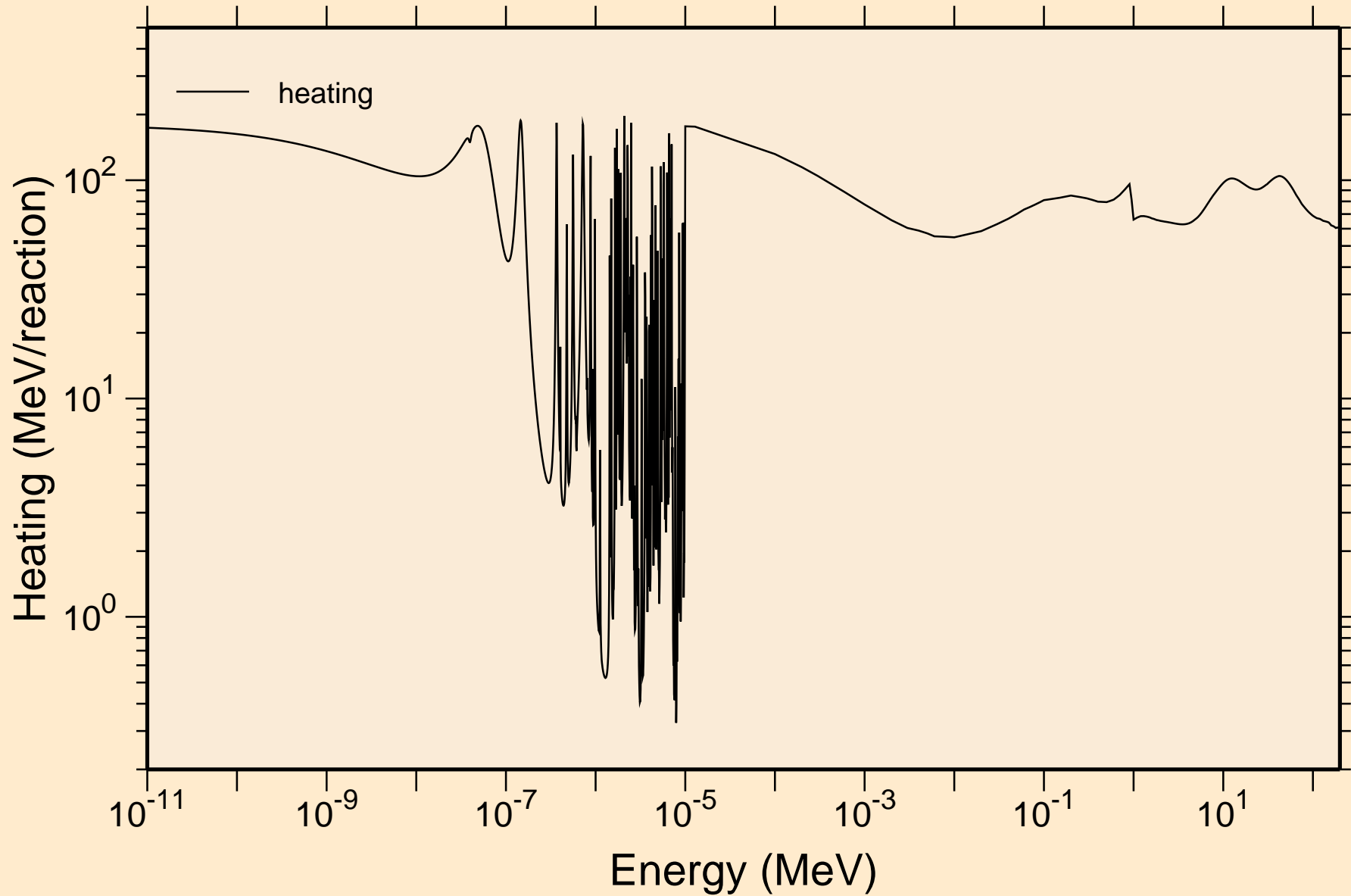

LR263 NEUTRON ACER TENDL-2024 LIBRARY; T=0.K

Damage

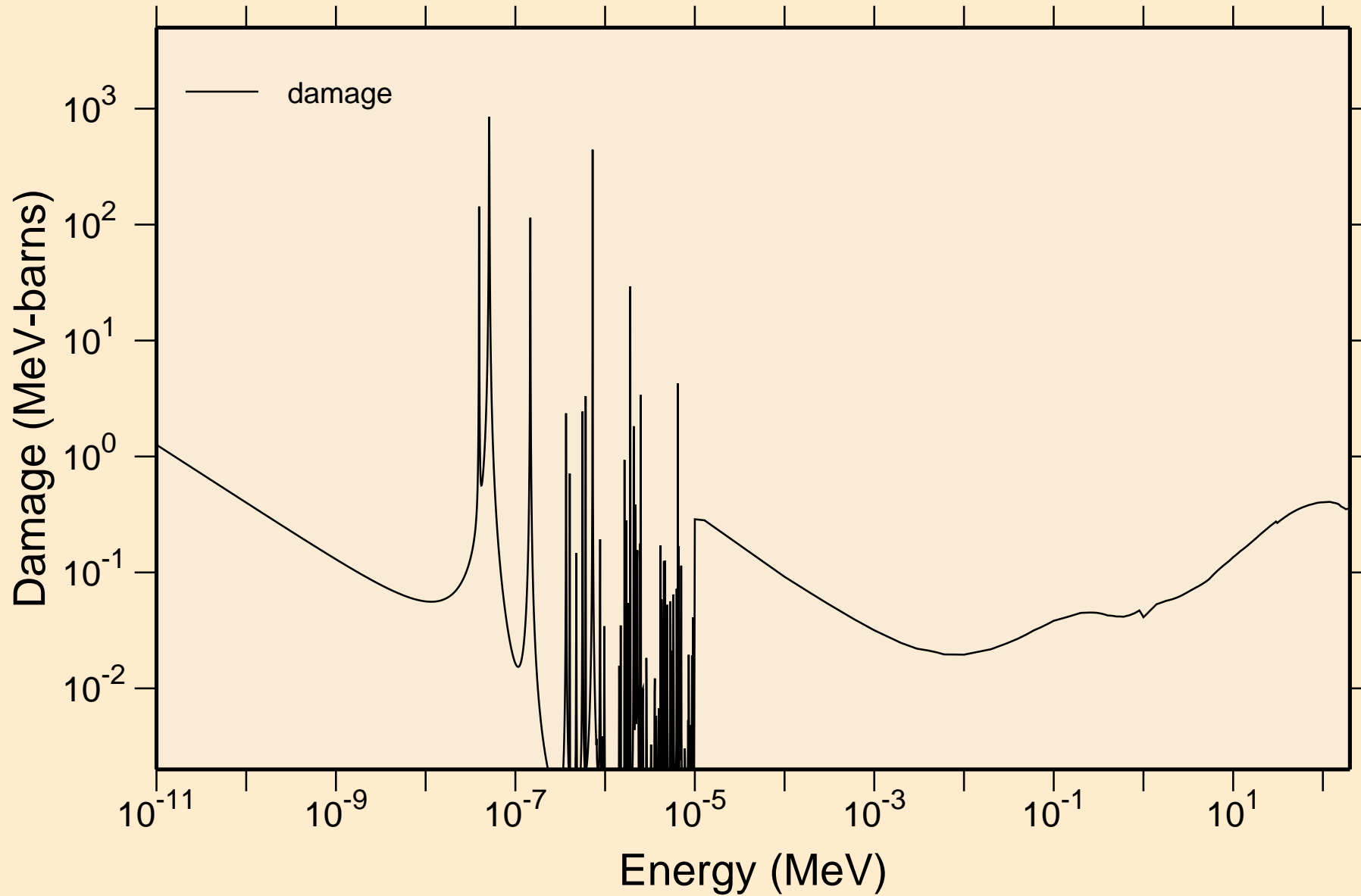

LR263 NEUTRON ACER TENDL-2024 LIBRARY; T=0.K

Non-threshold reactions

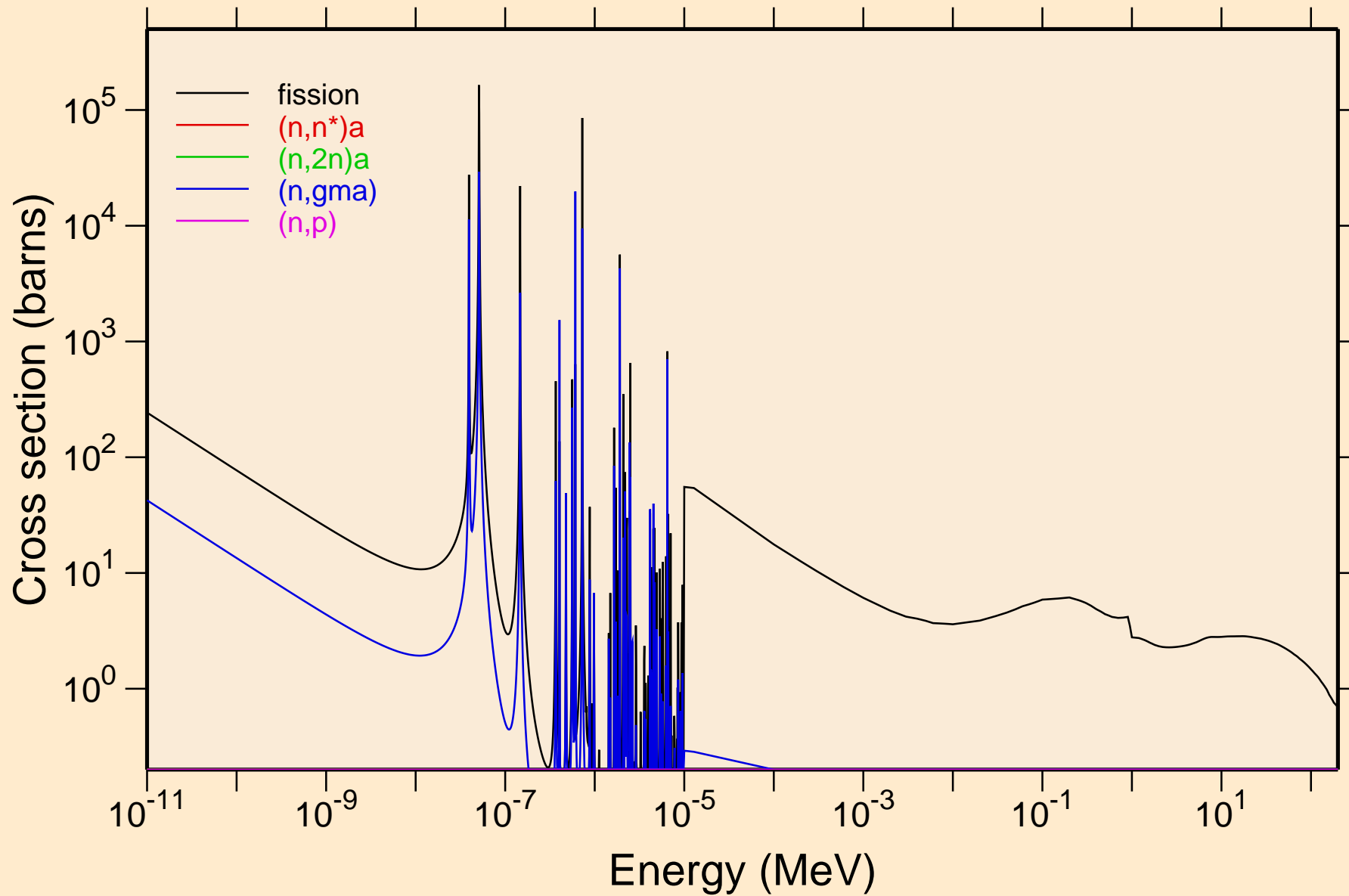

LR263 NEUTRON ACER TENDL-2024 LIBRARY; T=0.K
Non-threshold reactions

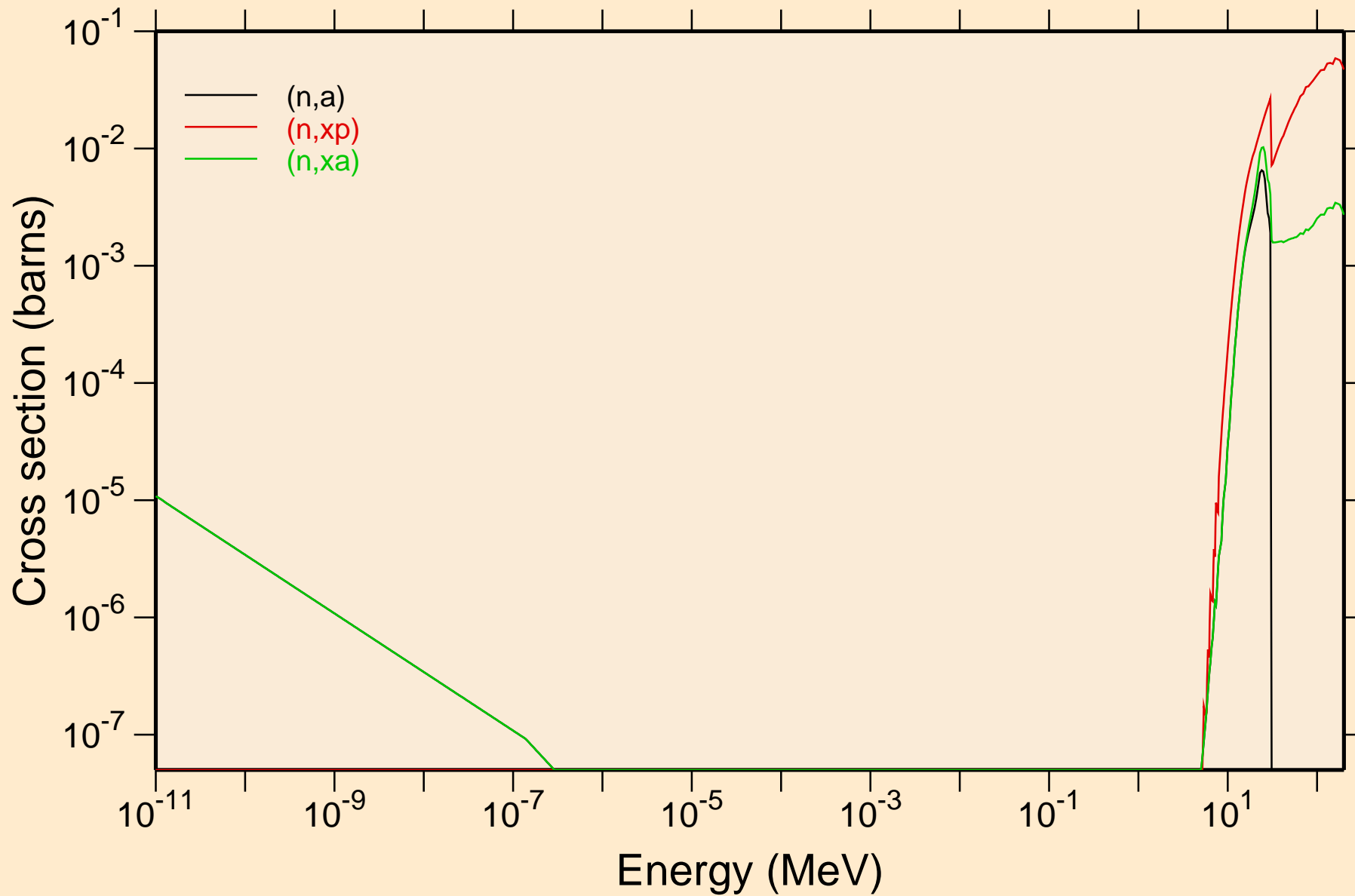

LR263 NEUTRON ACER TENDL-2024 LIBRARY; T=0.K

Principal cross sections

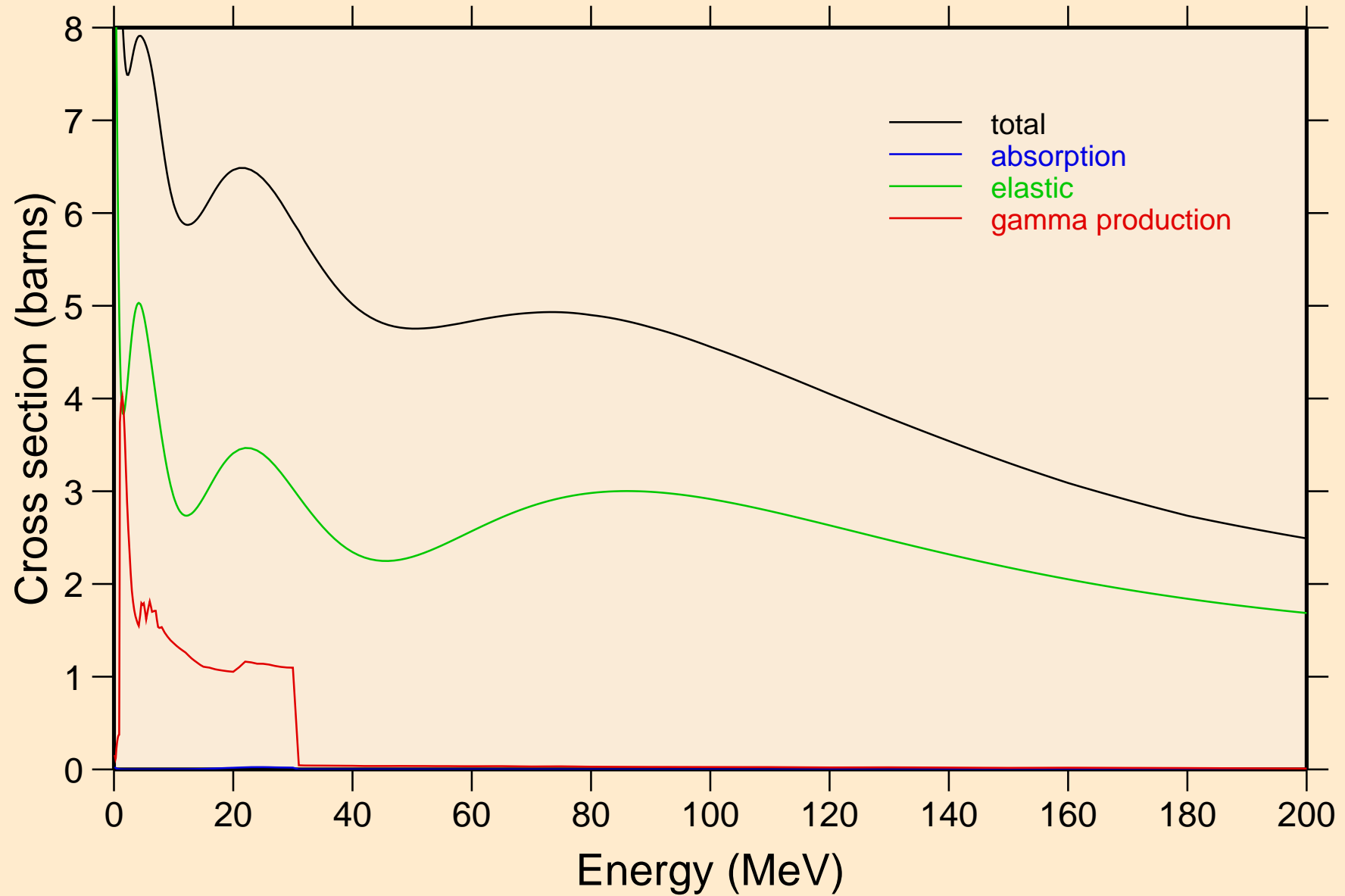

LR263 NEUTRON ACER TENDL-2024 LIBRARY; T=0.K

Heating

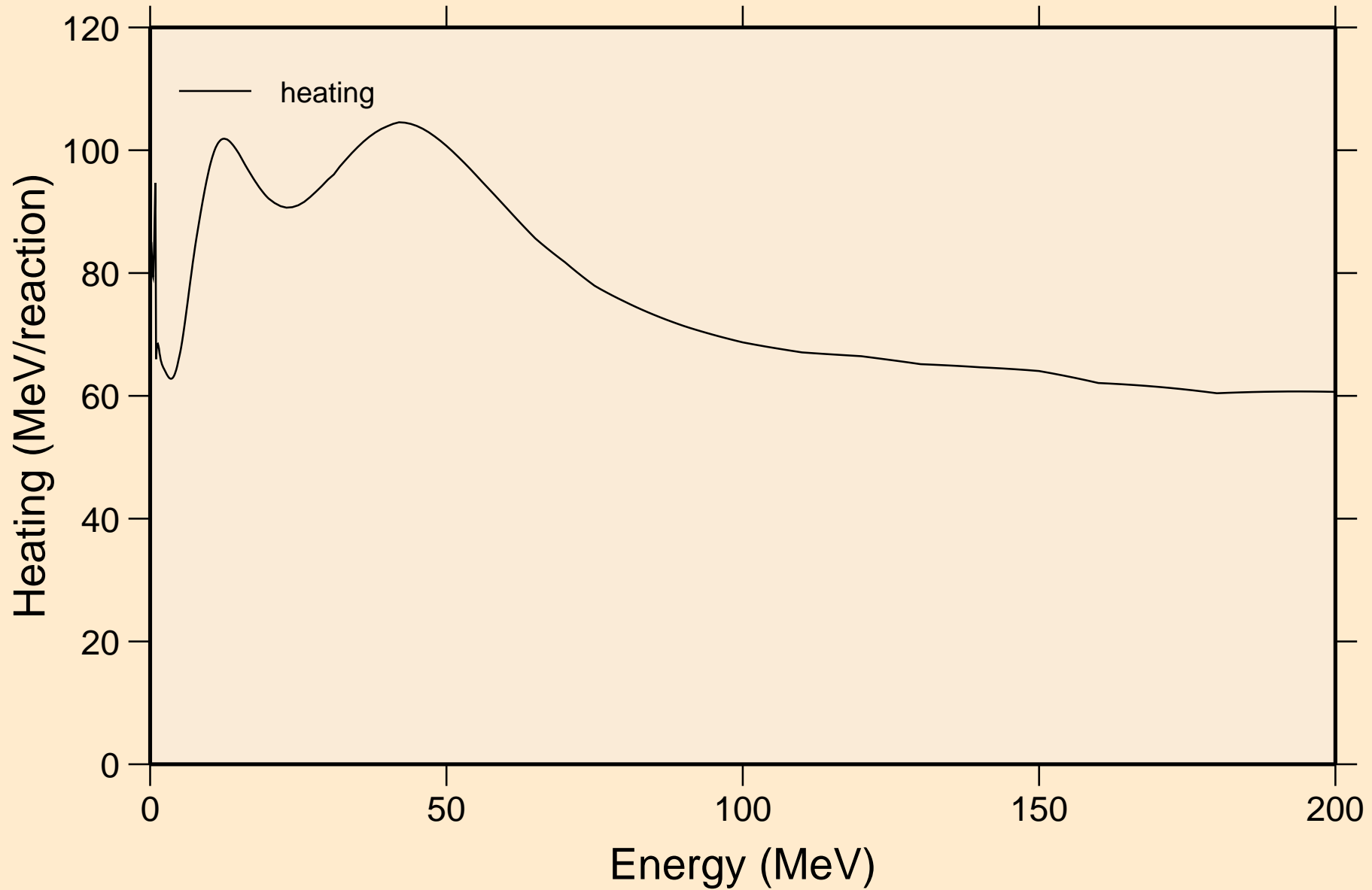

LR263 NEUTRON ACER TENDL-2024 LIBRARY; T=0.K
Damage

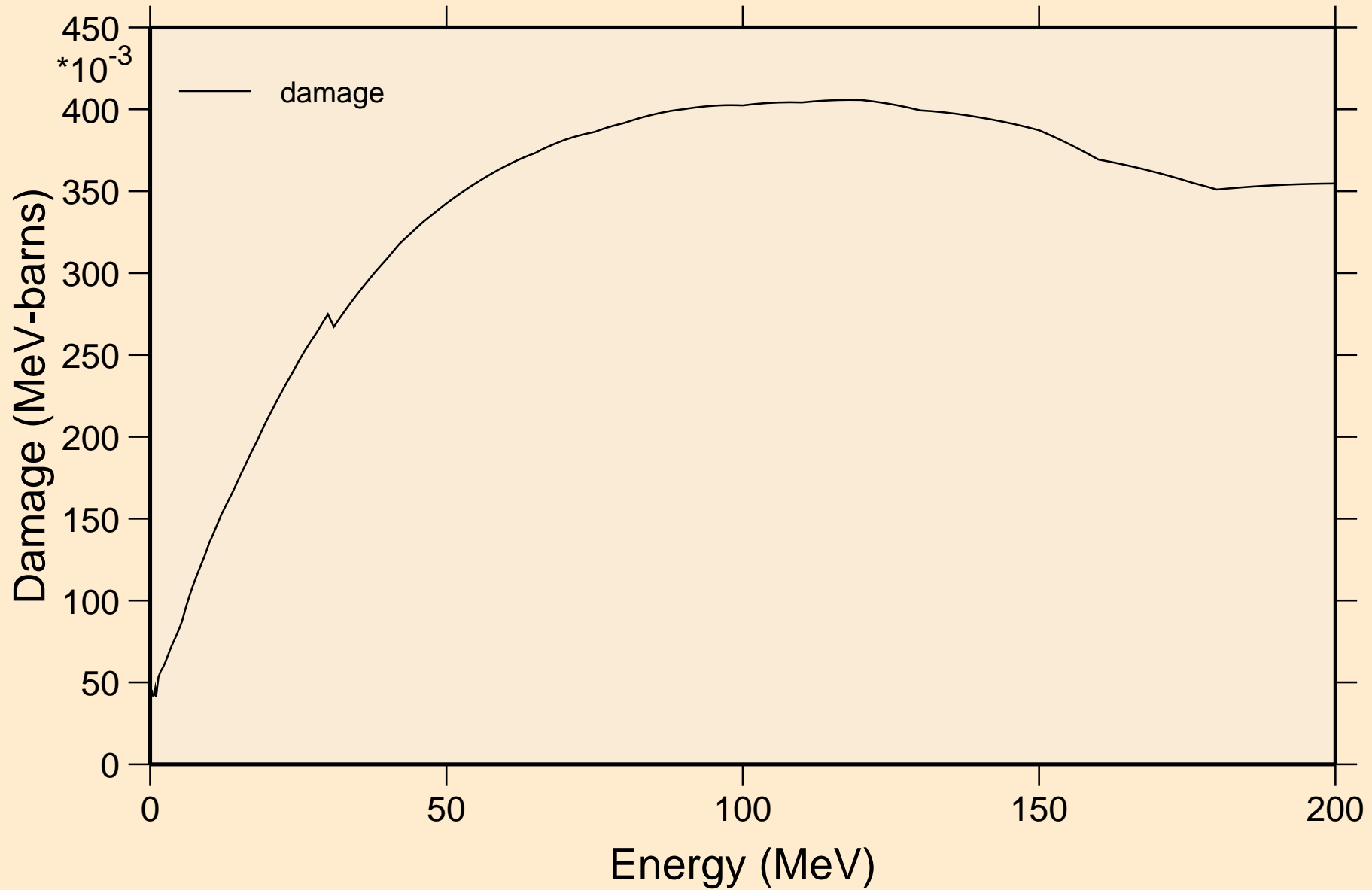

LR263 NEUTRON ACER TENDL-2024 LIBRARY; T=0.K
Non-threshold reactions

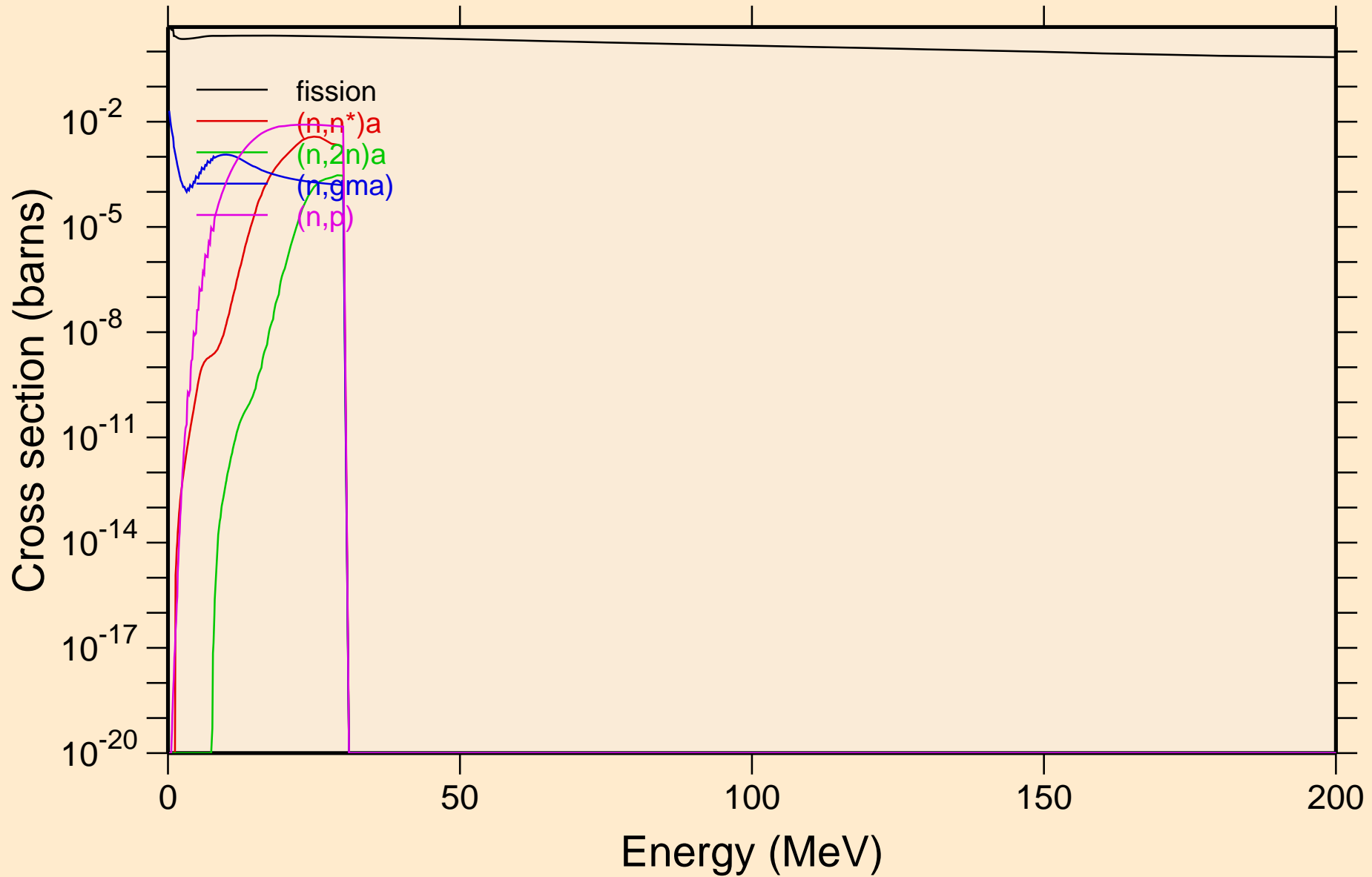

LR263 NEUTRON ACER TENDL-2024 LIBRARY; T=0.K
Non-threshold reactions

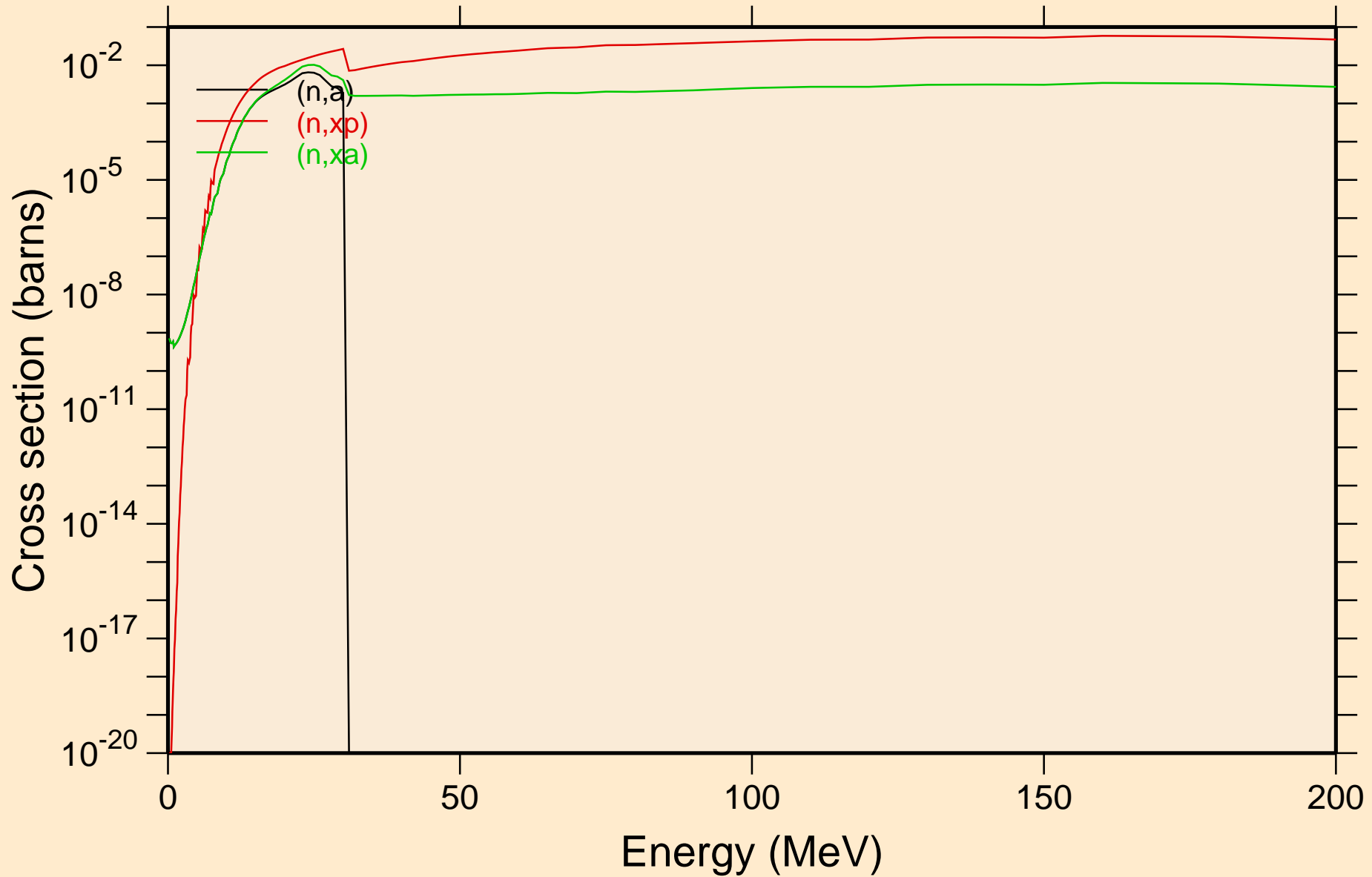

LR263 NEUTRON ACER TENDL-2024 LIBRARY; T=0.K
Inelastic levels

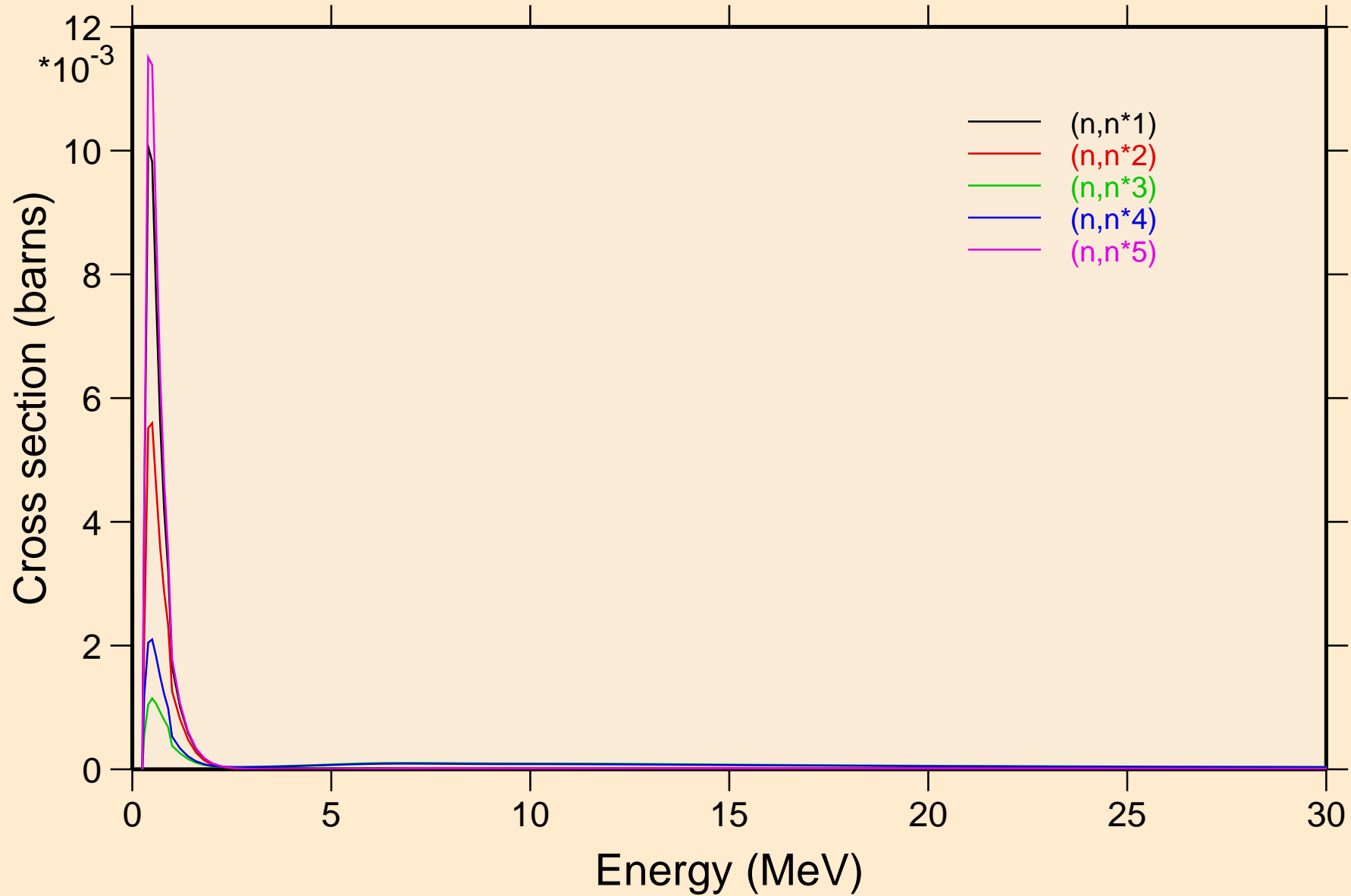

LR263 NEUTRON ACER TENDL-2024 LIBRARY; T=0.K

Threshold reactions

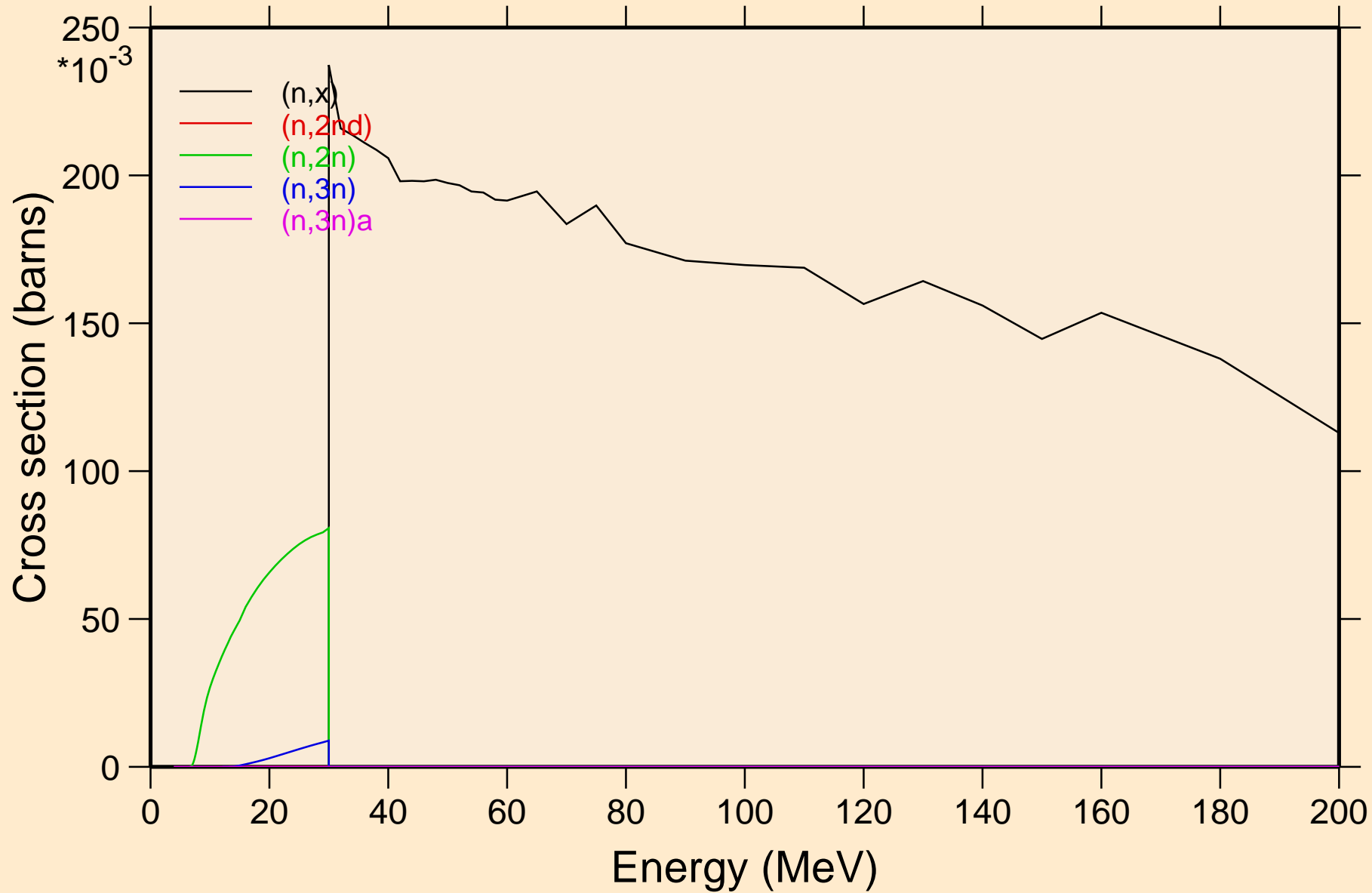

LR263 NEUTRON ACER TENDL-2024 LIBRARY; T=0.K
Threshold reactions

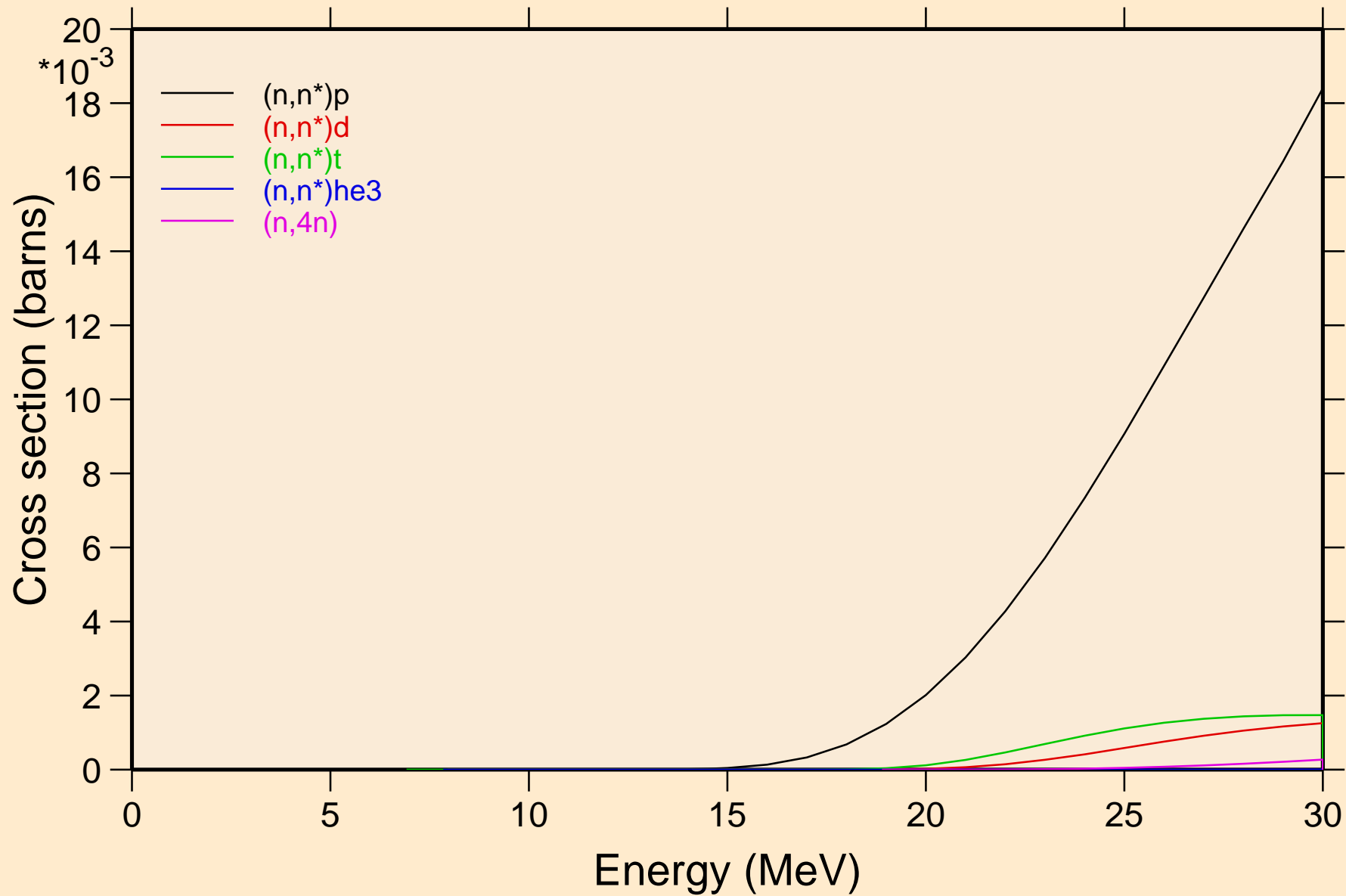

LR263 NEUTRON ACER TENDL-2024 LIBRARY; T=0.K
Threshold reactions

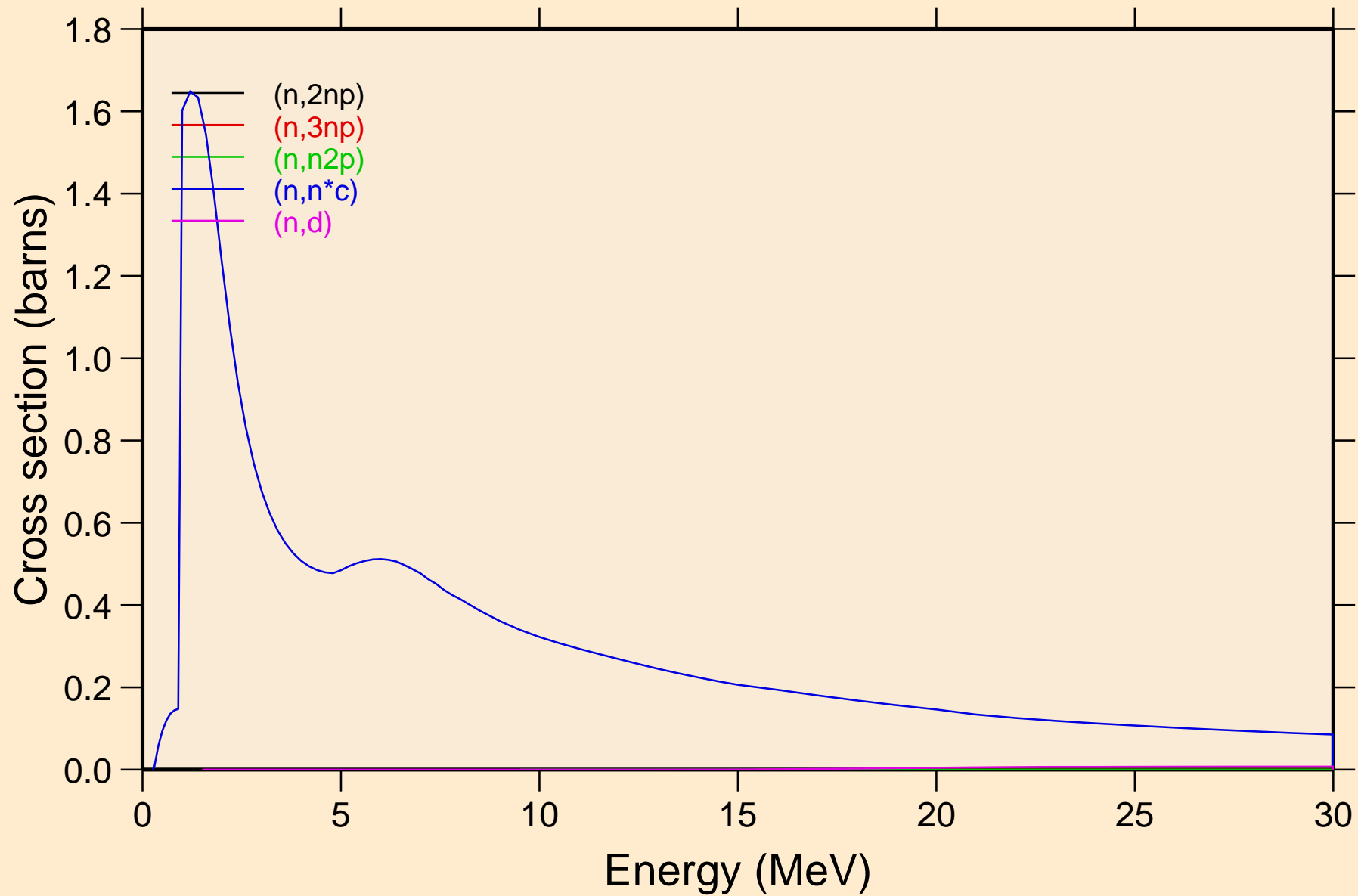

LR263 NEUTRON ACER TENDL-2024 LIBRARY; T=0.K
Threshold reactions

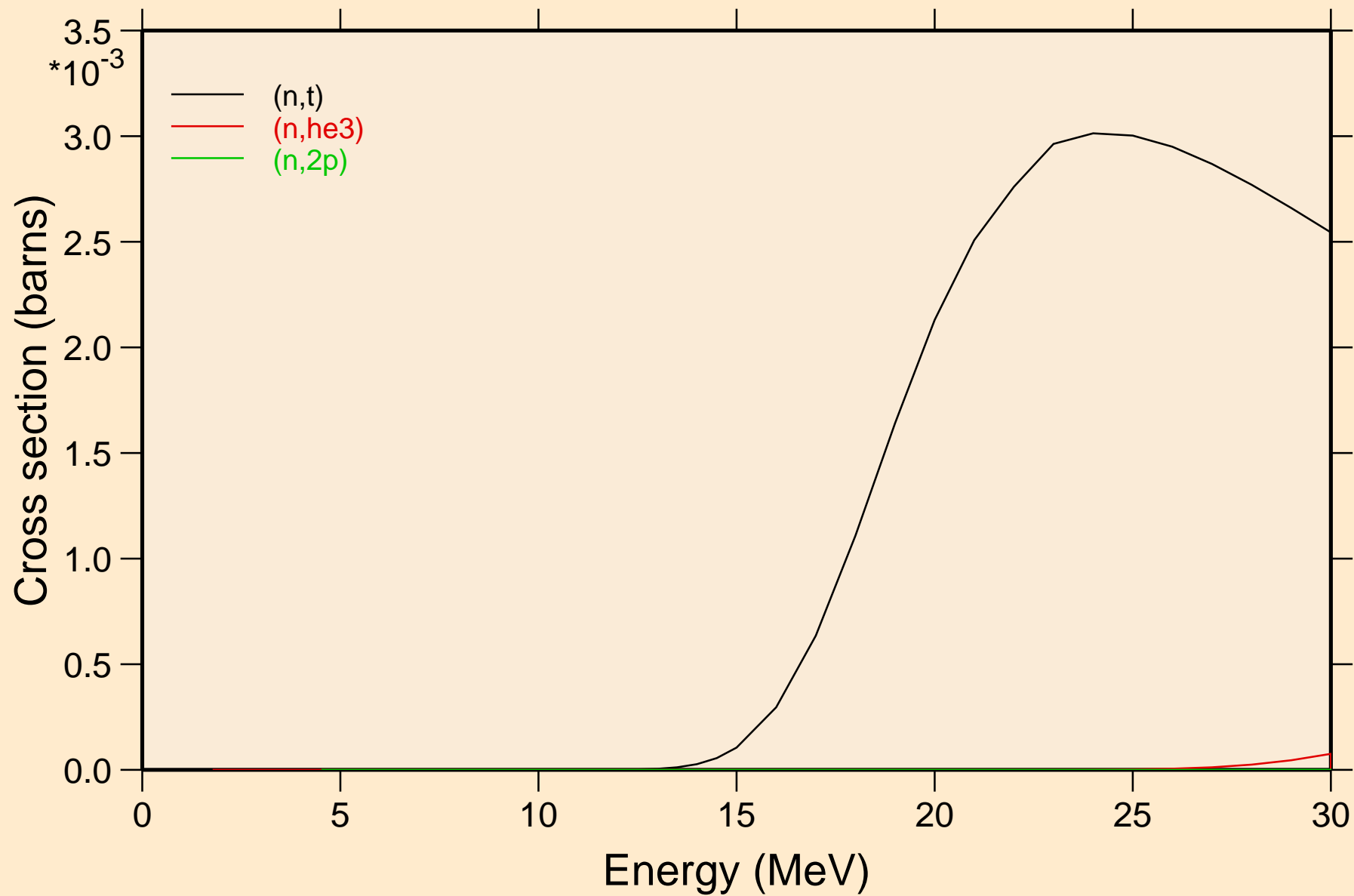

LR263 NEUTRON ACER TENDL-2024 LIBRARY; T=0.K
Threshold reactions

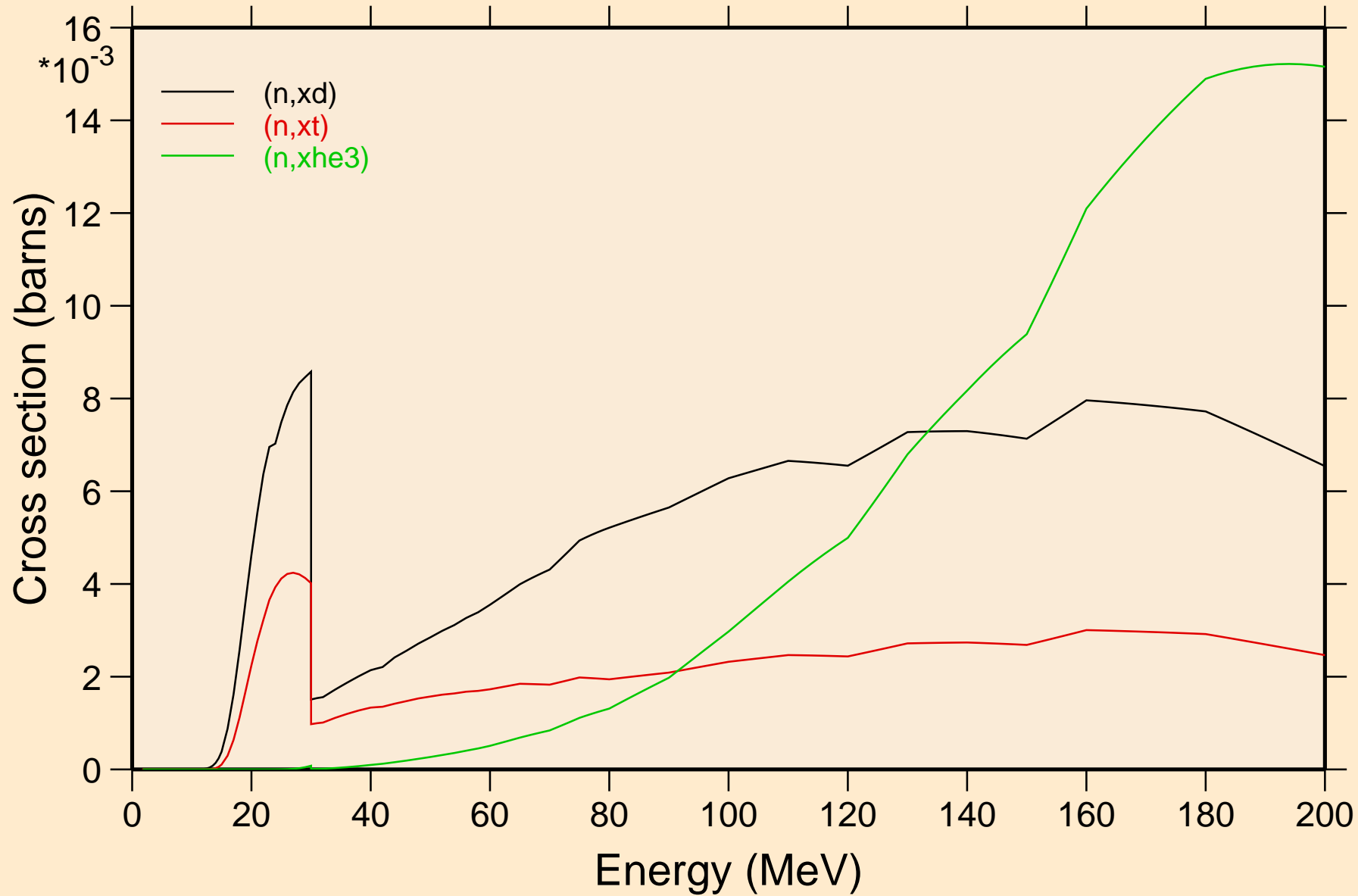

LR263 NEUTRON ACER TENDL-2024 LIBRARY; T=0.K
angular distribution for elastic

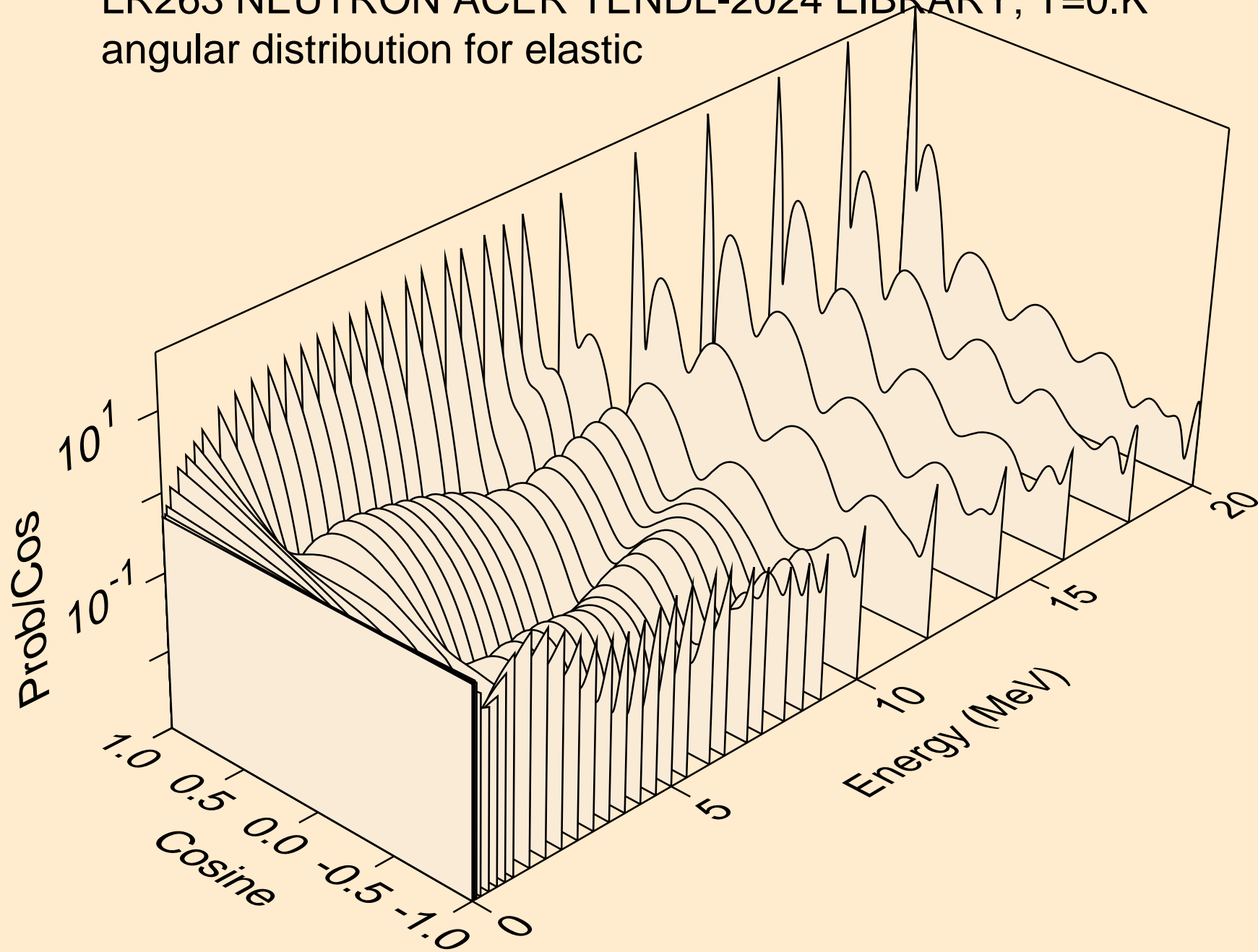

LR263 NEUTRON ACER TENDL-2024 LIBRARY; T=0.K
angular distribution for elastic

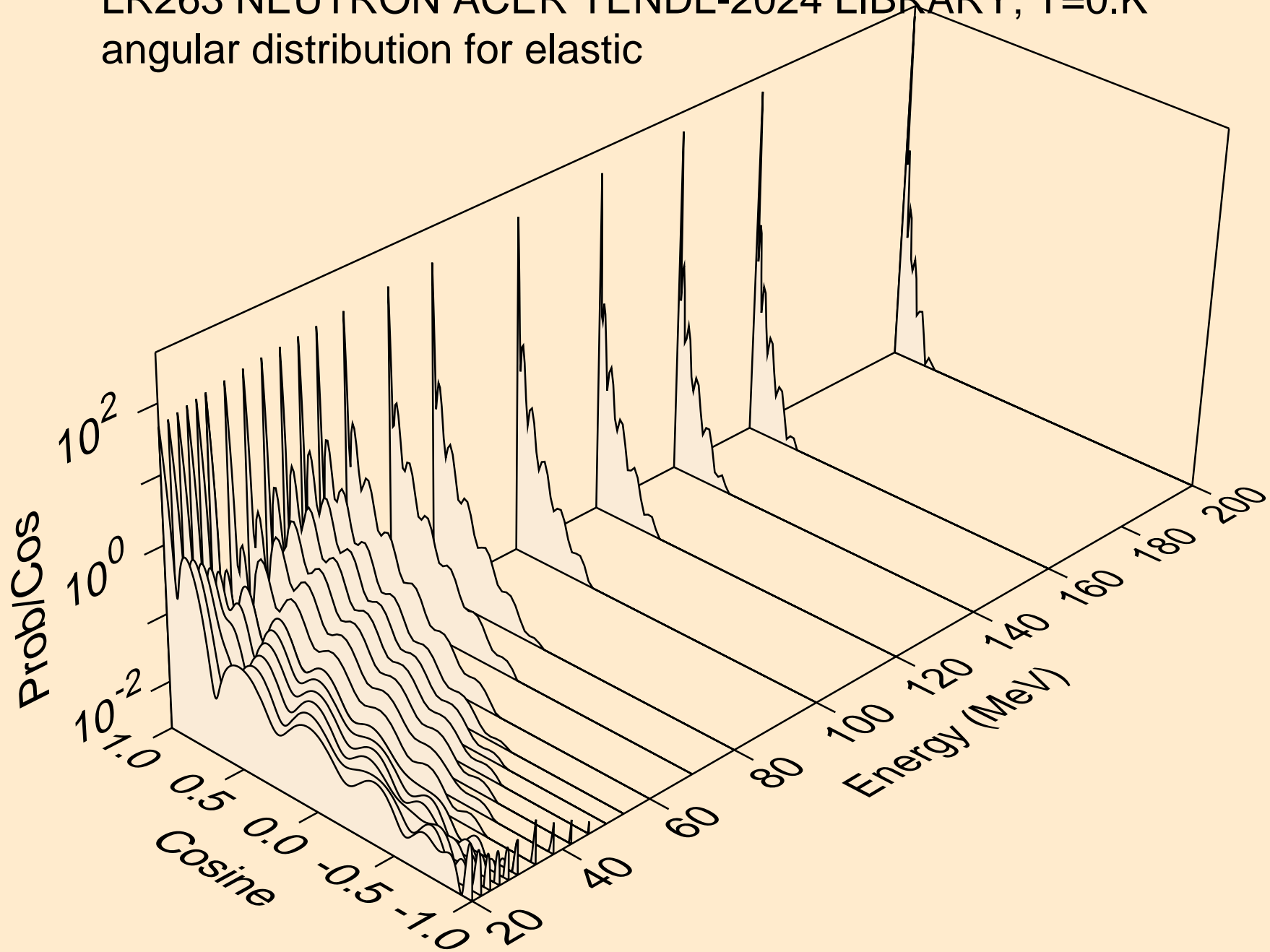

LR263 NEUTRON ACER TENDL-2024 LIBRARY; T=0.K
angular distribution for (n,n*1)

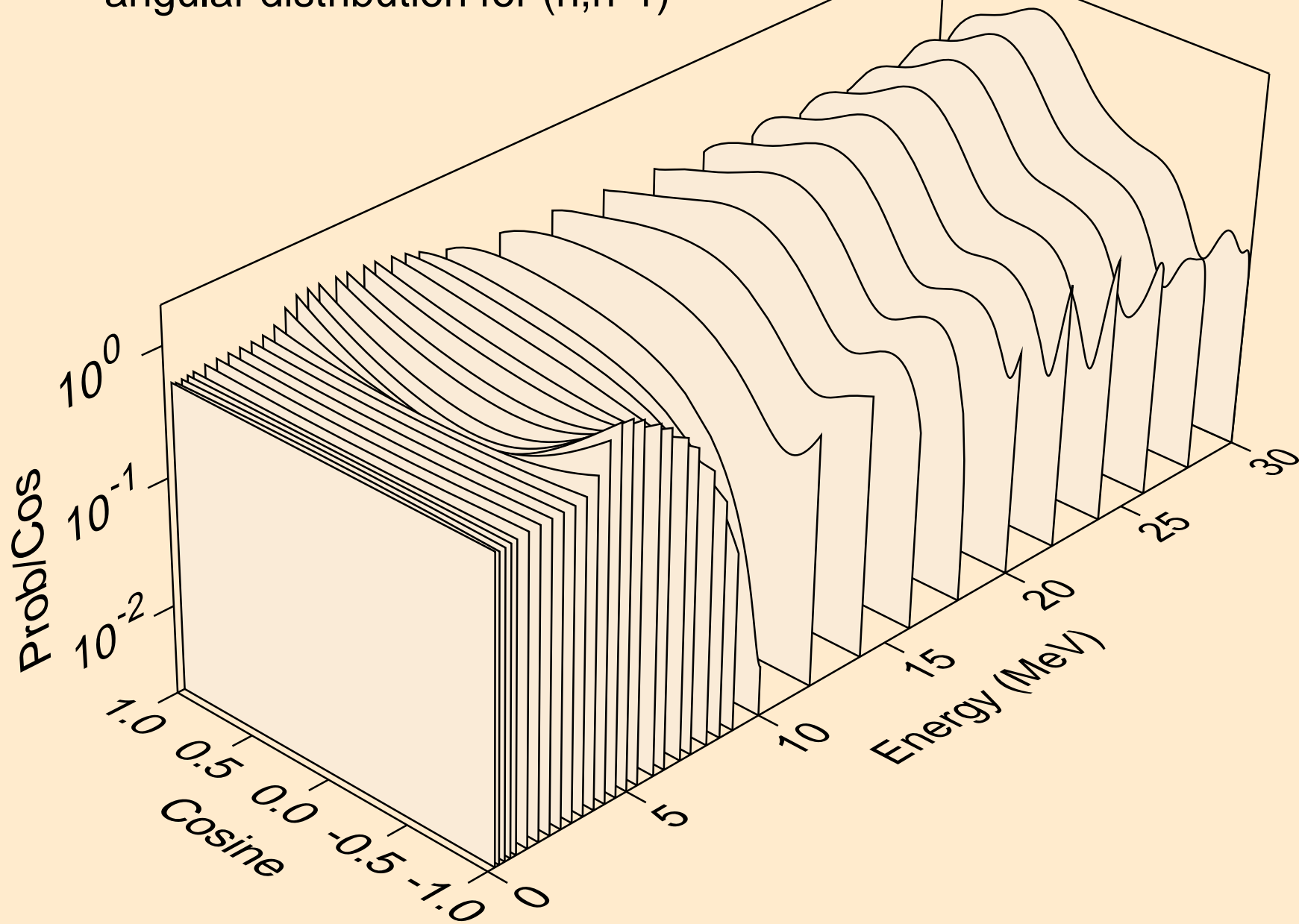

LR263 NEUTRON ACER TENDL-2024 LIBRARY; T=0.K
angular distribution for (n,n*2)

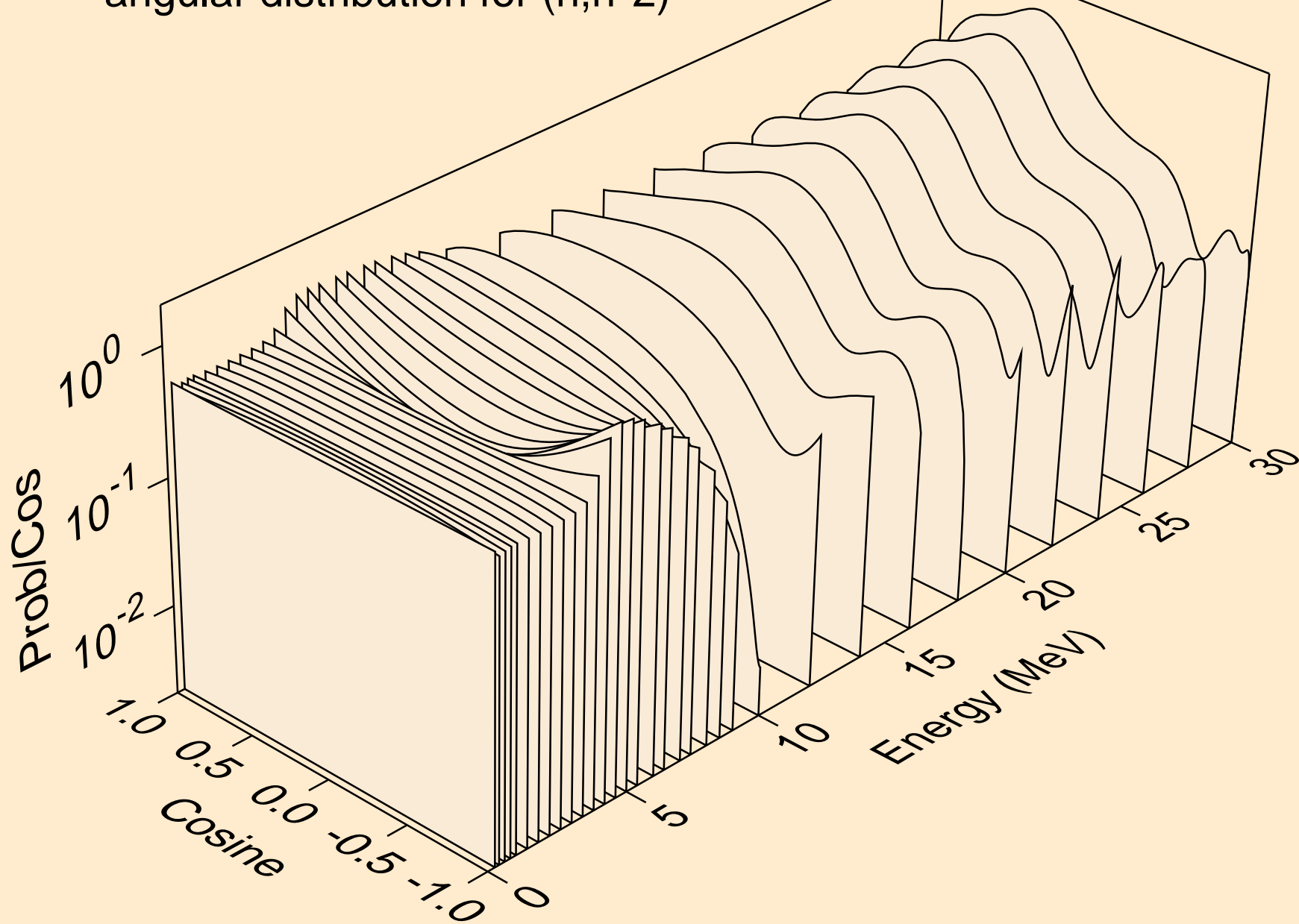

LR263 NEUTRON ACER TENDL-2024 LIBRARY; T=0.K
angular distribution for (n,n*3)

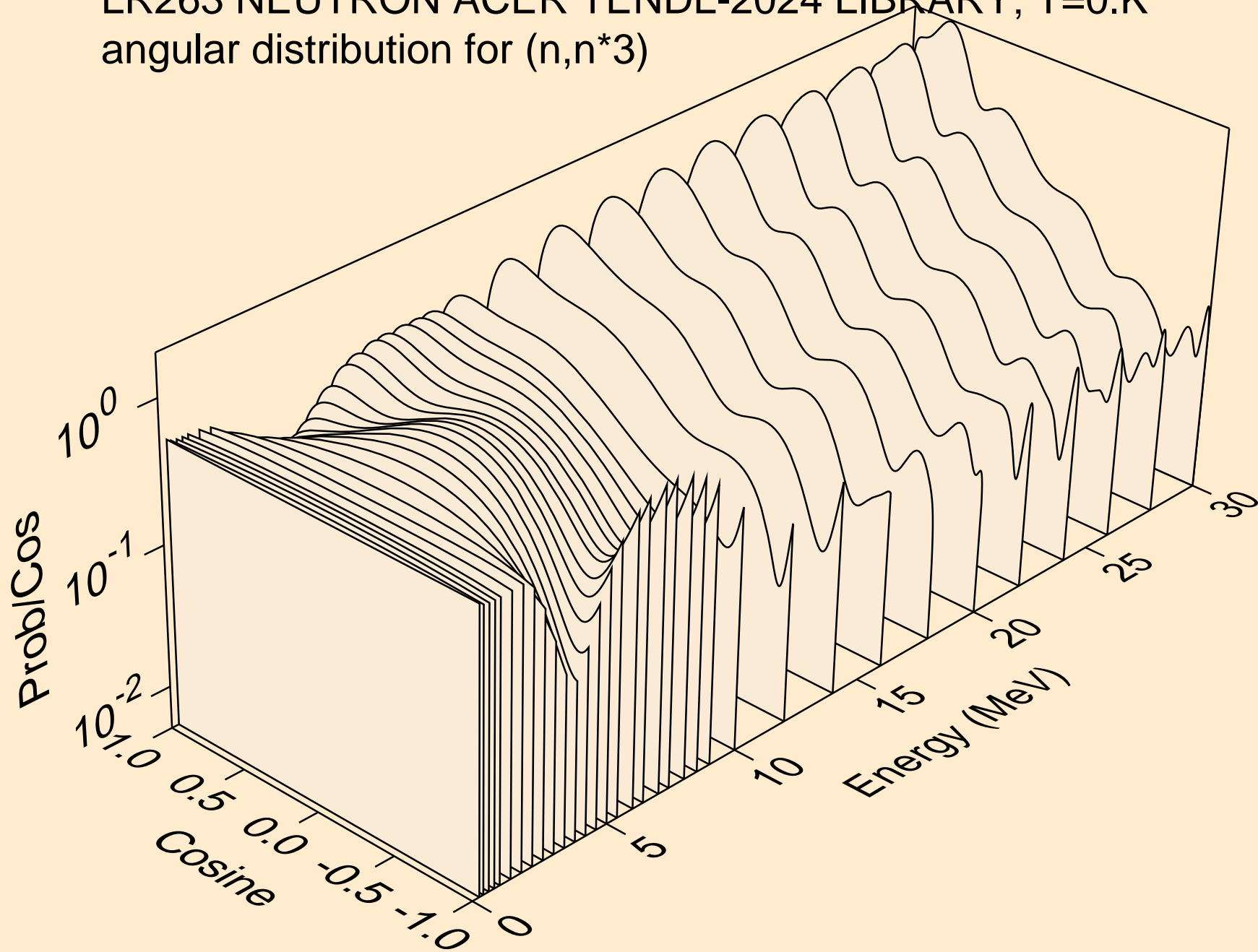

LR263 NEUTRON ACER TENDL-2024 LIBRARY; T=0.K
angular distribution for (n,n*4)

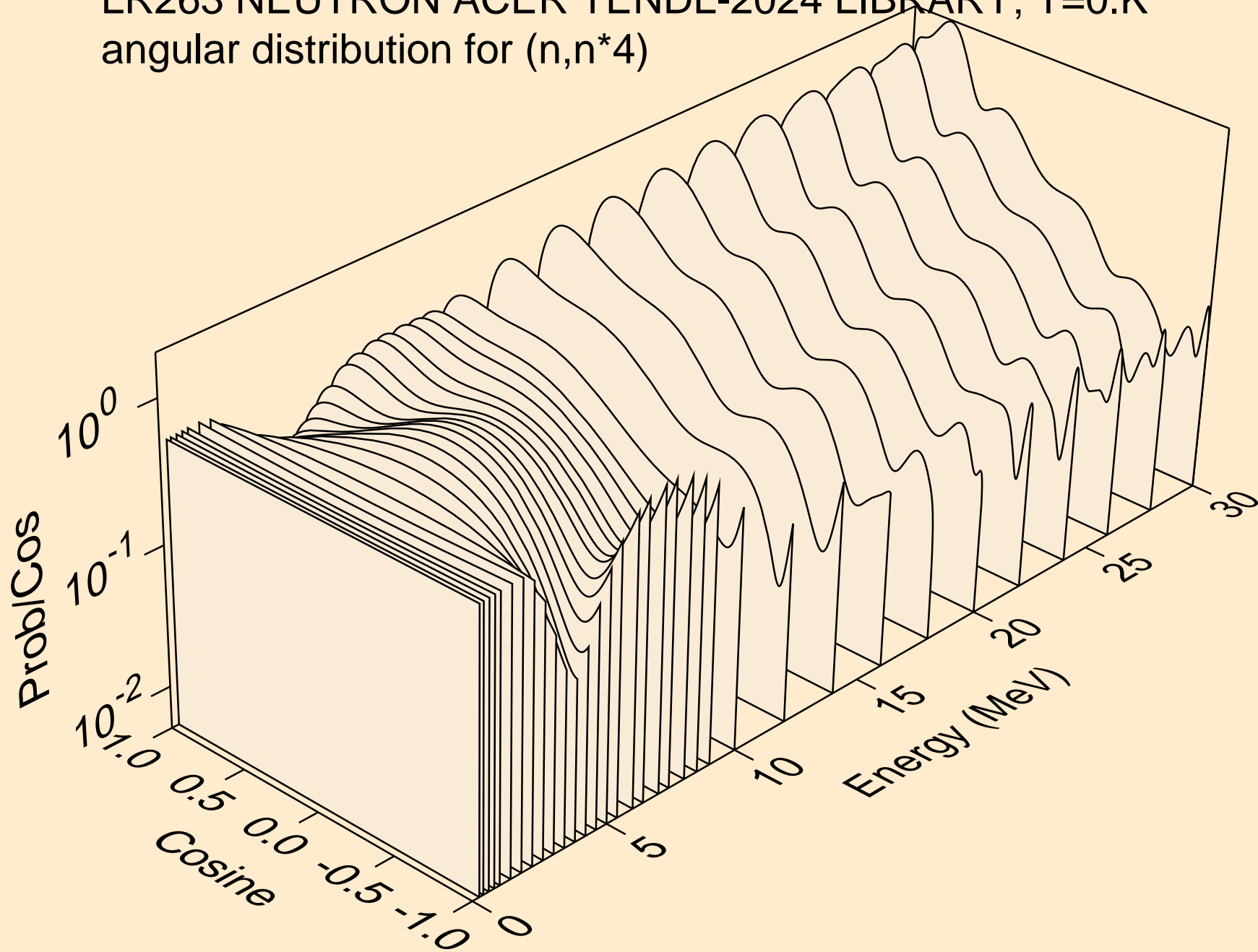

LR263 NEUTRON ACER TENDL-2024 LIBRARY; T=0.K
angular distribution for (n,n*5)

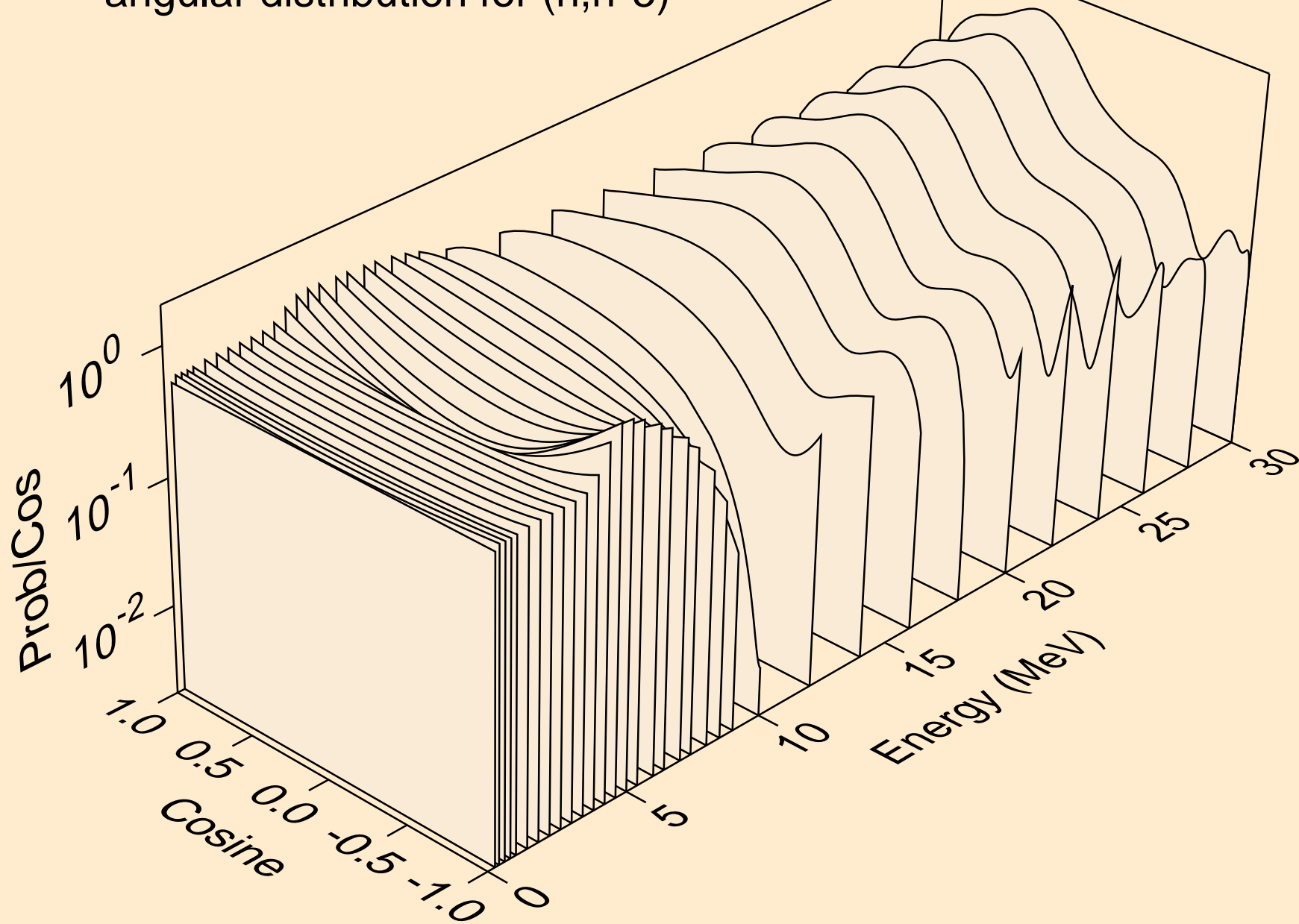

LR263 NEUTRON ACER TENDL-2024 LIBRARY; T=0.K

Total fission nubar

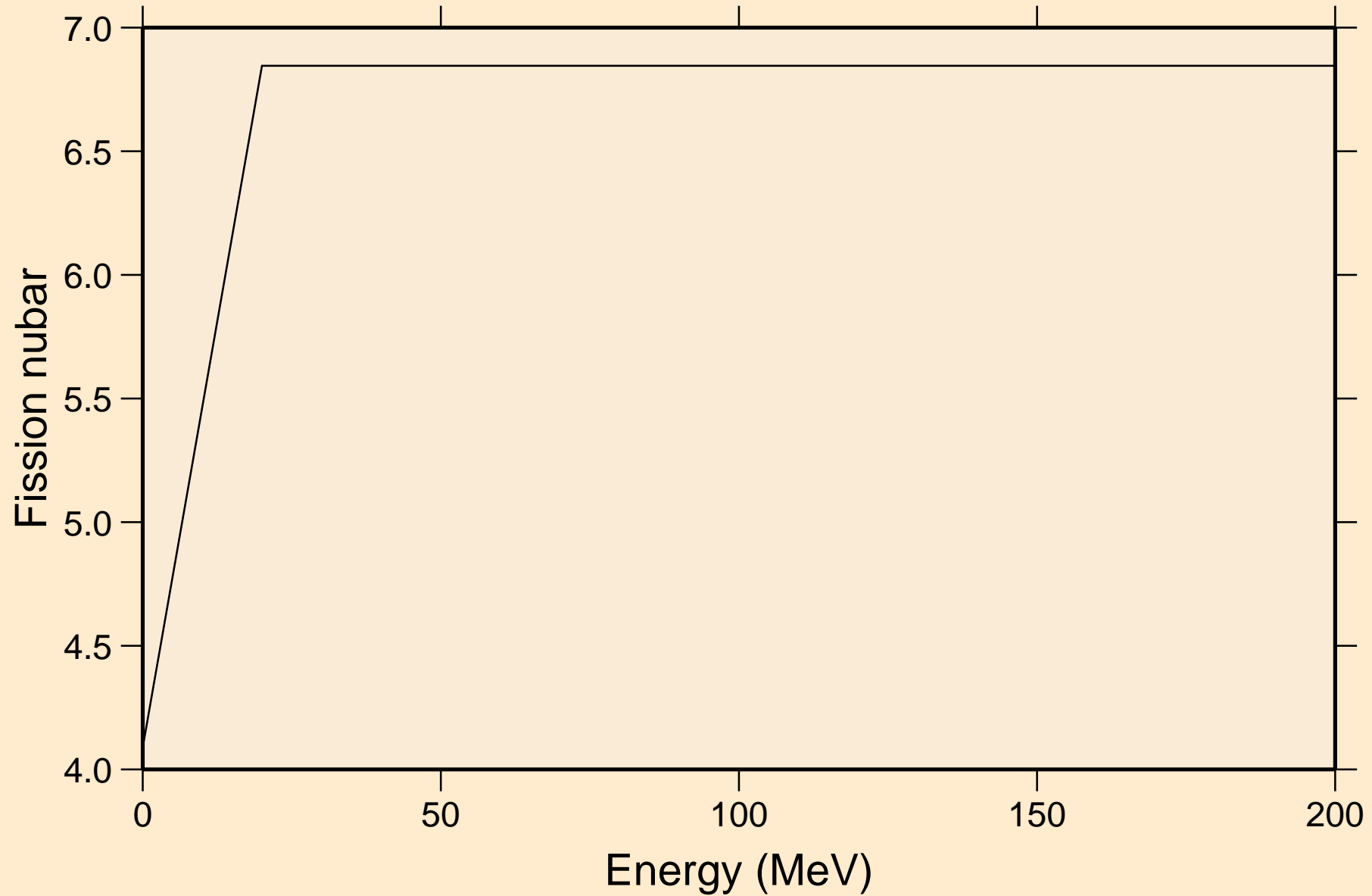

LR263 NEUTRON ACER TENDL-2024 LIBRARY; T=0.K
Neutron emission for (n,x)

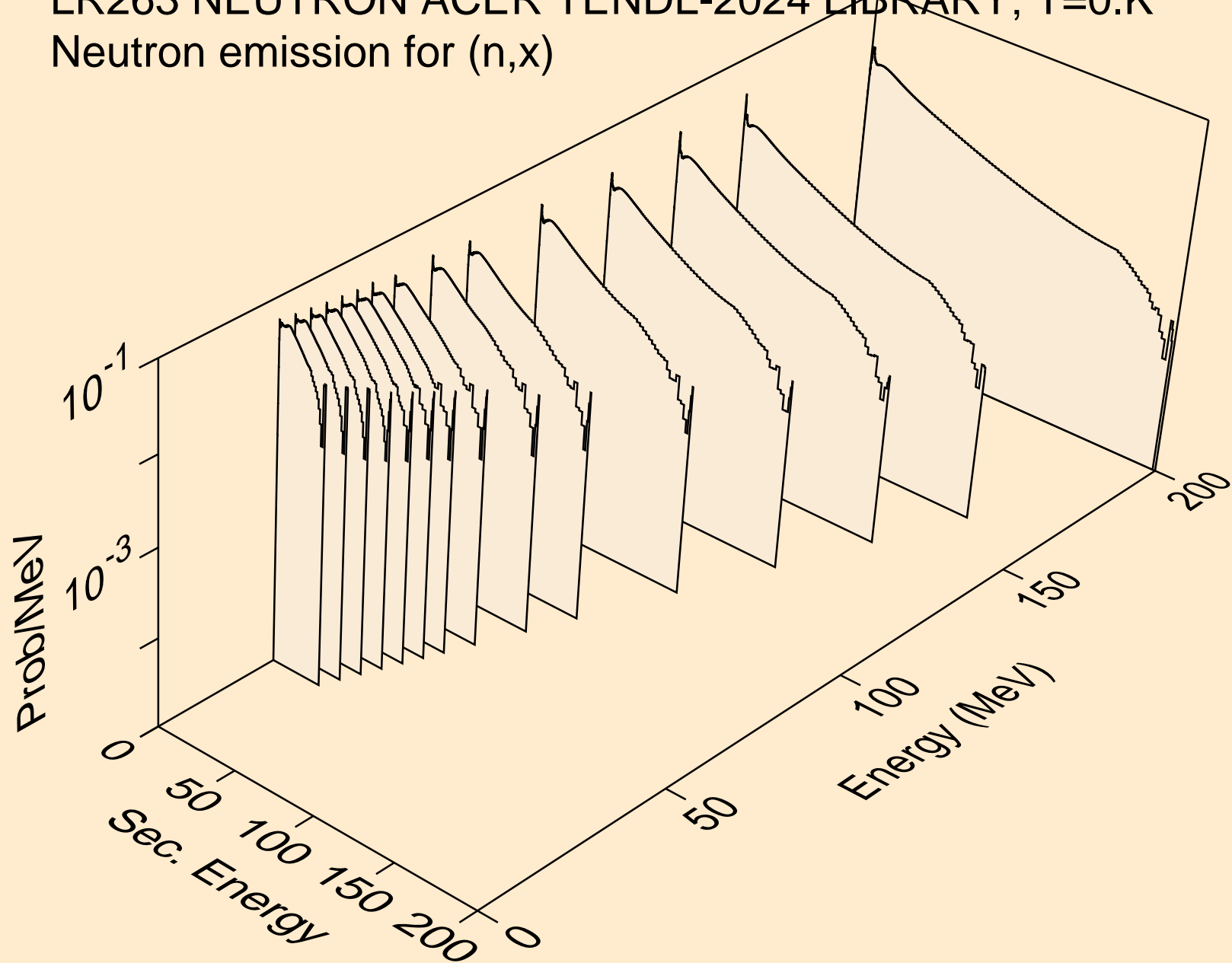

LR263 NEUTRON ACER TENDL-2024 LIBRARY; T=0.K
Neutron emission for (n,2nd)

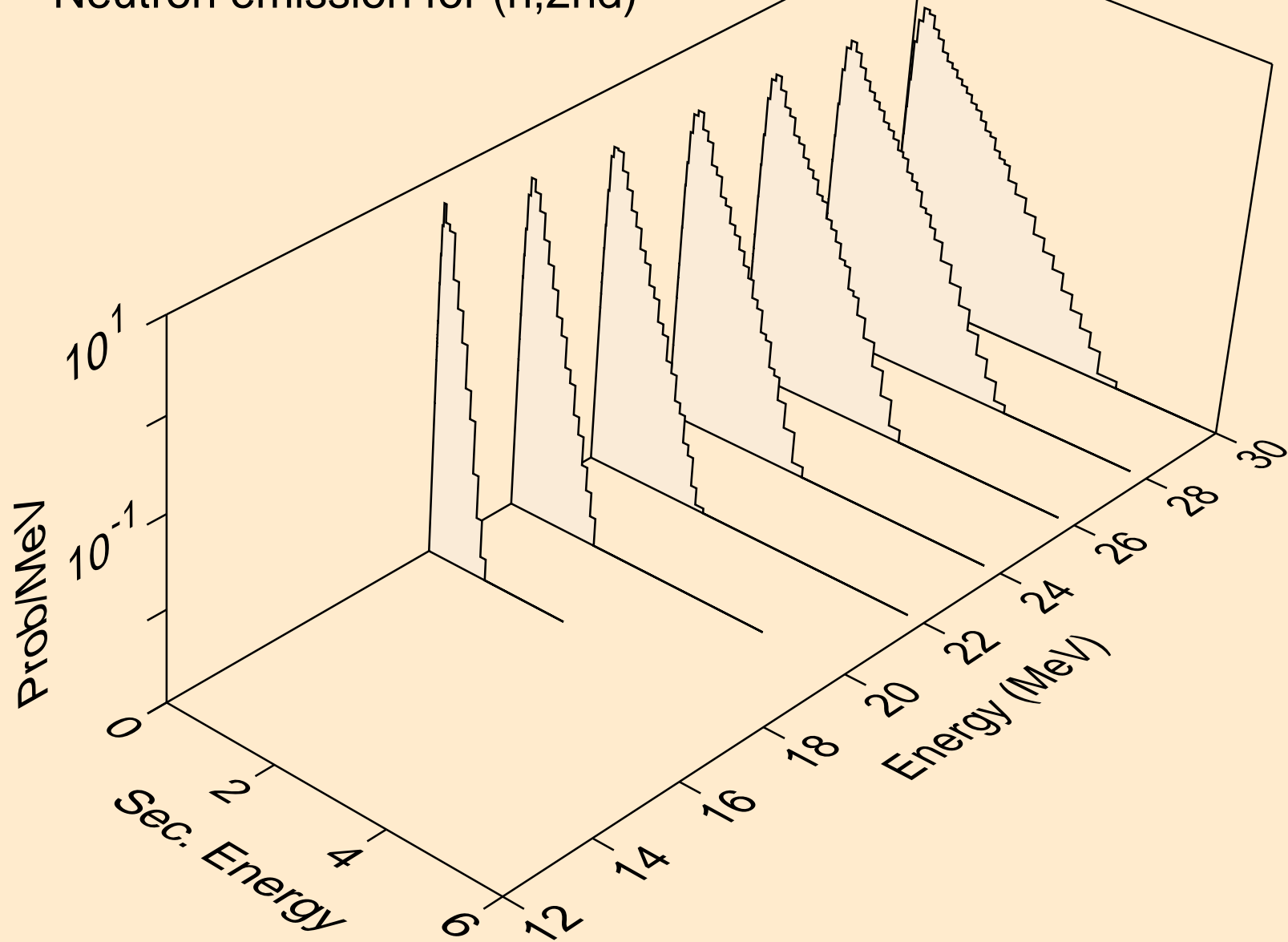

LR263 NEUTRON ACER TENDL-2024 LIBRARY; T=0.K
Neutron emission for (n,2n)

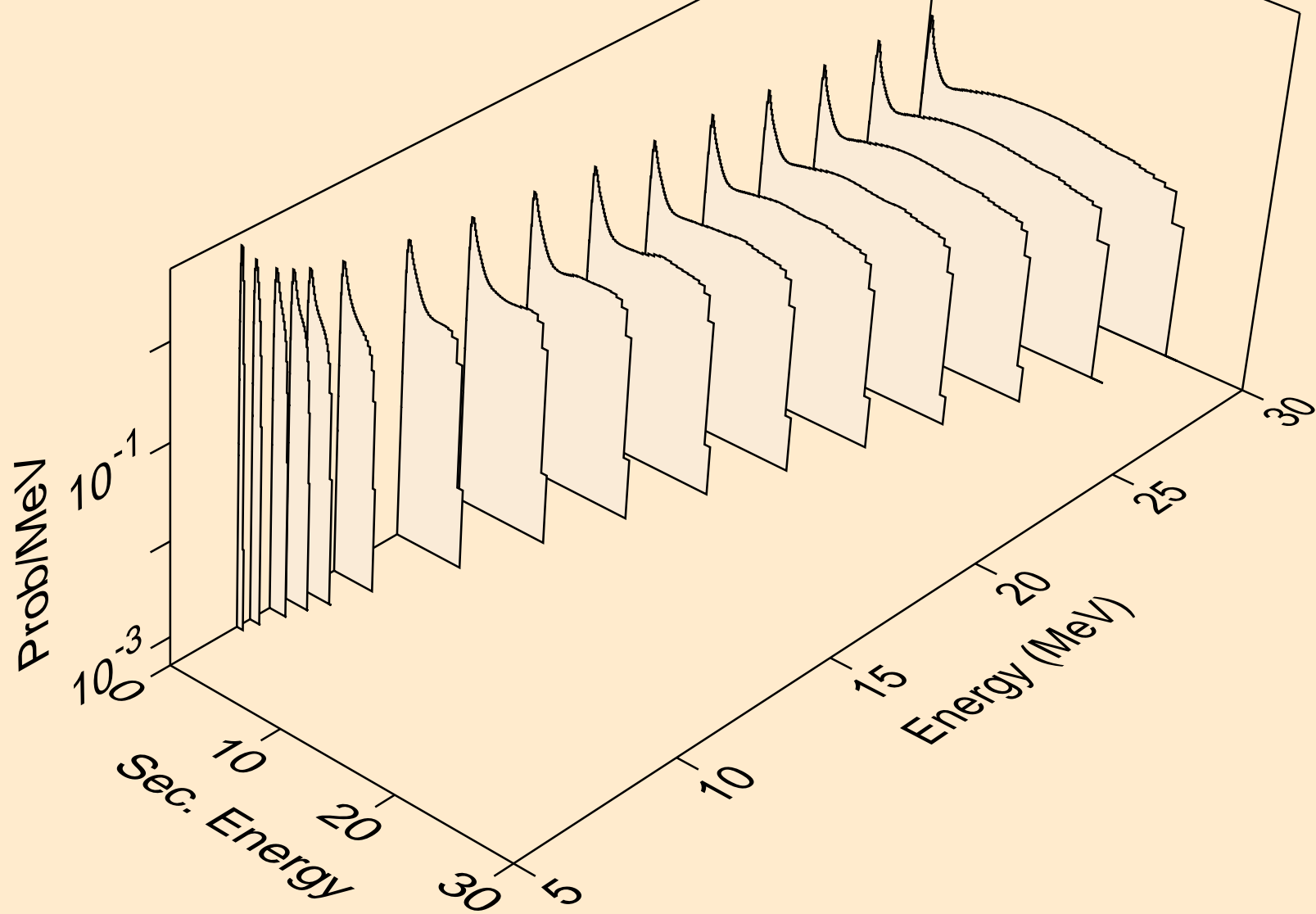

LR263 NEUTRON ACER TENDL-2024 LIBRARY; T=0.K
Neutron emission for (n,3n)

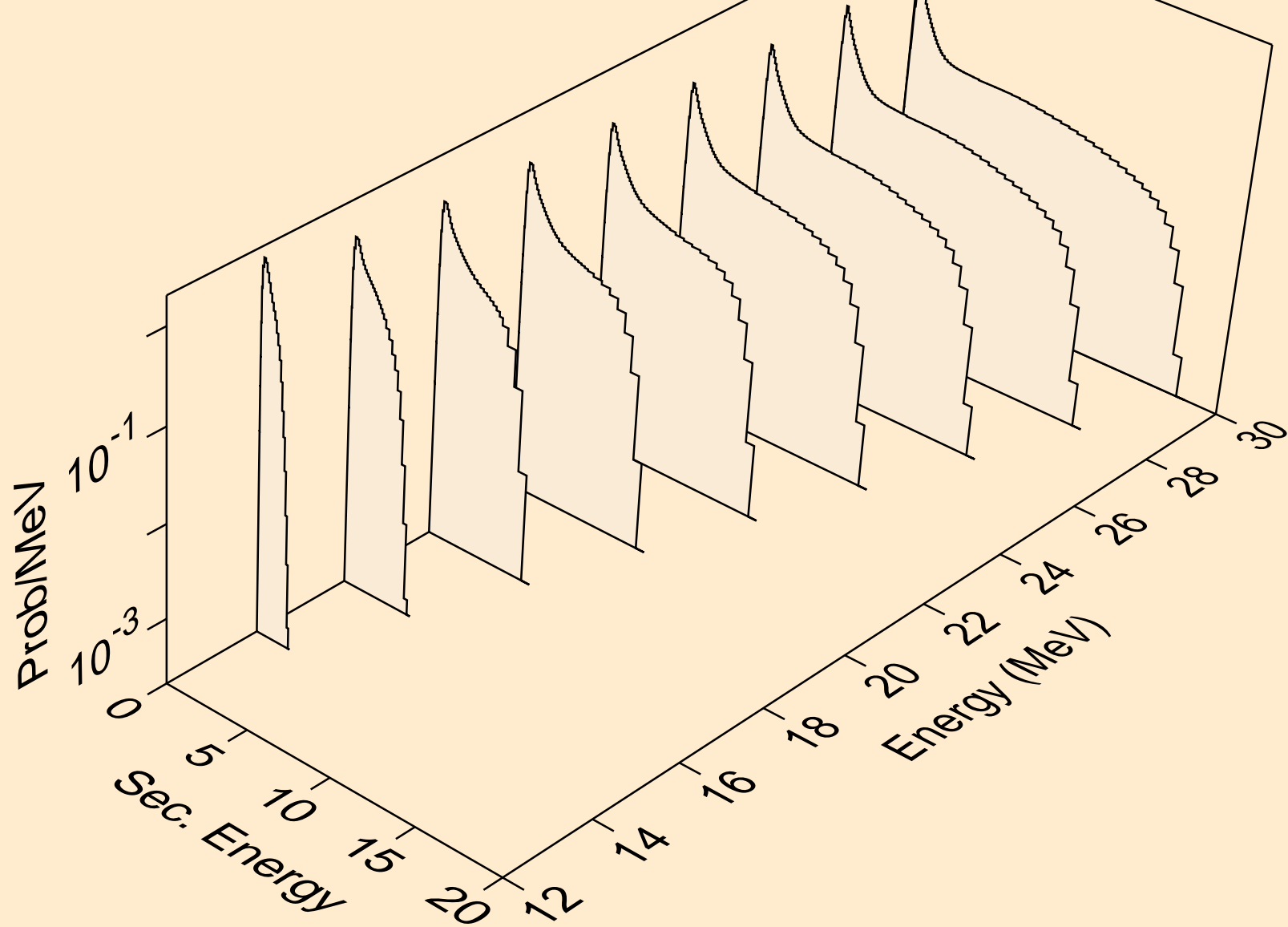

LR263 NEUTRON ACER TENDL-2024 LIBRARY; T=0.K
Neutron emission for fission

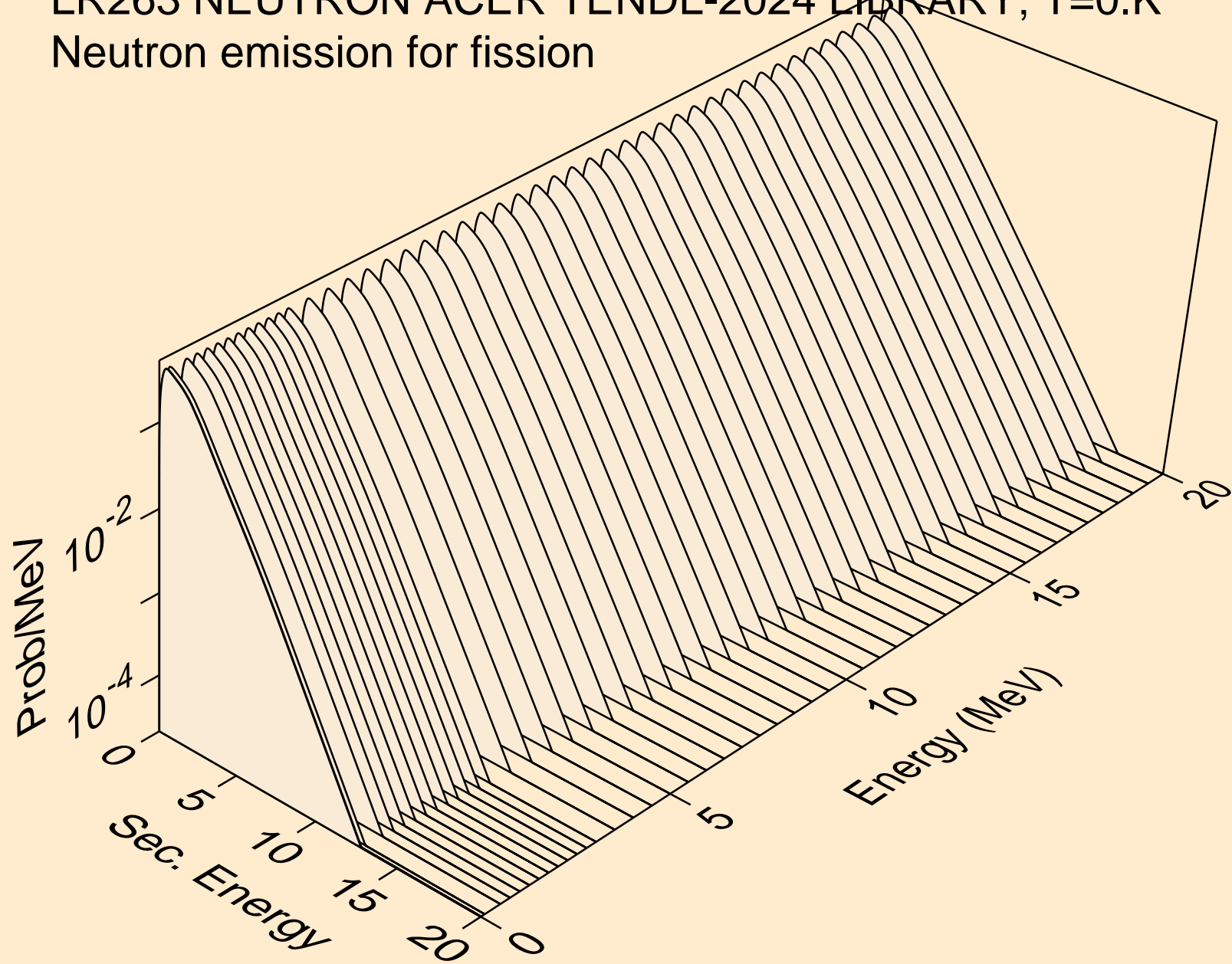

LR263 NEUTRON ACER TENDL-2024 LIBRARY; T=0.K
Neutron emission for (n,n*)a

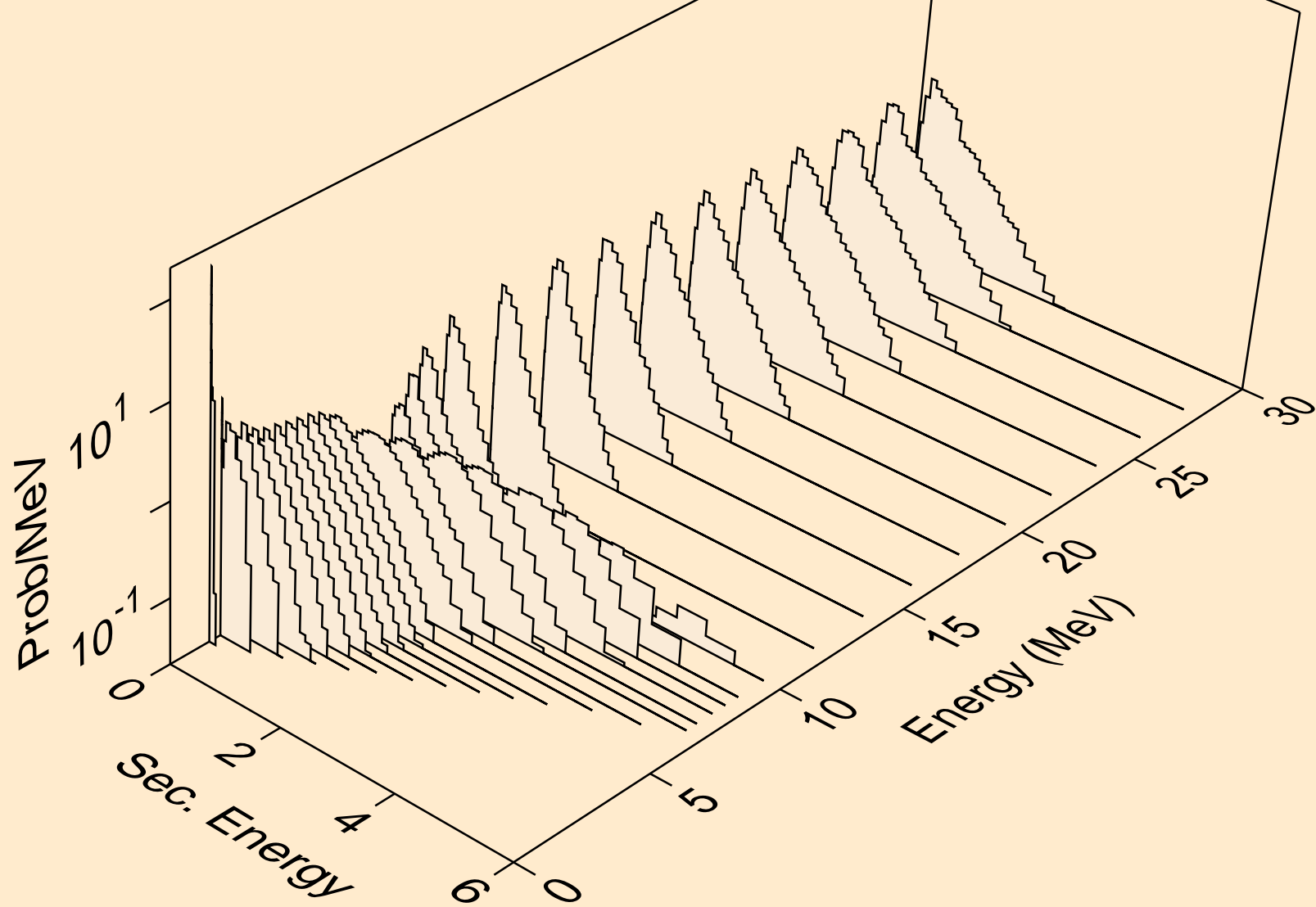

LR263 NEUTRON ACER TENDL-2024 LIBRARY; T=0.K
Neutron emission for (n,2n)a

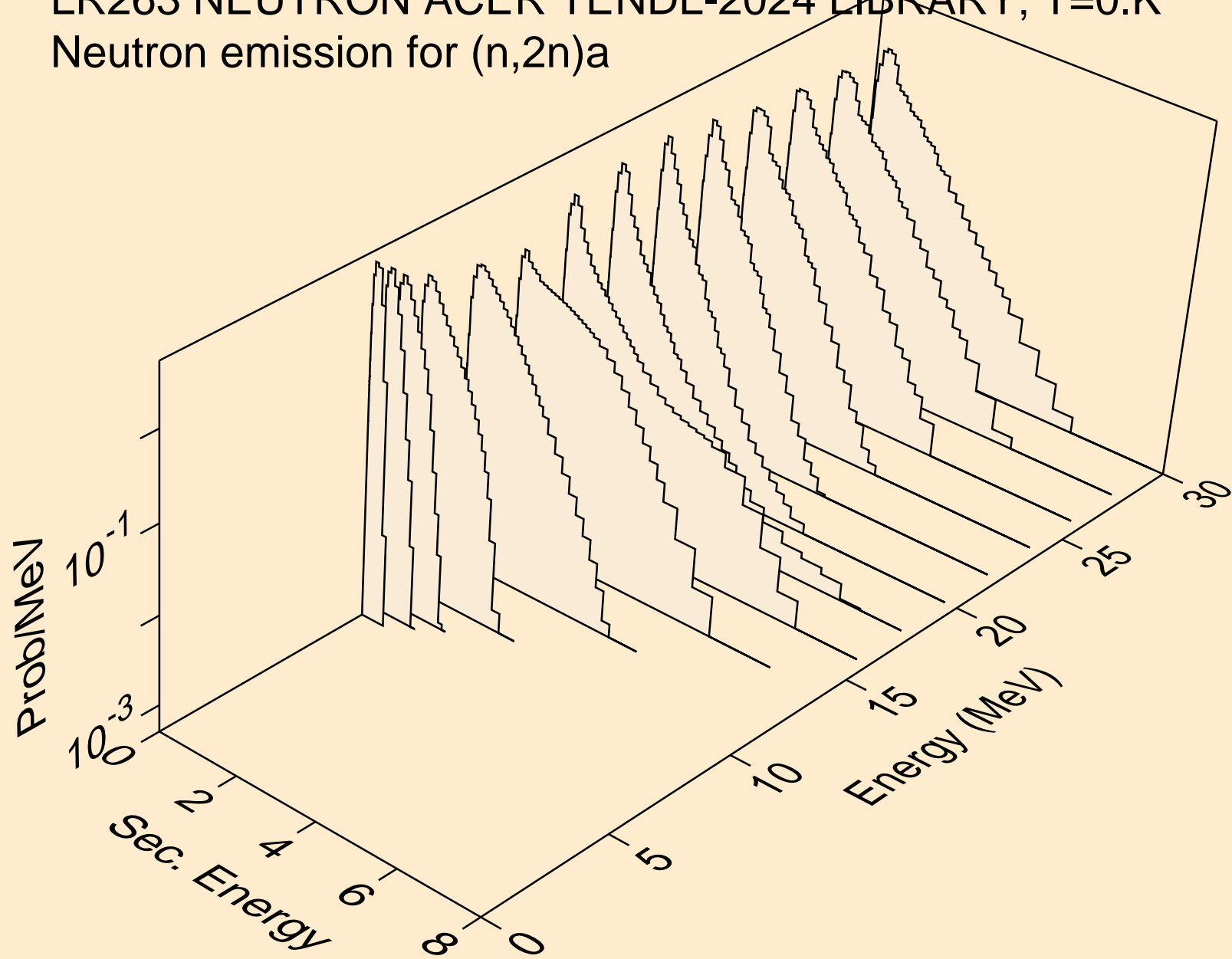

LR263 NEUTRON ACER TENDL-2024 LIBRARY; T=0.K
Neutron emission for (n,3n)a

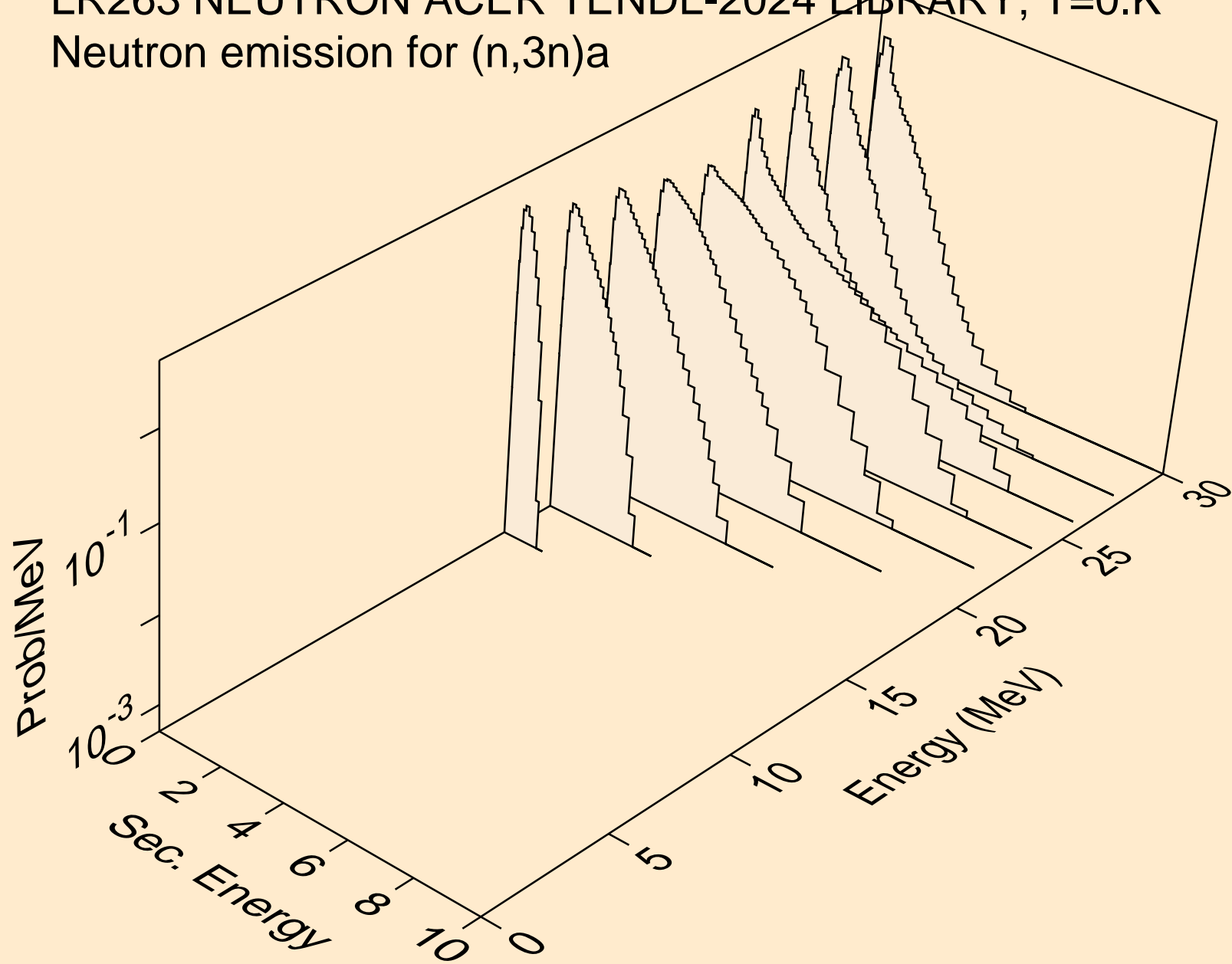

LR263 NEUTRON ACER TENDL-2024 LIBRARY; T=0.K
Neutron emission for (n,n*)p

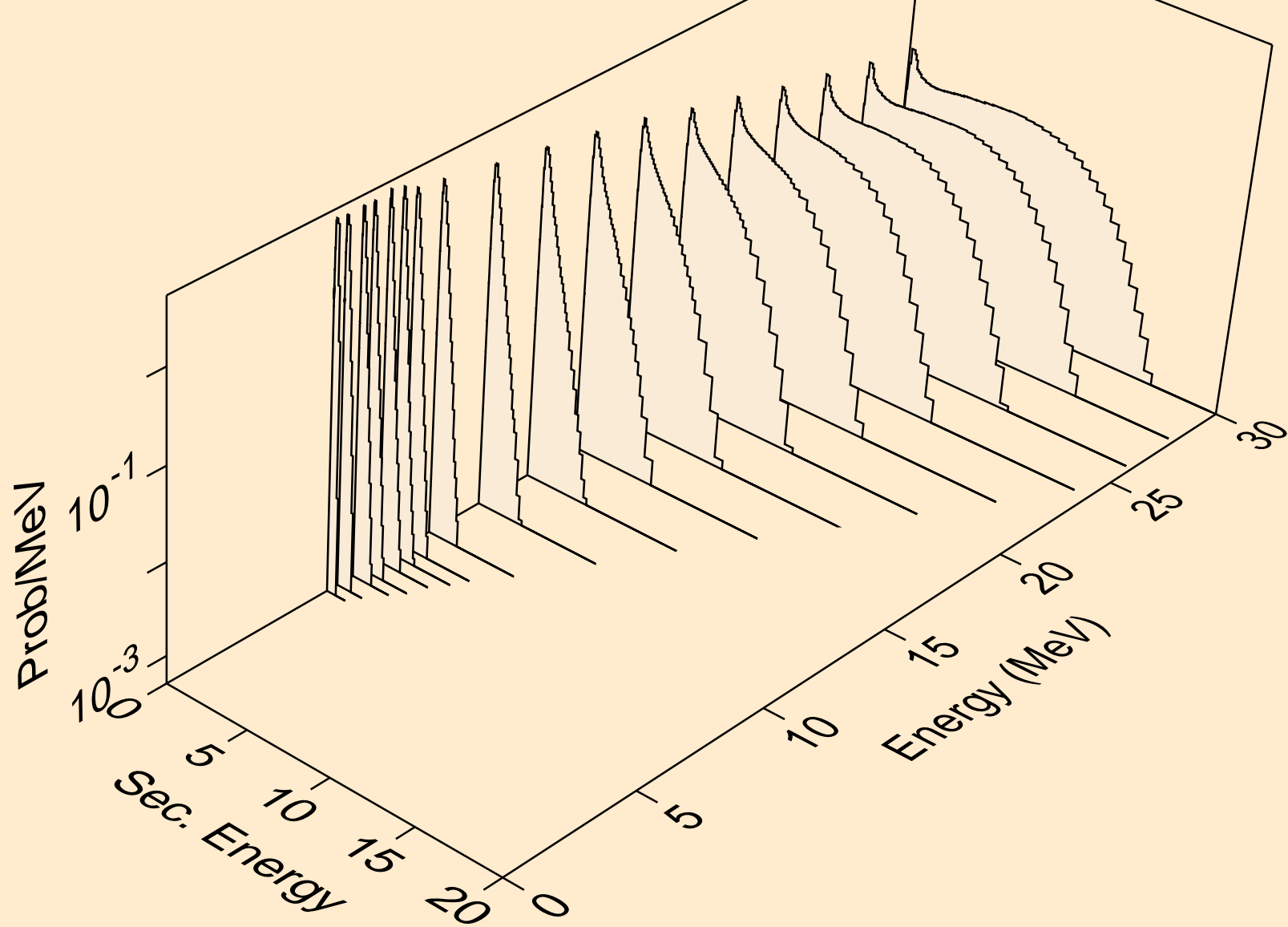

LR263 NEUTRON ACER TENDL-2024 LIBRARY; T=0.K
Neutron emission for (n,n*)d

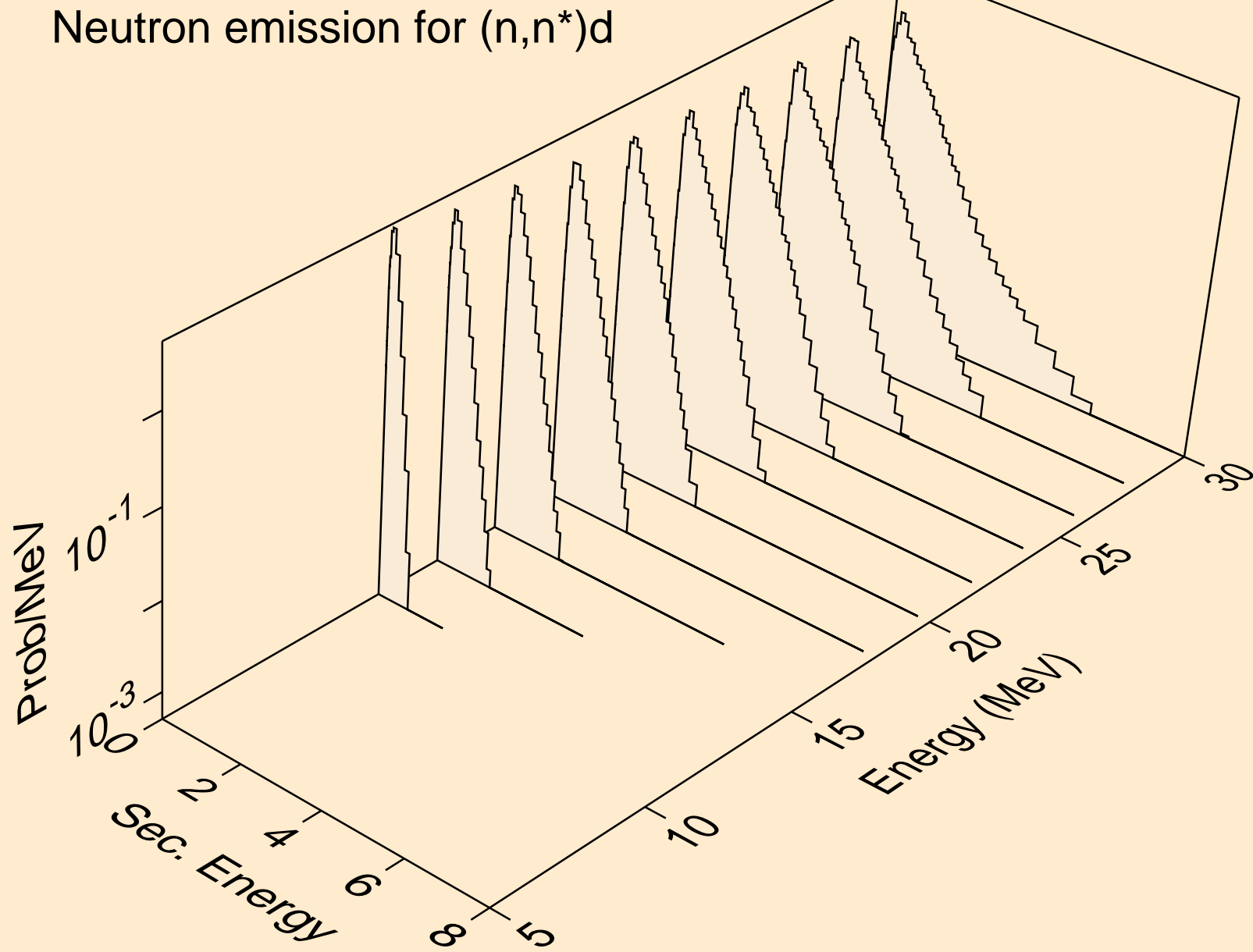

LR263 NEUTRON ACER TENDL-2024 LIBRARY; T=0.K
Neutron emission for (n,n*)t

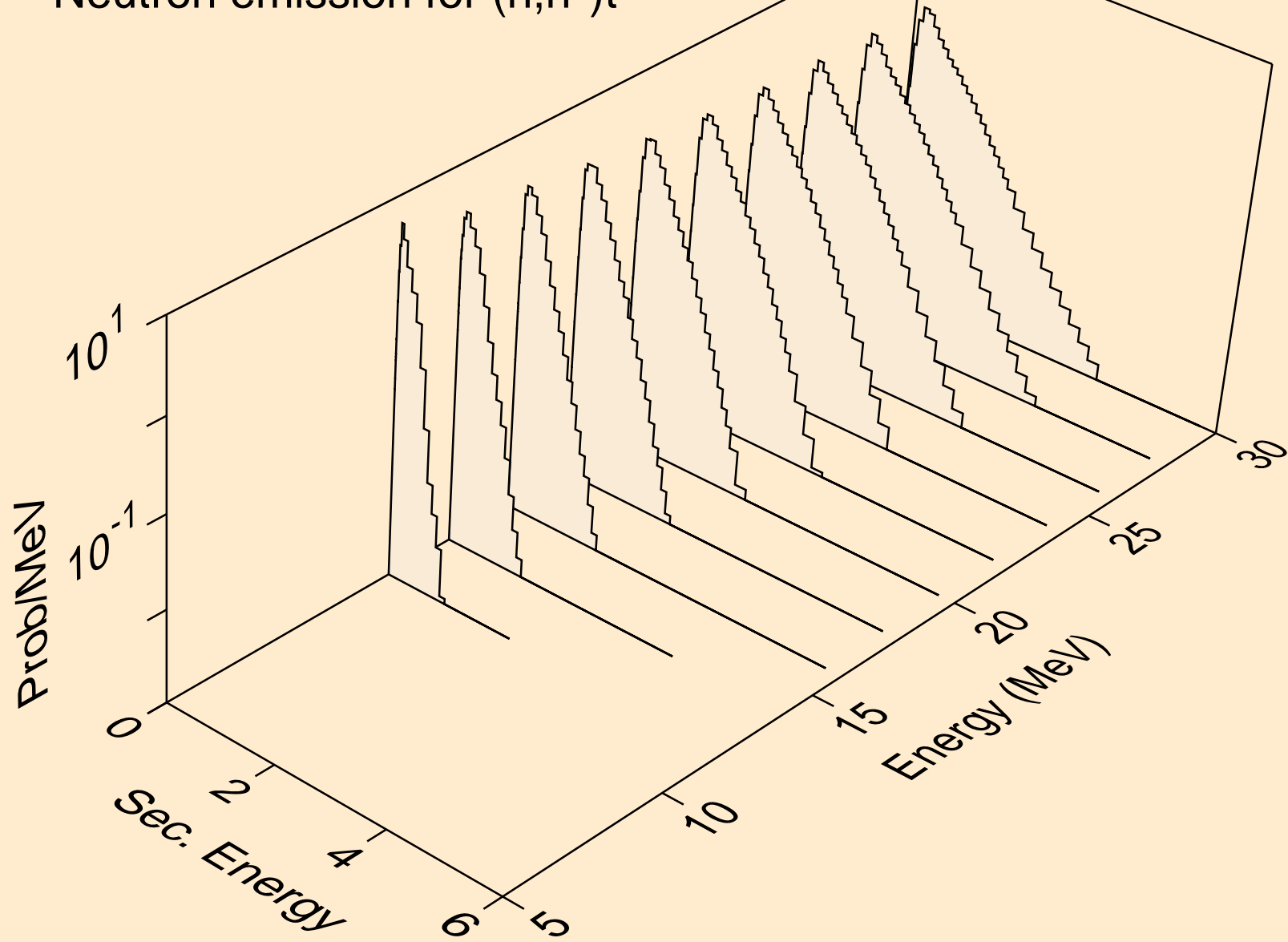

LR263 NEUTRON ACER TENDL-2024 LIBRARY; T=0.K
Neutron emission for (n,n*)he3

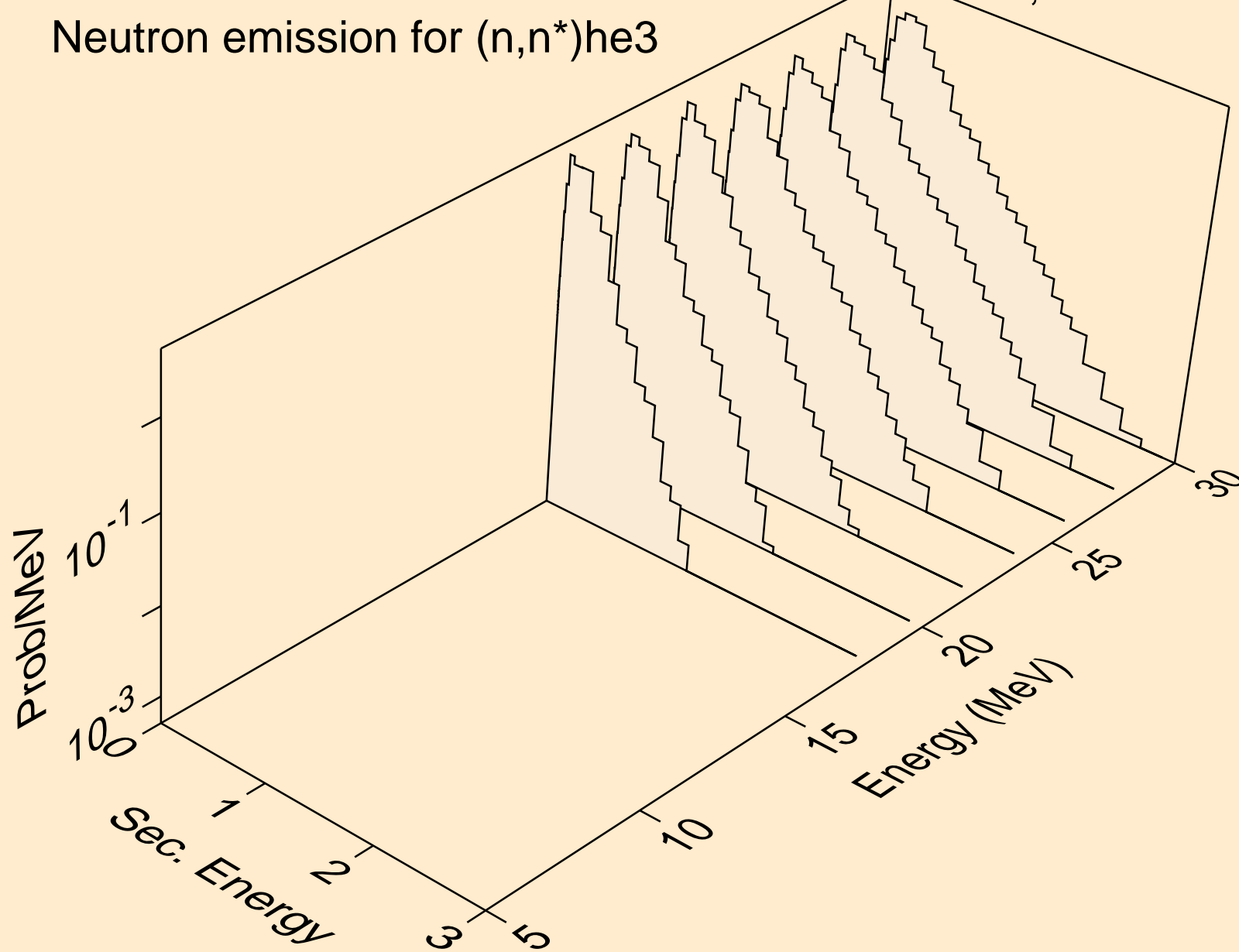

LR263 NEUTRON ACER TENDL-2024 LIBRARY; T=0.K
Neutron emission for (n,4n)

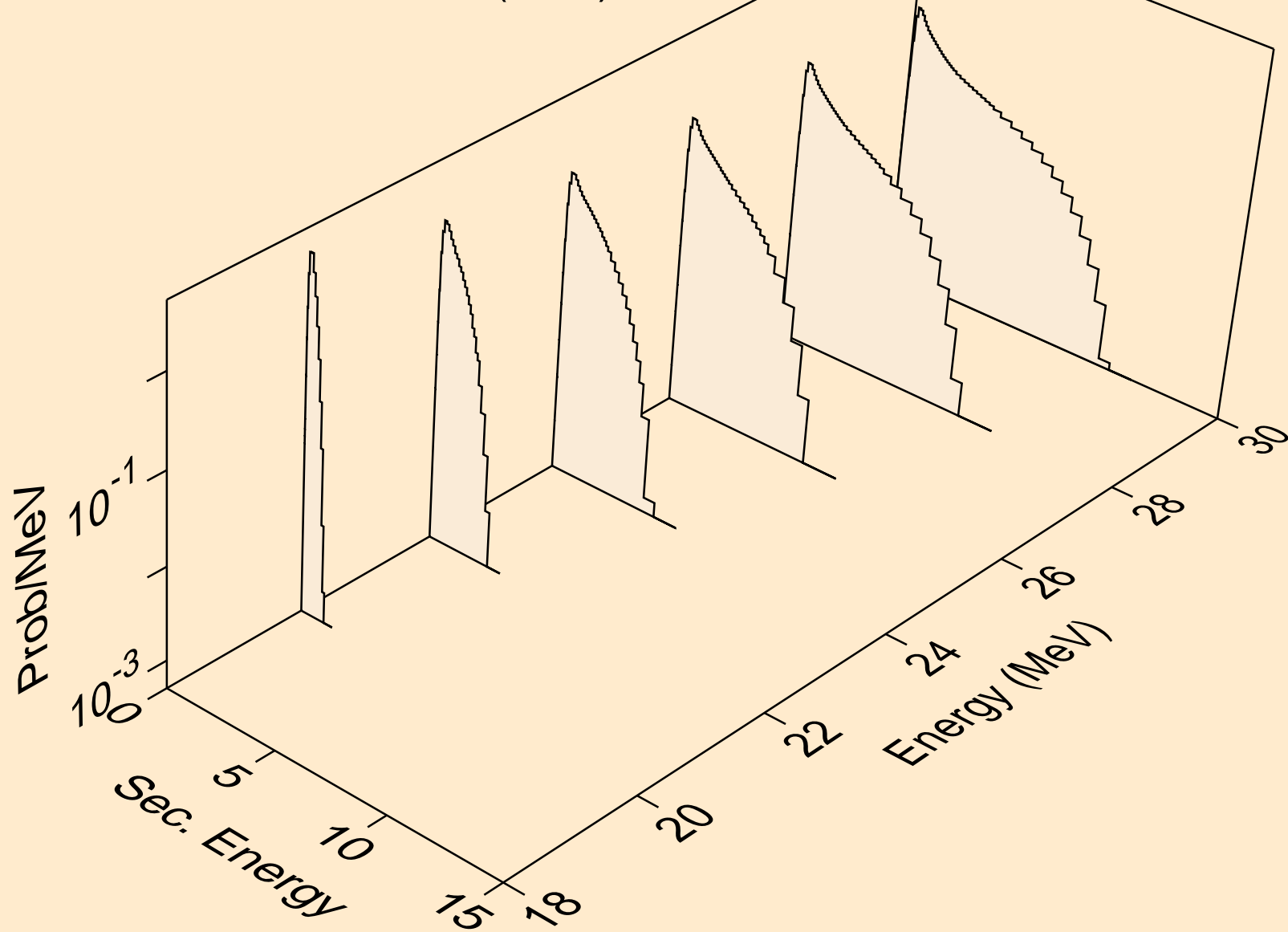

LR263 NEUTRON ACER TENDL-2024 LIBRARY; T=0.K
Neutron emission for (n,2np)

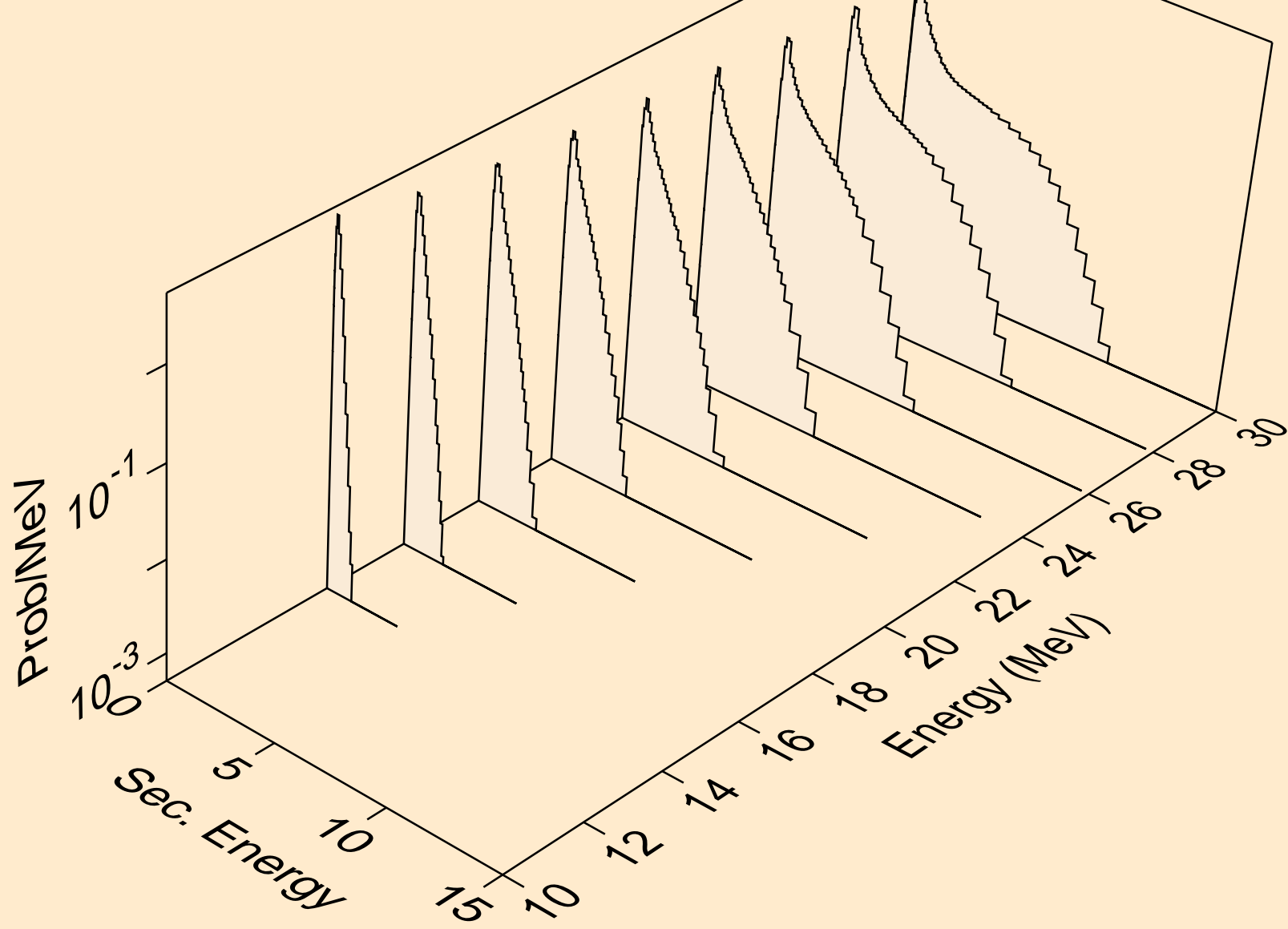

LR263 NEUTRON ACER TENDL-2024 LIBRARY; T=0.K
Neutron emission for (n,3np)

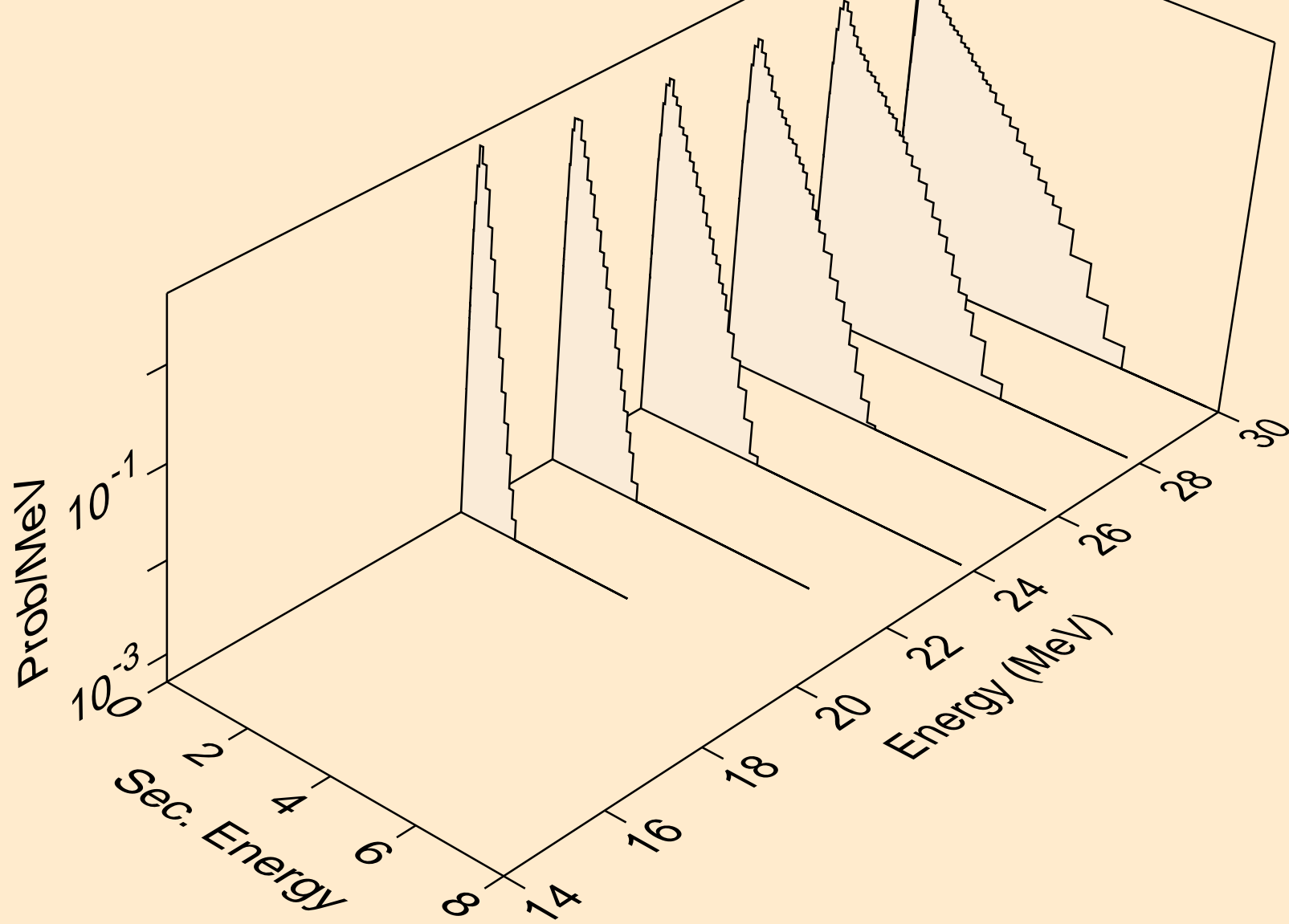

LR263 NEUTRON ACER TENDL-2024 LIBRARY; T=0.K
Neutron emission for (n,n2p)

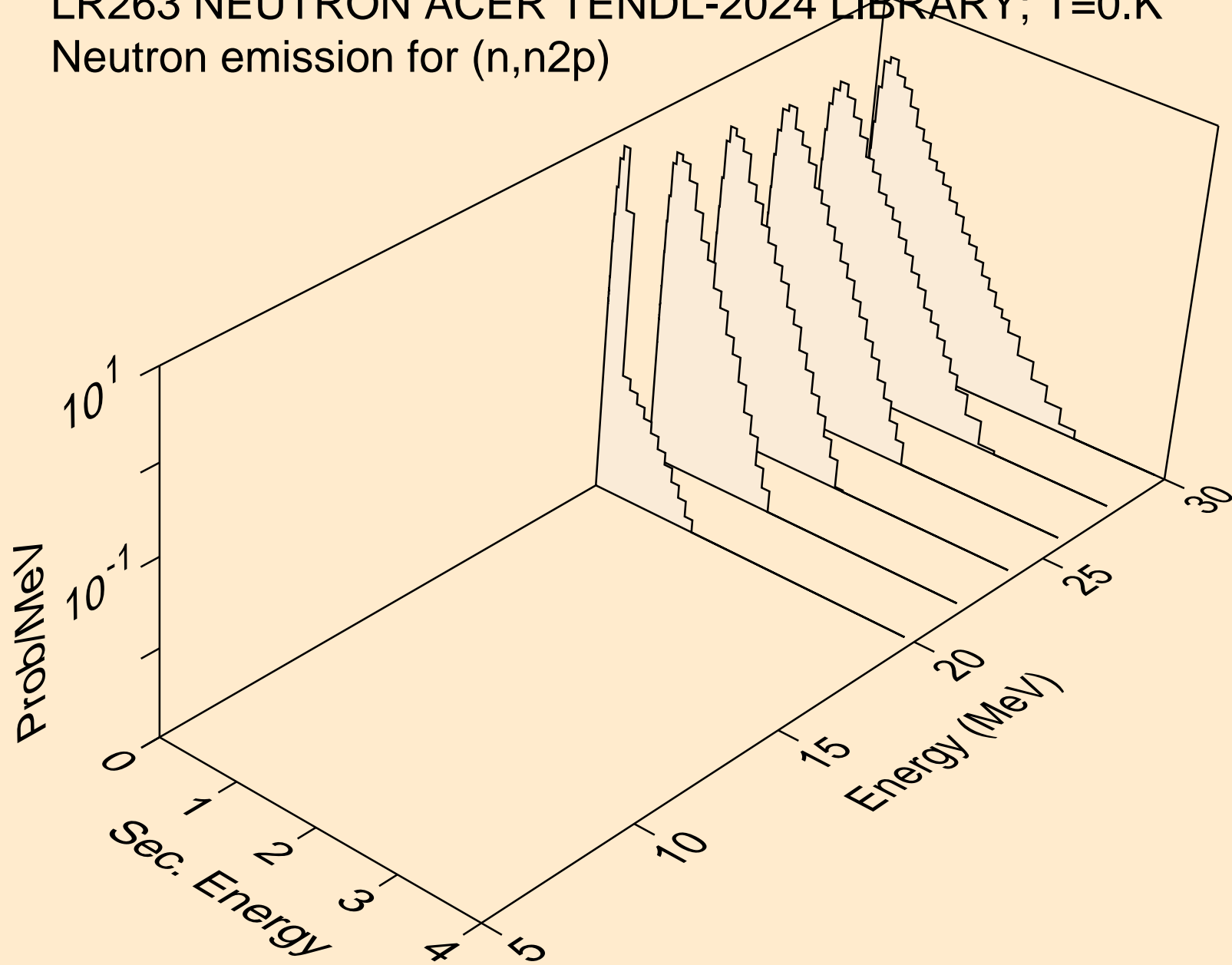

LR263 NEUTRON ACER TENDL-2024 LIBRARY; T=0.K
Neutron emission for (n,n*c)

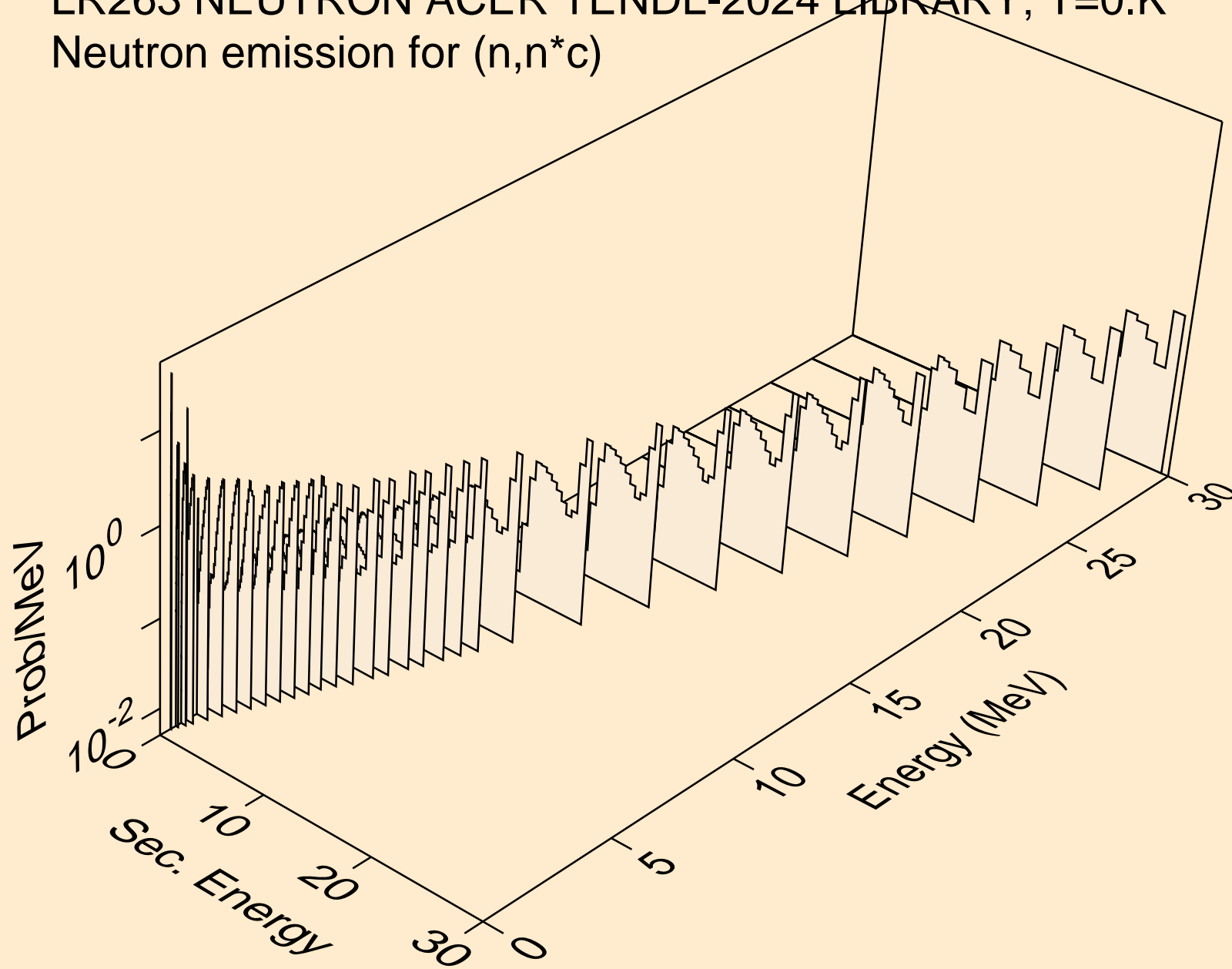

LR263 NEUTRON ACER TENDL-2024 LIBRARY; T=0.K

Delayed nubar

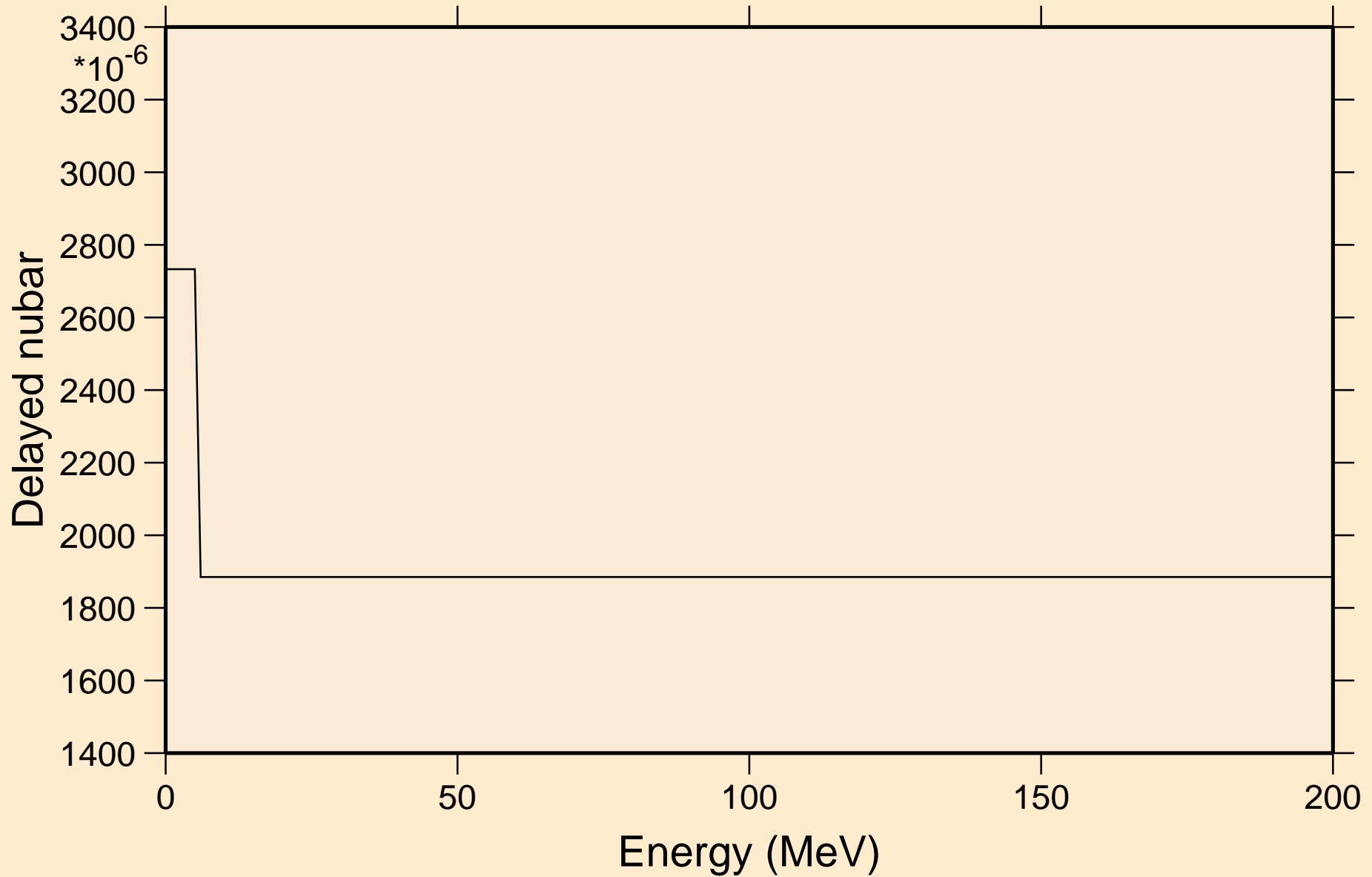

LR263 NEUTRON ACER TENDL-2024 LIBRARY; T=0.K

Delayed neutron spectra

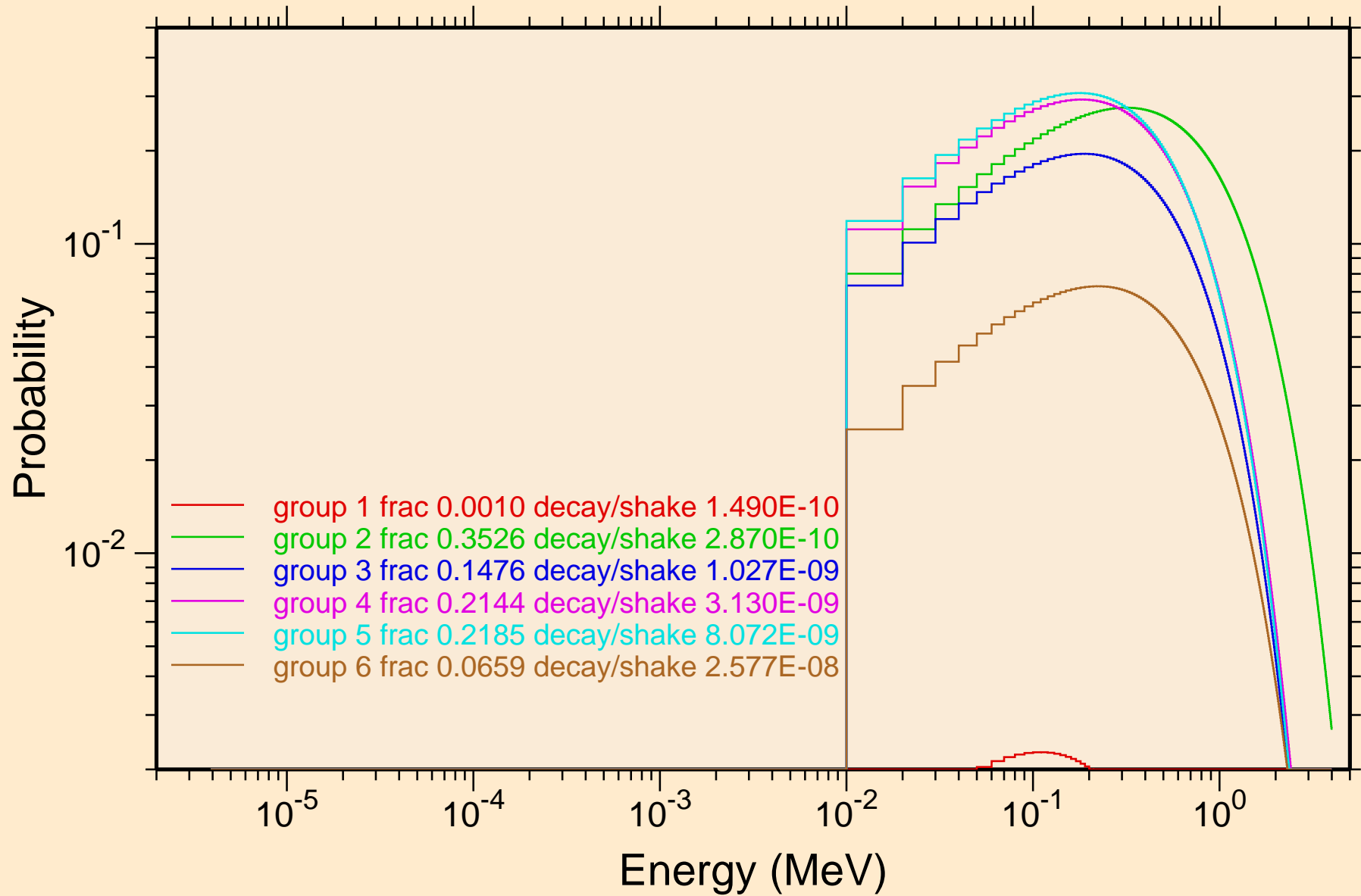

LR263 NEUTRON ACER TENDL-2024 LIBRARY; T=0.K
Photon emission for (n,x)

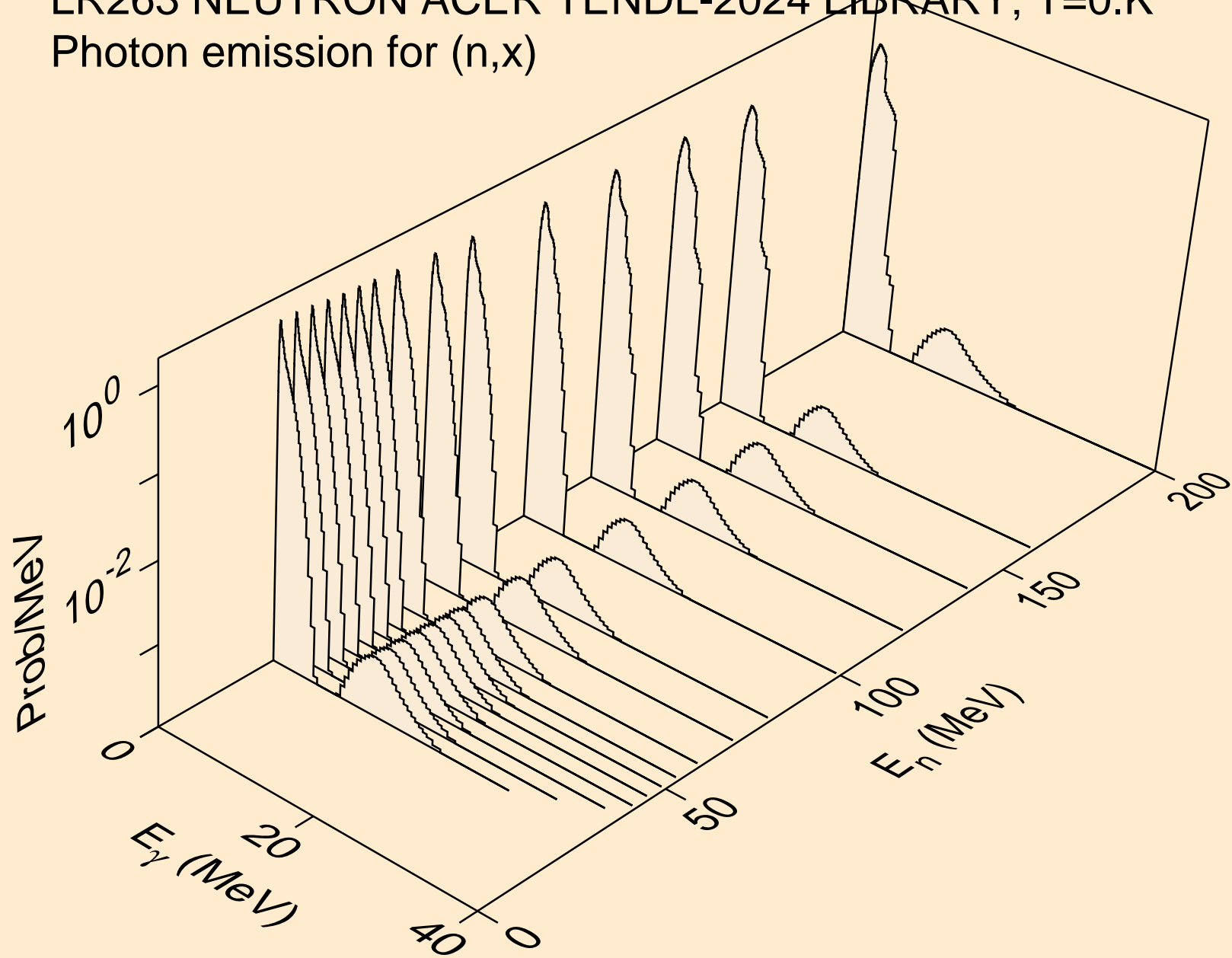

LR263 NEUTRON ACER TENDL-2024 LIBRARY; T=0.K
Photon emission for (n,2nd)

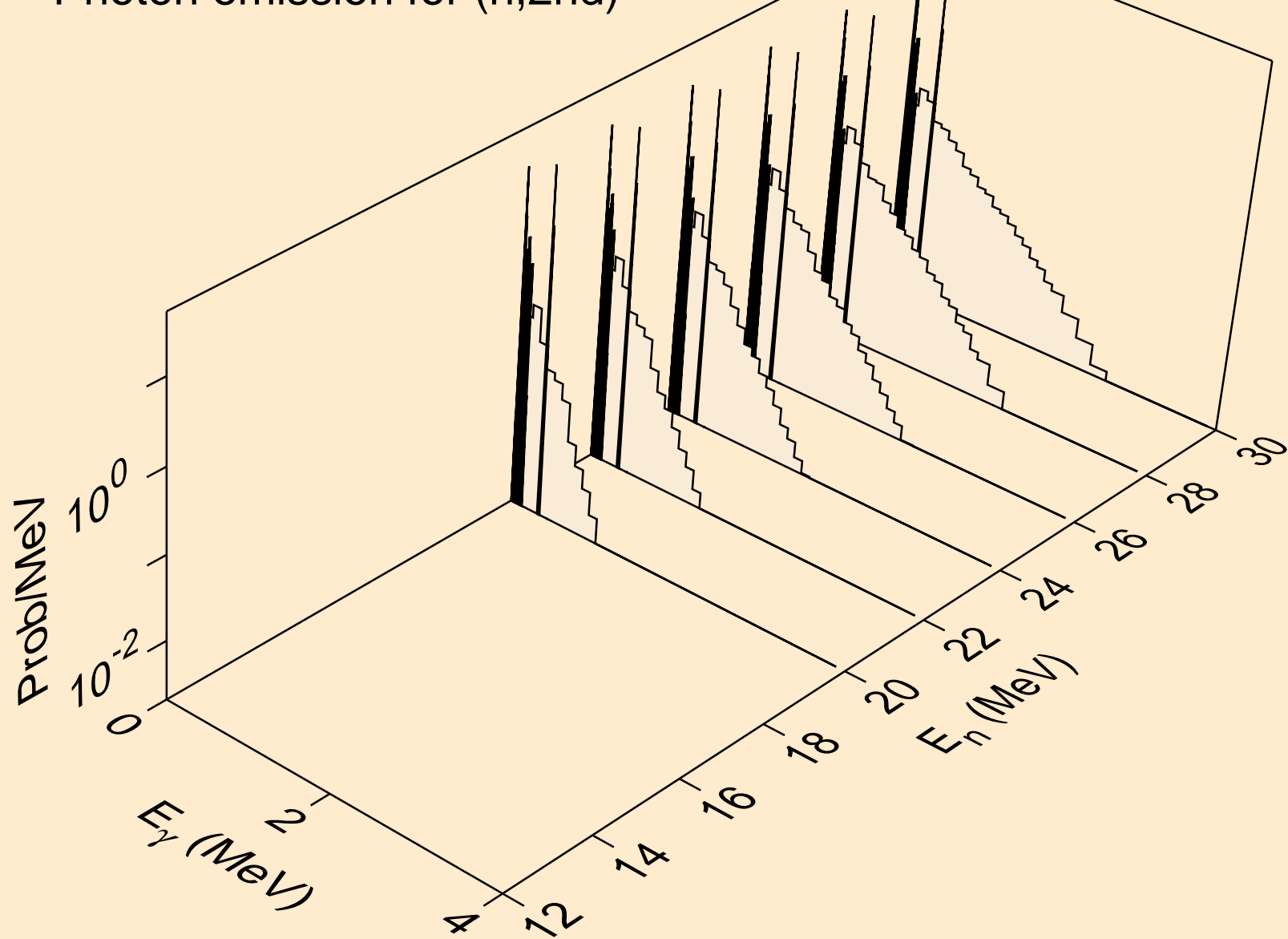

LR263 NEUTRON ACER TENDL-2024 LIBRARY; T=0.K
Photon emission for (n,2n)

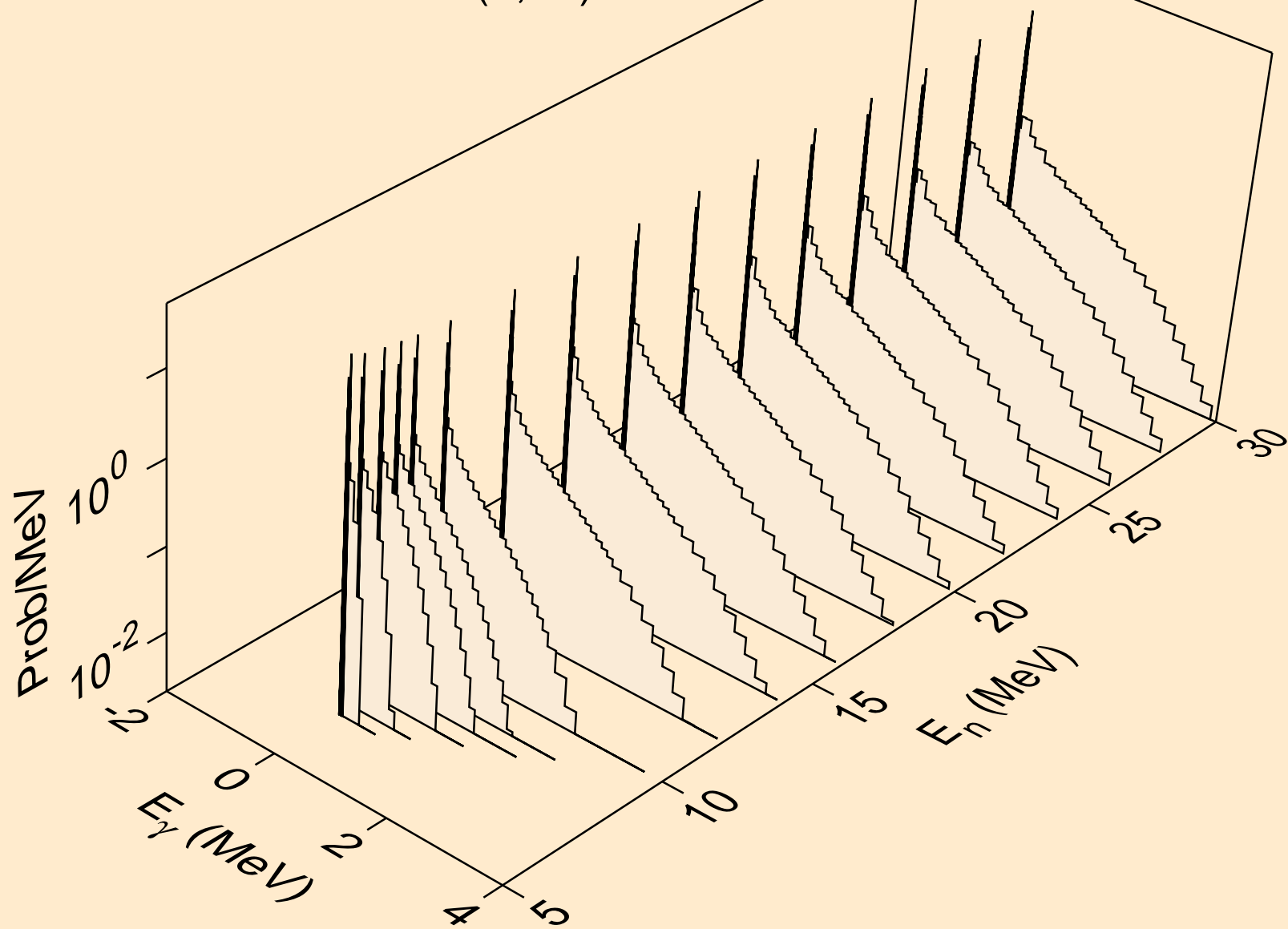

LR263 NEUTRON ACER TENDL-2024 LIBRARY; T=0.K
Photon emission for (n,3n)

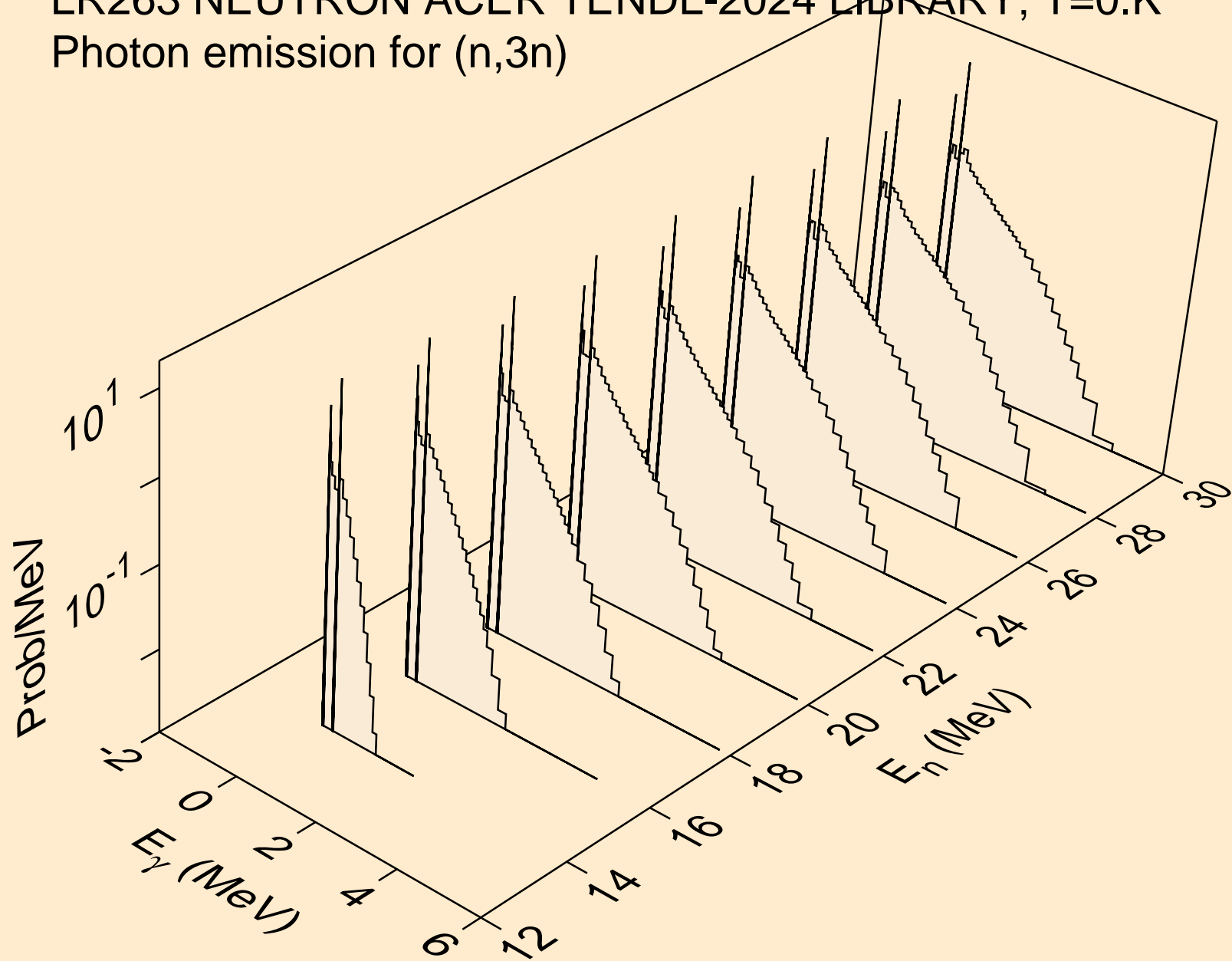

LR263 NEUTRON ACER TENDL-2024 LIBRARY; T=0.K
Photon emission for (n,n*)a

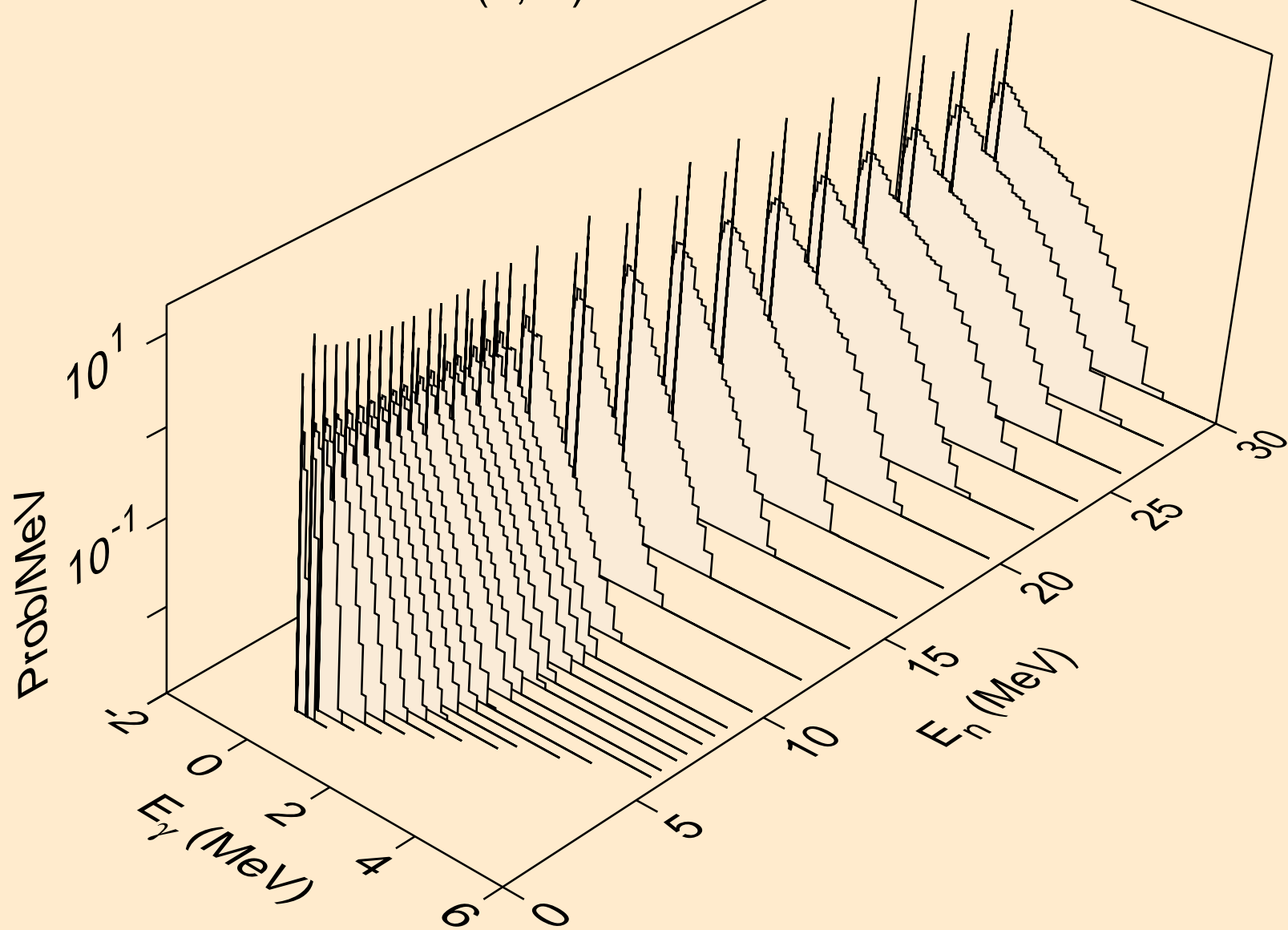

LR263 NEUTRON ACER TENDL-2024 LIBRARY; T=0.K
Photon emission for (n,2n)a

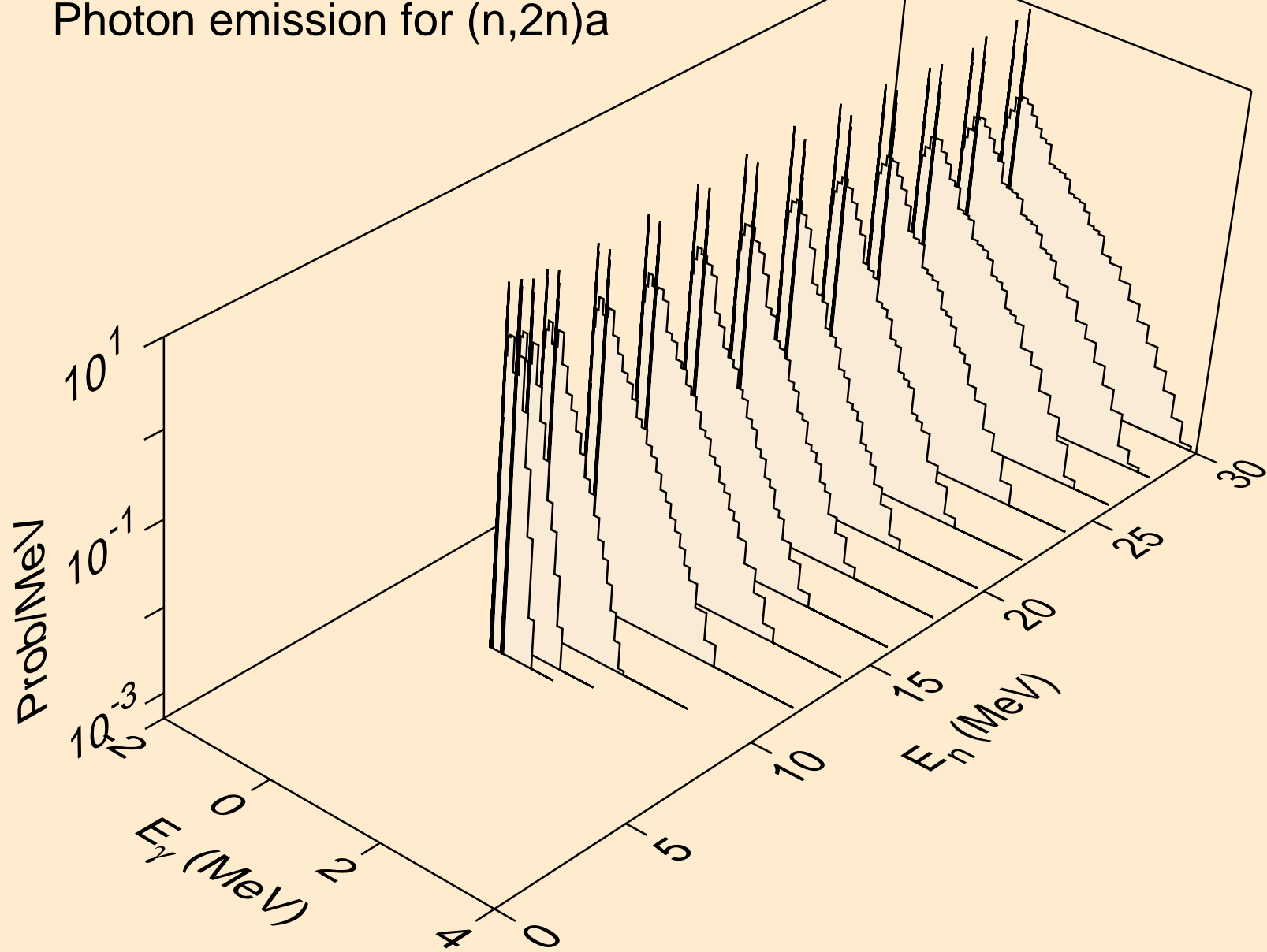

LR263 NEUTRON ACER TENDL-2024 LIBRARY; T=0.K
Photon emission for (n,3n)a

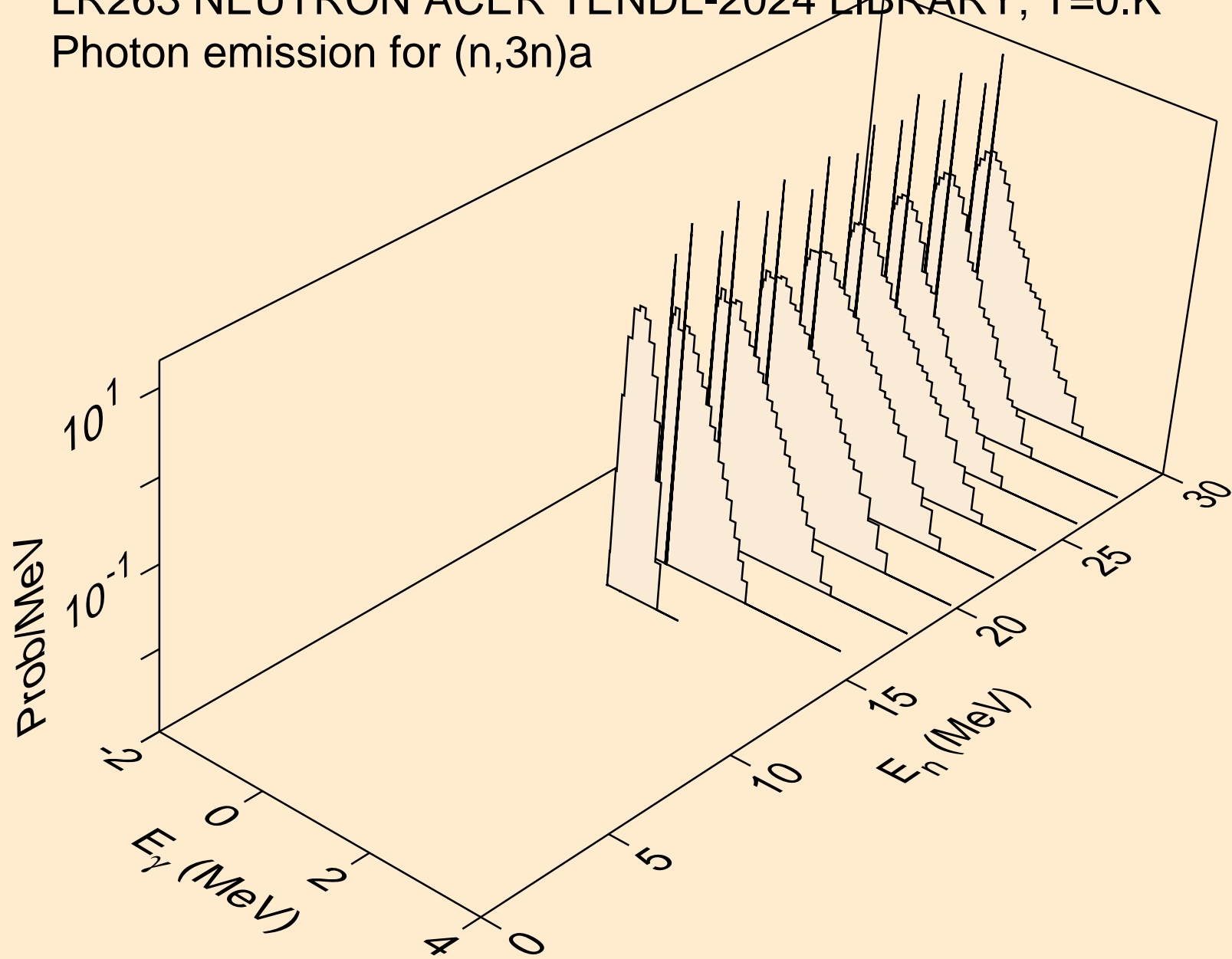

LR263 NEUTRON ACER TENDL-2024 LIBRARY; T=0.K
Photon emission for (n,n*)p

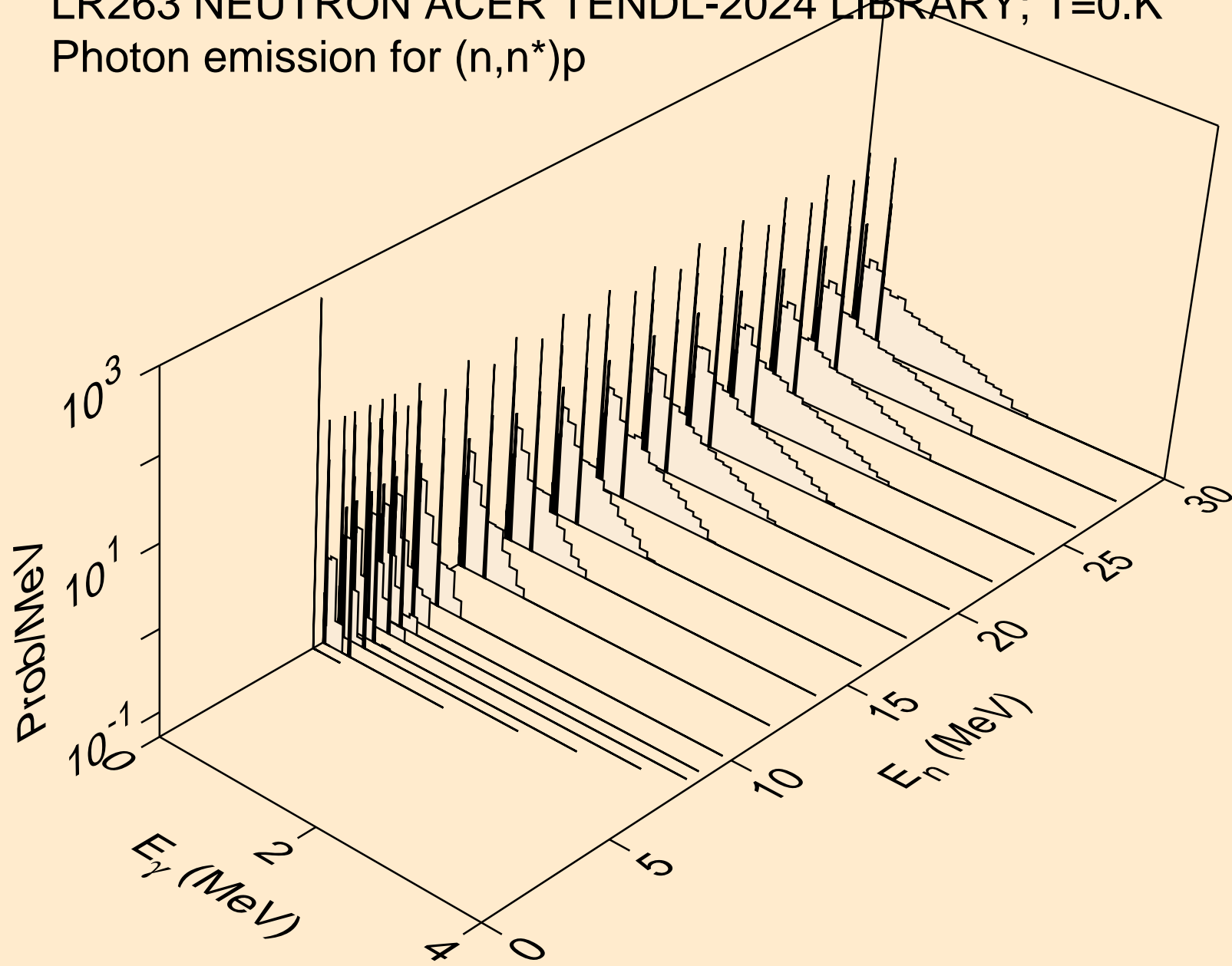

LR263 NEUTRON ACER TENDL-2024 LIBRARY; T=0.K
Photon emission for (n,n*)d

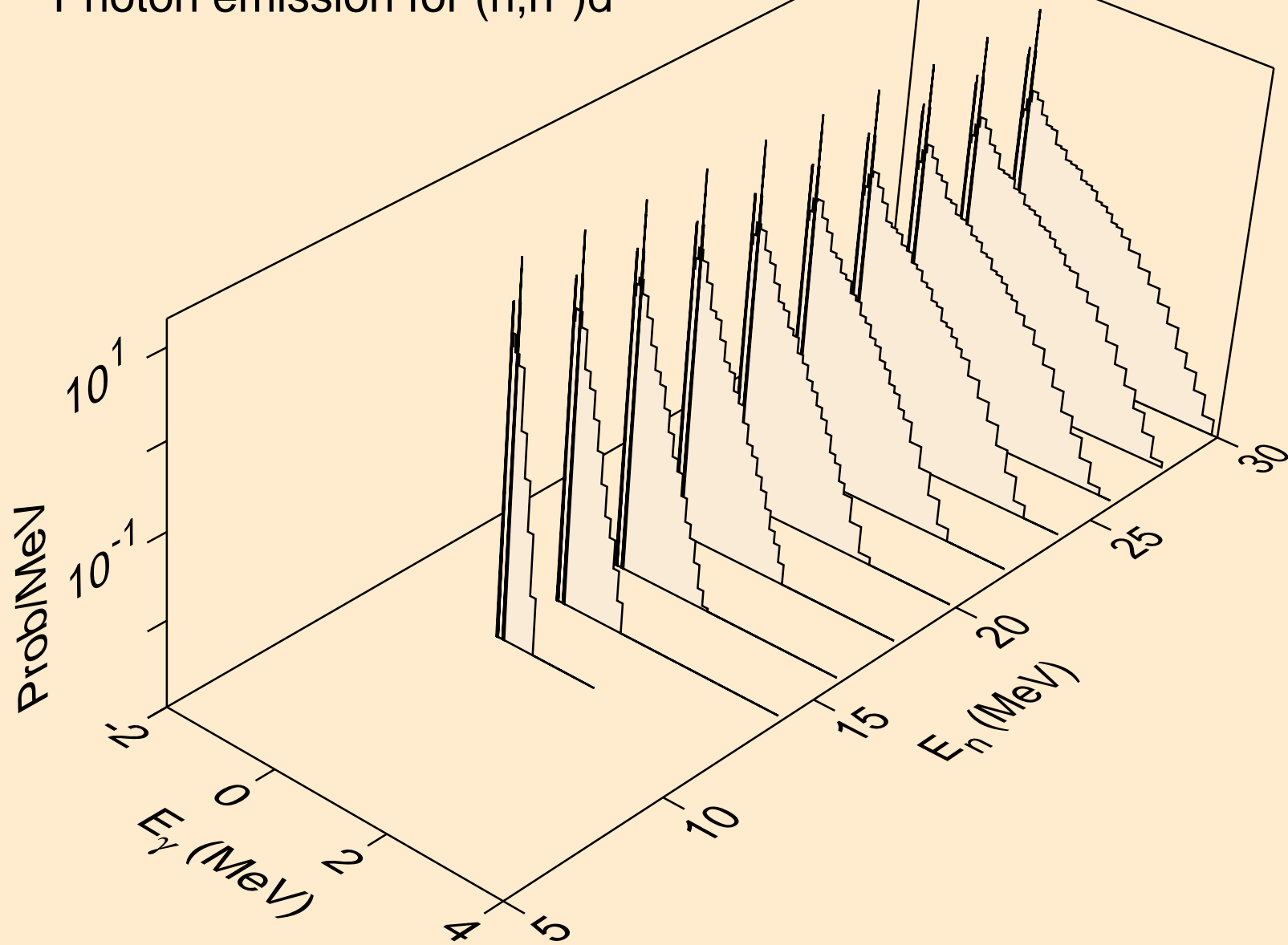

LR263 NEUTRON ACER TENDL-2024 LIBRARY; T=0.K

Photon emission for (n,n*)t

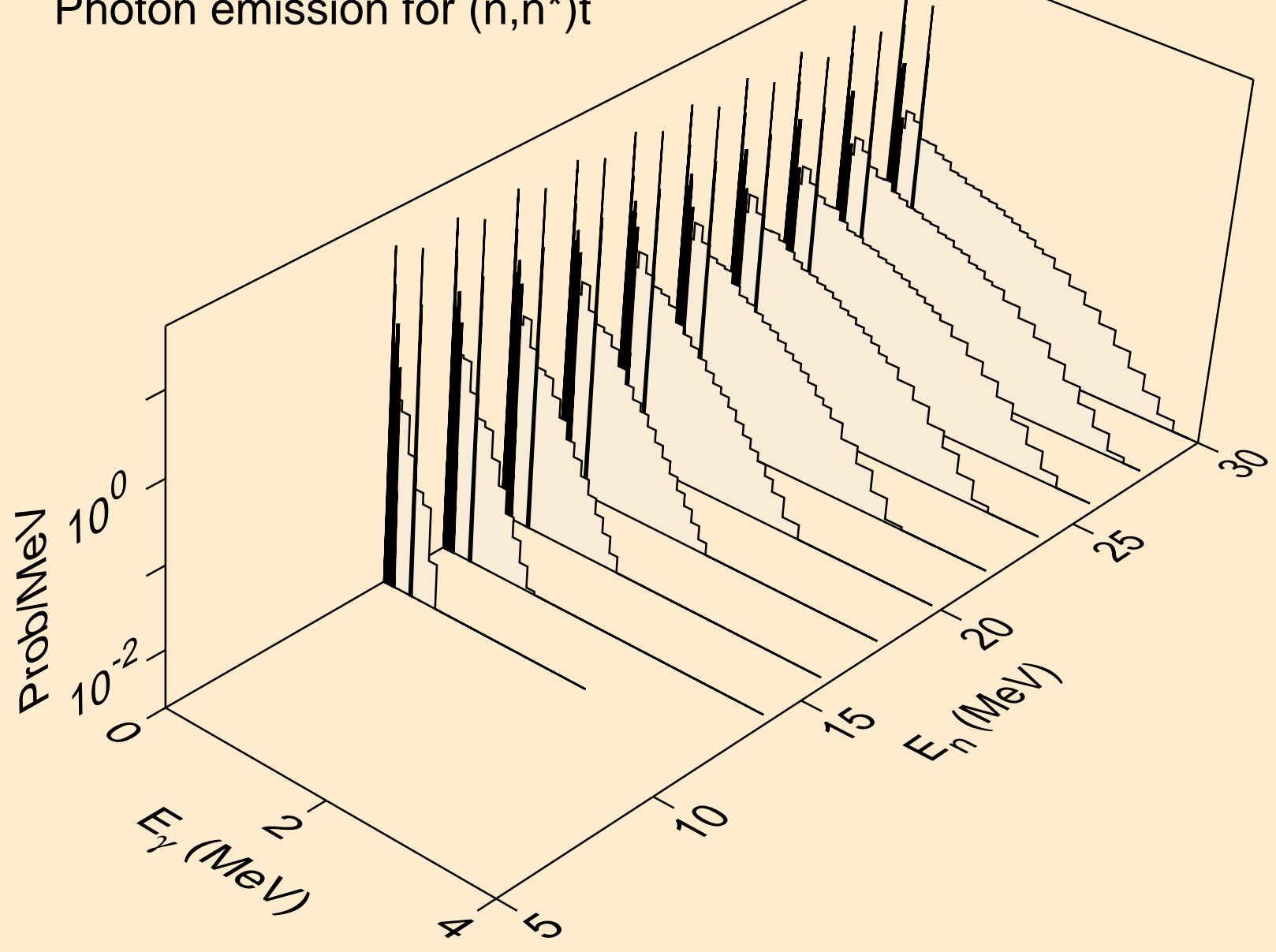

LR263 NEUTRON ACER TENDL-2024 LIBRARY; T=0.K
Photon emission for (n,n*)he3

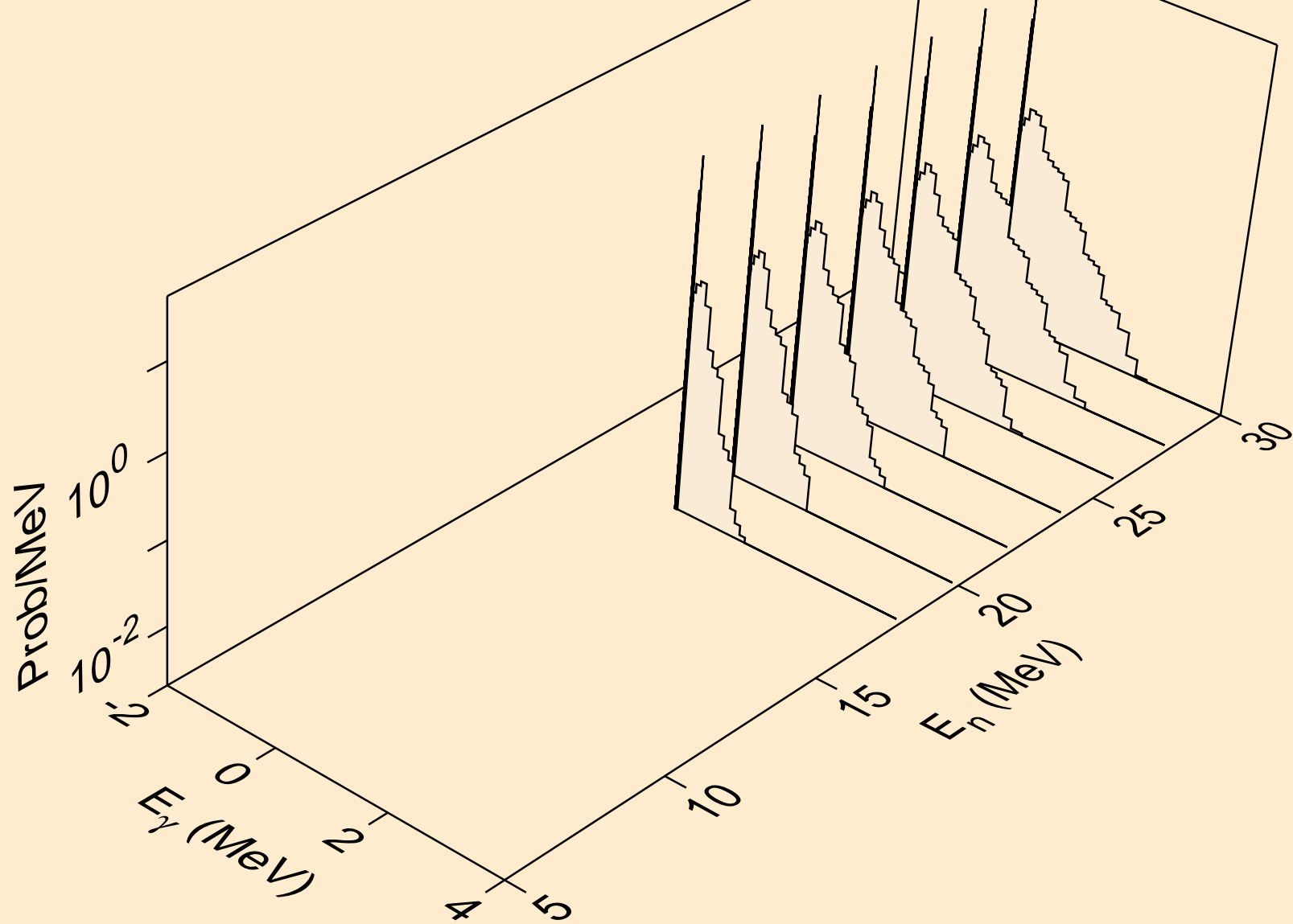

LR263 NEUTRON ACER TENDL-2024 LIBRARY; T=0.K
Photon emission for (n,4n)

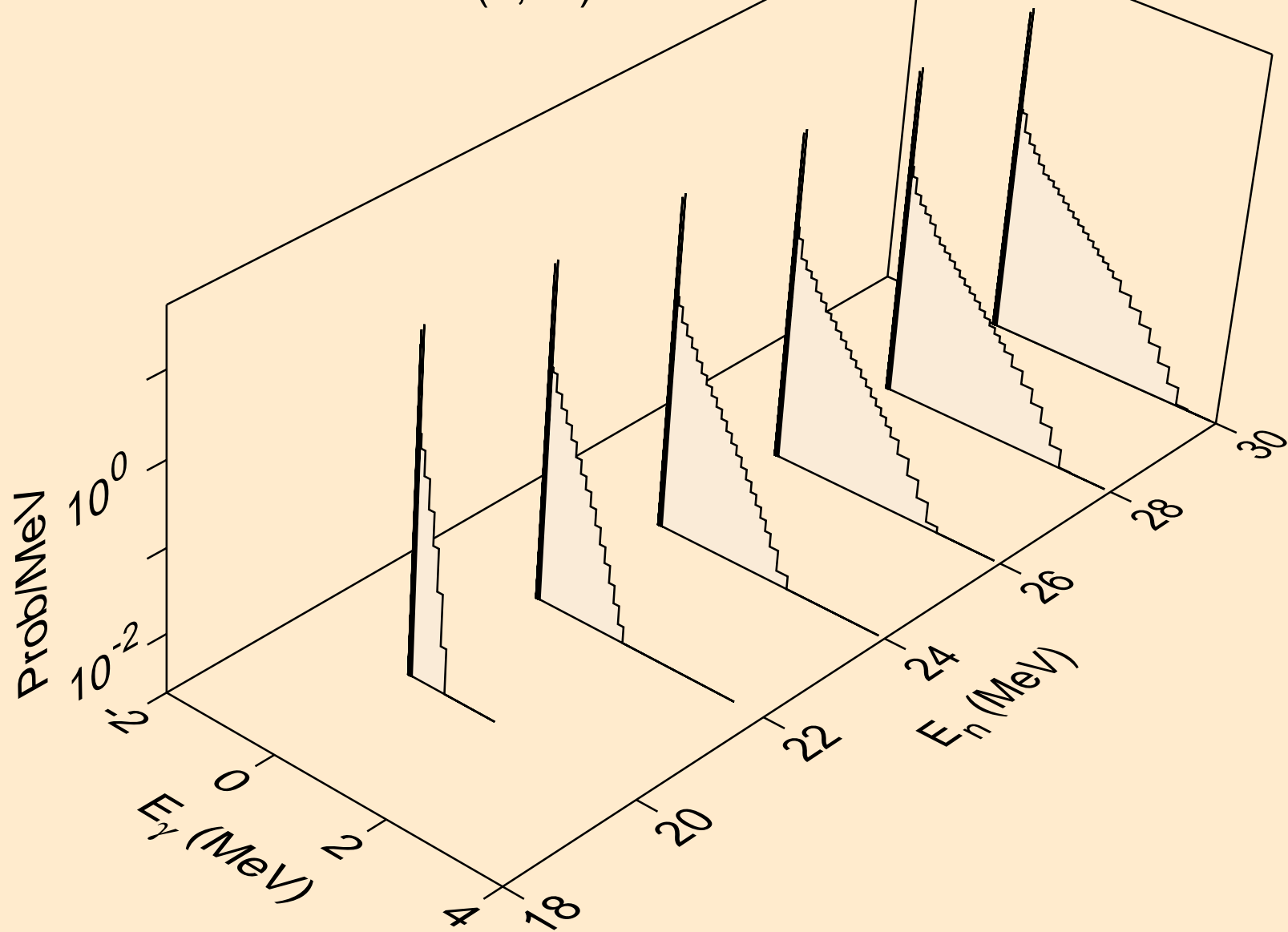

LR263 NEUTRON ACER TENDL-2024 LIBRARY; T=0.K
Photon emission for (n,2np)

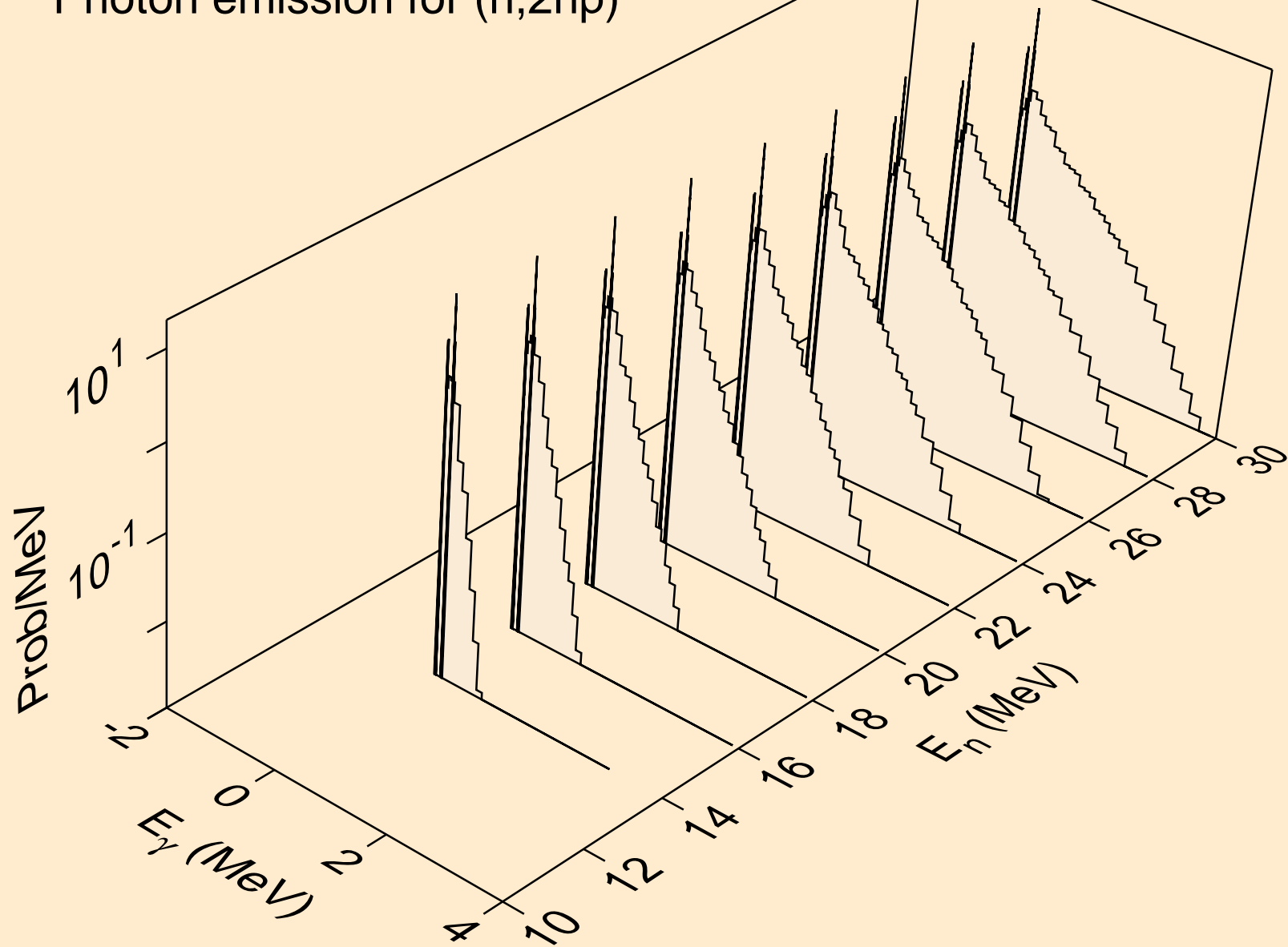

LR263 NEUTRON ACER TENDL-2024 LIBRARY; T=0.K
Photon emission for (n,3np)

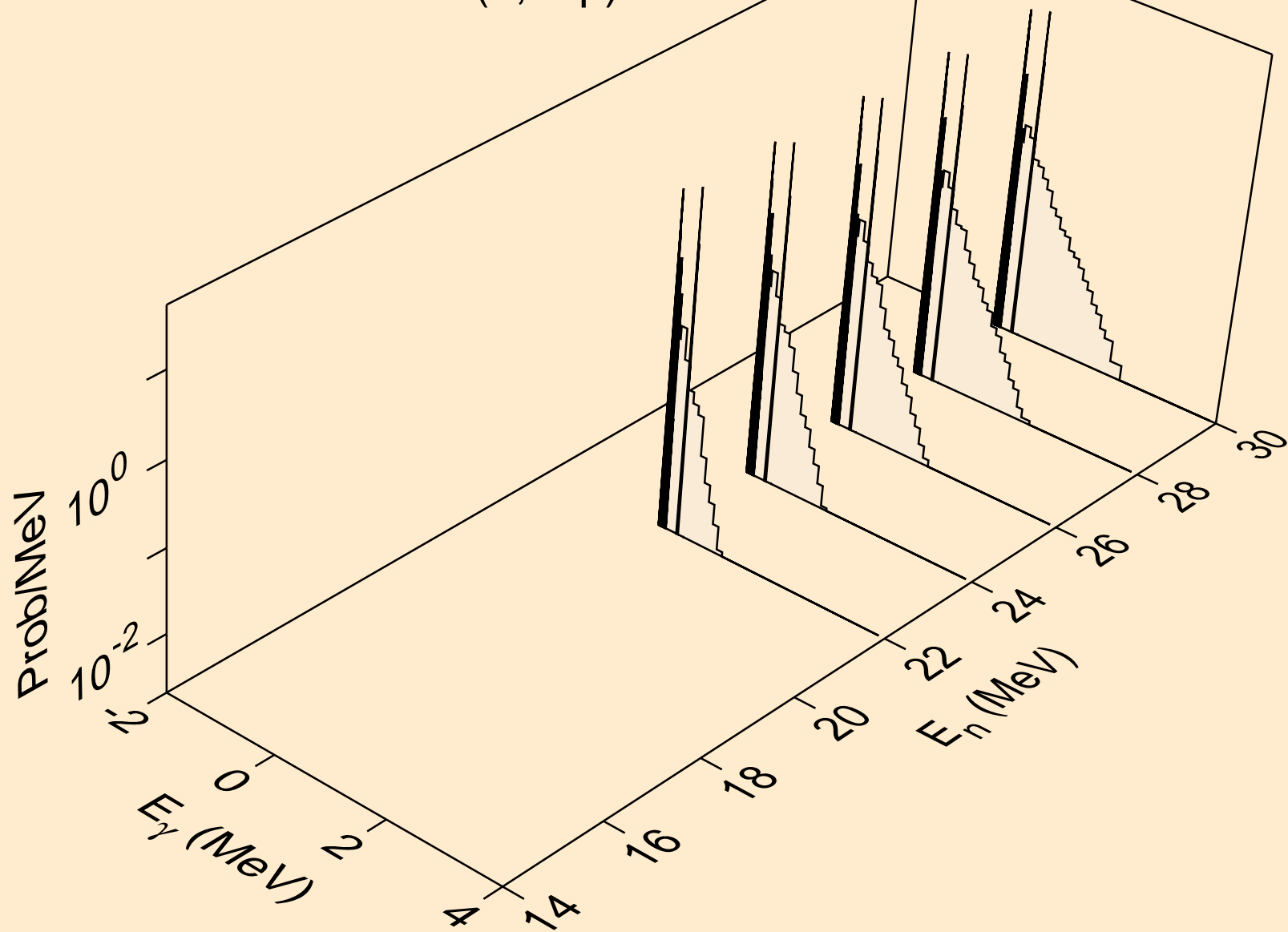

LR263 NEUTRON ACER TENDL-2024 LIBRARY; T=0.K
Photon emission for (n,n2p)

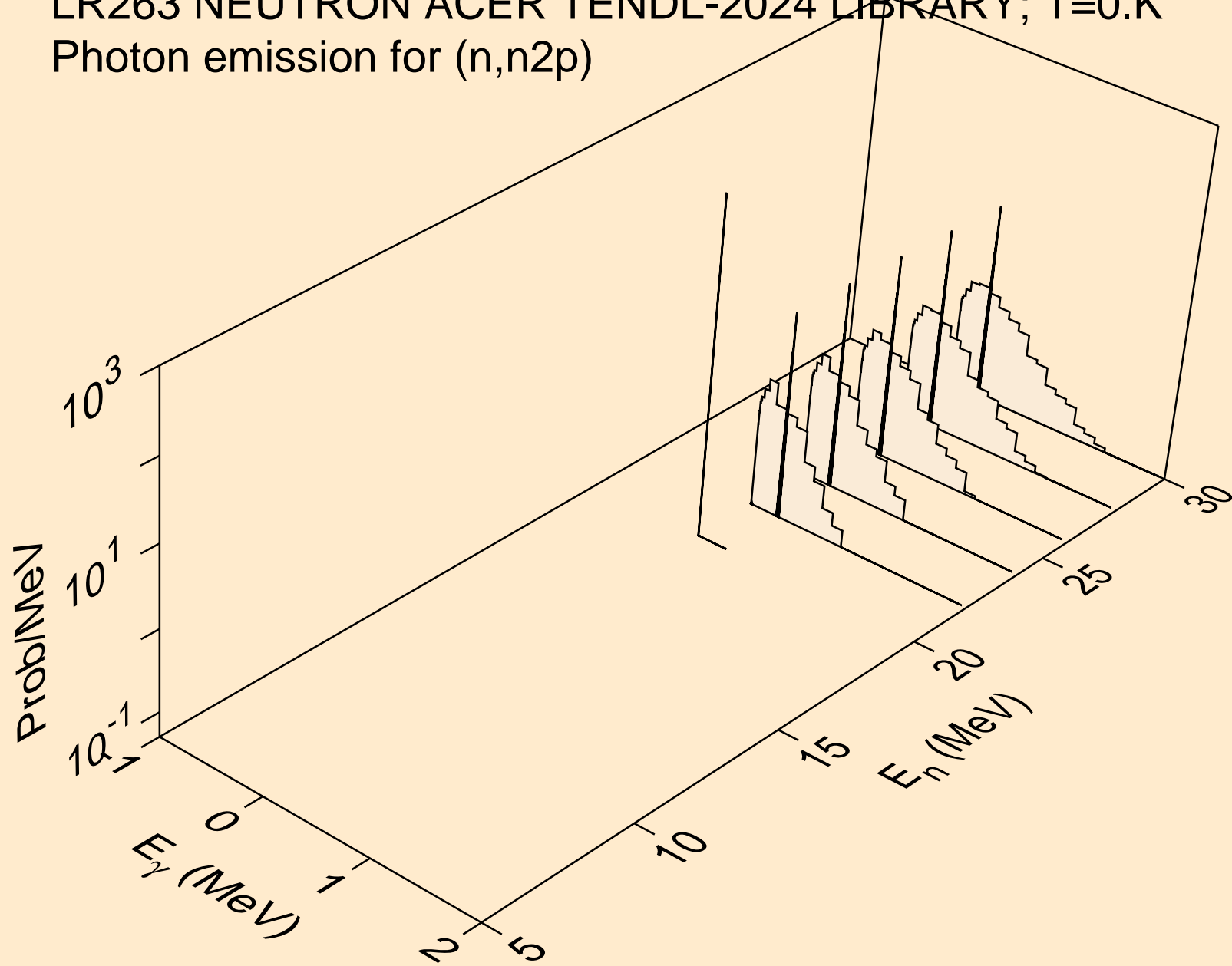

LR263 NEUTRON ACER TENDL-2024 LIBRARY; T=0.K
Photon emission for (n,n*c)

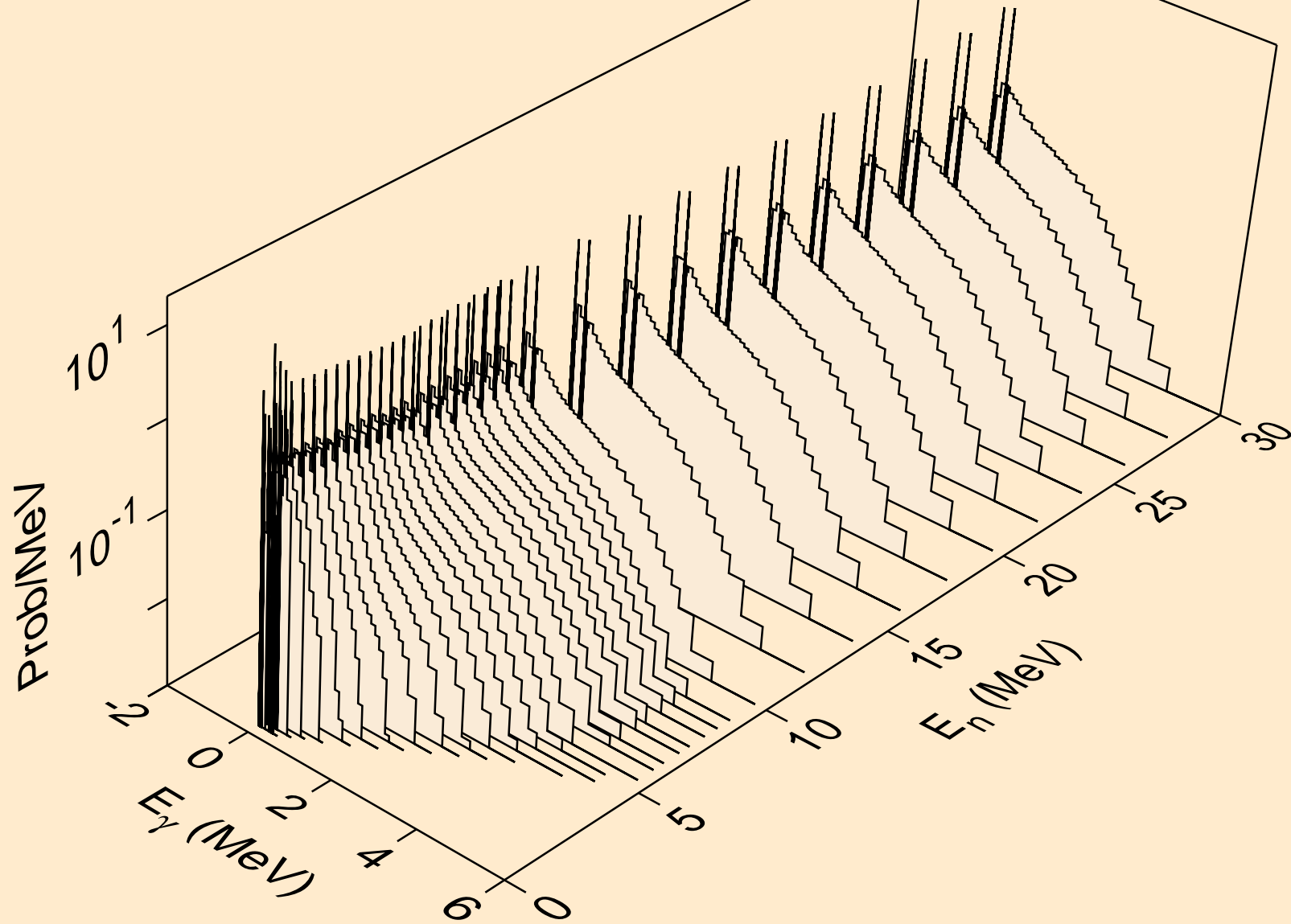

LR263 NEUTRON ACER TENDL-2024 LIBRARY; T=0.K
Photon emission for (n,gma)

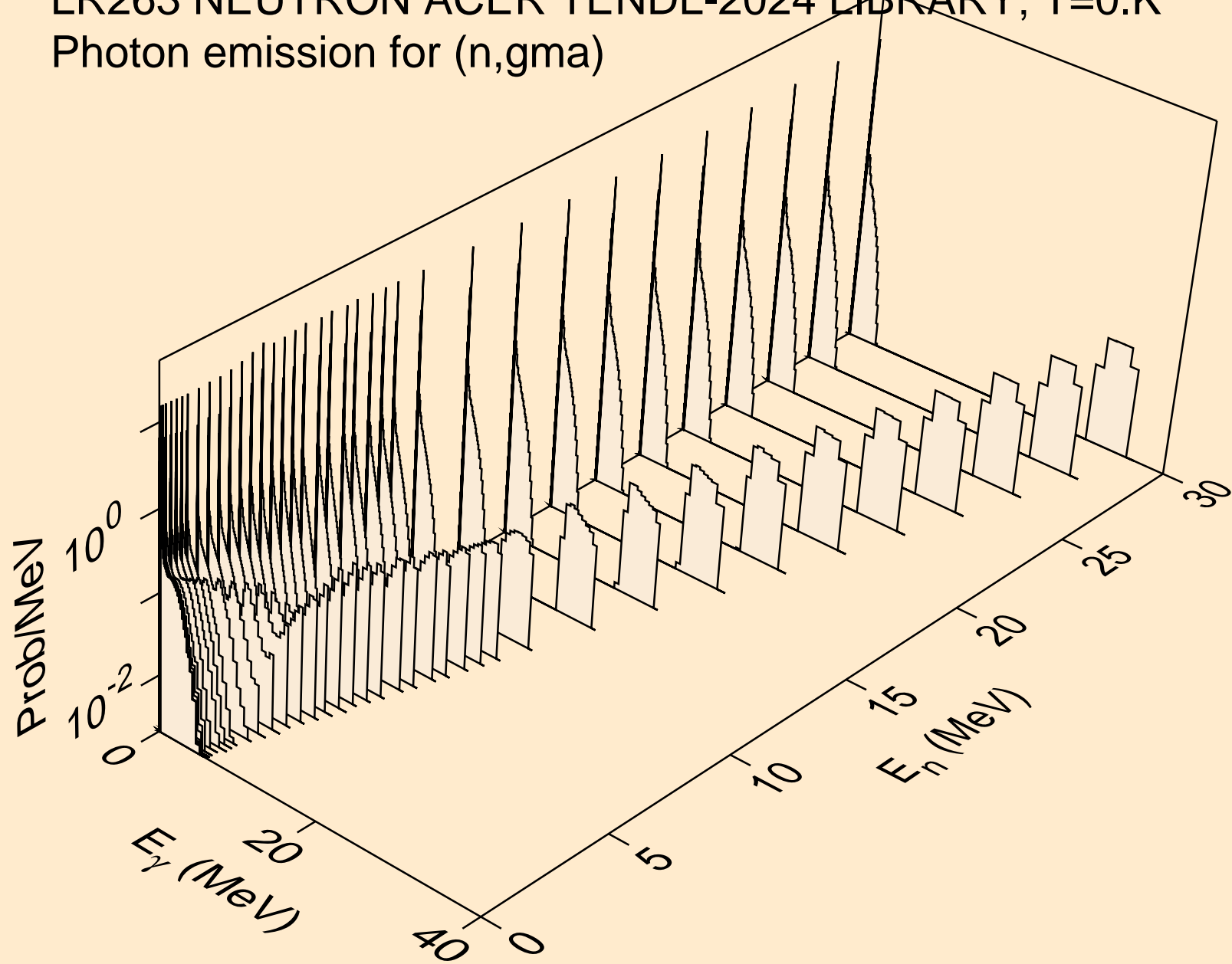

LR263 NEUTRON ACER TENDL-2024 LIBRARY; T=0.K
Photon emission for (n,p)

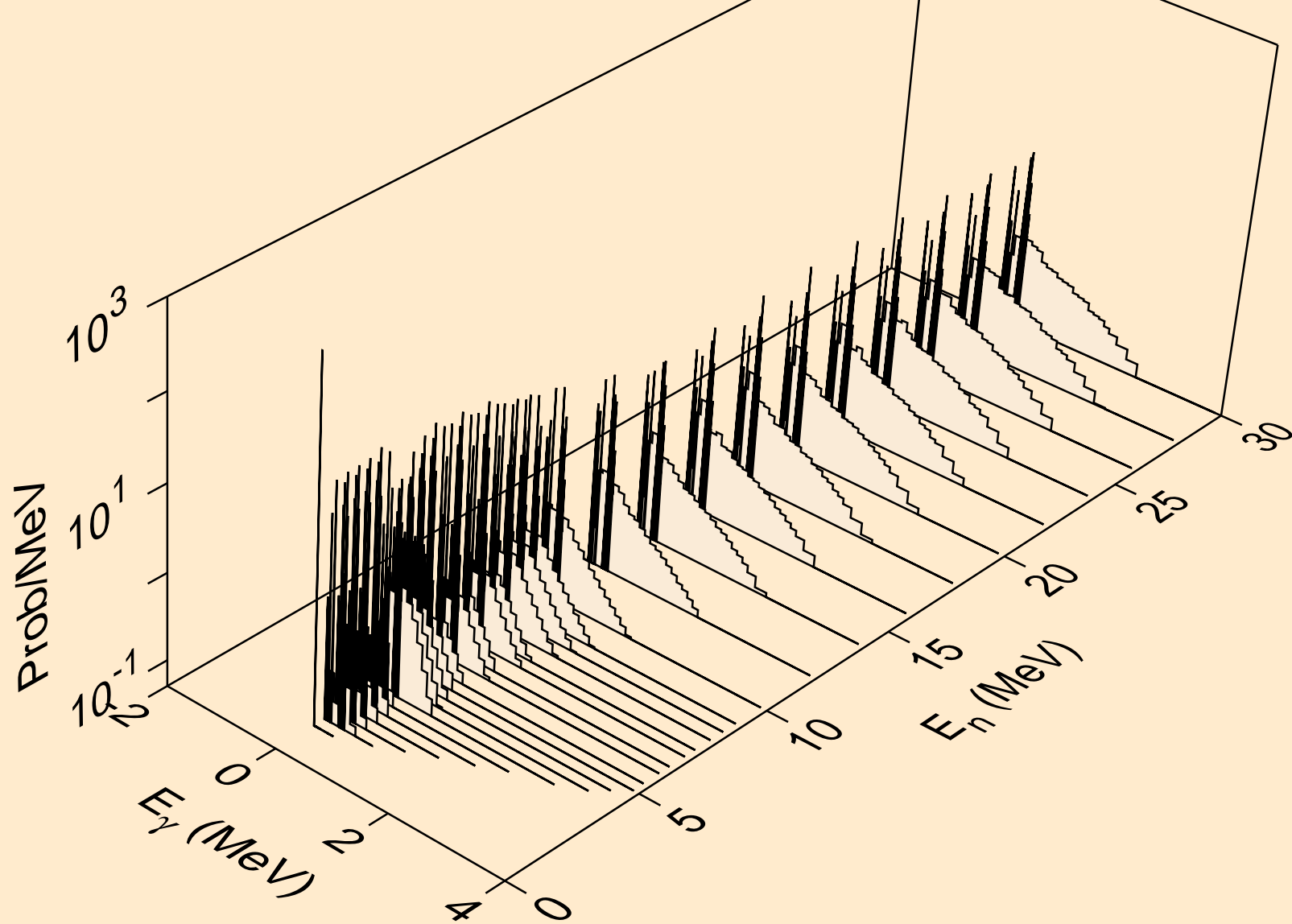

LR263 NEUTRON ACER TENDL-2024 LIBRARY; T=0.K
Photon emission for (n,d)

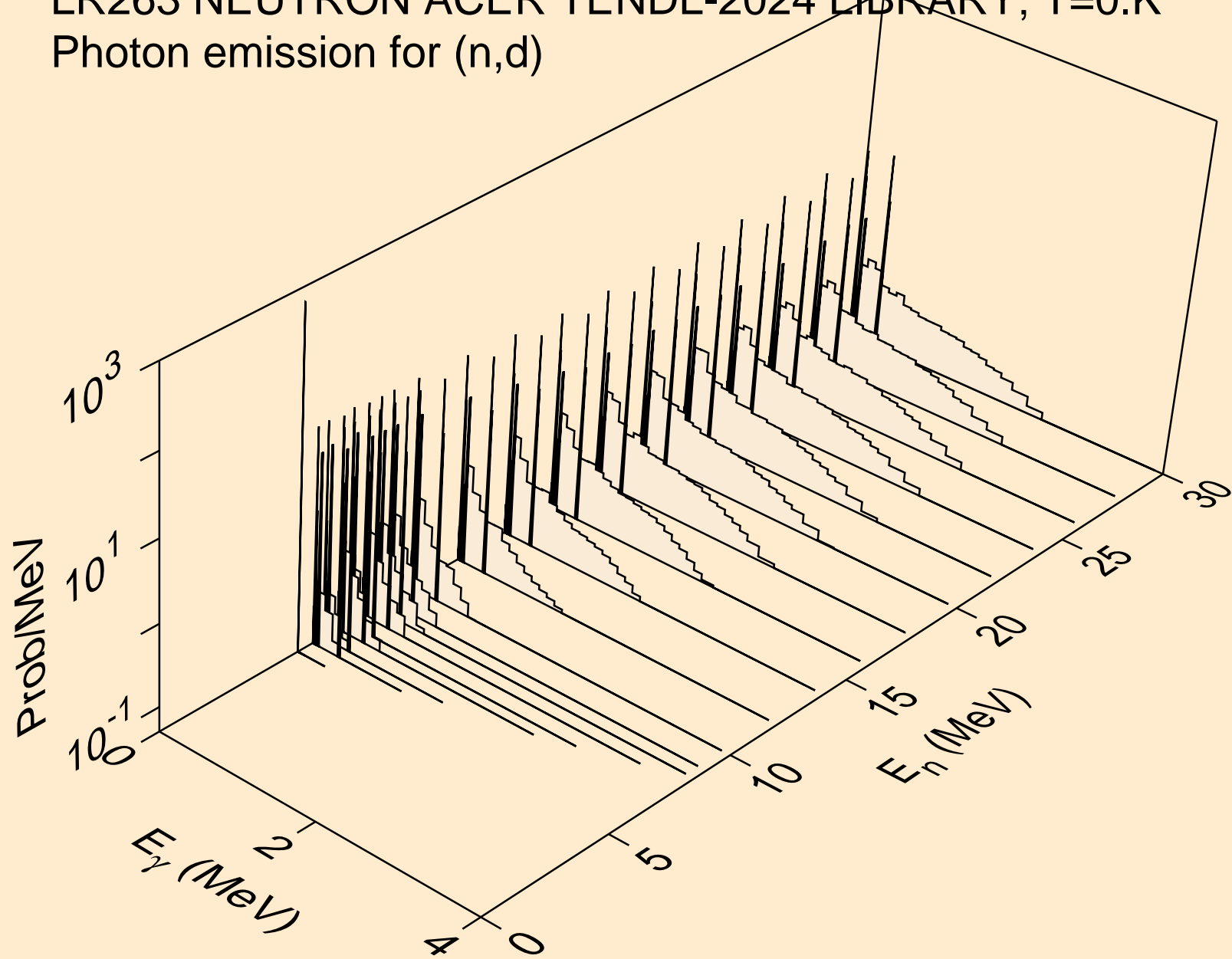

LR263 NEUTRON ACER TENDL-2024 LIBRARY; T=0.K
Photon emission for (n,t)

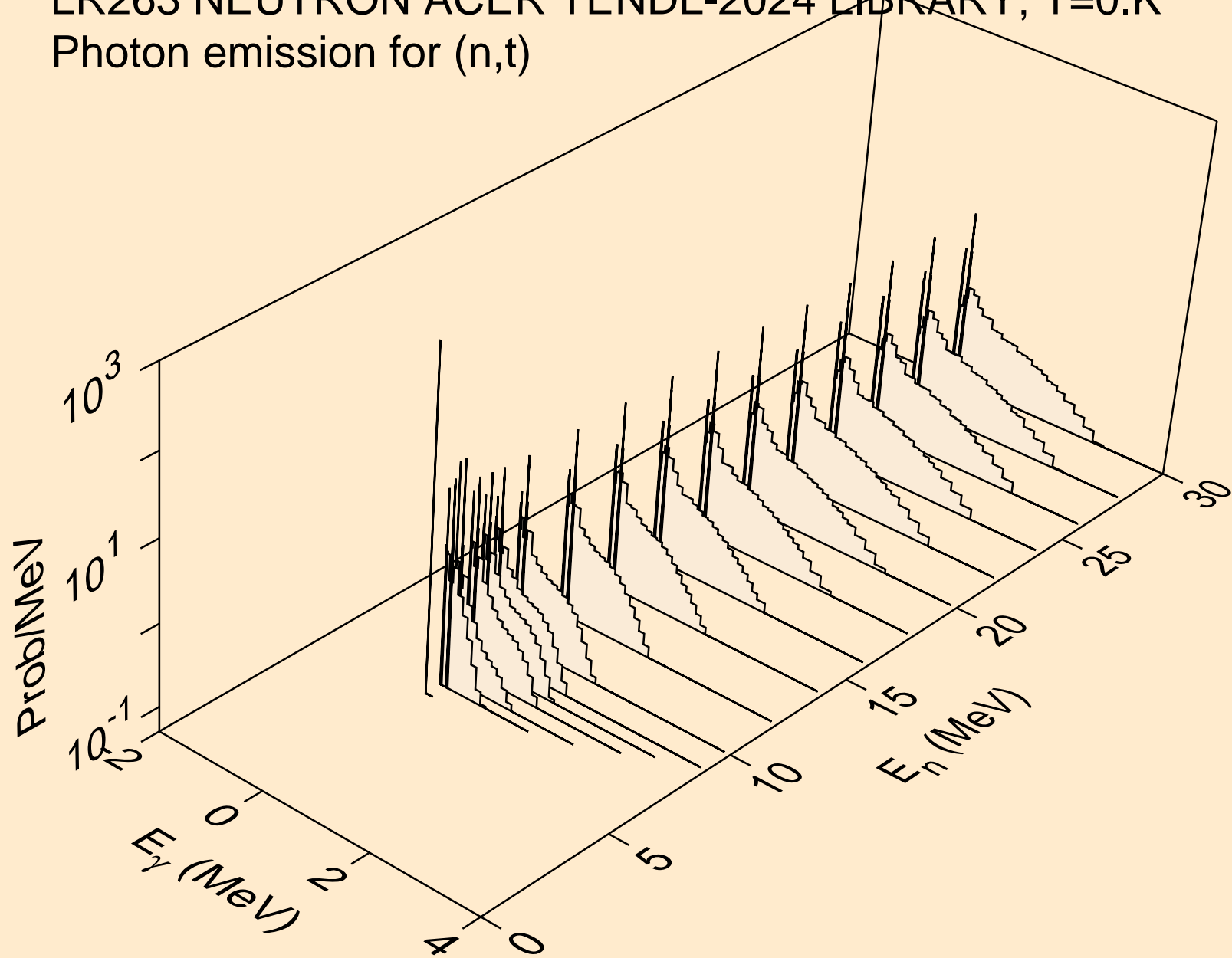

LR263 NEUTRON ACER TENDL-2024 LIBRARY; T=0.K
Photon emission for (n,he3)

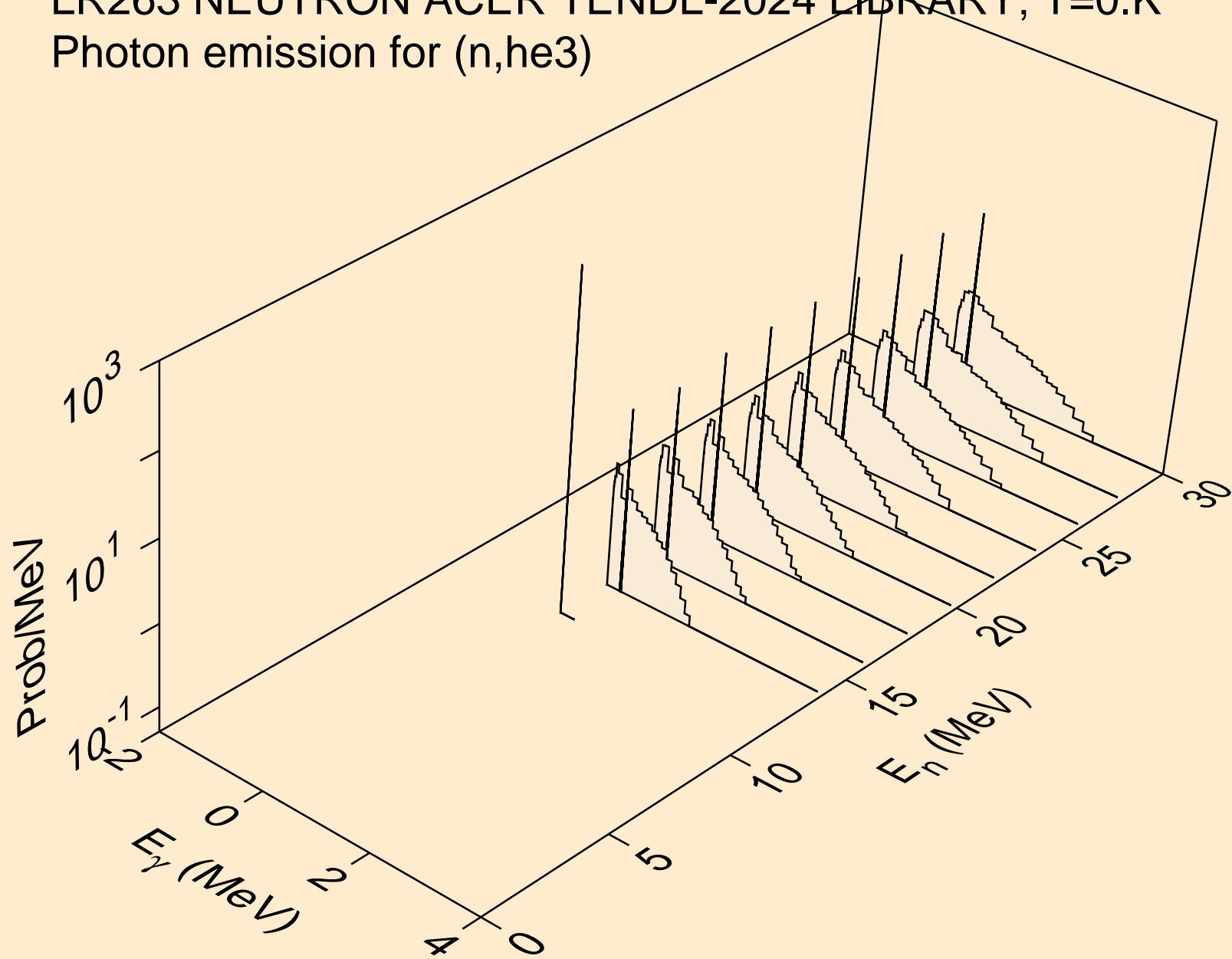

LR263 NEUTRON ACER TENDL-2024 LIBRARY; T=0.K
Photon emission for (n,a)

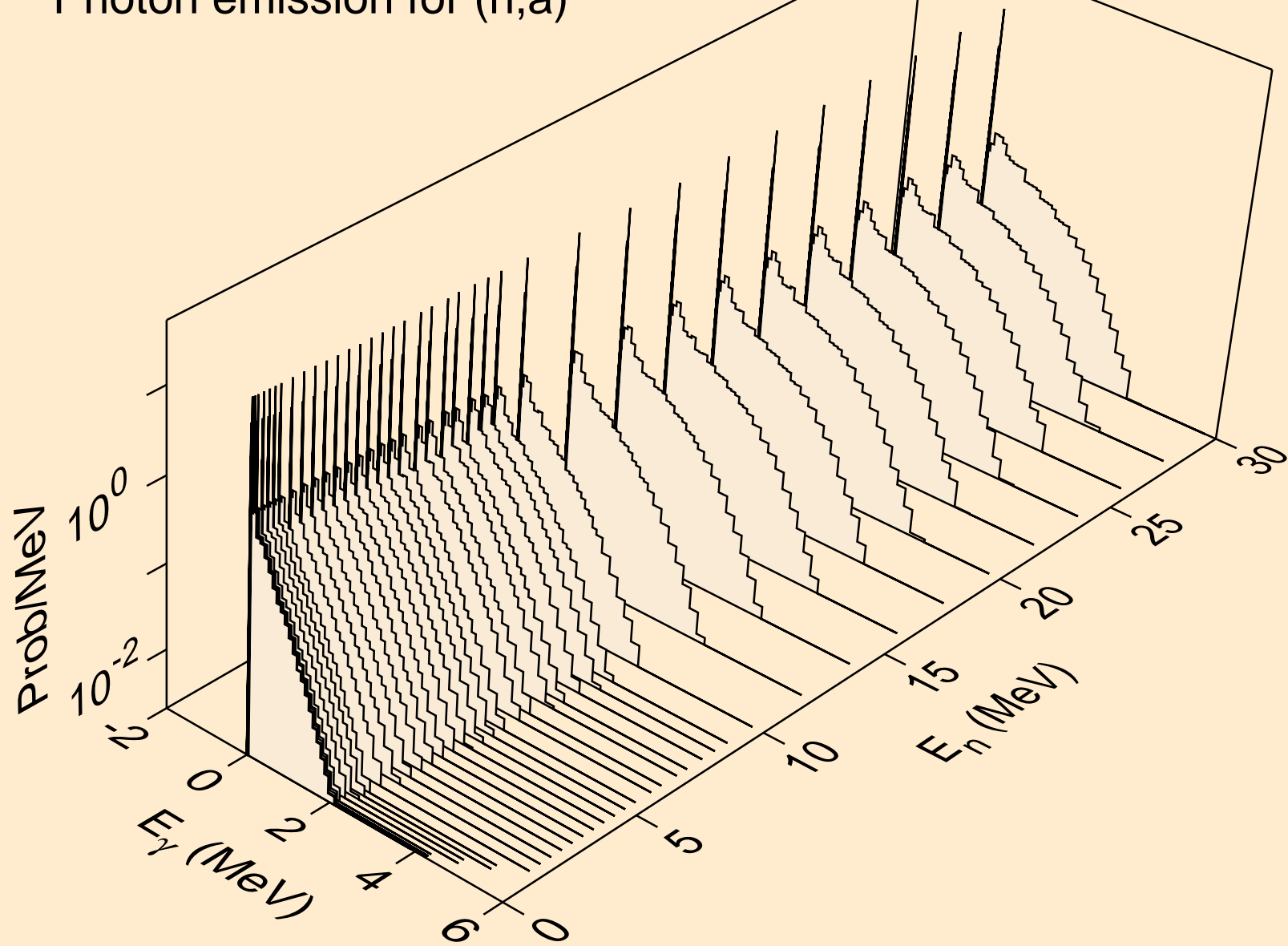

LR263 NEUTRON ACER TENDL-2024 LIBRARY; T=0.K
Photon emission for (n,2p)

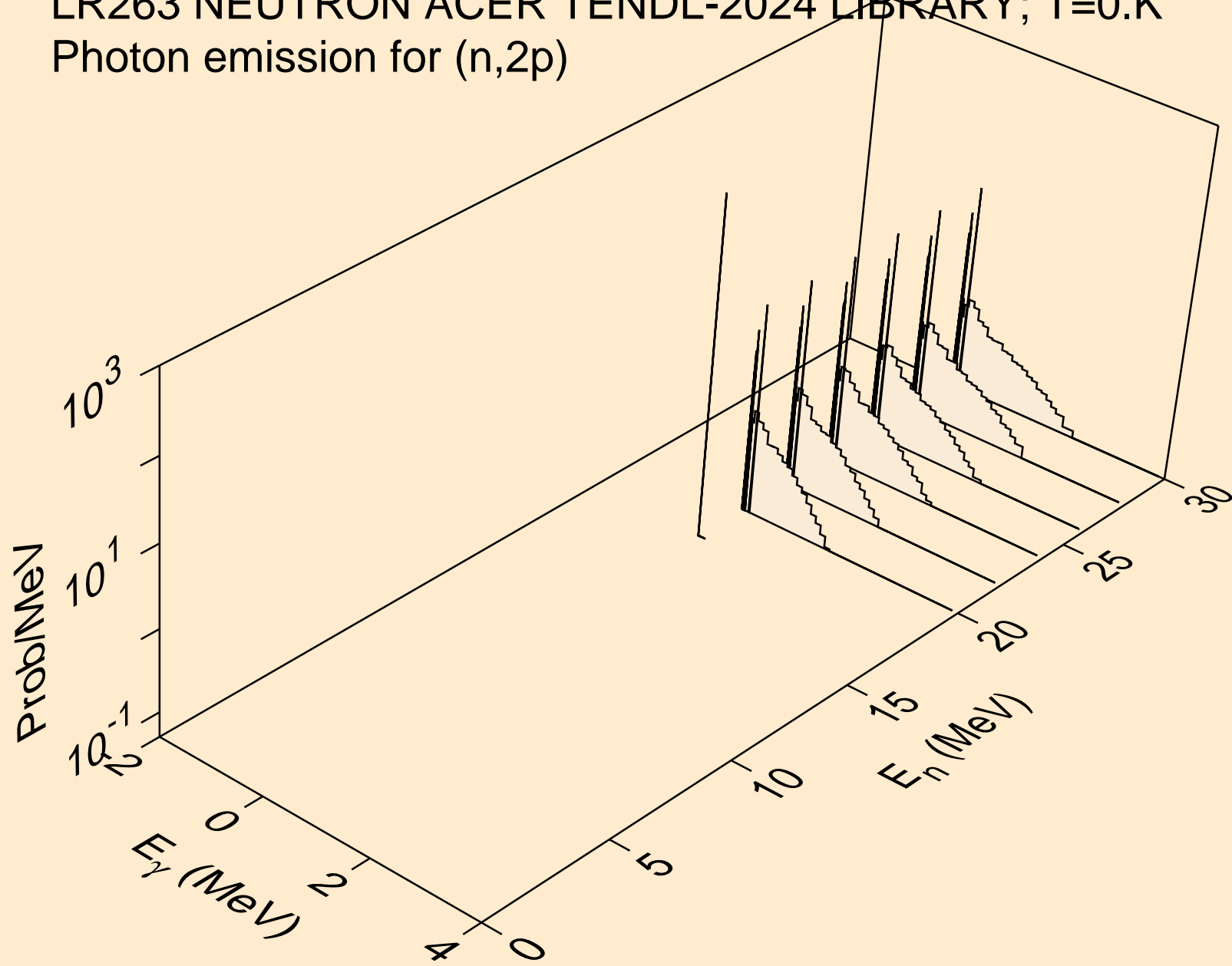

LR263 NEUTRON ACER TENDL-2024 LIBRARY; T=0.K
thermal capture photon spectrum

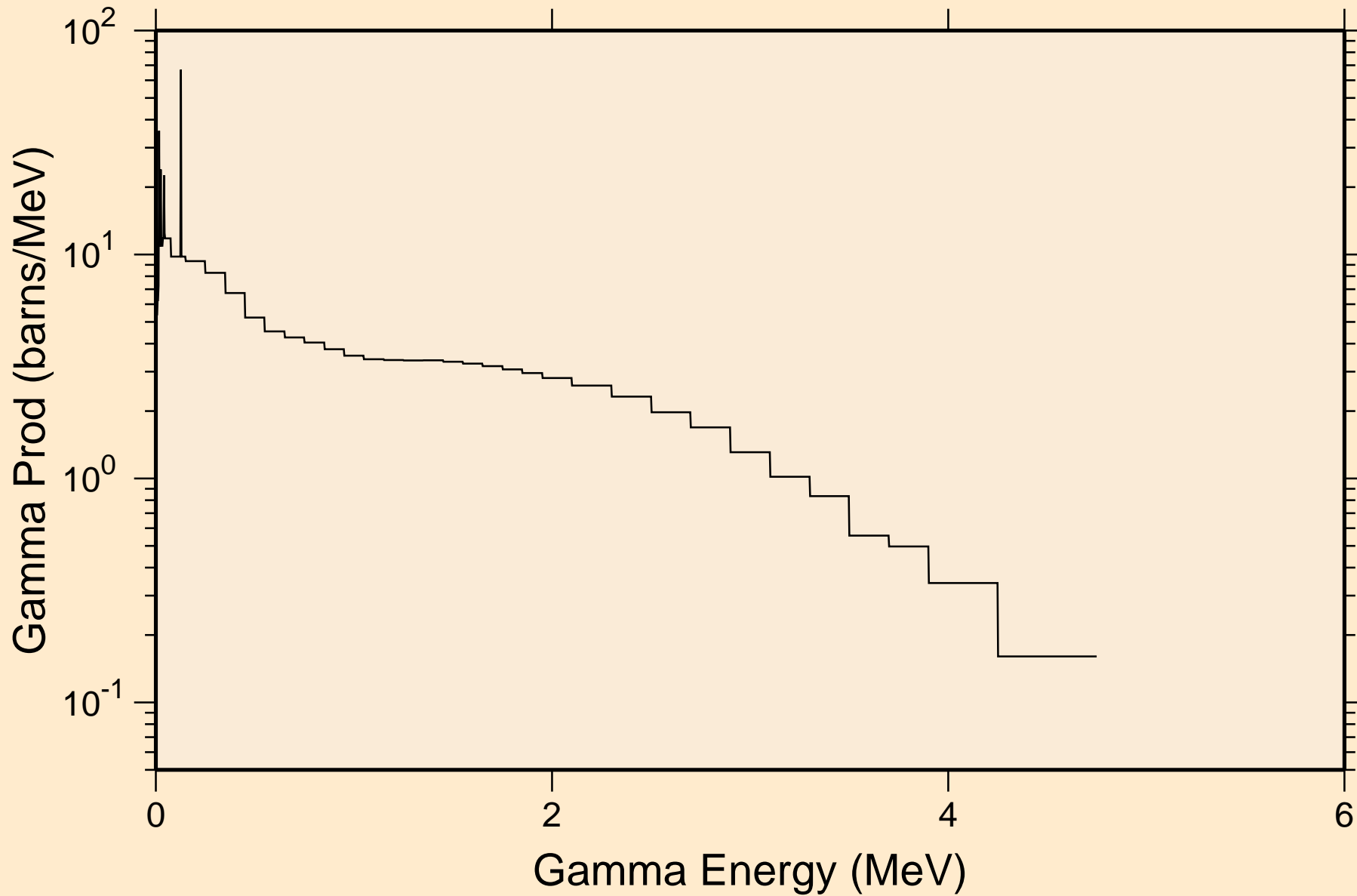

LR263 NEUTRON ACER TENDL-2024 LIBRARY; T=0.K
14 MeV photon spectrum

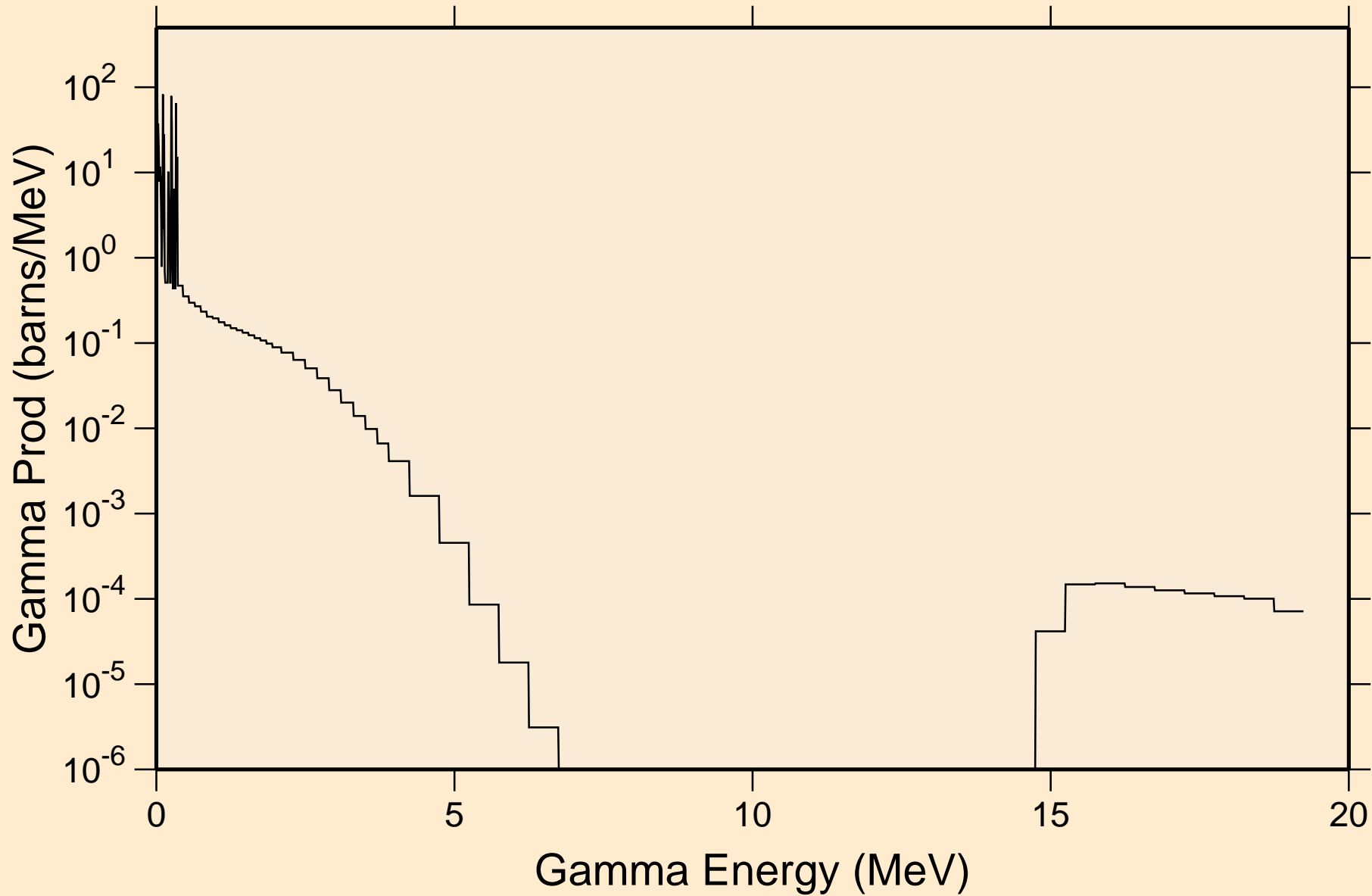

LR263 NEUTRON ACER TENDL-2024 LIBRARY; T=0.K

Particle heating contributions

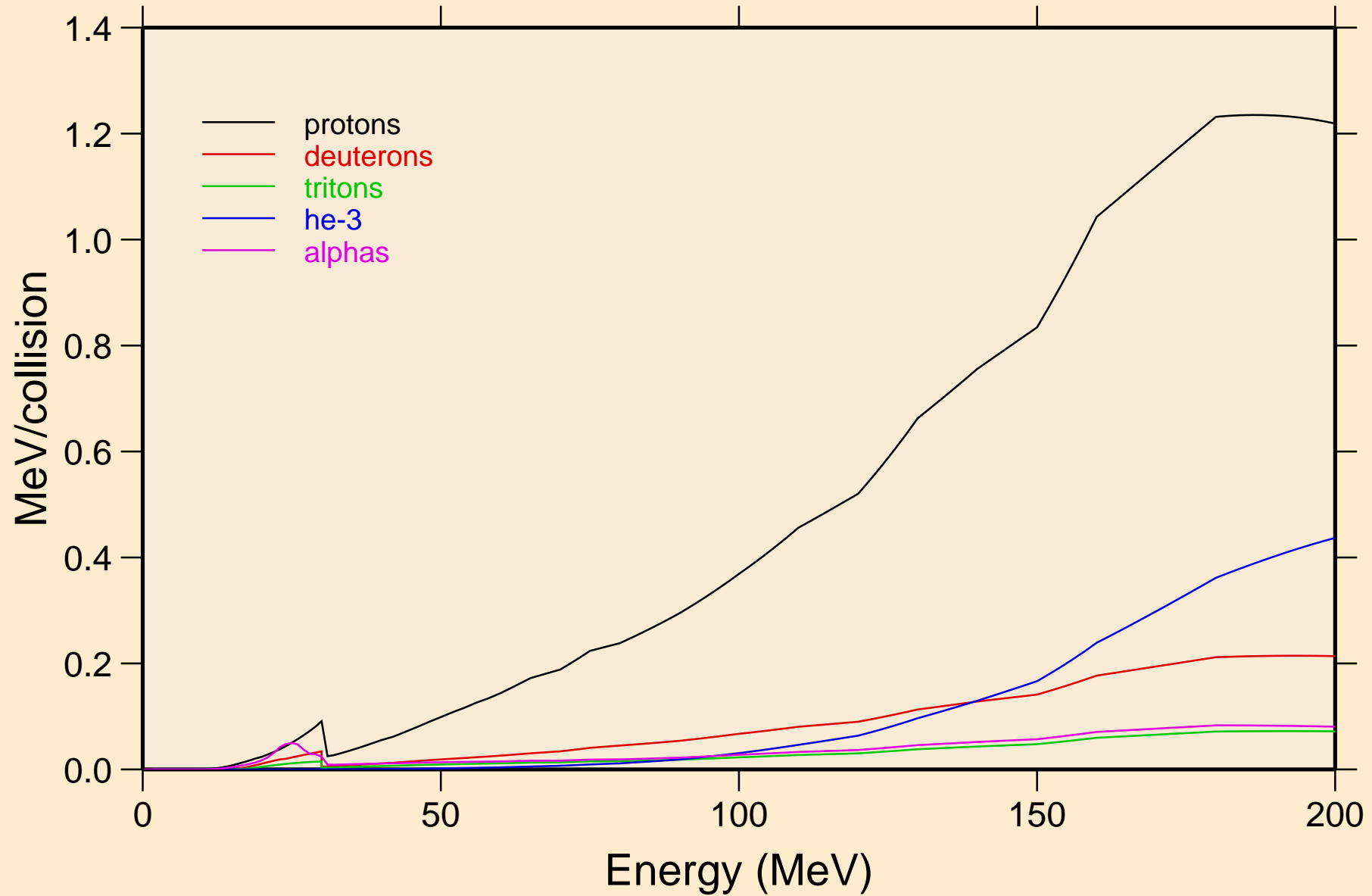

LR263 NEUTRON ACER TENDL-2024 LIBRARY; T=0.K
Recoil Heating

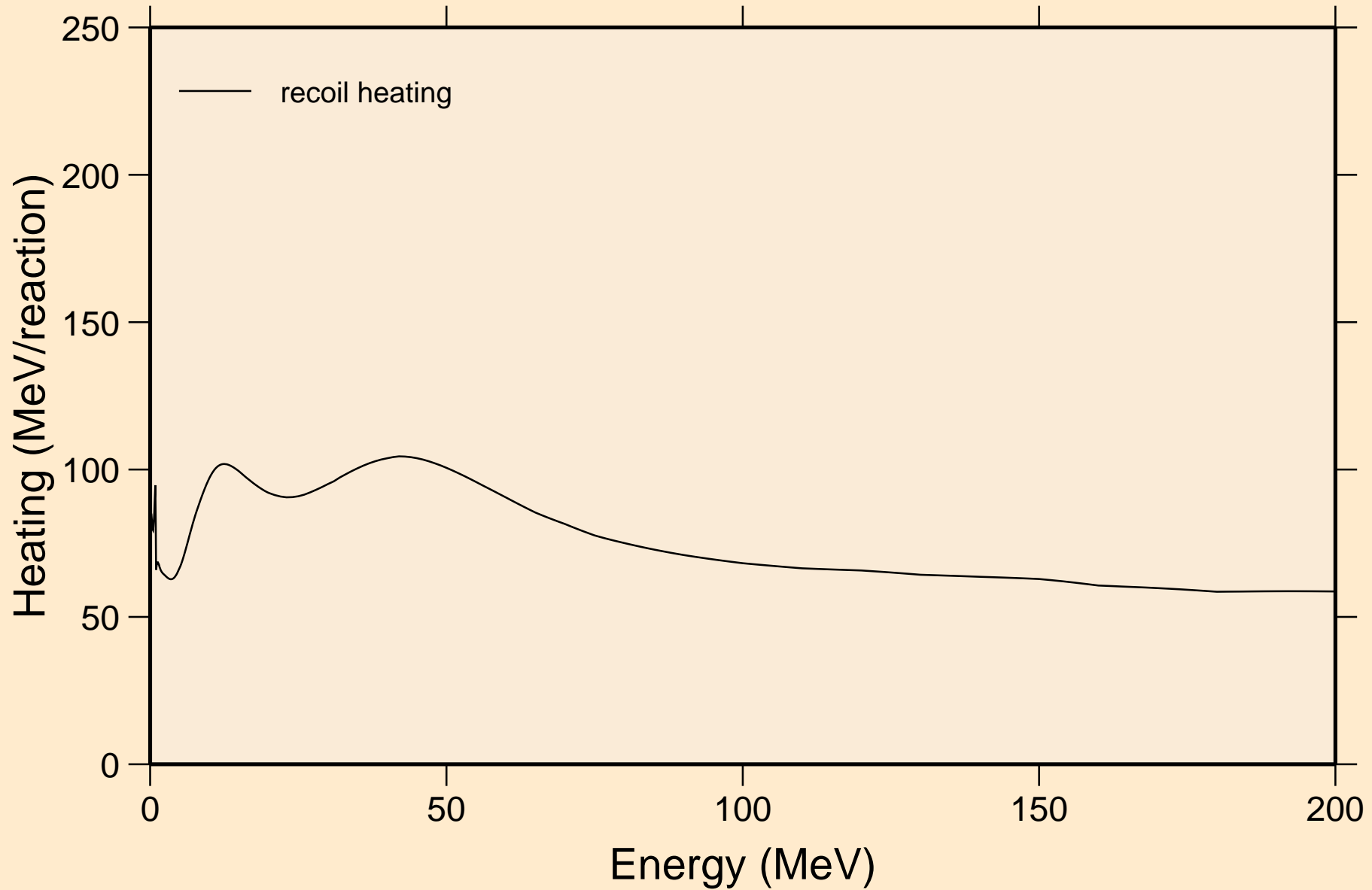

LR263 NEUTRON ACER TENDL-2024 LIBRARY; T=0.K
Particle production cross sections

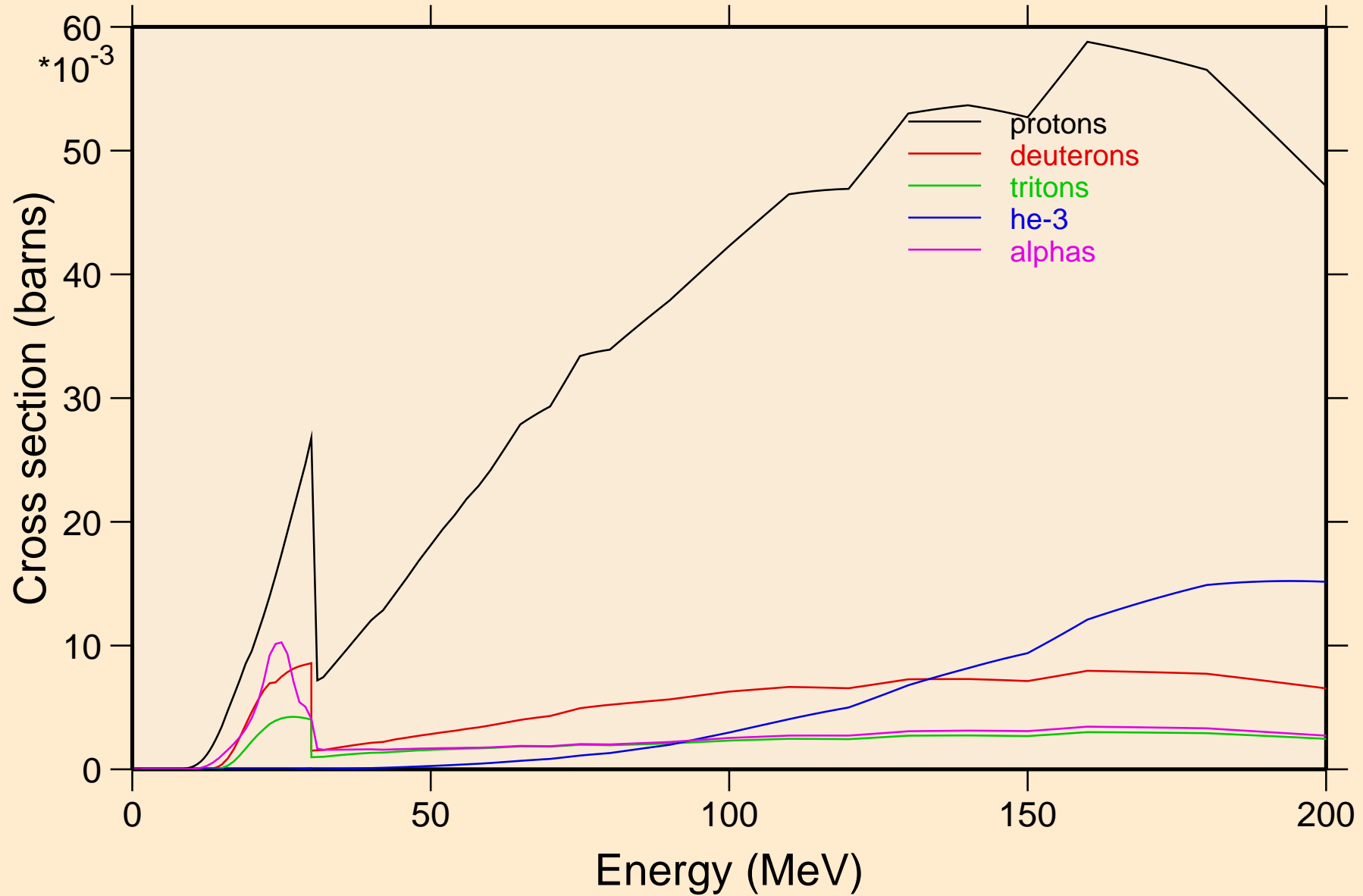

LR263 NEUTRON ACER TENDL-2024 LIBRARY; T=0.K
protons from (n,x)

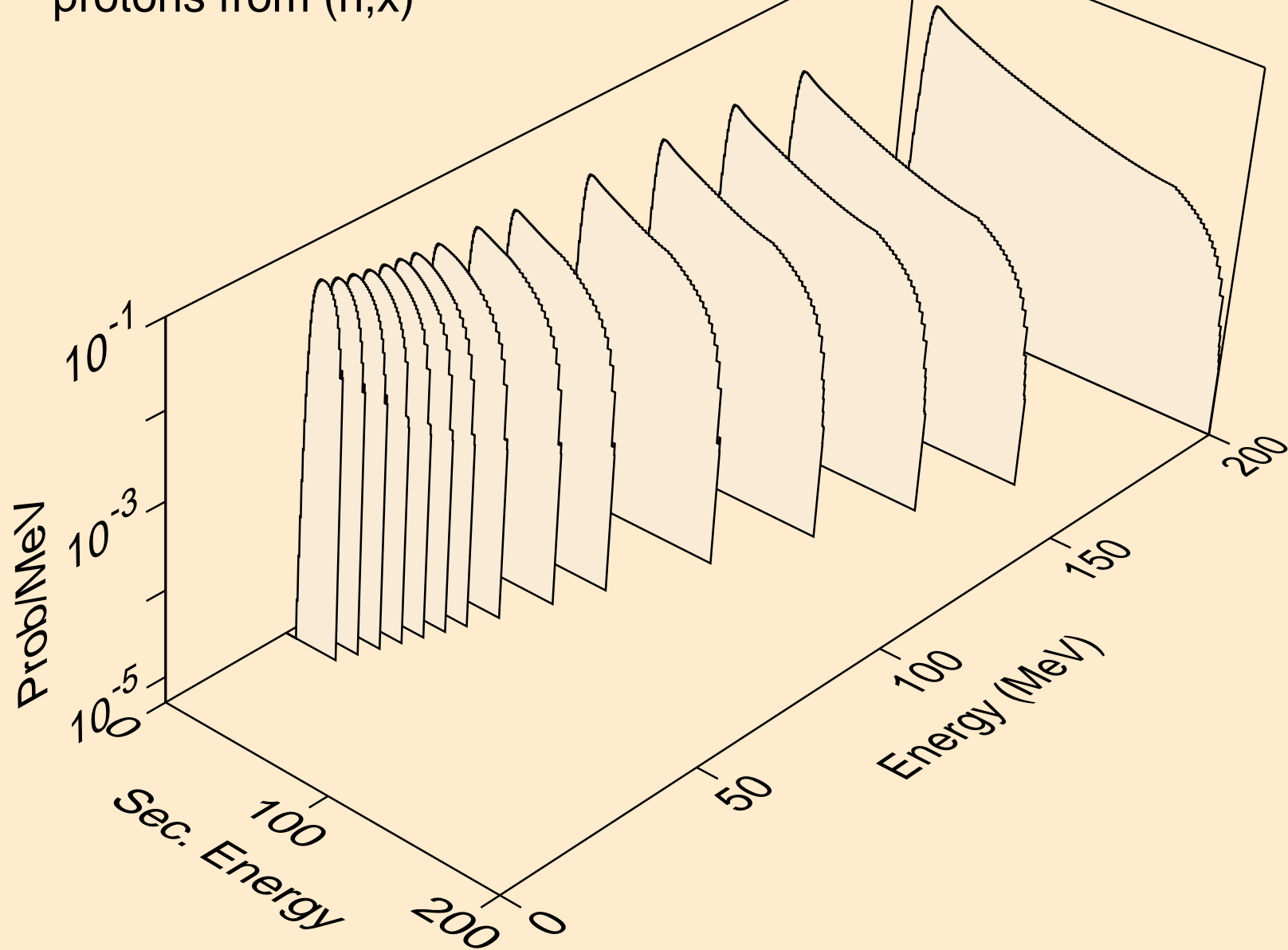

LR263 NEUTRON ACER TENDL-2024 LIBRARY; T=0.K
protons from (n,n*)p

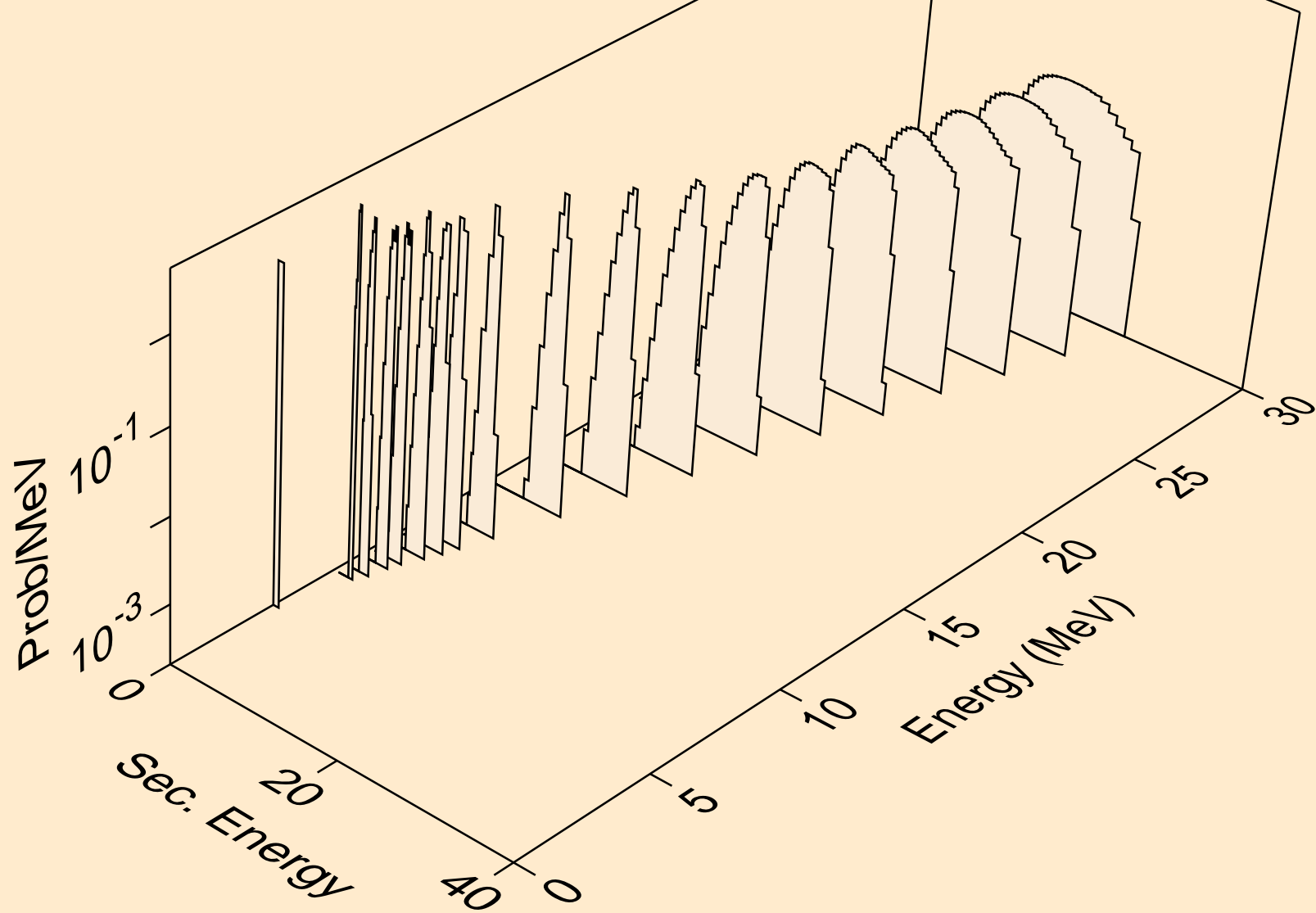

LR263 NEUTRON ACER TENDL-2024 LIBRARY; T=0.K
protons from (n,2np)

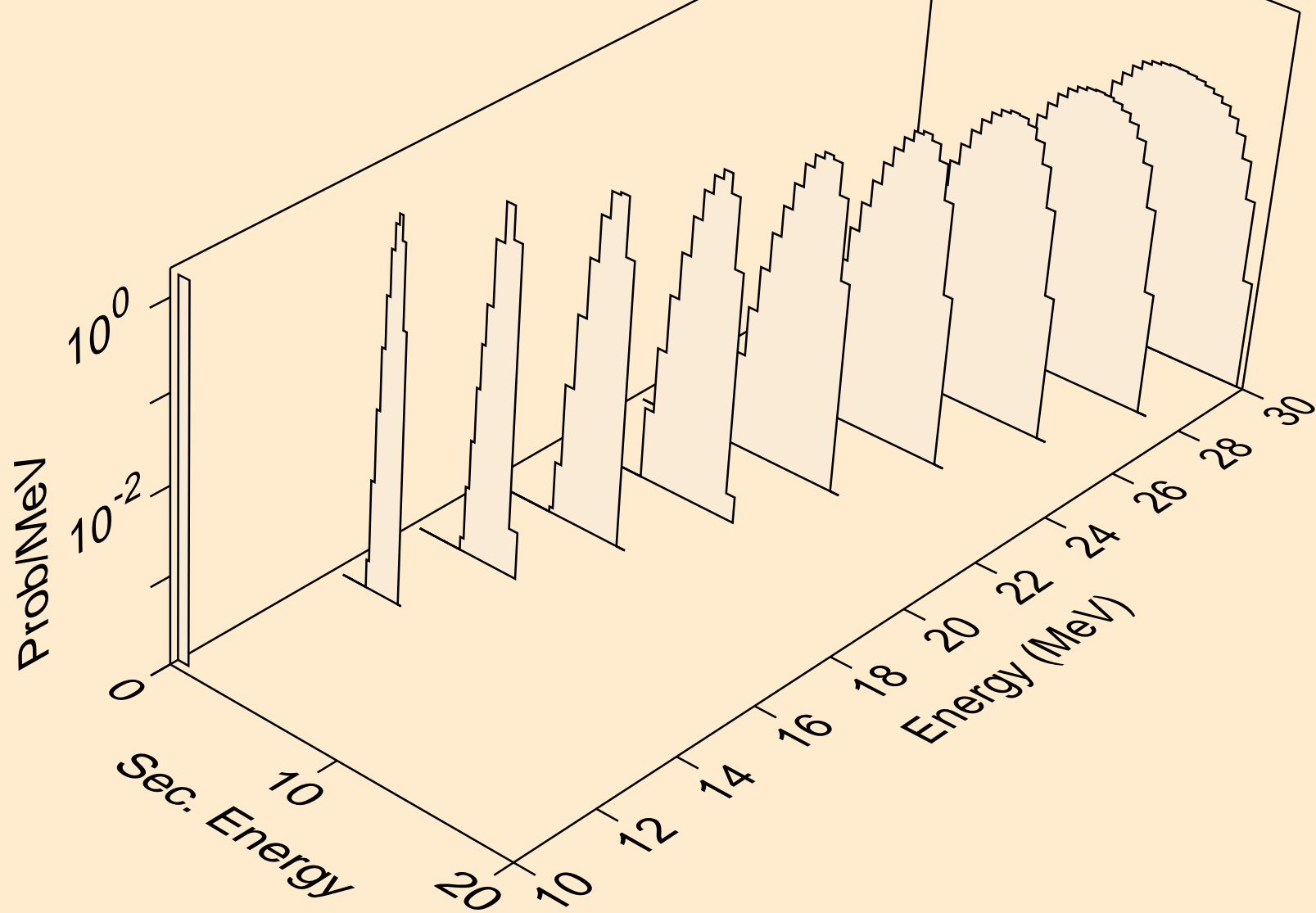

LR263 NEUTRON ACER TENDL-2024 LIBRARY; T=0.K
protons from (n,3np)

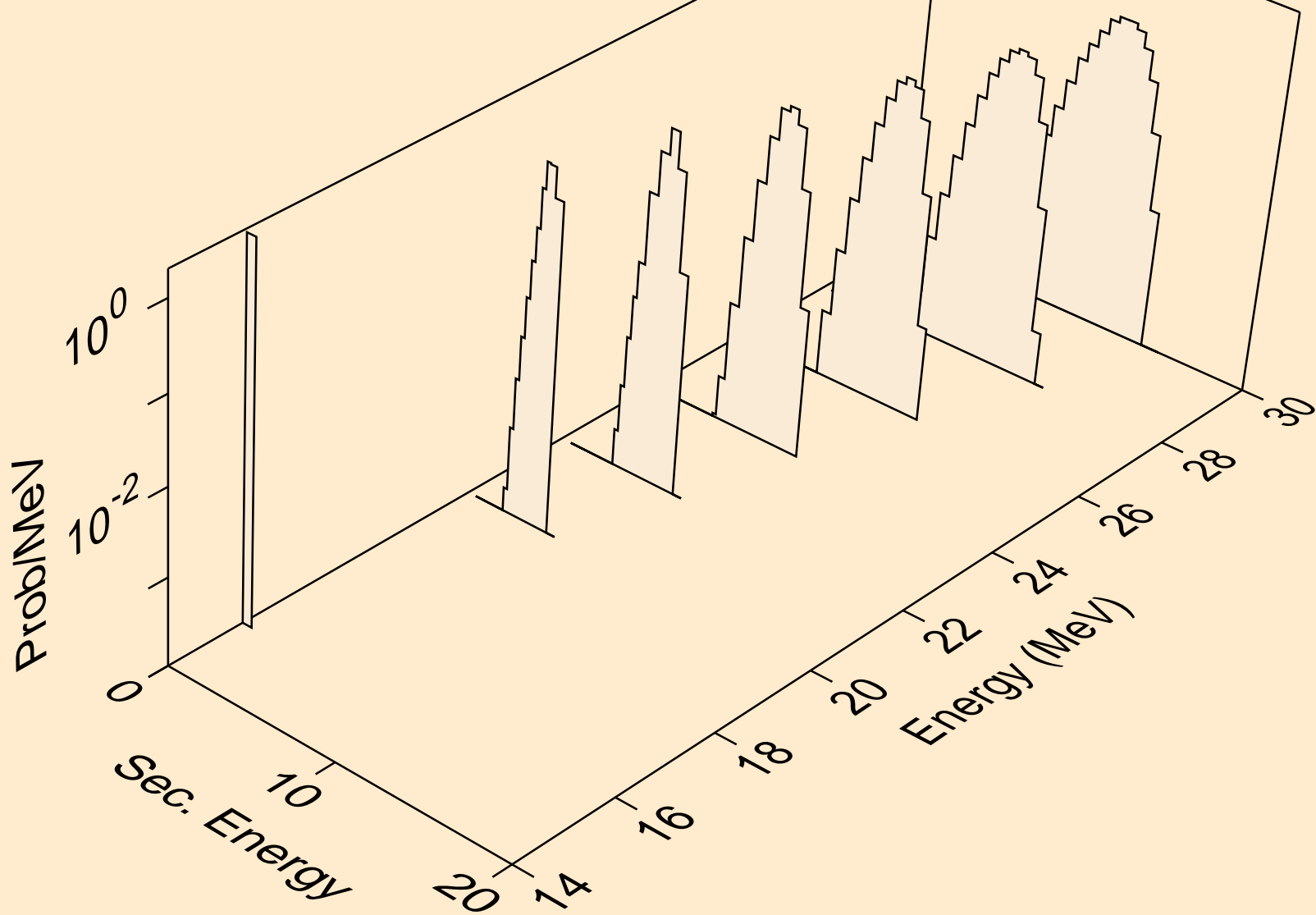

LR263 NEUTRON ACER TENDL-2024 LIBRARY; T=0.K
protons from (n,n2p)

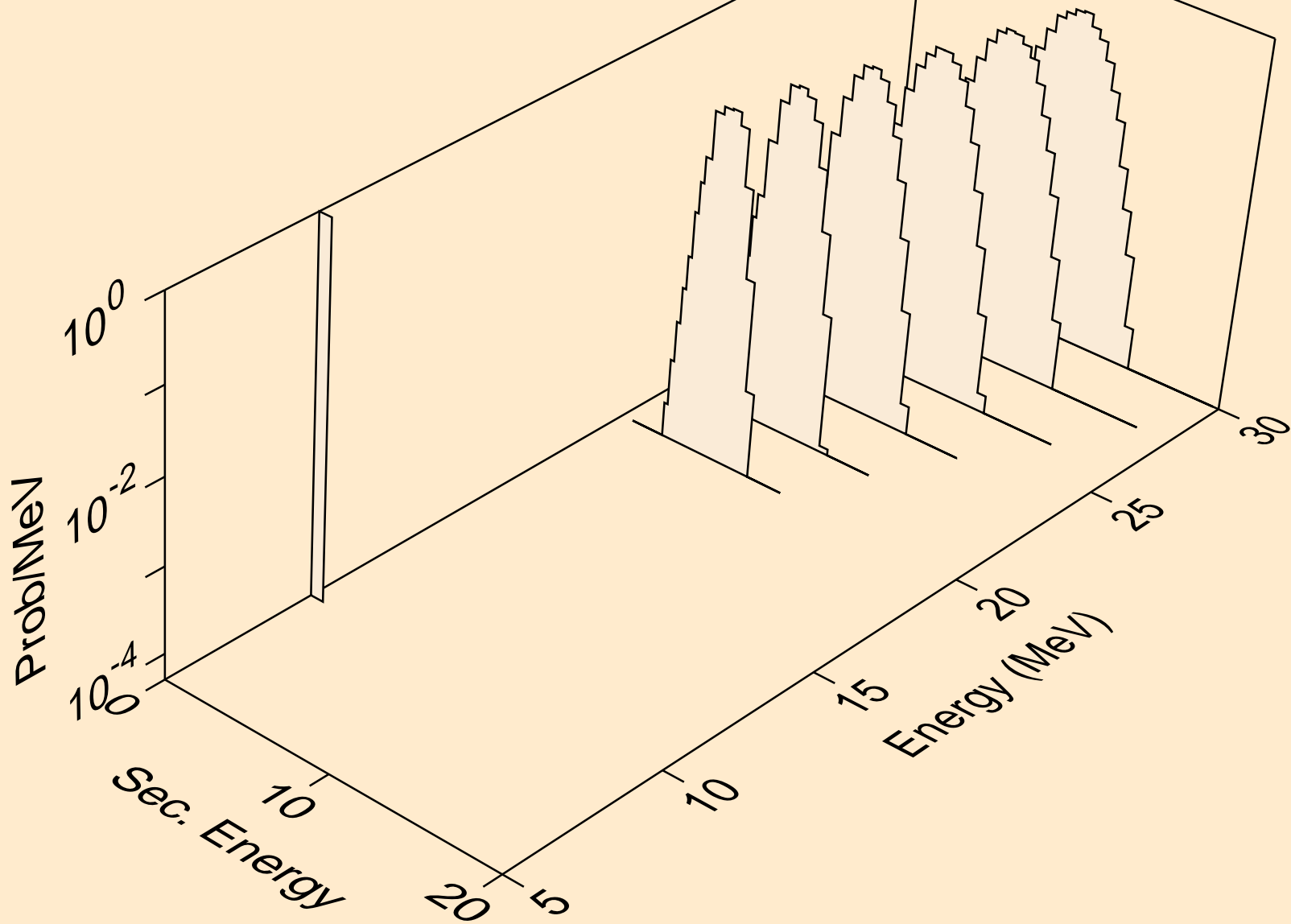

LR263 NEUTRON ACER TENDL-2024 LIBRARY; T=0.K
protons from (n,p)

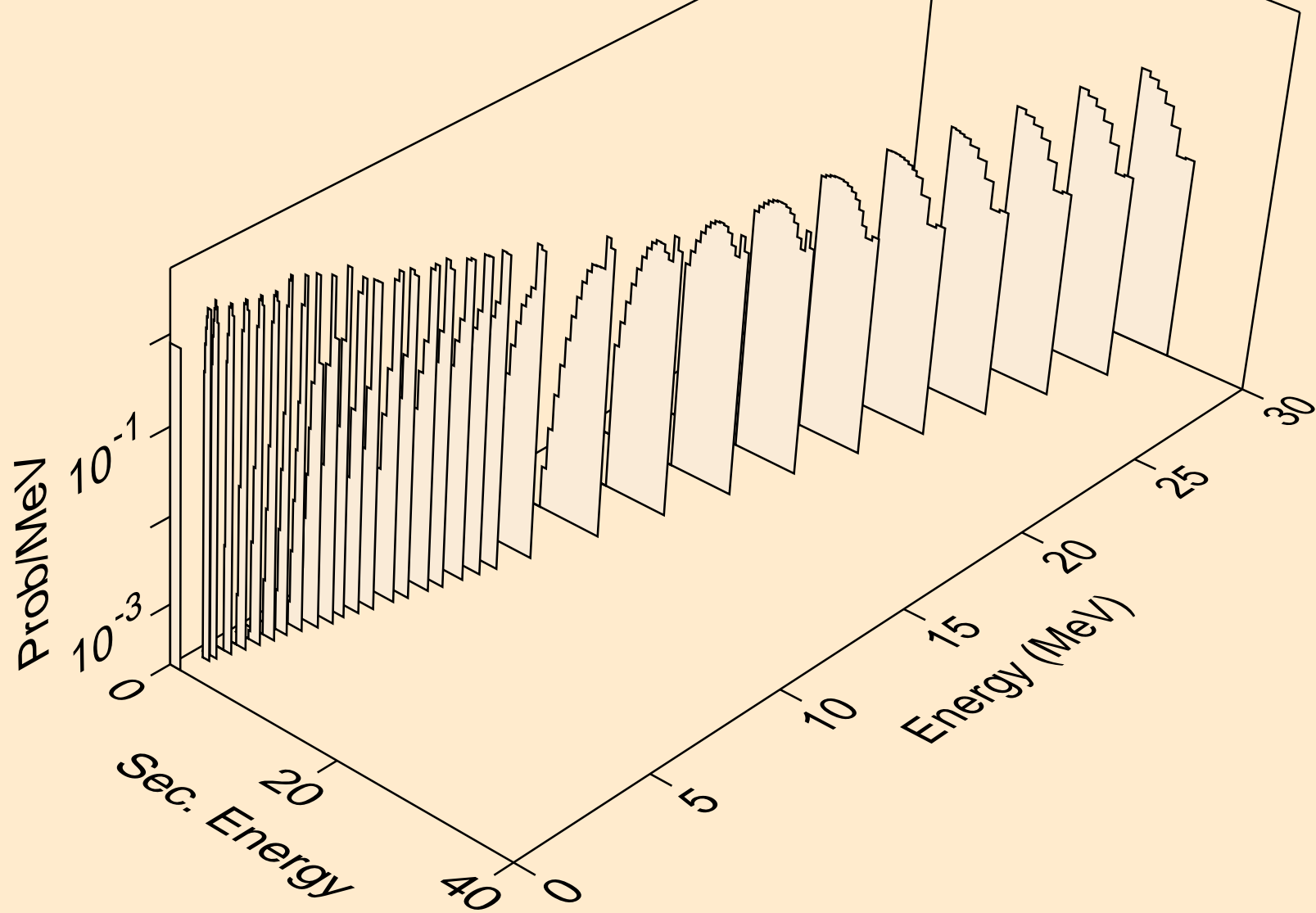

LR263 NEUTRON ACER TENDL-2024 LIBRARY; T=0.K
protons from (n,2p)

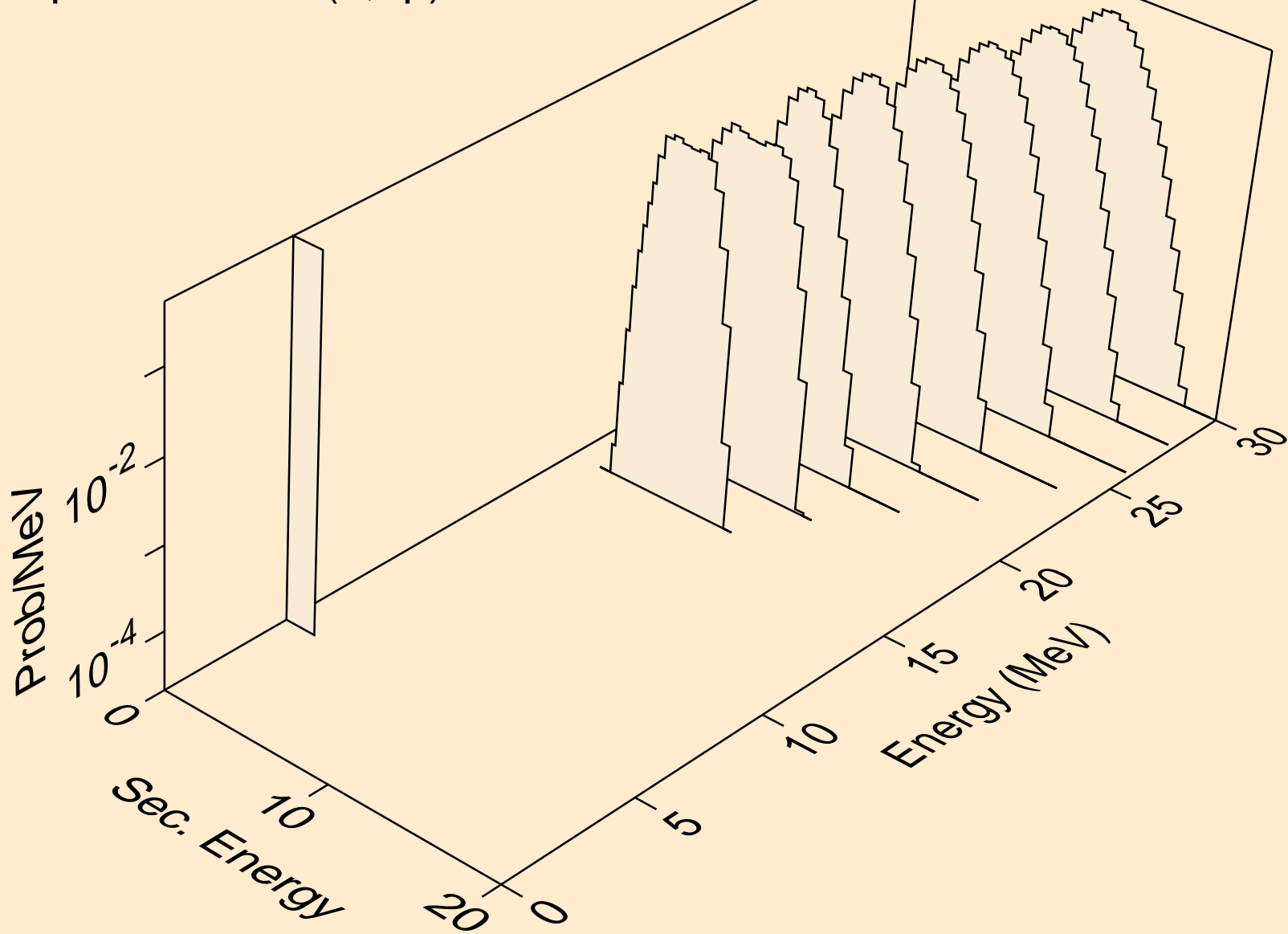

LR263 NEUTRON ACER TENDL-2024 LIBRARY; T=0.K
deuterons from (n,x)

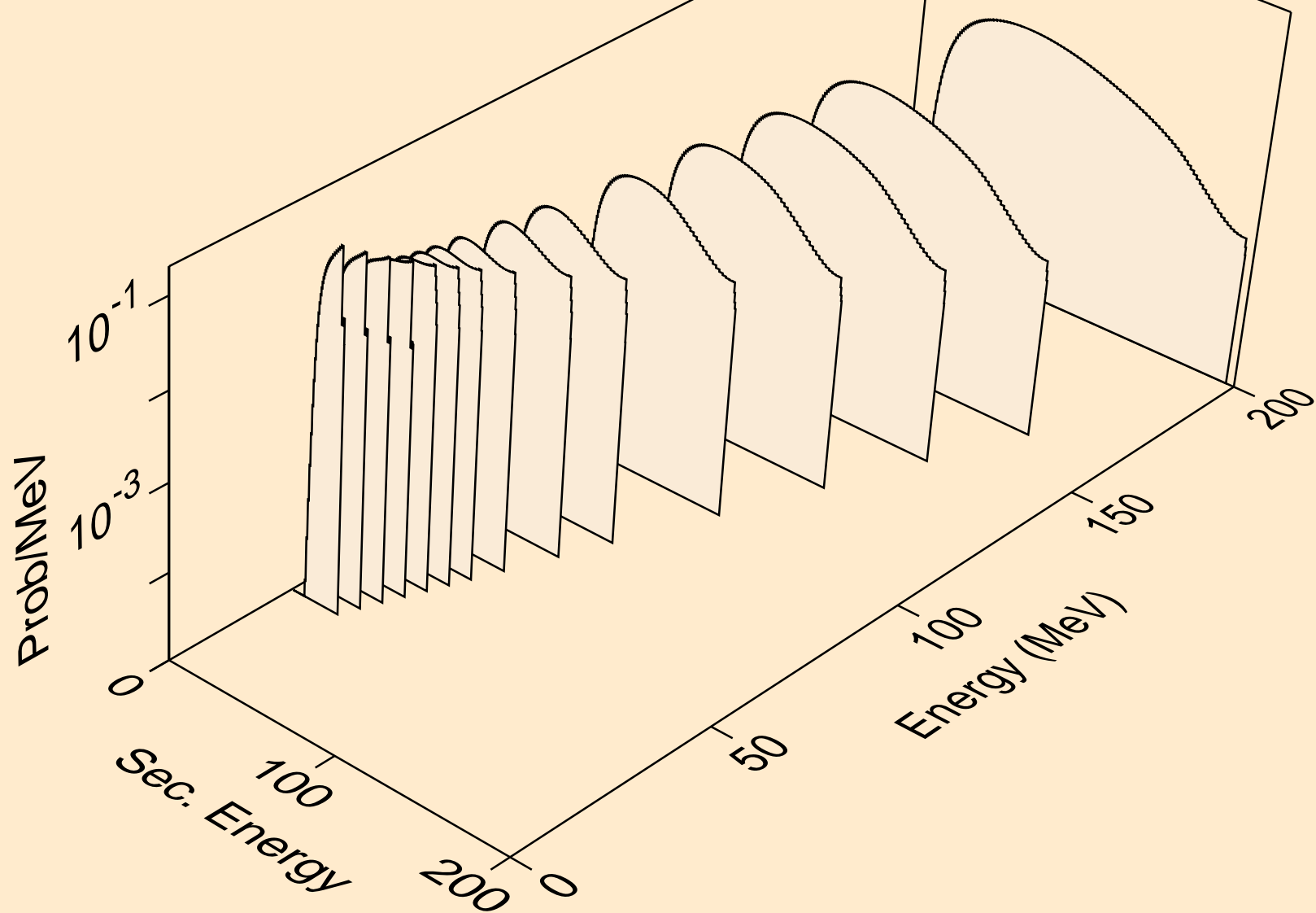

LR263 NEUTRON ACER TENDL-2024 LIBRARY; T=0.K
deuterons from (n,2nd)

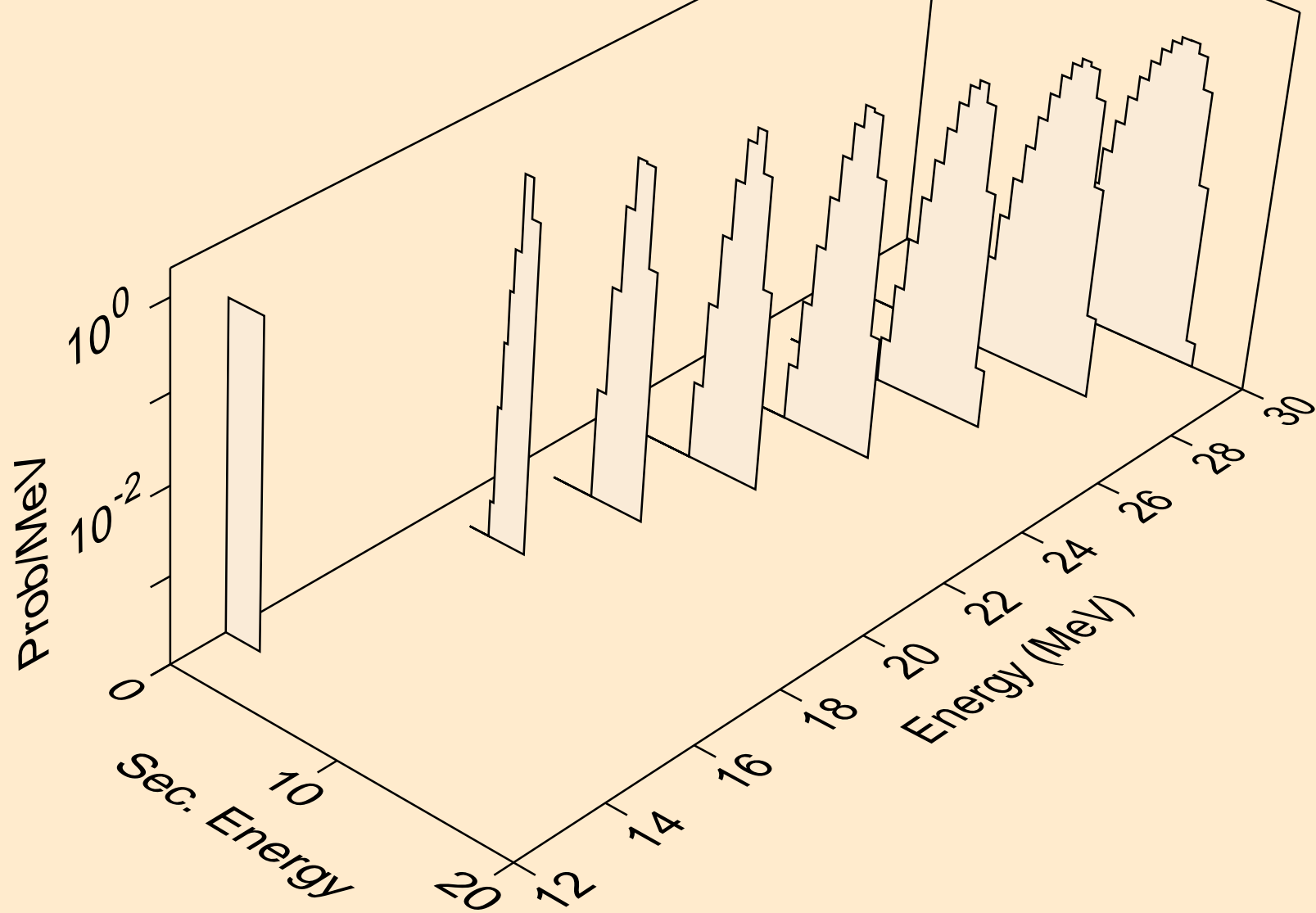

LR263 NEUTRON ACER TENDL-2024 LIBRARY; T=0.K
deuterons from (n,n*)d

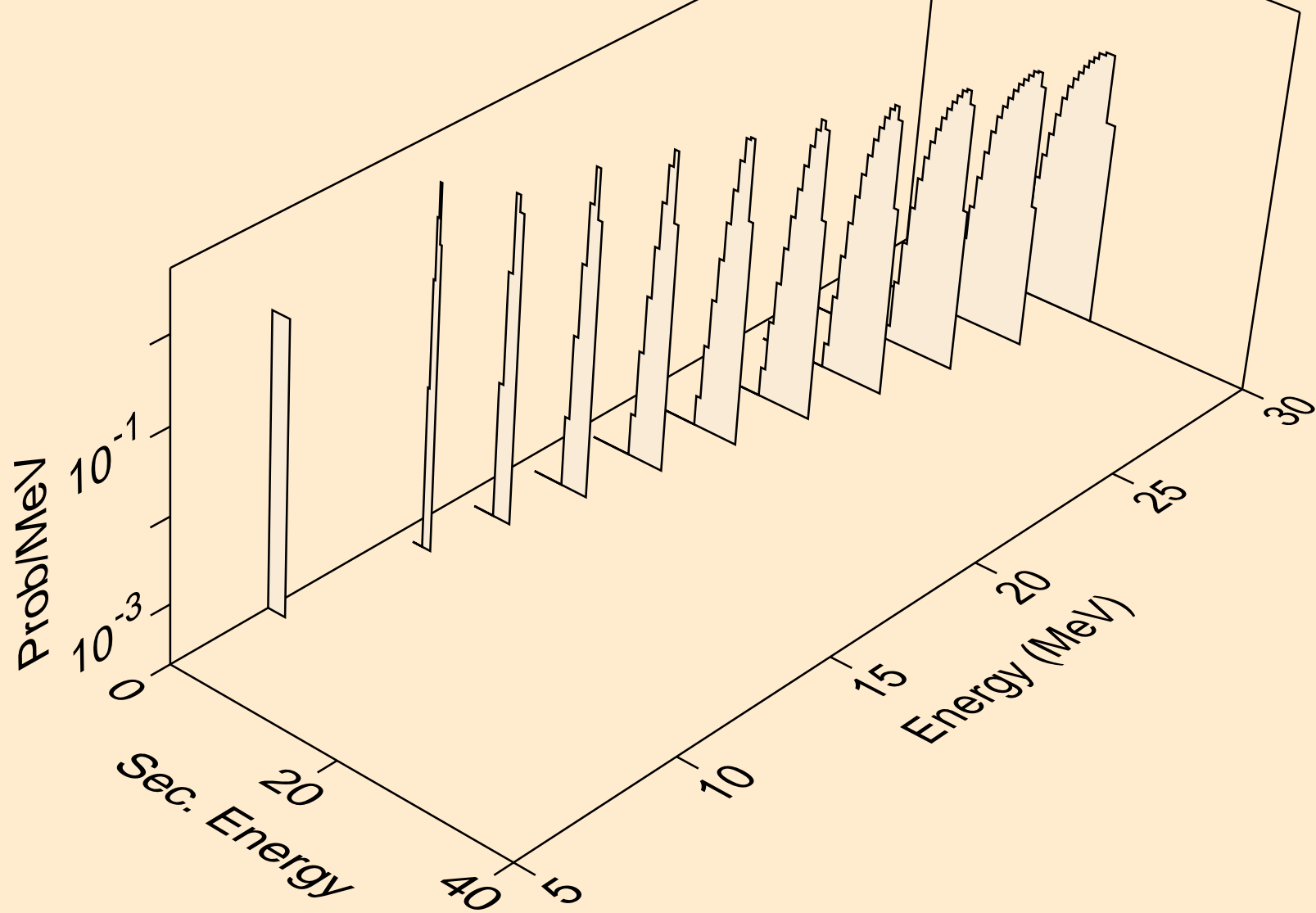

LR263 NEUTRON ACER TENDL-2024 LIBRARY; T=0.K
deuterons from (n,d)

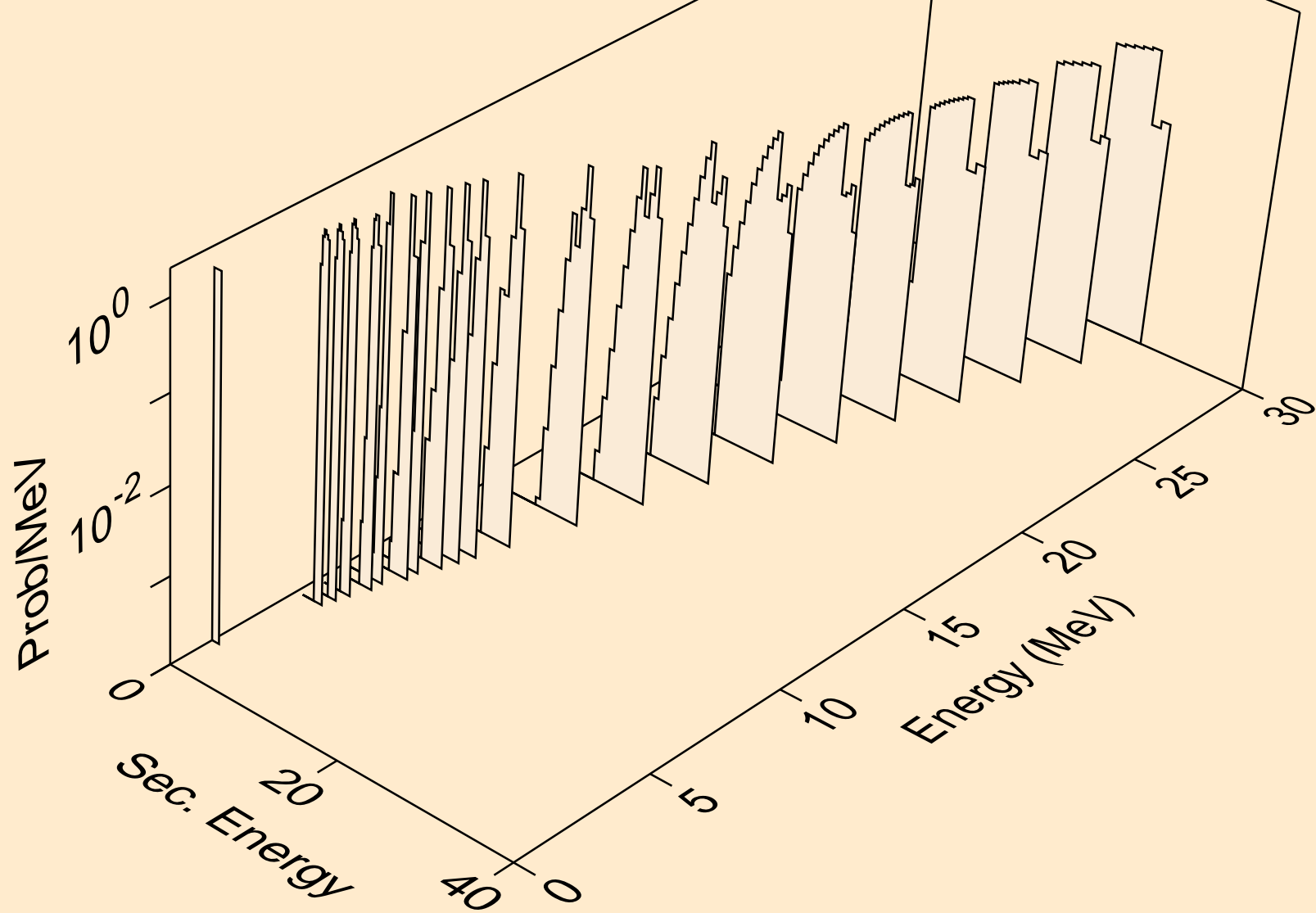

LR263 NEUTRON ACER TENDL-2024 LIBRARY; T=0.K
tritons from (n,x)

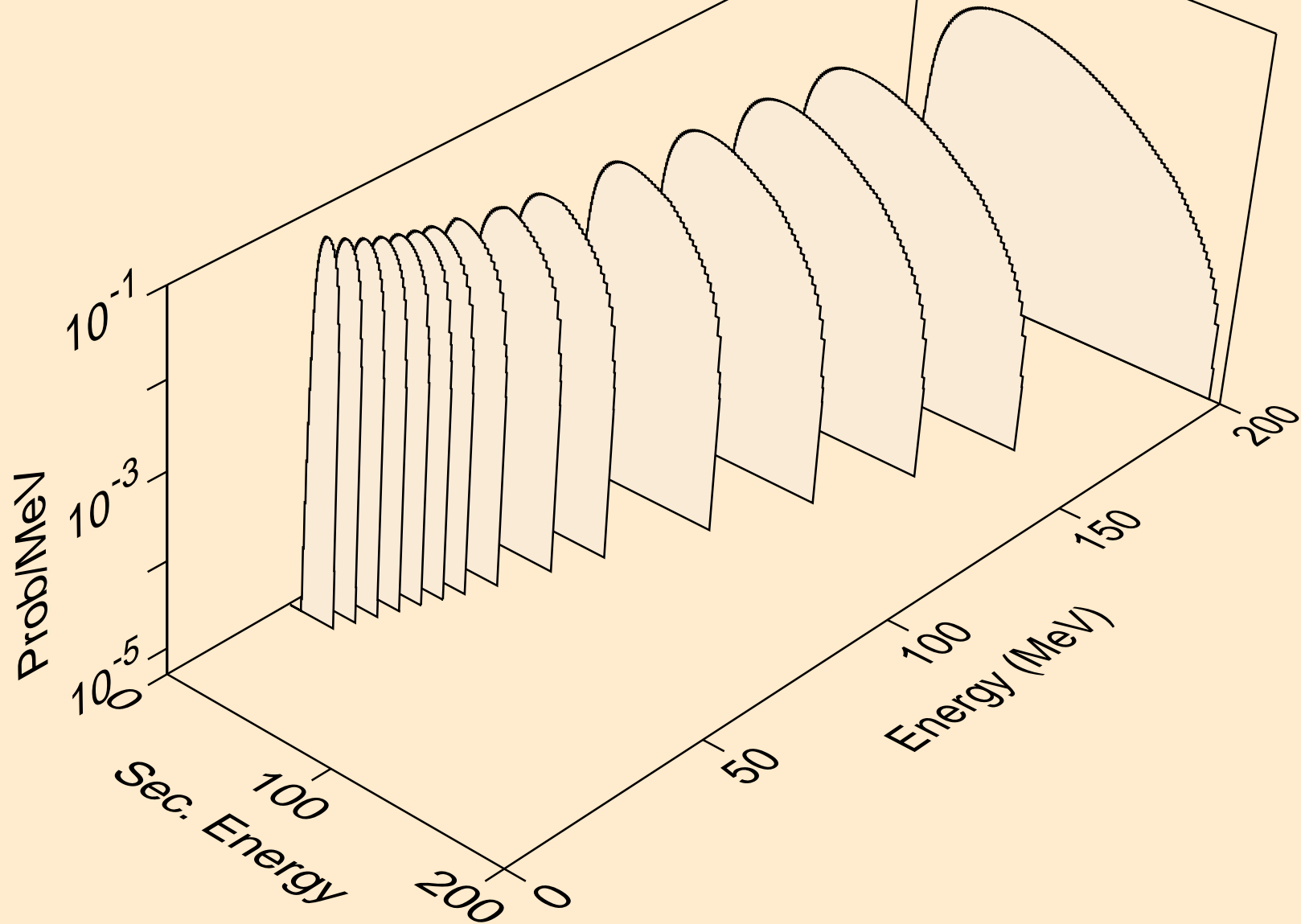

LR263 NEUTRON ACER TENDL-2024 LIBRARY; T=0.K
tritons from (n,n*)t

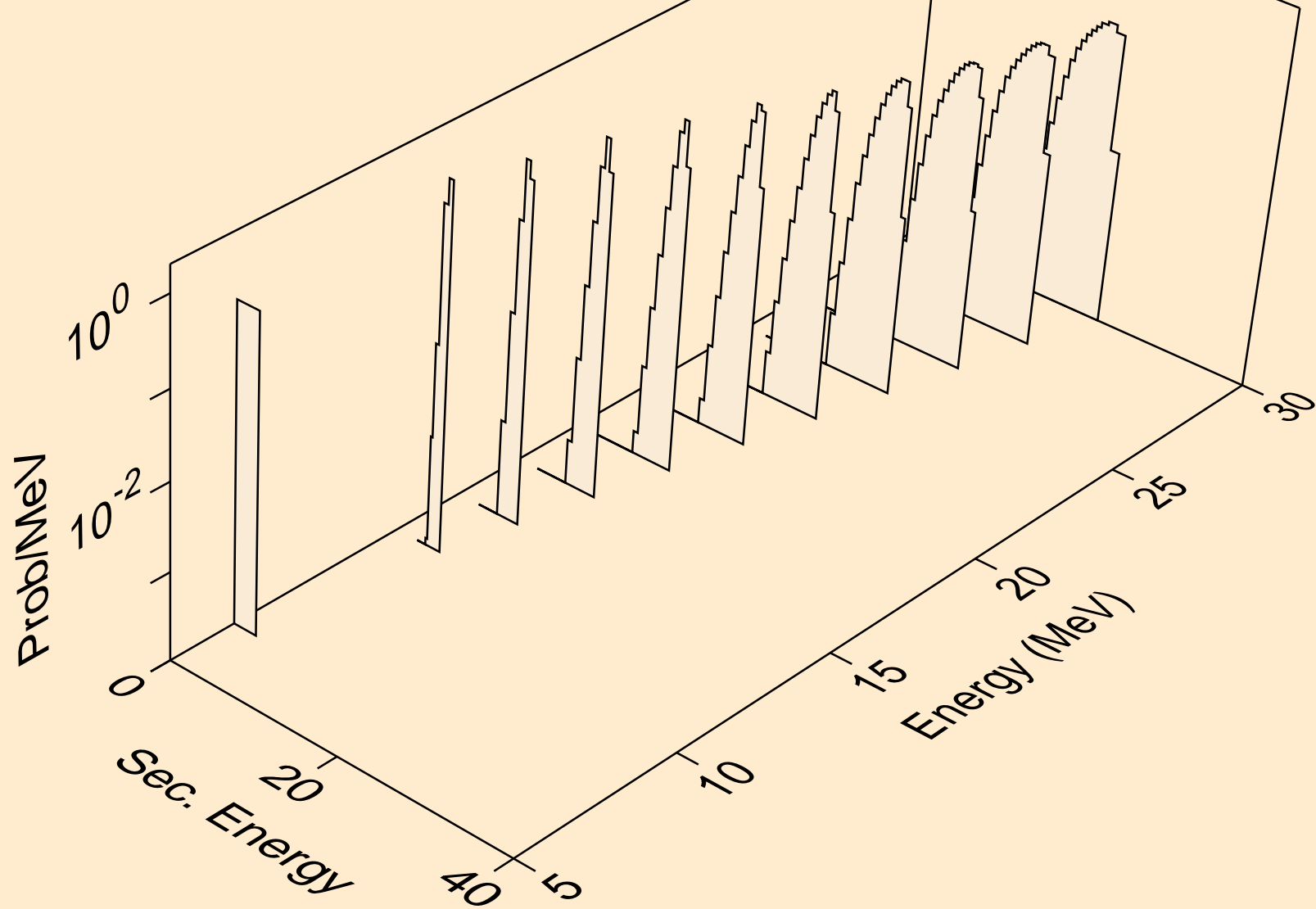

LR263 NEUTRON ACER TENDL-2024 LIBRARY; T=0.K
tritons from (n,t)

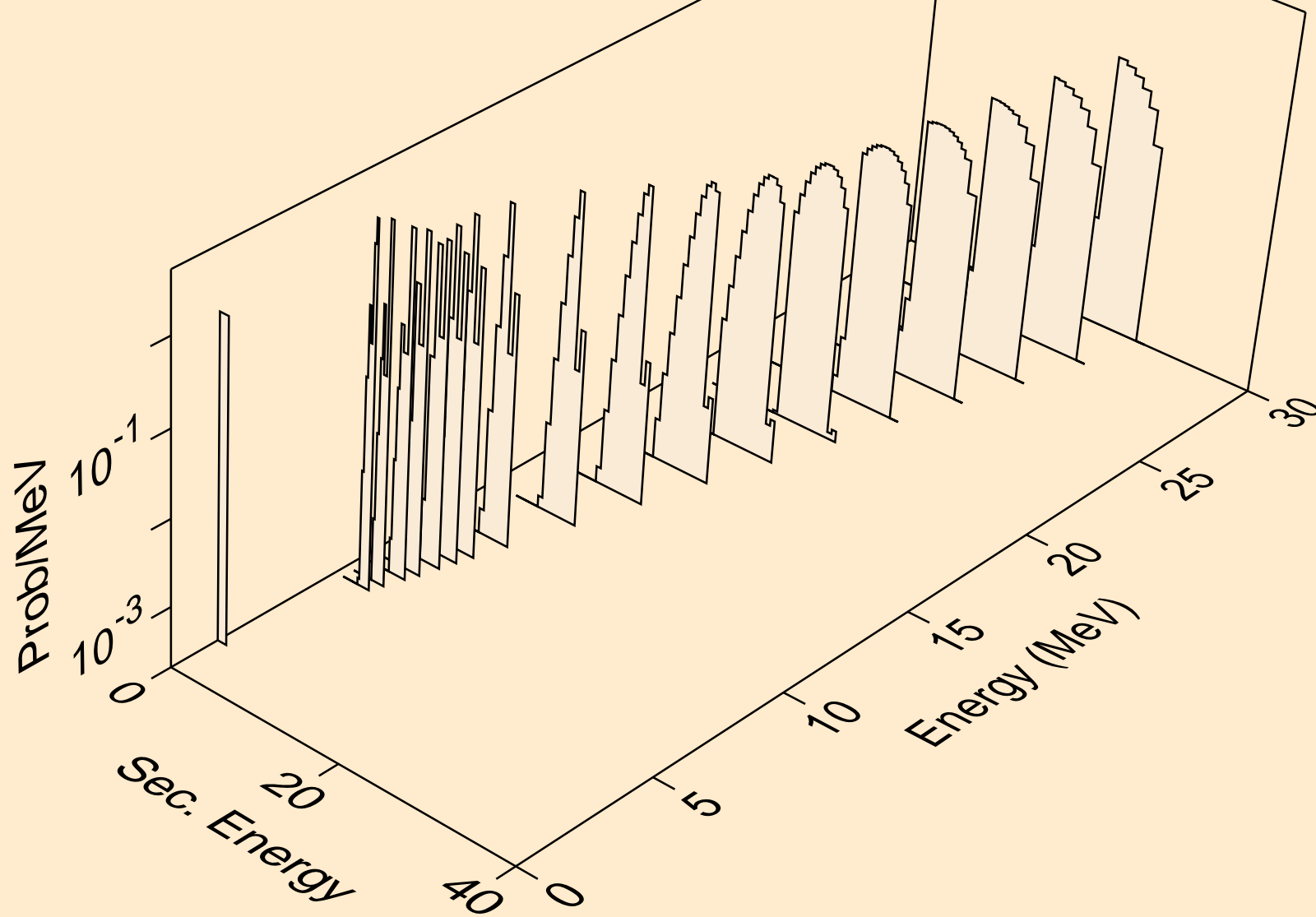

LR263 NEUTRON ACER TENDL-2024 LIBRARY; T=0.K
he3s from (n,x)

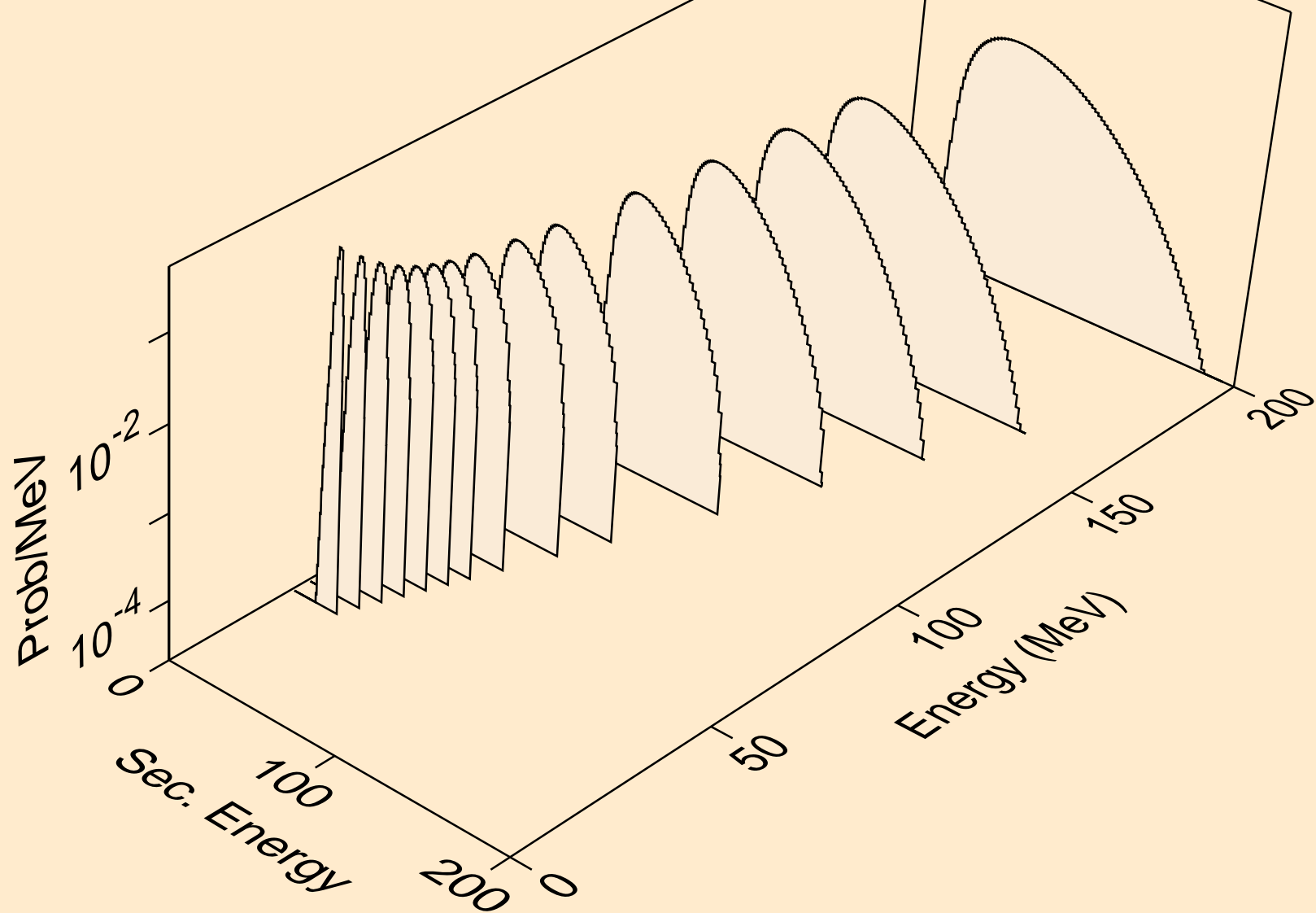

LR263 NEUTRON ACER TENDL-2024 LIBRARY; T=0.K
he3s from (n,n*)he3

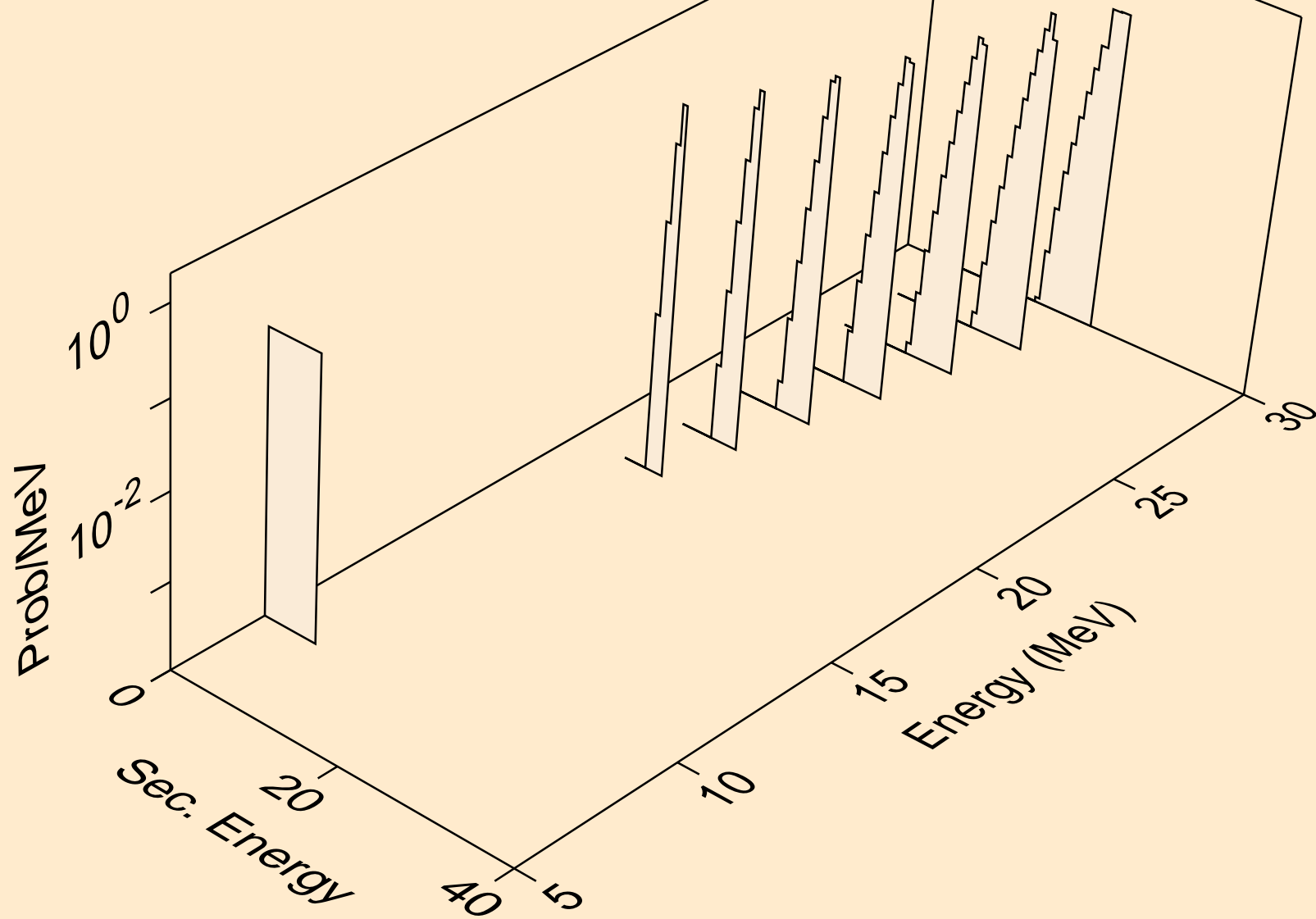

LR263 NEUTRON ACER TENDL-2024 LIBRARY; T=0.K
he3s from (n,he3)

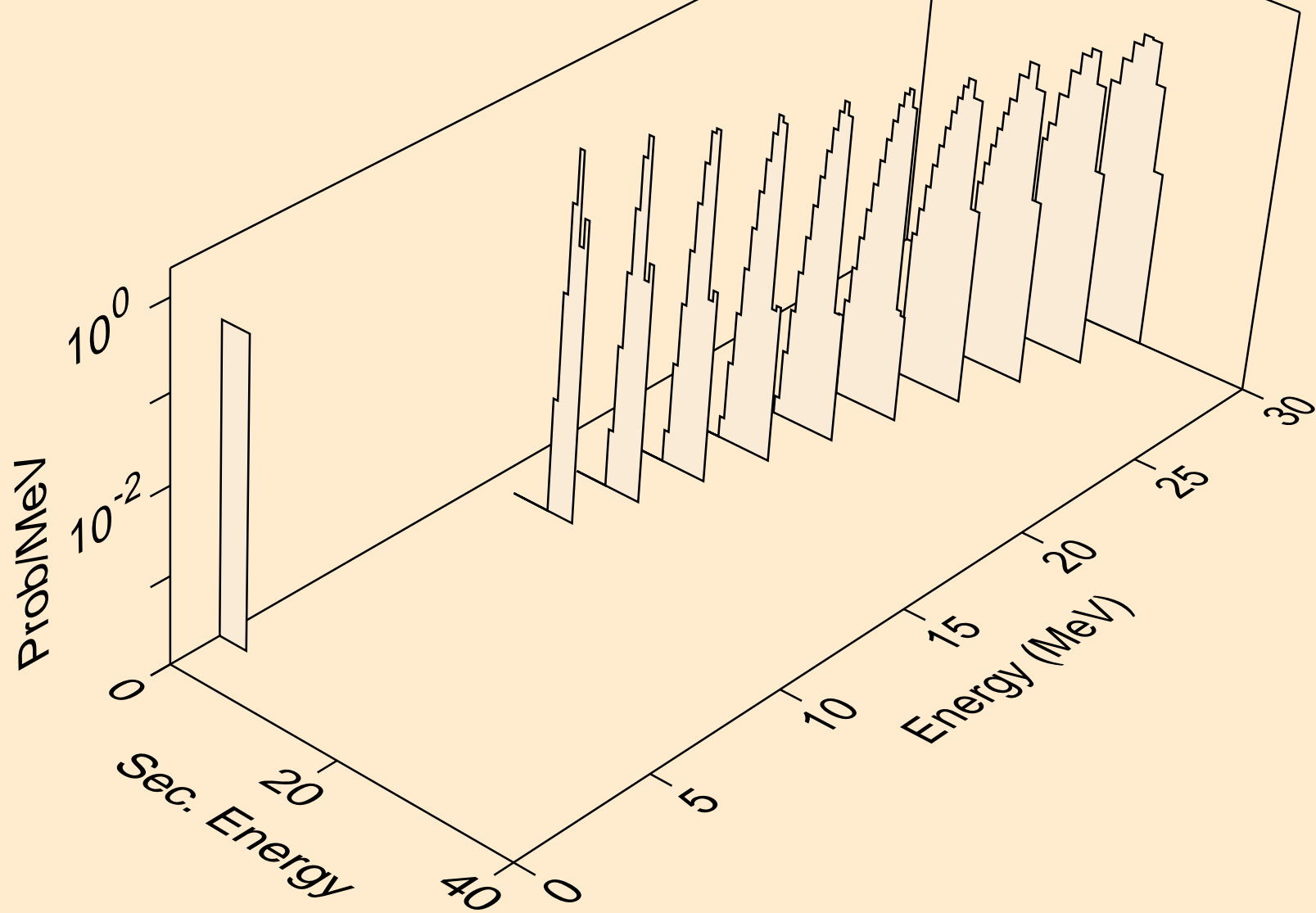

LR263 NEUTRON ACER TENDL-2024 LIBRARY; T=0.K
alphas from (n,x)

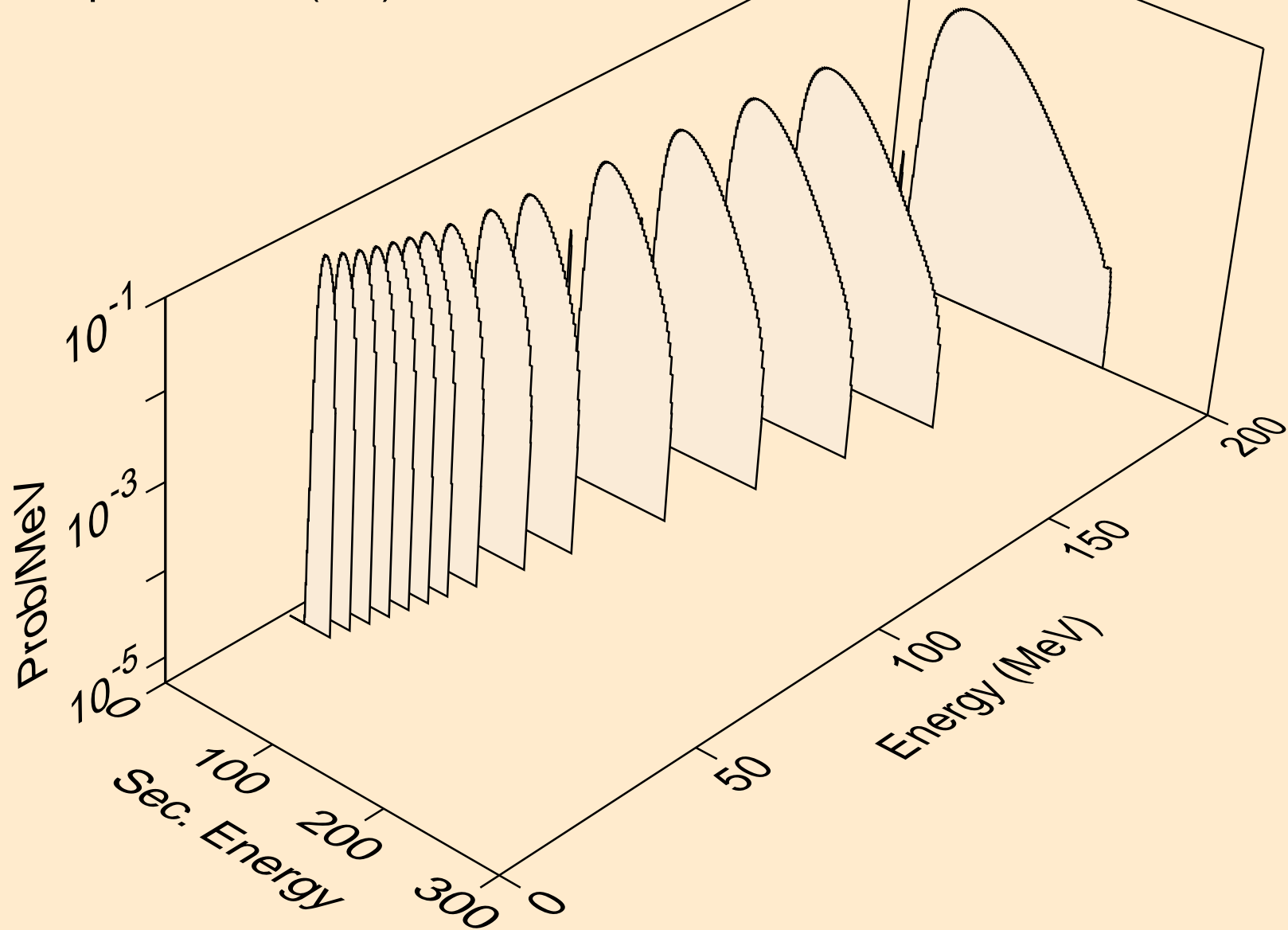

LR263 NEUTRON ACER TENDL-2024 LIBRARY; T=0.K
alphas from (n,n*)a

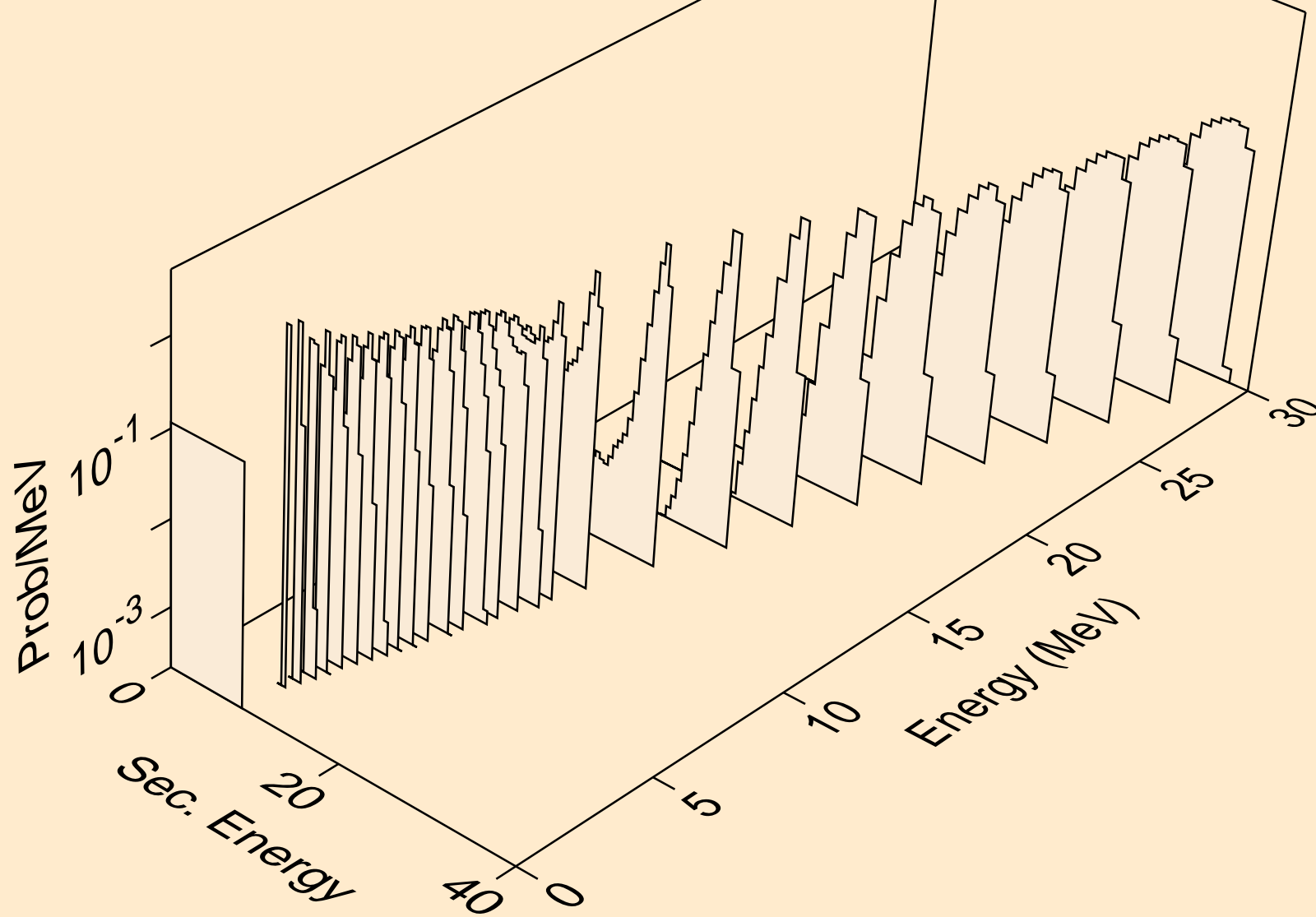

LR263 NEUTRON ACER TENDL-2024 LIBRARY; T=0.K
alphas from (n,2n)a

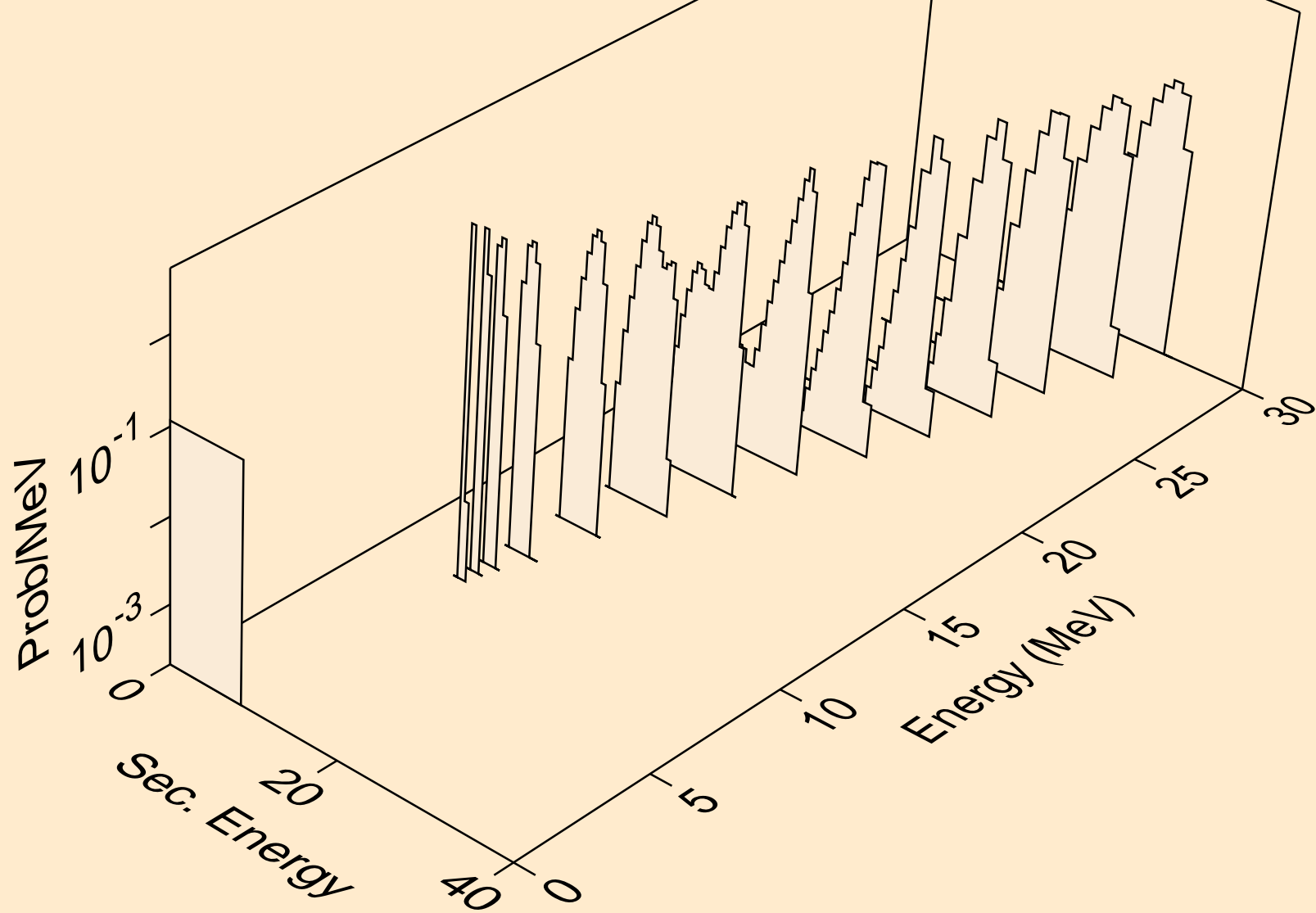

LR263 NEUTRON ACER TENDL-2024 LIBRARY; T=0.K
alphas from (n,3n)a

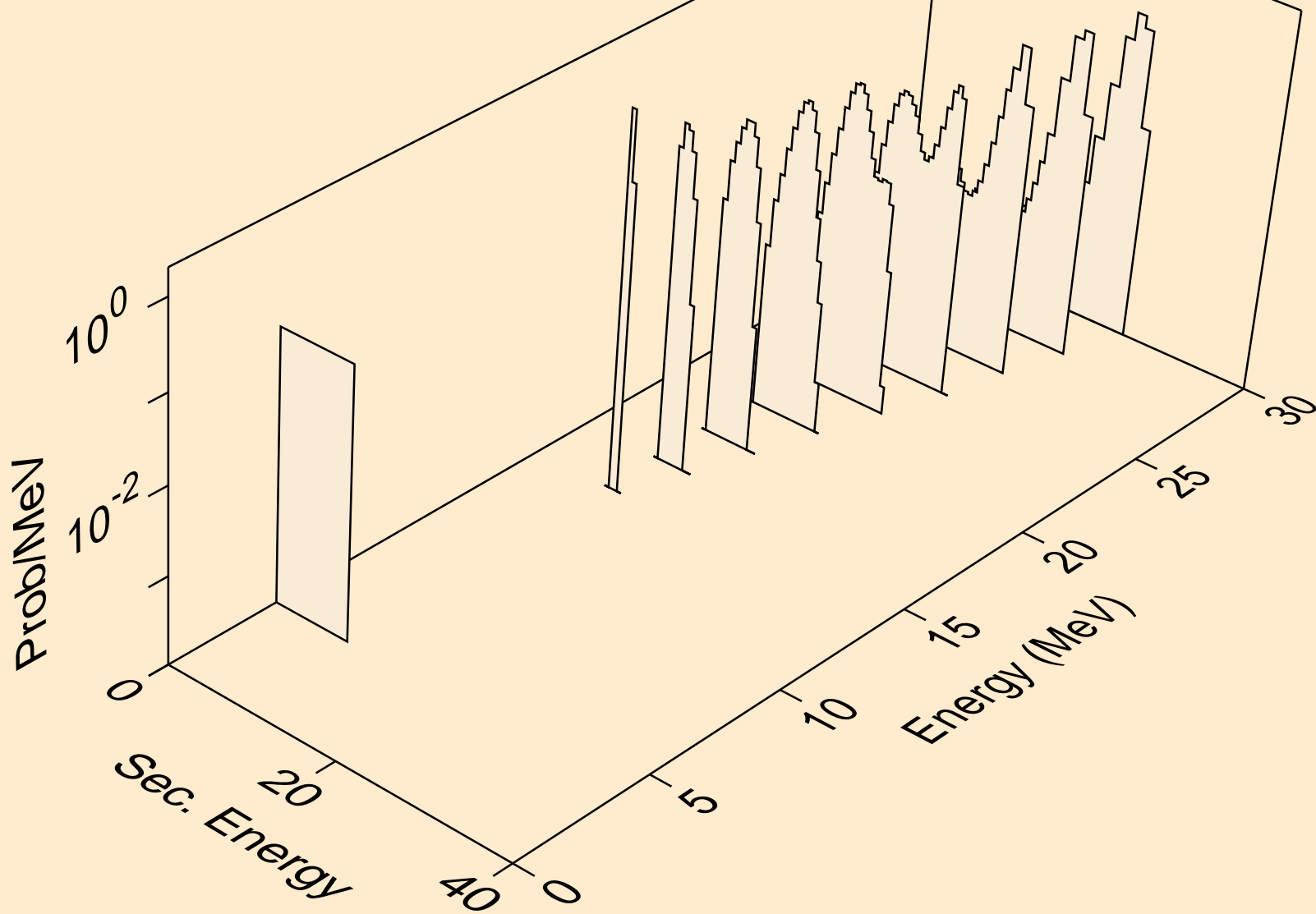

LR263 NEUTRON ACER TENDL-2024 LIBRARY; T=0.K
alphas from (n,a)

