

LU157M NEUTRON ACER TENDL-2024 LIBRARY; T=0.K

Principal cross sections

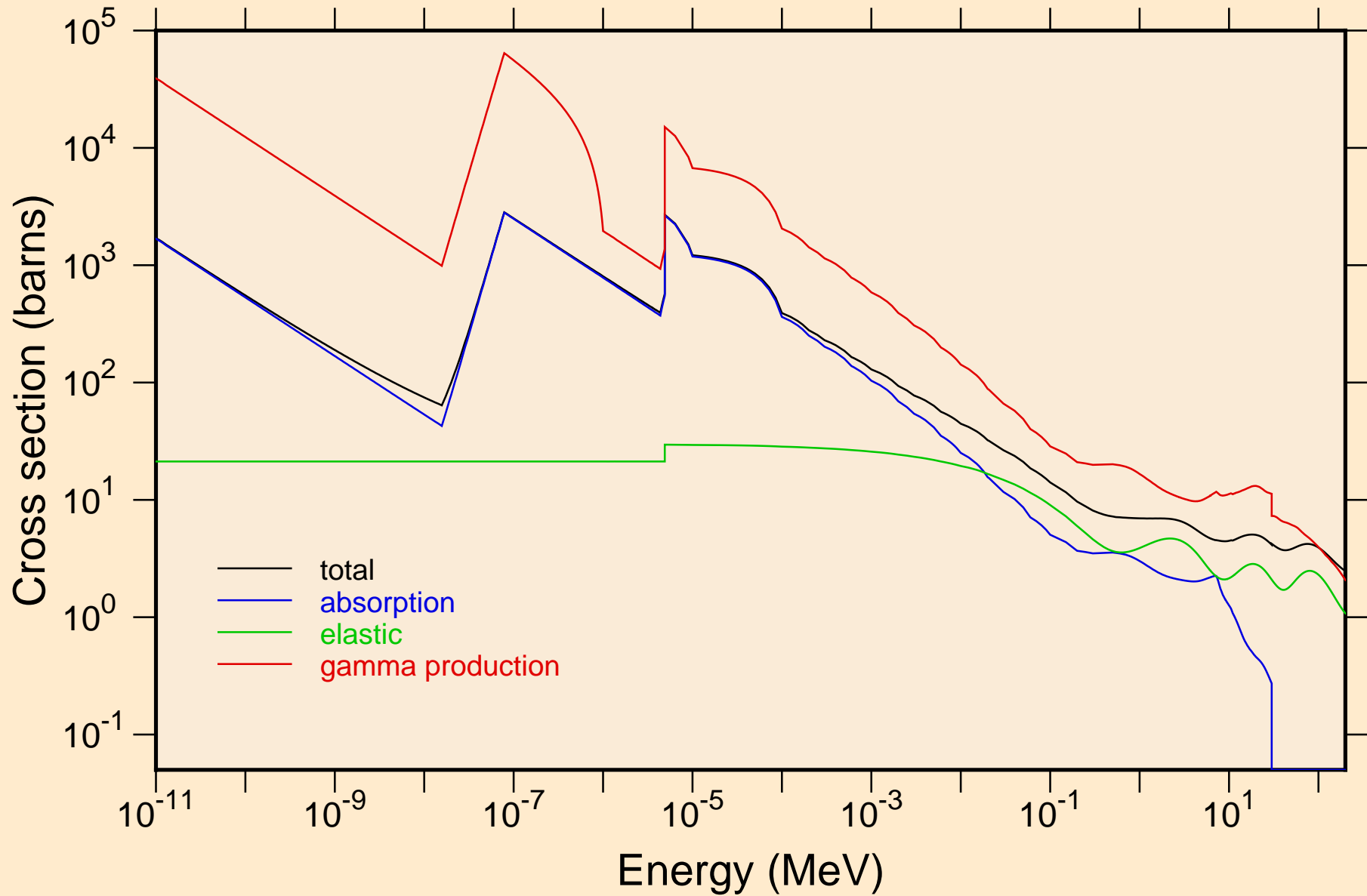

LU157M NEUTRON ACER TENDL-2024 LIBRARY; T=0.K

Heating

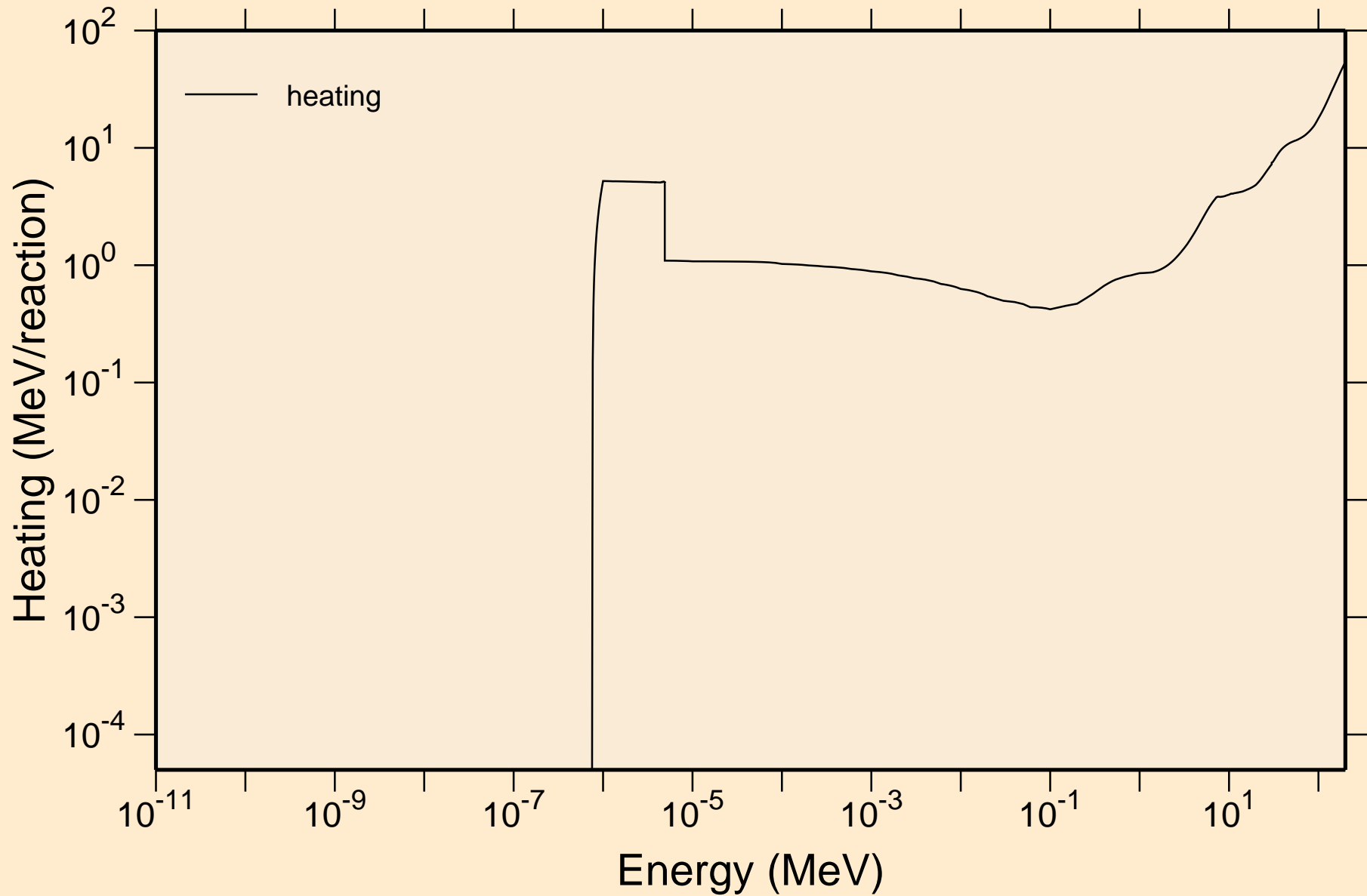

LU157M NEUTRON ACER TENDL-2024 LIBRARY; T=0.K

Damage

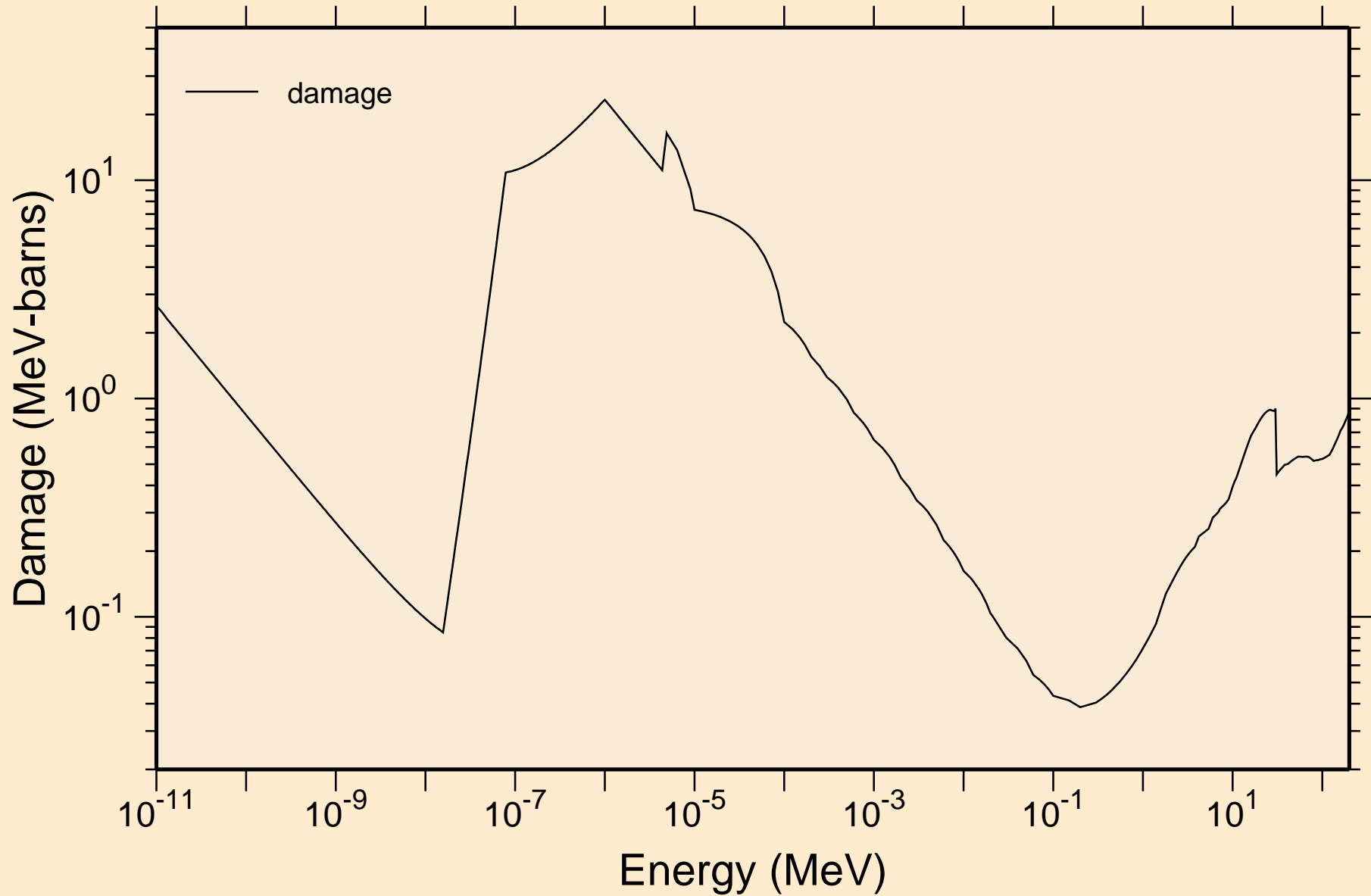

LU157M NEUTRON ACER TENDL-2024 LIBRARY; T=0.K
Non-threshold reactions

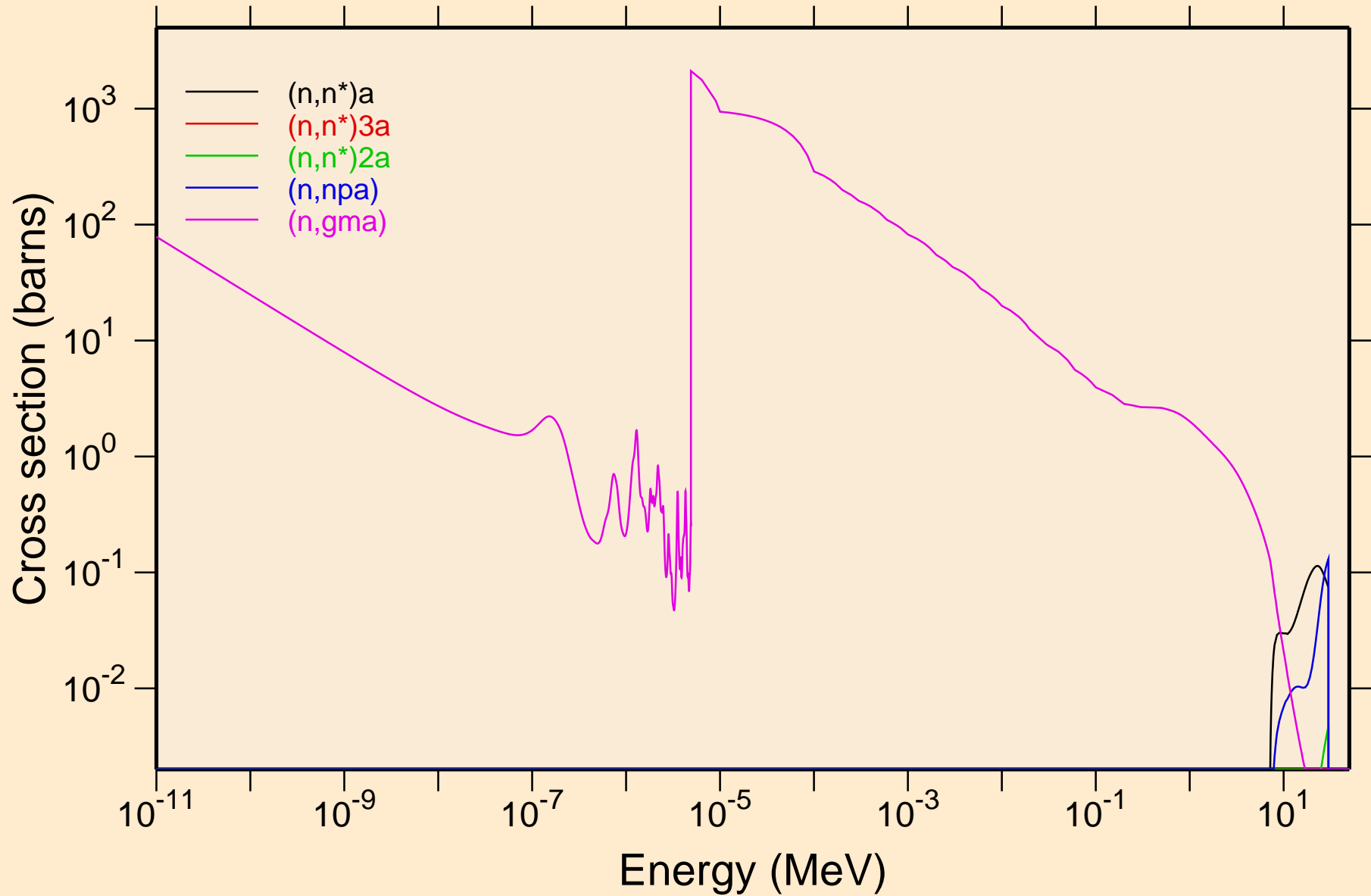

LU157M NEUTRON ACER TENDL-2024 LIBRARY; T=0.K
Non-threshold reactions

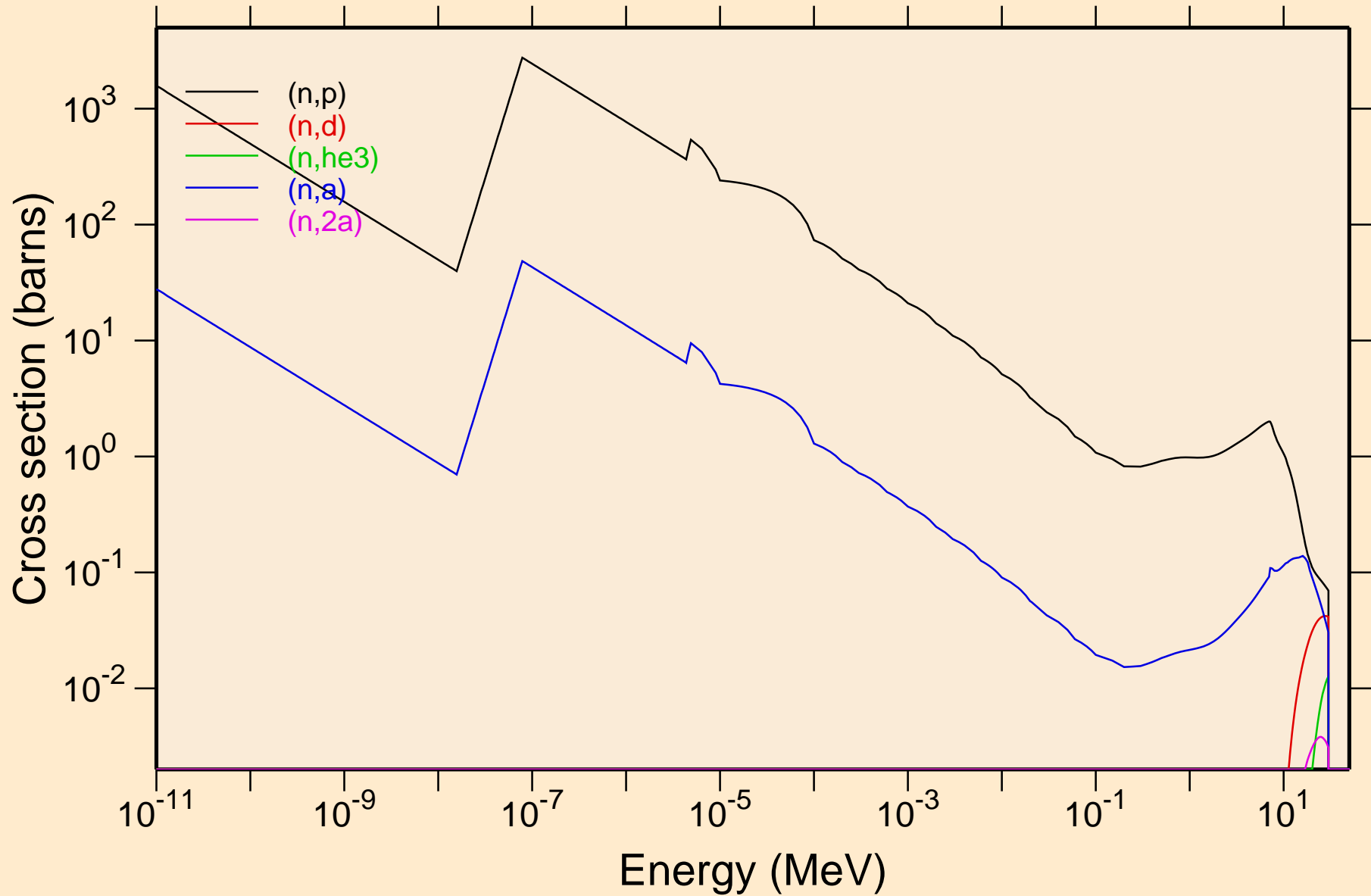

LU157M NEUTRON ACER TENDL-2024 LIBRARY; T=0.K
Non-threshold reactions

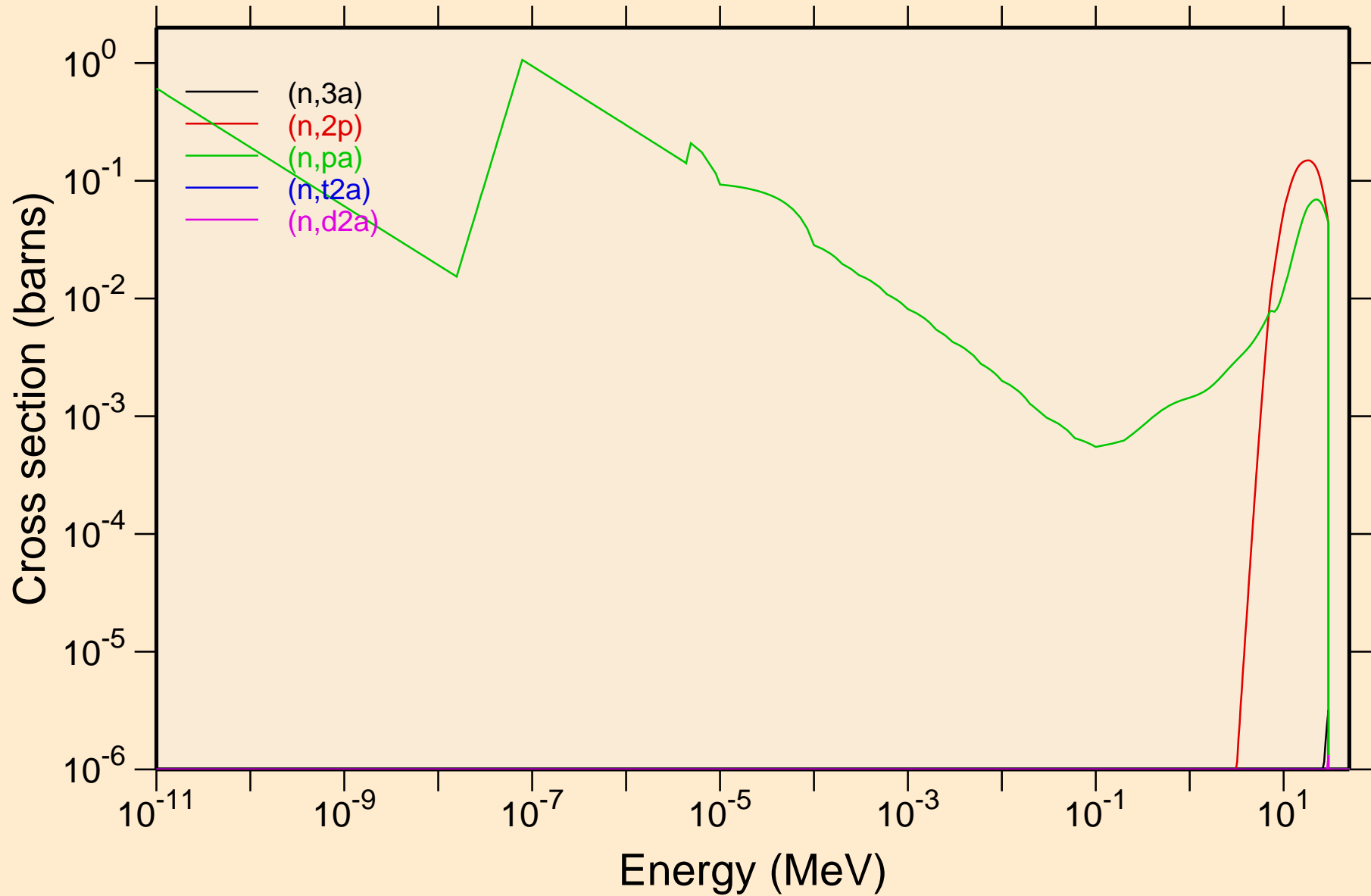

LU157M NEUTRON ACER TENDL-2024 LIBRARY; T=0.K

Non-threshold reactions

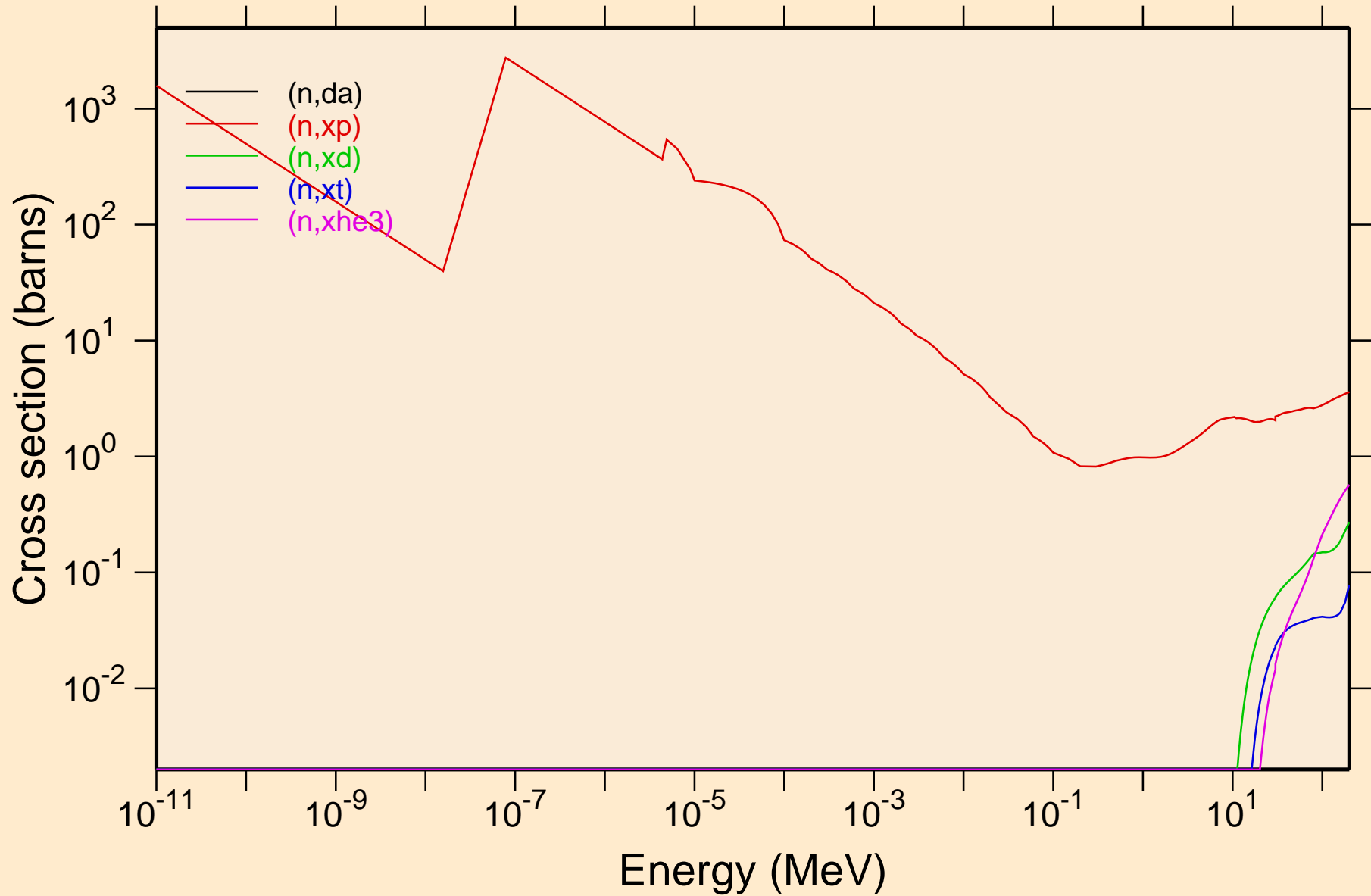

LU157M NEUTRON ACER TENDL-2024 LIBRARY; T=0.K
Non-threshold reactions

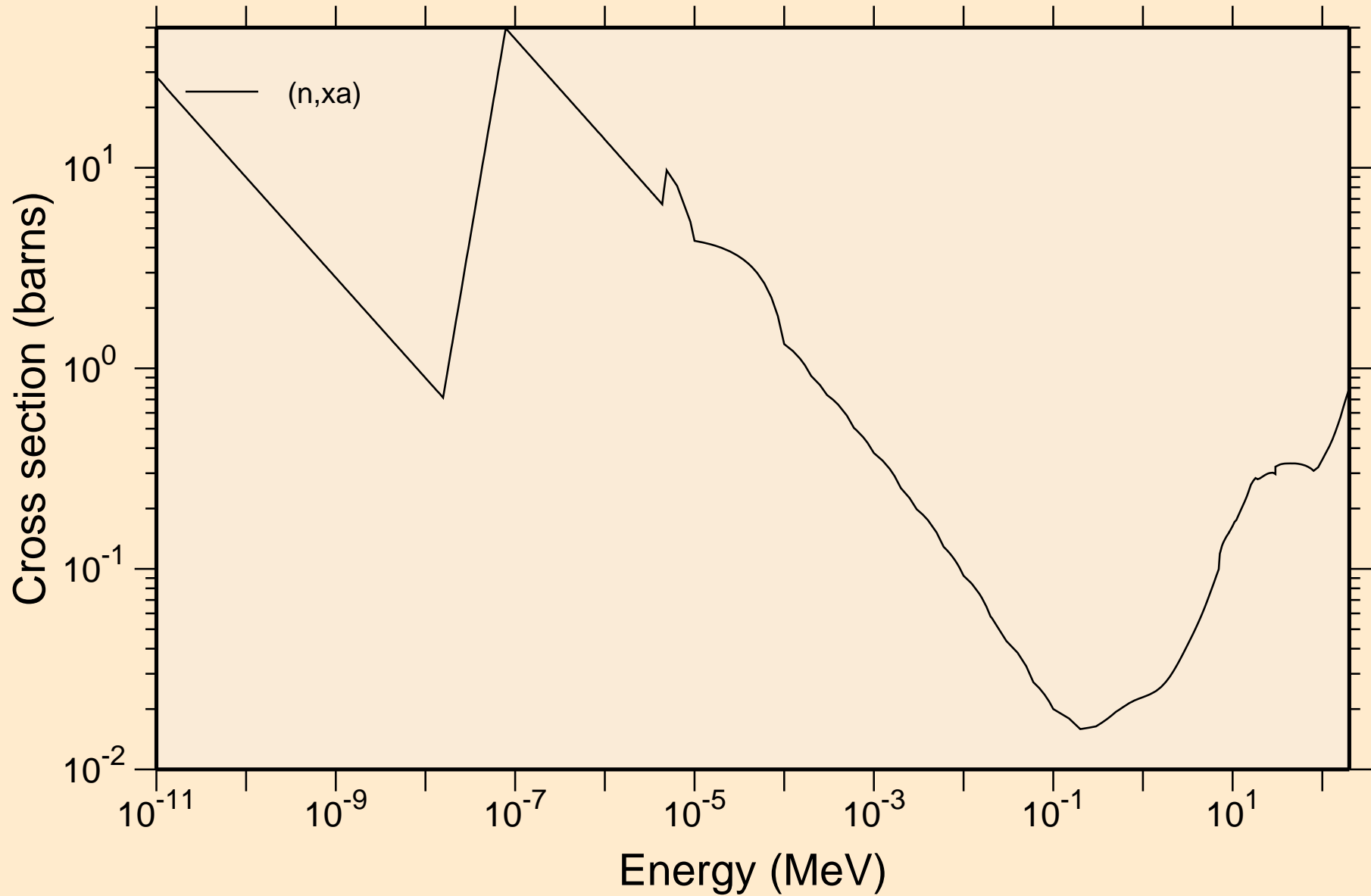

LU157M NEUTRON ACER TENDL-2024 LIBRARY; T=0.K

Principal cross sections

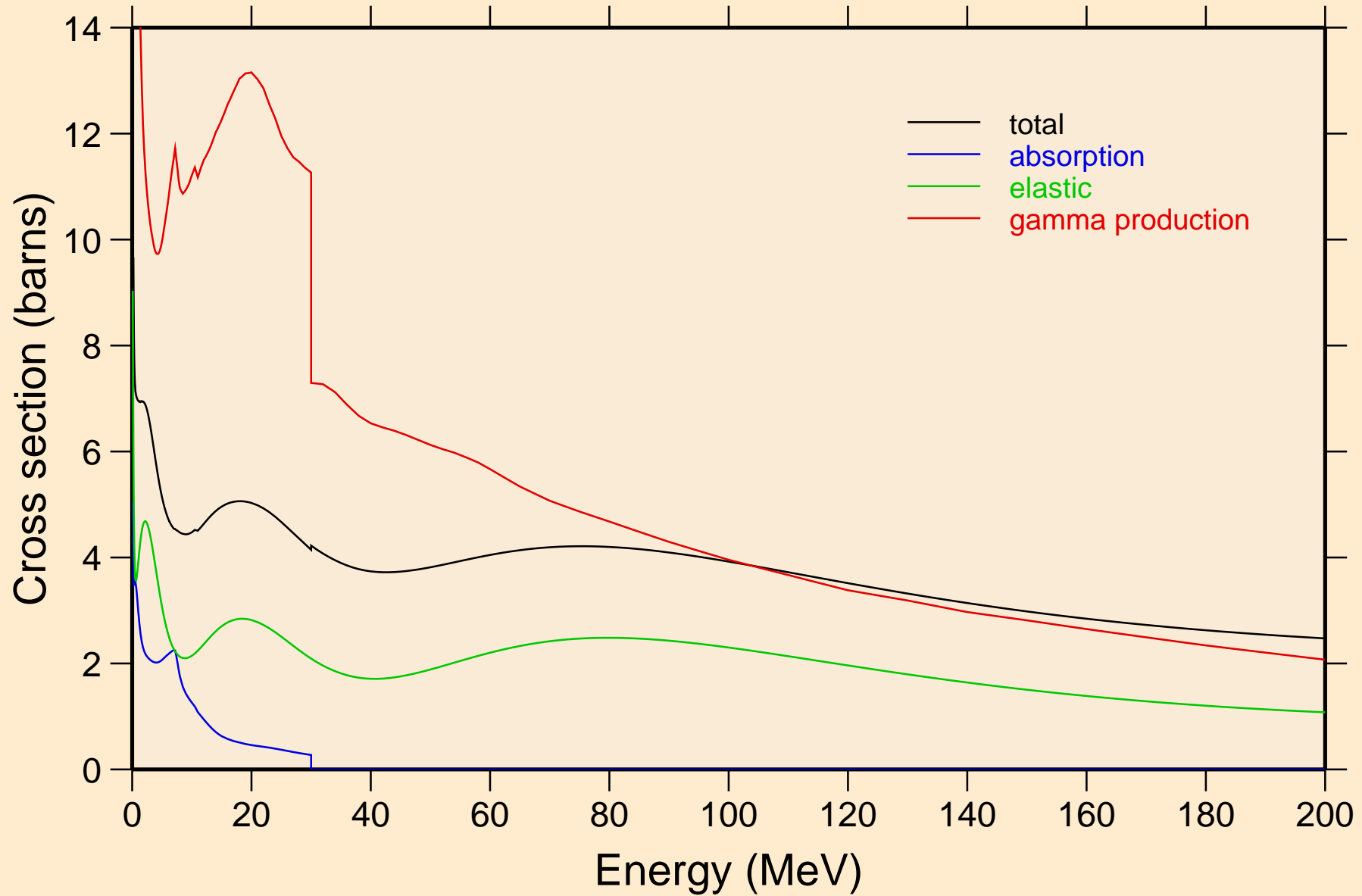

LU157M NEUTRON ACER TENDL-2024 LIBRARY; T=0.K

Heating

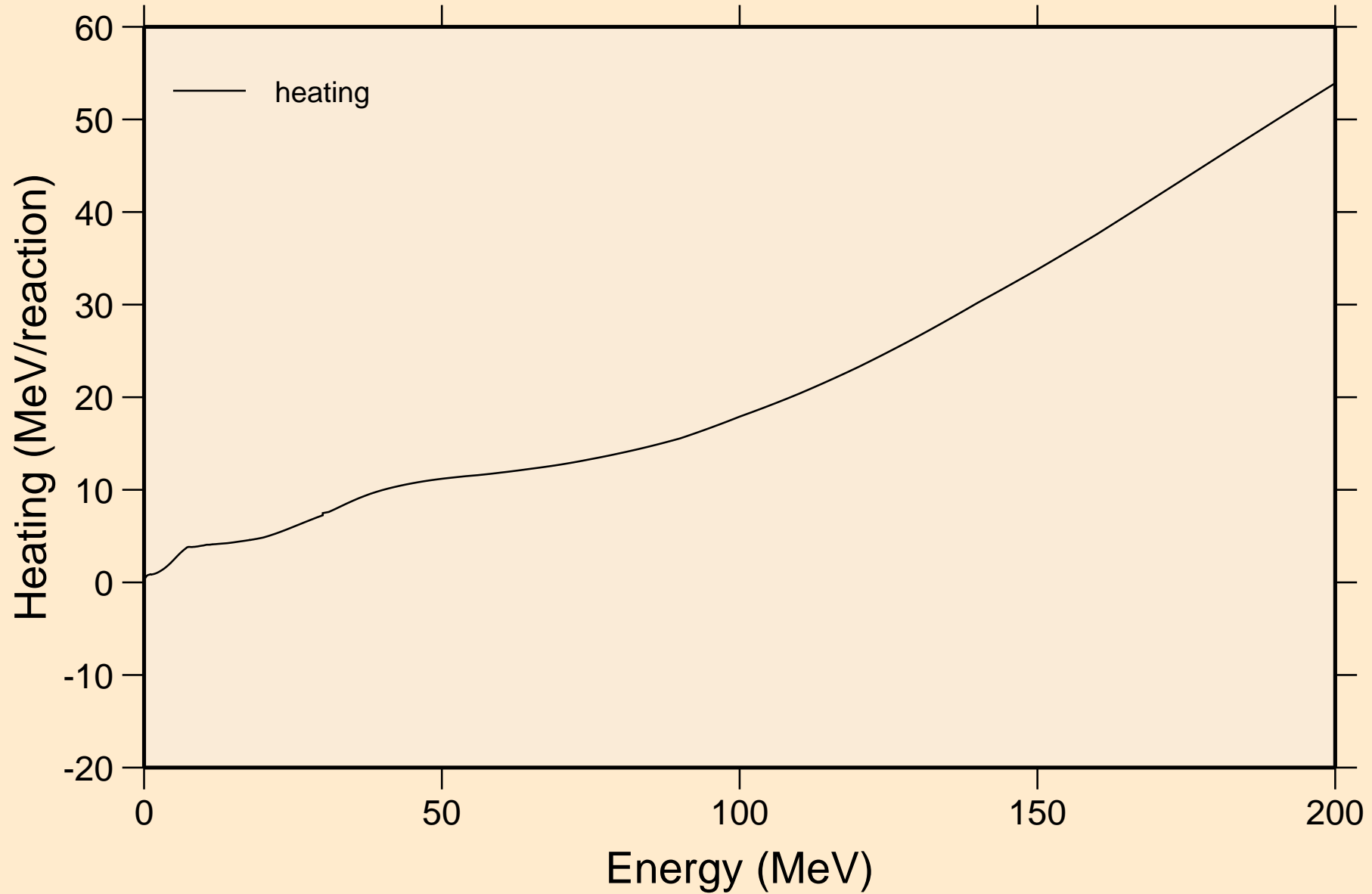

LU157M NEUTRON ACER TENDL-2024 LIBRARY; T=0.K
Damage

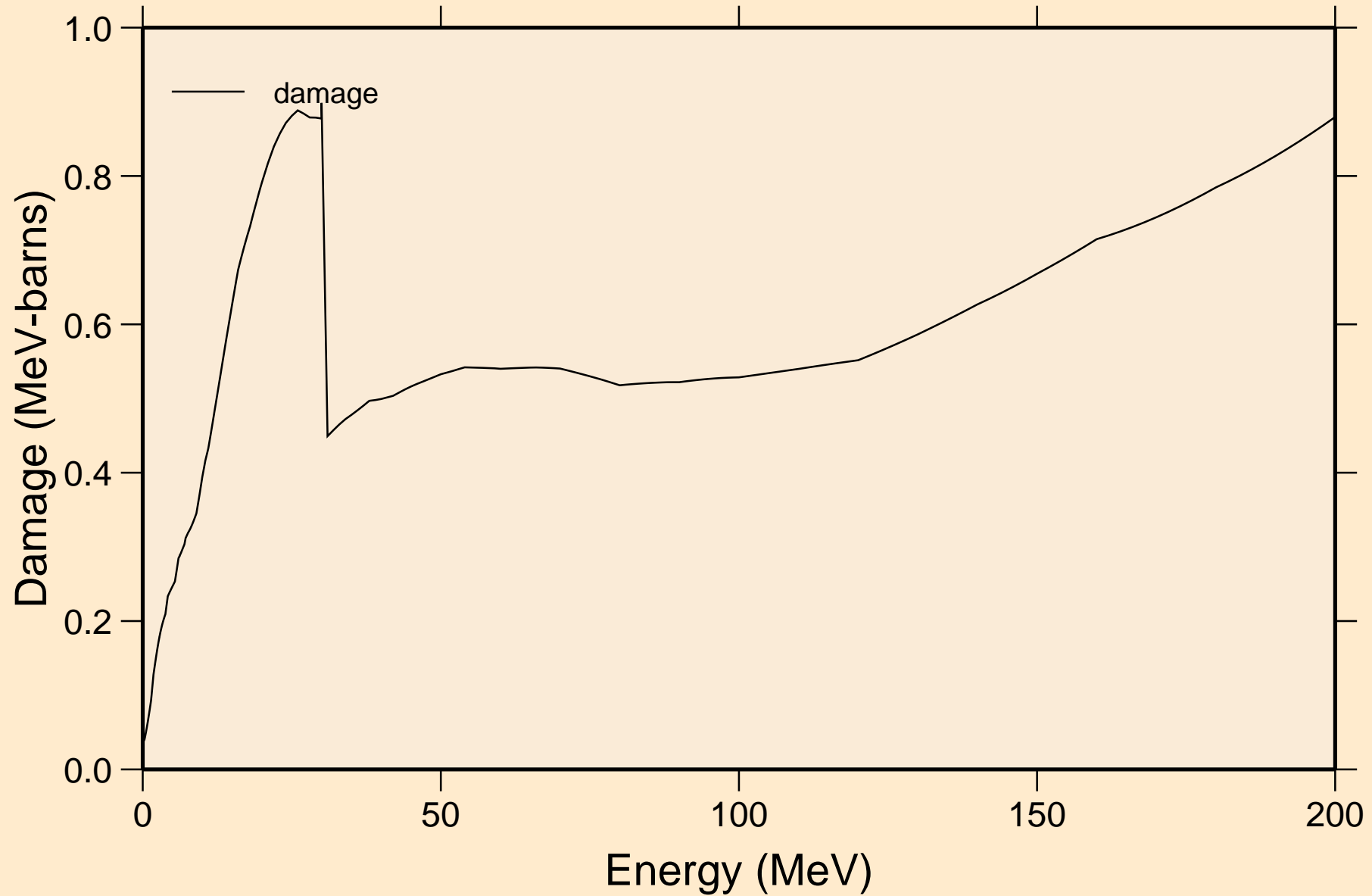

LU157M NEUTRON ACER TENDL-2024 LIBRARY; T=0.K
Non-threshold reactions

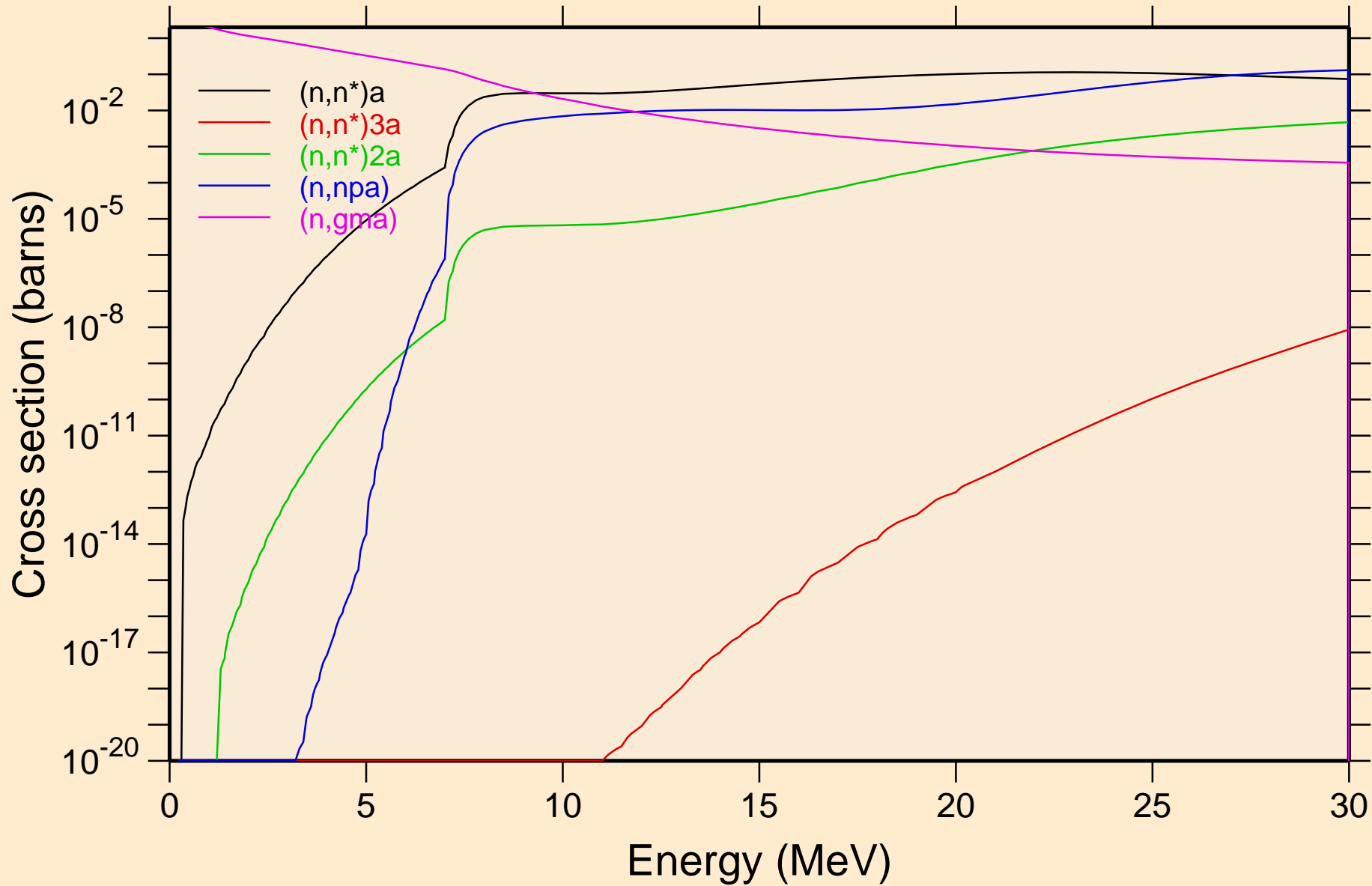

LU157M NEUTRON ACER TENDL-2024 LIBRARY; T=0.K

Non-threshold reactions

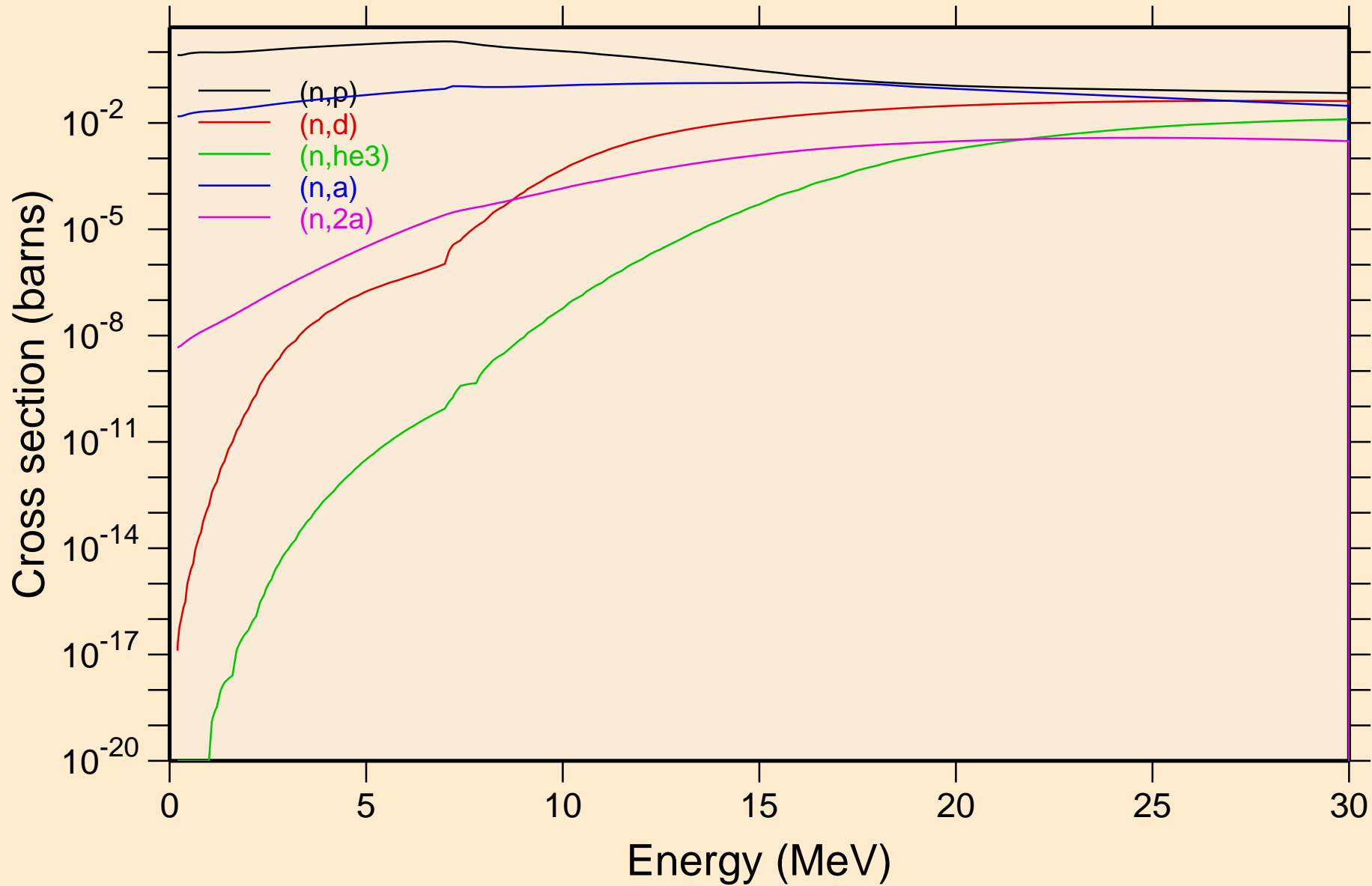

LU157M NEUTRON ACER TENDL-2024 LIBRARY; T=0.K
Non-threshold reactions

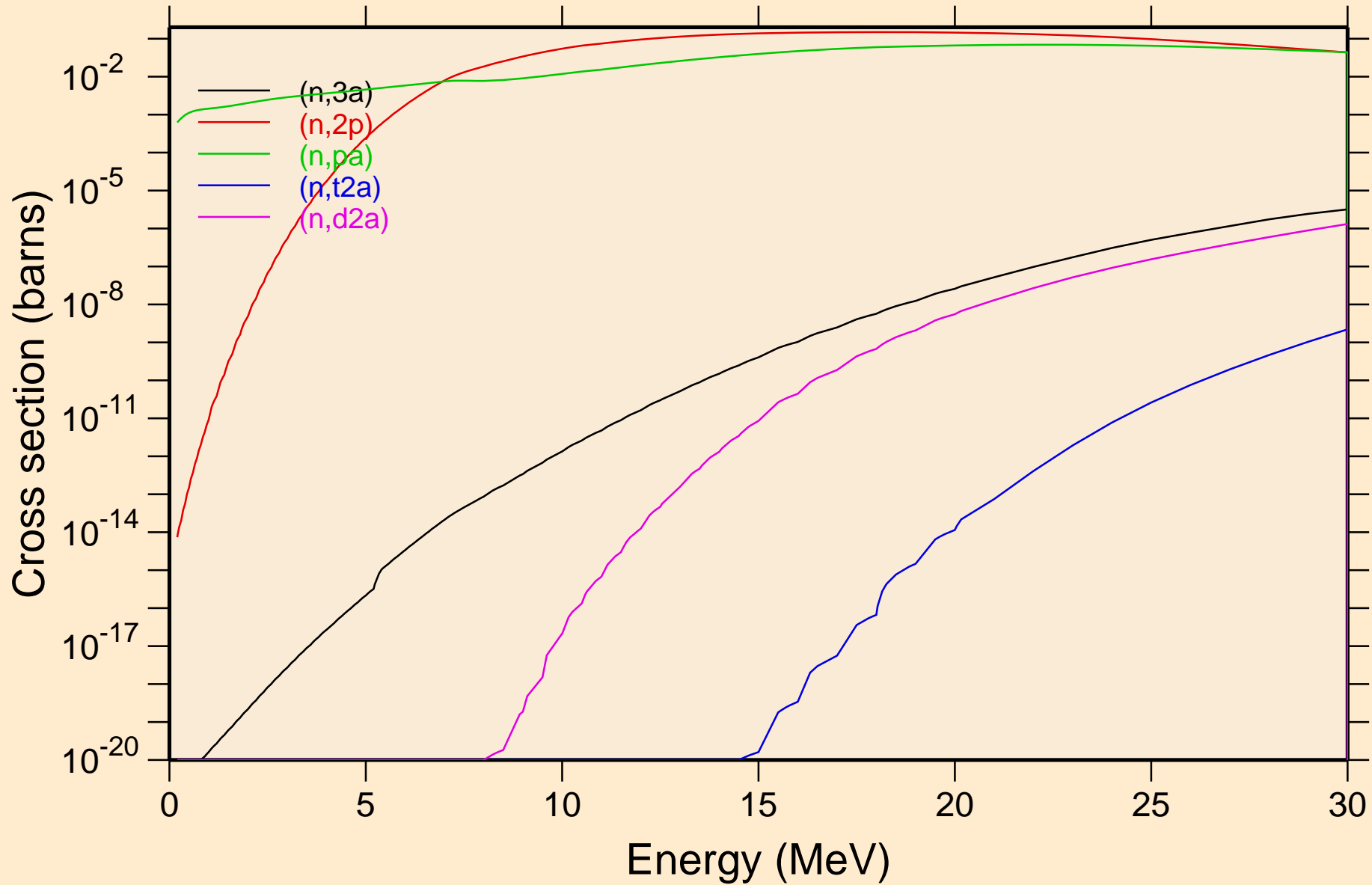

LU157M NEUTRON ACER TENDL-2024 LIBRARY; T=0.K
Non-threshold reactions

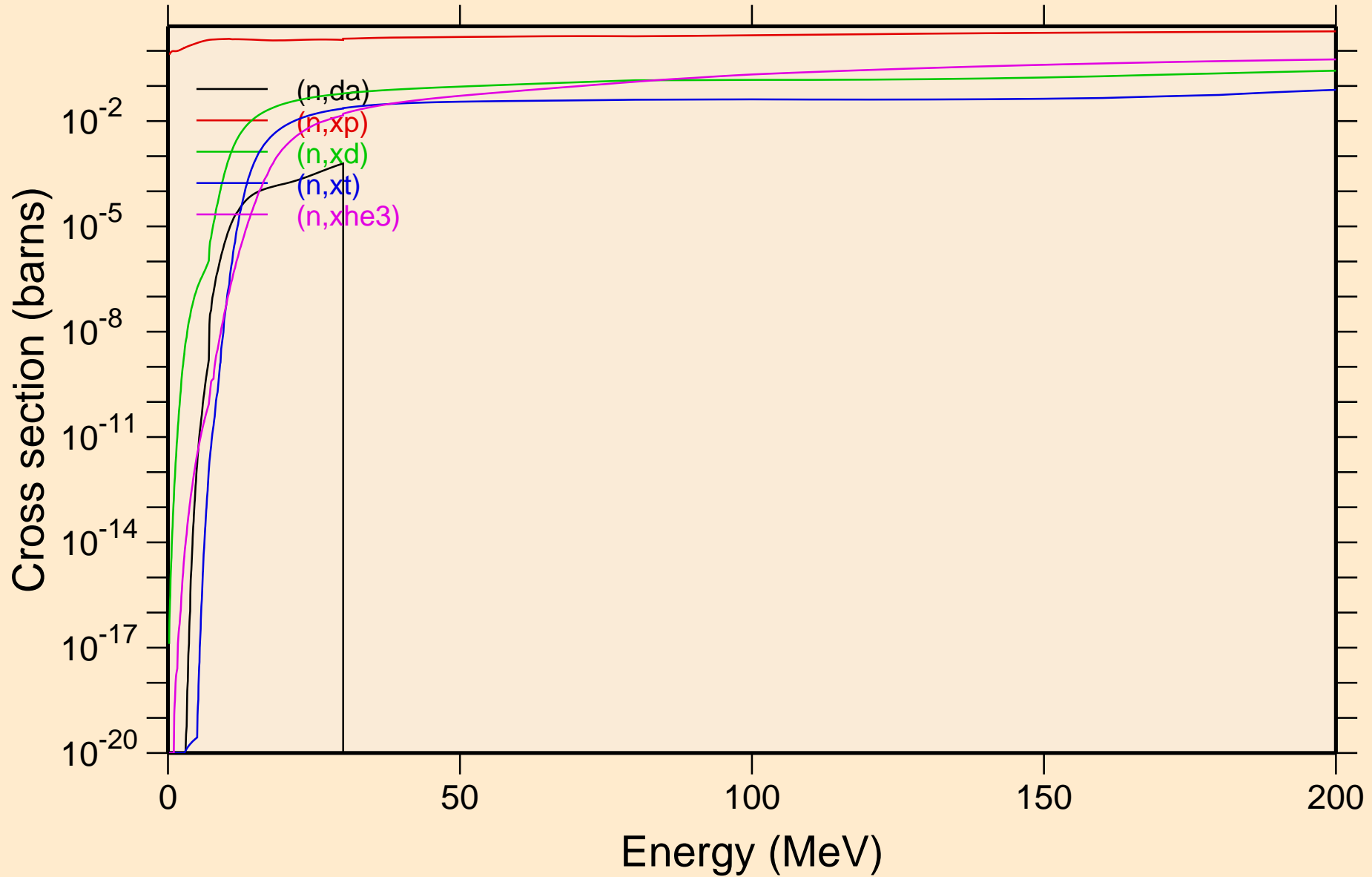

LU157M NEUTRON ACER TENDL-2024 LIBRARY; T=0.K
Non-threshold reactions

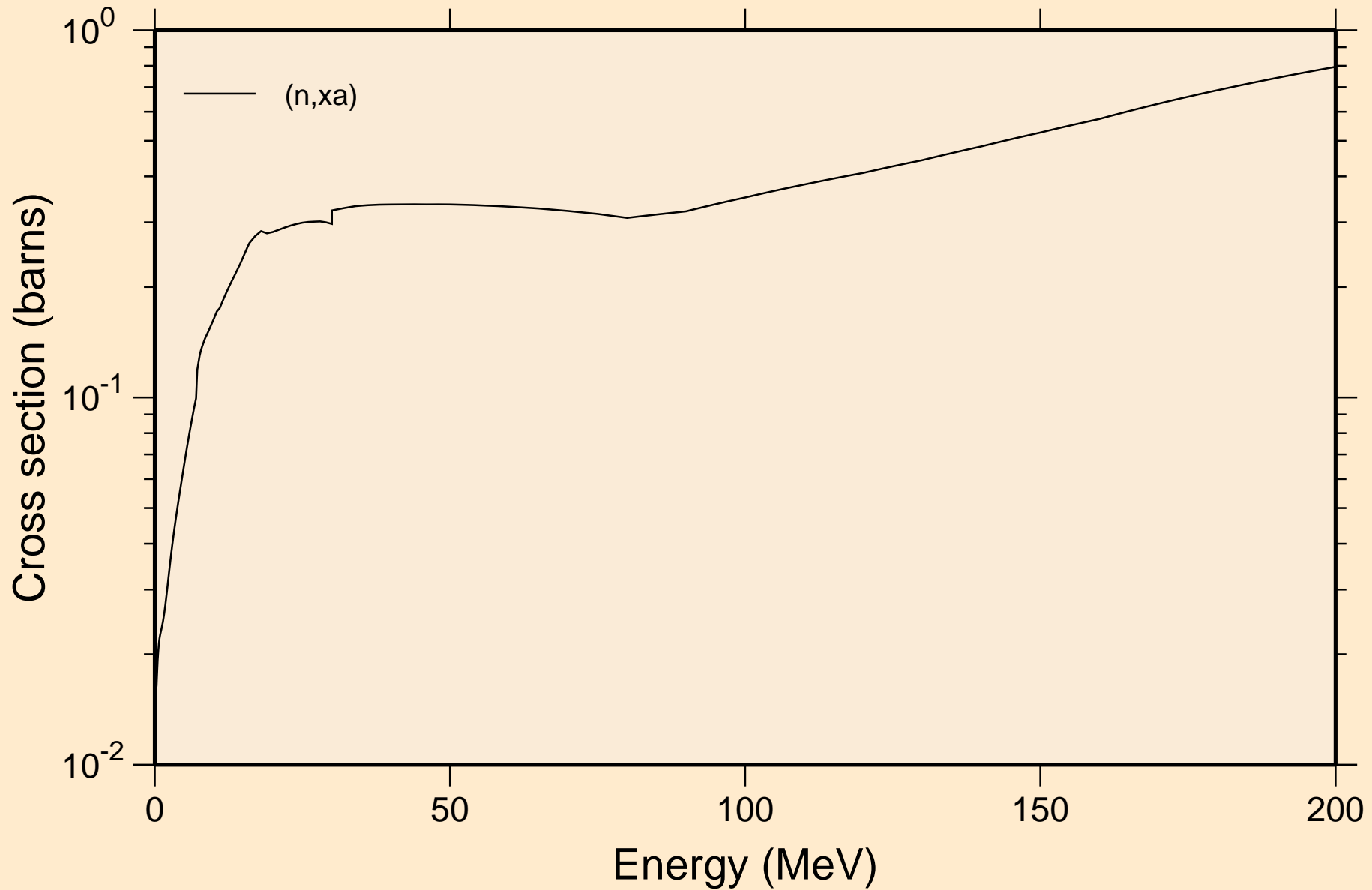

LU157M NEUTRON ACER TENDL-2024 LIBRARY; T=0.K
Inelastic levels

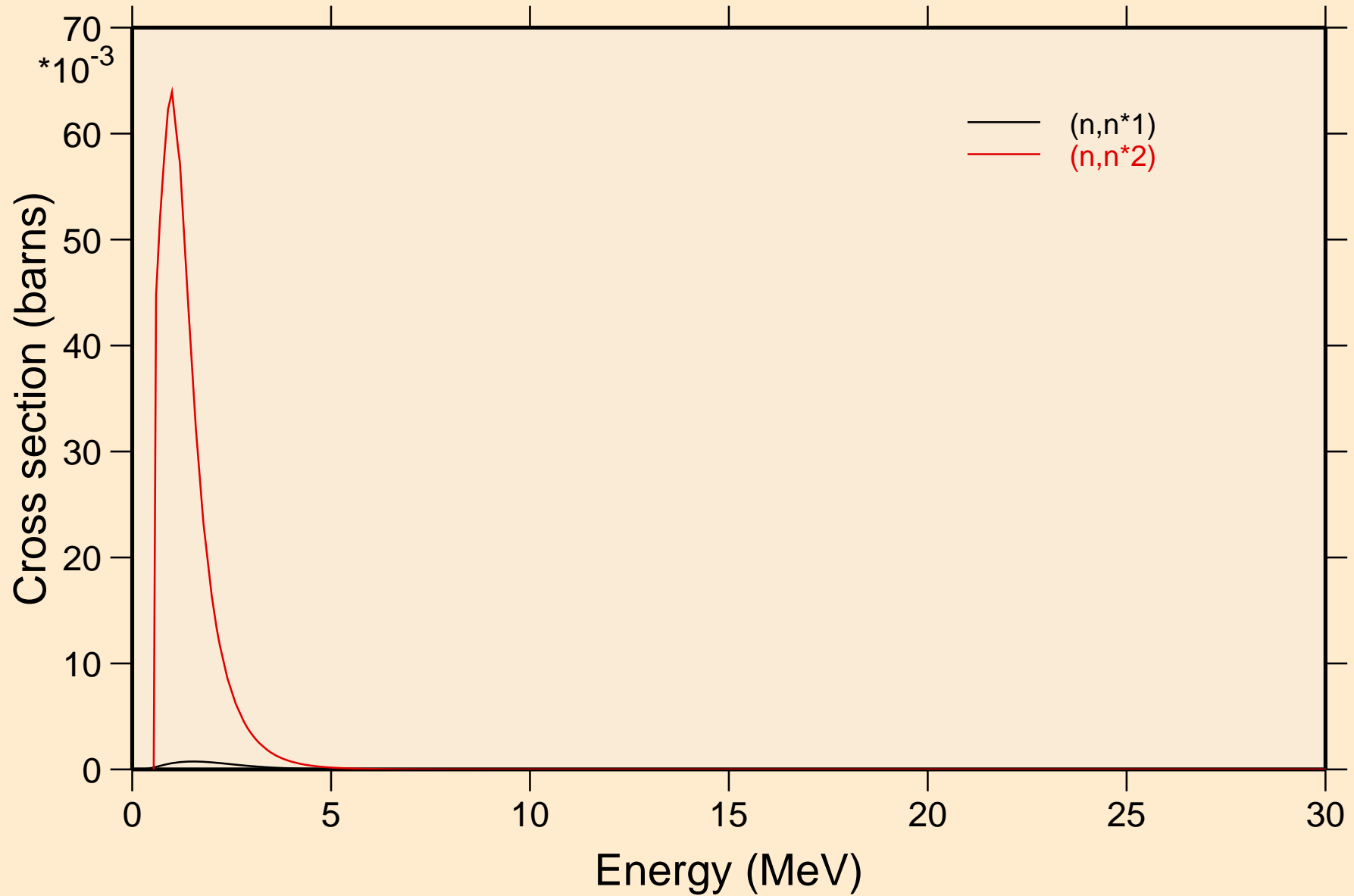

LU157M NEUTRON ACER TENDL-2024 LIBRARY; T=0.K
Threshold reactions

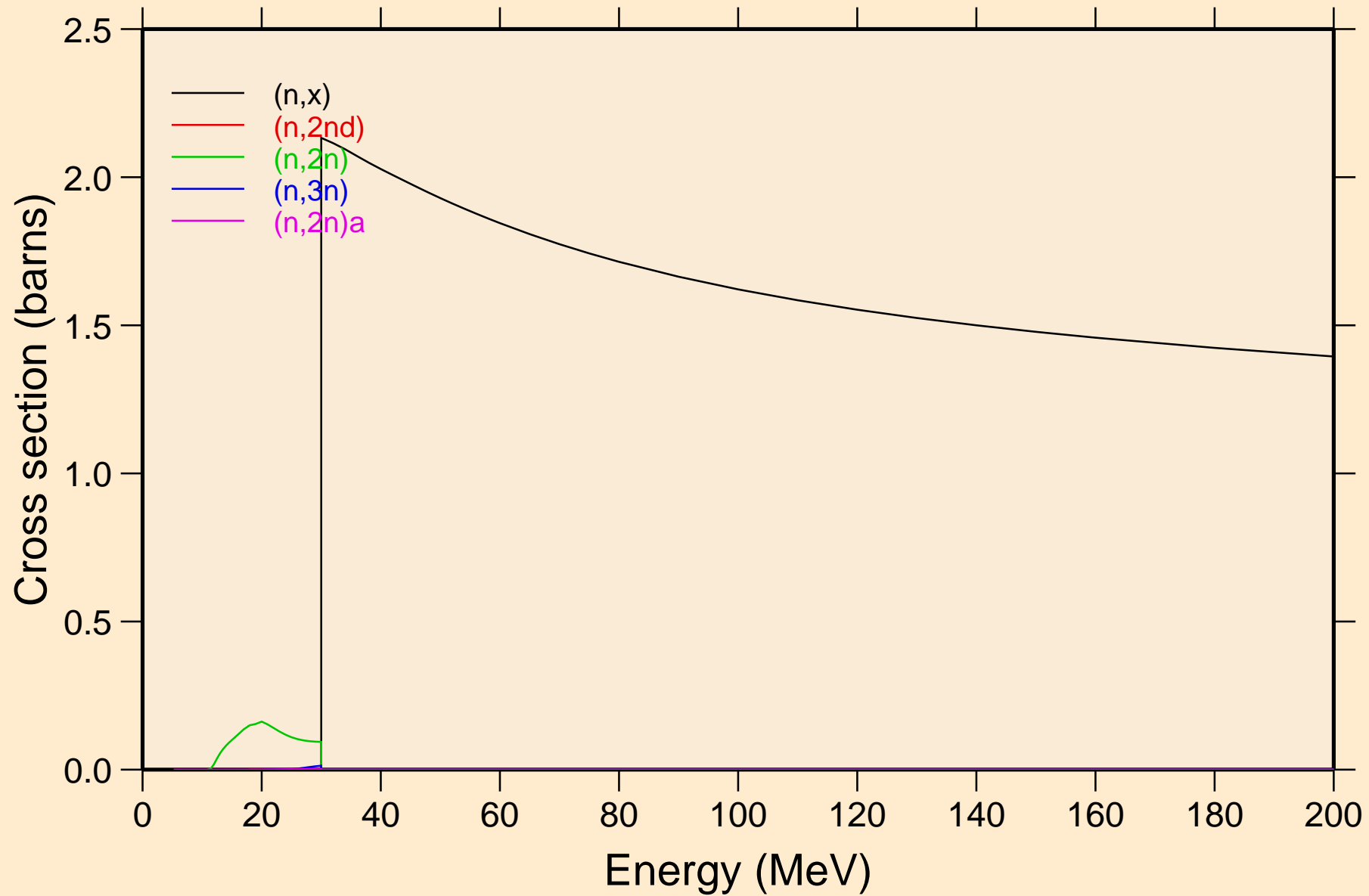

LU157M NEUTRON ACER TENDL-2024 LIBRARY; T=0.K
Threshold reactions

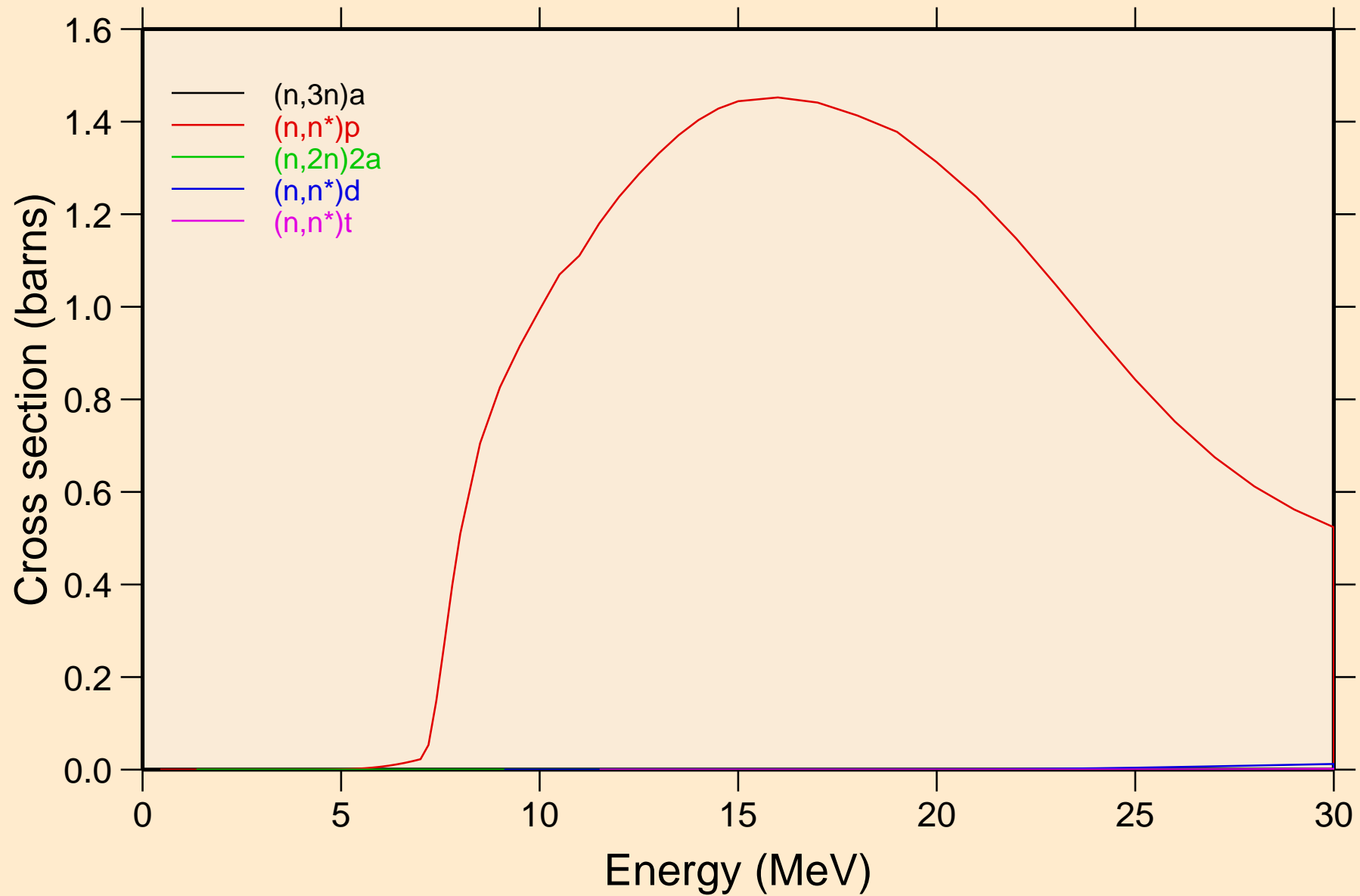

LU157M NEUTRON ACER TENDL-2024 LIBRARY; T=0.K
Threshold reactions

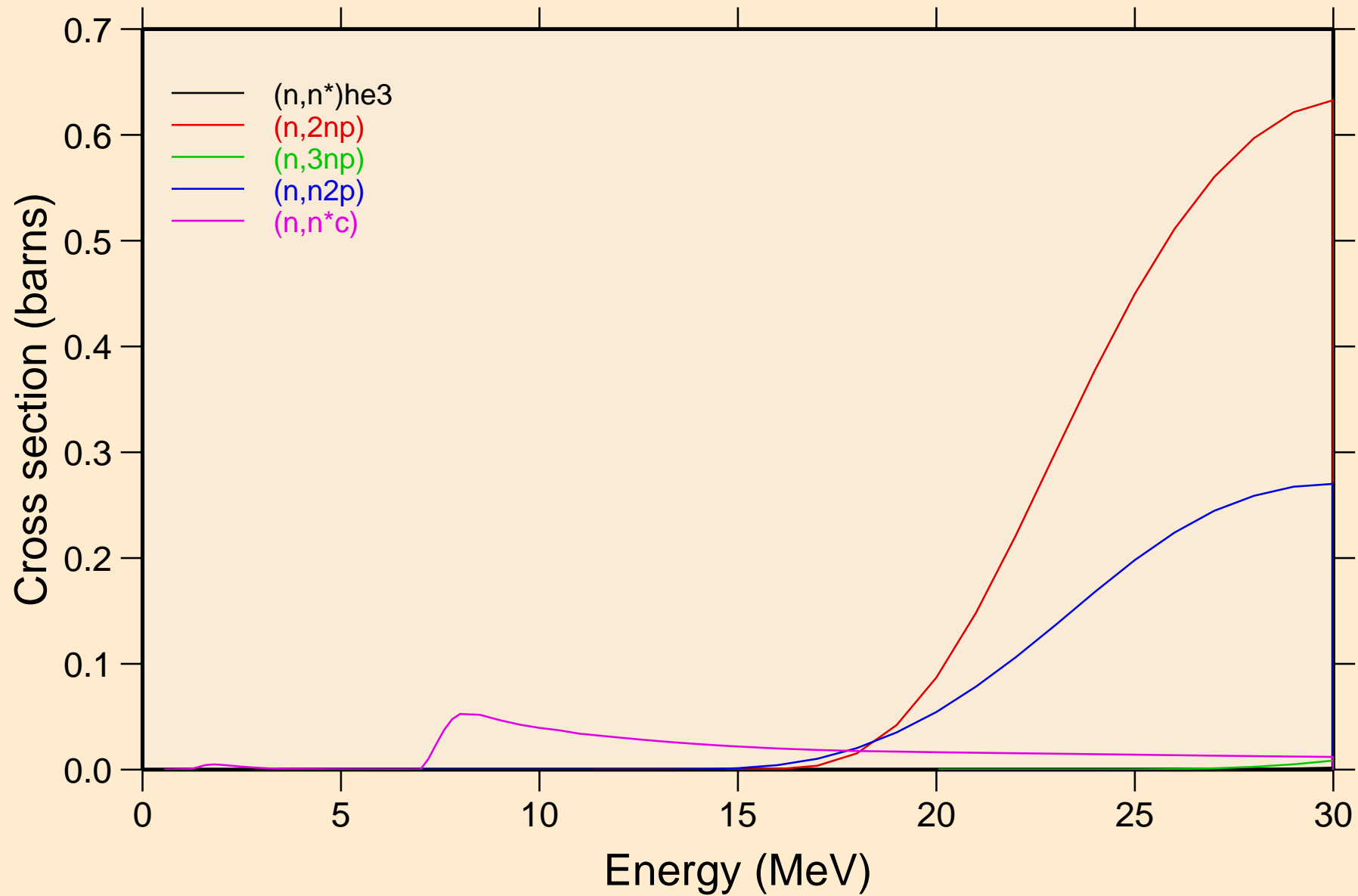

LU157M NEUTRON ACER TENDL-2024 LIBRARY; T=0.K
Threshold reactions

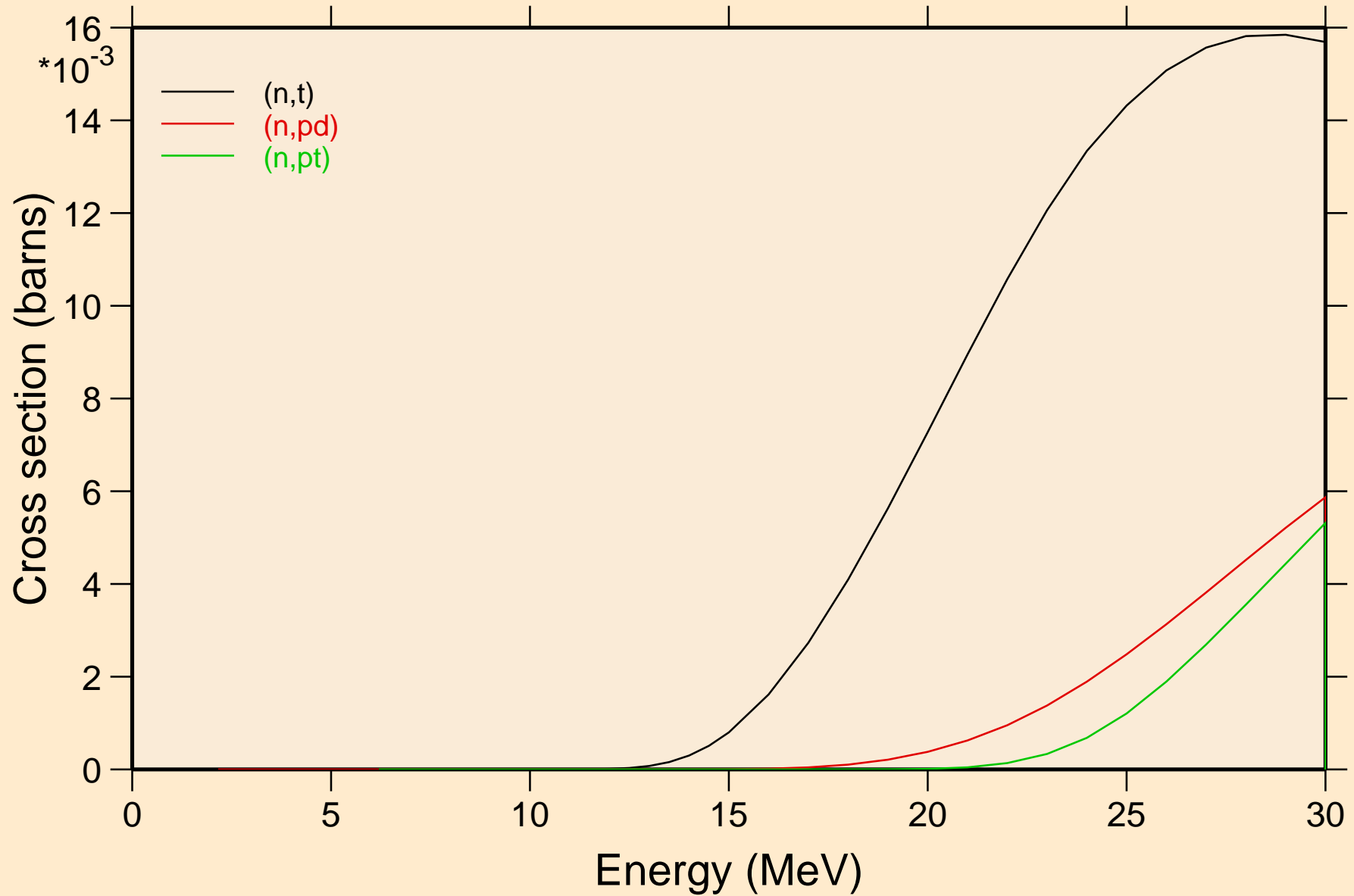

LU157M NEUTRON ACER TENDL-2024 LIBRARY; T=0.K
angular distribution for elastic

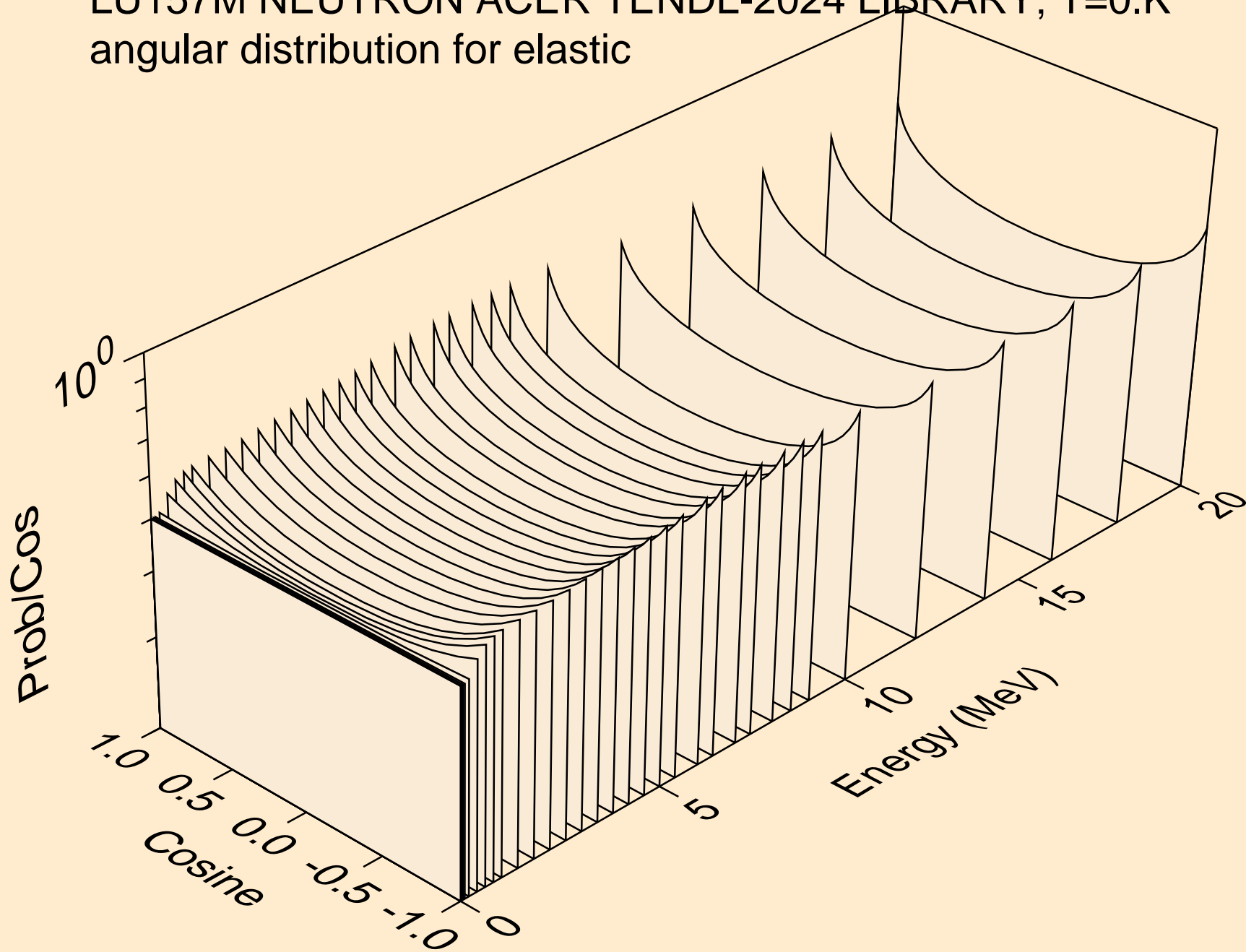

LU157M NEUTRON ACER TENDL-2024 LIBRARY; T=0.K
angular distribution for elastic

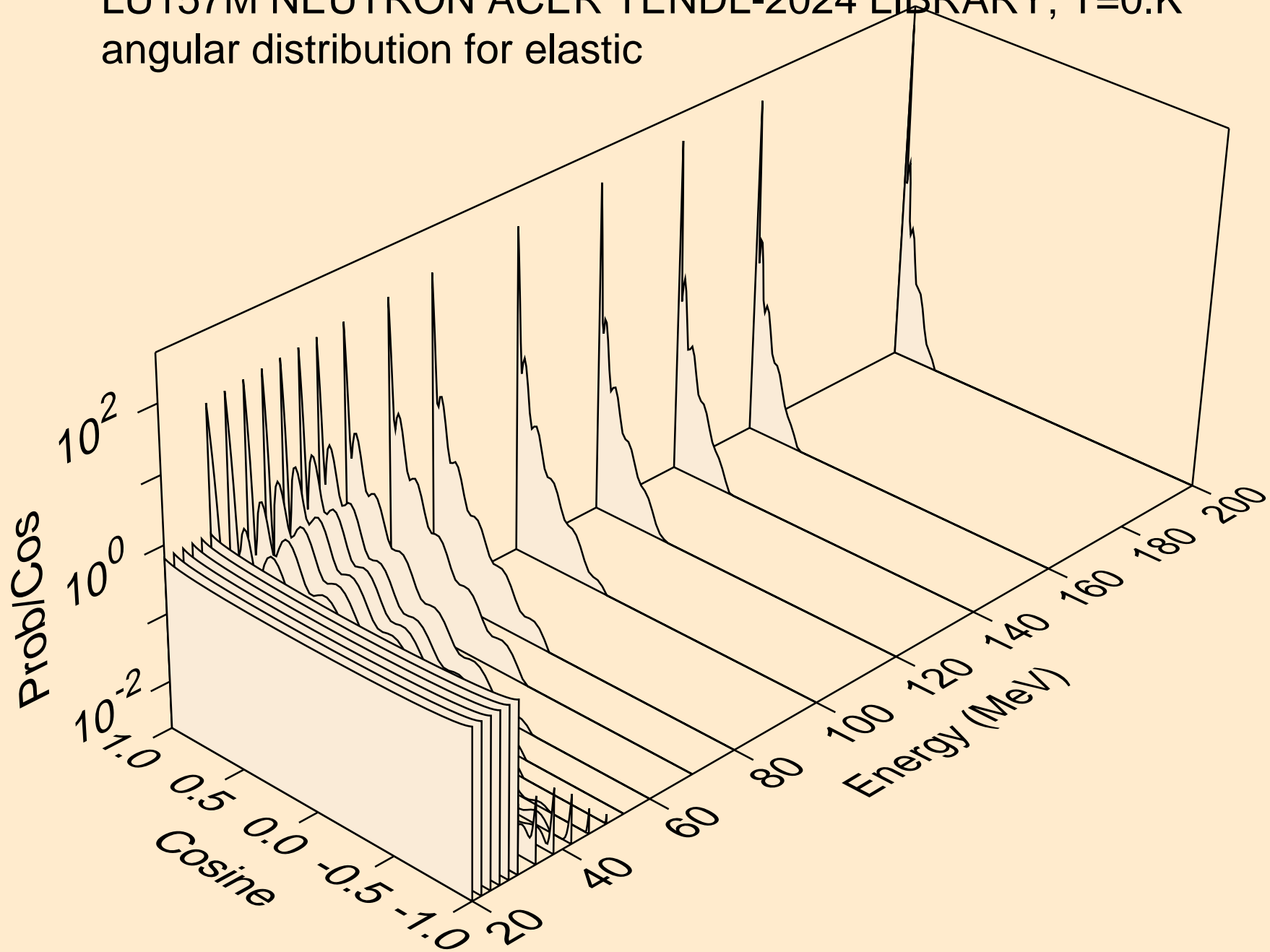

LU157M NEUTRON ACER TENDL-2024 LIBRARY; T=0.K
angular distribution for (n,n*1)

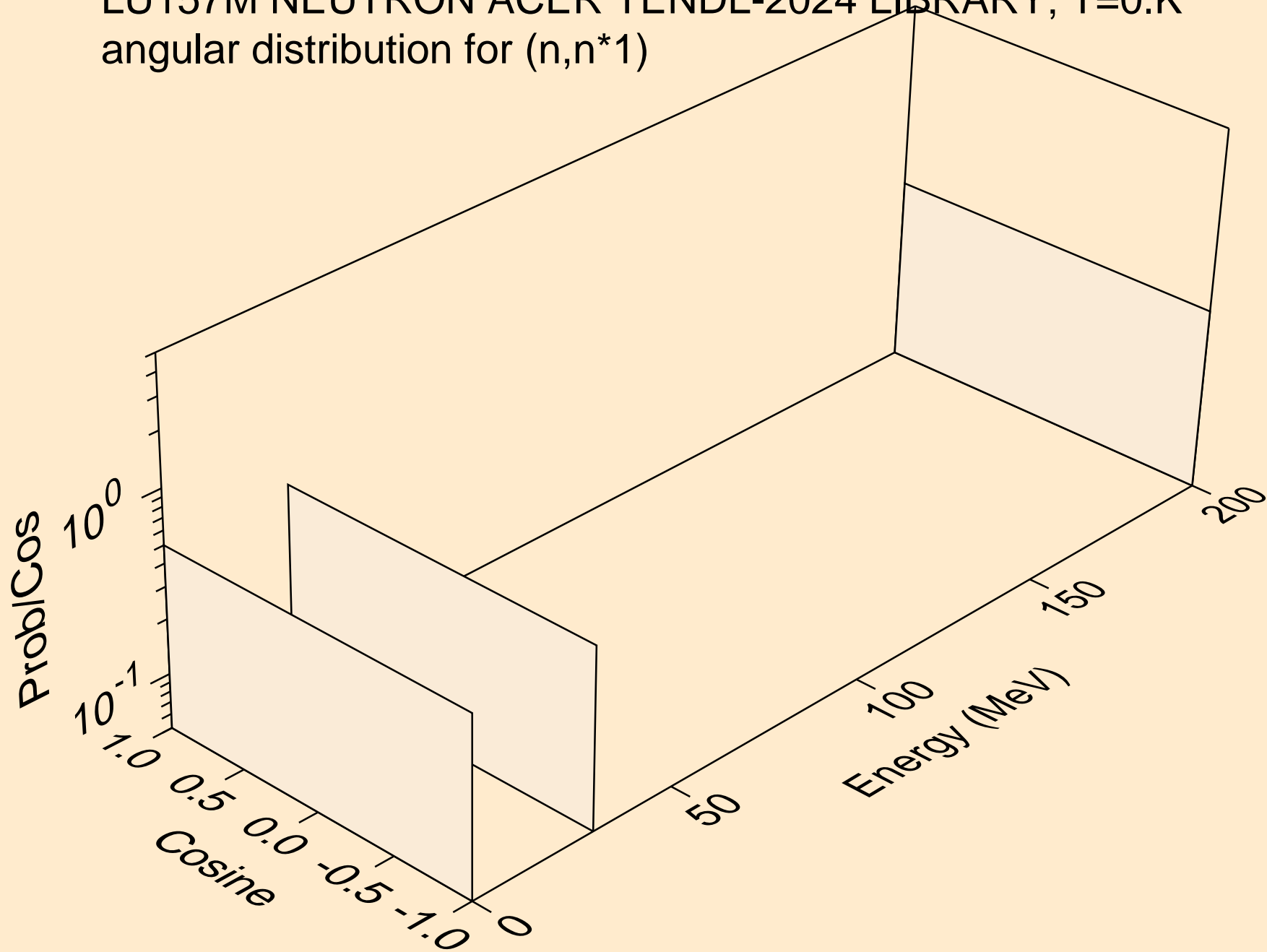

LU157M NEUTRON ACER TENDL-2024 LIBRARY; T=0.K
angular distribution for (n,n*2)

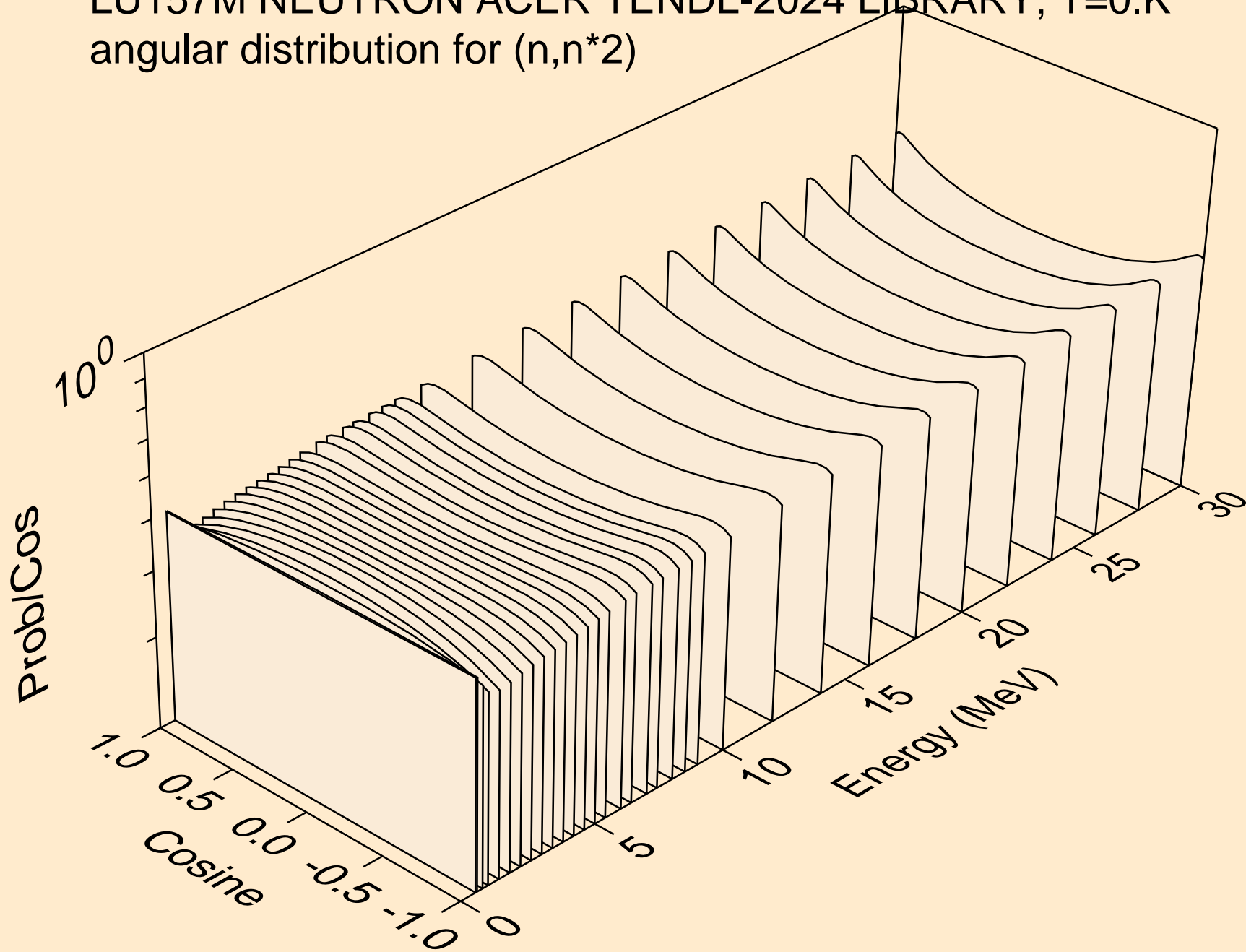

LU157M NEUTRON ACER TENDL-2024 LIBRARY; T=0.K
Neutron emission for (n,x)

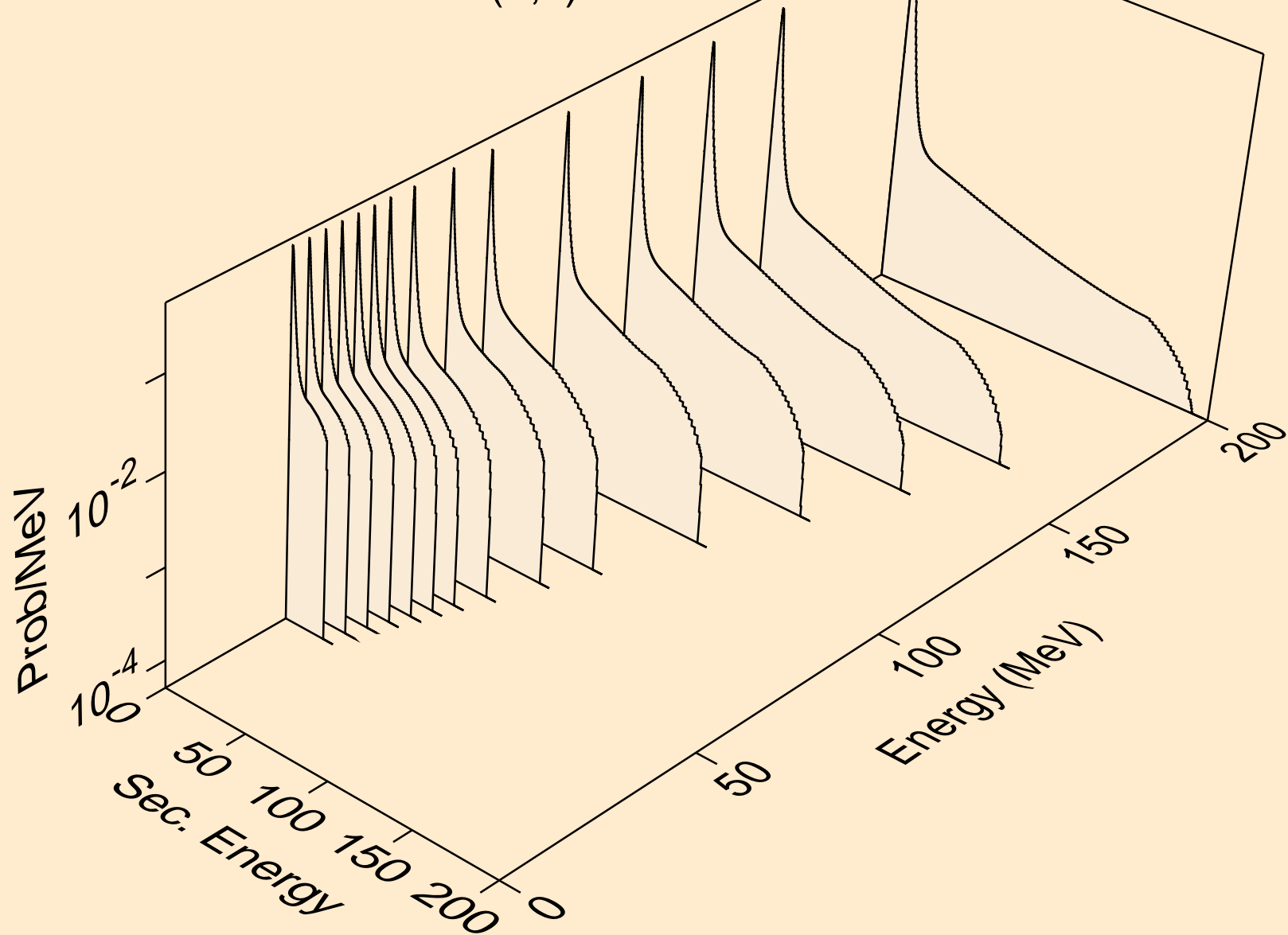

LU157M NEUTRON ACER TENDL-2024 LIBRARY; T=0.K
Neutron emission for (n,2nd)

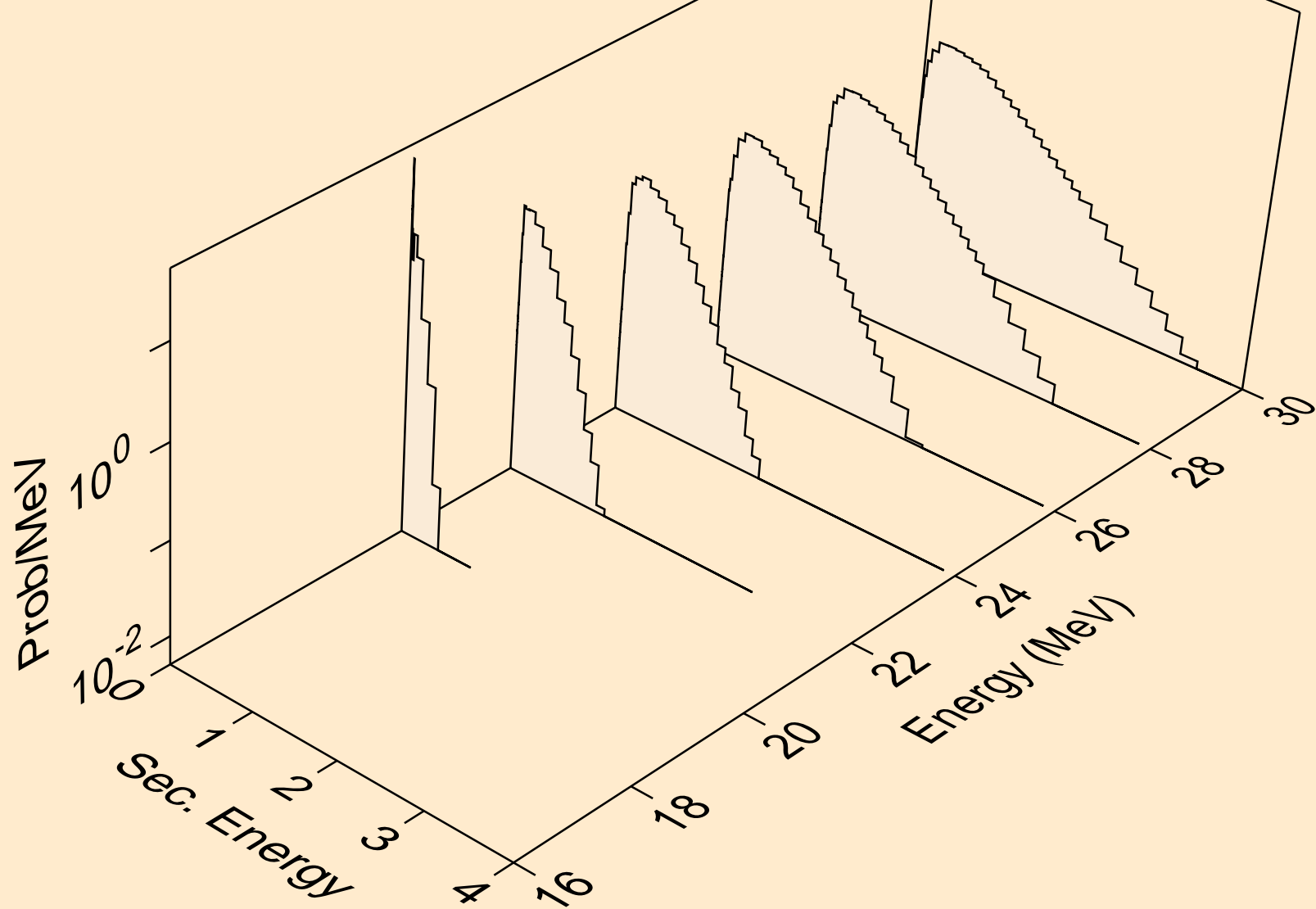

LU157M NEUTRON ACER TENDL-2024 LIBRARY; T=0.K
Neutron emission for (n,2n)

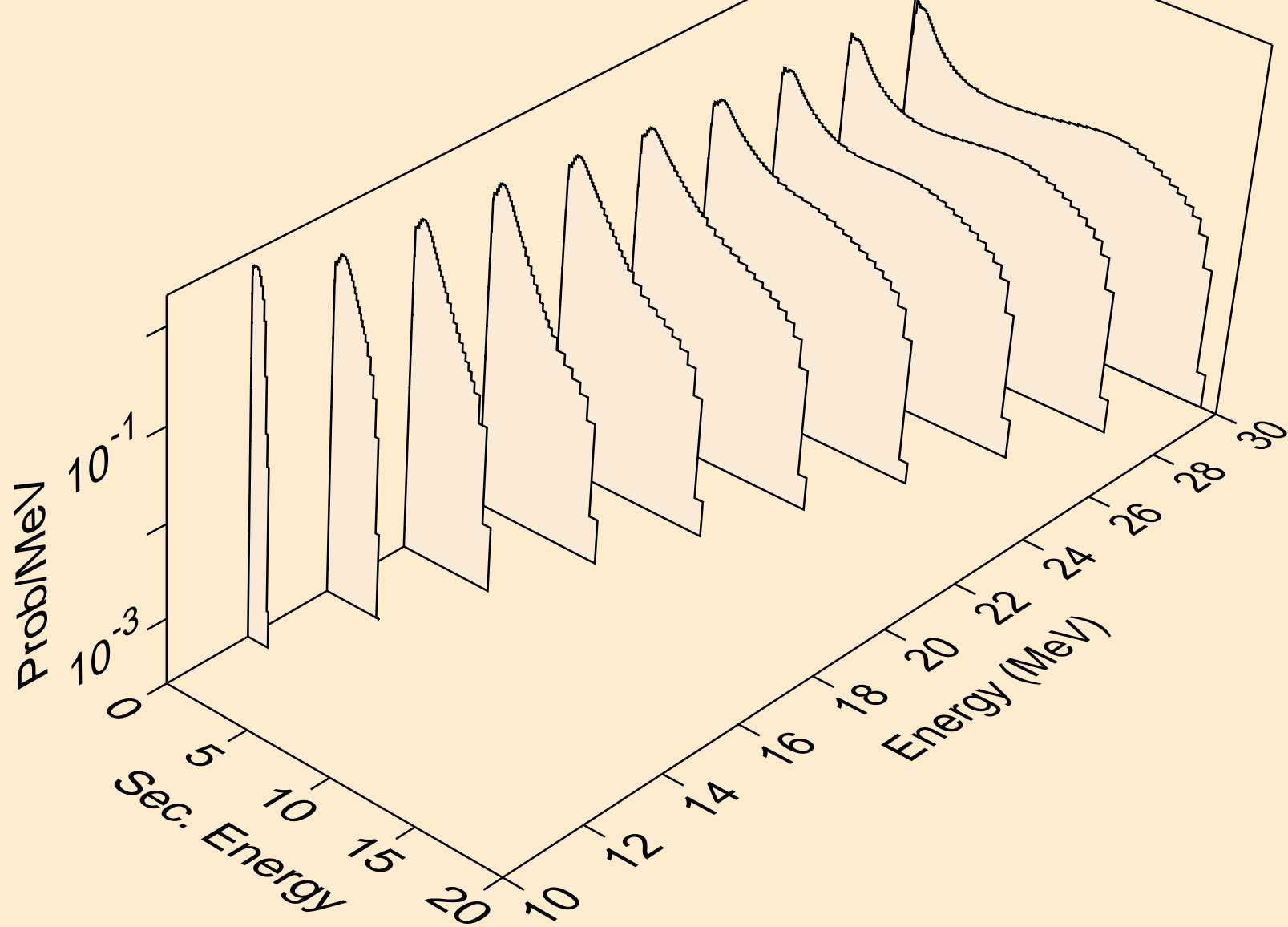

LU157M NEUTRON ACER TENDL-2024 LIBRARY; T=0.K
Neutron emission for (n,3n)

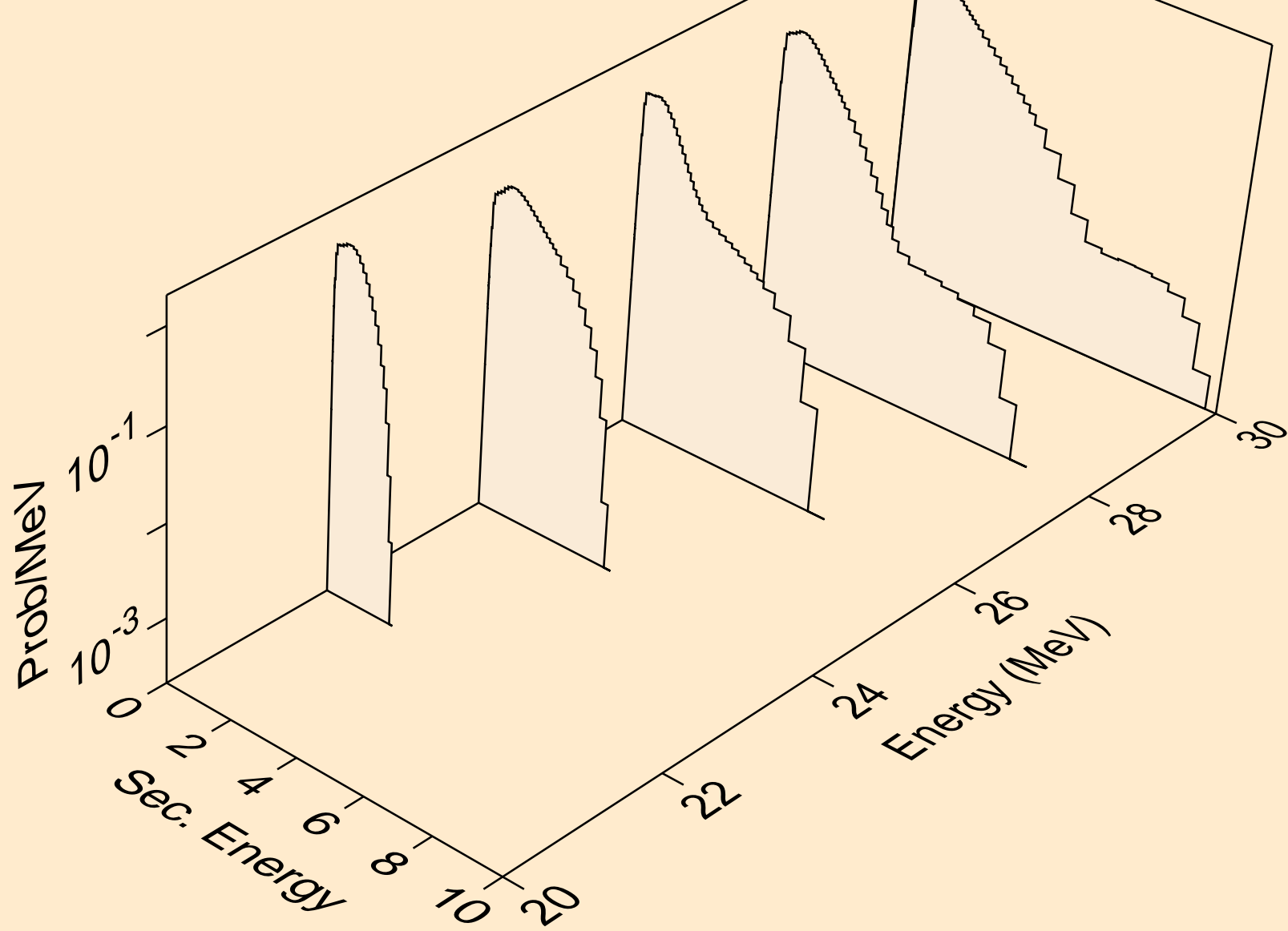

LU157M NEUTRON ACER TENDL-2024 LIBRARY; T=0.K
Neutron emission for (n,n*)a

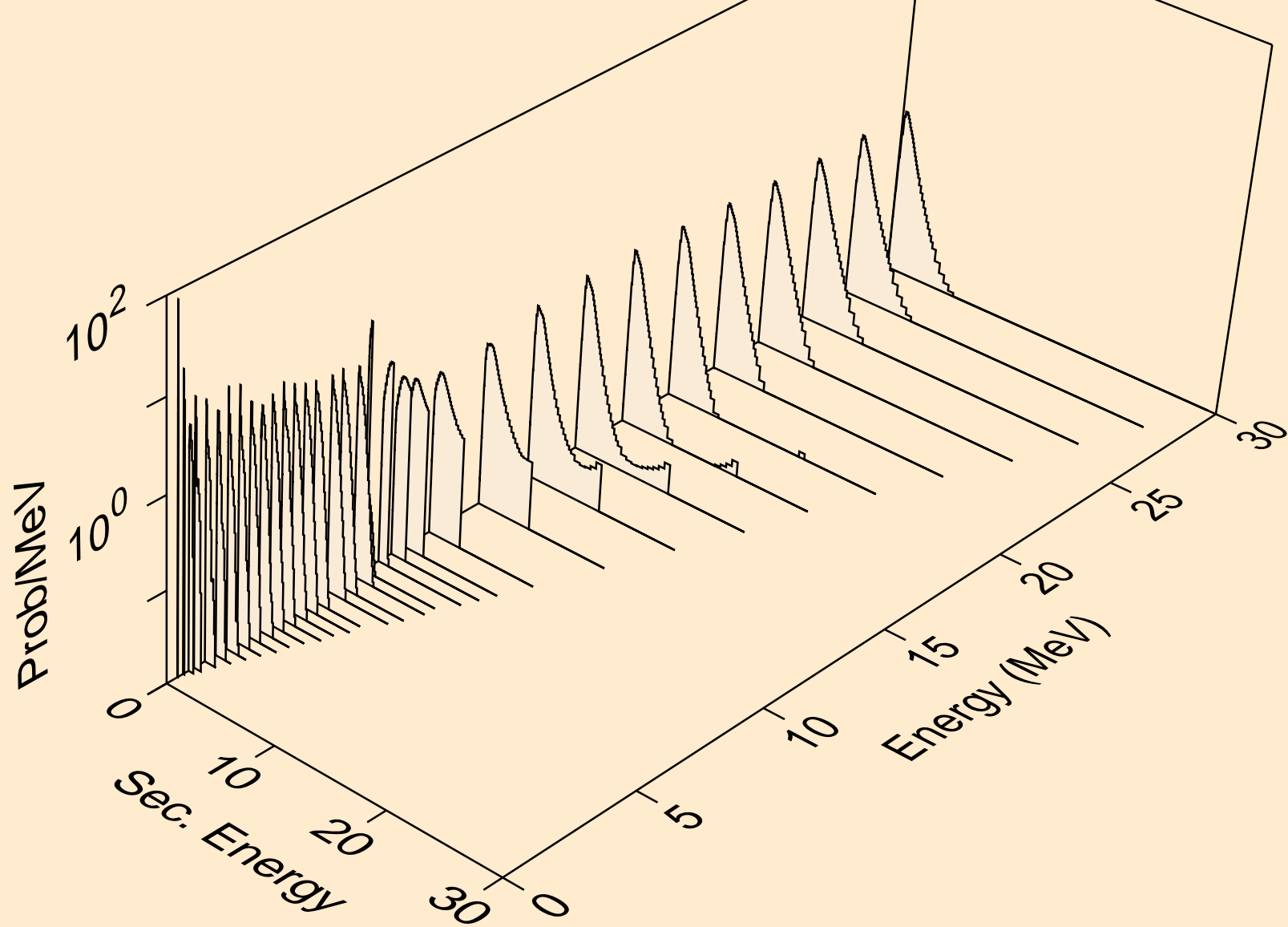

LU157M NEUTRON ACER TENDL-2024 LIBRARY; T=0.K
Neutron emission for (n,n*)3a

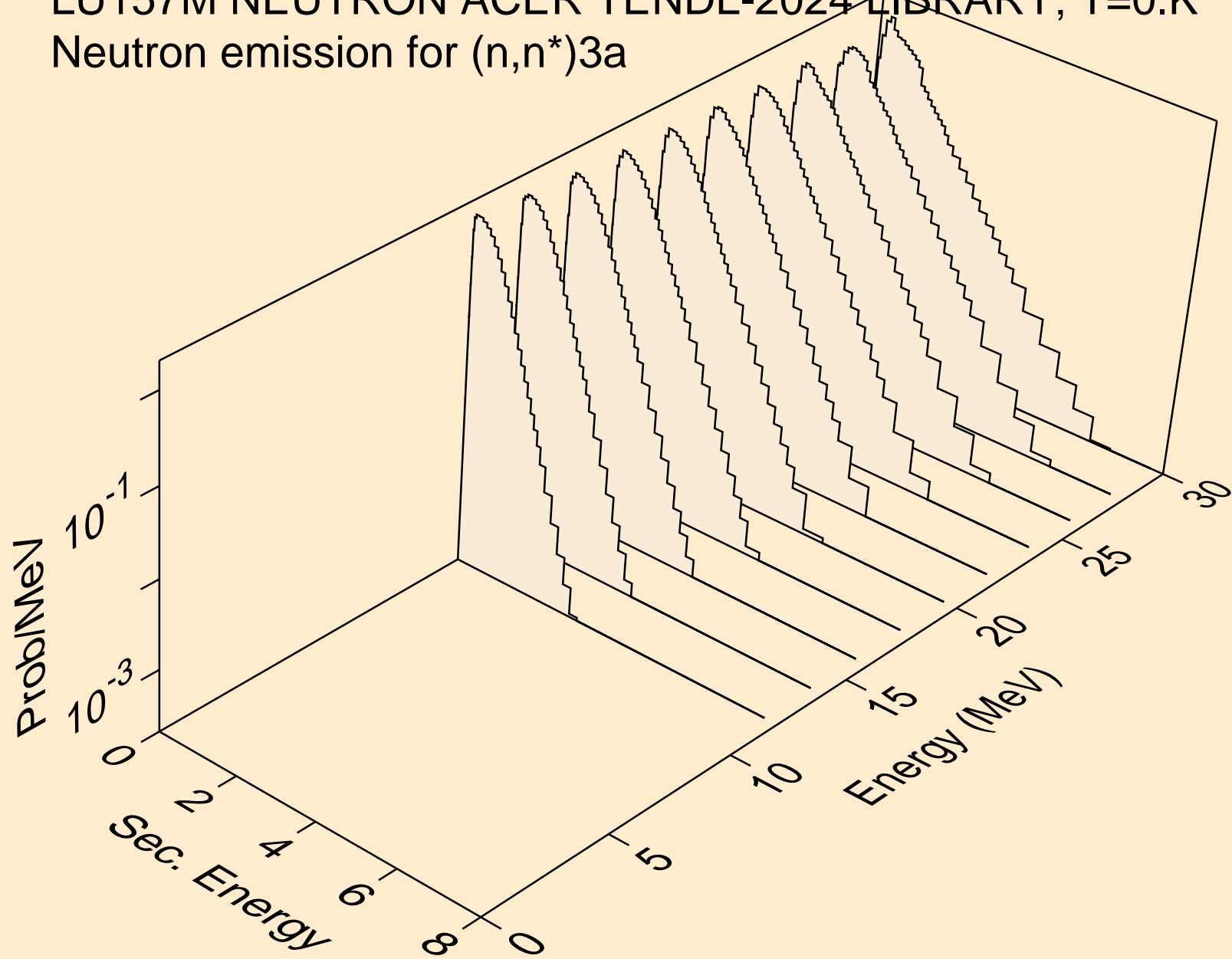

LU157M NEUTRON ACER TENDL-2024 LIBRARY; T=0.K
Neutron emission for (n,2n)a

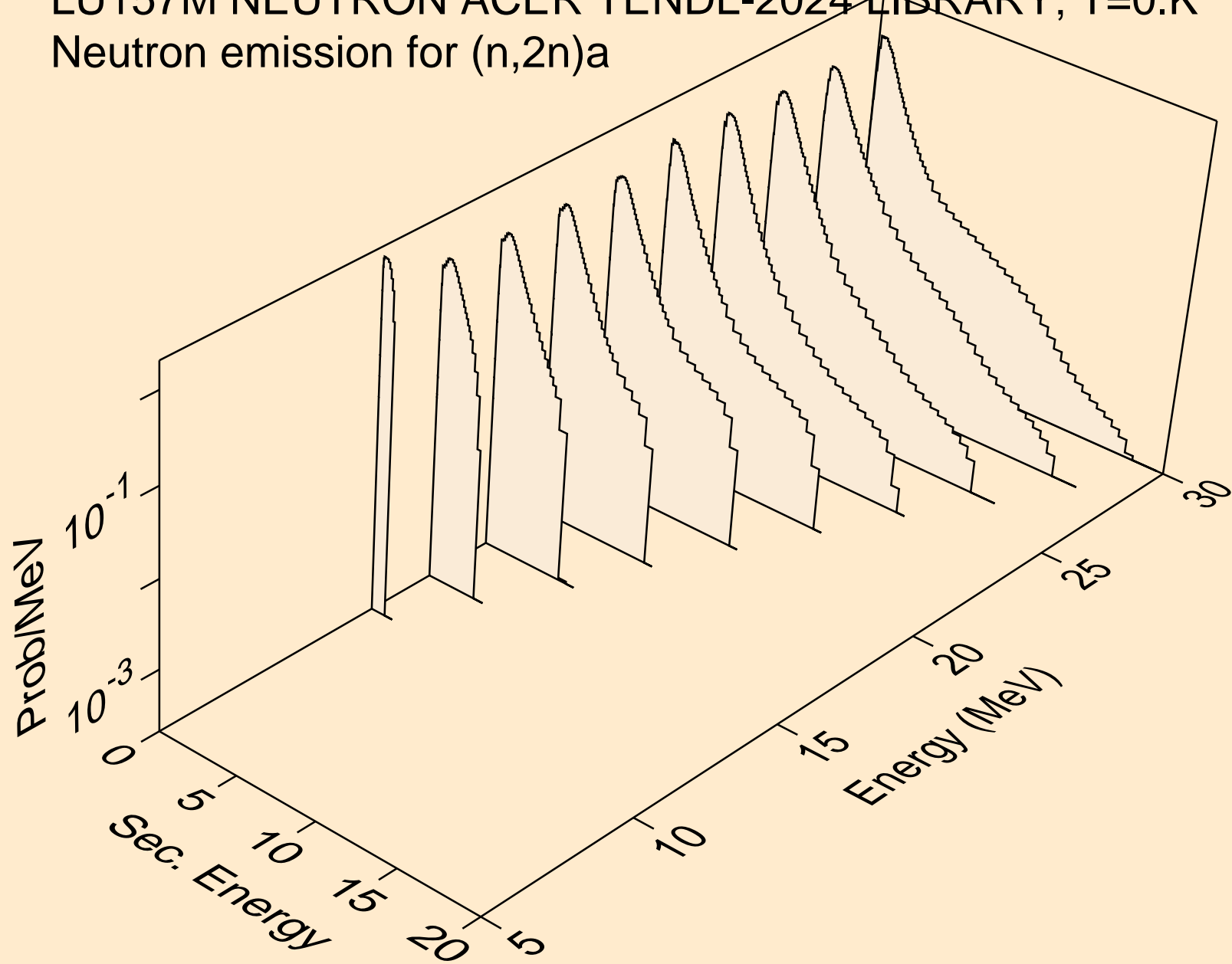

LU157M NEUTRON ACER TENDL-2024 LIBRARY; T=0.K
Neutron emission for (n,3n)a

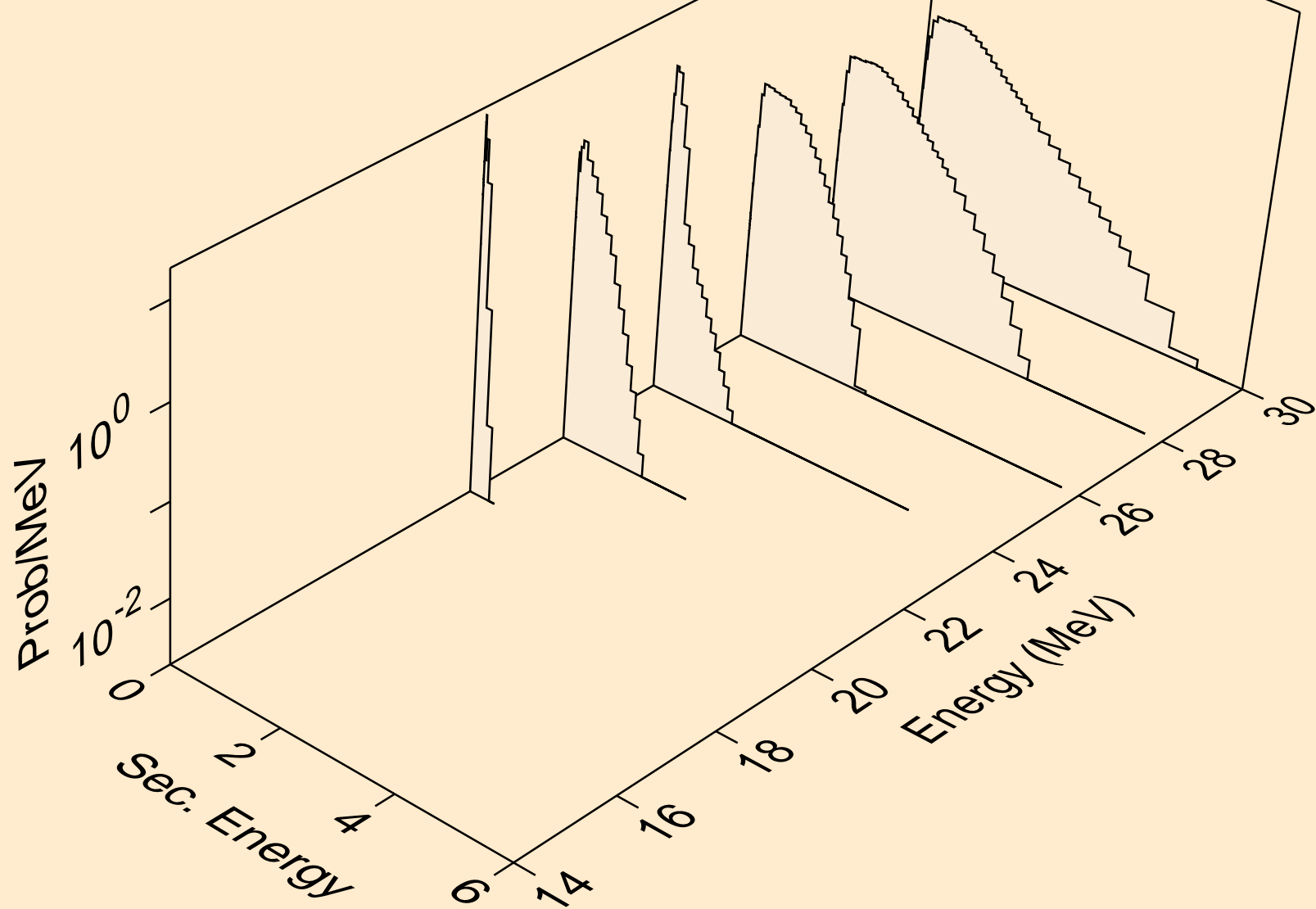

LU157M NEUTRON ACER TENDL-2024 LIBRARY; T=0.K
Neutron emission for (n,n*)p

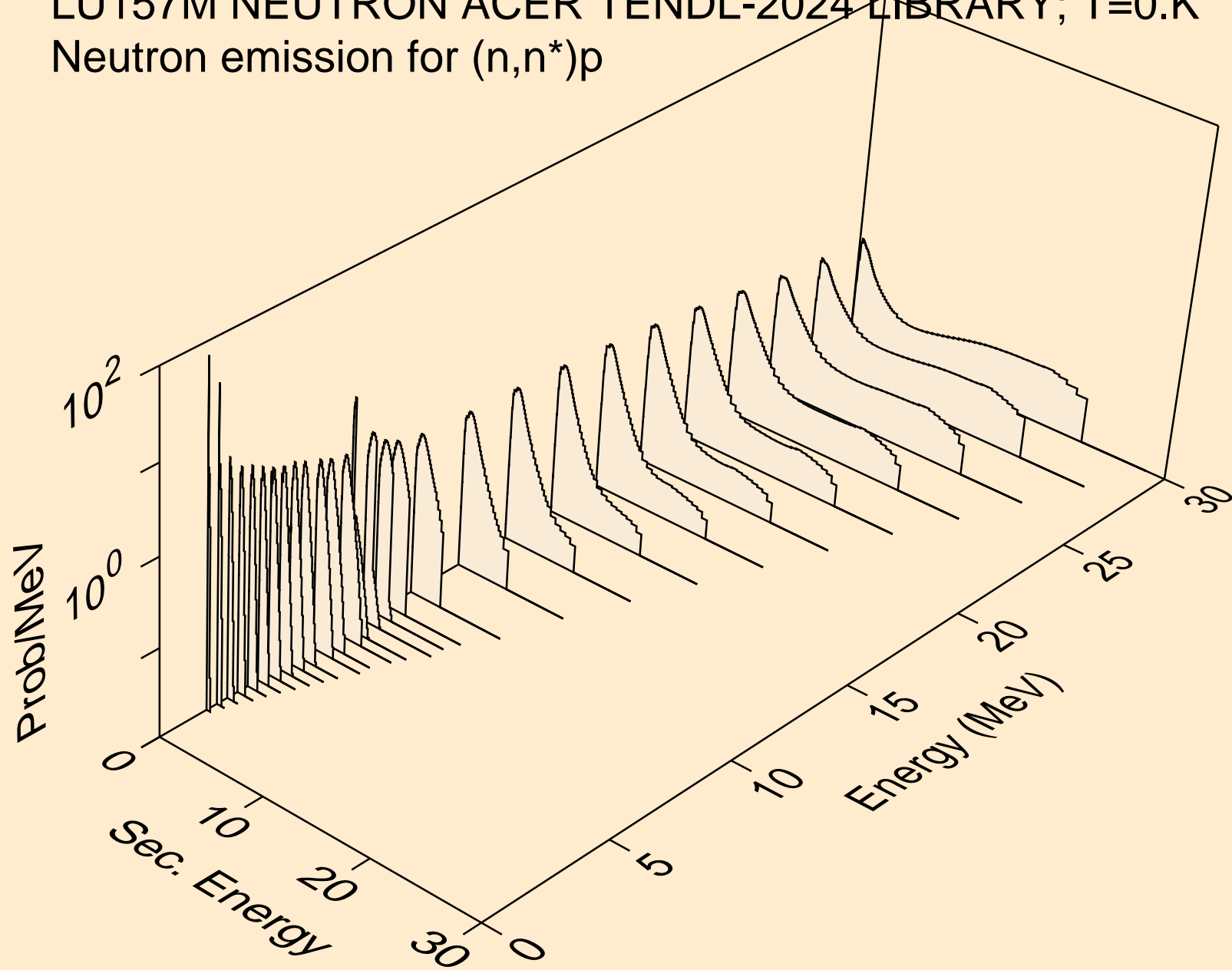

LU157M NEUTRON ACER TENDL-2024 LIBRARY; T=0.K
Neutron emission for (n,n*)2a

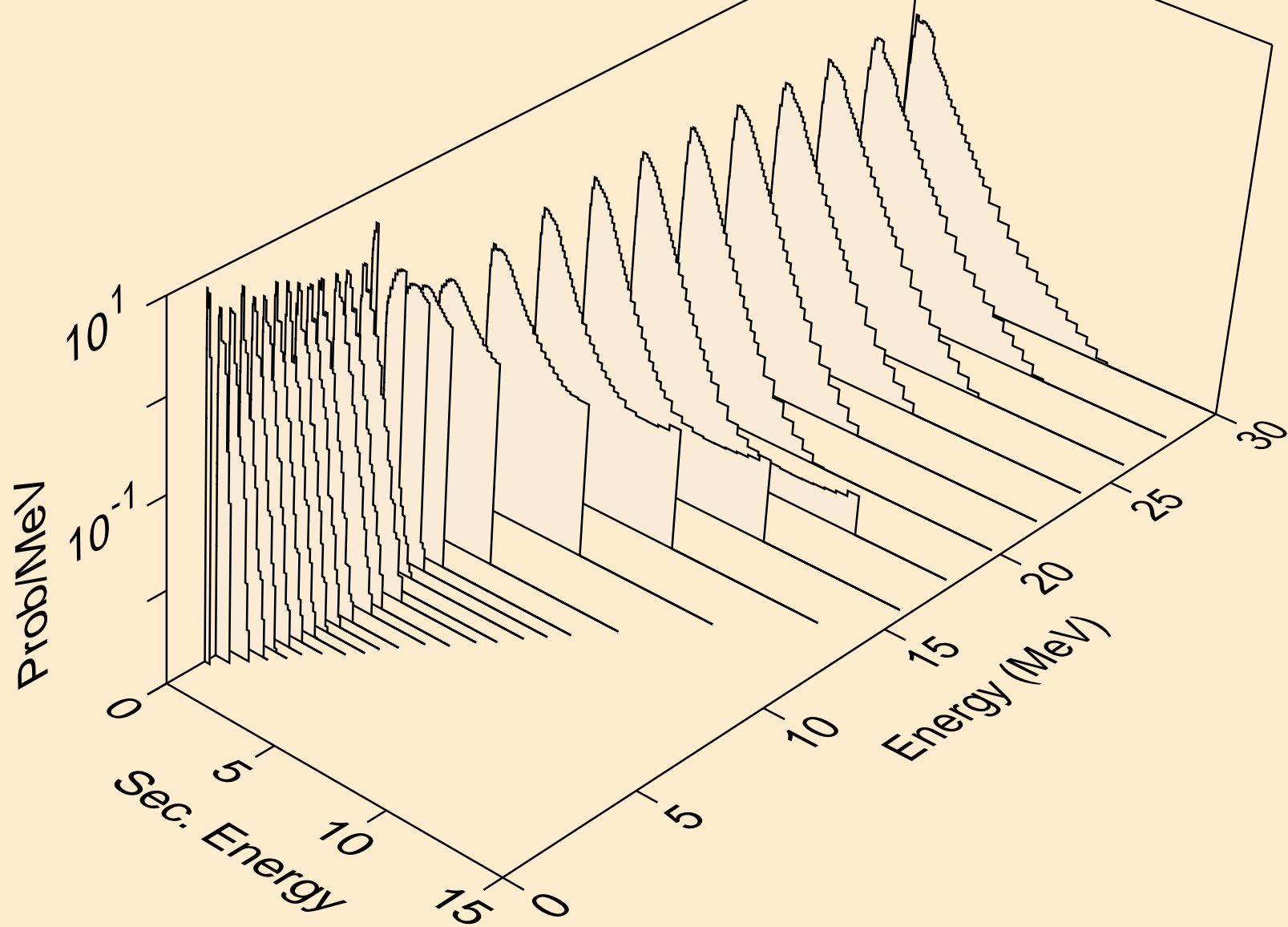

LU157M NEUTRON ACER TENDL-2024 LIBRARY; T=0.K
Neutron emission for (n,2n)2a

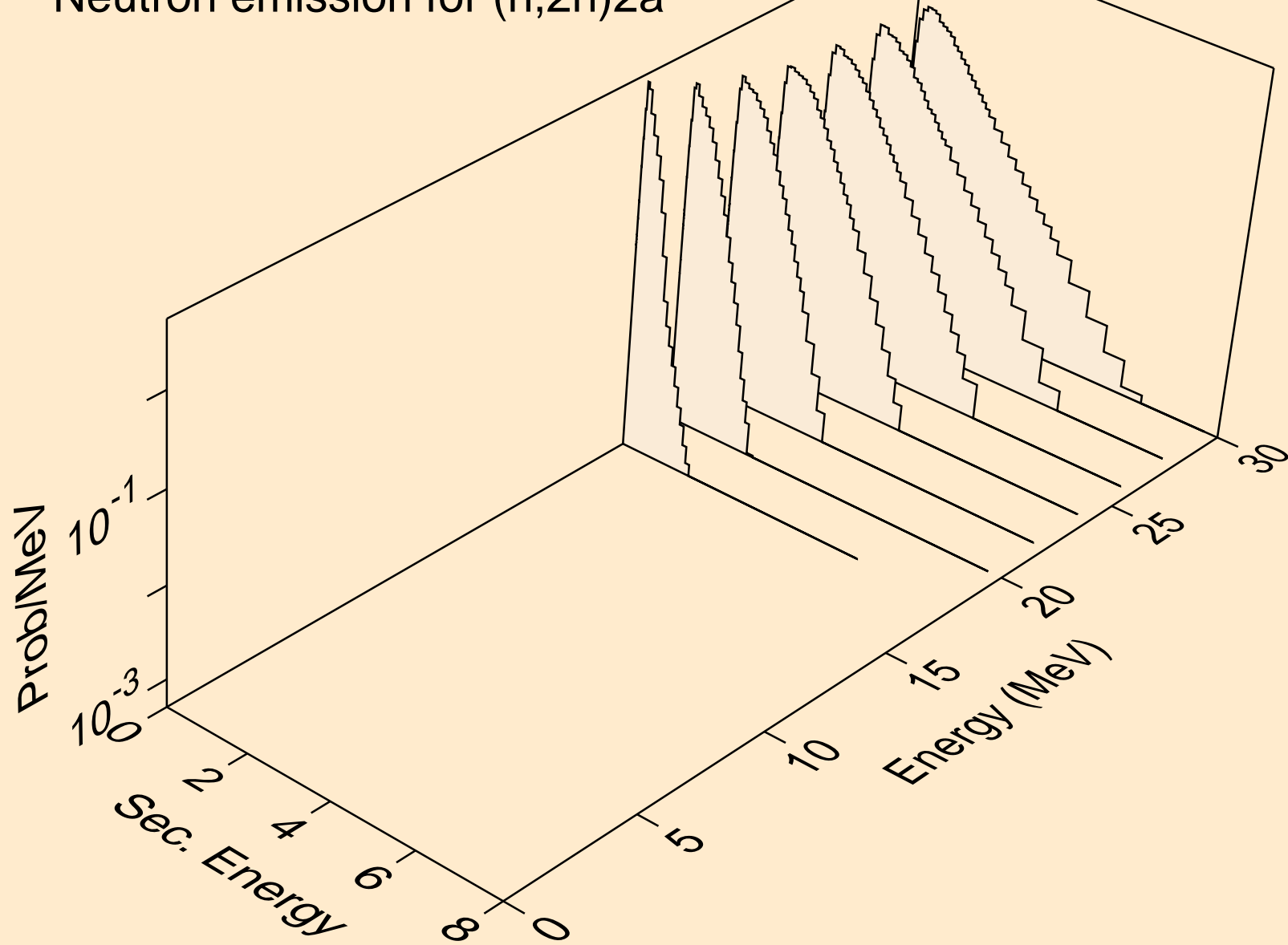

LU157M NEUTRON ACER TENDL-2024 LIBRARY; T=0.K
Neutron emission for (n,n*)d

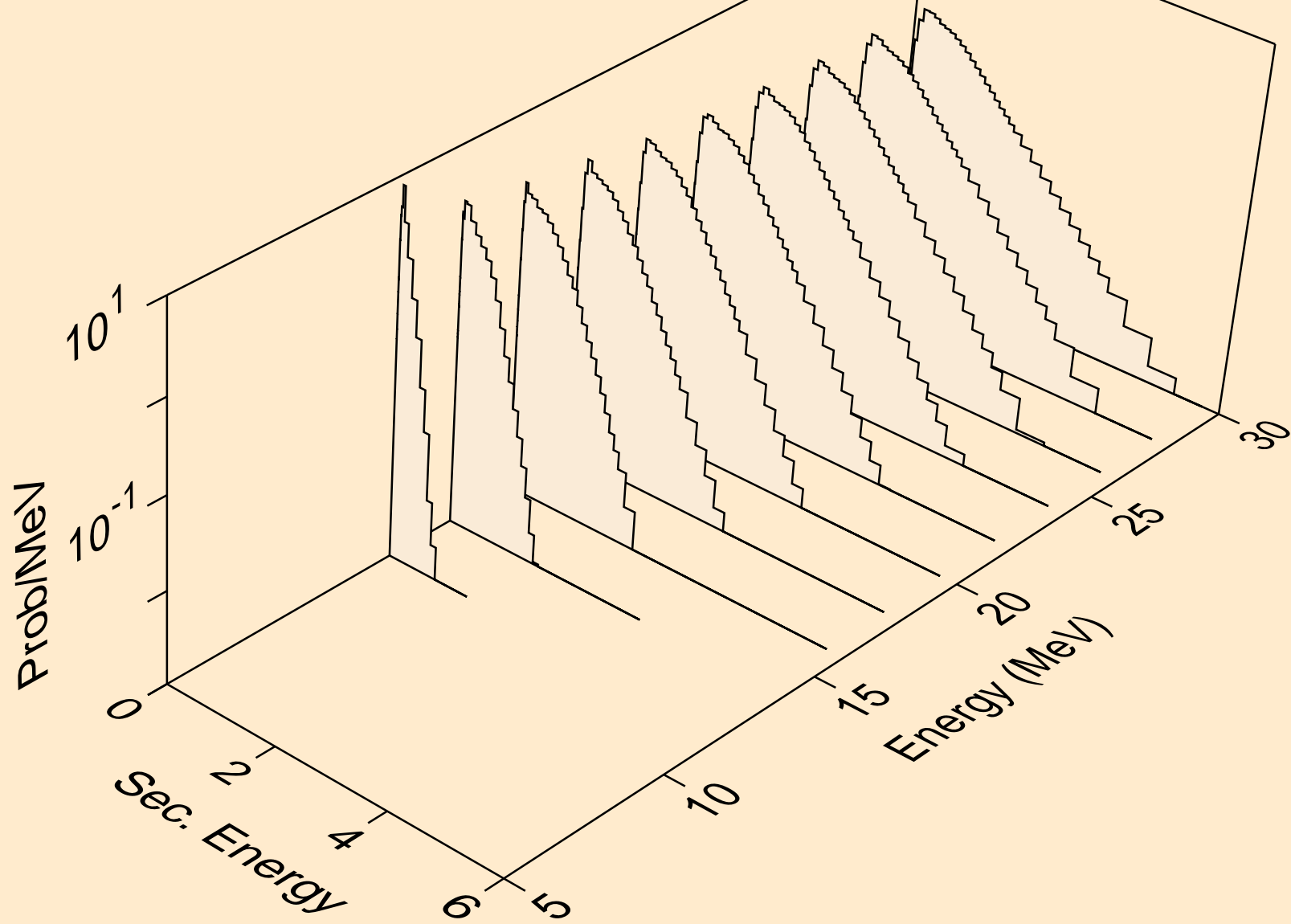

LU157M NEUTRON ACER TENDL-2024 LIBRARY; T=0.K
Neutron emission for (n,n*)t

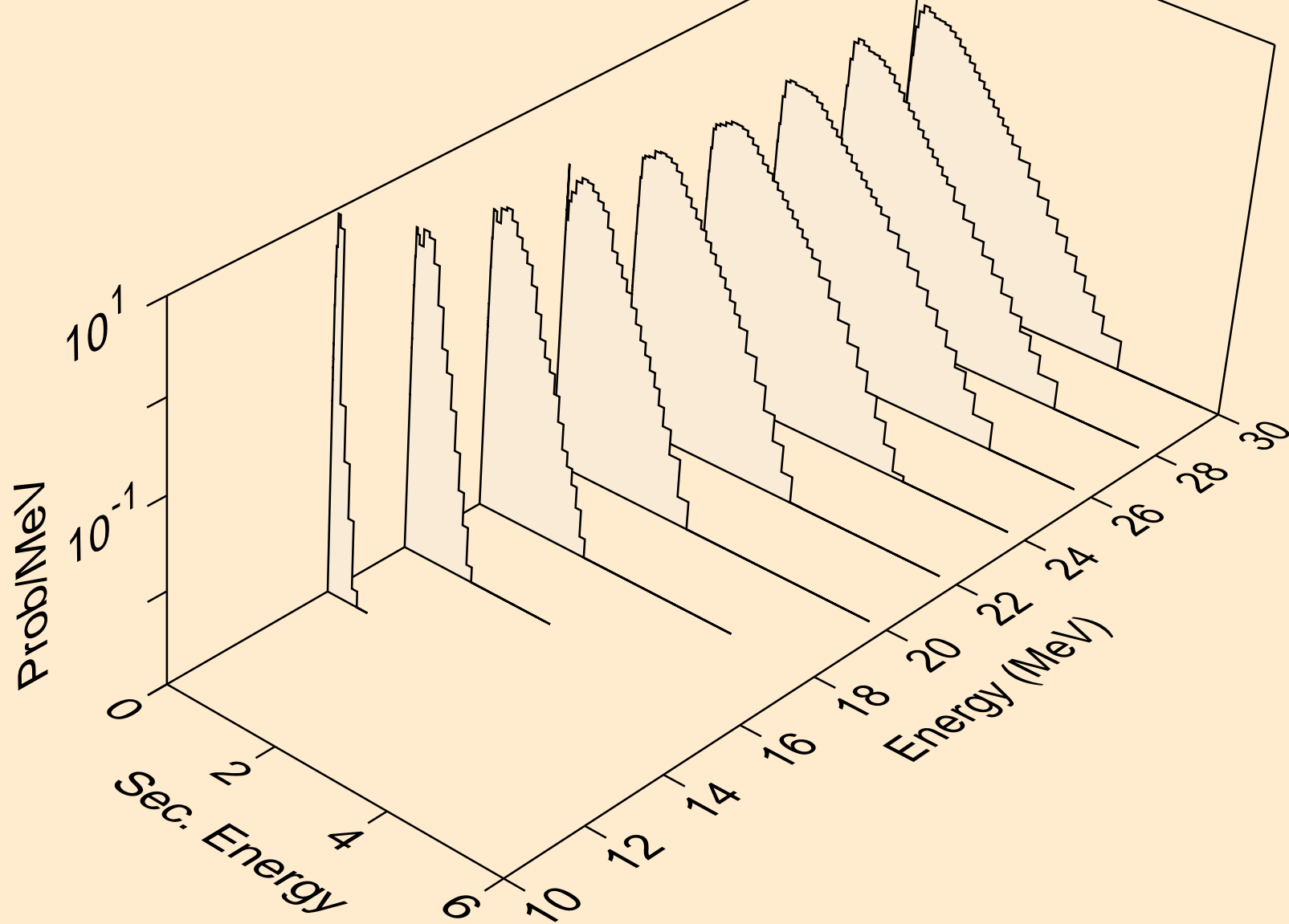

LU157M NEUTRON ACER TENDL-2024 LIBRARY; T=0.K
Neutron emission for (n,n*)he3

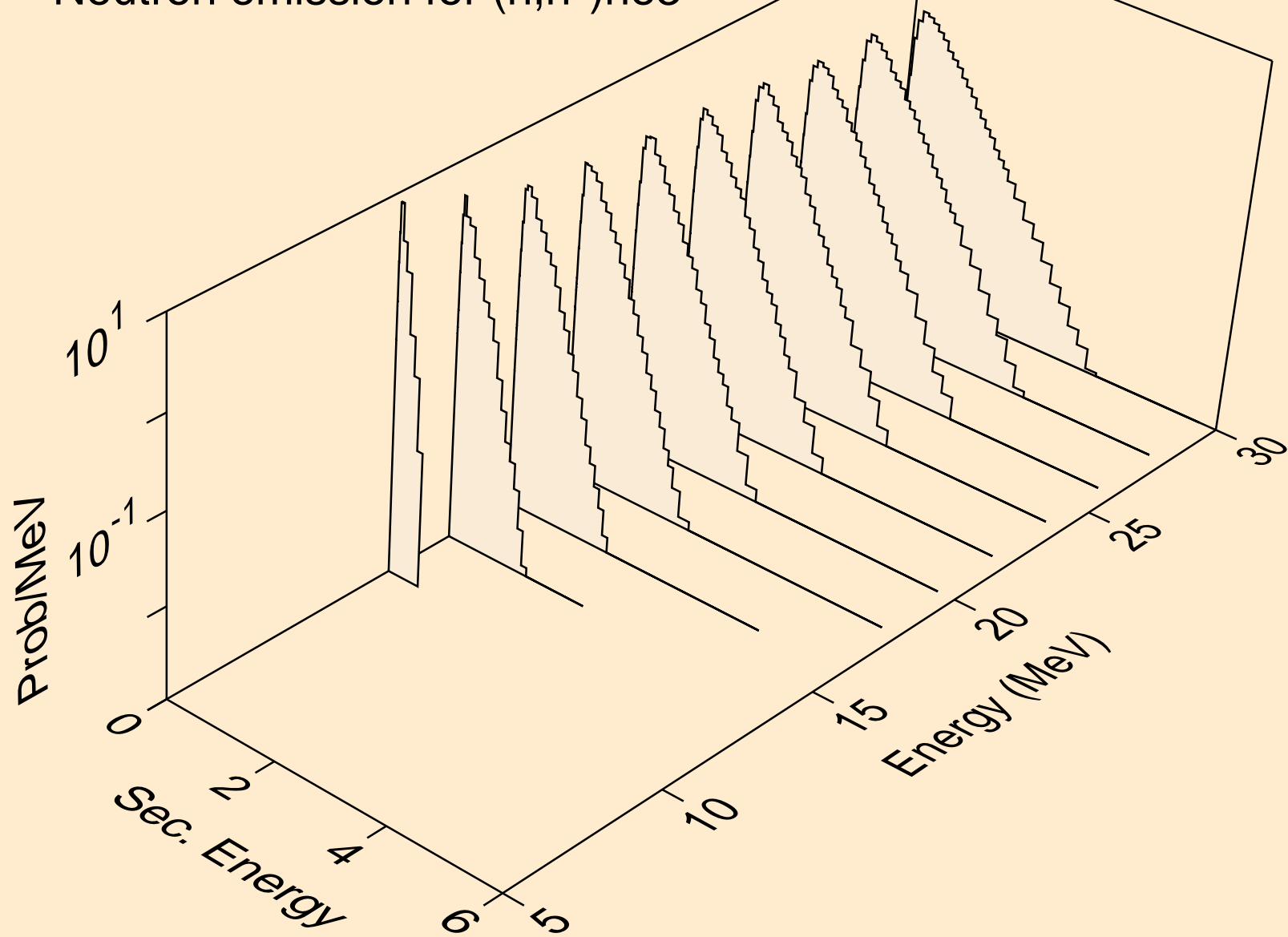

LU157M NEUTRON ACER TENDL-2024 LIBRARY; T=0.K
Neutron emission for (n,2np)

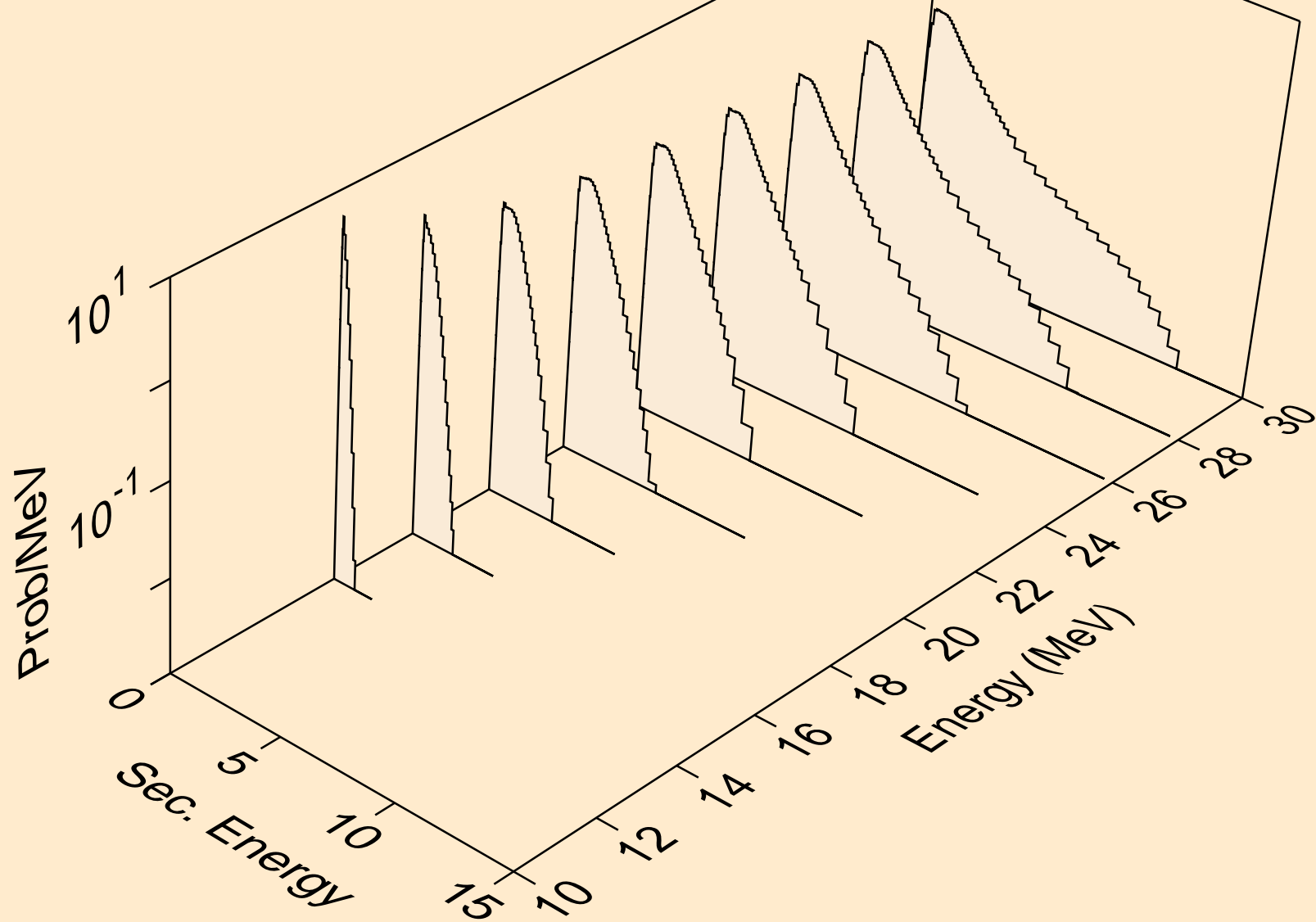

LU157M NEUTRON ACER TENDL-2024 LIBRARY; T=0.K
Neutron emission for (n,3np)

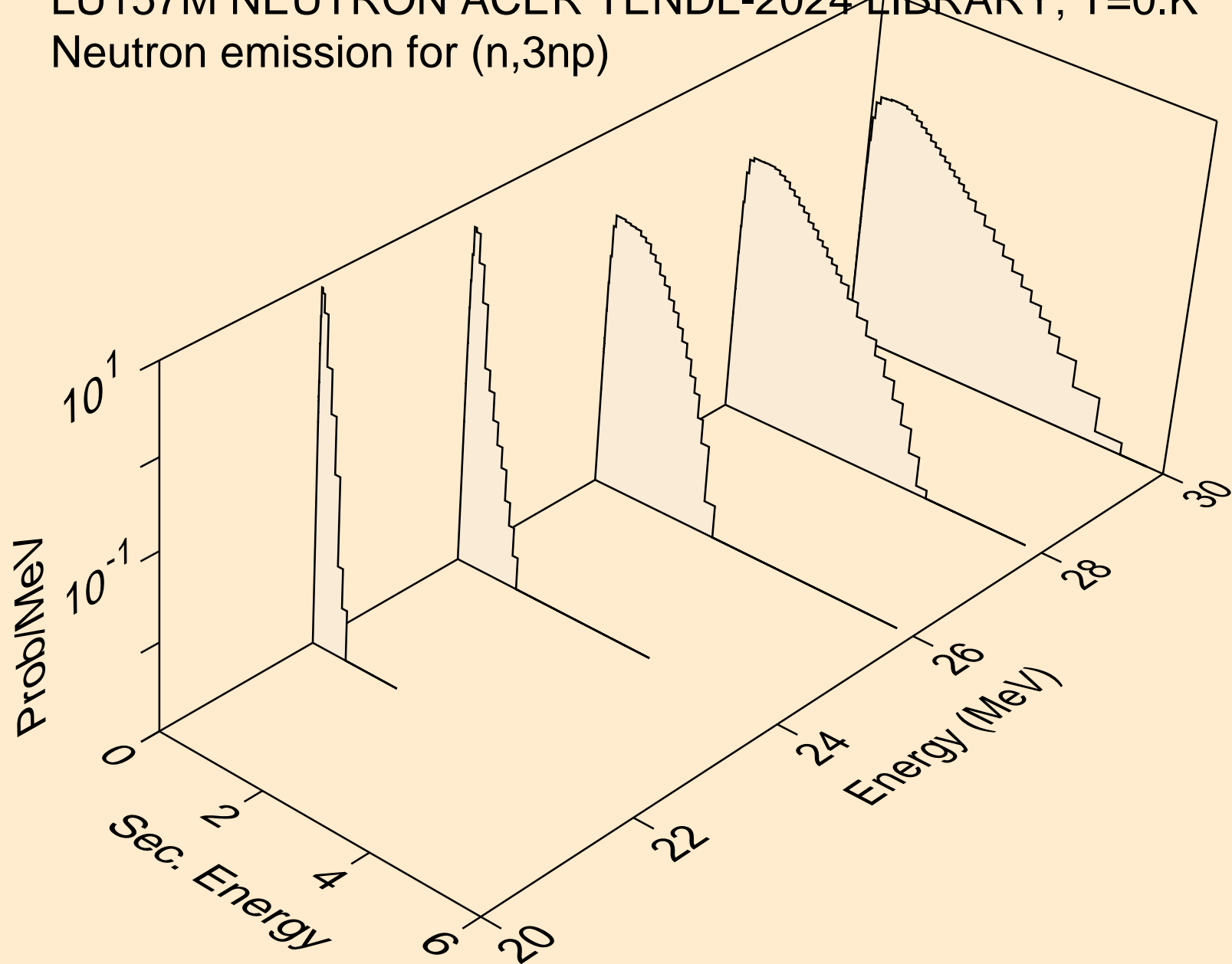

LU157M NEUTRON ACER TENDL-2024 LIBRARY; T=0.K
Neutron emission for (n,n2p)

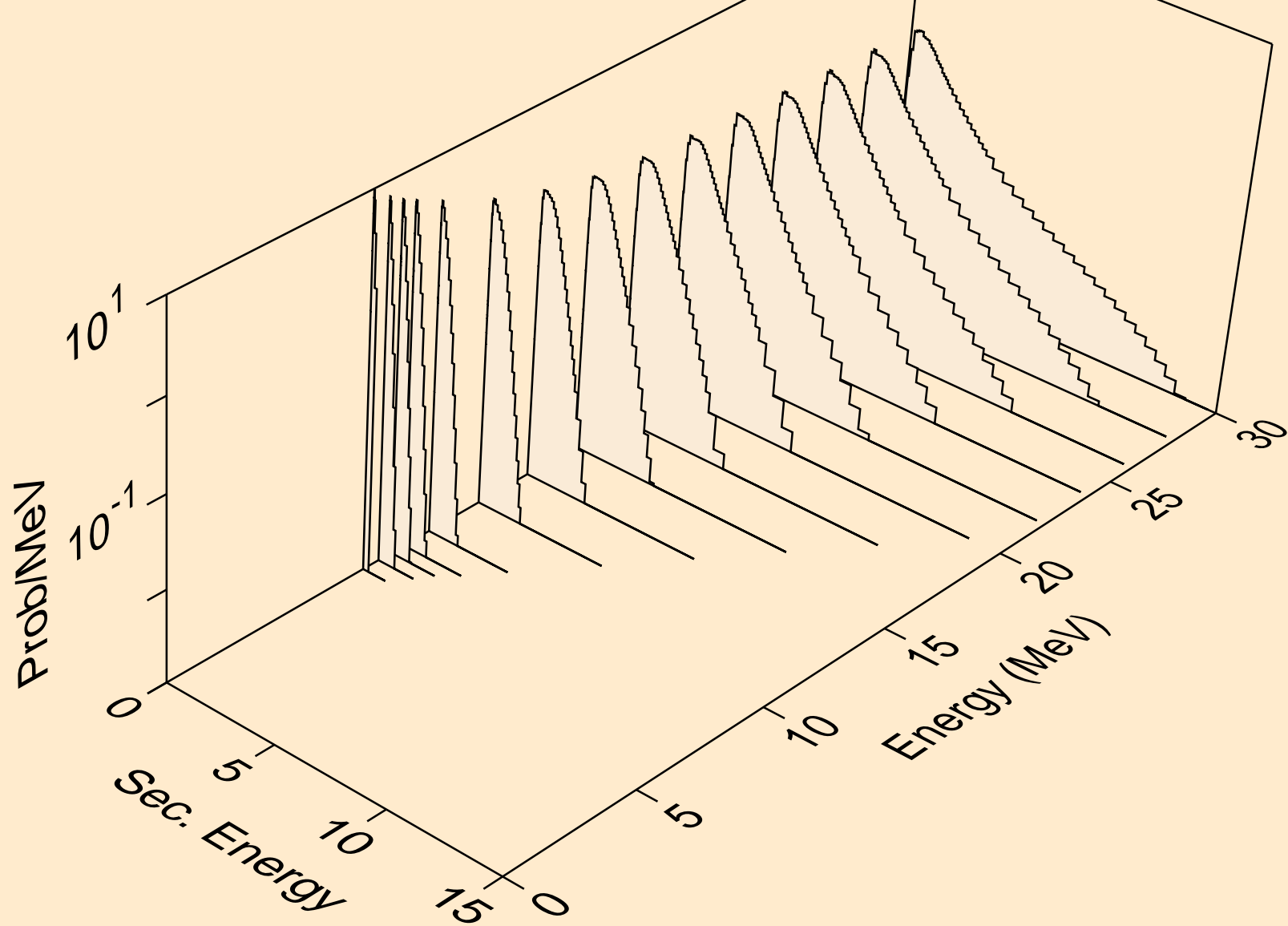

LU157M NEUTRON ACER TENDL-2024 LIBRARY; T=0.K
Neutron emission for (n,npa)

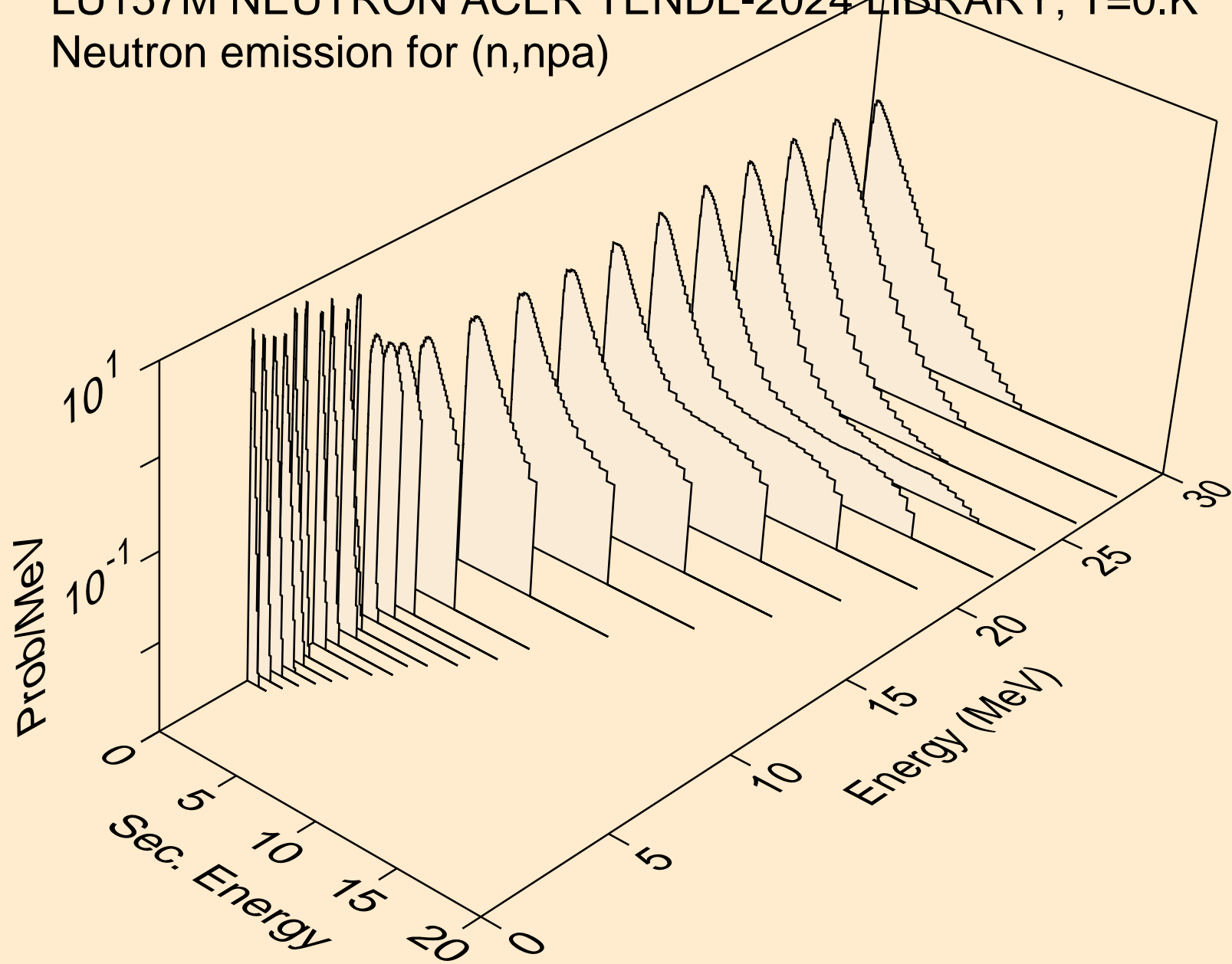

LU157M NEUTRON ACER TENDL-2024 LIBRARY; T=0.K
Neutron emission for (n,n*c)

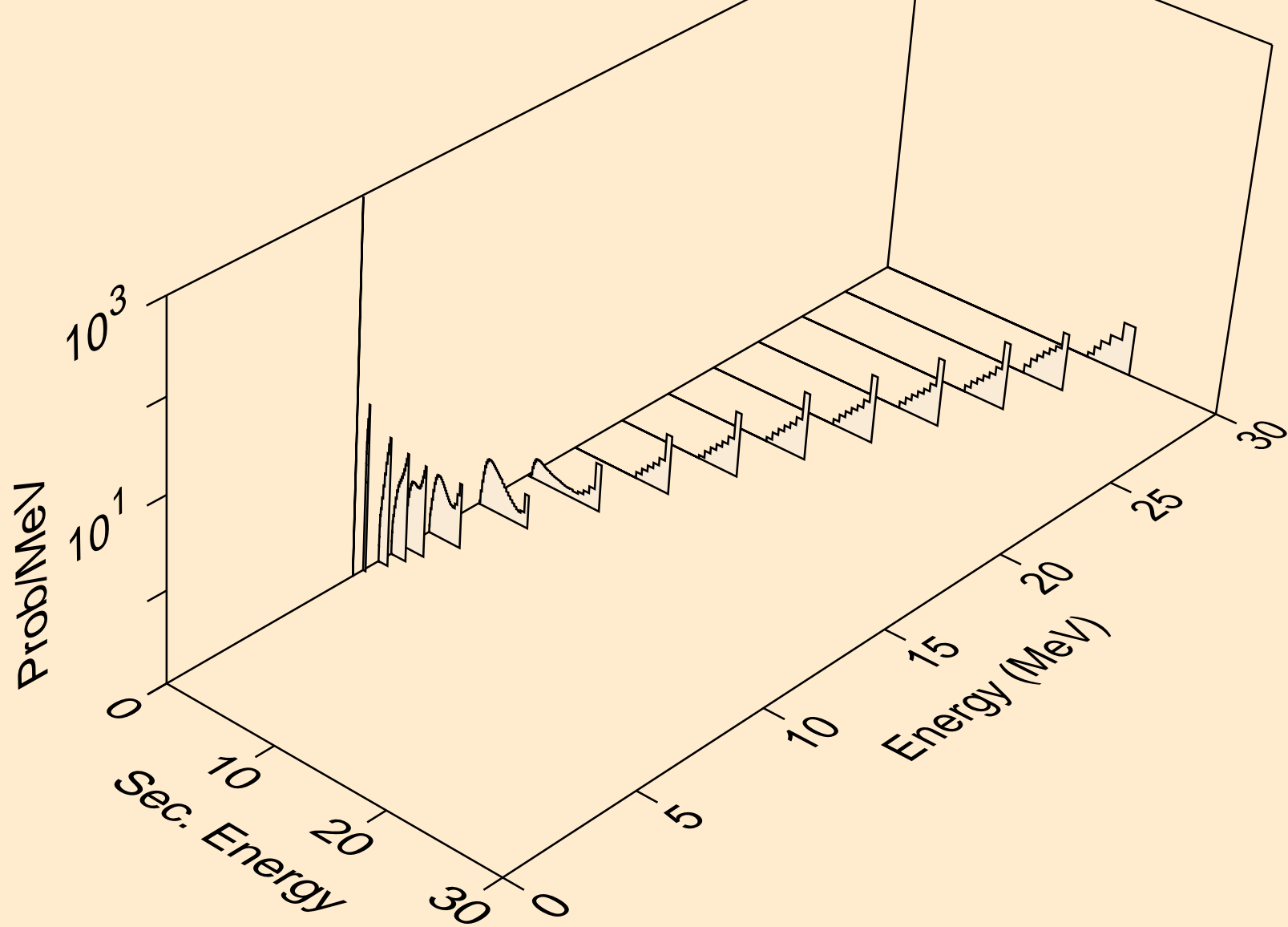

LU157M NEUTRON ACER TENDL-2024 LIBRARY; T=0.K
Photon emission for (n,x)

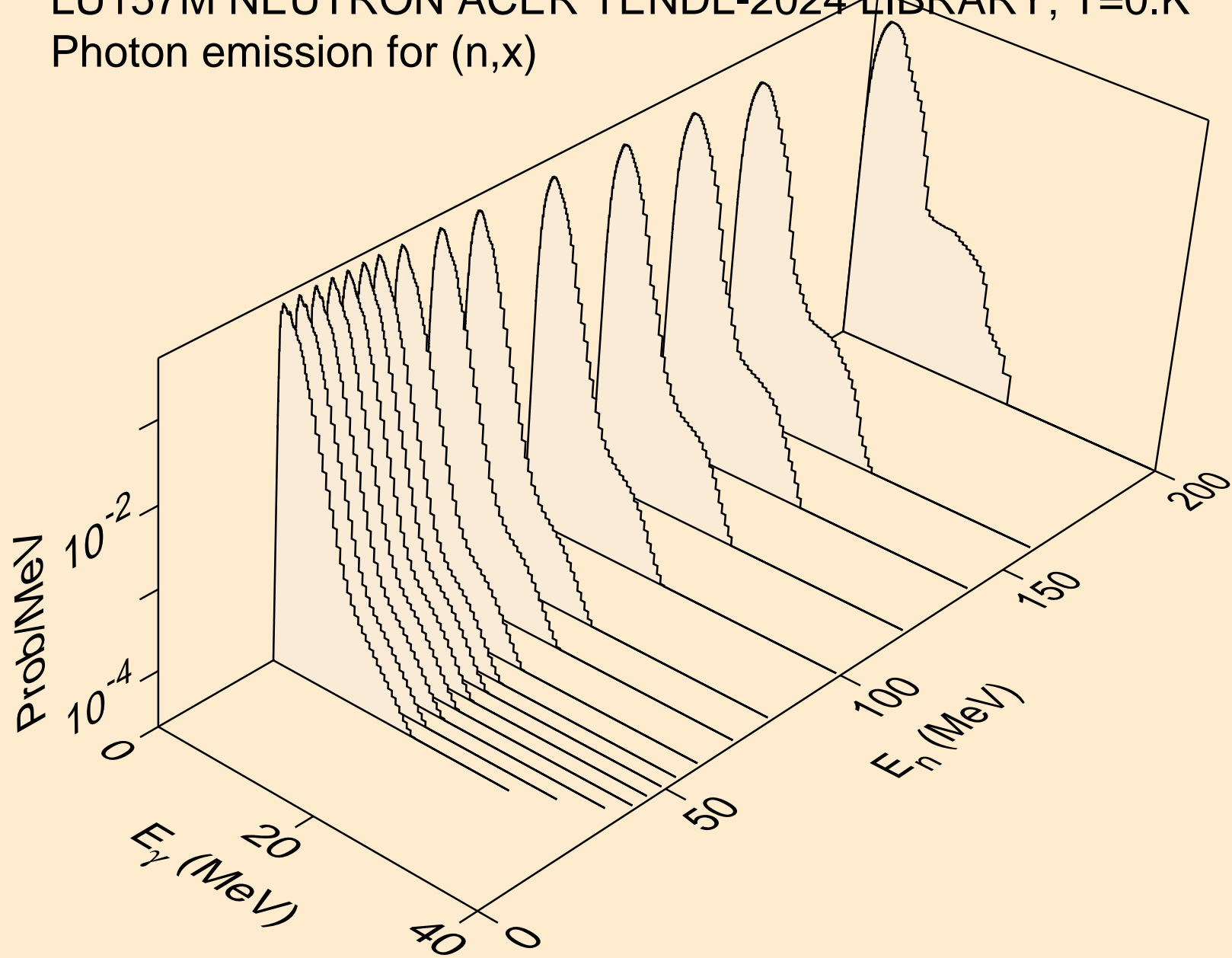

LU157M NEUTRON ACER TENDL-2024 LIBRARY; T=0.K
Photon emission for (n,2nd)

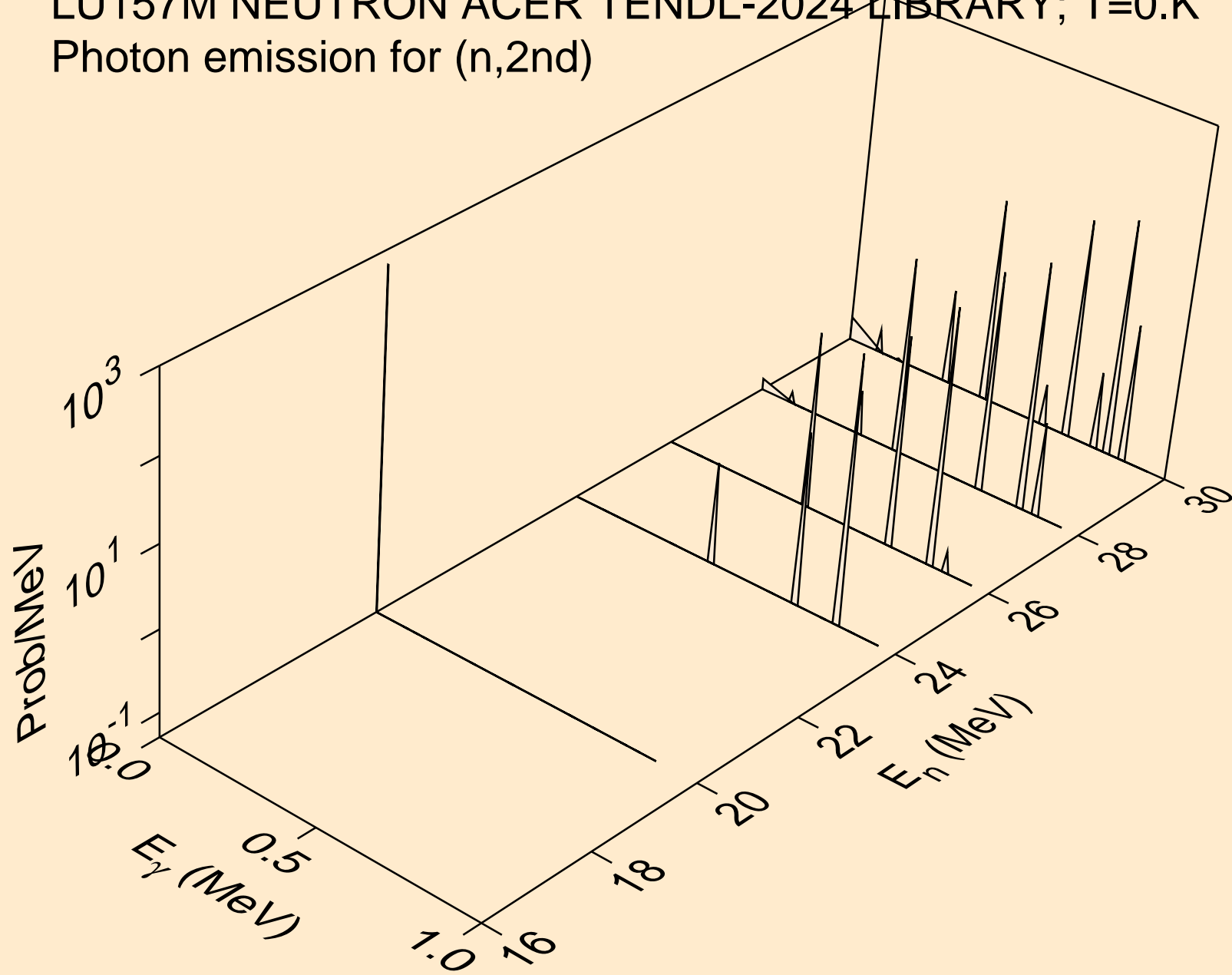

LU157M NEUTRON ACER TENDL-2024 LIBRARY; T=0.K
Photon emission for (n,2n)

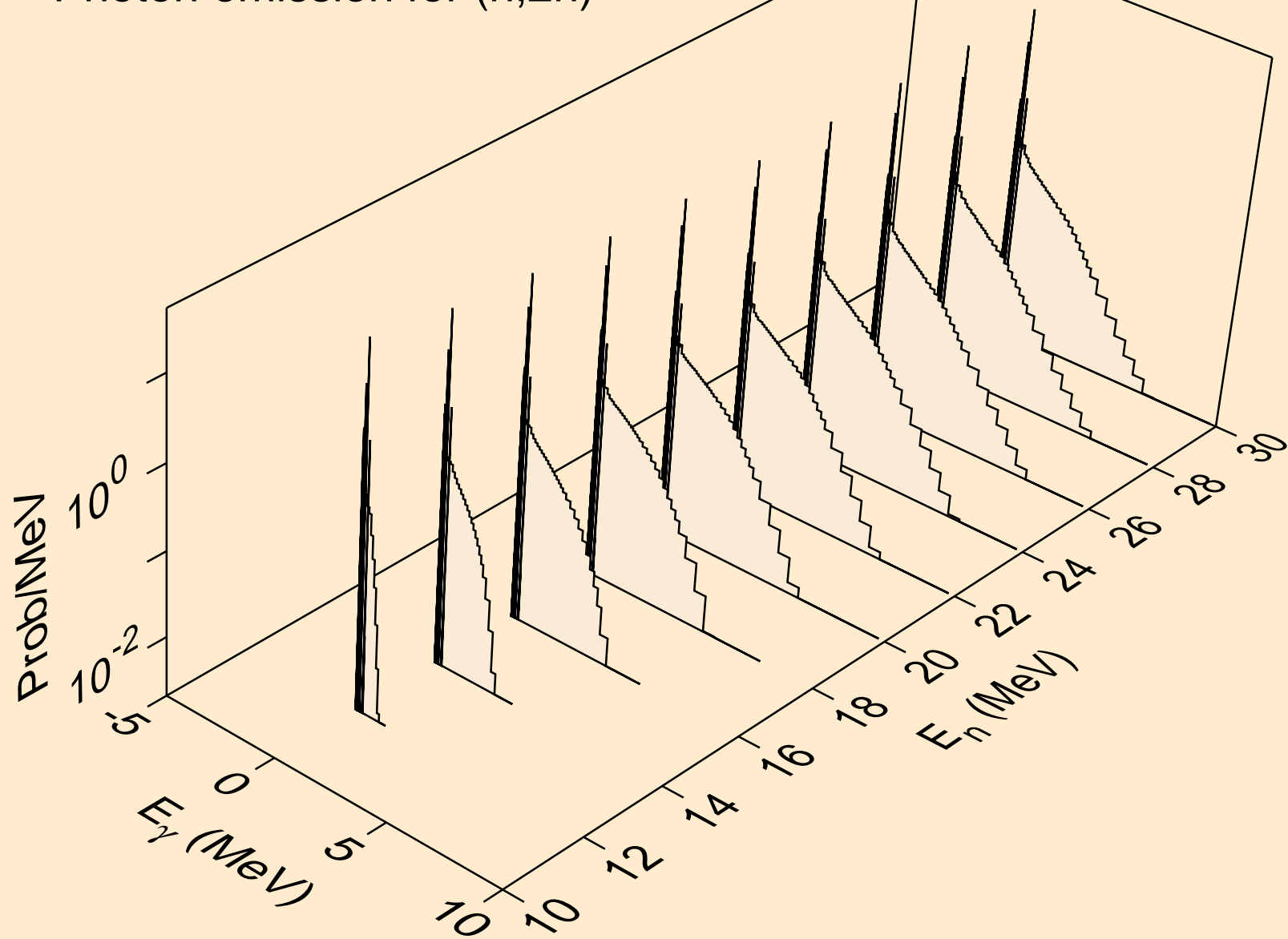

LU157M NEUTRON ACER TENDL-2024 LIBRARY; T=0.K
Photon emission for (n,3n)

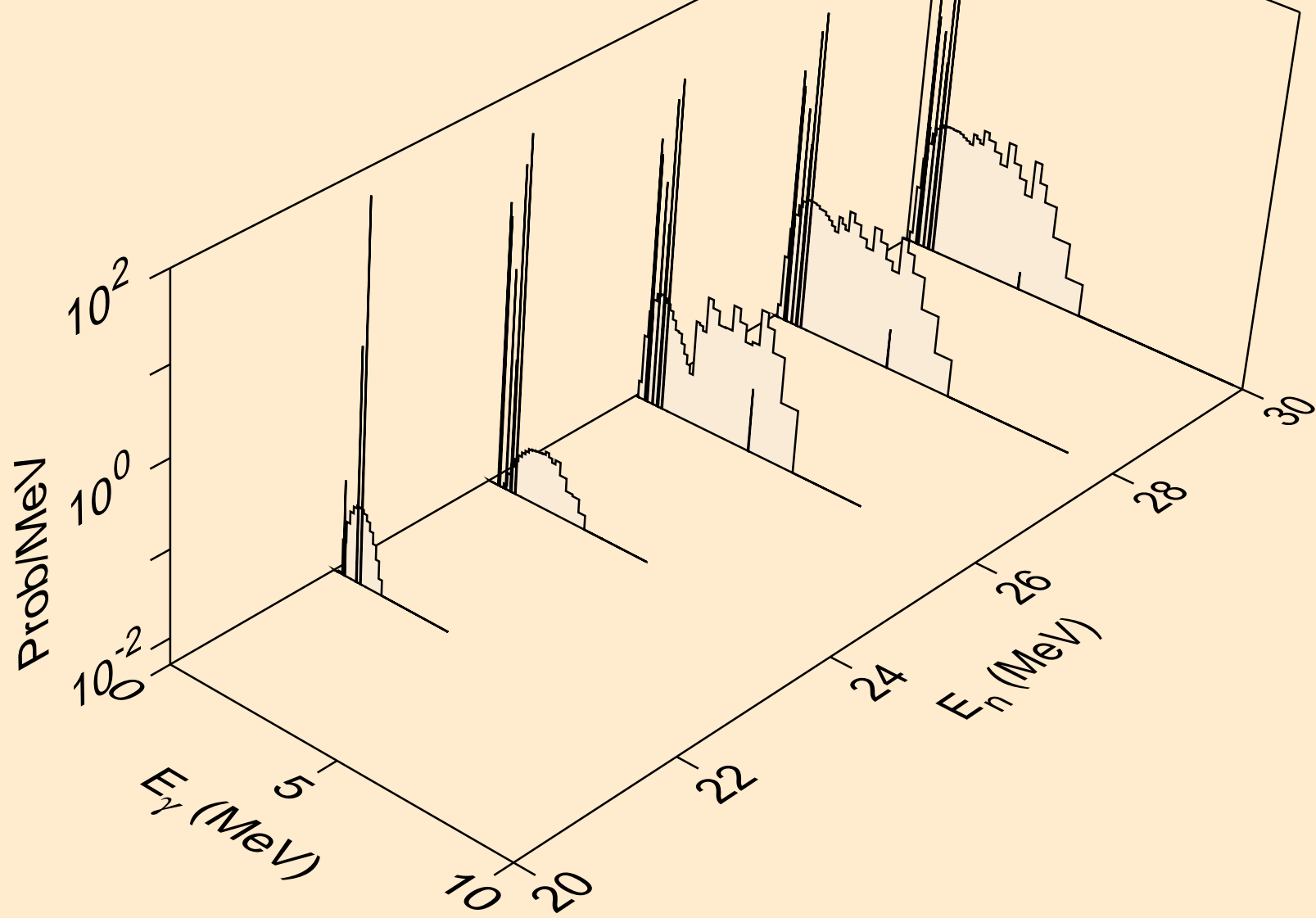

LU157M NEUTRON ACER TENDL-2024 LIBRARY; T=0.K
Photon emission for (n,n*)a

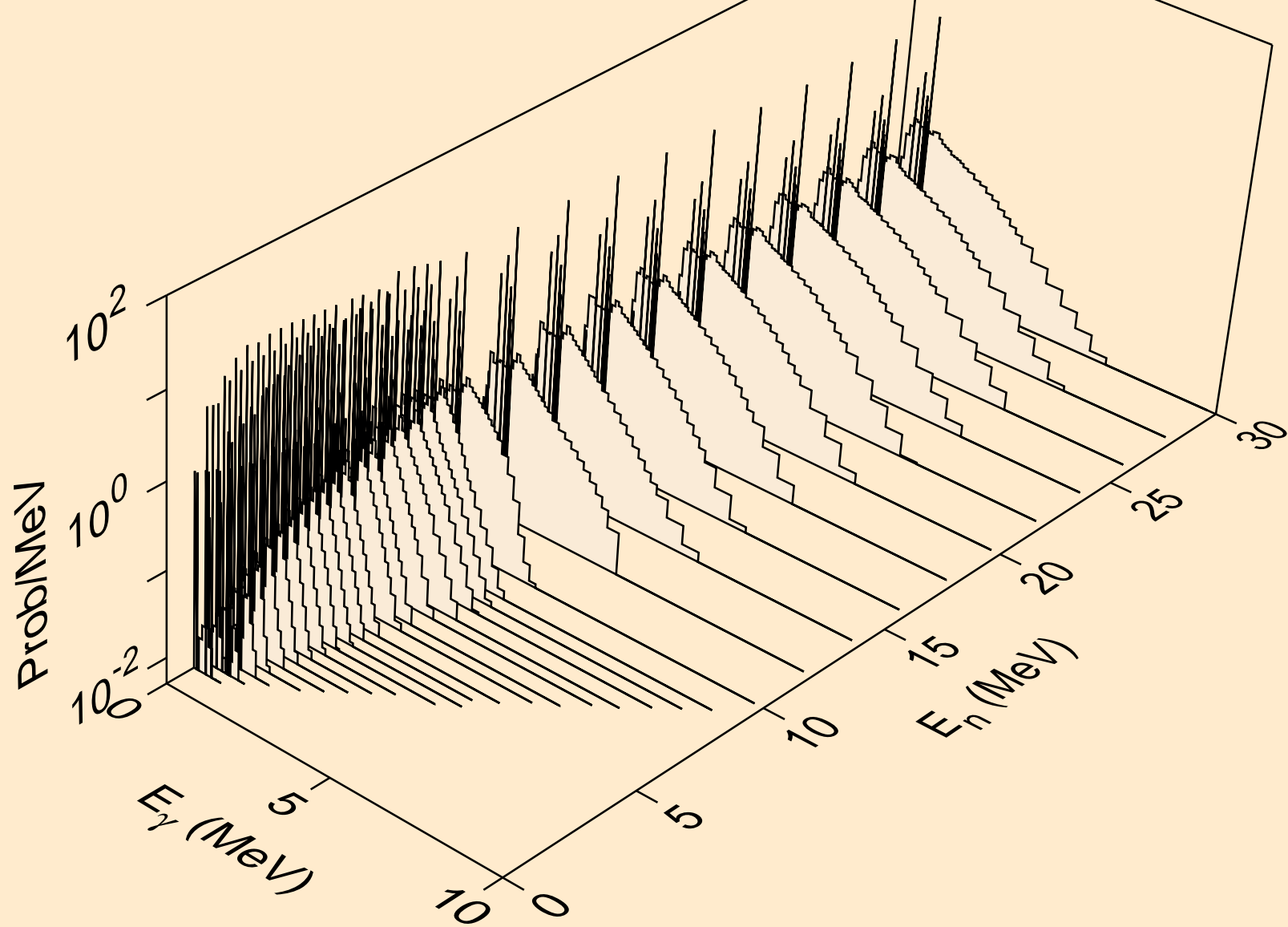

LU157M NEUTRON ACER TENDL-2024 LIBRARY; T=0.K
Photon emission for (n,n*)3a

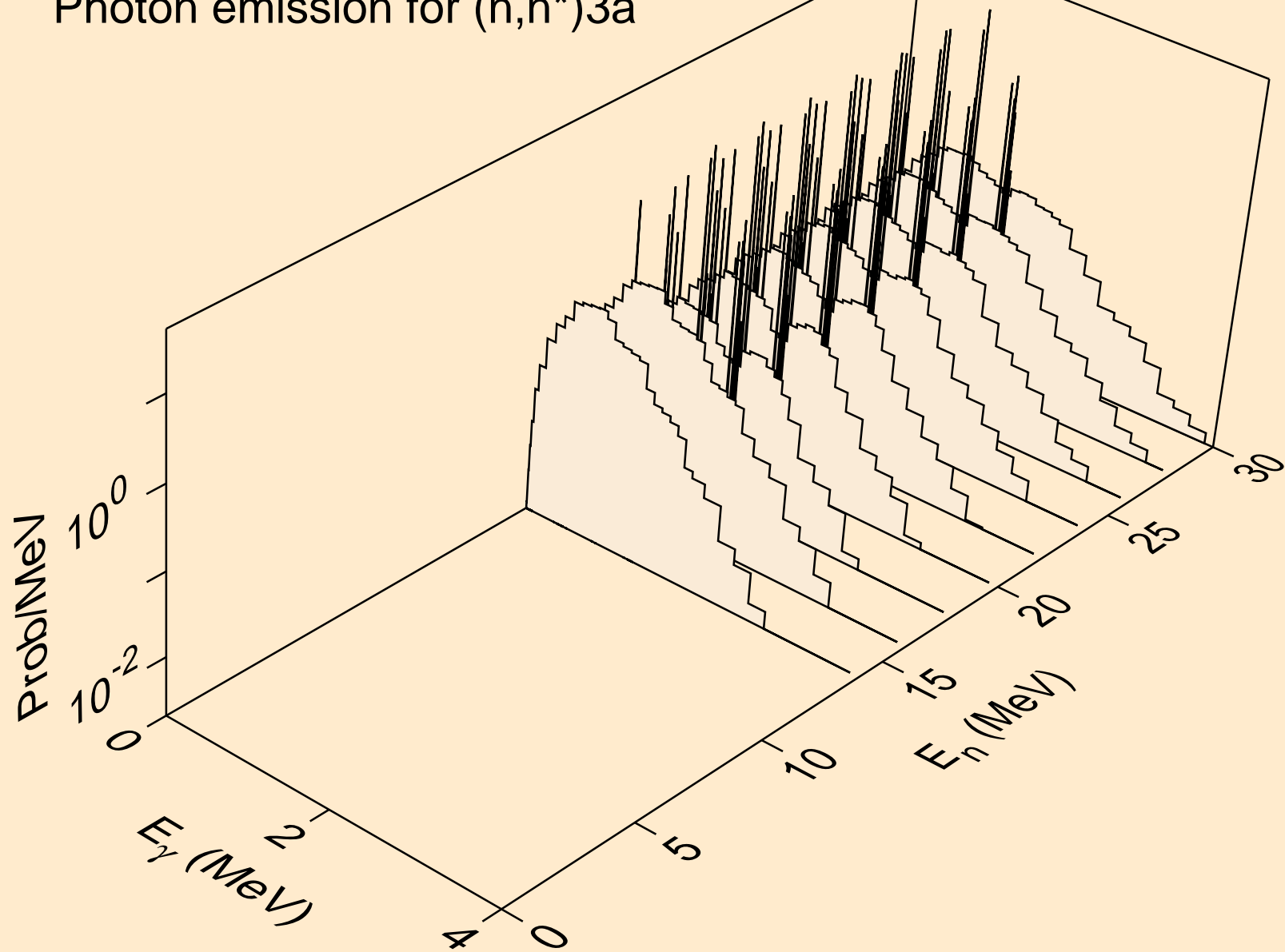

LU157M NEUTRON ACER TENDL-2024 LIBRARY; T=0.K
Photon emission for (n,2n)a

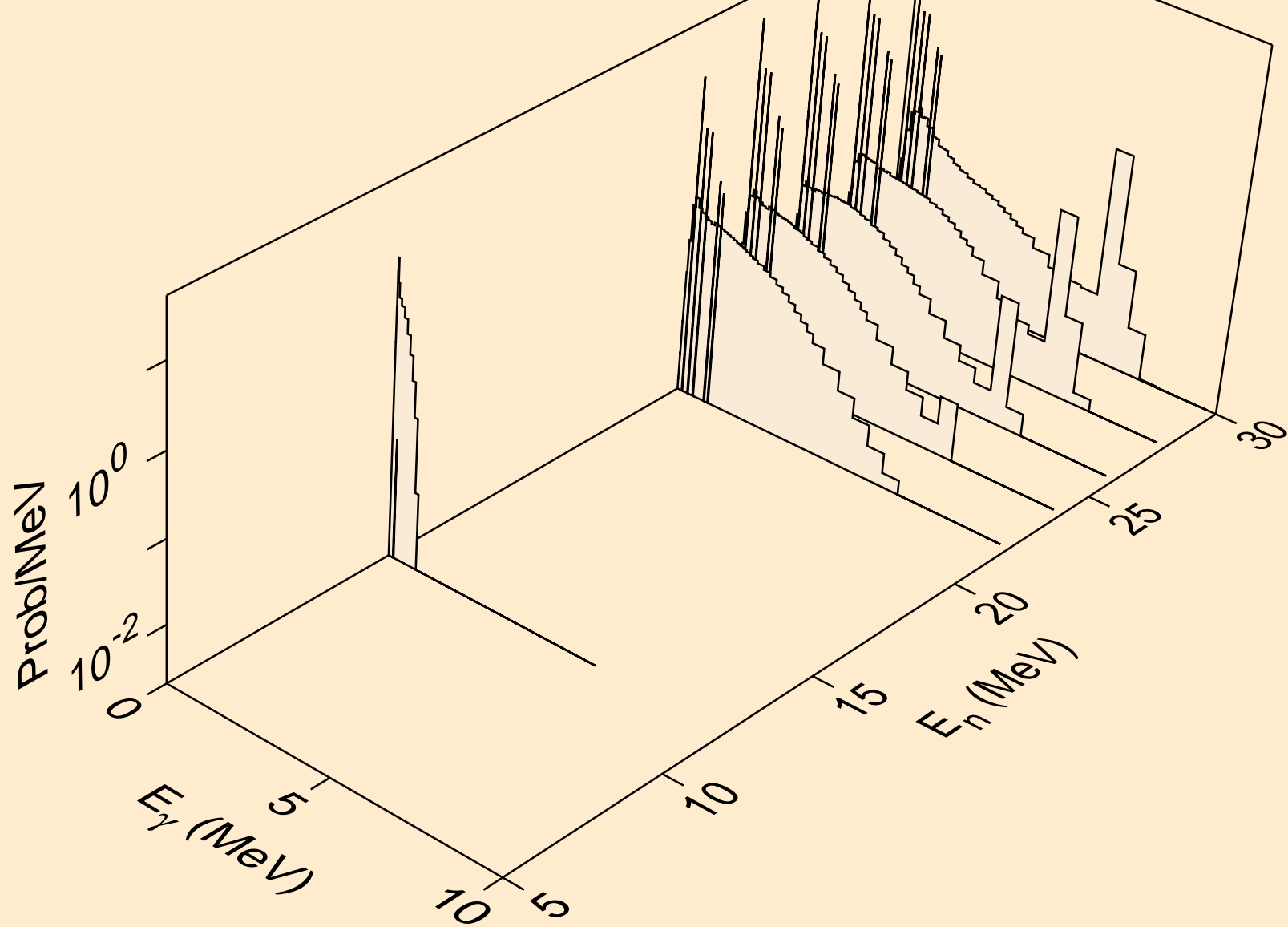

LU157M NEUTRON ACER TENDL-2024 LIBRARY; T=0.K
Photon emission for (n,3n)a

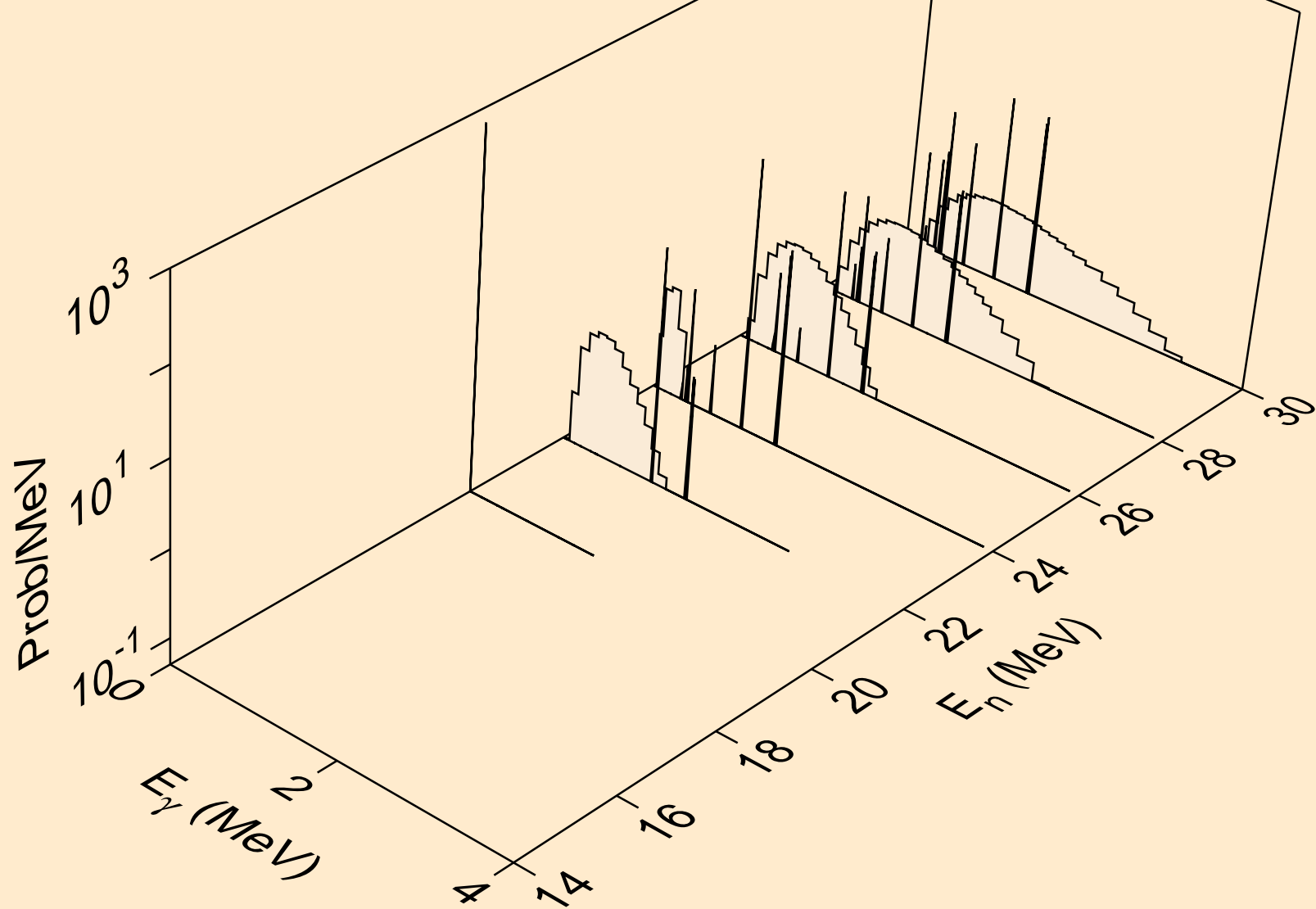

LU157M NEUTRON ACER TENDL-2024 LIBRARY; T=0.K
Photon emission for (n,n*)p

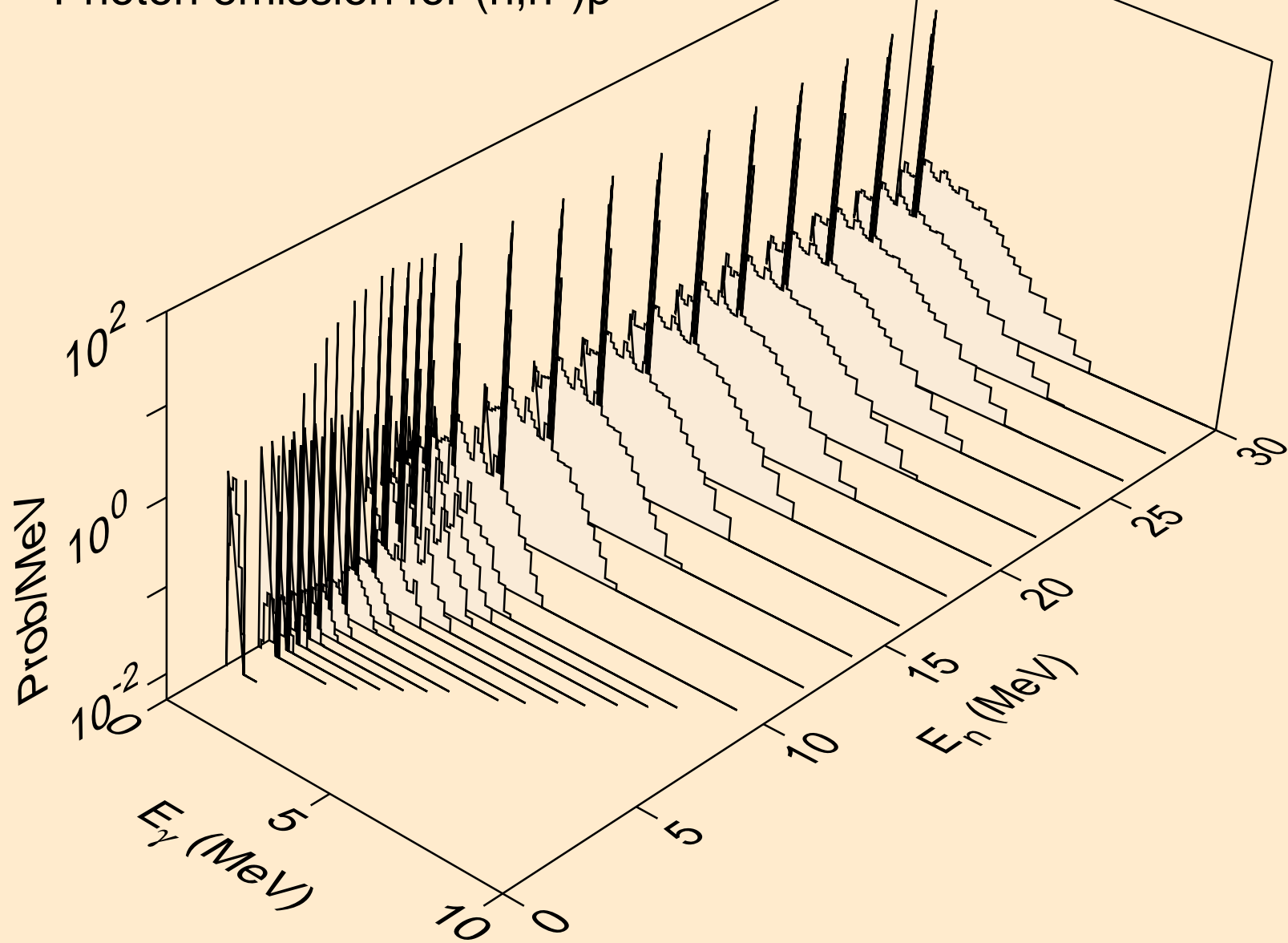

LU157M NEUTRON ACER TENDL-2024 LIBRARY; T=0.K
Photon emission for (n,n*)2a

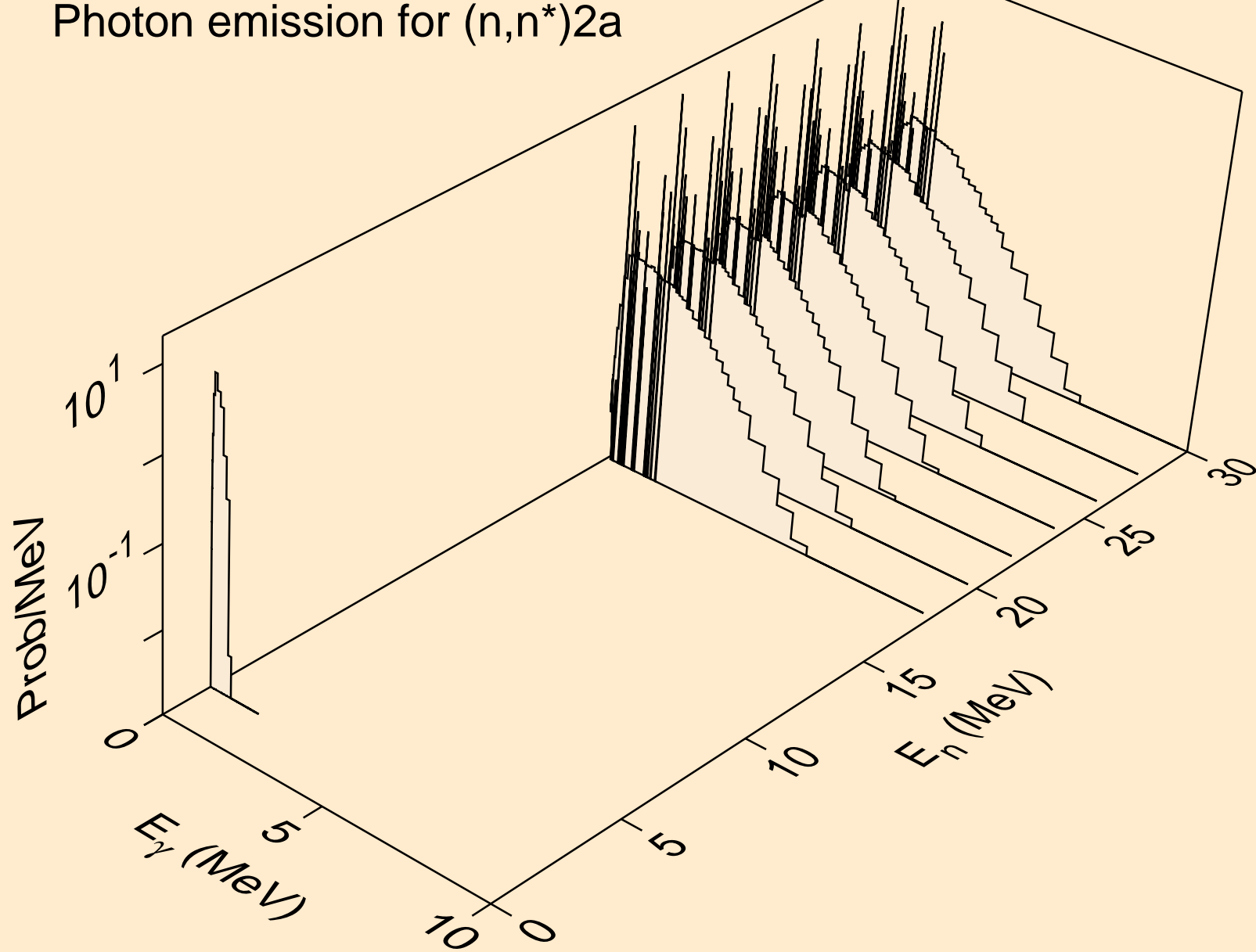

LU157M NEUTRON ACER TENDL-2024 LIBRARY; T=0.K
Photon emission for (n,2n)2a

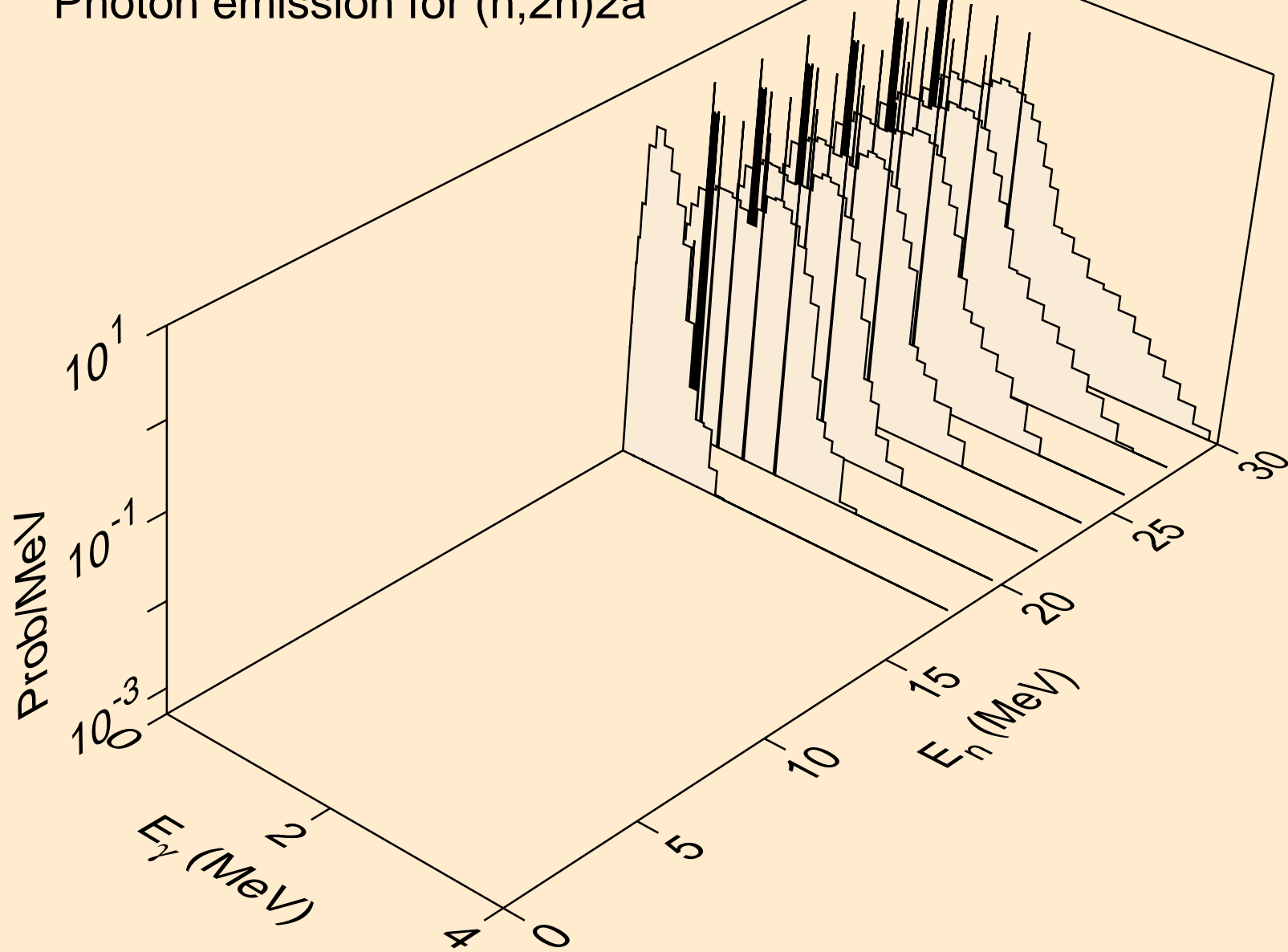

LU157M NEUTRON ACER TENDL-2024 LIBRARY; T=0.K
Photon emission for (n,n*)d

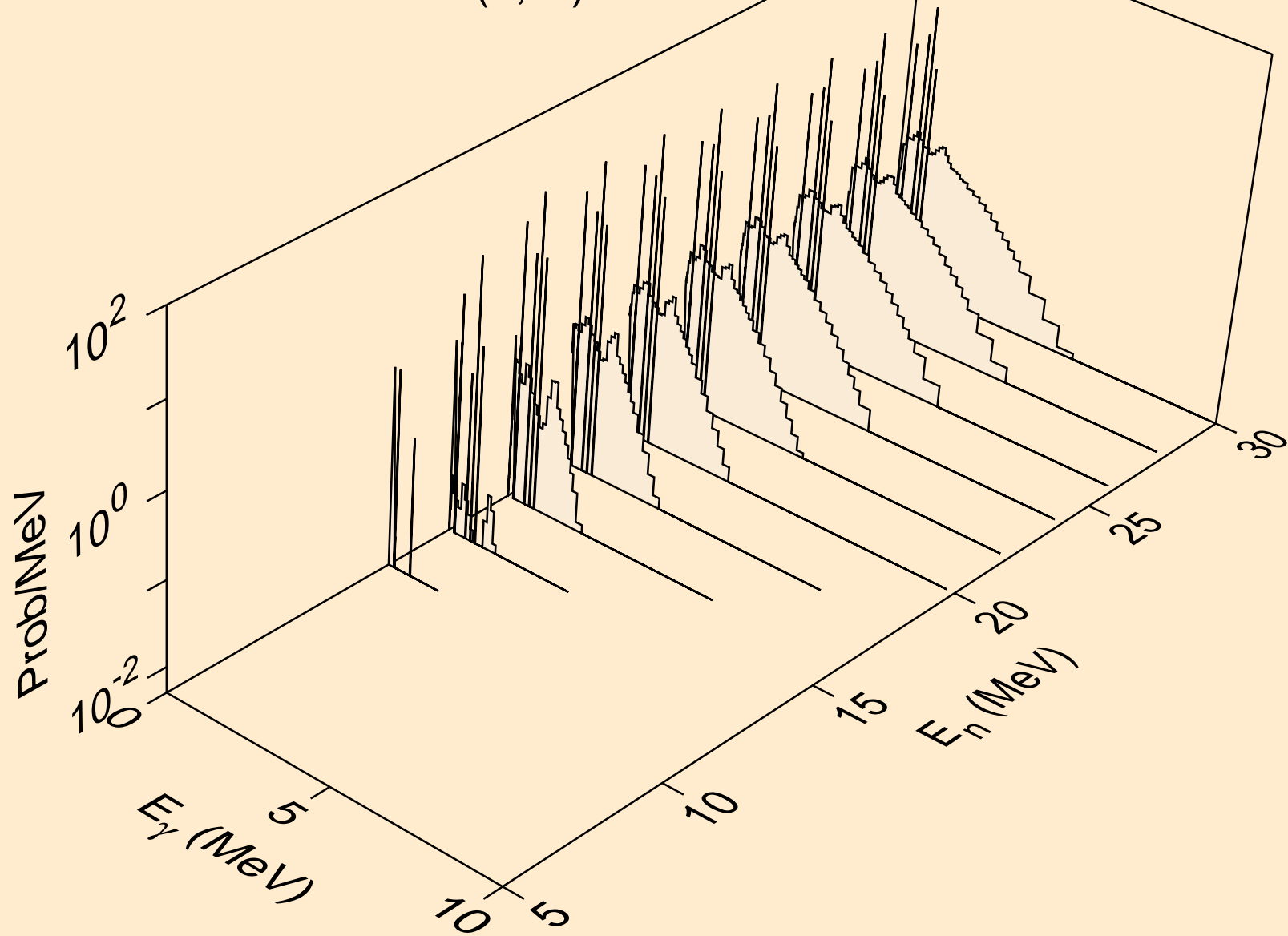

LU157M NEUTRON ACER TENDL-2024 LIBRARY; T=0.K
Photon emission for (n,n*)t

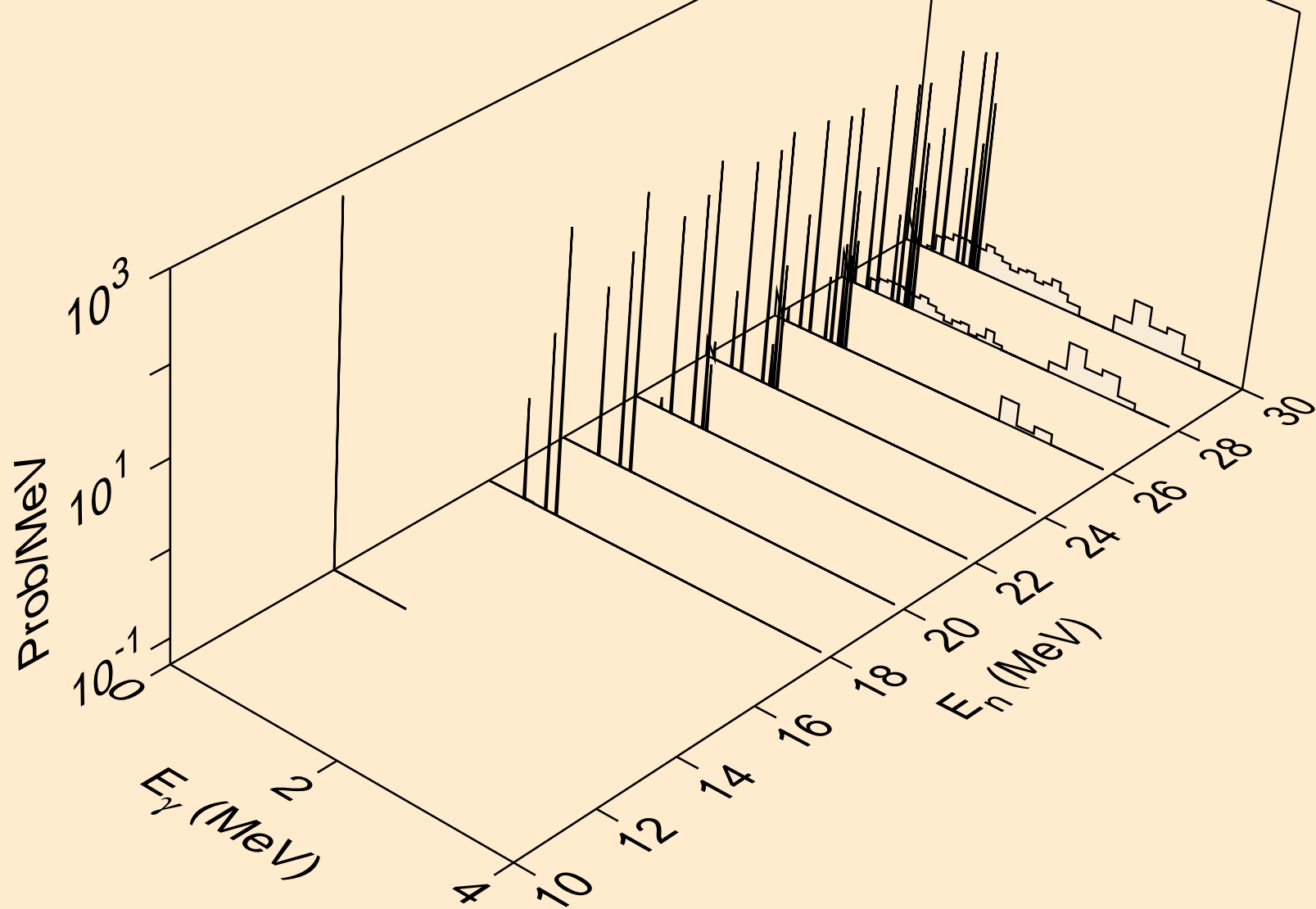

LU157M NEUTRON ACER TENDL-2024 LIBRARY; T=0.K
Photon emission for (n,n*)he3

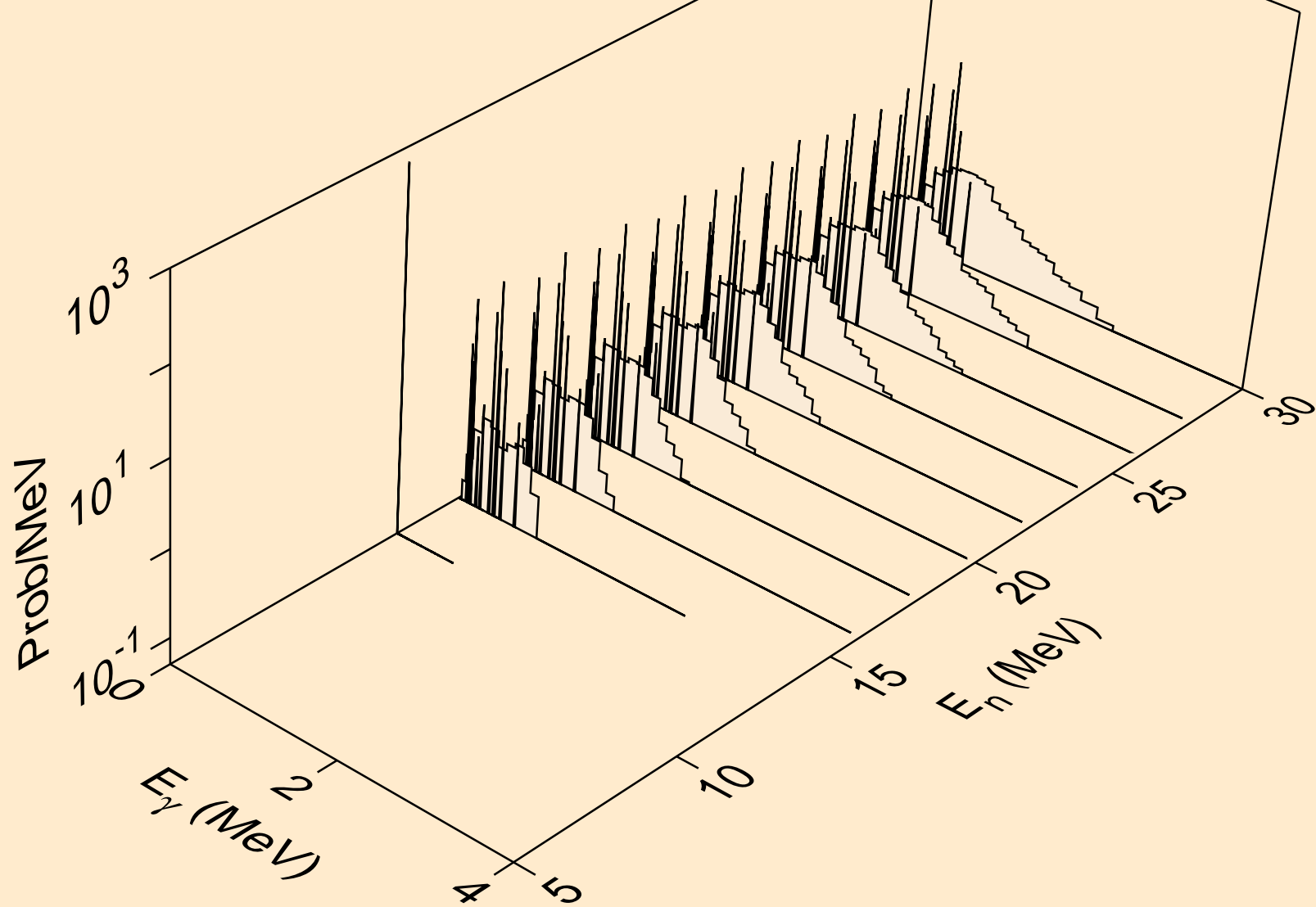

LU157M NEUTRON ACER TENDL-2024 LIBRARY; T=0.K
Photon emission for (n,2np)

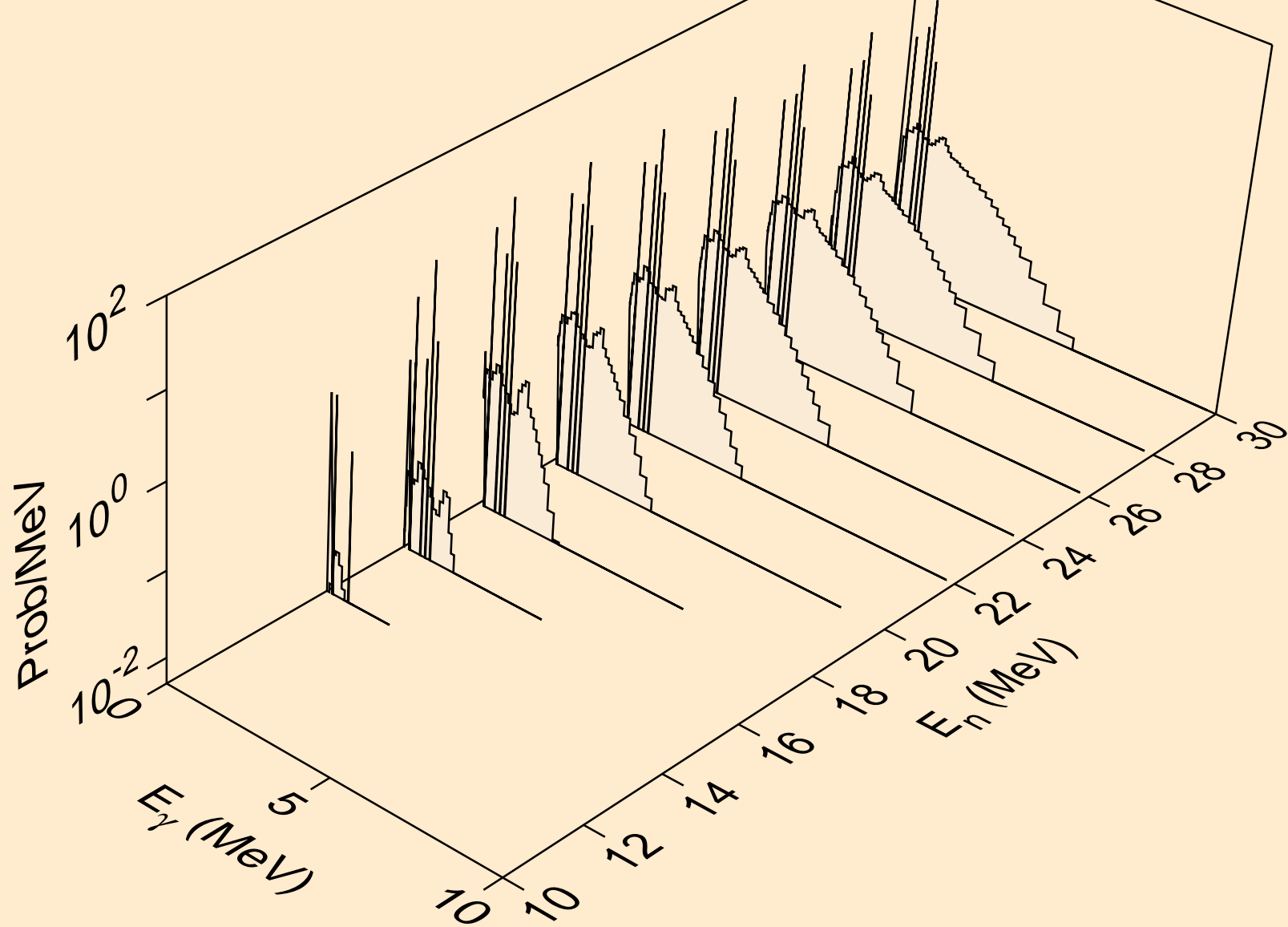

LU157M NEUTRON ACER TENDL-2024 LIBRARY; T=0.K
Photon emission for (n,3np)

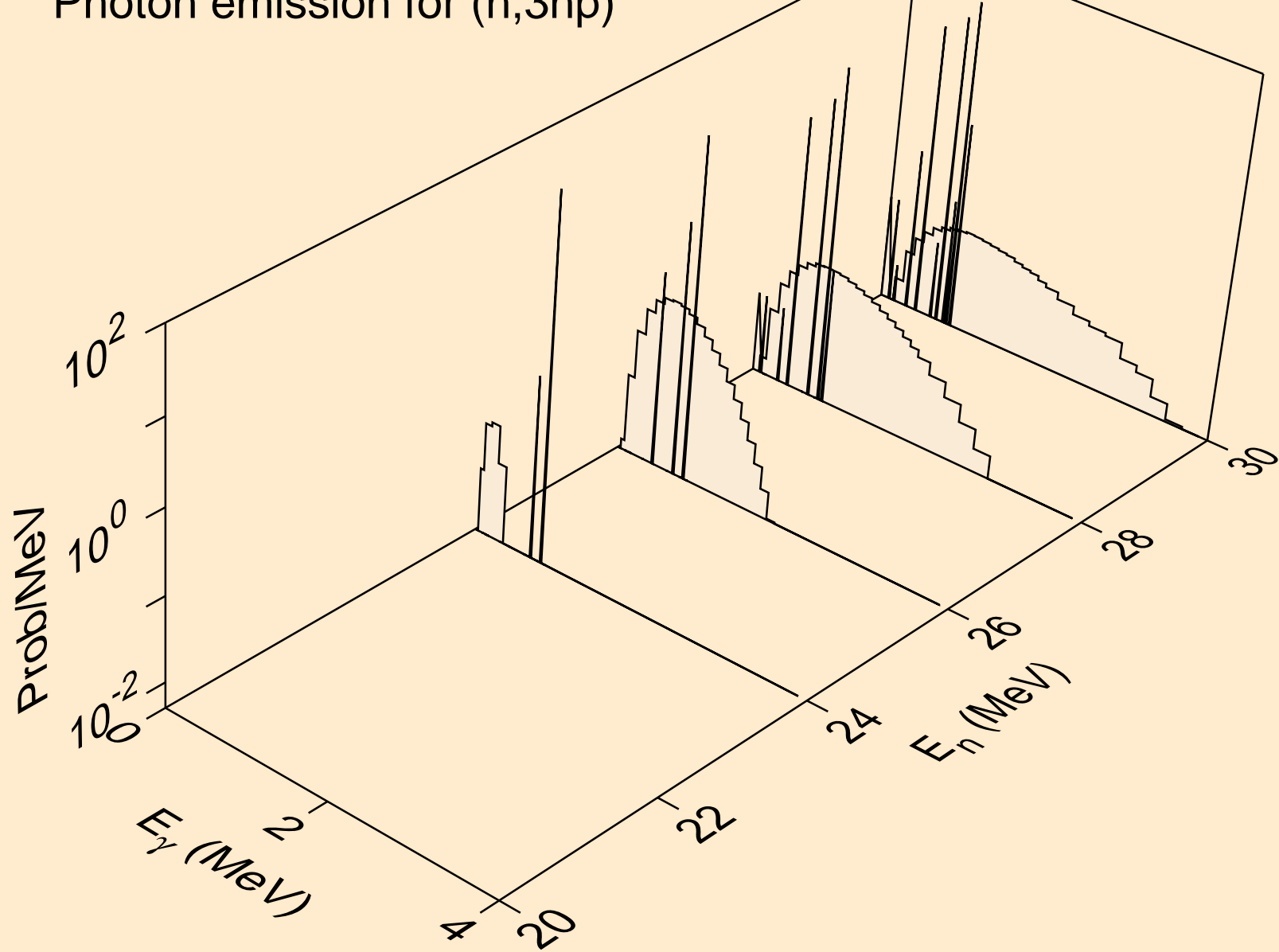

LU157M NEUTRON ACER TENDL-2024 LIBRARY; T=0.K
Photon emission for (n,n2p)

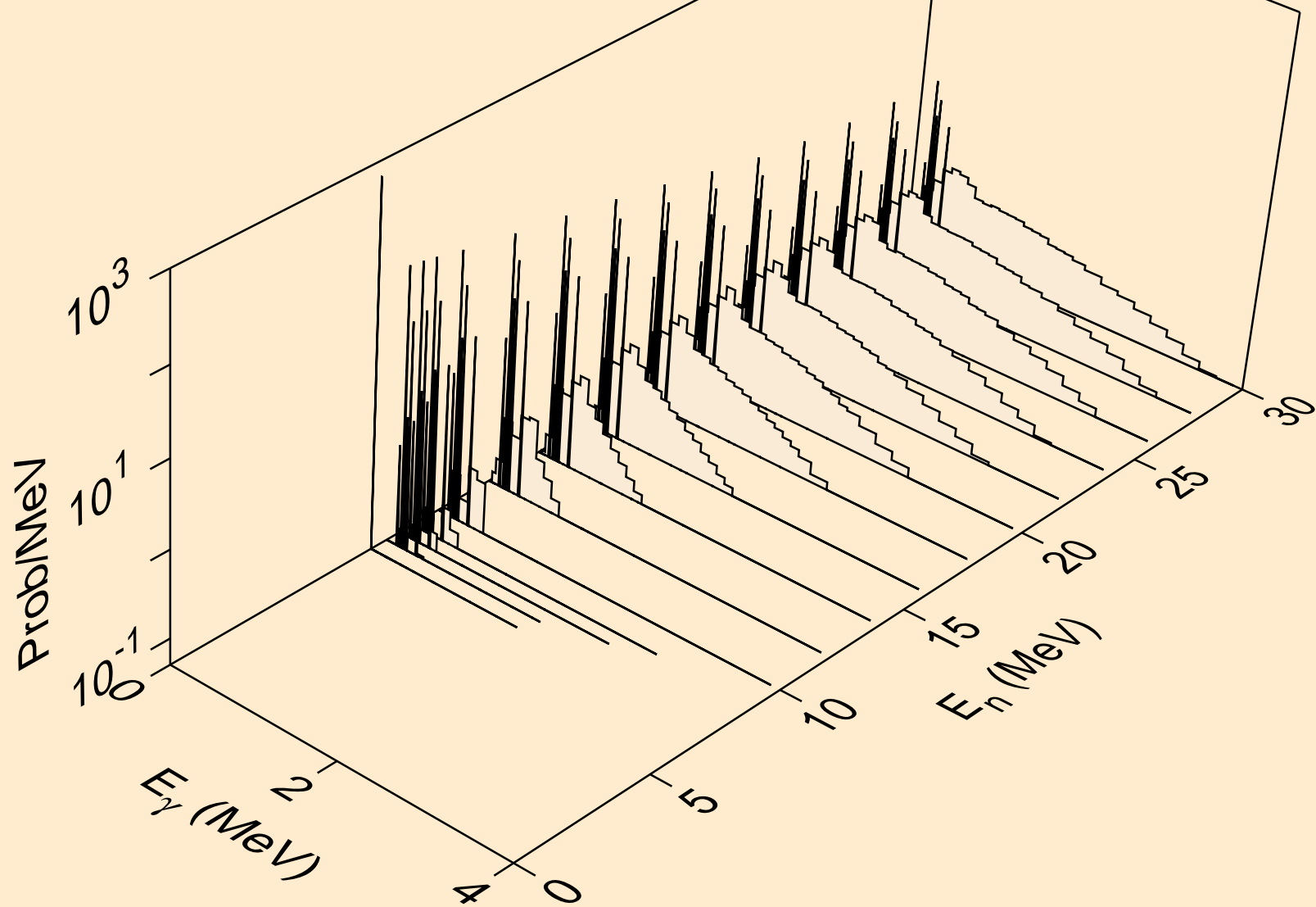

LU157M NEUTRON ACER TENDL-2024 LIBRARY; T=0.K
Photon emission for (n,npa)

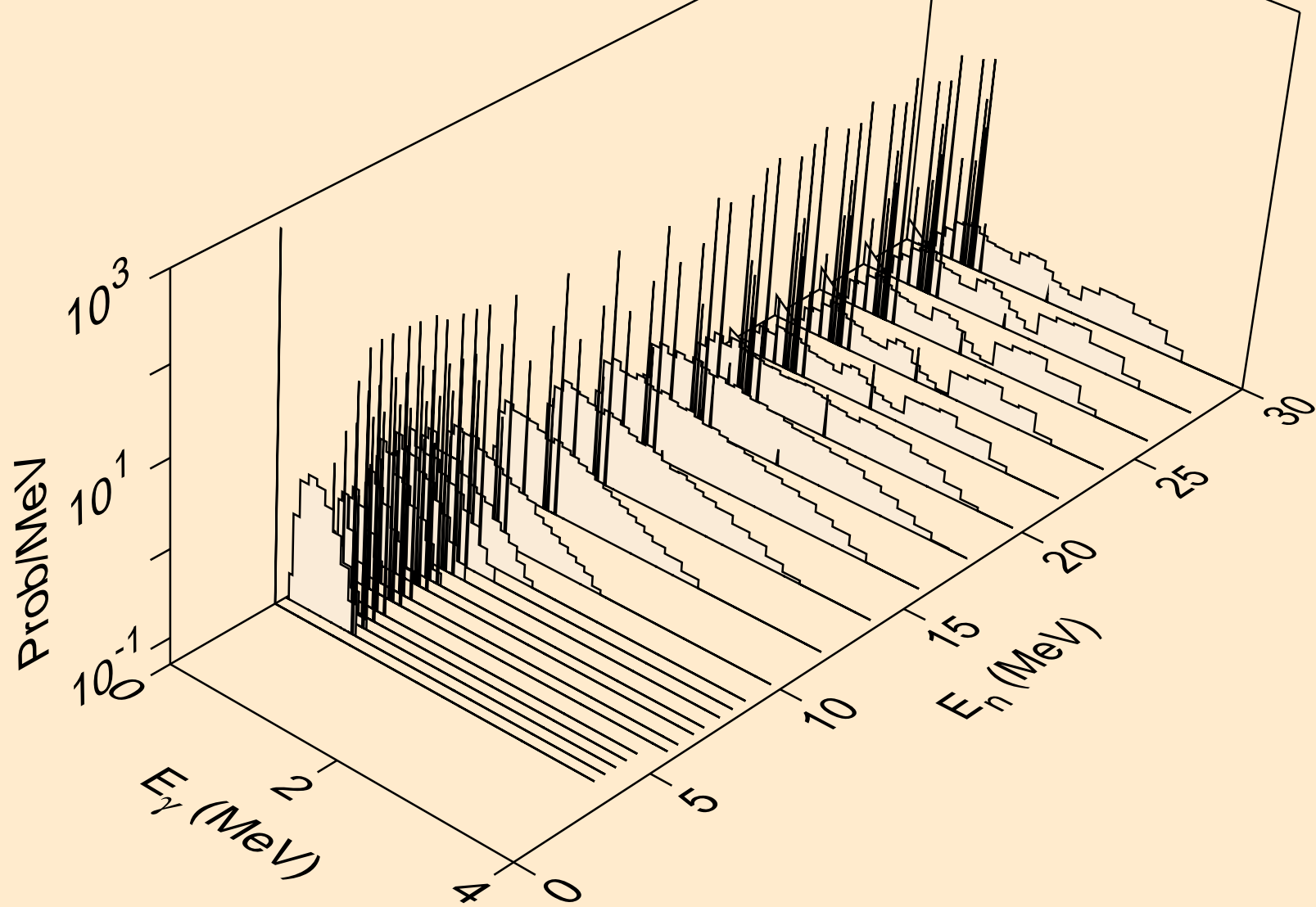

LU157M NEUTRON ACER TENDL-2024 LIBRARY; T=0.K
Photon emission for (n,n*2)

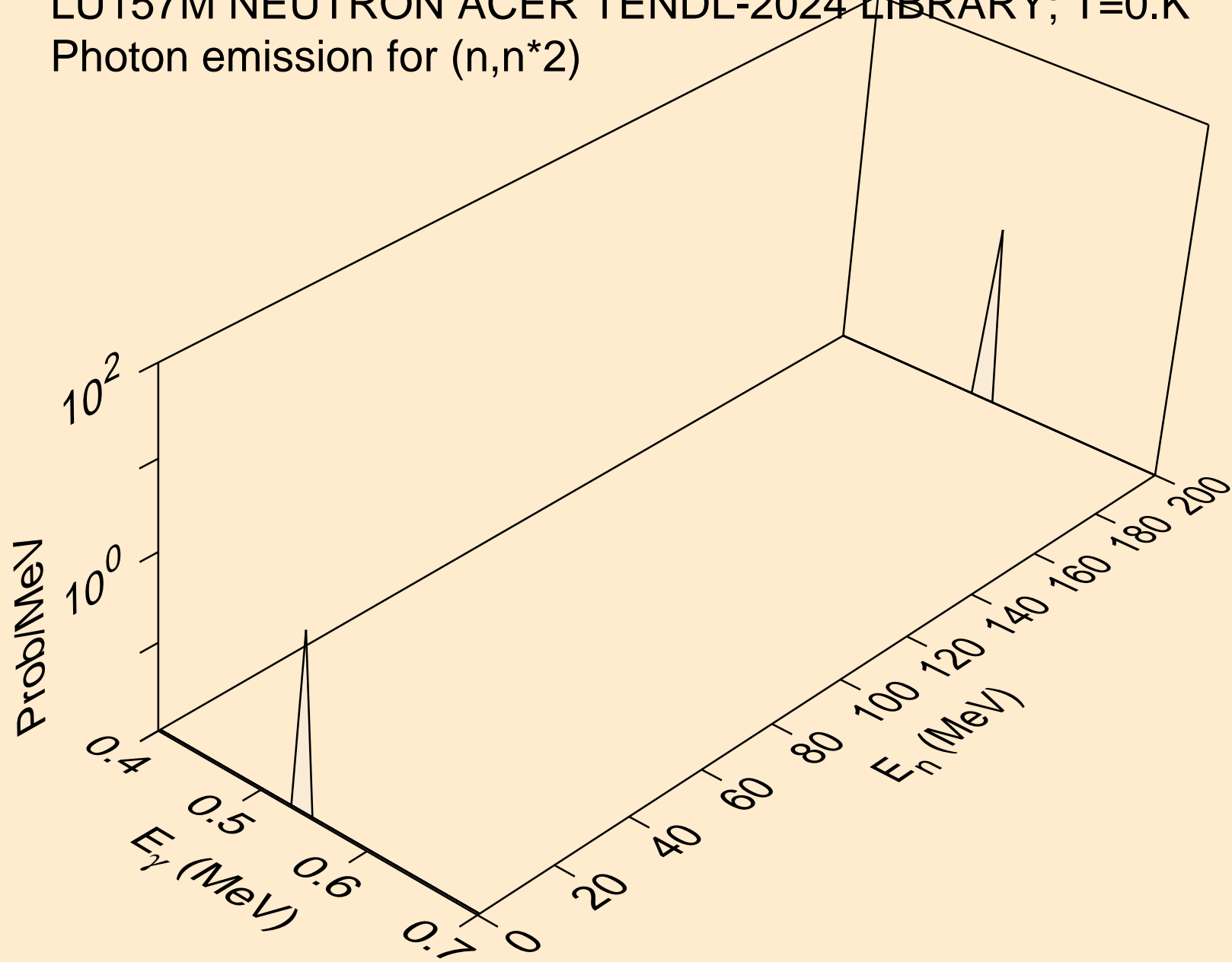

LU157M NEUTRON ACER TENDL-2024 LIBRARY; T=0.K
Photon emission for (n,n*c)

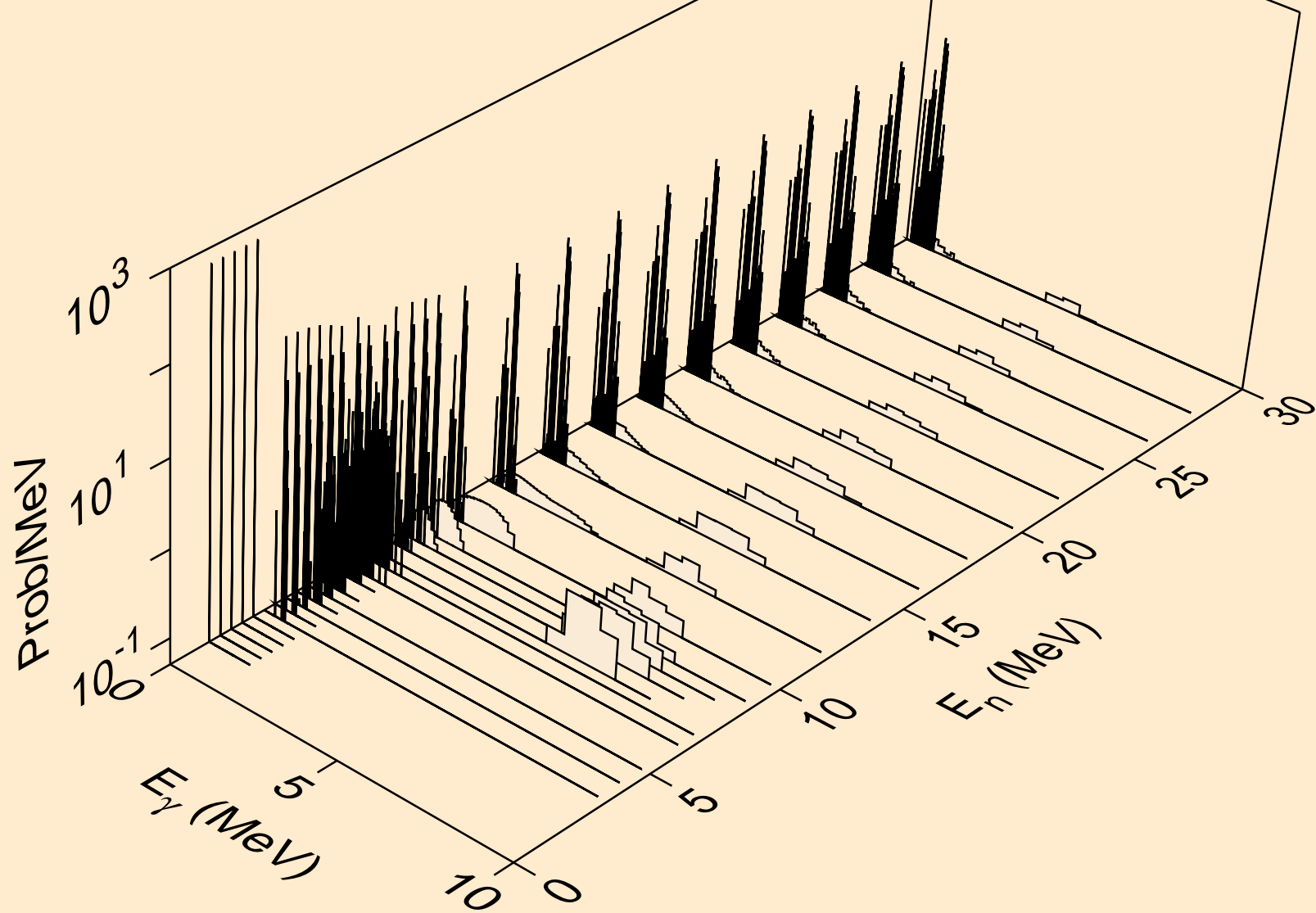

LU157M NEUTRON ACER TENDL-2024 LIBRARY; T=0.K
Photon emission for (n,gma)

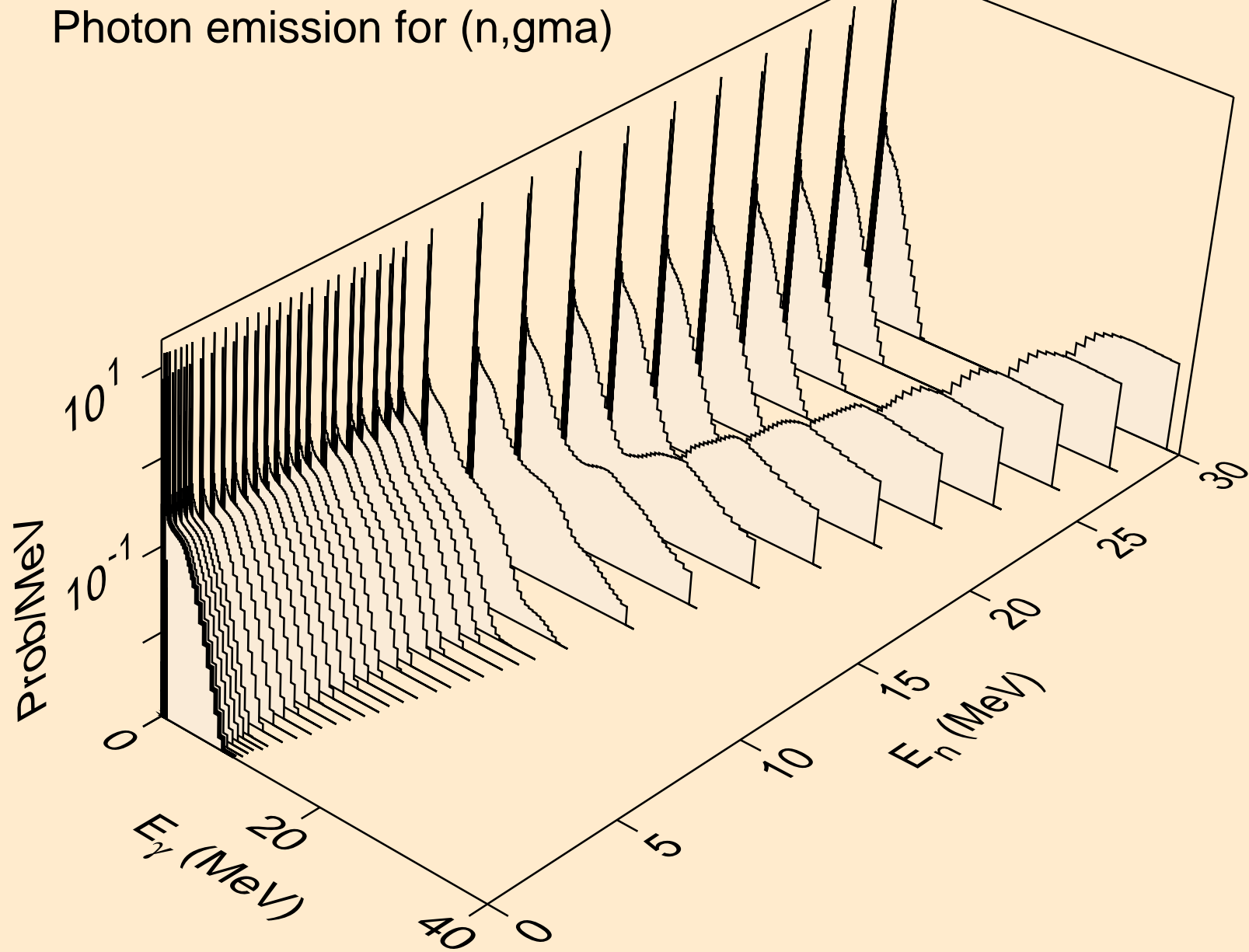

LU157M NEUTRON ACER TENDL-2024 LIBRARY; T=0.K
Photon emission for (n,p)

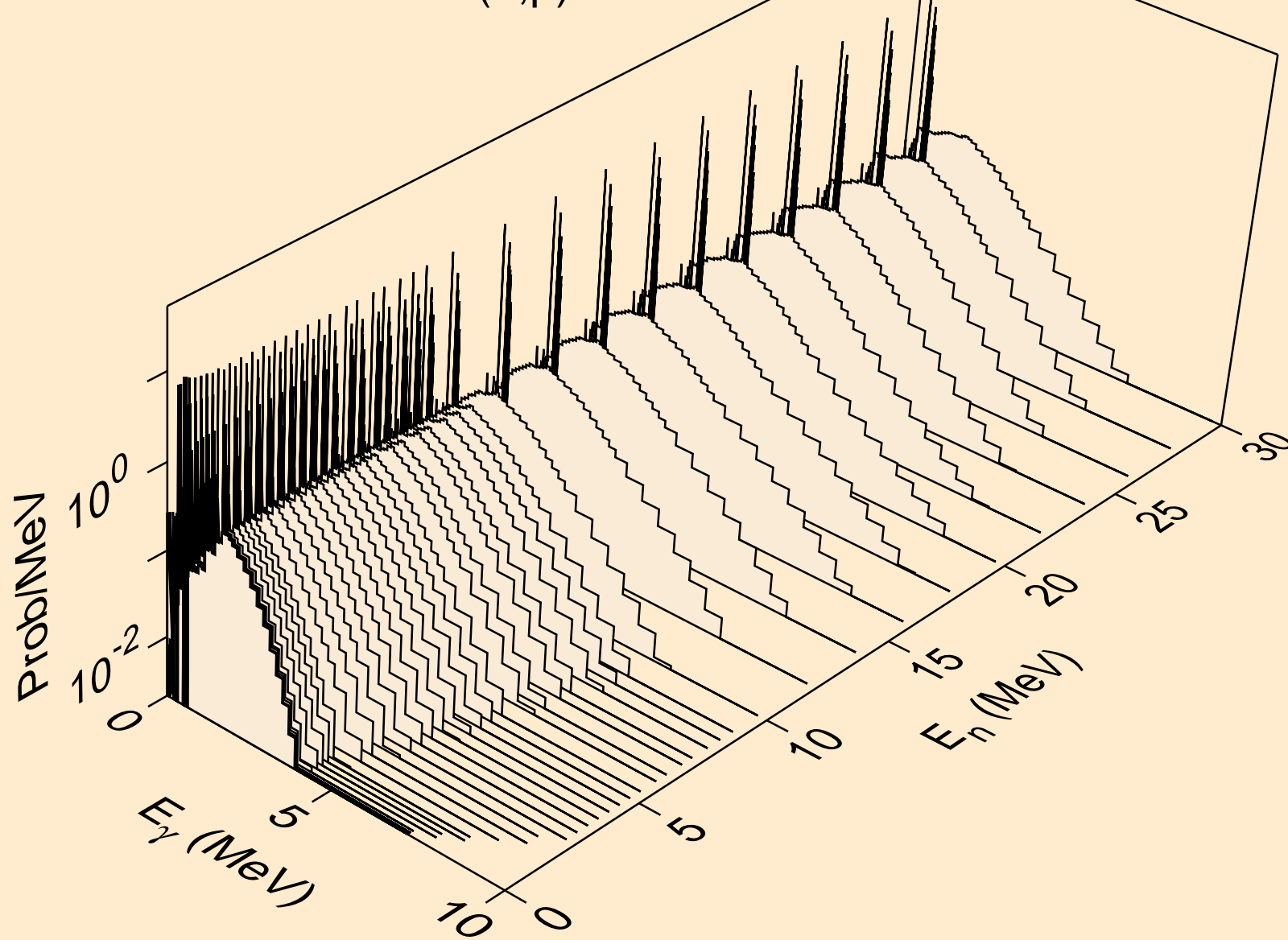

LU157M NEUTRON ACER TENDL-2024 LIBRARY; T=0.K
Photon emission for (n,d)

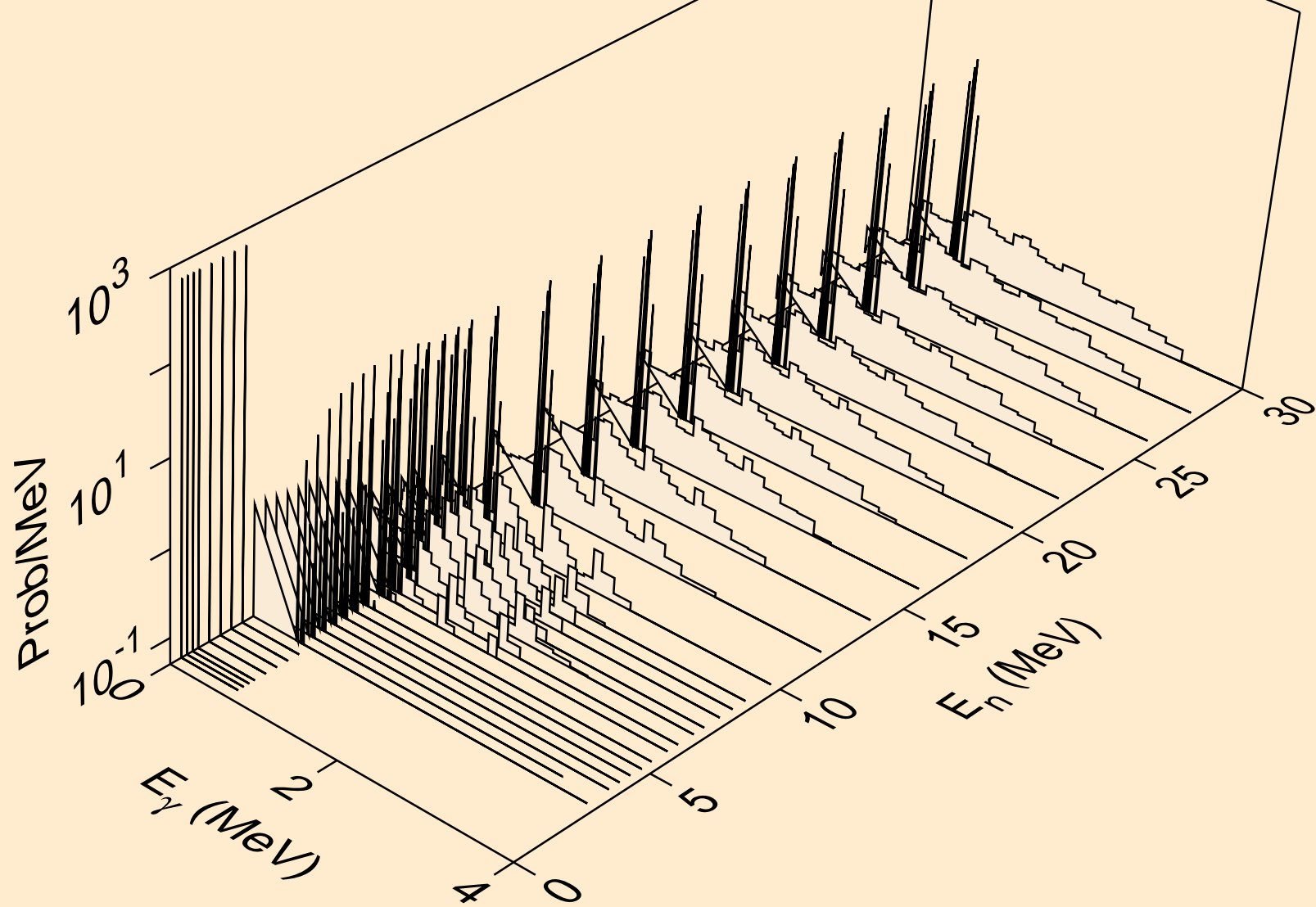

LU157M NEUTRON ACER TENDL-2024 LIBRARY; T=0.K
Photon emission for (n,t)

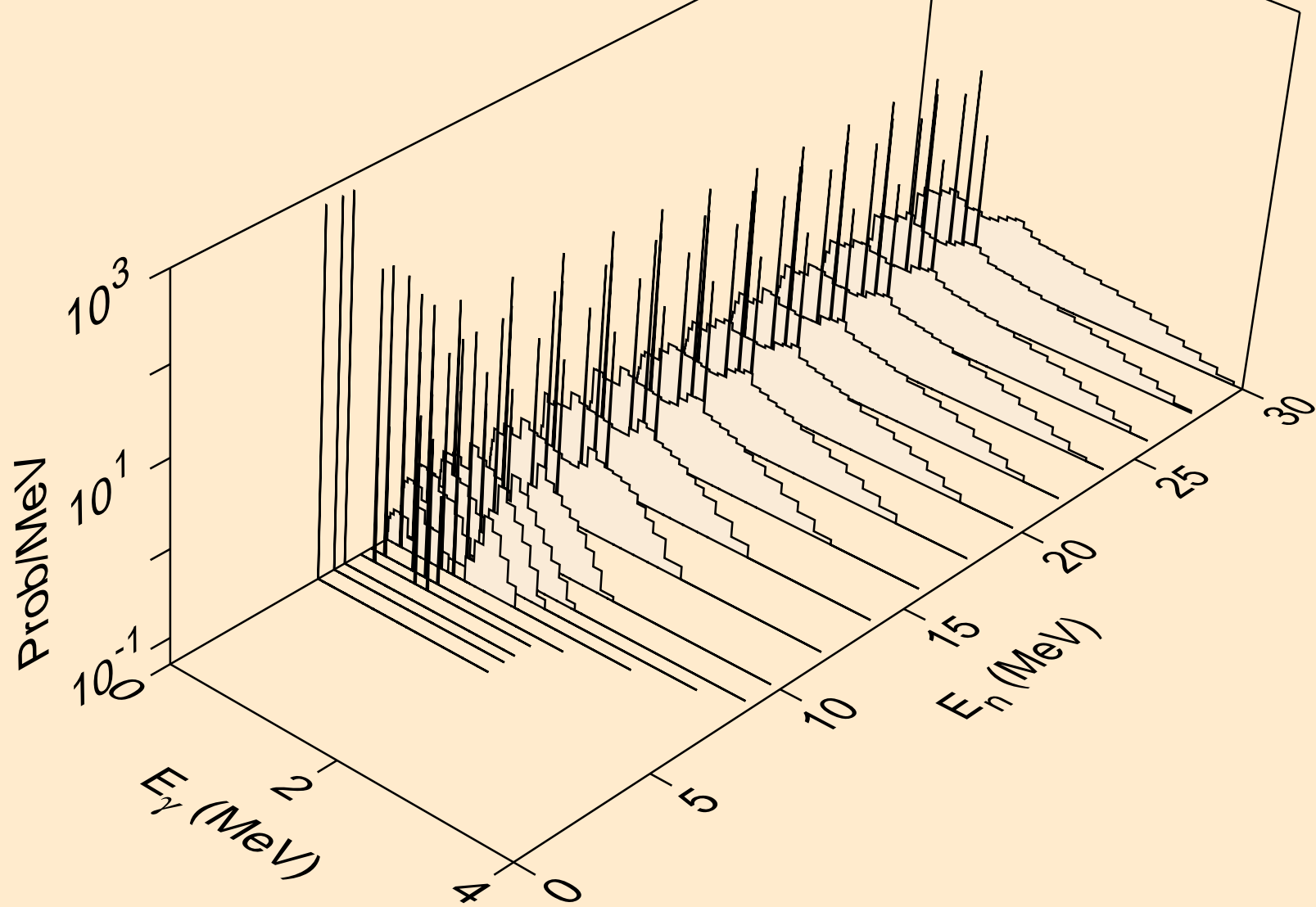

LU157M NEUTRON ACER TENDL-2024 LIBRARY; T=0.K
Photon emission for (n,he3)

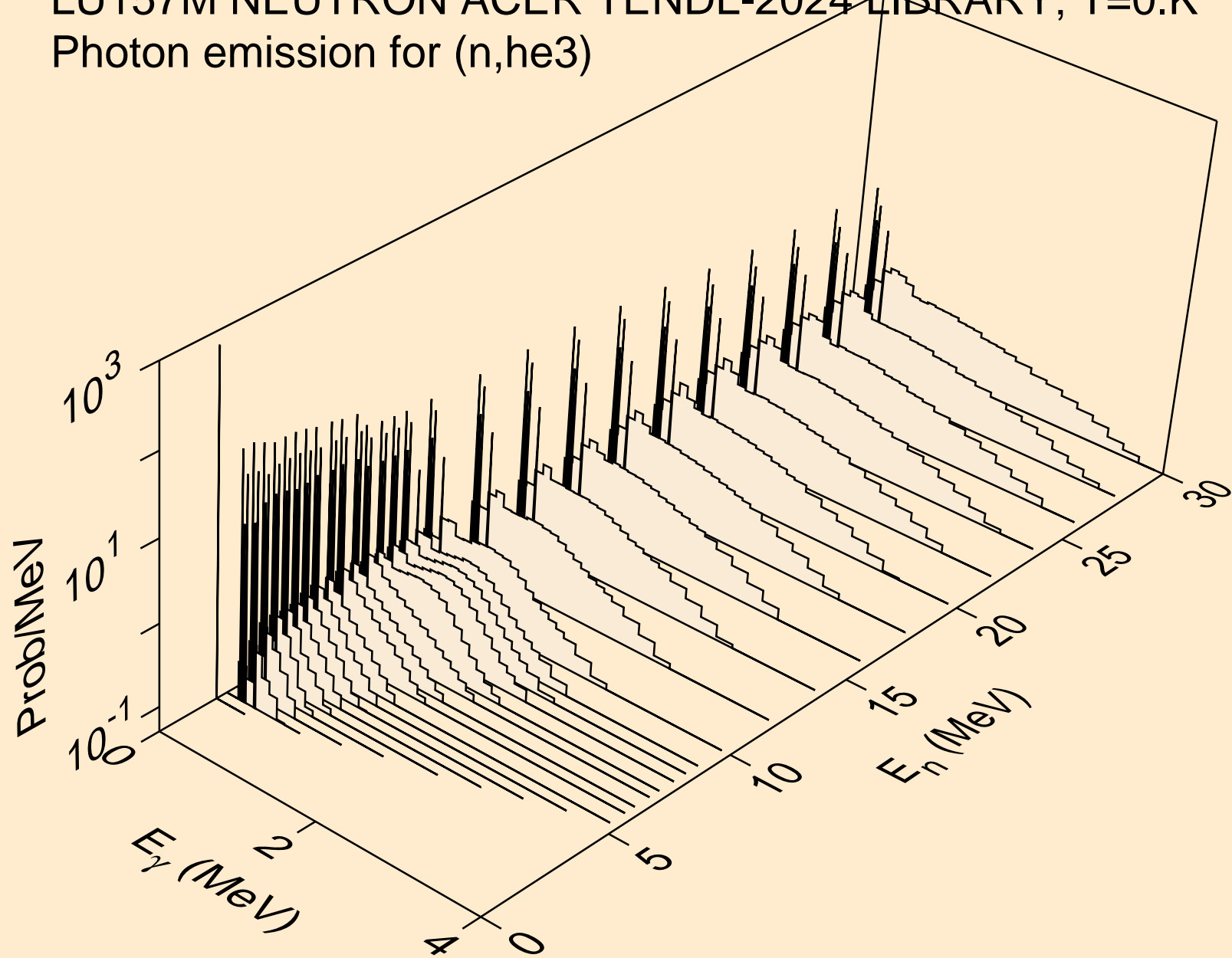

LU157M NEUTRON ACER TENDL-2024 LIBRARY; T=0.K
Photon emission for (n,a)

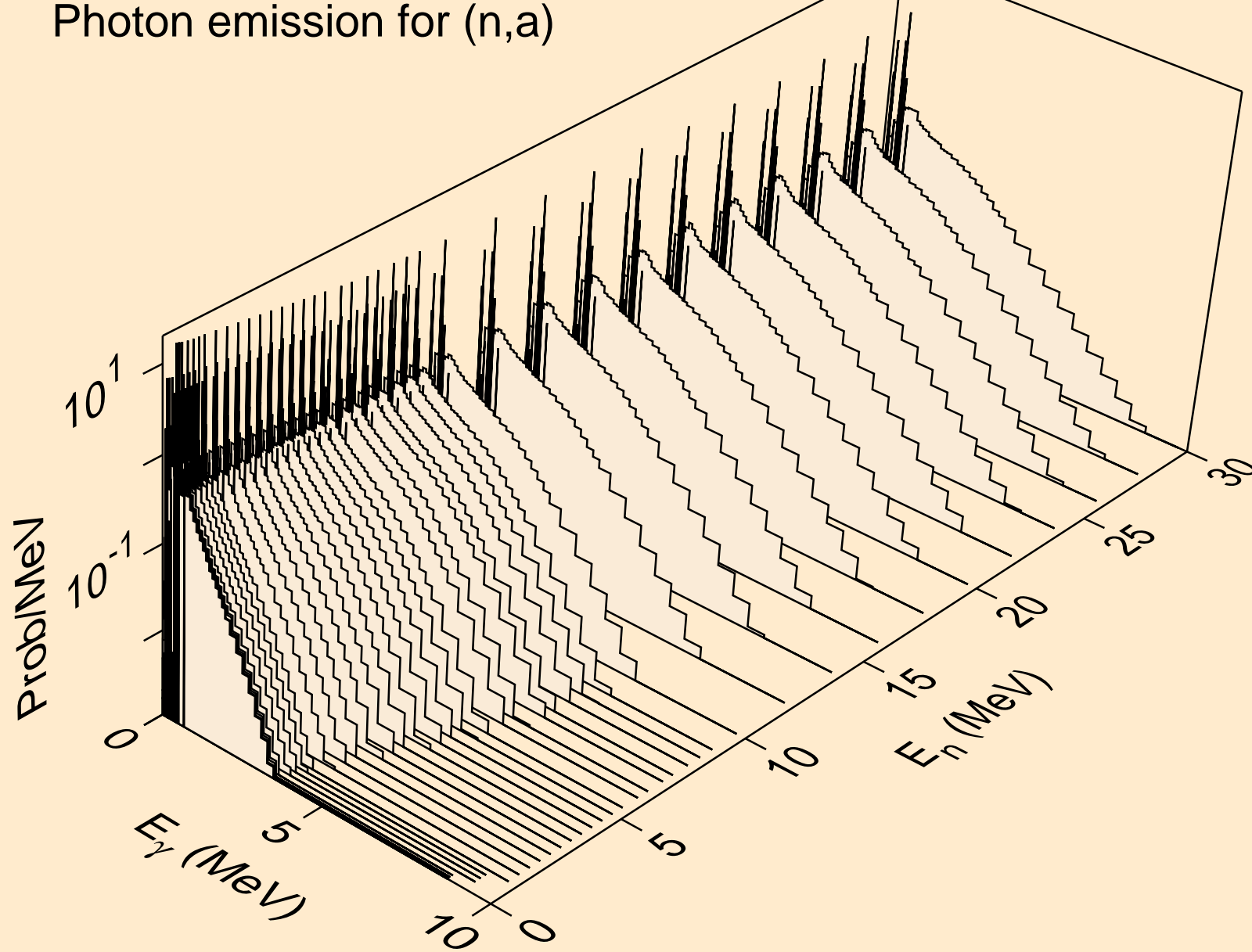

LU157M NEUTRON ACER TENDL-2024 LIBRARY; T=0.K
Photon emission for (n,2a)

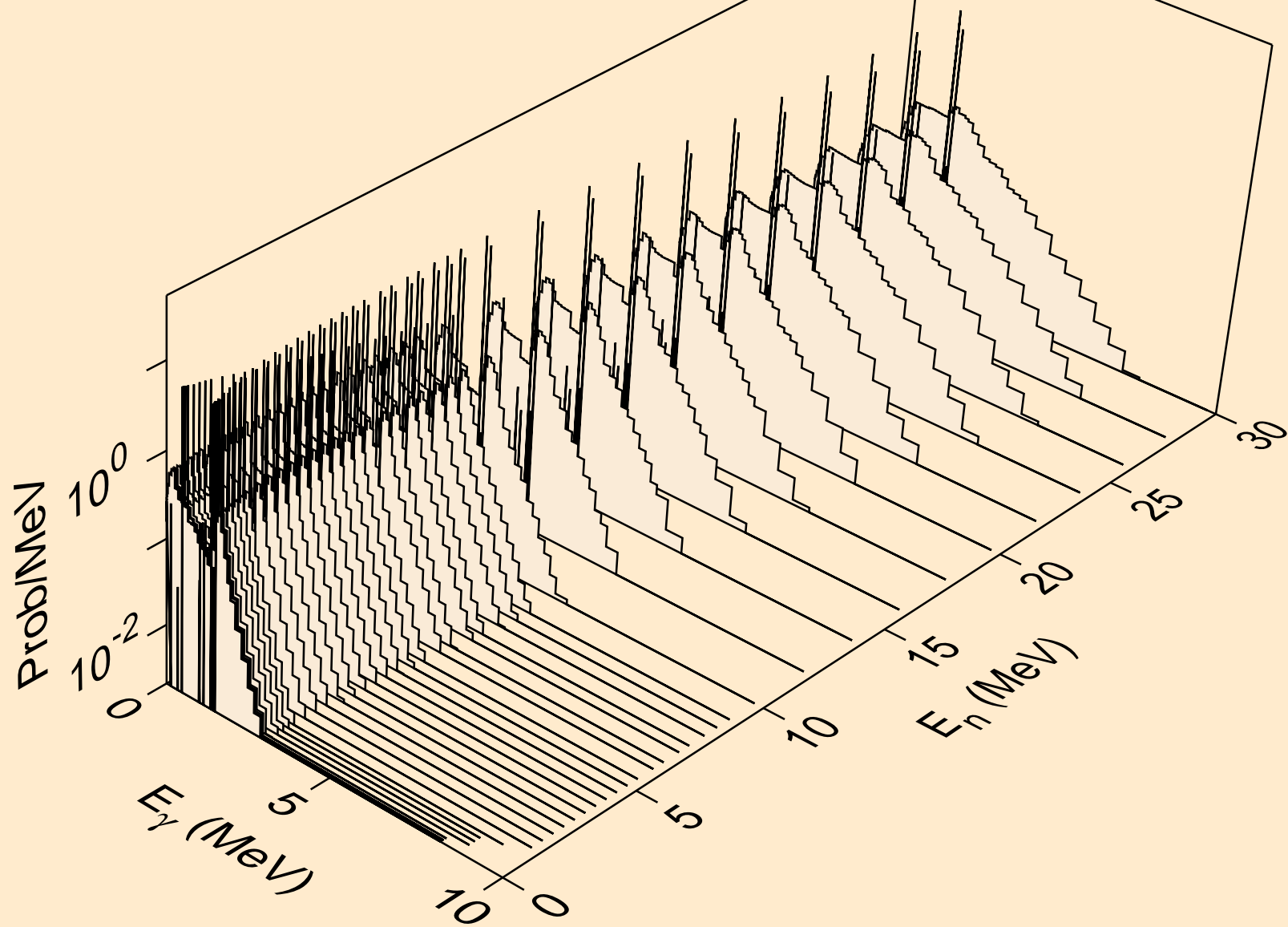

LU157M NEUTRON ACER TENDL-2024 LIBRARY; T=0.K
Photon emission for (n,3a)

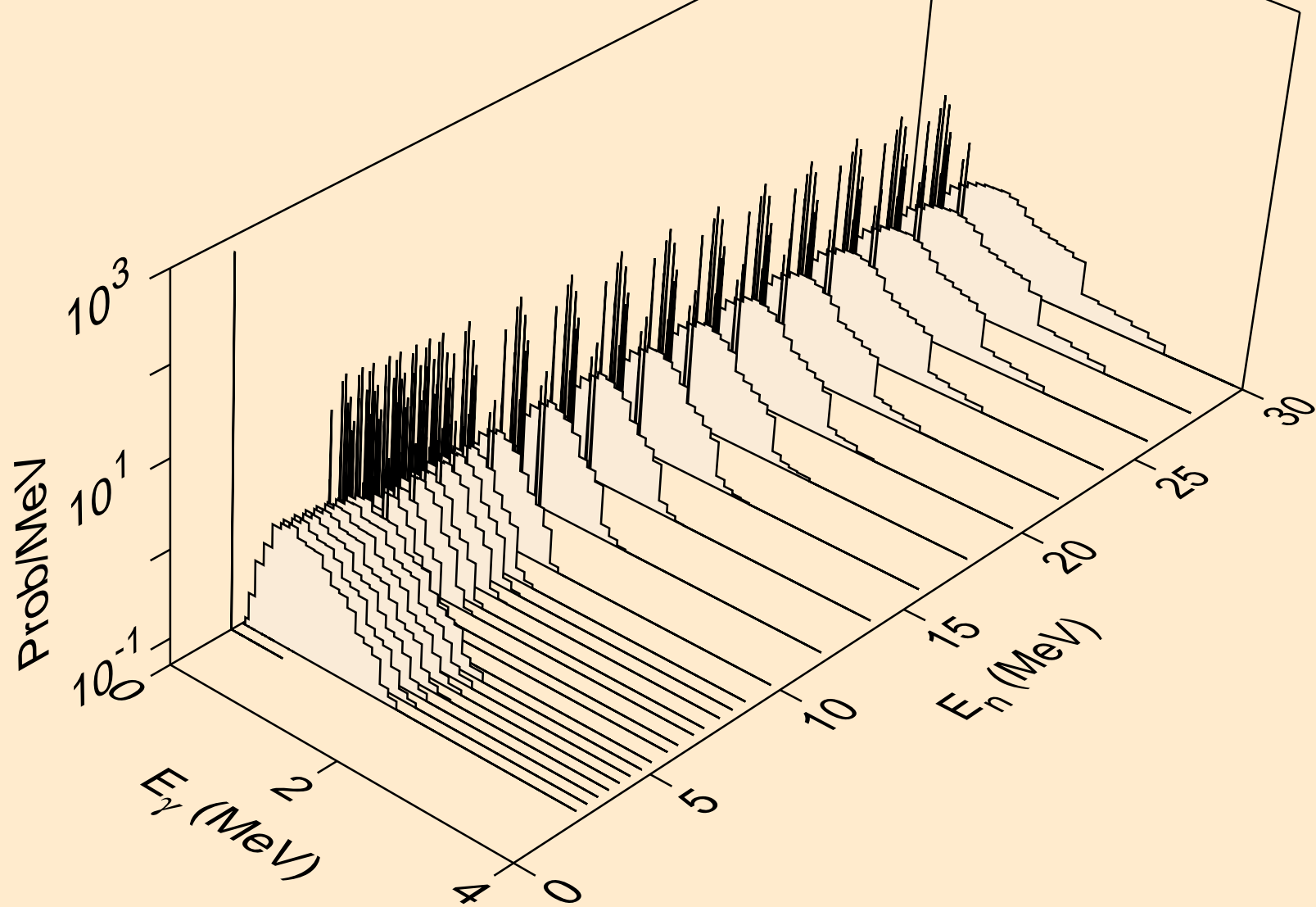

LU157M NEUTRON ACER TENDL-2024 LIBRARY; T=0.K
Photon emission for (n,2p)

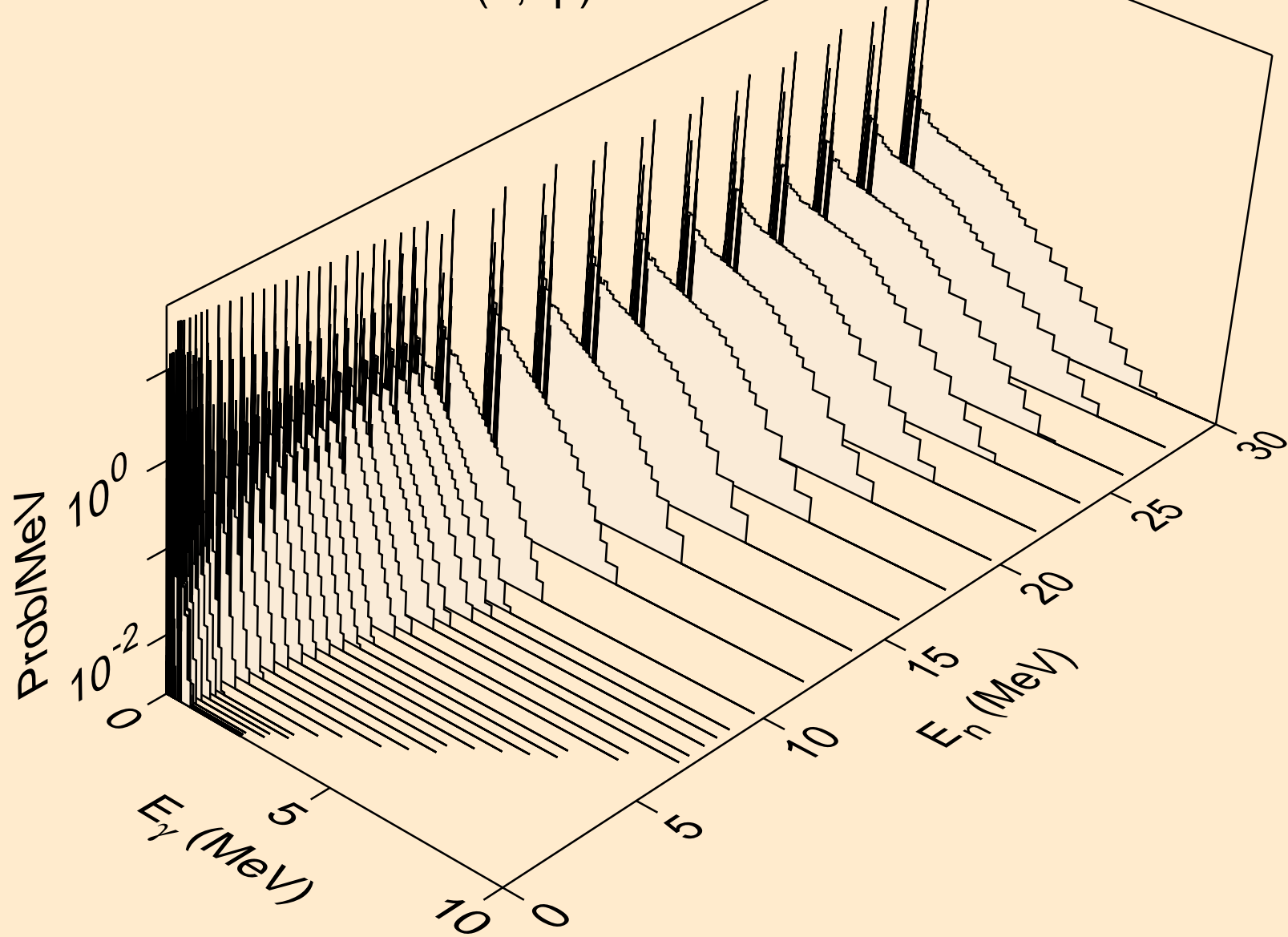

LU157M NEUTRON ACER TENDL-2024 LIBRARY; T=0.K
Photon emission for (n,p α)

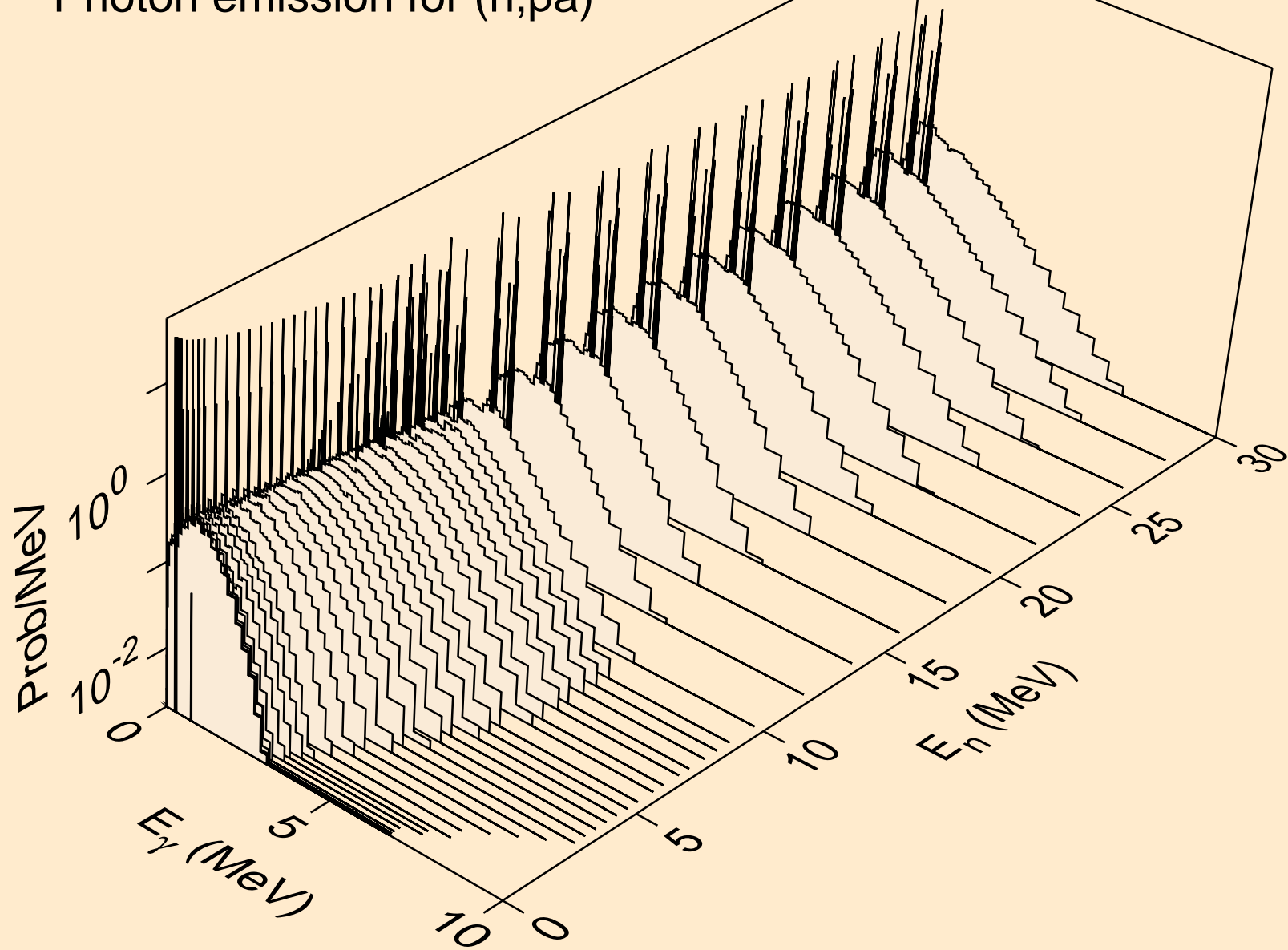

LU157M NEUTRON ACER TENDL-2024 LIBRARY; T=0.K
Photon emission for (n,t2a)

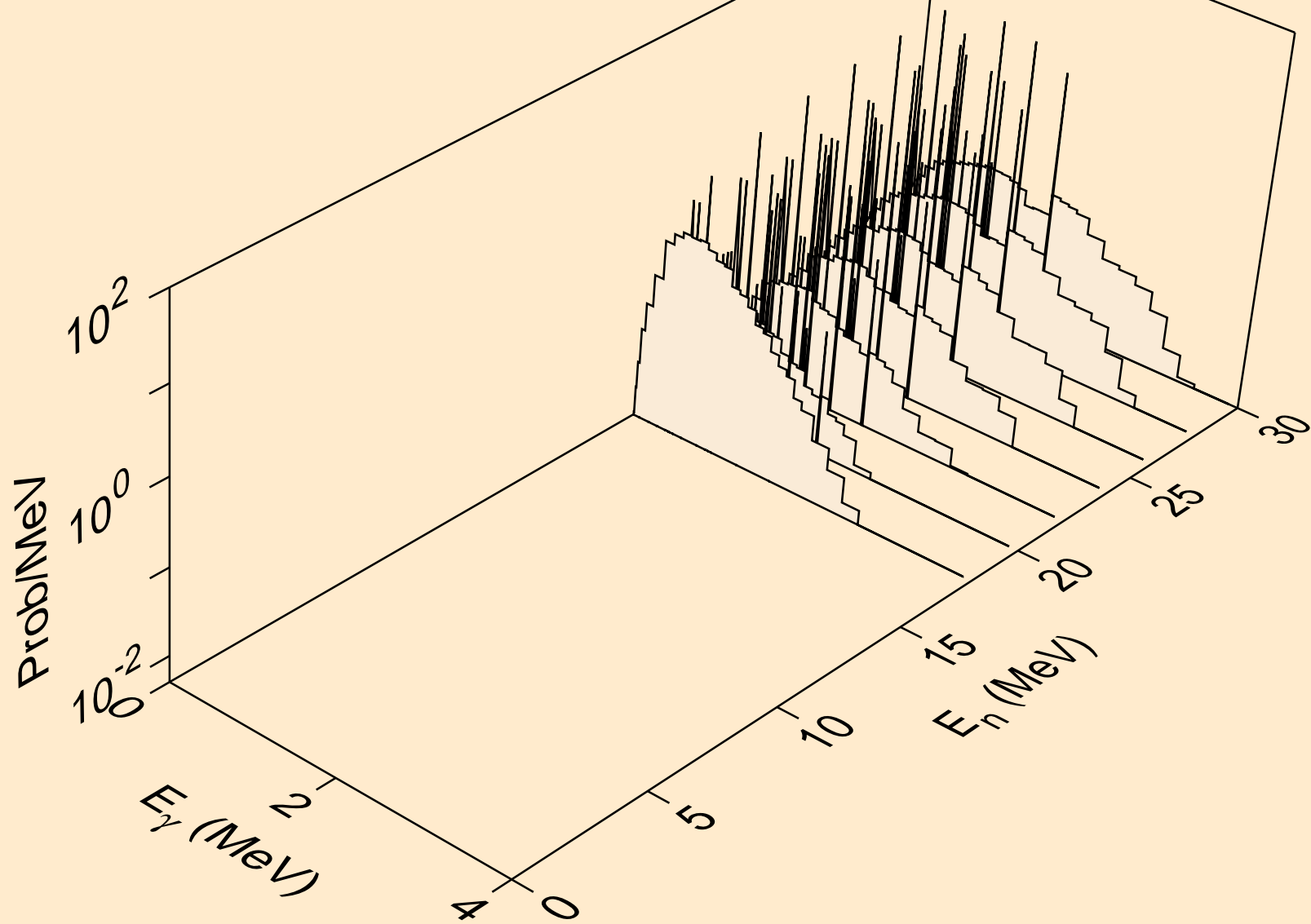

LU157M NEUTRON ACER TENDL-2024 LIBRARY; T=0.K
Photon emission for (n,d2a)

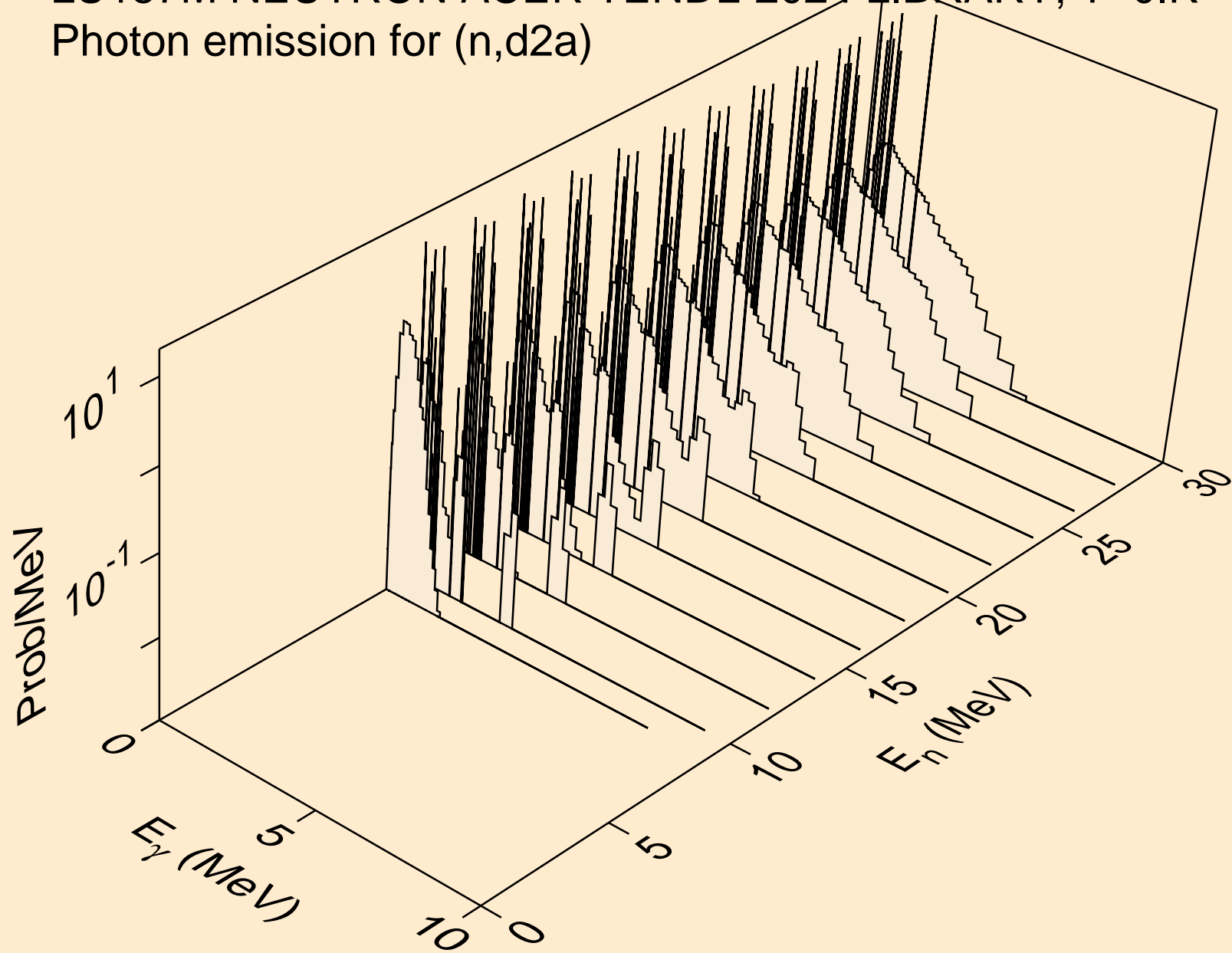

LU157M NEUTRON ACER TENDL-2024 LIBRARY; T=0.K
Photon emission for (n,pd)

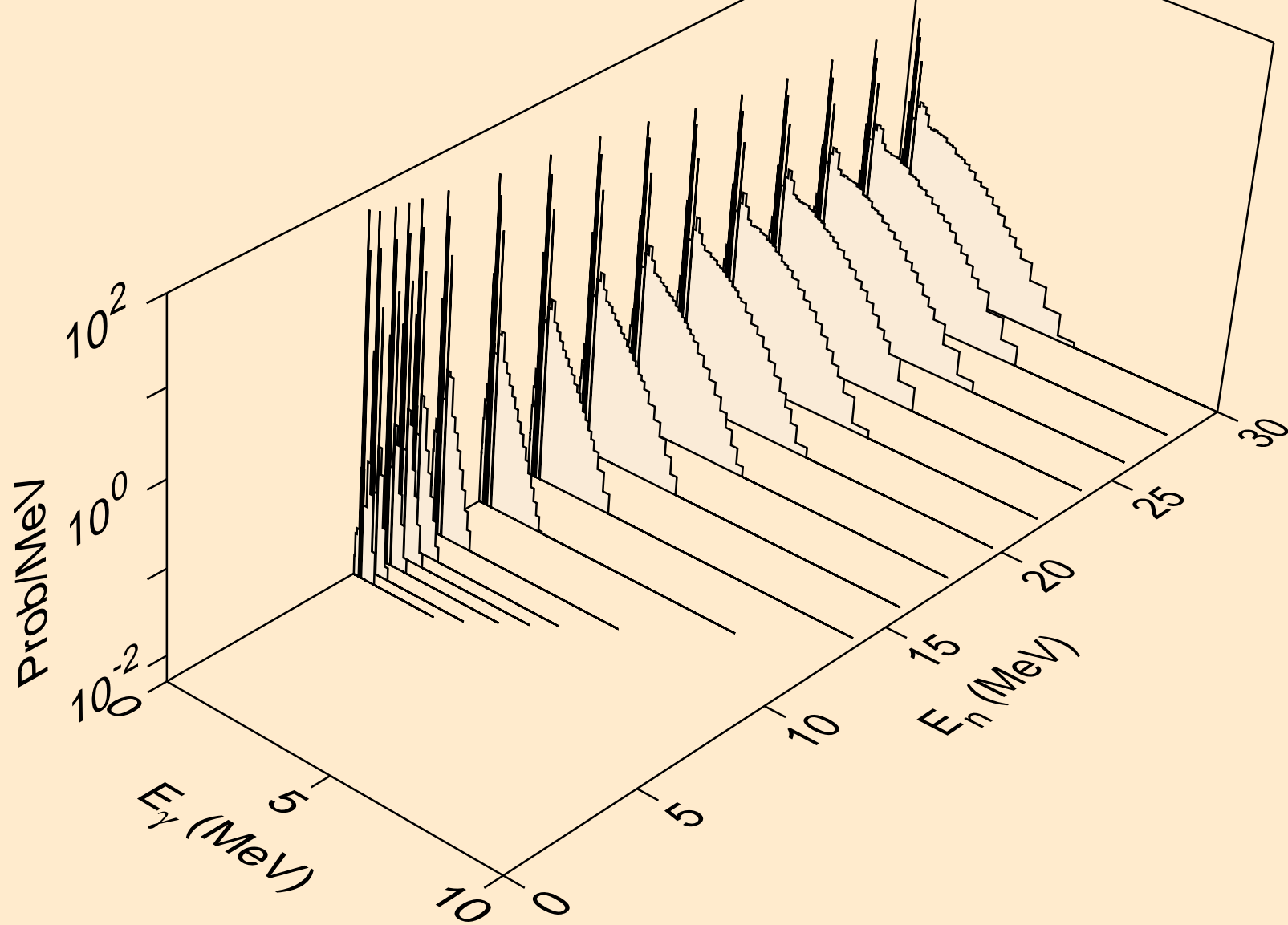

LU157M NEUTRON ACER TENDL-2024 LIBRARY; T=0.K
Photon emission for (n,pt)

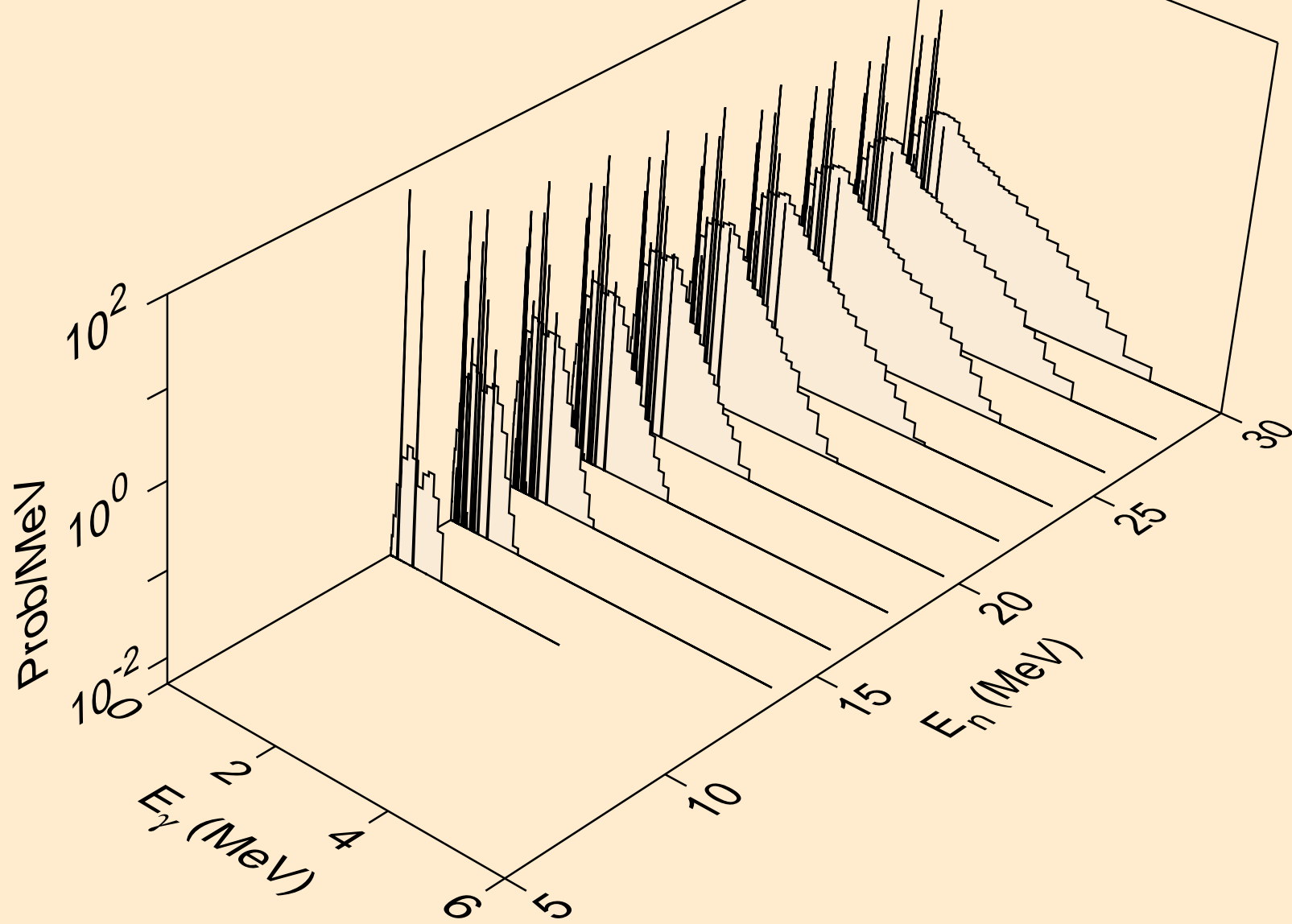

LU157M NEUTRON ACER TENDL-2024 LIBRARY; T=0.K
Photon emission for (n,da)

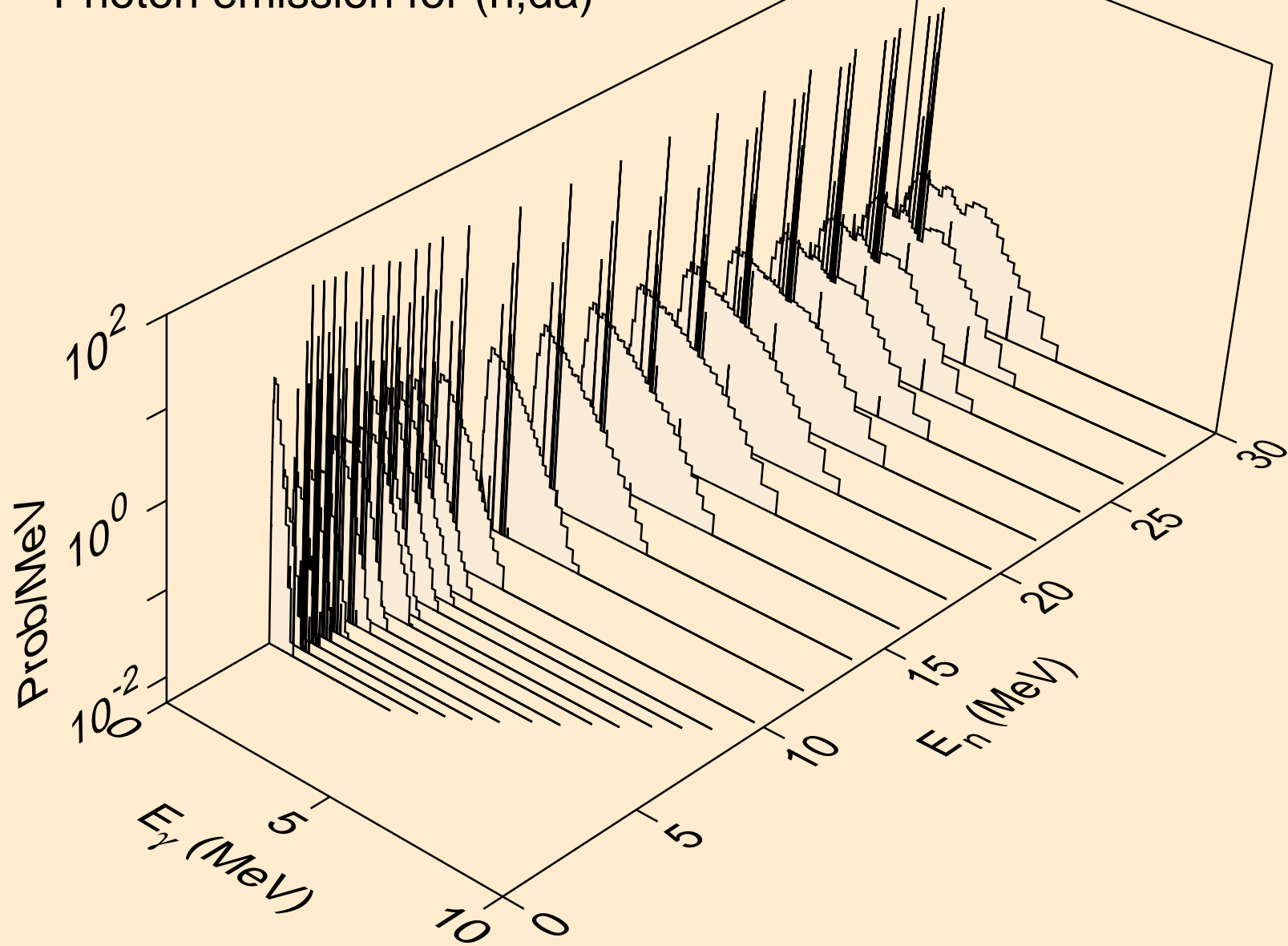

LU157M NEUTRON ACER TENDL-2024 LIBRARY; T=0.K
thermal capture photon spectrum

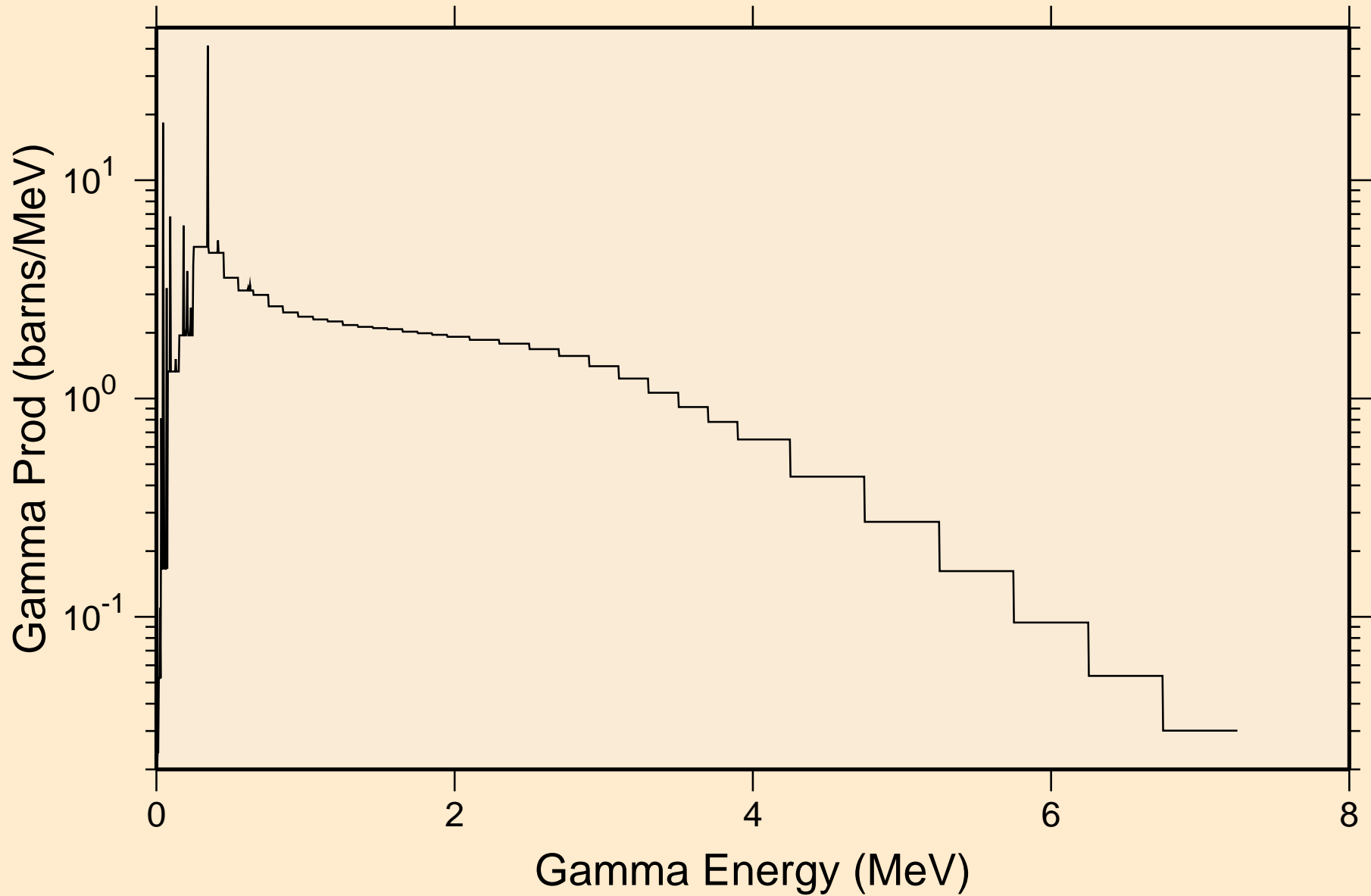

LU157M NEUTRON ACER TENDL-2024 LIBRARY; T=0.K
14 MeV photon spectrum

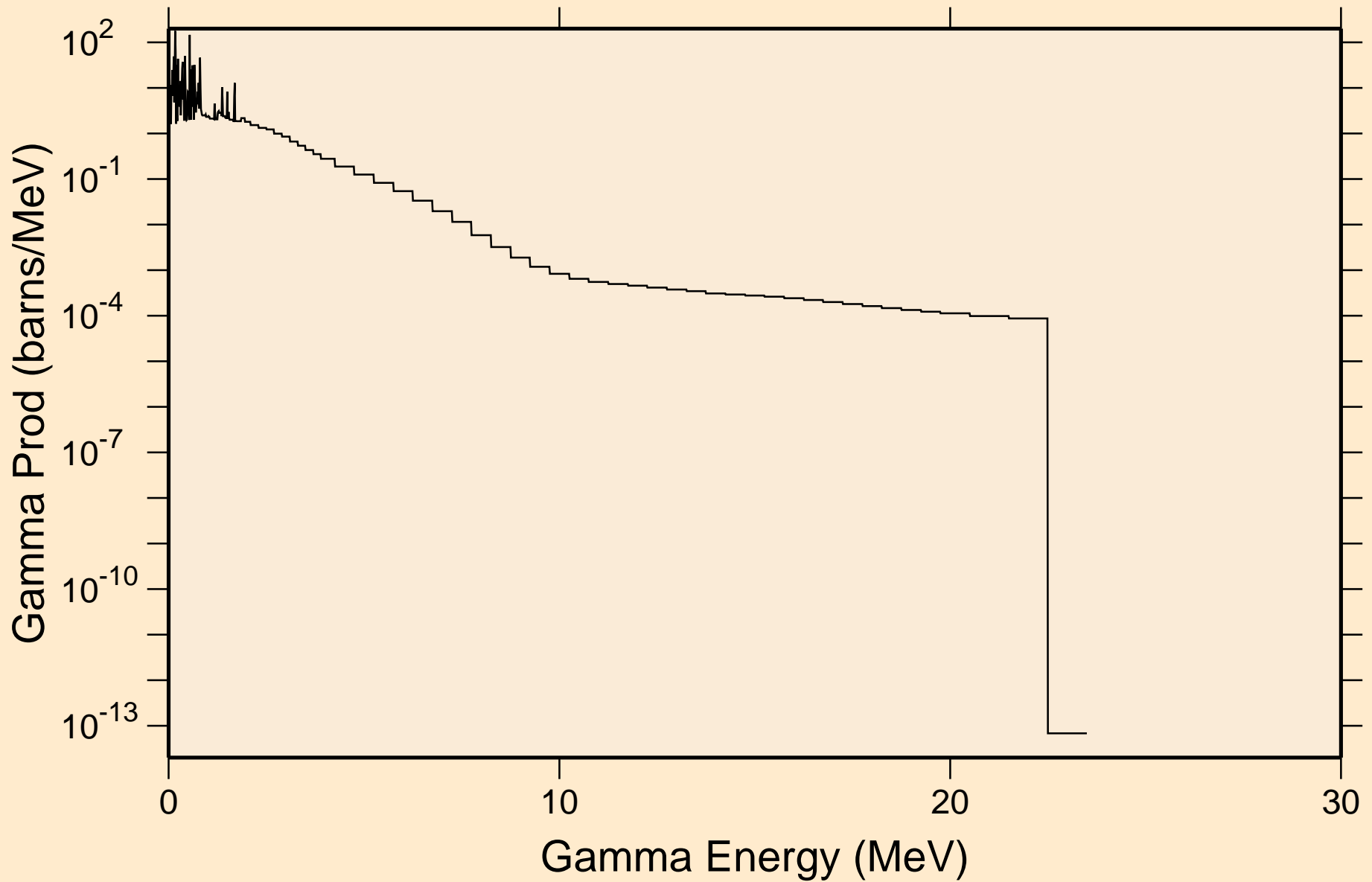

LU157M NEUTRON ACER TENDL-2024 LIBRARY; T=0.K

Particle heating contributions

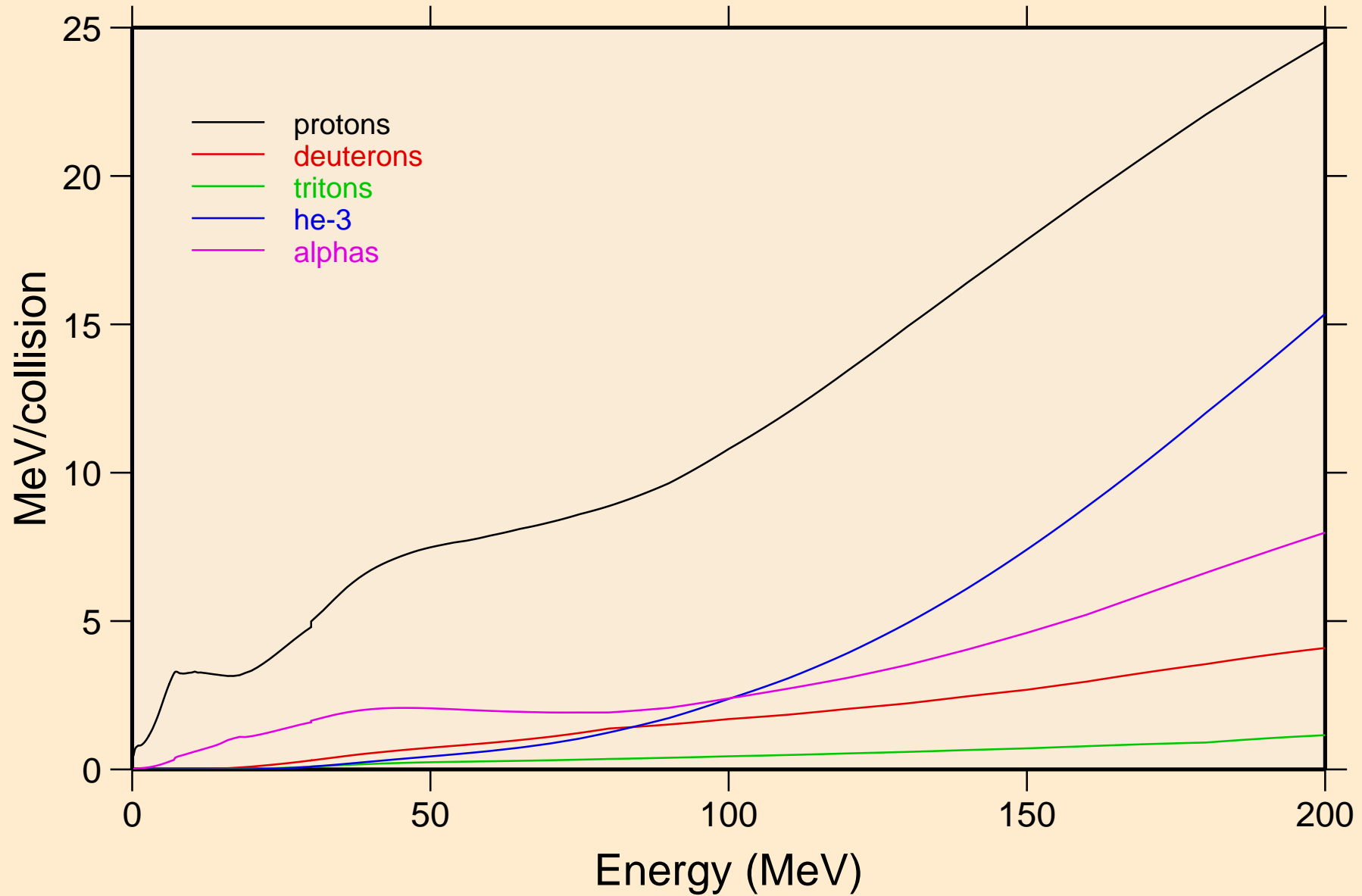

LU157M NEUTRON ACER TENDL-2024 LIBRARY; T=0.K
Recoil Heating

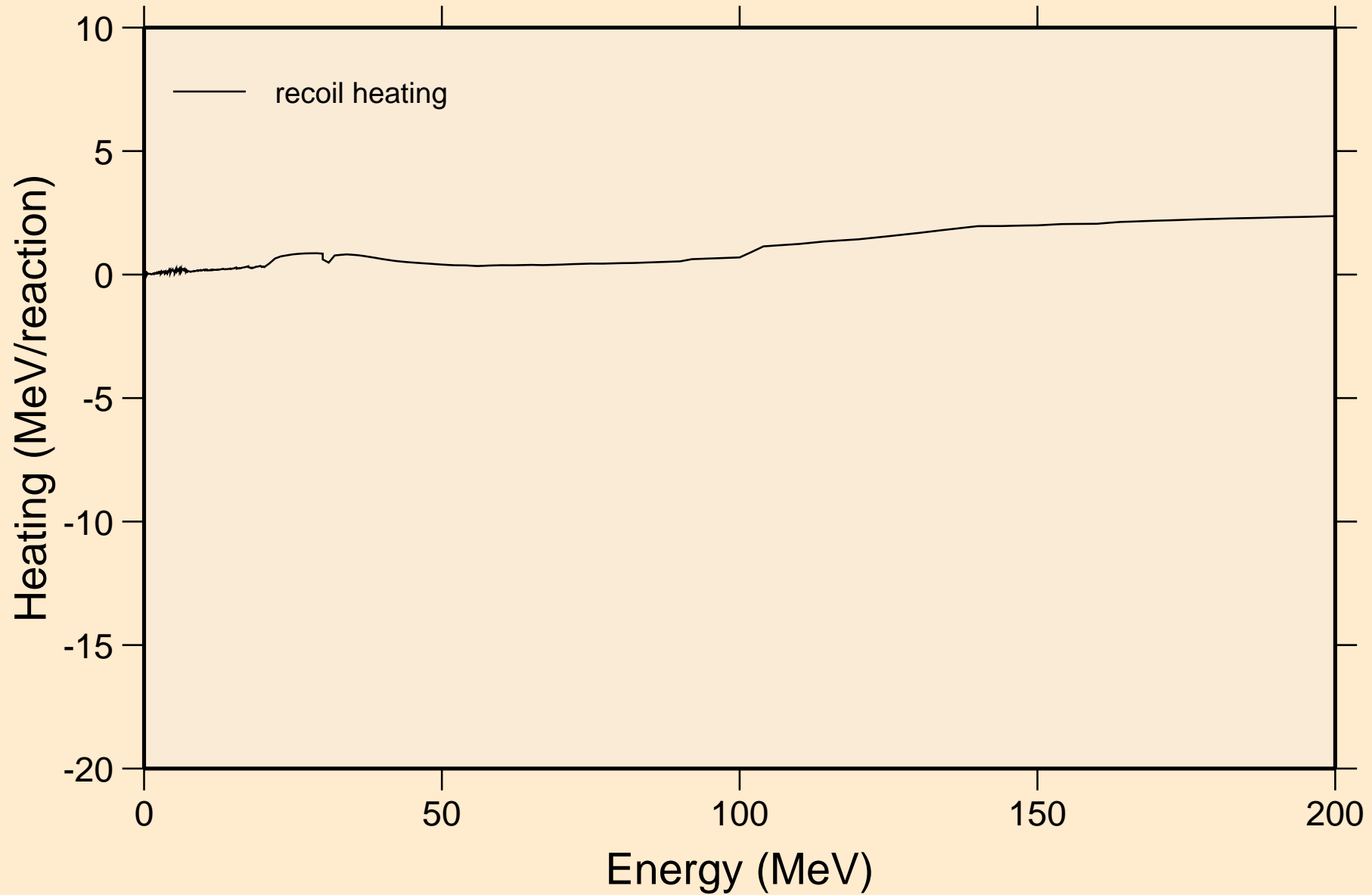

LU157M NEUTRON ACER TENDL-2024 LIBRARY; T=0.K

Particle production cross sections

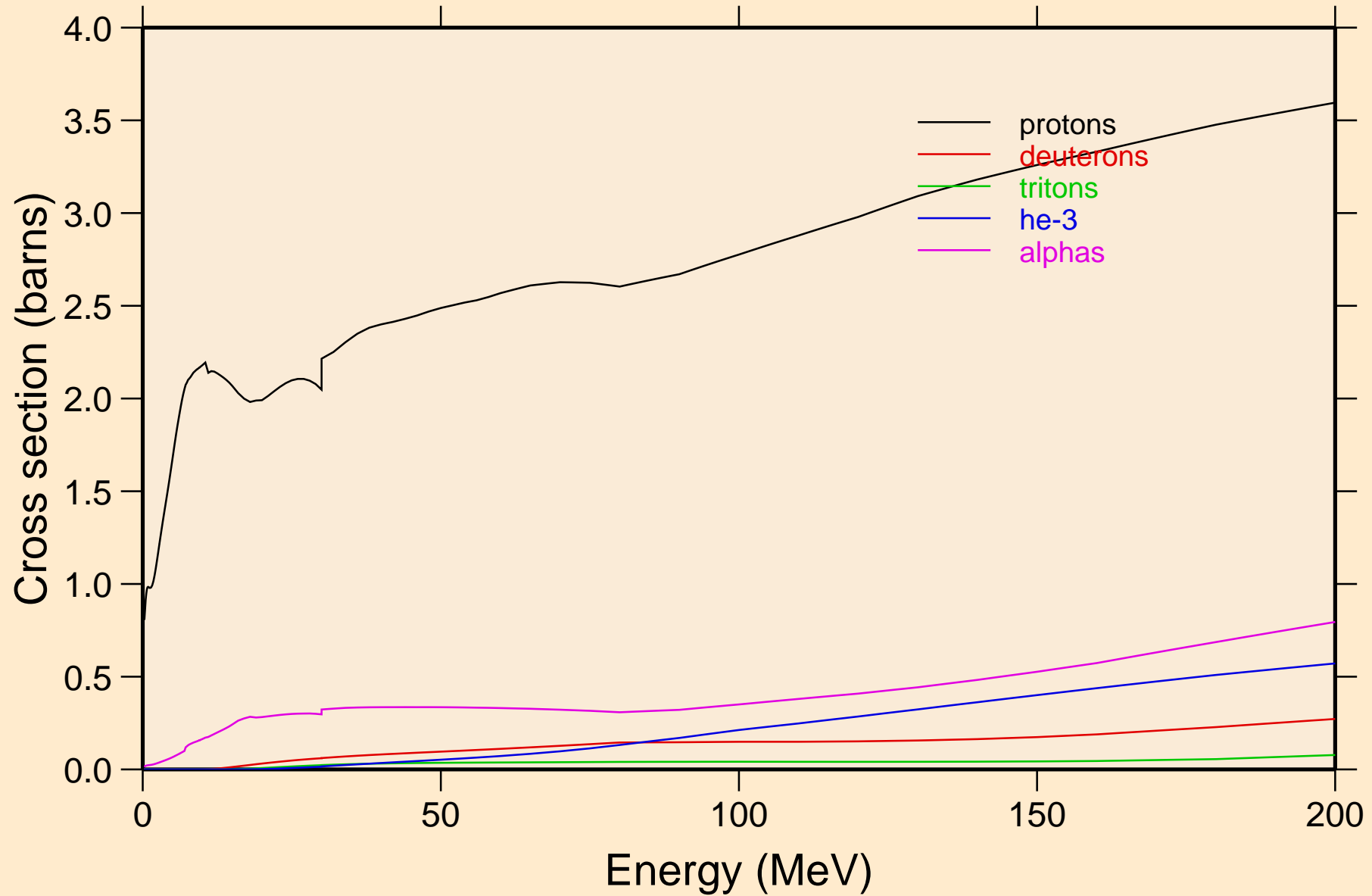

LU157M NEUTRON ACER TENDL-2024 LIBRARY; T=0.K
protons from (n,x)

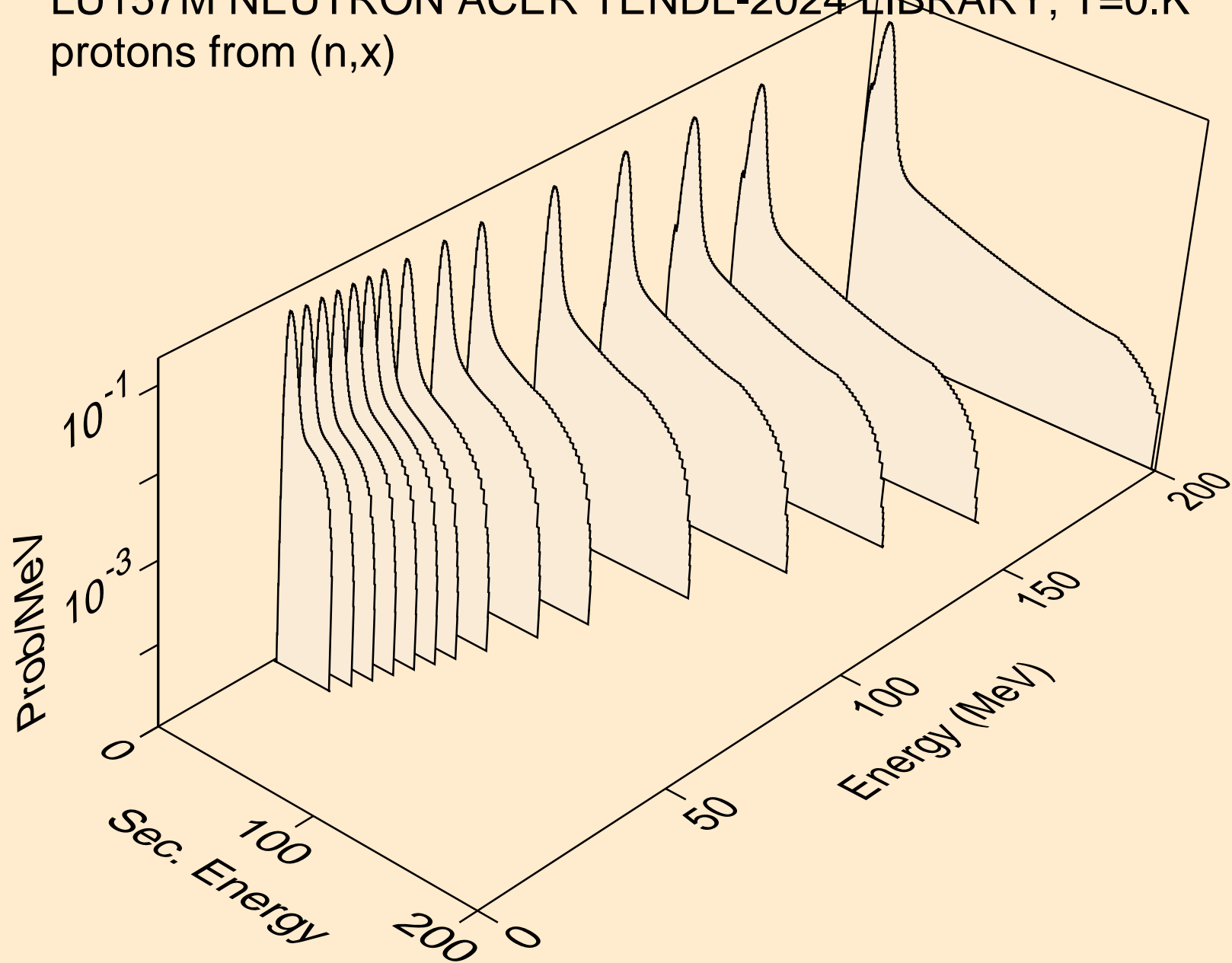

LU157M NEUTRON ACER TENDL-2024 LIBRARY; T=0.K
protons from (n,n*)p

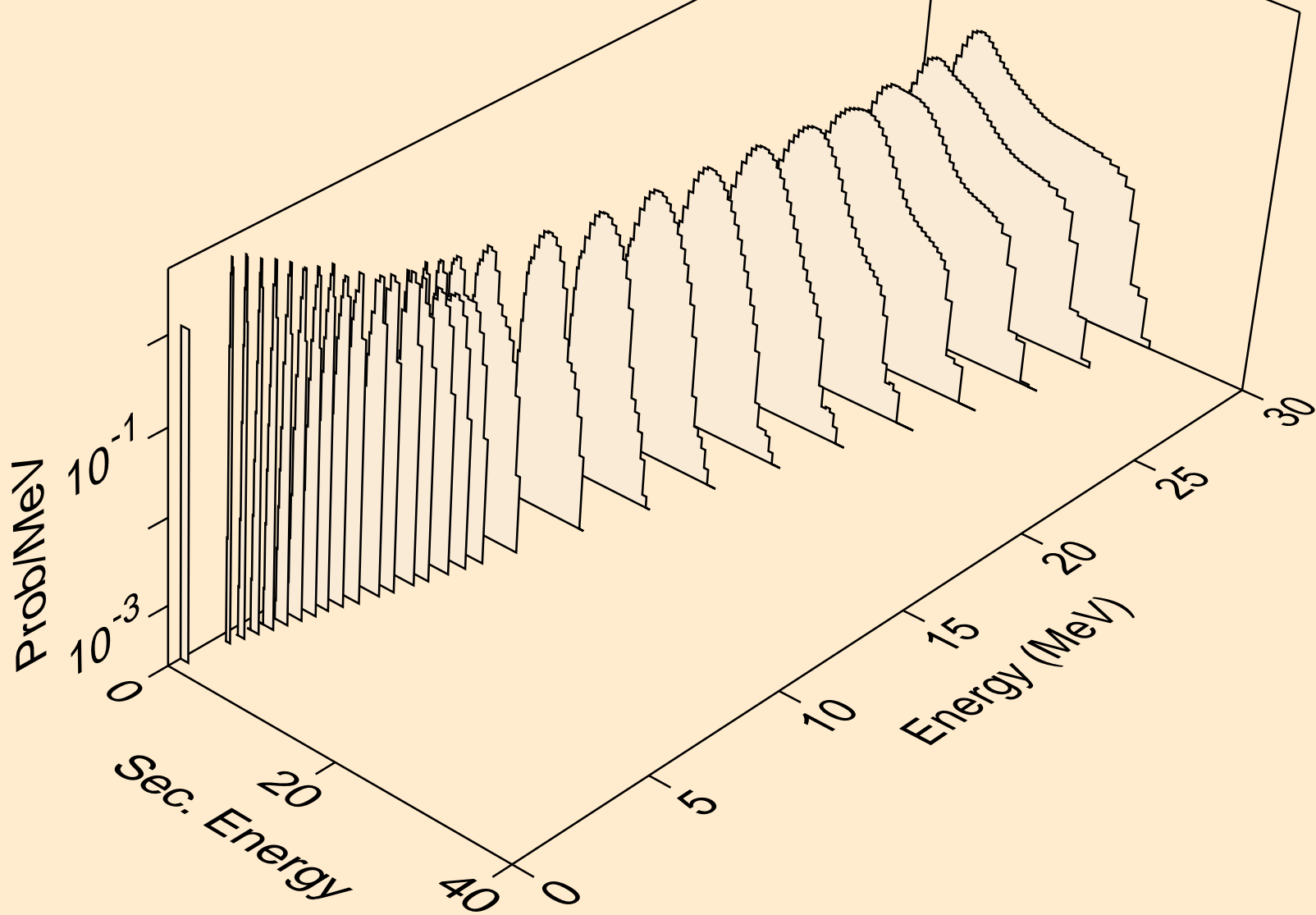

LU157M NEUTRON ACER TENDL-2024 LIBRARY; T=0.K
protons from (n,2np)

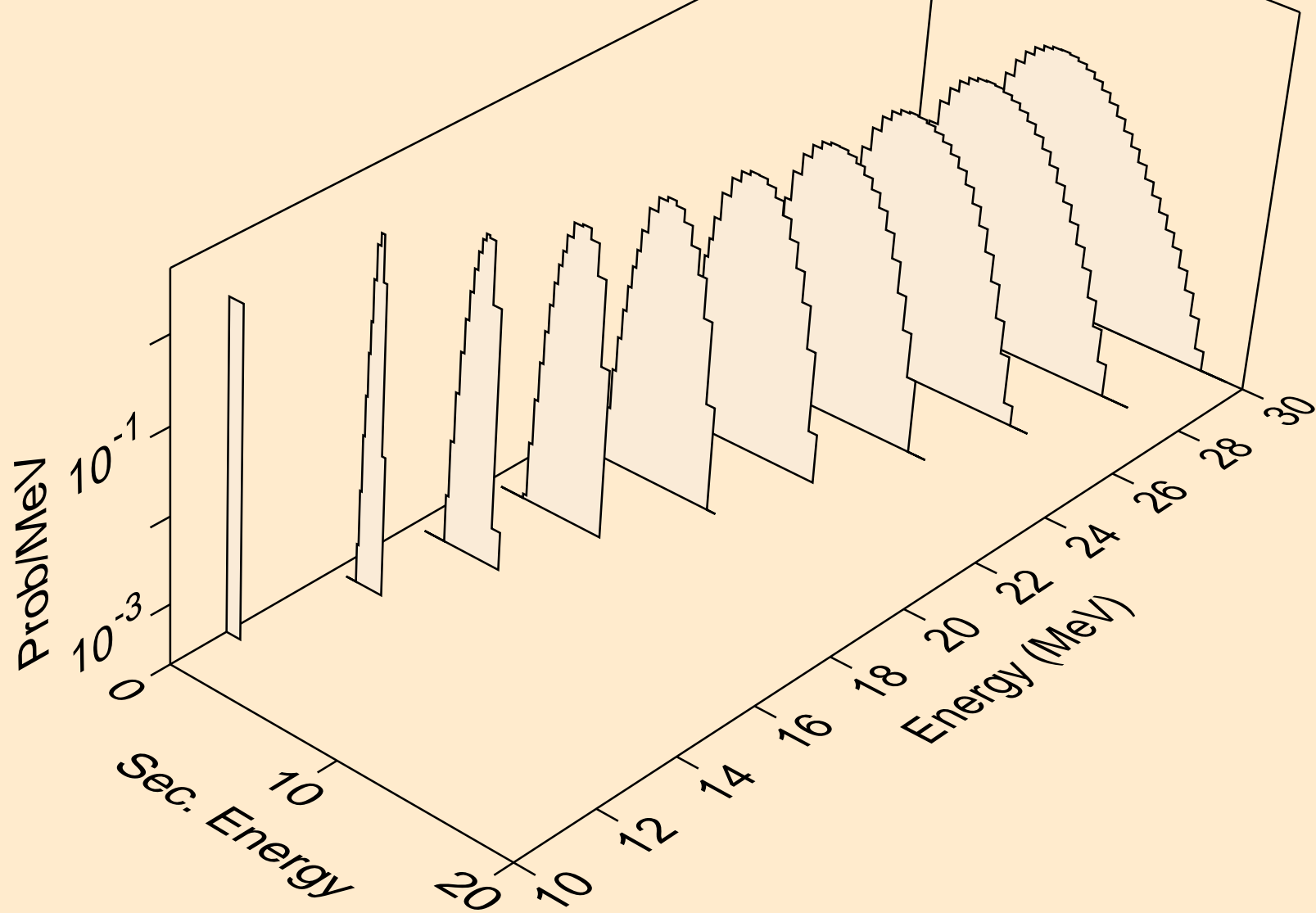

LU157M NEUTRON ACER TENDL-2024 LIBRARY; T=0.K
protons from (n,3np)

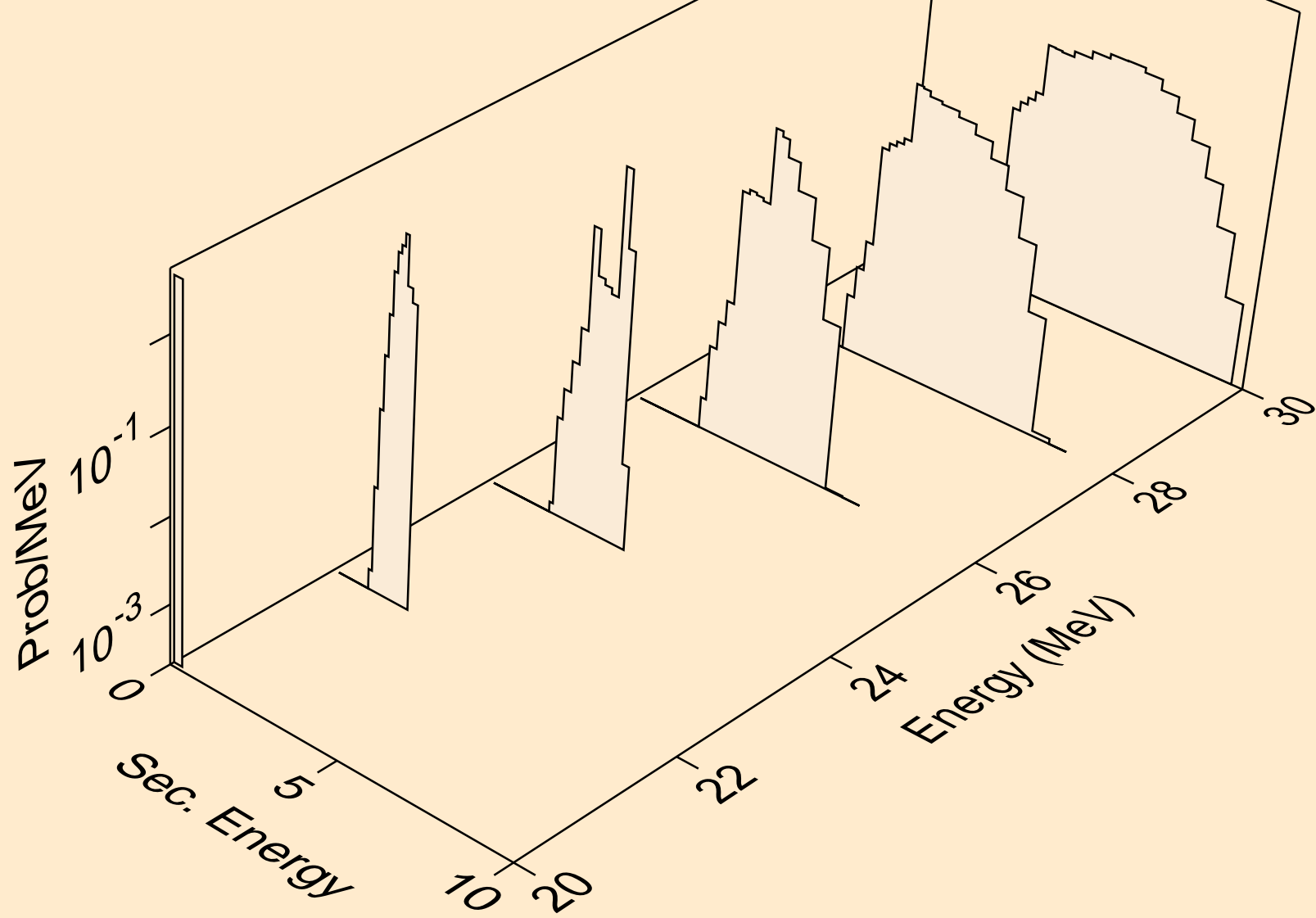

LU157M NEUTRON ACER TENDL-2024 LIBRARY; T=0.K
protons from (n,n2p)

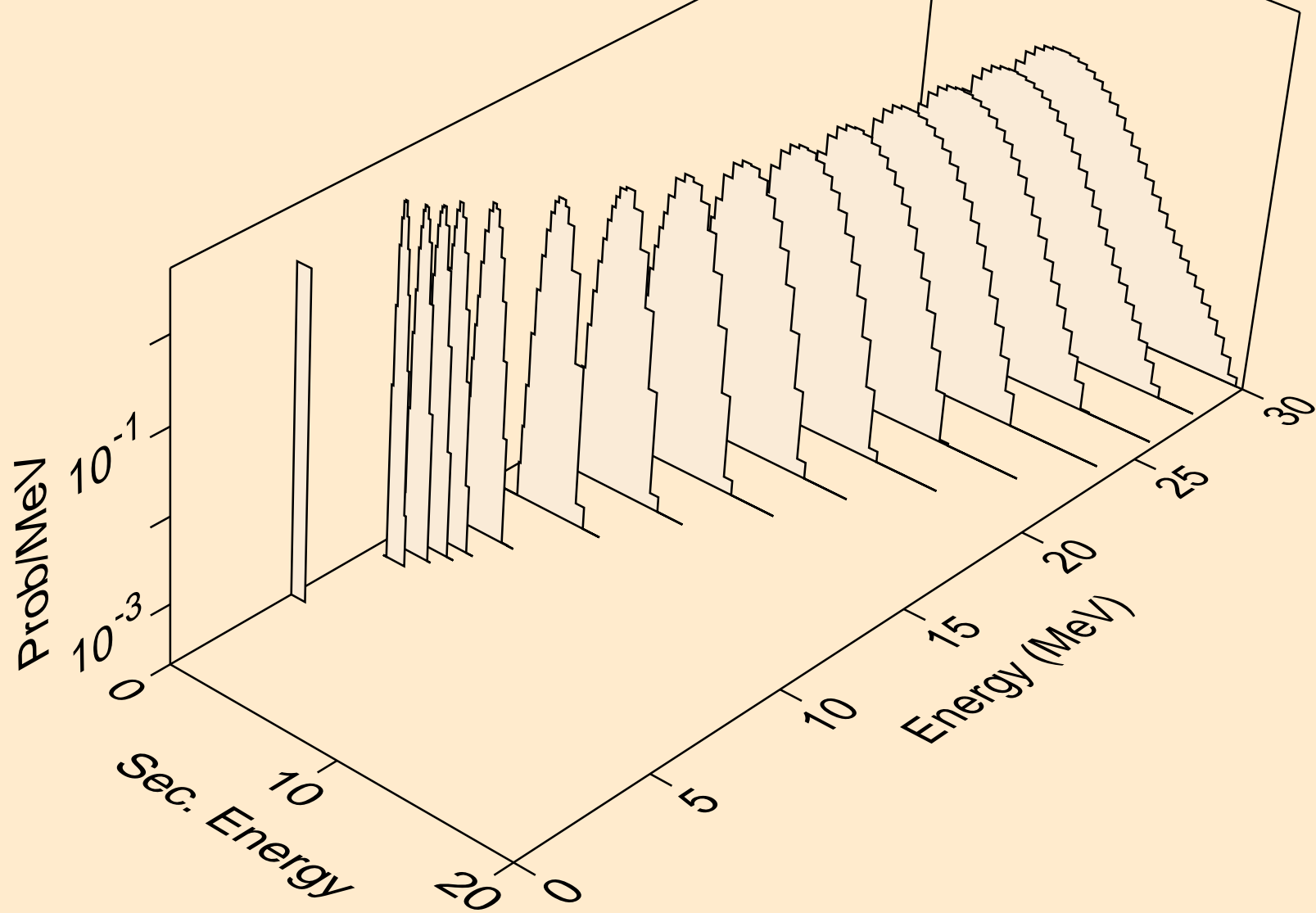

LU157M NEUTRON ACER TENDL-2024 LIBRARY; T=0.K
protons from (n,npa)

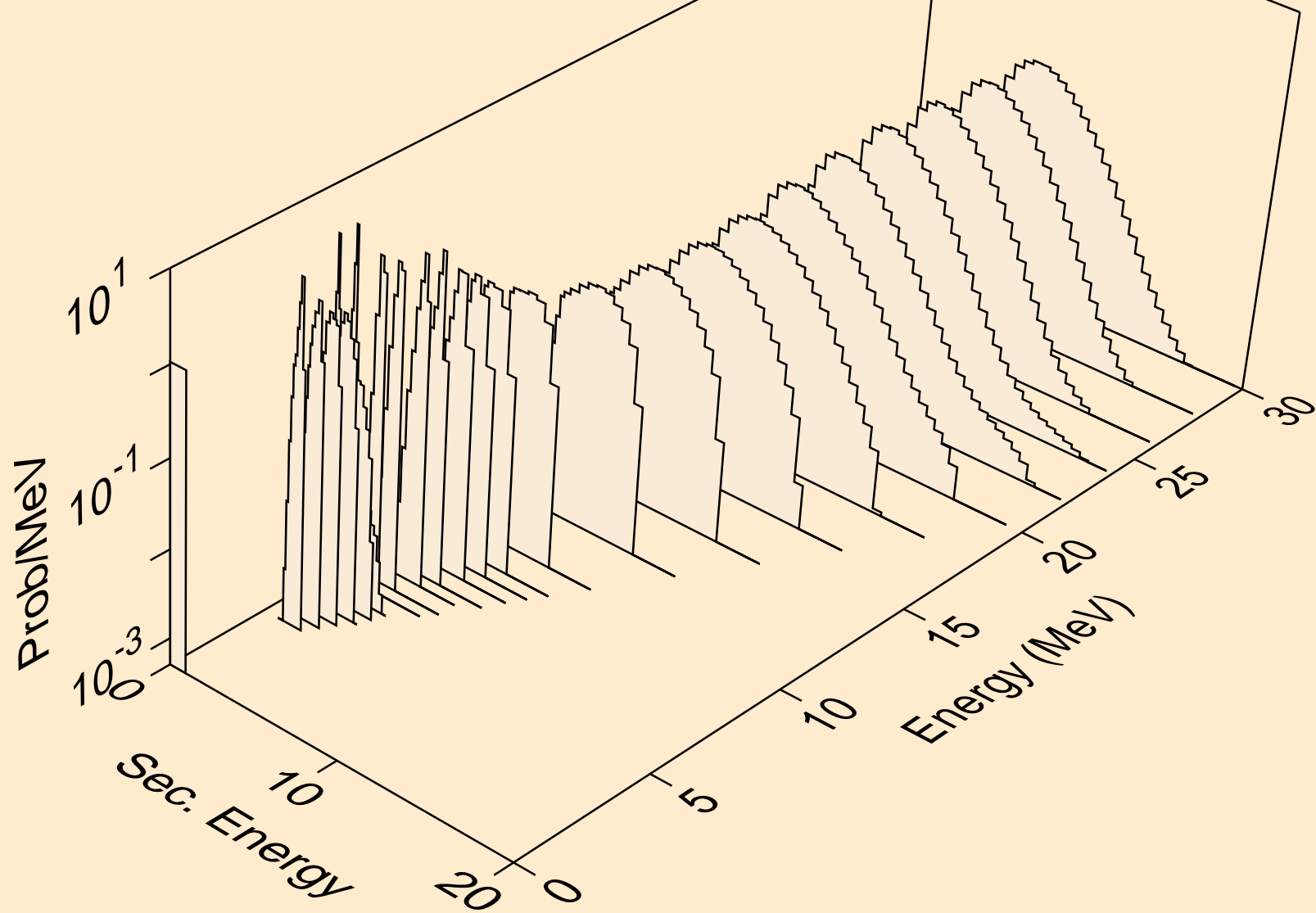

LU157M NEUTRON ACER TENDL-2024 LIBRARY; T=0.K
protons from (n,p)

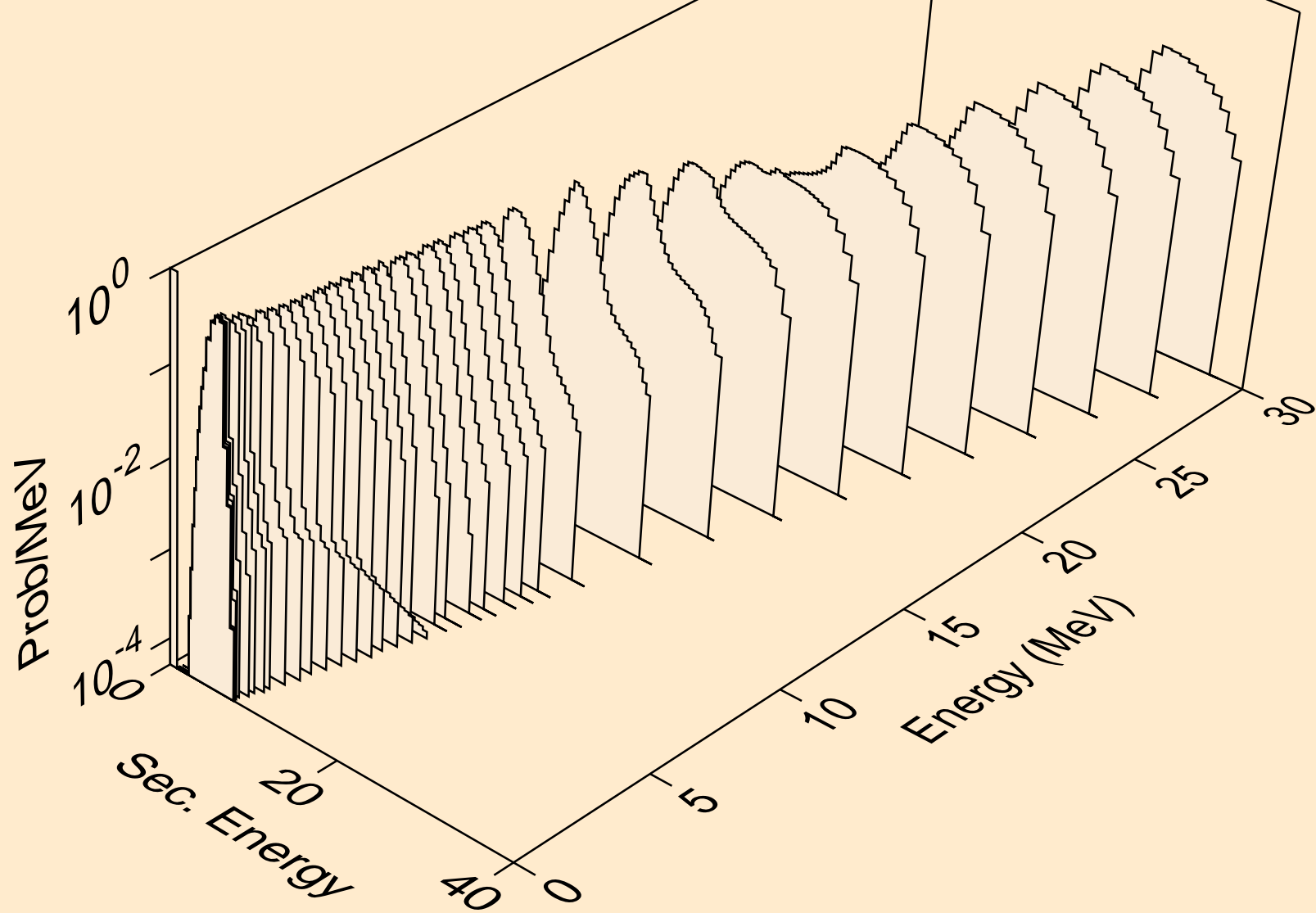

LU157M NEUTRON ACER TENDL-2024 LIBRARY; T=0.K
protons from (n,2p)

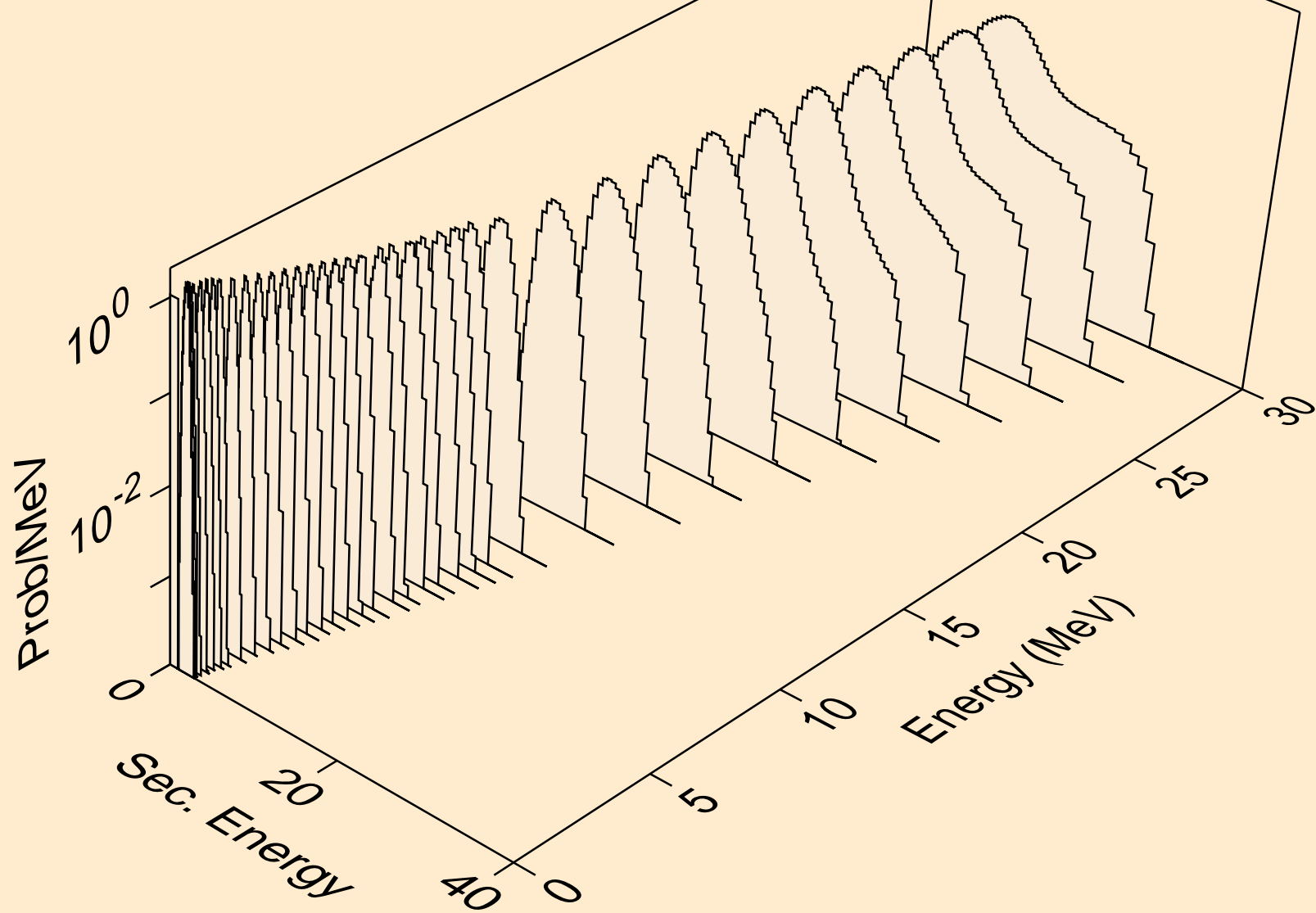

LU157M NEUTRON ACER TENDL-2024 LIBRARY; T=0.K
protons from (n,p)

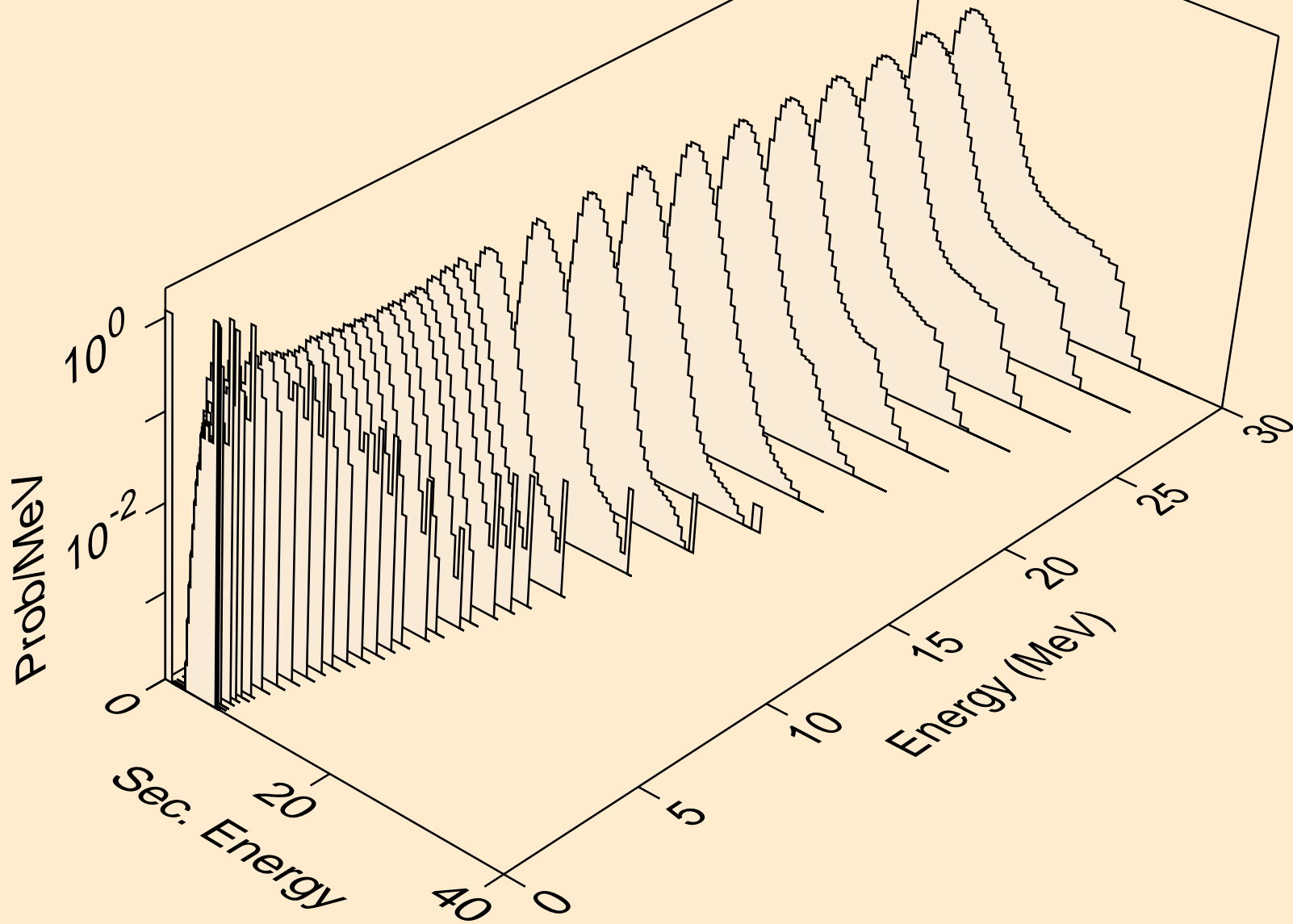

LU157M NEUTRON ACER TENDL-2024 LIBRARY; T=0.K
protons from (n,pd)

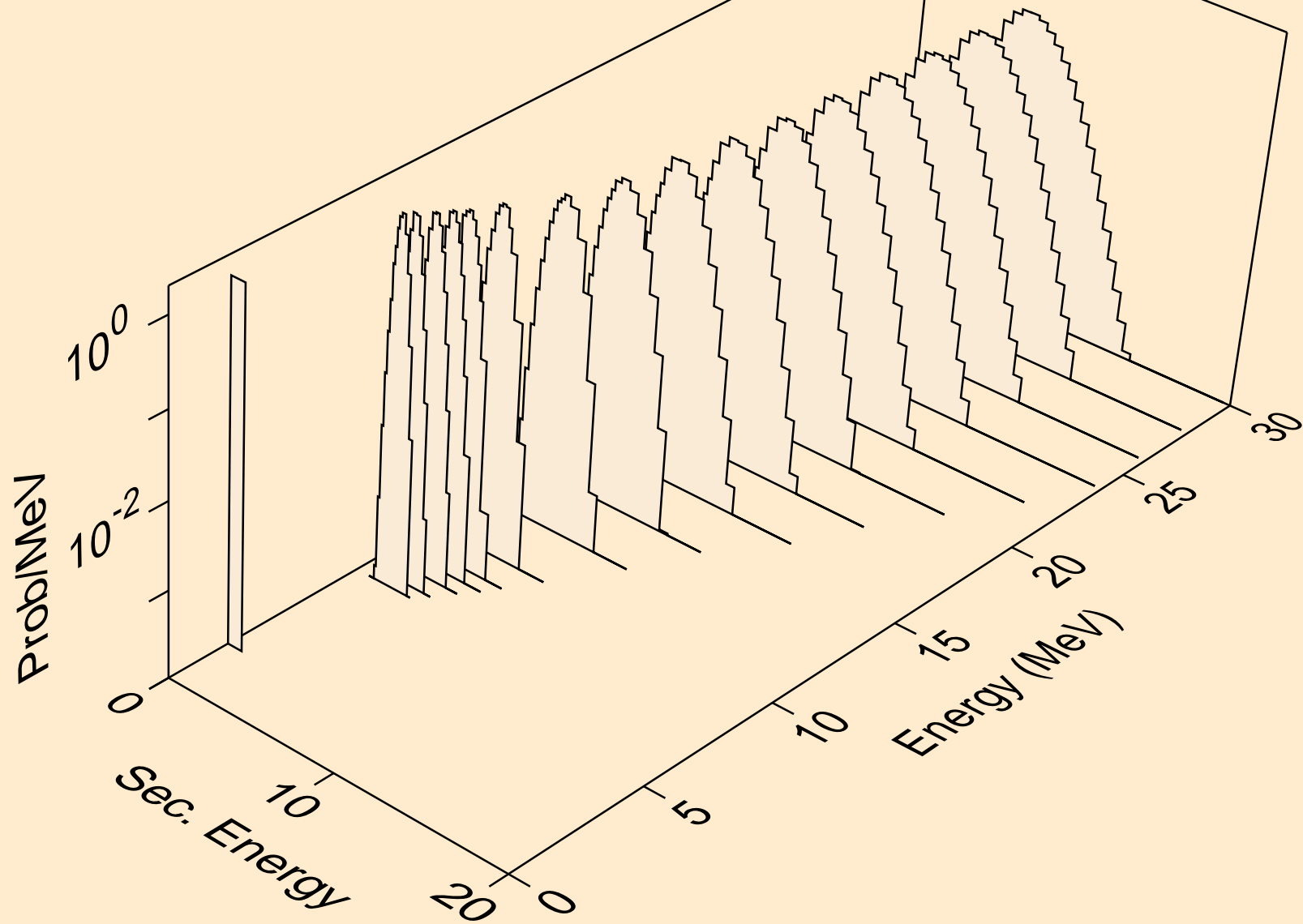

LU157M NEUTRON ACER TENDL-2024 LIBRARY; T=0.K
protons from (n,pt)

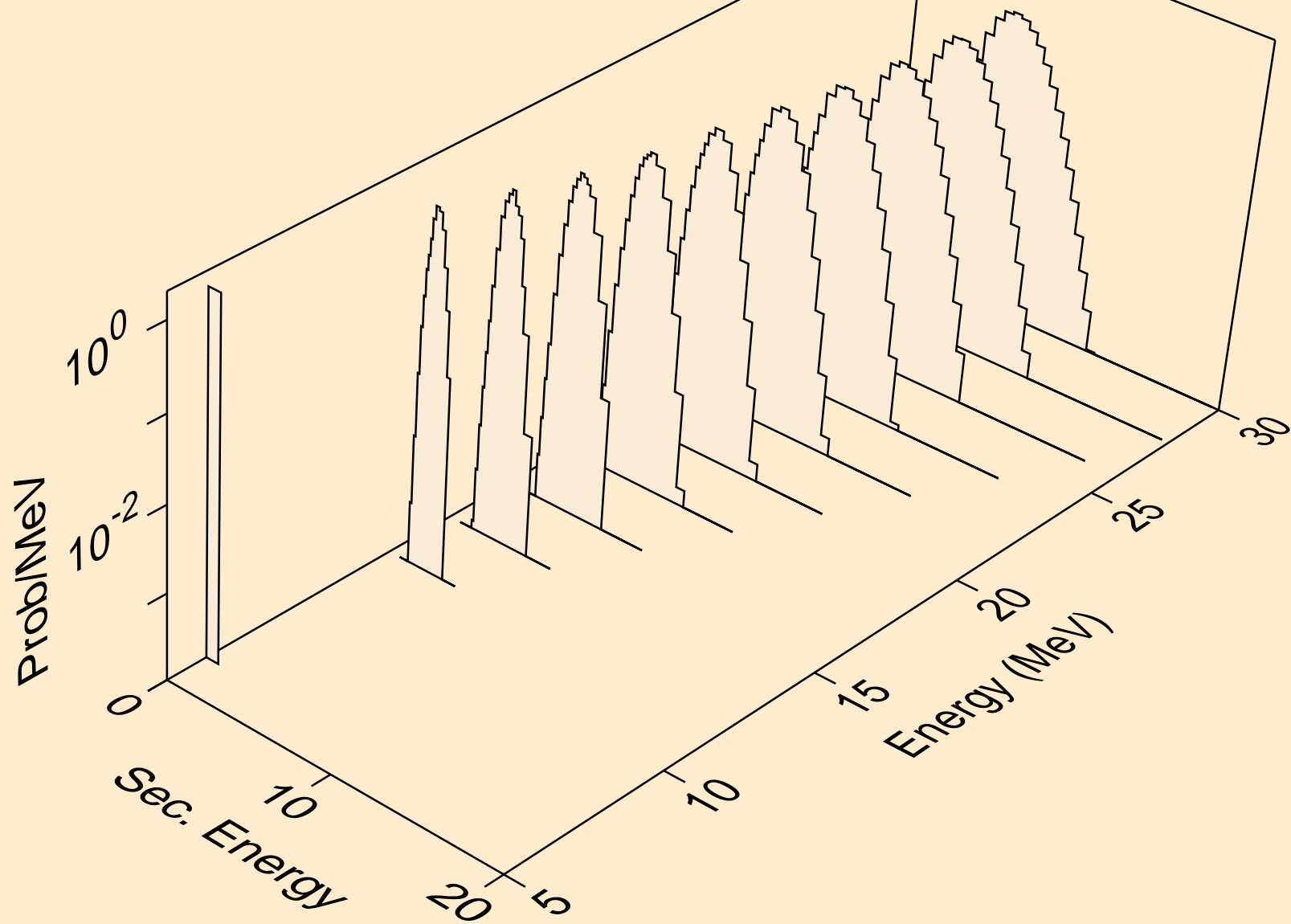

LU157M NEUTRON ACER TENDL-2024 LIBRARY; T=0.K
deuterons from (n,x)

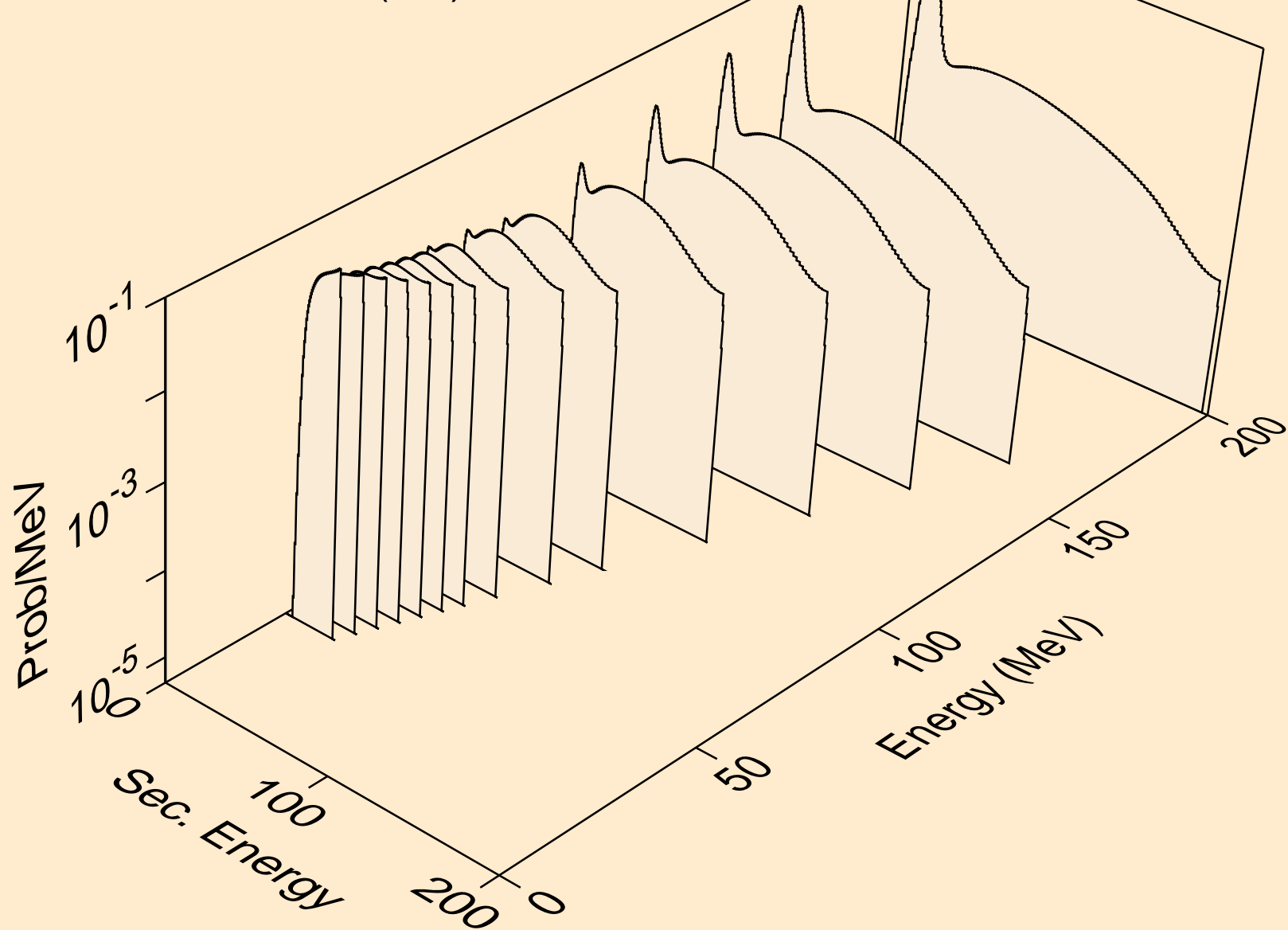

LU157M NEUTRON ACER TENDL-2024 LIBRARY; T=0.K
deuterons from (n,2nd)

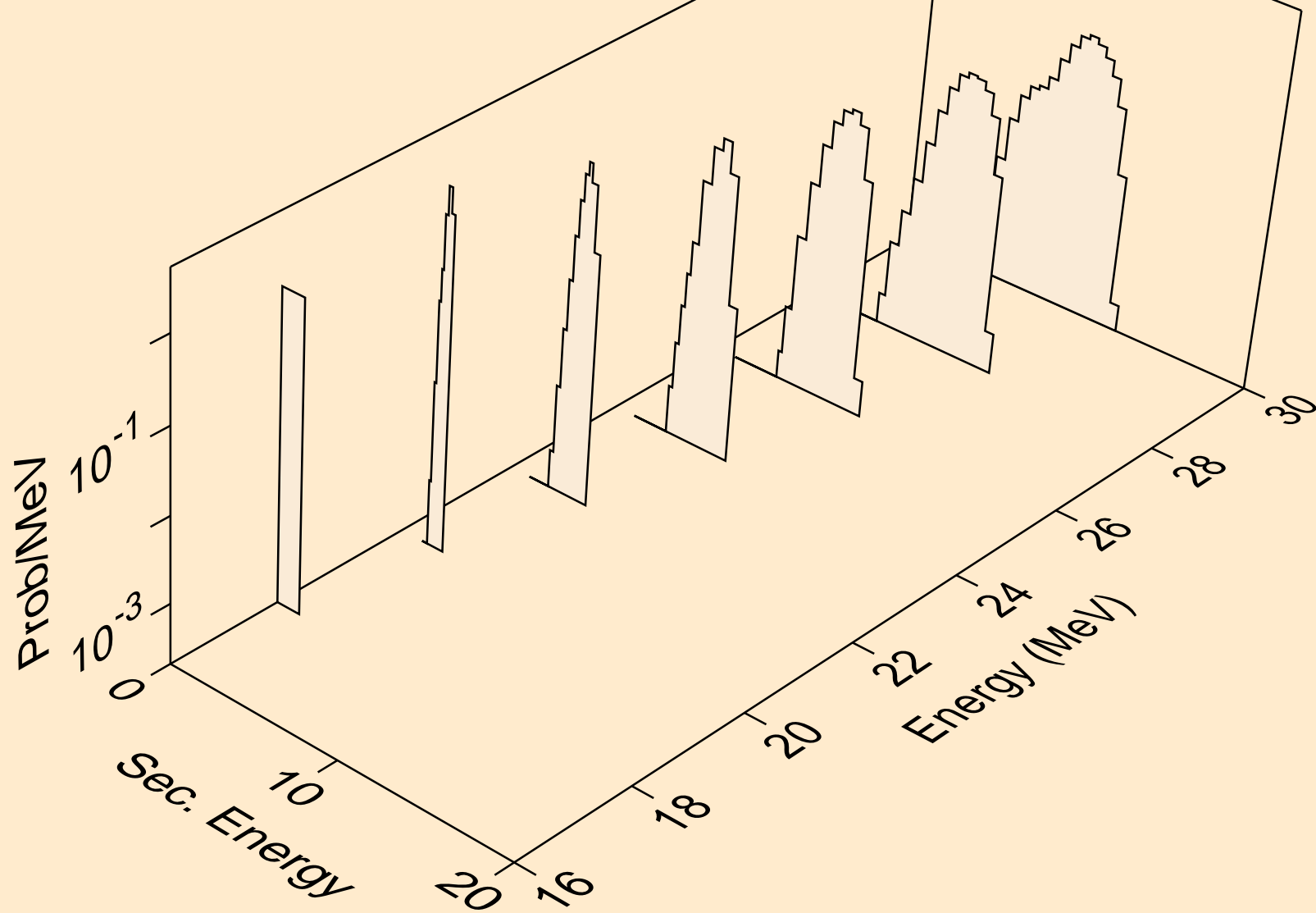

LU157M NEUTRON ACER TENDL-2024 LIBRARY; T=0.K
deuterons from (n,n*)d

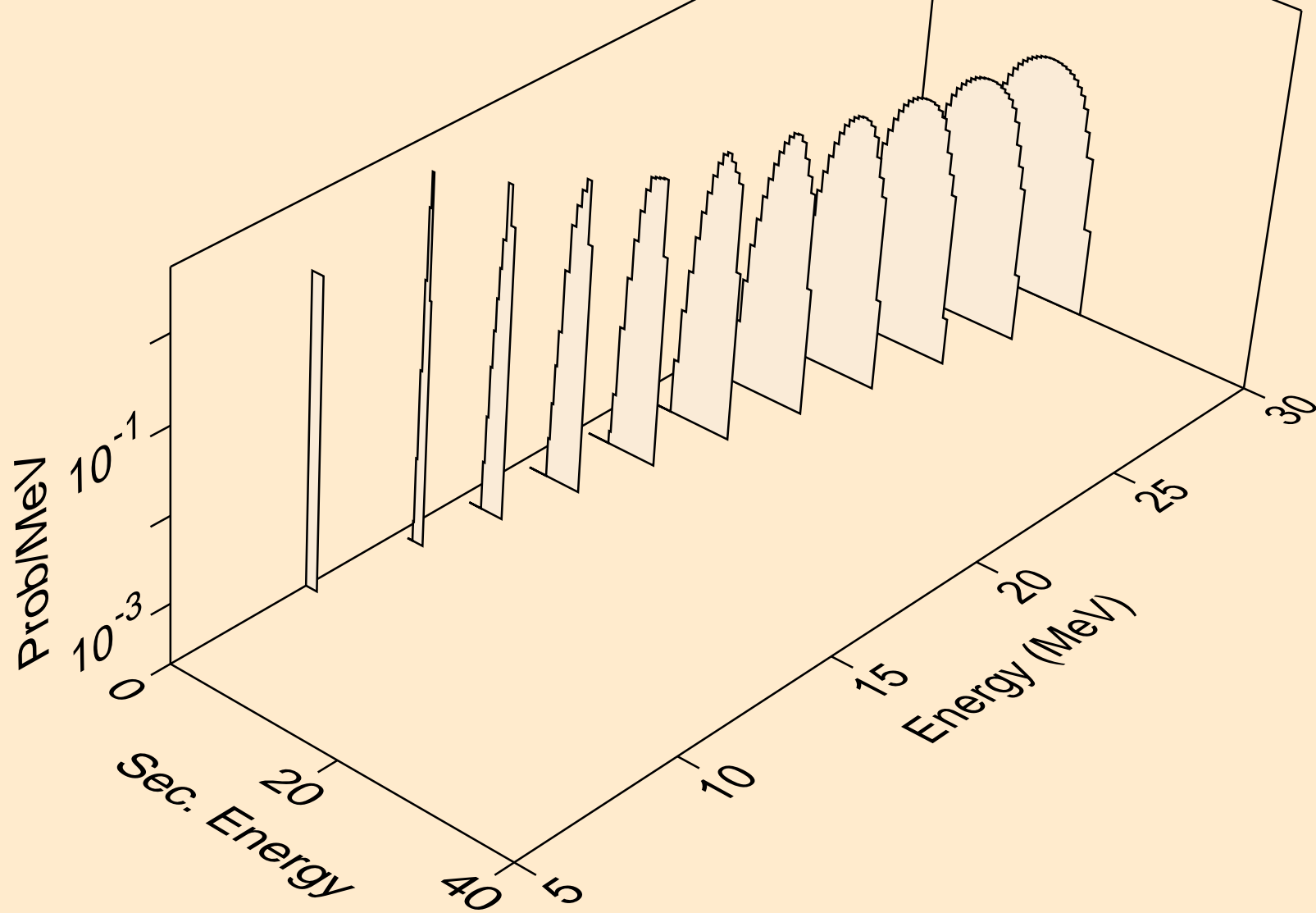

LU157M NEUTRON ACER TENDL-2024 LIBRARY; T=0.K
deuterons from (n,d)

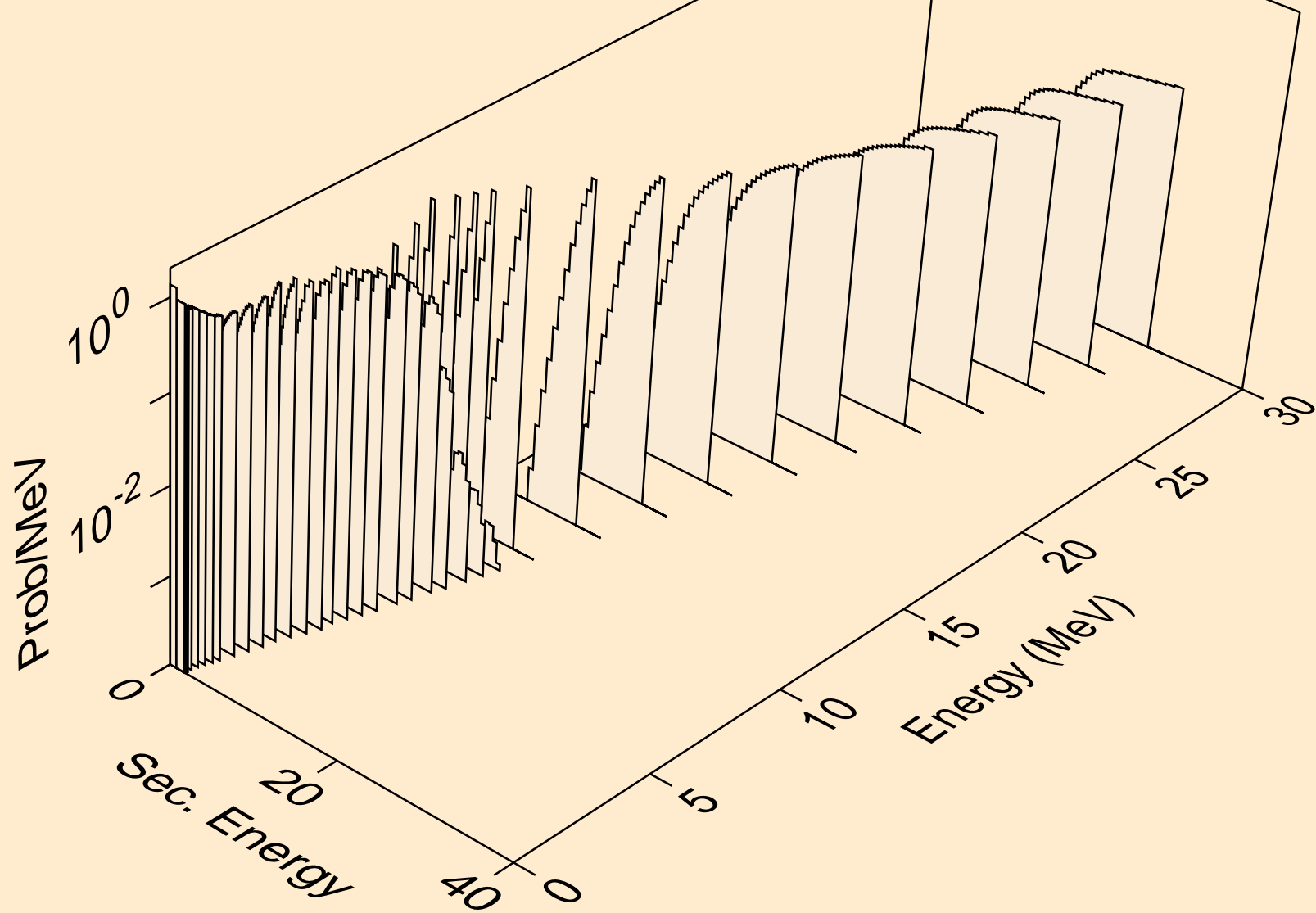

LU157M NEUTRON ACER TENDL-2024 LIBRARY; T=0.K
deuterons from (n,d2a)

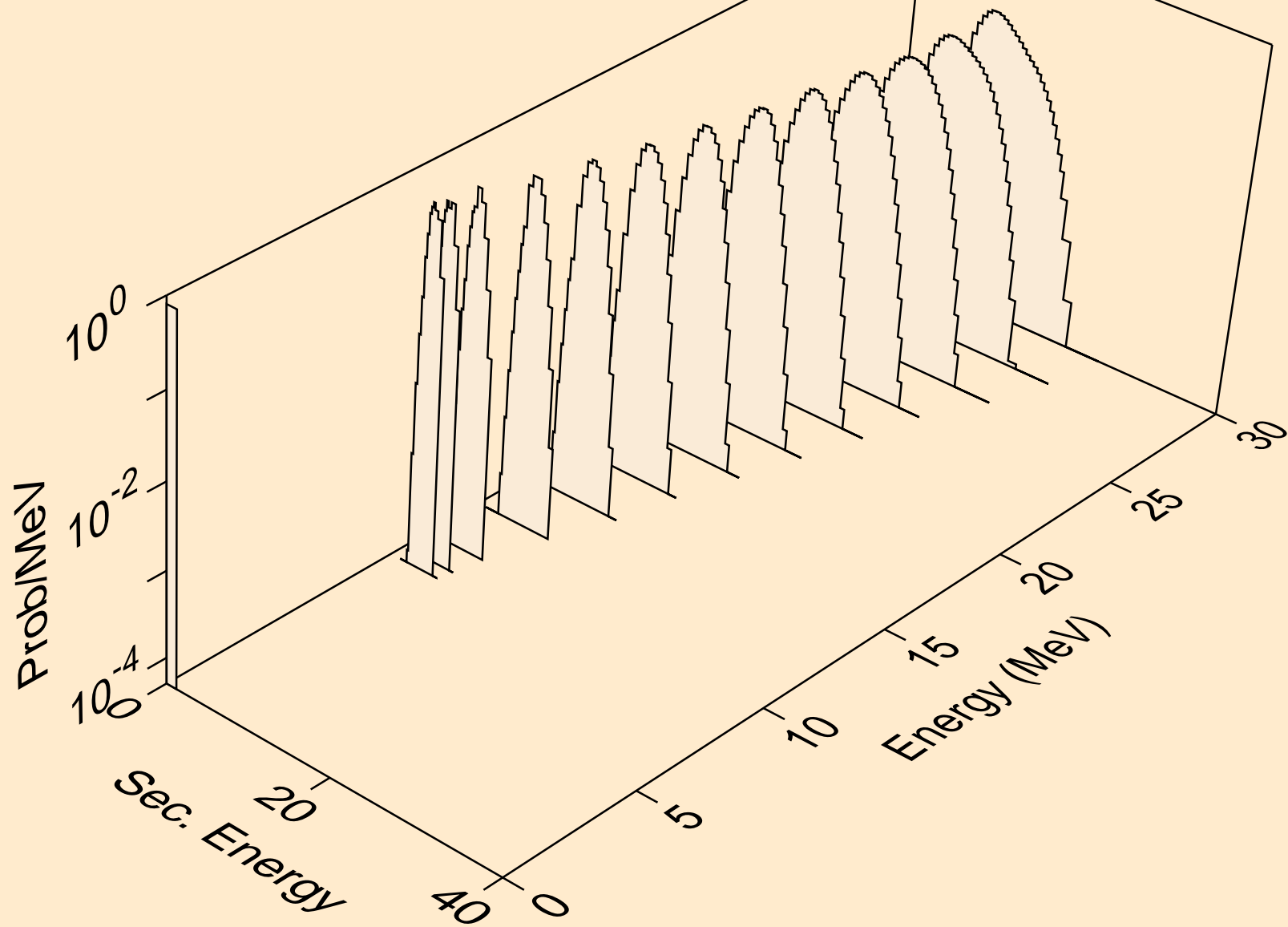

LU157M NEUTRON ACER TENDL-2024 LIBRARY; T=0.K
deuterons from (n,pd)

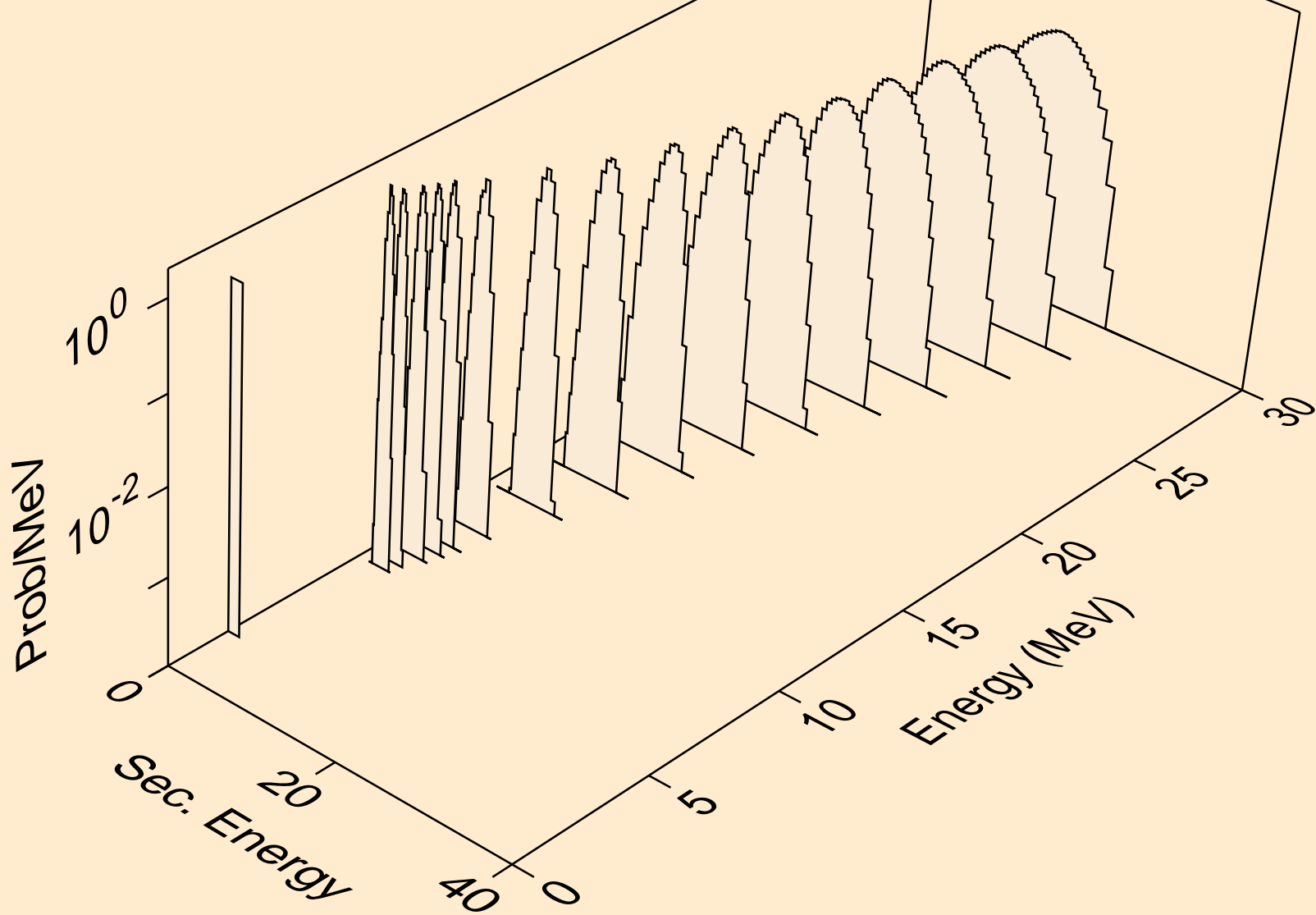

LU157M NEUTRON ACER TENDL-2024 LIBRARY; T=0.K
deuterons from (n,da)

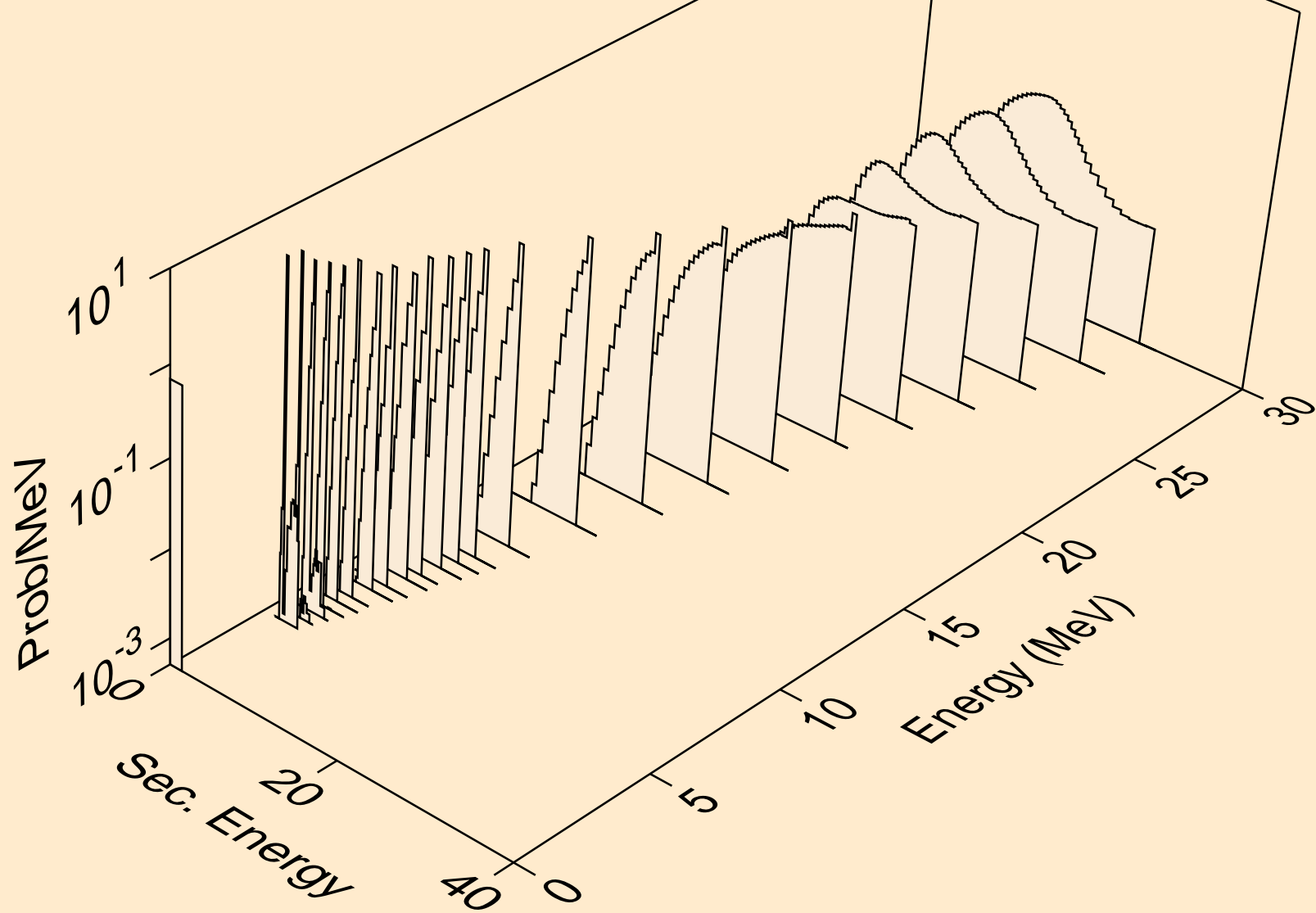

LU157M NEUTRON ACER TENDL-2024 LIBRARY; T=0.K
tritons from (n,x)

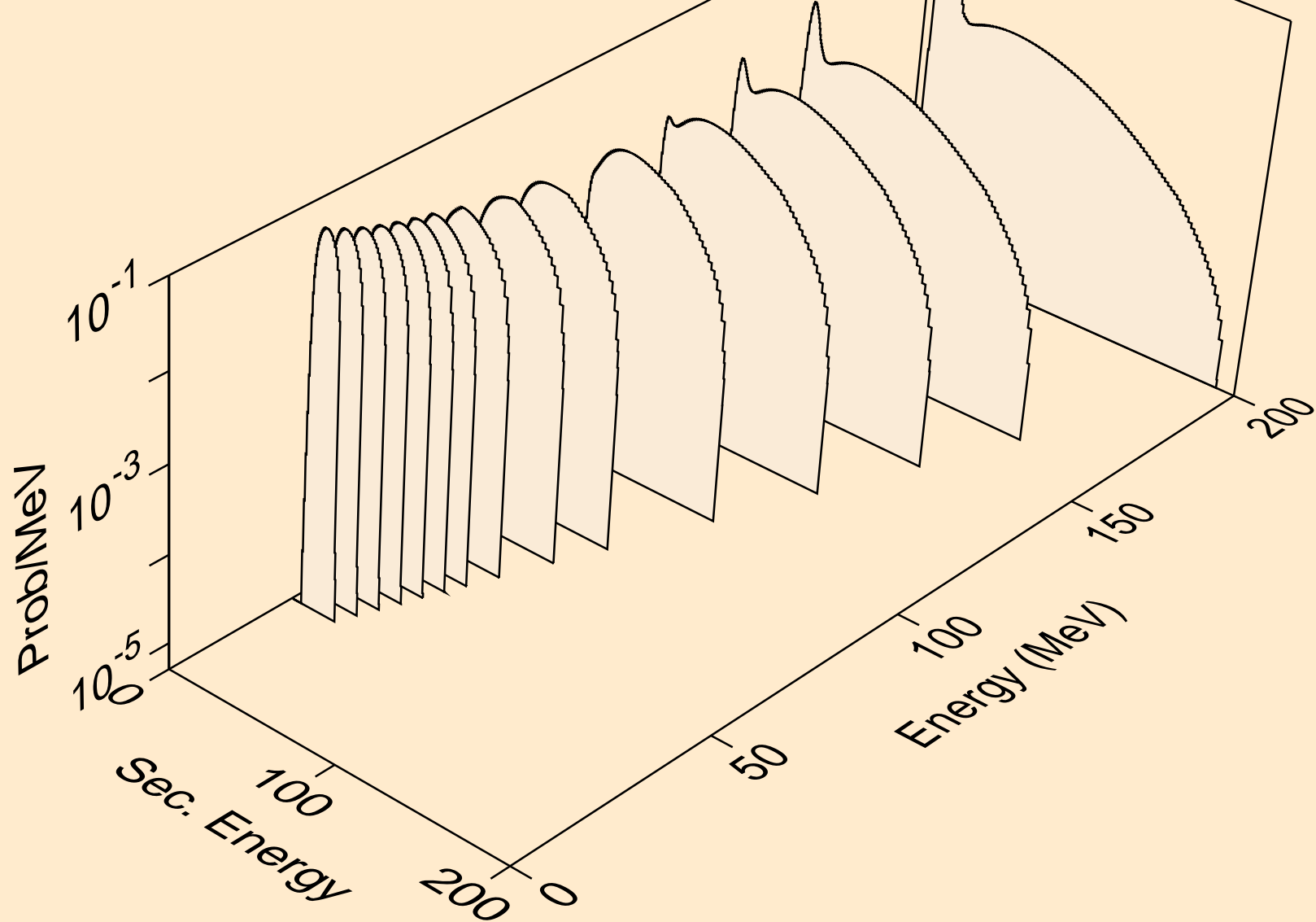

LU157M NEUTRON ACER TENDL-2024 LIBRARY; T=0.K
tritons from (n,n*)t

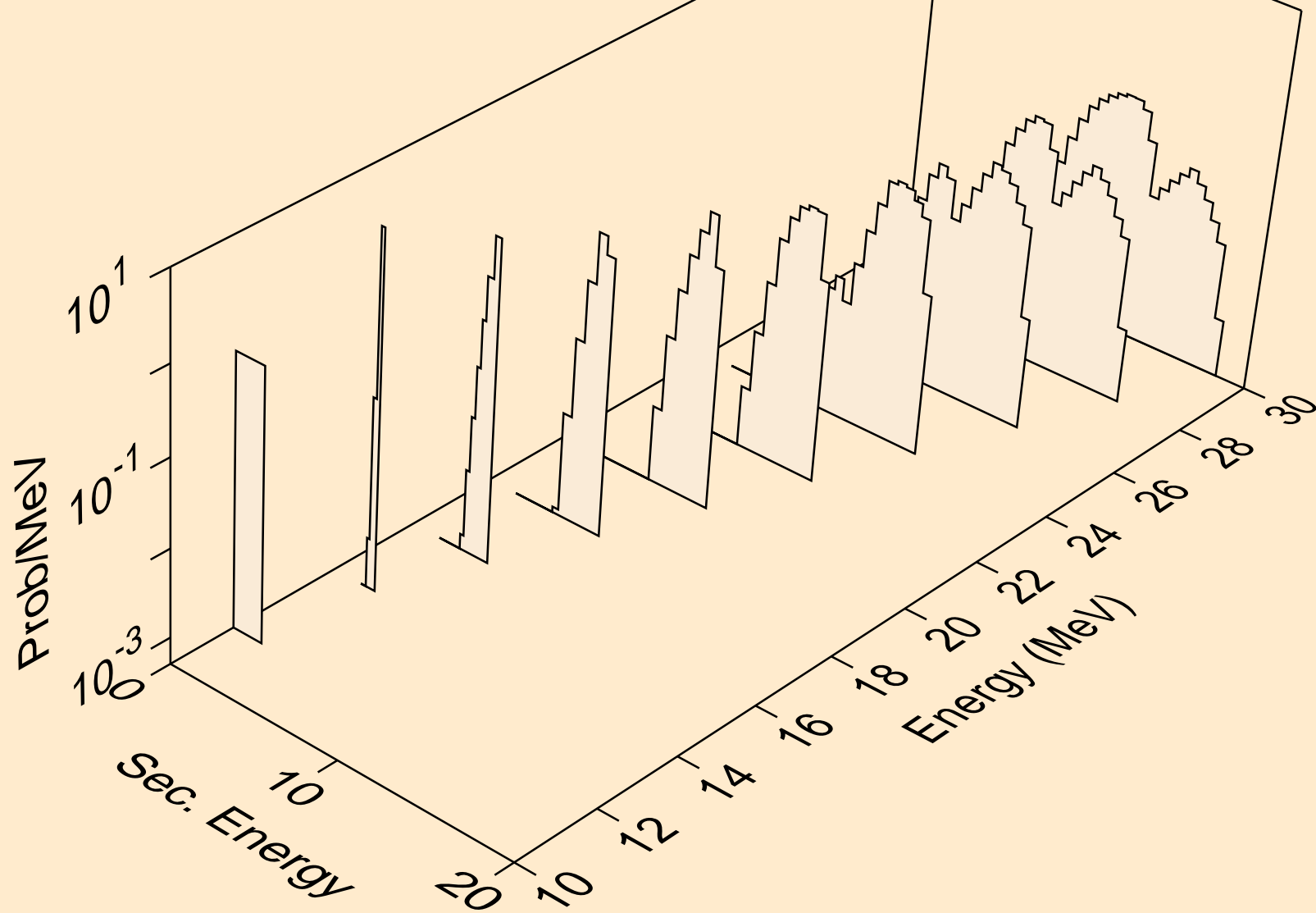

LU157M NEUTRON ACER TENDL-2024 LIBRARY; T=0.K
tritons from (n,t)

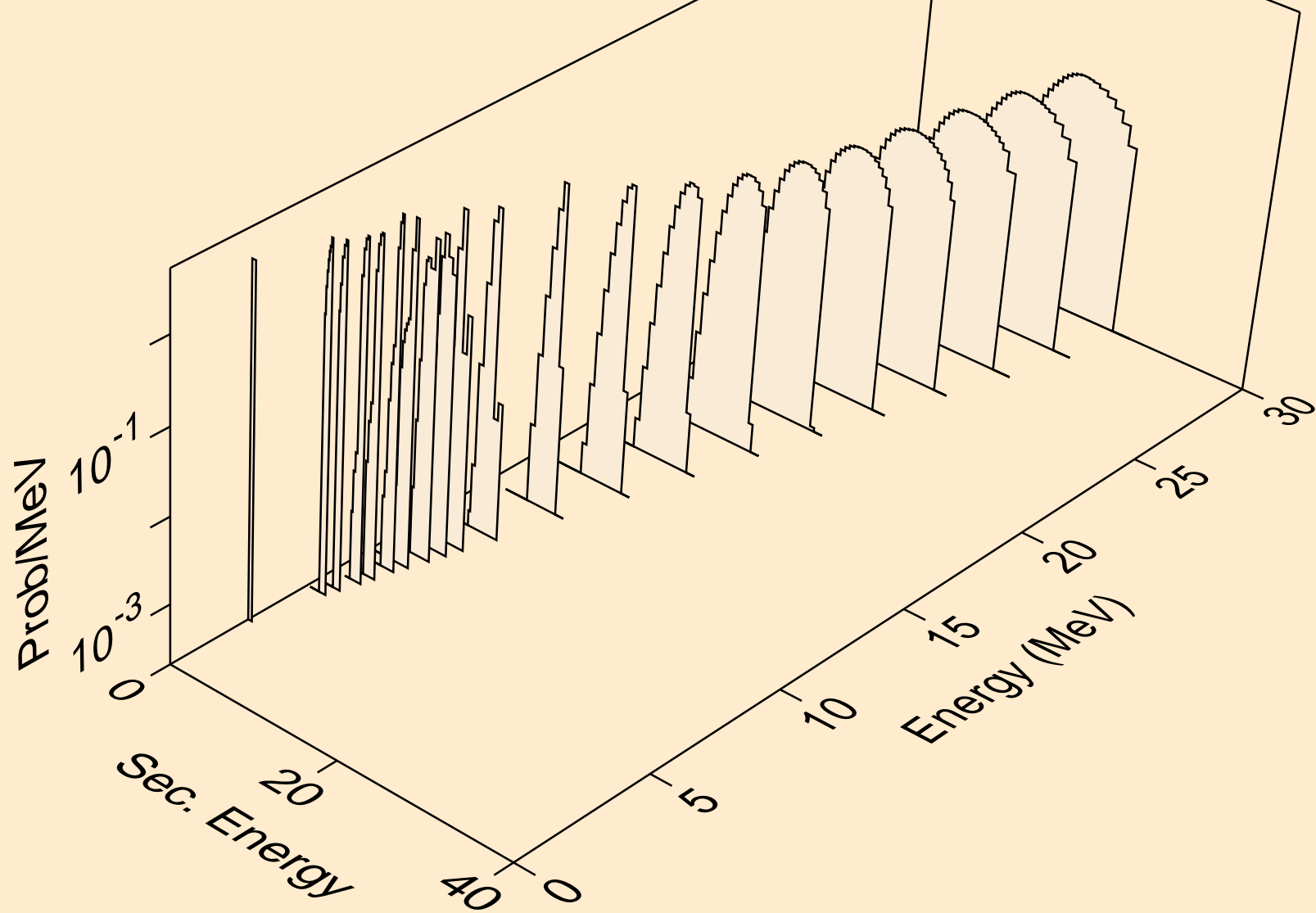

LU157M NEUTRON ACER TENDL-2024 LIBRARY; T=0.K
tritons from (n,t2a)

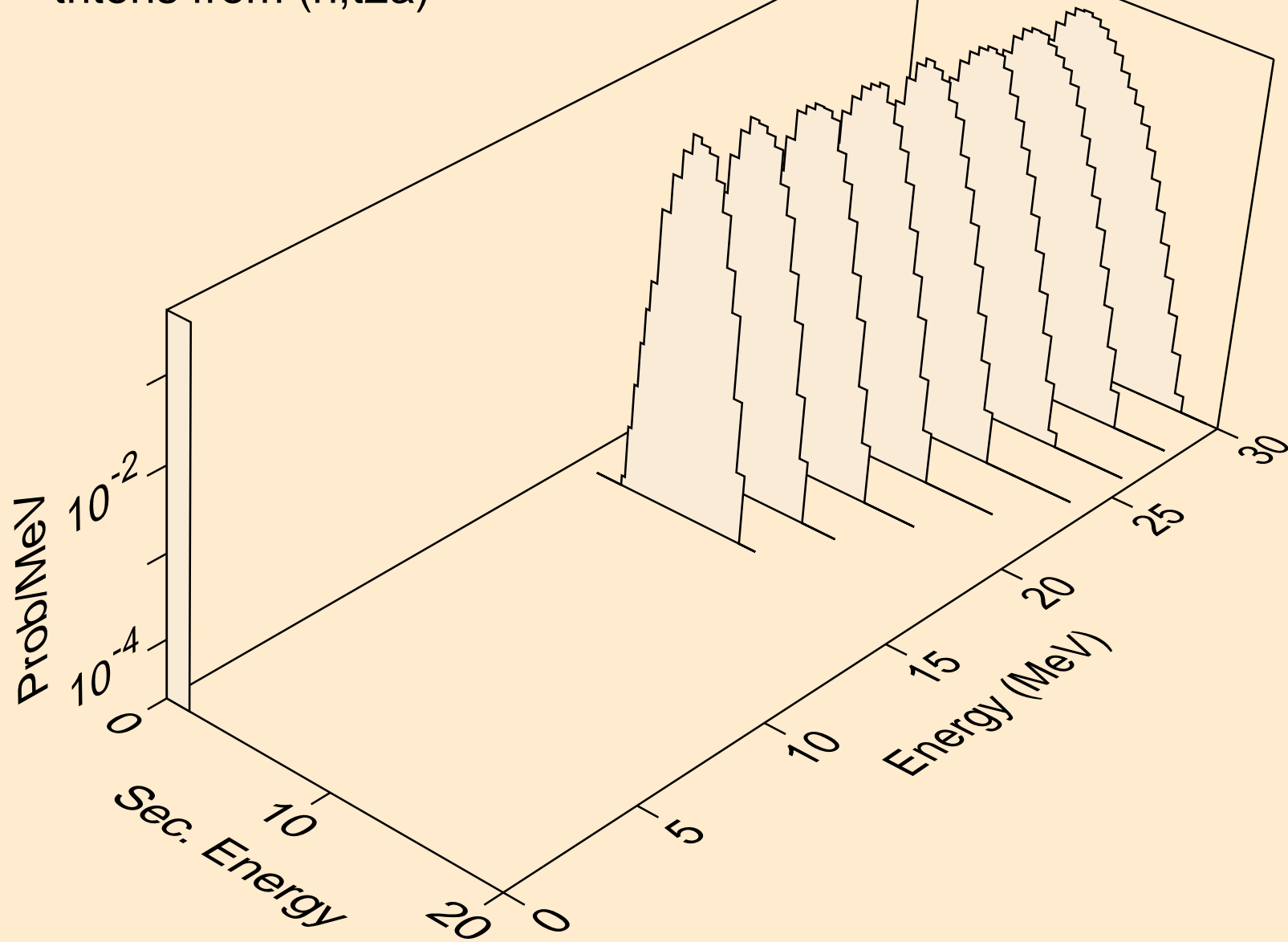

LU157M NEUTRON ACER TENDL-2024 LIBRARY; T=0.K
tritons from (n,pt)

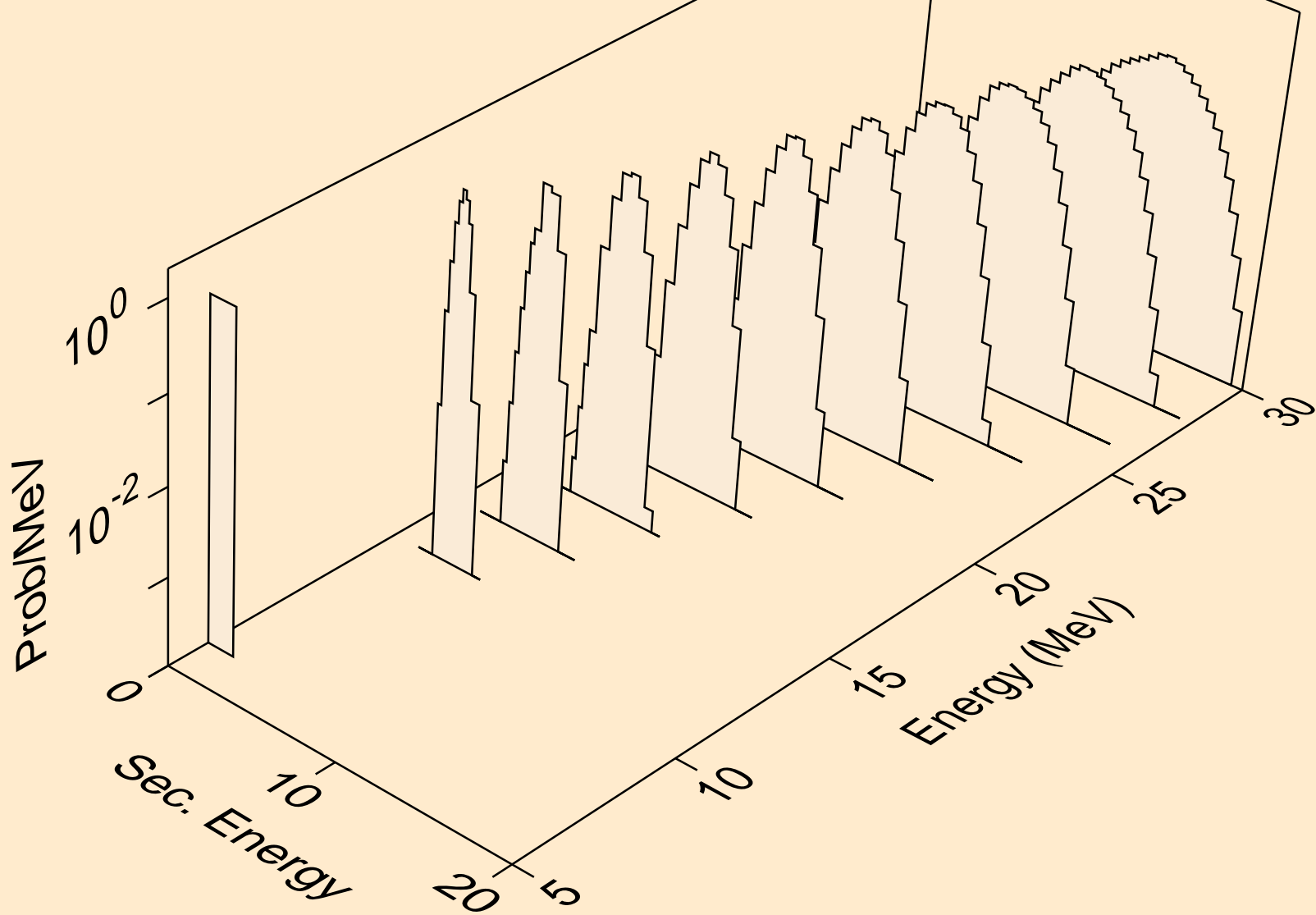

LU157M NEUTRON ACER TENDL-2024 LIBRARY; T=0.K
he3s from (n,x)

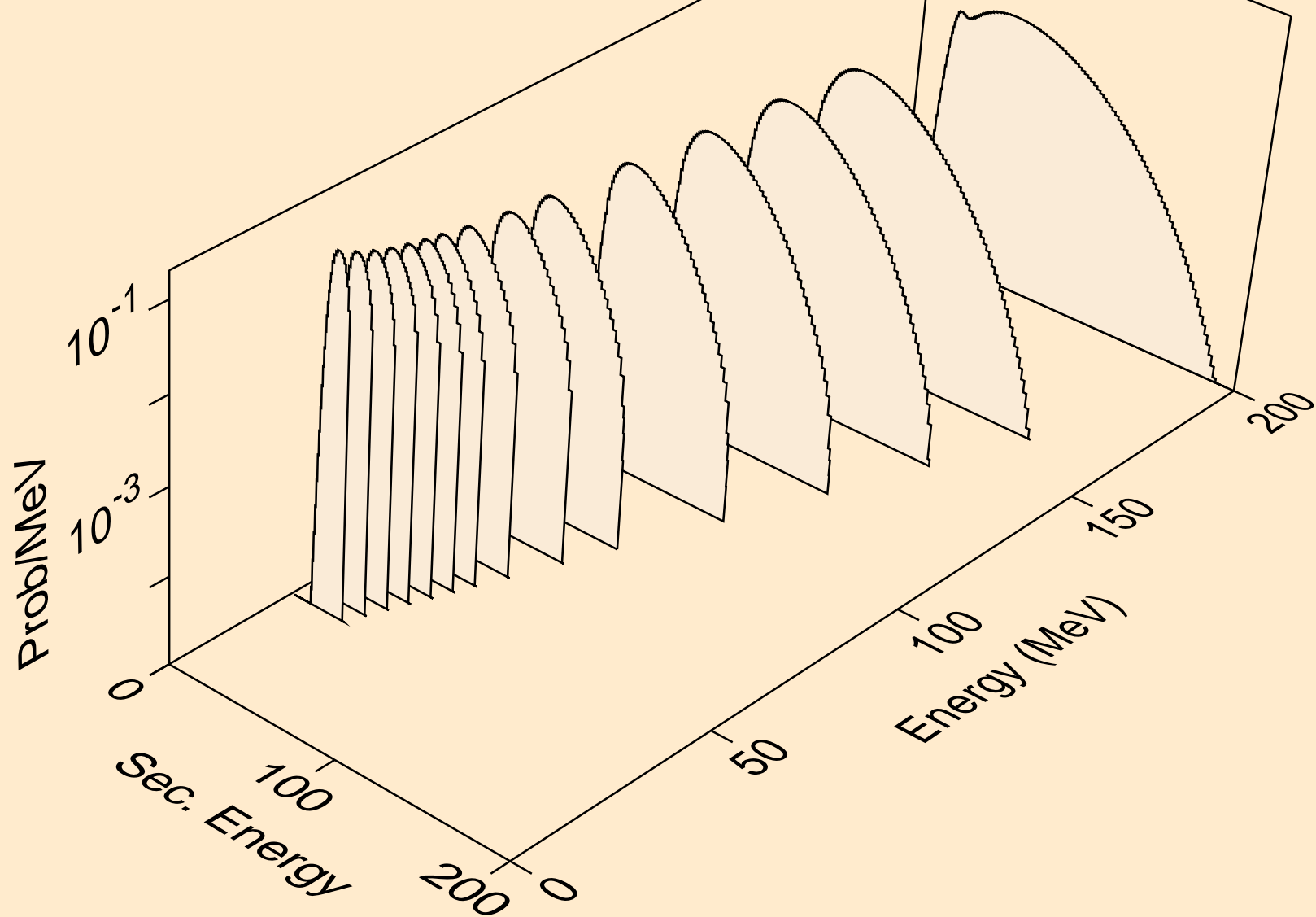

LU157M NEUTRON ACER TENDL-2024 LIBRARY; T=0.K
he3s from (n,n*)he3

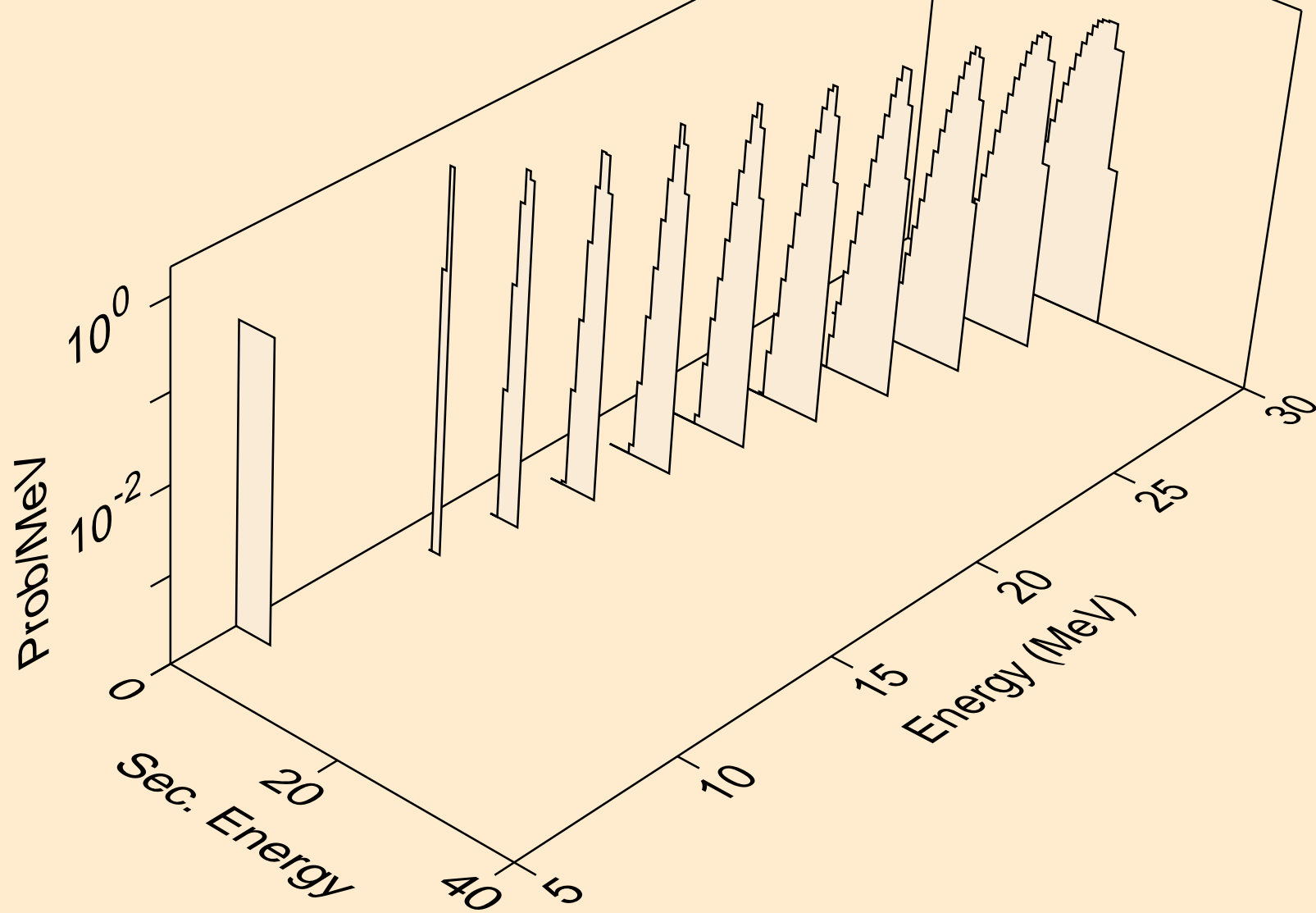

LU157M NEUTRON ACER TENDL-2024 LIBRARY; T=0.K
he3s from (n,he3)

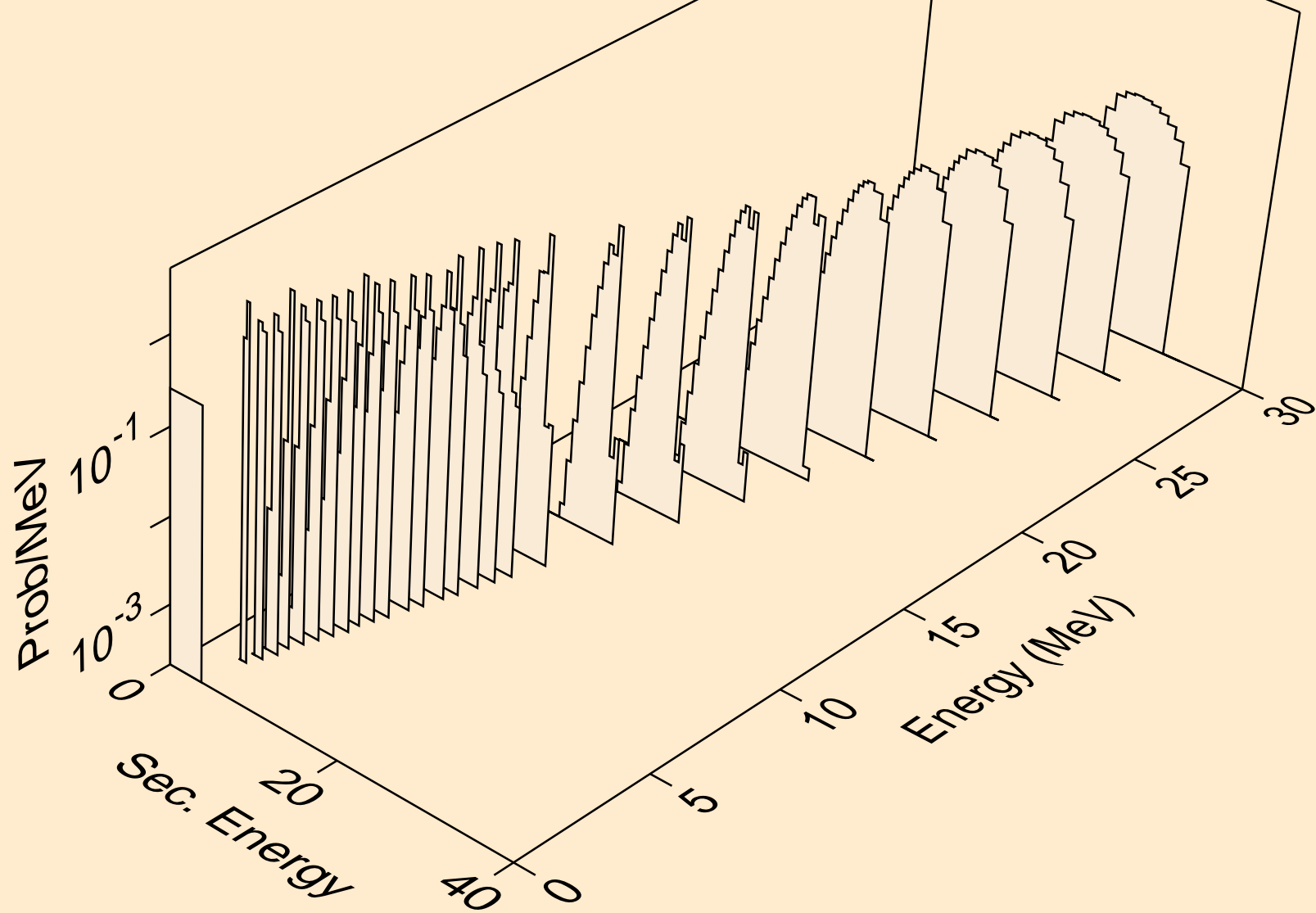

LU157M NEUTRON ACER TENDL-2024 LIBRARY; T=0.K
alphas from (n,x)

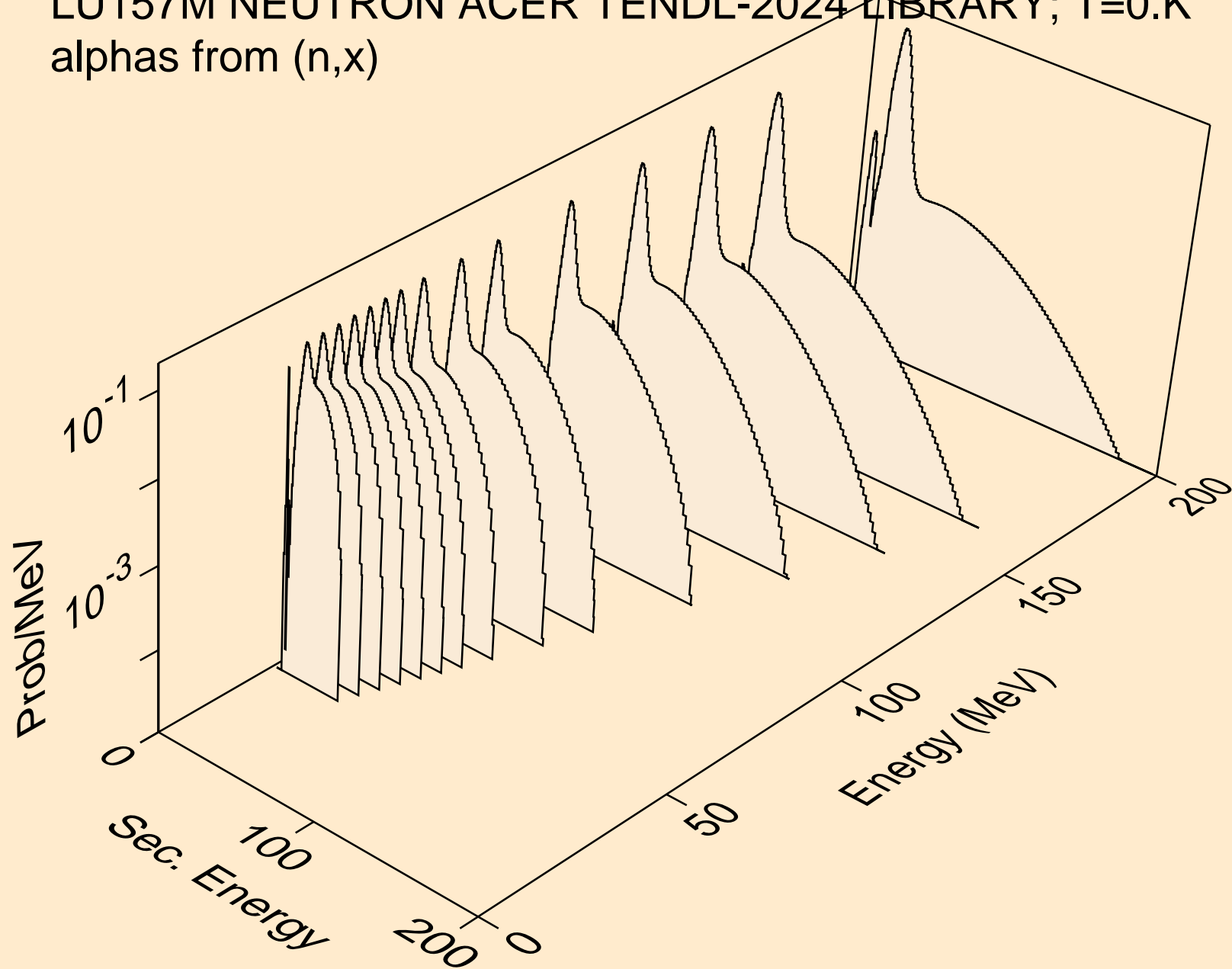

LU157M NEUTRON ACER TENDL-2024 LIBRARY; T=0.K
alphas from (n,n*)a

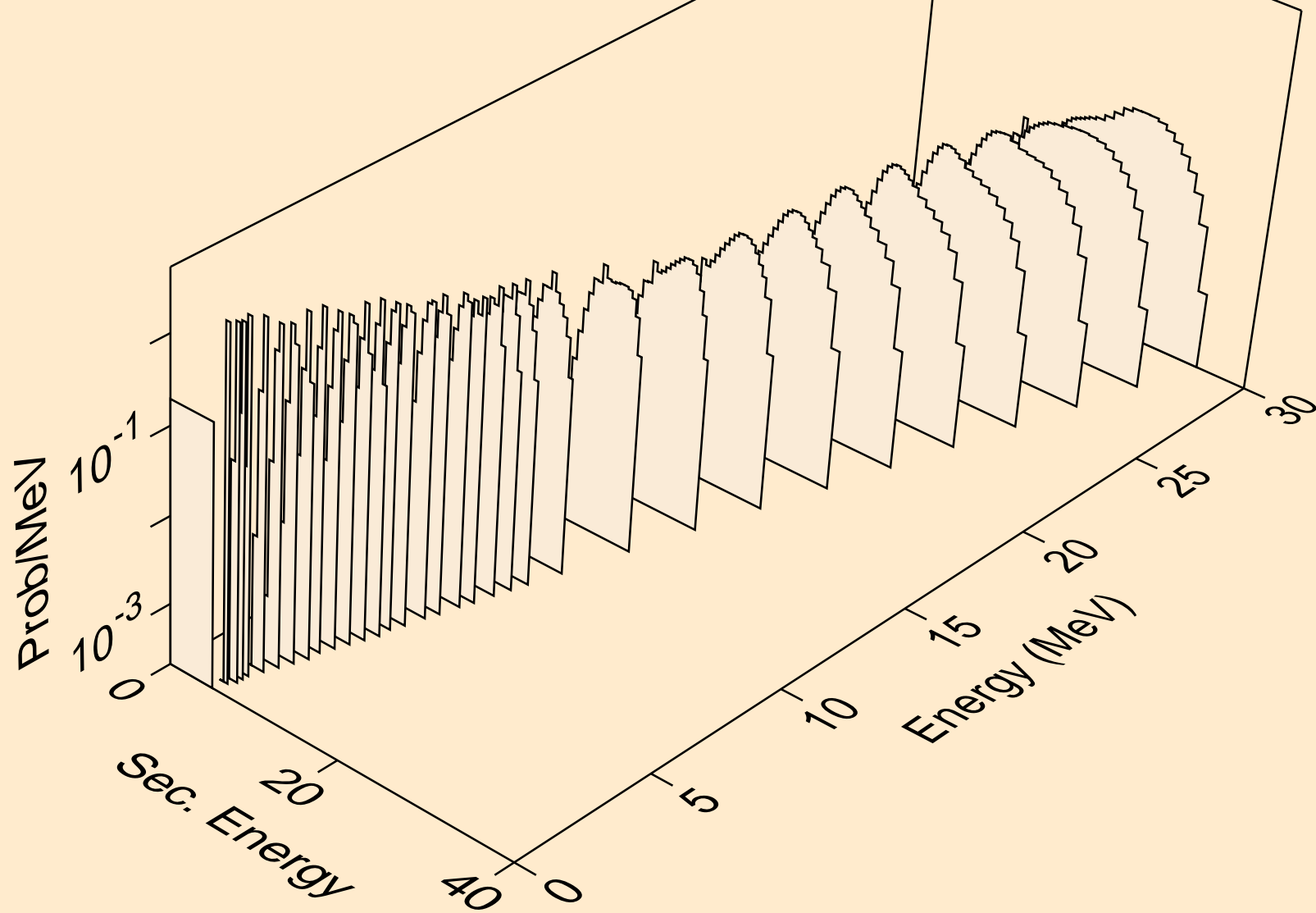

LU157M NEUTRON ACER TENDL-2024 LIBRARY; T=0.K
alphas from (n,n*)3a

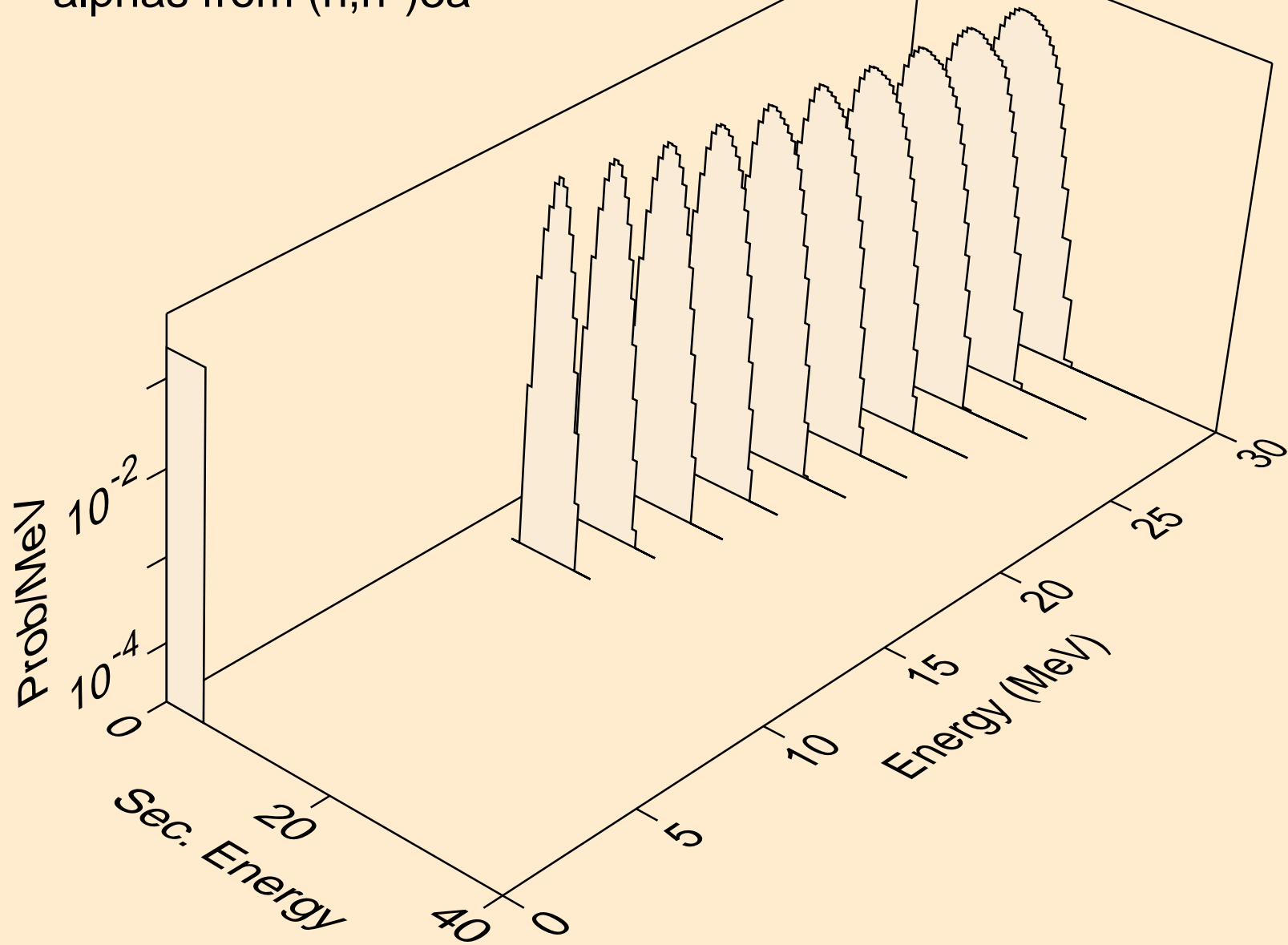

LU157M NEUTRON ACER TENDL-2024 LIBRARY; T=0.K
alphas from (n,2n)a

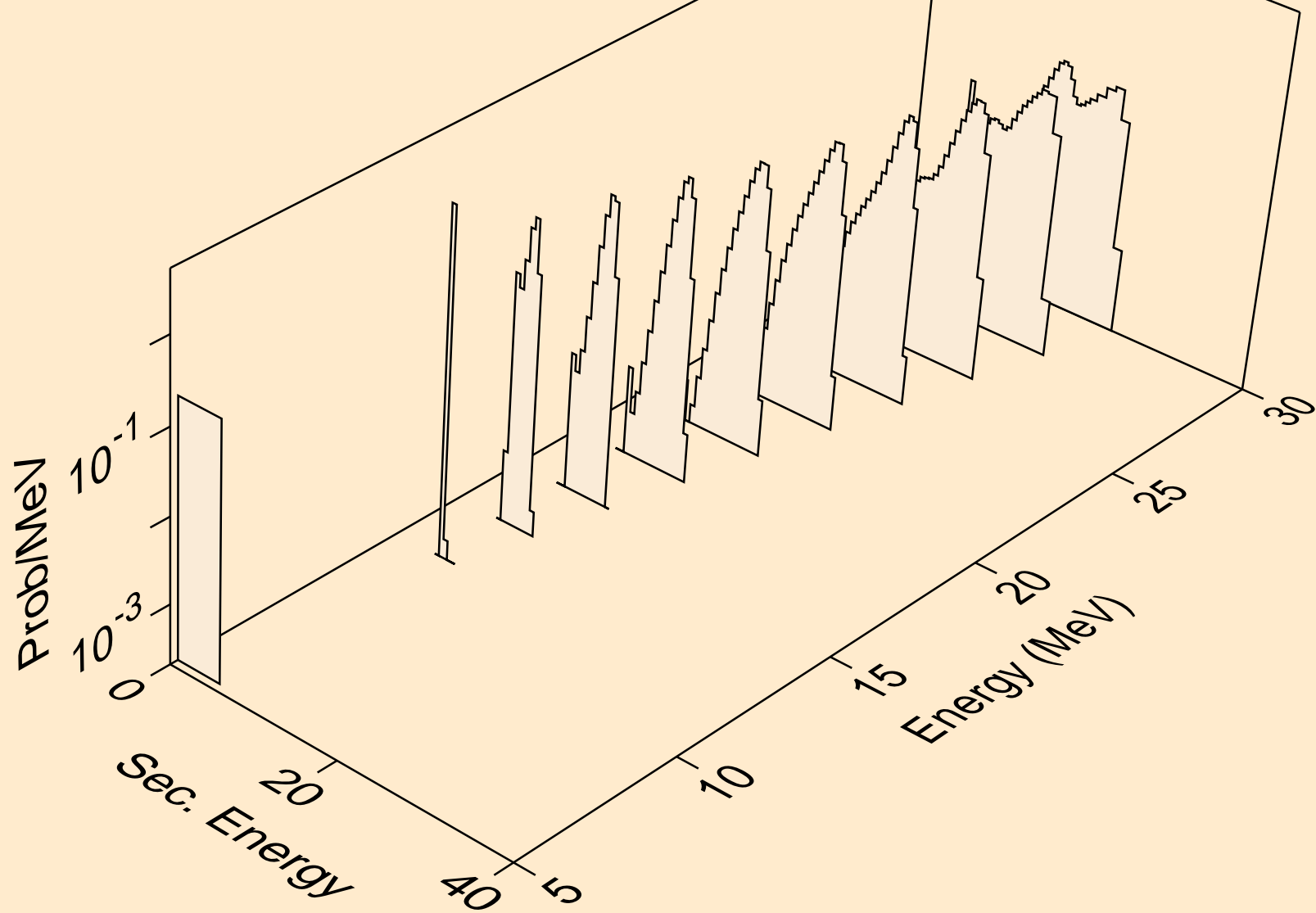

LU157M NEUTRON ACER TENDL-2024 LIBRARY; T=0.K
alphas from (n,3n)a

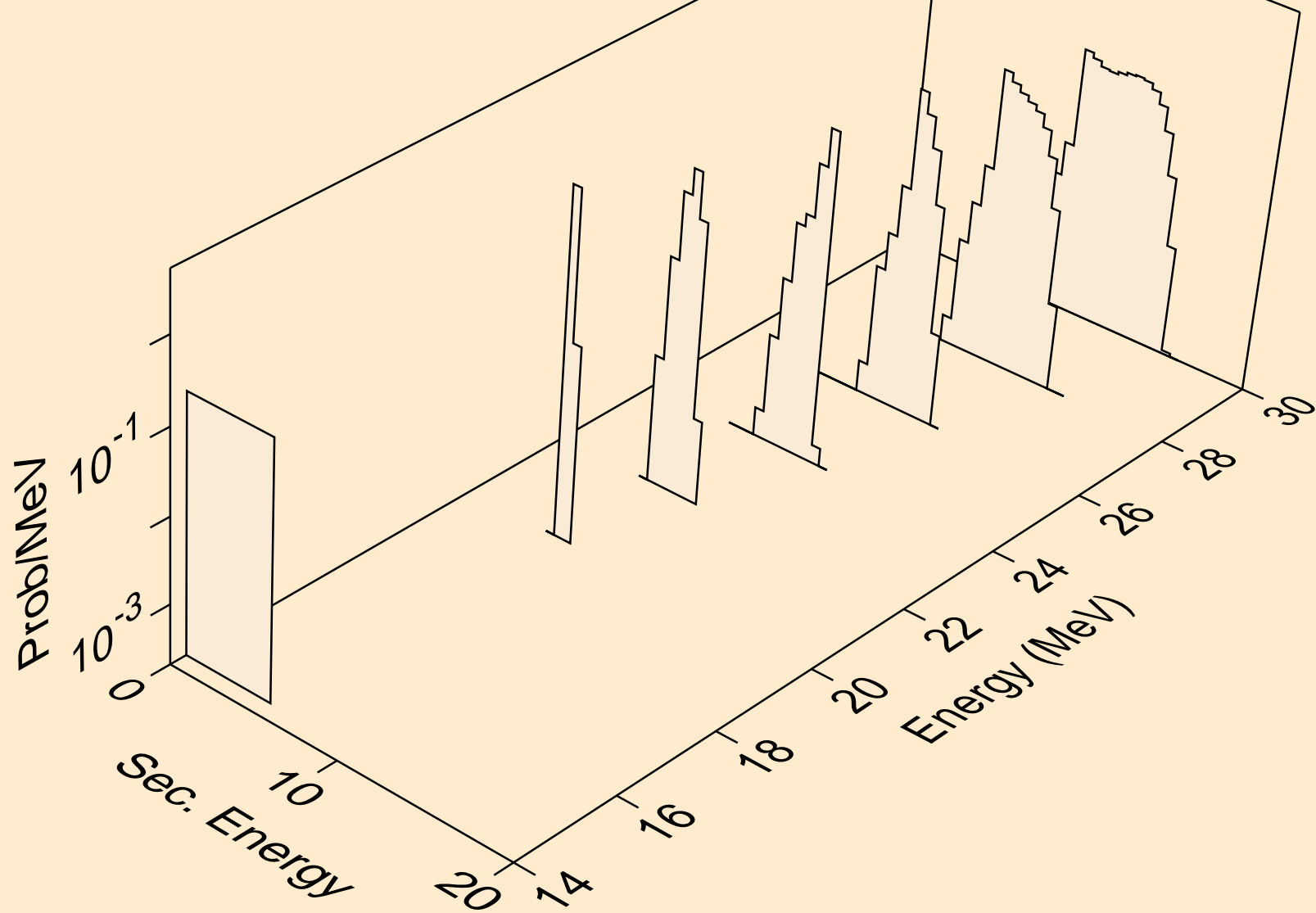

LU157M NEUTRON ACER TENDL-2024 LIBRARY; T=0.K
alphas from (n,n*)2a

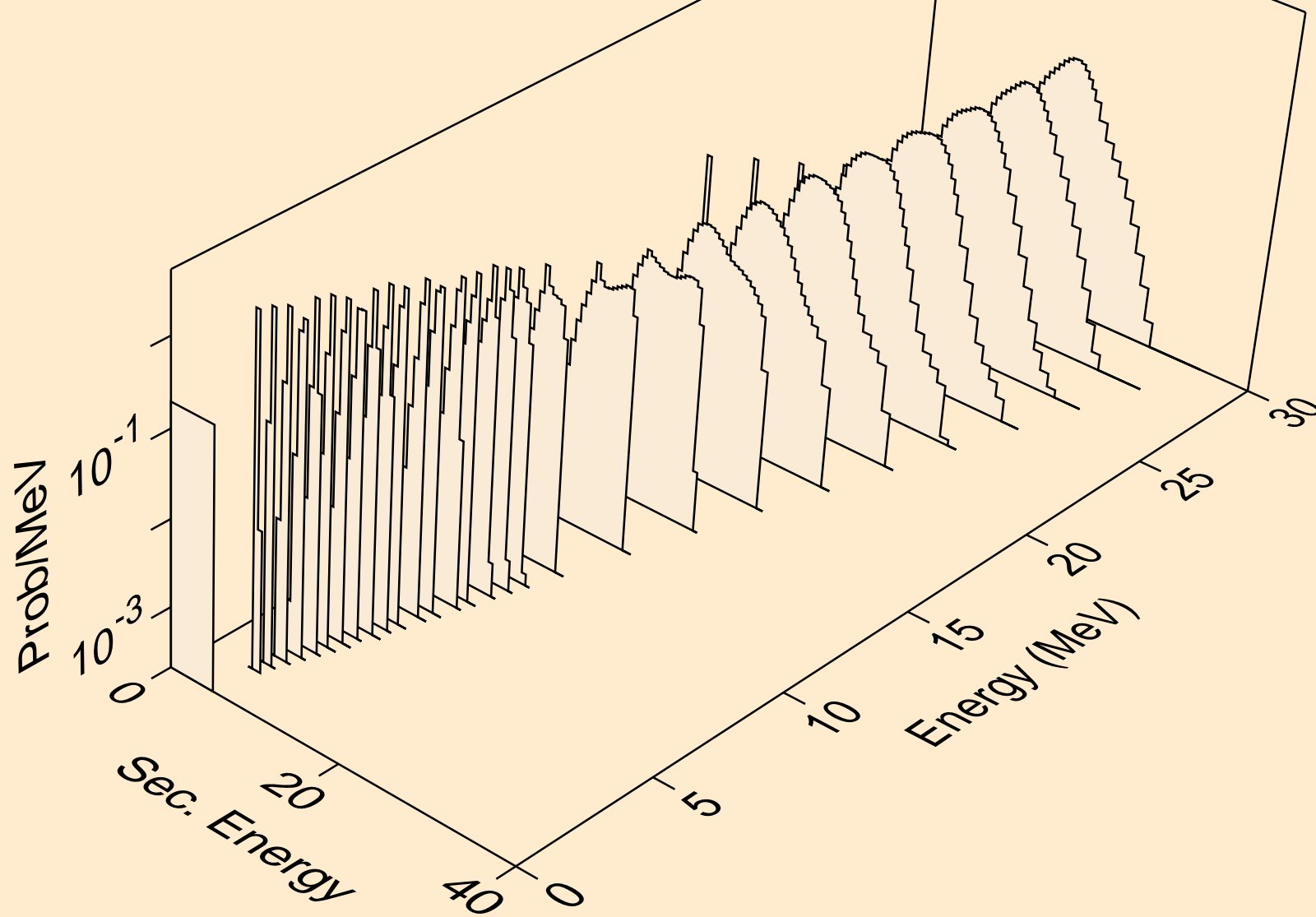

LU157M NEUTRON ACER TENDL-2024 LIBRARY; T=0.K
alphas from (n,2n)2a

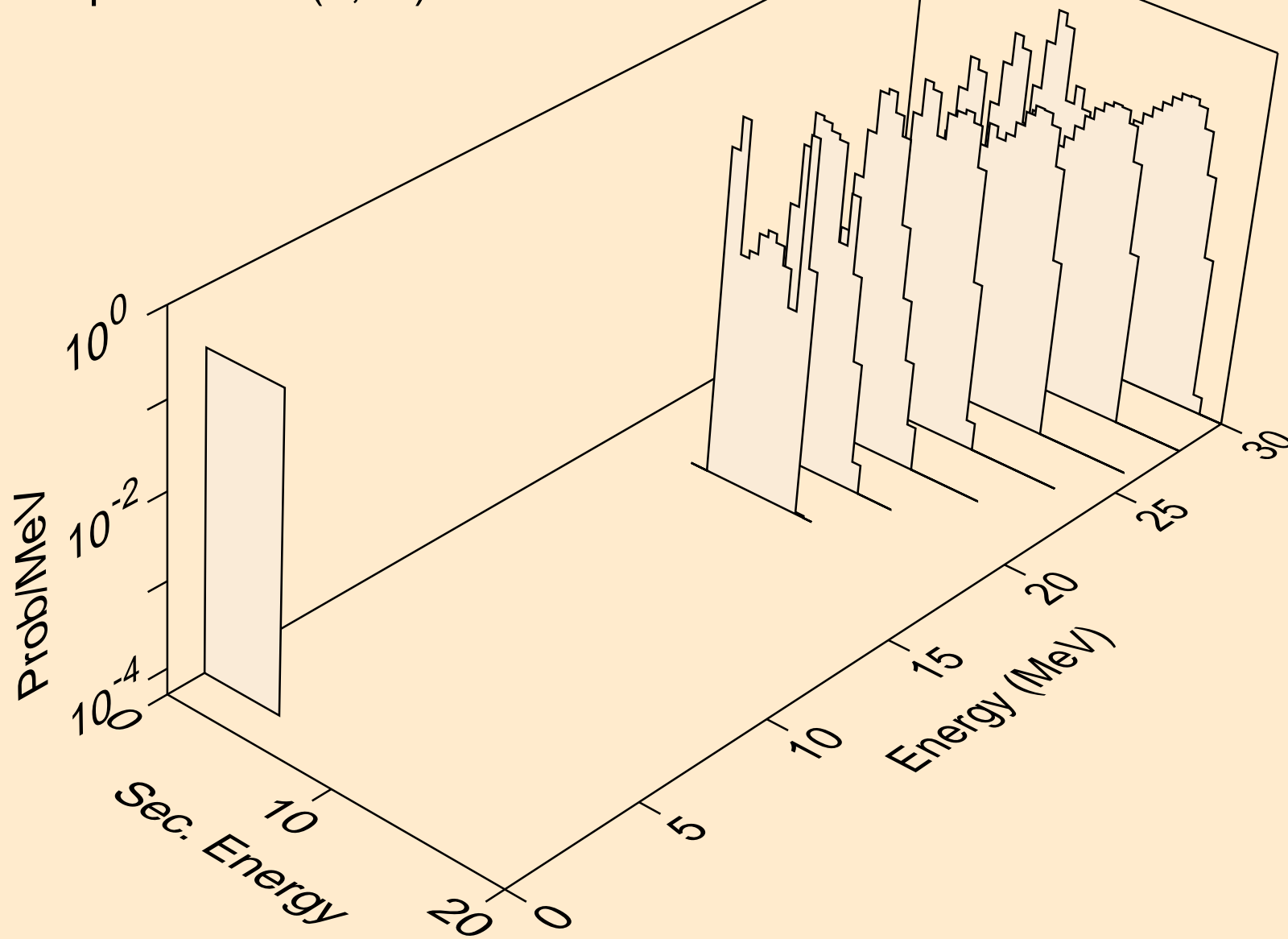

LU157M NEUTRON ACER TENDL-2024 LIBRARY; T=0.K
alphas from (n,npa)

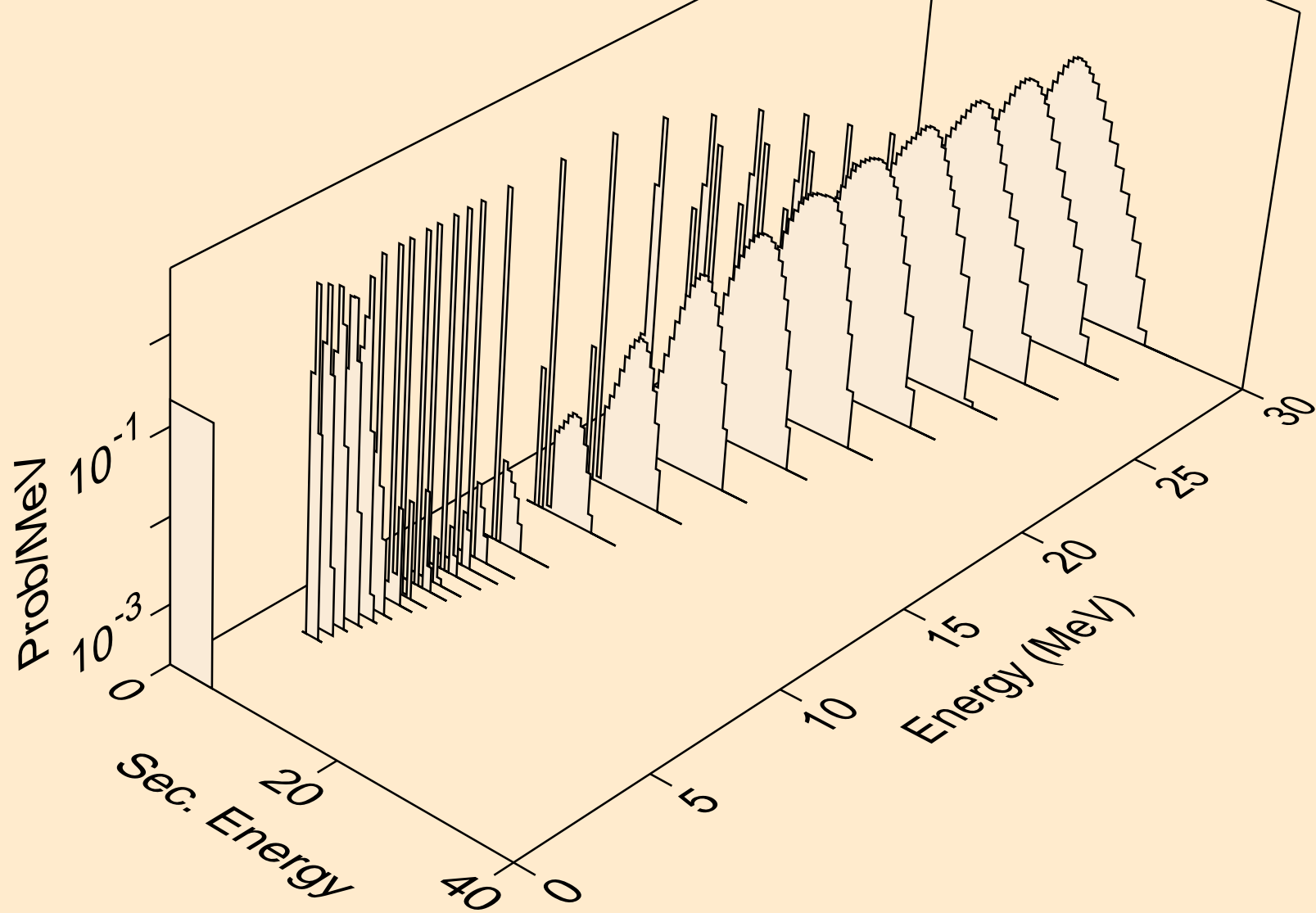

LU157M NEUTRON ACER TENDL-2024 LIBRARY; T=0.K
alphas from (n,a)

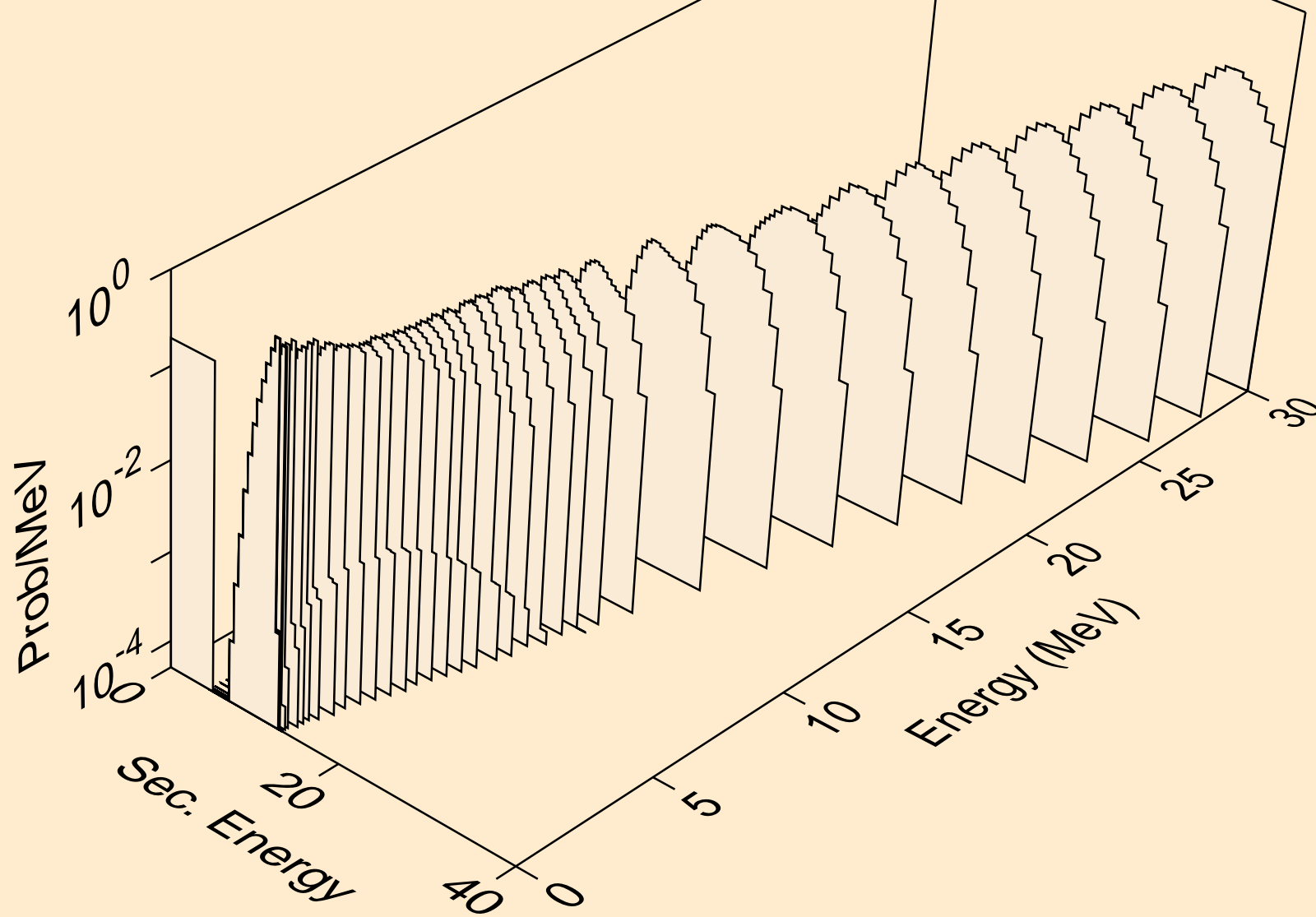

LU157M NEUTRON ACER TENDL-2024 LIBRARY; T=0.K
alphas from (n,2a)

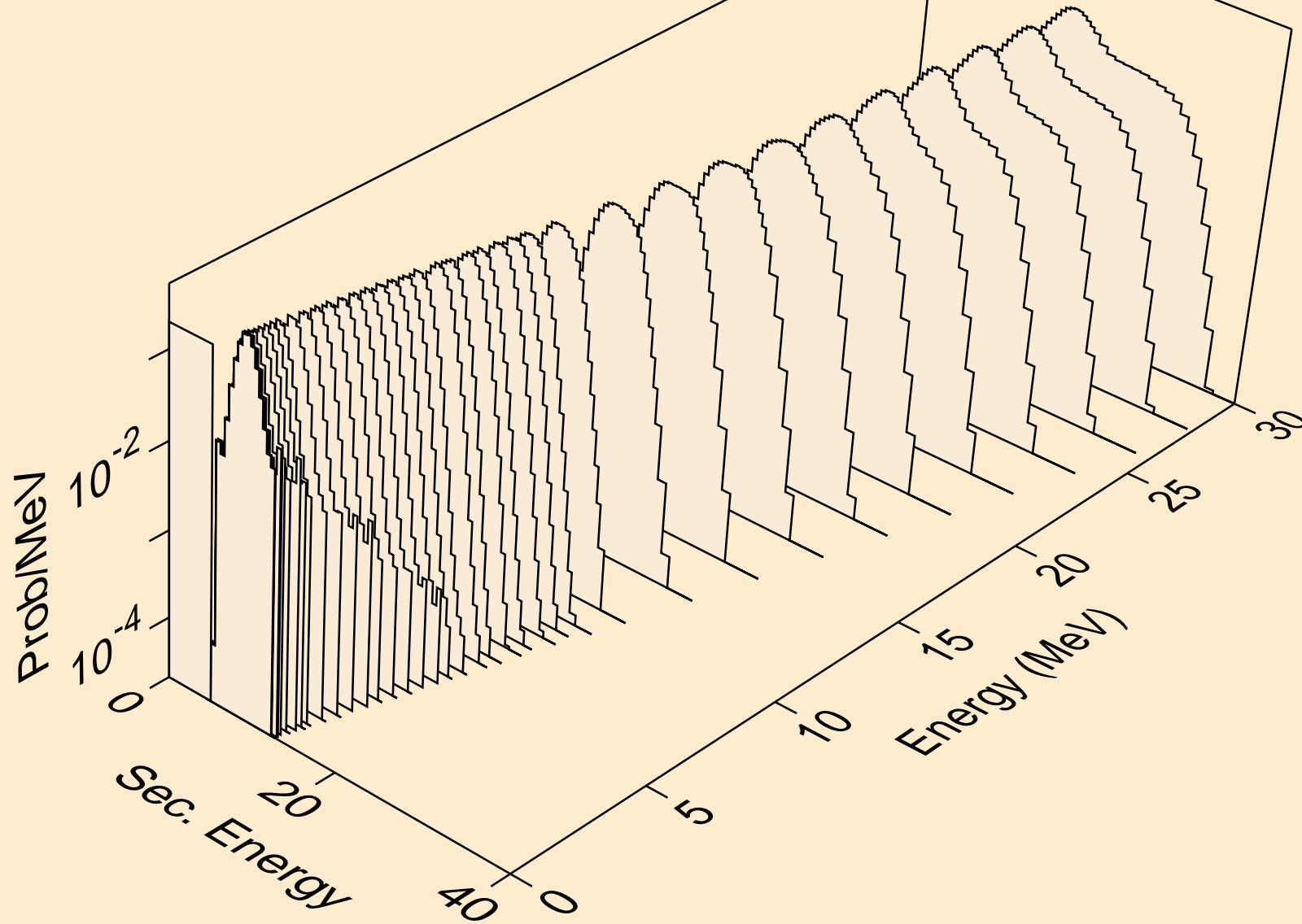

LU157M NEUTRON ACER TENDL-2024 LIBRARY; T=0.K
alphas from (n,3a)

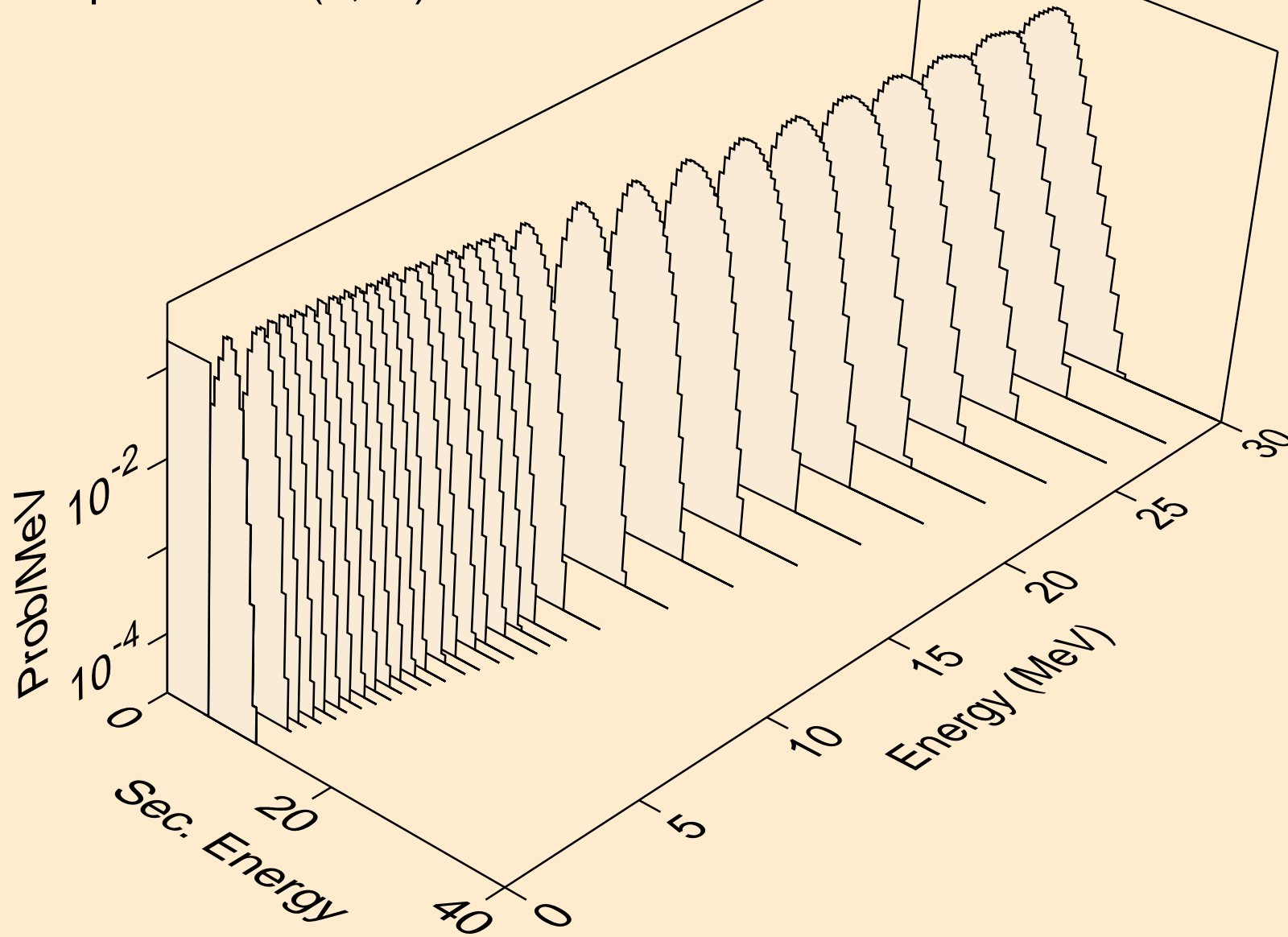

LU157M NEUTRON ACER TENDL-2024 LIBRARY; T=0.K
alphas from (n,pa)

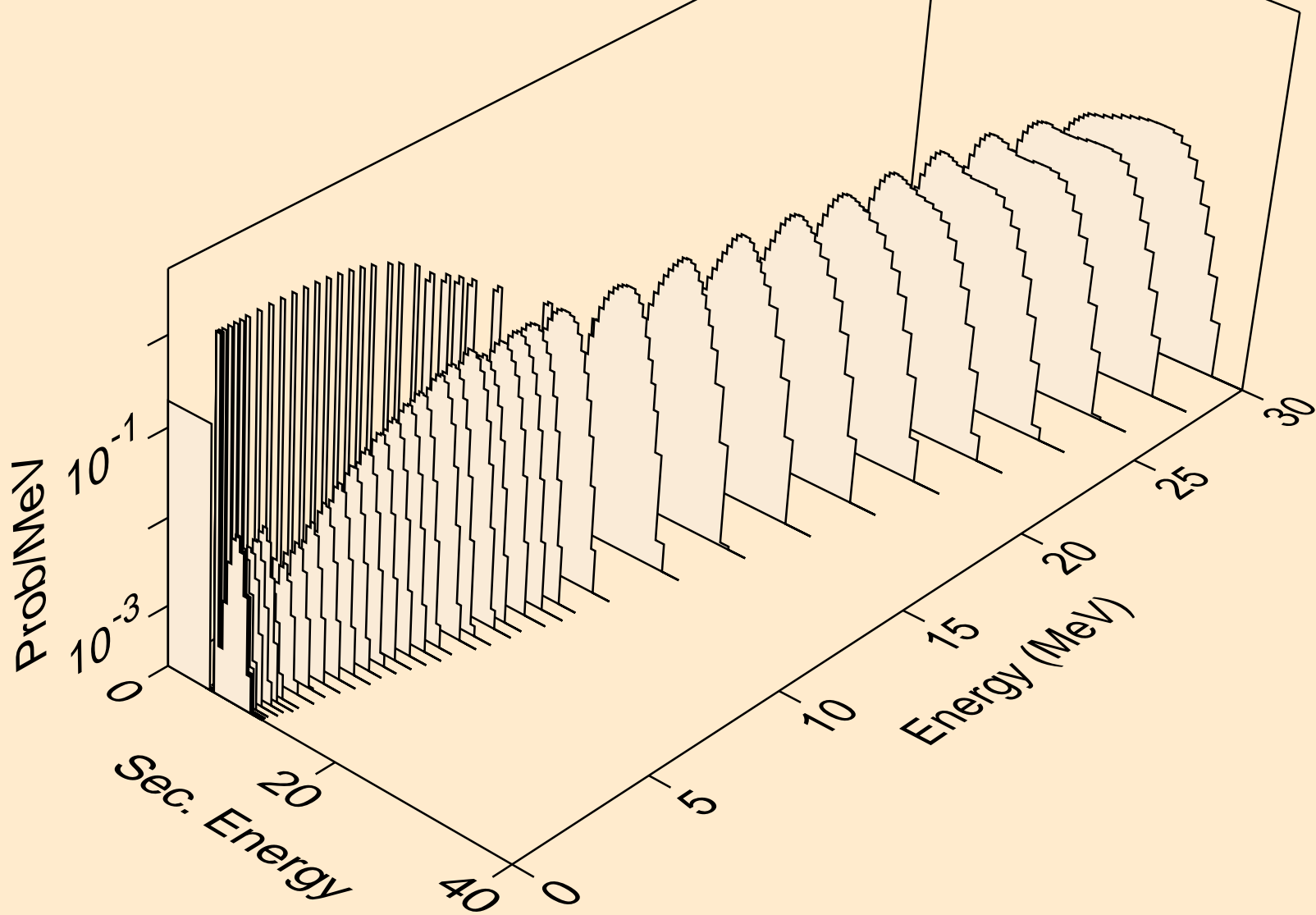

LU157M NEUTRON ACER TENDL-2024 LIBRARY; T=0.K
alphas from (n,t2a)

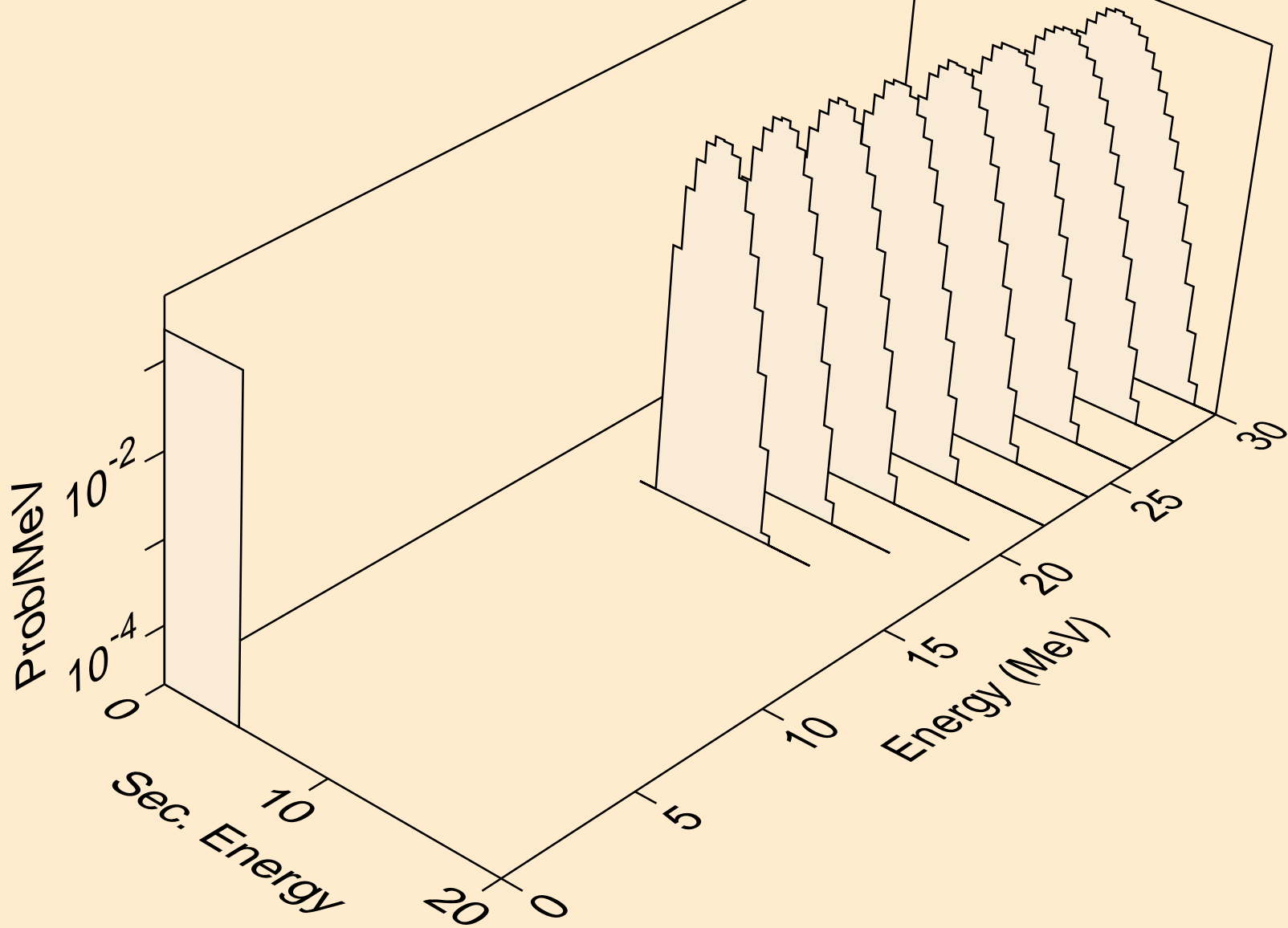

LU157M NEUTRON ACER TENDL-2024 LIBRARY; T=0.K
alphas from (n,d2a)

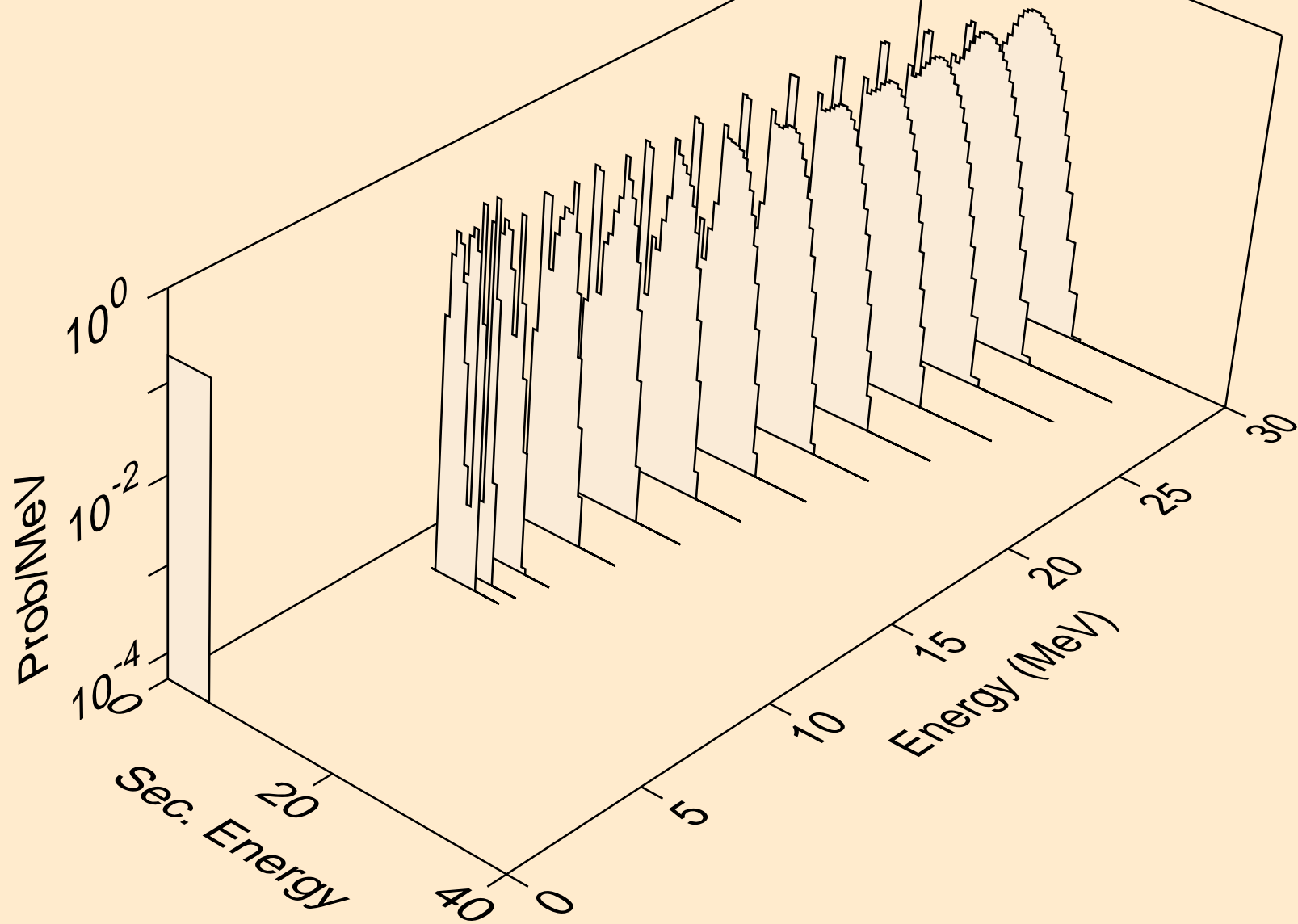

LU157M NEUTRON ACER TENDL-2024 LIBRARY; T=0.K
alphas from (n,da)

