

PA238 NEUTRON ACER TENDL-2024 LIBRARY; T=0.K

Principal cross sections

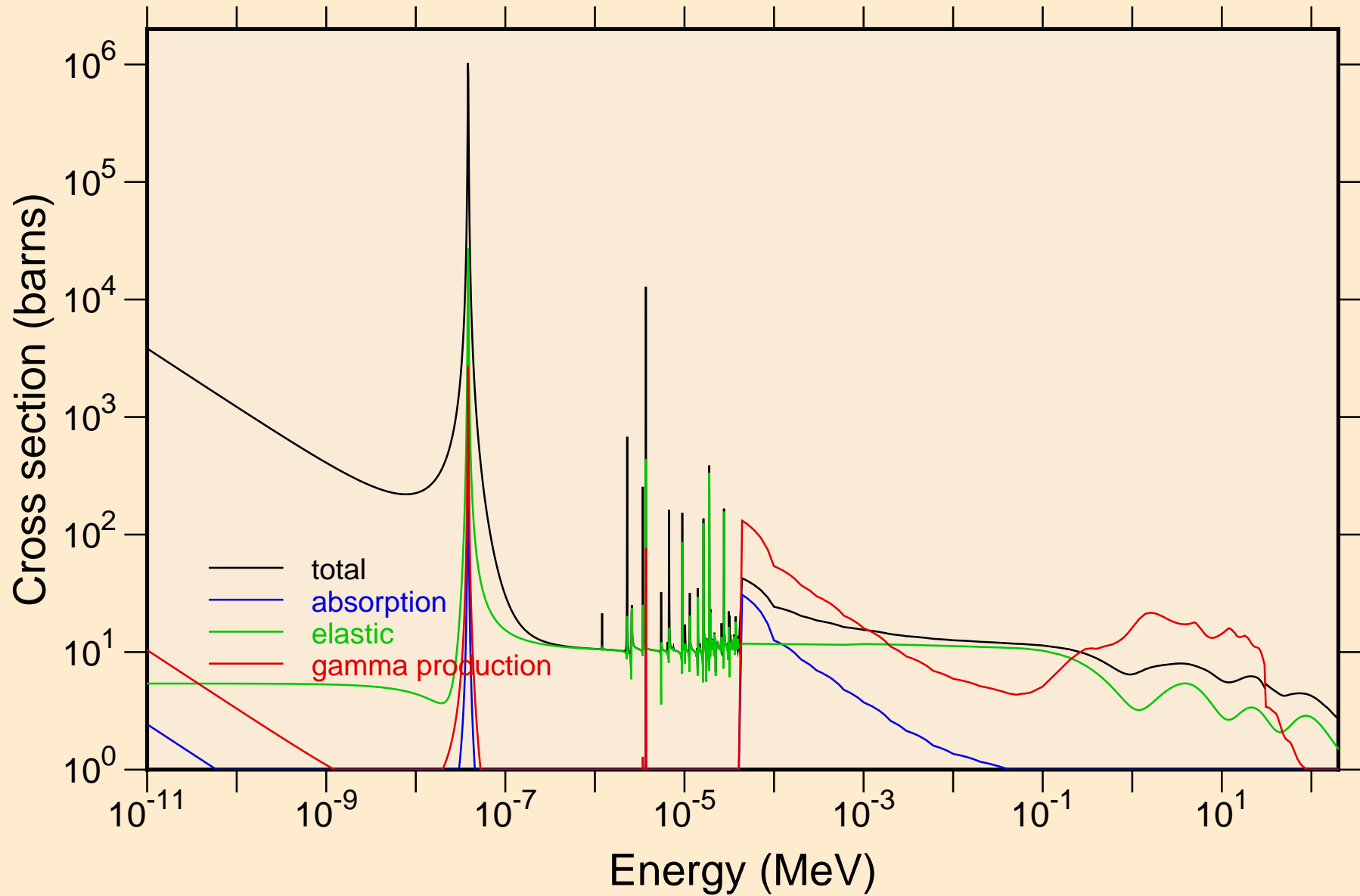

PA238 NEUTRON ACER TENDL-2024 LIBRARY; T=0.K
resonance total cross section

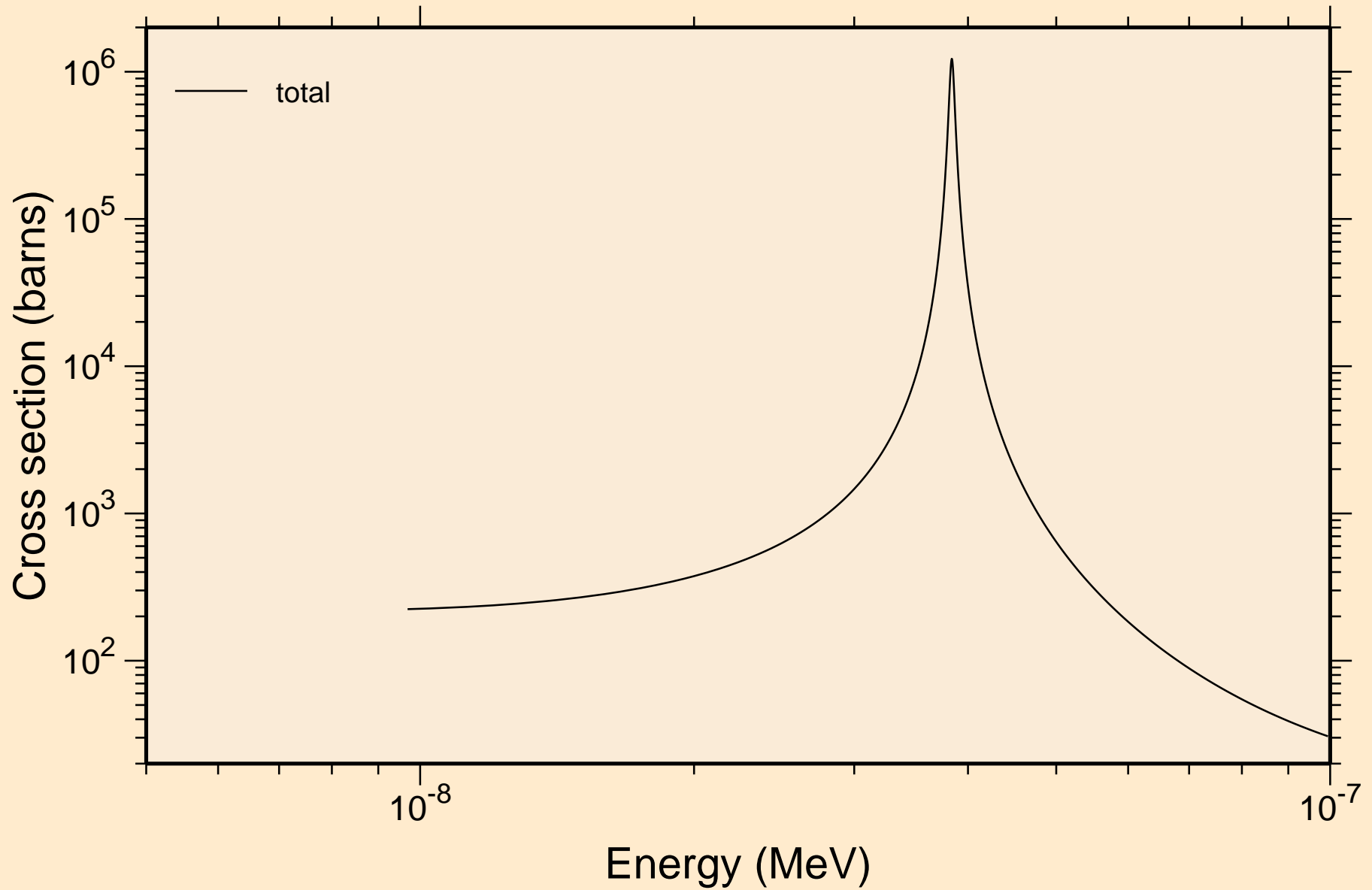

PA238 NEUTRON ACER TENDL-2024 LIBRARY; T=0.K
resonance total cross section

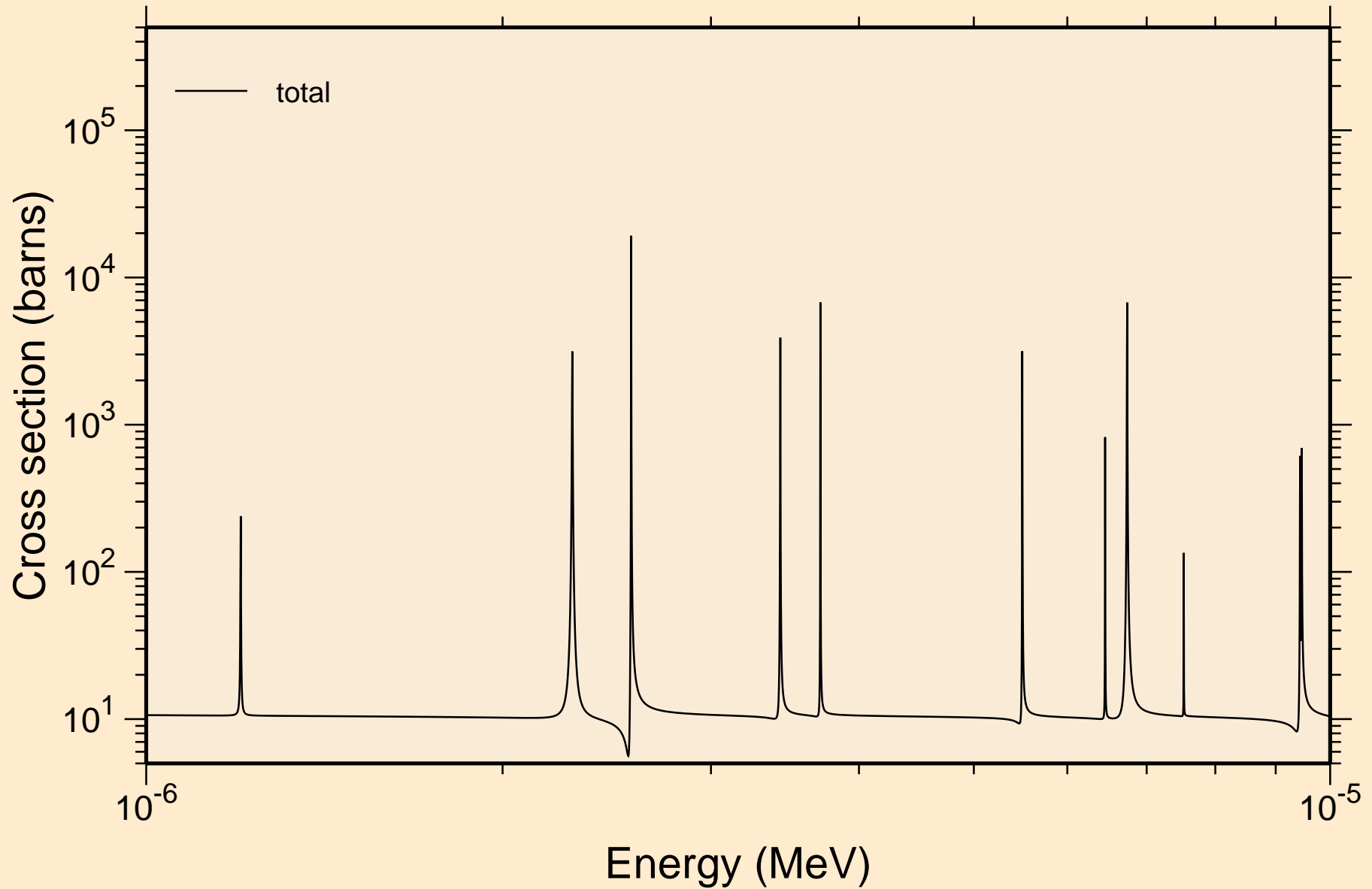

PA238 NEUTRON ACER TENDL-2024 LIBRARY; T=0.K
resonance total cross section

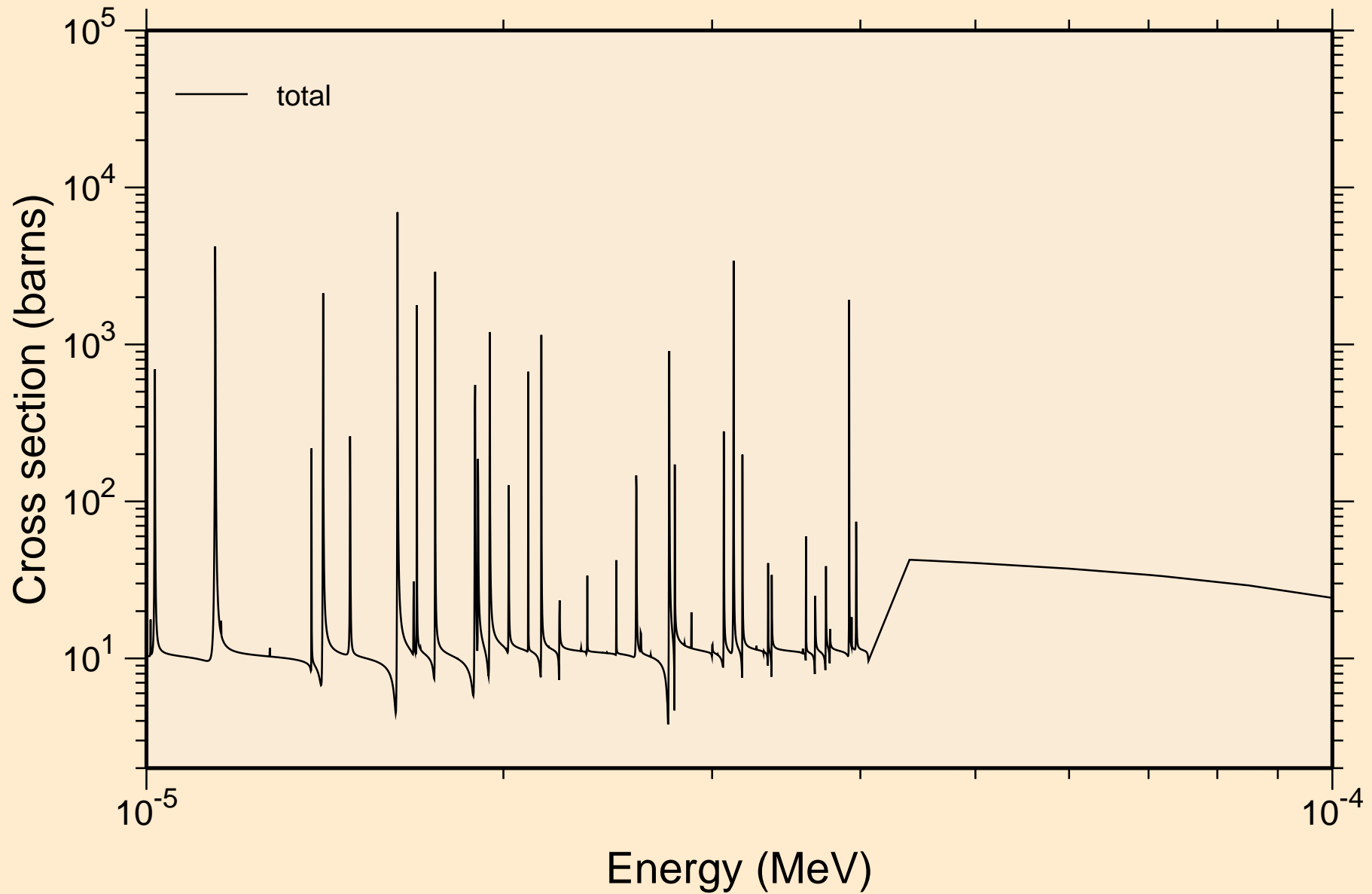

PA238 NEUTRON ACER TENDL-2024 LIBRARY; T=0.K
resonance total cross section

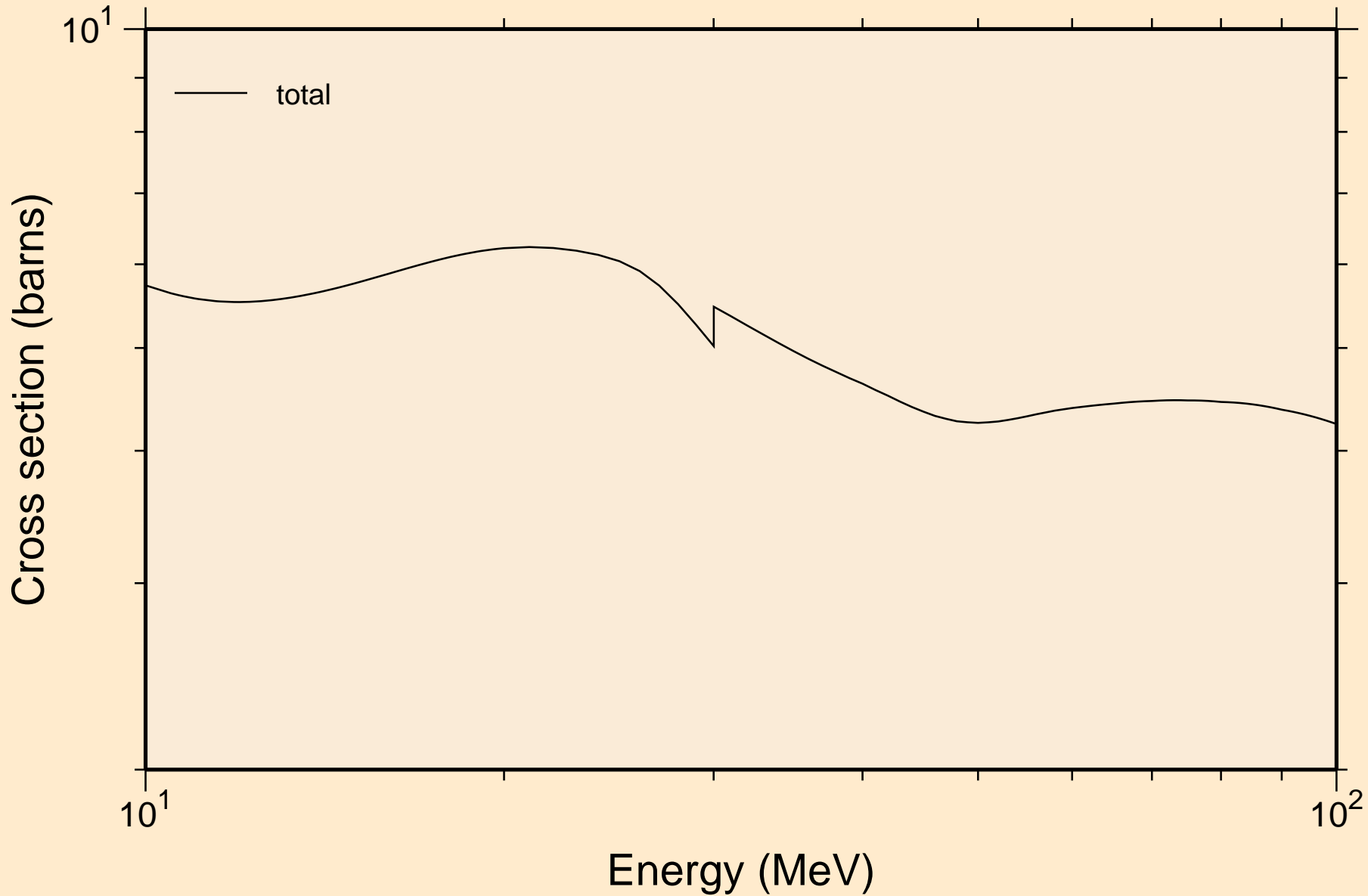

PA238 NEUTRON ACER TENDL-2024 LIBRARY; T=0.K
resonance absorption cross sections

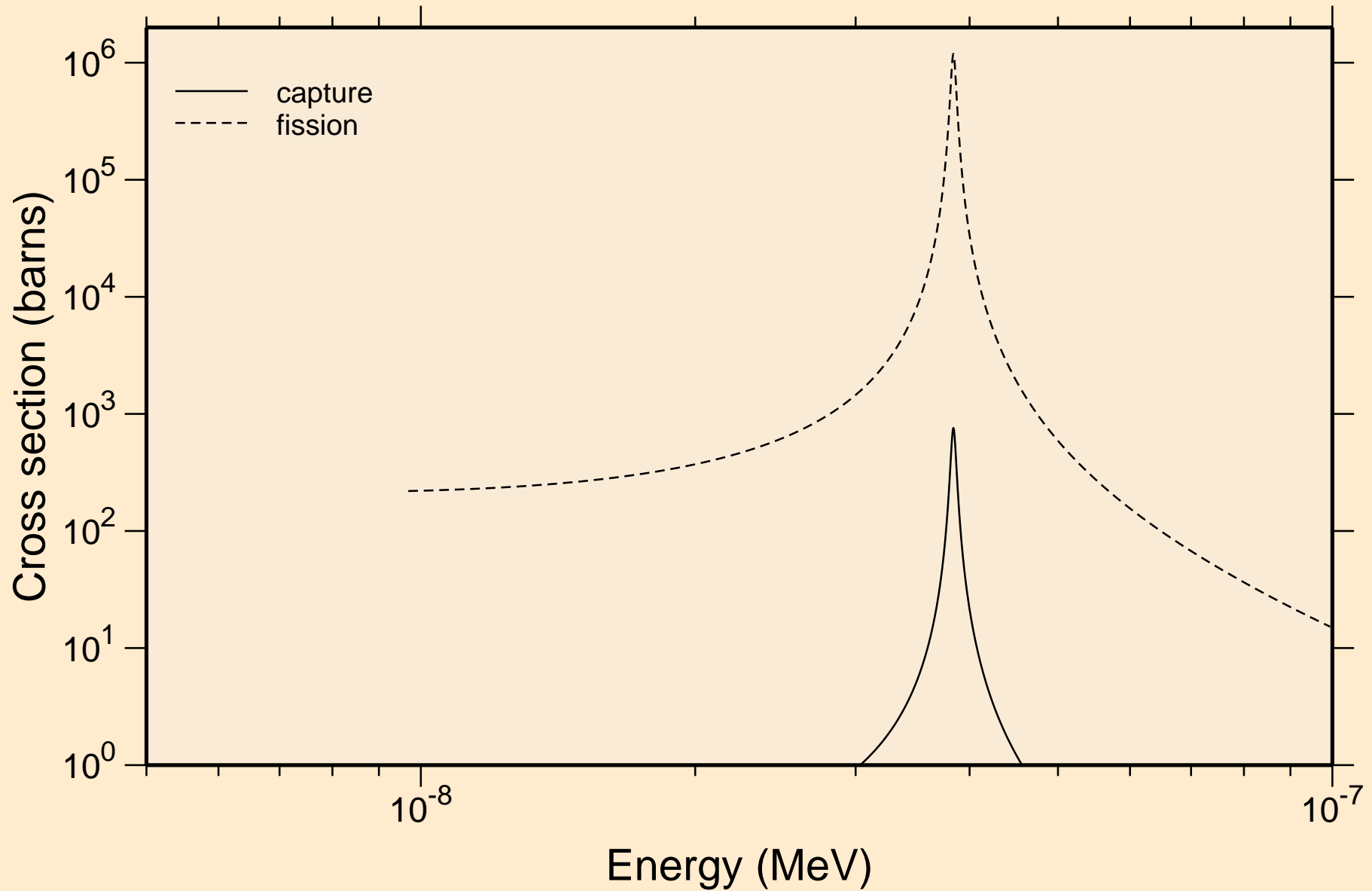

PA238 NEUTRON ACER TENDL-2024 LIBRARY; T=0.K
resonance absorption cross sections

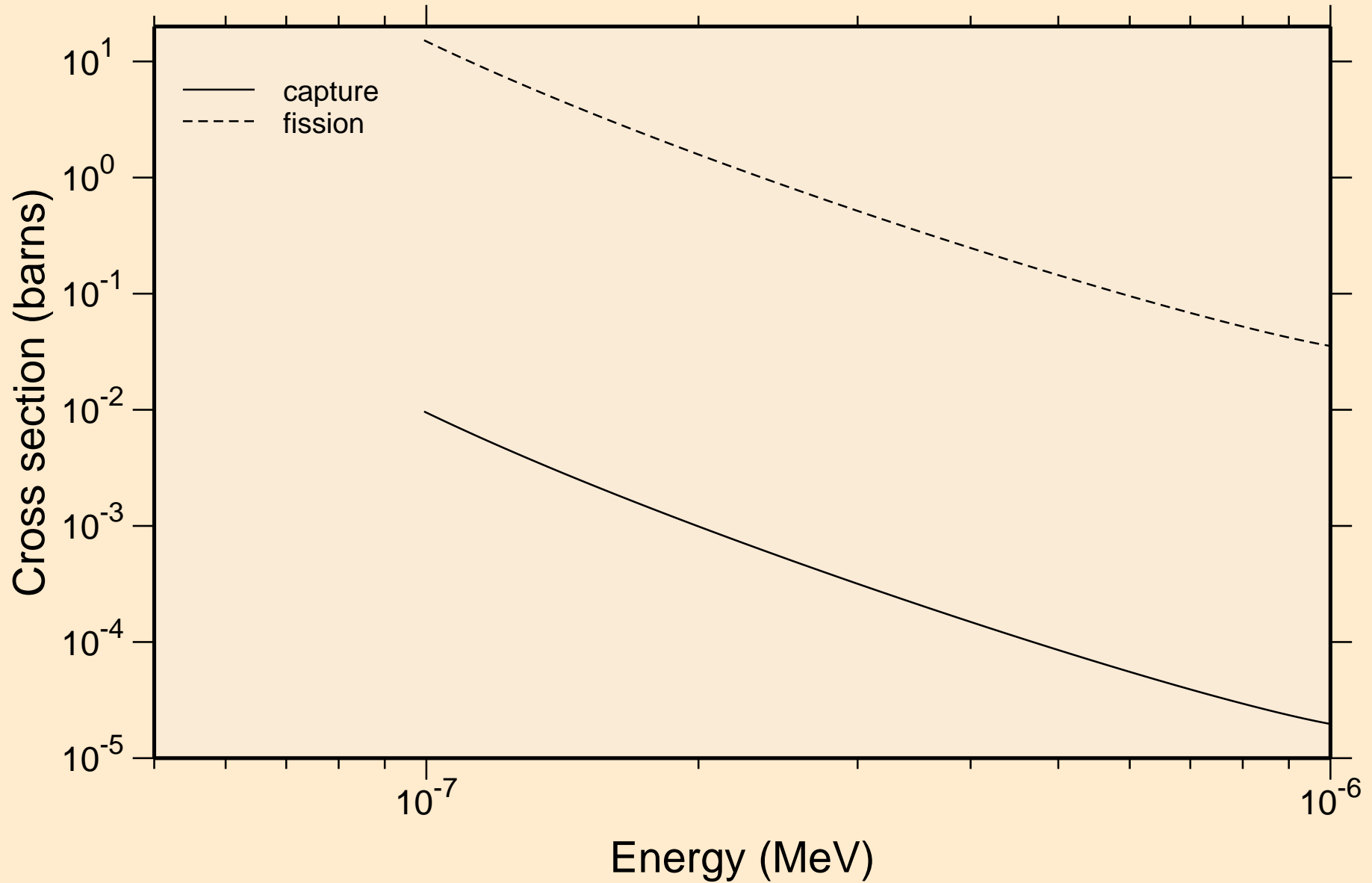

PA238 NEUTRON ACER TENDL-2024 LIBRARY; T=0.K
resonance absorption cross sections

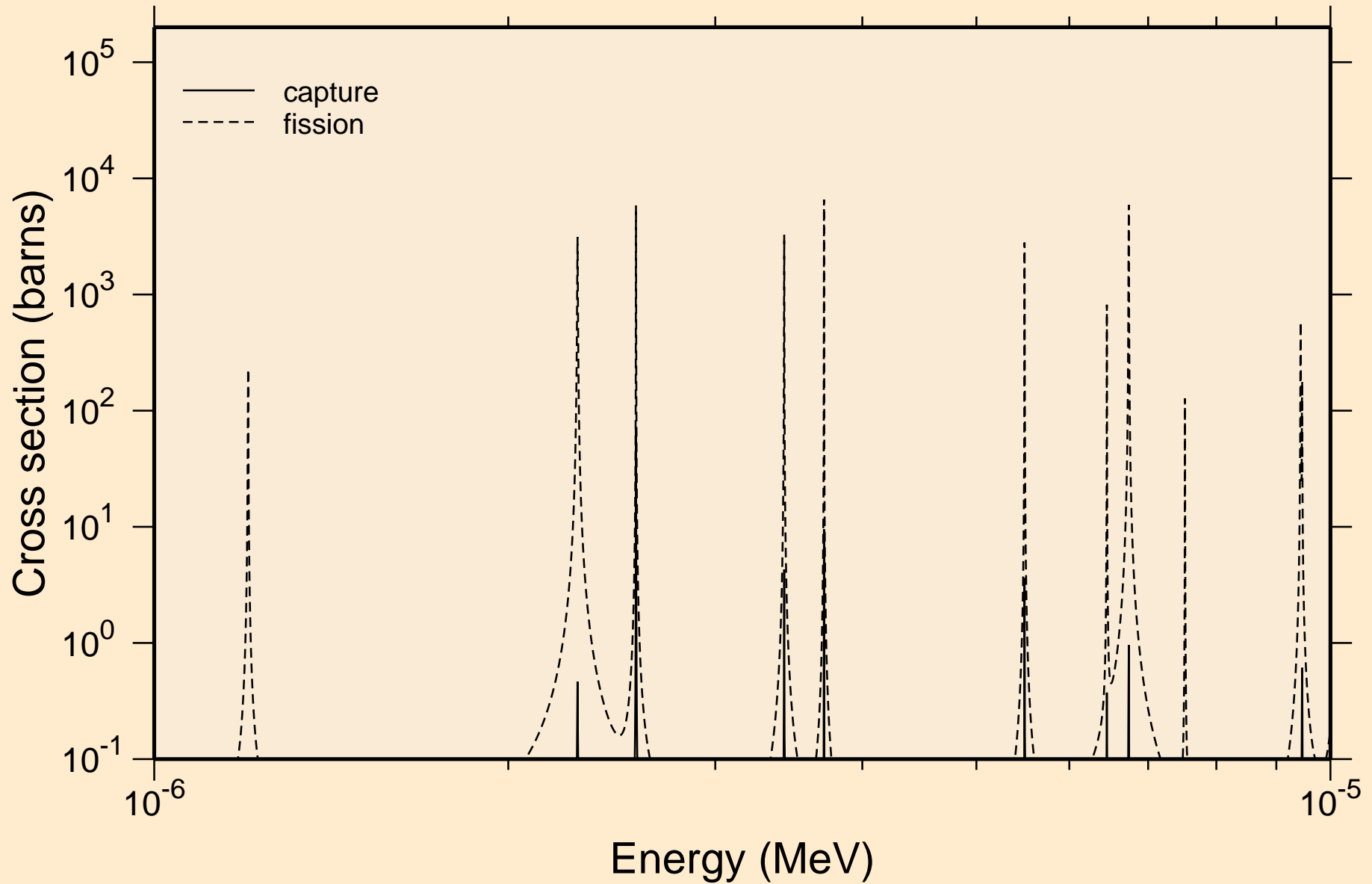

PA238 NEUTRON ACER TENDL-2024 LIBRARY; T=0.K
resonance absorption cross sections

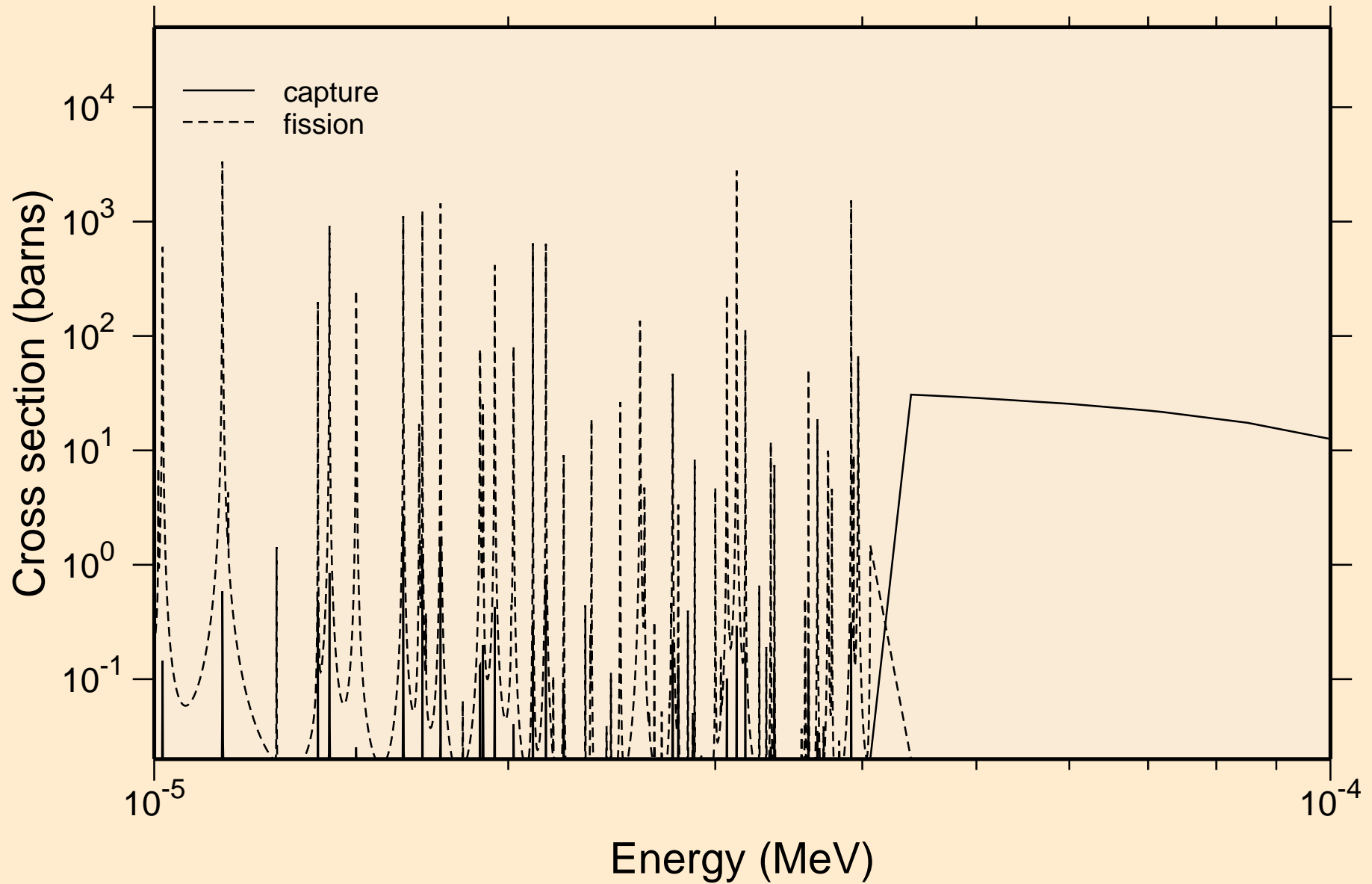

PA238 NEUTRON ACER TENDL-2024 LIBRARY; T=0.K
resonance absorption cross sections

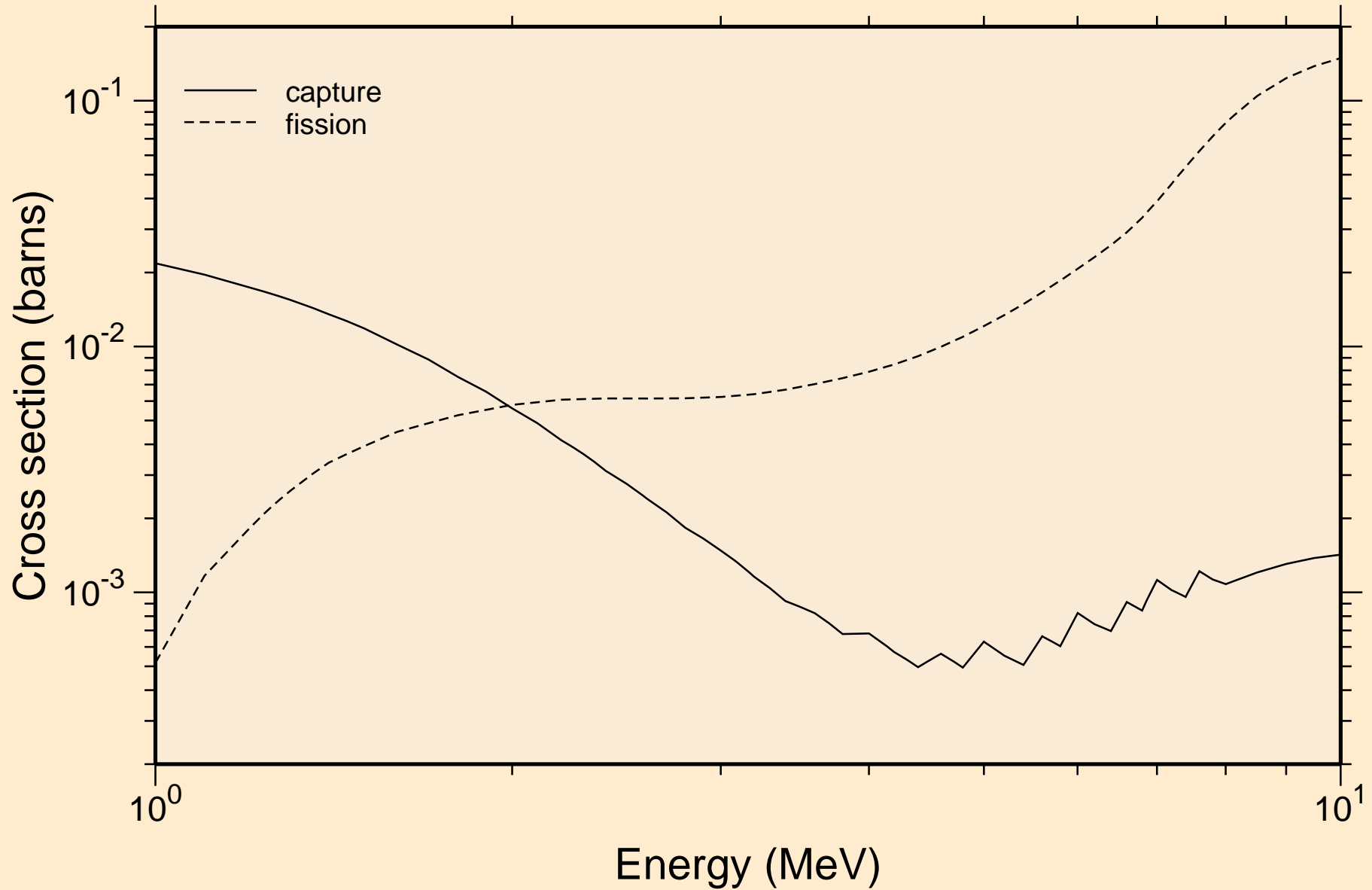

PA238 NEUTRON ACER TENDL-2024 LIBRARY; T=0.K

Heating

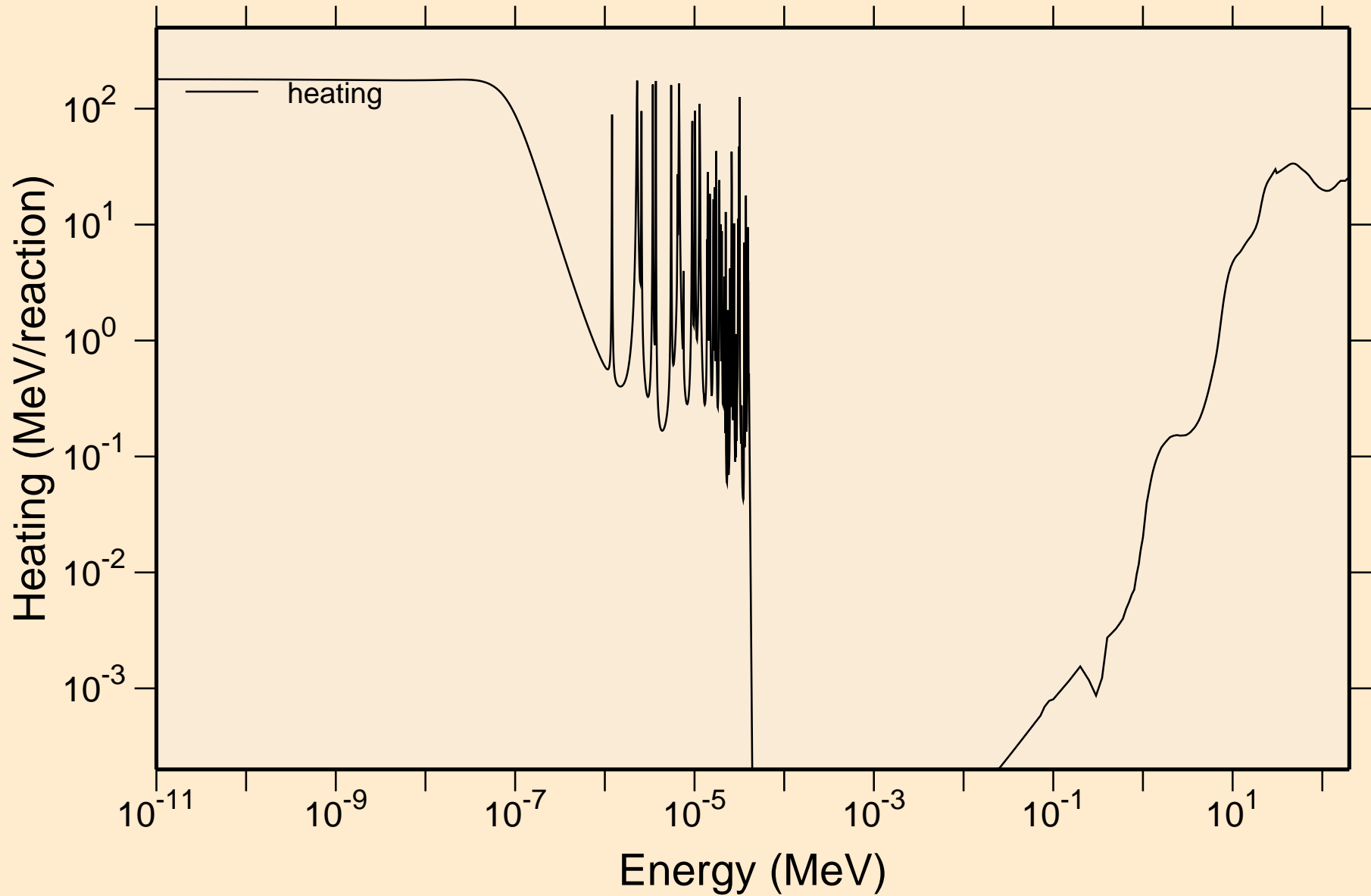

PA238 NEUTRON ACER TENDL-2024 LIBRARY; T=0.K
Damage

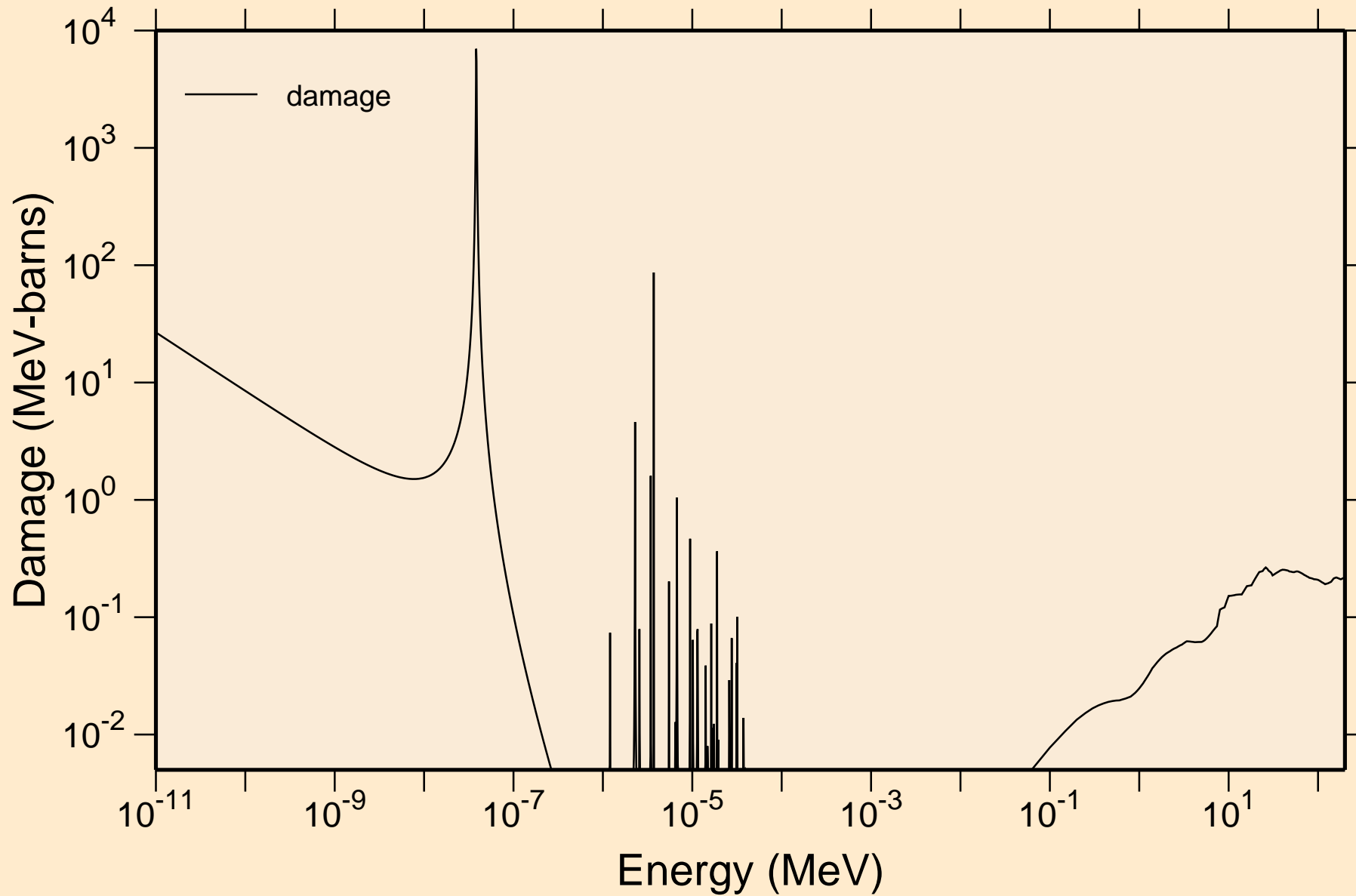

PA238 NEUTRON ACER TENDL-2024 LIBRARY; T=0.K

Non-threshold reactions

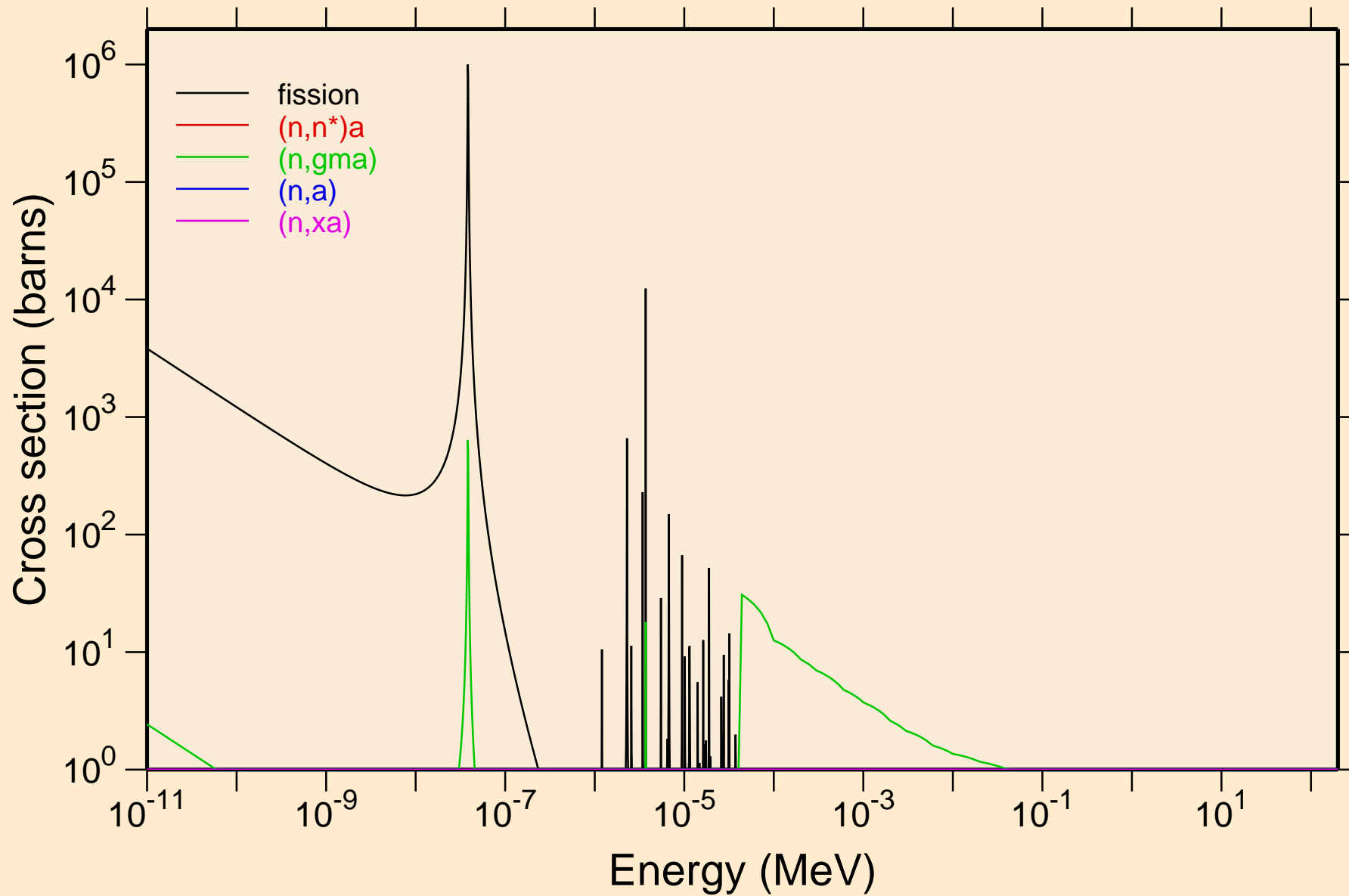

PA238 NEUTRON ACER TENDL-2024 LIBRARY; T=0.K

Principal cross sections

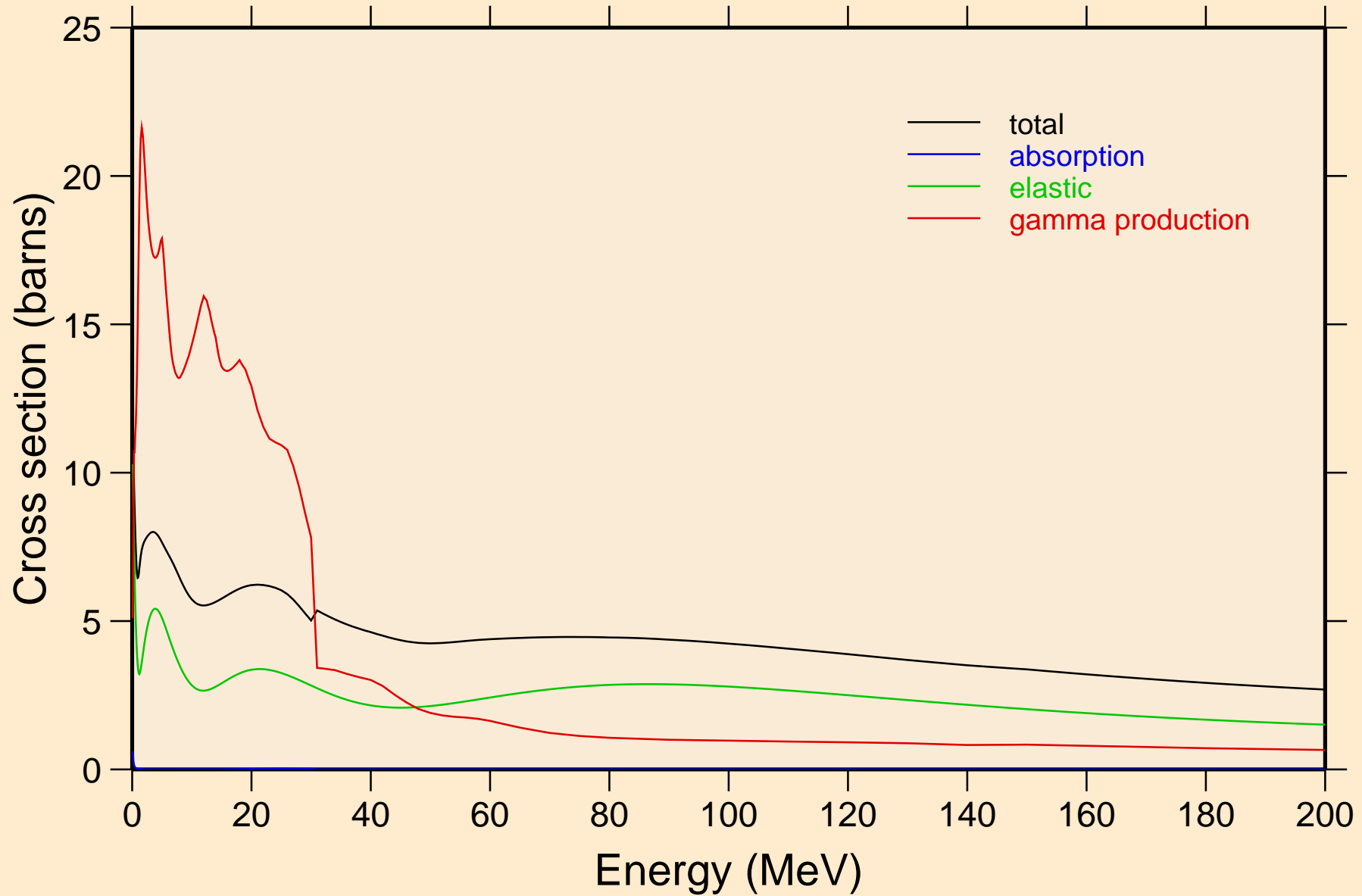

PA238 NEUTRON ACER TENDL-2024 LIBRARY; T=0.K

Heating

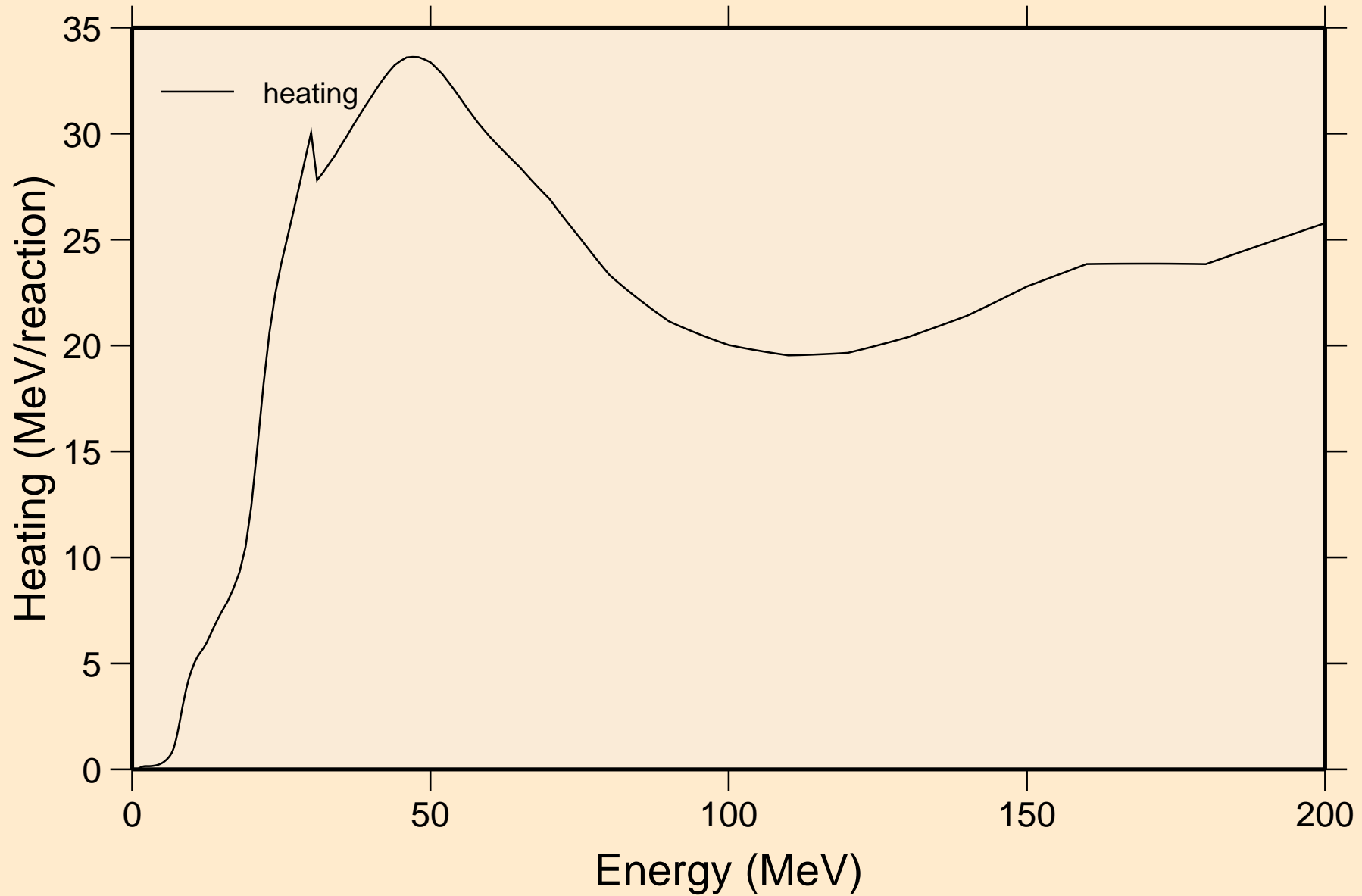

PA238 NEUTRON ACER TENDL-2024 LIBRARY; T=0.K
Damage

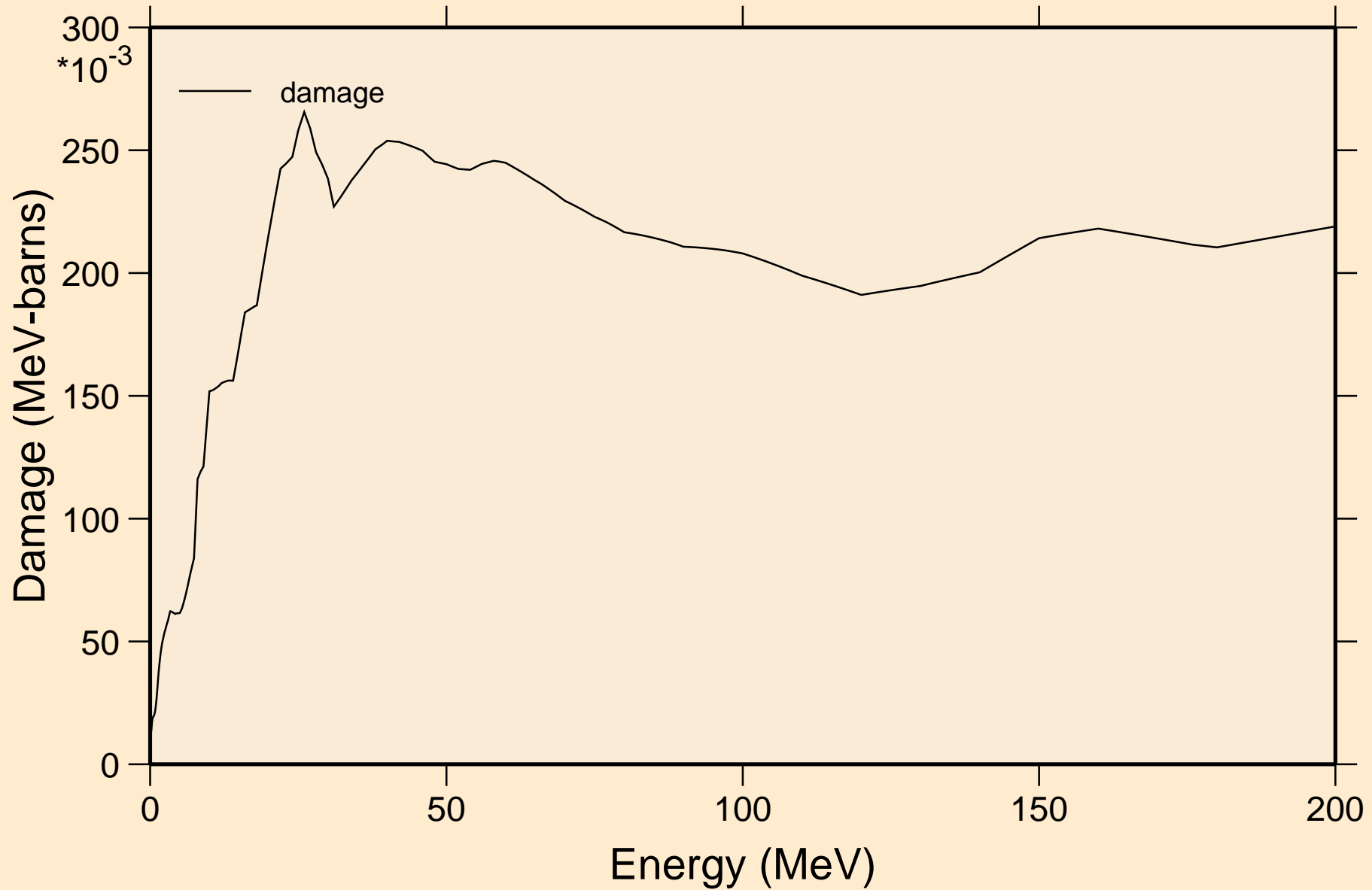

PA238 NEUTRON ACER TENDL-2024 LIBRARY; T=0.K
Non-threshold reactions

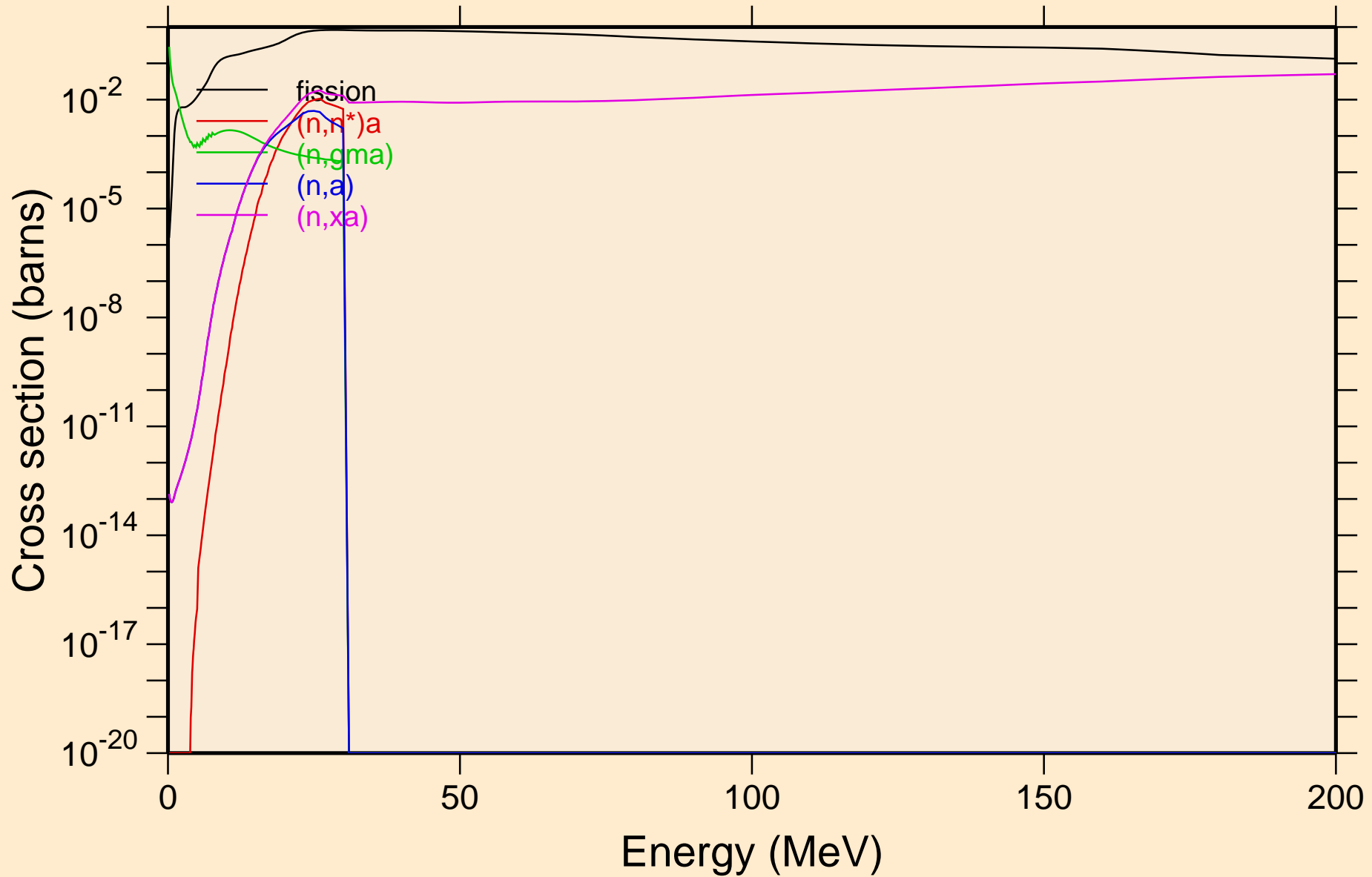

PA238 NEUTRON ACER TENDL-2024 LIBRARY; T=0.K
Inelastic levels

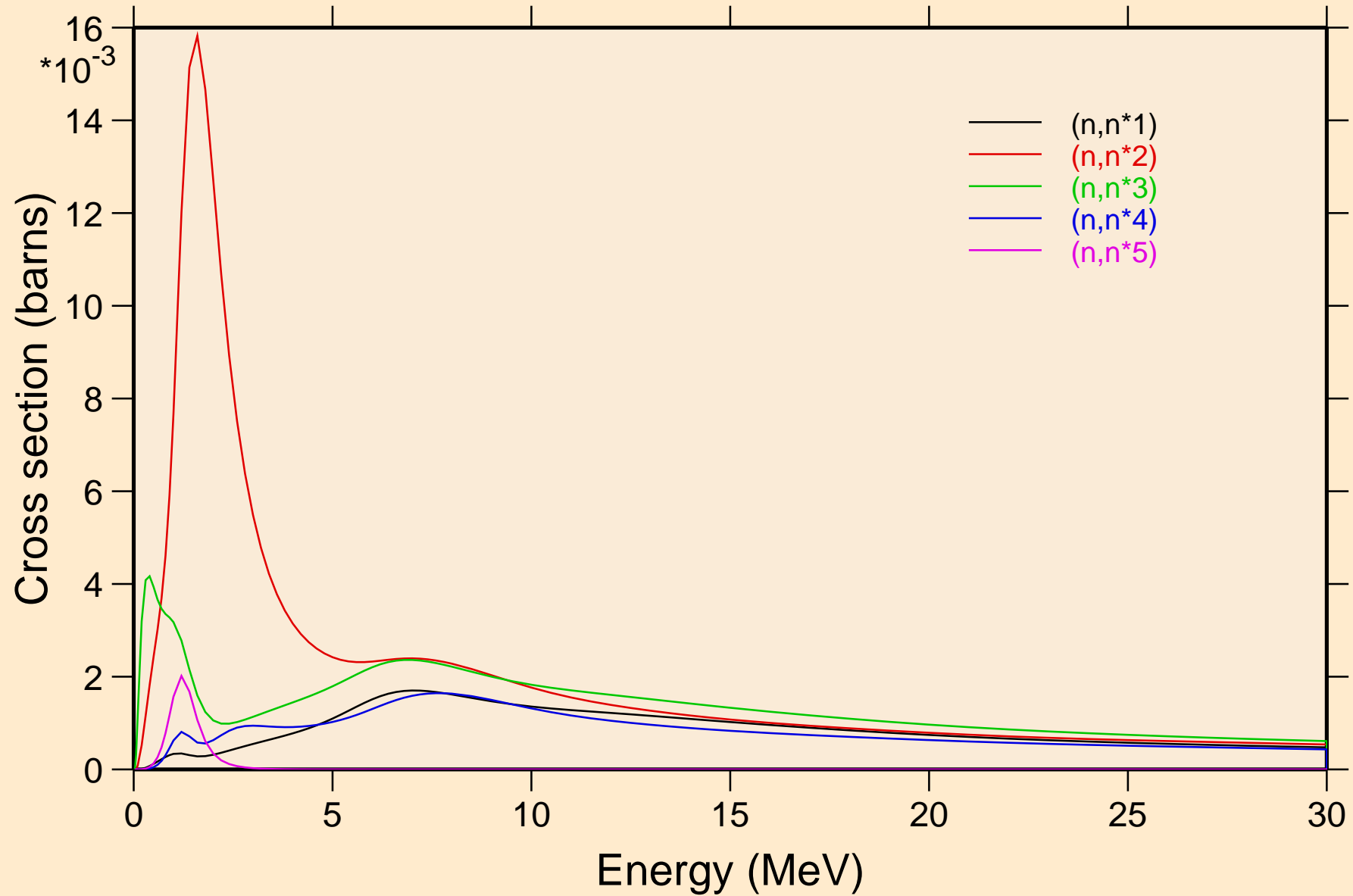

PA238 NEUTRON ACER TENDL-2024 LIBRARY; T=0.K
Inelastic levels

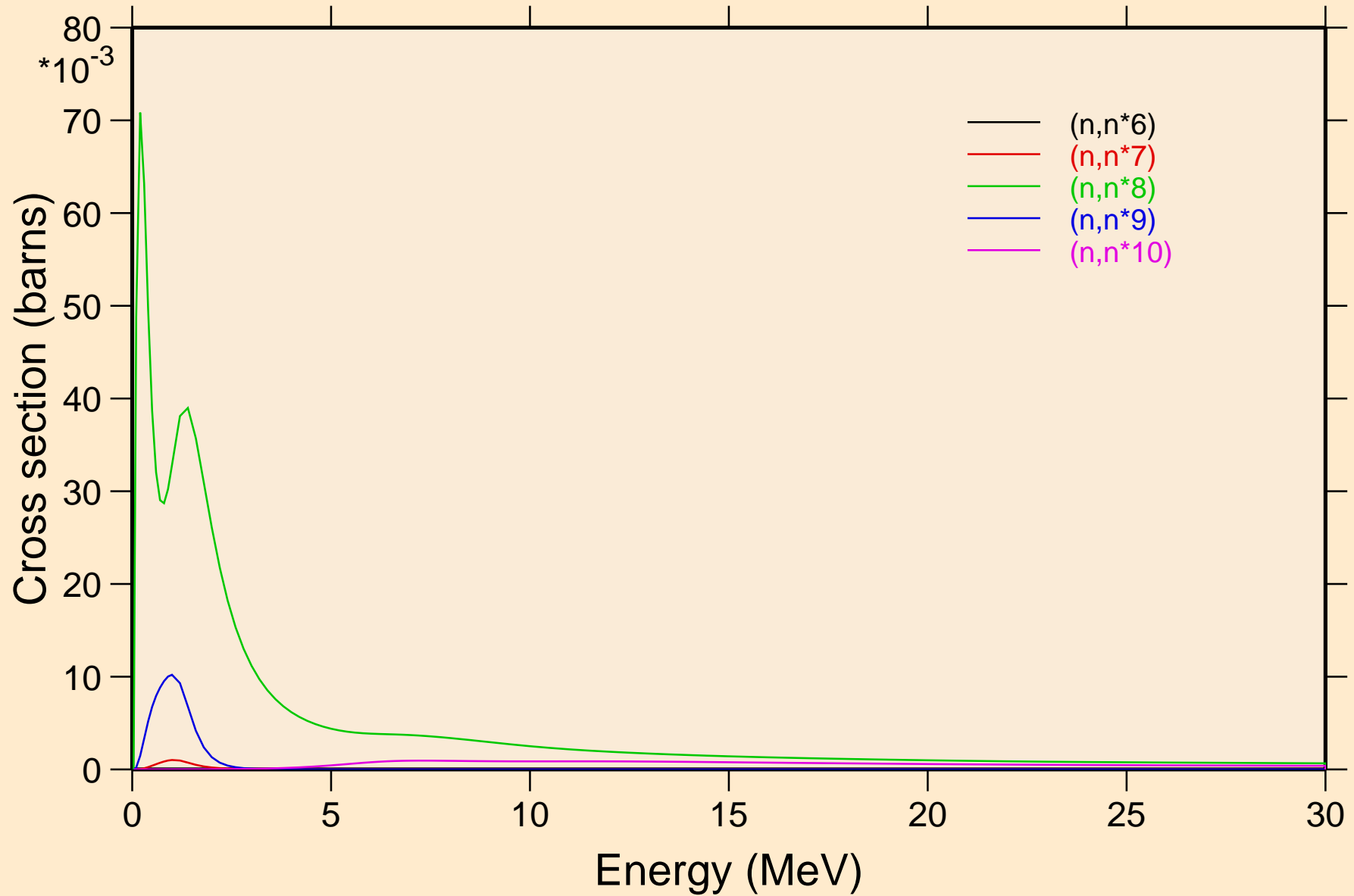

PA238 NEUTRON ACER TENDL-2024 LIBRARY; T=0.K
Inelastic levels

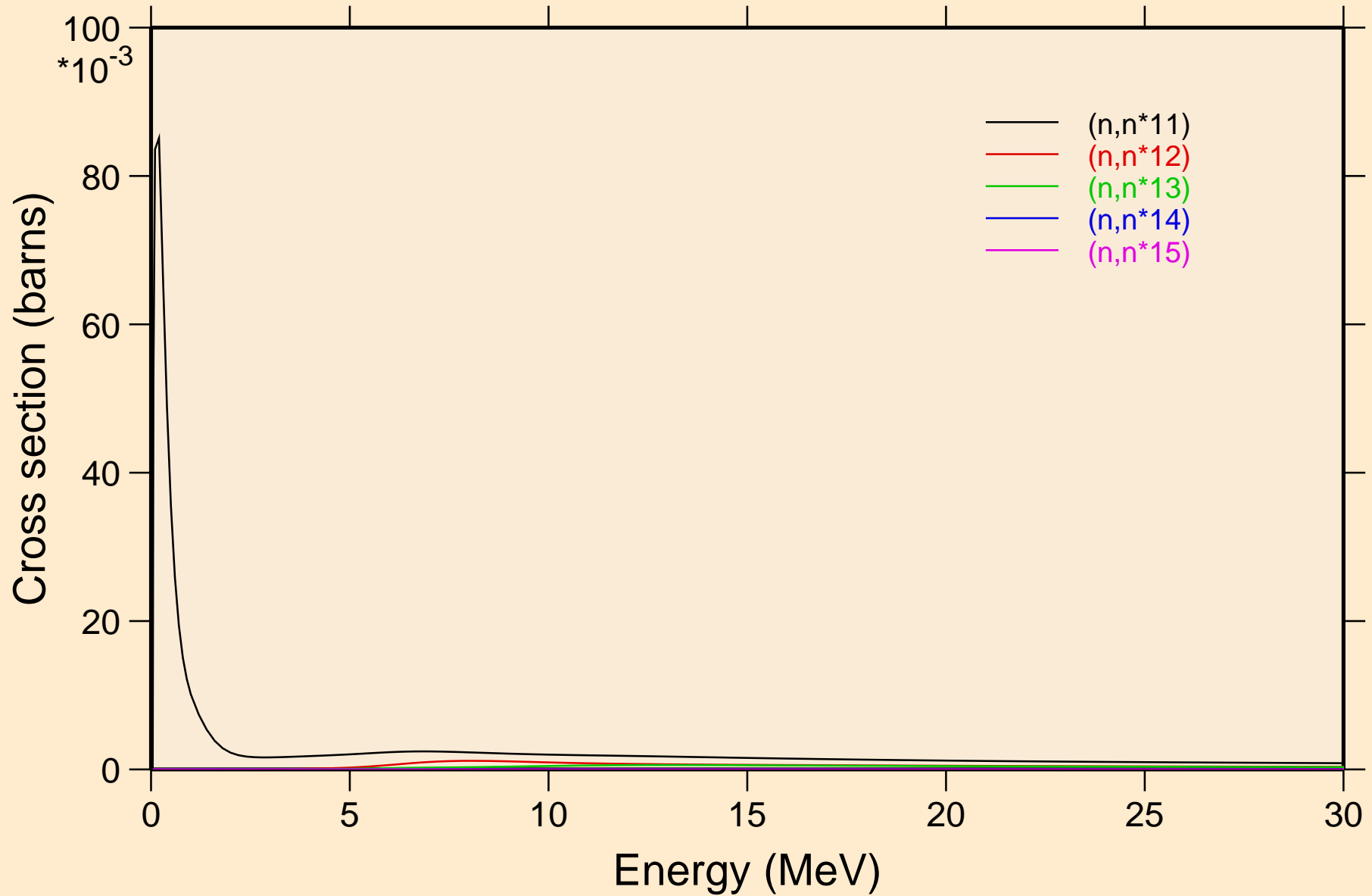

PA238 NEUTRON ACER TENDL-2024 LIBRARY; T=0.K
Inelastic levels

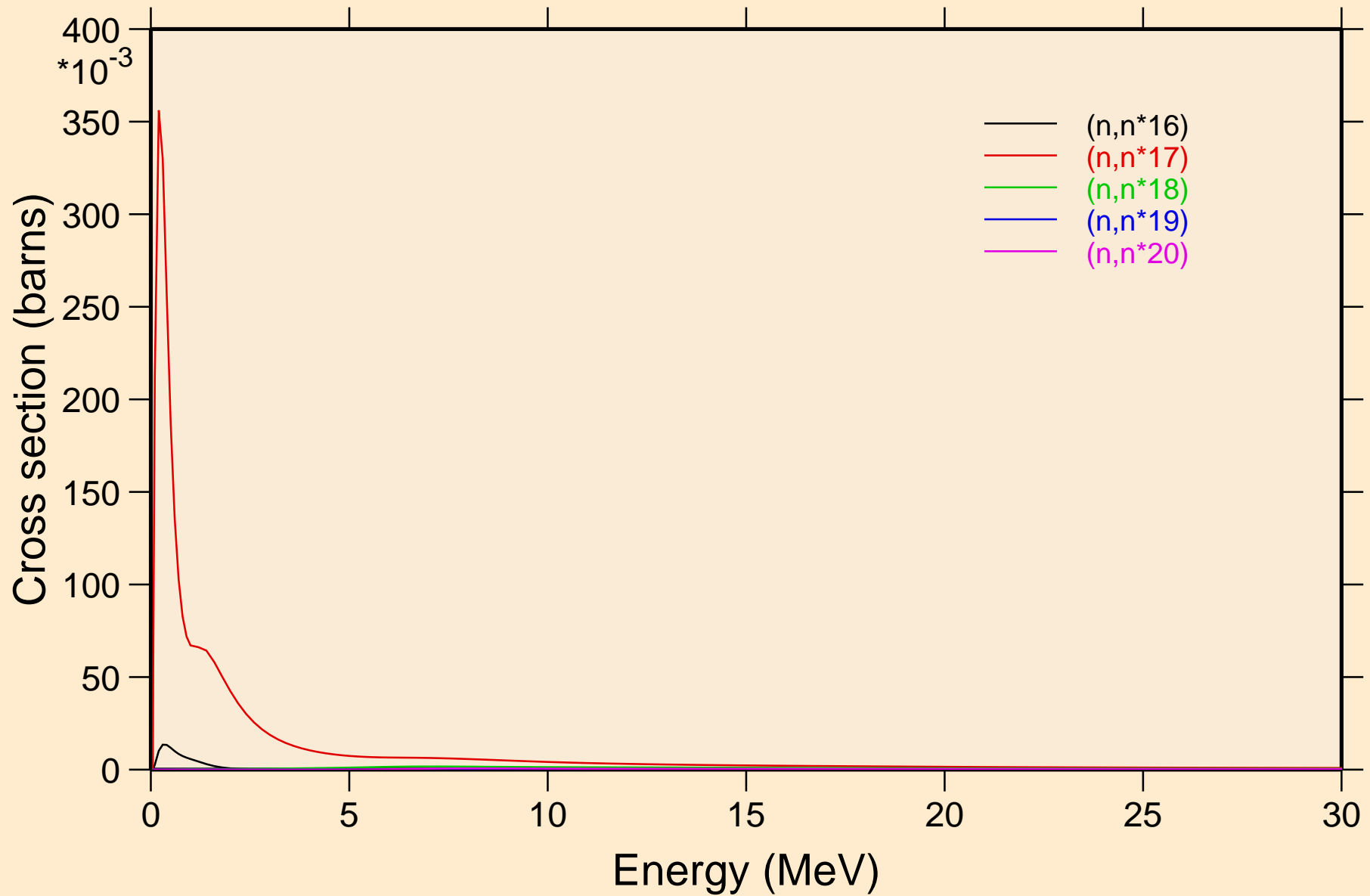

PA238 NEUTRON ACER TENDL-2024 LIBRARY; T=0.K
Inelastic levels

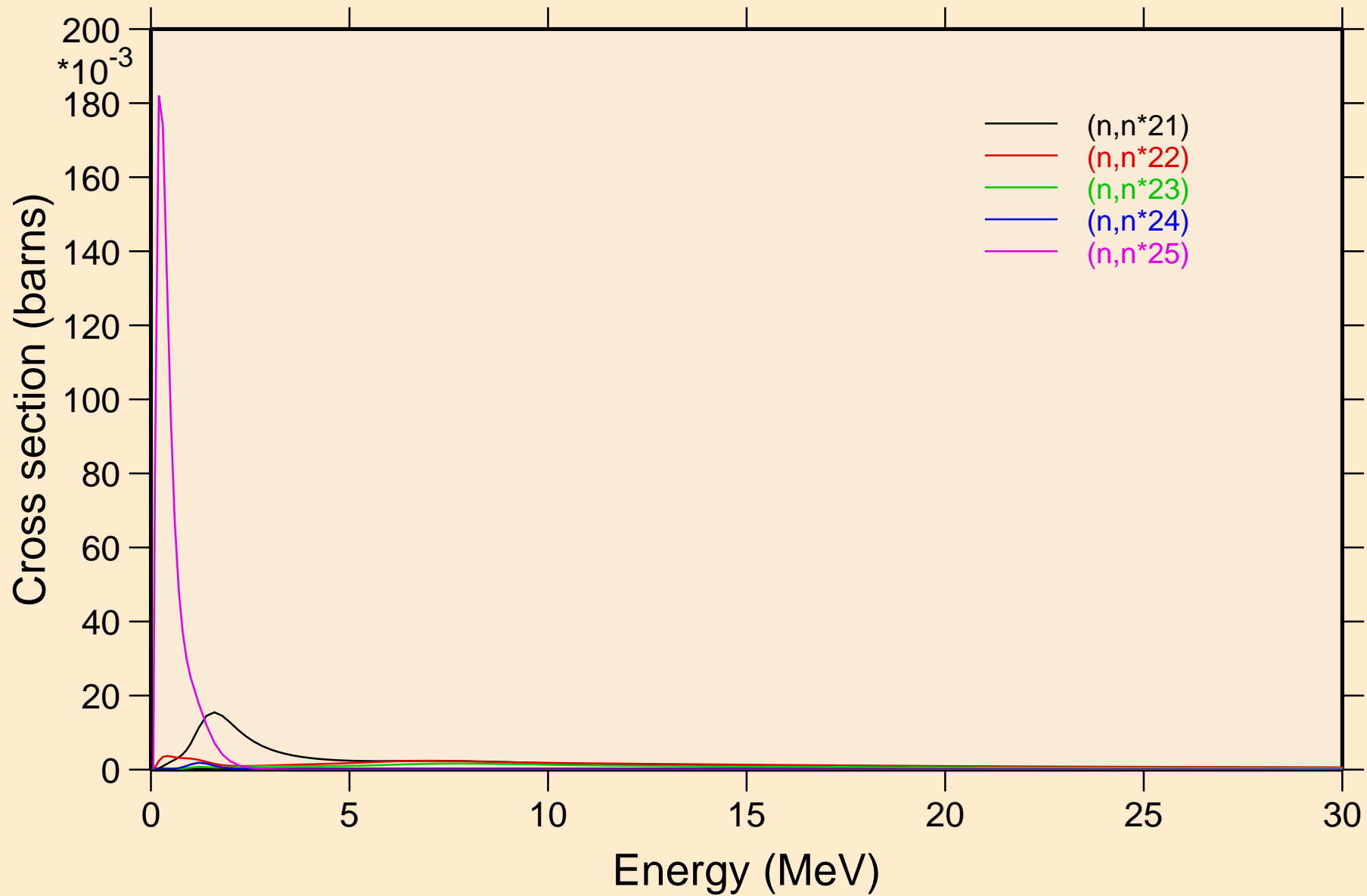

PA238 NEUTRON ACER TENDL-2024 LIBRARY; T=0.K
Inelastic levels

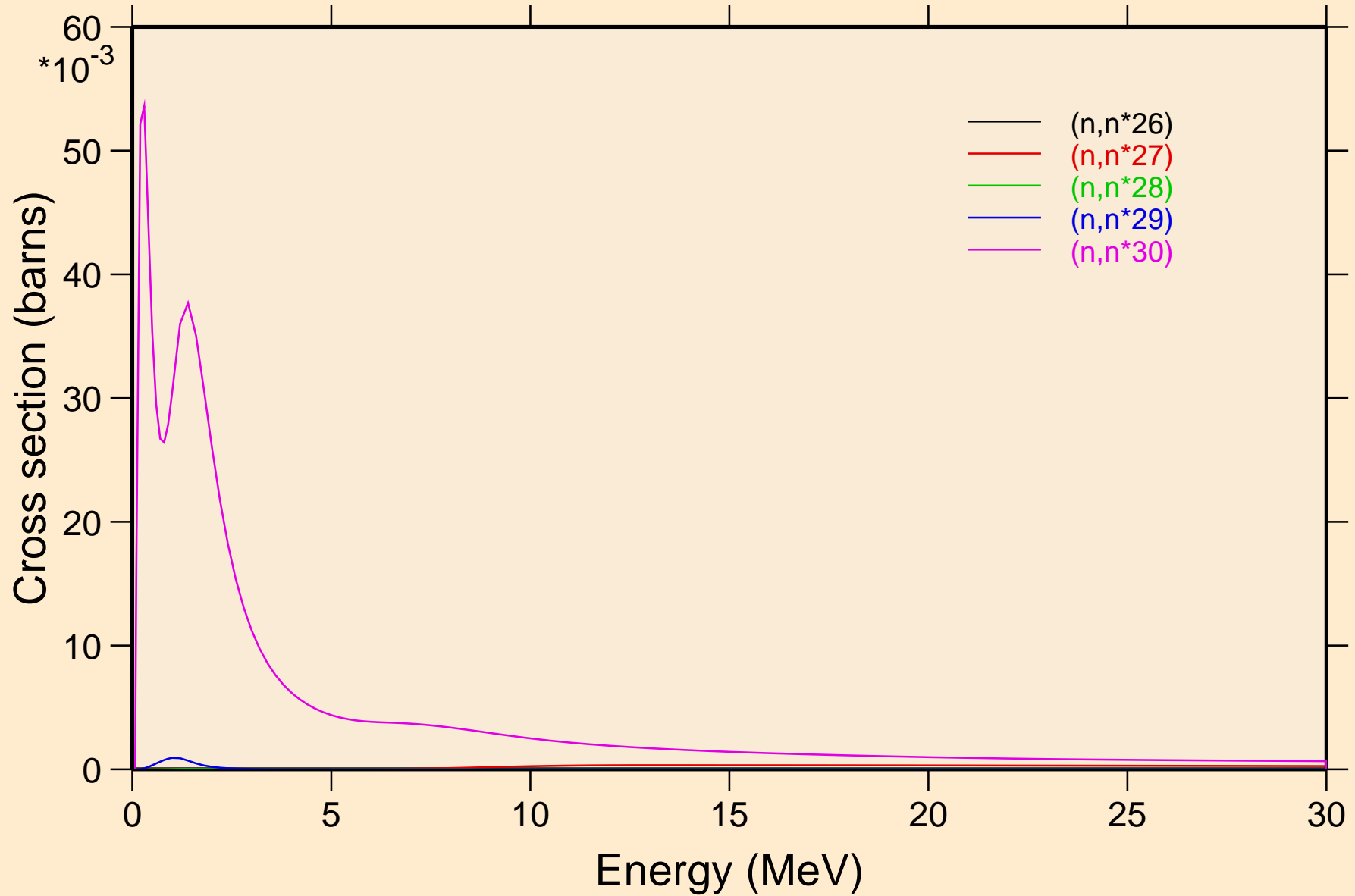

PA238 NEUTRON ACER TENDL-2024 LIBRARY; T=0.K
Threshold reactions

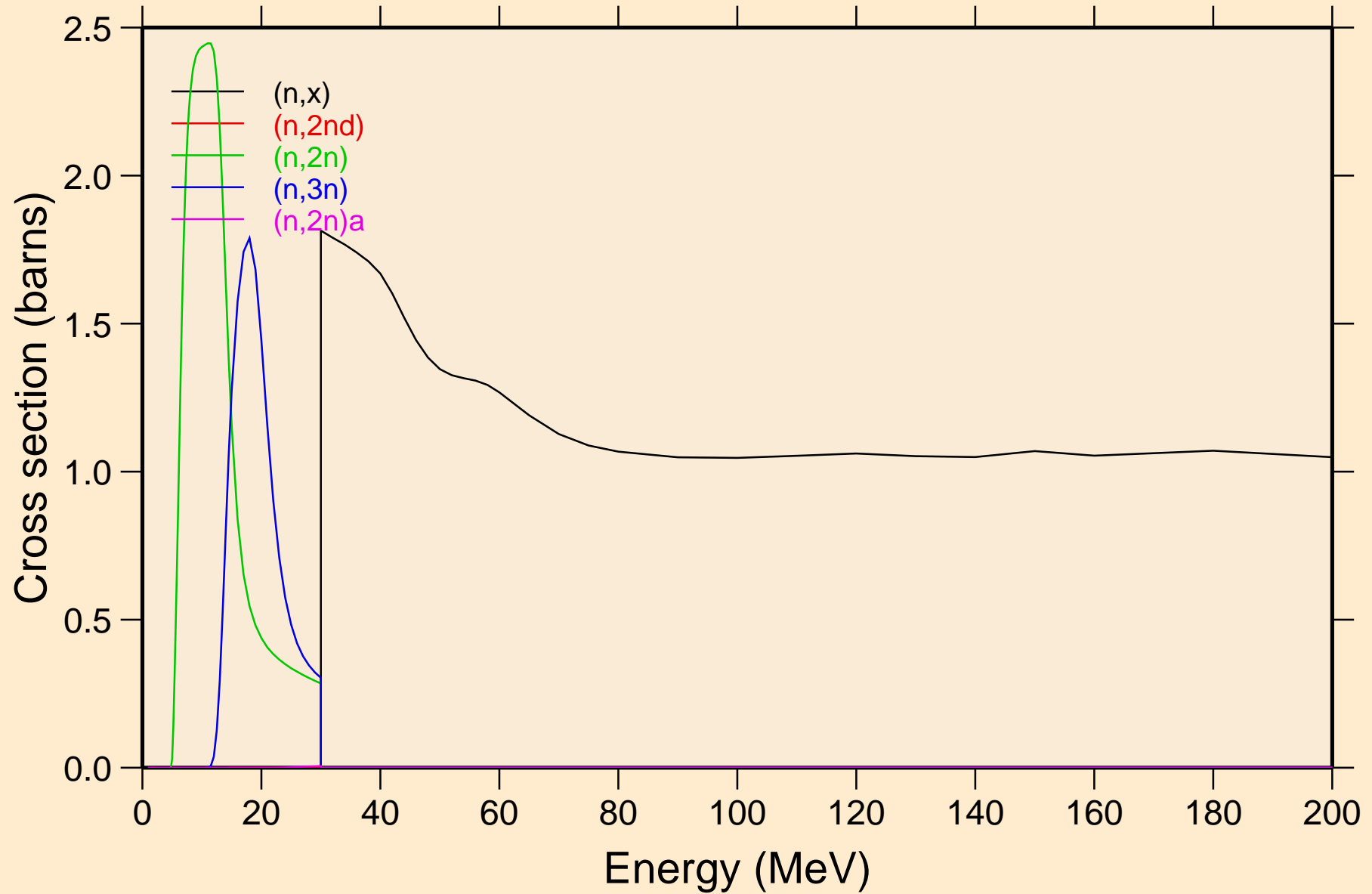

PA238 NEUTRON ACER TENDL-2024 LIBRARY; T=0.K
Threshold reactions

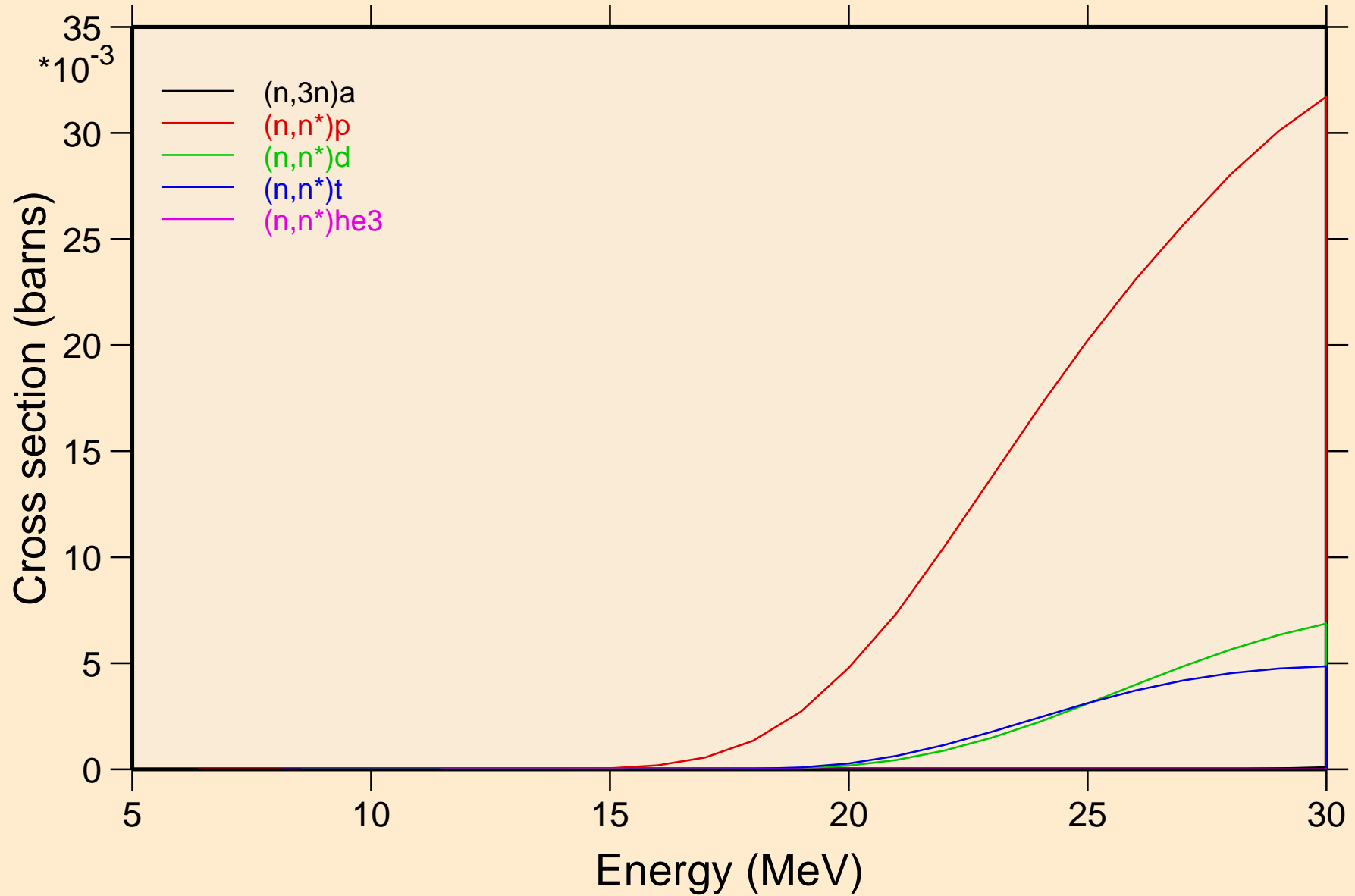

PA238 NEUTRON ACER TENDL-2024 LIBRARY; T=0.K
Threshold reactions

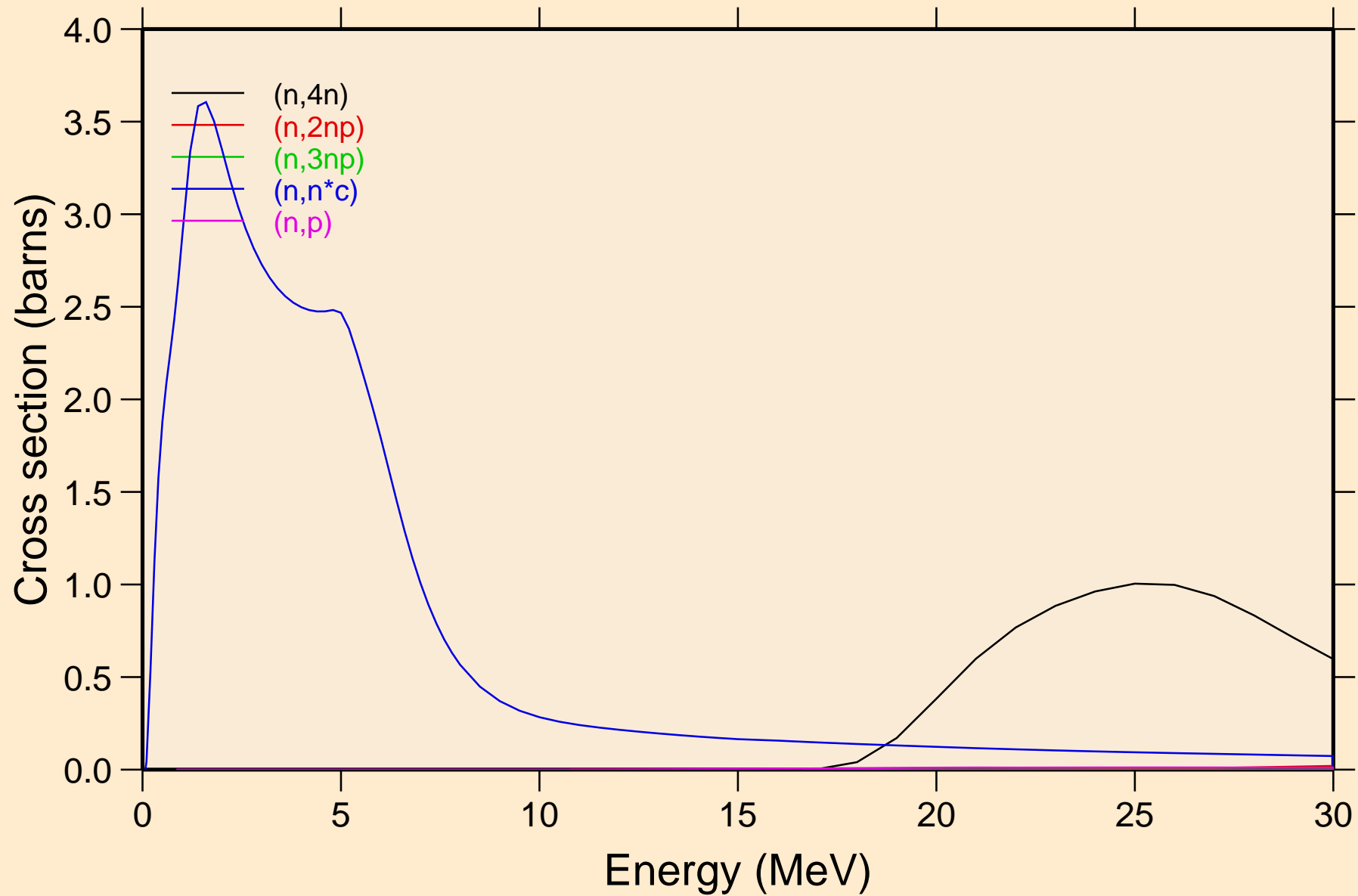

PA238 NEUTRON ACER TENDL-2024 LIBRARY; T=0.K
Threshold reactions

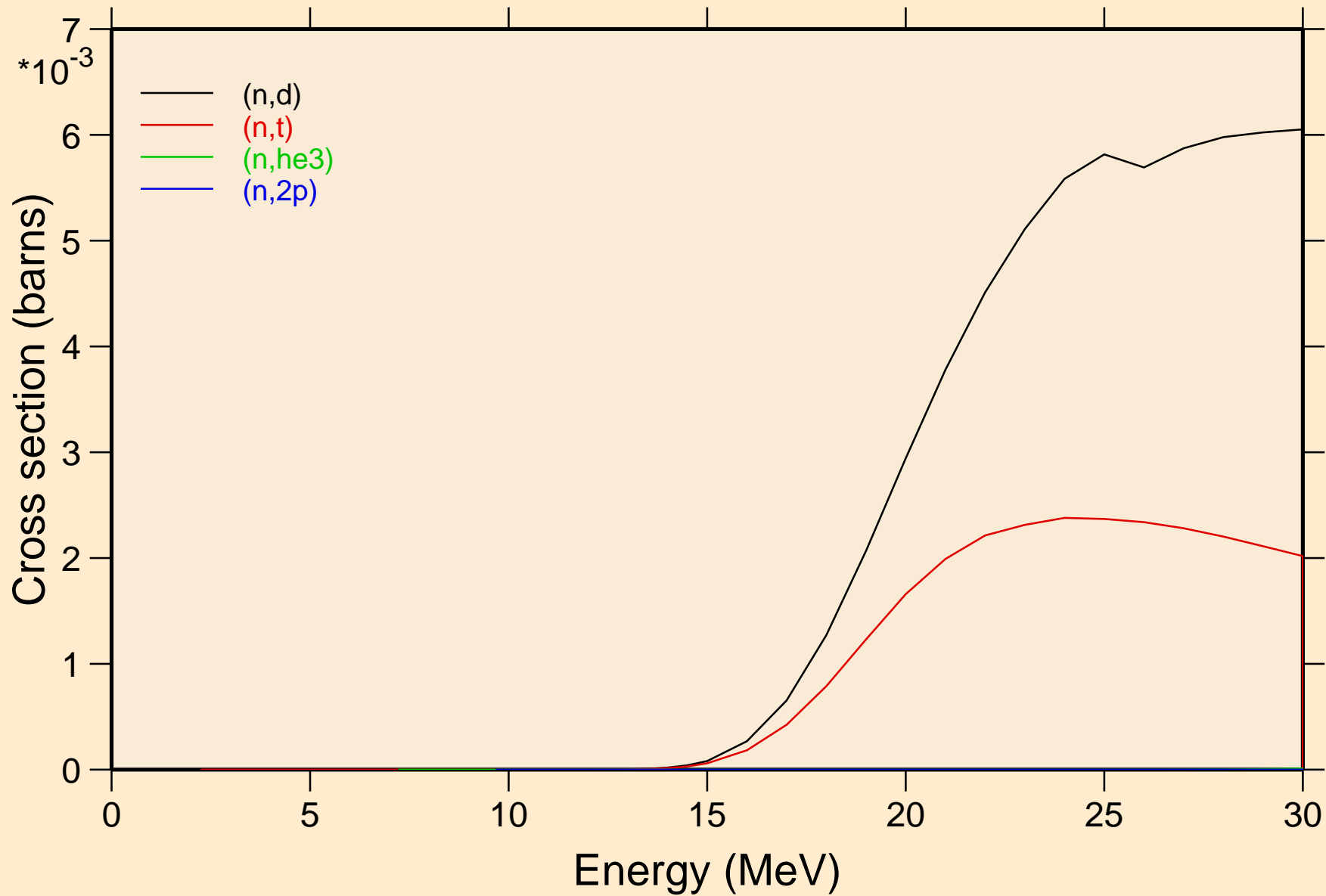

PA238 NEUTRON ACER TENDL-2024 LIBRARY; T=0.K
Threshold reactions

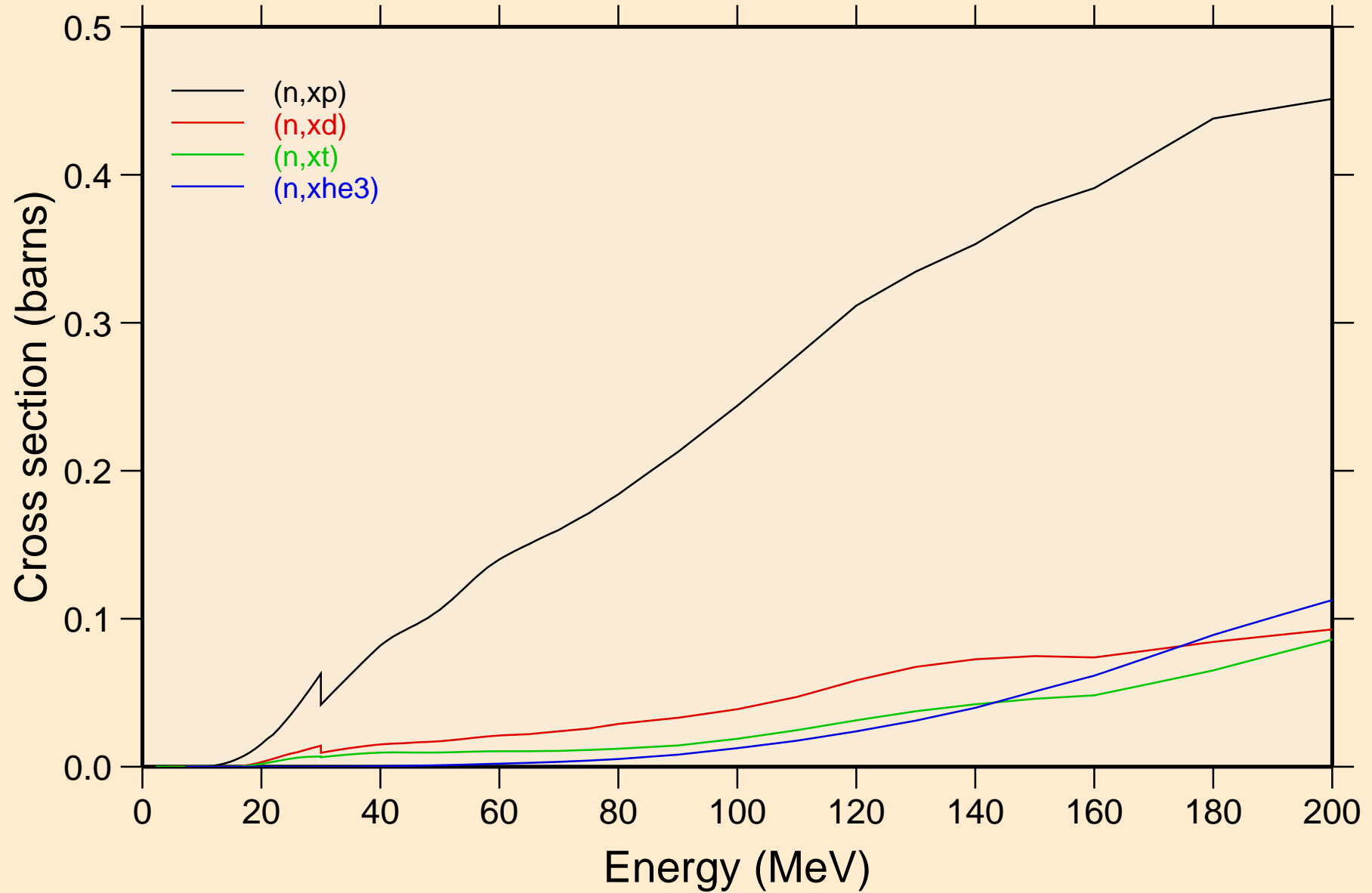

PA238 NEUTRON ACER TENDL-2024 LIBRARY; T=0.K
angular distribution for elastic

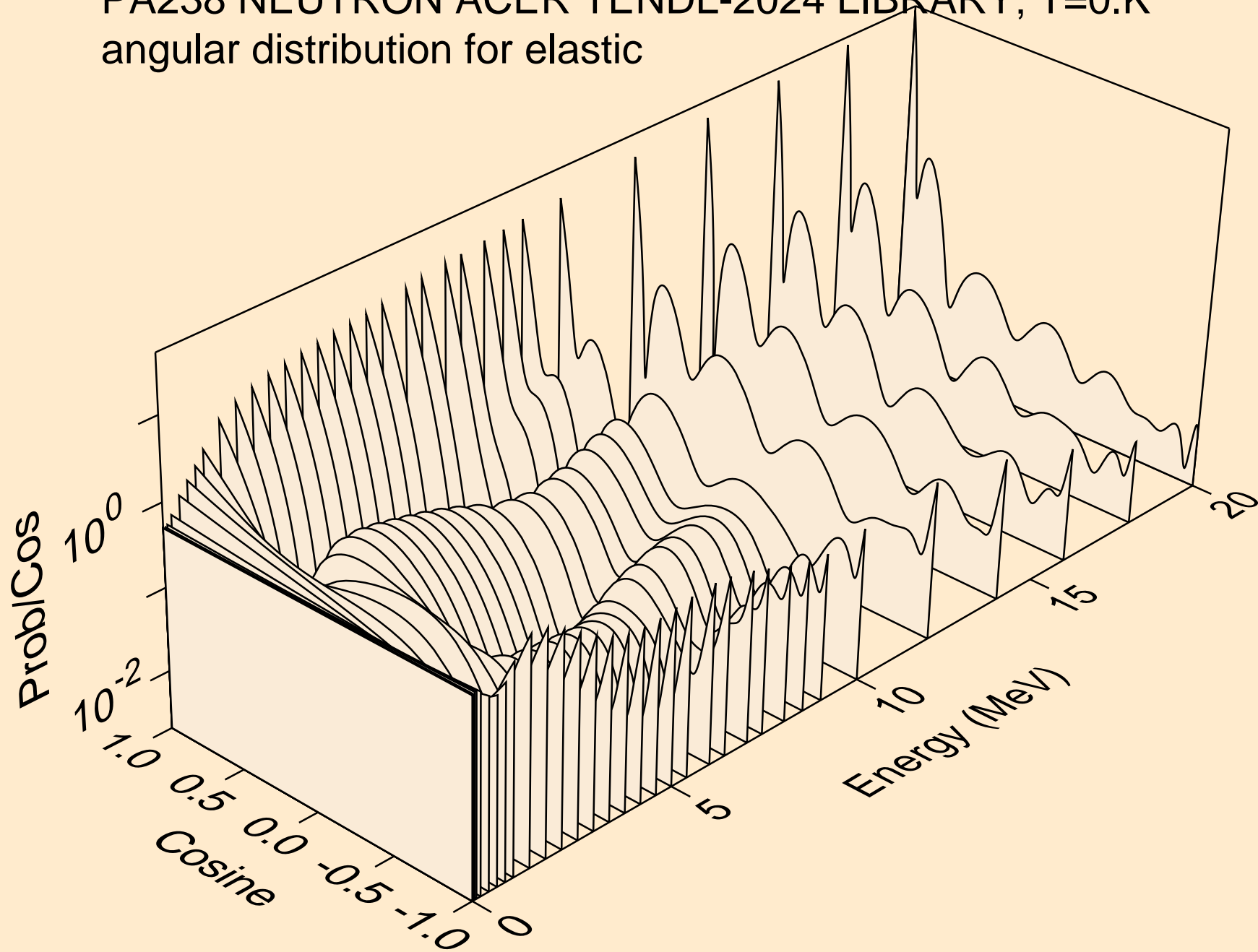

PA238 NEUTRON ACER TENDL-2024 LIBRARY; T=0.K
angular distribution for elastic

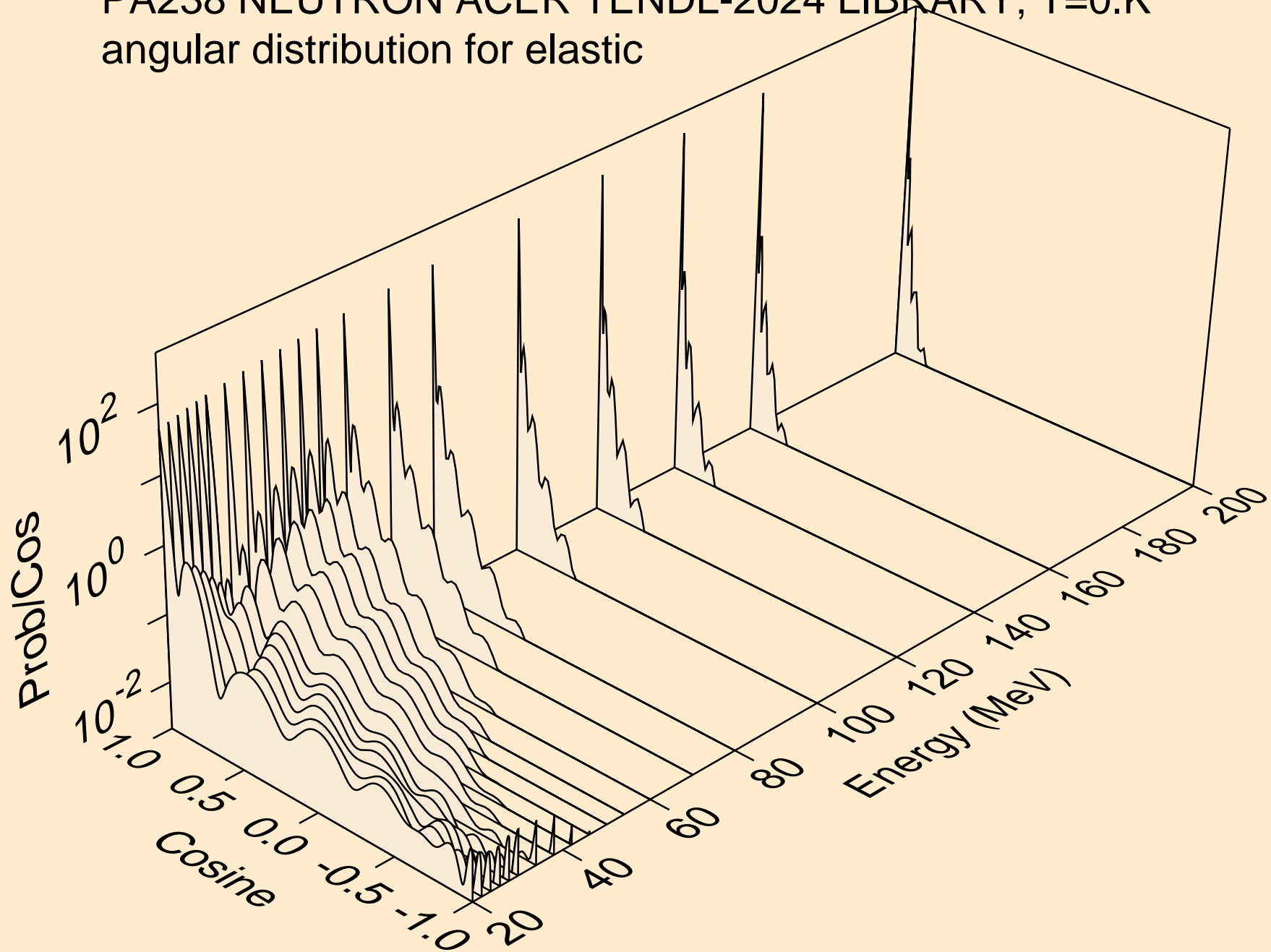

PA238 NEUTRON ACER TENDL-2024 LIBRARY; T=0.K
angular distribution for (n,n*1)

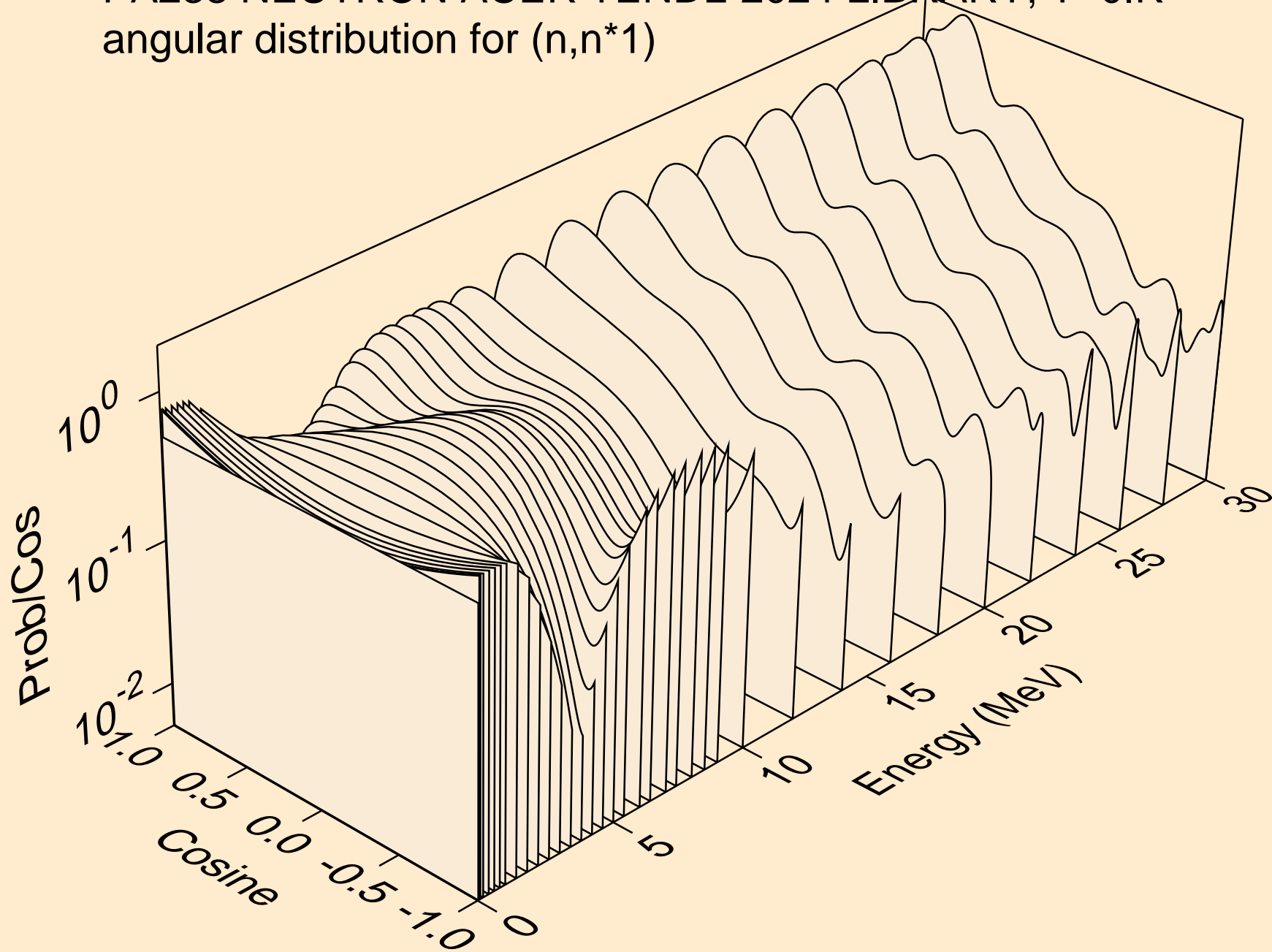

PA238 NEUTRON ACER TENDL-2024 LIBRARY; T=0.K
angular distribution for (n,n*2)

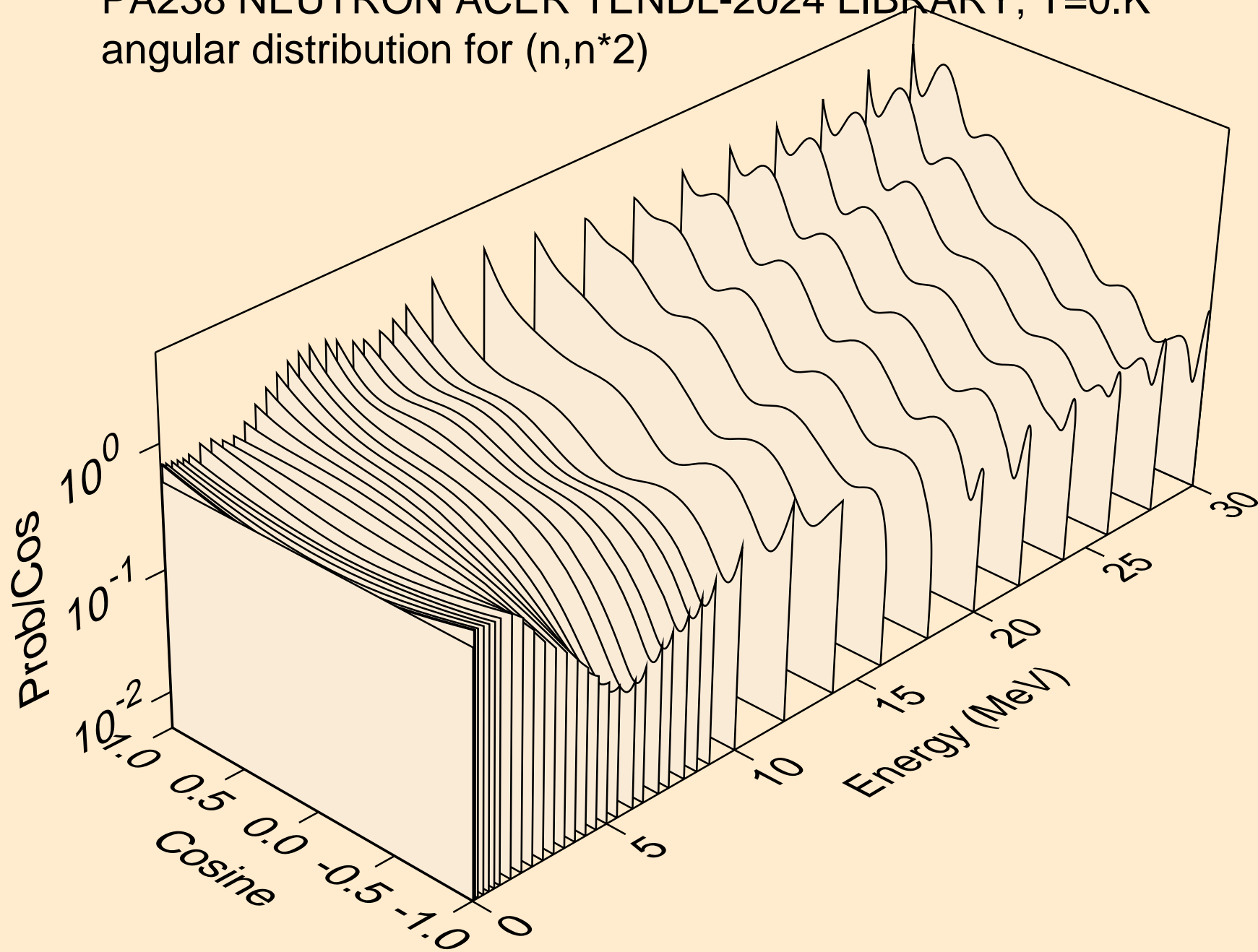

PA238 NEUTRON ACER TENDL-2024 LIBRARY; T=0.K
angular distribution for (n,n*3)

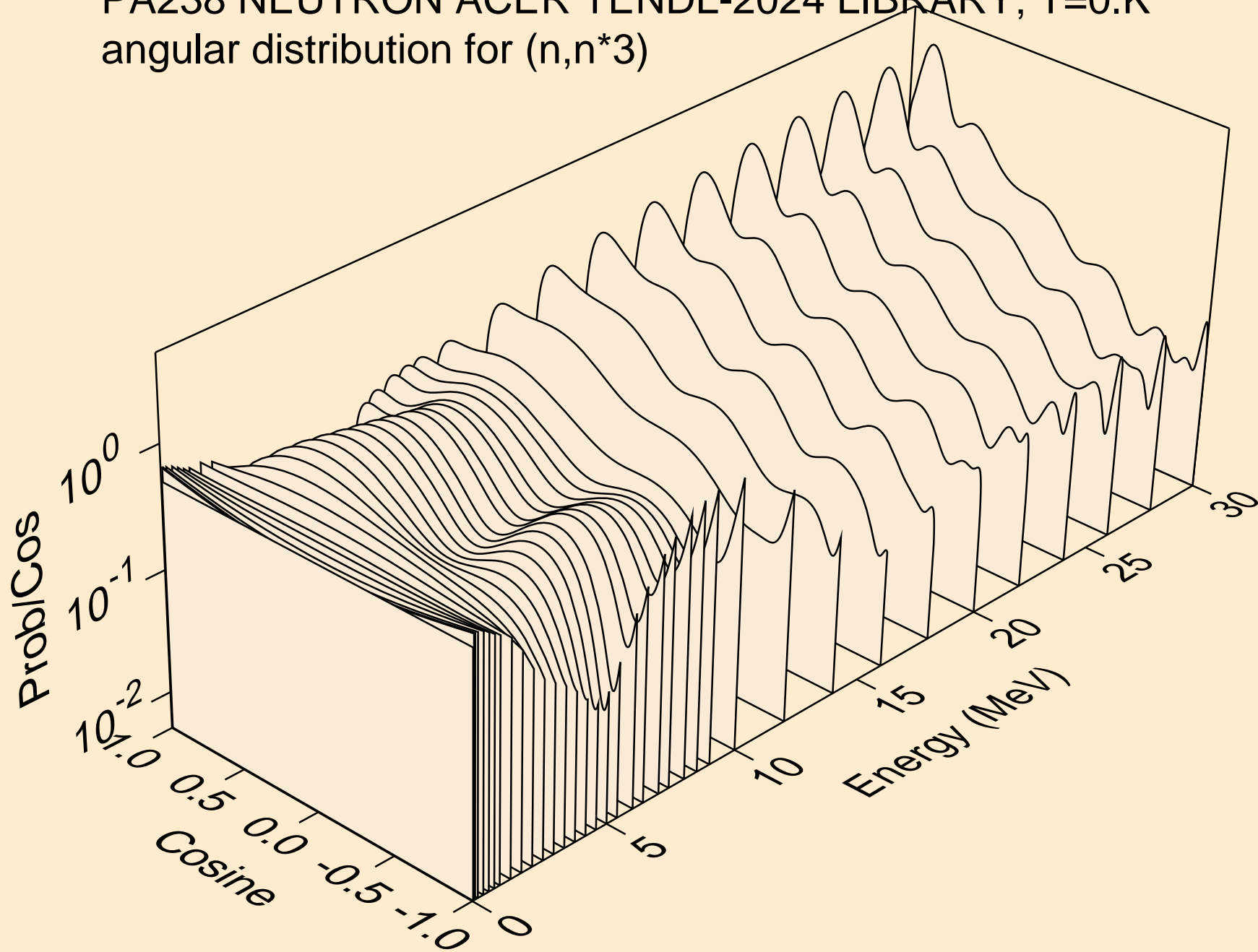

PA238 NEUTRON ACER TENDL-2024 LIBRARY; T=0.K
angular distribution for (n,n*4)

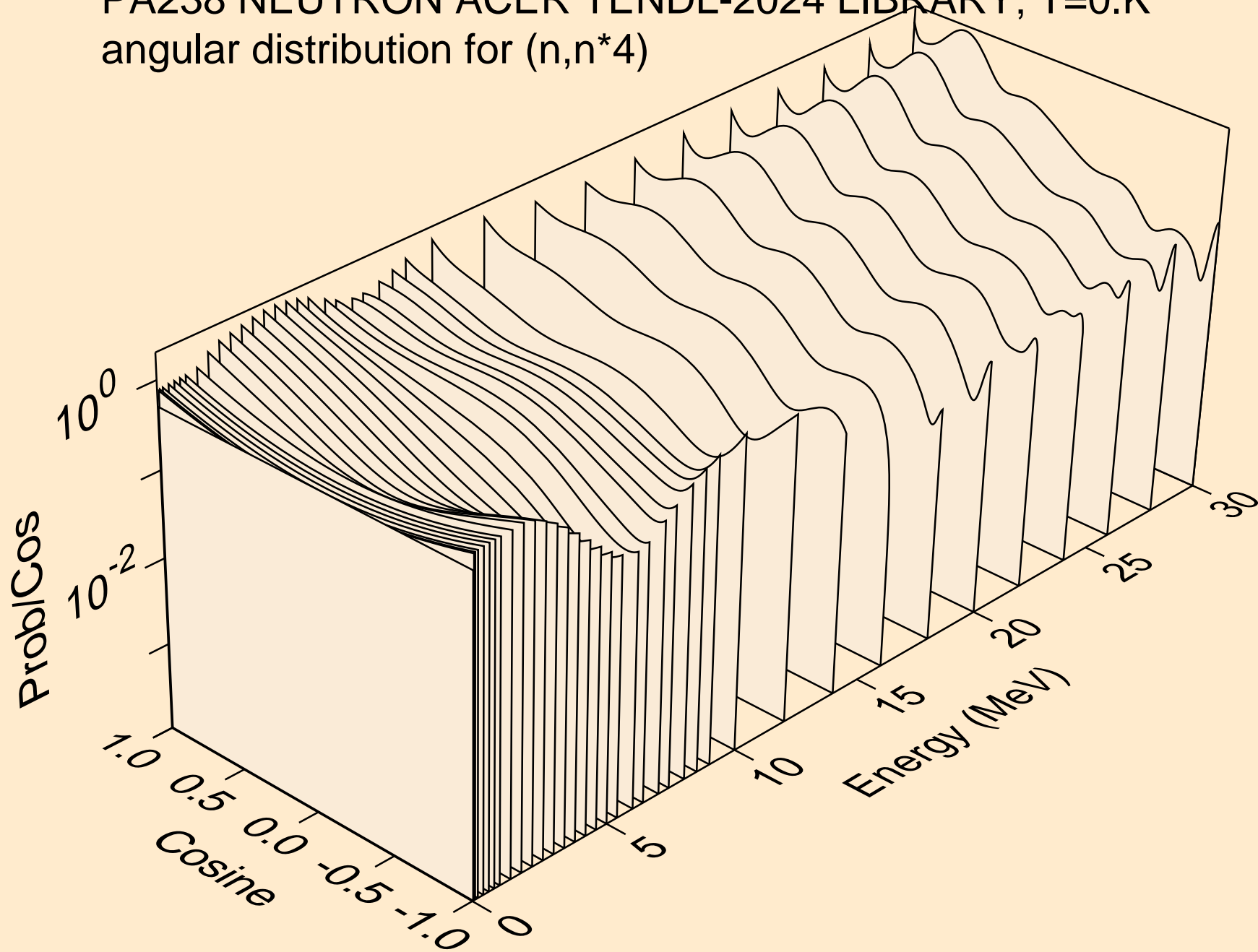

PA238 NEUTRON ACER TENDL-2024 LIBRARY; T=0.K
angular distribution for (n,n*5)

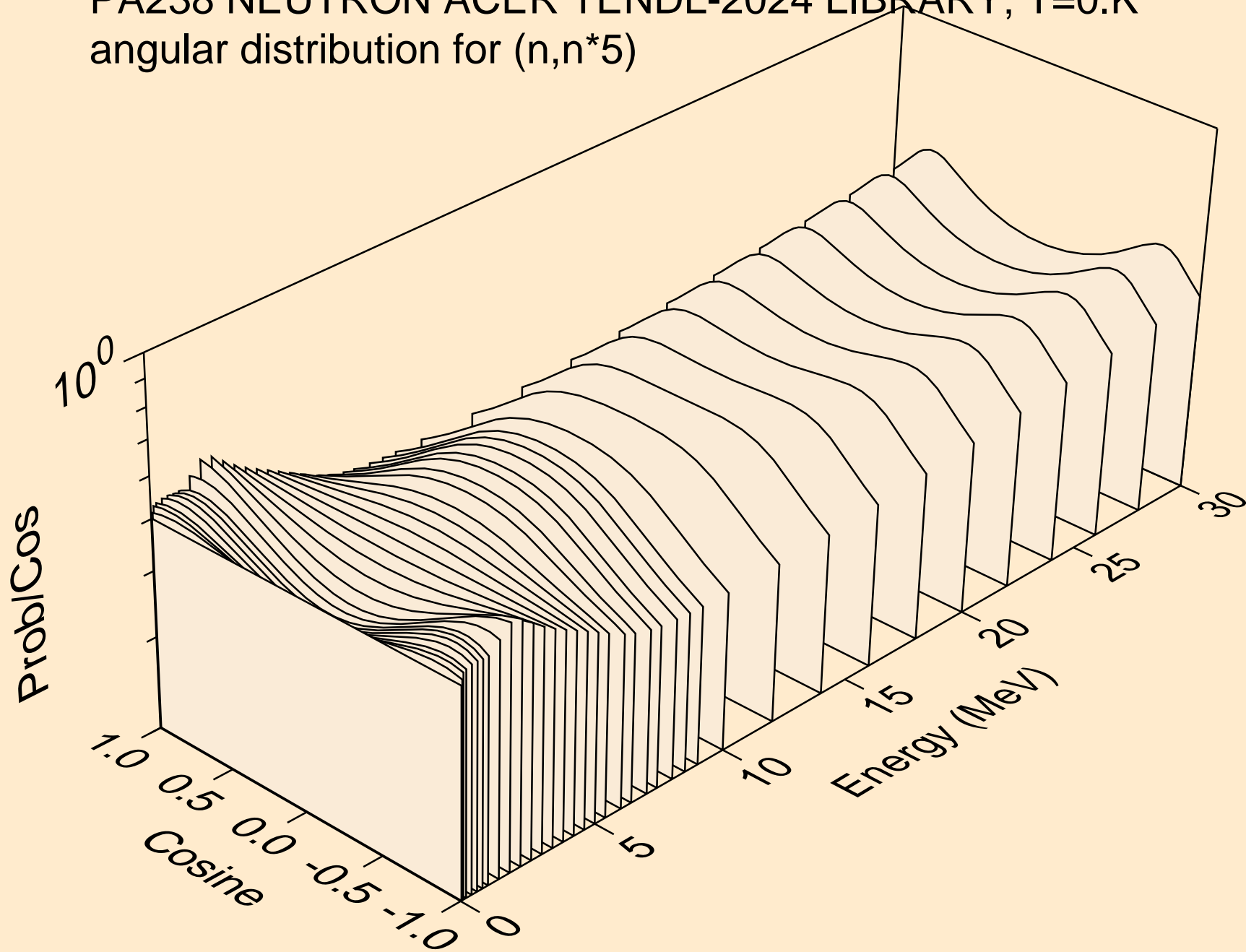

PA238 NEUTRON ACER TENDL-2024 LIBRARY; T=0.K
angular distribution for (n,n*6)

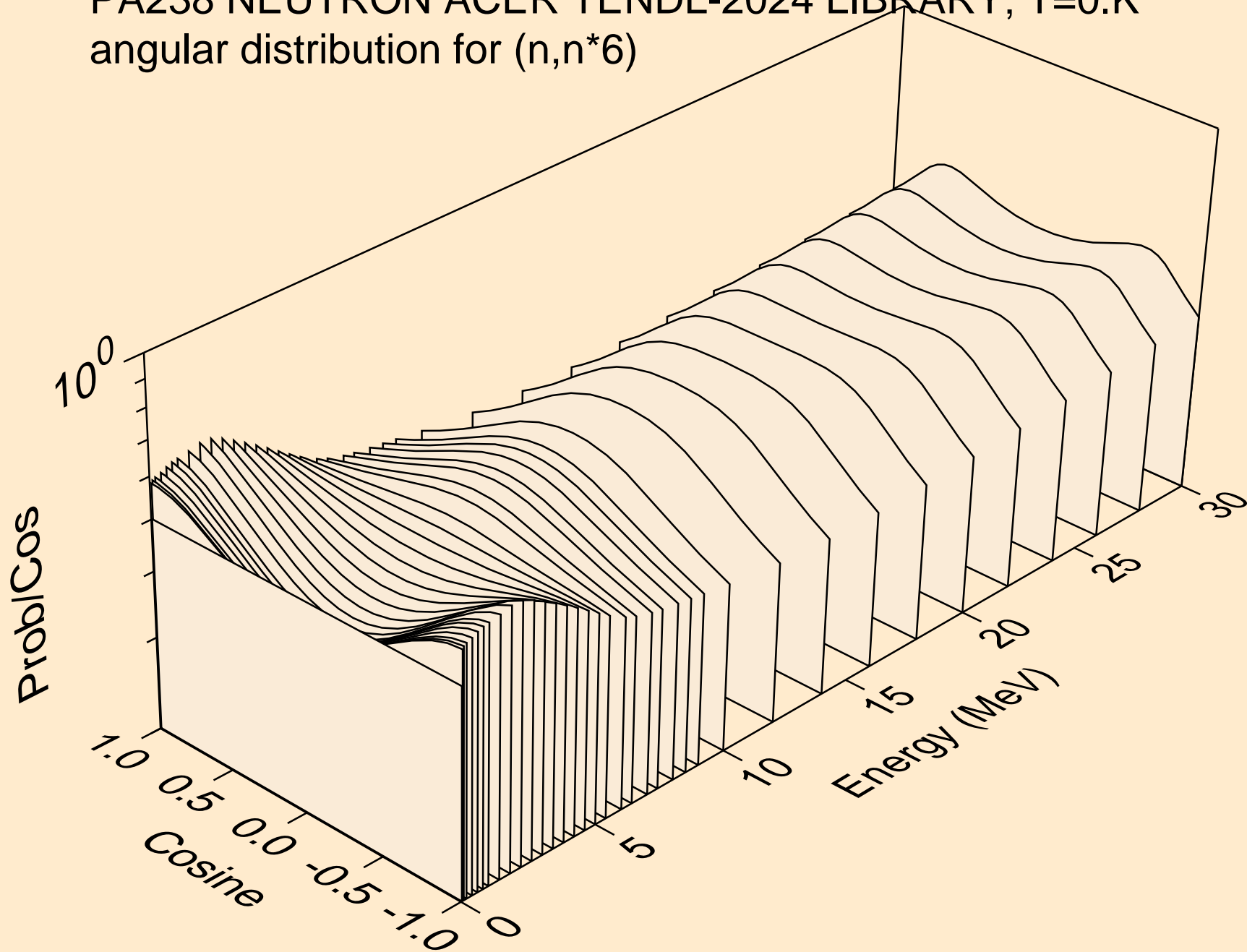

PA238 NEUTRON ACER TENDL-2024 LIBRARY; T=0.K
angular distribution for (n,n*7)

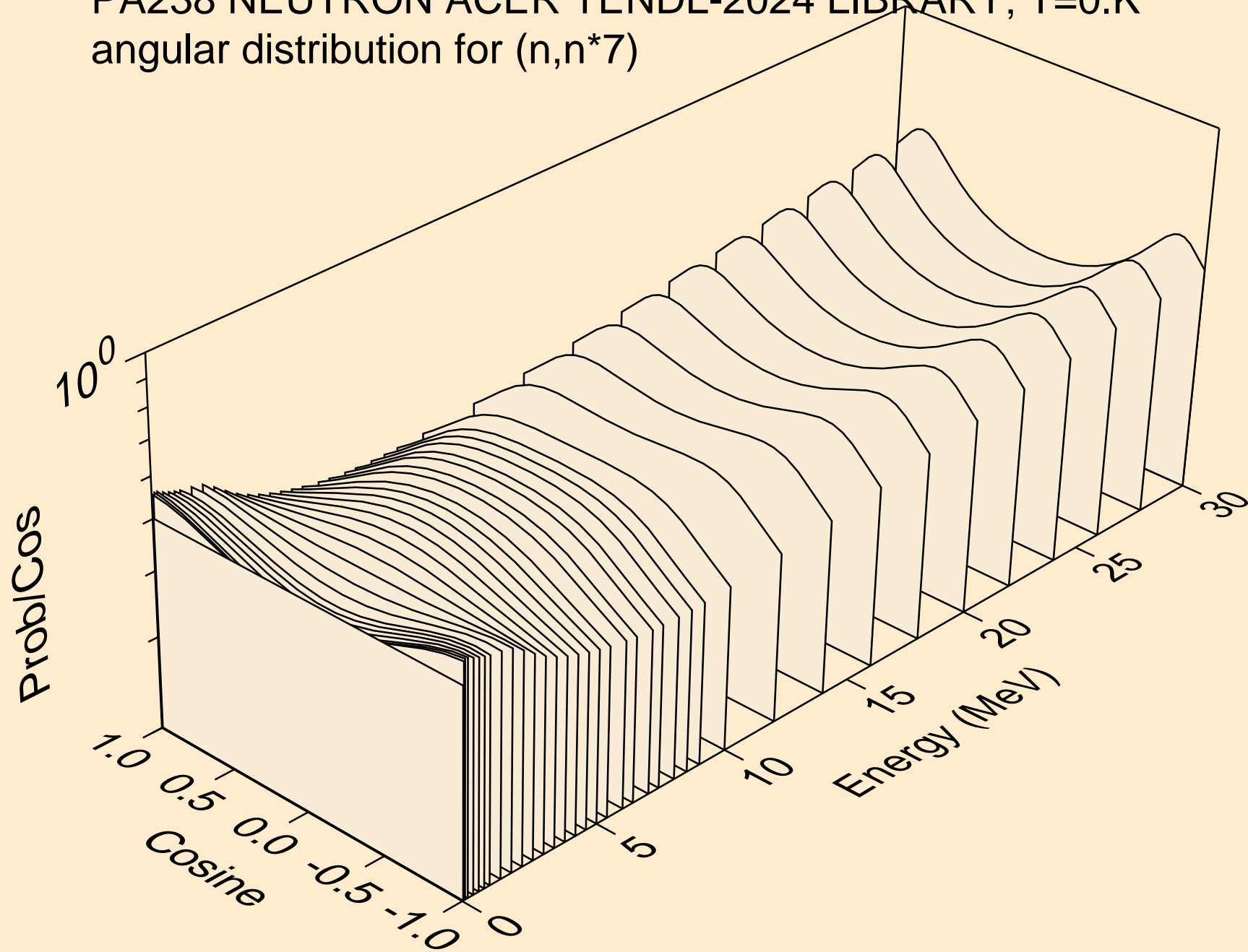

PA238 NEUTRON ACER TENDL-2024 LIBRARY; T=0.K
angular distribution for (n,n*8)

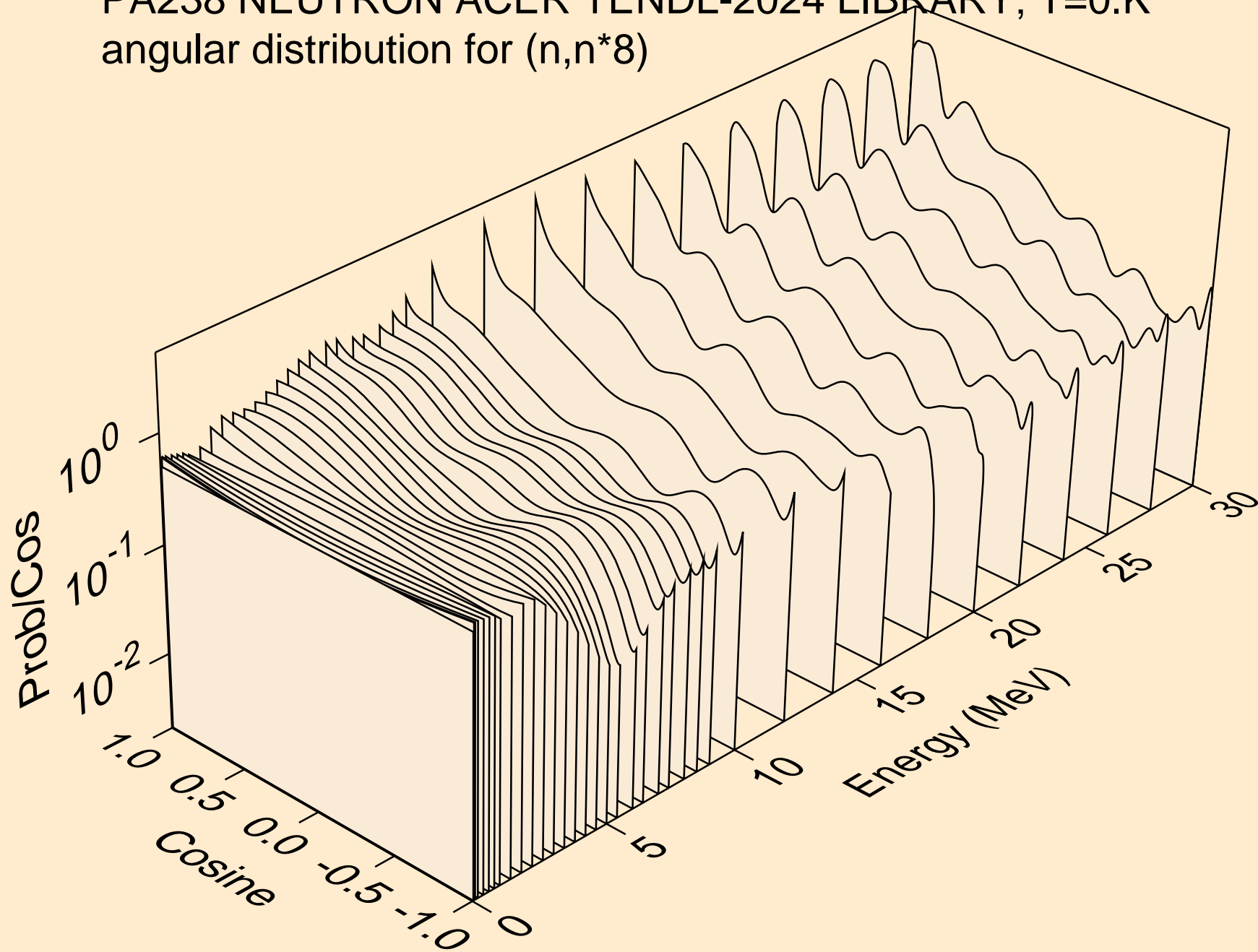

PA238 NEUTRON ACER TENDL-2024 LIBRARY; T=0.K
angular distribution for (n,n*9)

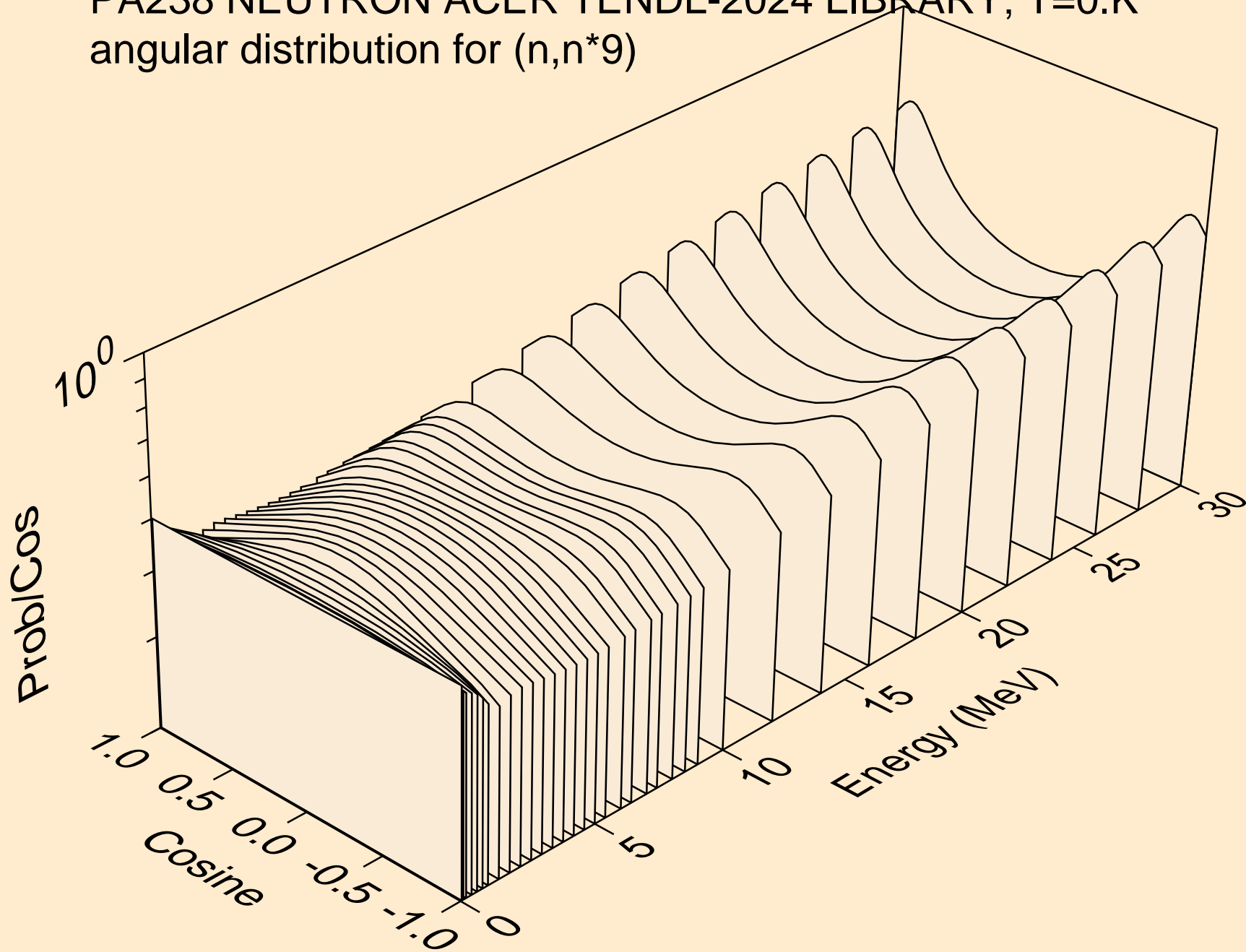

PA238 NEUTRON ACER TENDL-2024 LIBRARY; T=0.K
angular distribution for (n,n*10)

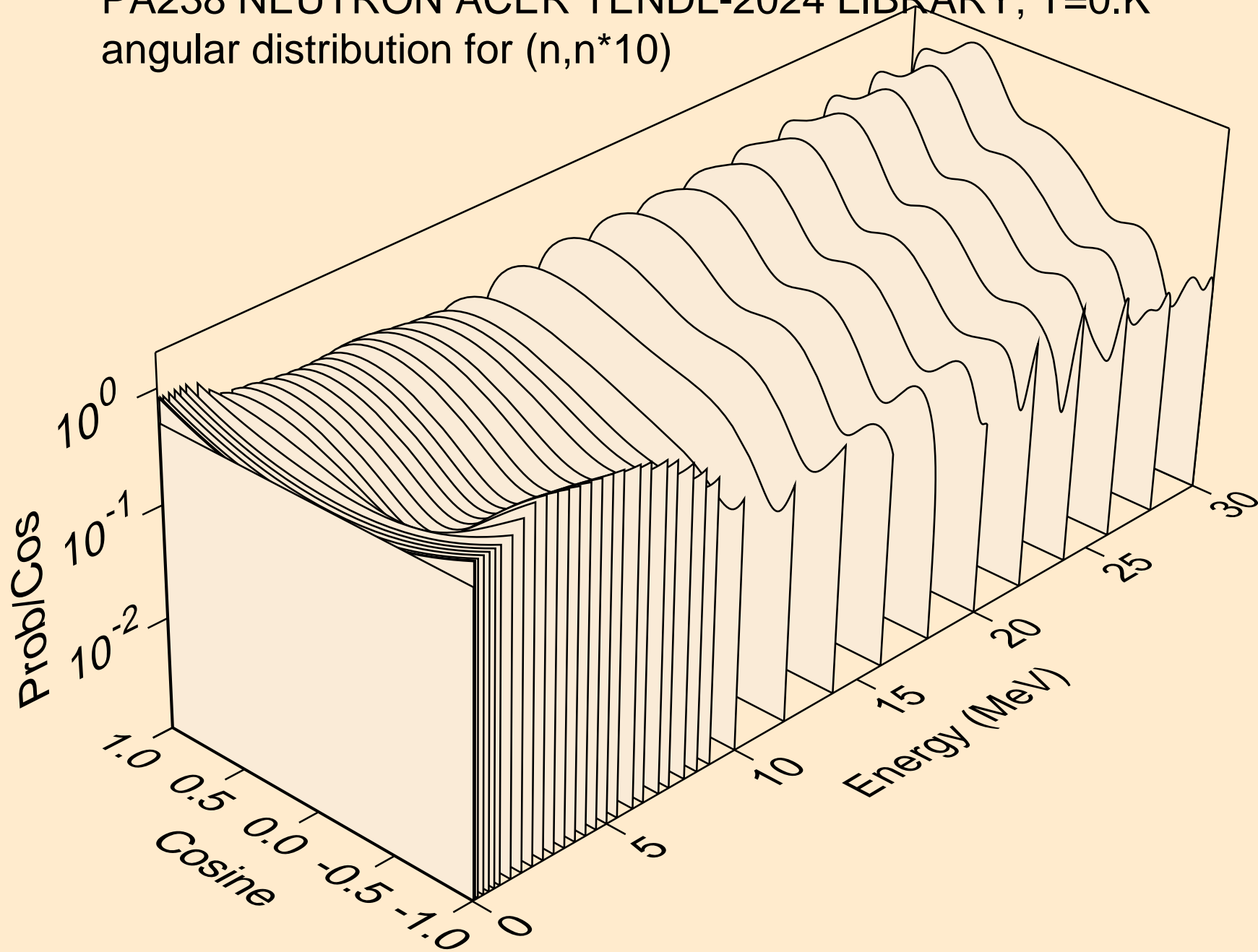

PA238 NEUTRON ACER TENDL-2024 LIBRARY; T=0.K
angular distribution for (n,n*11)

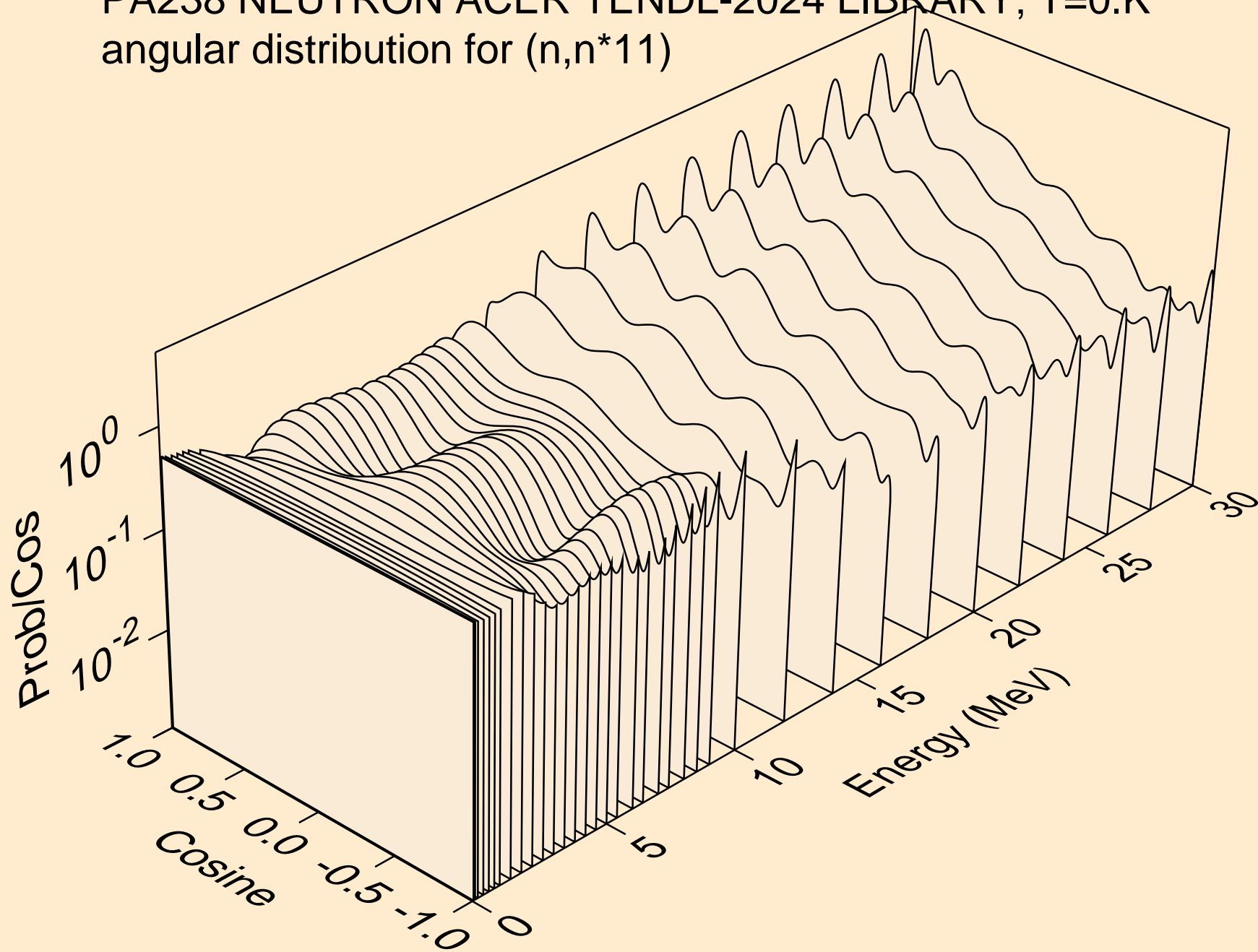

PA238 NEUTRON ACER TENDL-2024 LIBRARY; T=0.K
angular distribution for (n,n*12)

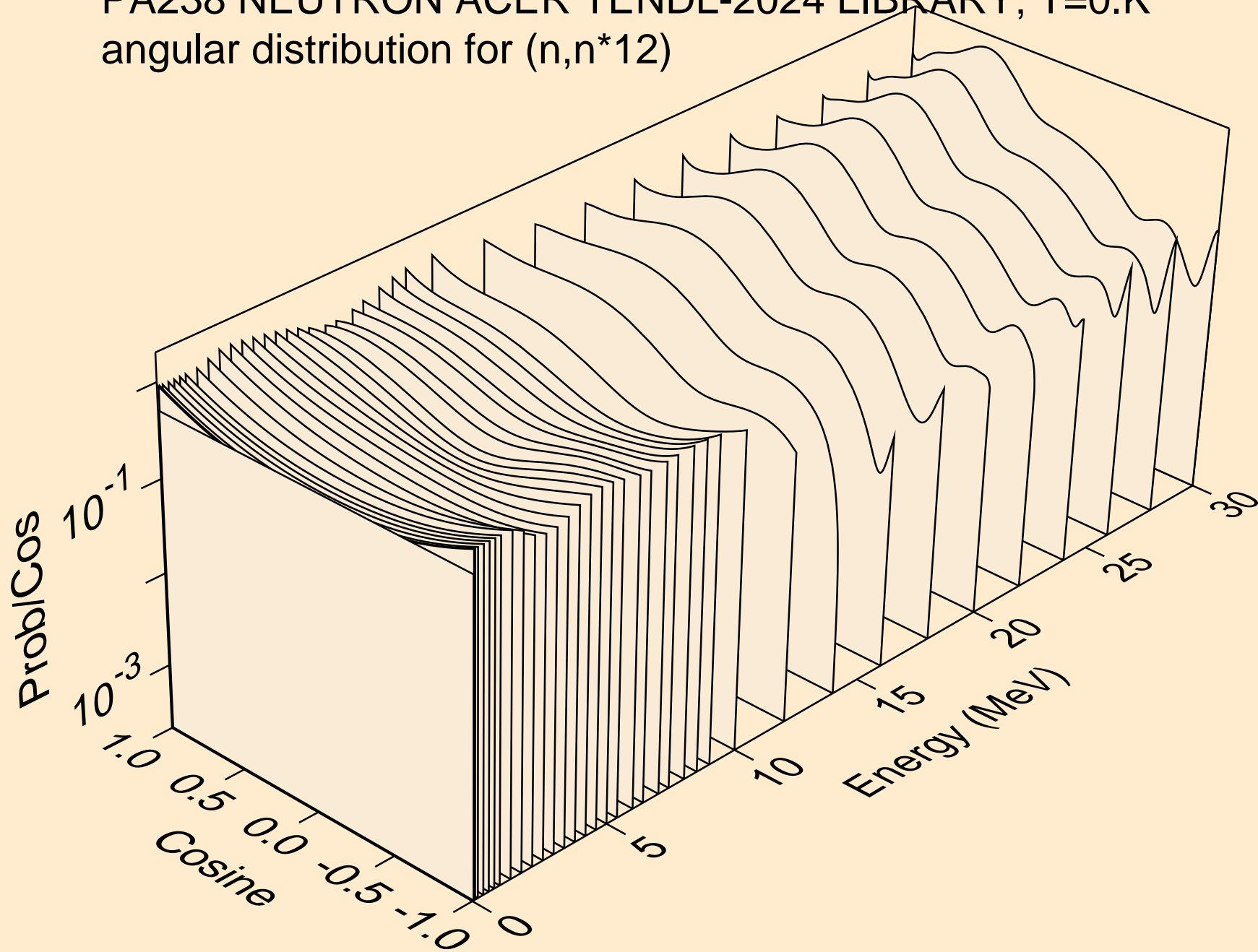

PA238 NEUTRON ACER TENDL-2024 LIBRARY; T=0.K
angular distribution for (n,n*13)

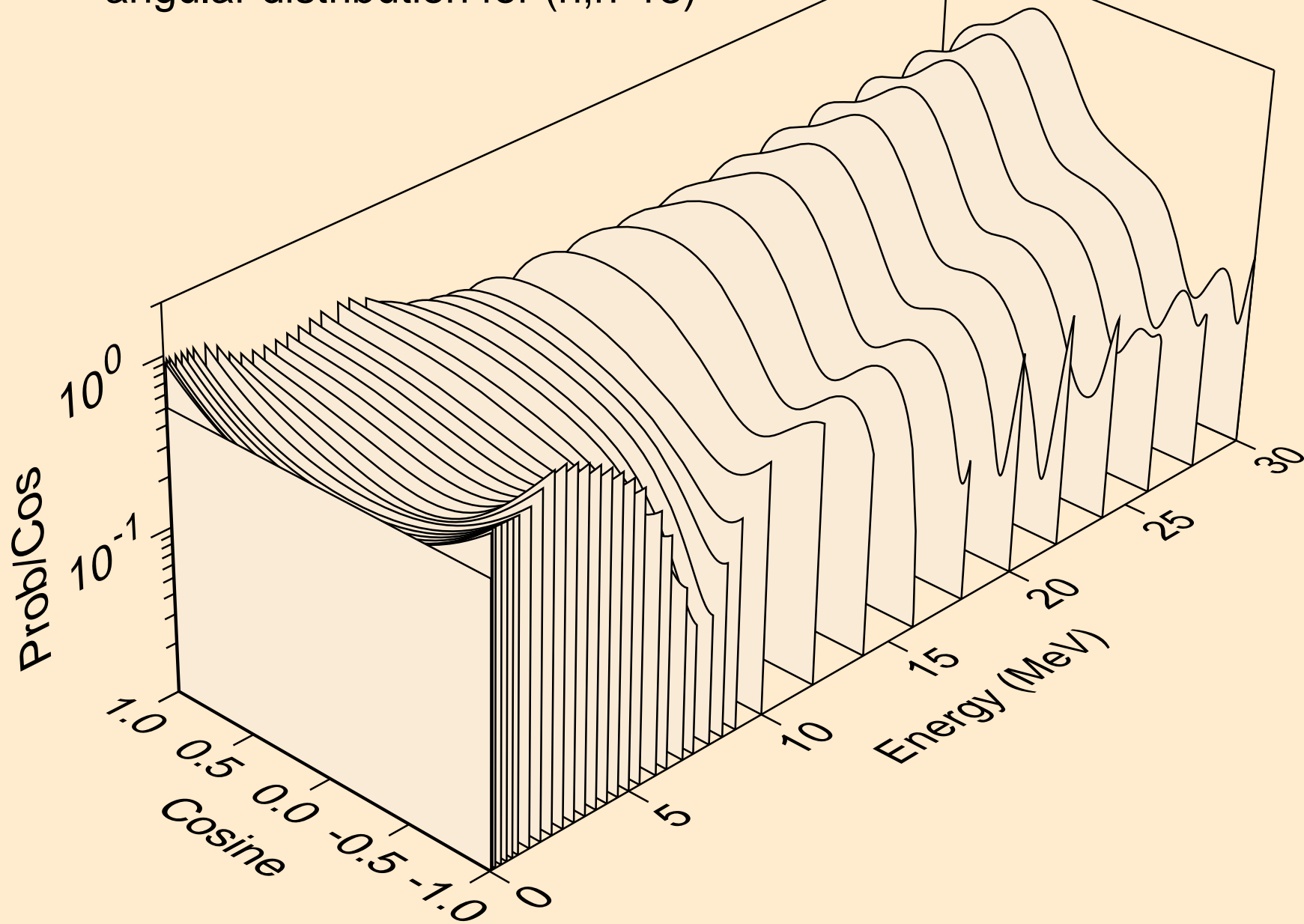

PA238 NEUTRON ACER TENDL-2024 LIBRARY; T=0.K
angular distribution for (n,n*14)

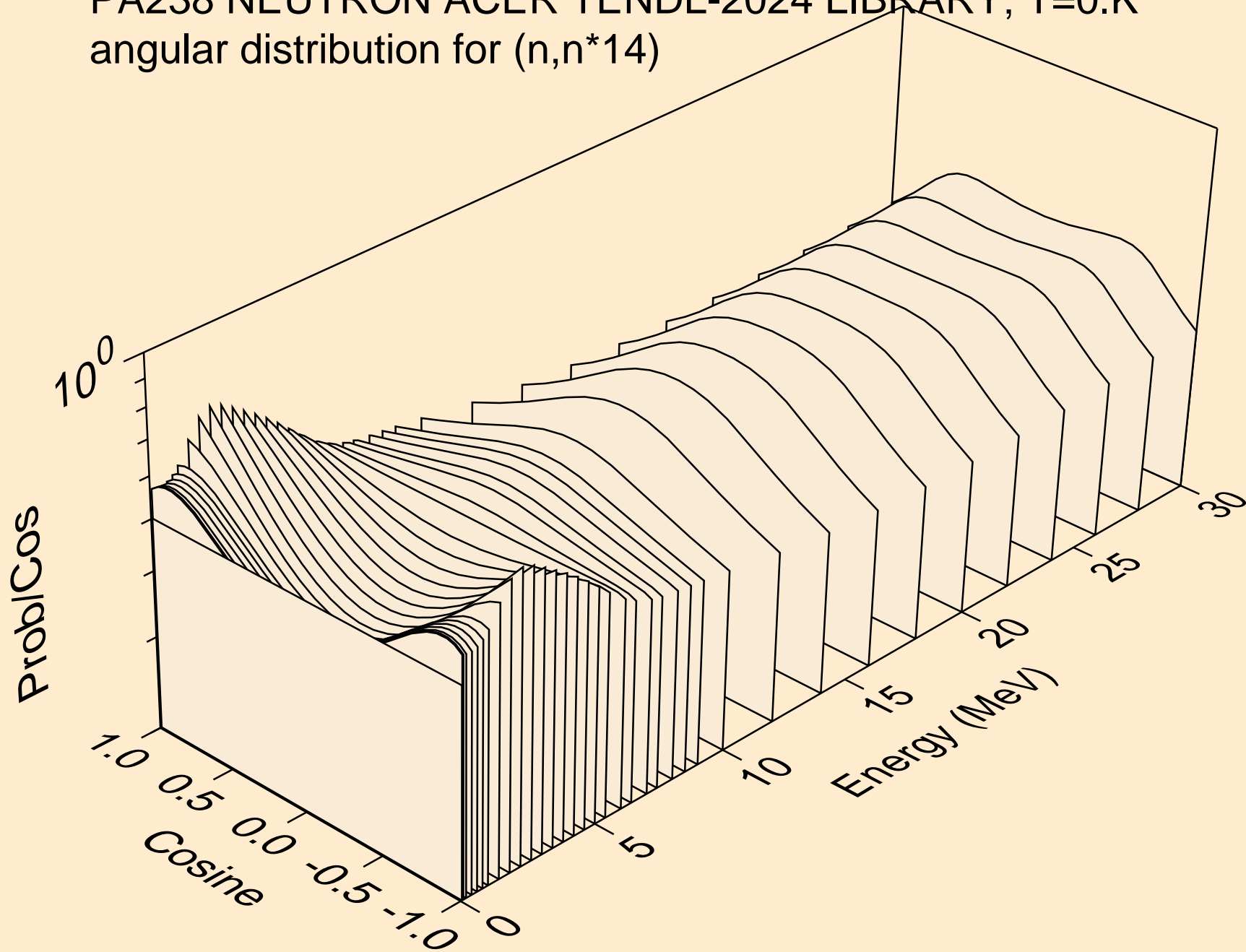

PA238 NEUTRON ACER TENDL-2024 LIBRARY; T=0.K
angular distribution for (n,n*15)

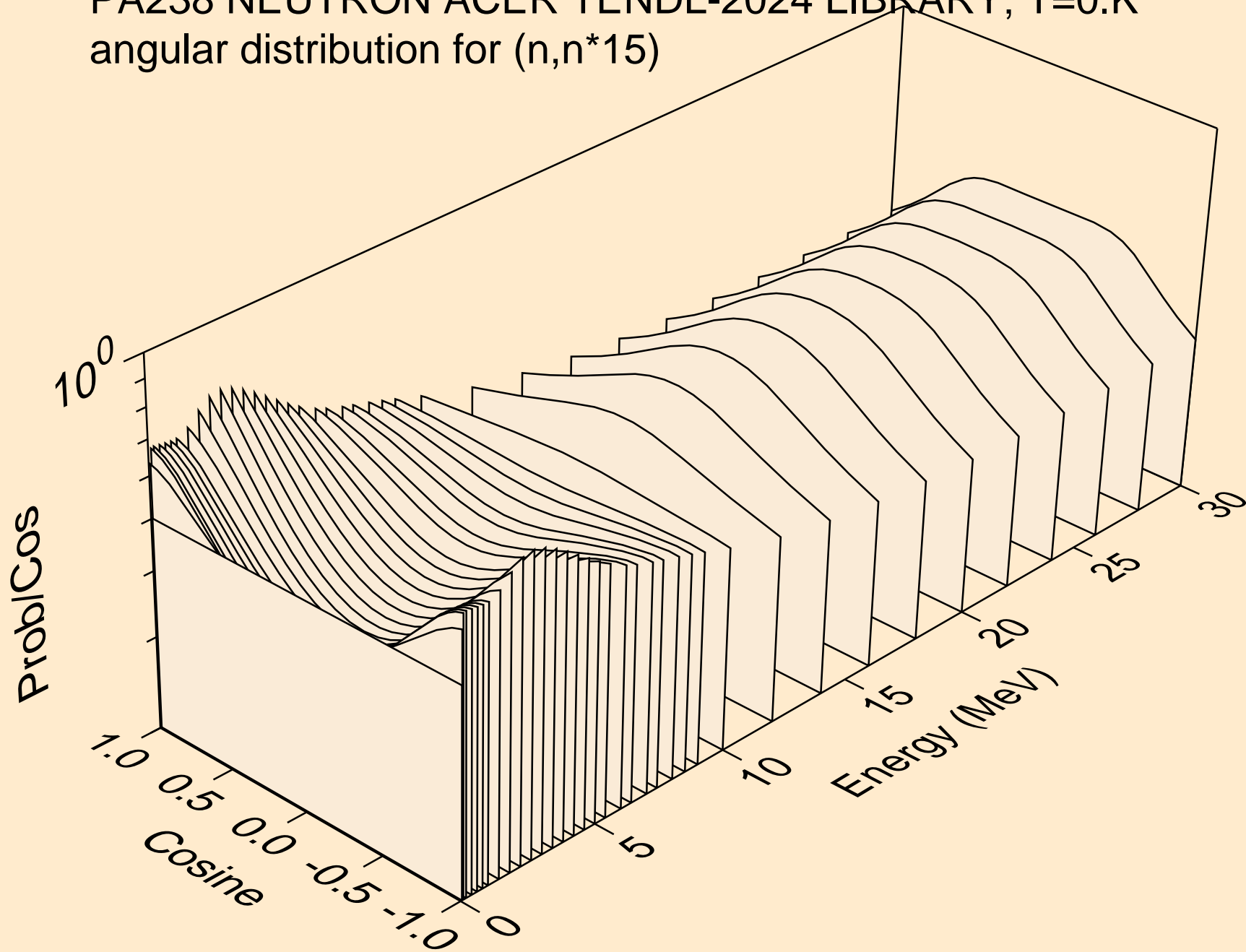

PA238 NEUTRON ACER TENDL-2024 LIBRARY; T=0.K
angular distribution for (n,n*16)

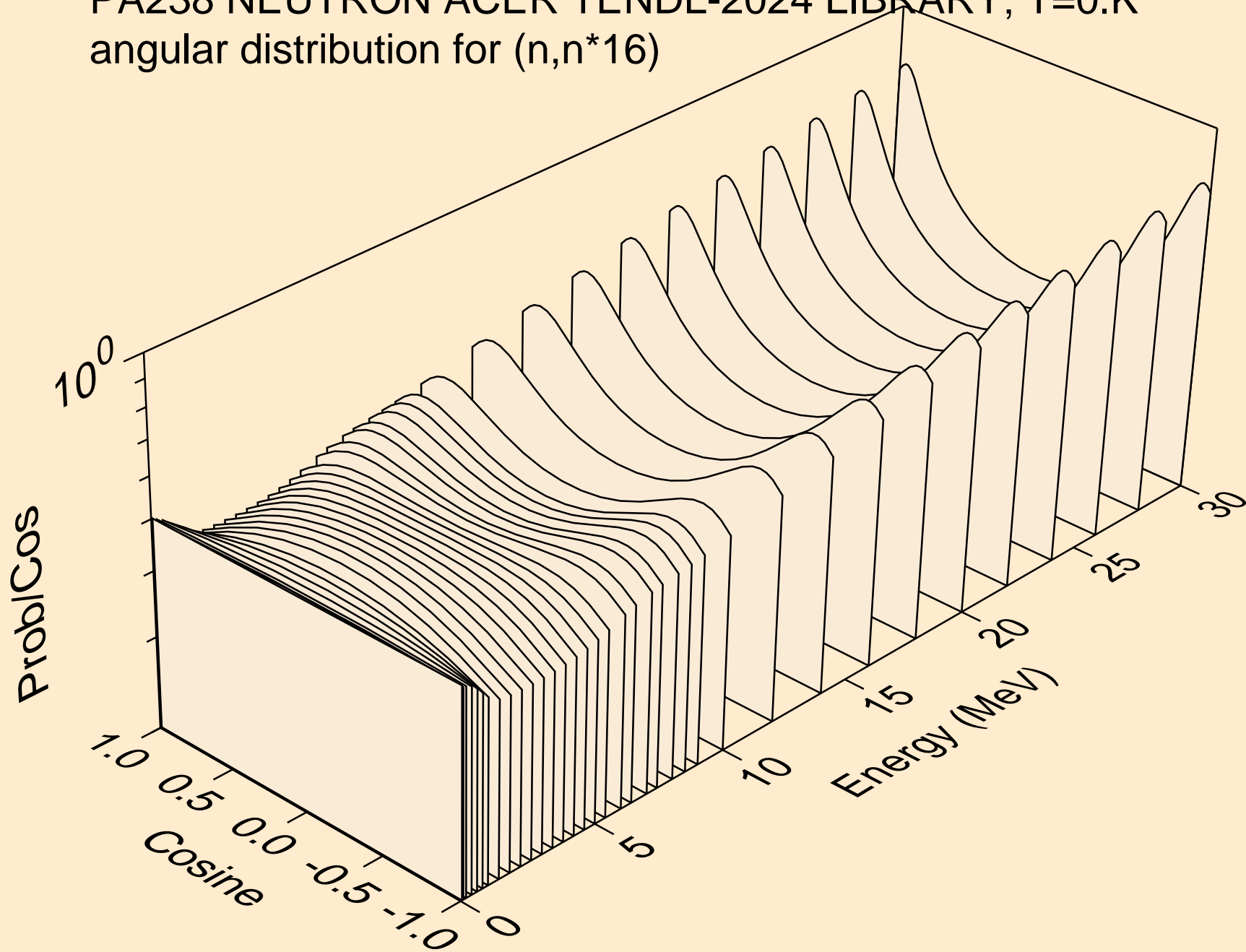

PA238 NEUTRON ACER TENDL-2024 LIBRARY; T=0.K
angular distribution for (n,n*17)

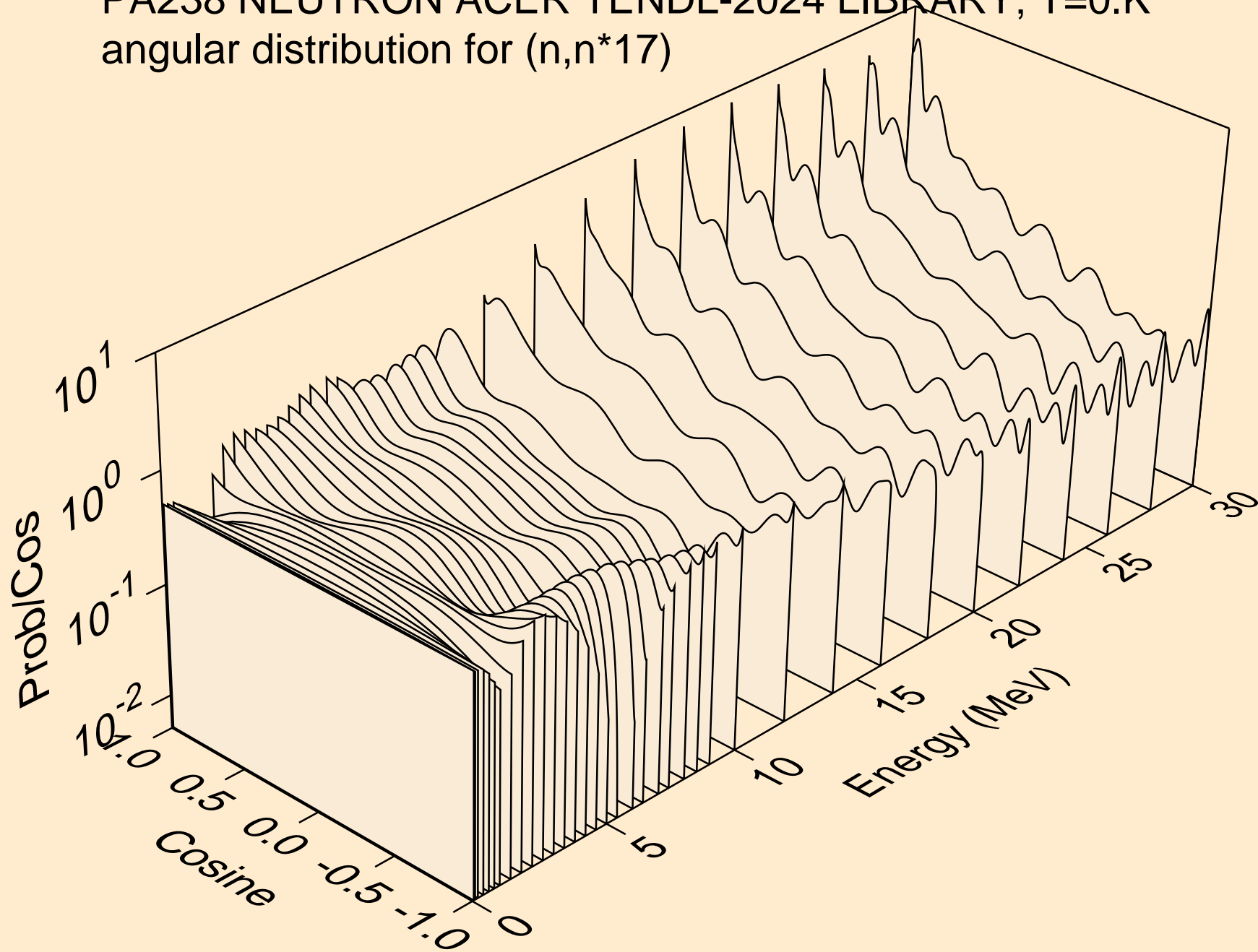

PA238 NEUTRON ACER TENDL-2024 LIBRARY; T=0.K
angular distribution for (n,n*18)

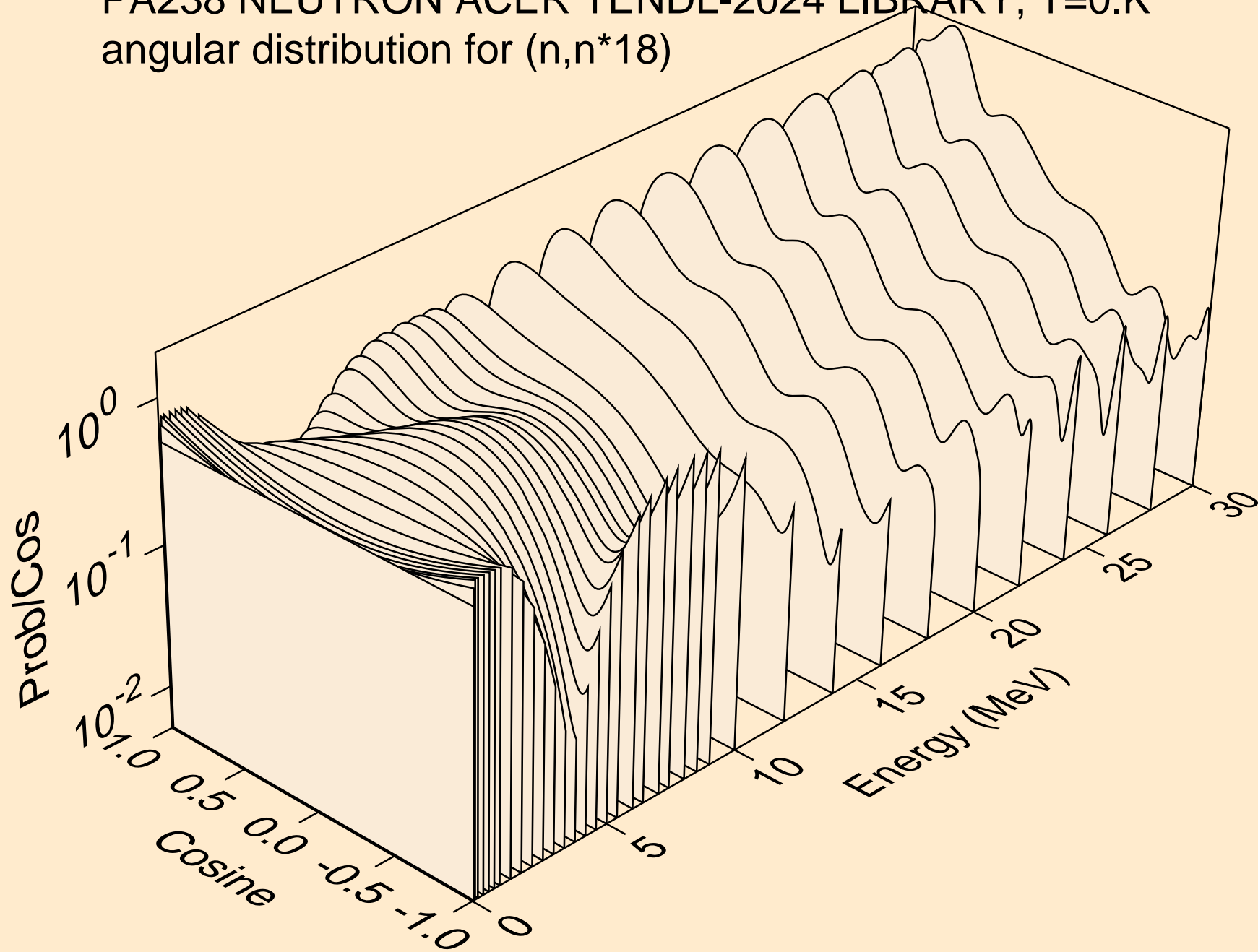

PA238 NEUTRON ACER TENDL-2024 LIBRARY; T=0.K
angular distribution for (n,n*19)

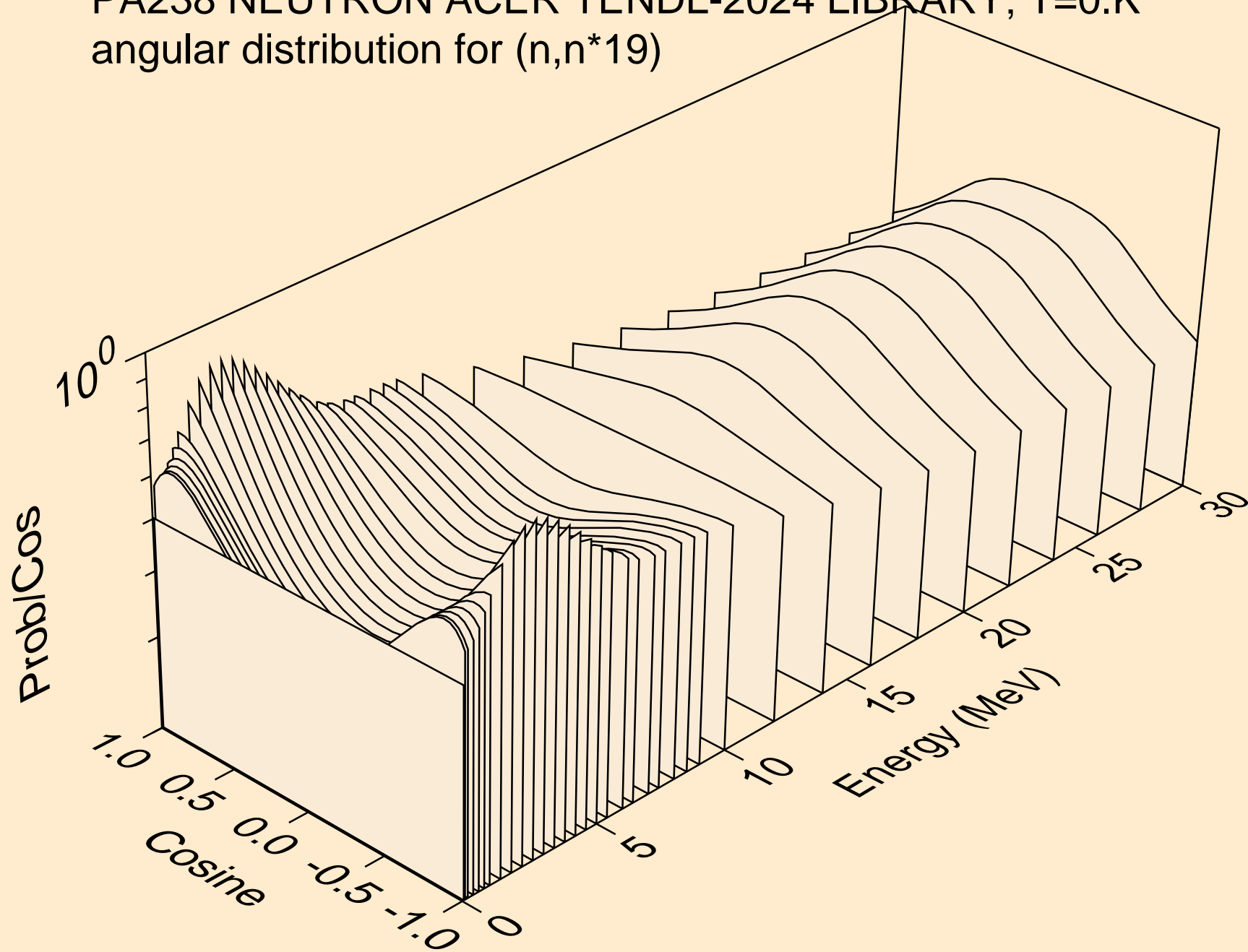

PA238 NEUTRON ACER TENDL-2024 LIBRARY; T=0.K
angular distribution for (n,n*20)

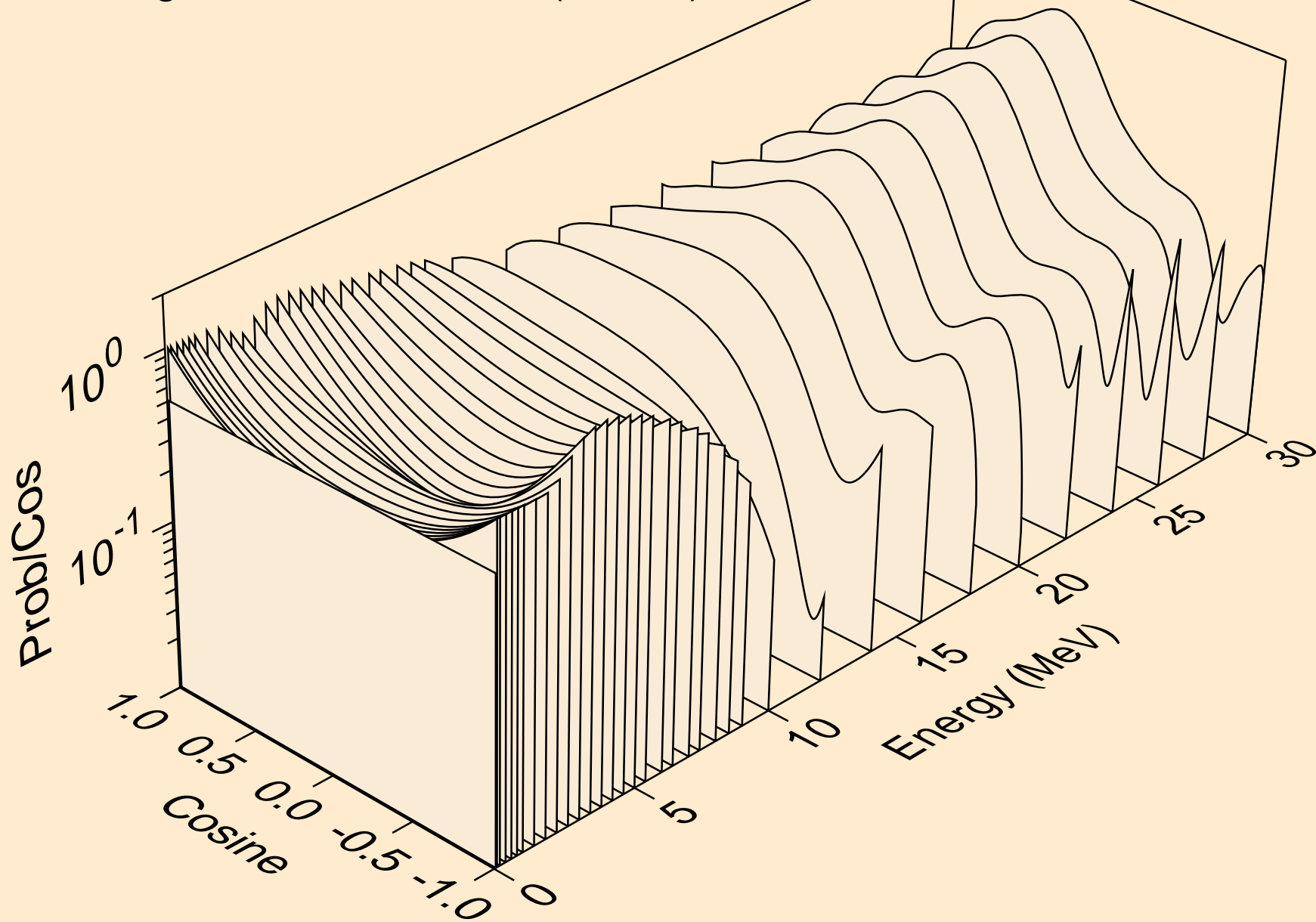

PA238 NEUTRON ACER TENDL-2024 LIBRARY; T=0.K
angular distribution for (n,n*21)

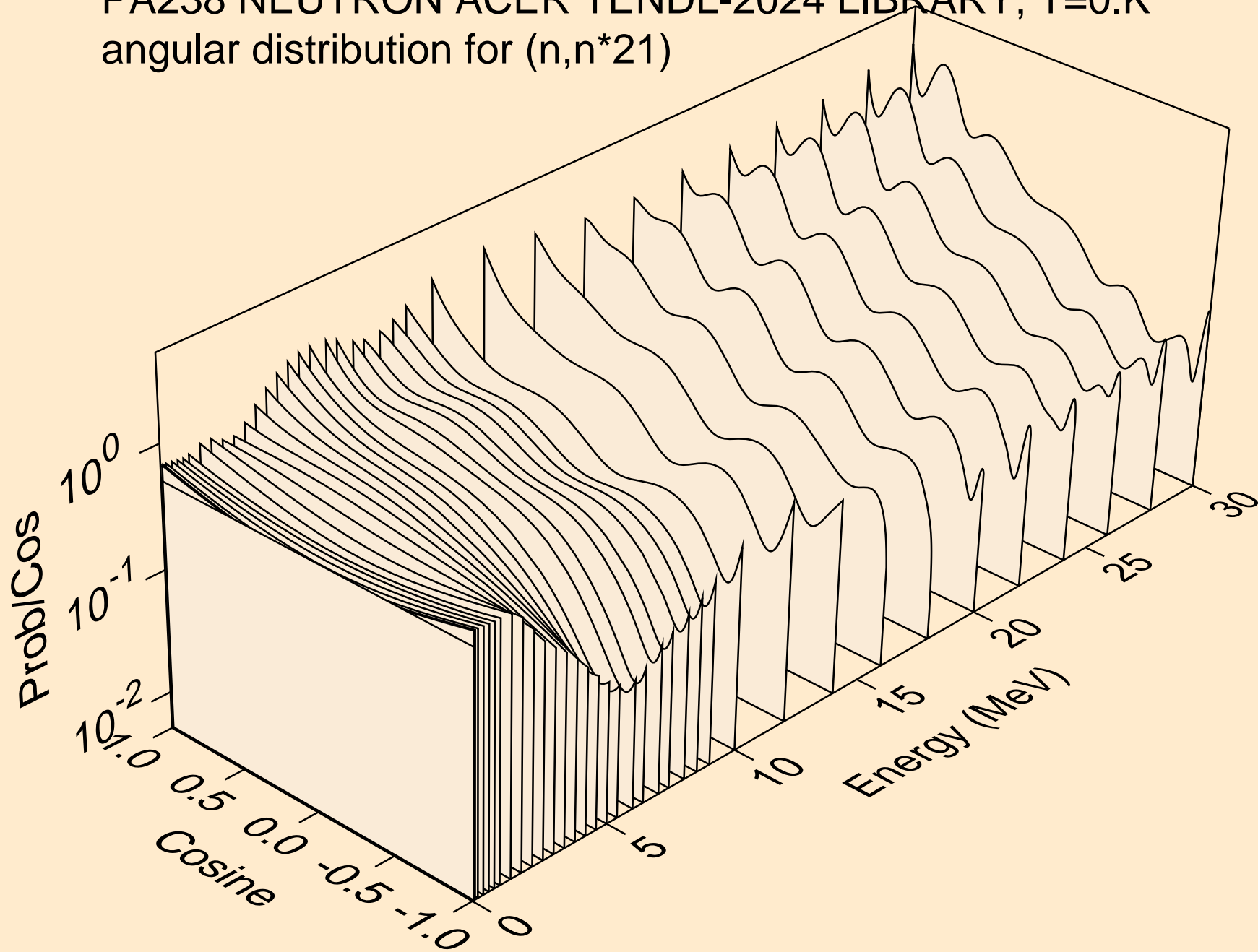

PA238 NEUTRON ACER TENDL-2024 LIBRARY; T=0.K
angular distribution for (n,n*22)

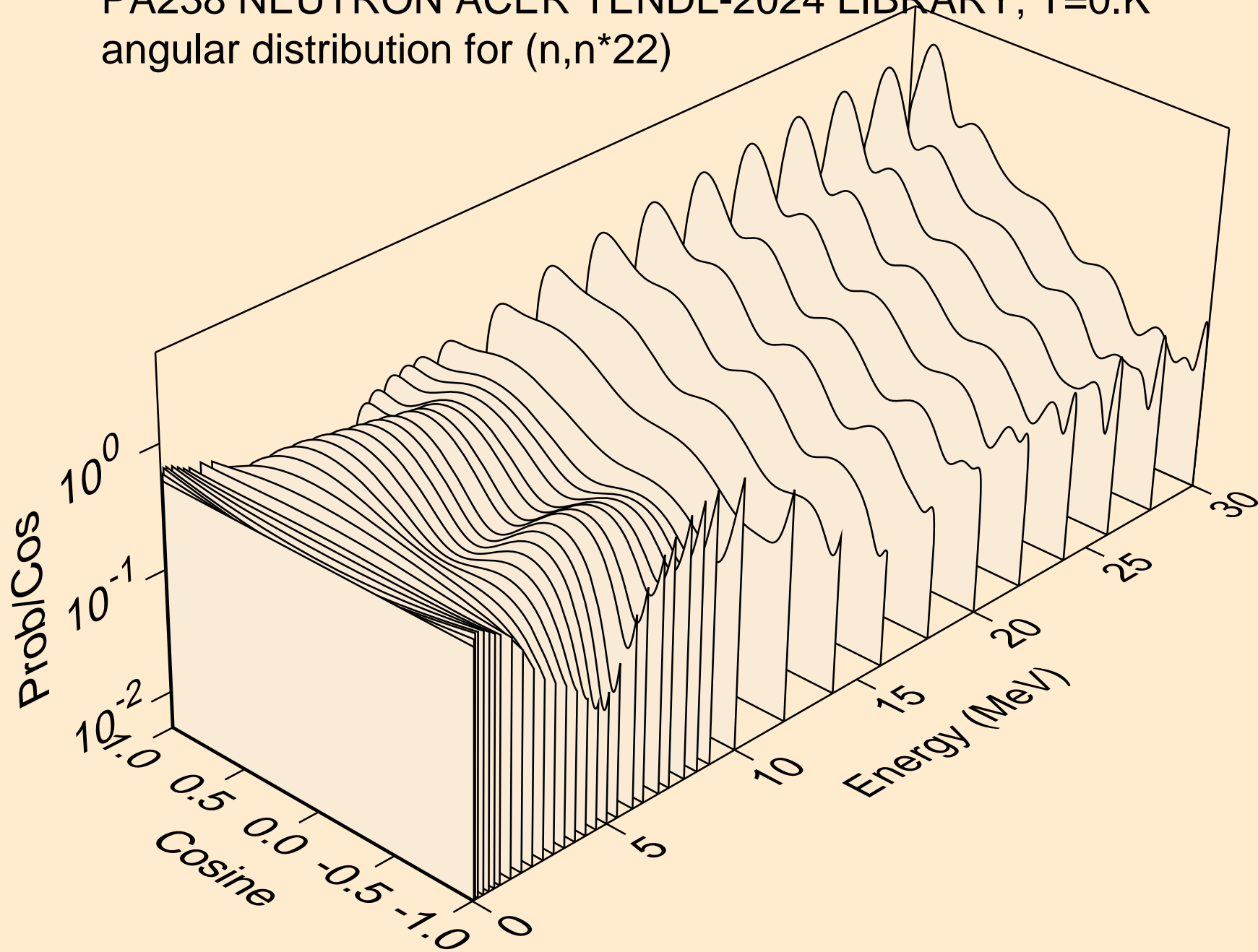

PA238 NEUTRON ACER TENDL-2024 LIBRARY; T=0.K
angular distribution for (n,n*23)

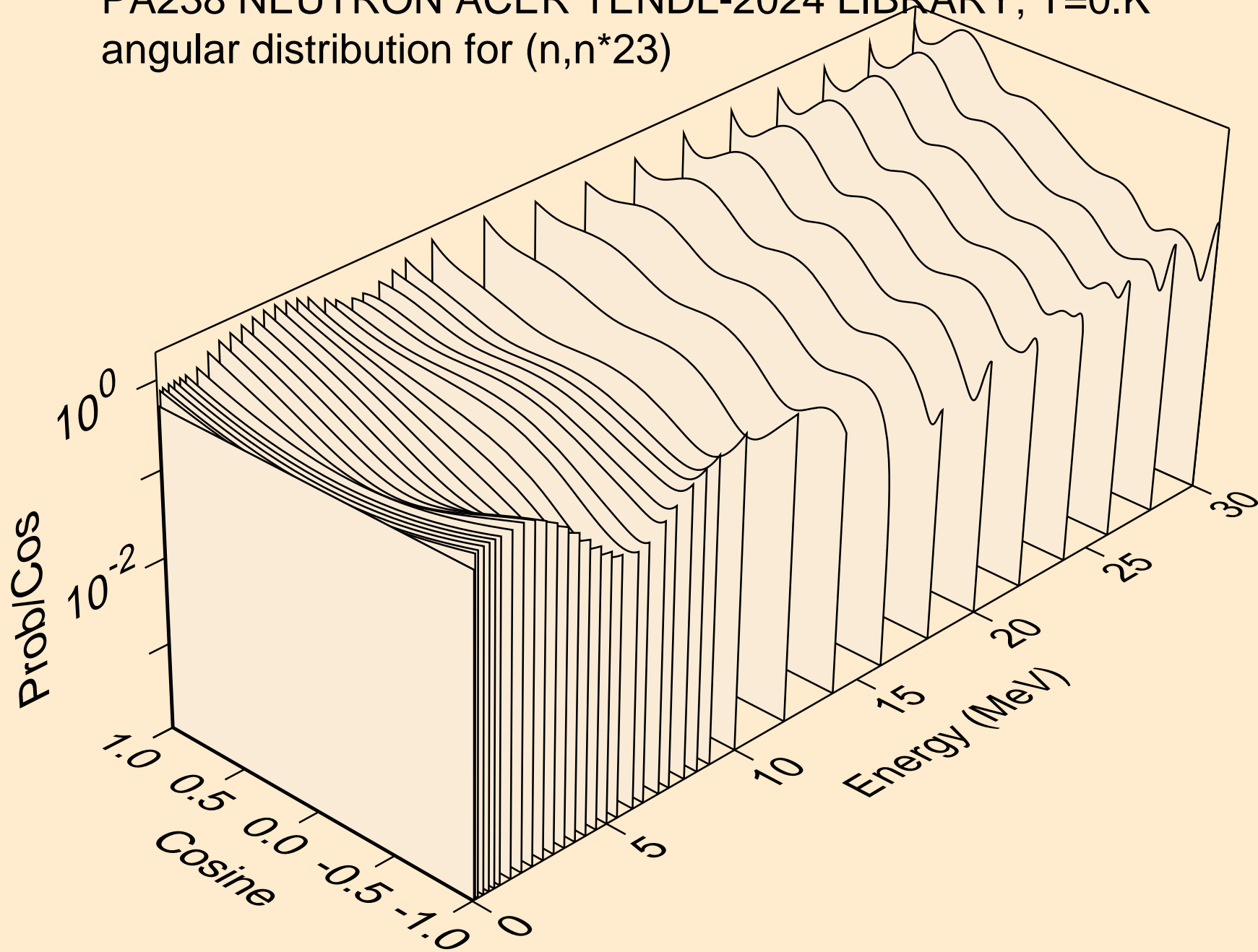

PA238 NEUTRON ACER TENDL-2024 LIBRARY; T=0.K
angular distribution for (n,n*24)

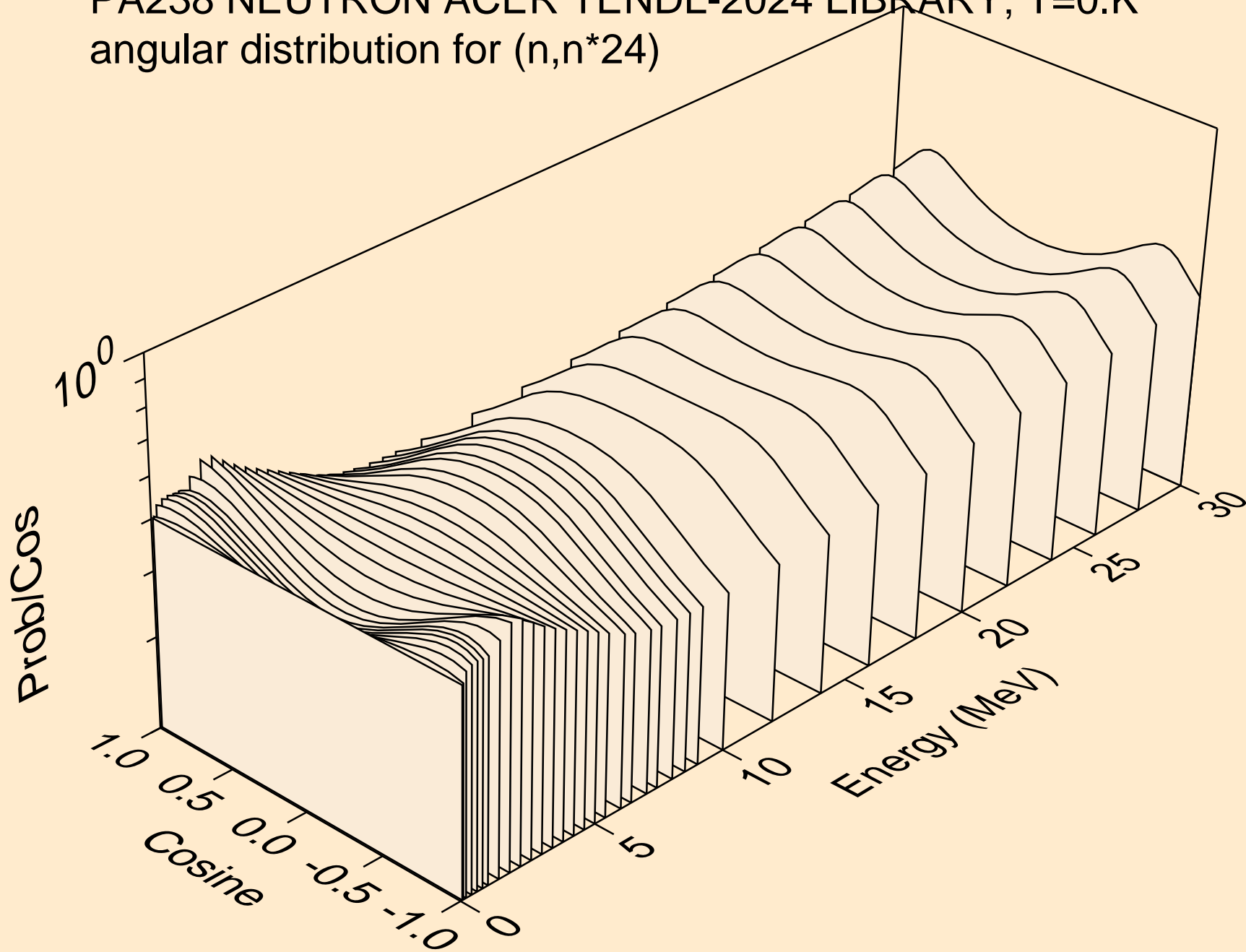

PA238 NEUTRON ACER TENDL-2024 LIBRARY; T=0.K
angular distribution for (n,n*25)

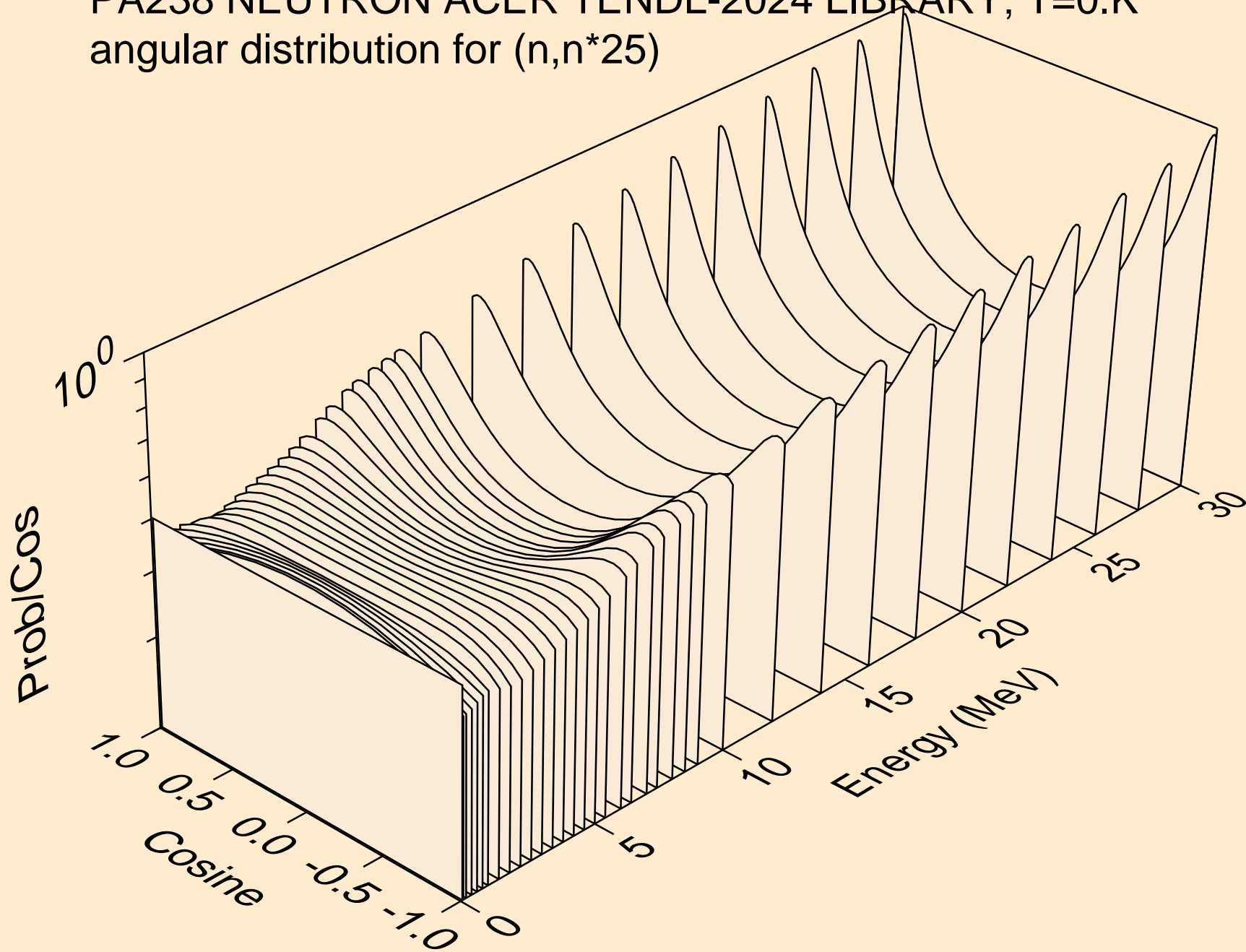

PA238 NEUTRON ACER TENDL-2024 LIBRARY; T=0.K
angular distribution for (n,n*26)

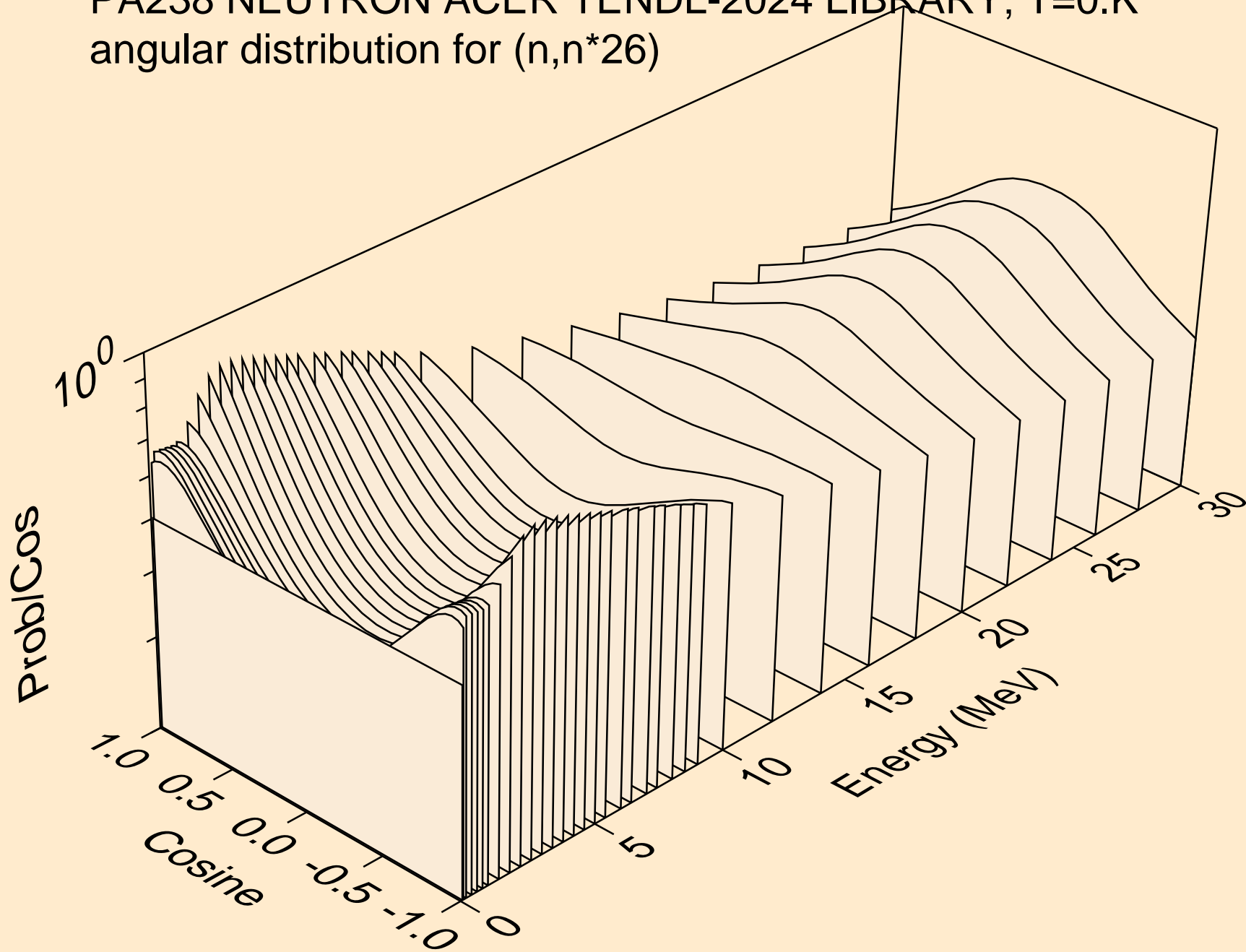

PA238 NEUTRON ACER TENDL-2024 LIBRARY; T=0.K
angular distribution for (n,n*27)

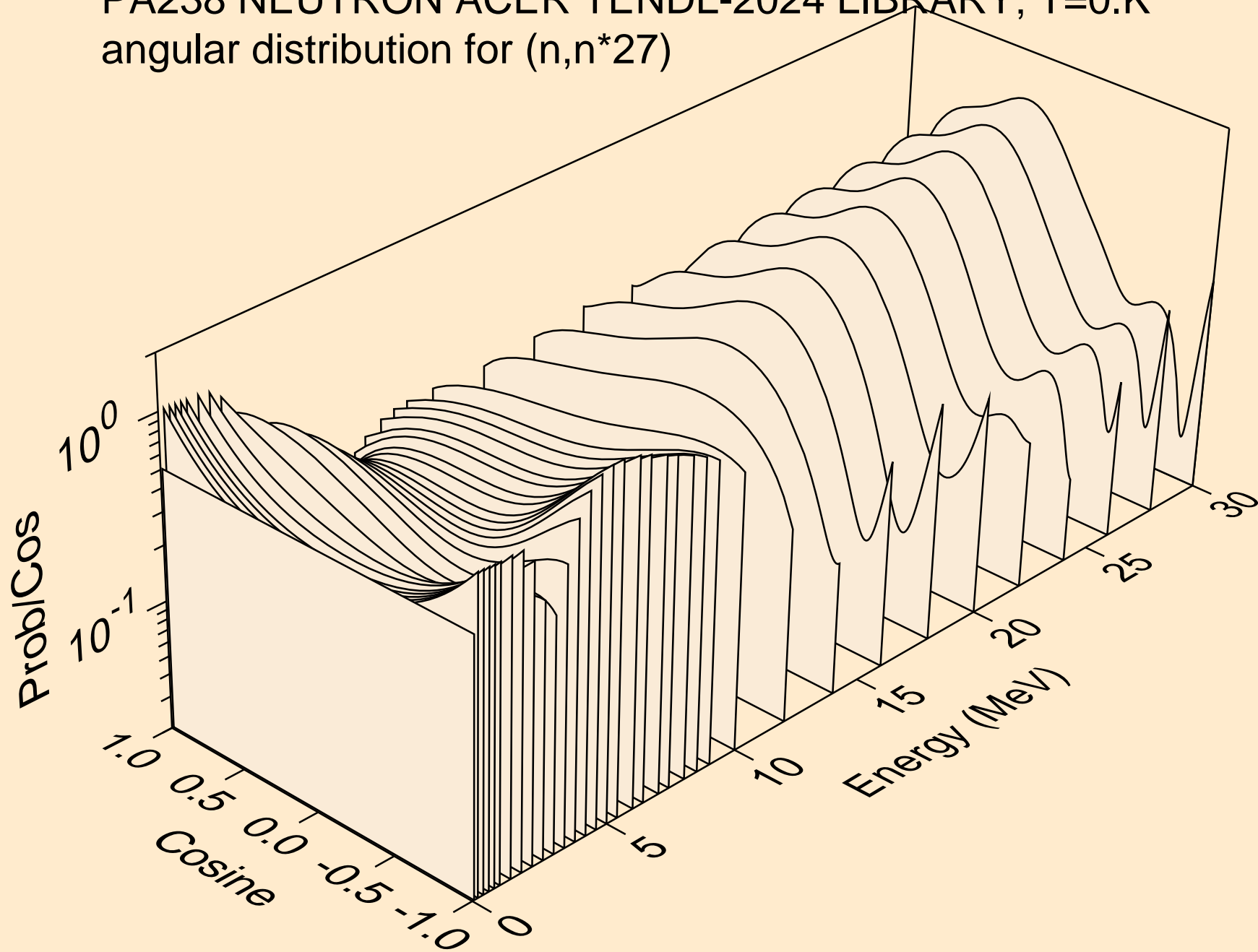

PA238 NEUTRON ACER TENDL-2024 LIBRARY; T=0.K
angular distribution for (n,n*28)

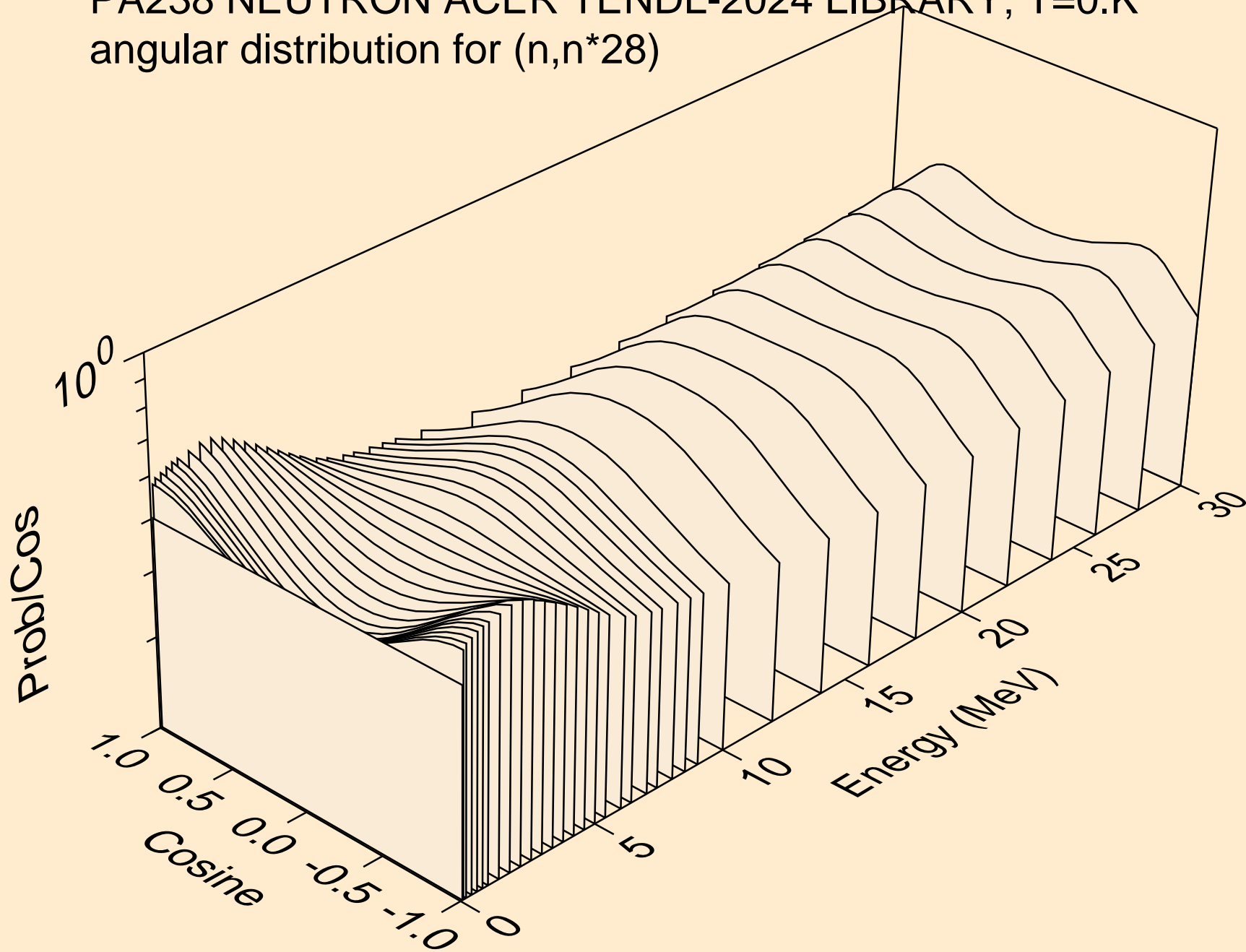

PA238 NEUTRON ACER TENDL-2024 LIBRARY; T=0.K
angular distribution for (n,n*29)

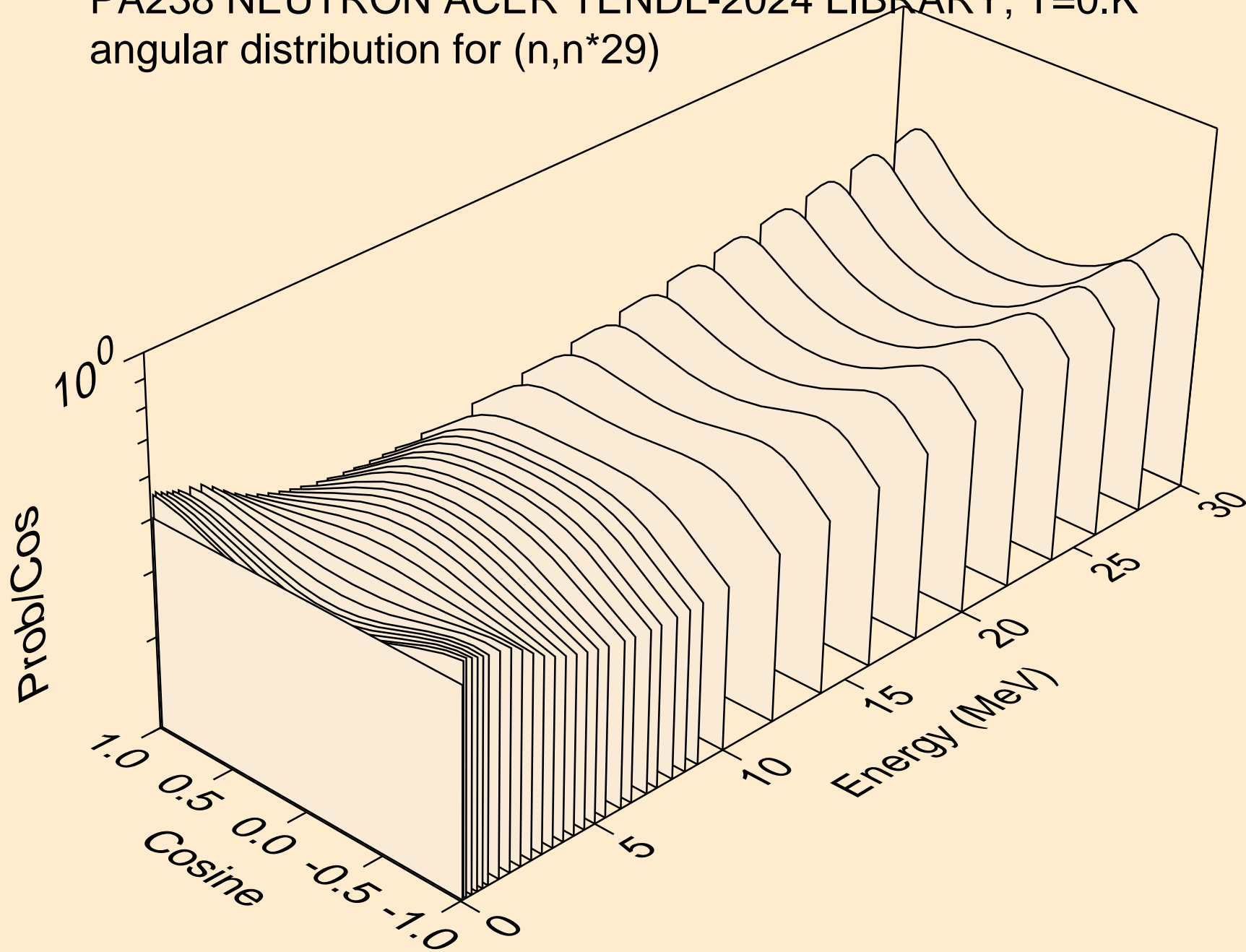

PA238 NEUTRON ACER TENDL-2024 LIBRARY; T=0.K
angular distribution for (n,n*30)

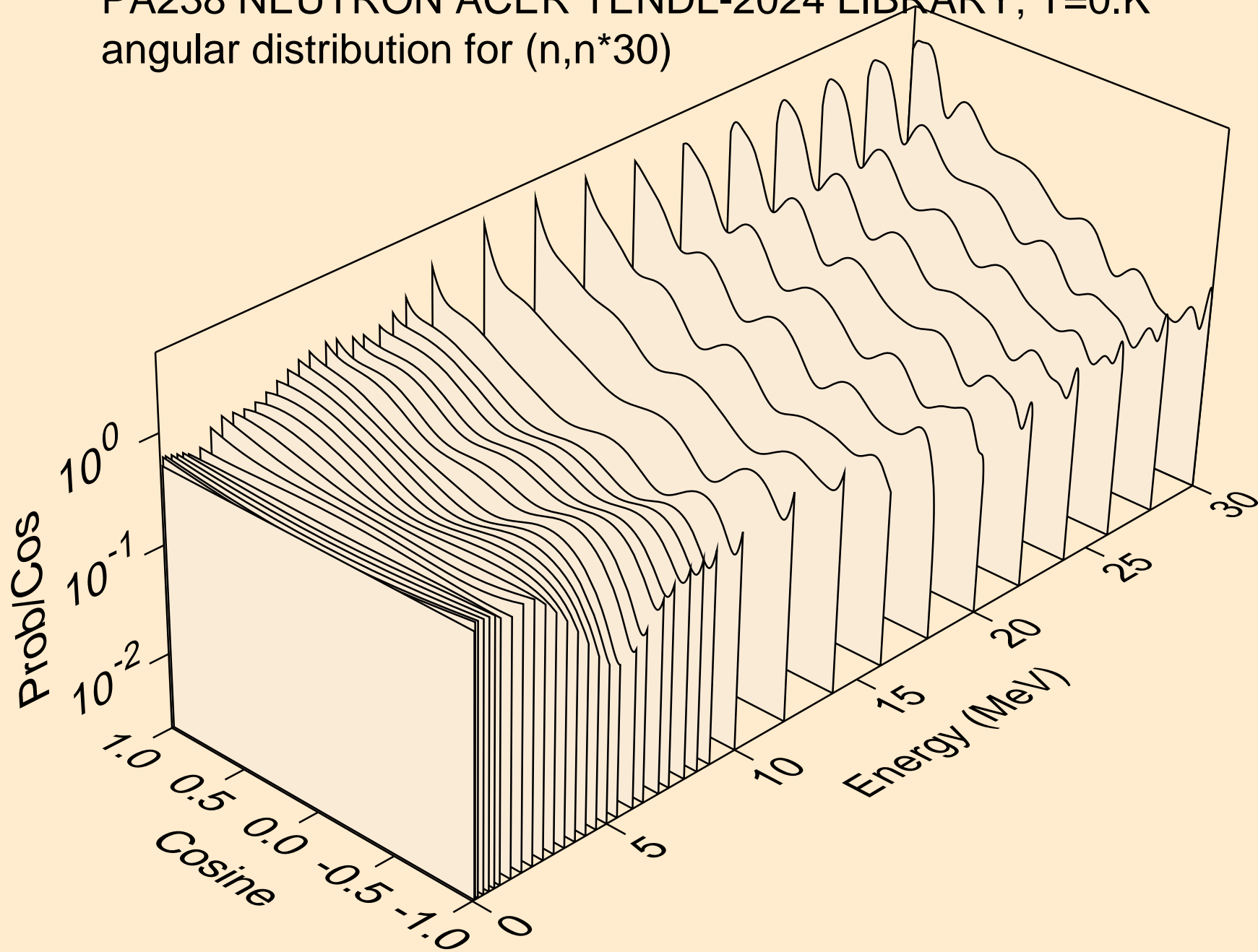

PA238 NEUTRON ACER TENDL-2024 LIBRARY; T=0.K

Total fission nubar

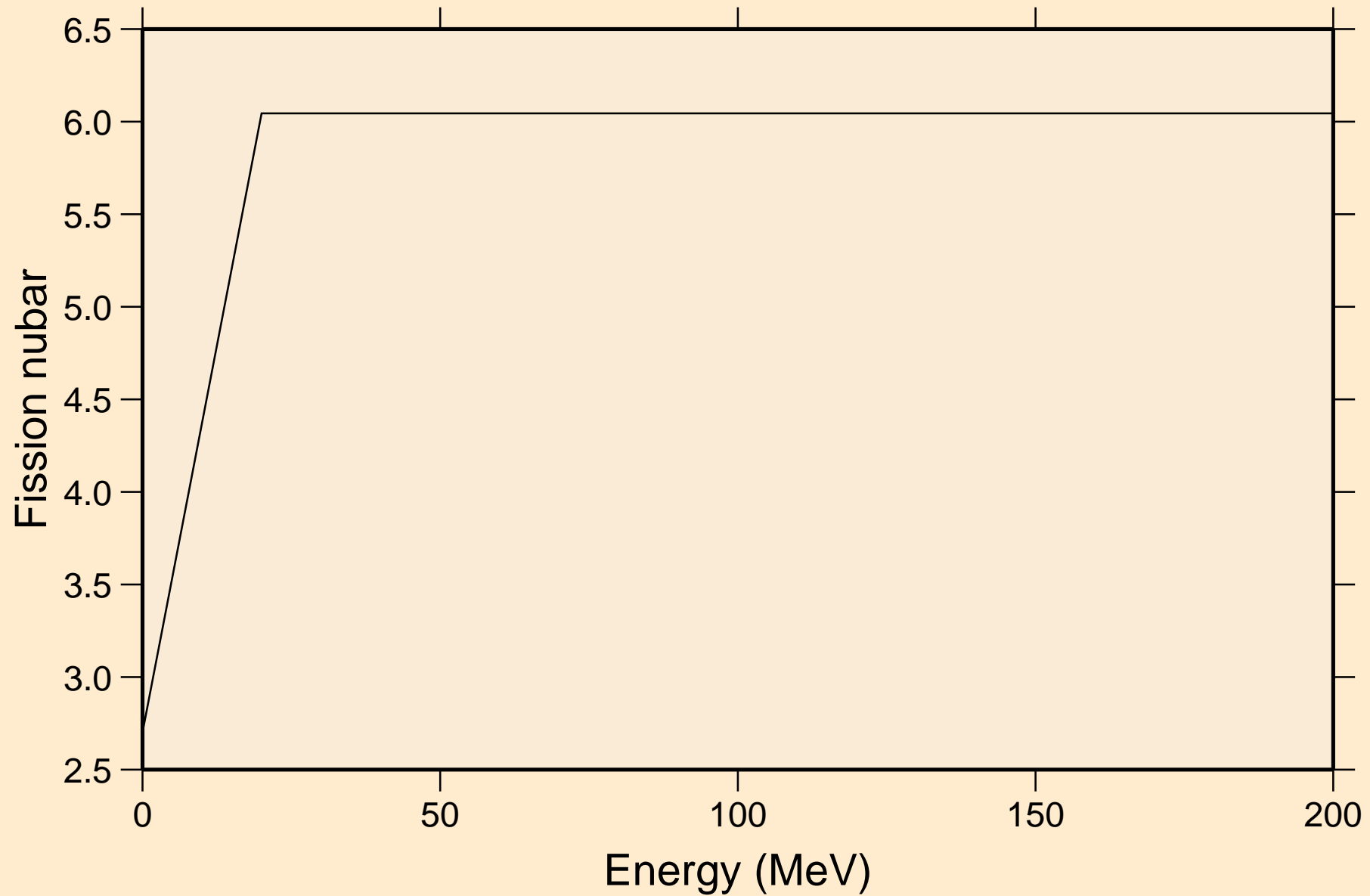

PA238 NEUTRON ACER TENDL-2024 LIBRARY; T=0.K
Neutron emission for (n,x)

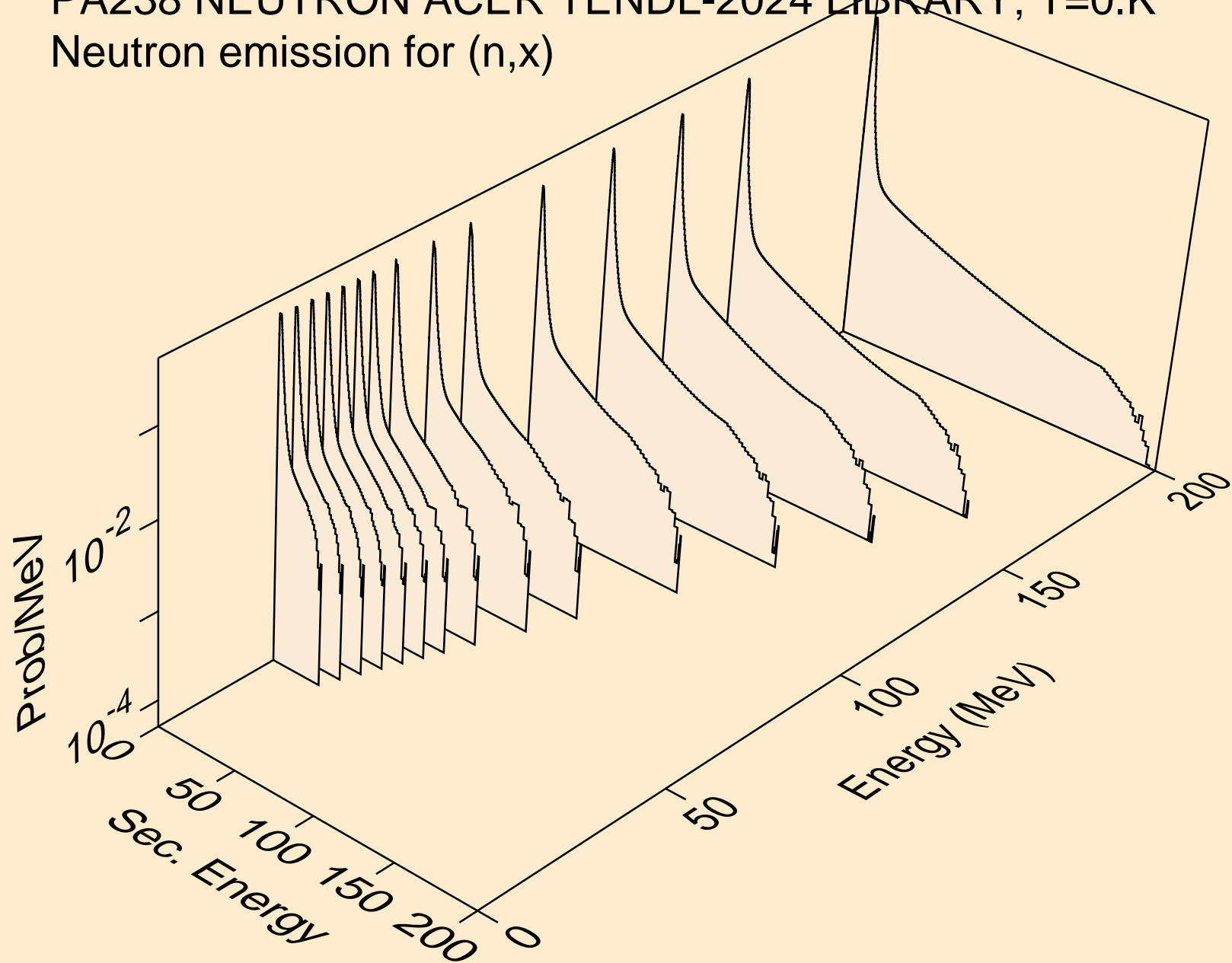

PA238 NEUTRON ACER TENDL-2024 LIBRARY; T=0.K
Neutron emission for (n,2nd)

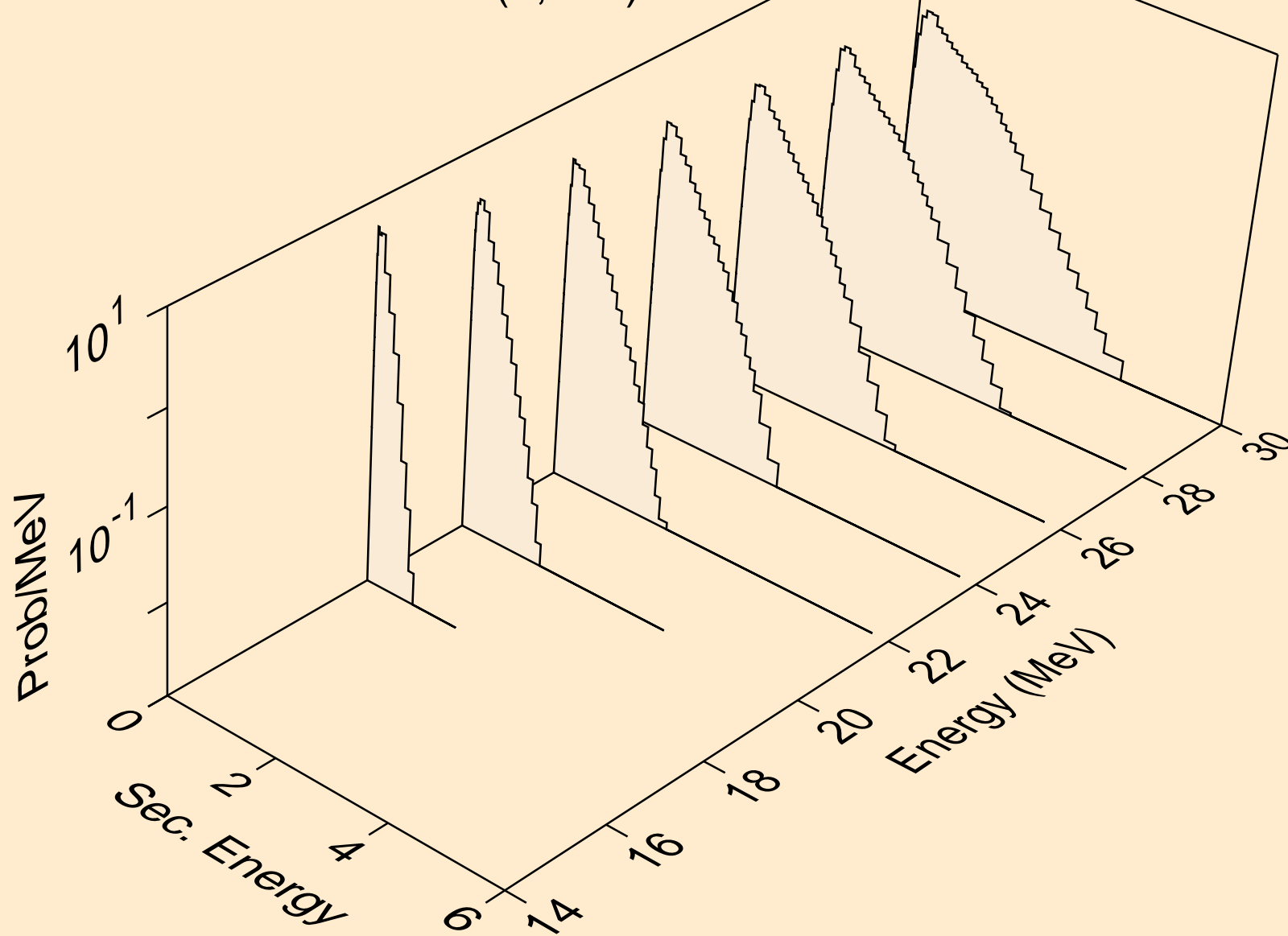

PA238 NEUTRON ACER TENDL-2024 LIBRARY; T=0.K
Neutron emission for (n,2n)

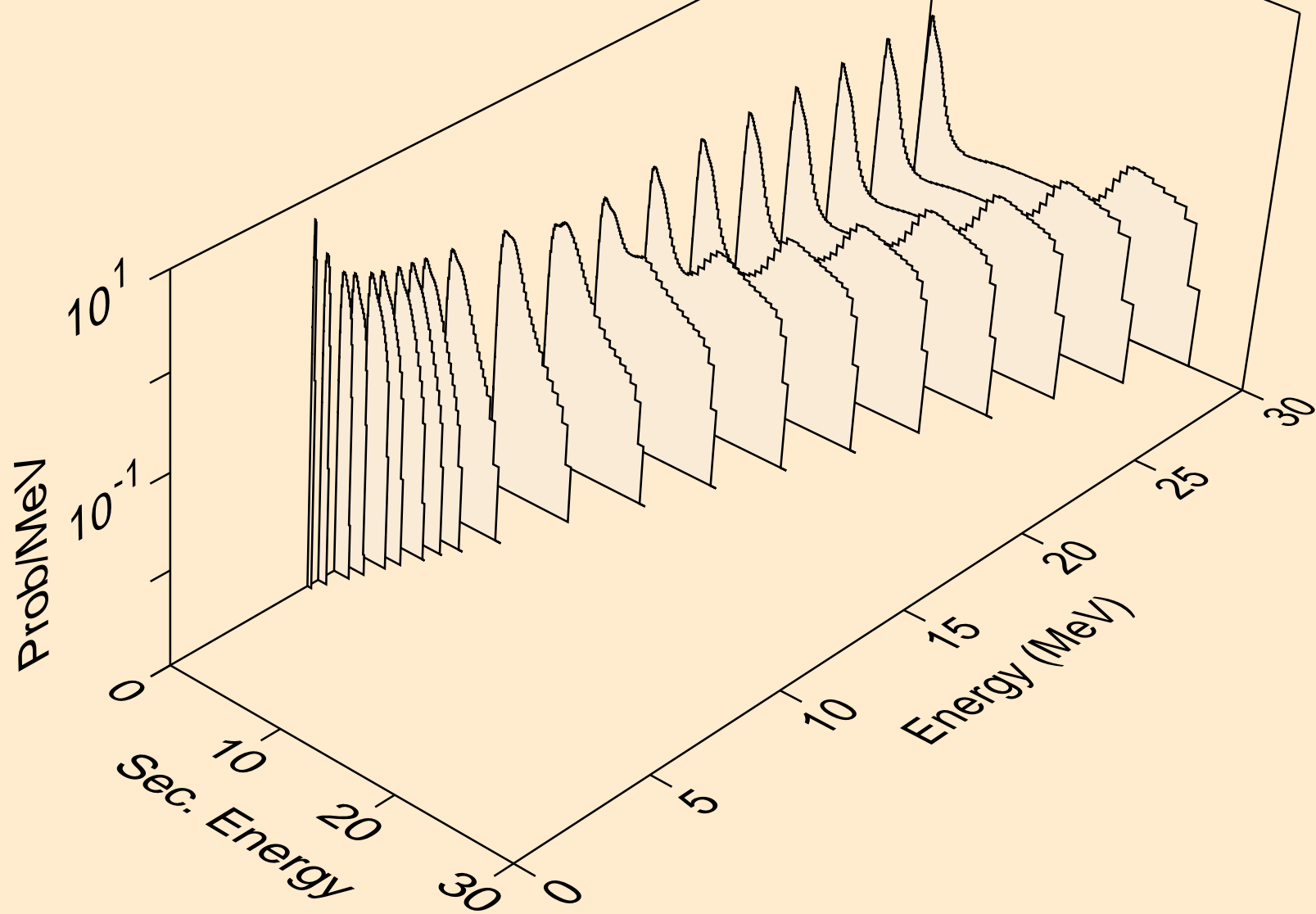

PA238 NEUTRON ACER TENDL-2024 LIBRARY; T=0.K
Neutron emission for (n,3n)

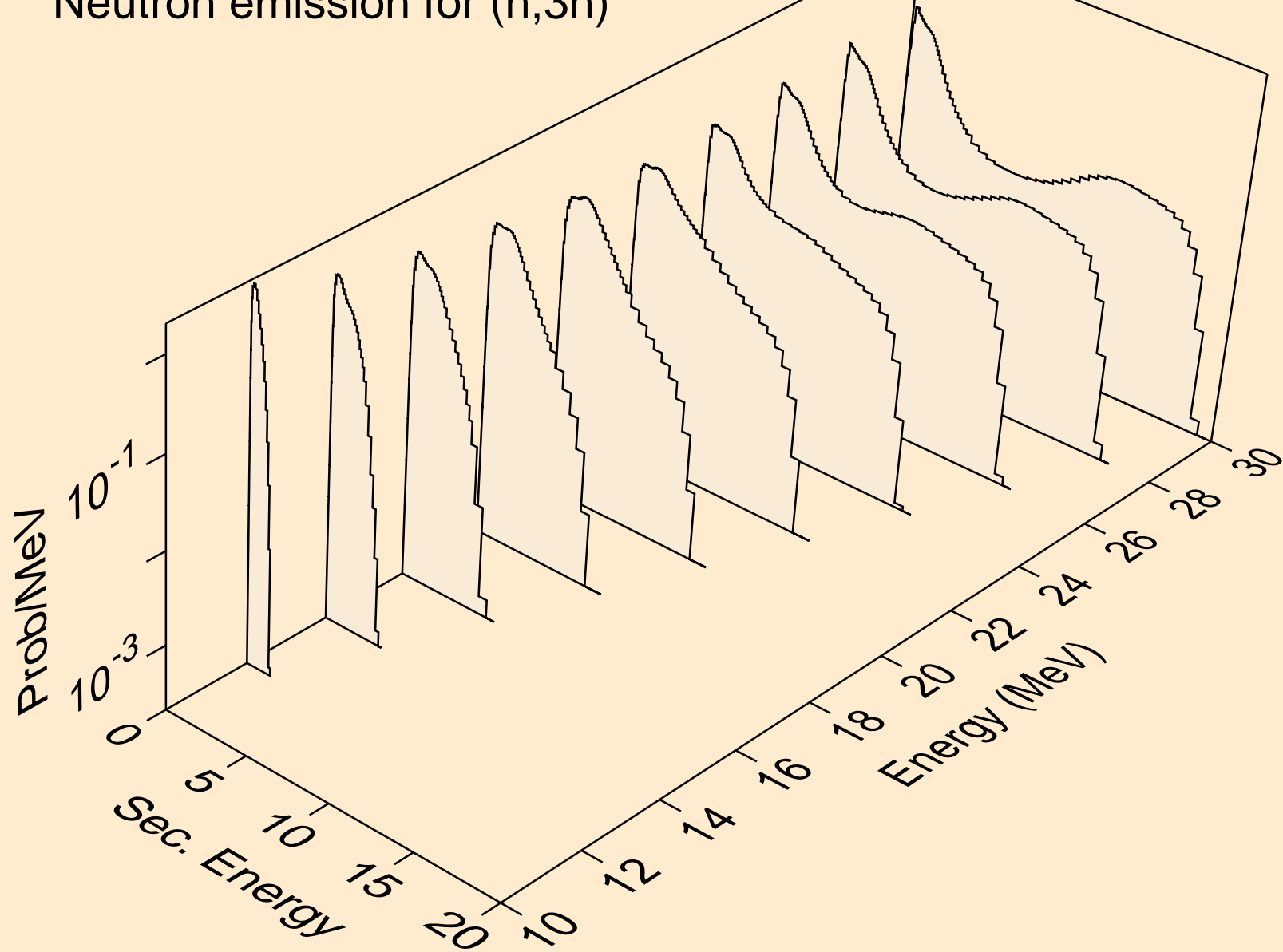

PA238 NEUTRON ACER TENDL-2024 LIBRARY; T=0.K
Neutron emission for fission

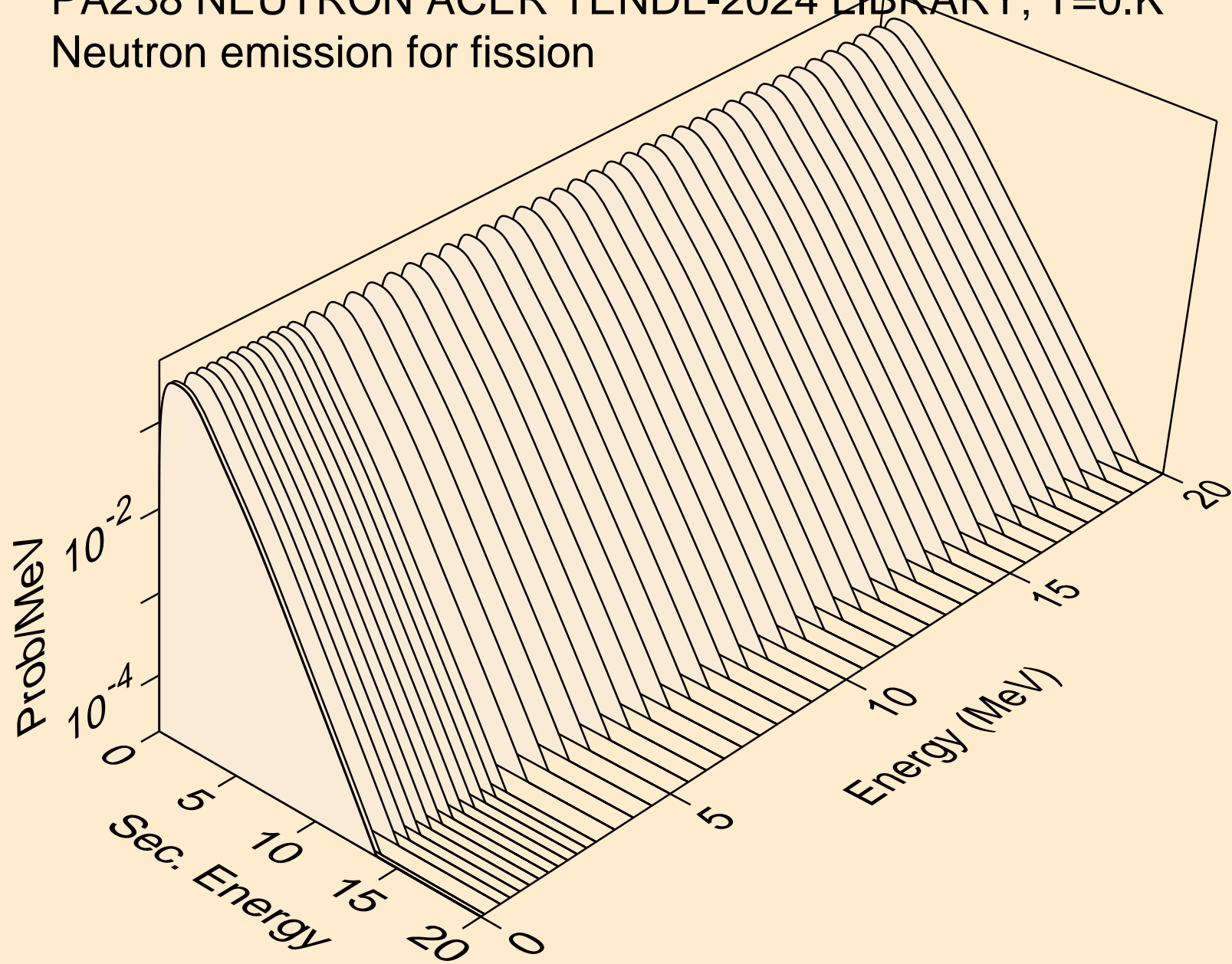

PA238 NEUTRON ACER TENDL-2024 LIBRARY; T=0.K
Neutron emission for (n,n*)a

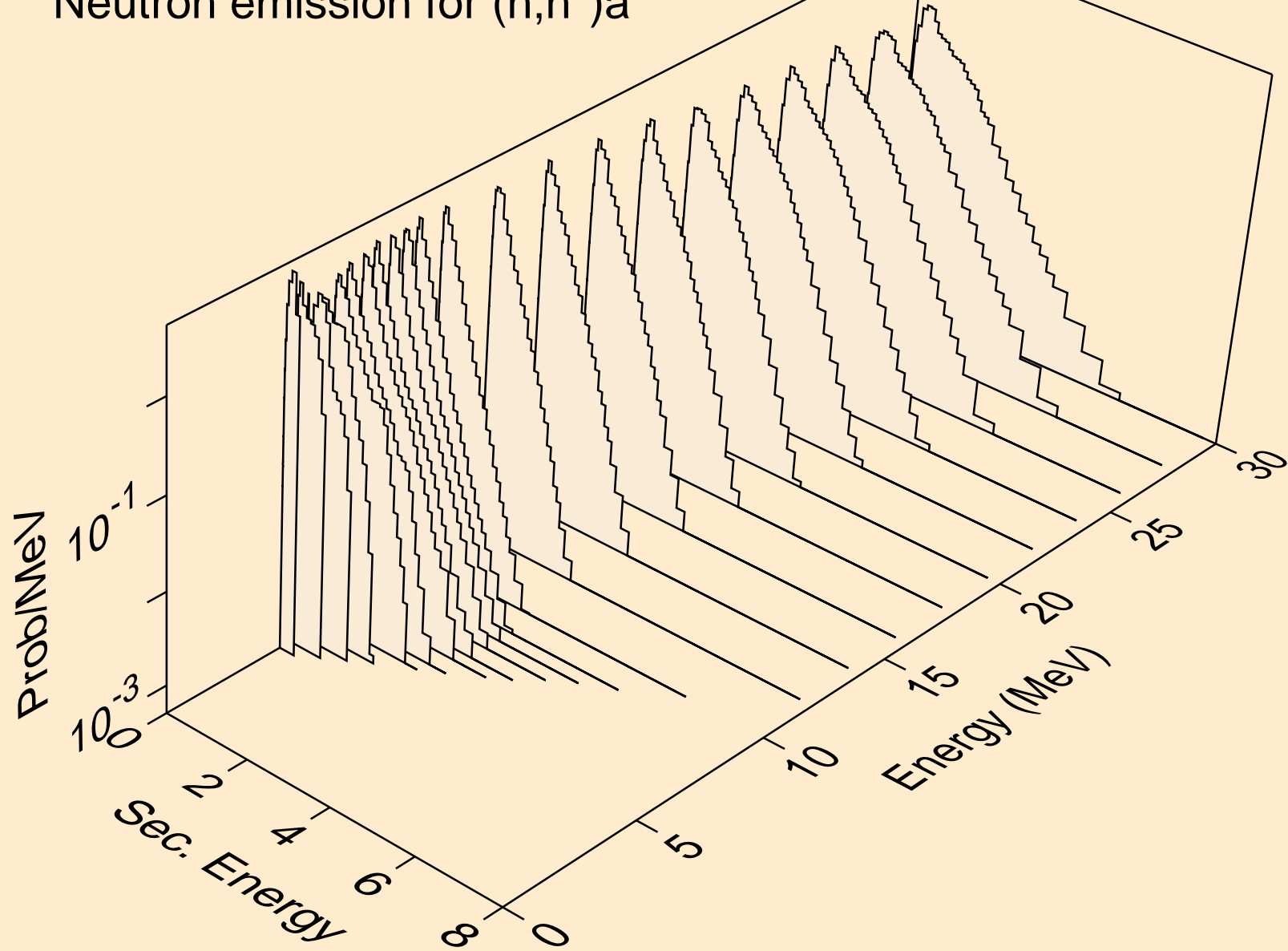

PA238 NEUTRON ACER TENDL-2024 LIBRARY; T=0.K
Neutron emission for (n,2n)a

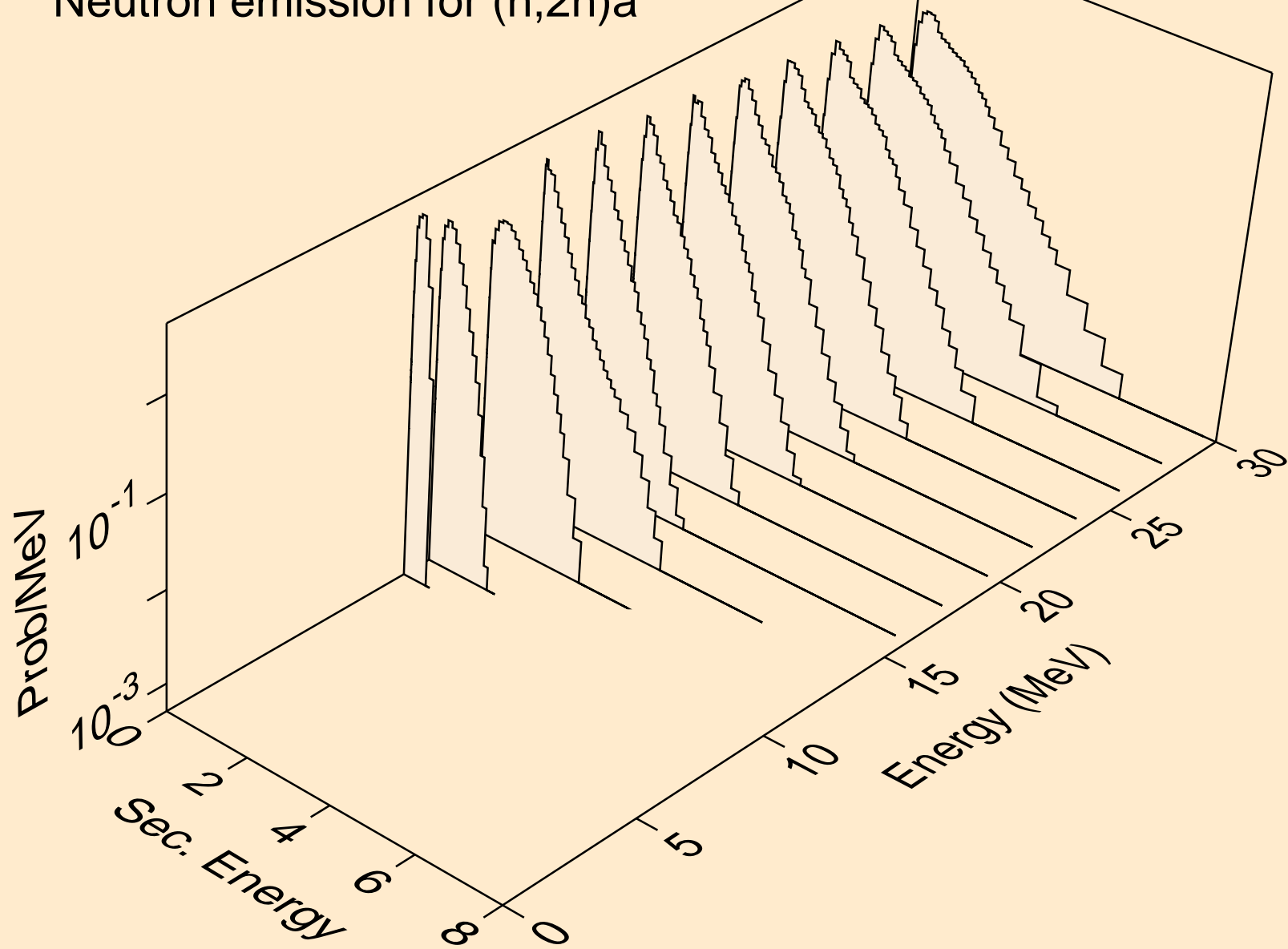

PA238 NEUTRON ACER TENDL-2024 LIBRARY; T=0.K
Neutron emission for (n,3n)a

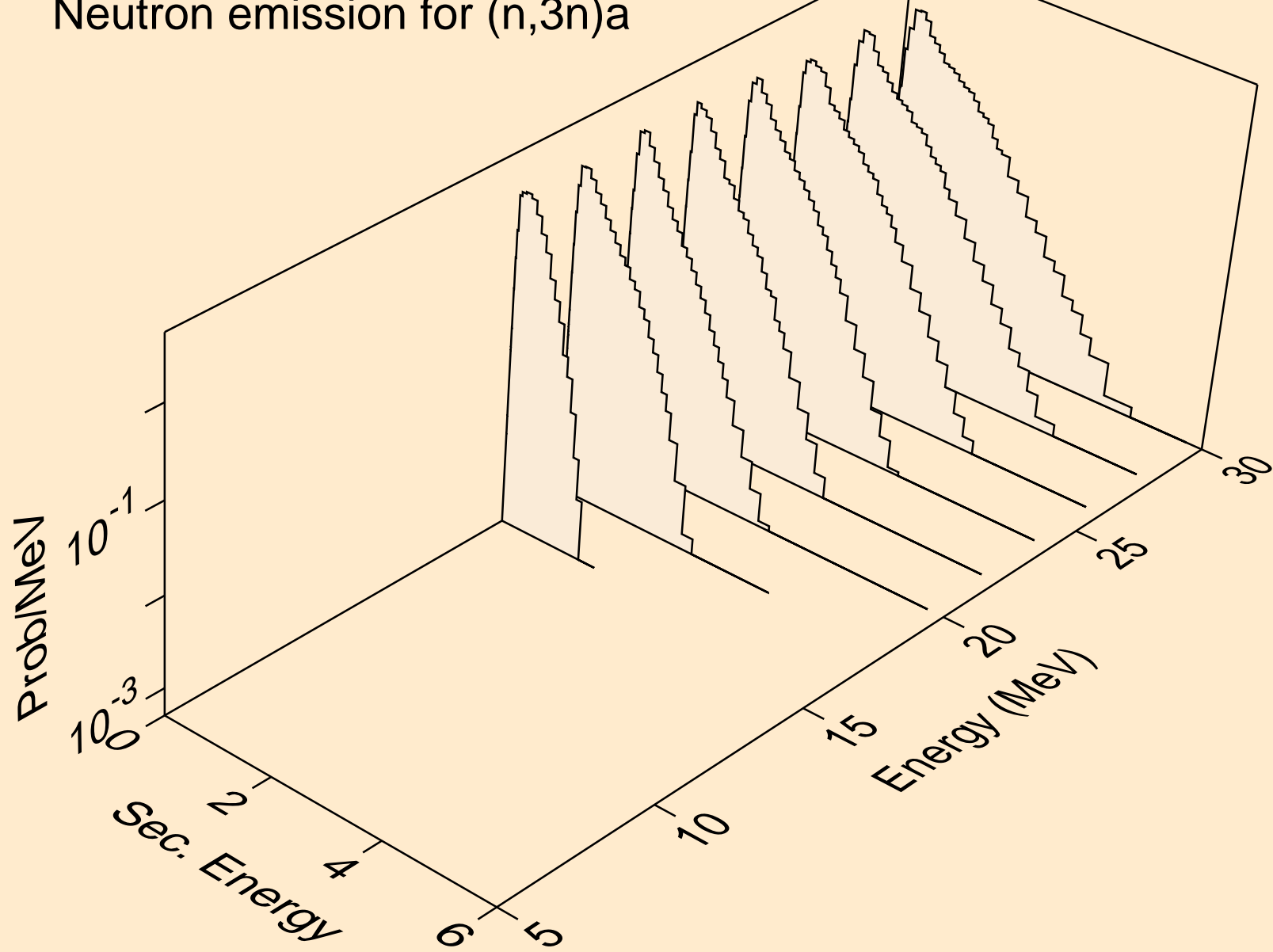

PA238 NEUTRON ACER TENDL-2024 LIBRARY; T=0.K
Neutron emission for (n,n*)p

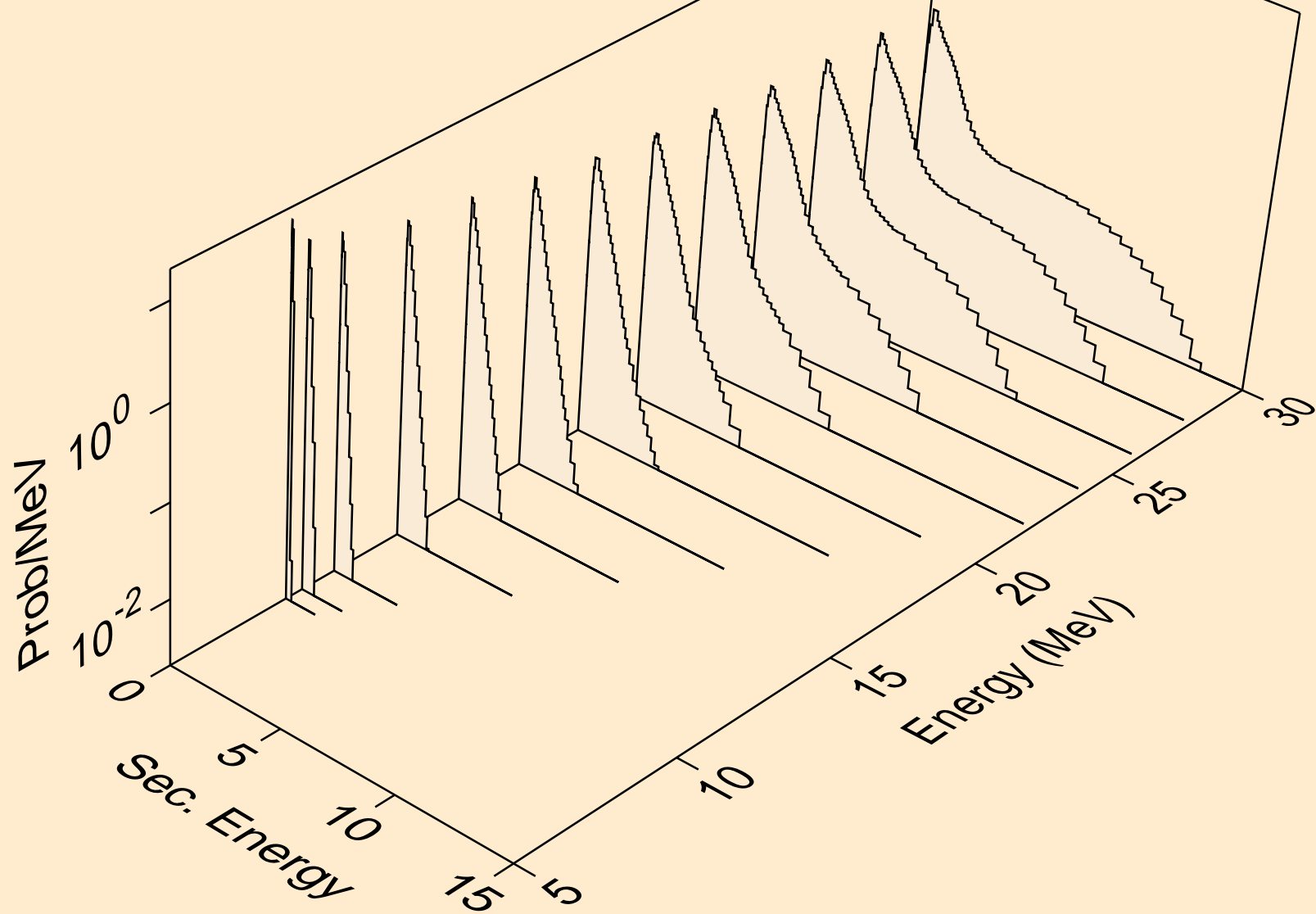

PA238 NEUTRON ACER TENDL-2024 LIBRARY; T=0.K
Neutron emission for (n,n*)d

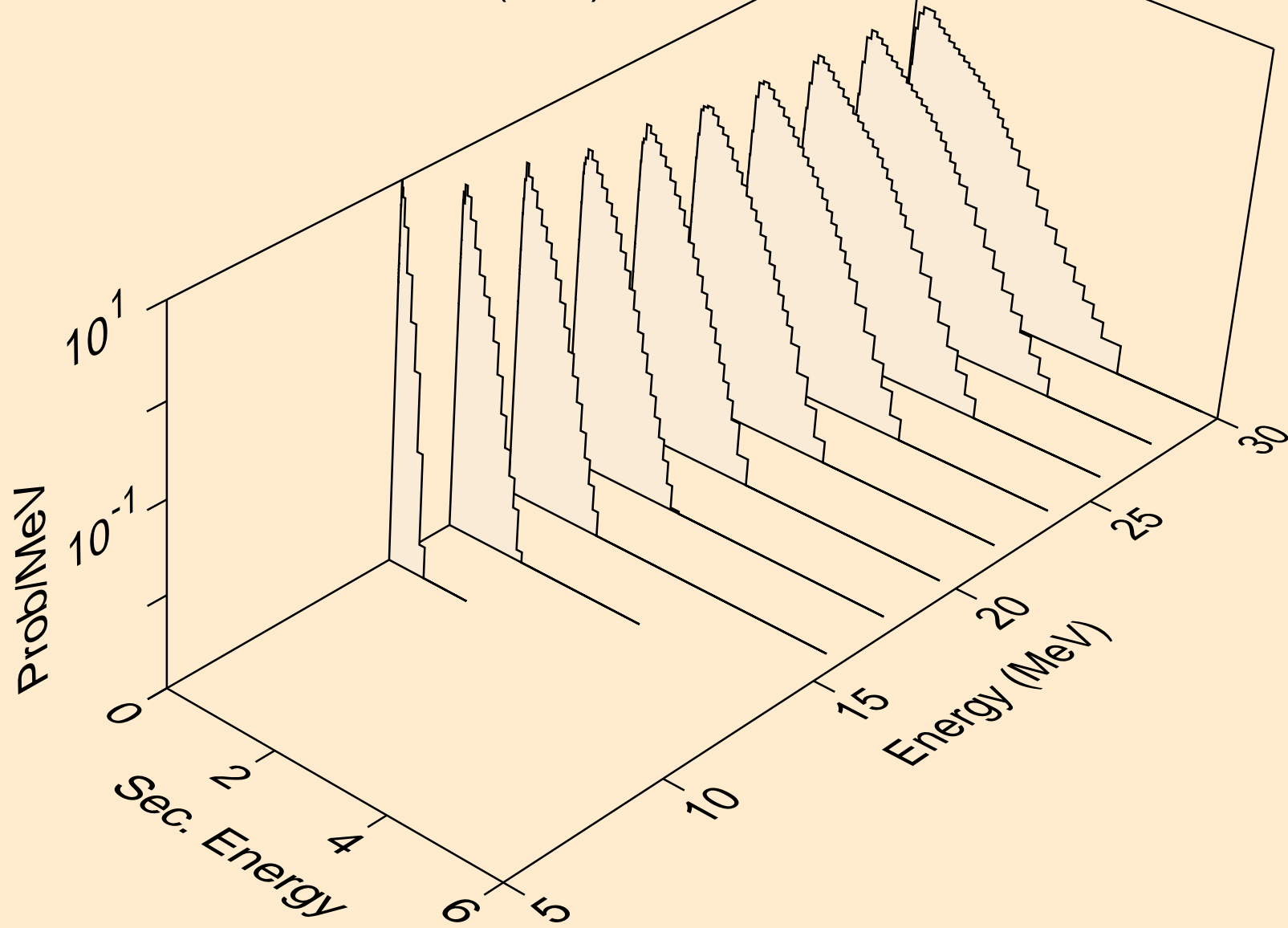

PA238 NEUTRON ACER TENDL-2024 LIBRARY; T=0.K
Neutron emission for (n,n*)t

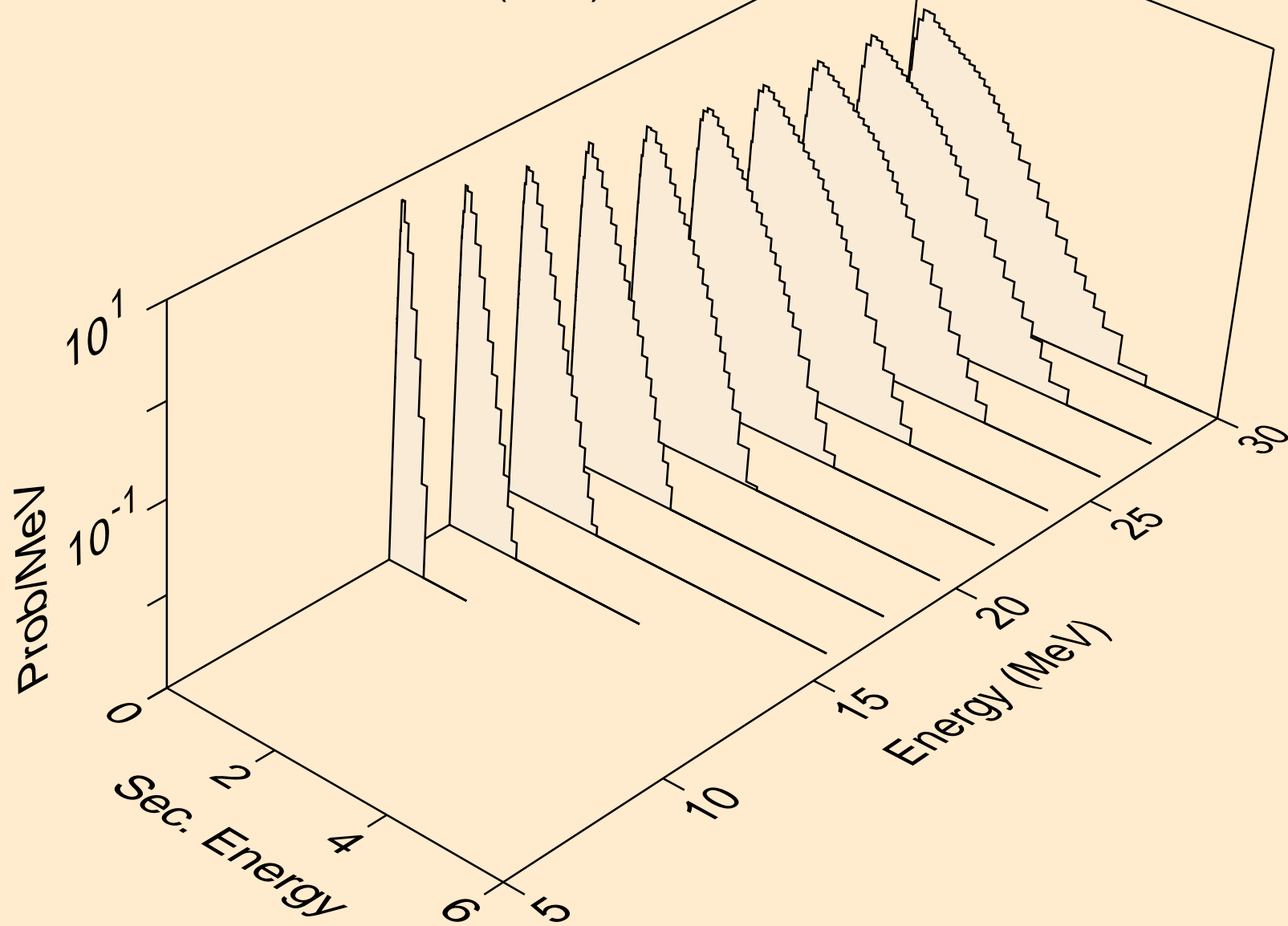

PA238 NEUTRON ACER TENDL-2024 LIBRARY; T=0.K
Neutron emission for (n,n*)he3

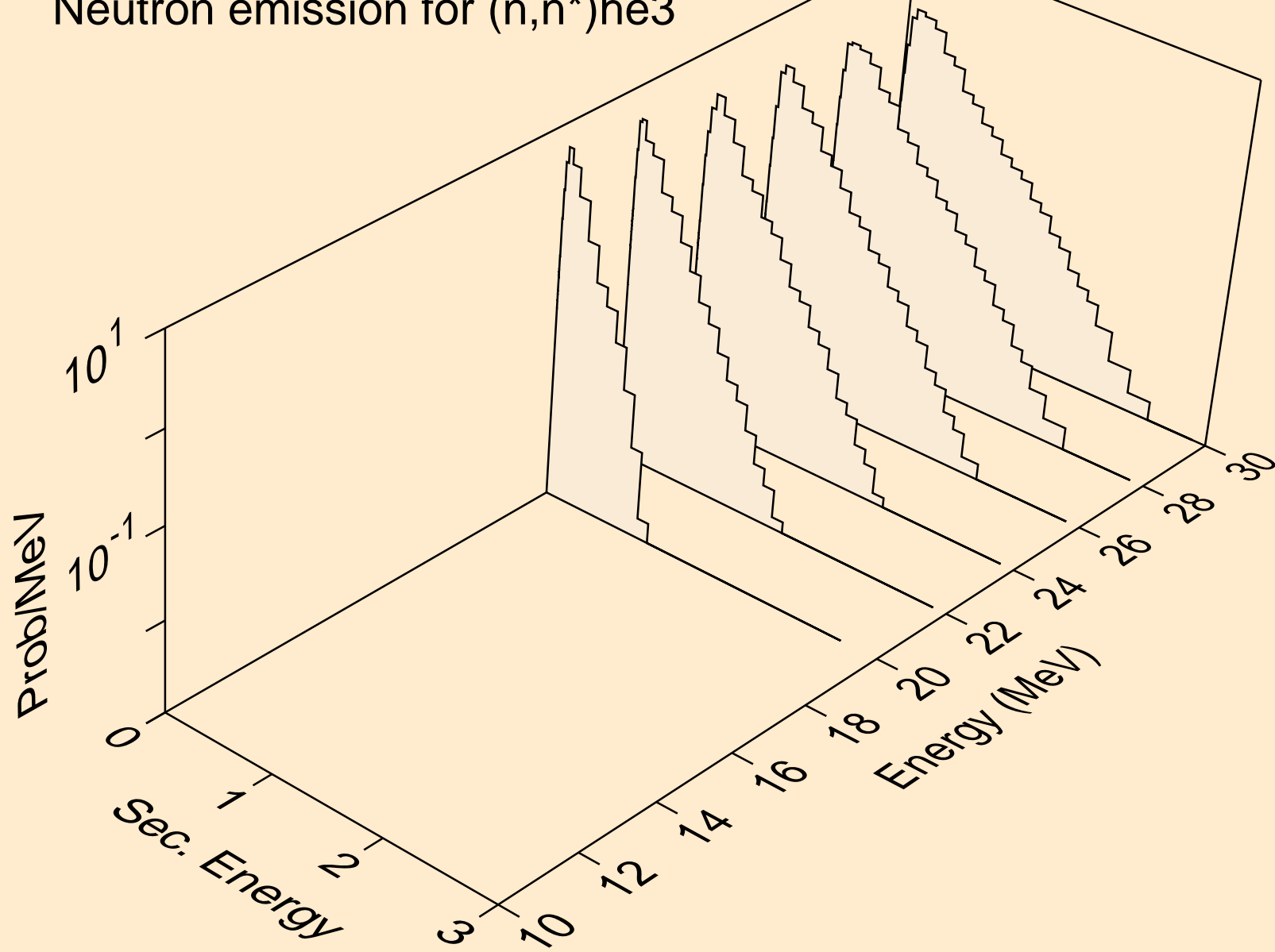

PA238 NEUTRON ACER TENDL-2024 LIBRARY; T=0.K
Neutron emission for (n,4n)

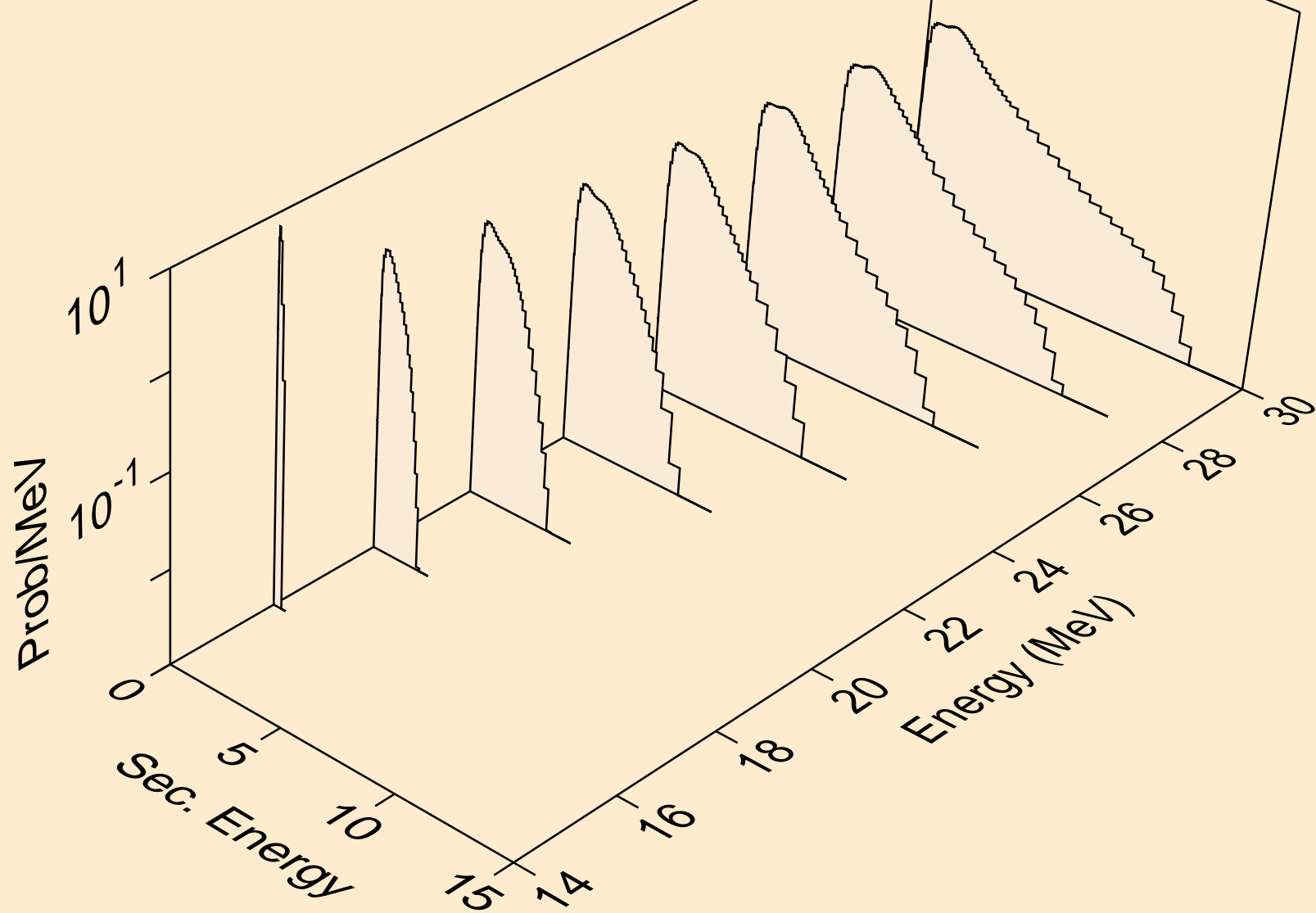

PA238 NEUTRON ACER TENDL-2024 LIBRARY; T=0.K
Neutron emission for (n,2np)

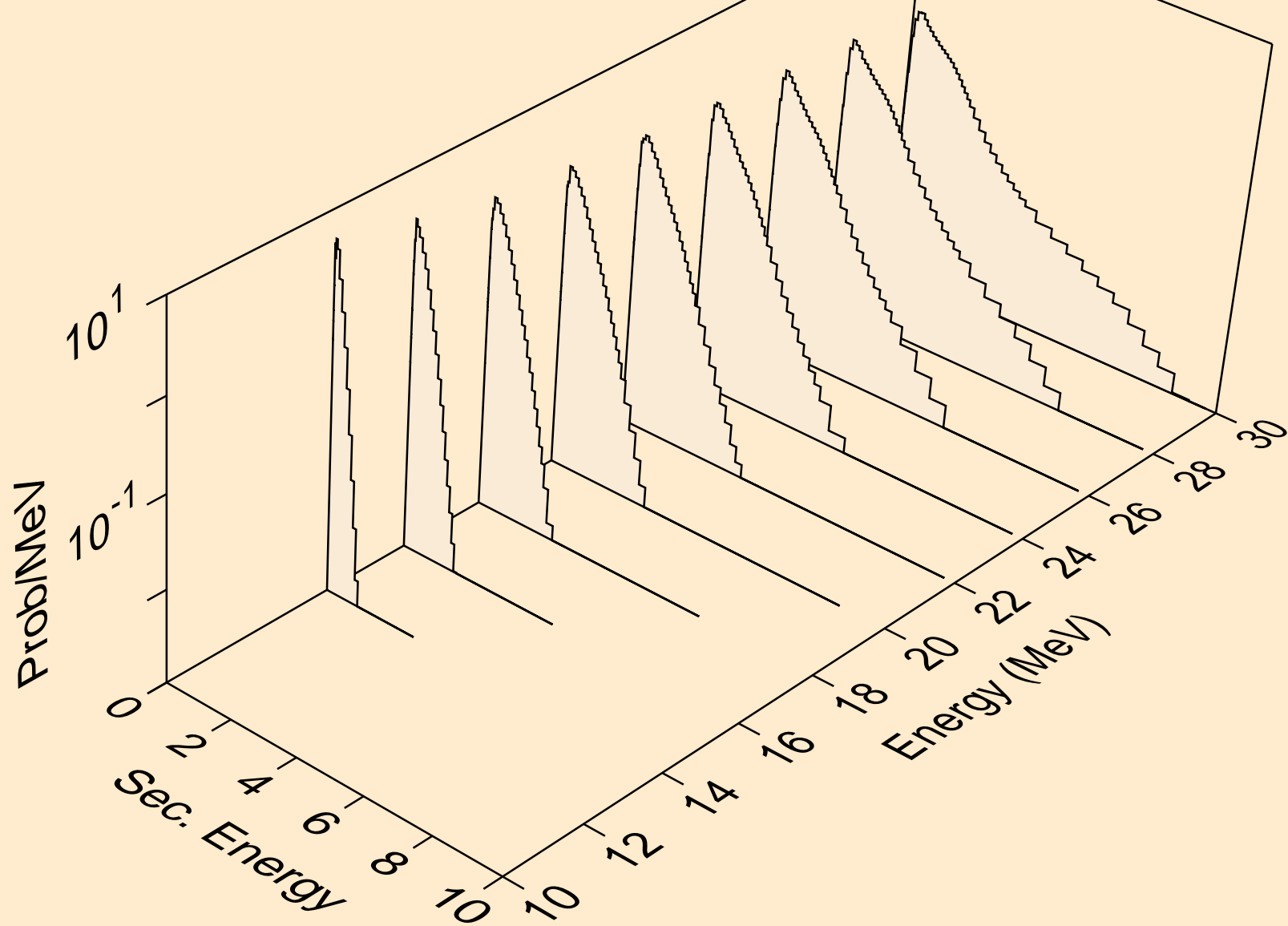

PA238 NEUTRON ACER TENDL-2024 LIBRARY; T=0.K
Neutron emission for (n,3np)

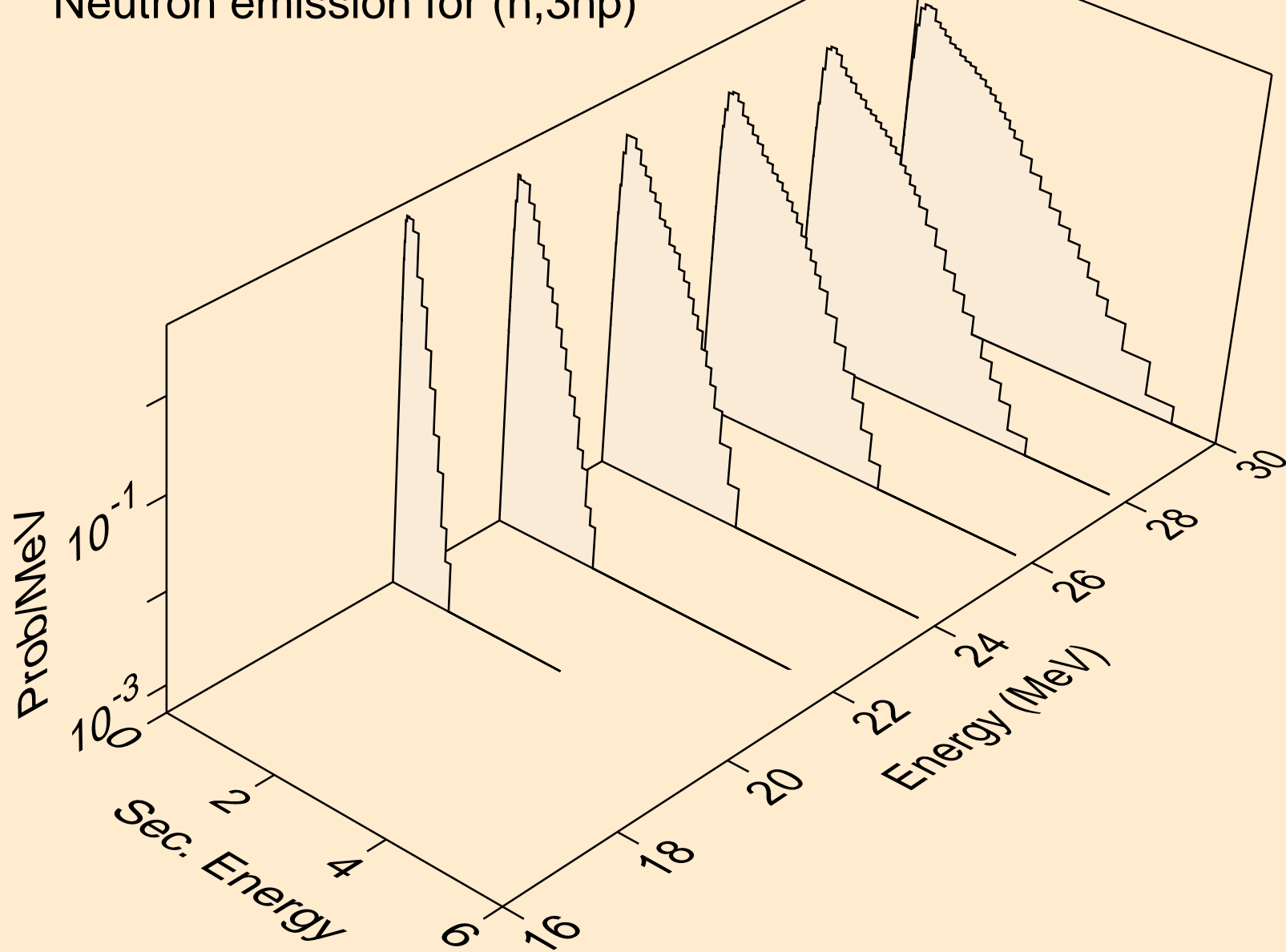

PA238 NEUTRON ACER TENDL-2024 LIBRARY; T=0.K
Neutron emission for (n,n*c)

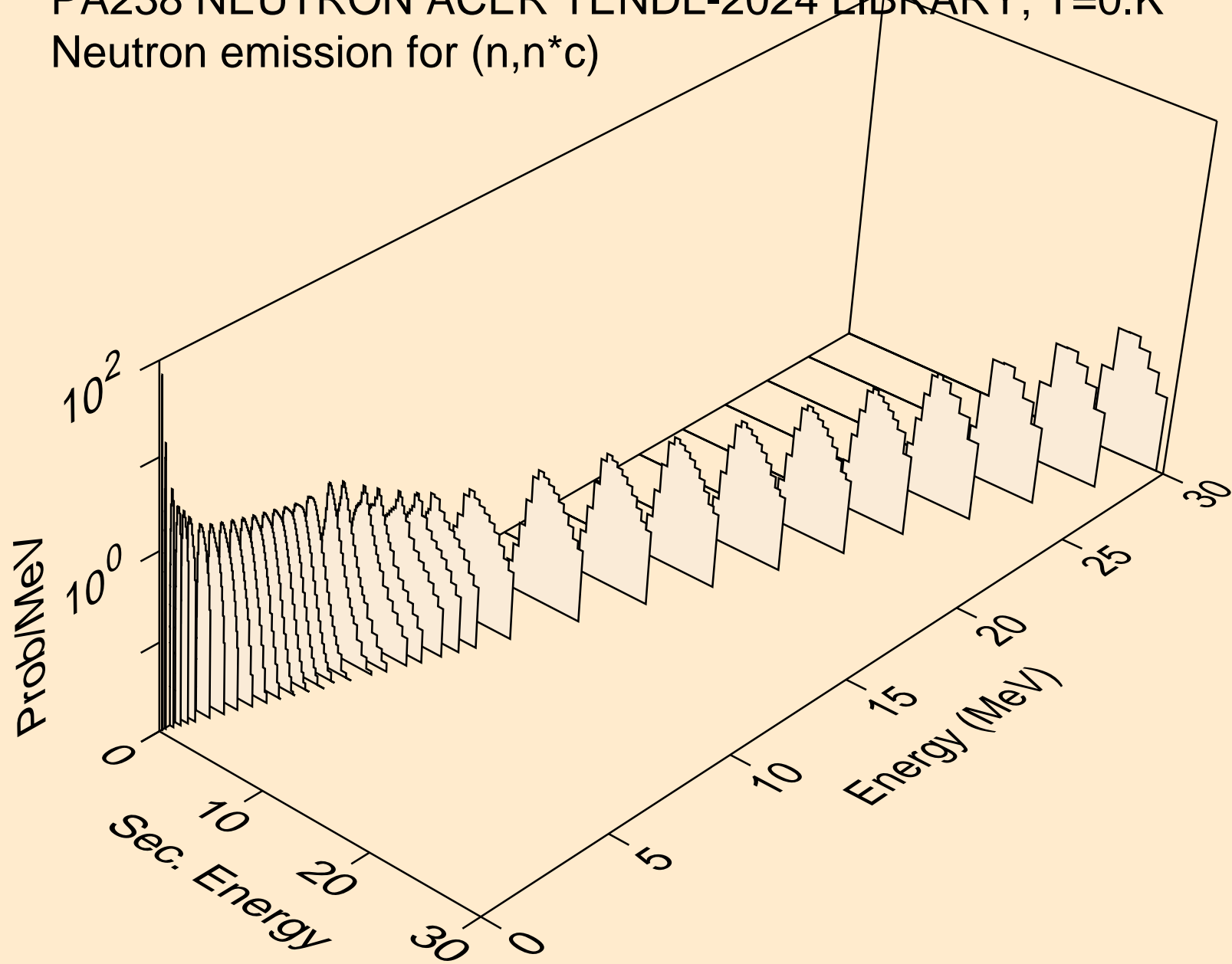

PA238 NEUTRON ACER TENDL-2024 LIBRARY; T=0.K

Delayed nubar

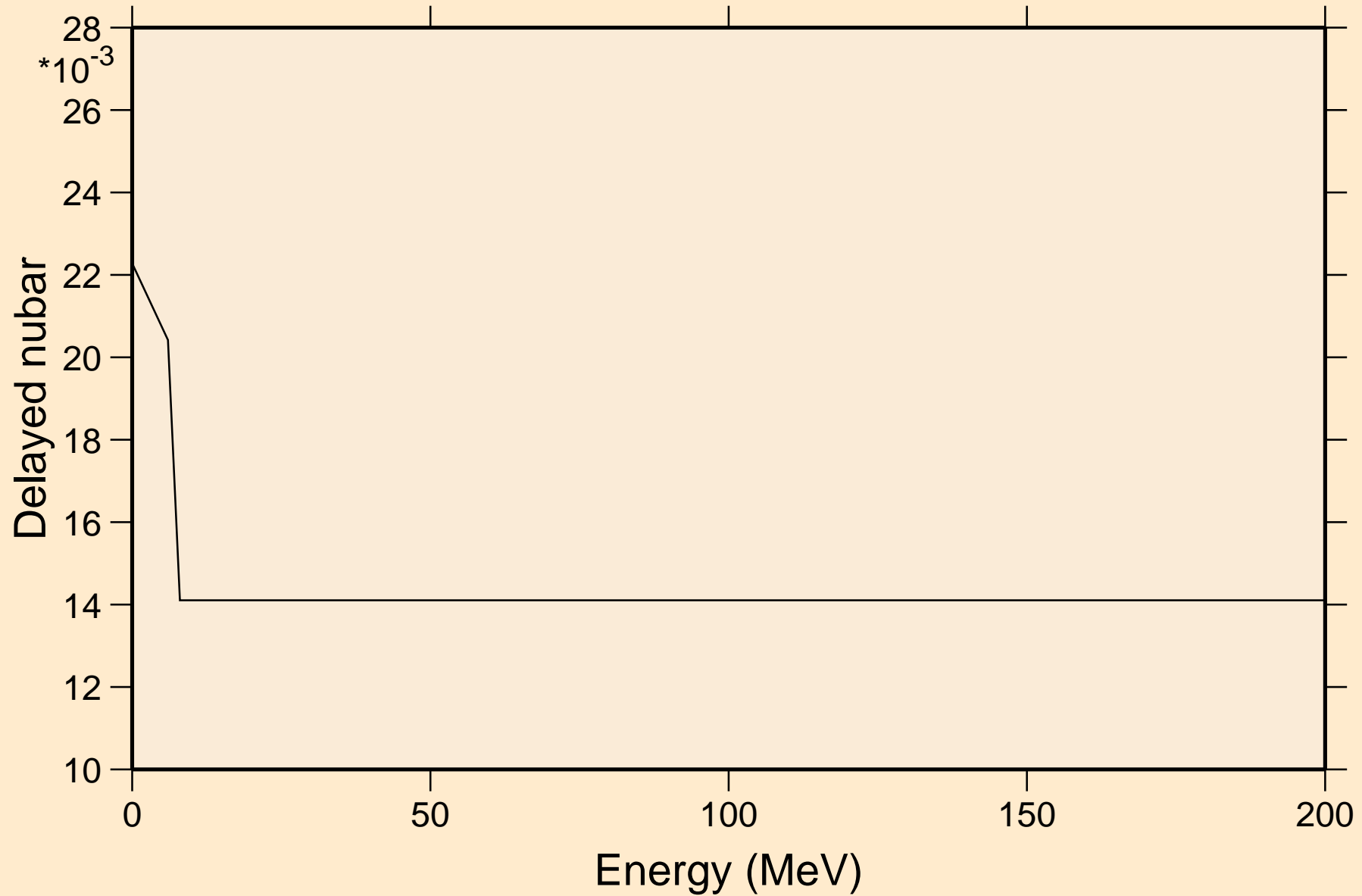

PA238 NEUTRON ACER TENDL-2024 LIBRARY; T=0.K

Delayed neutron spectra

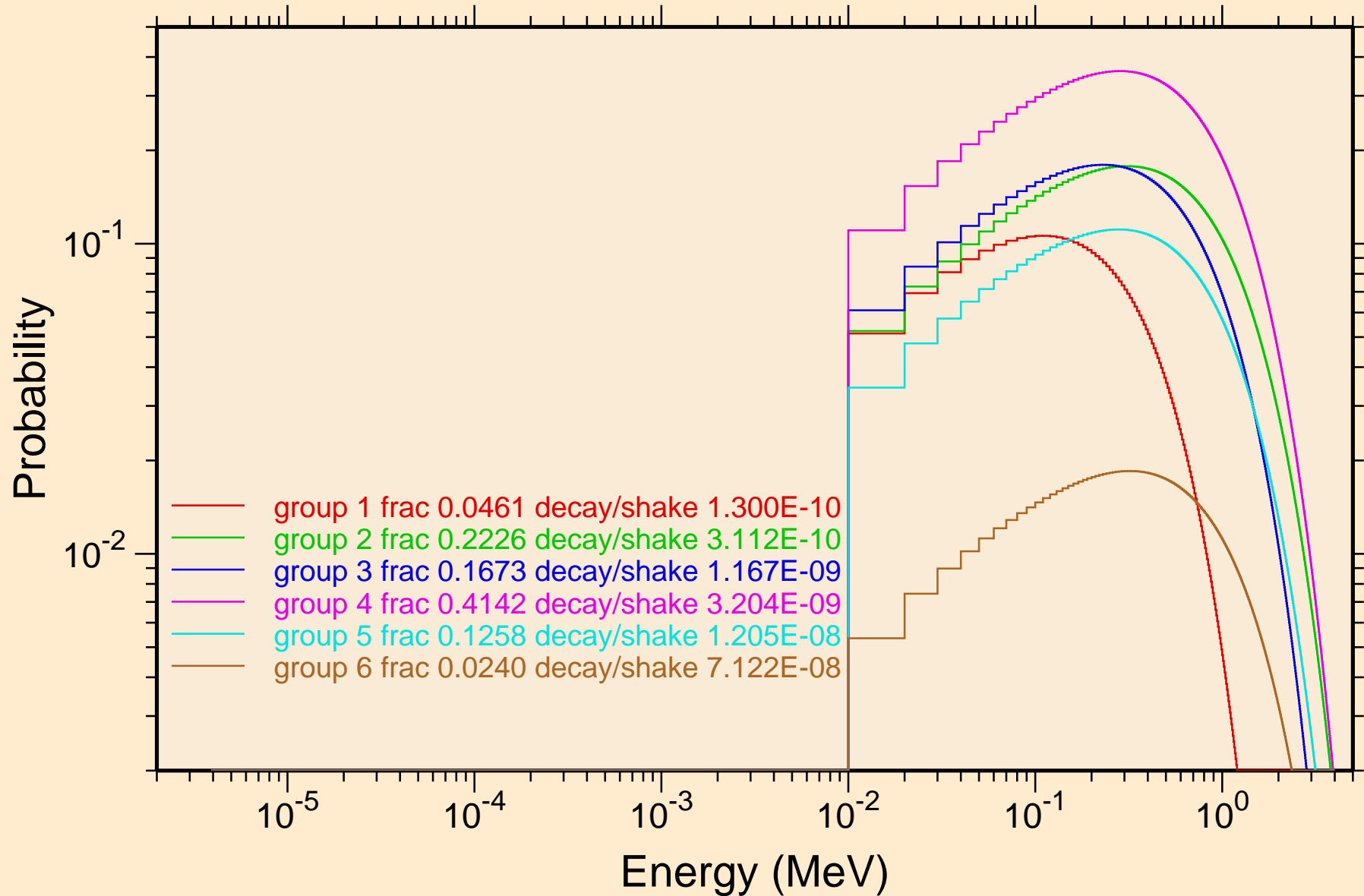

PA238 NEUTRON ACER TENDL-2024 LIBRARY; T=0.K
Photon emission for (n,x)

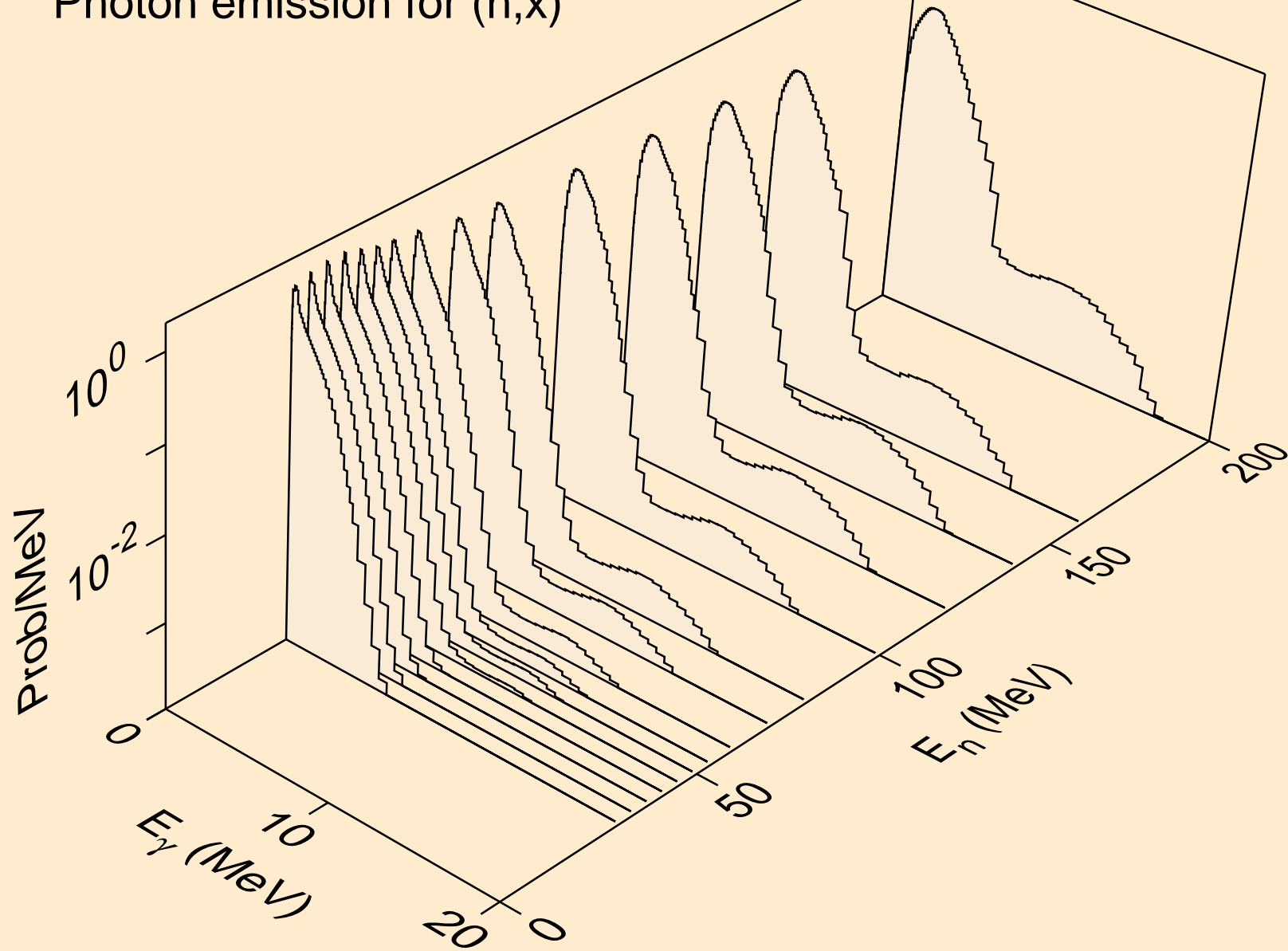

PA238 NEUTRON ACER TENDL-2024 LIBRARY; T=0.K
Photon emission for (n,2nd)

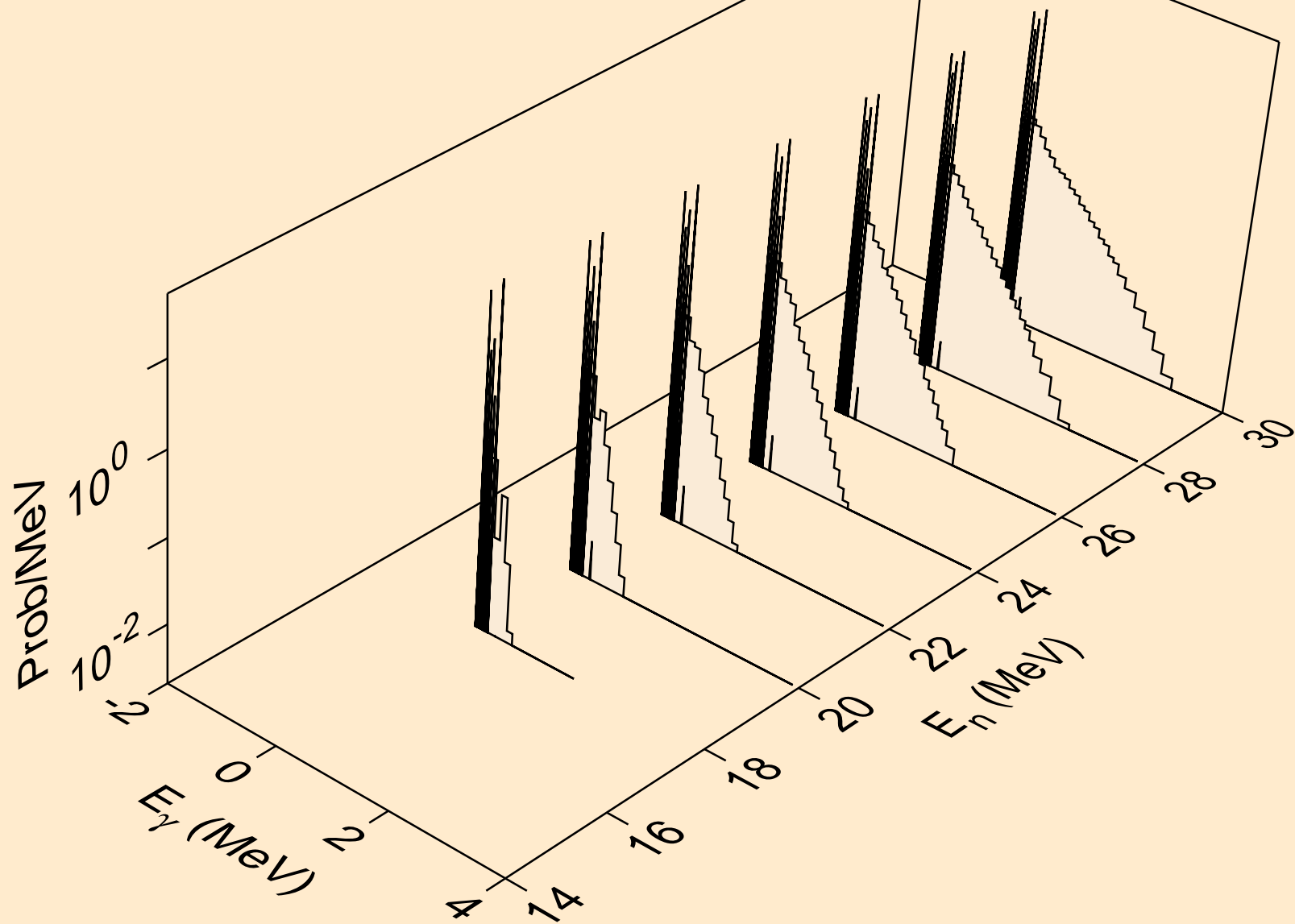

PA238 NEUTRON ACER TENDL-2024 LIBRARY; T=0.K
Photon emission for (n,2n)

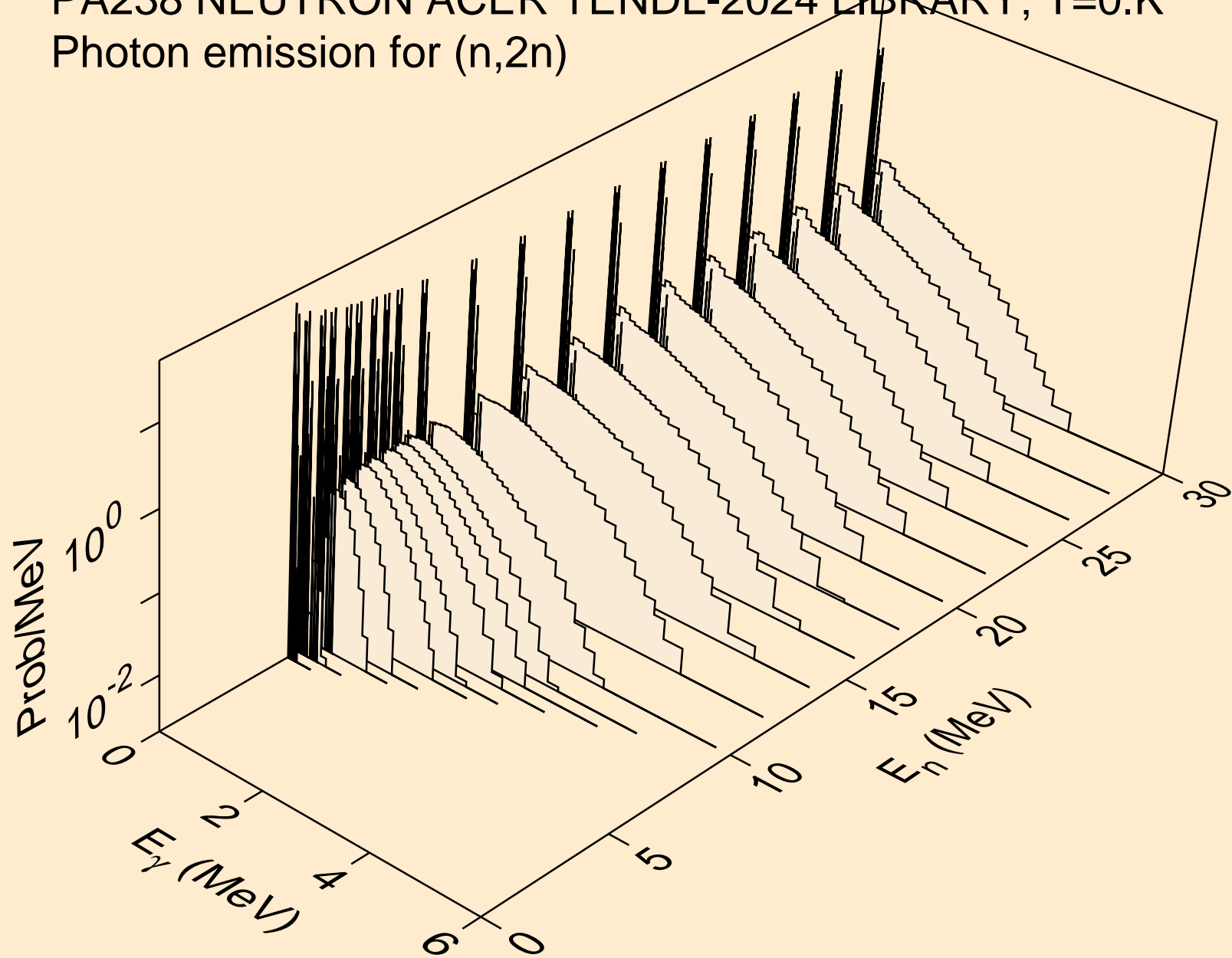

PA238 NEUTRON ACER TENDL-2024 LIBRARY; T=0.K
Photon emission for (n,3n)

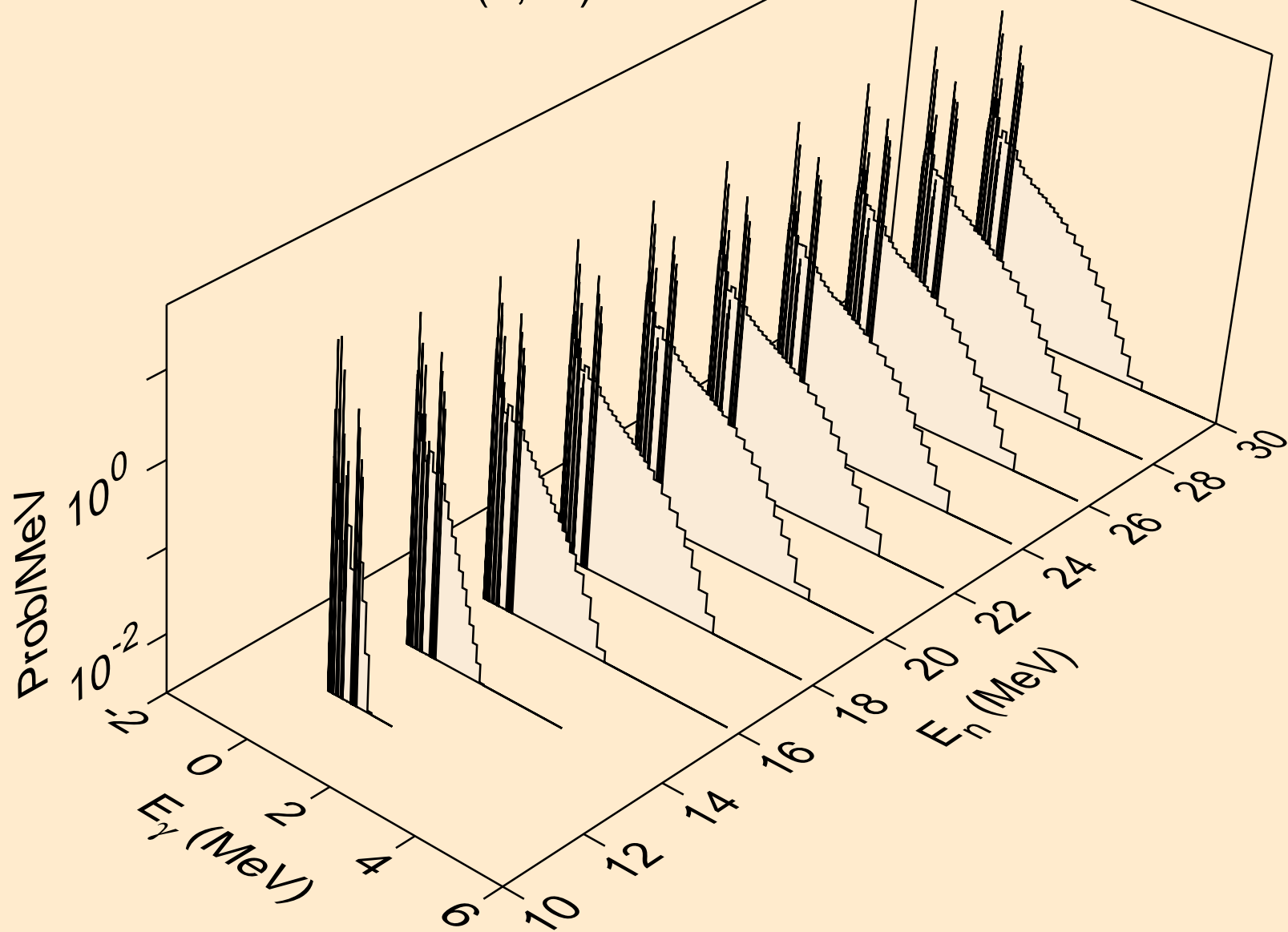

PA238 NEUTRON ACER TENDL-2024 LIBRARY; T=0.K
Photon emission for (n,n*)a

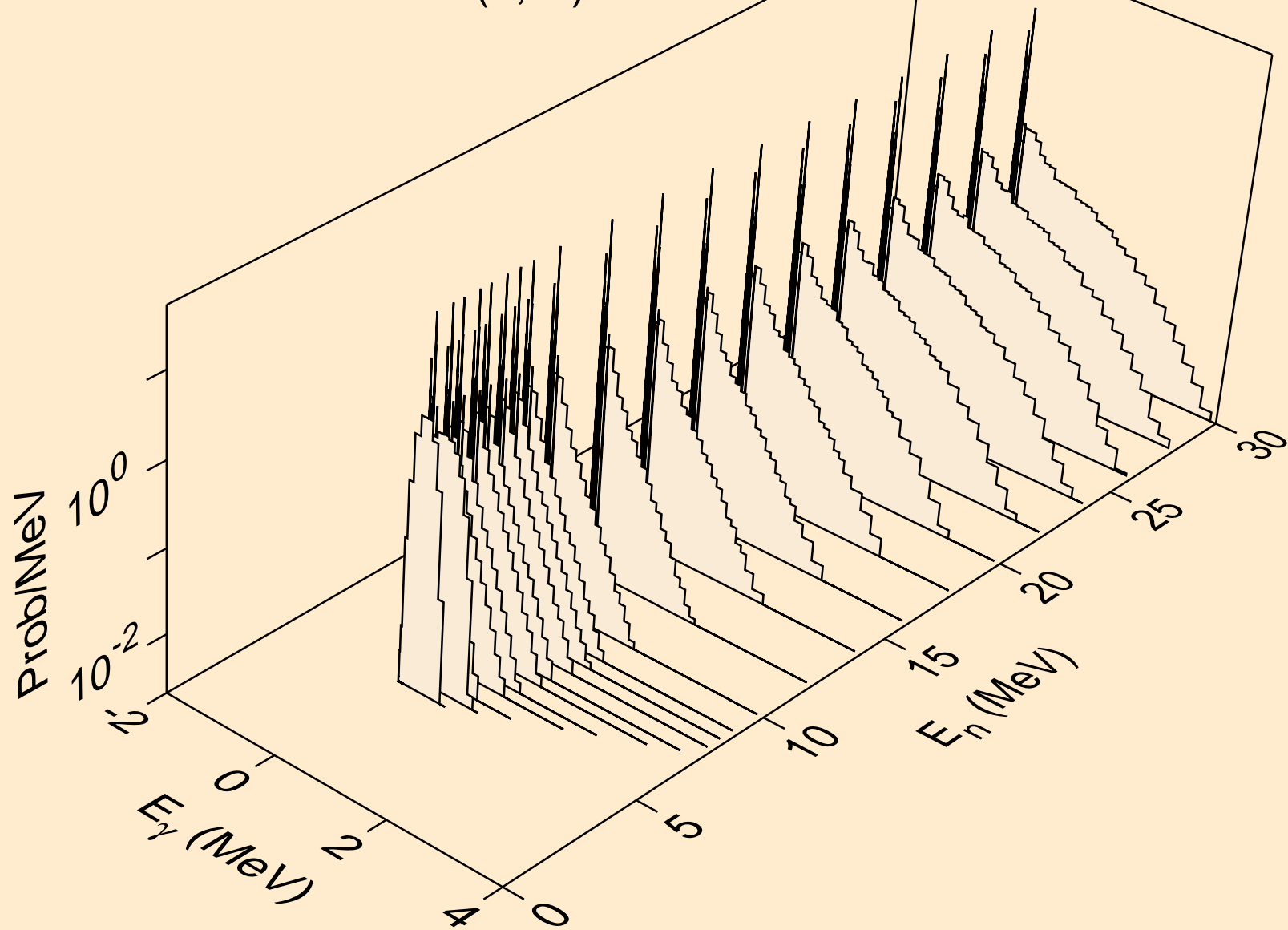

PA238 NEUTRON ACER TENDL-2024 LIBRARY; T=0.K
Photon emission for (n,2n)a

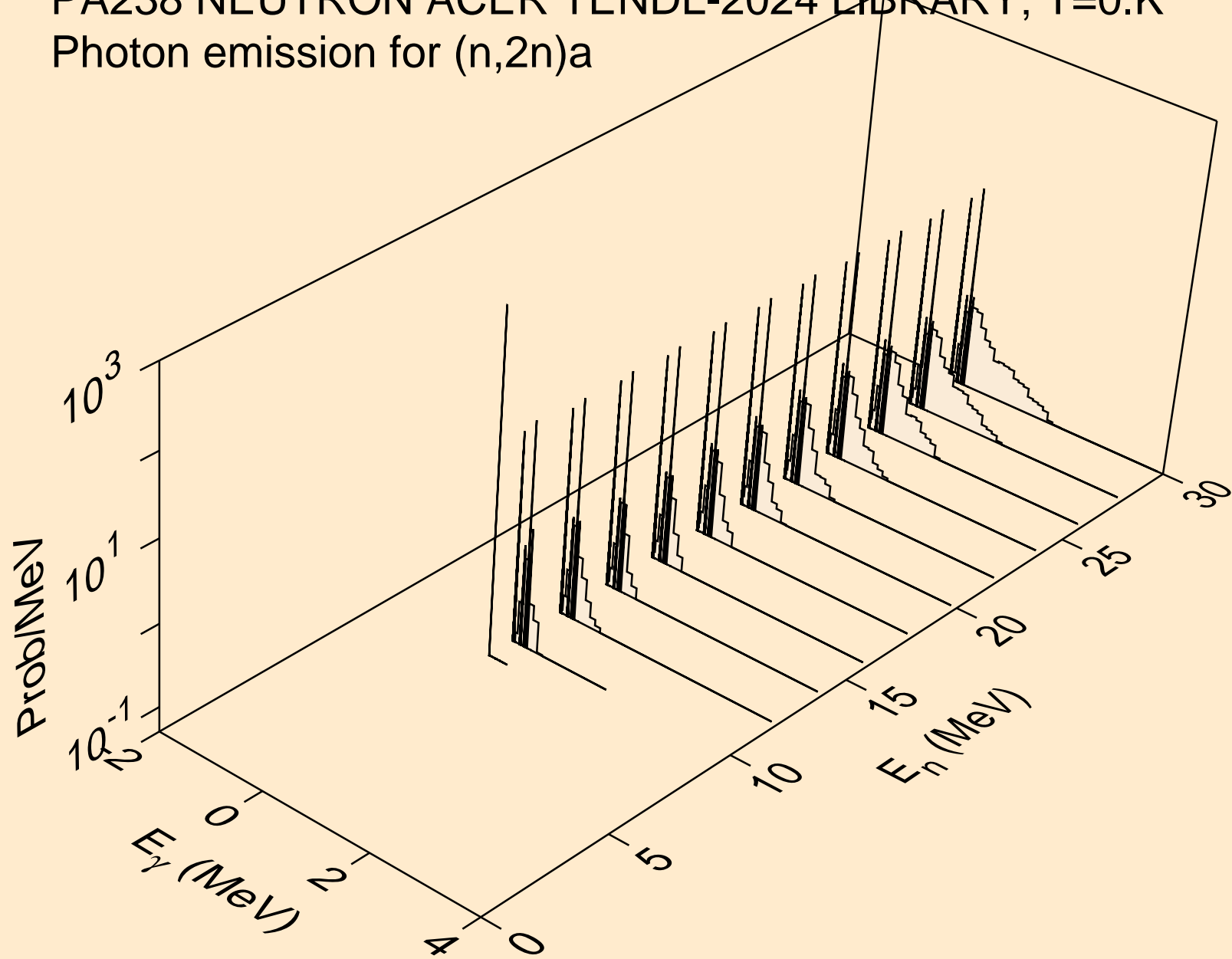

PA238 NEUTRON ACER TENDL-2024 LIBRARY; T=0.K
Photon emission for (n,3n)a

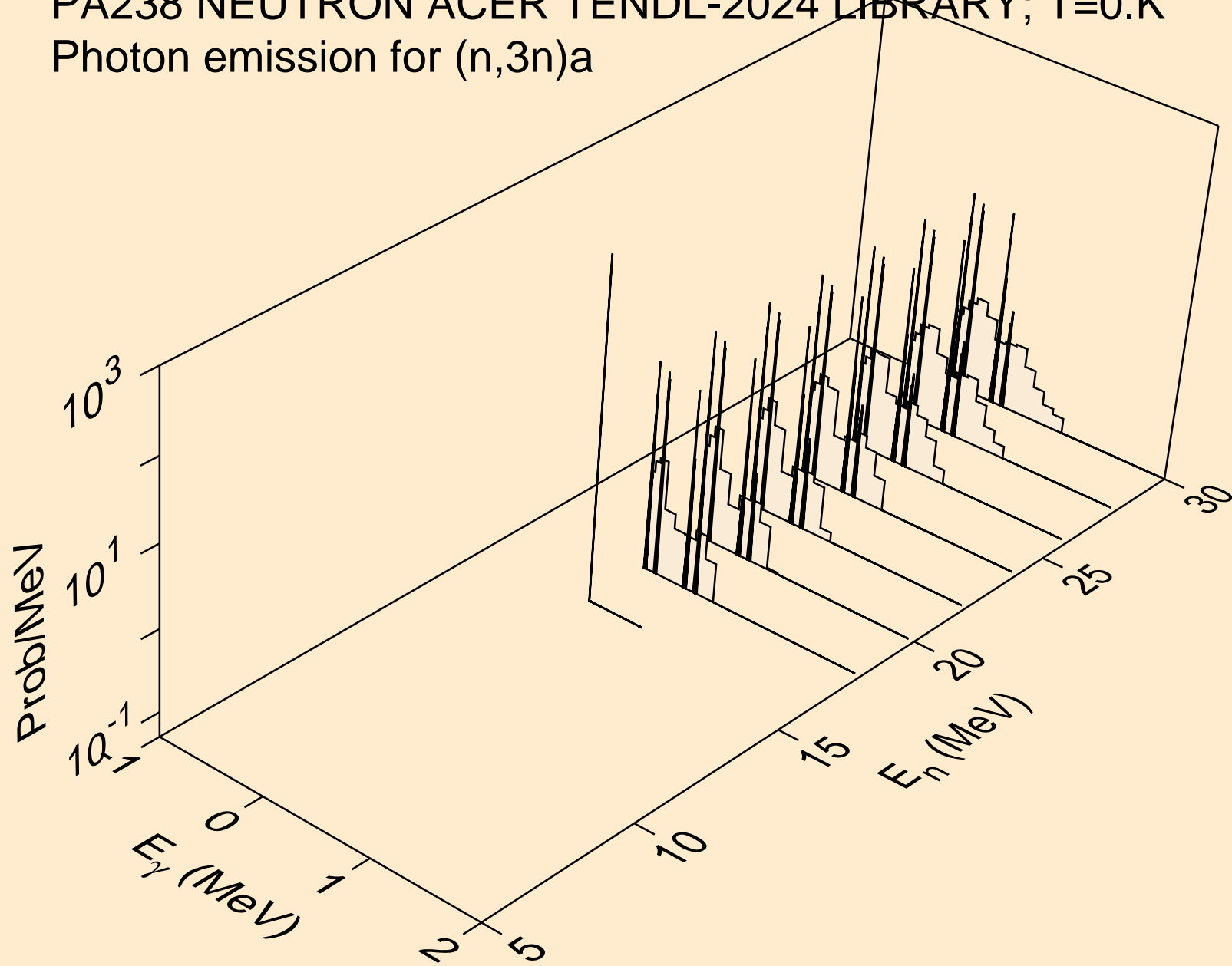

PA238 NEUTRON ACER TENDL-2024 LIBRARY; T=0.K
Photon emission for (n,n*)p

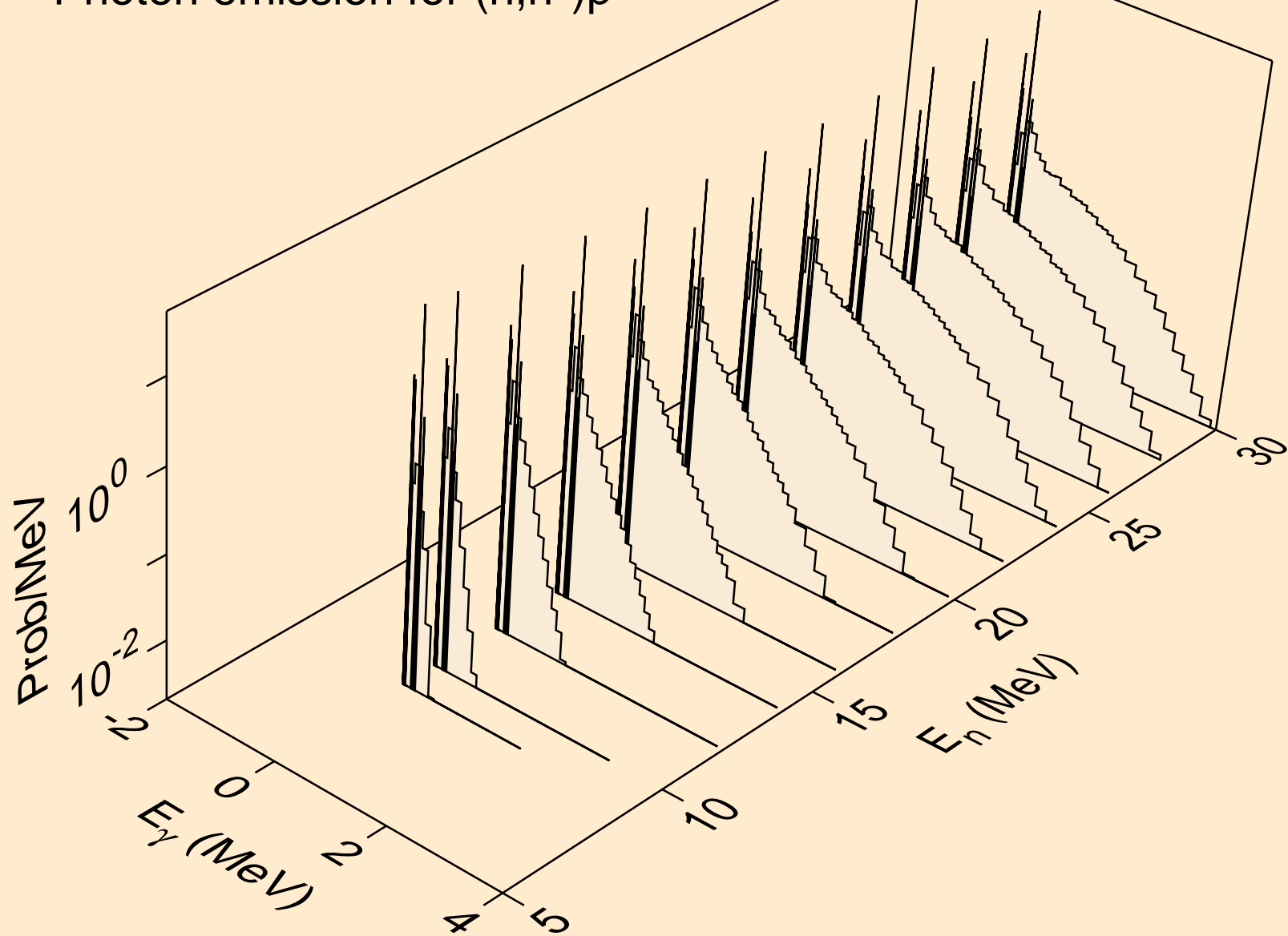

PA238 NEUTRON ACER TENDL-2024 LIBRARY; T=0.K
Photon emission for (n,n*)d

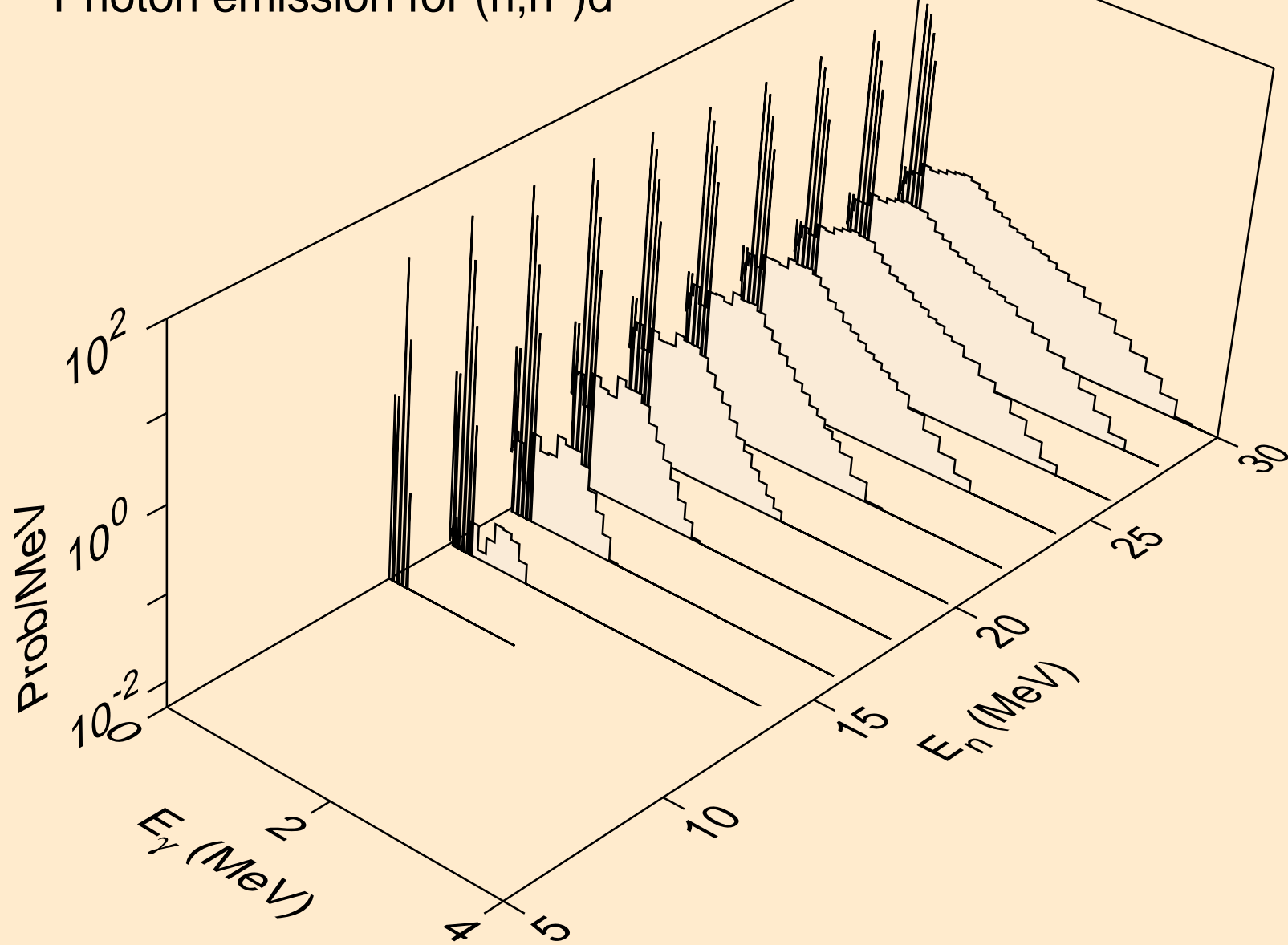

PA238 NEUTRON ACER TENDL-2024 LIBRARY; T=0.K
Photon emission for (n,n*)t

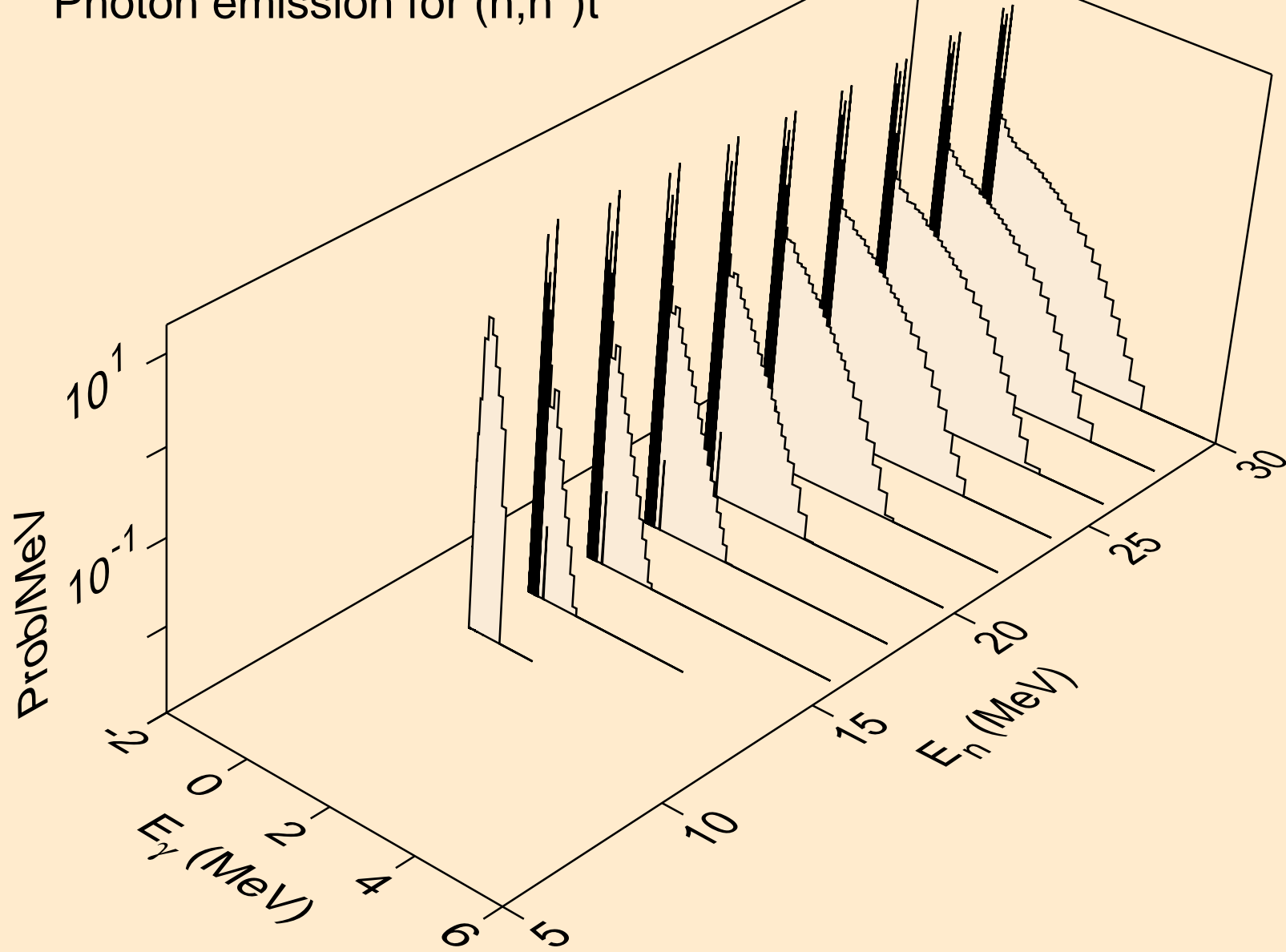

PA238 NEUTRON ACER TENDL-2024 LIBRARY; T=0.K
Photon emission for (n,n*)he3

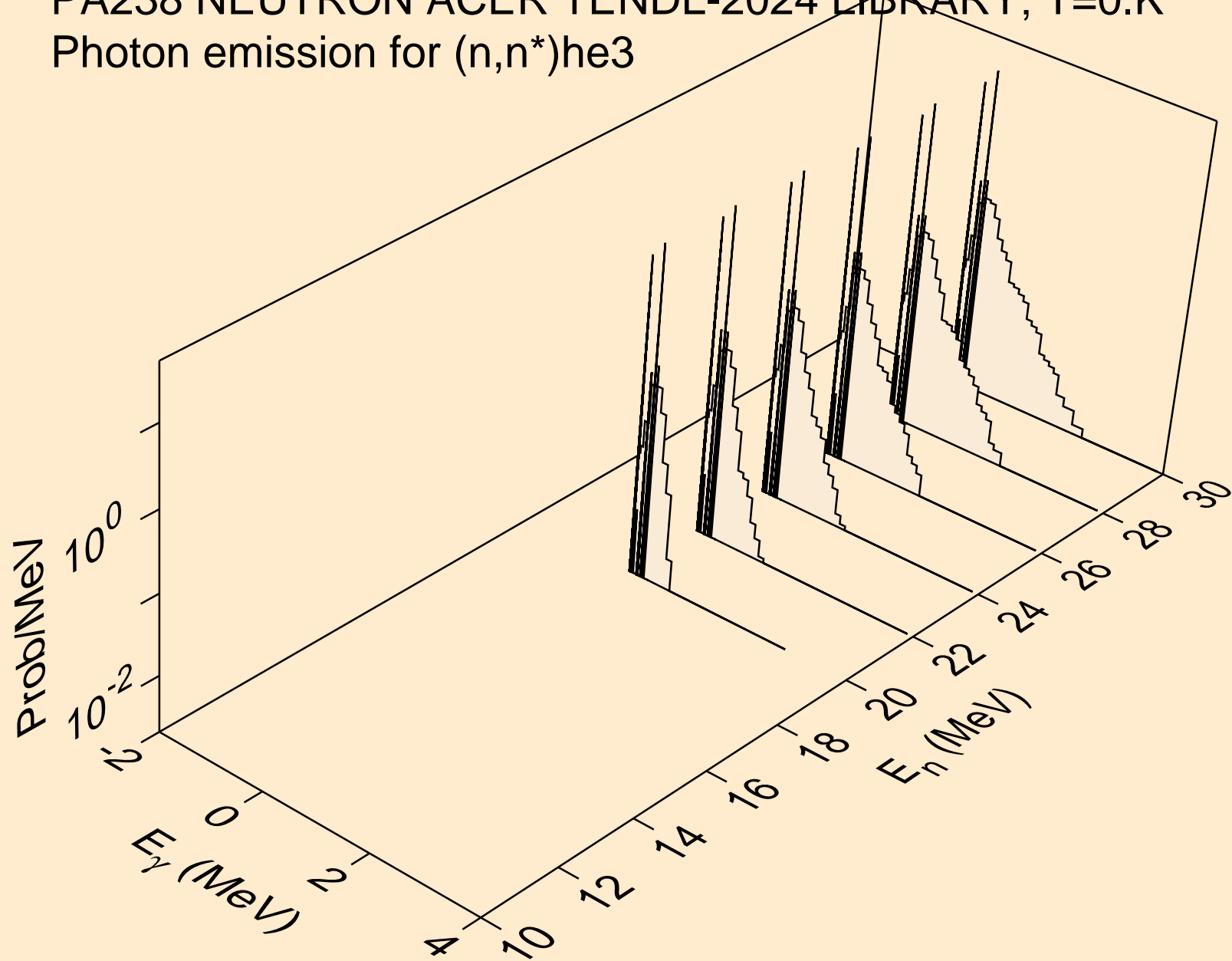

PA238 NEUTRON ACER TENDL-2024 LIBRARY; T=0.K
Photon emission for (n,4n)

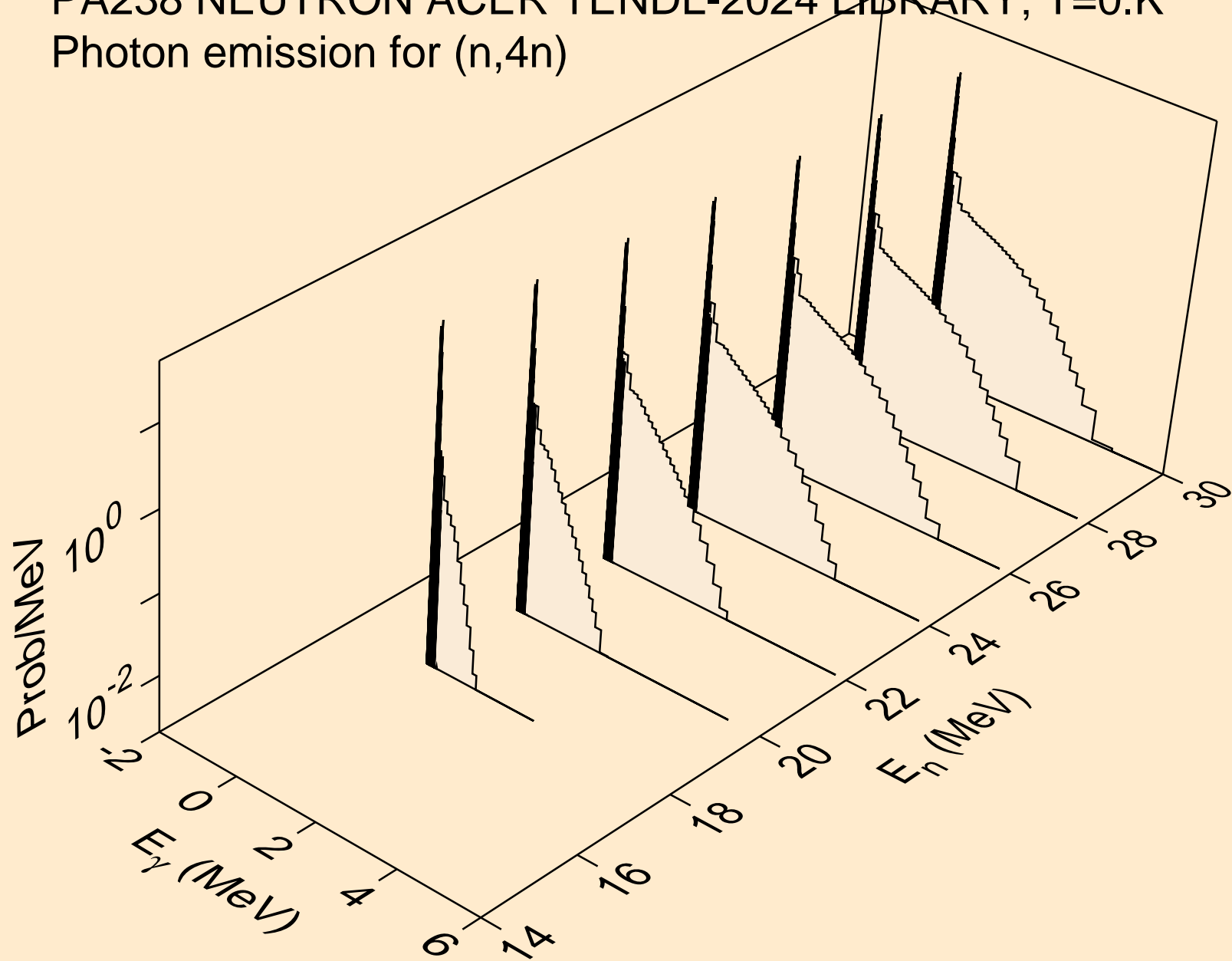

PA238 NEUTRON ACER TENDL-2024 LIBRARY; T=0.K
Photon emission for (n,2np)

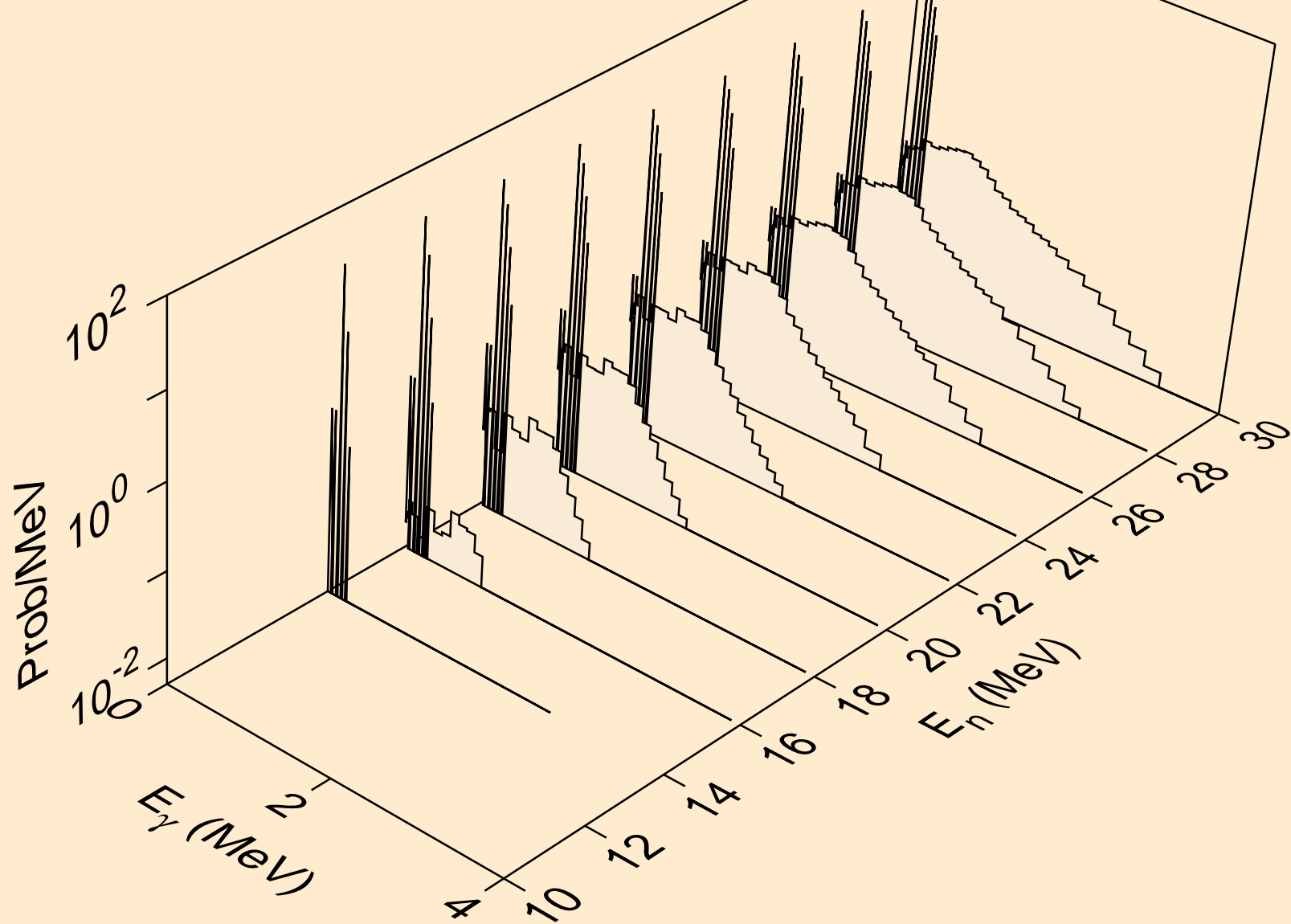

PA238 NEUTRON ACER TENDL-2024 LIBRARY; T=0.K
Photon emission for (n,3np)

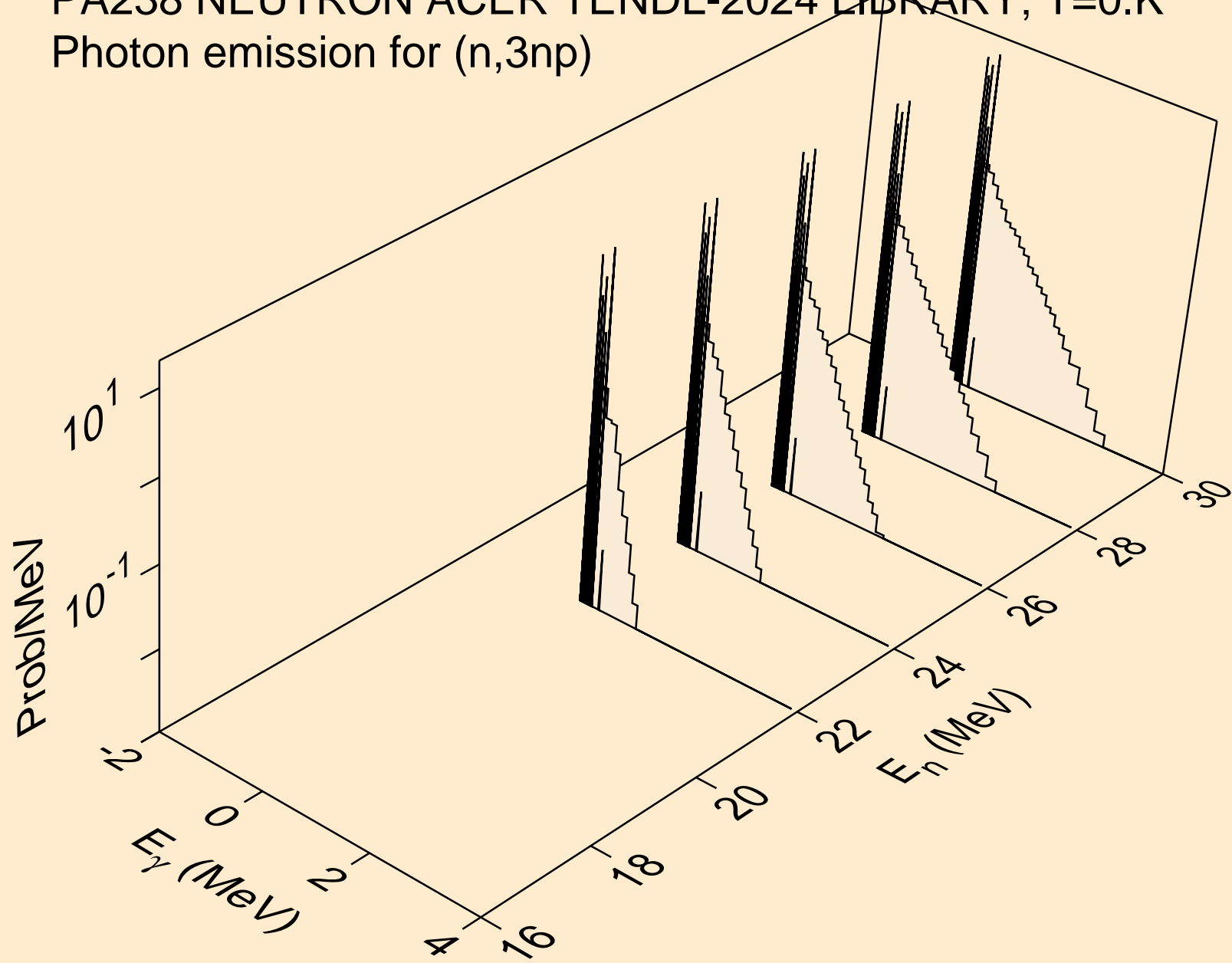

PA238 NEUTRON ACER TENDL-2024 LIBRARY; T=0.K
Photon emission for (n,n*c)

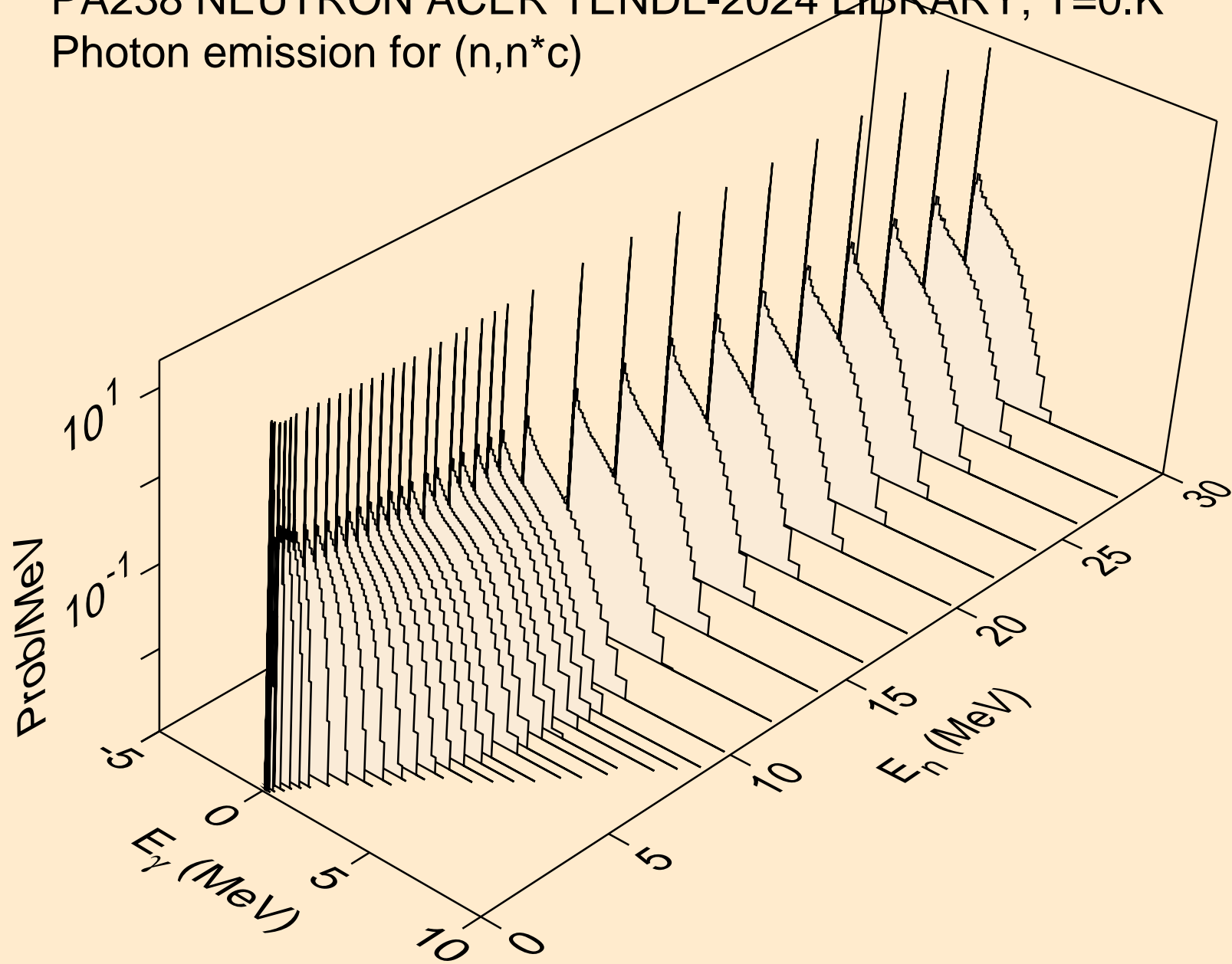

PA238 NEUTRON ACER TENDL-2024 LIBRARY; T=0.K
Photon emission for (n,gma)

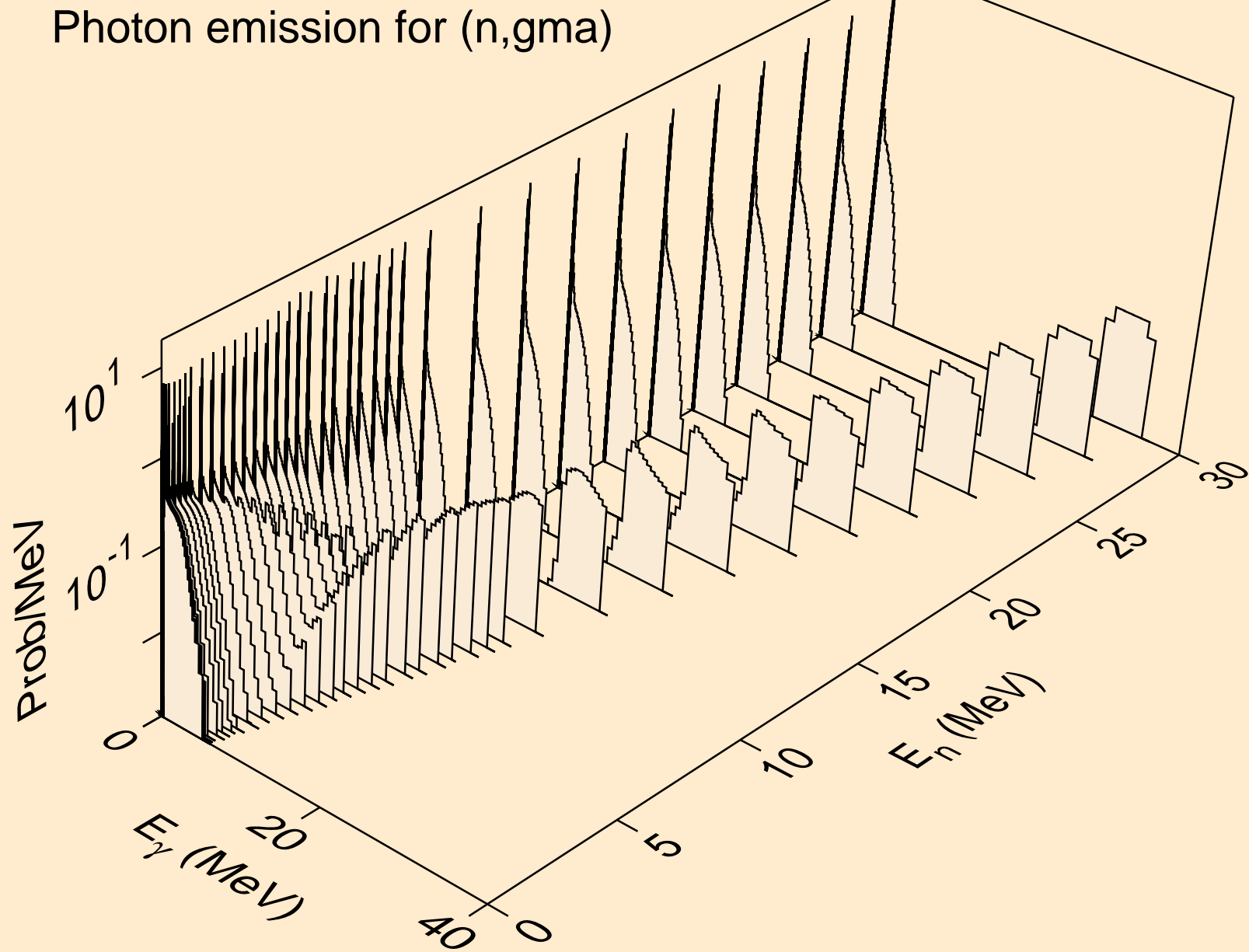

PA238 NEUTRON ACER TENDL-2024 LIBRARY; T=0.K
Photon emission for (n,p)

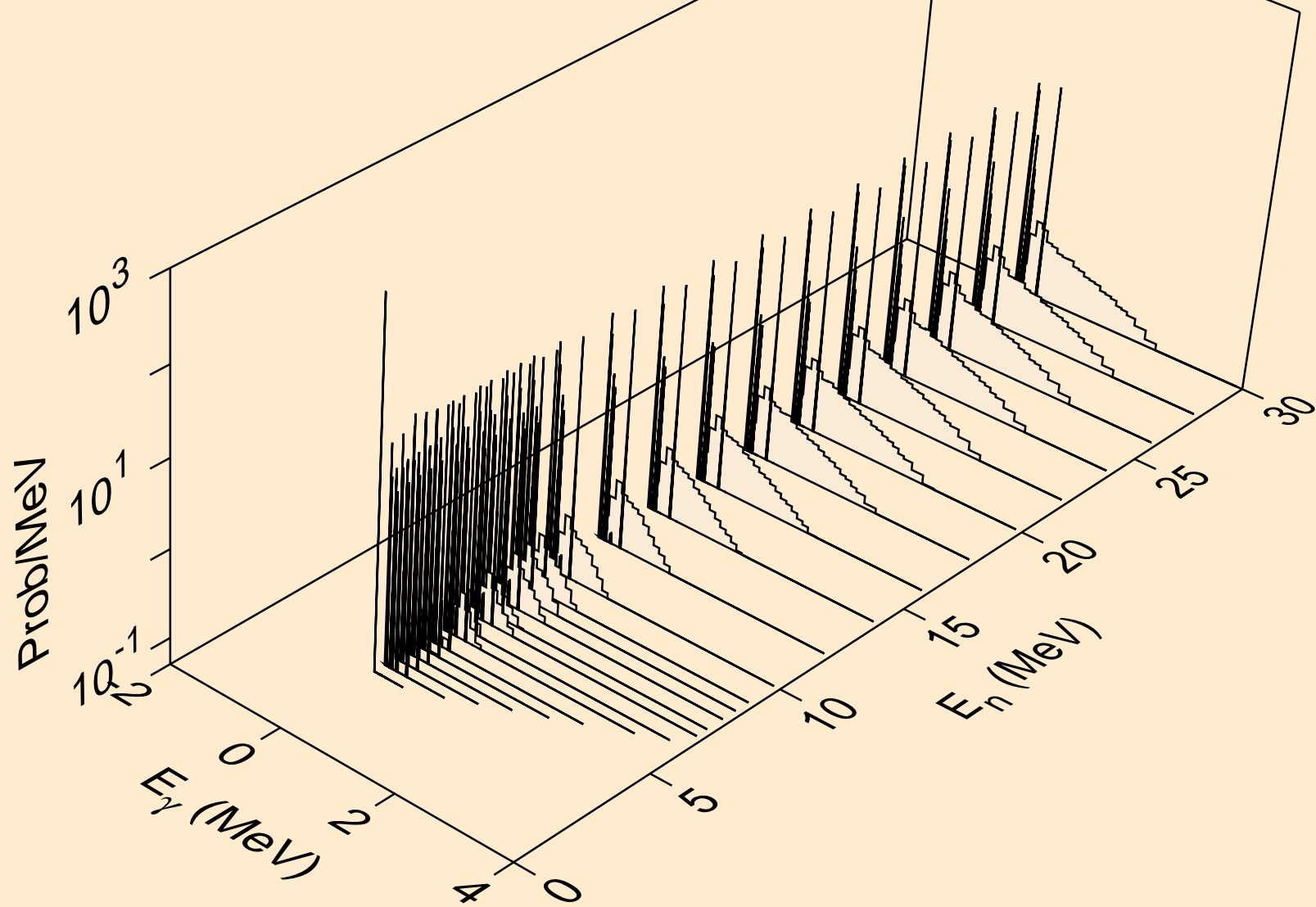

PA238 NEUTRON ACER TENDL-2024 LIBRARY; T=0.K
Photon emission for (n,d)

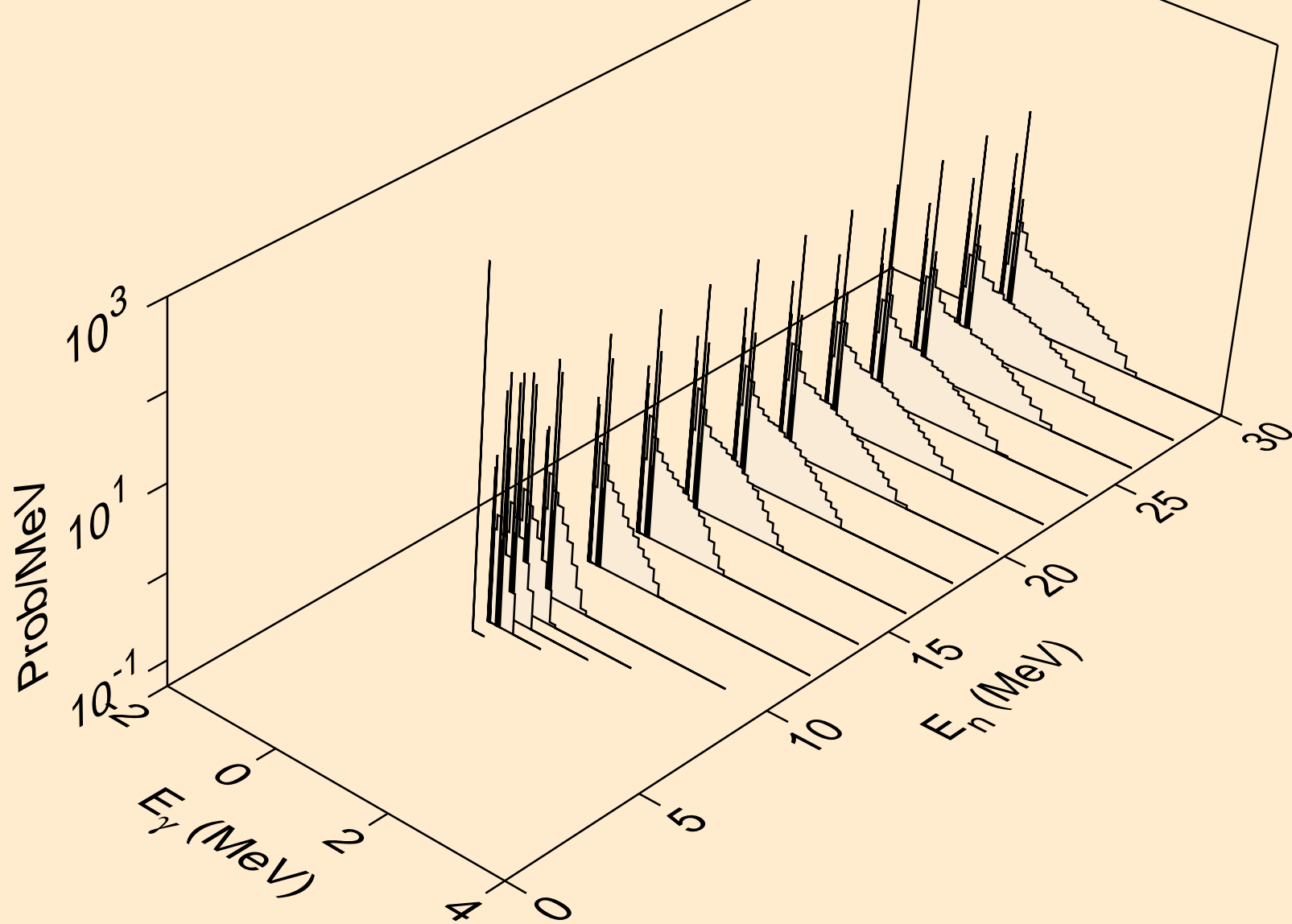

PA238 NEUTRON ACER TENDL-2024 LIBRARY; T=0.K
Photon emission for (n,t)

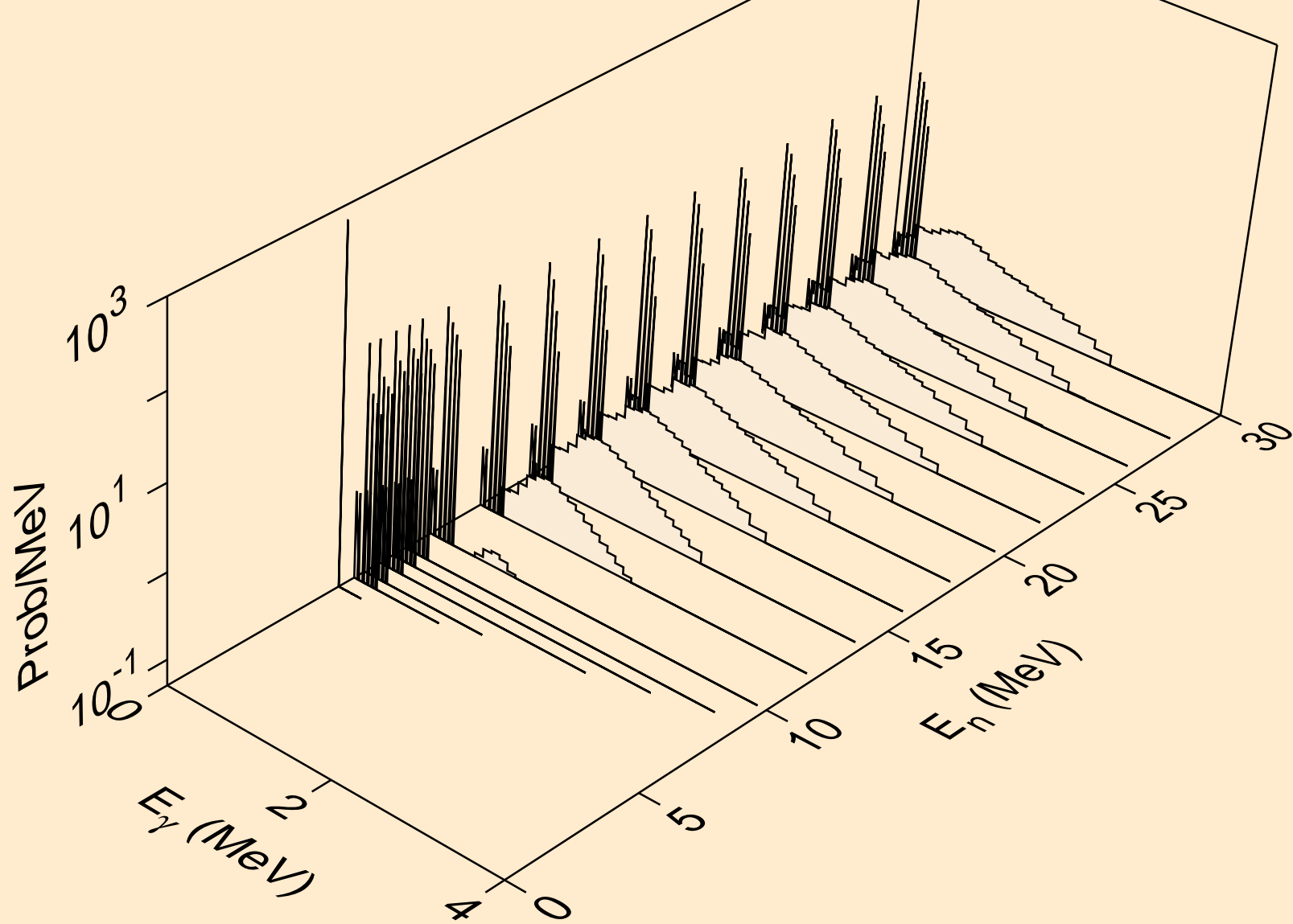

PA238 NEUTRON ACER TENDL-2024 LIBRARY; T=0.K
Photon emission for (n,he3)

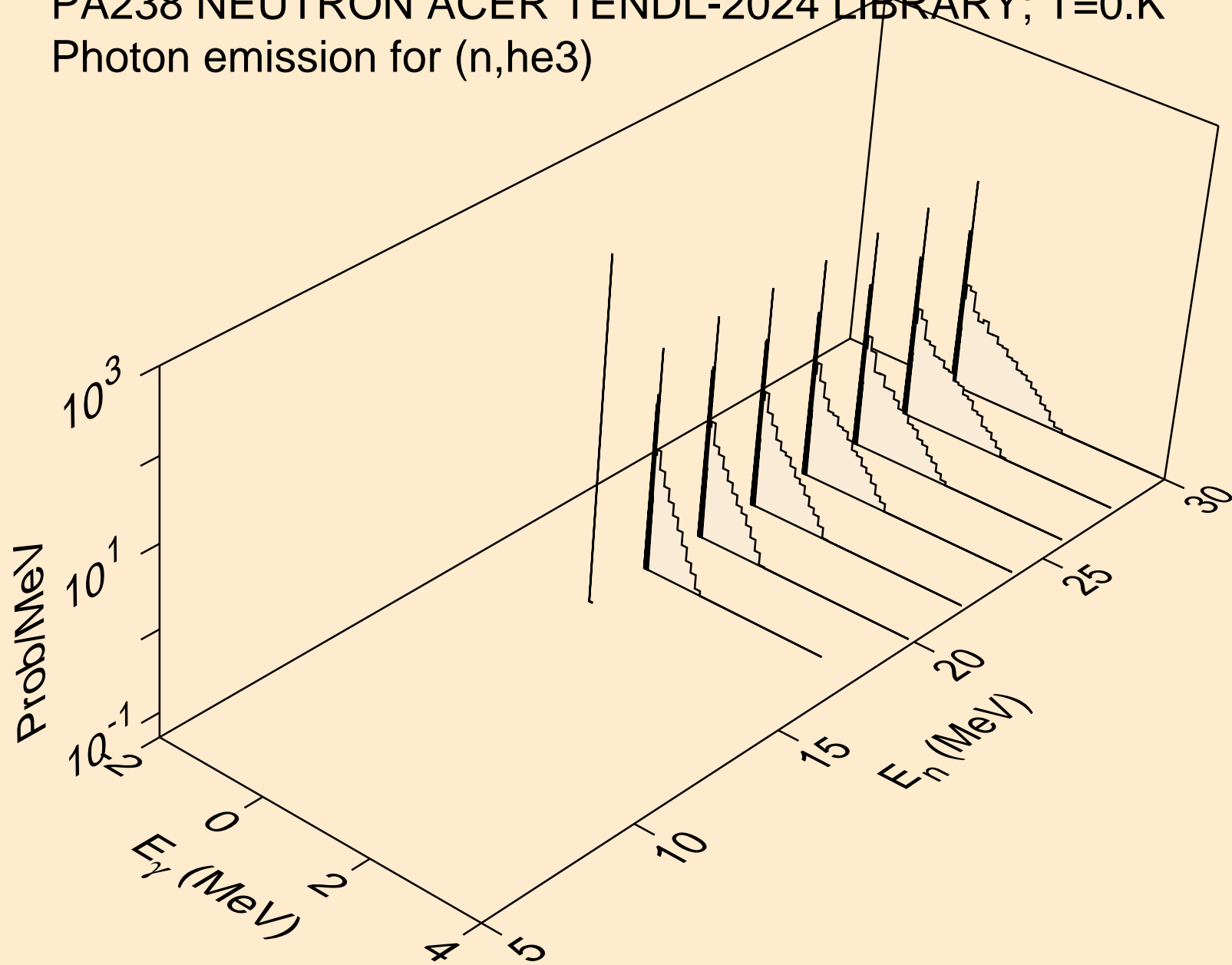

PA238 NEUTRON ACER TENDL-2024 LIBRARY; T=0.K
Photon emission for (n,a)

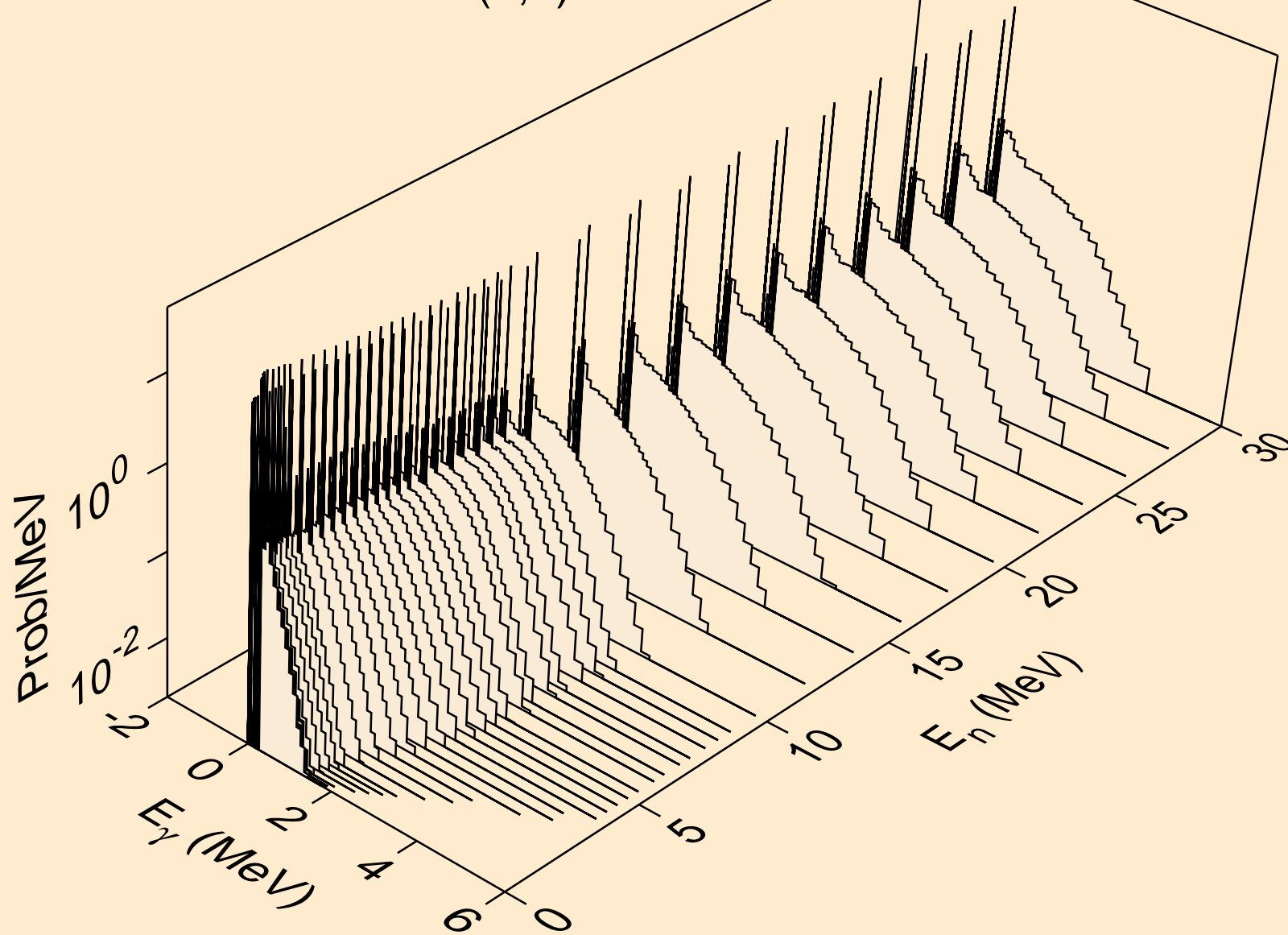

PA238 NEUTRON ACER TENDL-2024 LIBRARY; T=0.K
Photon emission for (n,2p)

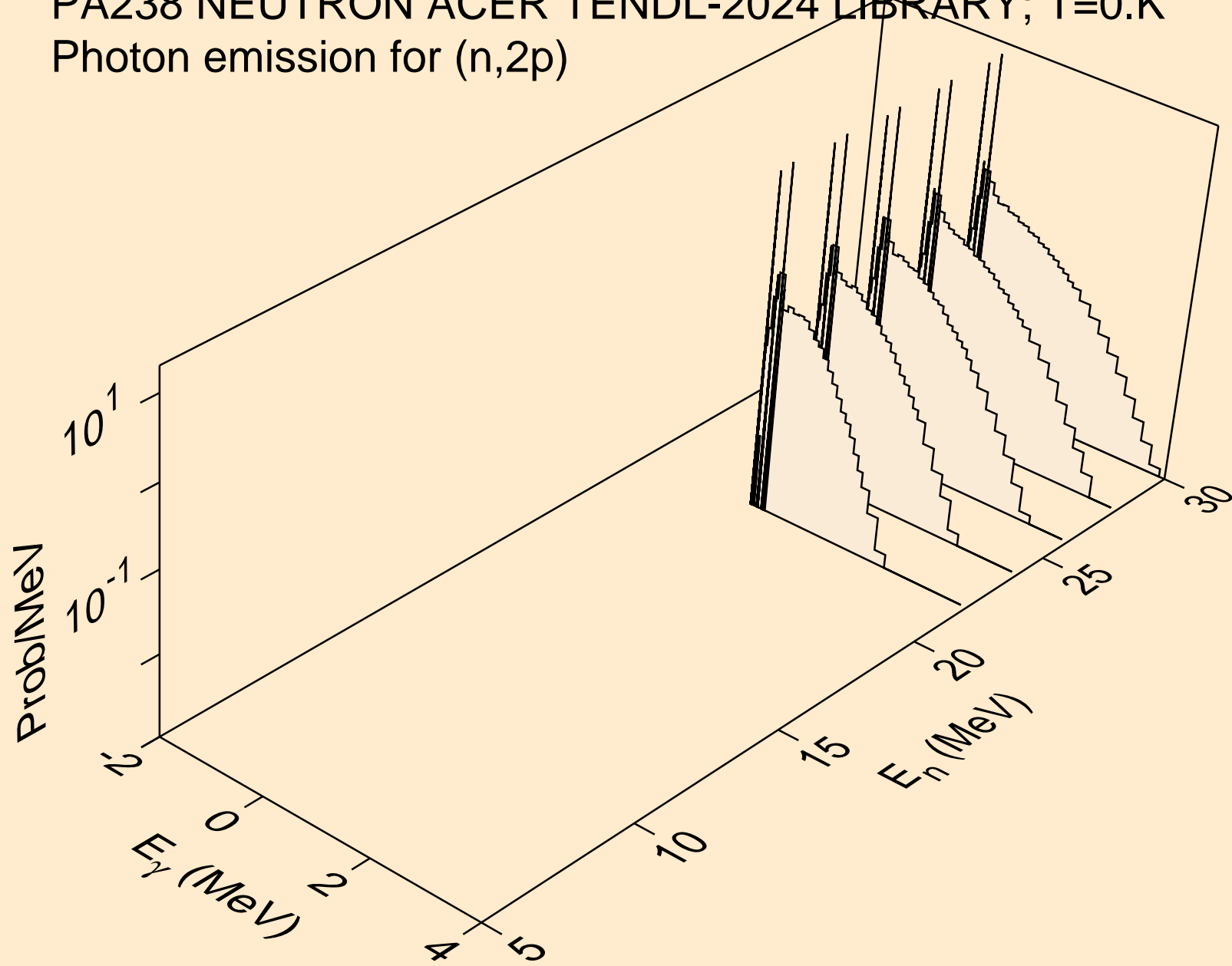

PA238 NEUTRON ACER TENDL-2024 LIBRARY; T=0.K
thermal capture photon spectrum

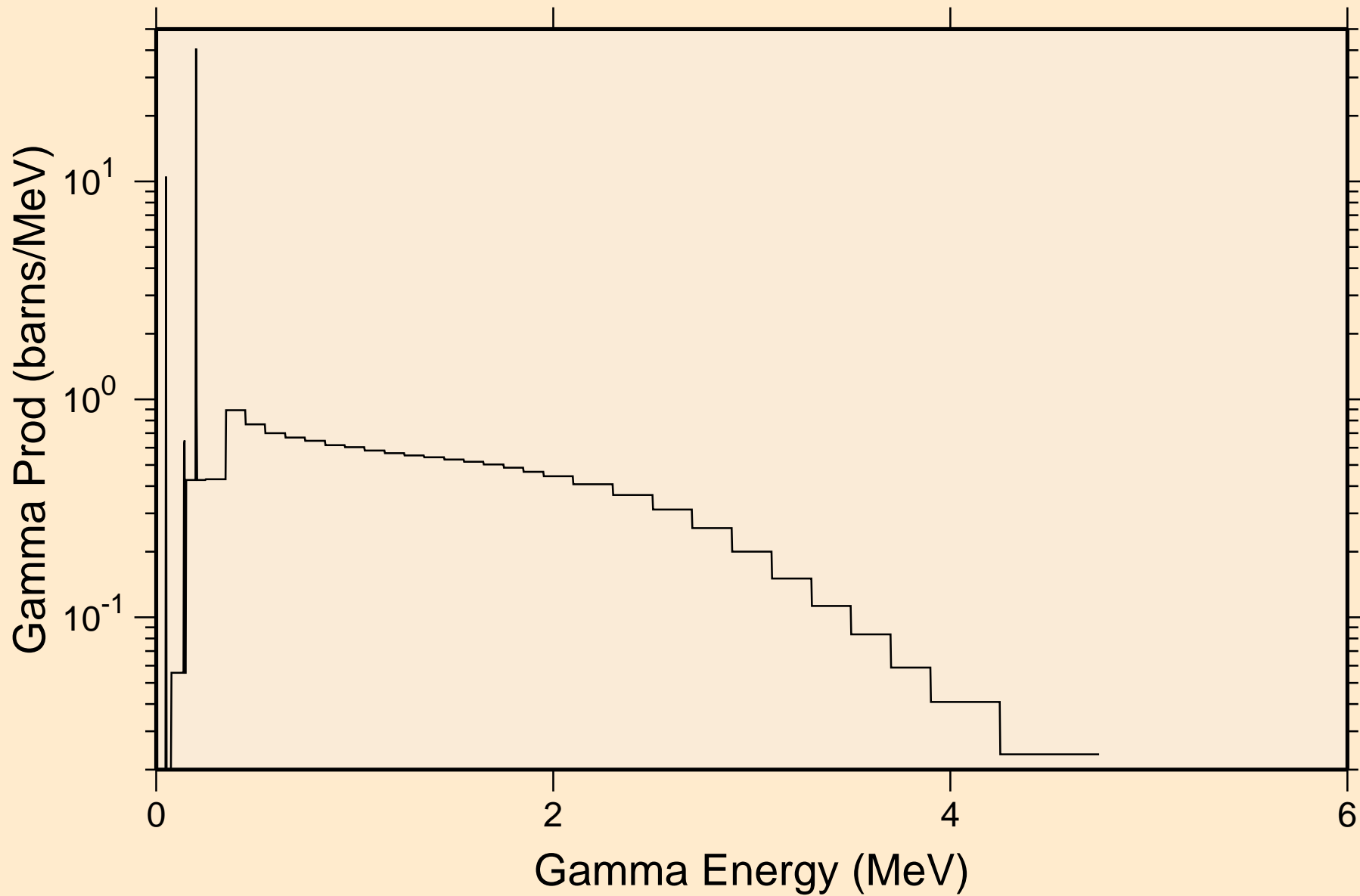

PA238 NEUTRON ACER TENDL-2024 LIBRARY; T=0.K
14 MeV photon spectrum

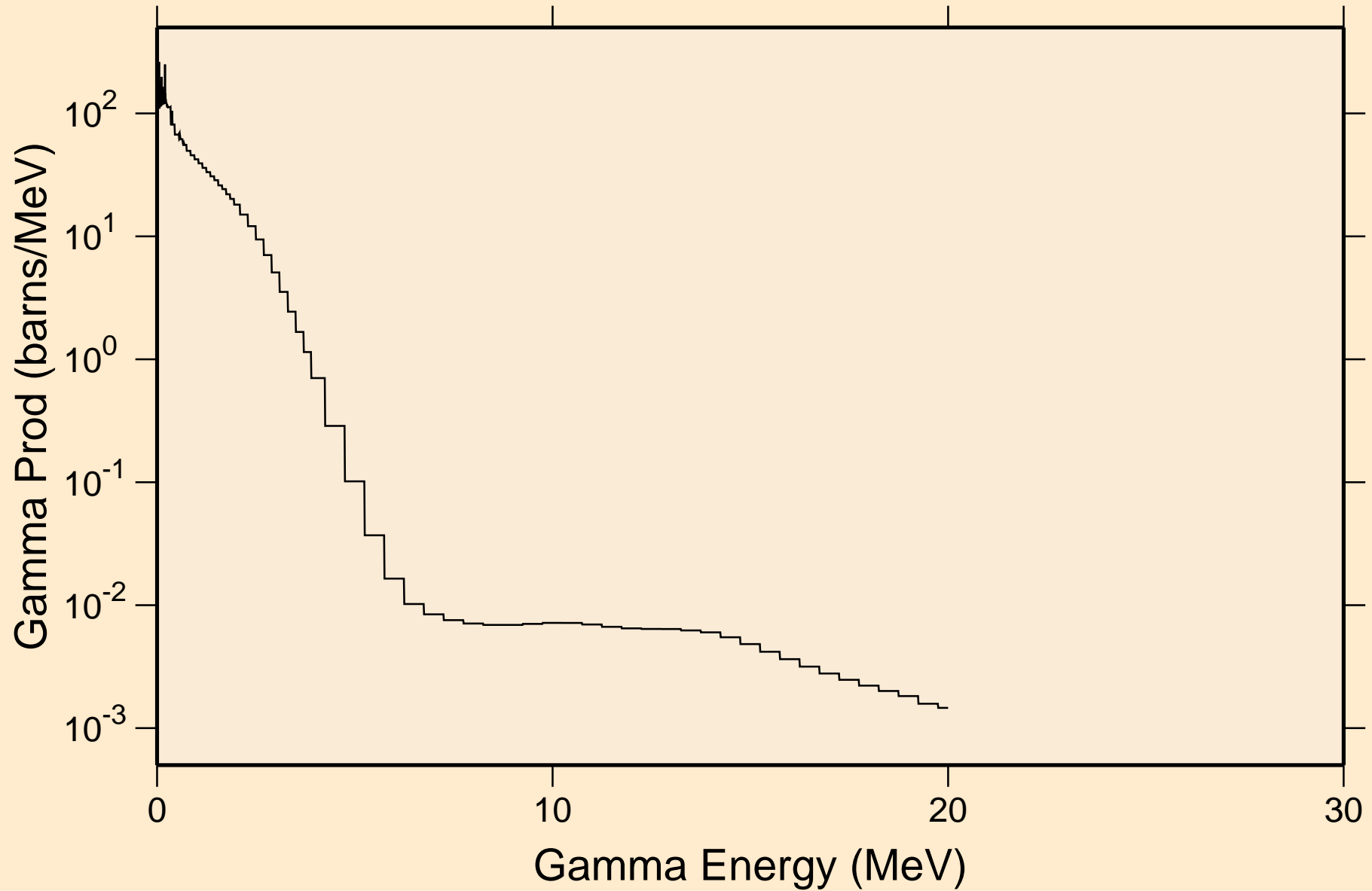

PA238 NEUTRON ACER TENDL-2024 LIBRARY; T=0.K
Particle heating contributions

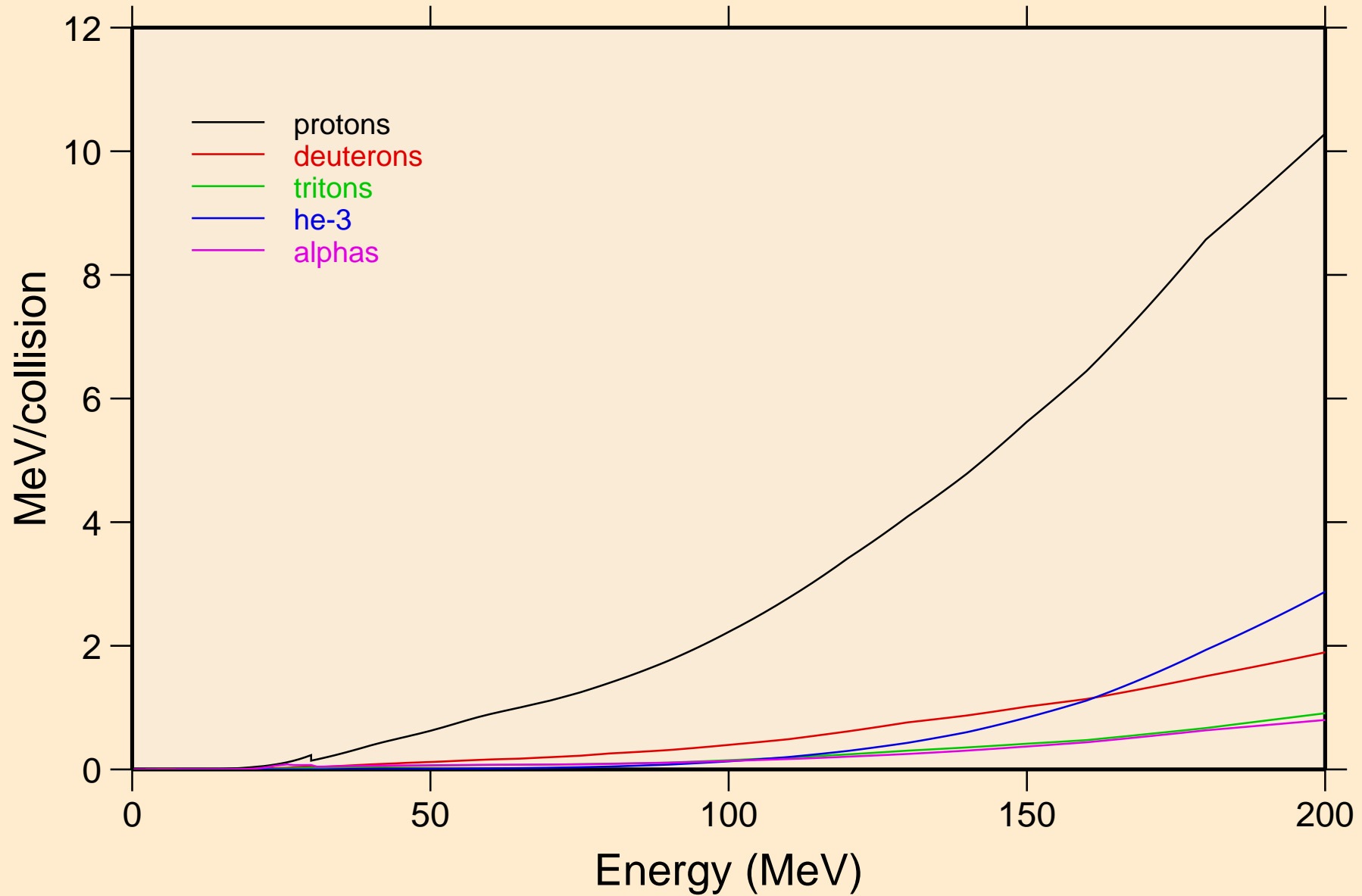

PA238 NEUTRON ACER TENDL-2024 LIBRARY; T=0.K
Recoil Heating

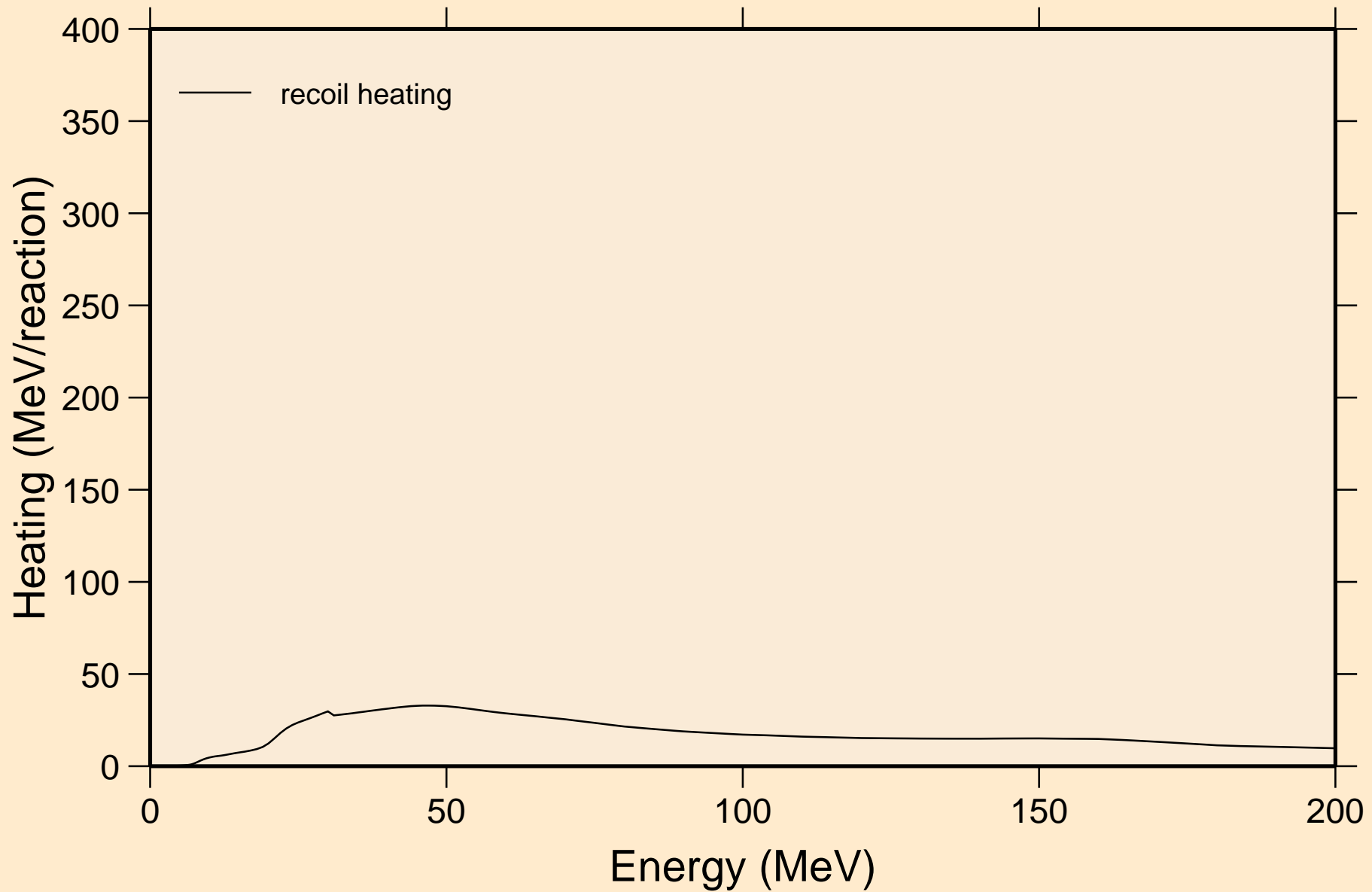

PA238 NEUTRON ACER TENDL-2024 LIBRARY; T=0.K
Particle production cross sections

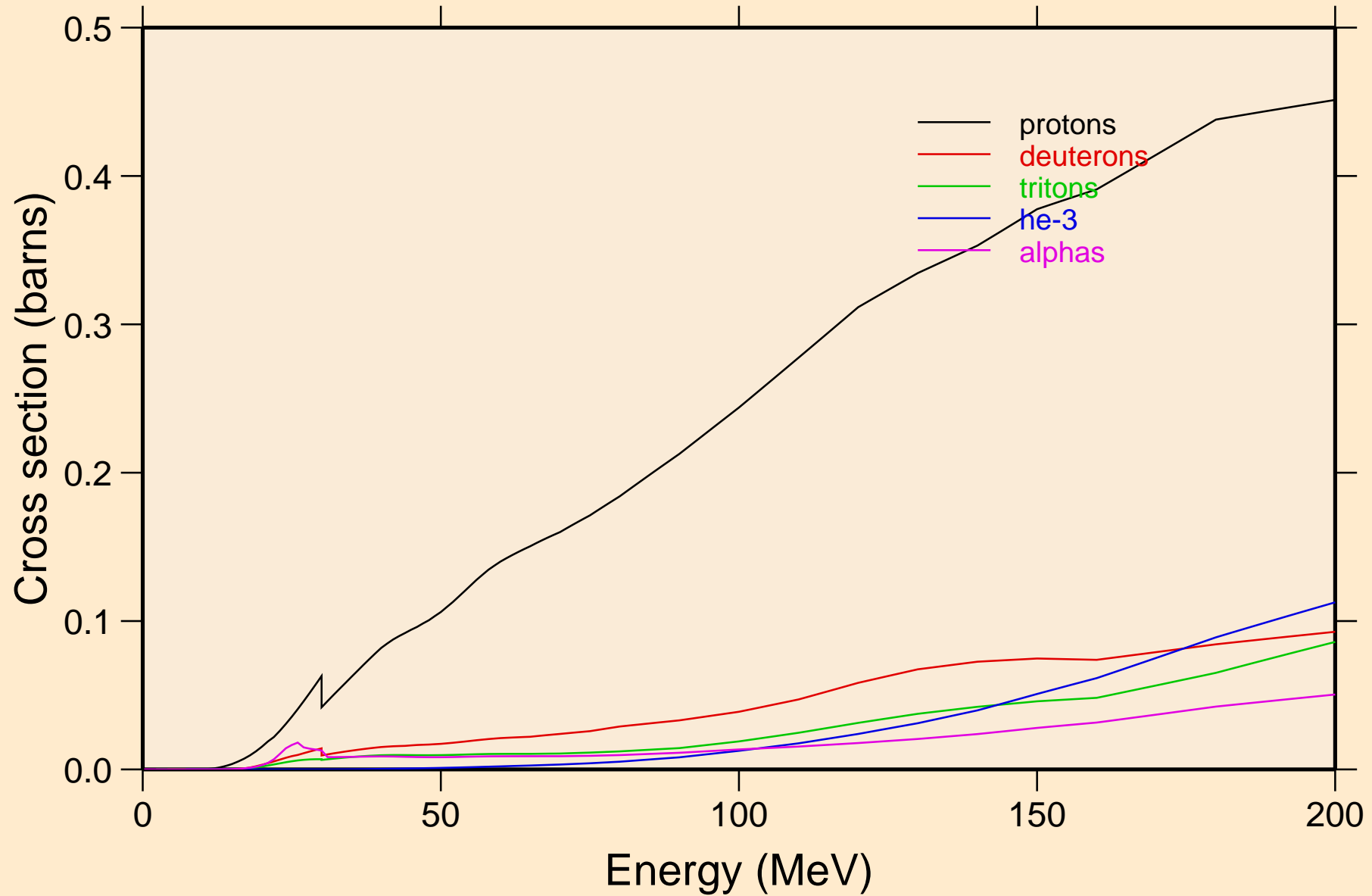

PA238 NEUTRON ACER TENDL-2024 LIBRARY; T=0.K
protons from (n,x)

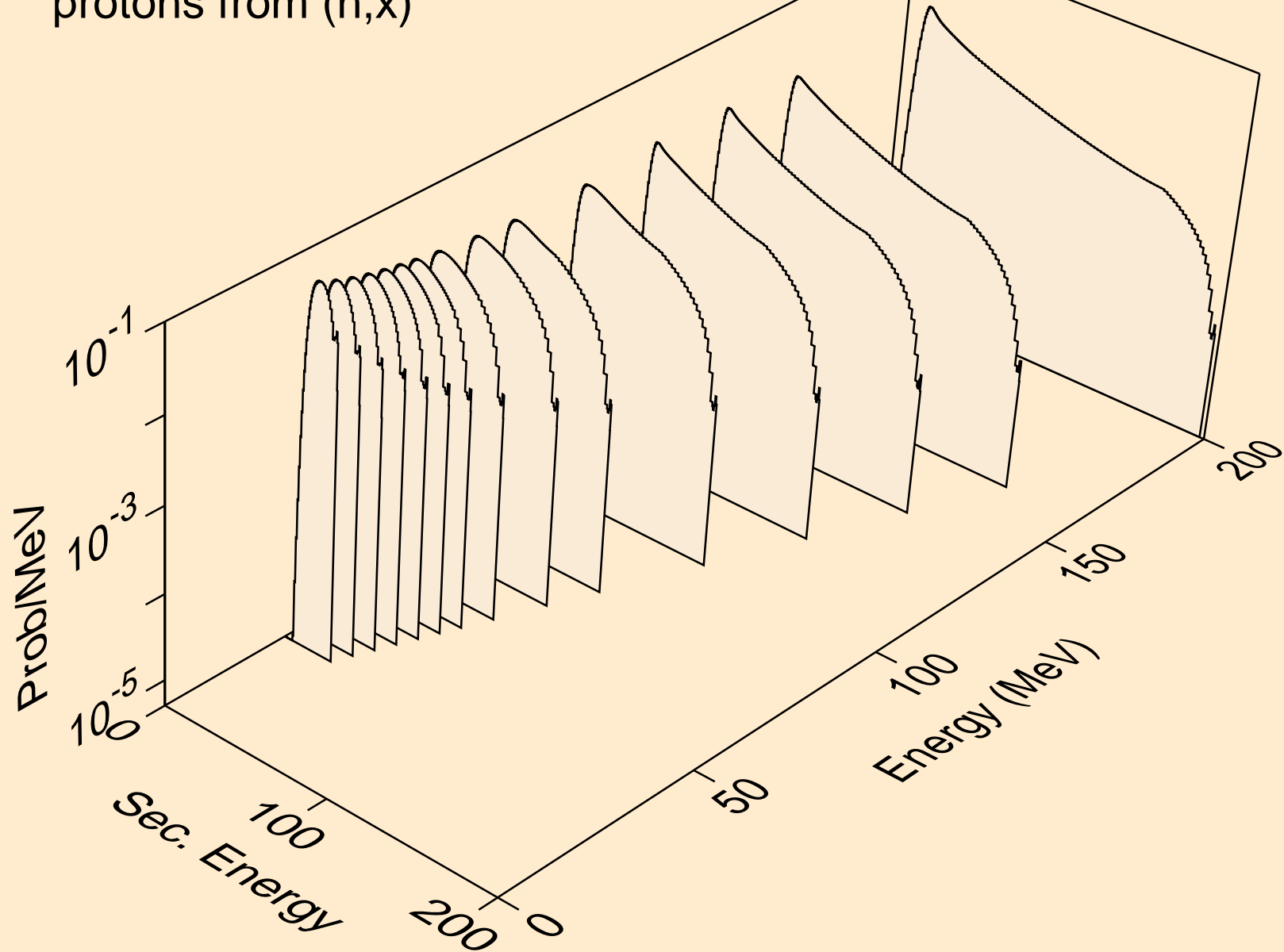

PA238 NEUTRON ACER TENDL-2024 LIBRARY; T=0.K
protons from (n,n*)p

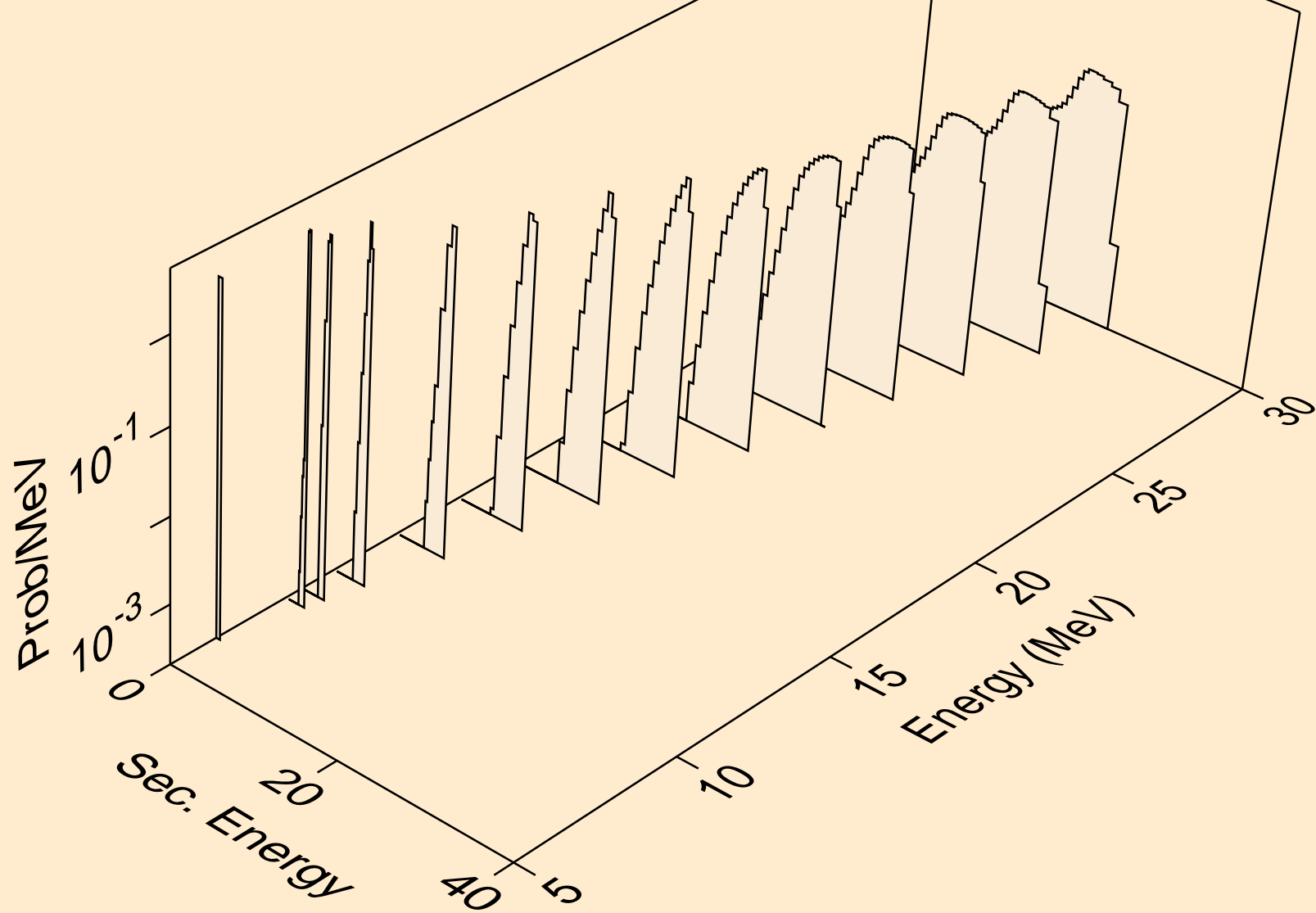

PA238 NEUTRON ACER TENDL-2024 LIBRARY; T=0.K
protons from (n,2np)

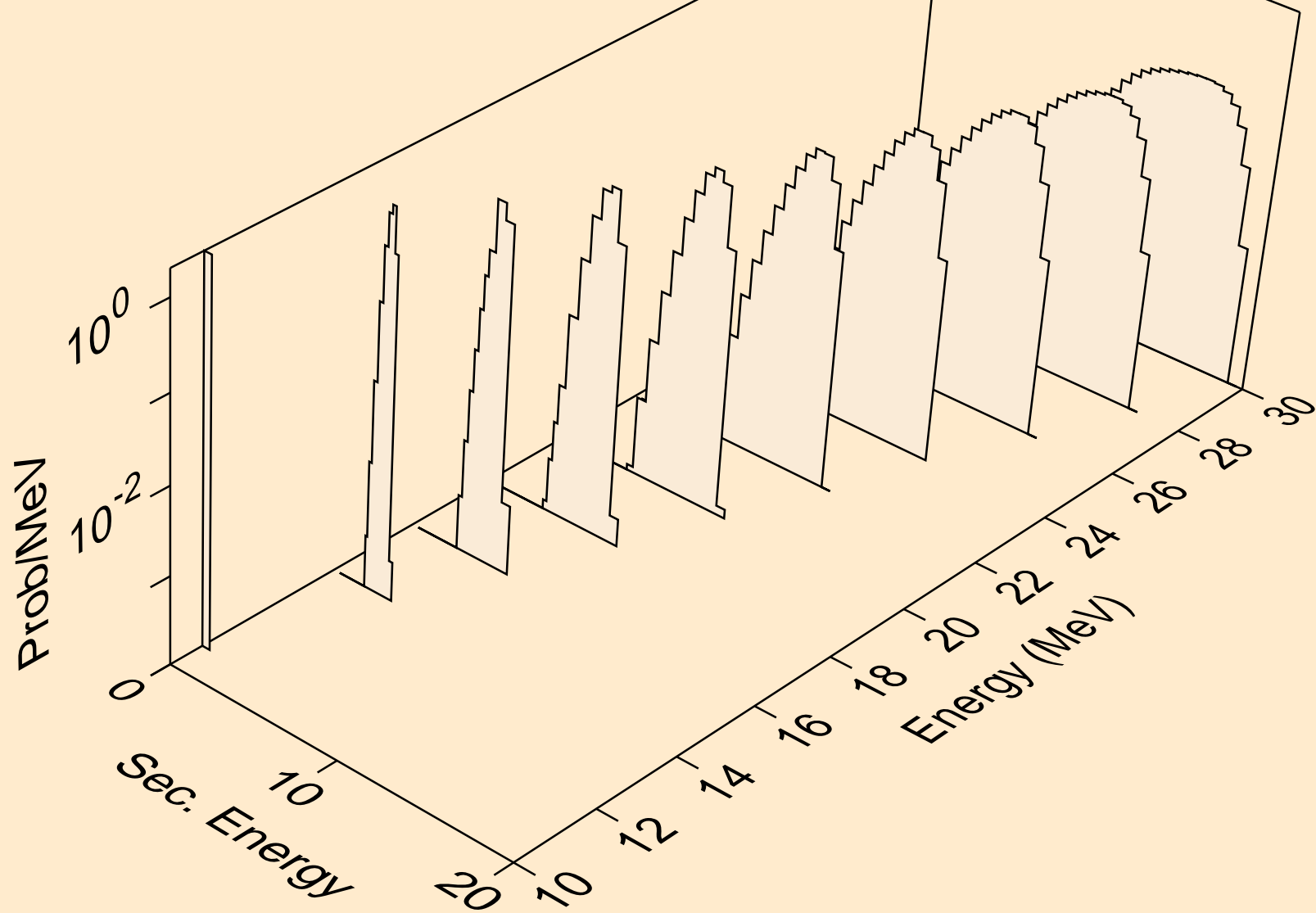

PA238 NEUTRON ACER TENDL-2024 LIBRARY; T=0.K
protons from (n,3np)

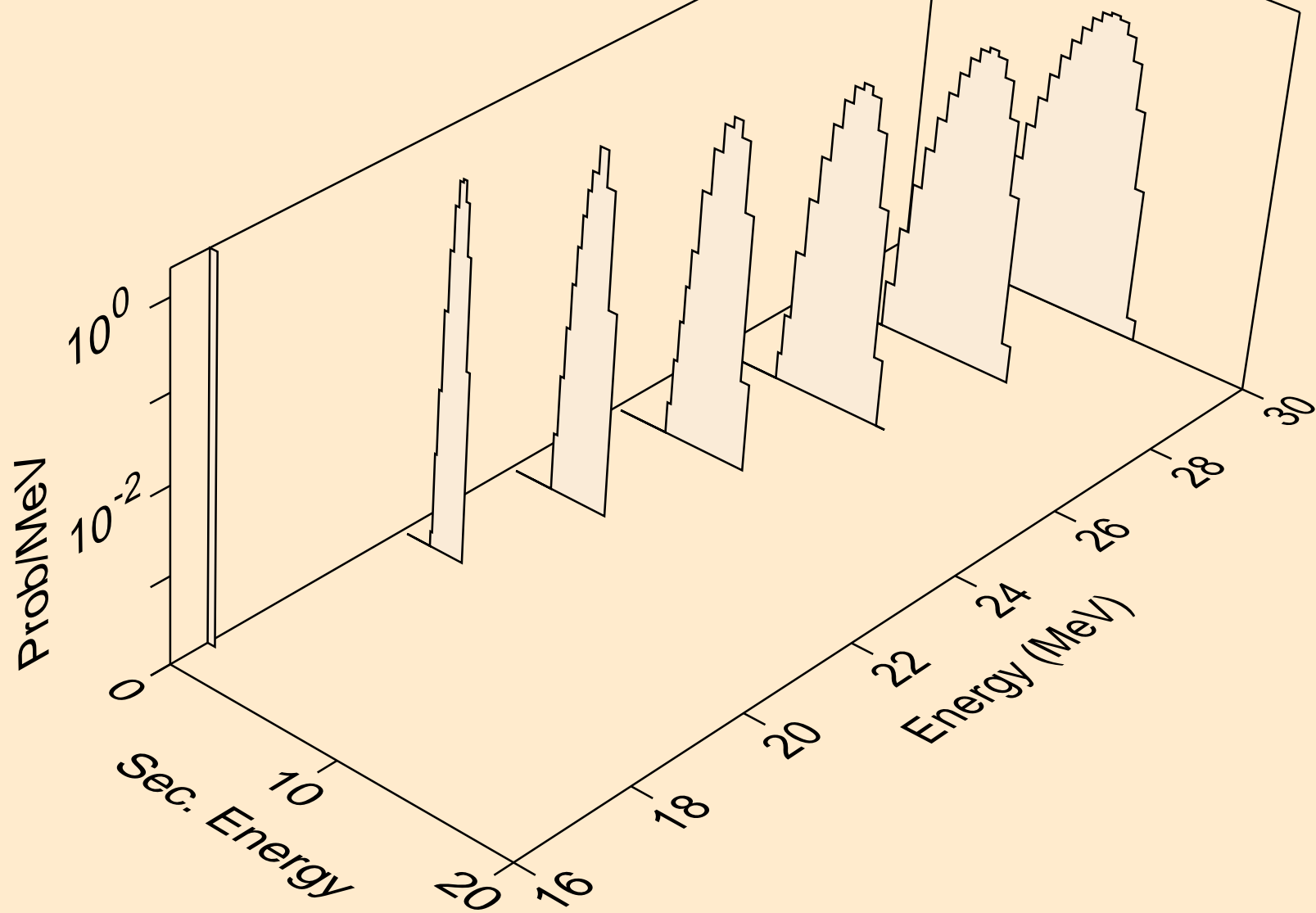

PA238 NEUTRON ACER TENDL-2024 LIBRARY; T=0.K
protons from (n,p)

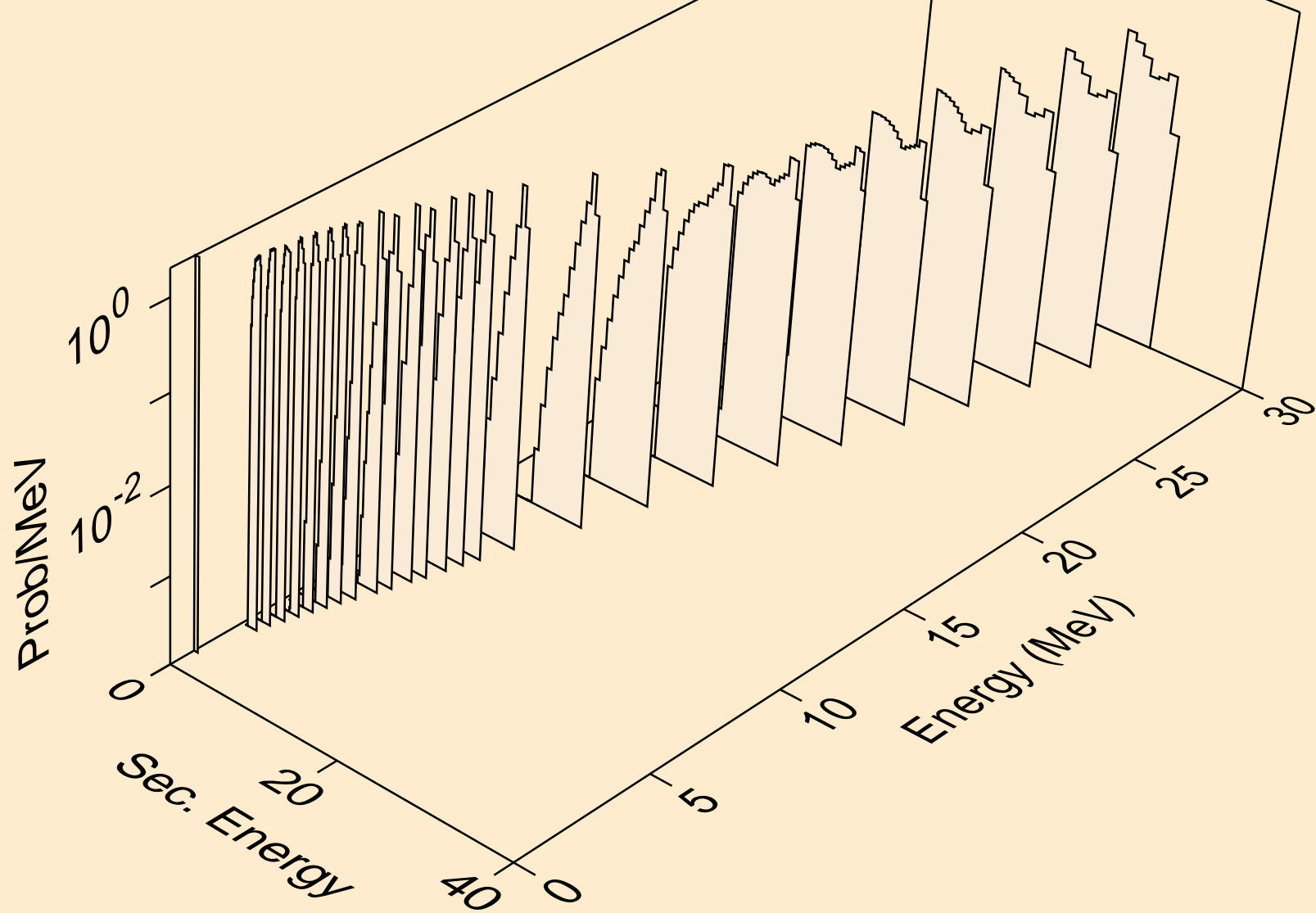

PA238 NEUTRON ACER TENDL-2024 LIBRARY; T=0.K
protons from (n,2p)

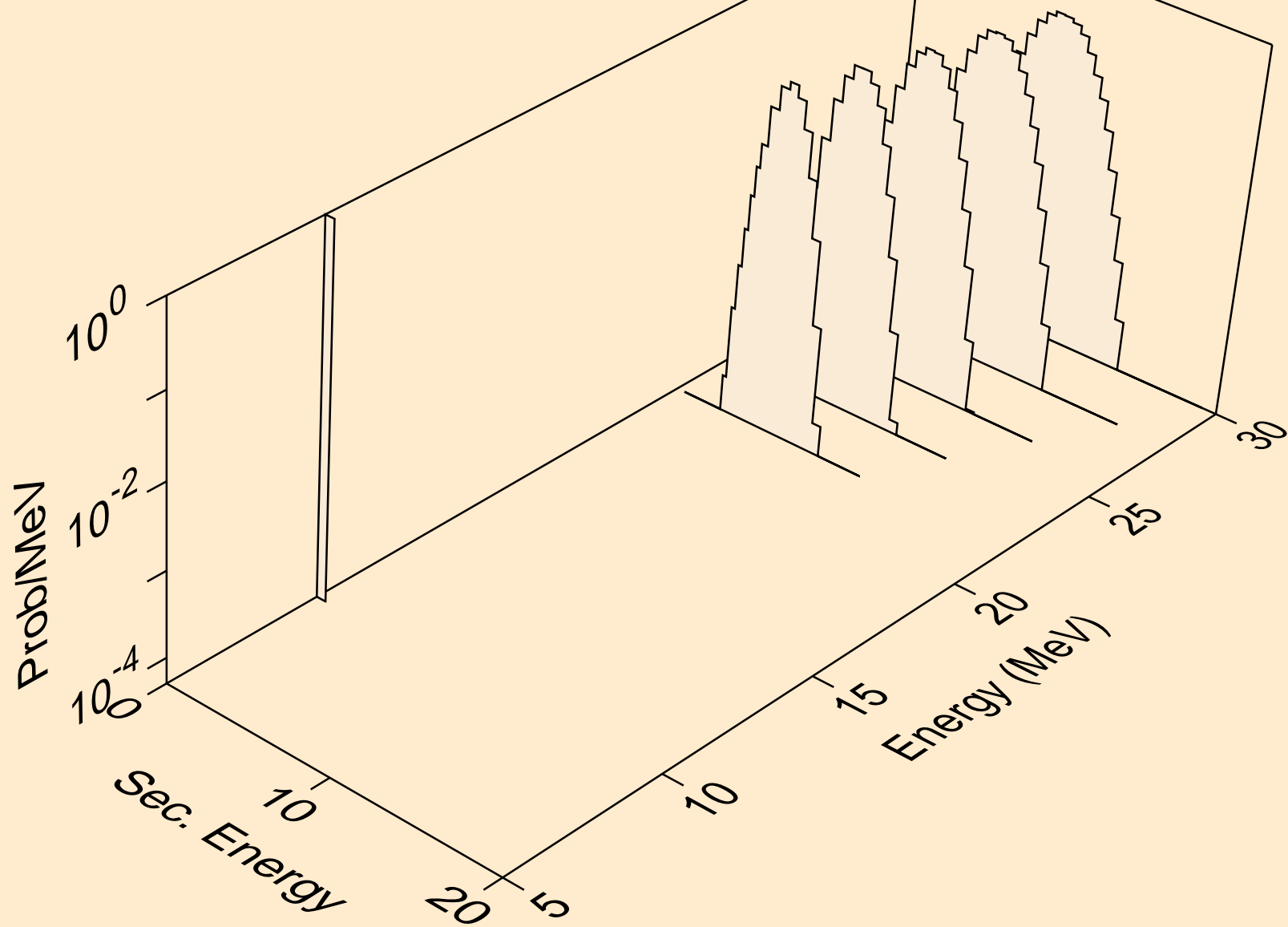

PA238 NEUTRON ACER TENDL-2024 LIBRARY; T=0.K
deuterons from (n,x)

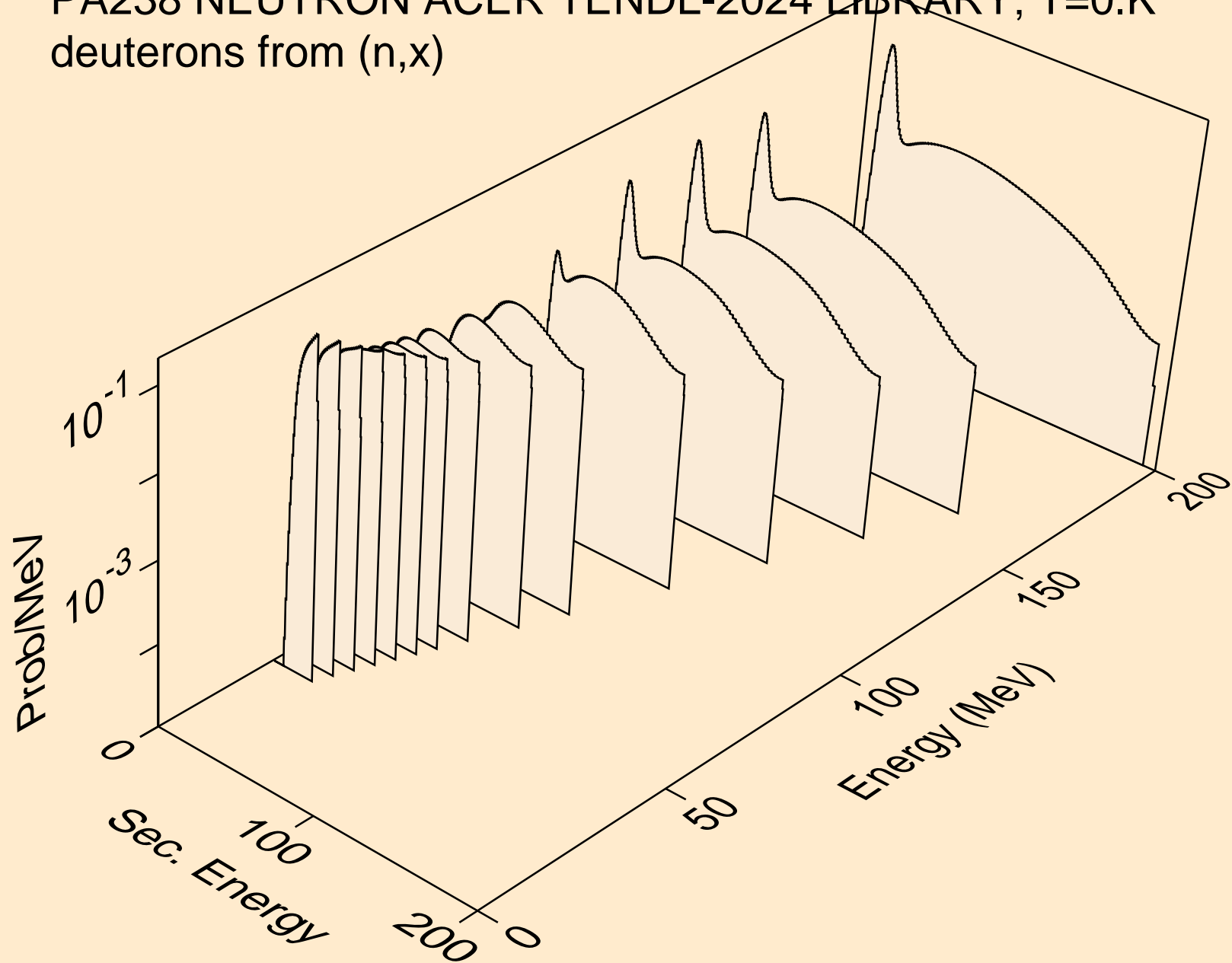

PA238 NEUTRON ACER TENDL-2024 LIBRARY; T=0.K
deuterons from (n,2nd)

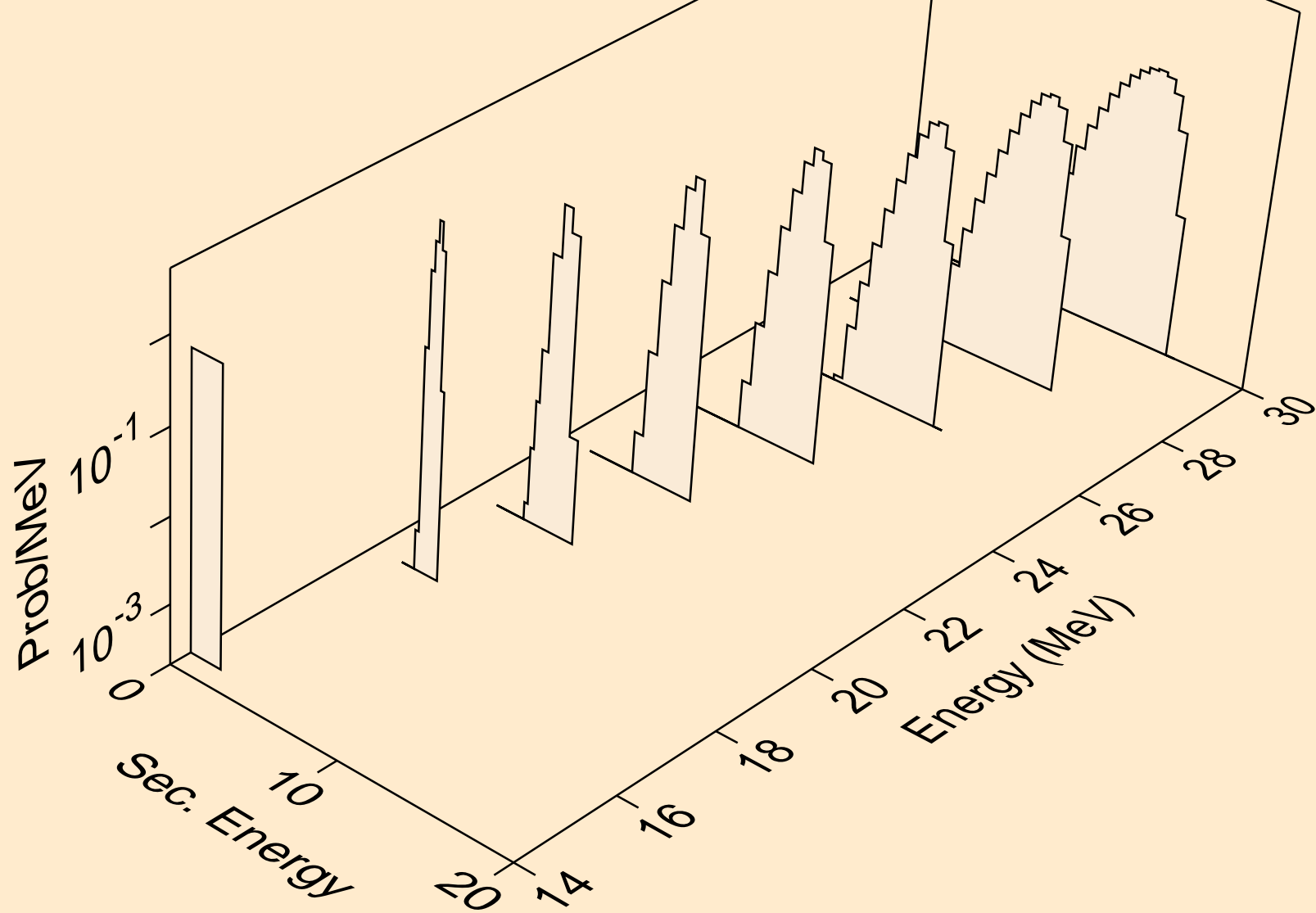

PA238 NEUTRON ACER TENDL-2024 LIBRARY; T=0.K
deuterons from (n,n*)d

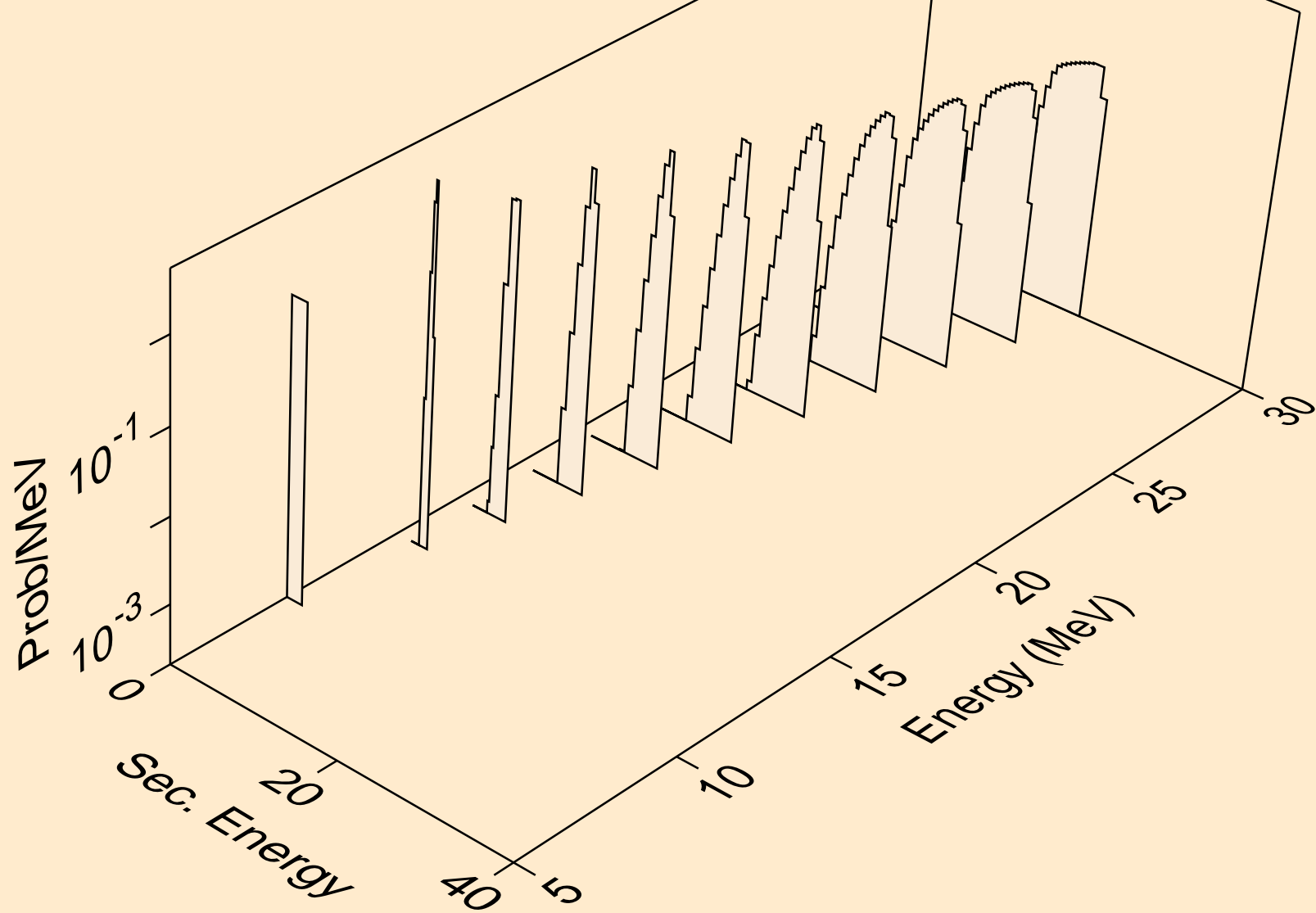

PA238 NEUTRON ACER TENDL-2024 LIBRARY; T=0.K
deuterons from (n,d)

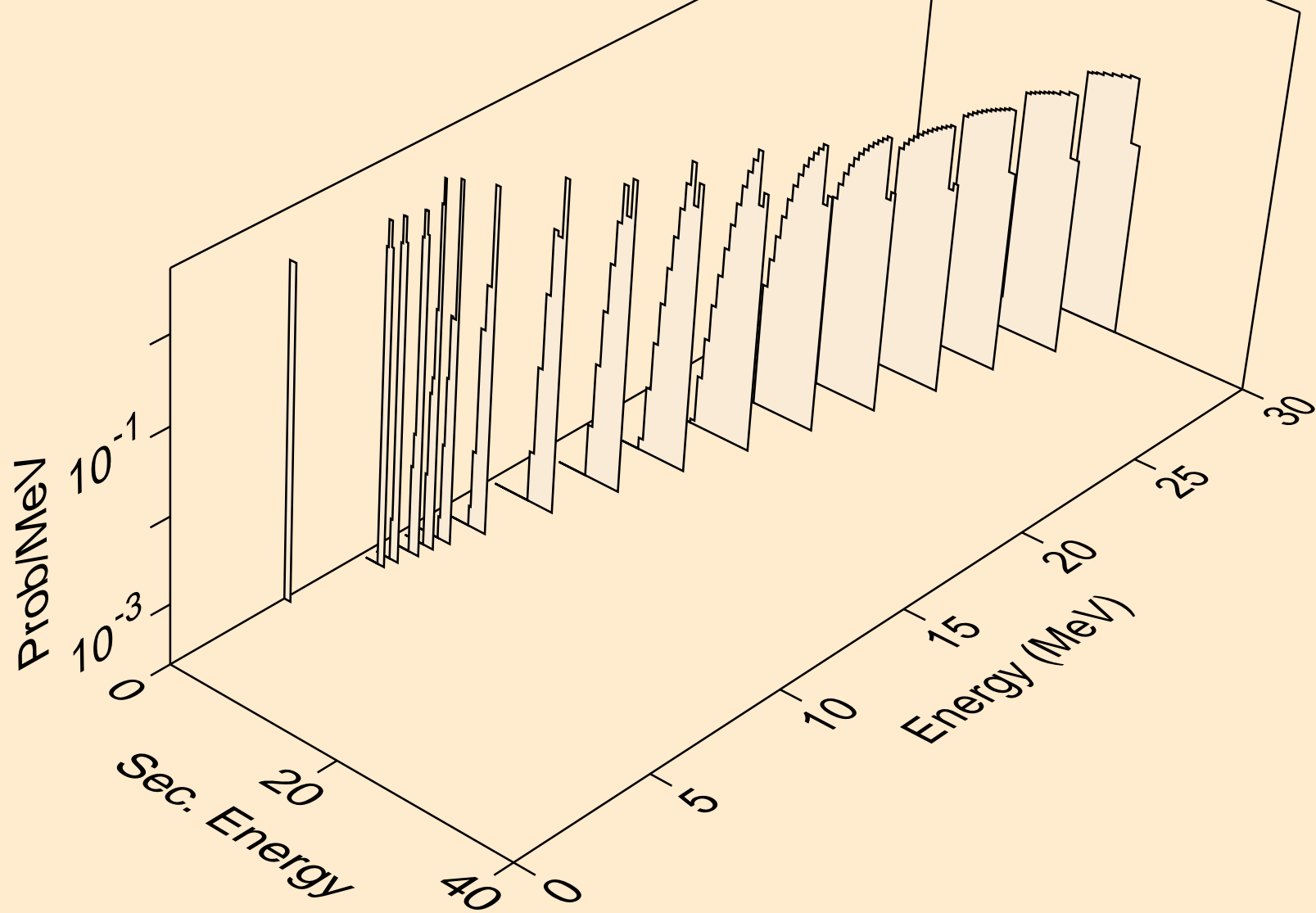

PA238 NEUTRON ACER TENDL-2024 LIBRARY; T=0.K
tritons from (n,x)

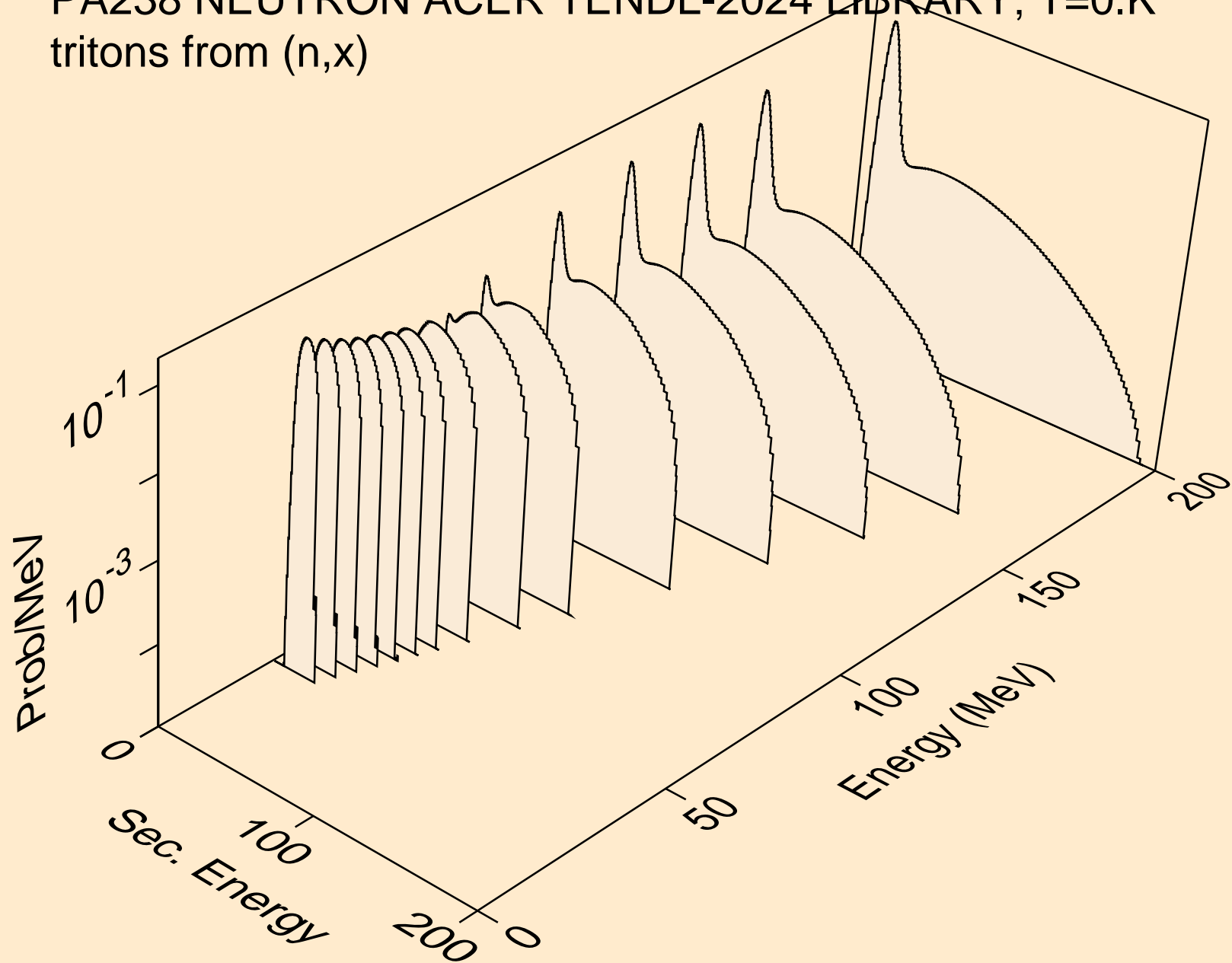

PA238 NEUTRON ACER TENDL-2024 LIBRARY; T=0.K
tritons from (n,n*)t

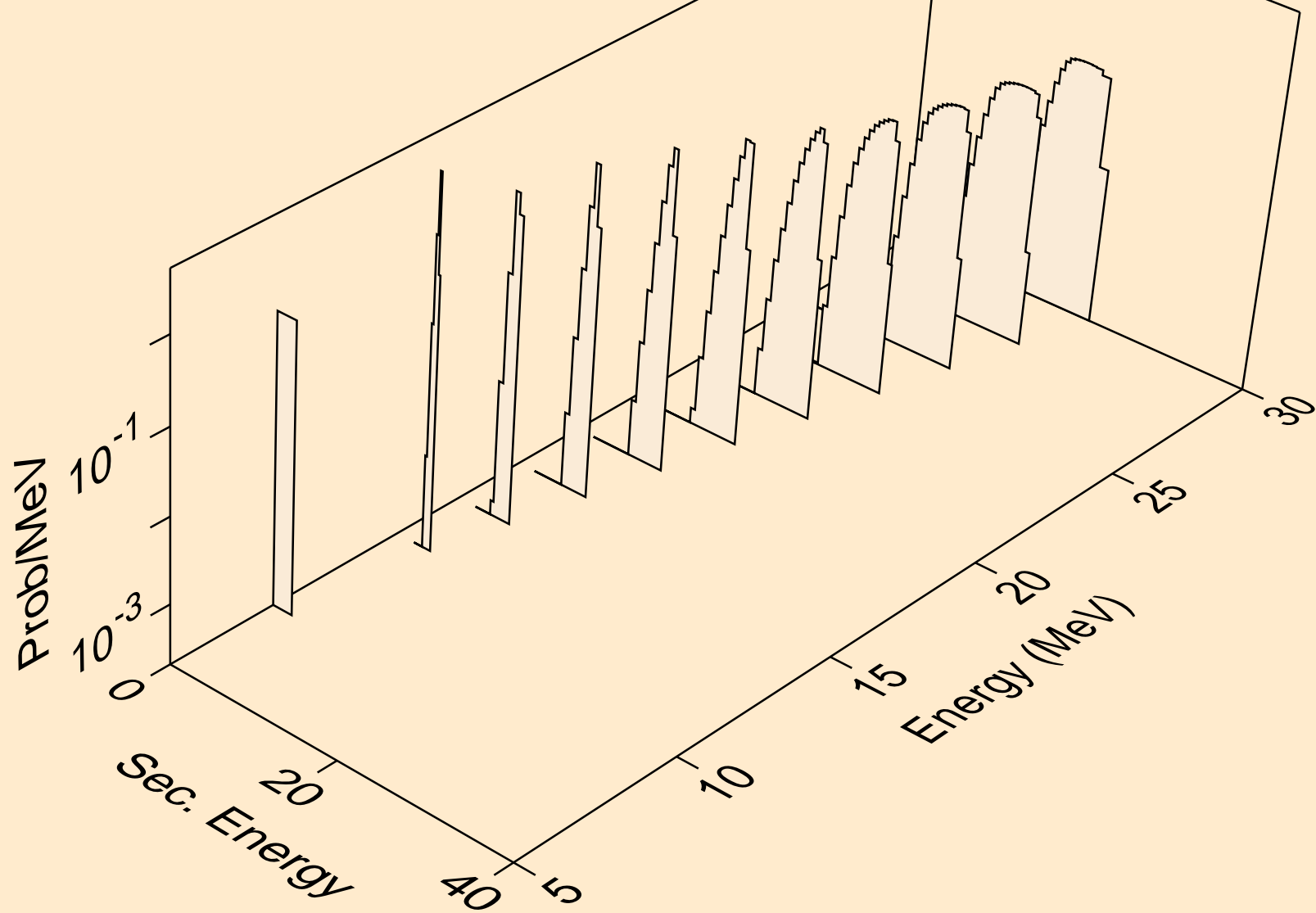

PA238 NEUTRON ACER TENDL-2024 LIBRARY; T=0.K
tritons from (n,t)

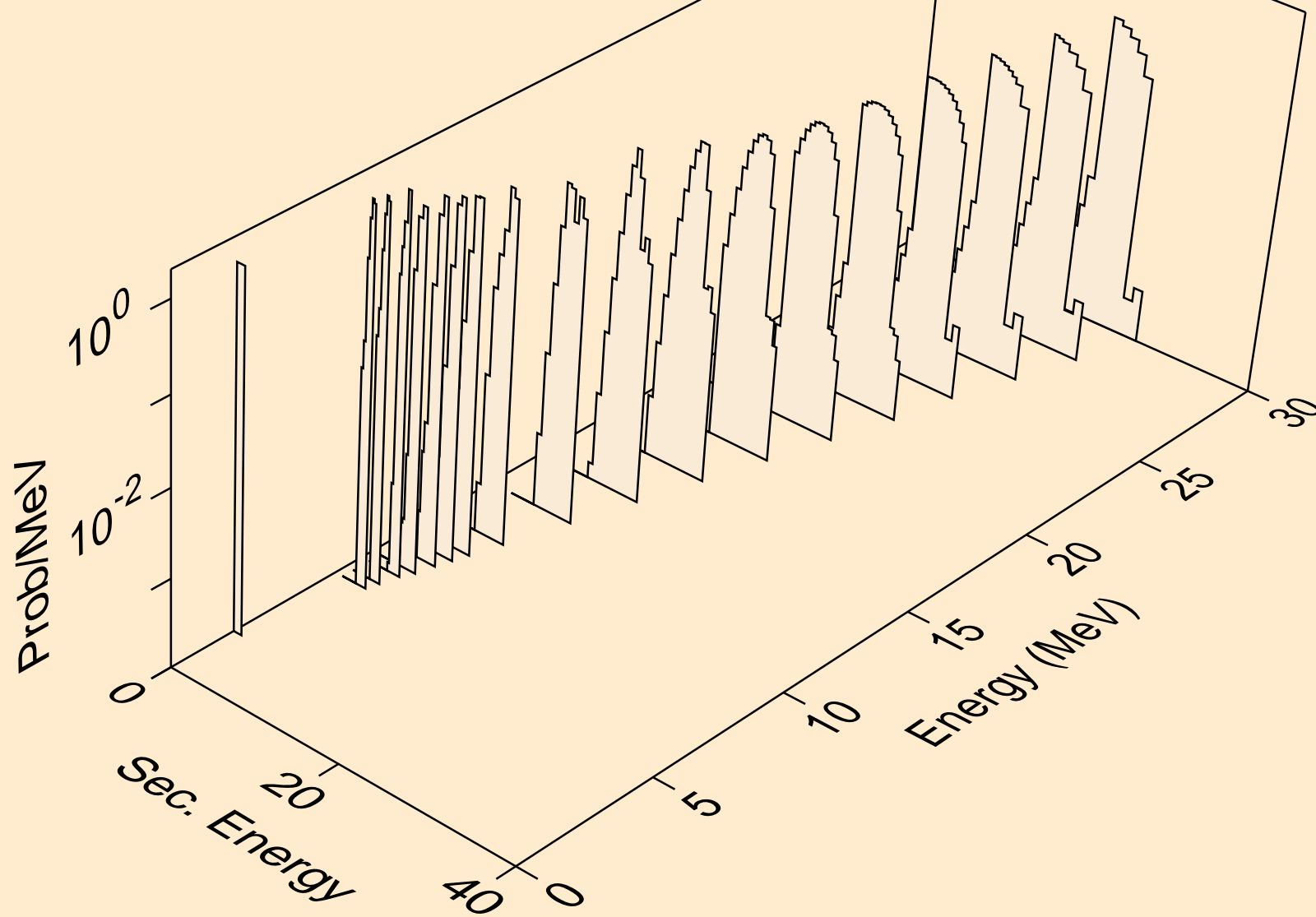

PA238 NEUTRON ACER TENDL-2024 LIBRARY; T=0.K
he3s from (n,x)

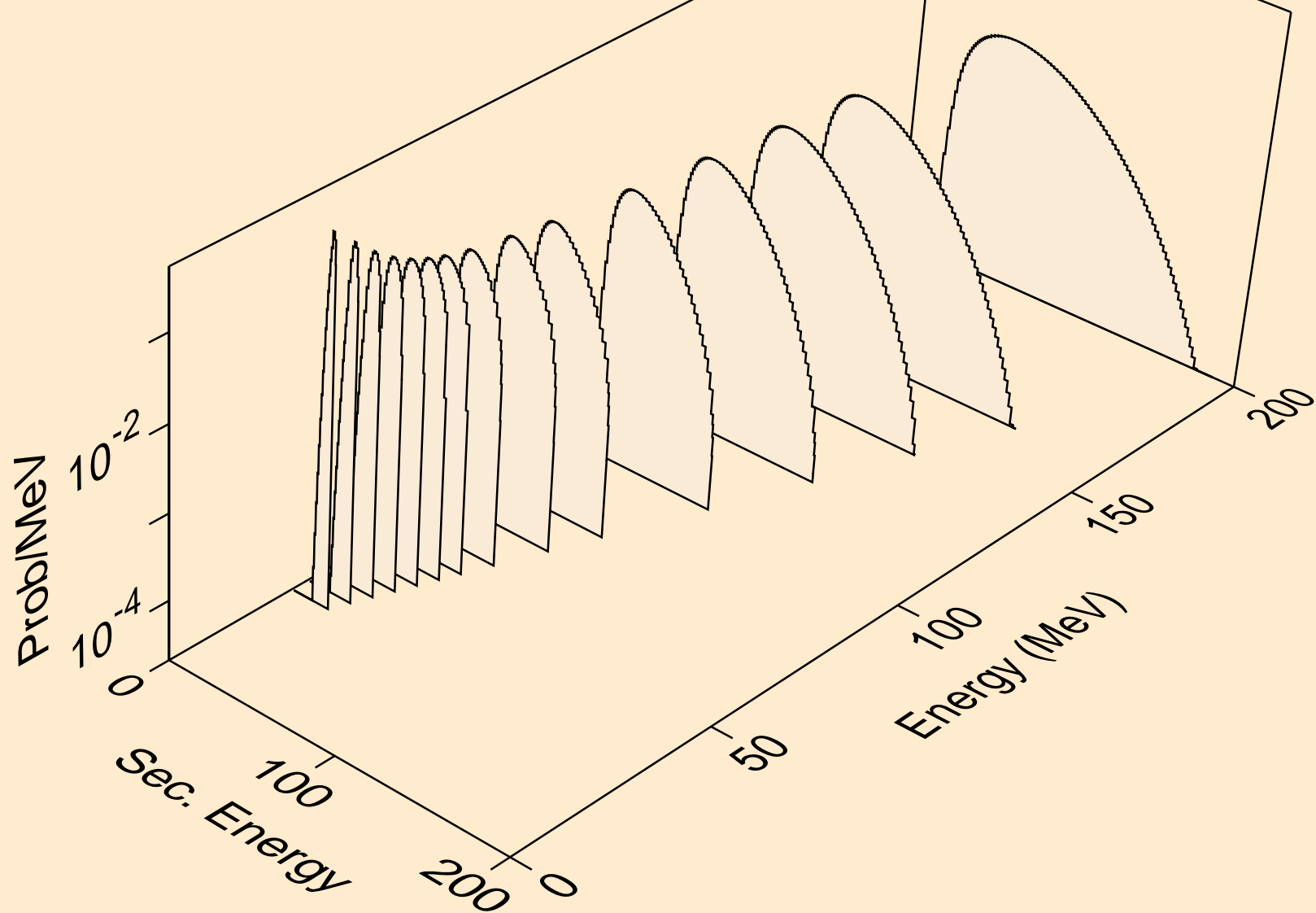

PA238 NEUTRON ACER TENDL-2024 LIBRARY; T=0.K
he3s from (n,n*)he3

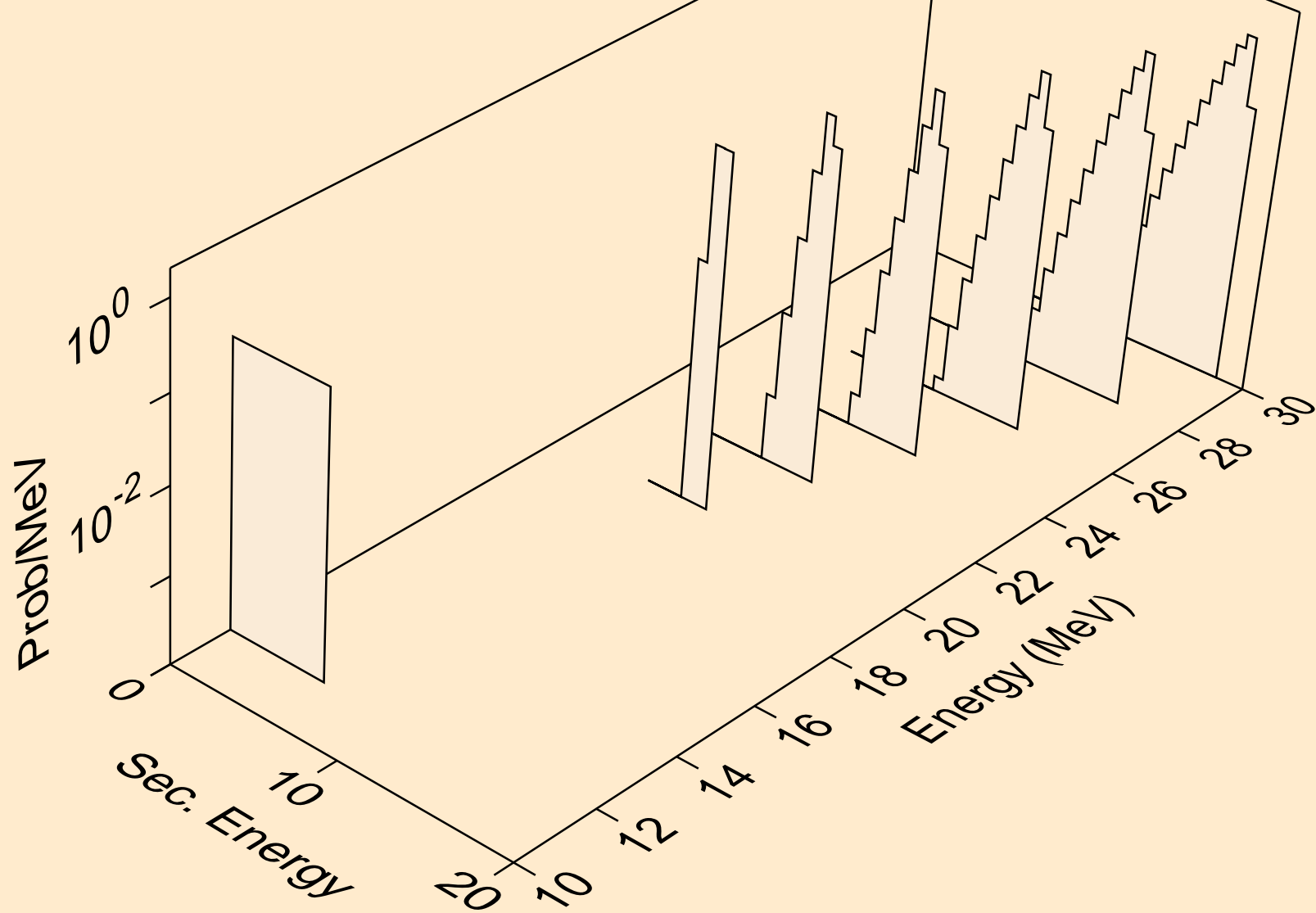

PA238 NEUTRON ACER TENDL-2024 LIBRARY; T=0.K
he3s from (n,he3)

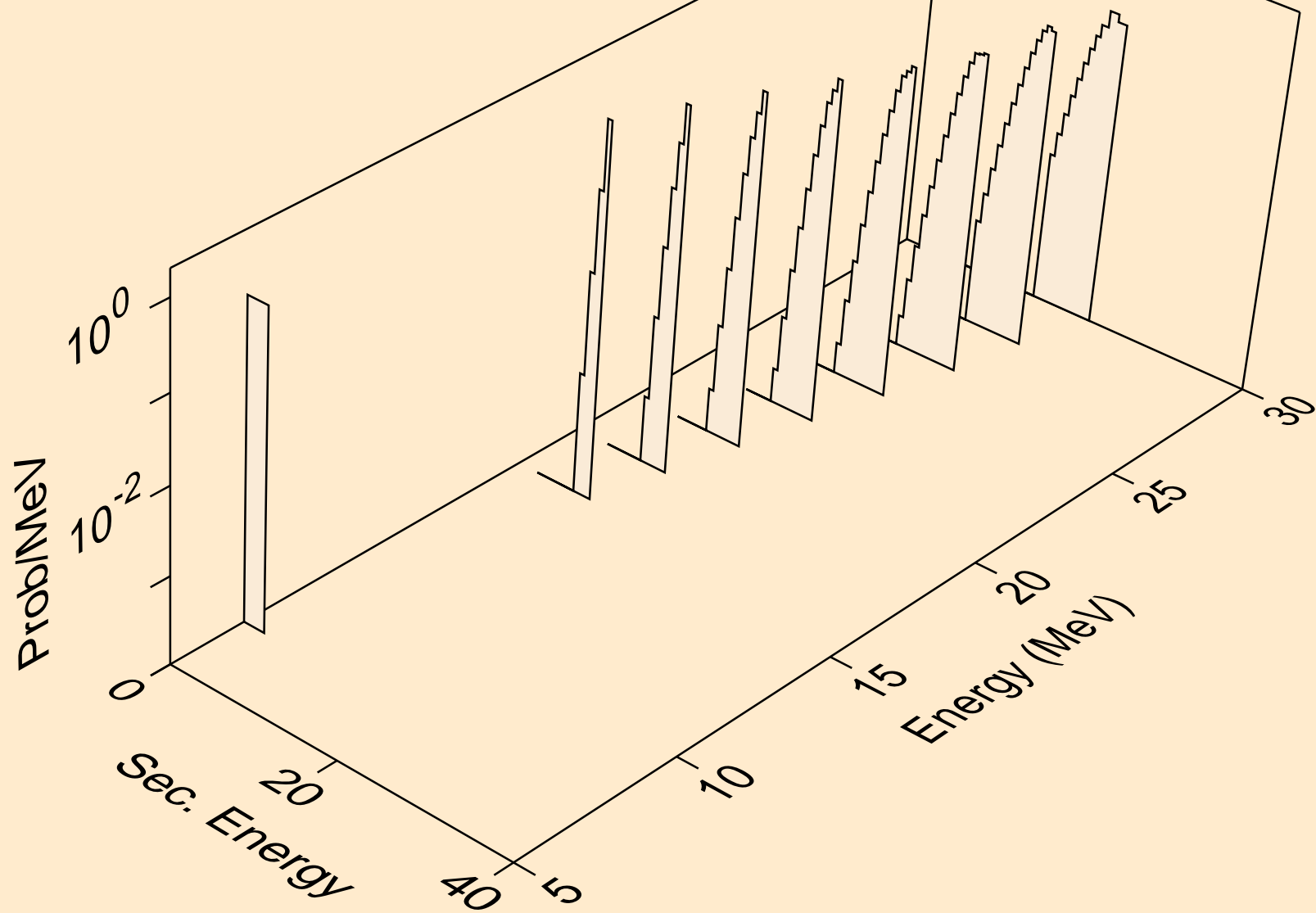

PA238 NEUTRON ACER TENDL-2024 LIBRARY; T=0.K
alphas from (n,x)

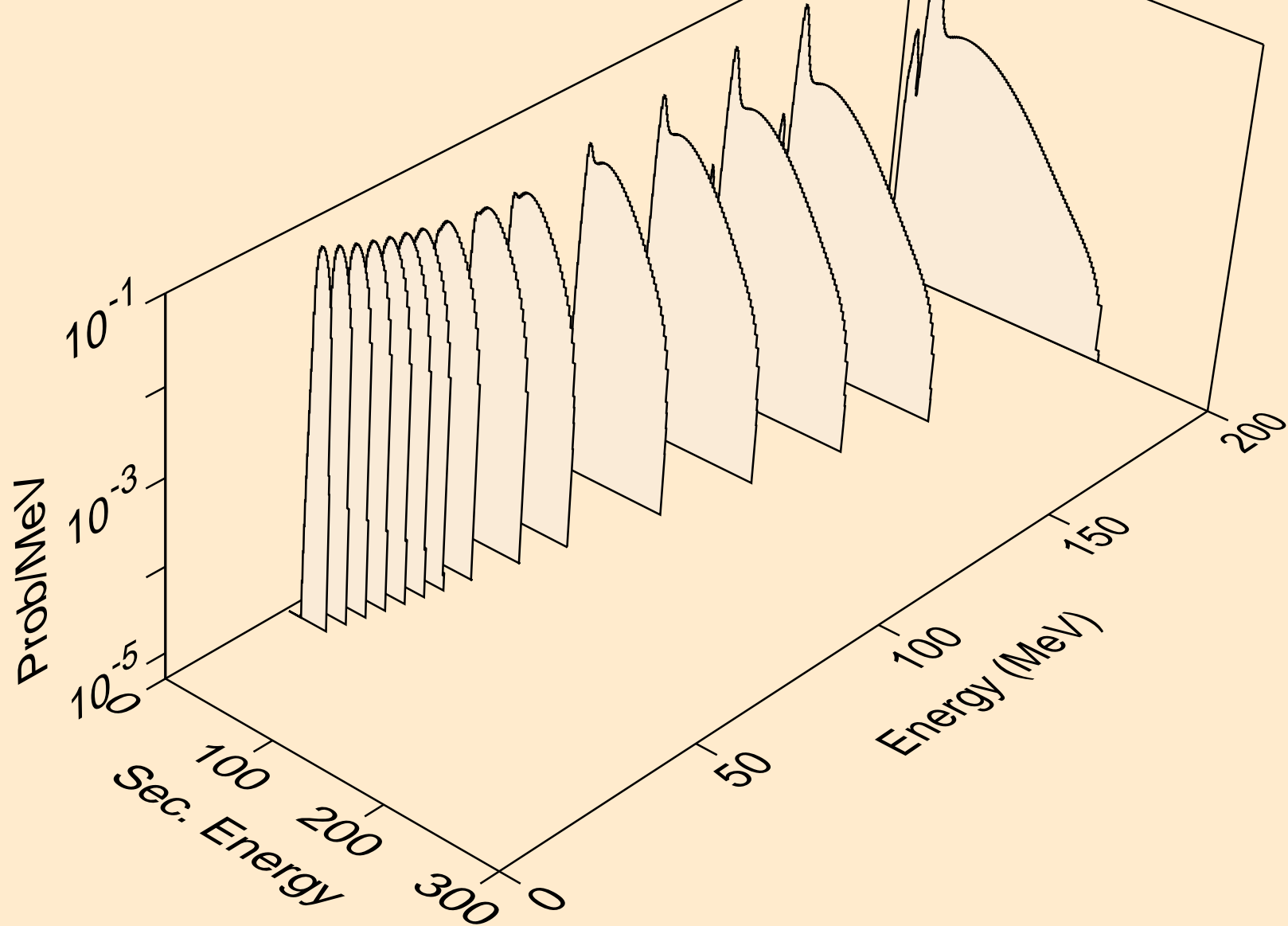

PA238 NEUTRON ACER TENDL-2024 LIBRARY; T=0.K
alphas from (n,n*)a

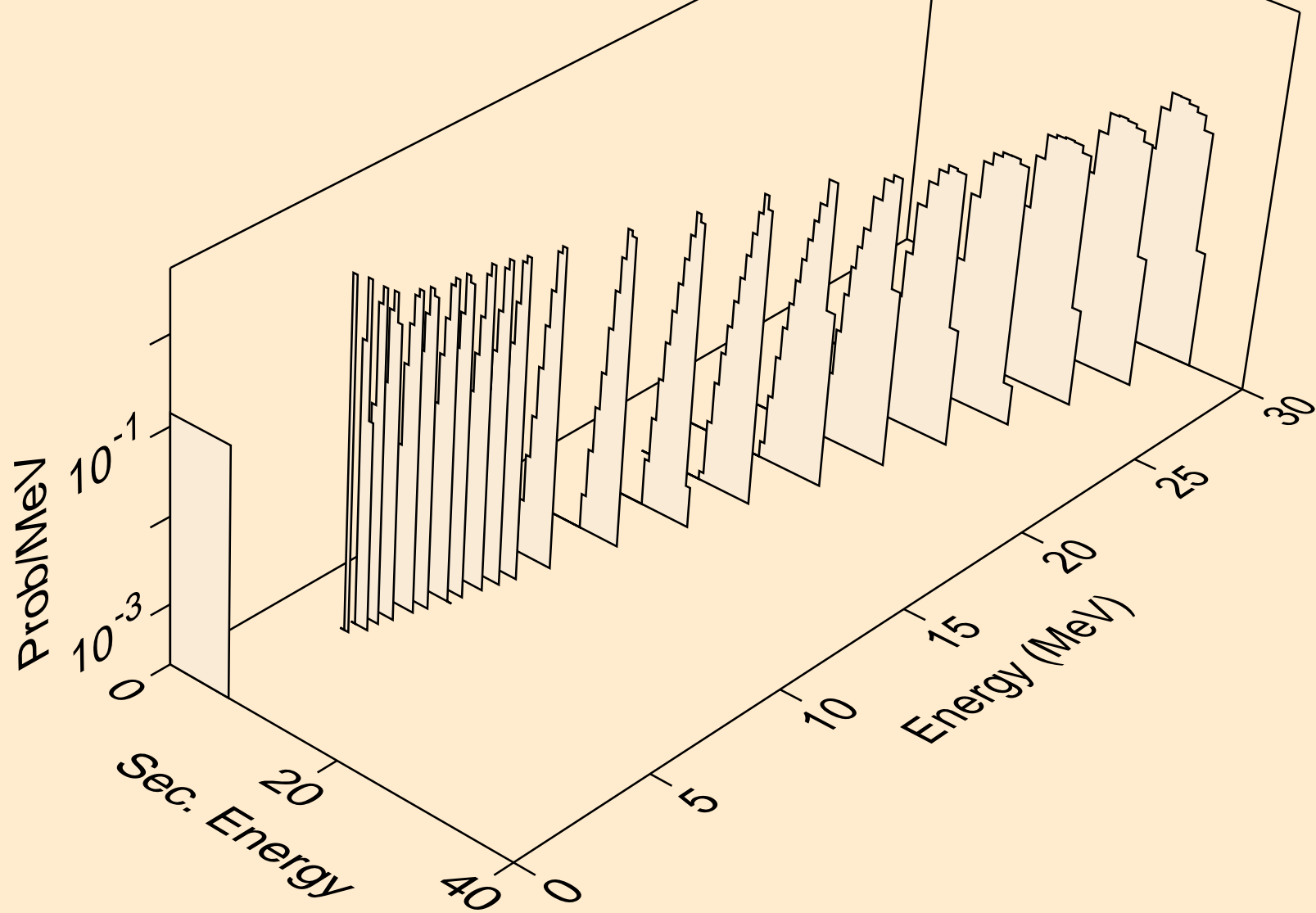

PA238 NEUTRON ACER TENDL-2024 LIBRARY; T=0.K
alphas from (n,2n)a

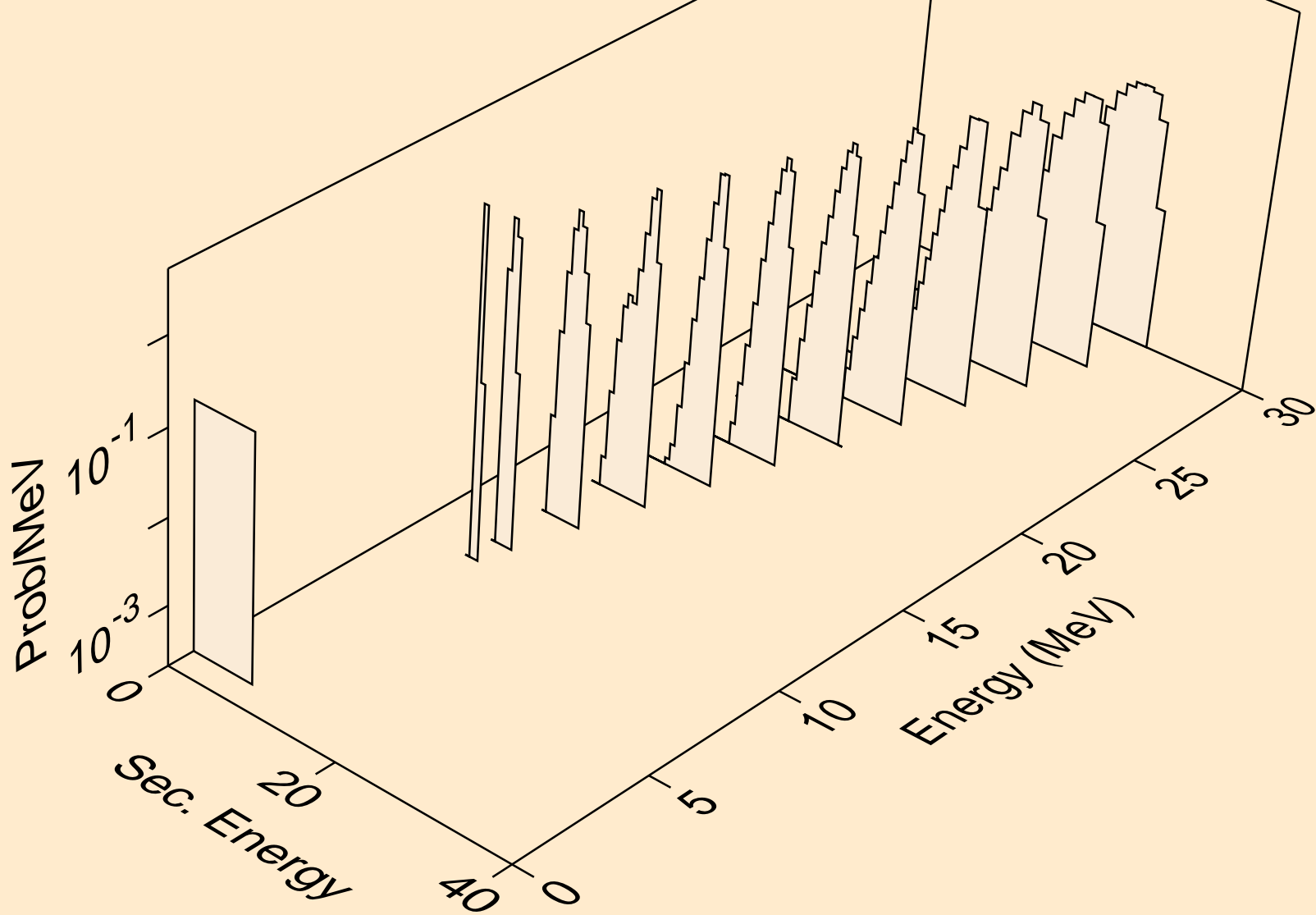

PA238 NEUTRON ACER TENDL-2024 LIBRARY; T=0.K
alphas from (n,3n)a

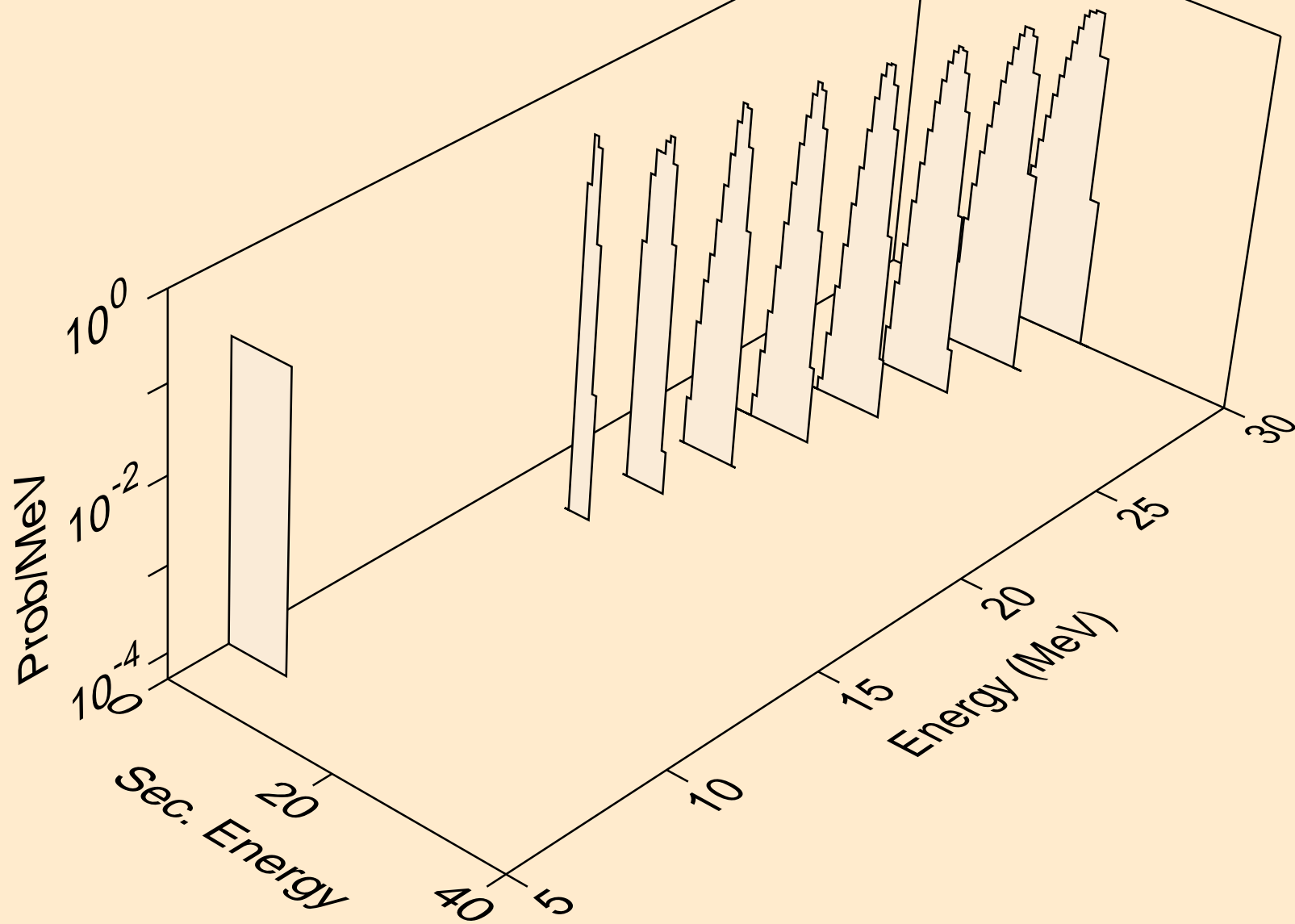

PA238 NEUTRON ACER TENDL-2024 LIBRARY; T=0.K
alphas from (n,a)

