

PB185M NEUTRON ACER TENDL-2024 LIBRARY; T=0.K  
Principal cross sections

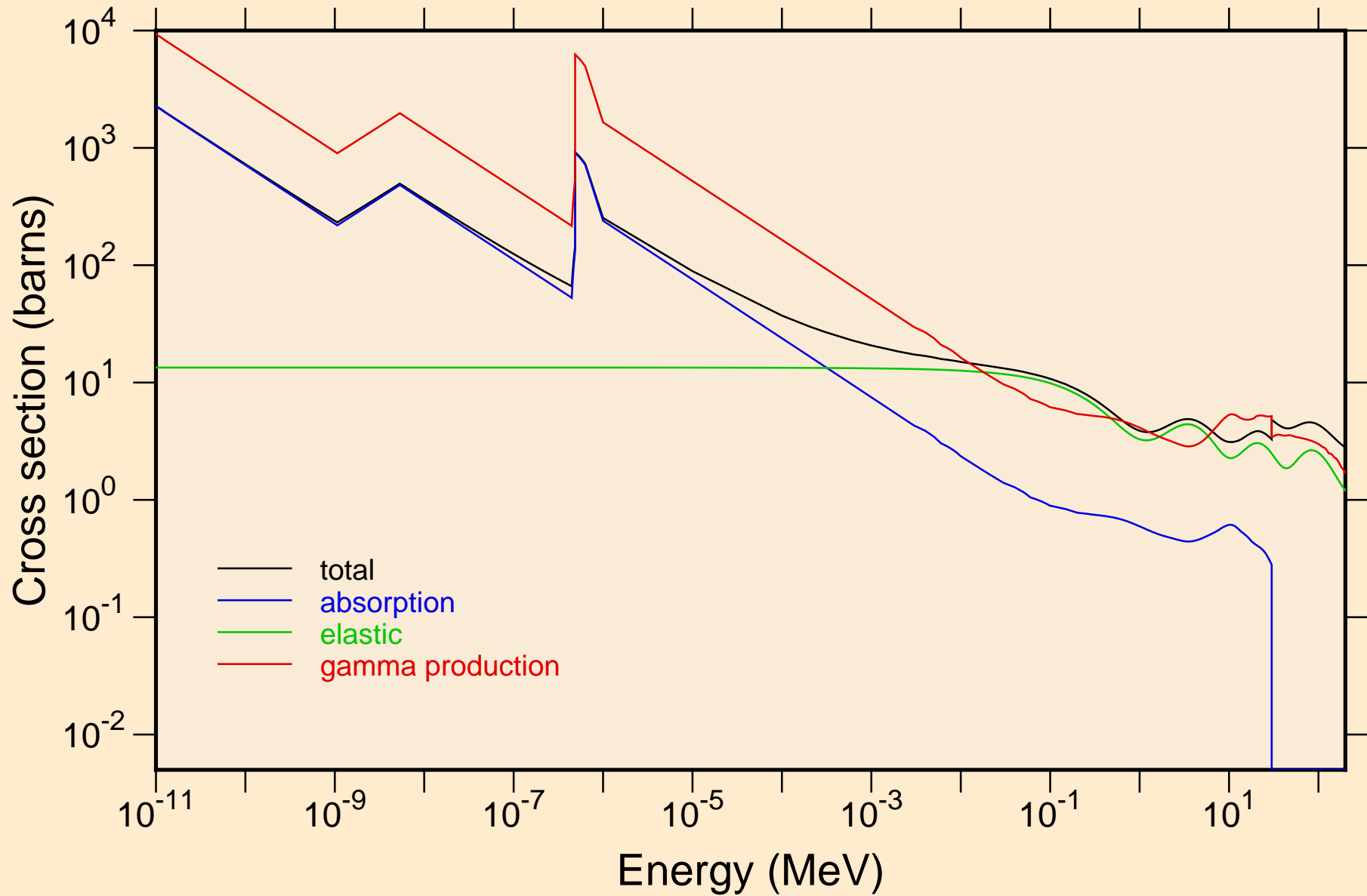

# PB185M NEUTRON ACER TENDL-2024 LIBRARY; T=0.K

## Heating

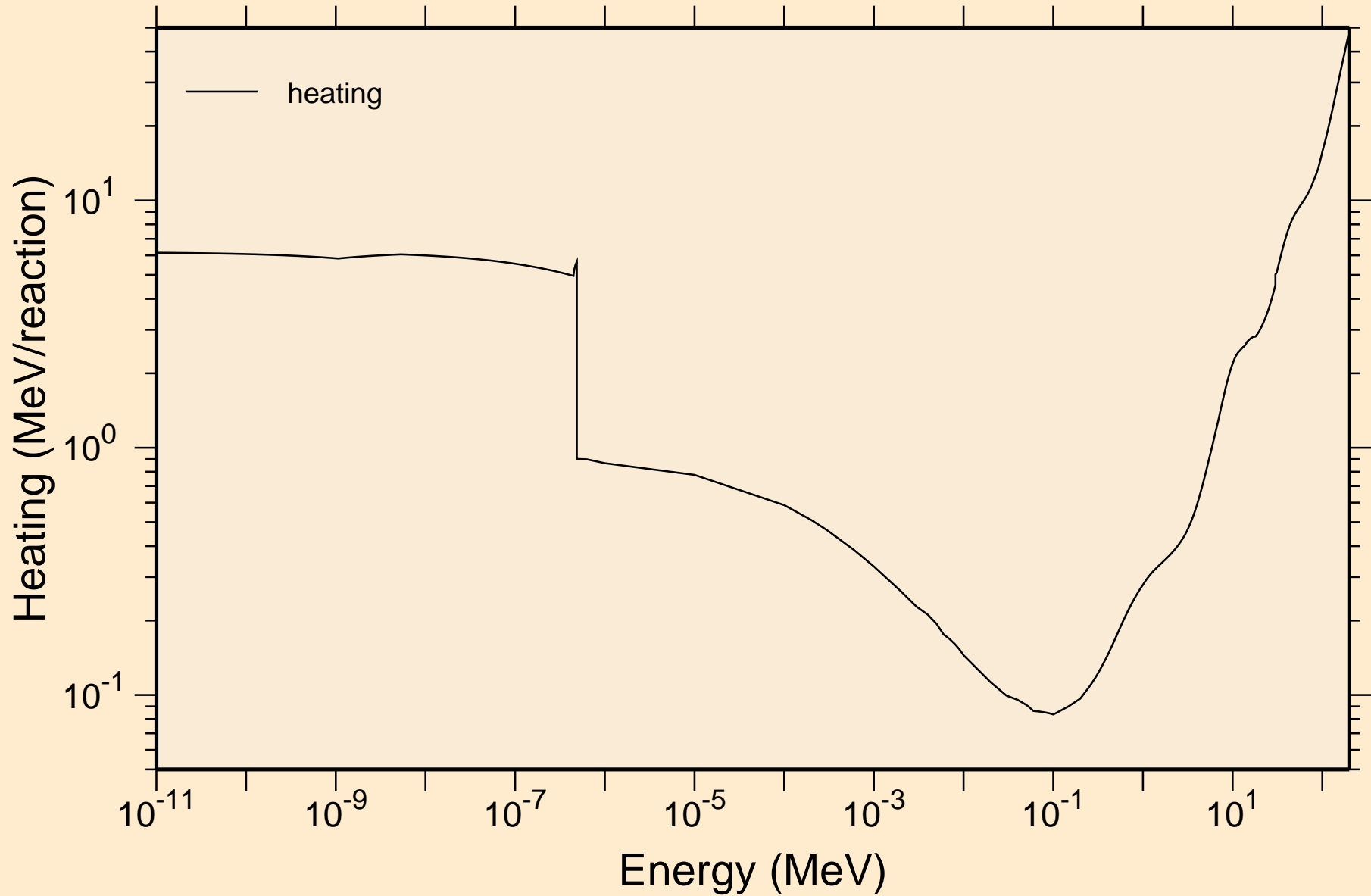

PB185M NEUTRON ACER TENDL-2024 LIBRARY; T=0.K  
Damage

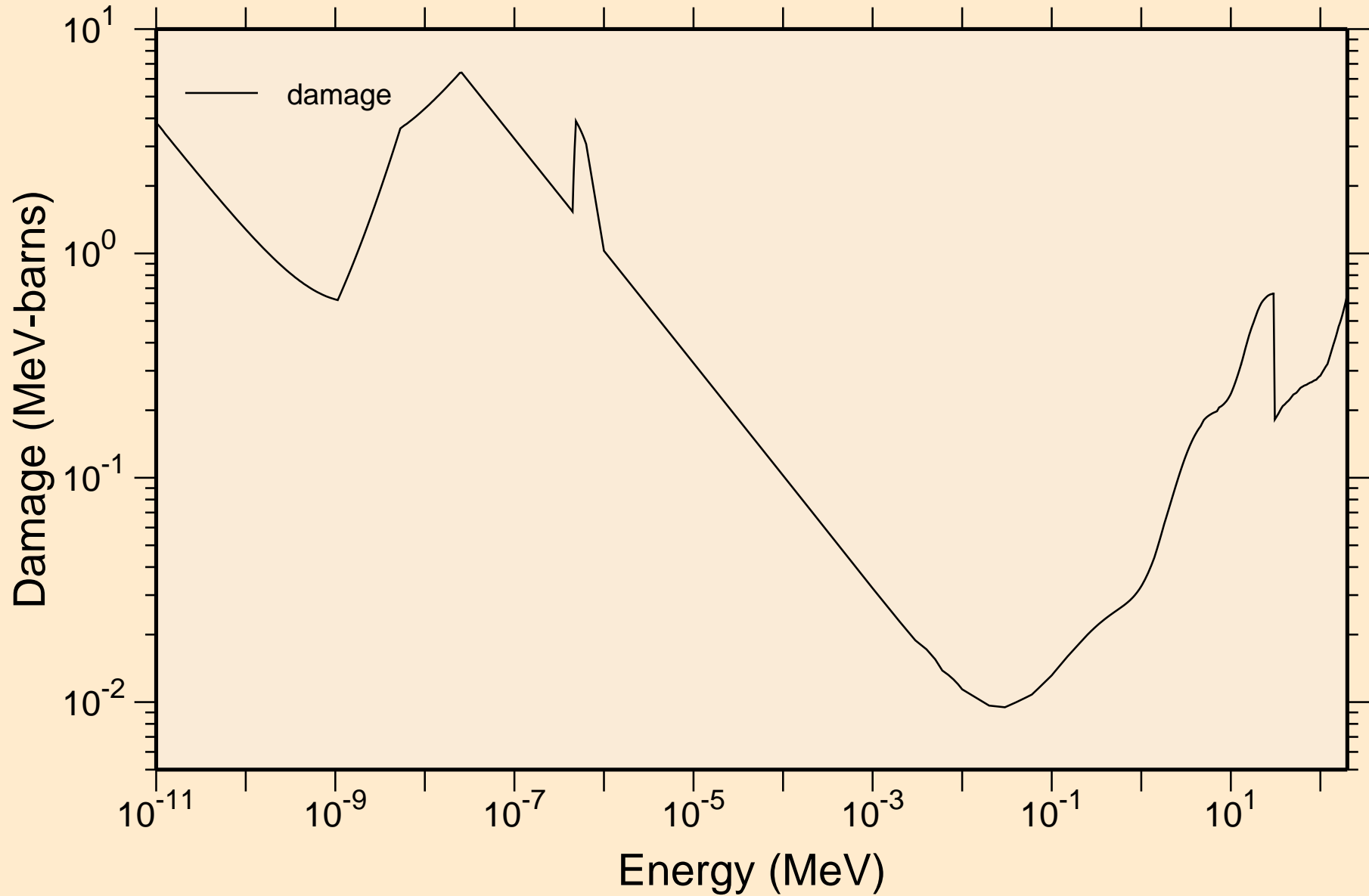

PB185M NEUTRON ACER TENDL-2024 LIBRARY; T=0.K  
Non-threshold reactions

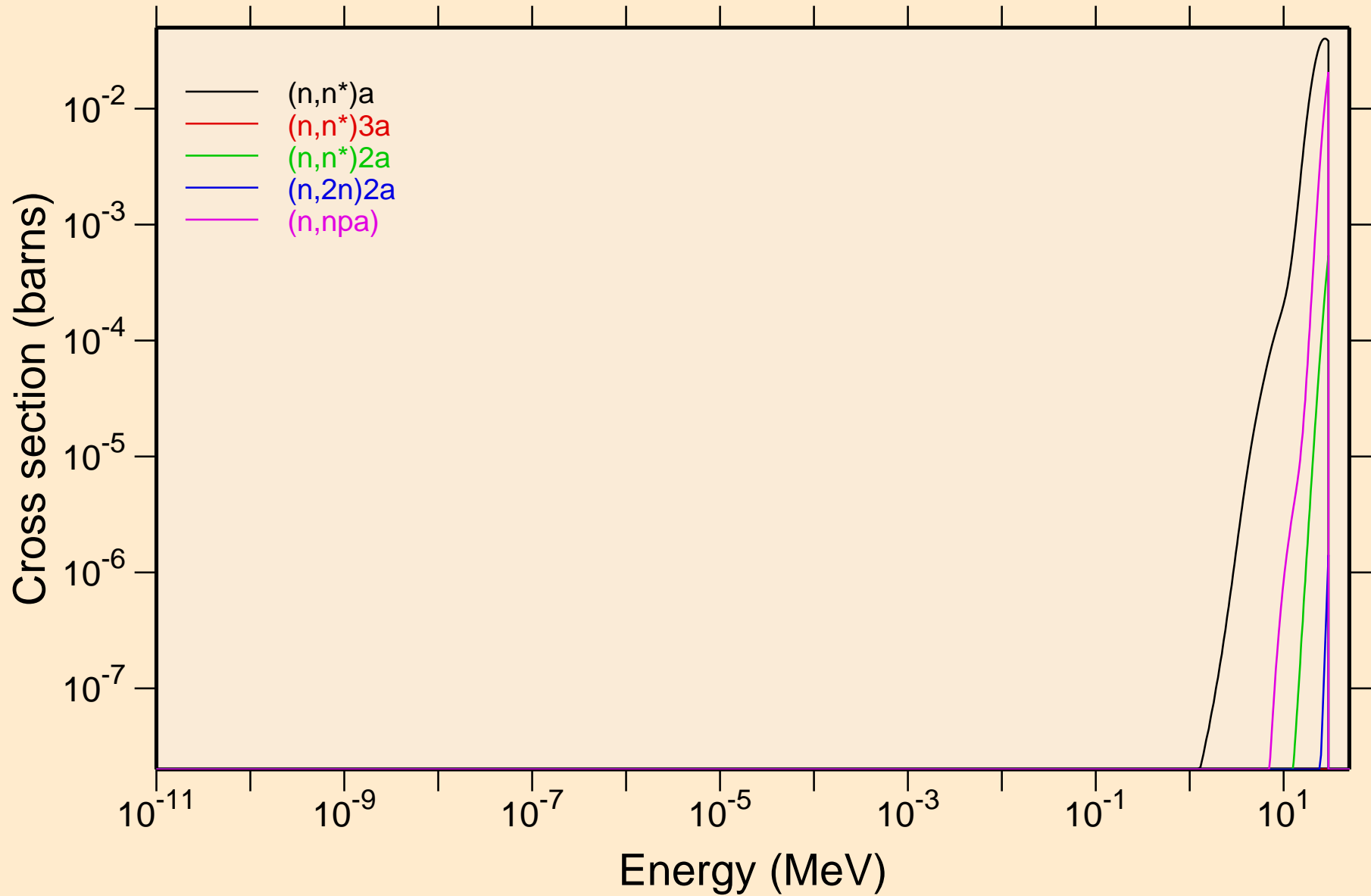

PB185M NEUTRON ACER TENDL-2024 LIBRARY; T=0.K  
Non-threshold reactions

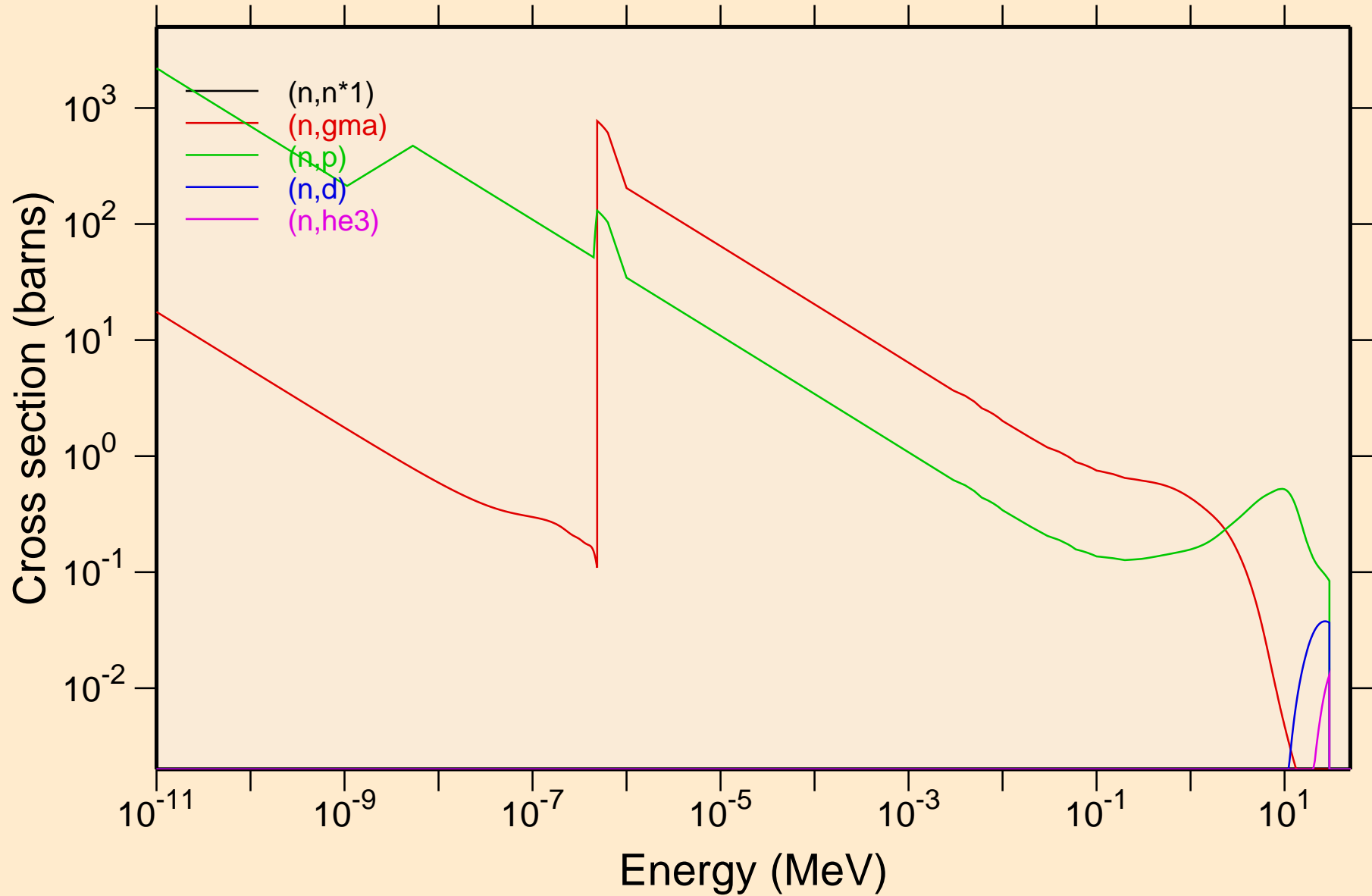

PB185M NEUTRON ACER TENDL-2024 LIBRARY; T=0.K  
Non-threshold reactions

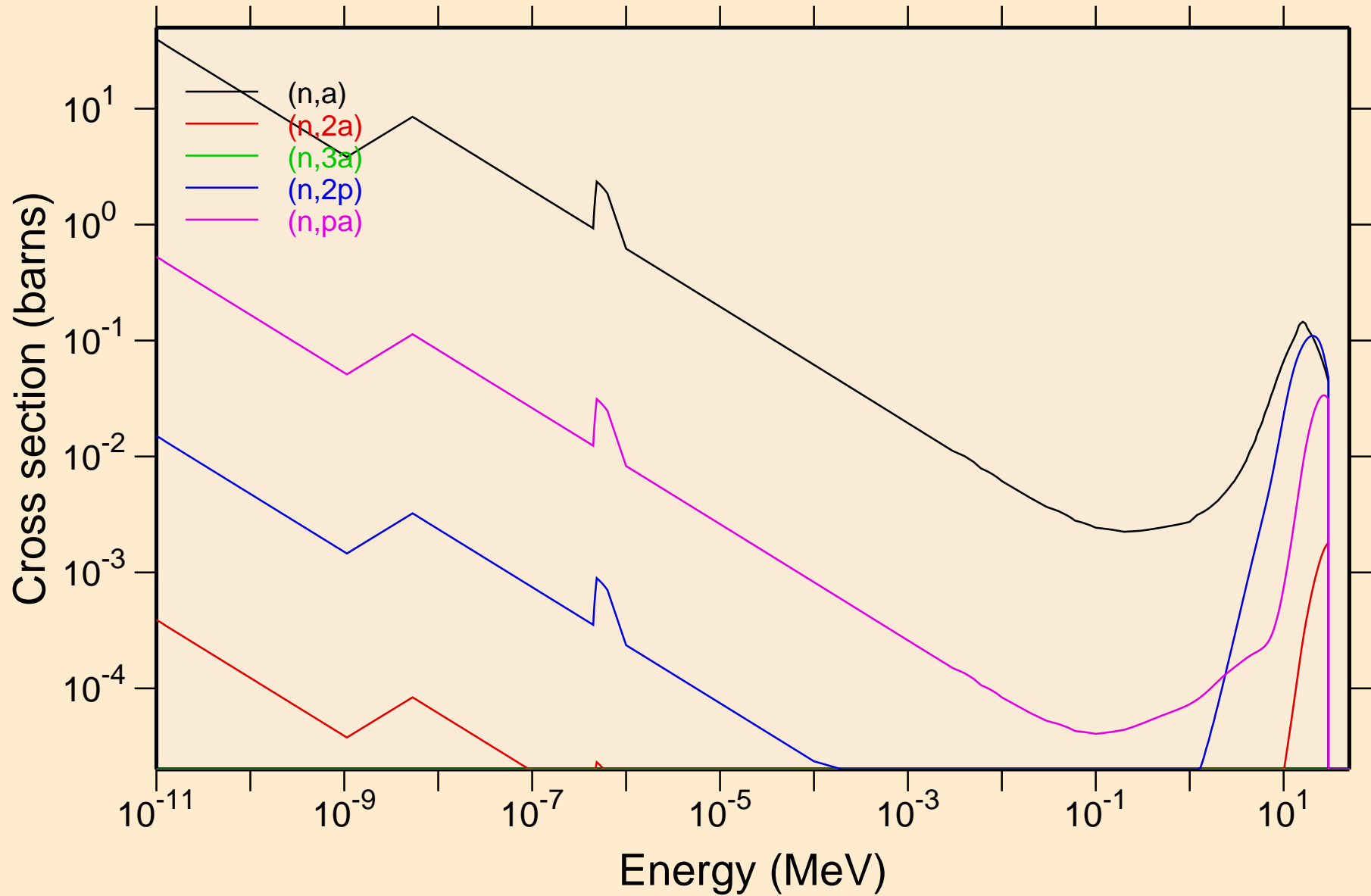

PB185M NEUTRON ACER TENDL-2024 LIBRARY; T=0.K  
Non-threshold reactions

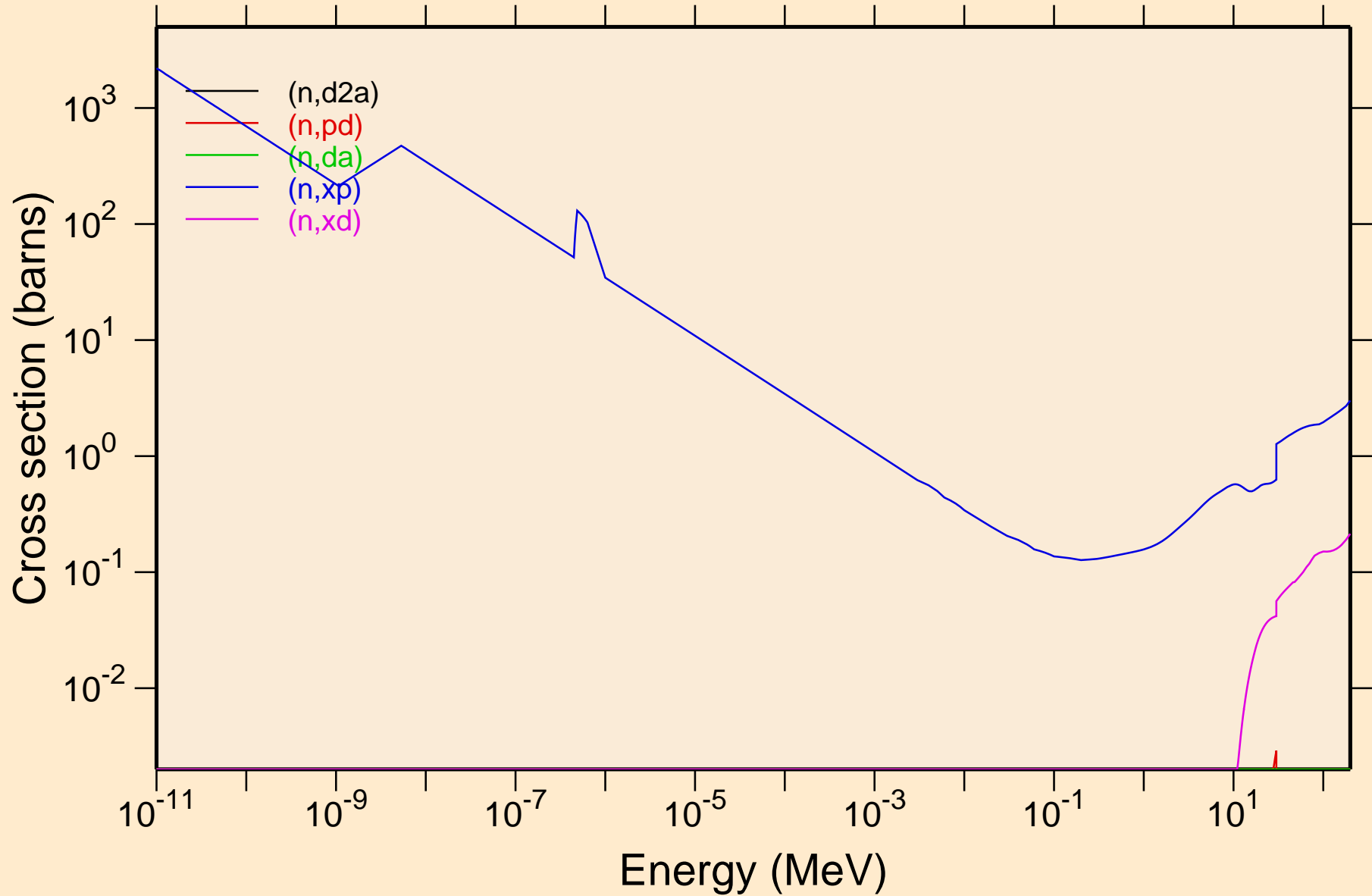

PB185M NEUTRON ACER TENDL-2024 LIBRARY; T=0.K  
Non-threshold reactions

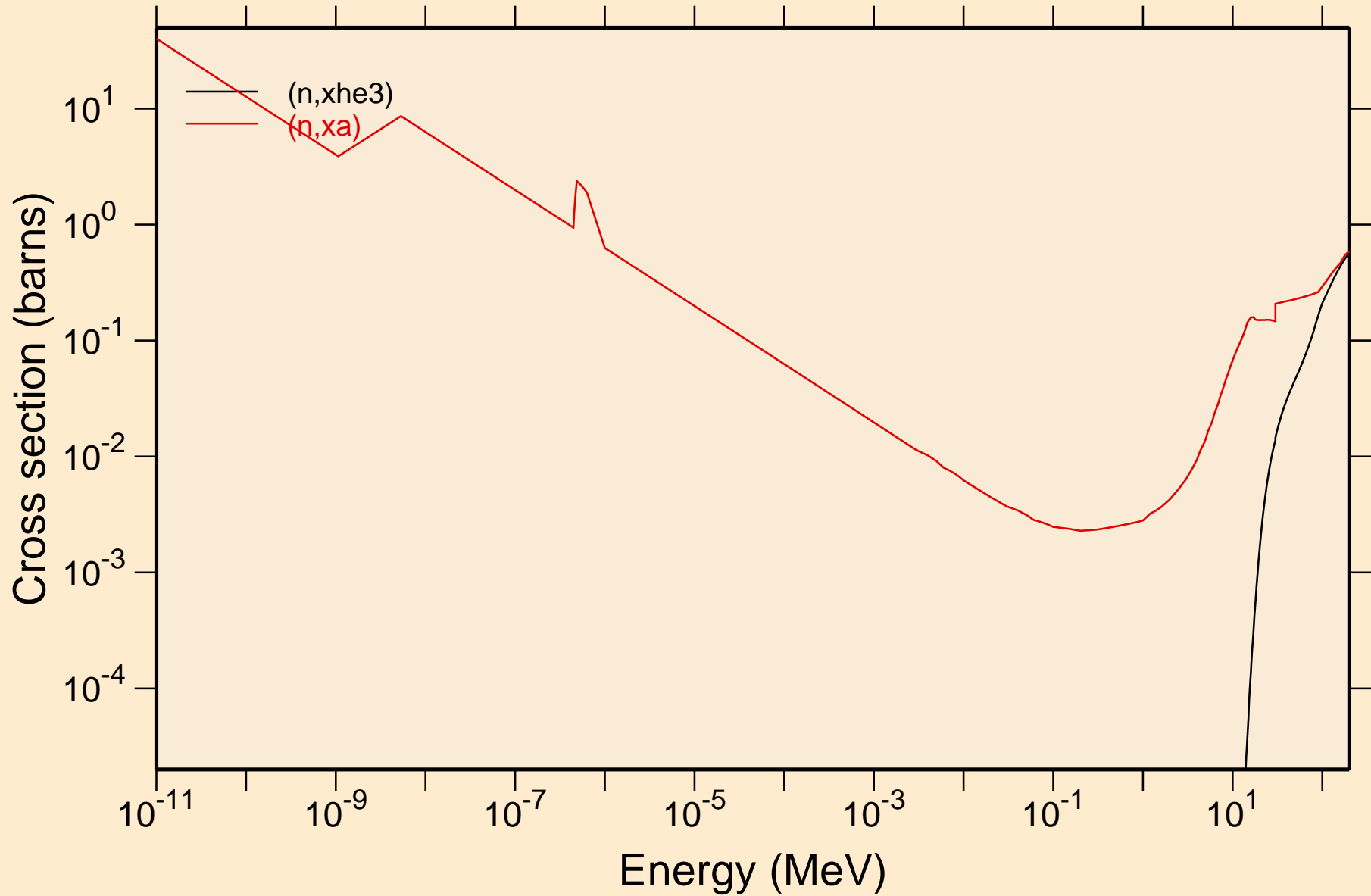



# PB185M NEUTRON ACER TENDL-2024 LIBRARY; T=0.K

## Principal cross sections

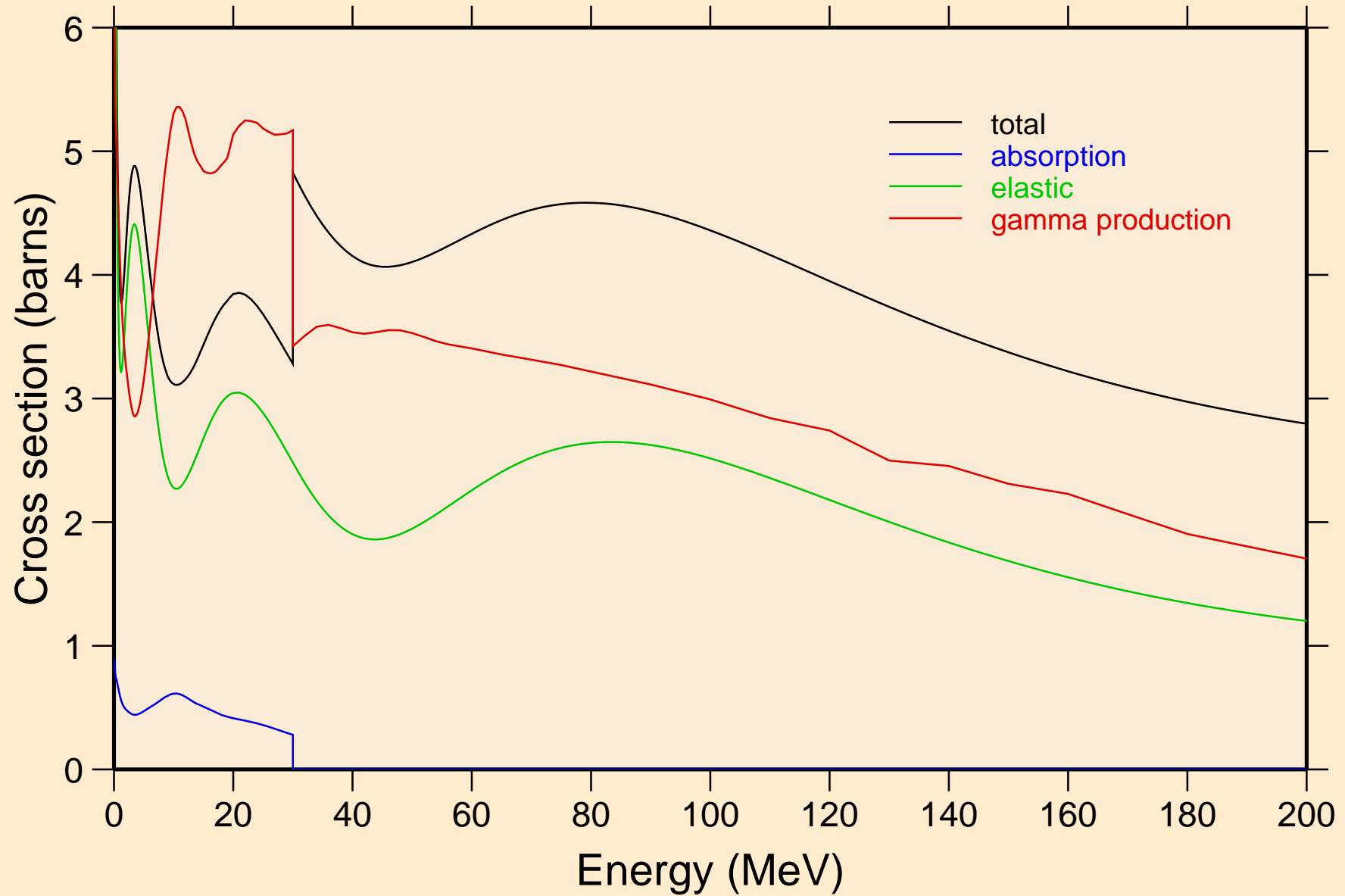

# PB185M NEUTRON ACER TENDL-2024 LIBRARY; T=0.K

## Heating

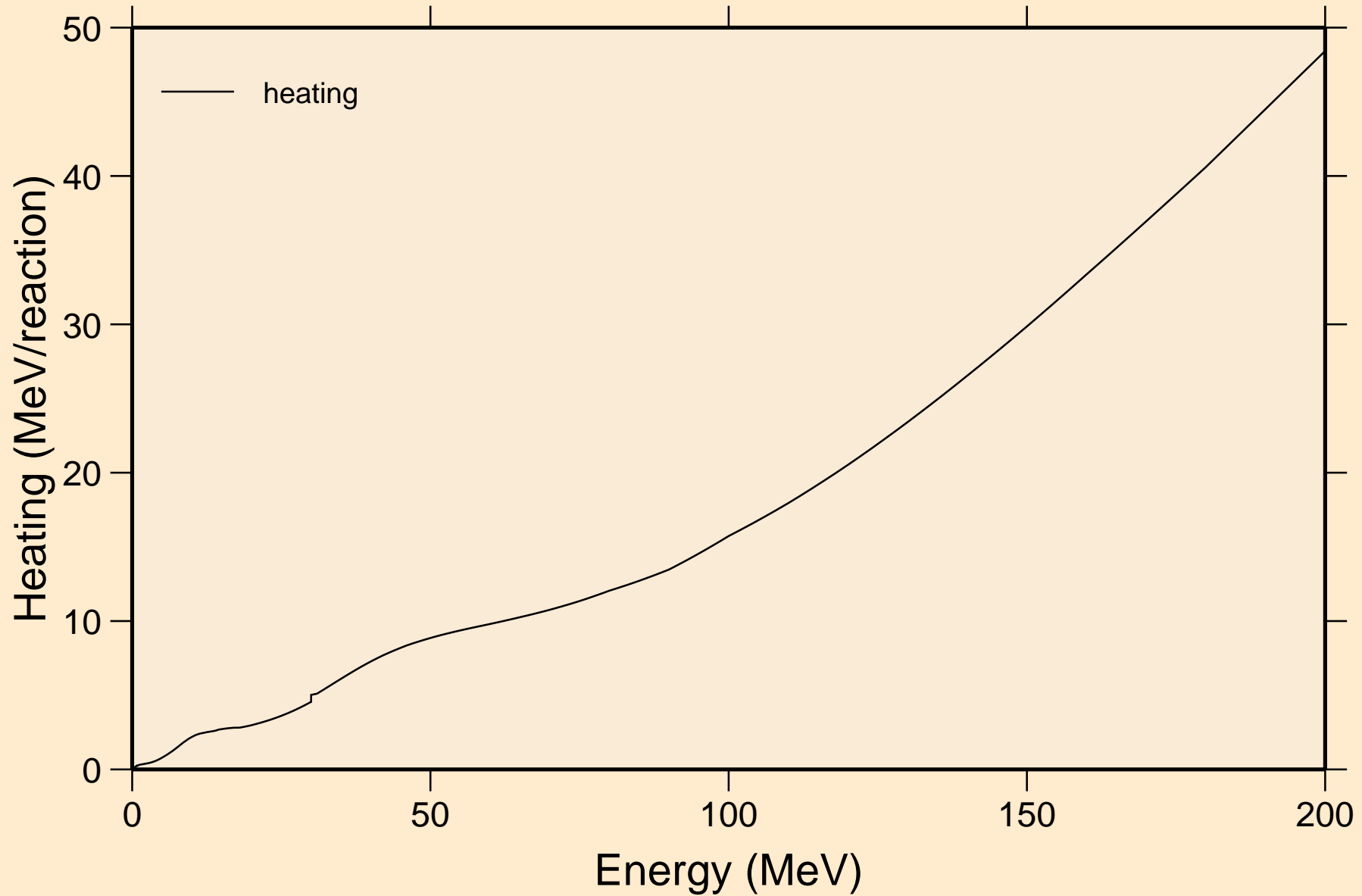

PB185M NEUTRON ACER TENDL-2024 LIBRARY; T=0.K  
Damage

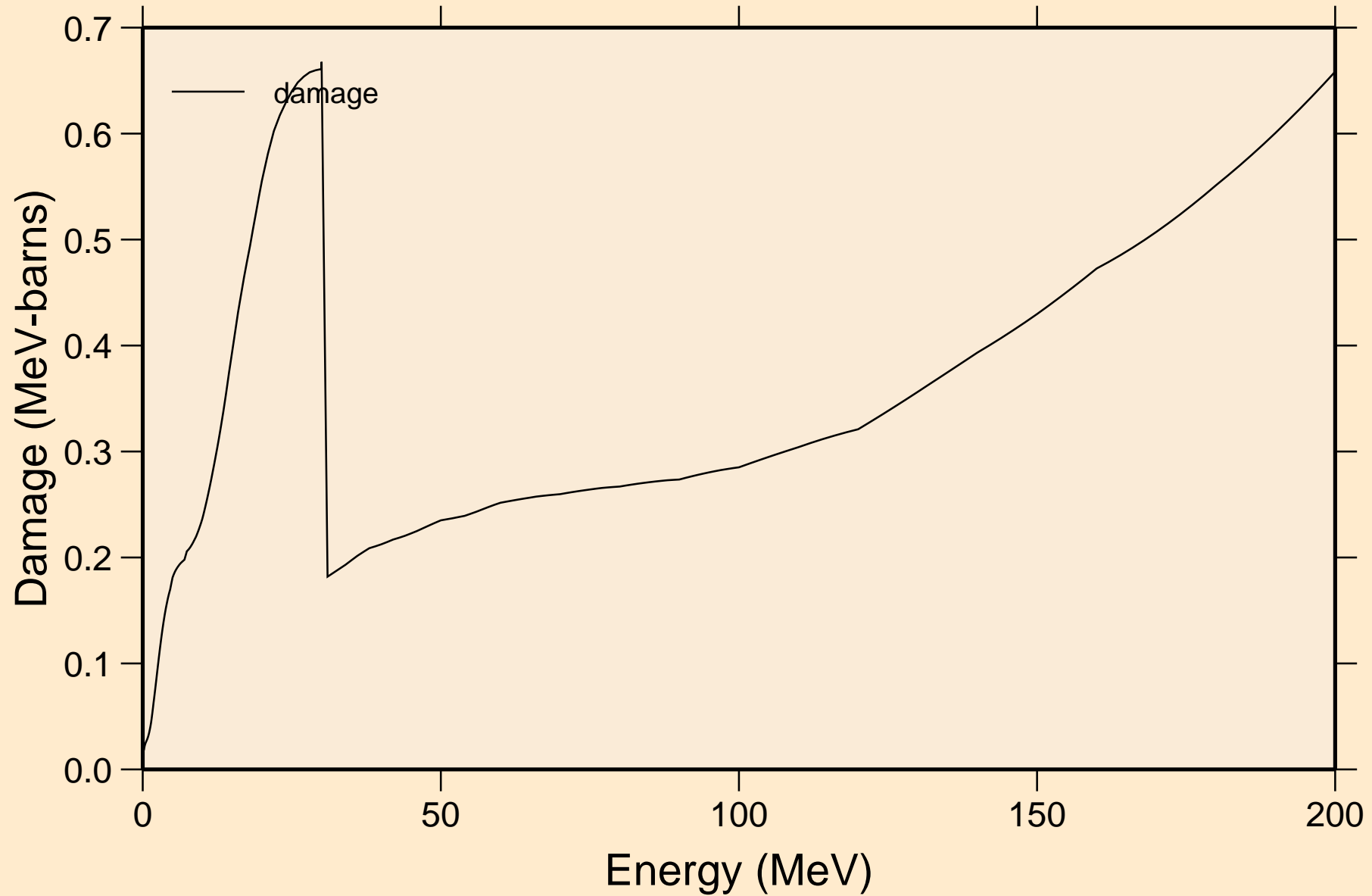

PB185M NEUTRON ACER TENDL-2024 LIBRARY; T=0.K  
Non-threshold reactions

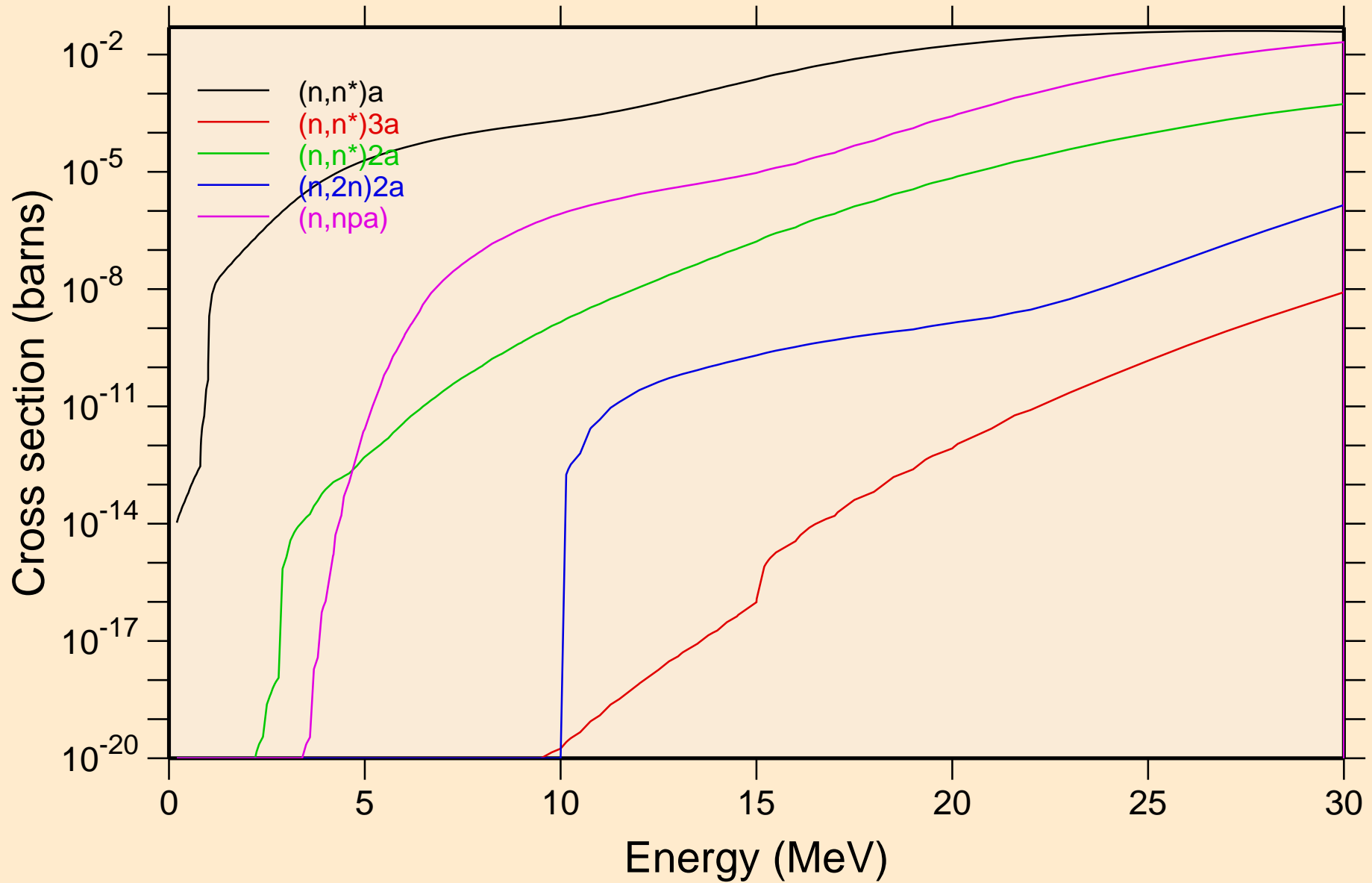

PB185M NEUTRON ACER TENDL-2024 LIBRARY; T=0.K  
Non-threshold reactions

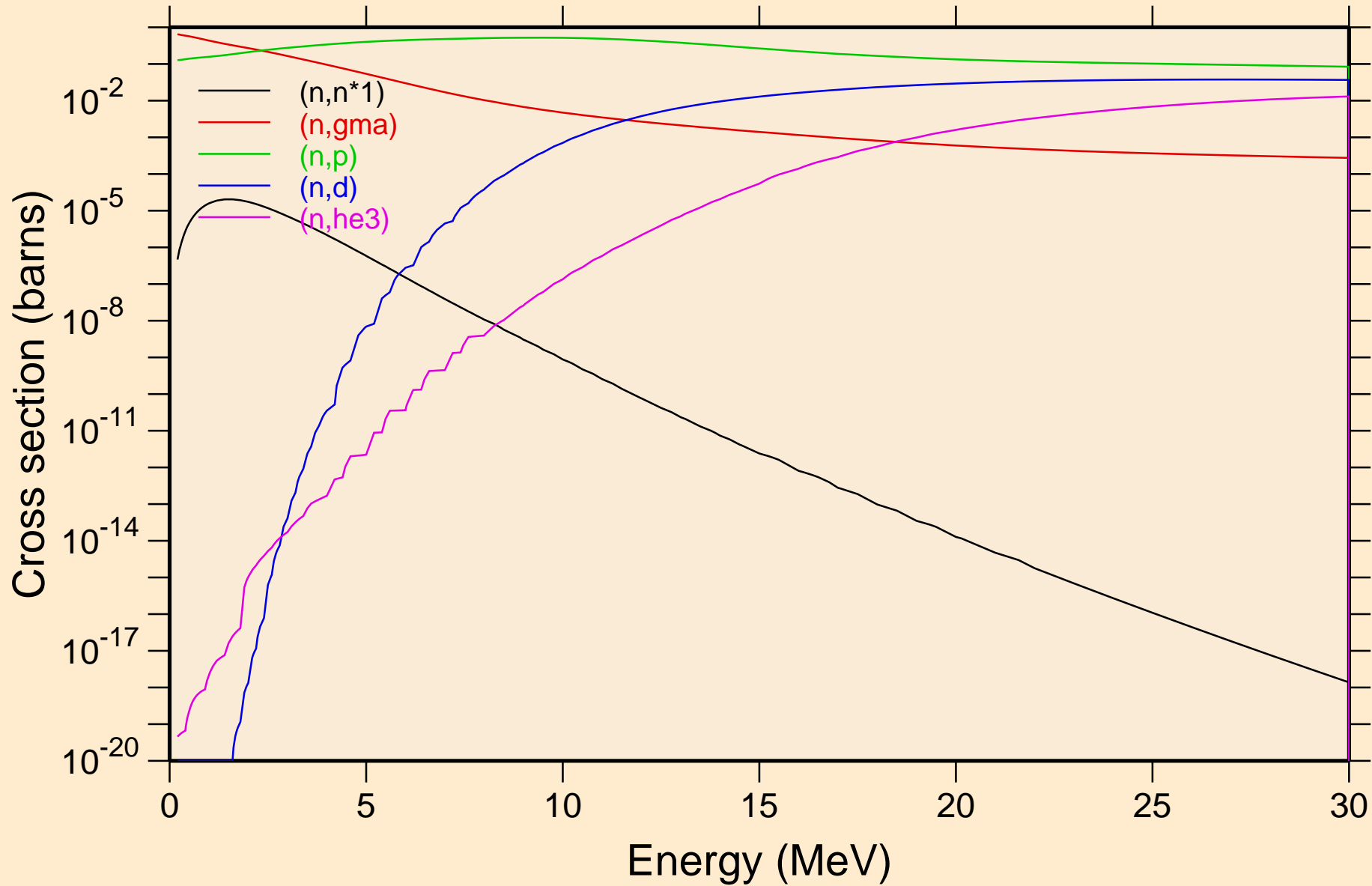

PB185M NEUTRON ACER TENDL-2024 LIBRARY; T=0.K  
Non-threshold reactions

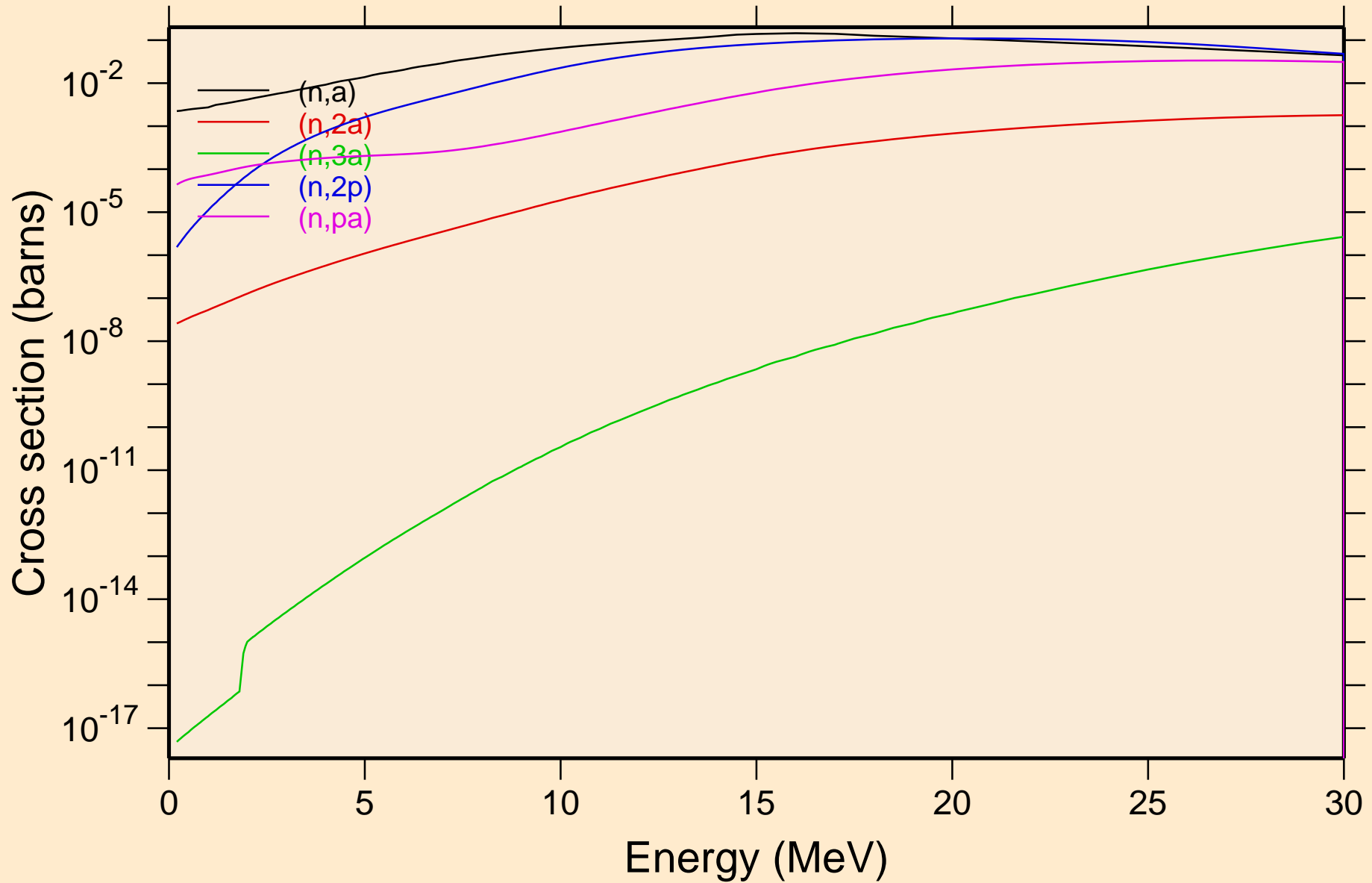

PB185M NEUTRON ACER TENDL-2024 LIBRARY; T=0.K  
Non-threshold reactions

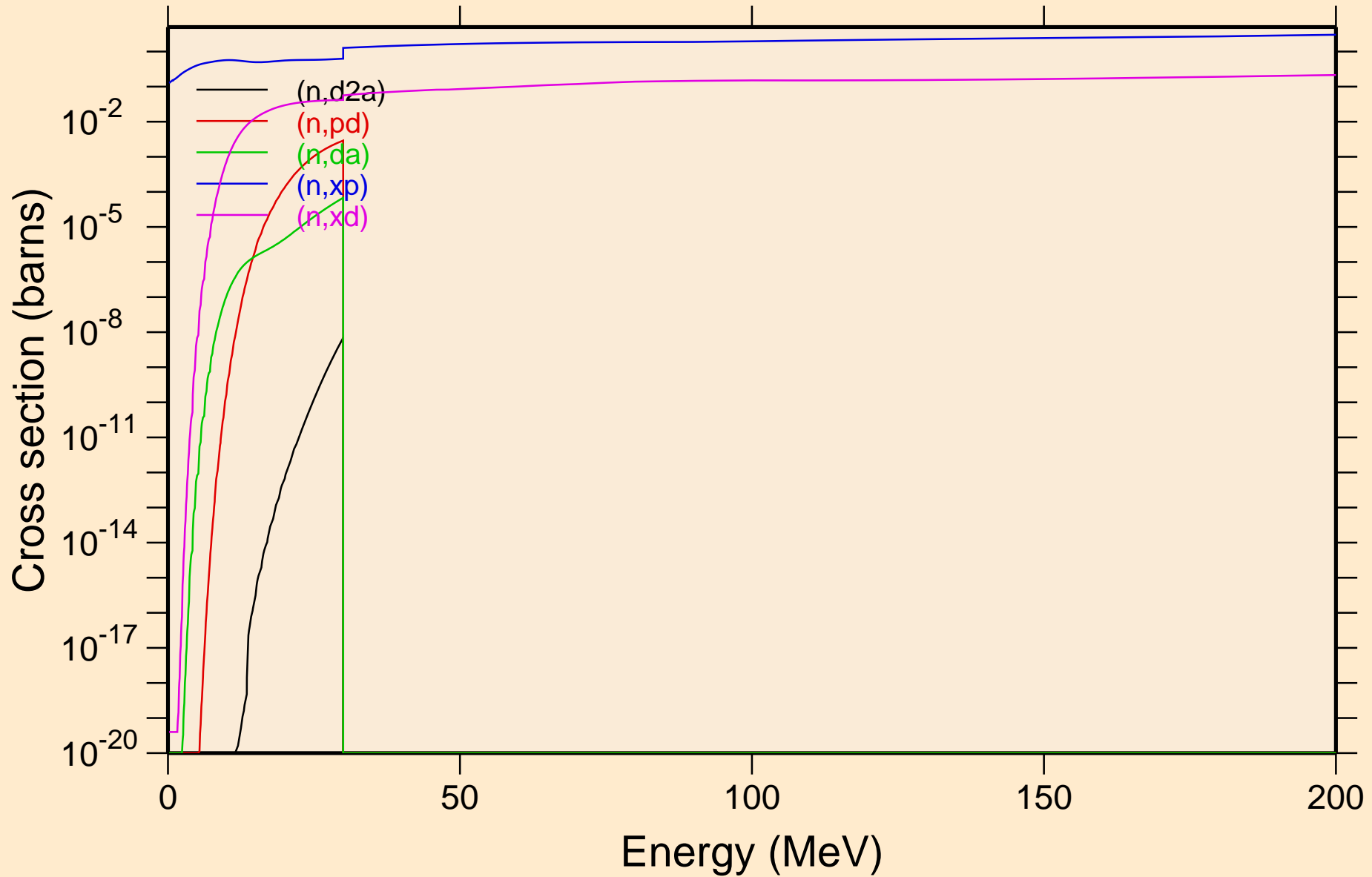

PB185M NEUTRON ACER TENDL-2024 LIBRARY; T=0.K  
Non-threshold reactions

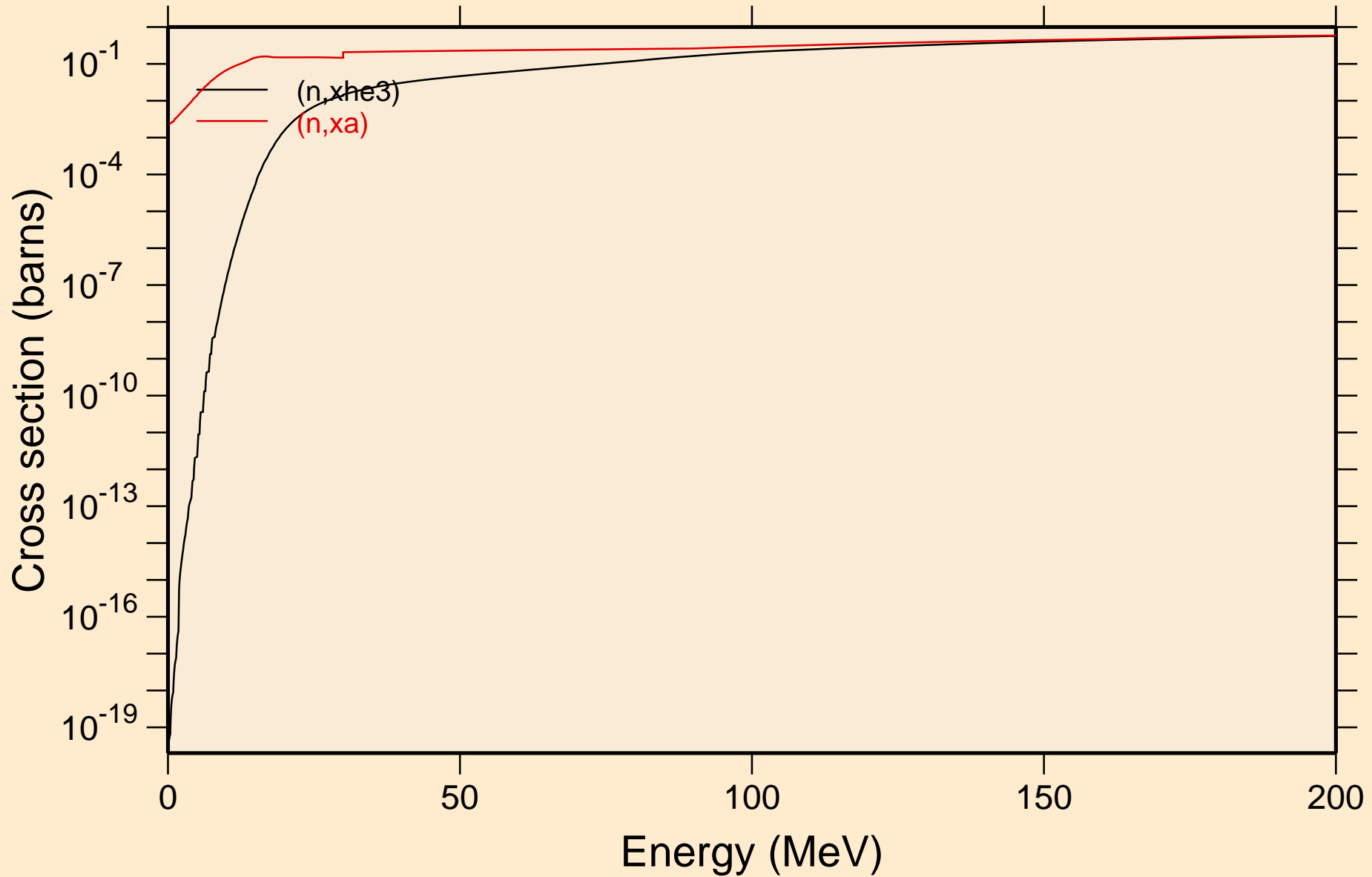



PB185M NEUTRON ACER TENDL-2024 LIBRARY; T=0.K  
Inelastic levels

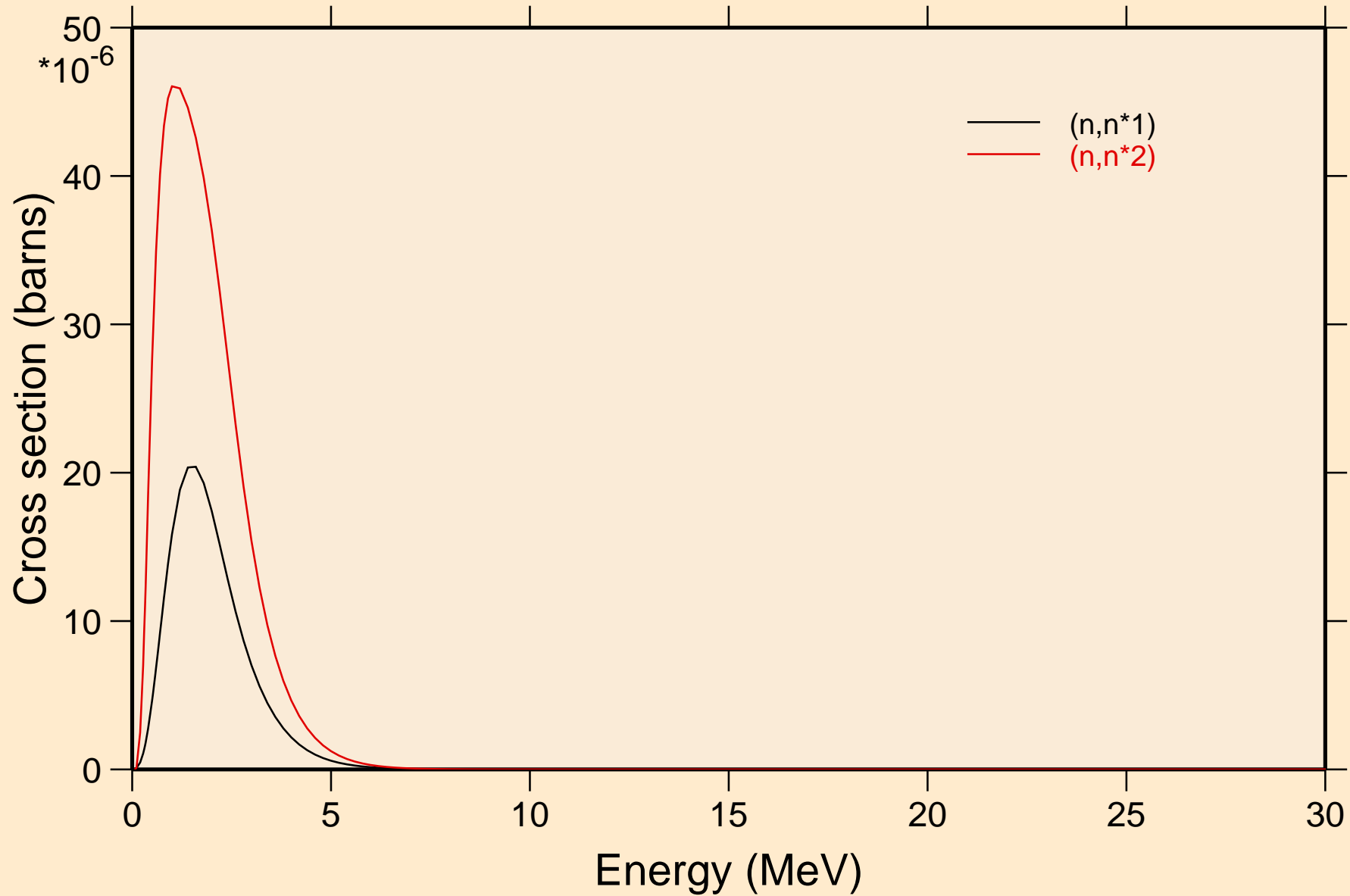

PB185M NEUTRON ACER TENDL-2024 LIBRARY; T=0.K  
Threshold reactions

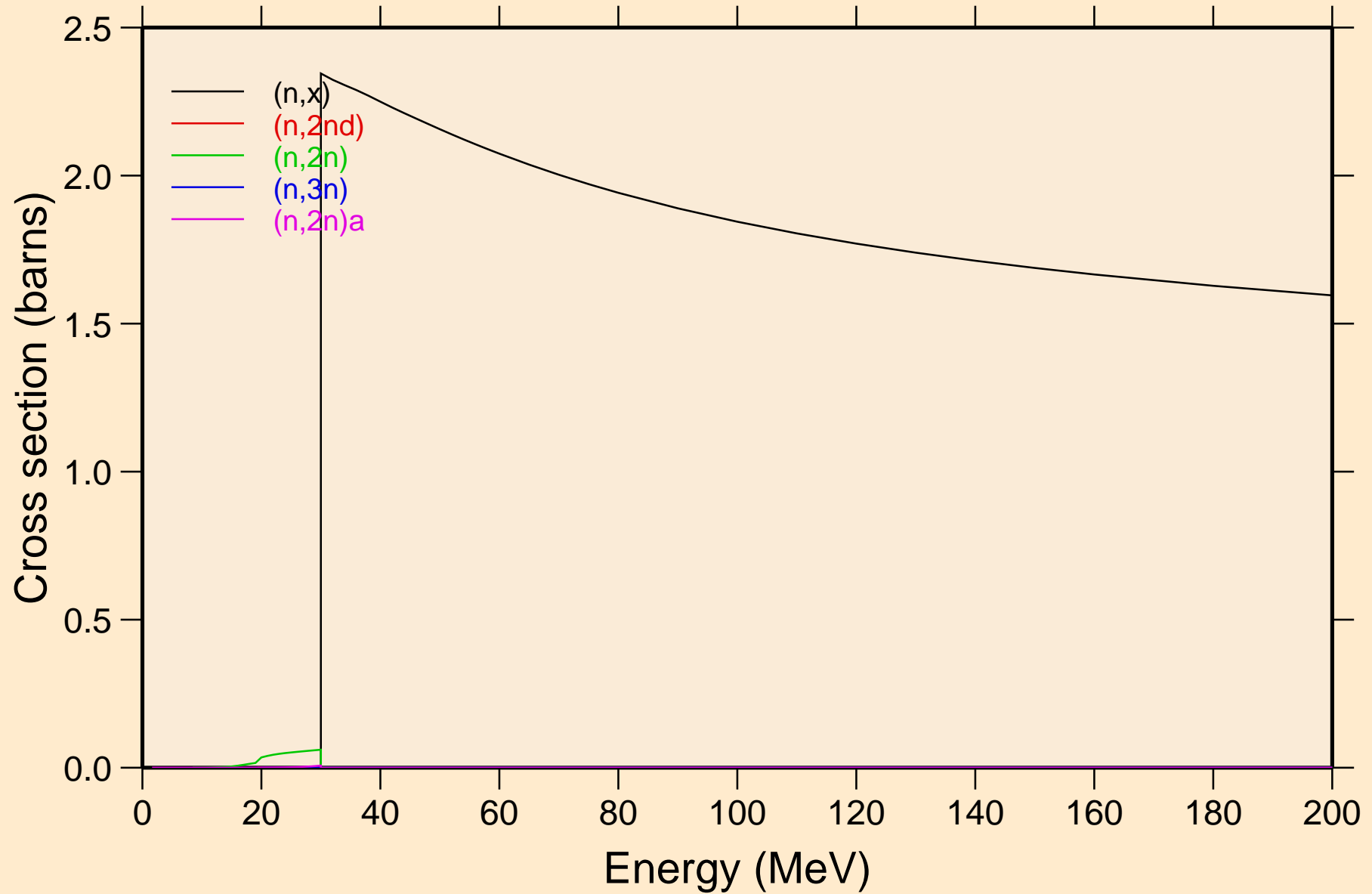

PB185M NEUTRON ACER TENDL-2024 LIBRARY; T=0.K  
Threshold reactions

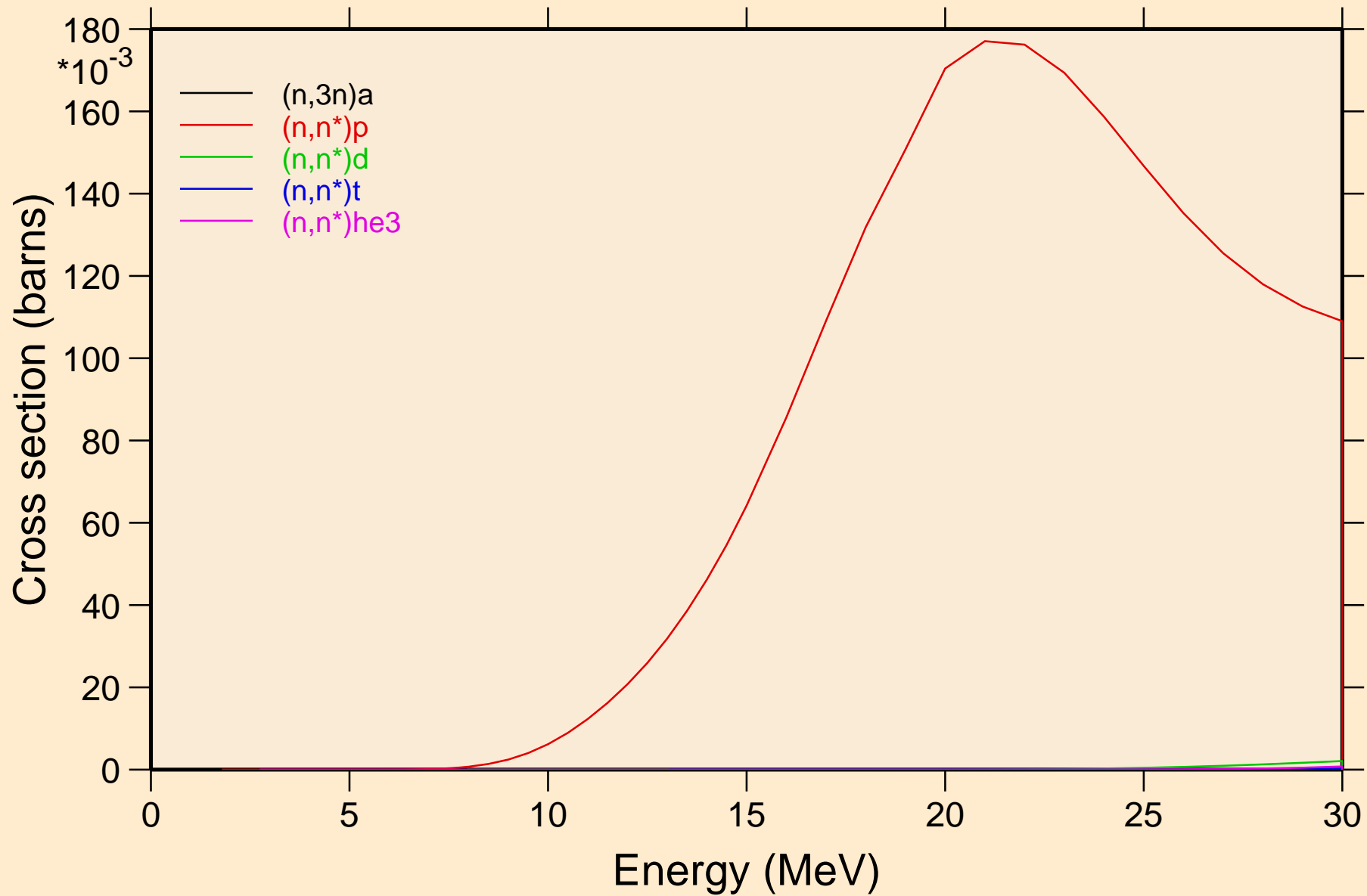

PB185M NEUTRON ACER TENDL-2024 LIBRARY; T=0.K  
Threshold reactions

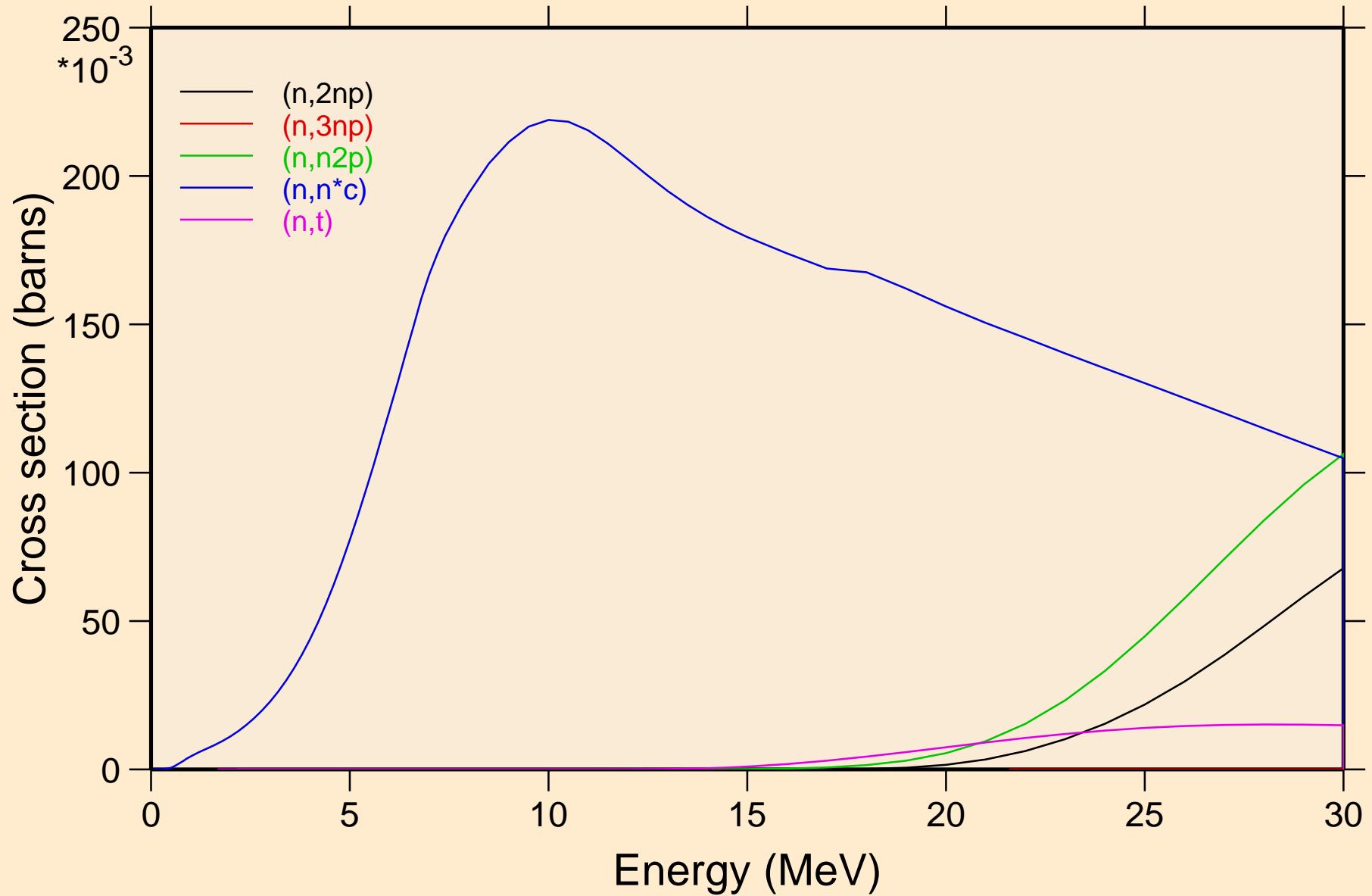

PB185M NEUTRON ACER TENDL-2024 LIBRARY; T=0.K  
Threshold reactions

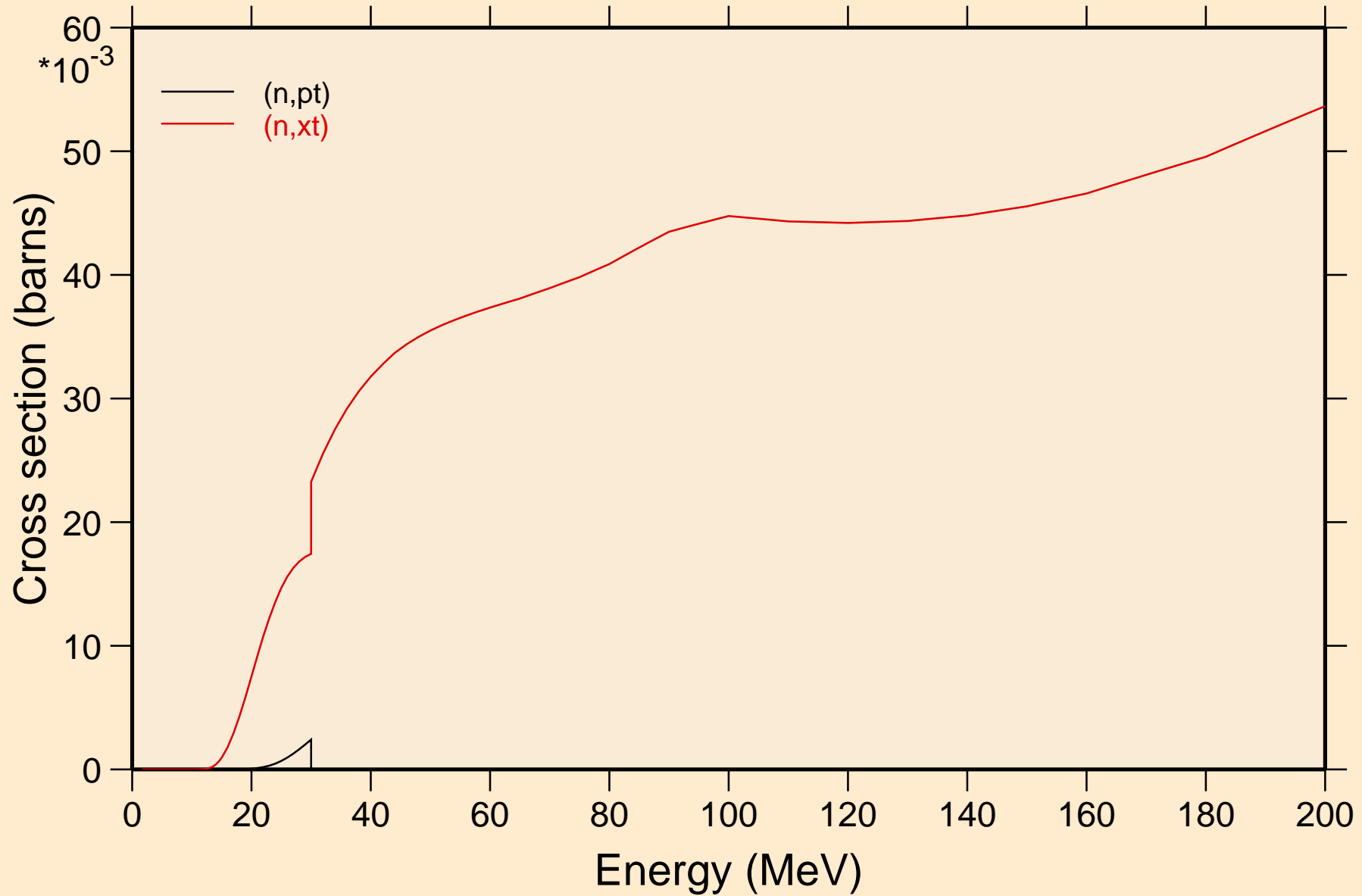

PB185M NEUTRON ACER TENDL-2024 LIBRARY; T=0.K  
angular distribution for elastic

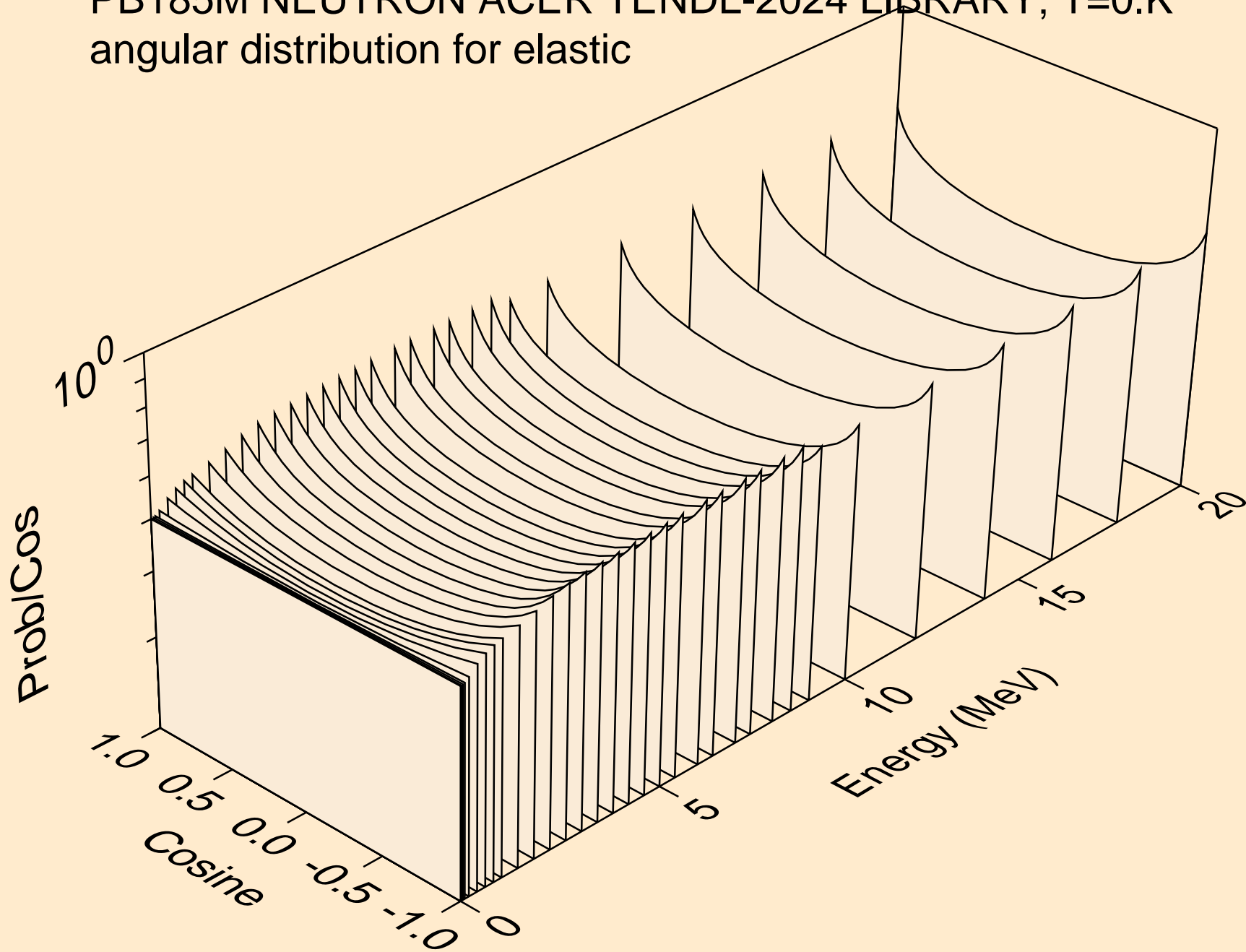

PB185M NEUTRON ACER TENDL-2024 LIBRARY; T=0.K  
angular distribution for elastic

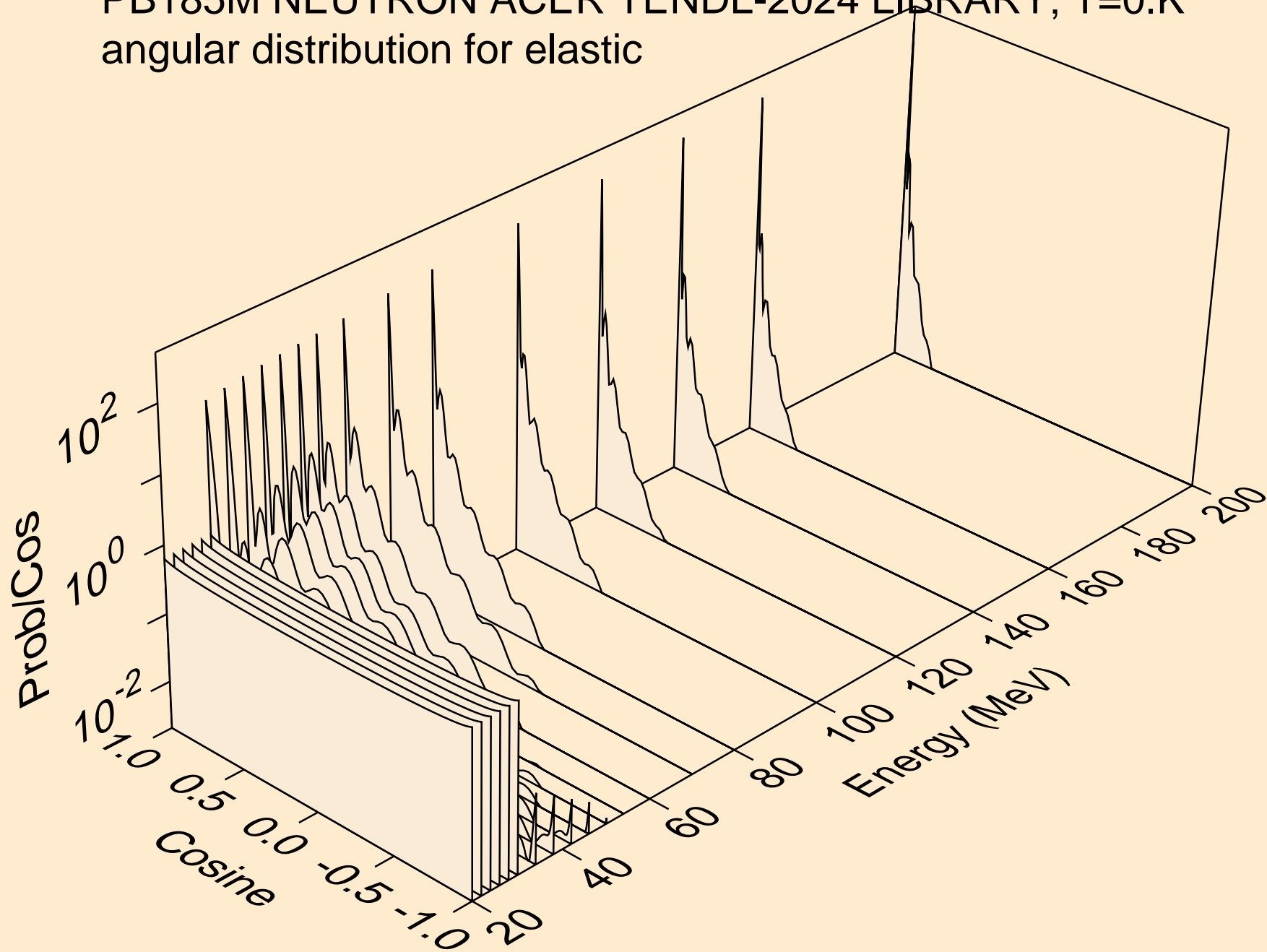

PB185M NEUTRON ACER TENDL-2024 LIBRARY; T=0.K  
angular distribution for (n,n\*1)

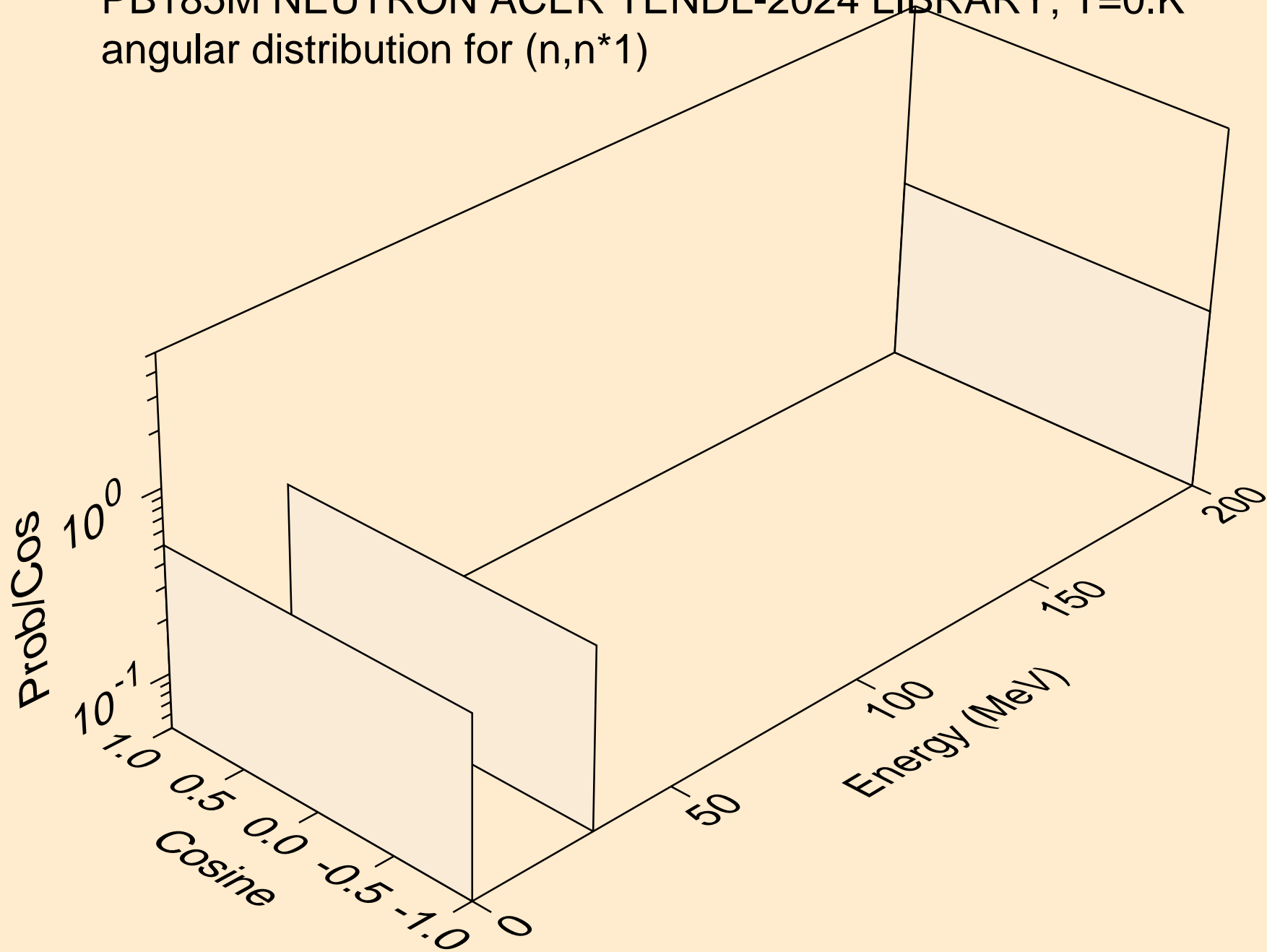



PB185M NEUTRON ACER TENDL-2024 LIBRARY; T=0.K  
angular distribution for (n,n\*2)

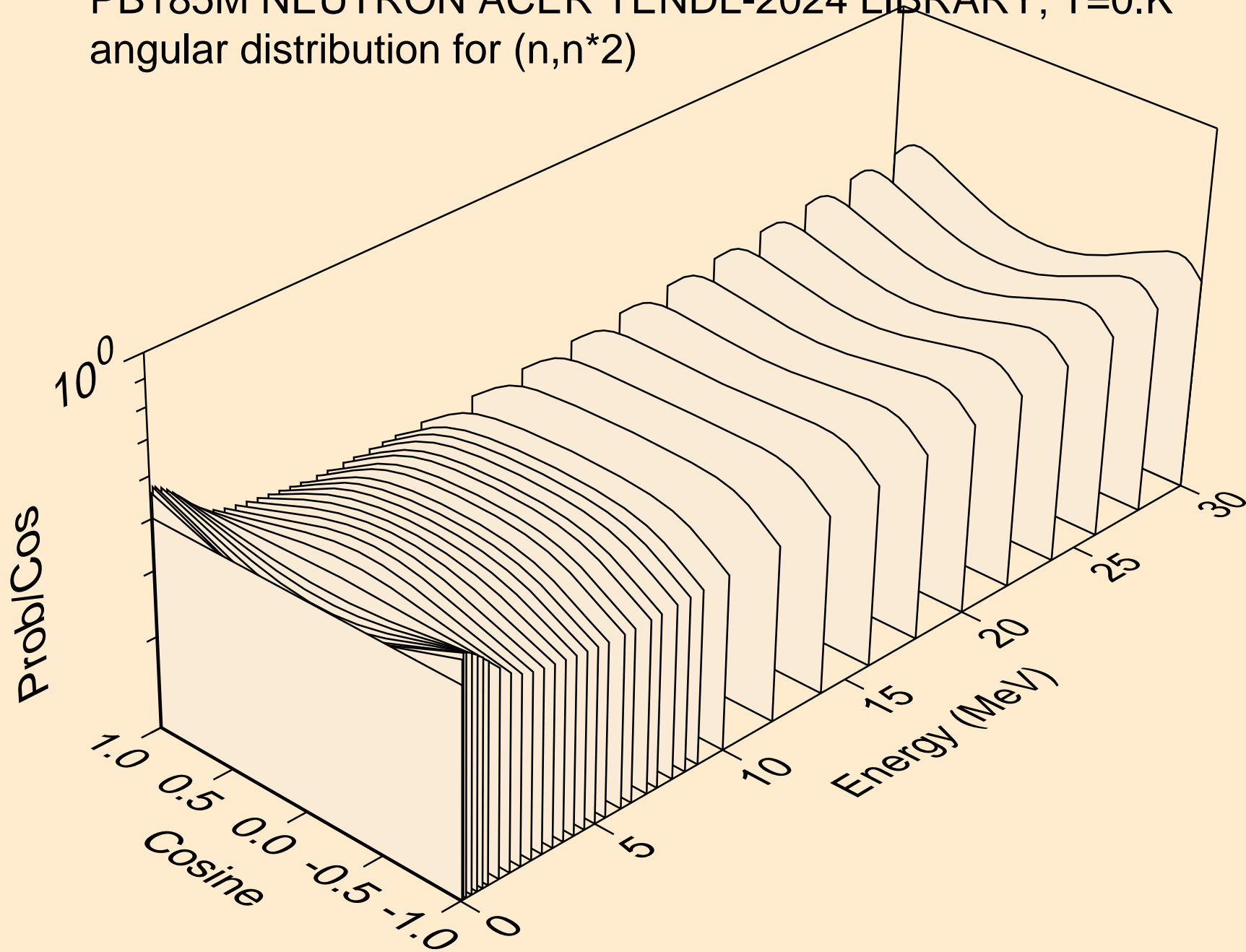

PB185M NEUTRON ACER TENDL-2024 LIBRARY; T=0.K  
Neutron emission for (n,x)

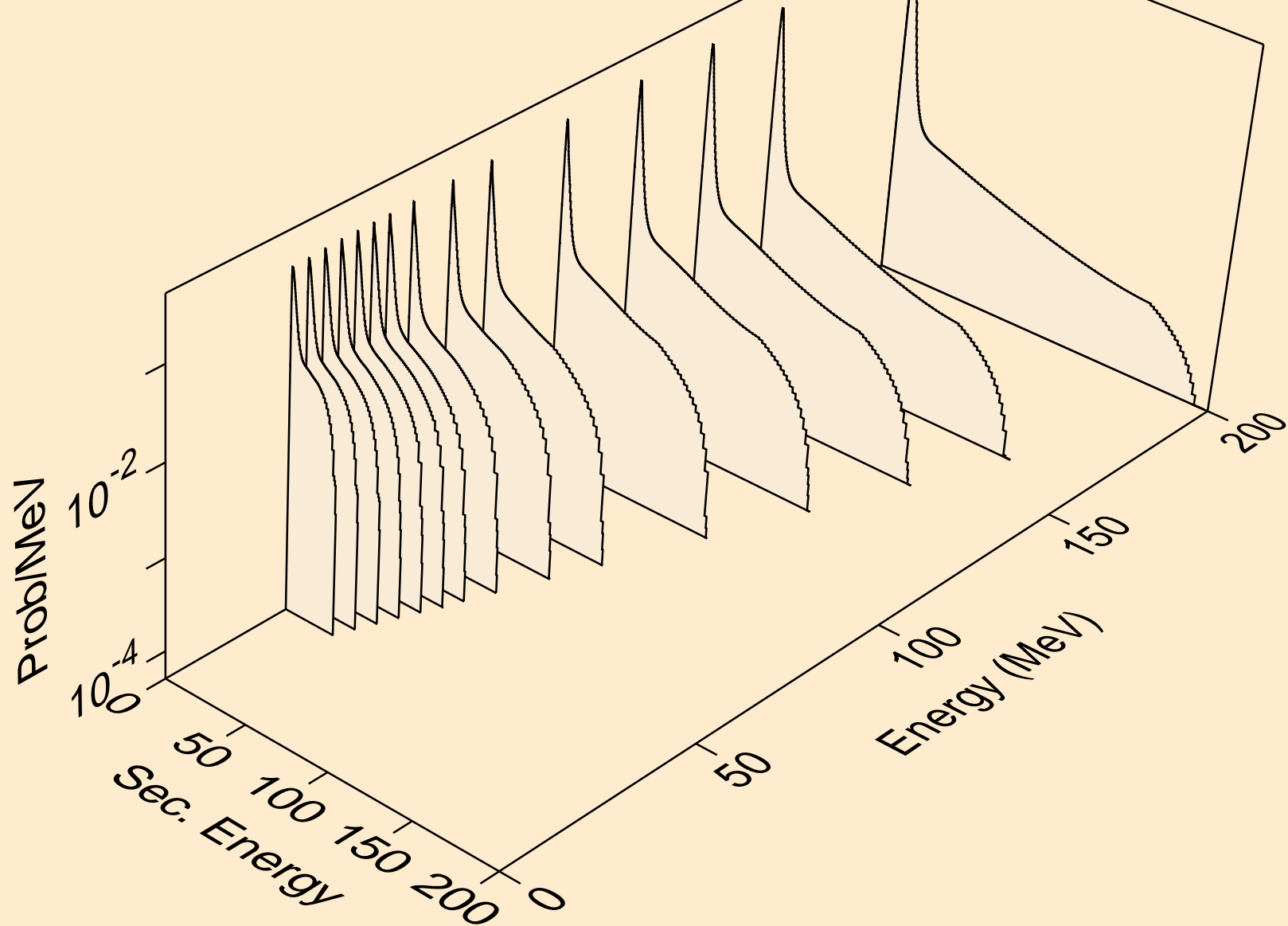

PB185M NEUTRON ACER TENDL-2024 LIBRARY; T=0.K  
Neutron emission for (n,2nd)

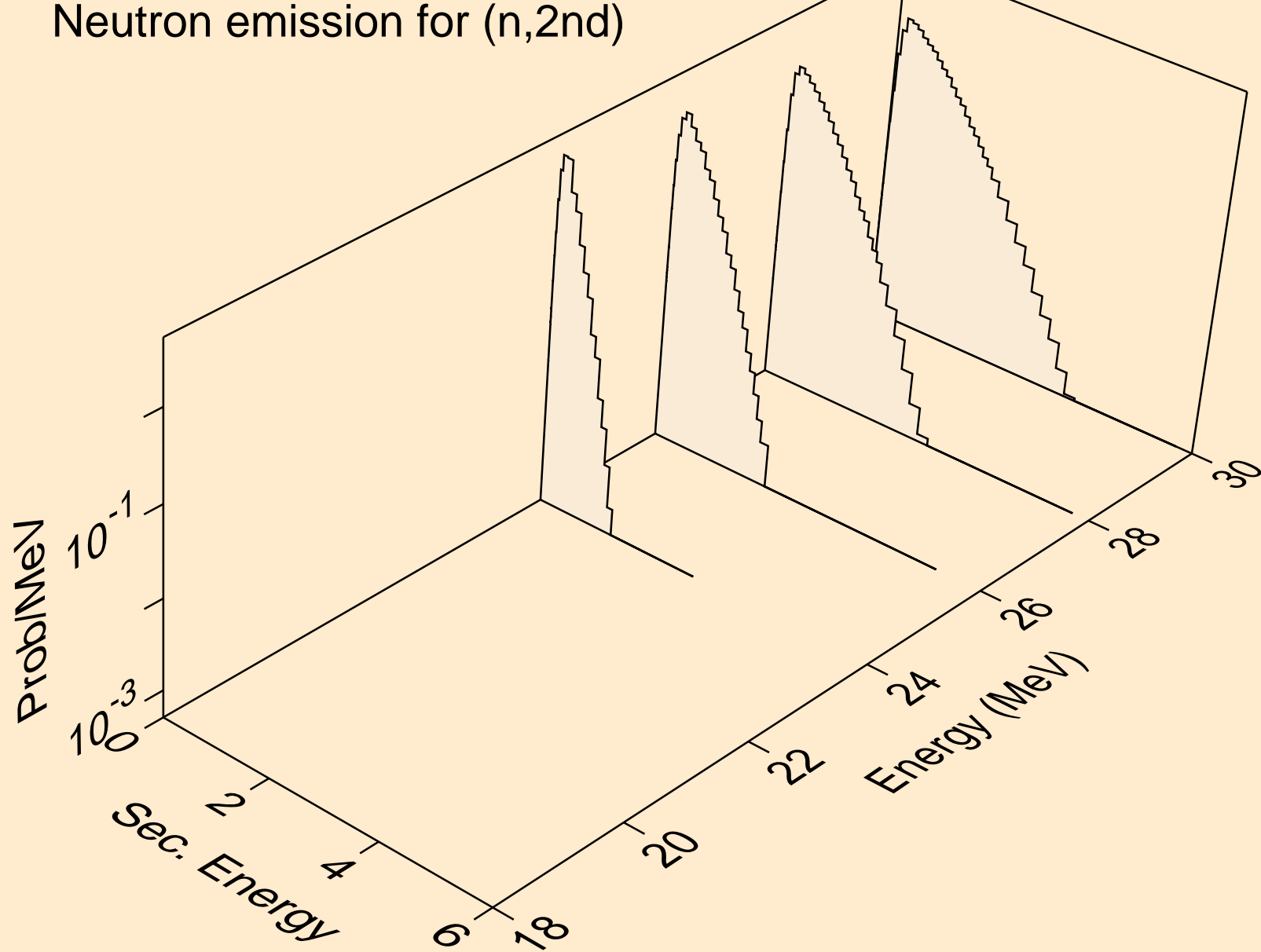

PB185M NEUTRON ACER TENDL-2024 LIBRARY; T=0.K  
Neutron emission for (n,2n)

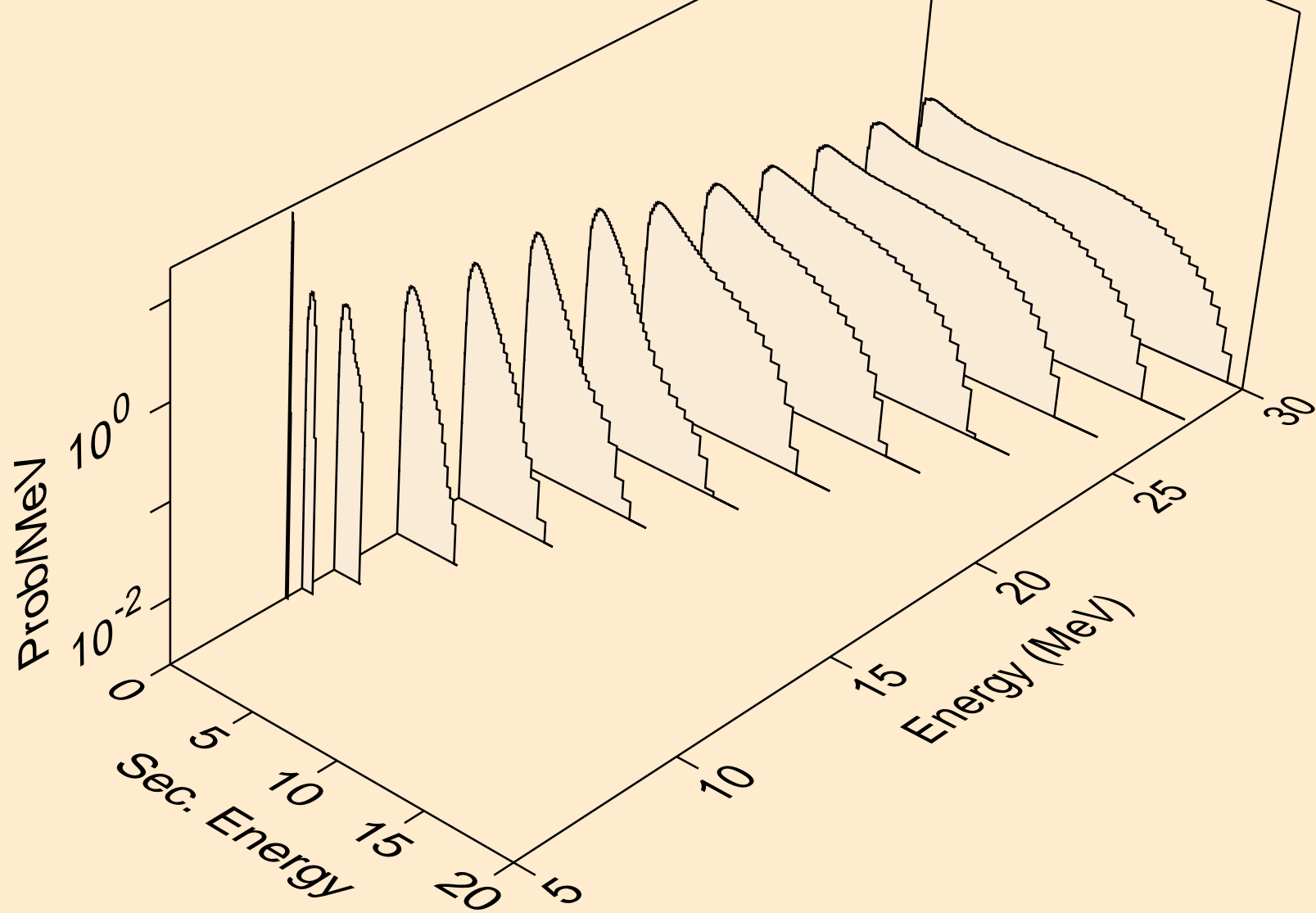

PB185M NEUTRON ACER TENDL-2024 LIBRARY; T=0.K  
Neutron emission for (n,3n)

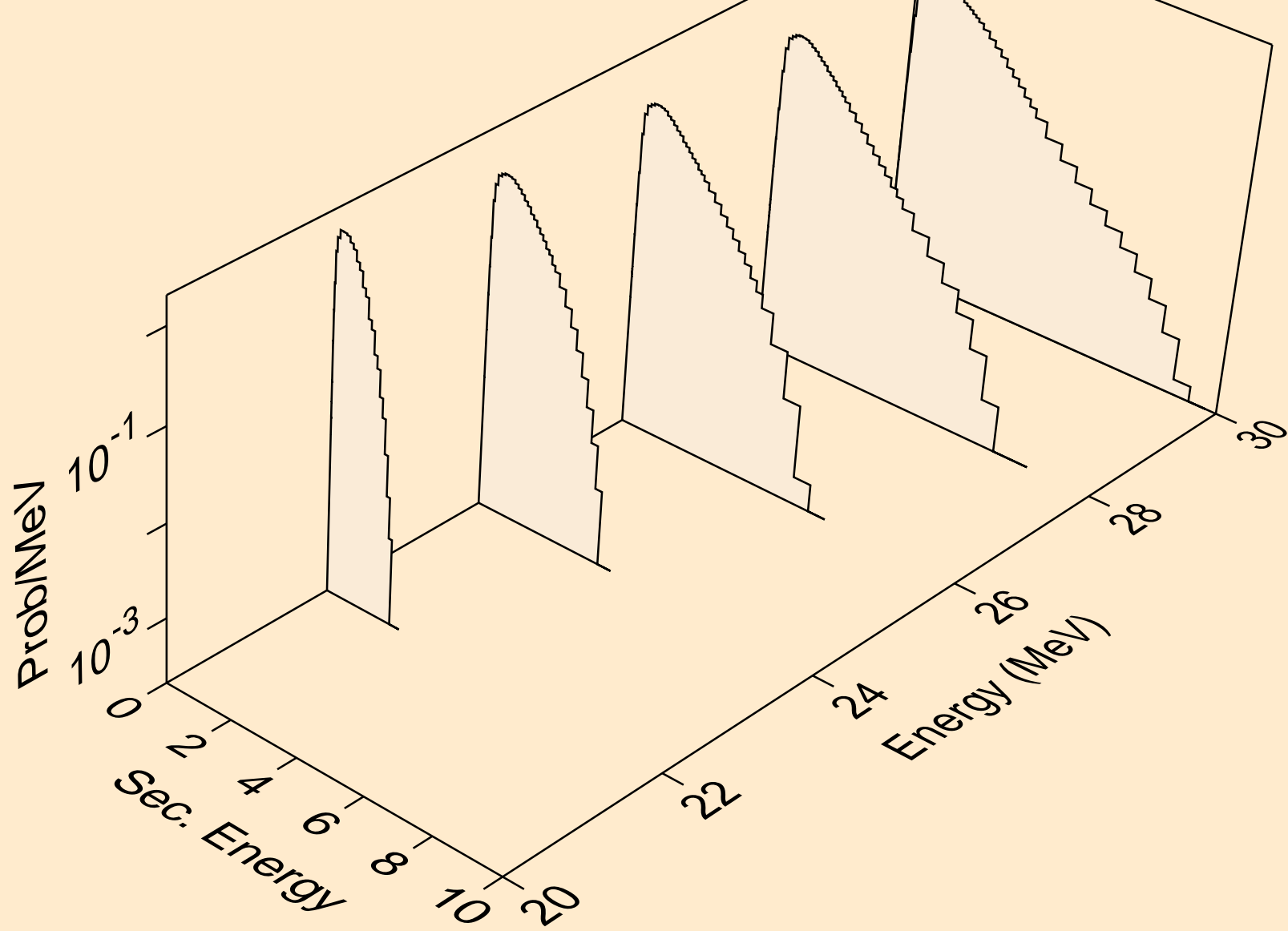

PB185M NEUTRON ACER TENDL-2024 LIBRARY; T=0.K  
Neutron emission for (n,n\*)a

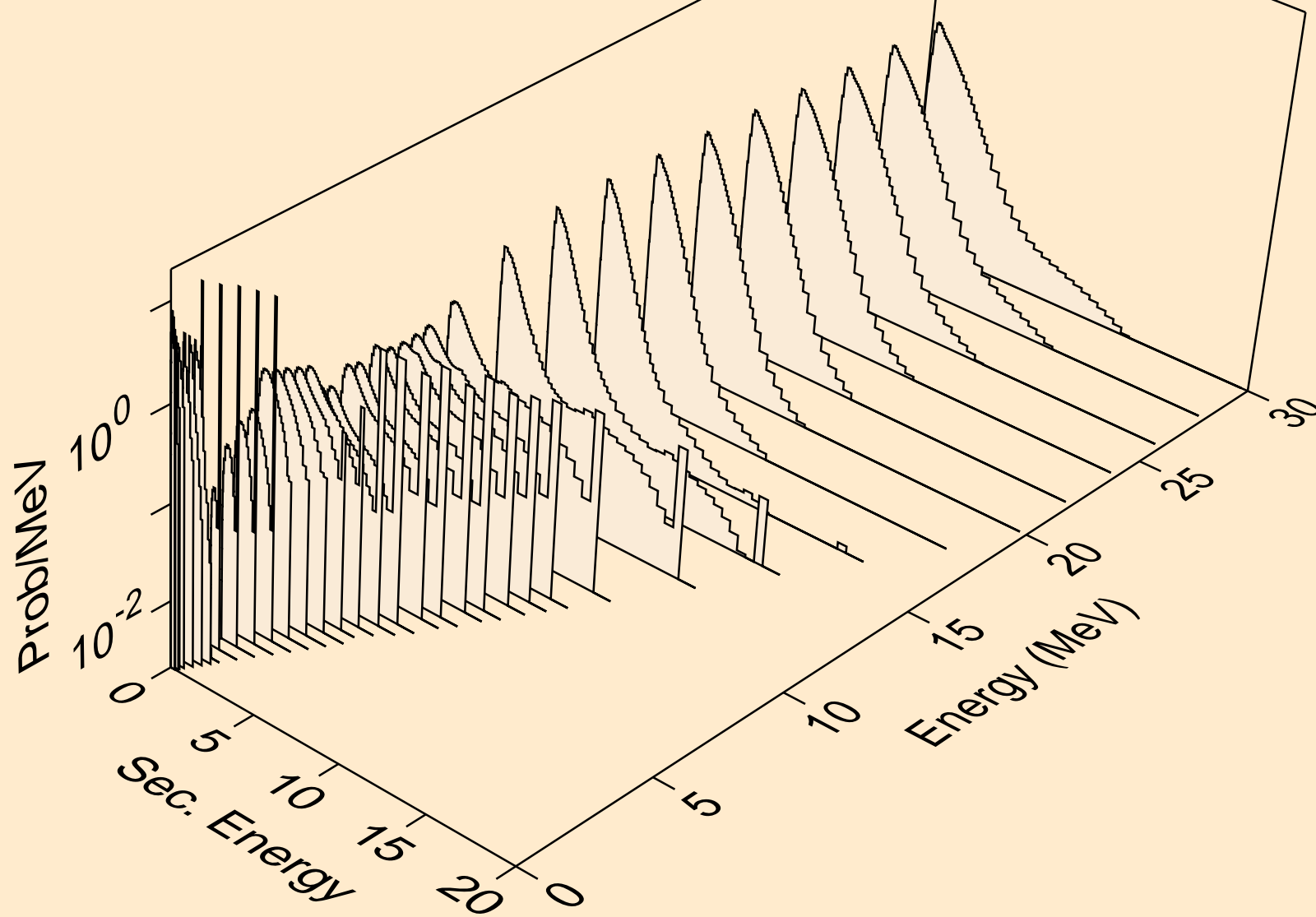

PB185M NEUTRON ACER TENDL-2024 LIBRARY; T=0.K  
Neutron emission for (n,n\*)3a

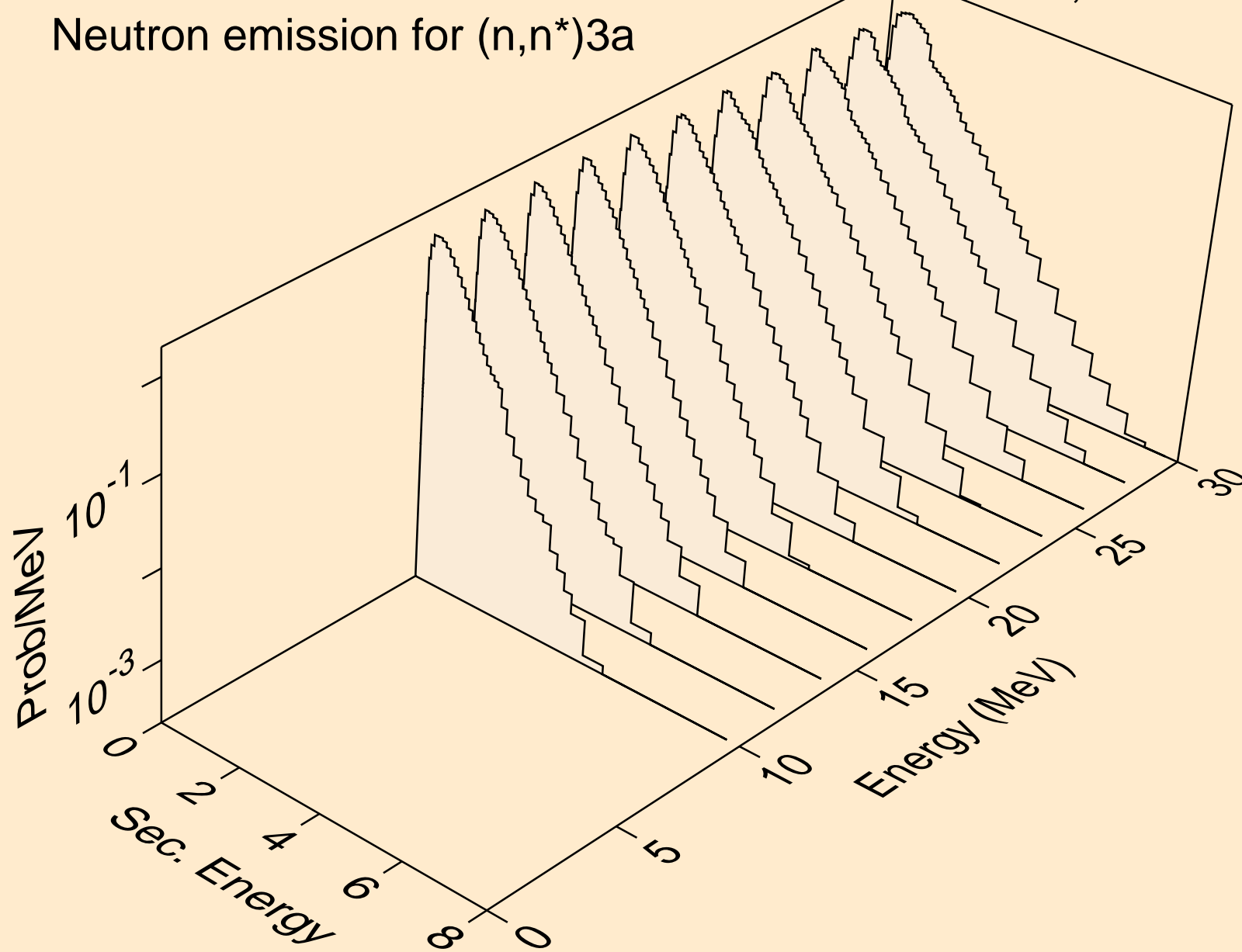

PB185M NEUTRON ACER TENDL-2024 LIBRARY; T=0.K  
Neutron emission for (n,2n)a

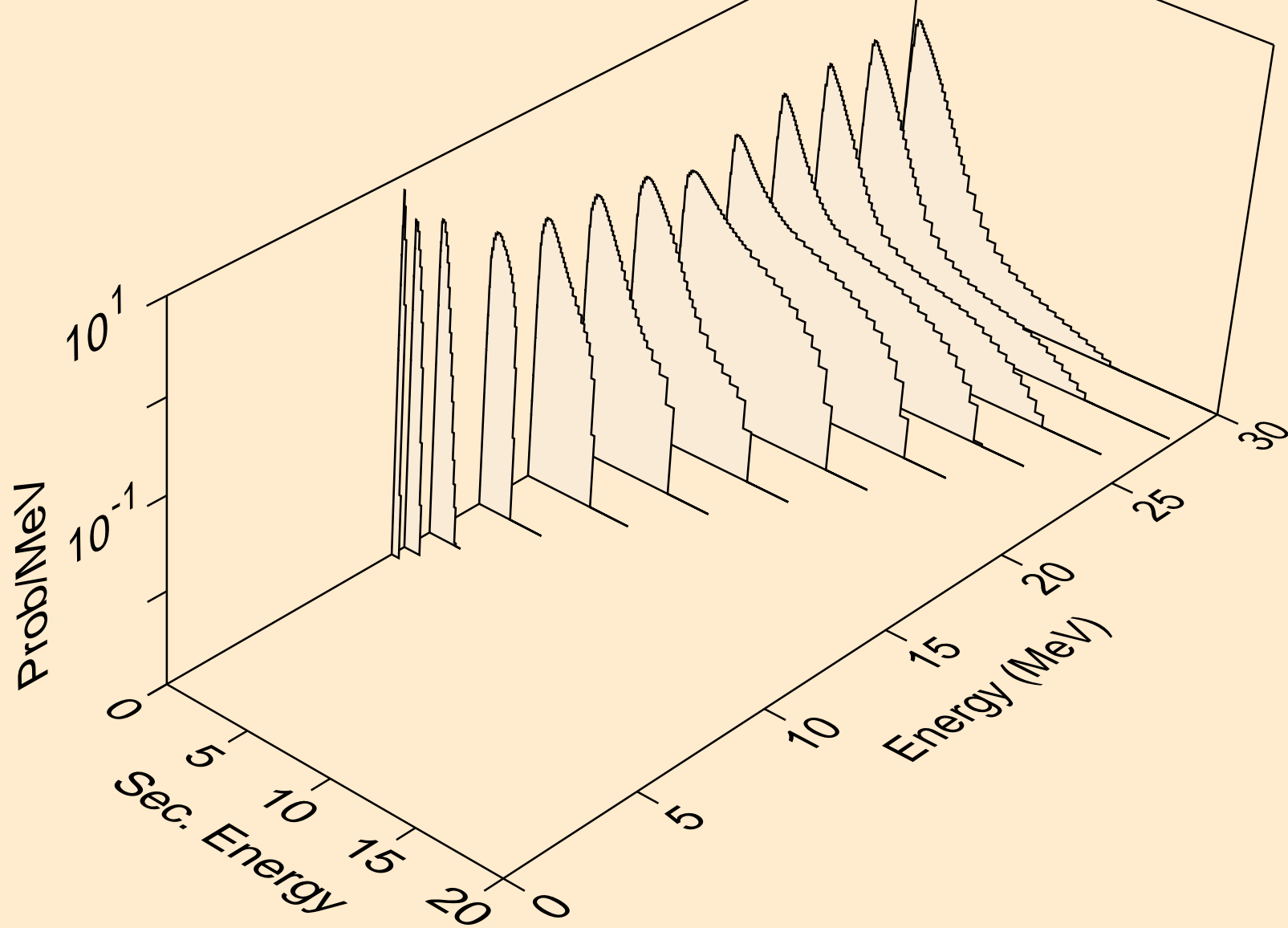



PB185M NEUTRON ACER TENDL-2024 LIBRARY; T=0.K  
Neutron emission for (n,3n)a

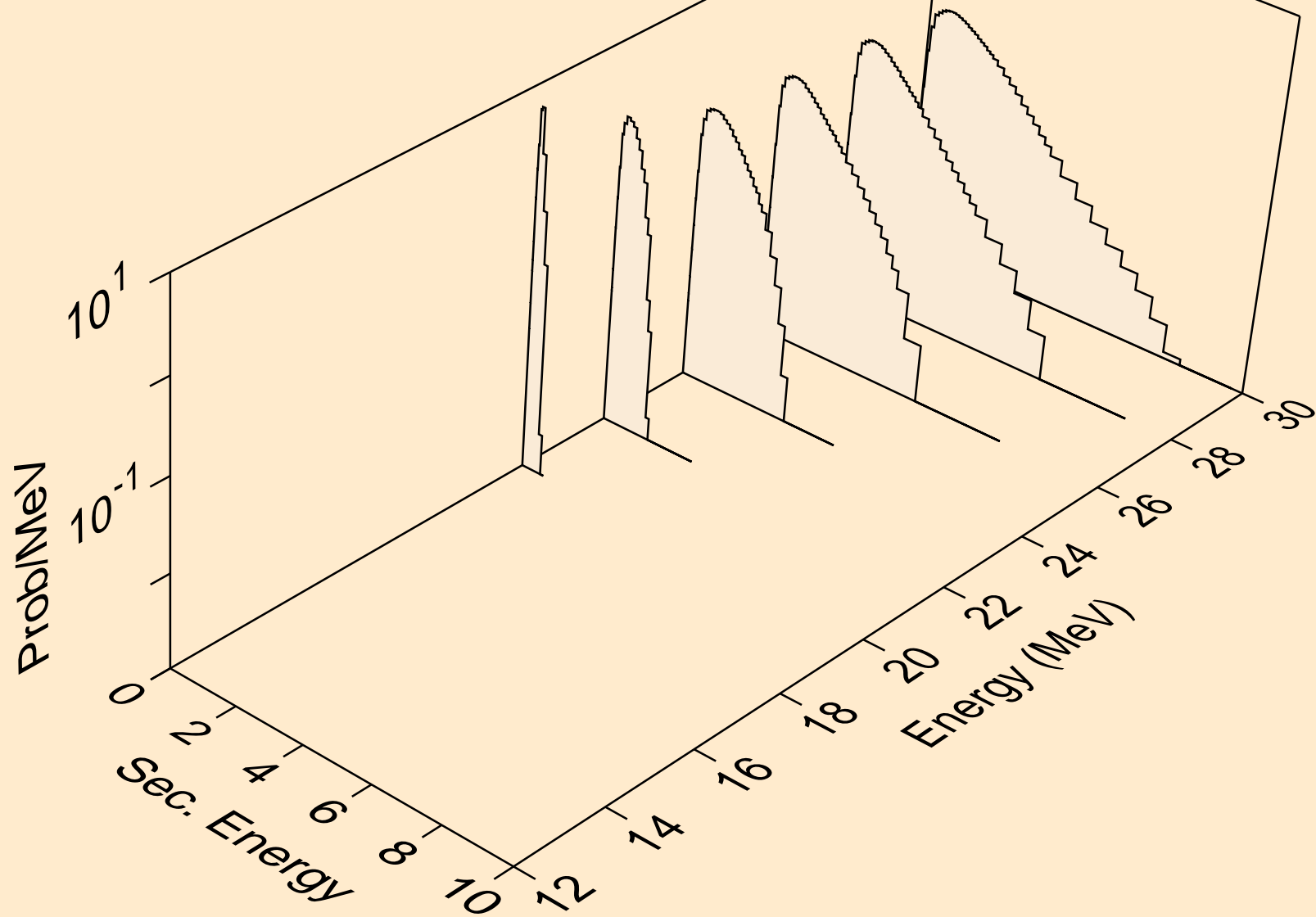

PB185M NEUTRON ACER TENDL-2024 LIBRARY; T=0.K  
Neutron emission for (n,n\*)p

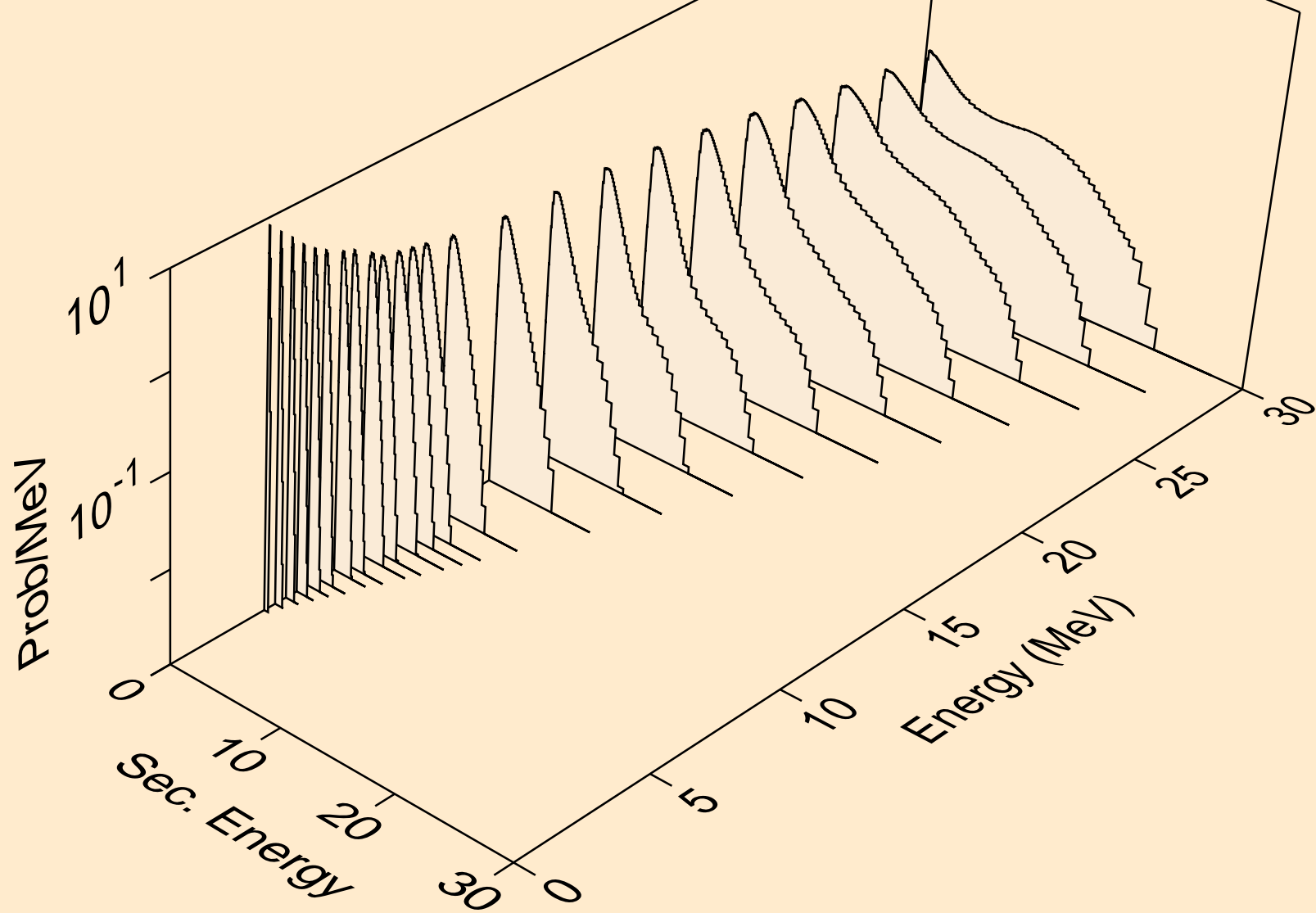

PB185M NEUTRON ACER TENDL-2024 LIBRARY; T=0.K  
Neutron emission for (n,n\*)2a

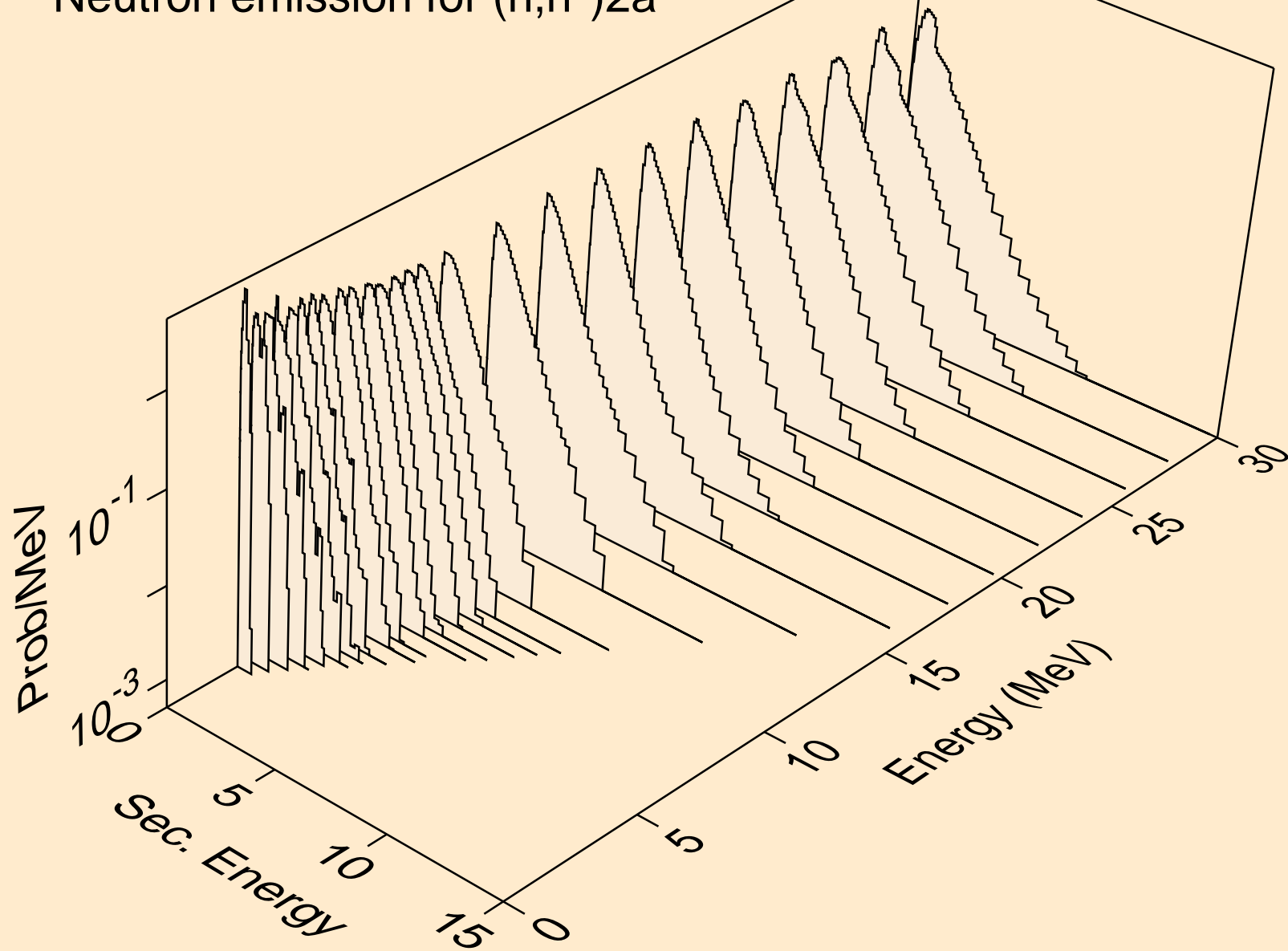

PB185M NEUTRON ACER TENDL-2024 LIBRARY; T=0.K  
Neutron emission for (n,2n)2a

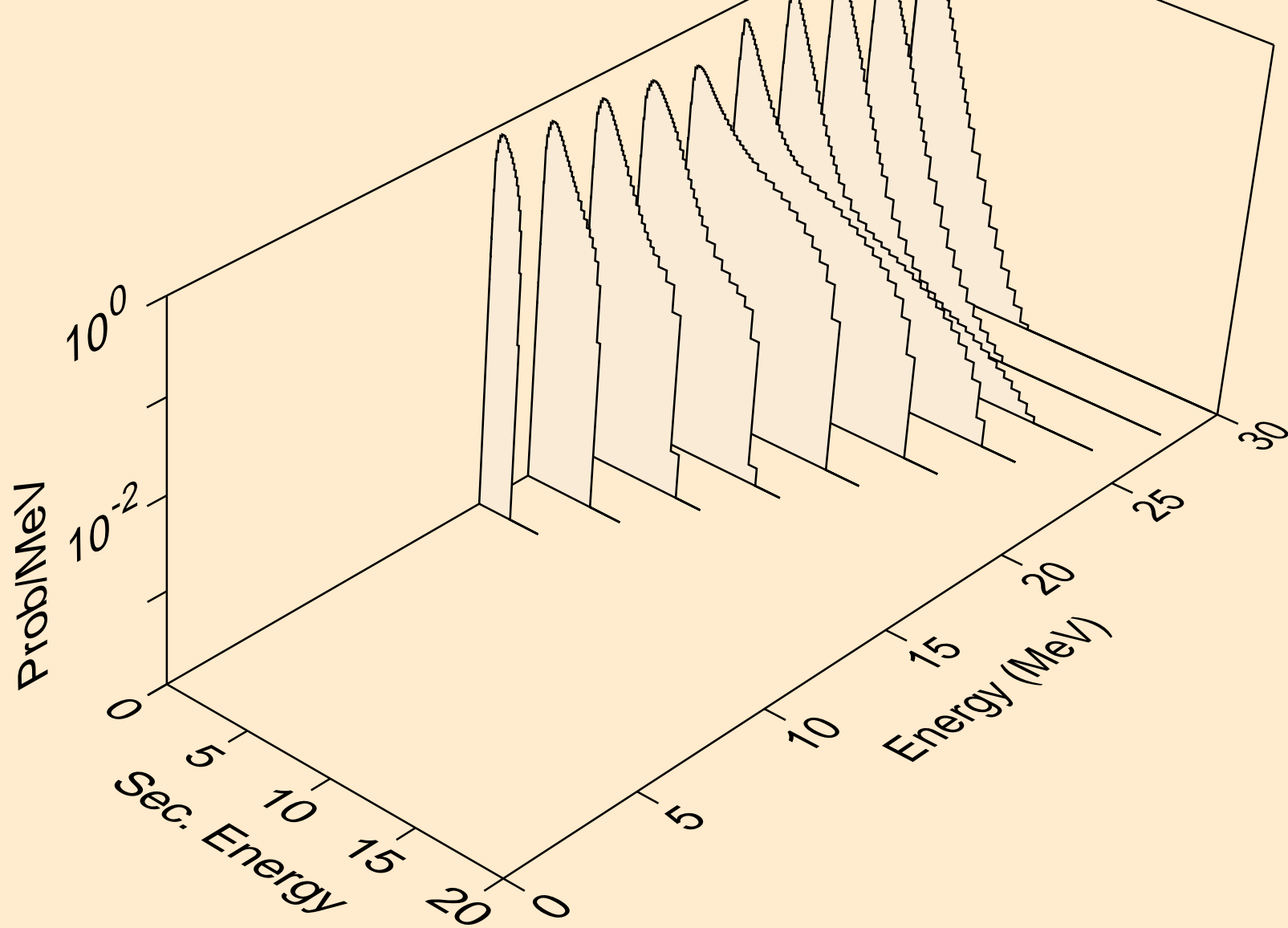

PB185M NEUTRON ACER TENDL-2024 LIBRARY; T=0.K  
Neutron emission for (n,n\*)d

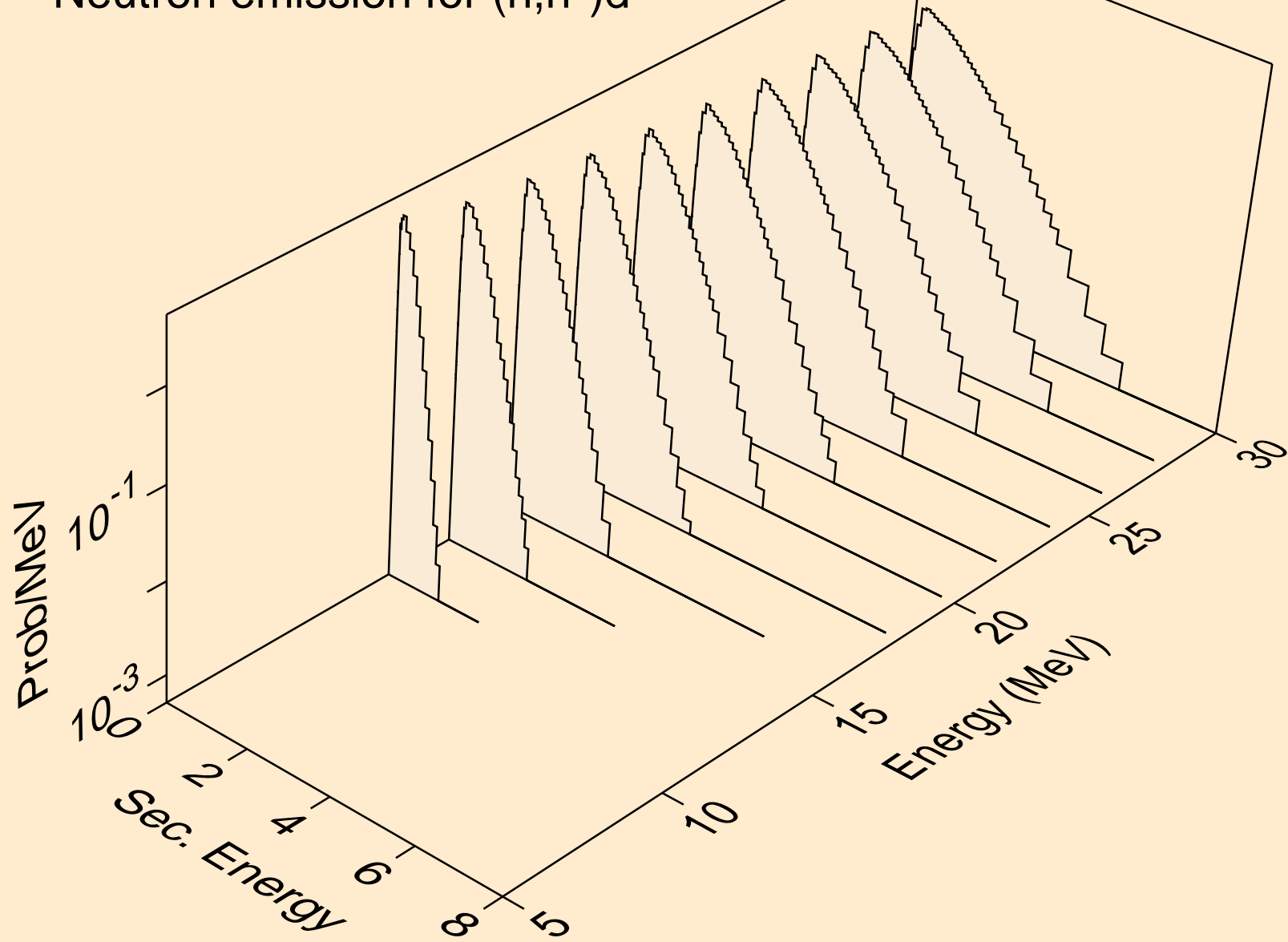

PB185M NEUTRON ACER TENDL-2024 LIBRARY; T=0.K  
Neutron emission for (n,n\*)t

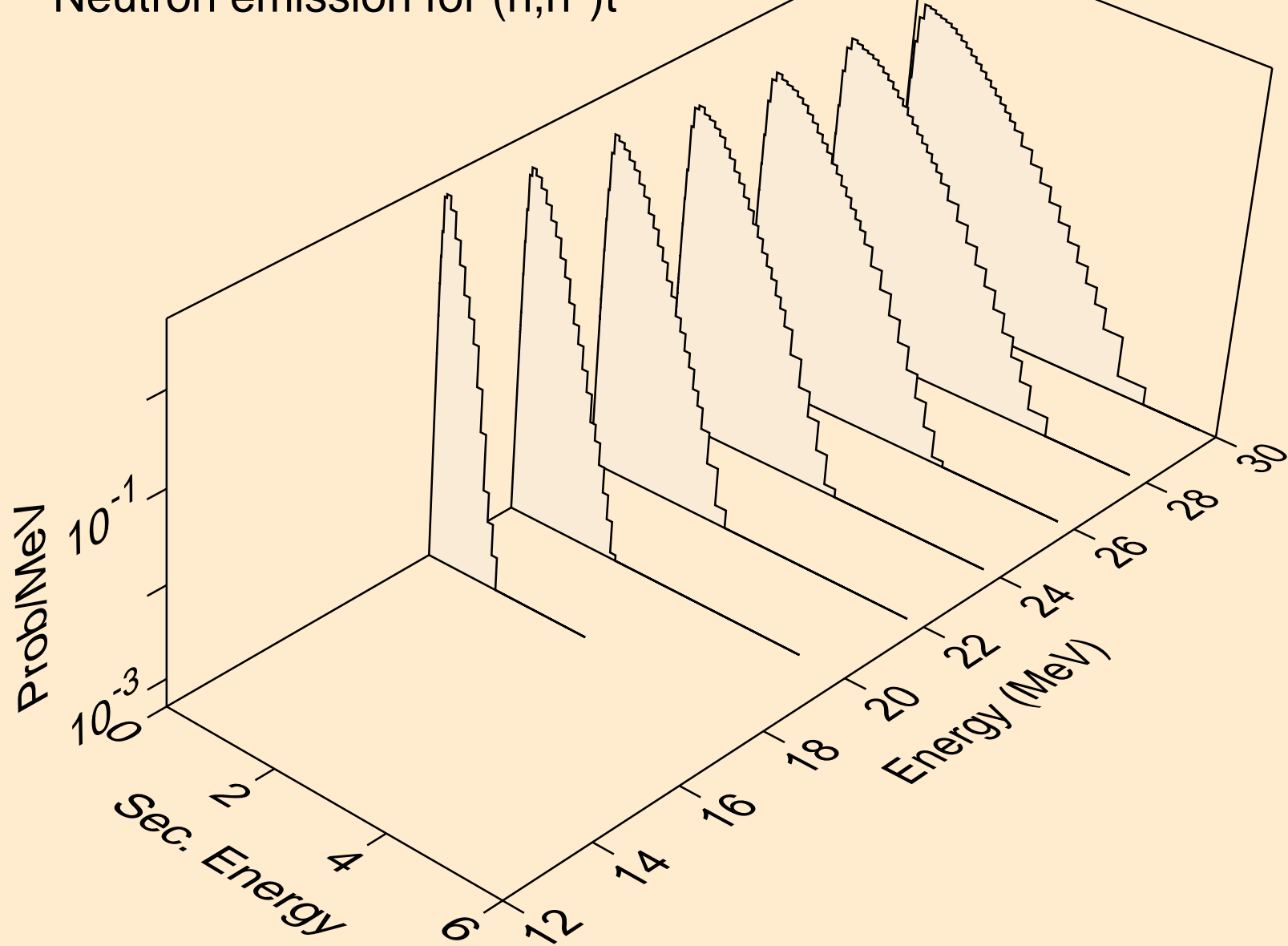

PB185M NEUTRON ACER TENDL-2024 LIBRARY; T=0.K  
Neutron emission for (n,n\*)he3

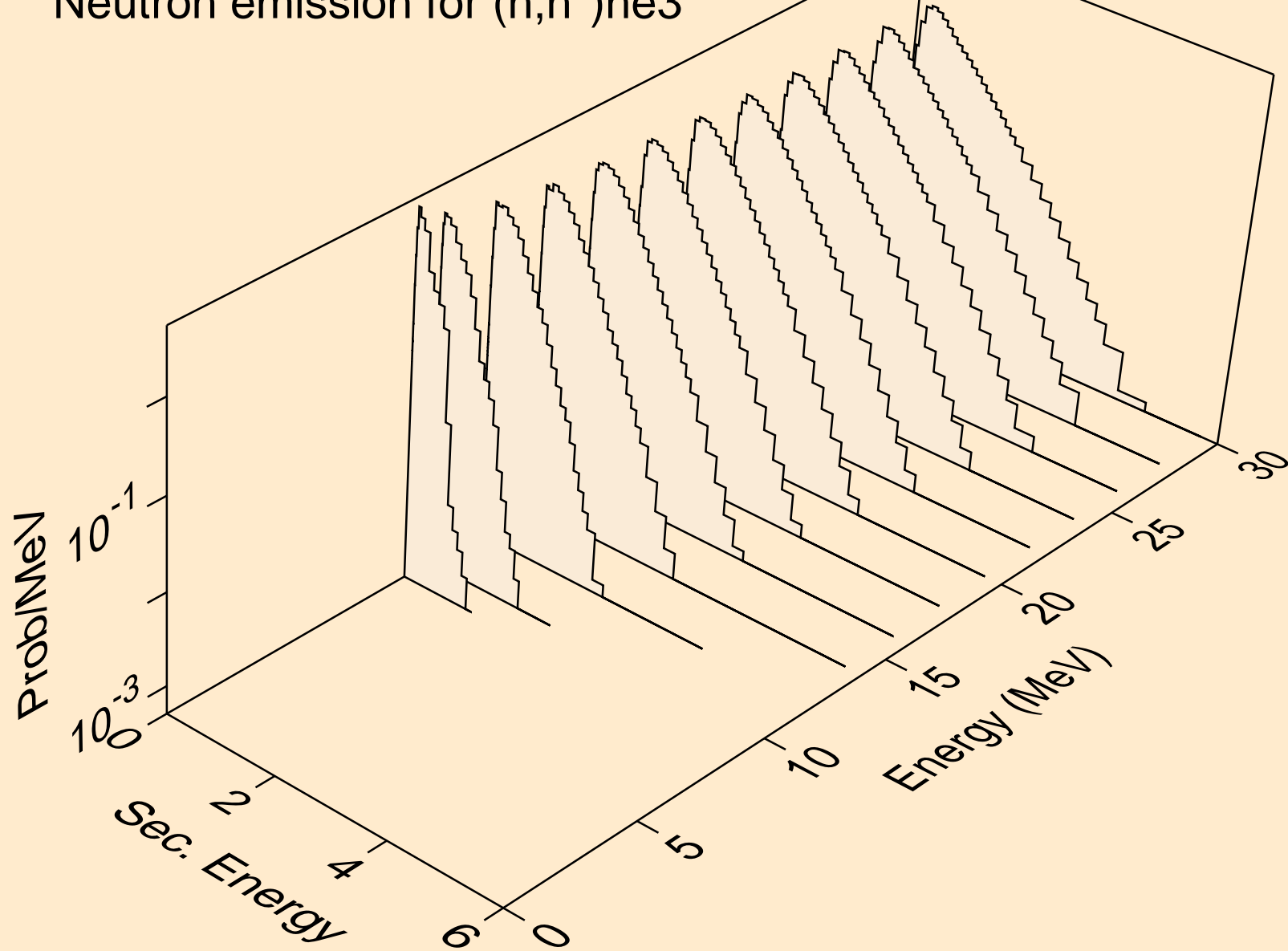

PB185M NEUTRON ACER TENDL-2024 LIBRARY; T=0.K  
Neutron emission for (n,2np)

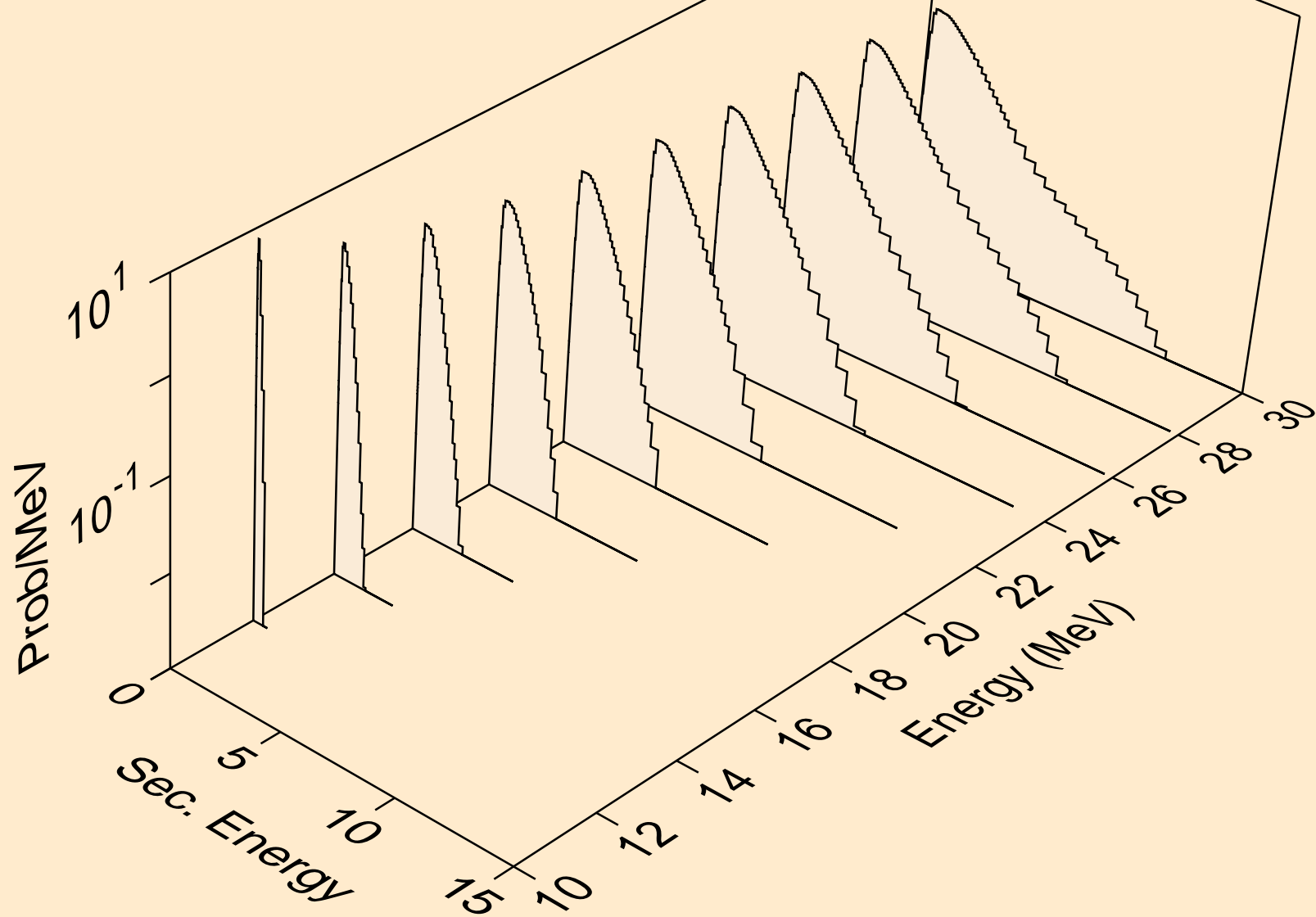



PB185M NEUTRON ACER TENDL-2024 LIBRARY; T=0.K  
Neutron emission for (n,3np)

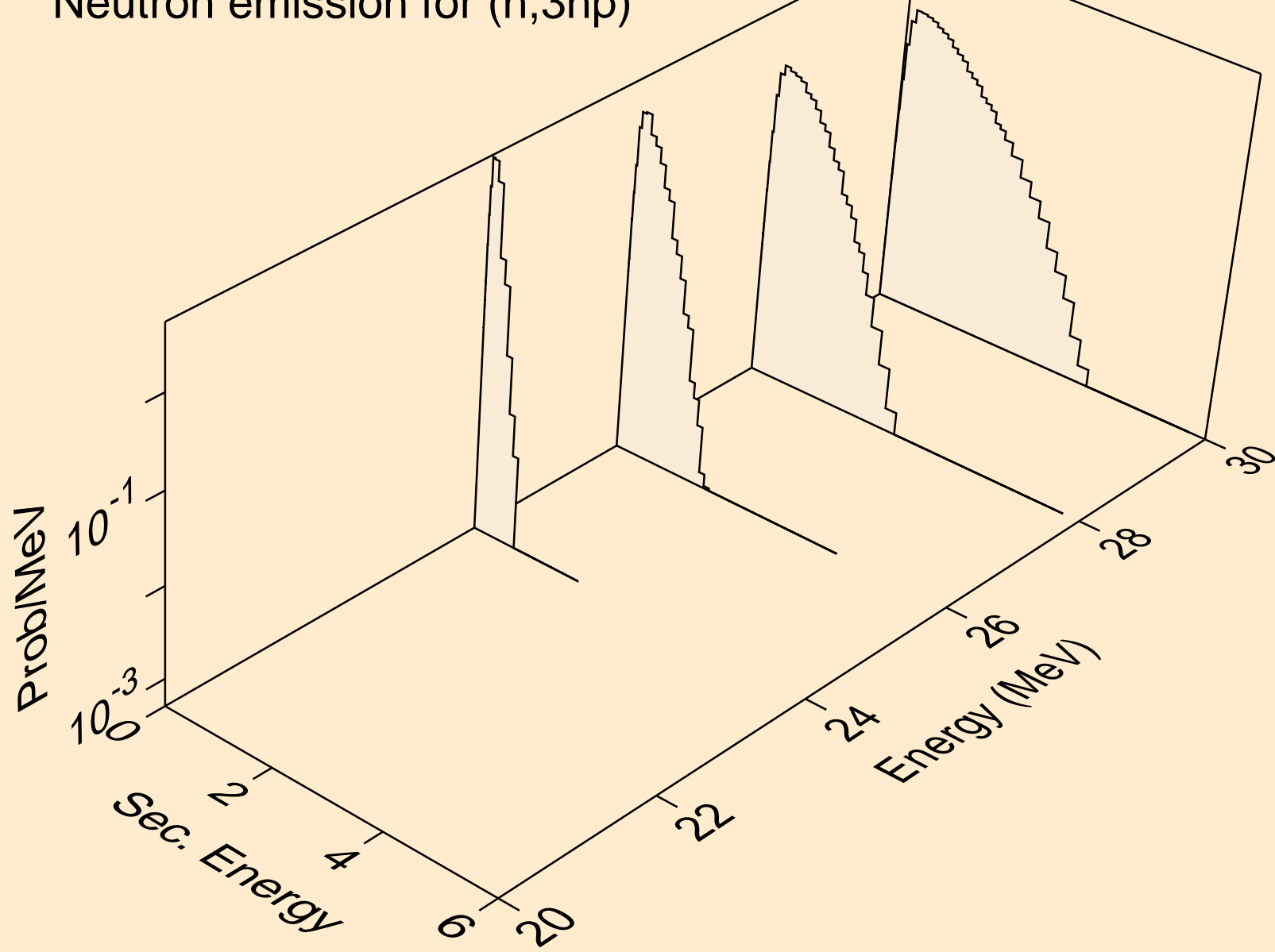

PB185M NEUTRON ACER TENDL-2024 LIBRARY; T=0.K  
Neutron emission for (n,n2p)

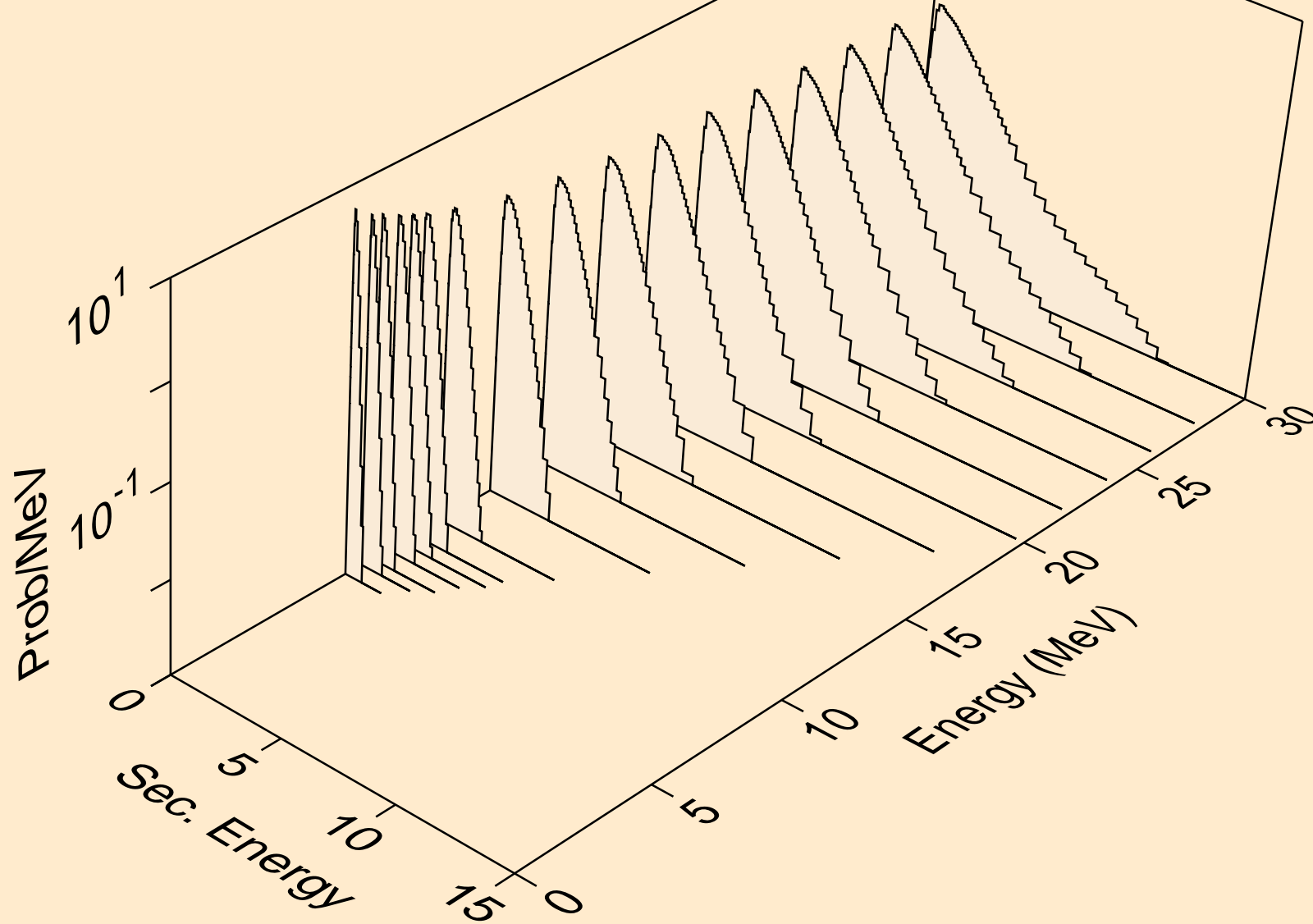

PB185M NEUTRON ACER TENDL-2024 LIBRARY; T=0.K  
Neutron emission for (n,npa)

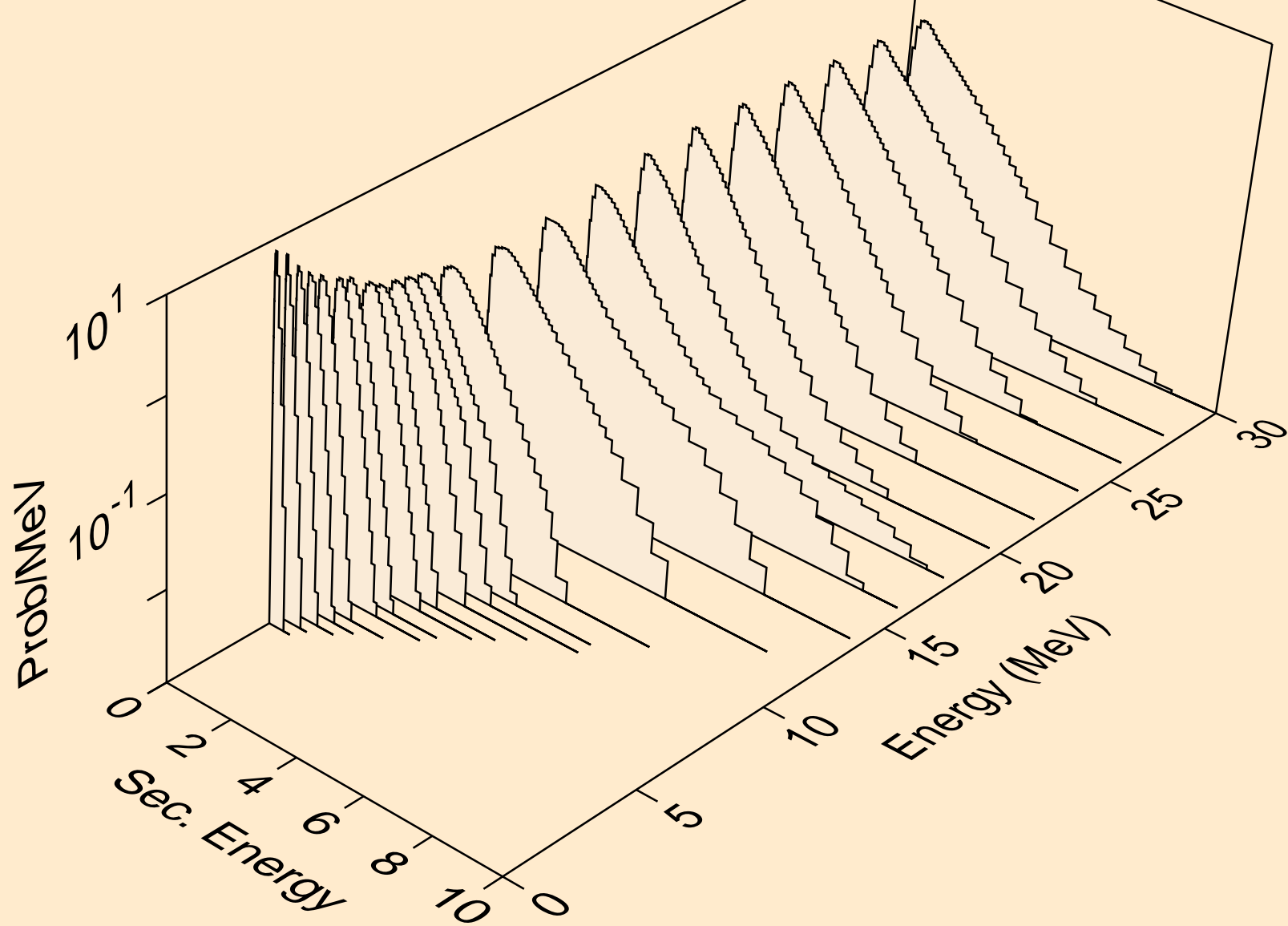

PB185M NEUTRON ACER TENDL-2024 LIBRARY; T=0.K  
Neutron emission for (n,n\*c)

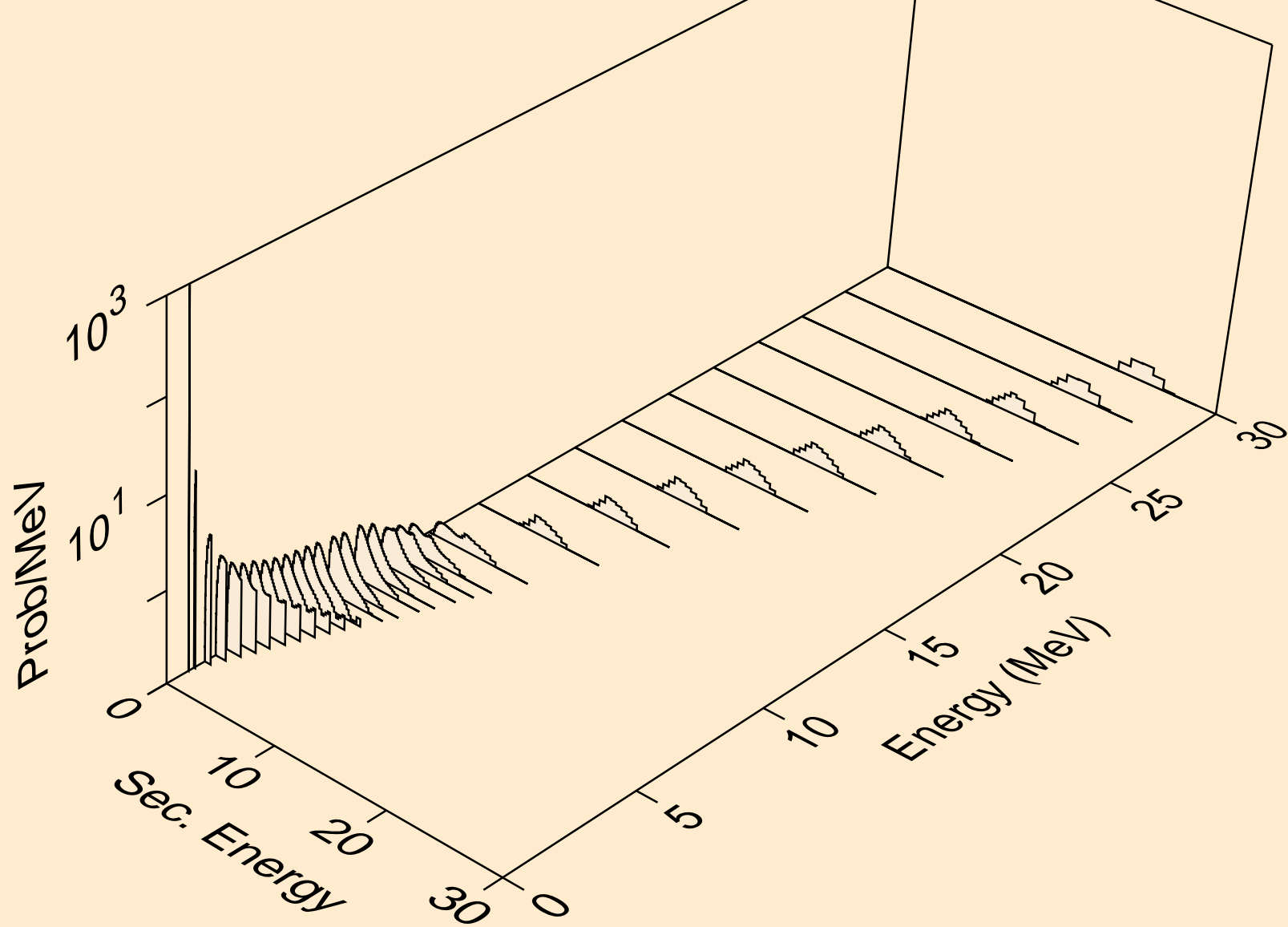

PB185M NEUTRON ACER TENDL-2024 LIBRARY; T=0.K  
Photon emission for (n,x)

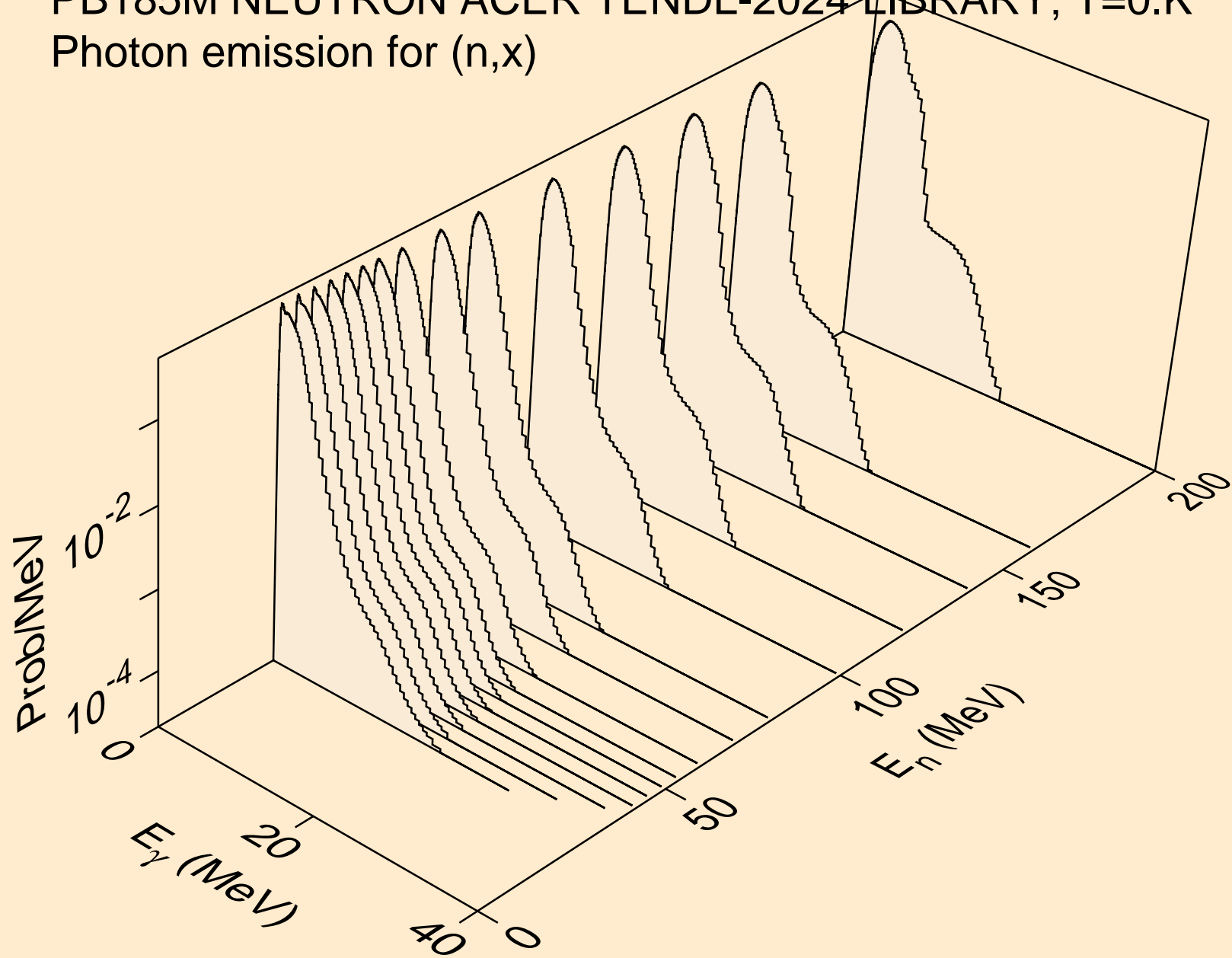

PB185M NEUTRON ACER TENDL-2024 LIBRARY; T=0.K  
Photon emission for (n,2nd)

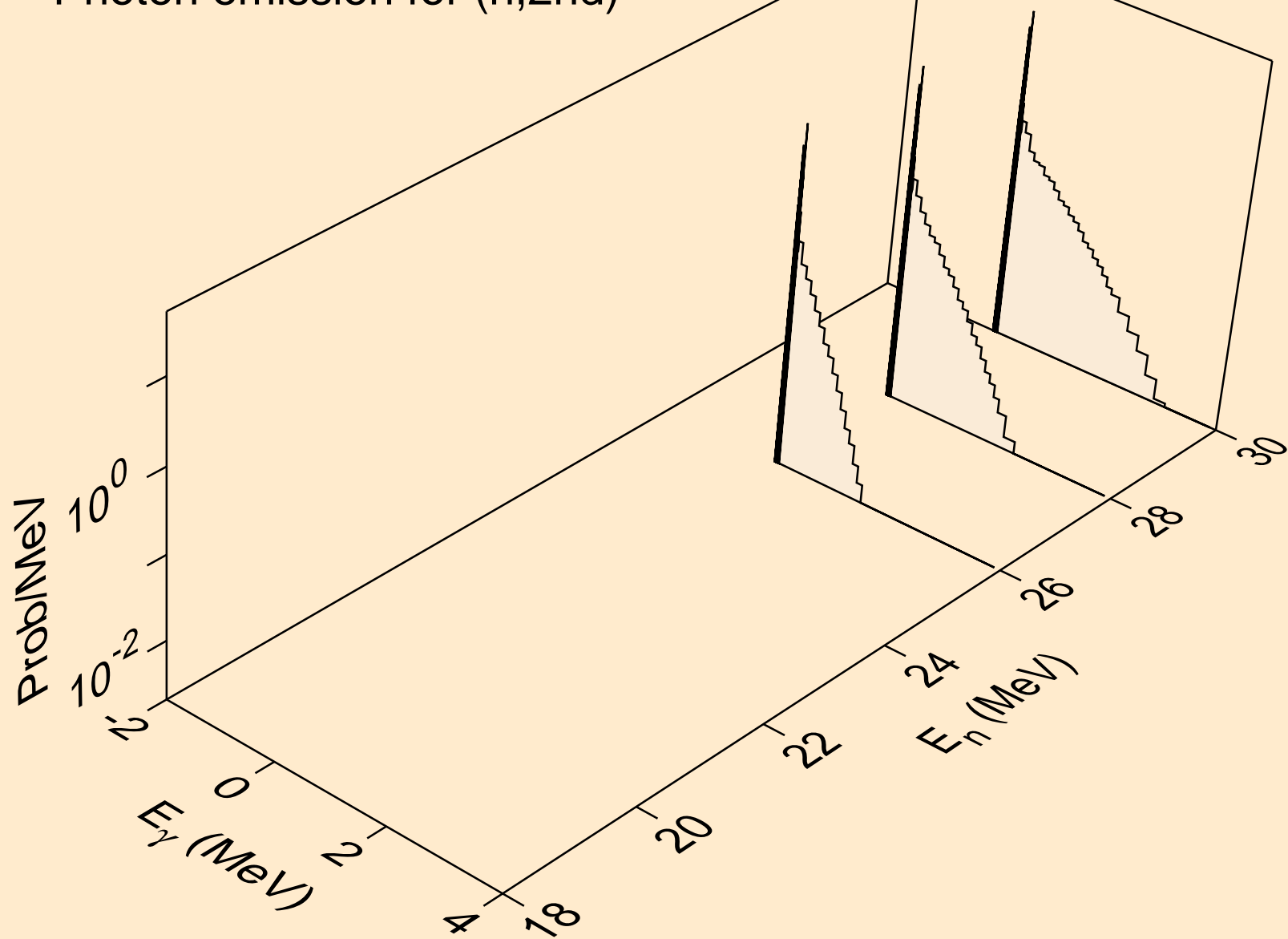

PB185M NEUTRON ACER TENDL-2024 LIBRARY; T=0.K  
Photon emission for (n,2n)

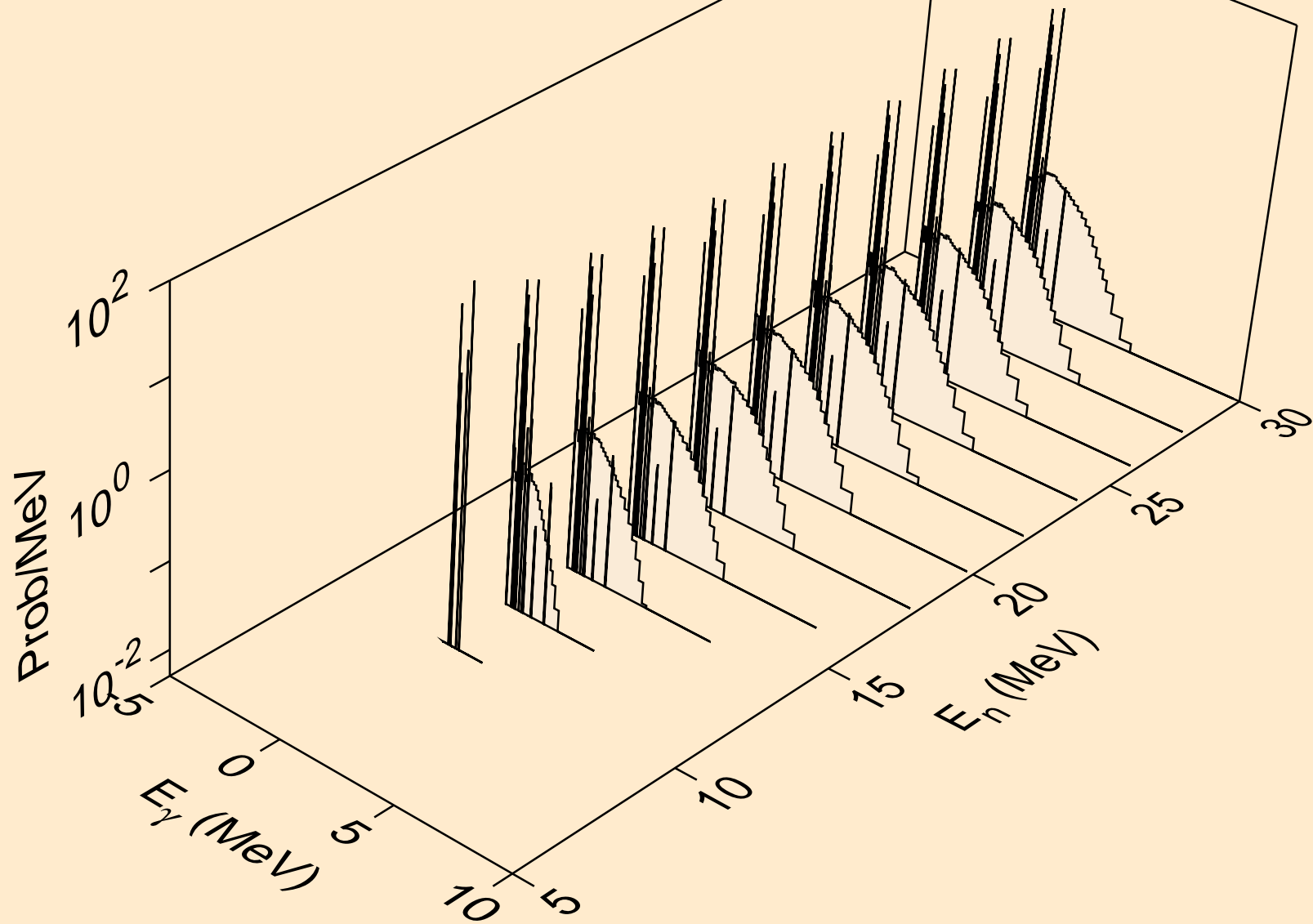

PB185M NEUTRON ACER TENDL-2024 LIBRARY; T=0.K  
Photon emission for (n,3n)

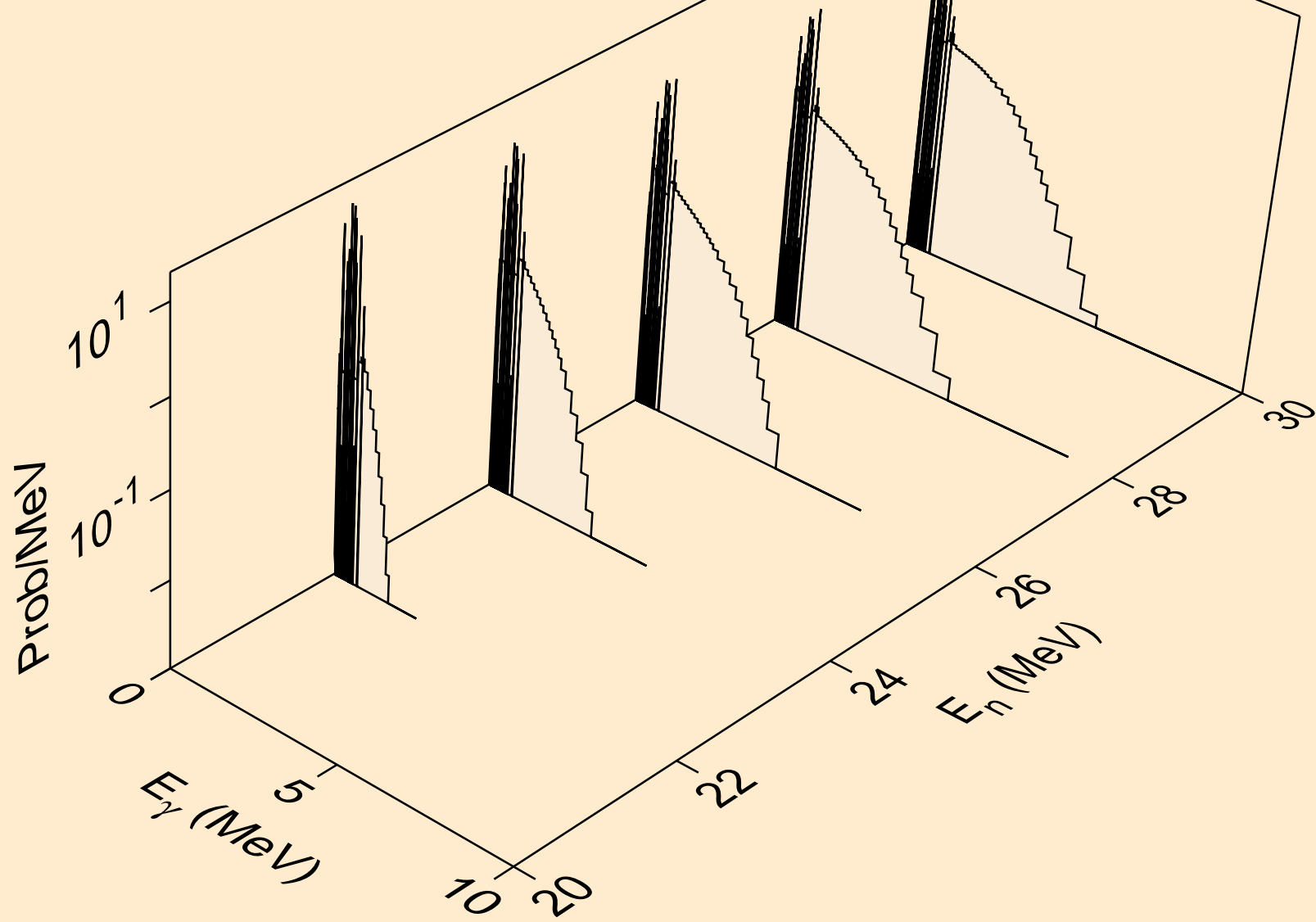



PB185M NEUTRON ACER TENDL-2024 LIBRARY; T=0.K  
Photon emission for (n,n\*)a

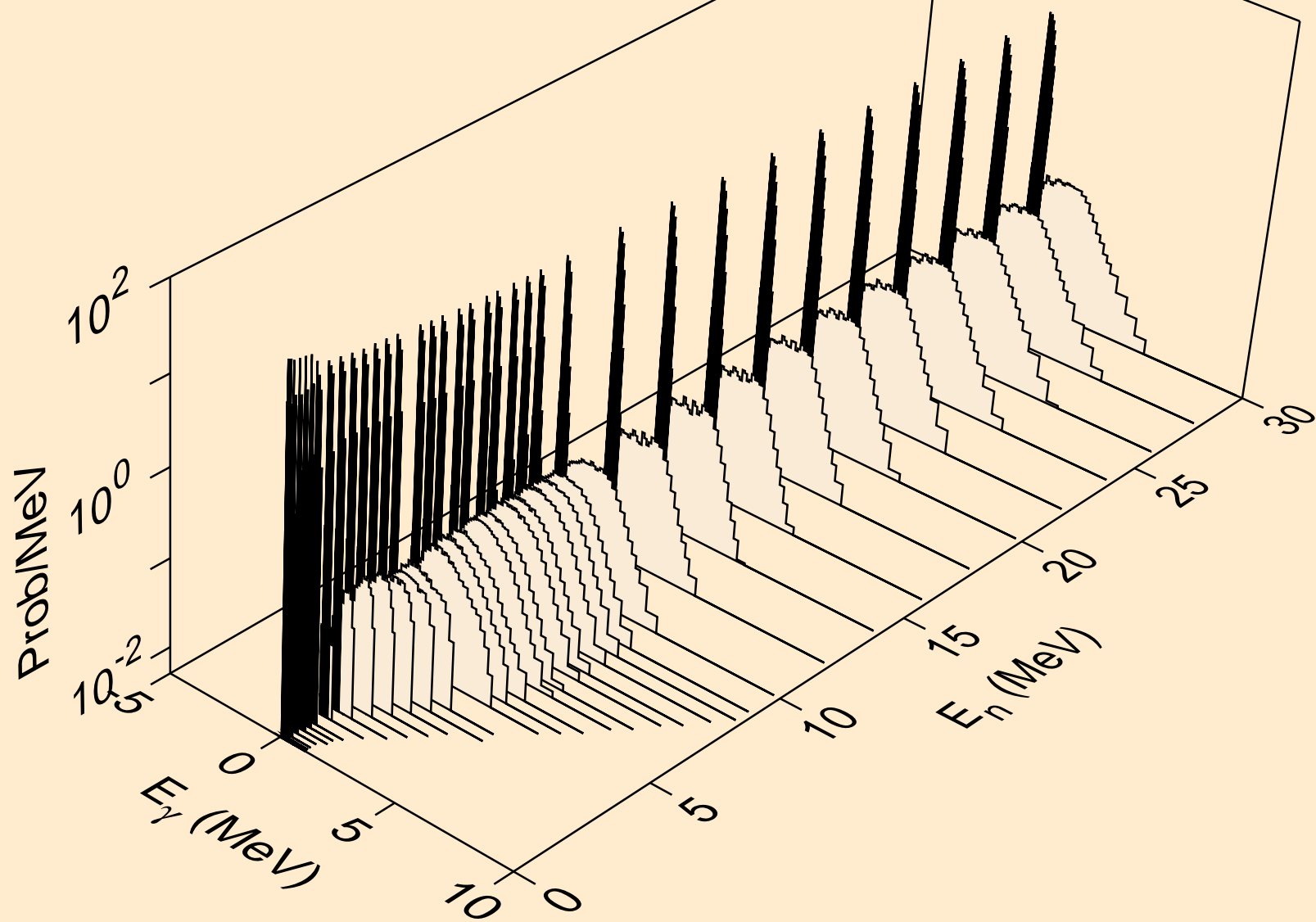

PB185M NEUTRON ACER TENDL-2024 LIBRARY; T=0.K  
Photon emission for (n,n\*)3a

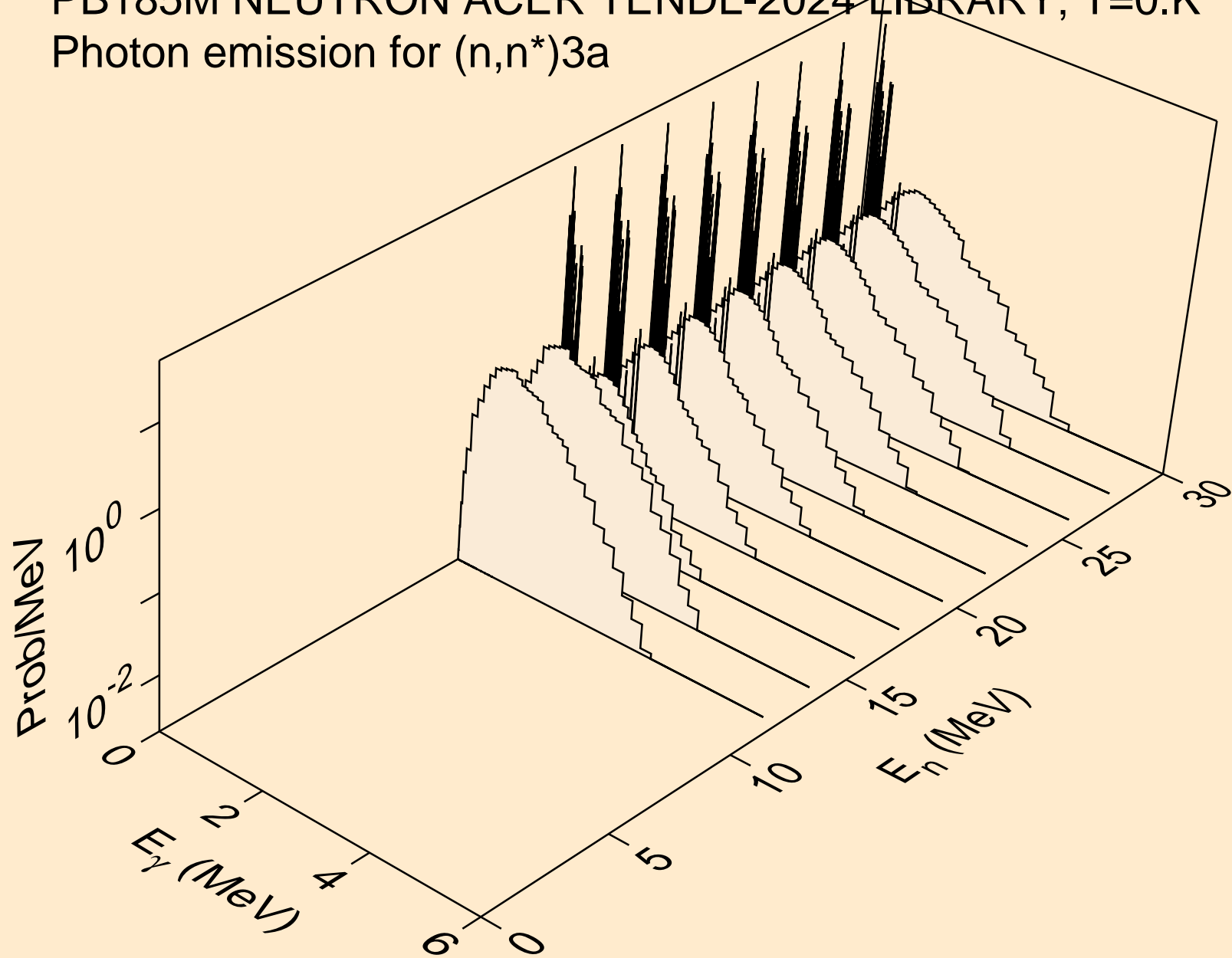

PB185M NEUTRON ACER TENDL-2024 LIBRARY; T=0.K  
Photon emission for (n,2n)a

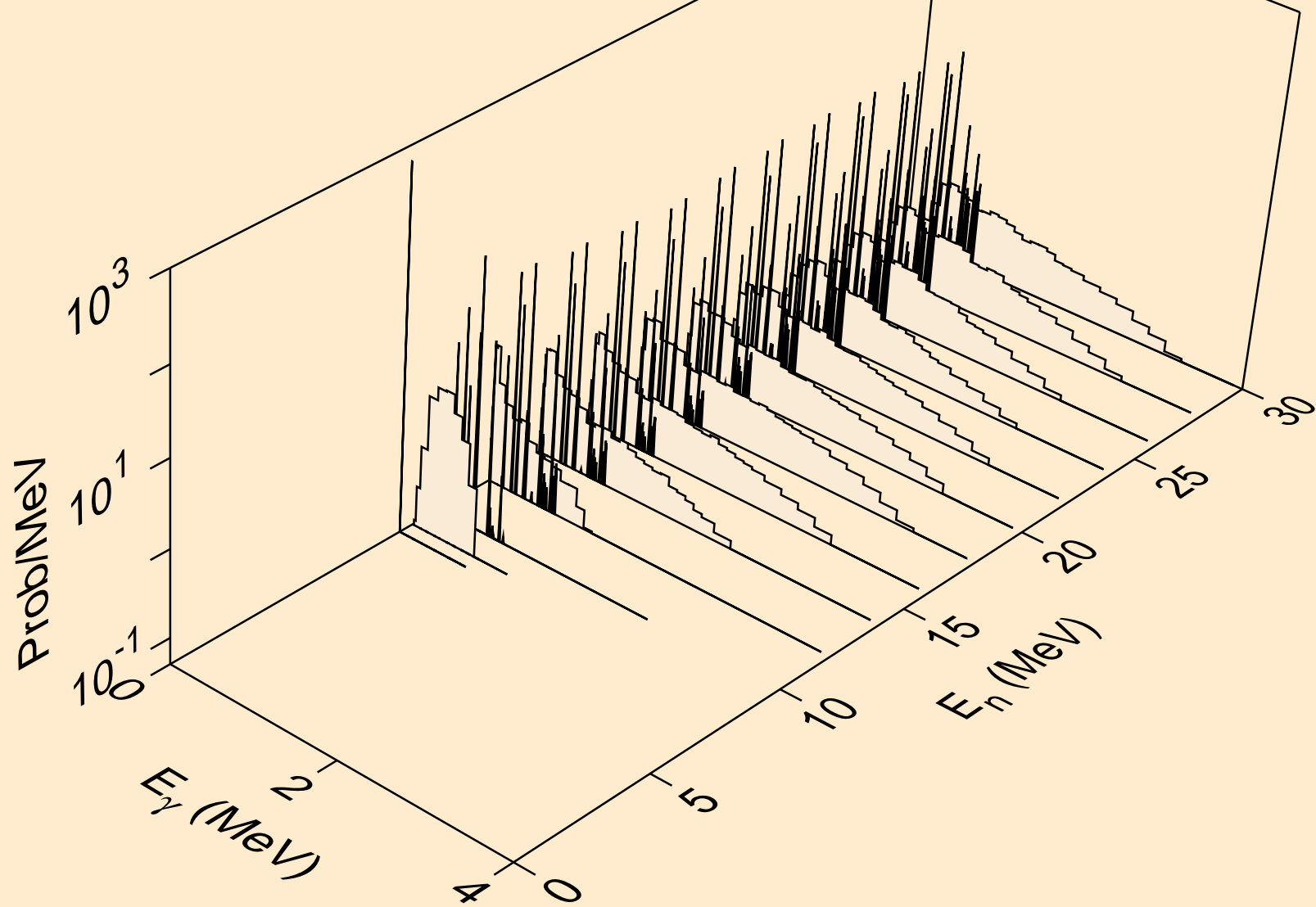

PB185M NEUTRON ACER TENDL-2024 LIBRARY; T=0.K  
Photon emission for (n,3n)a

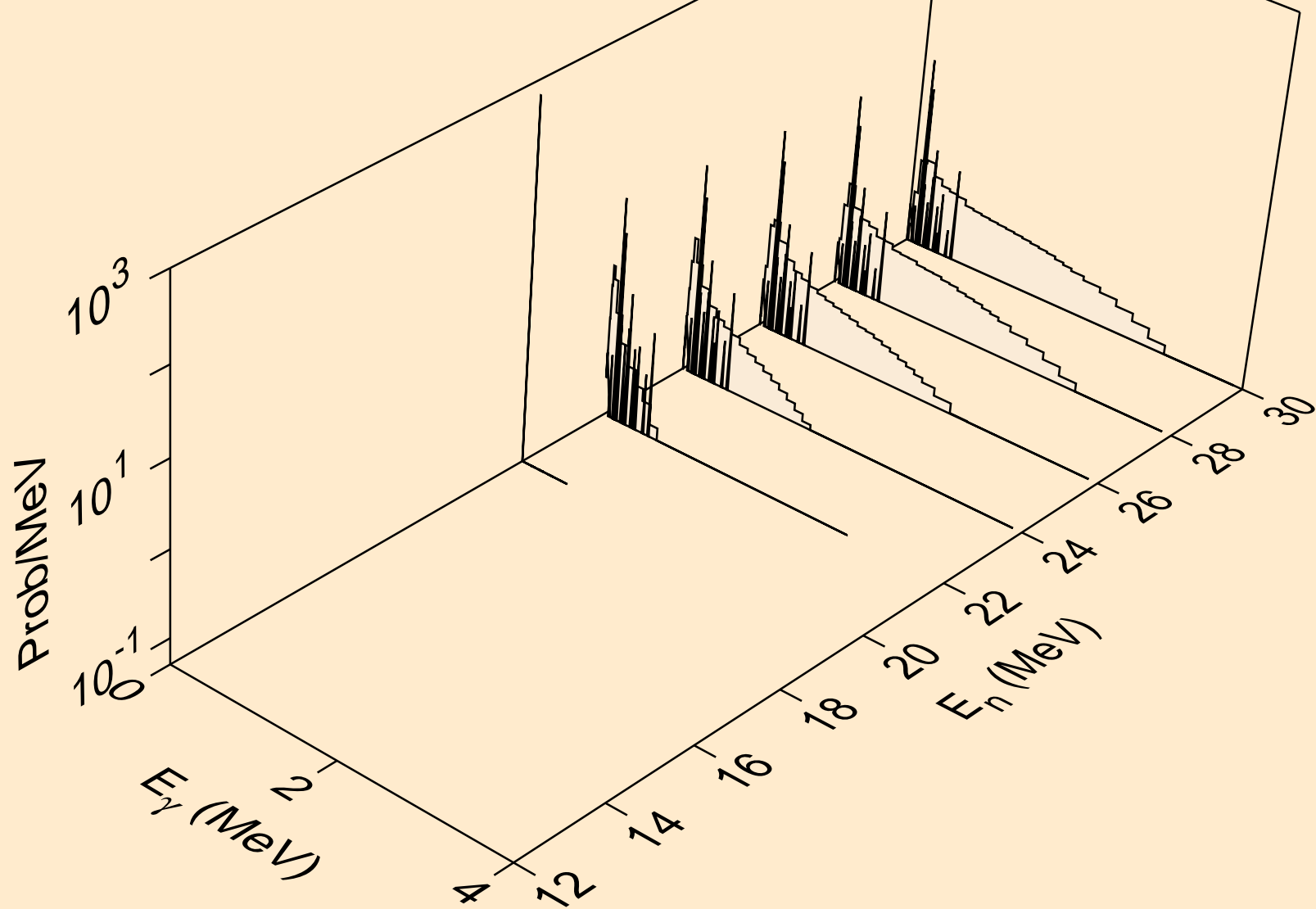

PB185M NEUTRON ACER TENDL-2024 LIBRARY; T=0.K  
Photon emission for (n,n\*)p

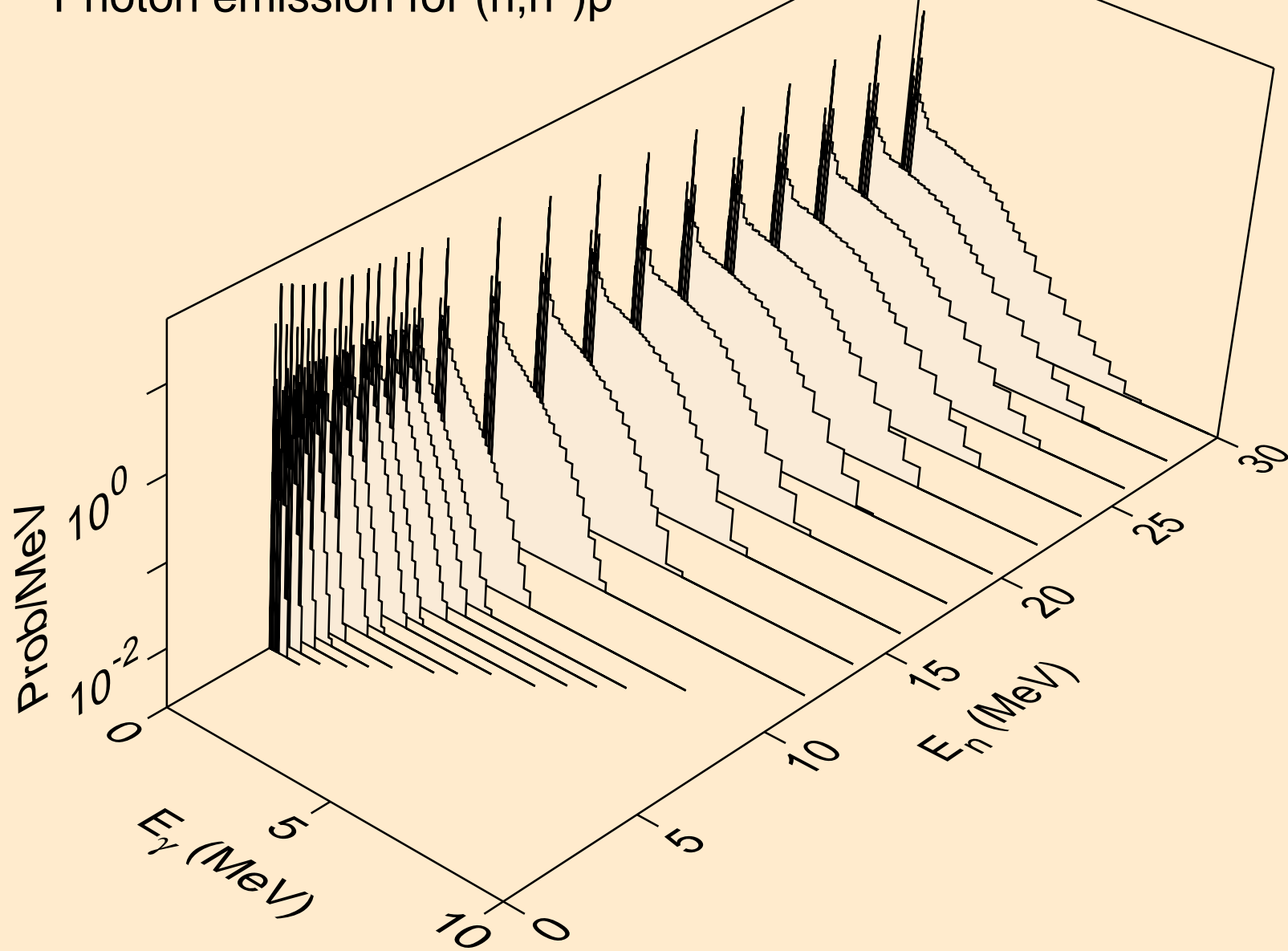

PB185M NEUTRON ACER TENDL-2024 LIBRARY; T=0.K  
Photon emission for (n,n\*)2a

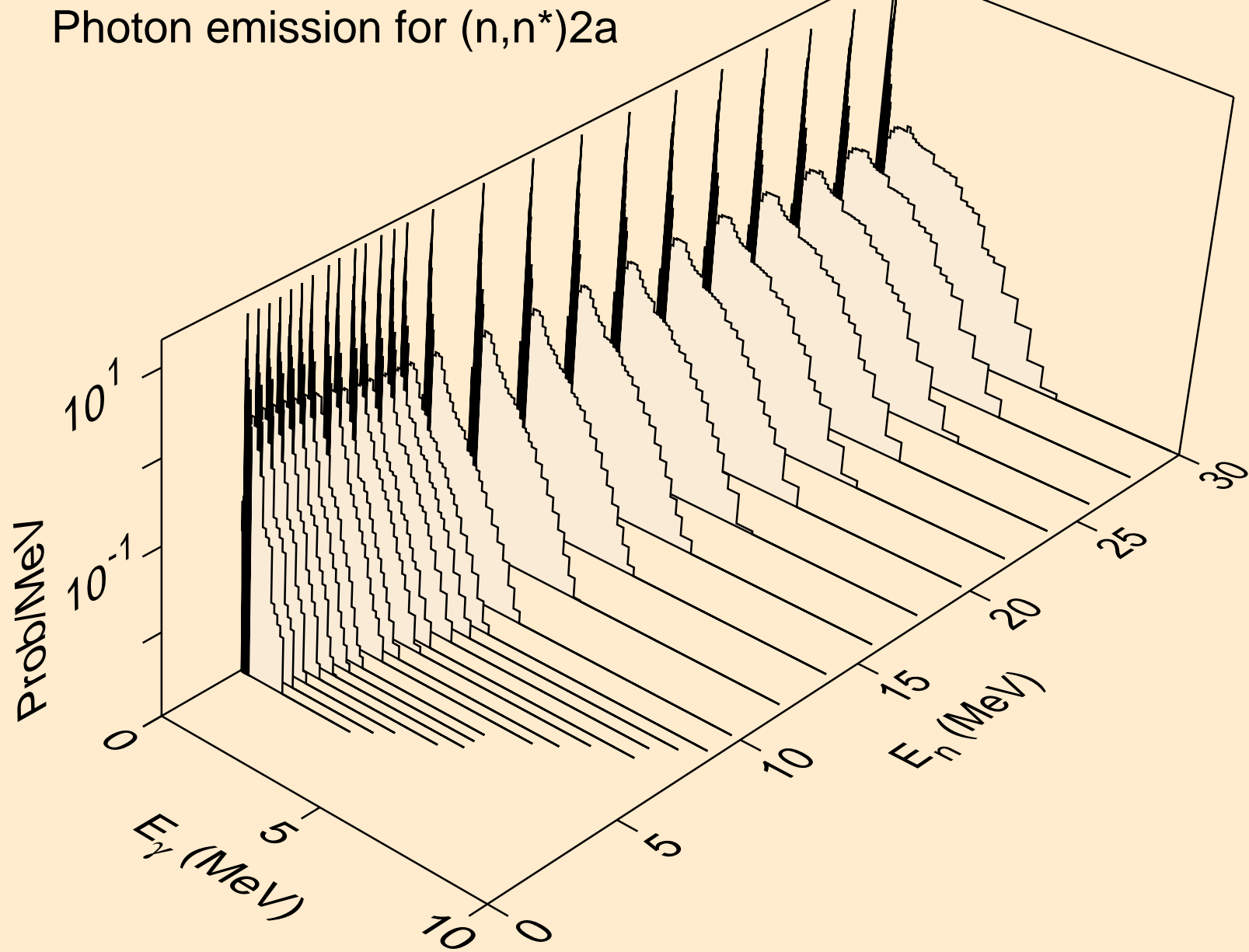

PB185M NEUTRON ACER TENDL-2024 LIBRARY; T=0.K  
Photon emission for (n,2n)2a

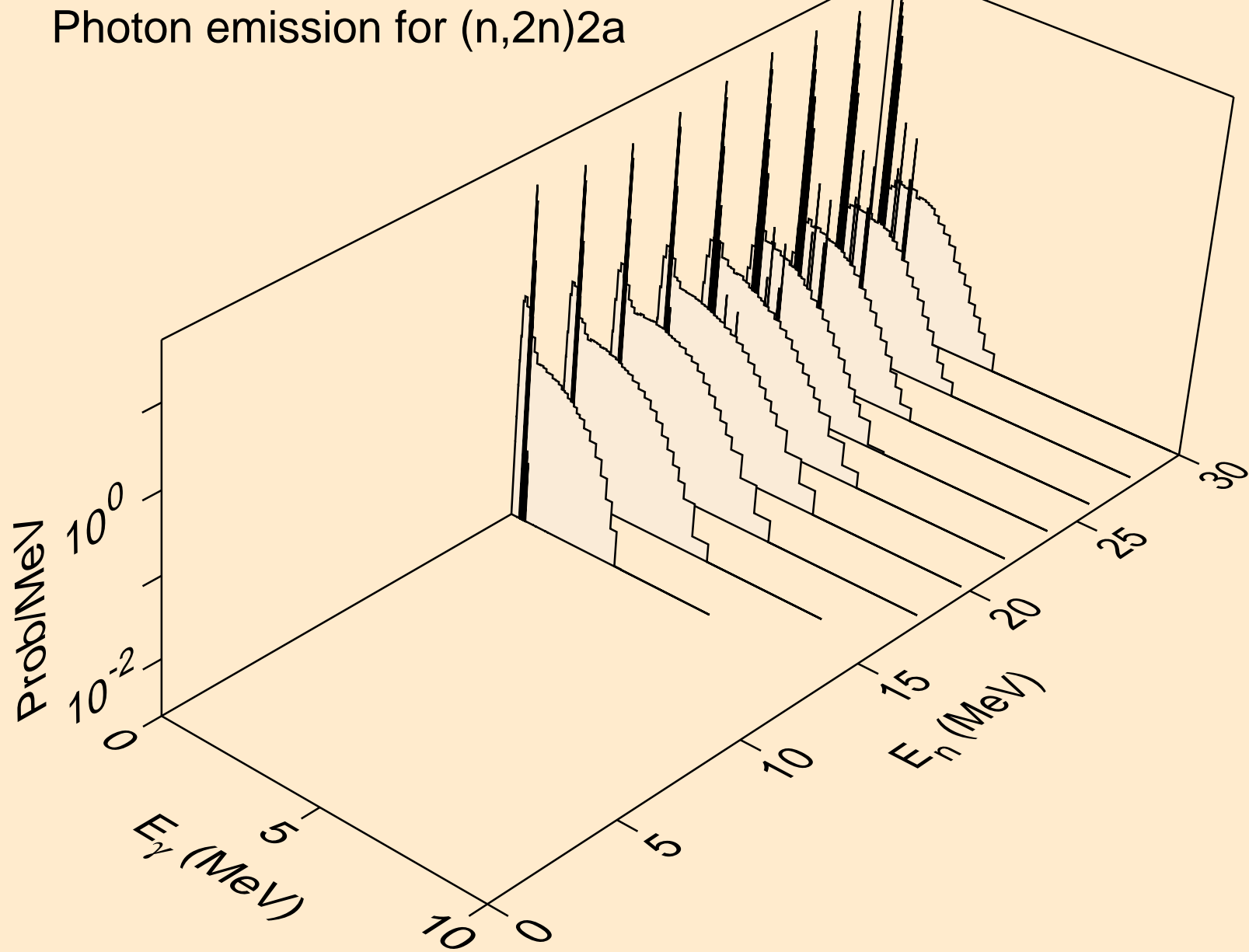

PB185M NEUTRON ACER TENDL-2024 LIBRARY; T=0.K  
Photon emission for (n,n\*)d

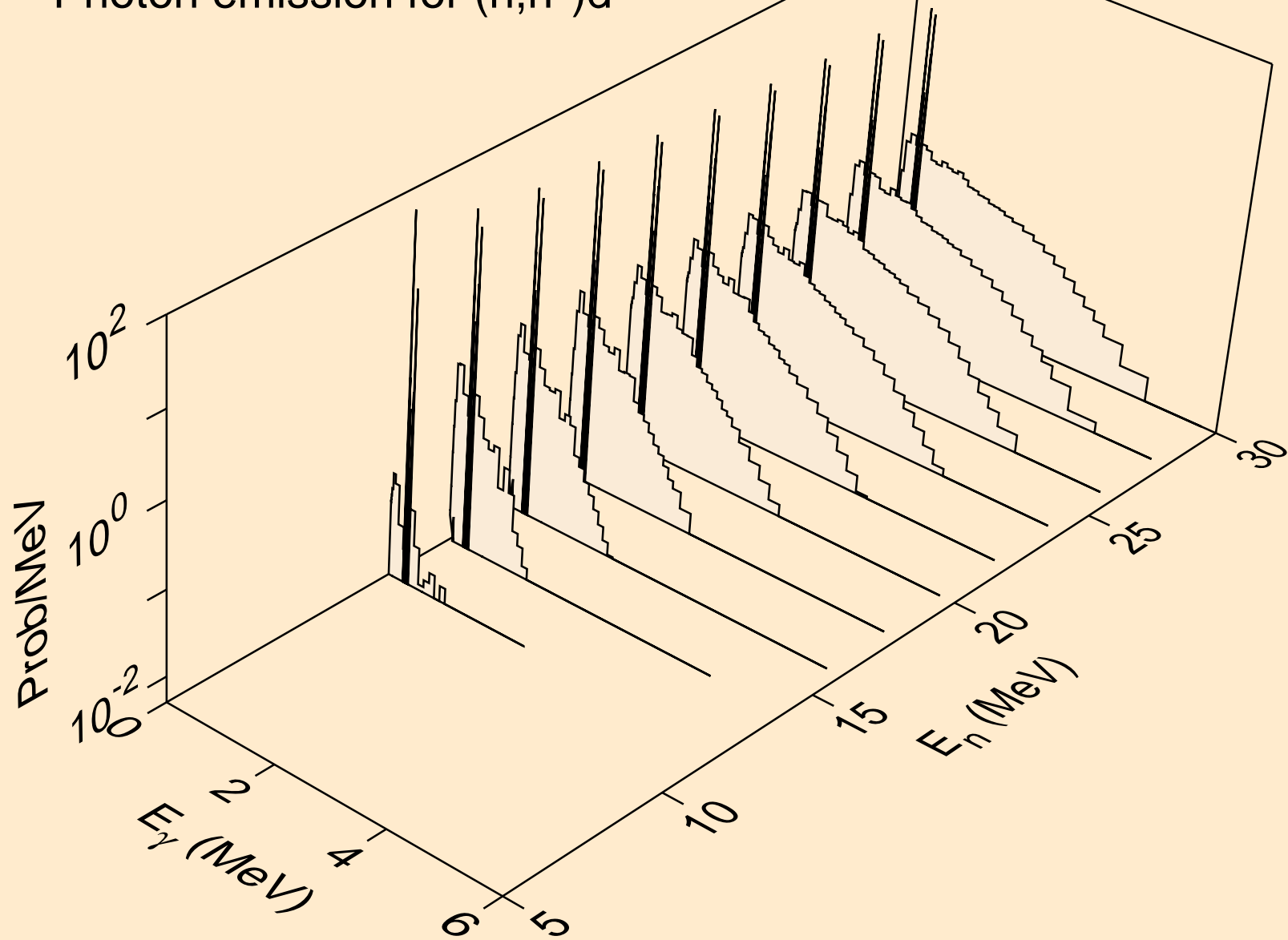



PB185M NEUTRON ACER TENDL-2024 LIBRARY; T=0.K  
Photon emission for (n,n\*)t

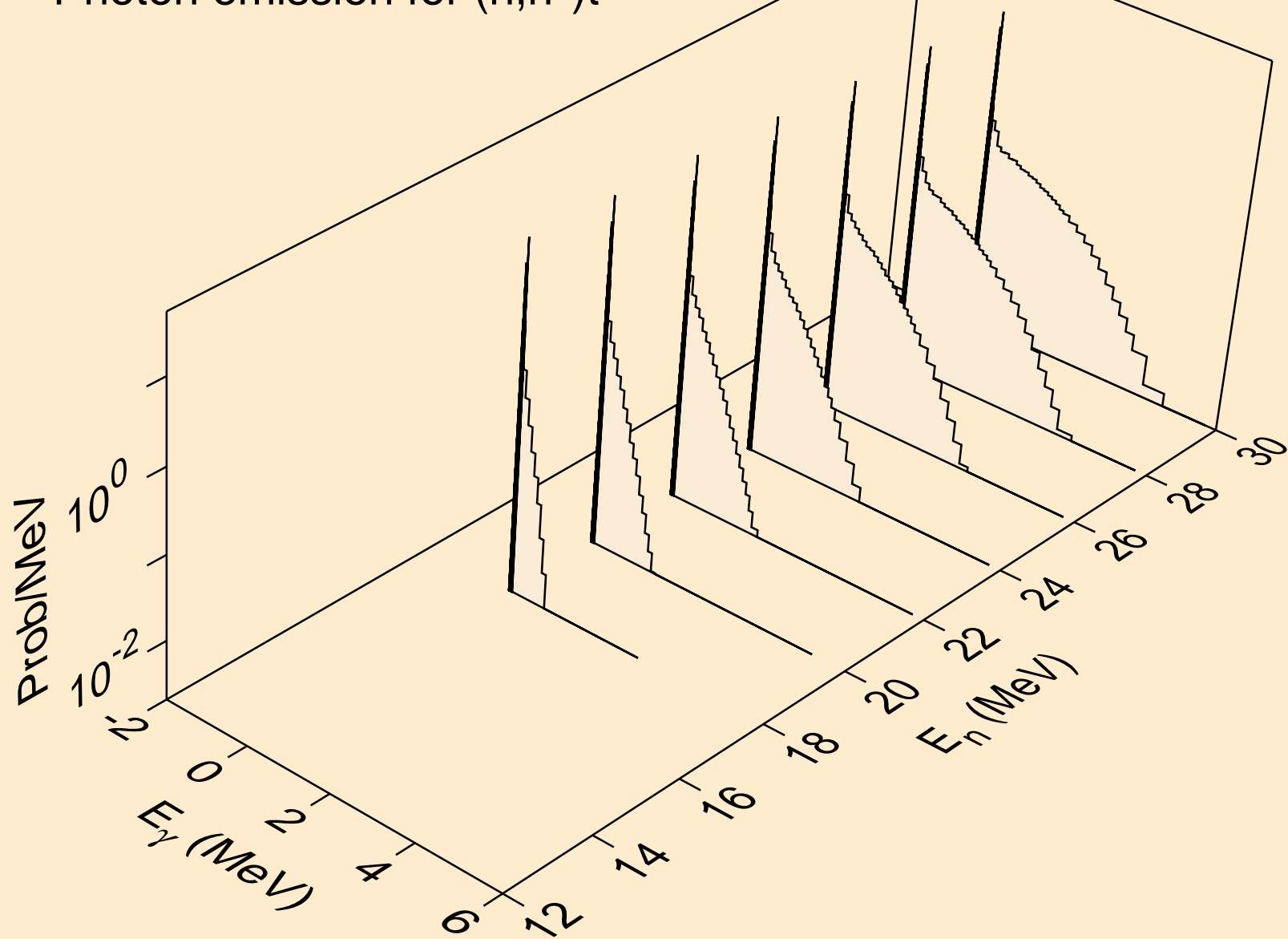

PB185M NEUTRON ACER TENDL-2024 LIBRARY; T=0.K  
Photon emission for (n,n\*)he3

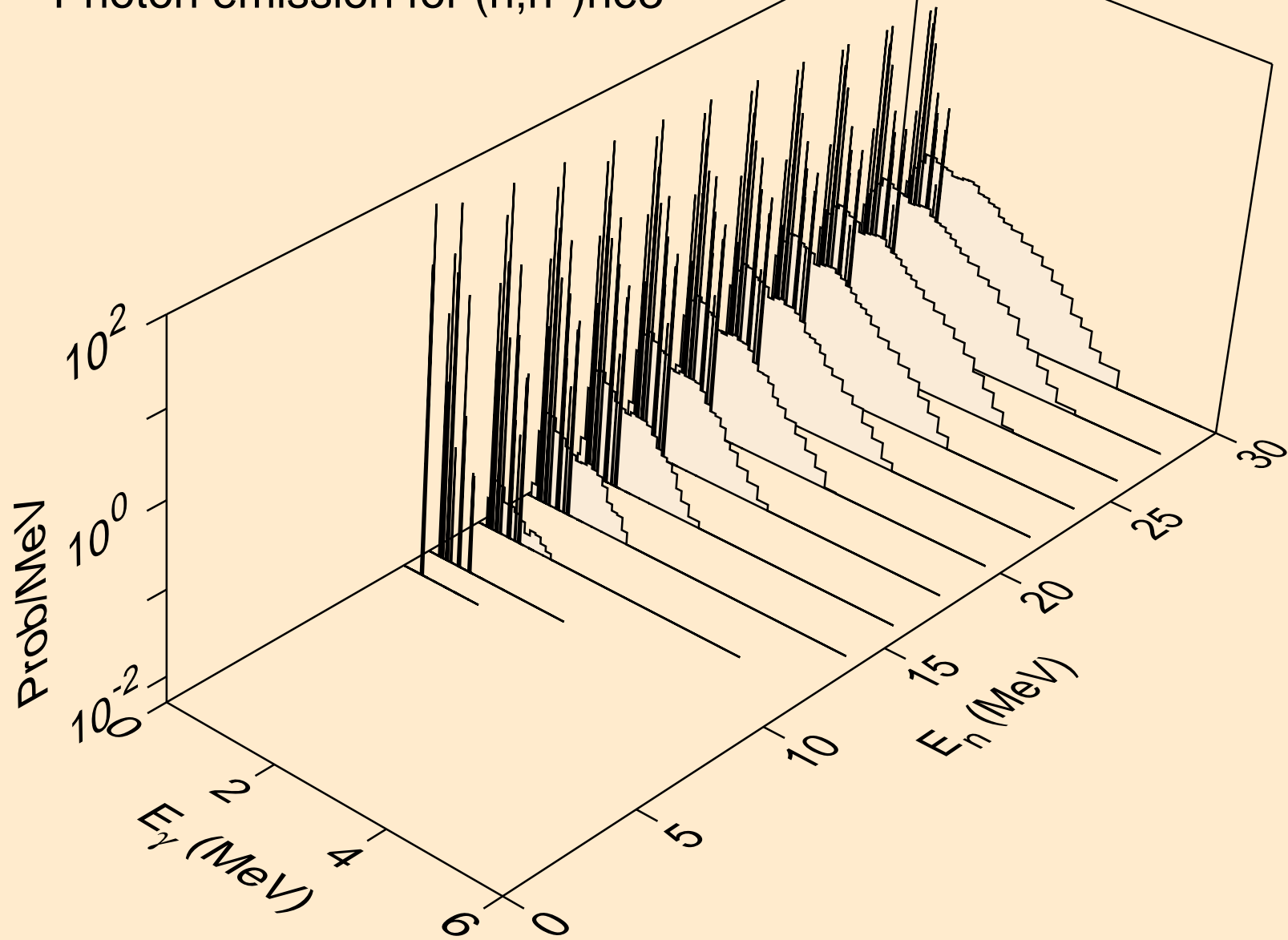

PB185M NEUTRON ACER TENDL-2024 LIBRARY; T=0.K  
Photon emission for (n,2np)

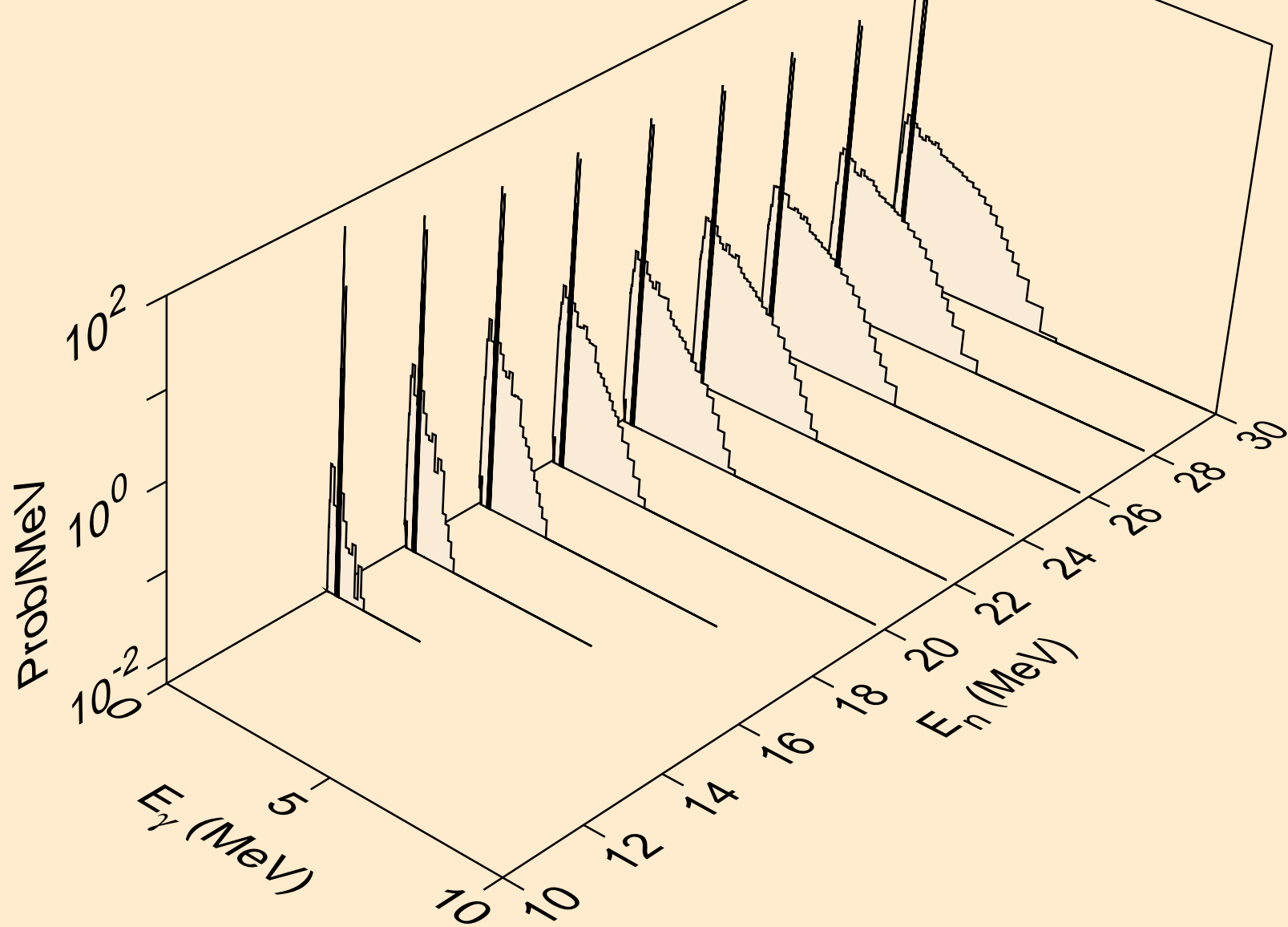

PB185M NEUTRON ACER TENDL-2024 LIBRARY; T=0.K  
Photon emission for (n,3np)

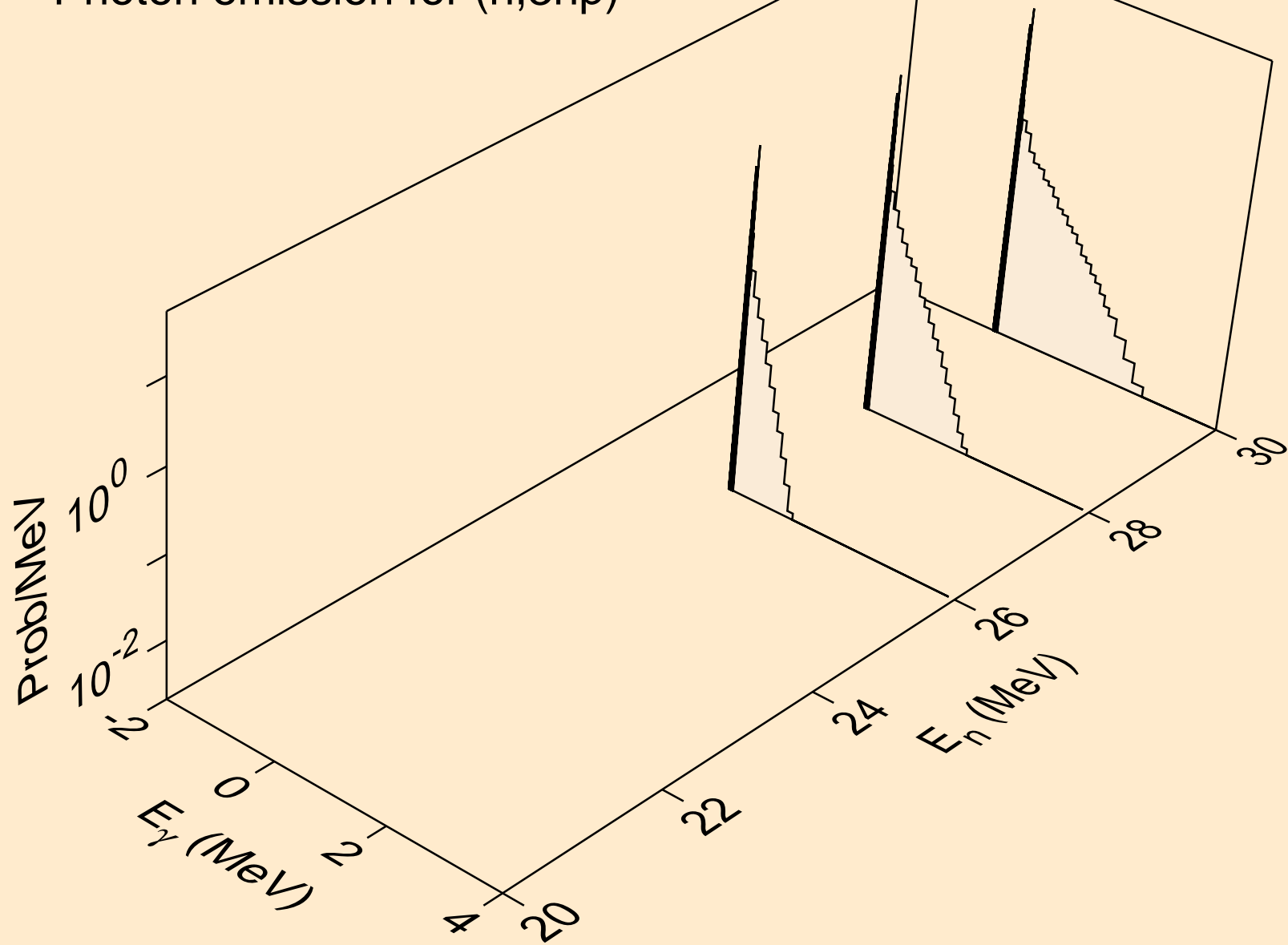

PB185M NEUTRON ACER TENDL-2024 LIBRARY; T=0.K  
Photon emission for (n,n2p)

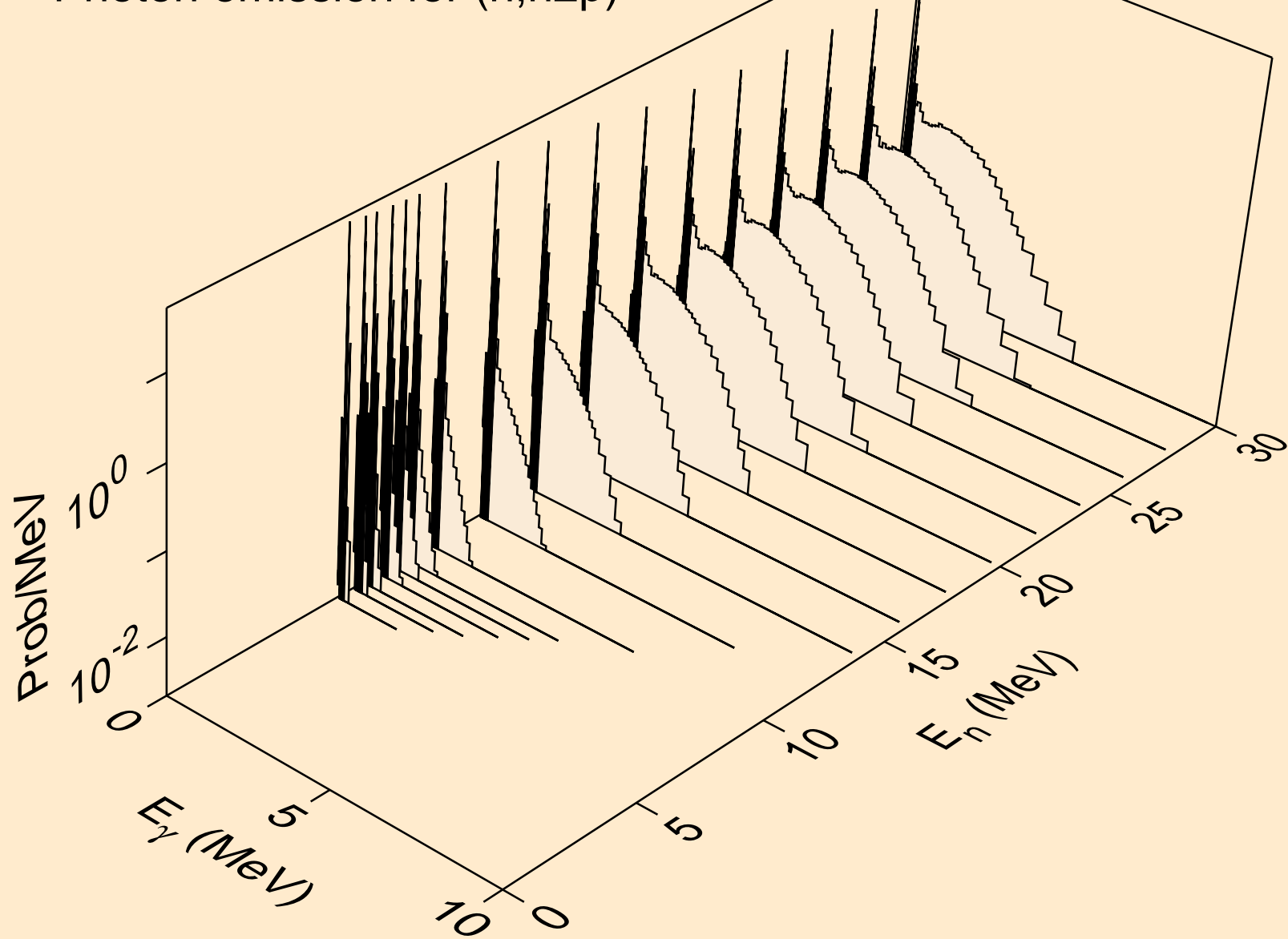

PB185M NEUTRON ACER TENDL-2024 LIBRARY; T=0.K  
Photon emission for (n,npa)

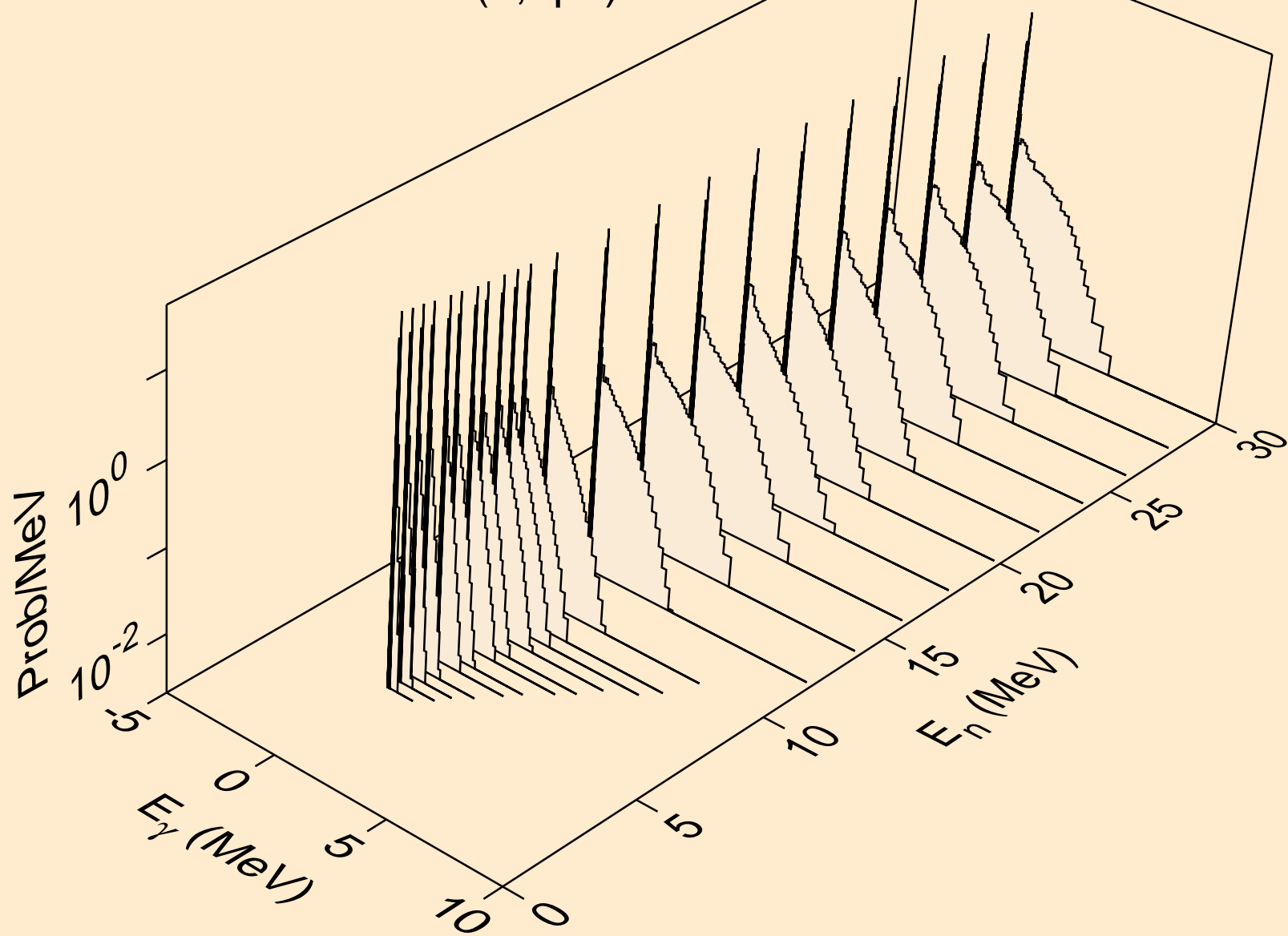

PB185M NEUTRON ACER TENDL-2024 LIBRARY; T=0.K  
Photon emission for (n,n\*2)

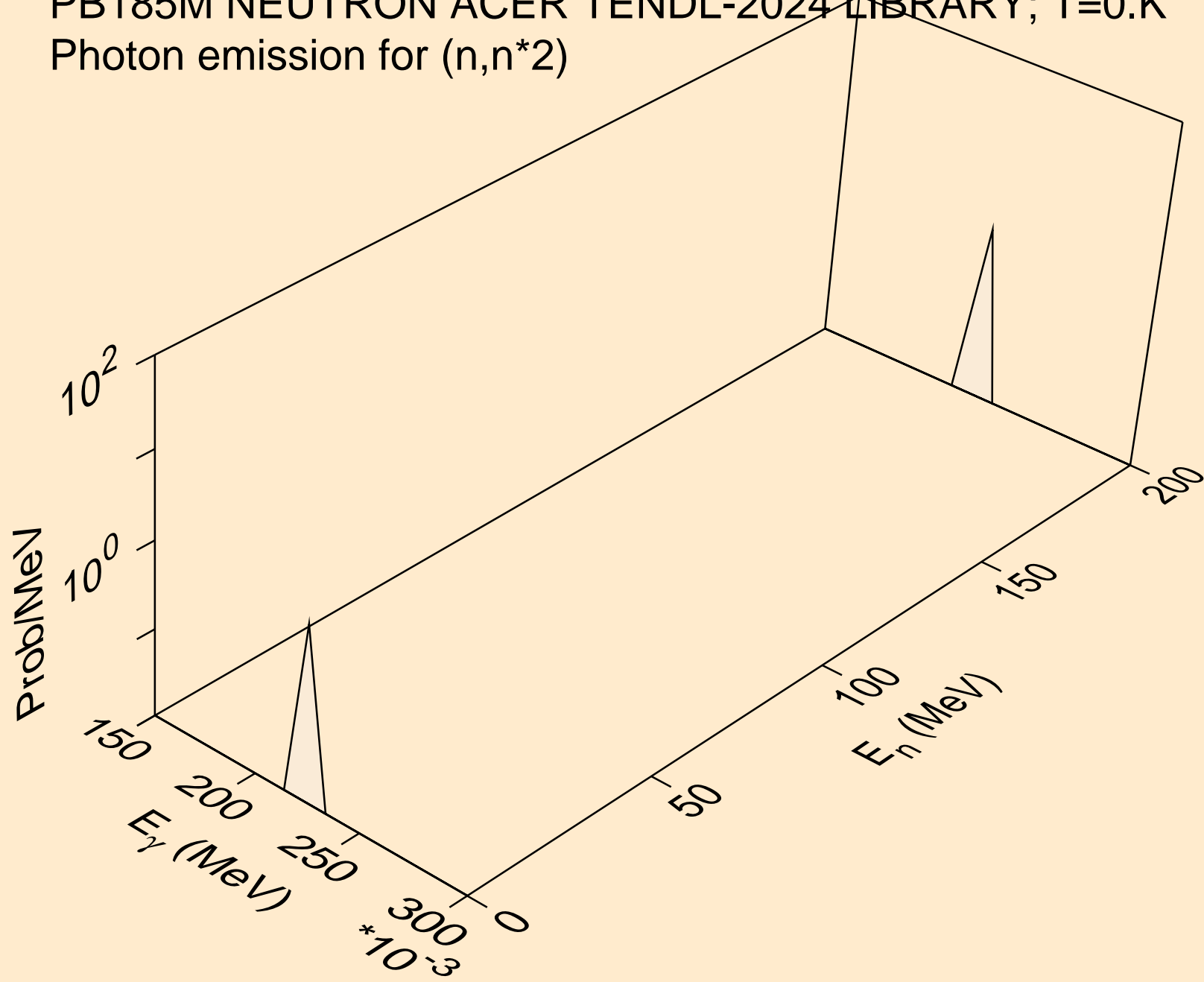

PB185M NEUTRON ACER TENDL-2024 LIBRARY; T=0.K  
Photon emission for (n,n\*c)

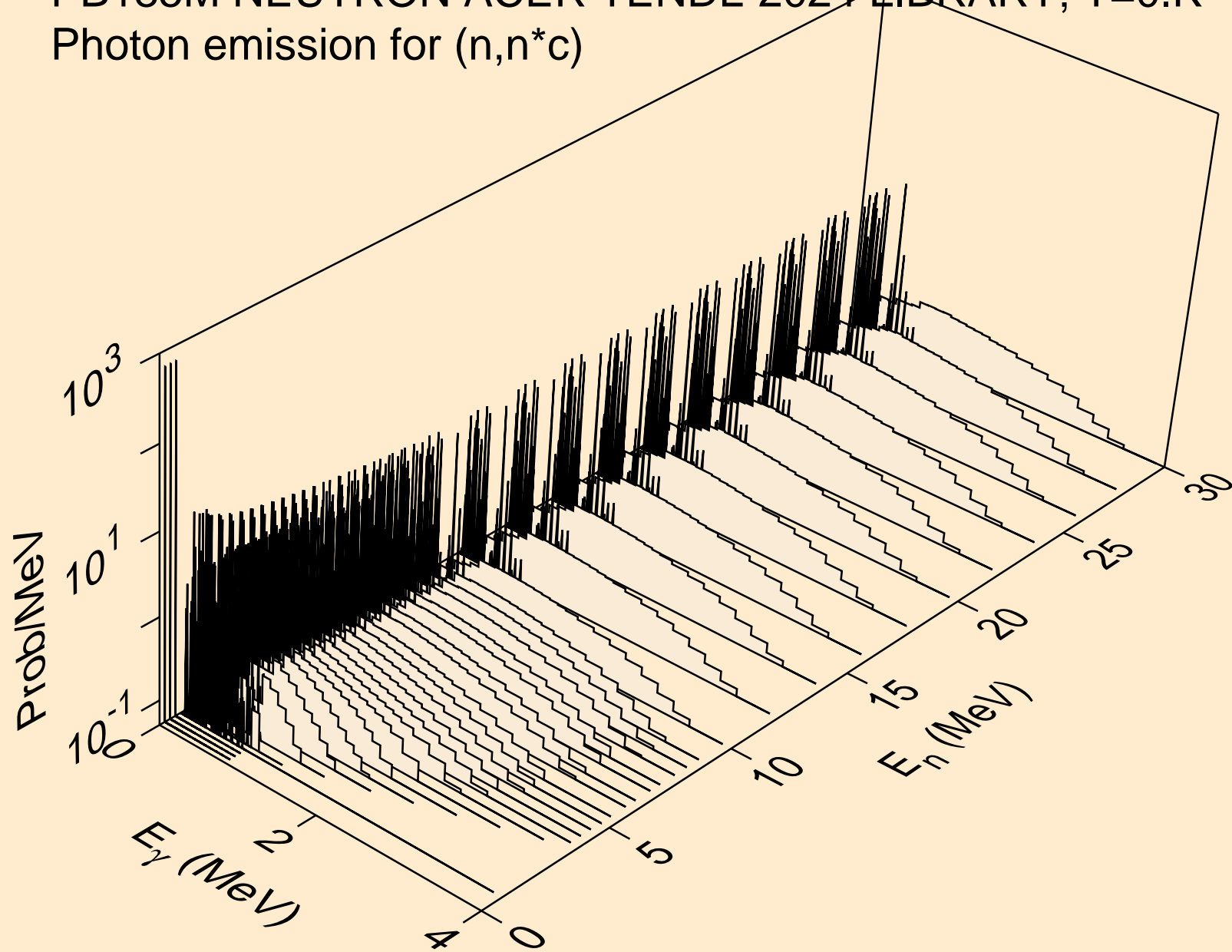



PB185M NEUTRON ACER TENDL-2024 LIBRARY; T=0.K  
Photon emission for (n,gma)

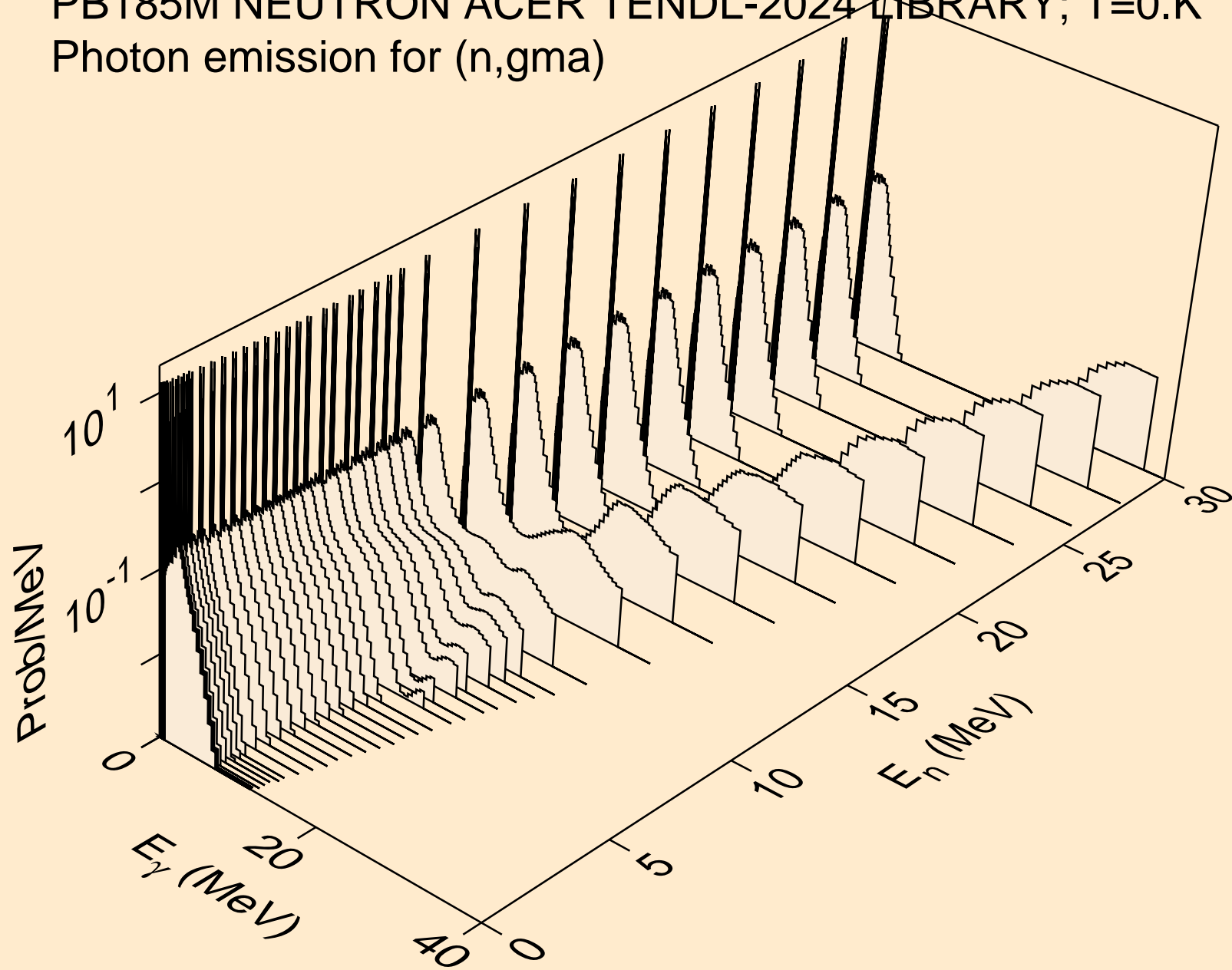

PB185M NEUTRON ACER TENDL-2024 LIBRARY; T=0.K  
Photon emission for (n,p)

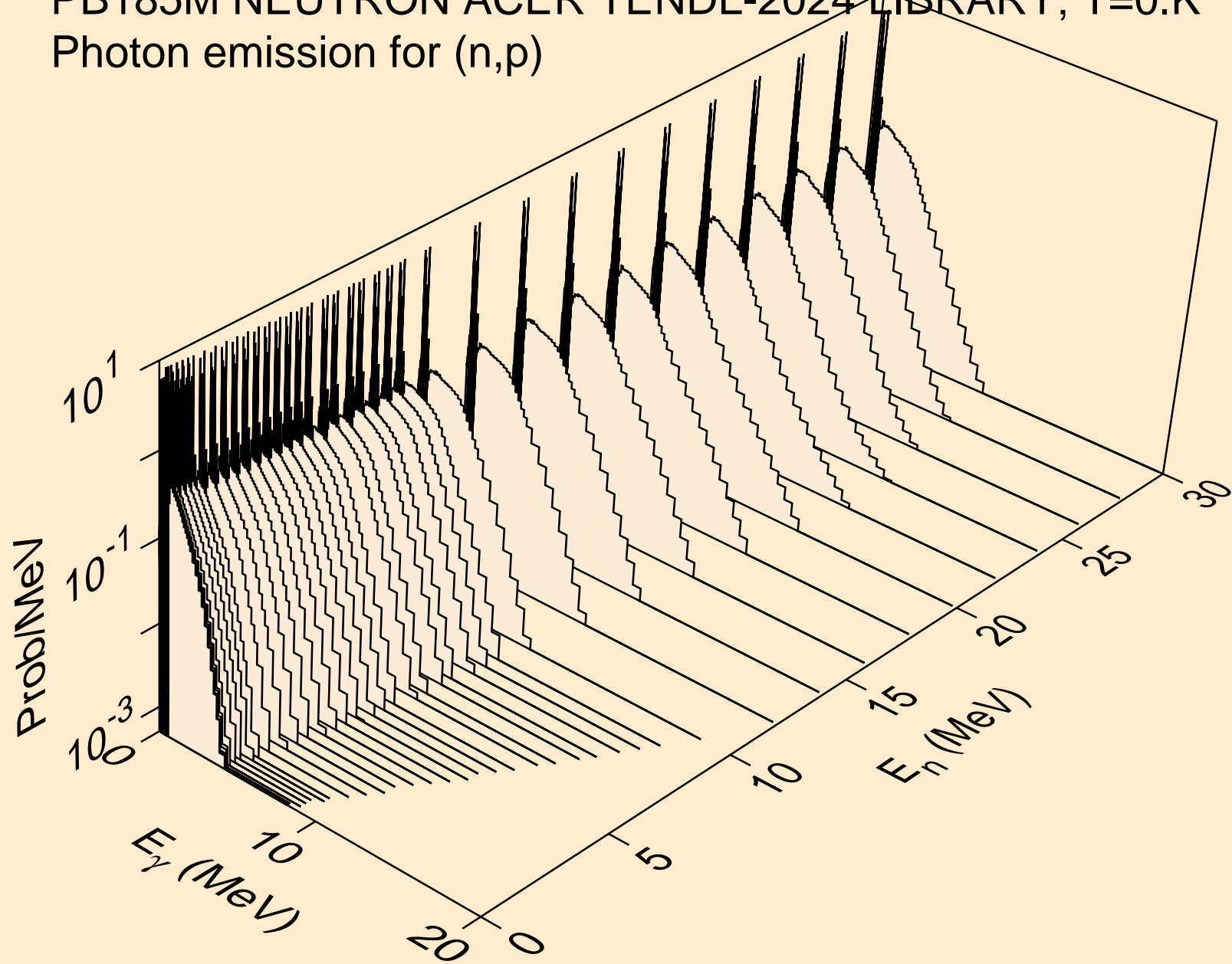

PB185M NEUTRON ACER TENDL-2024 LIBRARY; T=0.K  
Photon emission for (n,d)

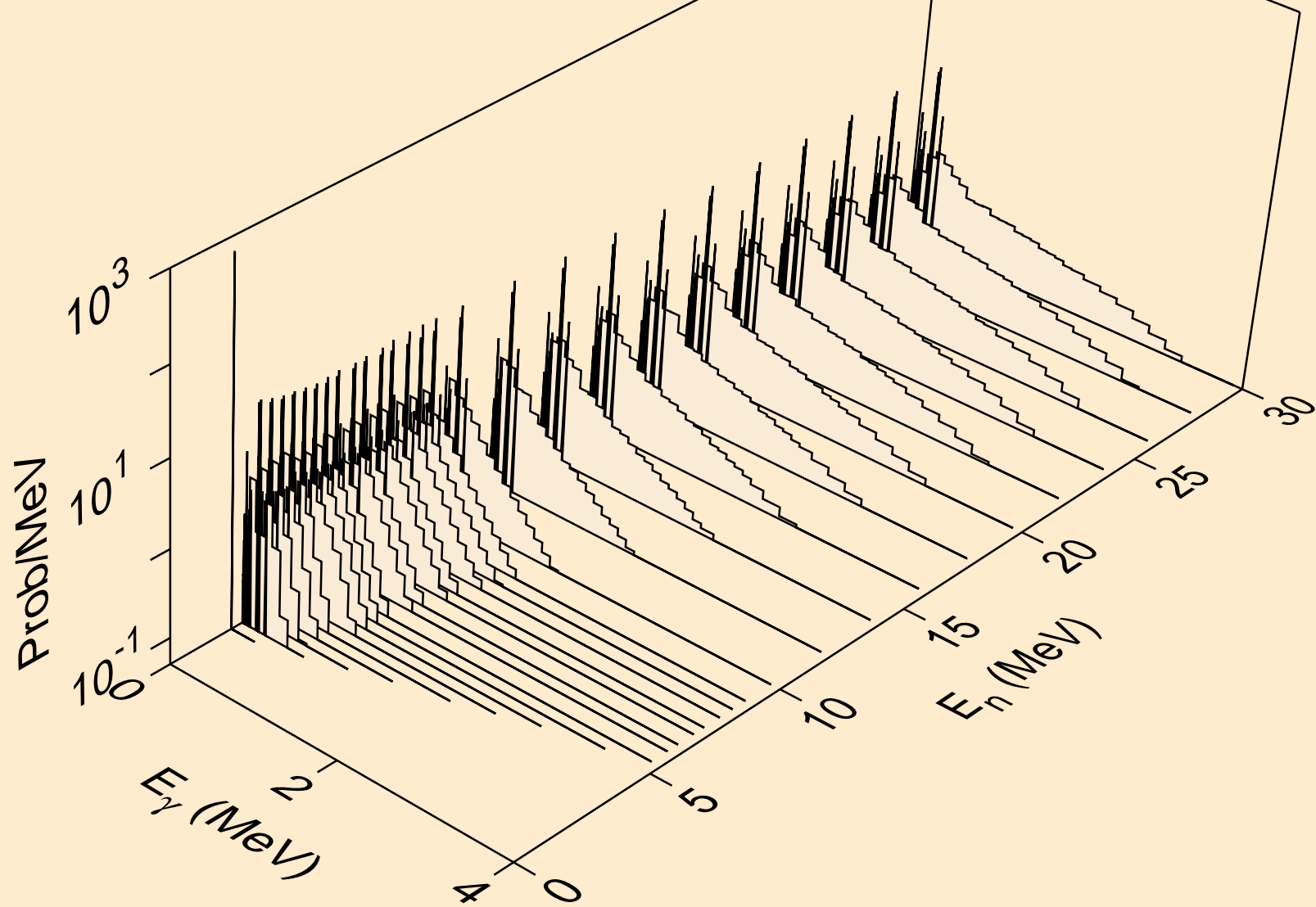

PB185M NEUTRON ACER TENDL-2024 LIBRARY; T=0.K  
Photon emission for (n,t)

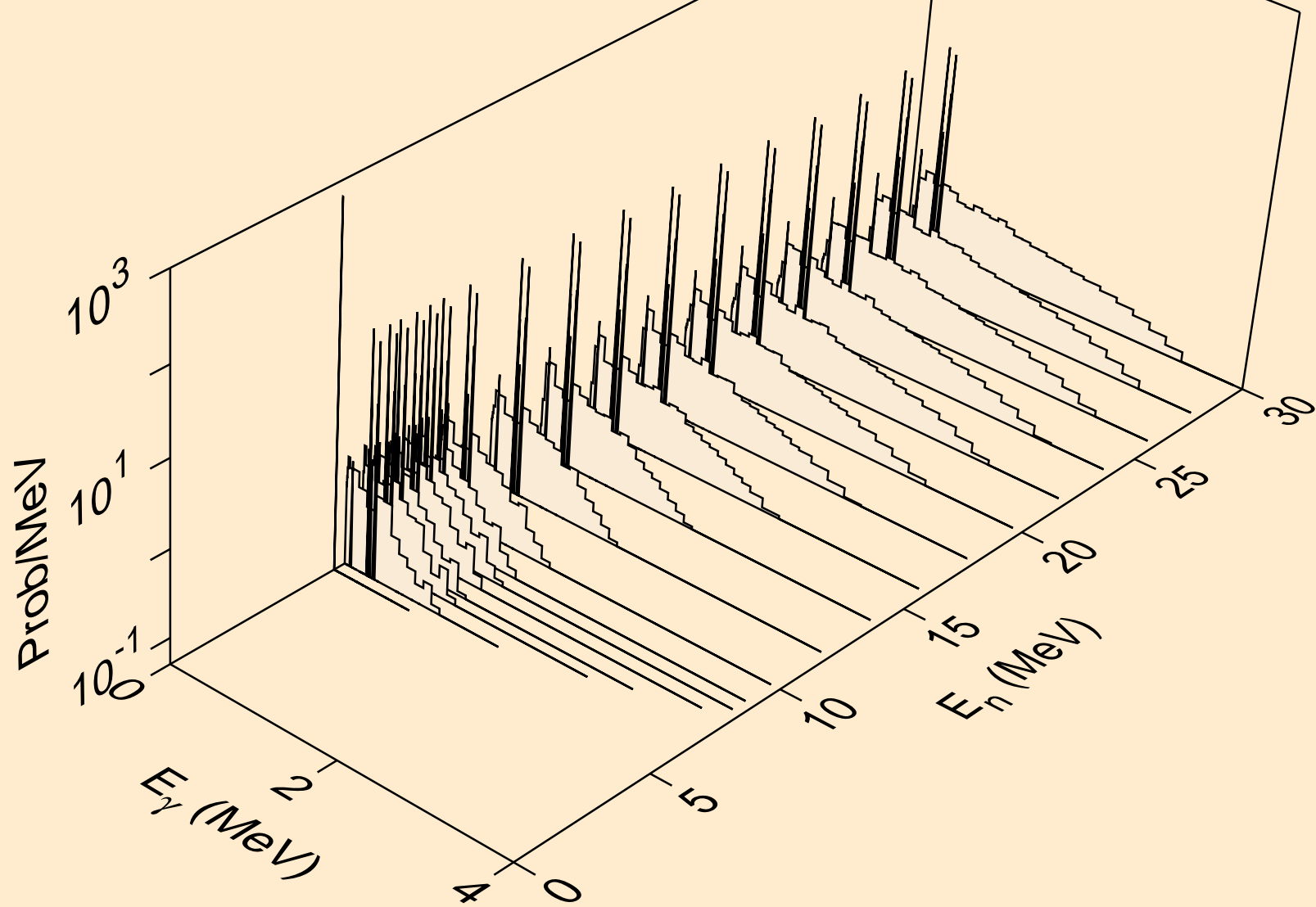

PB185M NEUTRON ACER TENDL-2024 LIBRARY; T=0.K  
Photon emission for (n,he3)

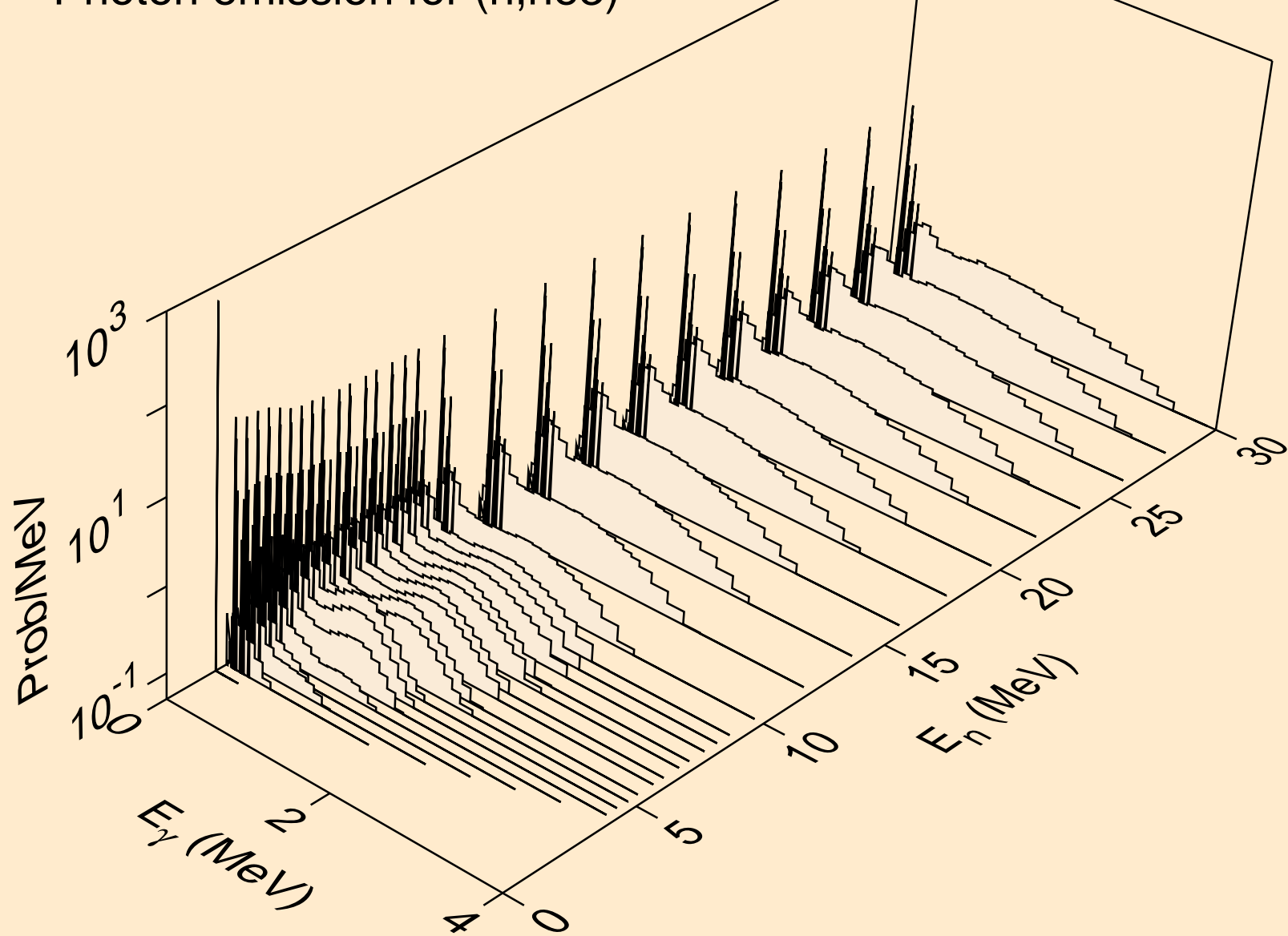

PB185M NEUTRON ACER TENDL-2024 LIBRARY; T=0.K  
Photon emission for (n,a)

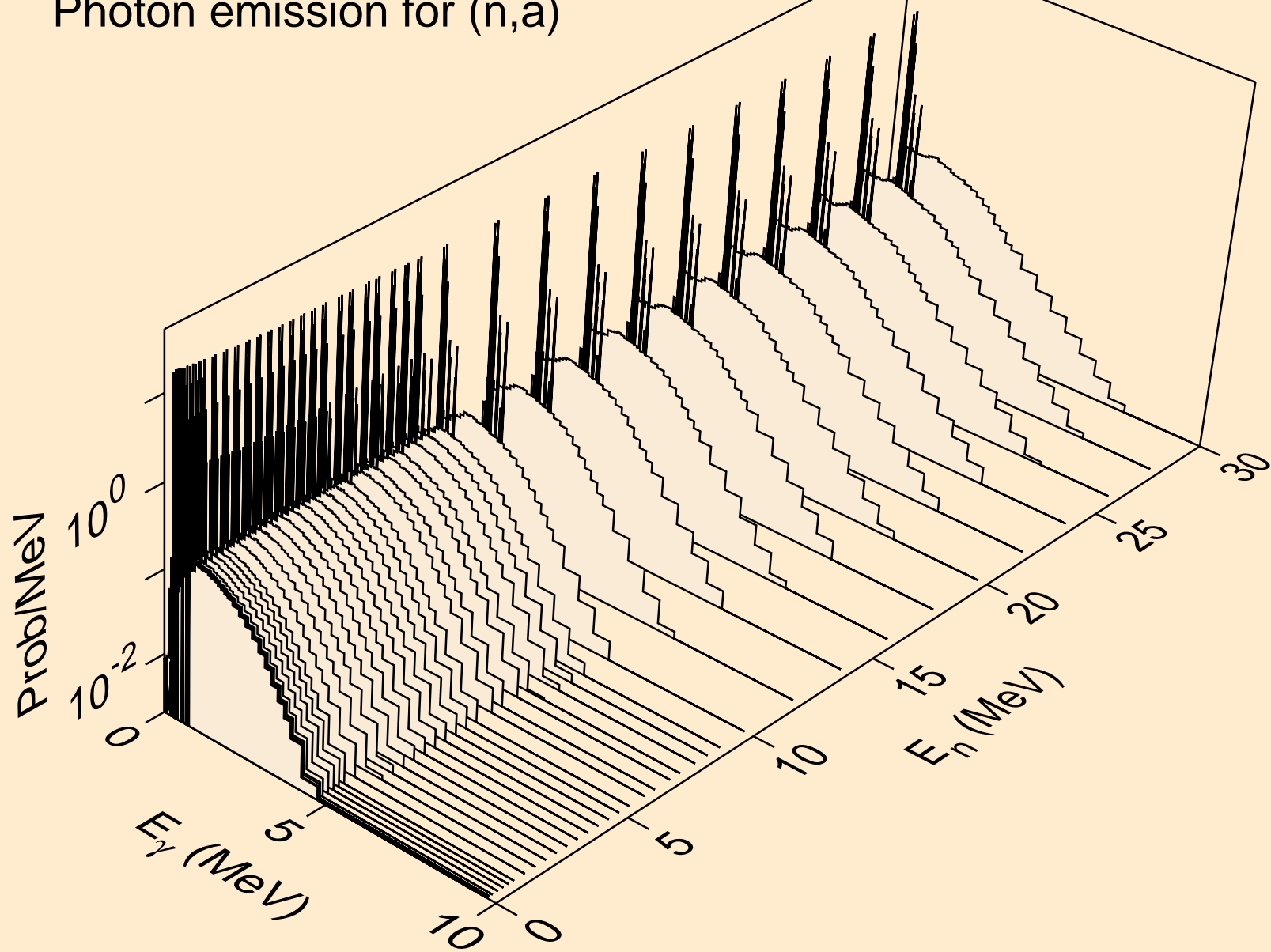

PB185M NEUTRON ACER TENDL-2024 LIBRARY; T=0.K  
Photon emission for (n,2a)

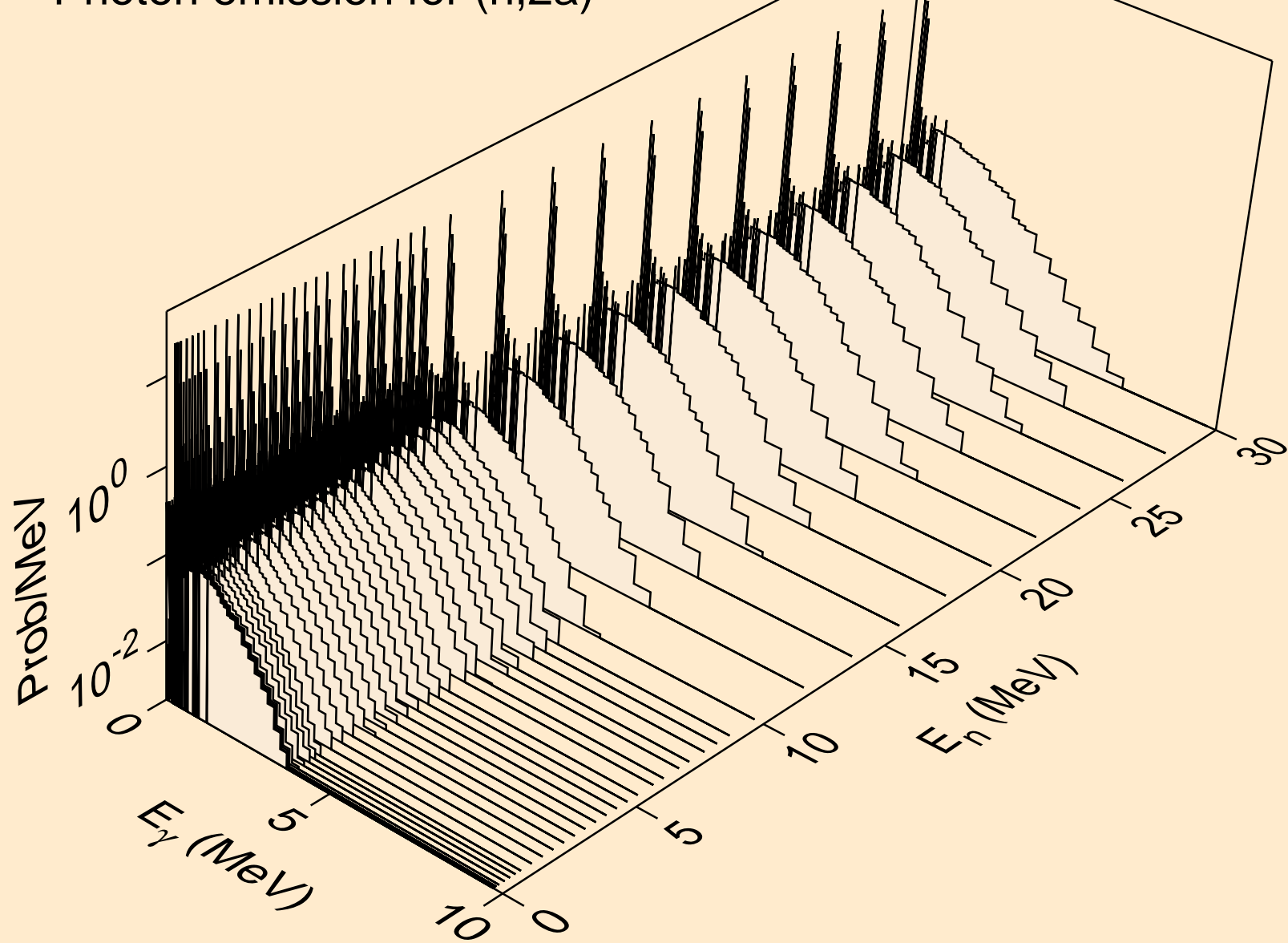

PB185M NEUTRON ACER TENDL-2024 LIBRARY; T=0.K  
Photon emission for (n,3a)

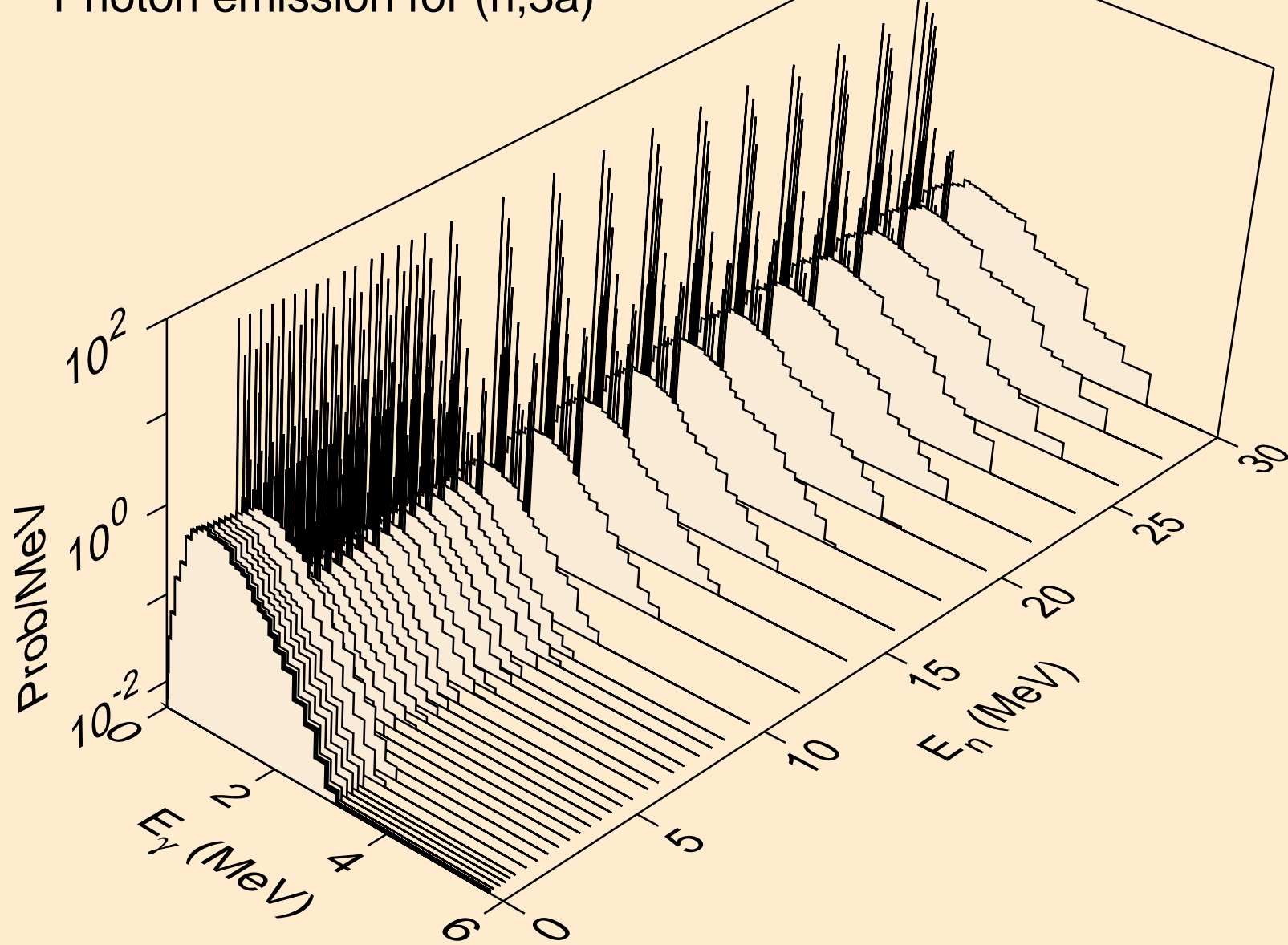



PB185M NEUTRON ACER TENDL-2024 LIBRARY; T=0.K  
Photon emission for (n,2p)

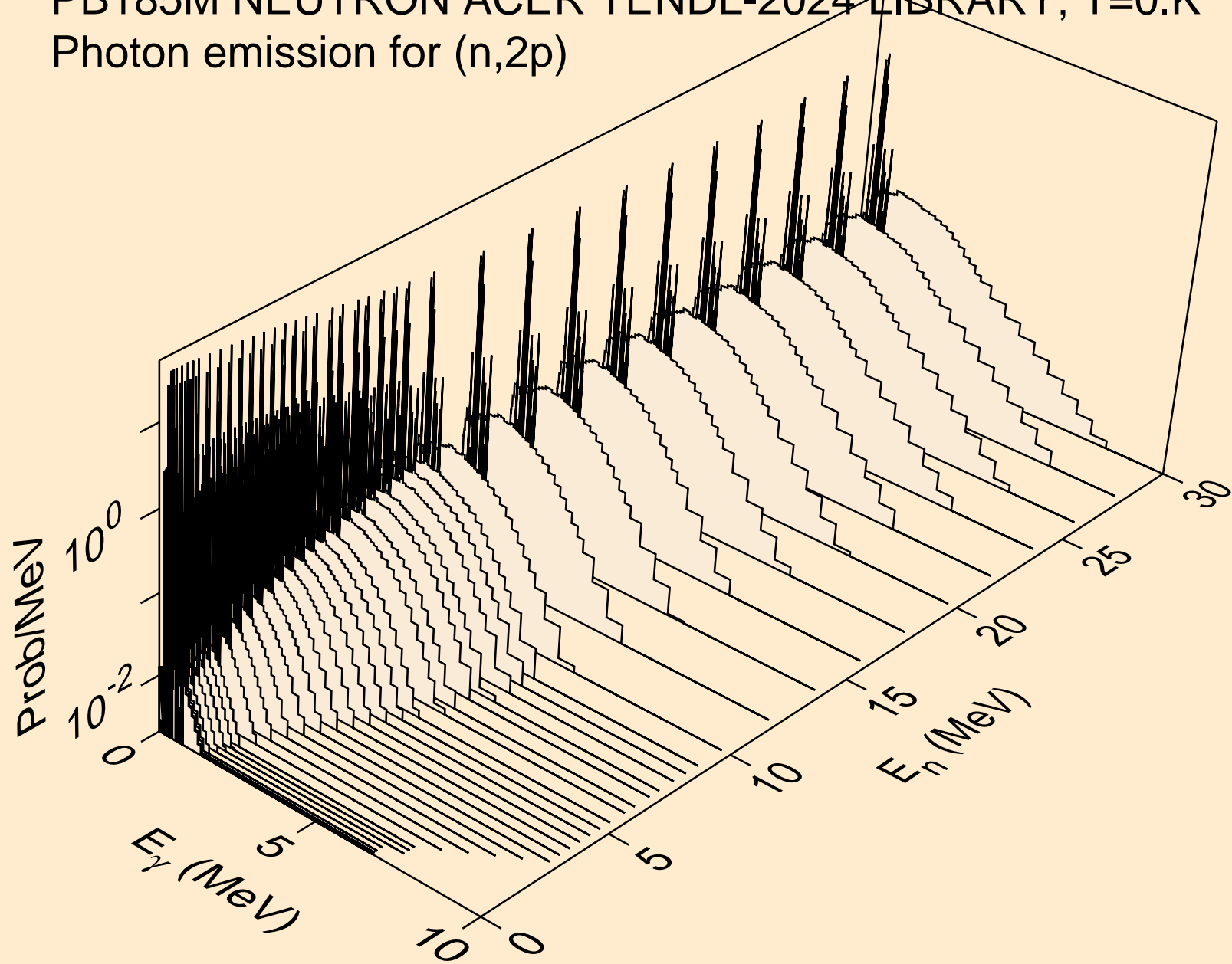

PB185M NEUTRON ACER TENDL-2024 LIBRARY; T=0.K  
Photon emission for (n,p $\alpha$ )

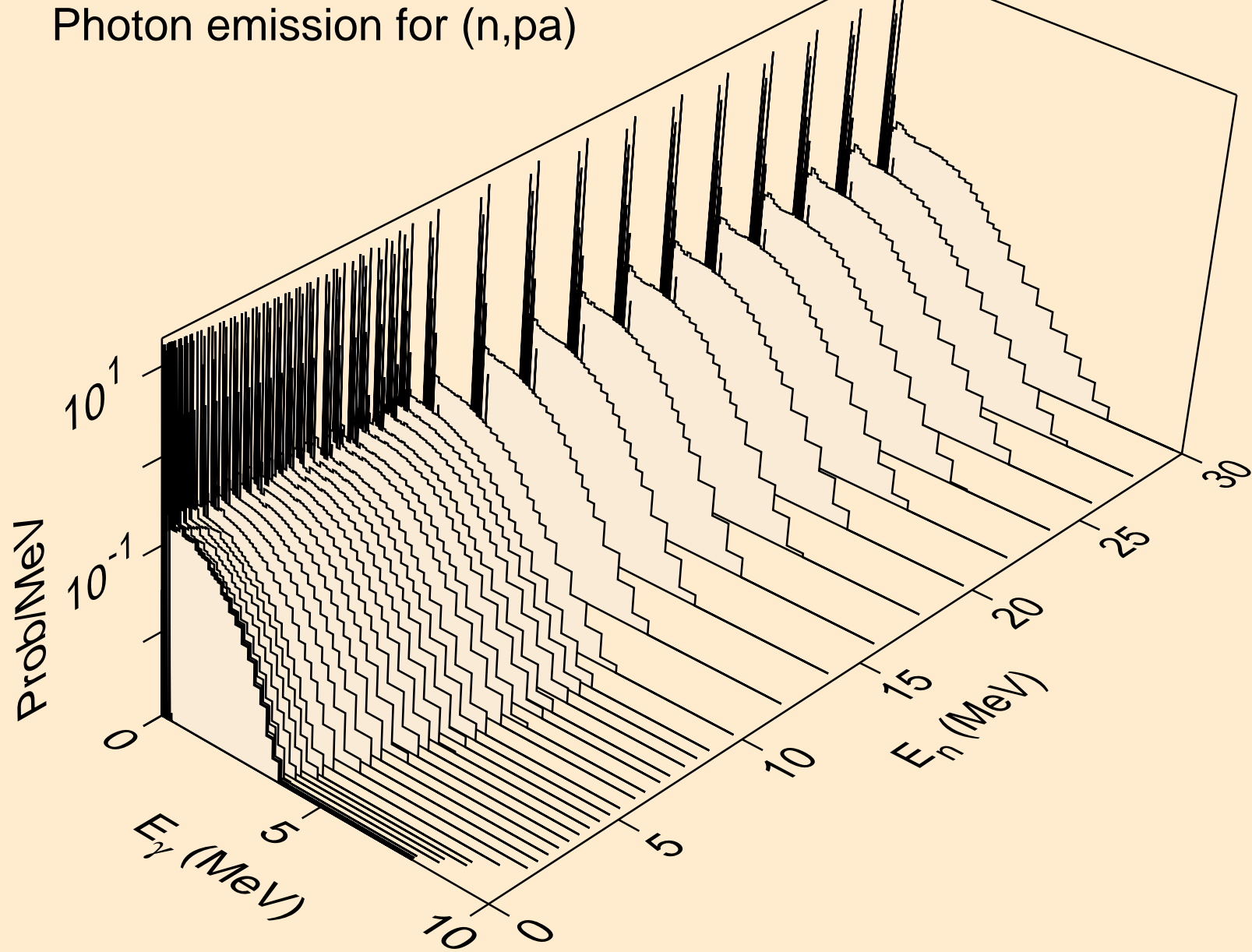

PB185M NEUTRON ACER TENDL-2024 LIBRARY; T=0.K  
Photon emission for (n,d2a)

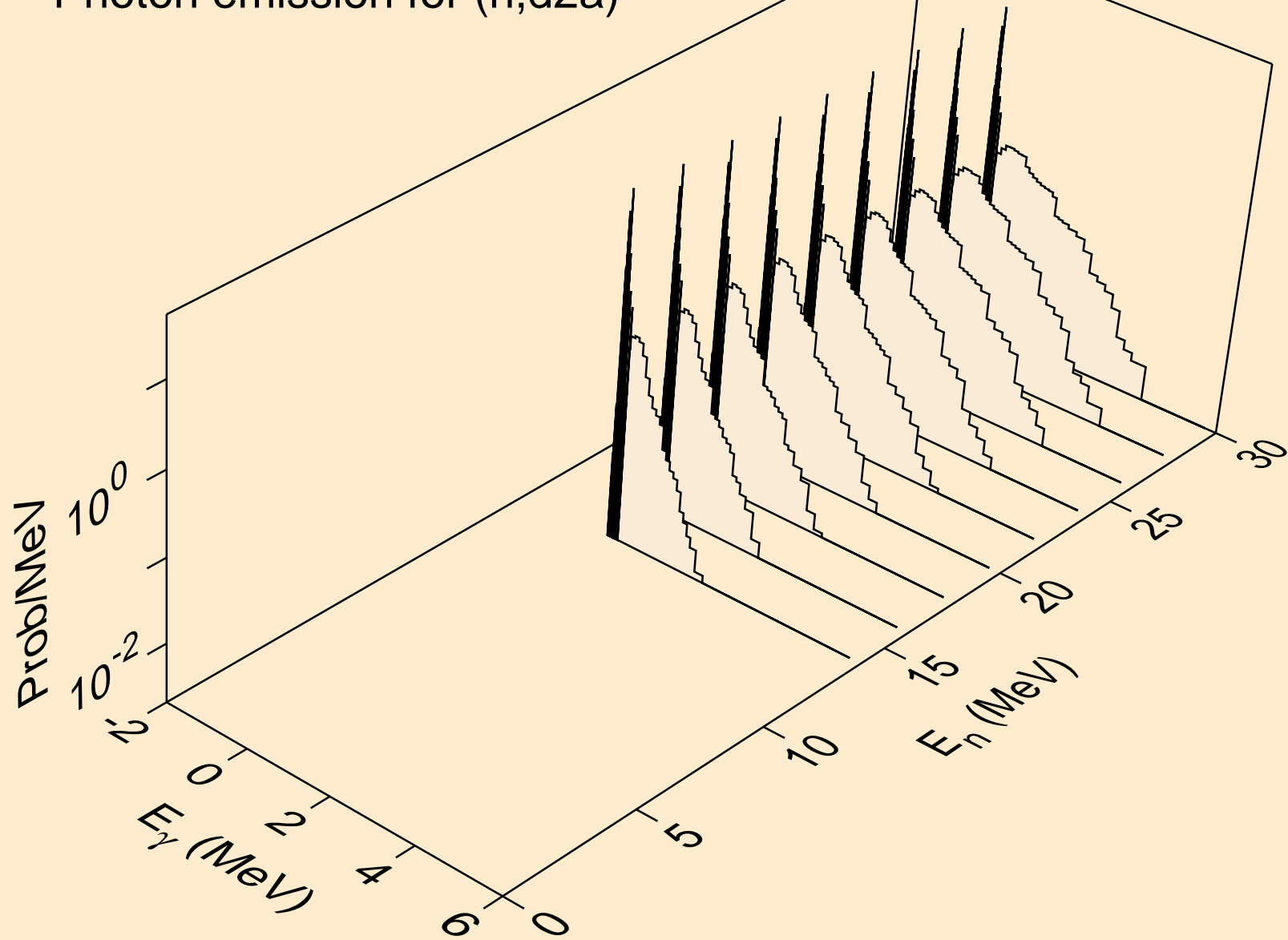

PB185M NEUTRON ACER TENDL-2024 LIBRARY; T=0.K  
Photon emission for (n,pd)

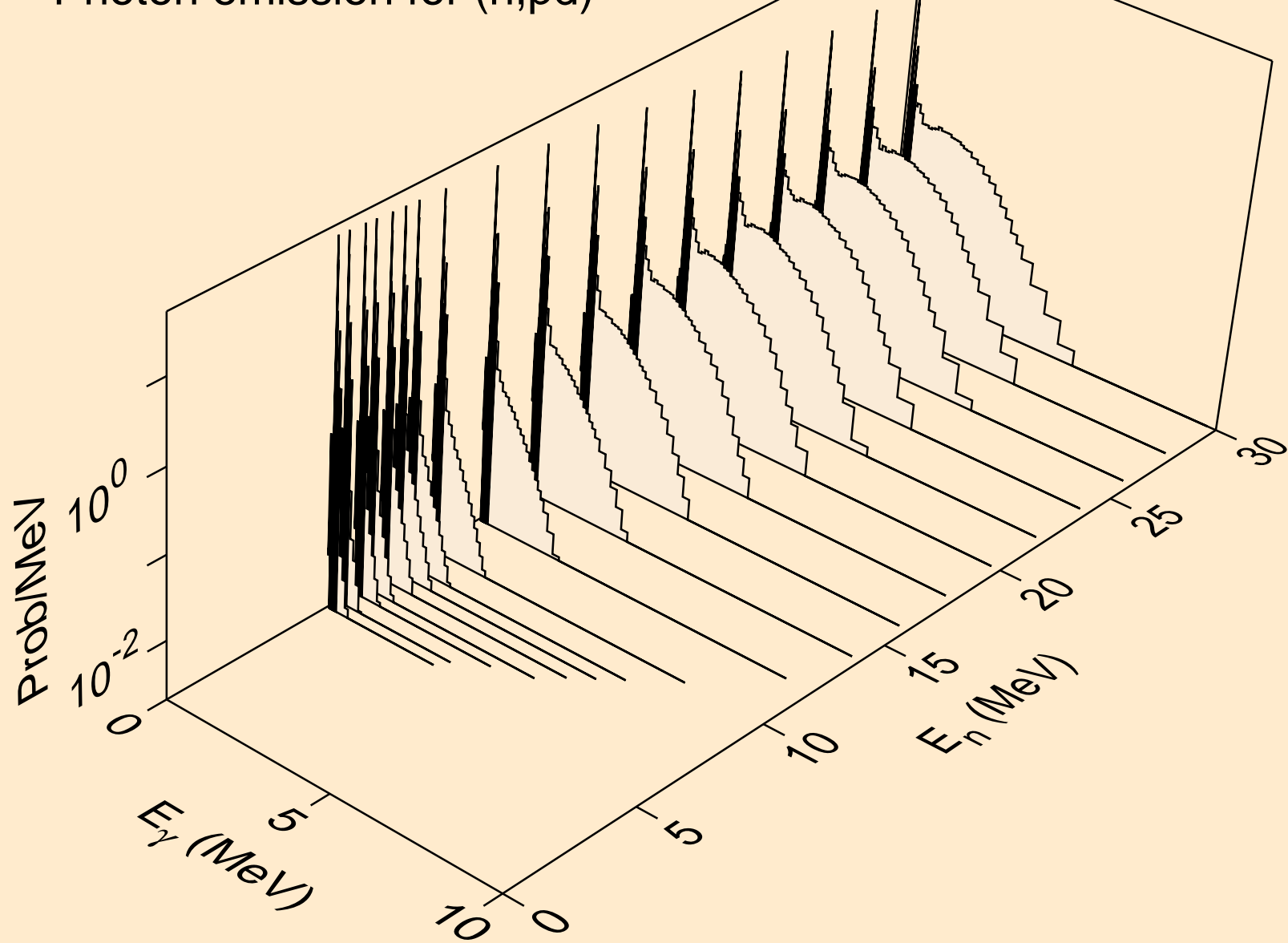

PB185M NEUTRON ACER TENDL-2024 LIBRARY; T=0.K  
Photon emission for (n,pt)

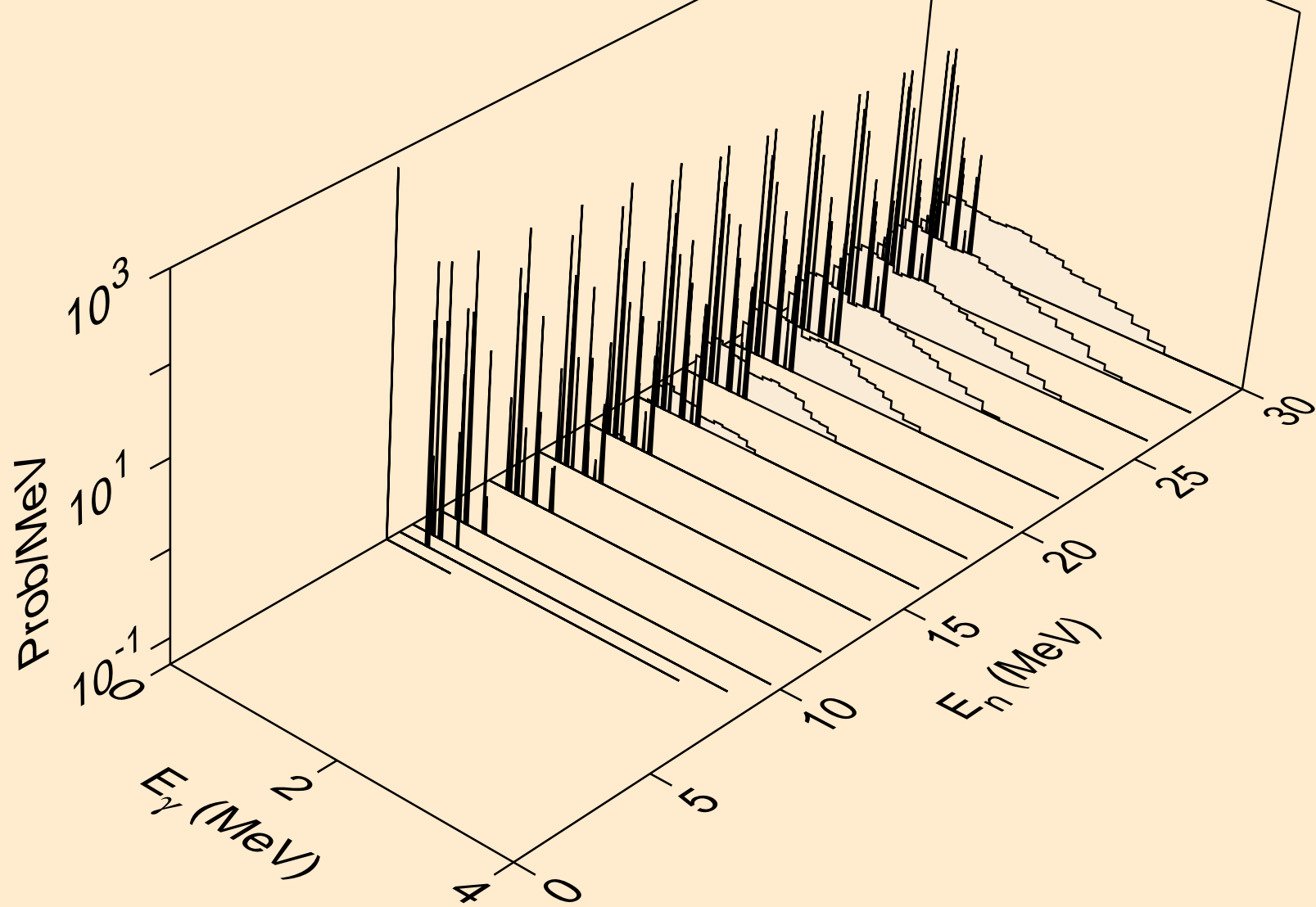

PB185M NEUTRON ACER TENDL-2024 LIBRARY; T=0.K  
Photon emission for (n,da)

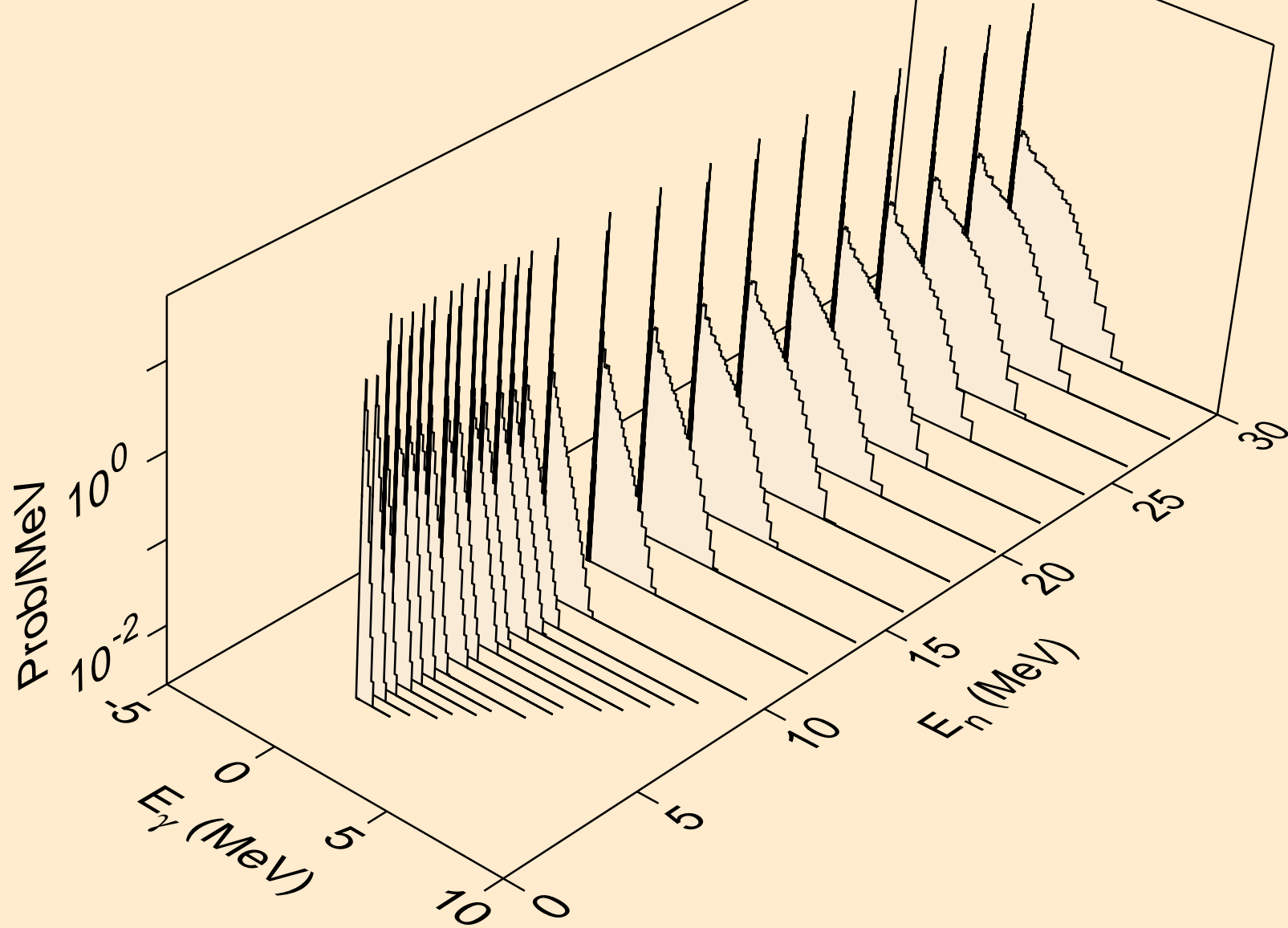

PB185M NEUTRON ACER TENDL-2024 LIBRARY; T=0.K  
thermal capture photon spectrum

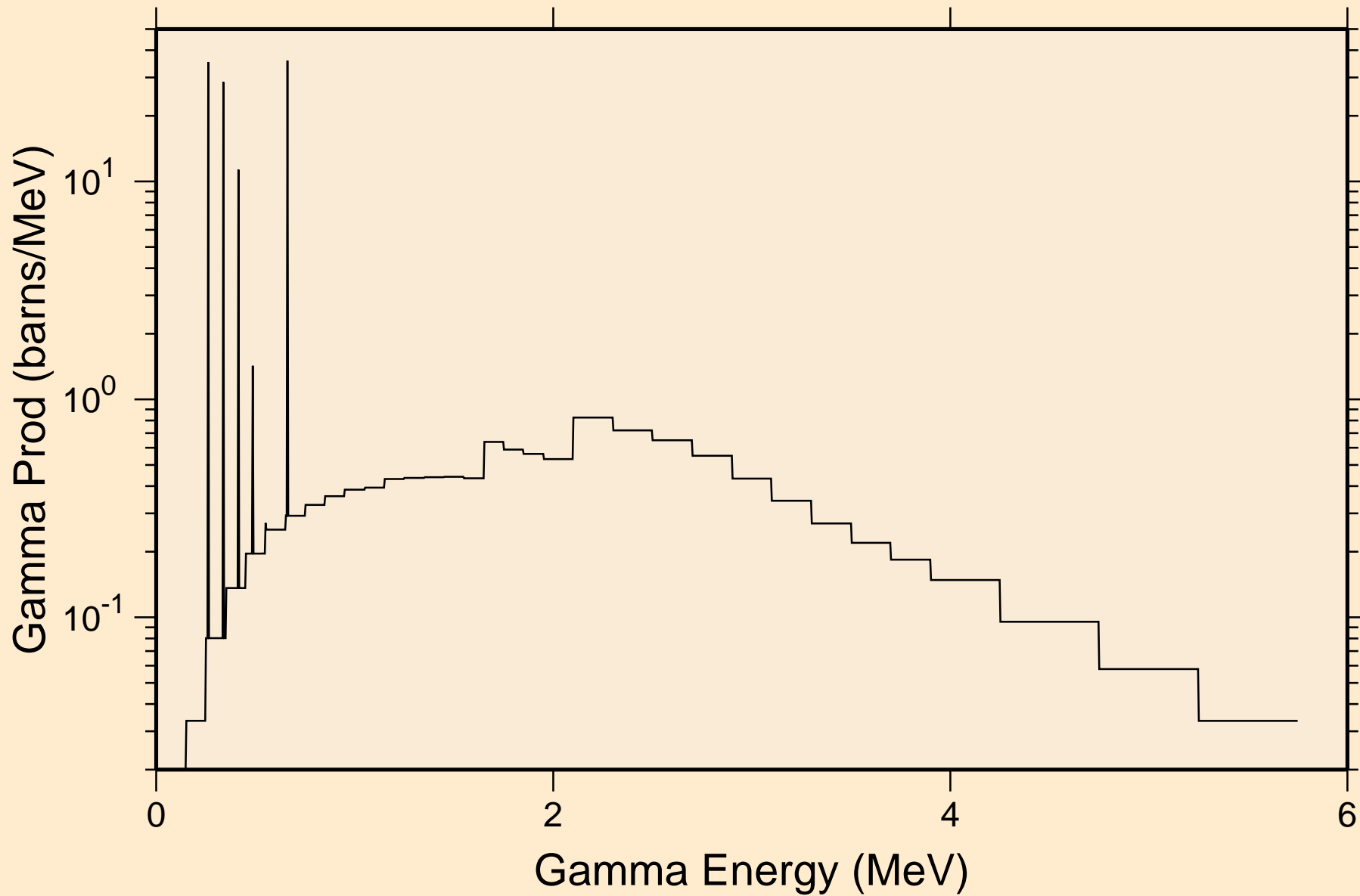

PB185M NEUTRON ACER TENDL-2024 LIBRARY; T=0.K  
14 MeV photon spectrum

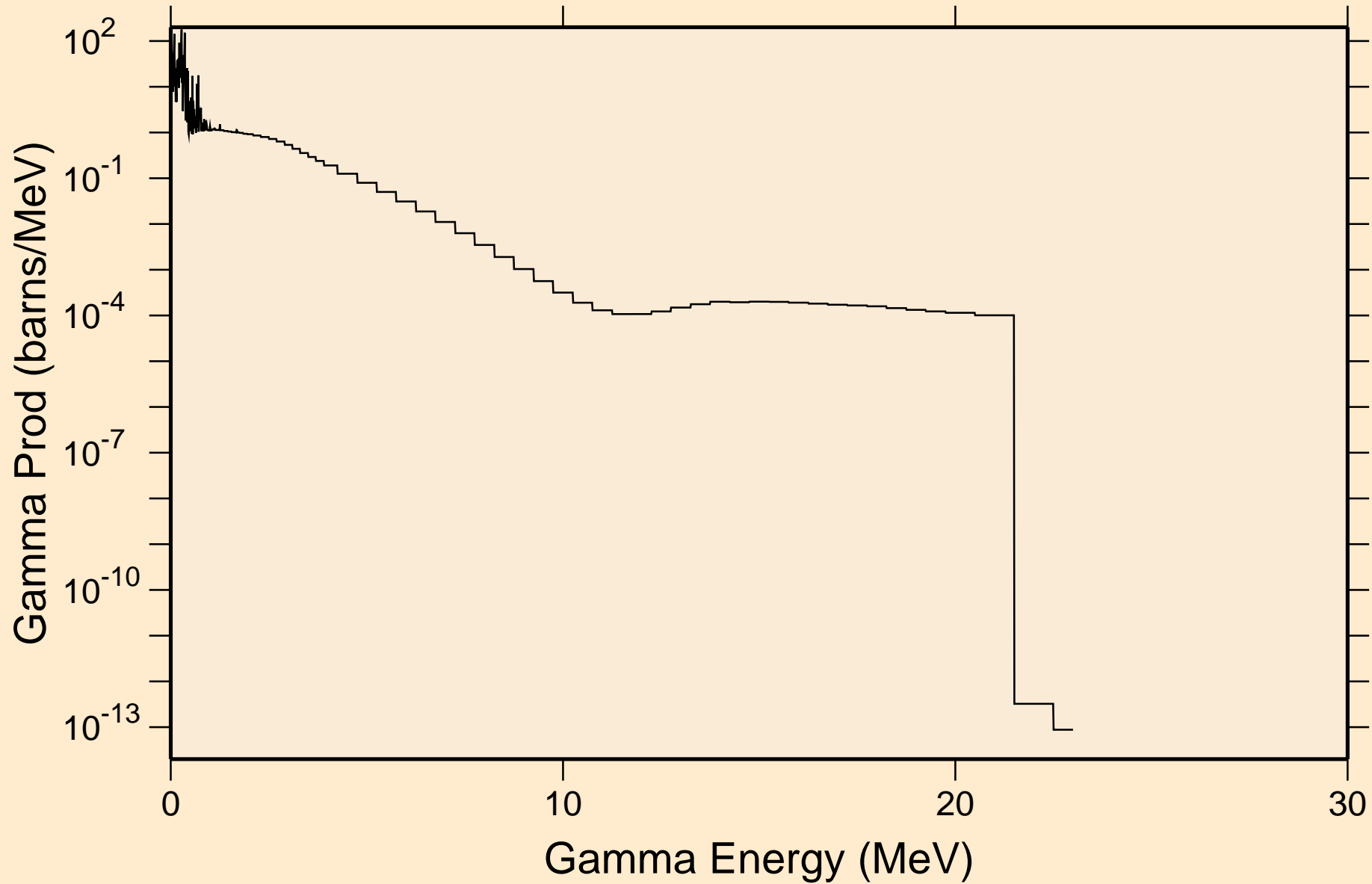



# PB185M NEUTRON ACER TENDL-2024 LIBRARY; T=0.K

## Particle heating contributions

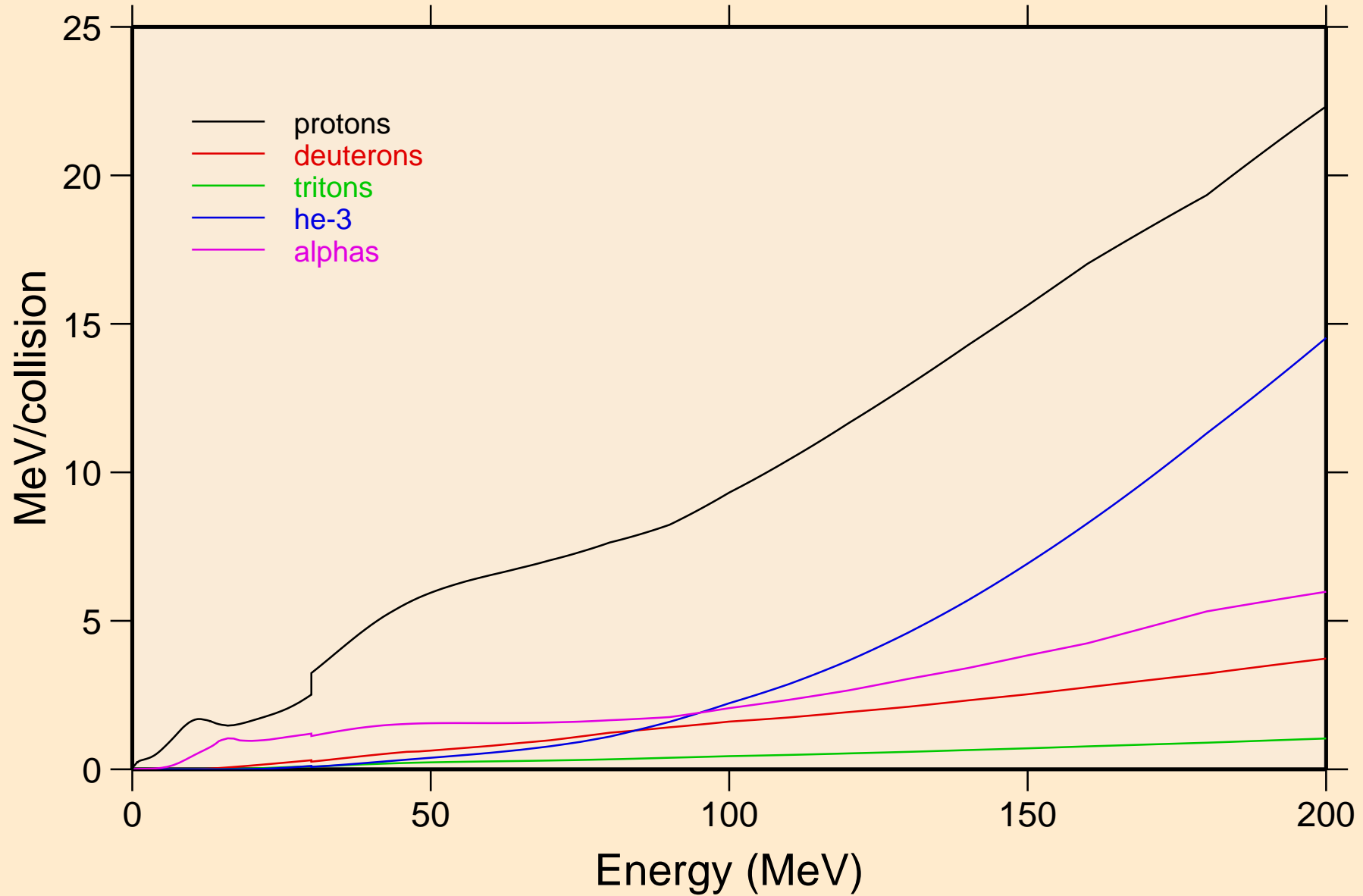

PB185M NEUTRON ACER TENDL-2024 LIBRARY; T=0.K  
Recoil Heating

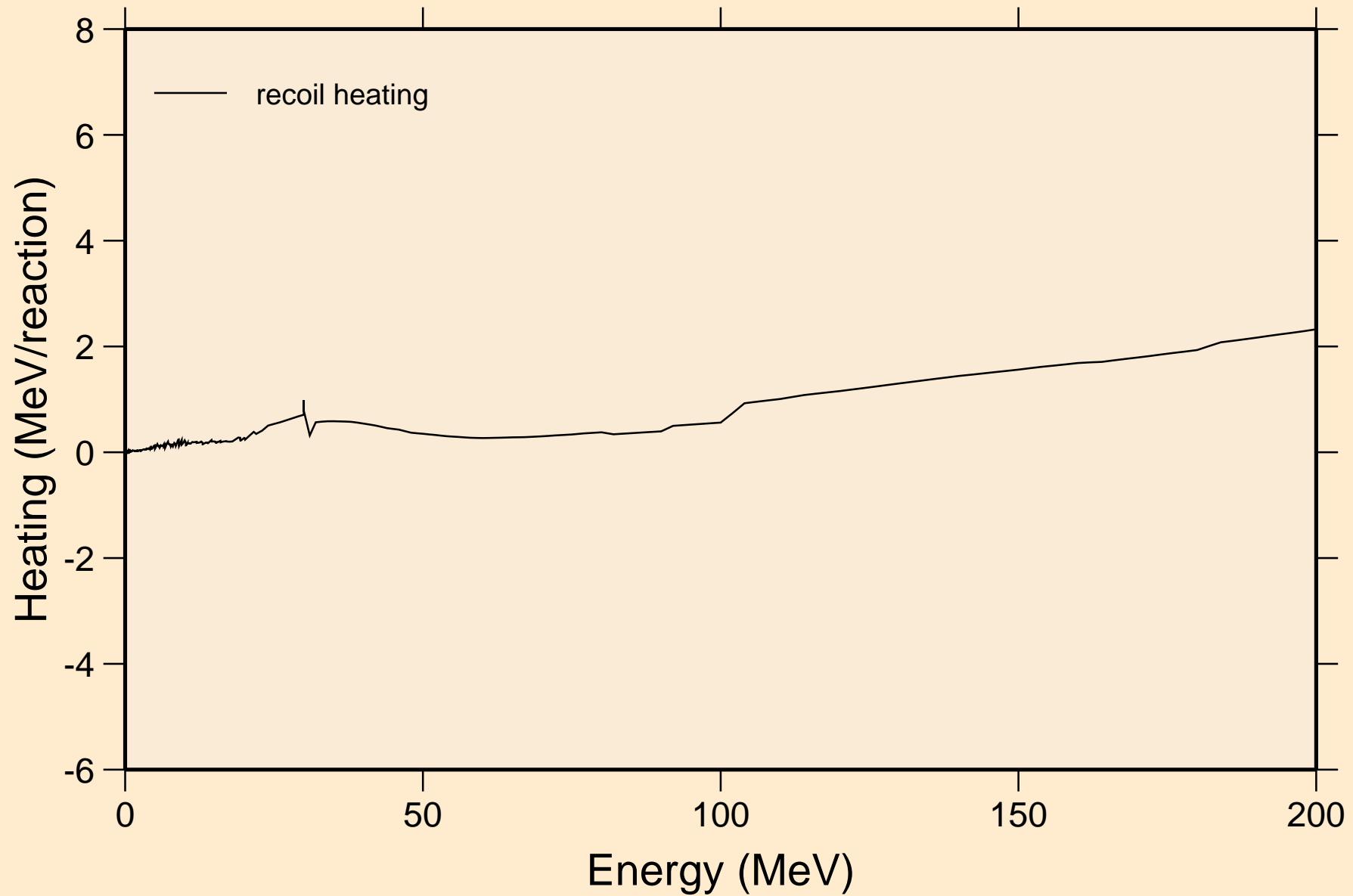

# PB185M NEUTRON ACER TENDL-2024 LIBRARY; T=0.K

## Particle production cross sections

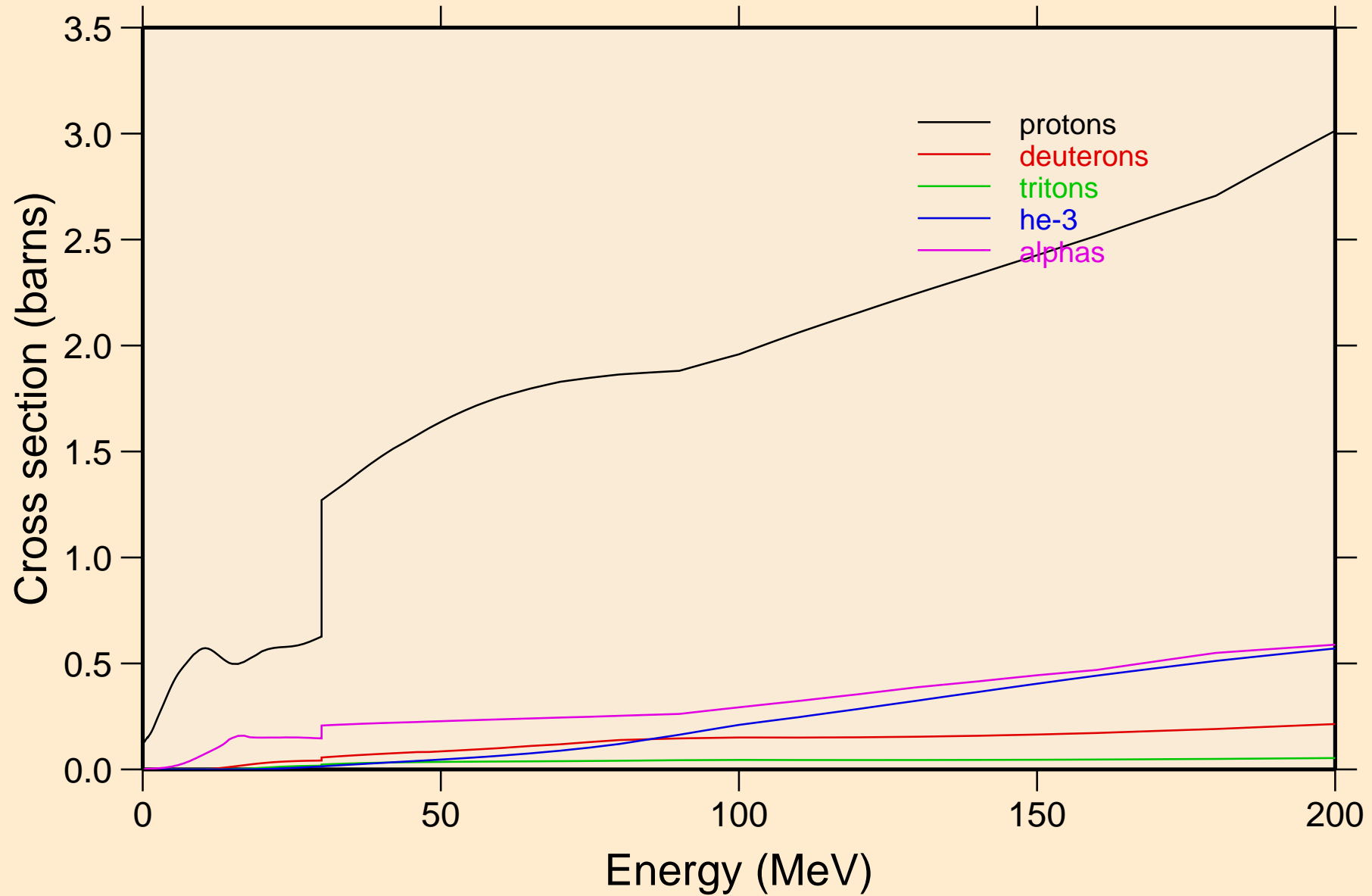

PB185M NEUTRON ACER TENDL-2024 LIBRARY; T=0.K  
protons from (n,x)

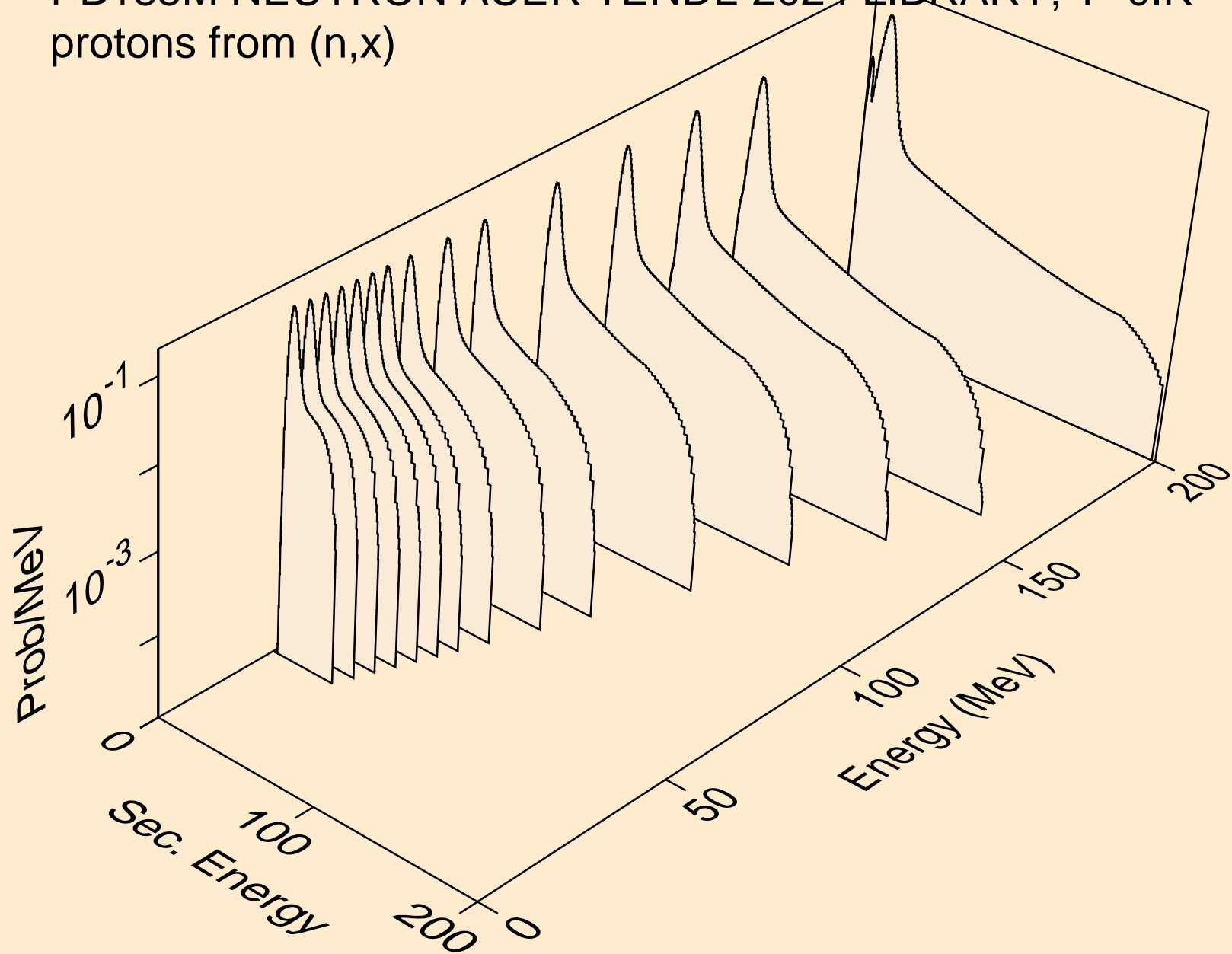

PB185M NEUTRON ACER TENDL-2024 LIBRARY; T=0.K  
protons from (n,n\*)p

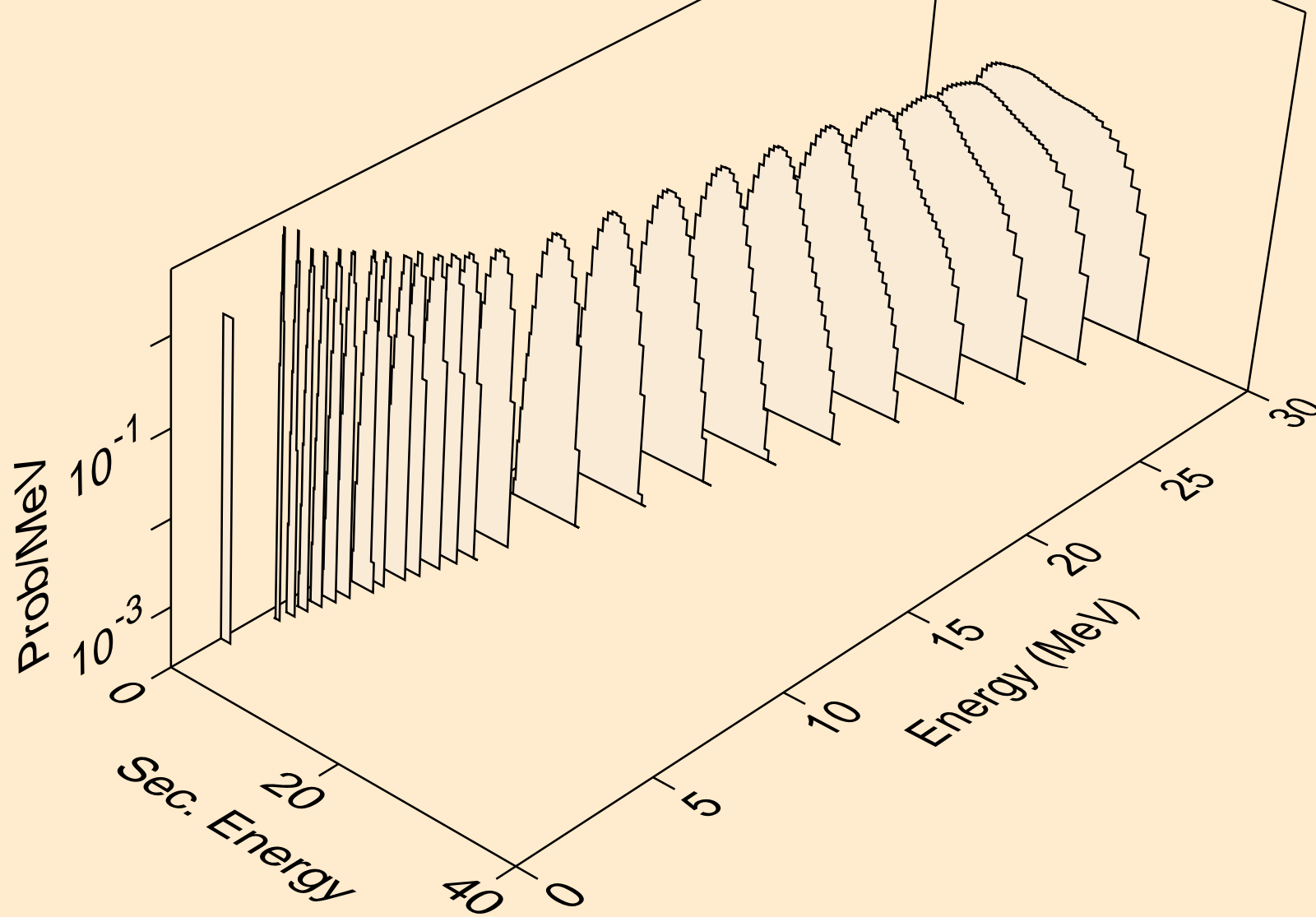

PB185M NEUTRON ACER TENDL-2024 LIBRARY; T=0.K  
protons from (n,2np)

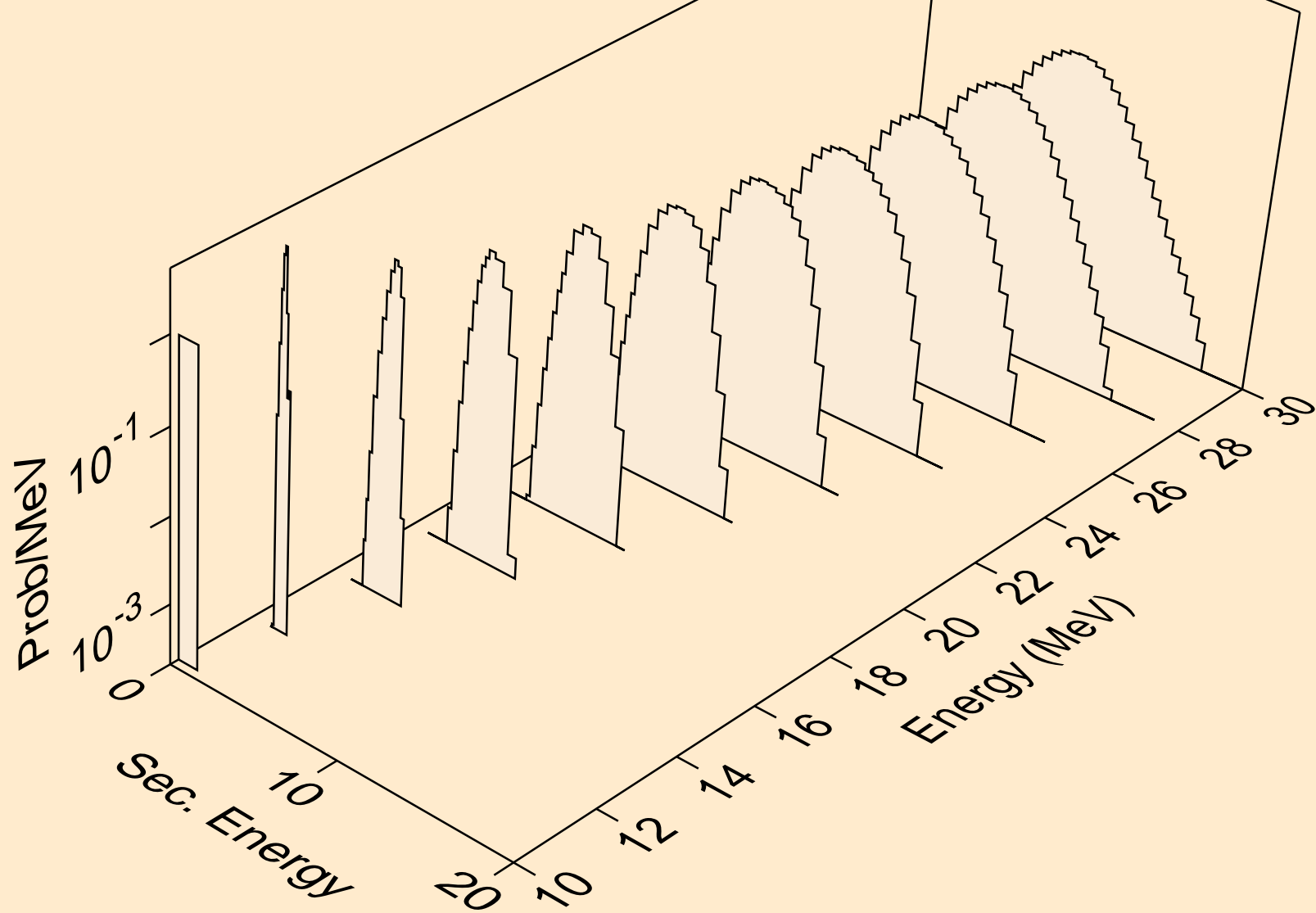

PB185M NEUTRON ACER TENDL-2024 LIBRARY; T=0.K  
protons from (n,3np)

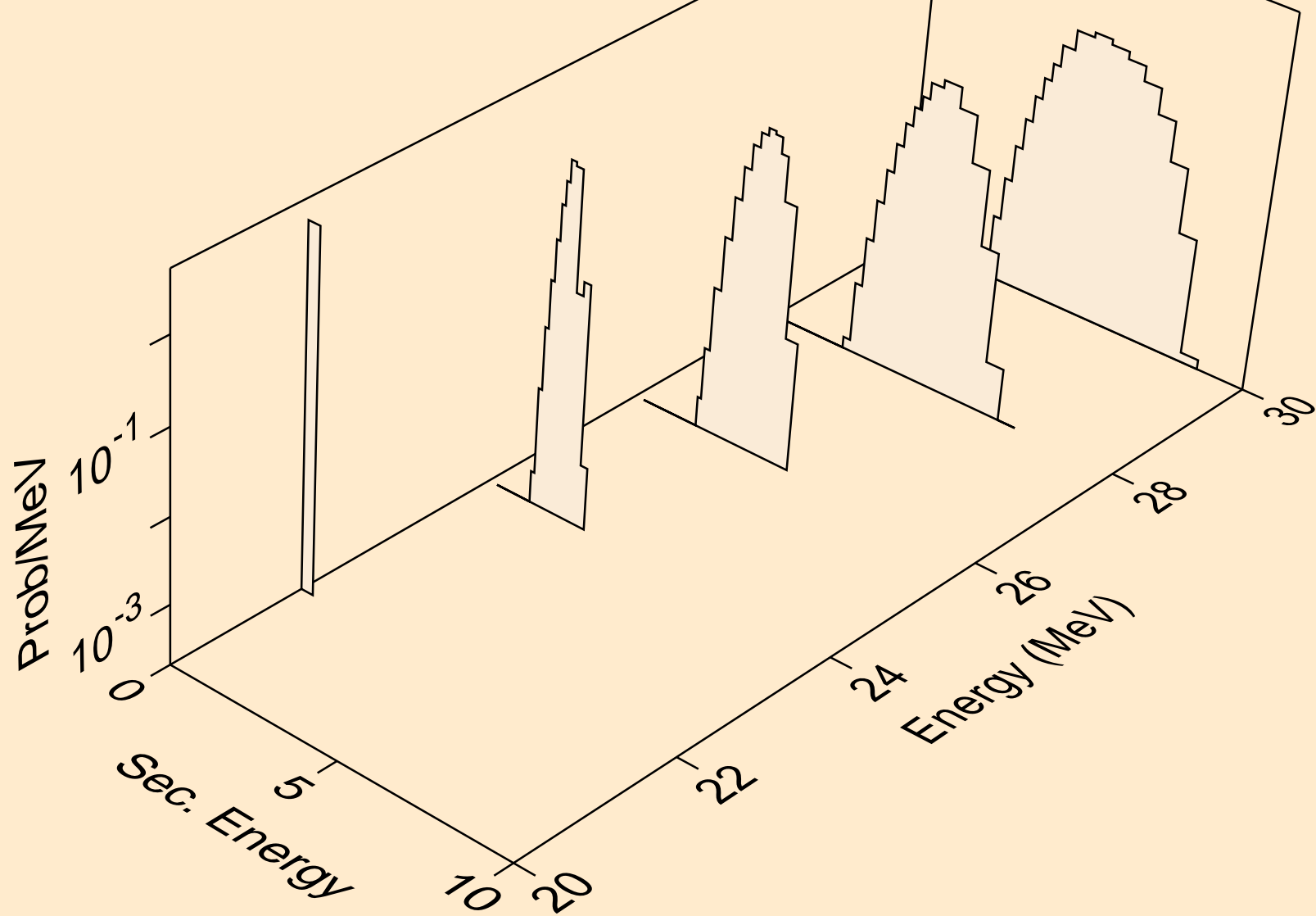

PB185M NEUTRON ACER TENDL-2024 LIBRARY; T=0.K  
protons from (n,n2p)

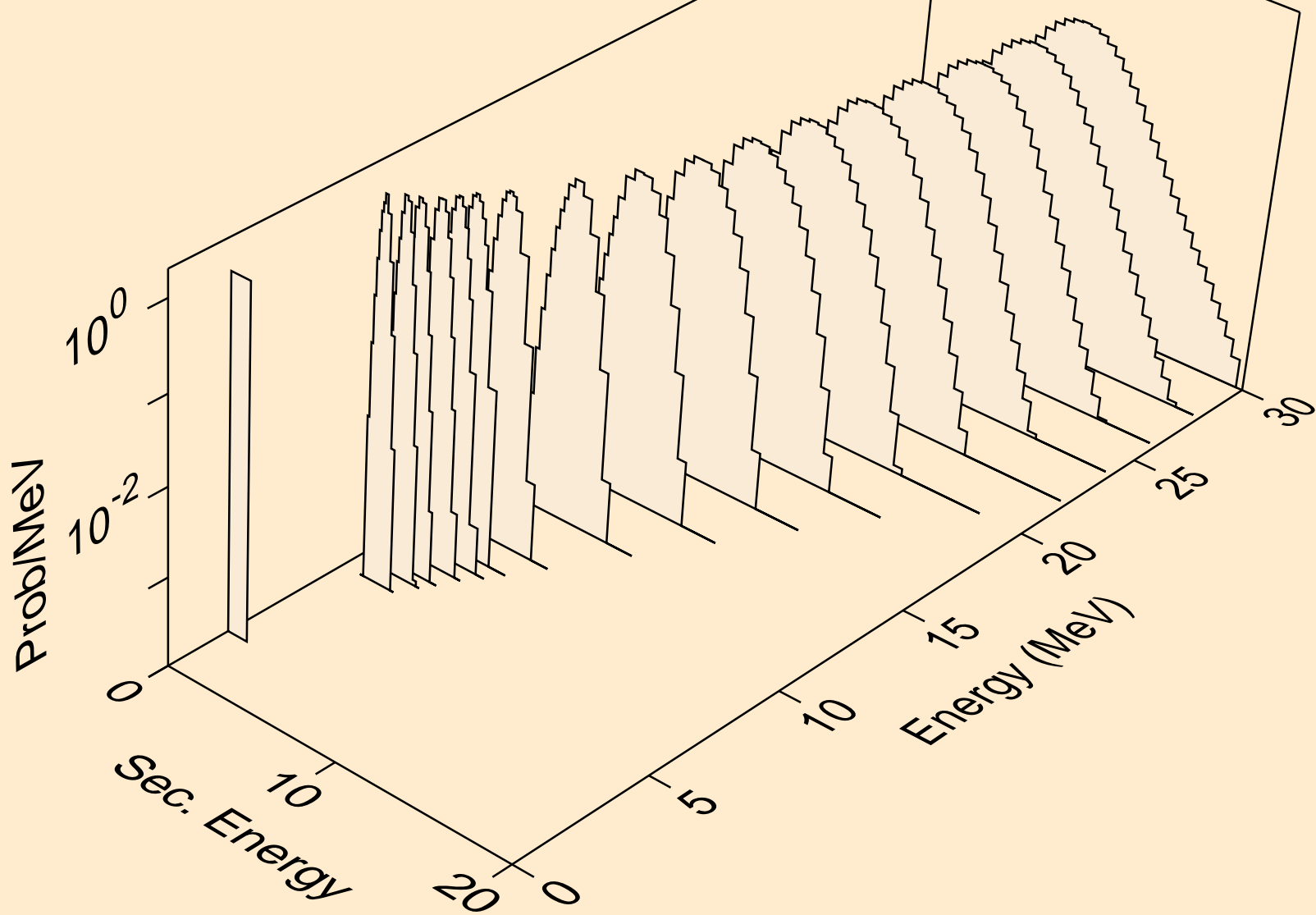



PB185M NEUTRON ACER TENDL-2024 LIBRARY; T=0.K  
protons from (n,npa)

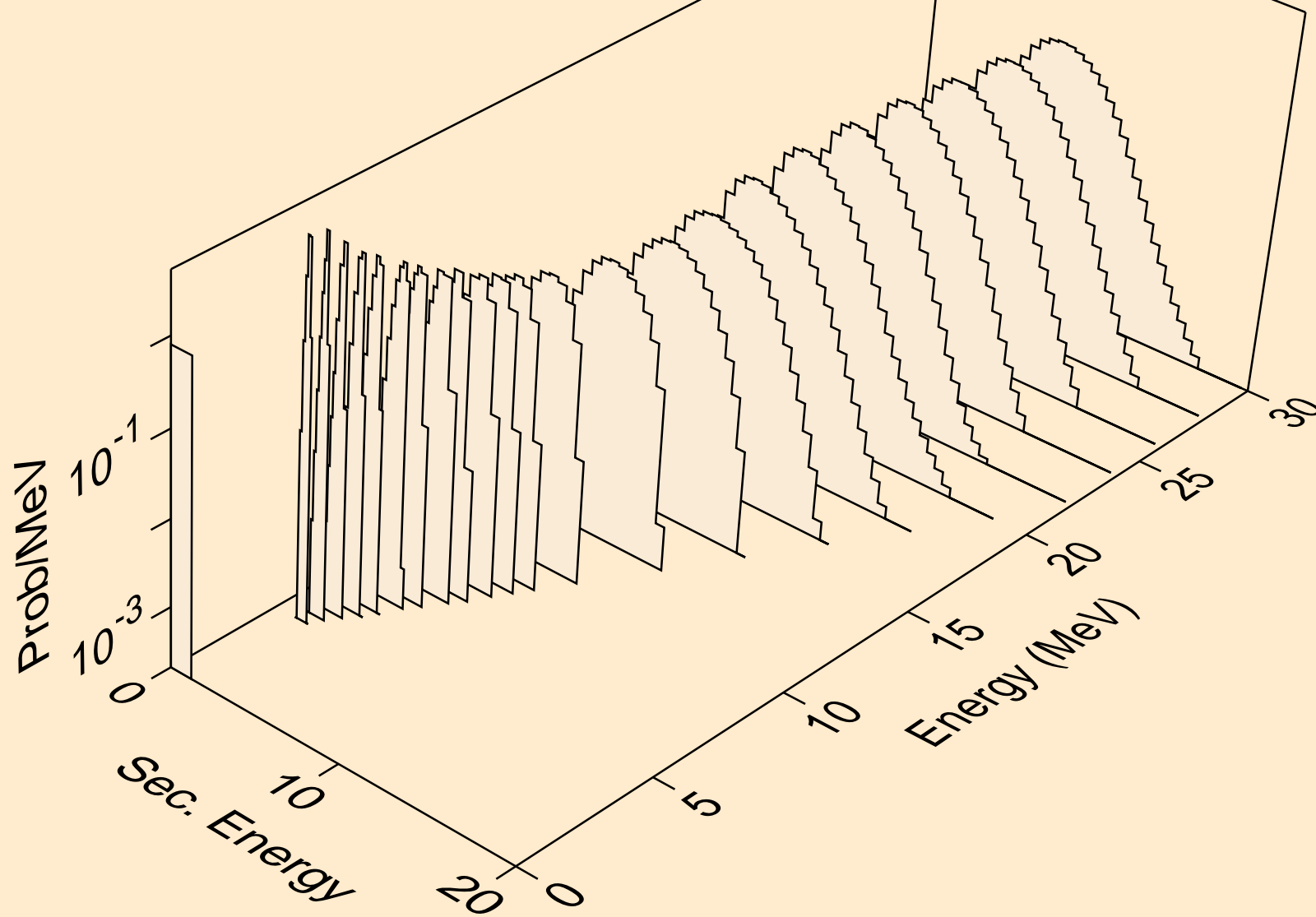

PB185M NEUTRON ACER TENDL-2024 LIBRARY; T=0.K  
protons from (n,p)

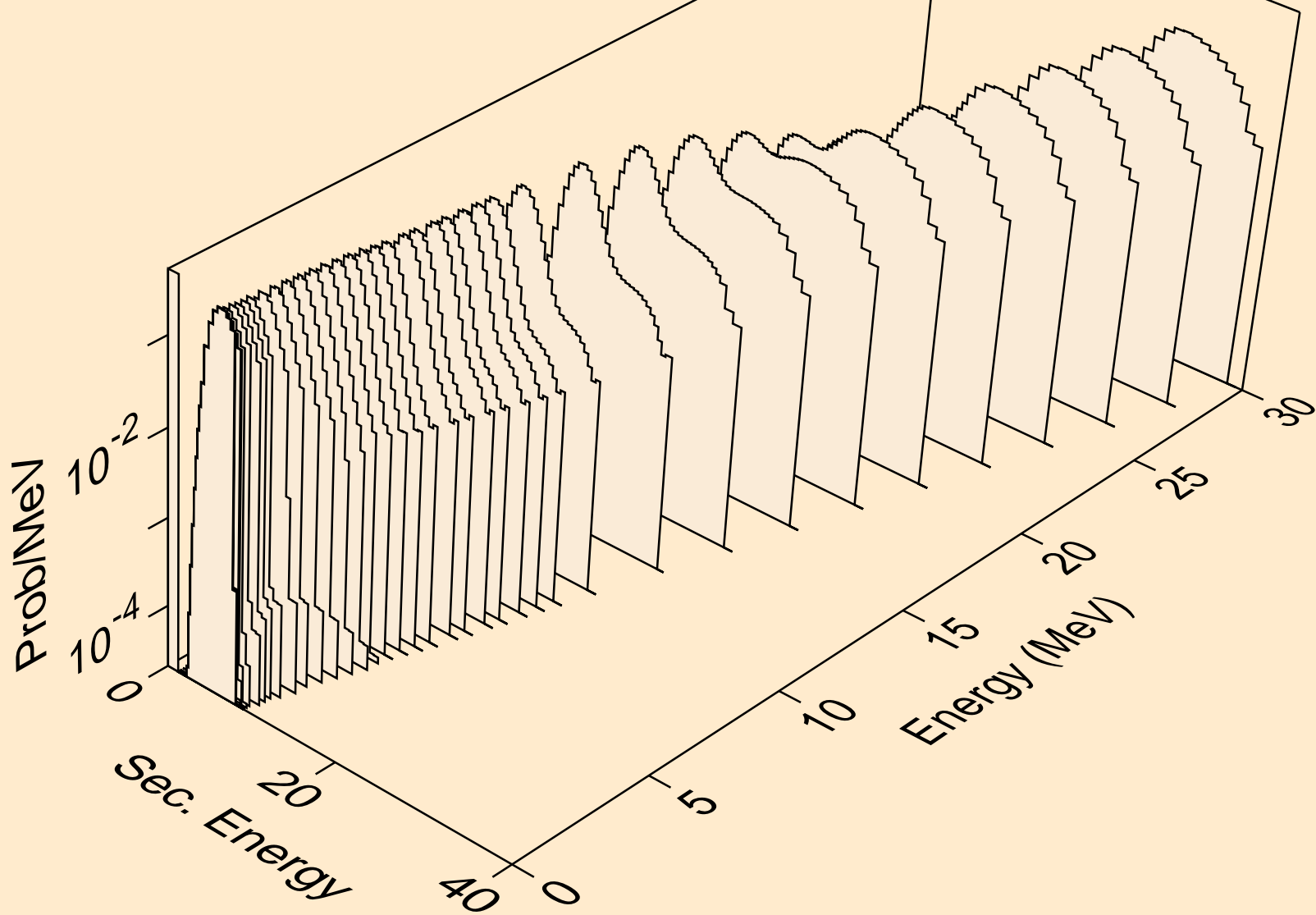

PB185M NEUTRON ACER TENDL-2024 LIBRARY; T=0.K  
protons from (n,2p)

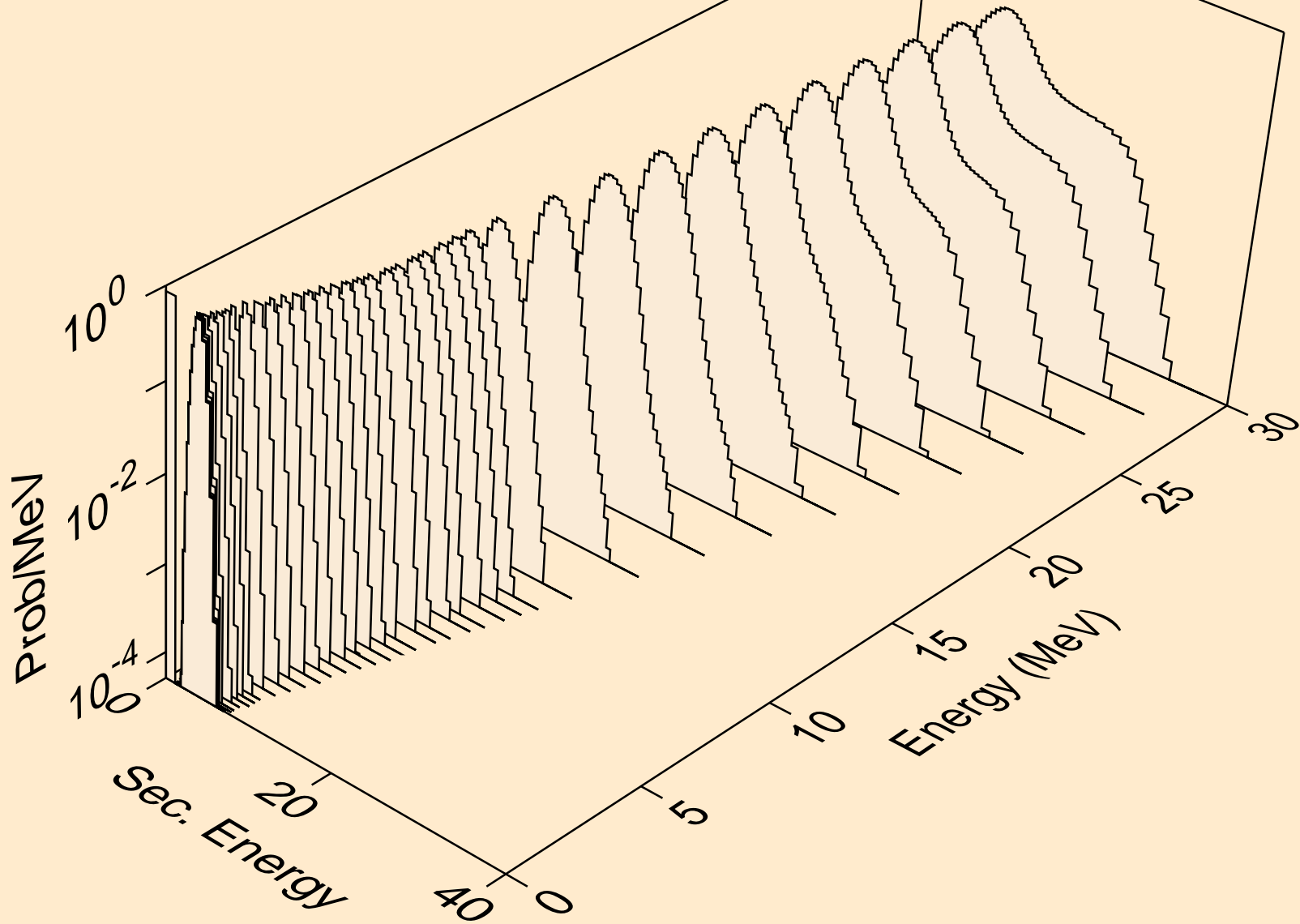

PB185M NEUTRON ACER TENDL-2024 LIBRARY; T=0.K  
protons from (n,p)

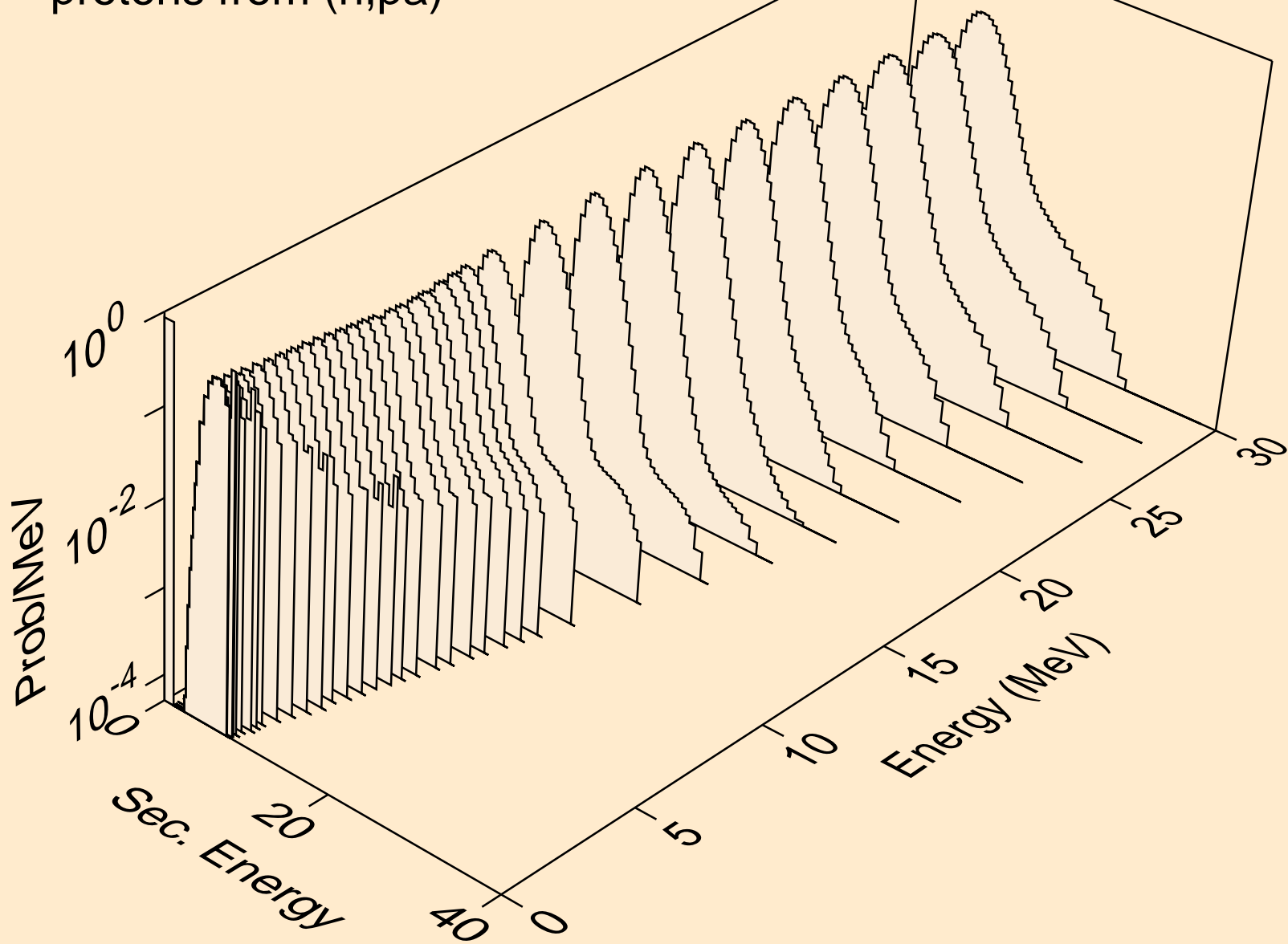

PB185M NEUTRON ACER TENDL-2024 LIBRARY; T=0.K  
protons from (n,pd)

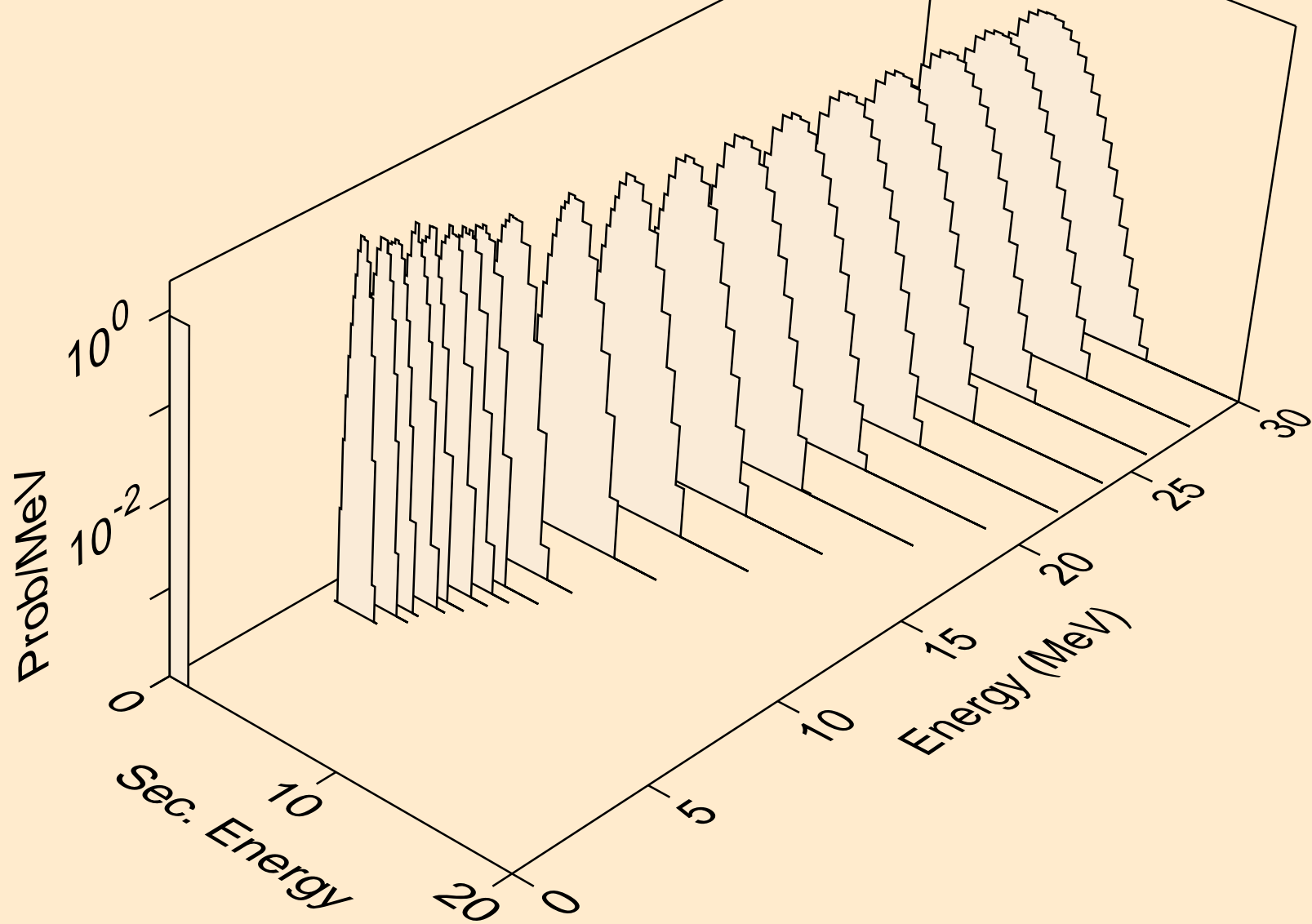

PB185M NEUTRON ACER TENDL-2024 LIBRARY; T=0.K  
protons from (n,pt)

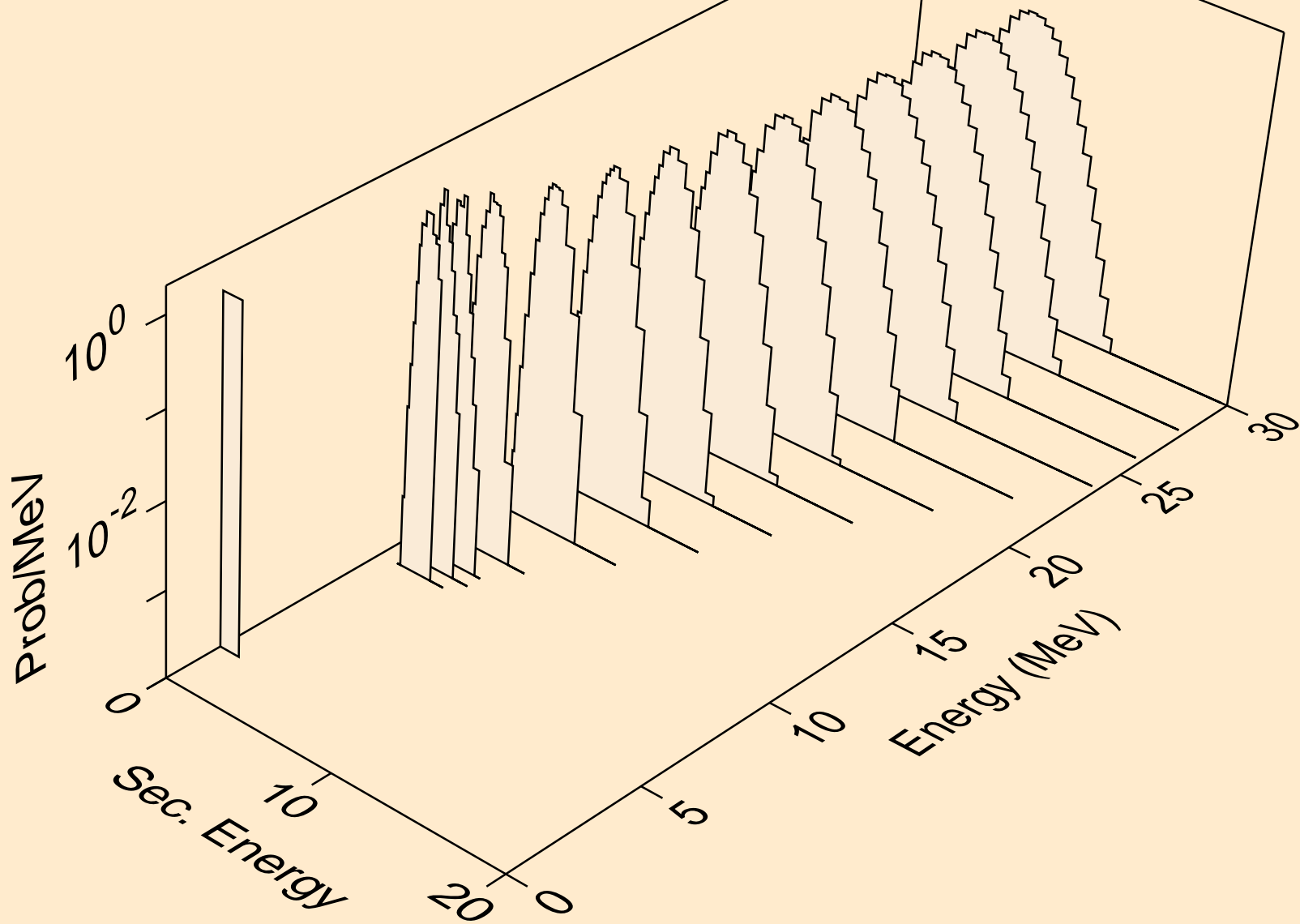

PB185M NEUTRON ACER TENDL-2024 LIBRARY; T=0.K  
deuterons from (n,x)

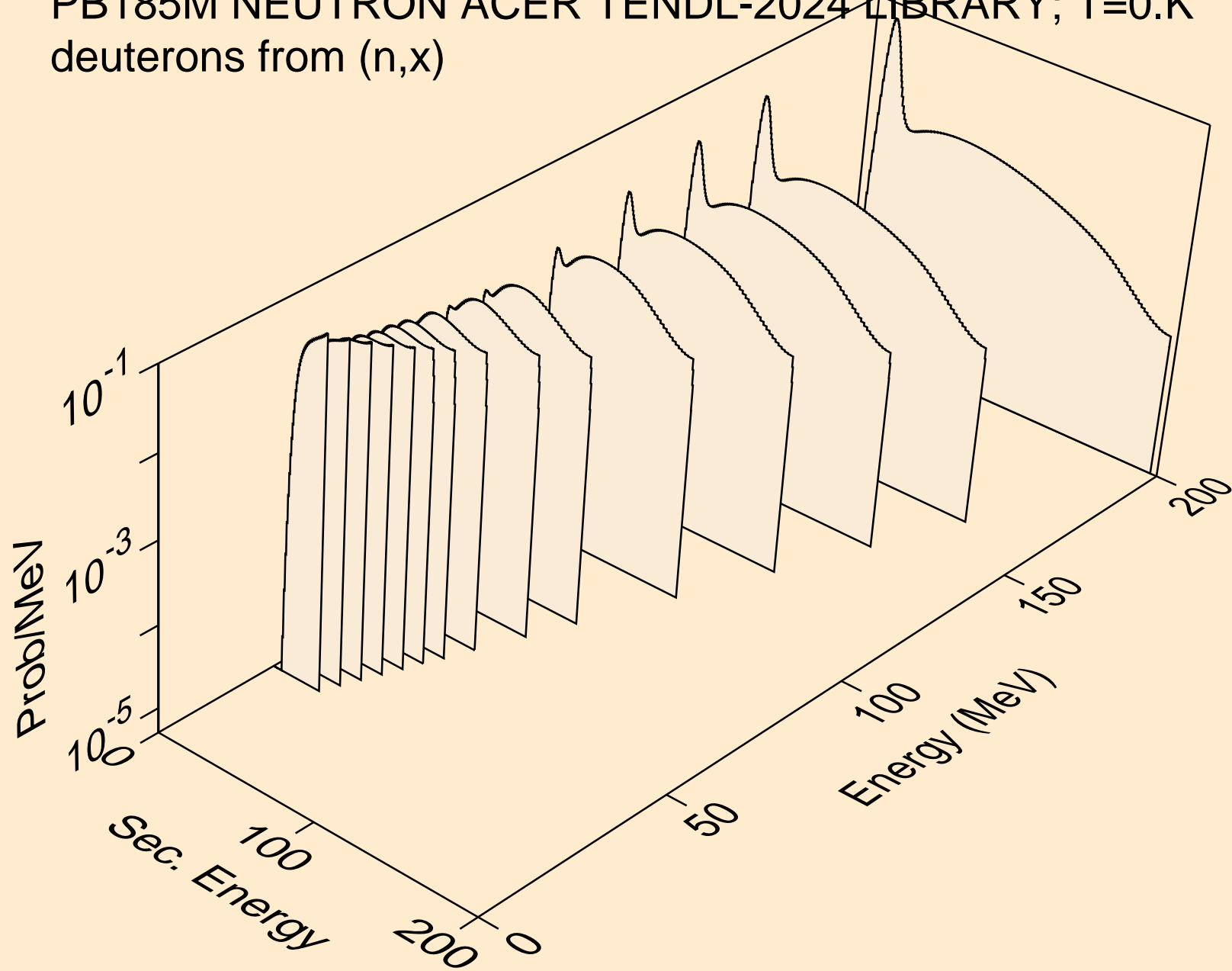

PB185M NEUTRON ACER TENDL-2024 LIBRARY; T=0.K  
deuterons from (n,2nd)

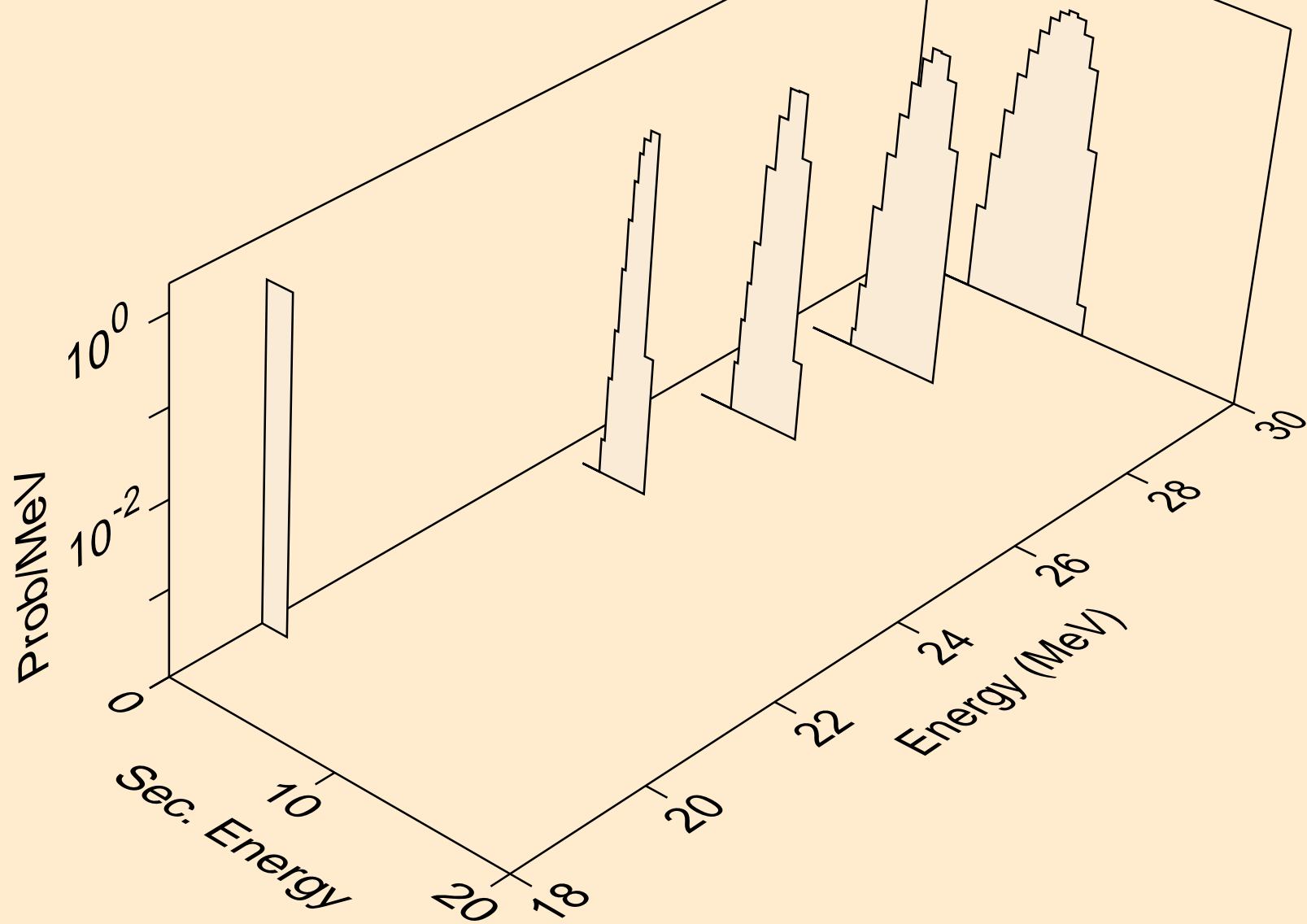



PB185M NEUTRON ACER TENDL-2024 LIBRARY; T=0.K  
deuterons from (n,n\*)d

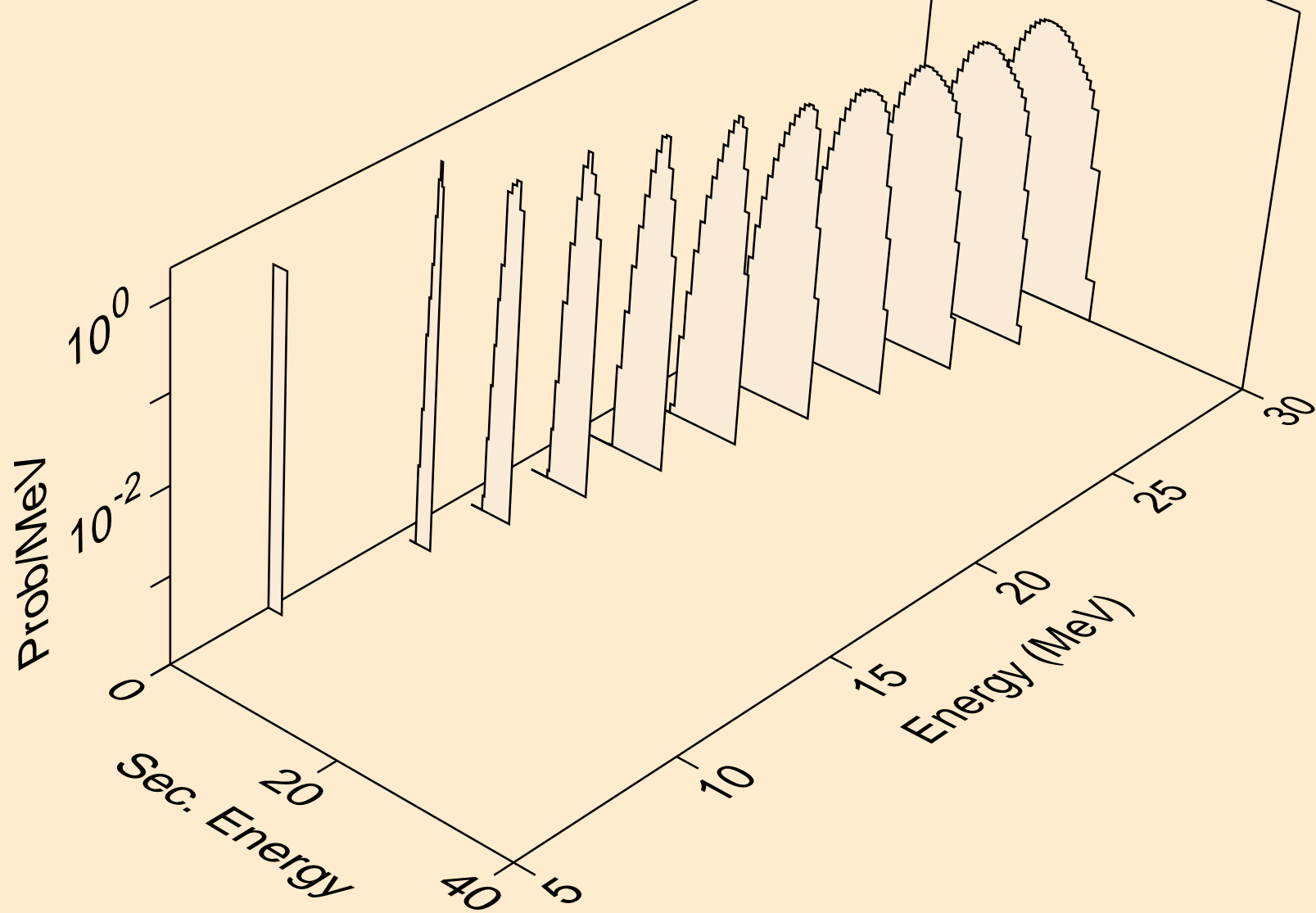

PB185M NEUTRON ACER TENDL-2024 LIBRARY; T=0.K  
deuterons from (n,d)

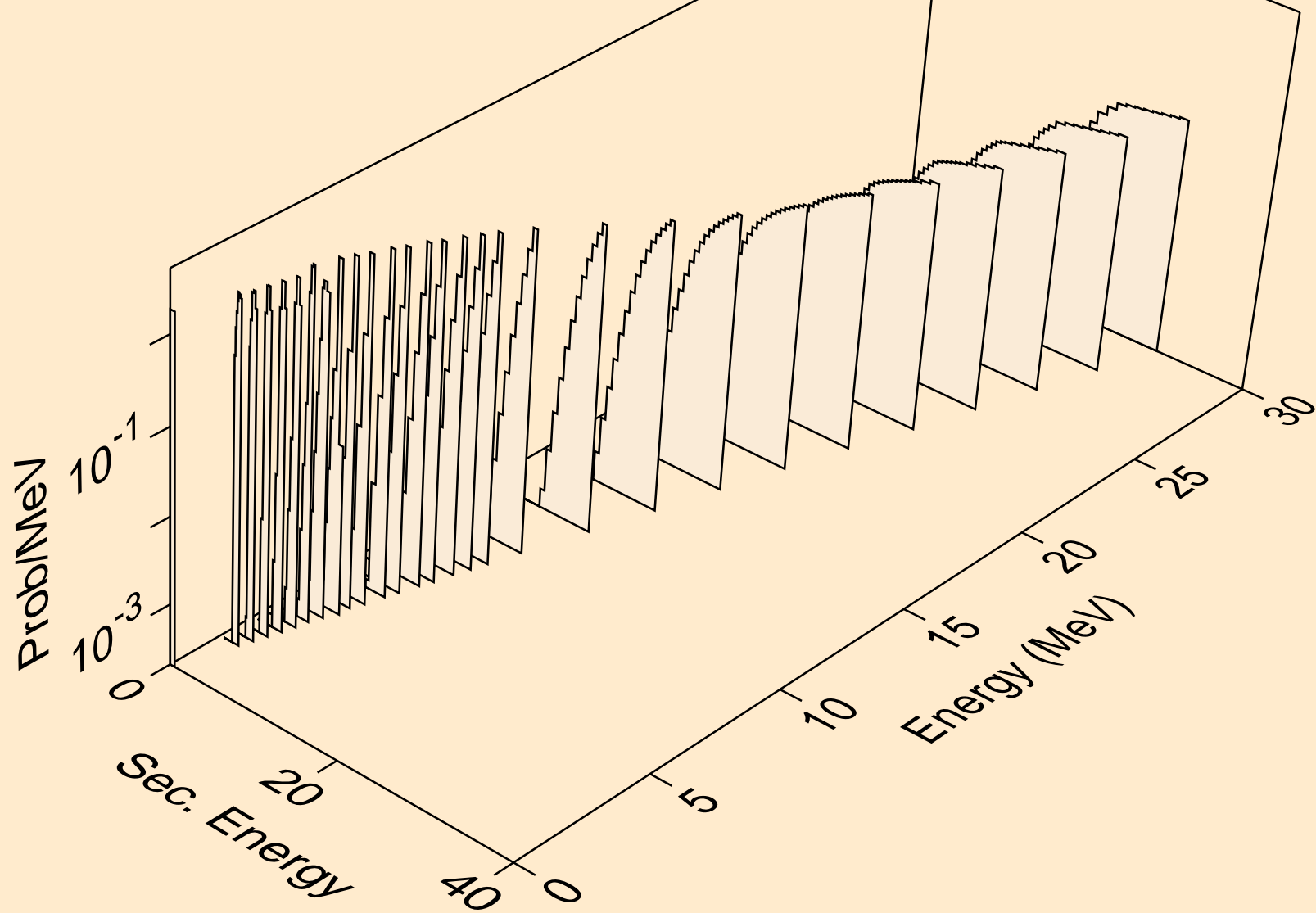

PB185M NEUTRON ACER TENDL-2024 LIBRARY; T=0.K  
deuterons from (n,d2a)

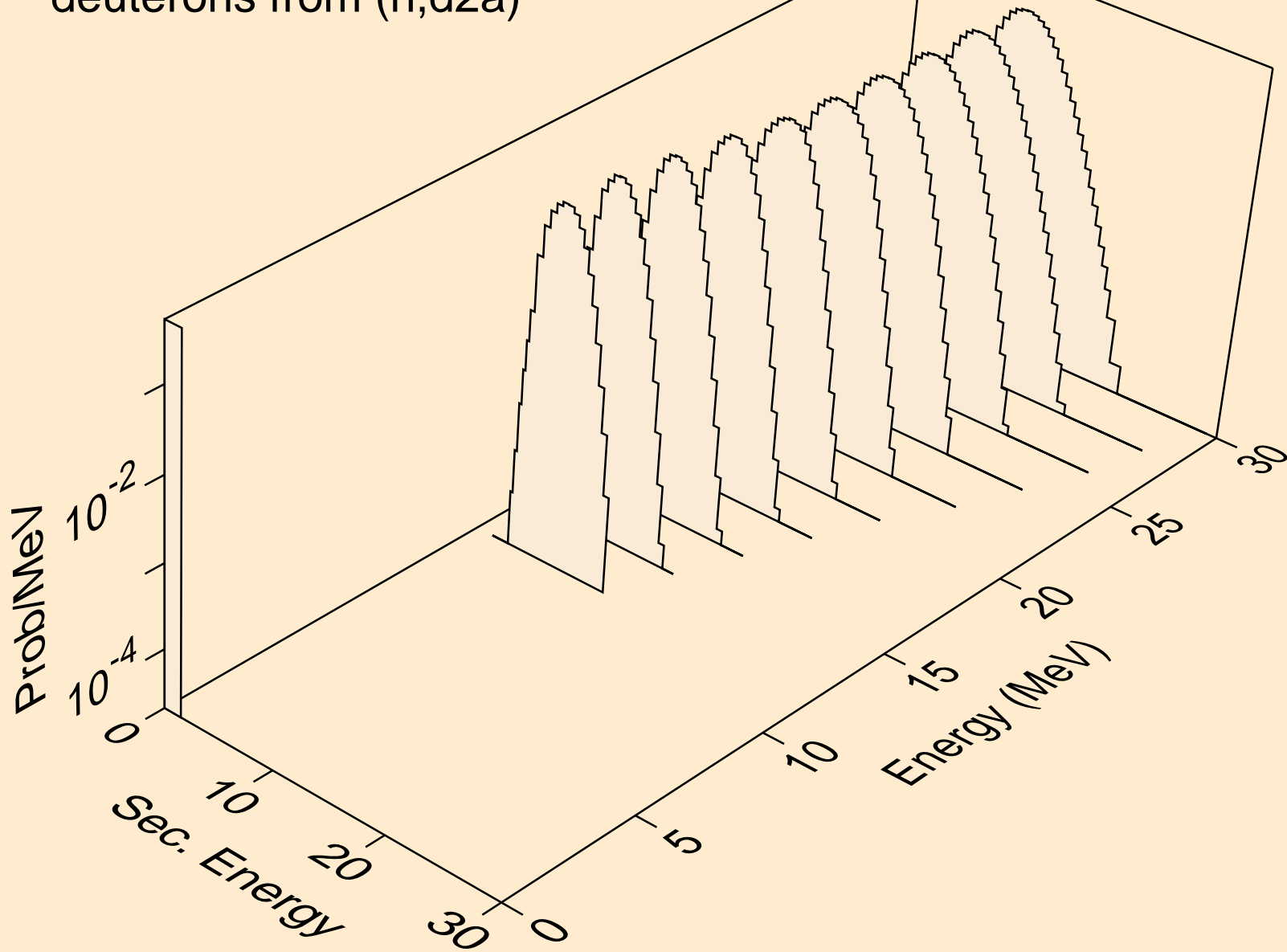

PB185M NEUTRON ACER TENDL-2024 LIBRARY; T=0.K  
deuterons from (n,pd)

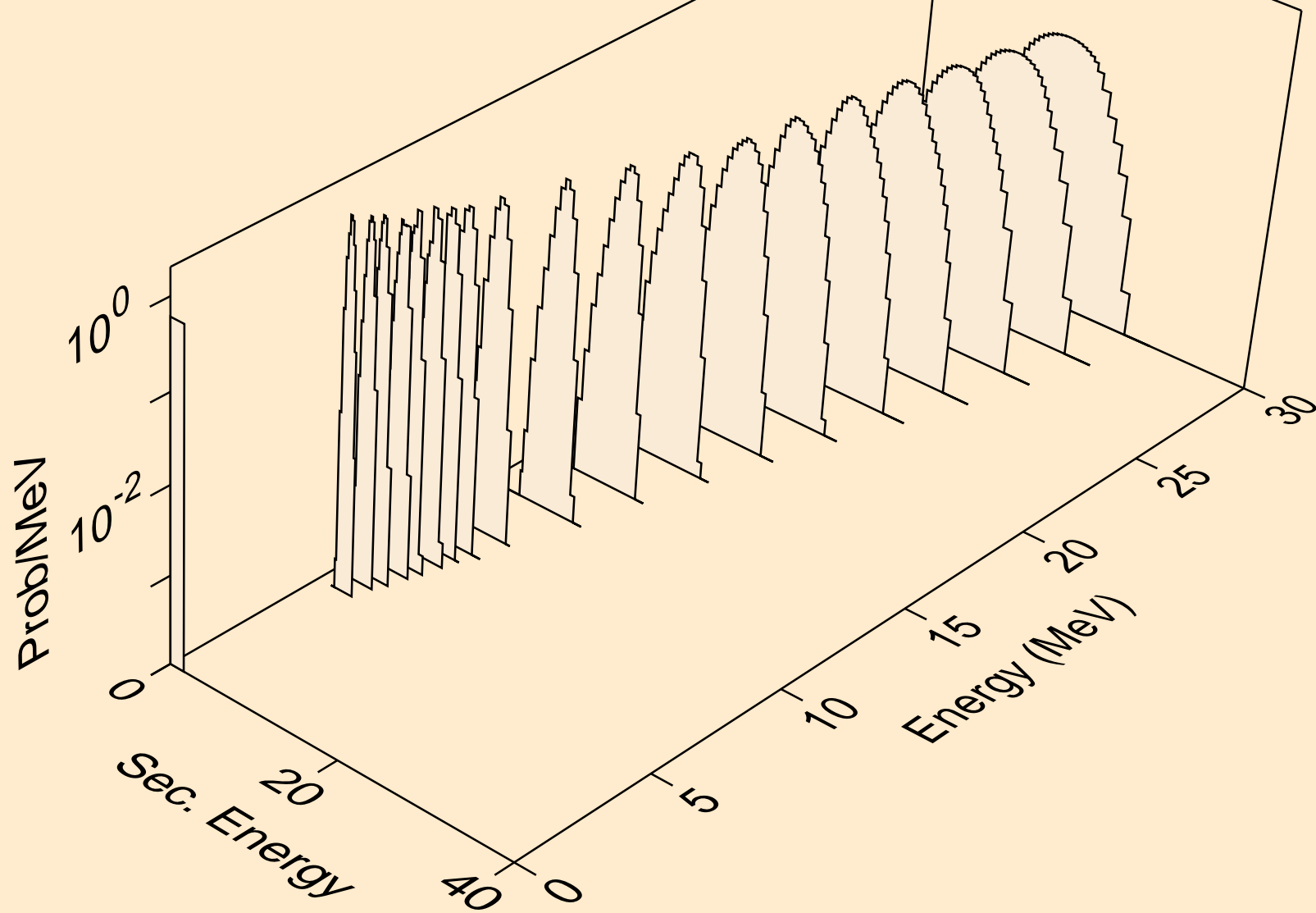

PB185M NEUTRON ACER TENDL-2024 LIBRARY; T=0.K  
deuterons from (n,da)

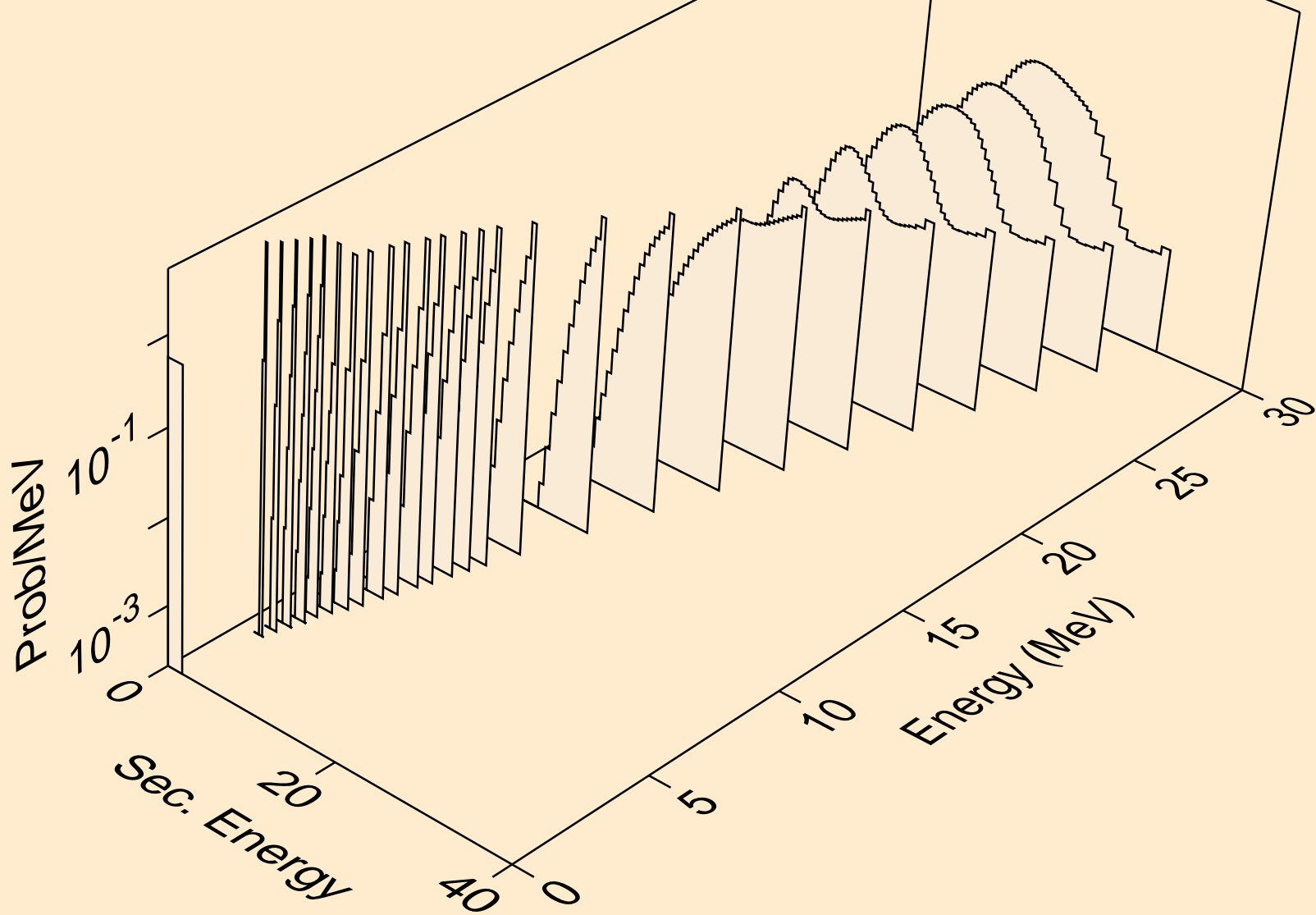

PB185M NEUTRON ACER TENDL-2024 LIBRARY; T=0.K  
tritons from (n,x)

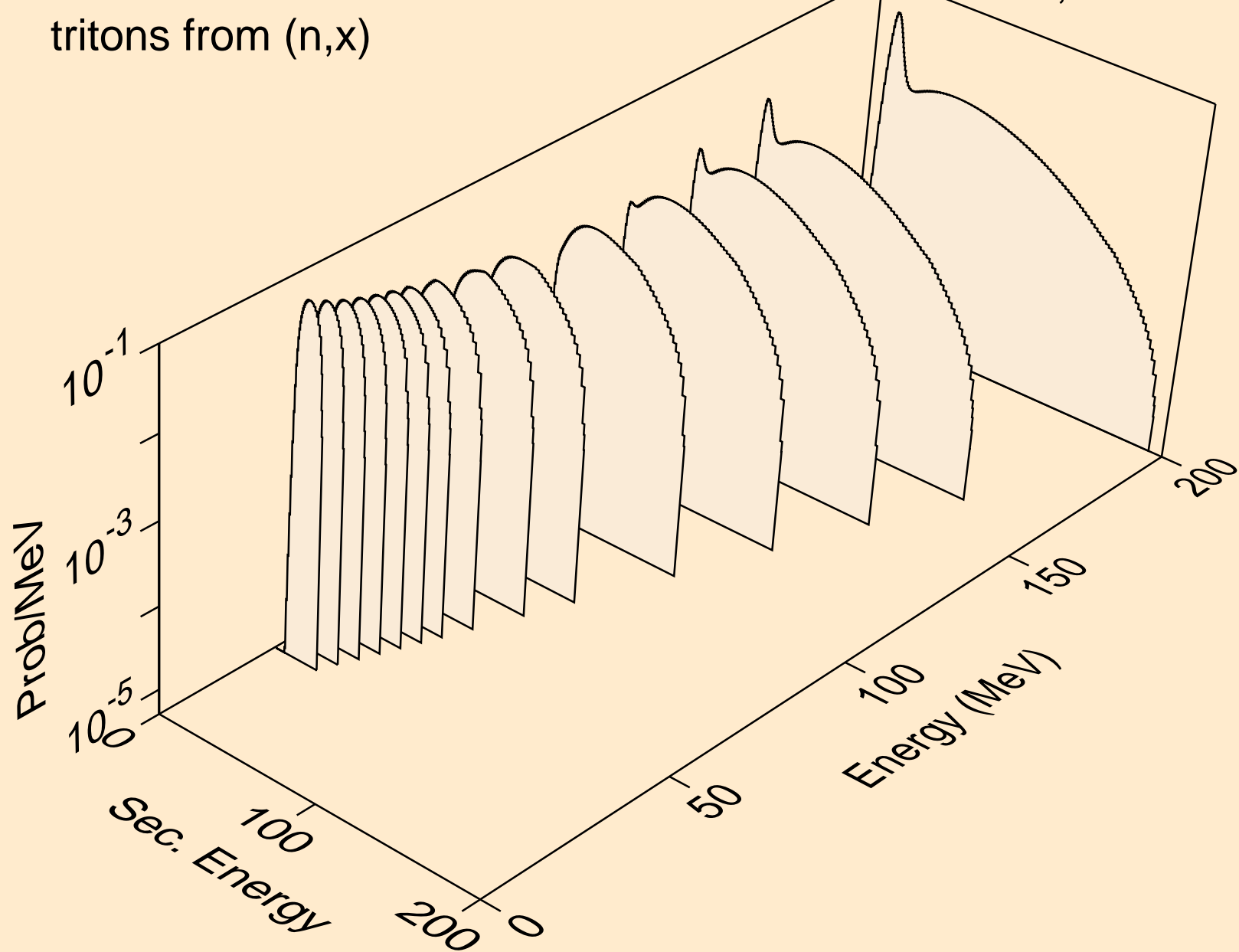

PB185M NEUTRON ACER TENDL-2024 LIBRARY; T=0.K  
tritons from (n,n\*)t

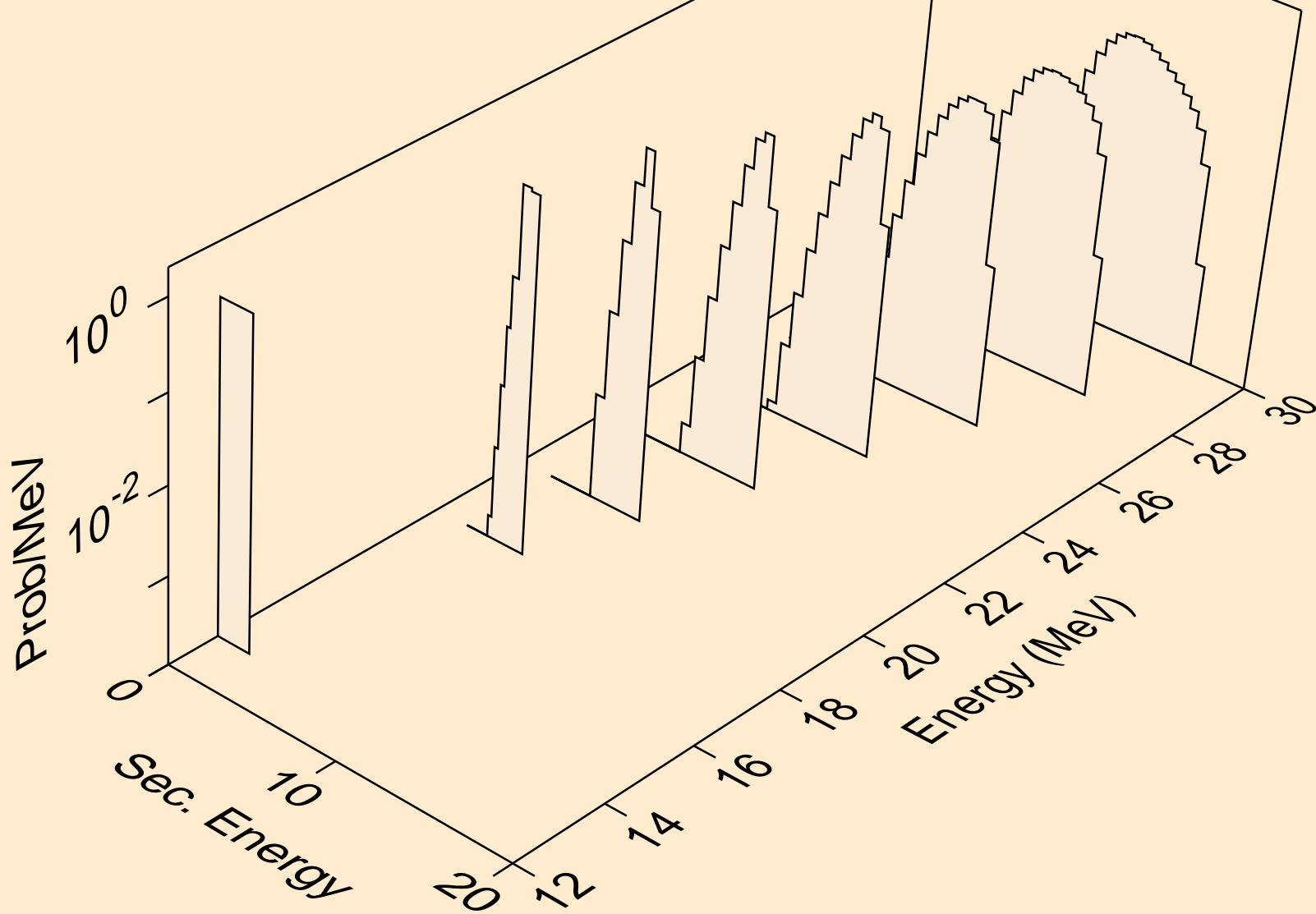

PB185M NEUTRON ACER TENDL-2024 LIBRARY; T=0.K  
tritons from (n,t)

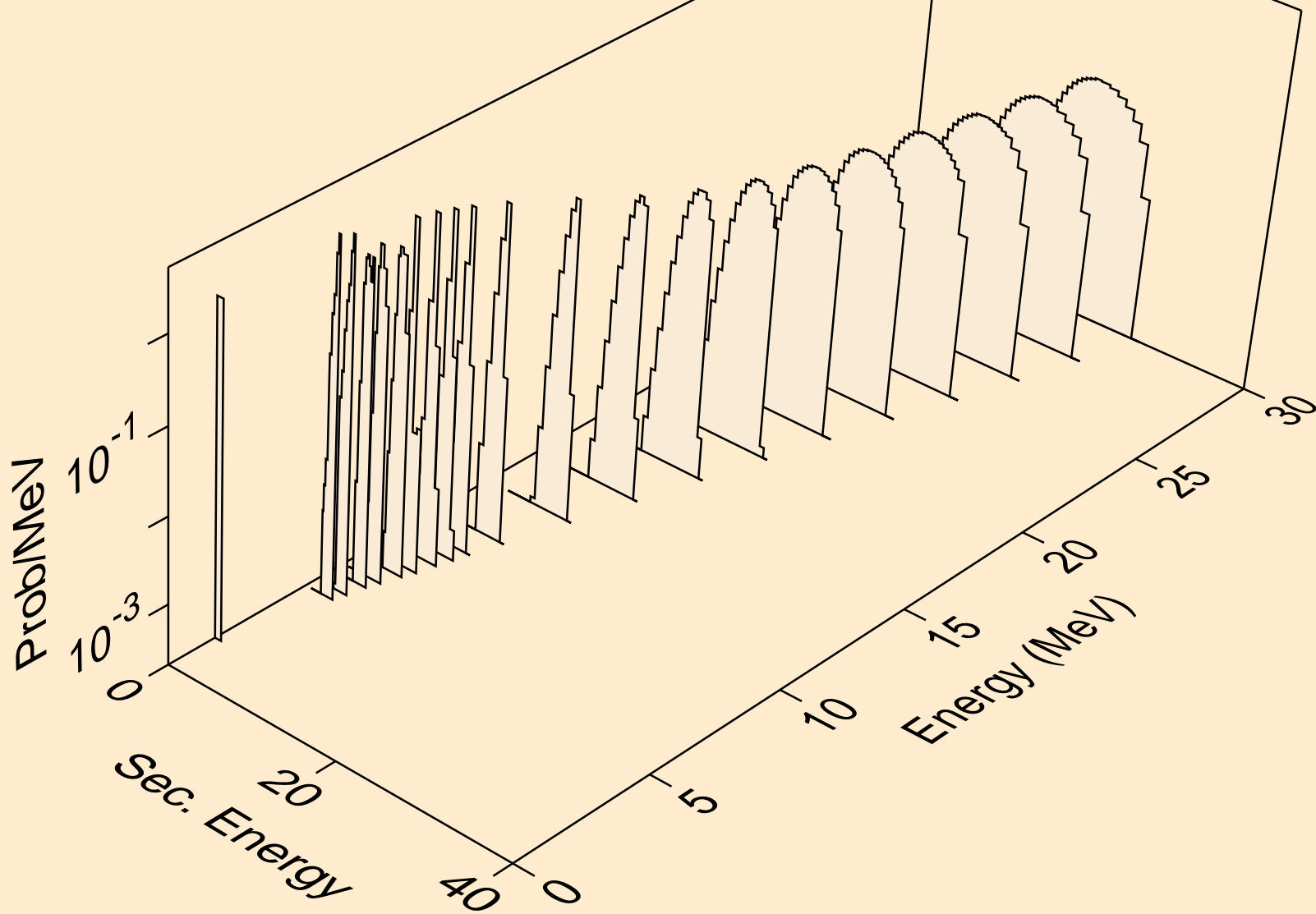



PB185M NEUTRON ACER TENDL-2024 LIBRARY; T=0.K  
tritons from (n,pt)

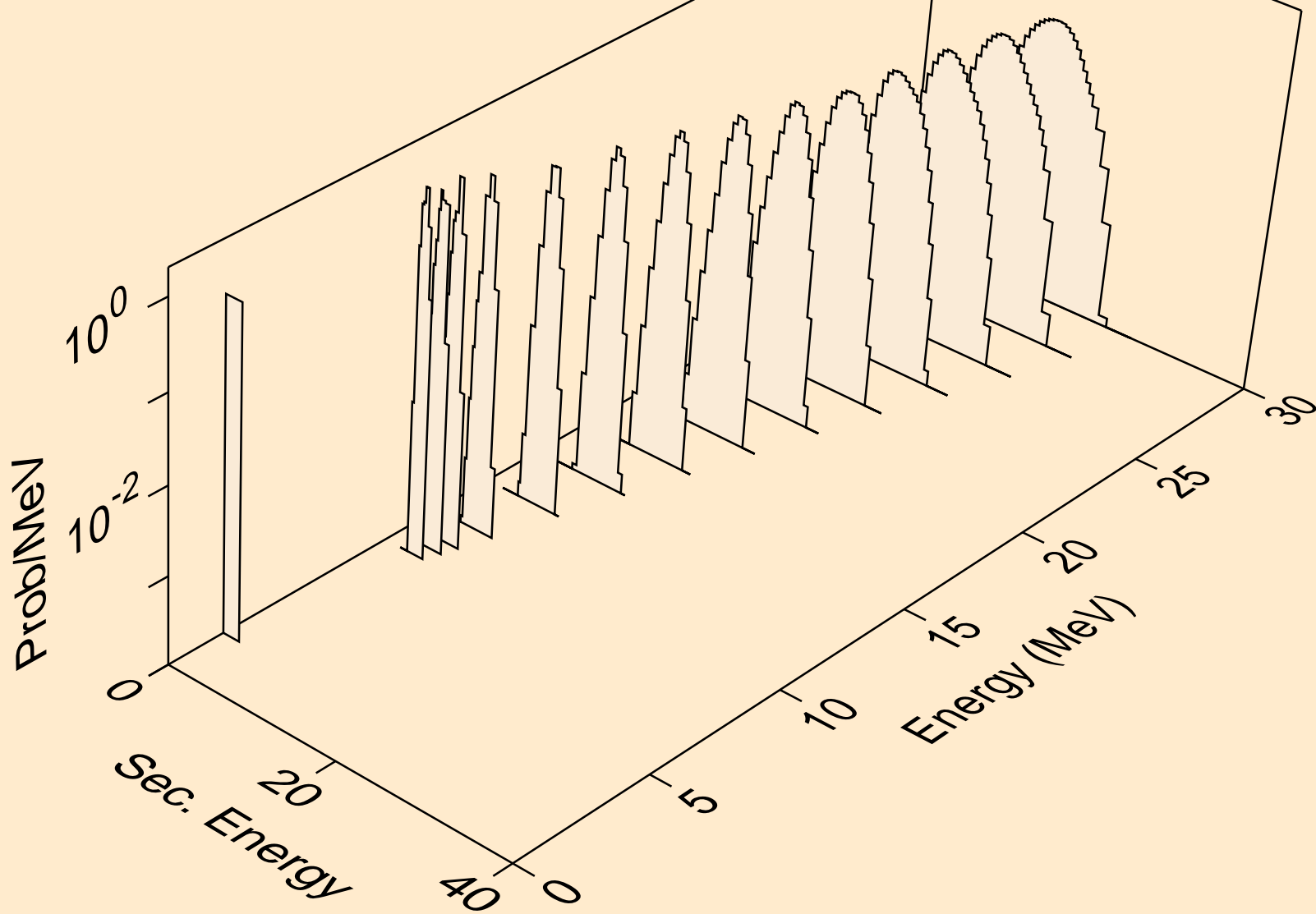

PB185M NEUTRON ACER TENDL-2024 LIBRARY; T=0.K  
he3s from (n,x)

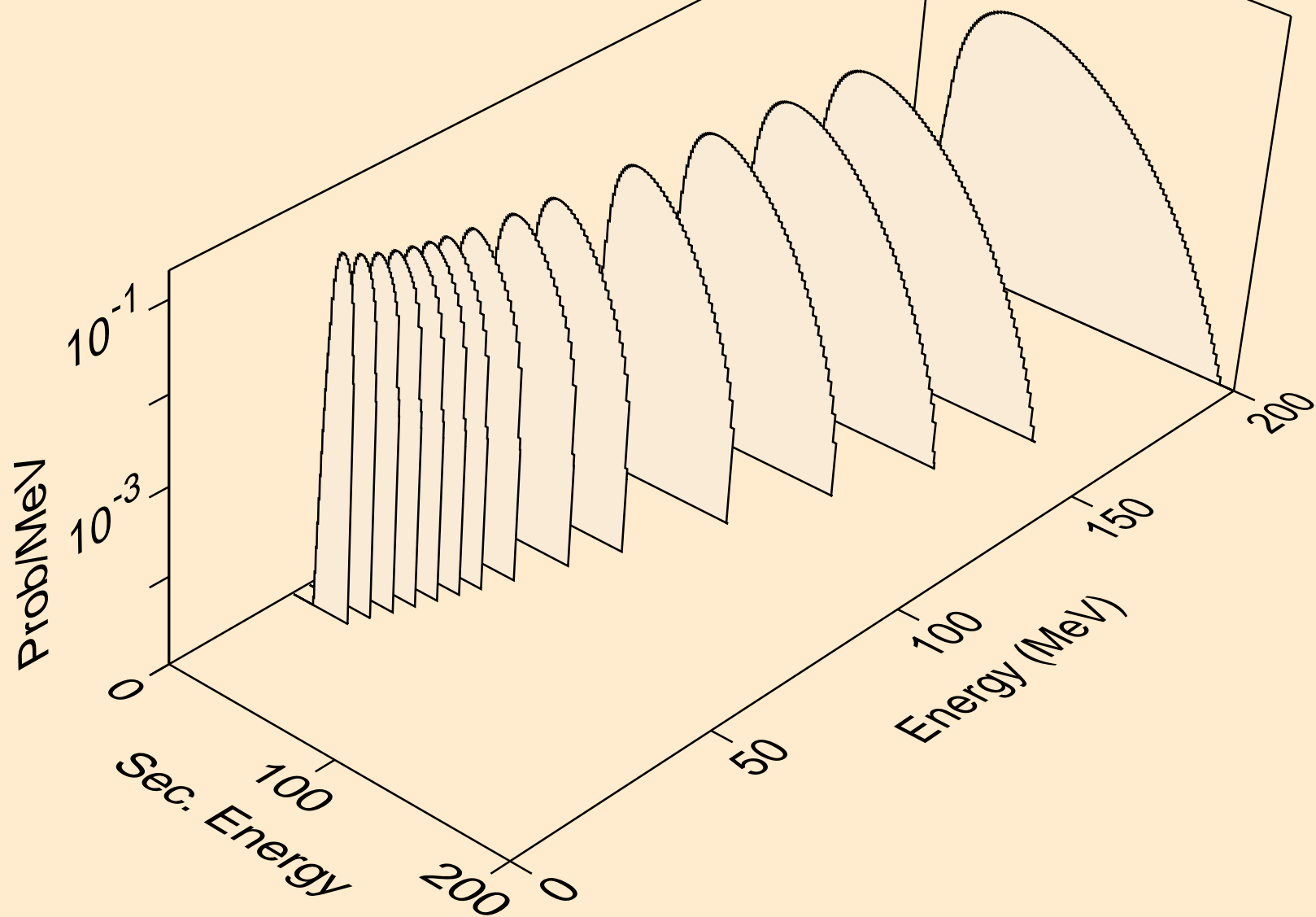

PB185M NEUTRON ACER TENDL-2024 LIBRARY; T=0.K  
he3s from (n,n\*)he3

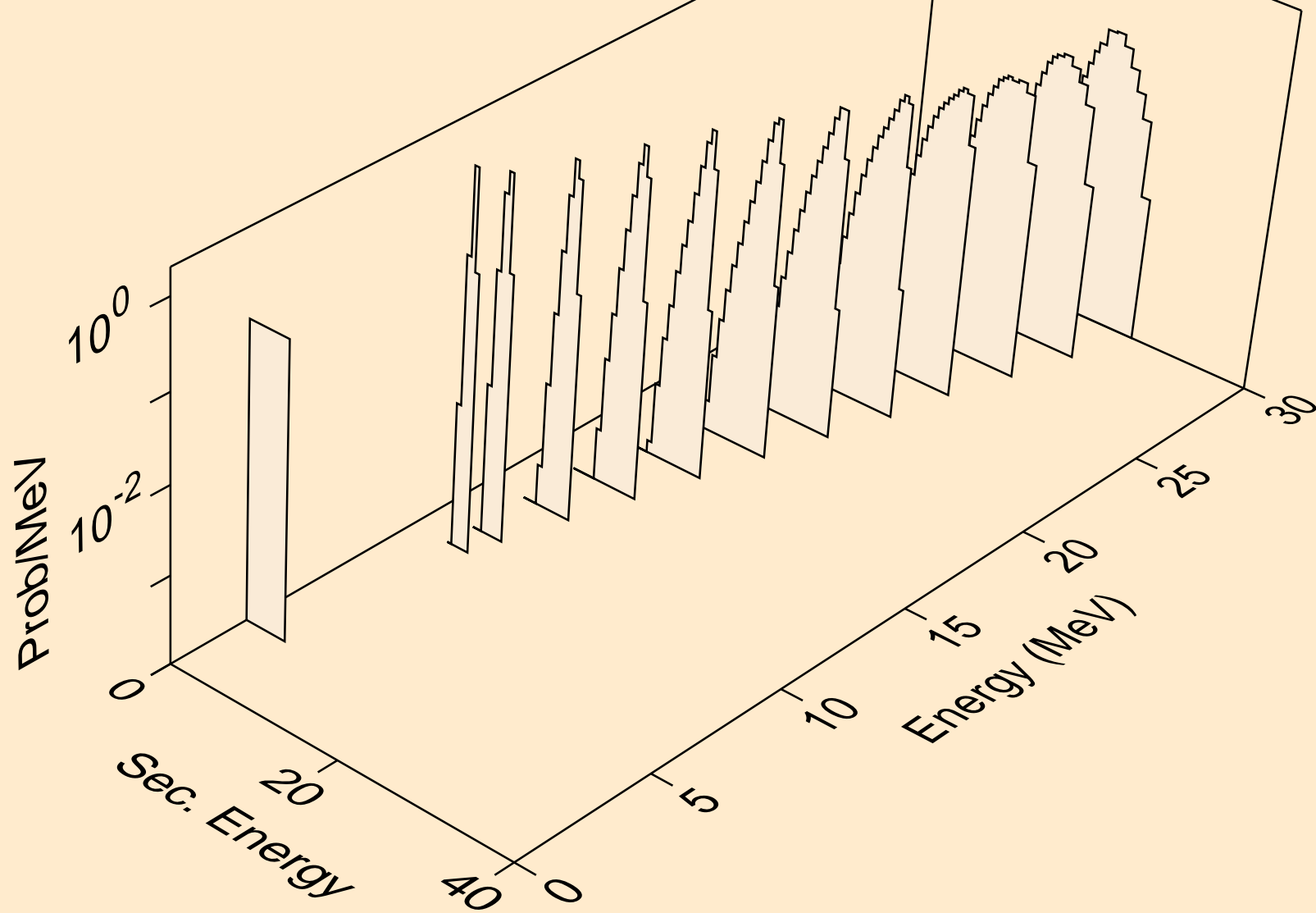

PB185M NEUTRON ACER TENDL-2024 LIBRARY; T=0.K  
he3s from (n,he3)

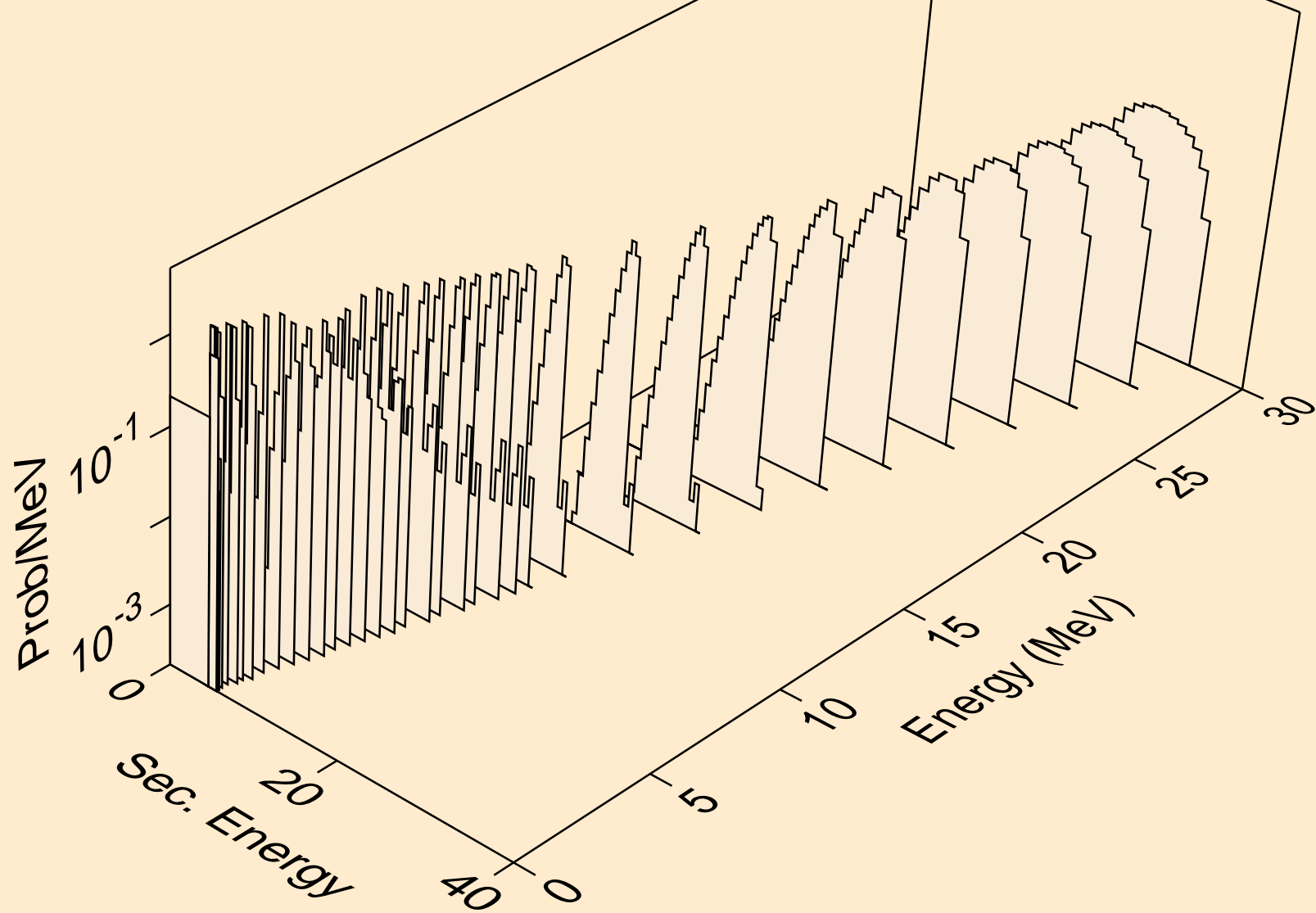

PB185M NEUTRON ACER TENDL-2024 LIBRARY; T=0.K  
alphas from (n,x)

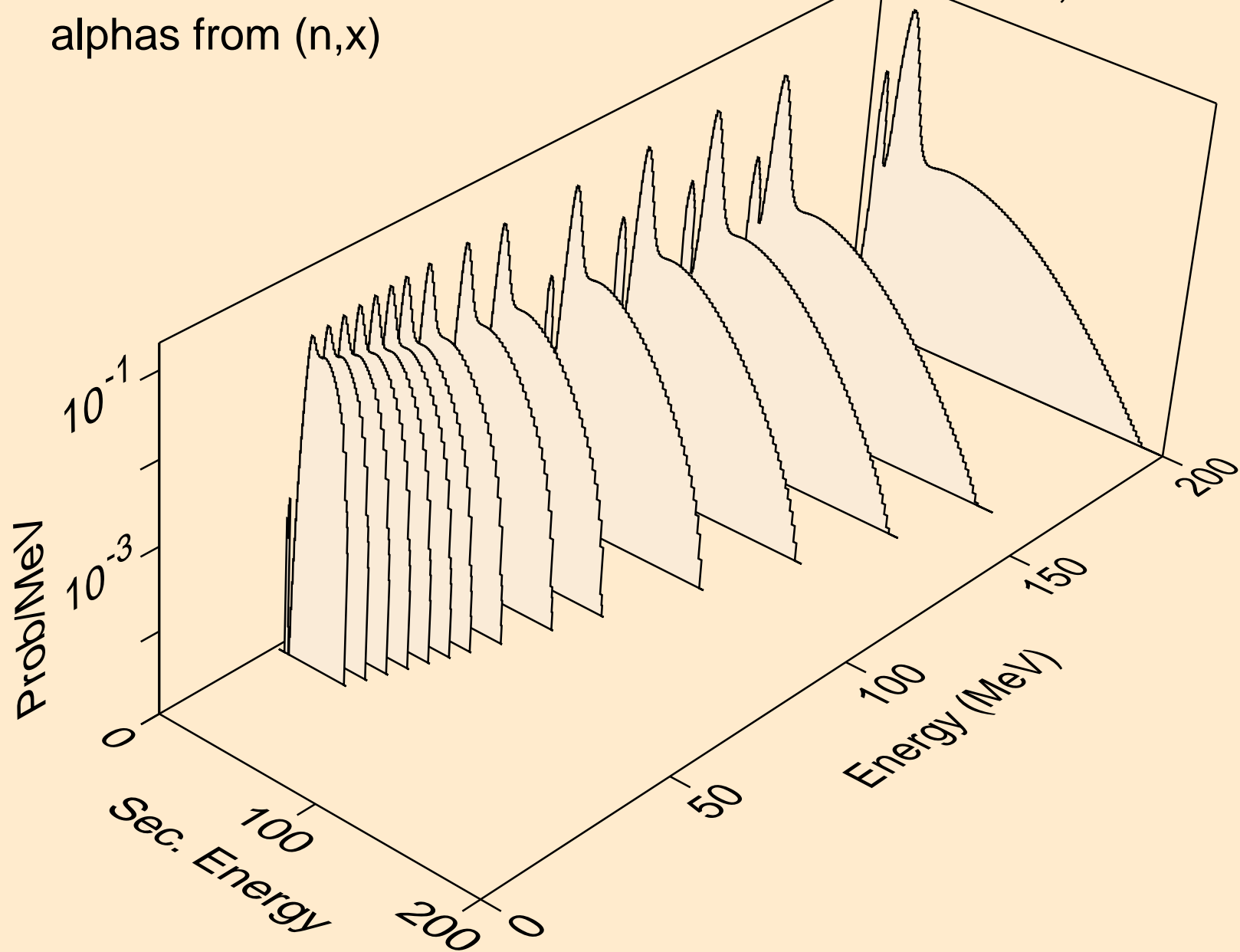

PB185M NEUTRON ACER TENDL-2024 LIBRARY; T=0.K  
alphas from (n,n\*)a

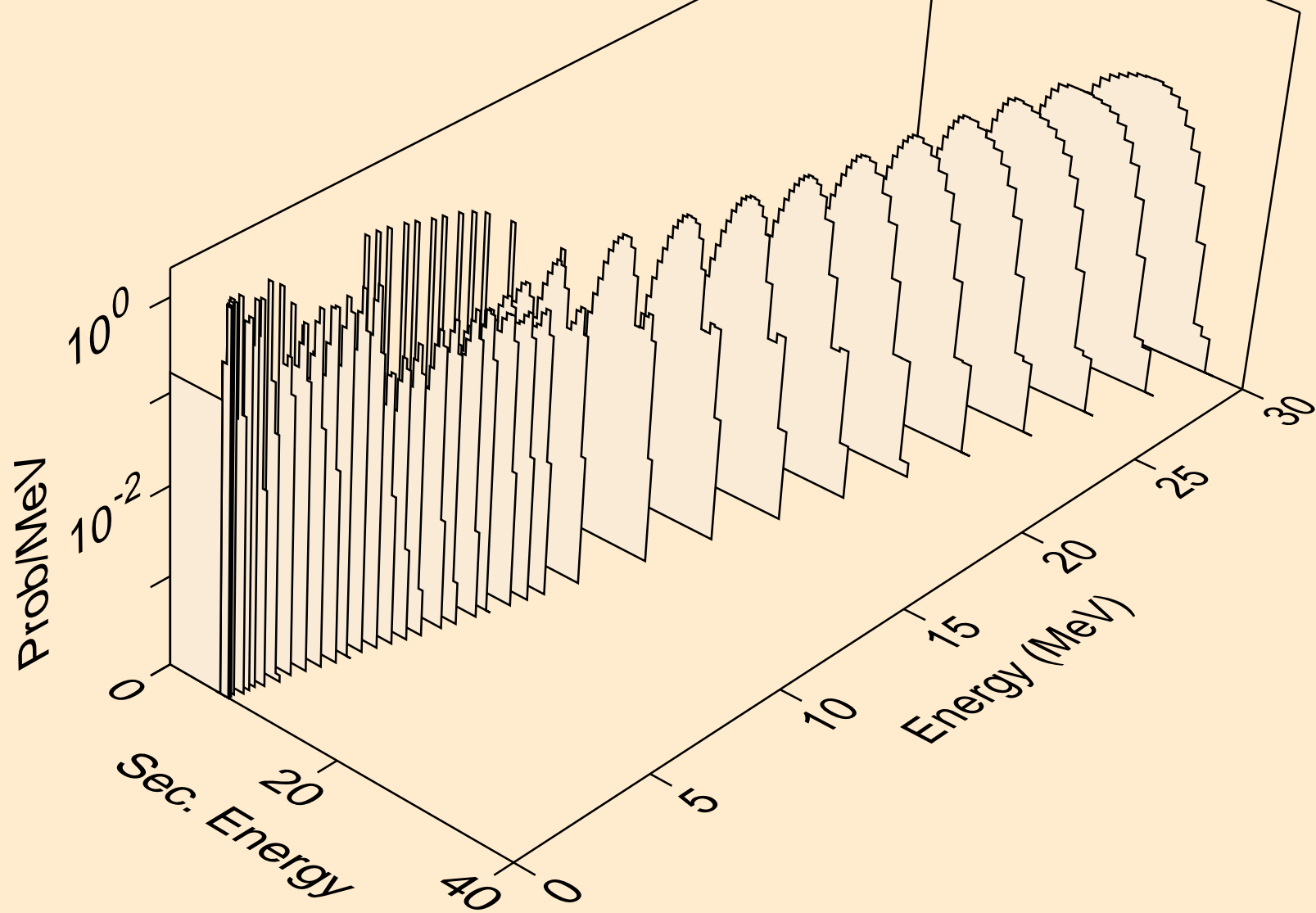

PB185M NEUTRON ACER TENDL-2024 LIBRARY; T=0.K  
alphas from (n,n\*)3a

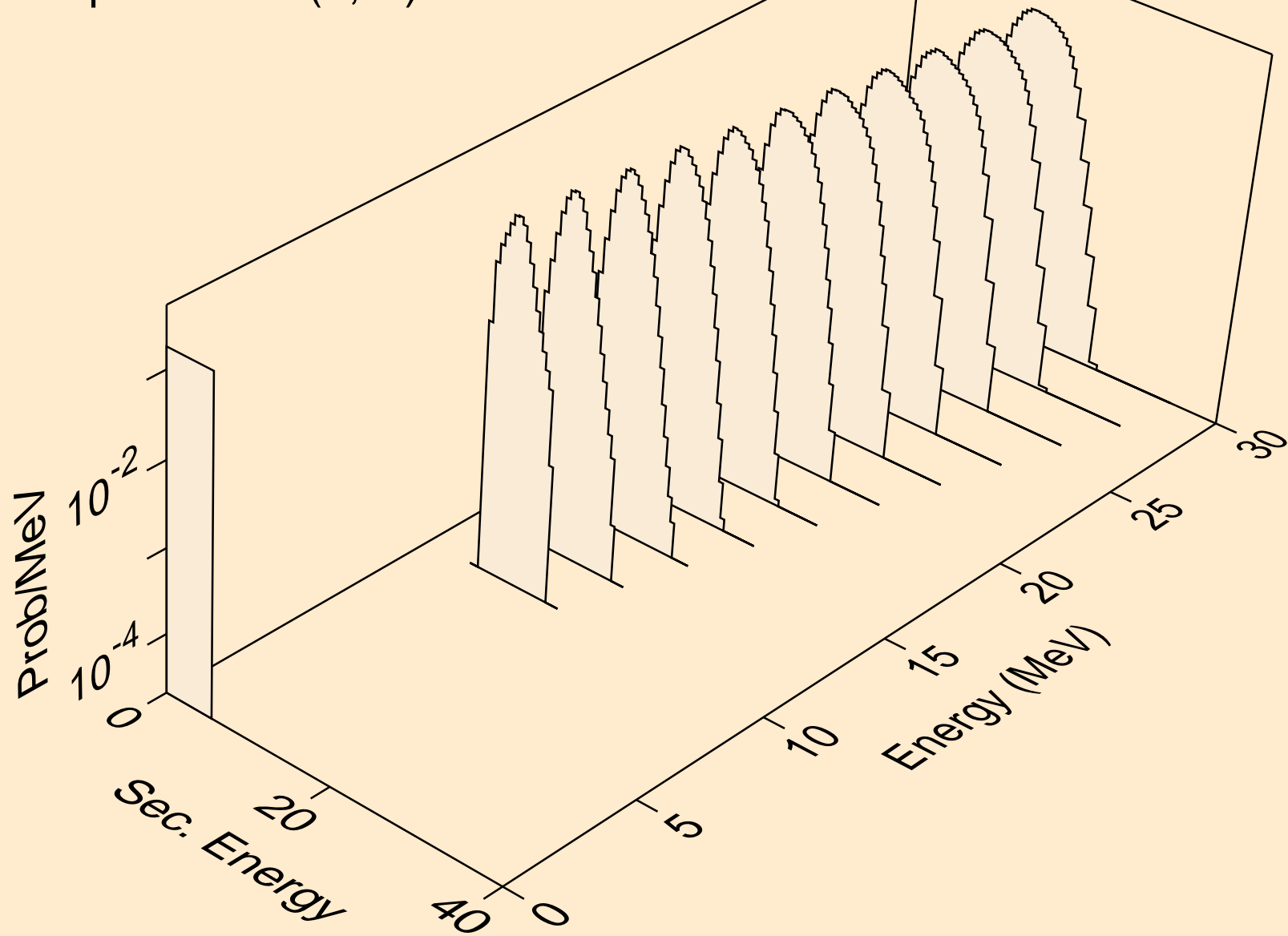

PB185M NEUTRON ACER TENDL-2024 LIBRARY; T=0.K  
alphas from (n,2n)a

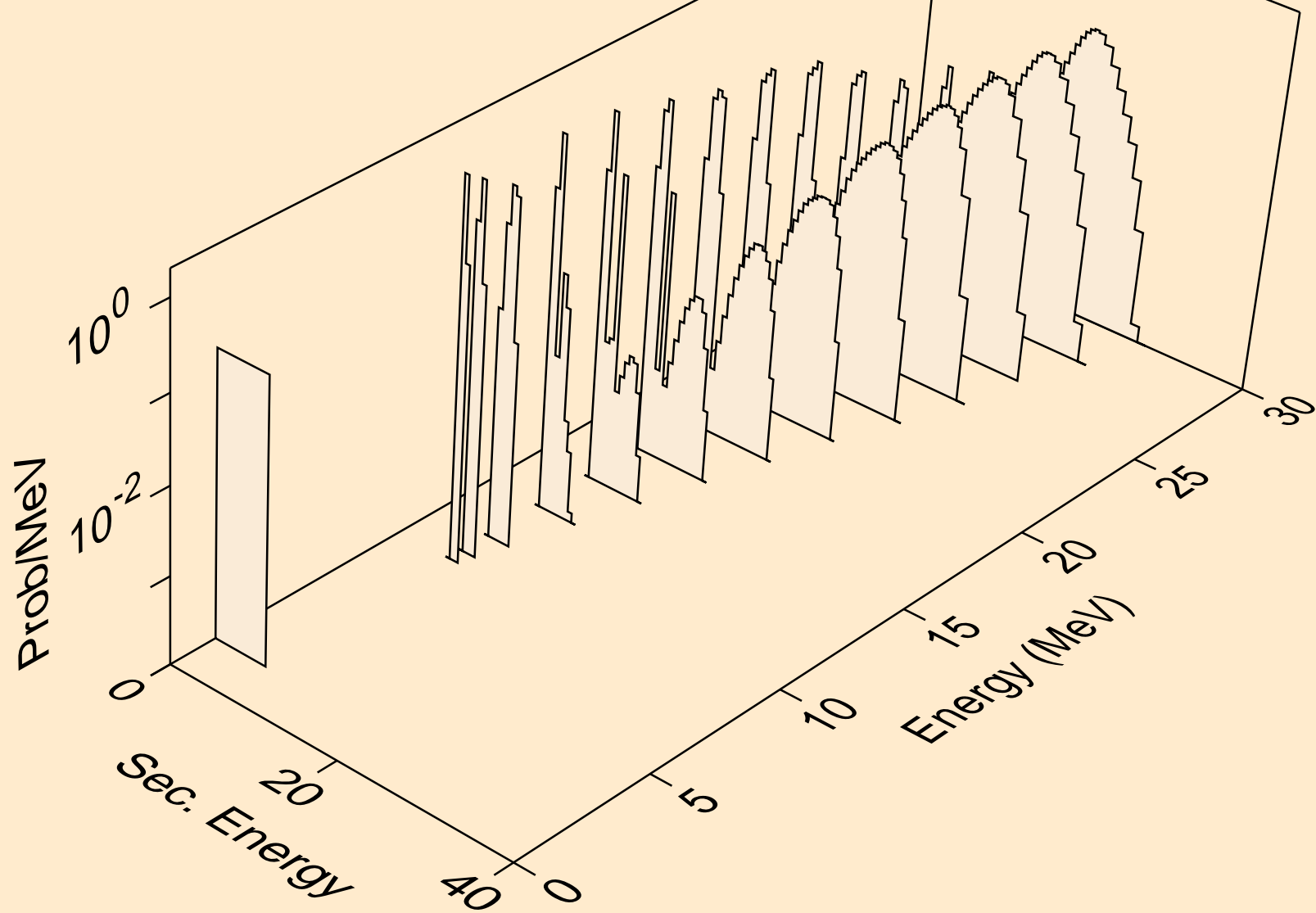



PB185M NEUTRON ACER TENDL-2024 LIBRARY; T=0.K  
alphas from (n,3n)a

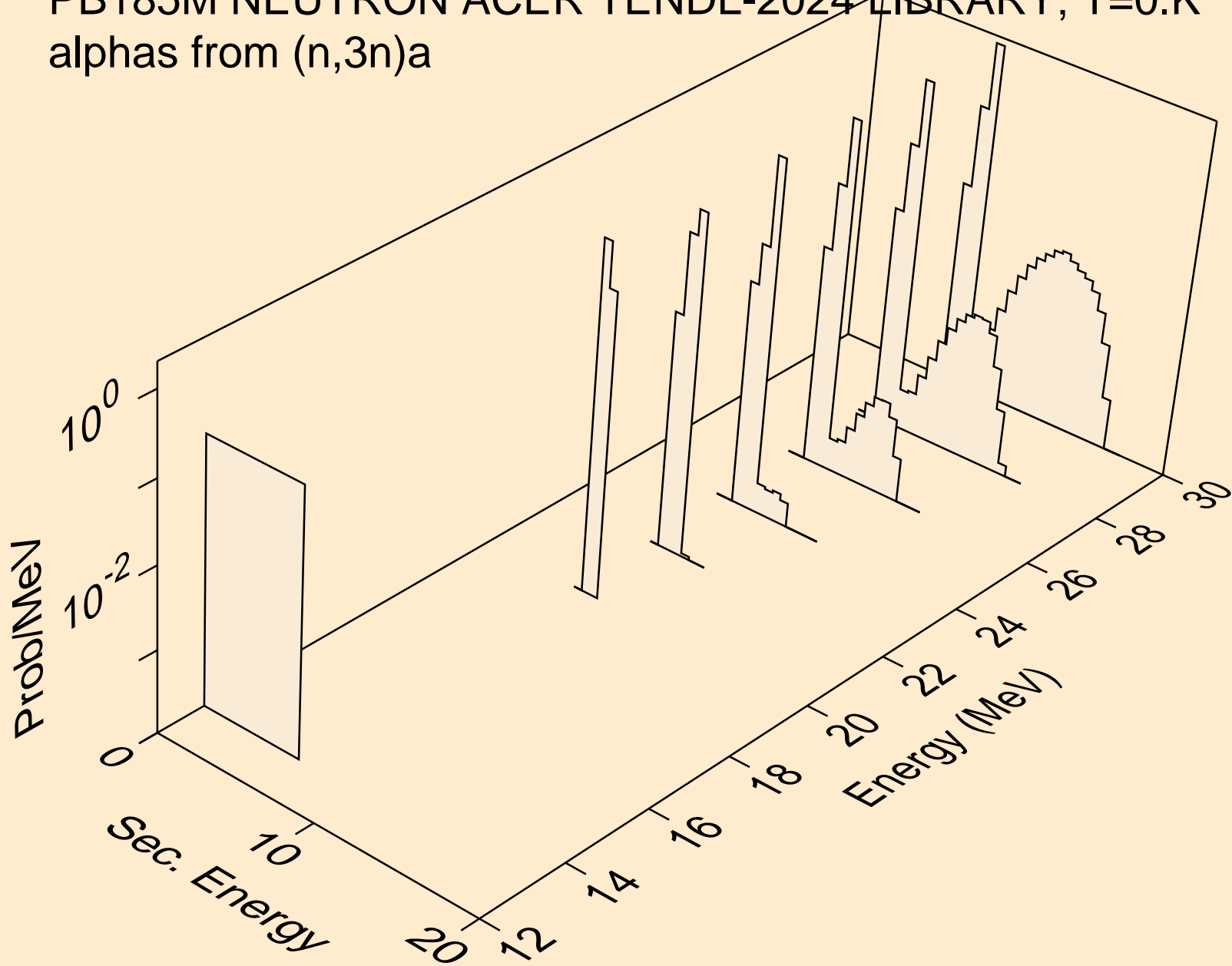

PB185M NEUTRON ACER TENDL-2024 LIBRARY; T=0.K  
alphas from (n,n\*)2a

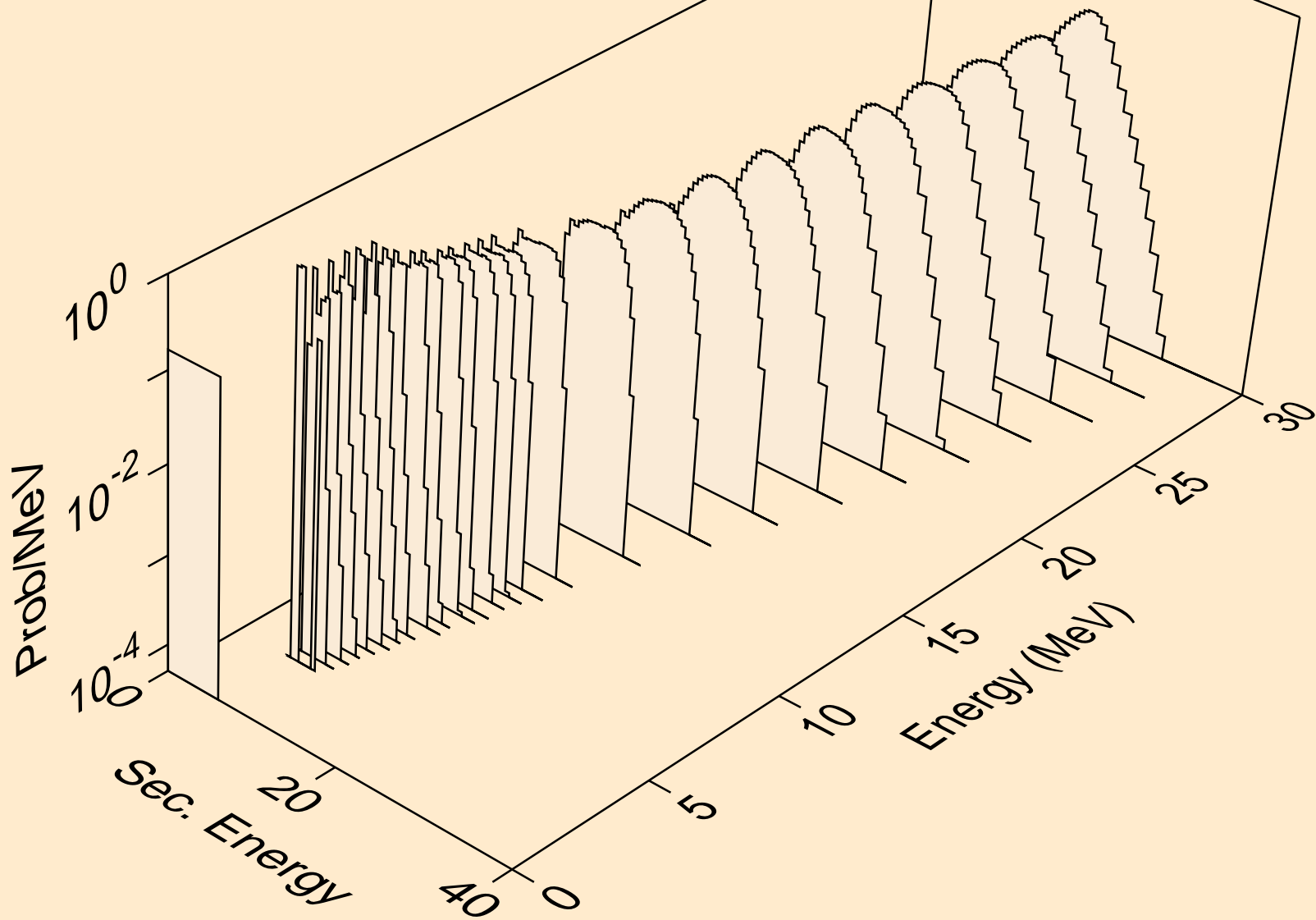

PB185M NEUTRON ACER TENDL-2024 LIBRARY; T=0.K  
alphas from (n,2n)2a

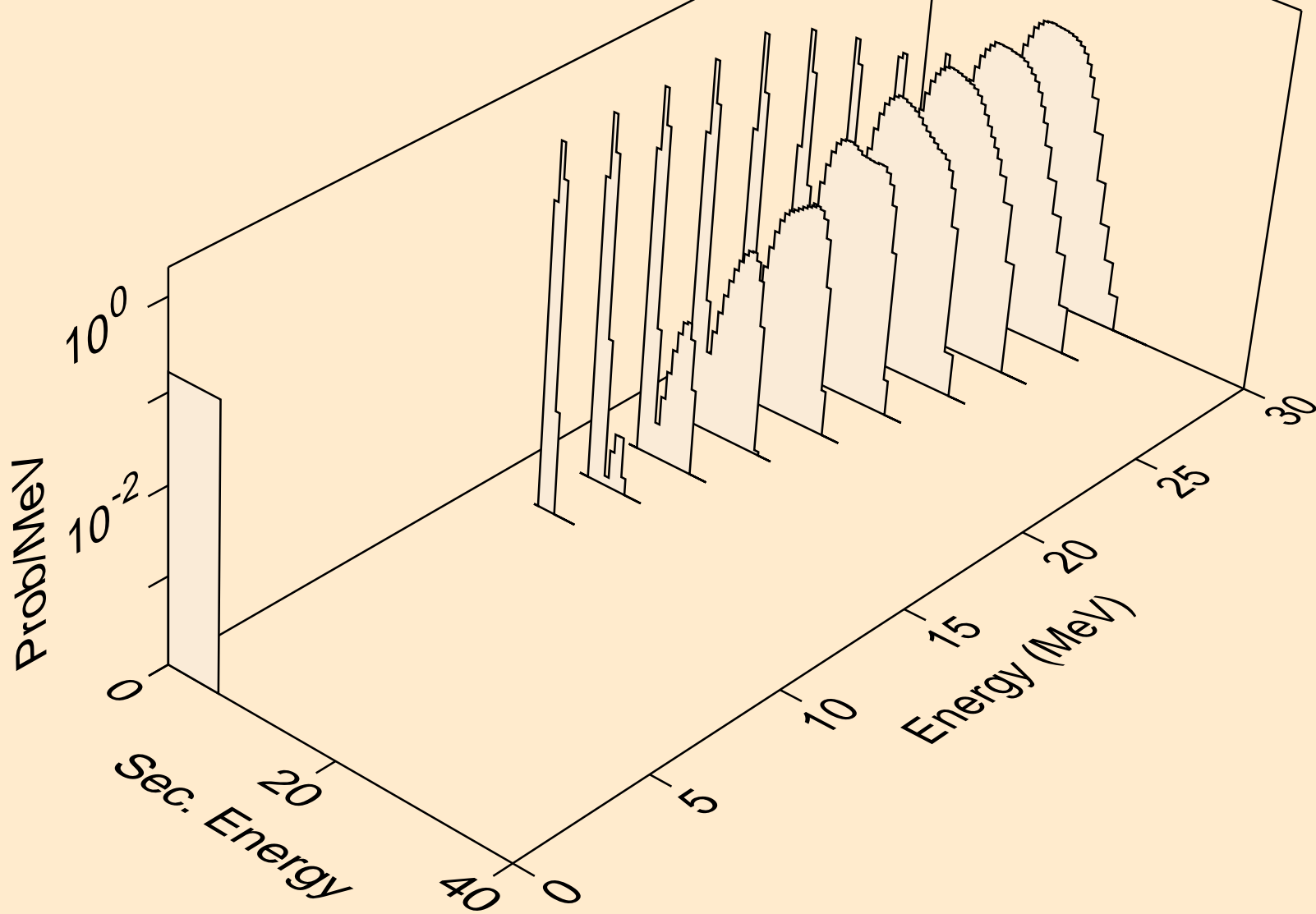

PB185M NEUTRON ACER TENDL-2024 LIBRARY; T=0.K  
alphas from (n,npa)

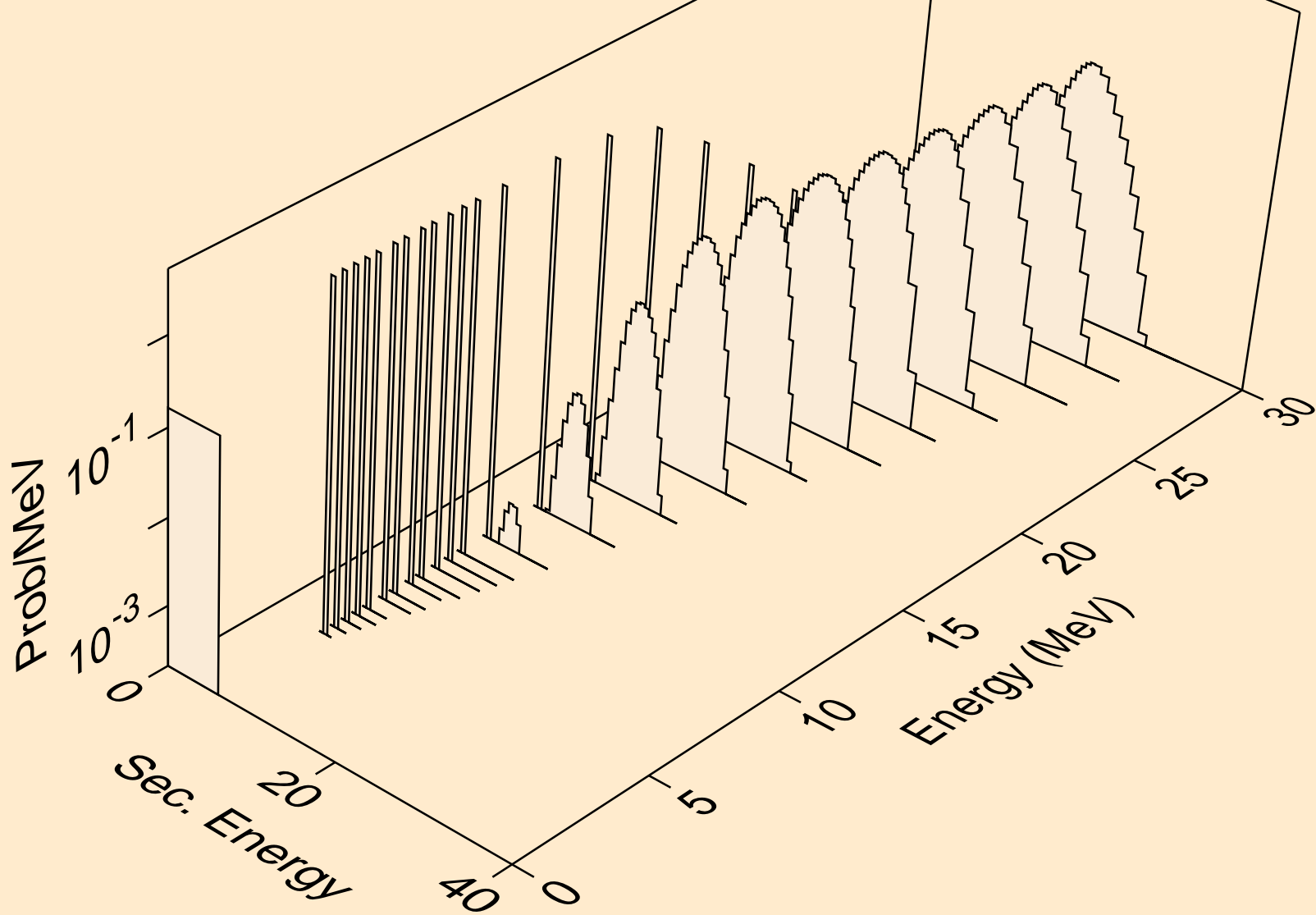

PB185M NEUTRON ACER TENDL-2024 LIBRARY; T=0.K  
alphas from (n,a)

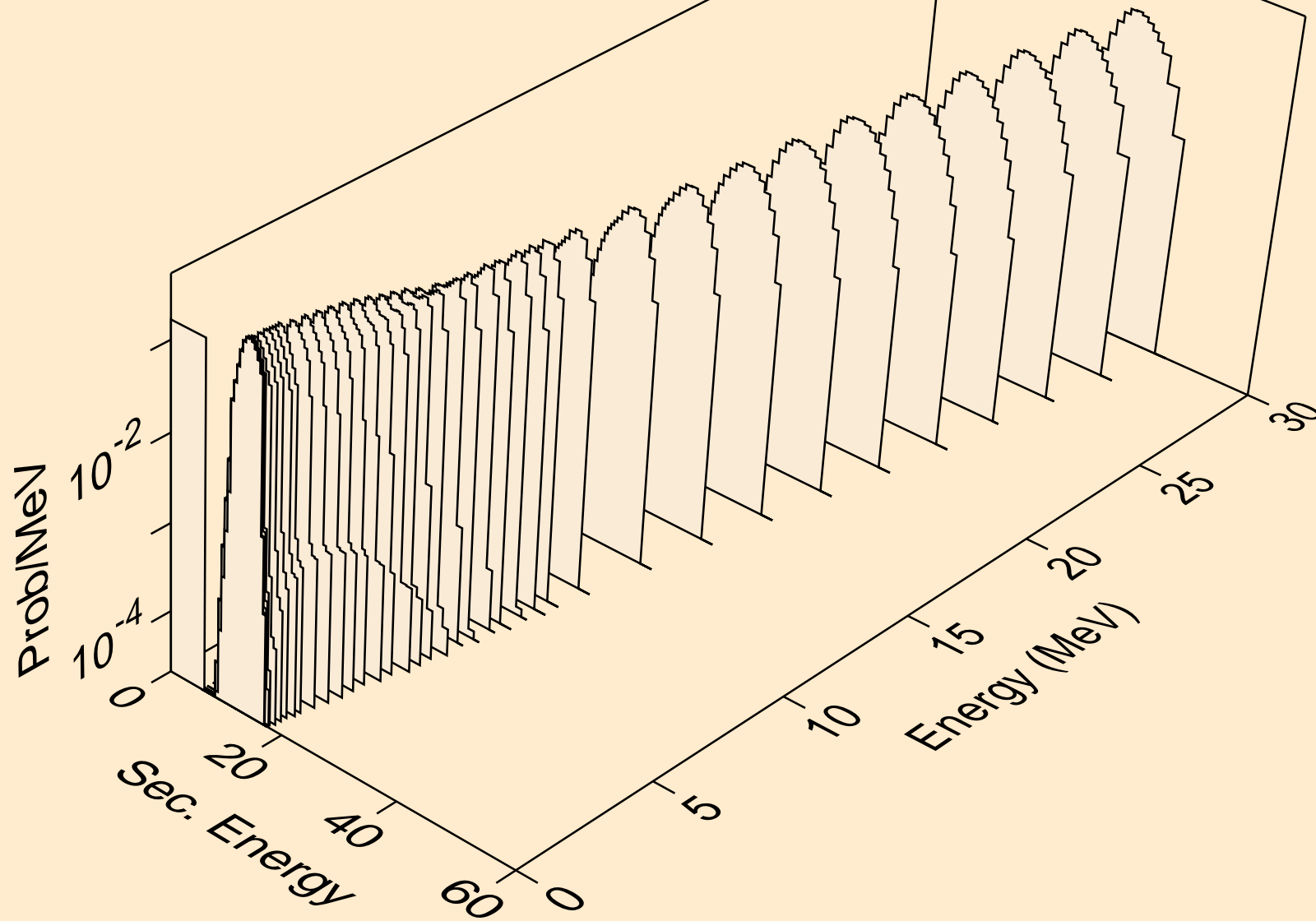

PB185M NEUTRON ACER TENDL-2024 LIBRARY; T=0.K  
alphas from (n,2a)

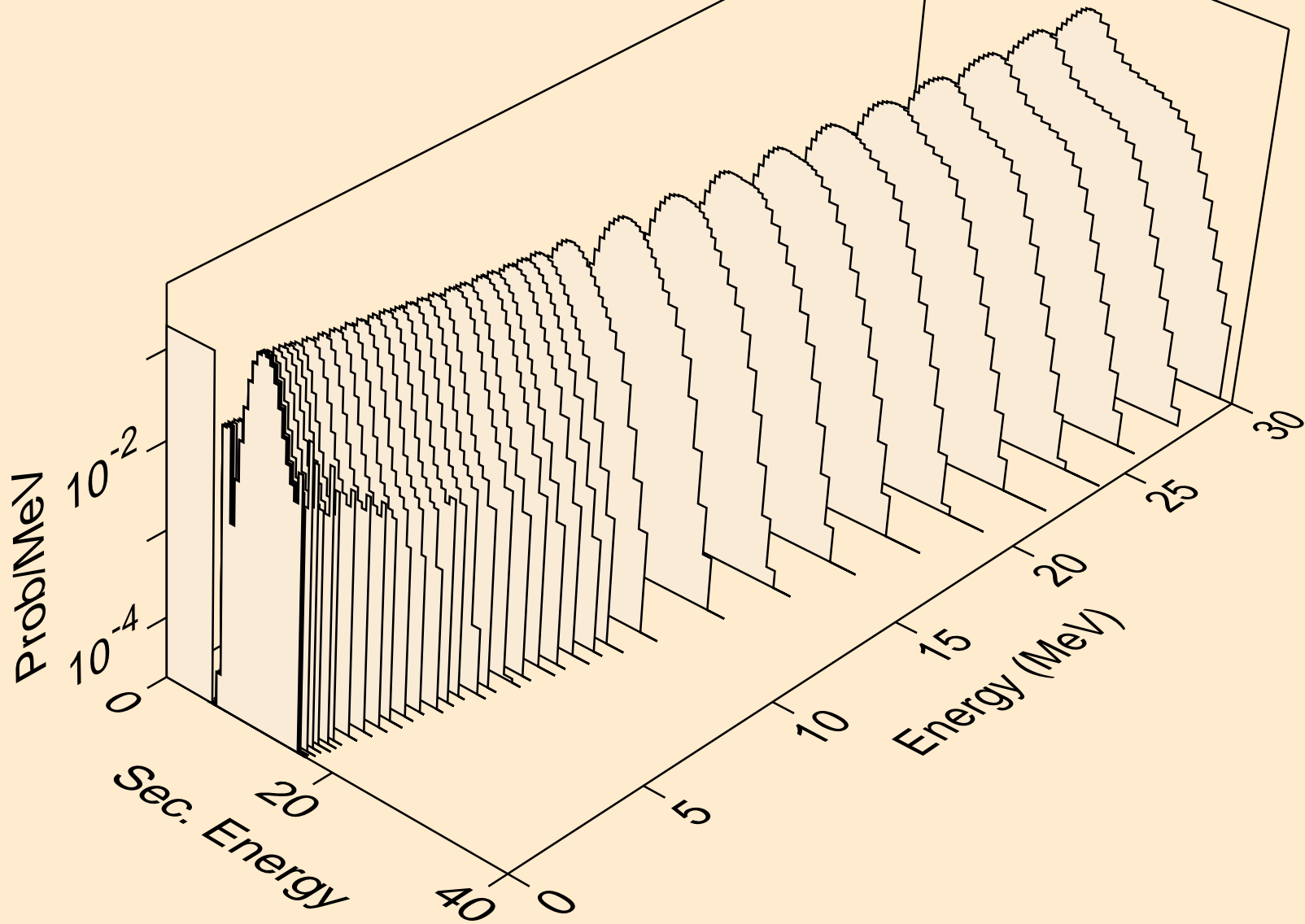

PB185M NEUTRON ACER TENDL-2024 LIBRARY; T=0.K  
alphas from (n,3a)

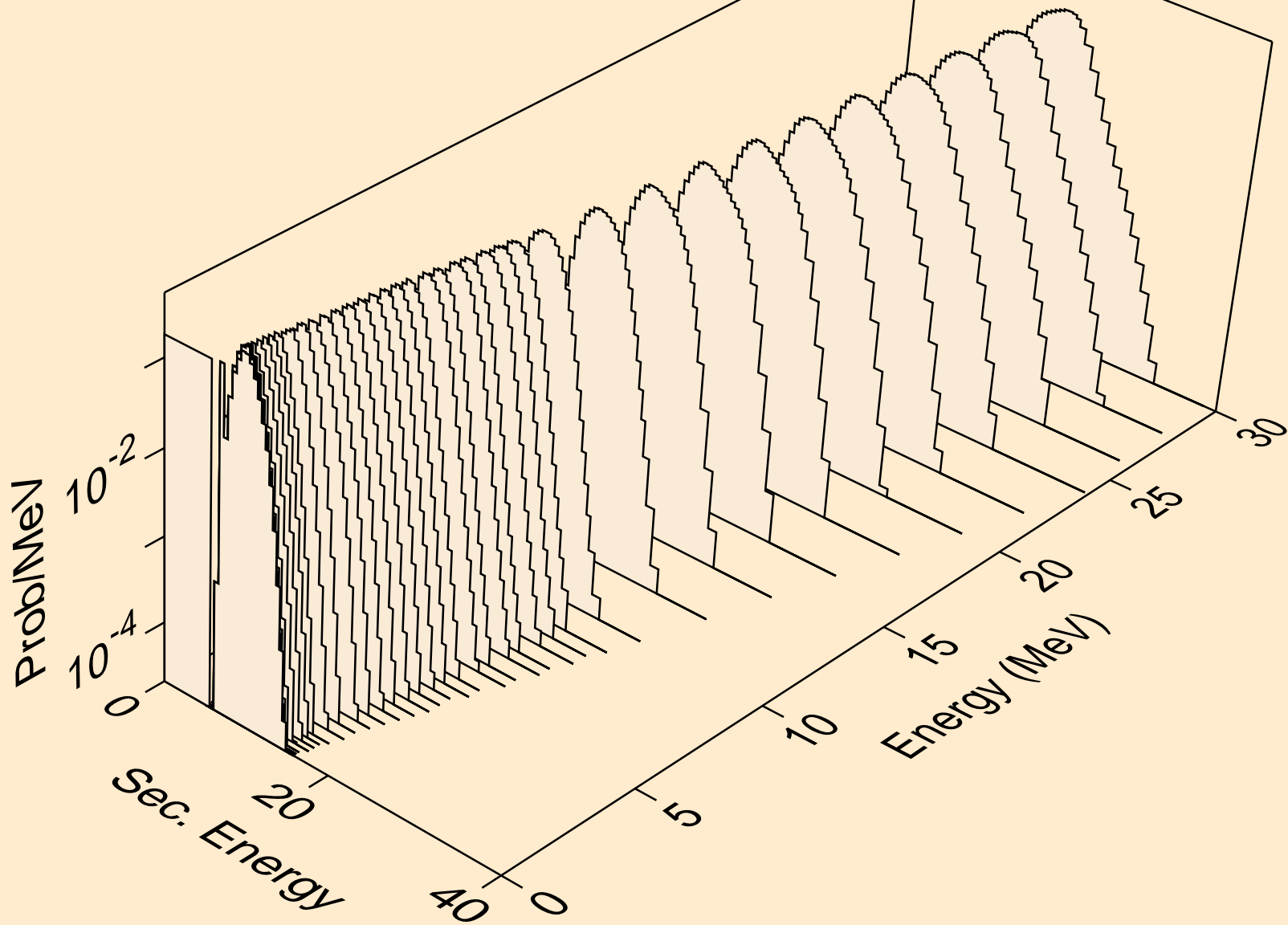

PB185M NEUTRON ACER TENDL-2024 LIBRARY; T=0.K  
alphas from (n,pa)

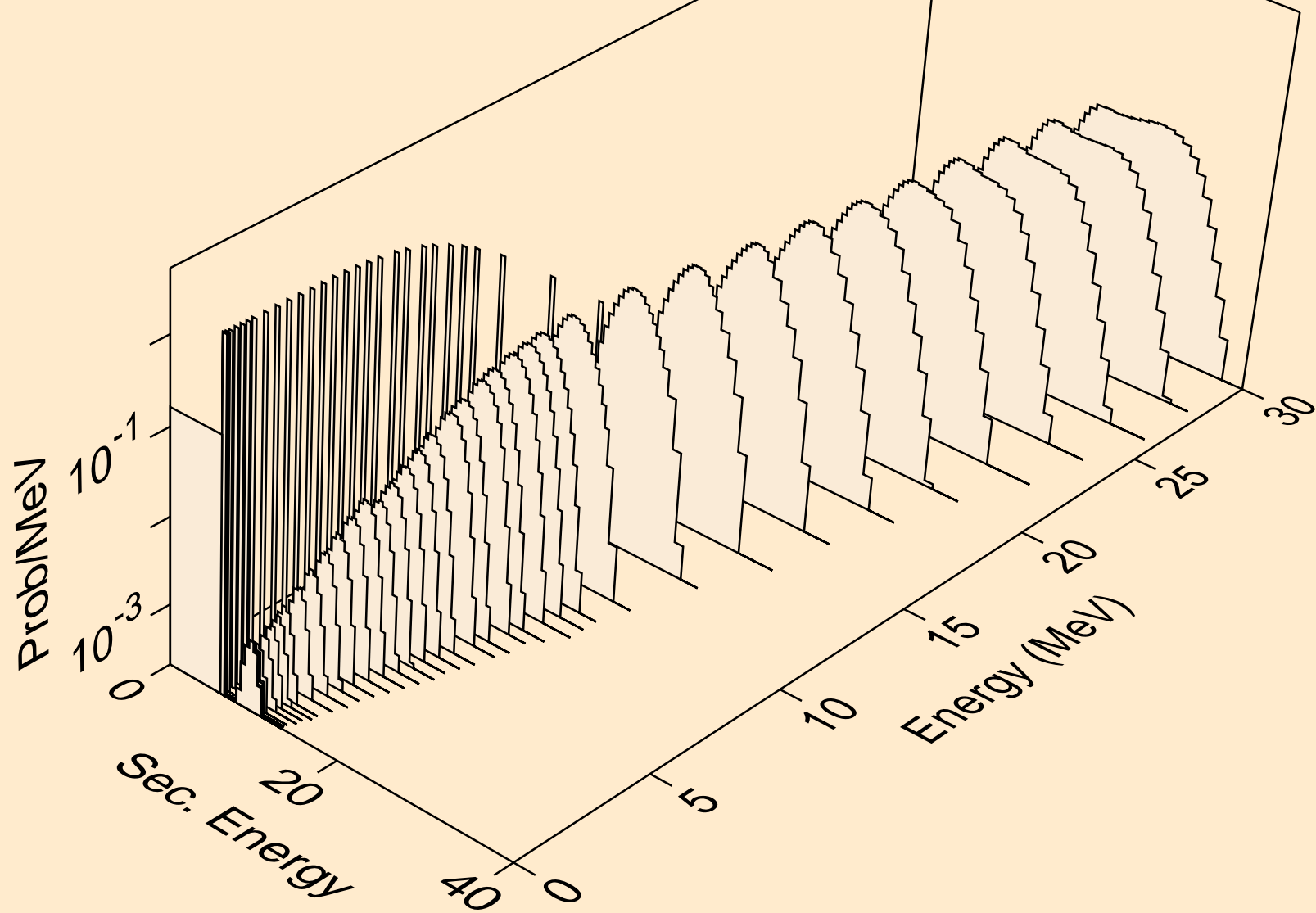



PB185M NEUTRON ACER TENDL-2024 LIBRARY; T=0.K  
alphas from (n,d2a)

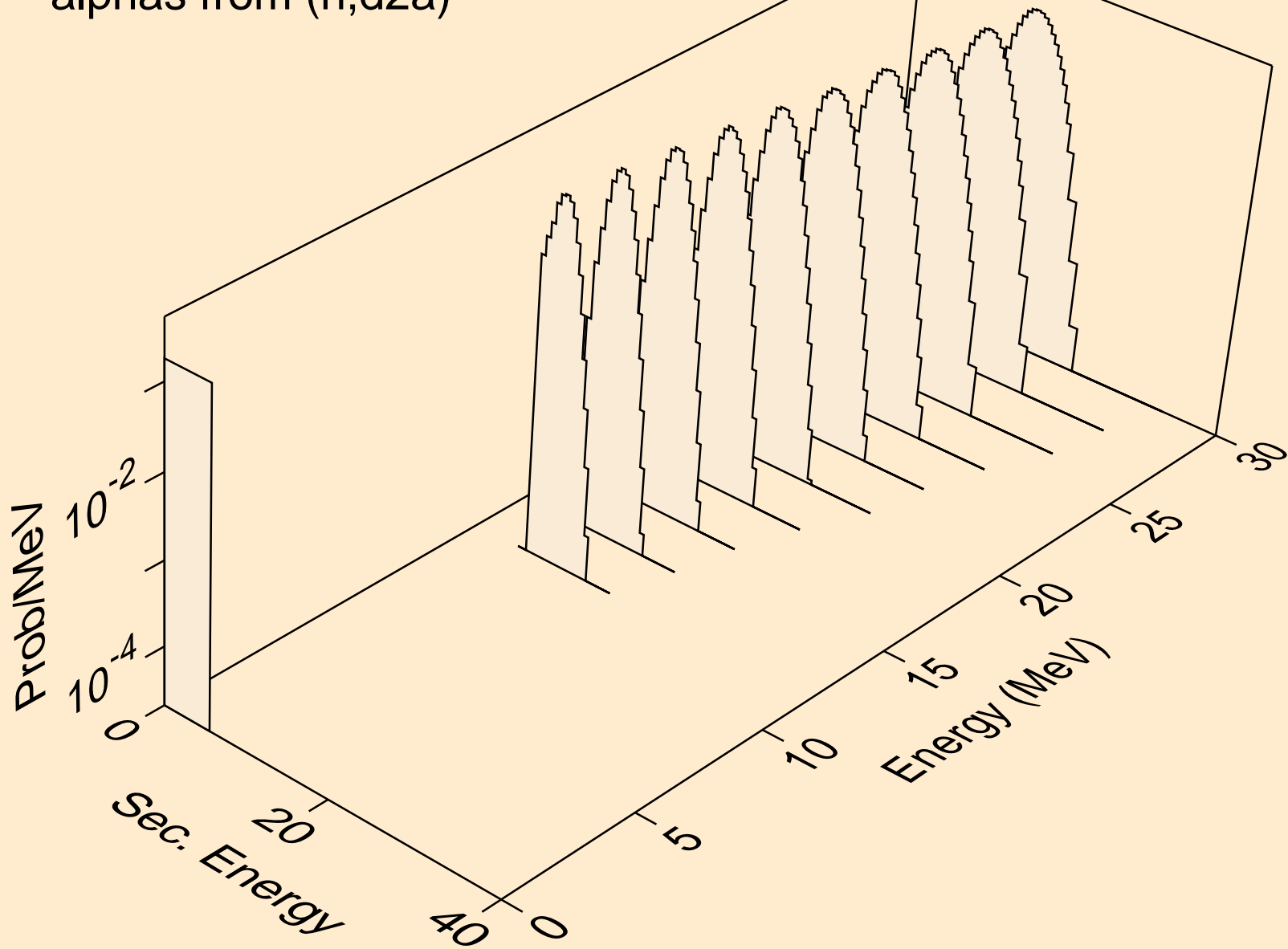

PB185M NEUTRON ACER TENDL-2024 LIBRARY; T=0.K  
alphas from (n,da)

