

# PD115M NEUTRON ACER TENDL-2024 LIBRARY; T=0.K

## Principal cross sections

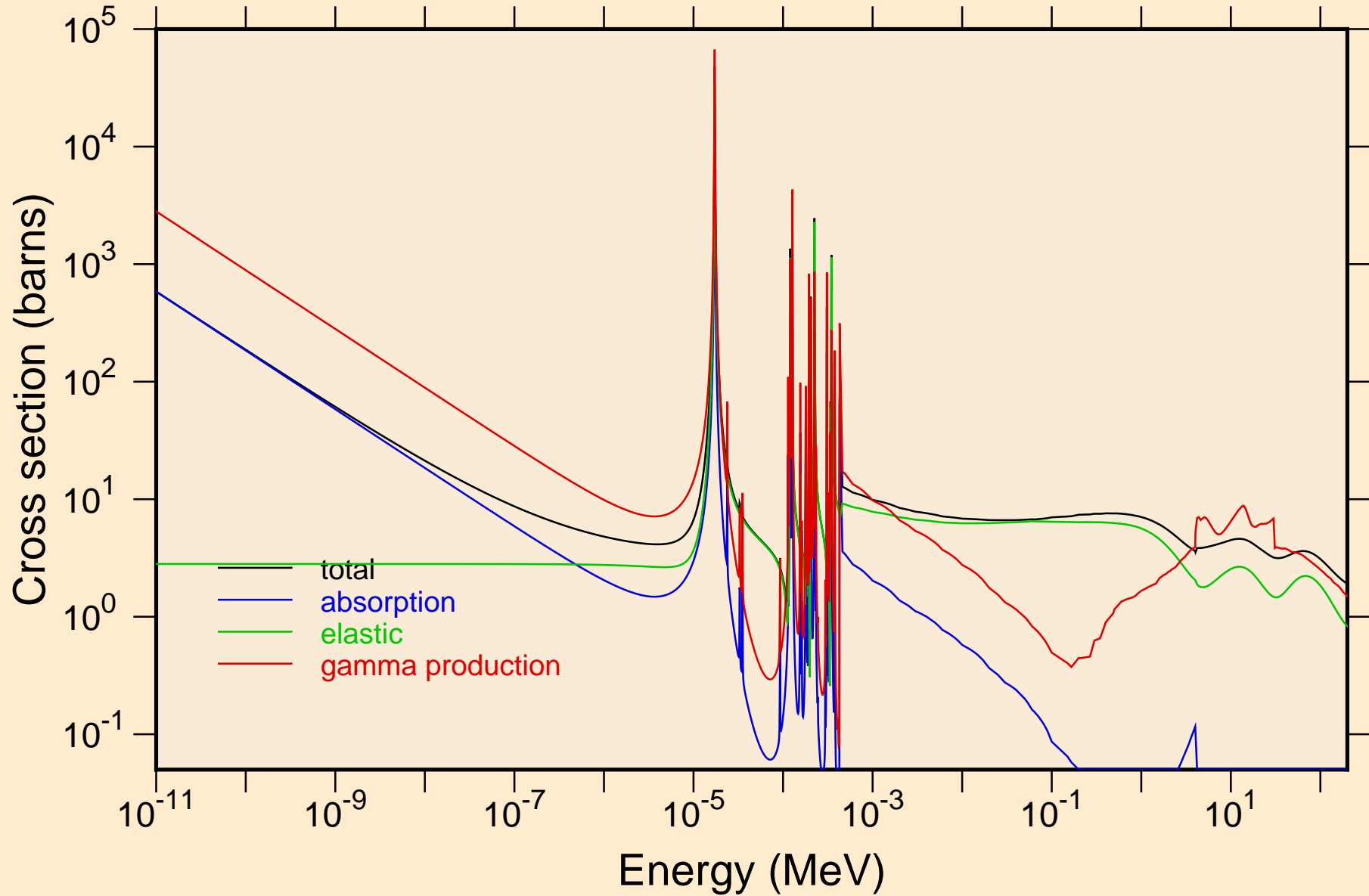

PD115M NEUTRON ACER TENDL-2024 LIBRARY; T=0.K  
resonance total cross section

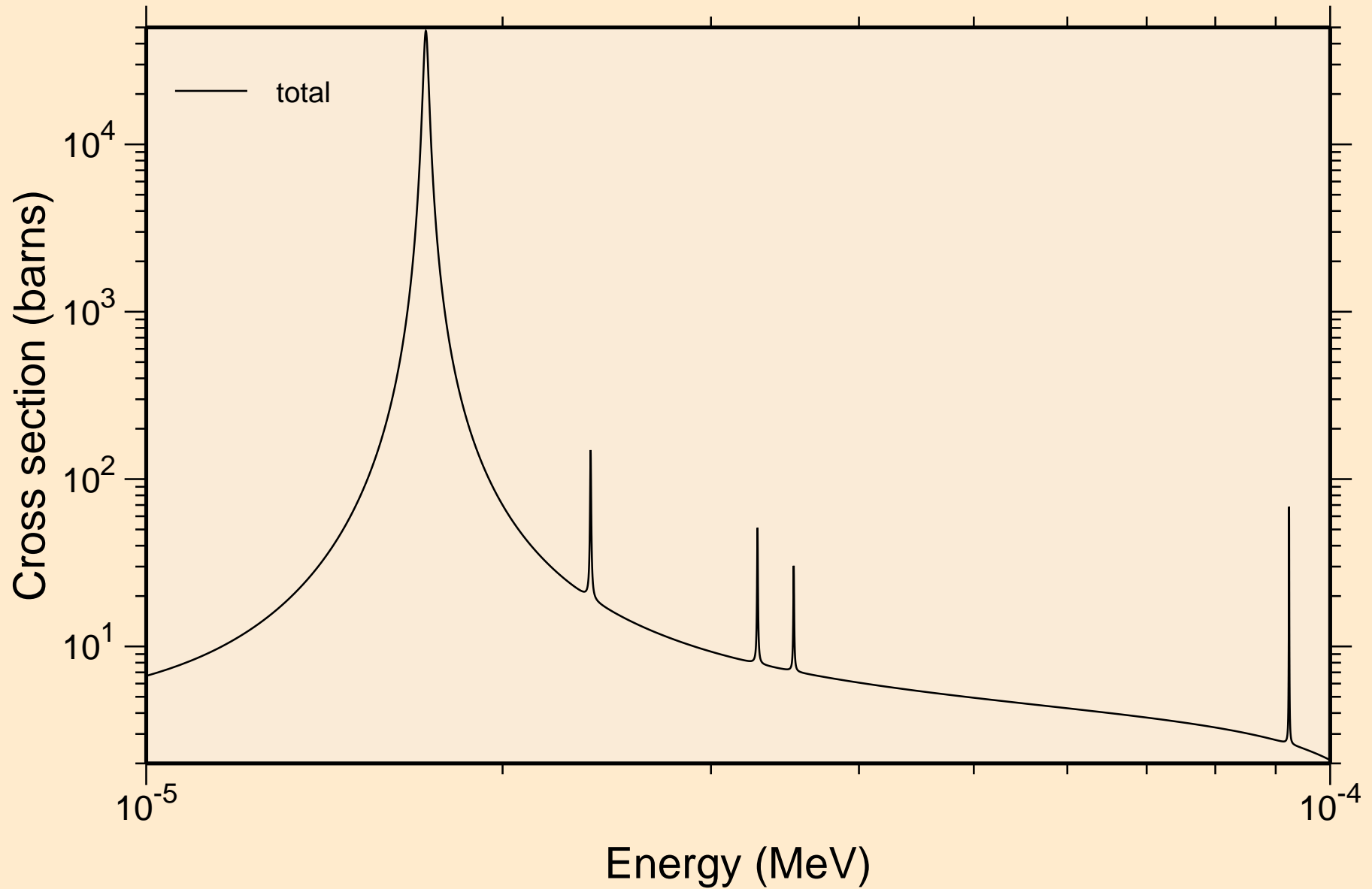

PD115M NEUTRON ACER TENDL-2024 LIBRARY; T=0.K  
resonance total cross section

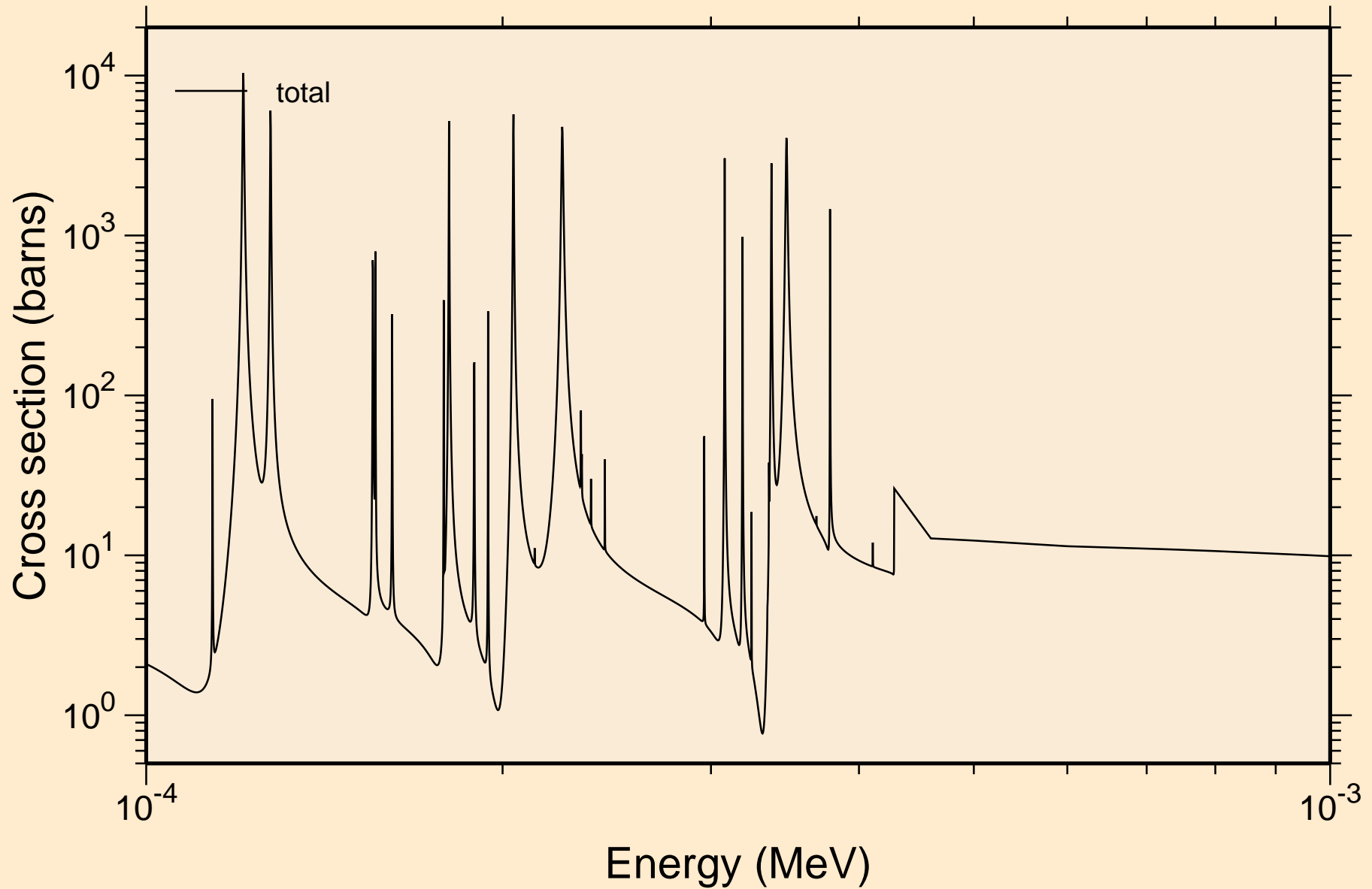

PD115M NEUTRON ACER TENDL-2024 LIBRARY; T=0.K  
resonance total cross section

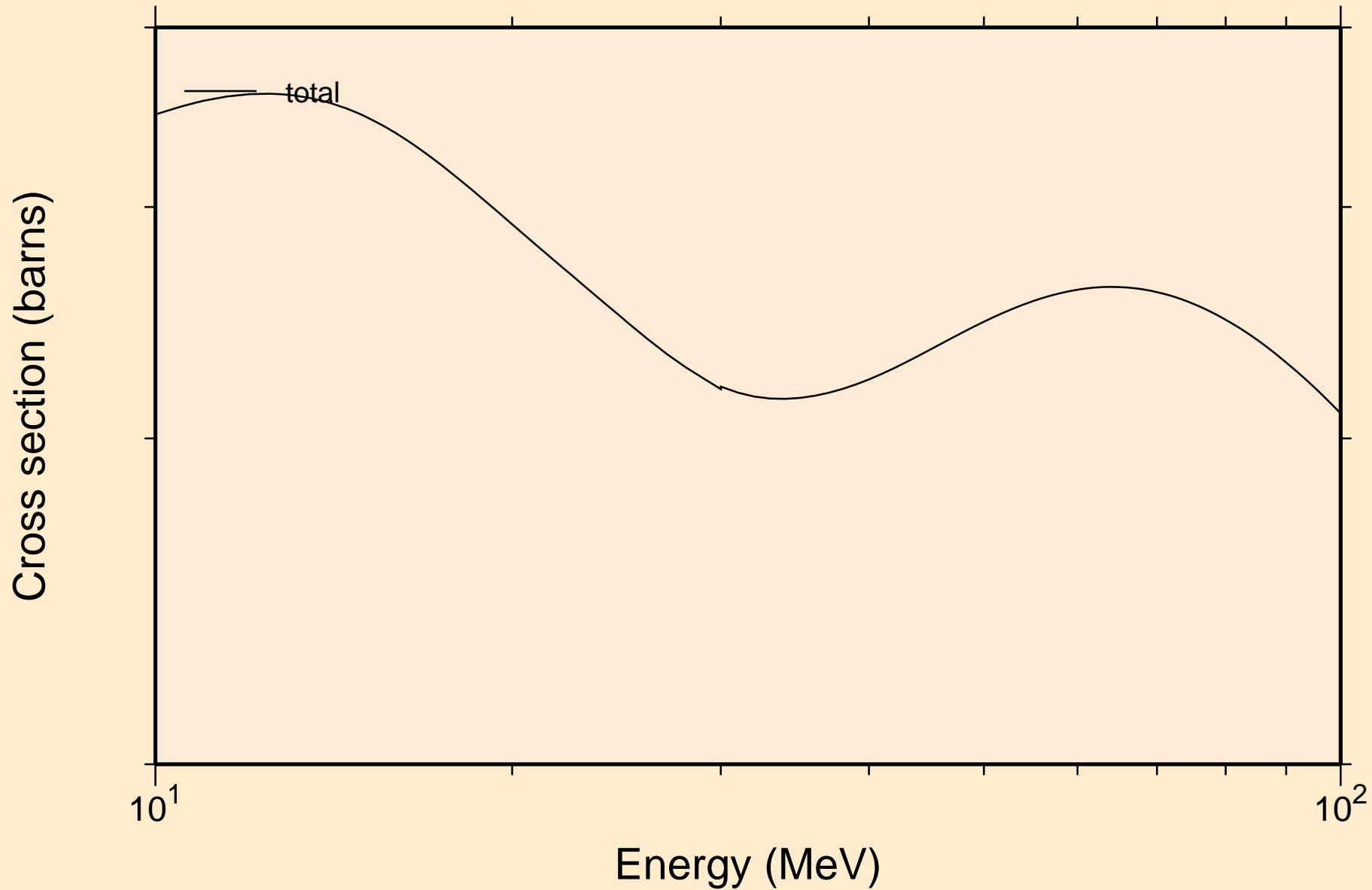

PD115M NEUTRON ACER TENDL-2024 LIBRARY; T=0.K  
resonance absorption cross sections

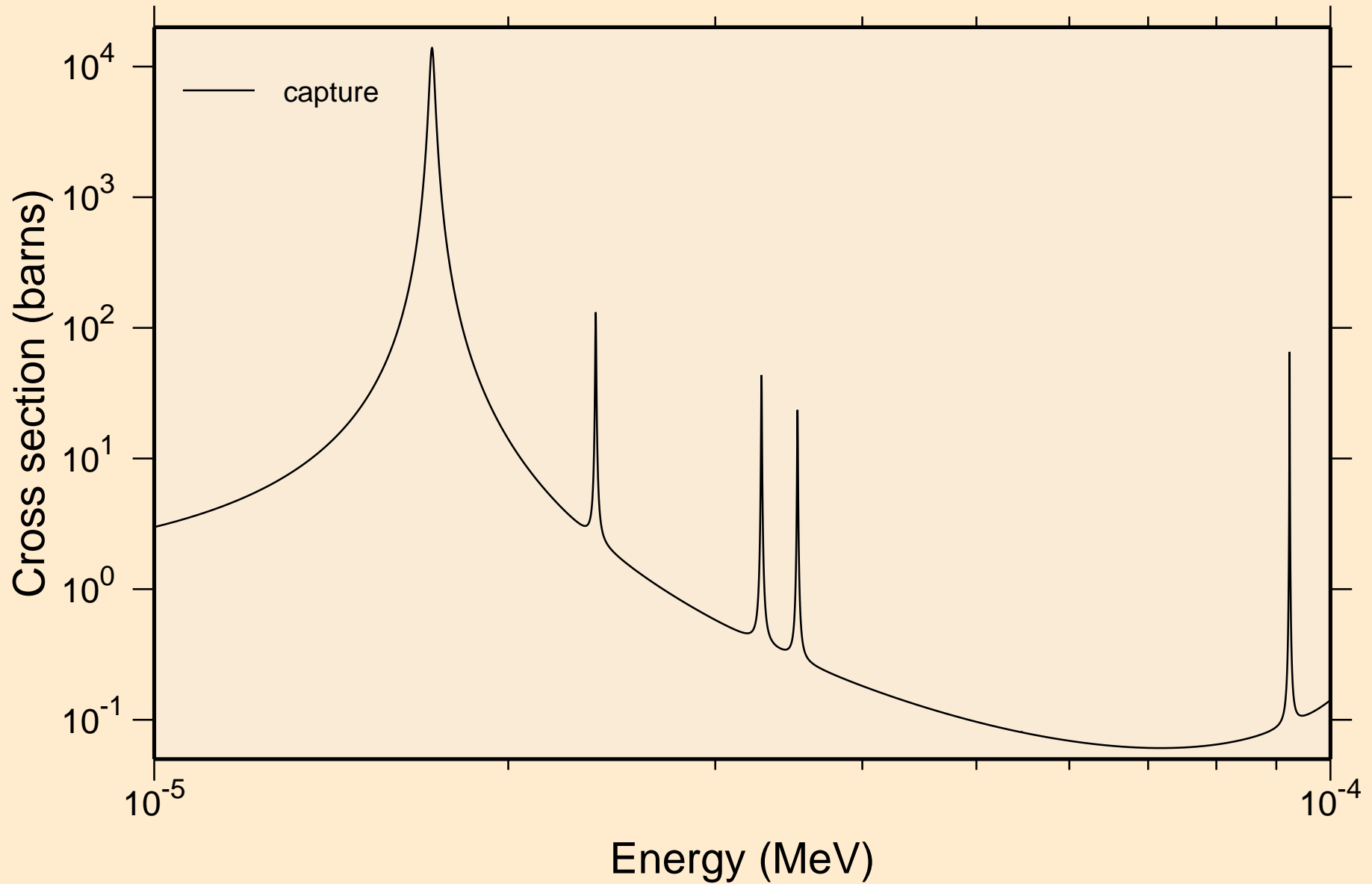

PD115M NEUTRON ACER TENDL-2024 LIBRARY; T=0.K  
resonance absorption cross sections

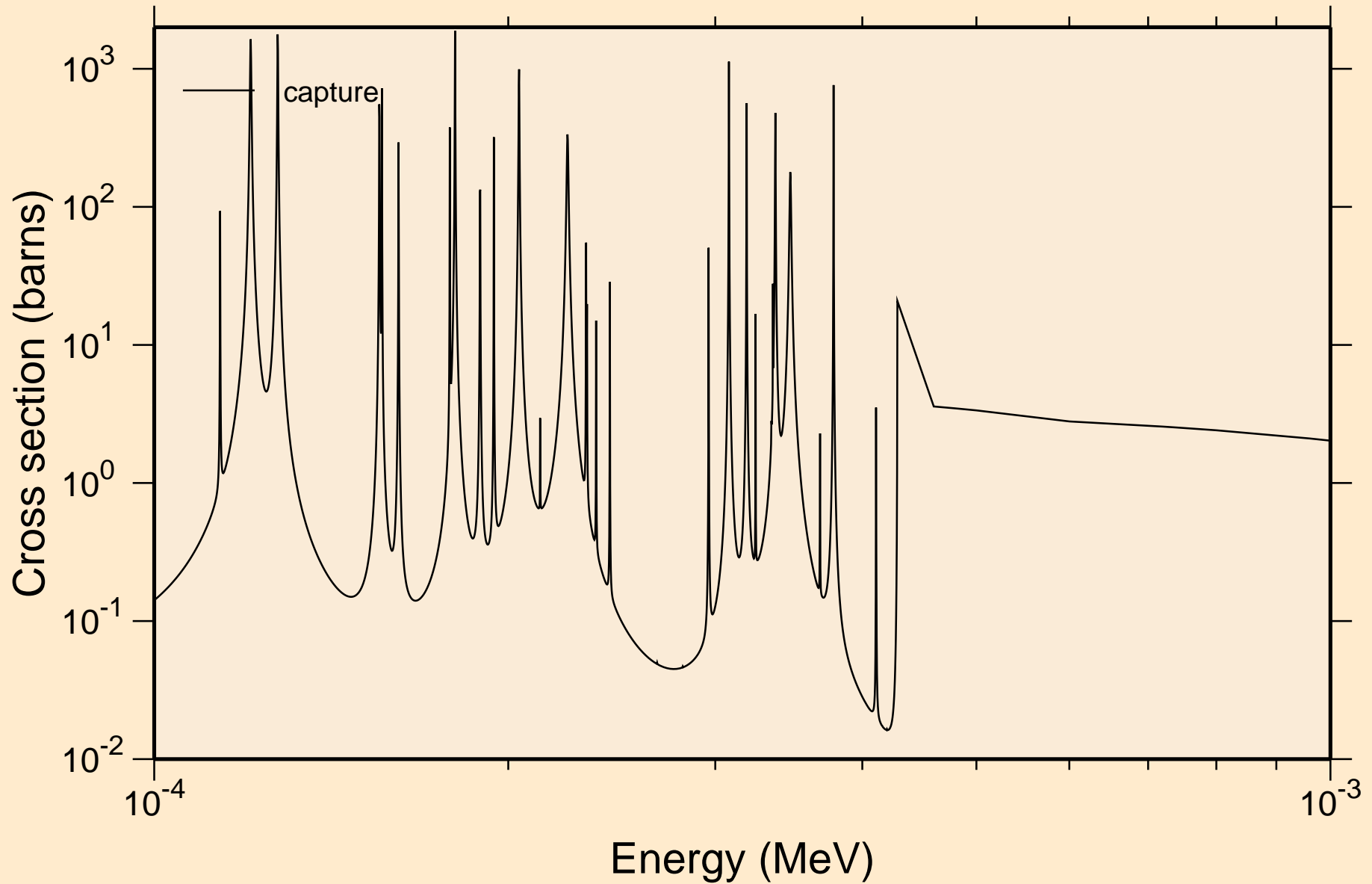

PD115M NEUTRON ACER TENDL-2024 LIBRARY; T=0.K  
resonance absorption cross sections

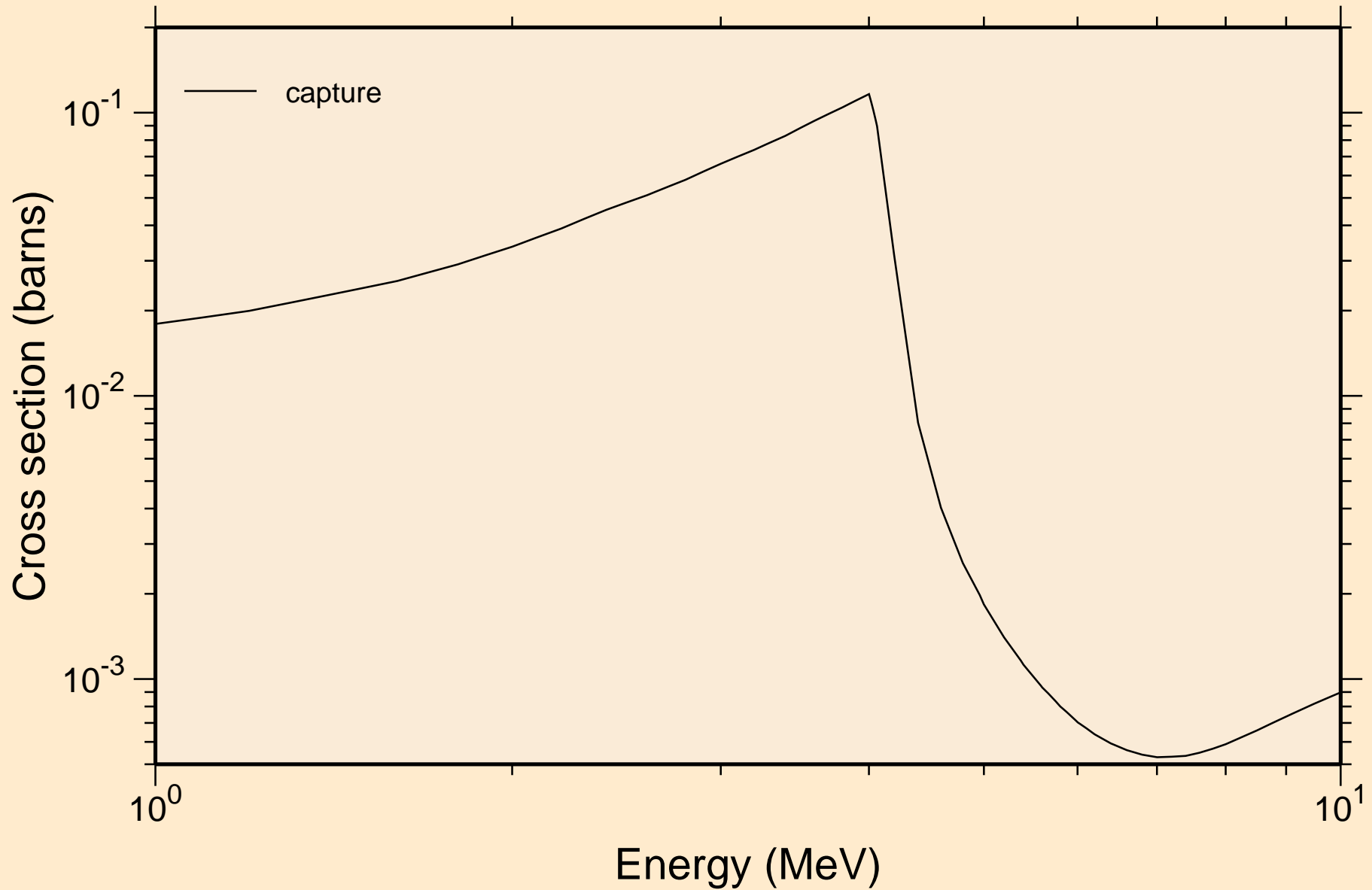

PD115M NEUTRON ACER TENDL-2024 LIBRARY; T=0.K  
Heating

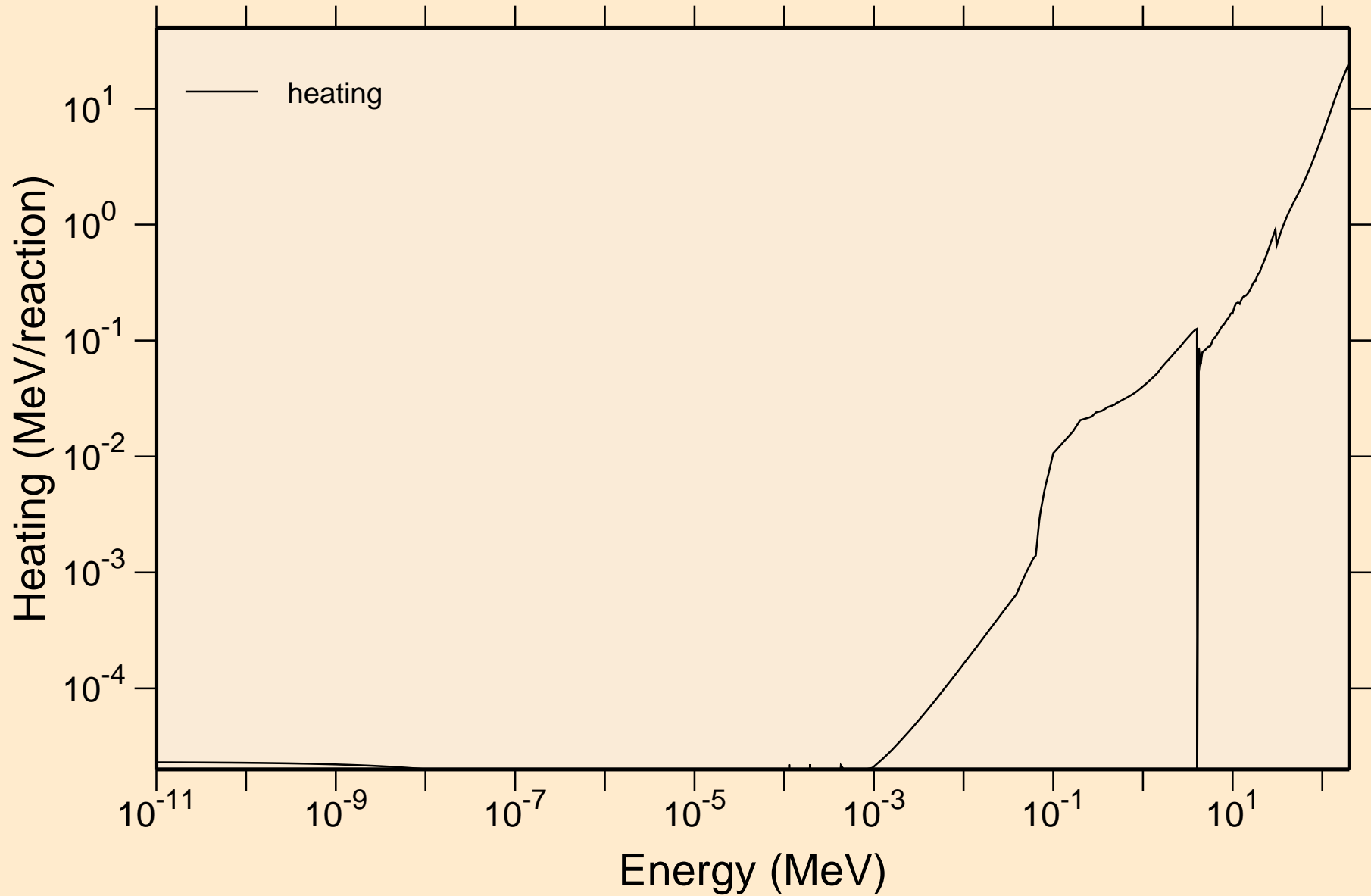



PD115M NEUTRON ACER TENDL-2024 LIBRARY; T=0.K  
Damage

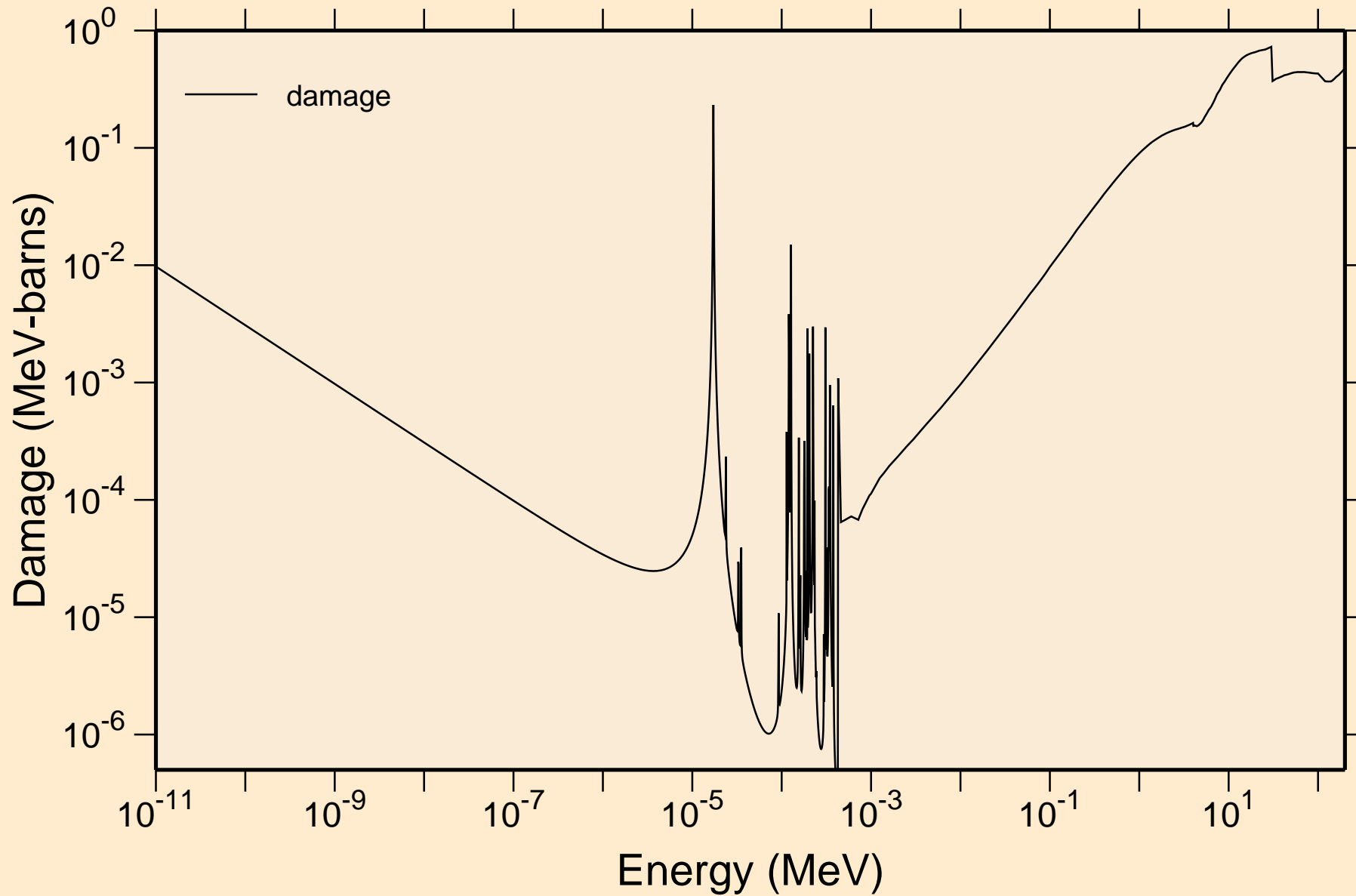

PD115M NEUTRON ACER TENDL-2024 LIBRARY; T=0.K  
Non-threshold reactions

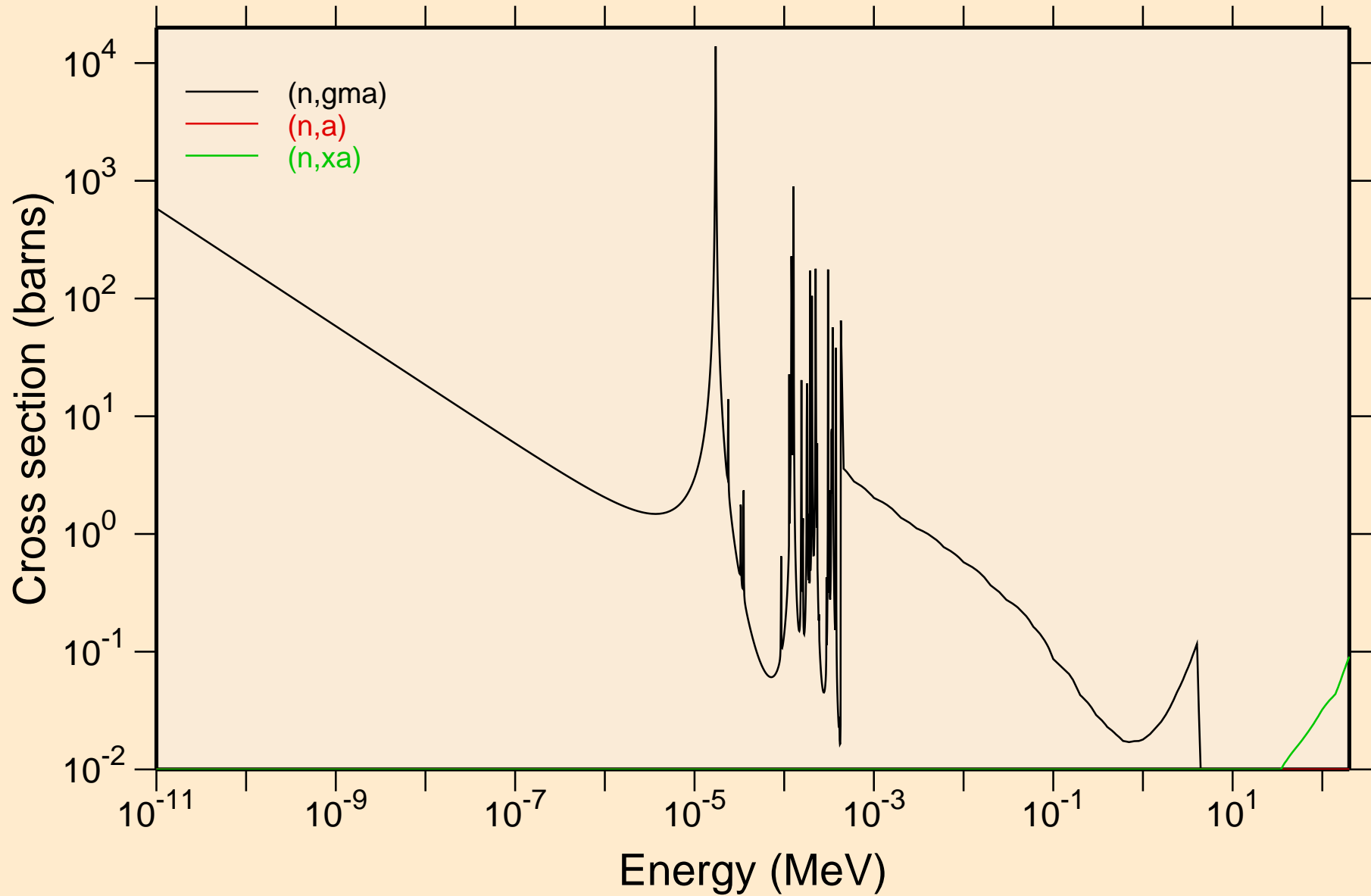

PD115M NEUTRON ACER TENDL-2024 LIBRARY; T=0.K  
Principal cross sections

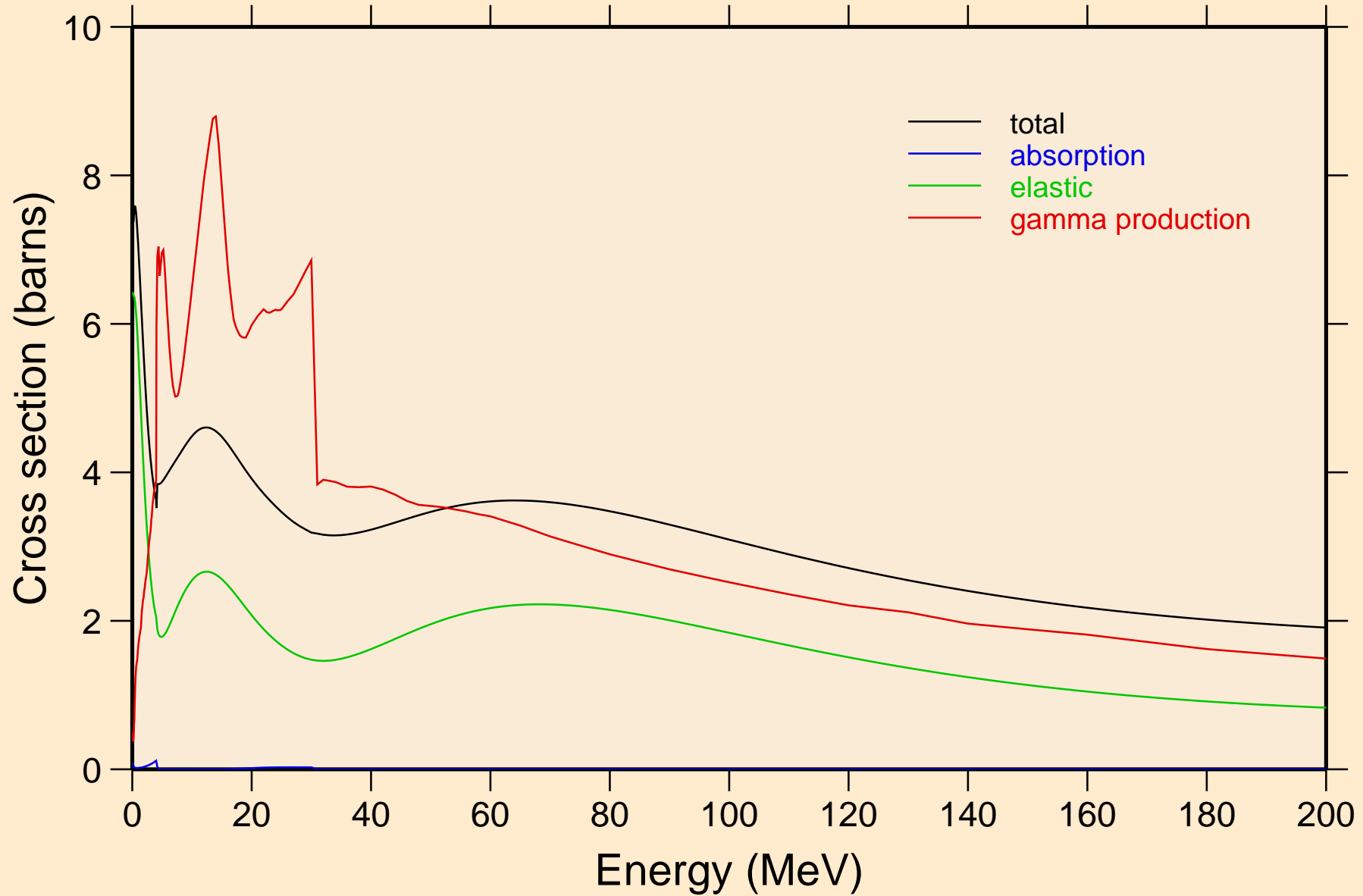

# PD115M NEUTRON ACER TENDL-2024 LIBRARY; T=0.K

## Heating

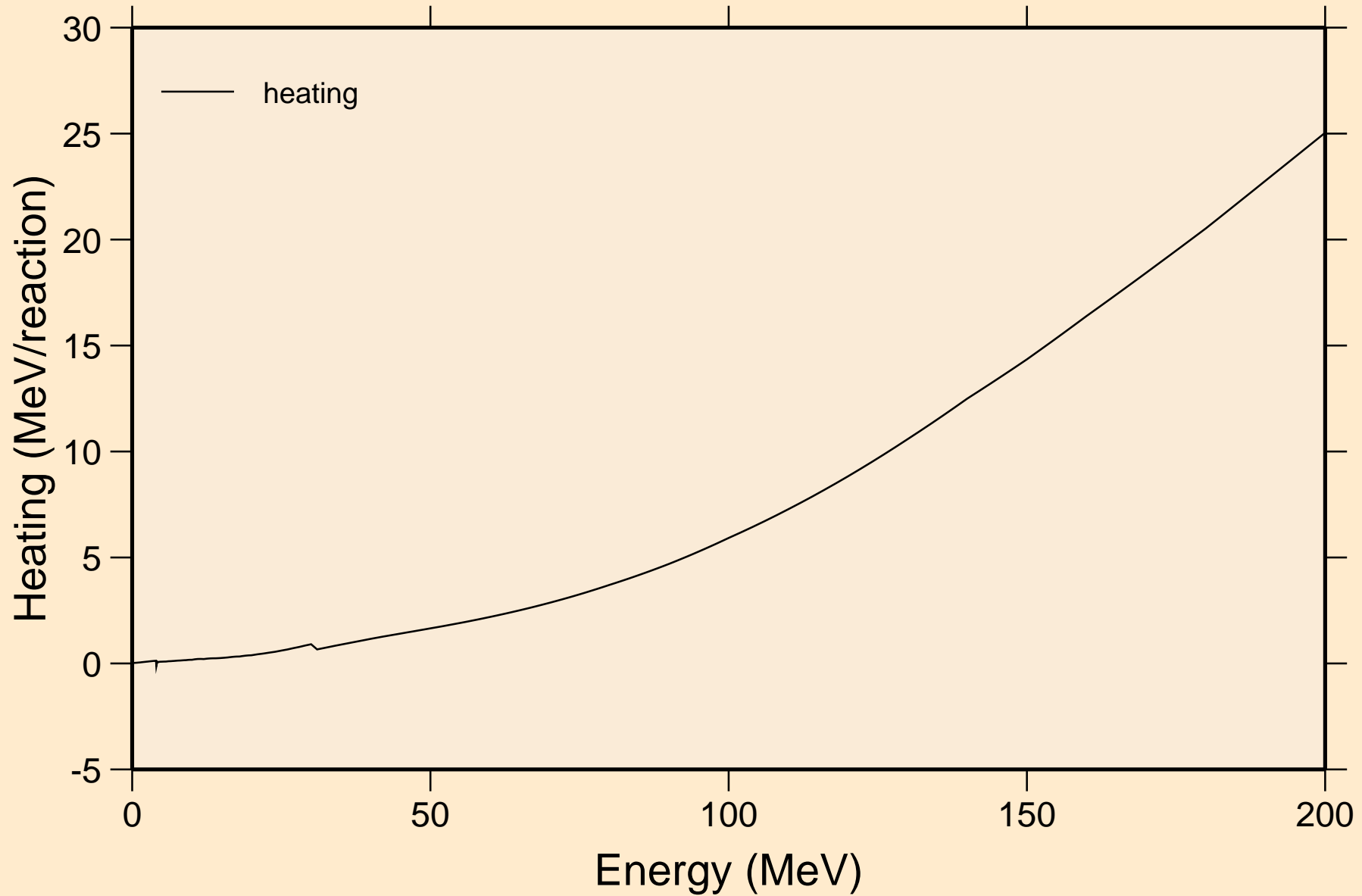

PD115M NEUTRON ACER TENDL-2024 LIBRARY; T=0.K  
Damage

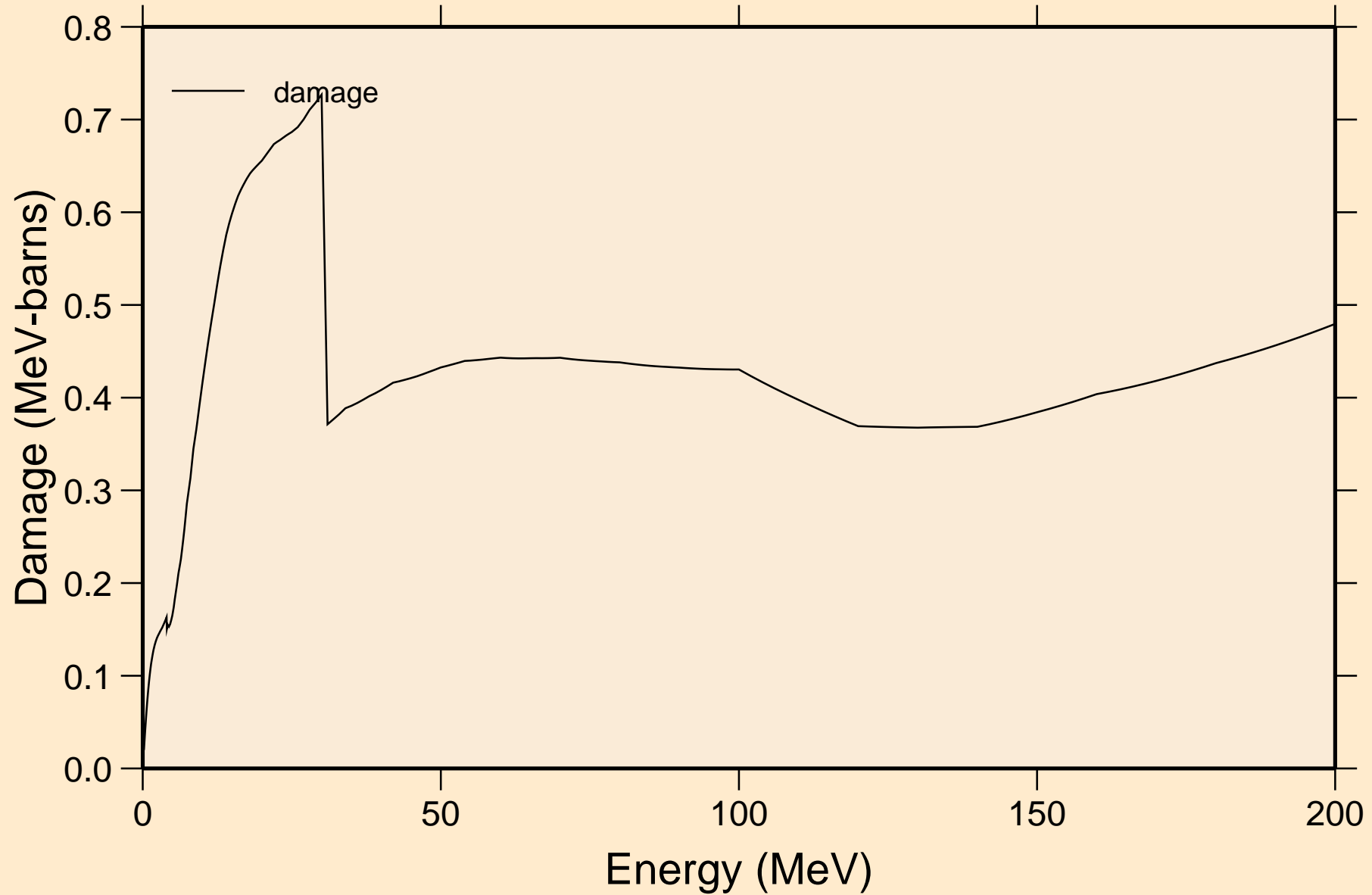

PD115M NEUTRON ACER TENDL-2024 LIBRARY; T=0.K  
Non-threshold reactions

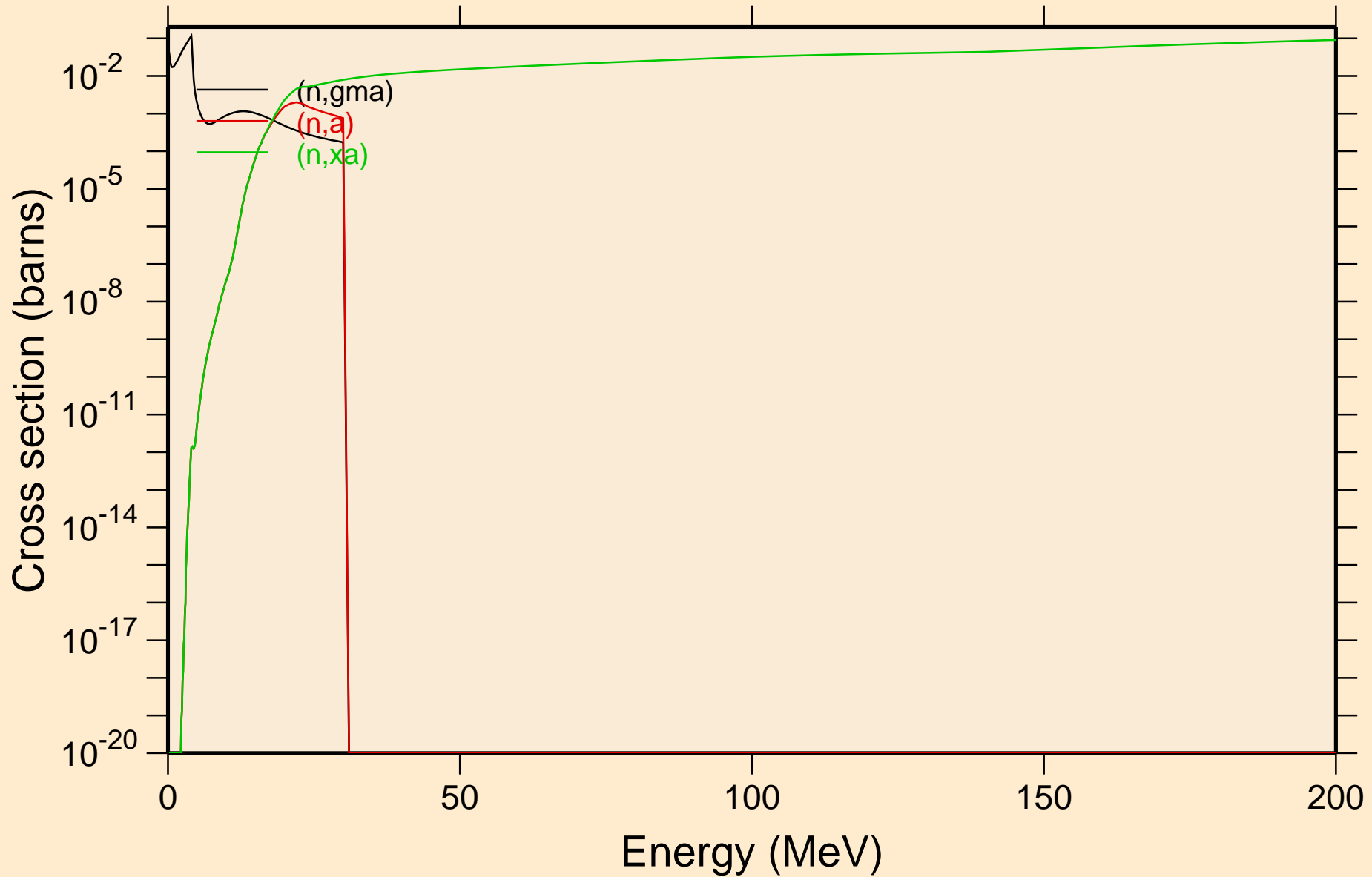

PD115M NEUTRON ACER TENDL-2024 LIBRARY; T=0.K  
Inelastic levels

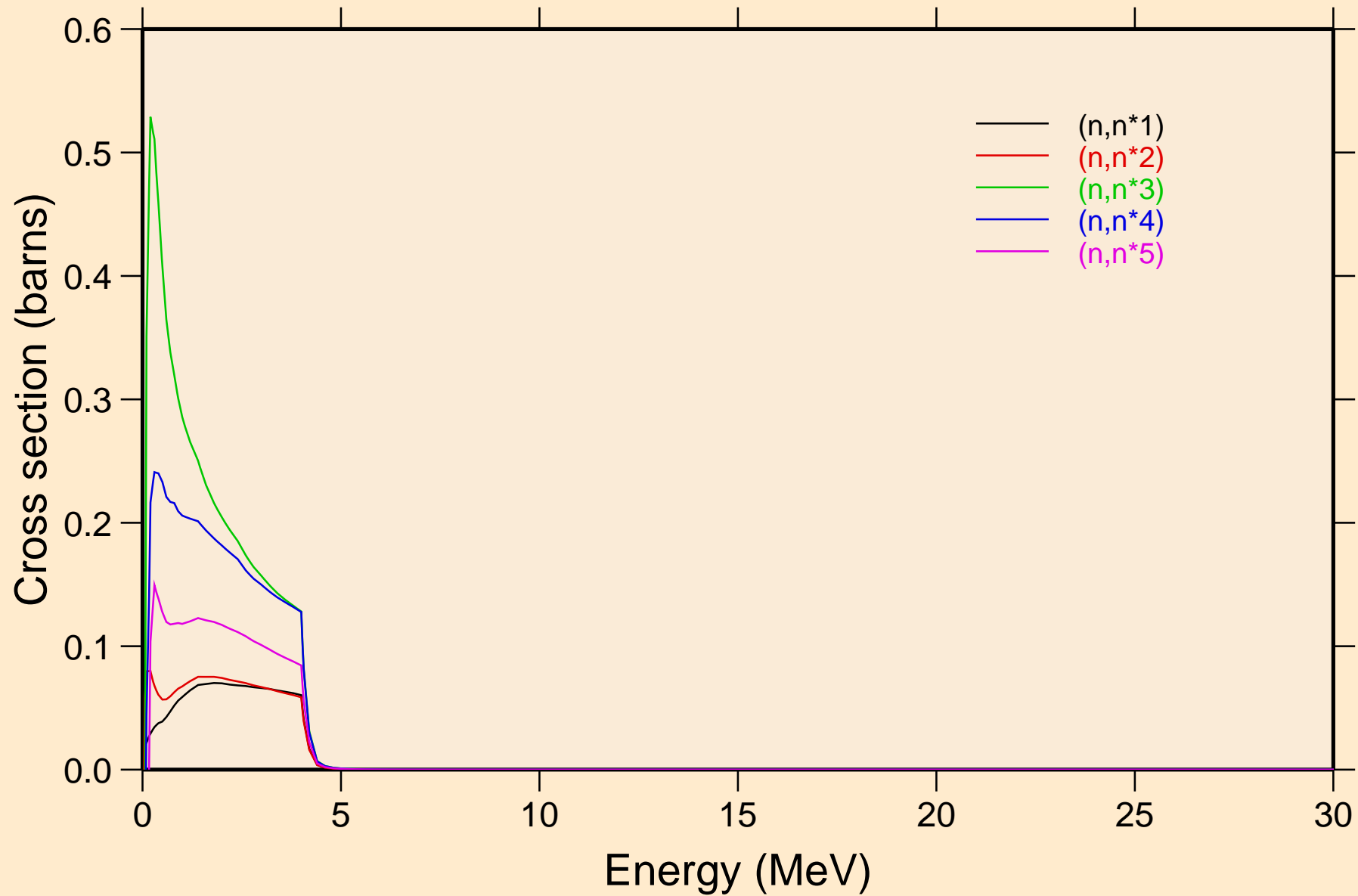

PD115M NEUTRON ACER TENDL-2024 LIBRARY; T=0.K  
Inelastic levels

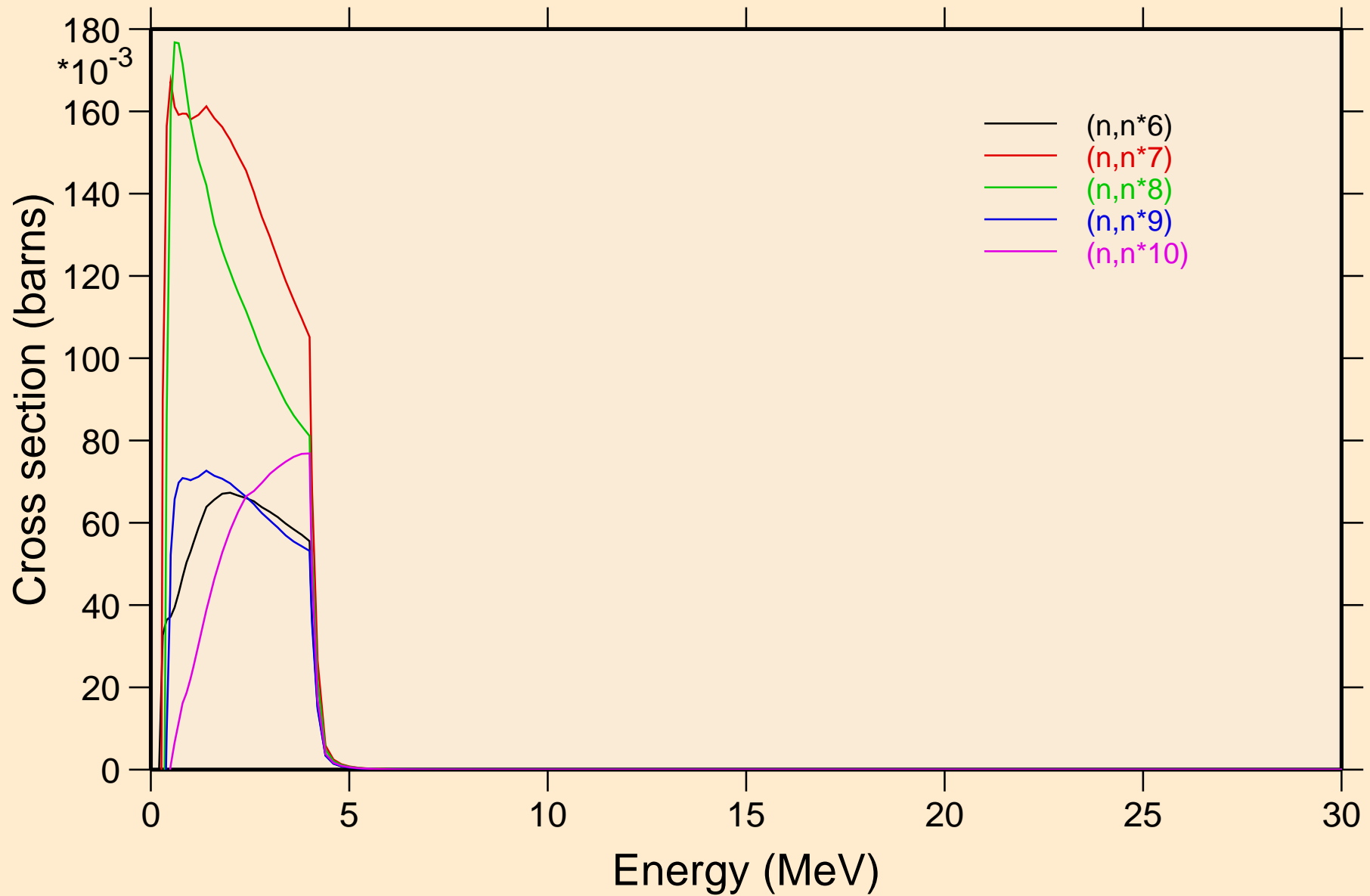



PD115M NEUTRON ACER TENDL-2024 LIBRARY; T=0.K  
Inelastic levels

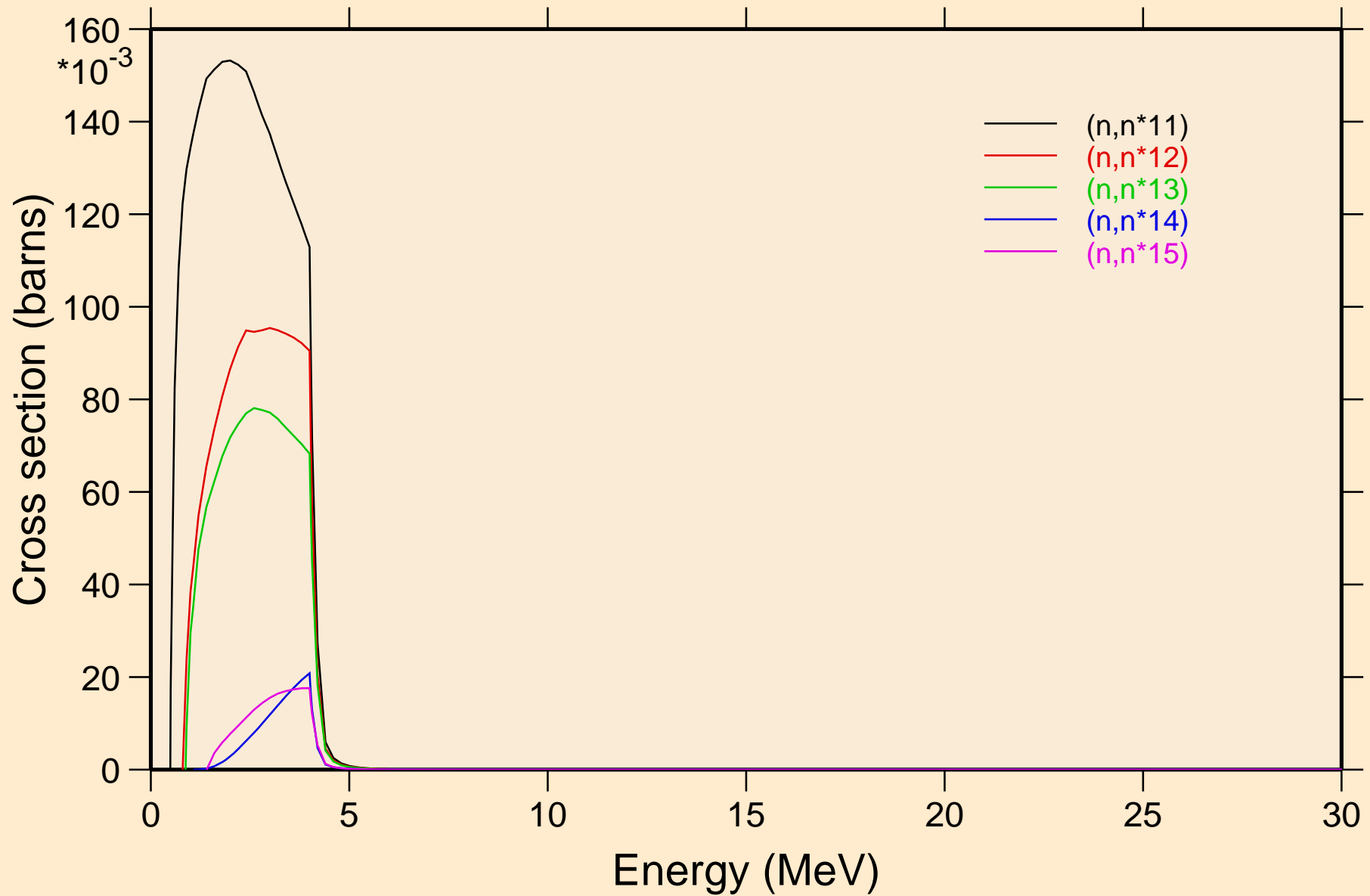

PD115M NEUTRON ACER TENDL-2024 LIBRARY; T=0.K  
Inelastic levels

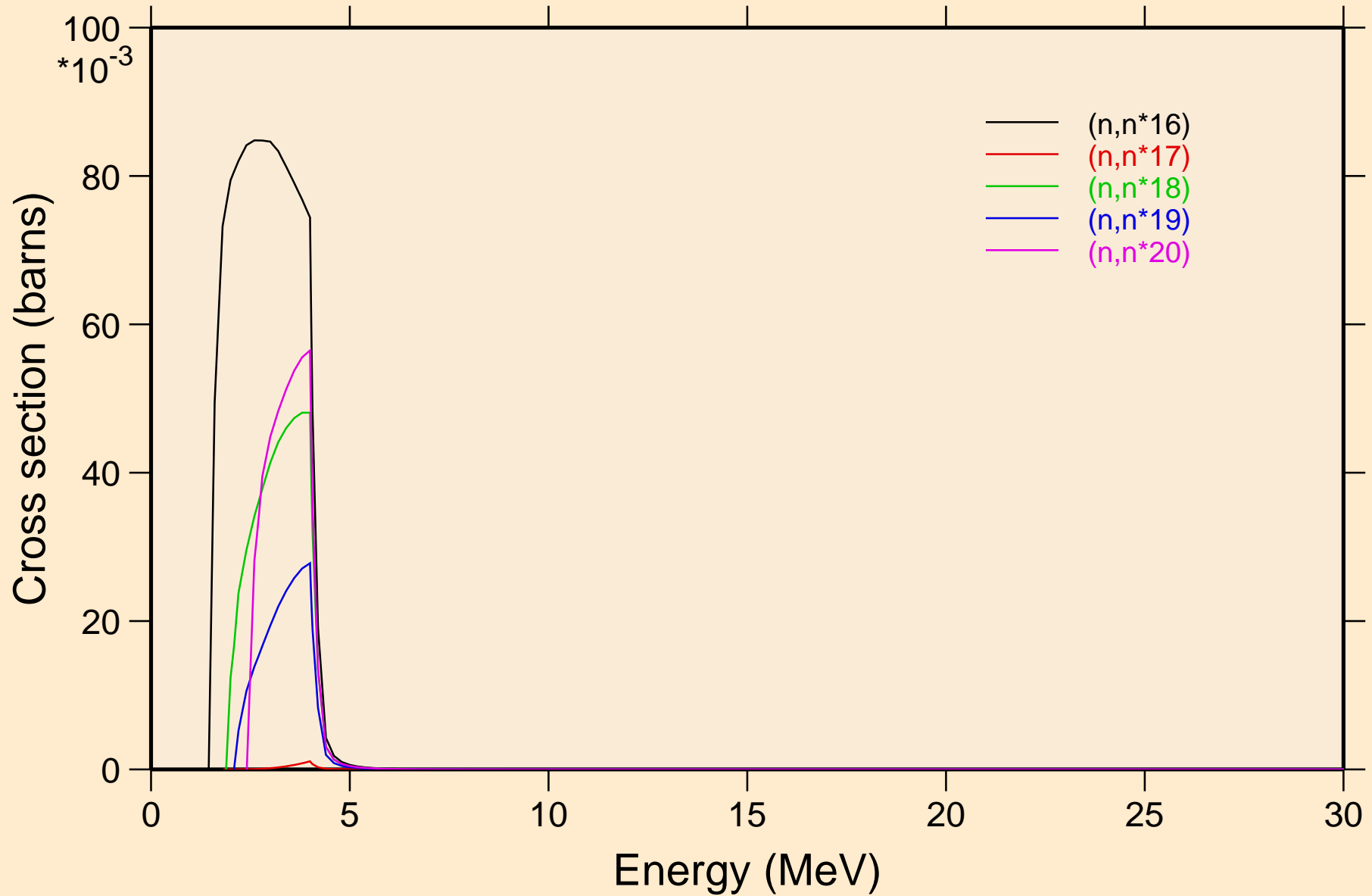

PD115M NEUTRON ACER TENDL-2024 LIBRARY; T=0.K  
Inelastic levels

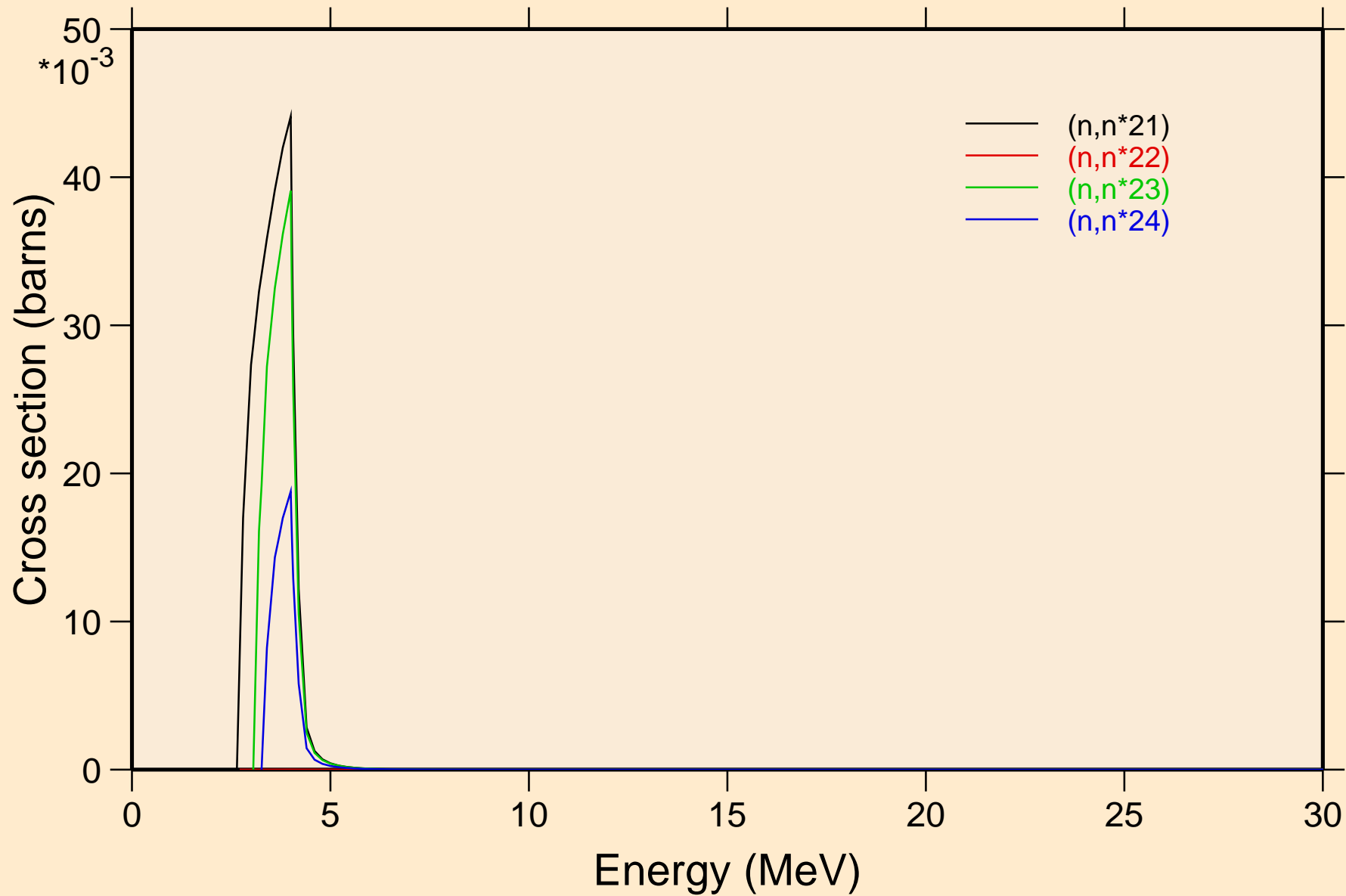

PD115M NEUTRON ACER TENDL-2024 LIBRARY; T=0.K  
Threshold reactions

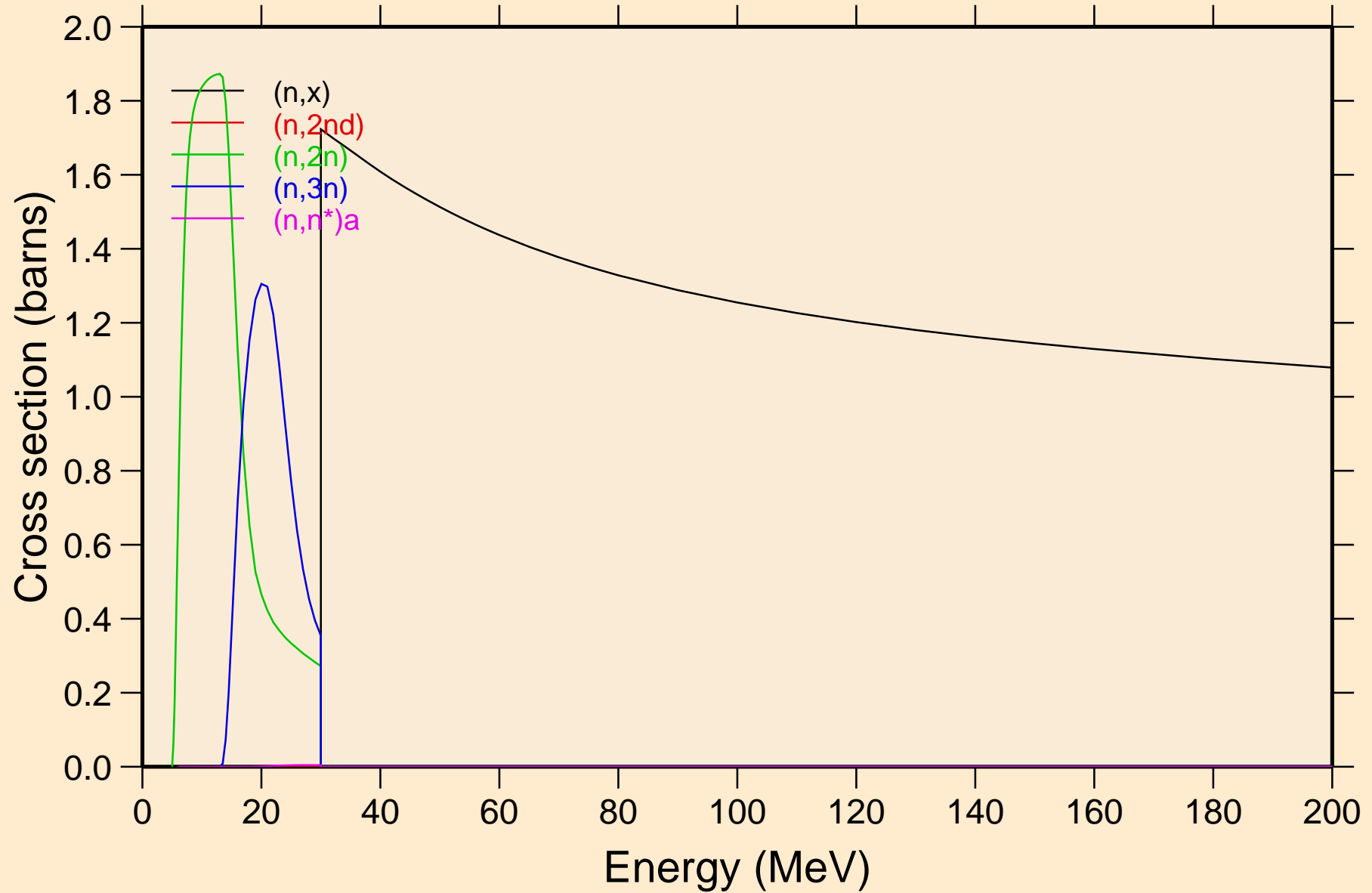

PD115M NEUTRON ACER TENDL-2024 LIBRARY; T=0.K  
Threshold reactions

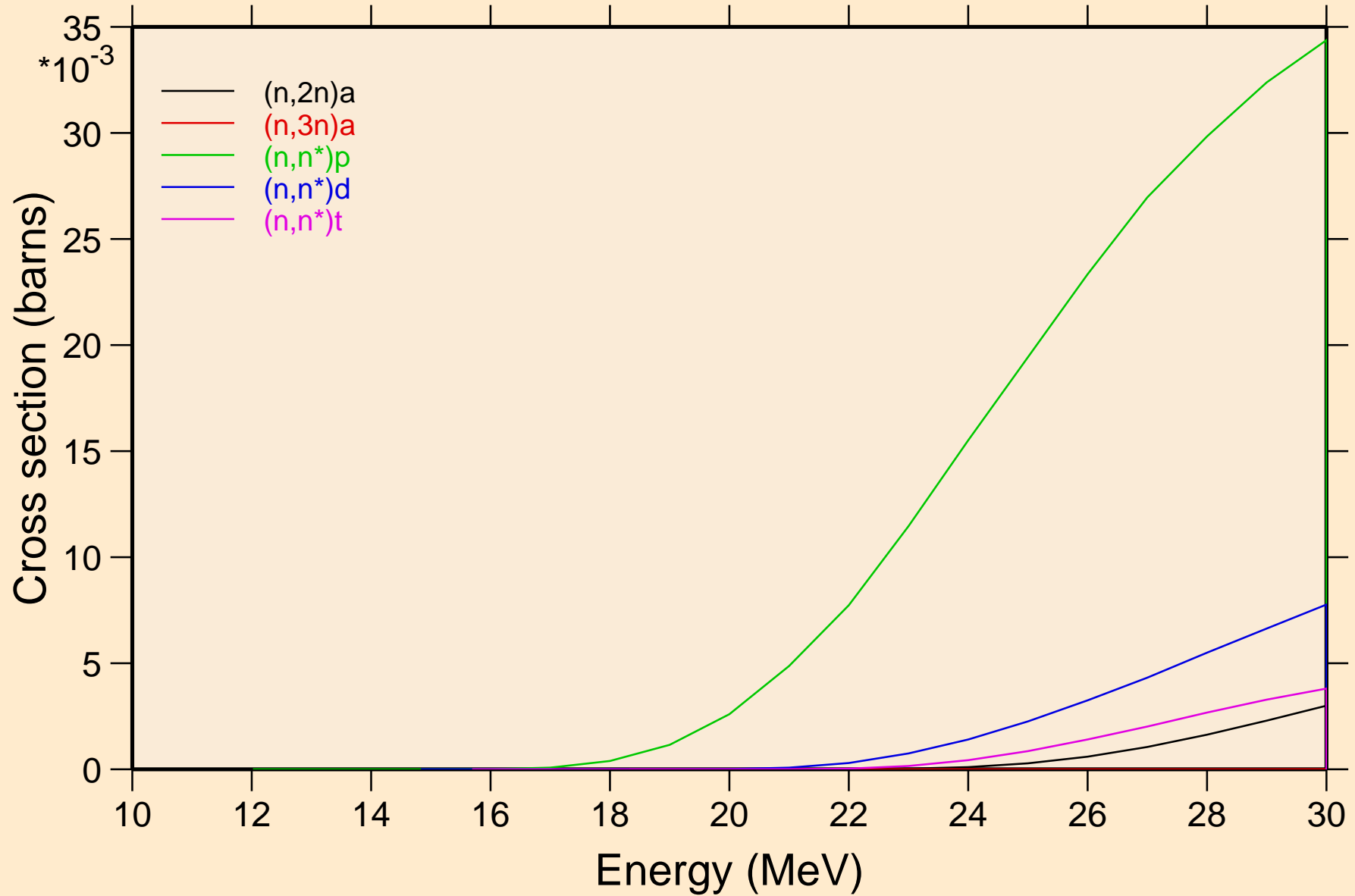

PD115M NEUTRON ACER TENDL-2024 LIBRARY; T=0.K  
Threshold reactions

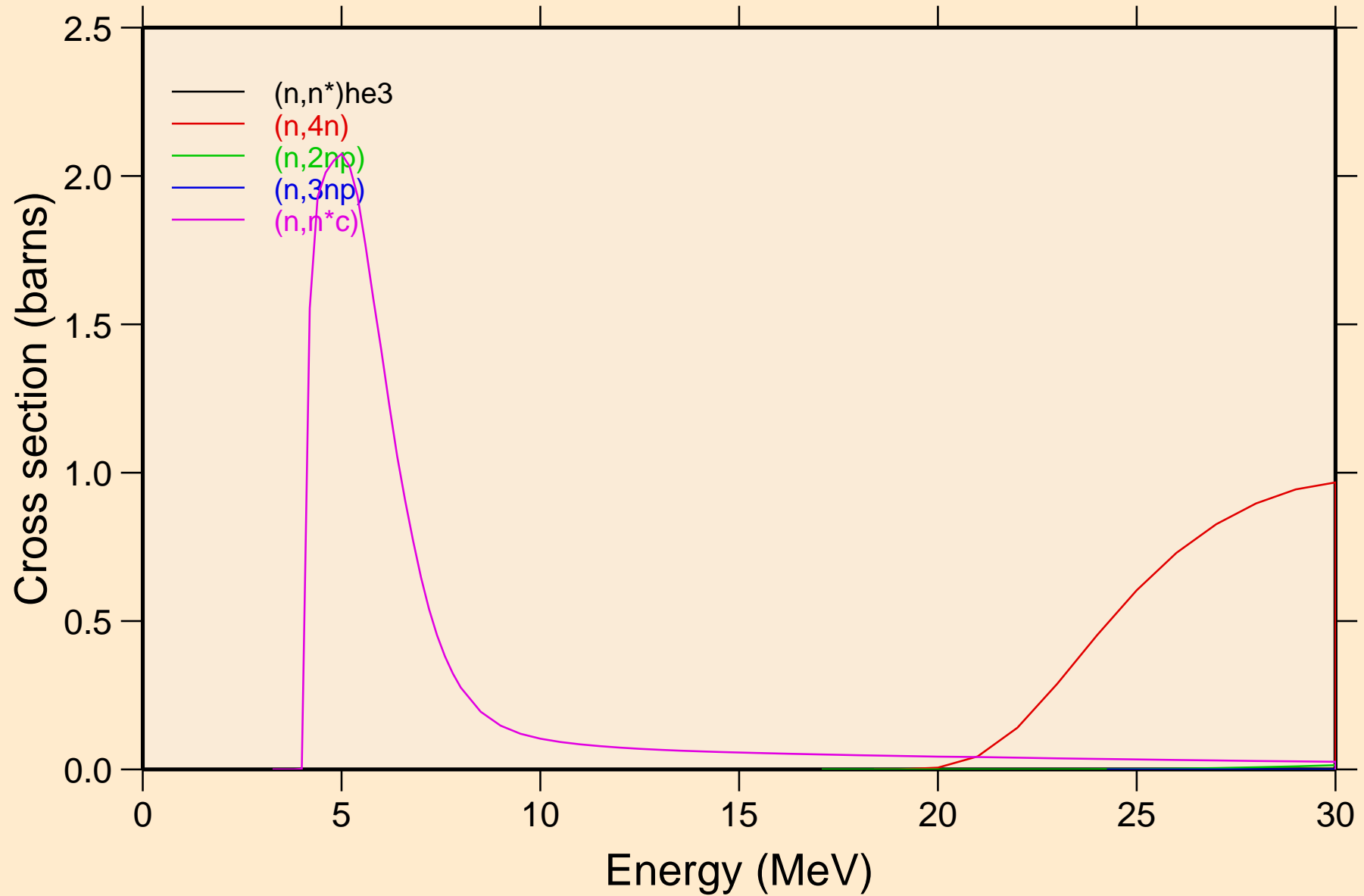

PD115M NEUTRON ACER TENDL-2024 LIBRARY; T=0.K  
Threshold reactions

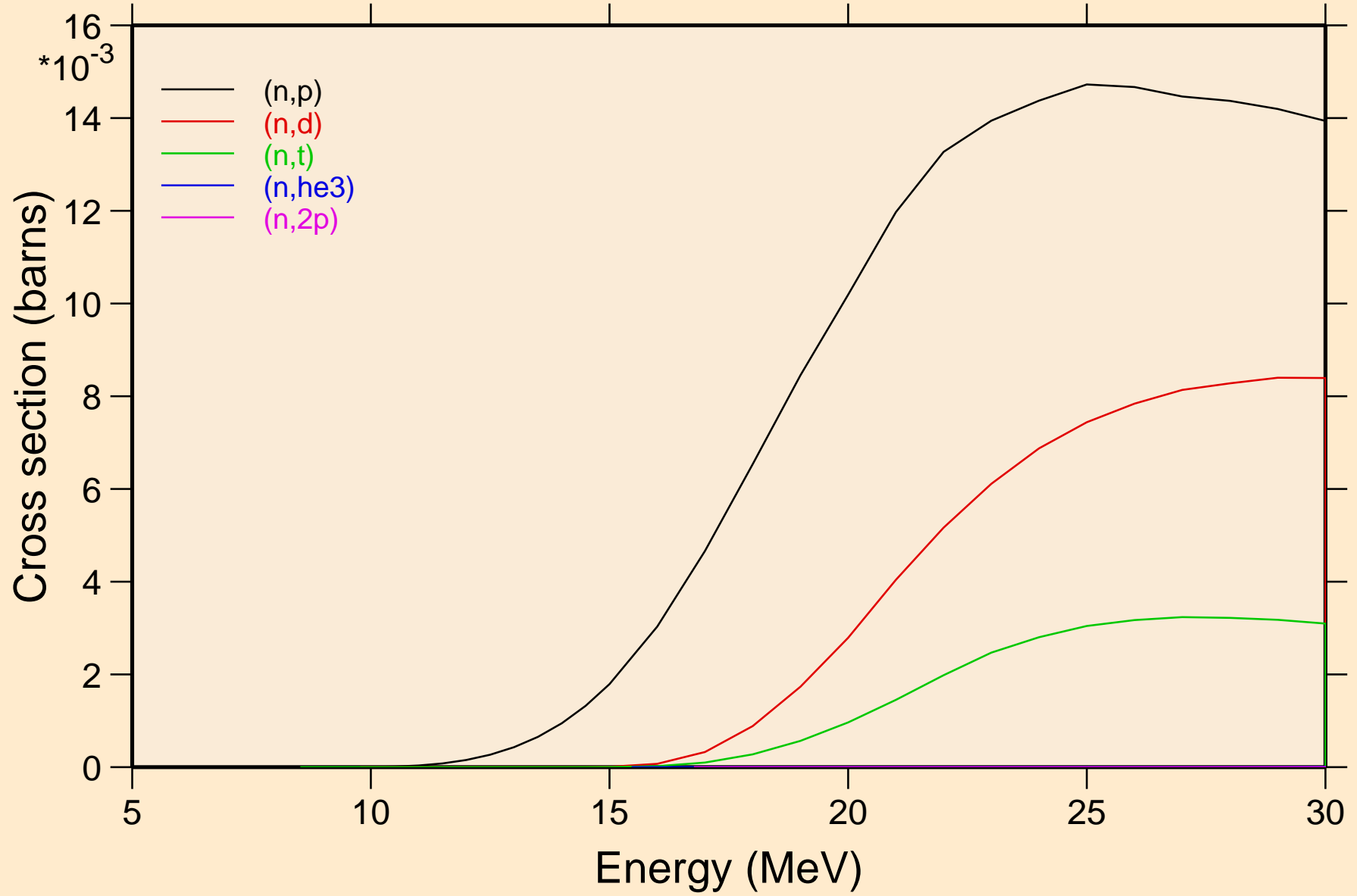

PD115M NEUTRON ACER TENDL-2024 LIBRARY; T=0.K  
Threshold reactions

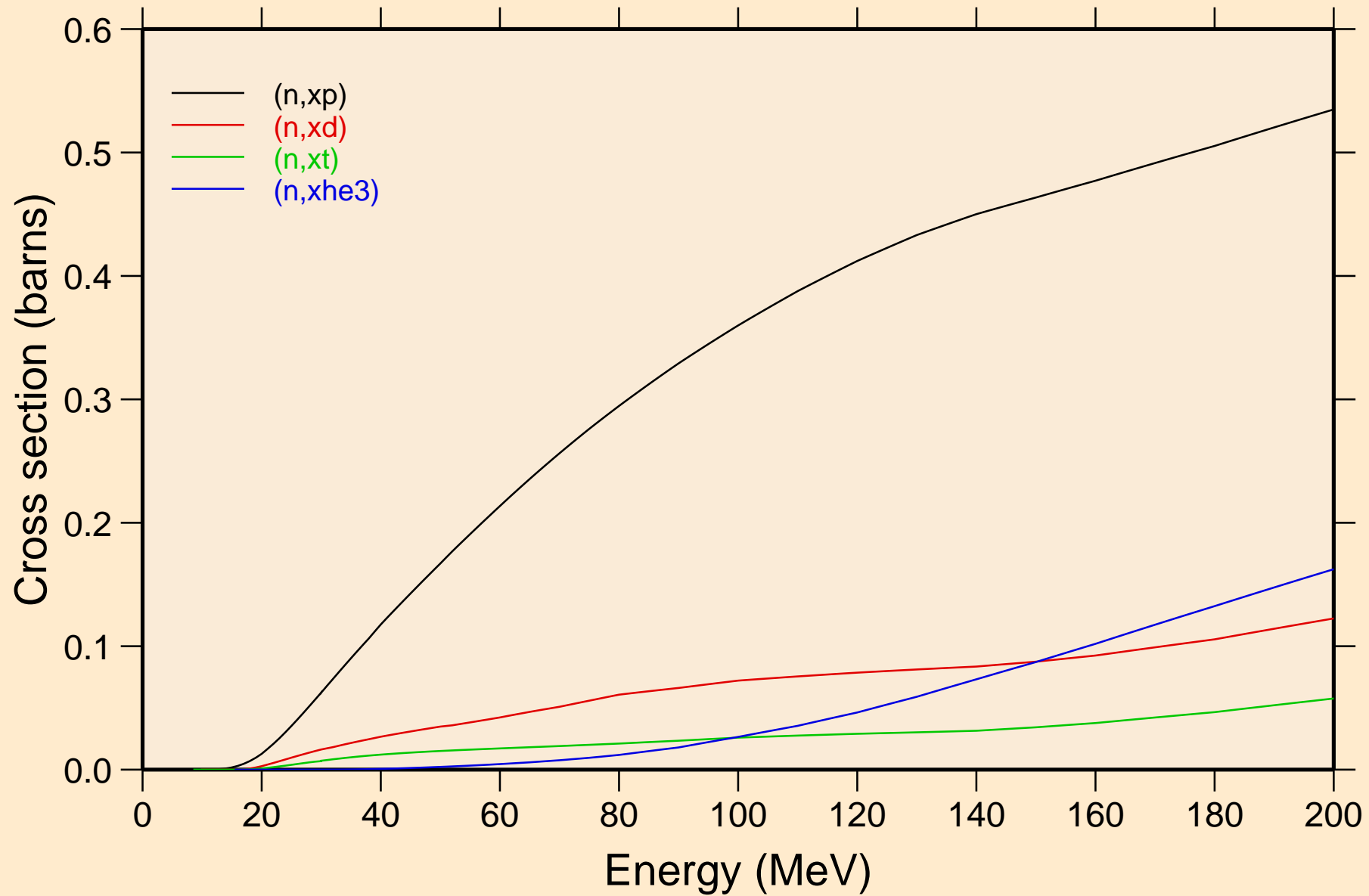



PD115M NEUTRON ACER TENDL-2024 LIBRARY; T=0.K  
angular distribution for elastic

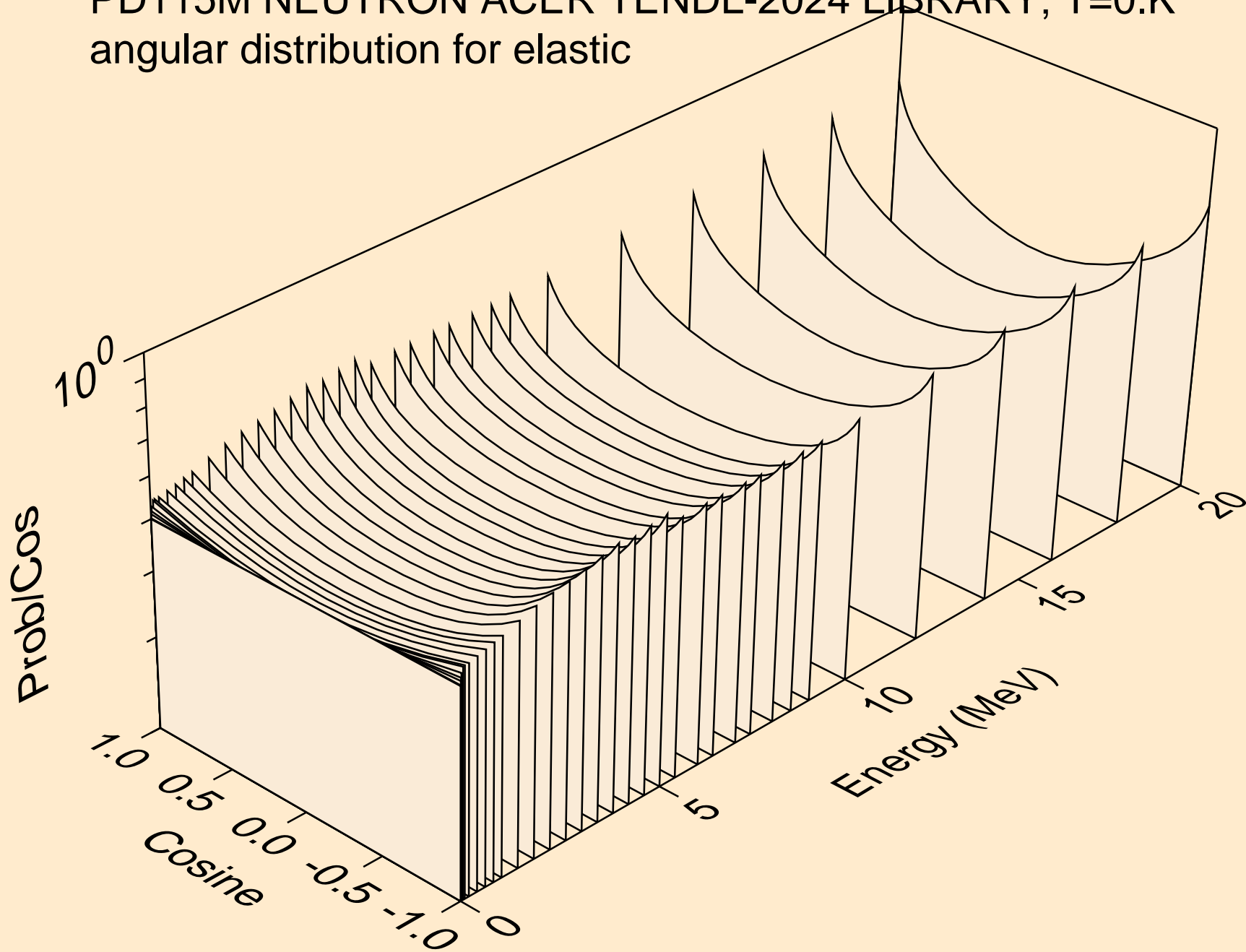

PD115M NEUTRON ACER TENDL-2024 LIBRARY; T=0.K  
angular distribution for elastic

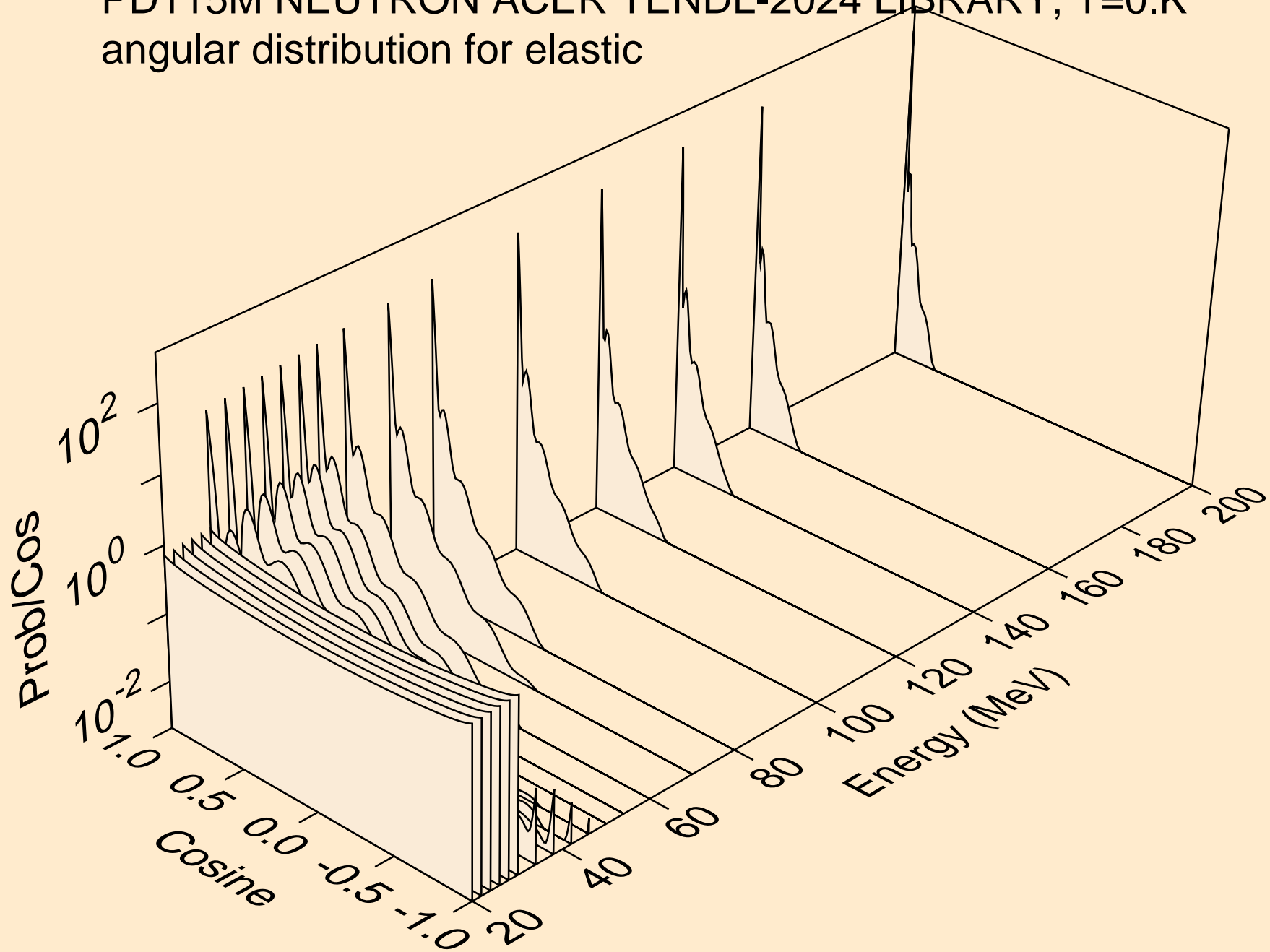

PD115M NEUTRON ACER TENDL-2024 LIBRARY; T=0.K  
angular distribution for (n,n\*1)

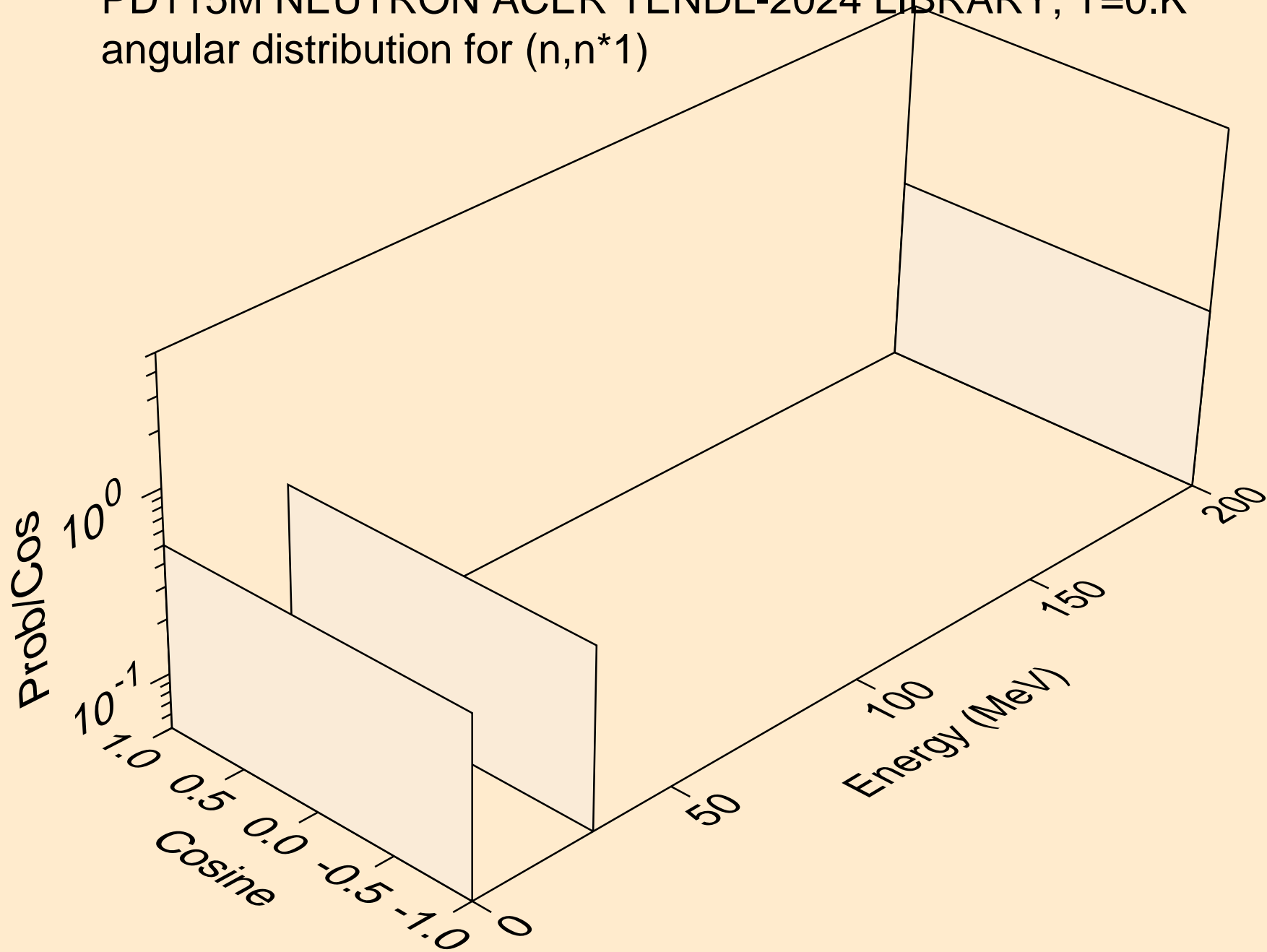

PD115M NEUTRON ACER TENDL-2024 LIBRARY; T=0.K  
angular distribution for (n,n\*2)

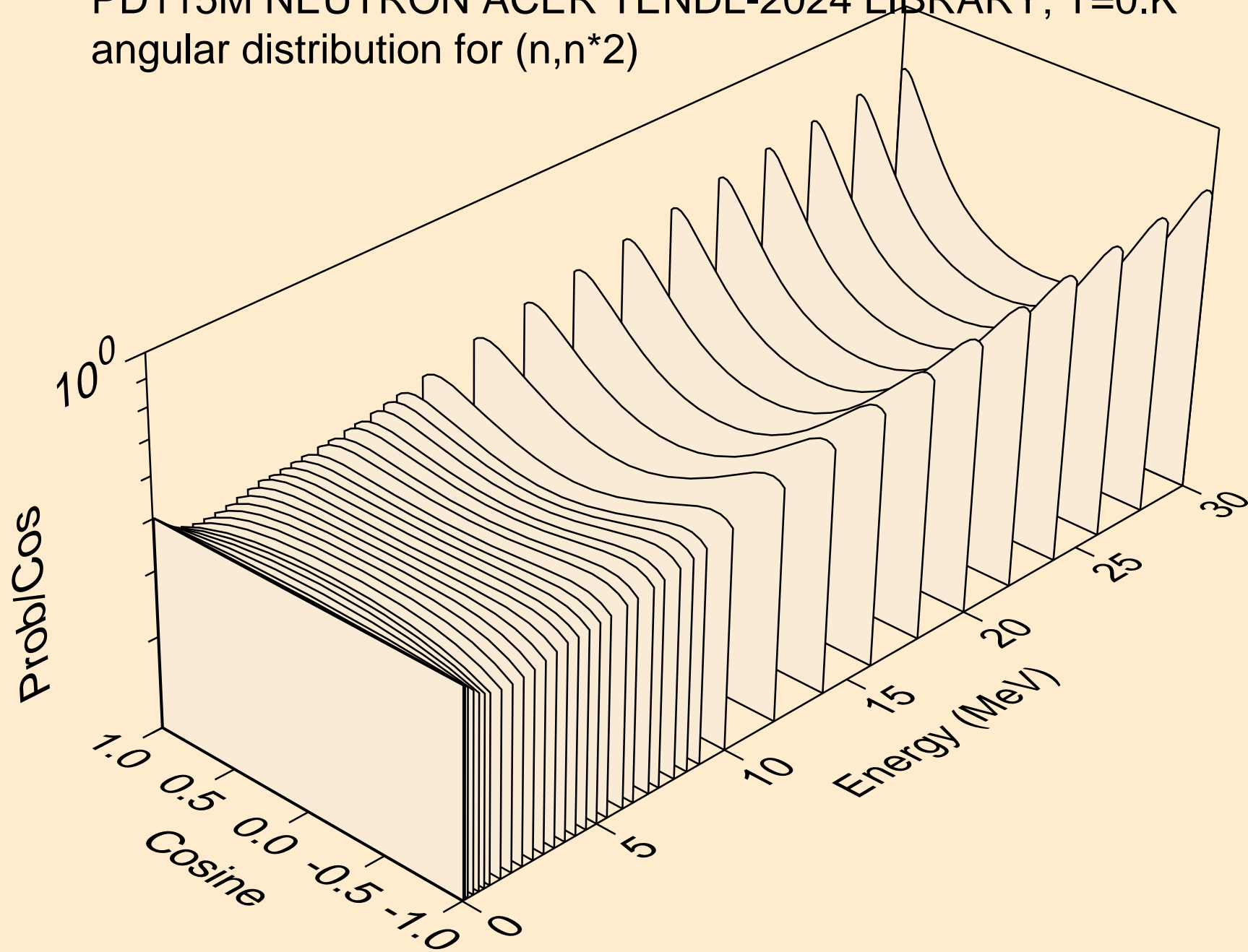

PD115M NEUTRON ACER TENDL-2024 LIBRARY; T=0.K  
angular distribution for (n,n\*3)

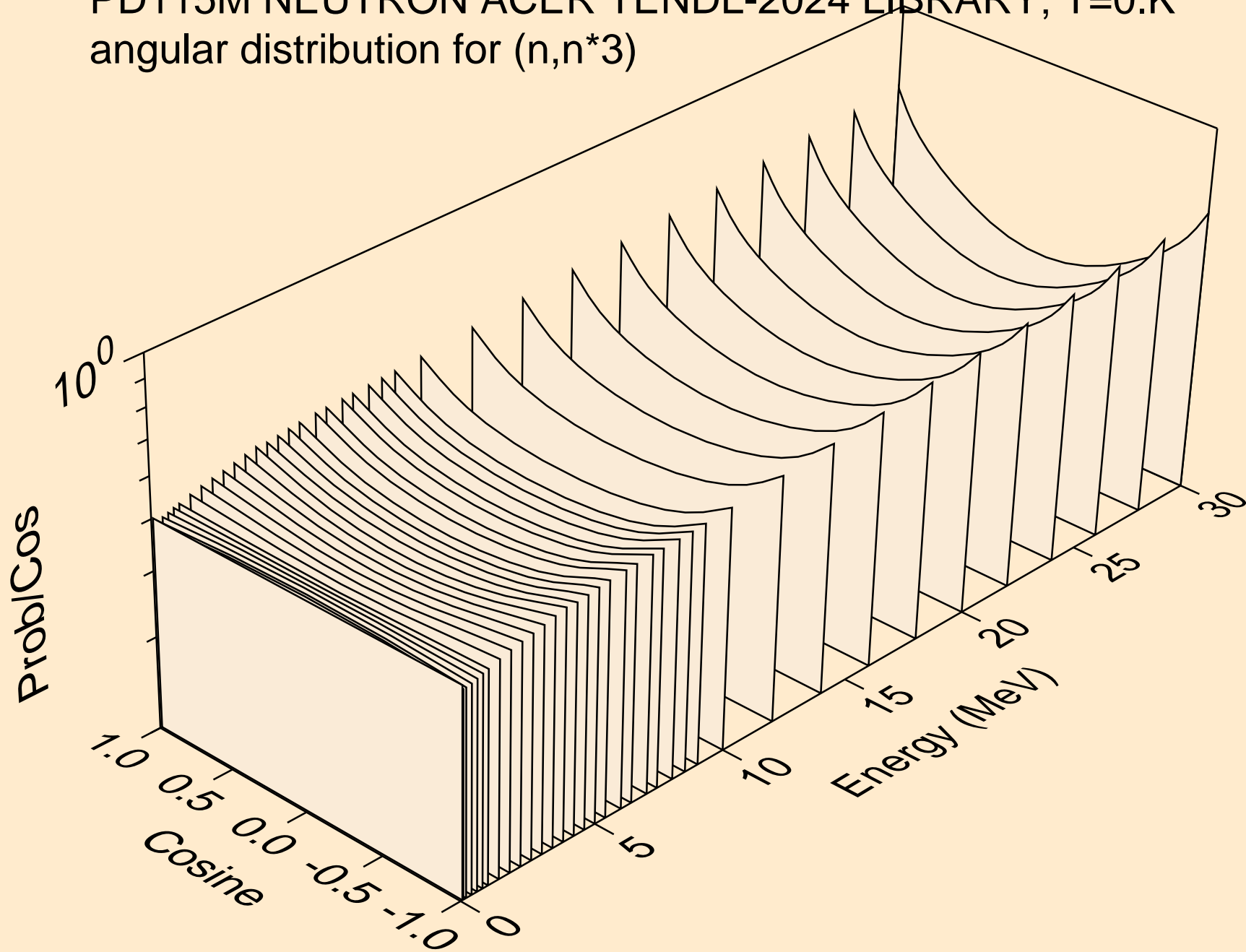

PD115M NEUTRON ACER TENDL-2024 LIBRARY; T=0.K  
angular distribution for (n,n\*4)

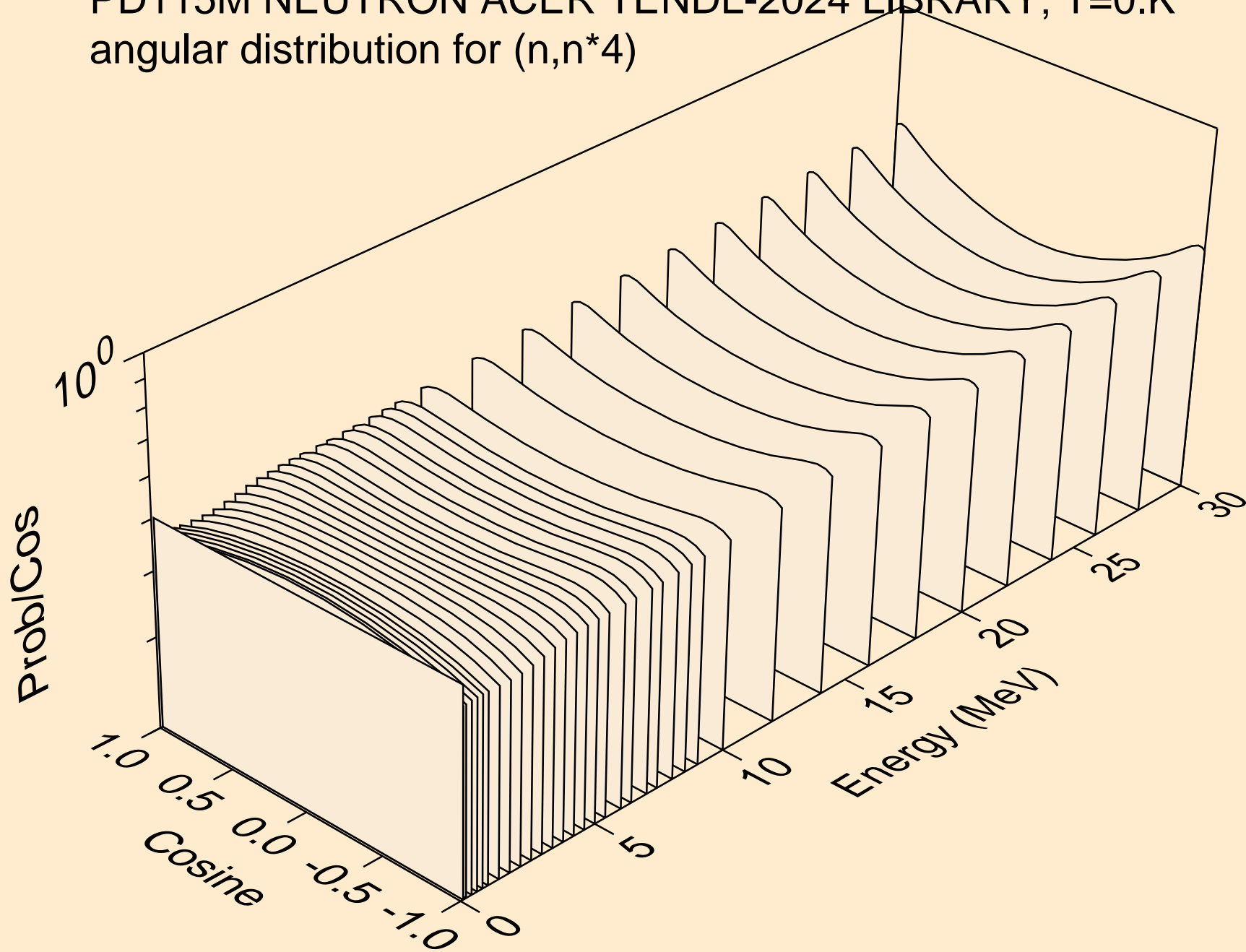

PD115M NEUTRON ACER TENDL-2024 LIBRARY; T=0.K  
angular distribution for (n,n\*5)

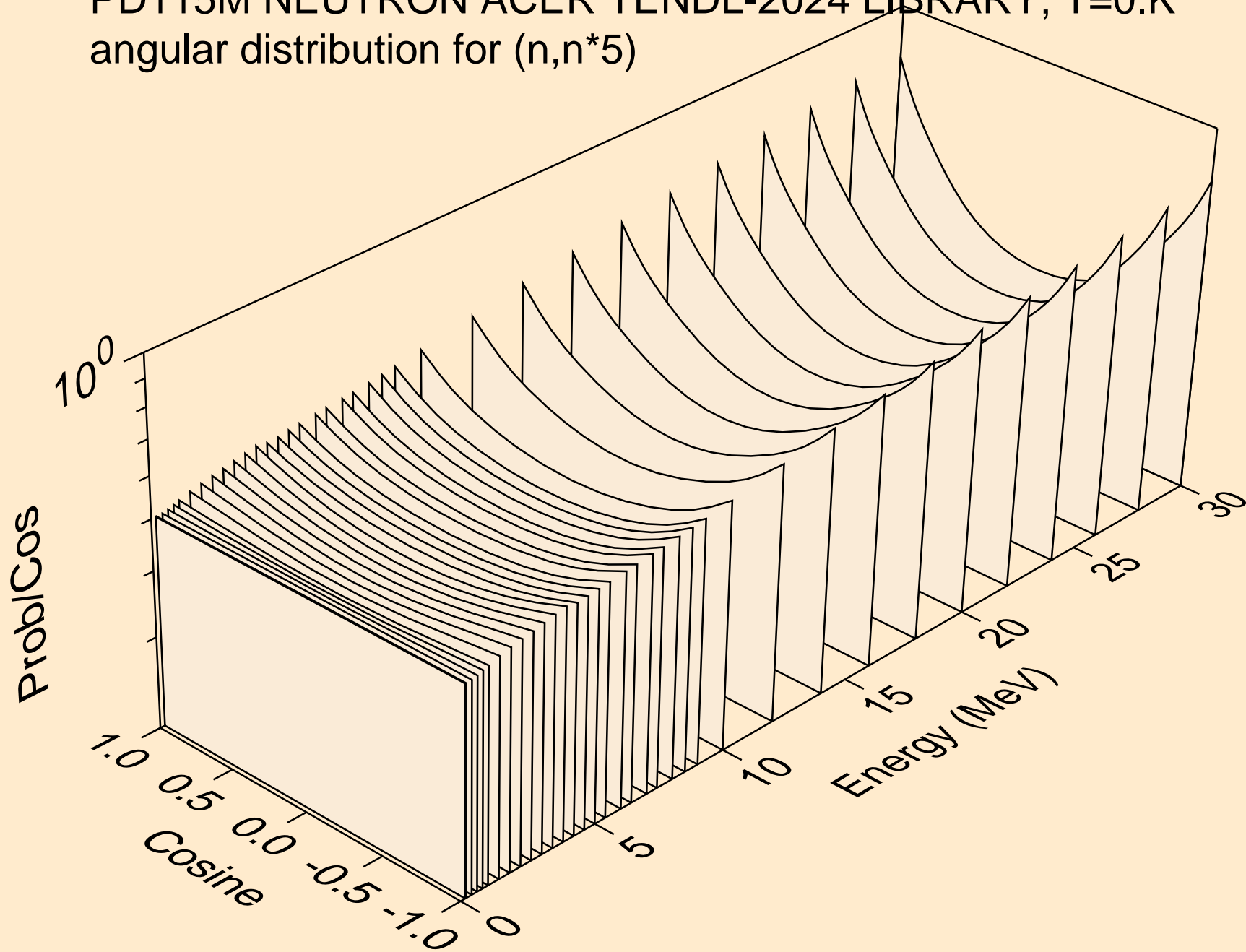

PD115M NEUTRON ACER TENDL-2024 LIBRARY; T=0.K  
angular distribution for (n,n\*6)

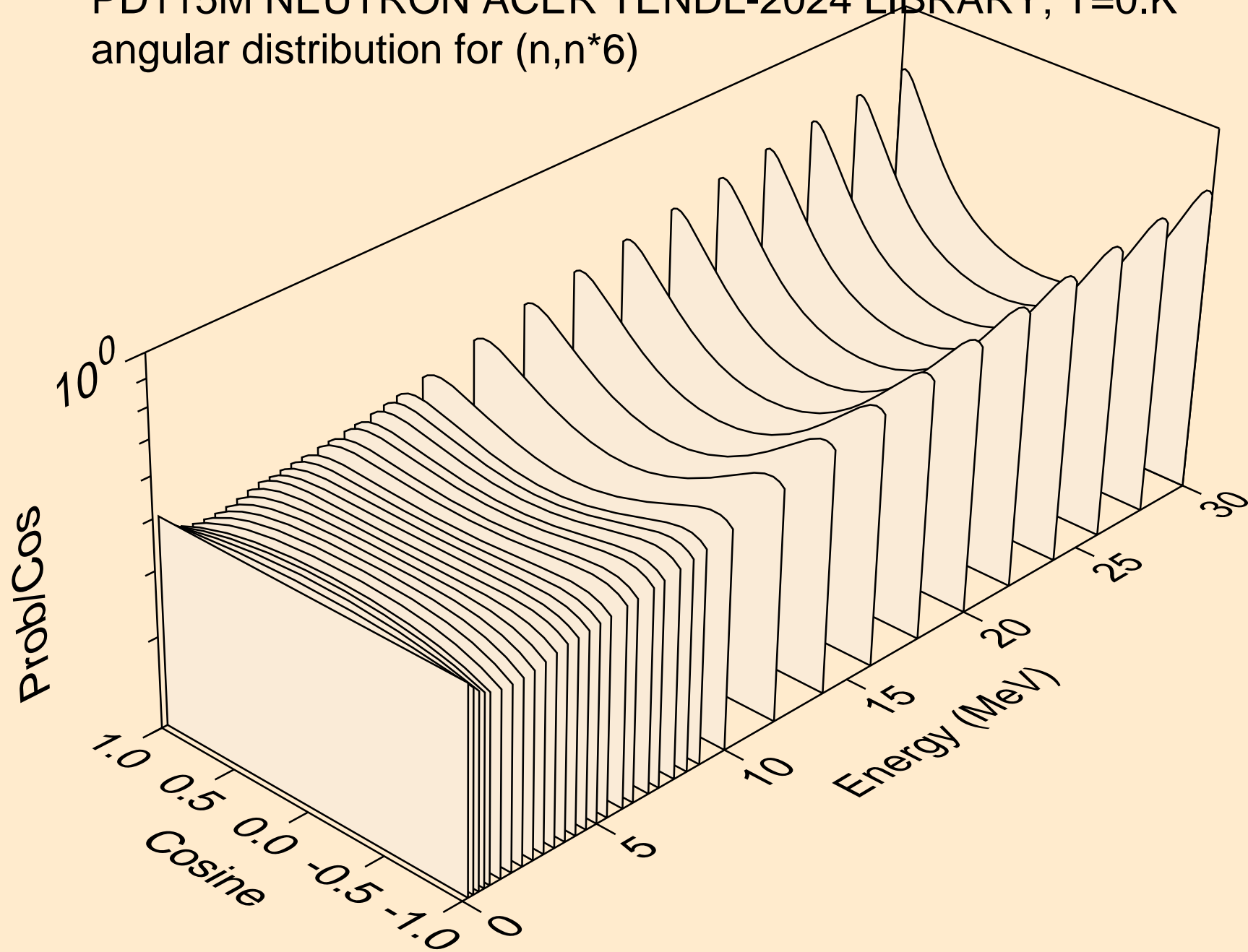



PD115M NEUTRON ACER TENDL-2024 LIBRARY; T=0.K  
angular distribution for (n,n\*7)

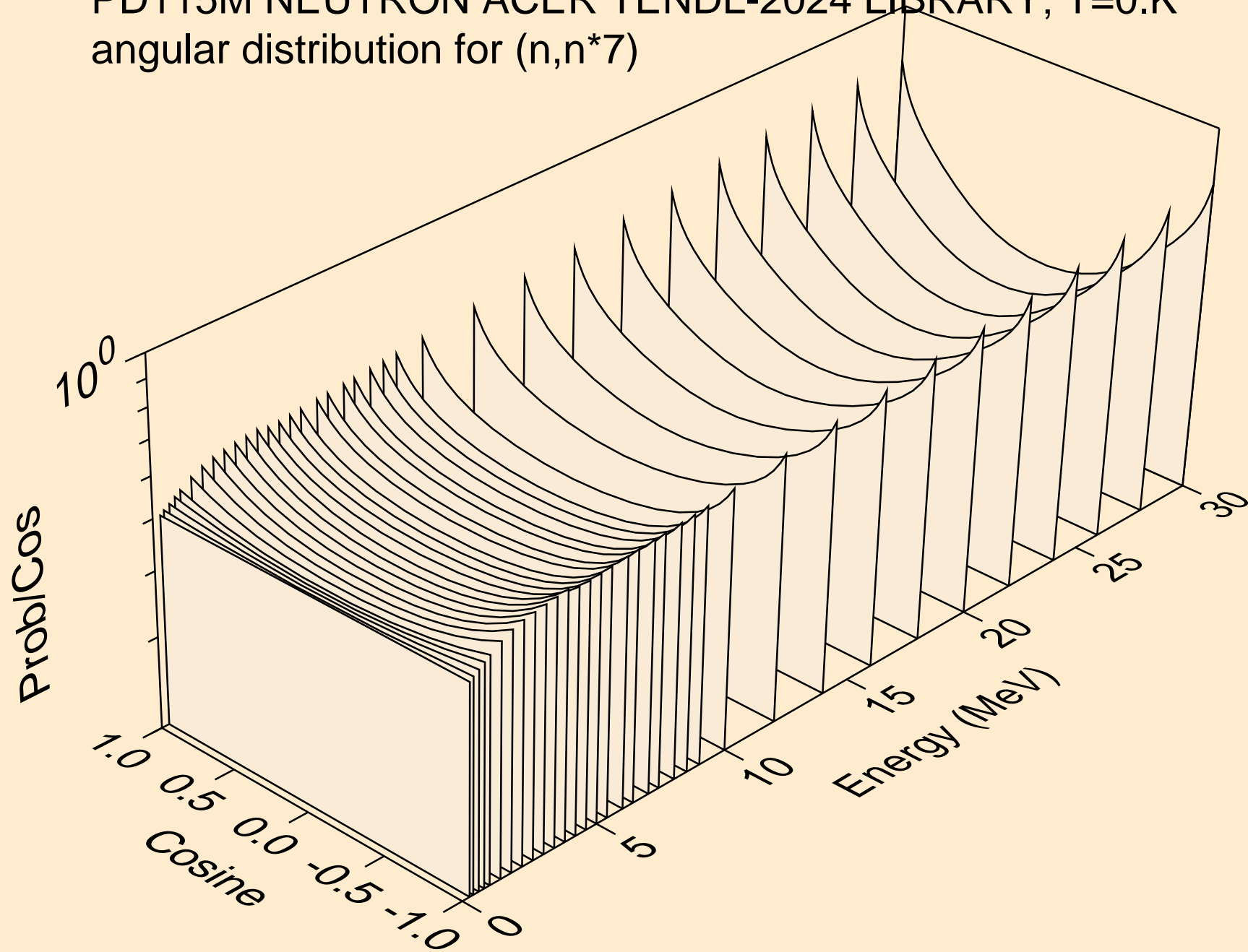

PD115M NEUTRON ACER TENDL-2024 LIBRARY; T=0.K  
angular distribution for (n,n\*8)

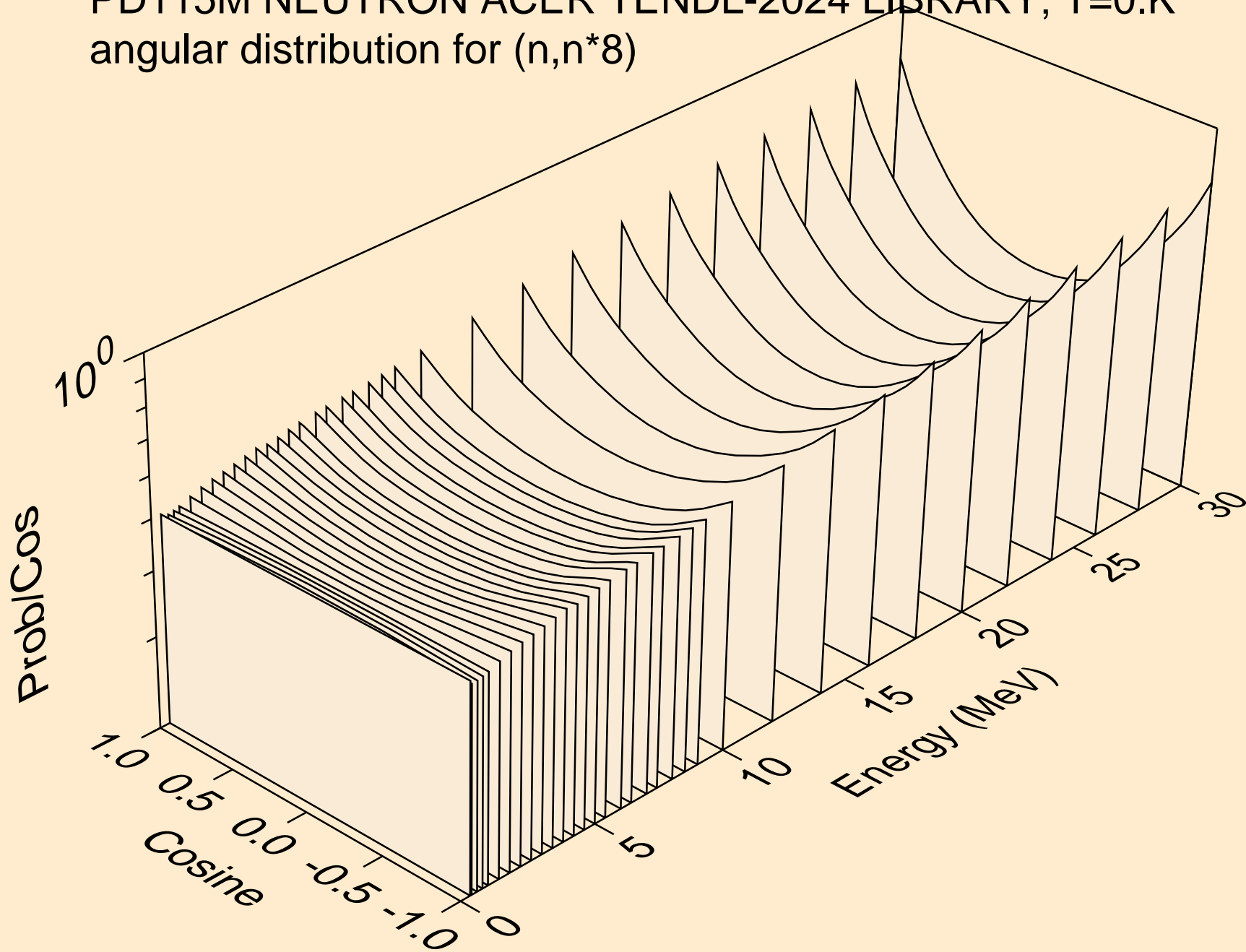

PD115M NEUTRON ACER TENDL-2024 LIBRARY; T=0.K  
angular distribution for (n,n\*9)

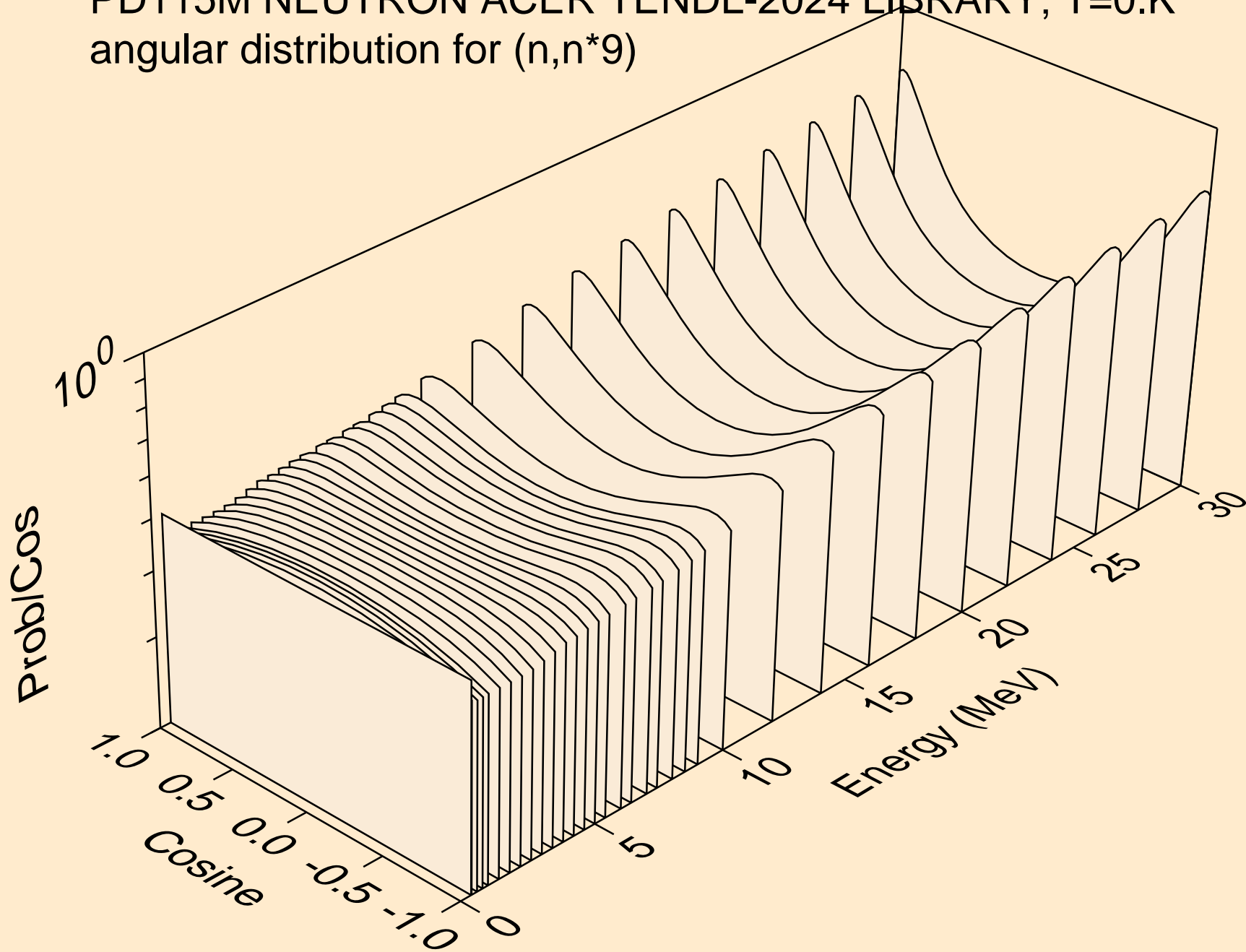

PD115M NEUTRON ACER TENDL-2024 LIBRARY; T=0.K  
angular distribution for (n,n\*10)

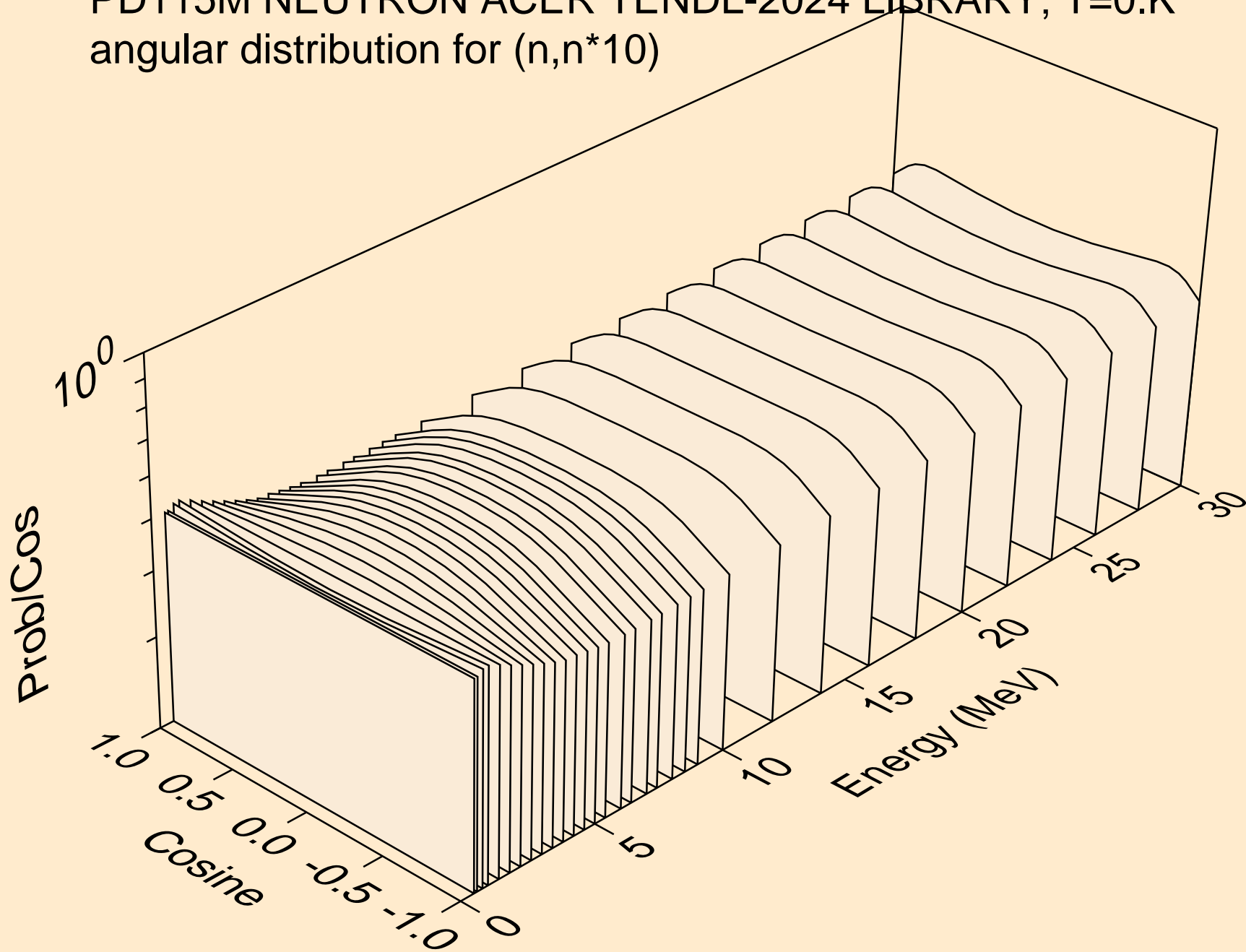

PD115M NEUTRON ACER TENDL-2024 LIBRARY; T=0.K  
angular distribution for (n,n\*11)

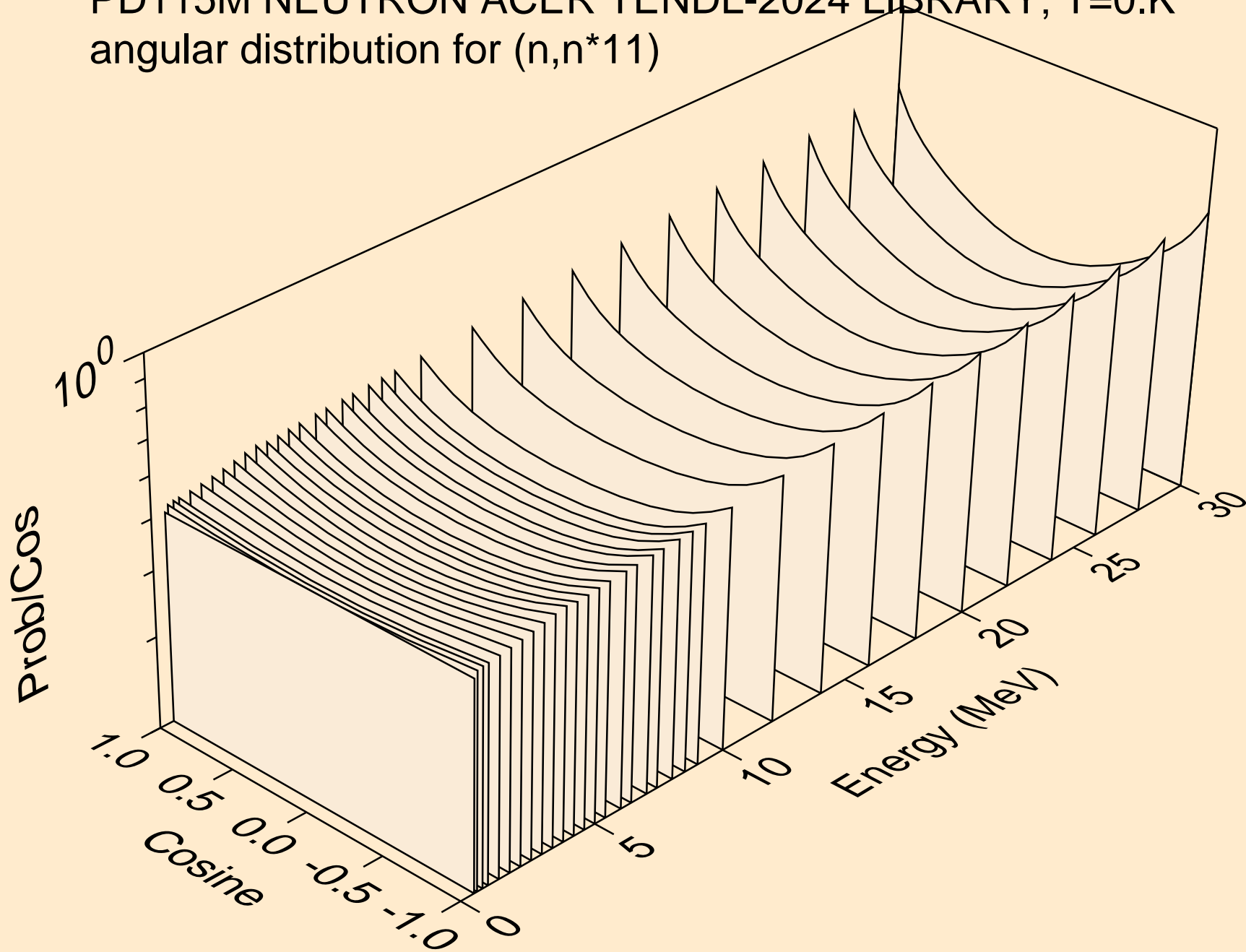

PD115M NEUTRON ACER TENDL-2024 LIBRARY; T=0.K  
angular distribution for (n,n\*12)

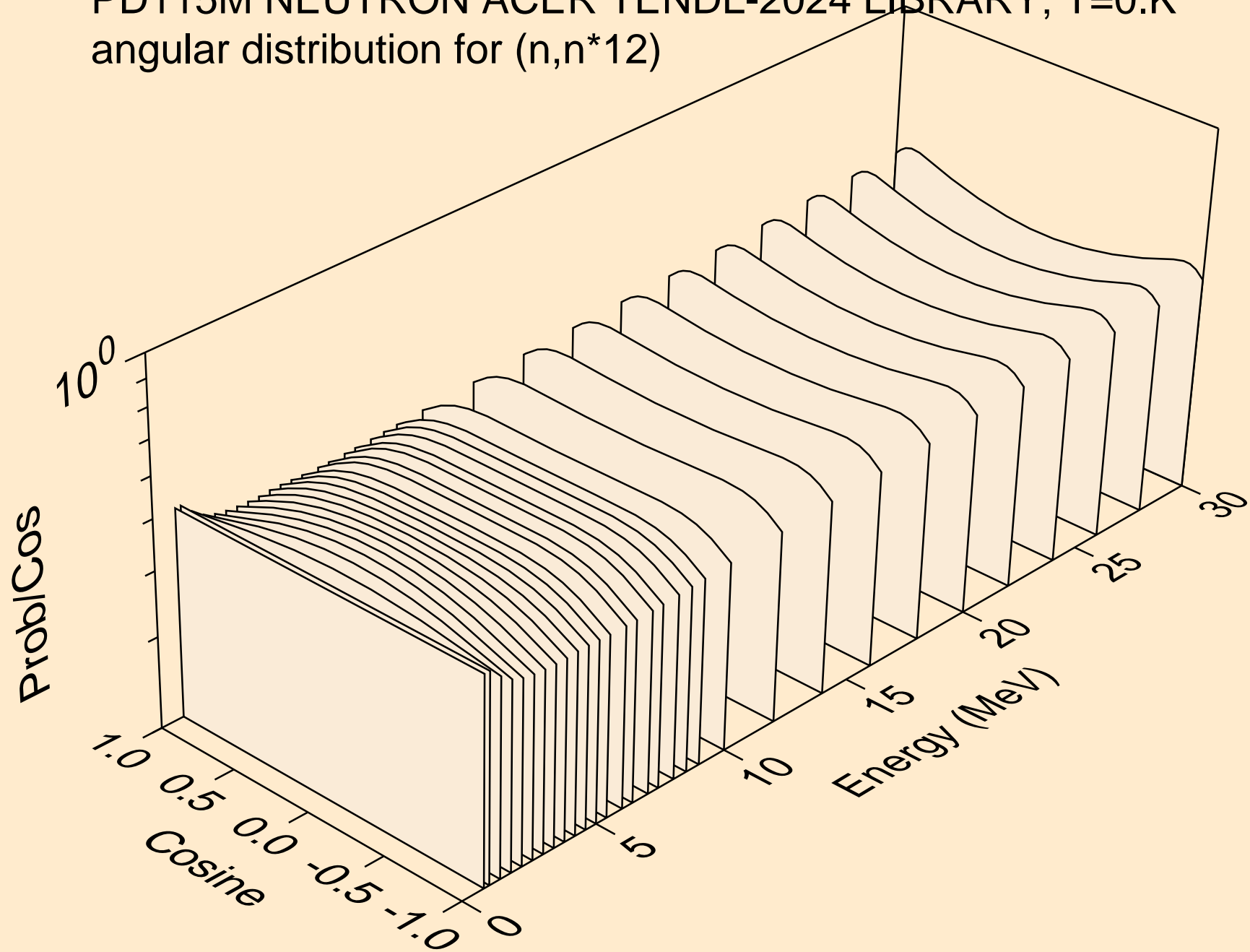

PD115M NEUTRON ACER TENDL-2024 LIBRARY; T=0.K  
angular distribution for (n,n\*13)

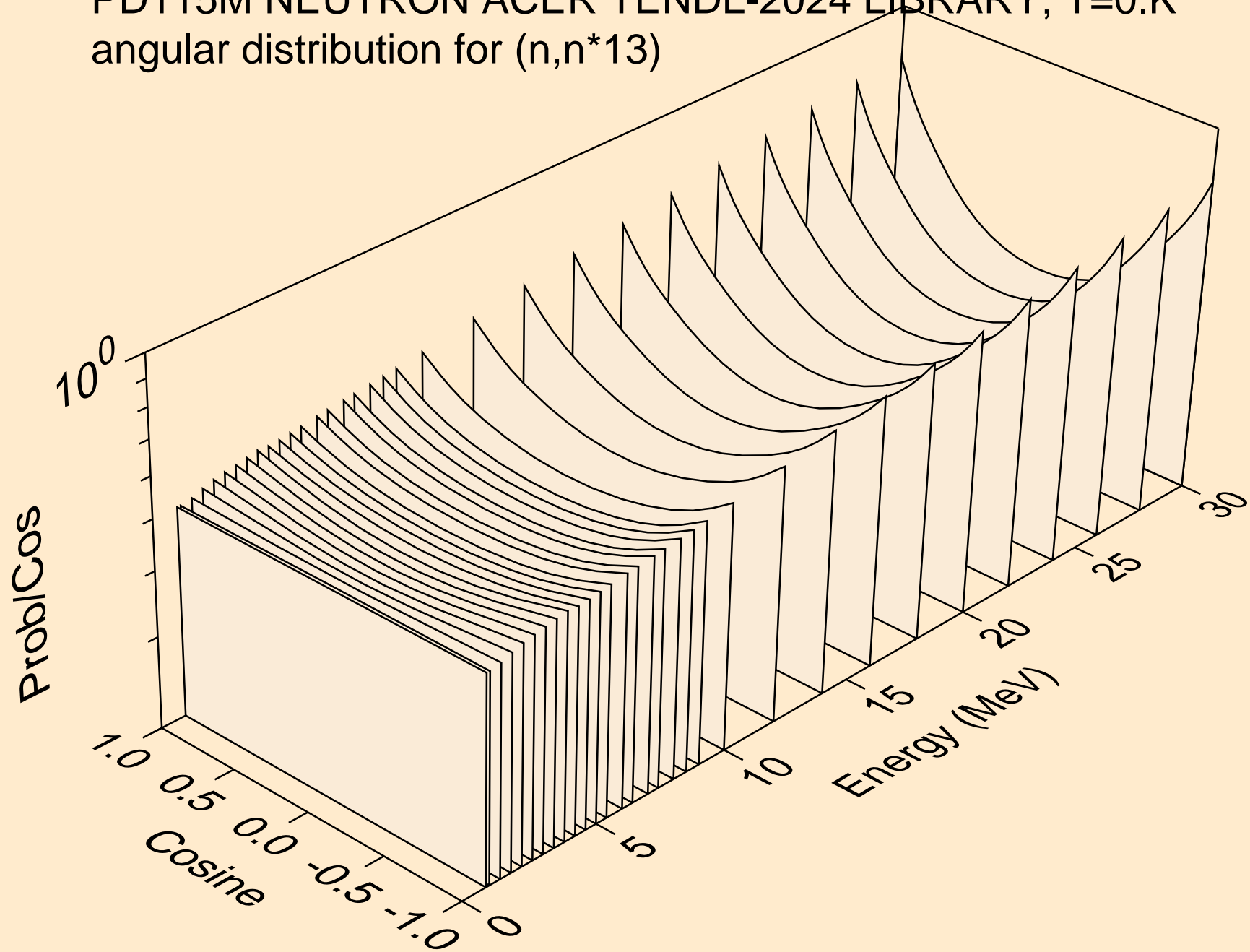

PD115M NEUTRON ACER TENDL-2024 LIBRARY; T=0.K  
angular distribution for (n,n\*14)

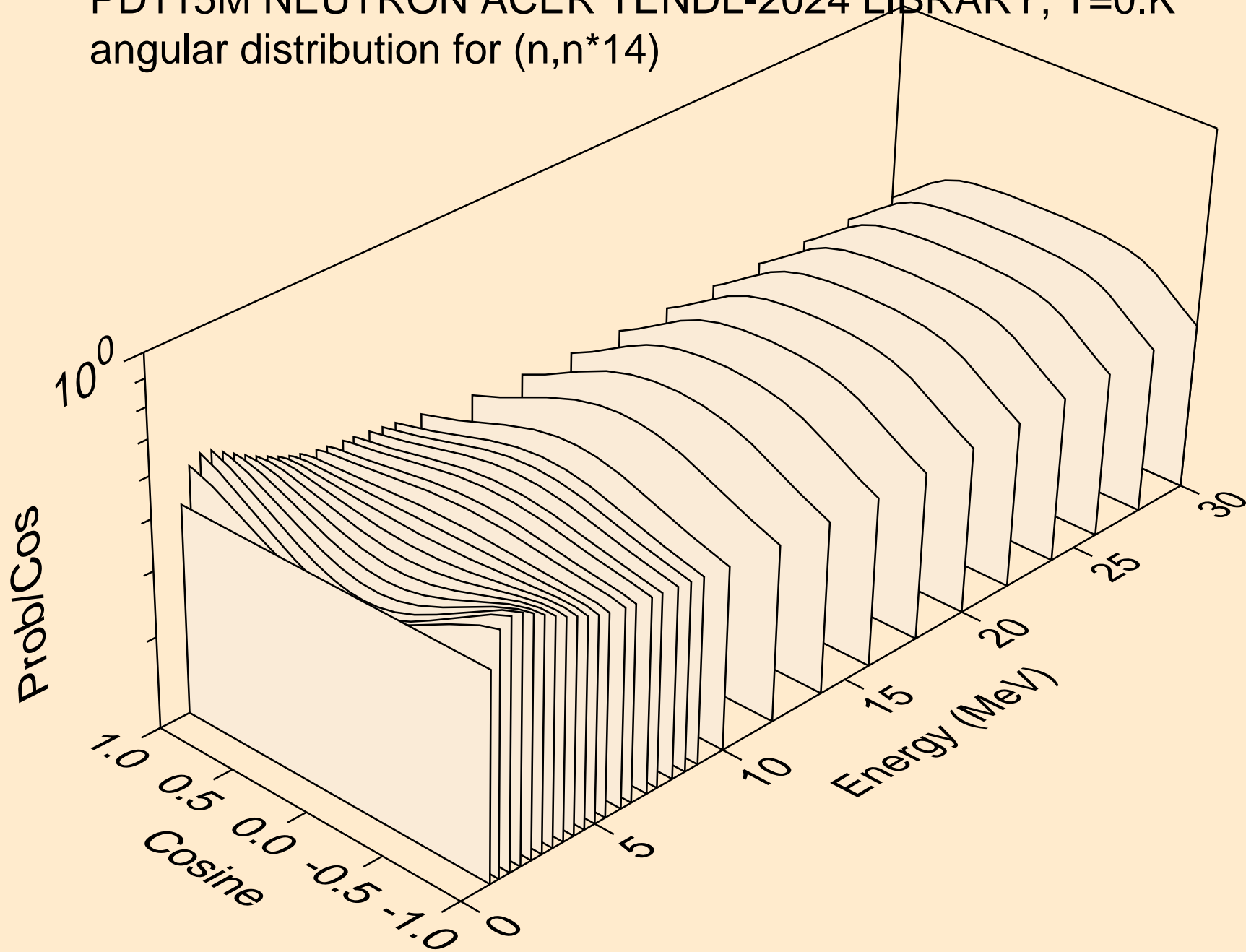



PD115M NEUTRON ACER TENDL-2024 LIBRARY; T=0.K  
angular distribution for (n,n\*15)

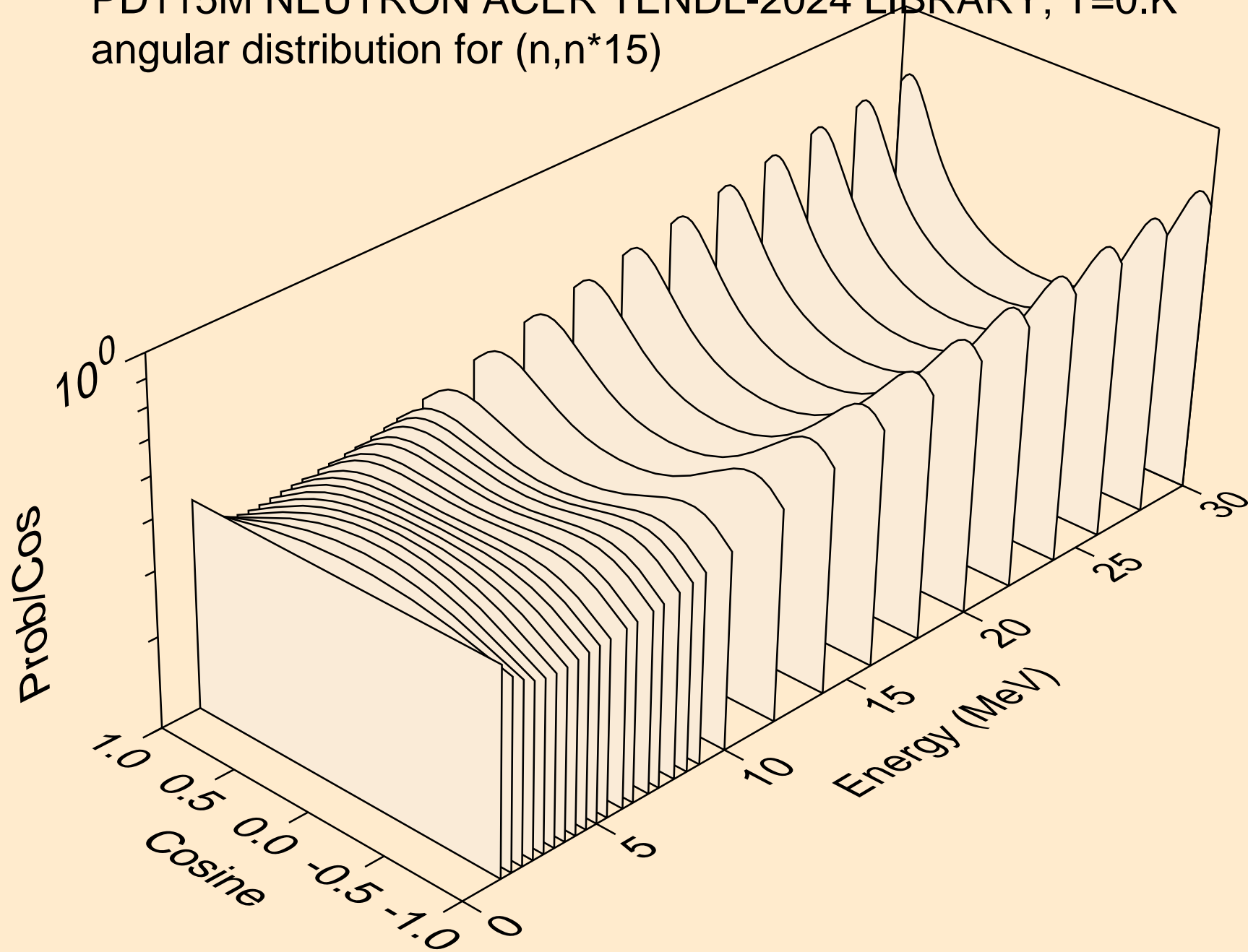

PD115M NEUTRON ACER TENDL-2024 LIBRARY; T=0.K  
angular distribution for (n,n\*16)

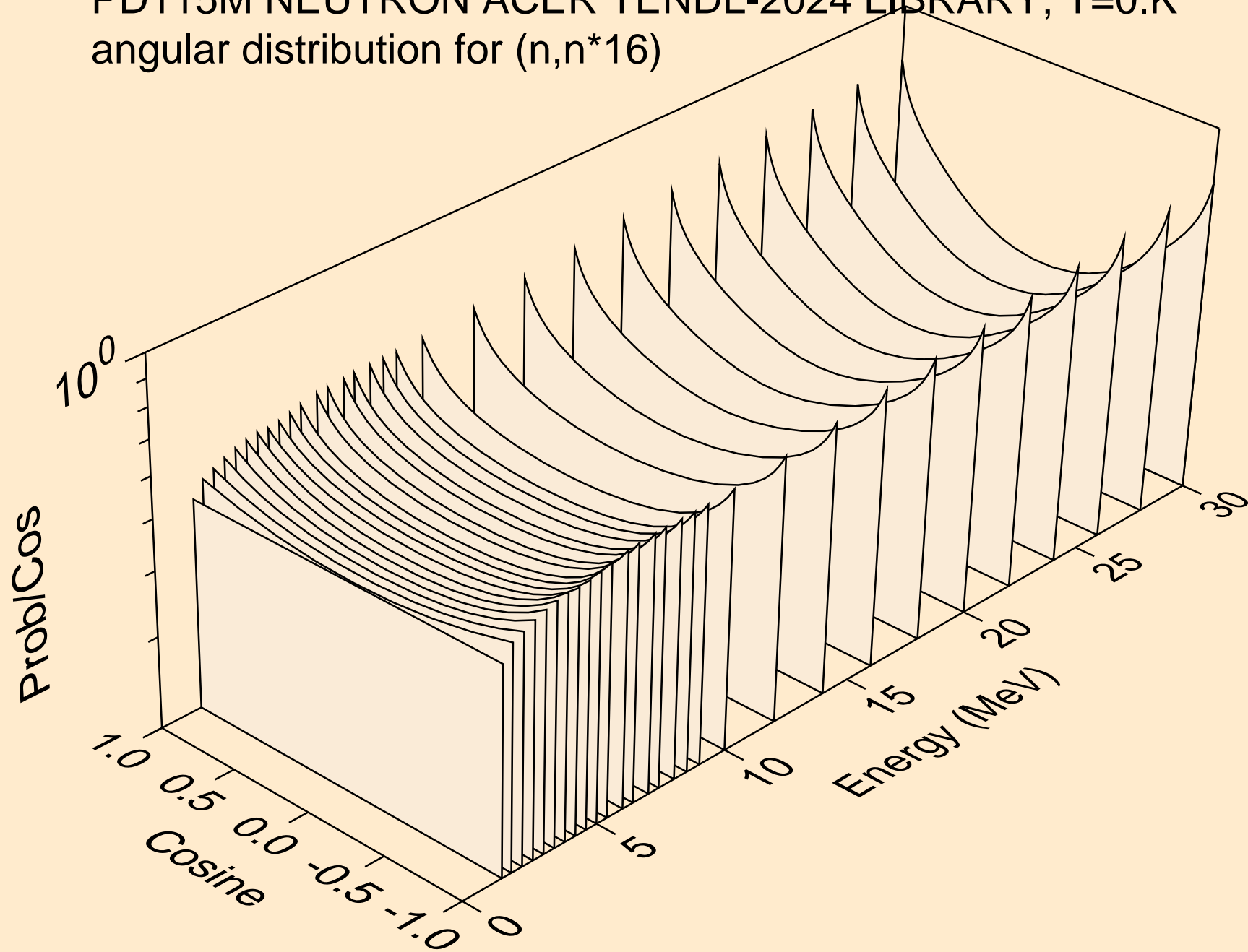

PD115M NEUTRON ACER TENDL-2024 LIBRARY; T=0.K  
angular distribution for (n,n\*17)

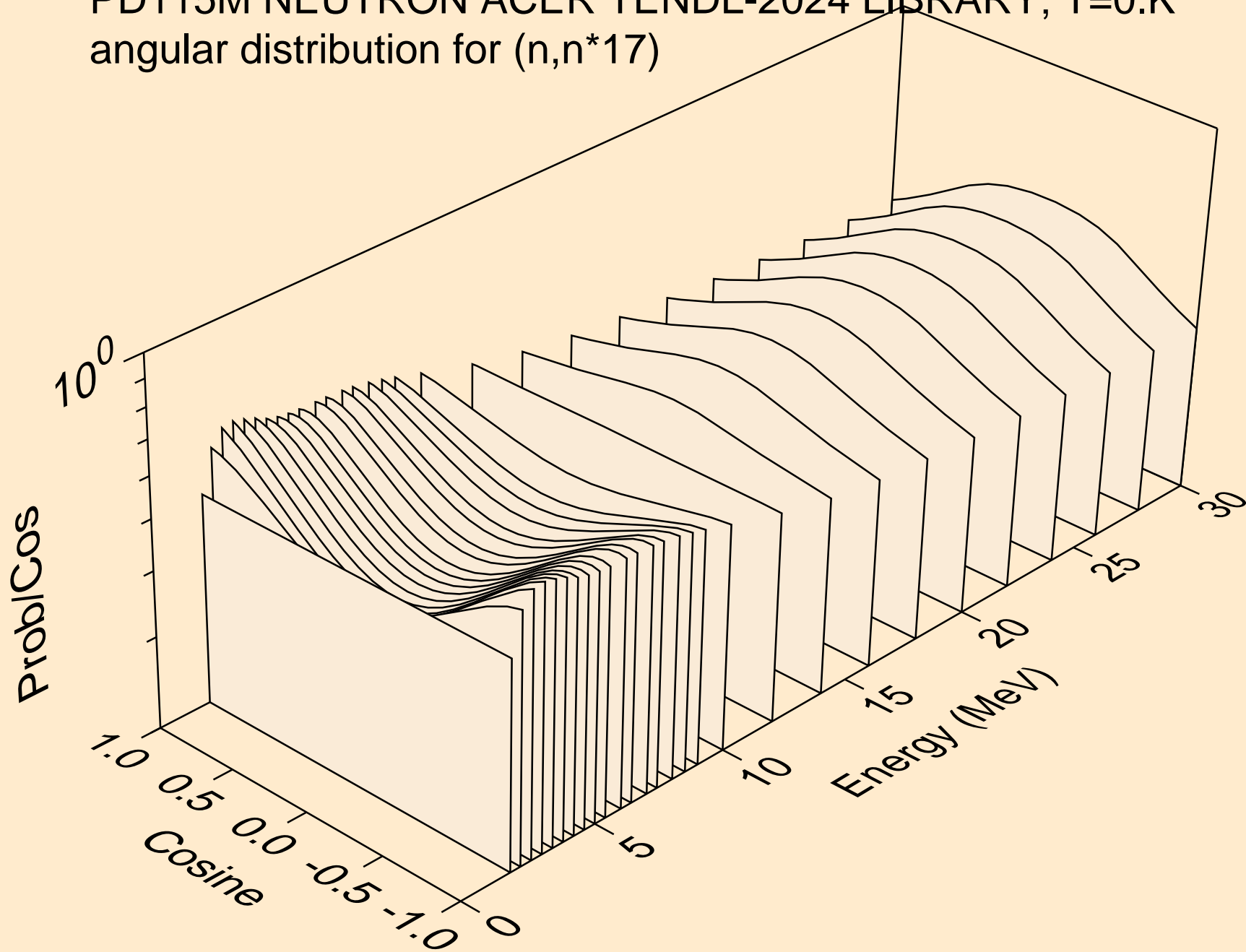

PD115M NEUTRON ACER TENDL-2024 LIBRARY; T=0.K  
angular distribution for (n,n\*18)

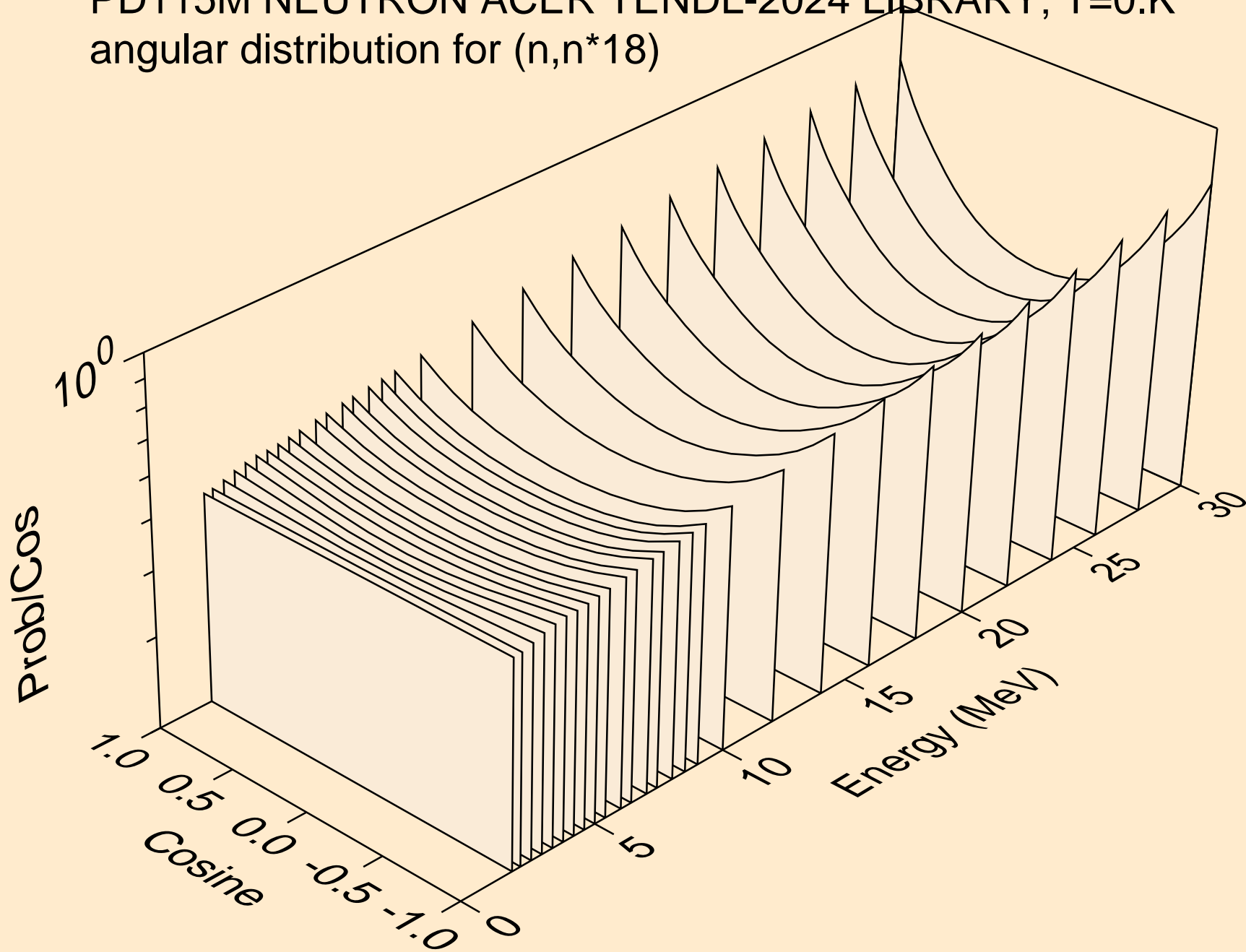

PD115M NEUTRON ACER TENDL-2024 LIBRARY; T=0.K  
angular distribution for (n,n\*19)

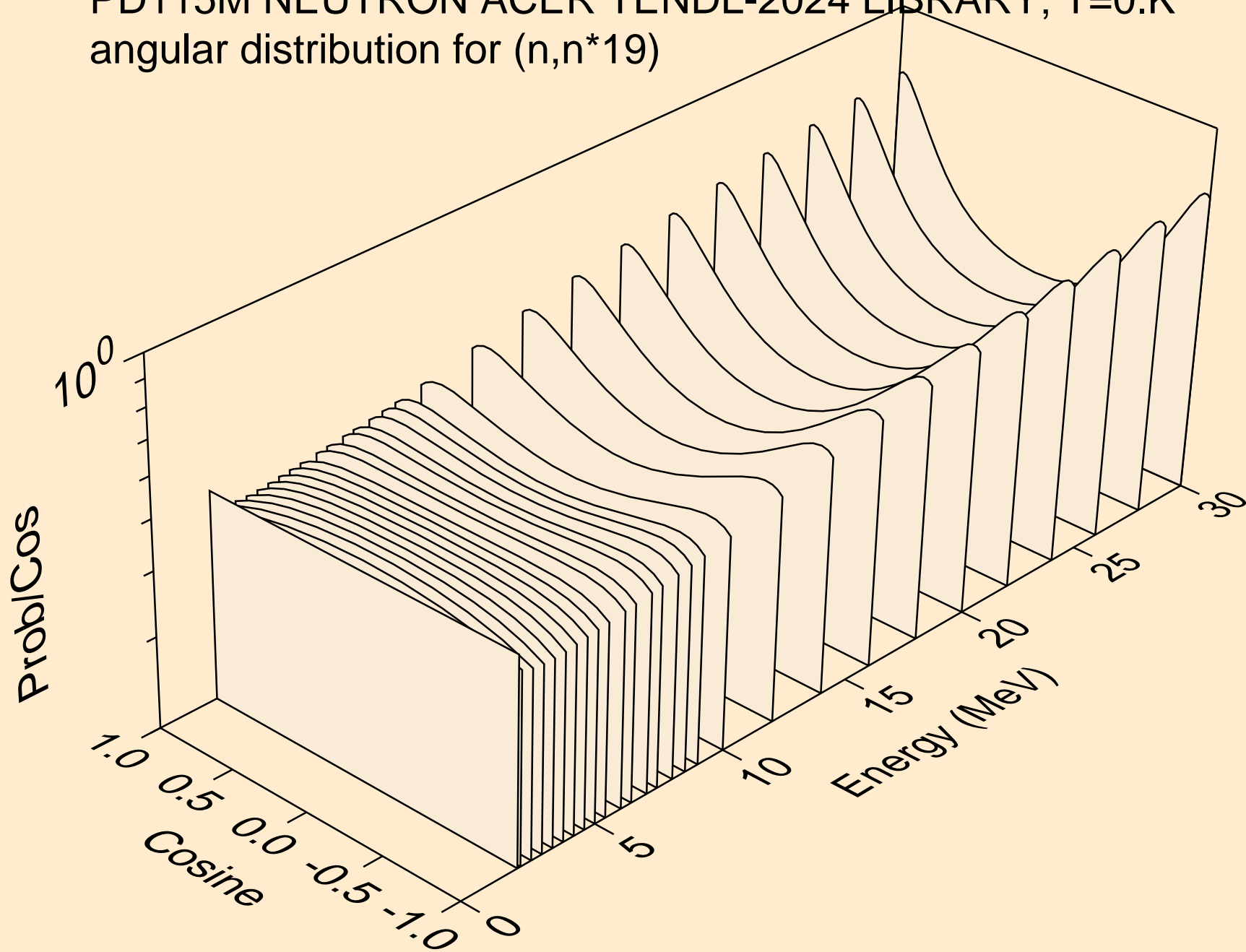

PD115M NEUTRON ACER TENDL-2024 LIBRARY; T=0.K  
angular distribution for (n,n\*20)

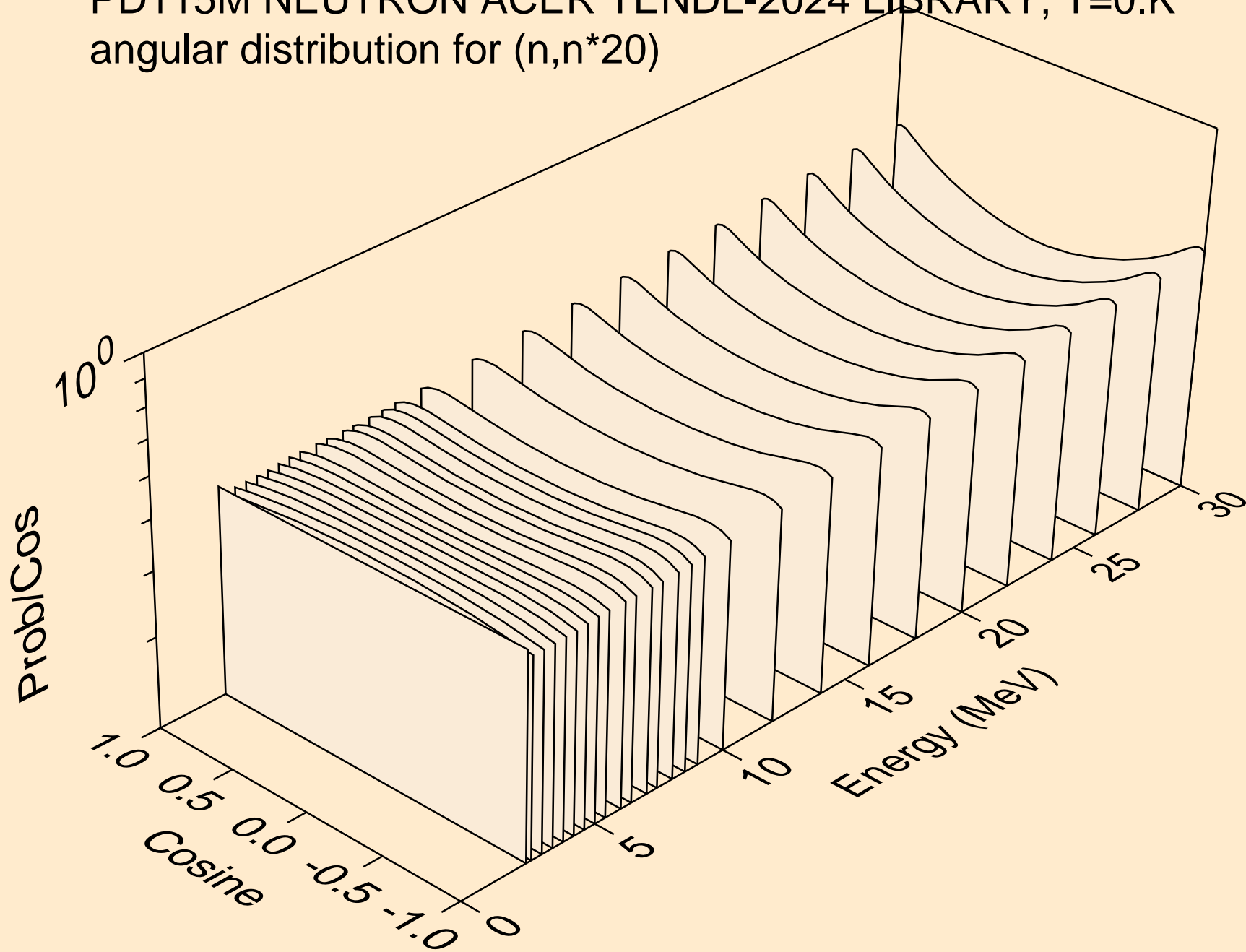

PD115M NEUTRON ACER TENDL-2024 LIBRARY; T=0.K  
angular distribution for (n,n\*21)

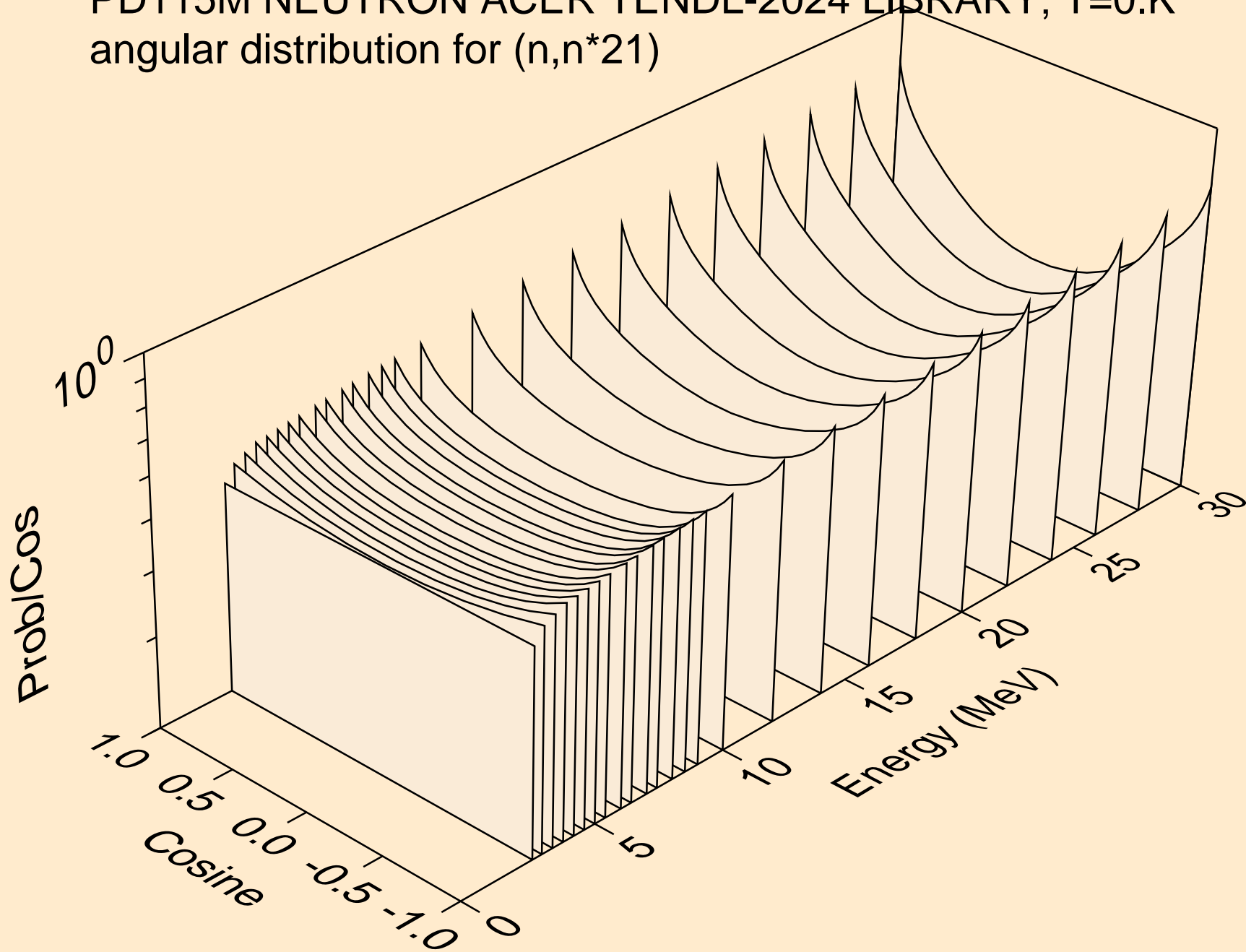

PD115M NEUTRON ACER TENDL-2024 LIBRARY; T=0.K  
angular distribution for (n,n\*22)

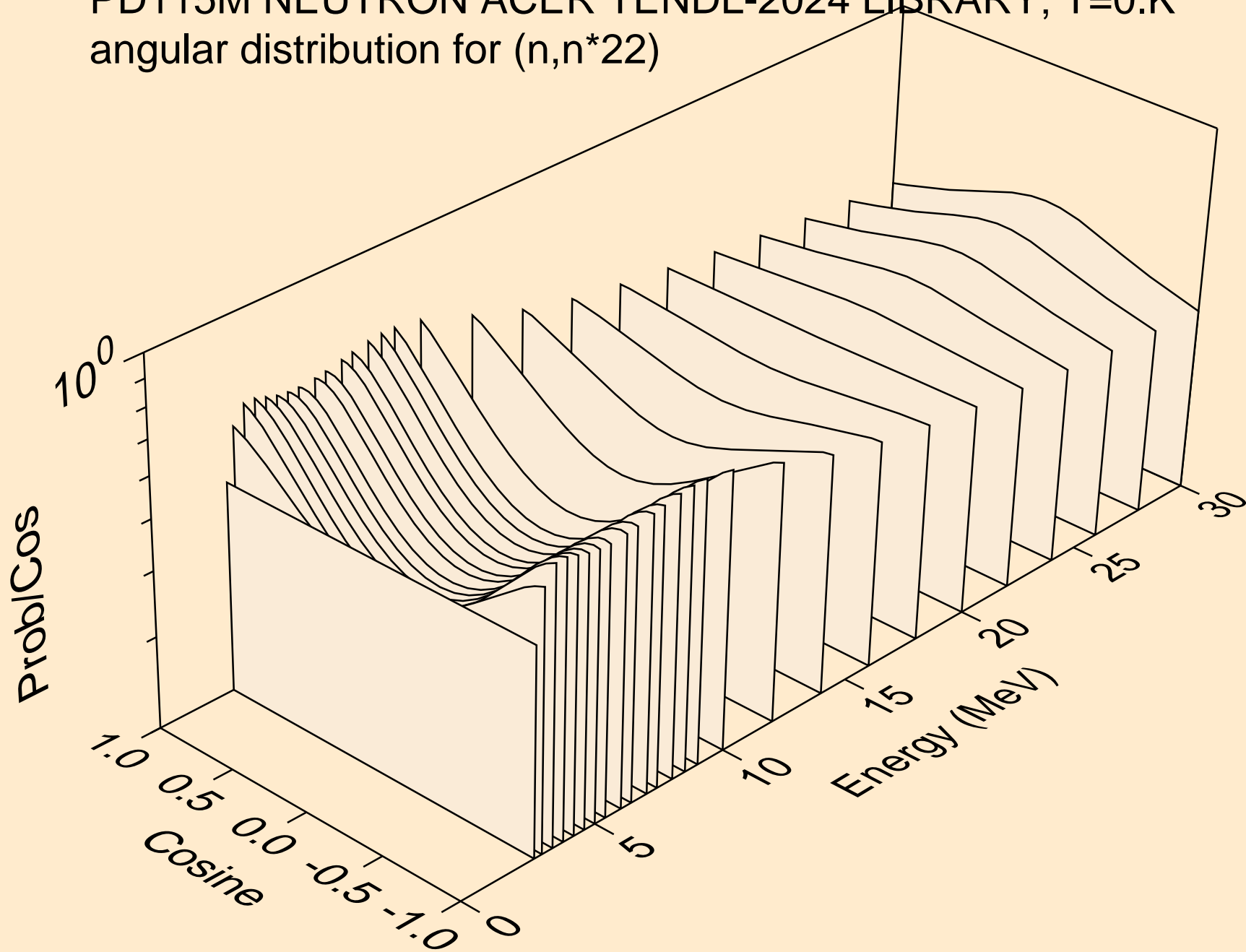



PD115M NEUTRON ACER TENDL-2024 LIBRARY; T=0.K  
angular distribution for (n,n\*23)

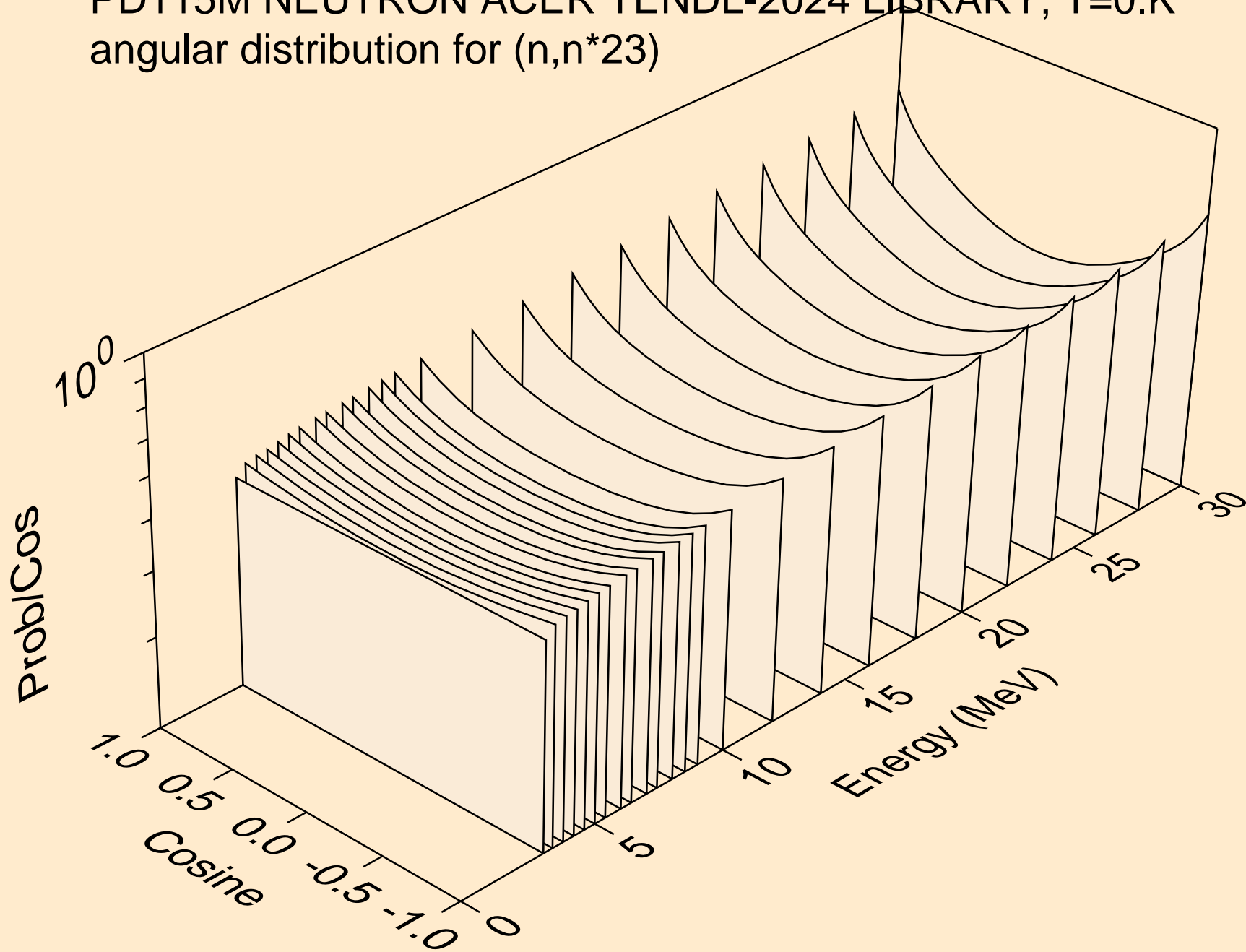

PD115M NEUTRON ACER TENDL-2024 LIBRARY; T=0.K  
angular distribution for (n,n\*24)

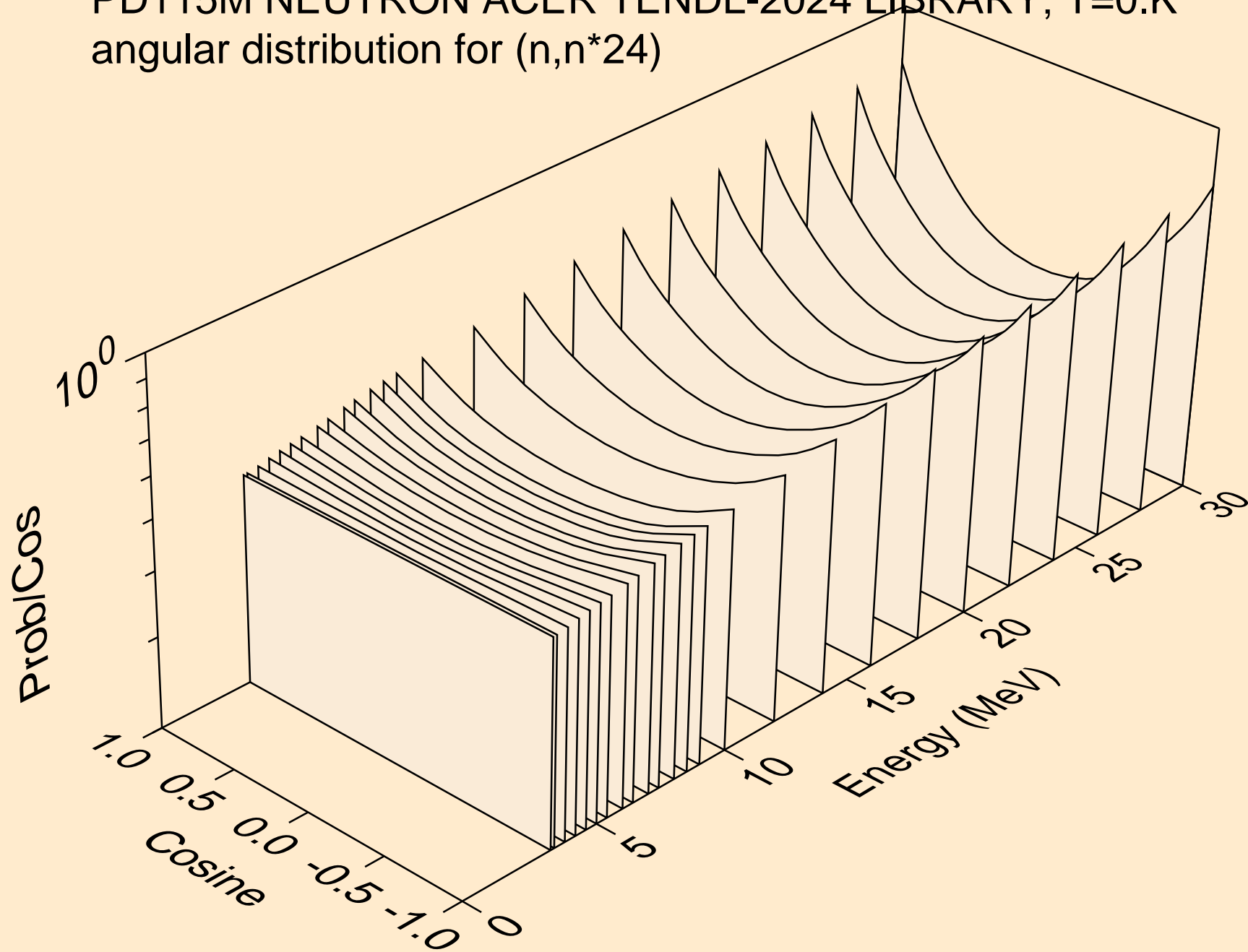

PD115M NEUTRON ACER TENDL-2024 LIBRARY; T=0.K  
Neutron emission for (n,x)

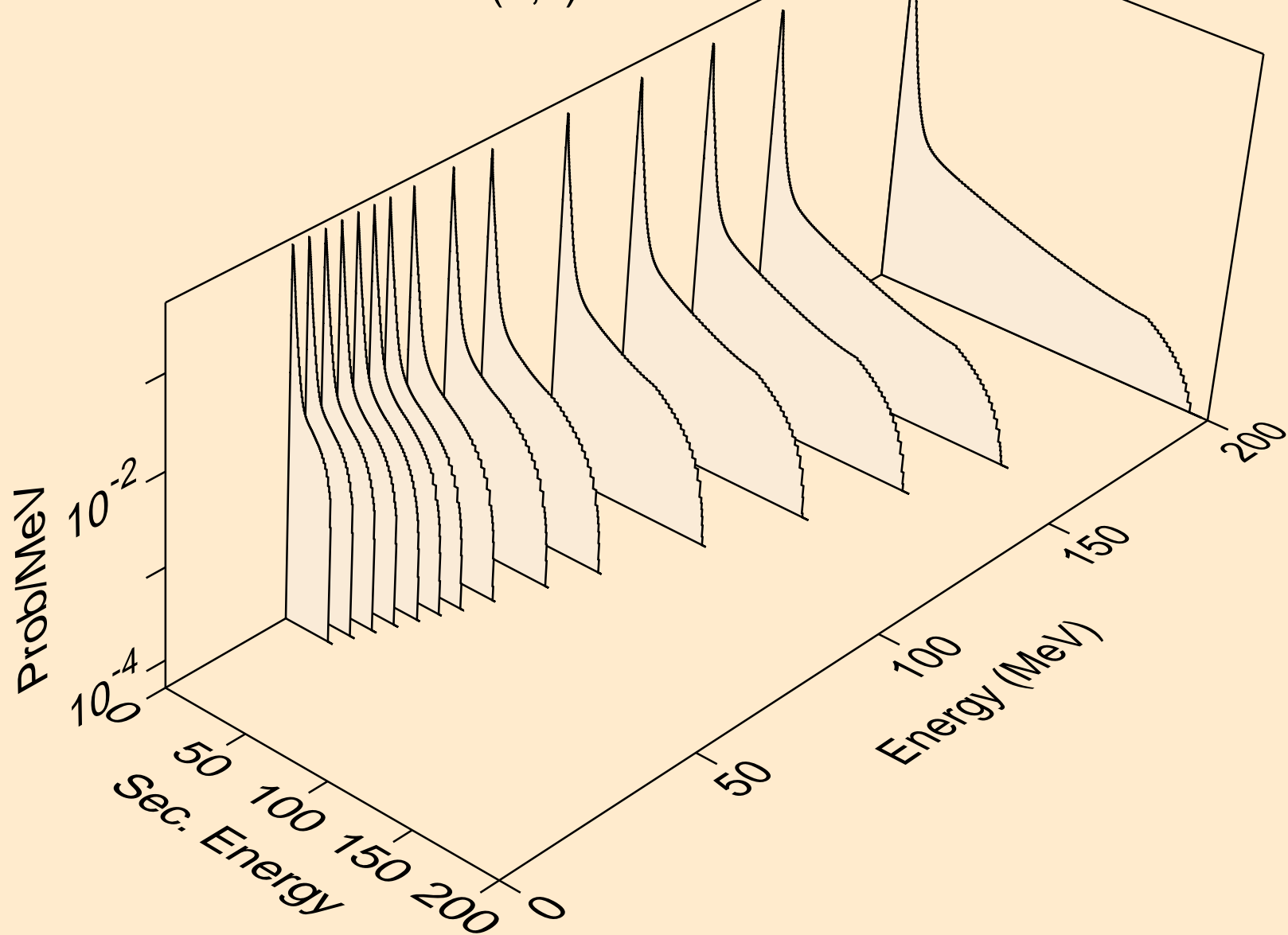

PD115M NEUTRON ACER TENDL-2024 LIBRARY; T=0.K  
Neutron emission for (n,2nd)

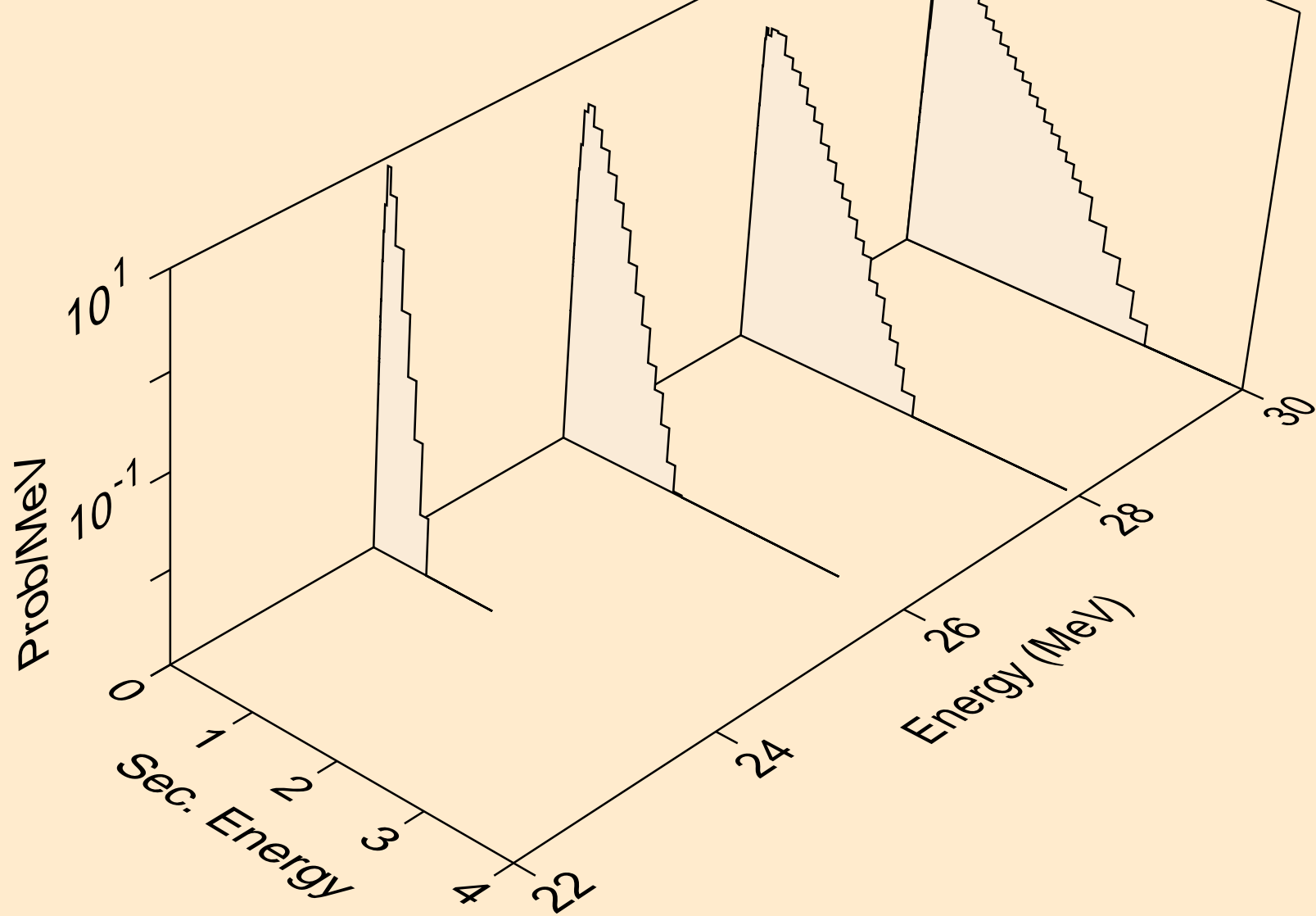

PD115M NEUTRON ACER TENDL-2024 LIBRARY; T=0.K  
Neutron emission for (n,2n)

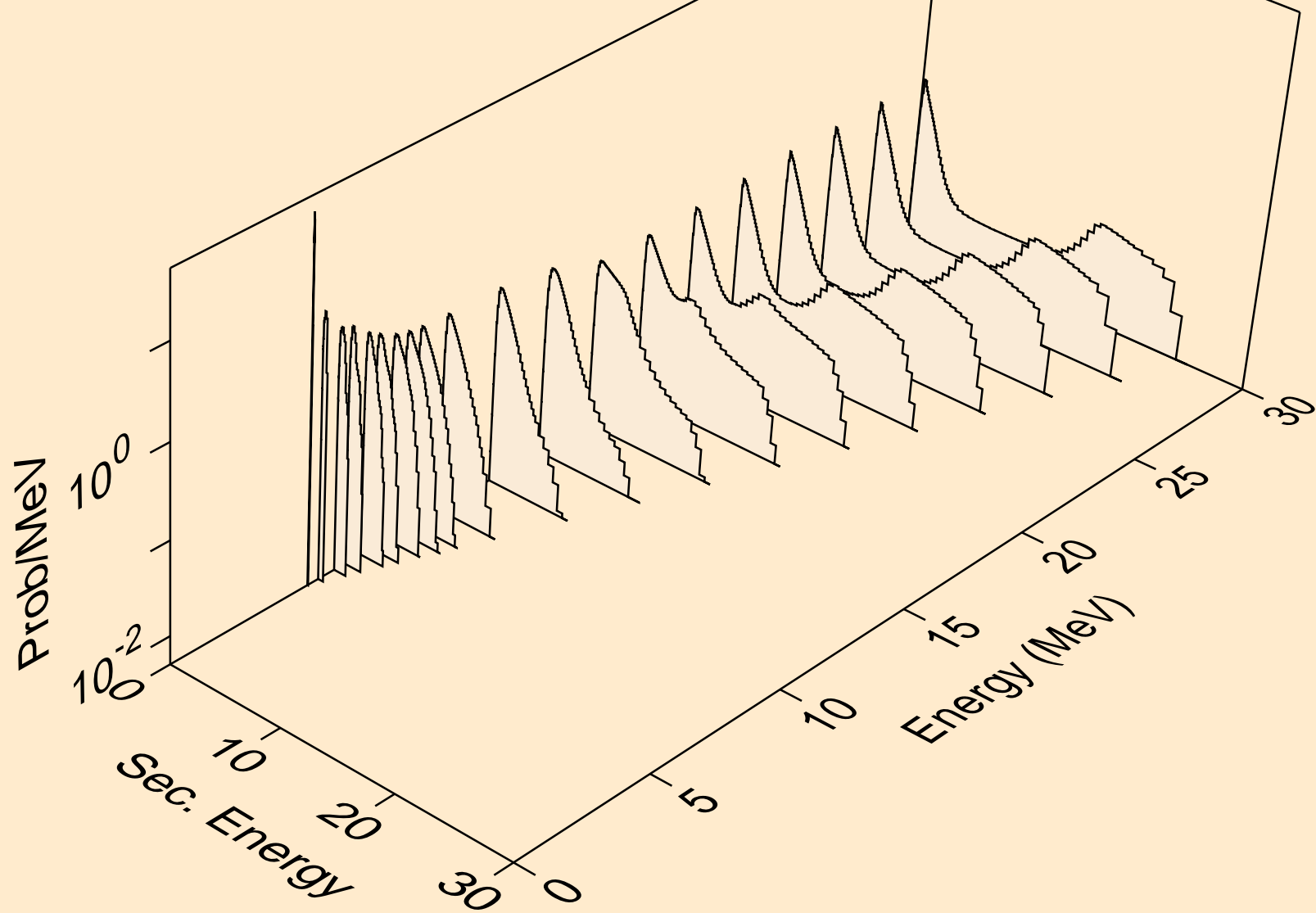

PD115M NEUTRON ACER TENDL-2024 LIBRARY; T=0.K  
Neutron emission for (n,3n)

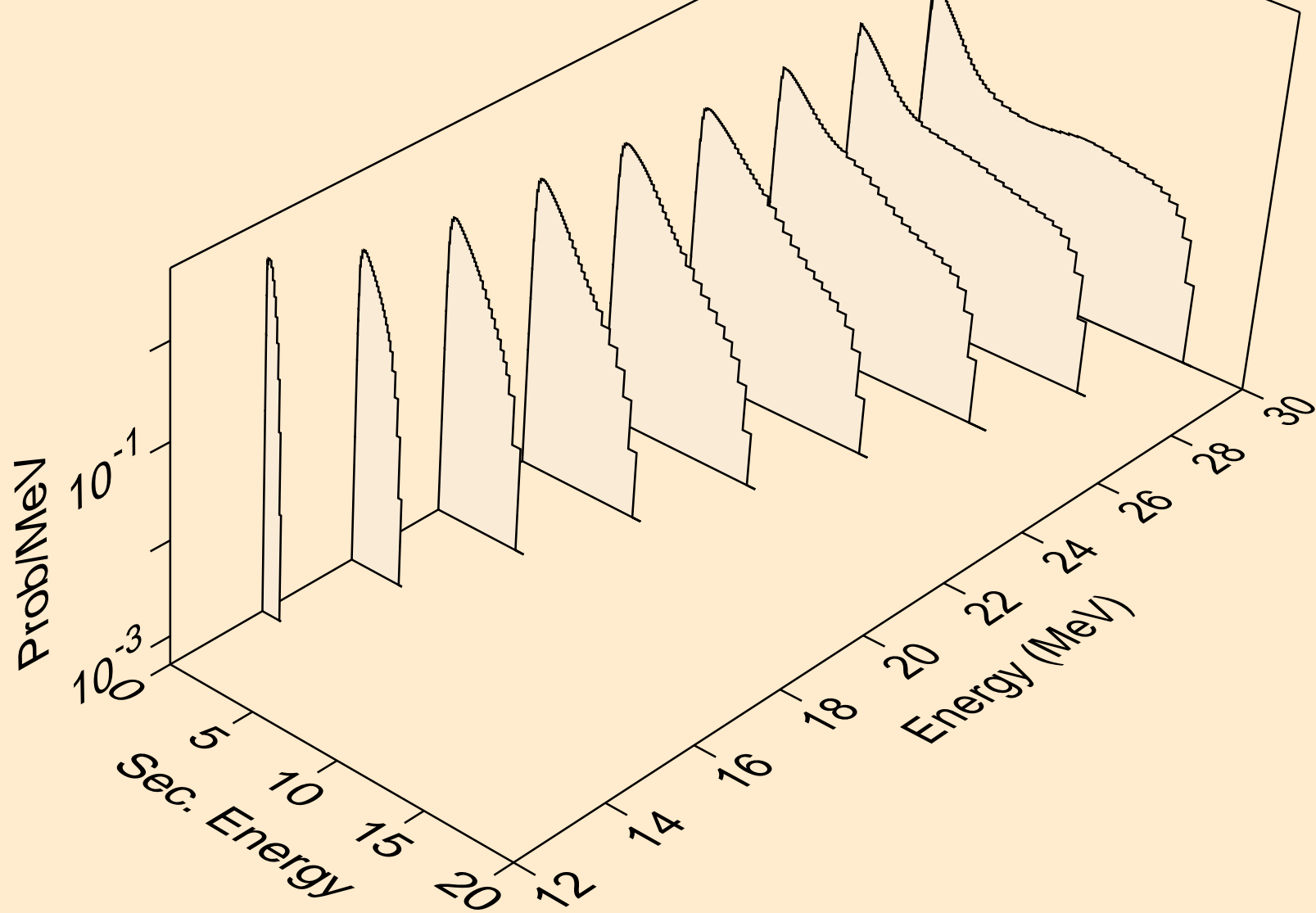

PD115M NEUTRON ACER TENDL-2024 LIBRARY; T=0.K  
Neutron emission for (n,n\*)a

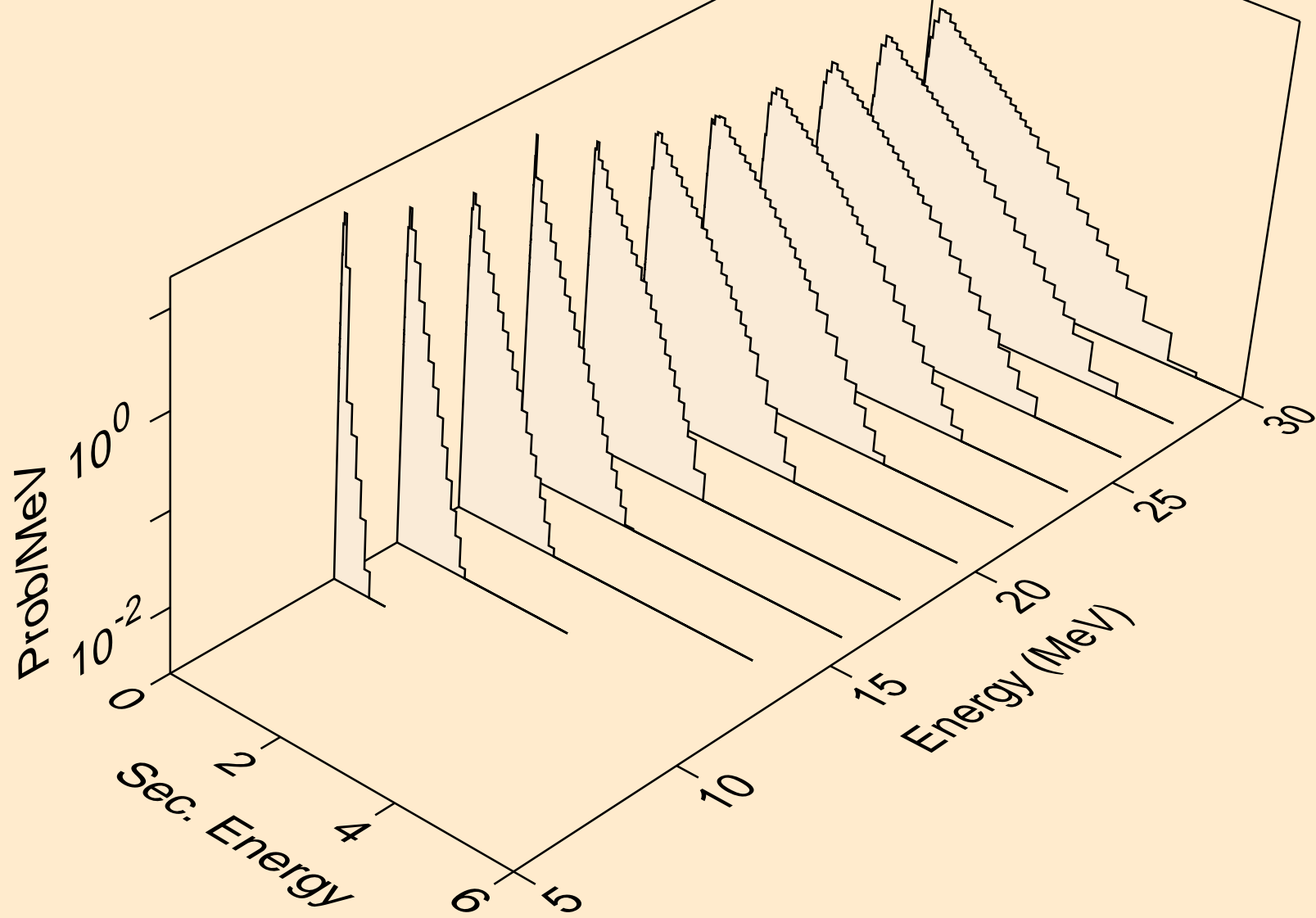

PD115M NEUTRON ACER TENDL-2024 LIBRARY; T=0.K  
Neutron emission for (n,2n)a

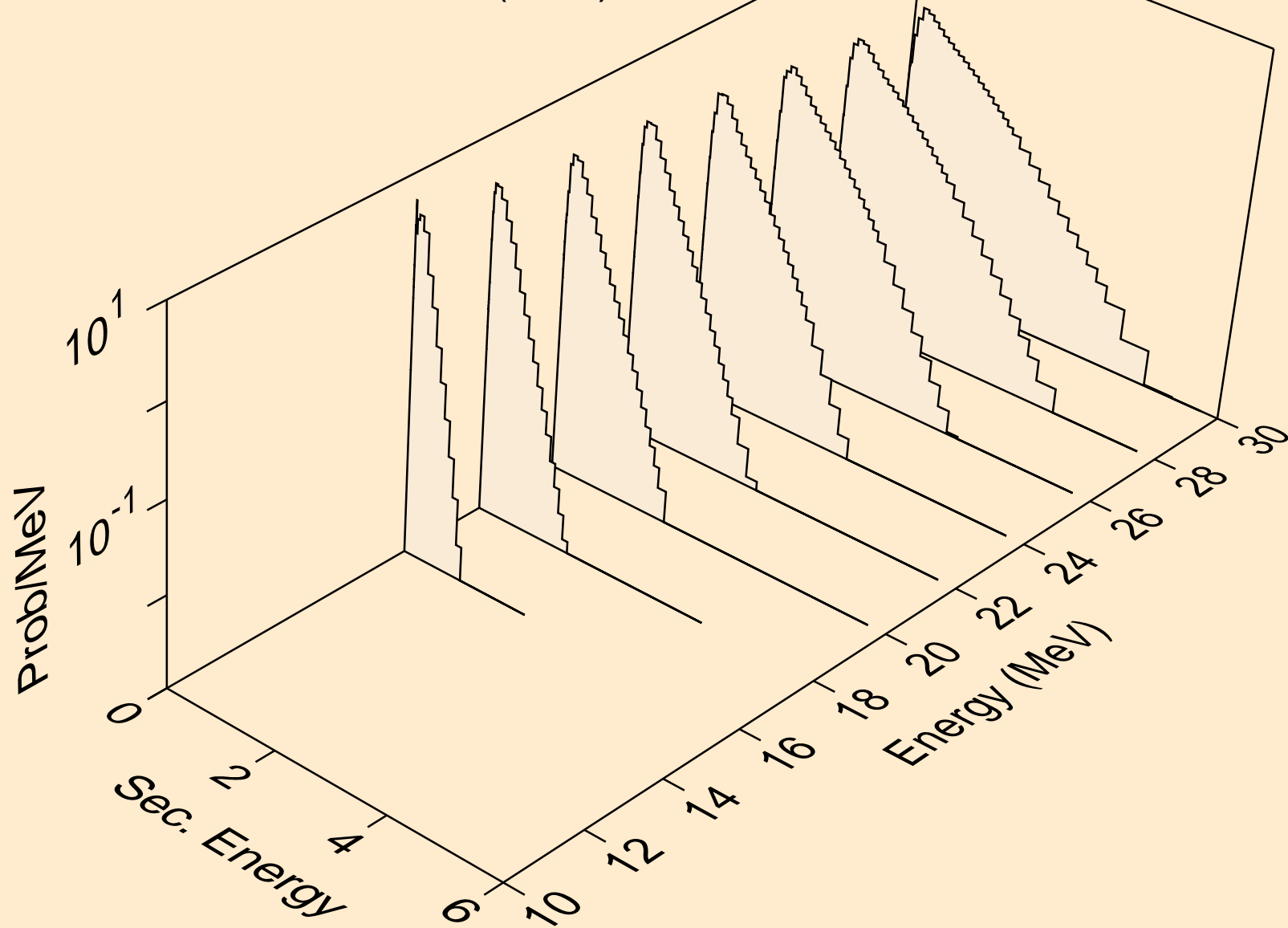



PD115M NEUTRON ACER TENDL-2024 LIBRARY; T=0.K  
Neutron emission for (n,3n)a

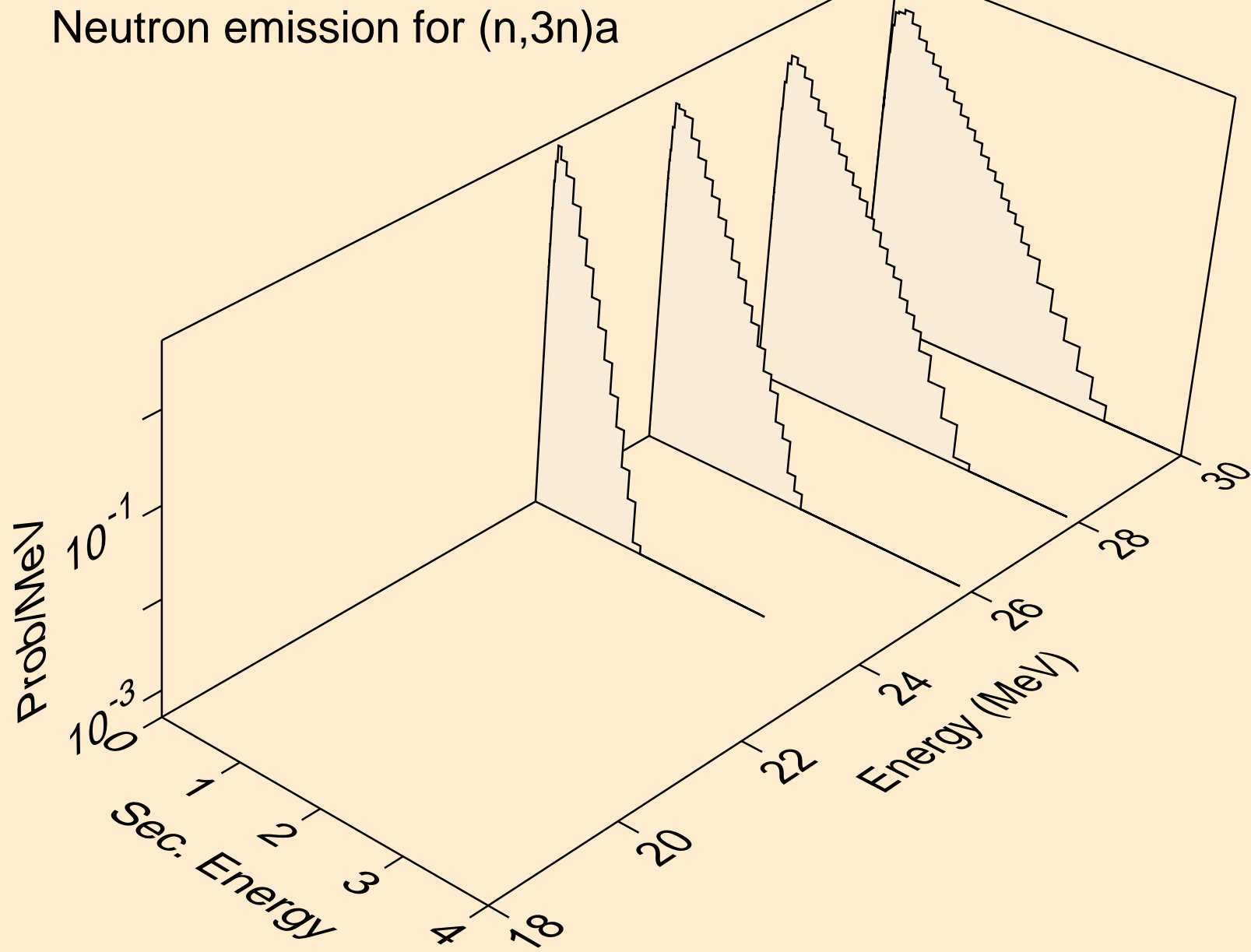

PD115M NEUTRON ACER TENDL-2024 LIBRARY; T=0.K  
Neutron emission for (n,n\*)p

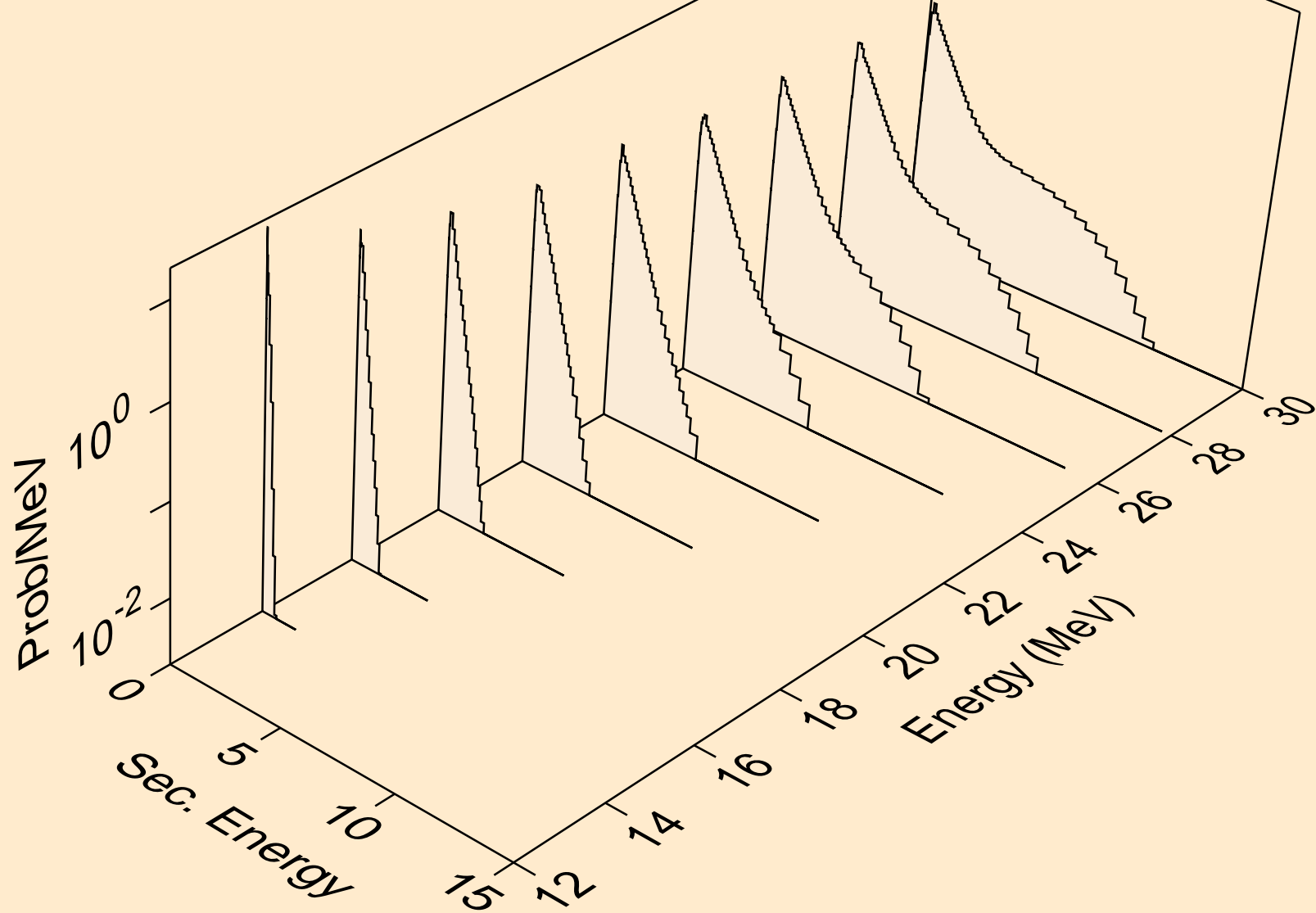

PD115M NEUTRON ACER TENDL-2024 LIBRARY; T=0.K  
Neutron emission for (n,n\*)d

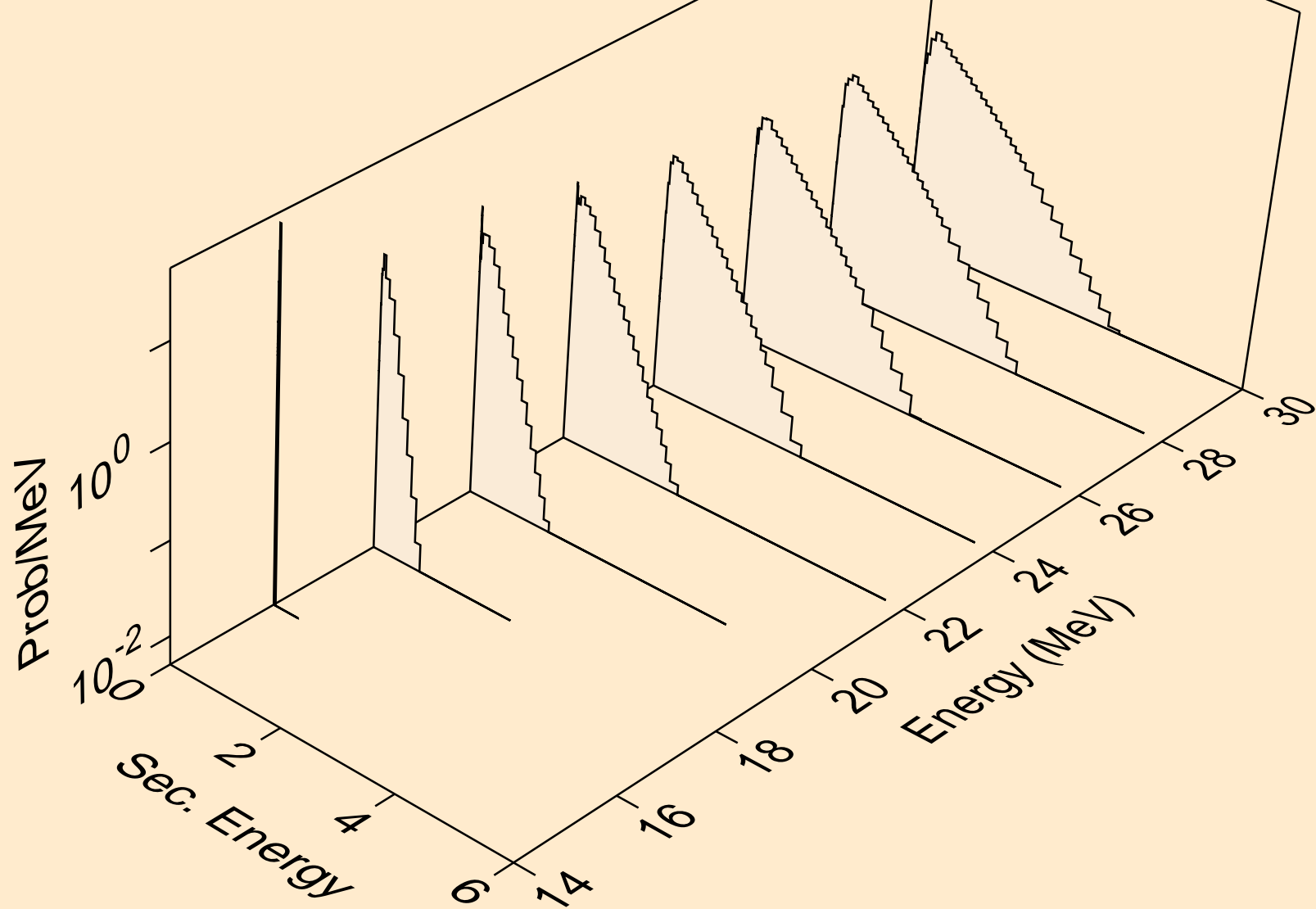

PD115M NEUTRON ACER TENDL-2024 LIBRARY; T=0.K  
Neutron emission for (n,n\*)t

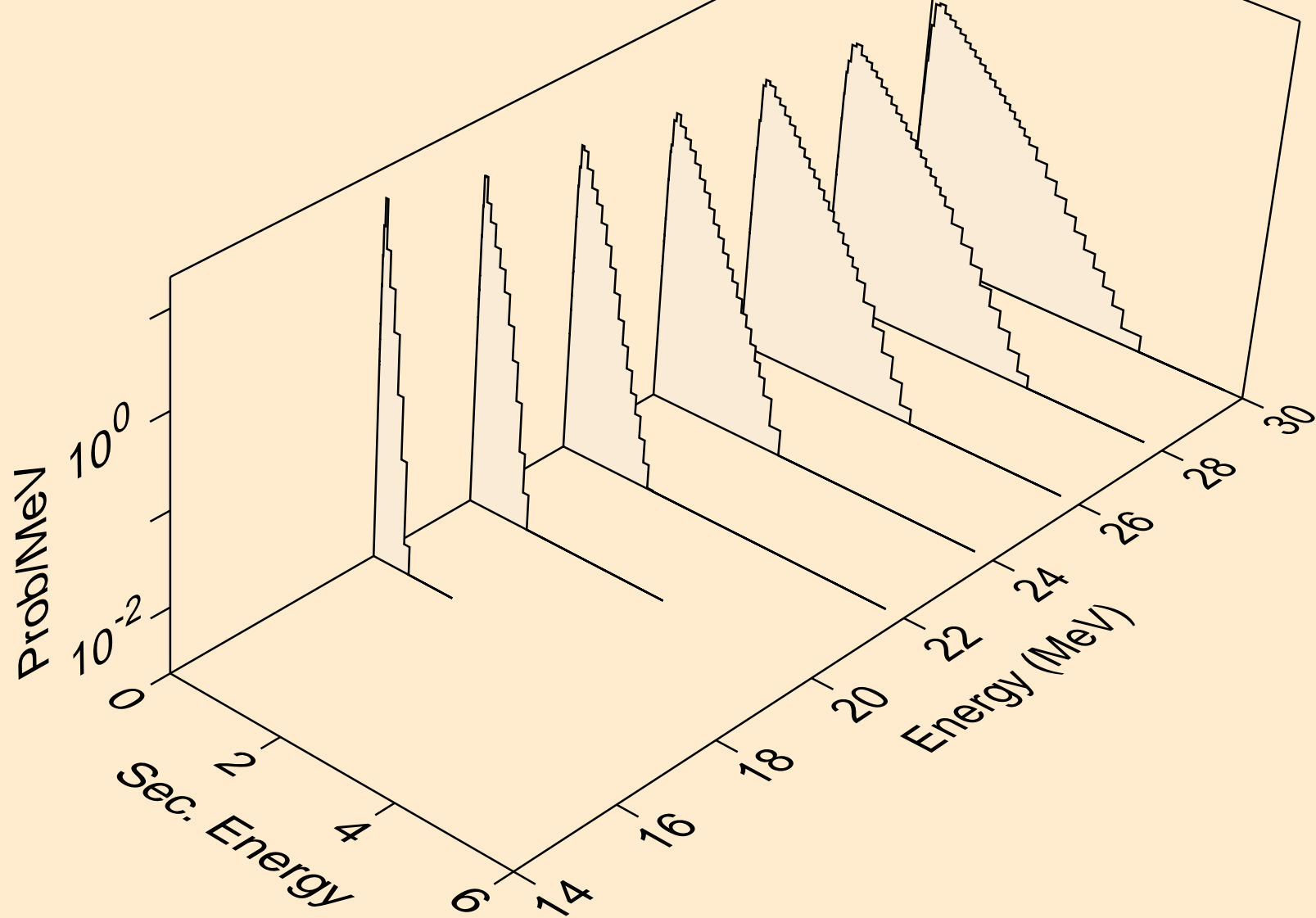

PD115M NEUTRON ACER TENDL-2024 LIBRARY; T=0.K  
Neutron emission for (n,n\*)he3

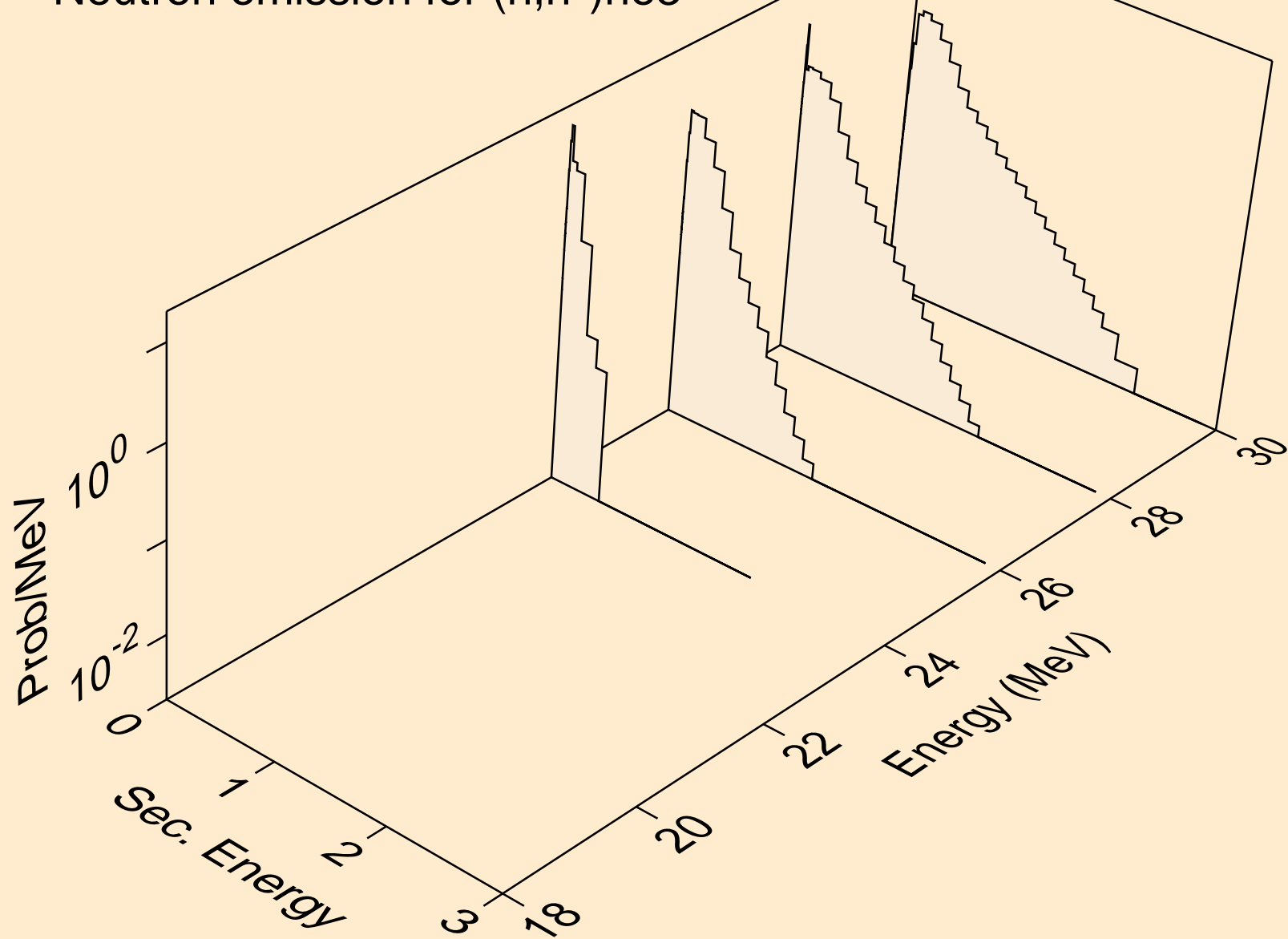

PD115M NEUTRON ACER TENDL-2024 LIBRARY; T=0.K  
Neutron emission for (n,4n)

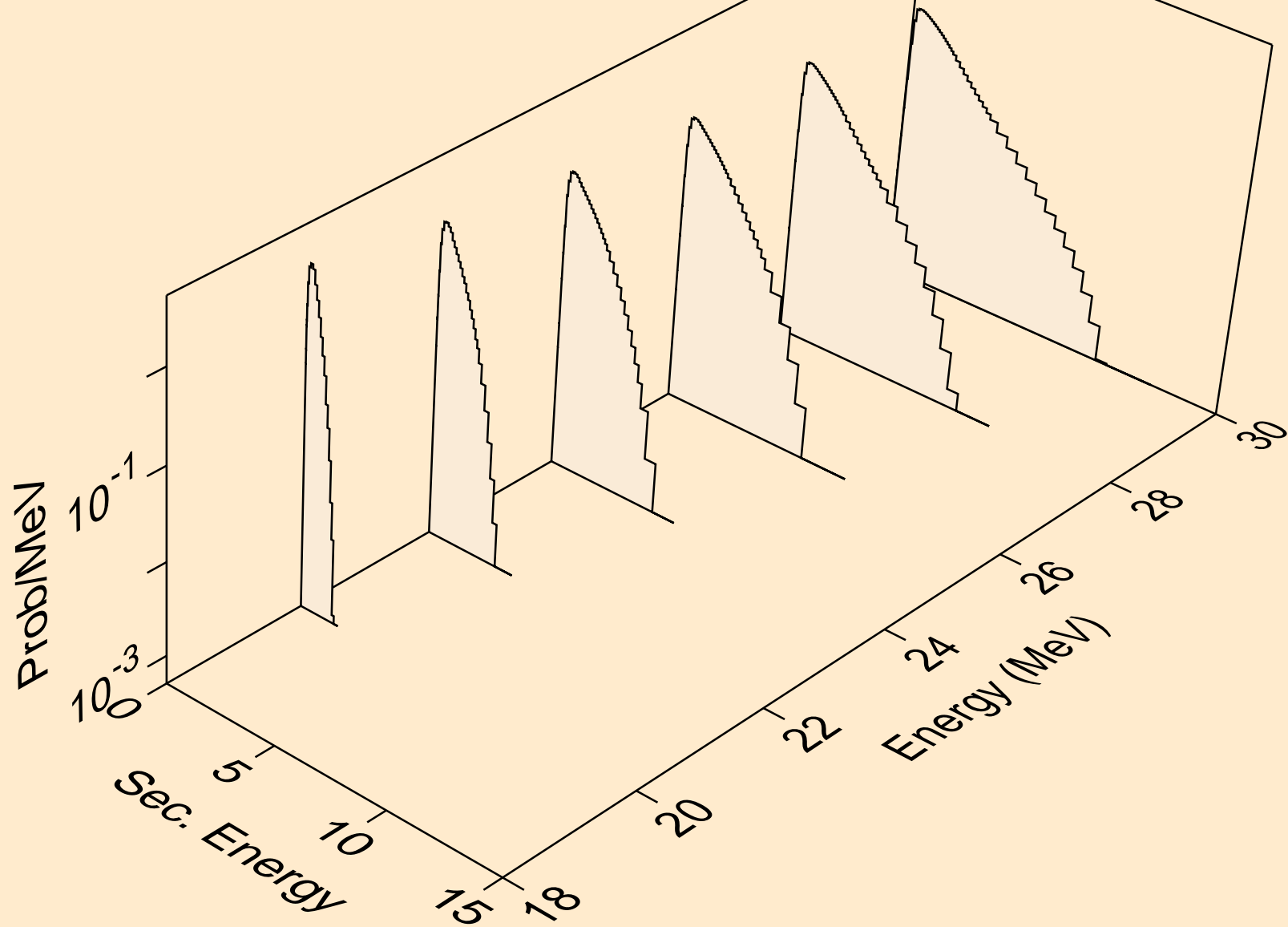

PD115M NEUTRON ACER TENDL-2024 LIBRARY; T=0.K  
Neutron emission for (n,2np)

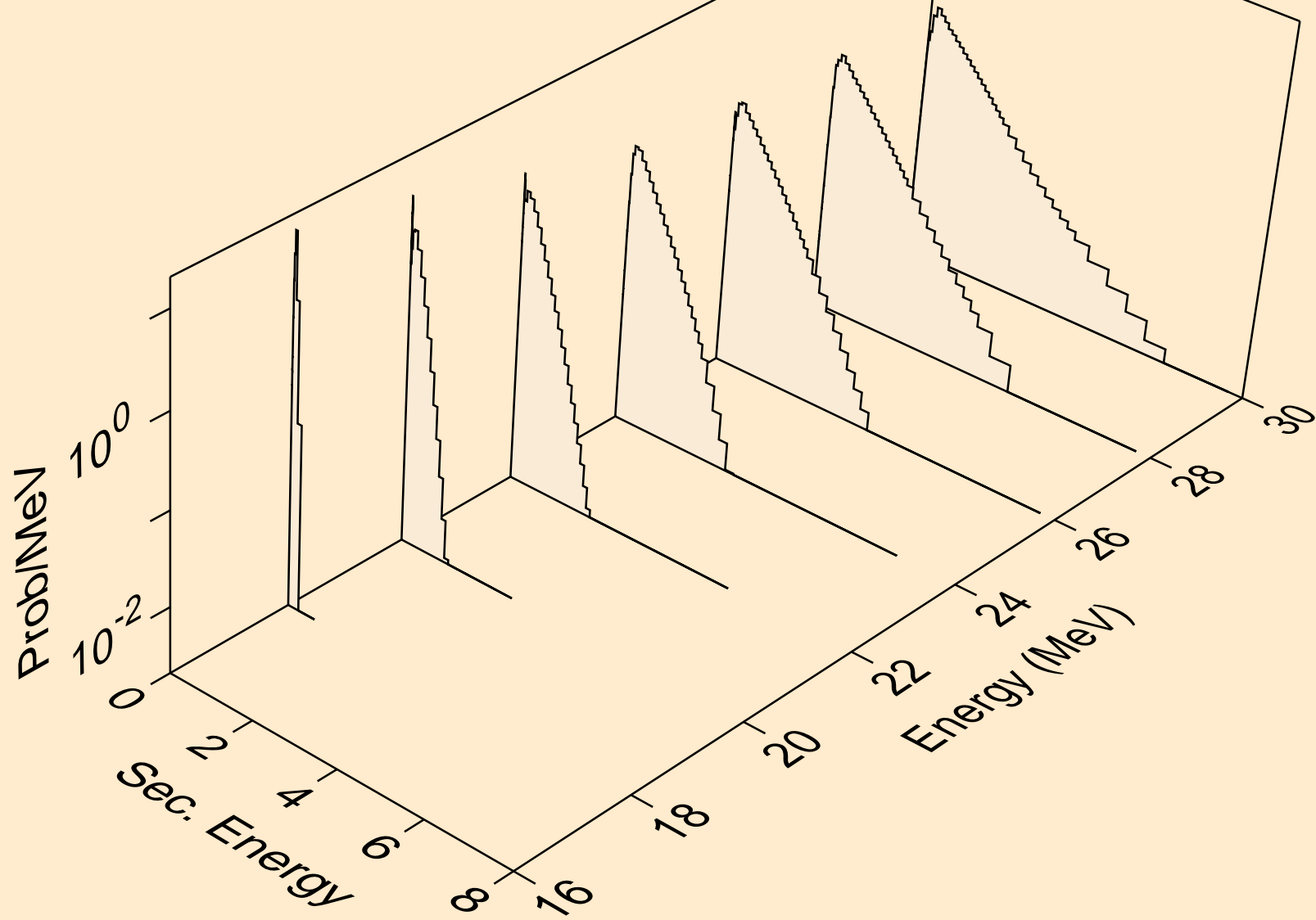

PD115M NEUTRON ACER TENDL-2024 LIBRARY; T=0.K  
Neutron emission for (n,3np)

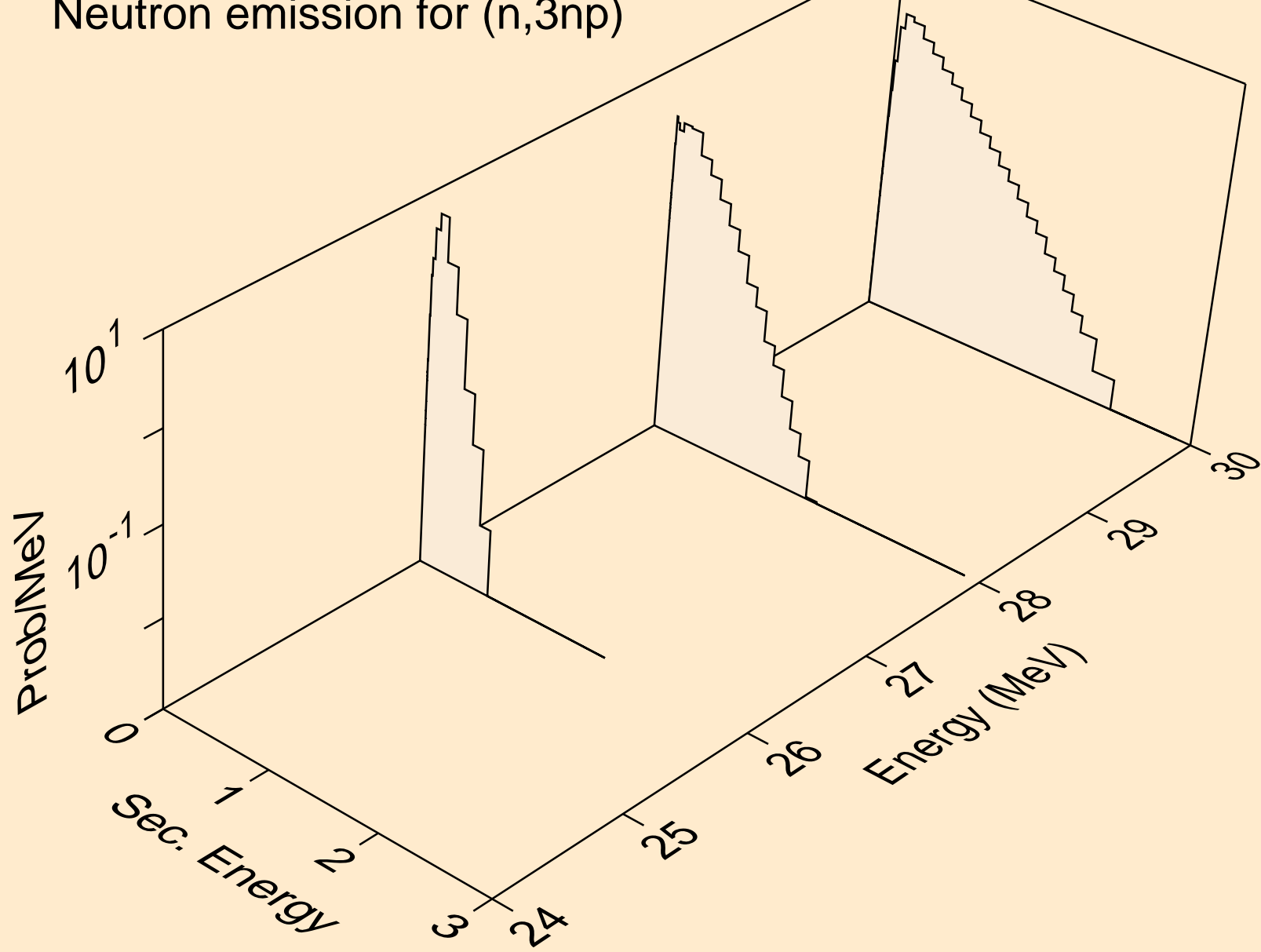



PD115M NEUTRON ACER TENDL-2024 LIBRARY; T=0.K  
Neutron emission for (n,n\*c)

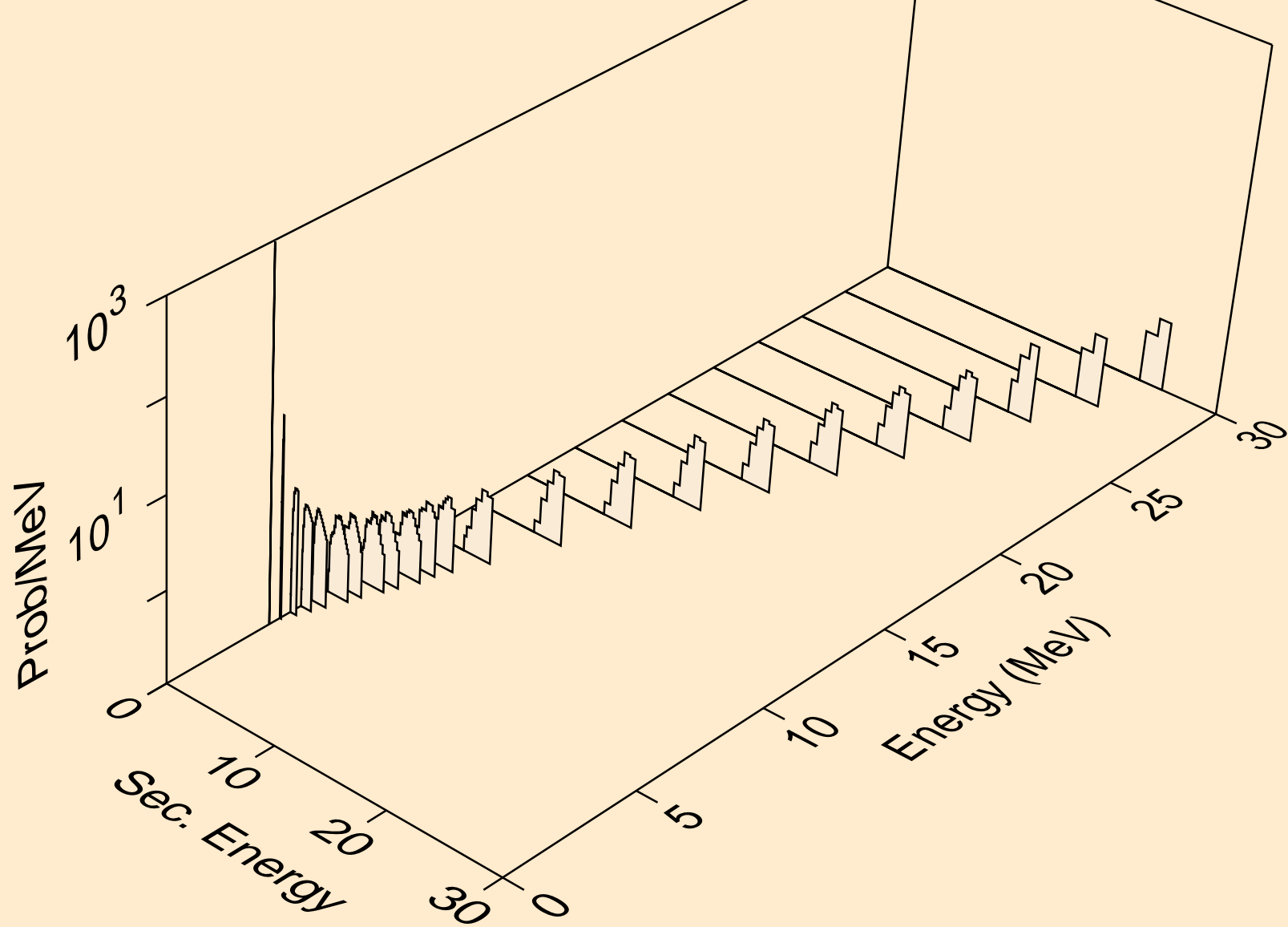

PD115M NEUTRON ACER TENDL-2024 LIBRARY; T=0.K  
Photon emission for (n,x)

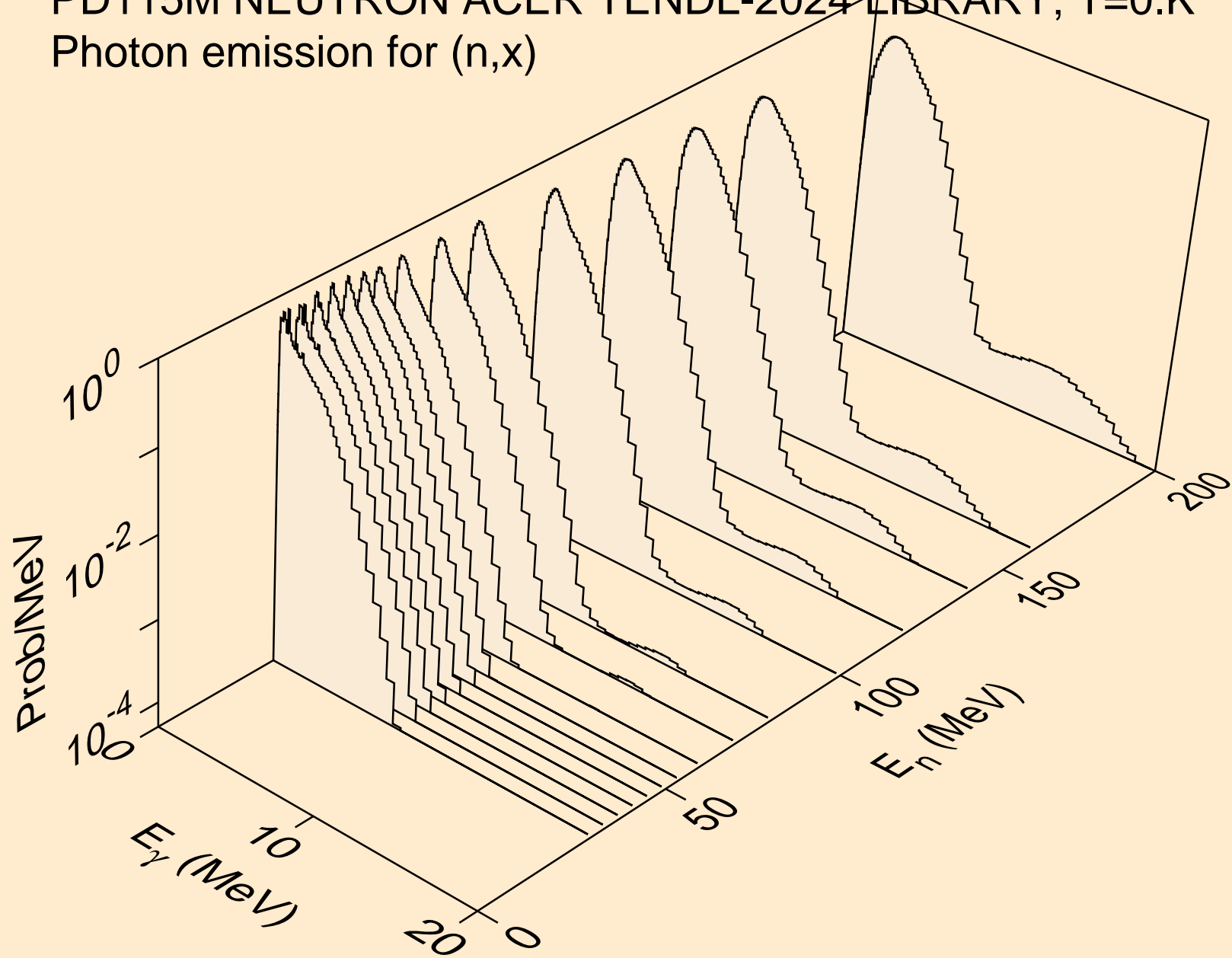

PD115M NEUTRON ACER TENDL-2024 LIBRARY; T=0.K  
Photon emission for (n,2nd)

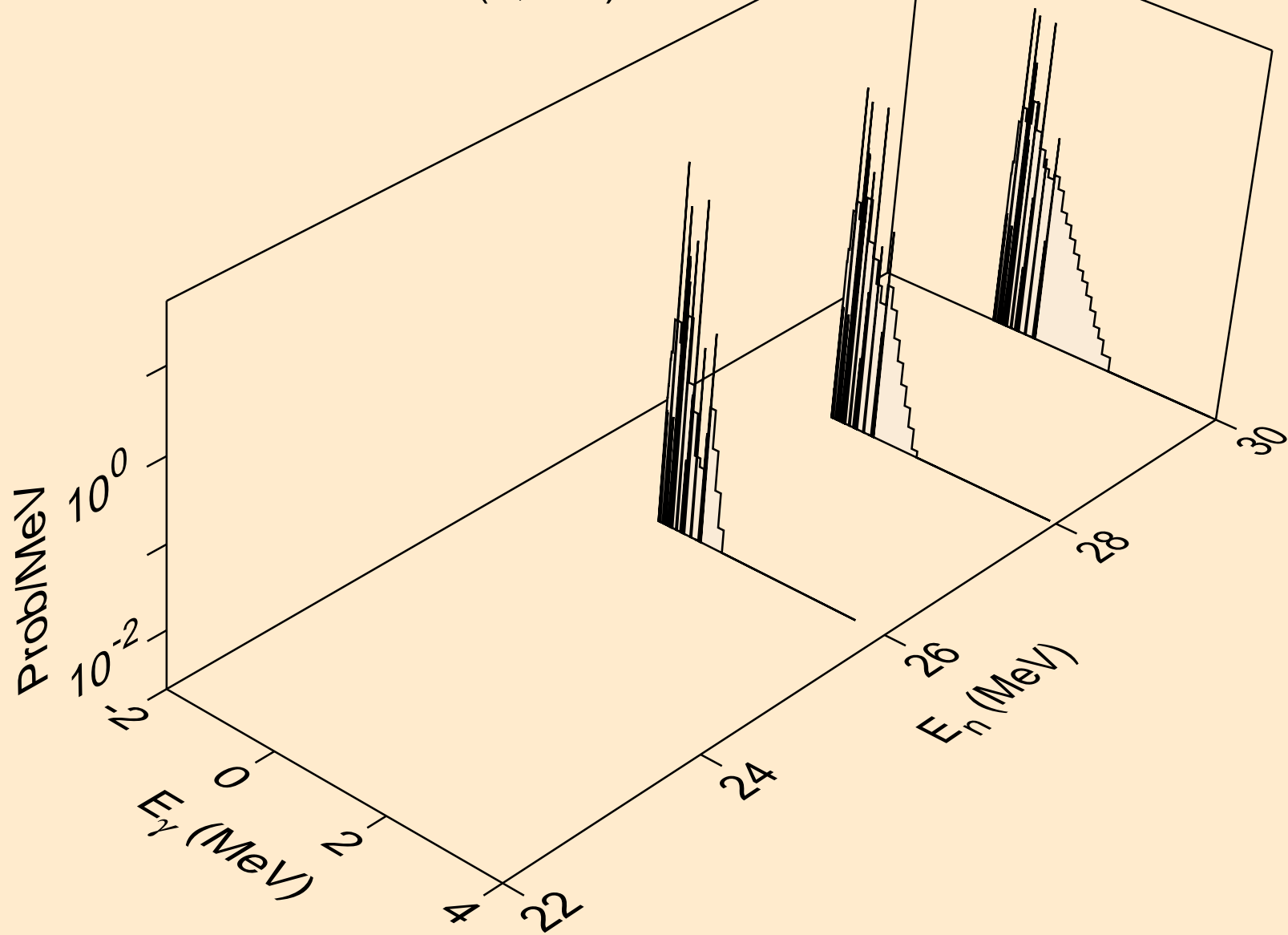

PD115M NEUTRON ACER TENDL-2024 LIBRARY; T=0.K  
Photon emission for (n,2n)

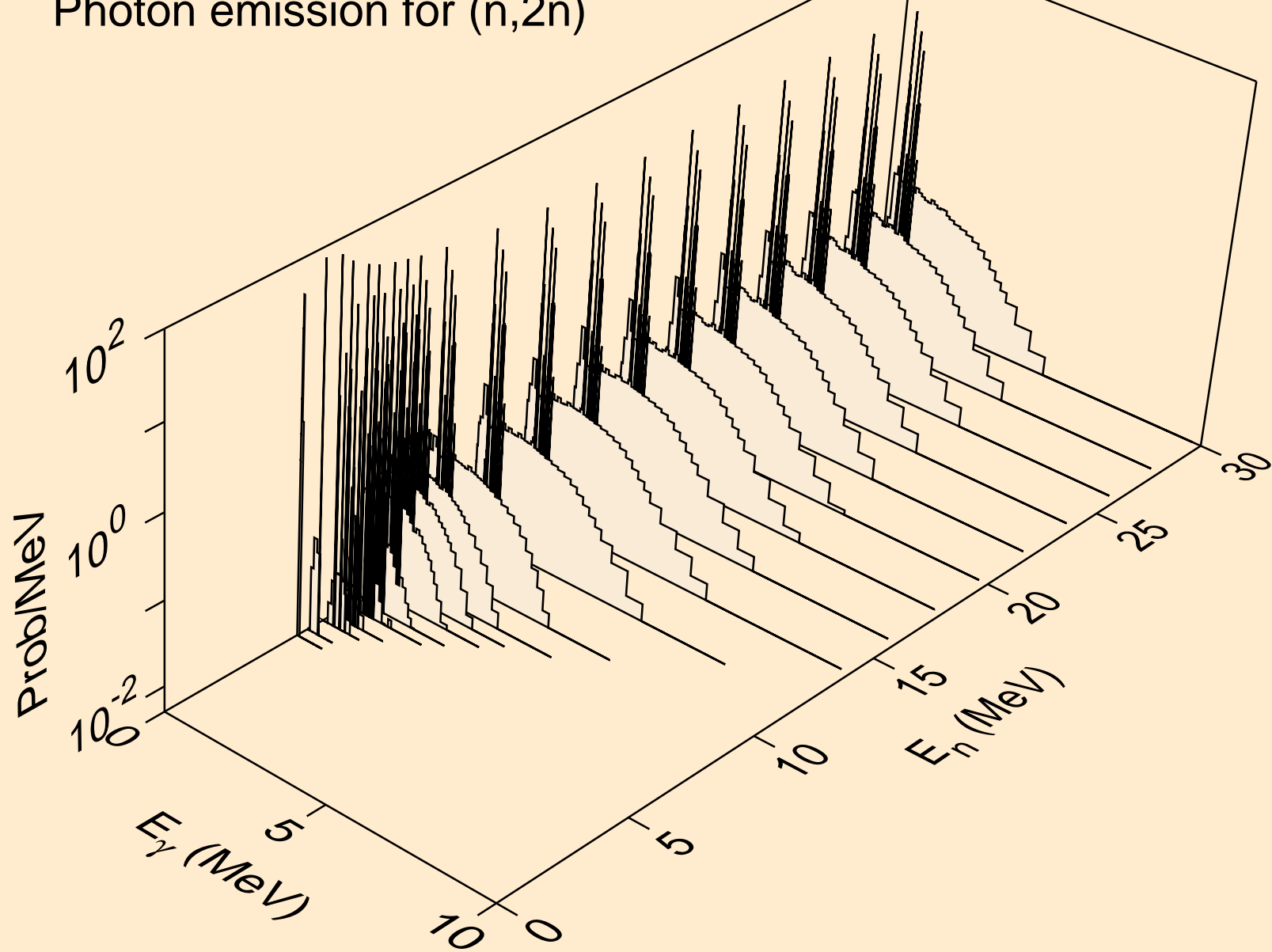

PD115M NEUTRON ACER TENDL-2024 LIBRARY; T=0.K  
Photon emission for (n,3n)

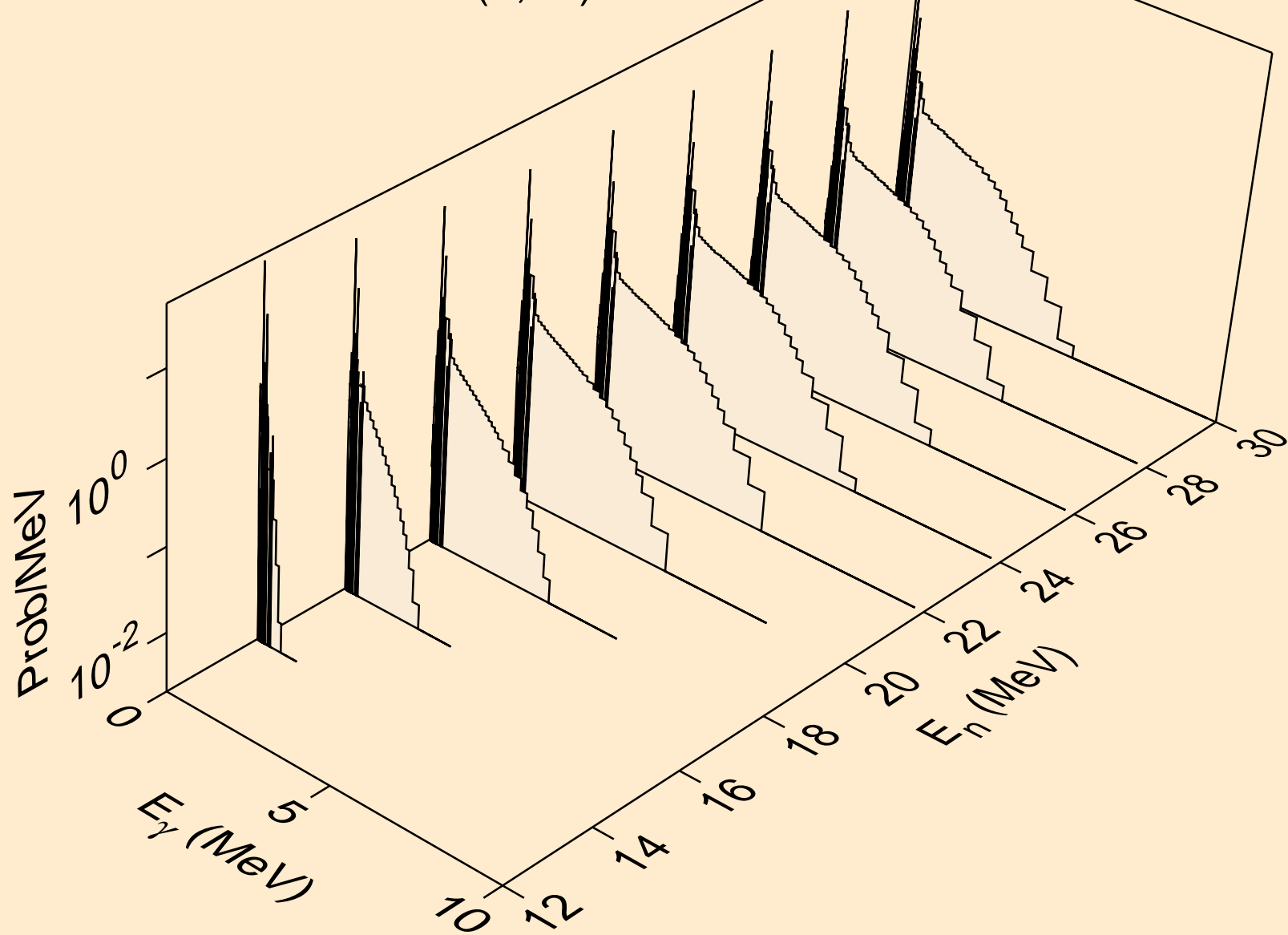

PD115M NEUTRON ACER TENDL-2024 LIBRARY; T=0.K  
Photon emission for (n,n\*)a

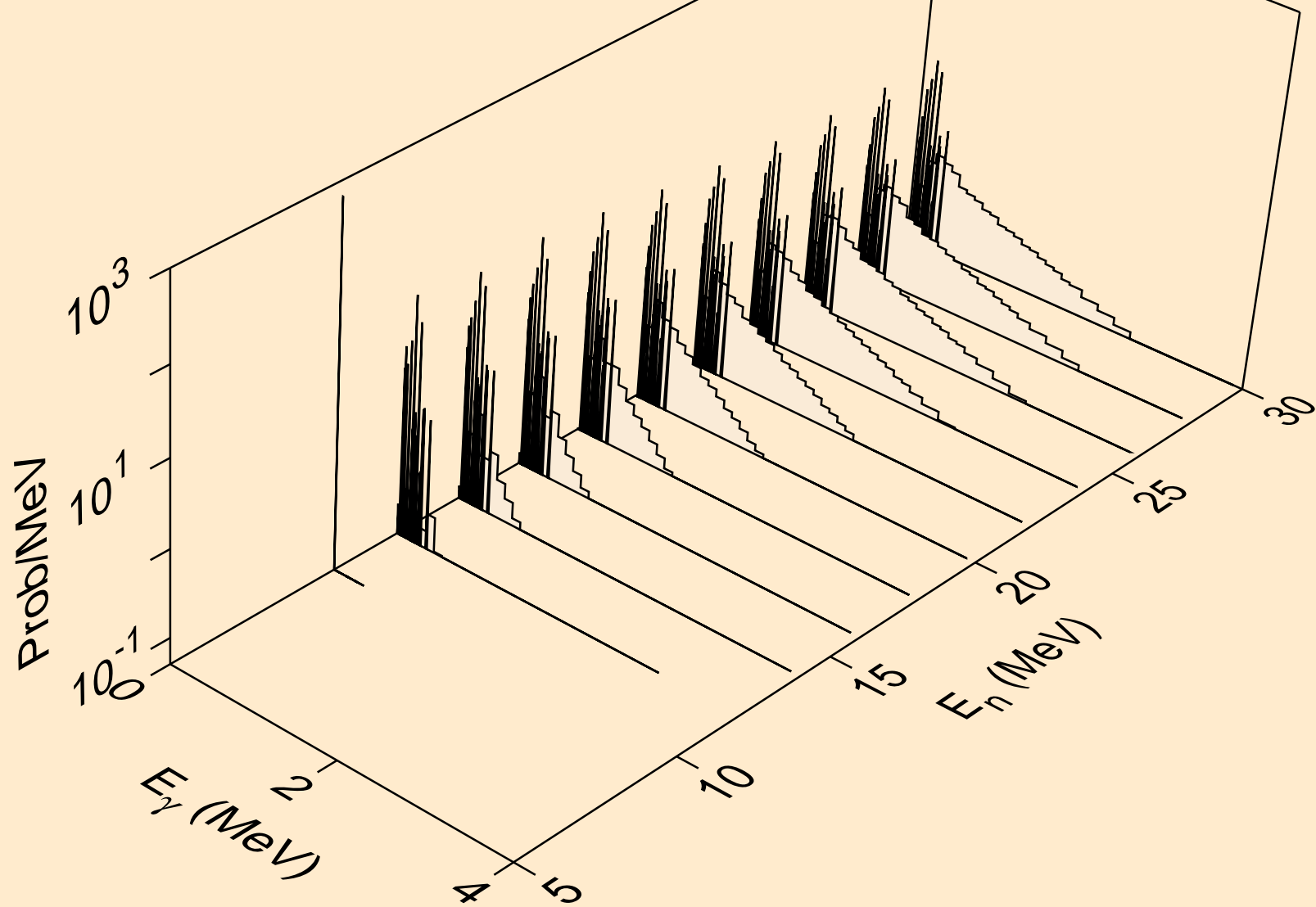

PD115M NEUTRON ACER TENDL-2024 LIBRARY; T=0.K  
Photon emission for (n,2n)a

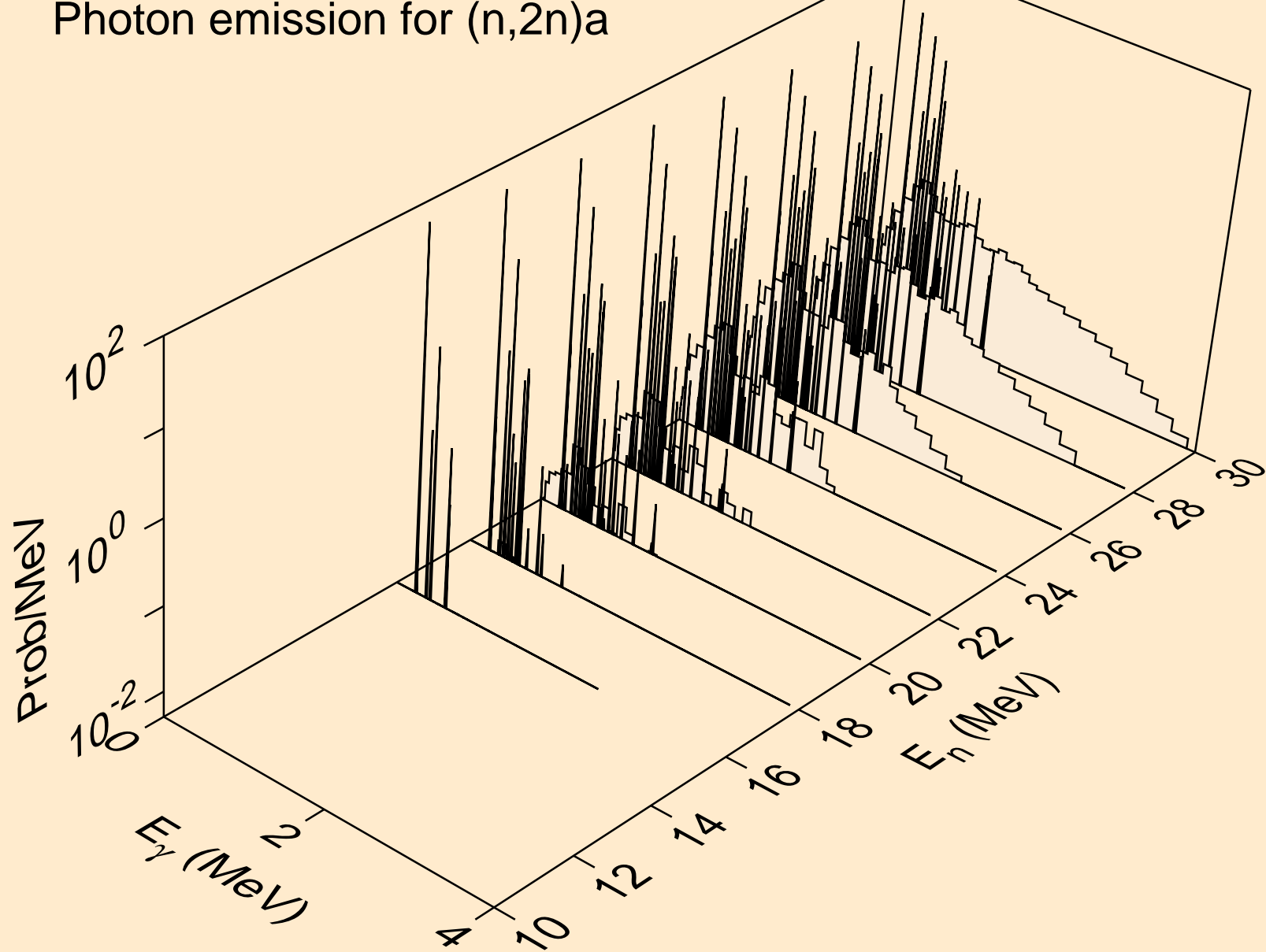

PD115M NEUTRON ACER TENDL-2024 LIBRARY; T=0.K  
Photon emission for (n,3n)a

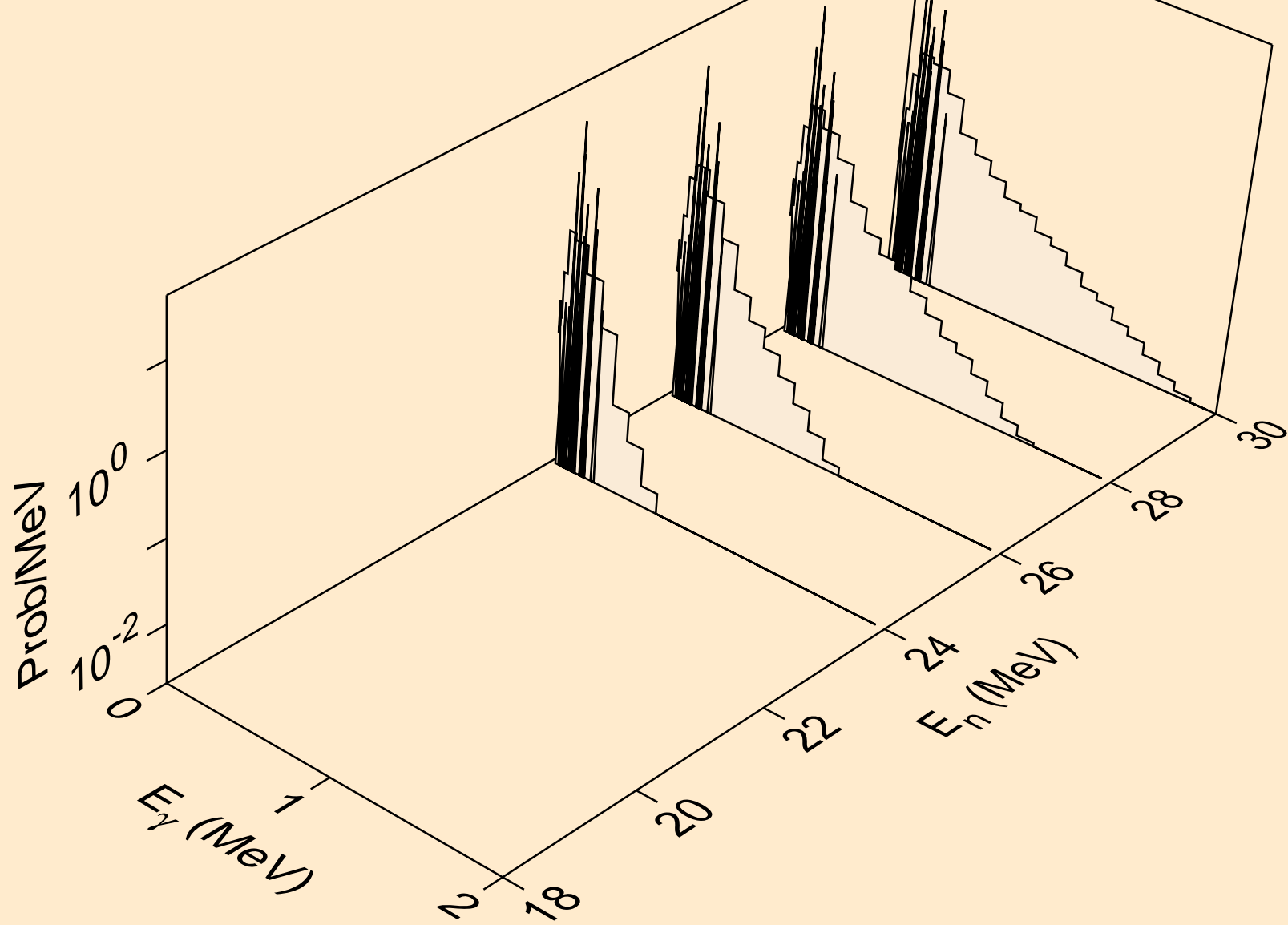



PD115M NEUTRON ACER TENDL-2024 LIBRARY; T=0.K  
Photon emission for (n,n\*)p

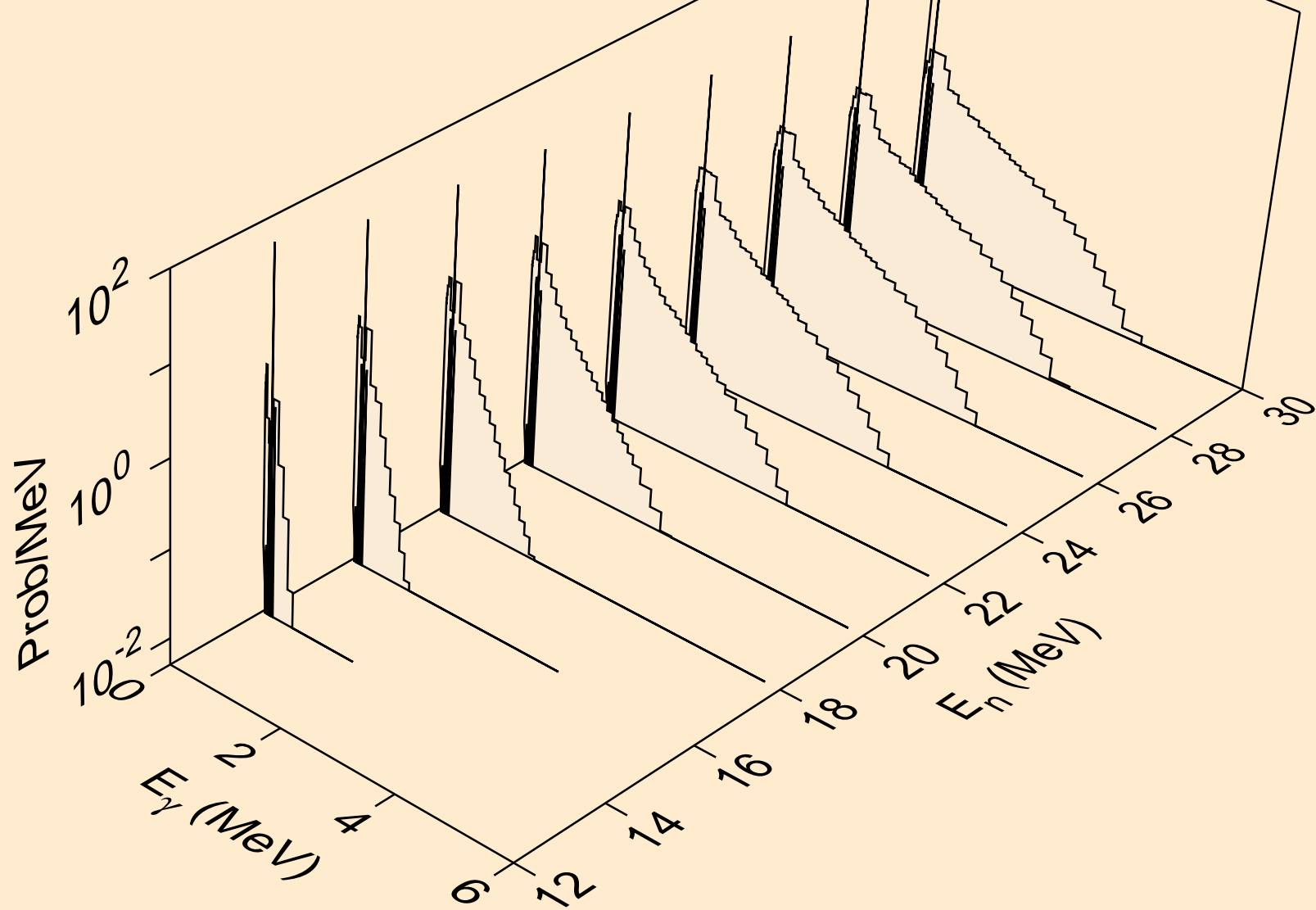

PD115M NEUTRON ACER TENDL-2024 LIBRARY; T=0.K  
Photon emission for (n,n\*)d

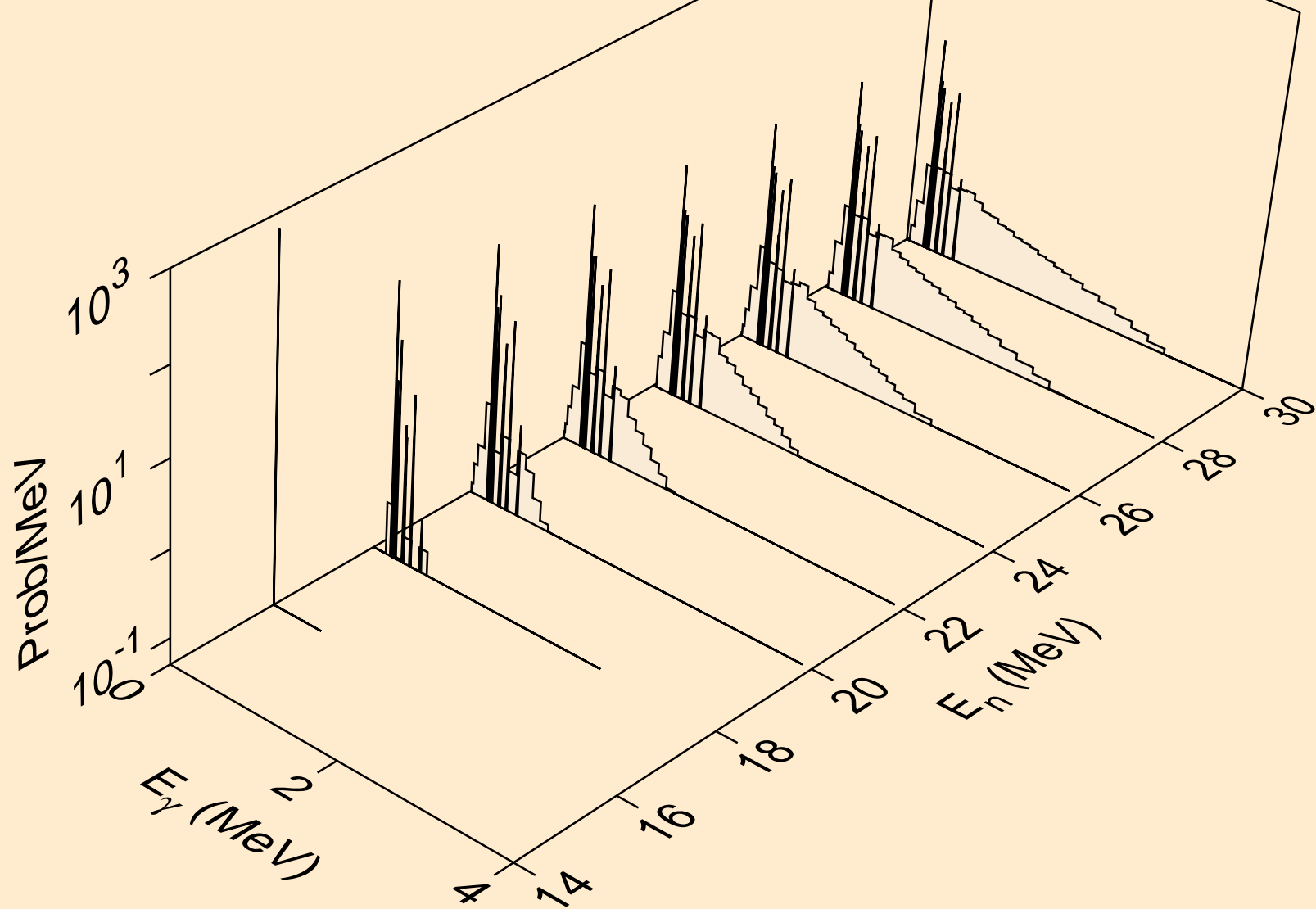

PD115M NEUTRON ACER TENDL-2024 LIBRARY; T=0.K  
Photon emission for (n,n\*)t

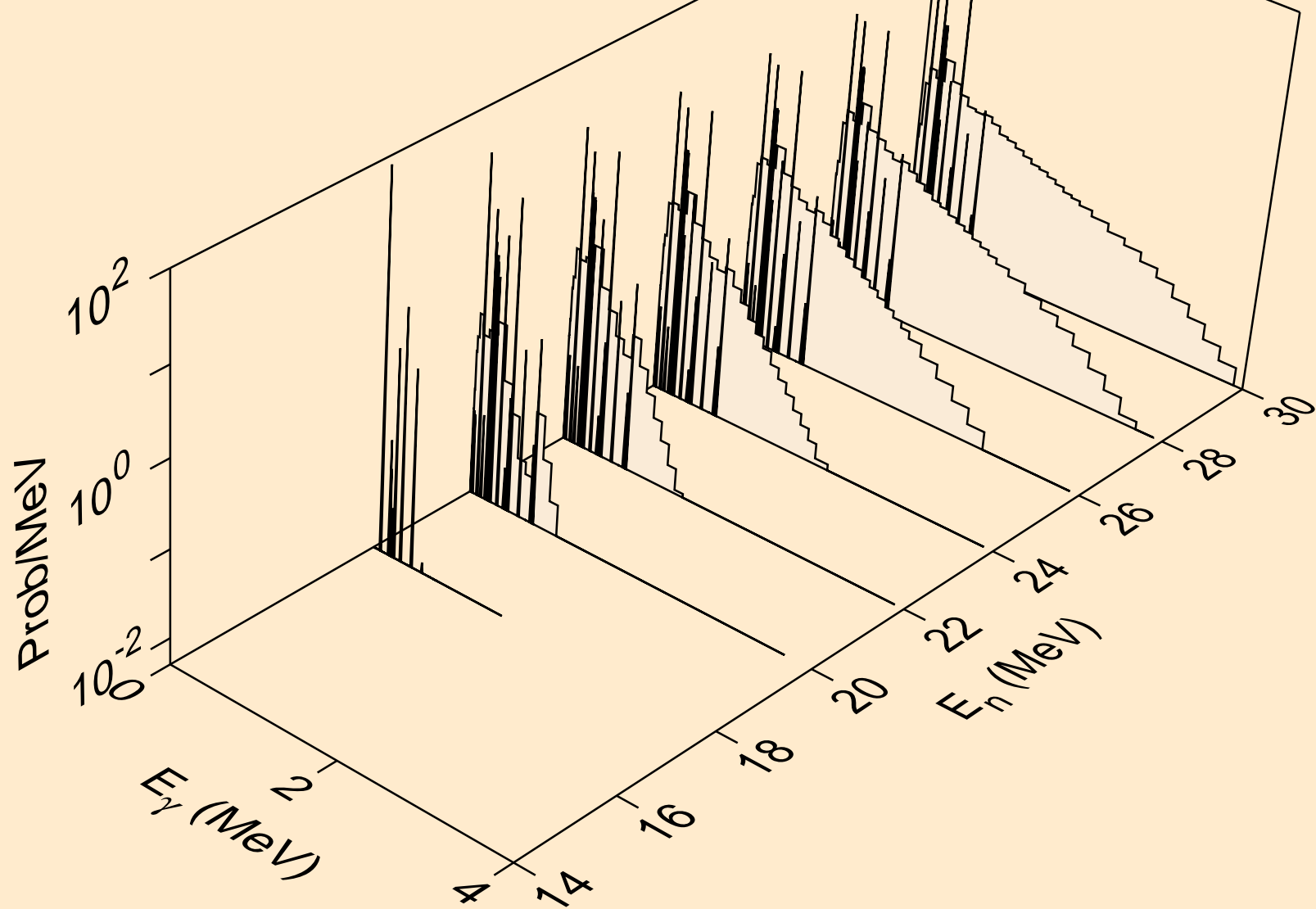

PD115M NEUTRON ACER TENDL-2024 LIBRARY; T=0.K  
Photon emission for (n,n\*)he3

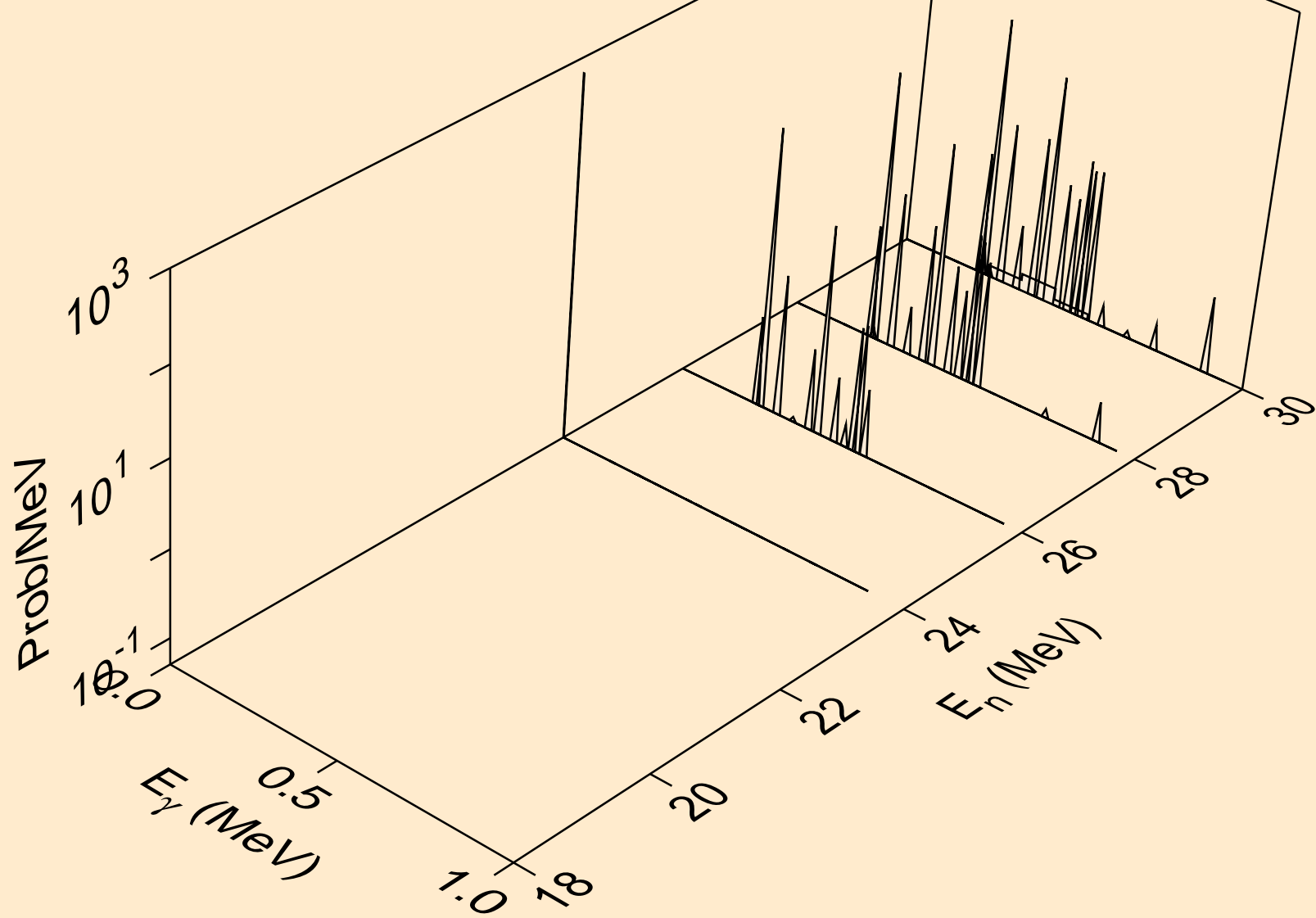

PD115M NEUTRON ACER TENDL-2024 LIBRARY; T=0.K  
Photon emission for (n,4n)

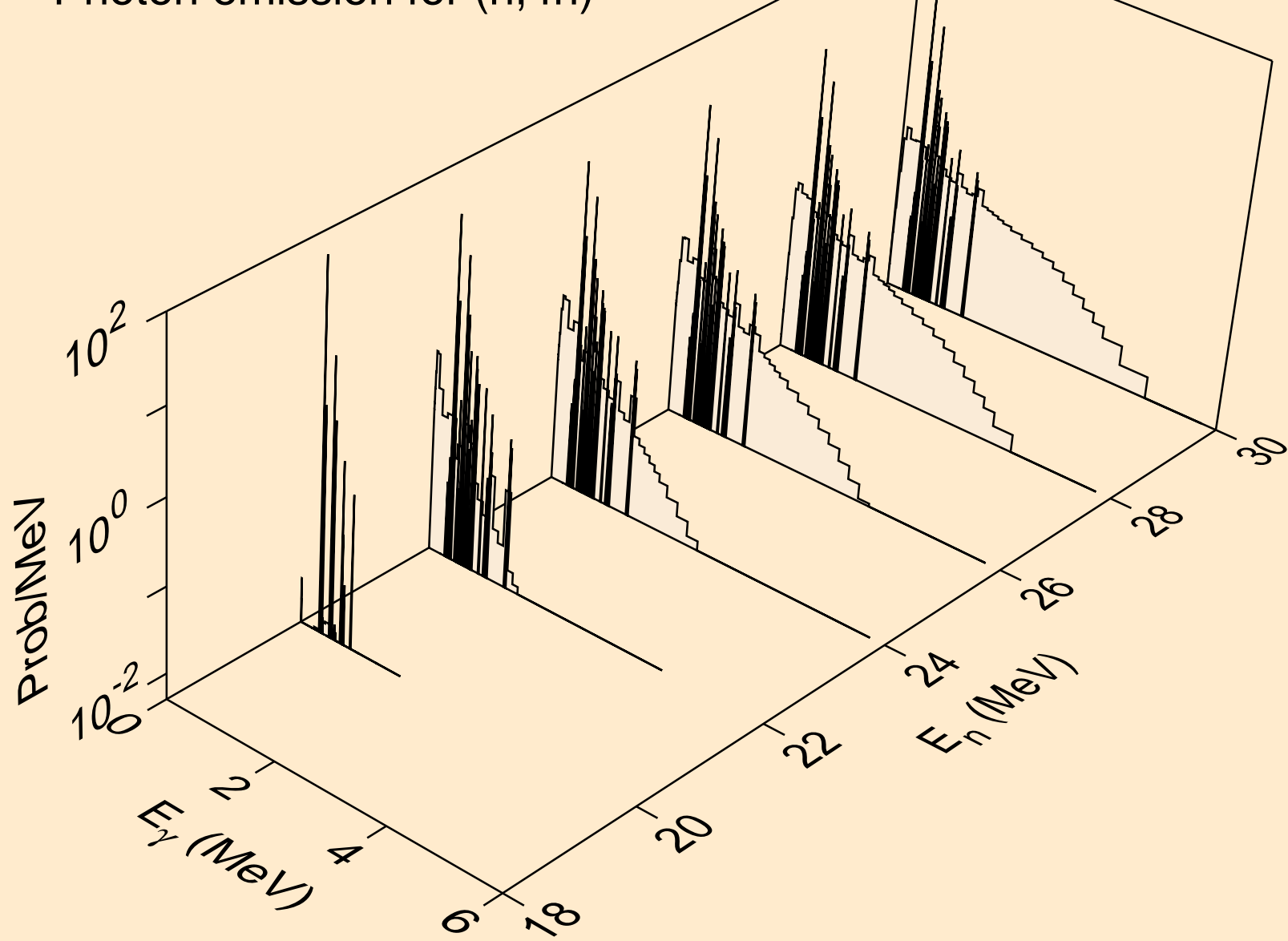

PD115M NEUTRON ACER TENDL-2024 LIBRARY; T=0.K  
Photon emission for (n,2np)

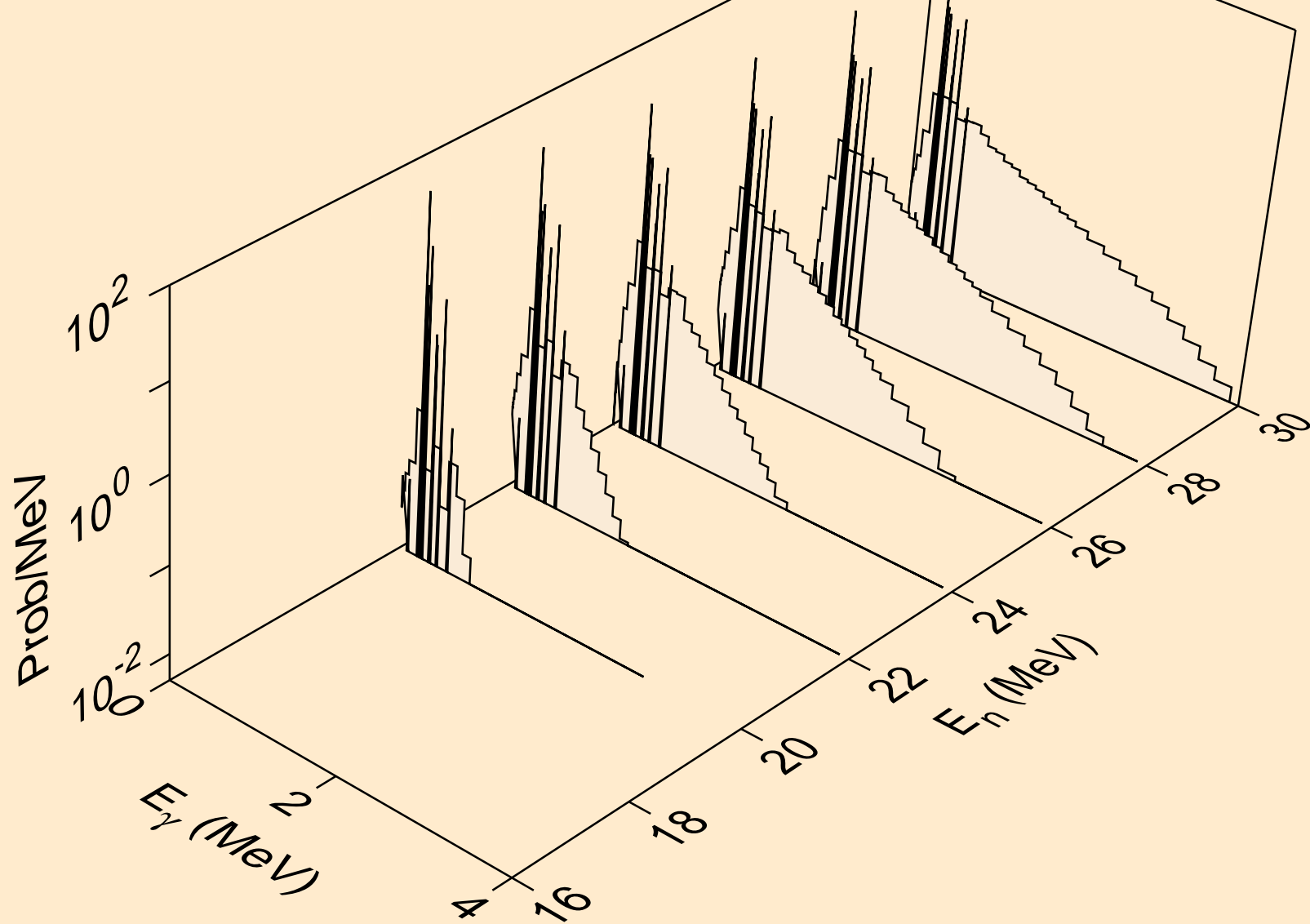

PD115M NEUTRON ACER TENDL-2024 LIBRARY; T=0.K  
Photon emission for (n,3np)

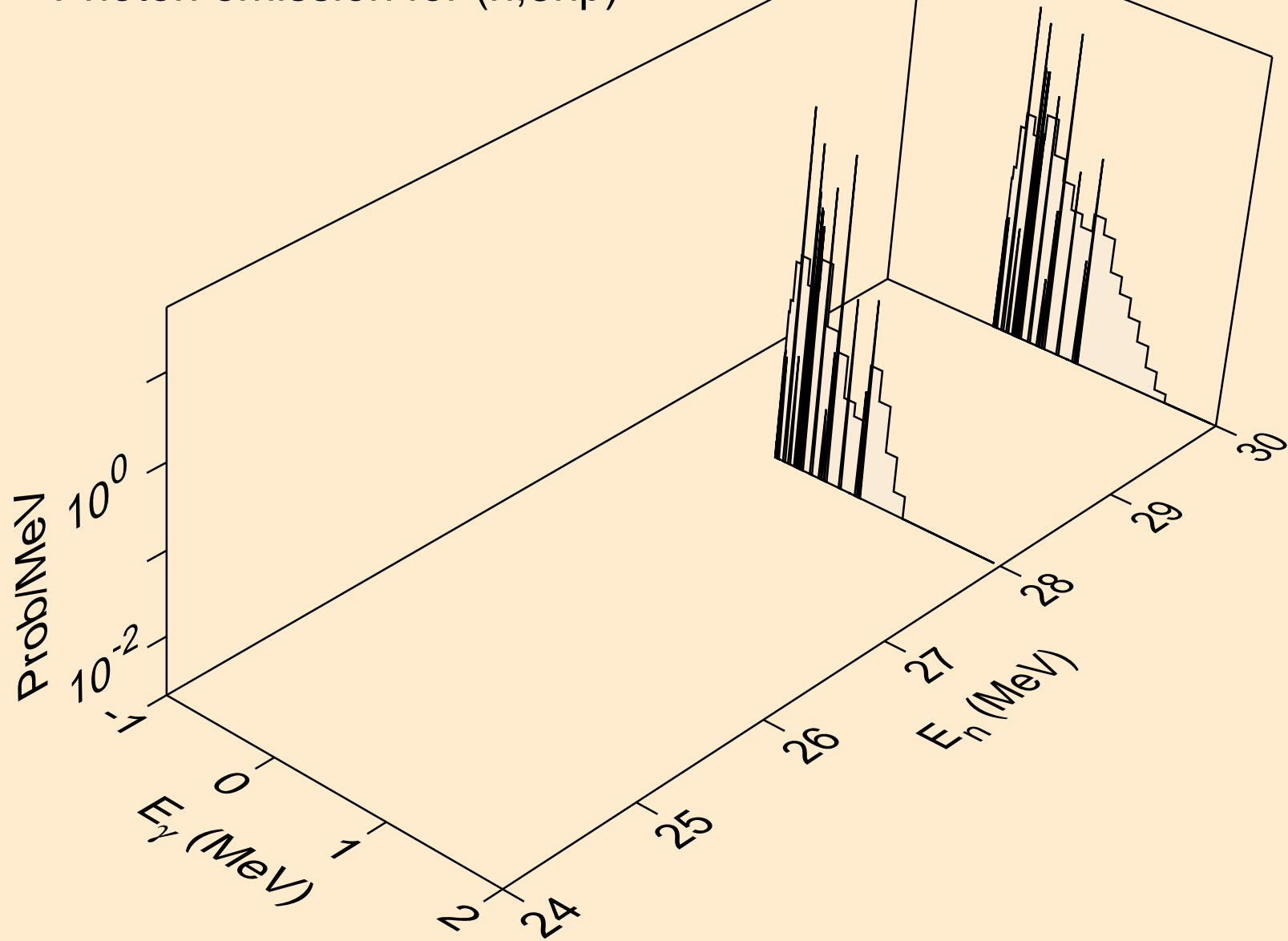

PD115M NEUTRON ACER TENDL-2024 LIBRARY; T=0.K  
Photon emission for (n,n\*2)

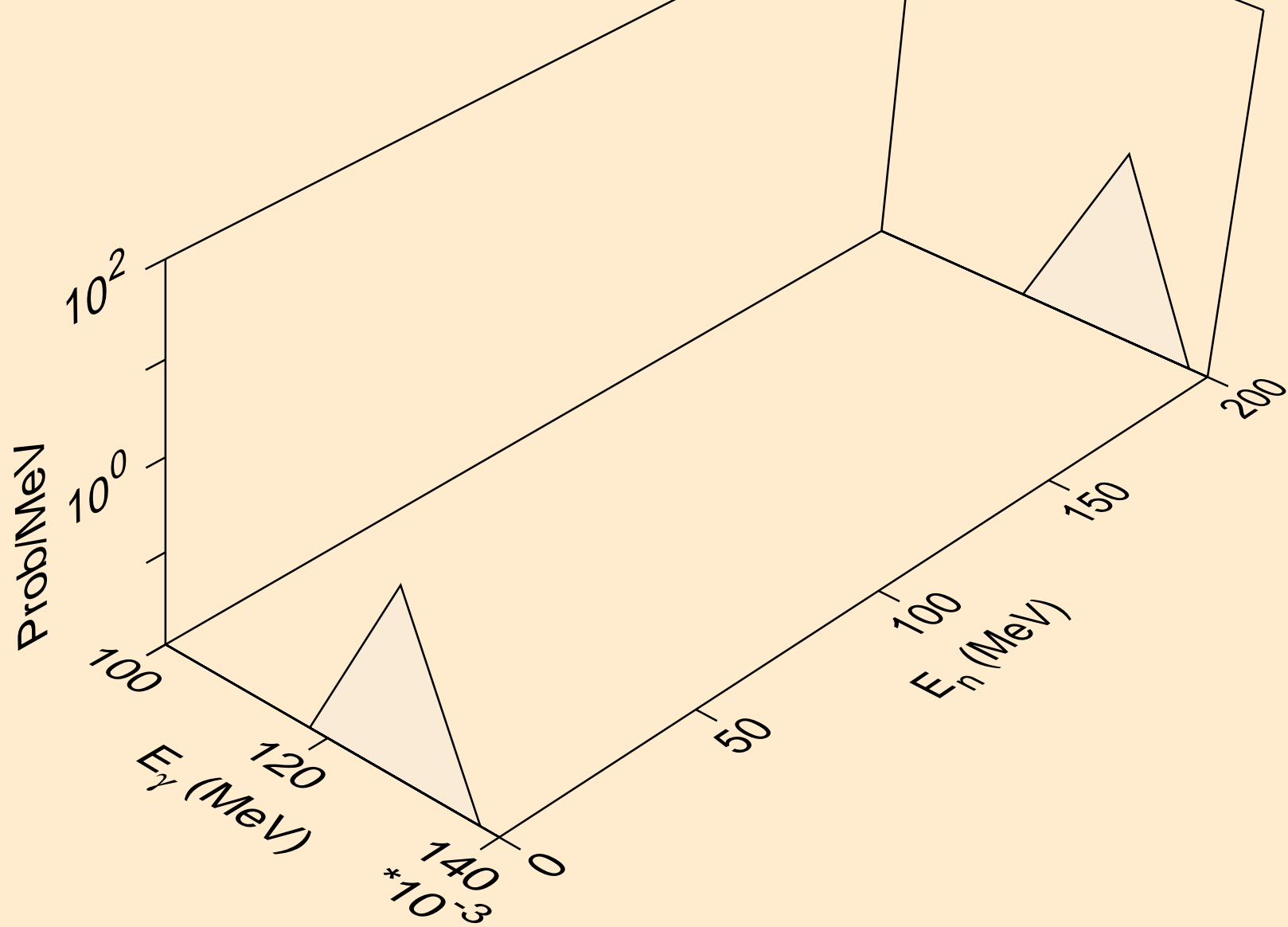



PD115M NEUTRON ACER TENDL-2024 LIBRARY; T=0.K  
Photon emission for (n,n\*3)

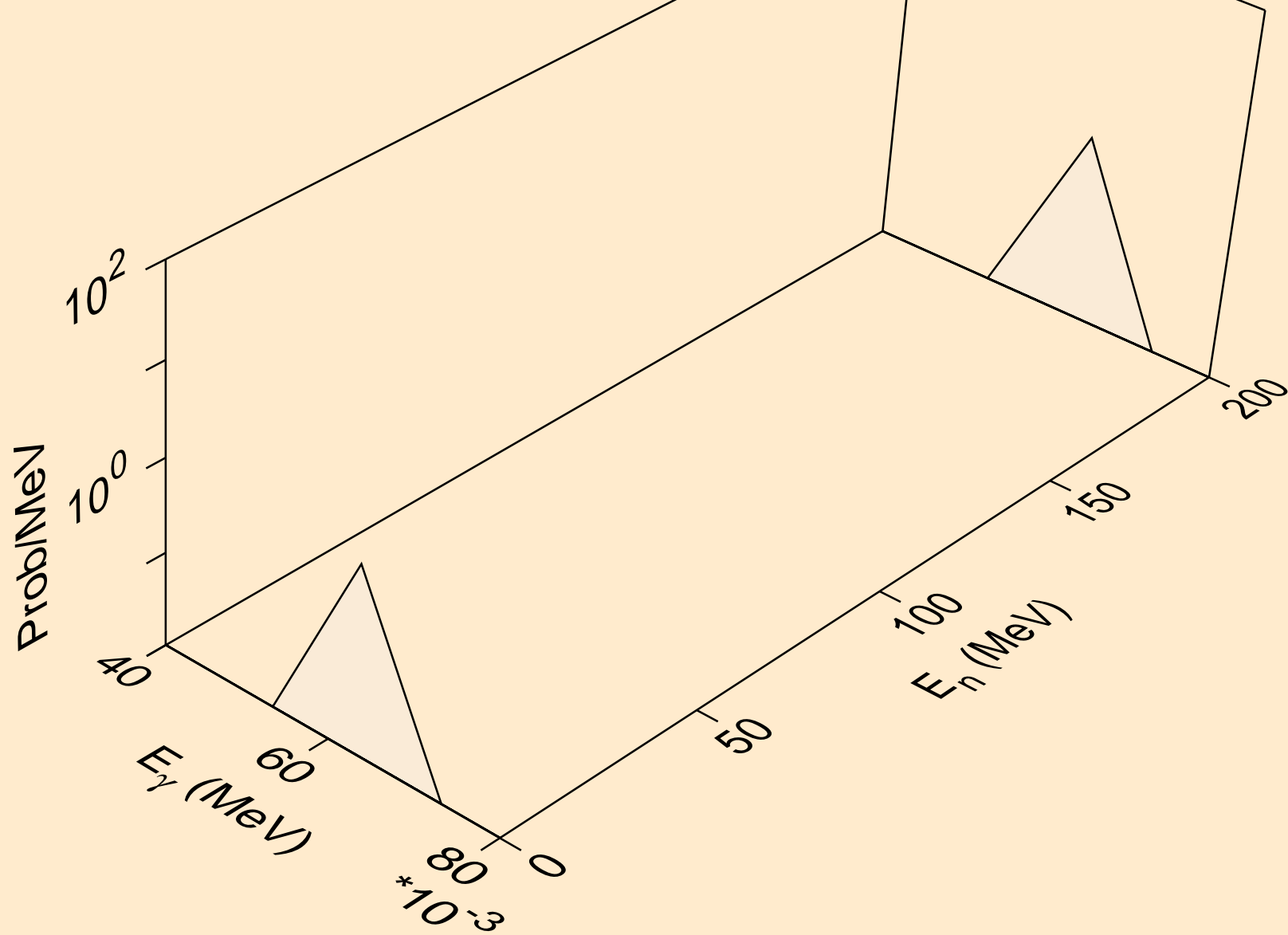

PD115M NEUTRON ACER TENDL-2024 LIBRARY; T=0.K  
Photon emission for (n,n\*4)

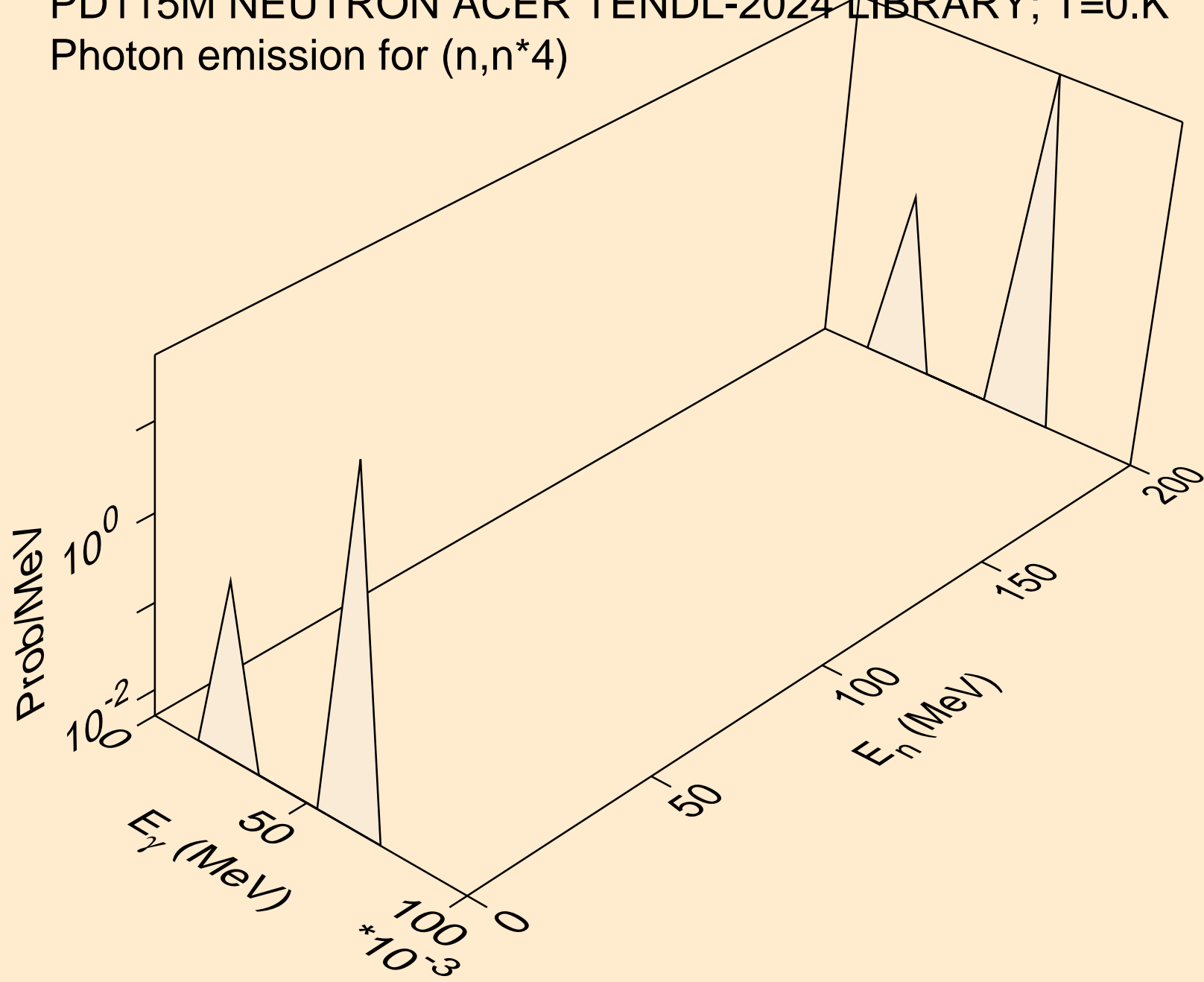

PD115M NEUTRON ACER TENDL-2024 LIBRARY; T=0.K  
Photon emission for (n,n\*5)

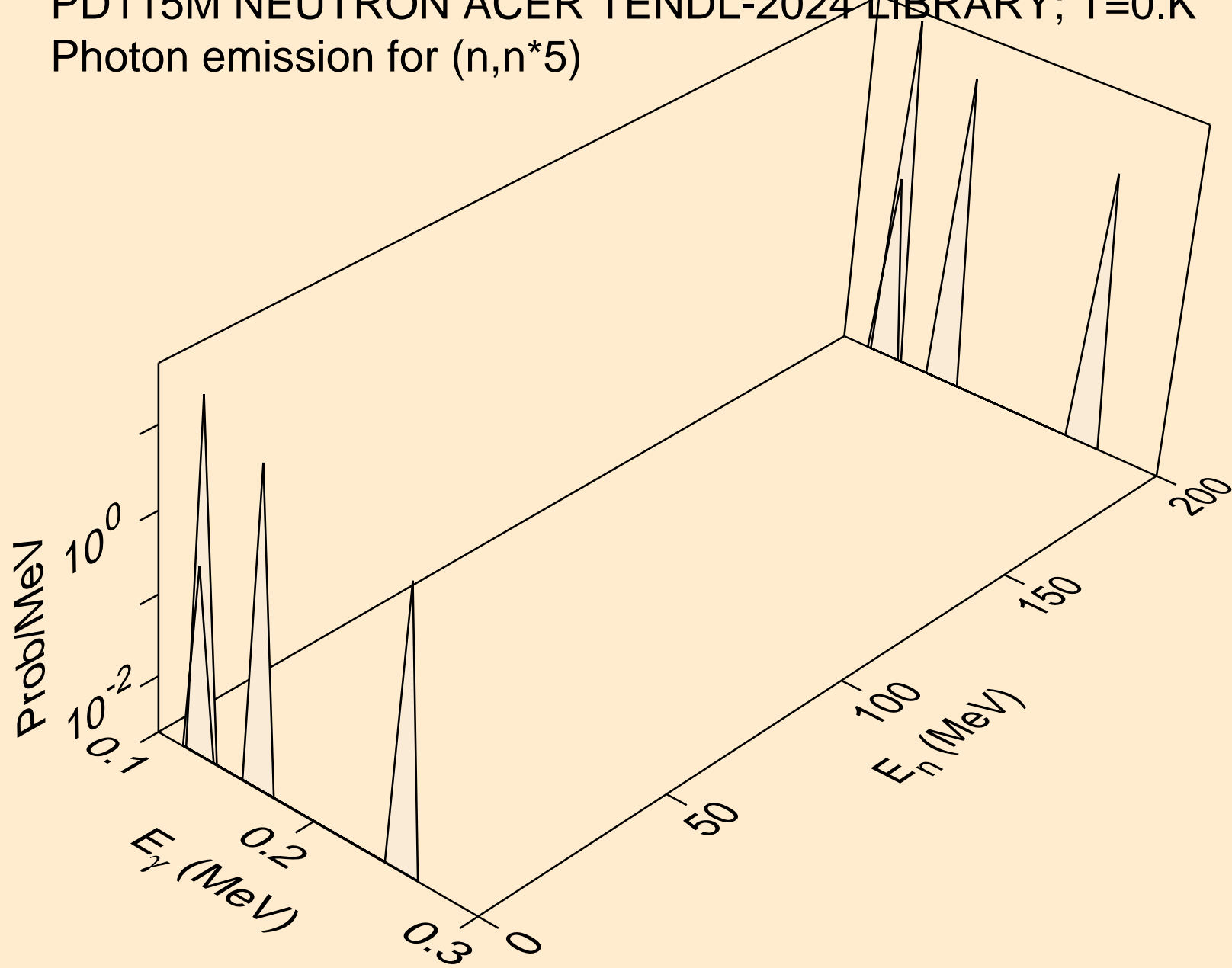

PD115M NEUTRON ACER TENDL-2024 LIBRARY; T=0.K  
Photon emission for (n,n\*6)

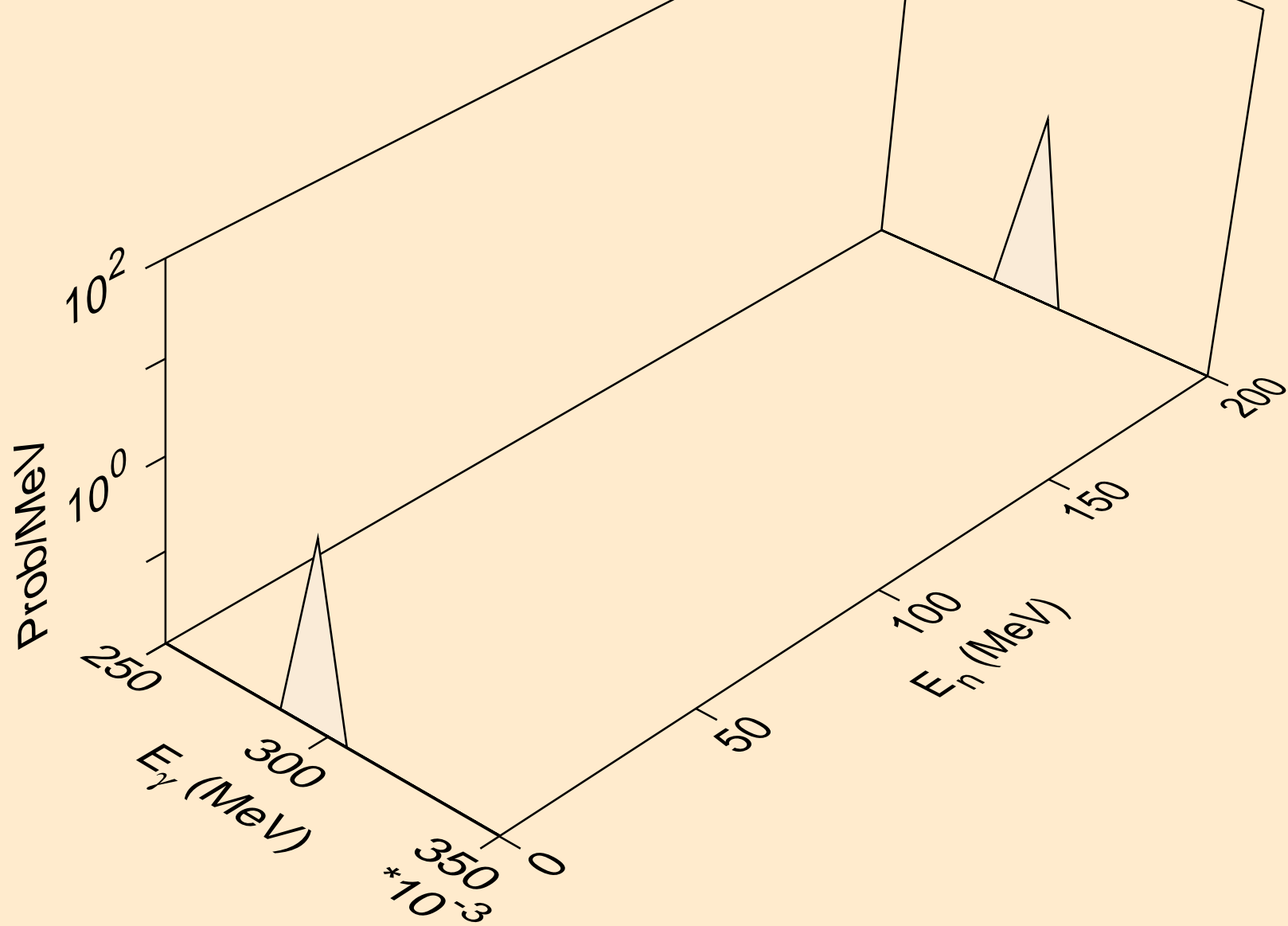

PD115M NEUTRON ACER TENDL-2024 LIBRARY; T=0.K  
Photon emission for (n,n\*7)

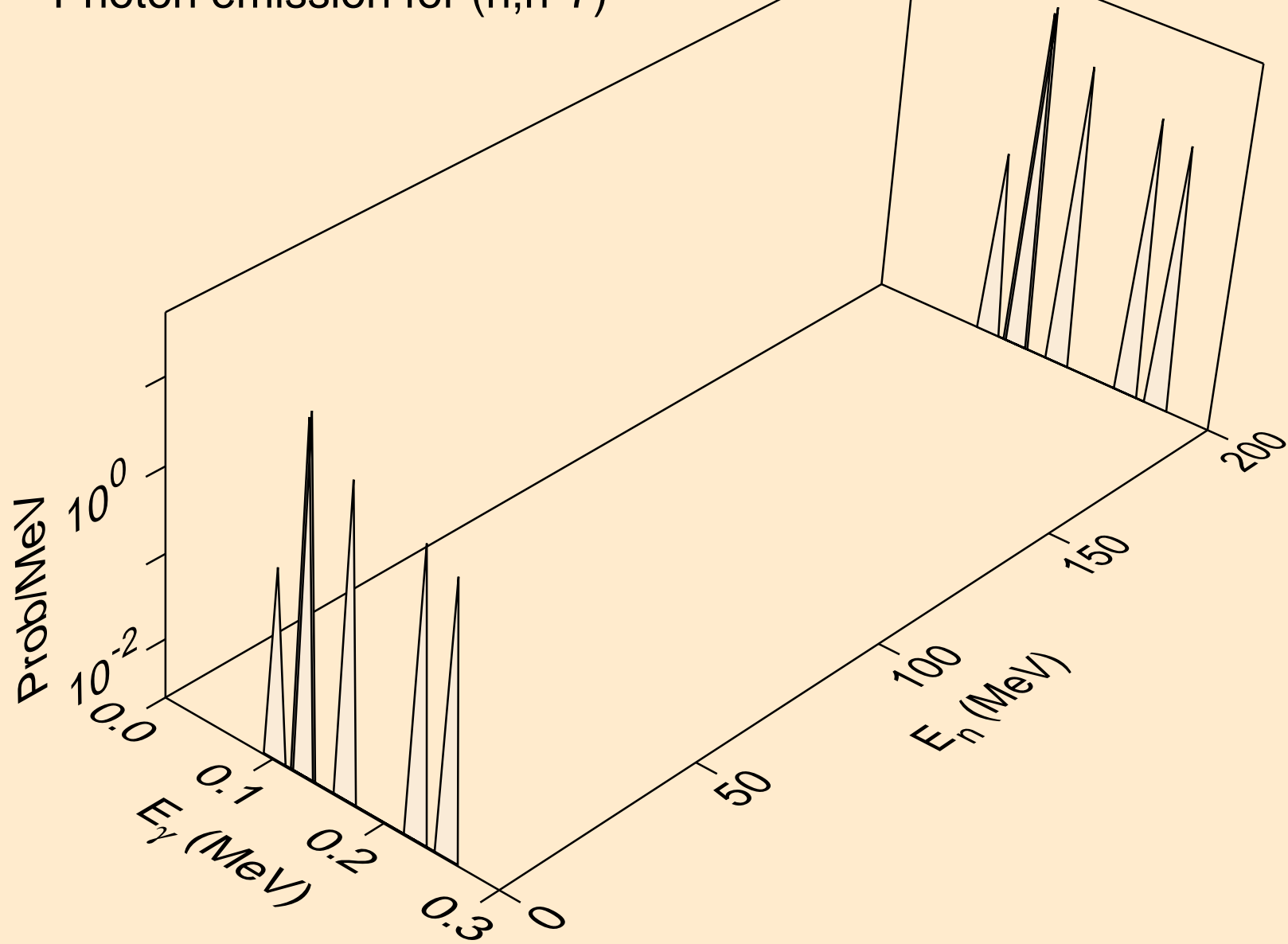

PD115M NEUTRON ACER TENDL-2024 LIBRARY; T=0.K  
Photon emission for (n,n\*8)

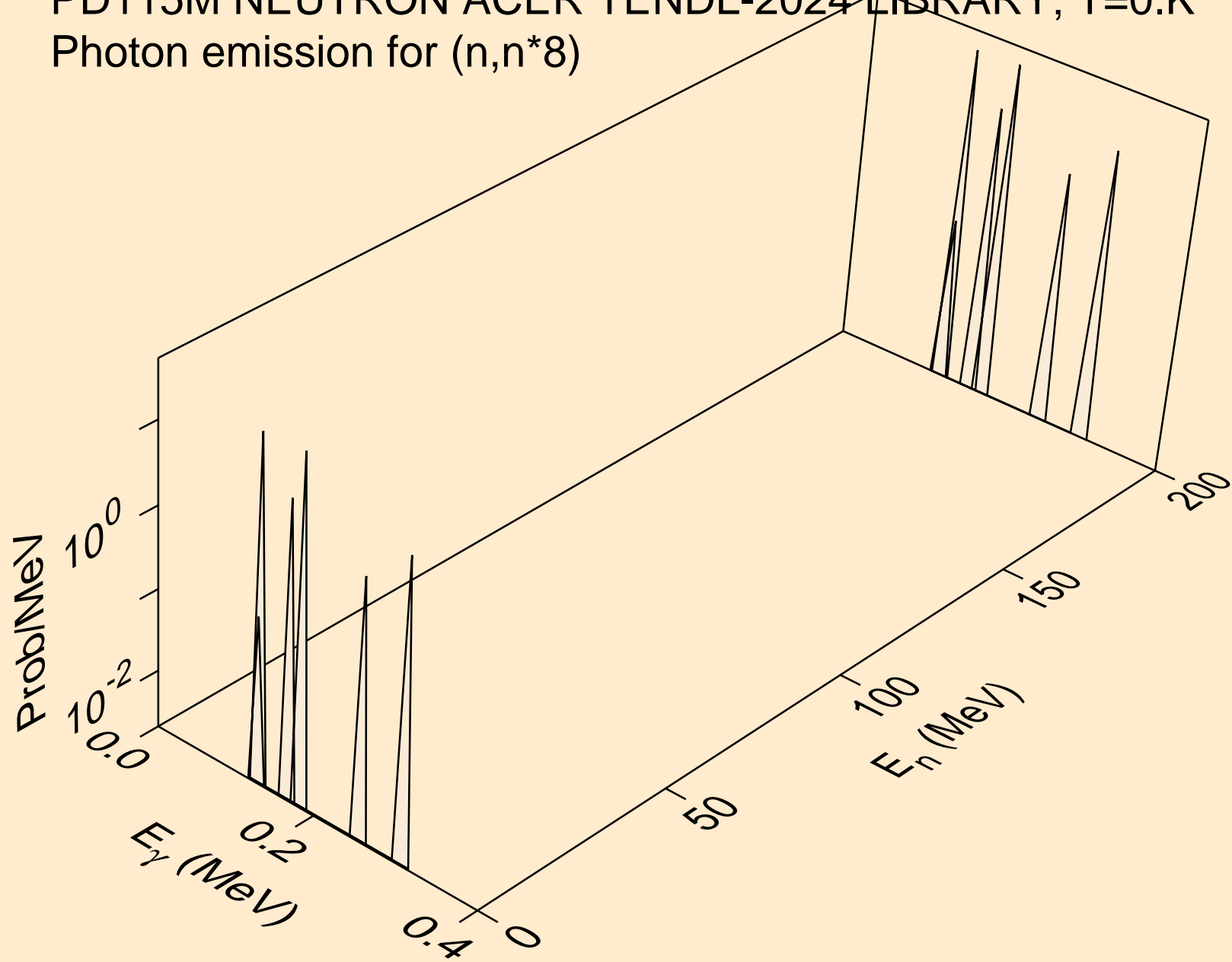

PD115M NEUTRON ACER TENDL-2024 LIBRARY; T=0.K  
Photon emission for (n,n\*9)

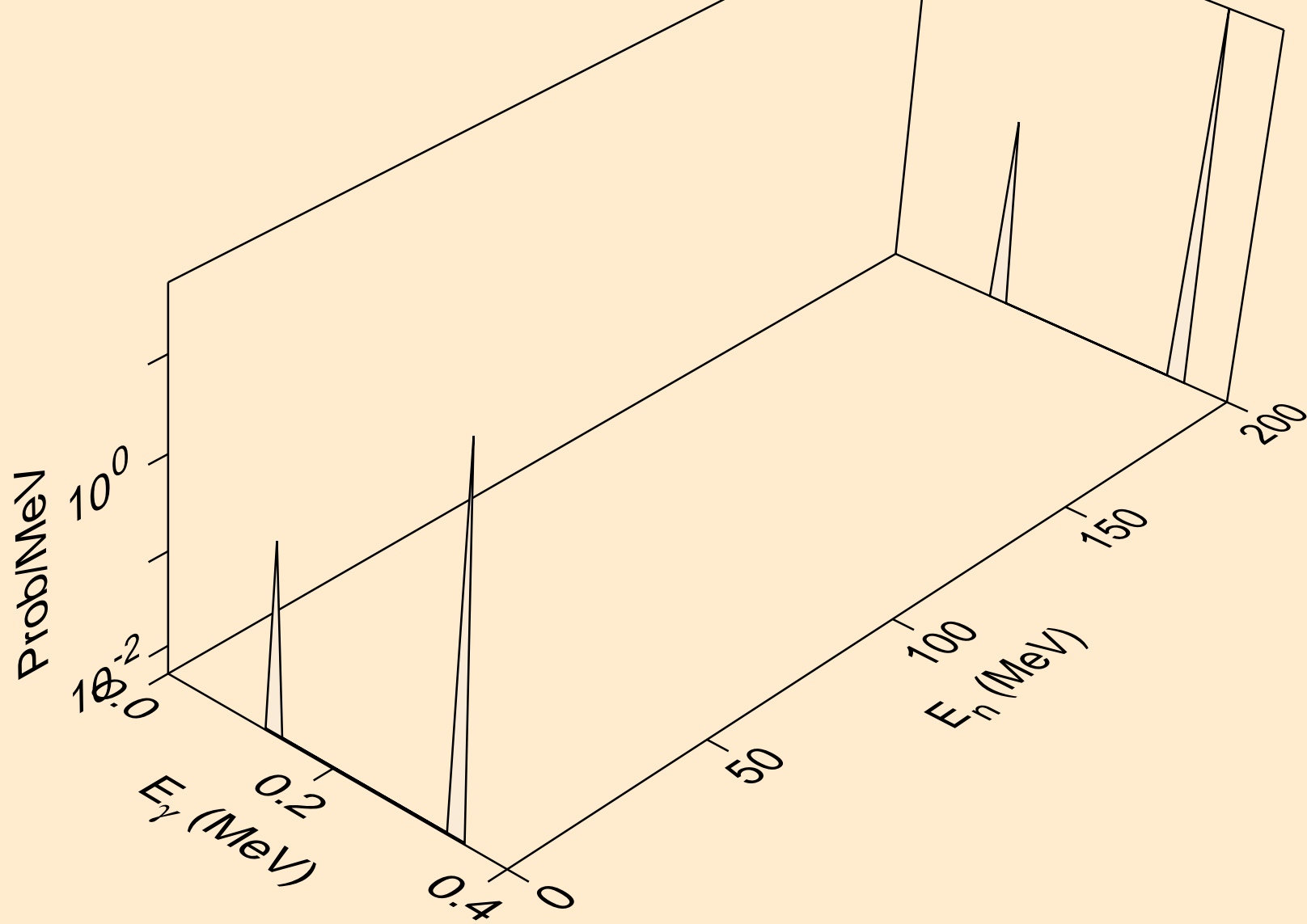

PD115M NEUTRON ACER TENDL-2024 LIBRARY; T=0.K  
Photon emission for (n,n\*10)

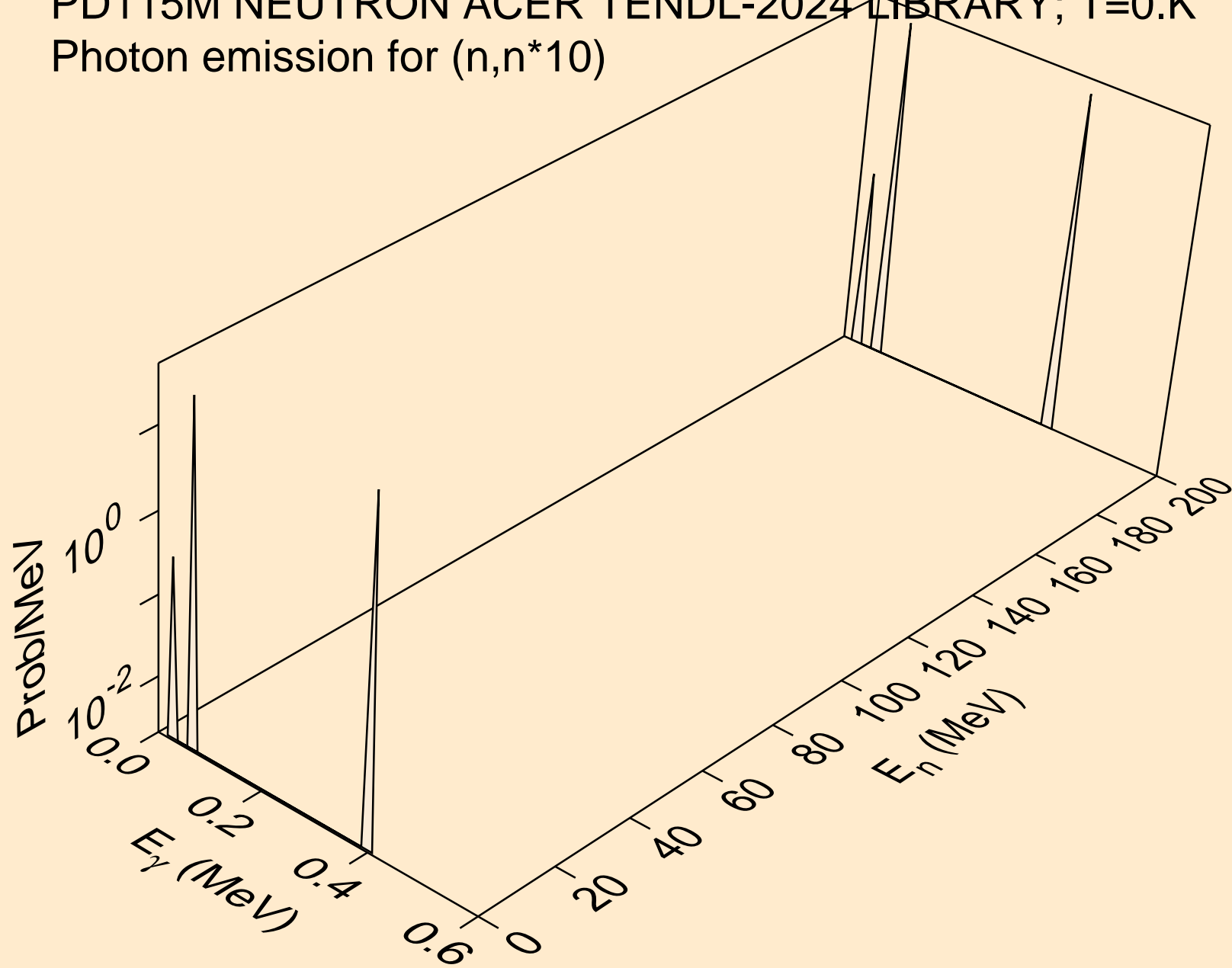



PD115M NEUTRON ACER TENDL-2024 LIBRARY; T=0.K  
Photon emission for (n,n\*11)

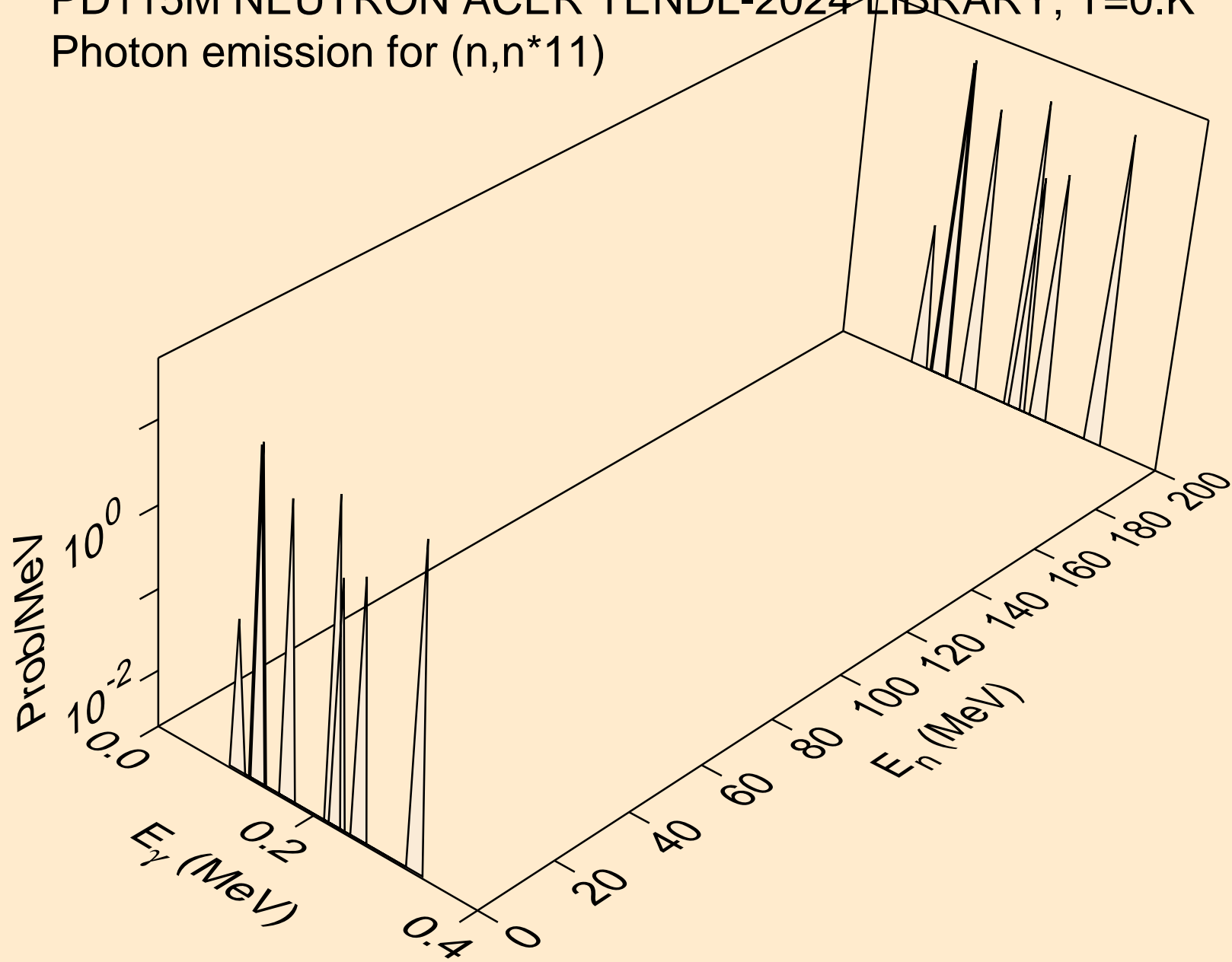

PD115M NEUTRON ACER TENDL-2024 LIBRARY; T=0.K  
Photon emission for (n,n\*12)

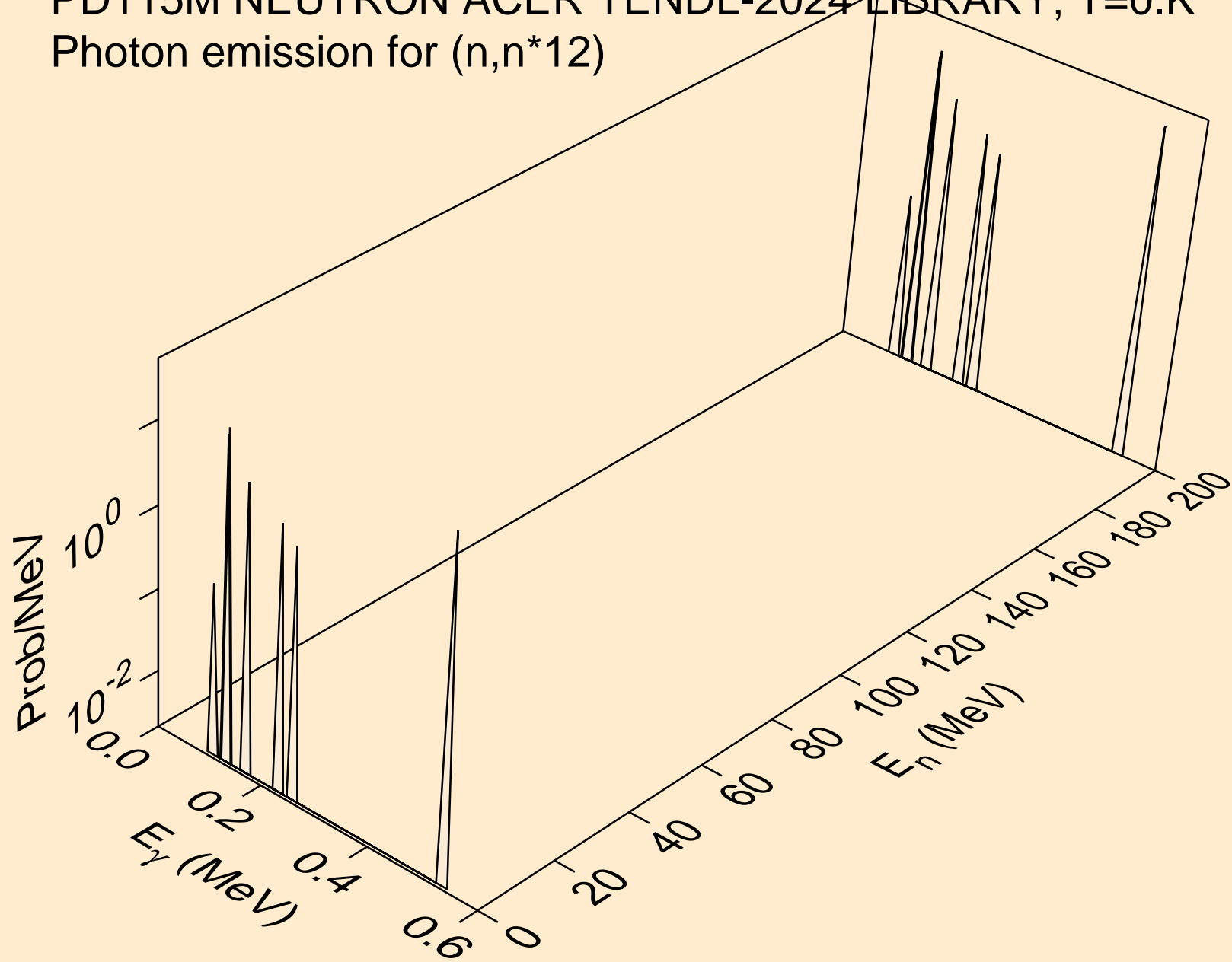

PD115M NEUTRON ACER TENDL-2024 LIBRARY; T=0.K  
Photon emission for (n,n\*13)

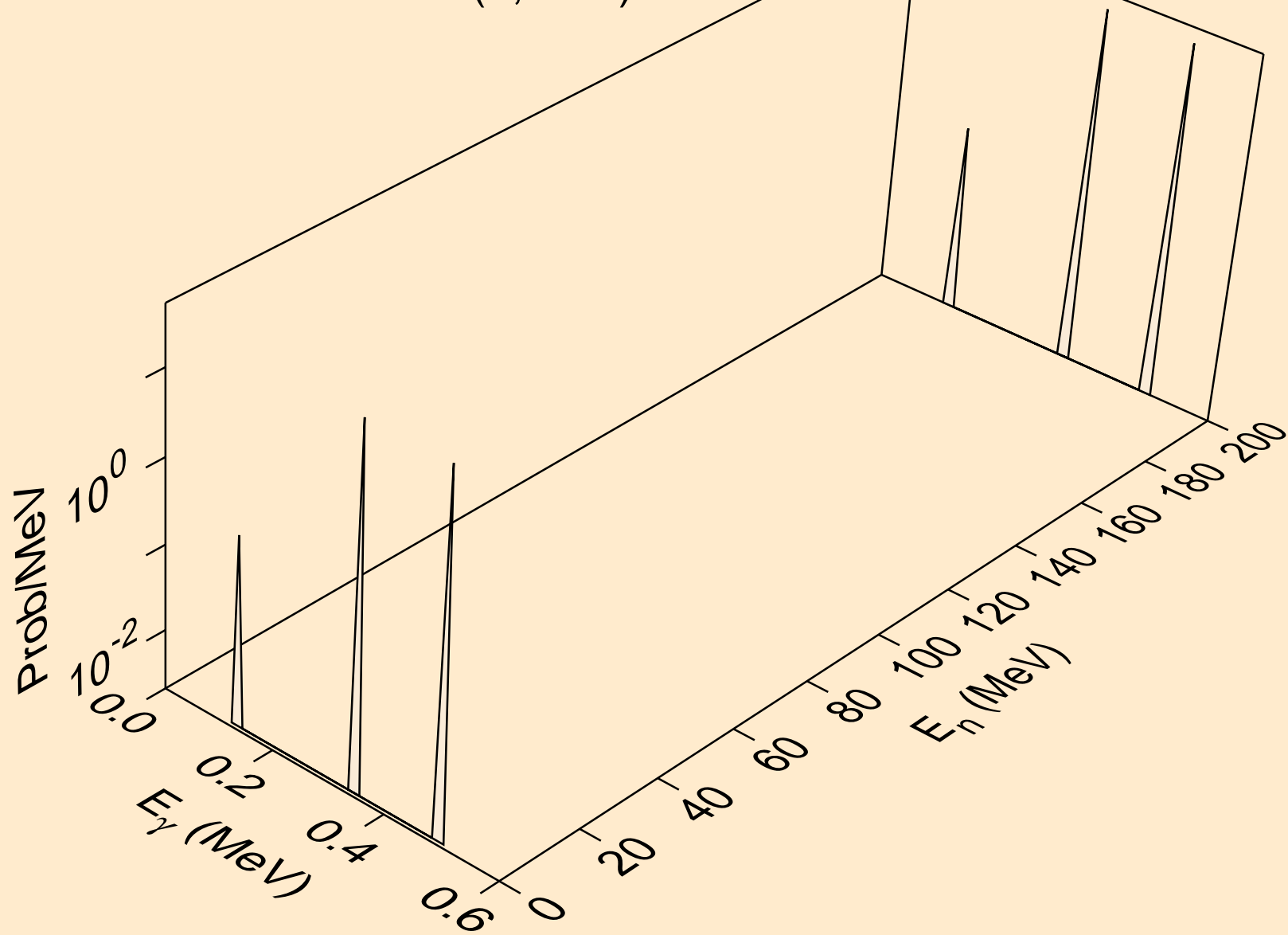

PD115M NEUTRON ACER TENDL-2024 LIBRARY; T=0.K  
Photon emission for (n,n\*14)

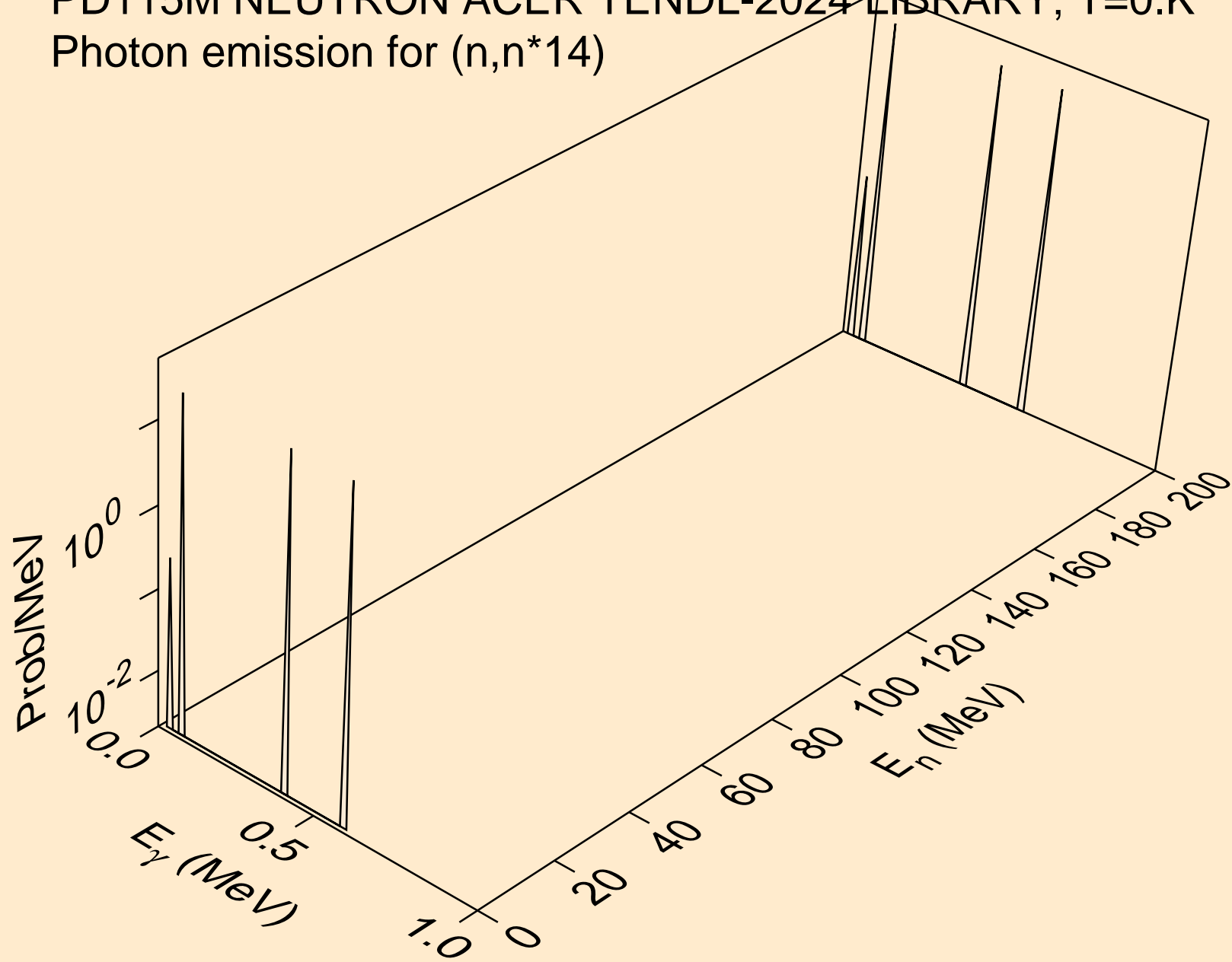

PD115M NEUTRON ACER TENDL-2024 LIBRARY; T=0.K  
Photon emission for (n,n\*15)

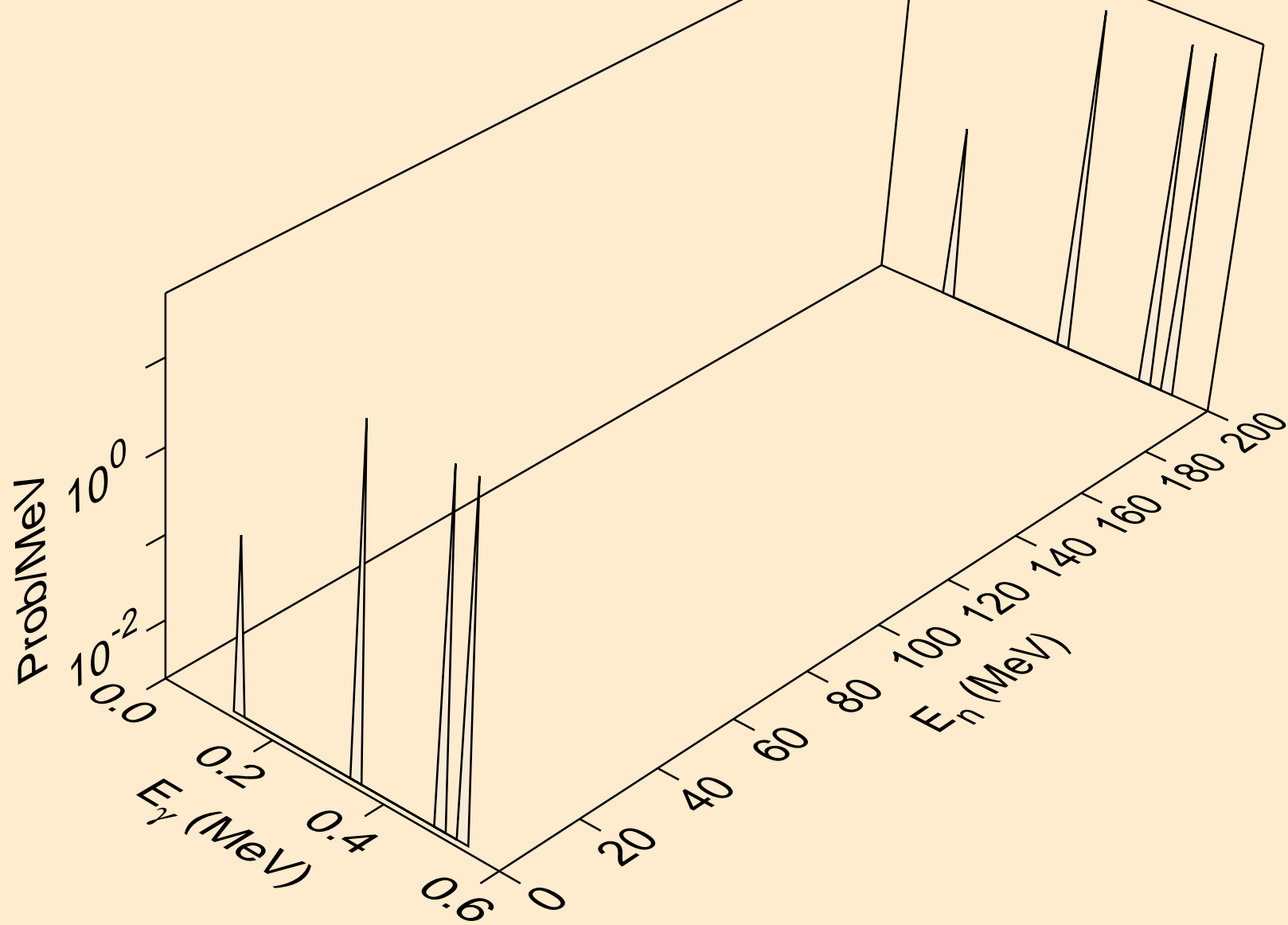

PD115M NEUTRON ACER TENDL-2024 LIBRARY; T=0.K  
Photon emission for (n,n\*16)

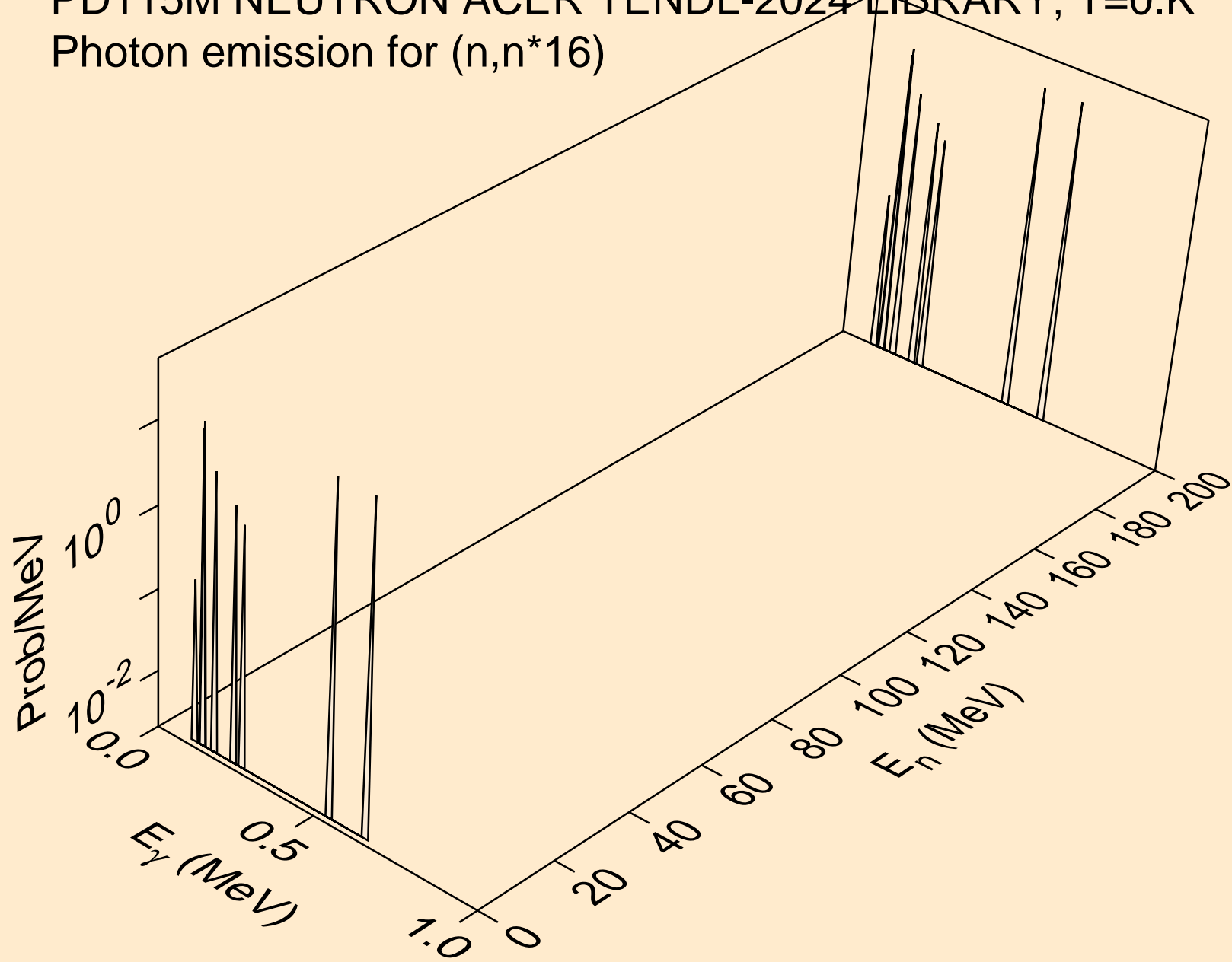

PD115M NEUTRON ACER TENDL-2024 LIBRARY; T=0.K  
Photon emission for (n,n\*17)

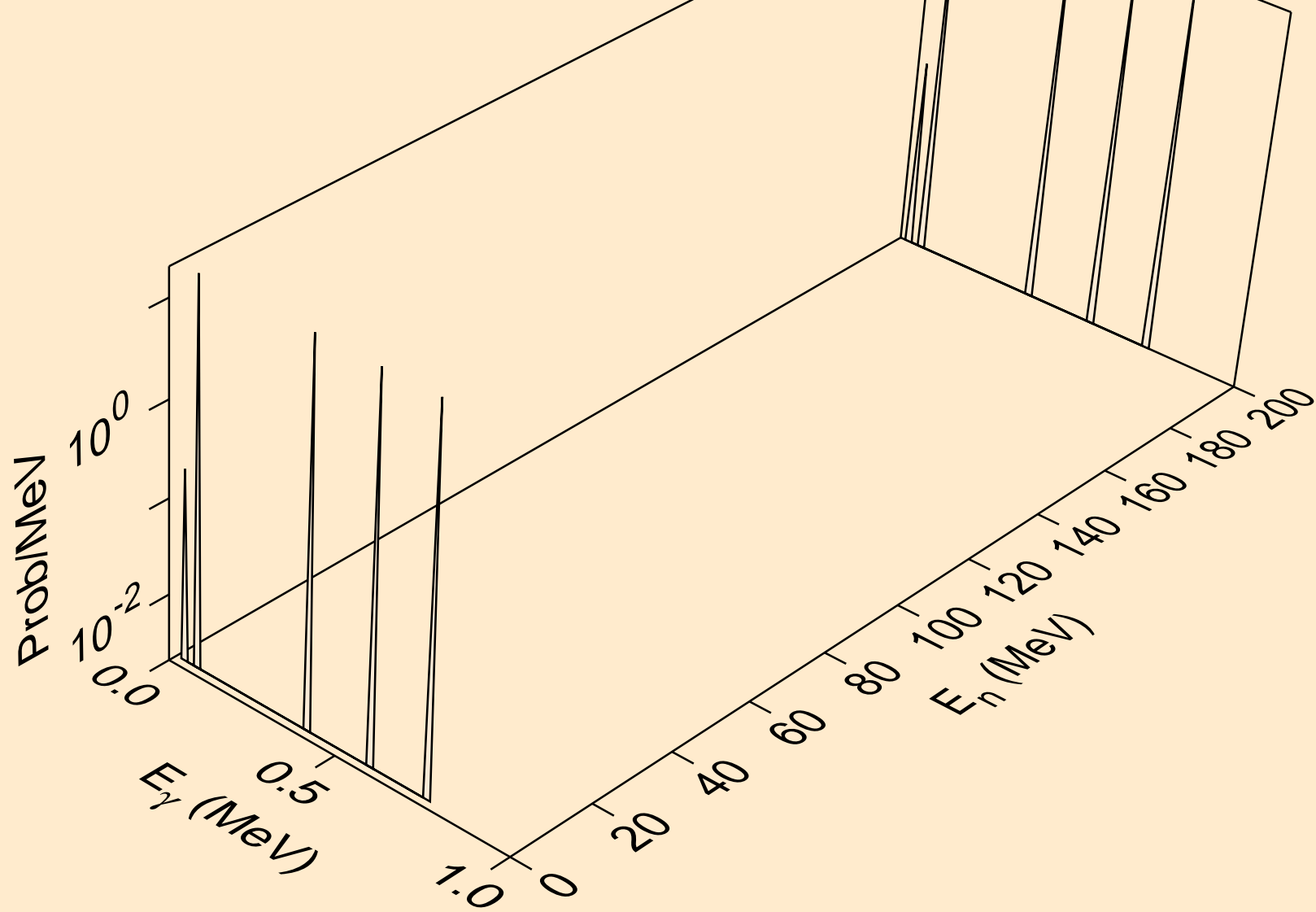

PD115M NEUTRON ACER TENDL-2024 LIBRARY; T=0.K  
Photon emission for (n,n\*18)

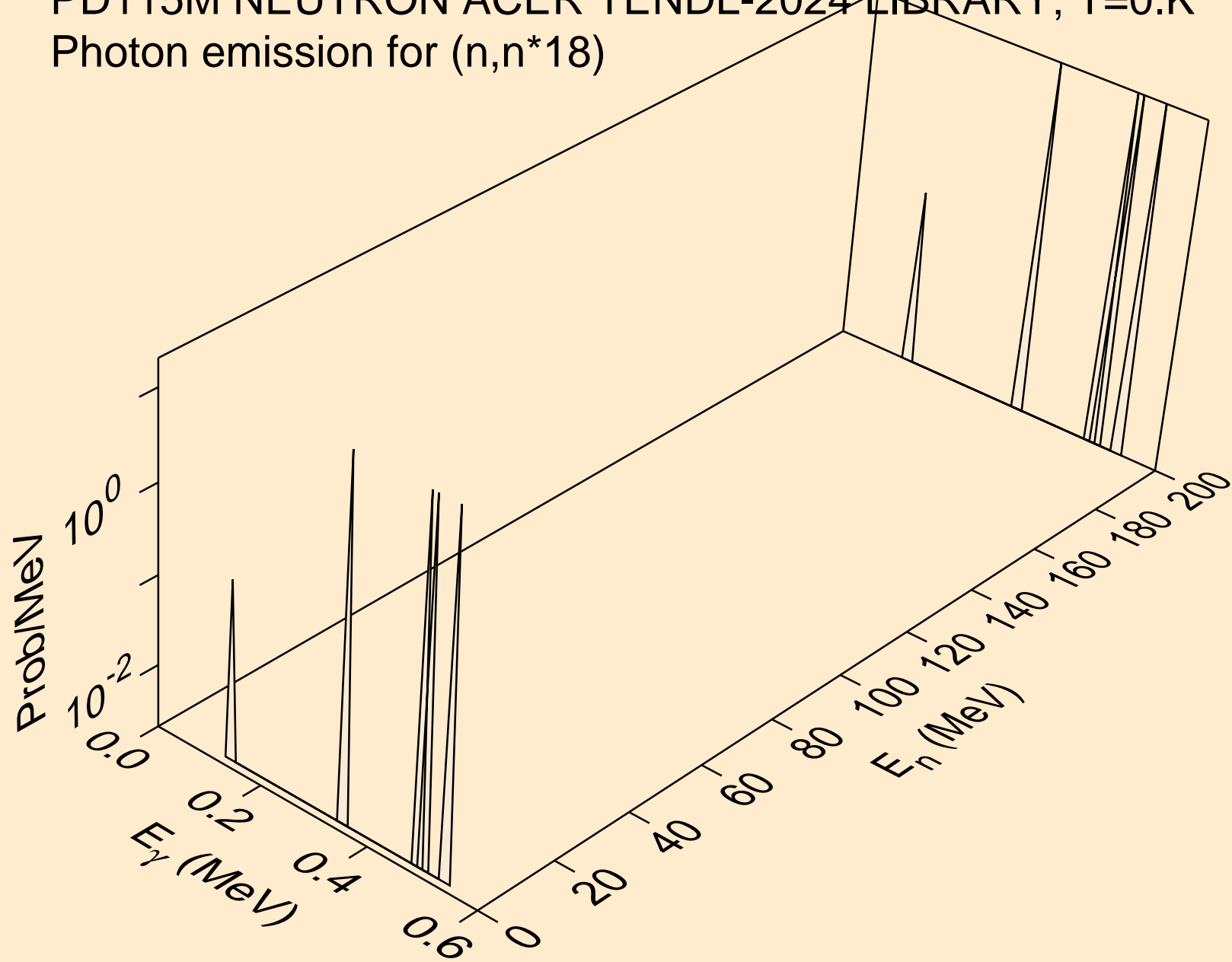



PD115M NEUTRON ACER TENDL-2024 LIBRARY; T=0.K  
Photon emission for (n,n\*19)

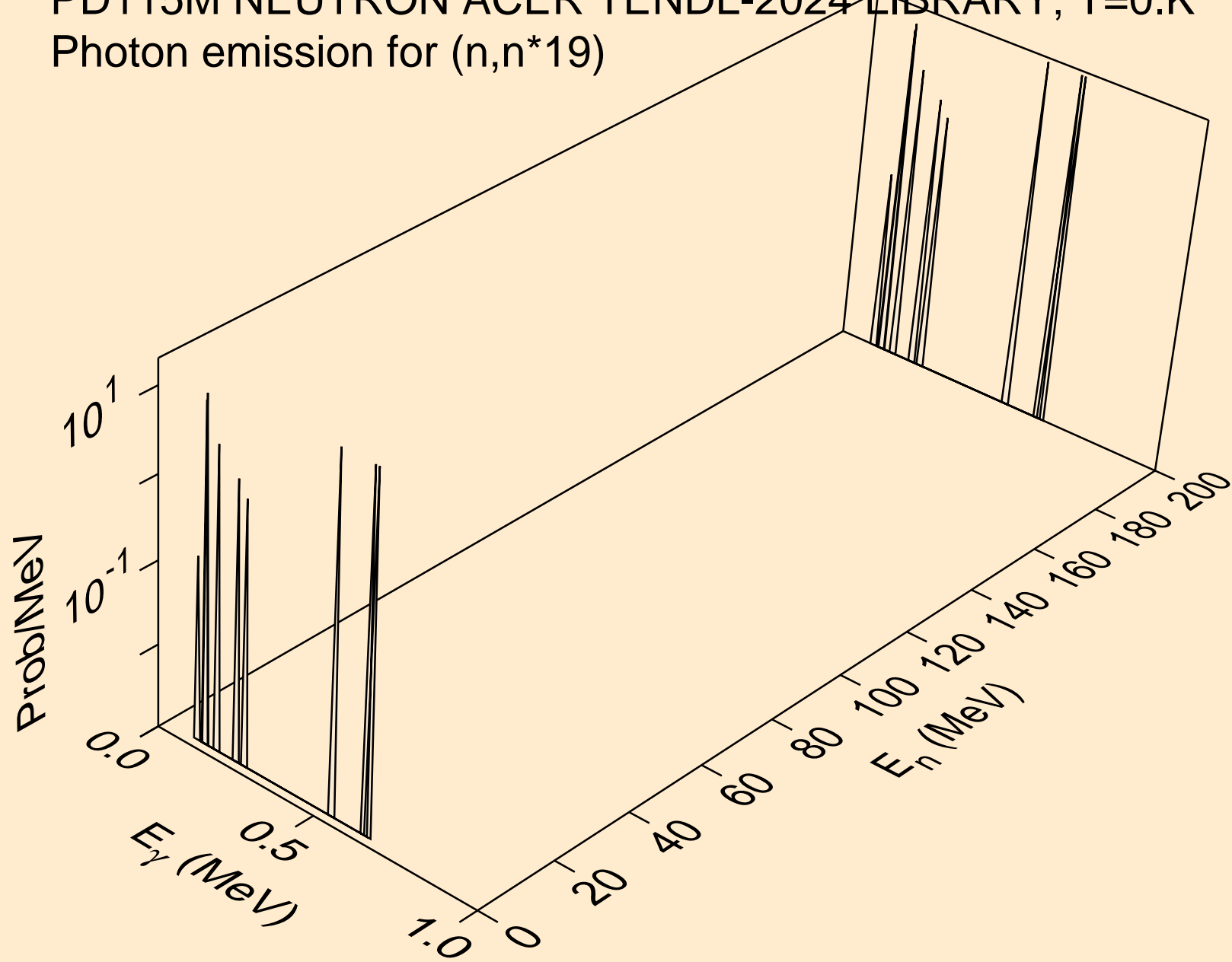

PD115M NEUTRON ACER TENDL-2024 LIBRARY; T=0.K  
Photon emission for (n,n\*20)

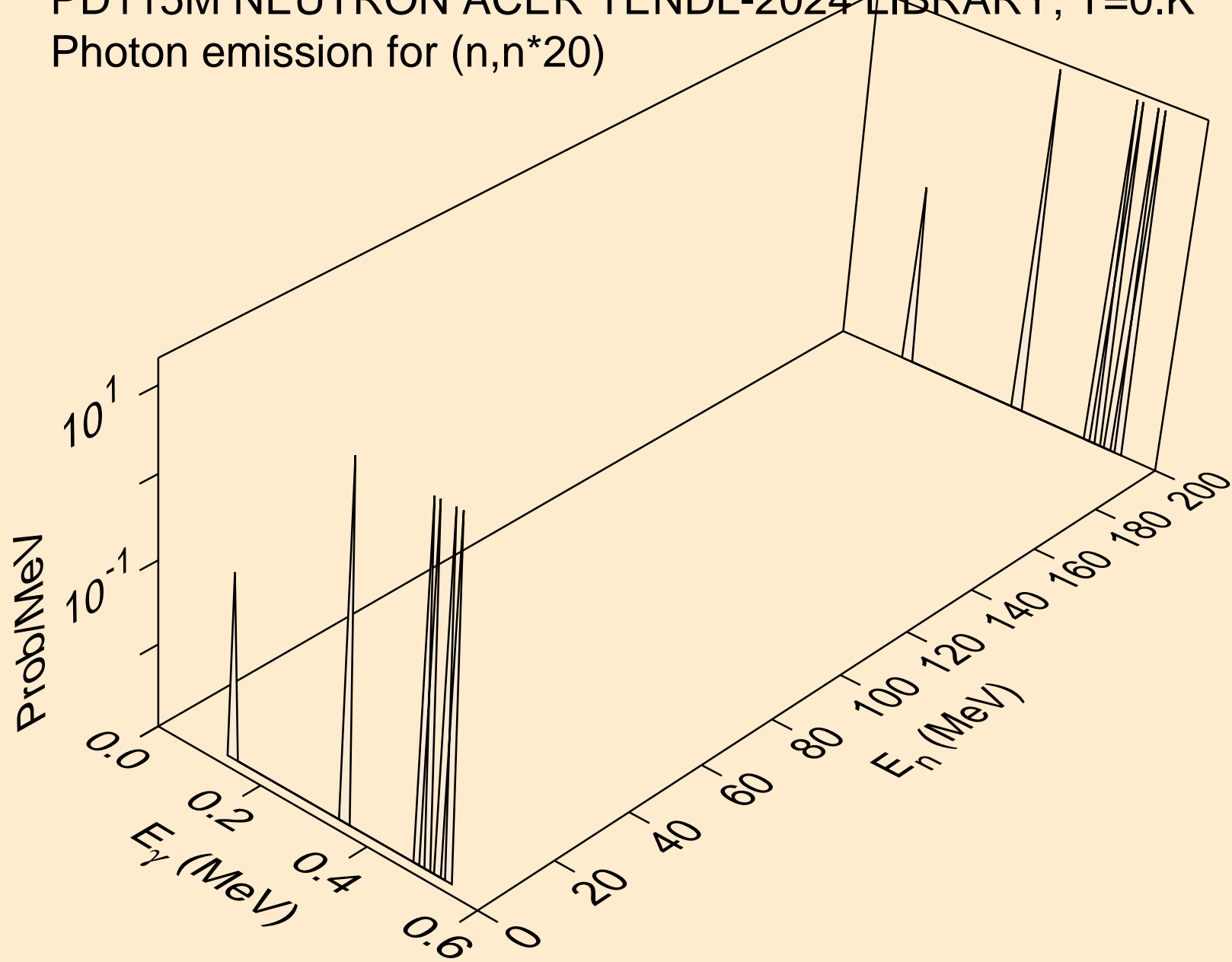

PD115M NEUTRON ACER TENDL-2024 LIBRARY; T=0.K  
Photon emission for (n,n\*21)

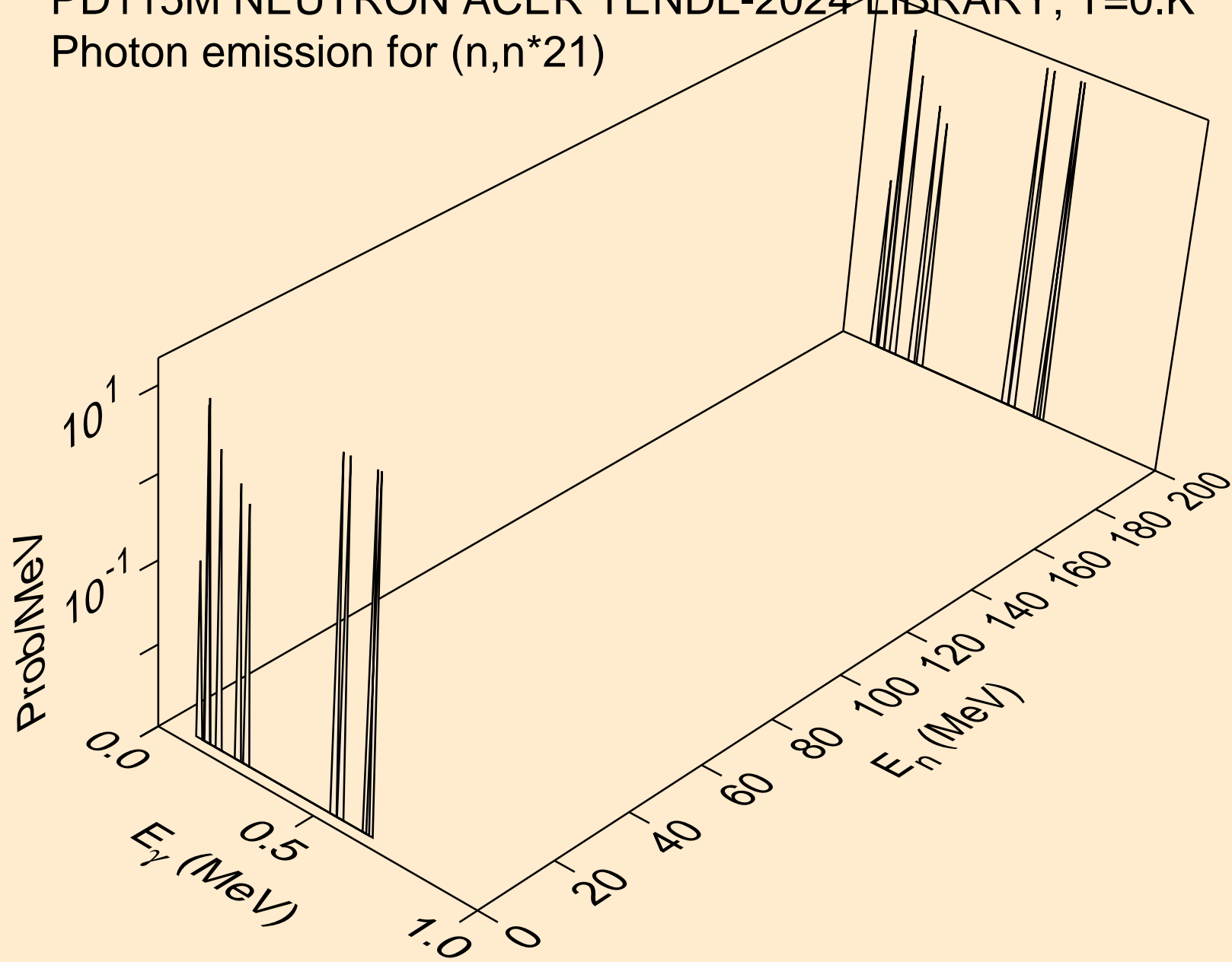

PD115M NEUTRON ACER TENDL-2024 LIBRARY; T=0.K  
Photon emission for (n,n\*22)

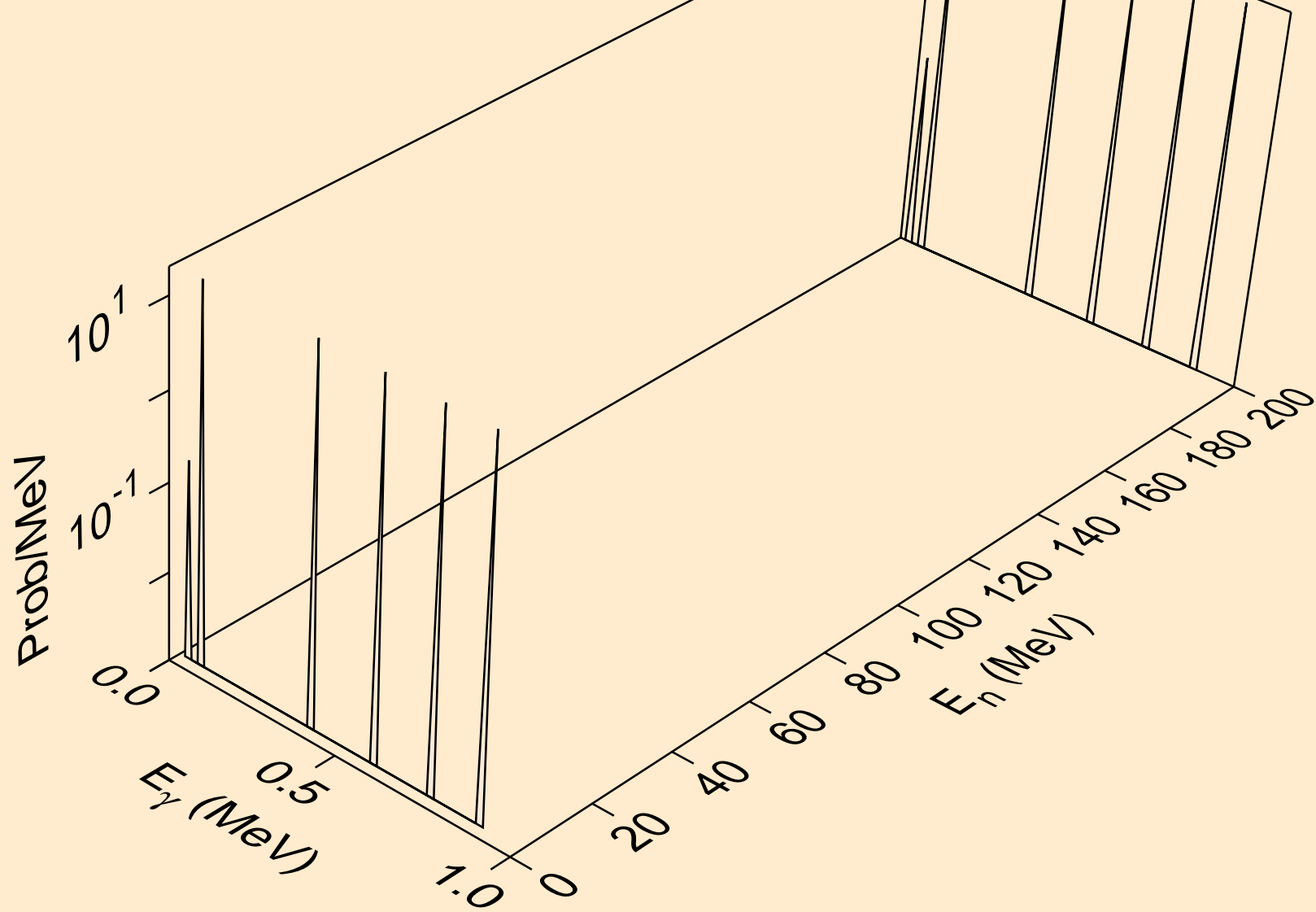

PD115M NEUTRON ACER TENDL-2024 LIBRARY; T=0.K  
Photon emission for (n,n\*23)

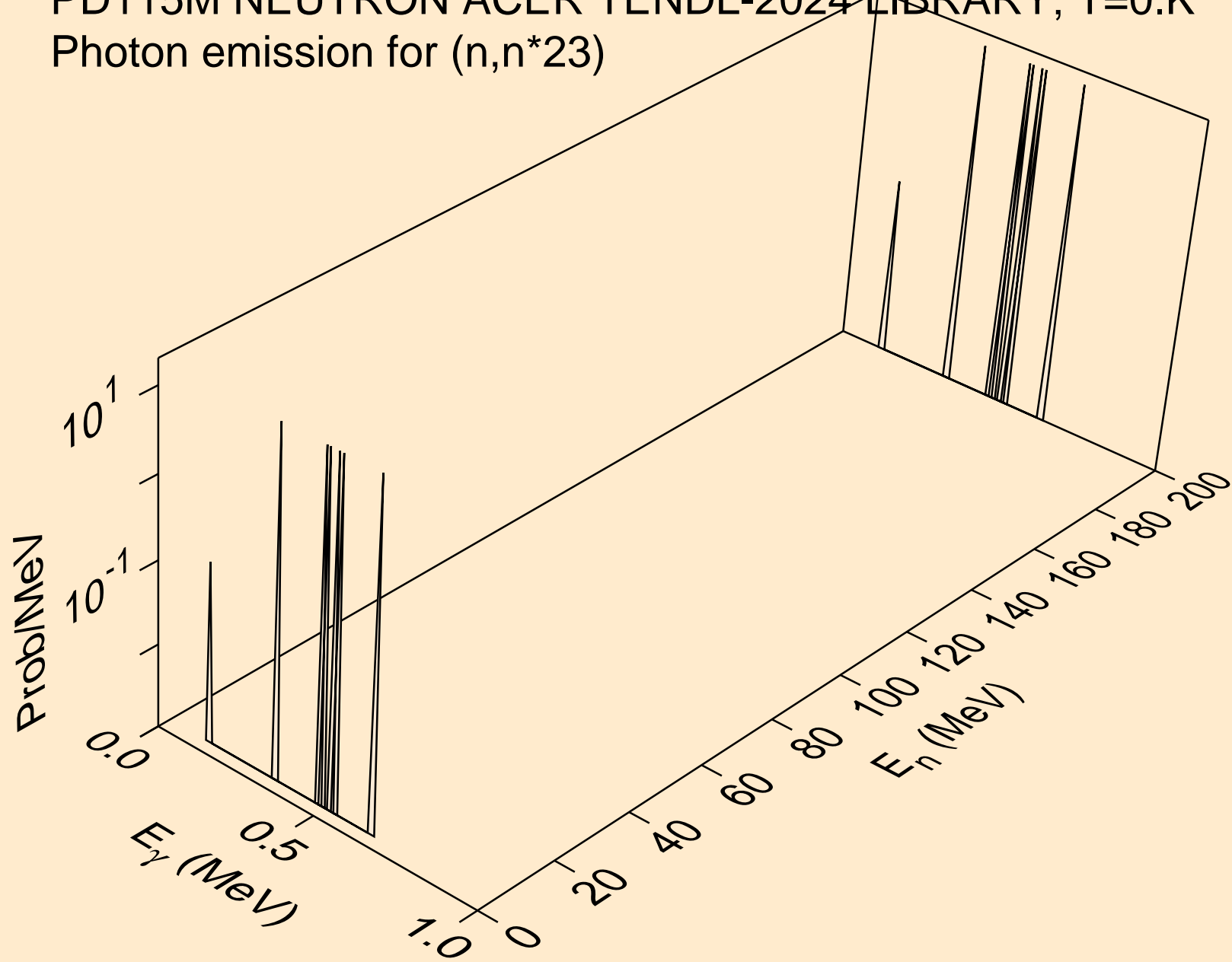

PD115M NEUTRON ACER TENDL-2024 LIBRARY; T=0.K  
Photon emission for (n,n\*24)

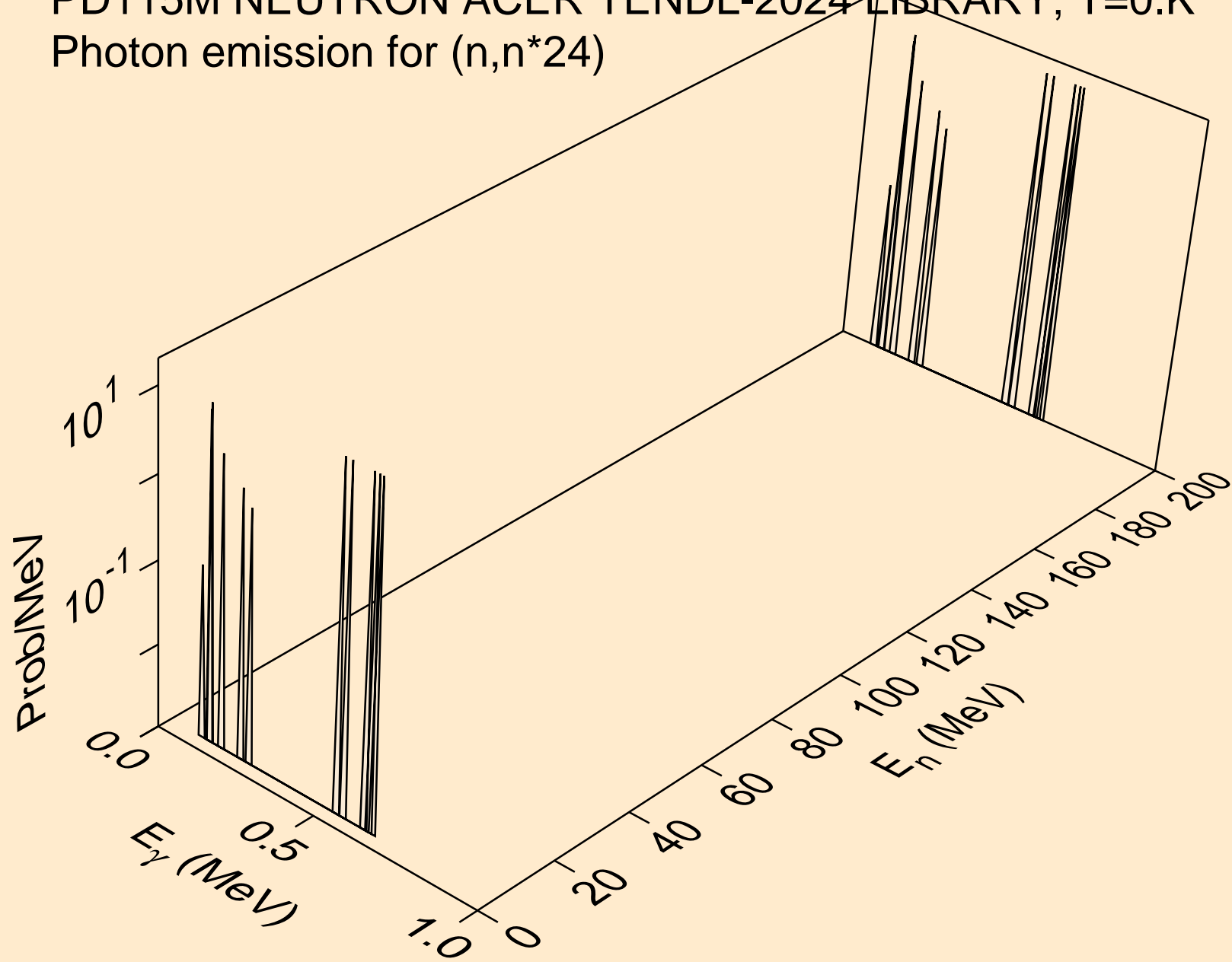

PD115M NEUTRON ACER TENDL-2024 LIBRARY; T=0.K  
Photon emission for (n,n\*c)

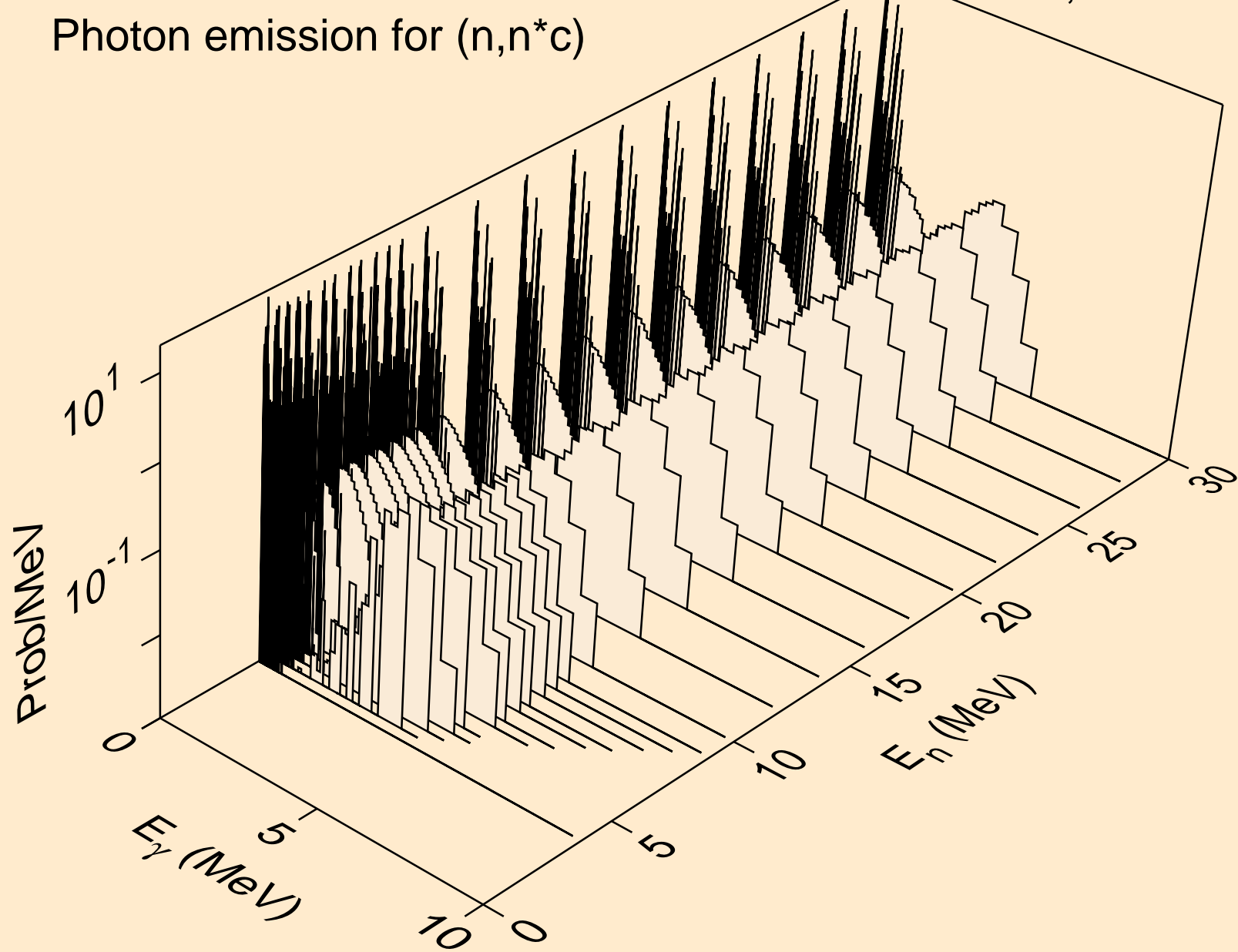

PD115M NEUTRON ACER TENDL-2024 LIBRARY; T=0.K  
Photon emission for (n,gma)

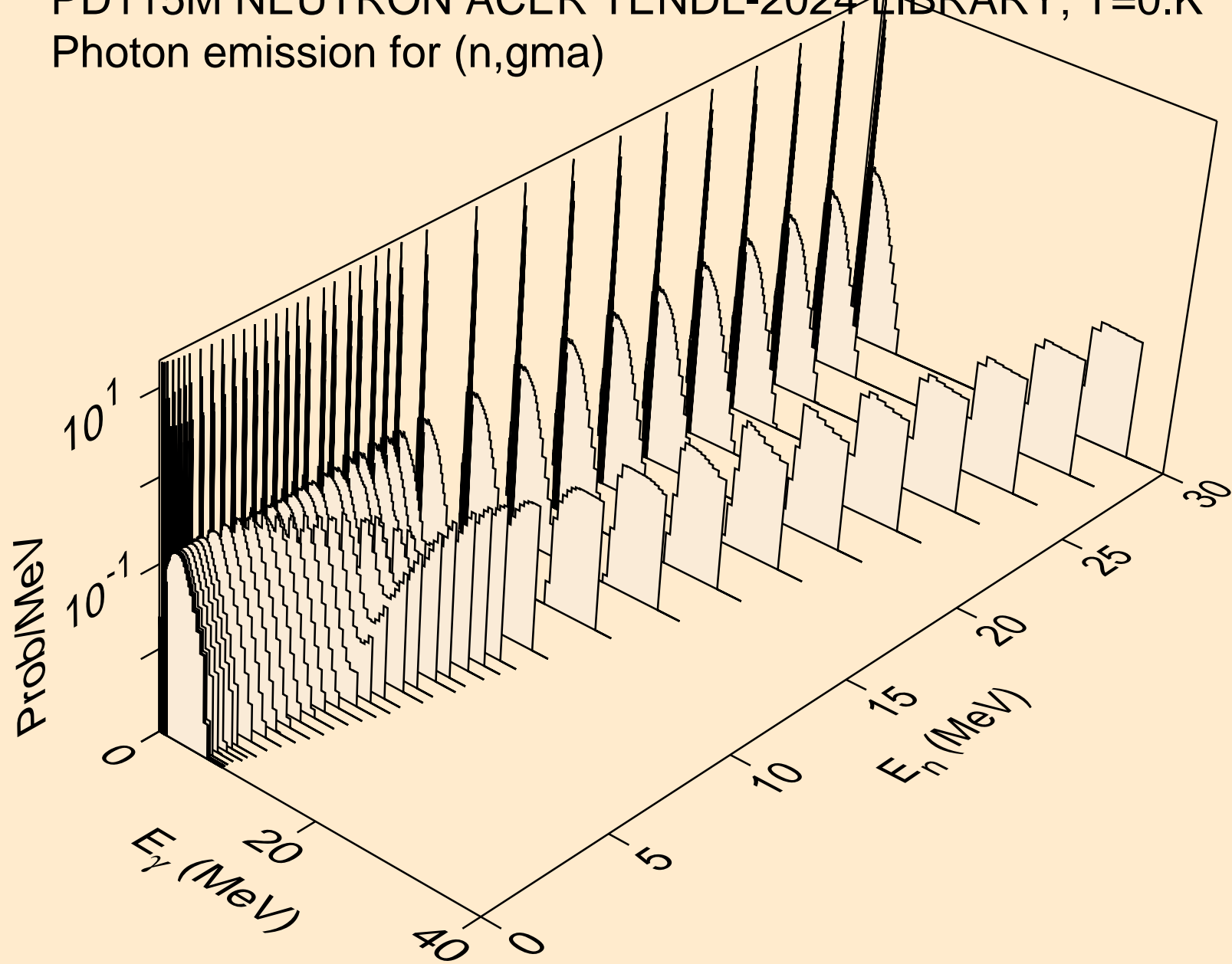



PD115M NEUTRON ACER TENDL-2024 LIBRARY; T=0.K  
Photon emission for (n,p)

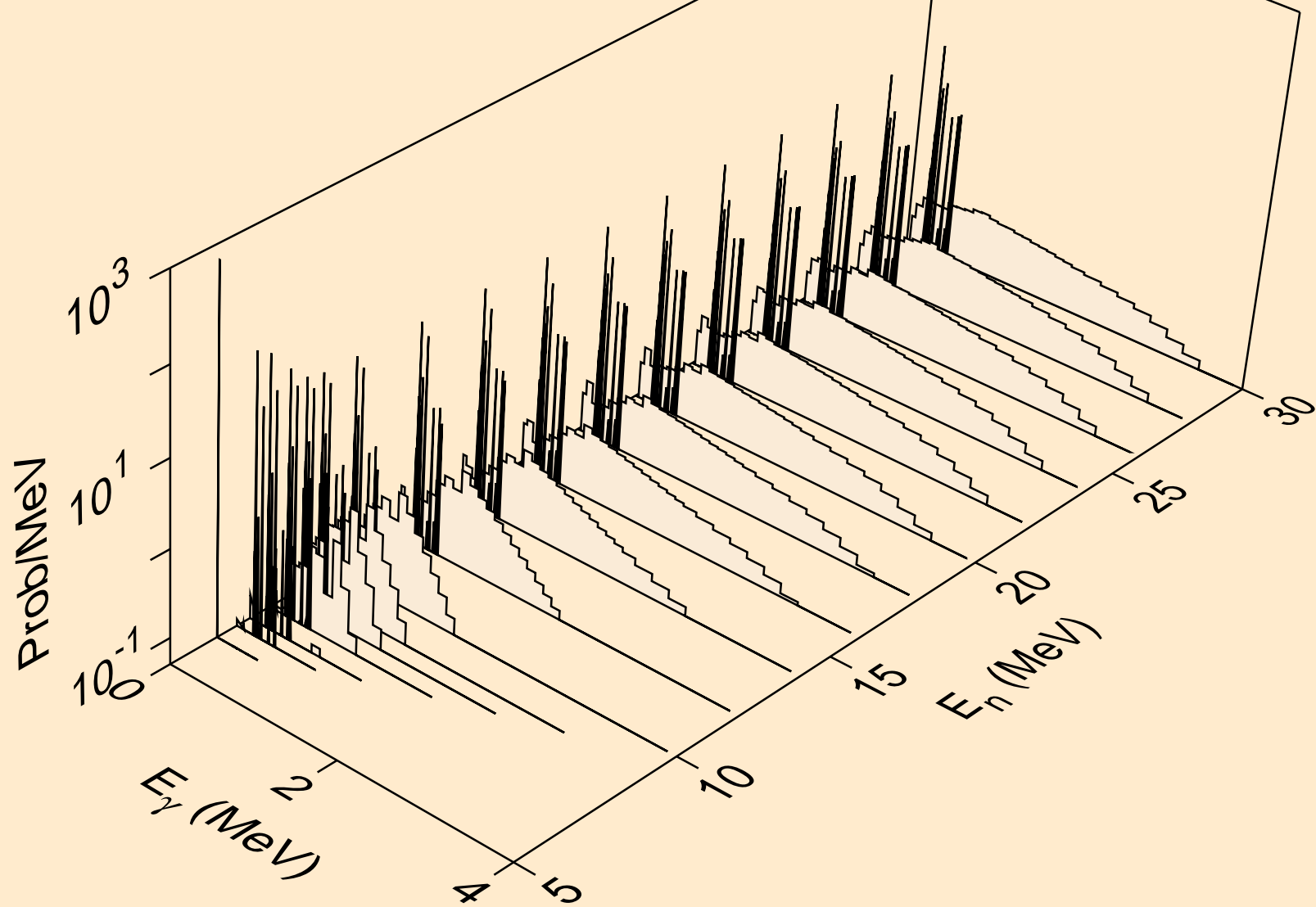

PD115M NEUTRON ACER TENDL-2024 LIBRARY; T=0.K  
Photon emission for (n,d)

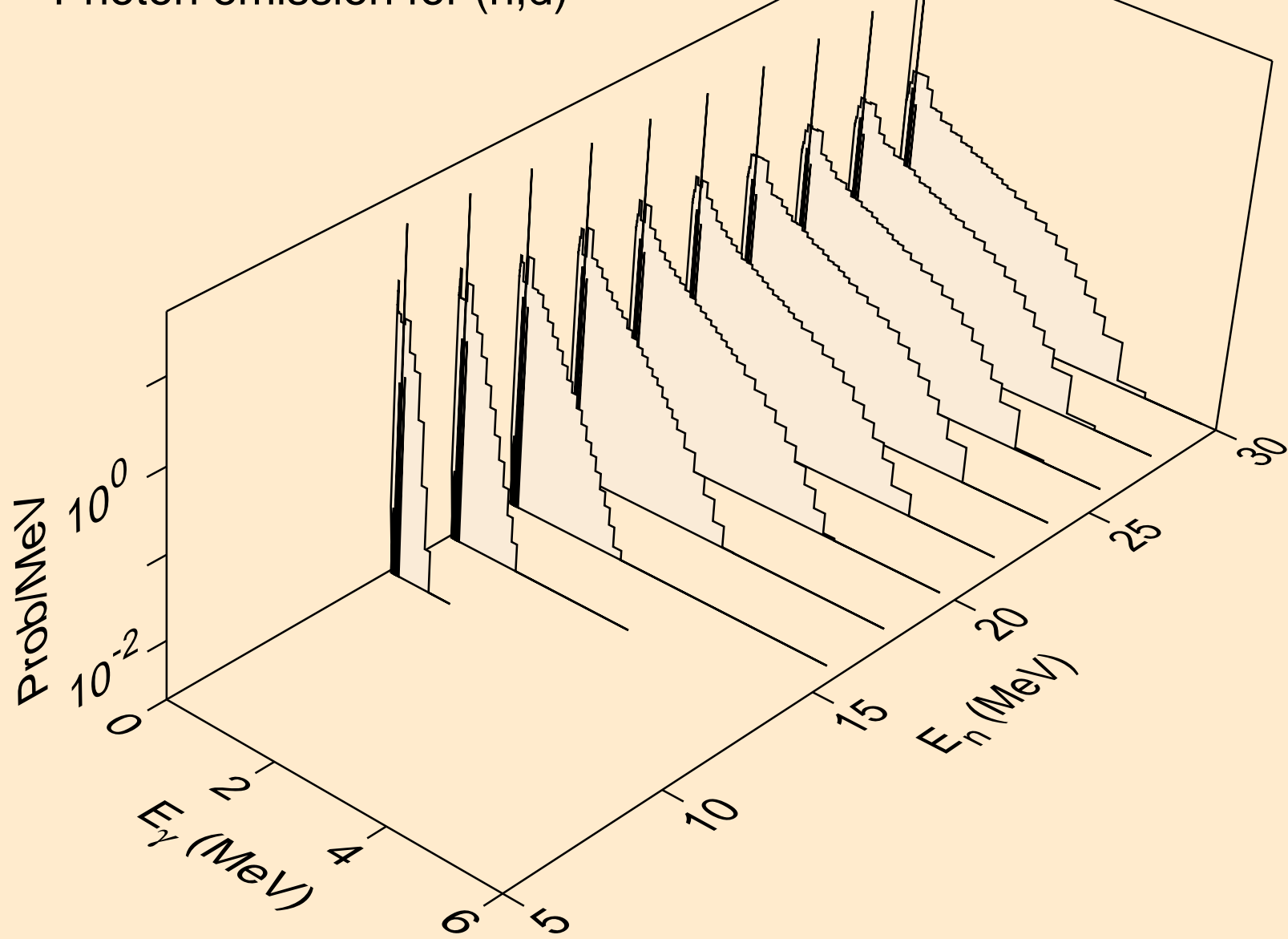

PD115M NEUTRON ACER TENDL-2024 LIBRARY; T=0.K  
Photon emission for (n,t)

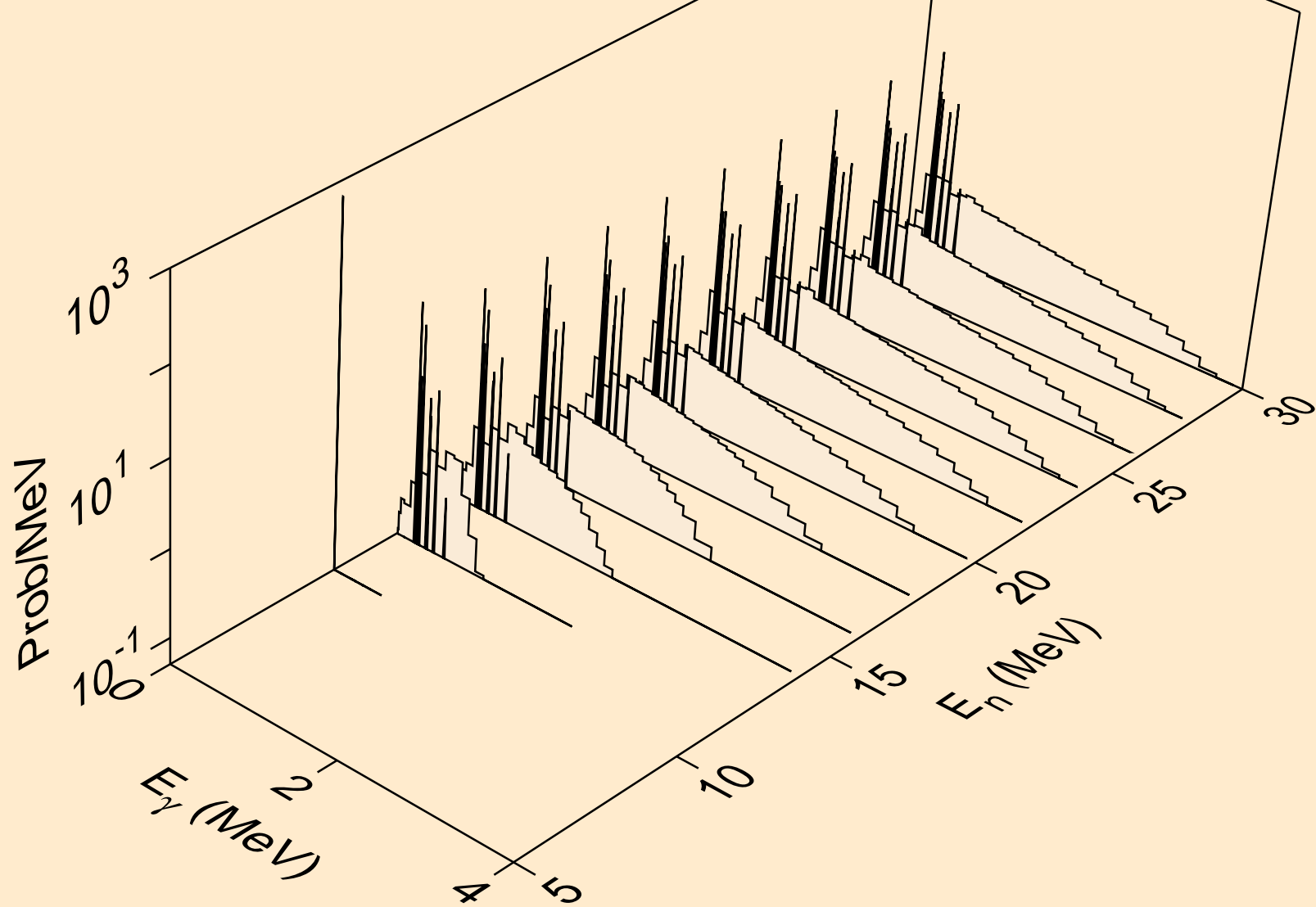

PD115M NEUTRON ACER TENDL-2024 LIBRARY; T=0.K  
Photon emission for (n,he3)

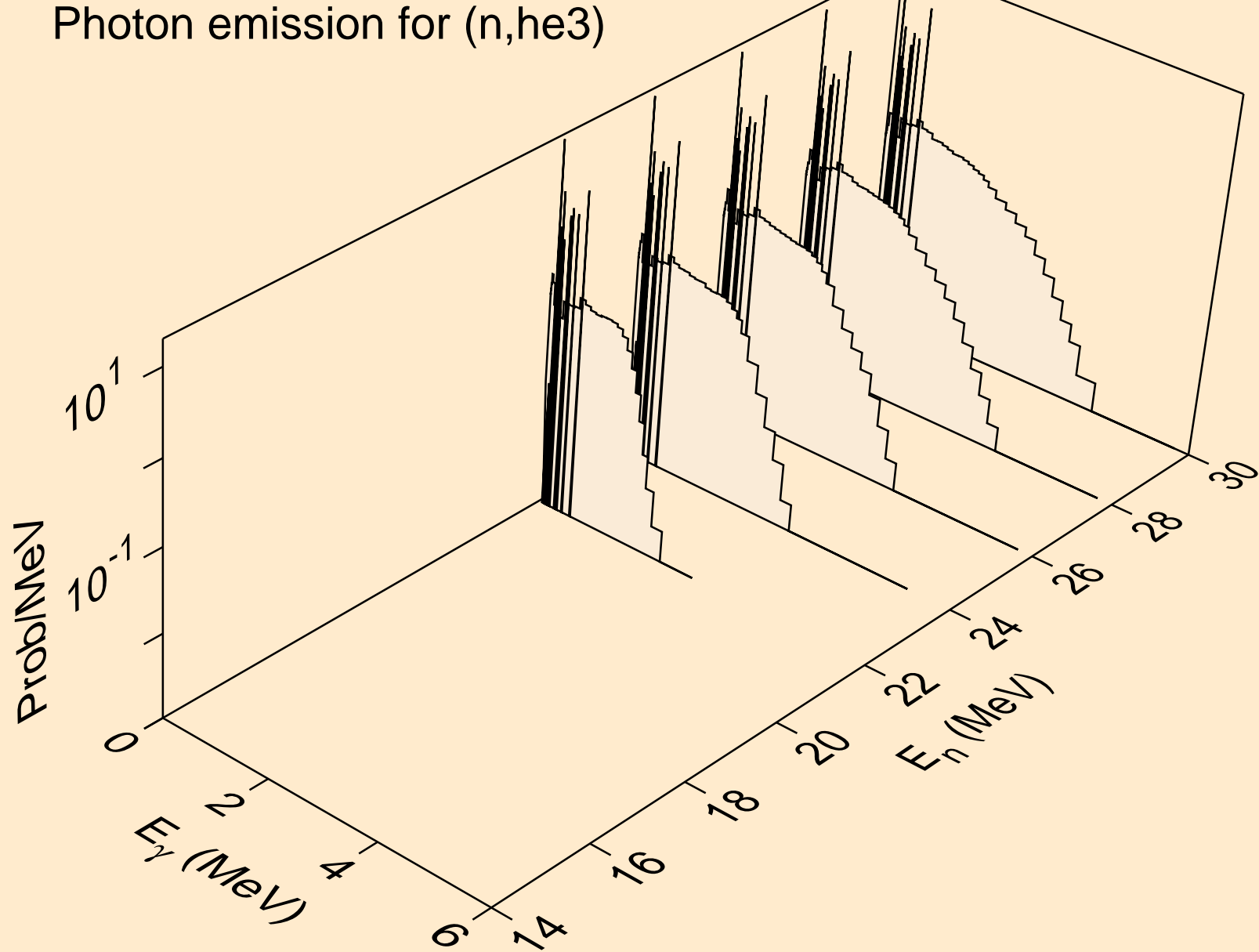

PD115M NEUTRON ACER TENDL-2024 LIBRARY; T=0.K  
Photon emission for (n,a)

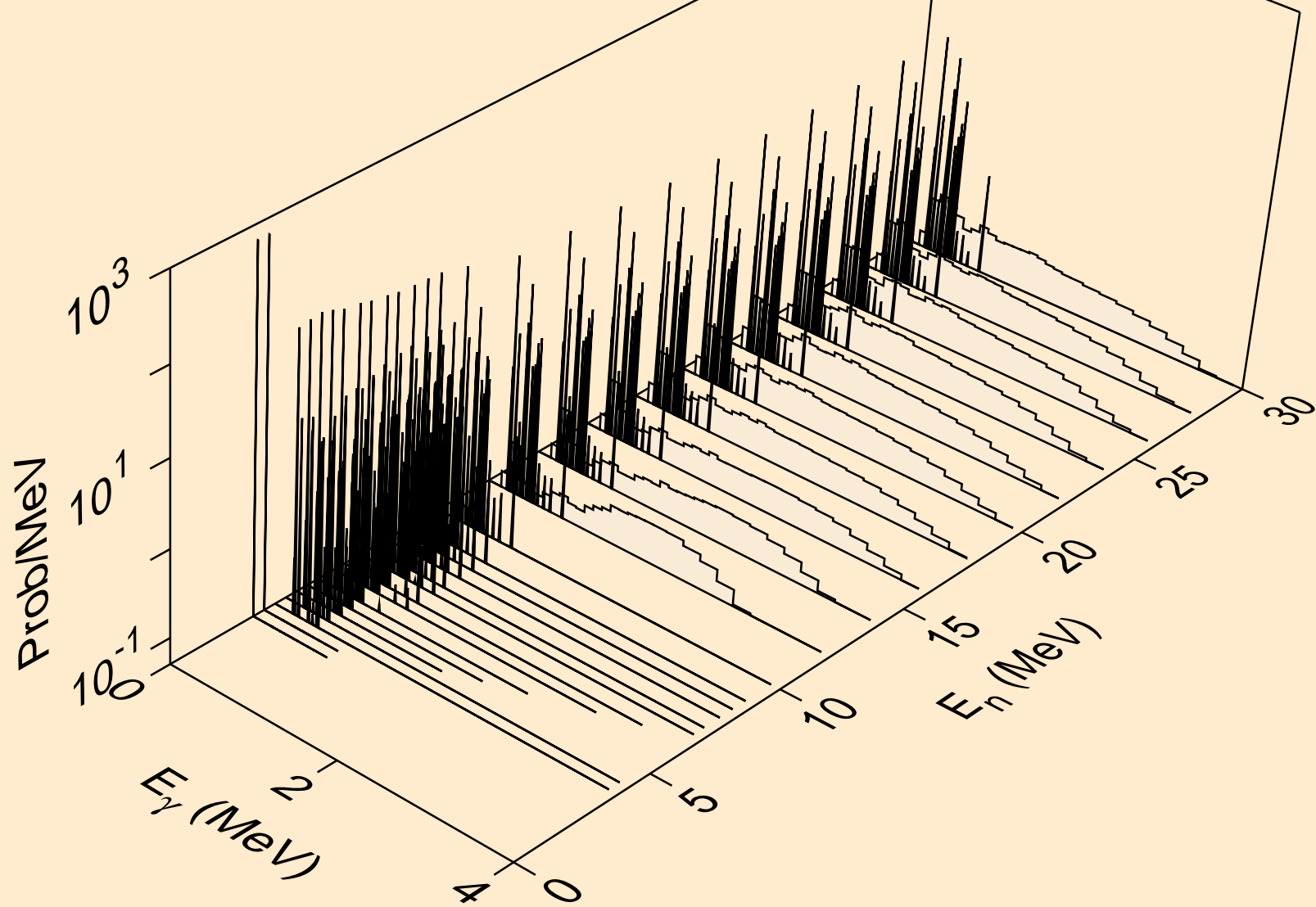

PD115M NEUTRON ACER TENDL-2024 LIBRARY; T=0.K  
Photon emission for (n,2p)

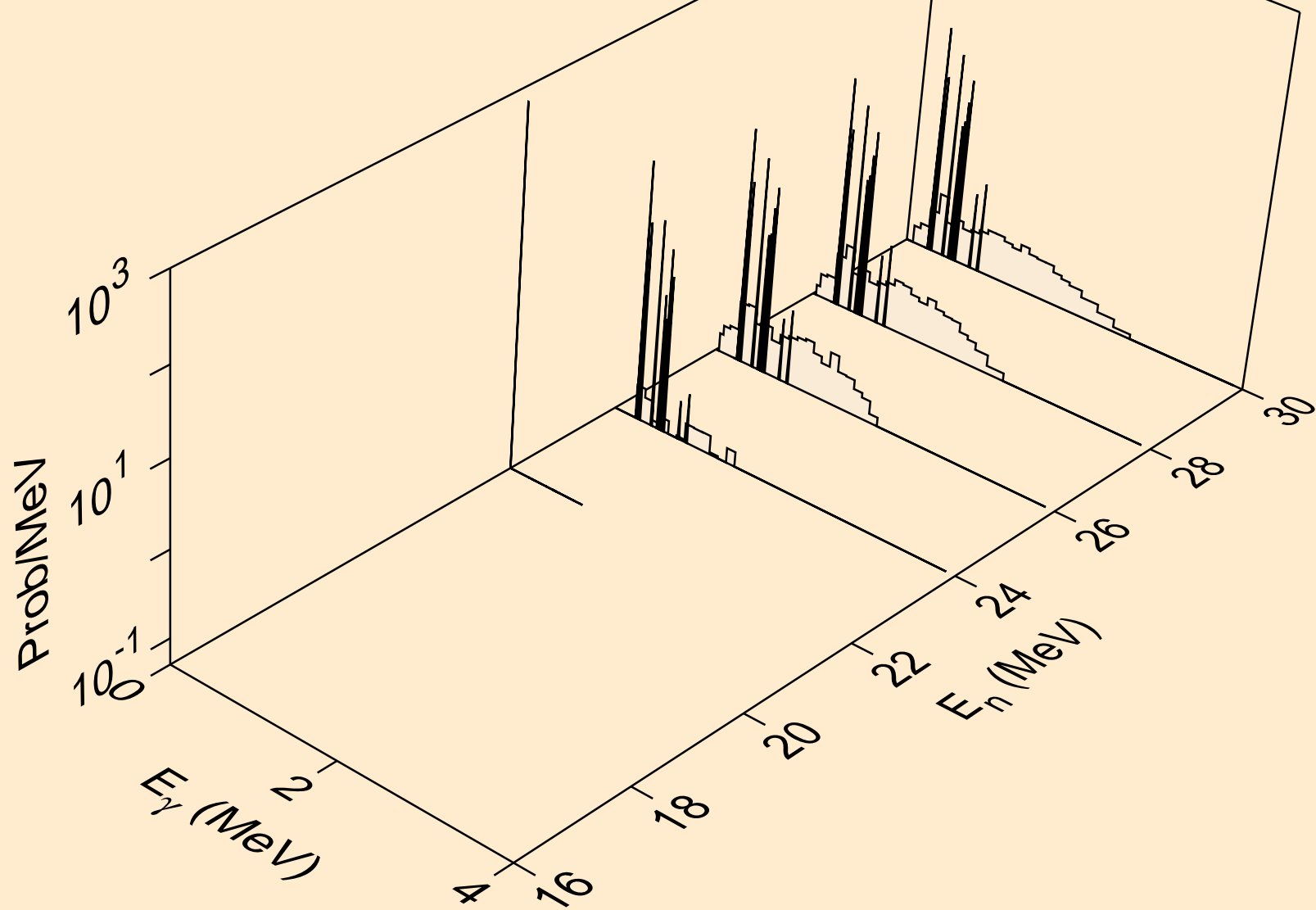

PD115M NEUTRON ACER TENDL-2024 LIBRARY; T=0.K  
thermal capture photon spectrum

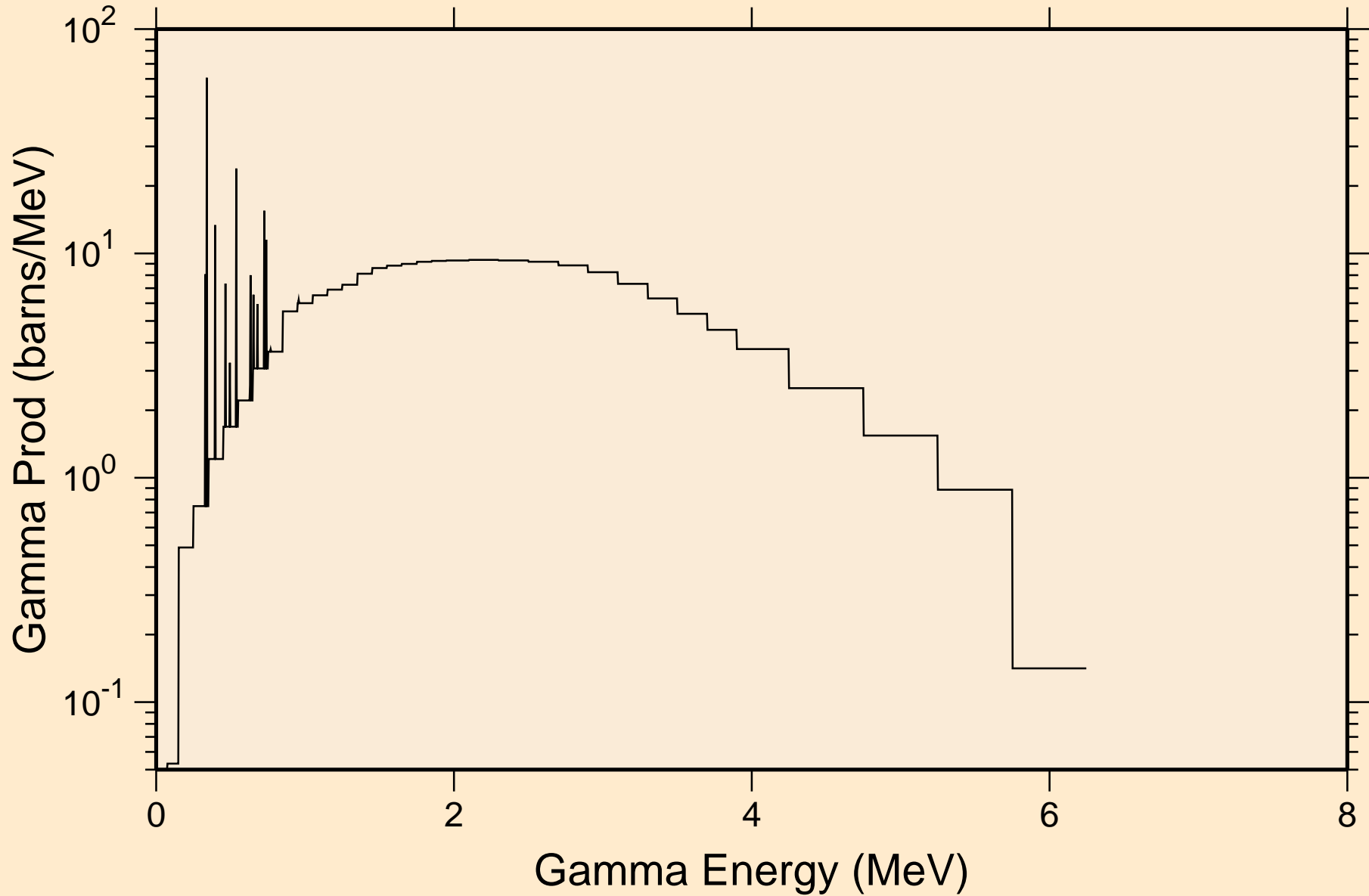

PD115M NEUTRON ACER TENDL-2024 LIBRARY; T=0.K  
14 MeV photon spectrum

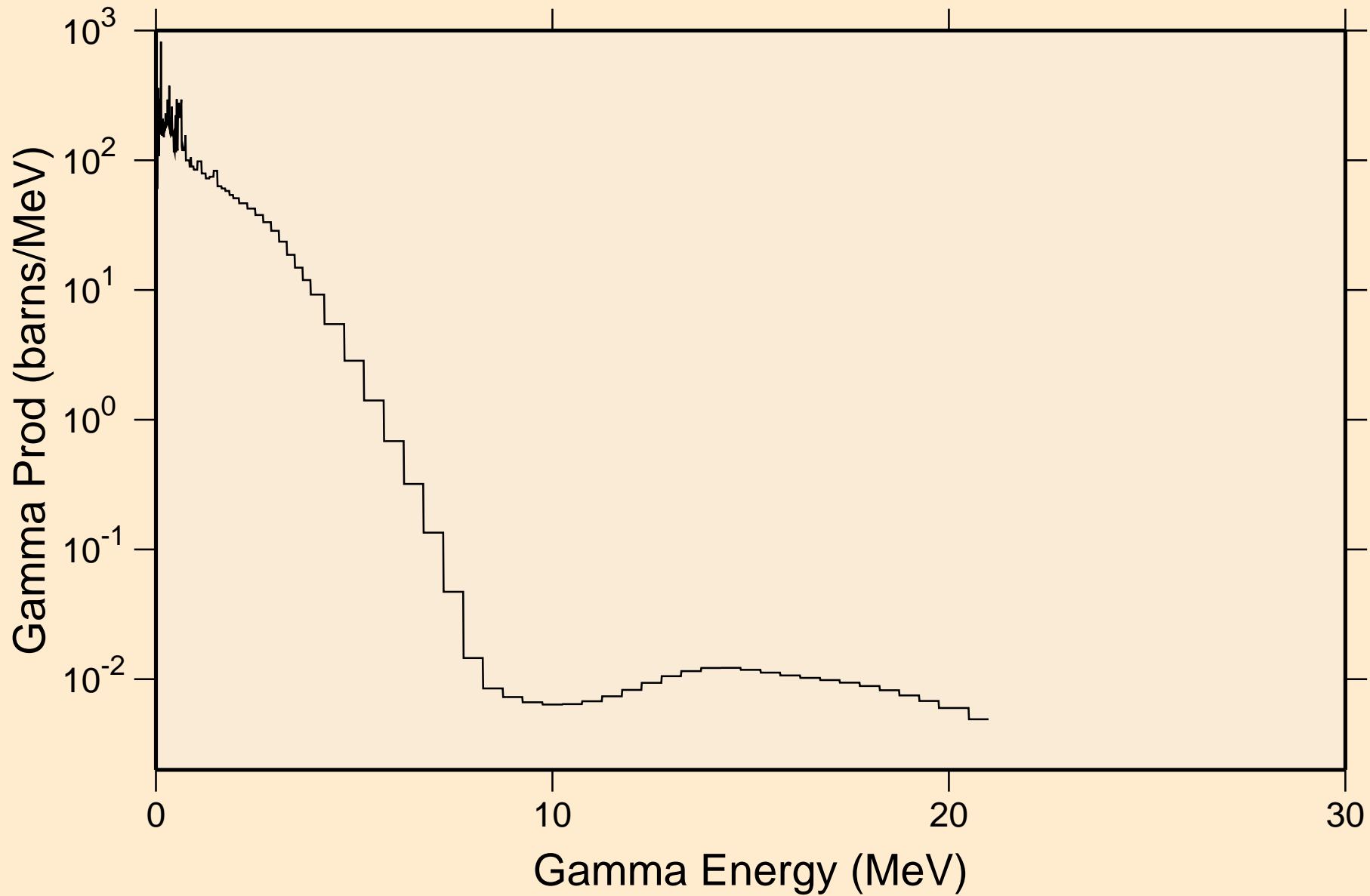



PD115M NEUTRON ACER TENDL-2024 LIBRARY; T=0.K  
Particle heating contributions

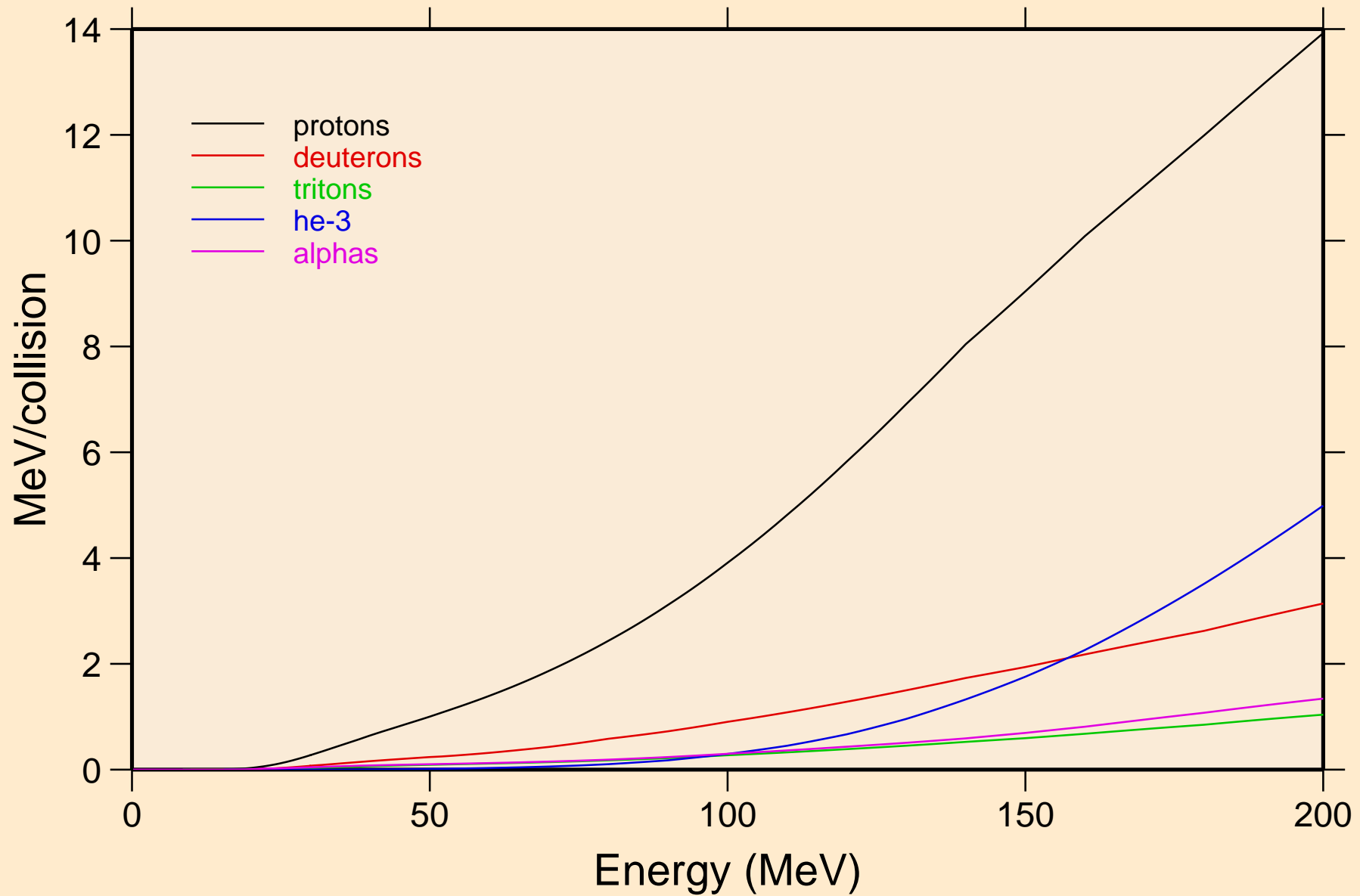

PD115M NEUTRON ACER TENDL-2024 LIBRARY; T=0.K  
Recoil Heating

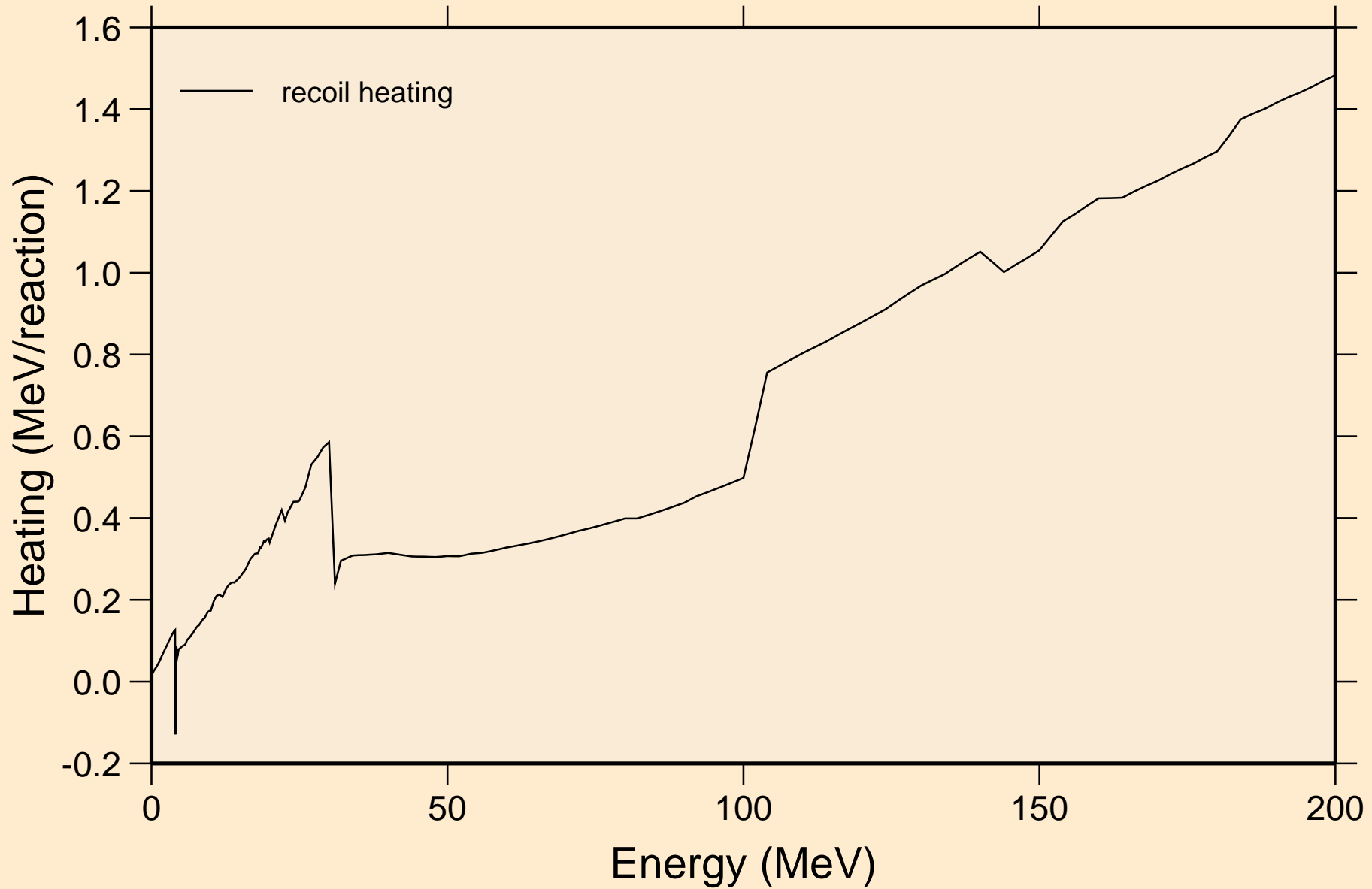

PD115M NEUTRON ACER TENDL-2024 LIBRARY; T=0.K  
Particle production cross sections

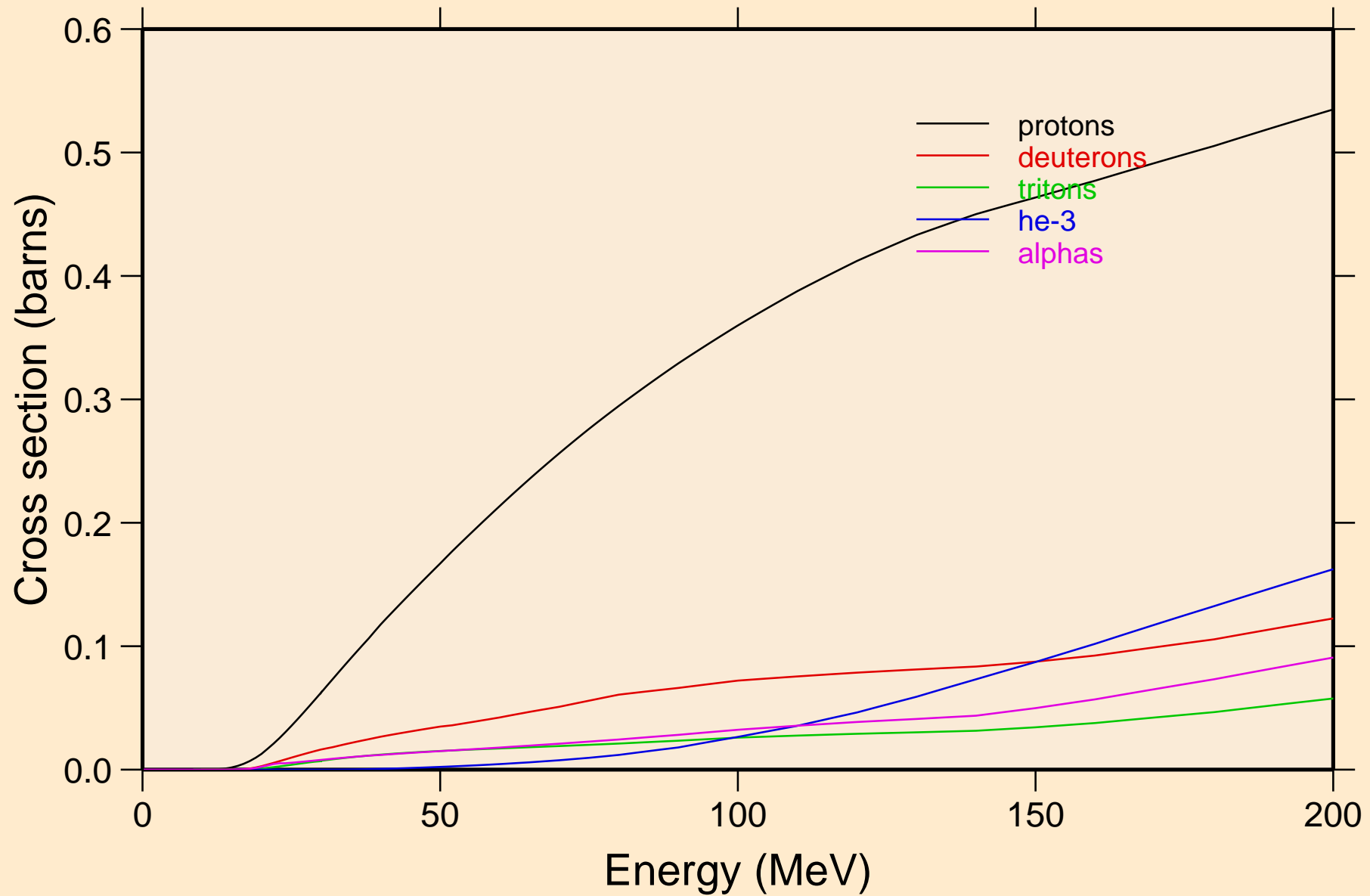

PD115M NEUTRON ACER TENDL-2024 LIBRARY; T=0.K  
protons from (n,x)

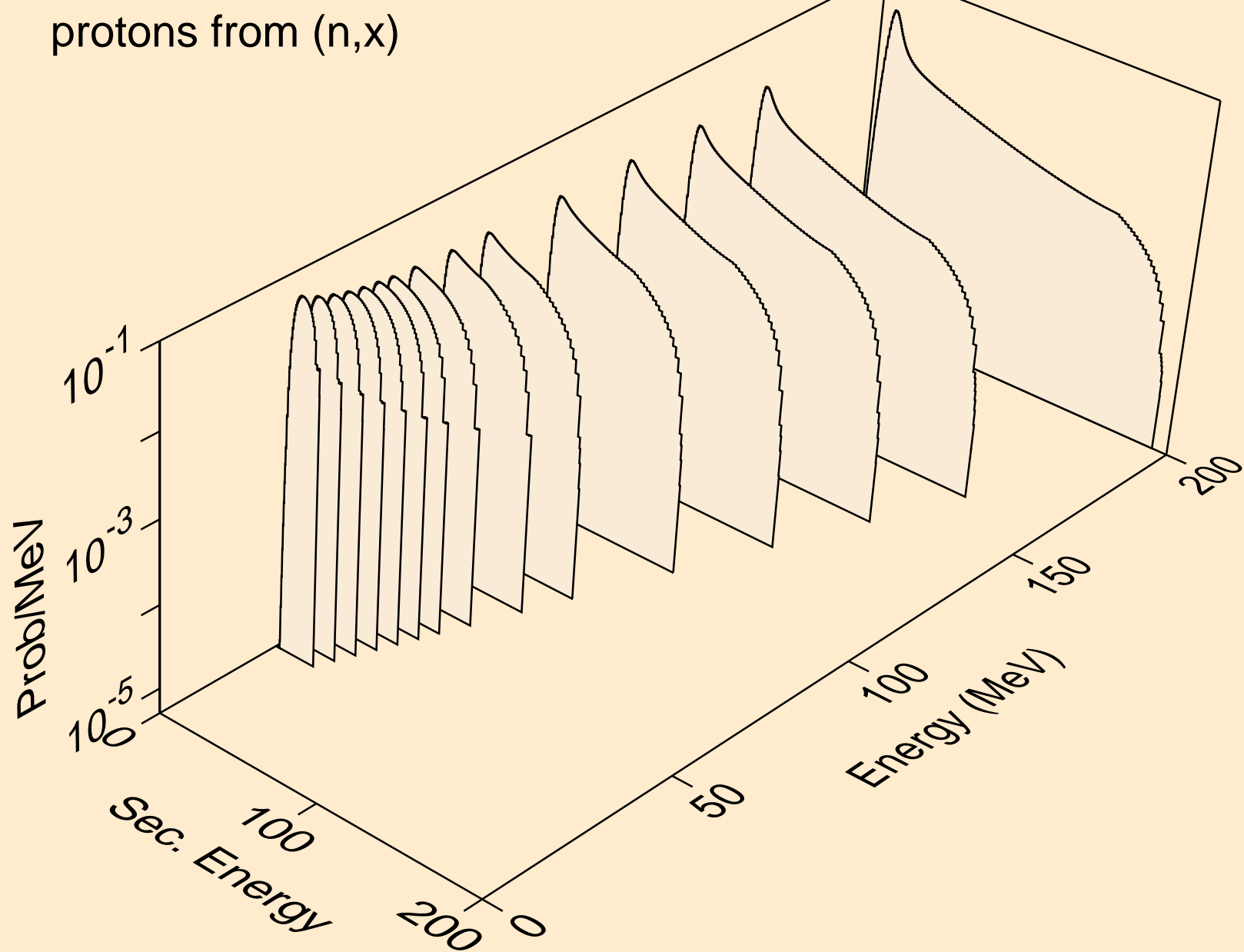

PD115M NEUTRON ACER TENDL-2024 LIBRARY; T=0.K  
protons from (n,n\*)p

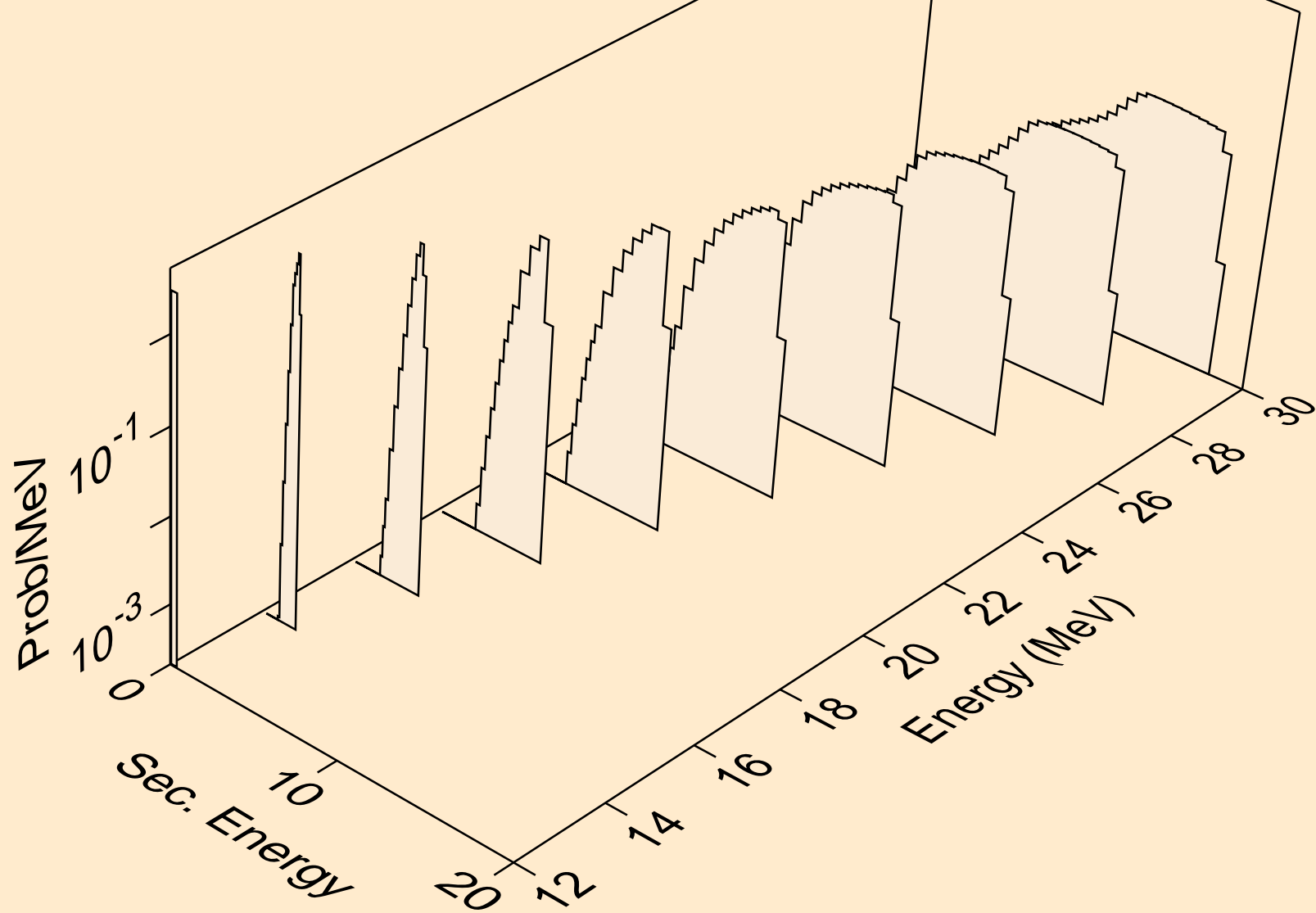

PD115M NEUTRON ACER TENDL-2024 LIBRARY; T=0.K  
protons from (n,2np)

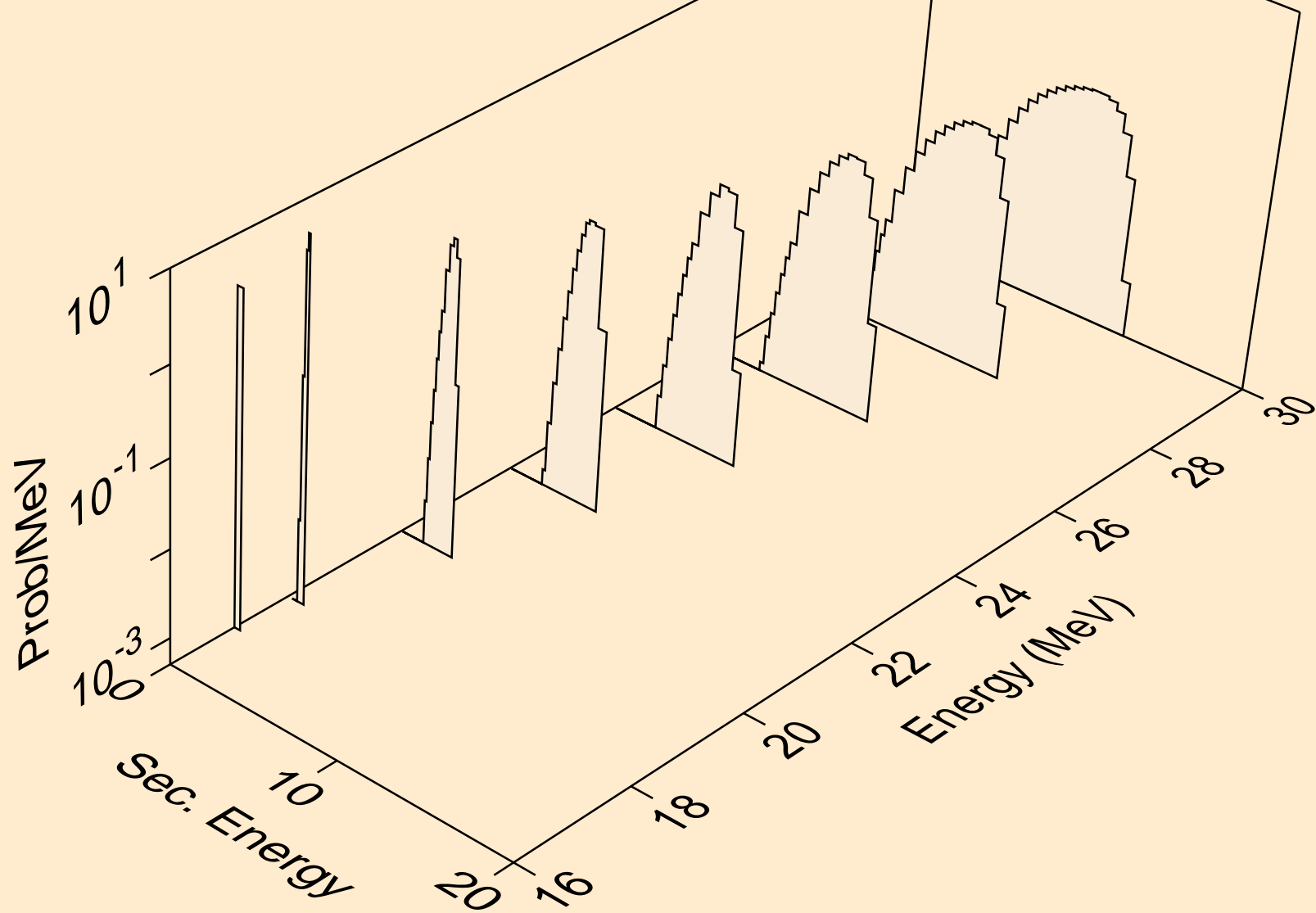

PD115M NEUTRON ACER TENDL-2024 LIBRARY; T=0.K  
protons from (n,3np)

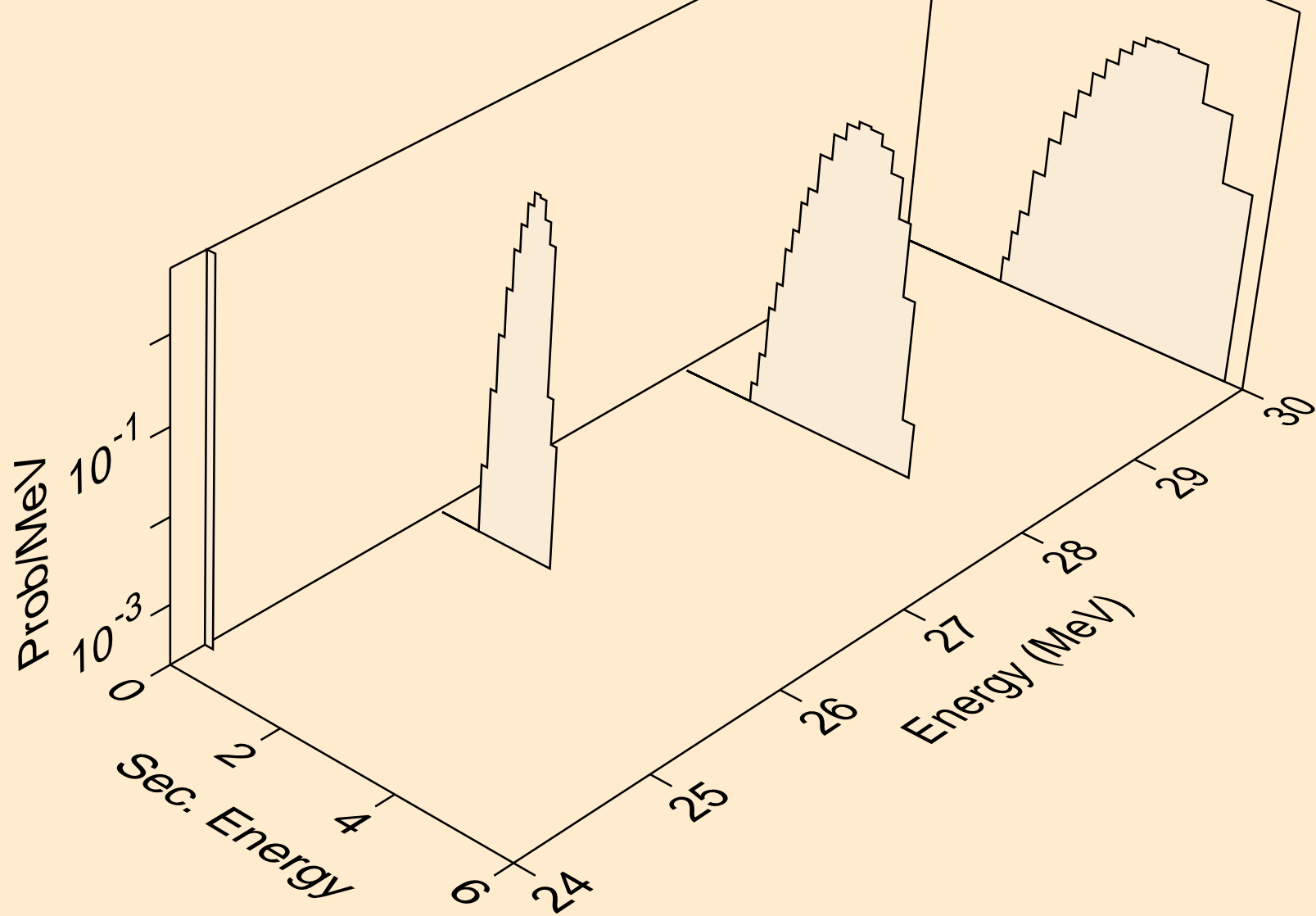

PD115M NEUTRON ACER TENDL-2024 LIBRARY; T=0.K  
protons from (n,p)

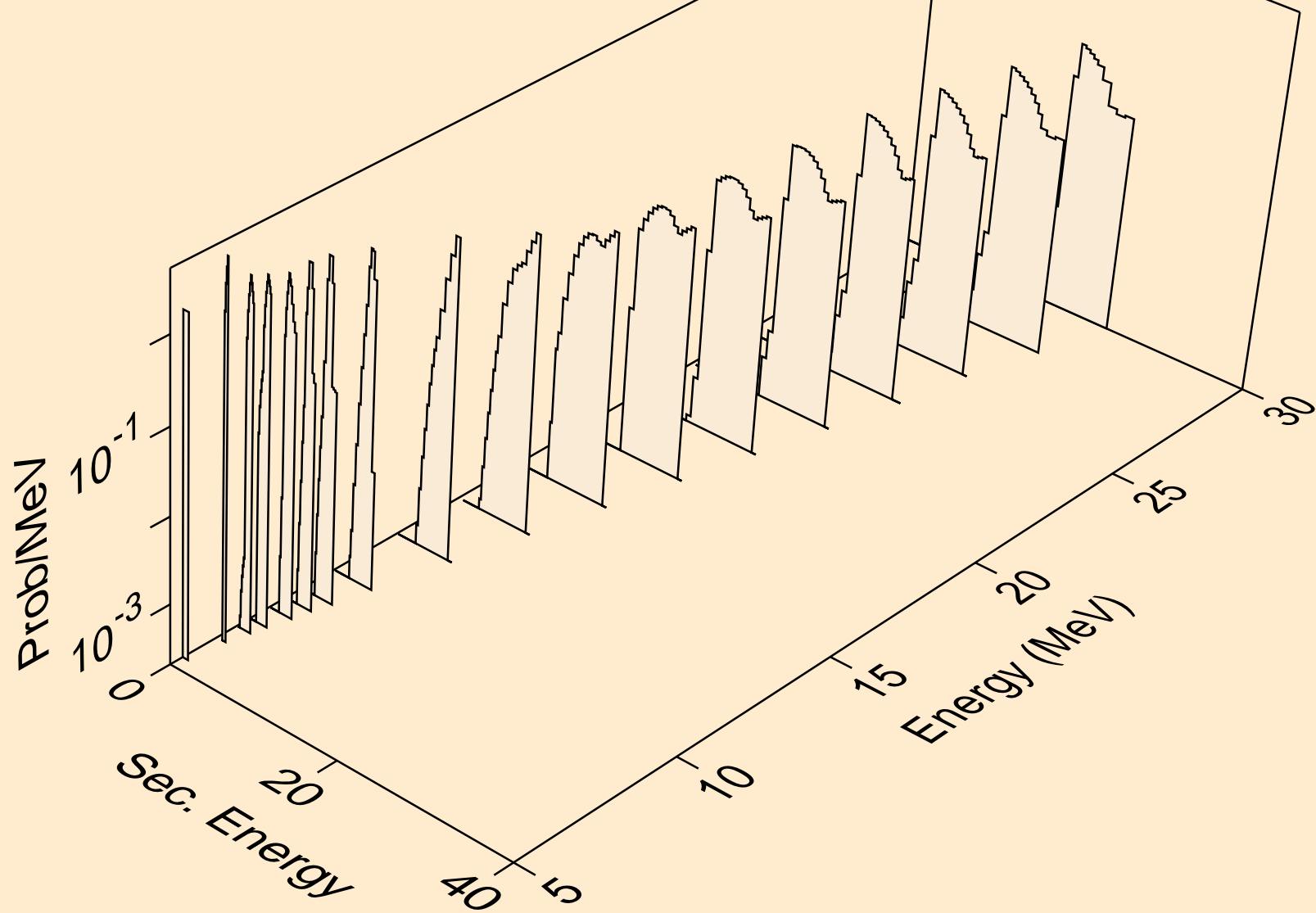



PD115M NEUTRON ACER TENDL-2024 LIBRARY; T=0.K  
protons from (n,2p)

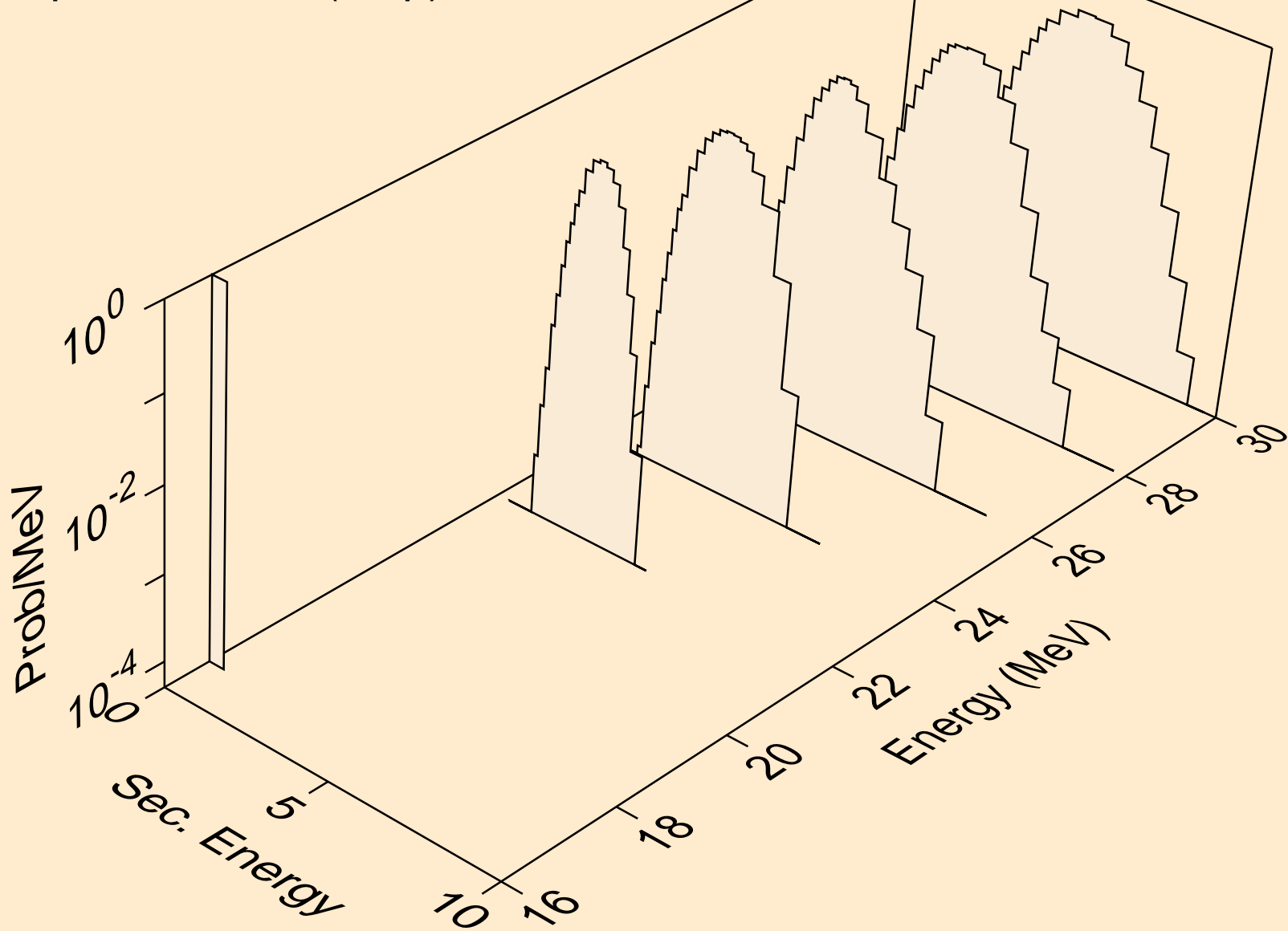

PD115M NEUTRON ACER TENDL-2024 LIBRARY; T=0.K  
deuterons from (n,x)

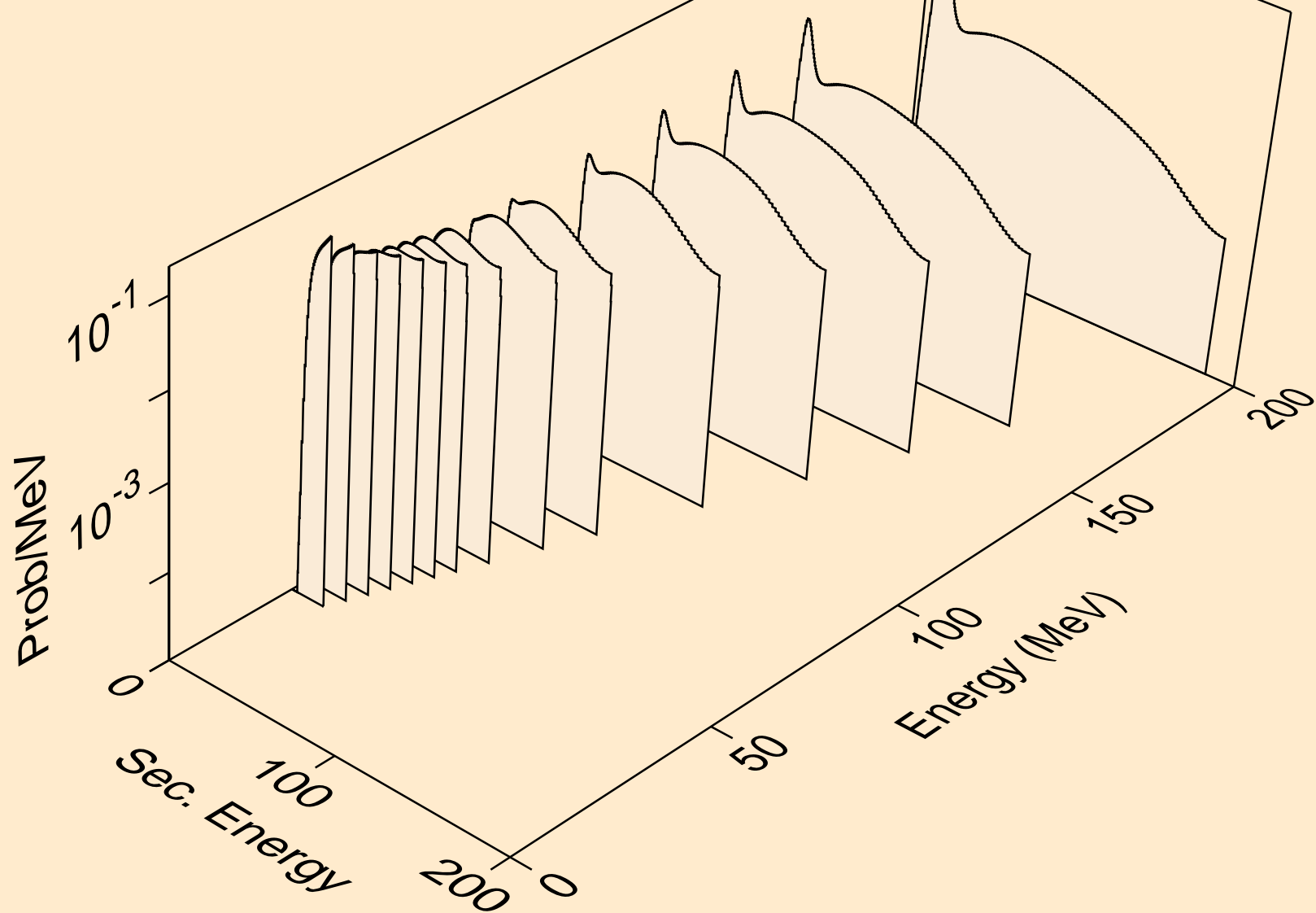

PD115M NEUTRON ACER TENDL-2024 LIBRARY; T=0.K  
deuterons from (n,2nd)

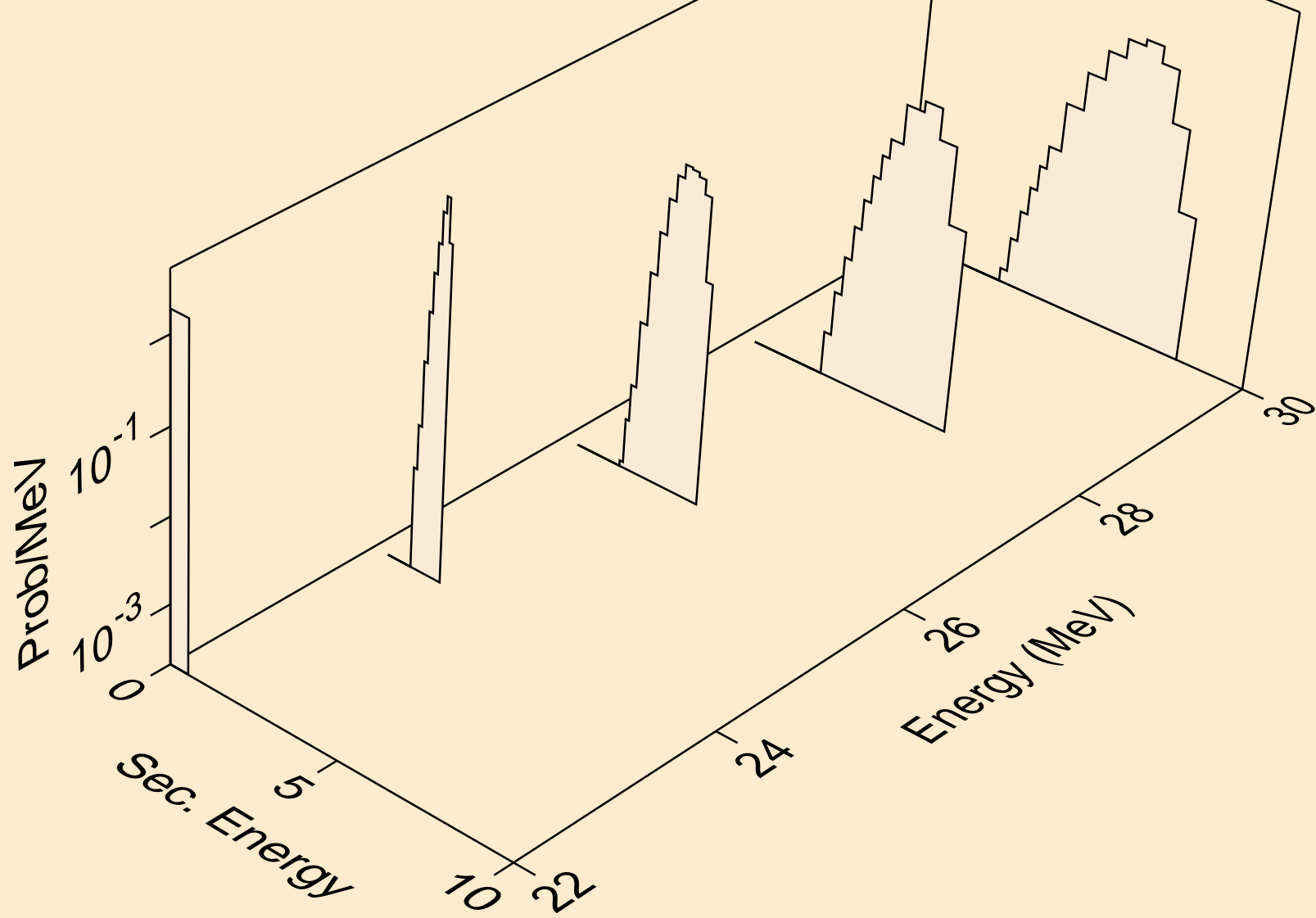

PD115M NEUTRON ACER TENDL-2024 LIBRARY; T=0.K  
deuterons from (n,n\*)d

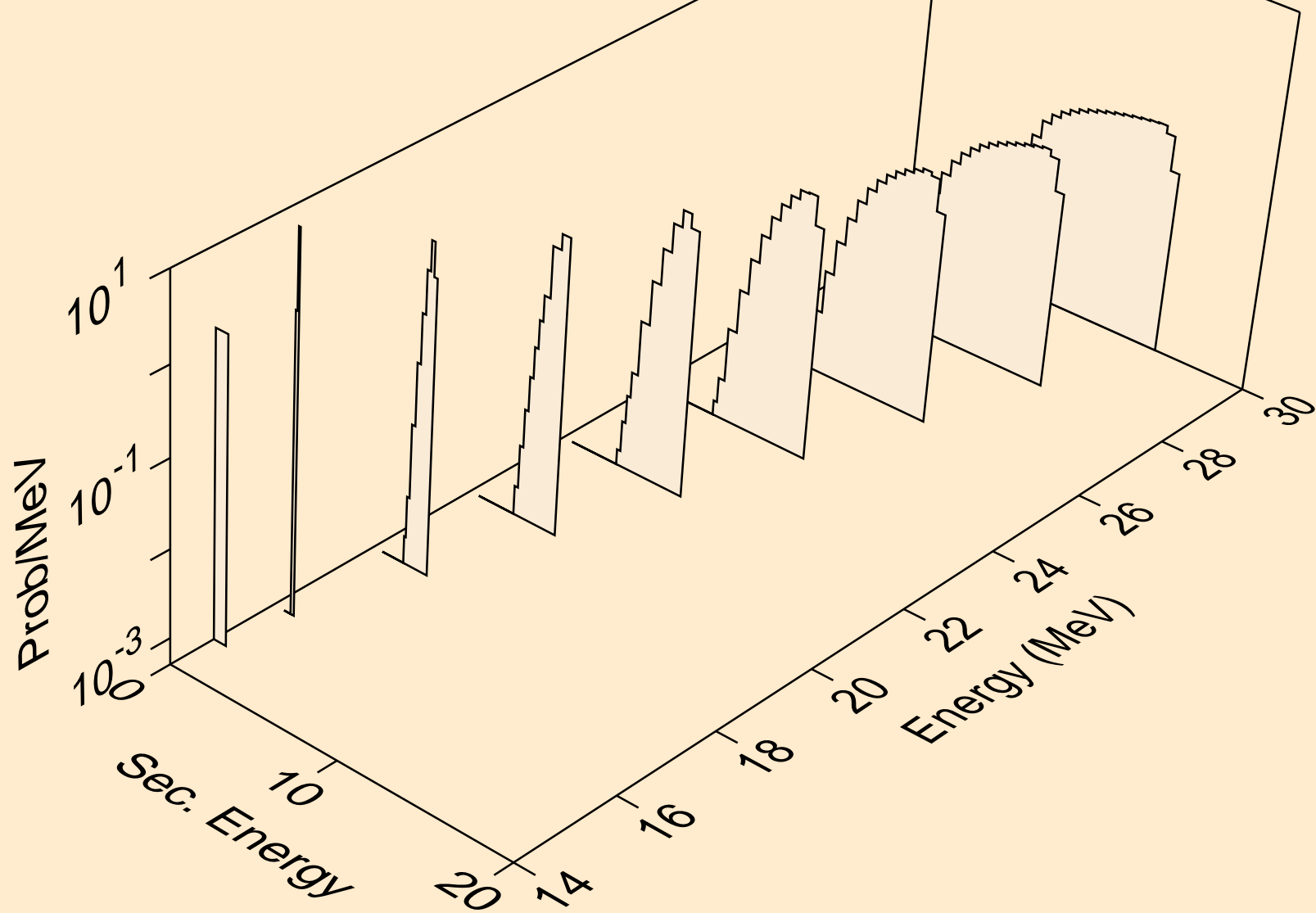

PD115M NEUTRON ACER TENDL-2024 LIBRARY; T=0.K  
deuterons from (n,d)

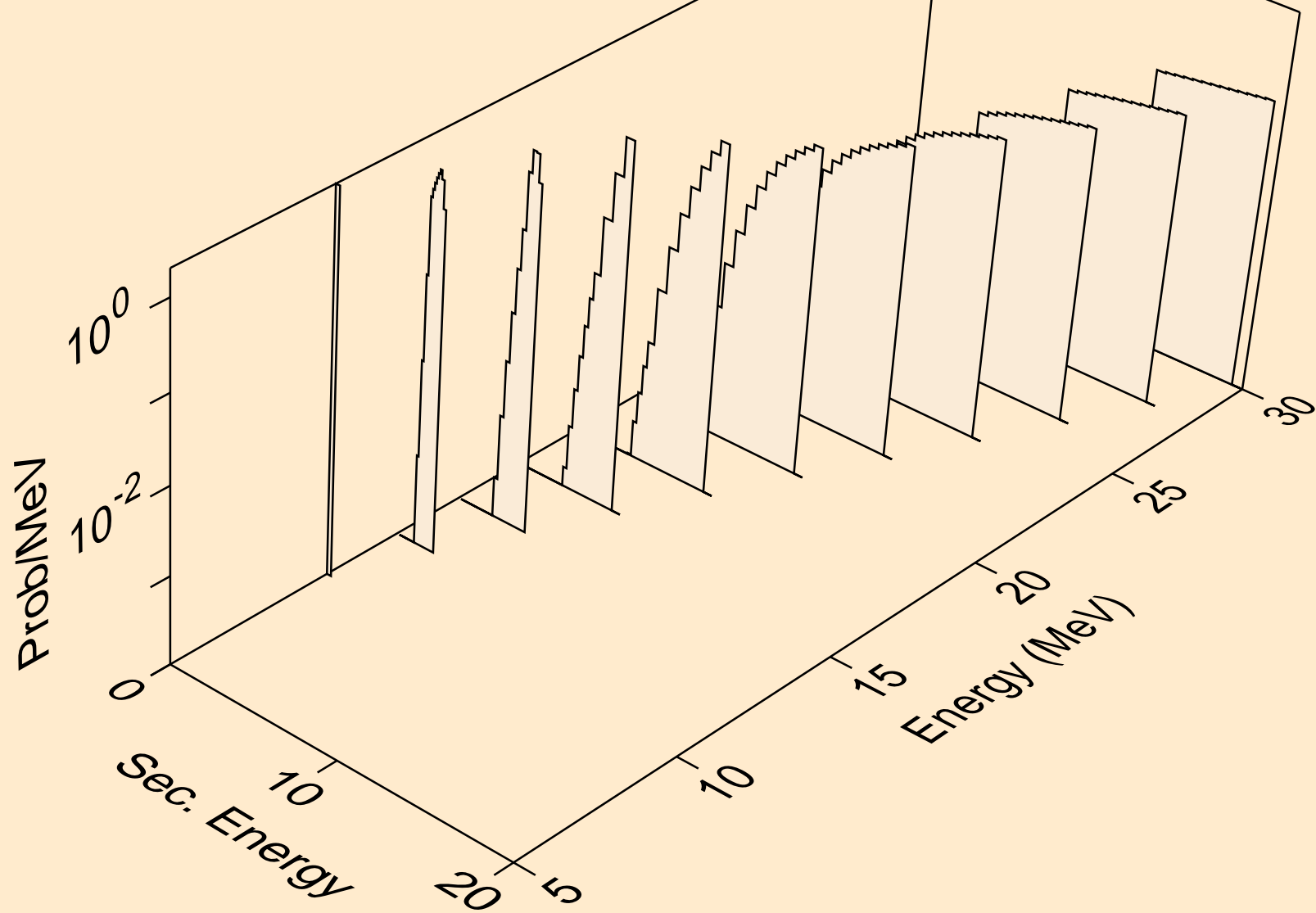

PD115M NEUTRON ACER TENDL-2024 LIBRARY; T=0.K  
tritons from (n,x)

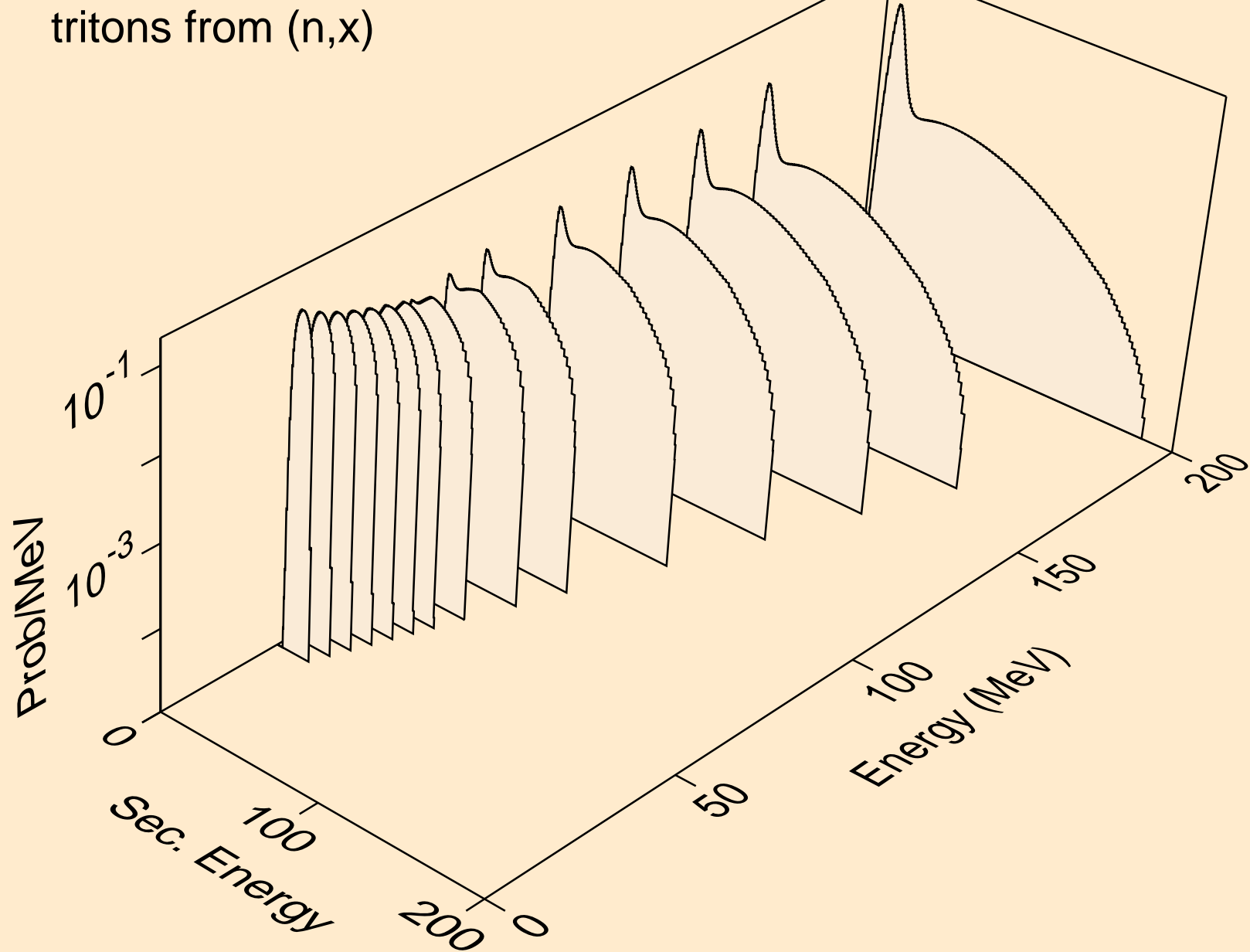

PD115M NEUTRON ACER TENDL-2024 LIBRARY; T=0.K  
tritons from (n,n\*)t

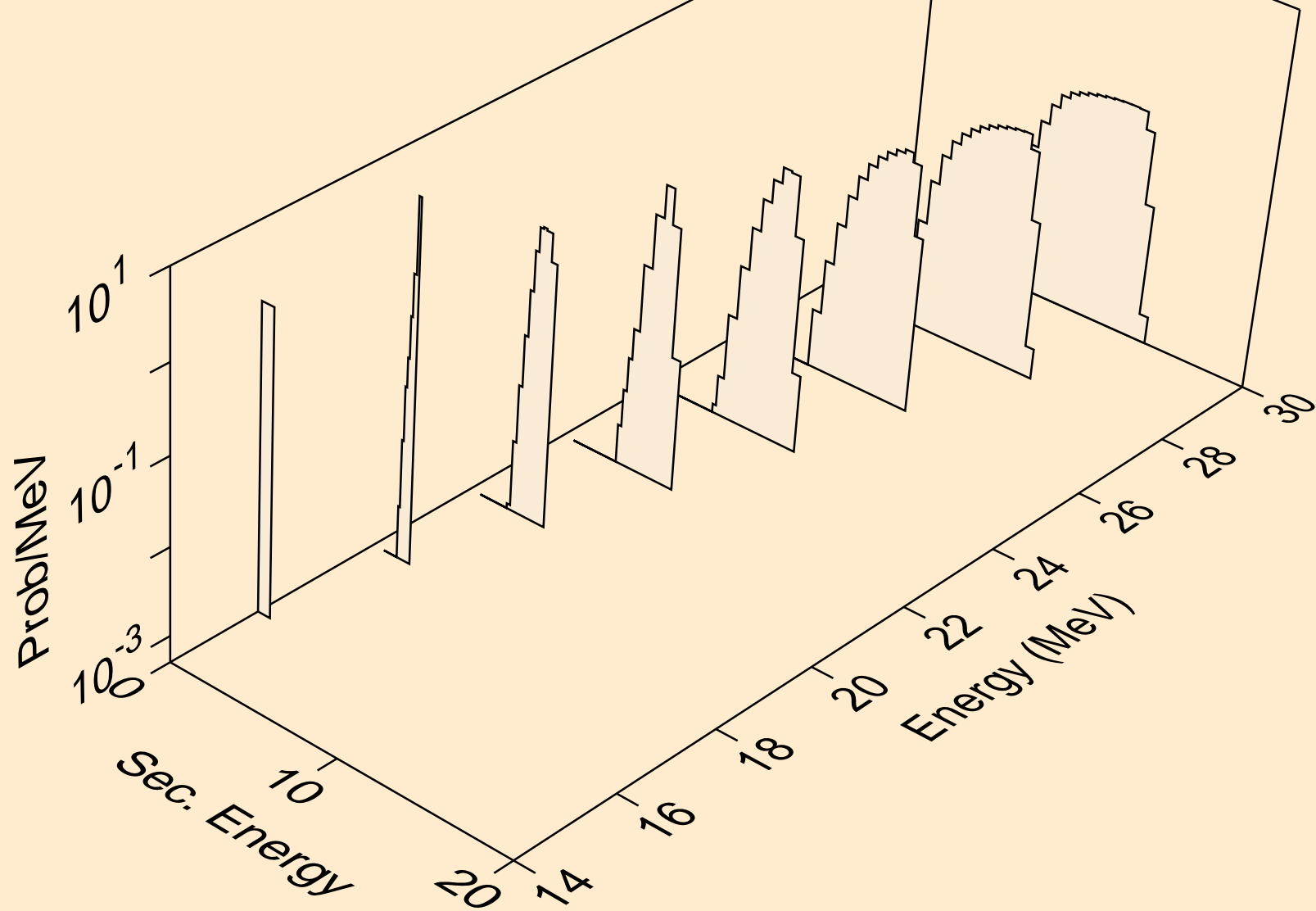

PD115M NEUTRON ACER TENDL-2024 LIBRARY; T=0.K  
tritons from (n,t)

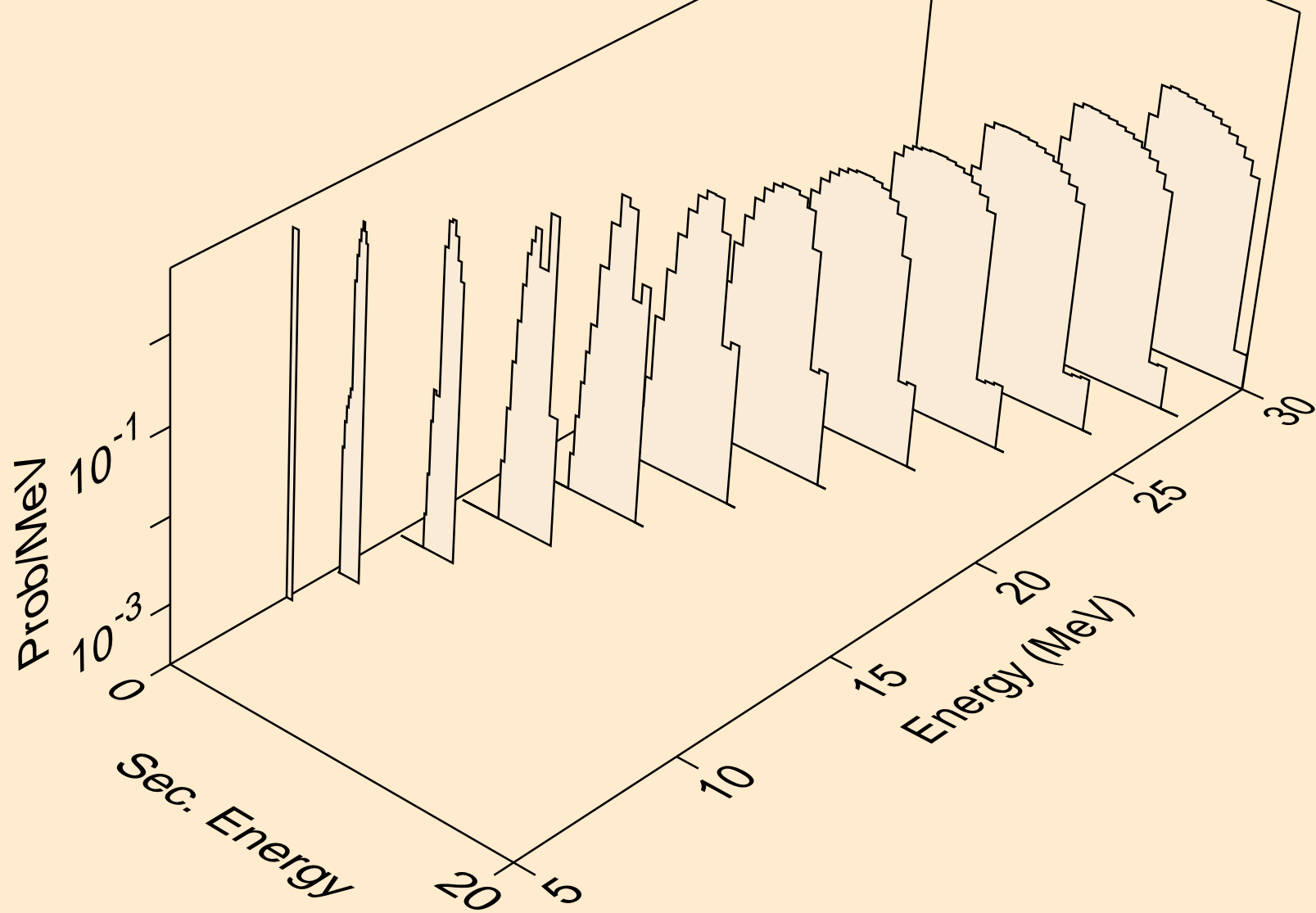



PD115M NEUTRON ACER TENDL-2024 LIBRARY; T=0.K  
he3s from (n,x)

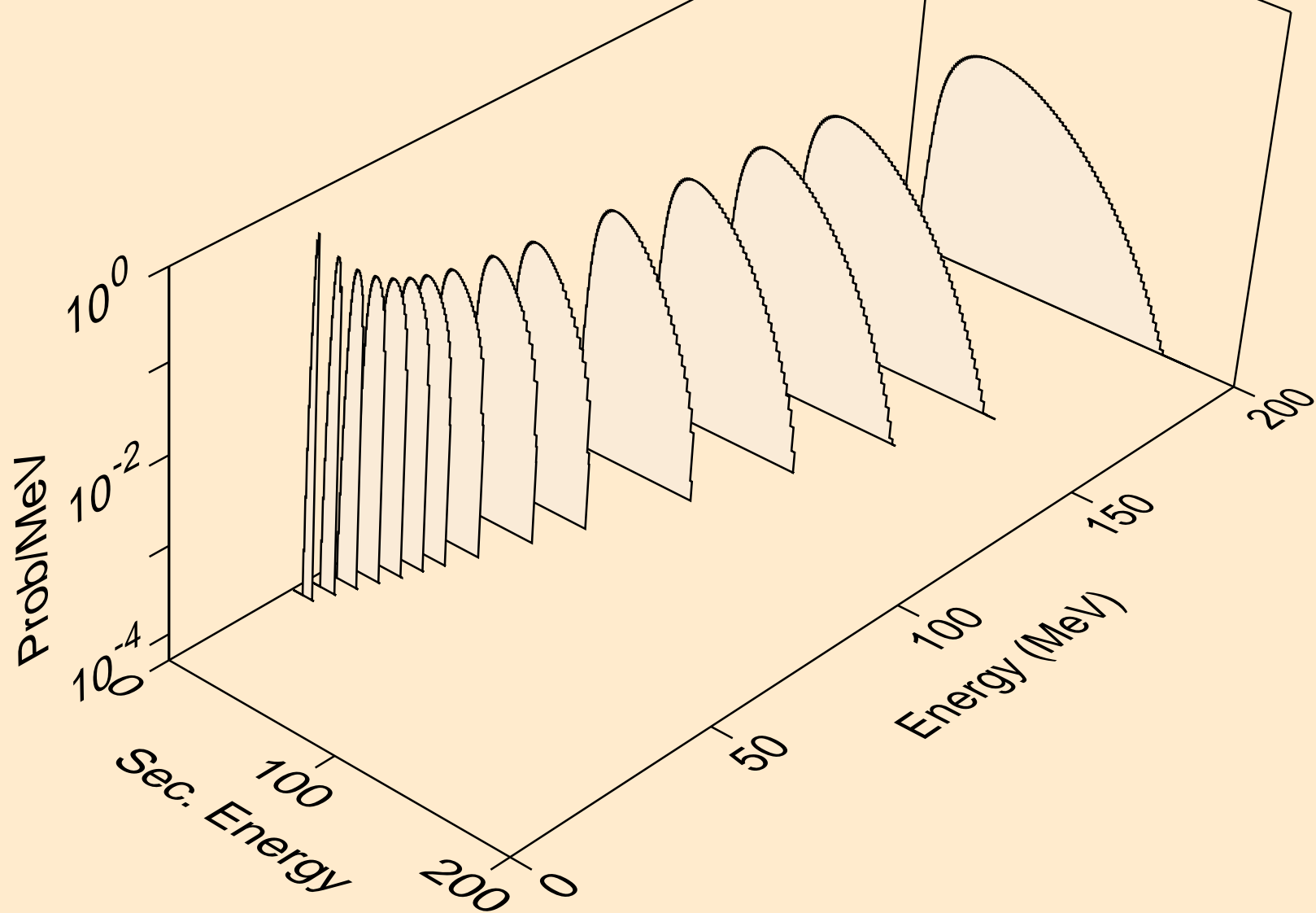

PD115M NEUTRON ACER TENDL-2024 LIBRARY; T=0.K  
he3s from (n,n\*)he3

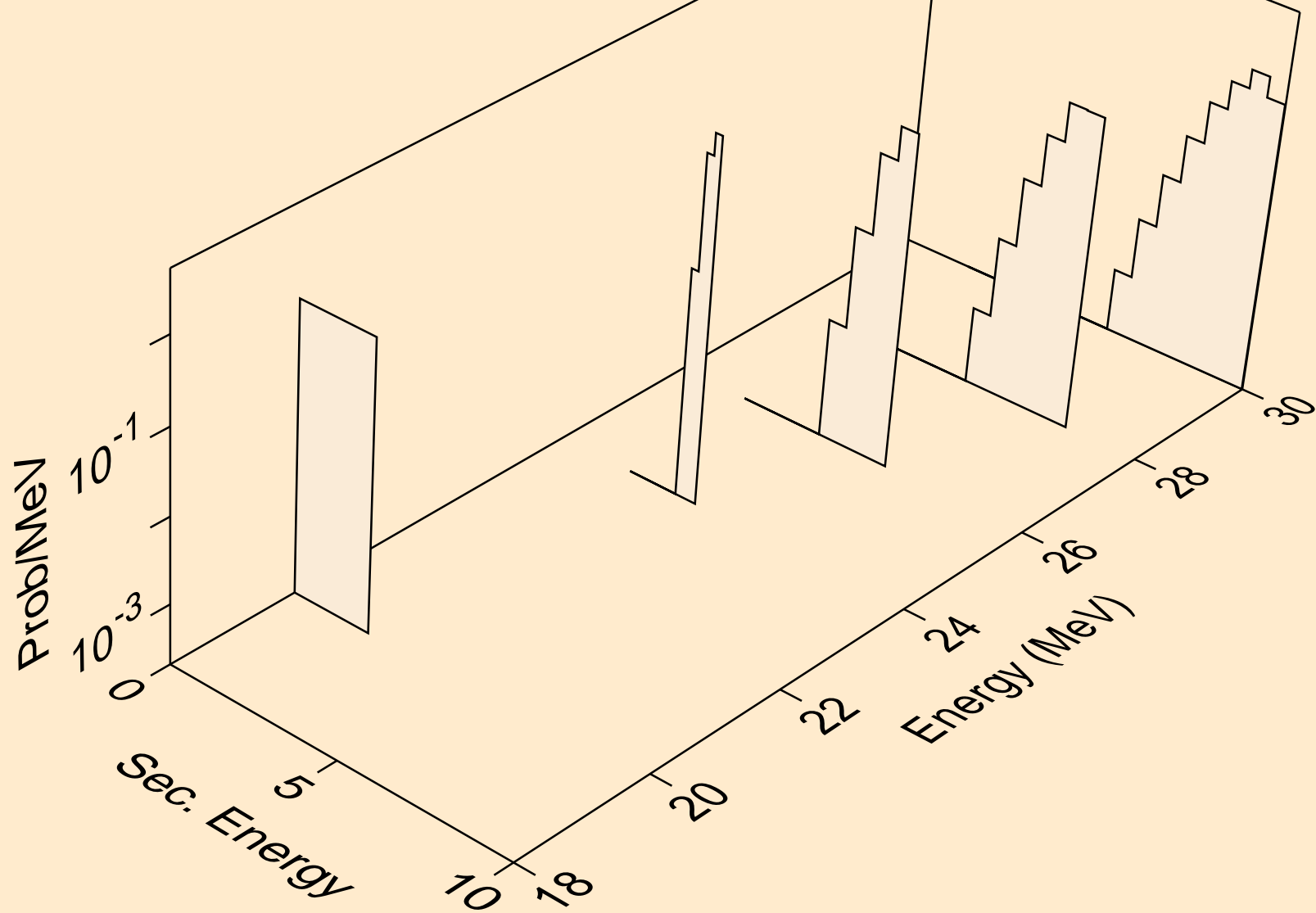

PD115M NEUTRON ACER TENDL-2024 LIBRARY; T=0.K  
he3s from (n,he3)

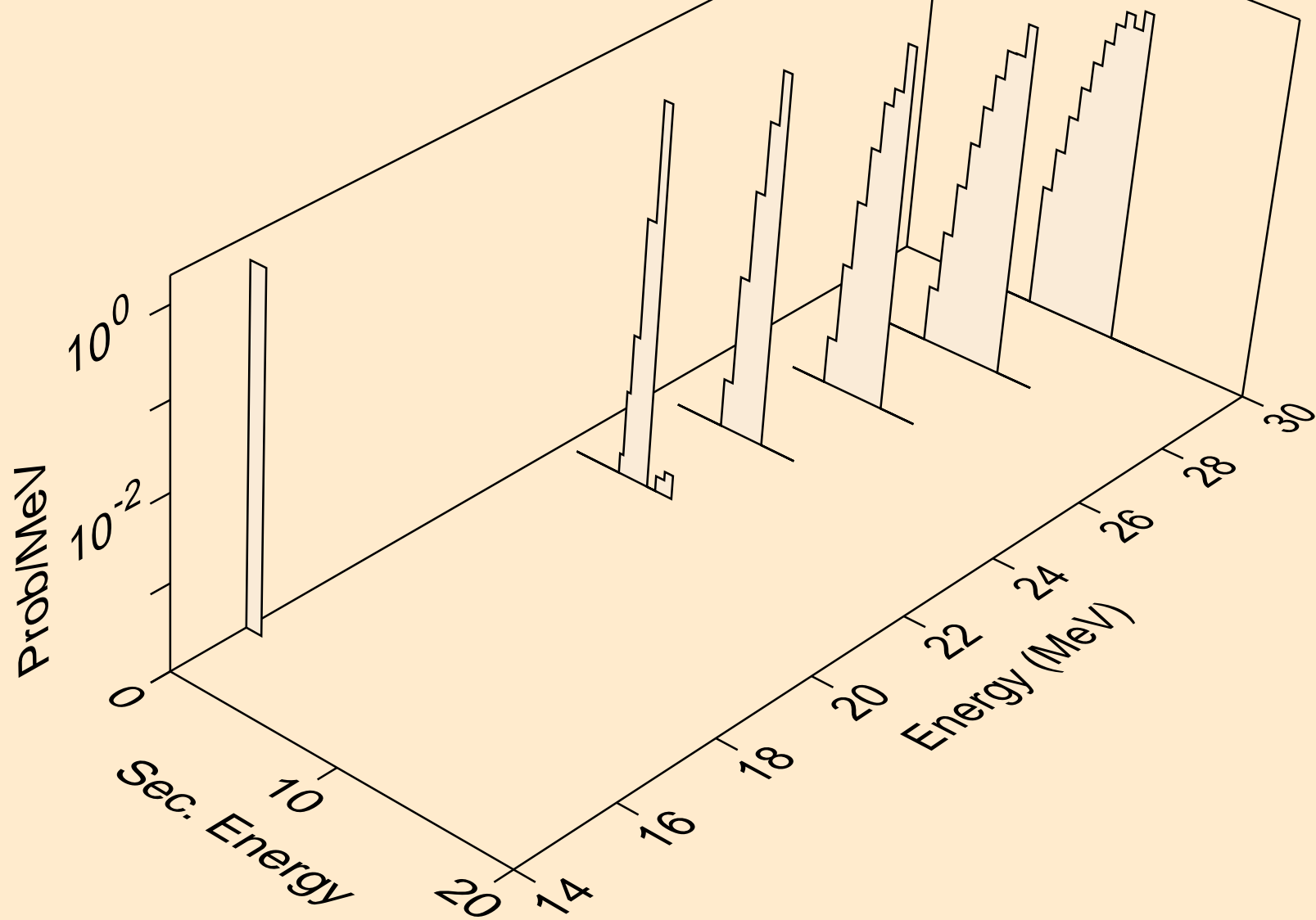

PD115M NEUTRON ACER TENDL-2024 LIBRARY; T=0.K  
alphas from (n,x)

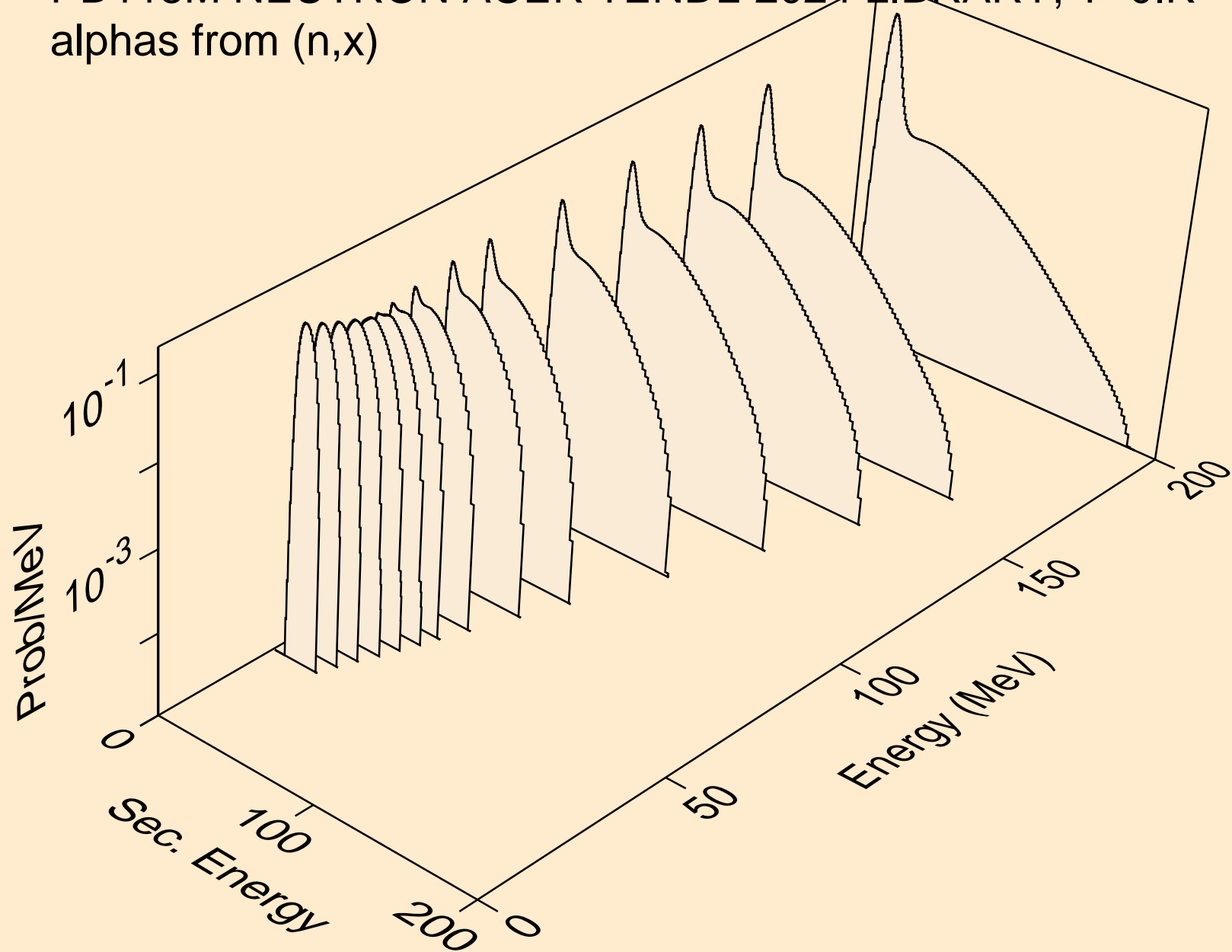

PD115M NEUTRON ACER TENDL-2024 LIBRARY; T=0.K  
alphas from (n,n\*)a

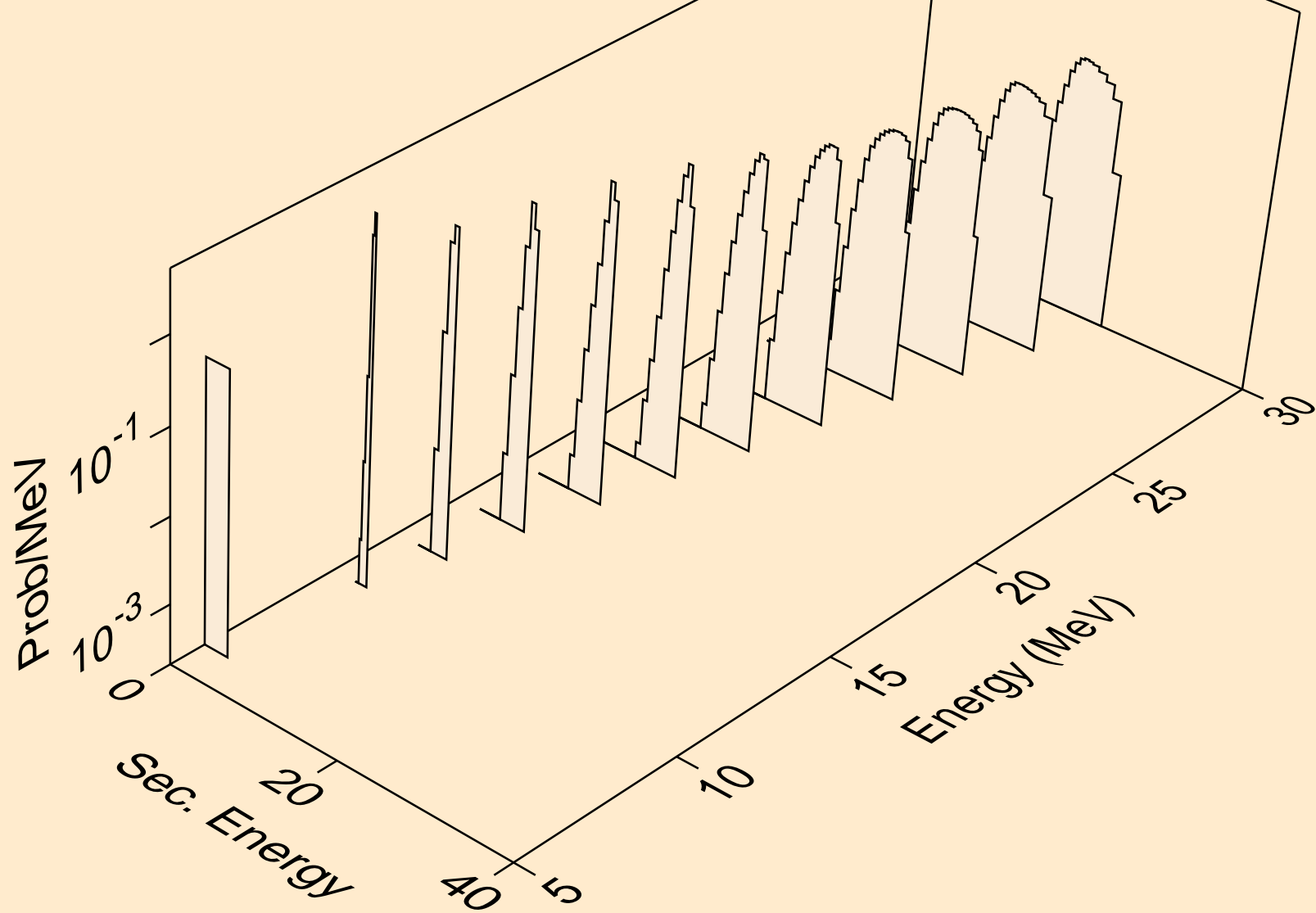

PD115M NEUTRON ACER TENDL-2024 LIBRARY; T=0.K  
alphas from (n,2n)a

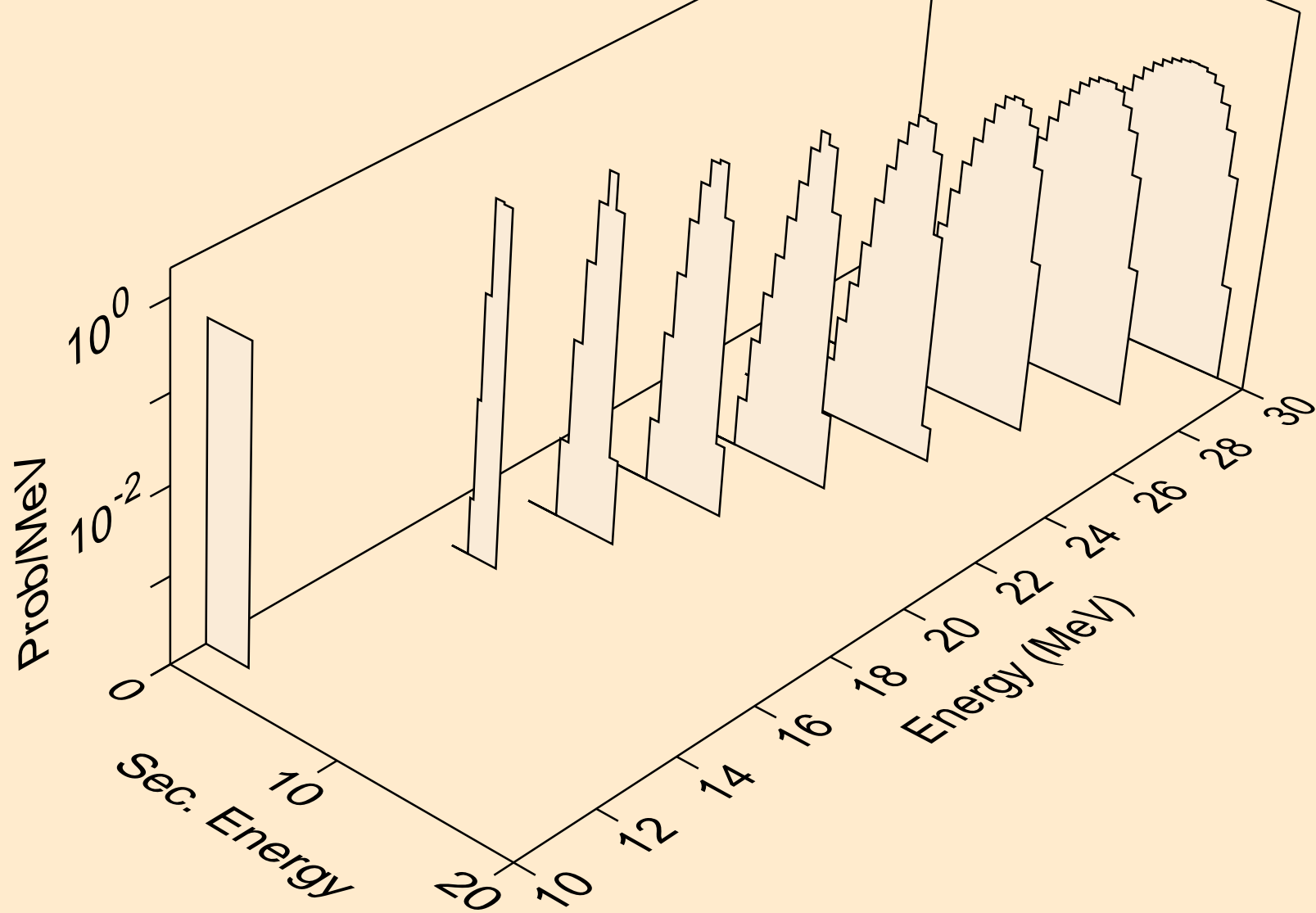

PD115M NEUTRON ACER TENDL-2024 LIBRARY; T=0.K  
alphas from (n,3n)a

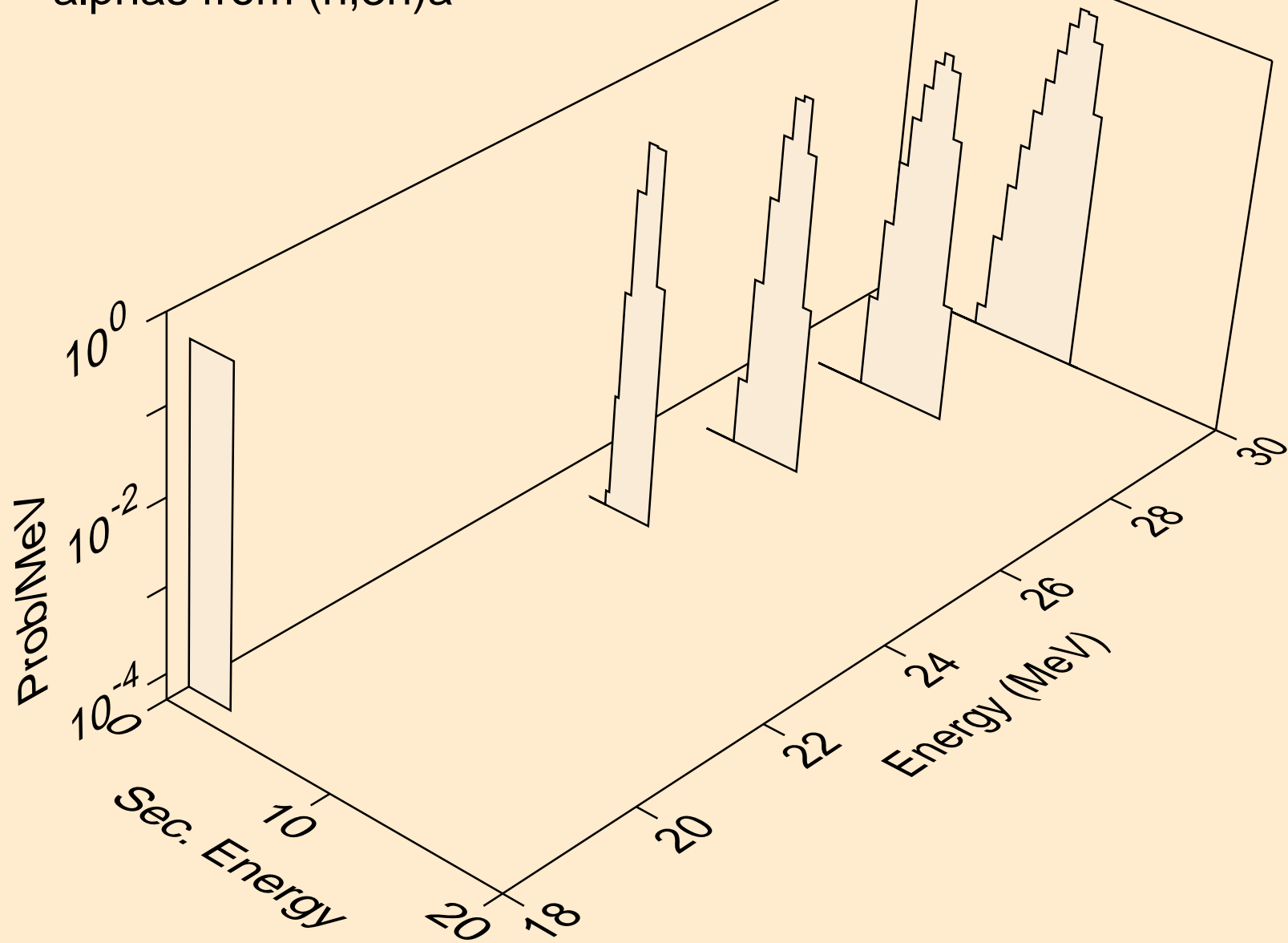

PD115M NEUTRON ACER TENDL-2024 LIBRARY; T=0.K  
alphas from (n,a)

