

PM138 NEUTRON ACER TENDL-2024 LIBRARY; T=0.K  
Principal cross sections

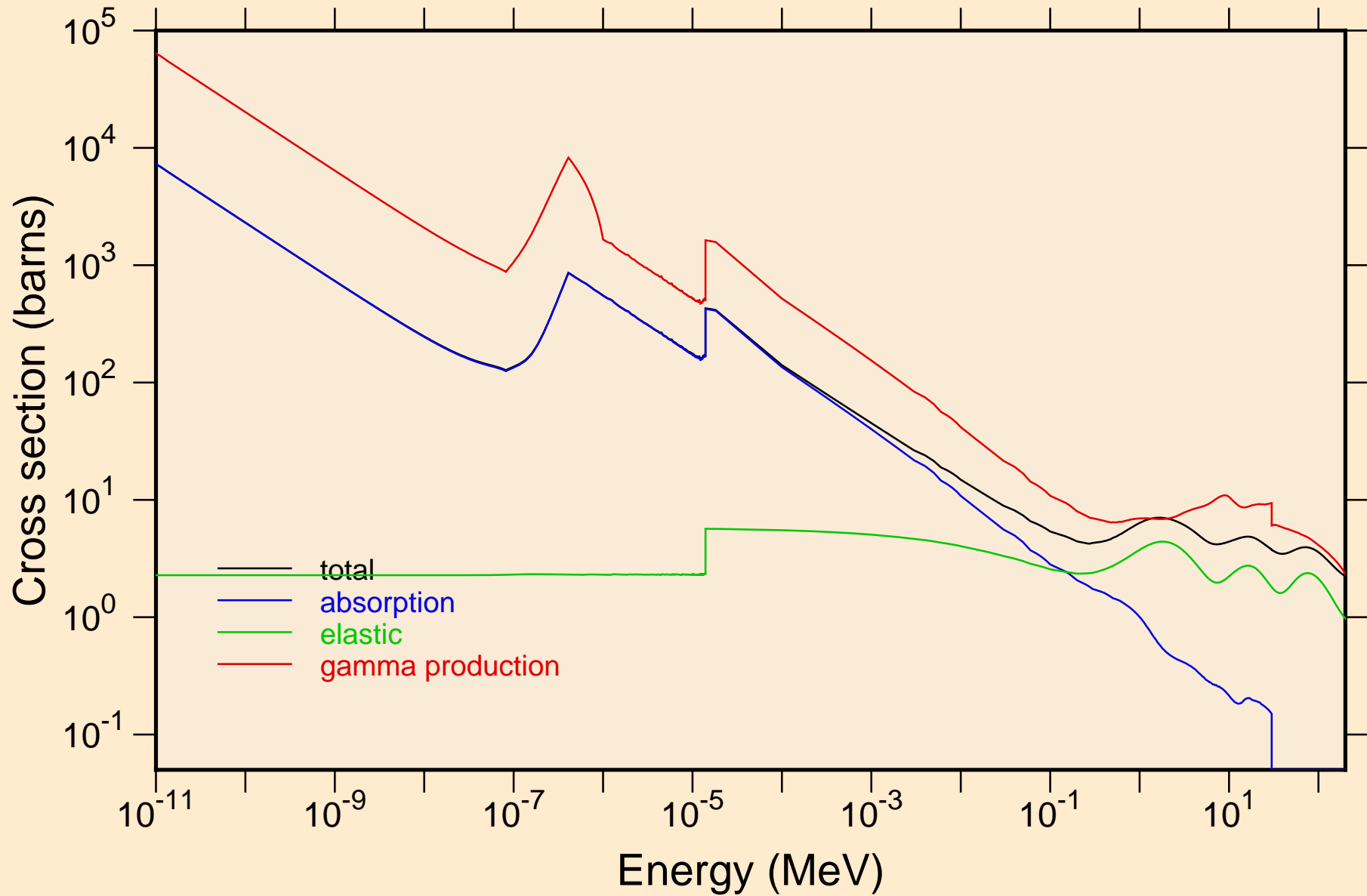

PM138 NEUTRON ACER TENDL-2024 LIBRARY; T=0.K  
resonance total cross section

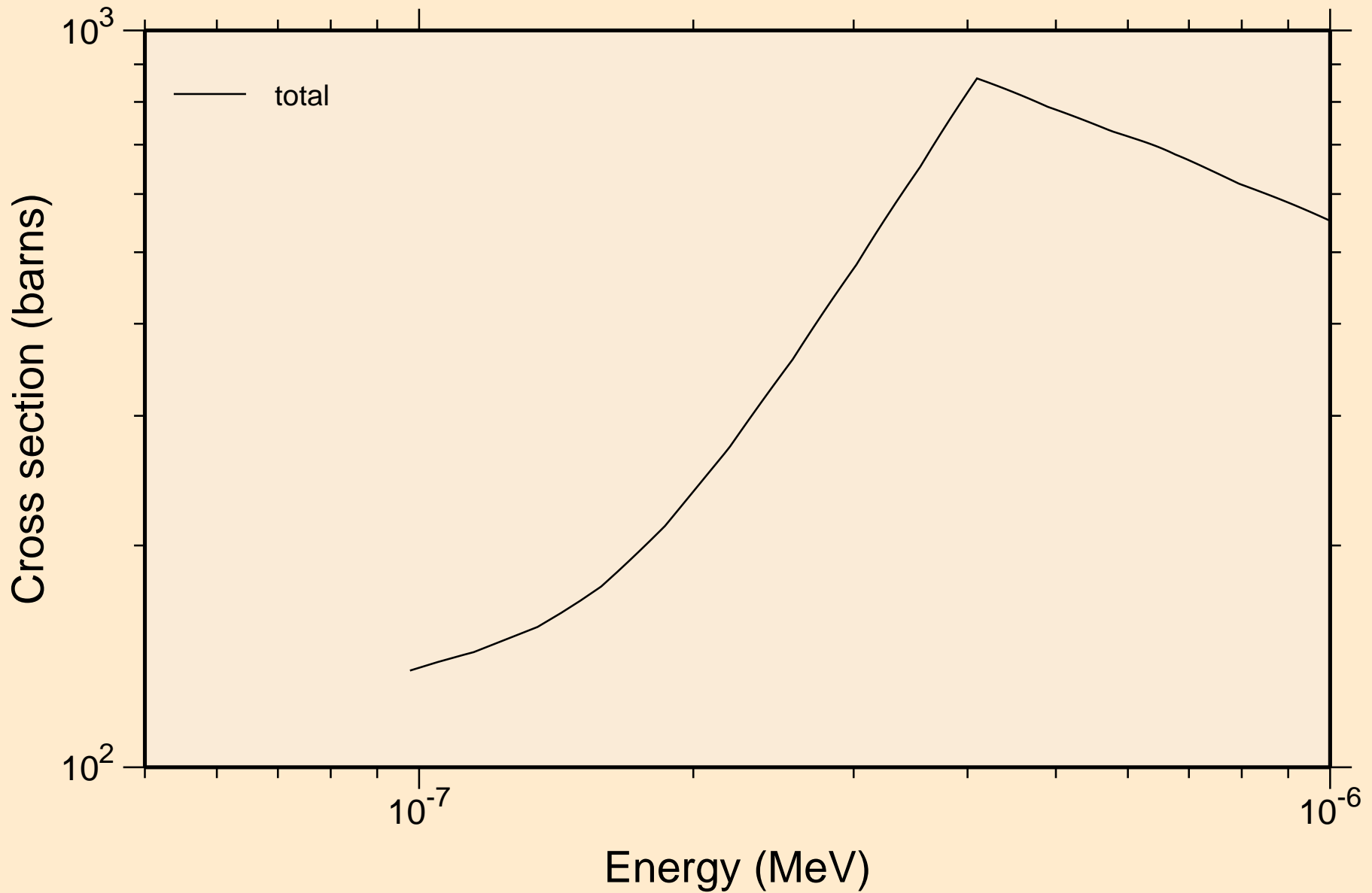

PM138 NEUTRON ACER TENDL-2024 LIBRARY; T=0.K  
resonance total cross section

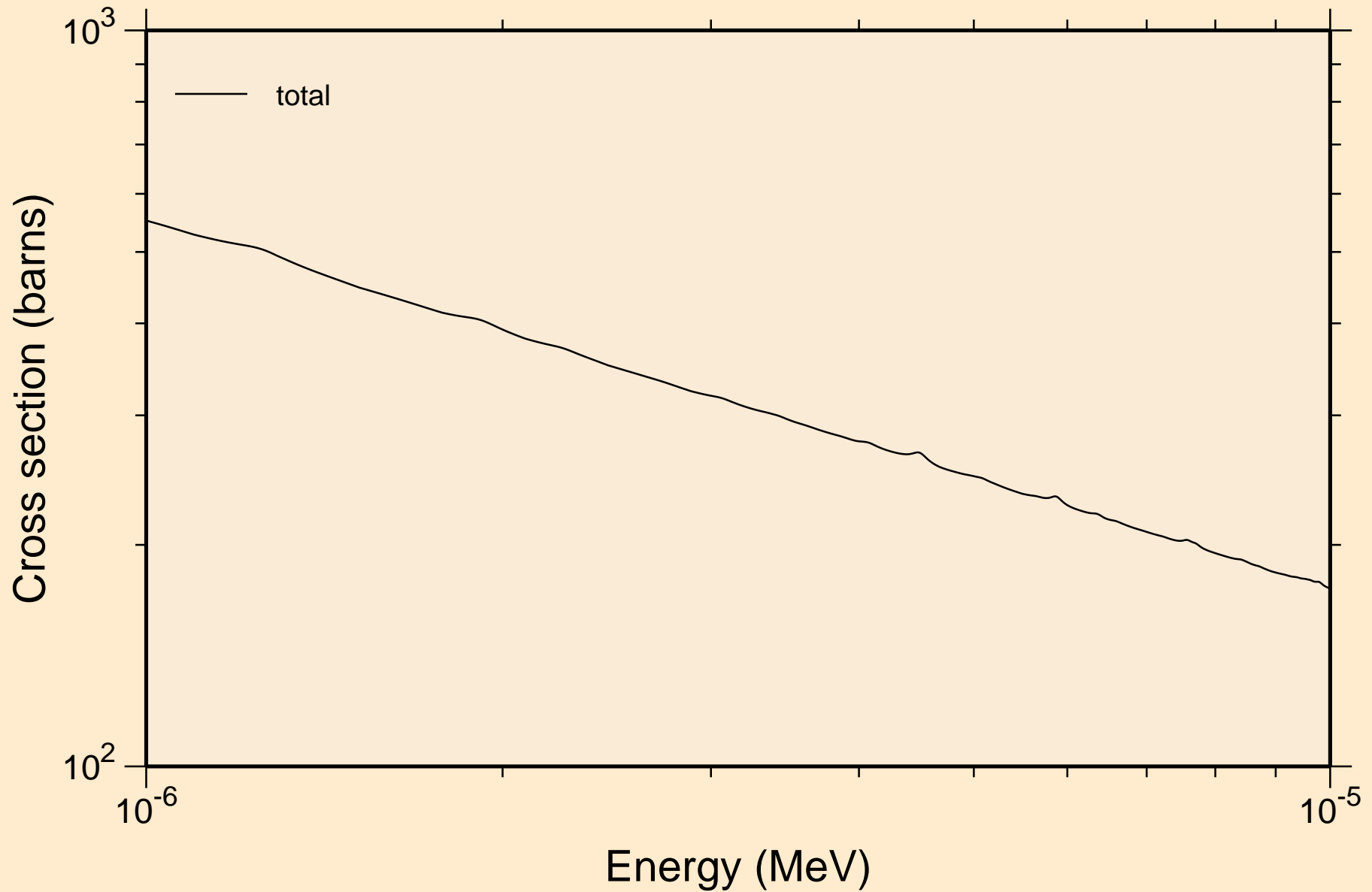

PM138 NEUTRON ACER TENDL-2024 LIBRARY; T=0.K  
resonance total cross section

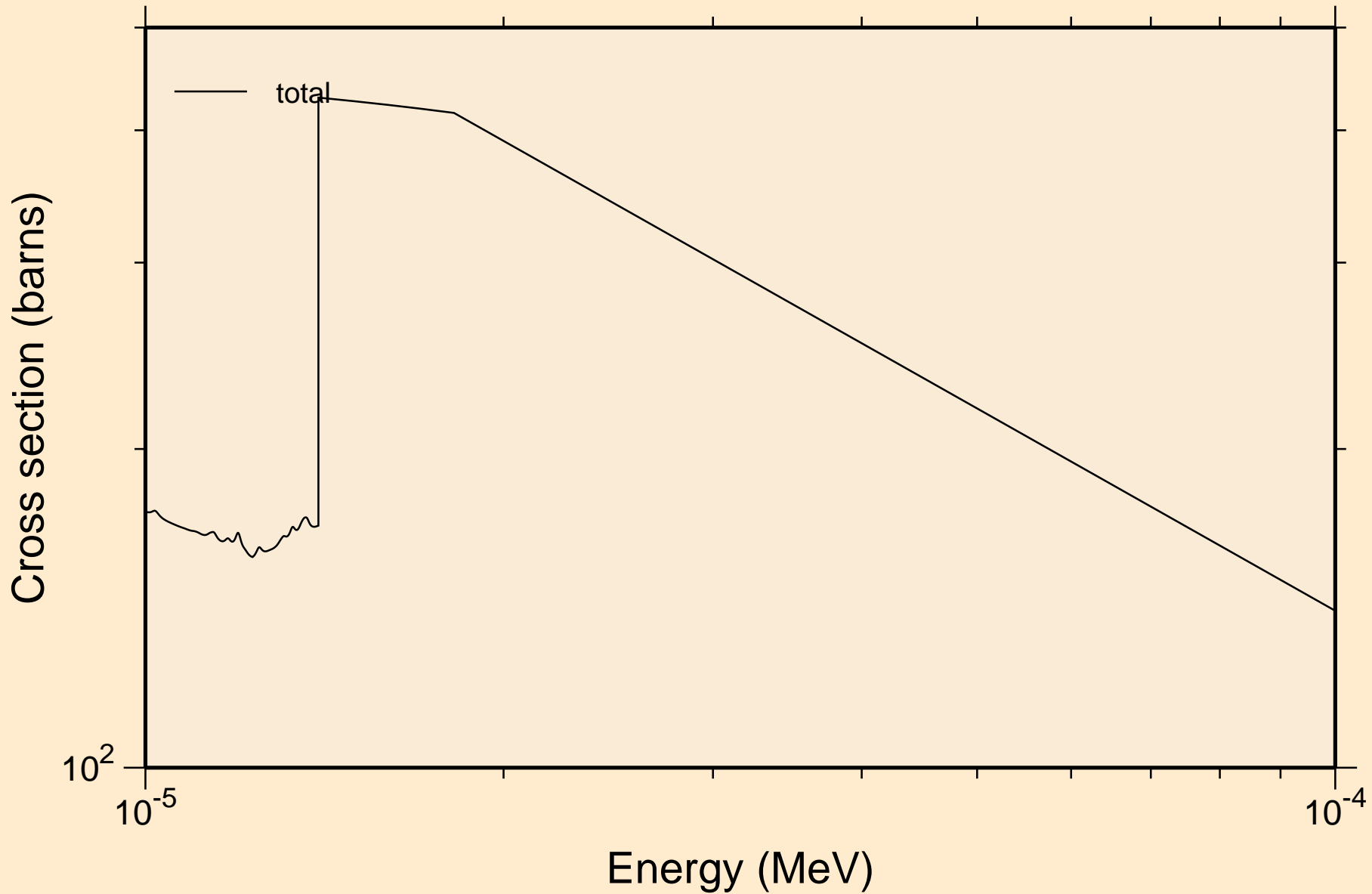

P̄M138 NEUTRON ACER TENDL-2024 LIBRARY; T=0.K  
resonance total cross section

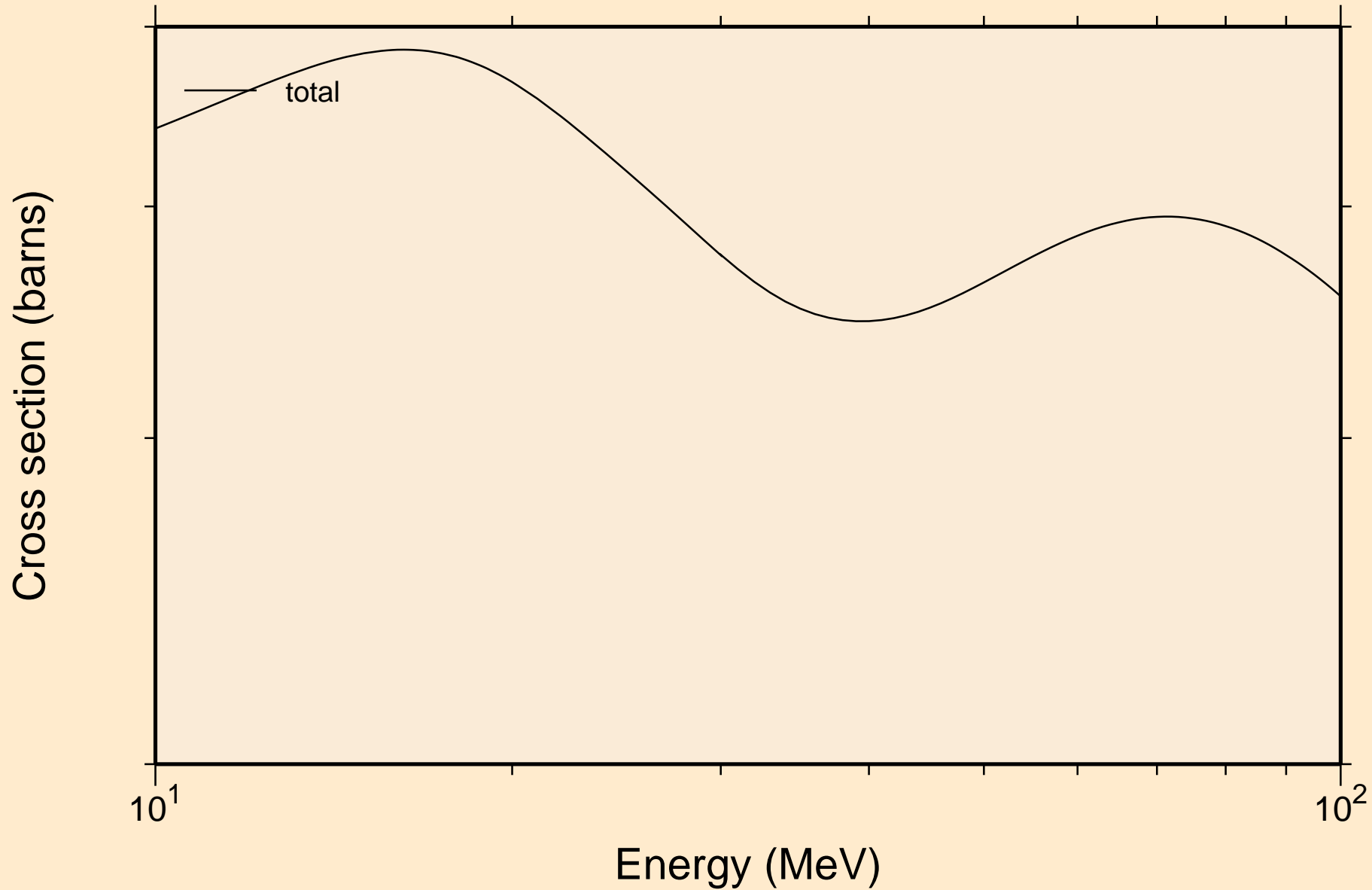

PM138 NEUTRON ACER TENDL-2024 LIBRARY; T=0.K  
resonance absorption cross sections

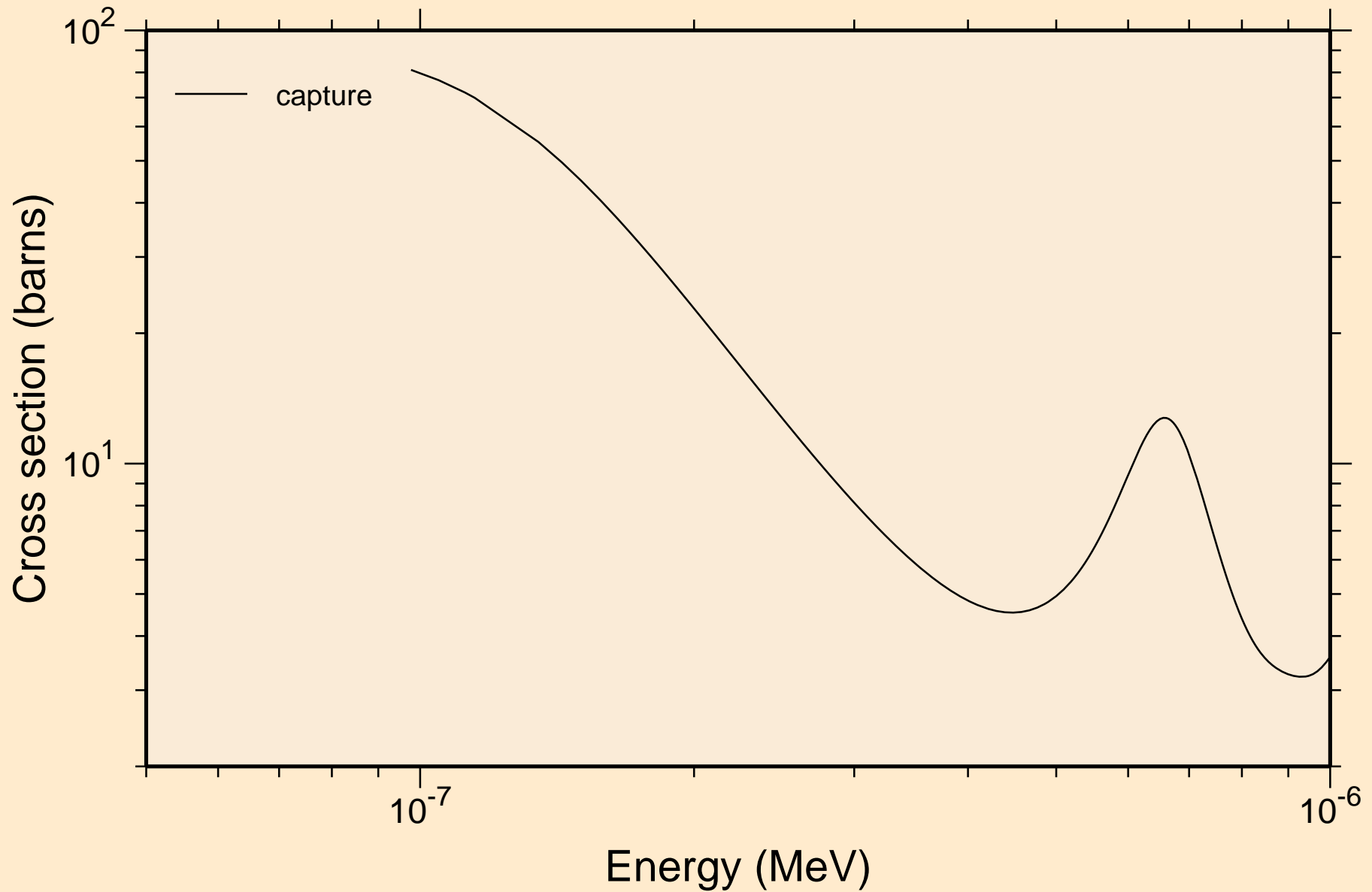

PM138 NEUTRON ACER TENDL-2024 LIBRARY; T=0.K  
resonance absorption cross sections

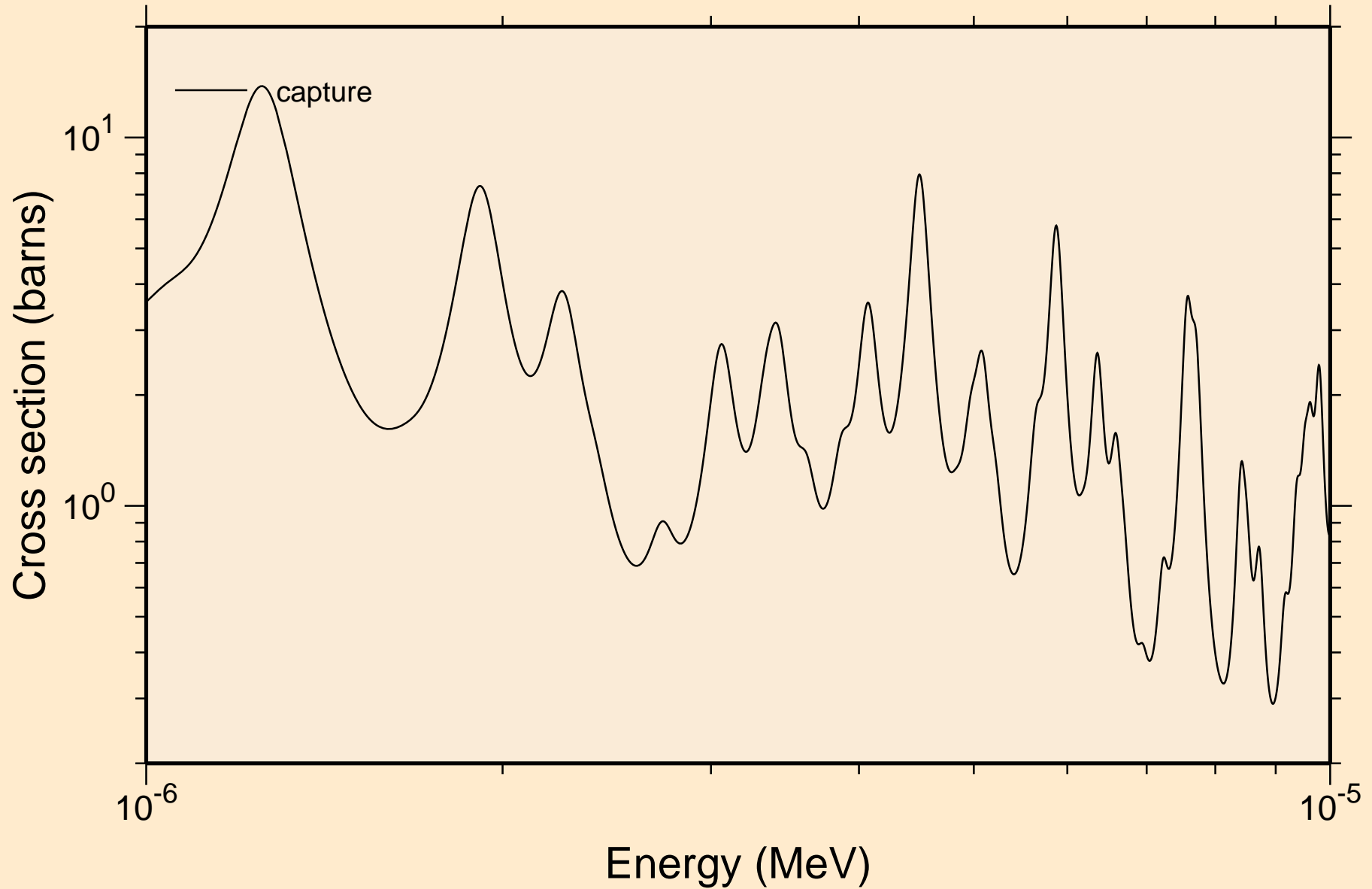

PM138 NEUTRON ACER TENDL-2024 LIBRARY; T=0.K  
resonance absorption cross sections

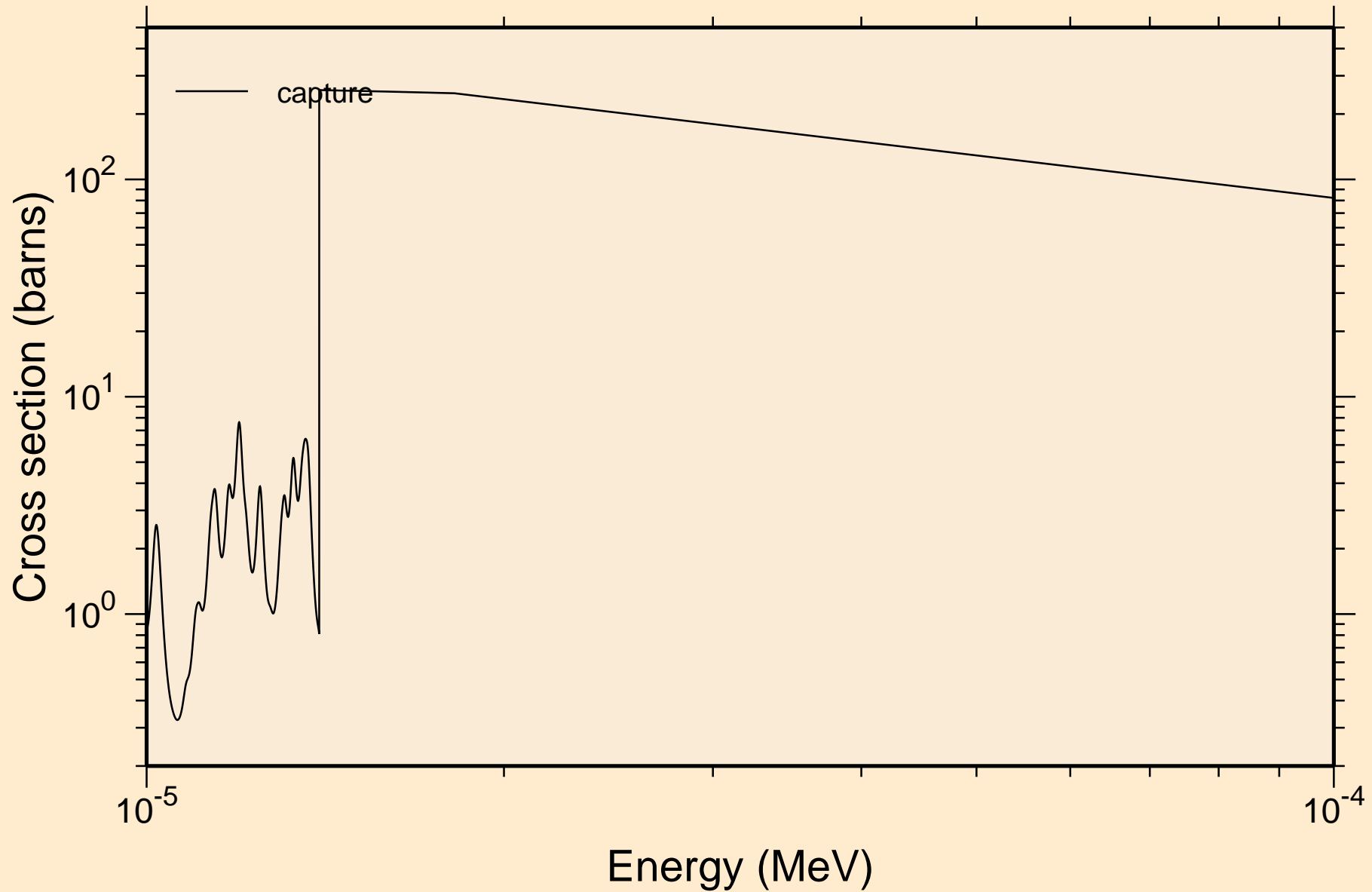



PM138 NEUTRON ACER TENDL-2024 LIBRARY; T=0.K  
resonance absorption cross sections

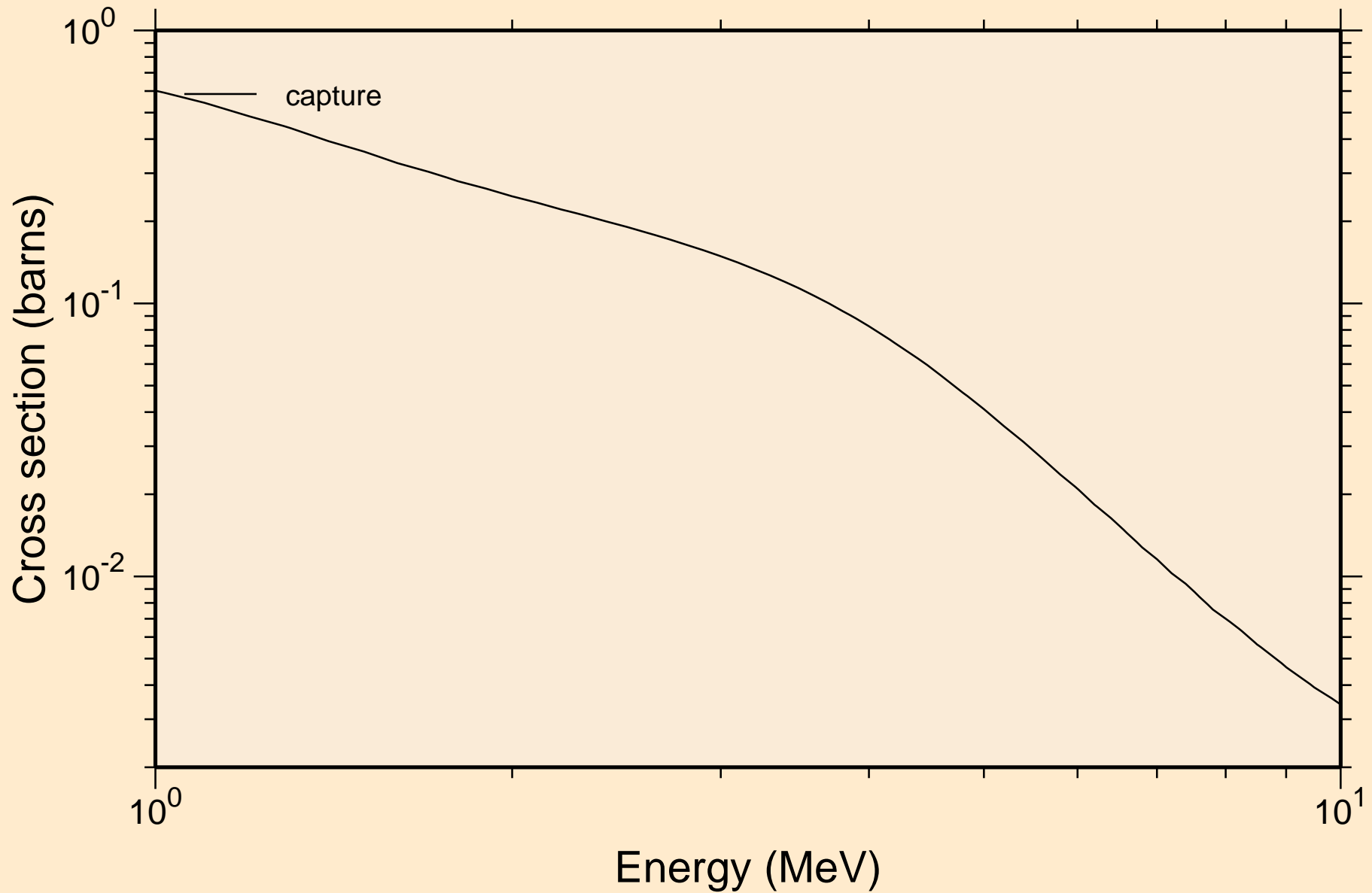

# PM138 NEUTRON ACER TENDL-2024 LIBRARY; T=0.K

## Heating

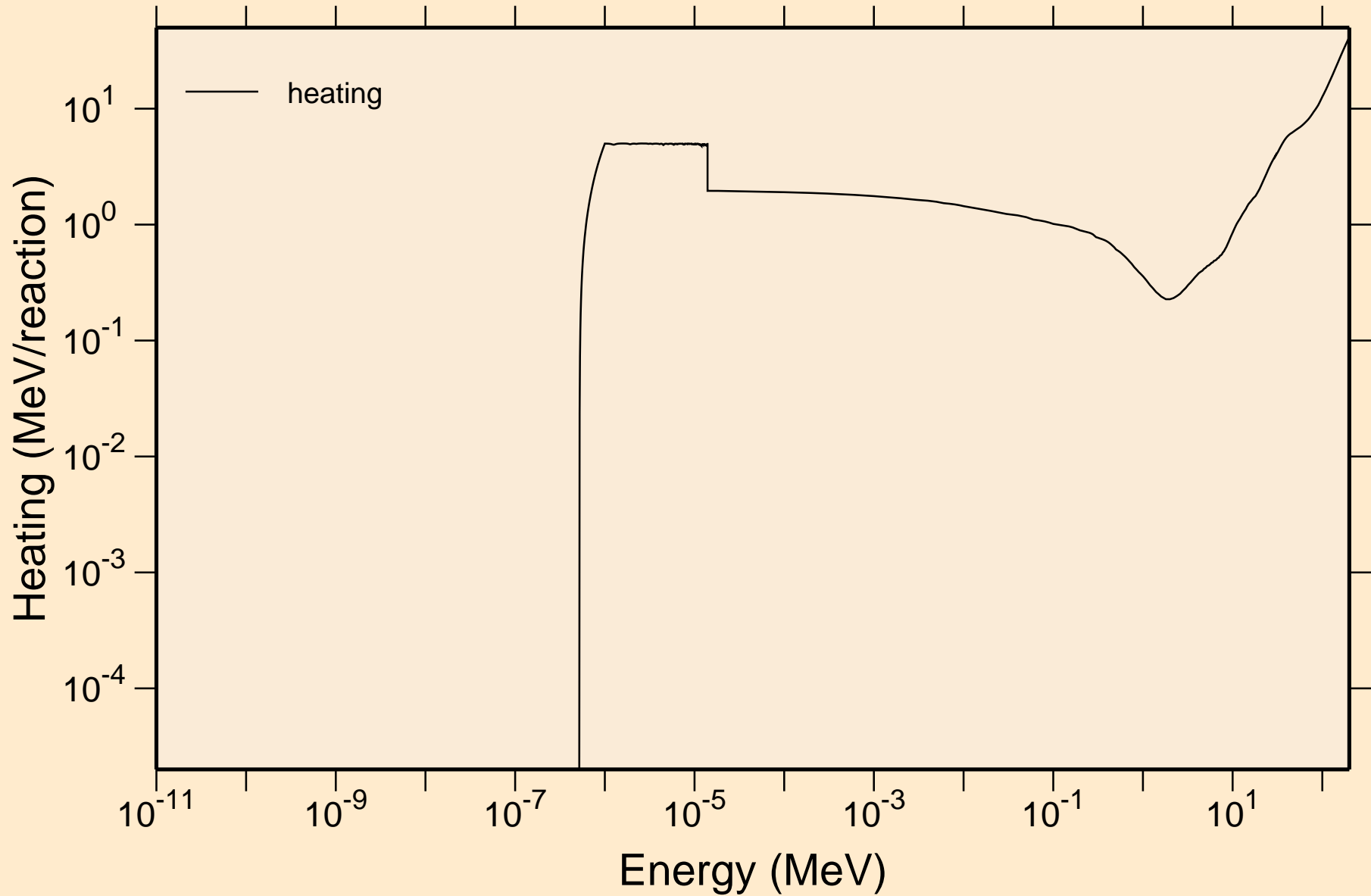

PM138 NEUTRON ACER TENDL-2024 LIBRARY; T=0.K  
Damage

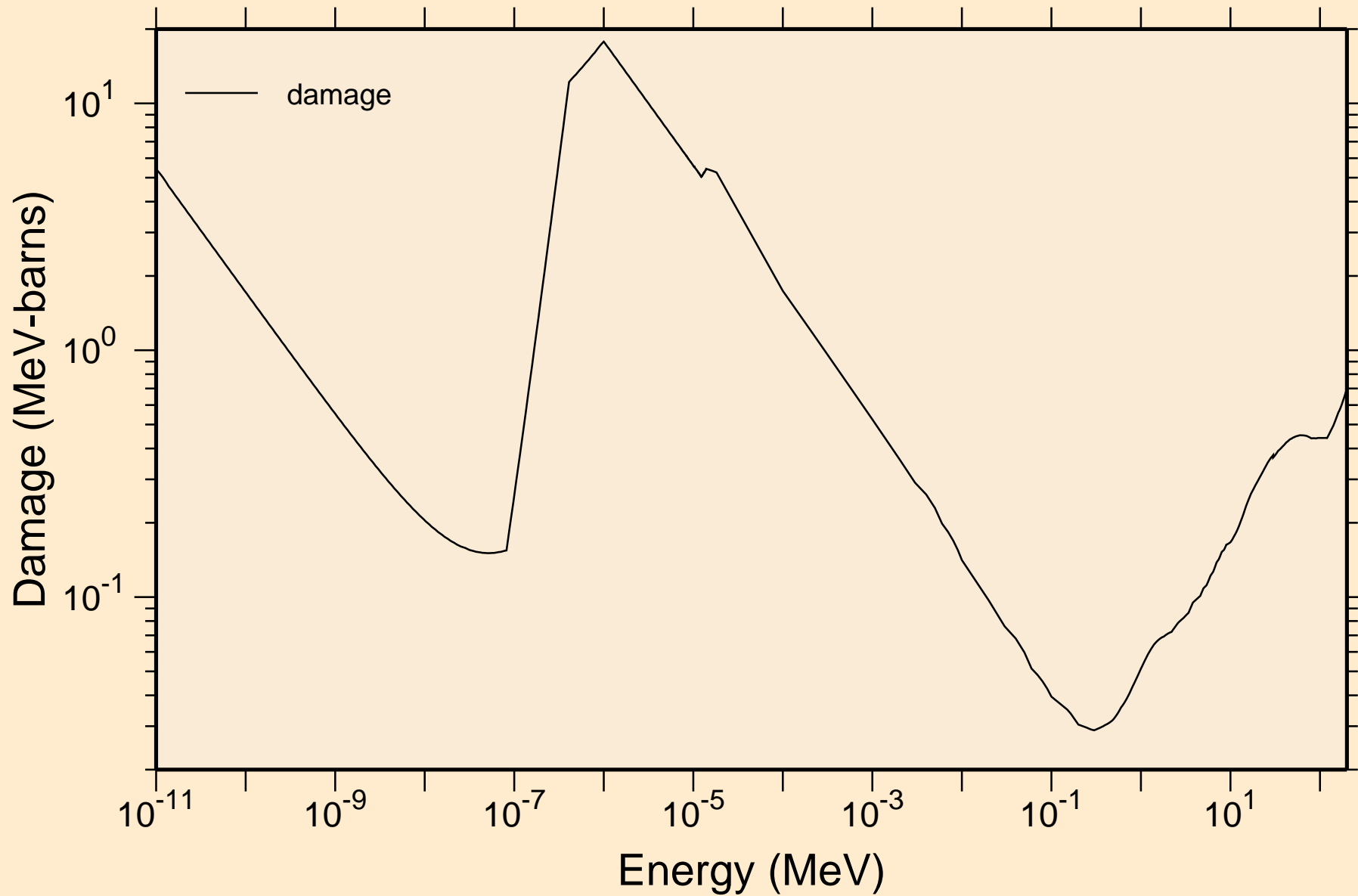

# PM138 NEUTRON ACER TENDL-2024 LIBRARY; T=0.K

## Non-threshold reactions

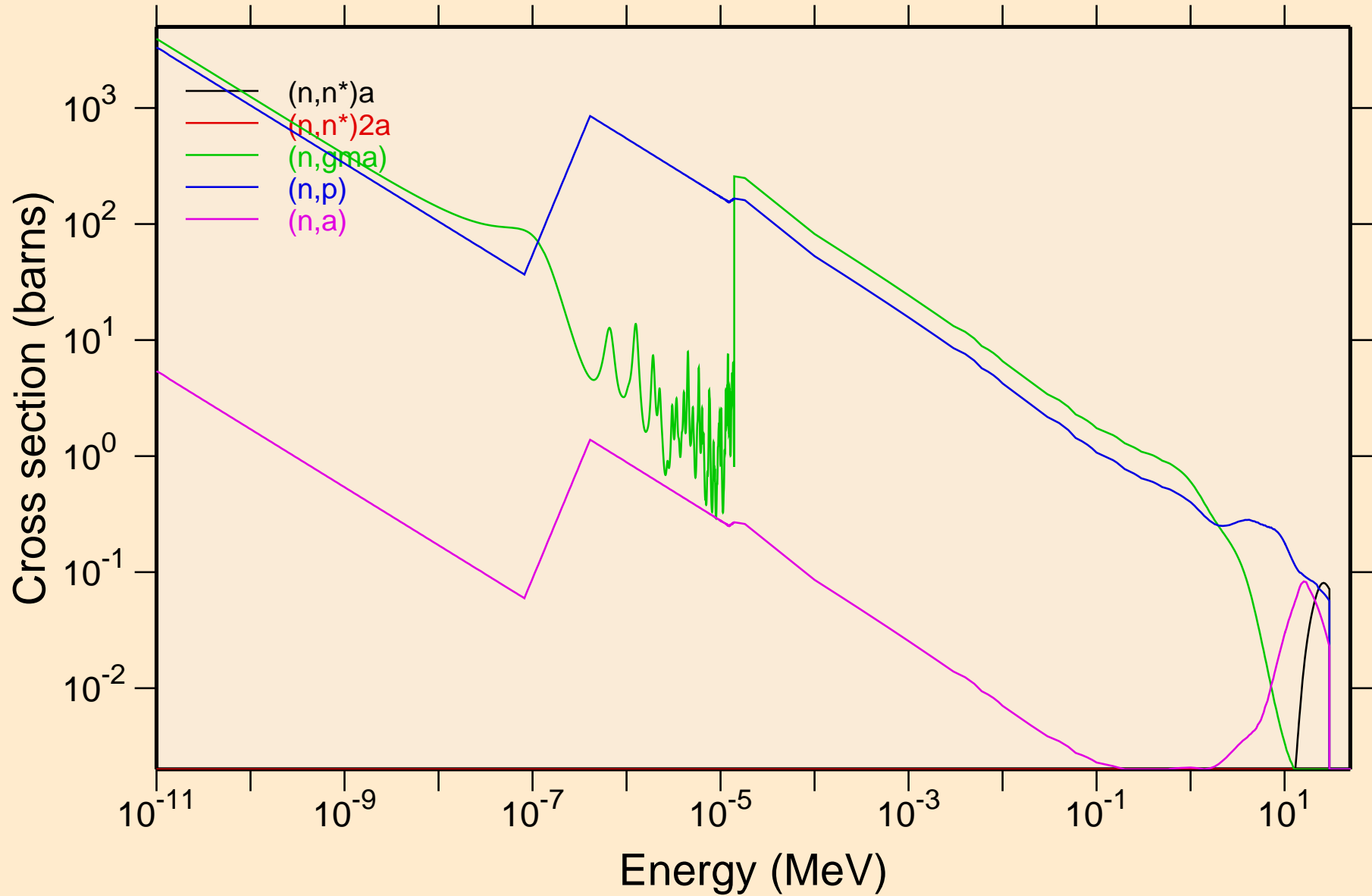

PM138 NEUTRON ACER TENDL-2024 LIBRARY; T=0.K  
Non-threshold reactions

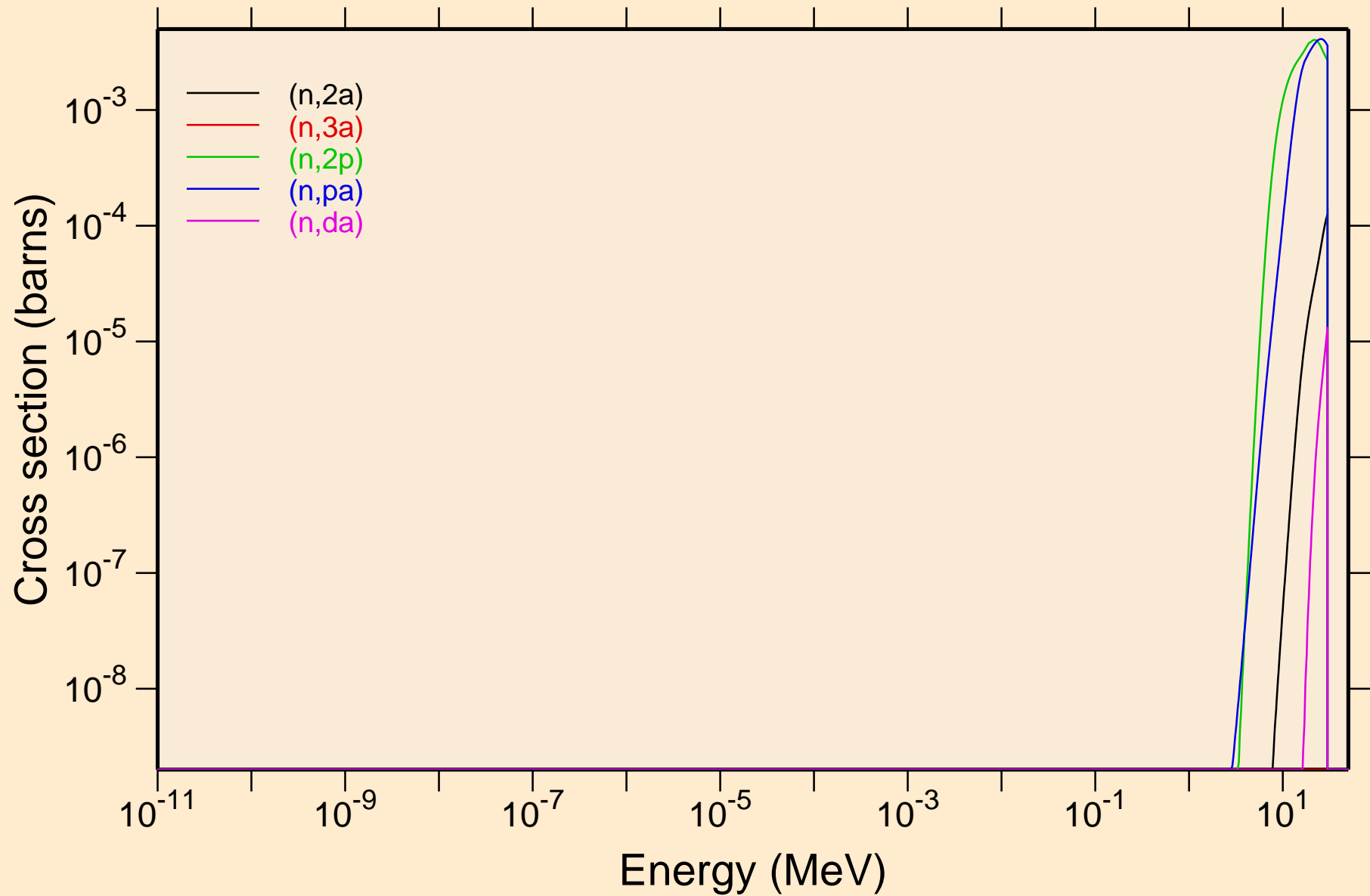

# PM138 NEUTRON ACER TENDL-2024 LIBRARY; T=0.K

## Non-threshold reactions

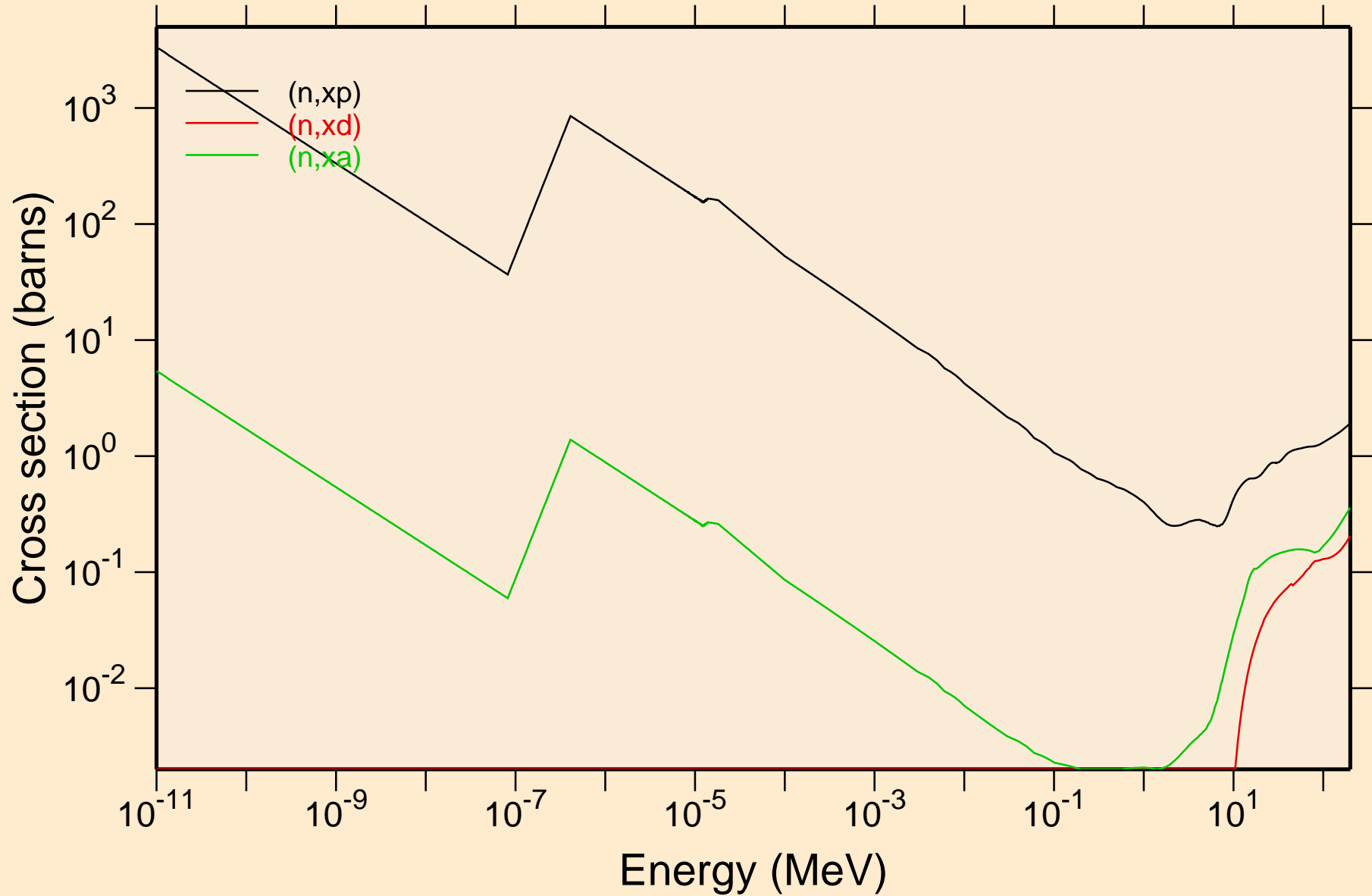

PM138 NEUTRON ACER TENDL-2024 LIBRARY; T=0.K  
Principal cross sections

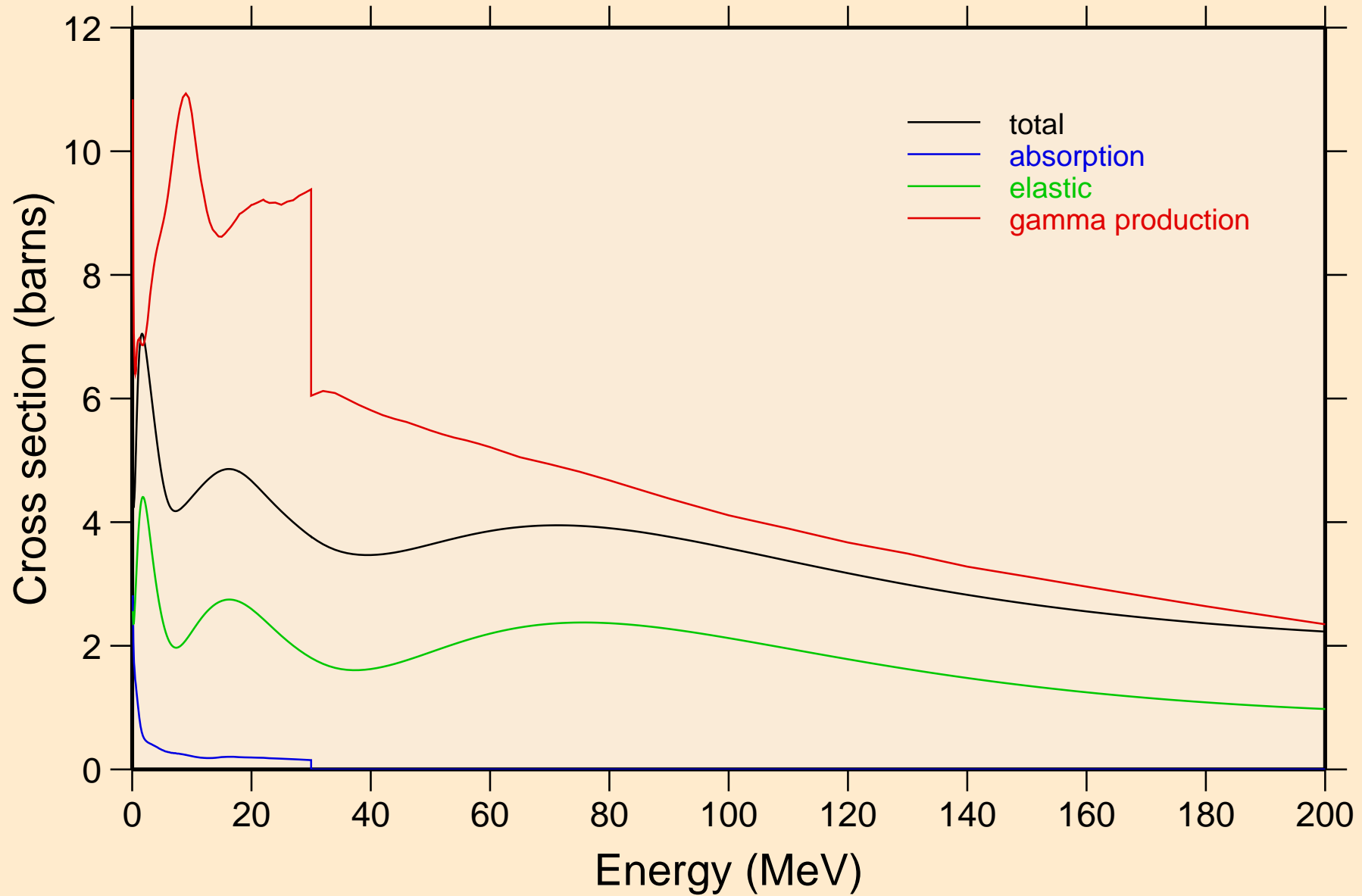

# PM138 NEUTRON ACER TENDL-2024 LIBRARY; T=0.K

## Heating

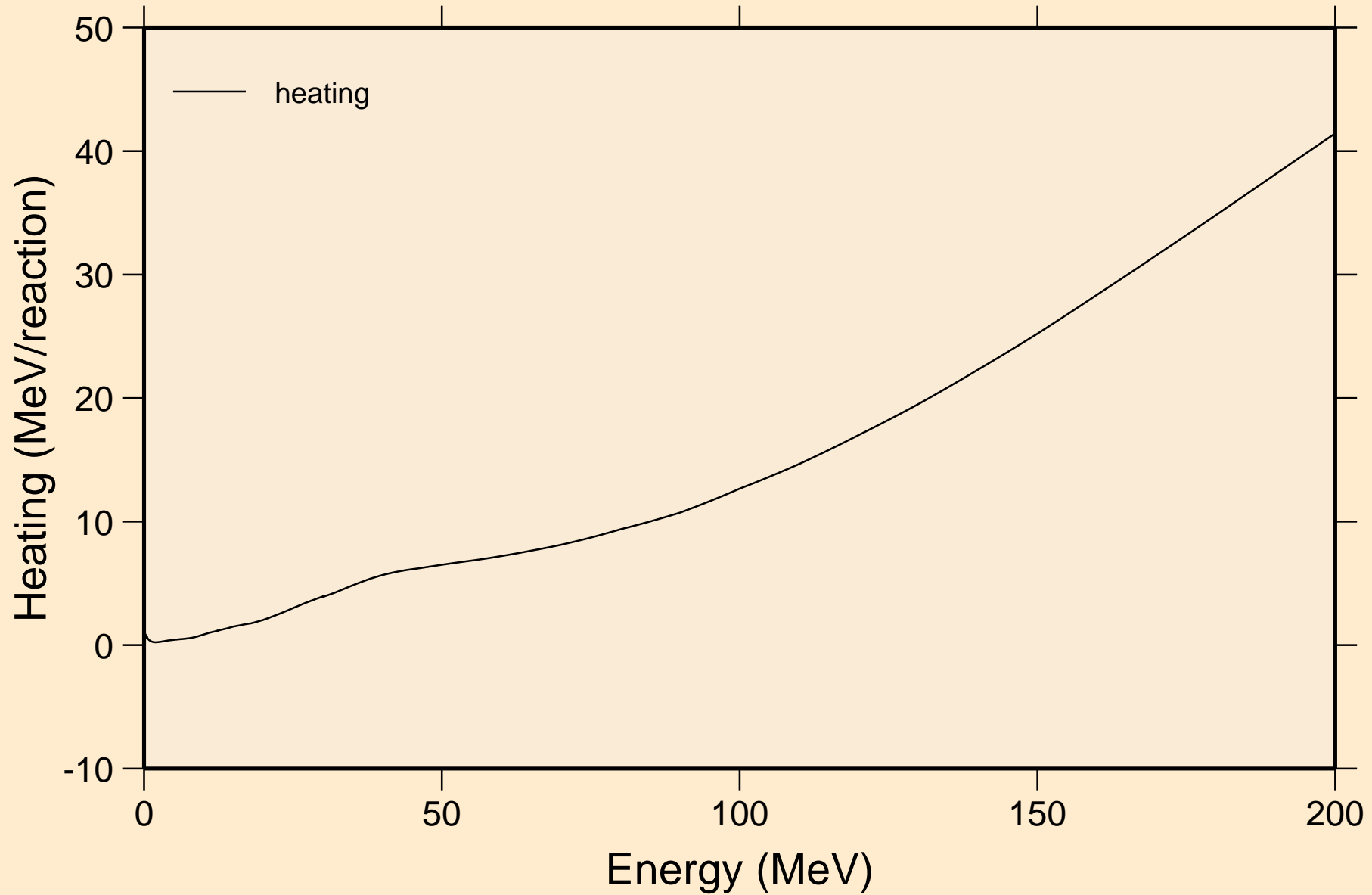



PM138 NEUTRON ACER TENDL-2024 LIBRARY; T=0.K  
Damage

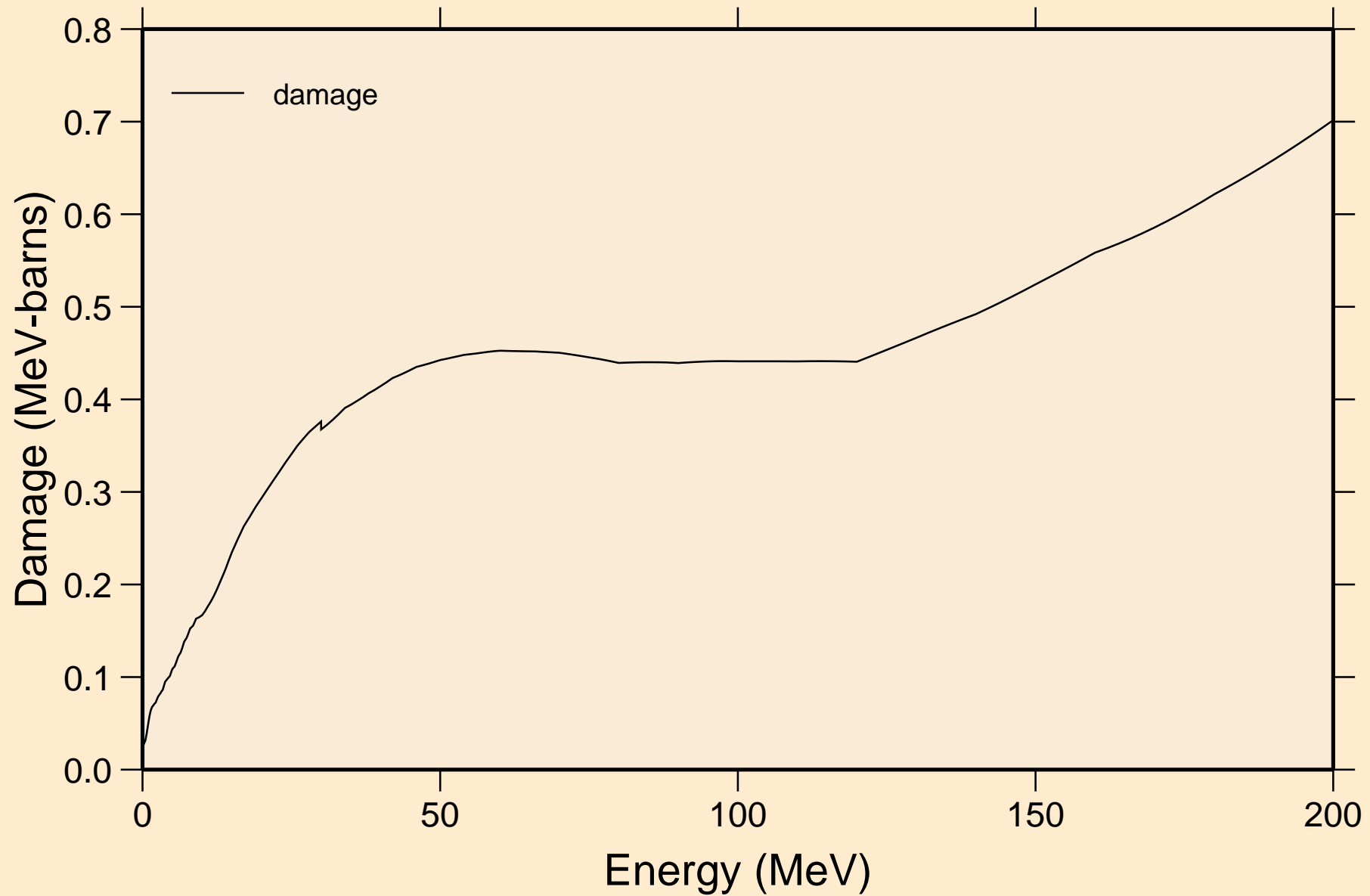

# PM138 NEUTRON ACER TENDL-2024 LIBRARY; T=0.K

## Non-threshold reactions

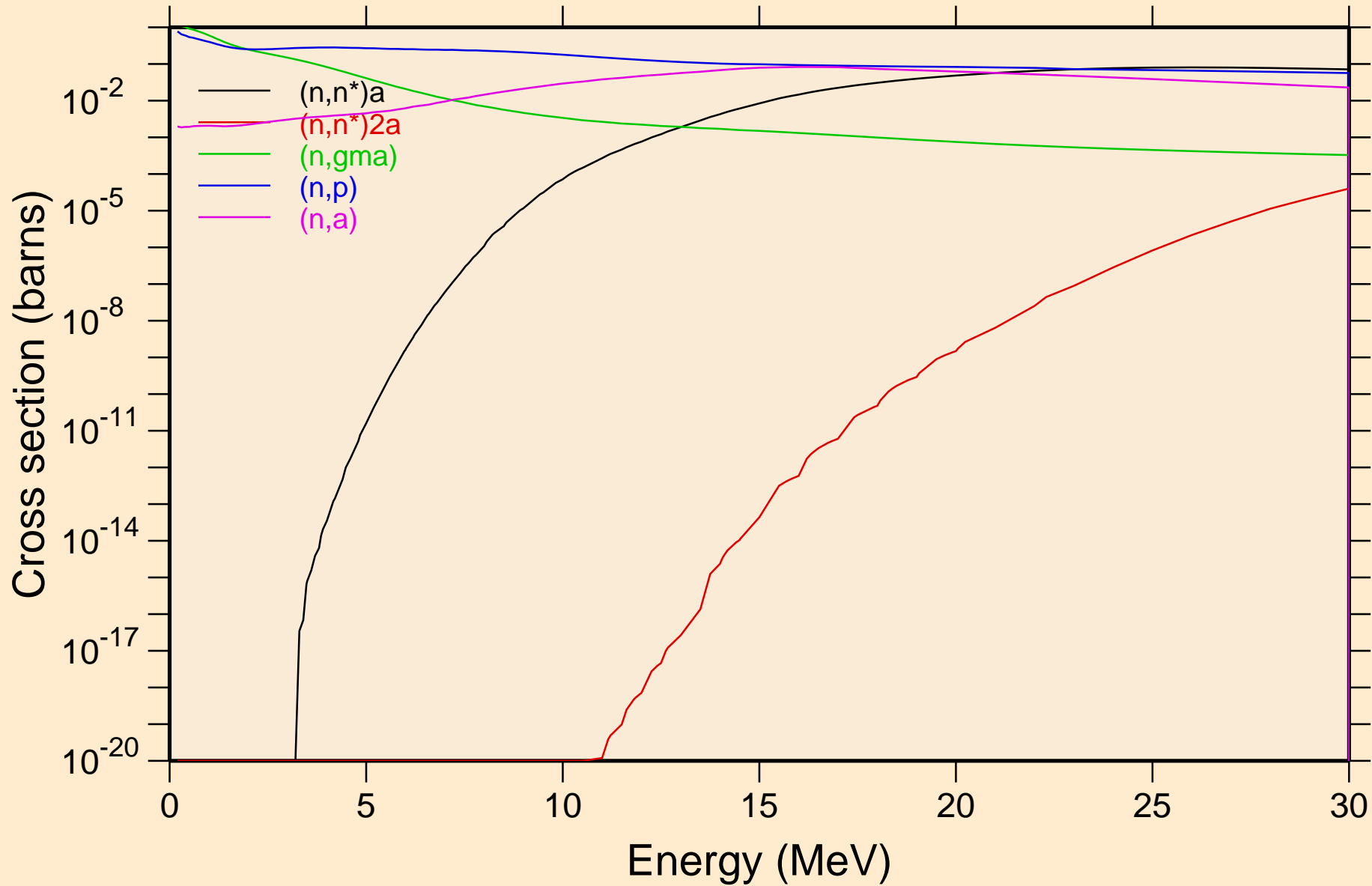

PM138 NEUTRON ACER TENDL-2024 LIBRARY; T=0.K  
Non-threshold reactions

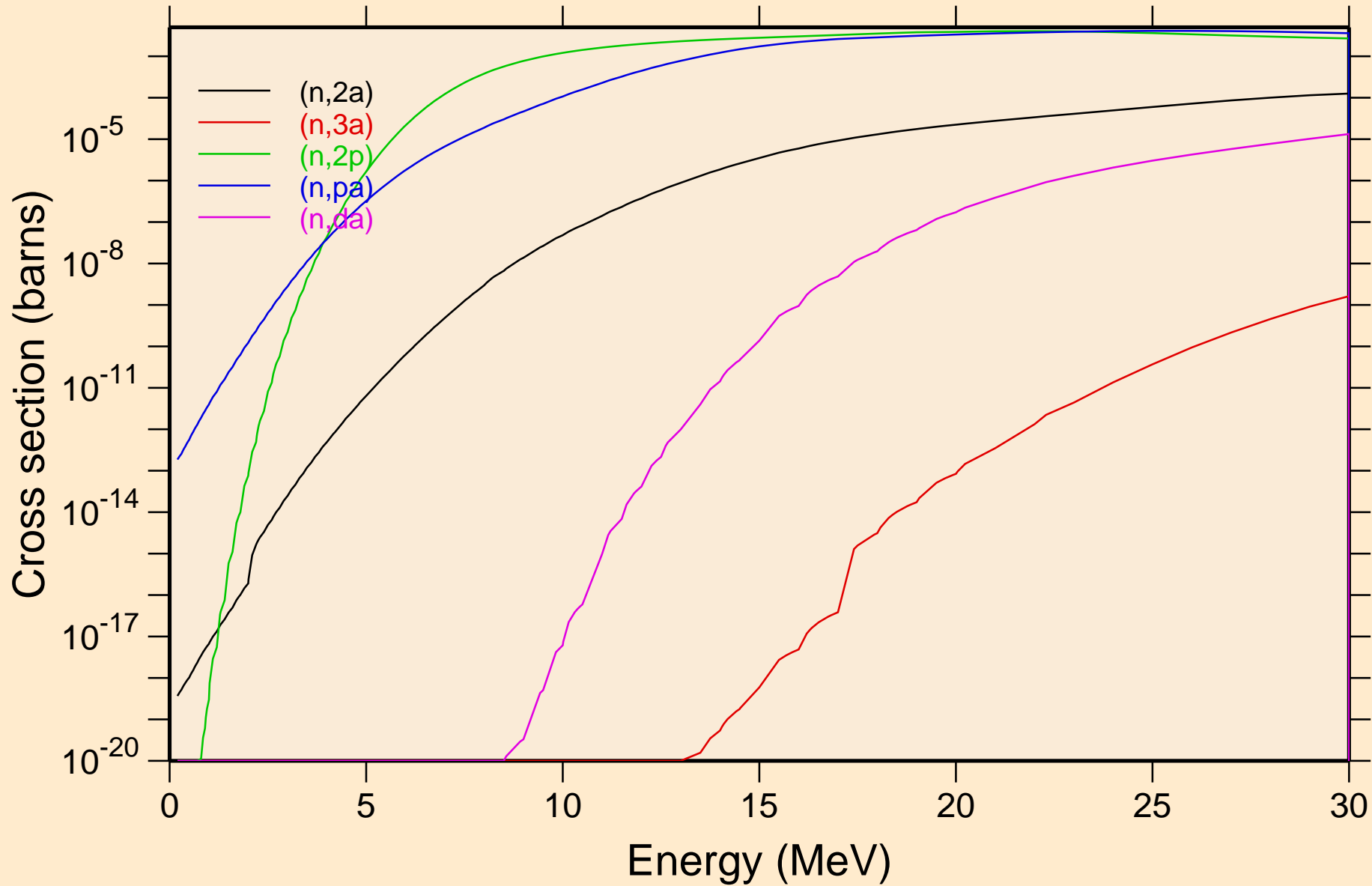

# PM138 NEUTRON ACER TENDL-2024 LIBRARY; T=0.K

## Non-threshold reactions

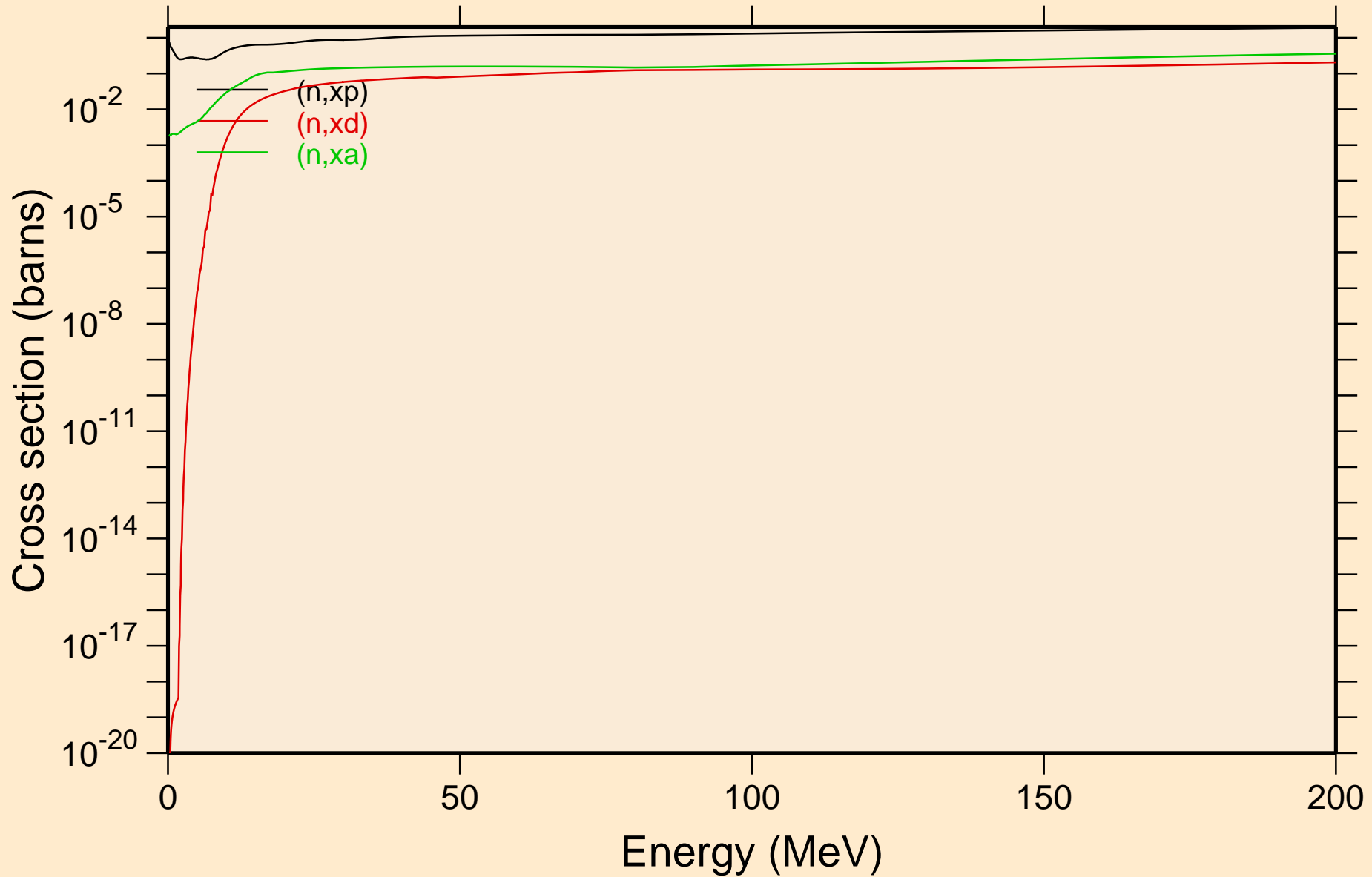

PM138 NEUTRON ACER TENDL-2024 LIBRARY; T=0.K  
Inelastic levels

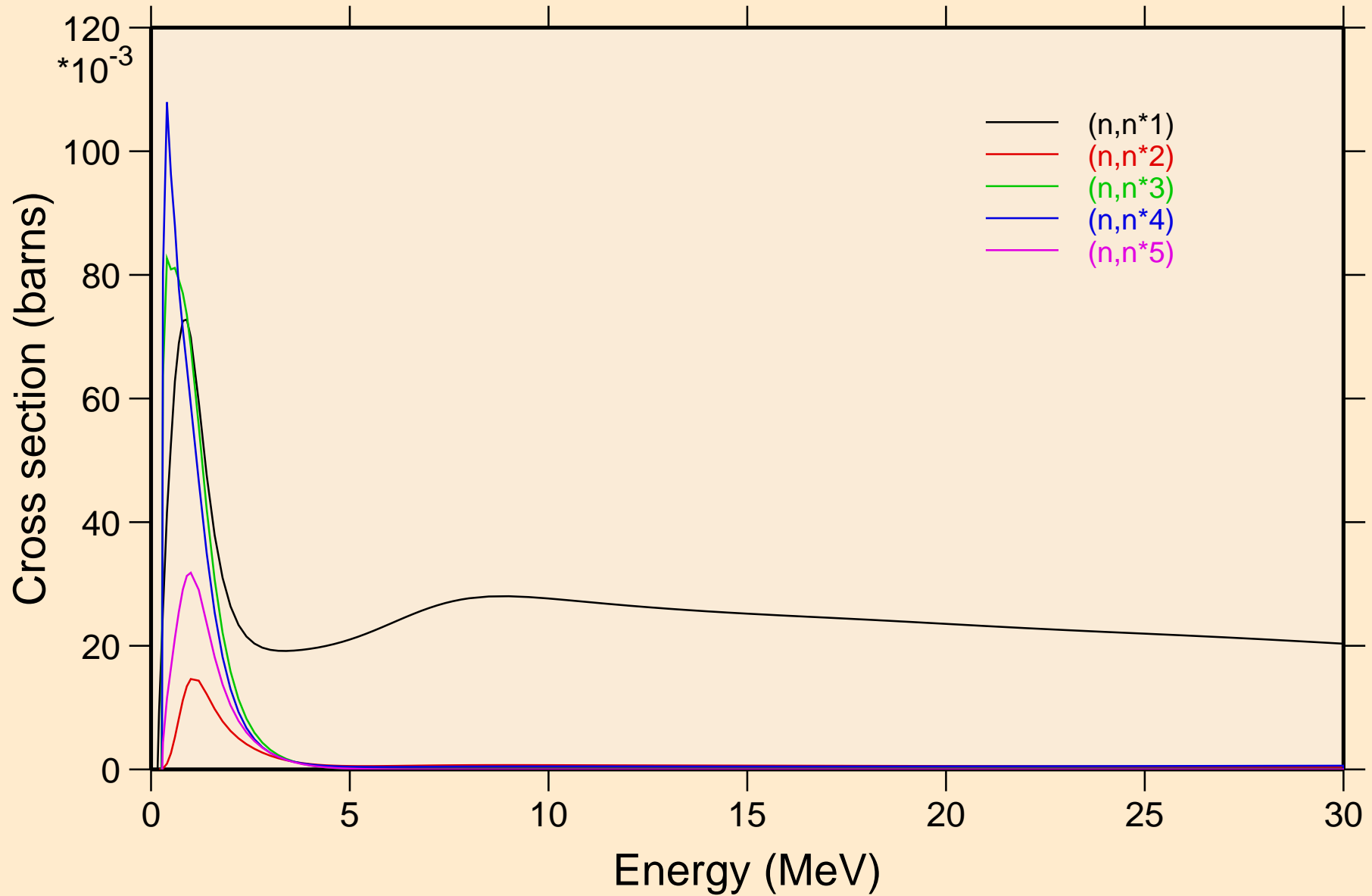

PM138 NEUTRON ACER TENDL-2024 LIBRARY; T=0.K  
Inelastic levels

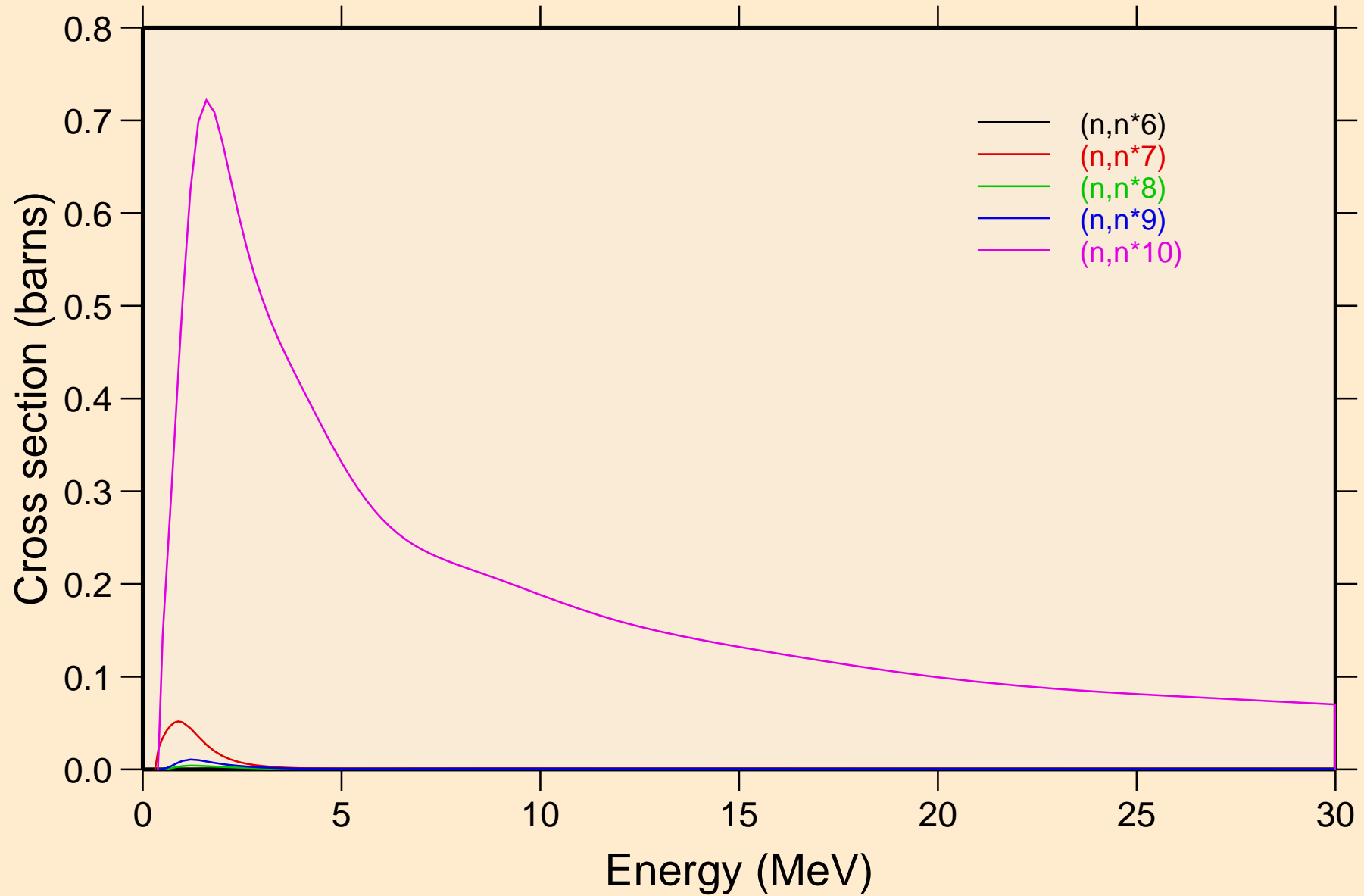

PM138 NEUTRON ACER TENDL-2024 LIBRARY; T=0.K  
Inelastic levels

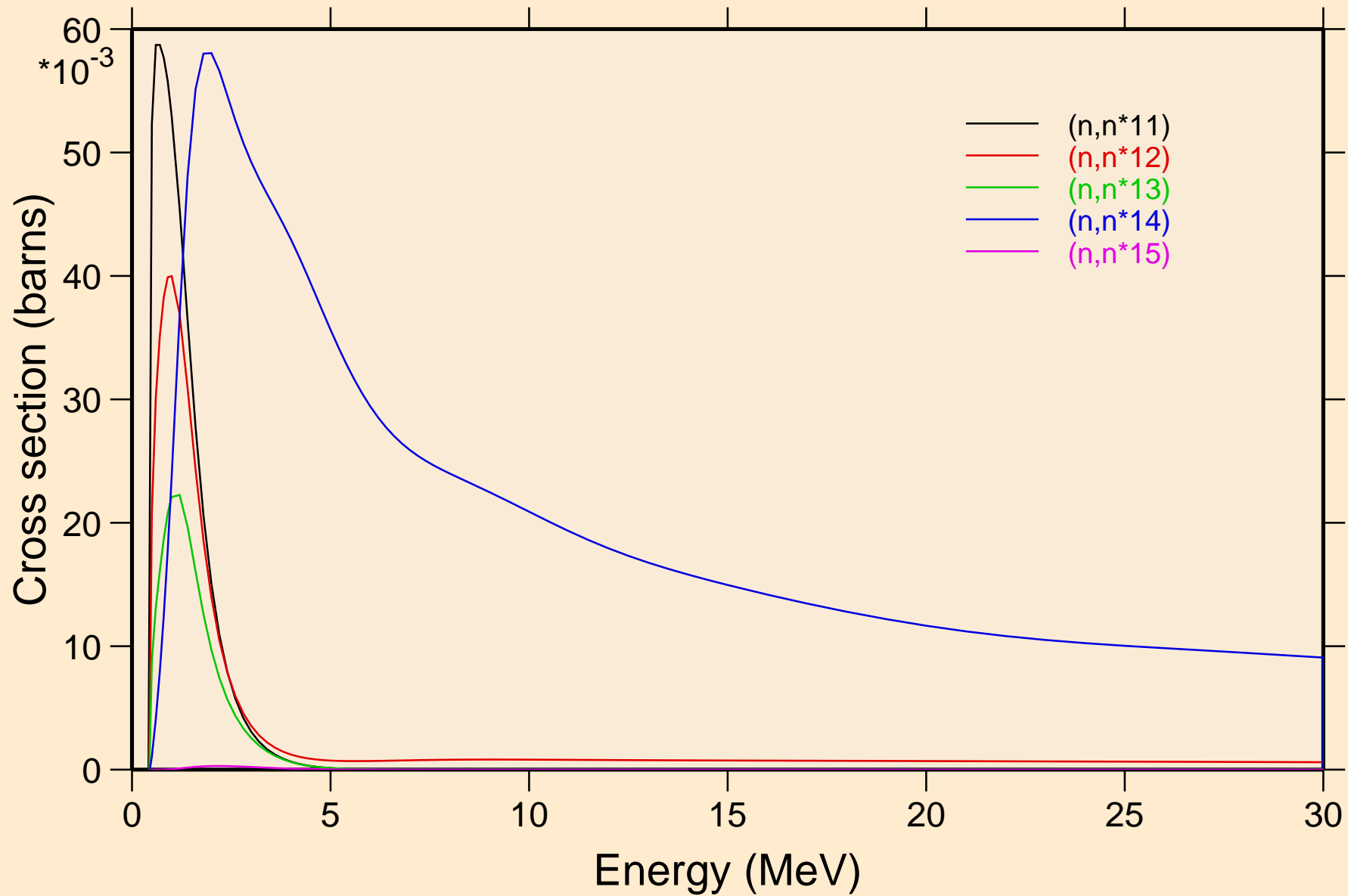

PM138 NEUTRON ACER TENDL-2024 LIBRARY; T=0.K  
Inelastic levels

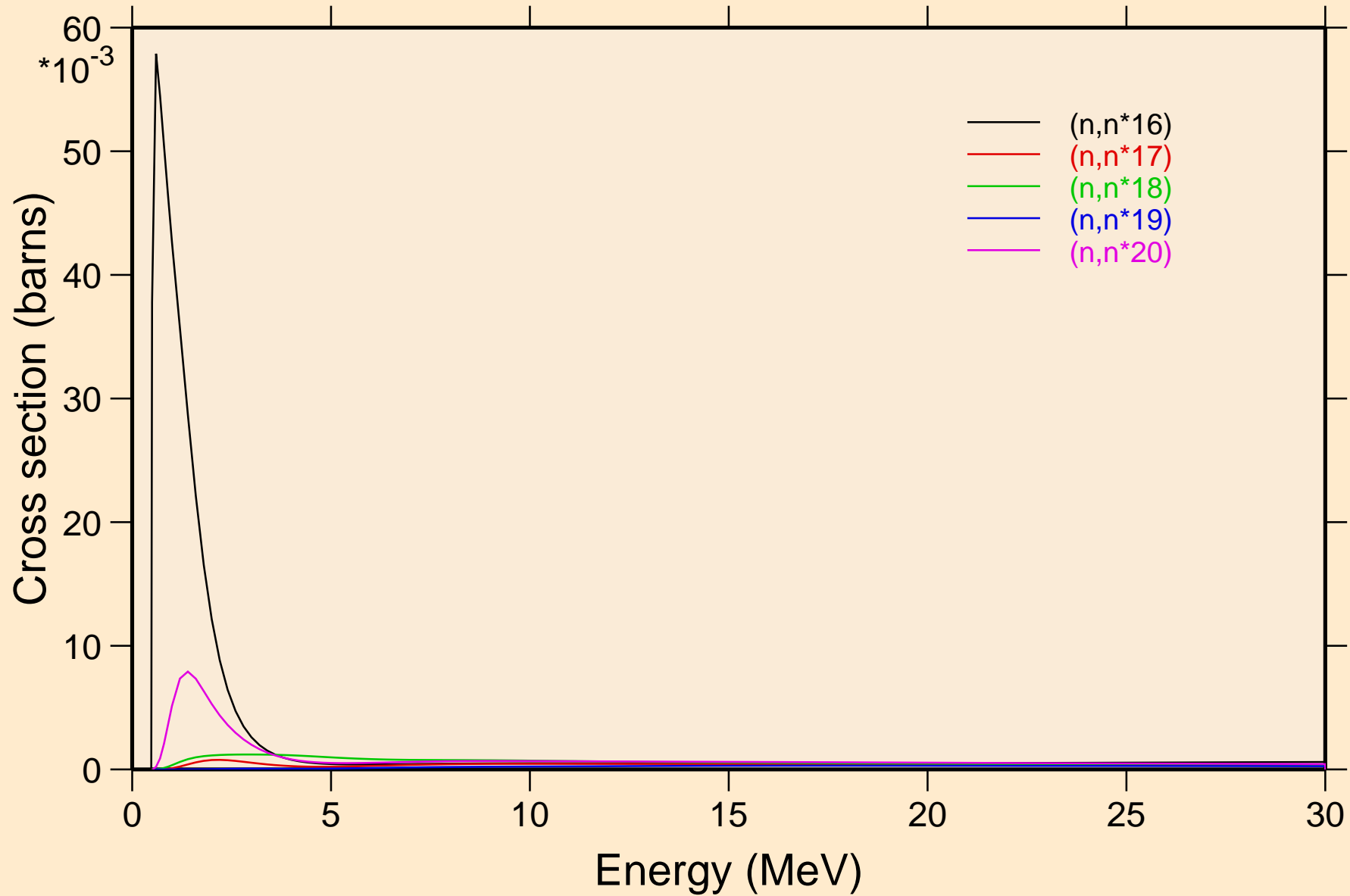



PM138 NEUTRON ACER TENDL-2024 LIBRARY; T=0.K  
Inelastic levels

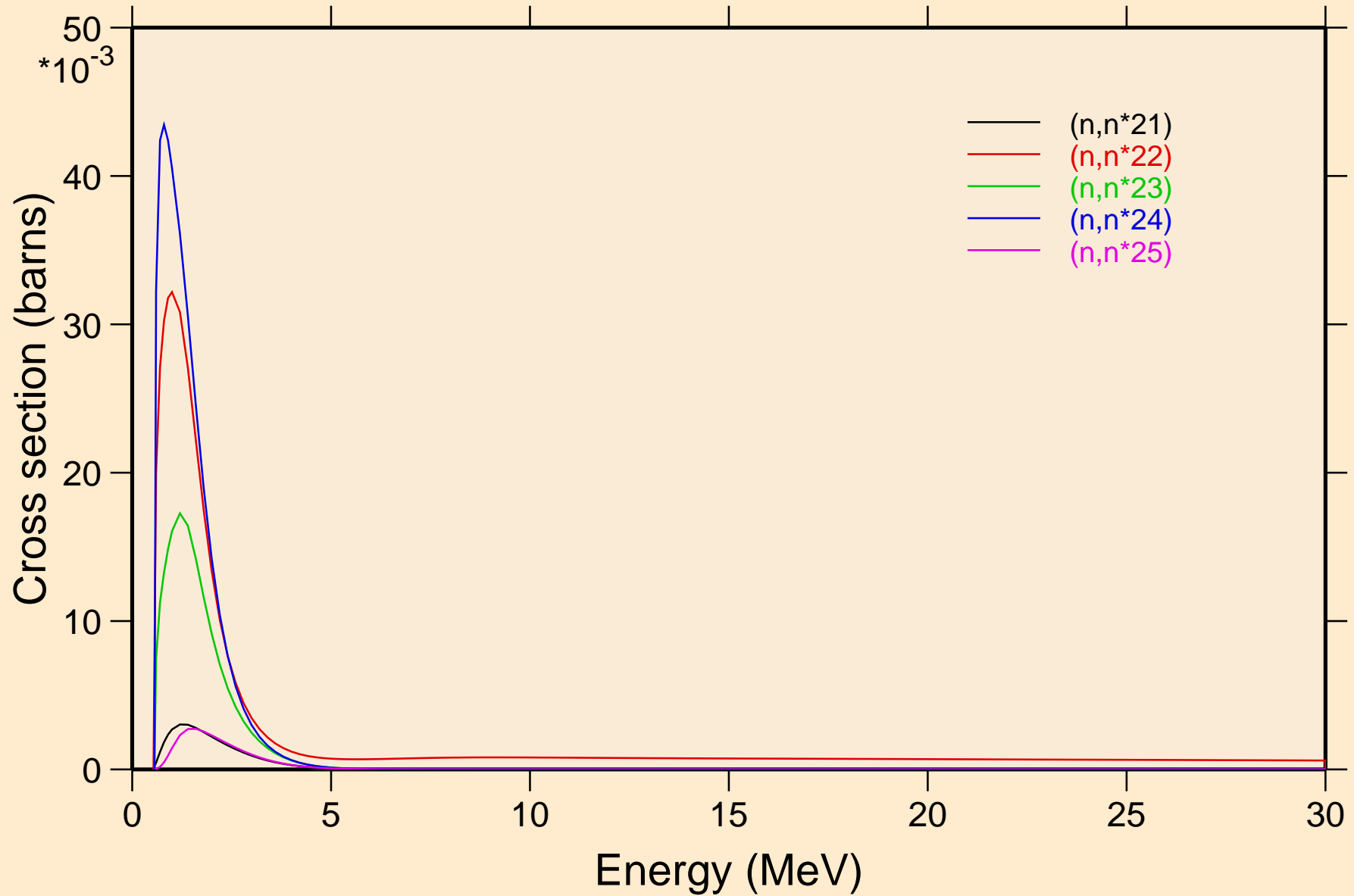

PM138 NEUTRON ACER TENDL-2024 LIBRARY; T=0.K  
Inelastic levels

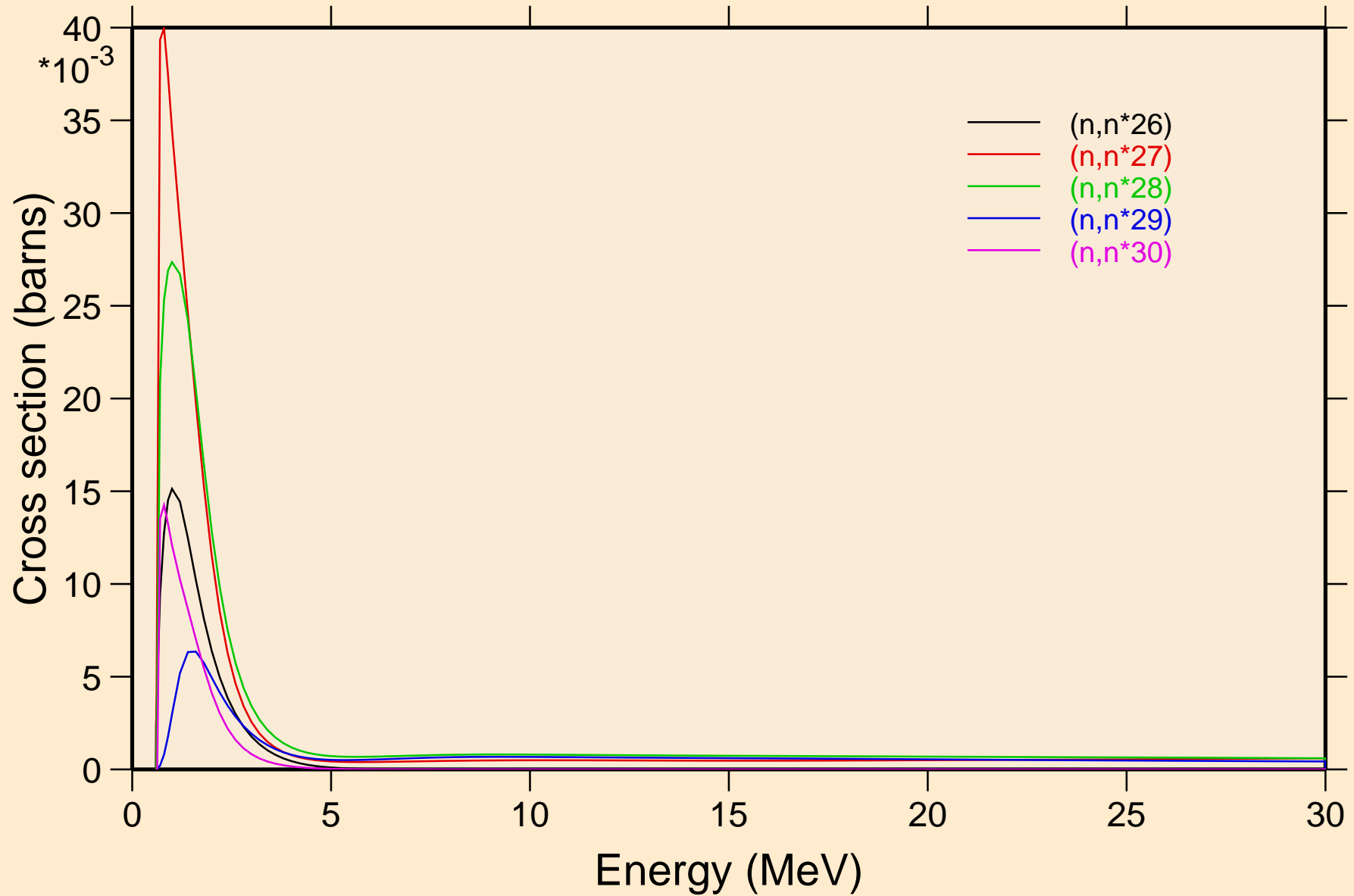

# PM138 NEUTRON ACER TENDL-2024 LIBRARY; T=0.K

## Threshold reactions

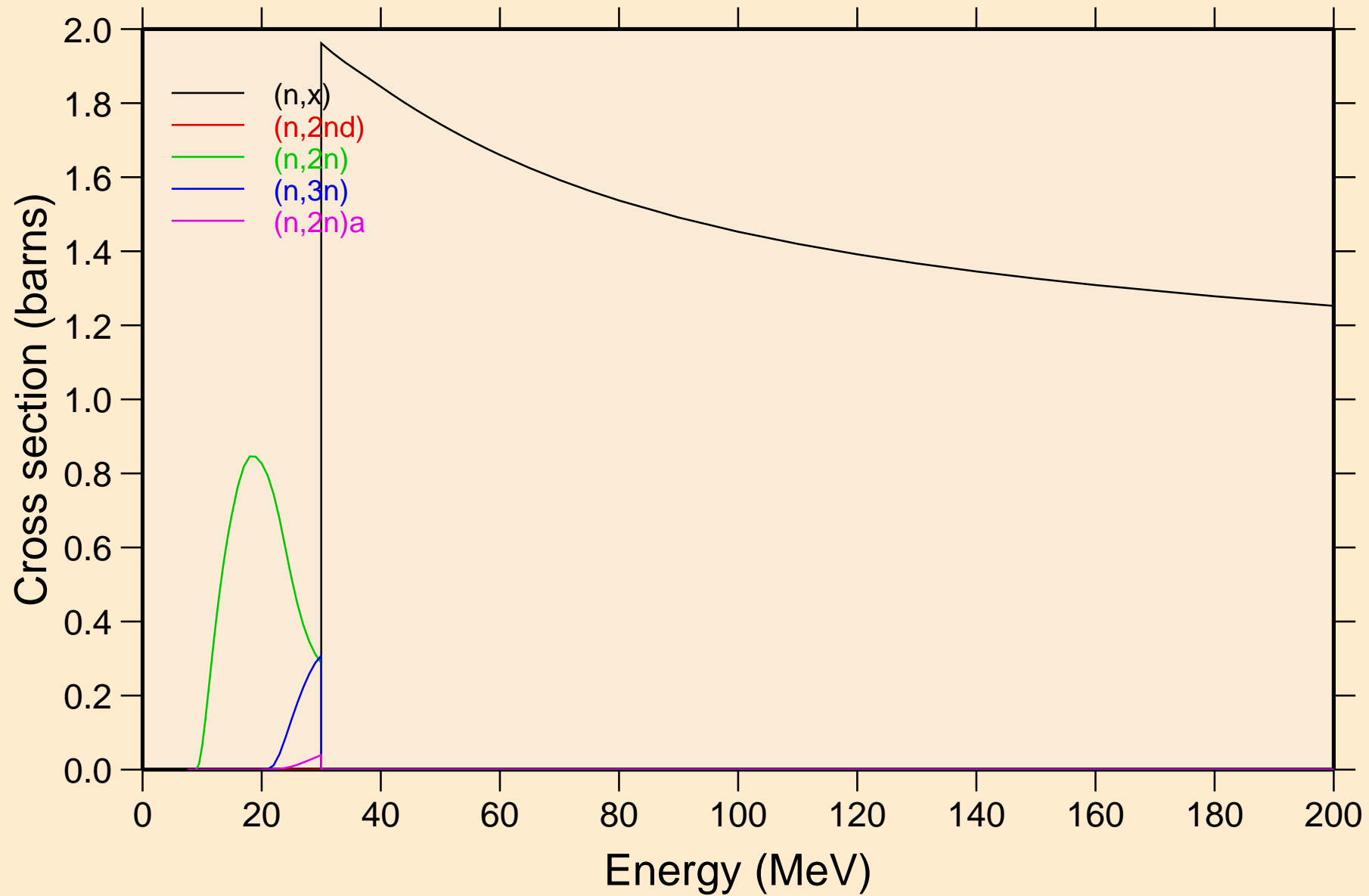

PM138 NEUTRON ACER TENDL-2024 LIBRARY; T=0.K  
Threshold reactions

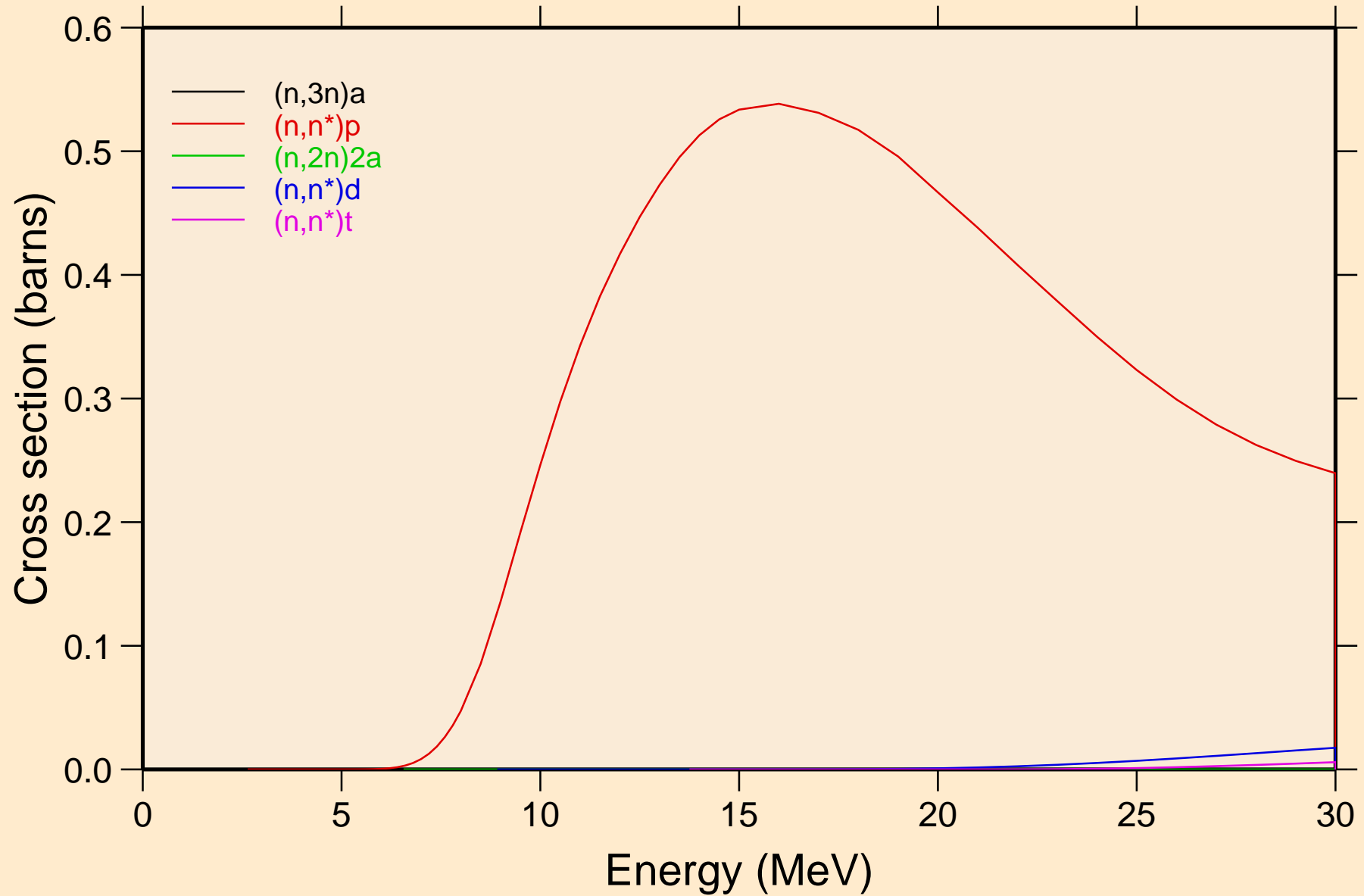

PM138 NEUTRON ACER TENDL-2024 LIBRARY; T=0.K  
Threshold reactions

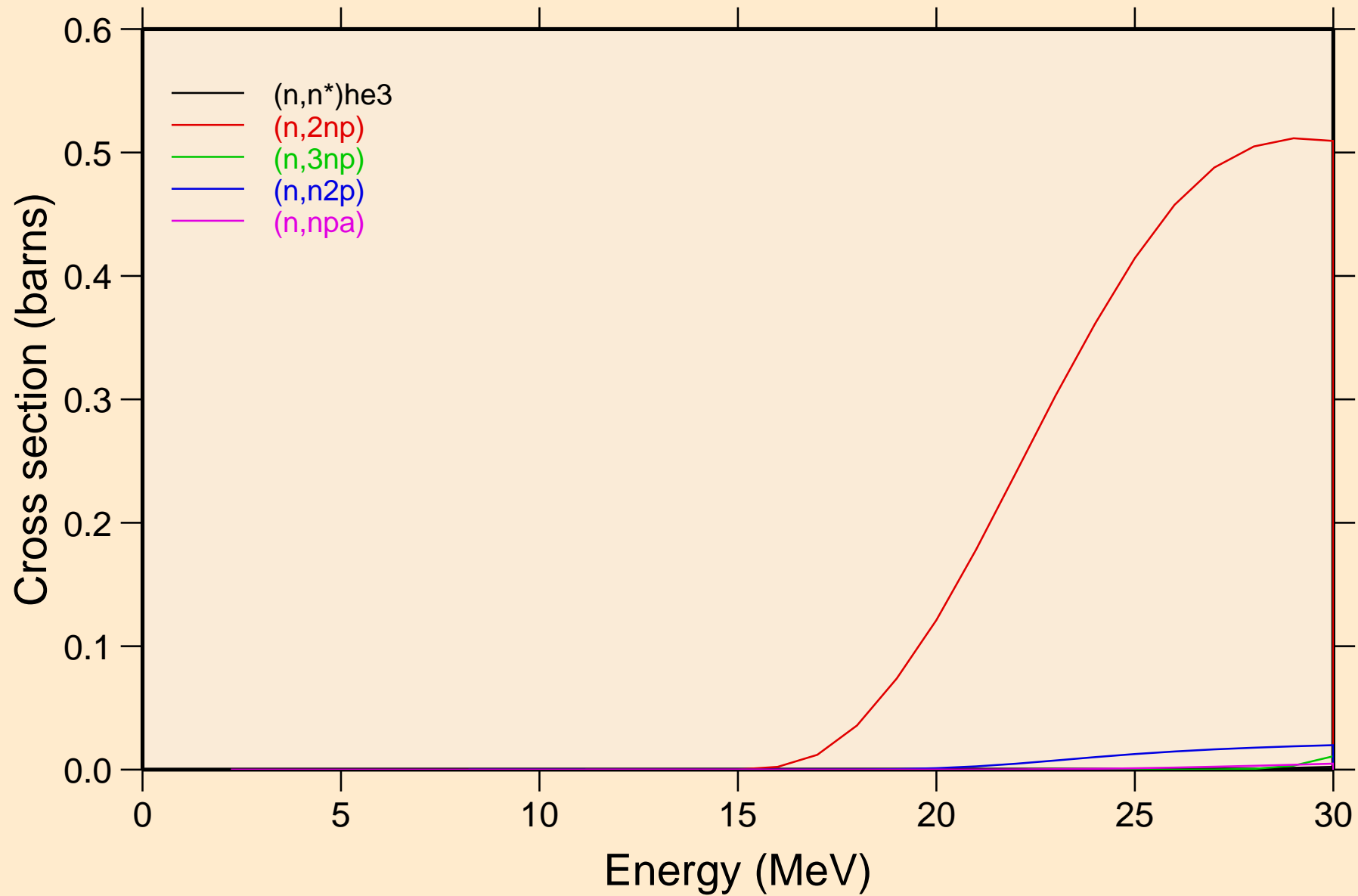

PM138 NEUTRON ACER TENDL-2024 LIBRARY; T=0.K  
Threshold reactions

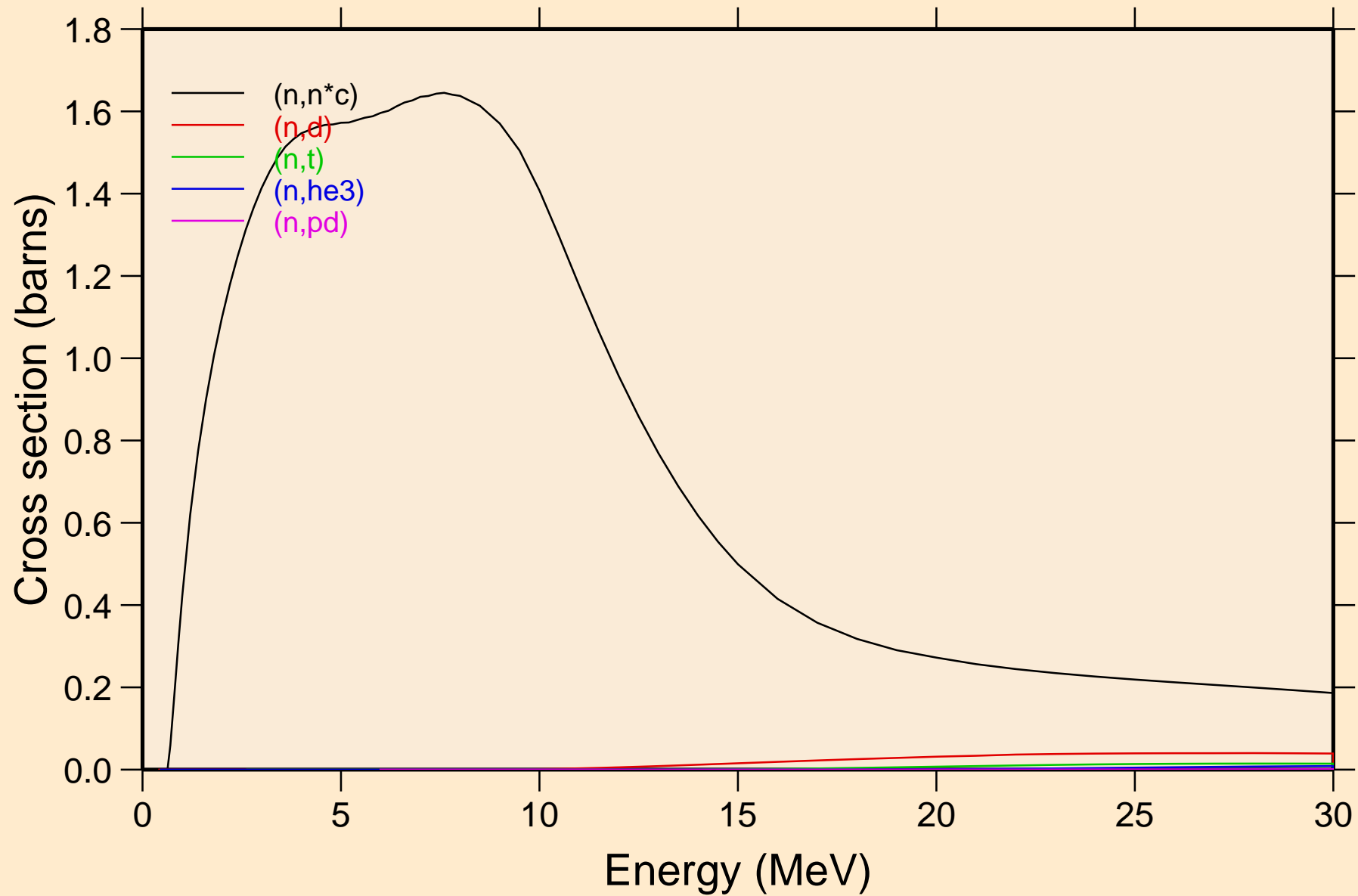

PM138 NEUTRON ACER TENDL-2024 LIBRARY; T=0.K  
Threshold reactions

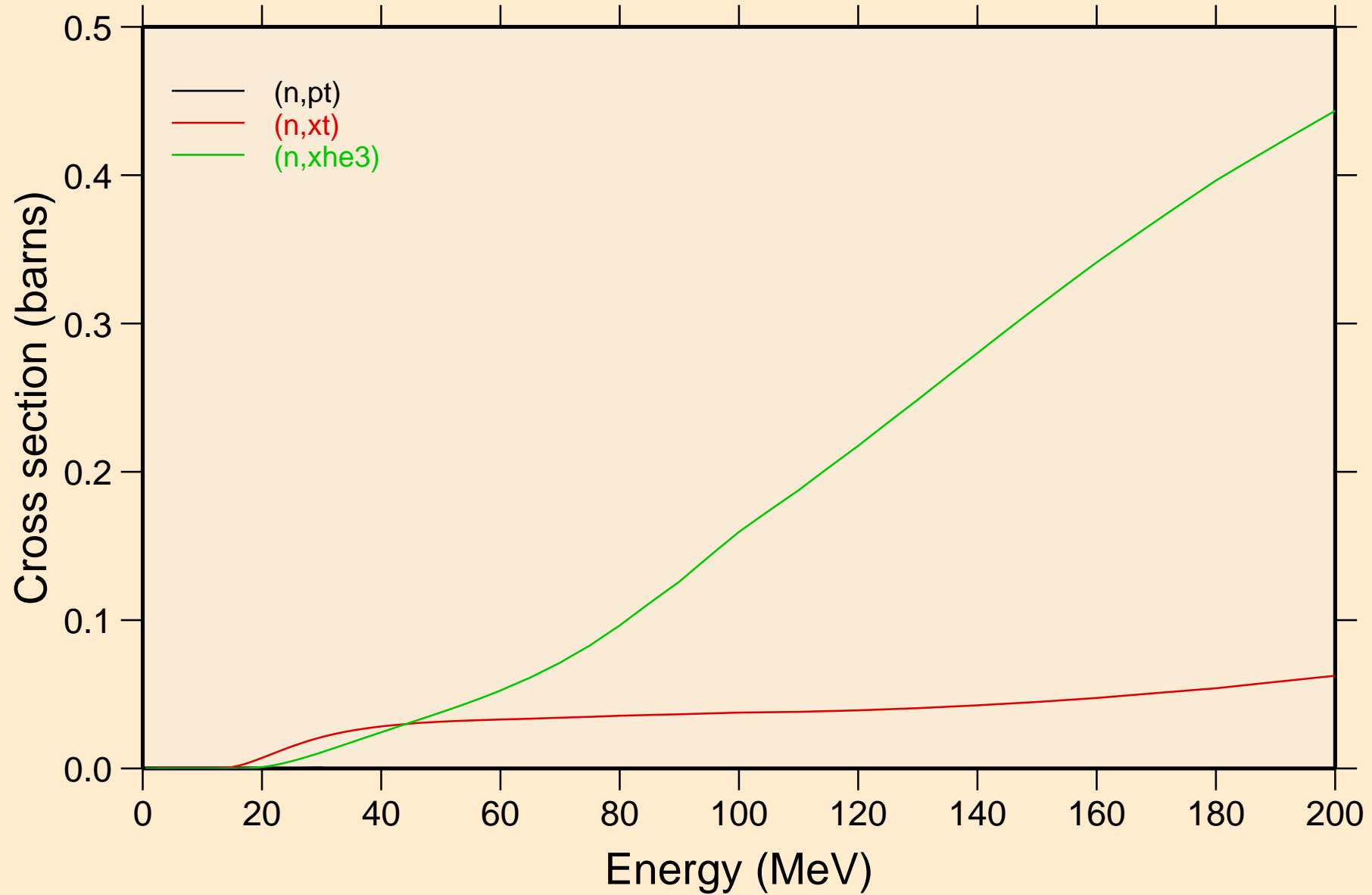

PM138 NEUTRON ACER TENDL-2024 LIBRARY; T=0.K  
angular distribution for elastic

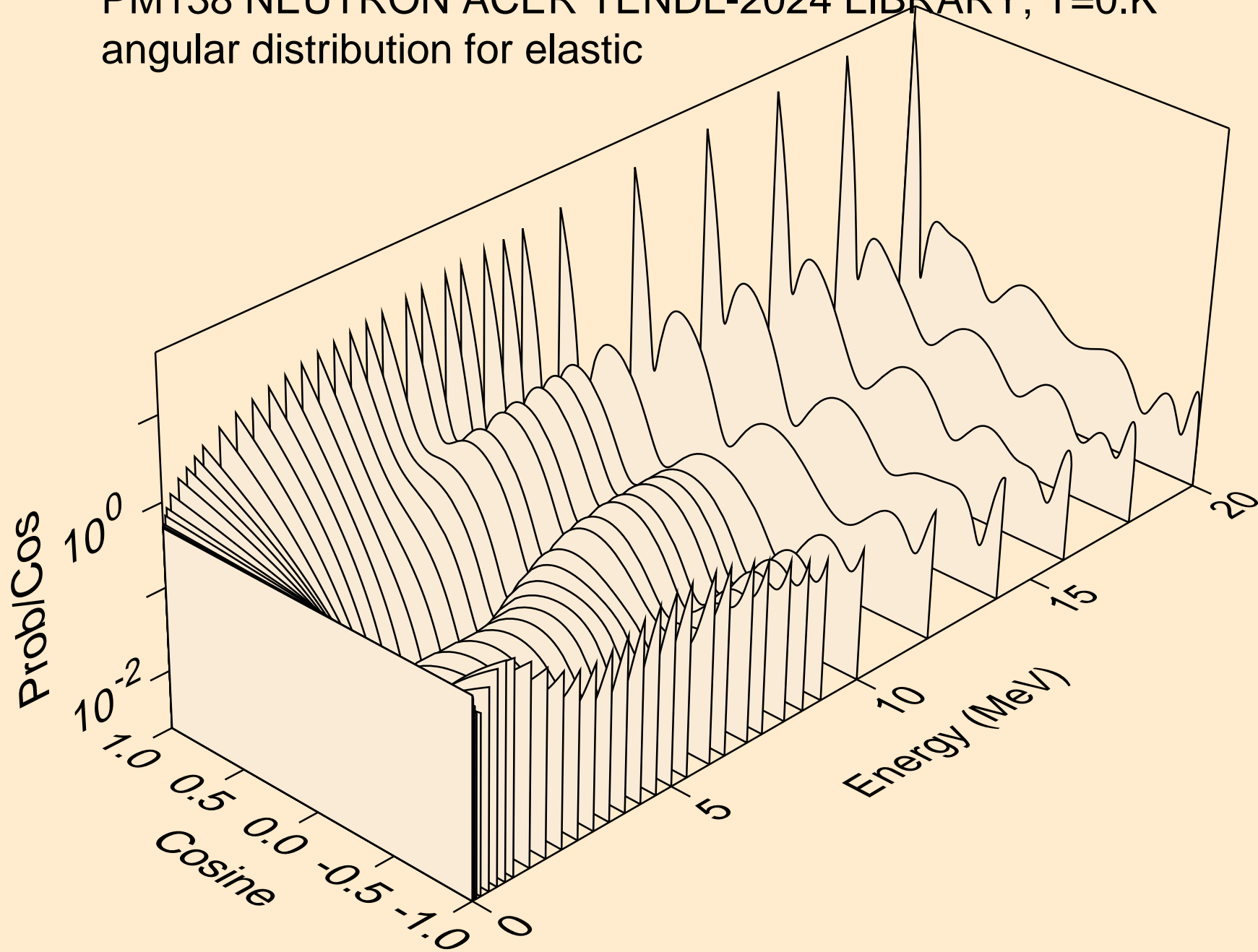



PM138 NEUTRON ACER TENDL-2024 LIBRARY; T=0.K  
angular distribution for elastic

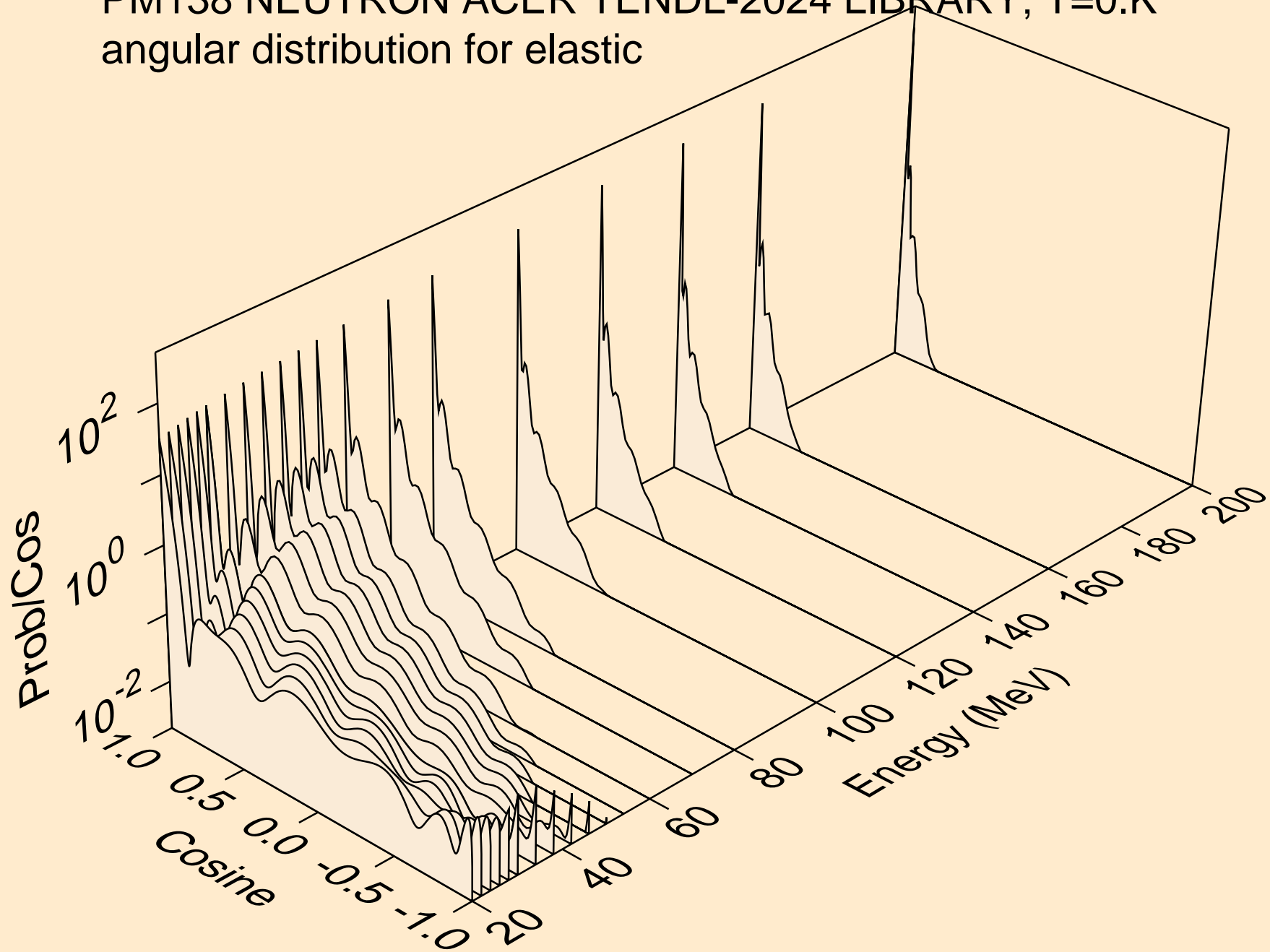

PM138 NEUTRON ACER TENDL-2024 LIBRARY; T=0.K  
angular distribution for (n,n\*1)

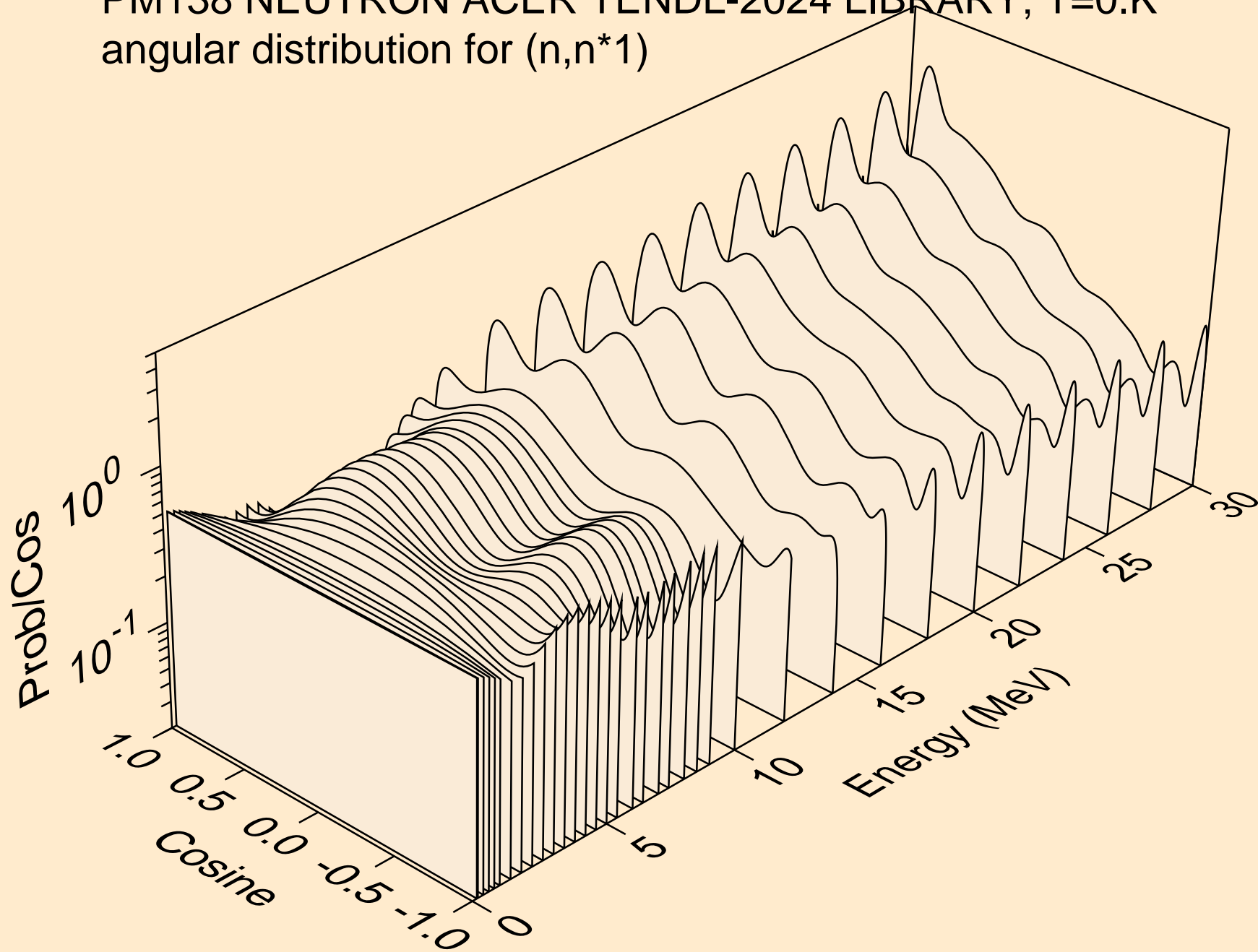

PM138 NEUTRON ACER TENDL-2024 LIBRARY; T=0.K  
angular distribution for (n,n\*2)

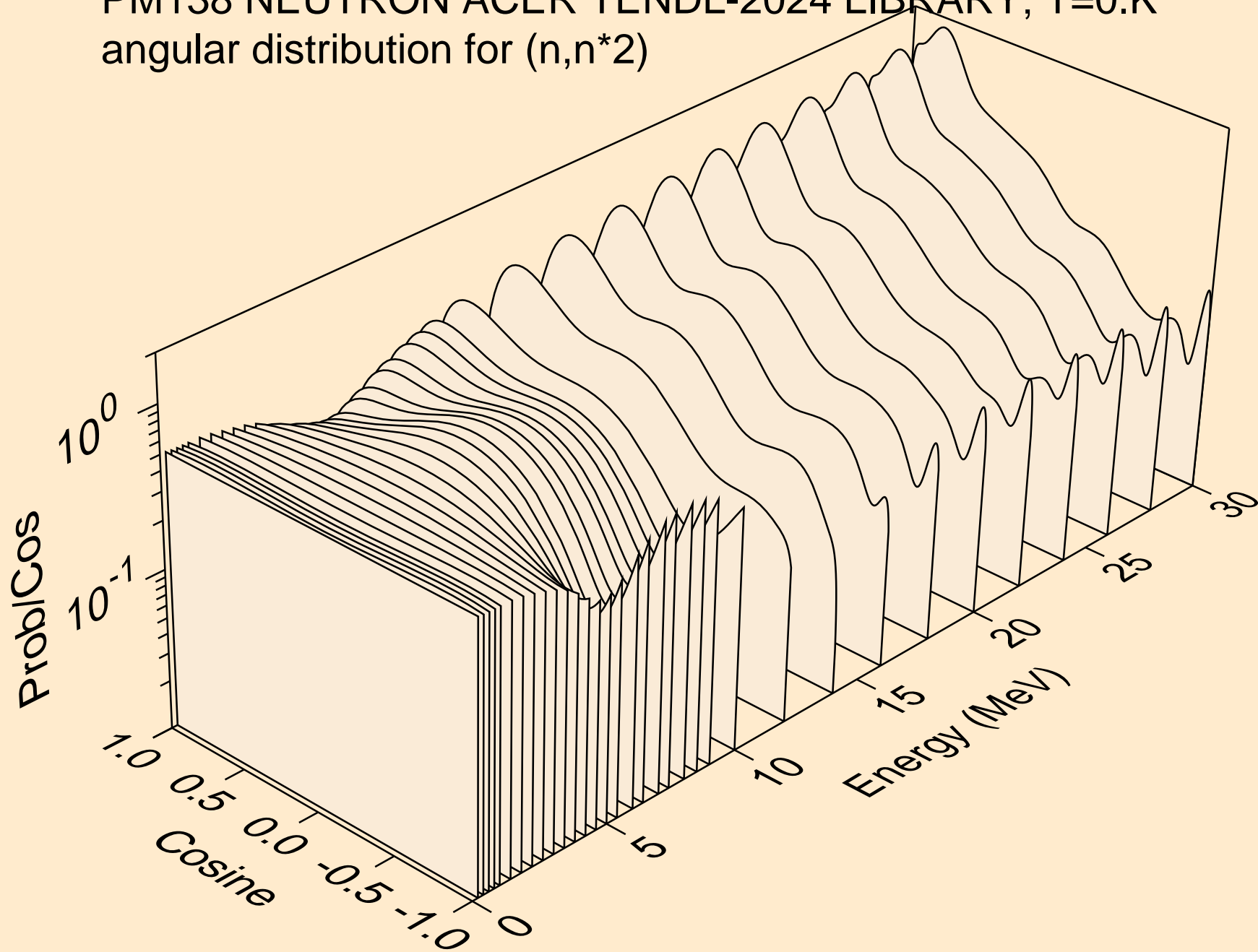

PM138 NEUTRON ACER TENDL-2024 LIBRARY; T=0.K  
angular distribution for (n,n\*3)

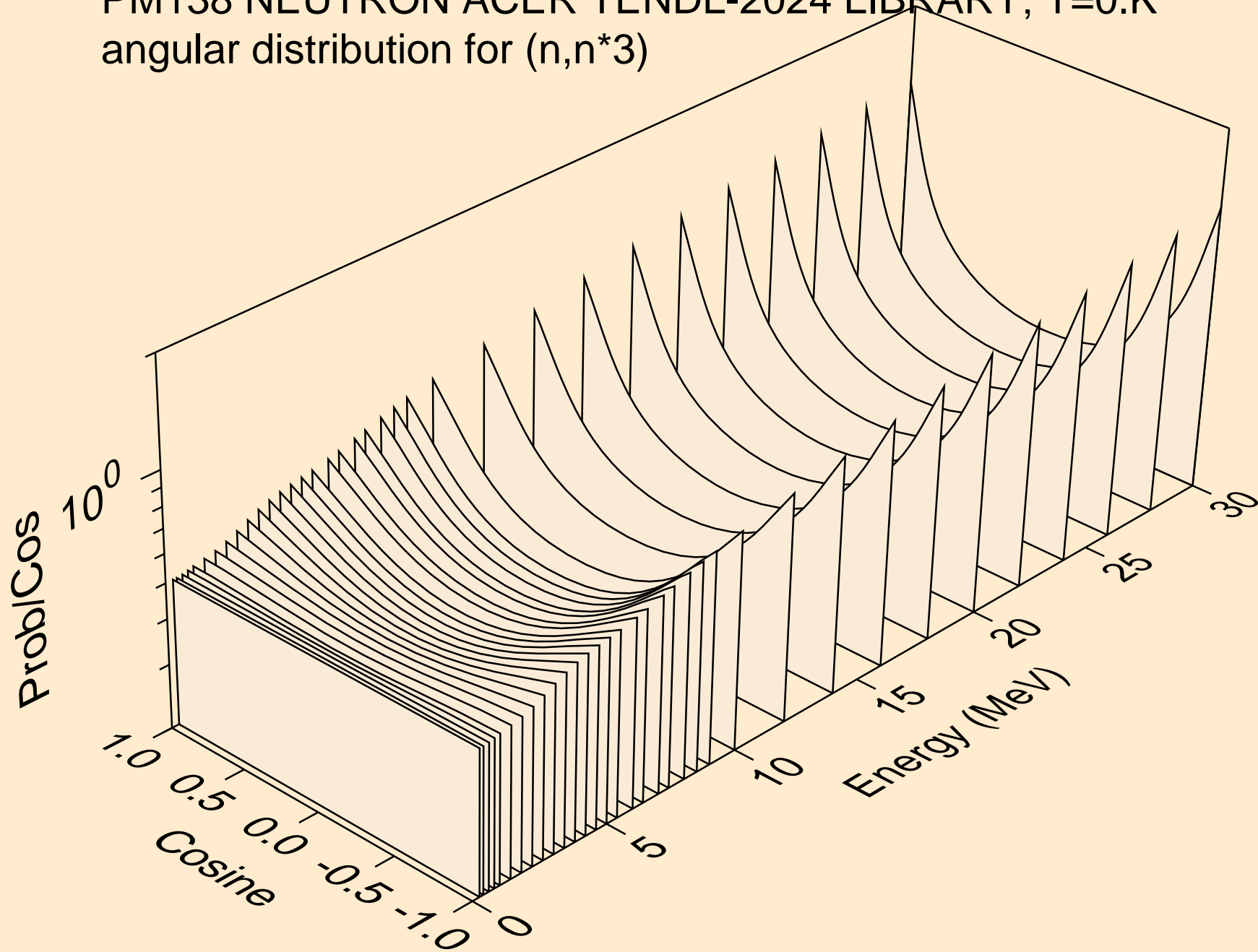

PM138 NEUTRON ACER TENDL-2024 LIBRARY; T=0.K  
angular distribution for (n,n\*4)

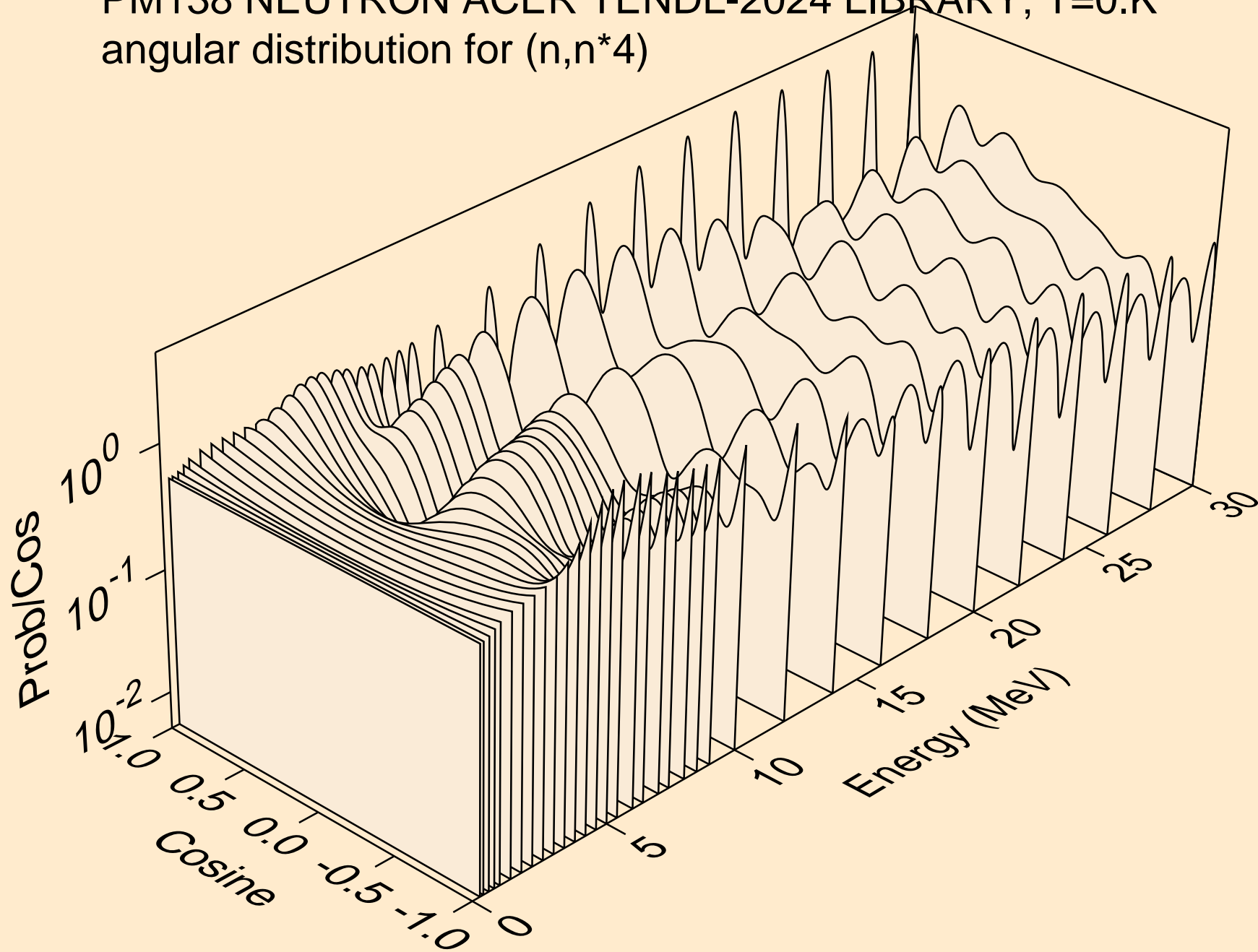

PM138 NEUTRON ACER TENDL-2024 LIBRARY; T=0.K  
angular distribution for (n,n\*5)

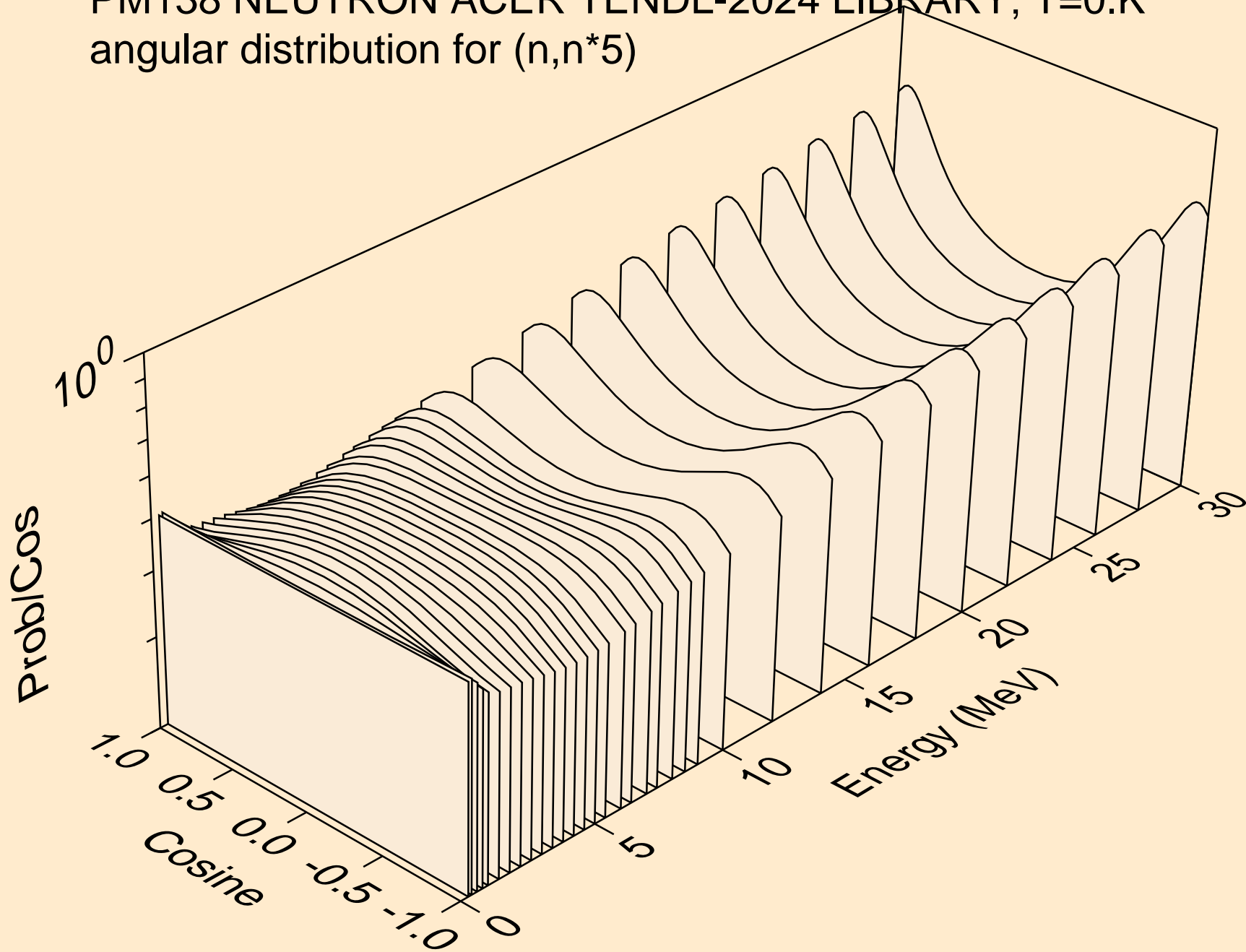

PM138 NEUTRON ACER TENDL-2024 LIBRARY; T=0.K  
angular distribution for (n,n\*6)

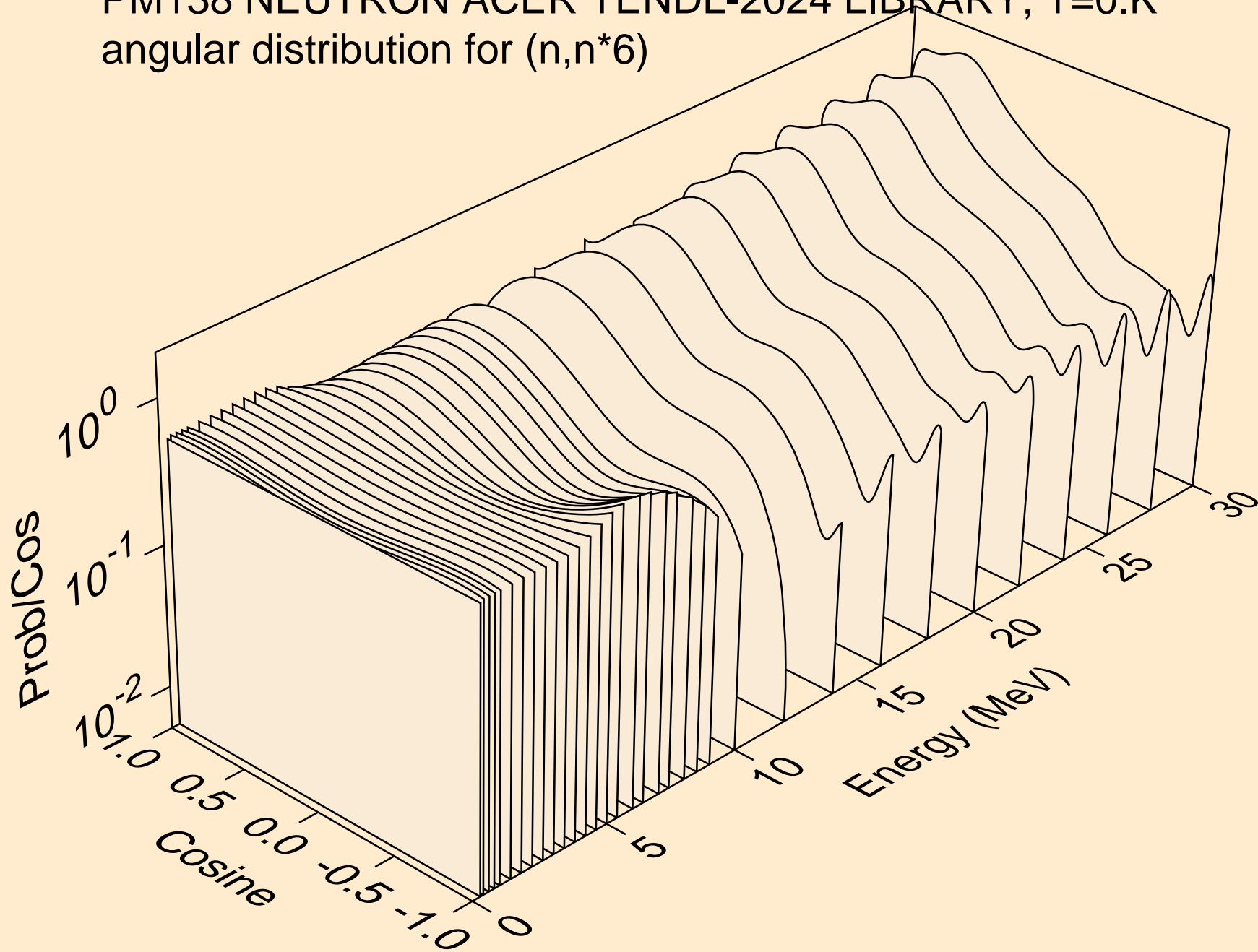

PM138 NEUTRON ACER TENDL-2024 LIBRARY; T=0.K  
angular distribution for (n,n\*7)

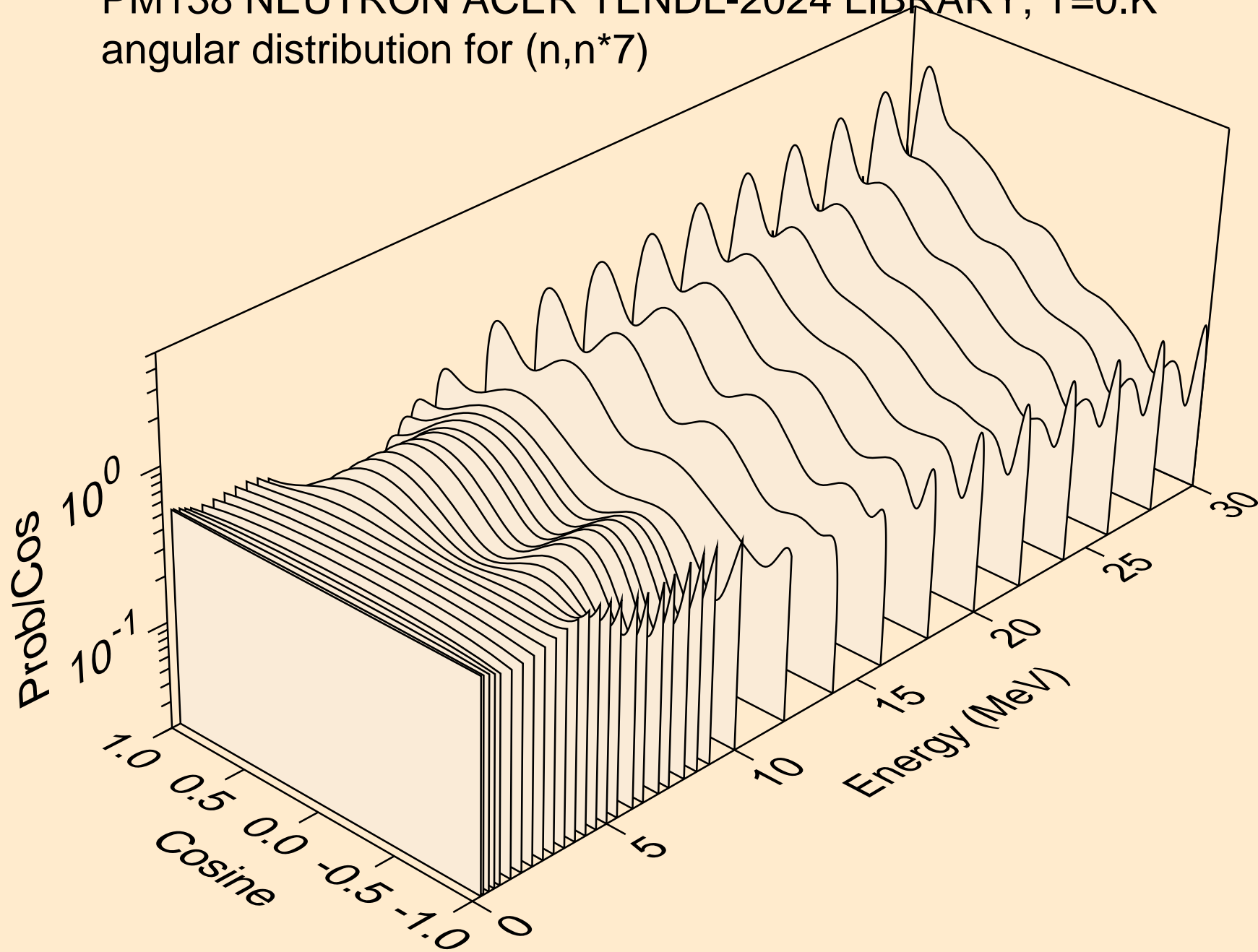



PM138 NEUTRON ACER TENDL-2024 LIBRARY; T=0.K  
angular distribution for (n,n\*8)

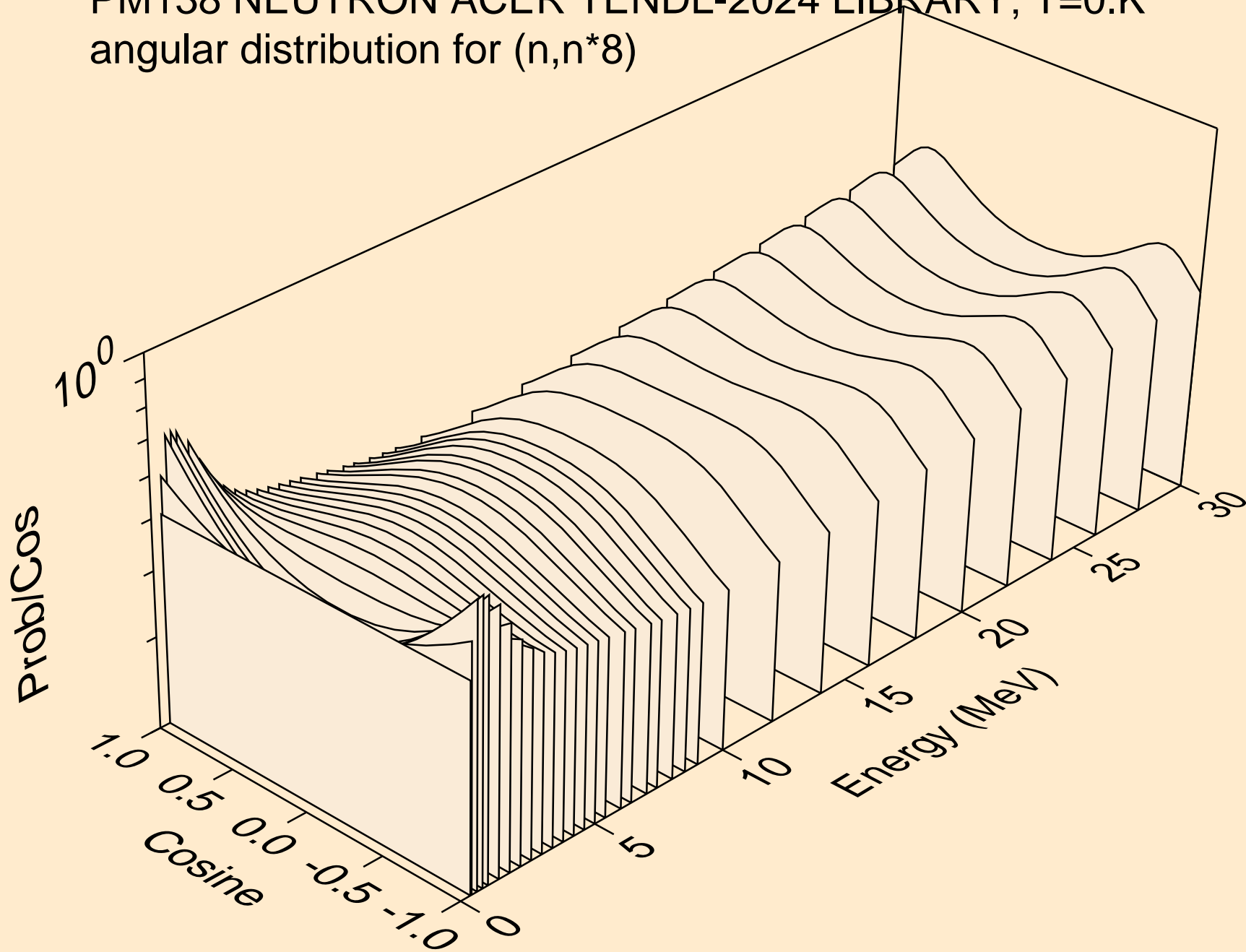

PM138 NEUTRON ACER TENDL-2024 LIBRARY; T=0.K  
angular distribution for (n,n\*9)

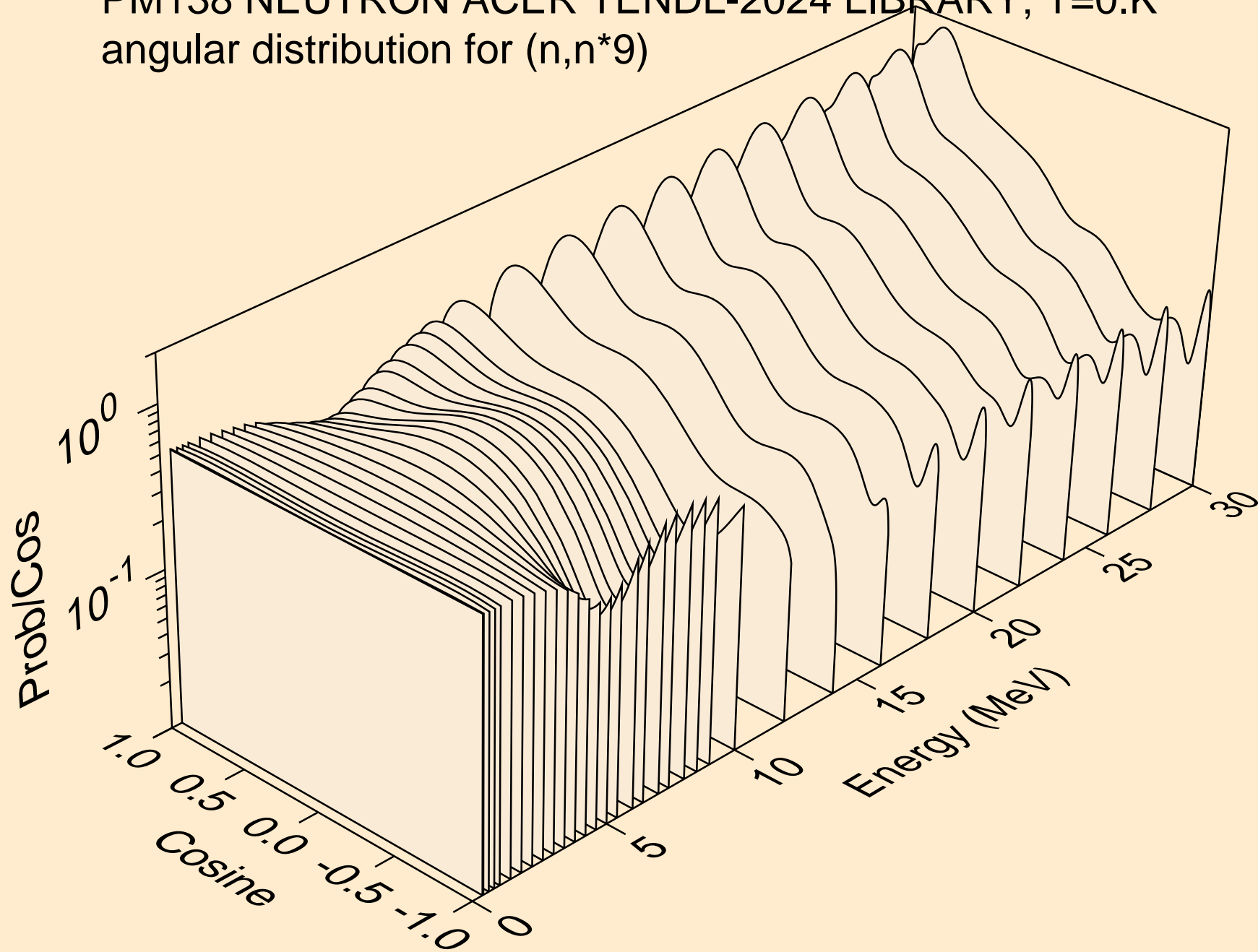

PM138 NEUTRON ACER TENDL-2024 LIBRARY; T=0.K  
angular distribution for (n,n\*10)

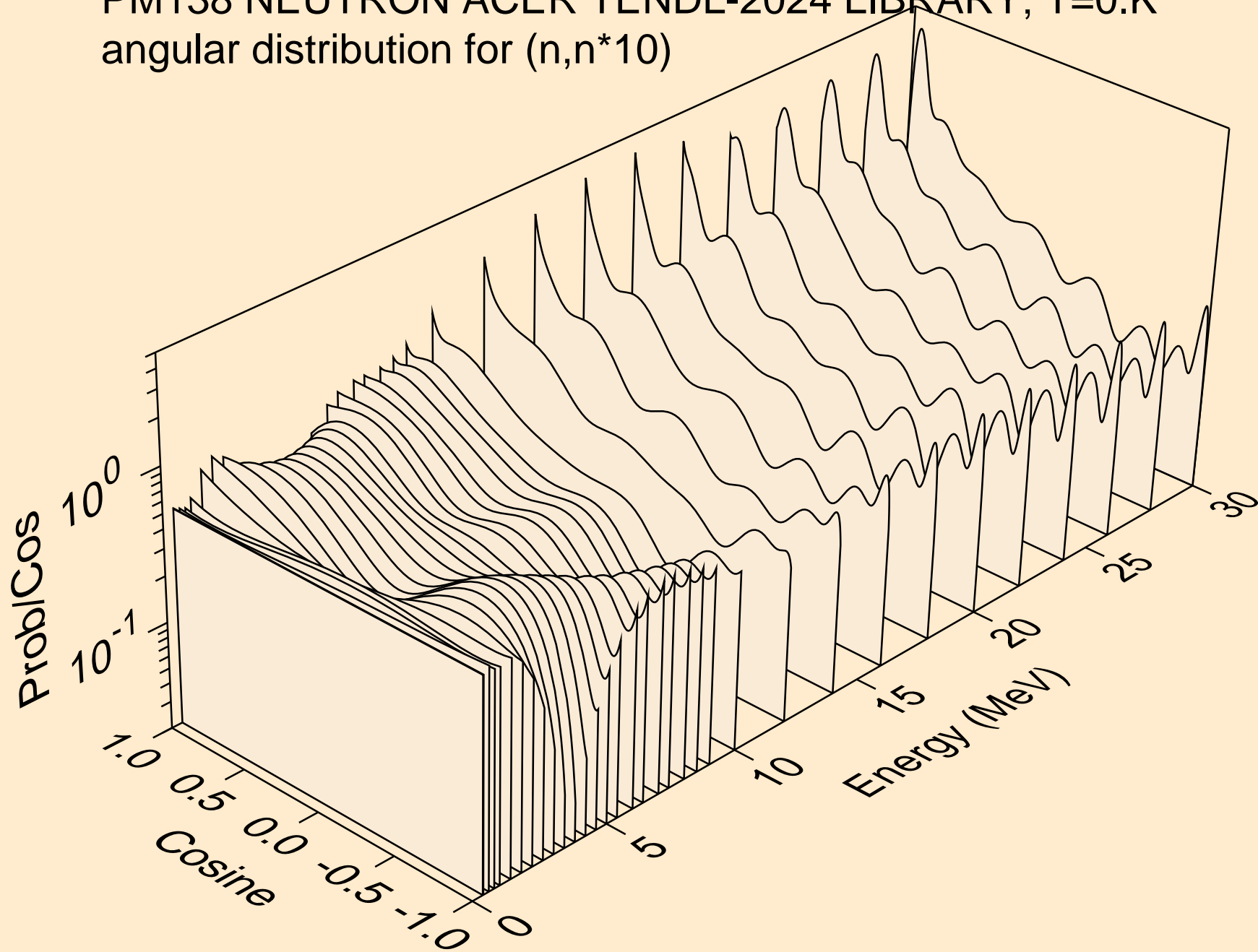

PM138 NEUTRON ACER TENDL-2024 LIBRARY; T=0.K  
angular distribution for (n,n\*11)

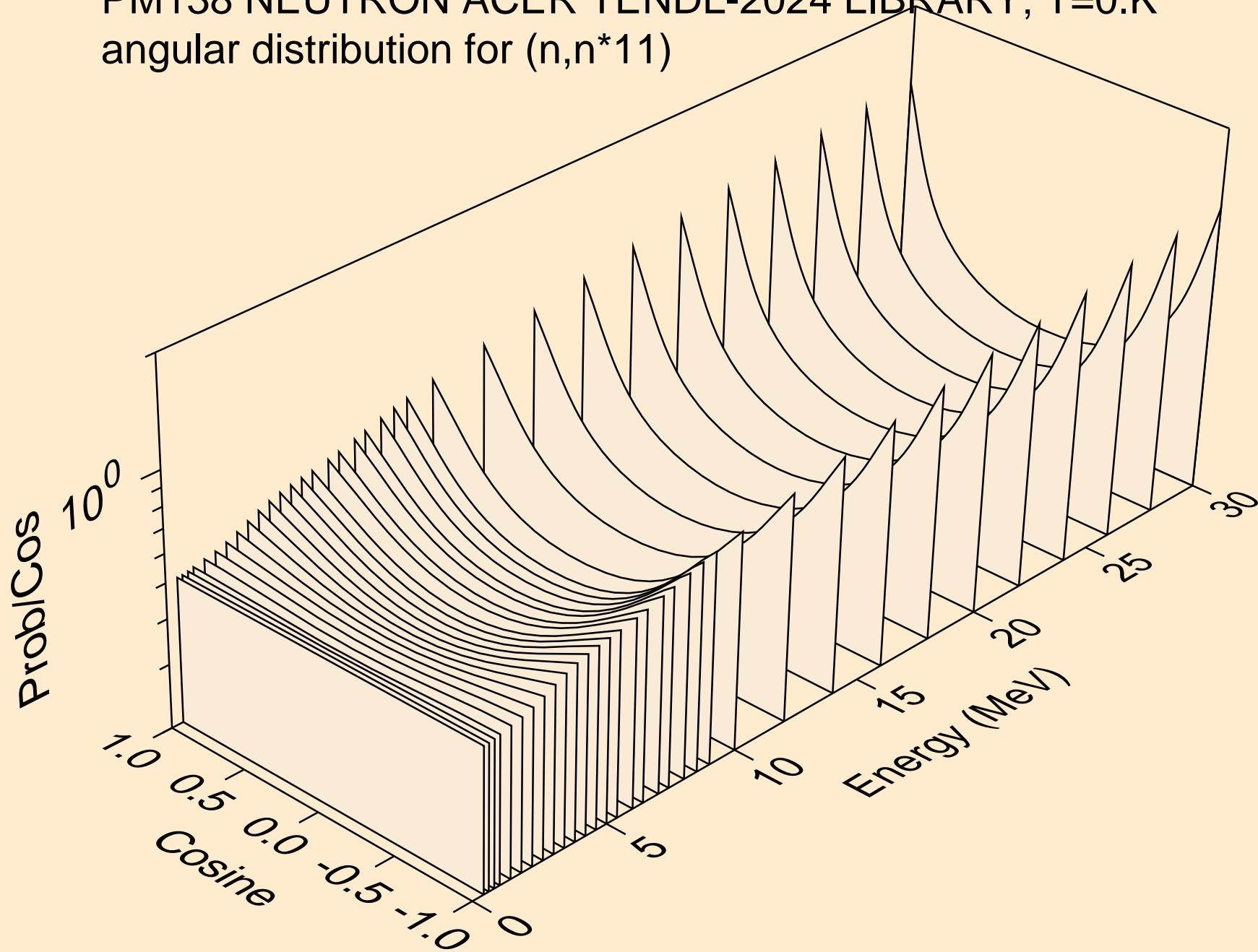

PM138 NEUTRON ACER TENDL-2024 LIBRARY; T=0.K  
angular distribution for (n,n\*12)

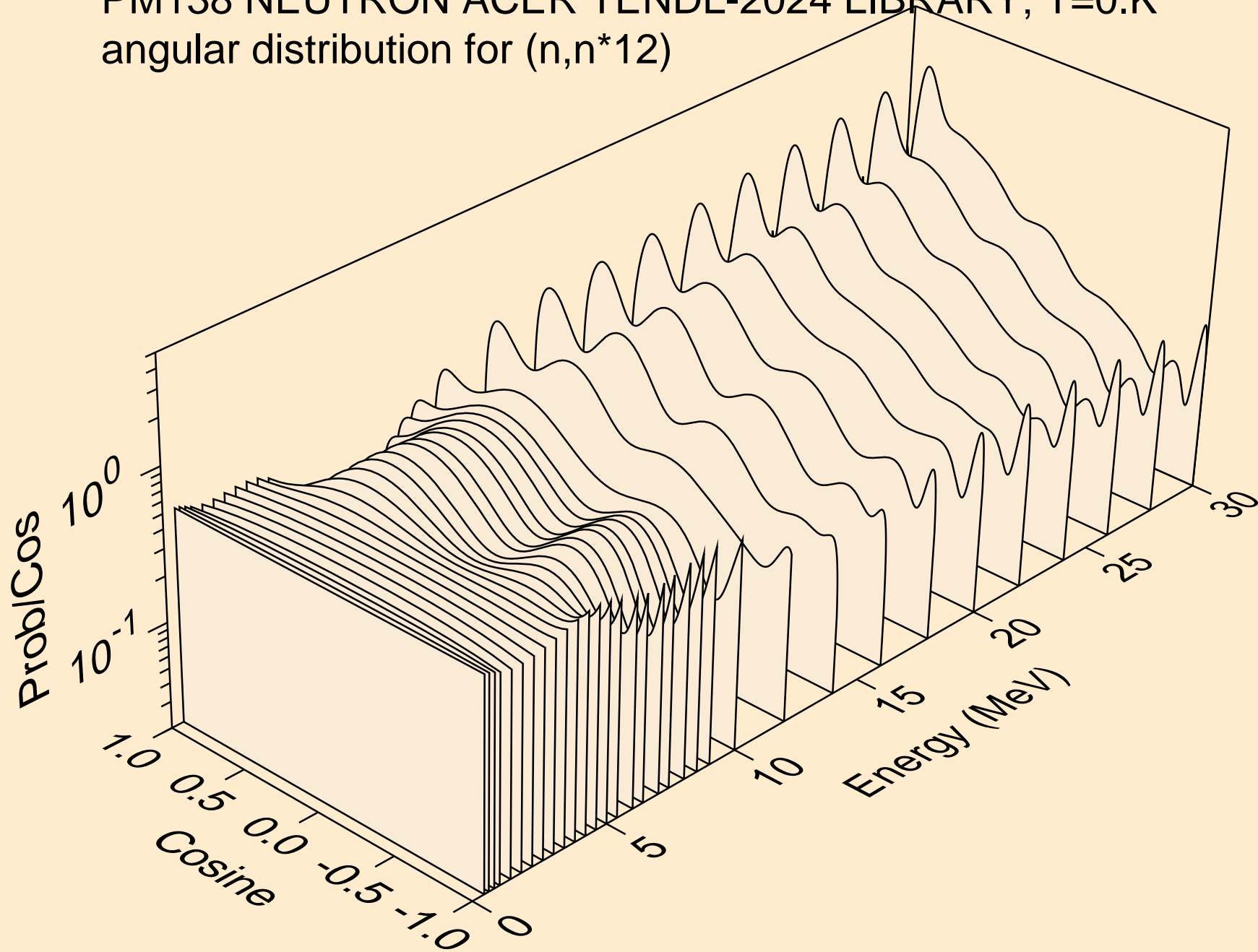

PM138 NEUTRON ACER TENDL-2024 LIBRARY; T=0.K  
angular distribution for (n,n\*13)

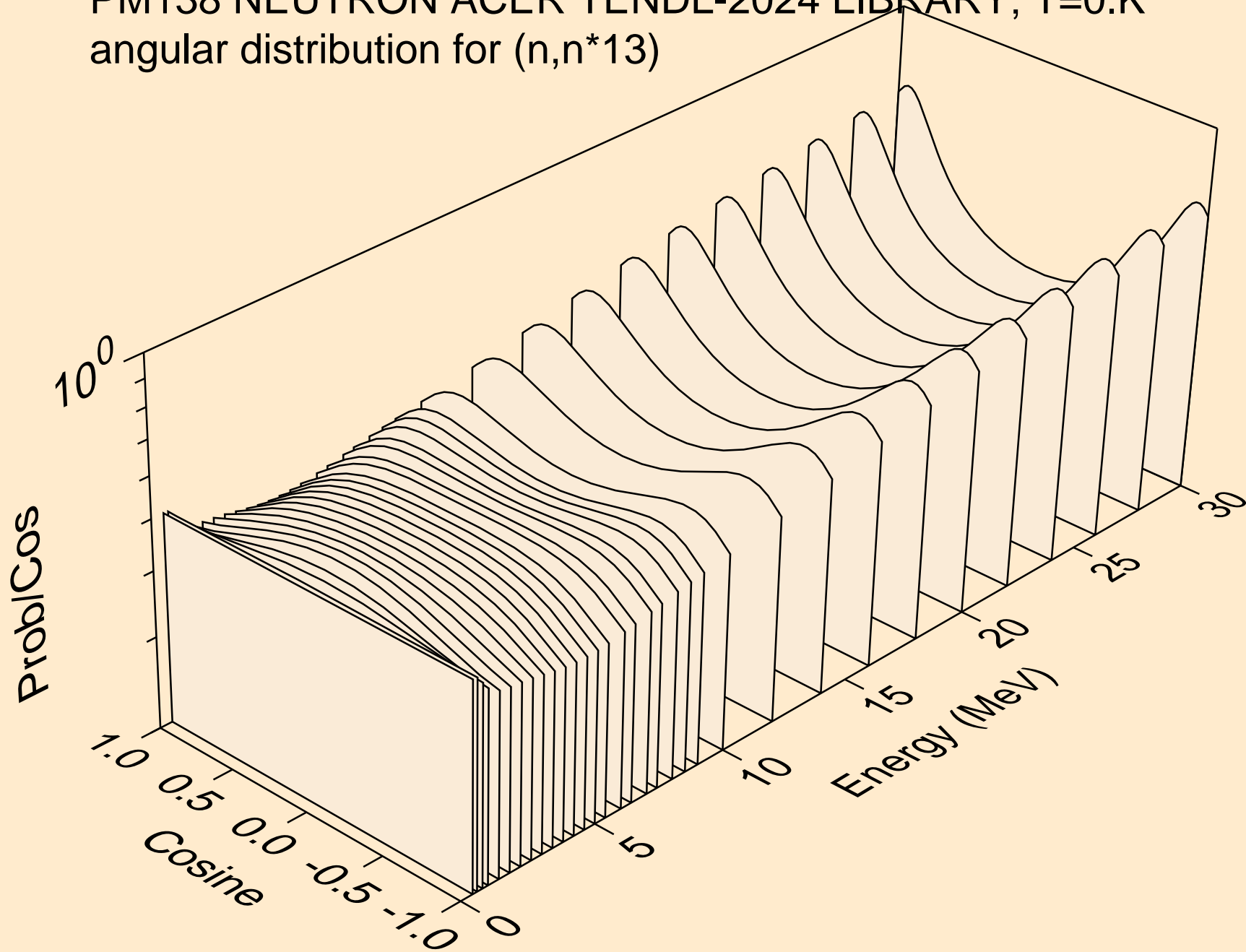

PM138 NEUTRON ACER TENDL-2024 LIBRARY; T=0.K  
angular distribution for (n,n\*14)

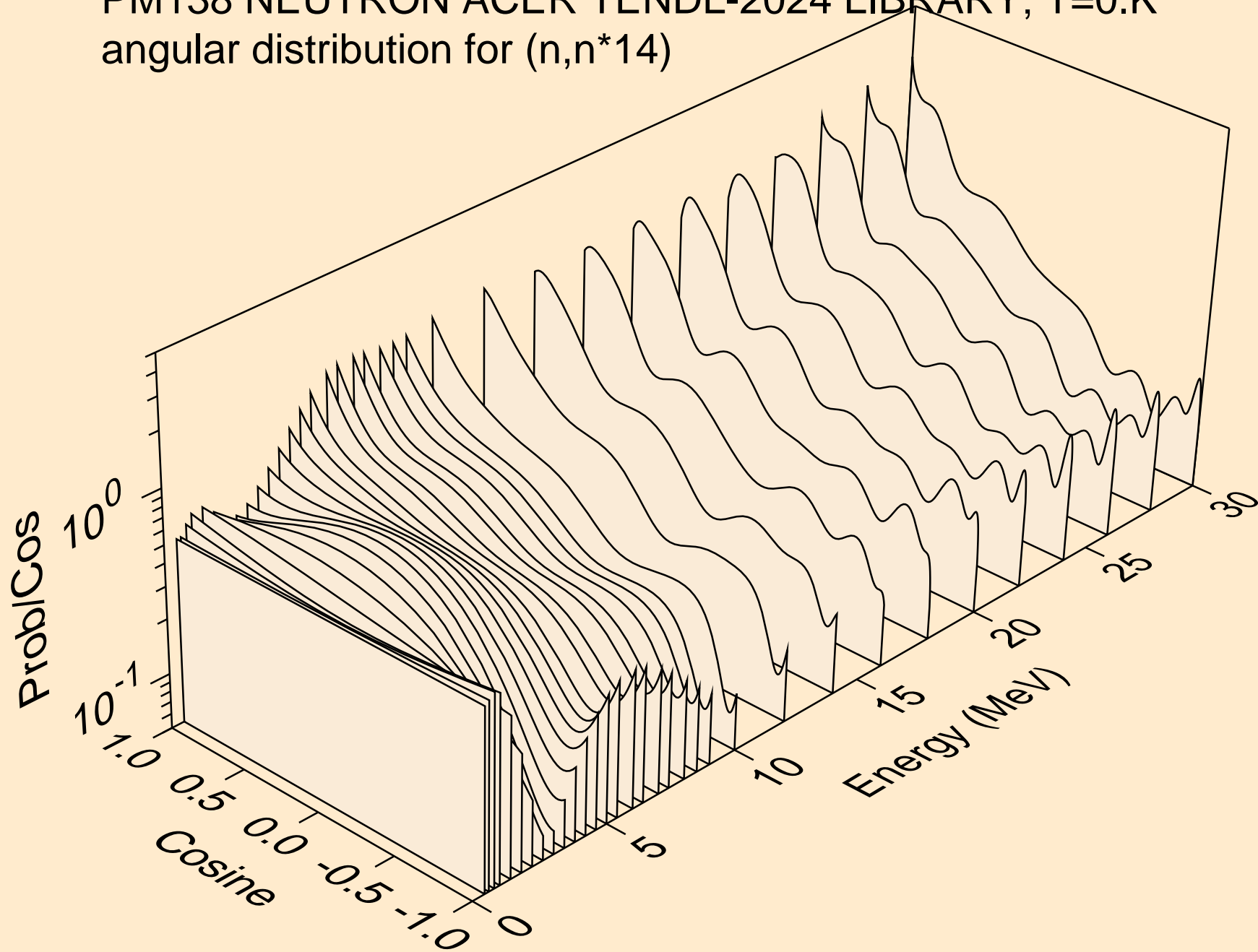

PM138 NEUTRON ACER TENDL-2024 LIBRARY; T=0.K  
angular distribution for (n,n\*15)

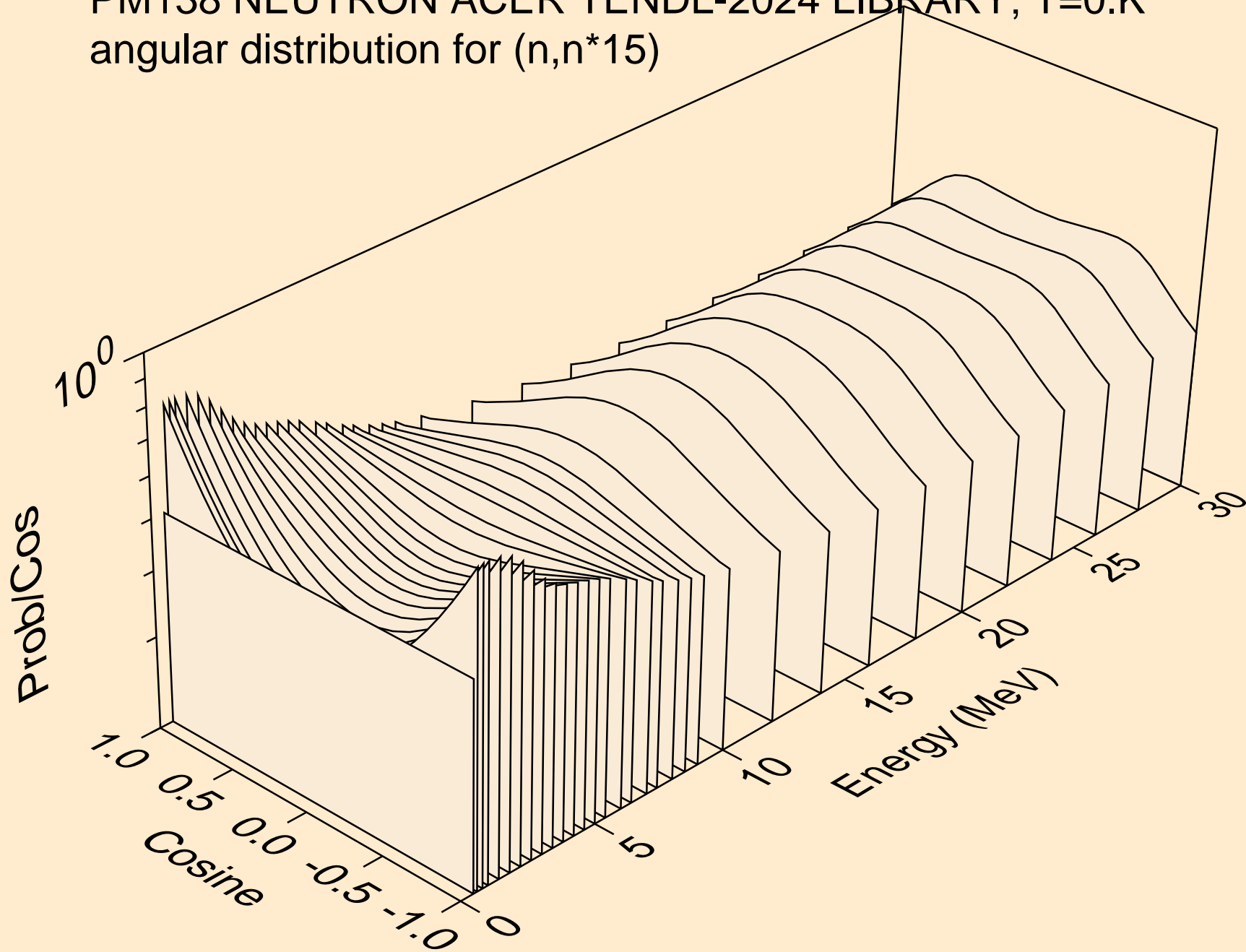



PM138 NEUTRON ACER TENDL-2024 LIBRARY; T=0.K  
angular distribution for (n,n\*16)

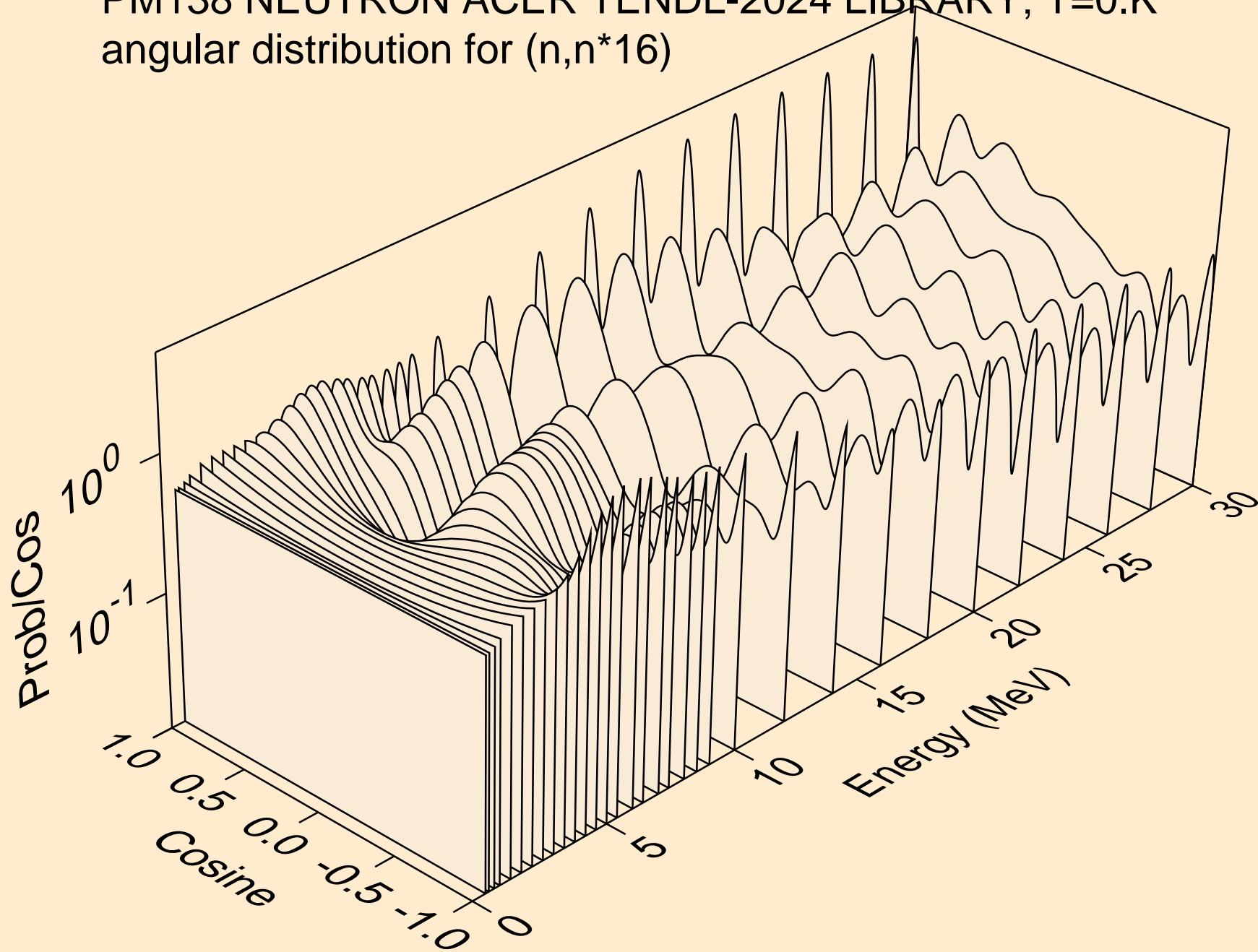

PM138 NEUTRON ACER TENDL-2024 LIBRARY; T=0.K  
angular distribution for (n,n\*17)

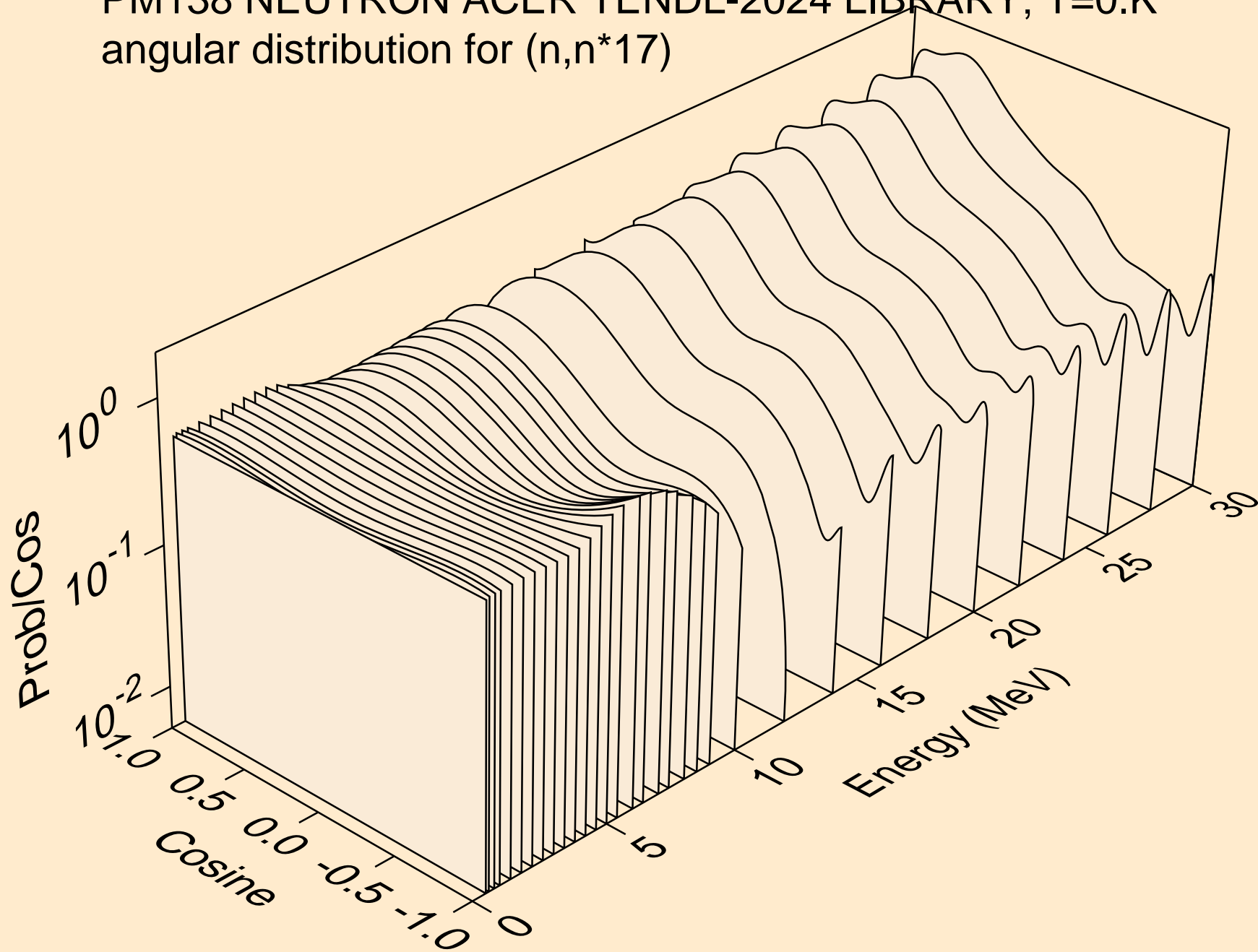

PM138 NEUTRON ACER TENDL-2024 LIBRARY; T=0.K  
angular distribution for (n,n\*18)

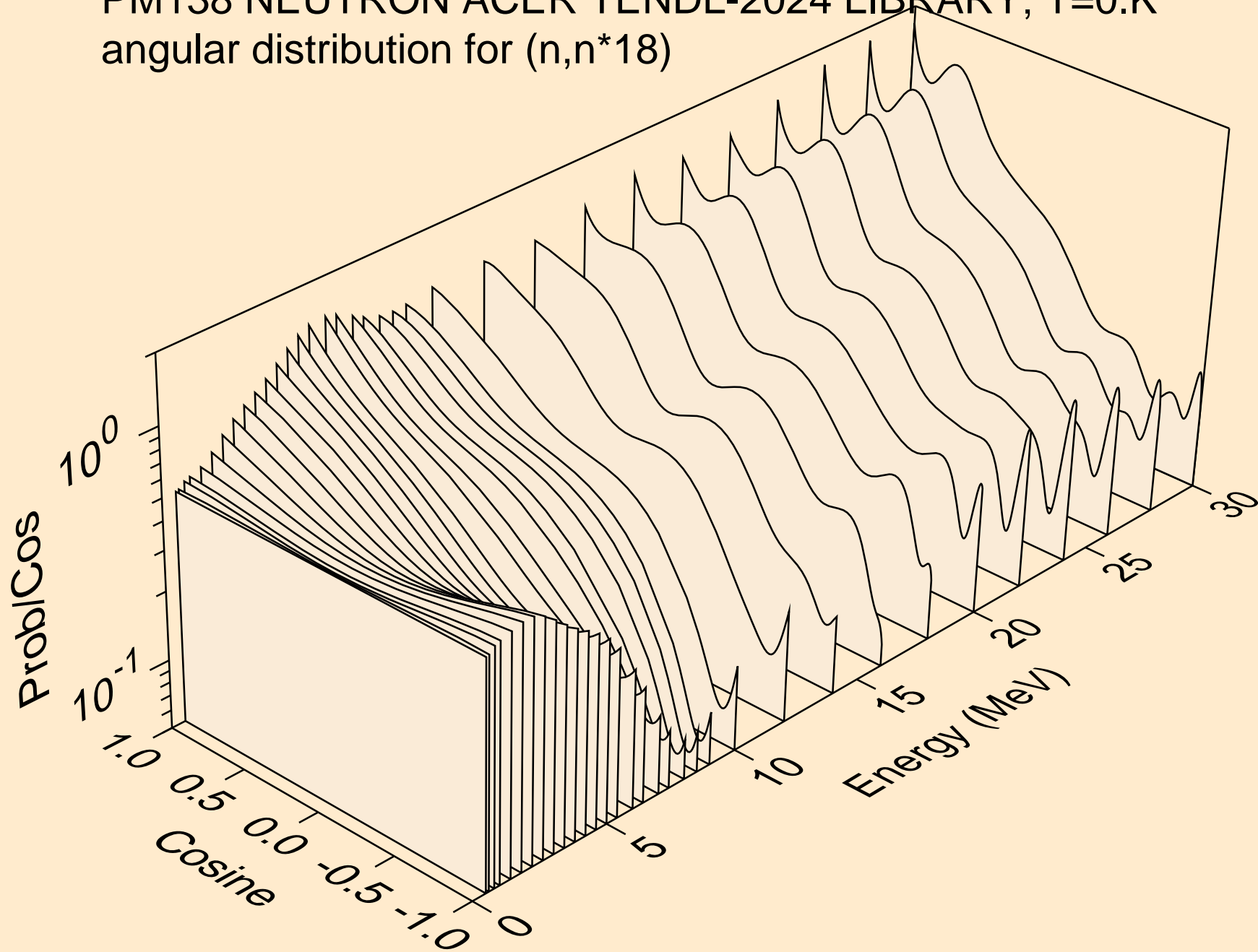

PM138 NEUTRON ACER TENDL-2024 LIBRARY; T=0.K  
angular distribution for (n,n\*19)

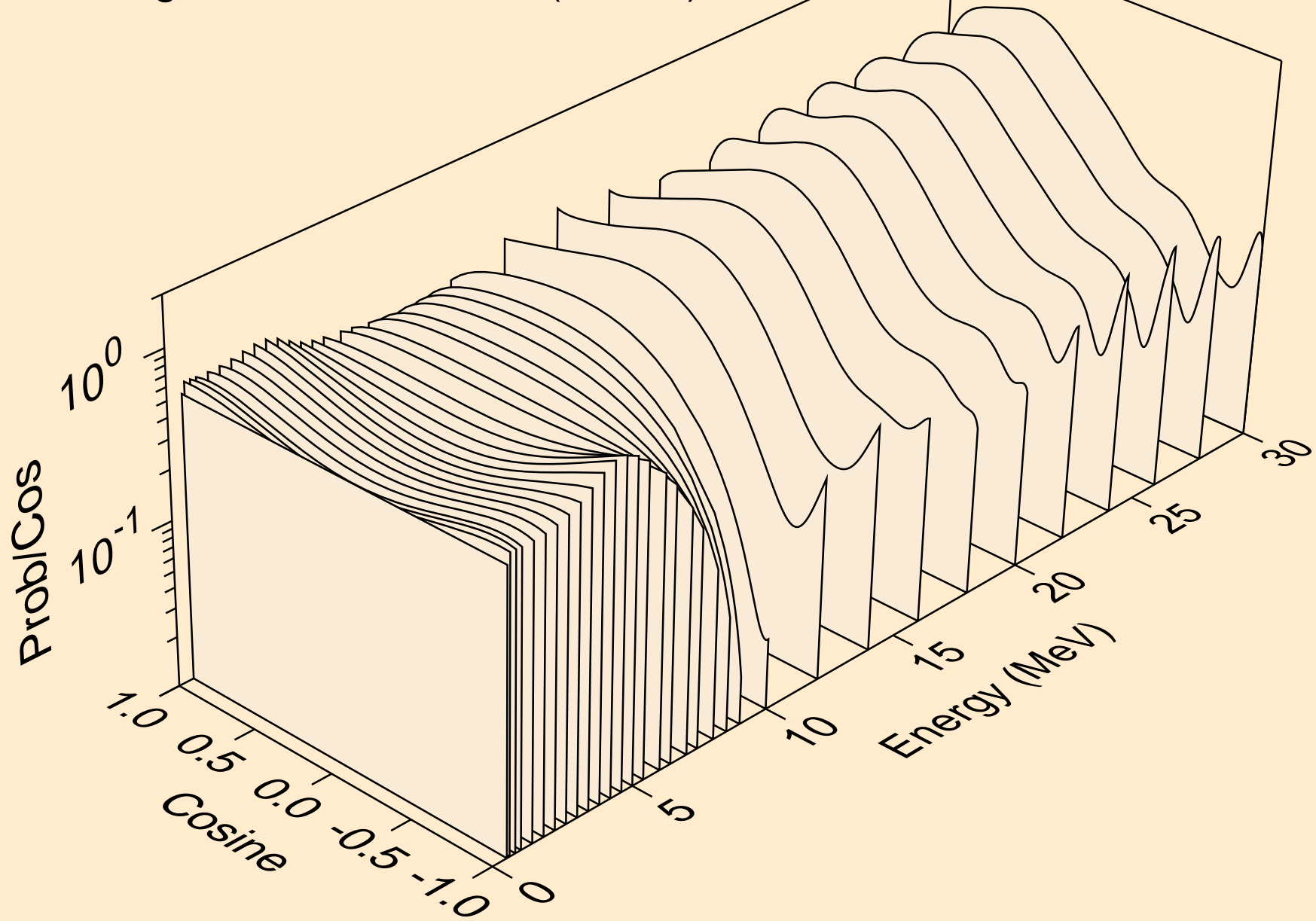

PM138 NEUTRON ACER TENDL-2024 LIBRARY; T=0.K  
angular distribution for (n,n\*20)

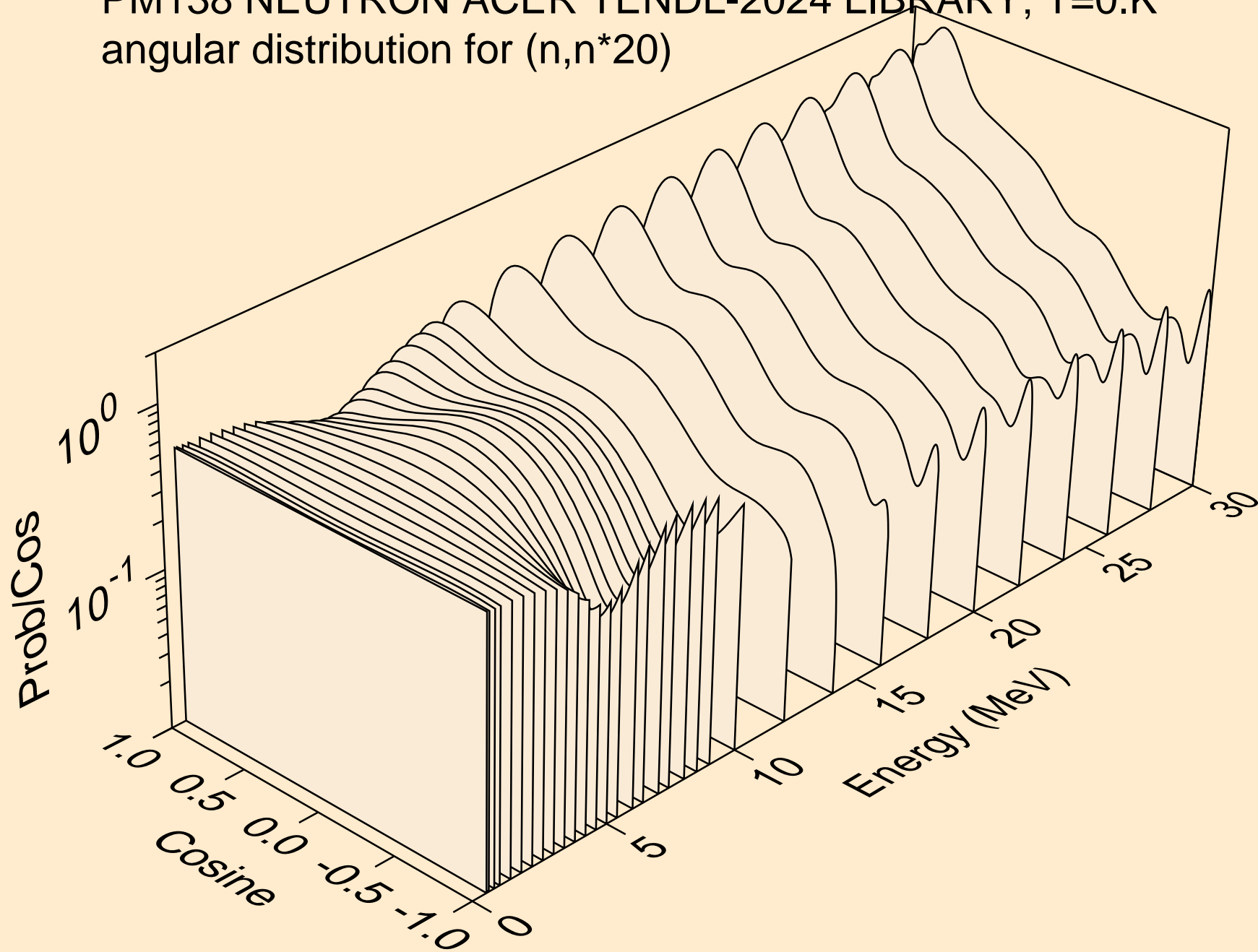

PM138 NEUTRON ACER TENDL-2024 LIBRARY; T=0.K  
angular distribution for (n,n\*21)

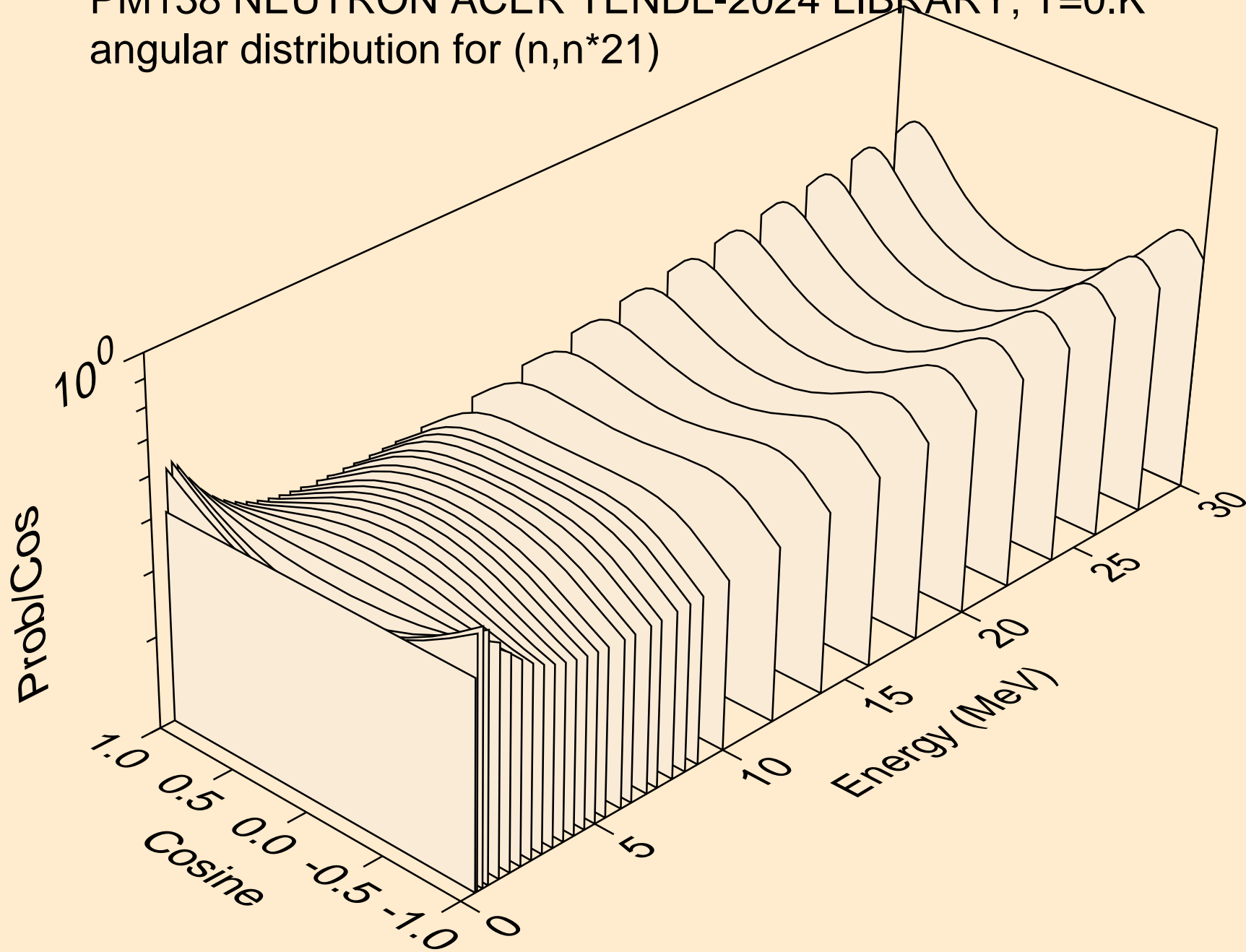

PM138 NEUTRON ACER TENDL-2024 LIBRARY; T=0.K  
angular distribution for (n,n\*22)

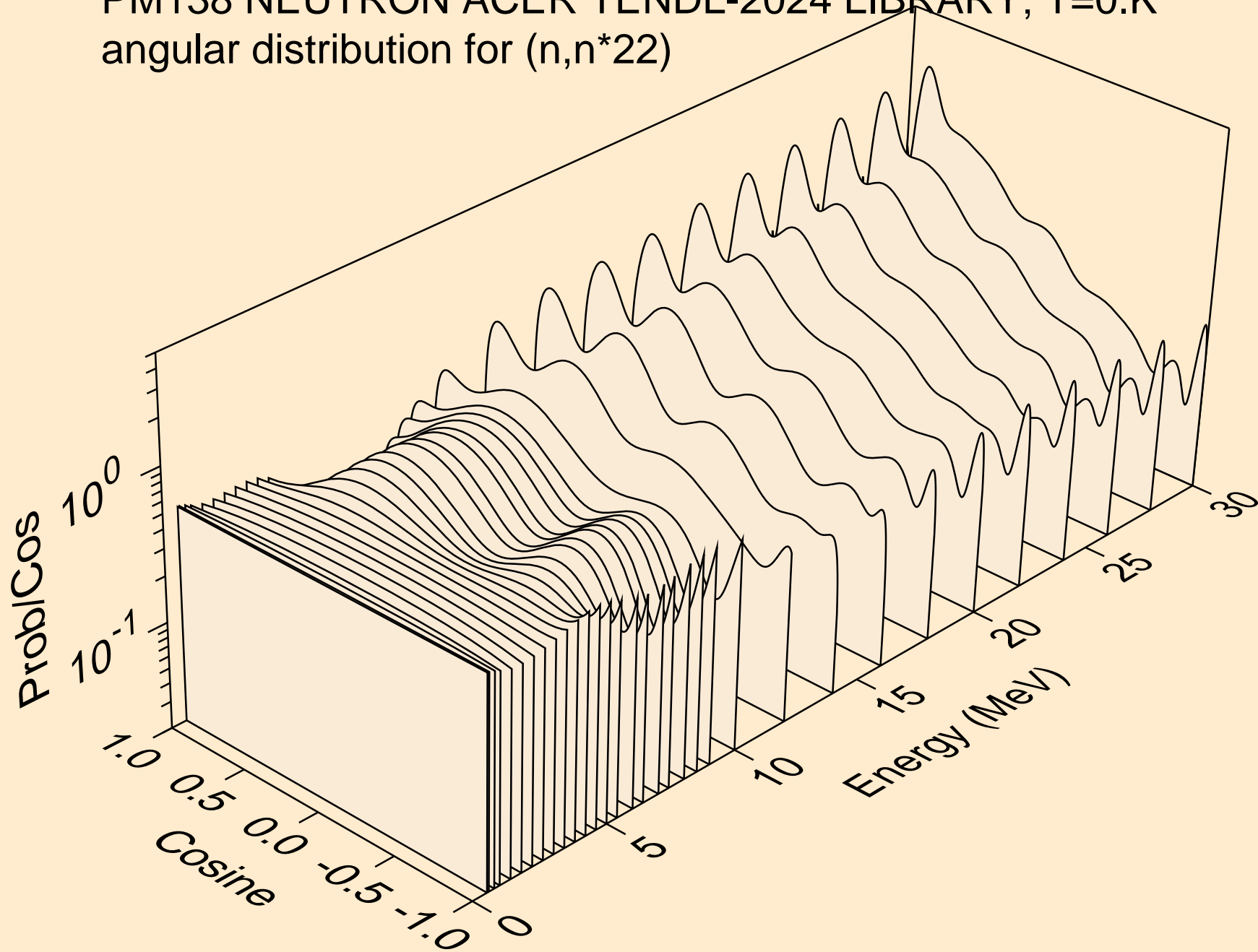

PM138 NEUTRON ACER TENDL-2024 LIBRARY; T=0.K  
angular distribution for (n,n\*23)

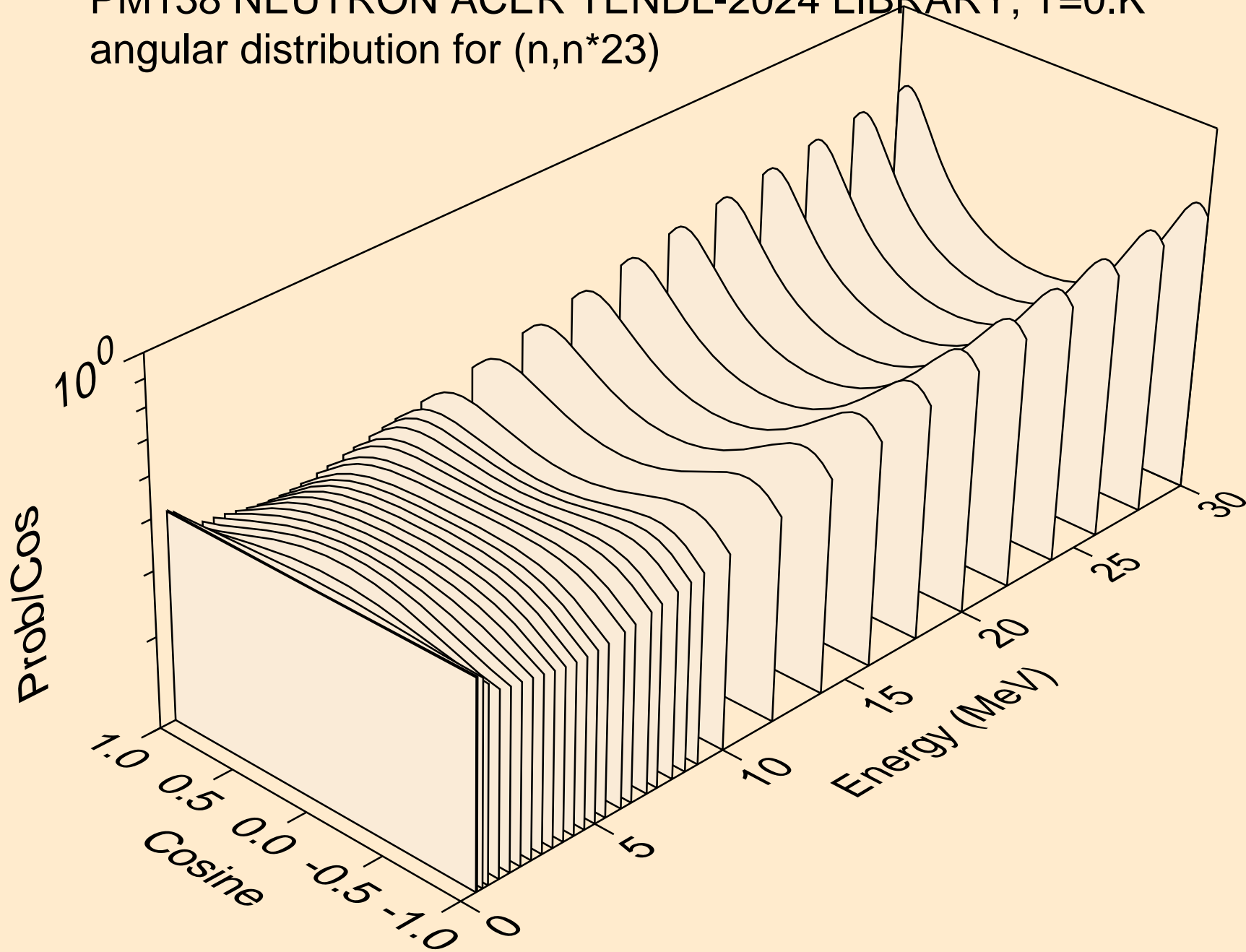



PM138 NEUTRON ACER TENDL-2024 LIBRARY; T=0.K  
angular distribution for (n,n\*24)

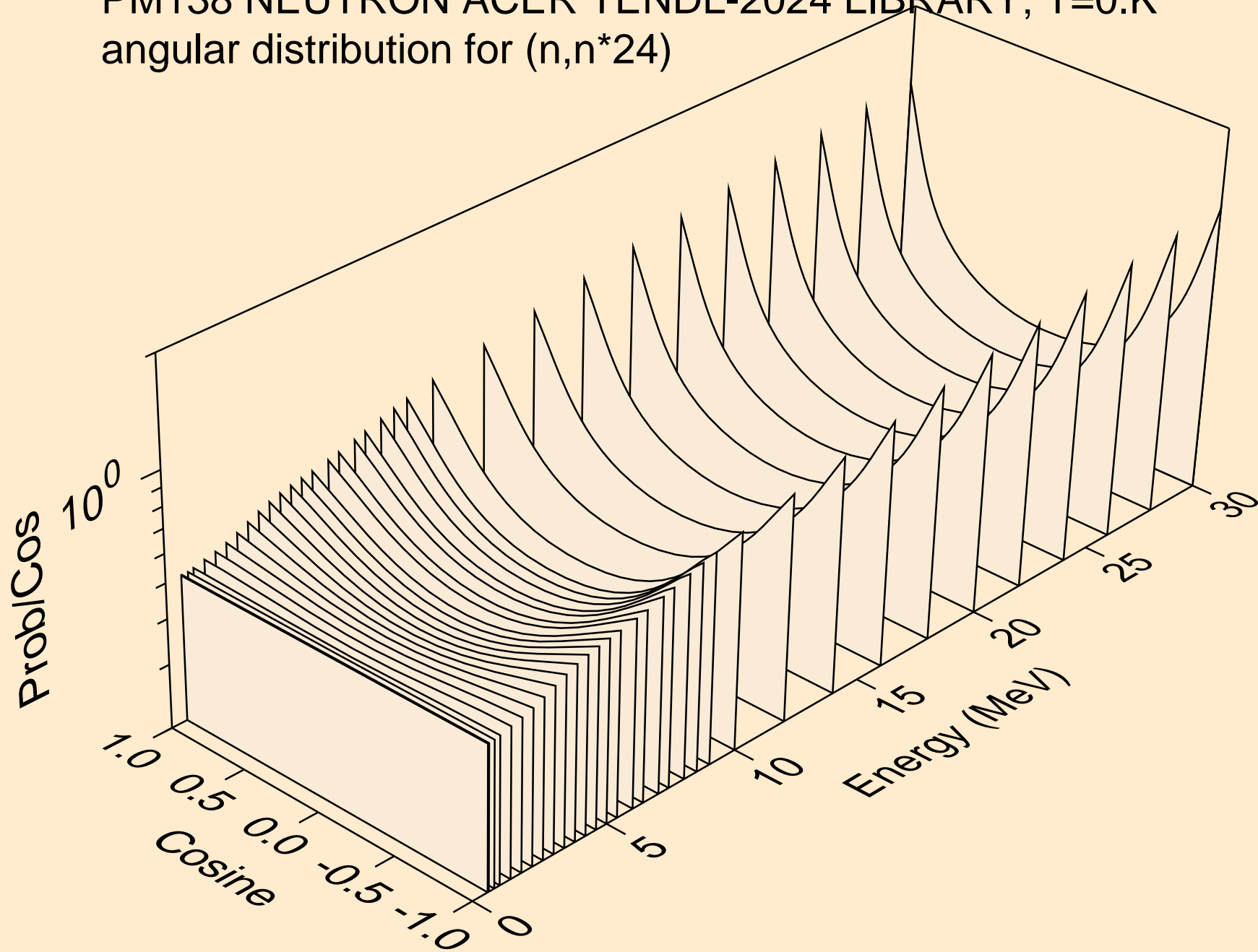

PM138 NEUTRON ACER TENDL-2024 LIBRARY; T=0.K  
angular distribution for (n,n\*25)

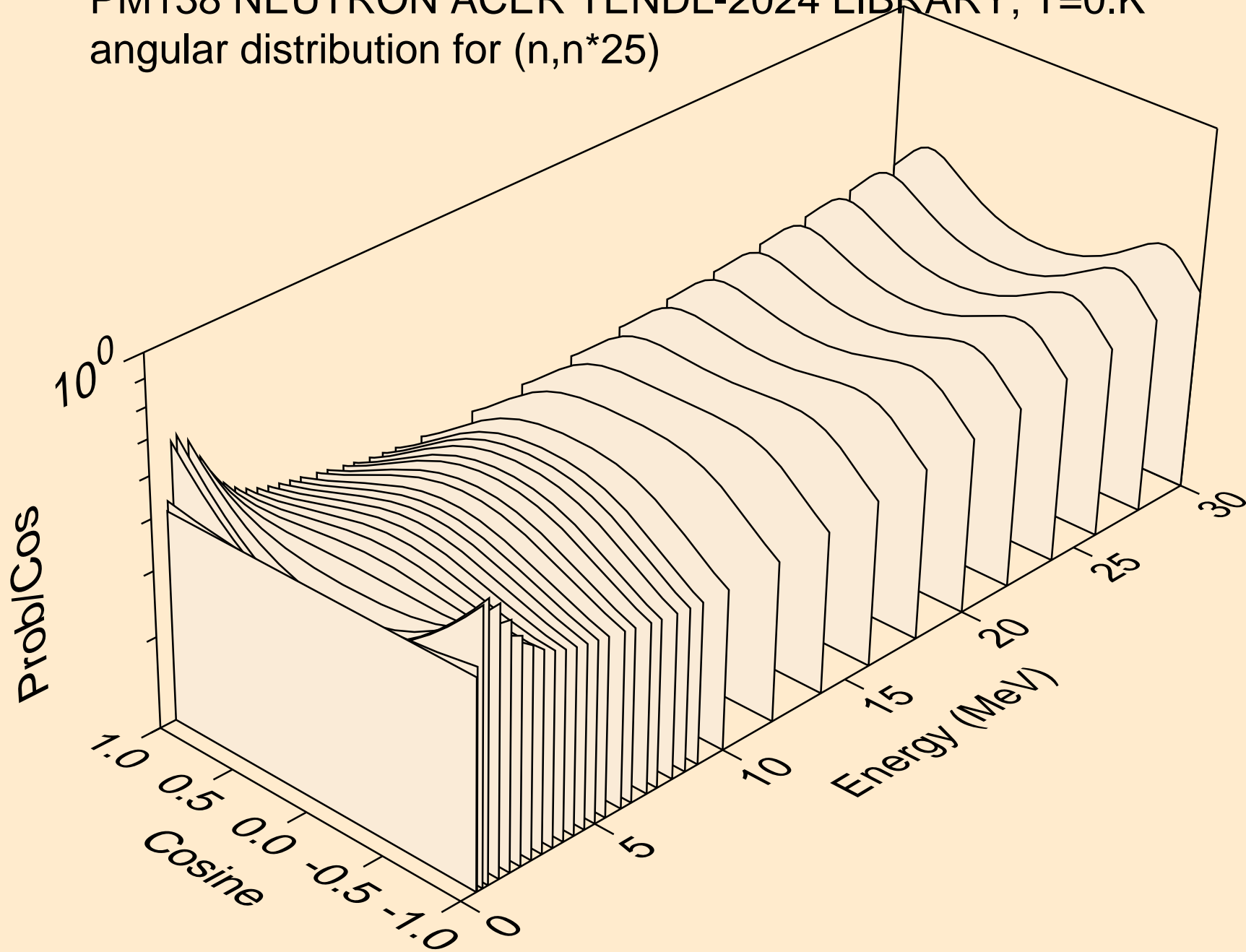

PM138 NEUTRON ACER TENDL-2024 LIBRARY; T=0.K  
angular distribution for (n,n\*26)

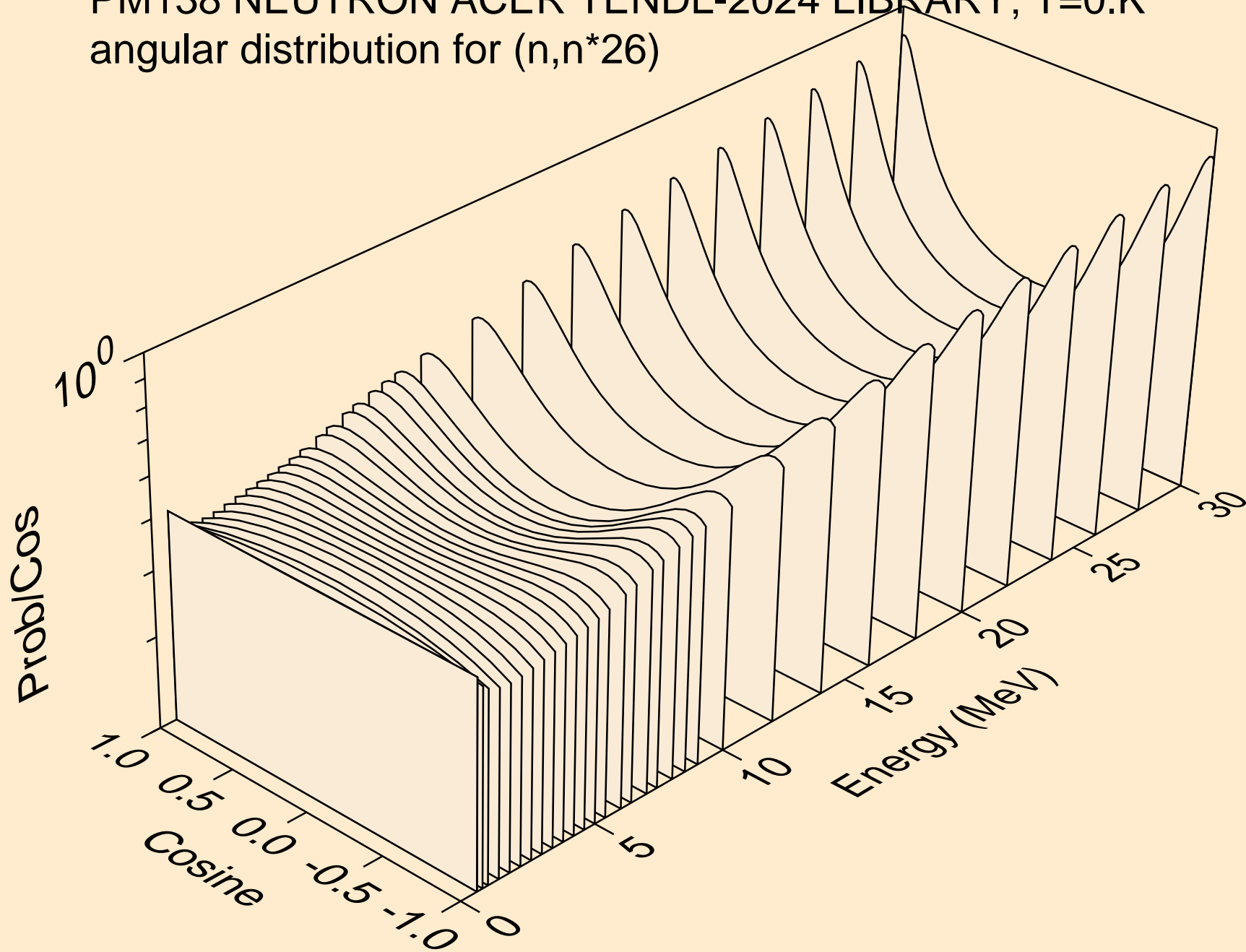

PM138 NEUTRON ACER TENDL-2024 LIBRARY; T=0.K  
angular distribution for (n,n\*27)

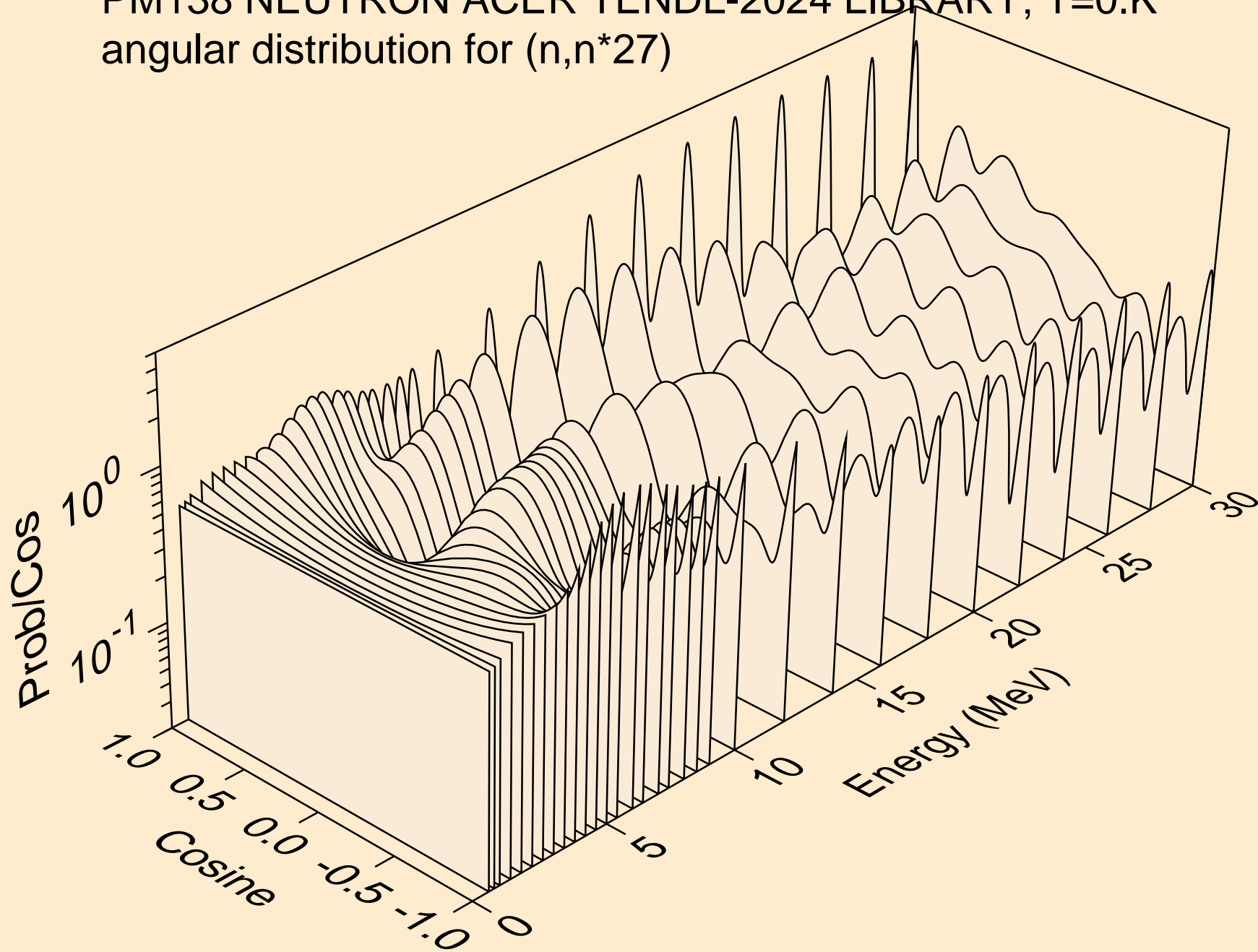

PM138 NEUTRON ACER TENDL-2024 LIBRARY; T=0.K  
angular distribution for (n,n\*28)

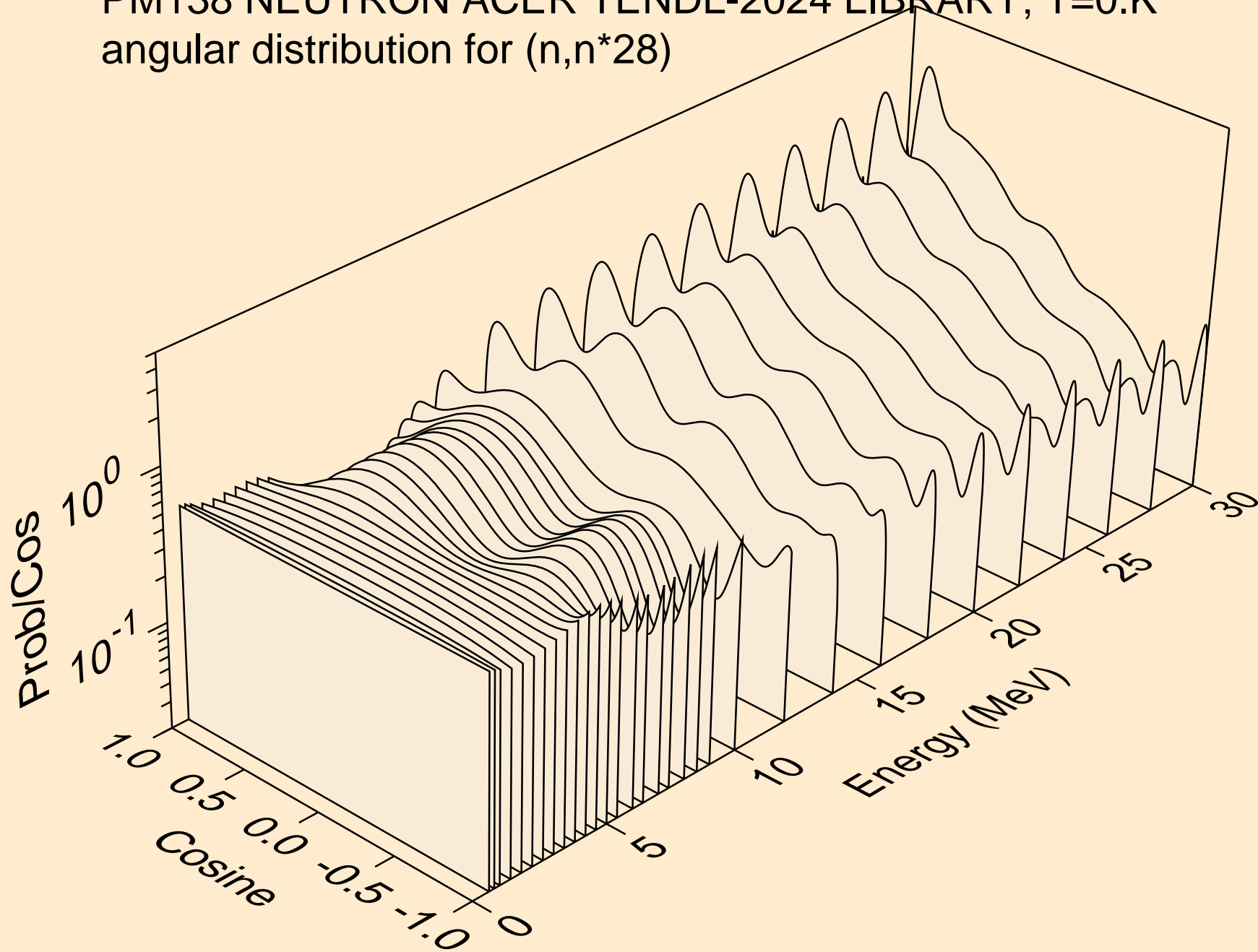

PM138 NEUTRON ACER TENDL-2024 LIBRARY; T=0.K  
angular distribution for (n,n\*29)

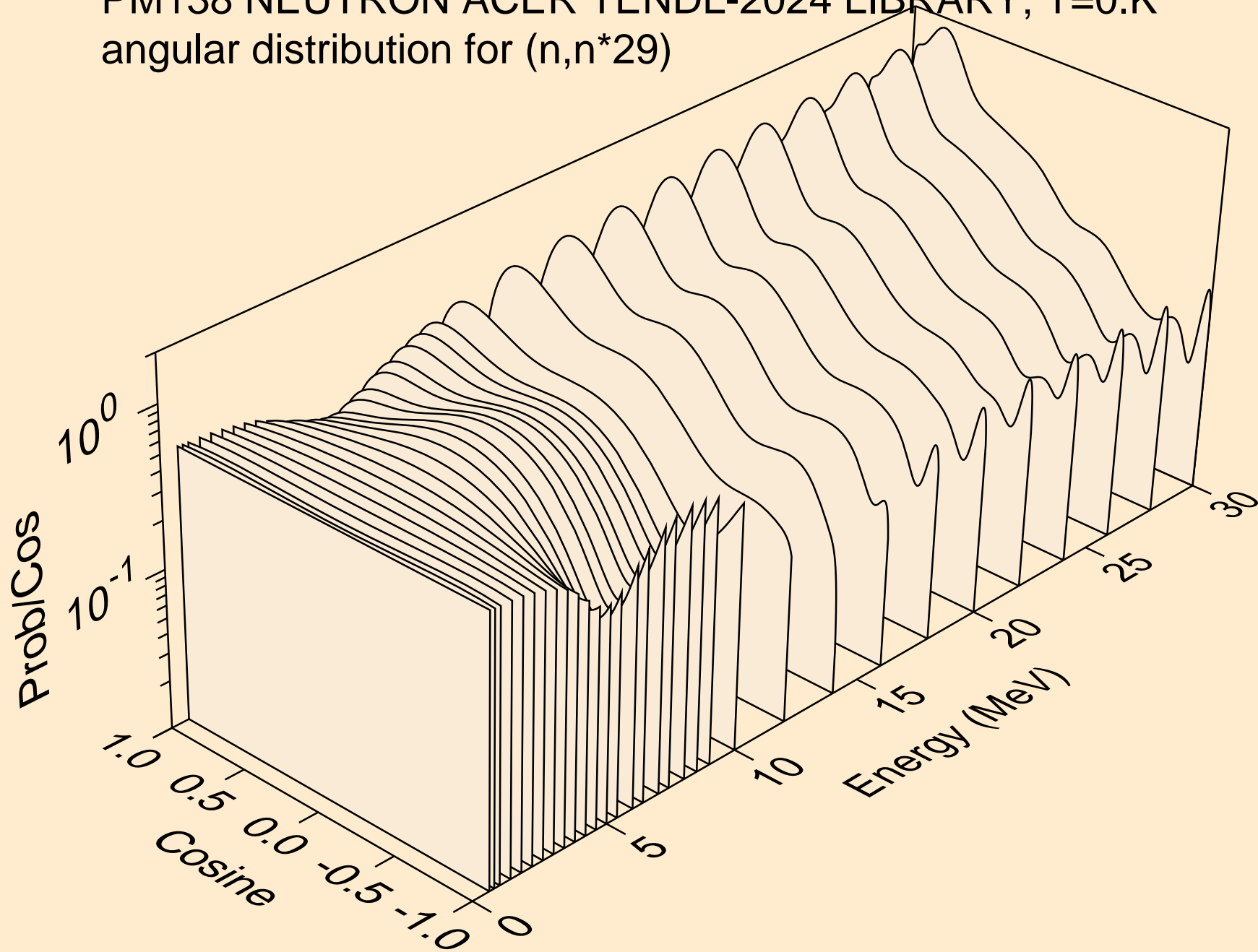

PM138 NEUTRON ACER TENDL-2024 LIBRARY; T=0.K  
angular distribution for (n,n\*30)

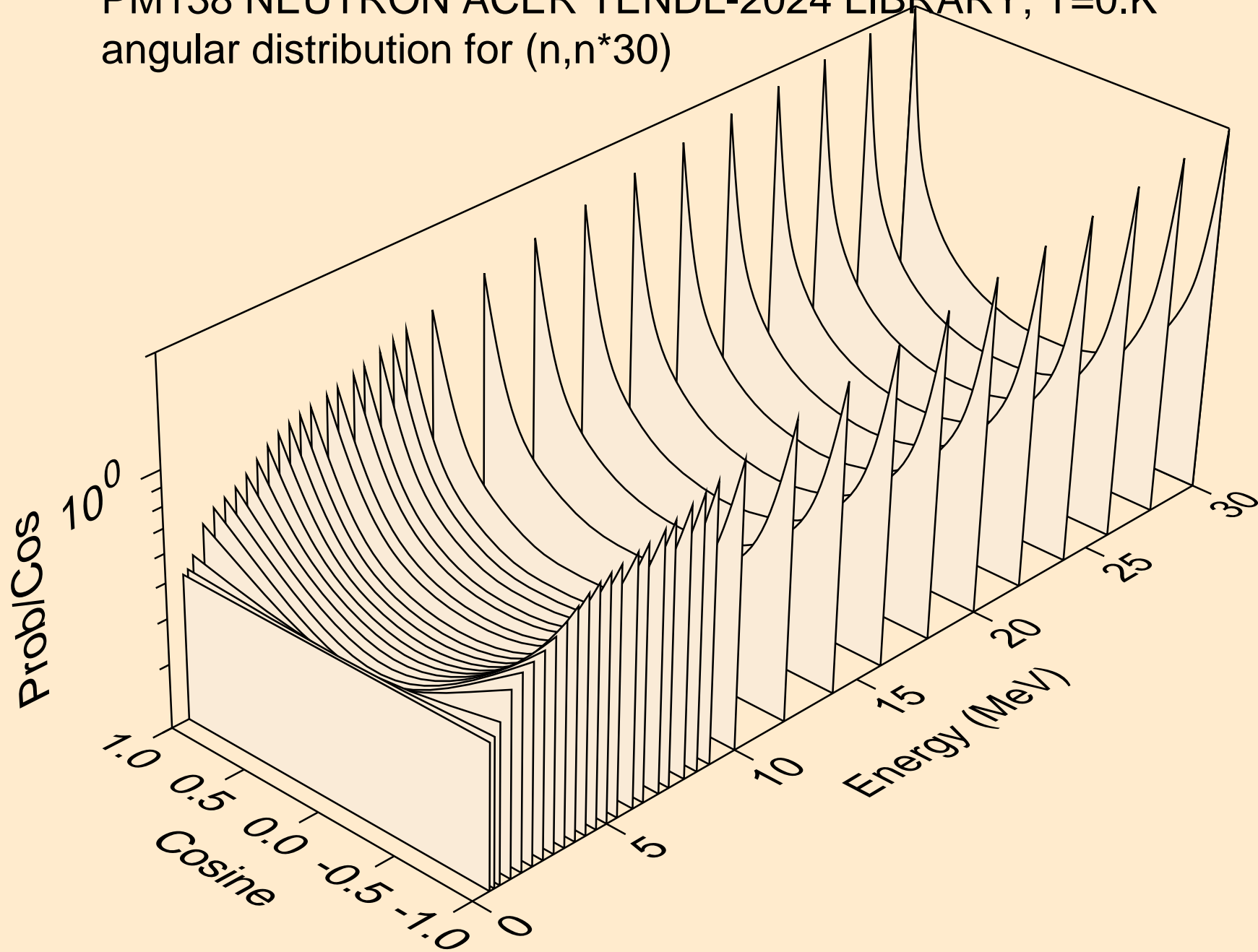

PM138 NEUTRON ACER TENDL-2024 LIBRARY; T=0.K  
Neutron emission for (n,x)

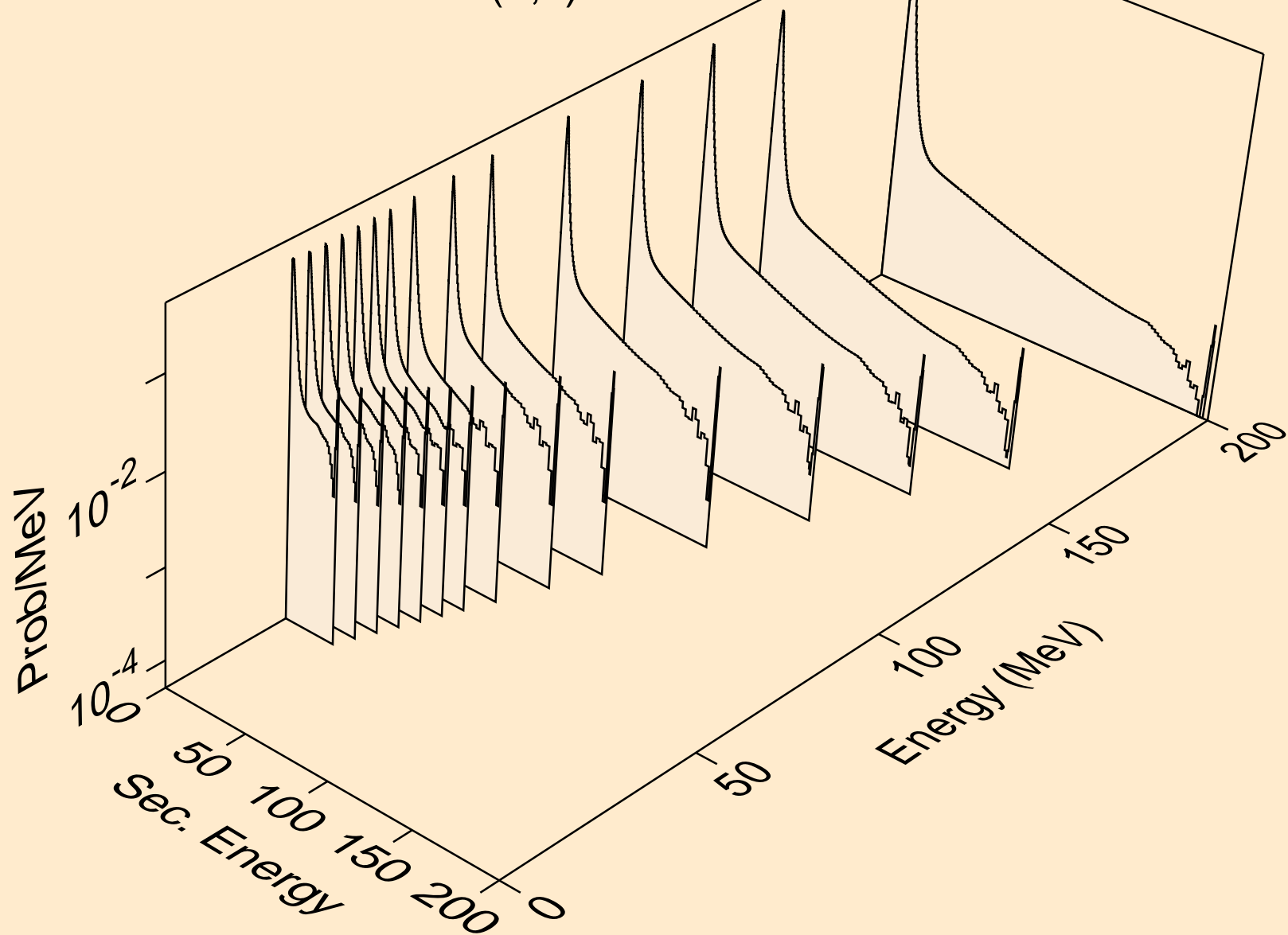



PM138 NEUTRON ACER TENDL-2024 LIBRARY; T=0.K  
Neutron emission for (n,2nd)

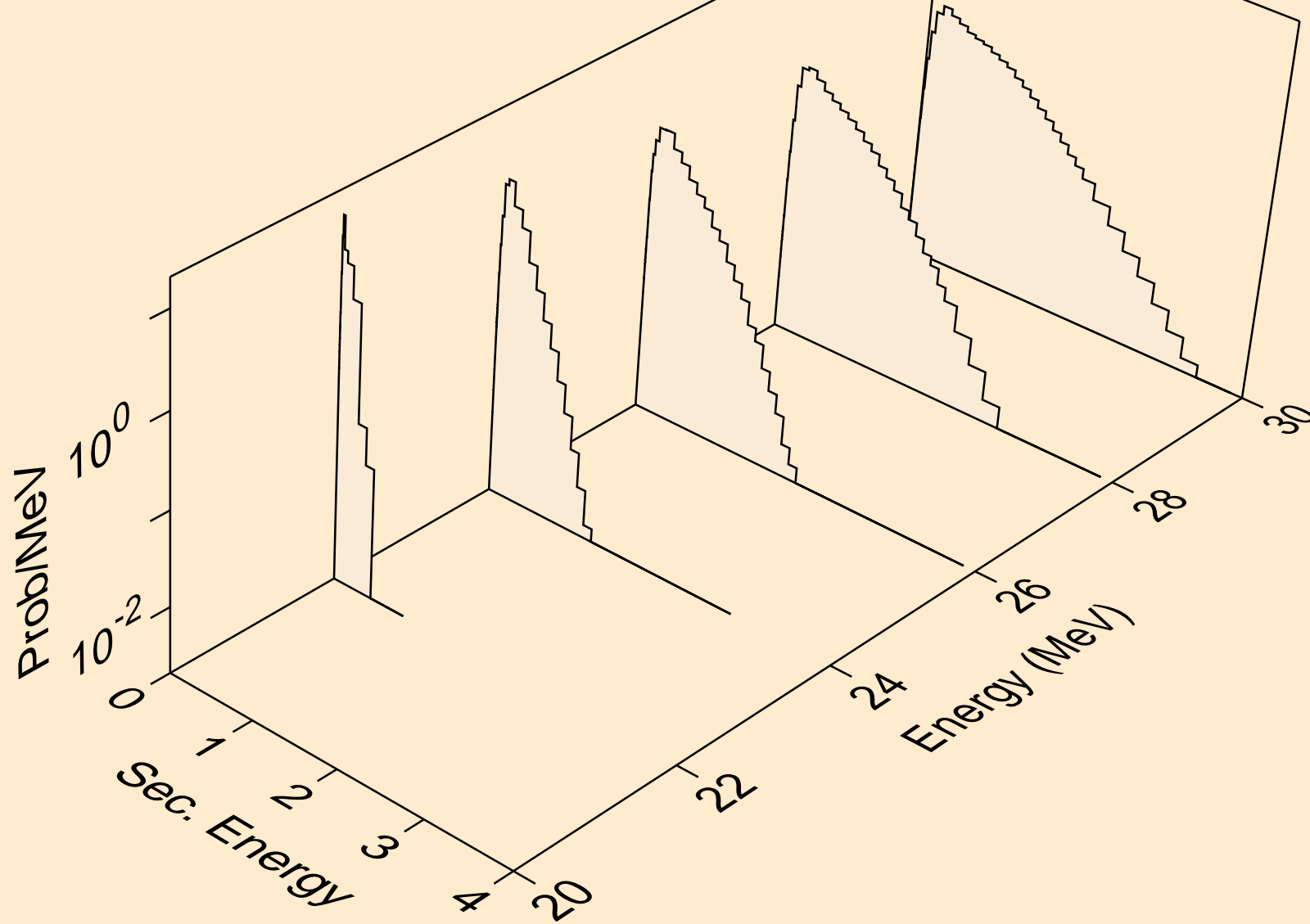

PM138 NEUTRON ACER TENDL-2024 LIBRARY; T=0.K  
Neutron emission for (n,2n)

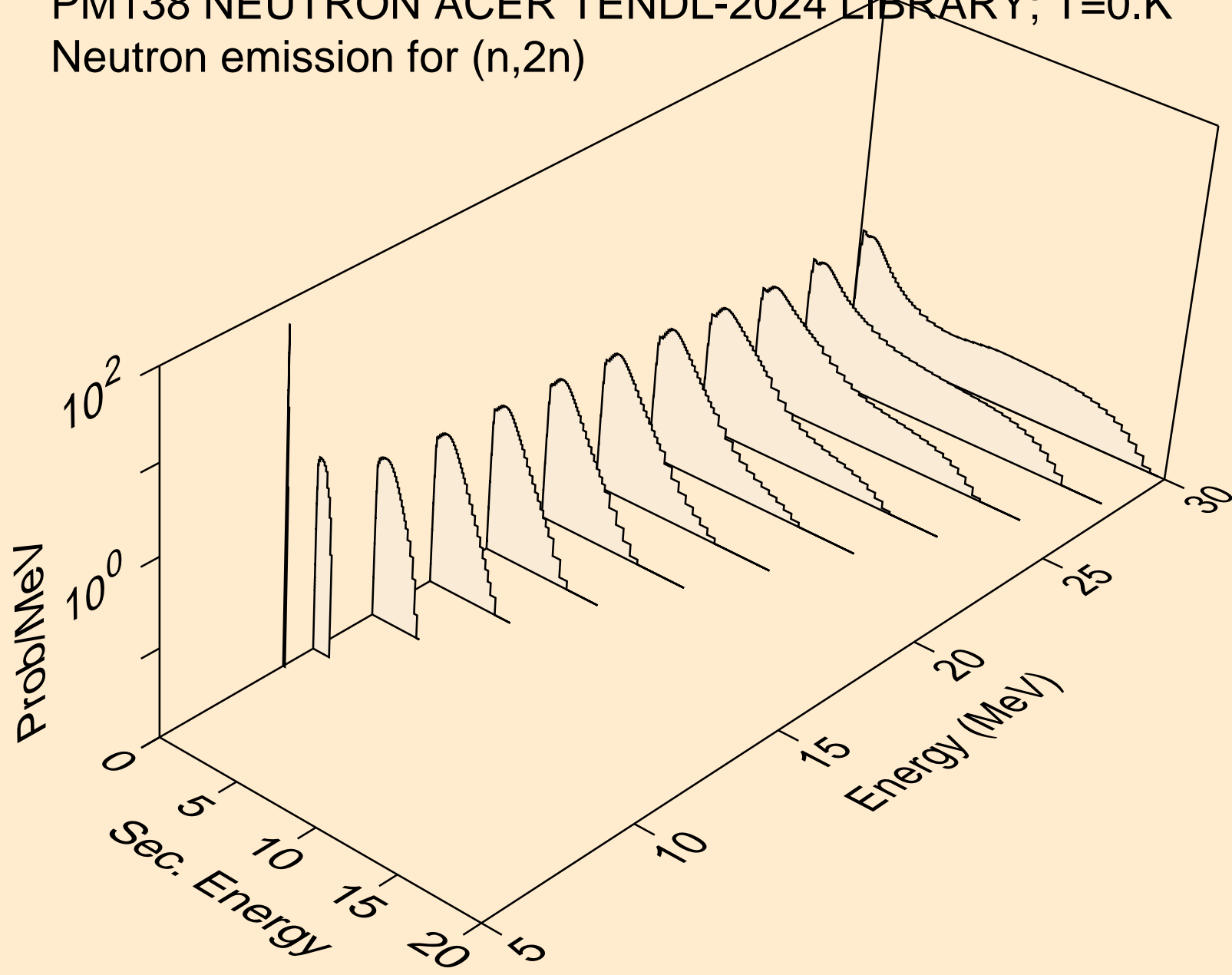

PM138 NEUTRON ACER TENDL-2024 LIBRARY; T=0.K  
Neutron emission for (n,3n)

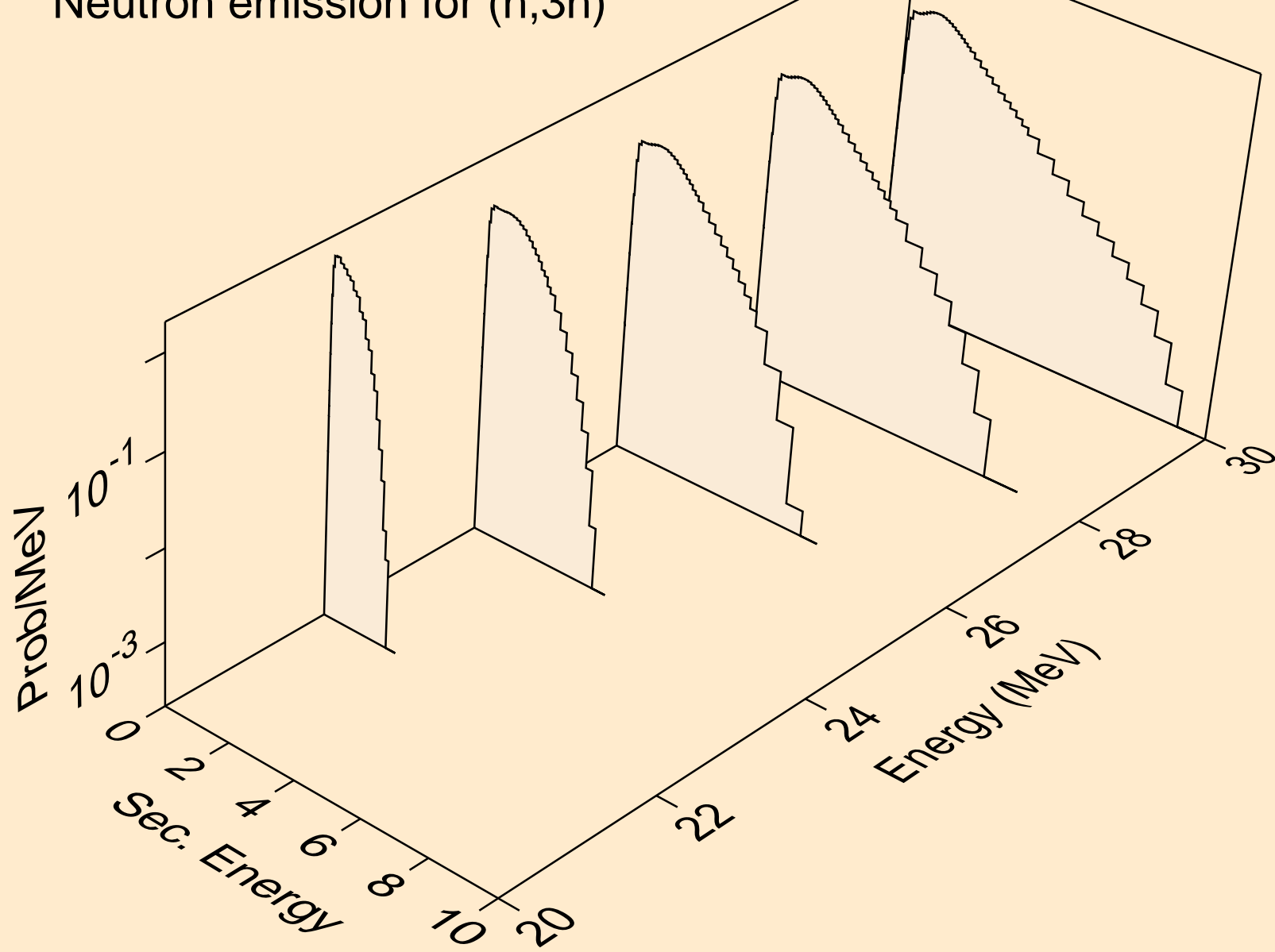

PM138 NEUTRON ACER TENDL-2024 LIBRARY; T=0.K  
Neutron emission for (n,n\*)a

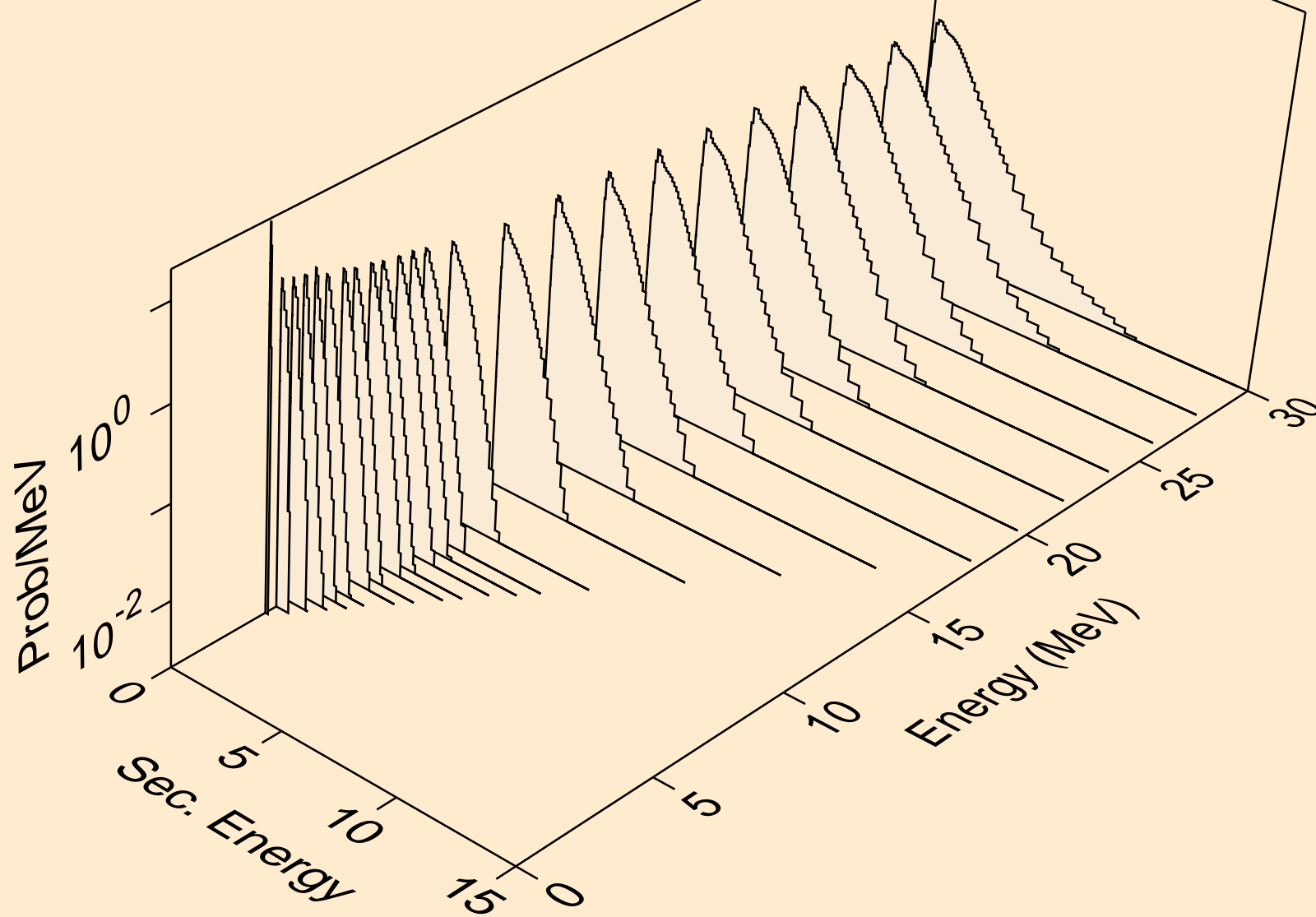

PM138 NEUTRON ACER TENDL-2024 LIBRARY; T=0.K  
Neutron emission for (n,2n)a

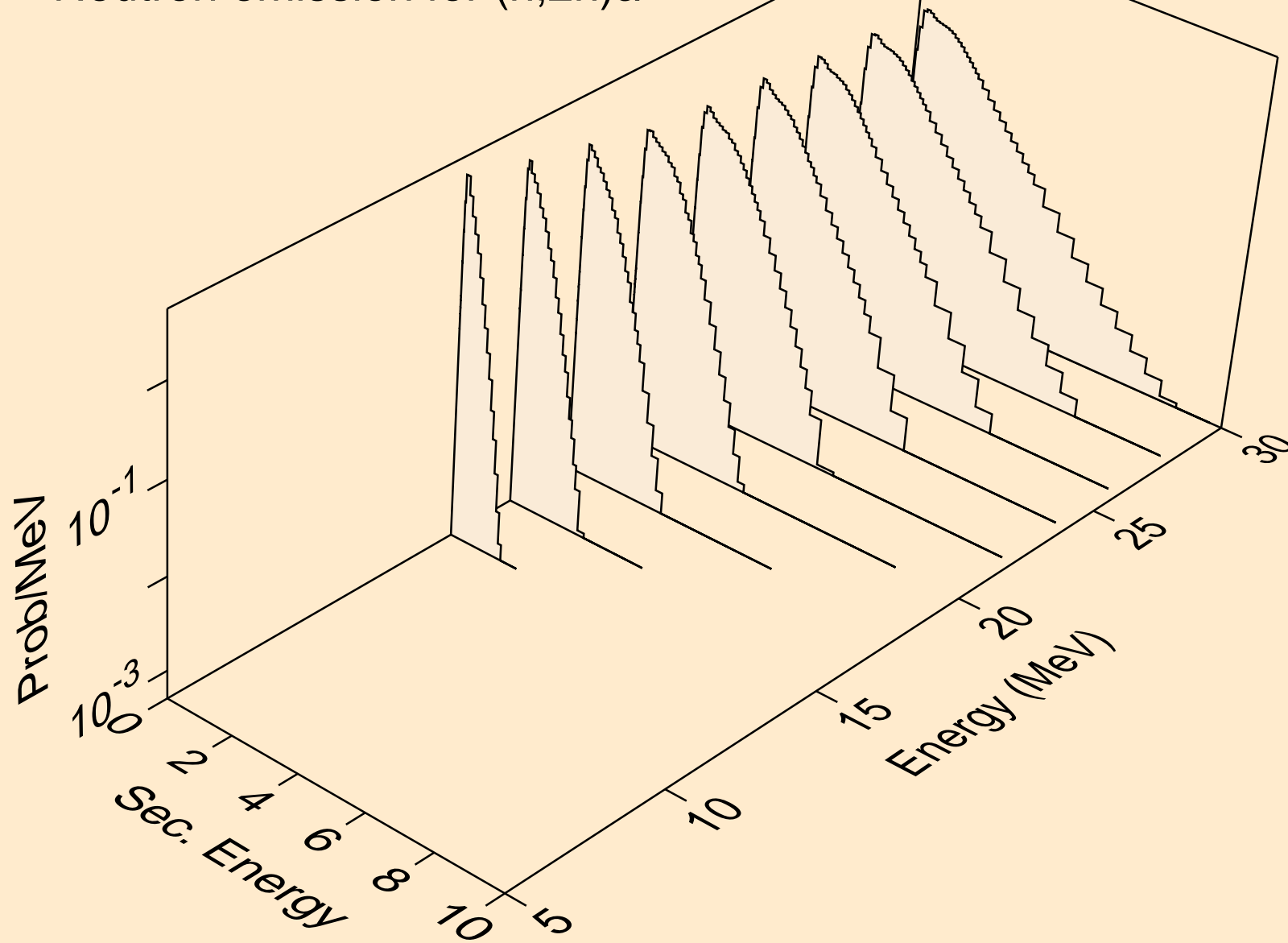

PM138 NEUTRON ACER TENDL-2024 LIBRARY; T=0.K  
Neutron emission for (n,3n)a

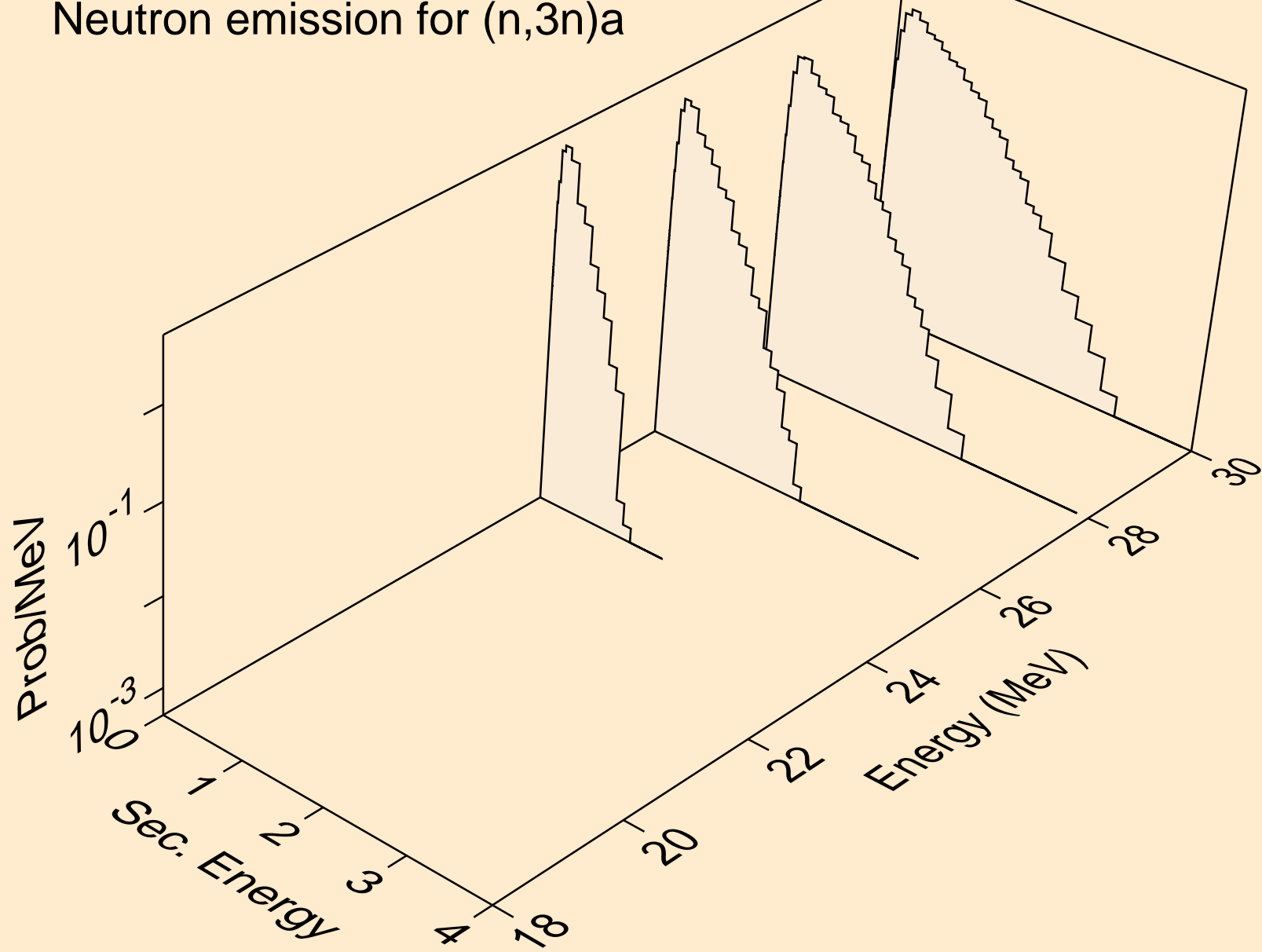

PM138 NEUTRON ACER TENDL-2024 LIBRARY; T=0.K  
Neutron emission for (n,n\*)p

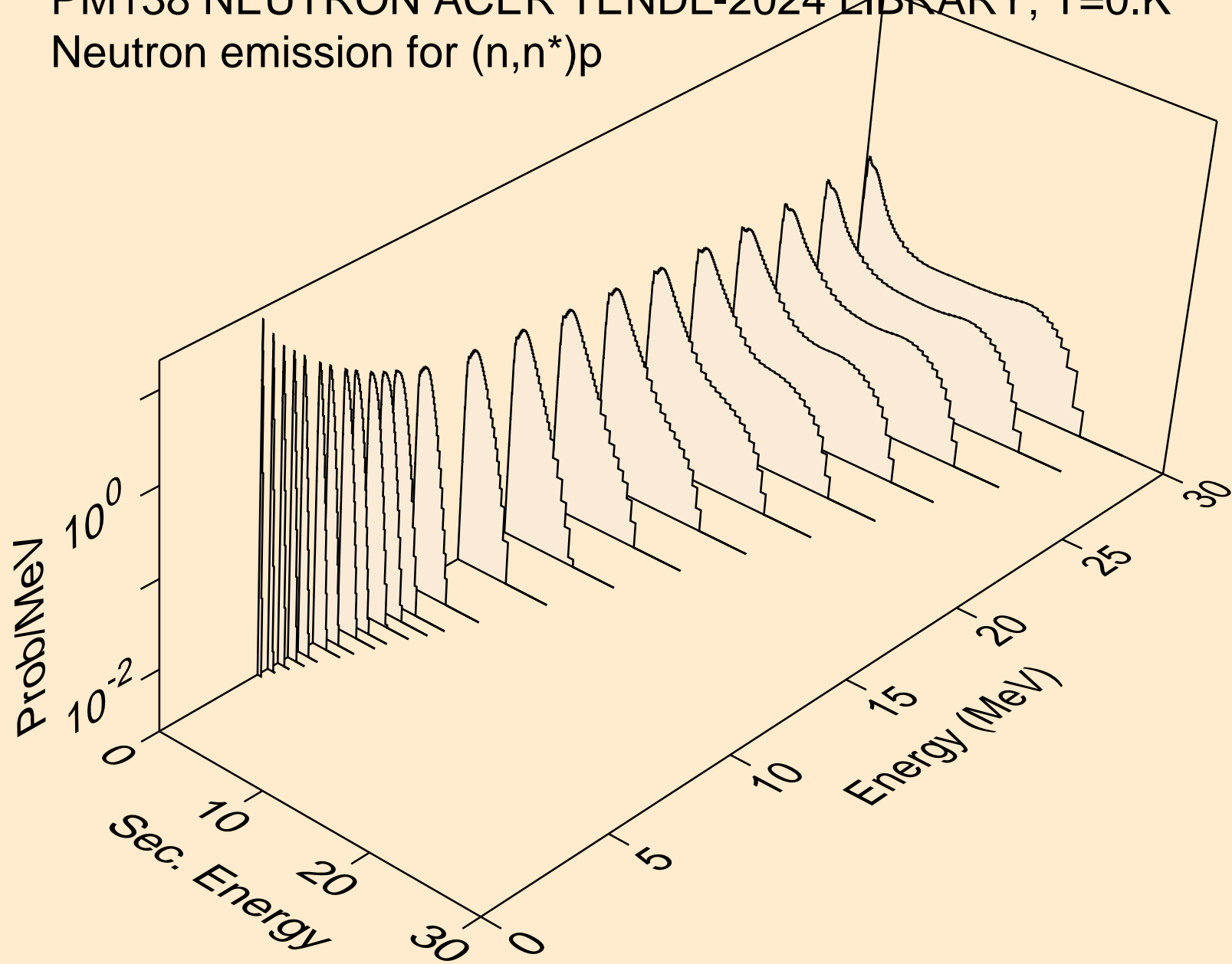

PM138 NEUTRON ACER TENDL-2024 LIBRARY; T=0.K  
Neutron emission for (n,n\*)2a

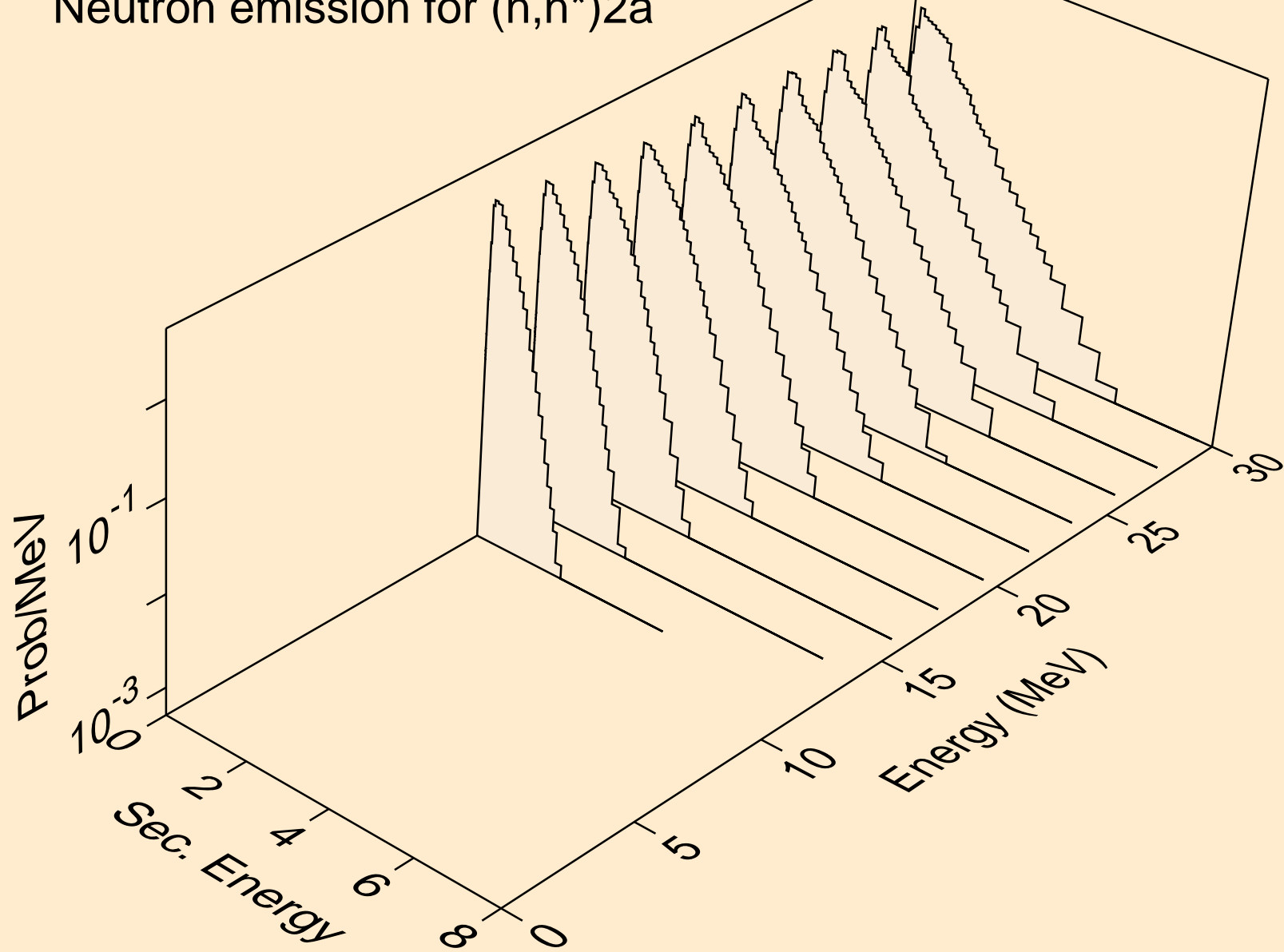



PM138 NEUTRON ACER TENDL-2024 LIBRARY; T=0.K  
Neutron emission for (n,2n)2a

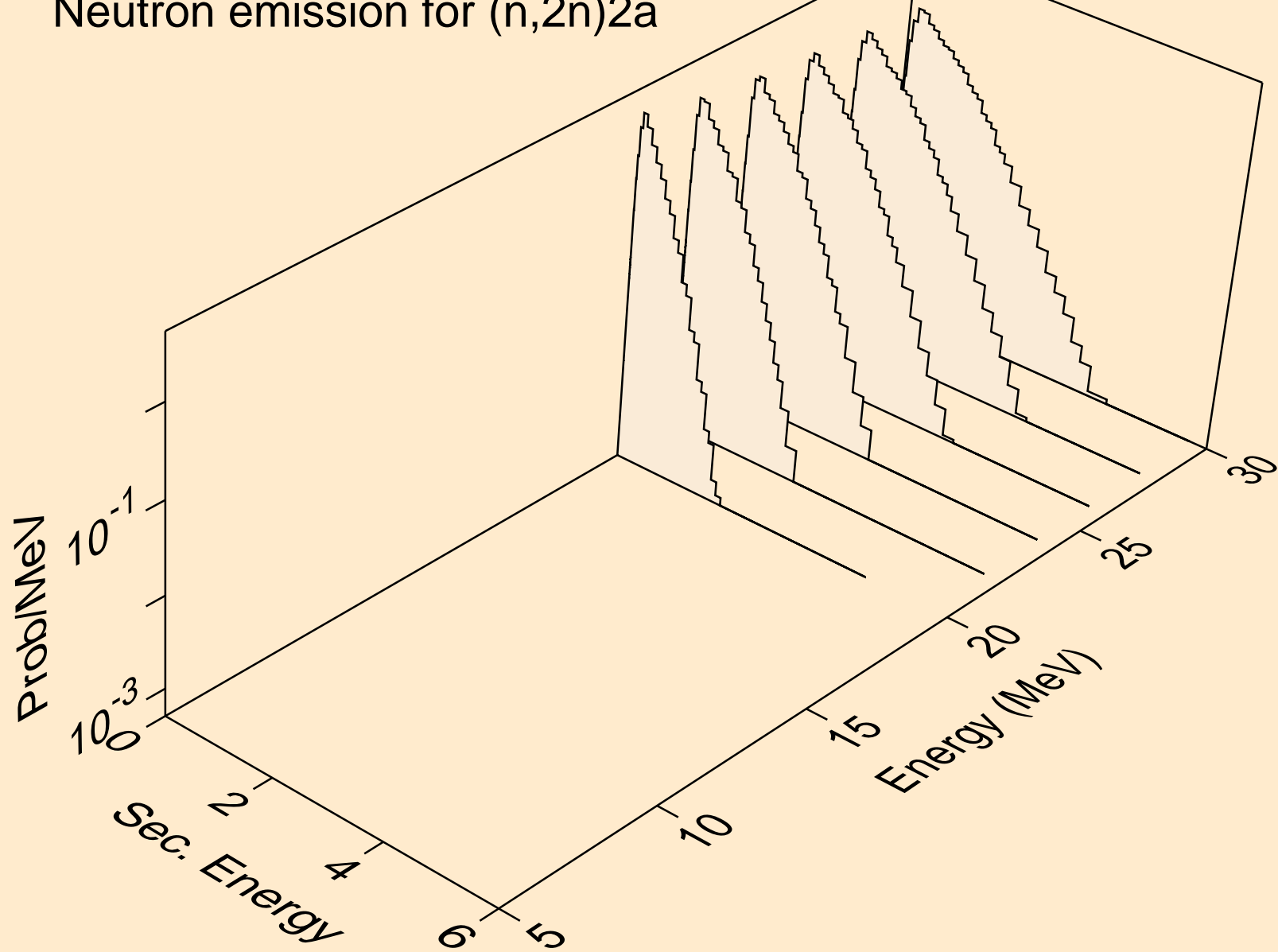

PM138 NEUTRON ACER TENDL-2024 LIBRARY; T=0.K  
Neutron emission for (n,n\*)d

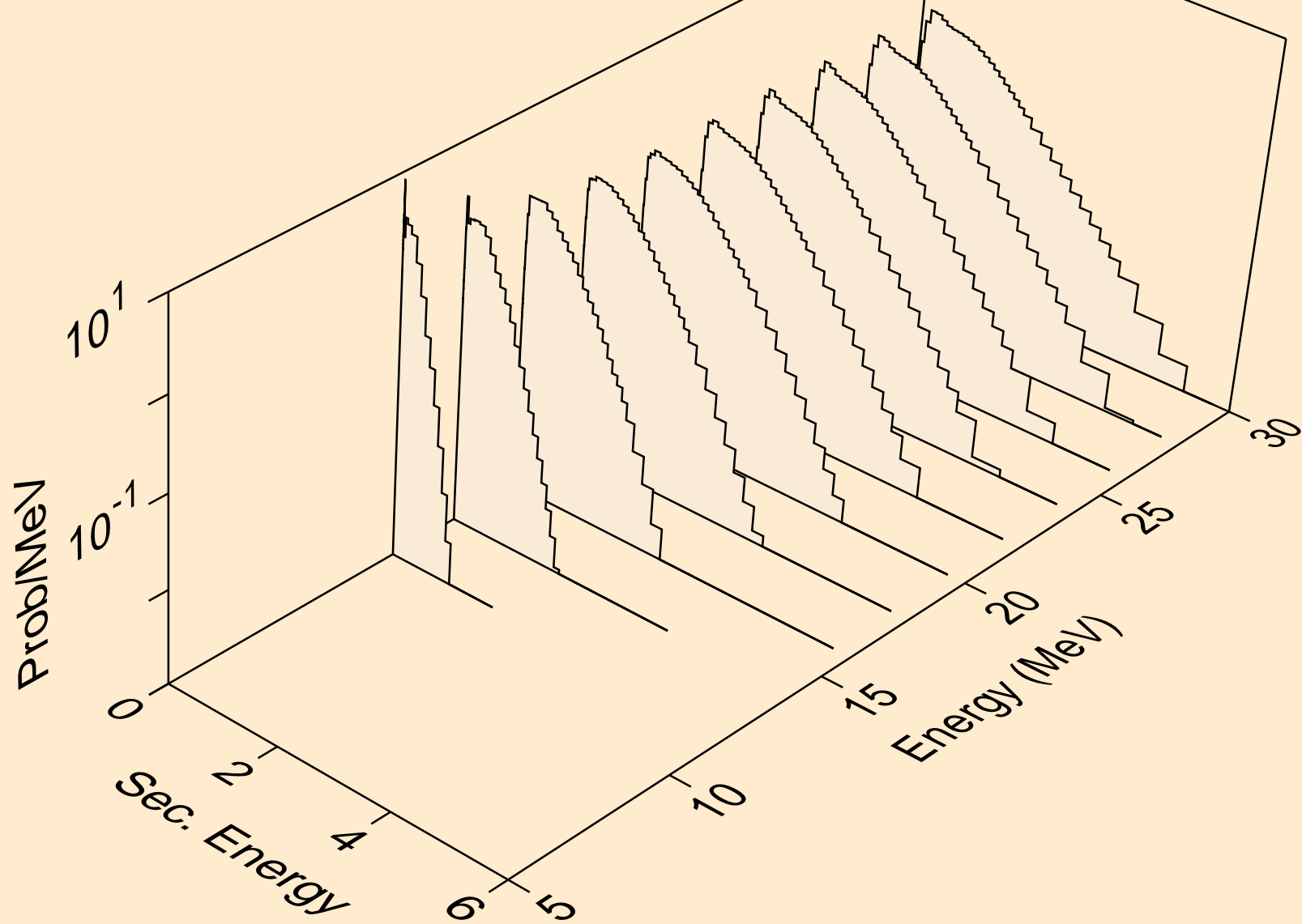

PM138 NEUTRON ACER TENDL-2024 LIBRARY; T=0.K  
Neutron emission for (n,n\*)t

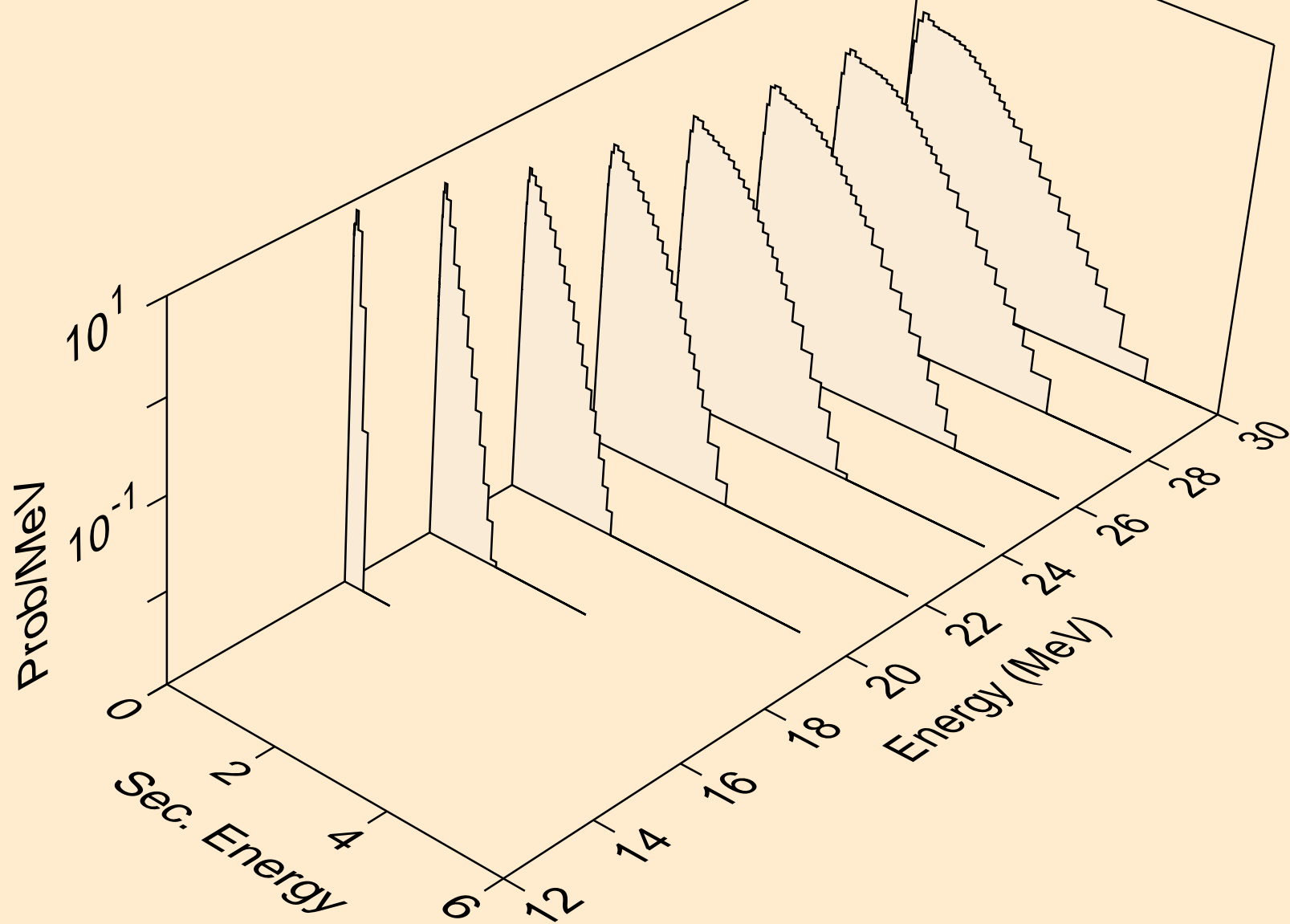

PM138 NEUTRON ACER TENDL-2024 LIBRARY; T=0.K  
Neutron emission for (n,n\*)he3

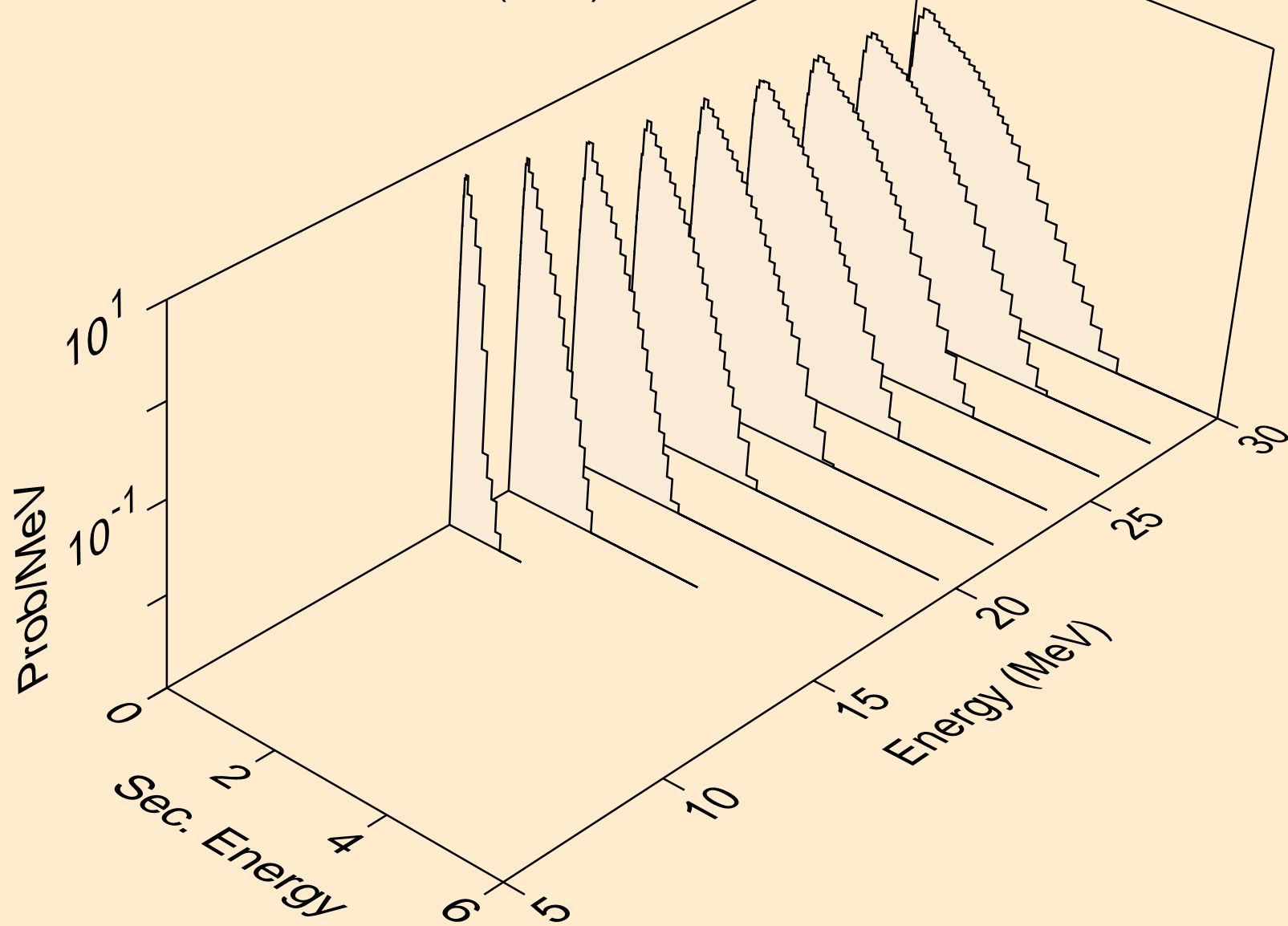

PM138 NEUTRON ACER TENDL-2024 LIBRARY; T=0.K  
Neutron emission for (n,2np)

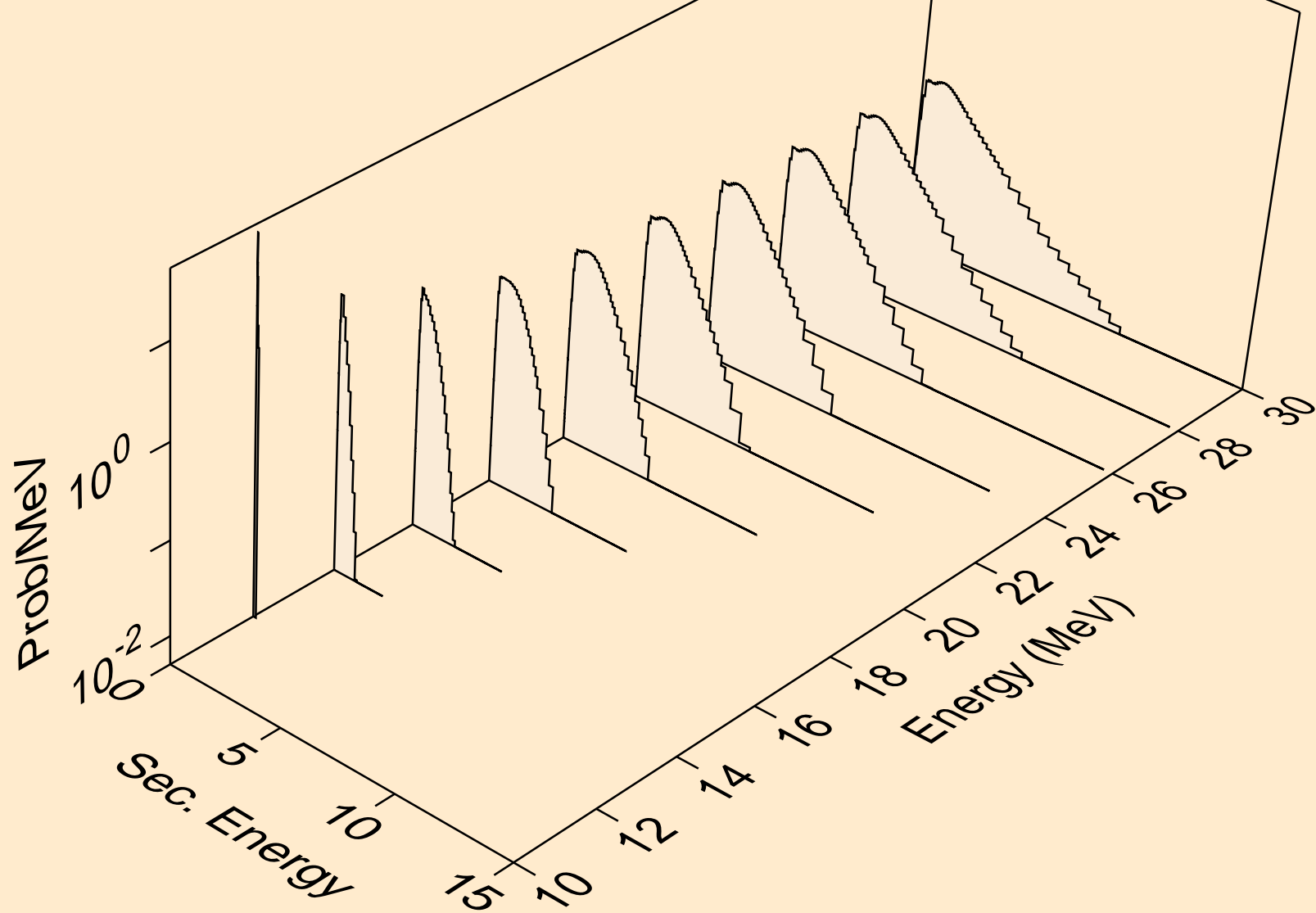

PM138 NEUTRON ACER TENDL-2024 LIBRARY; T=0.K  
Neutron emission for (n,3np)

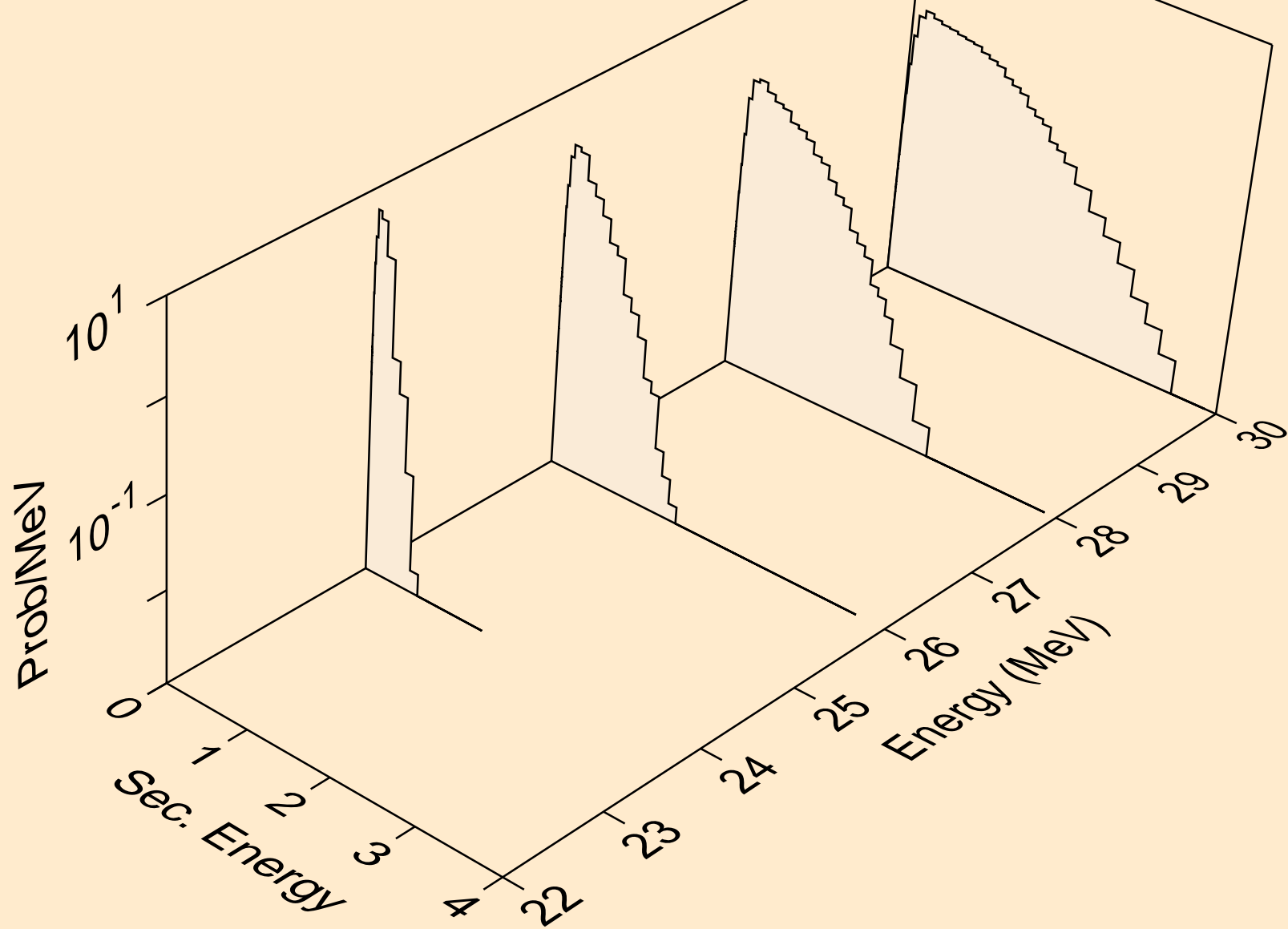

PM138 NEUTRON ACER TENDL-2024 LIBRARY; T=0.K  
Neutron emission for (n,n2p)

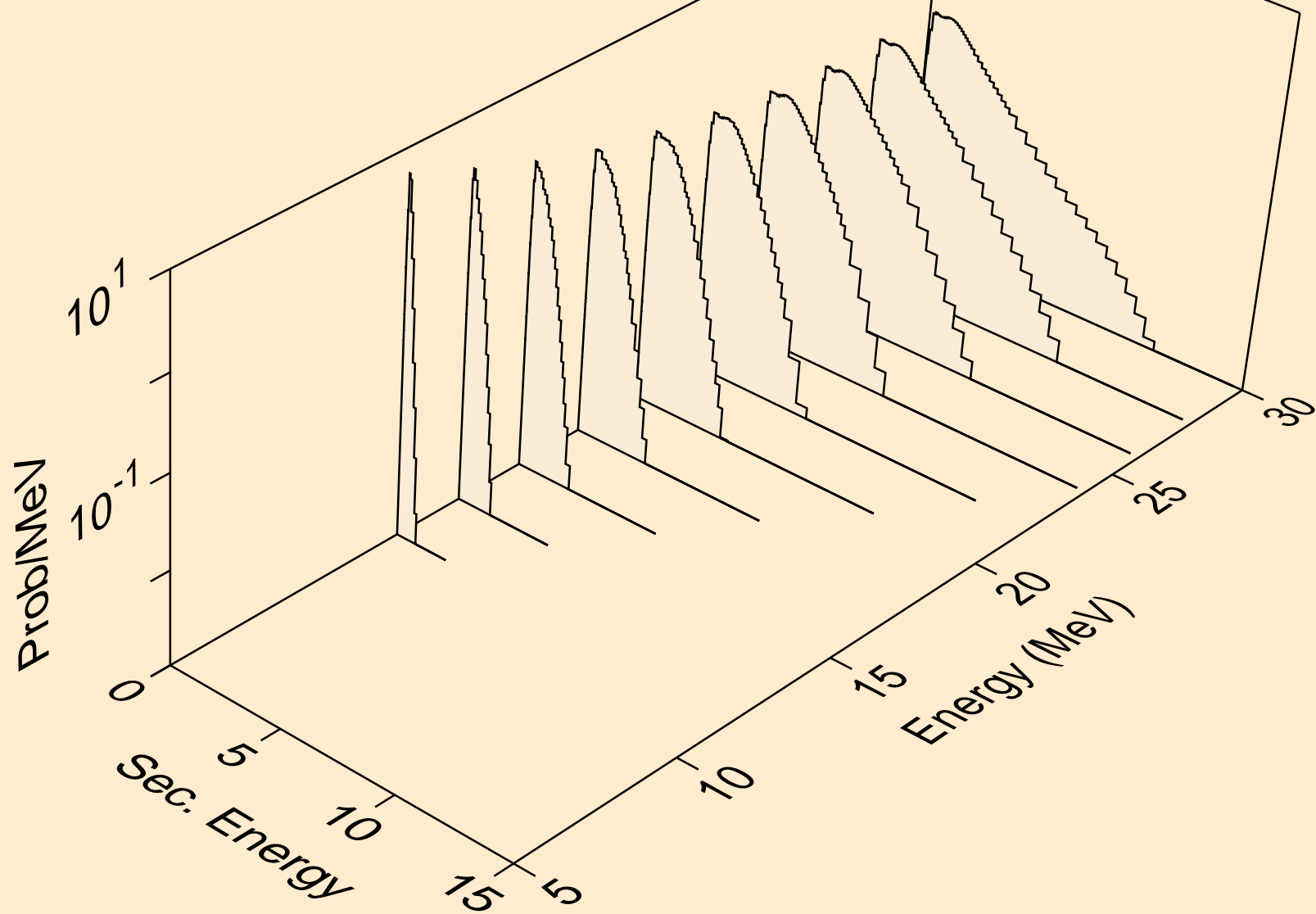

PM138 NEUTRON ACER TENDL-2024 LIBRARY; T=0.K  
Neutron emission for (n,npa)

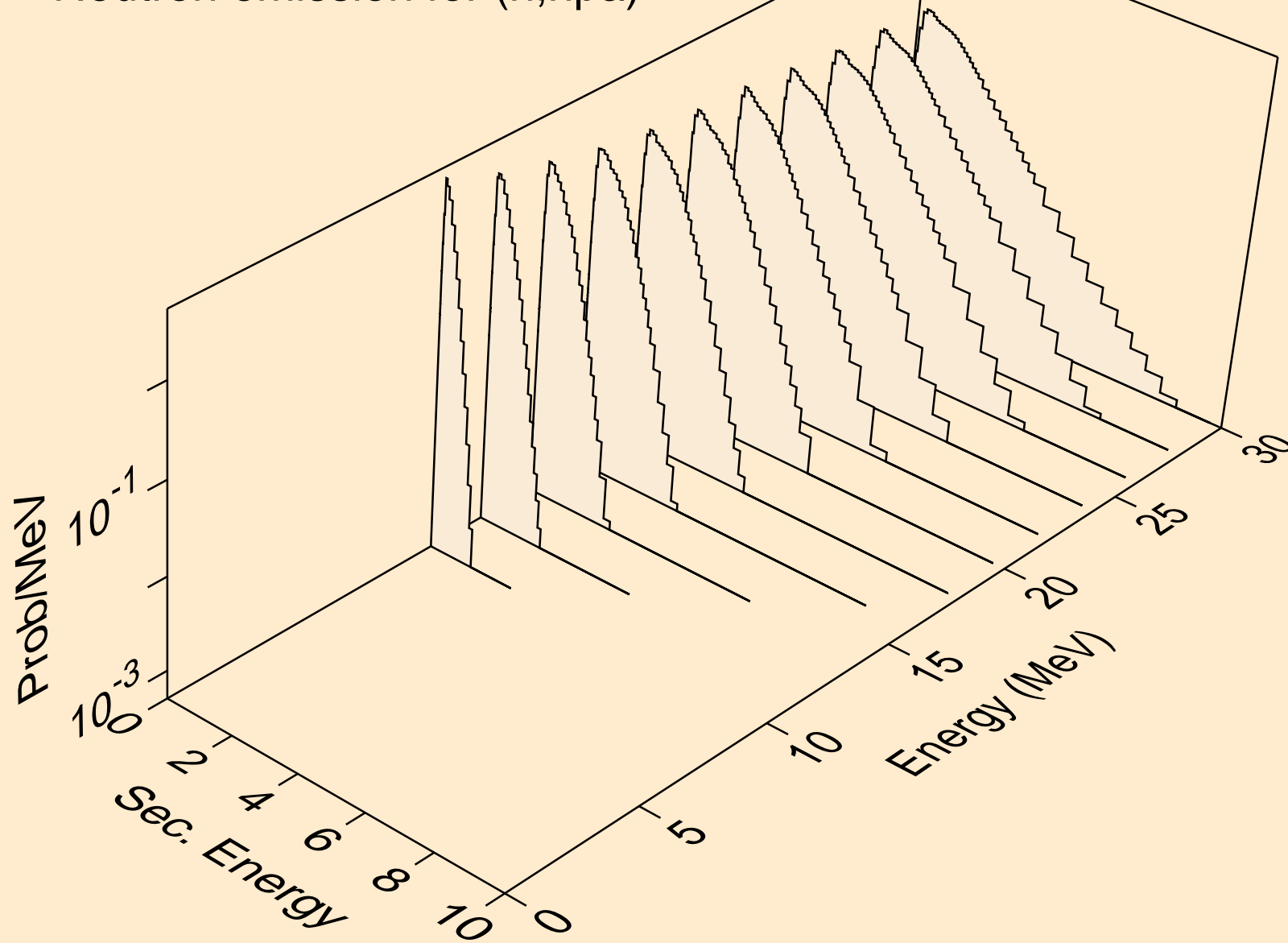



PM138 NEUTRON ACER TENDL-2024 LIBRARY; T=0.K  
Neutron emission for (n,n\*c)

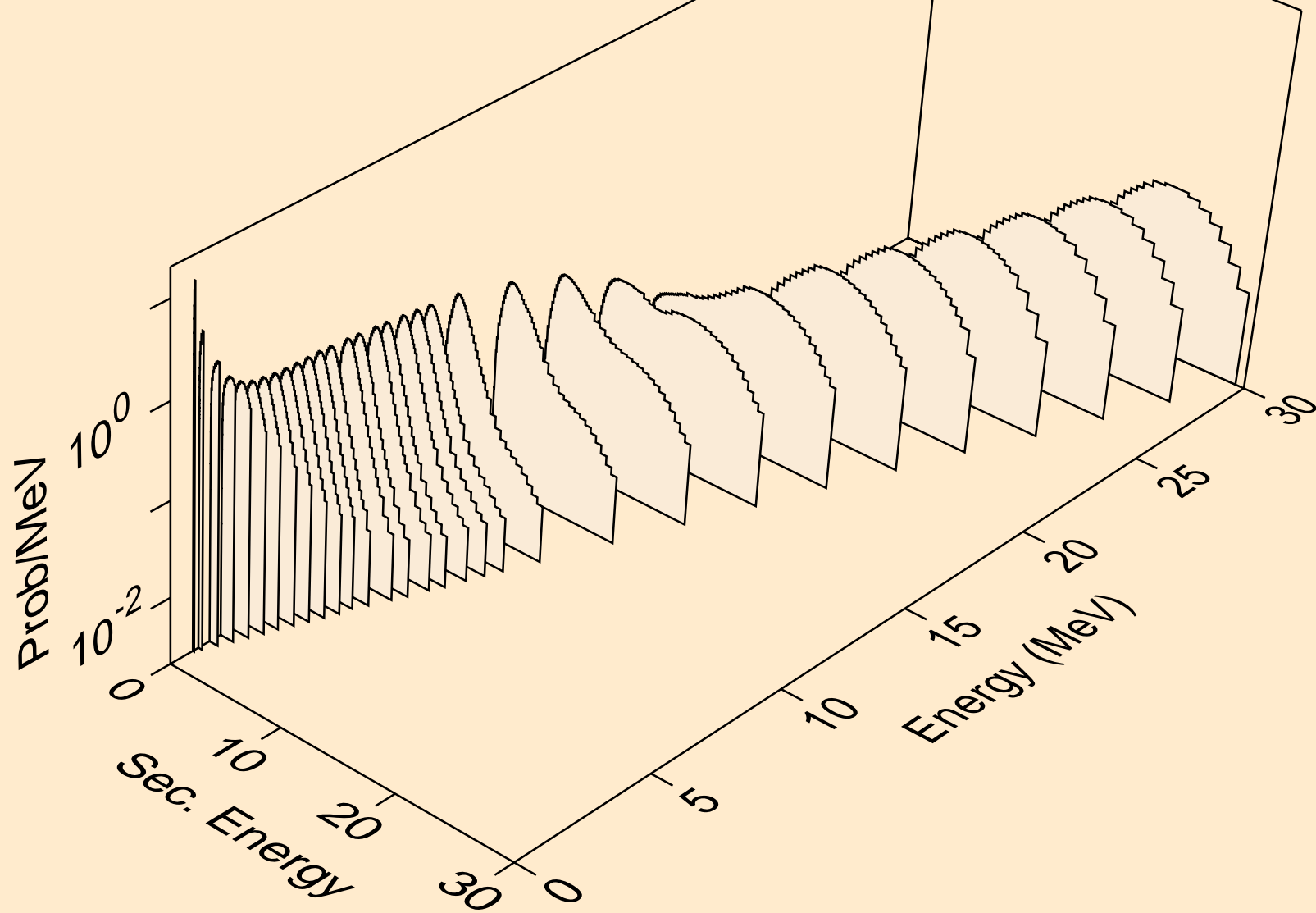

PM138 NEUTRON ACER TENDL-2024 LIBRARY; T=0.K  
Photon emission for (n,x)

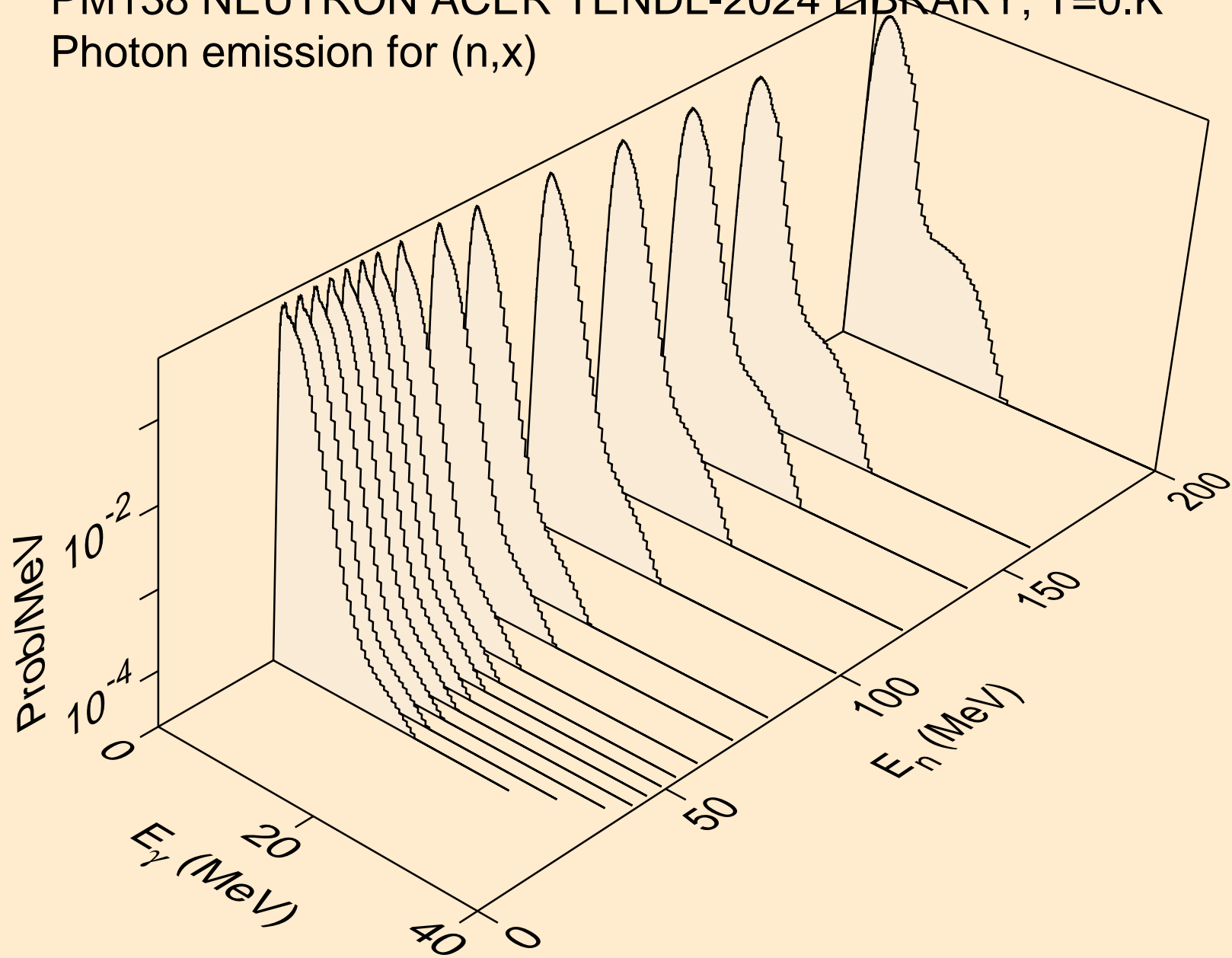

PM138 NEUTRON ACER TENDL-2024 LIBRARY; T=0.K  
Photon emission for (n,2nd)

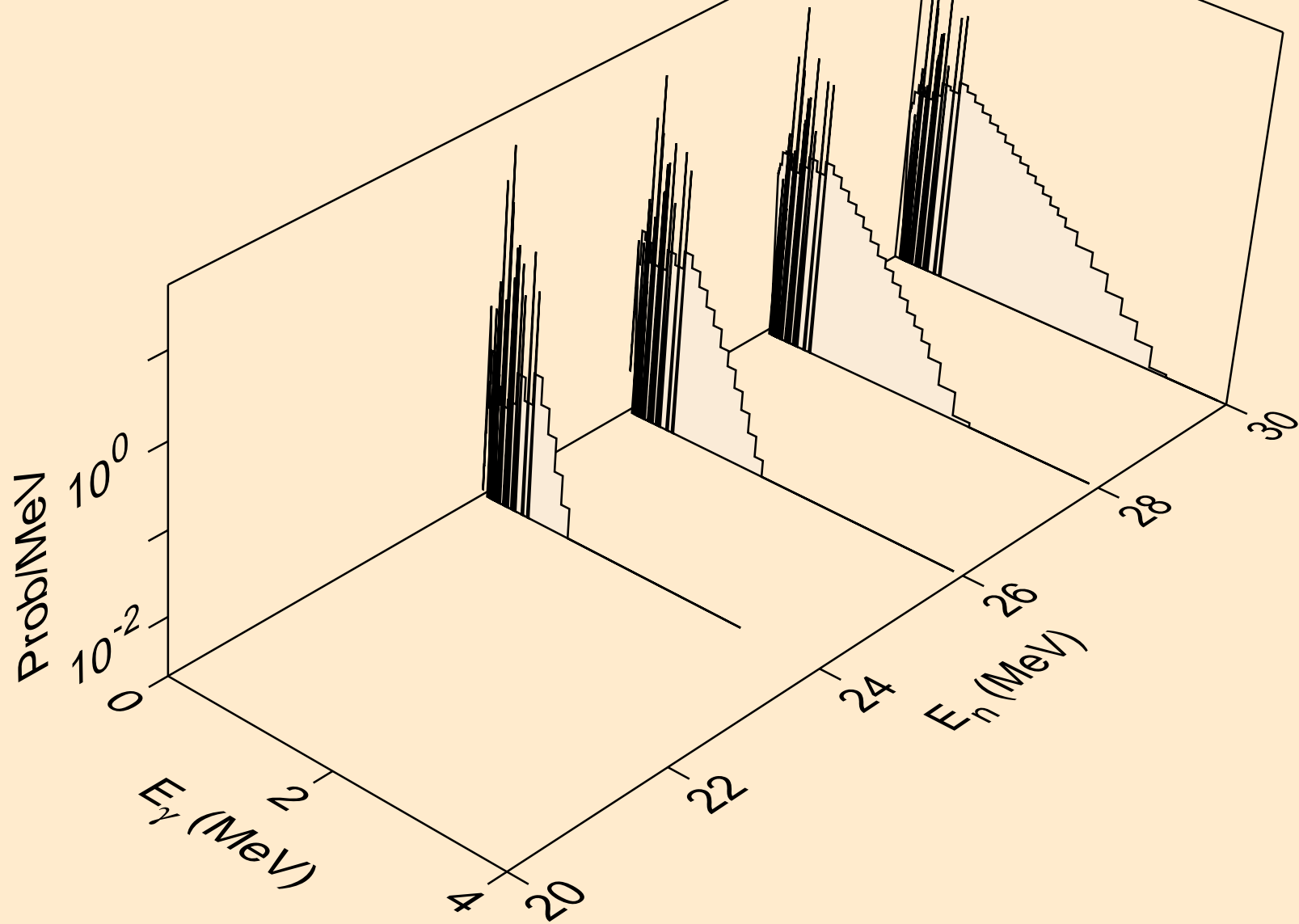

PM138 NEUTRON ACER TENDL-2024 LIBRARY; T=0.K  
Photon emission for (n,2n)

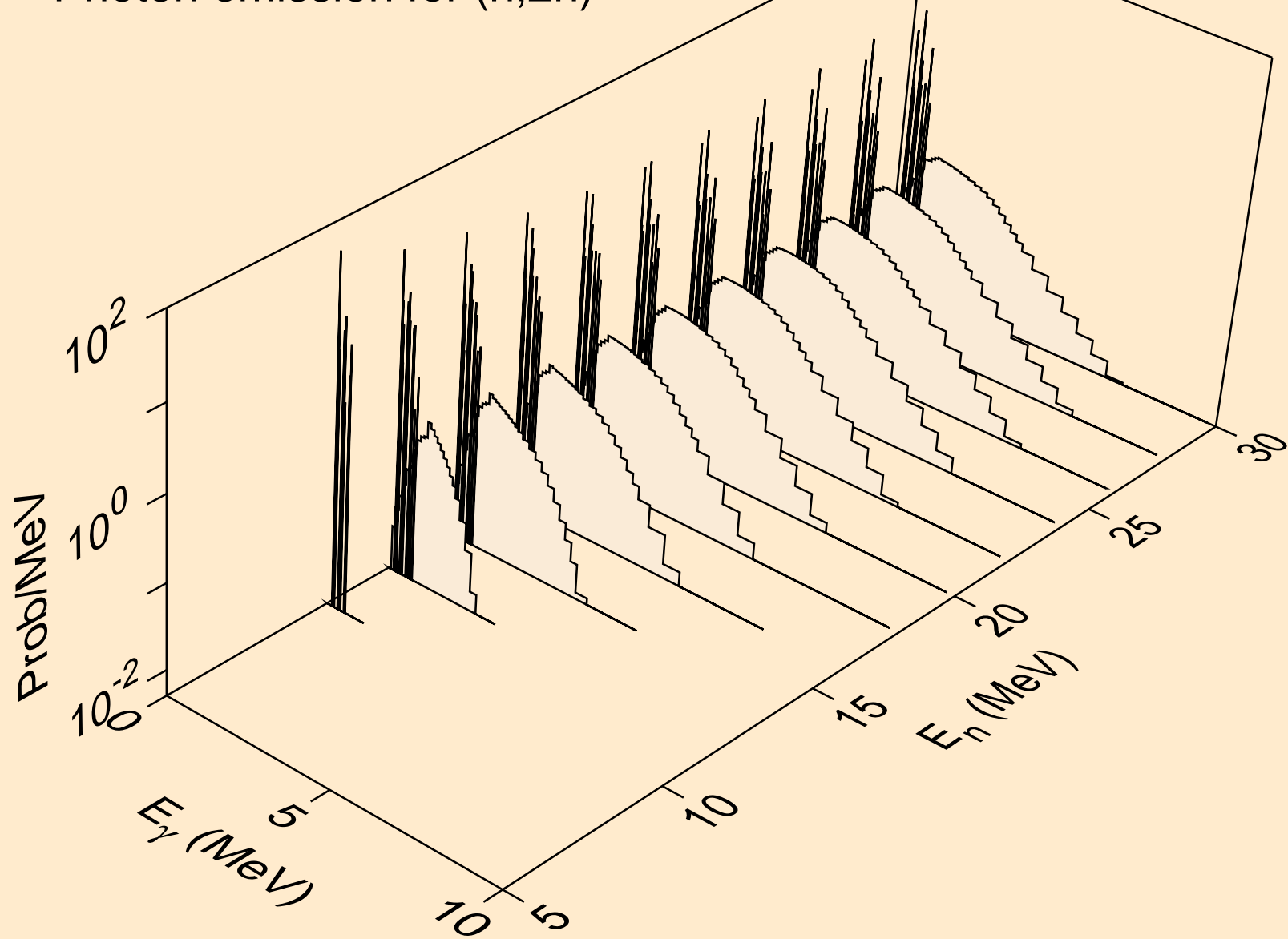

PM138 NEUTRON ACER TENDL-2024 LIBRARY; T=0.K  
Photon emission for (n,3n)

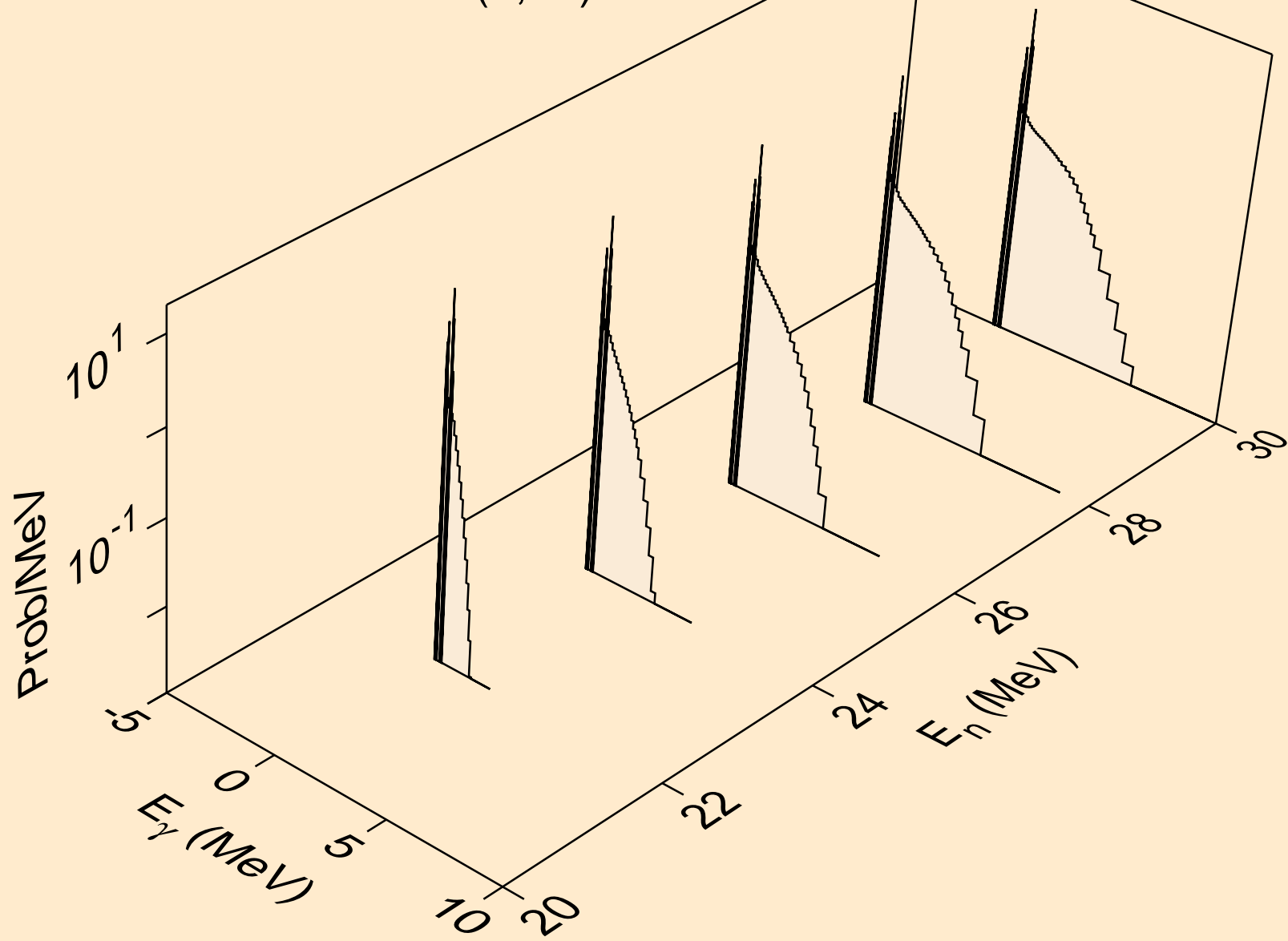

PM138 NEUTRON ACER TENDL-2024 LIBRARY; T=0.K  
Photon emission for (n,n\*)a

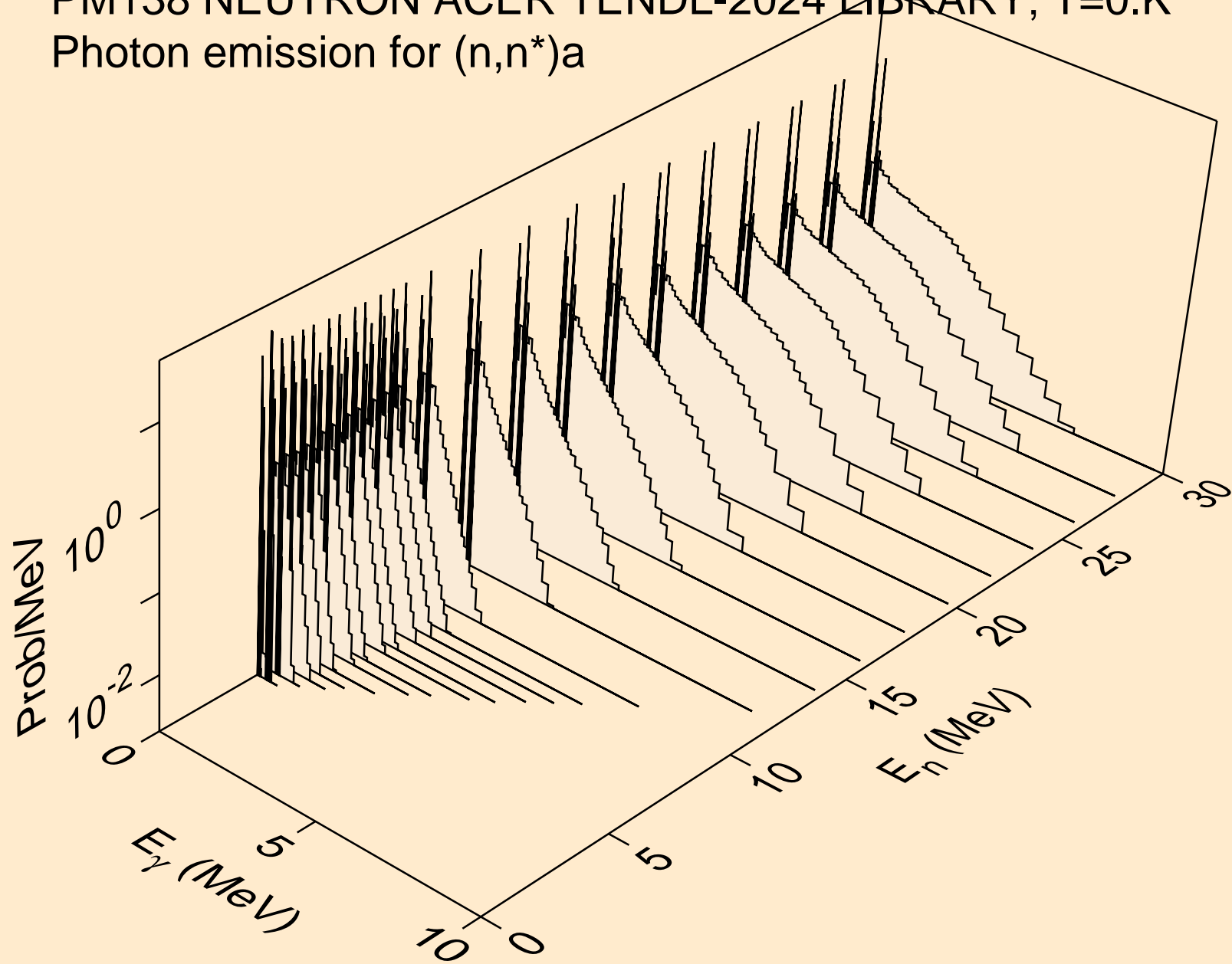

PM138 NEUTRON ACER TENDL-2024 LIBRARY; T=0.K  
Photon emission for (n,2n)a

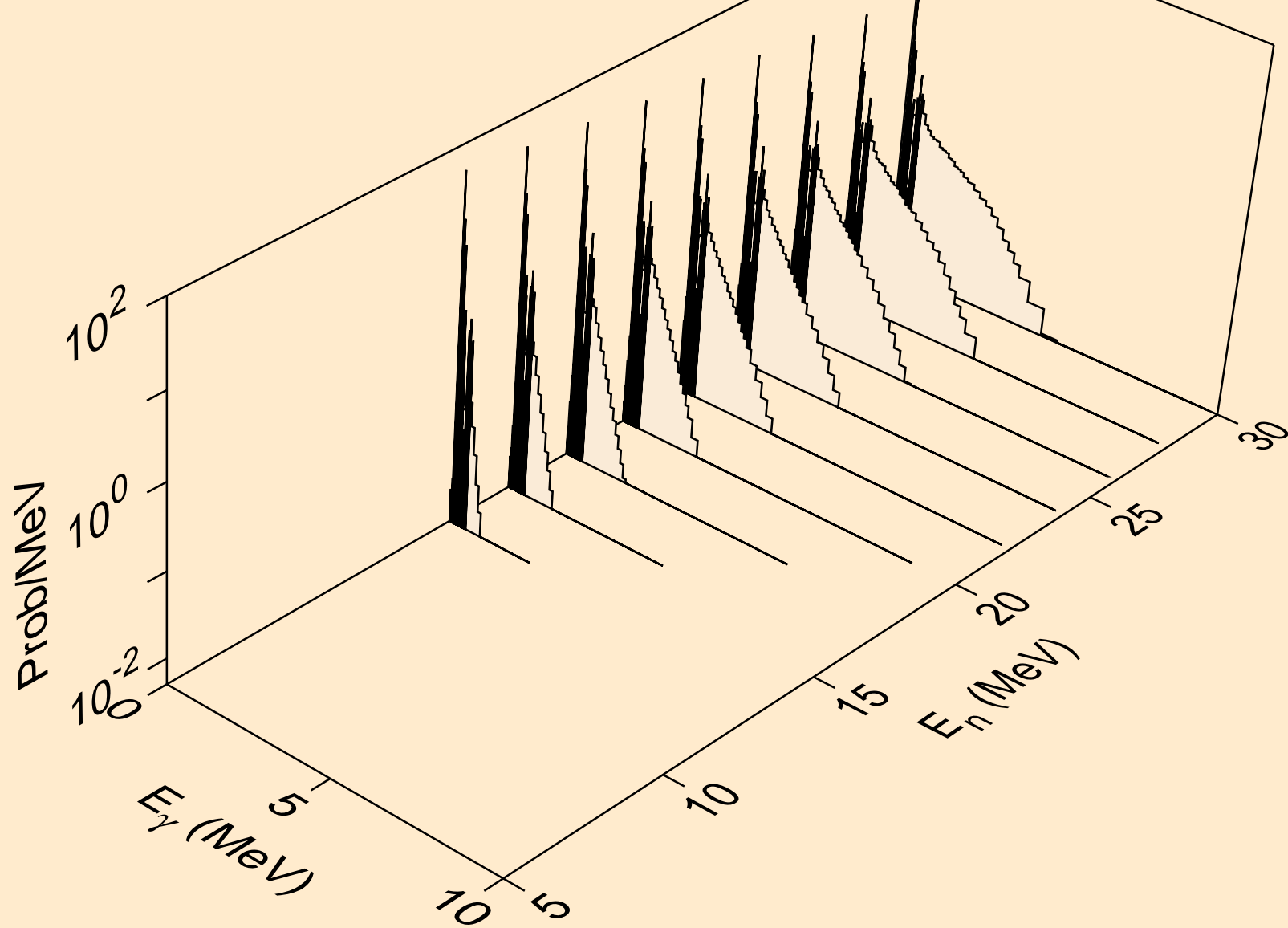

PM138 NEUTRON ACER TENDL-2024 LIBRARY; T=0.K  
Photon emission for (n,3n)a

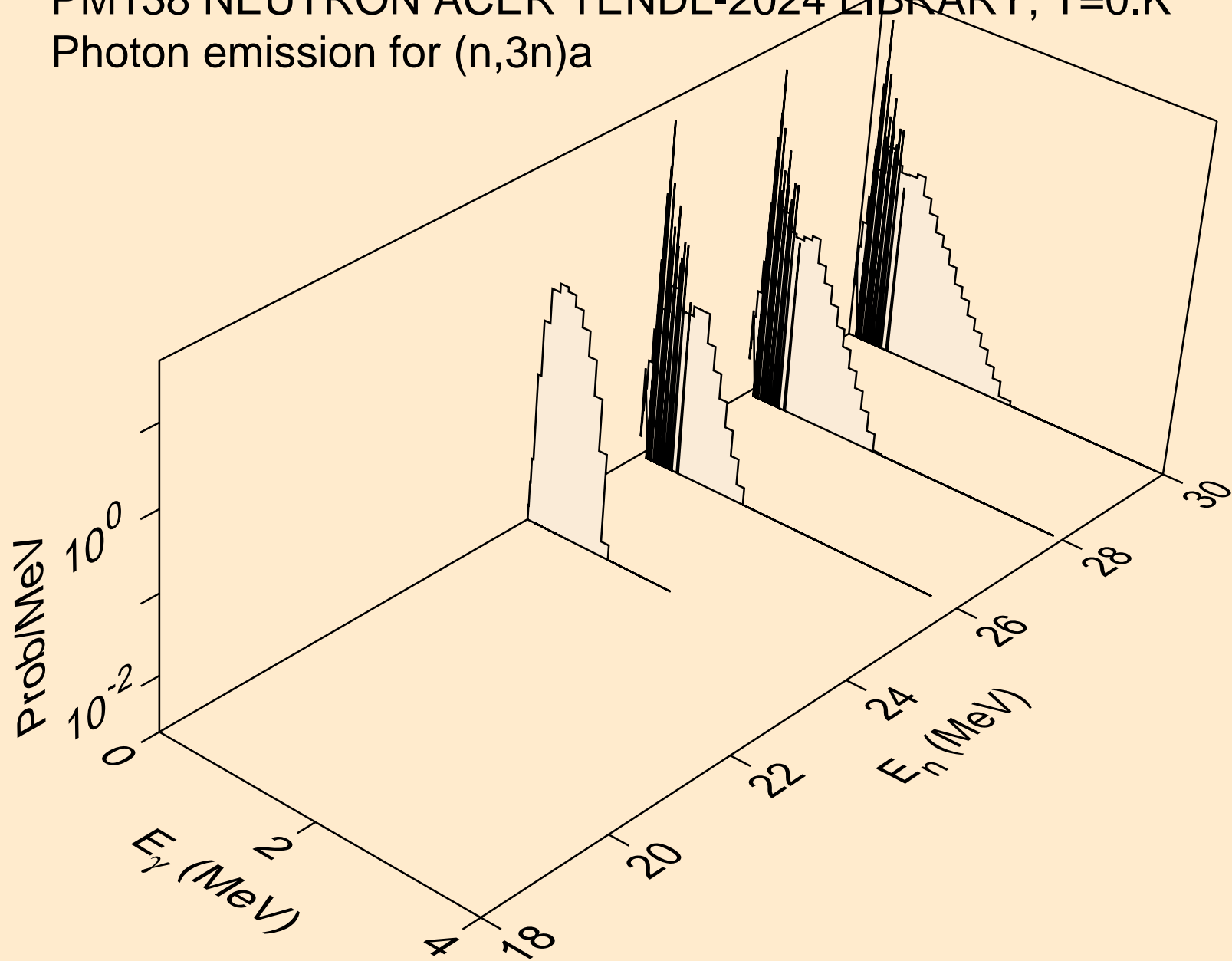



PM138 NEUTRON ACER TENDL-2024 LIBRARY; T=0.K  
Photon emission for (n,n\*)p

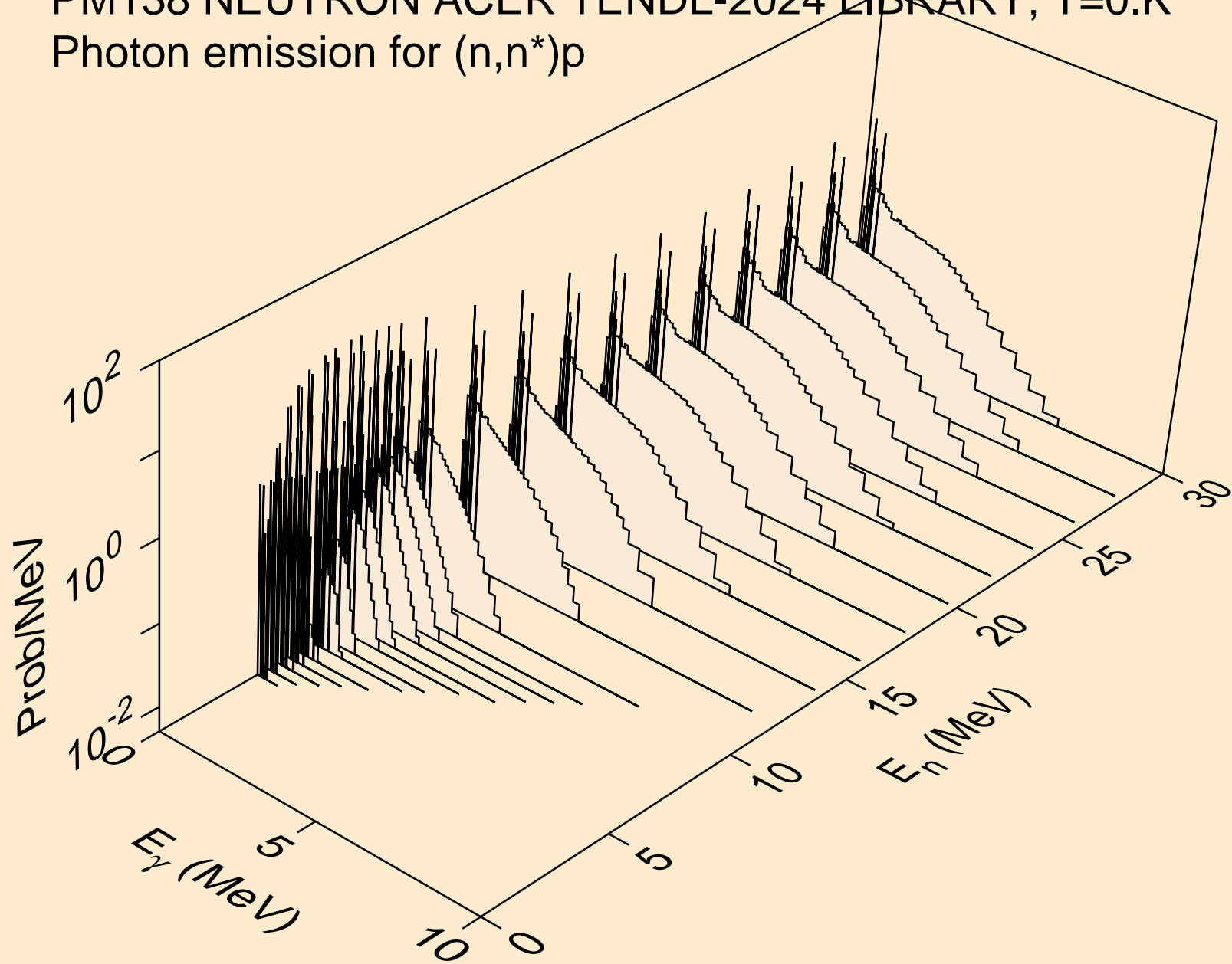

PM138 NEUTRON ACER TENDL-2024 LIBRARY; T=0.K  
Photon emission for (n,n\*)2a

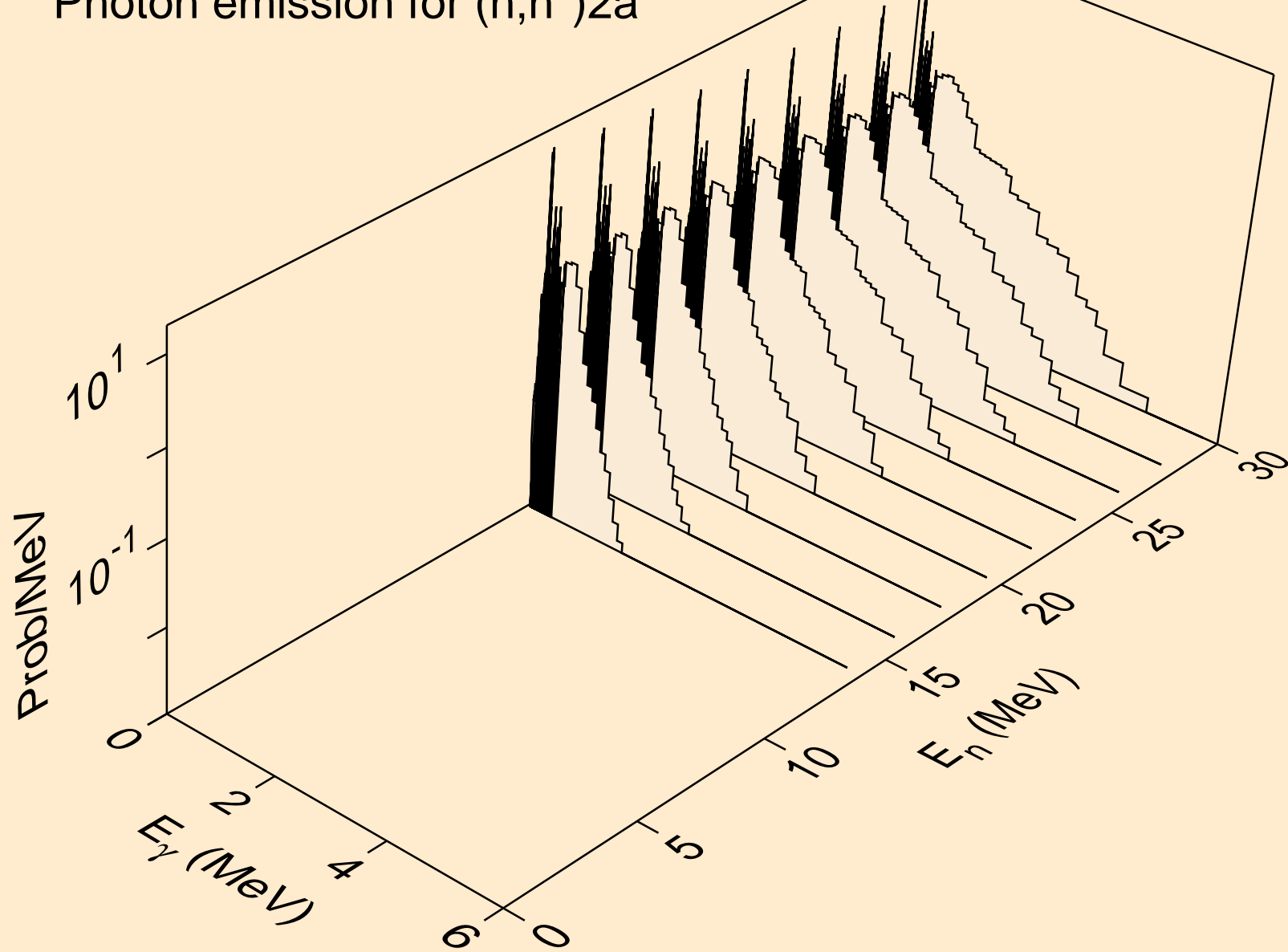

PM138 NEUTRON ACER TENDL-2024 LIBRARY; T=0.K  
Photon emission for (n,2n)2a

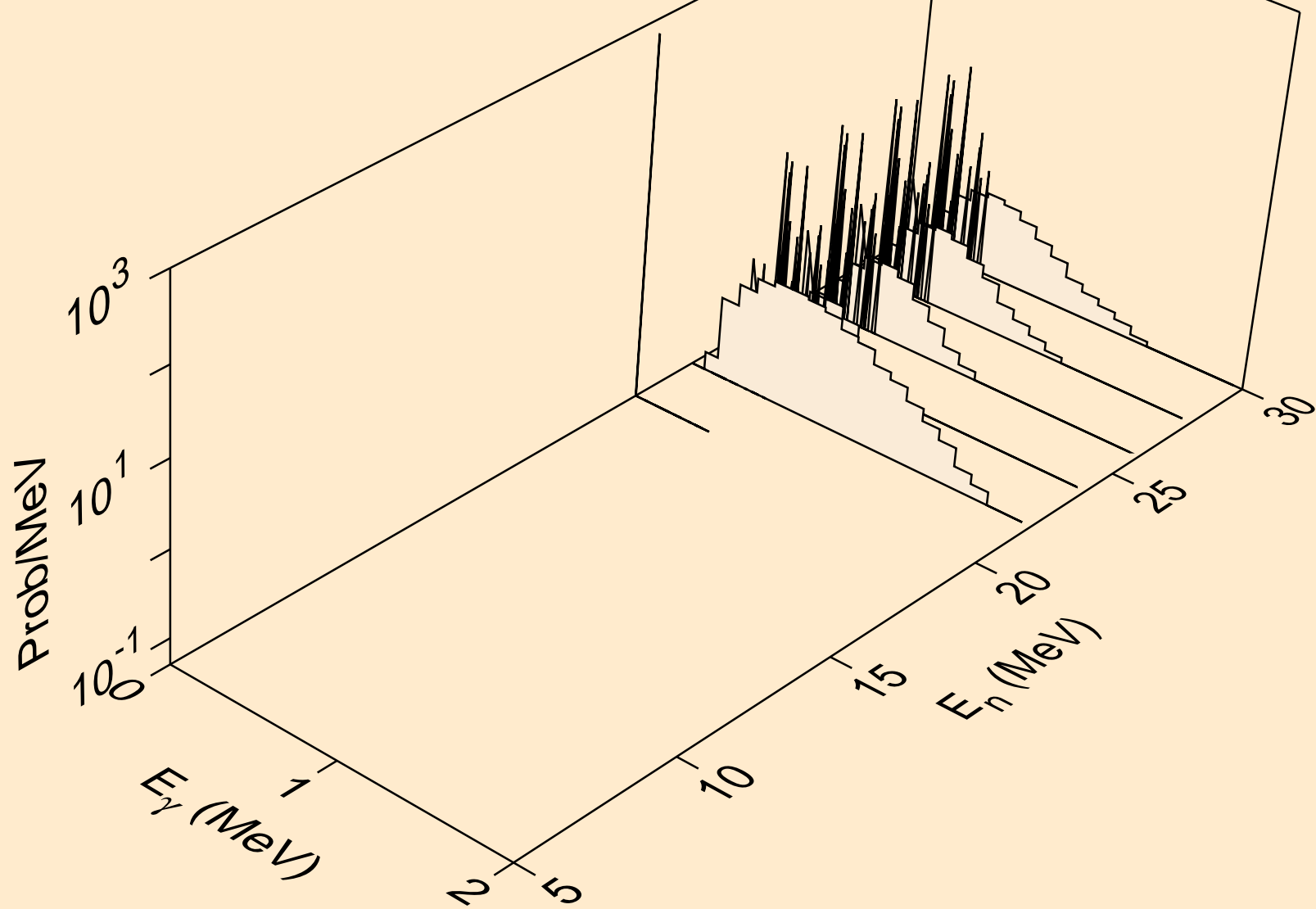

PM138 NEUTRON ACER TENDL-2024 LIBRARY; T=0.K  
Photon emission for (n,n\*)d

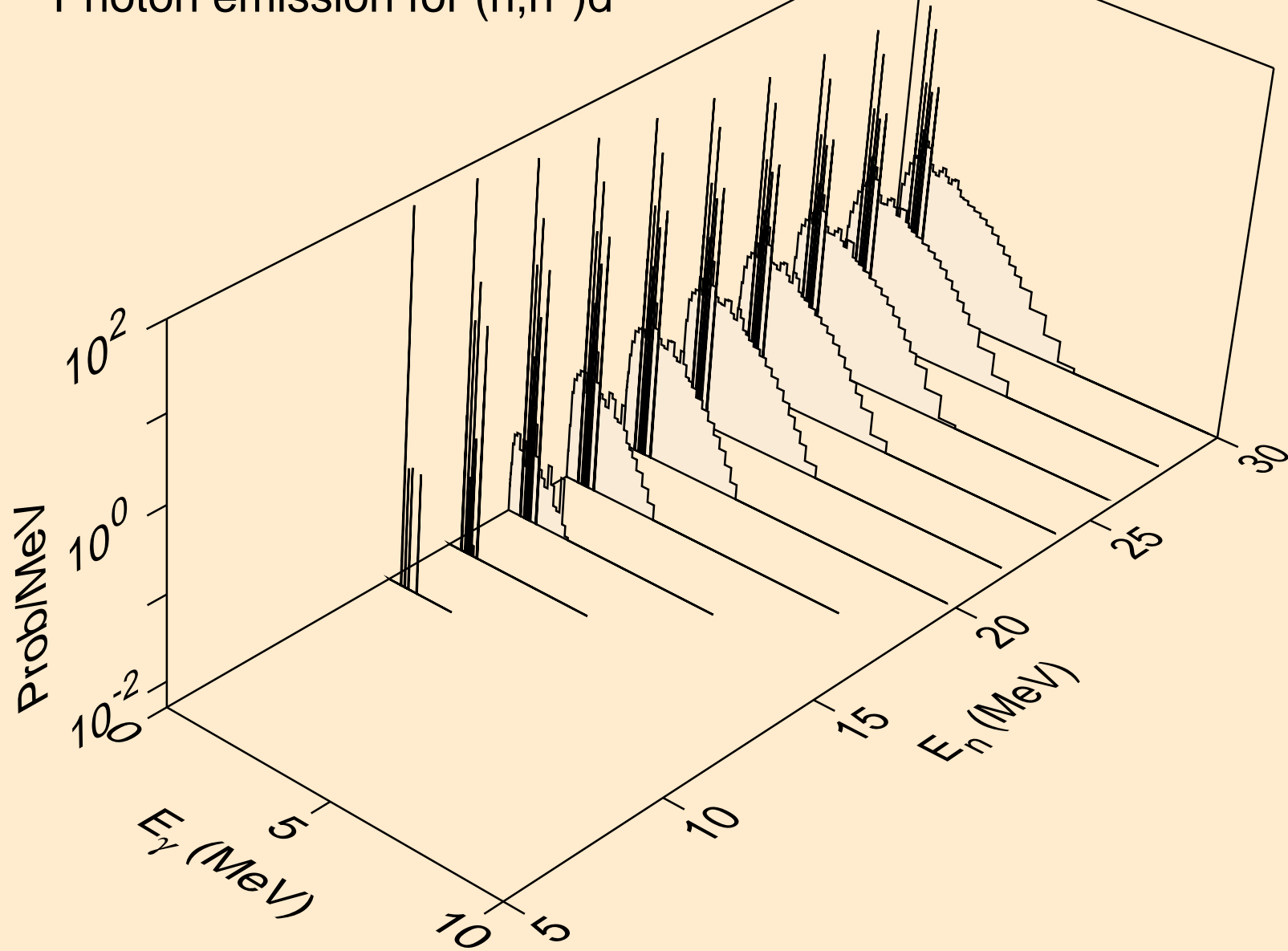

PM138 NEUTRON ACER TENDL-2024 LIBRARY; T=0.K  
Photon emission for (n,n\*)t

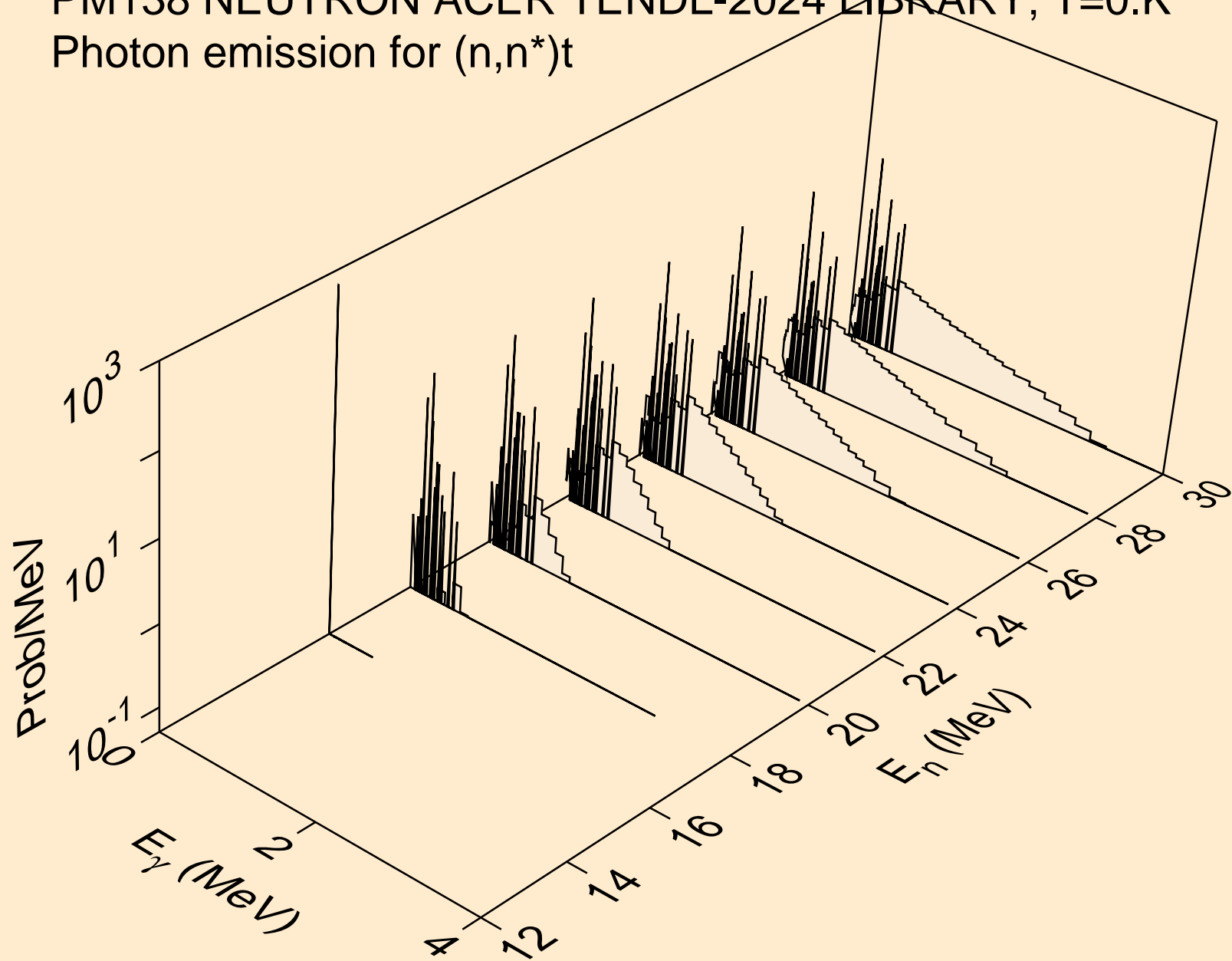

PM138 NEUTRON ACER TENDL-2024 LIBRARY; T=0.K  
Photon emission for (n,n\*)he3

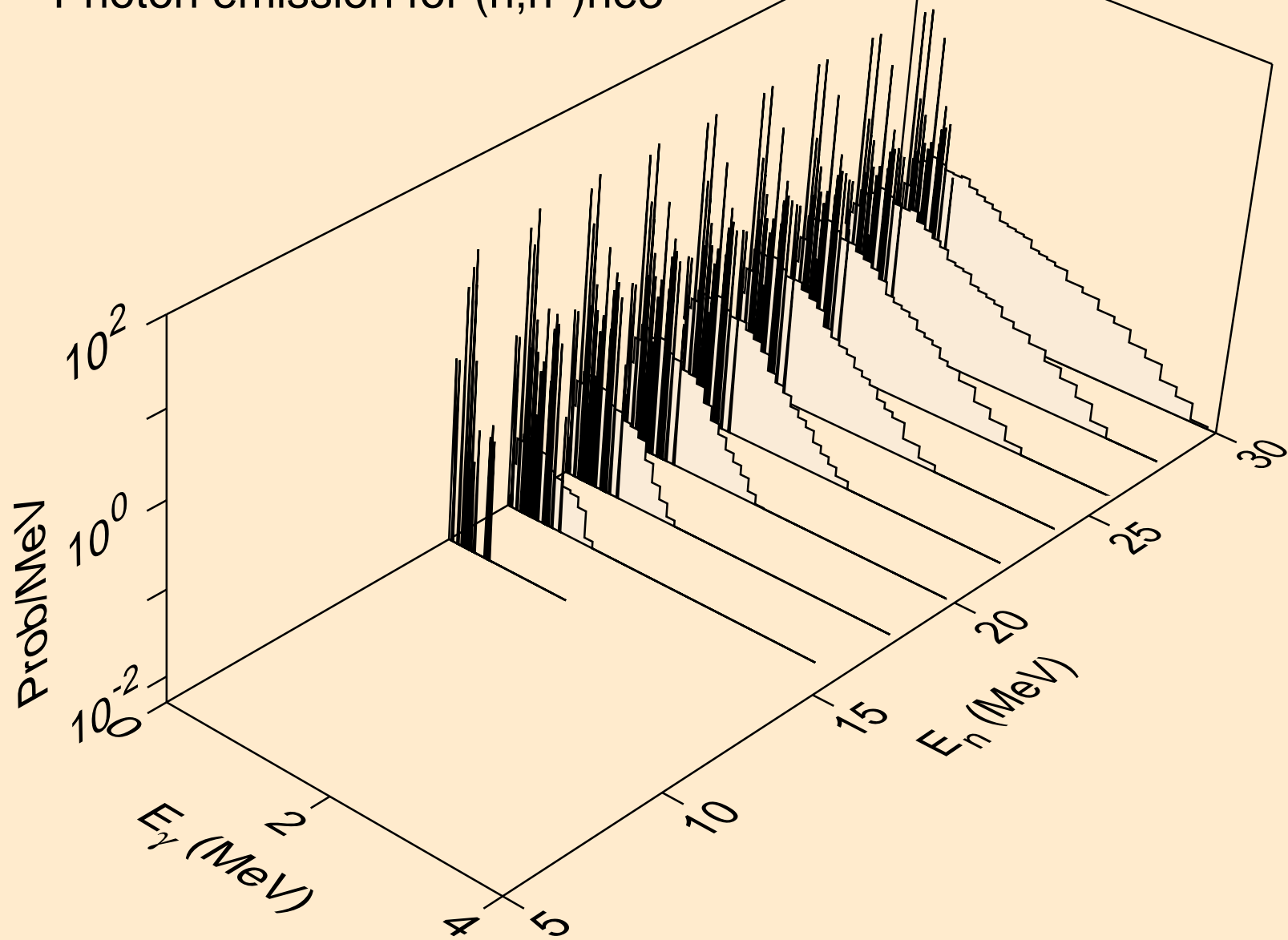

PM138 NEUTRON ACER TENDL-2024 LIBRARY; T=0.K  
Photon emission for (n,2np)

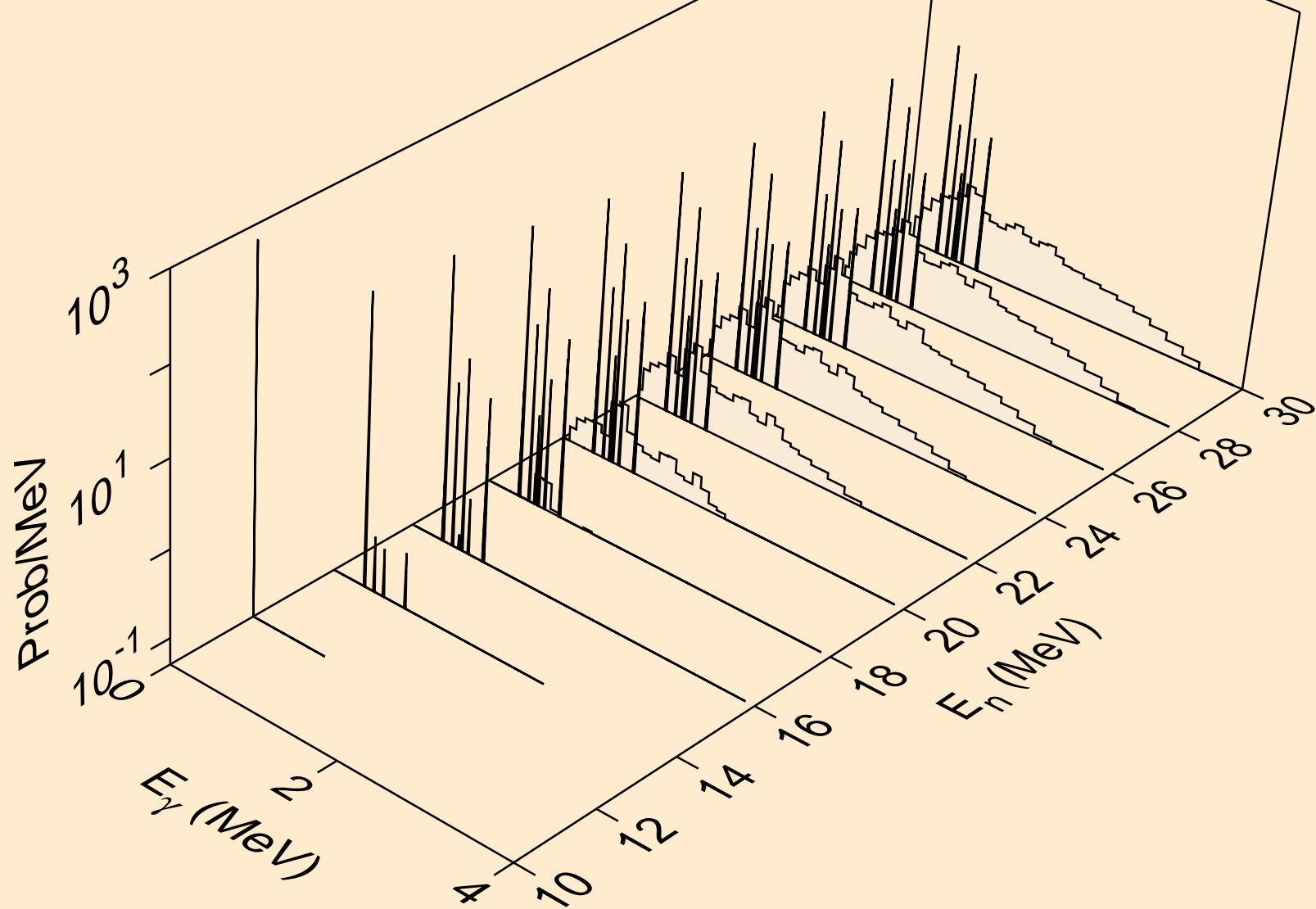

PM138 NEUTRON ACER TENDL-2024 LIBRARY; T=0.K  
Photon emission for (n,3np)

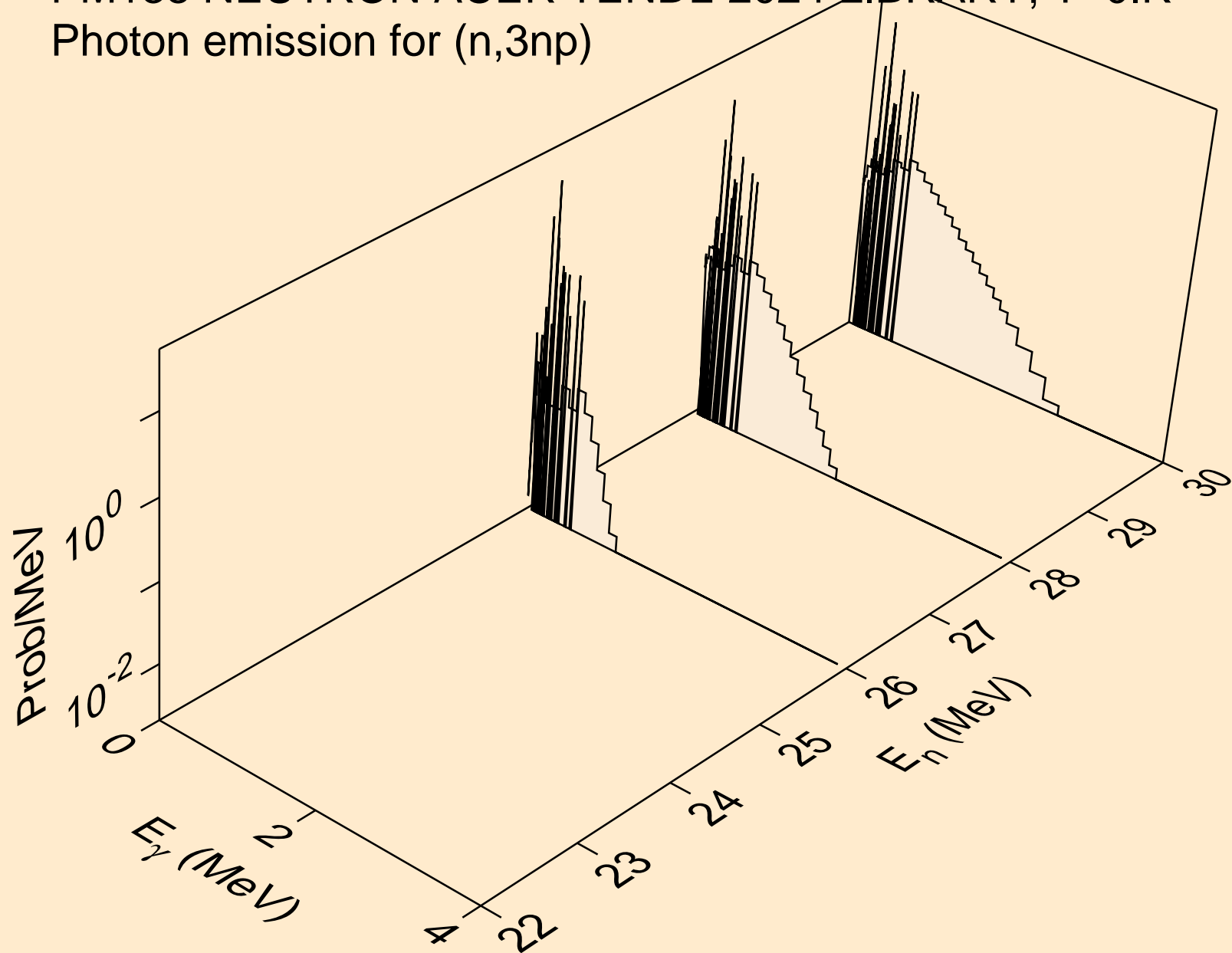



PM138 NEUTRON ACER TENDL-2024 LIBRARY; T=0.K  
Photon emission for (n,n2p)

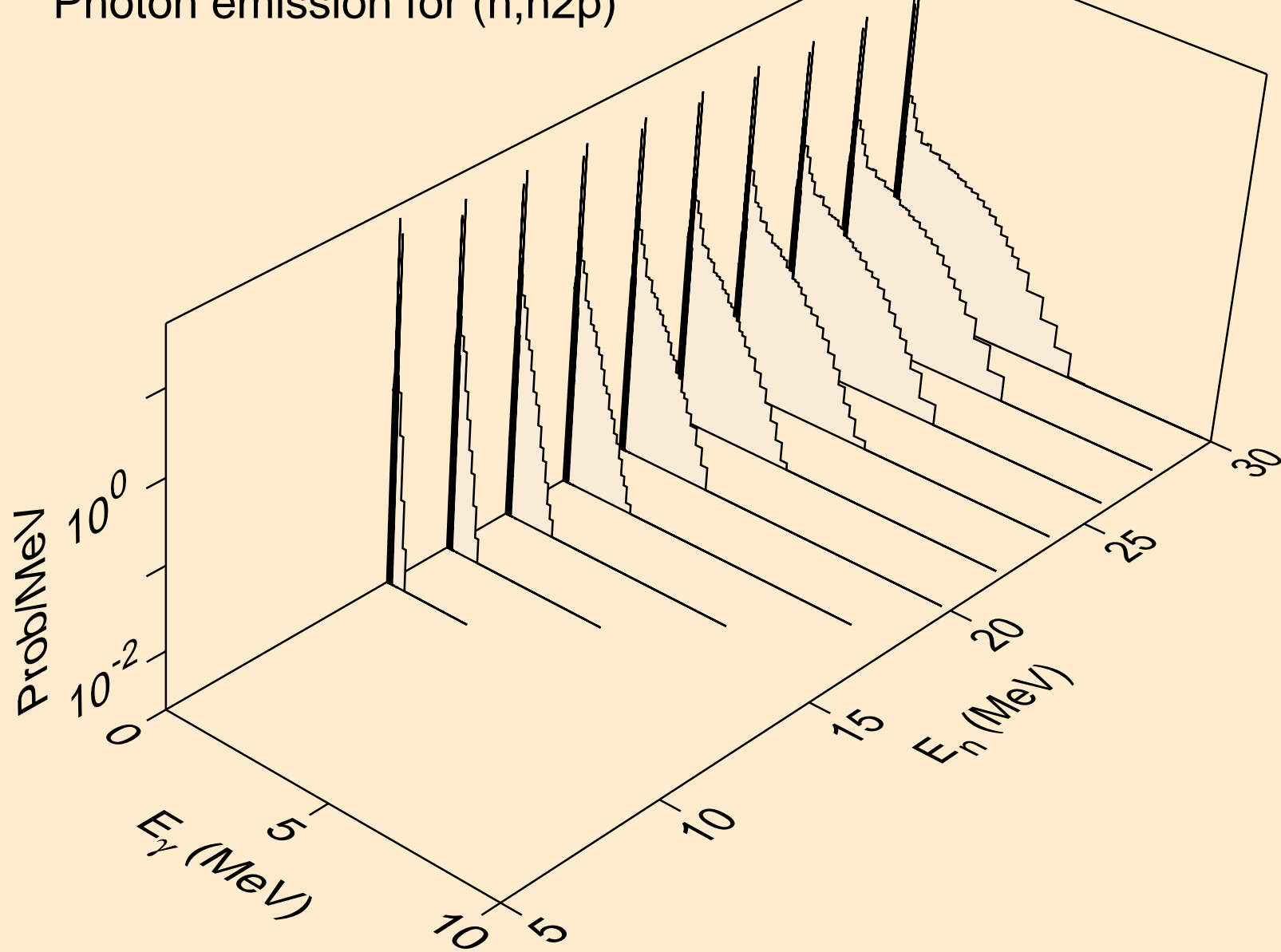

PM138 NEUTRON ACER TENDL-2024 LIBRARY; T=0.K  
Photon emission for (n,npa)

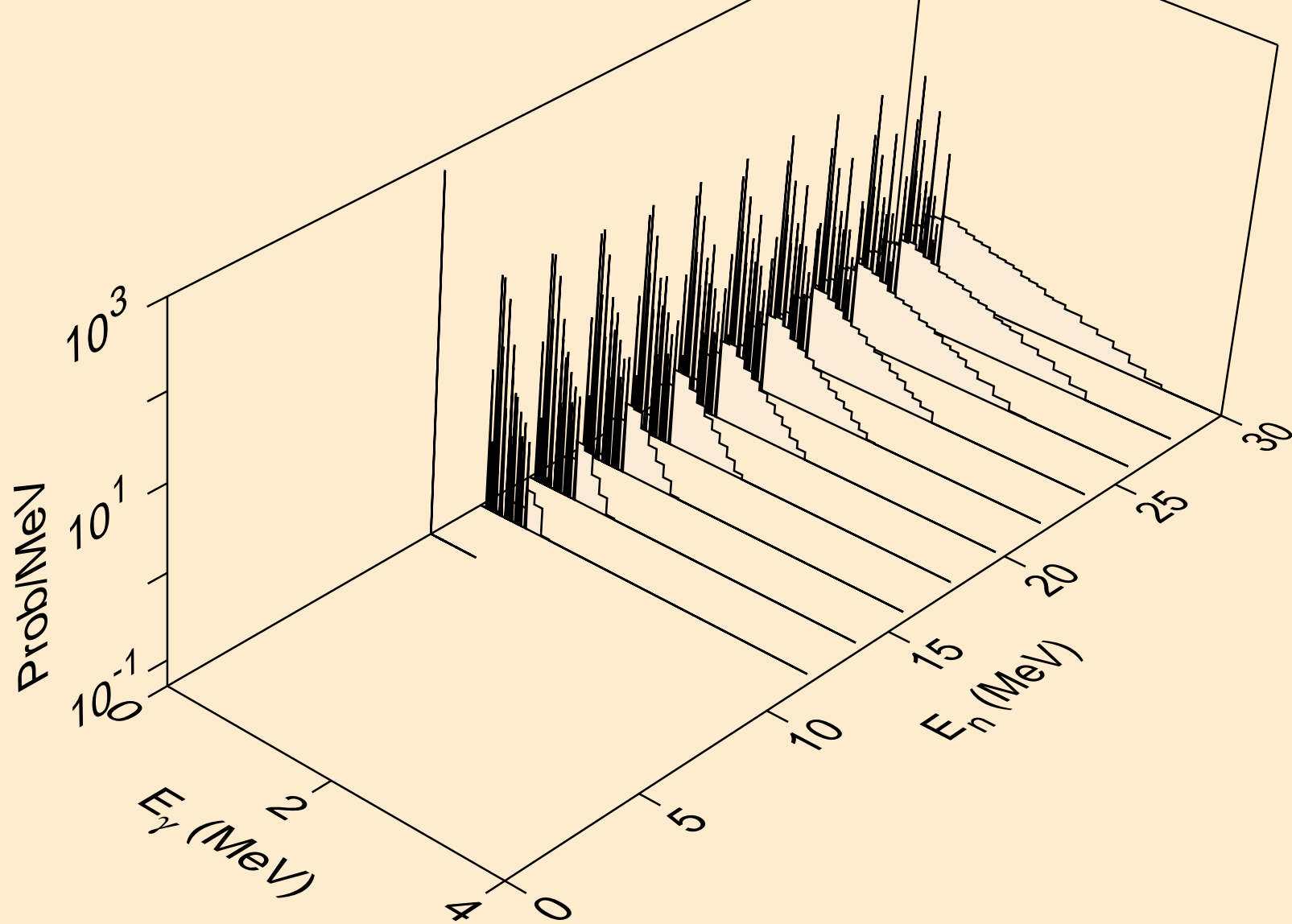

PM138 NEUTRON ACER TENDL-2024 LIBRARY; T=0.K  
Photon emission for (n,n\*c)

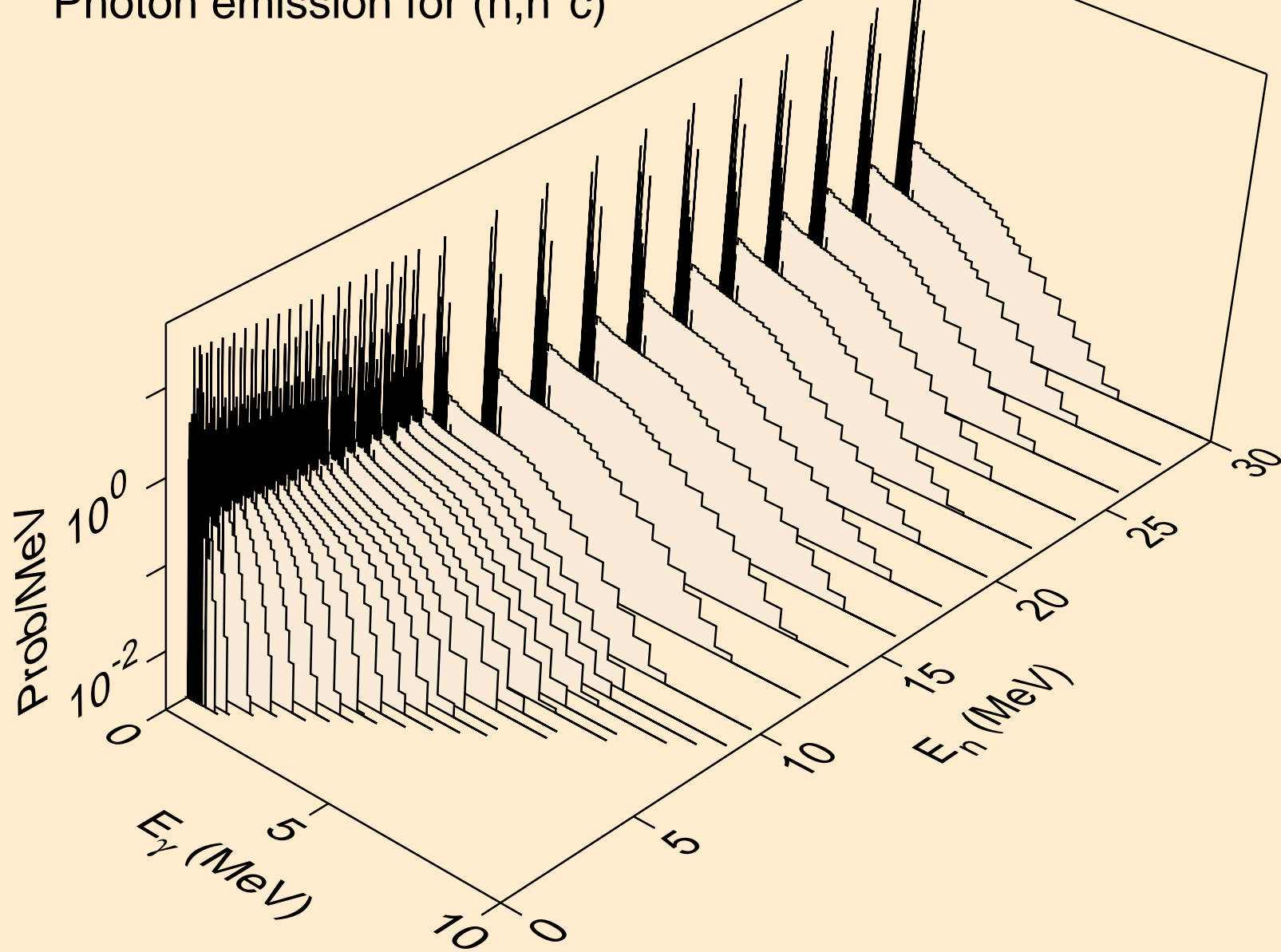

PM138 NEUTRON ACER TENDL-2024 LIBRARY; T=0.K  
Photon emission for (n,gma)

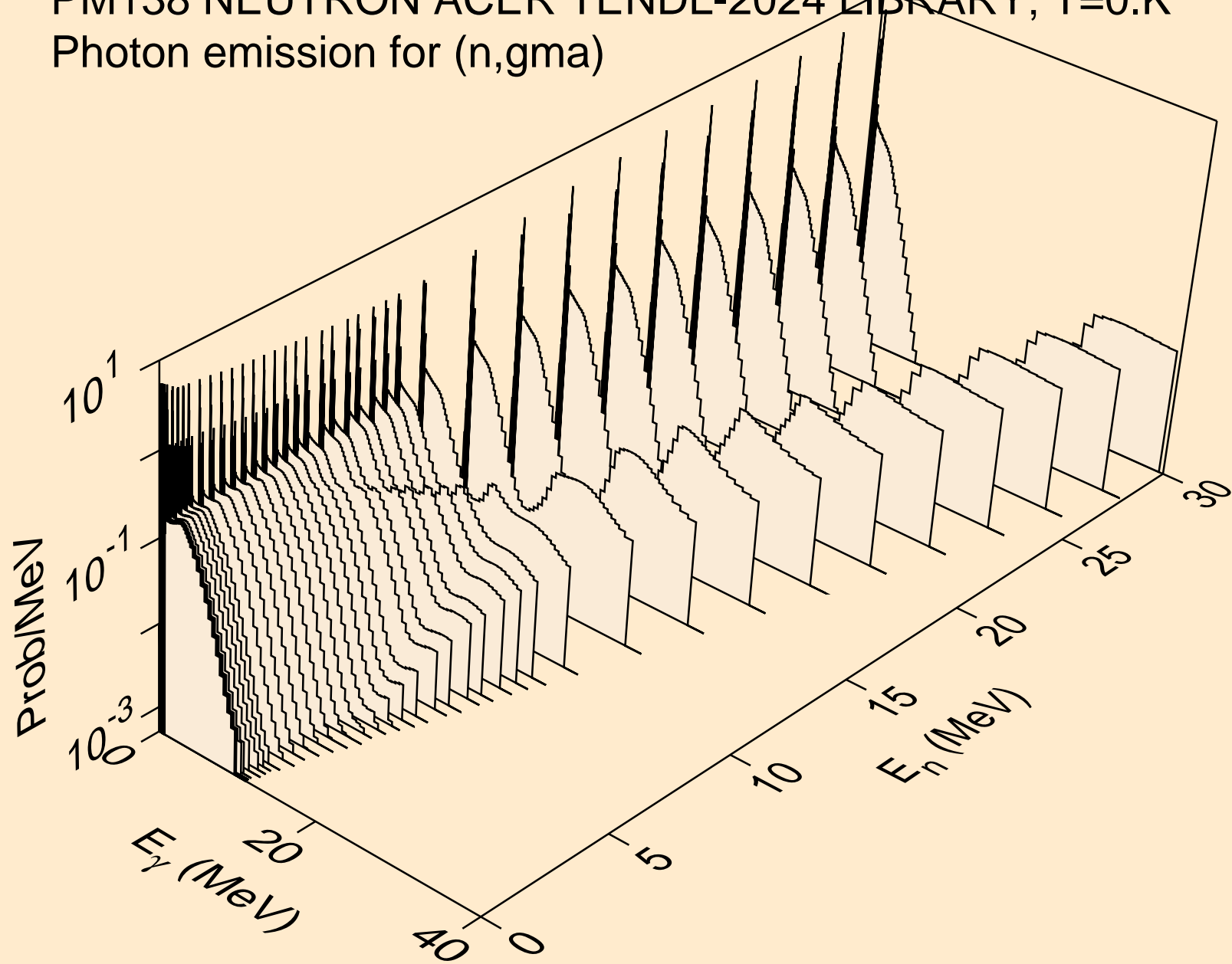

PM138 NEUTRON ACER TENDL-2024 LIBRARY; T=0.K  
Photon emission for (n,p)

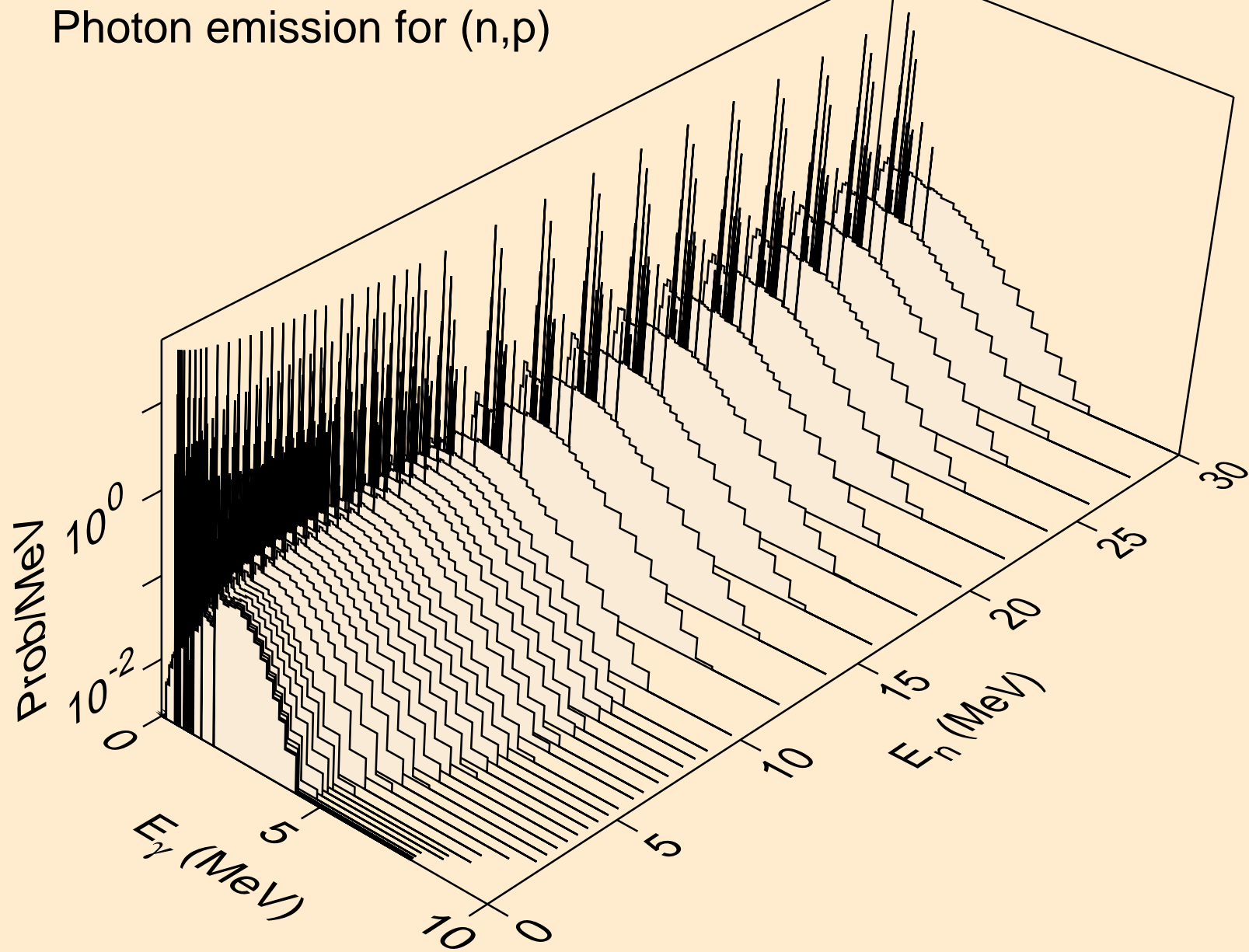

PM138 NEUTRON ACER TENDL-2024 LIBRARY; T=0.K  
Photon emission for (n,d)

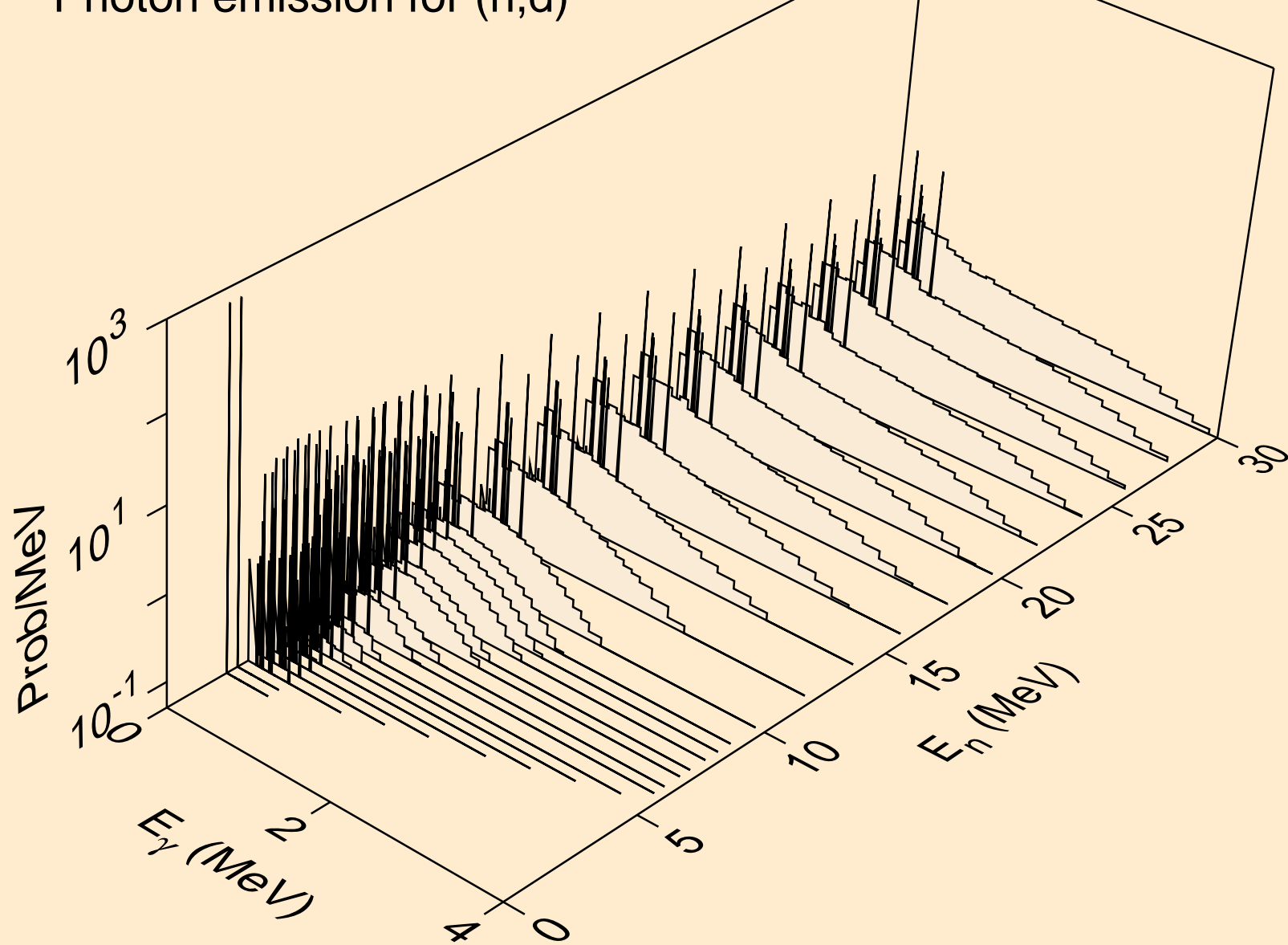

PM138 NEUTRON ACER TENDL-2024 LIBRARY; T=0.K  
Photon emission for (n,t)

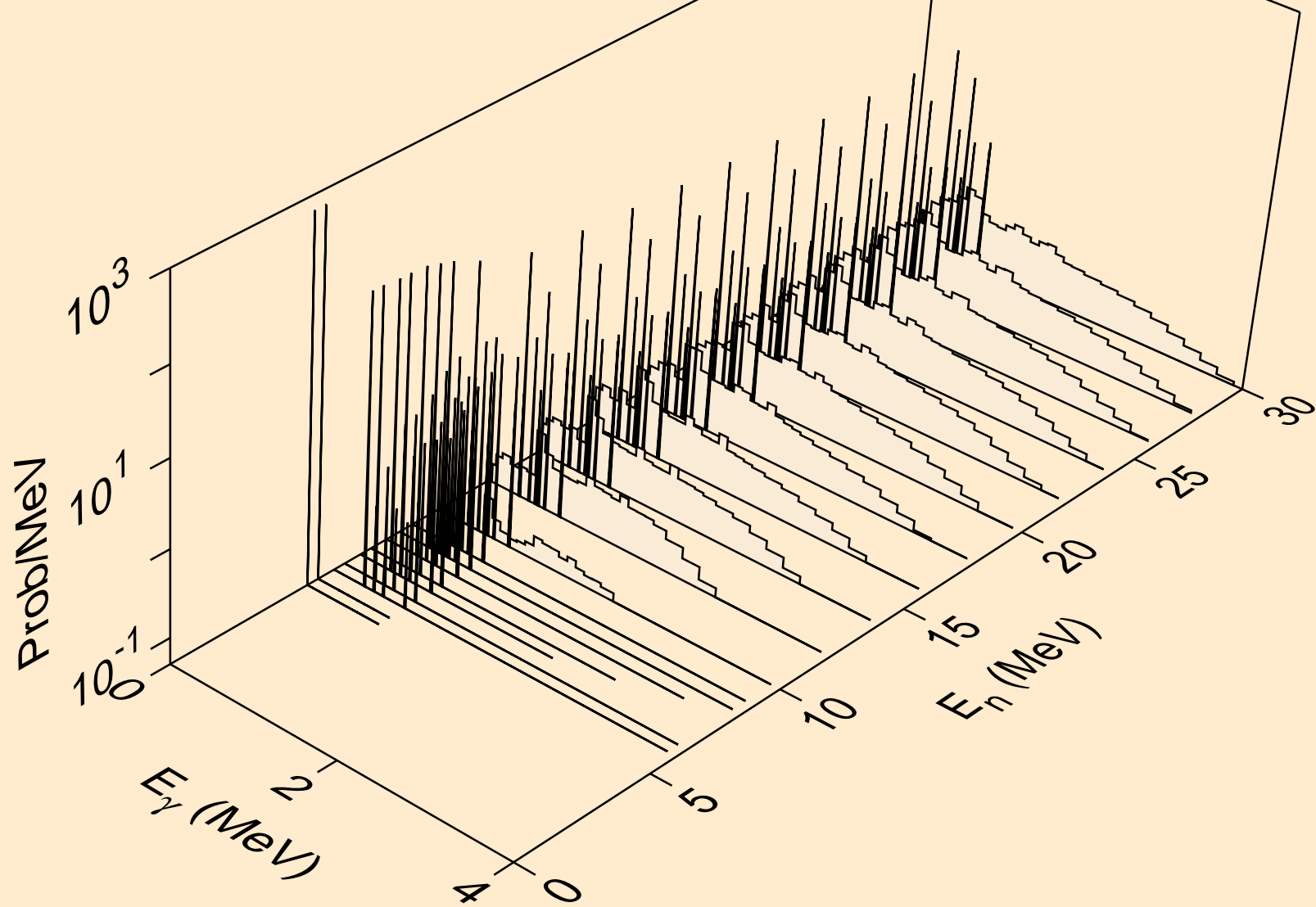

PM138 NEUTRON ACER TENDL-2024 LIBRARY; T=0.K  
Photon emission for (n,he3)

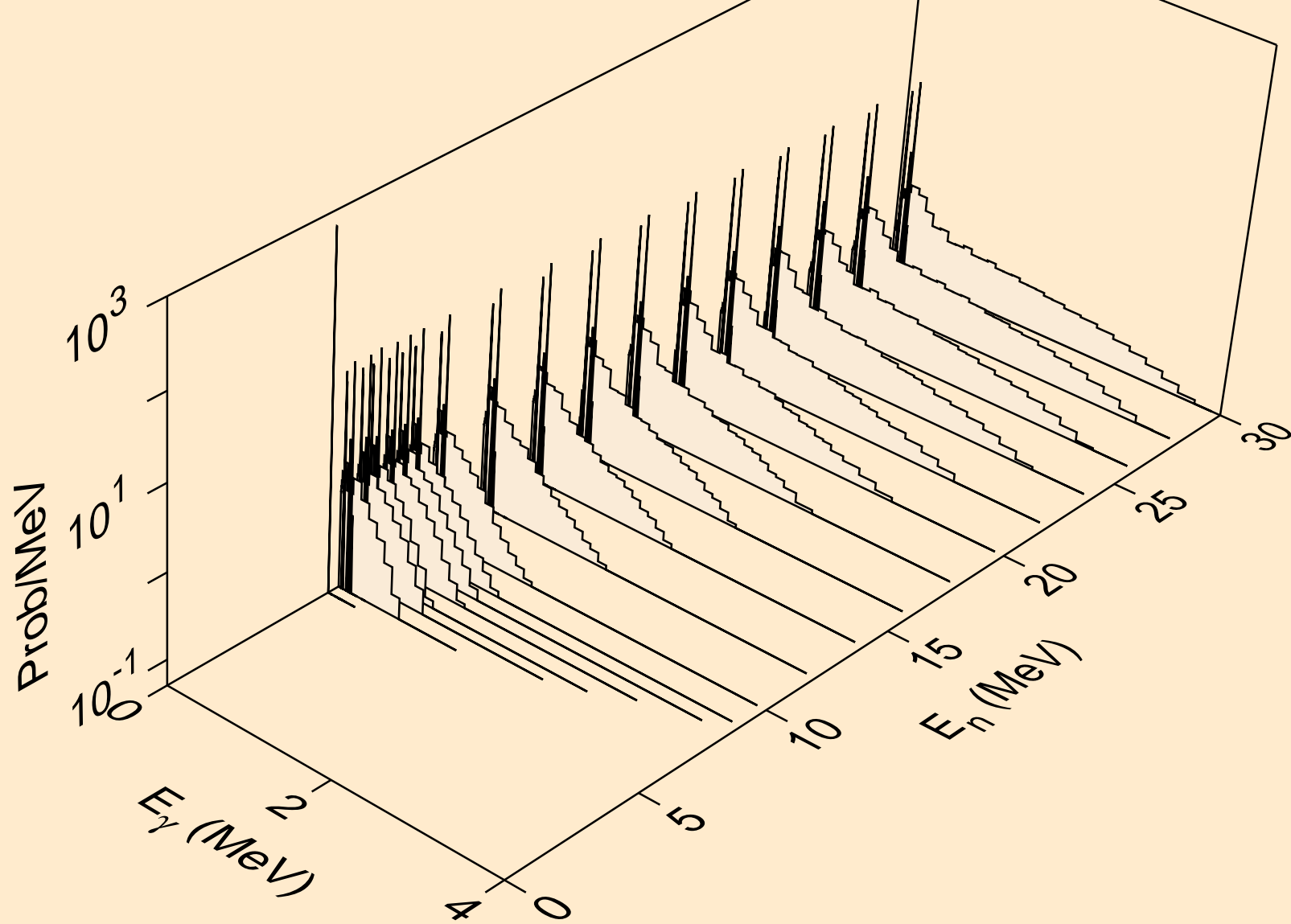



PM138 NEUTRON ACER TENDL-2024 LIBRARY; T=0.K  
Photon emission for (n,a)

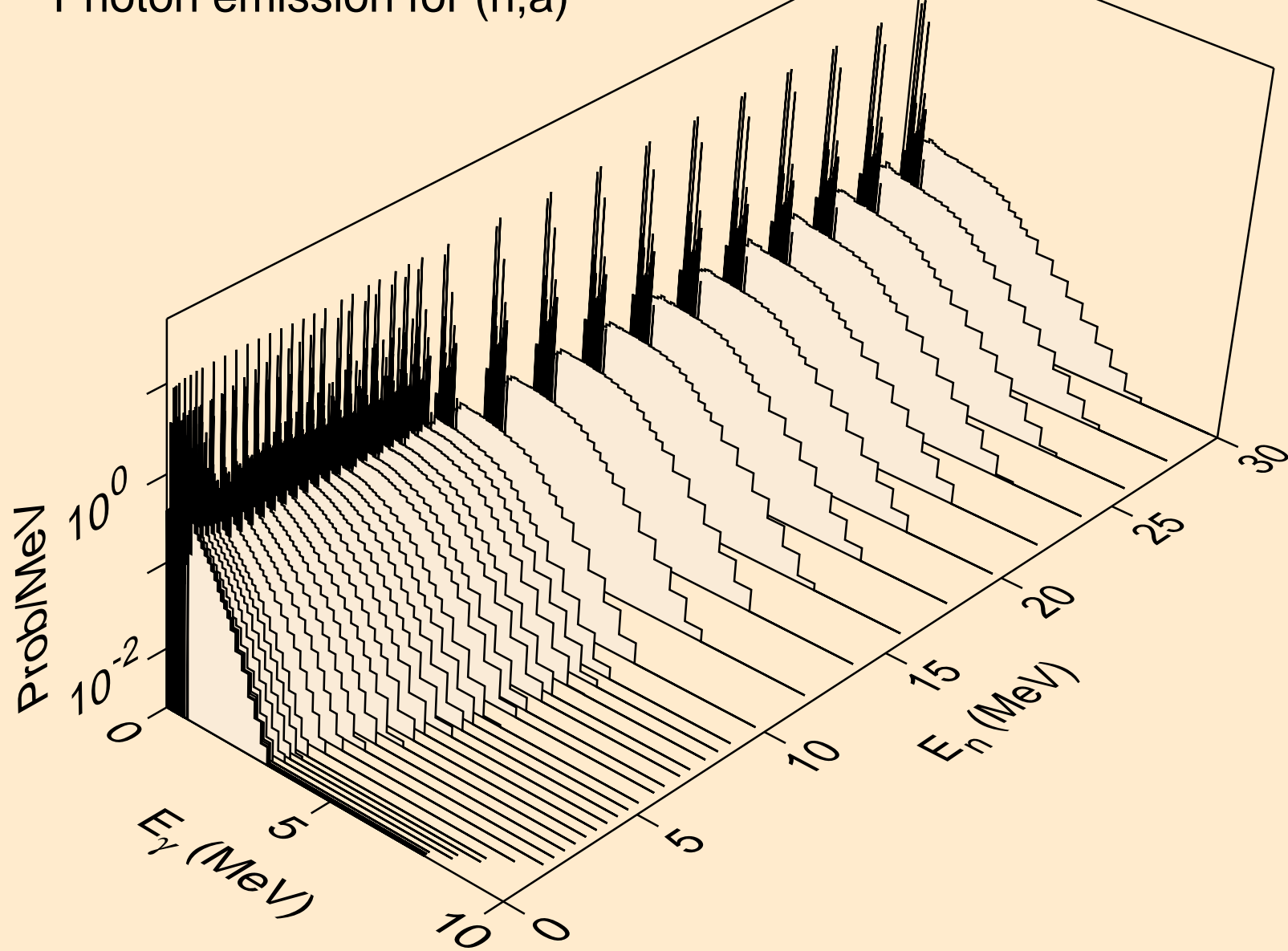

PM138 NEUTRON ACER TENDL-2024 LIBRARY; T=0.K  
Photon emission for (n,2a)

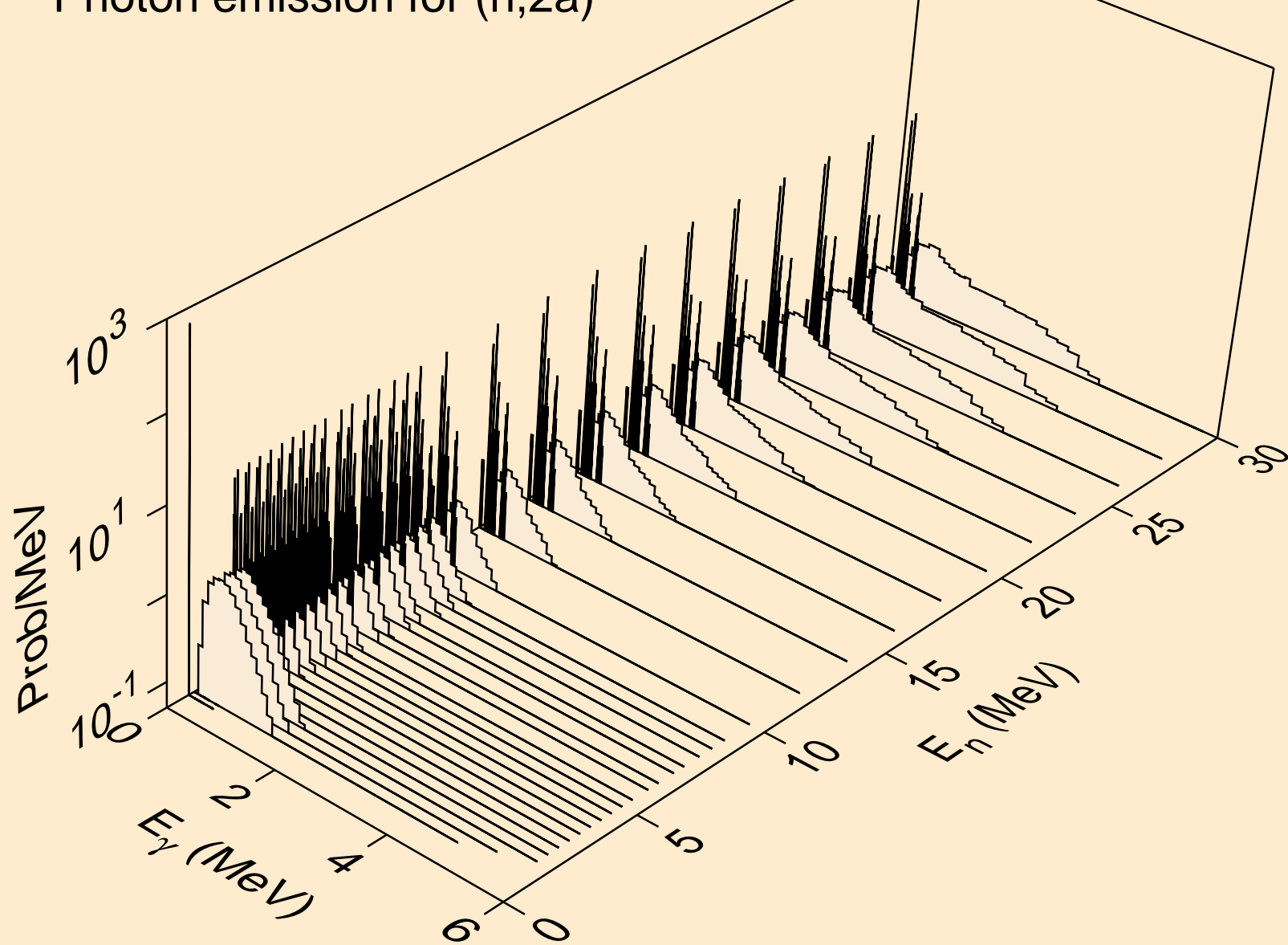

PM138 NEUTRON ACER TENDL-2024 LIBRARY; T=0.K  
Photon emission for (n,3a)

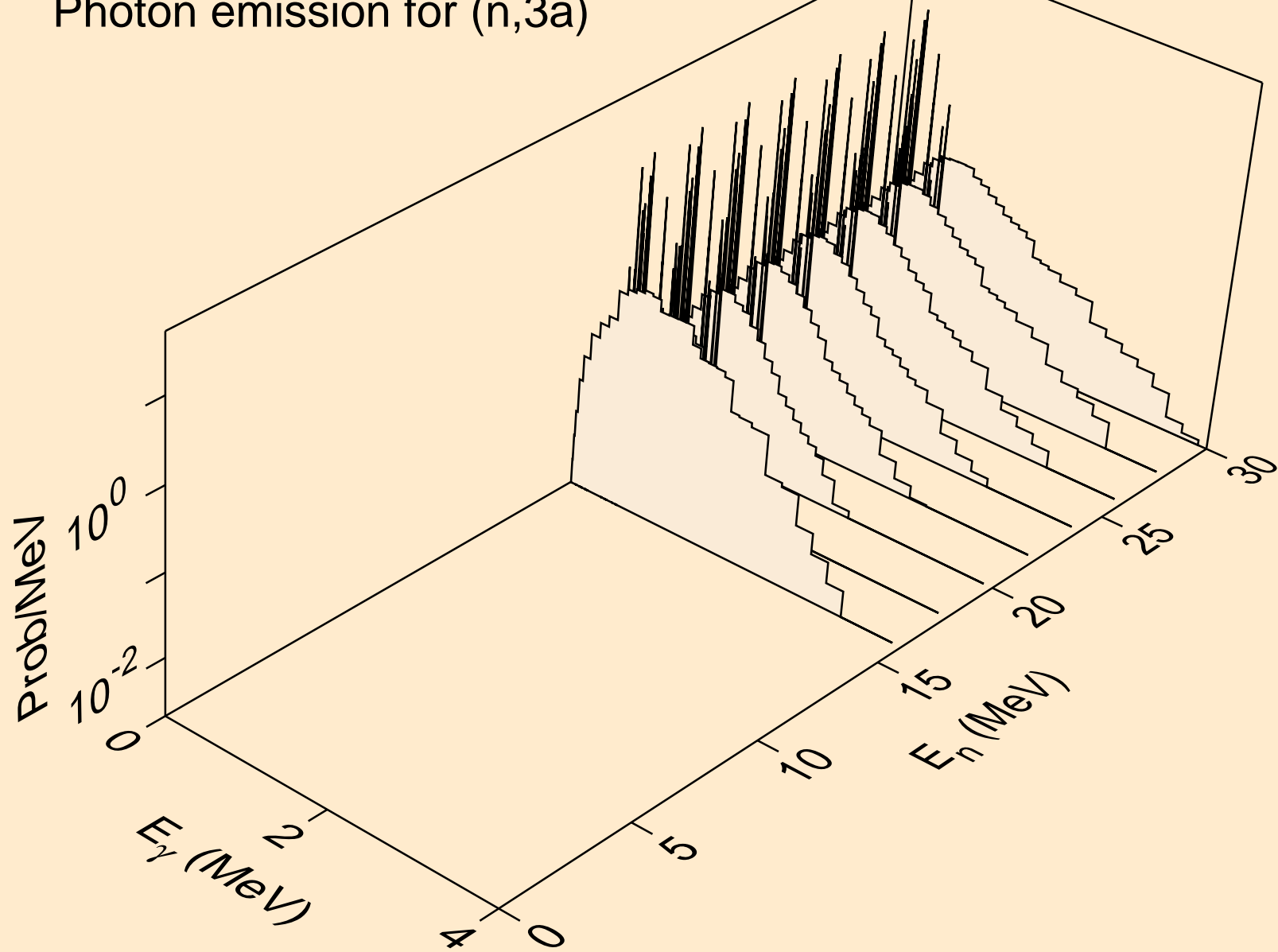

PM138 NEUTRON ACER TENDL-2024 LIBRARY; T=0.K  
Photon emission for (n,2p)

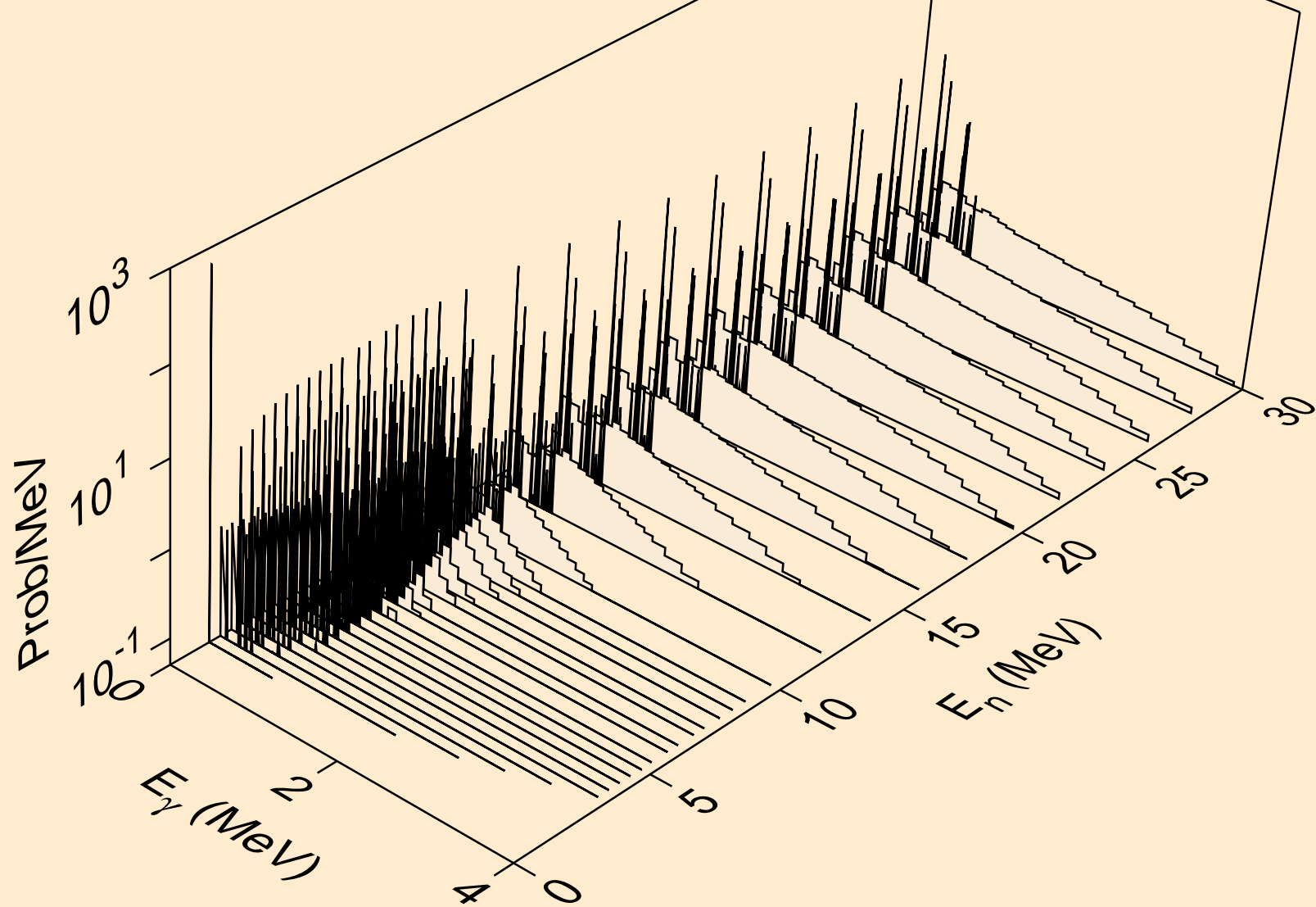

PM138 NEUTRON ACER TENDL-2024 LIBRARY; T=0.K  
Photon emission for (n,p $\alpha$ )

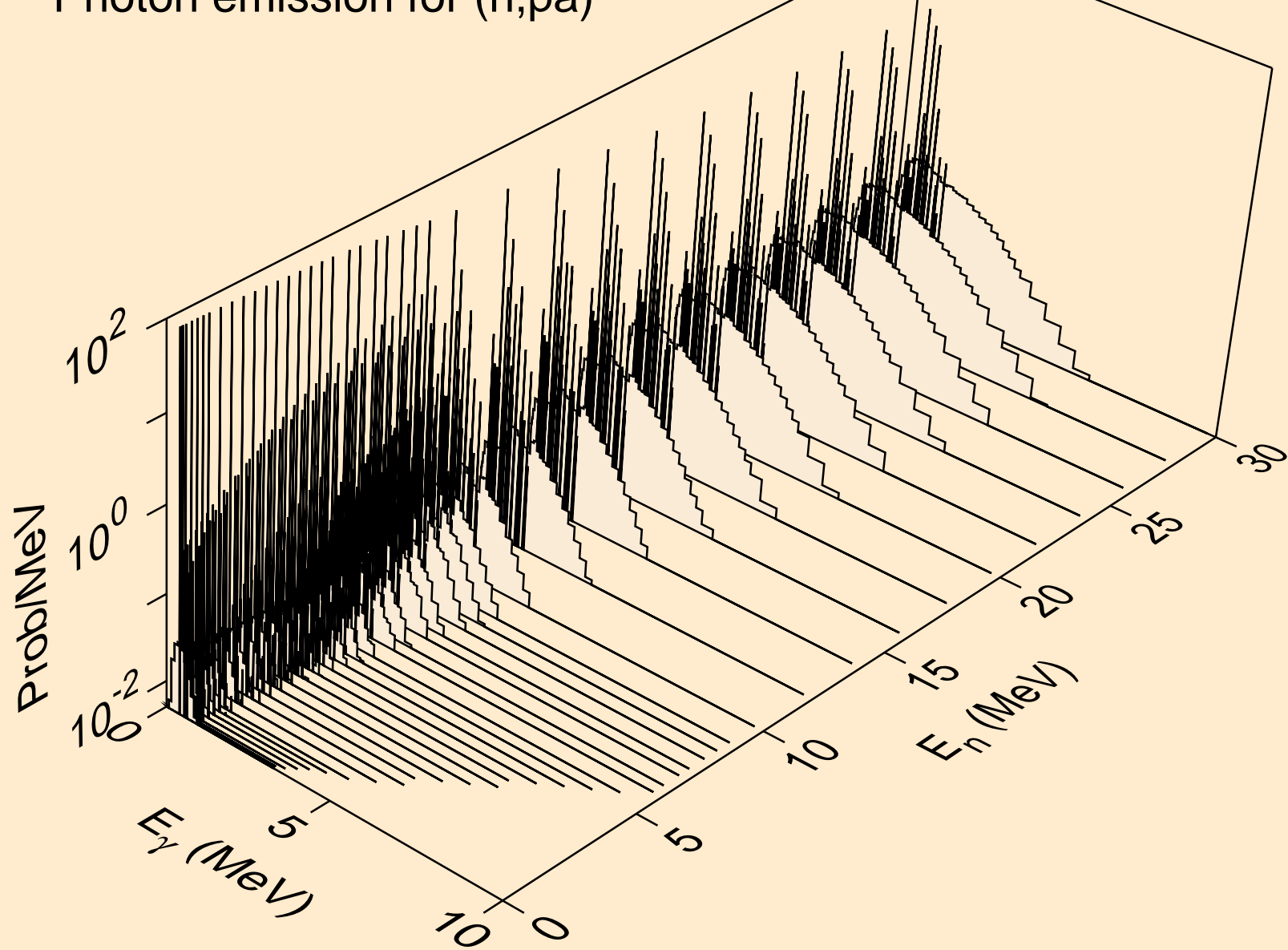

PM138 NEUTRON ACER TENDL-2024 LIBRARY; T=0.K  
Photon emission for (n,pd)

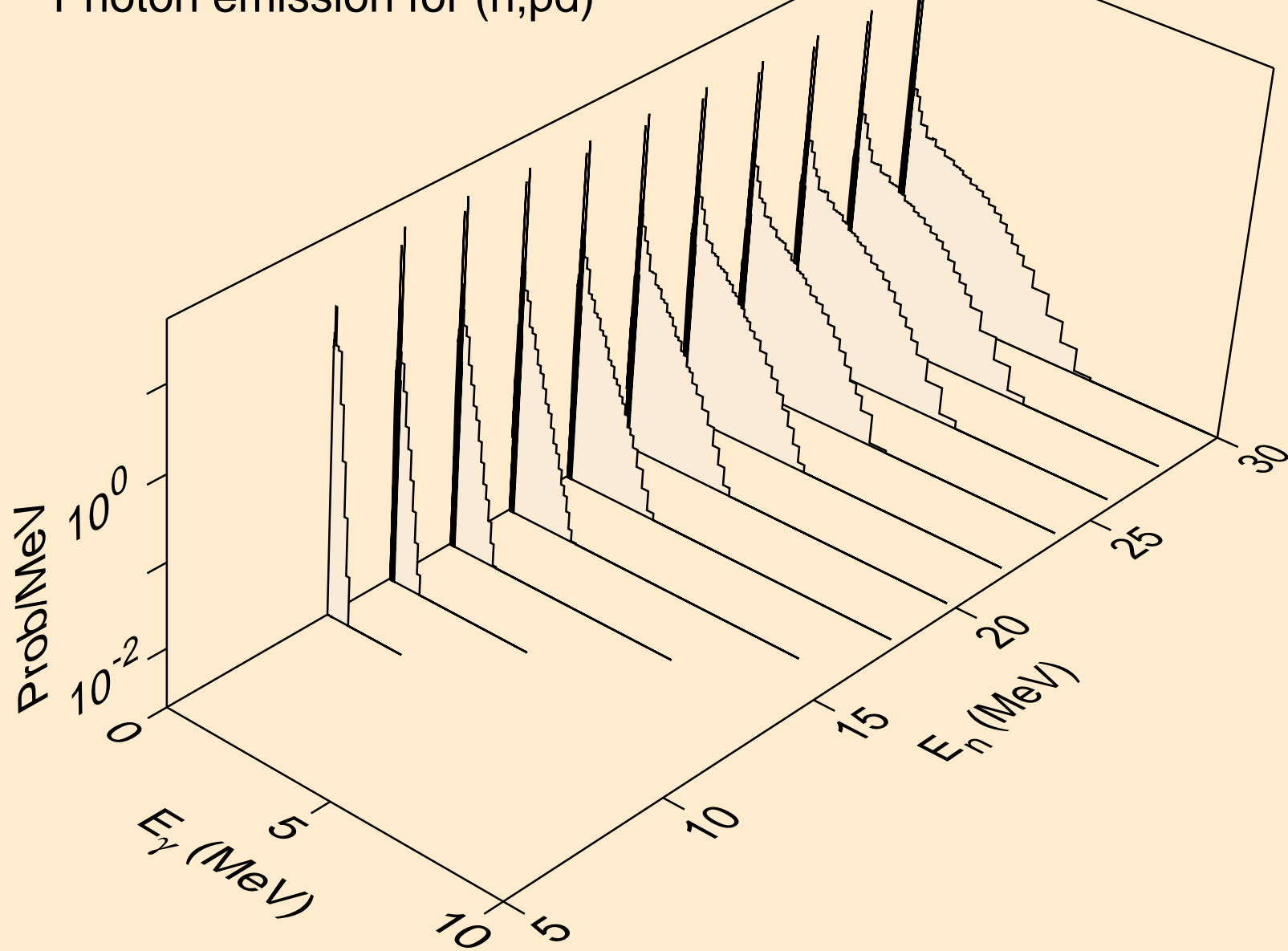

PM138 NEUTRON ACER TENDL-2024 LIBRARY; T=0.K  
Photon emission for (n,pt)

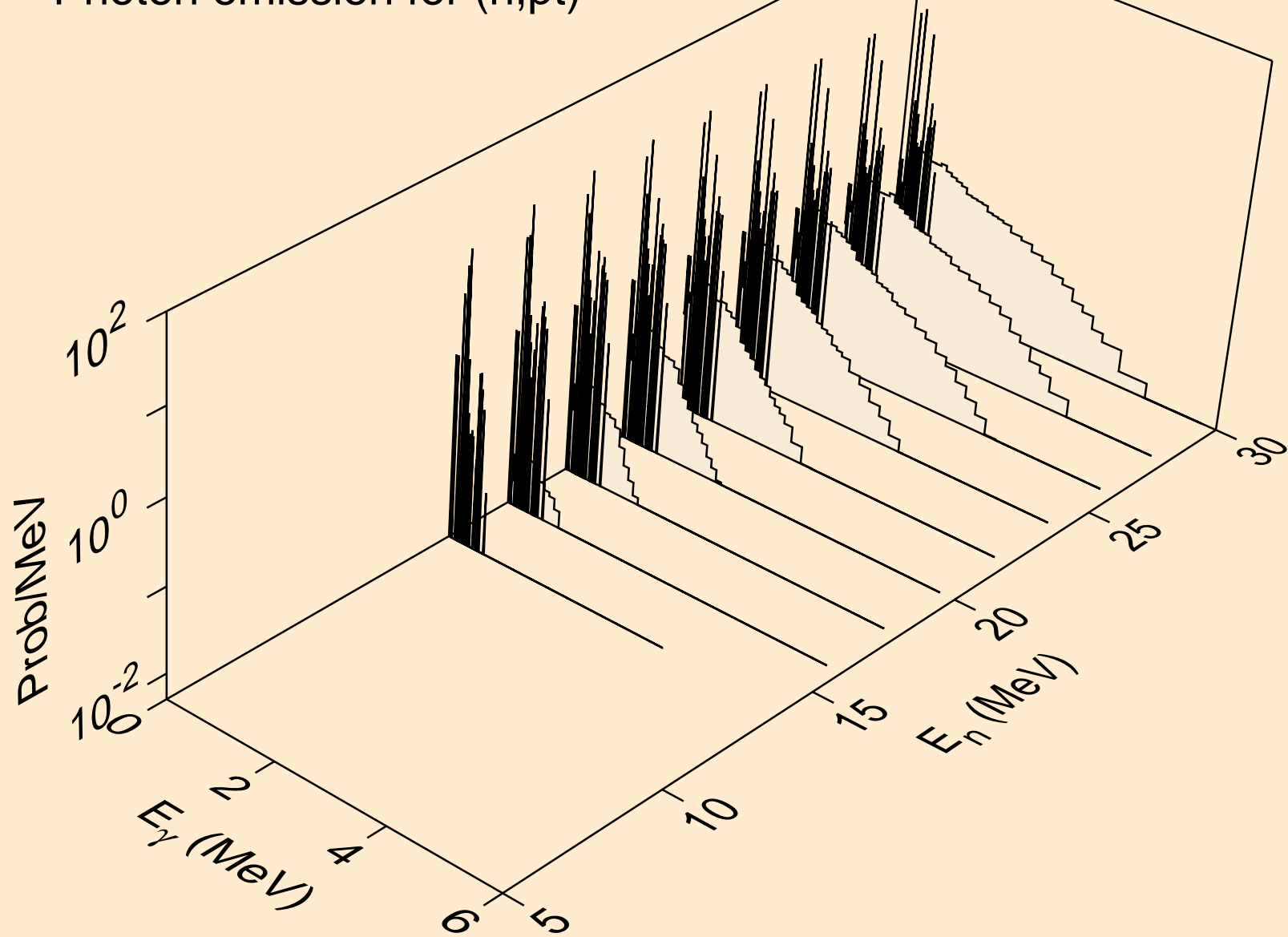

PM138 NEUTRON ACER TENDL-2024 LIBRARY; T=0.K  
Photon emission for (n,da)

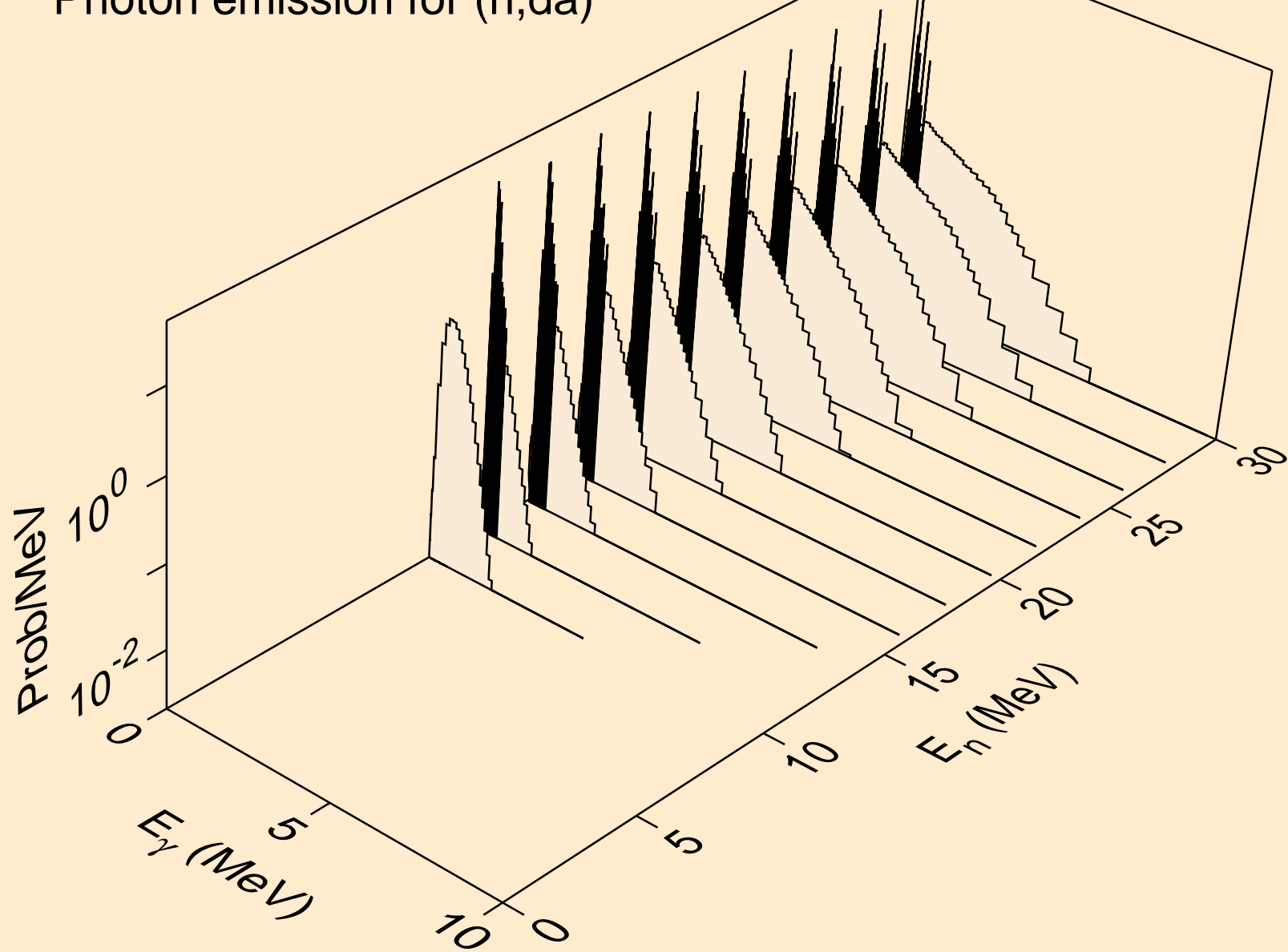



PM138 NEUTRON ACER TENDL-2024 LIBRARY; T=0.K  
thermal capture photon spectrum

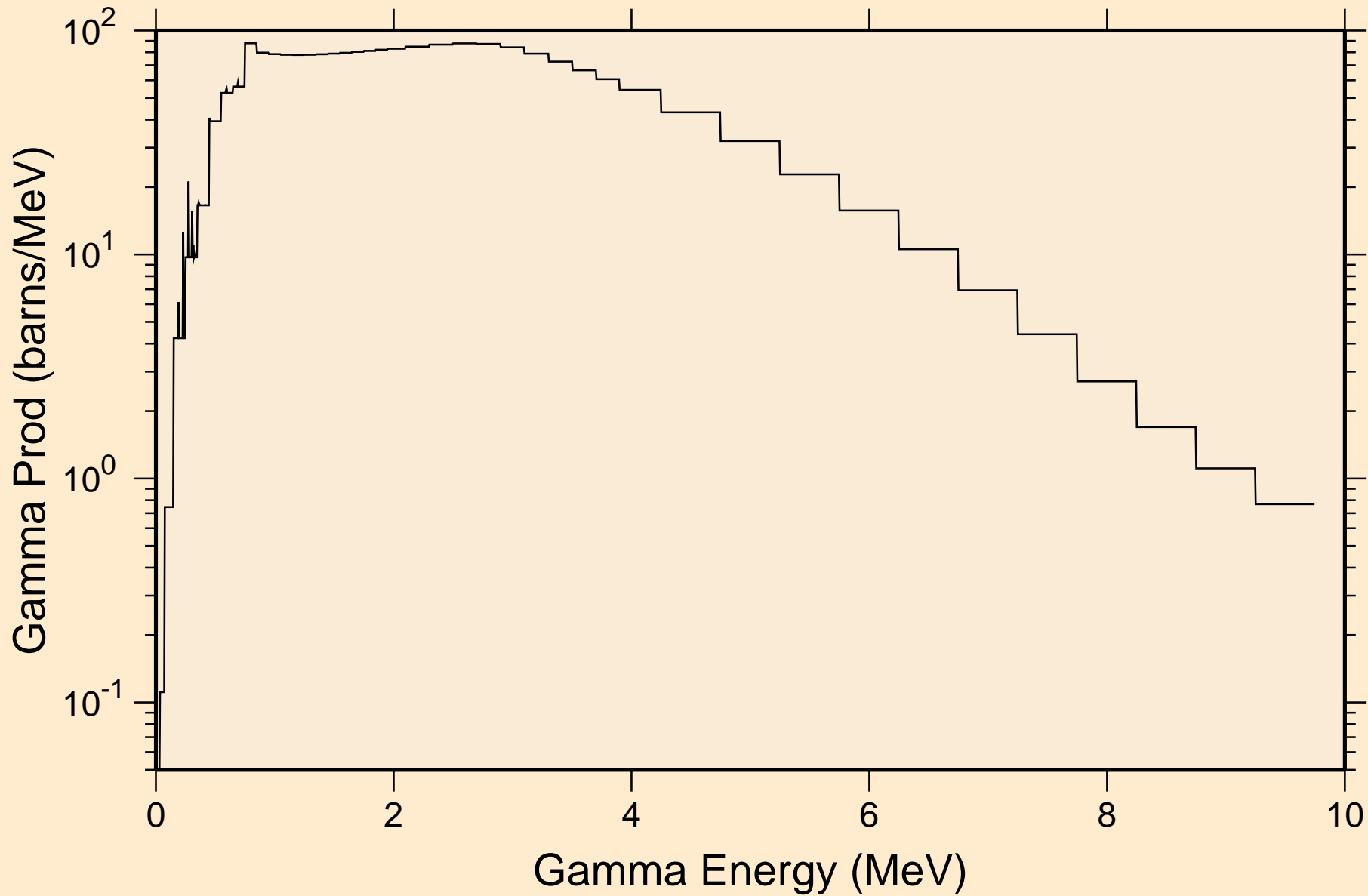

PM138 NEUTRON ACER TENDL-2024 LIBRARY; T=0.K  
14 MeV photon spectrum

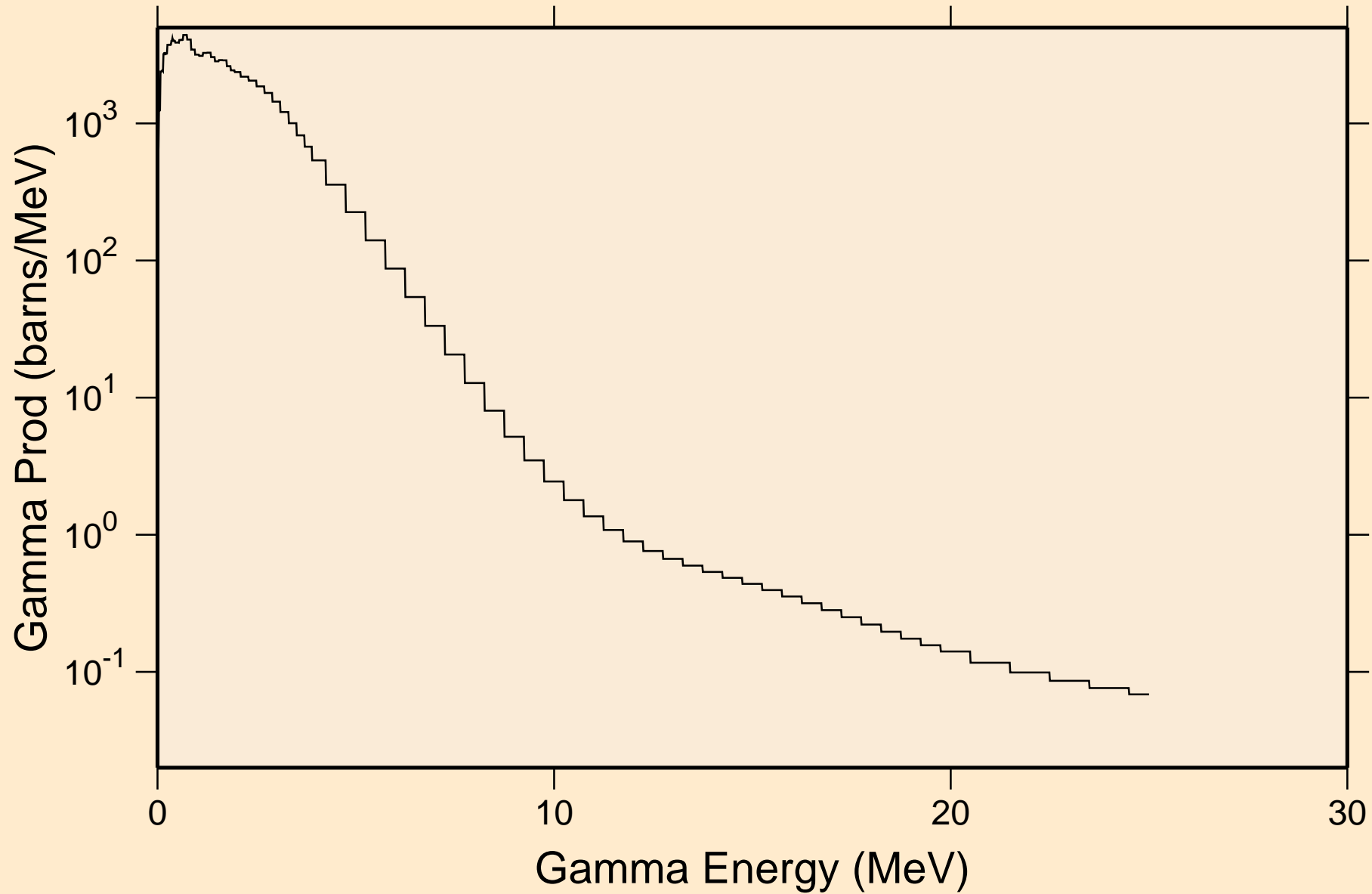

# PM138 NEUTRON ACER TENDL-2024 LIBRARY; T=0.K

## Particle heating contributions

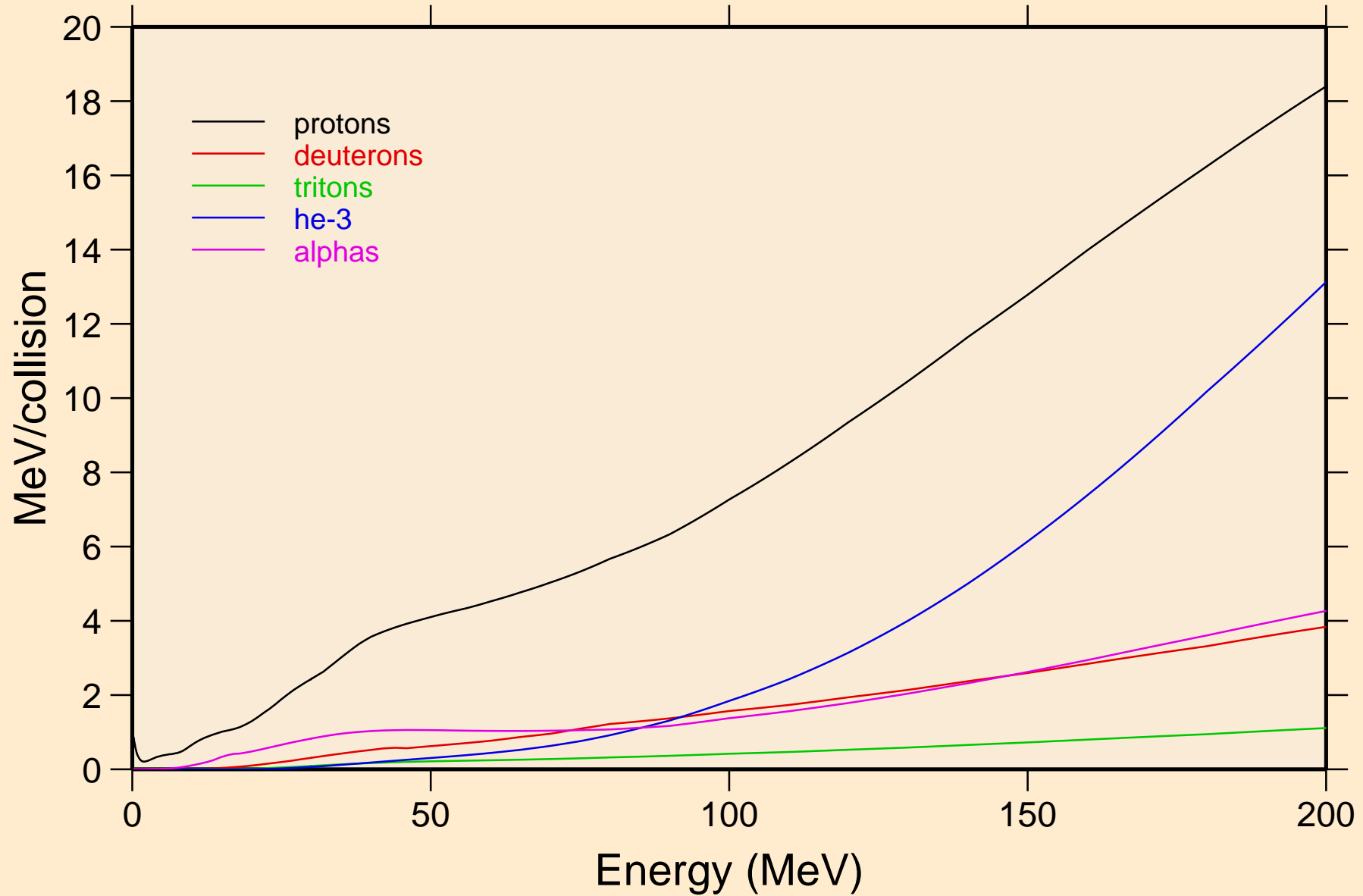

PM138 NEUTRON ACER TENDL-2024 LIBRARY; T=0.K  
Recoil Heating

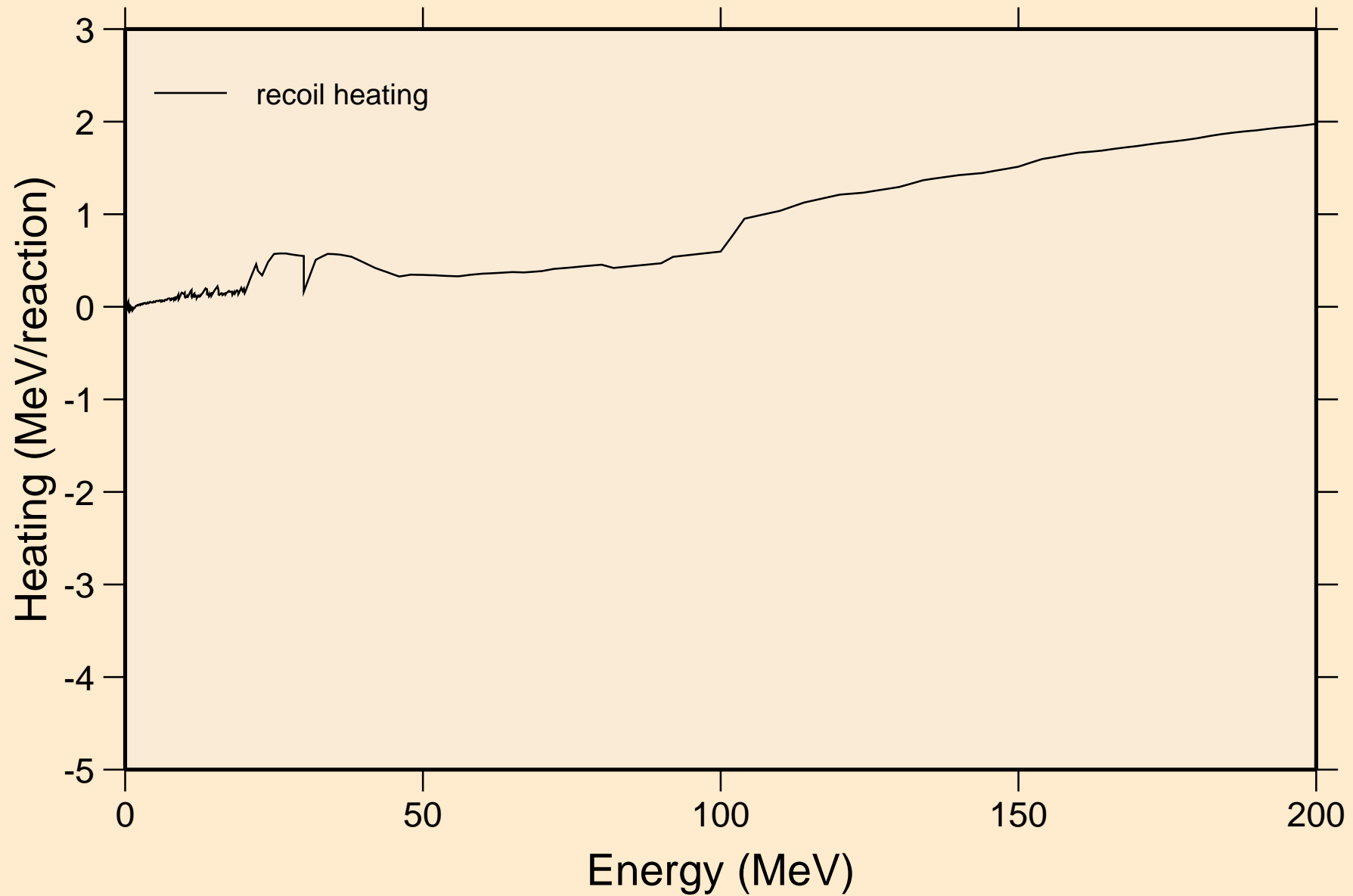

# PM138 NEUTRON ACER TENDL-2024 LIBRARY; T=0.K

## Particle production cross sections

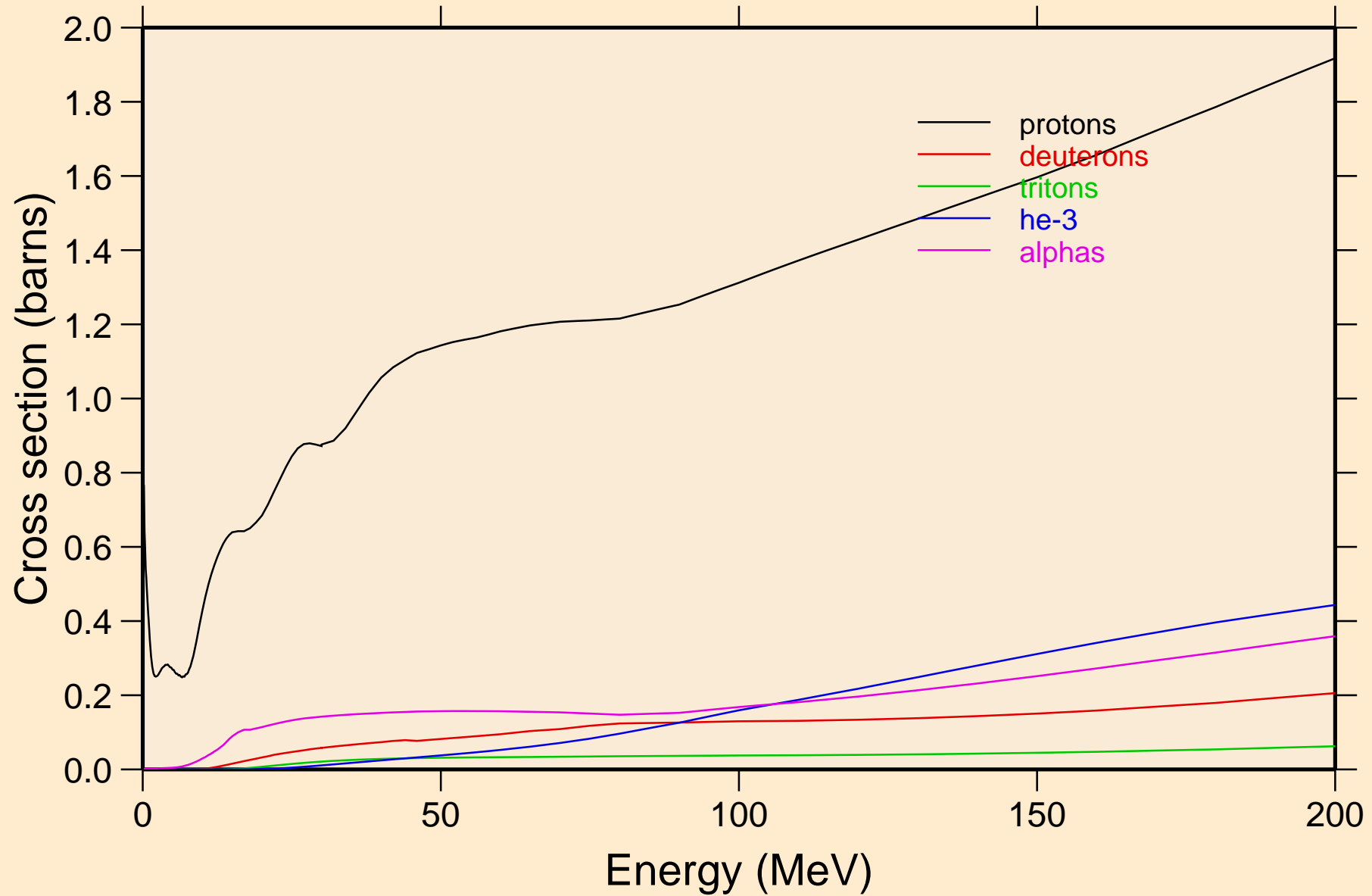

PM138 NEUTRON ACER TENDL-2024 LIBRARY; T=0.K  
protons from (n,x)

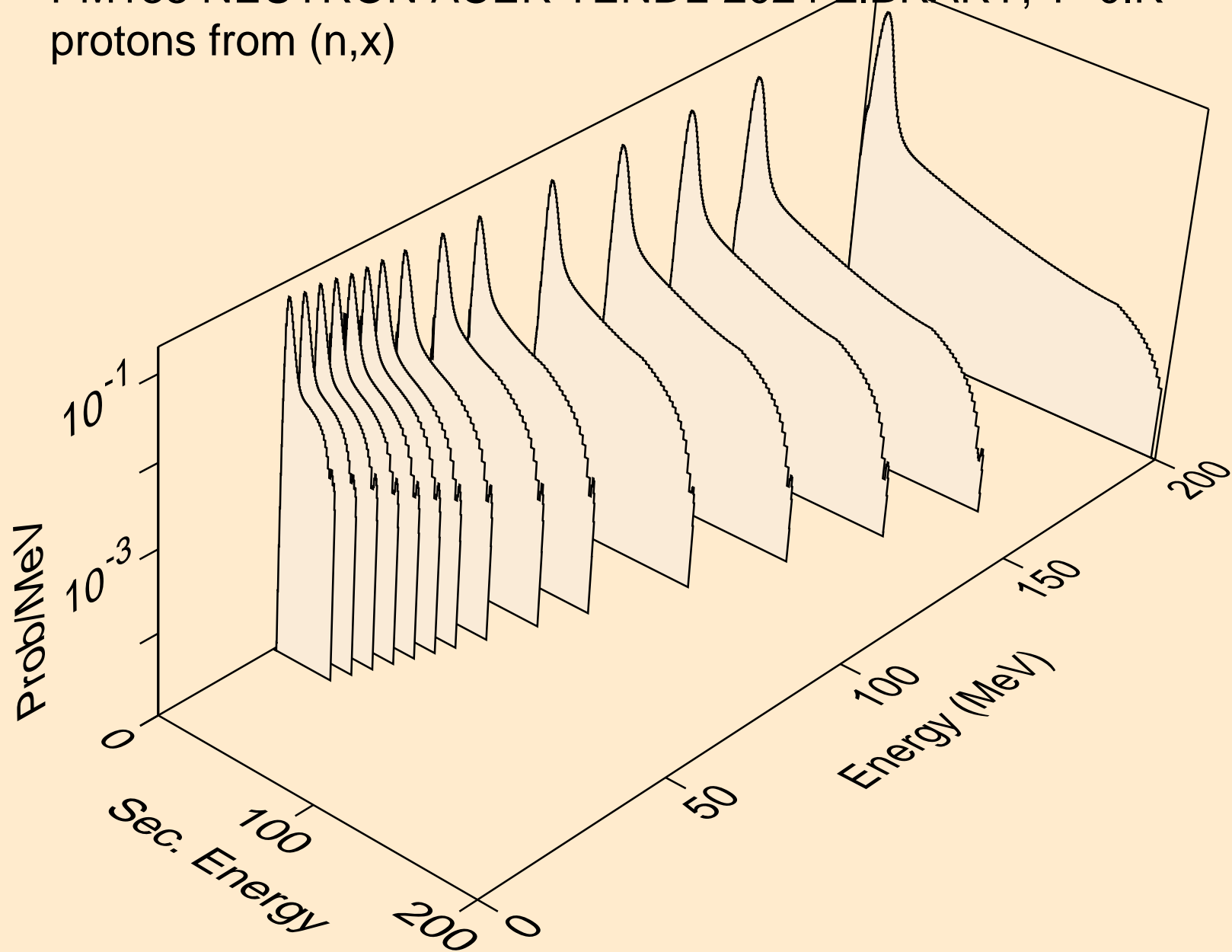

PM138 NEUTRON ACER TENDL-2024 LIBRARY; T=0.K  
protons from (n,n\*)p

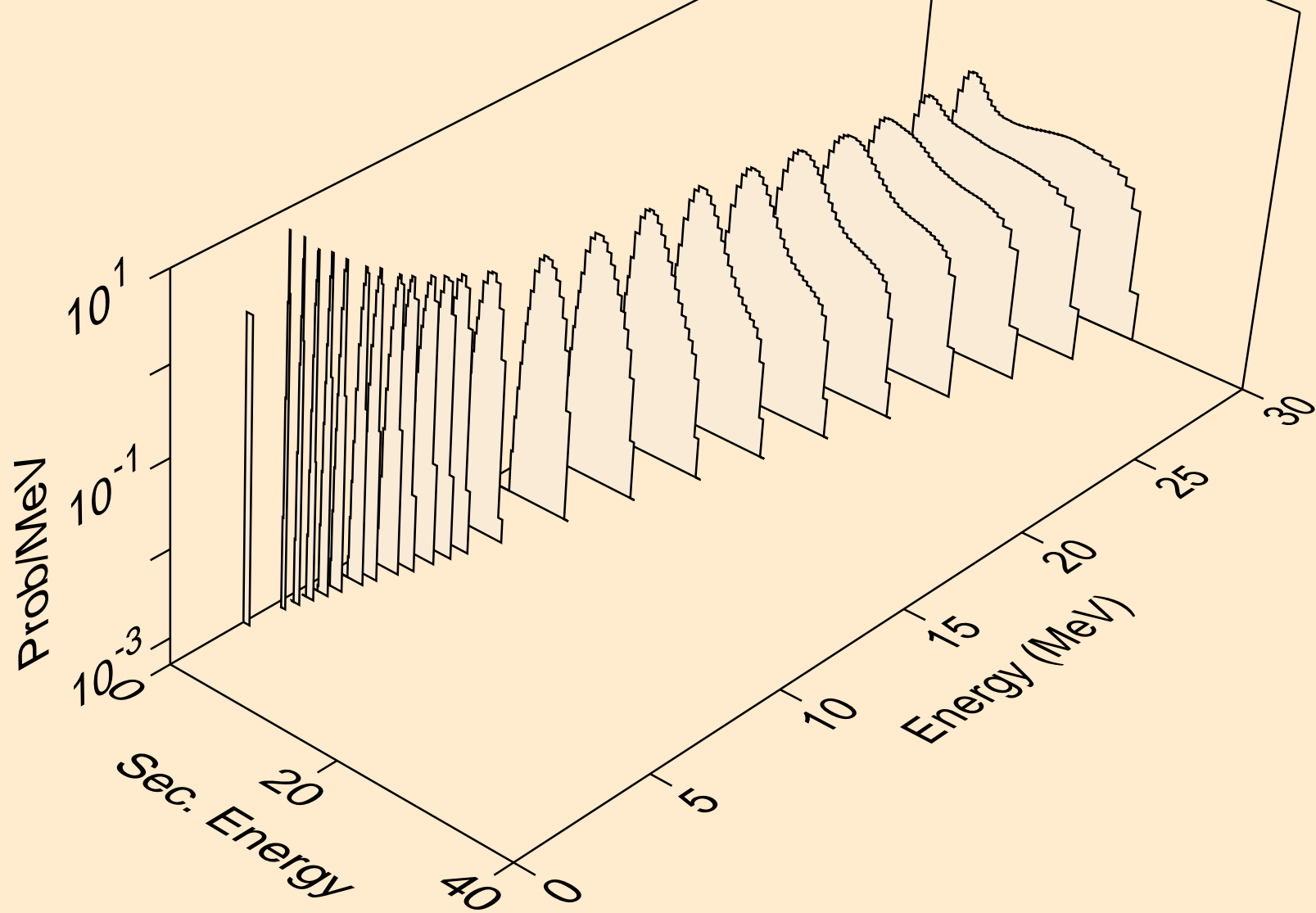

PM138 NEUTRON ACER TENDL-2024 LIBRARY; T=0.K  
protons from (n,2np)

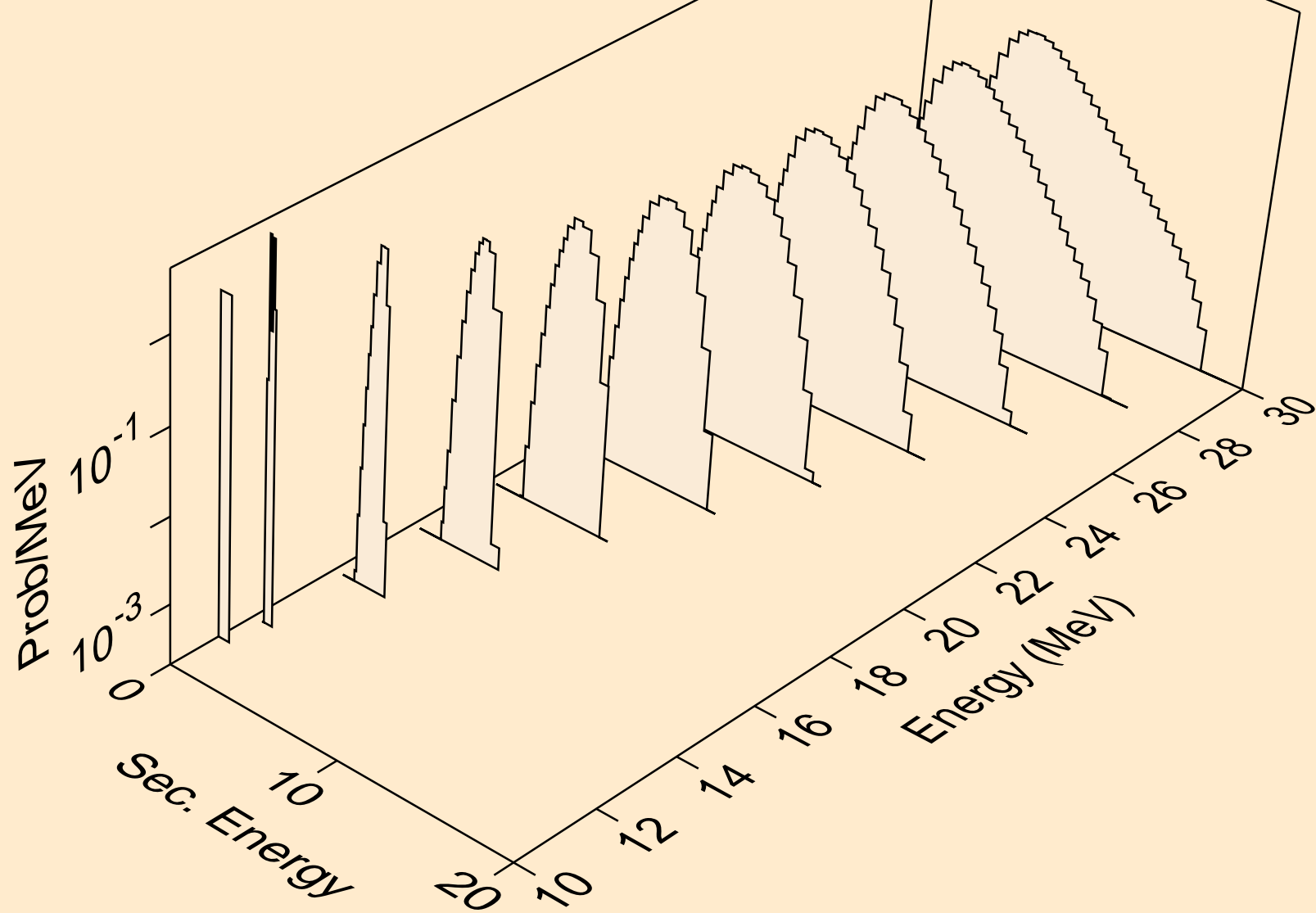



PM138 NEUTRON ACER TENDL-2024 LIBRARY; T=0.K  
protons from (n,3np)

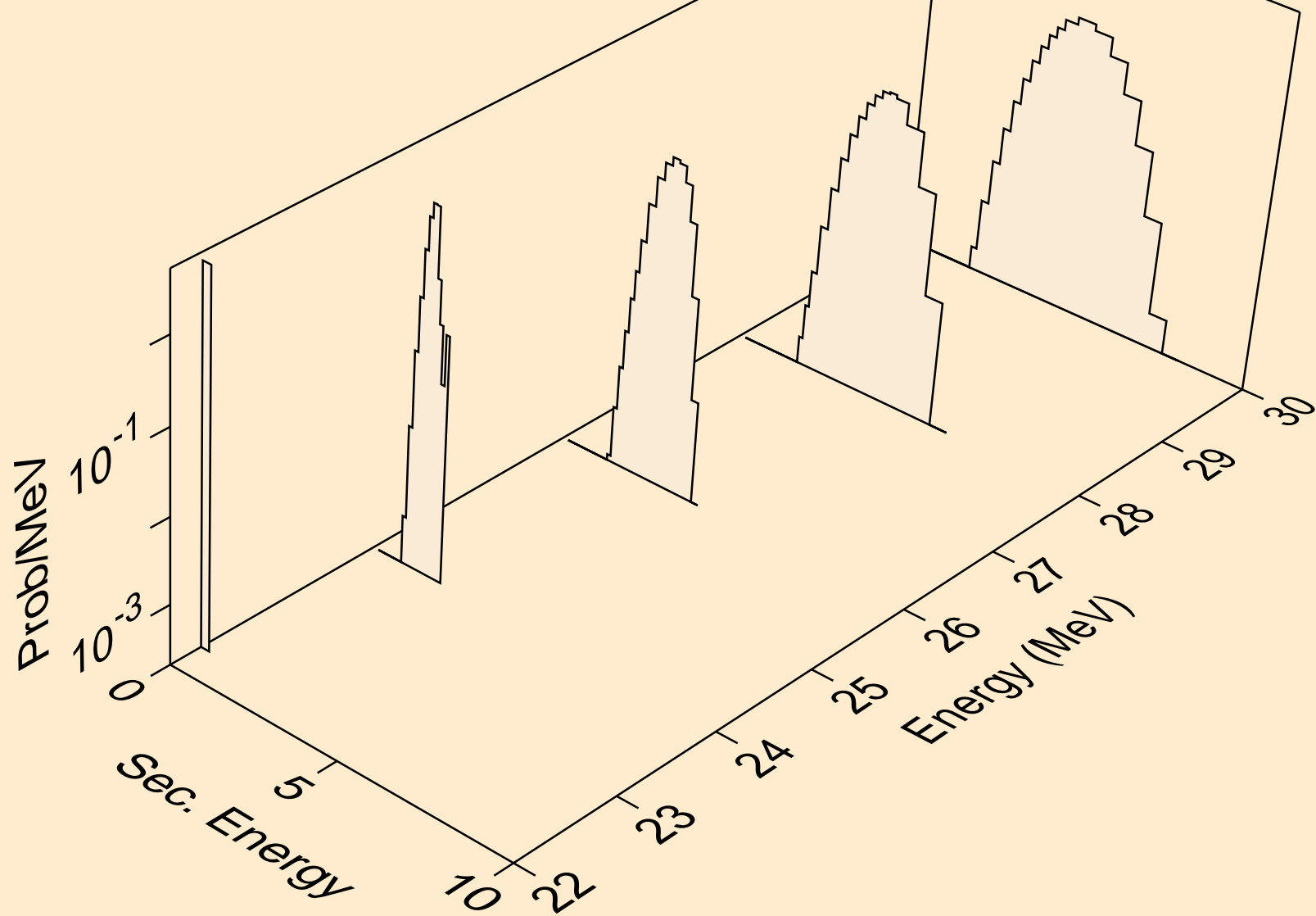

PM138 NEUTRON ACER TENDL-2024 LIBRARY; T=0.K  
protons from (n,n2p)

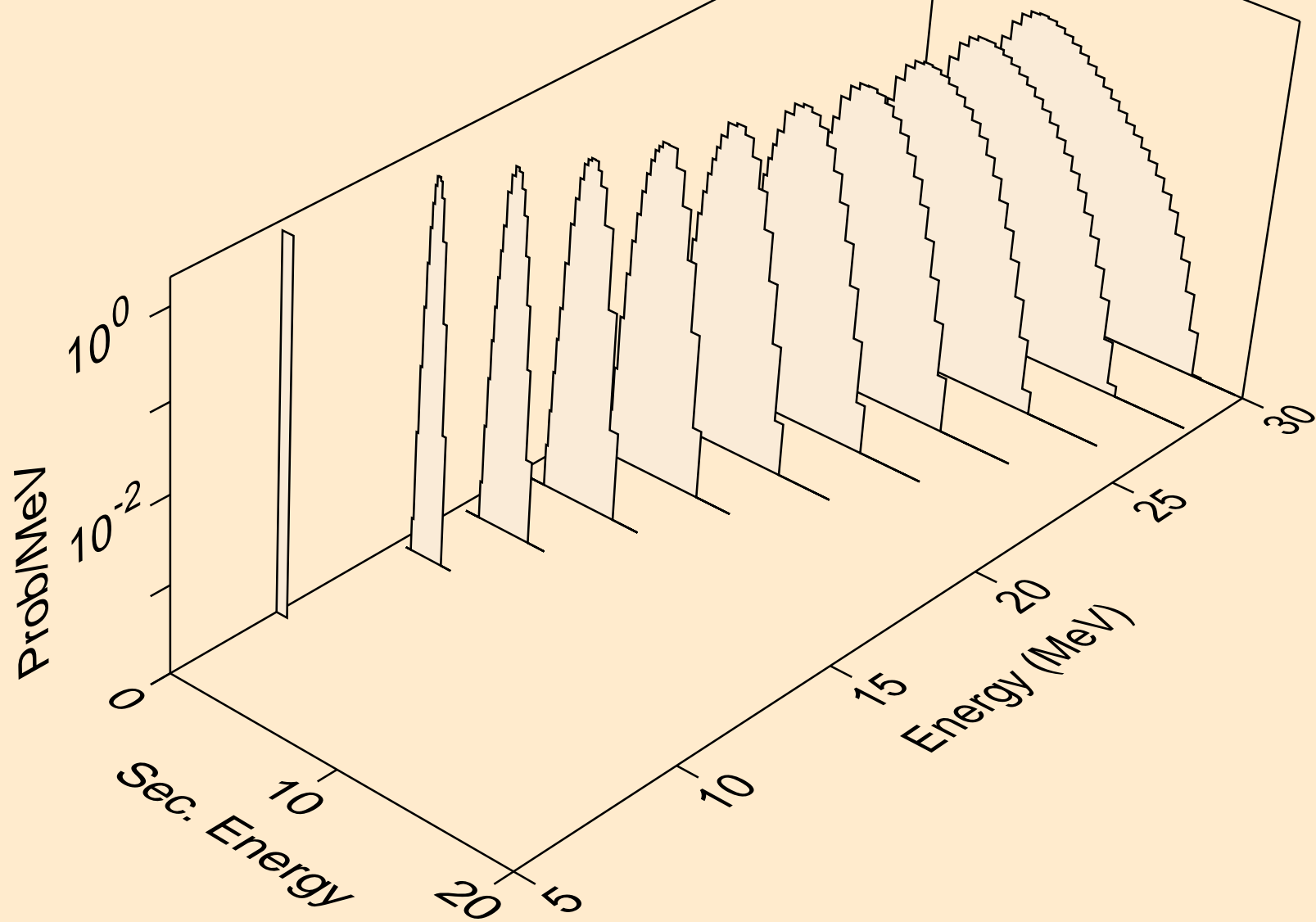

PM138 NEUTRON ACER TENDL-2024 LIBRARY; T=0.K  
protons from (n,npa)

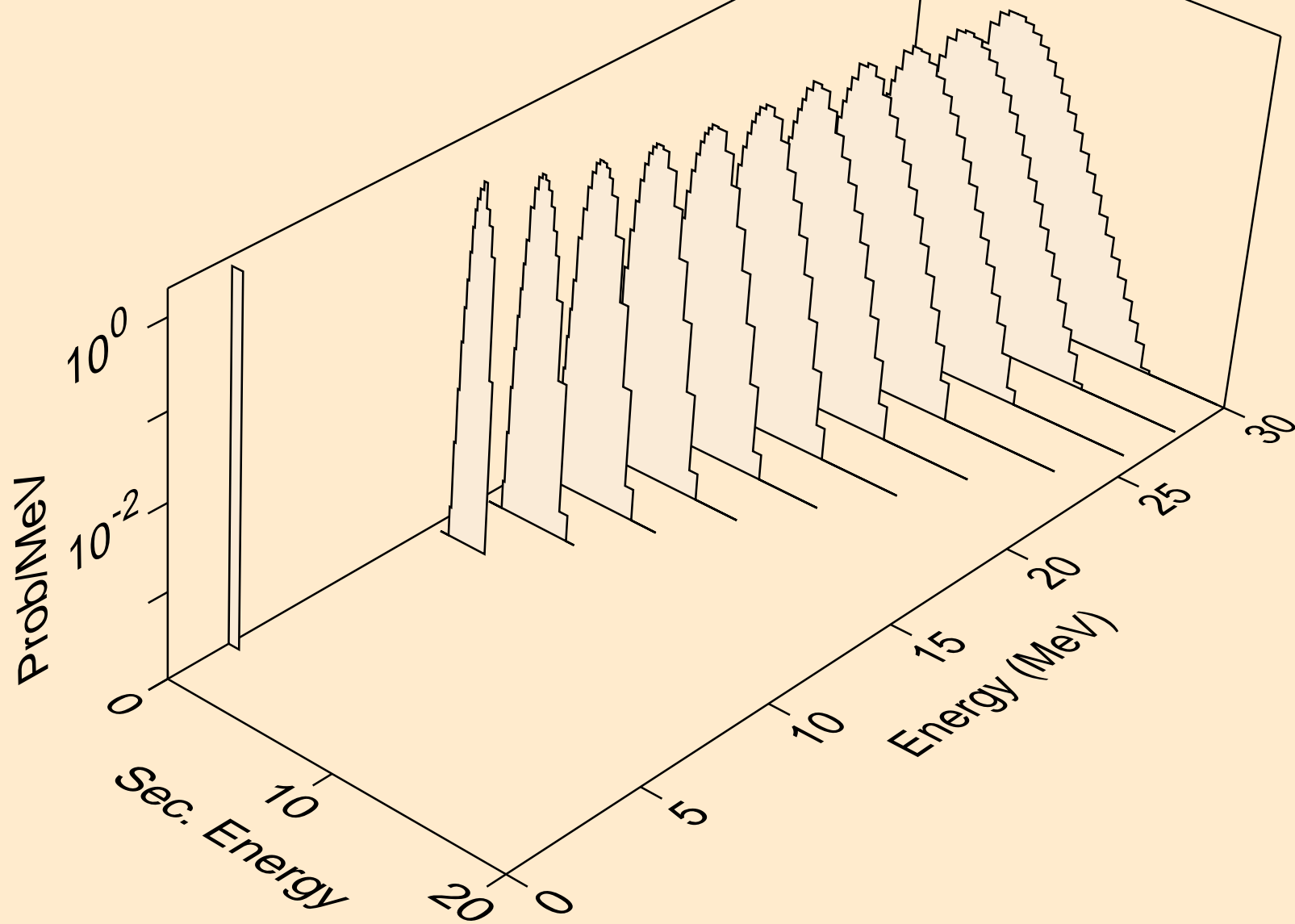

PM138 NEUTRON ACER TENDL-2024 LIBRARY; T=0.K  
protons from (n,p)

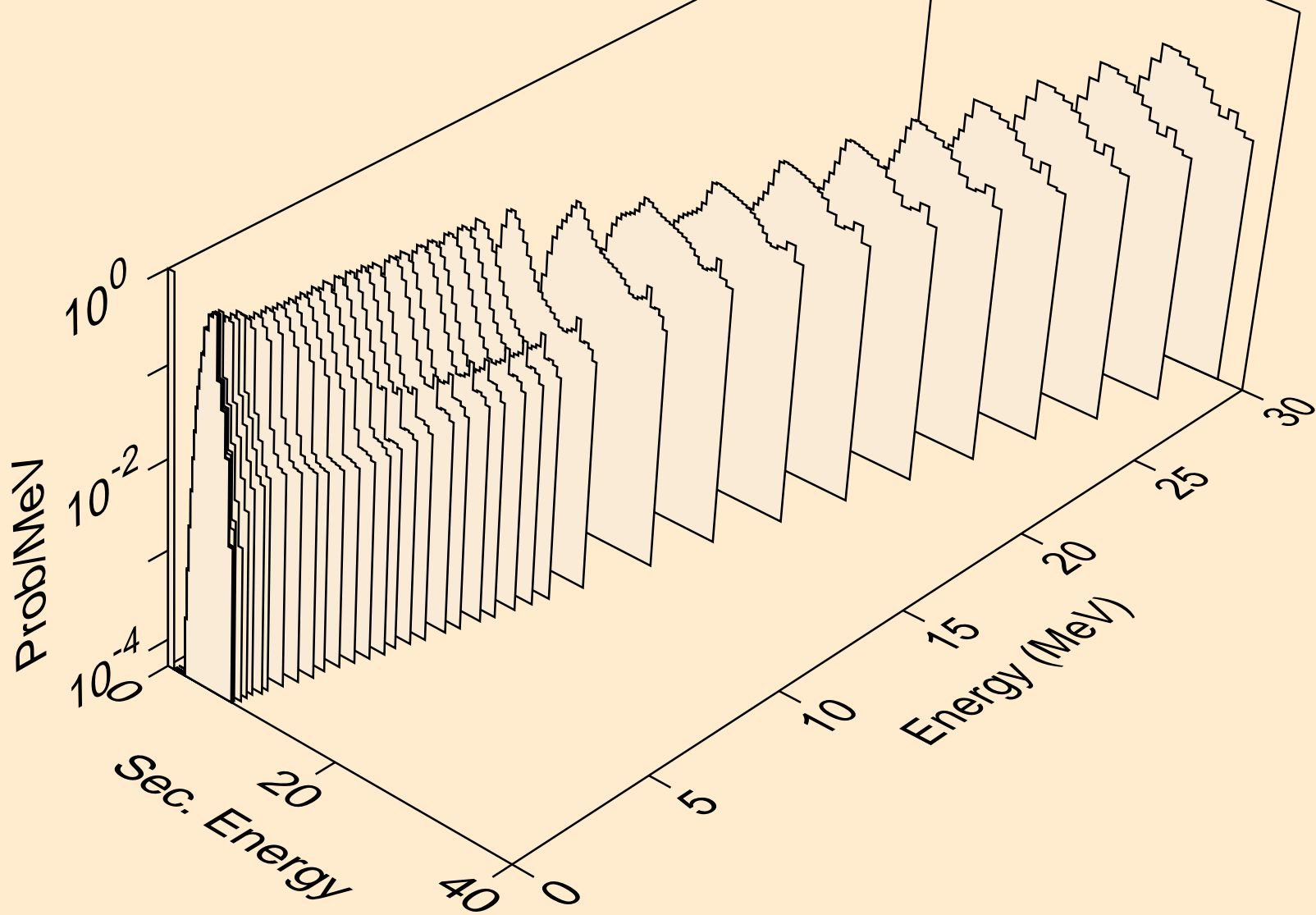

PM138 NEUTRON ACER TENDL-2024 LIBRARY; T=0.K  
protons from (n,2p)

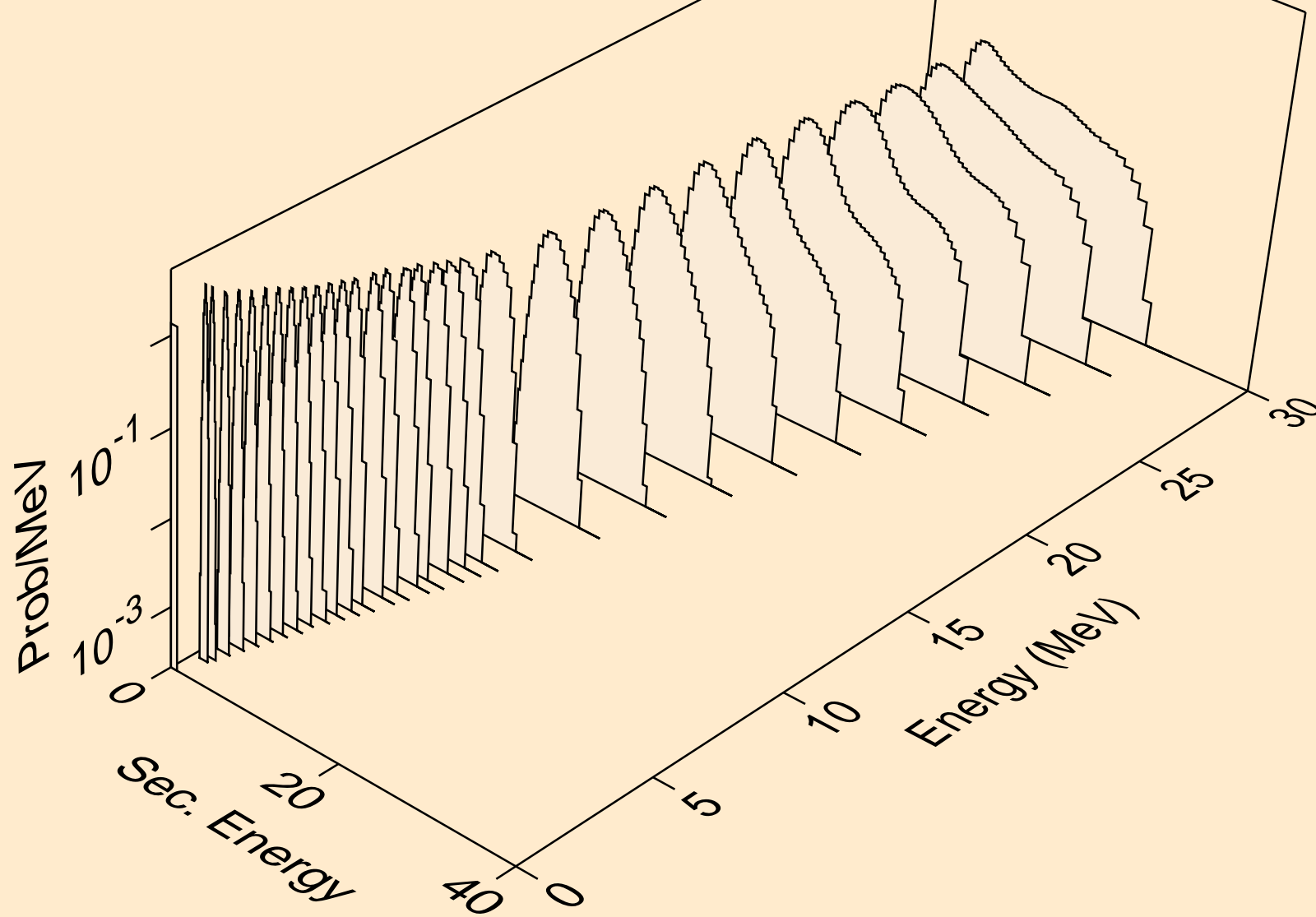

PM138 NEUTRON ACER TENDL-2024 LIBRARY; T=0.K  
protons from (n,p)

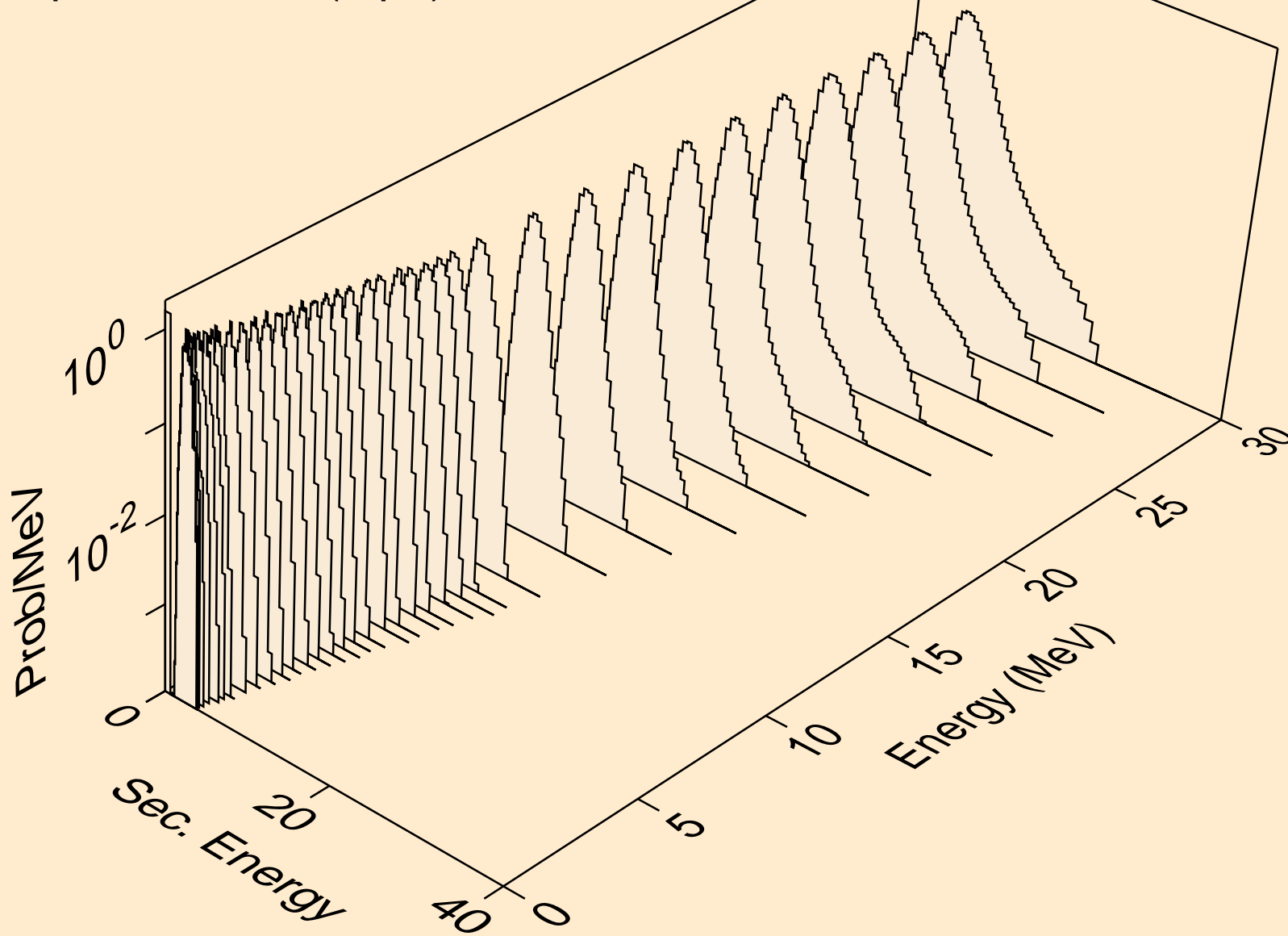

PM138 NEUTRON ACER TENDL-2024 LIBRARY; T=0.K  
protons from (n,pd)

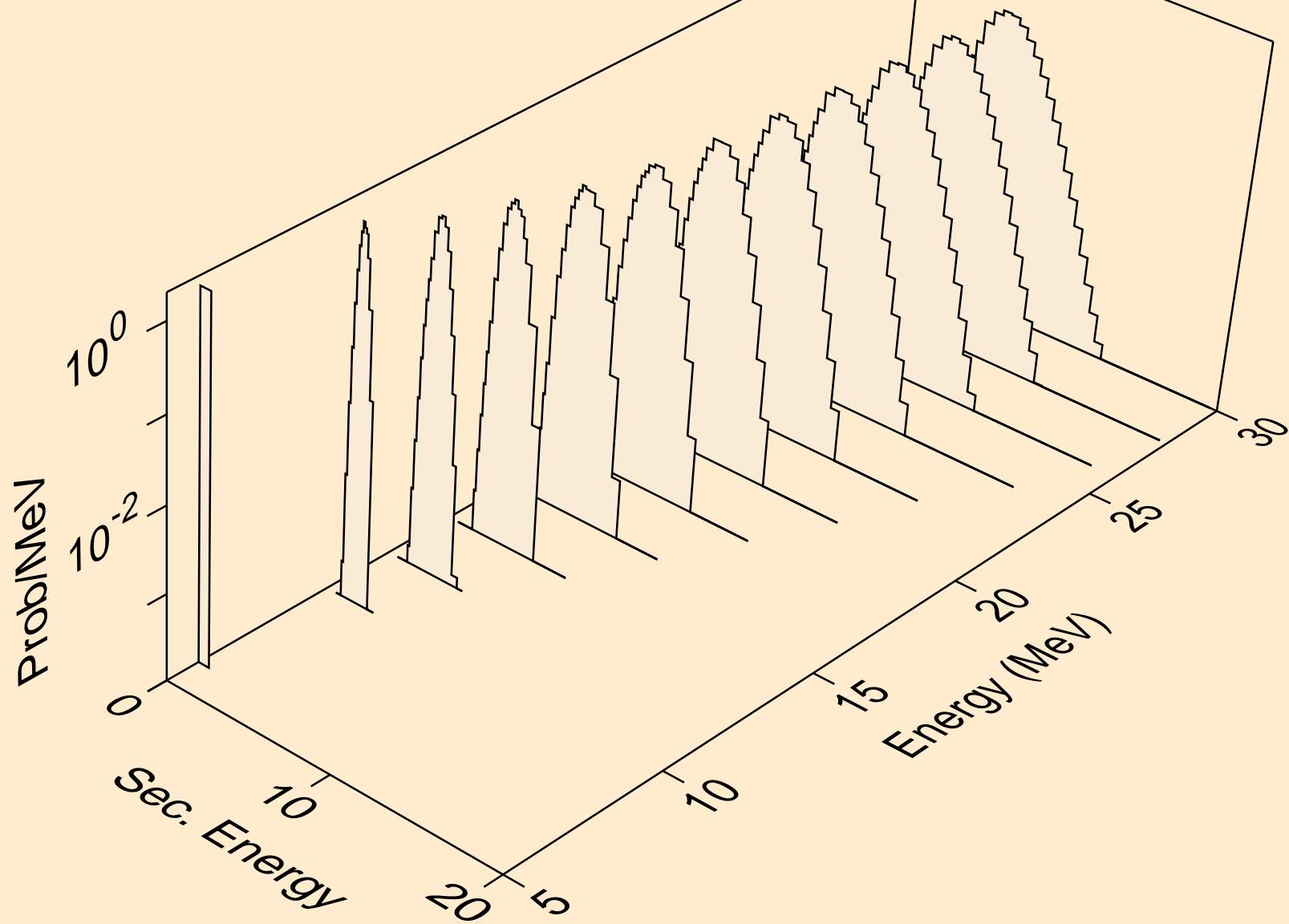

PM138 NEUTRON ACER TENDL-2024 LIBRARY; T=0.K  
protons from (n,pt)

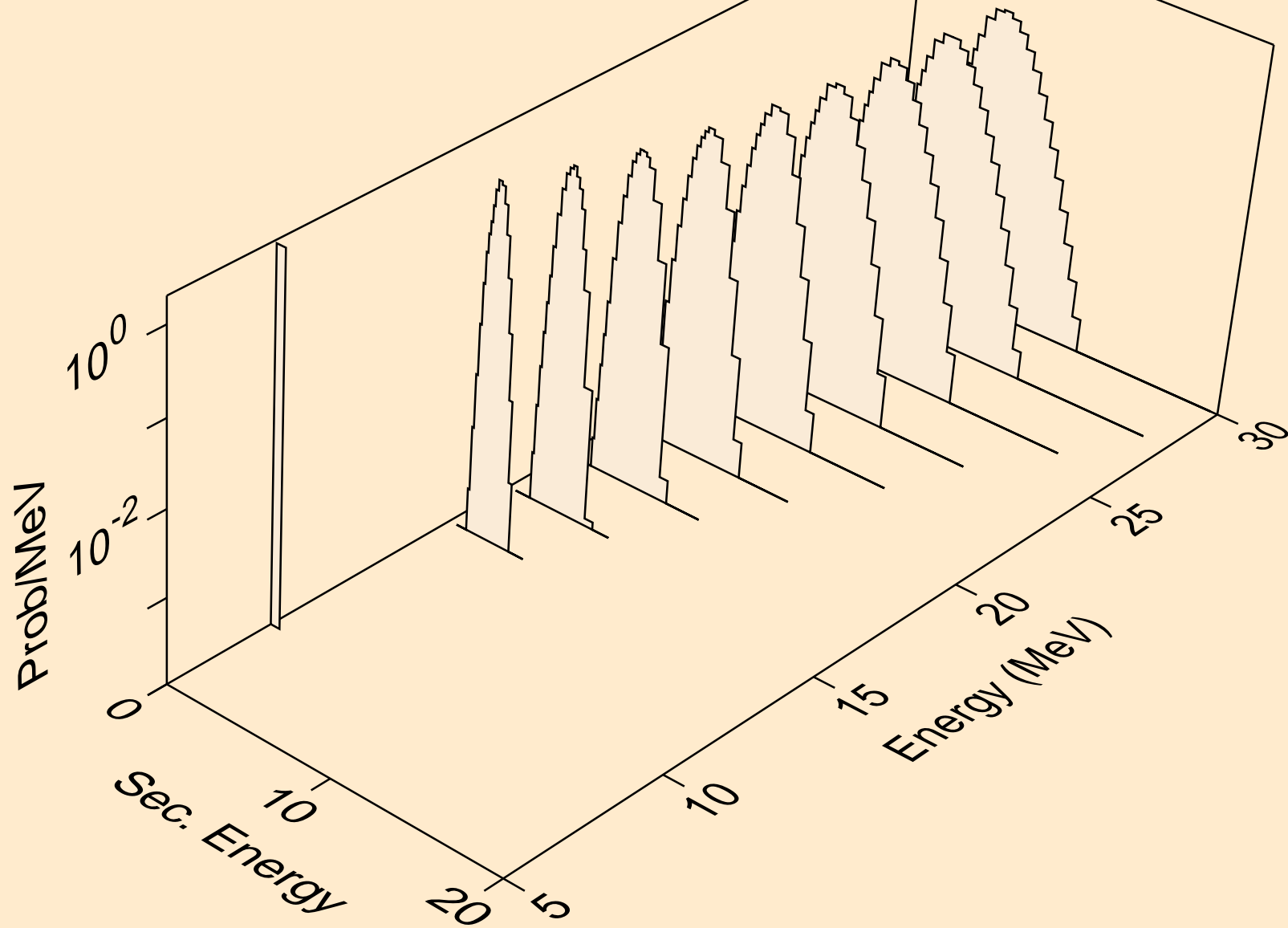



PM138 NEUTRON ACER TENDL-2024 LIBRARY; T=0.K  
deuterons from (n,x)

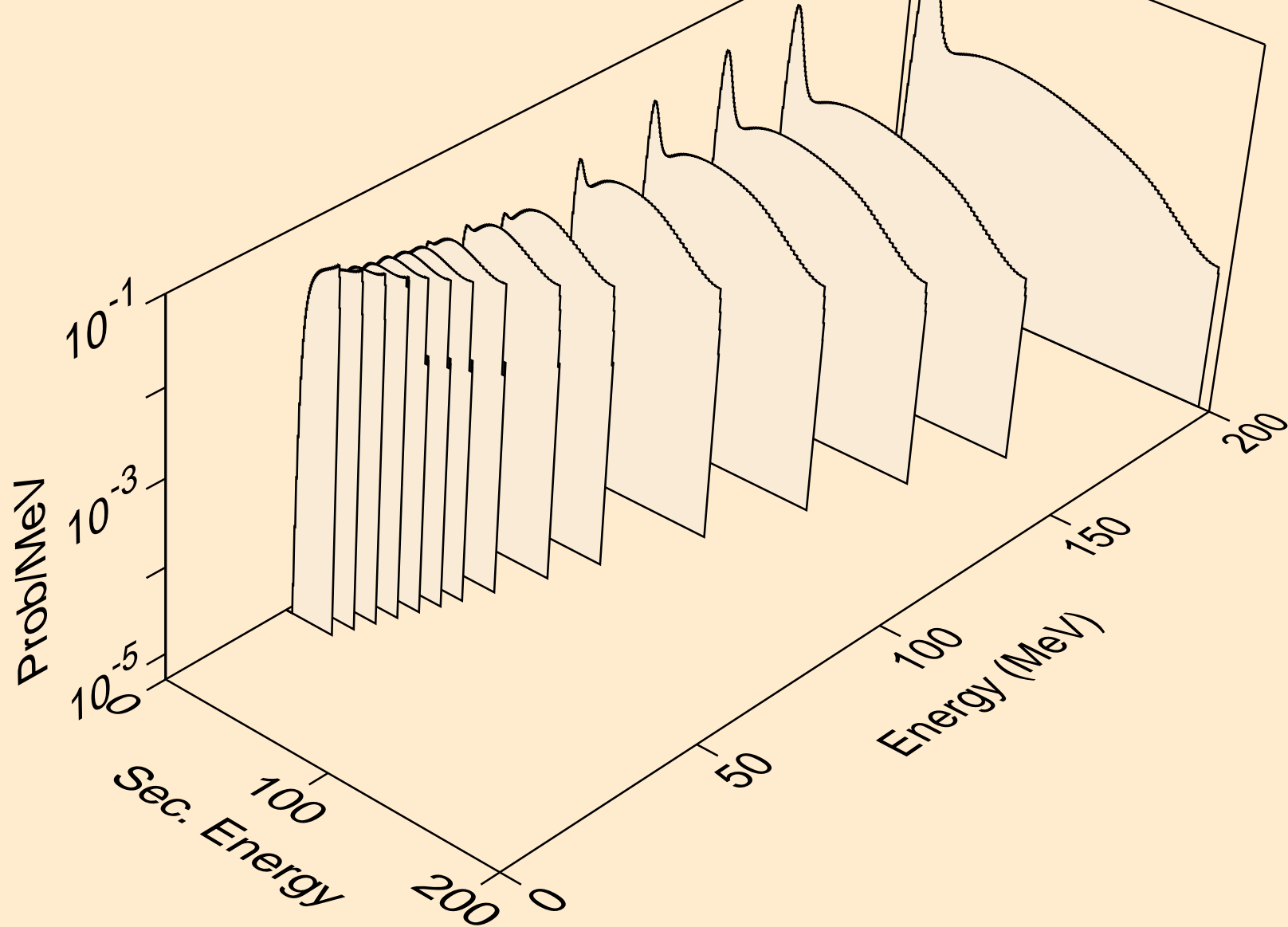

PM138 NEUTRON ACER TENDL-2024 LIBRARY; T=0.K  
deuterons from (n,2nd)

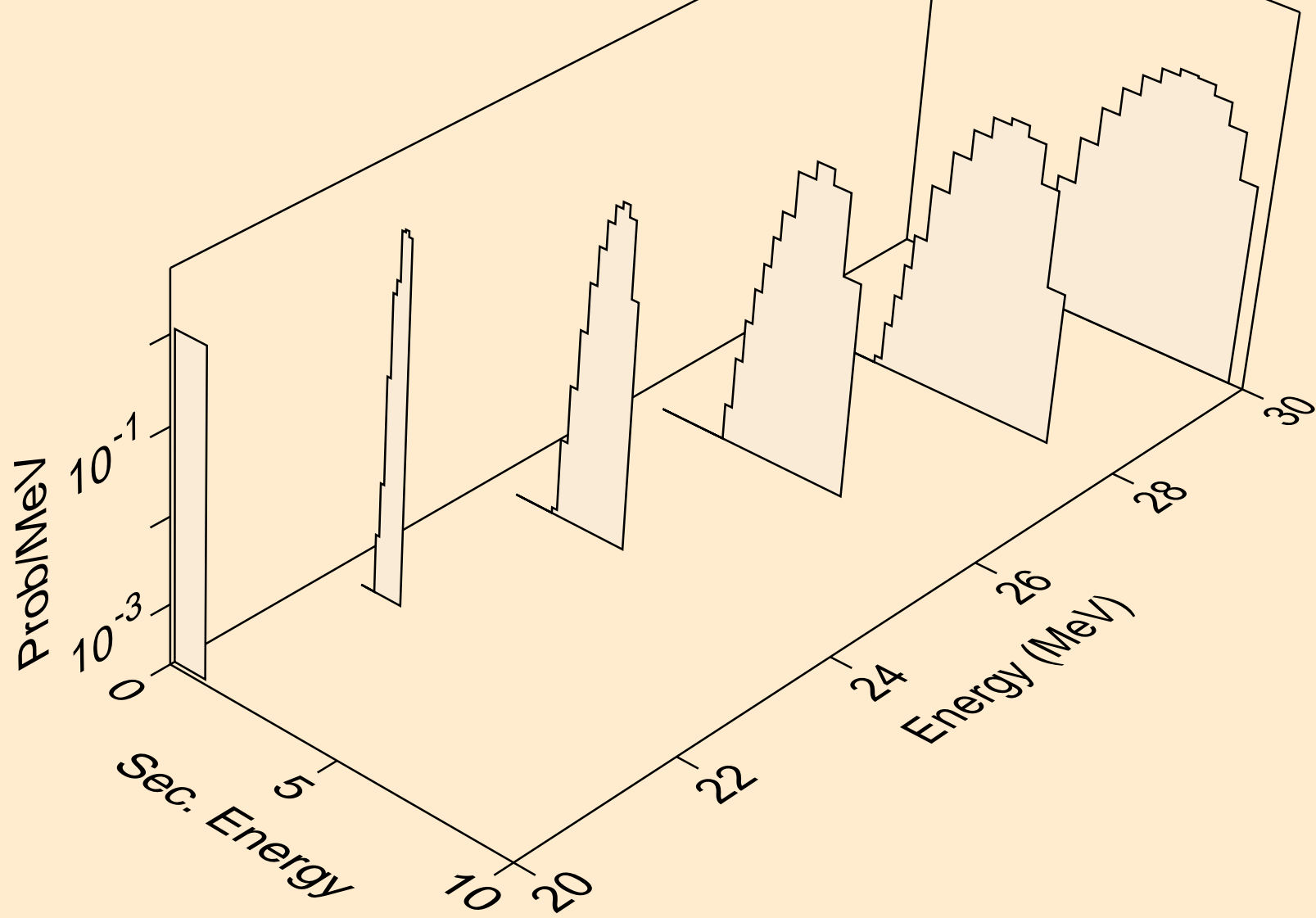

PM138 NEUTRON ACER TENDL-2024 LIBRARY; T=0.K  
deuterons from (n,n\*)d

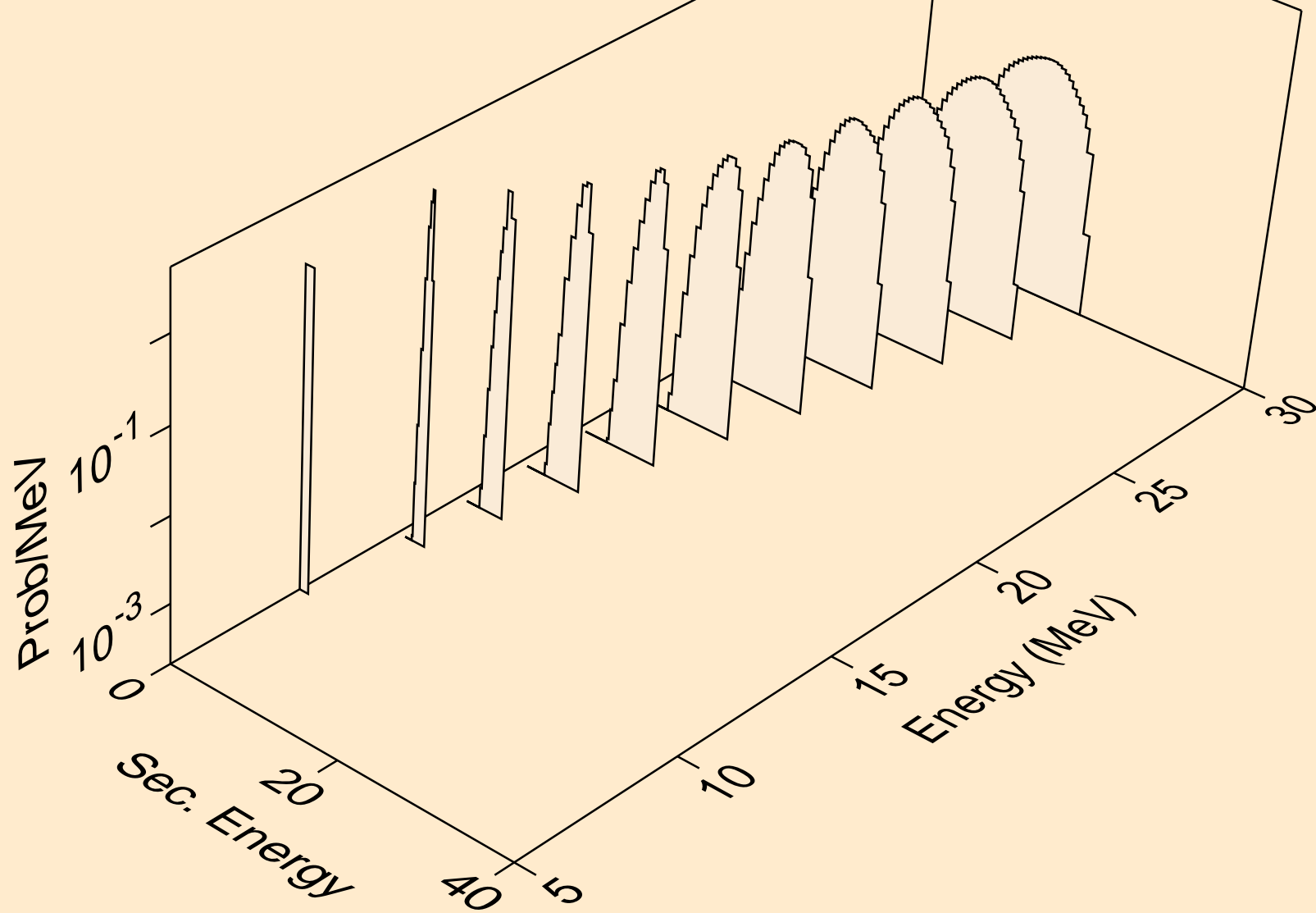

PM138 NEUTRON ACER TENDL-2024 LIBRARY; T=0.K  
deuterons from (n,d)

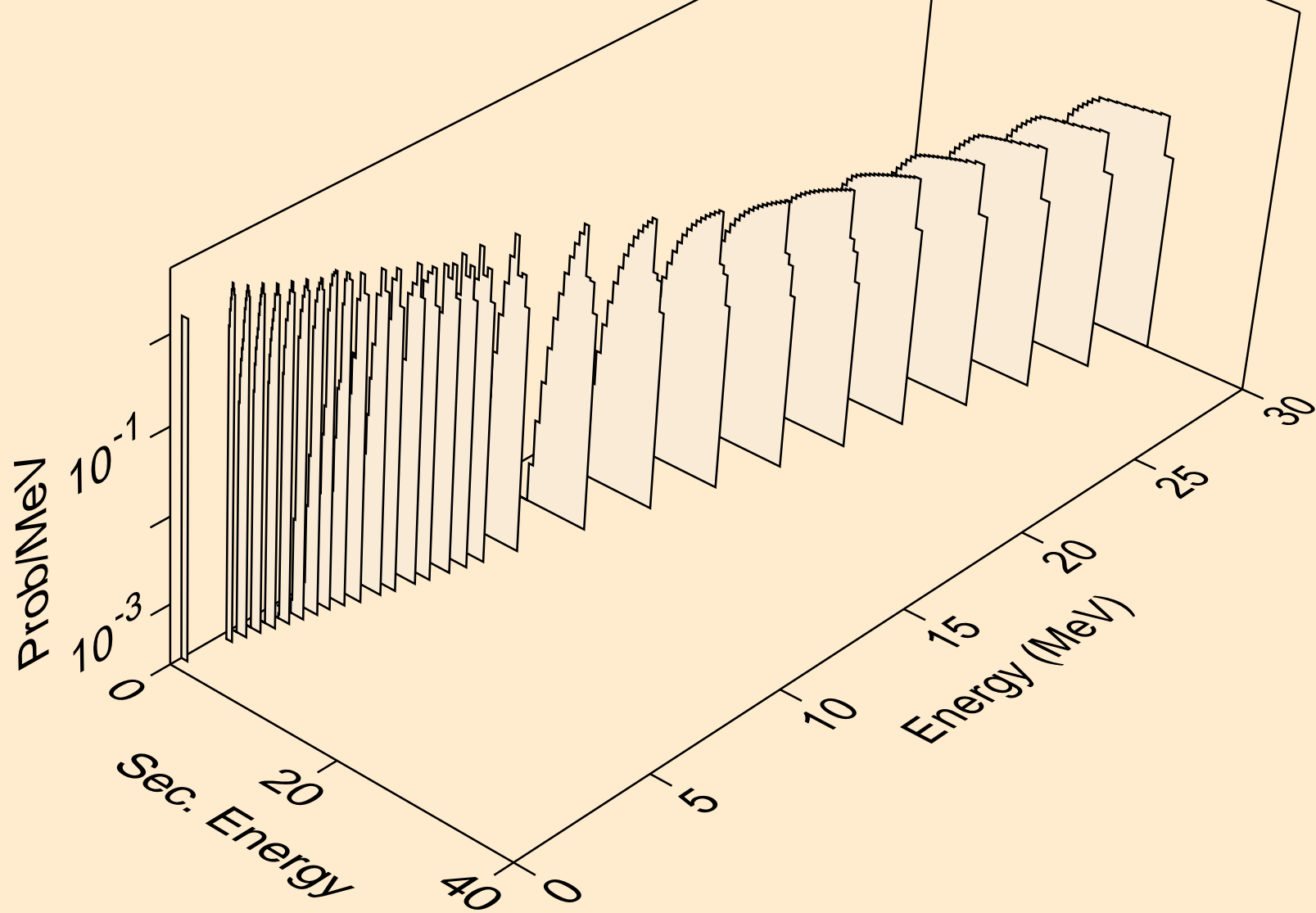

PM138 NEUTRON ACER TENDL-2024 LIBRARY; T=0.K  
deuterons from (n,pd)

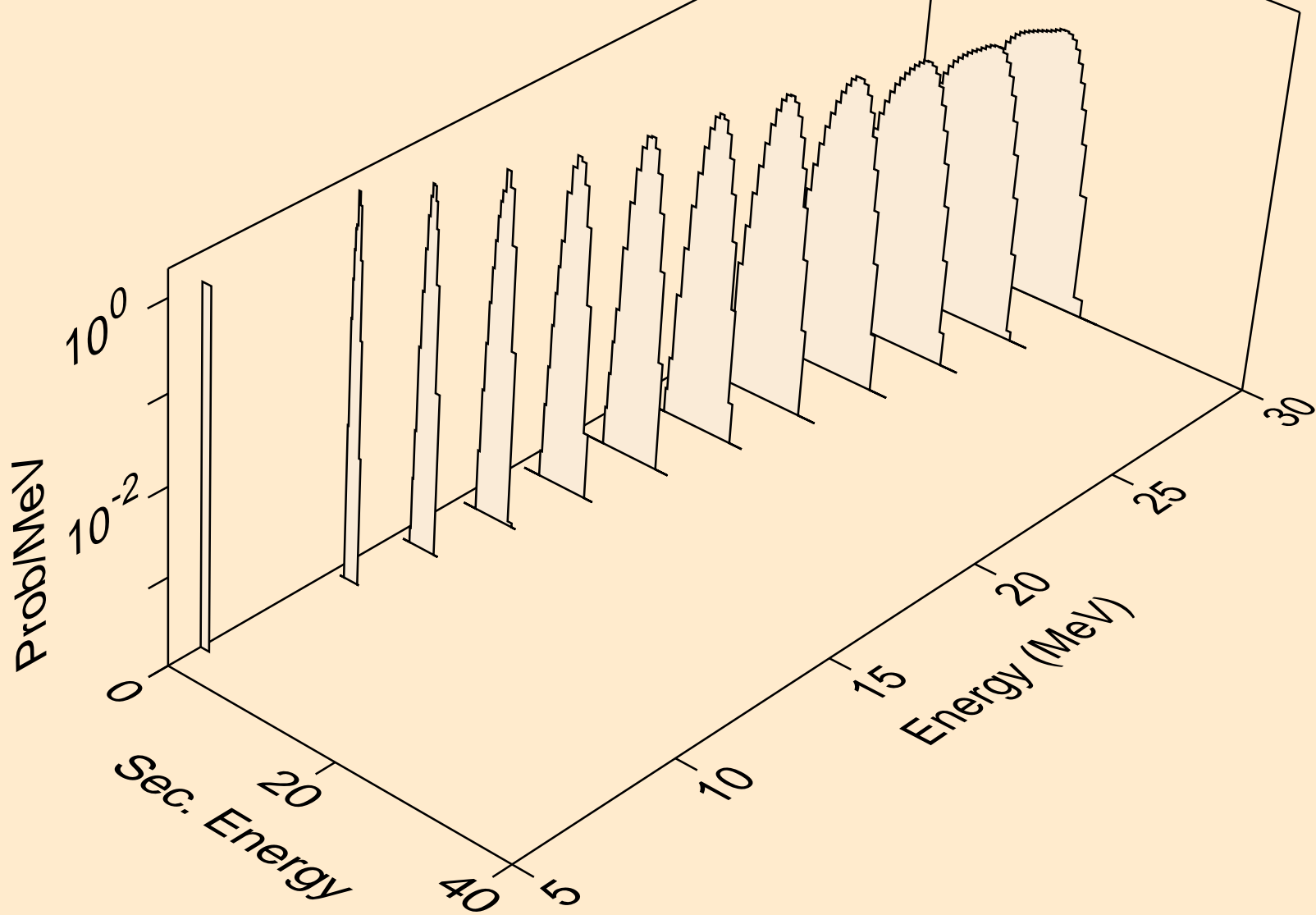

PM138 NEUTRON ACER TENDL-2024 LIBRARY; T=0.K  
deuterons from (n,da)

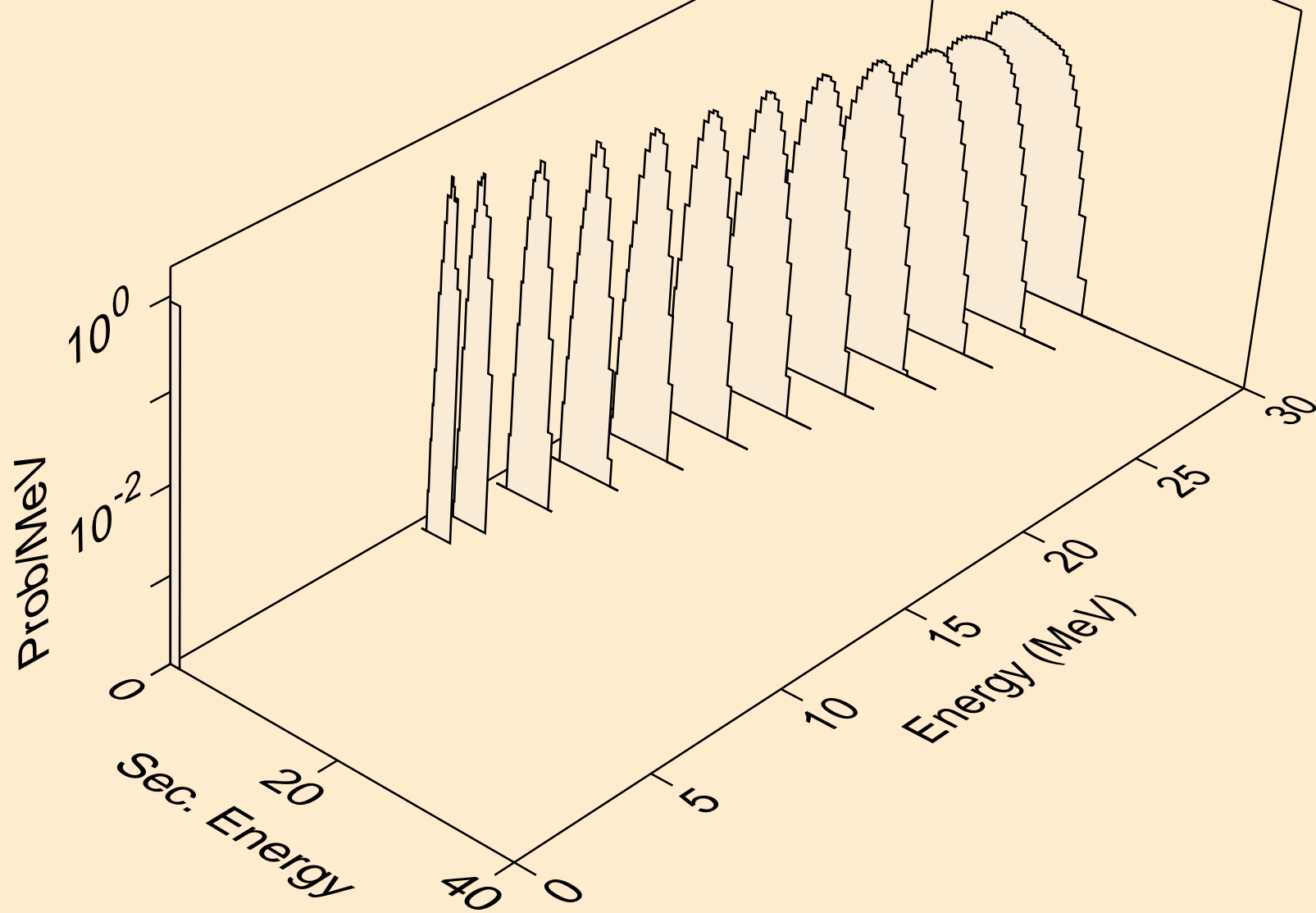

PM138 NEUTRON ACER TENDL-2024 LIBRARY; T=0.K  
tritons from (n,x)

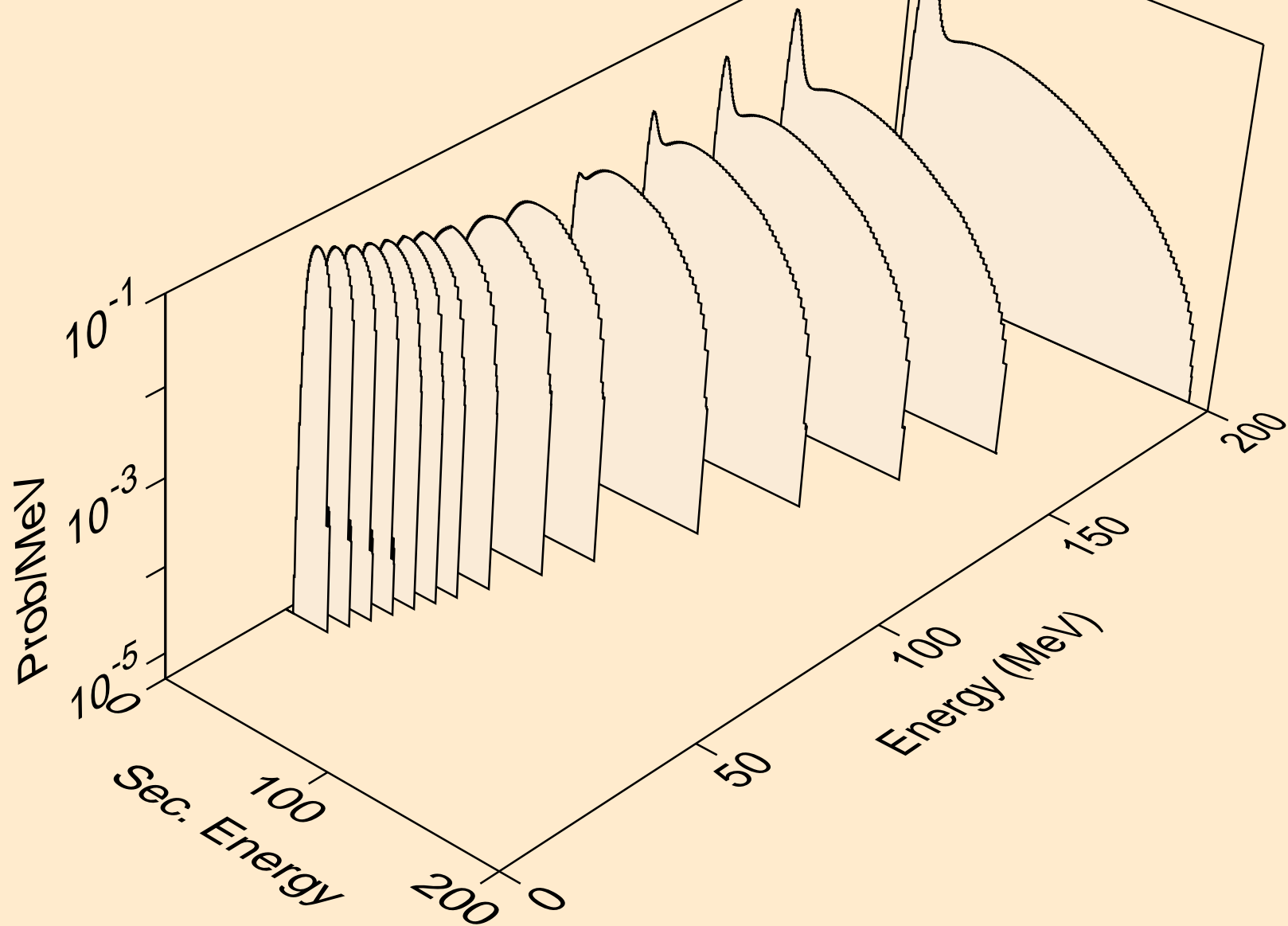

PM138 NEUTRON ACER TENDL-2024 LIBRARY; T=0.K  
tritons from (n,n\*)t

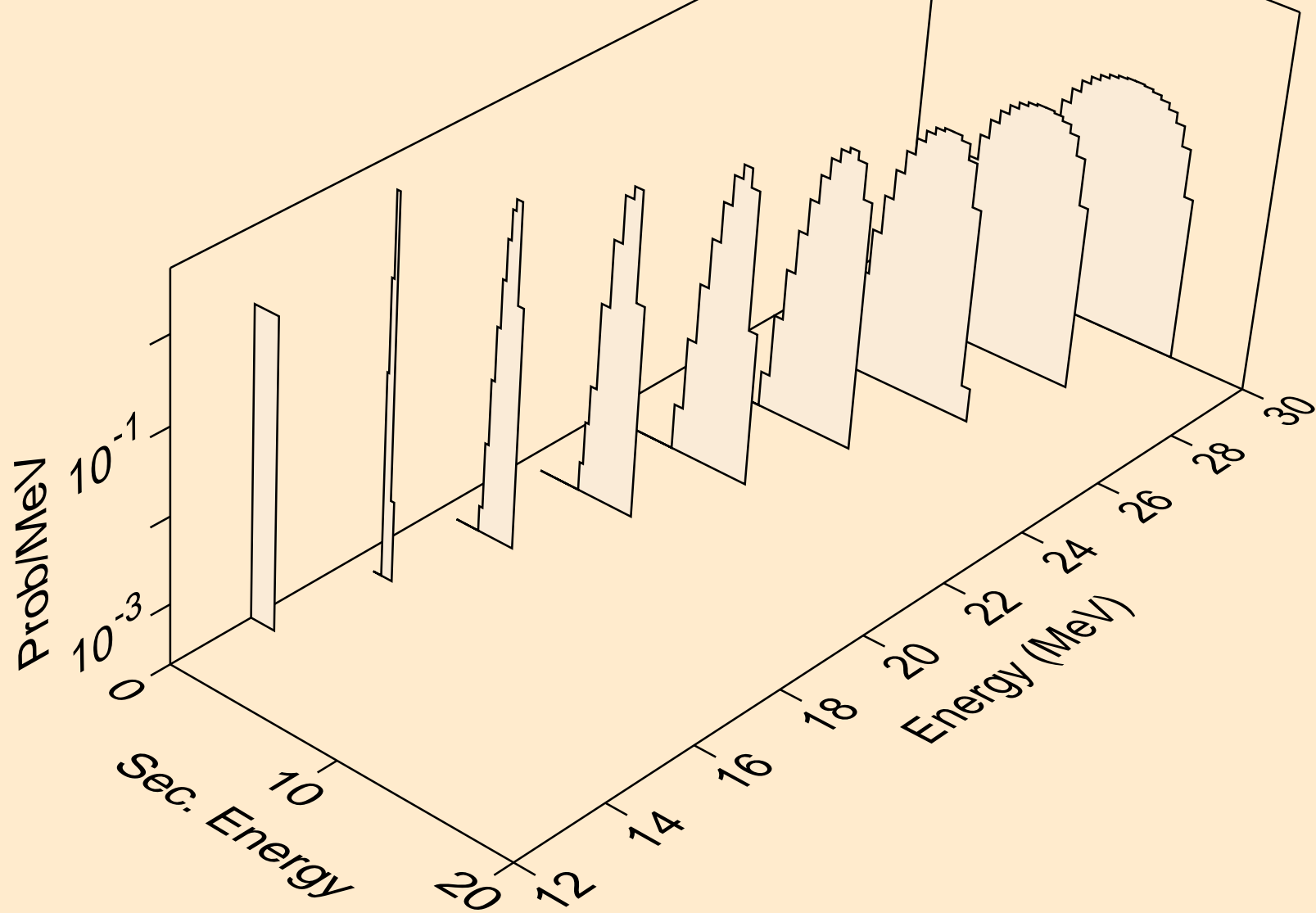



PM138 NEUTRON ACER TENDL-2024 LIBRARY; T=0.K  
tritons from (n,t)

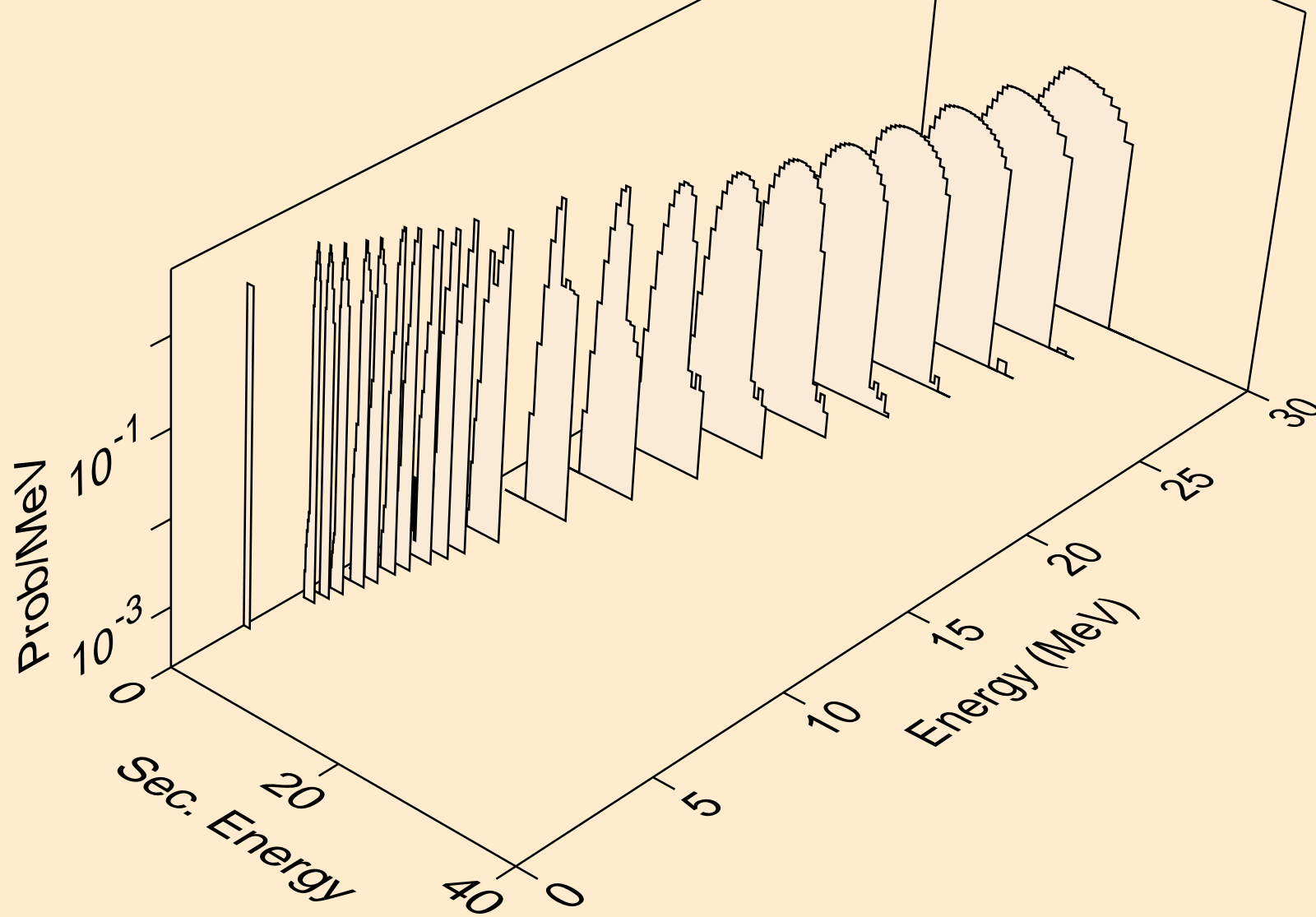

PM138 NEUTRON ACER TENDL-2024 LIBRARY; T=0.K  
tritons from (n,pt)

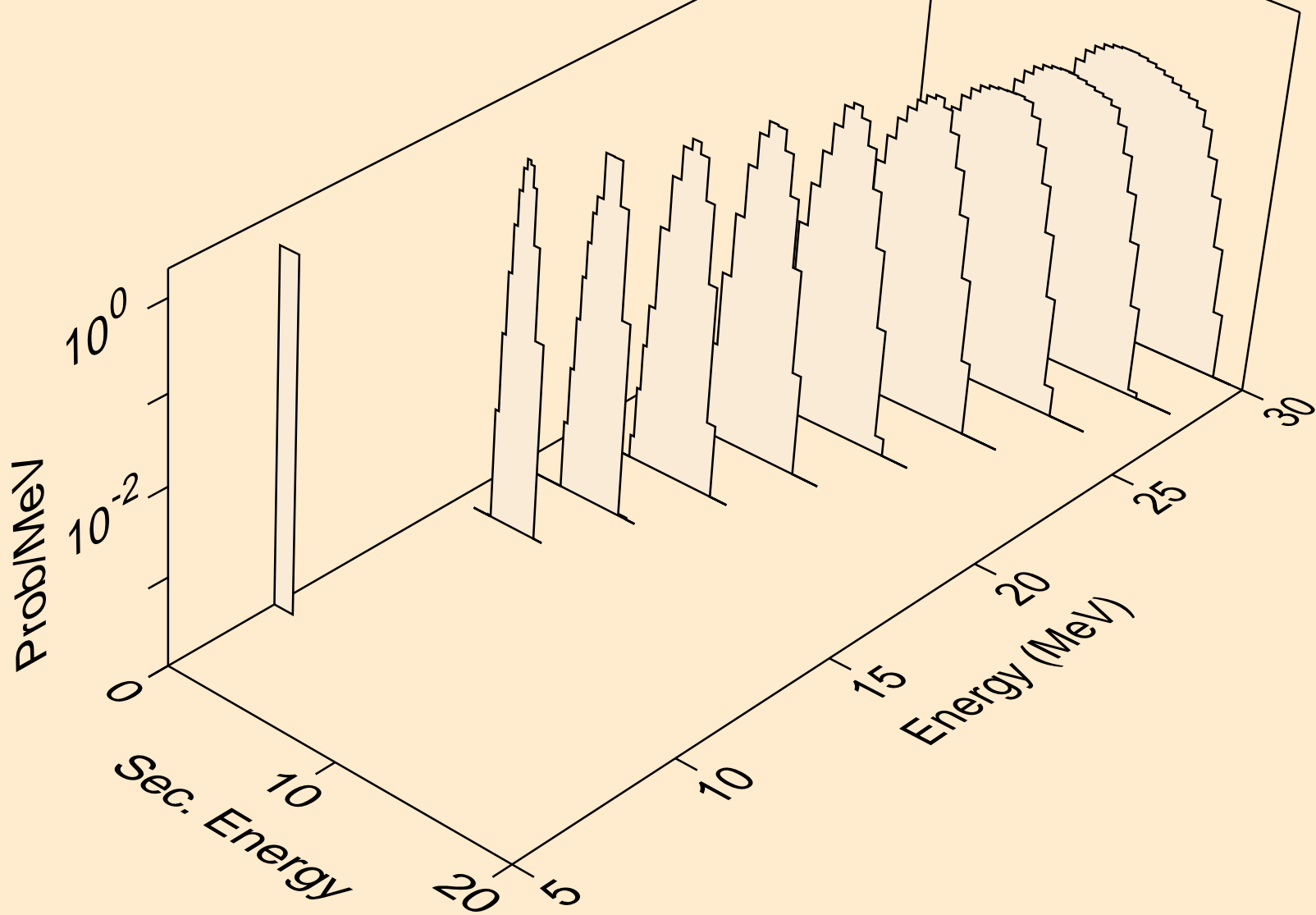

PM138 NEUTRON ACER TENDL-2024 LIBRARY; T=0.K  
he3s from (n,x)

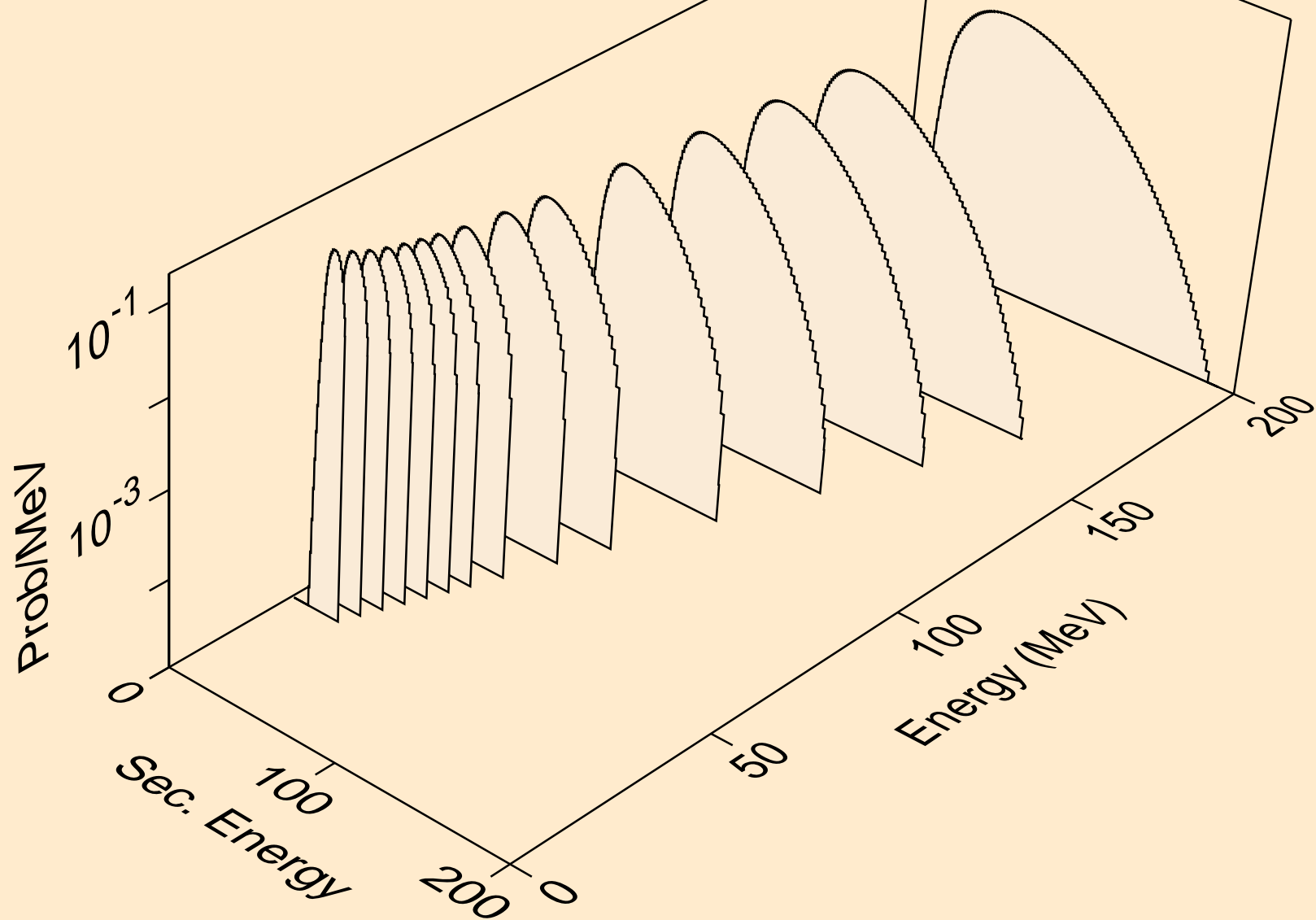

PM138 NEUTRON ACER TENDL-2024 LIBRARY; T=0.K  
he3s from (n,n\*)he3

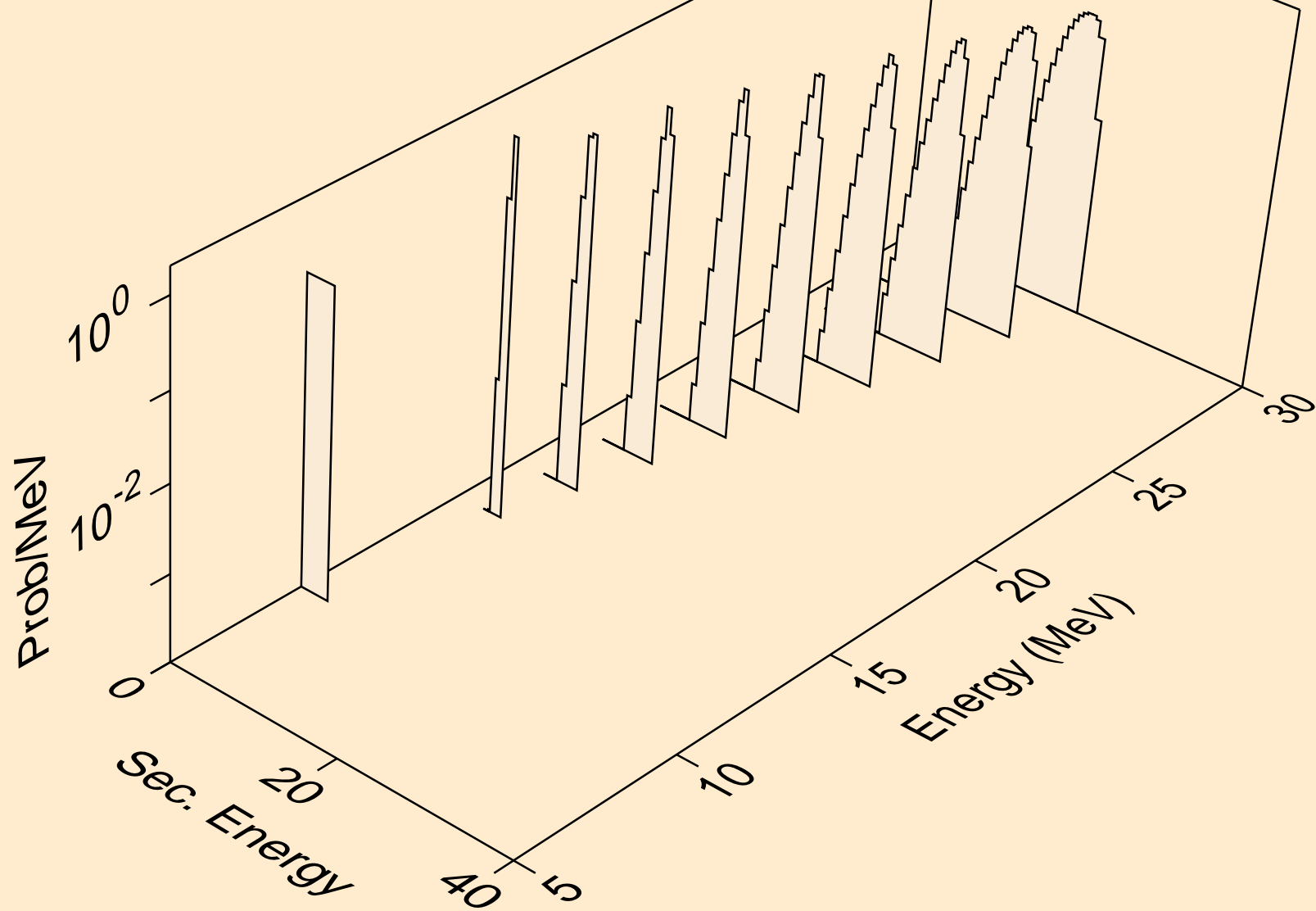

PM138 NEUTRON ACER TENDL-2024 LIBRARY; T=0.K  
he3s from (n,he3)

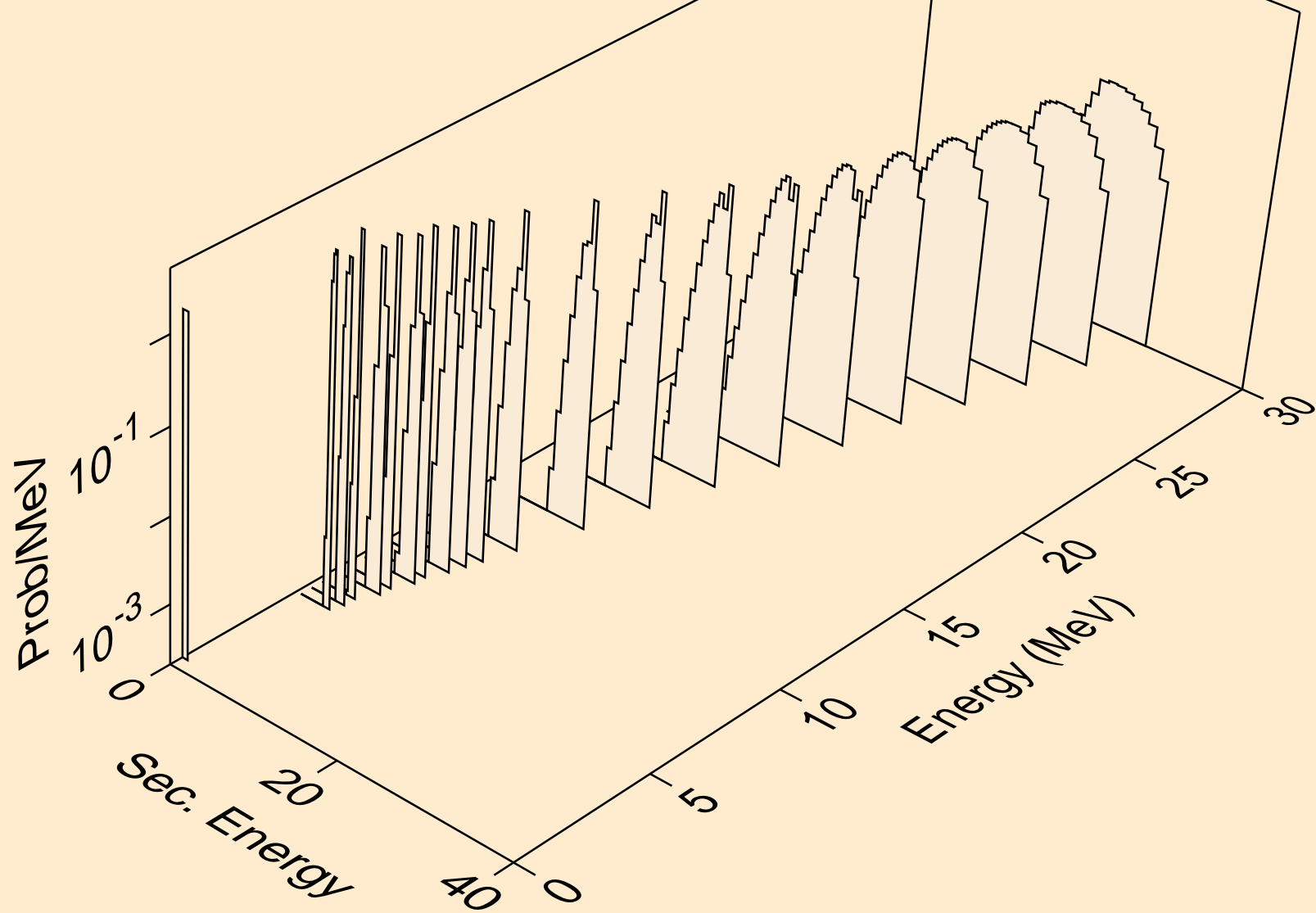

PM138 NEUTRON ACER TENDL-2024 LIBRARY; T=0.K  
alphas from (n,x)

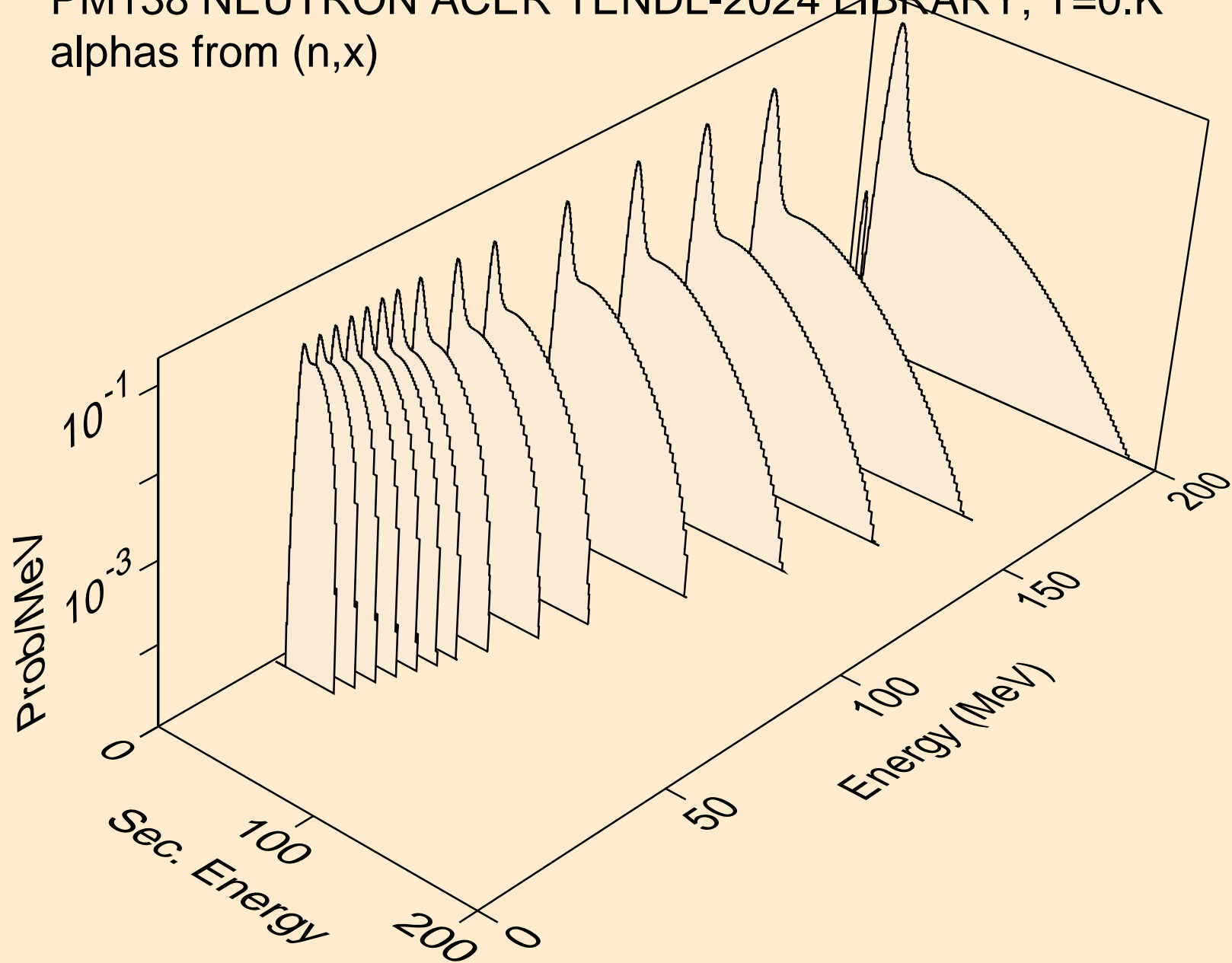

PM138 NEUTRON ACER TENDL-2024 LIBRARY; T=0.K  
alphas from (n,n\*)a

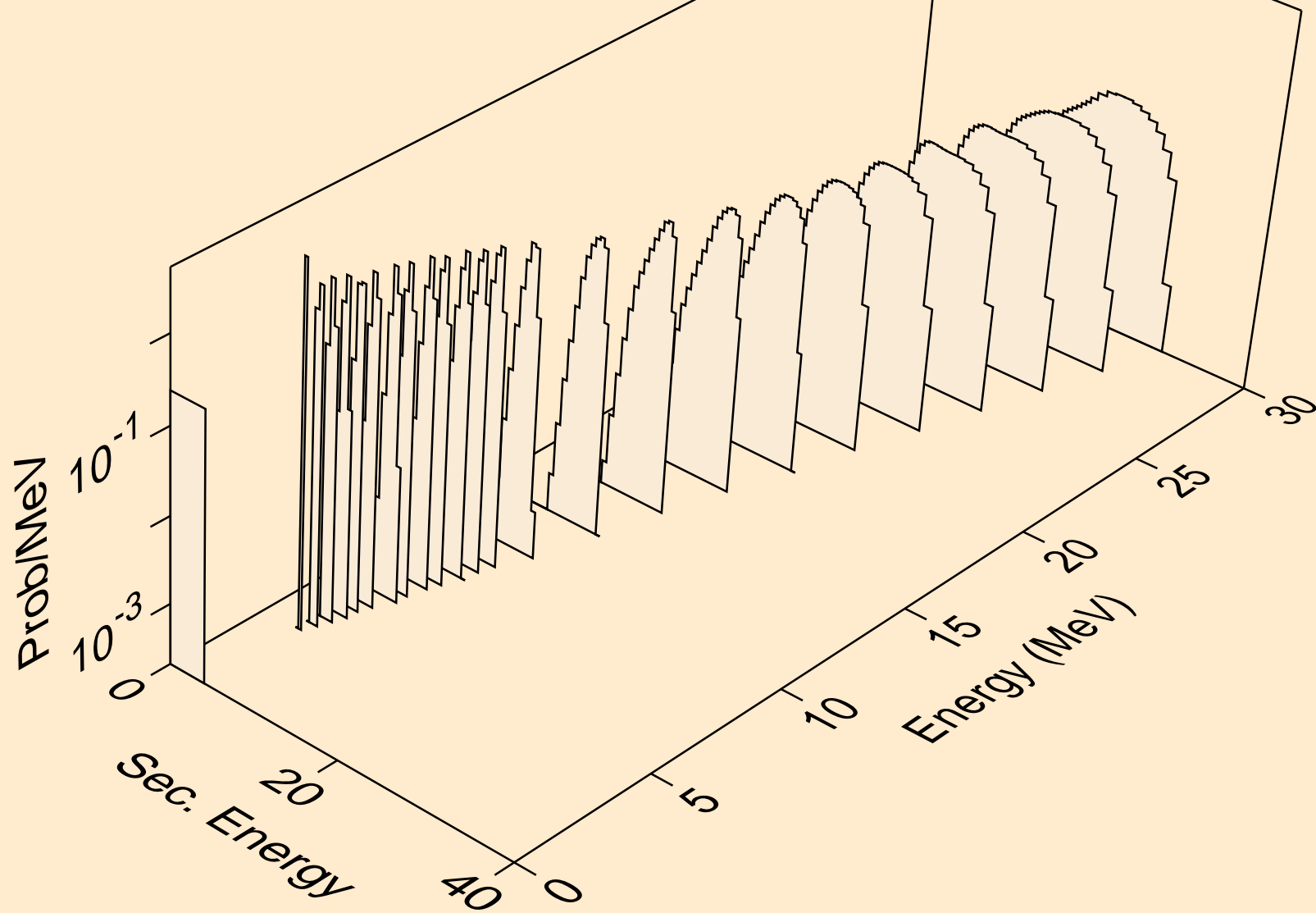

PM138 NEUTRON ACER TENDL-2024 LIBRARY; T=0.K  
alphas from (n,2n)a

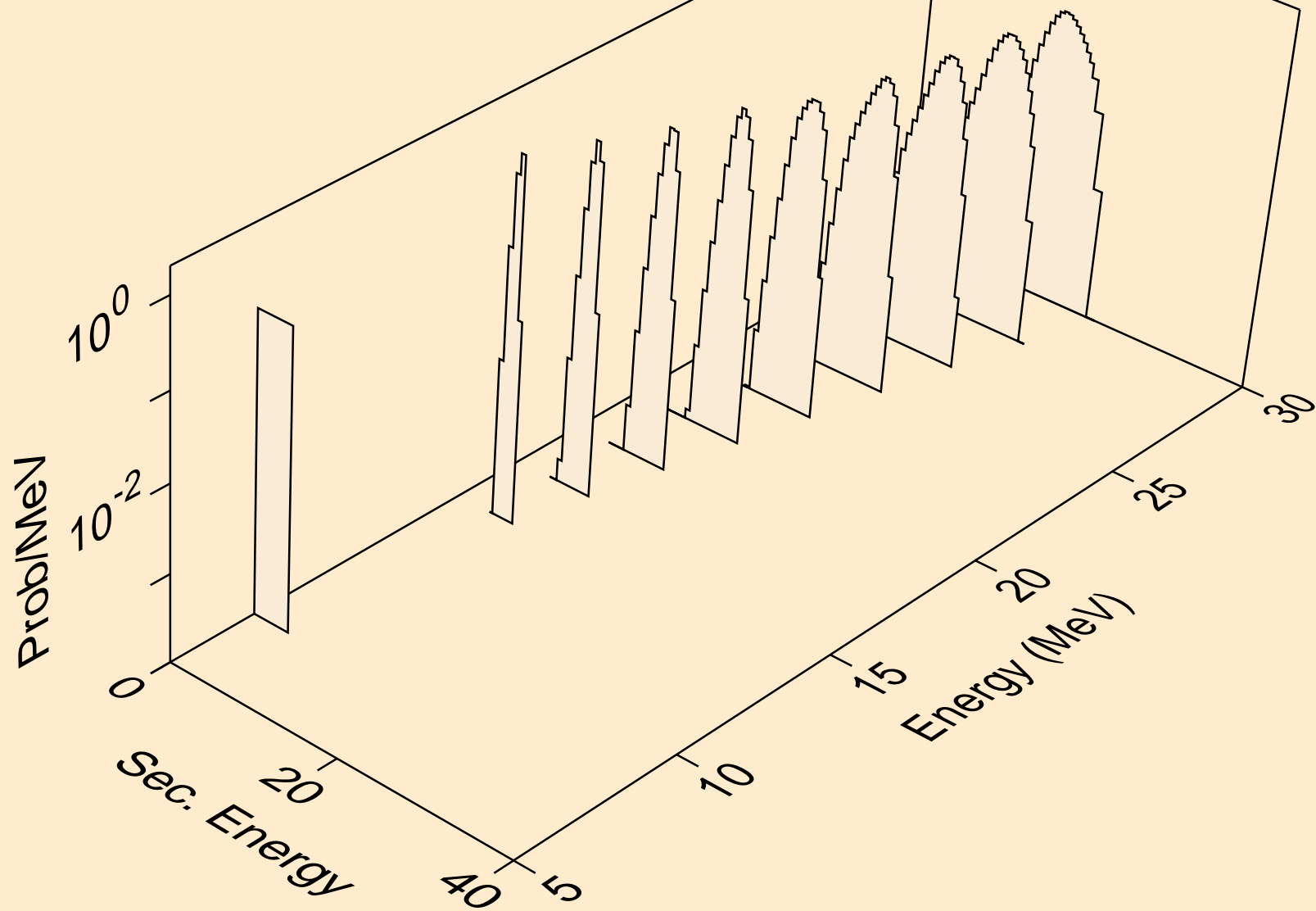



PM138 NEUTRON ACER TENDL-2024 LIBRARY; T=0.K  
alphas from (n,3n)a

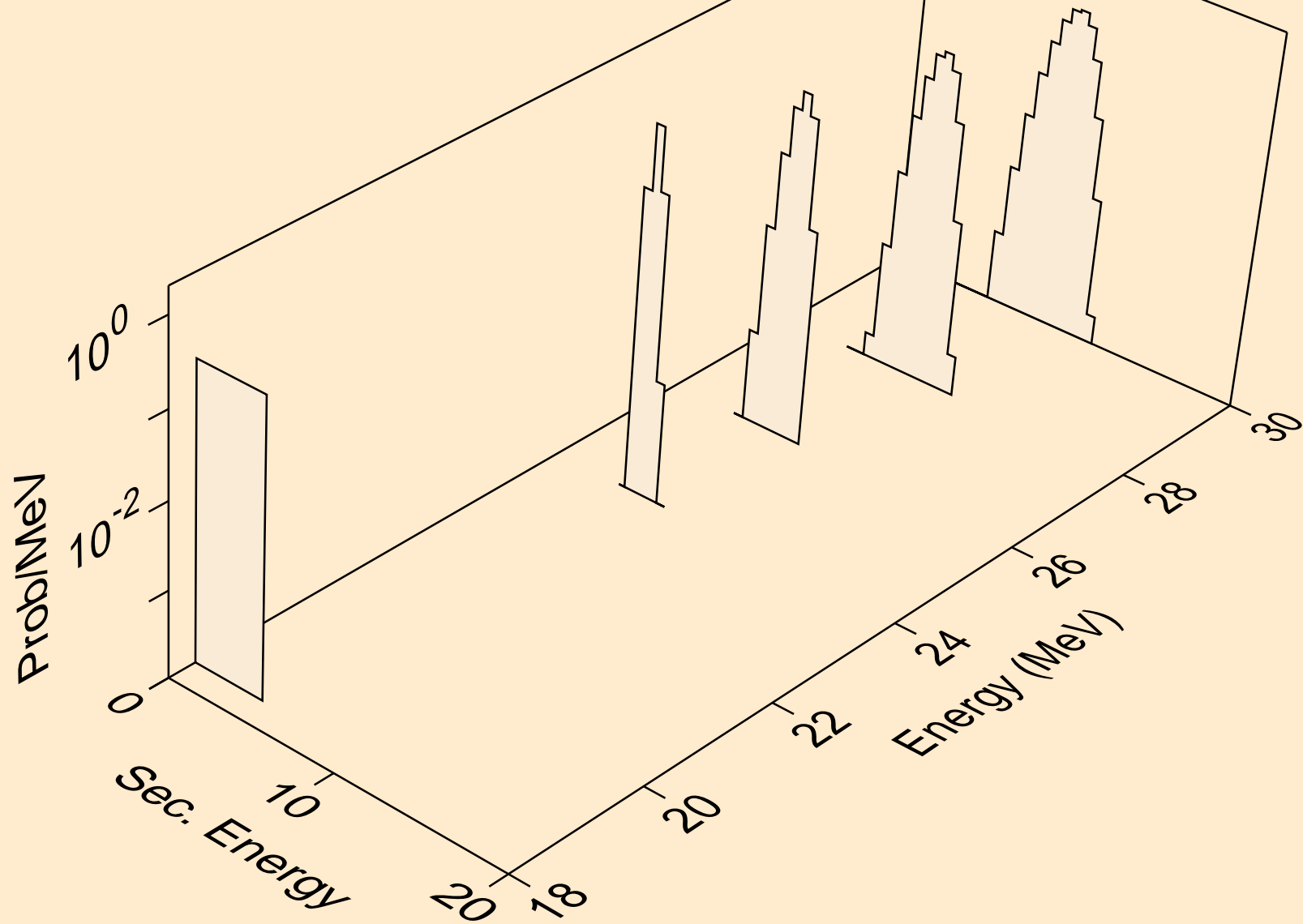

PM138 NEUTRON ACER TENDL-2024 LIBRARY; T=0.K  
alphas from (n,n\*)2a

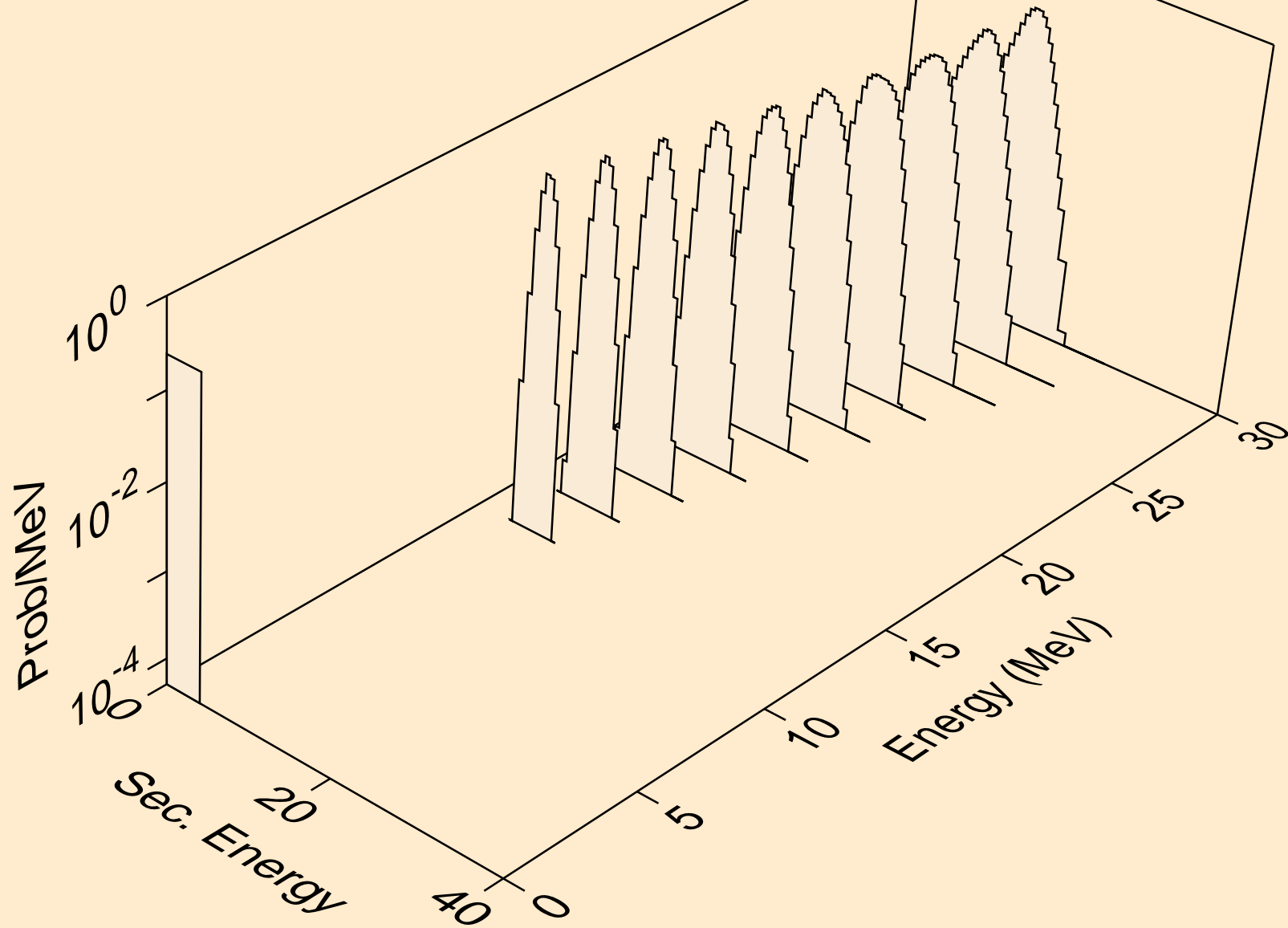

PM138 NEUTRON ACER TENDL-2024 LIBRARY; T=0.K  
alphas from (n,2n)2a

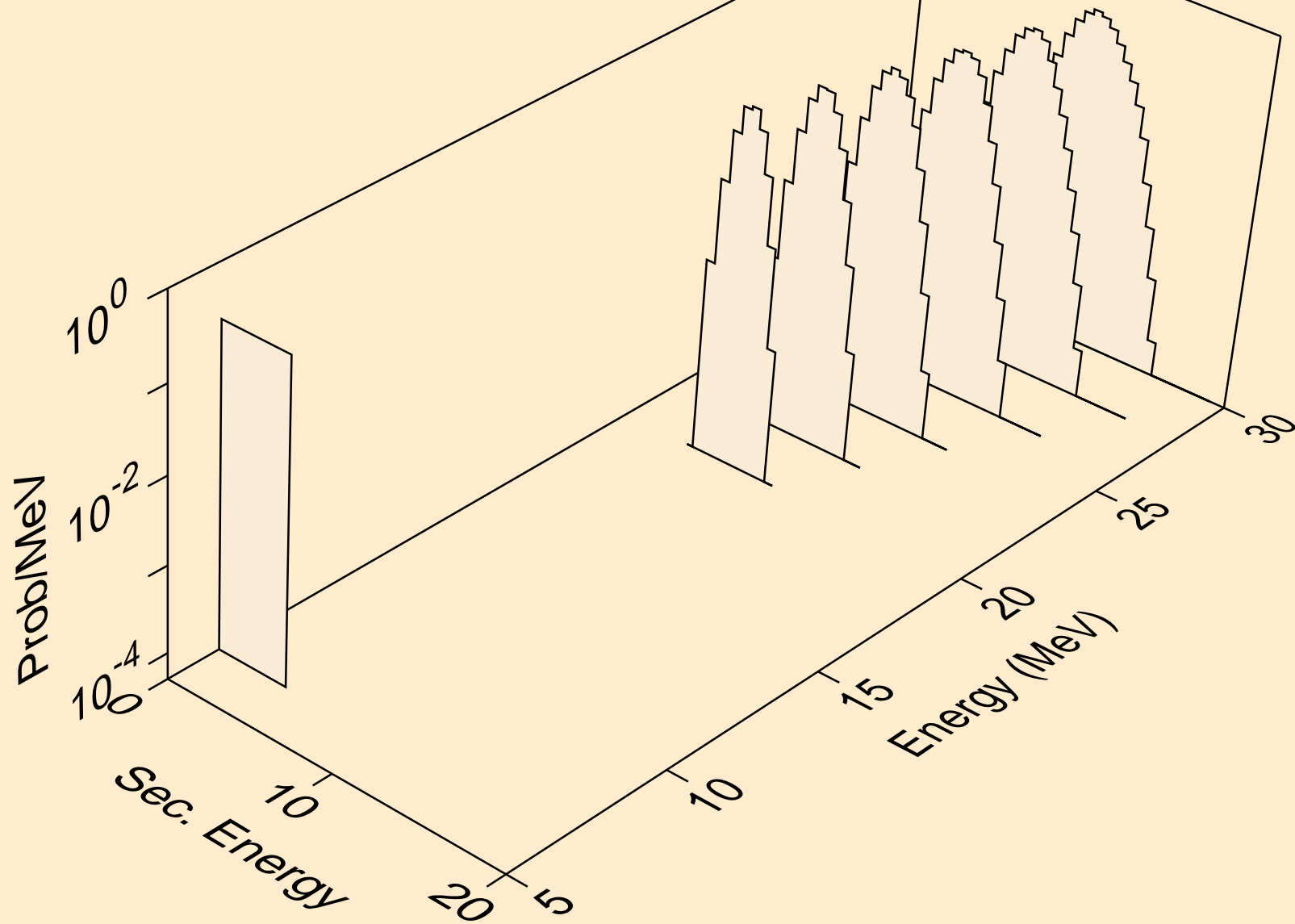

PM138 NEUTRON ACER TENDL-2024 LIBRARY; T=0.K  
alphas from (n,npa)

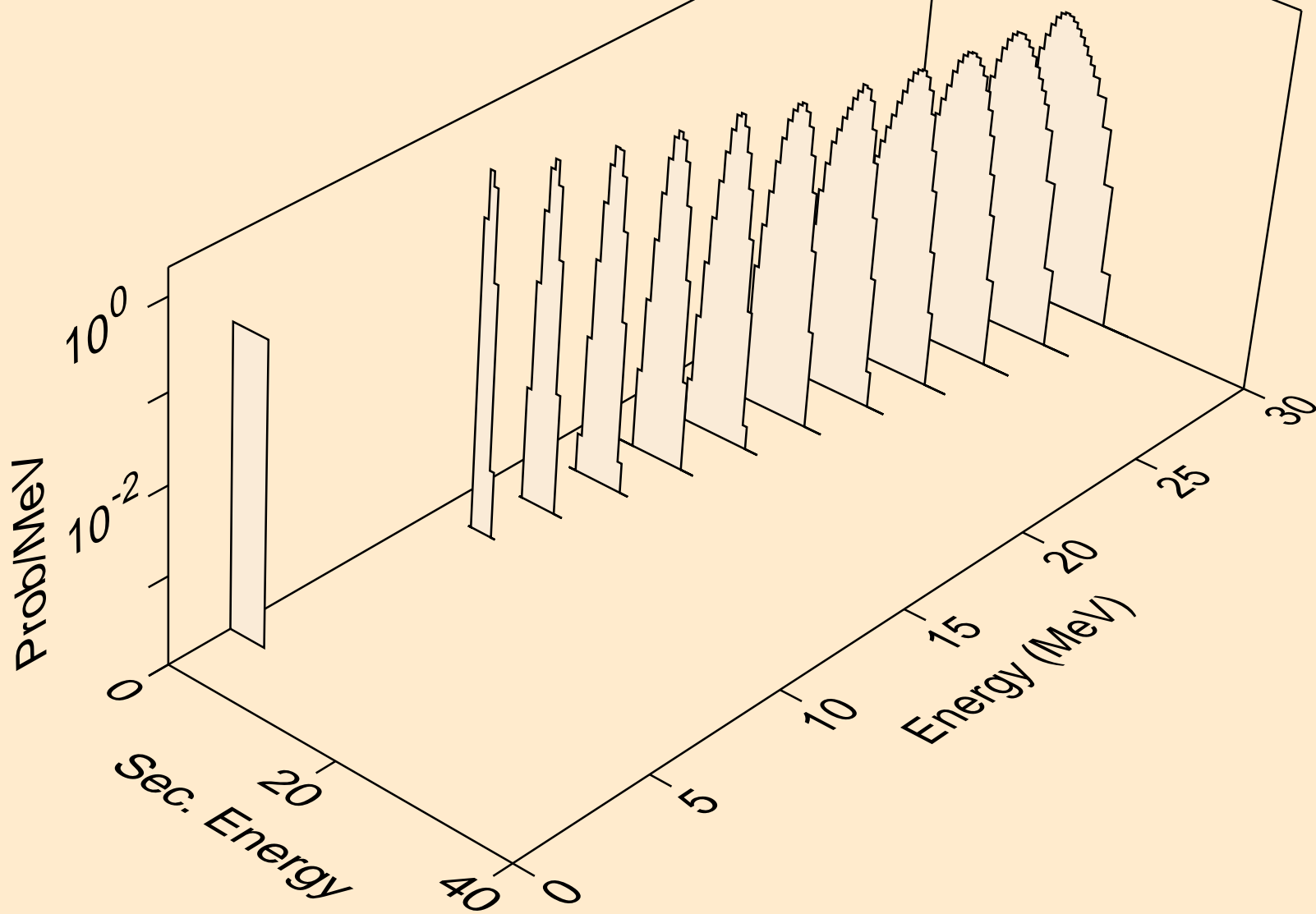

PM138 NEUTRON ACER TENDL-2024 LIBRARY; T=0.K  
alphas from (n,a)

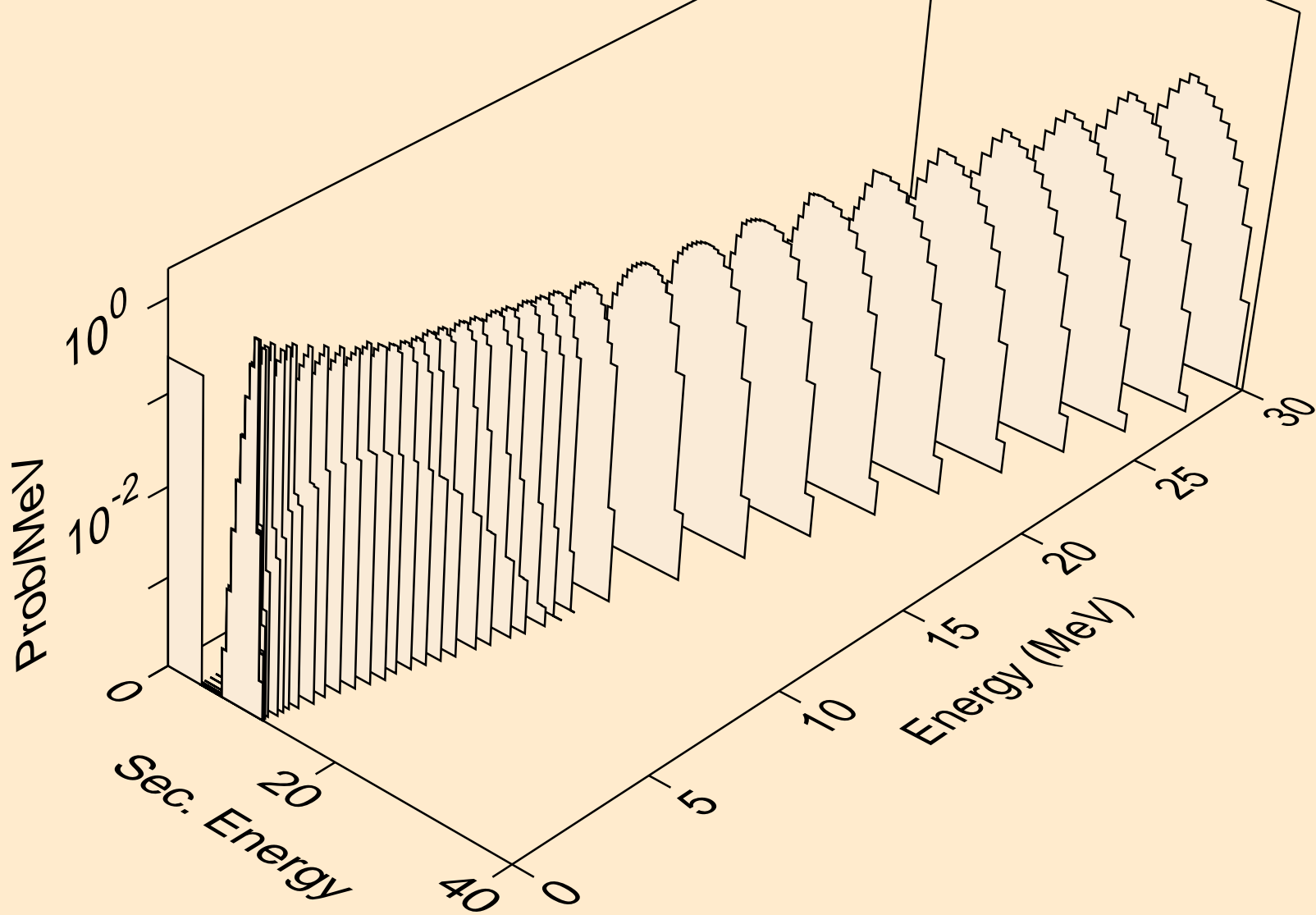

PM138 NEUTRON ACER TENDL-2024 LIBRARY; T=0.K  
alphas from (n,2a)

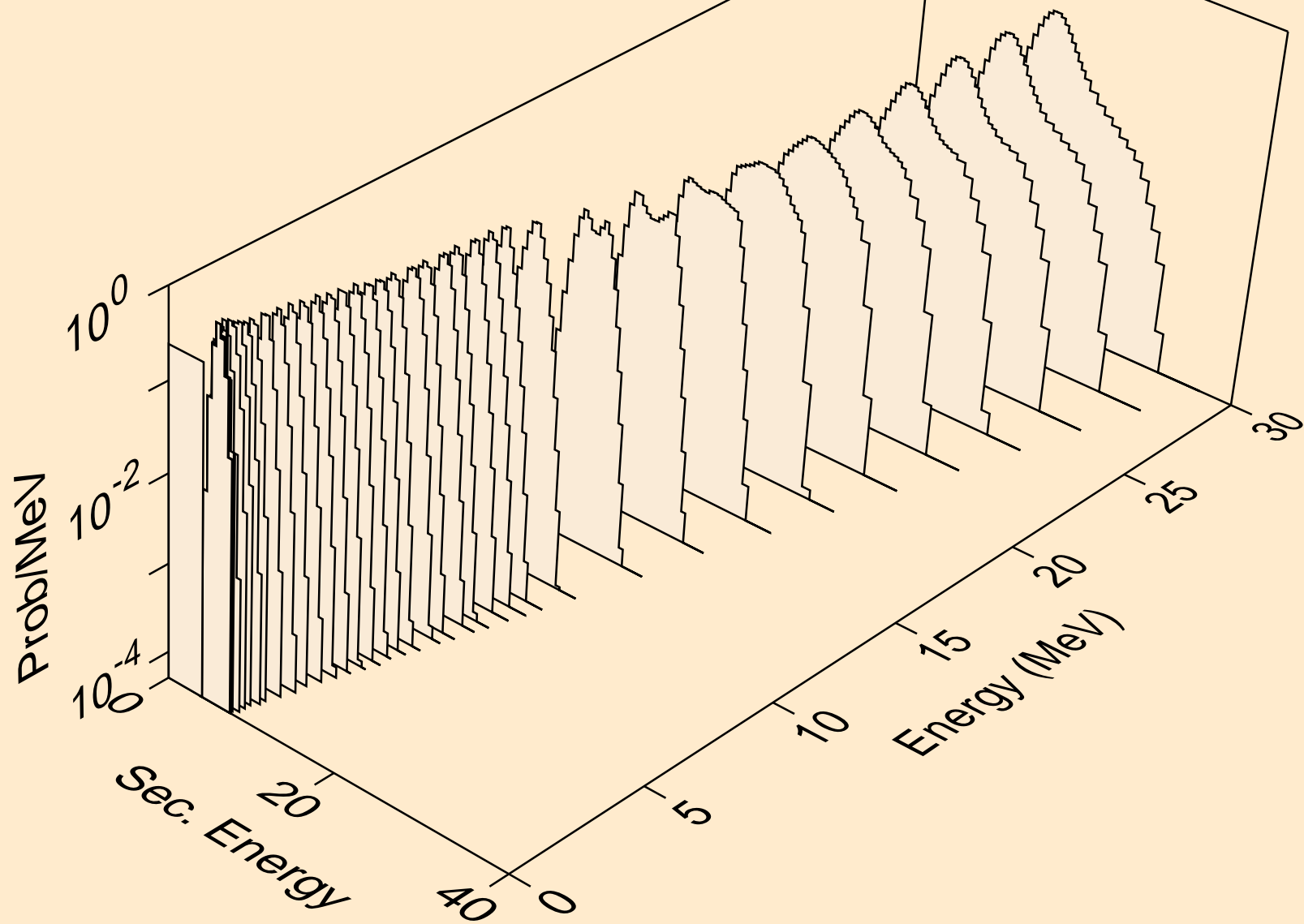

PM138 NEUTRON ACER TENDL-2024 LIBRARY; T=0.K  
alphas from (n,3a)

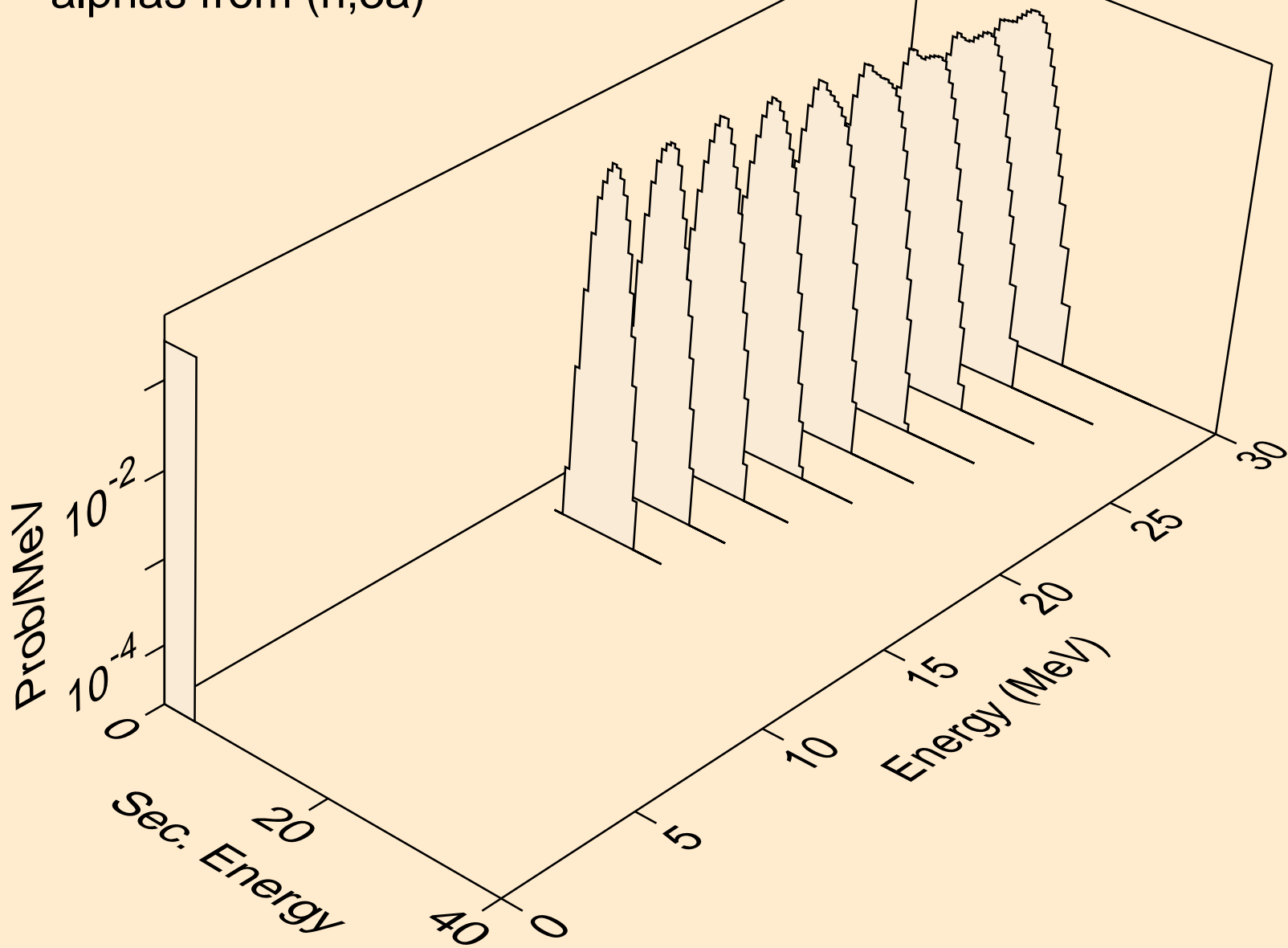

PM138 NEUTRON ACER TENDL-2024 LIBRARY; T=0.K  
alphas from (n,pa)

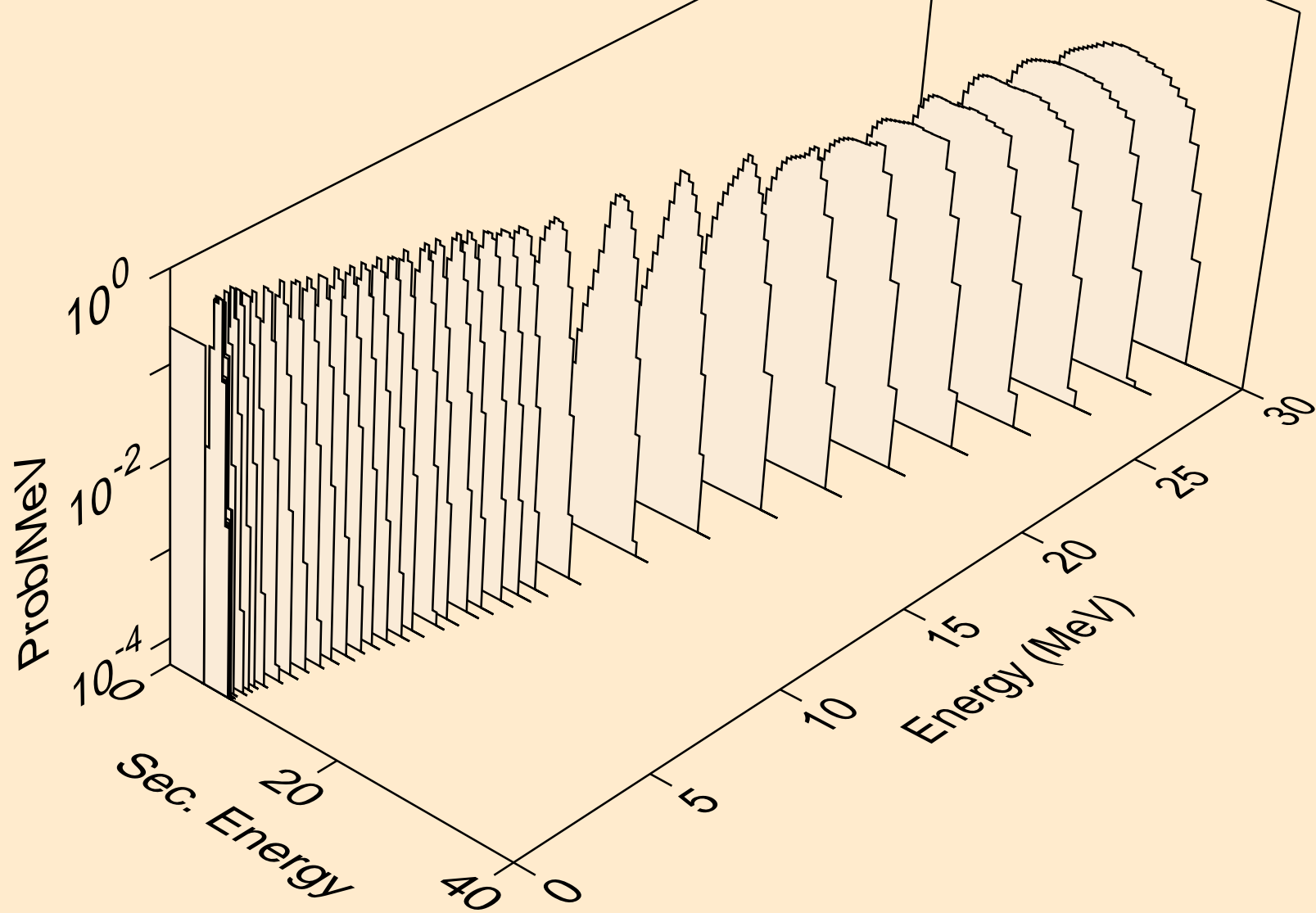



PM138 NEUTRON ACER TENDL-2024 LIBRARY; T=0.K  
alphas from (n,da)

