

RB090M NEUTRON ACER TENDL-2024 LIBRARY; T=0.K

Principal cross sections

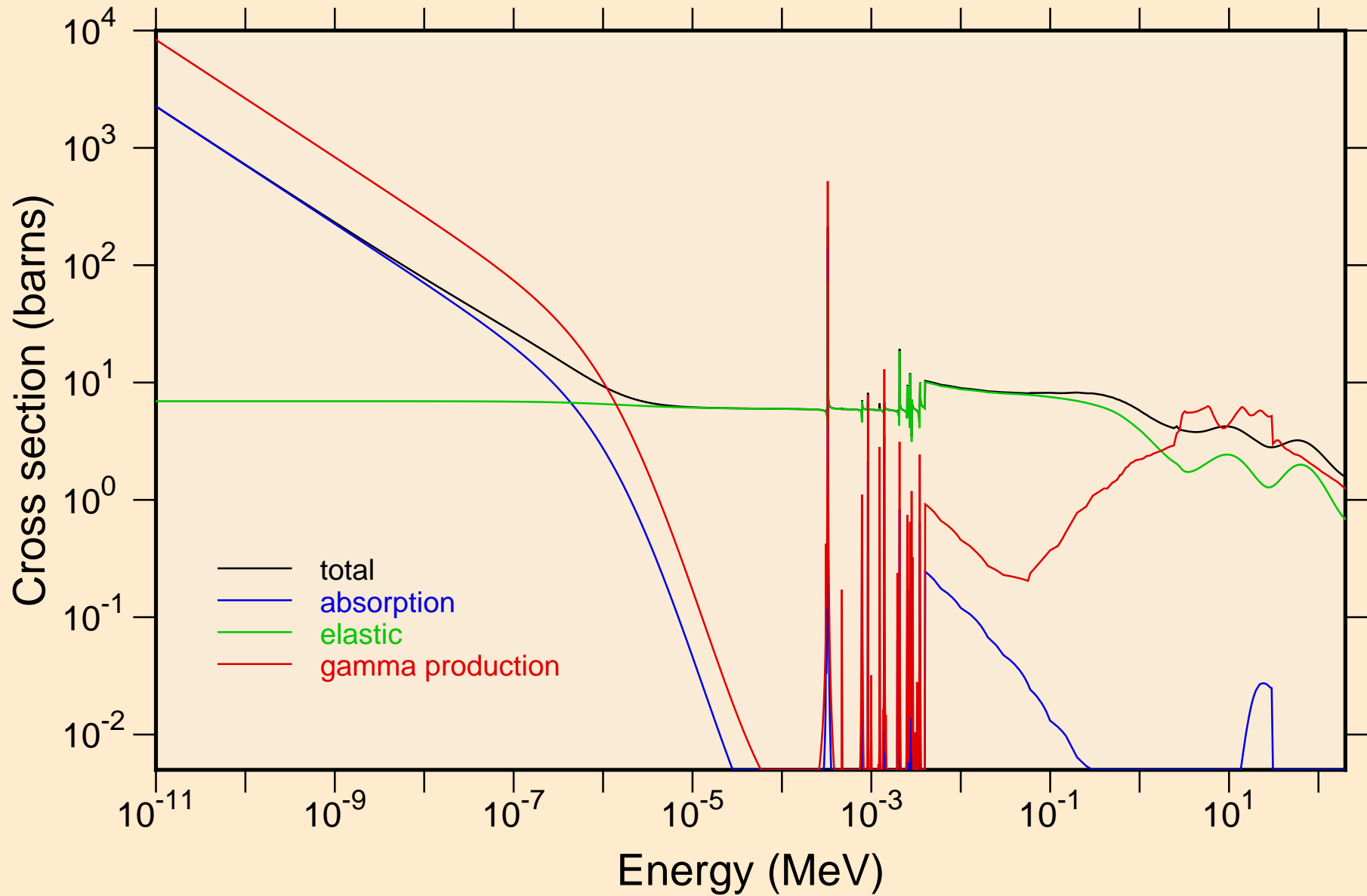

RB090M NEUTRON ACER TENDL-2024 LIBRARY; T=0.K
resonance total cross section

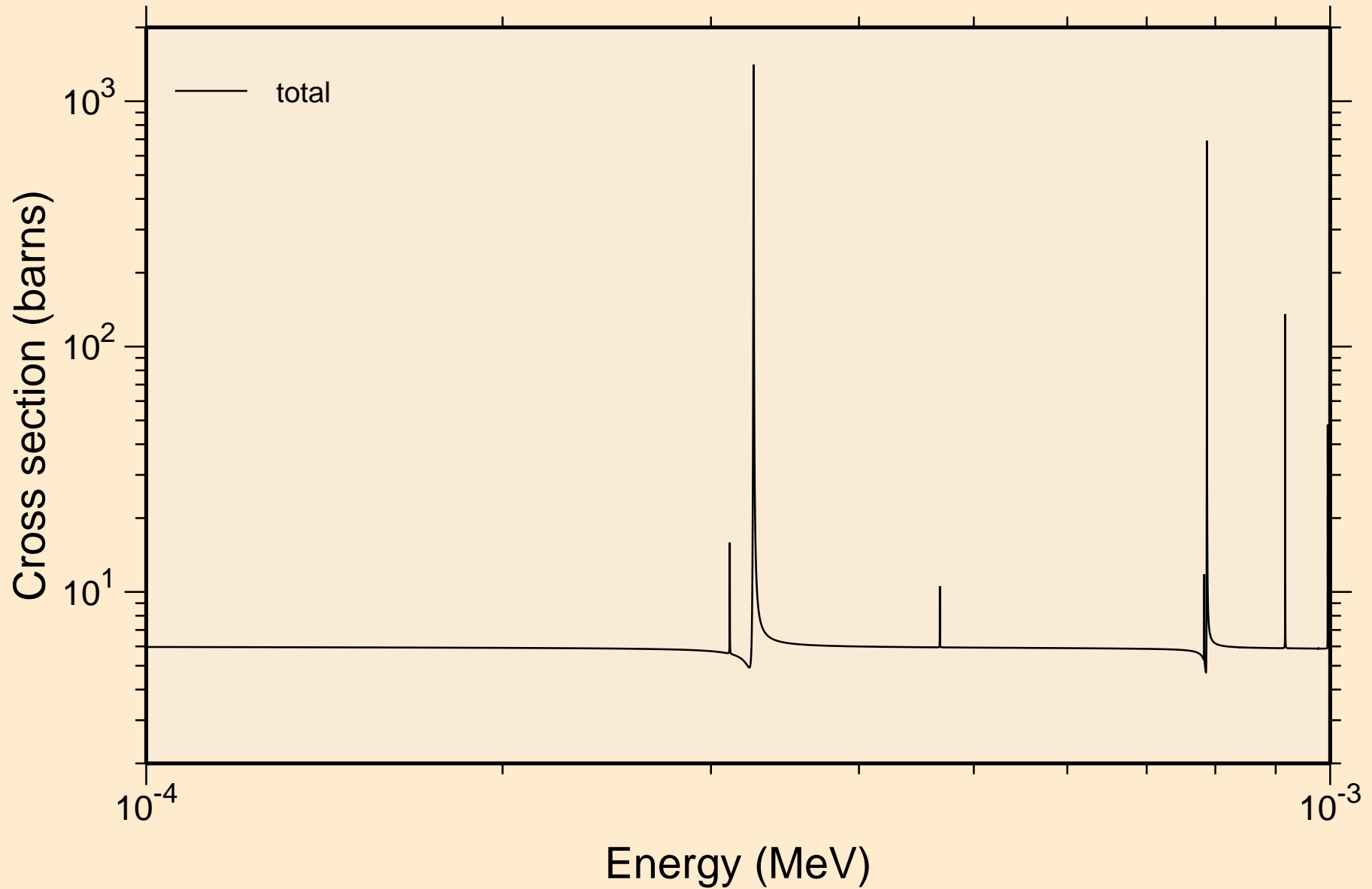

RB090M NEUTRON ACER TENDL-2024 LIBRARY; T=0.K
resonance total cross section

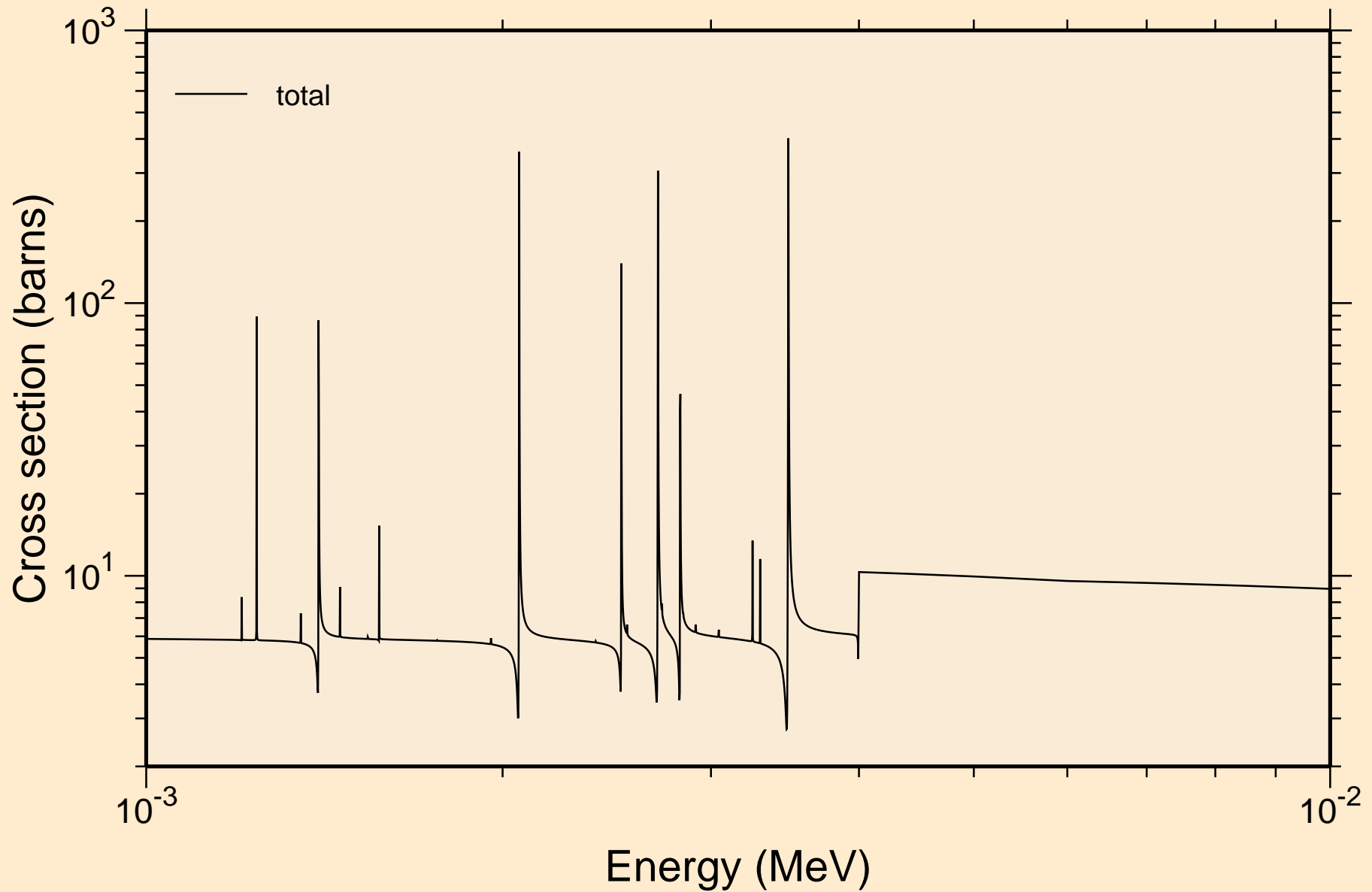

RB090M NEUTRON ACER TENDL-2024 LIBRARY; T=0.K
resonance total cross section

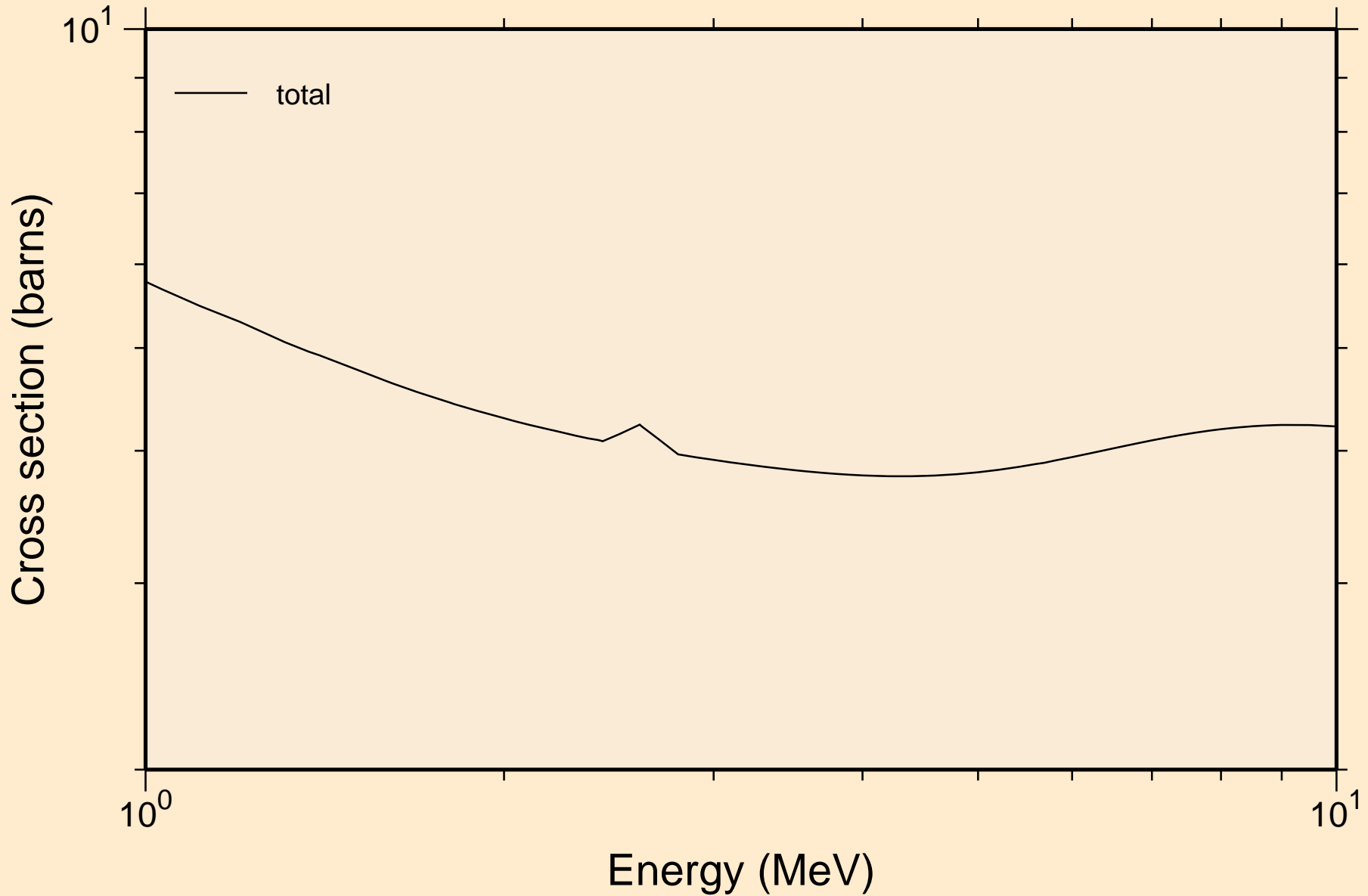

RB090M NEUTRON ACER TENDL-2024 LIBRARY; T=0.K
resonance absorption cross sections

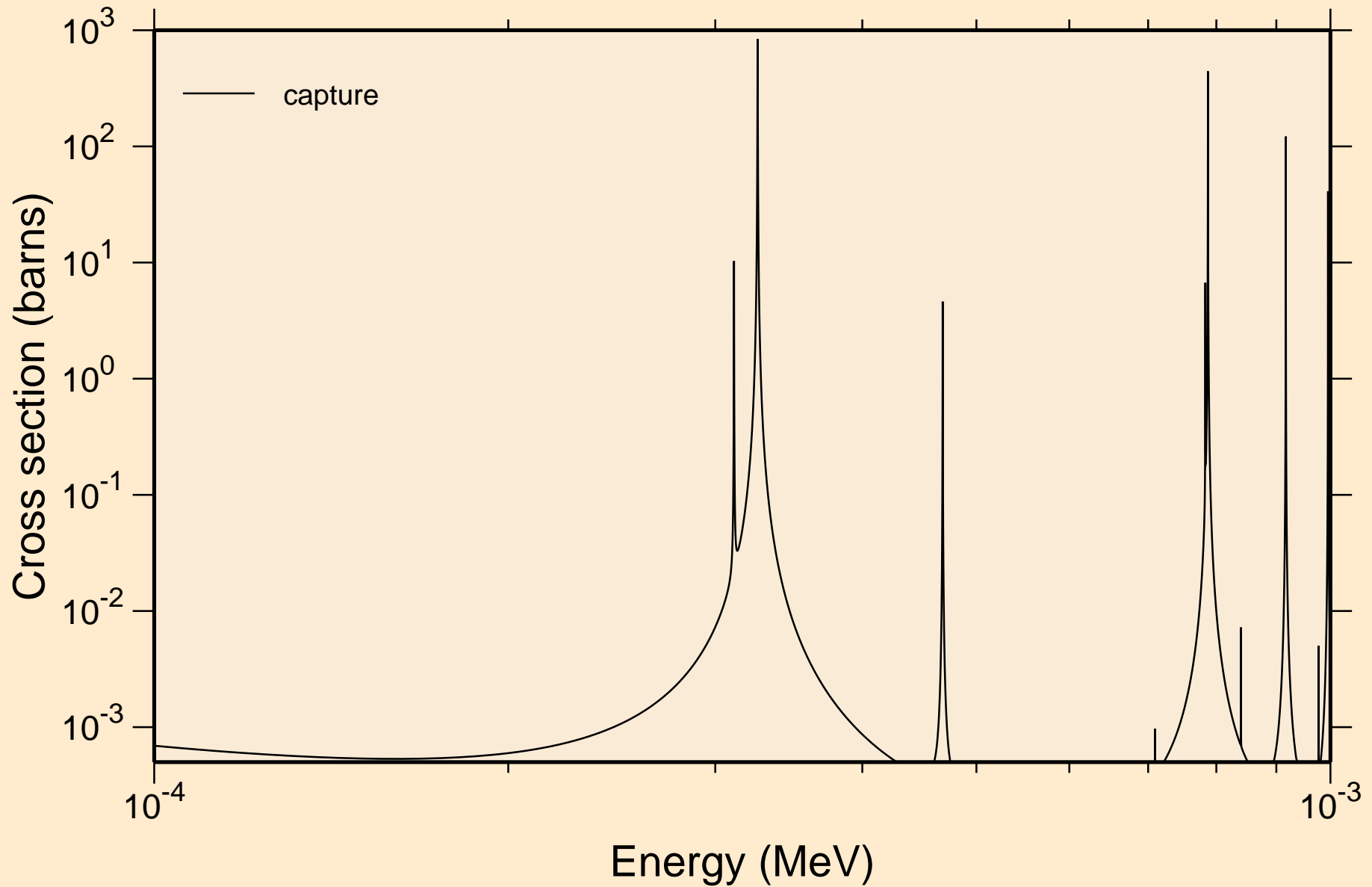

RB090M NEUTRON ACER TENDL-2024 LIBRARY; T=0.K
resonance absorption cross sections

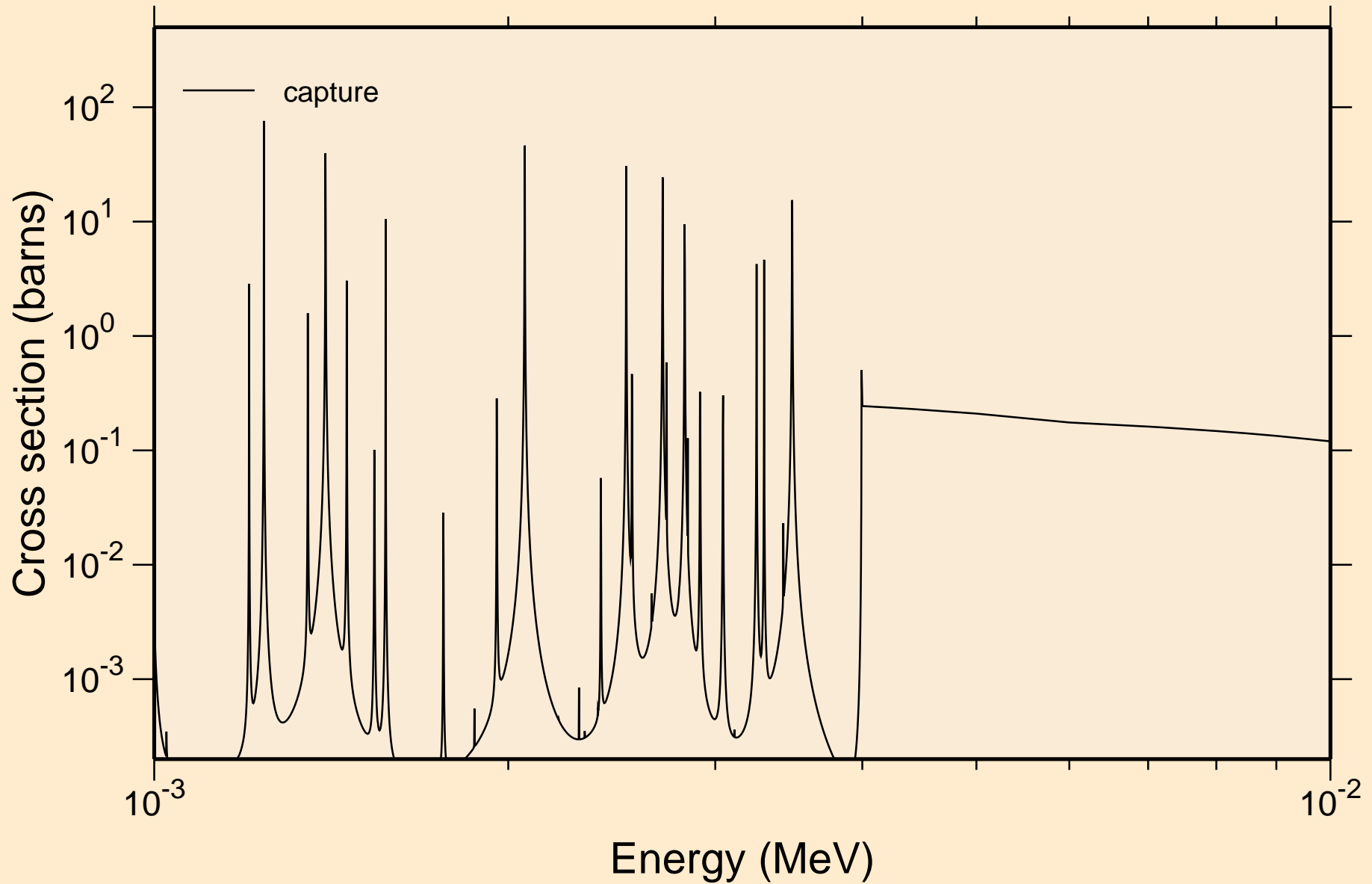

RB090M NEUTRON ACER TENDL-2024 LIBRARY; T=0.K
resonance absorption cross sections

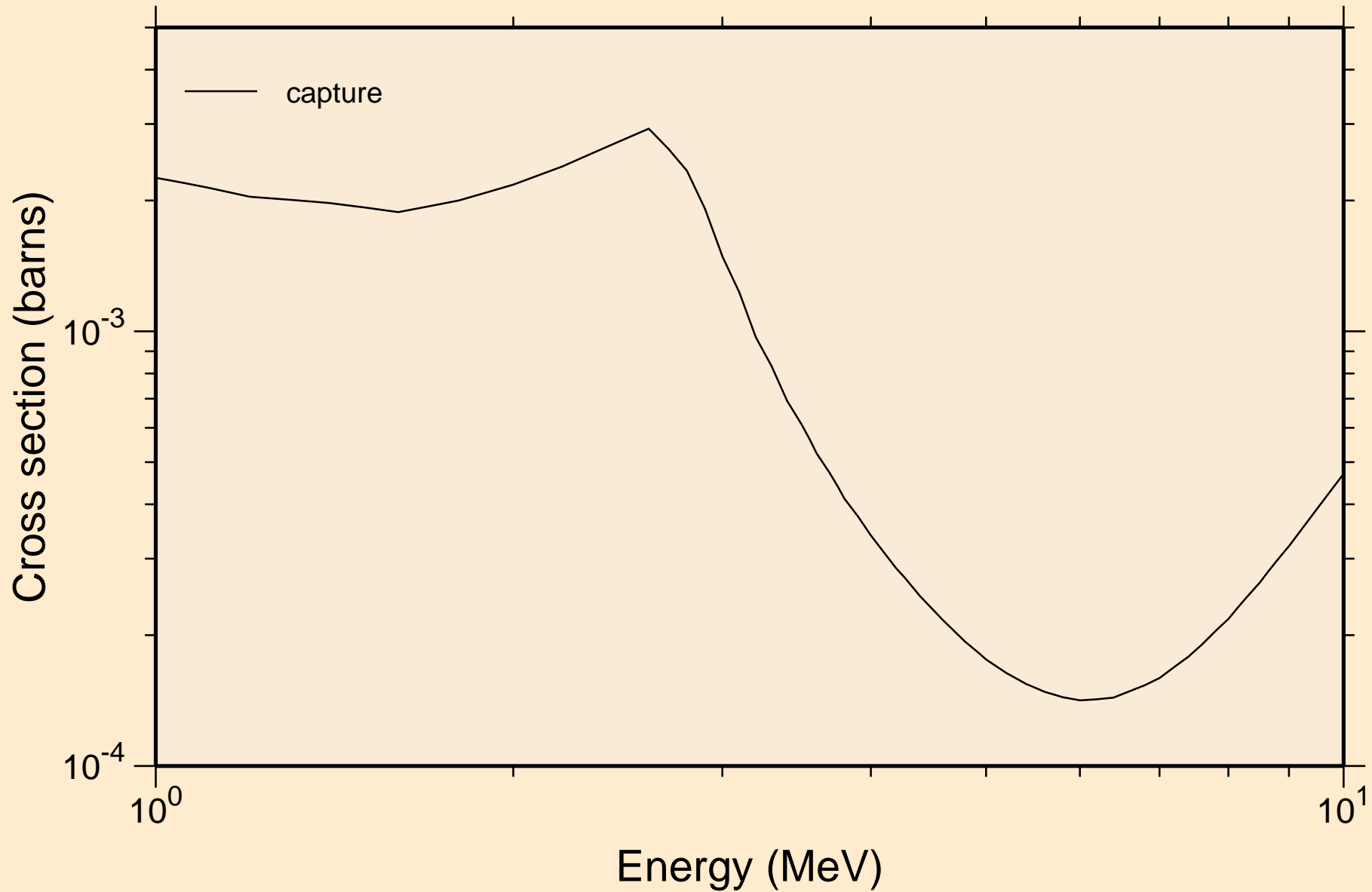

RB090M NEUTRON ACER TENDL-2024 LIBRARY; T=0.K
Heating

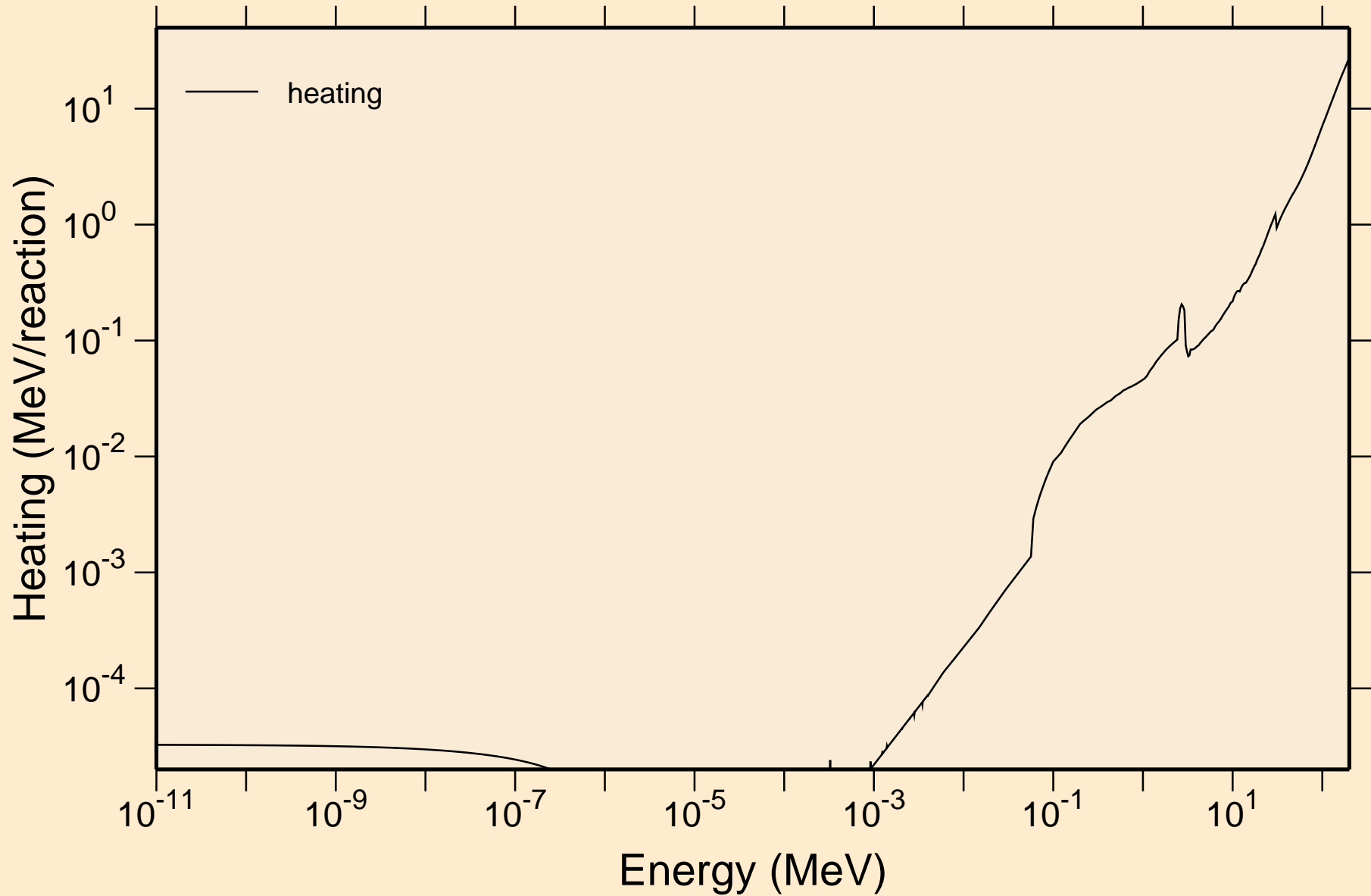

RB090M NEUTRON ACER TENDL-2024 LIBRARY; T=0.K
Damage

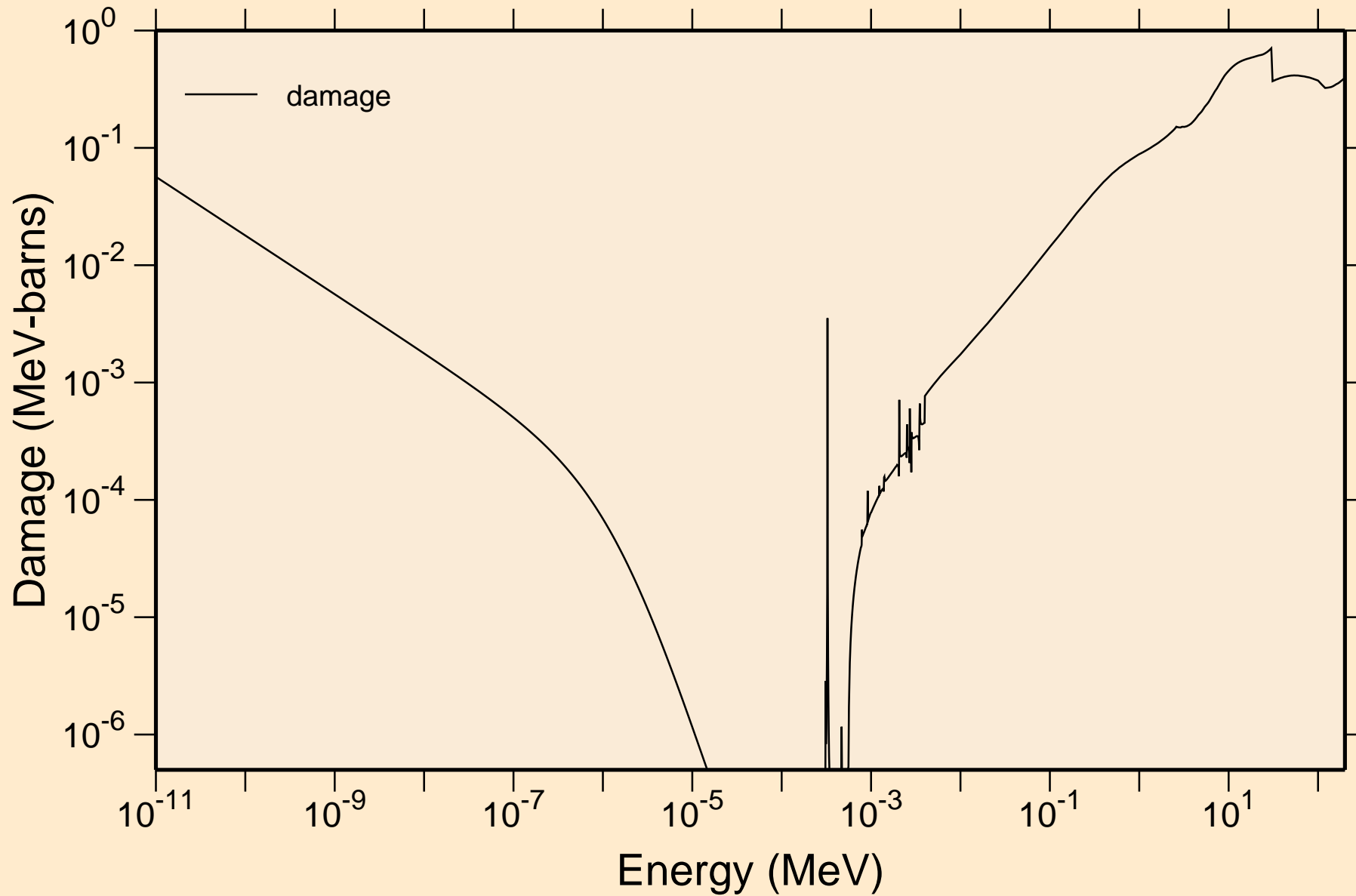

RB090M NEUTRON ACER TENDL-2024 LIBRARY; T=0.K
Non-threshold reactions

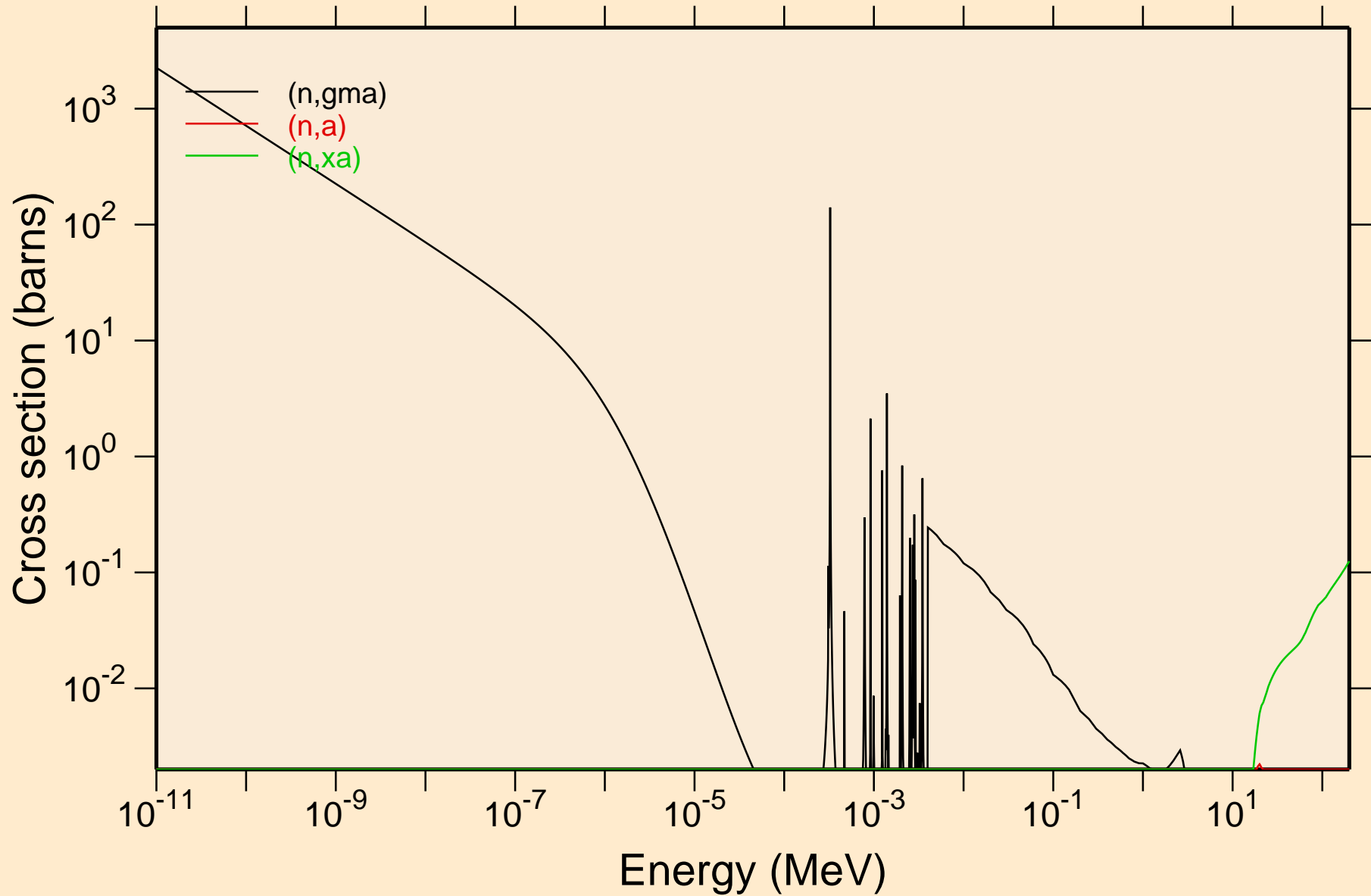

RB090M NEUTRON ACER TENDL-2024 LIBRARY; T=0.K

Principal cross sections

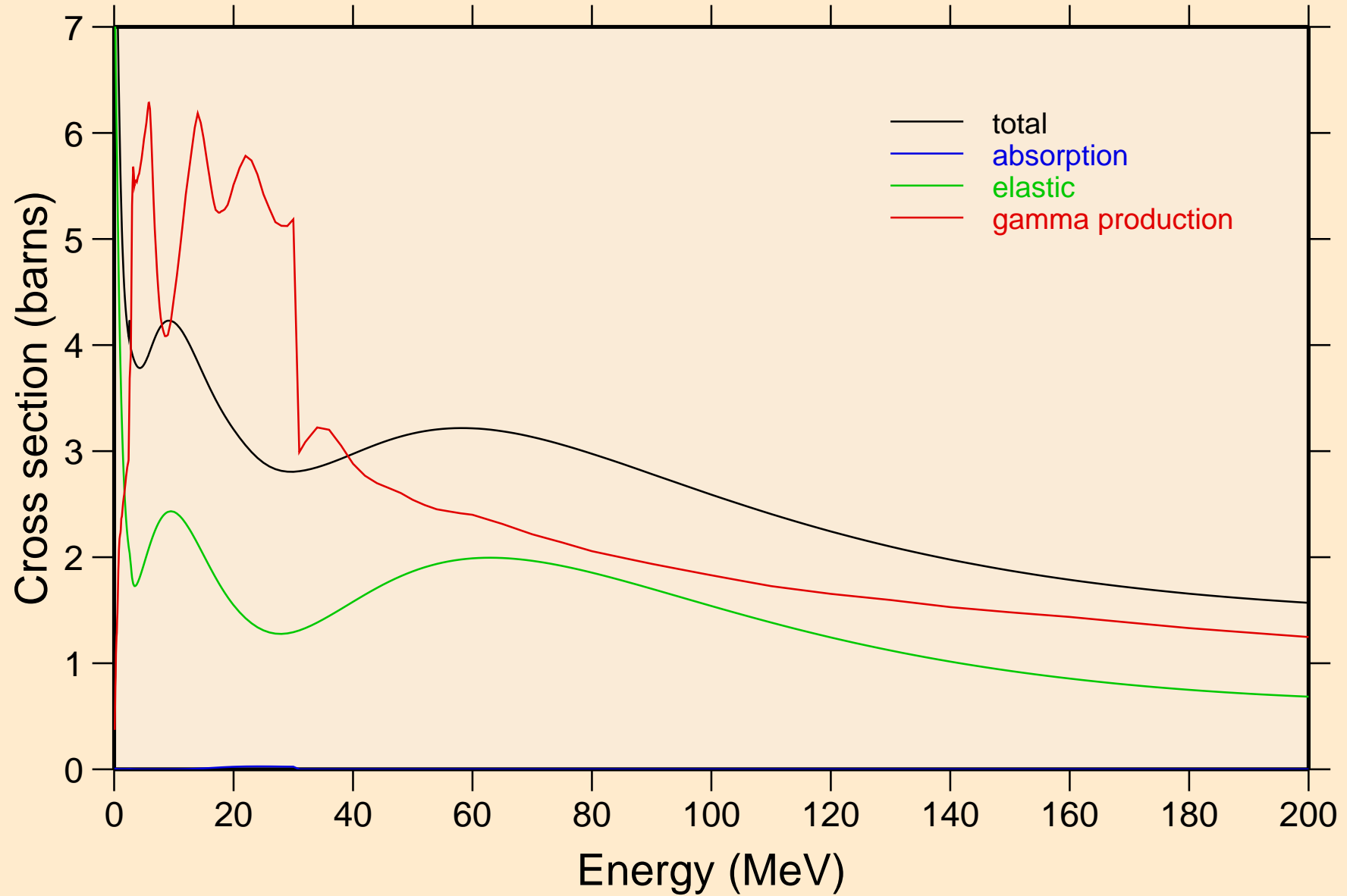

RB090M NEUTRON ACER TENDL-2024 LIBRARY; T=0.K

Heating

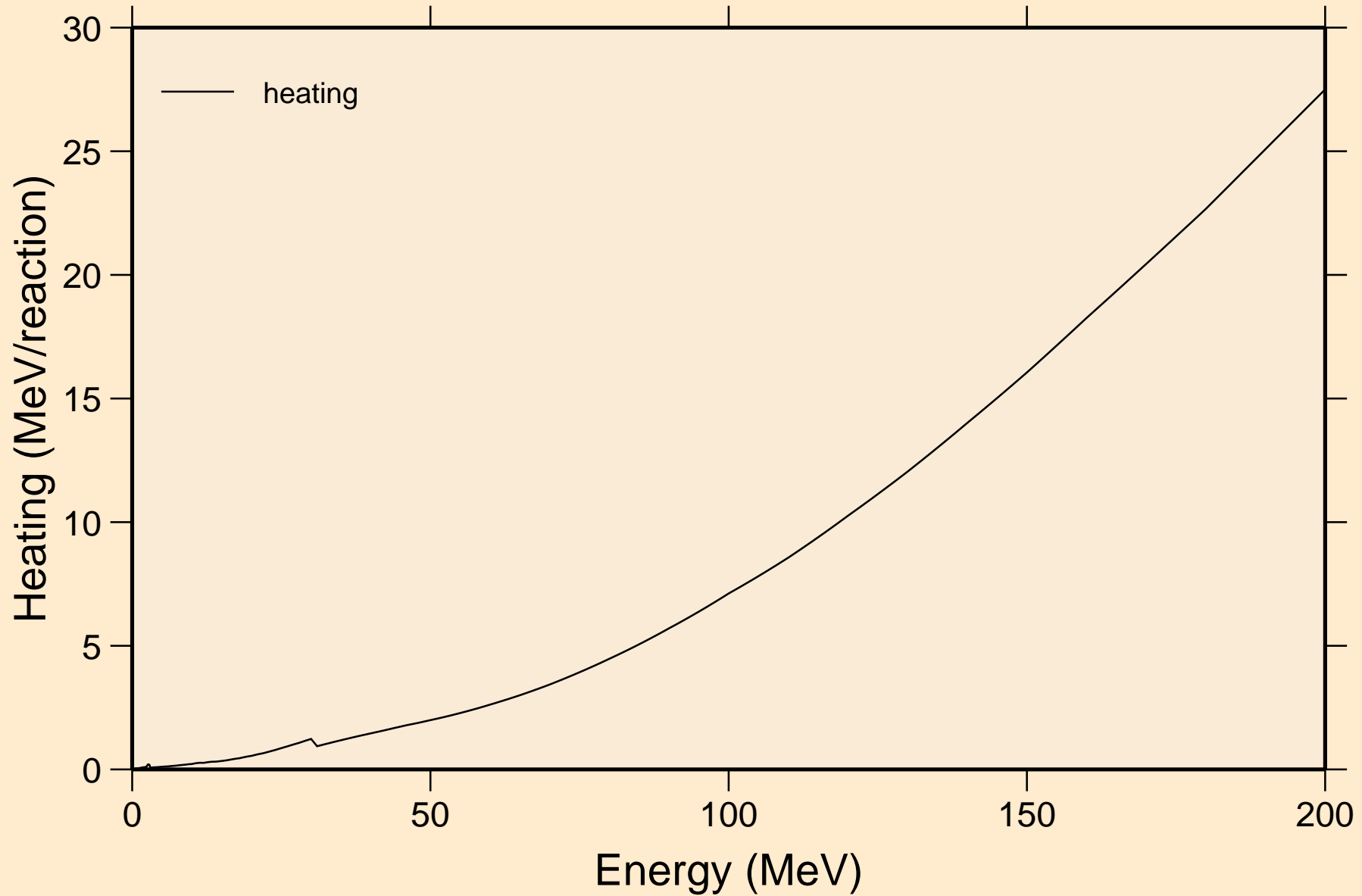

RB090M NEUTRON ACER TENDL-2024 LIBRARY; T=0.K
Damage

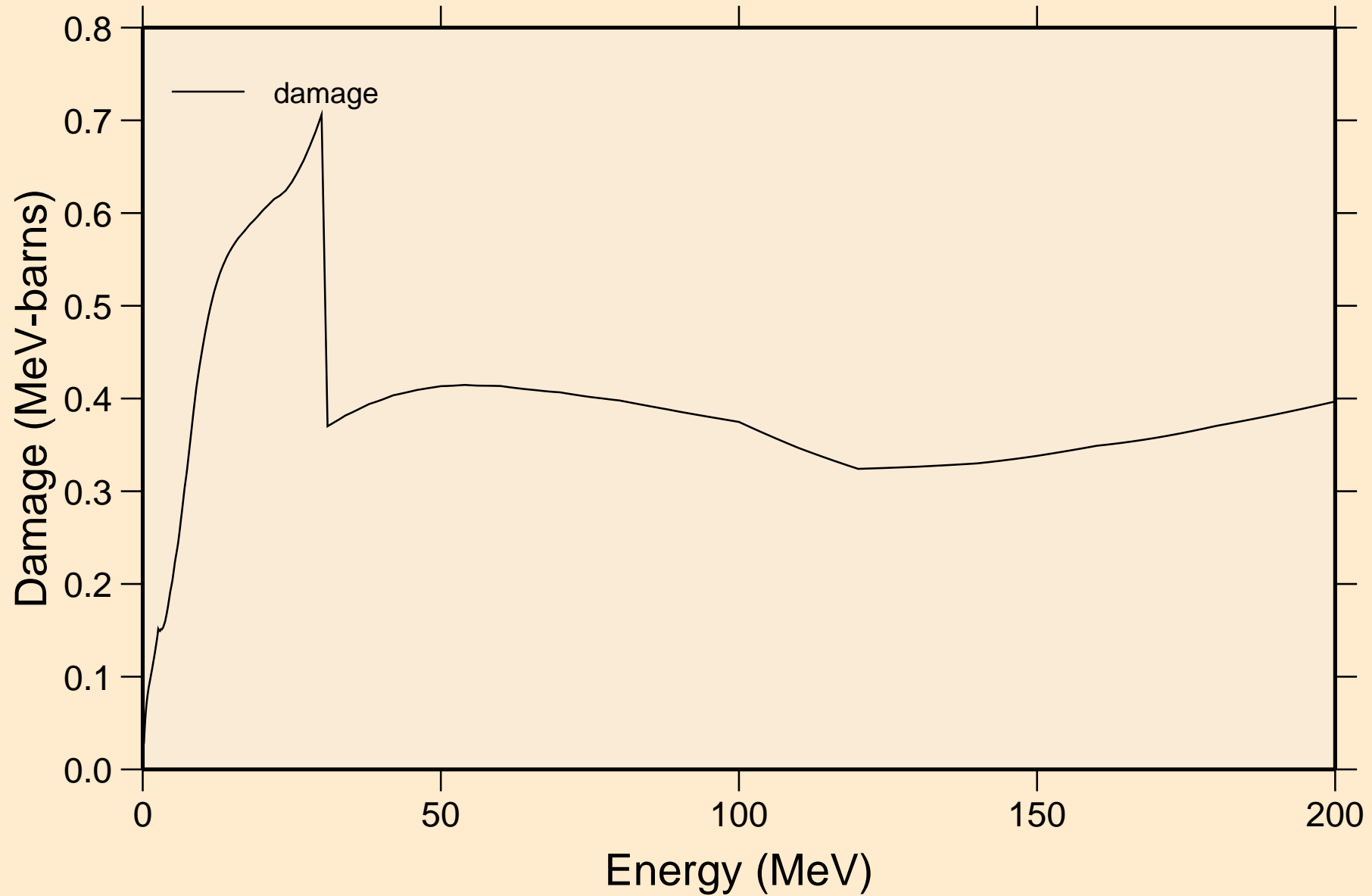

RB090M NEUTRON ACER TENDL-2024 LIBRARY; T=0.K
Non-threshold reactions

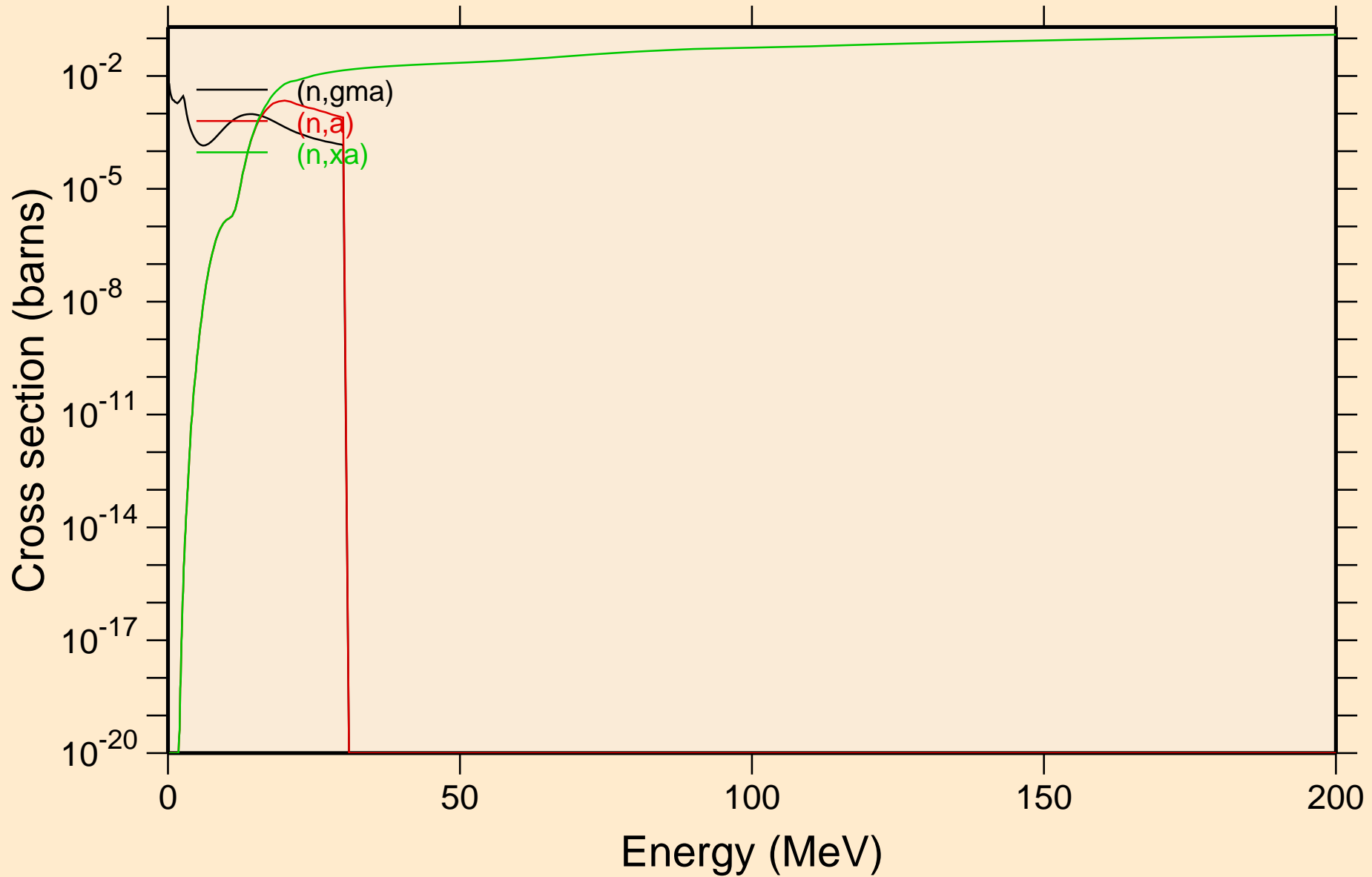

RB090M NEUTRON ACER TENDL-2024 LIBRARY; T=0.K
Inelastic levels

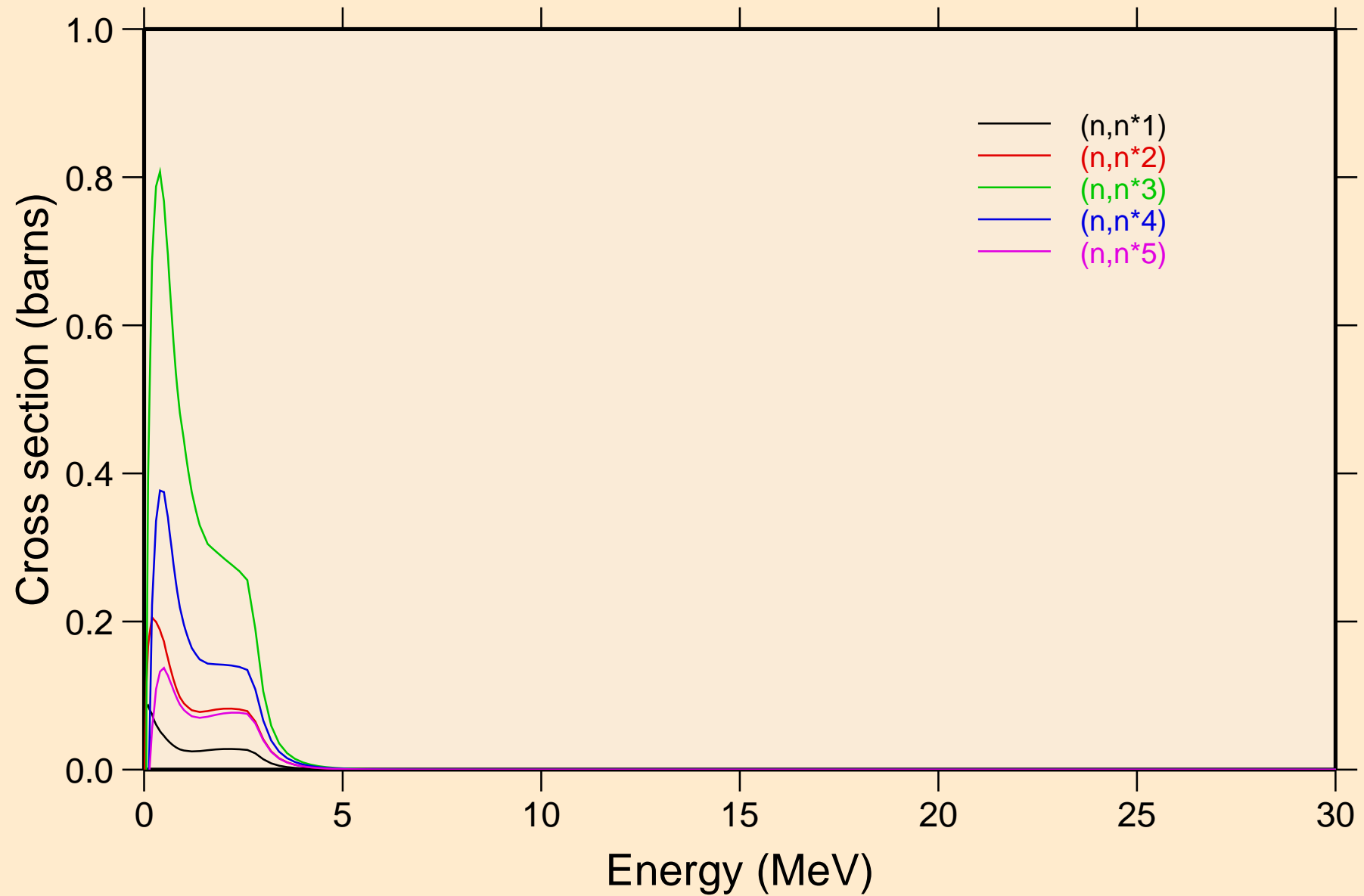

RB090M NEUTRON ACER TENDL-2024 LIBRARY; T=0.K
Inelastic levels

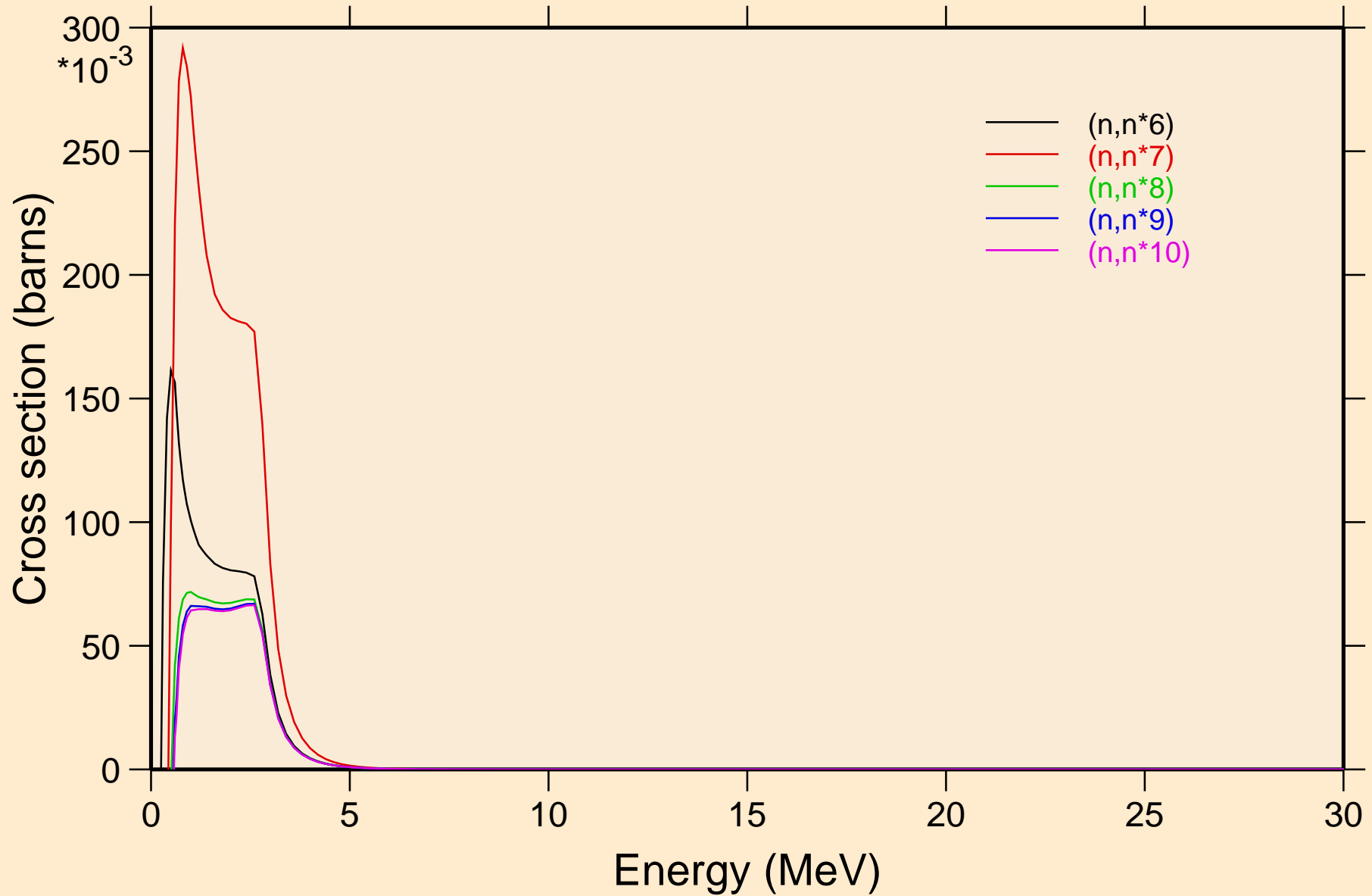

RB090M NEUTRON ACER TENDL-2024 LIBRARY; T=0.K
Inelastic levels

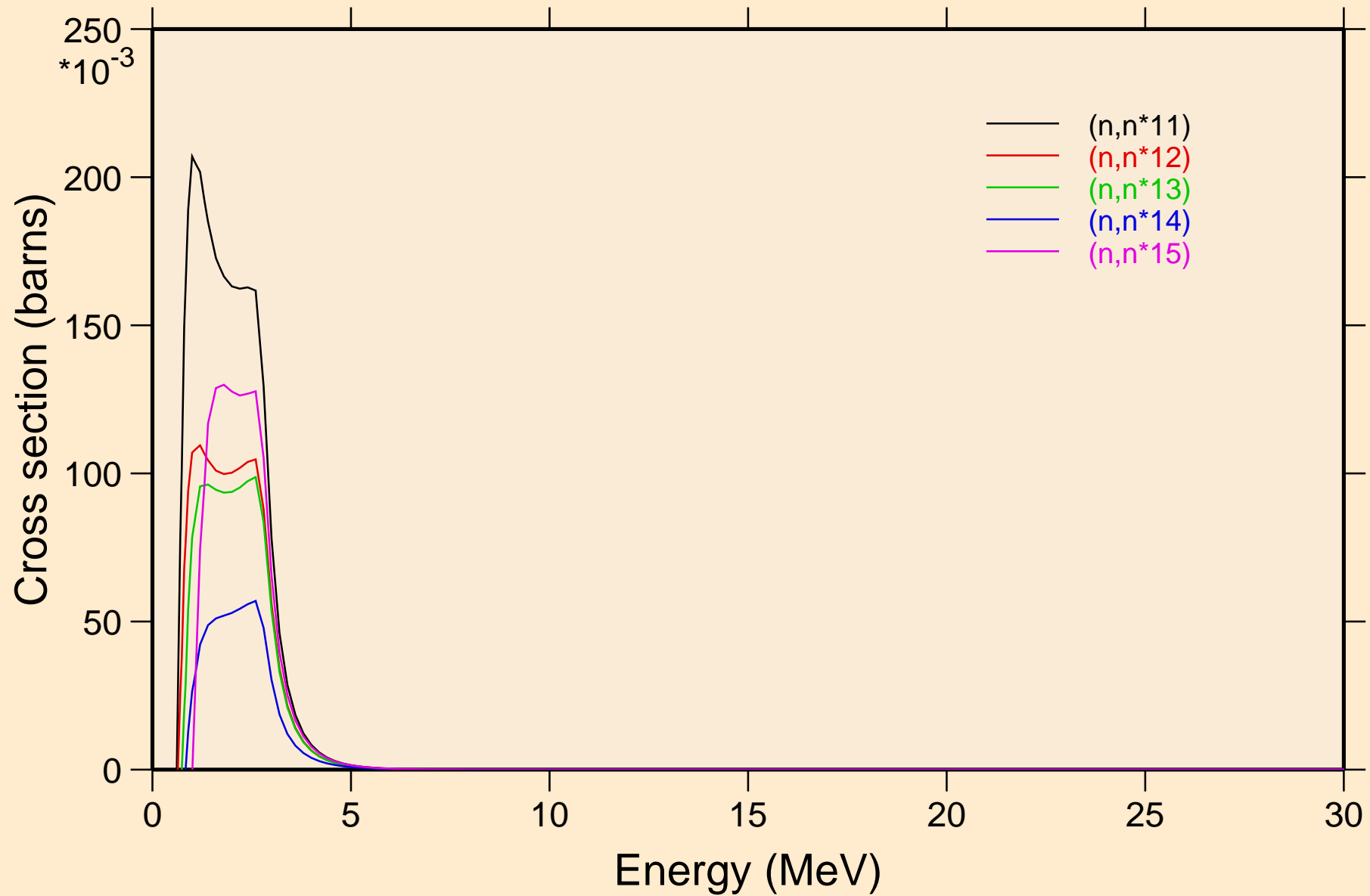

RB090M NEUTRON ACER TENDL-2024 LIBRARY; T=0.K
Inelastic levels

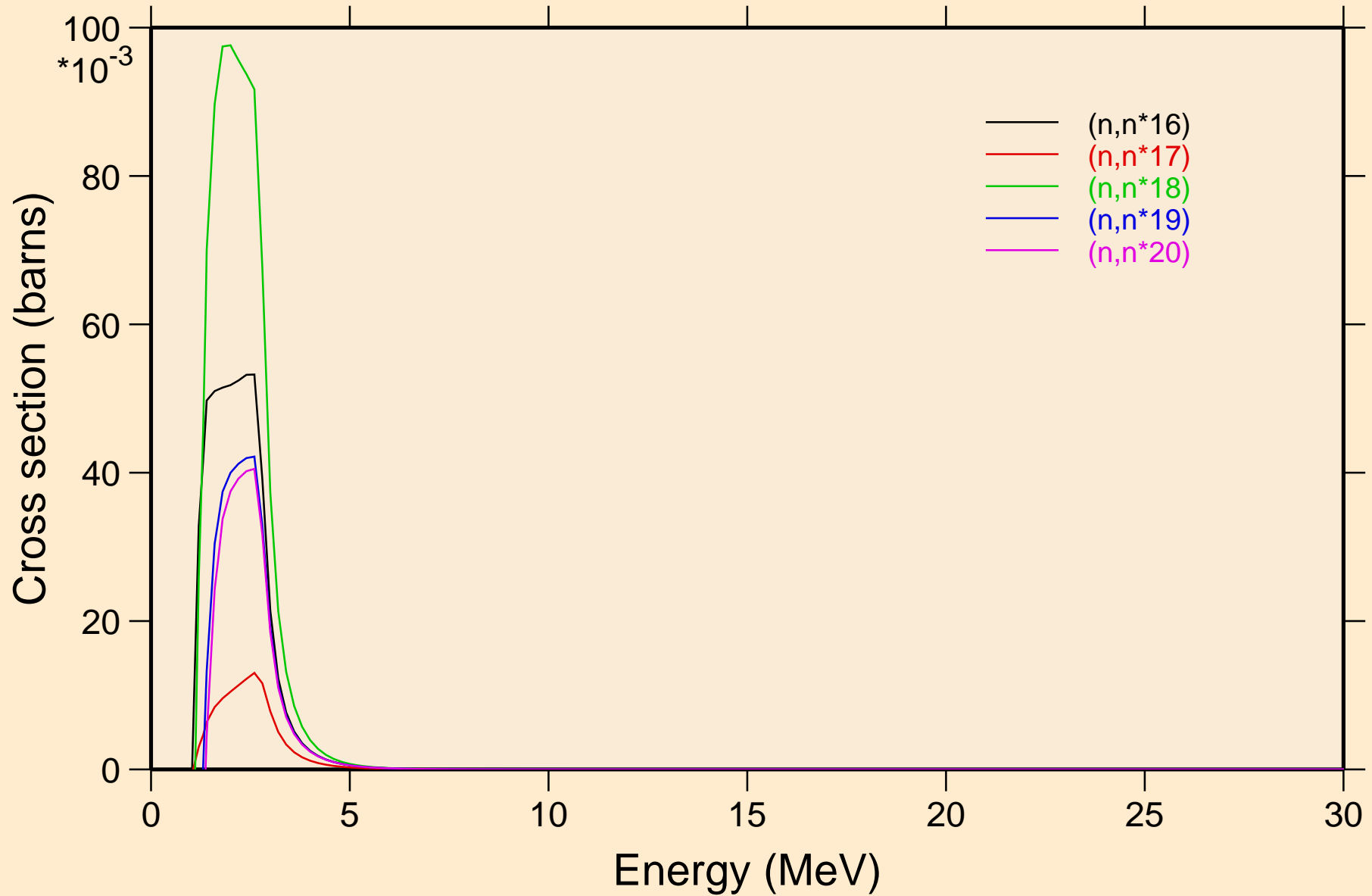

RB090M NEUTRON ACER TENDL-2024 LIBRARY; T=0.K
Inelastic levels

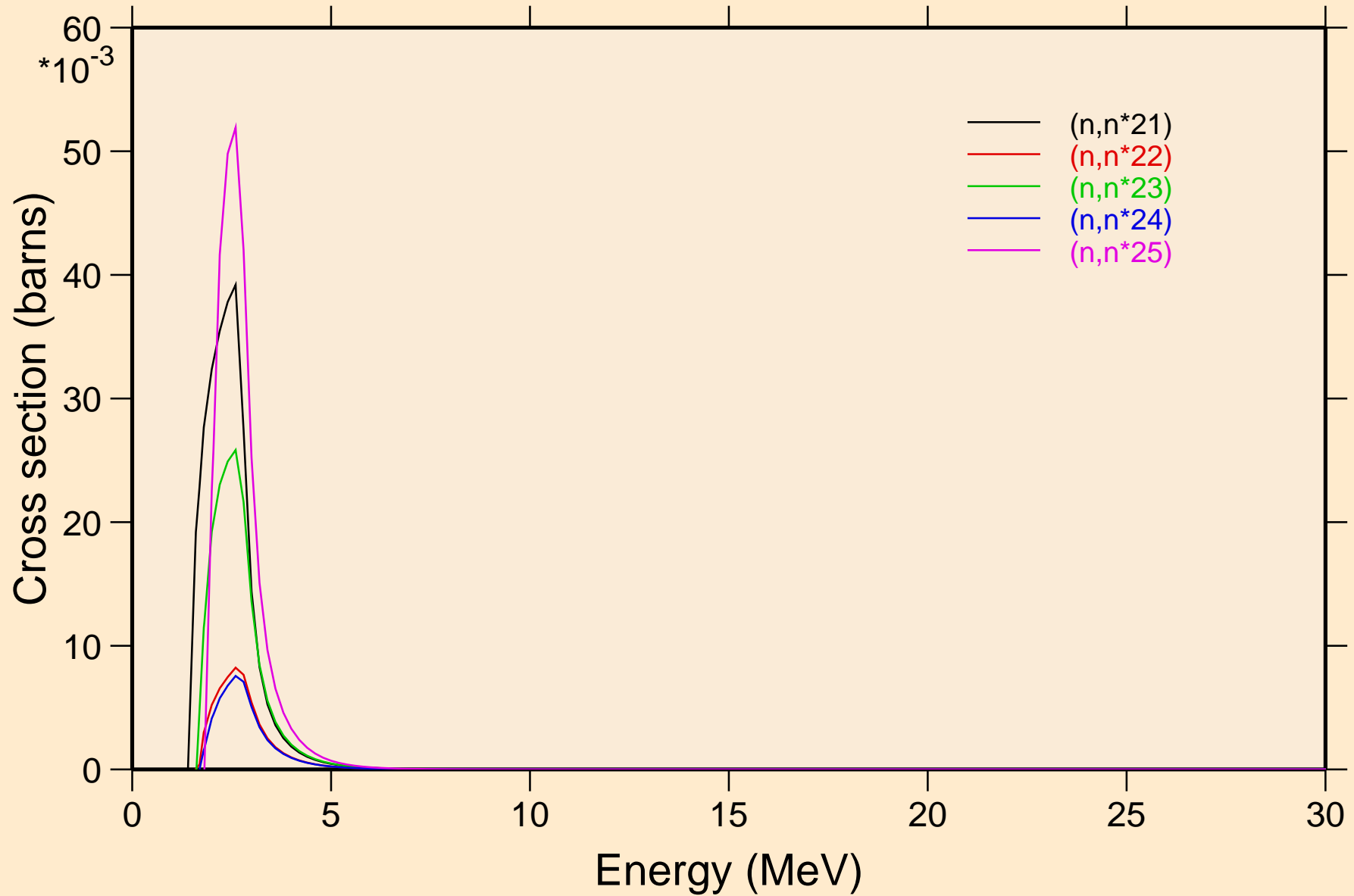

RB090M NEUTRON ACER TENDL-2024 LIBRARY; T=0.K
Inelastic levels

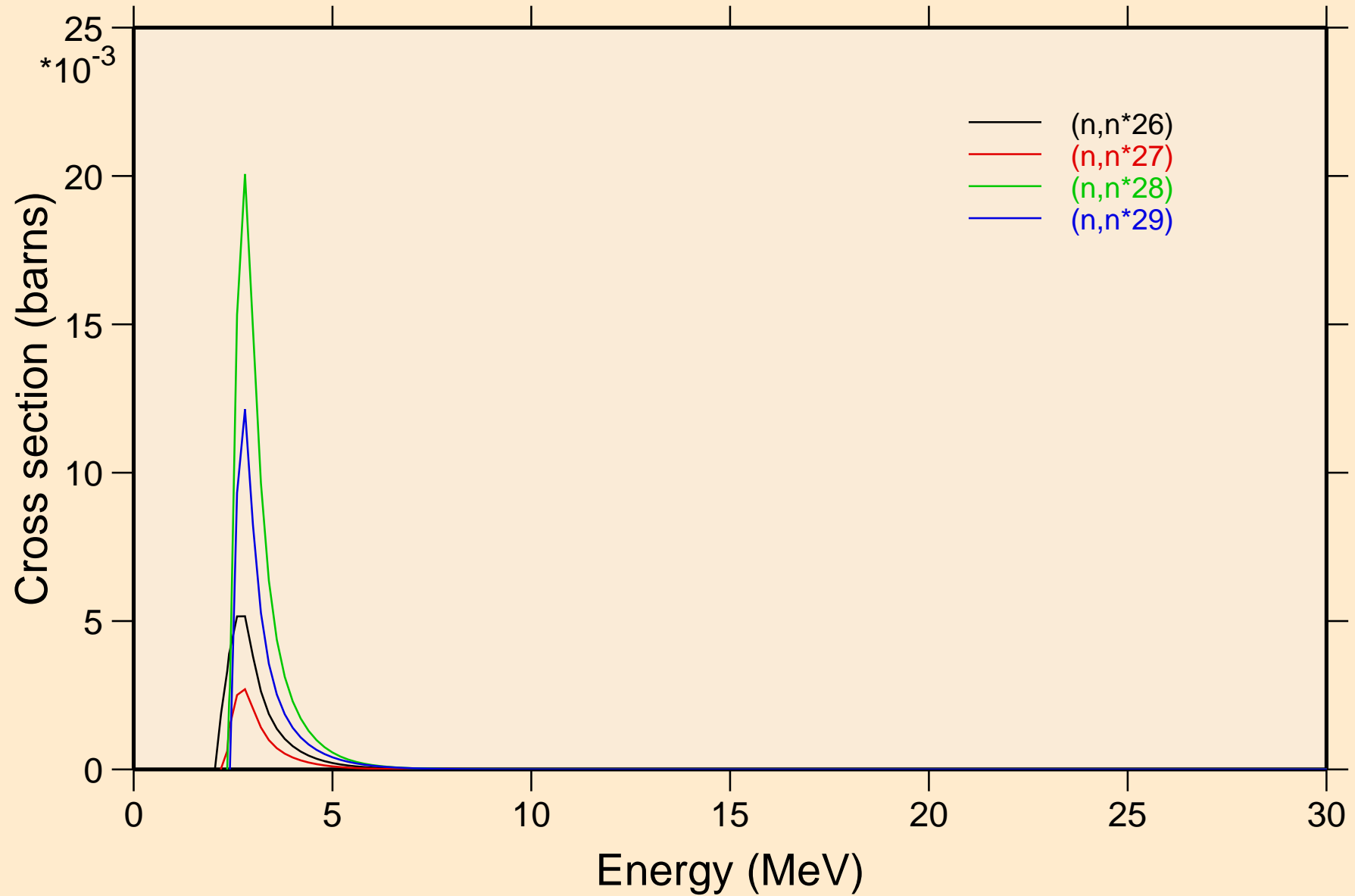

RB090M NEUTRON ACER TENDL-2024 LIBRARY; T=0.K
Threshold reactions

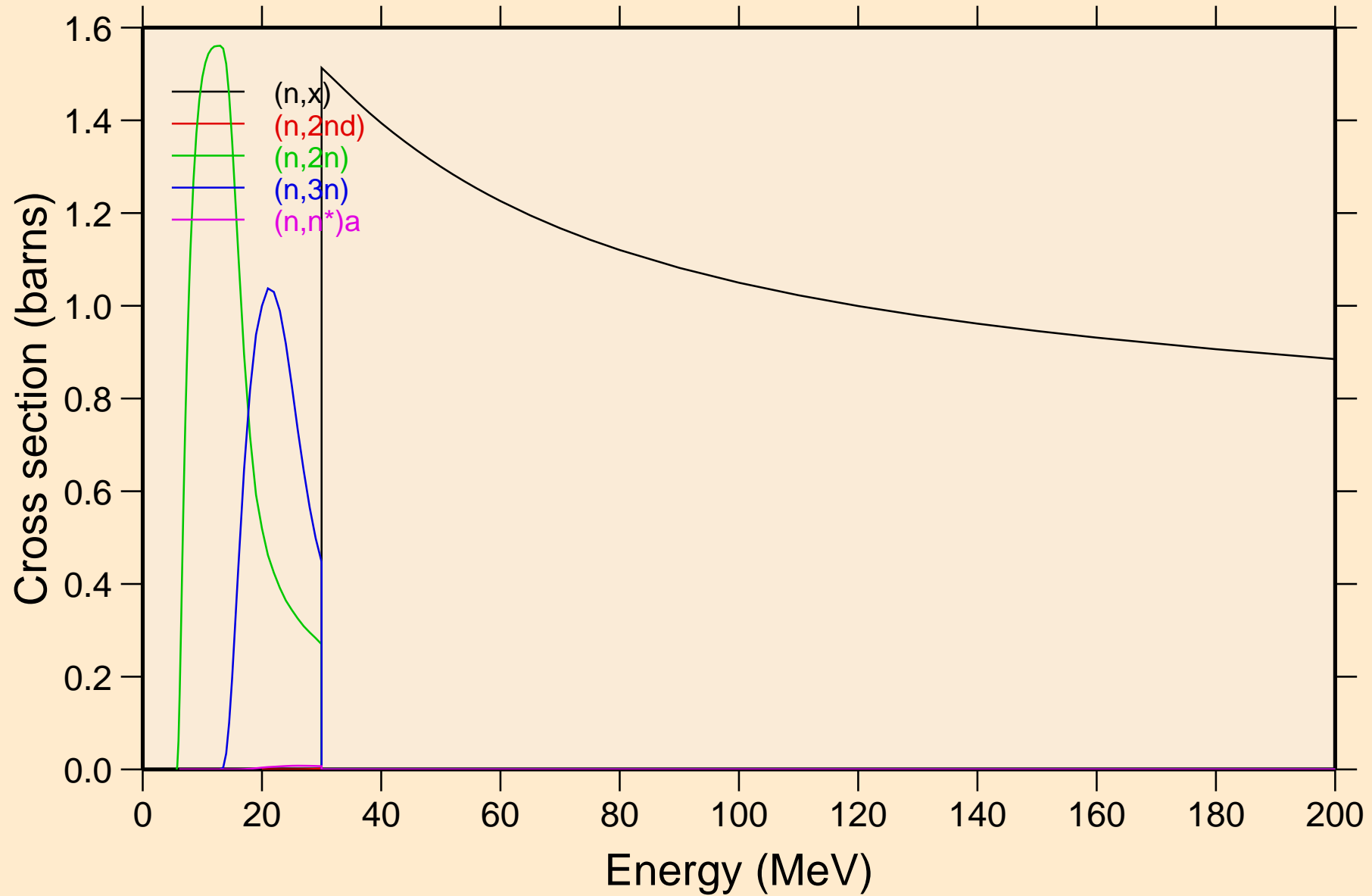

RB090M NEUTRON ACER TENDL-2024 LIBRARY; T=0.K
Threshold reactions

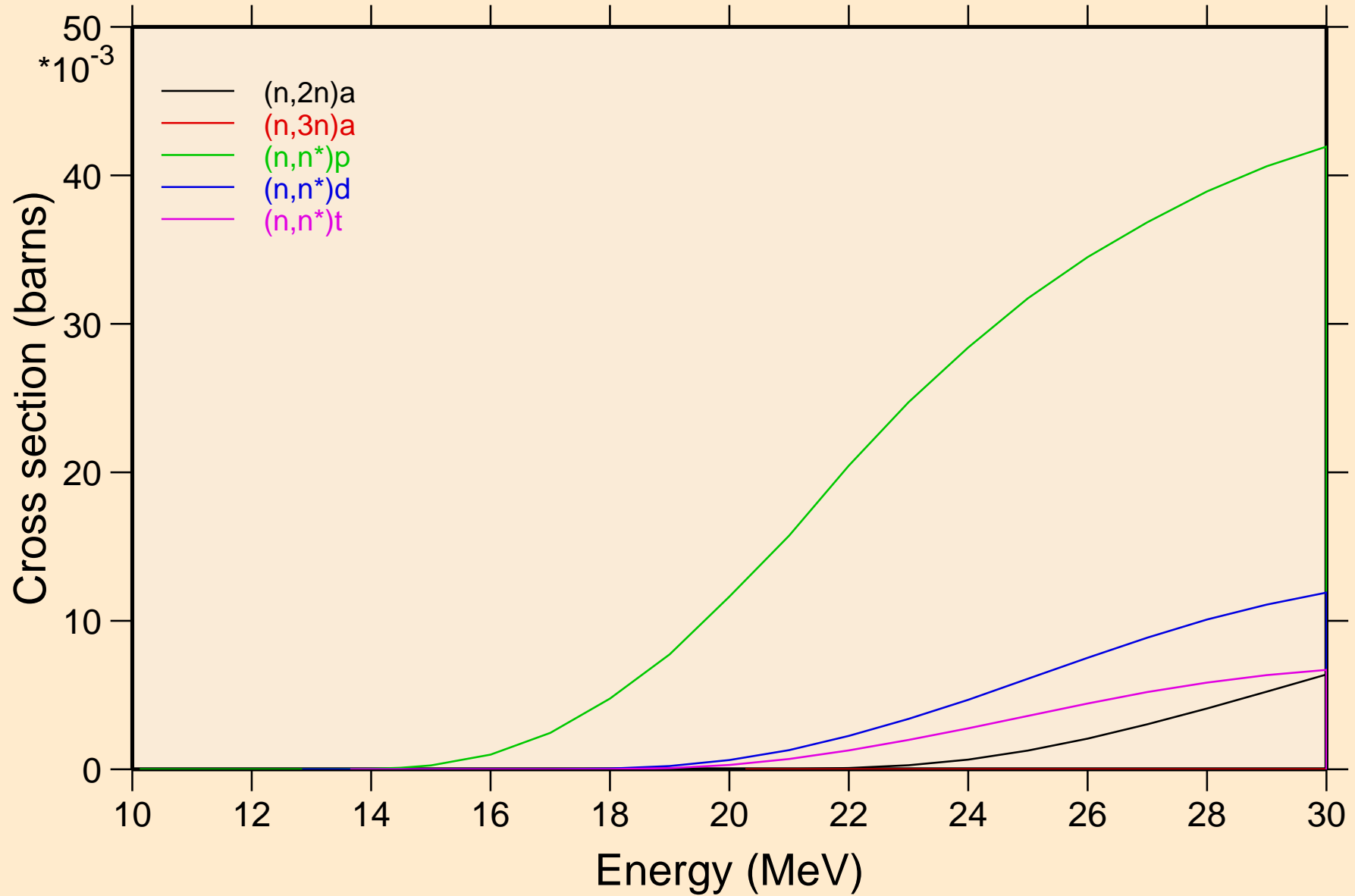

RB090M NEUTRON ACER TENDL-2024 LIBRARY; T=0.K
Threshold reactions

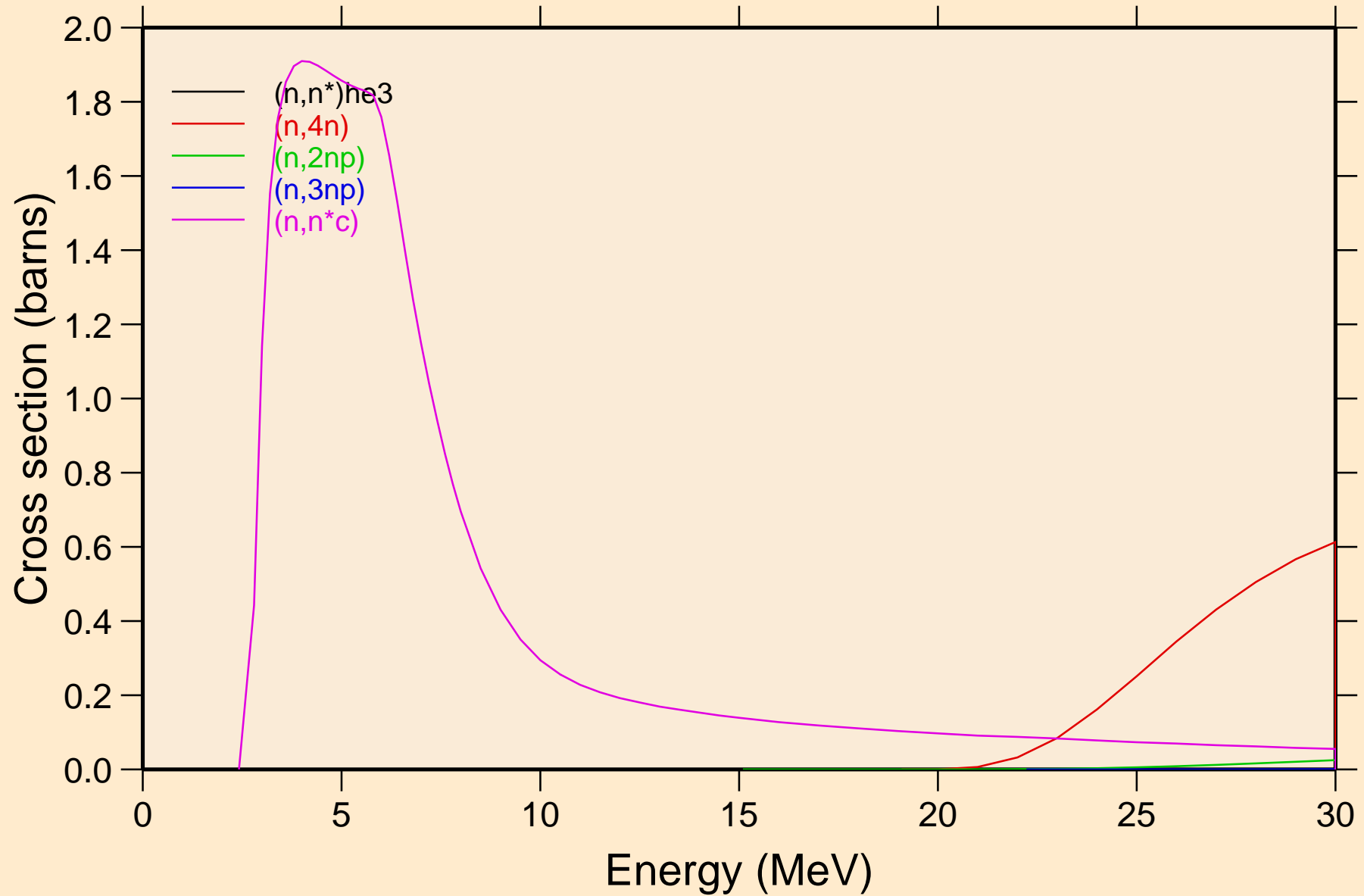

RB090M NEUTRON ACER TENDL-2024 LIBRARY; T=0.K
Threshold reactions

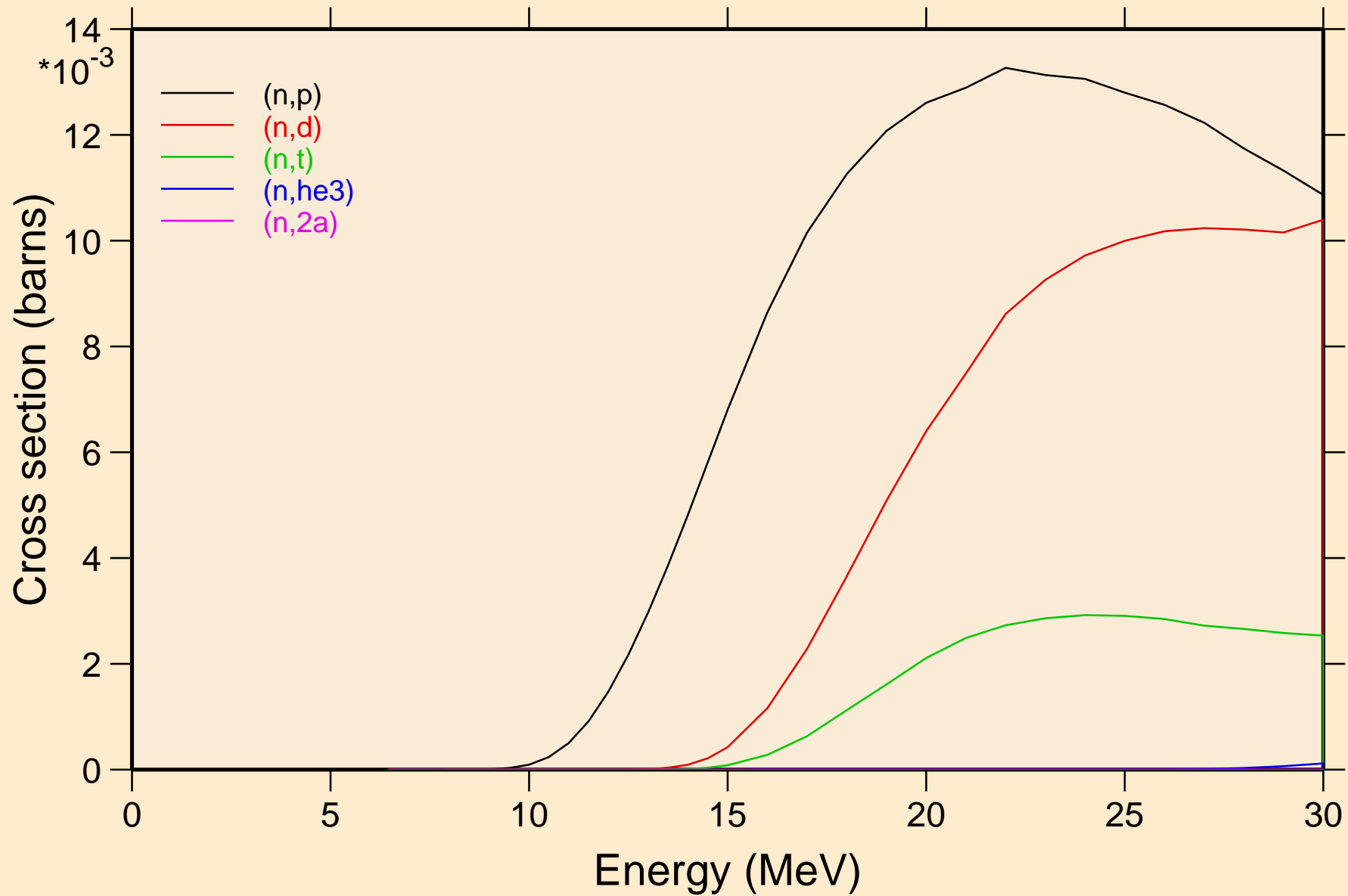

RB090M NEUTRON ACER TENDL-2024 LIBRARY; T=0.K
Threshold reactions

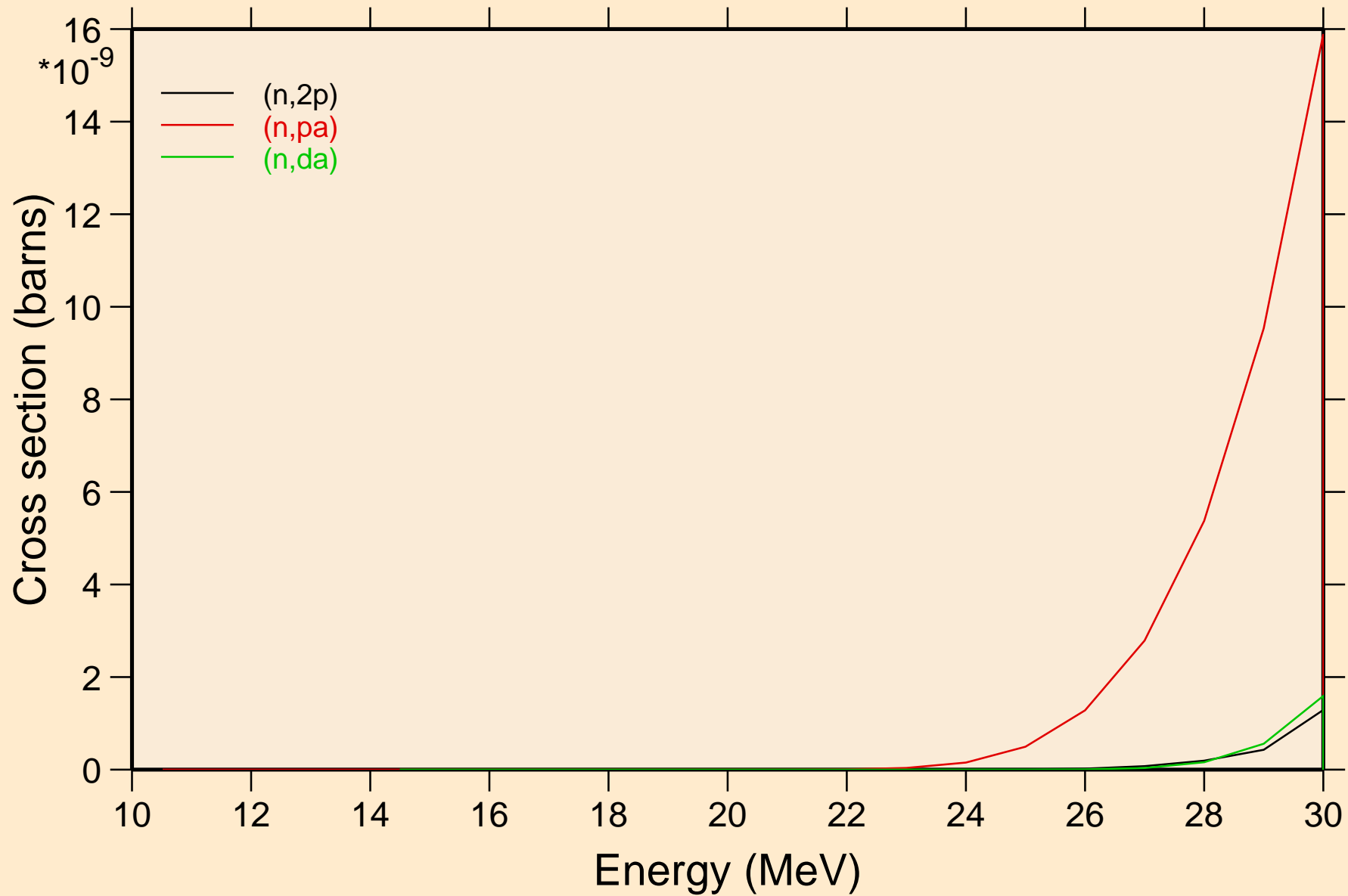

RB090M NEUTRON ACER TENDL-2024 LIBRARY; T=0.K
Threshold reactions

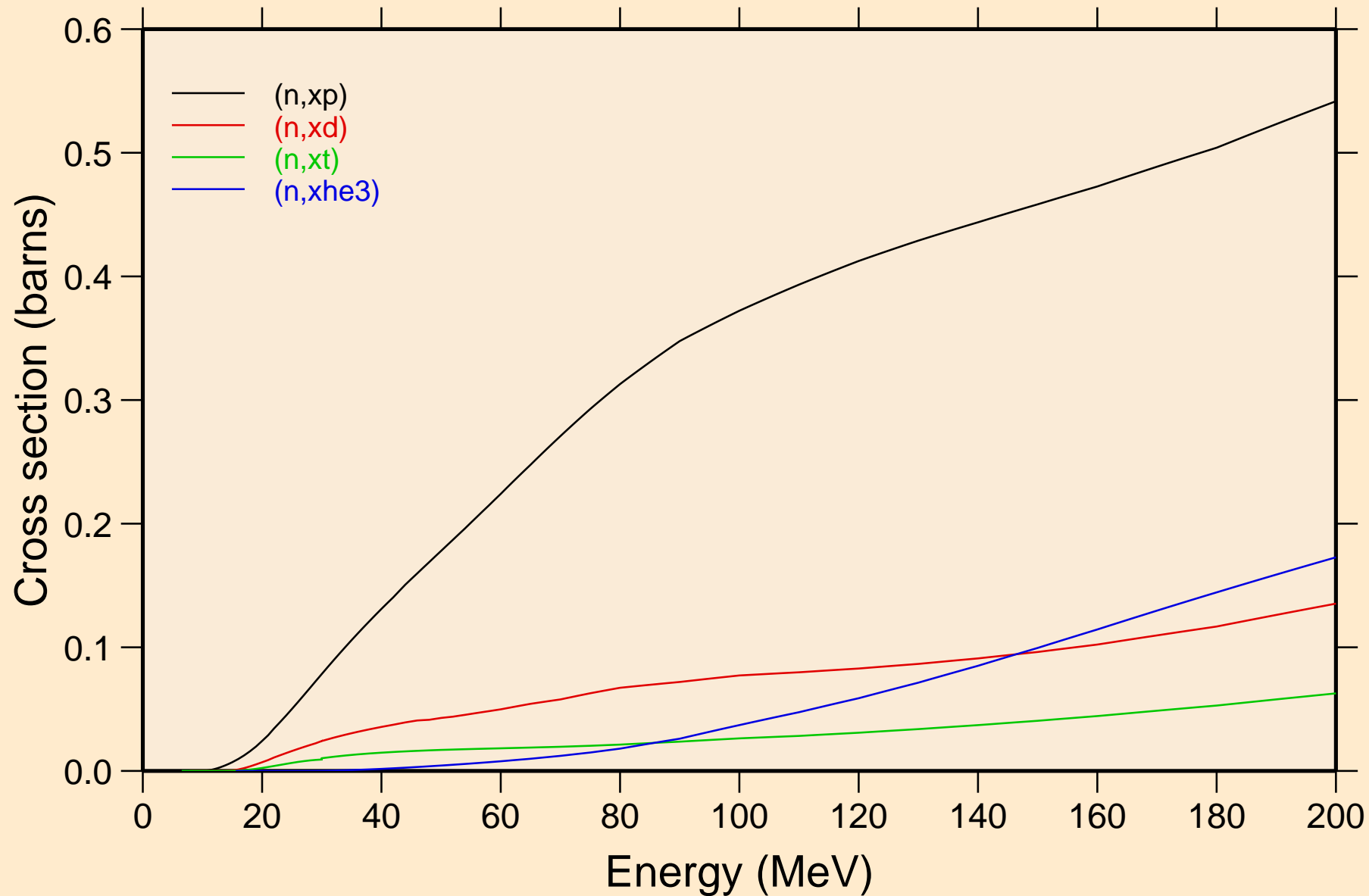

RB090M NEUTRON ACER TENDL-2024 LIBRARY; T=0.K
angular distribution for elastic

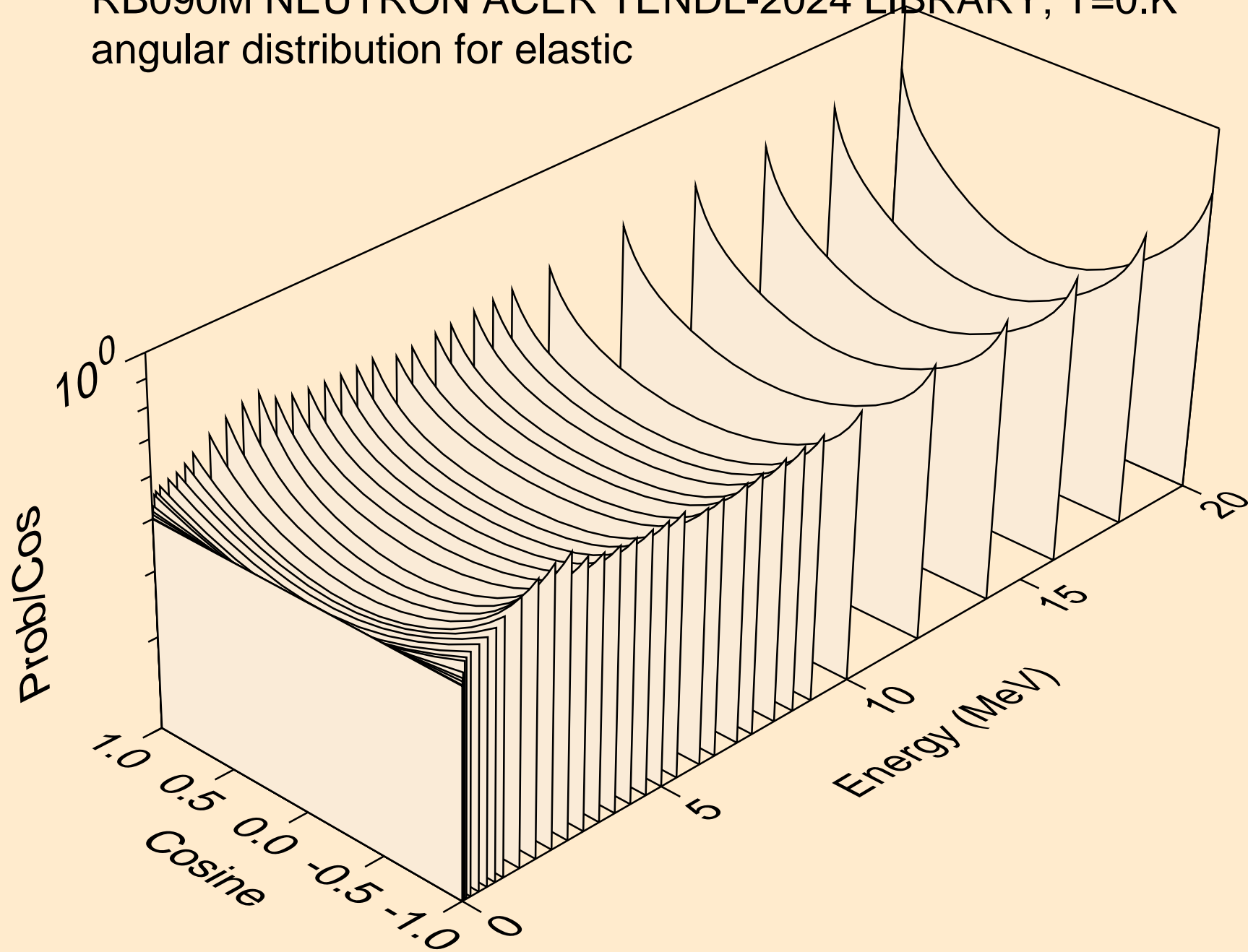

RB090M NEUTRON ACER TENDL-2024 LIBRARY; T=0.K
angular distribution for elastic

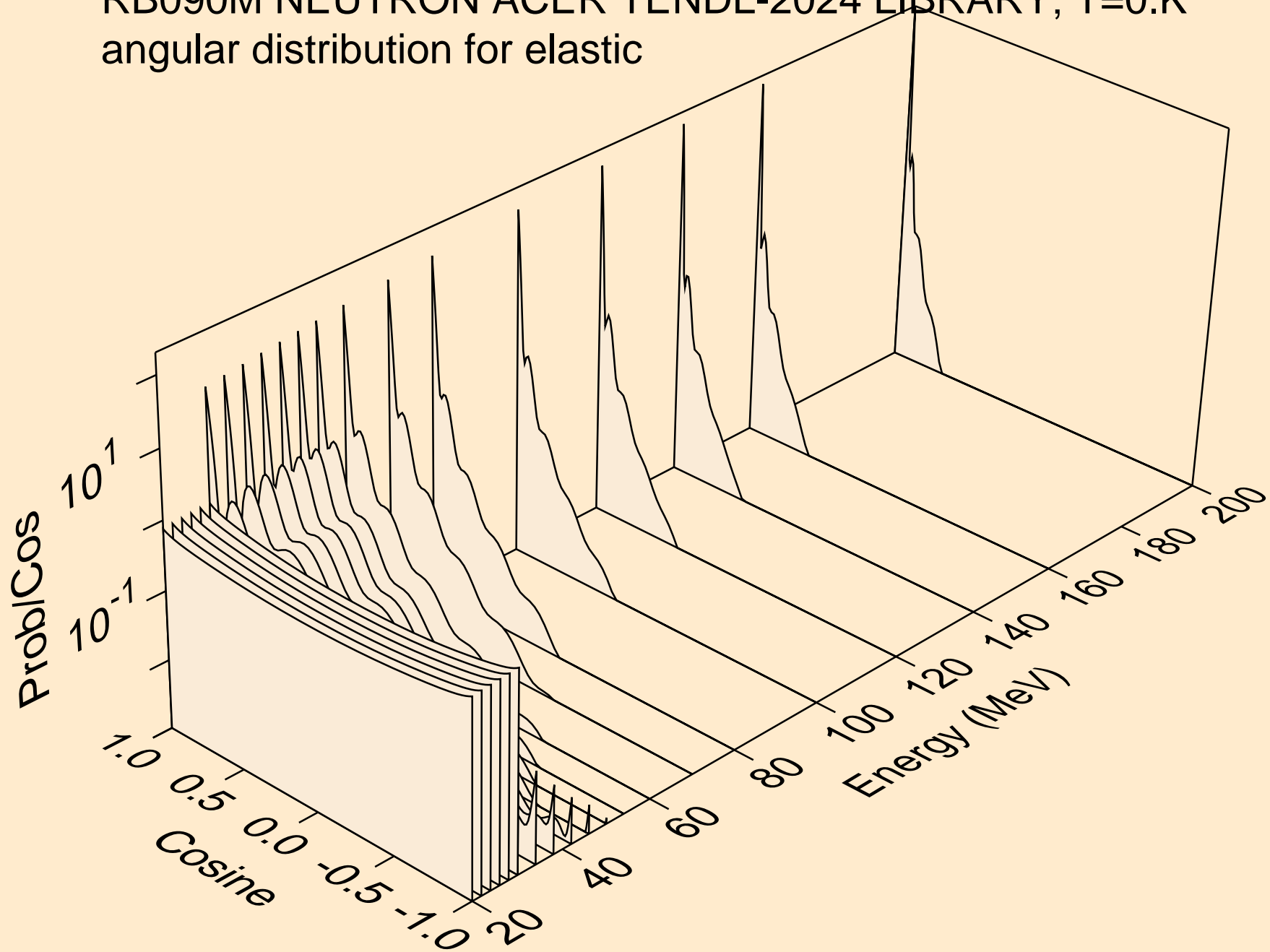

RB090M NEUTRON ACER TENDL-2024 LIBRARY; T=0.K
angular distribution for (n,n*1)

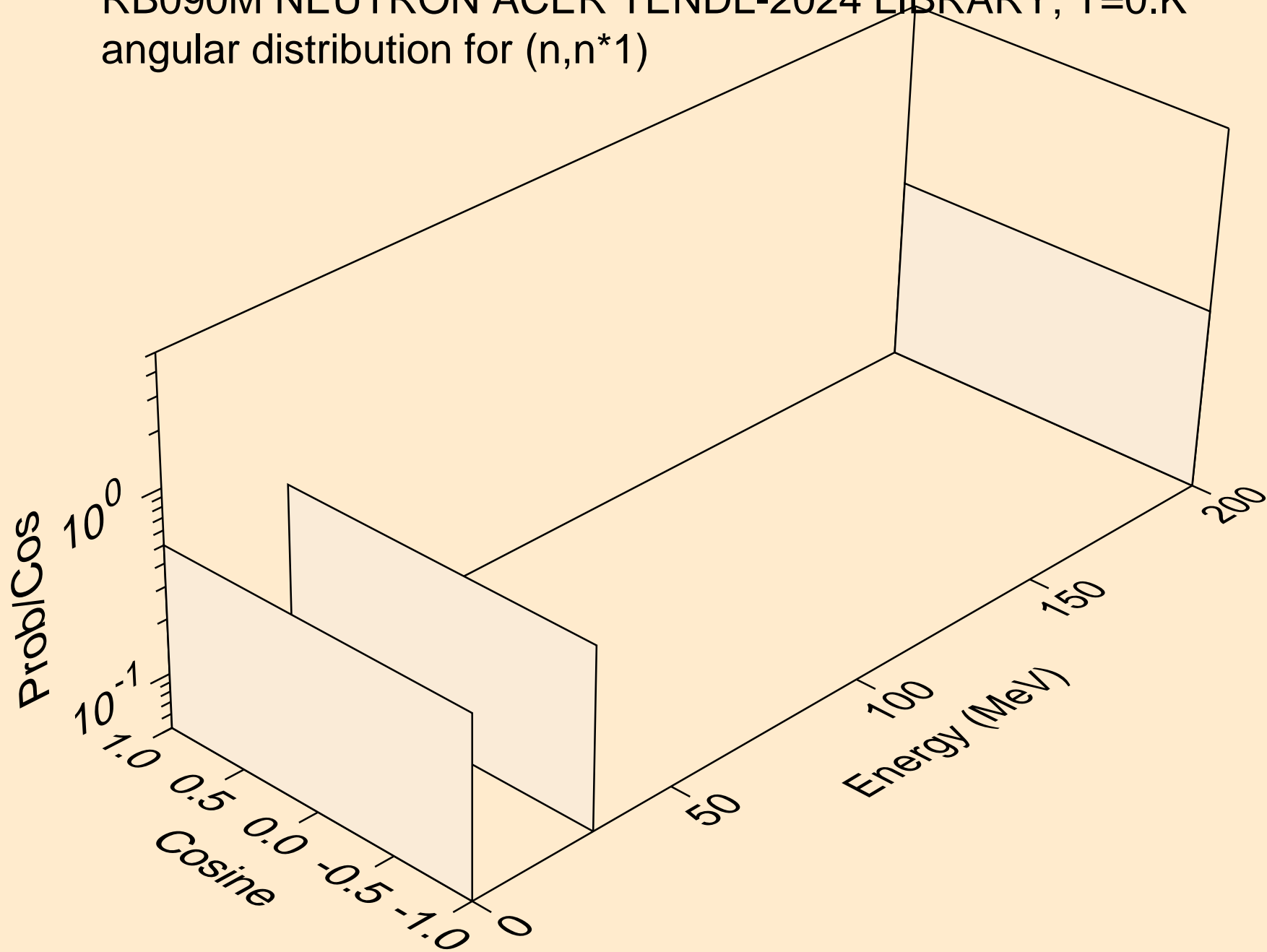

RB090M NEUTRON ACER TENDL-2024 LIBRARY; T=0.K
angular distribution for (n,n*2)

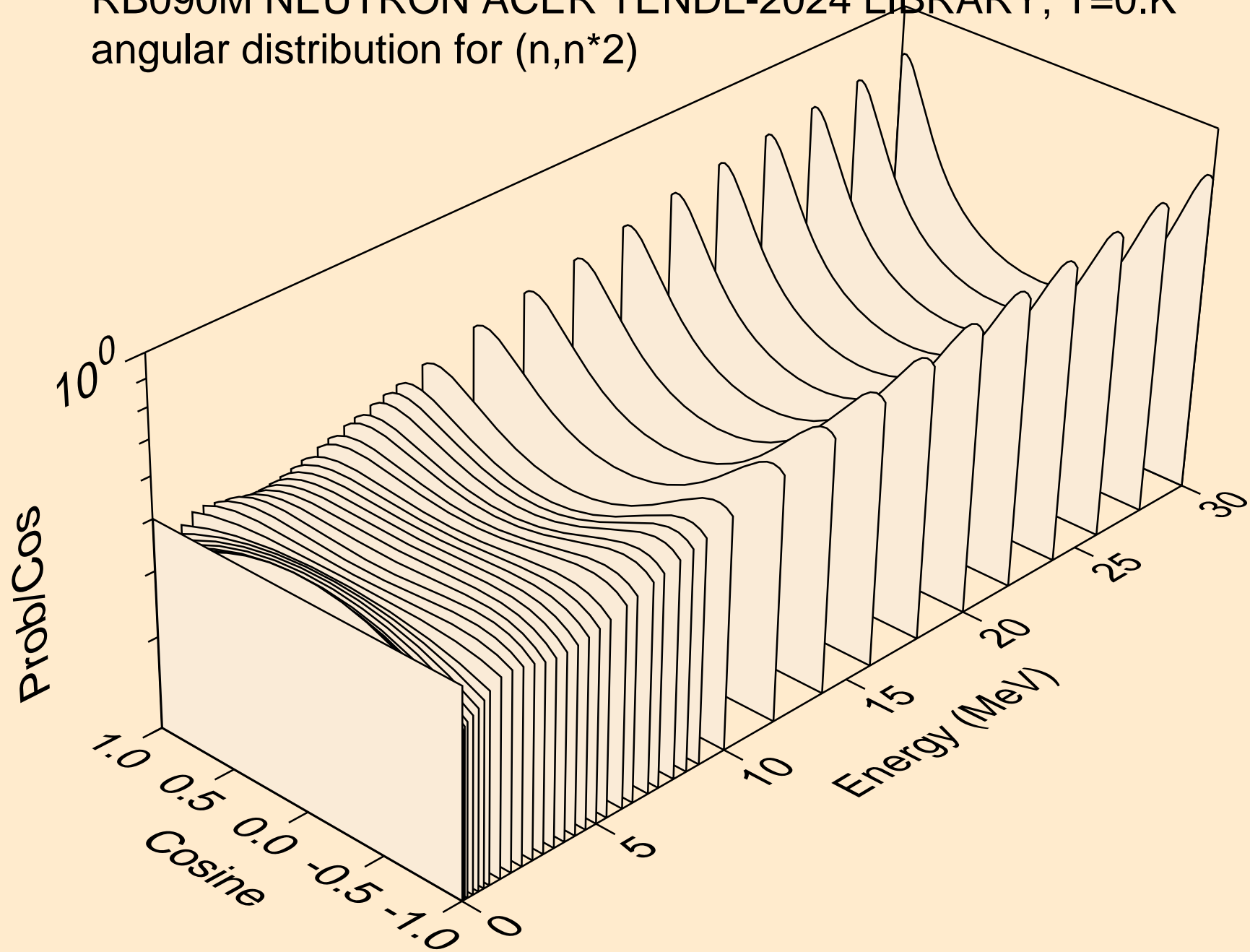

RB090M NEUTRON ACER TENDL-2024 LIBRARY; T=0.K
angular distribution for (n,n*3)

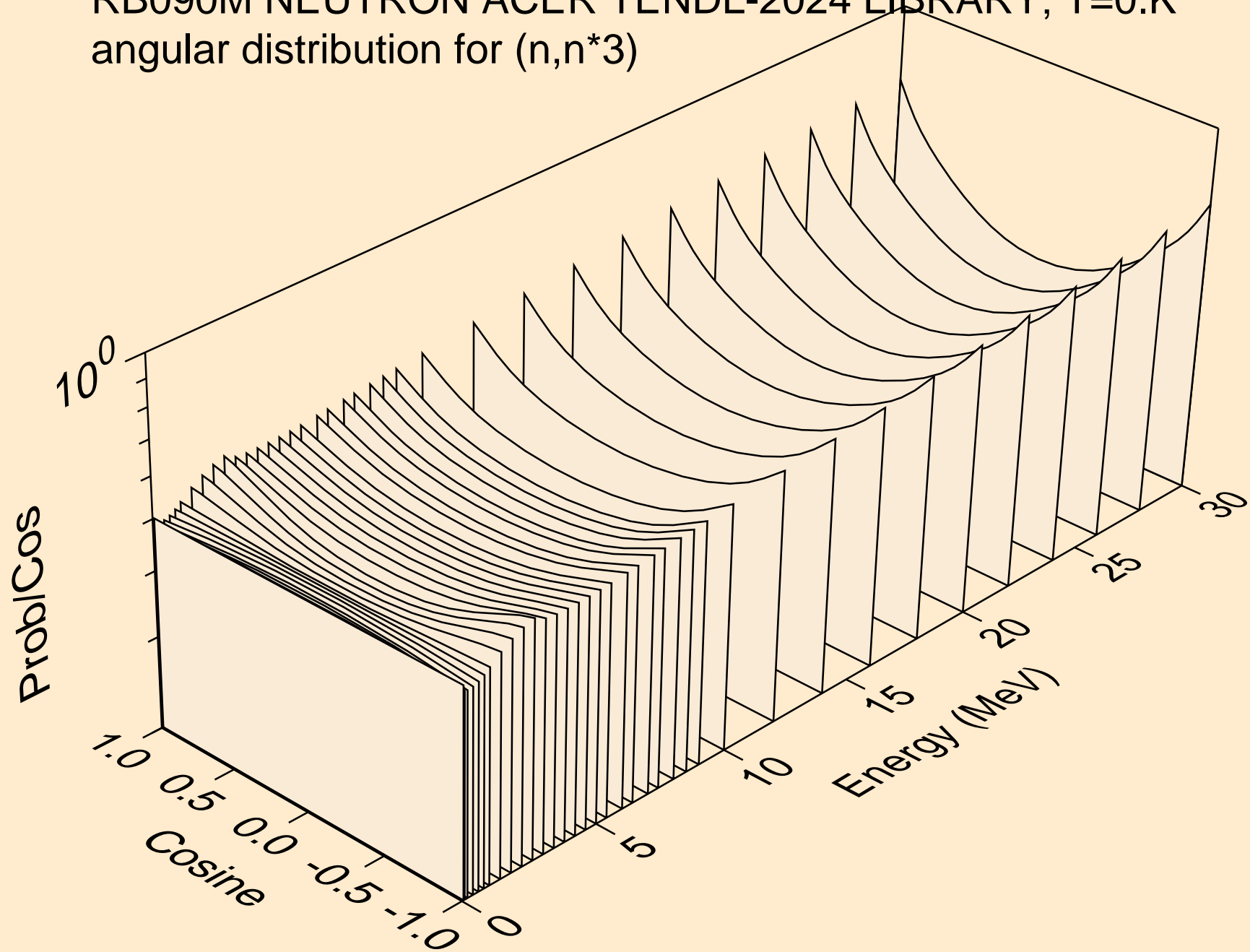

RB090M NEUTRON ACER TENDL-2024 LIBRARY; T=0.K
angular distribution for (n,n*4)

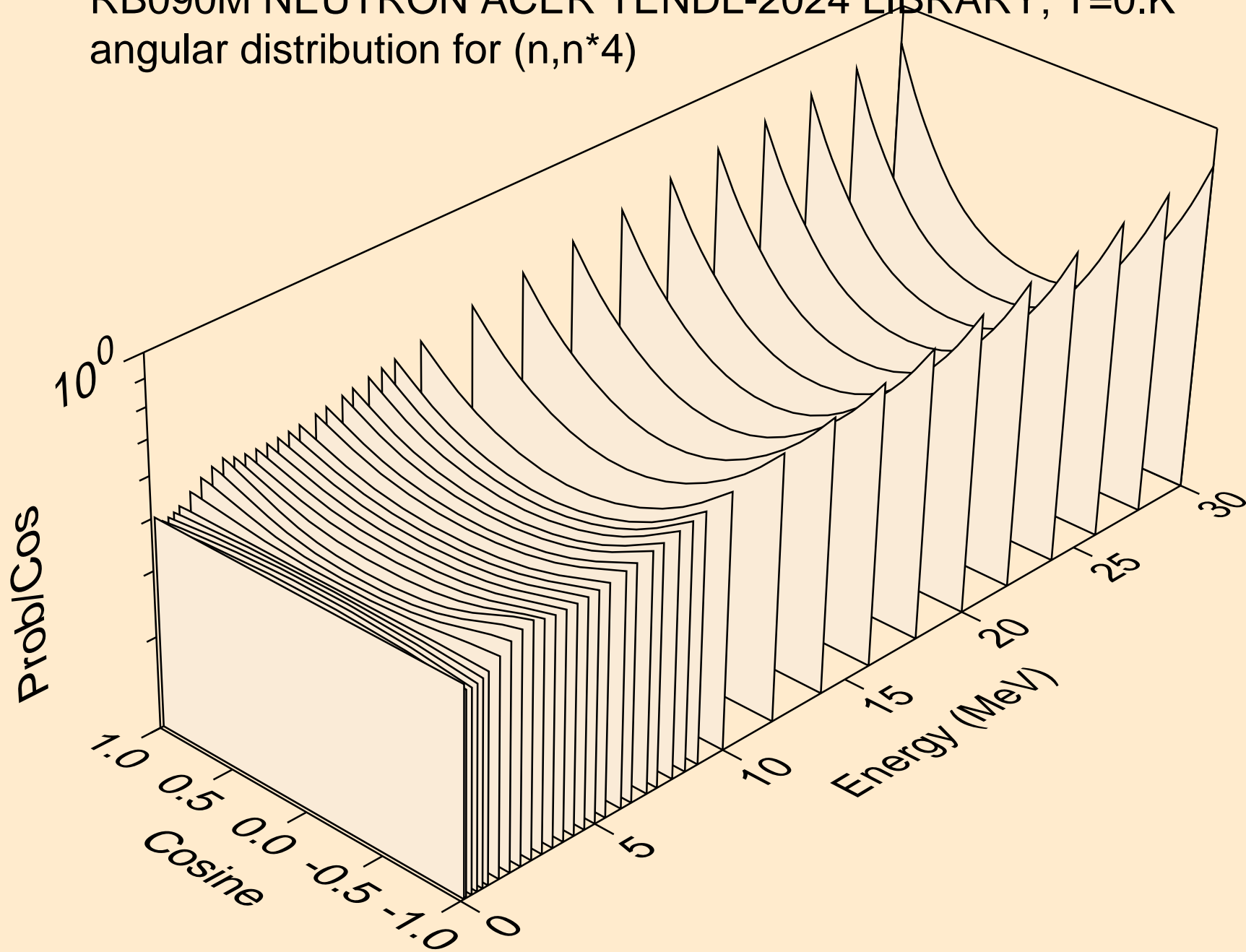

RB090M NEUTRON ACER TENDL-2024 LIBRARY; T=0.K
angular distribution for (n,n*5)

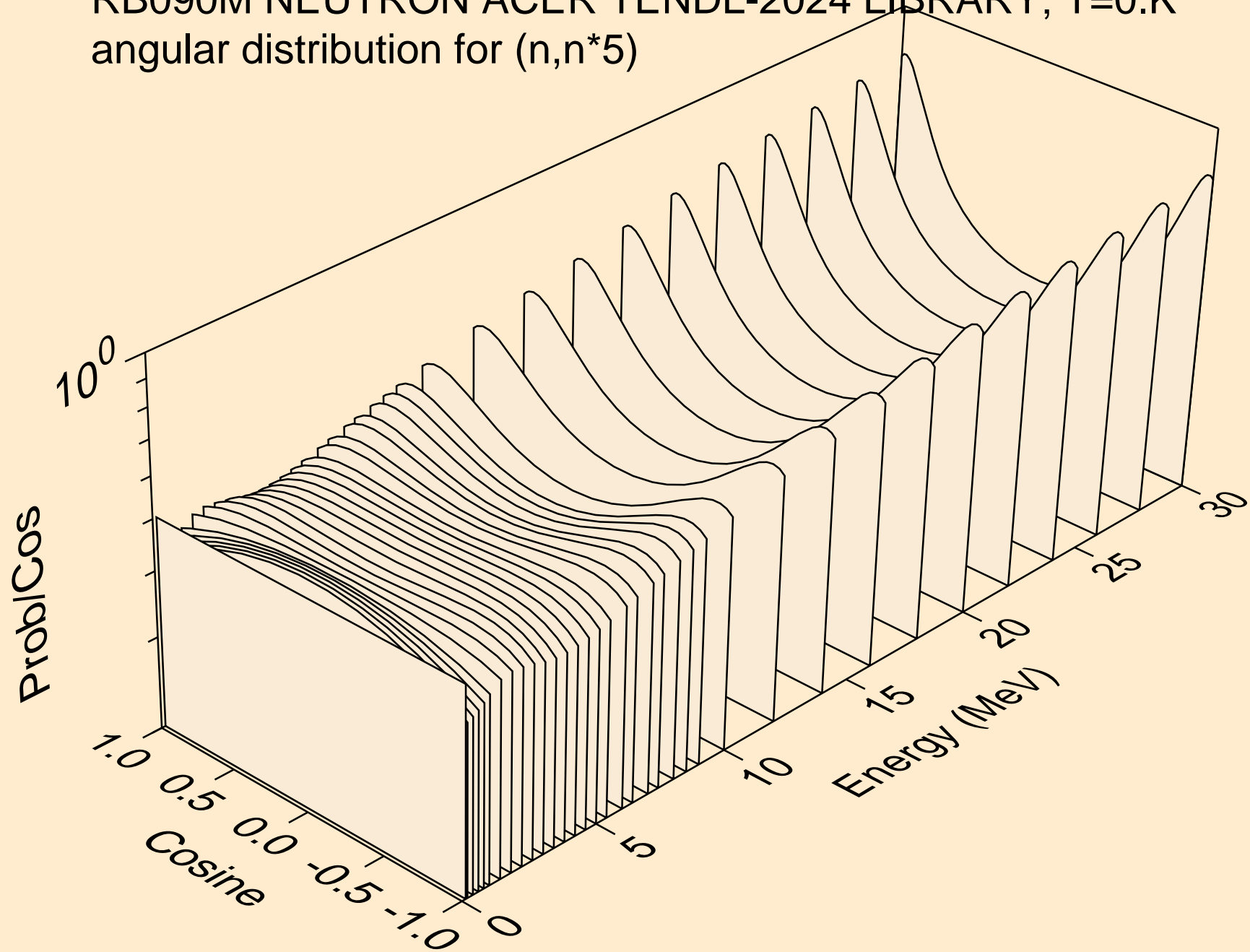

RB090M NEUTRON ACER TENDL-2024 LIBRARY; T=0.K
angular distribution for (n,n*6)

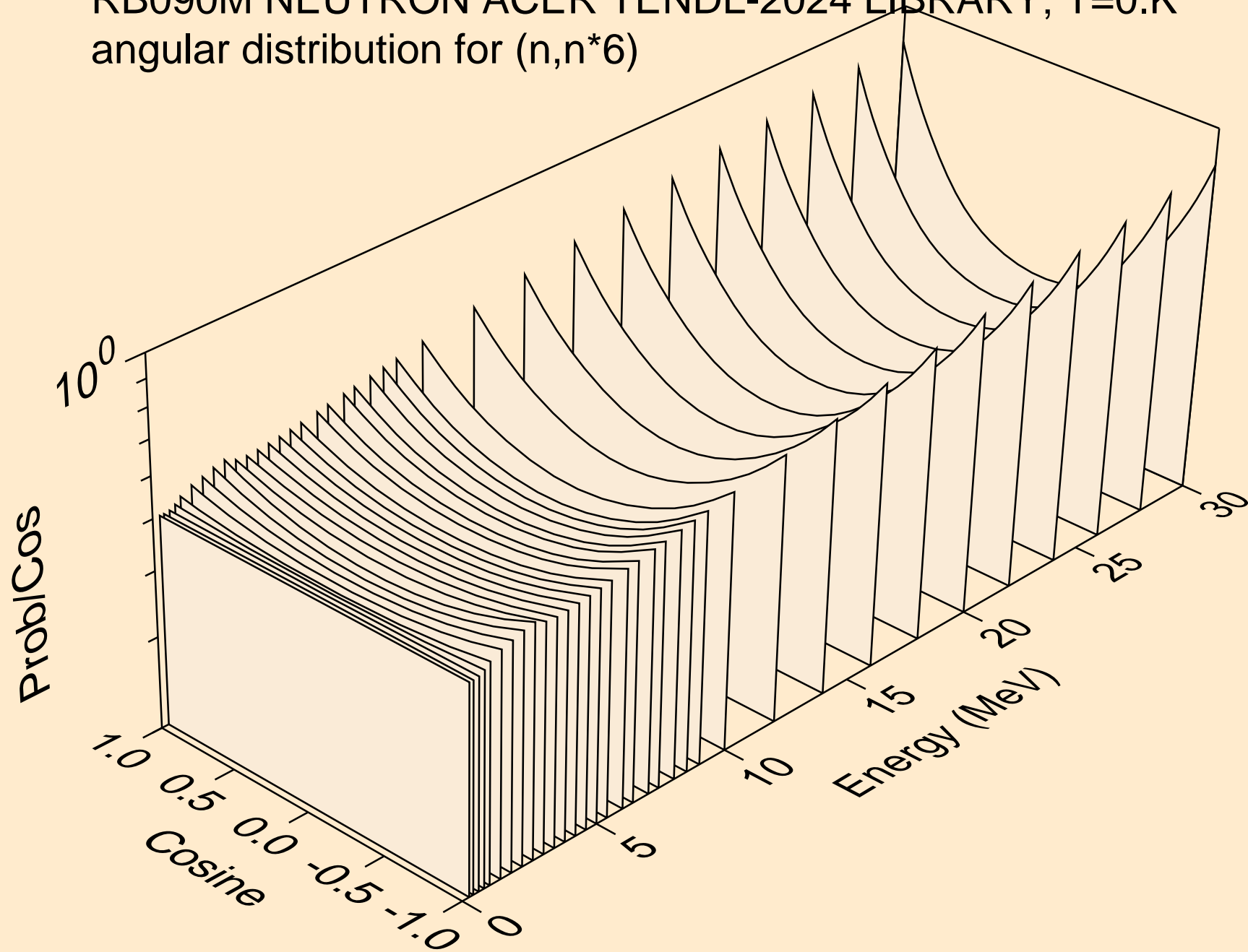

RB090M NEUTRON ACER TENDL-2024 LIBRARY; T=0.K
angular distribution for (n,n*7)

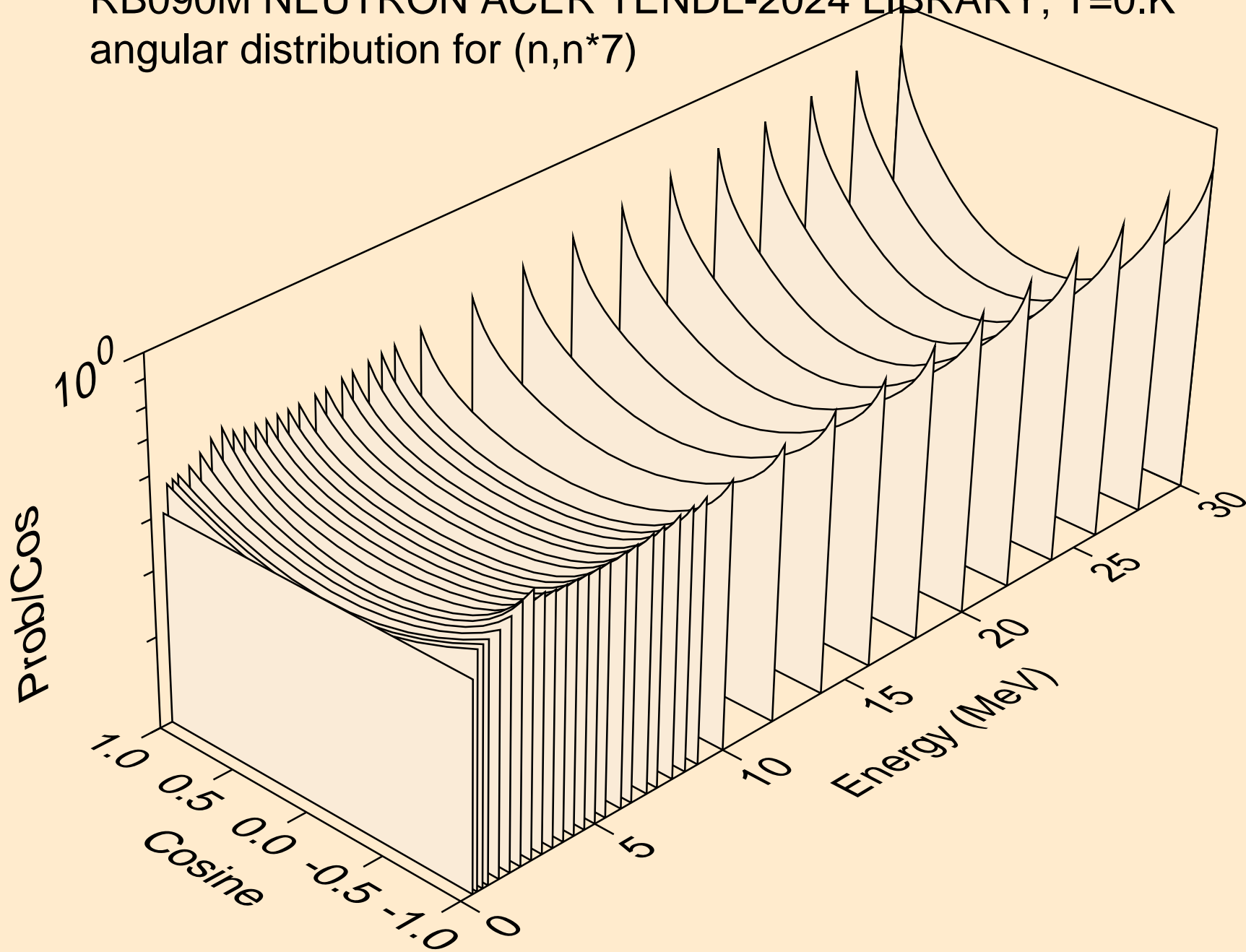

RB090M NEUTRON ACER TENDL-2024 LIBRARY; T=0.K
angular distribution for (n,n*8)

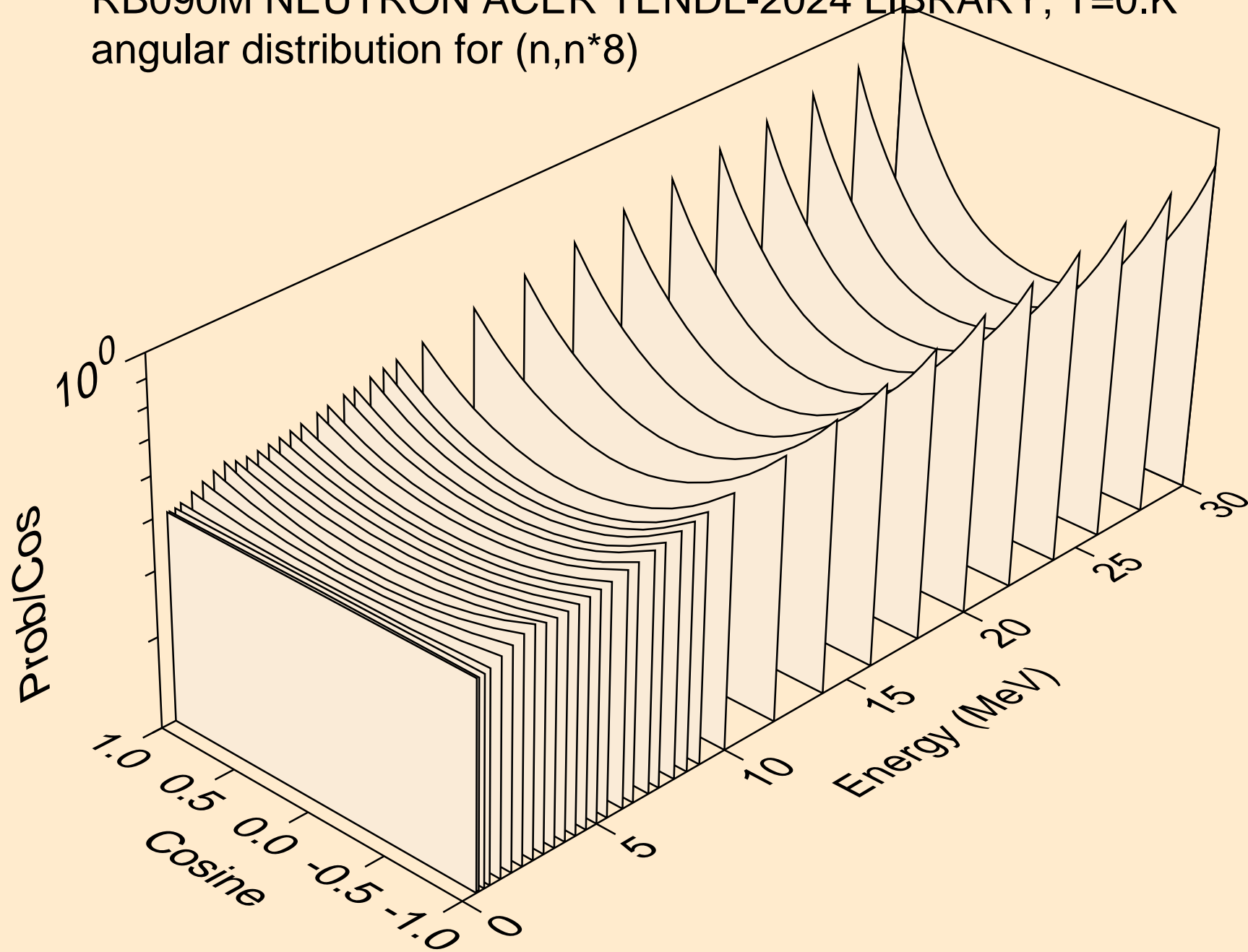

RB090M NEUTRON ACER TENDL-2024 LIBRARY; T=0.K
angular distribution for (n,n*9)

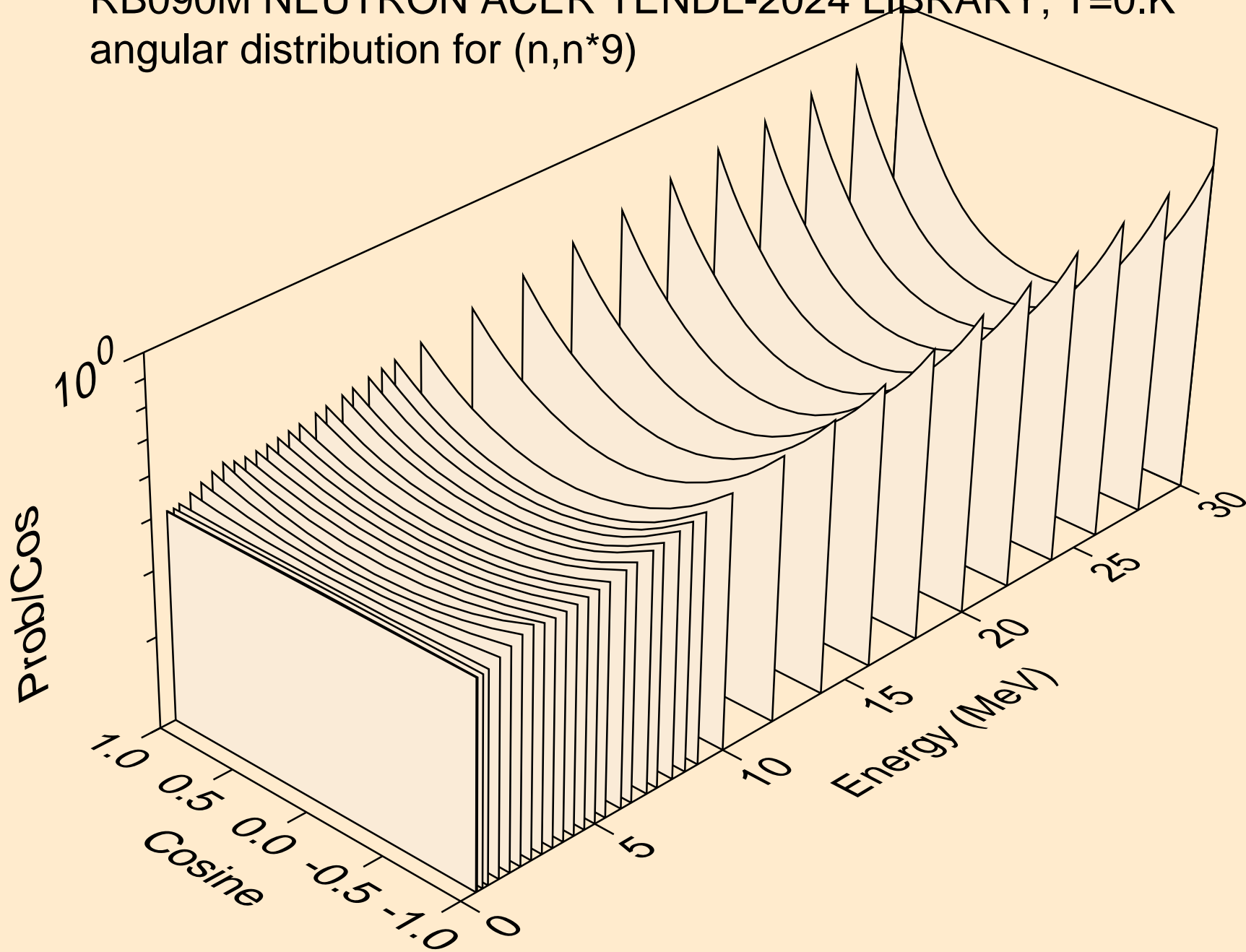

RB090M NEUTRON ACER TENDL-2024 LIBRARY; T=0.K
angular distribution for (n,n*10)

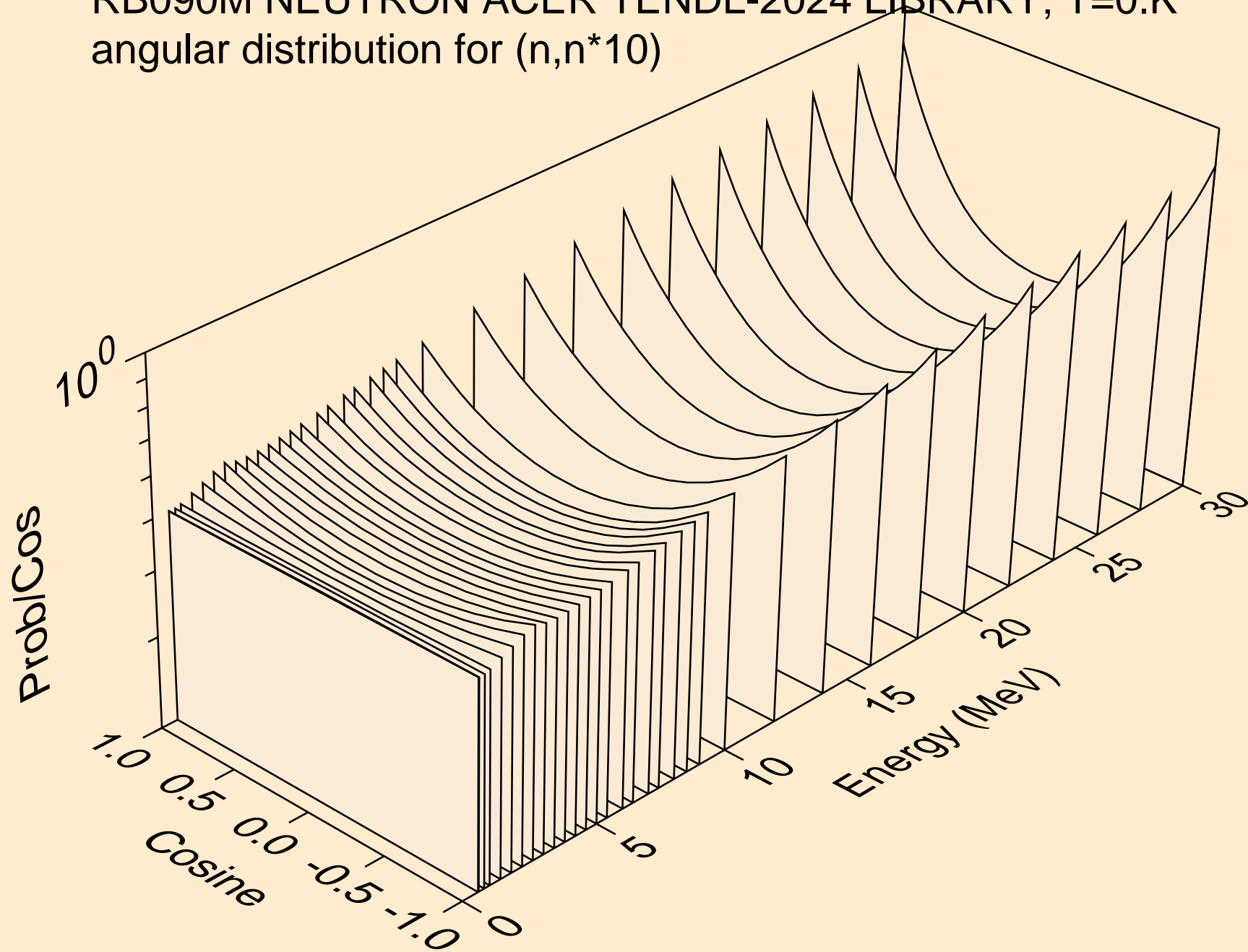

RB090M NEUTRON ACER TENDL-2024 LIBRARY; T=0.K
angular distribution for (n,n*11)

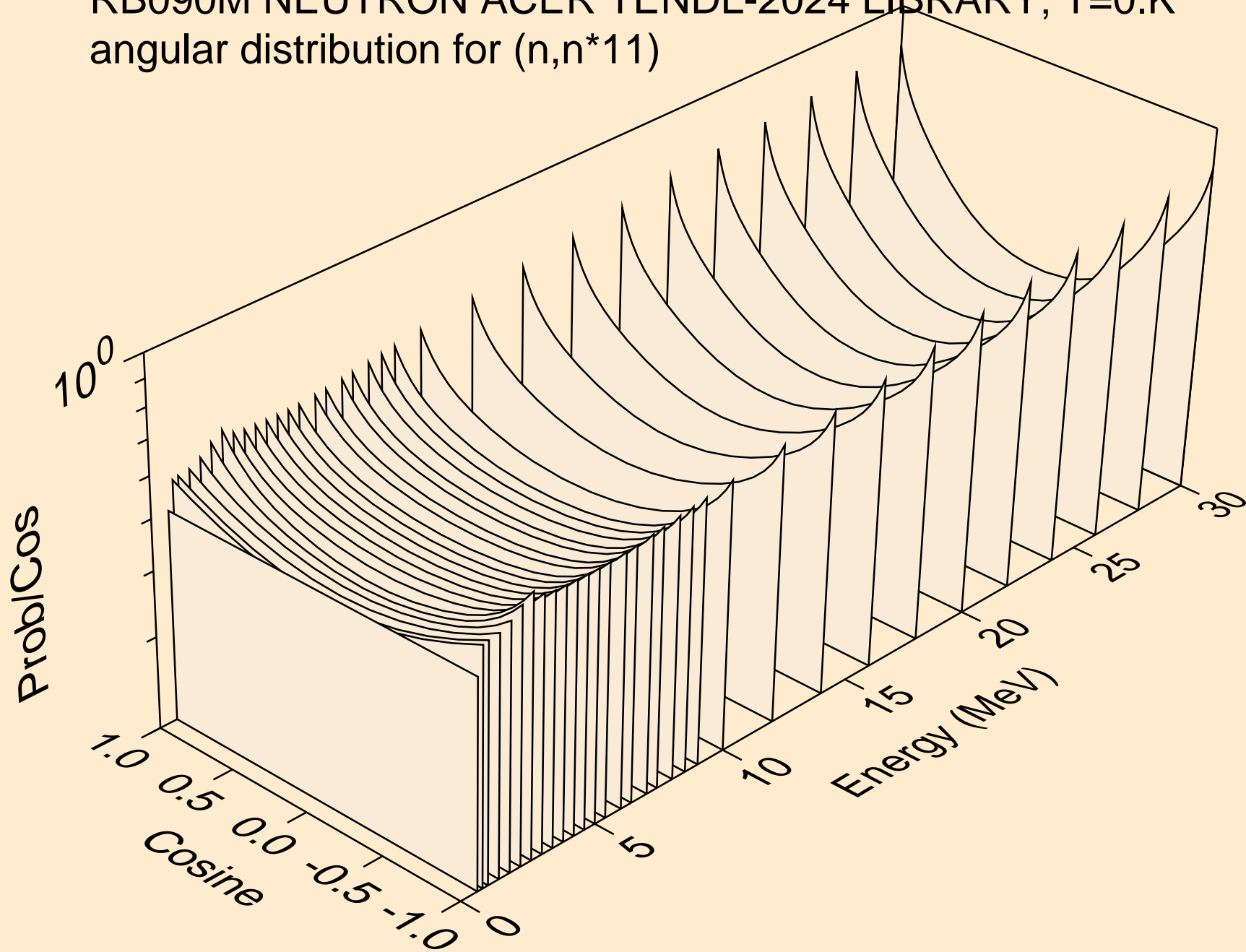

RB090M NEUTRON ACER TENDL-2024 LIBRARY; T=0.K
angular distribution for (n,n*12)

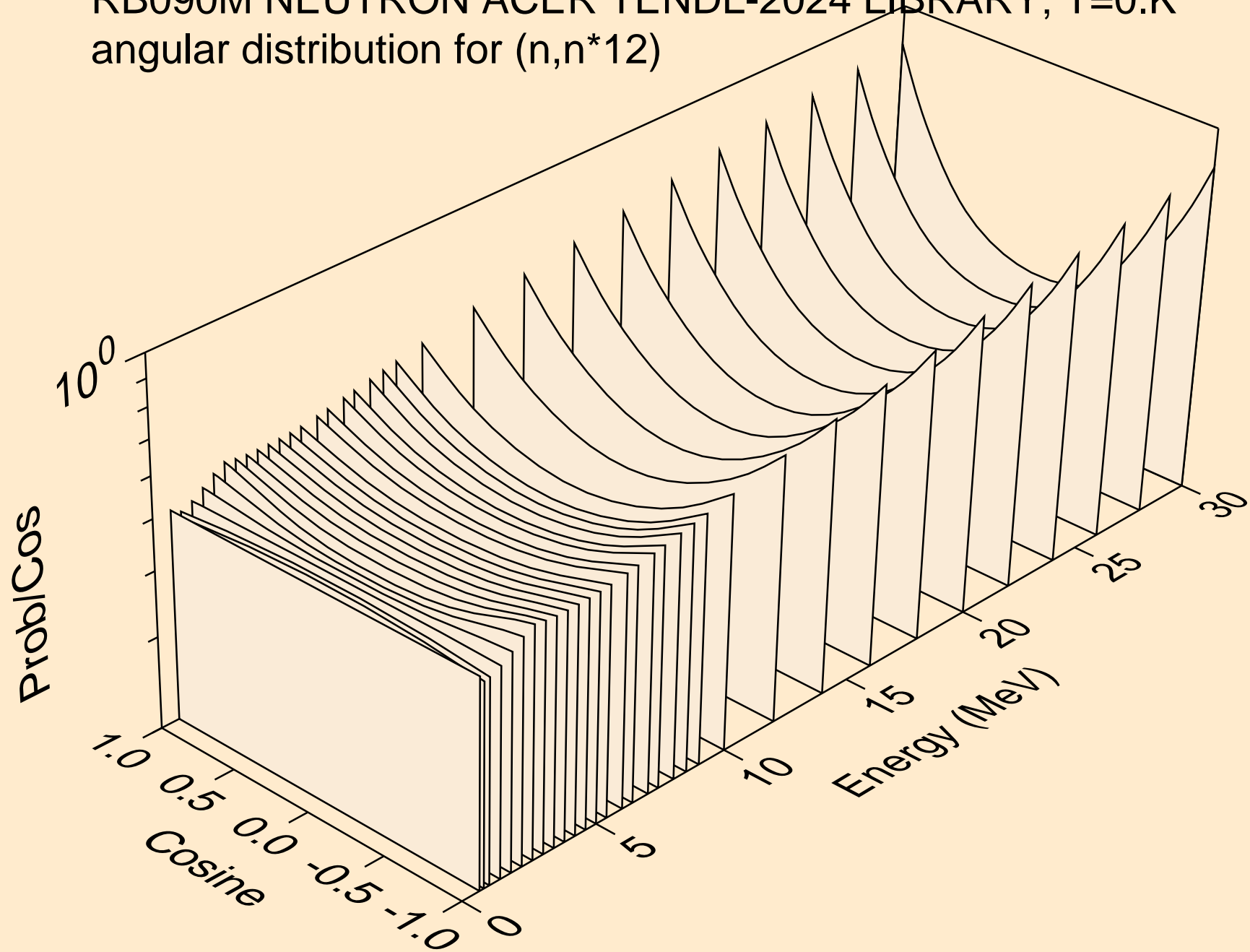

RB090M NEUTRON ACER TENDL-2024 LIBRARY; T=0.K
angular distribution for (n,n*13)

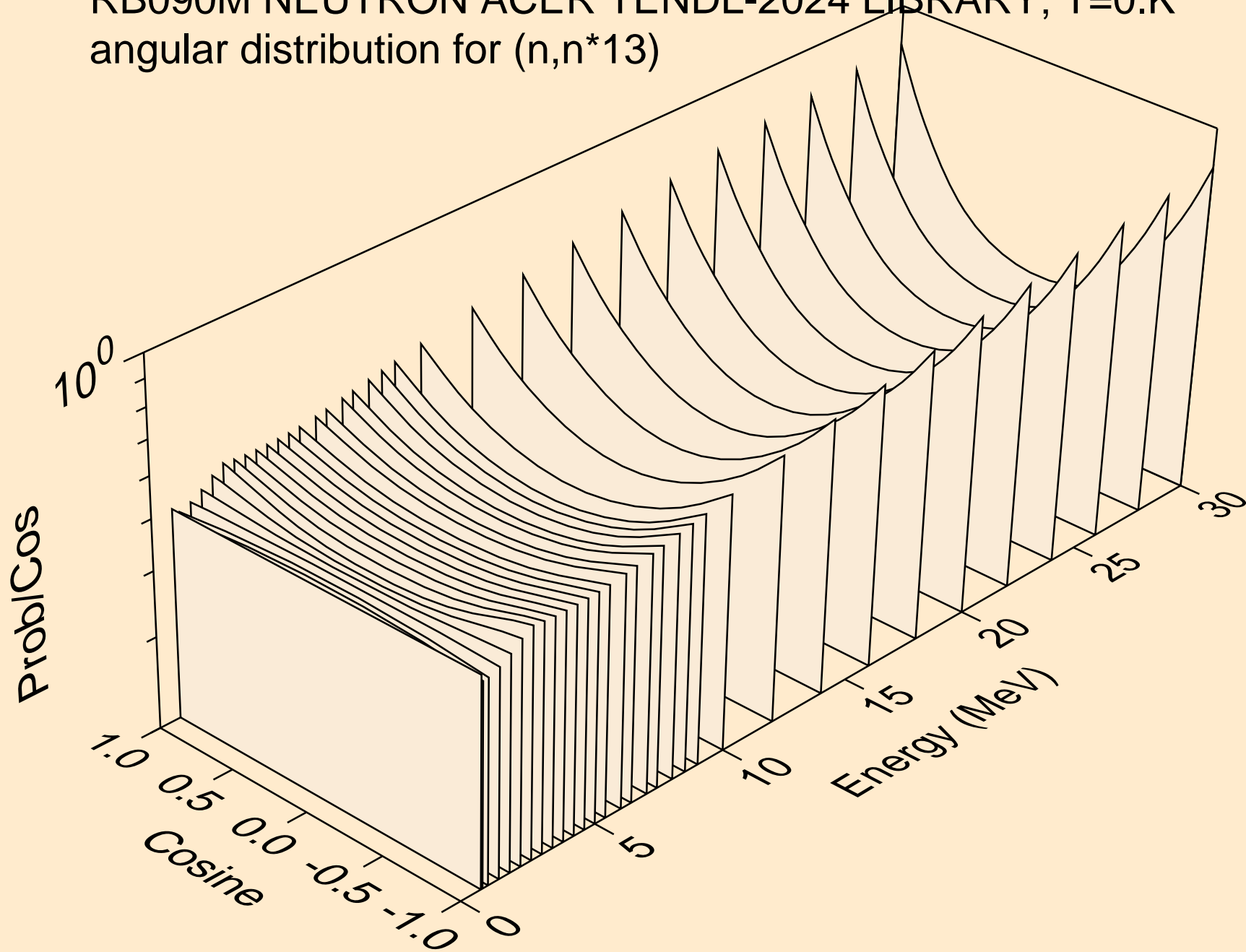

RB090M NEUTRON ACER TENDL-2024 LIBRARY; T=0.K
angular distribution for (n,n*14)

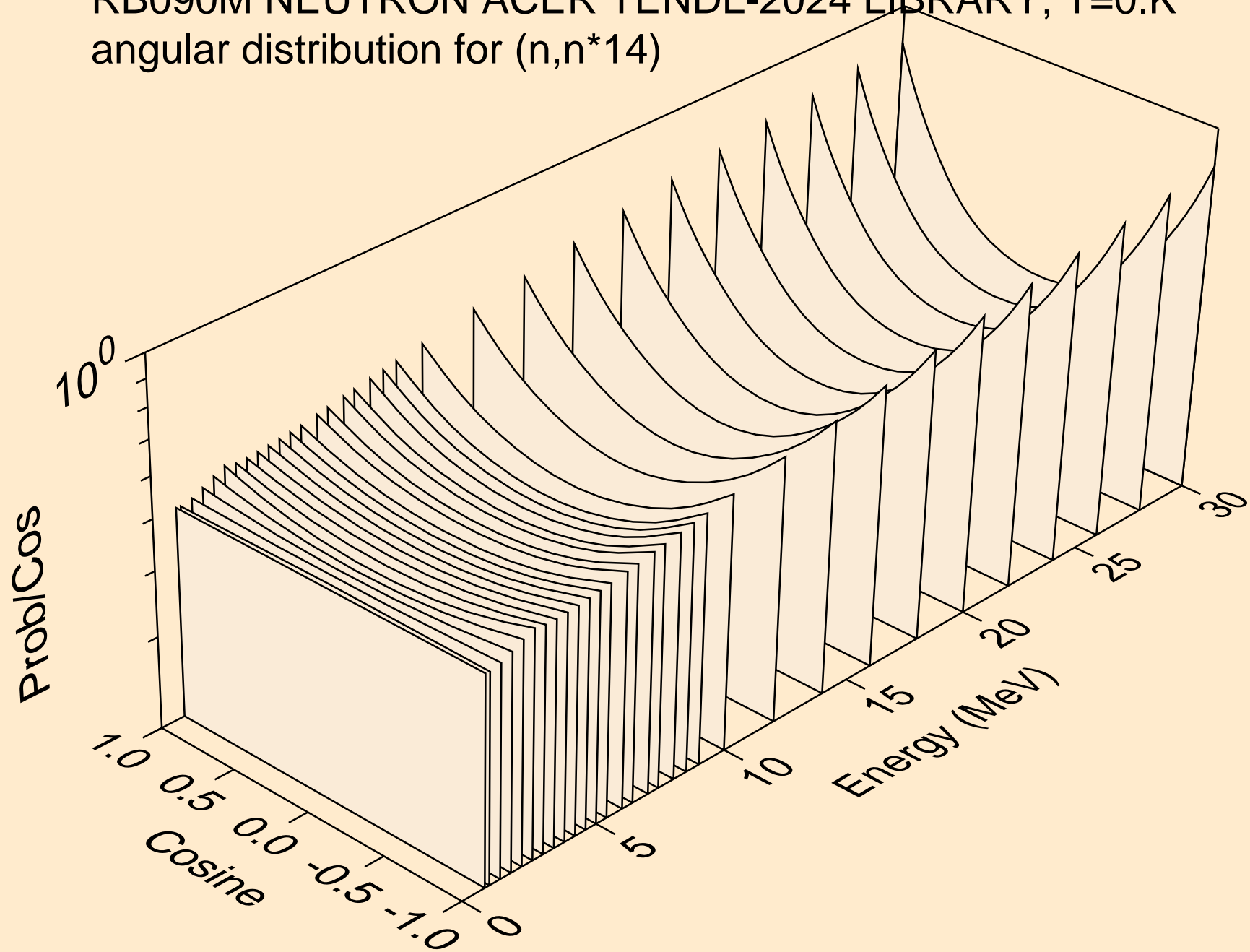

RB090M NEUTRON ACER TENDL-2024 LIBRARY; T=0.K
angular distribution for (n,n*15)

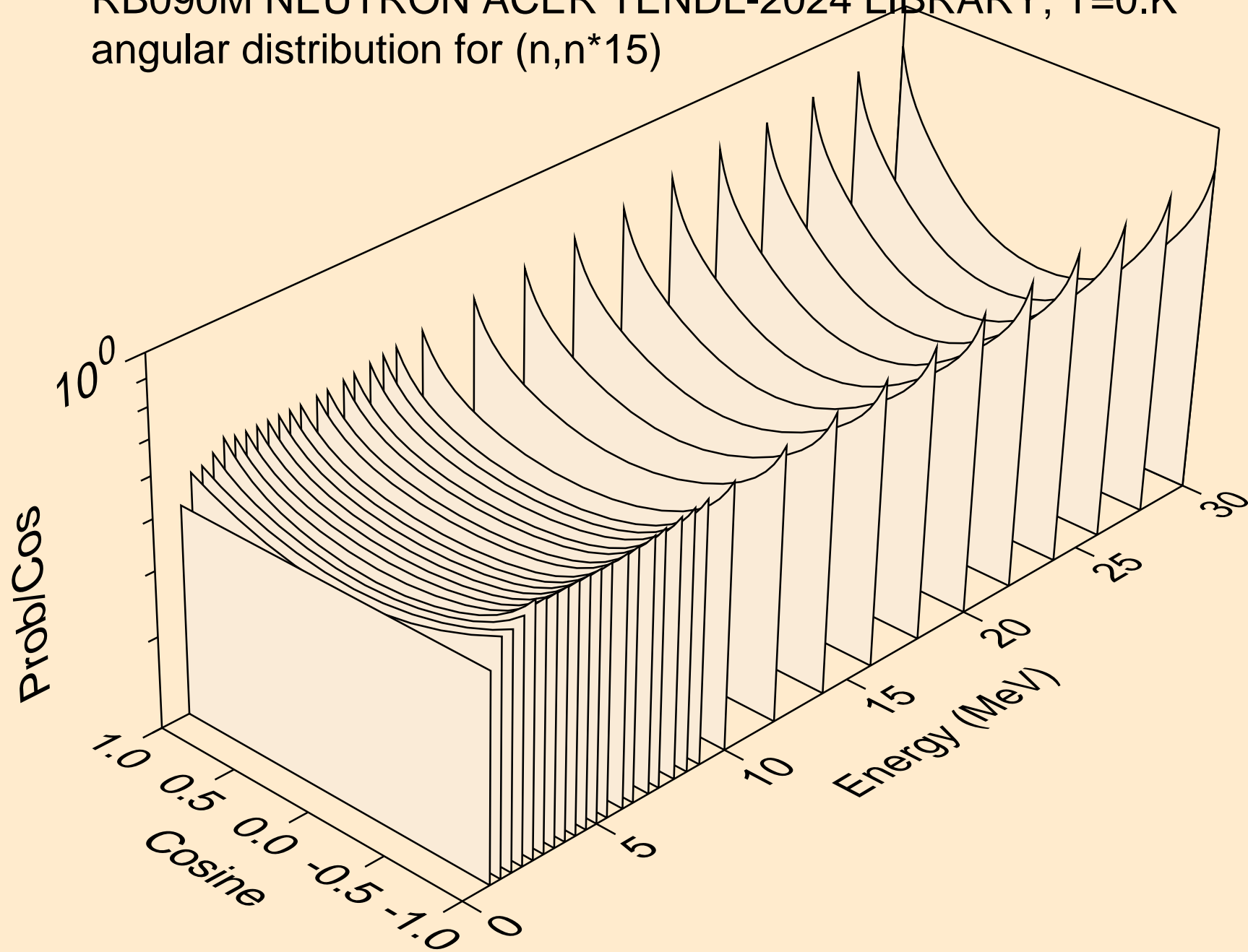

RB090M NEUTRON ACER TENDL-2024 LIBRARY; T=0.K
angular distribution for (n,n*16)

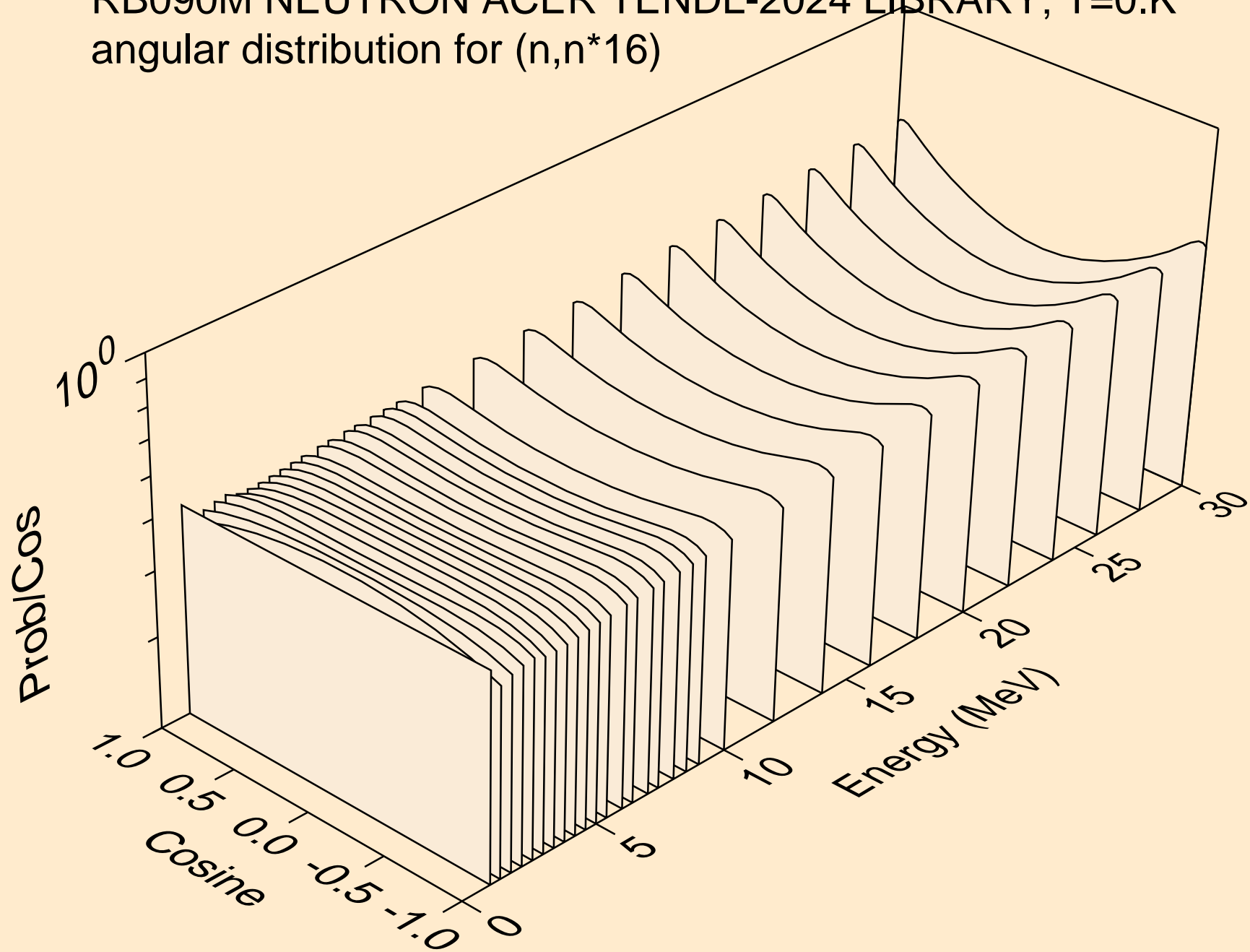

RB090M NEUTRON ACER TENDL-2024 LIBRARY; T=0.K
angular distribution for (n,n*17)

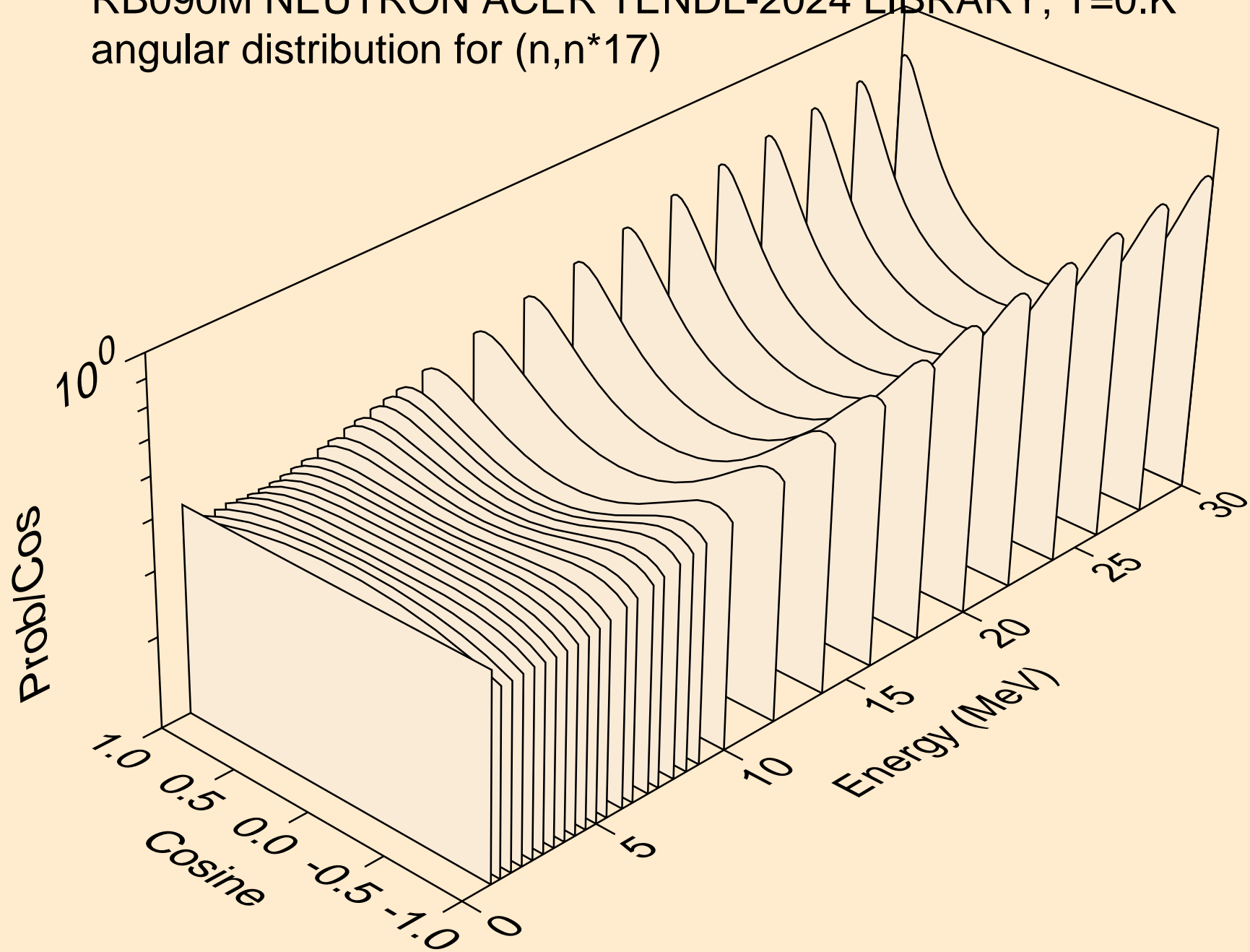

RB090M NEUTRON ACER TENDL-2024 LIBRARY; T=0.K
angular distribution for (n,n*18)

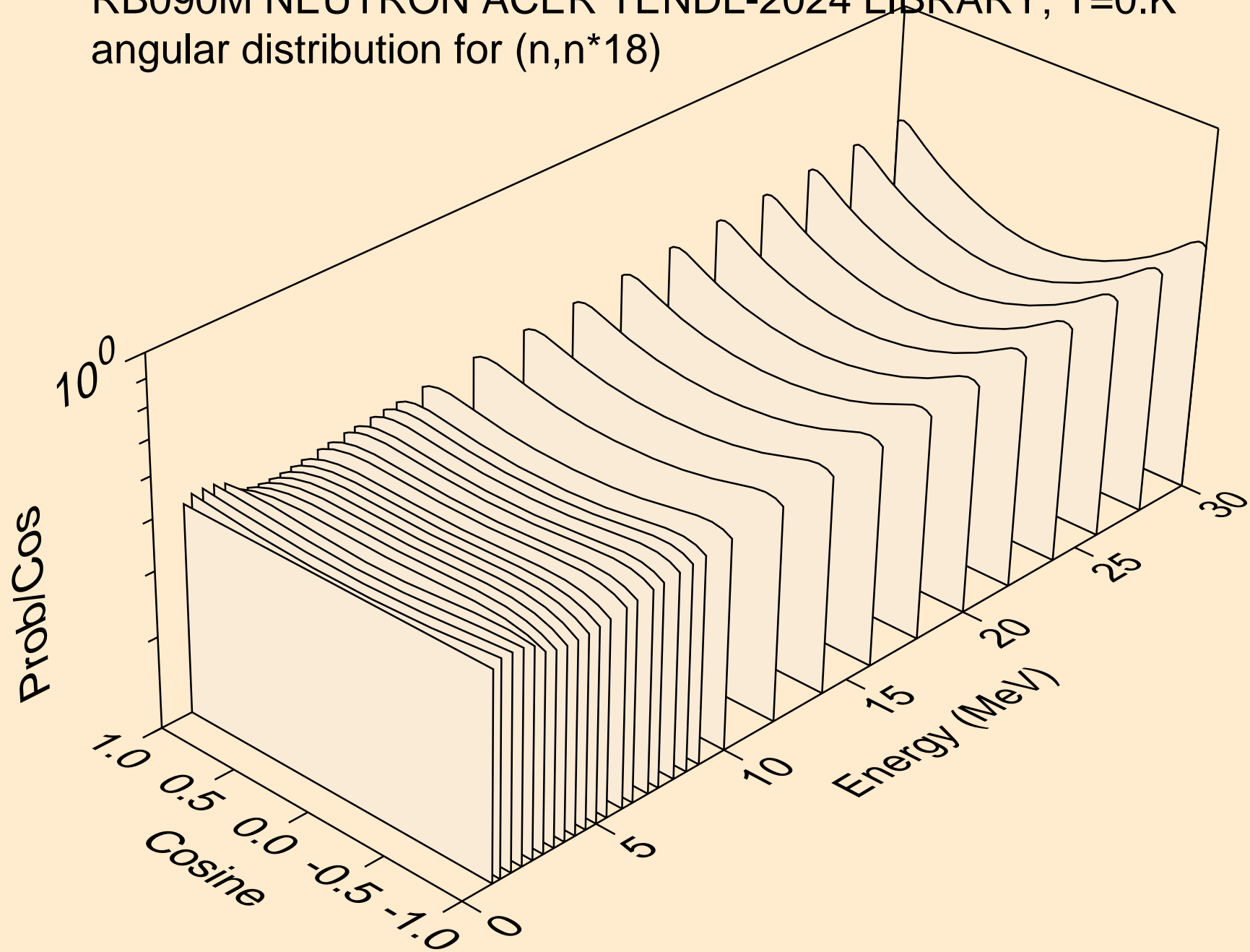

RB090M NEUTRON ACER TENDL-2024 LIBRARY; T=0.K
angular distribution for (n,n*19)

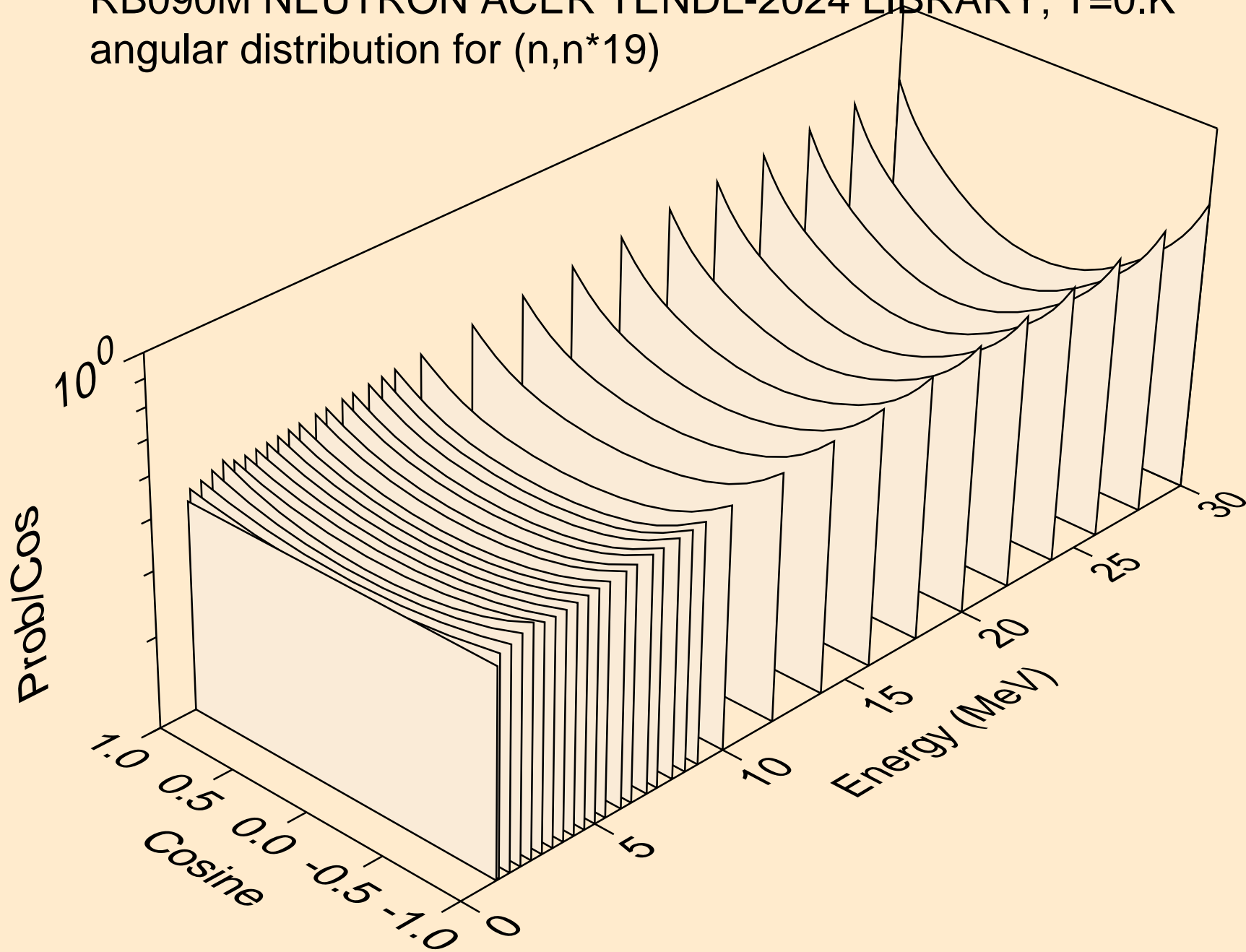

RB090M NEUTRON ACER TENDL-2024 LIBRARY; T=0.K
angular distribution for (n,n*20)

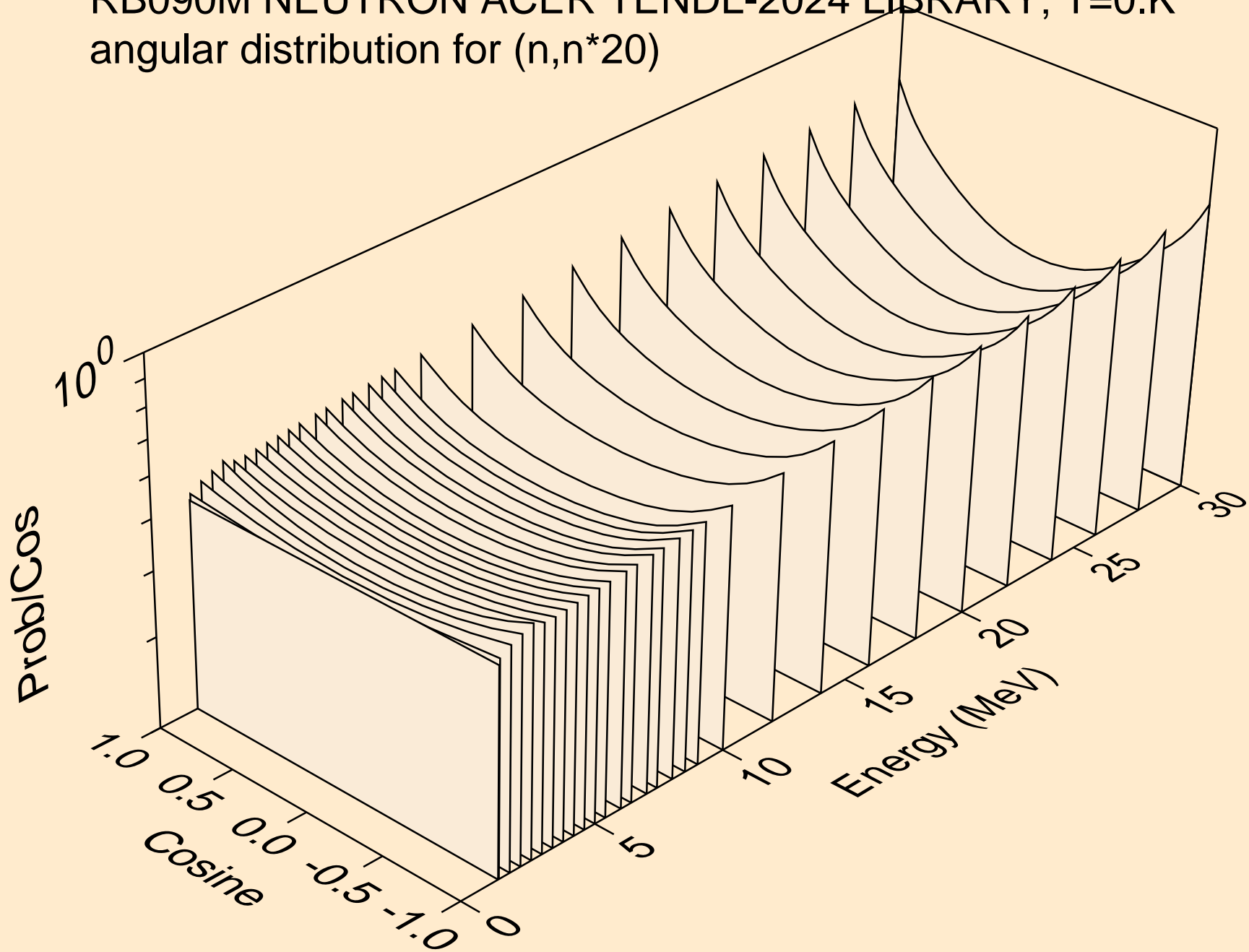

RB090M NEUTRON ACER TENDL-2024 LIBRARY; T=0.K
angular distribution for (n,n*21)

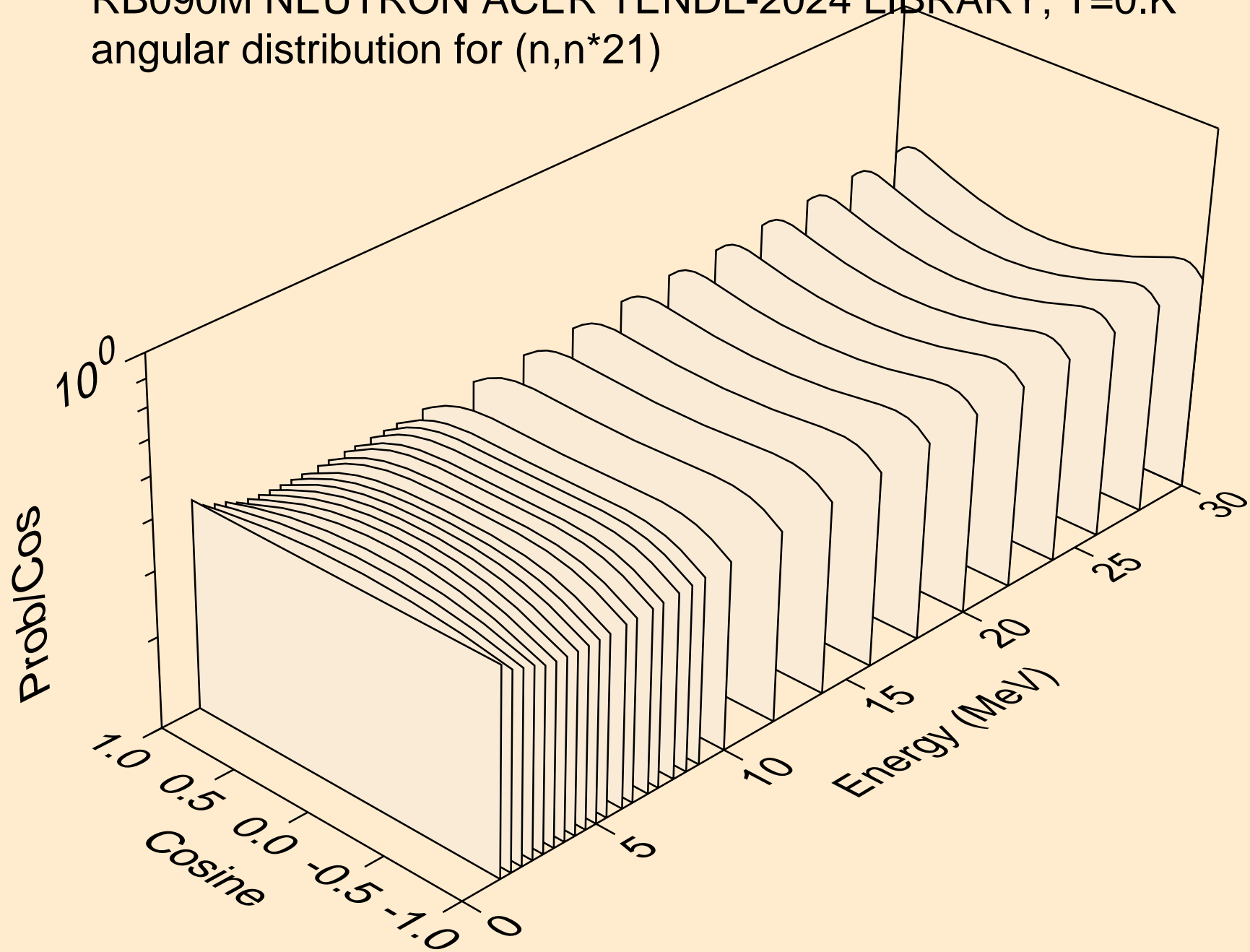

RB090M NEUTRON ACER TENDL-2024 LIBRARY; T=0.K
angular distribution for (n,n*22)

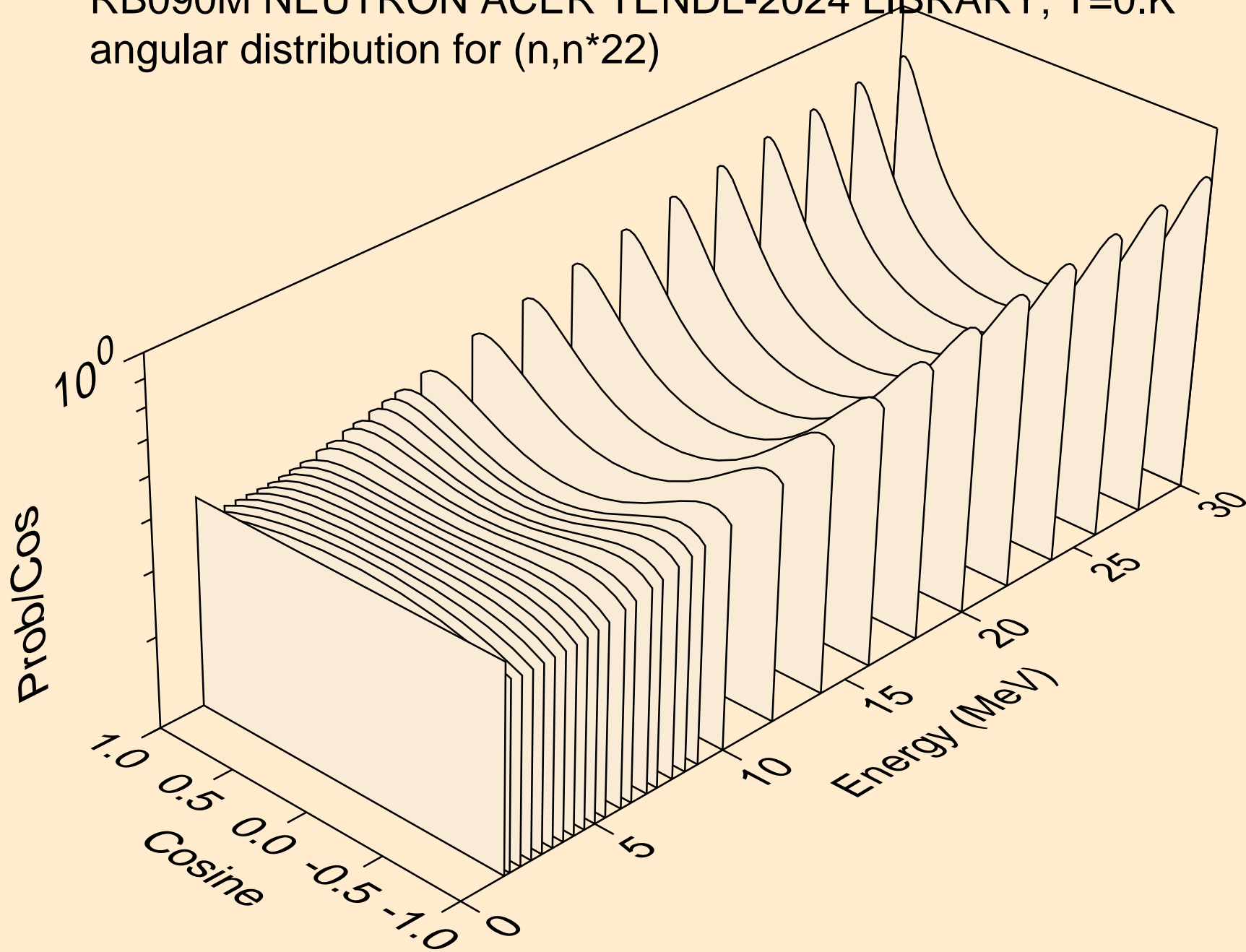

RB090M NEUTRON ACER TENDL-2024 LIBRARY; T=0.K
angular distribution for (n,n*23)

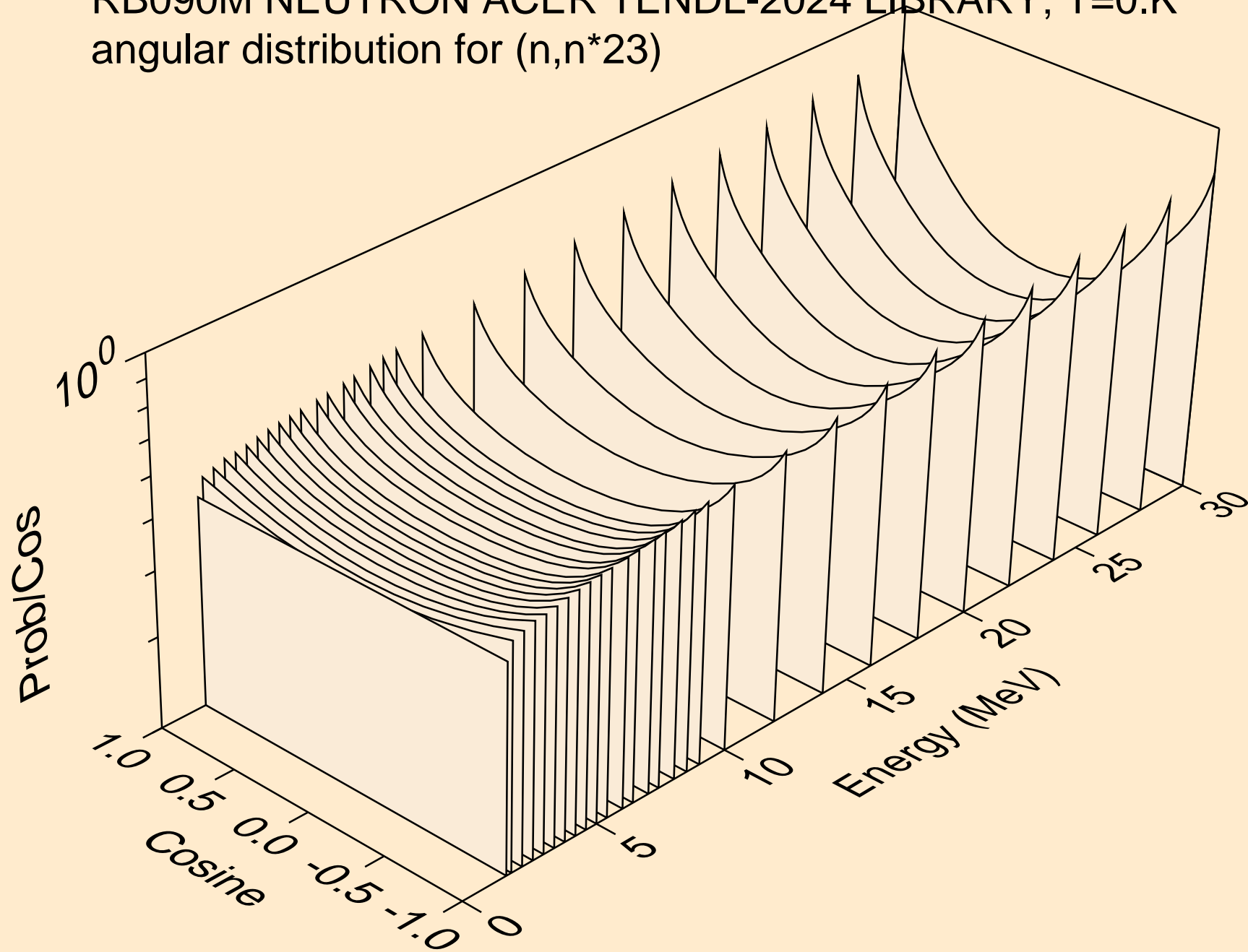

RB090M NEUTRON ACER TENDL-2024 LIBRARY; T=0.K
angular distribution for (n,n*24)

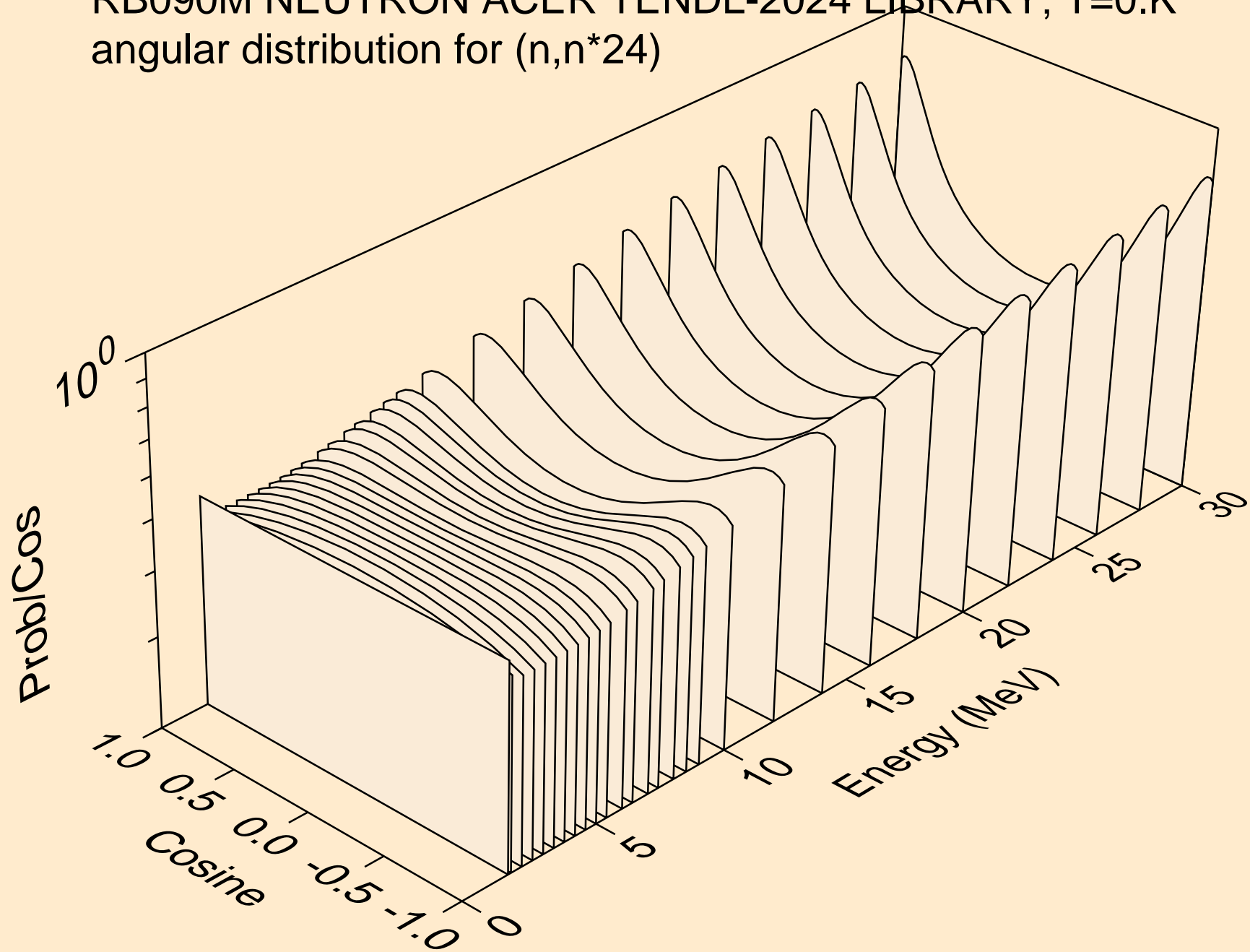

RB090M NEUTRON ACER TENDL-2024 LIBRARY; T=0.K
angular distribution for (n,n*25)

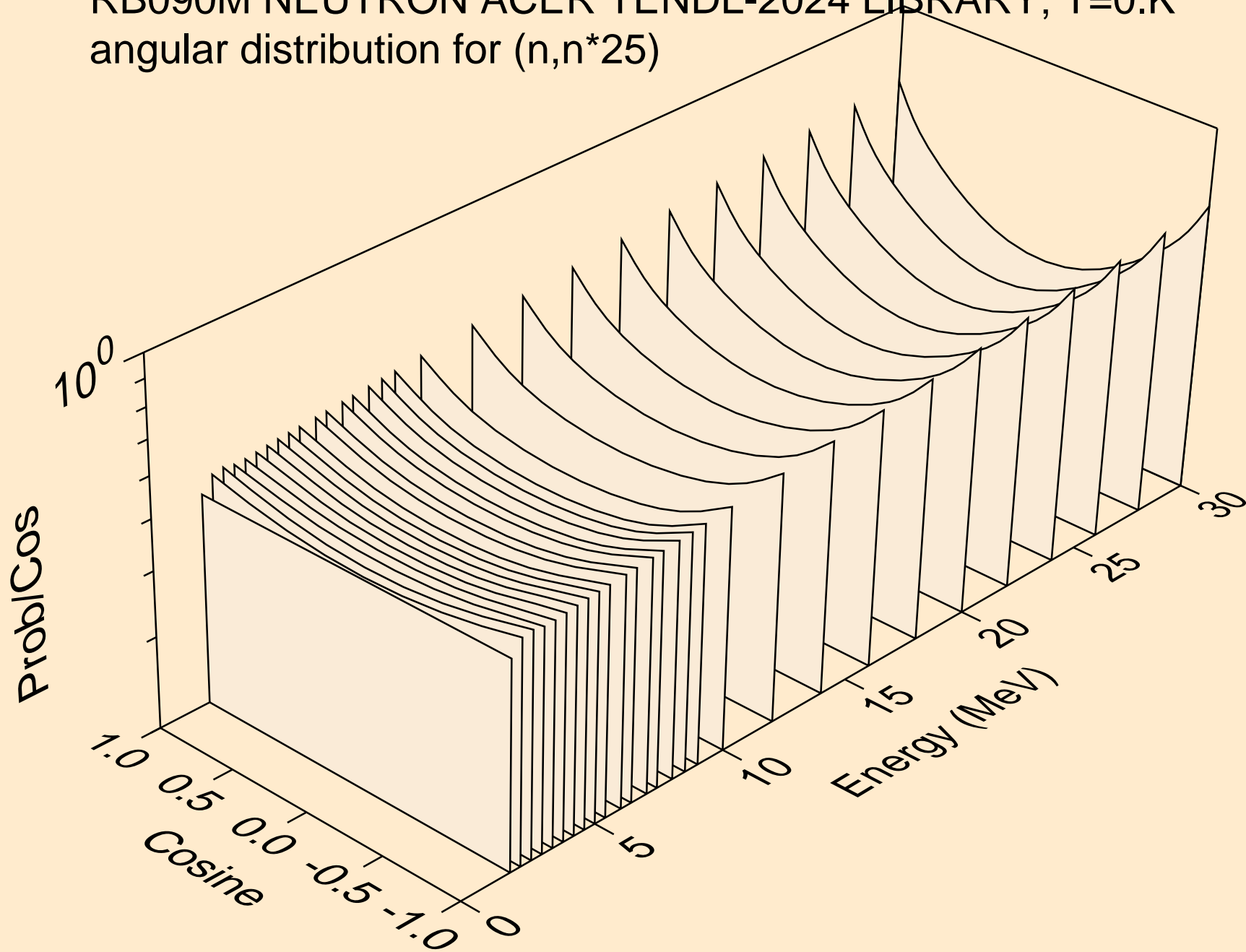

RB090M NEUTRON ACER TENDL-2024 LIBRARY; T=0.K
angular distribution for (n,n*26)

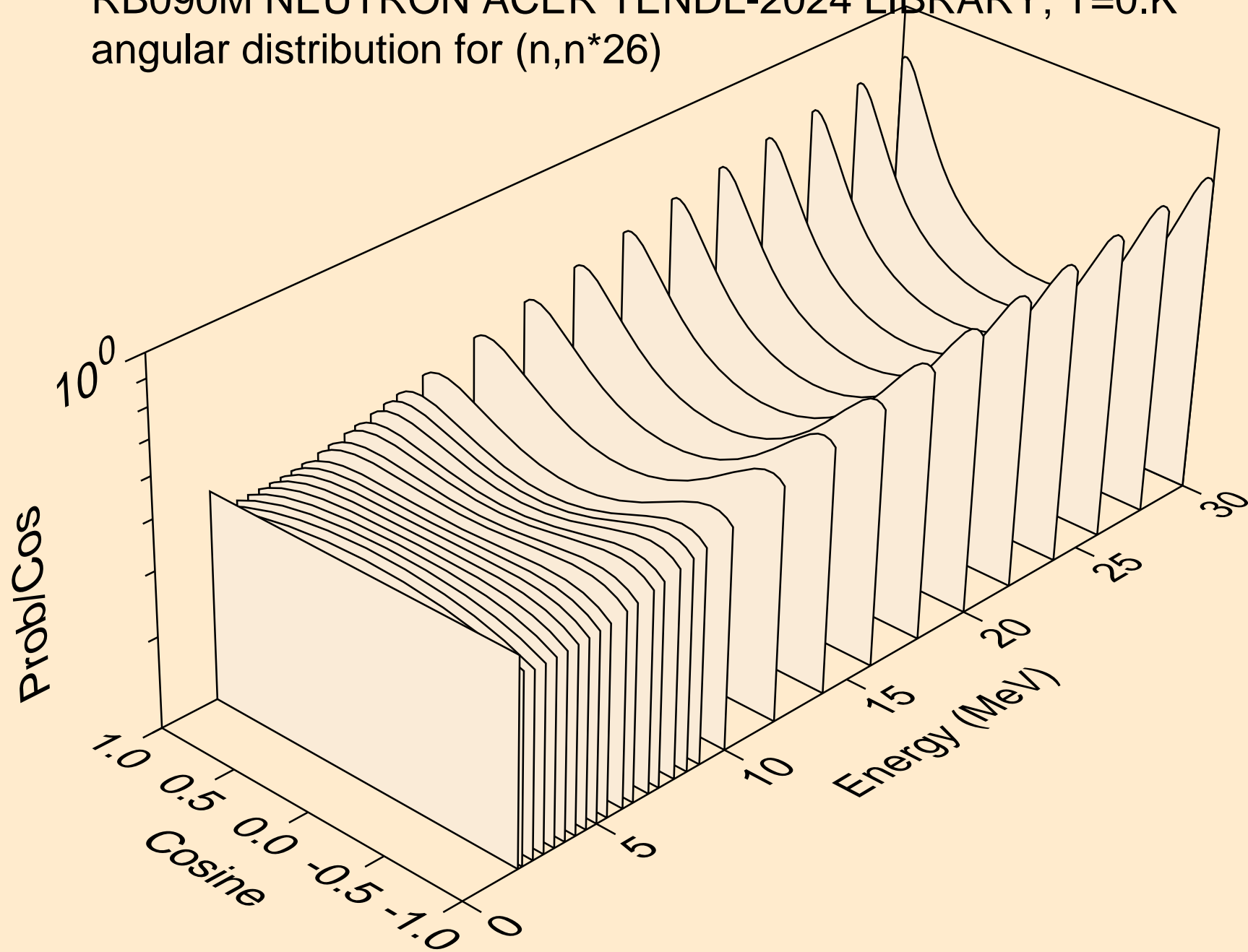

RB090M NEUTRON ACER TENDL-2024 LIBRARY; T=0.K
angular distribution for (n,n*27)

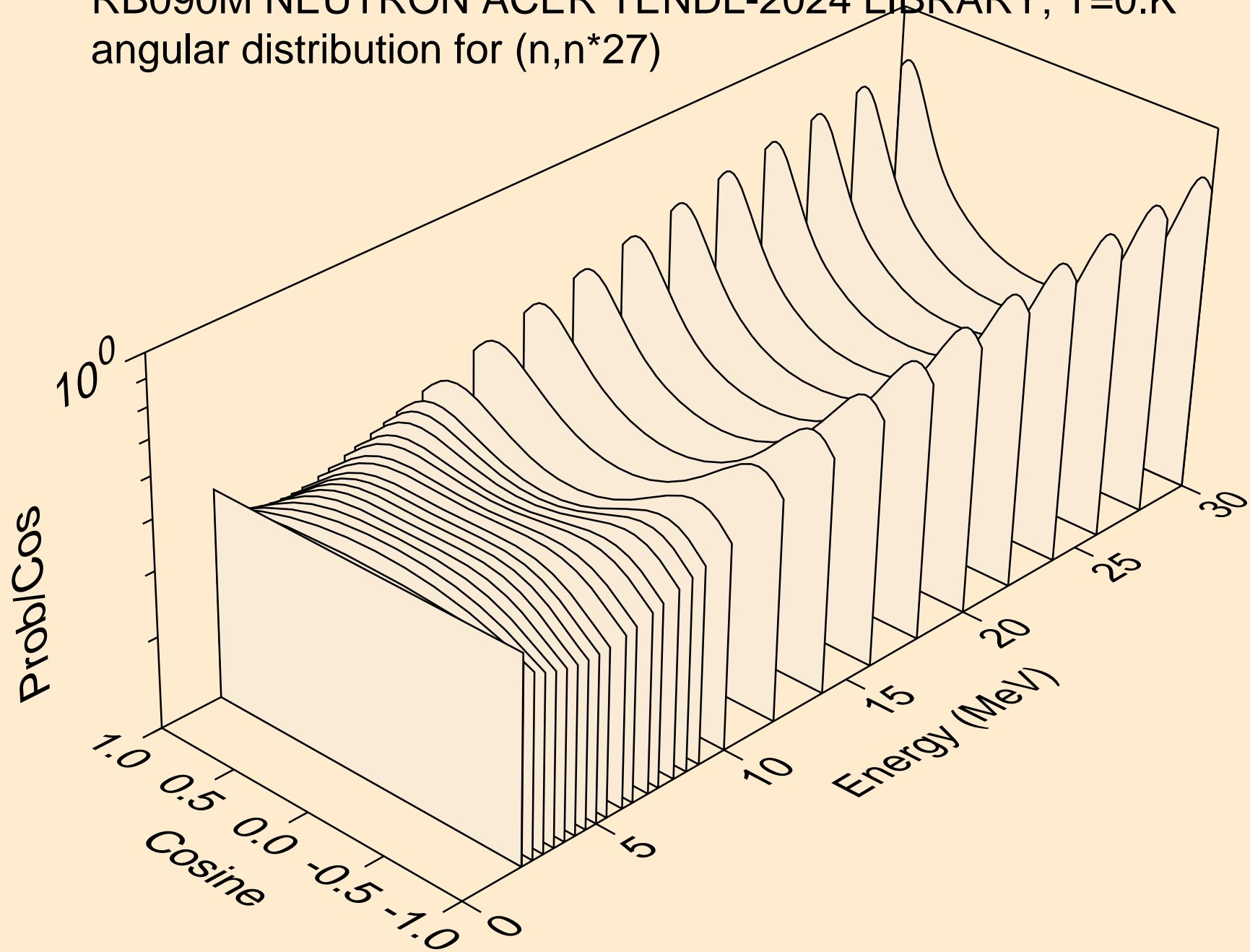

RB090M NEUTRON ACER TENDL-2024 LIBRARY; T=0.K
angular distribution for (n,n*28)

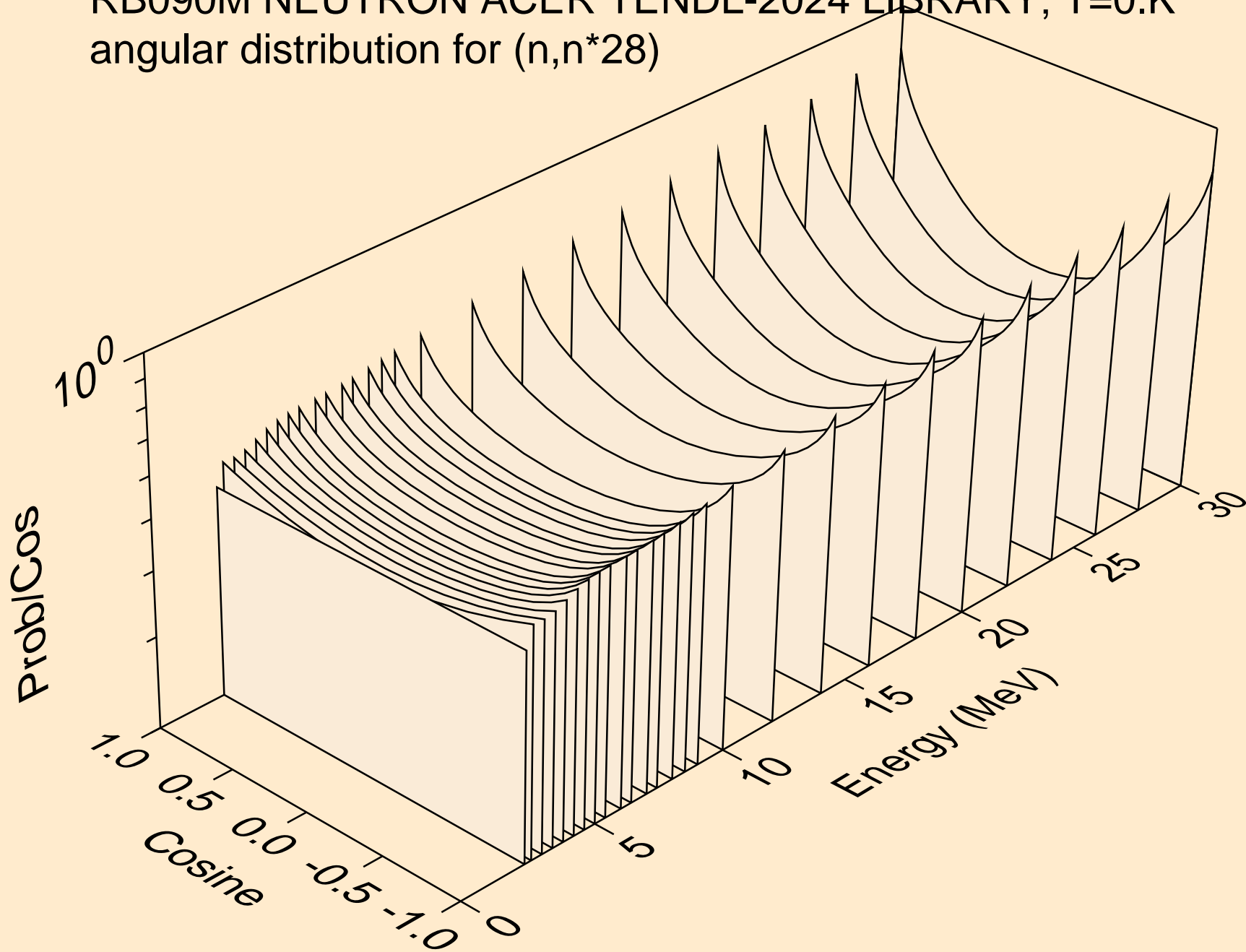

RB090M NEUTRON ACER TENDL-2024 LIBRARY; T=0.K
angular distribution for (n,n*29)

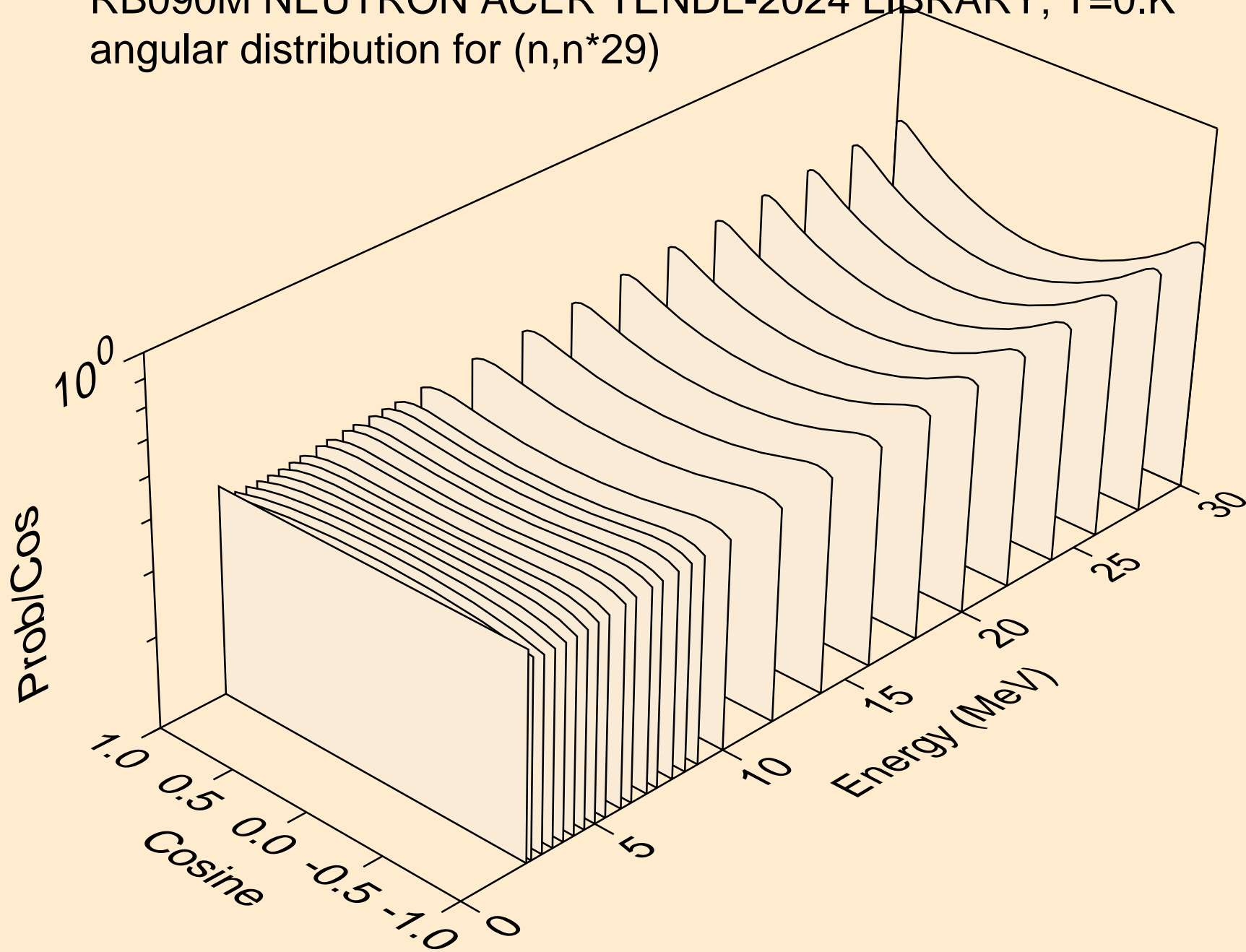

RB090M NEUTRON ACER TENDL-2024 LIBRARY; T=0.K
Neutron emission for (n,x)

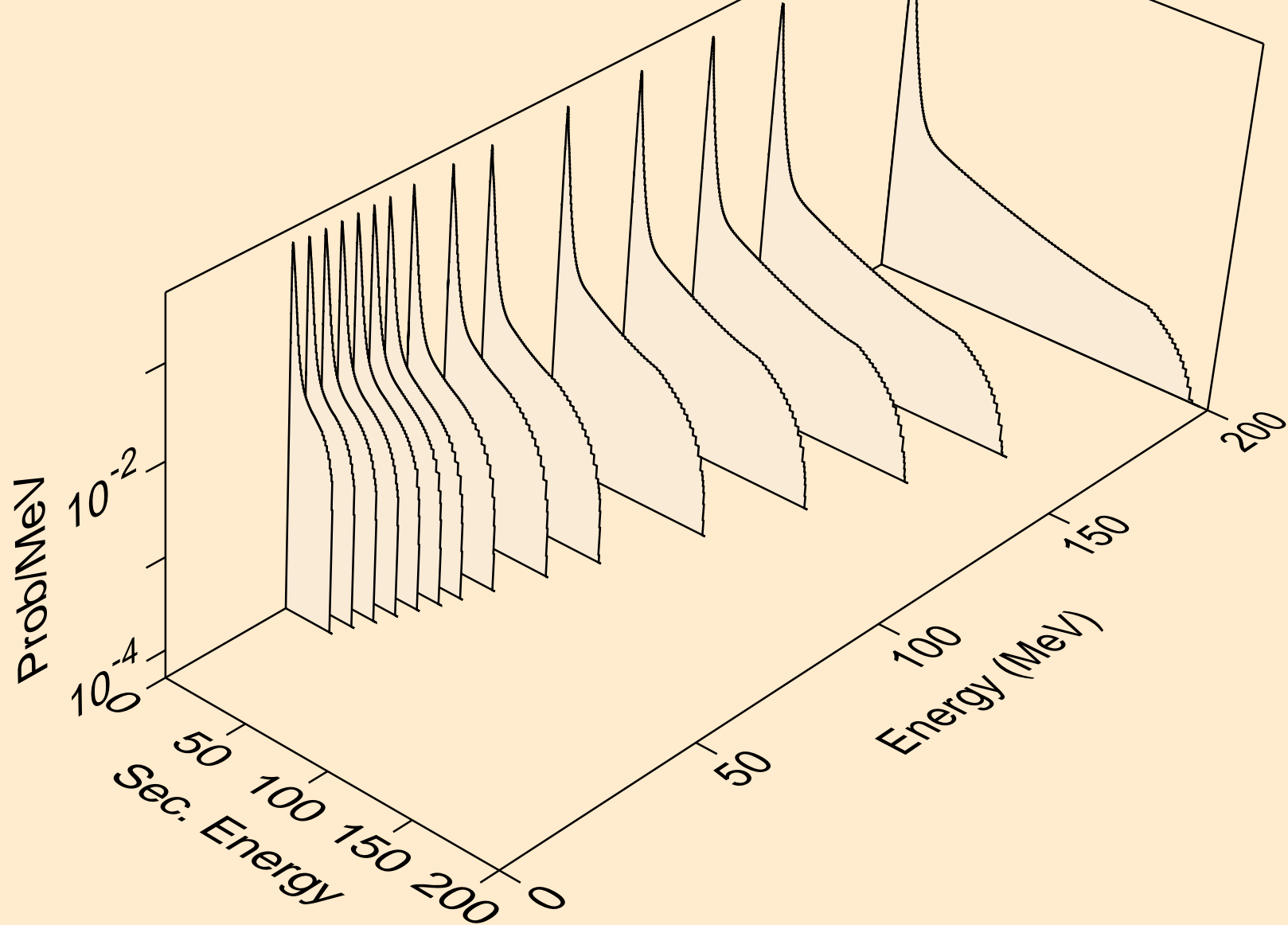

RB090M NEUTRON ACER TENDL-2024 LIBRARY; T=0.K
Neutron emission for (n,2nd)

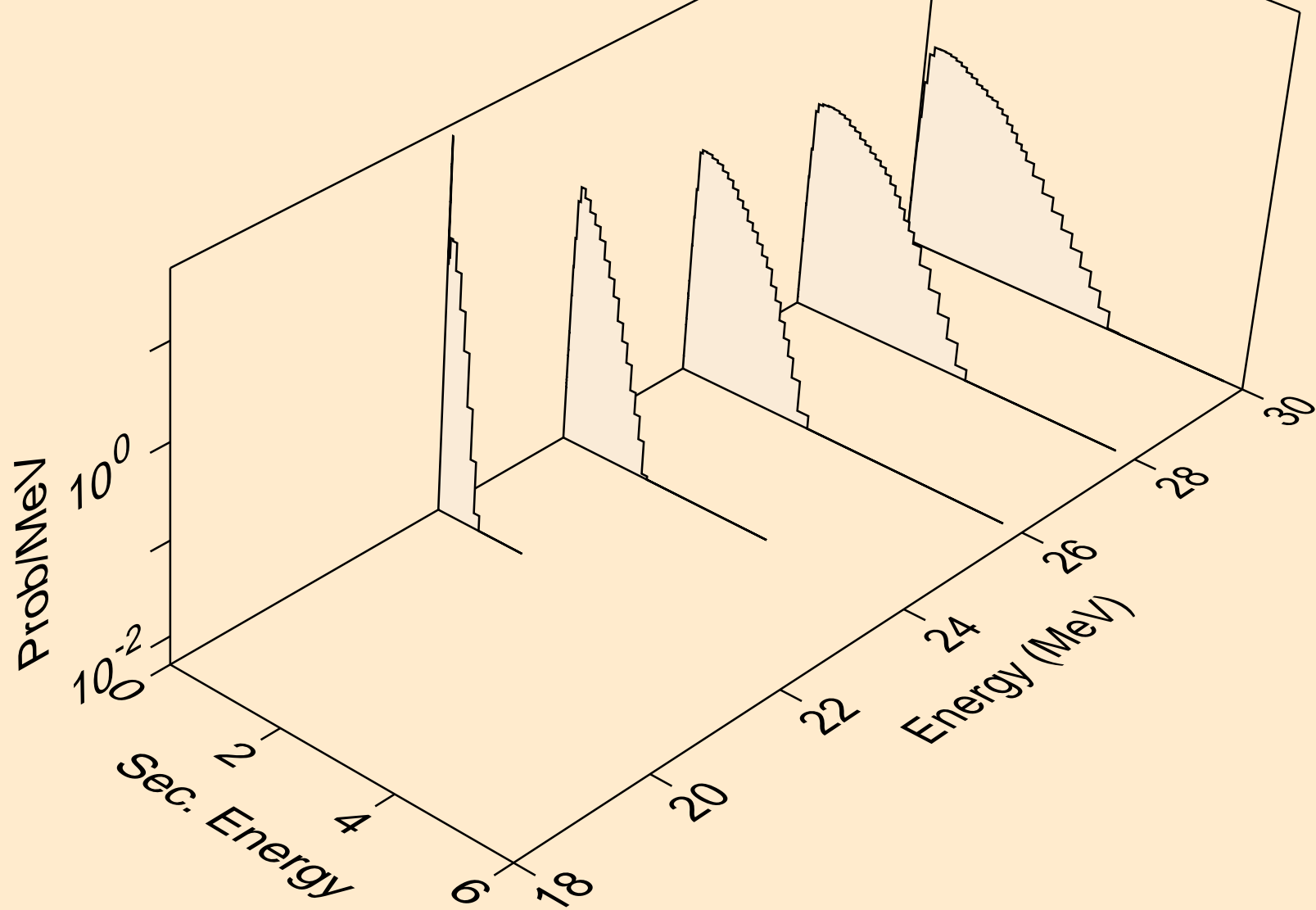

RB090M NEUTRON ACER TENDL-2024 LIBRARY; T=0.K
Neutron emission for (n,2n)

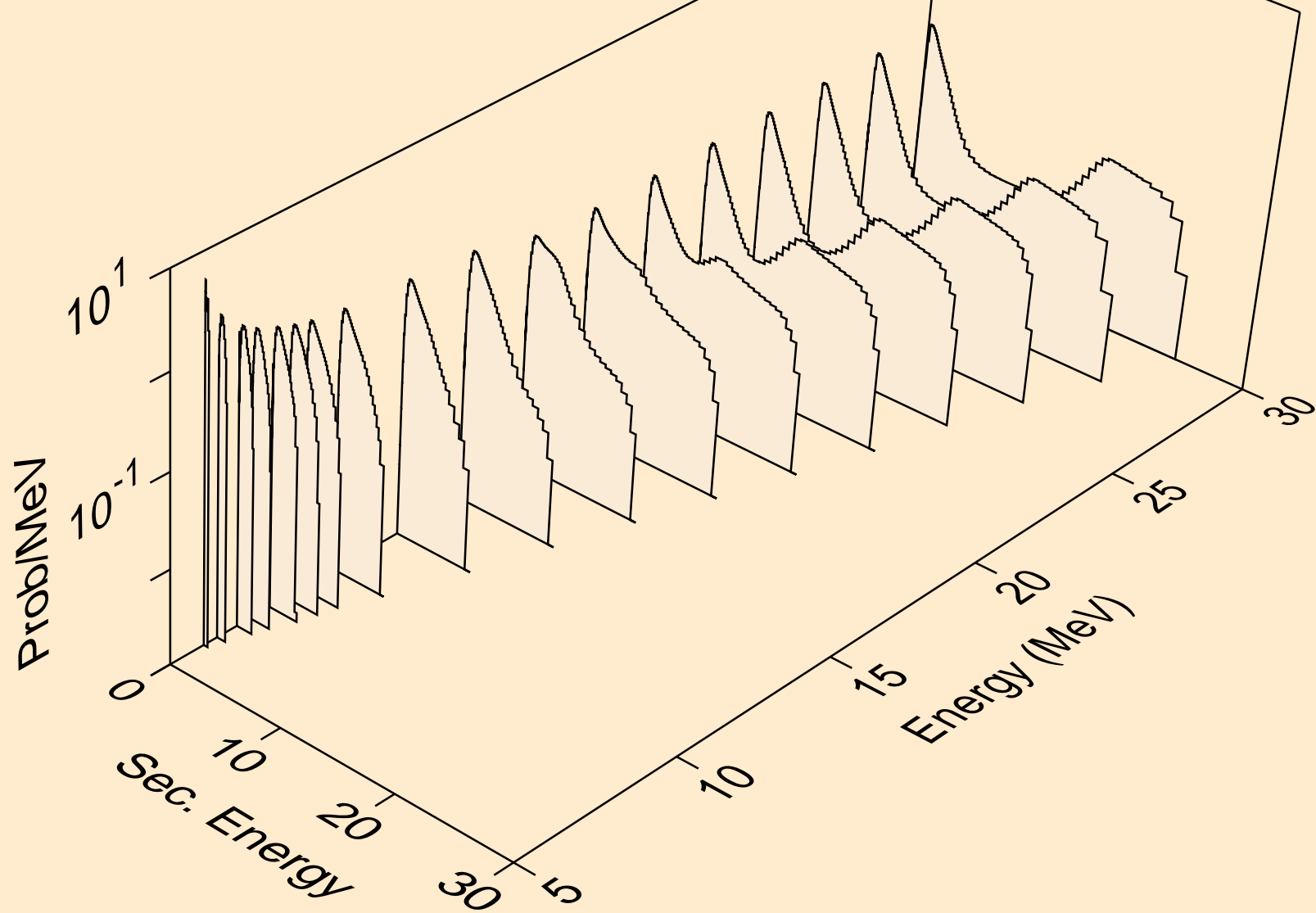

RB090M NEUTRON ACER TENDL-2024 LIBRARY; T=0.K
Neutron emission for (n,3n)

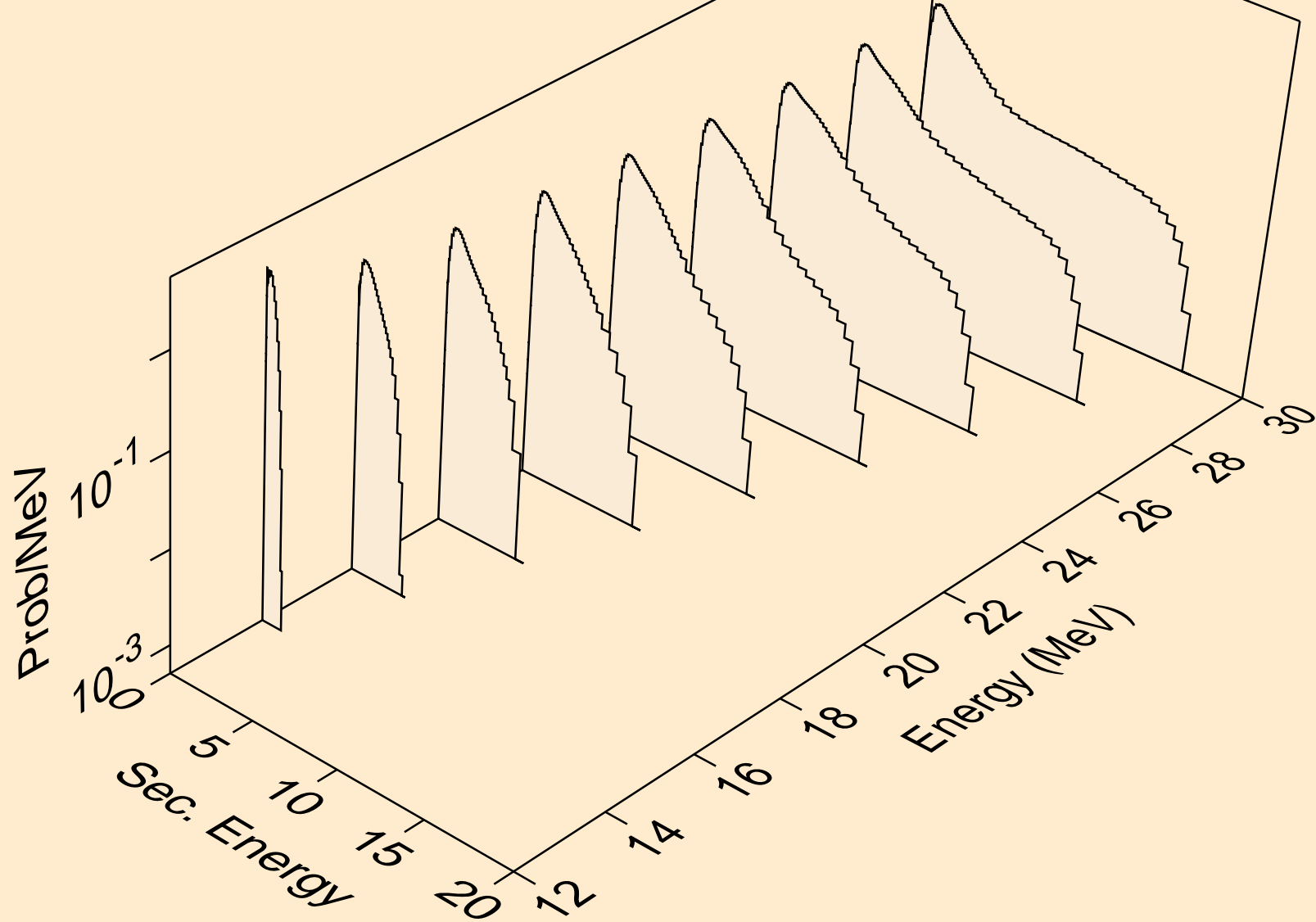

RB090M NEUTRON ACER TENDL-2024 LIBRARY; T=0.K
Neutron emission for (n,n*)a

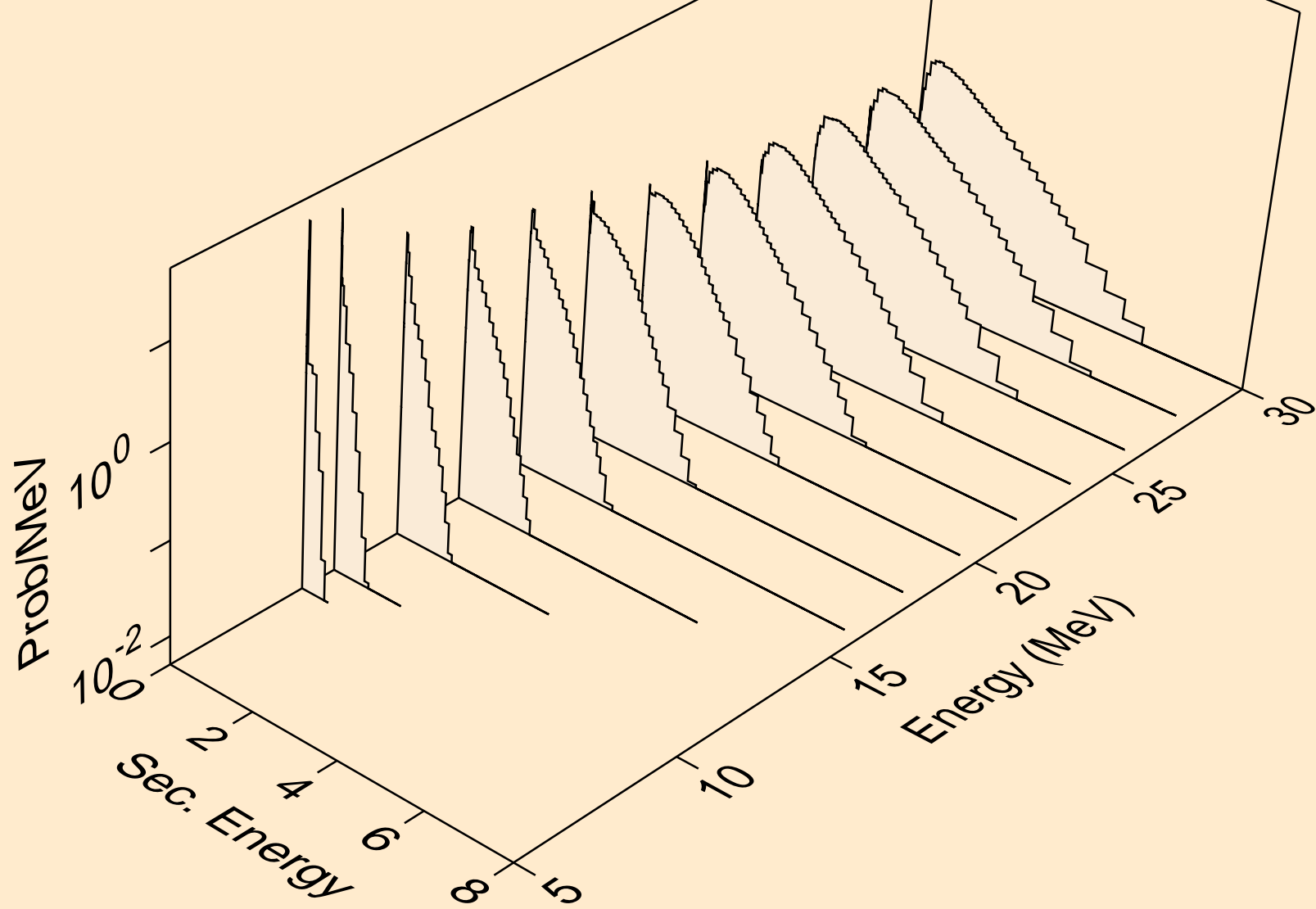

RB090M NEUTRON ACER TENDL-2024 LIBRARY; T=0.K
Neutron emission for (n,2n)a

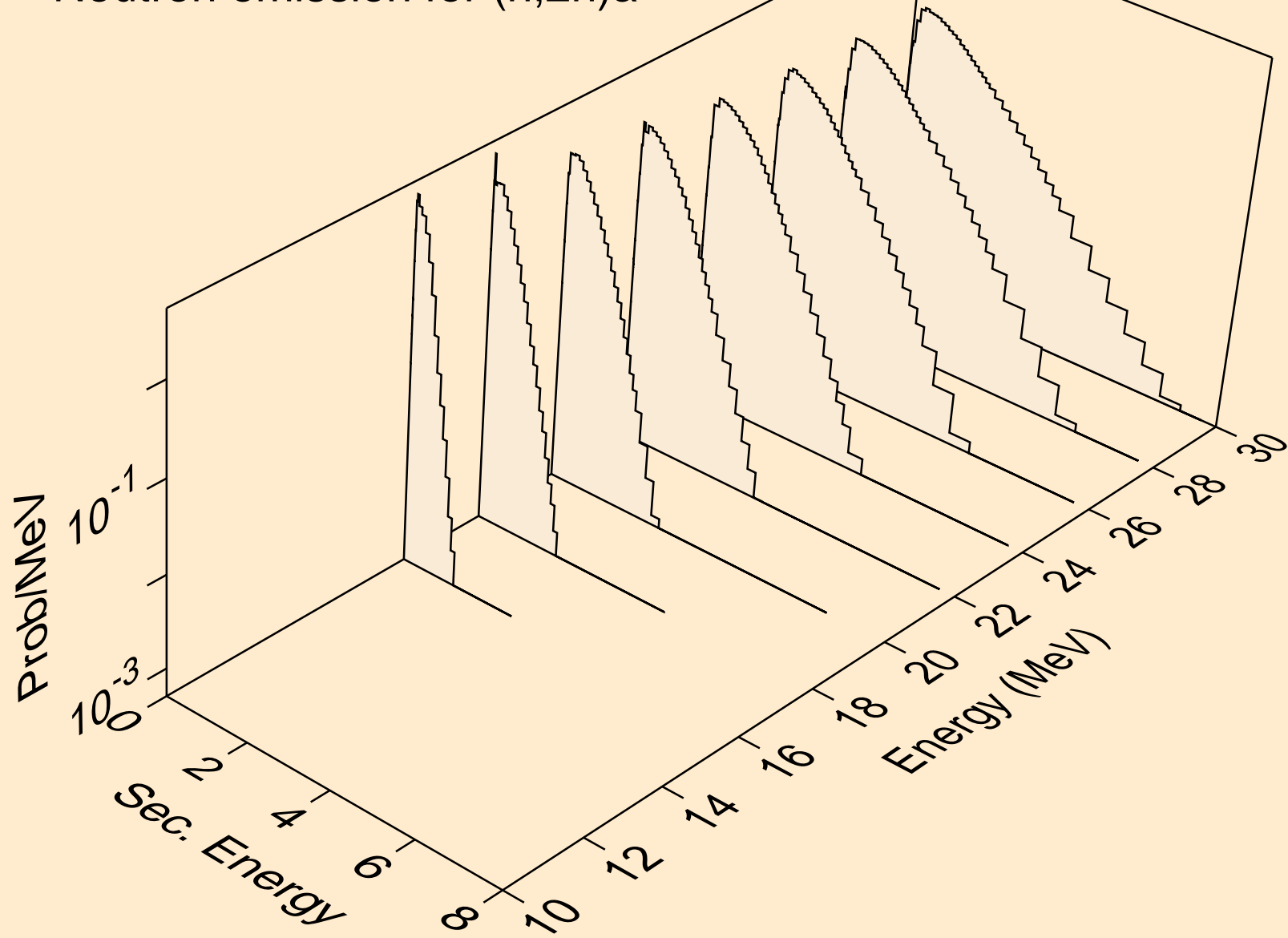

RB090M NEUTRON ACER TENDL-2024 LIBRARY; T=0.K
Neutron emission for (n,3n)a

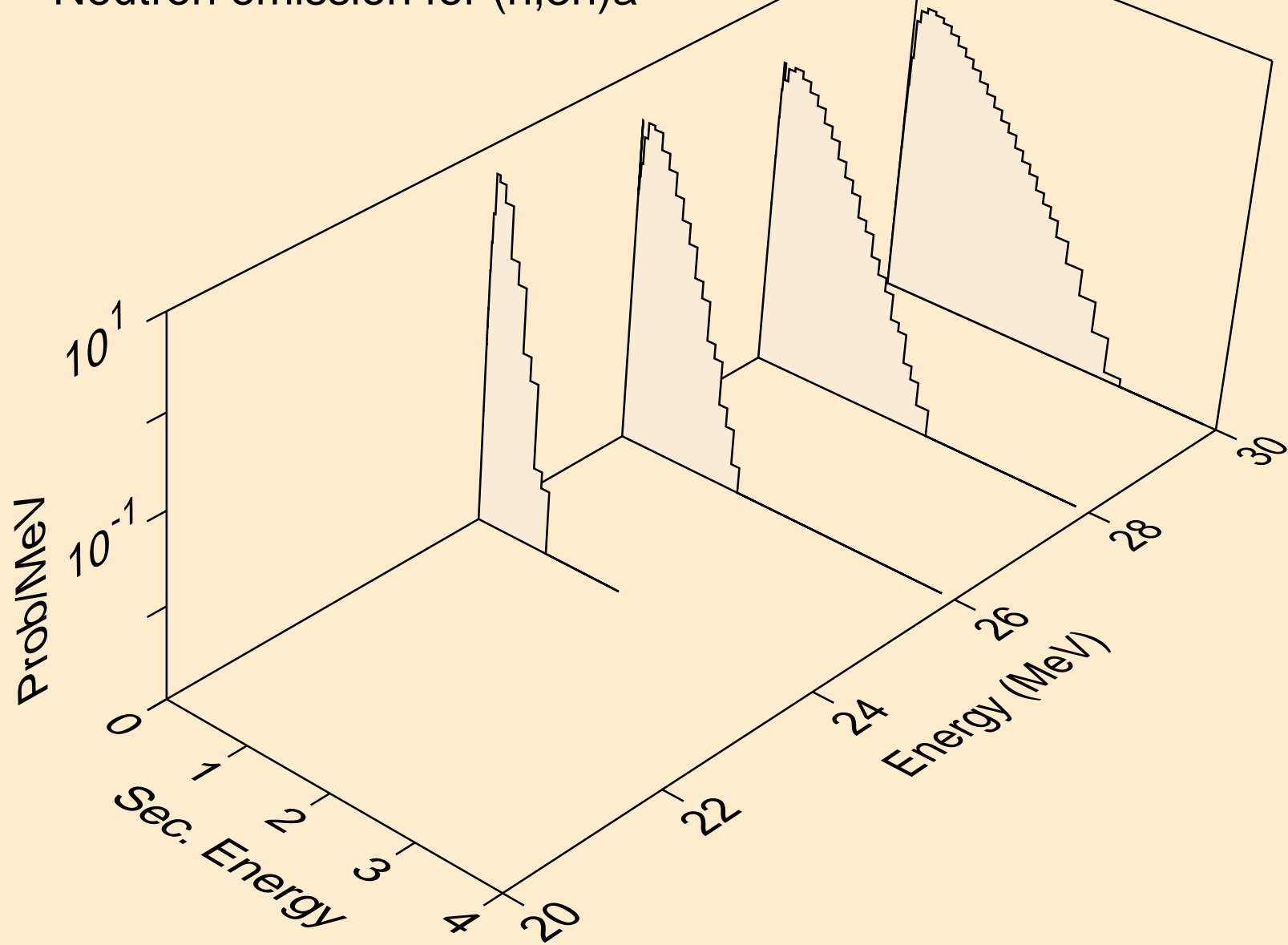

RB090M NEUTRON ACER TENDL-2024 LIBRARY; T=0.K
Neutron emission for (n,n*)p

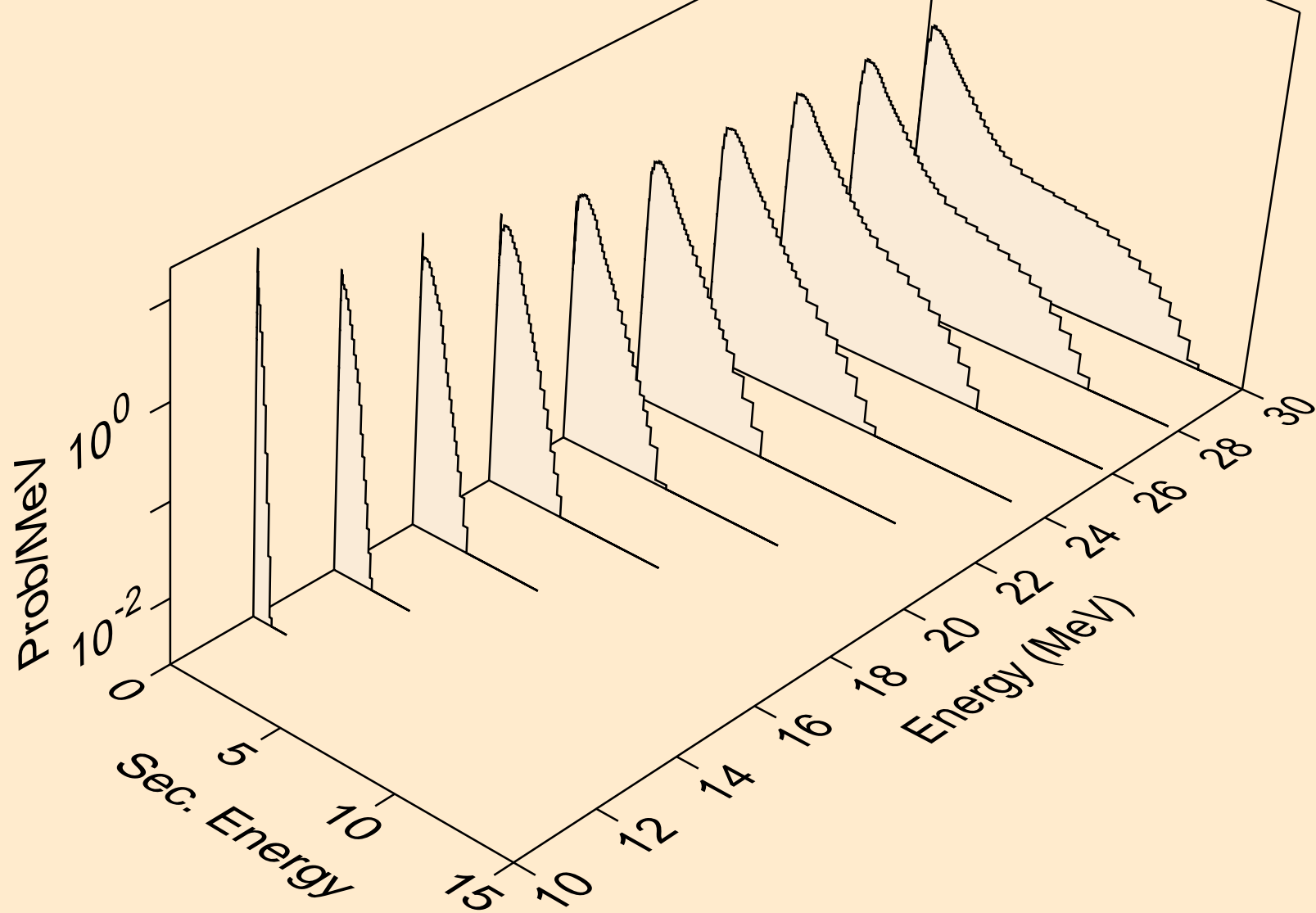

RB090M NEUTRON ACER TENDL-2024 LIBRARY; T=0.K
Neutron emission for (n,n*)d

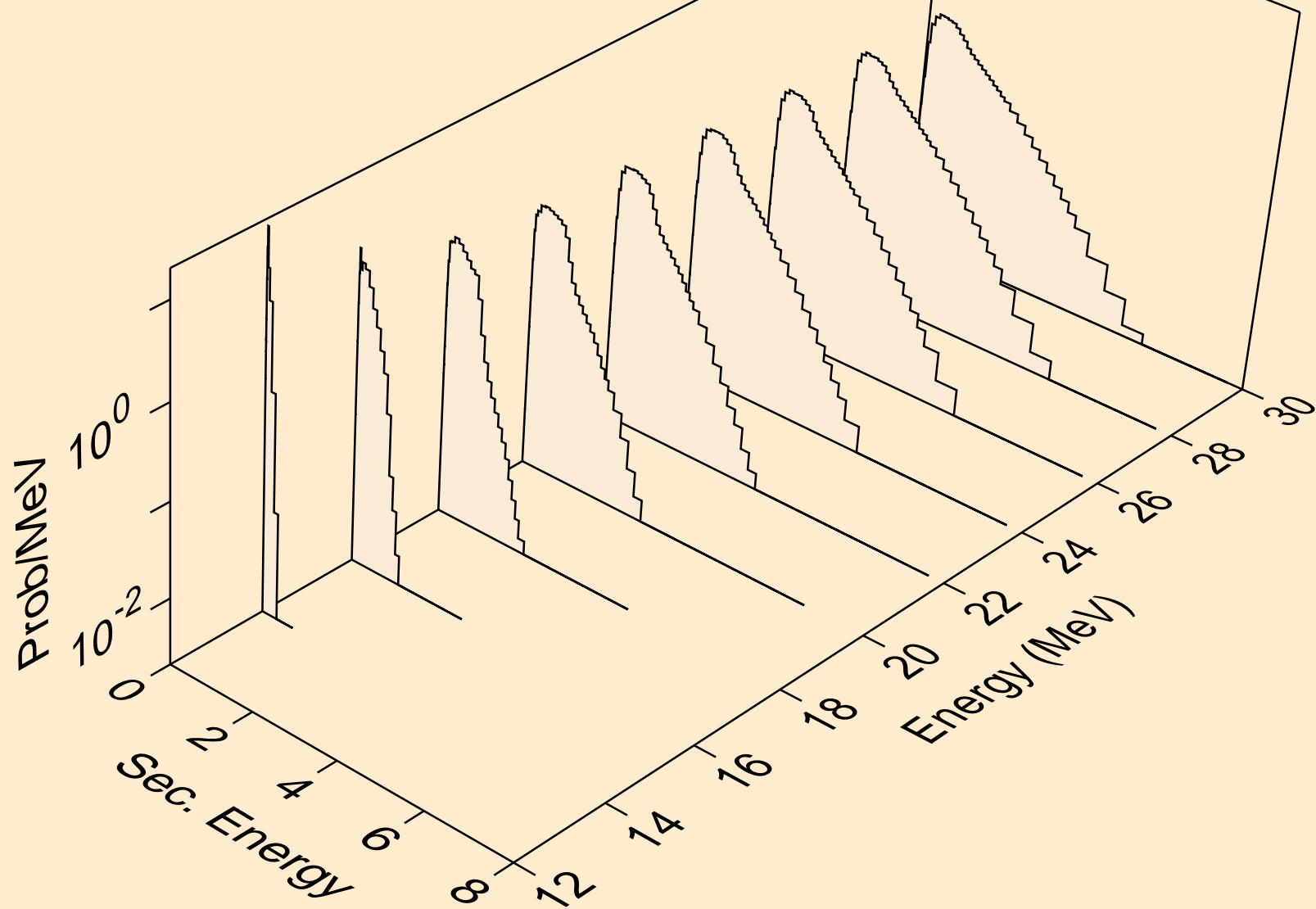

RB090M NEUTRON ACER TENDL-2024 LIBRARY; T=0.K
Neutron emission for (n,n*)t

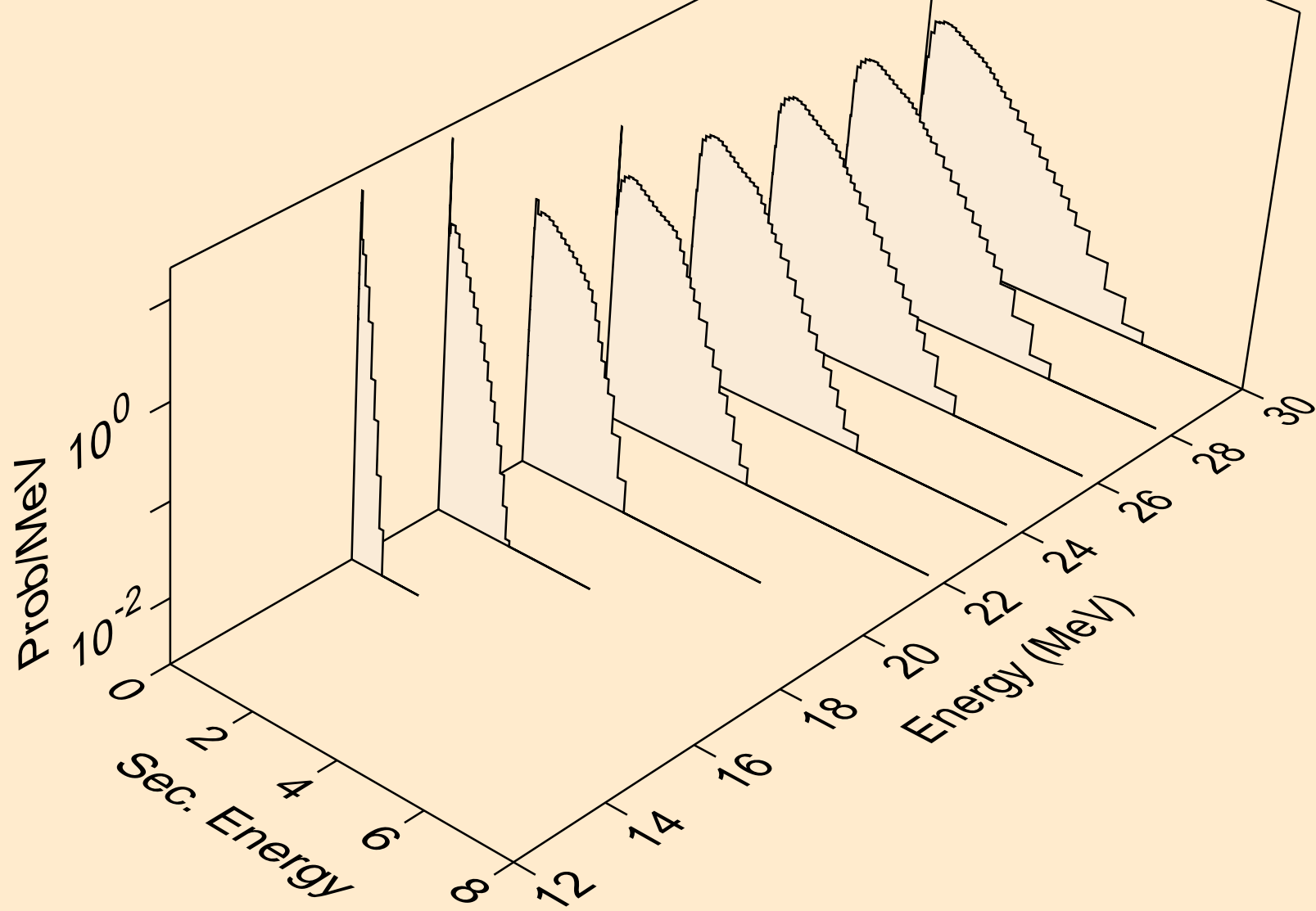

RB090M NEUTRON ACER TENDL-2024 LIBRARY; T=0.K
Neutron emission for (n,n*)he3

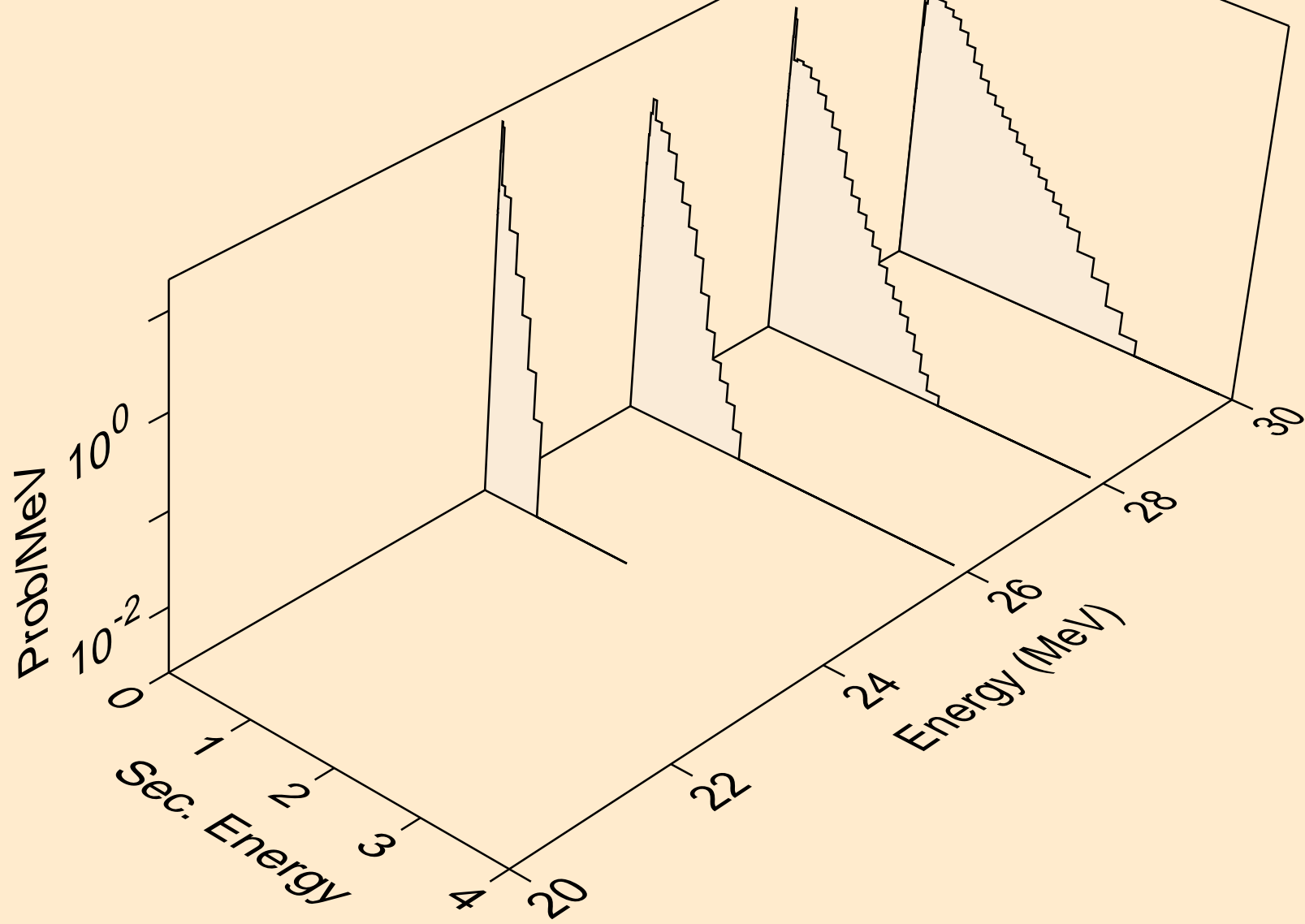

RB090M NEUTRON ACER TENDL-2024 LIBRARY; T=0.K
Neutron emission for (n,4n)

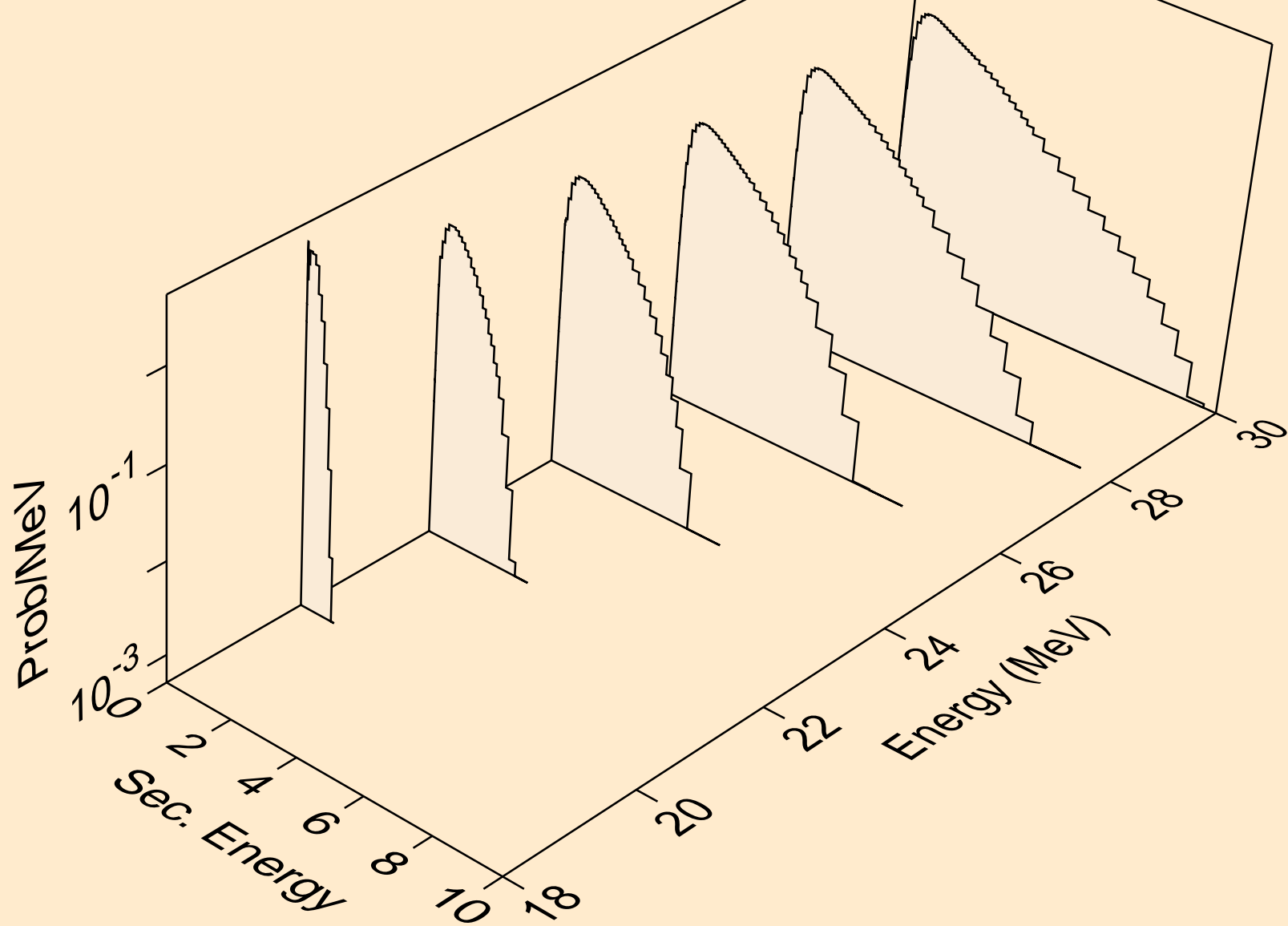

RB090M NEUTRON ACER TENDL-2024 LIBRARY; T=0.K
Neutron emission for (n,2np)

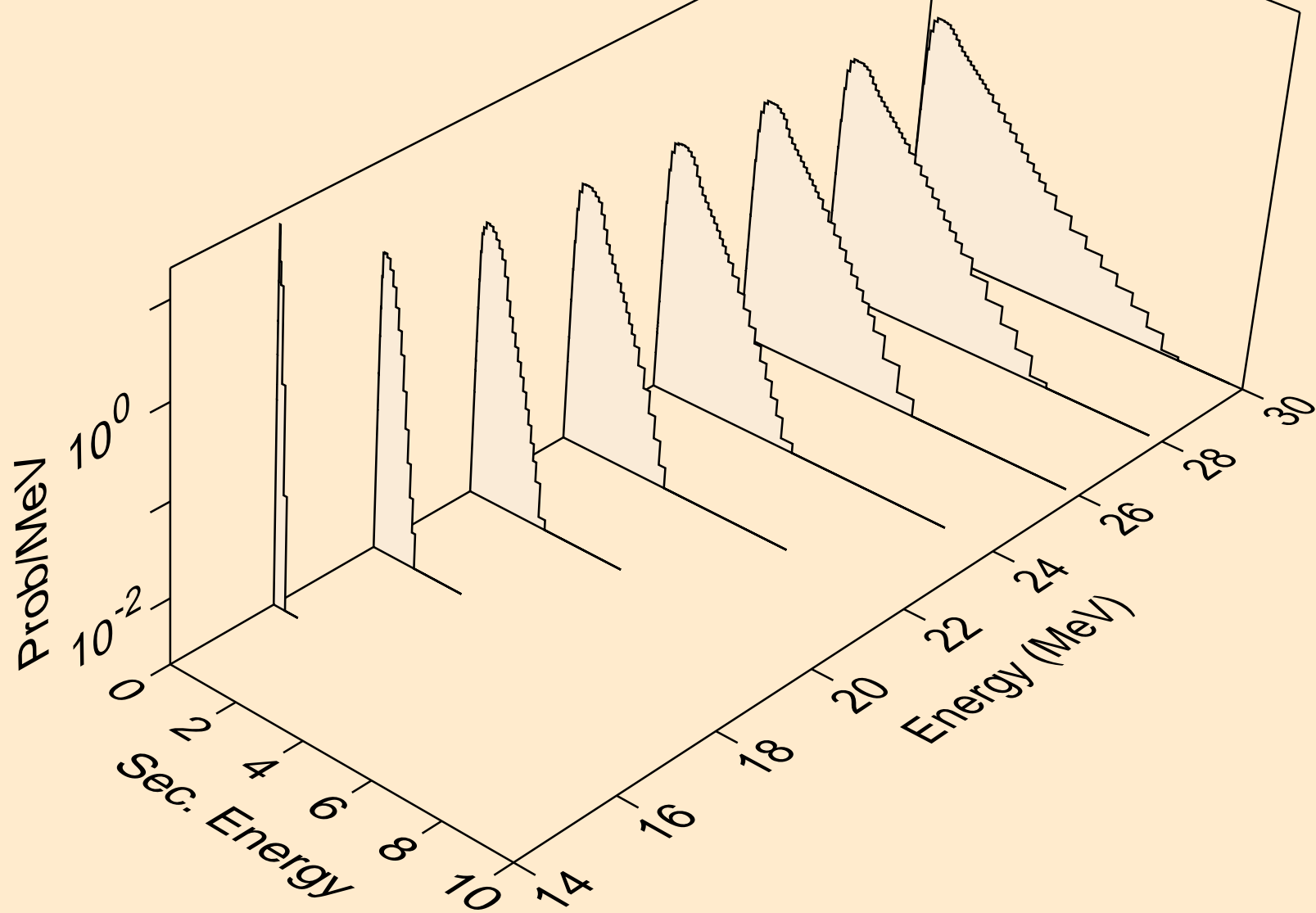

RB090M NEUTRON ACER TENDL-2024 LIBRARY; T=0.K
Neutron emission for (n,3np)

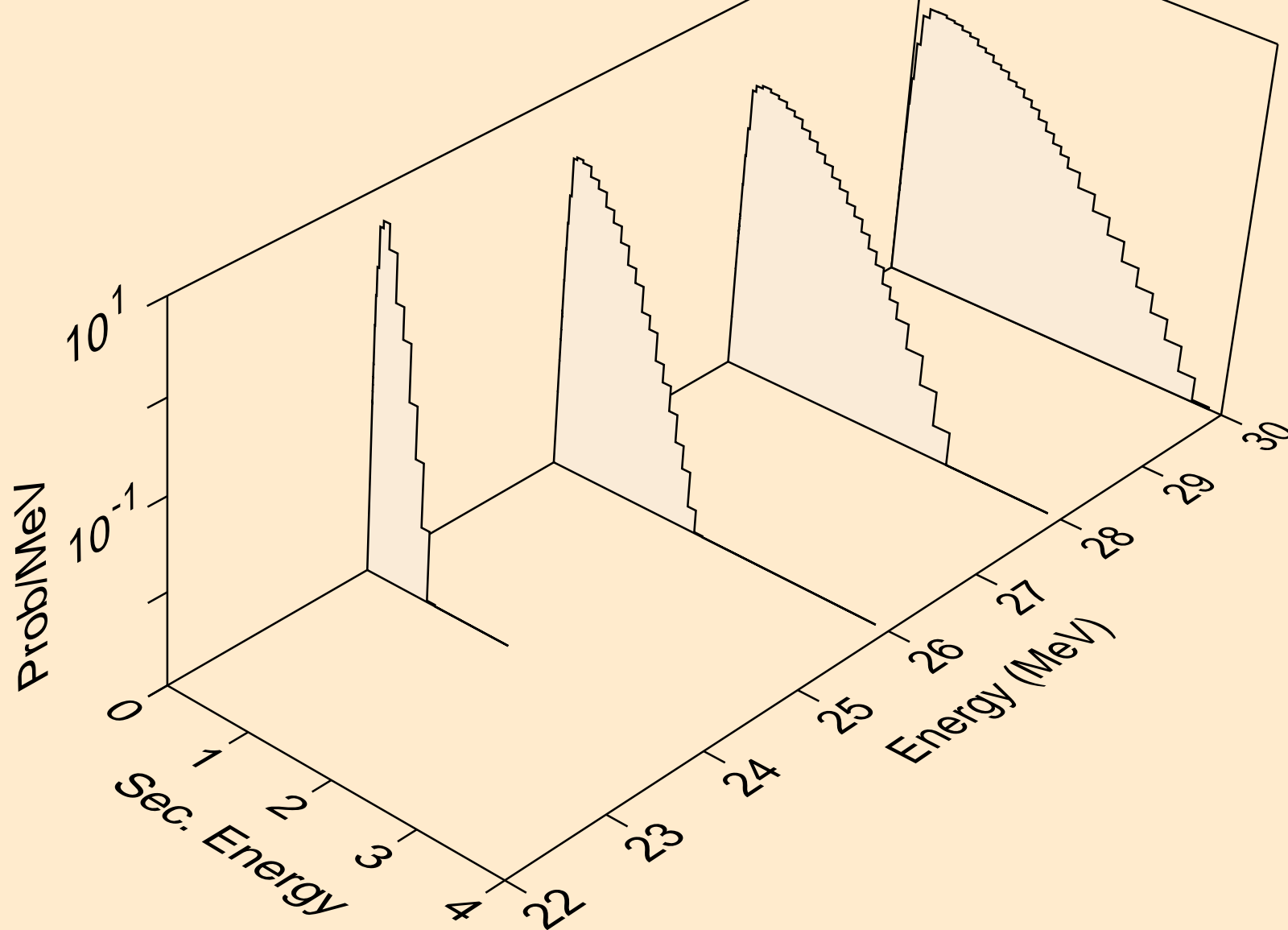

RB090M NEUTRON ACER TENDL-2024 LIBRARY; T=0.K
Neutron emission for (n,n*c)

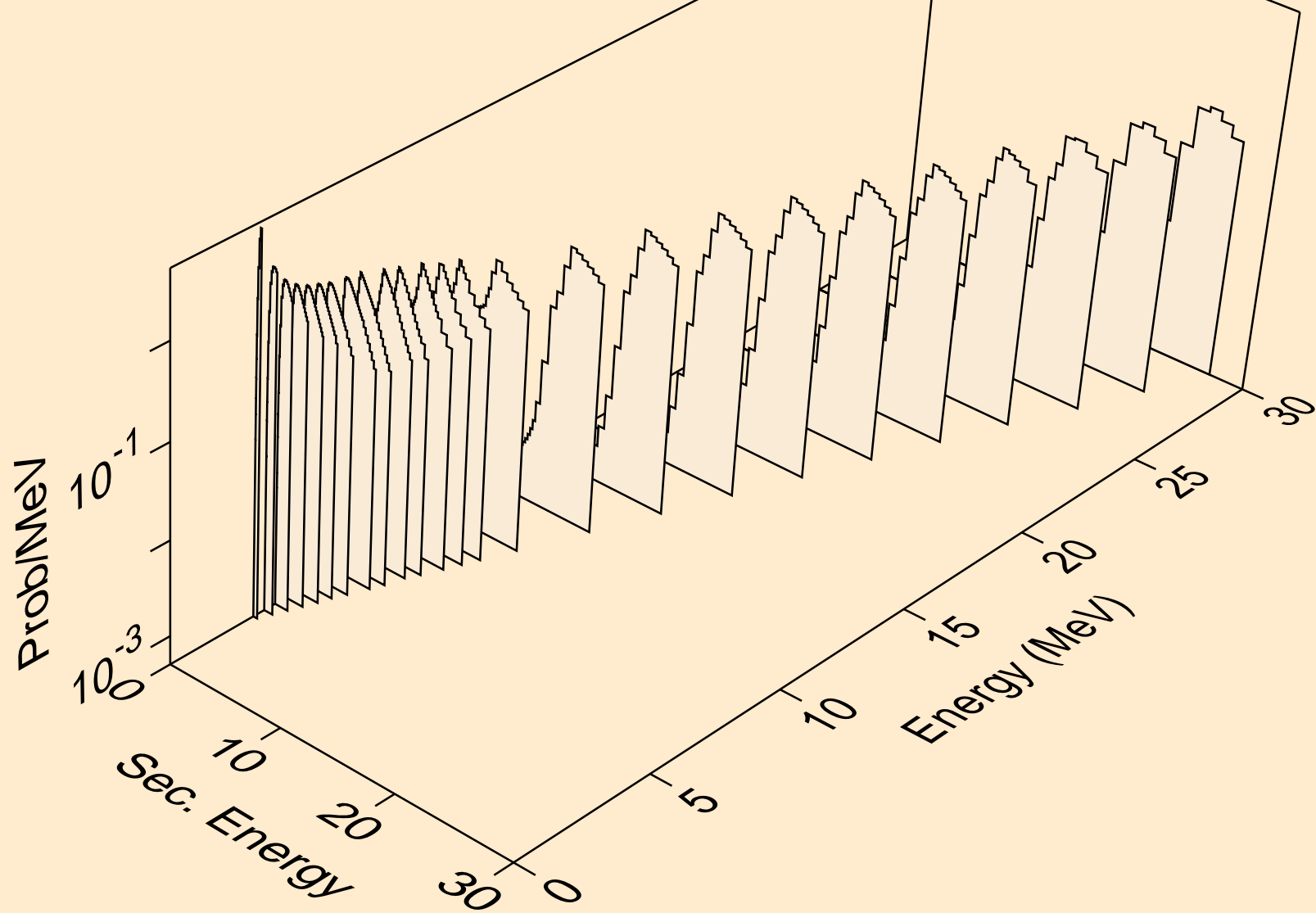

RB090M NEUTRON ACER TENDL-2024 LIBRARY; T=0.K
Photon emission for (n,x)

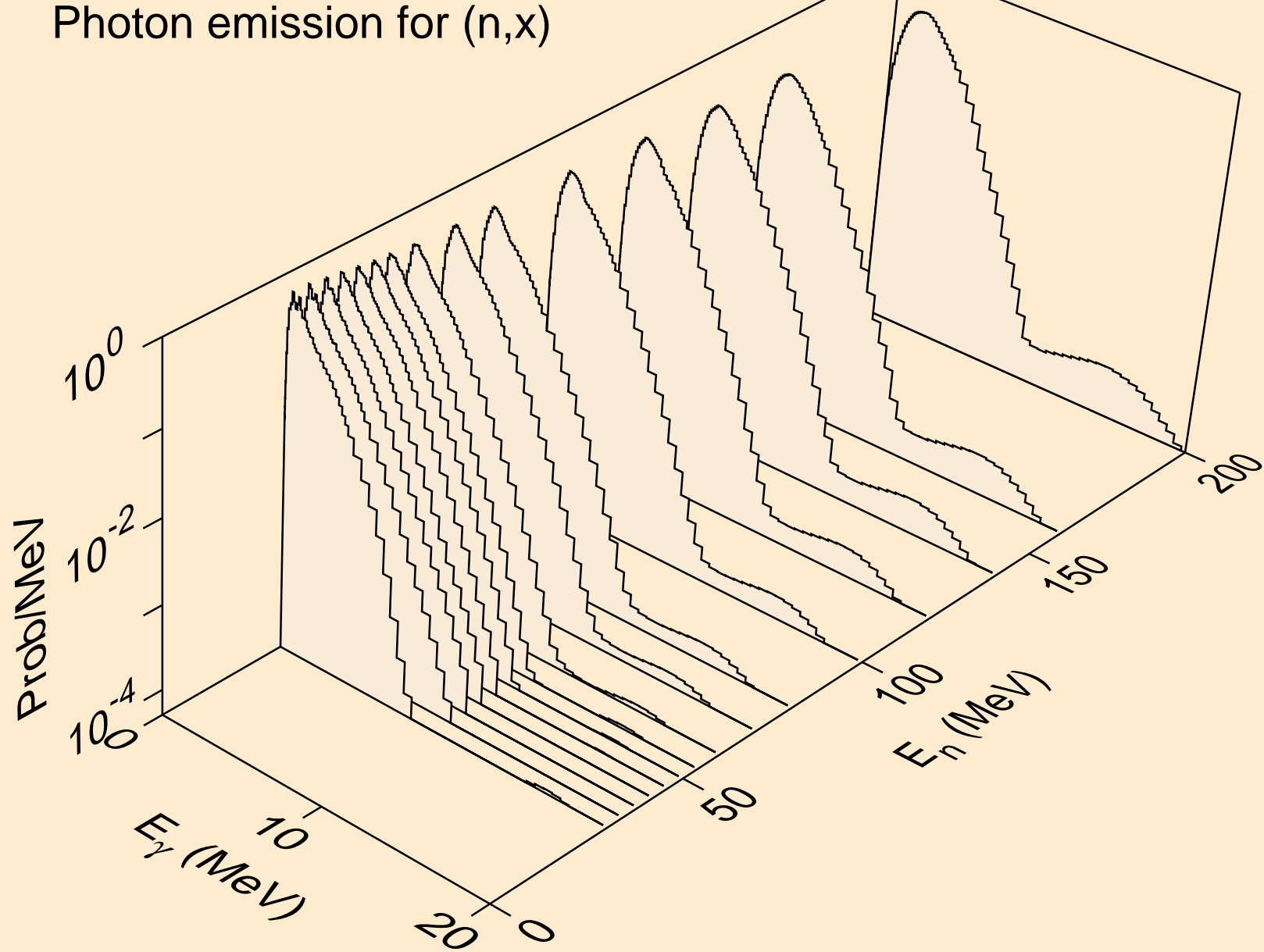

RB090M NEUTRON ACER TENDL-2024 LIBRARY; T=0.K
Photon emission for (n,2nd)

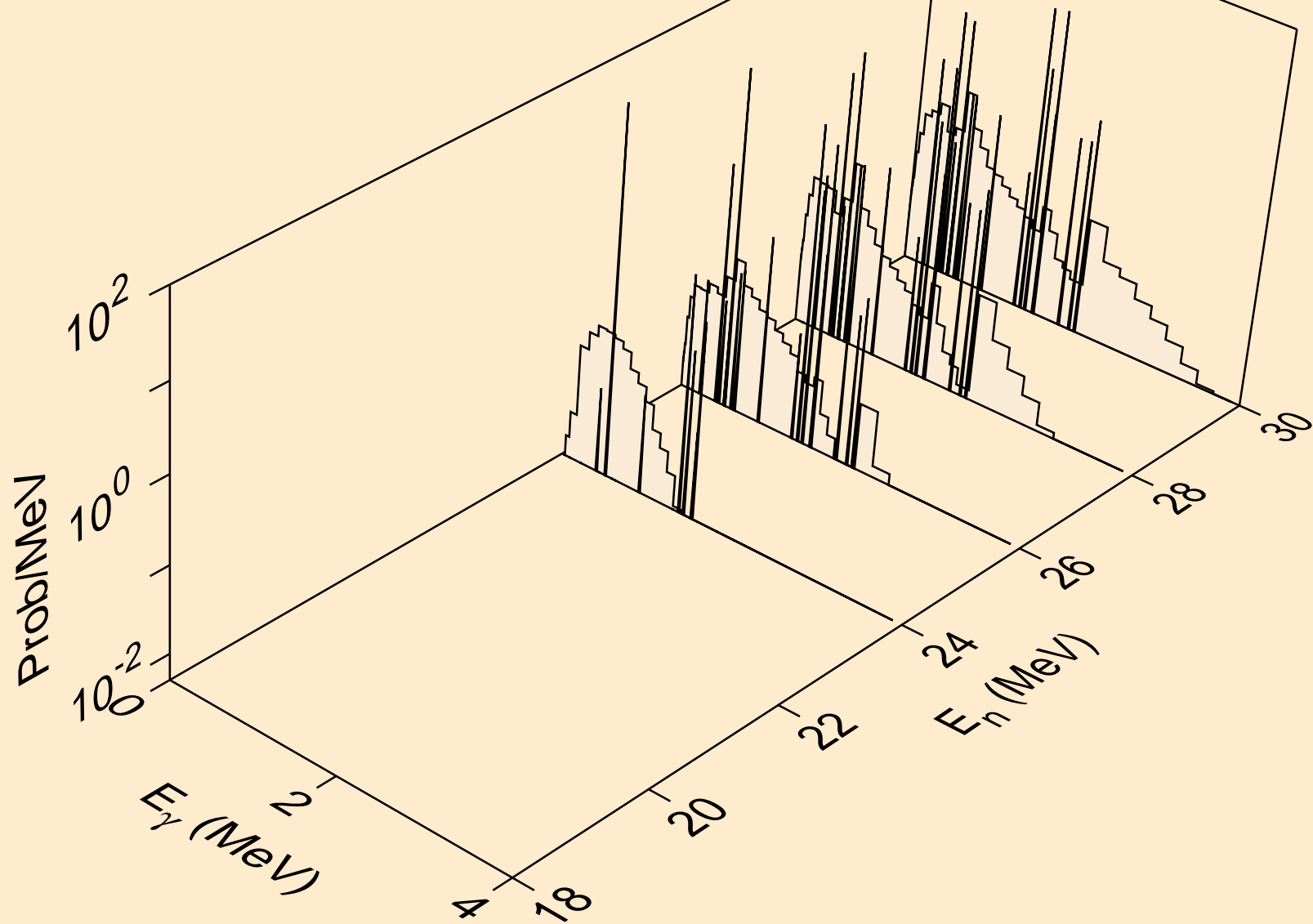

RB090M NEUTRON ACER TENDL-2024 LIBRARY; T=0.K
Photon emission for (n,2n)

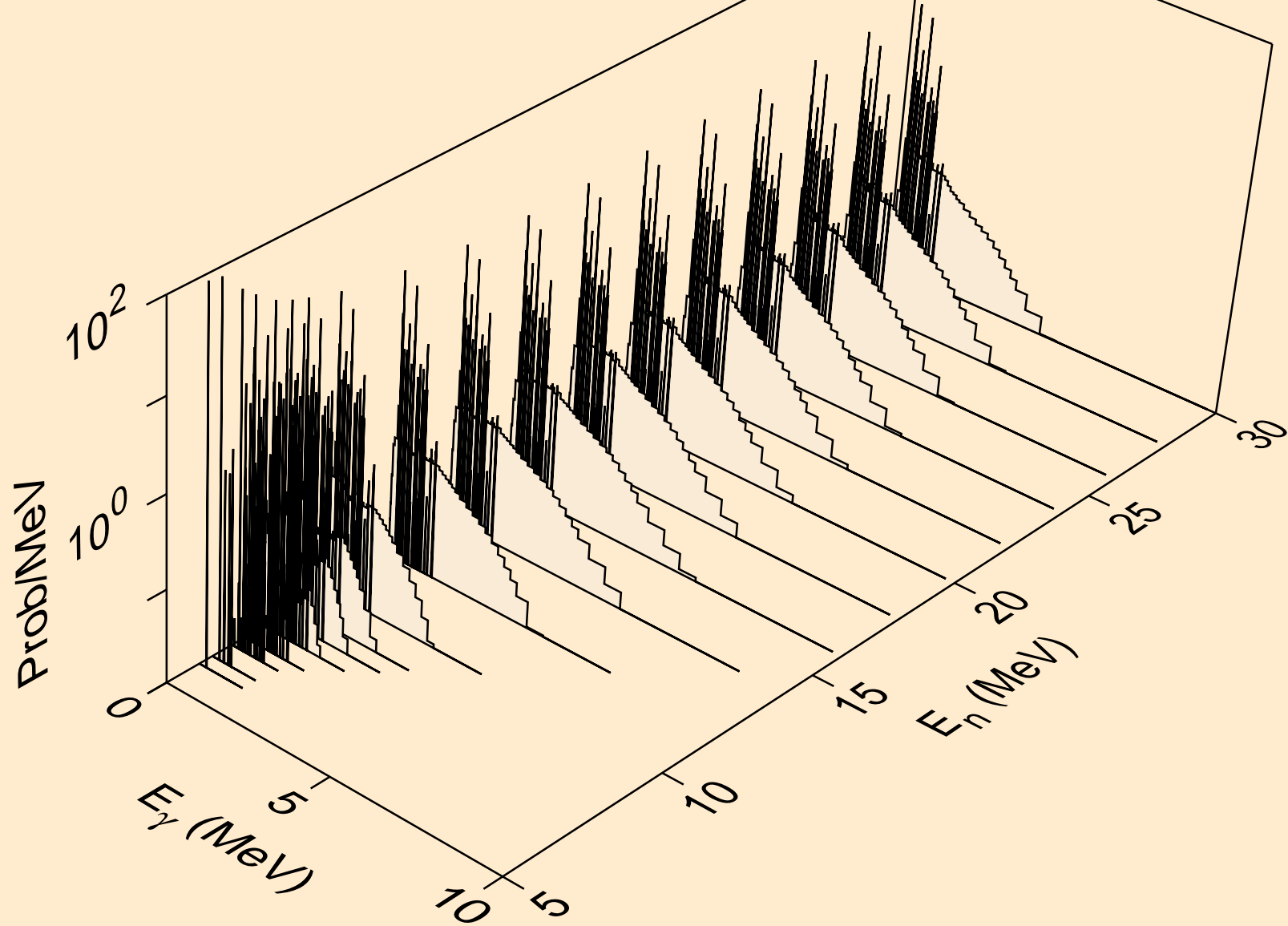

RB090M NEUTRON ACER TENDL-2024 LIBRARY; T=0.K
Photon emission for (n,3n)

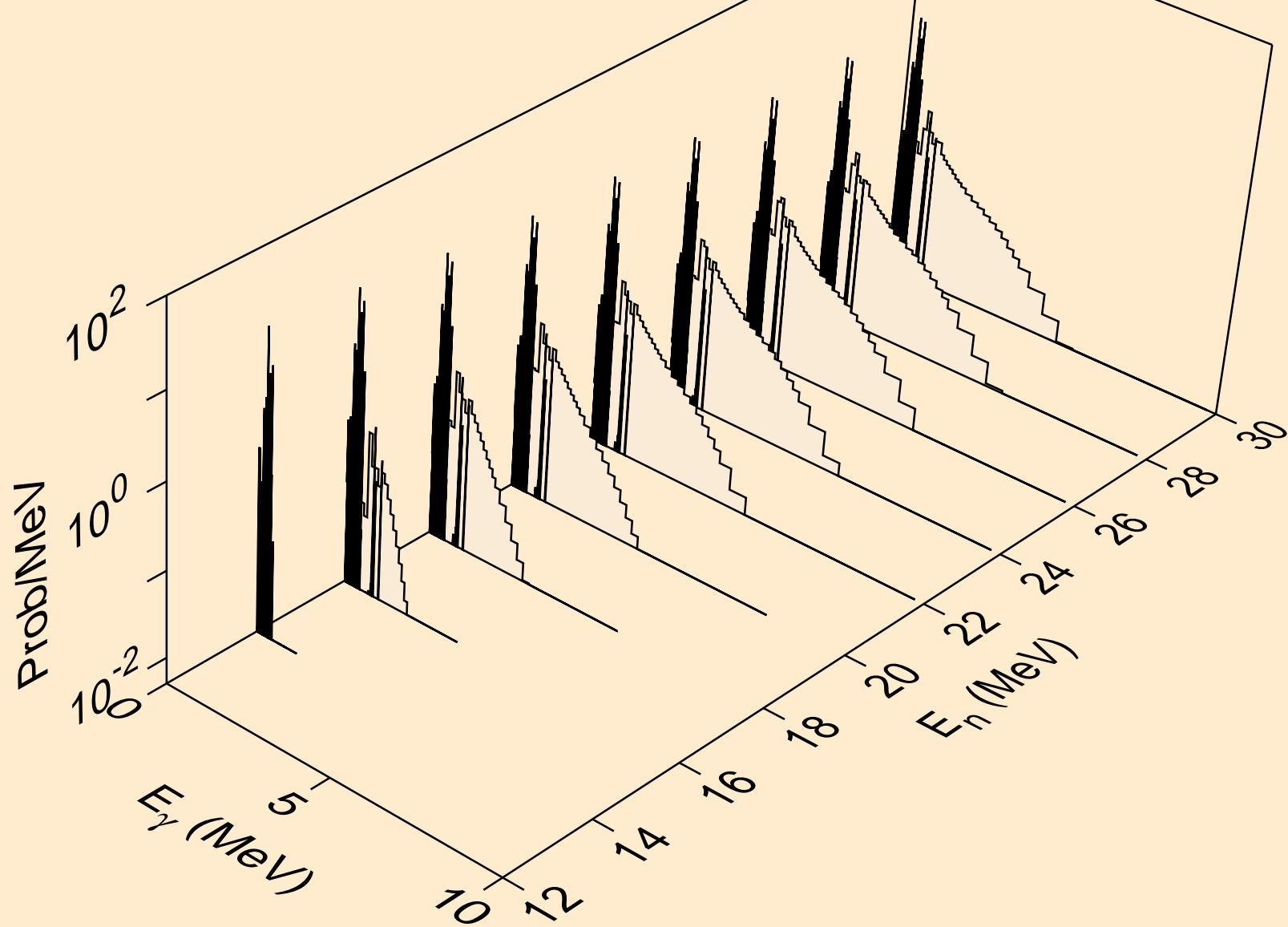

RB090M NEUTRON ACER TENDL-2024 LIBRARY; T=0.K
Photon emission for (n,n*)a

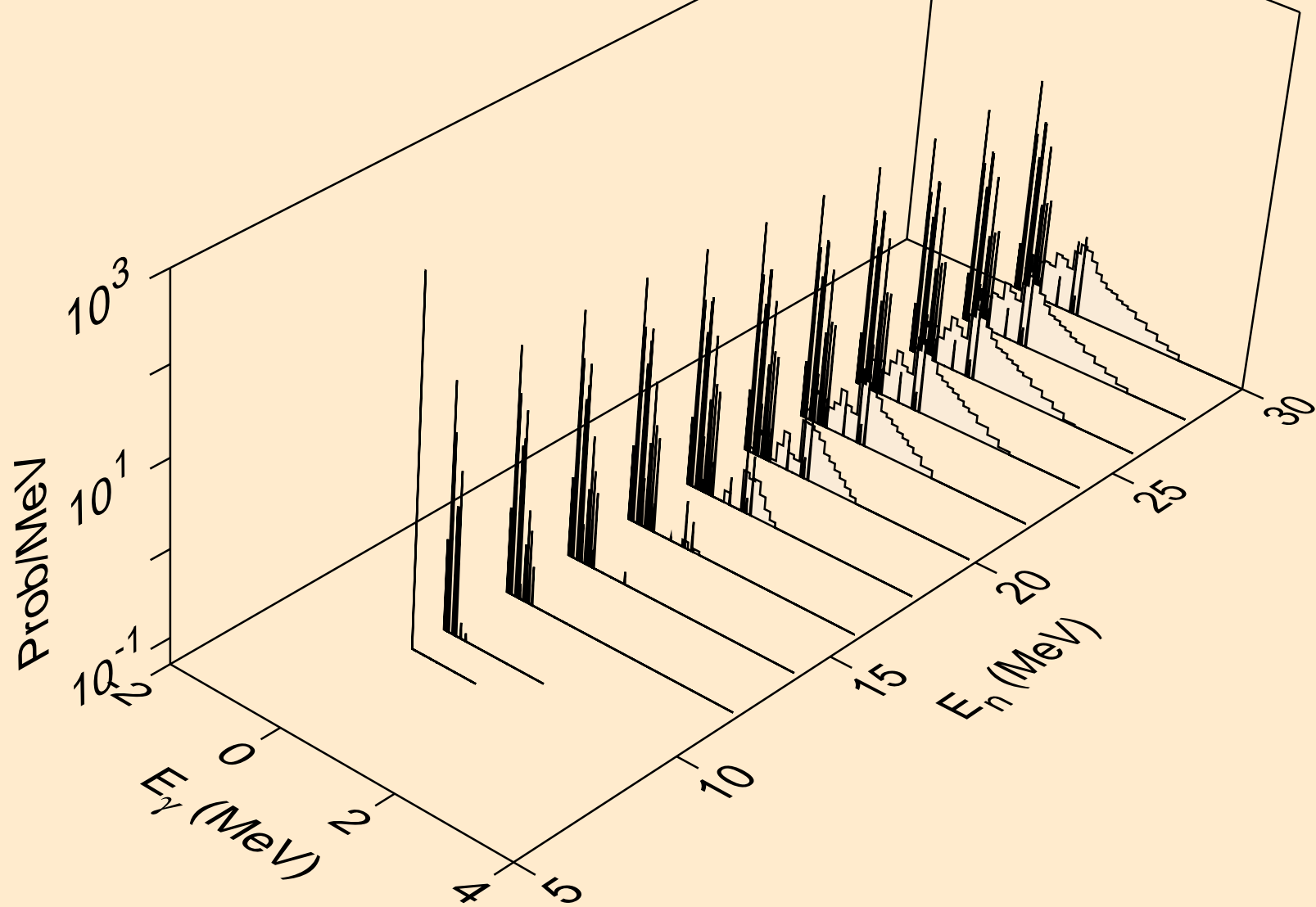

RB090M NEUTRON ACER TENDL-2024 LIBRARY; T=0.K
Photon emission for (n,2n)a

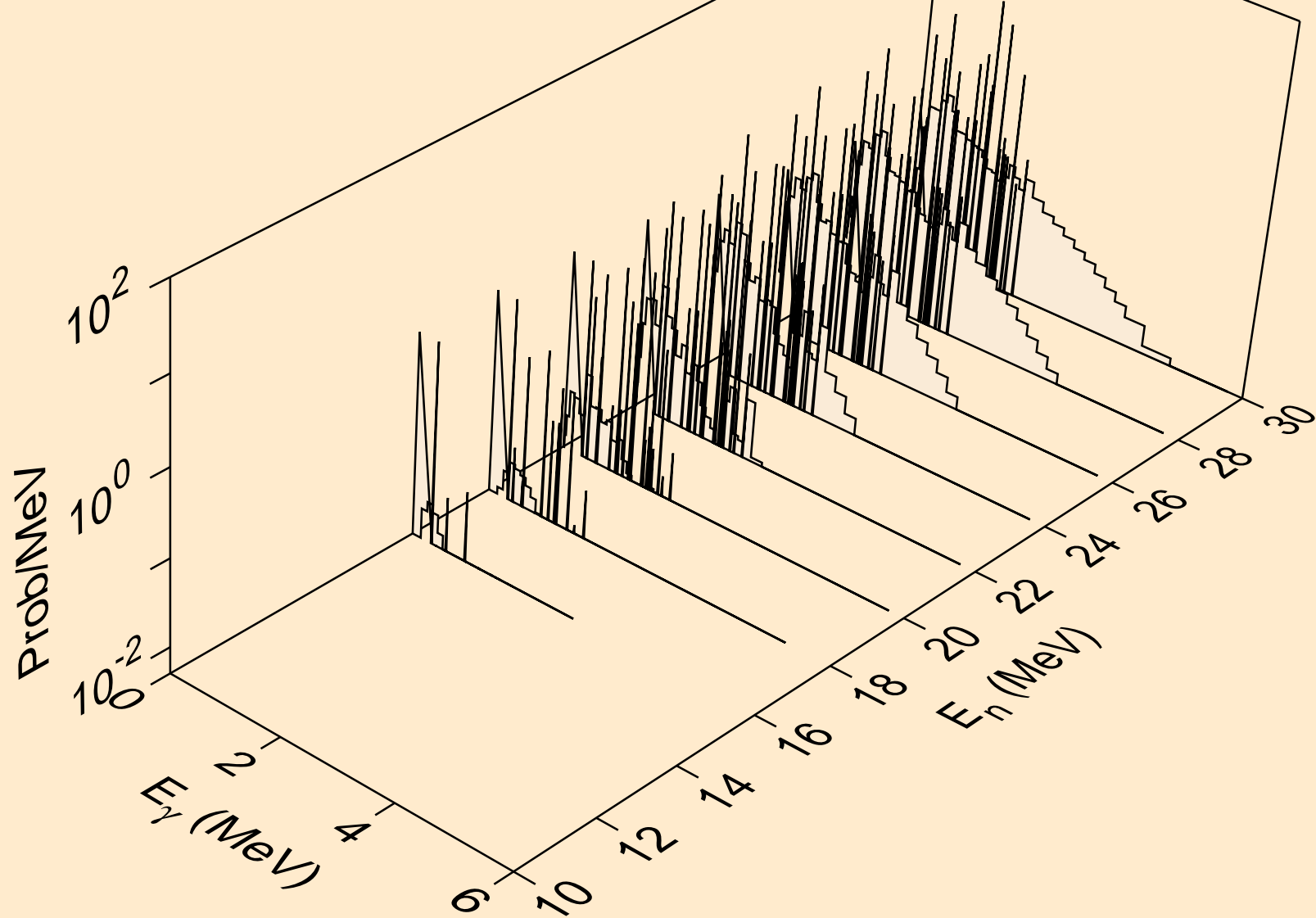

RB090M NEUTRON ACER TENDL-2024 LIBRARY; T=0.K
Photon emission for (n,3n)a

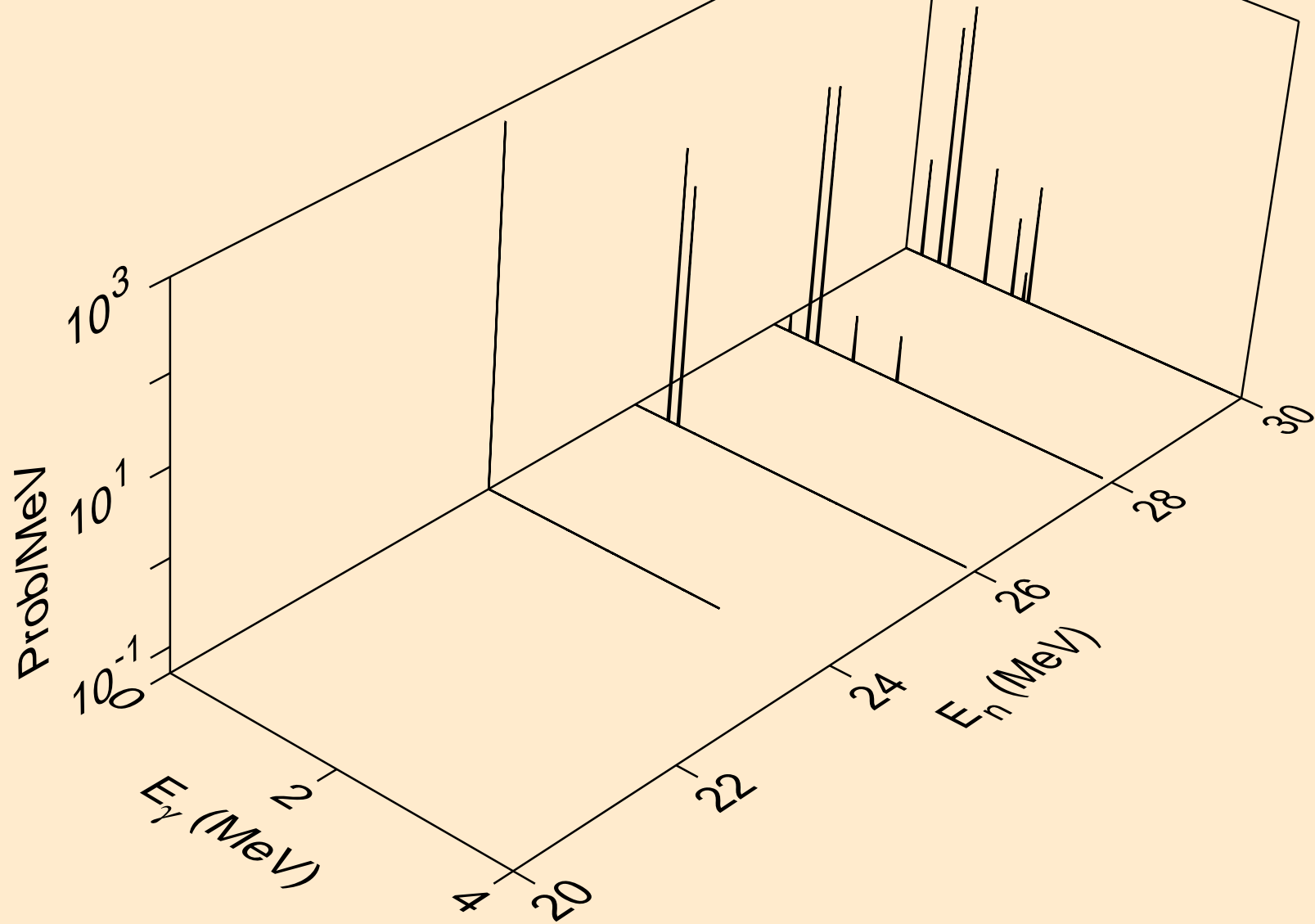

RB090M NEUTRON ACER TENDL-2024 LIBRARY; T=0.K
Photon emission for (n,n*)p

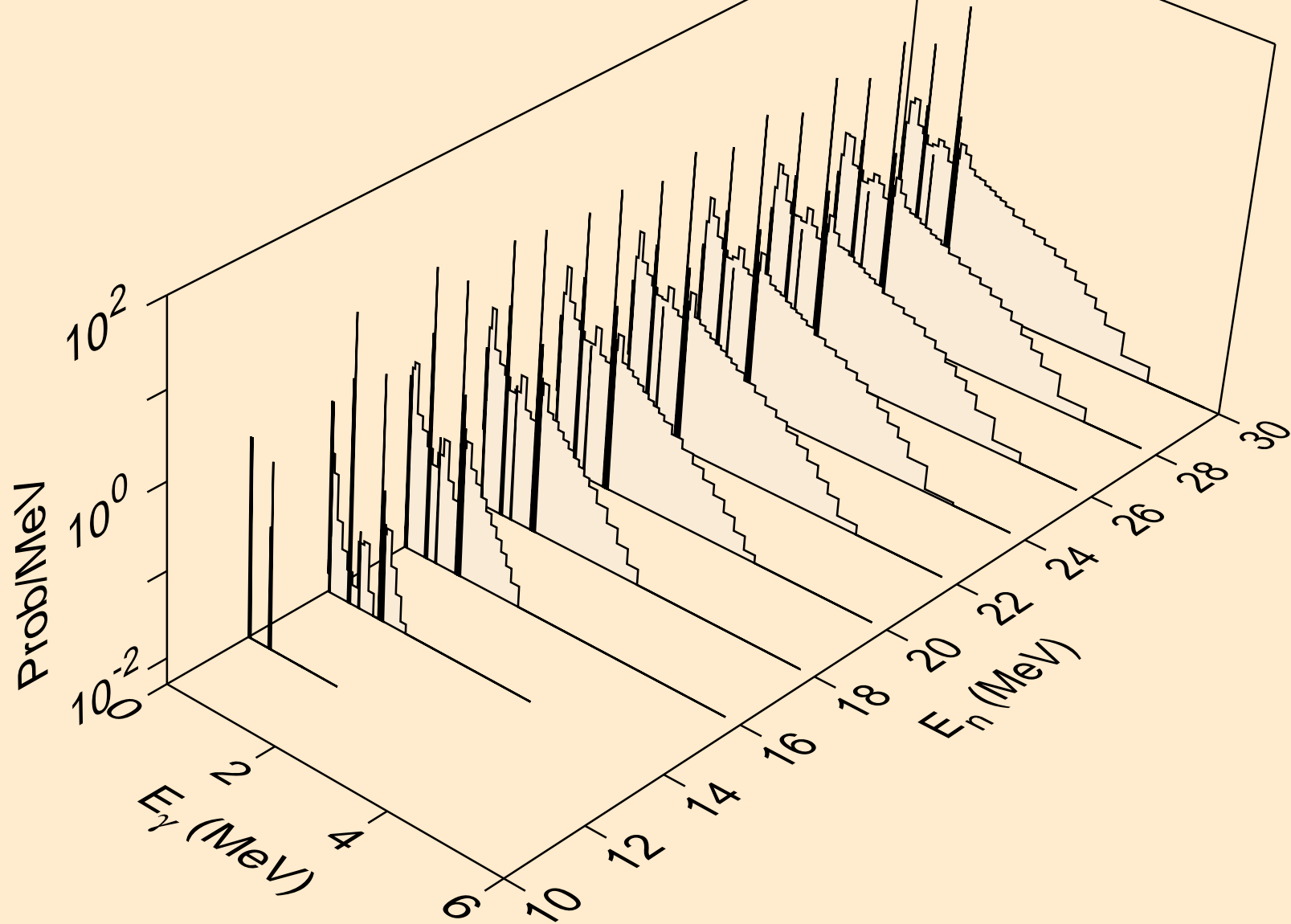

RB090M NEUTRON ACER TENDL-2024 LIBRARY; T=0.K
Photon emission for (n,n*)d

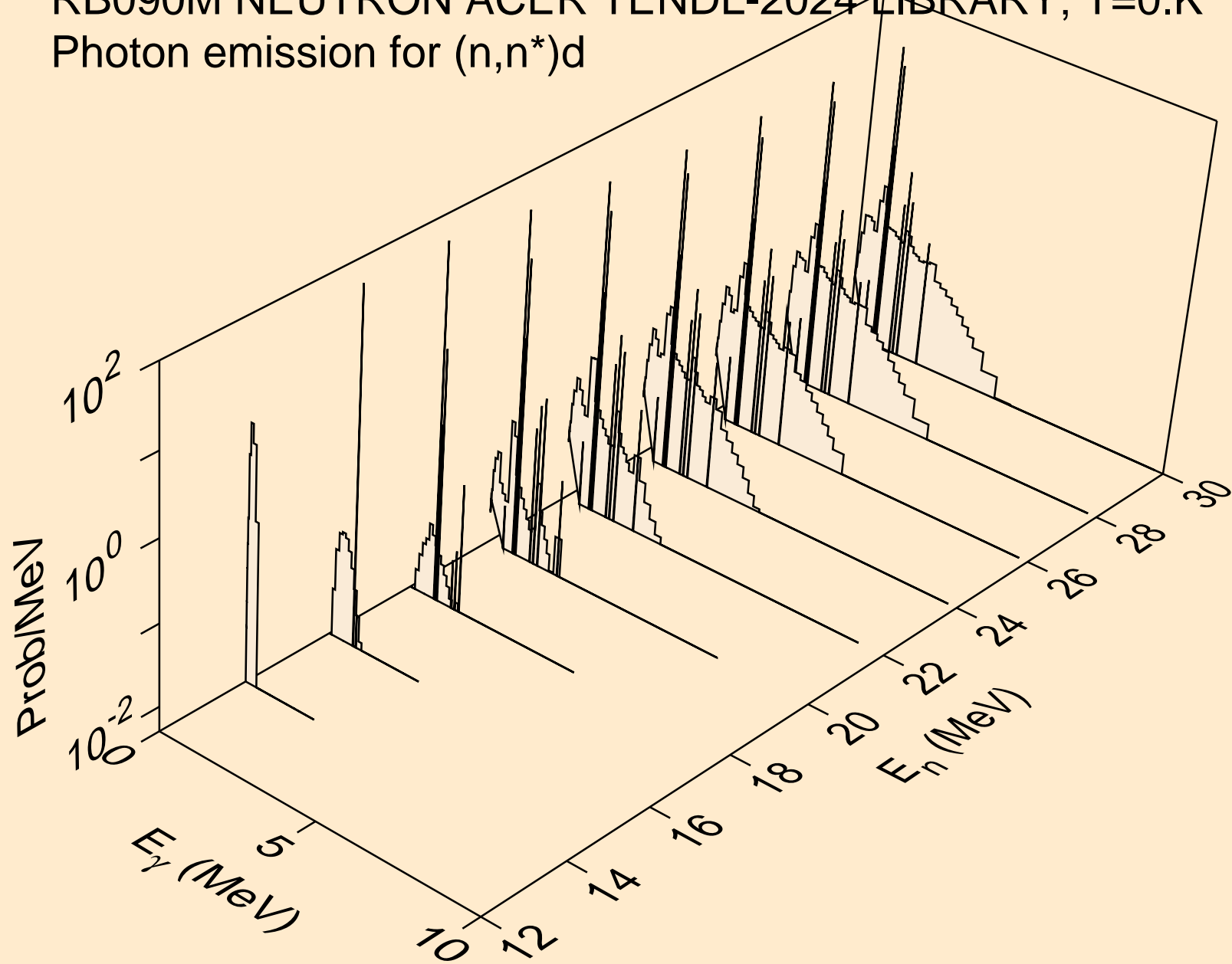

RB090M NEUTRON ACER TENDL-2024 LIBRARY; T=0.K
Photon emission for (n,n*)t

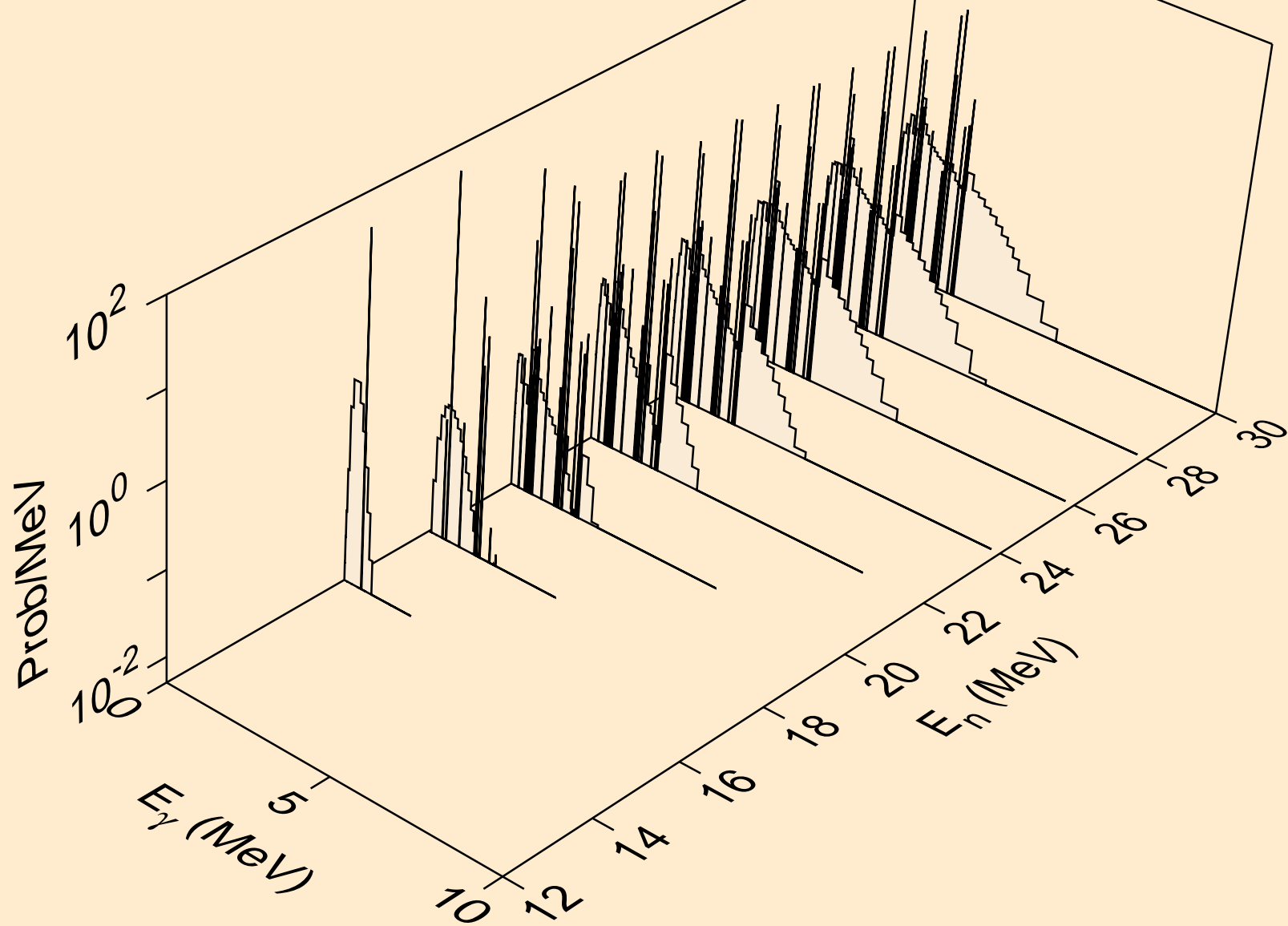

RB090M NEUTRON ACER TENDL-2024 LIBRARY; T=0.K
Photon emission for (n,n*)he3

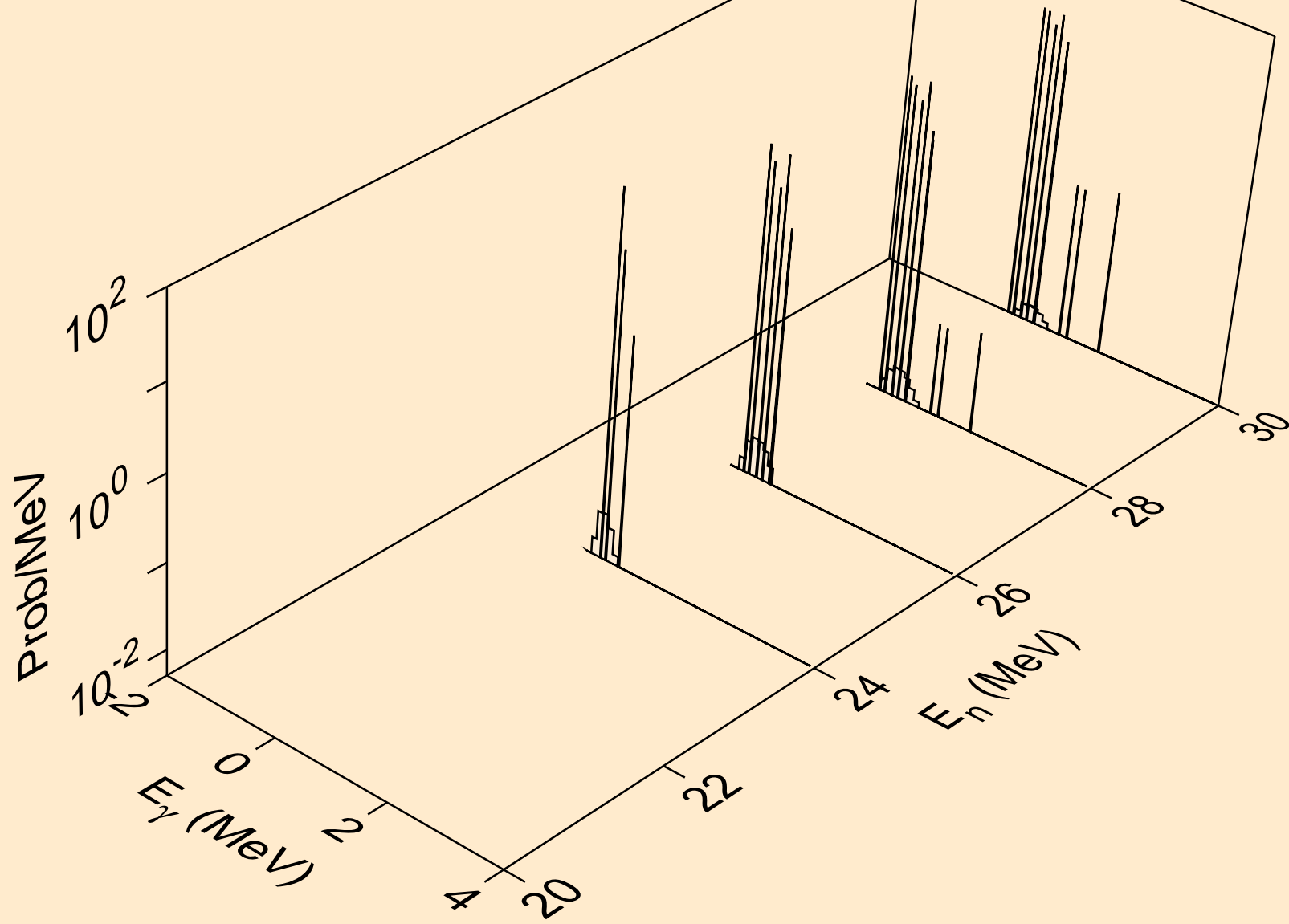

RB090M NEUTRON ACER TENDL-2024 LIBRARY; T=0.K
Photon emission for (n,4n)

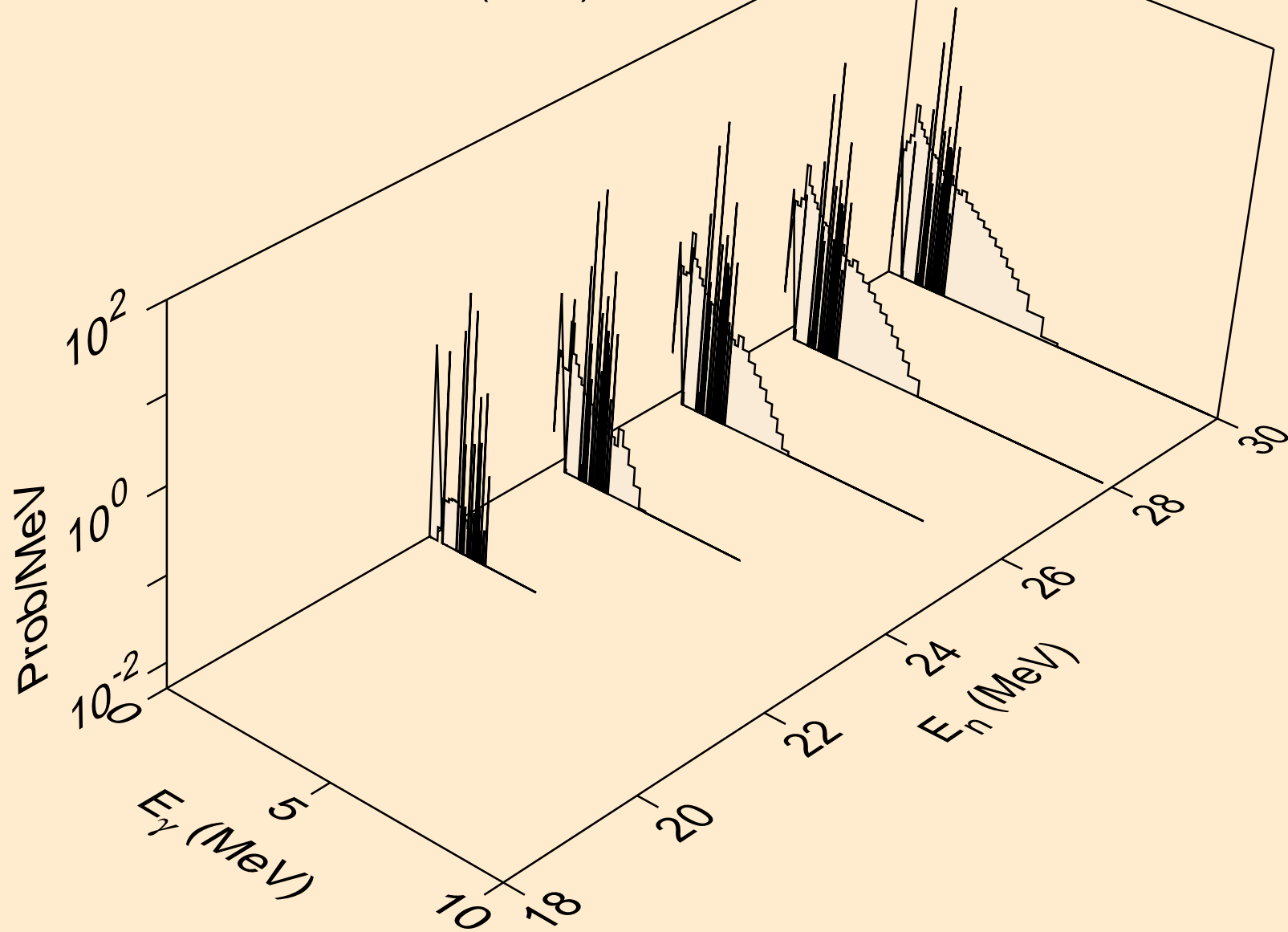

RB090M NEUTRON ACER TENDL-2024 LIBRARY; T=0.K
Photon emission for (n,2np)

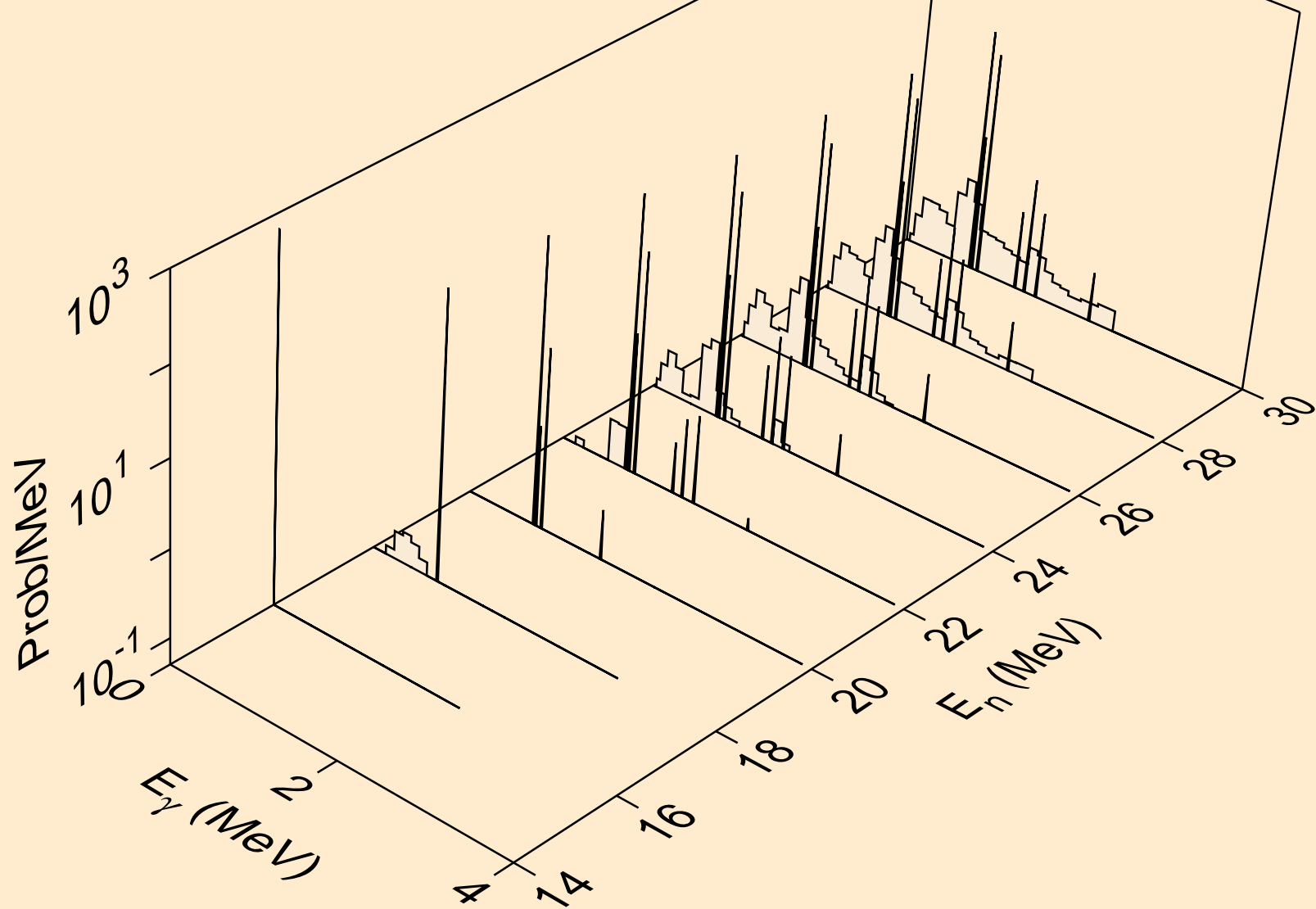

RB090M NEUTRON ACER TENDL-2024 LIBRARY; T=0.K
Photon emission for (n,3np)

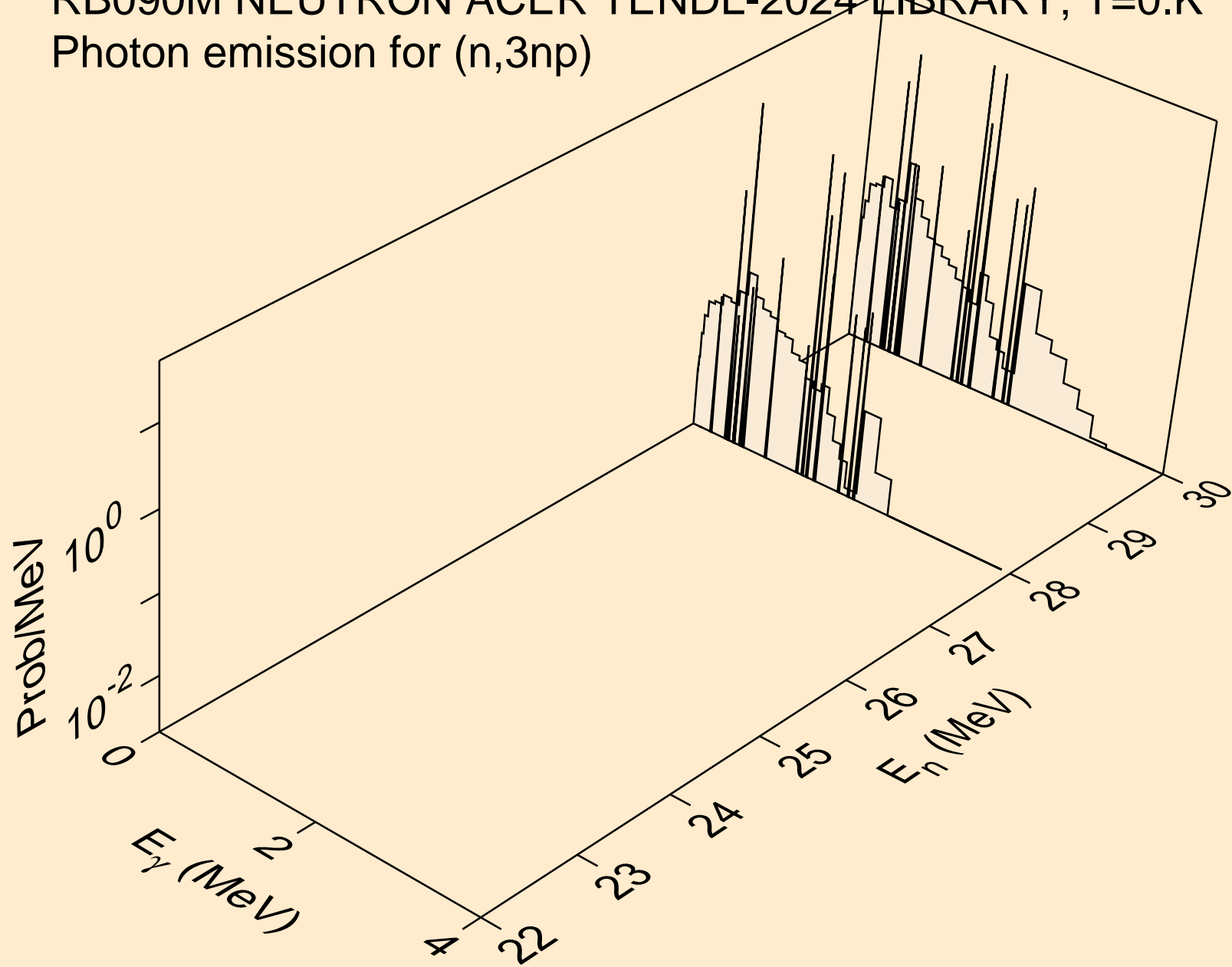

RB090M NEUTRON ACER TENDL-2024 LIBRARY; T=0.K
Photon emission for (n,n*2)

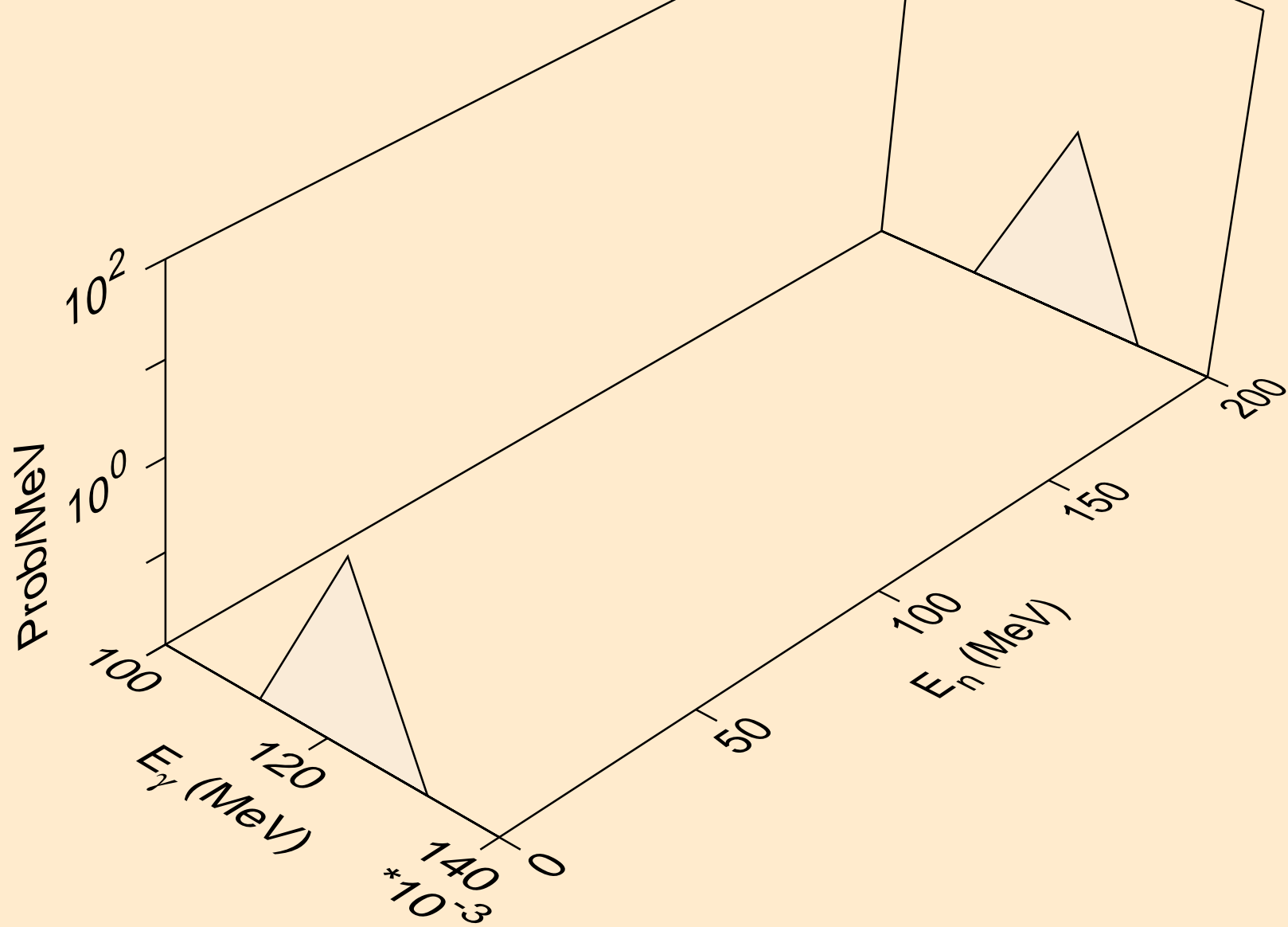

RB090M NEUTRON ACER TENDL-2024 LIBRARY; T=0.K
Photon emission for (n,n*3)

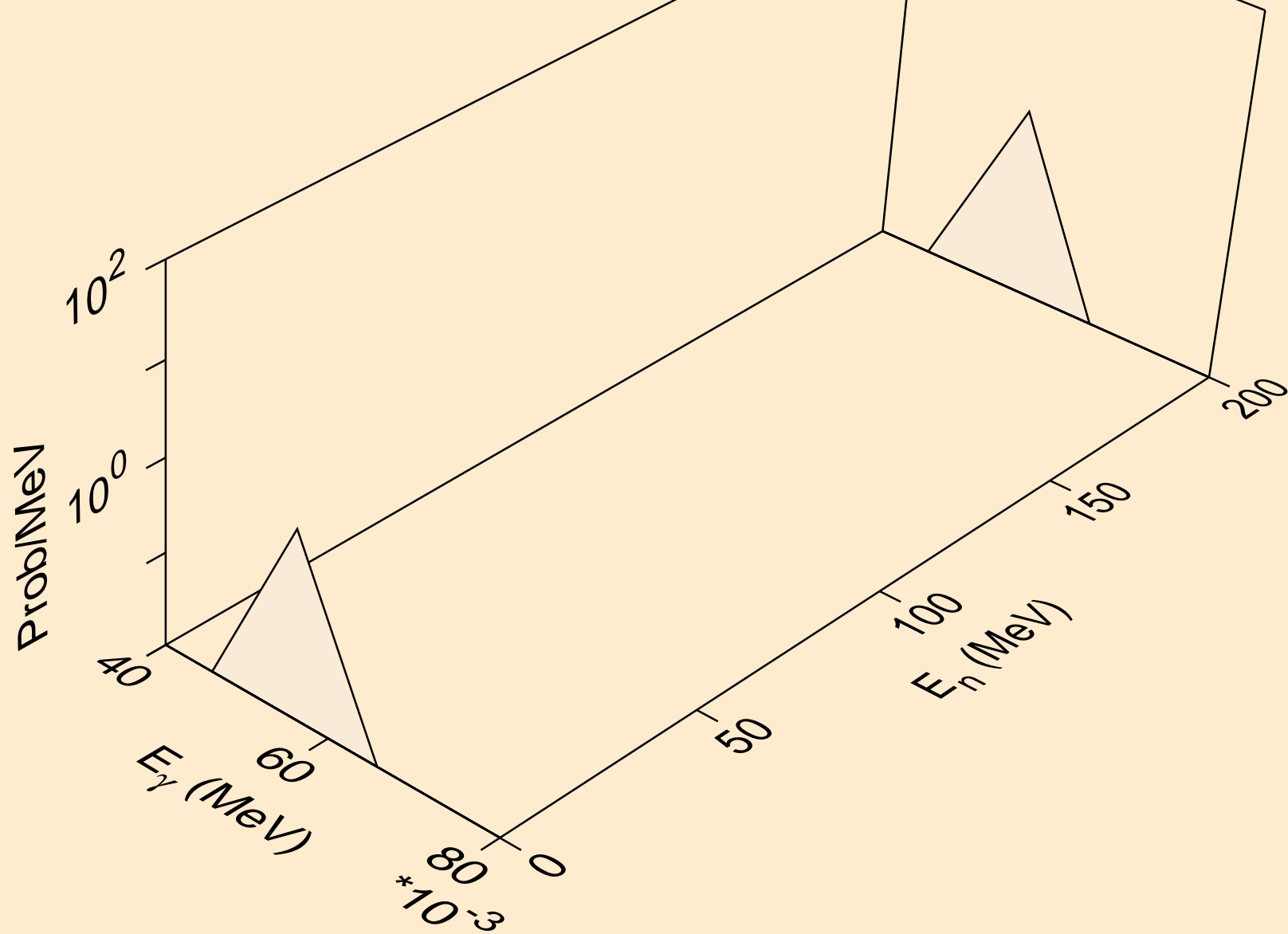

RB090M NEUTRON ACER TENDL-2024 LIBRARY; T=0.K
Photon emission for (n,n*4)

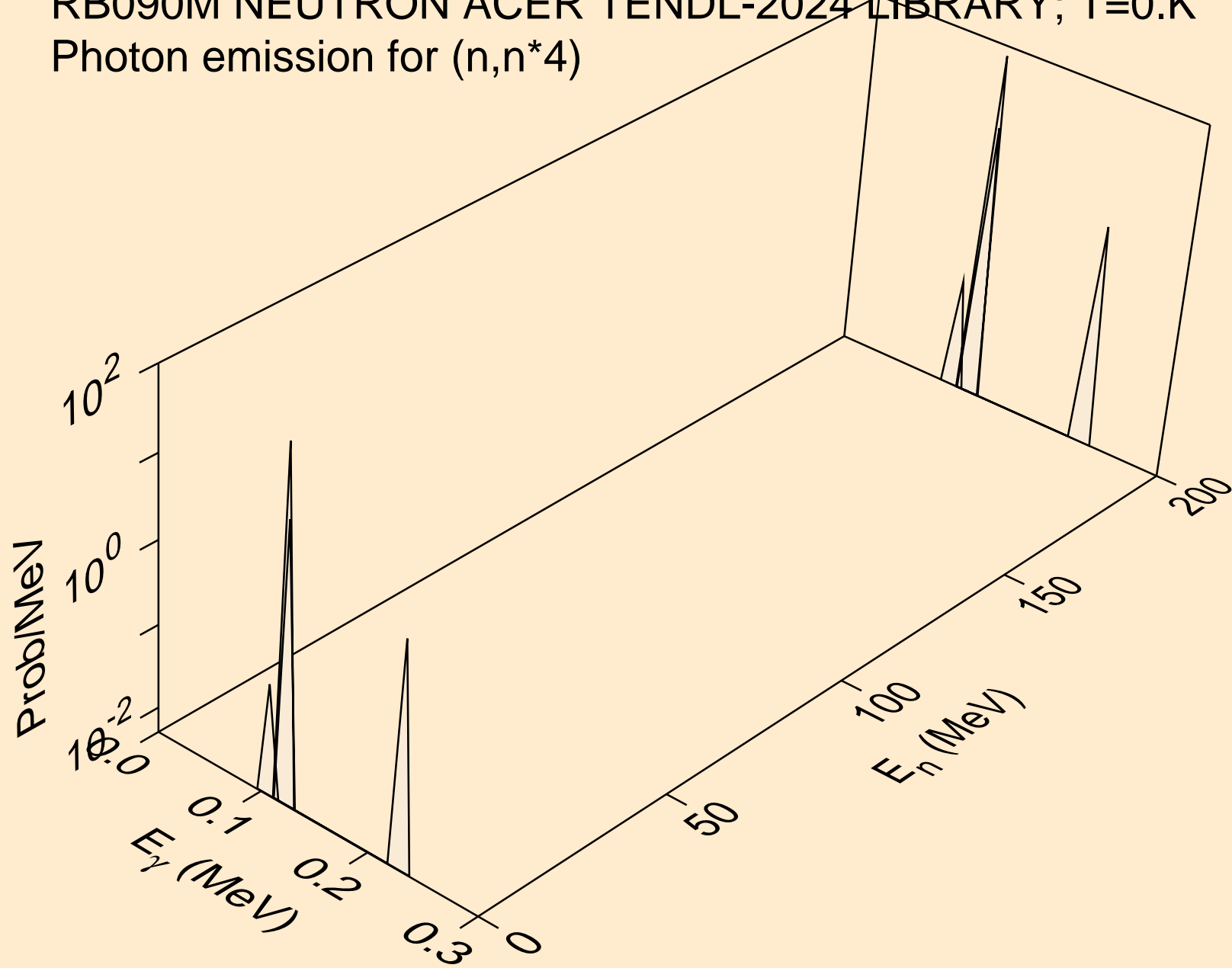

RB090M NEUTRON ACER TENDL-2024 LIBRARY; T=0.K
Photon emission for (n,n*5)

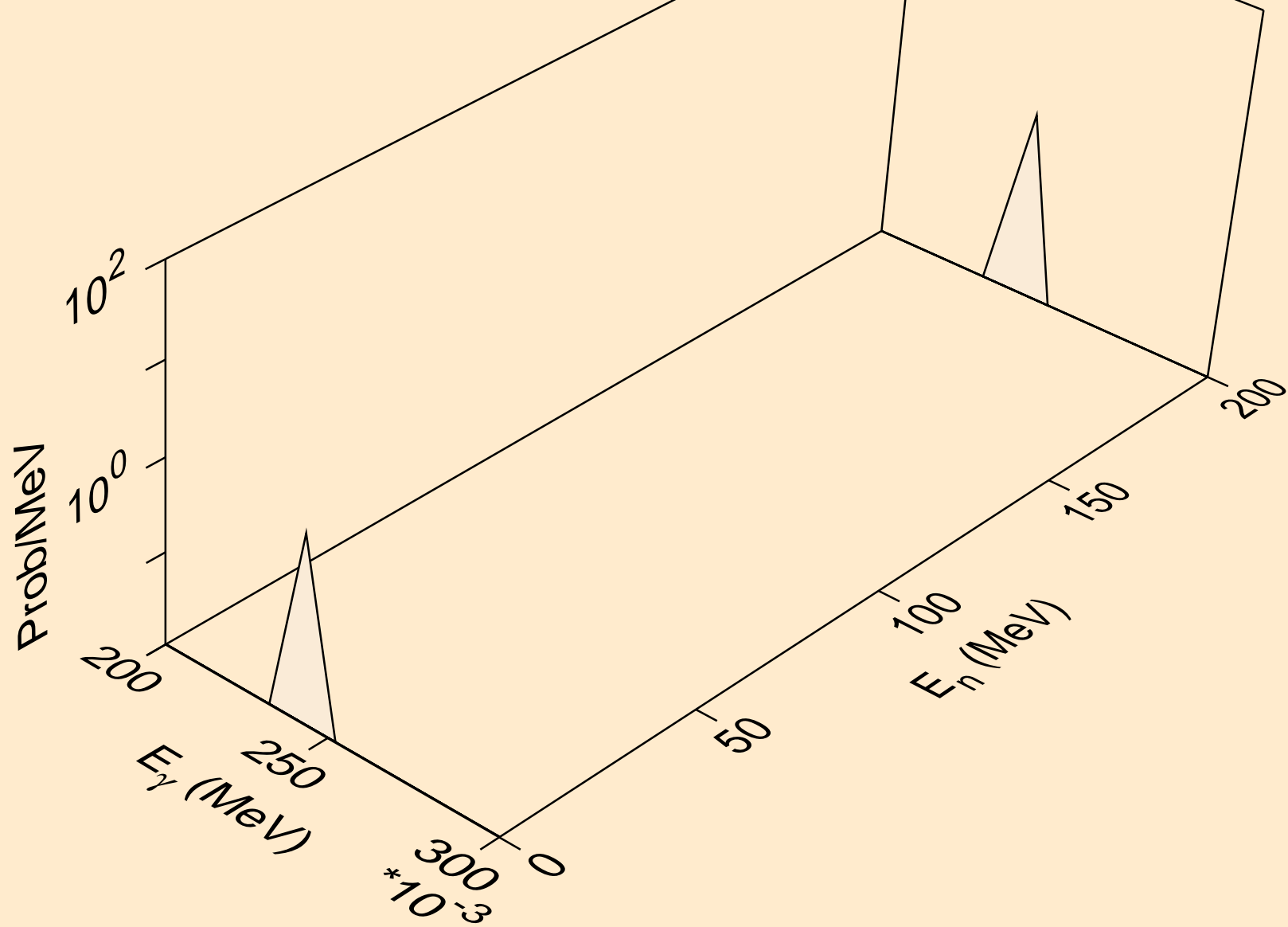

RB090M NEUTRON ACER TENDL-2024 LIBRARY; T=0.K
Photon emission for (n,n*6)

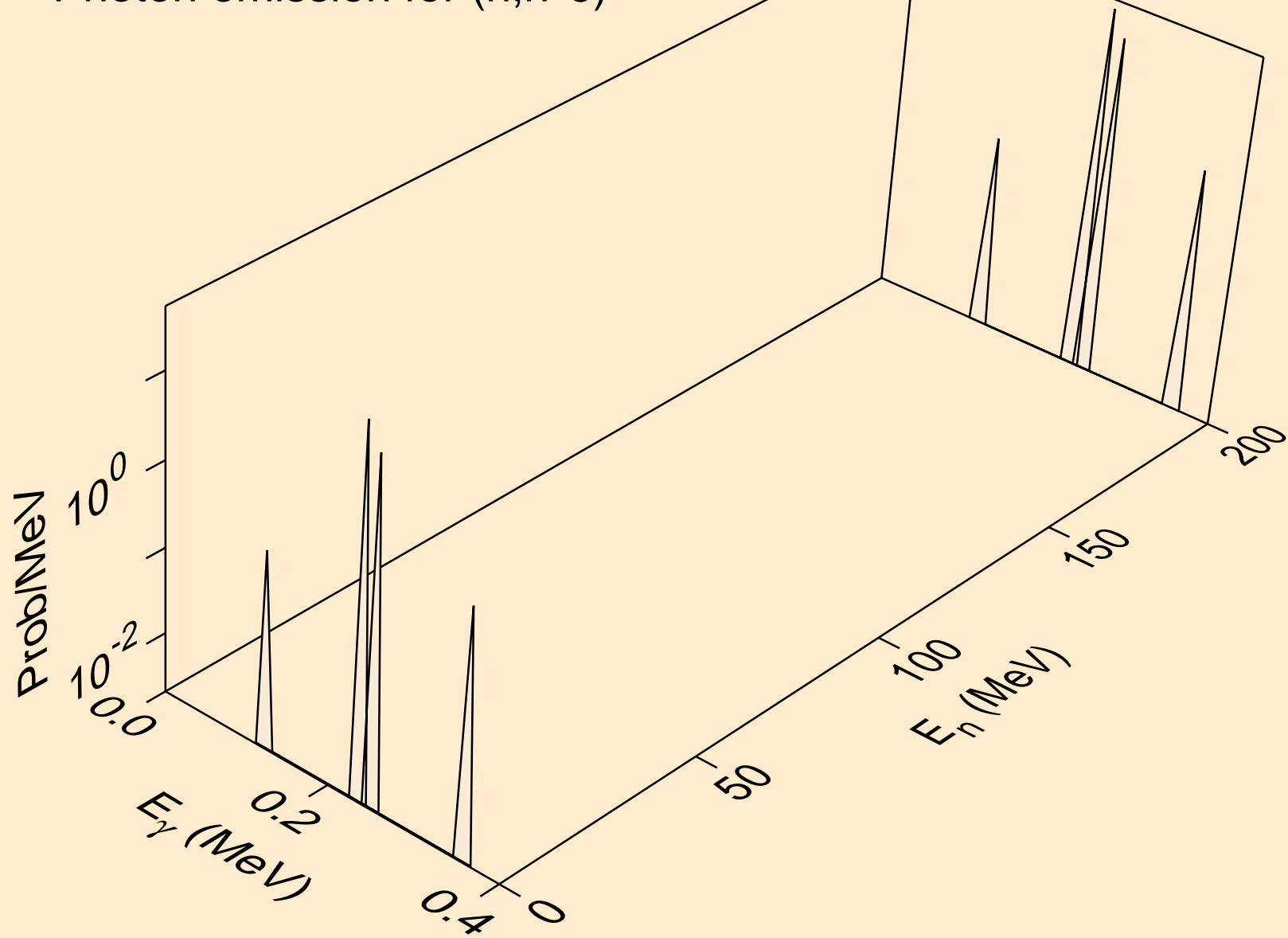

RB090M NEUTRON ACER TENDL-2024 LIBRARY; T=0.K
Photon emission for (n,n*7)

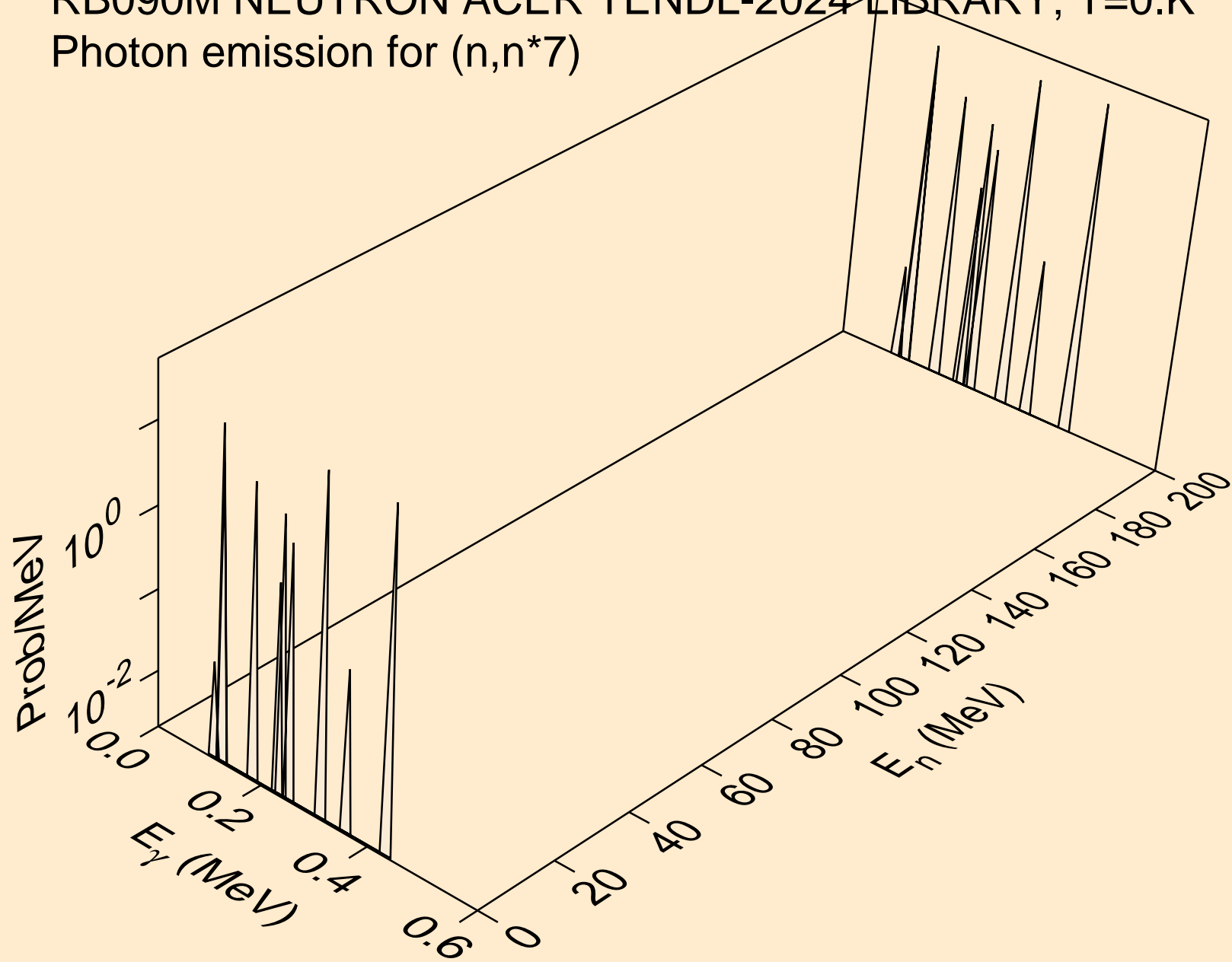

RB090M NEUTRON ACER TENDL-2024 LIBRARY; T=0.K
Photon emission for (n,n*8)

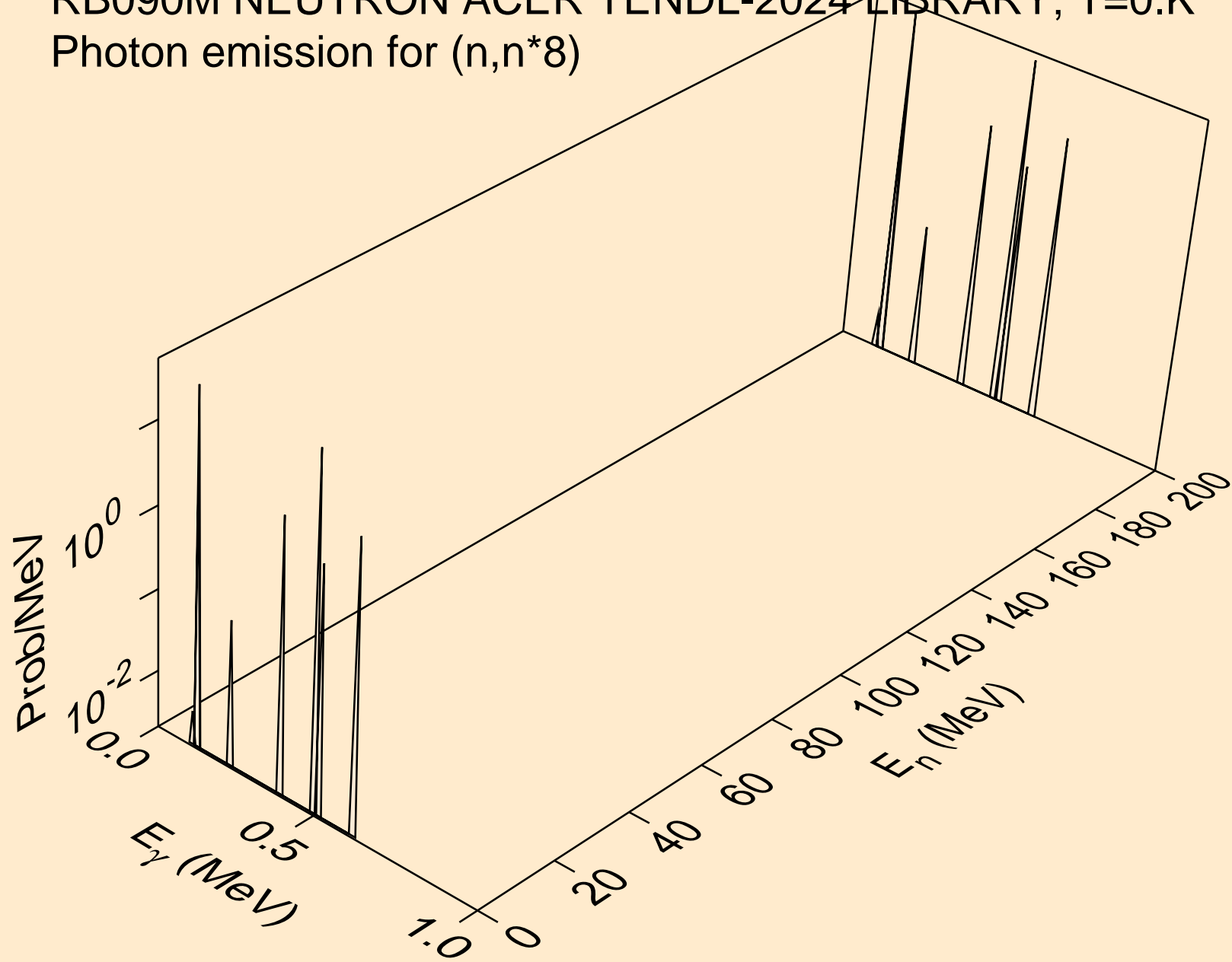

RB090M NEUTRON ACER TENDL-2024 LIBRARY; T=0.K
Photon emission for (n,n*9)

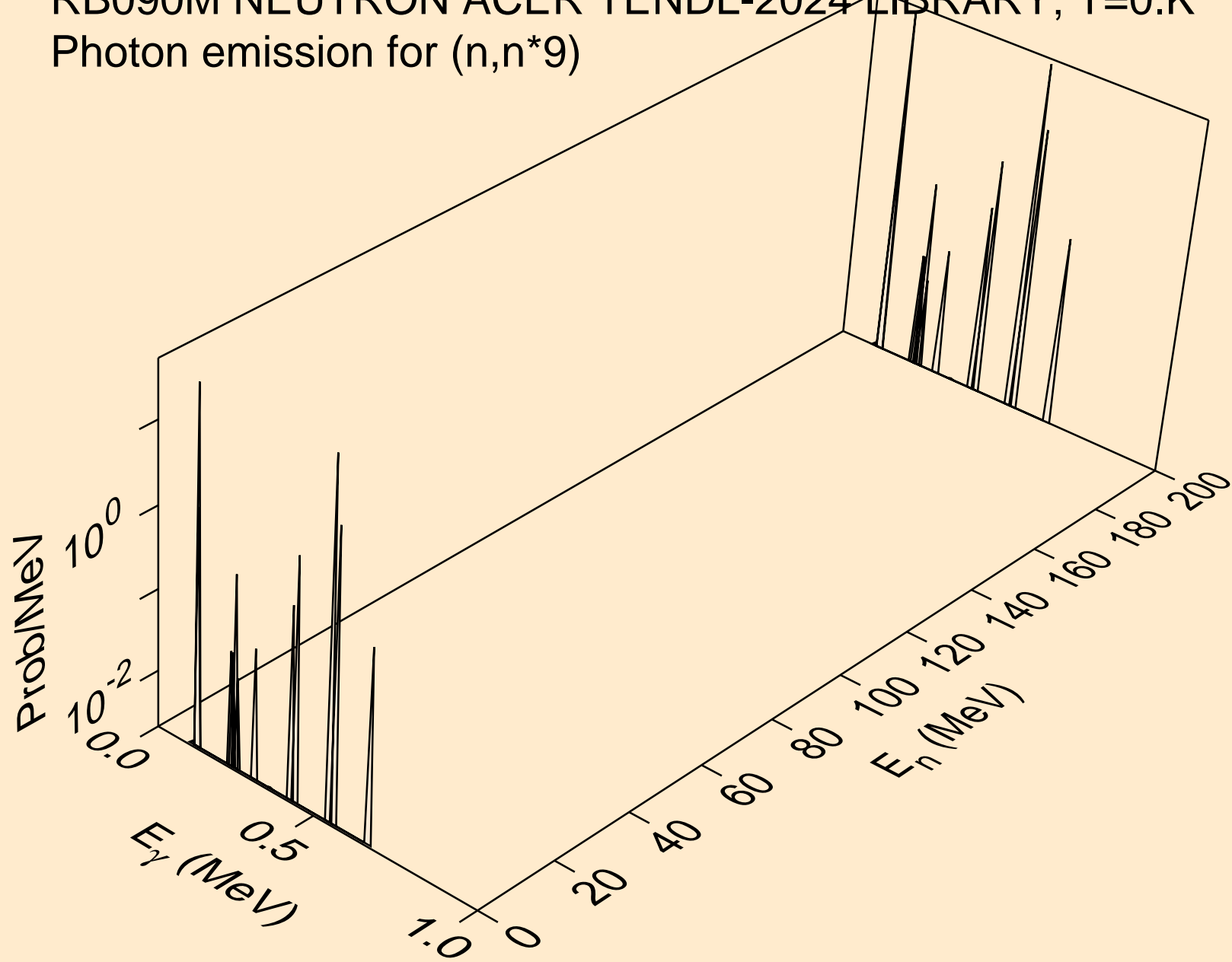

RB090M NEUTRON ACER TENDL-2024 LIBRARY; T=0.K
Photon emission for (n,n*10)

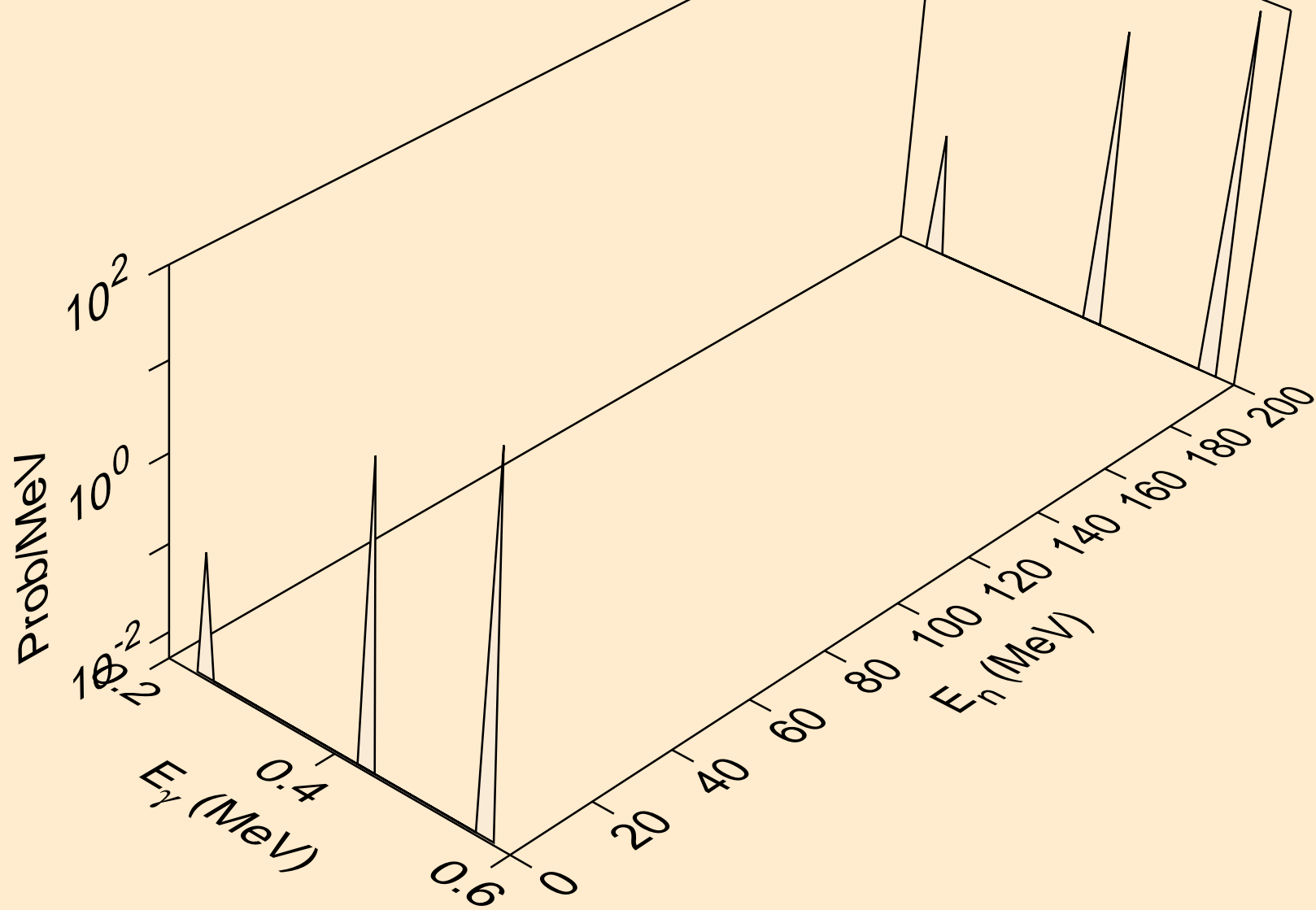

RB090M NEUTRON ACER TENDL-2024 LIBRARY; T=0.K
Photon emission for (n,n*11)

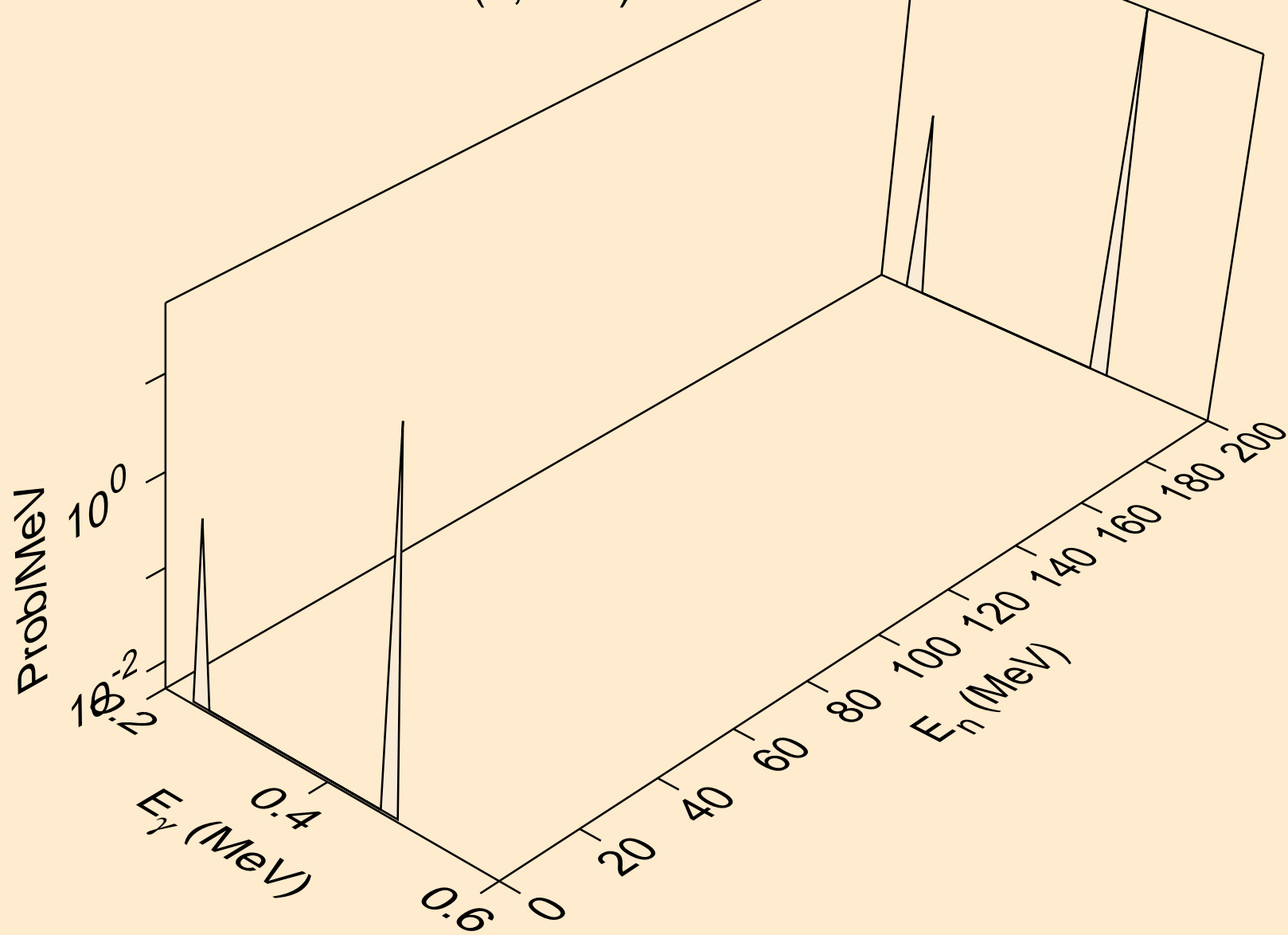

RB090M NEUTRON ACER TENDL-2024 LIBRARY; T=0.K
Photon emission for (n,n*12)

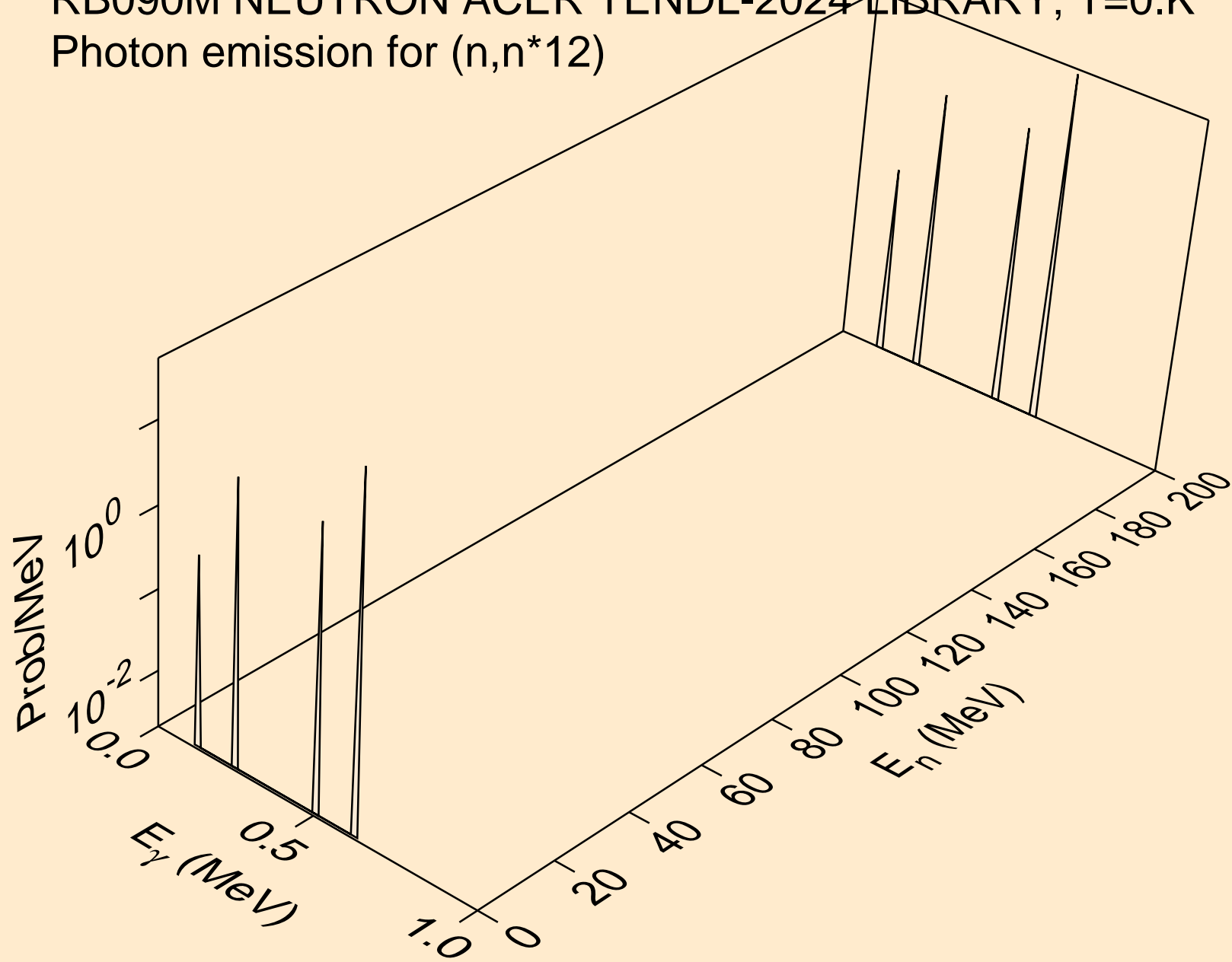

RB090M NEUTRON ACER TENDL-2024 LIBRARY; T=0.K
Photon emission for (n,n*13)

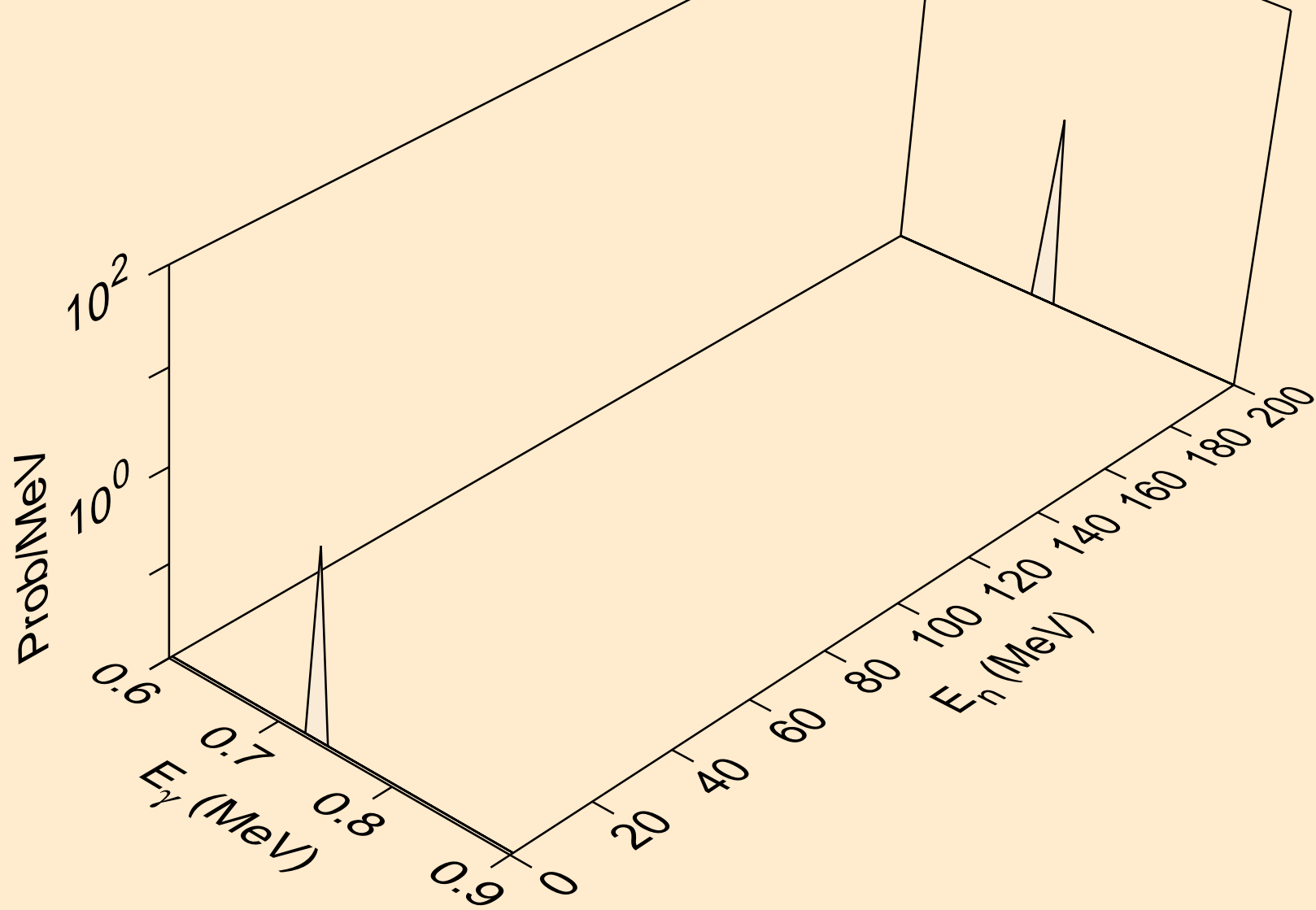

RB090M NEUTRON ACER TENDL-2024 LIBRARY; T=0.K
Photon emission for (n,n*14)

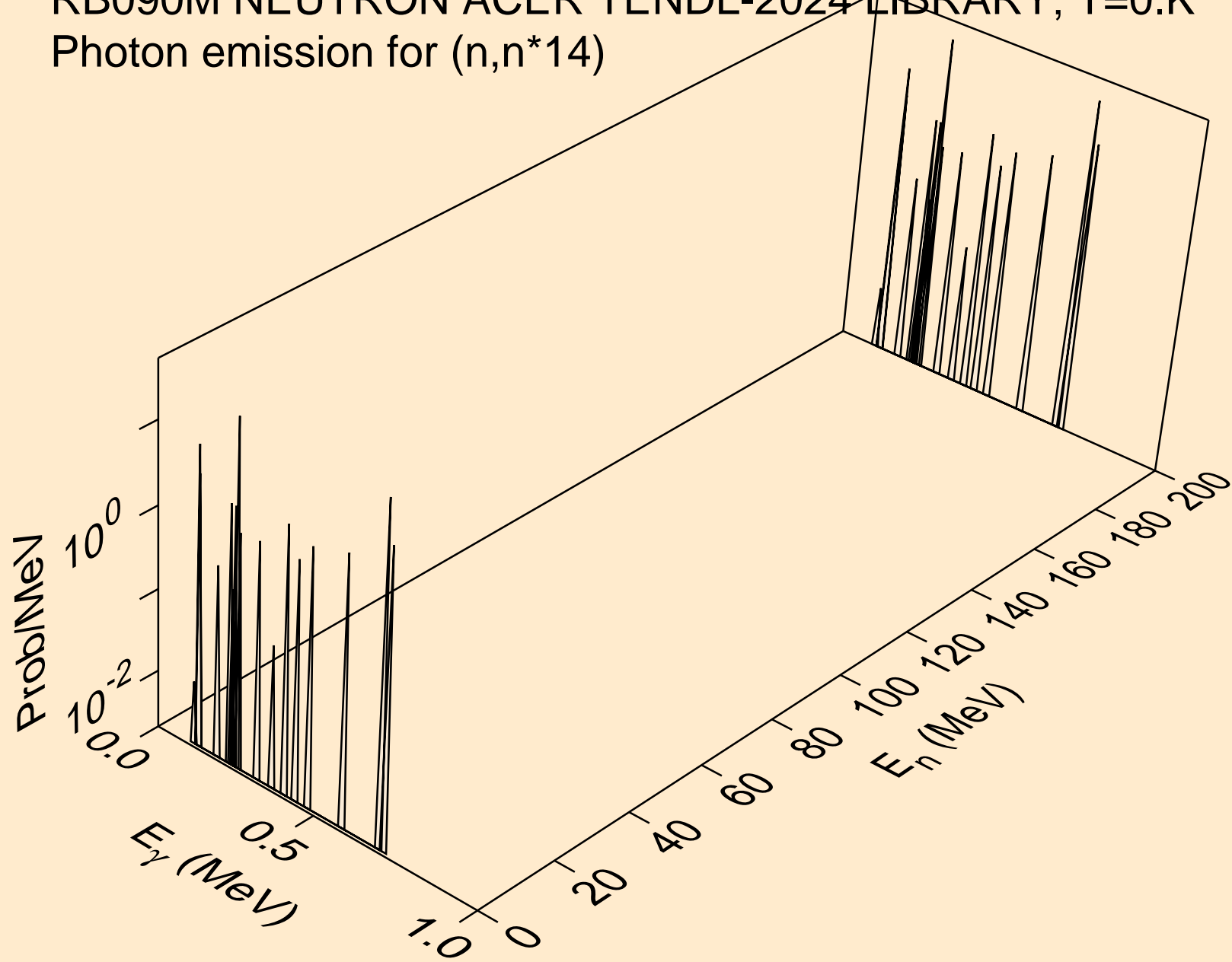

RB090M NEUTRON ACER TENDL-2024 LIBRARY; T=0.K
Photon emission for (n,n*15)

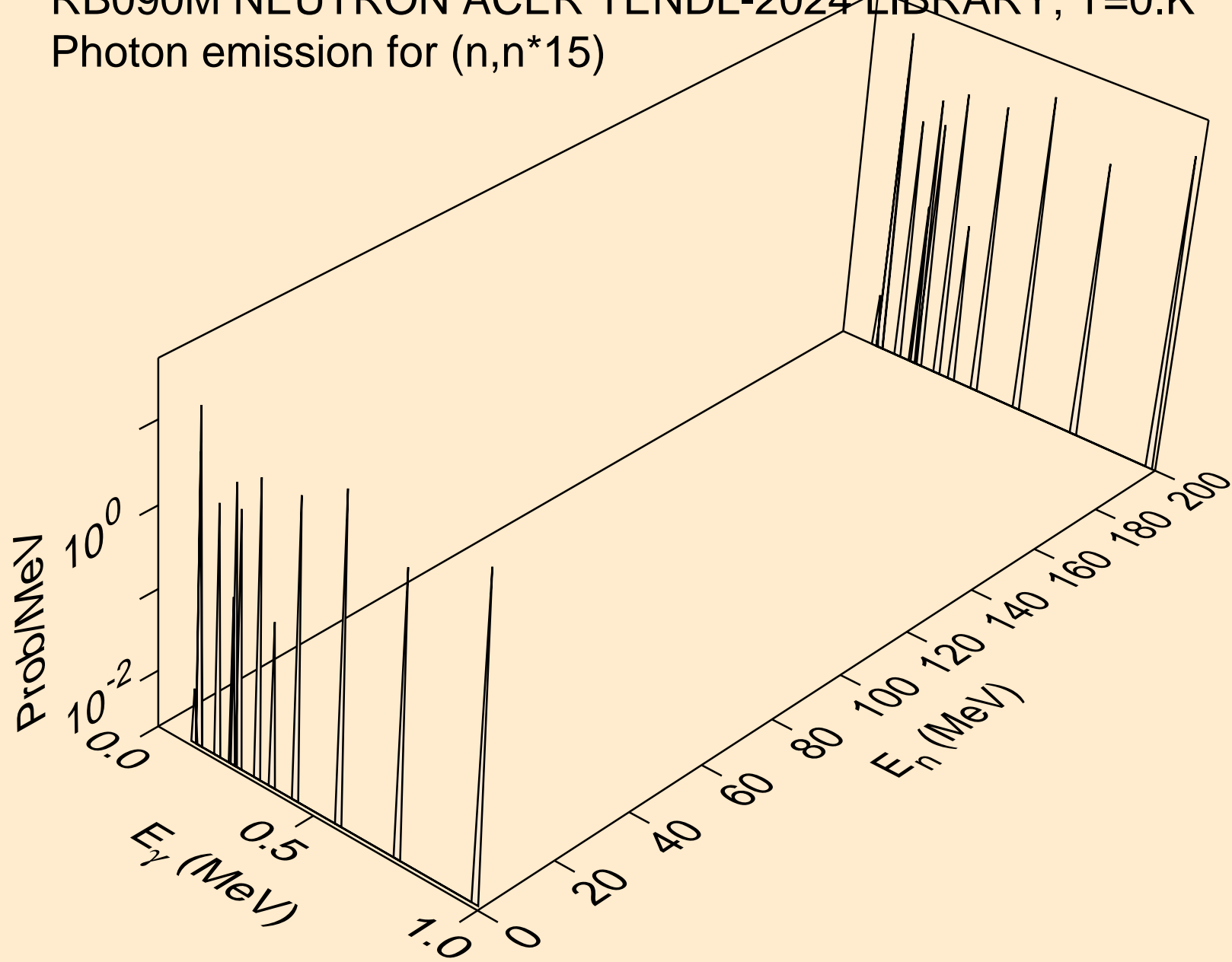

RB090M NEUTRON ACER TENDL-2024 LIBRARY; T=0.K
Photon emission for (n,n*16)

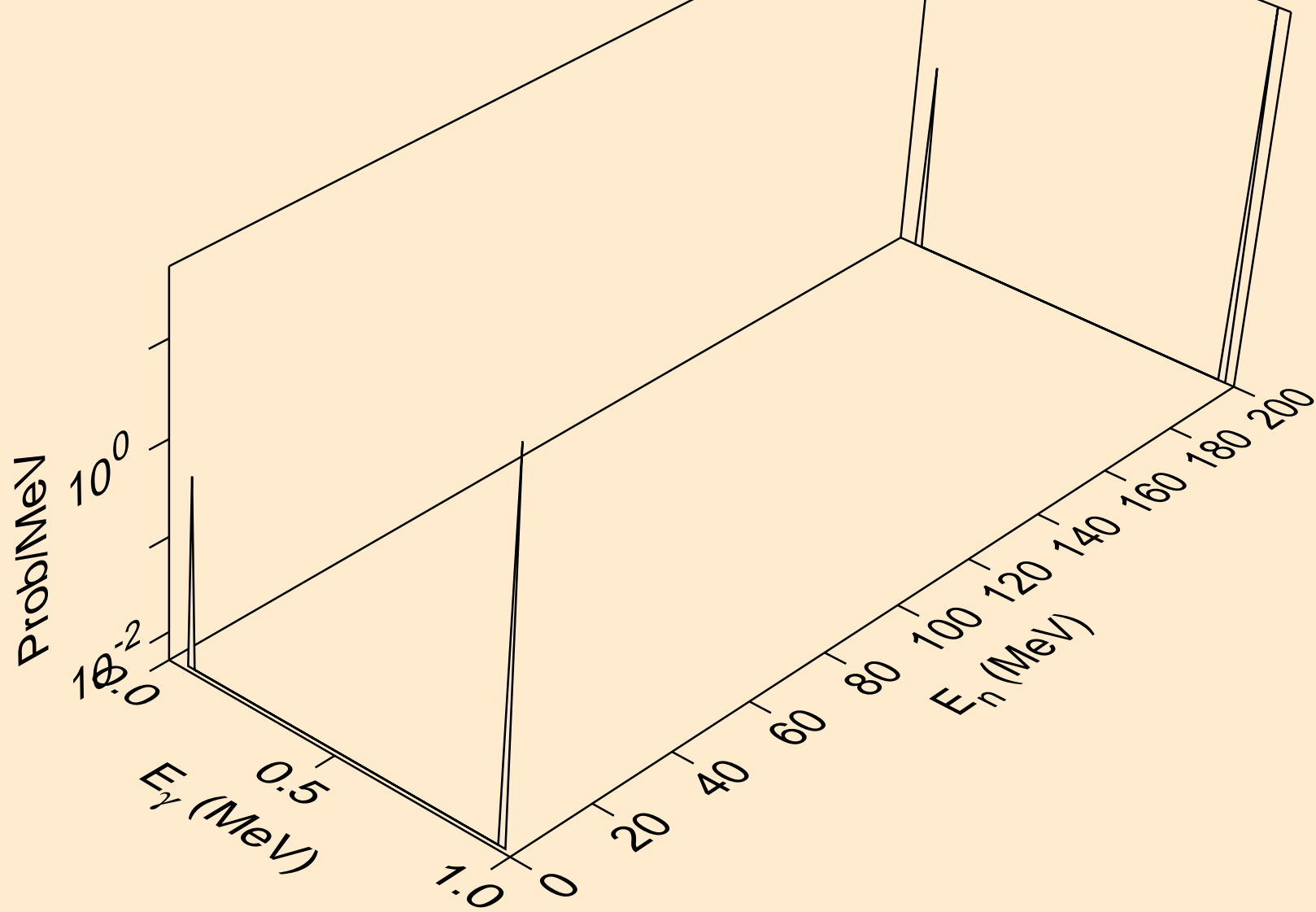

RB090M NEUTRON ACER TENDL-2024 LIBRARY; T=0.K
Photon emission for (n,n*17)

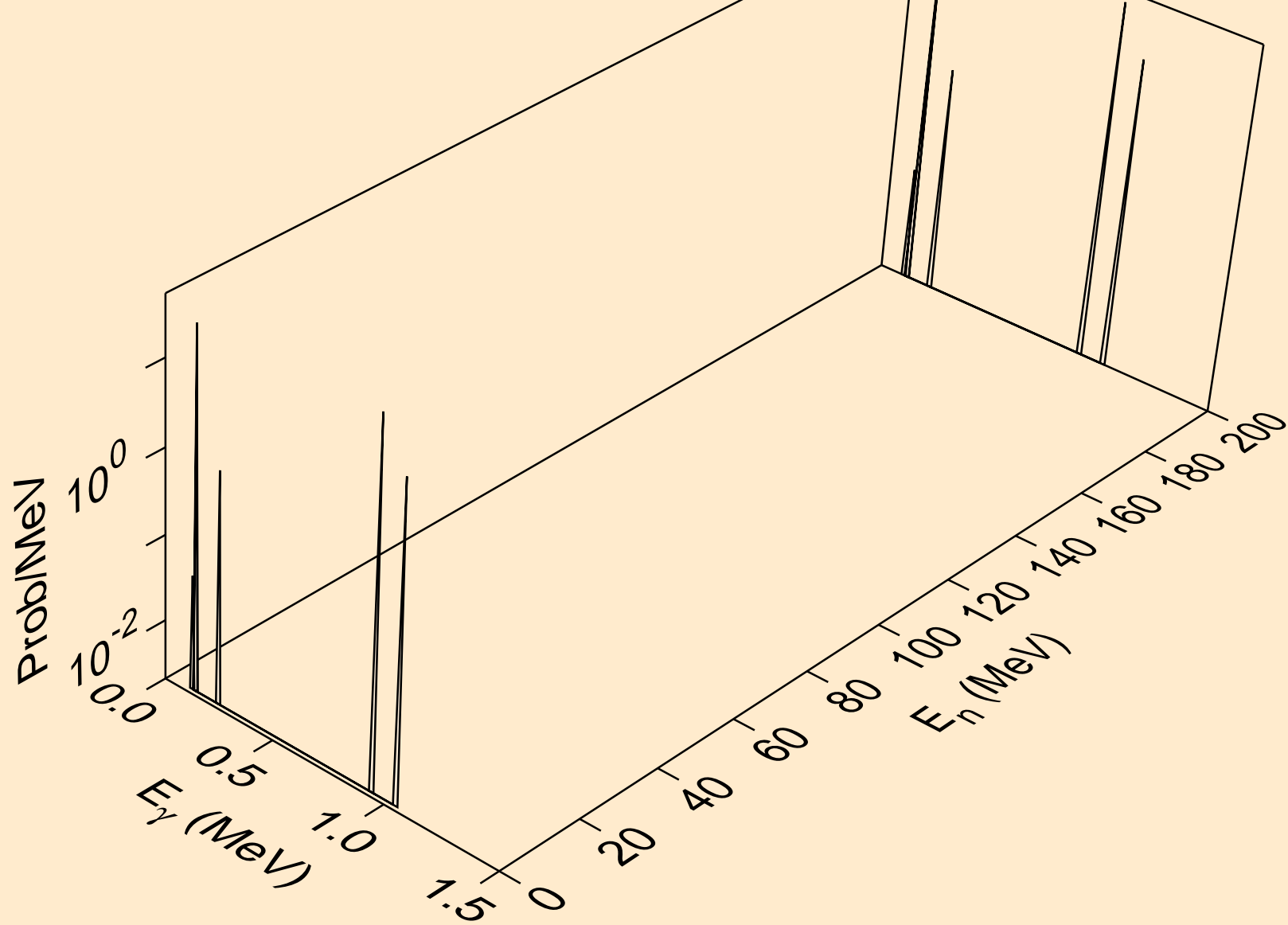

RB090M NEUTRON ACER TENDL-2024 LIBRARY; T=0.K
Photon emission for (n,n*18)

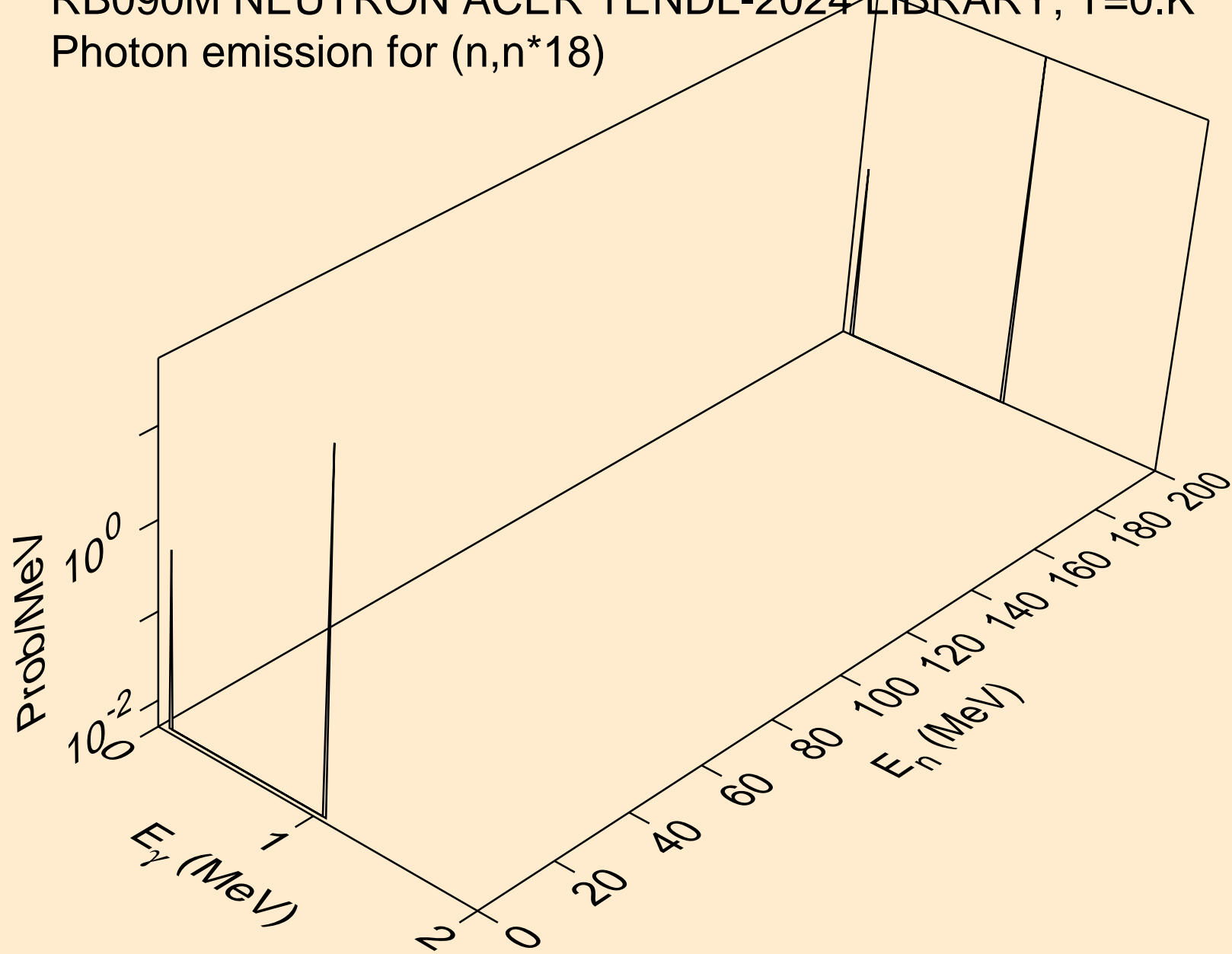

RB090M NEUTRON ACER TENDL-2024 LIBRARY; T=0.K
Photon emission for (n,n*19)

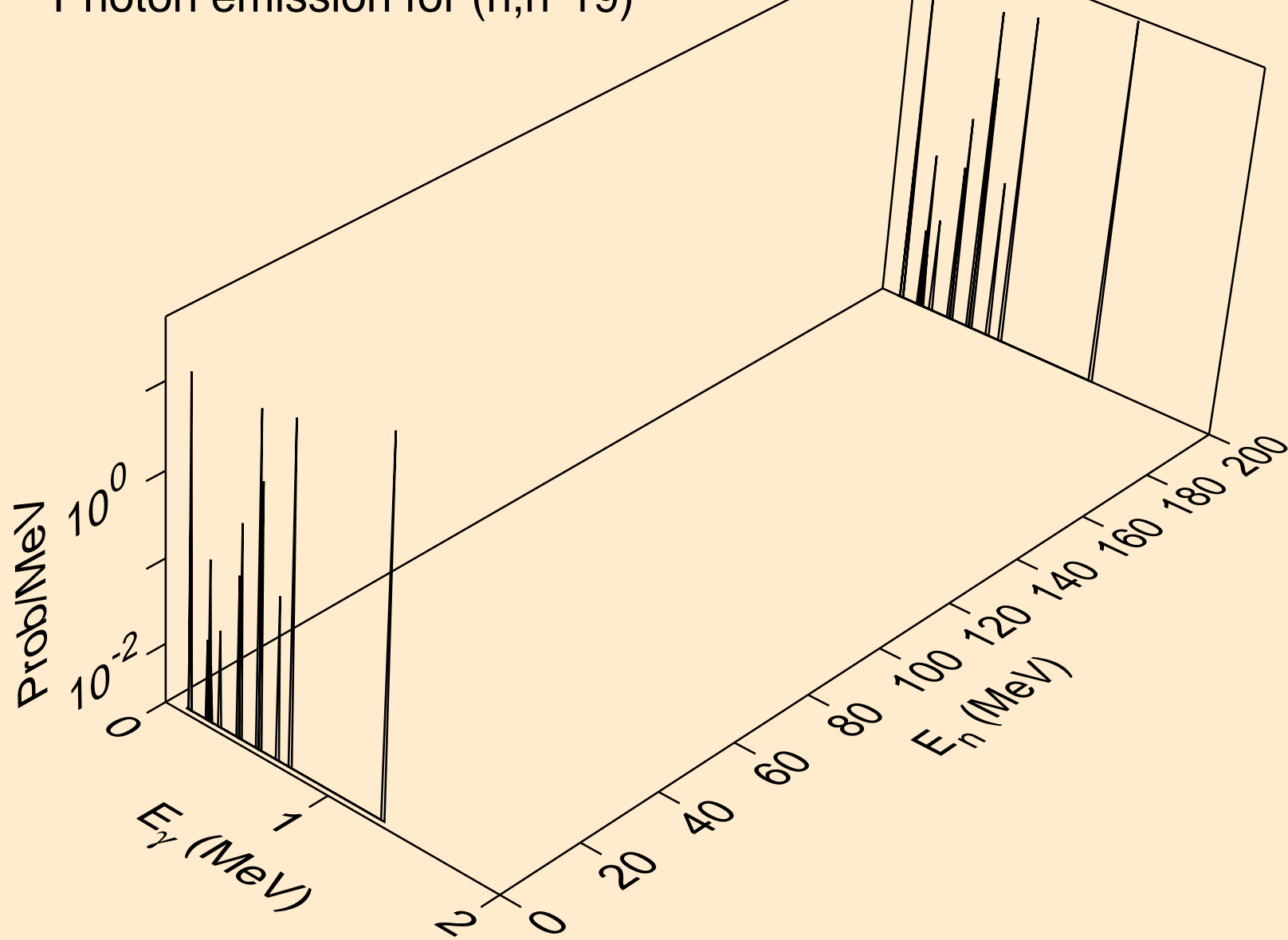

RB090M NEUTRON ACER TENDL-2024 LIBRARY; T=0.K
Photon emission for (n,n*20)

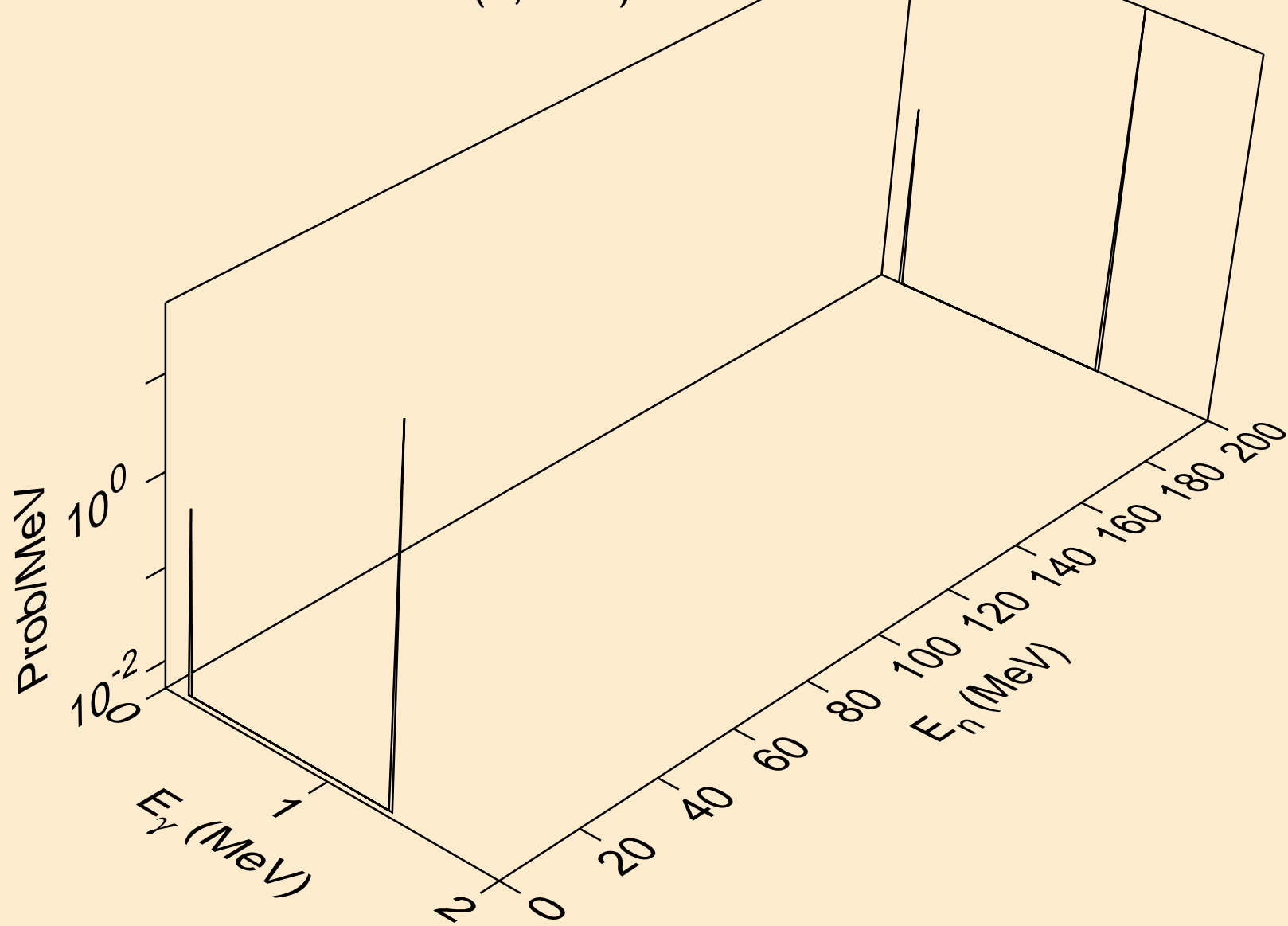

RB090M NEUTRON ACER TENDL-2024 LIBRARY; T=0.K
Photon emission for (n,n*21)

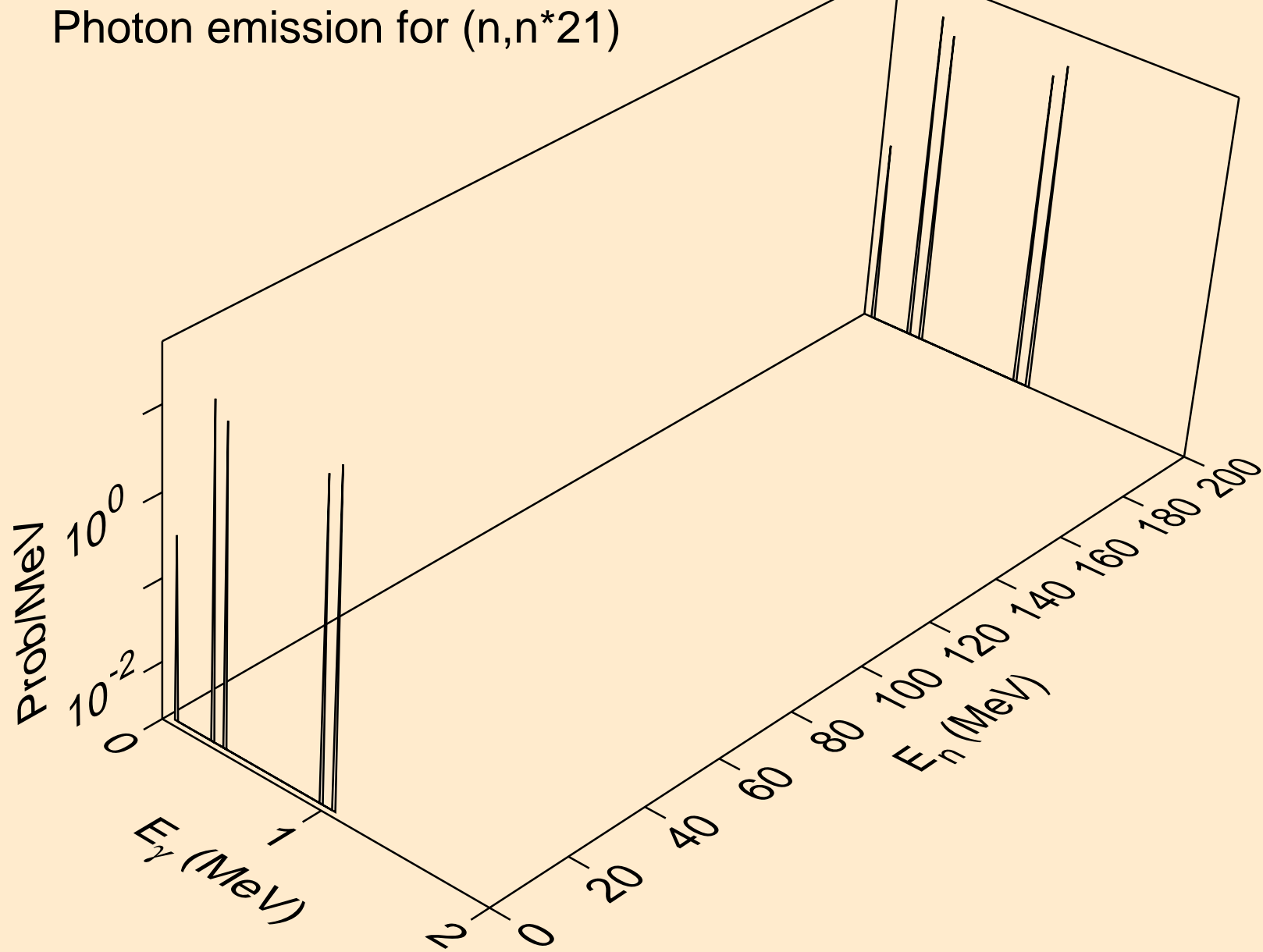

RB090M NEUTRON ACER TENDL-2024 LIBRARY; T=0.K
Photon emission for (n,n*22)

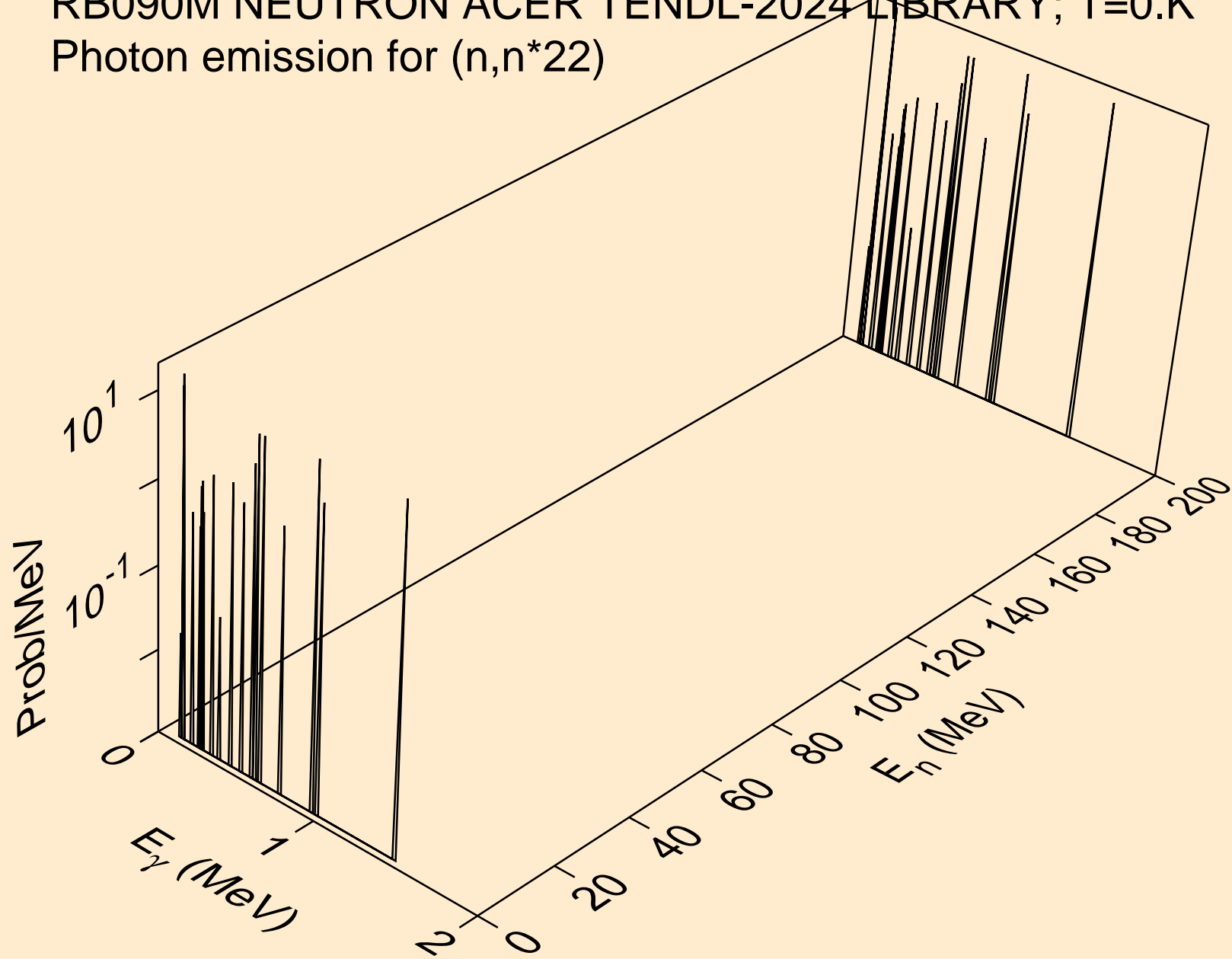

RB090M NEUTRON ACER TENDL-2024 LIBRARY; T=0.K
Photon emission for (n,n*23)

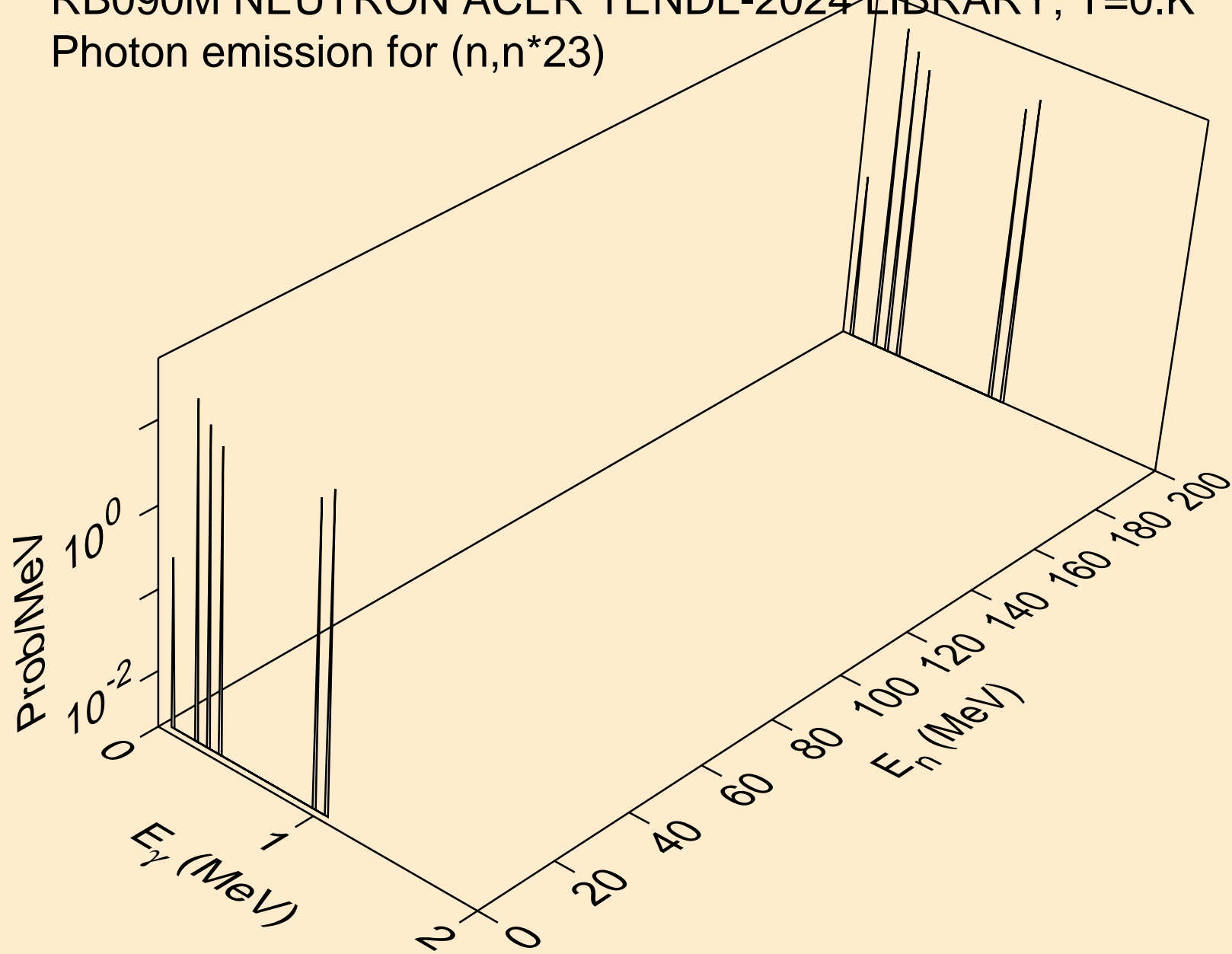

RB090M NEUTRON ACER TENDL-2024 LIBRARY; T=0.K
Photon emission for (n,n*24)

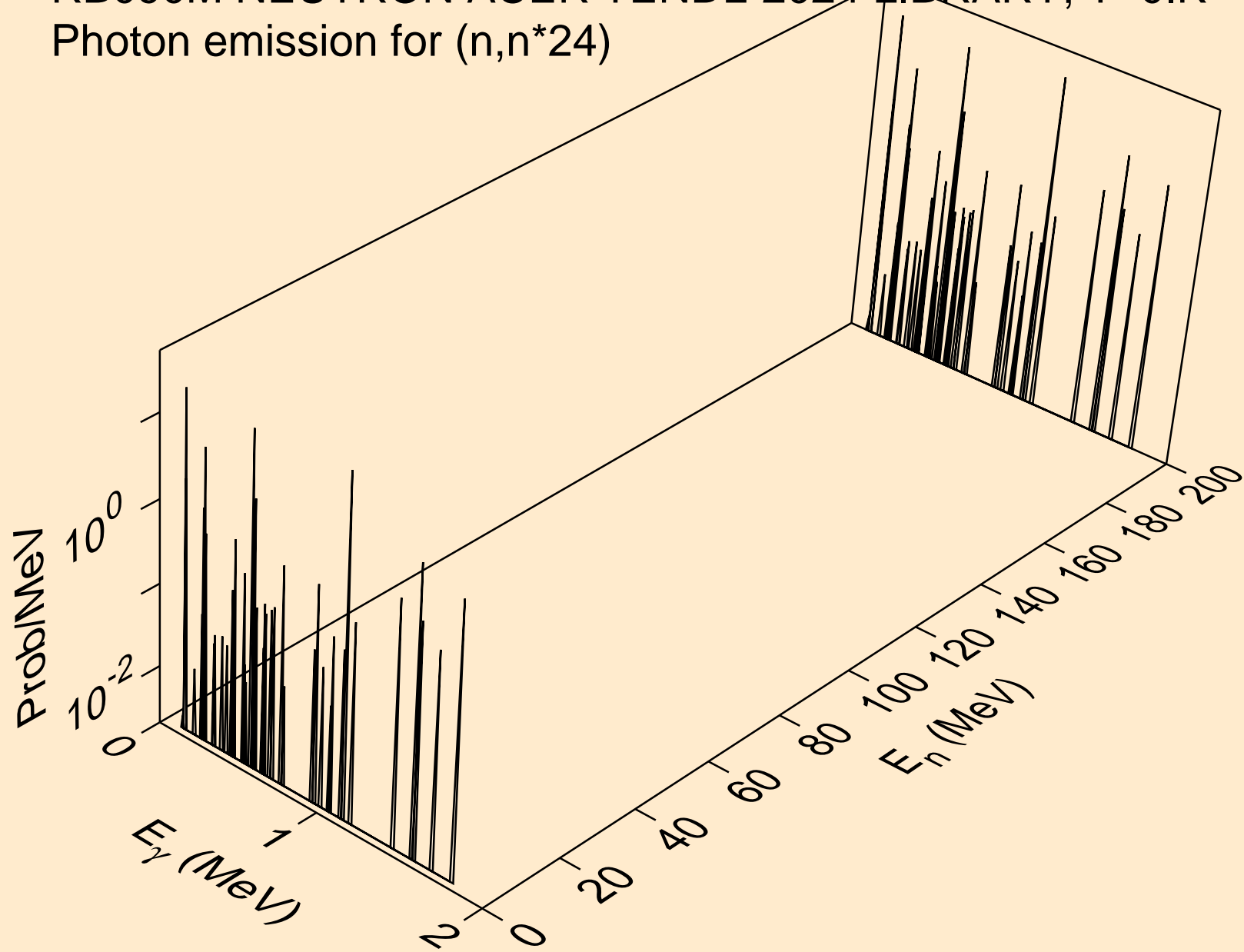

RB090M NEUTRON ACER TENDL-2024 LIBRARY; T=0.K
Photon emission for (n,n*25)

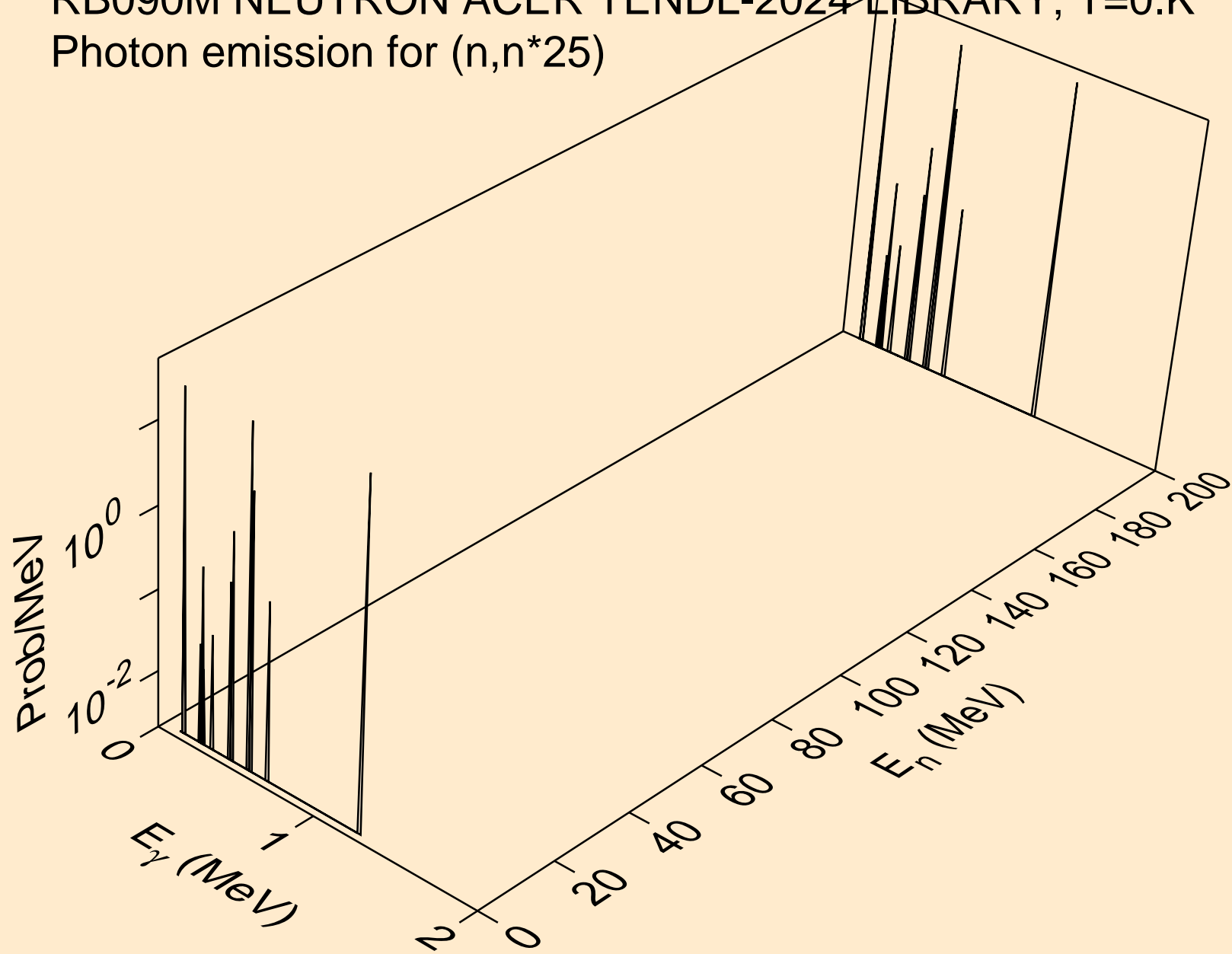

RB090M NEUTRON ACER TENDL-2024 LIBRARY; T=0.K
Photon emission for (n,n*26)

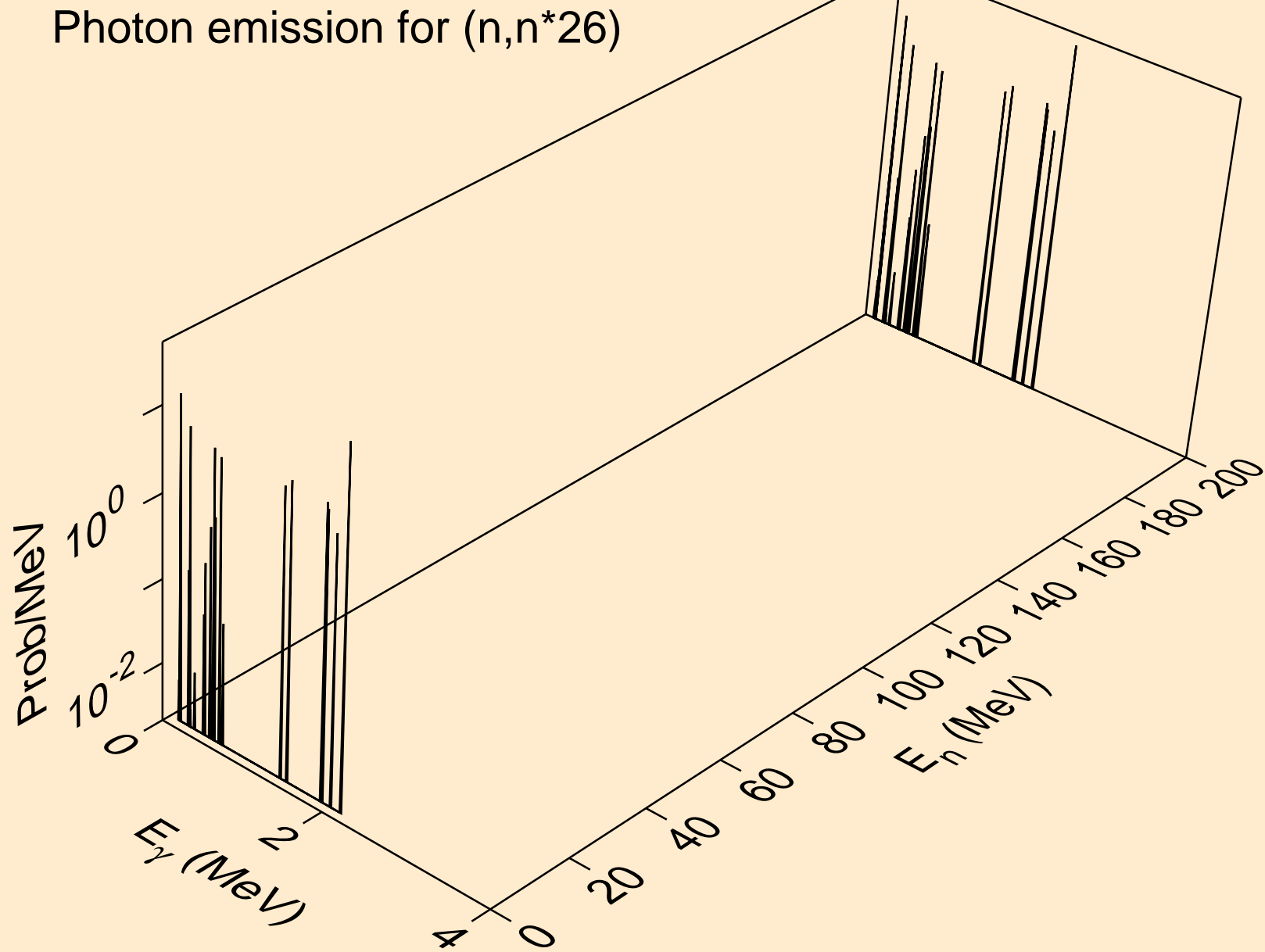

RB090M NEUTRON ACER TENDL-2024 LIBRARY; T=0.K
Photon emission for (n,n*27)

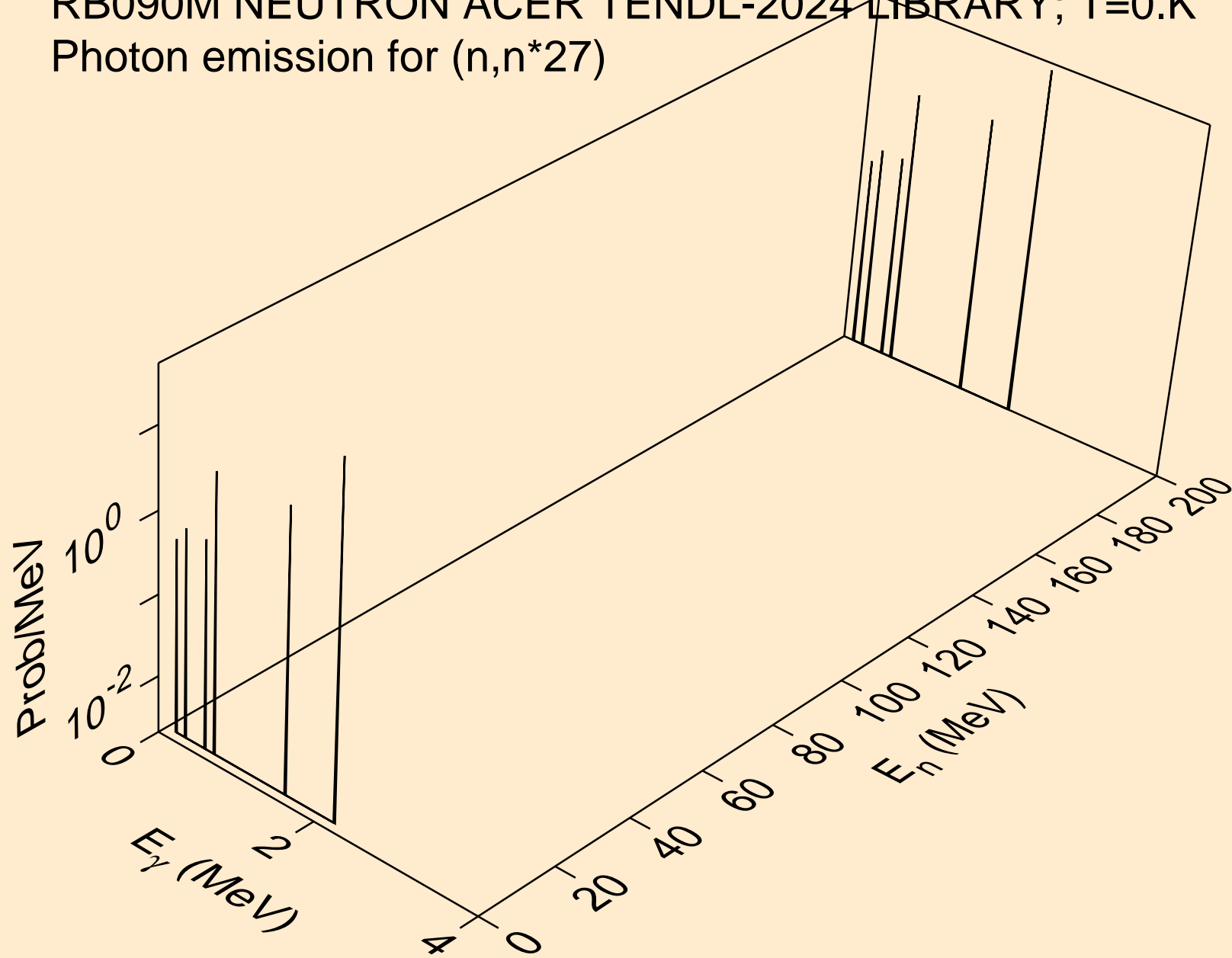

RB090M NEUTRON ACER TENDL-2024 LIBRARY; T=0.K
Photon emission for (n,n*28)

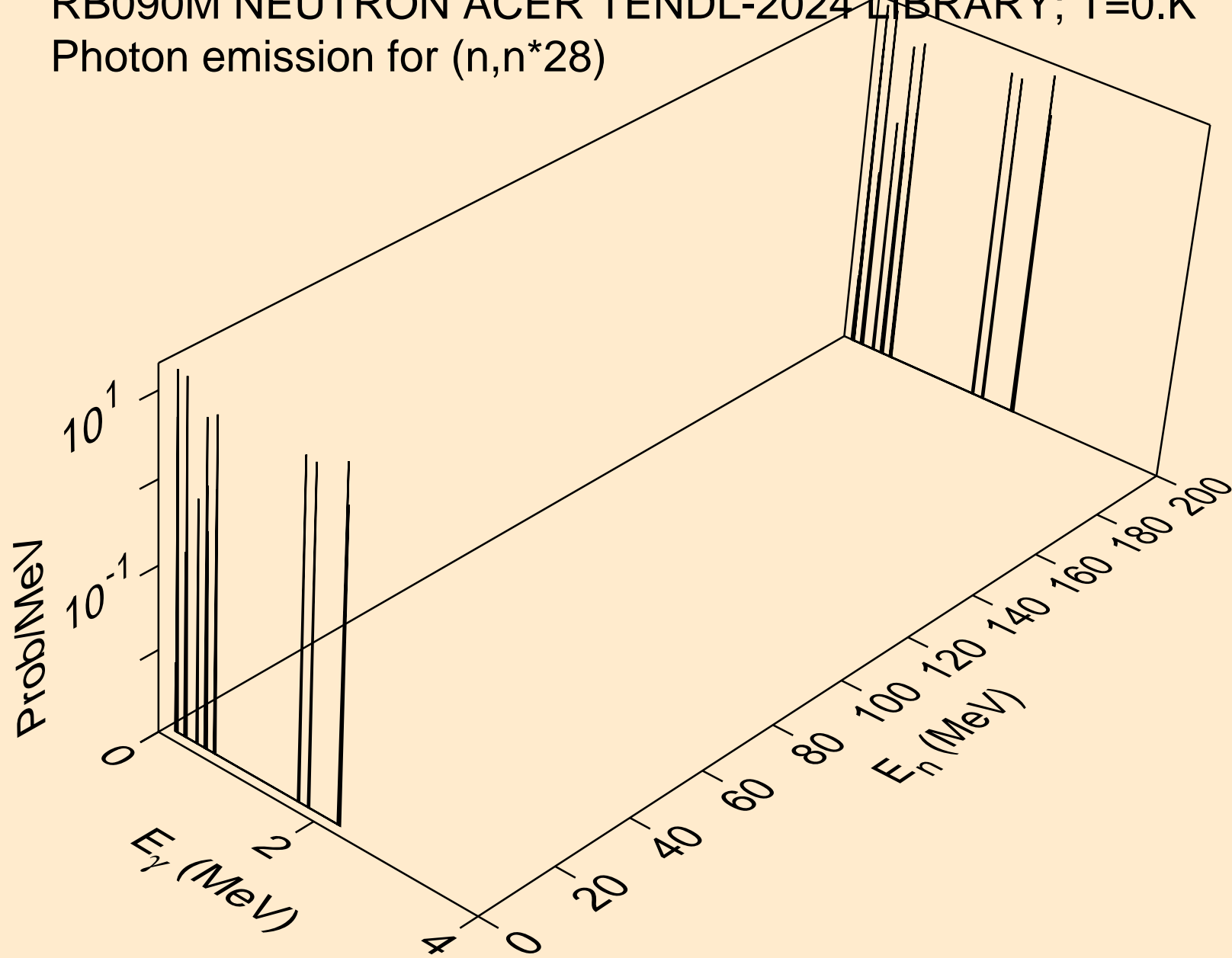

RB090M NEUTRON ACER TENDL-2024 LIBRARY; T=0.K
Photon emission for (n,n*29)

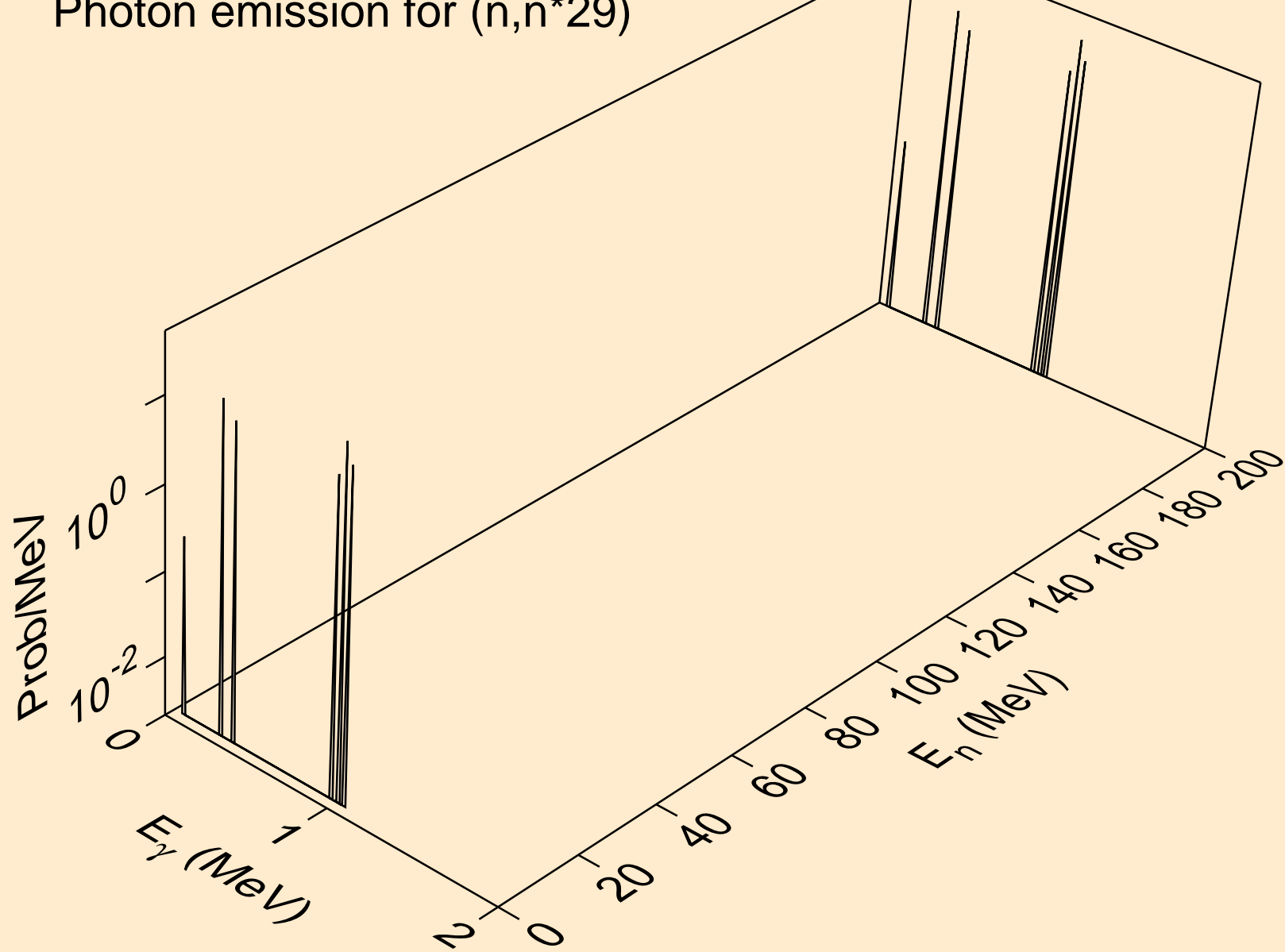

RB090M NEUTRON ACER TENDL-2024 LIBRARY; T=0.K
Photon emission for (n,n*c)

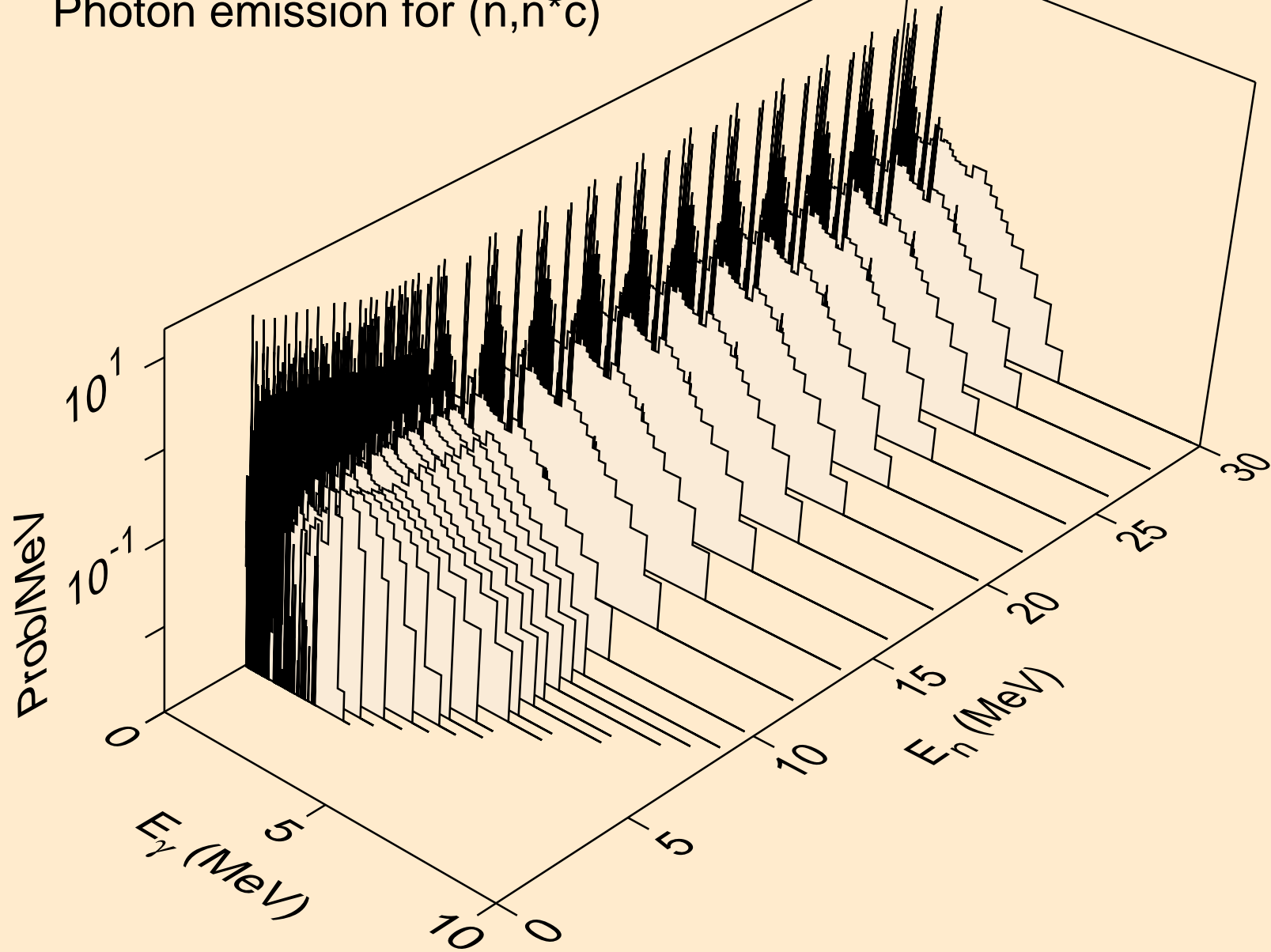

RB090M NEUTRON ACER TENDL-2024 LIBRARY; T=0.K
Photon emission for (n,gma)

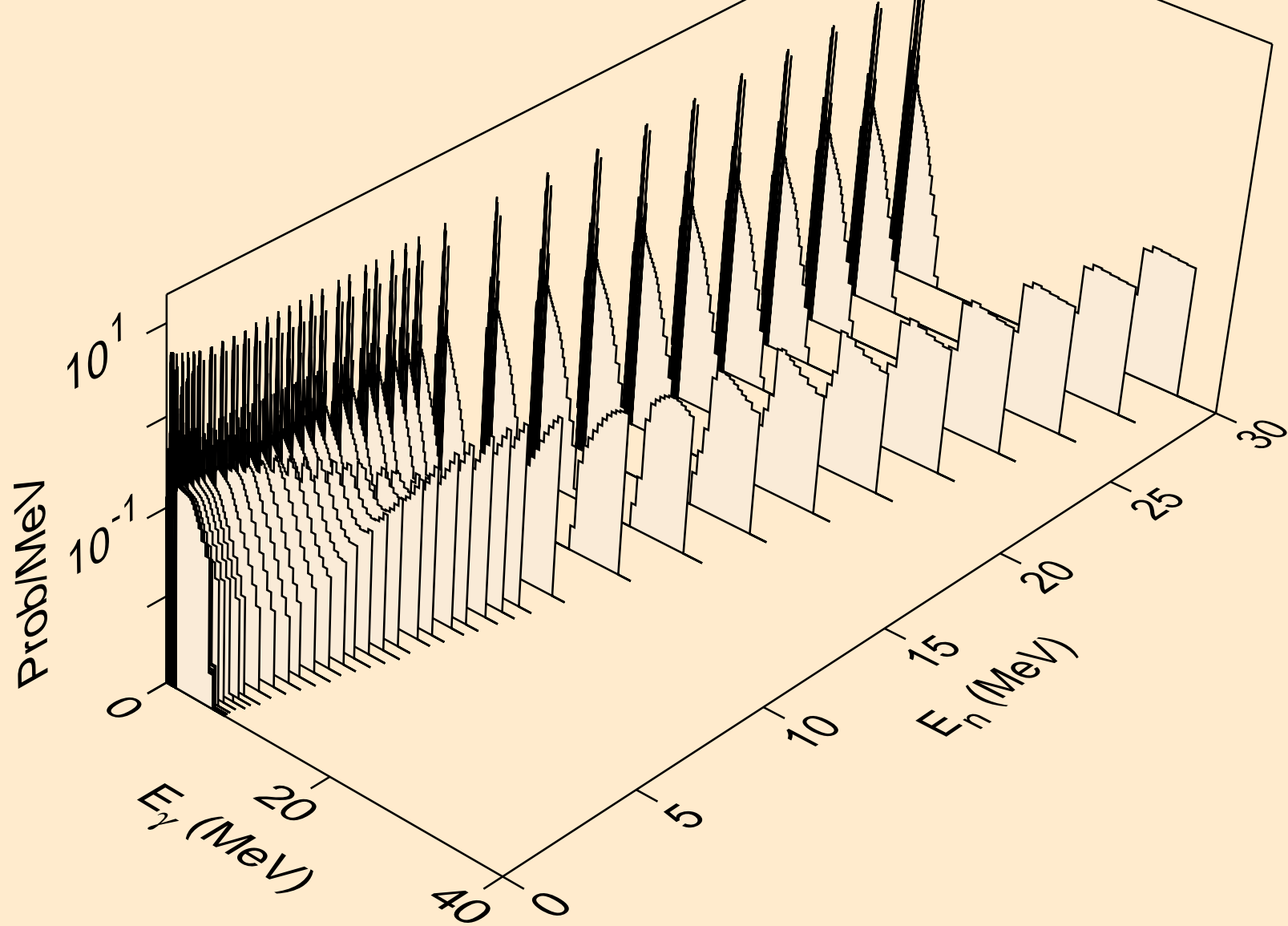

RB090M NEUTRON ACER TENDL-2024 LIBRARY; T=0.K
Photon emission for (n,p)

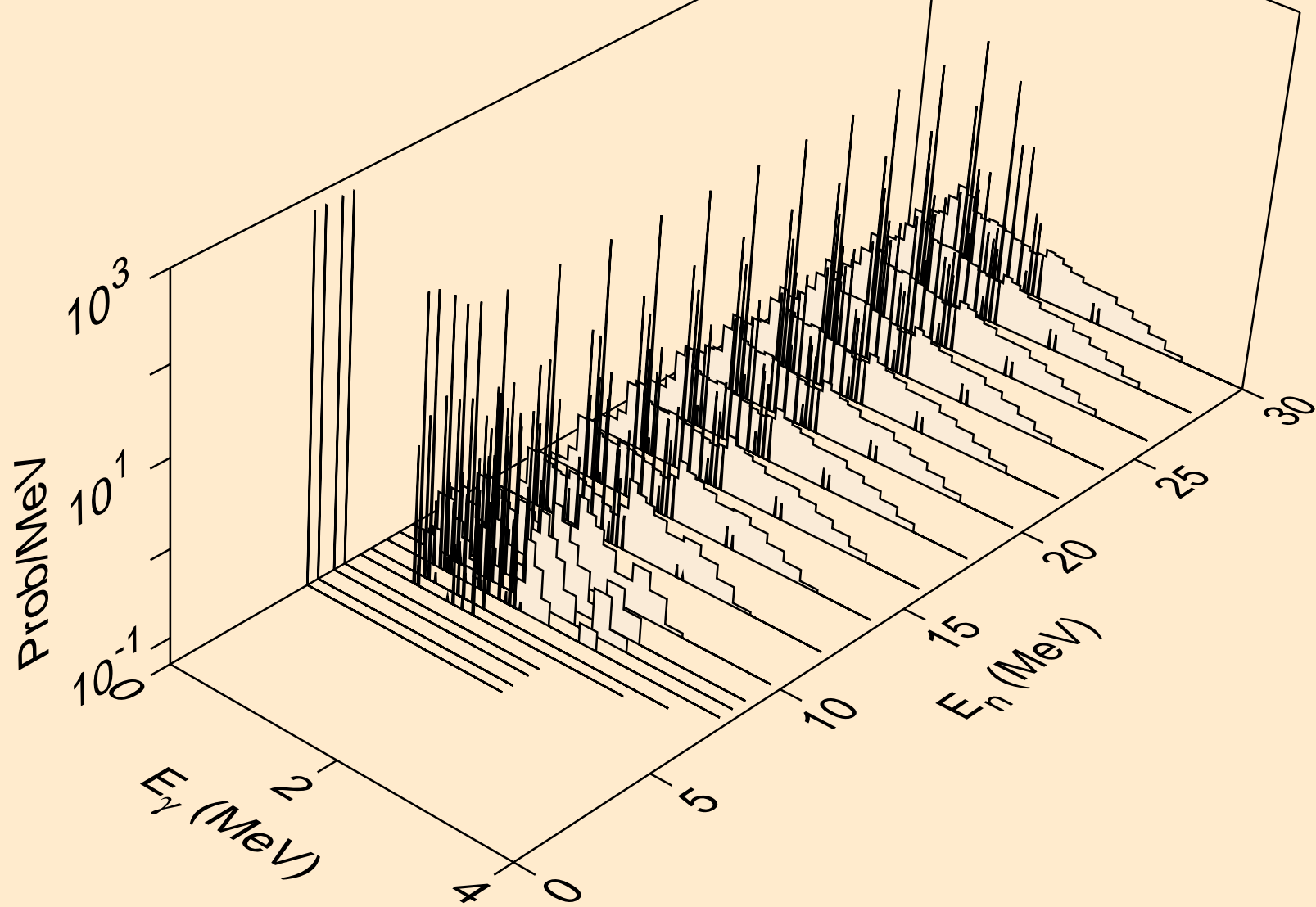

RB090M NEUTRON ACER TENDL-2024 LIBRARY; T=0.K
Photon emission for (n,d)

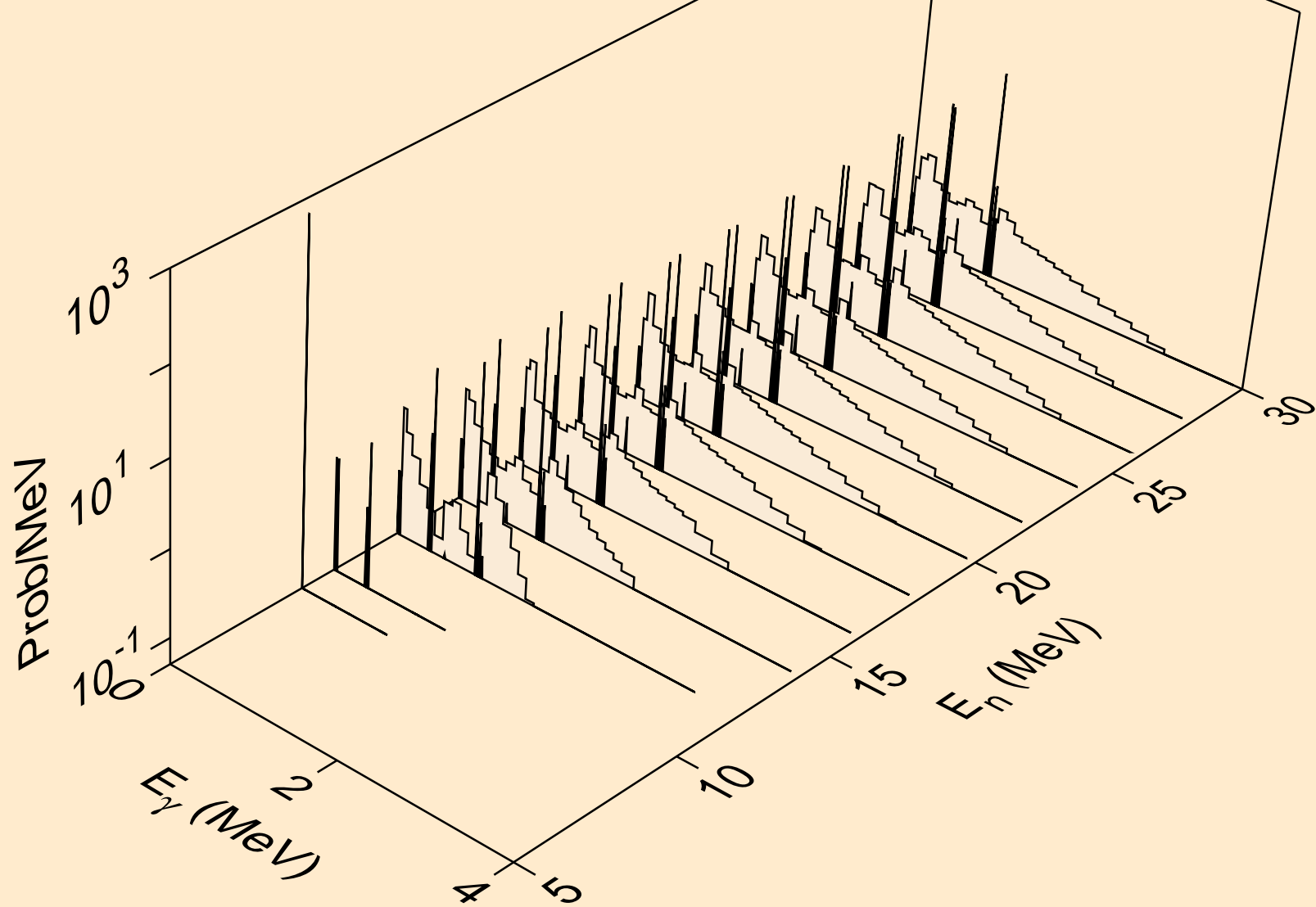

RB090M NEUTRON ACER TENDL-2024 LIBRARY; T=0.K
Photon emission for (n,t)

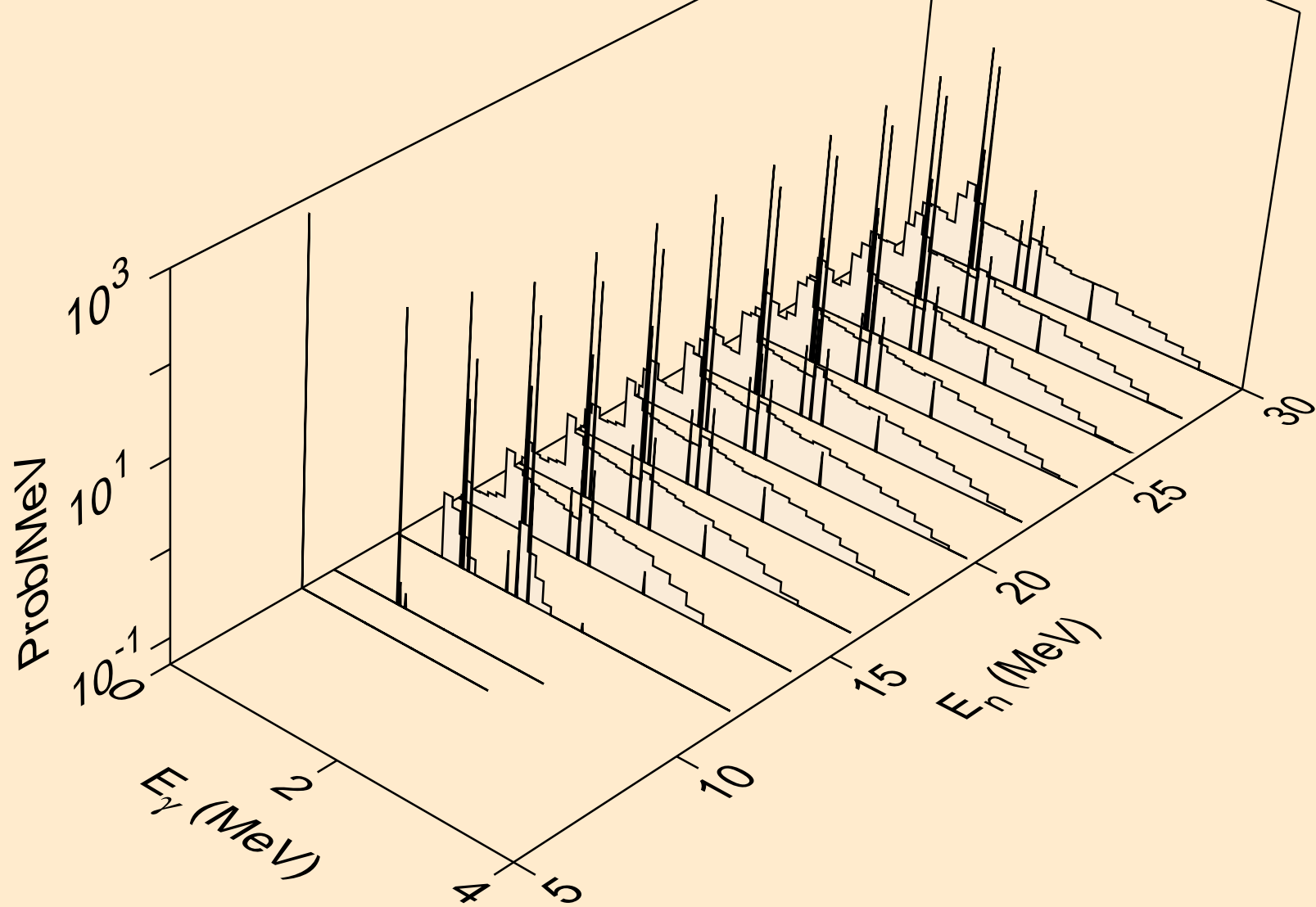

RB090M NEUTRON ACER TENDL-2024 LIBRARY; T=0.K
Photon emission for (n,he3)

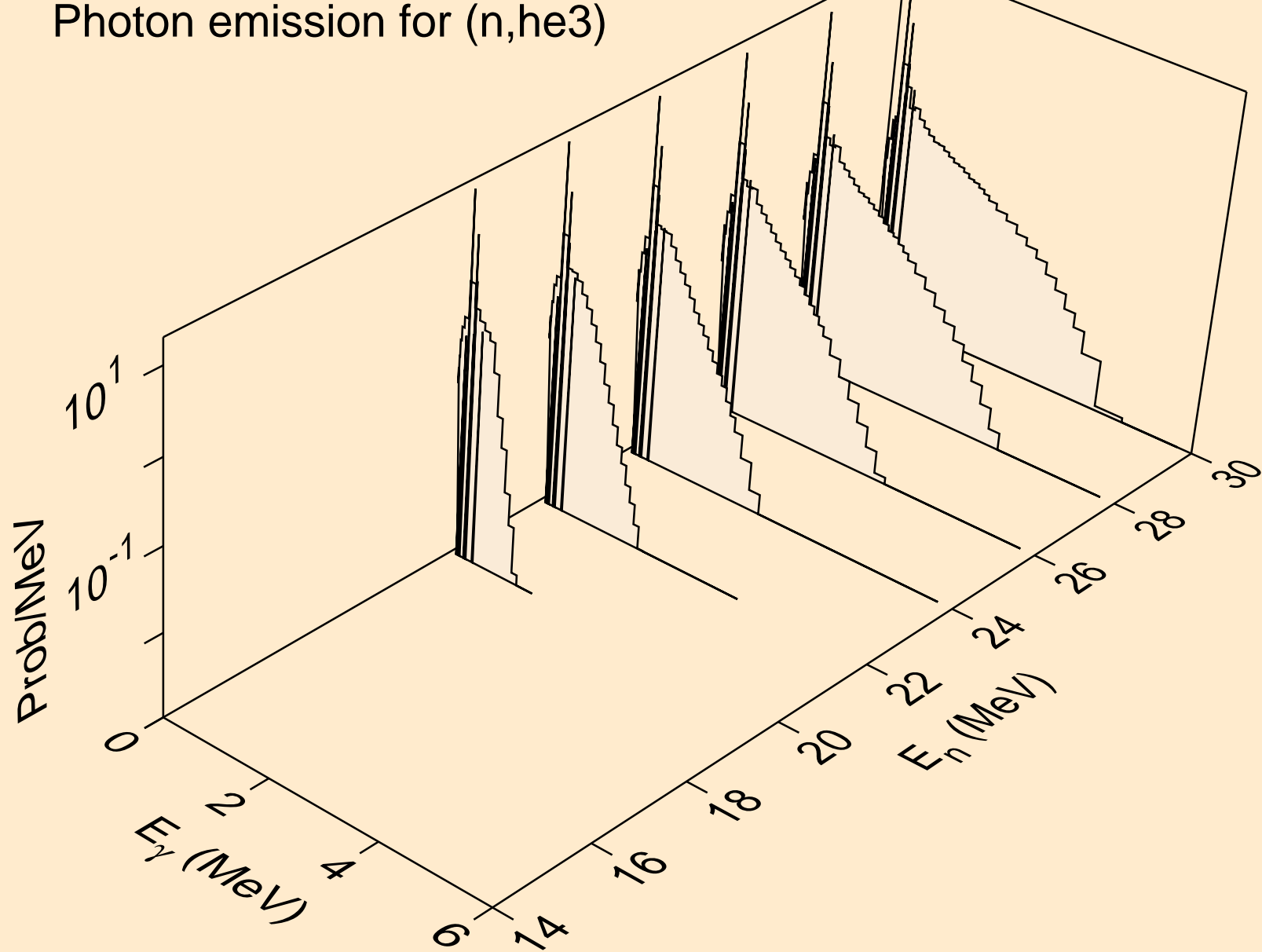

RB090M NEUTRON ACER TENDL-2024 LIBRARY; T=0.K
Photon emission for (n,a)

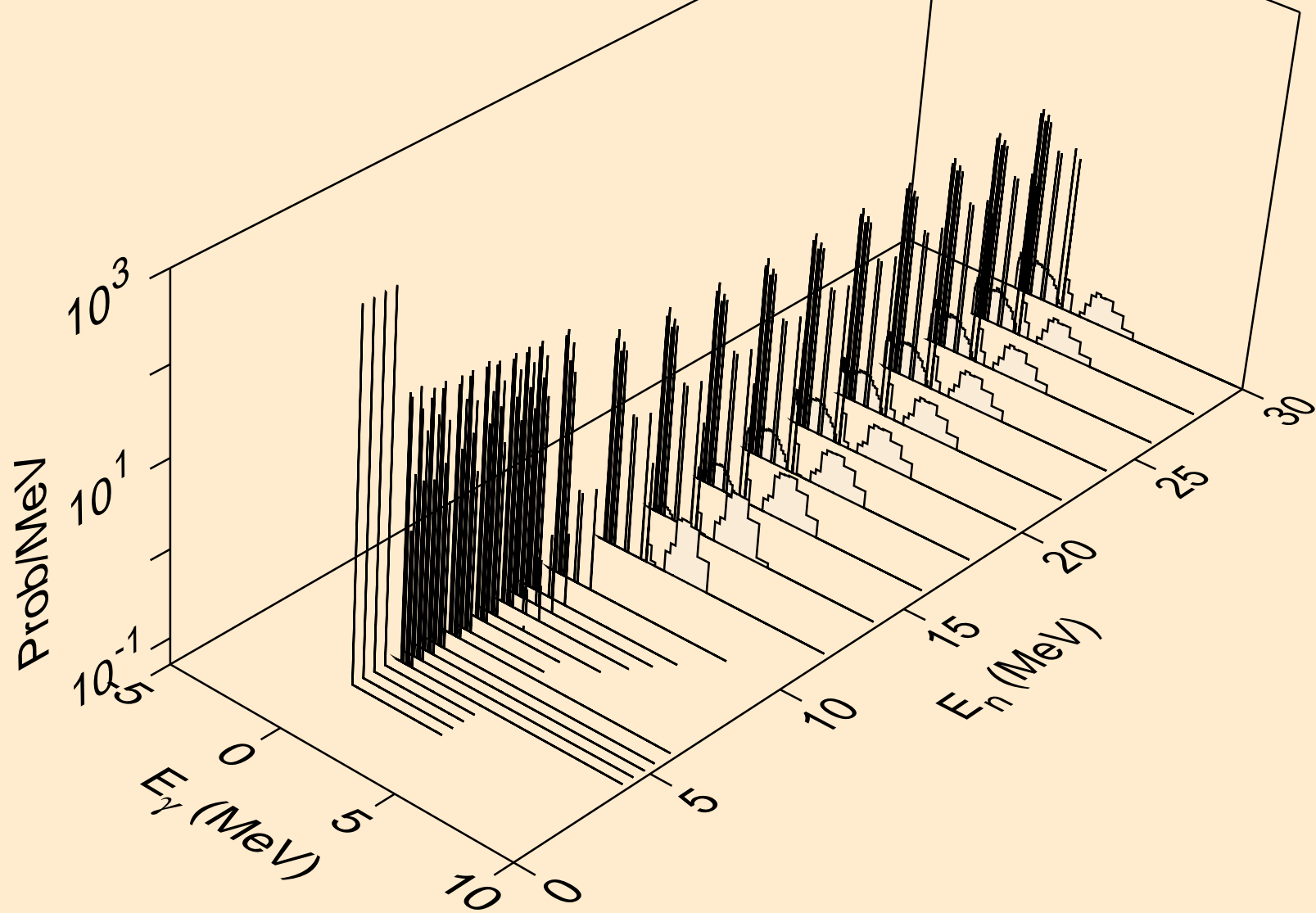

RB090M NEUTRON ACER TENDL-2024 LIBRARY; T=0.K
Photon emission for (n,2a)

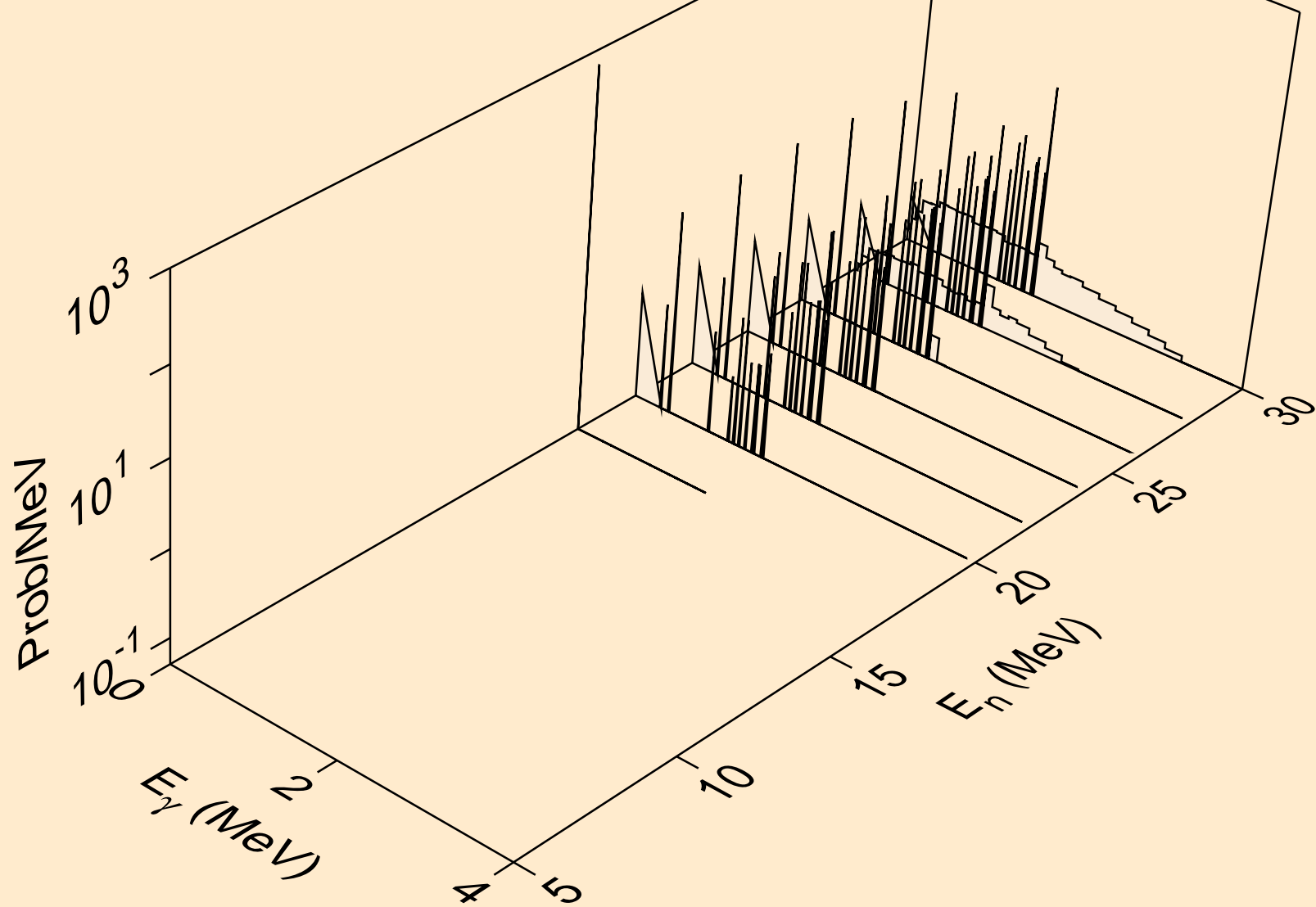

RB090M NEUTRON ACER TENDL-2024 LIBRARY; T=0.K
Photon emission for (n,2p)

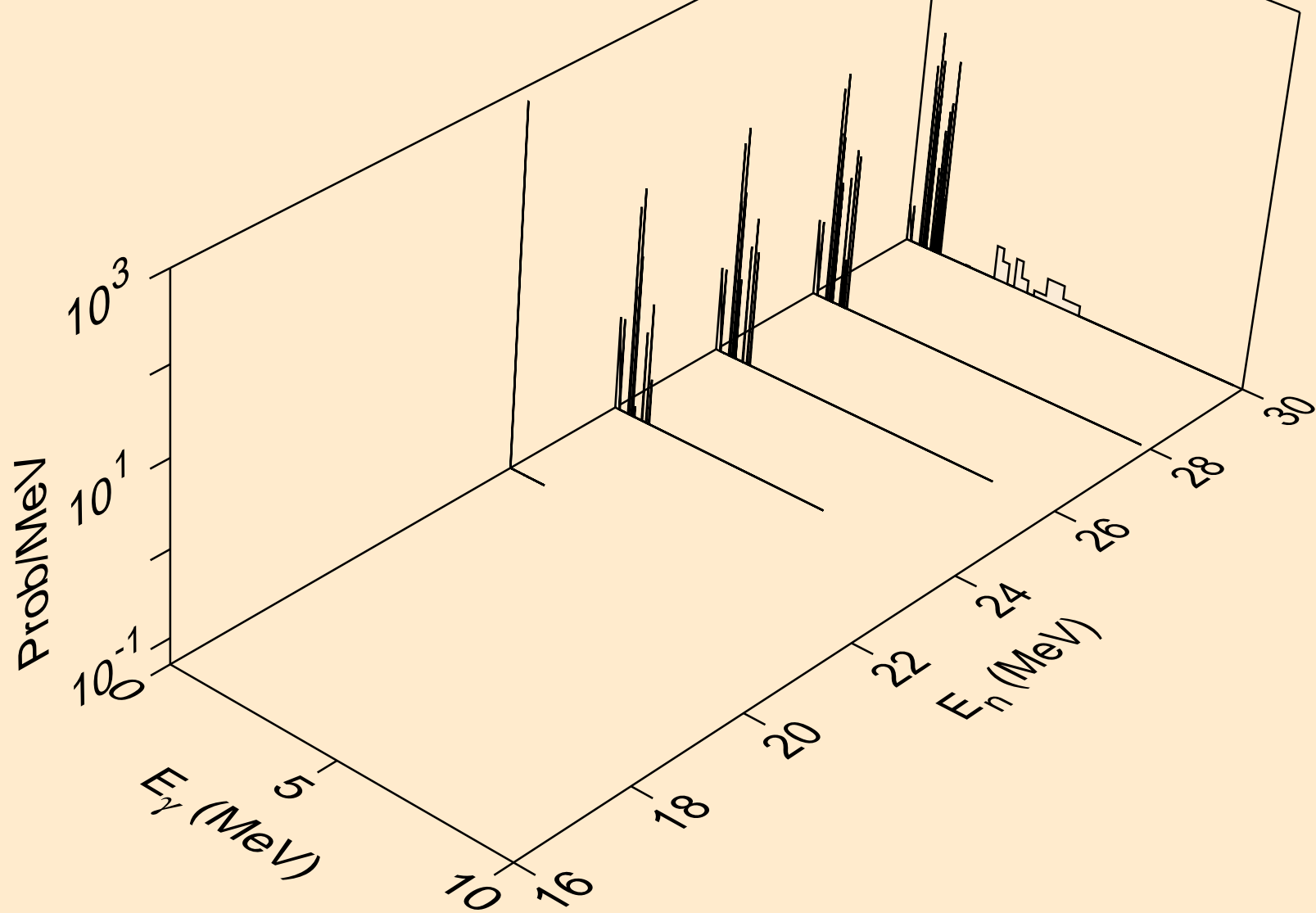

RB090M NEUTRON ACER TENDL-2024 LIBRARY; T=0.K
Photon emission for (n,p)

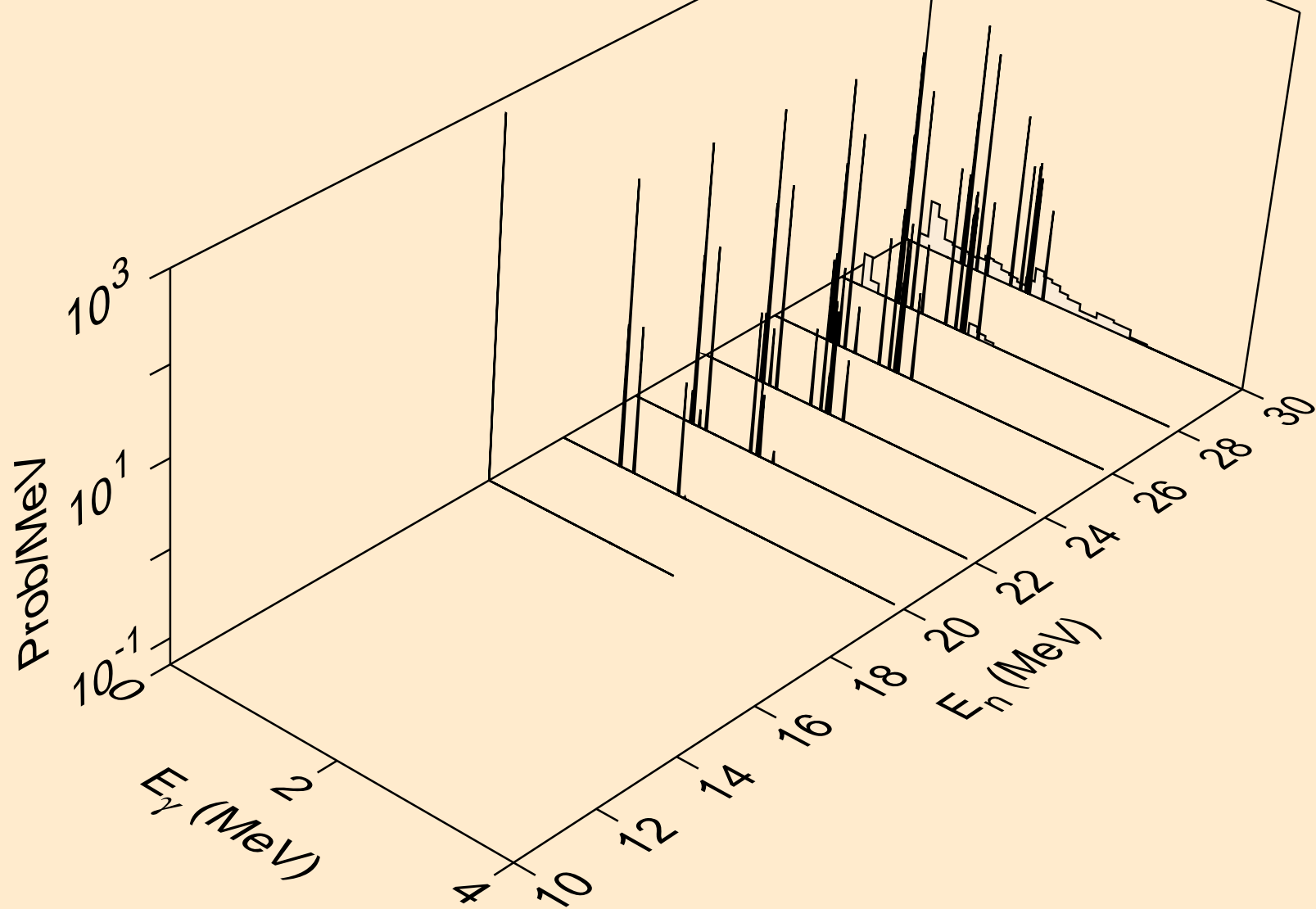

RB090M NEUTRON ACER TENDL-2024 LIBRARY; T=0.K
Photon emission for (n,da)

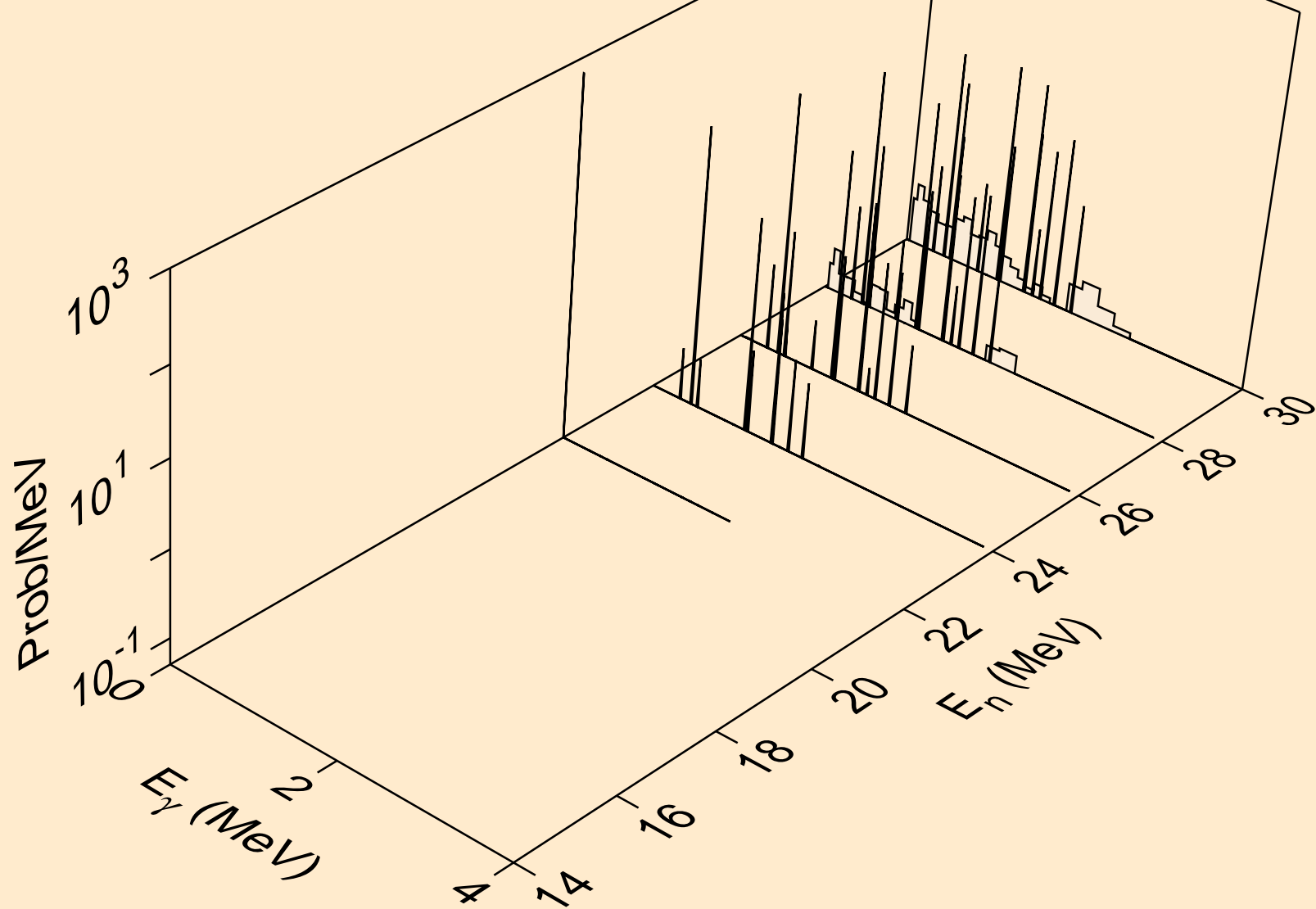

RB090M NEUTRON ACER TENDL-2024 LIBRARY; T=0.K
thermal capture photon spectrum

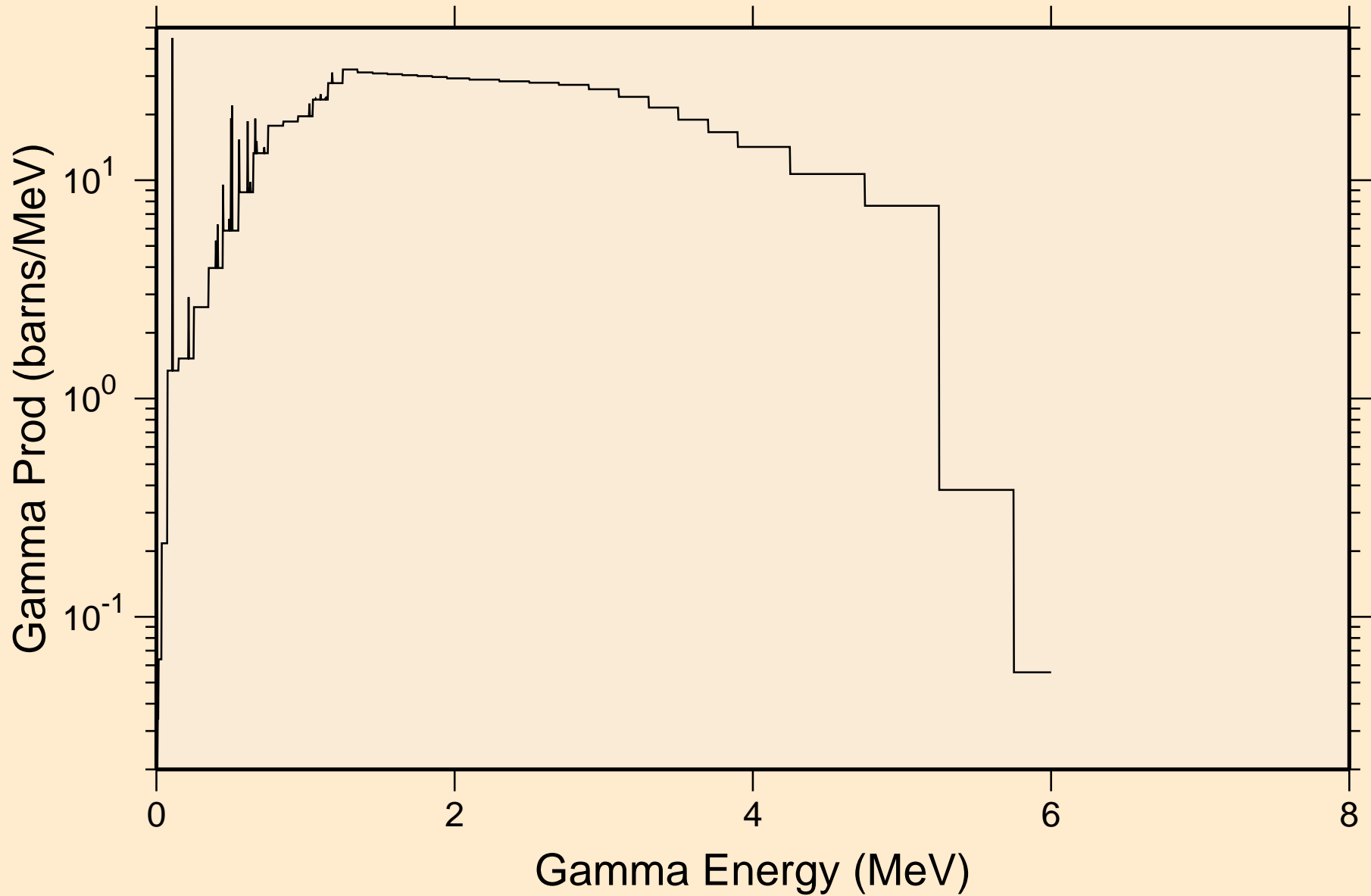

RB090M NEUTRON ACER TENDL-2024 LIBRARY; T=0.K
14 MeV photon spectrum

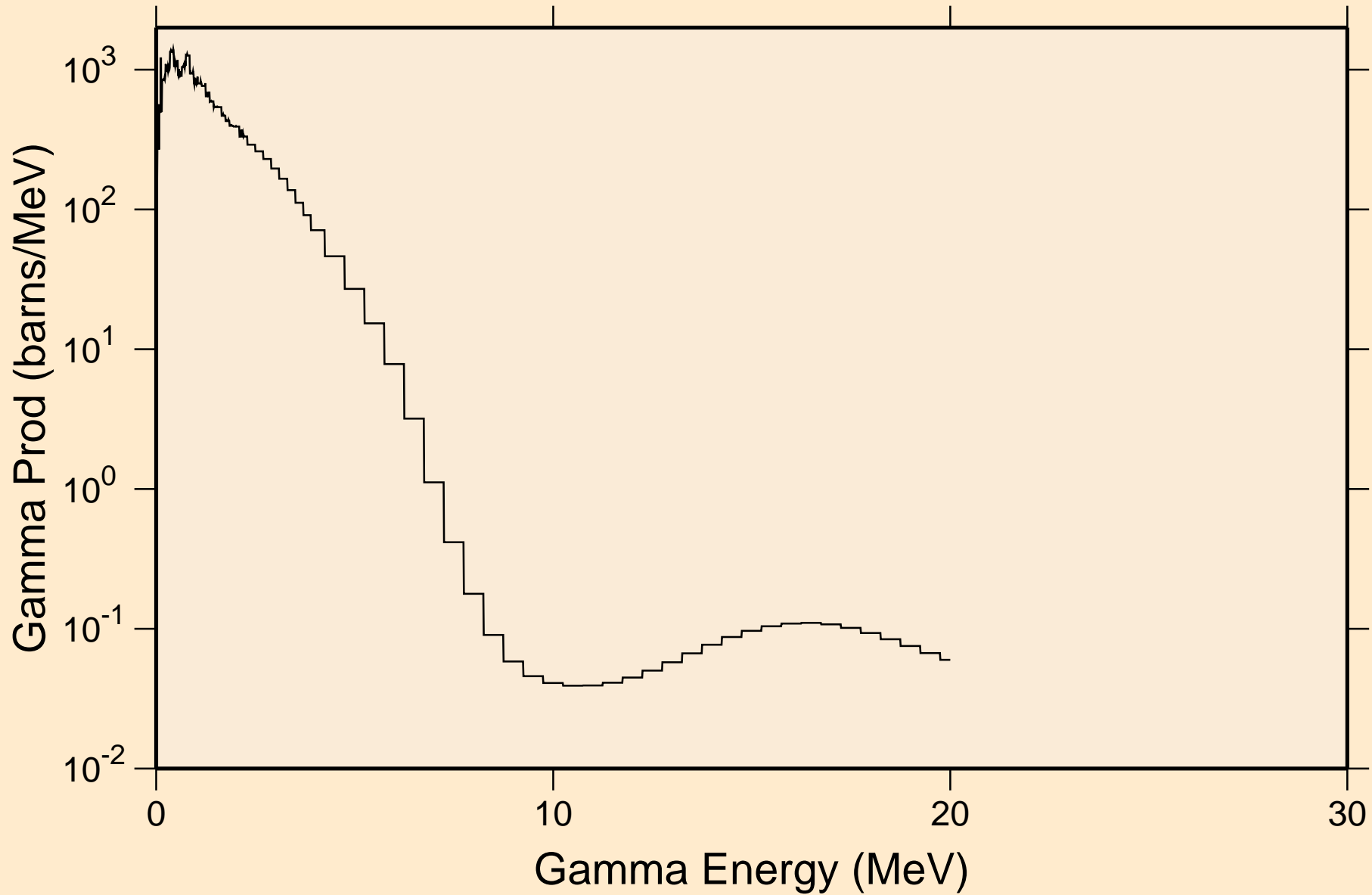

RB090M NEUTRON ACER TENDL-2024 LIBRARY; T=0.K
Particle heating contributions

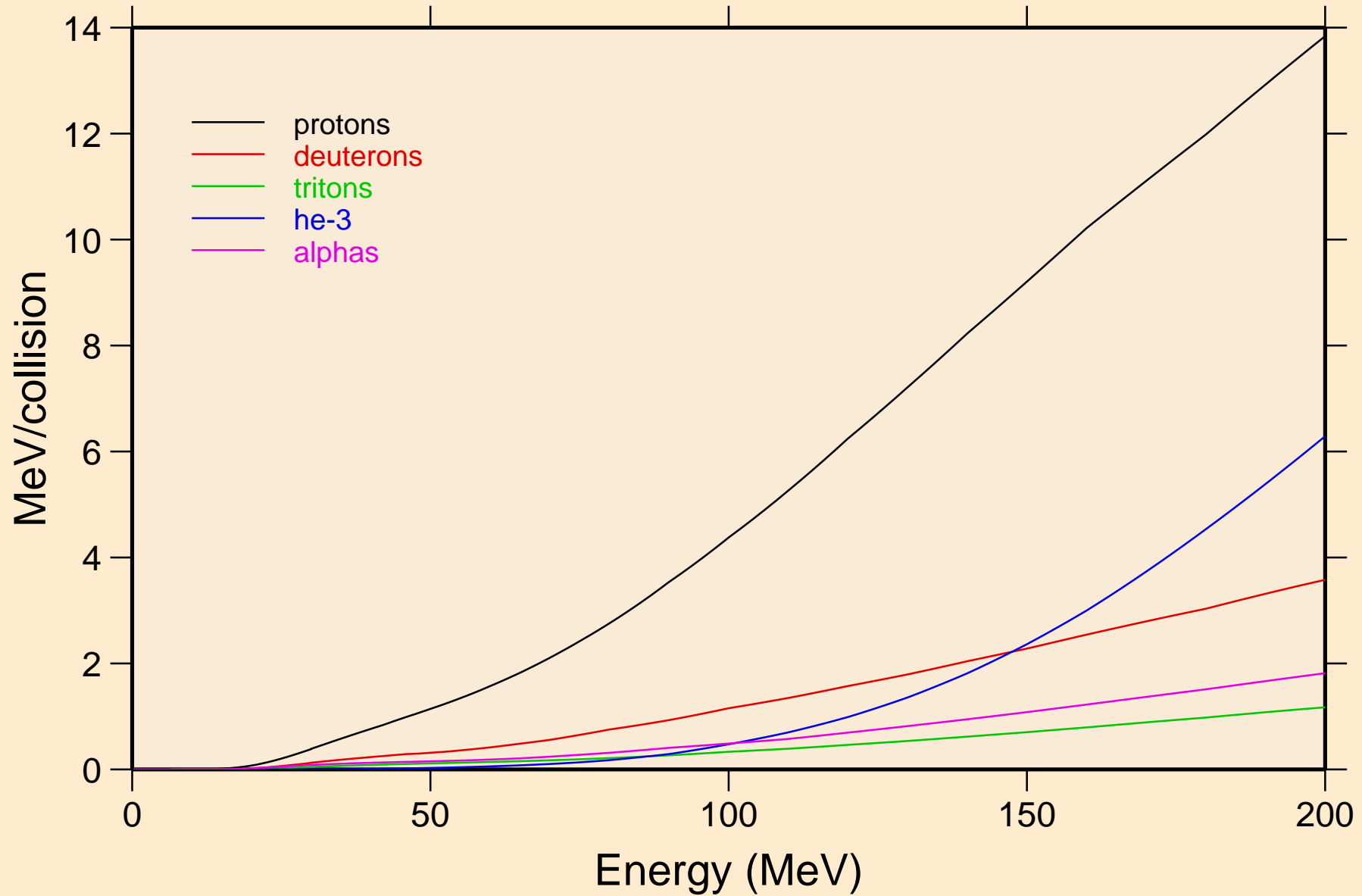

RB090M NEUTRON ACER TENDL-2024 LIBRARY; T=0.K
Recoil Heating

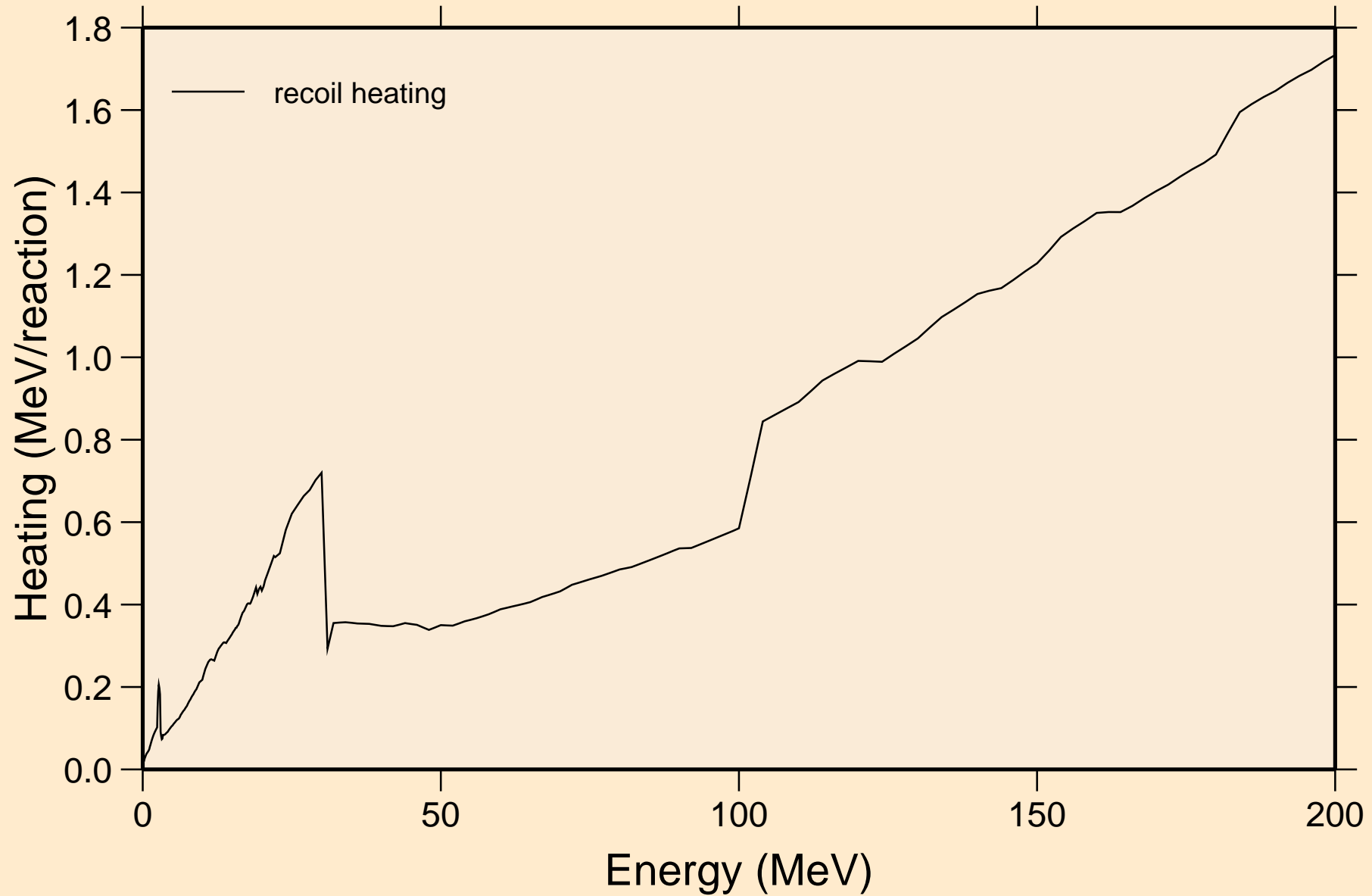

RB090M NEUTRON ACER TENDL-2024 LIBRARY; T=0.K
Particle production cross sections

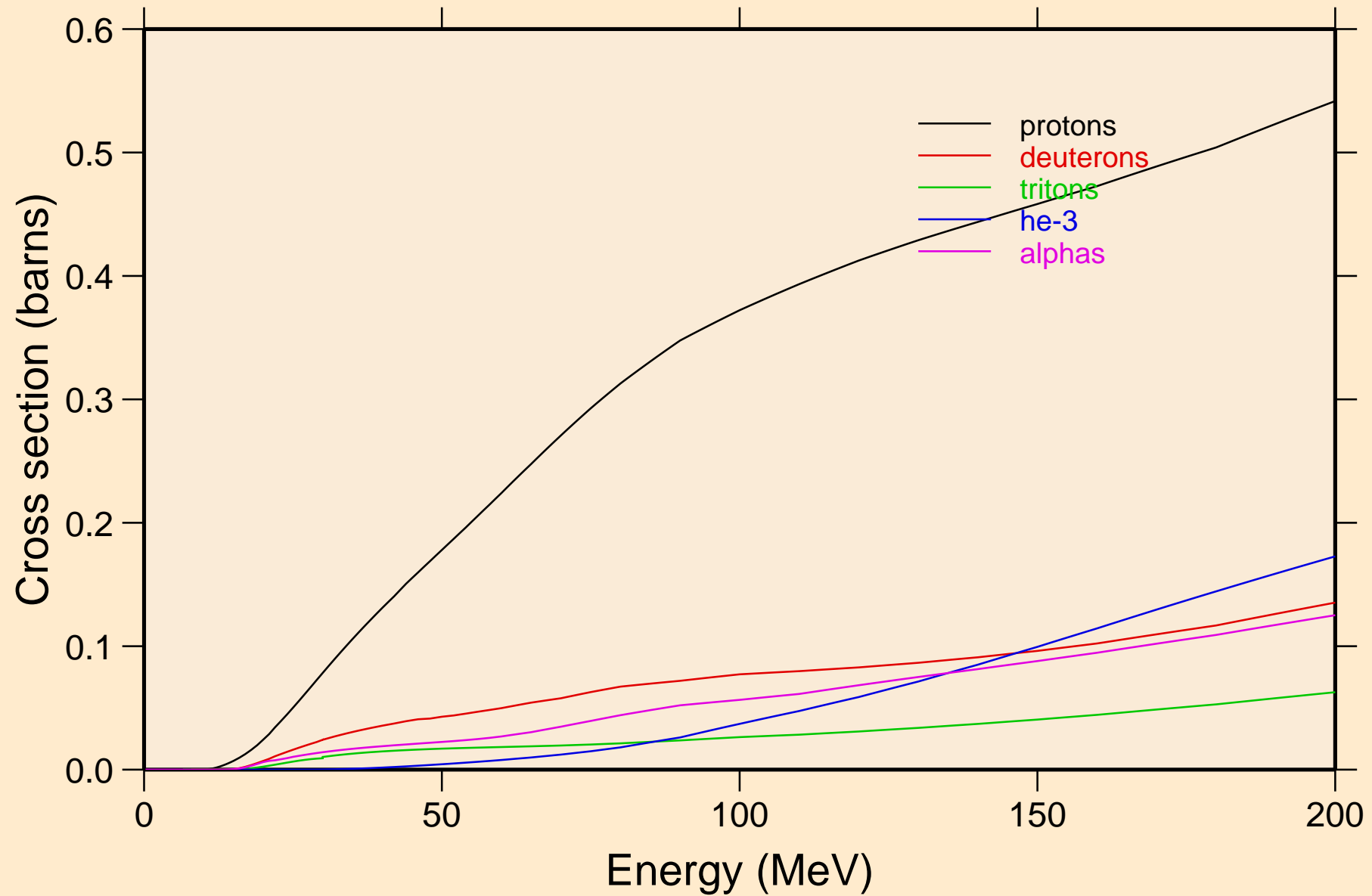

RB090M NEUTRON ACER TENDL-2024 LIBRARY; T=0.K
protons from (n,x)

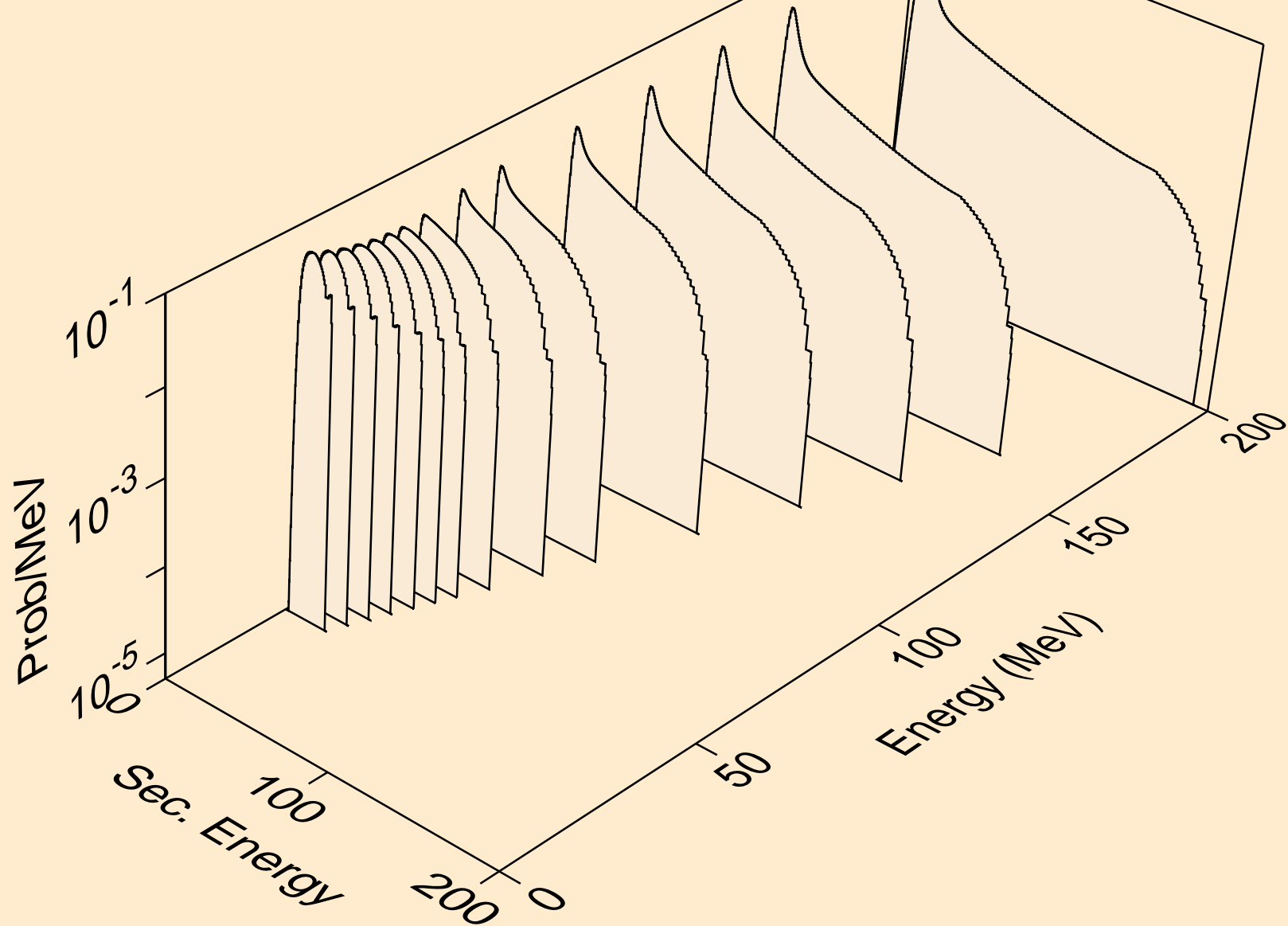

RB090M NEUTRON ACER TENDL-2024 LIBRARY; T=0.K
protons from (n,n*)p

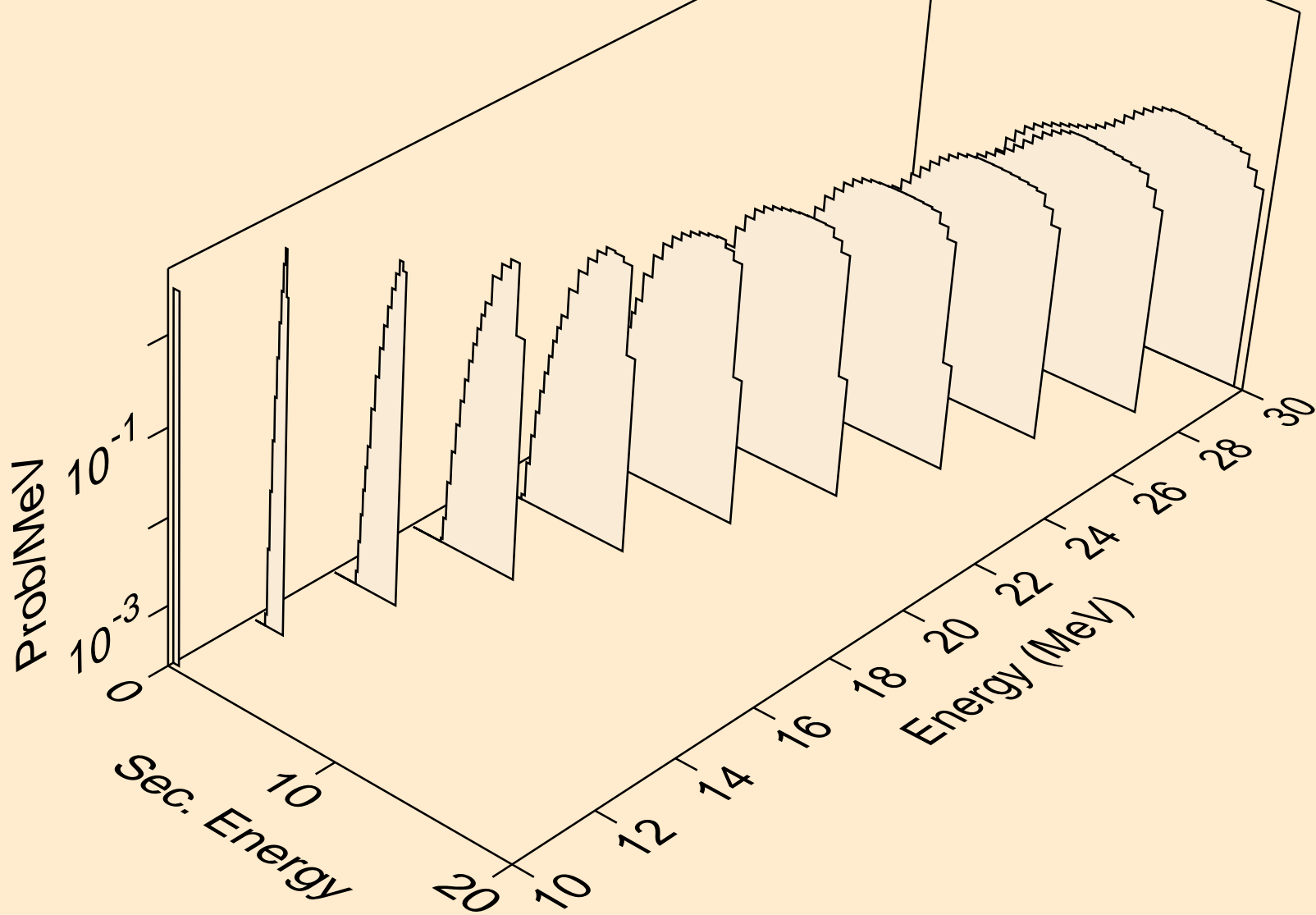

RB090M NEUTRON ACER TENDL-2024 LIBRARY; T=0.K
protons from (n,2np)

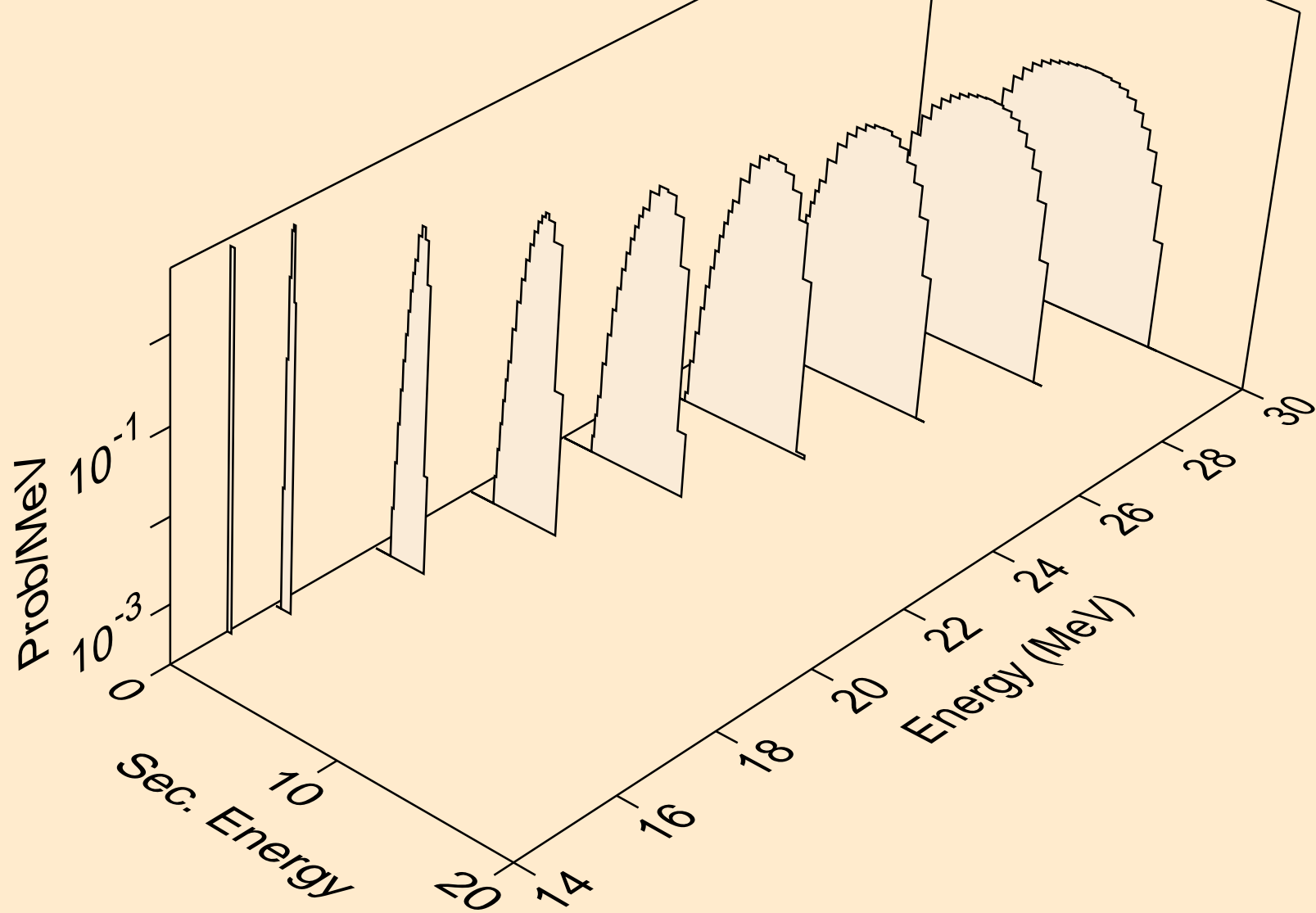

RB090M NEUTRON ACER TENDL-2024 LIBRARY; T=0.K
protons from (n,3np)

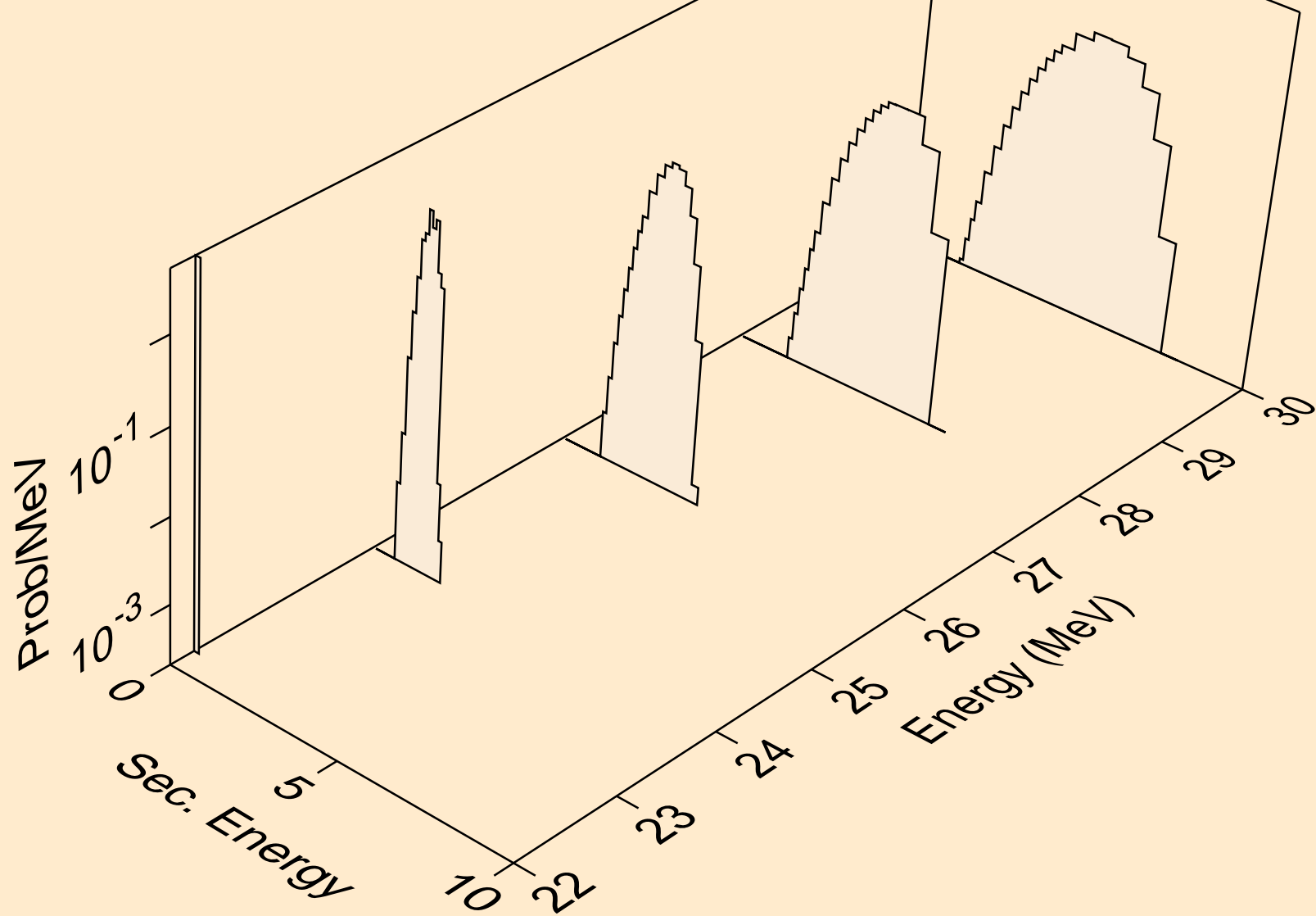

RB090M NEUTRON ACER TENDL-2024 LIBRARY; T=0.K
protons from (n,p)

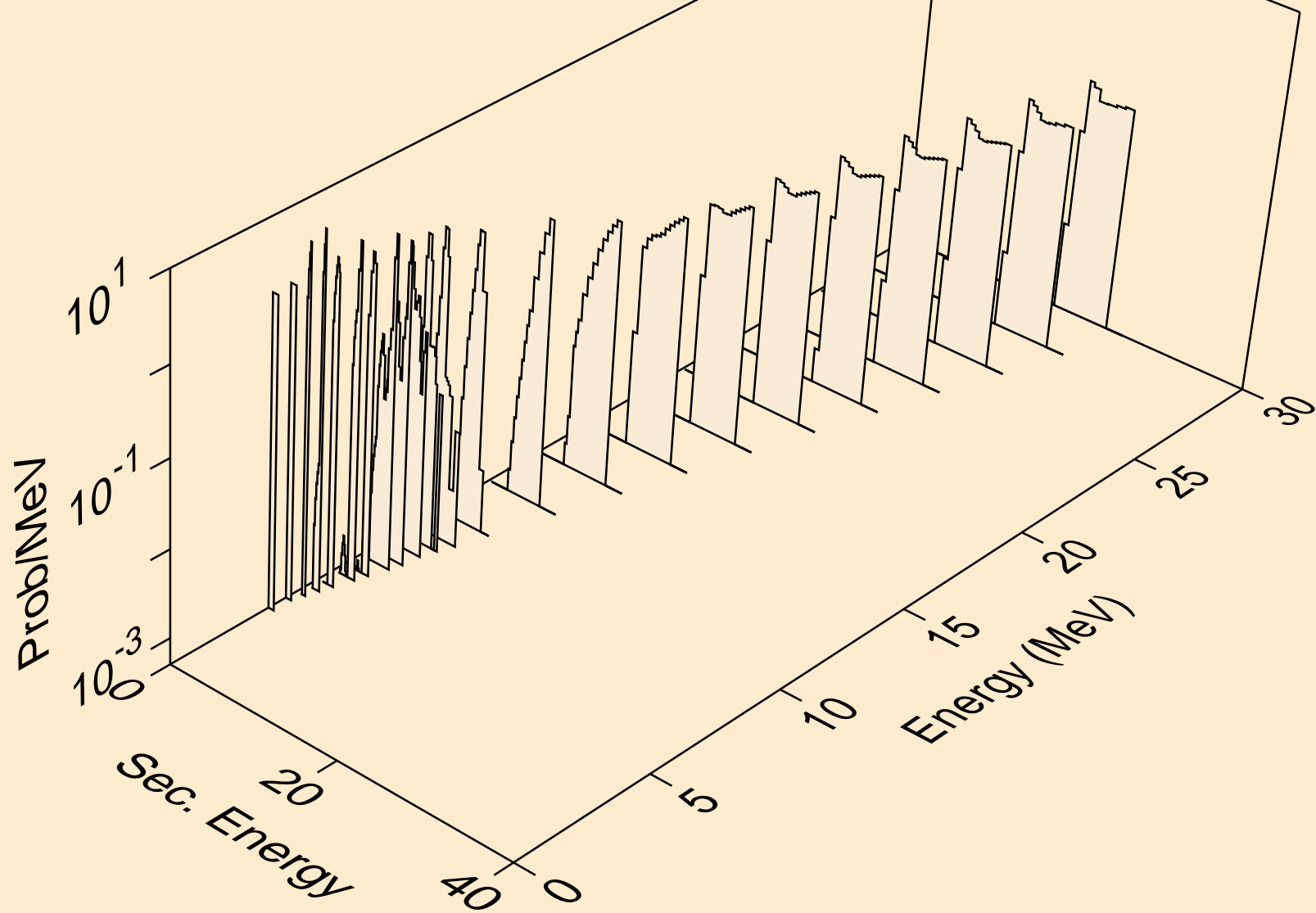

RB090M NEUTRON ACER TENDL-2024 LIBRARY; T=0.K
protons from (n,2p)

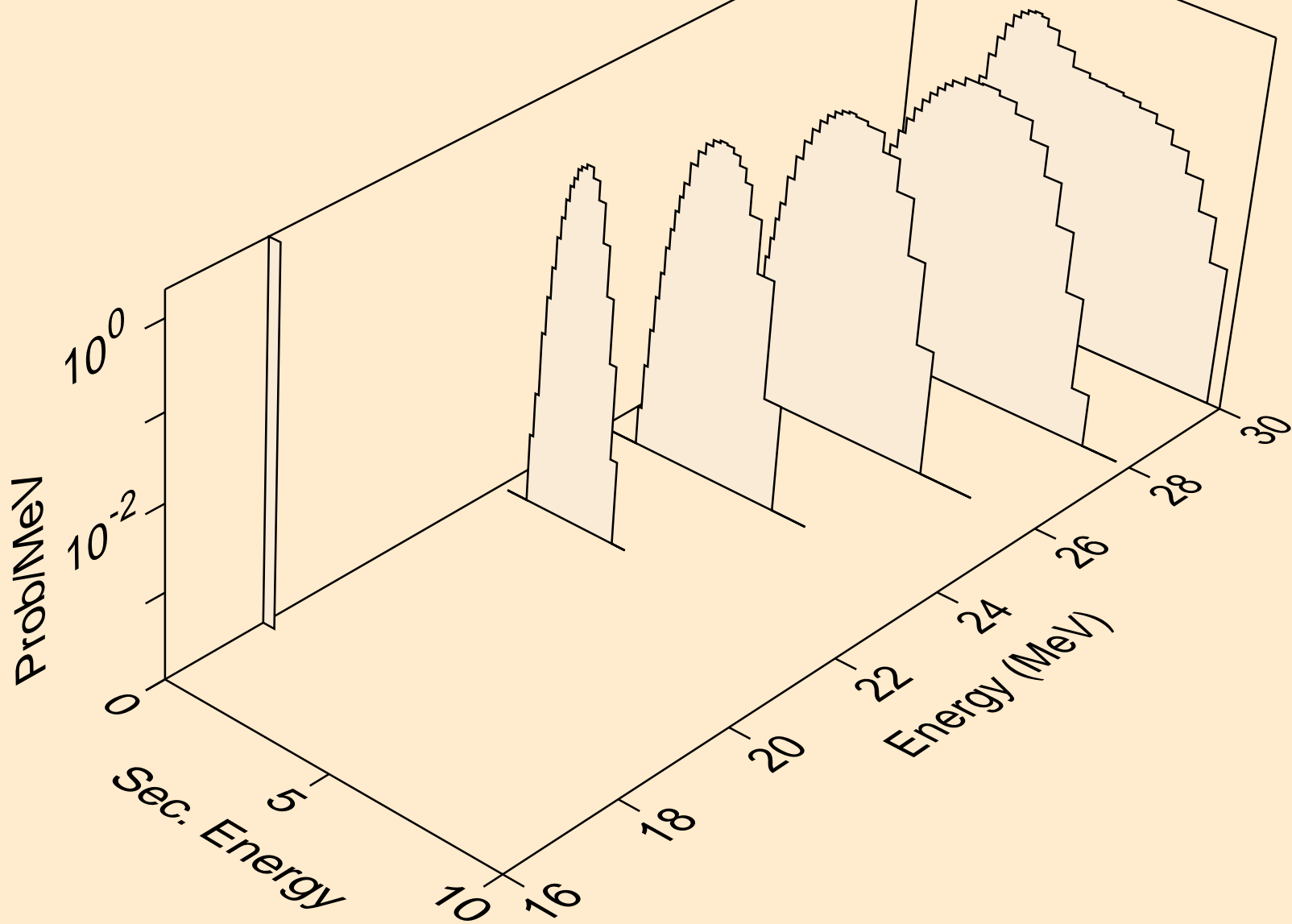

RB090M NEUTRON ACER TENDL-2024 LIBRARY; T=0.K
protons from (n,pa)

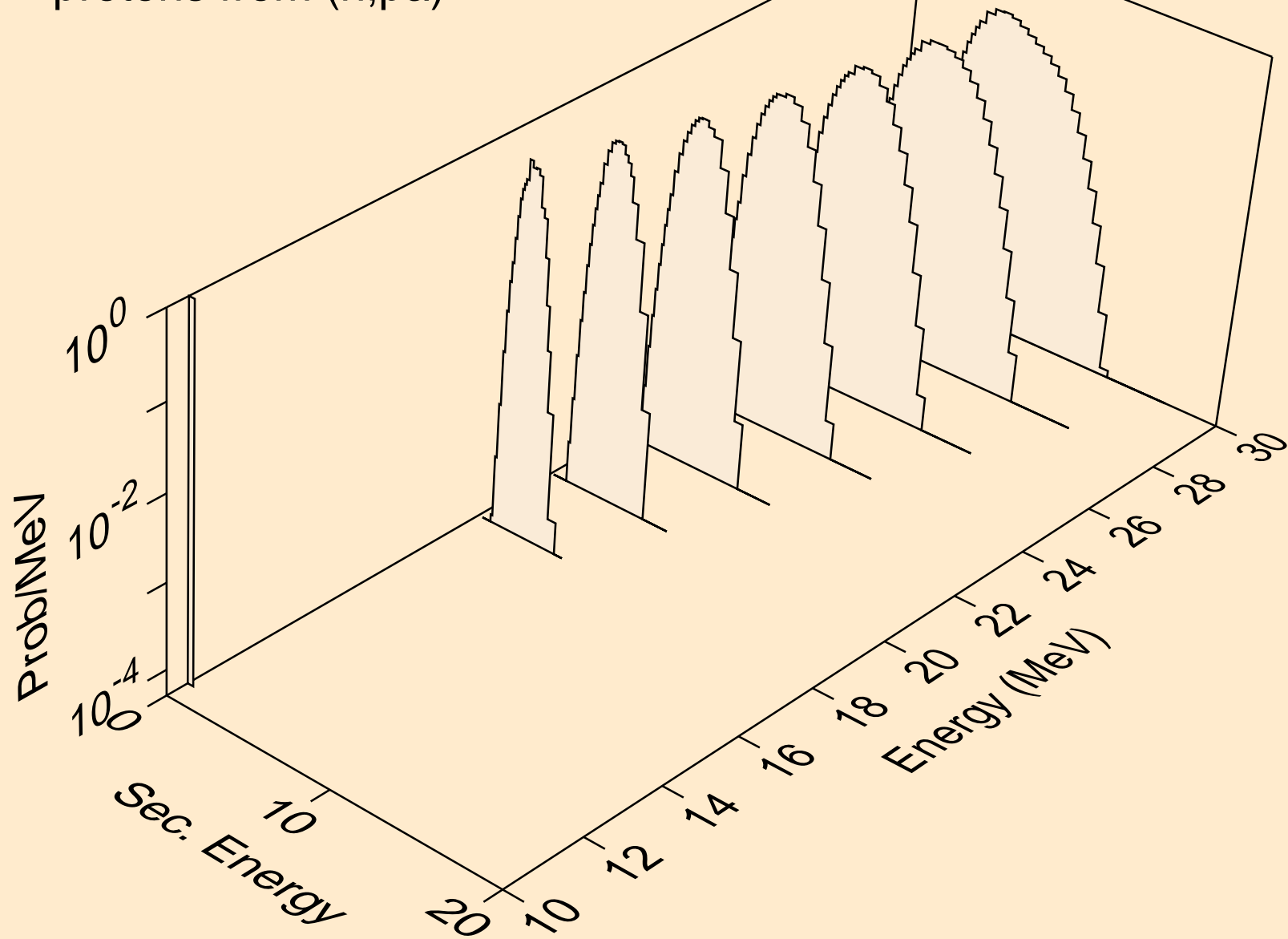

RB090M NEUTRON ACER TENDL-2024 LIBRARY; T=0.K
deuterons from (n,x)

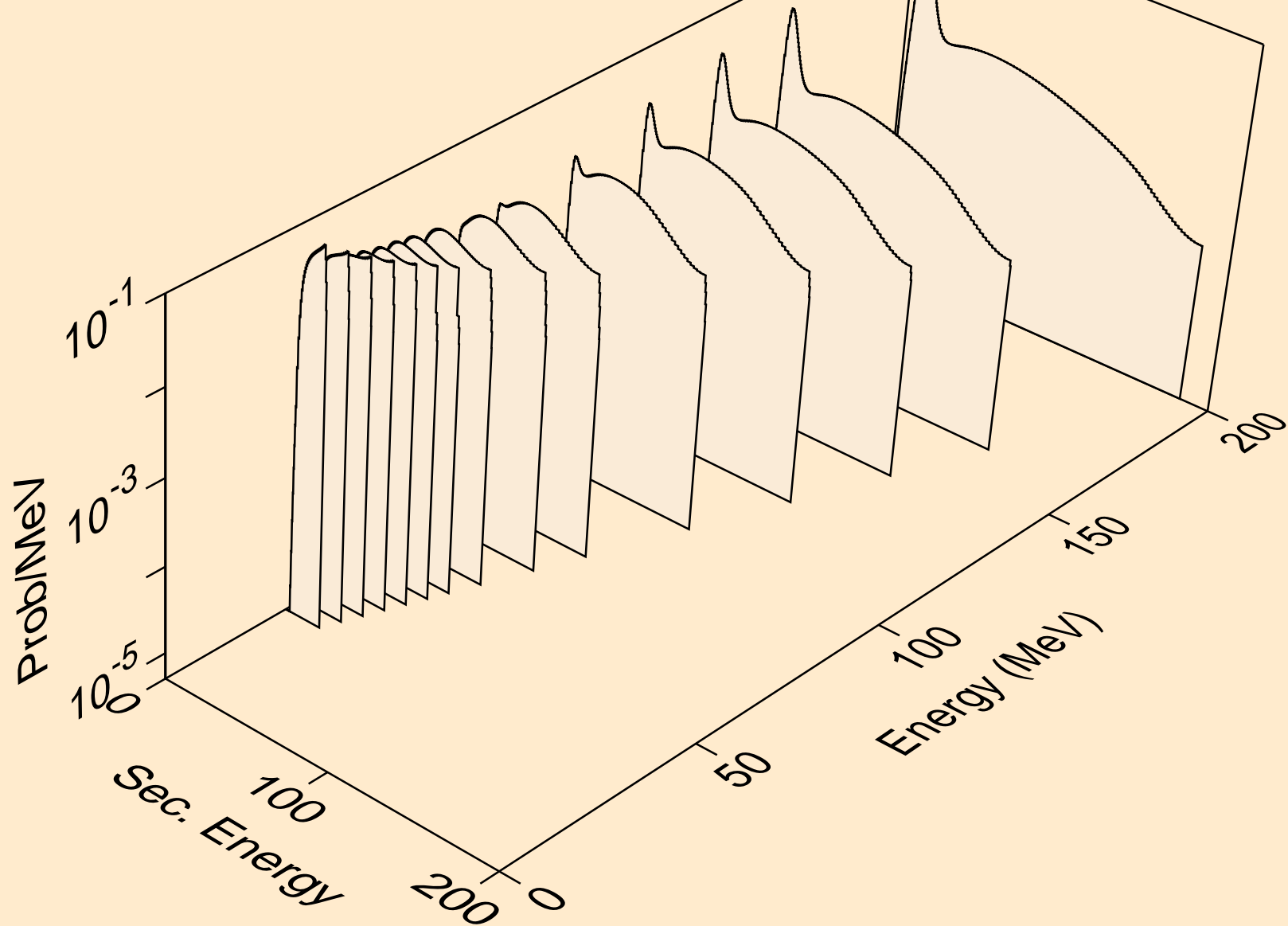

RB090M NEUTRON ACER TENDL-2024 LIBRARY; T=0.K
deuterons from (n,2nd)

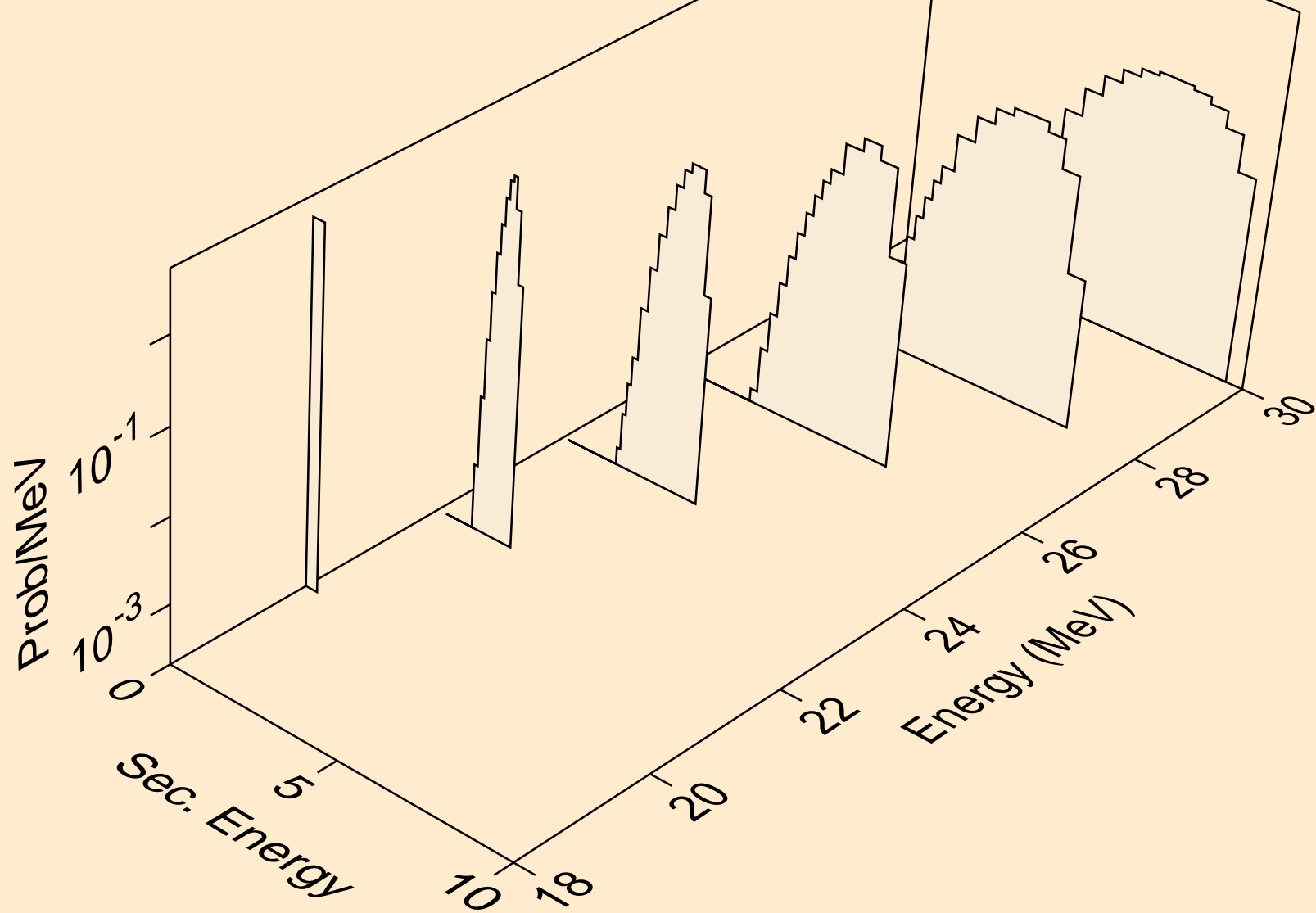

RB090M NEUTRON ACER TENDL-2024 LIBRARY; T=0.K
deuterons from (n,n*)d

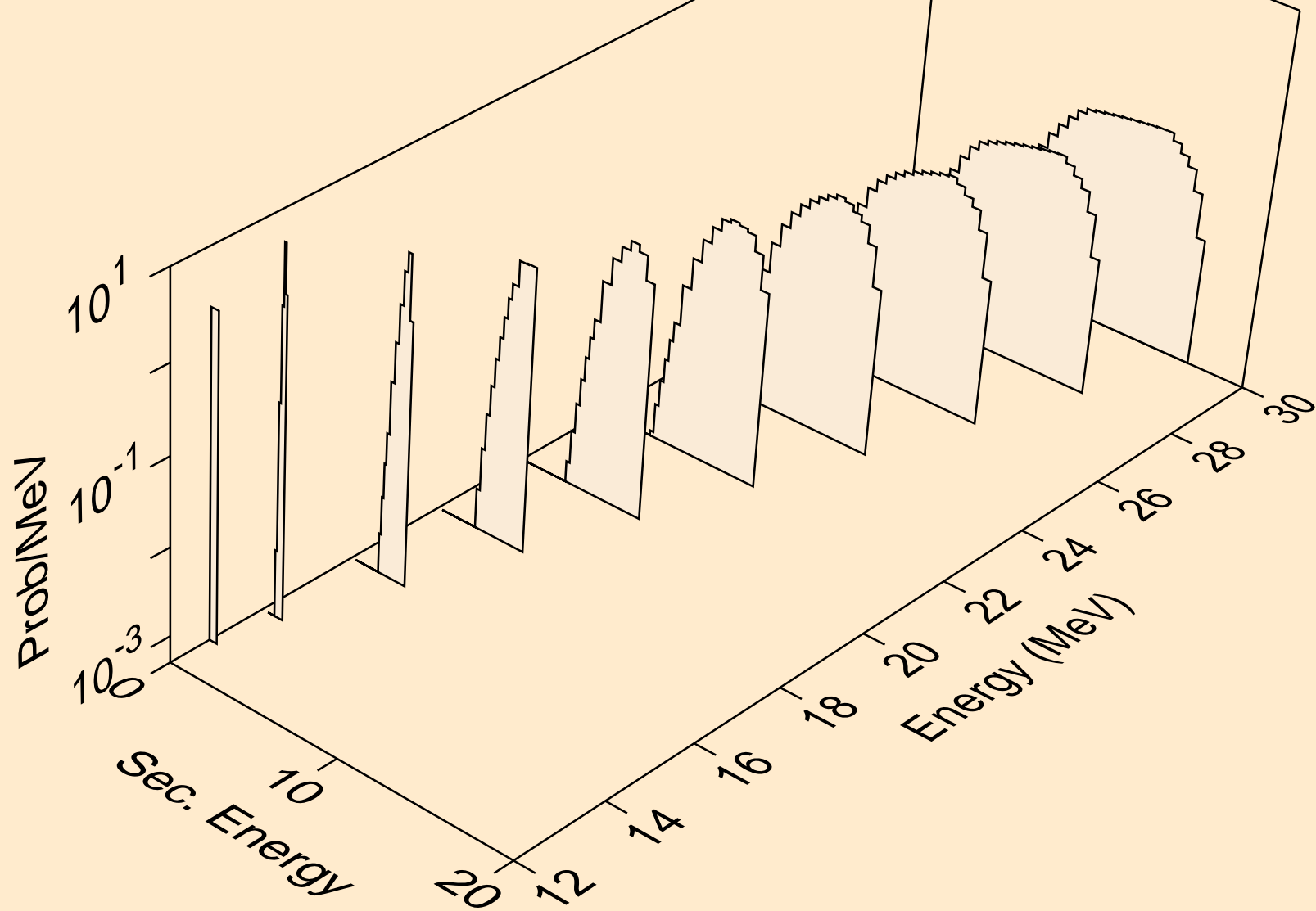

RB090M NEUTRON ACER TENDL-2024 LIBRARY; T=0.K
deuterons from (n,d)

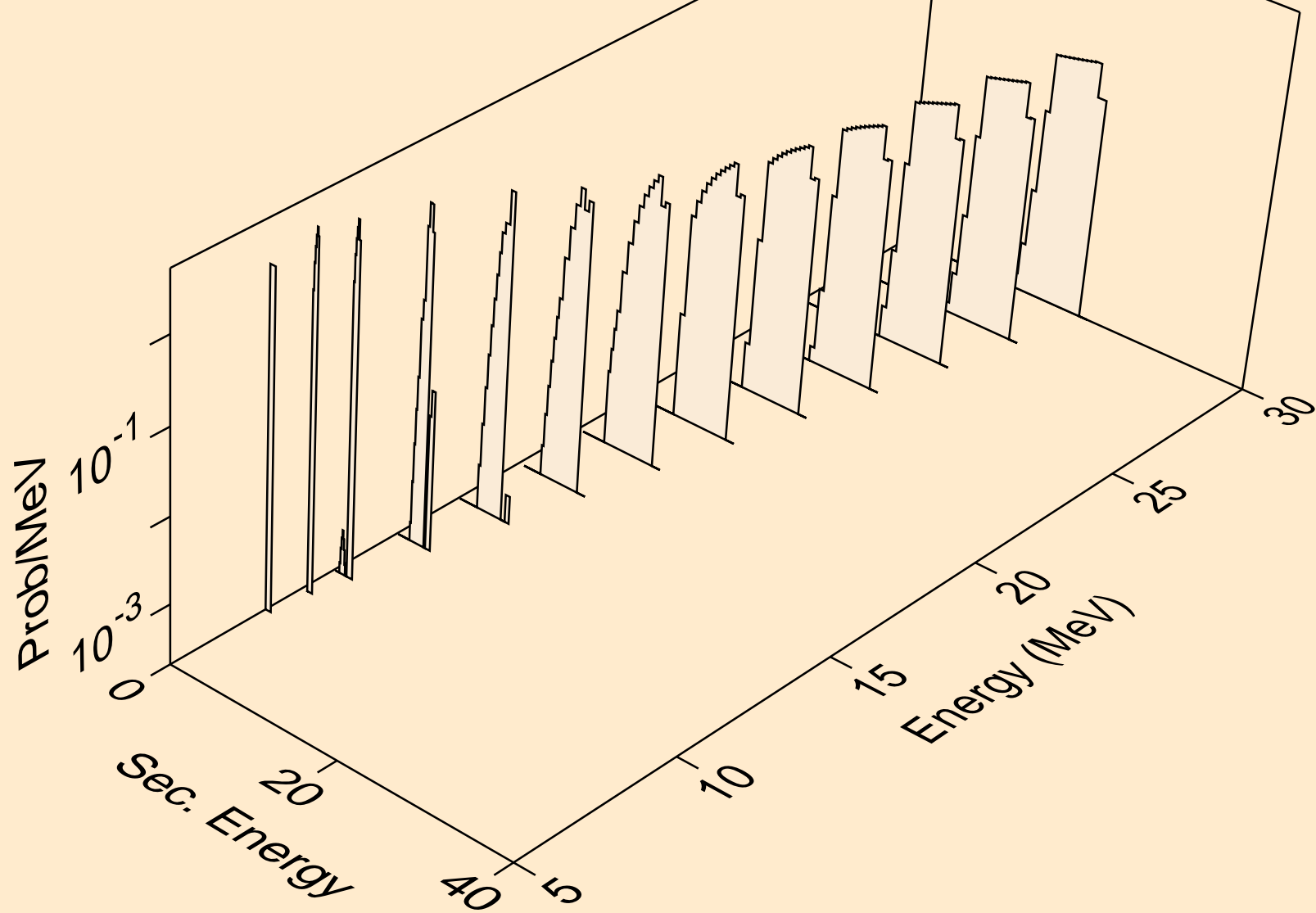

RB090M NEUTRON ACER TENDL-2024 LIBRARY; T=0.K
deuterons from (n,da)

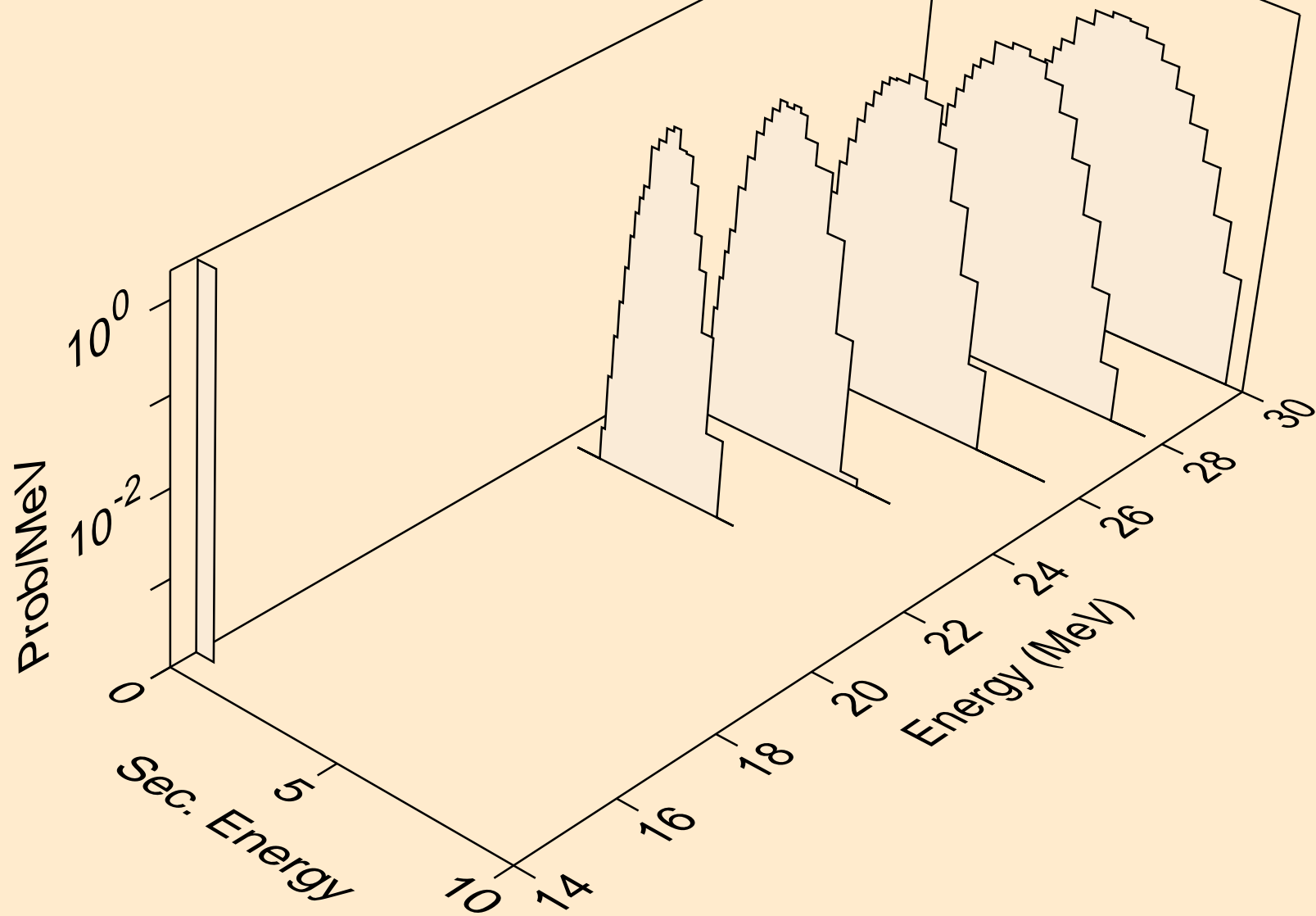

RB090M NEUTRON ACER TENDL-2024 LIBRARY; T=0.K
tritons from (n,x)

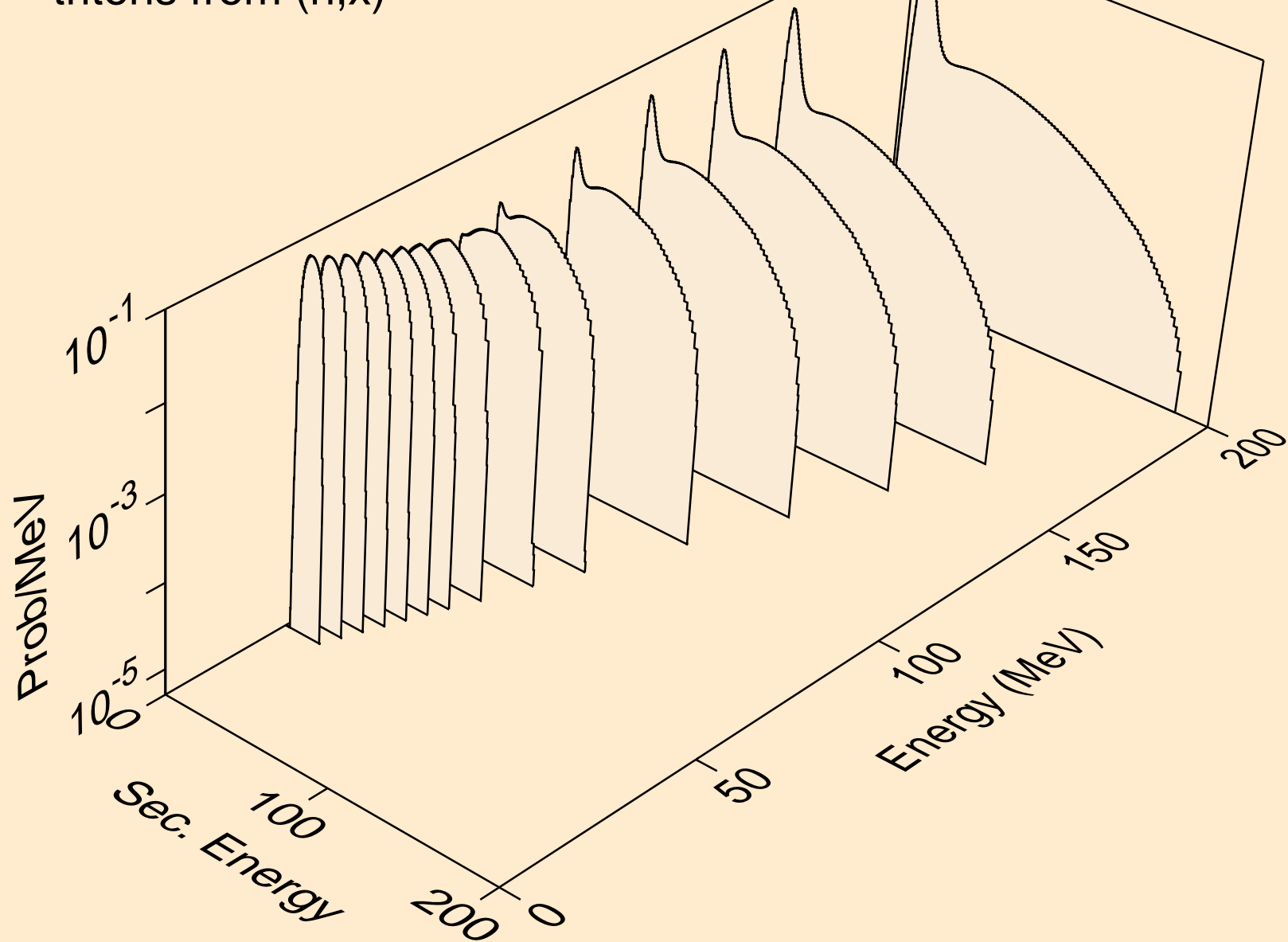

RB090M NEUTRON ACER TENDL-2024 LIBRARY; T=0.K
tritons from (n,n*)t

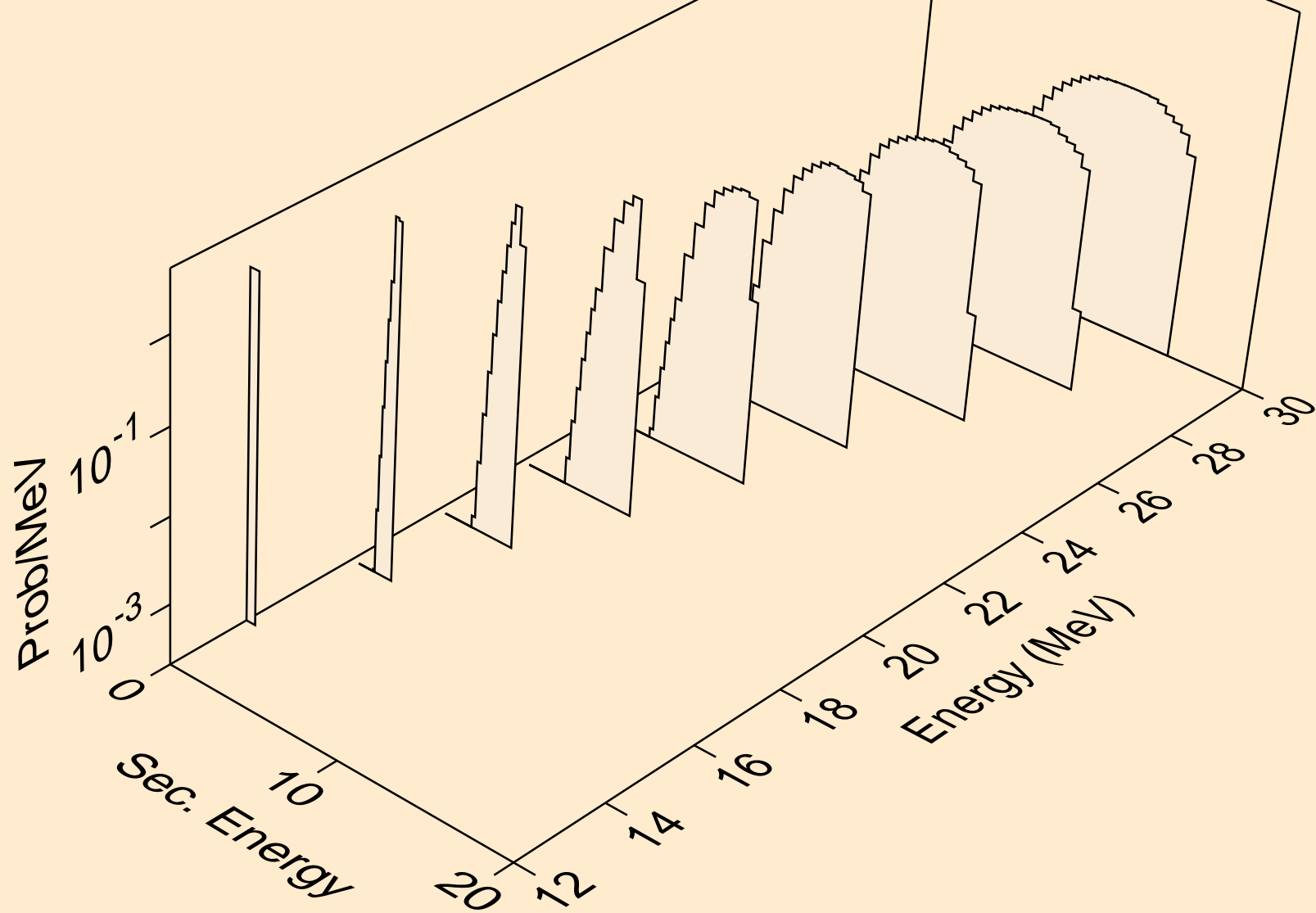

RB090M NEUTRON ACER TENDL-2024 LIBRARY; T=0.K
tritons from (n,t)

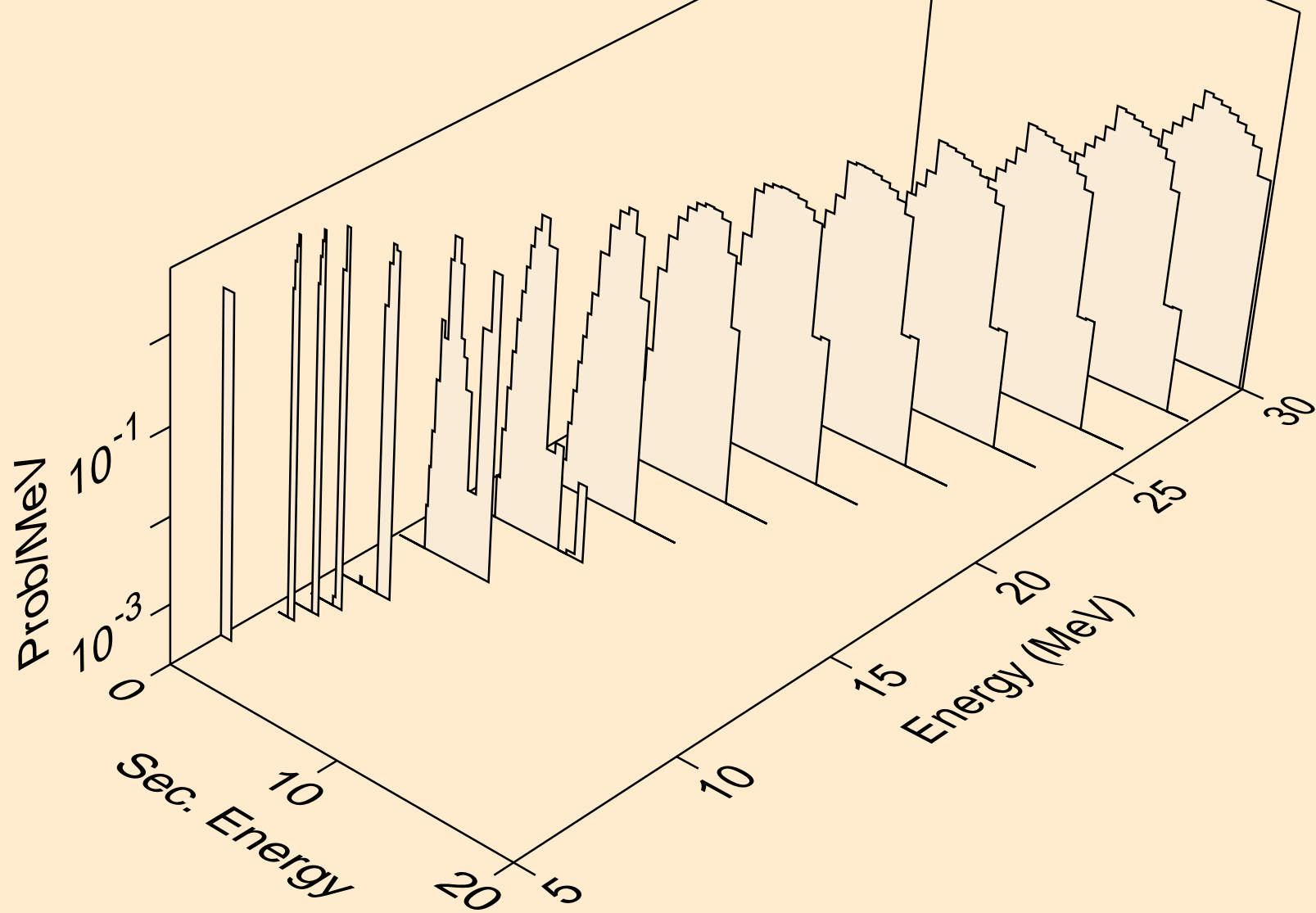

RB090M NEUTRON ACER TENDL-2024 LIBRARY; T=0.K
he3s from (n,x)

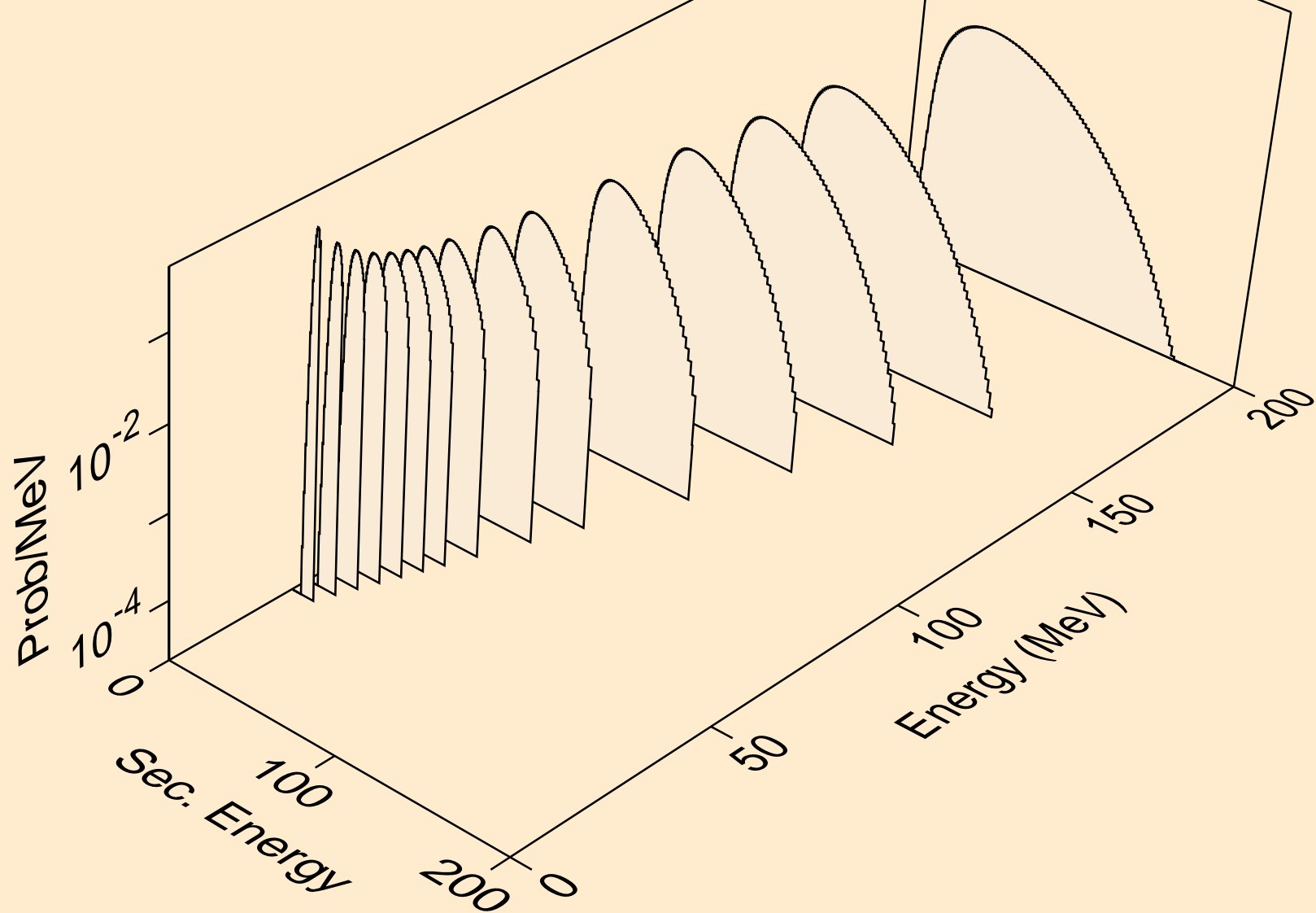

RB090M NEUTRON ACER TENDL-2024 LIBRARY; T=0.K
he3s from (n,n*)he3

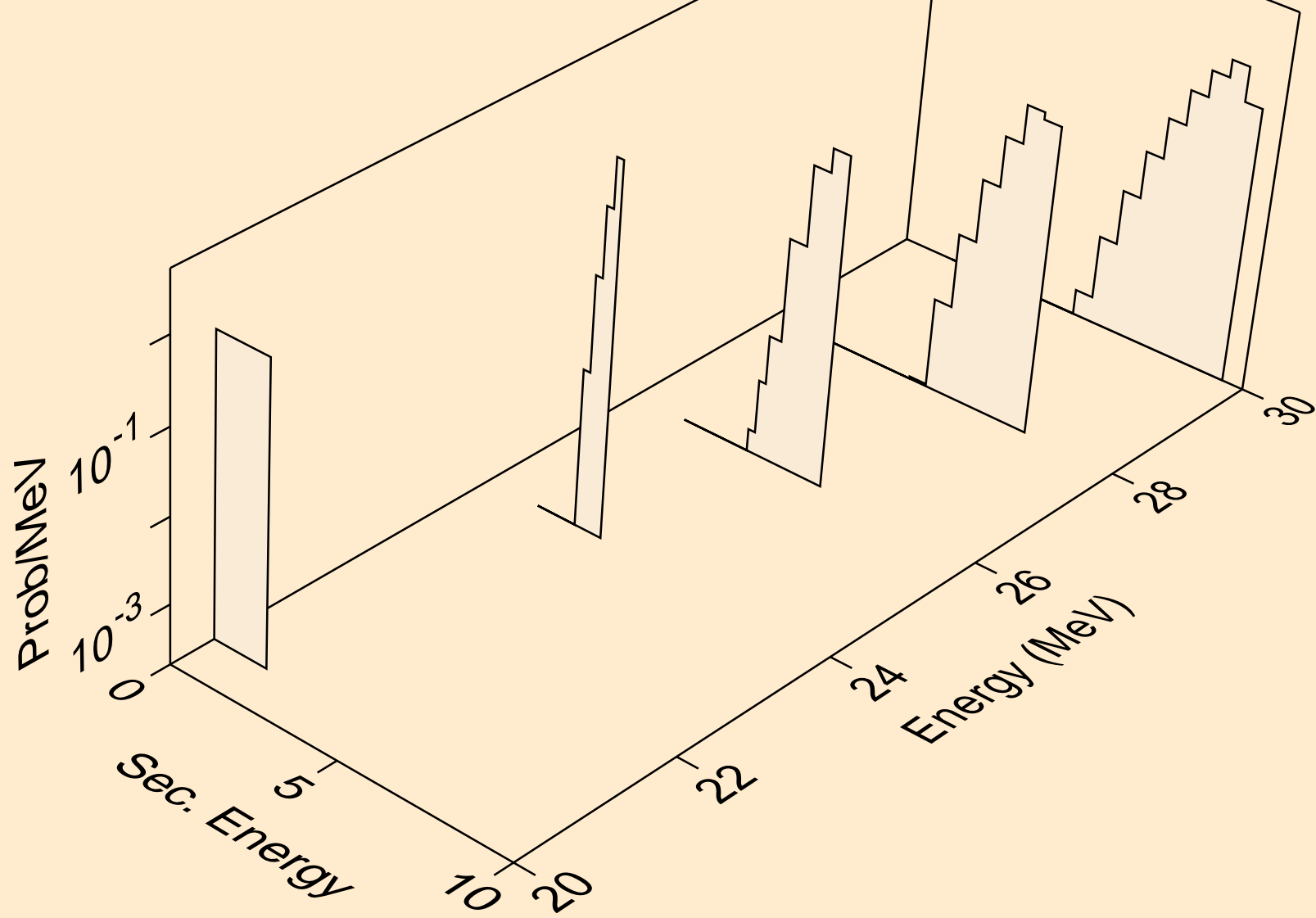

RB090M NEUTRON ACER TENDL-2024 LIBRARY; T=0.K
he3s from (n,he3)

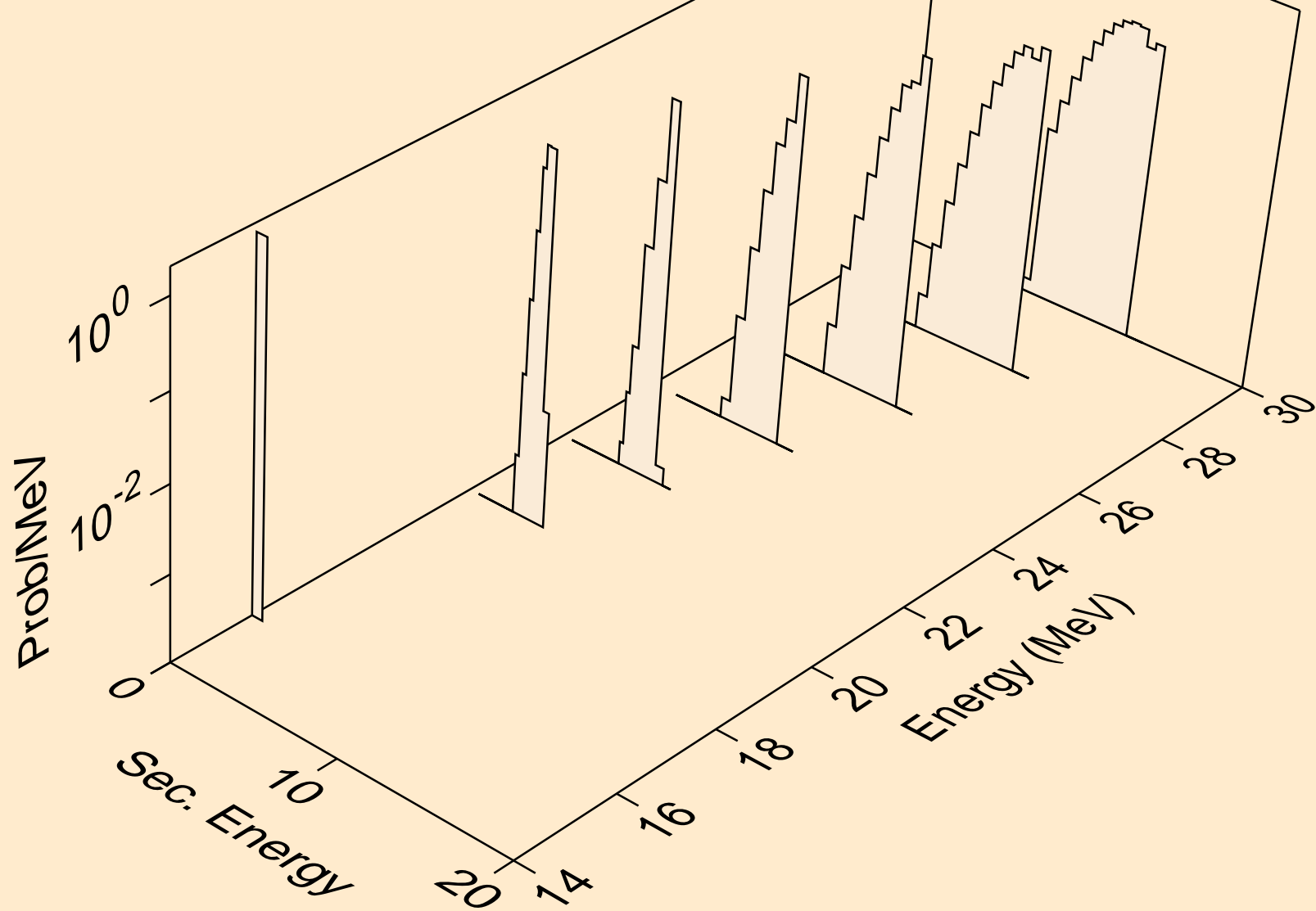

RB090M NEUTRON ACER TENDL-2024 LIBRARY; T=0.K
alphas from (n,x)

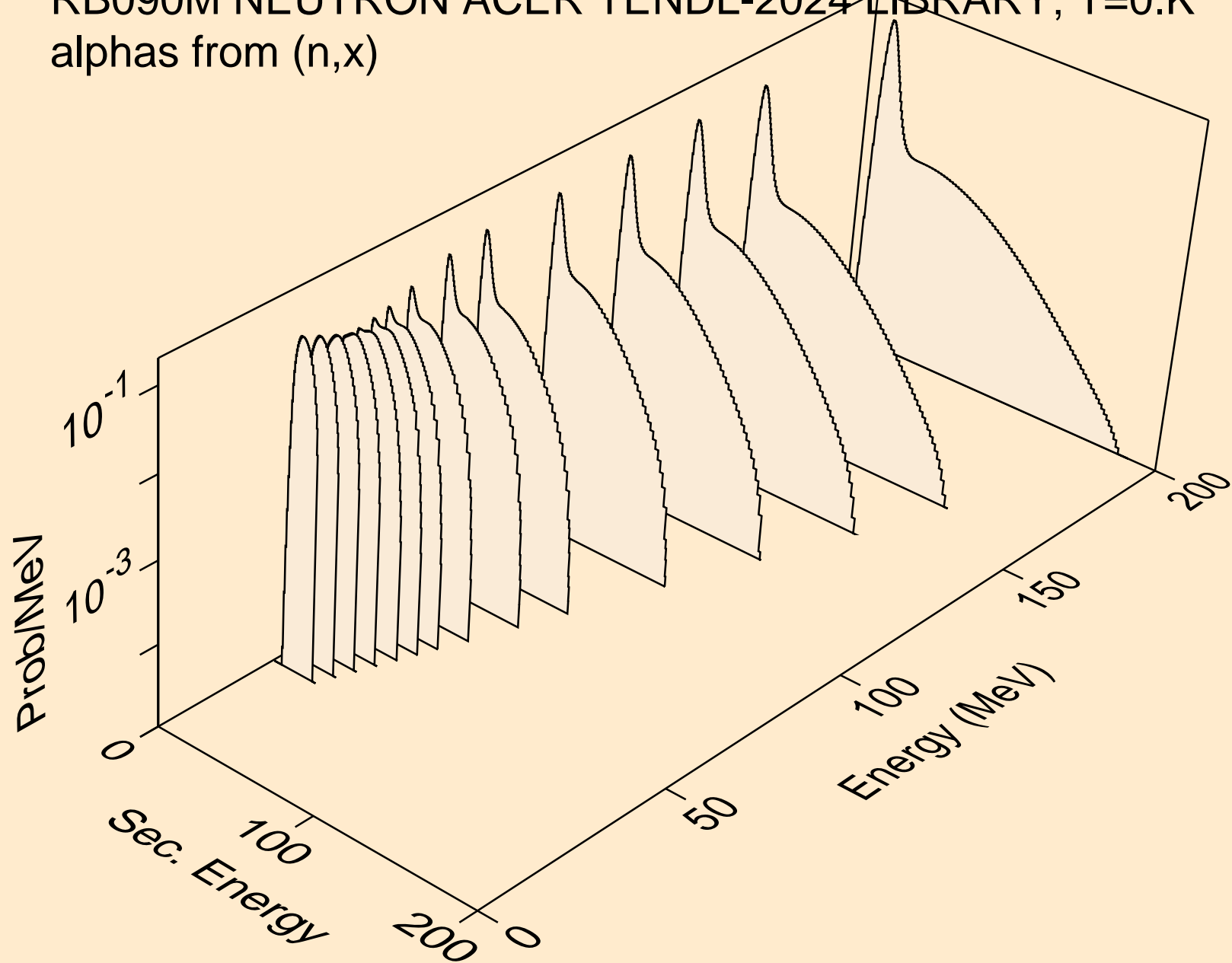

RB090M NEUTRON ACER TENDL-2024 LIBRARY; T=0.K
alphas from (n,n*)a

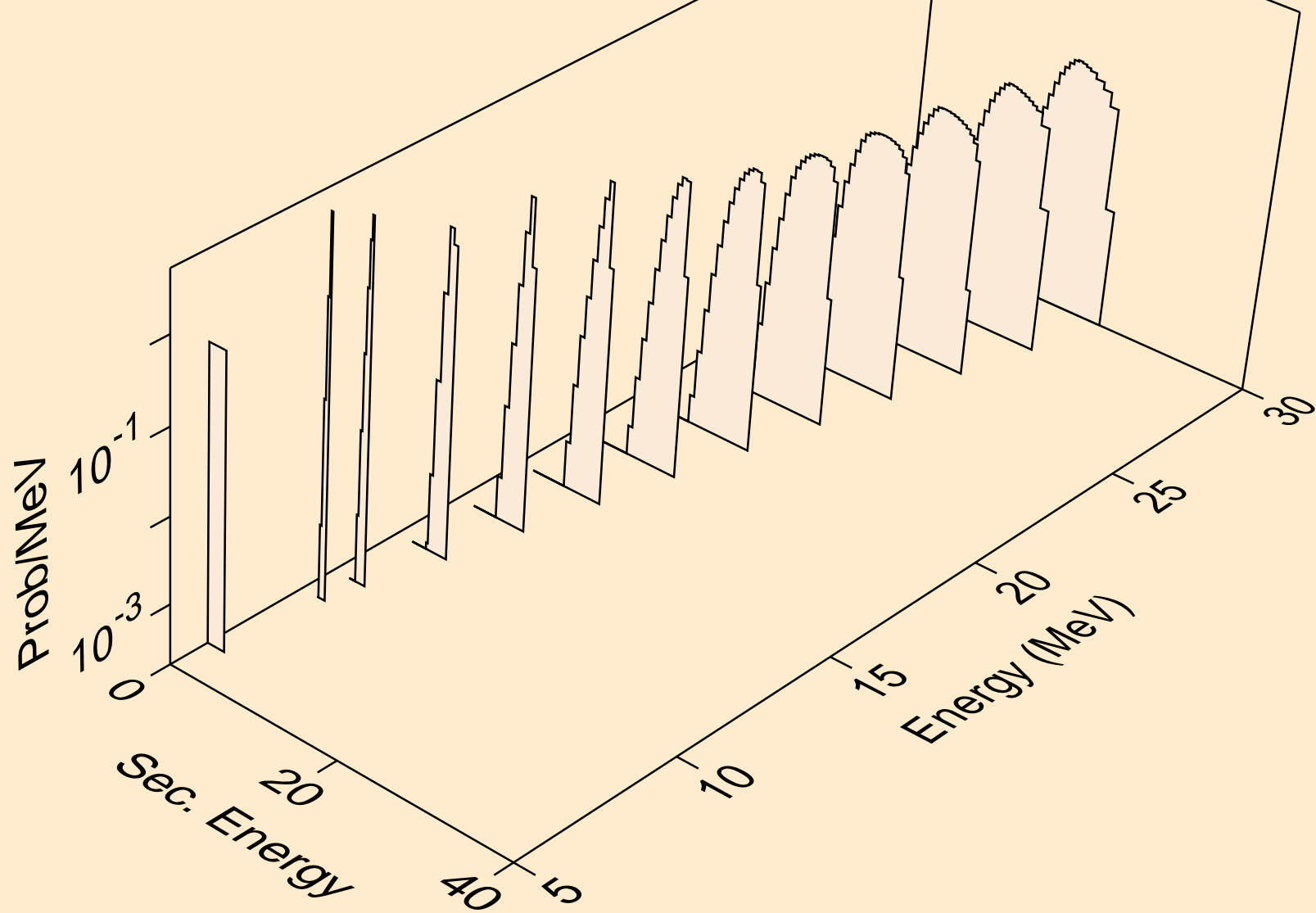

RB090M NEUTRON ACER TENDL-2024 LIBRARY; T=0.K
alphas from (n,2n)a

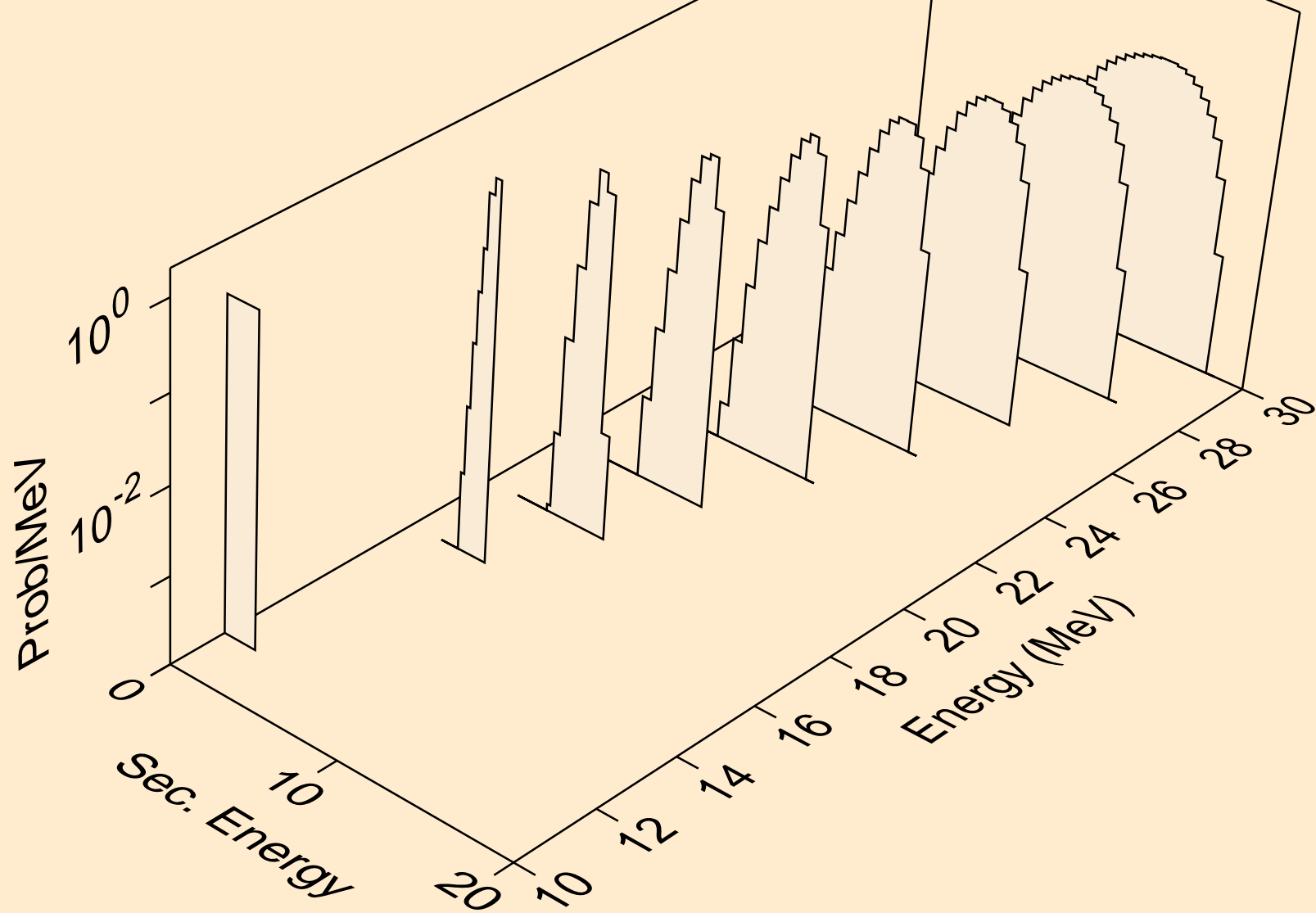

RB090M NEUTRON ACER TENDL-2024 LIBRARY; T=0.K
alphas from (n,3n)a

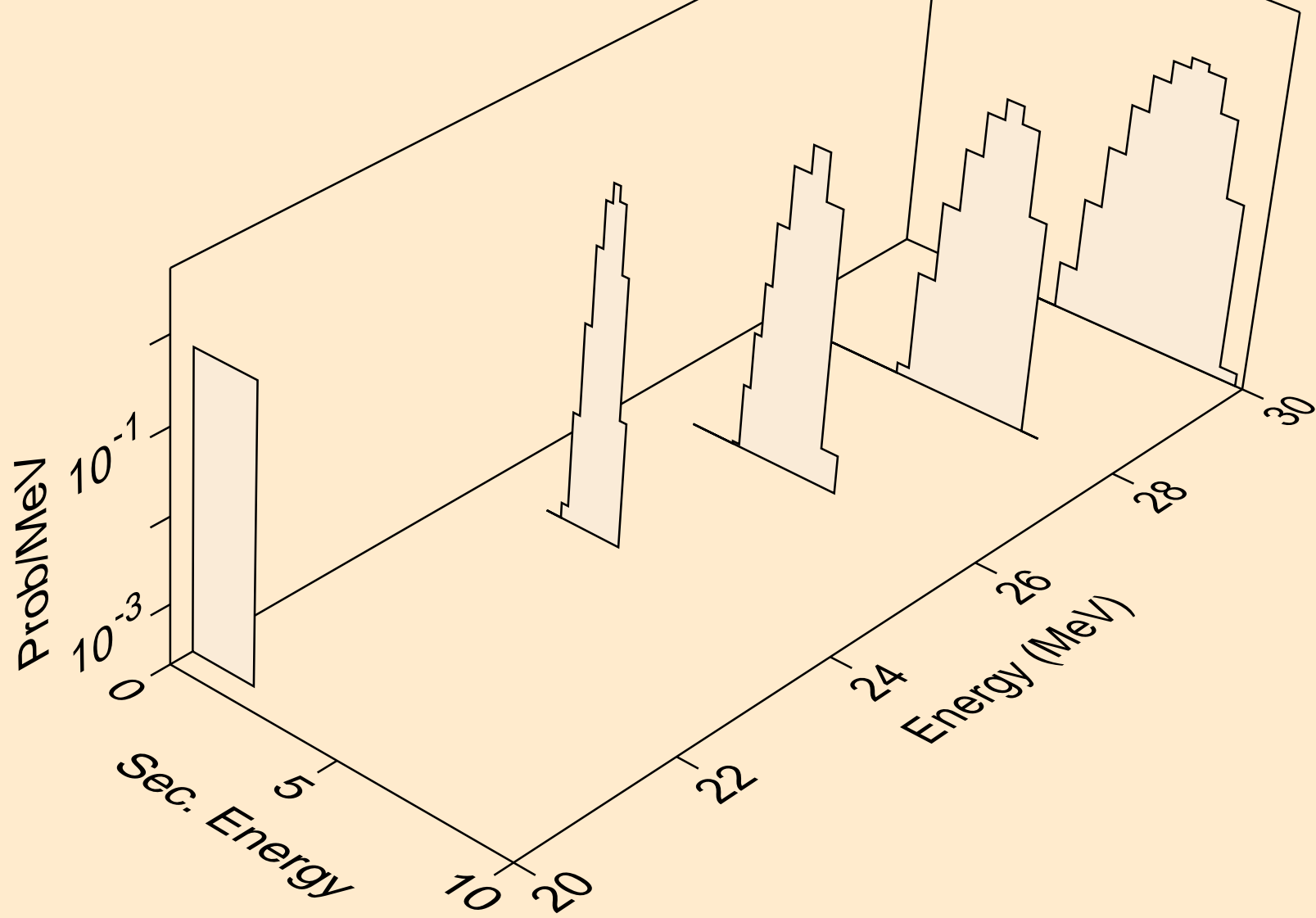

RB090M NEUTRON ACER TENDL-2024 LIBRARY; T=0.K
alphas from (n,a)

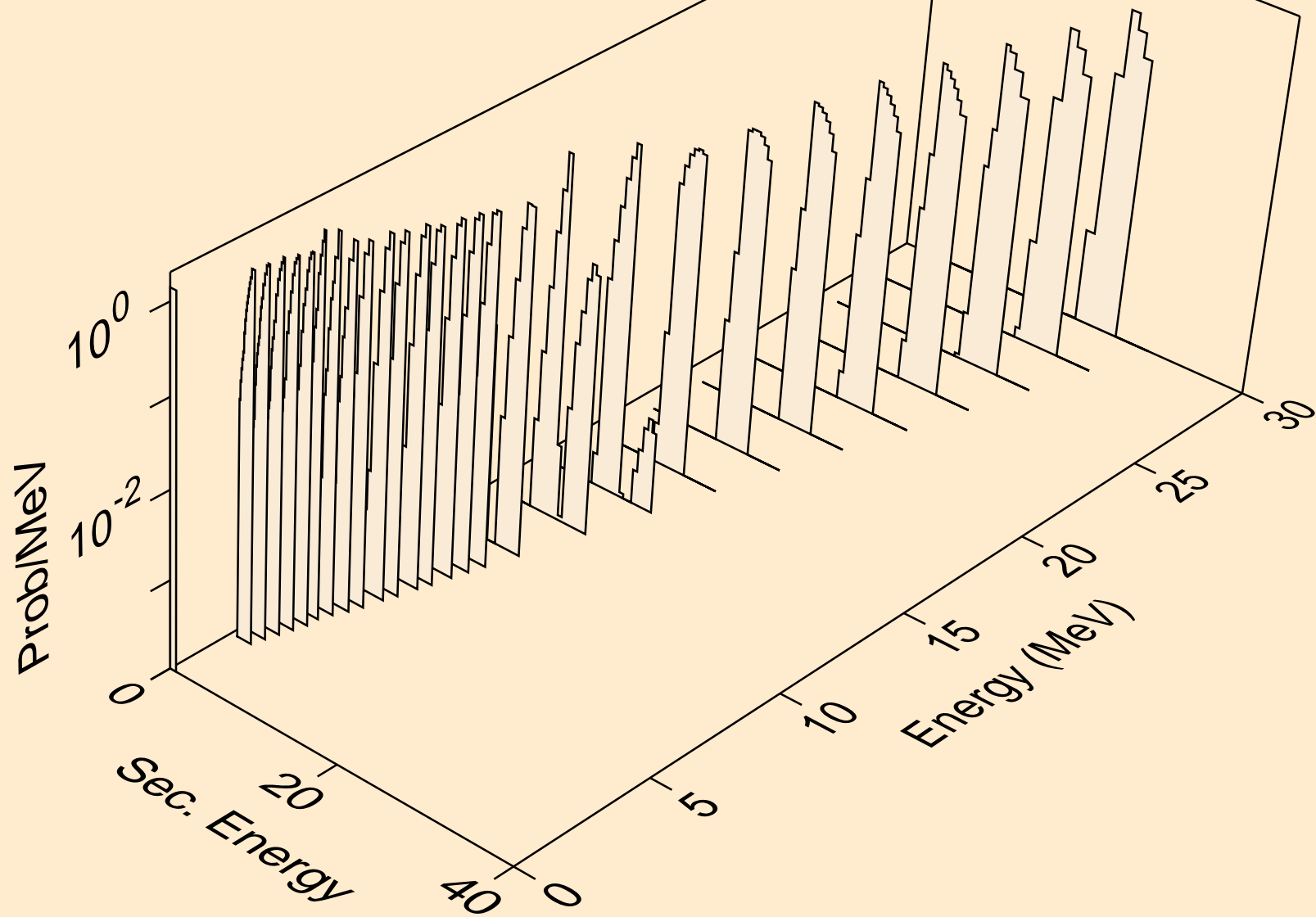

RB090M NEUTRON ACER TENDL-2024 LIBRARY; T=0.K
alphas from (n,2a)

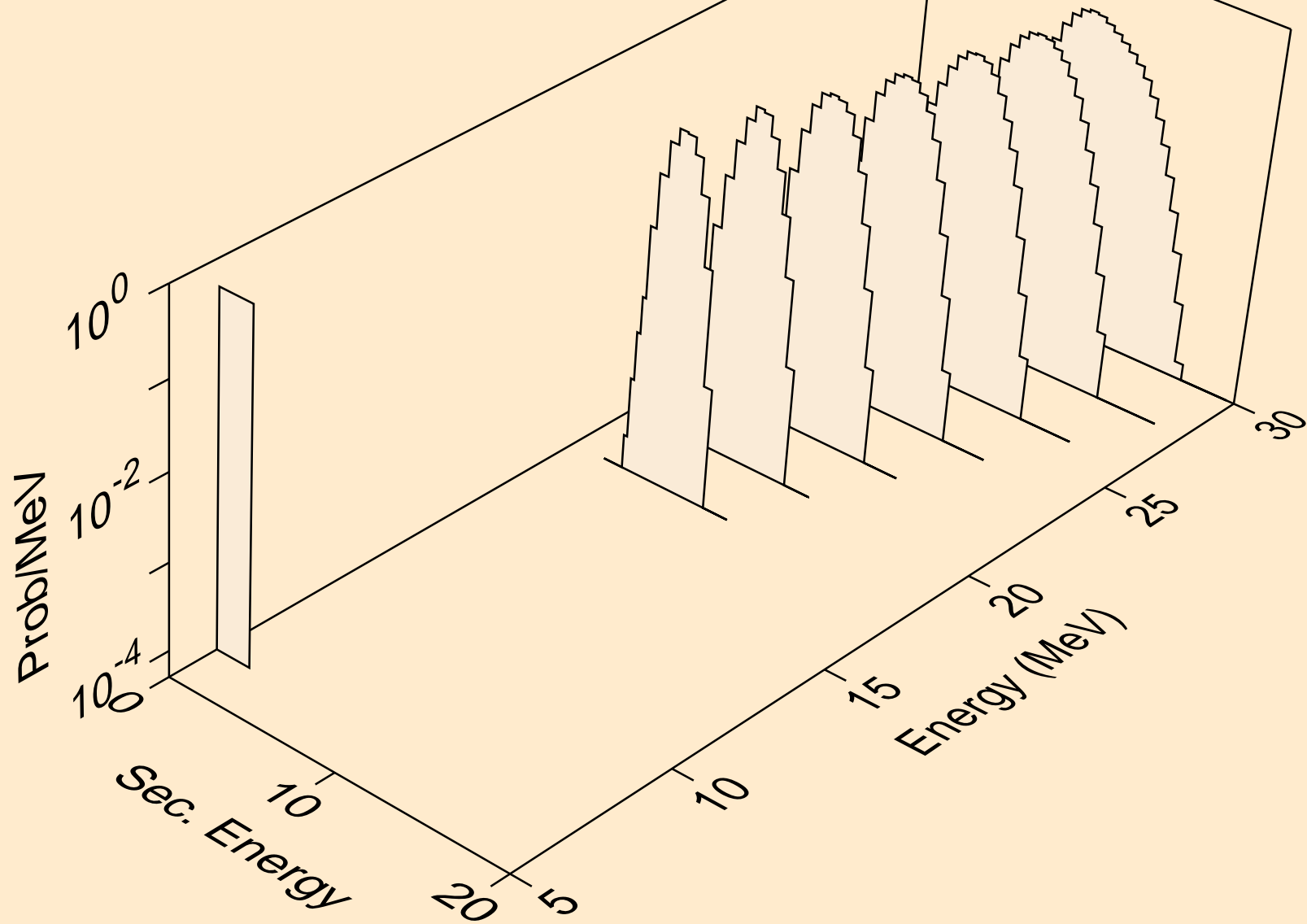

RB090M NEUTRON ACER TENDL-2024 LIBRARY; T=0.K
alphas from (n,pa)

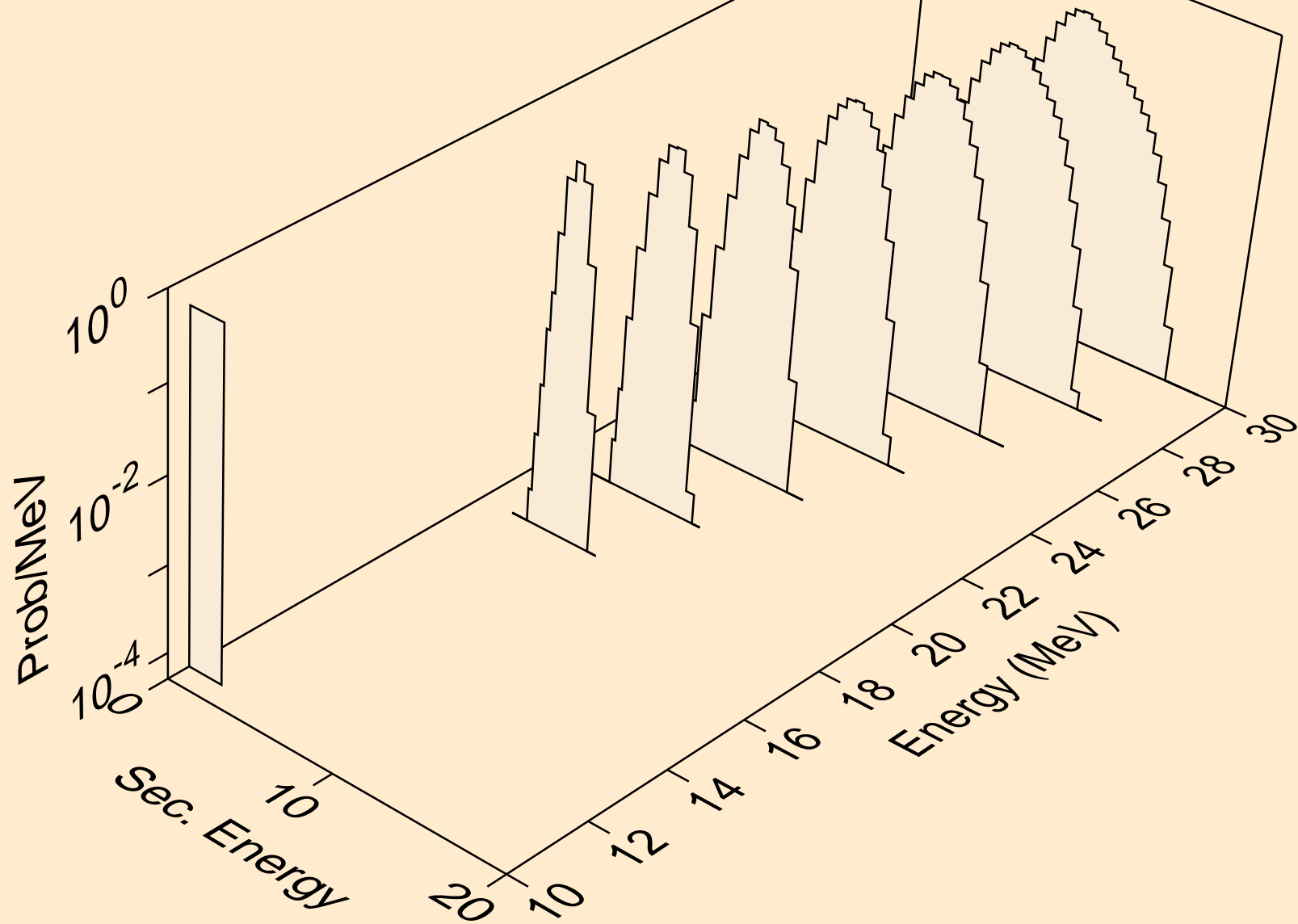

RB090M NEUTRON ACER TENDL-2024 LIBRARY; T=0.K
alphas from (n,da)

