

RE185 NEUTRON ACER TENDL-2024 LIBRARY; T=0.K

Principal cross sections

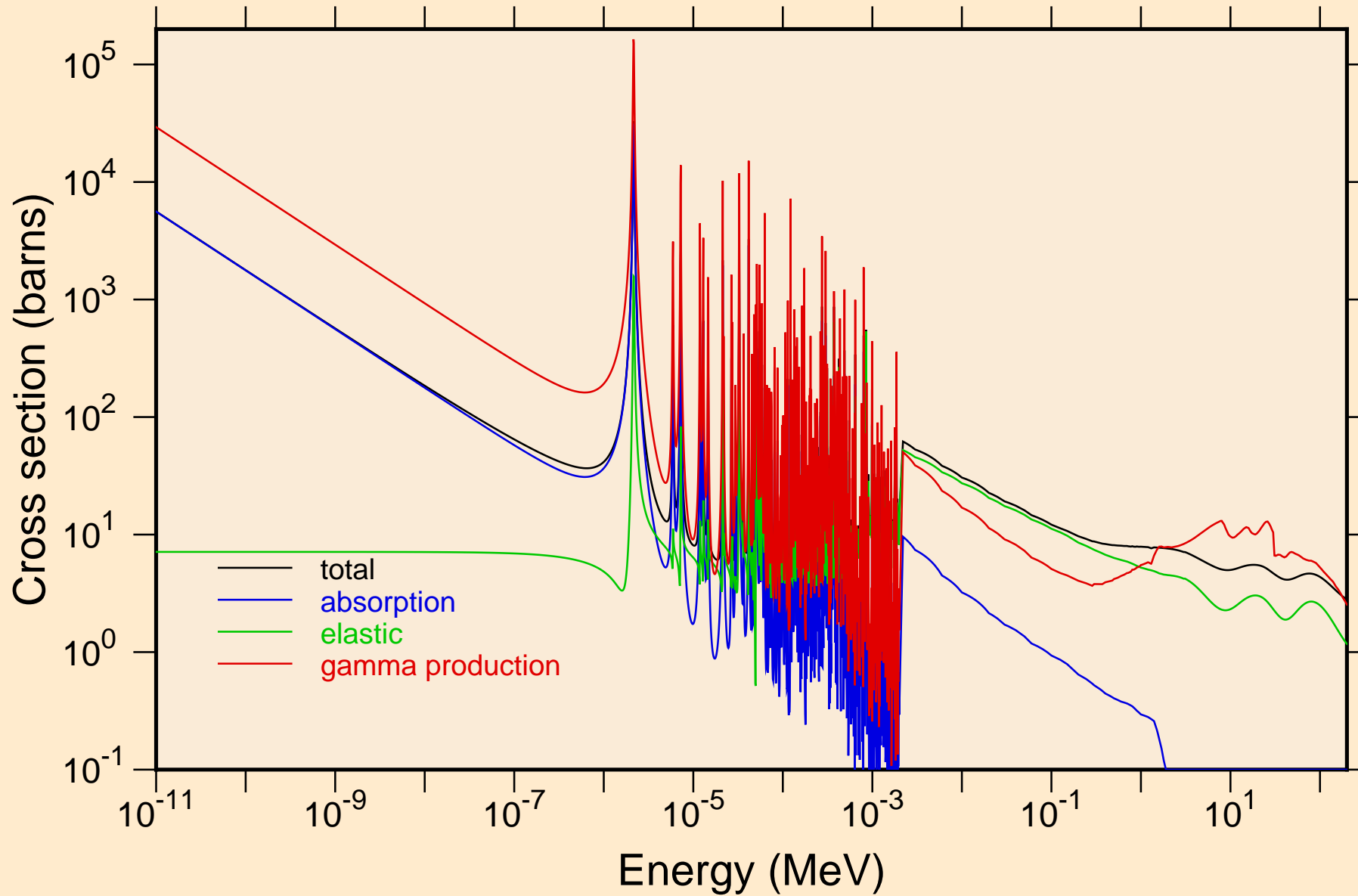

RE185 NEUTRON ACER TENDL-2024 LIBRARY; T=0.K
resonance total cross section

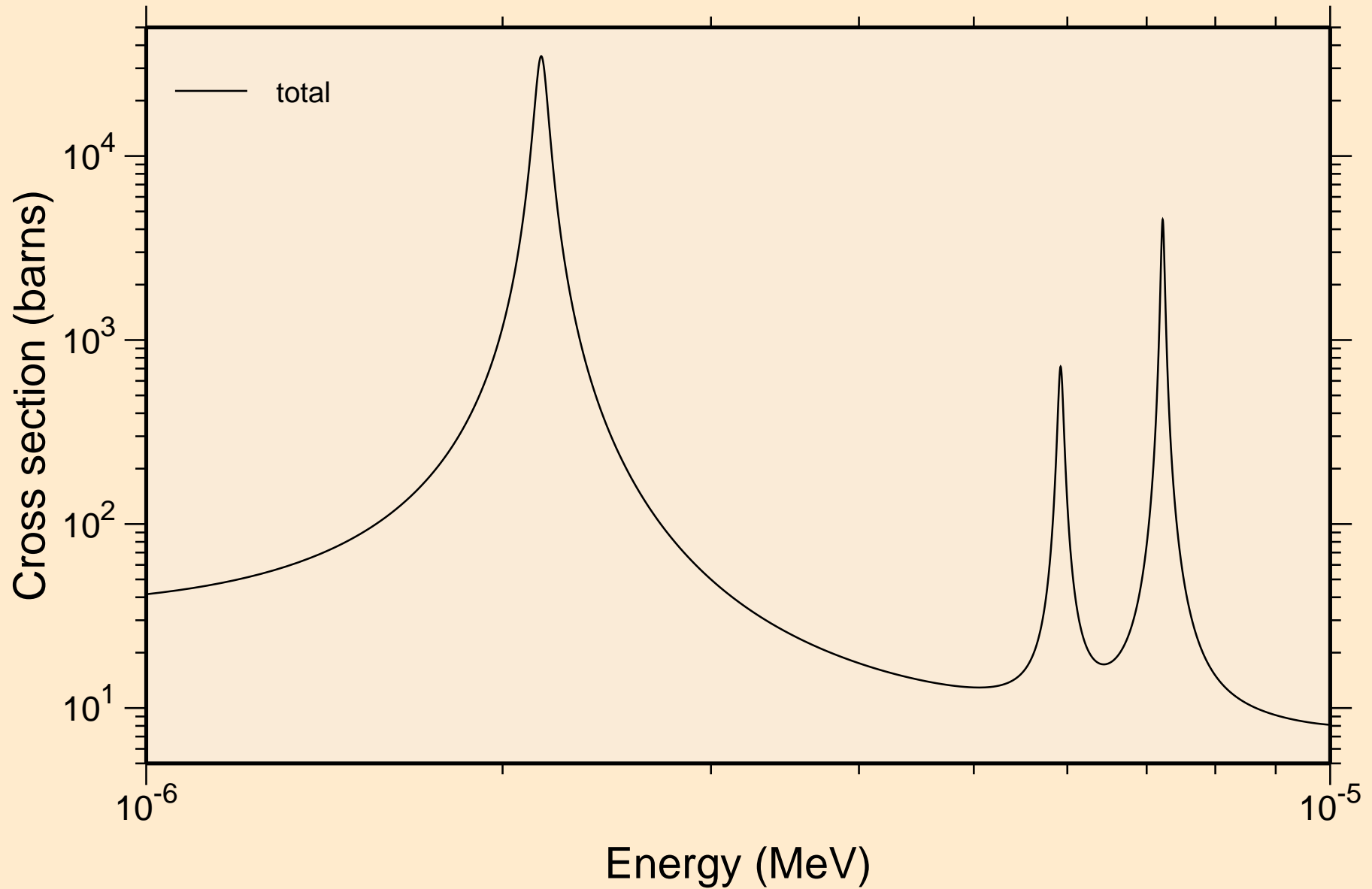

RE185 NEUTRON ACER TENDL-2024 LIBRARY; T=0.K
resonance total cross section

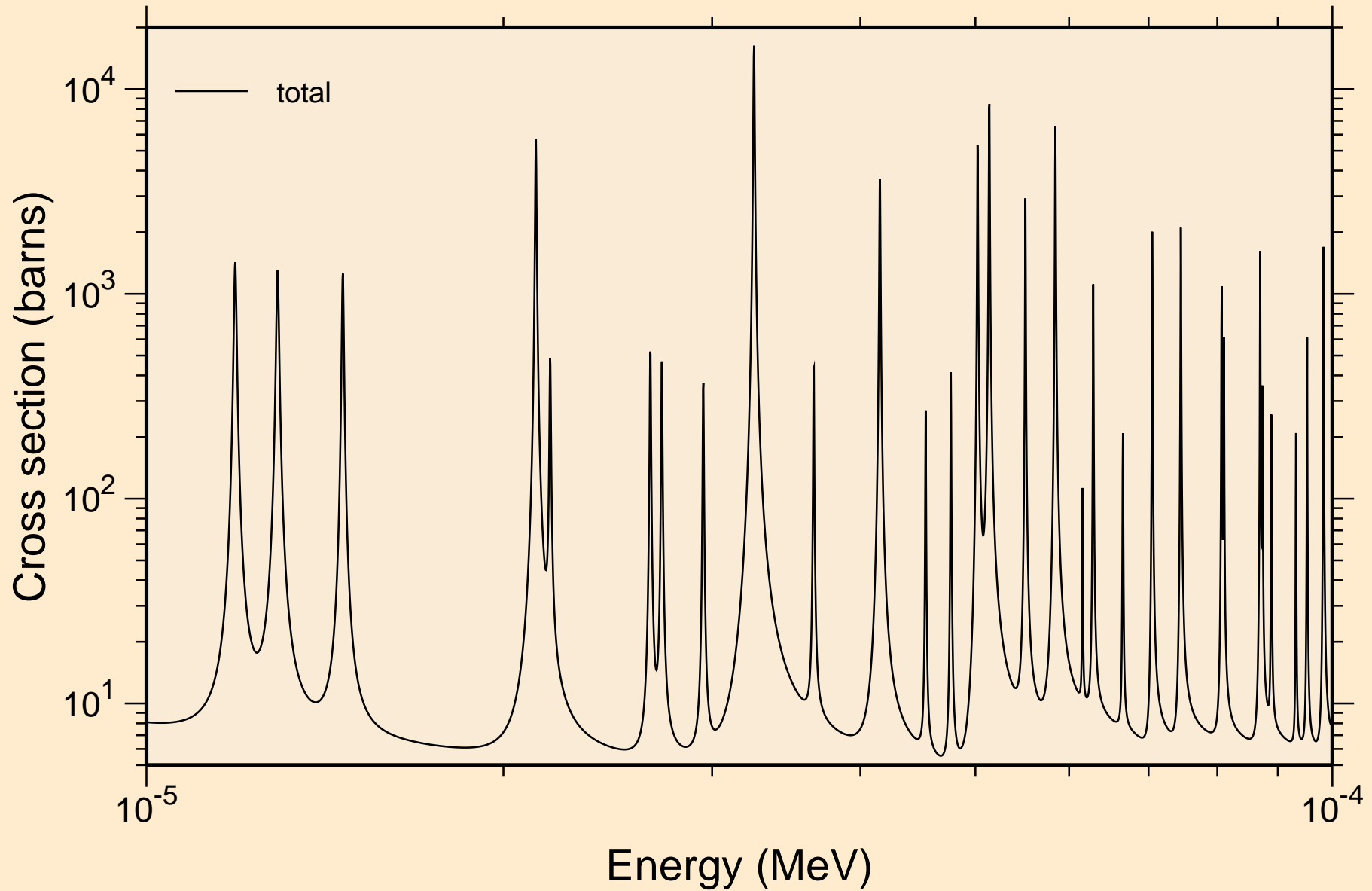

RE185 NEUTRON ACER TENDL-2024 LIBRARY; T=0.K
resonance total cross section

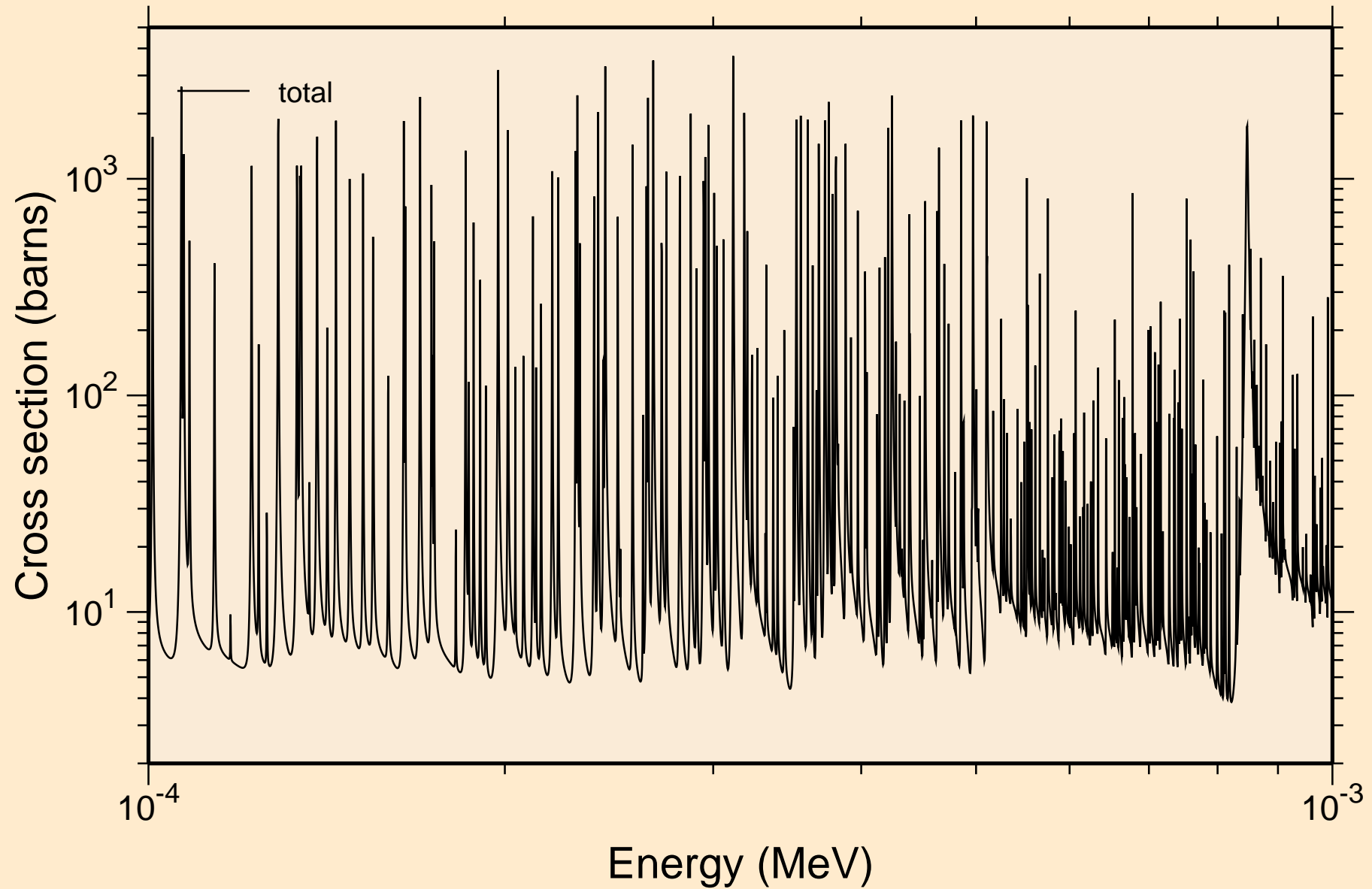

RE185 NEUTRON ACER TENDL-2024 LIBRARY; T=0.K
resonance total cross section

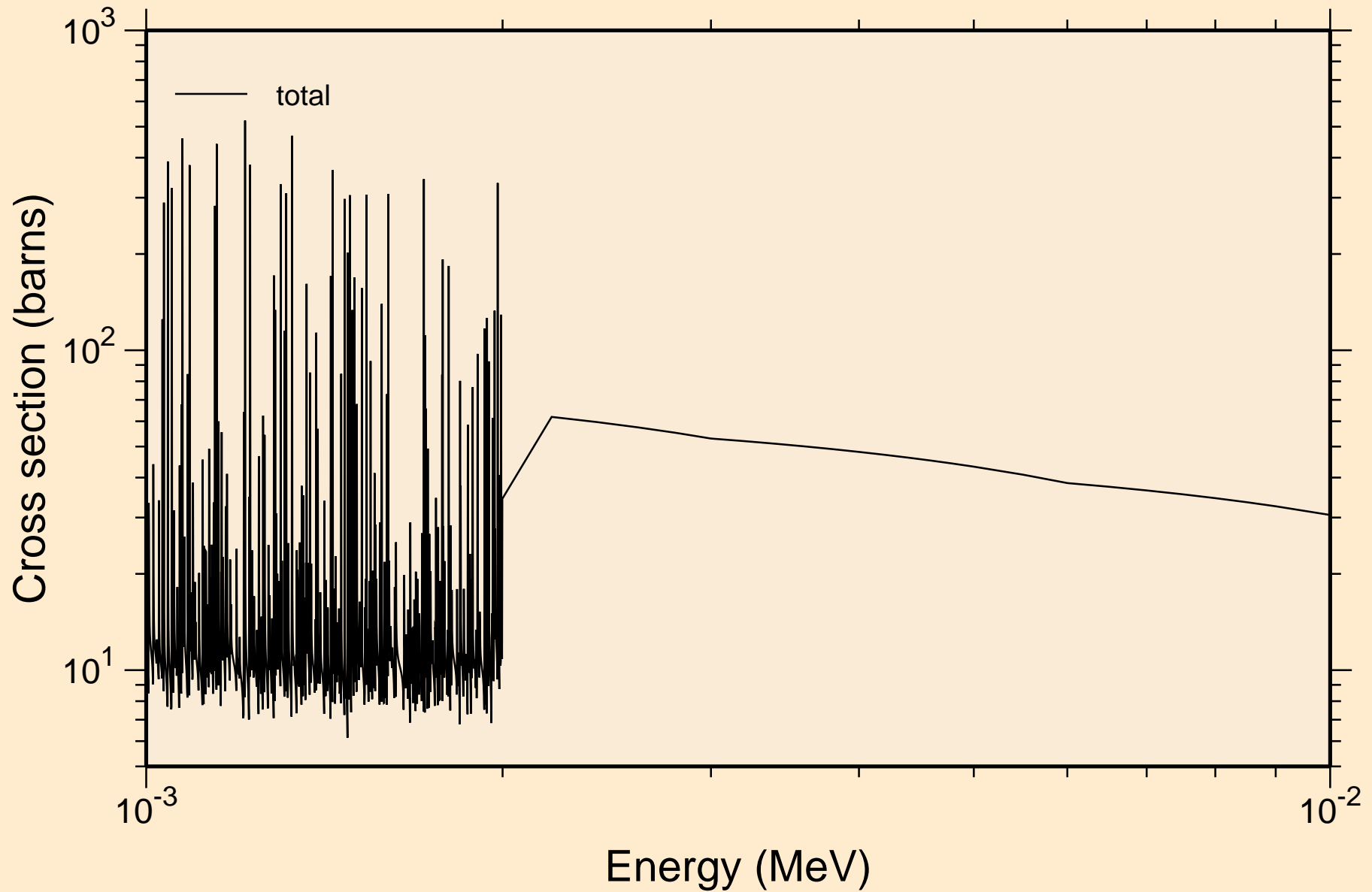

RE185 NEUTRON ACER TENDL-2024 LIBRARY; T=0.K
resonance total cross section

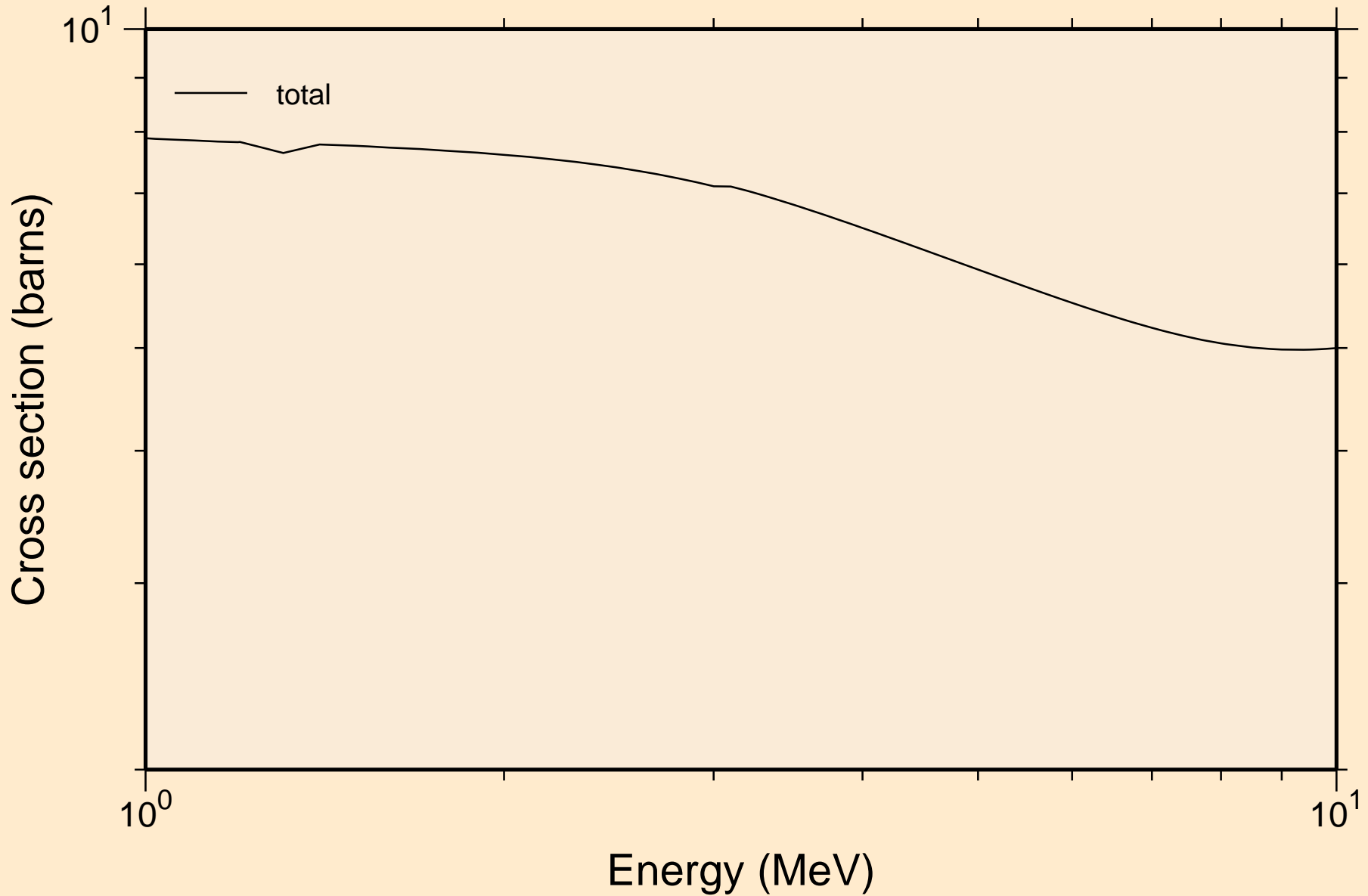

RE185 NEUTRON ACER TENDL-2024 LIBRARY; T=0.K
resonance absorption cross sections

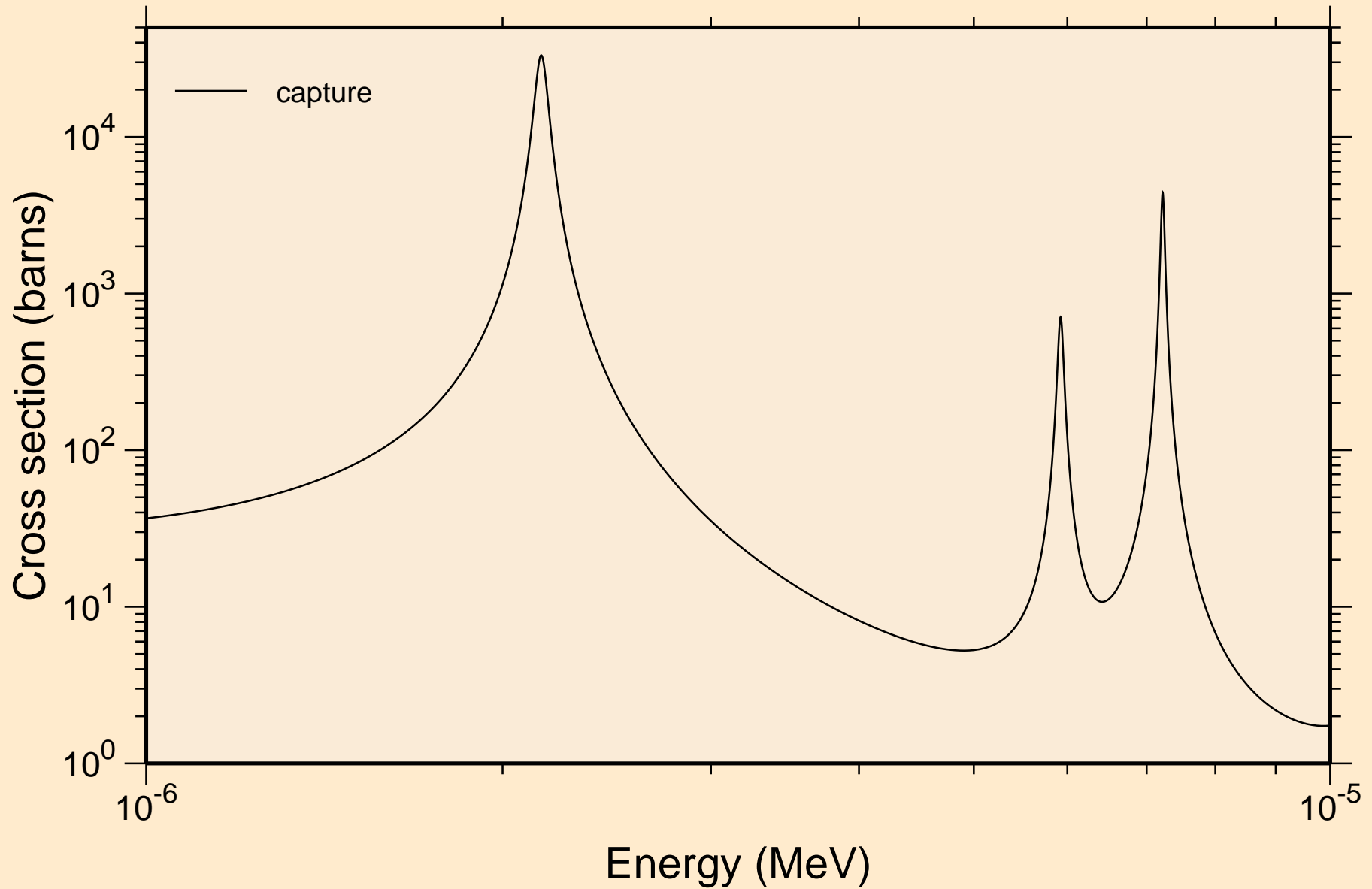

RE185 NEUTRON ACER TENDL-2024 LIBRARY; T=0.K
resonance absorption cross sections

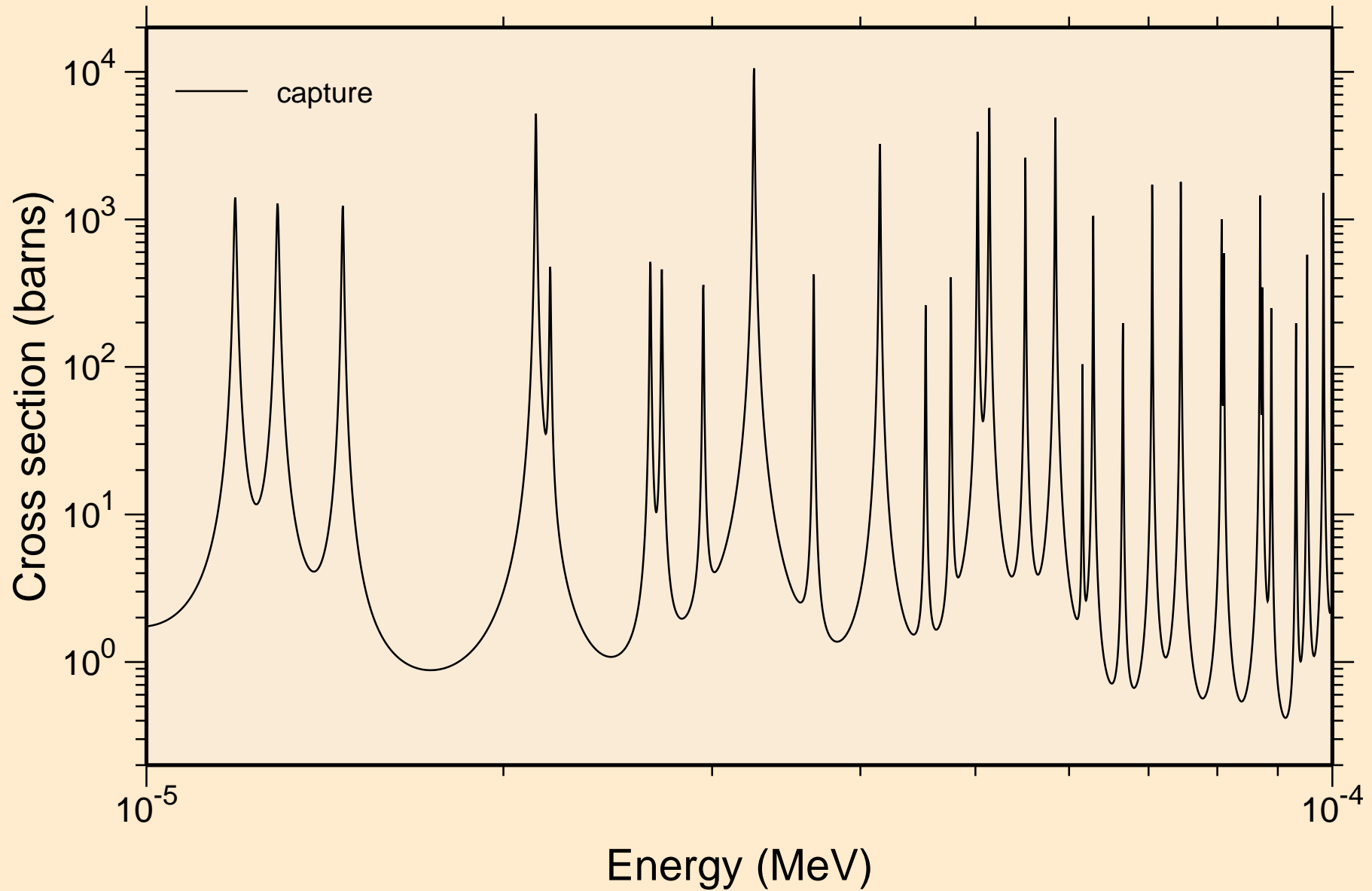

RE185 NEUTRON ACER TENDL-2024 LIBRARY; T=0.K
resonance absorption cross sections

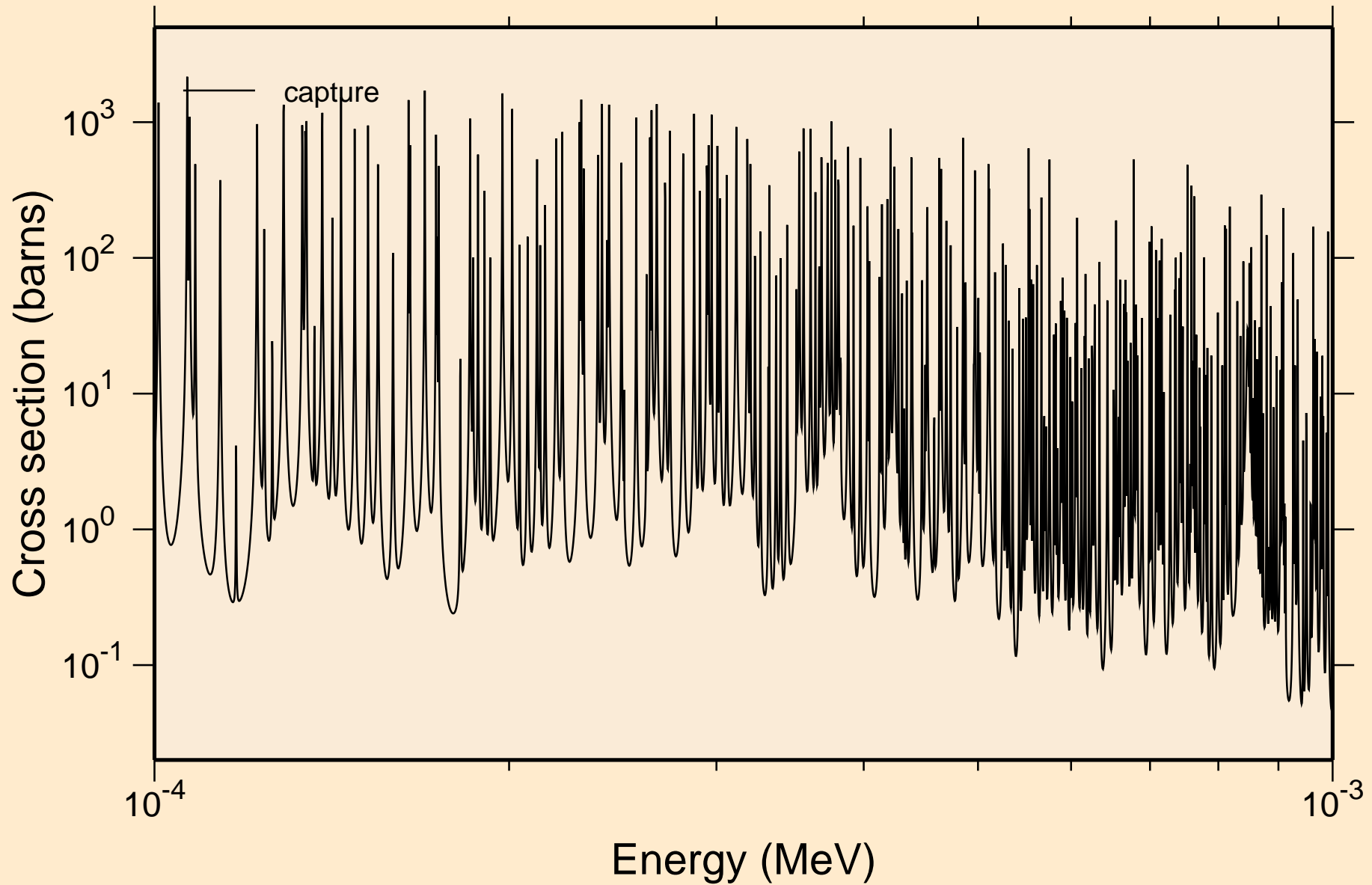

RE185 NEUTRON ACER TENDL-2024 LIBRARY; T=0.K
resonance absorption cross sections

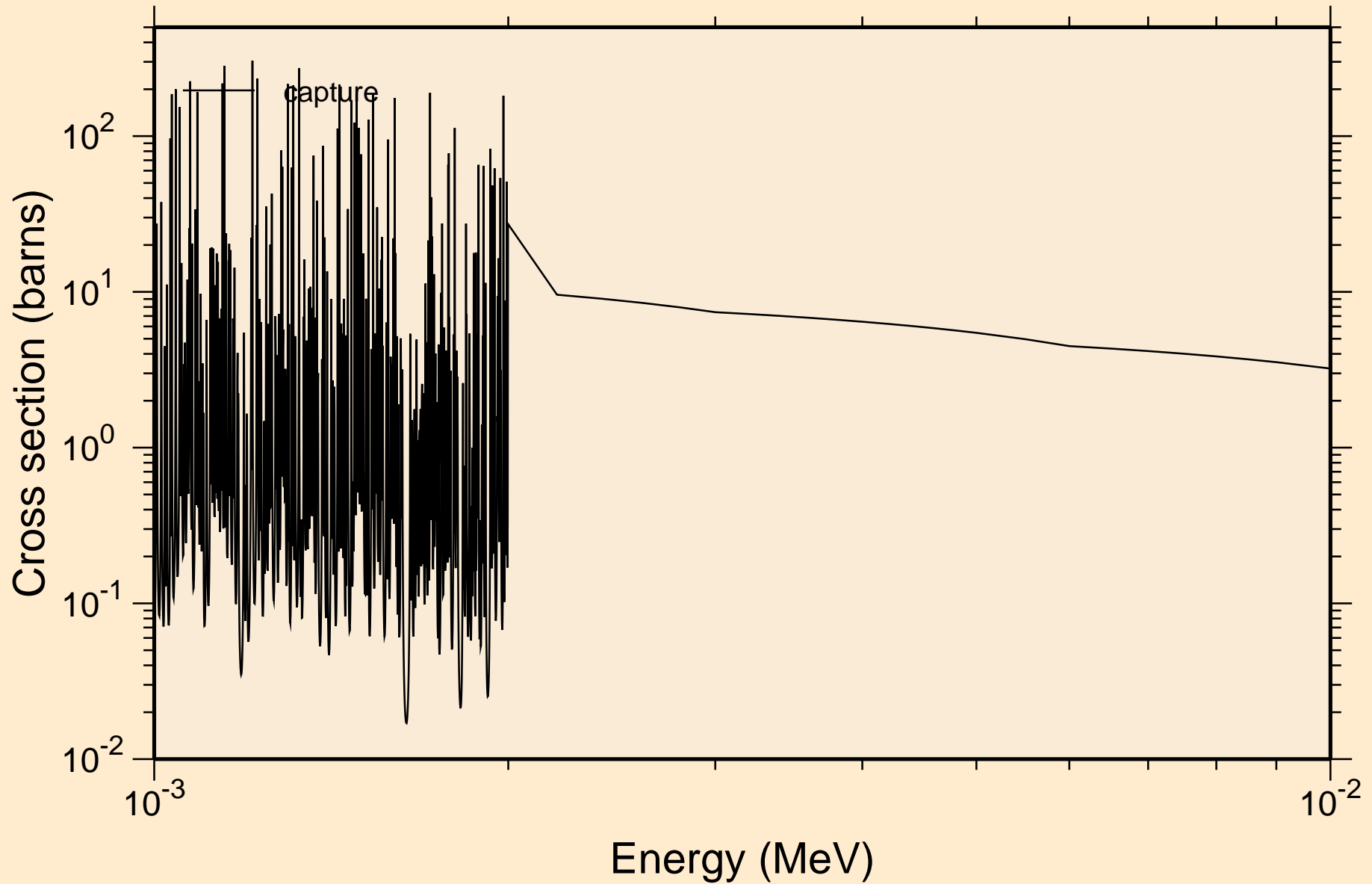

RE185 NEUTRON ACER TENDL-2024 LIBRARY; T=0.K
resonance absorption cross sections

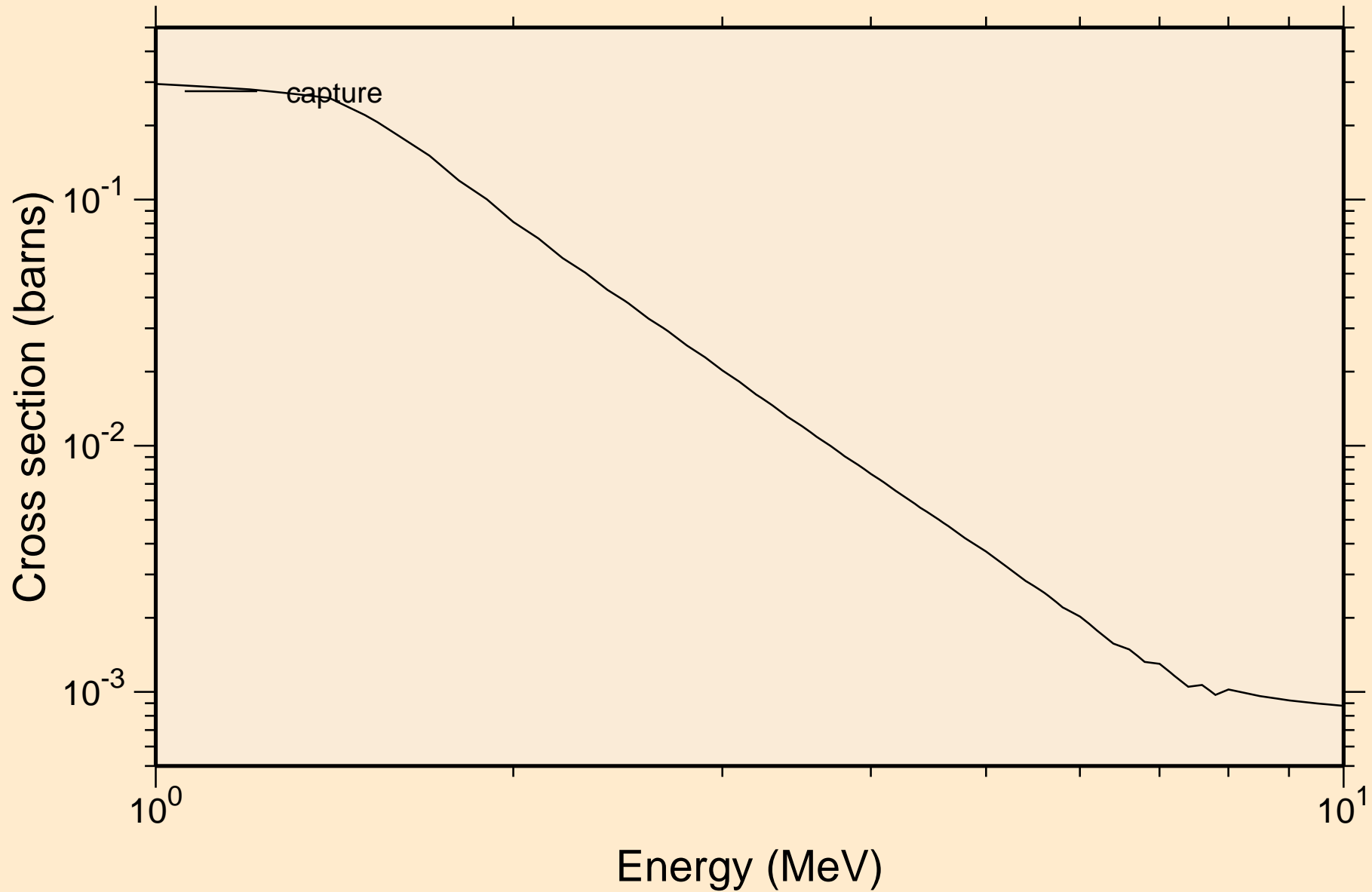

RE185 NEUTRON ACER TENDL-2024 LIBRARY; T=0.K

Heating

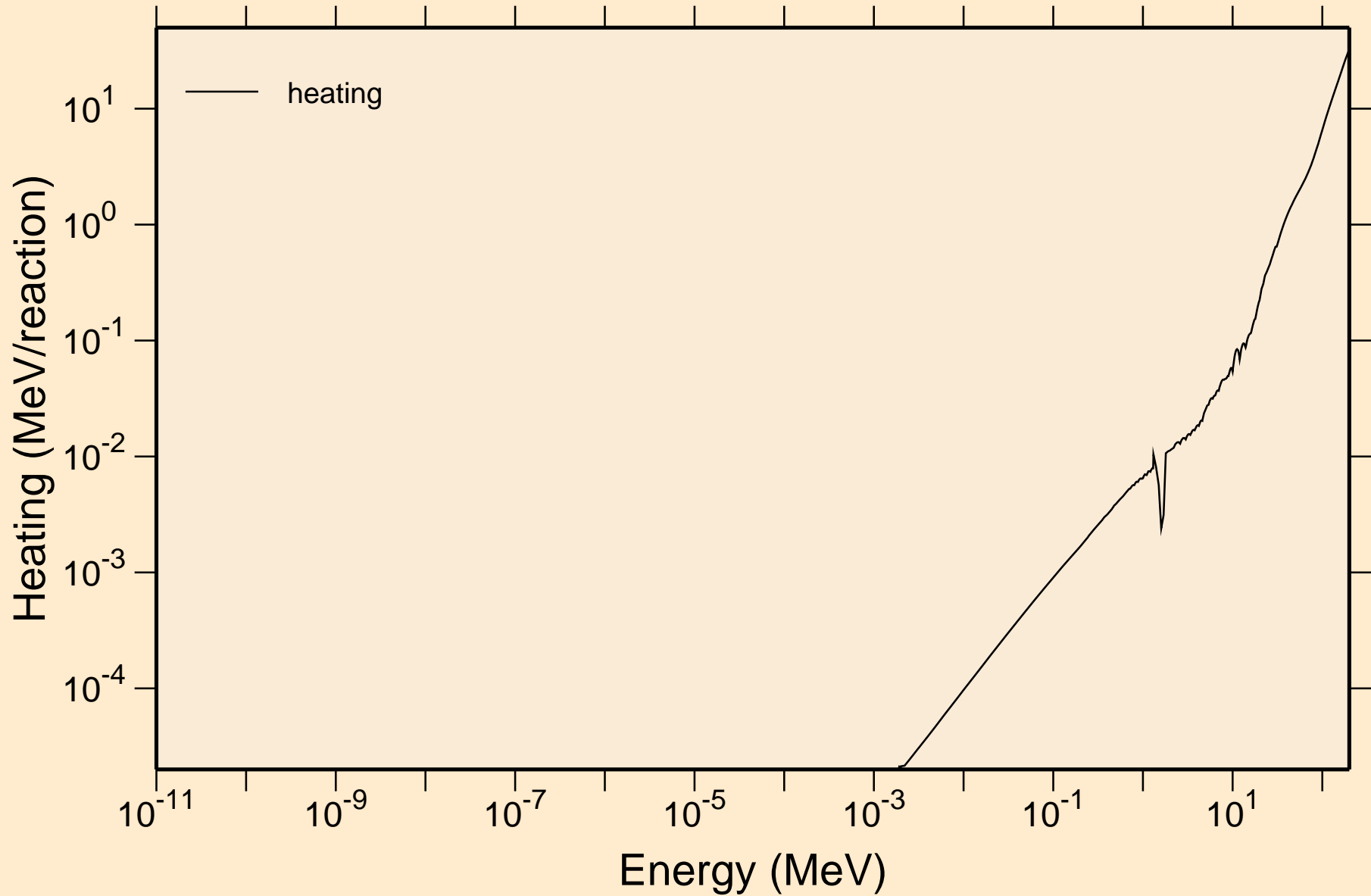

RE185 NEUTRON ACER TENDL-2024 LIBRARY; T=0.K
Damage

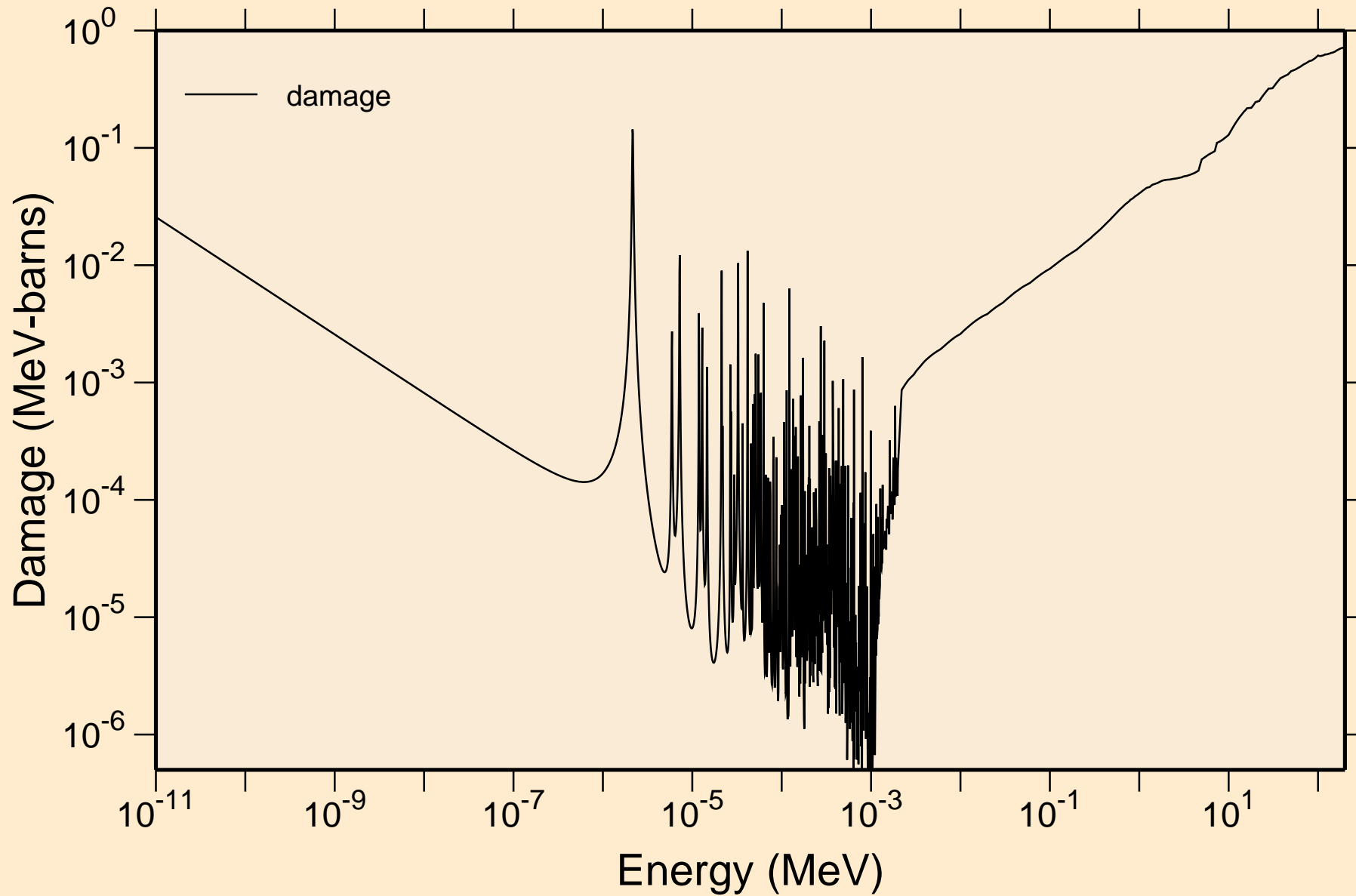

RE185 NEUTRON ACER TENDL-2024 LIBRARY; T=0.K
Non-threshold reactions

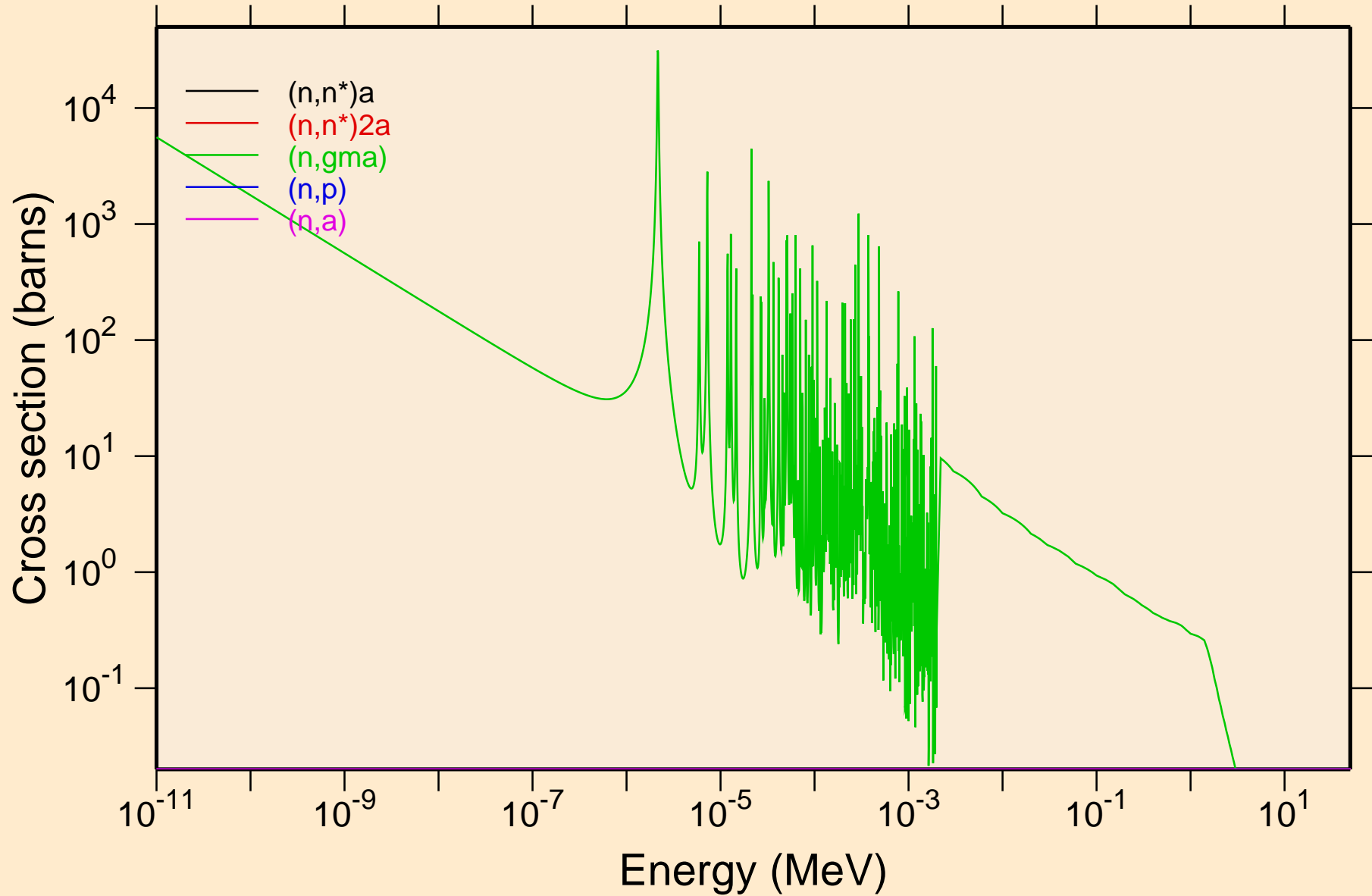

RE185 NEUTRON ACER TENDL-2024 LIBRARY; T=0.K
Non-threshold reactions

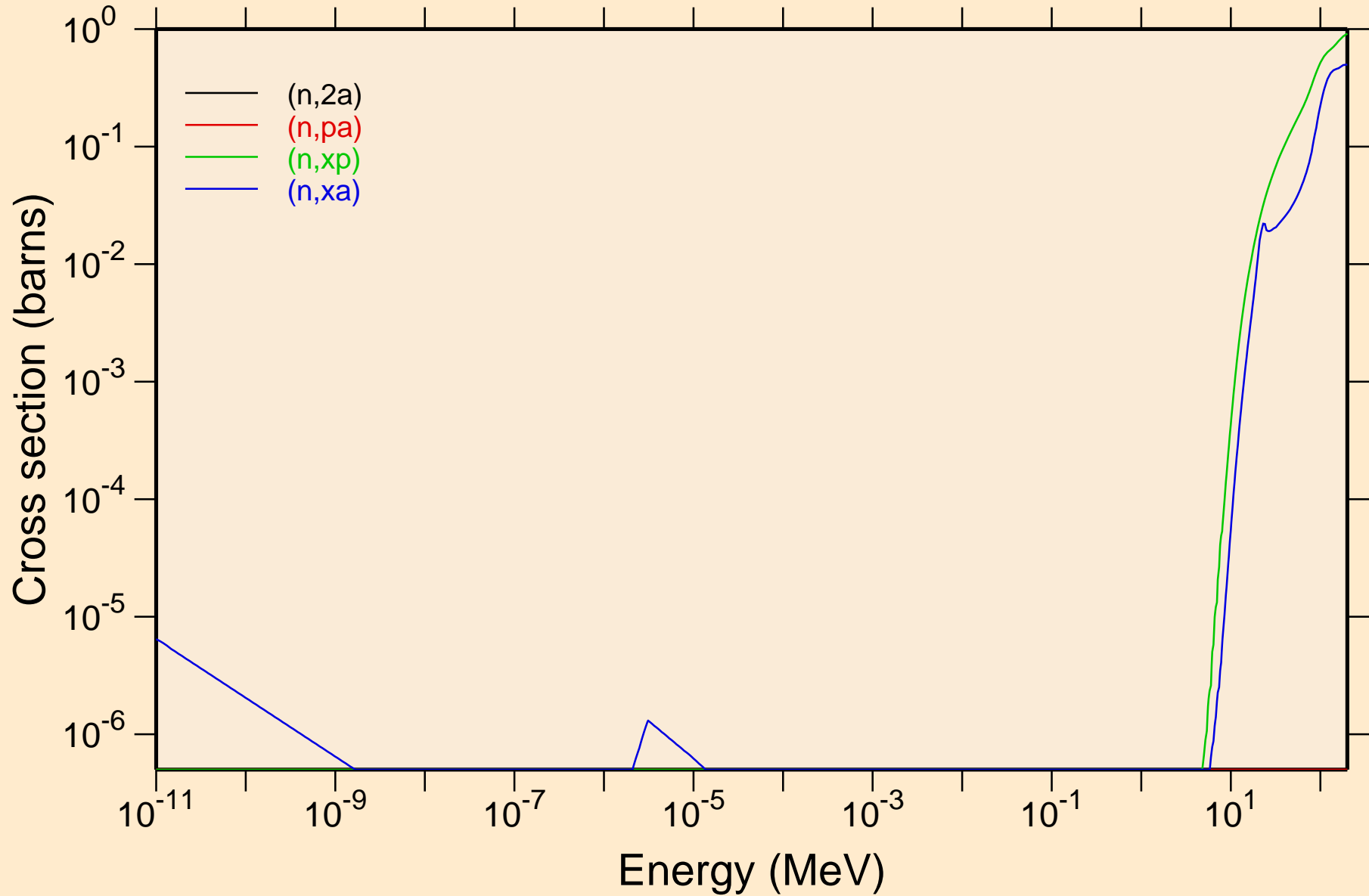

RE185 NEUTRON ACER TENDL-2024 LIBRARY; T=0.K

Principal cross sections

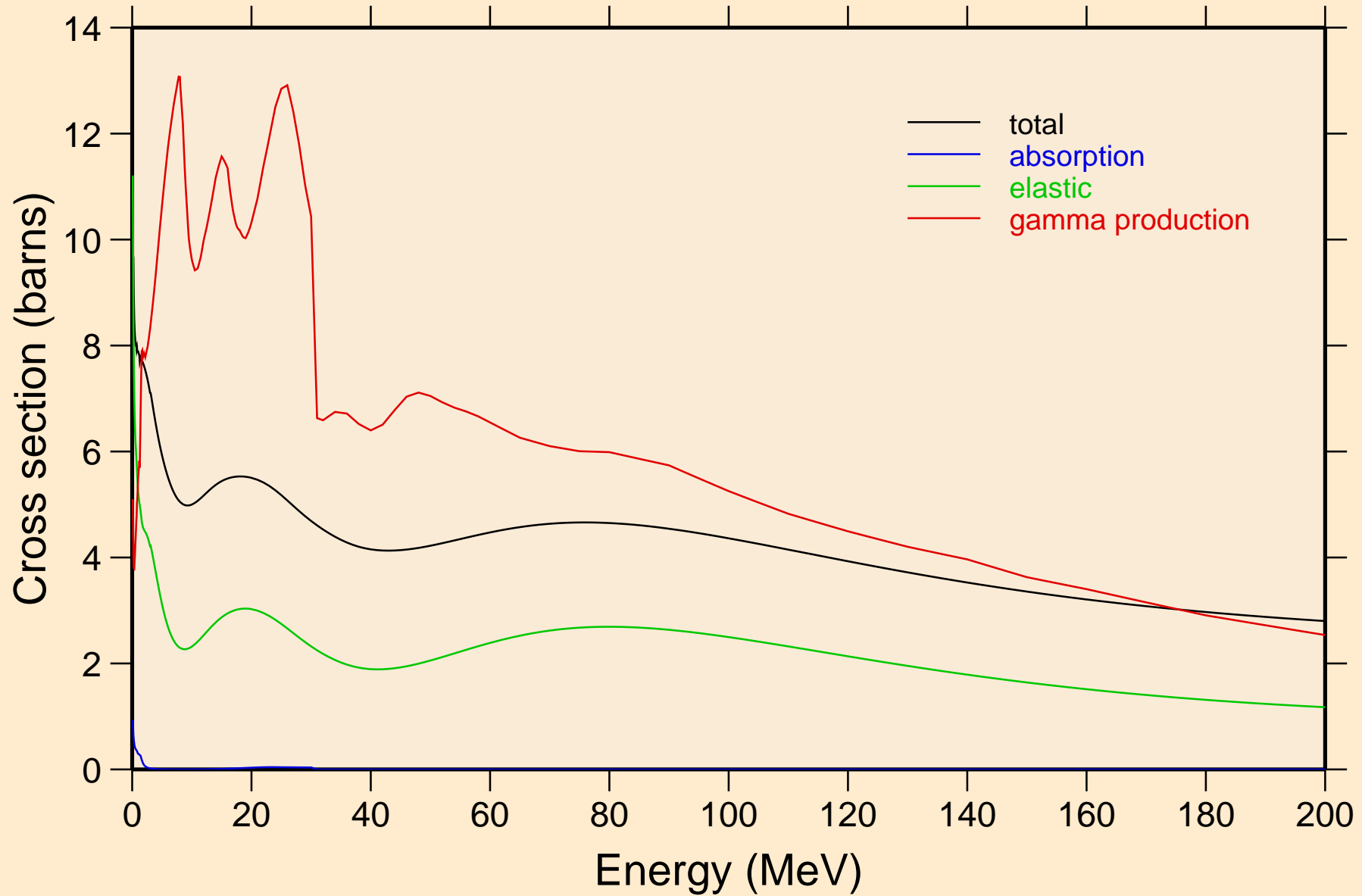

RE185 NEUTRON ACER TENDL-2024 LIBRARY; T=0.K

Heating

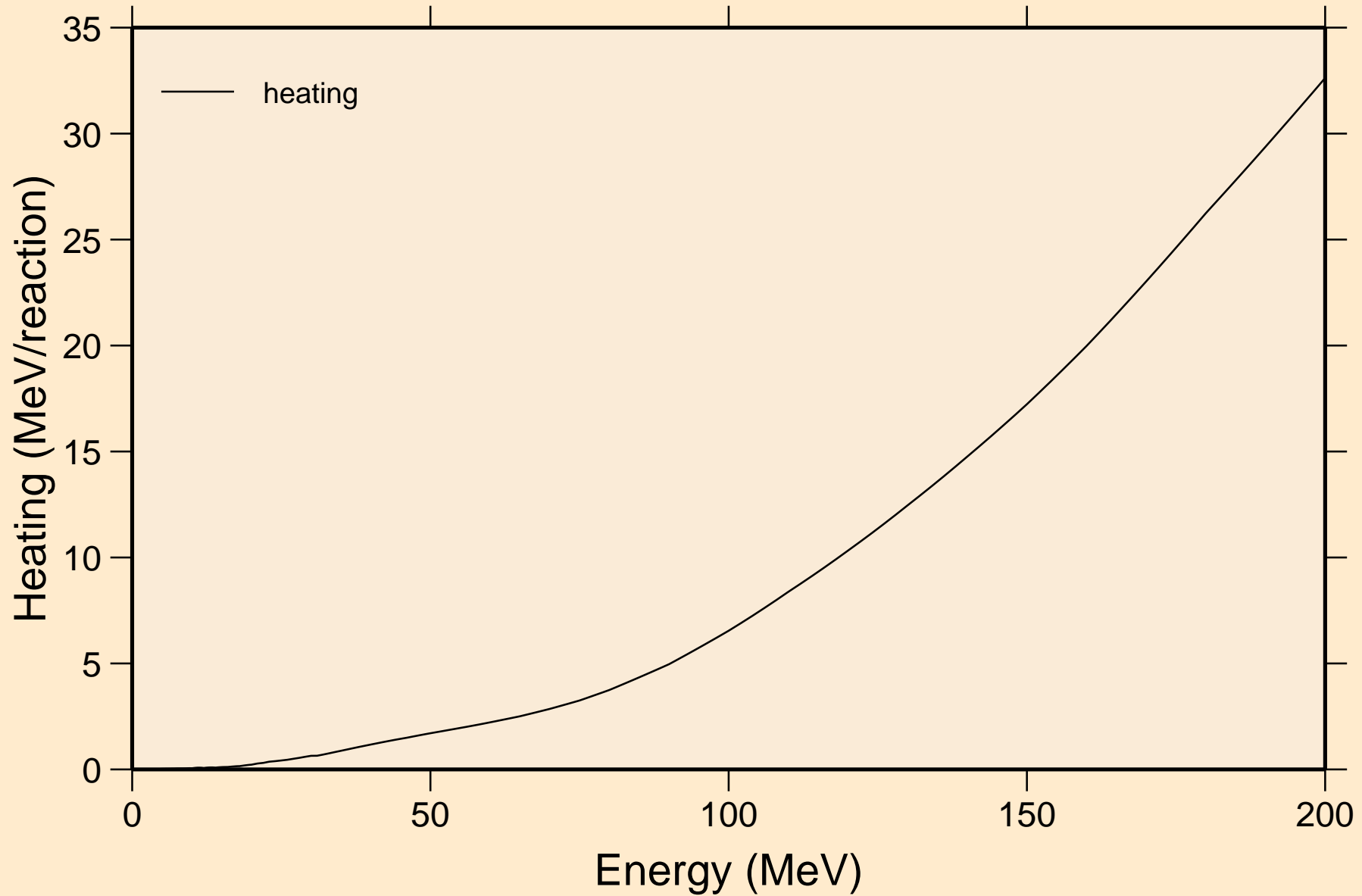

RE185 NEUTRON ACER TENDL-2024 LIBRARY; T=0.K

Damage

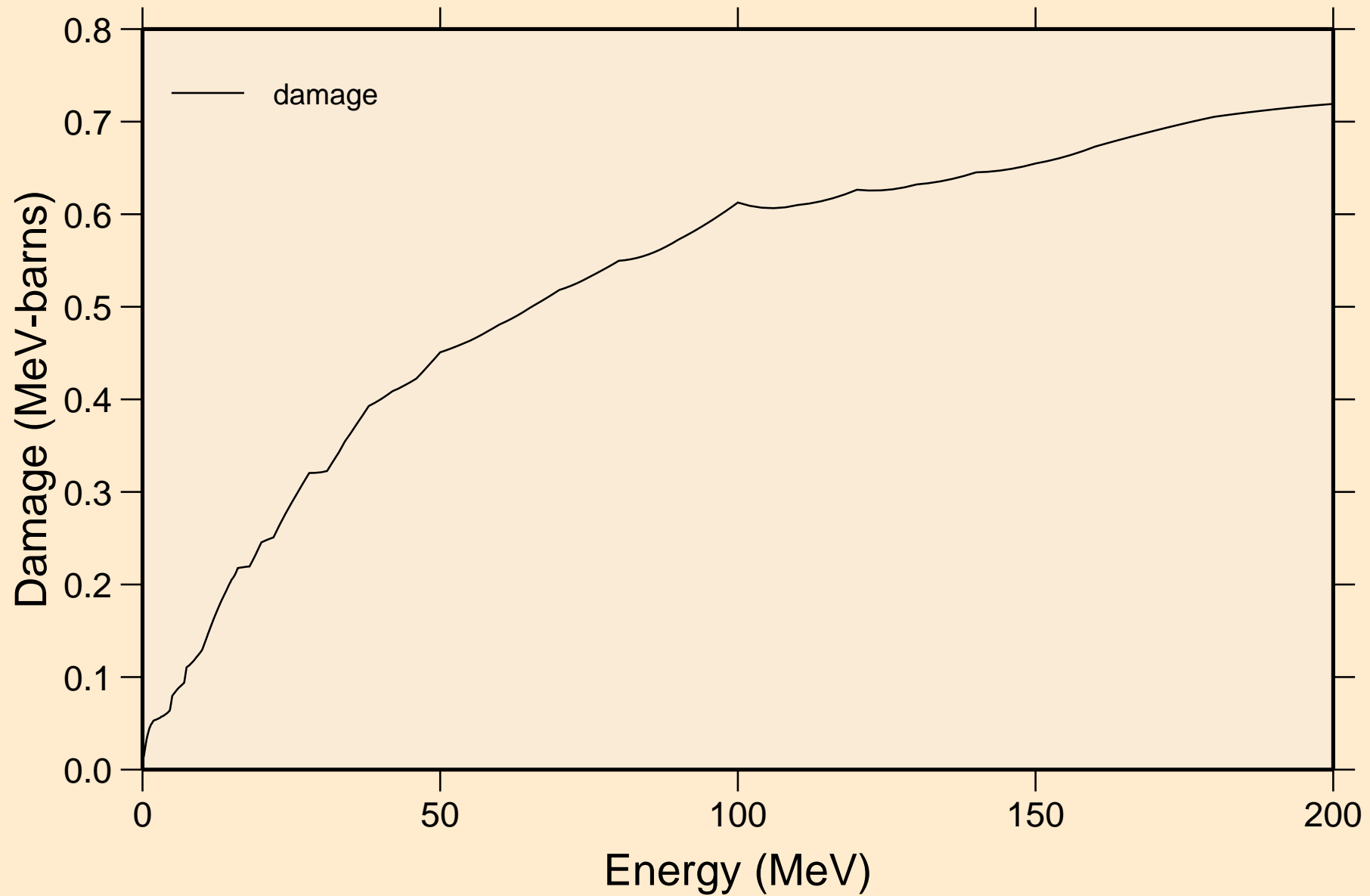

RE185 NEUTRON ACER TENDL-2024 LIBRARY; T=0.K
Non-threshold reactions

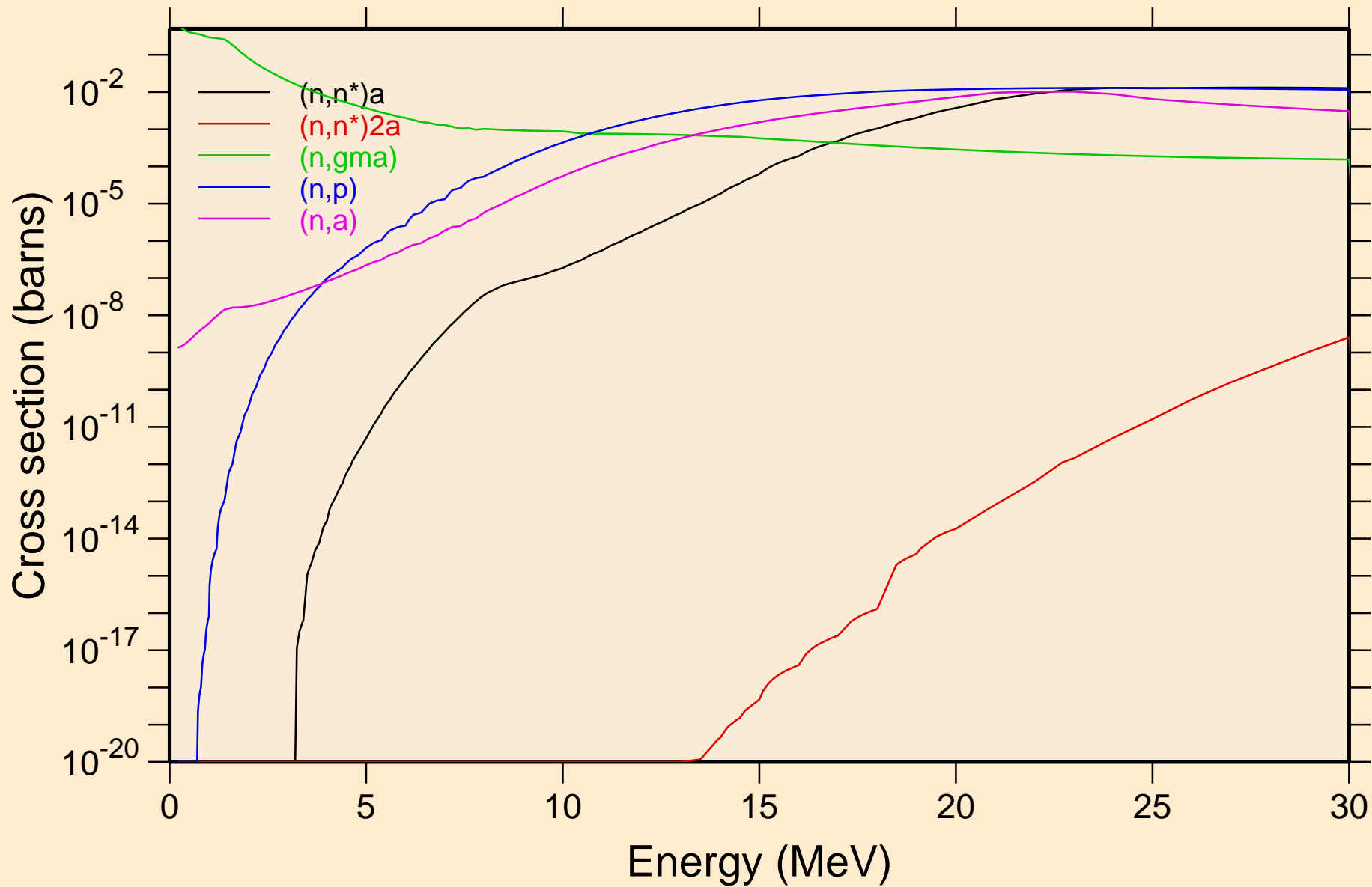

RE185 NEUTRON ACER TENDL-2024 LIBRARY; T=0.K
Non-threshold reactions

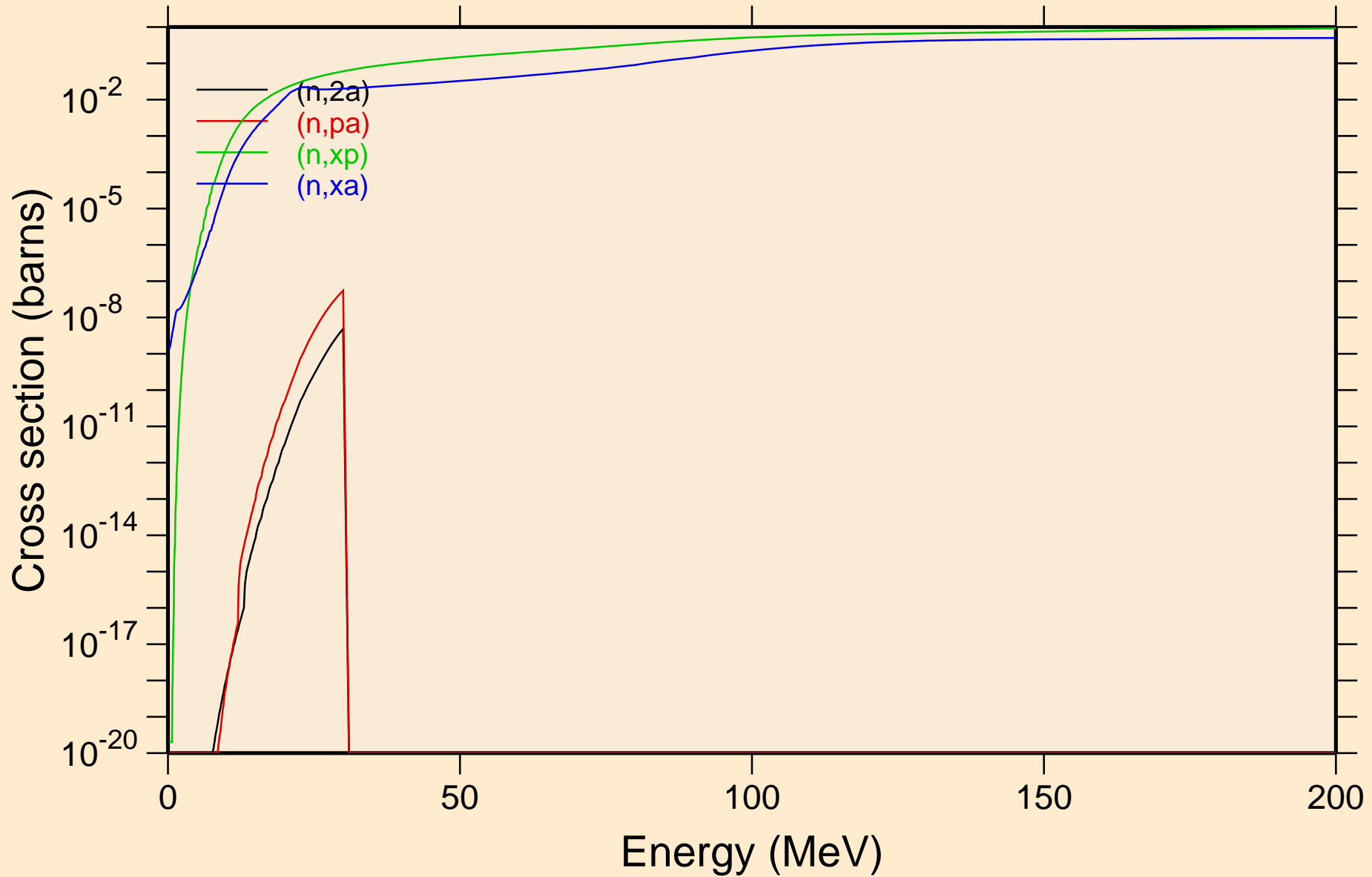

RE185 NEUTRON ACER TENDL-2024 LIBRARY; T=0.K
Inelastic levels

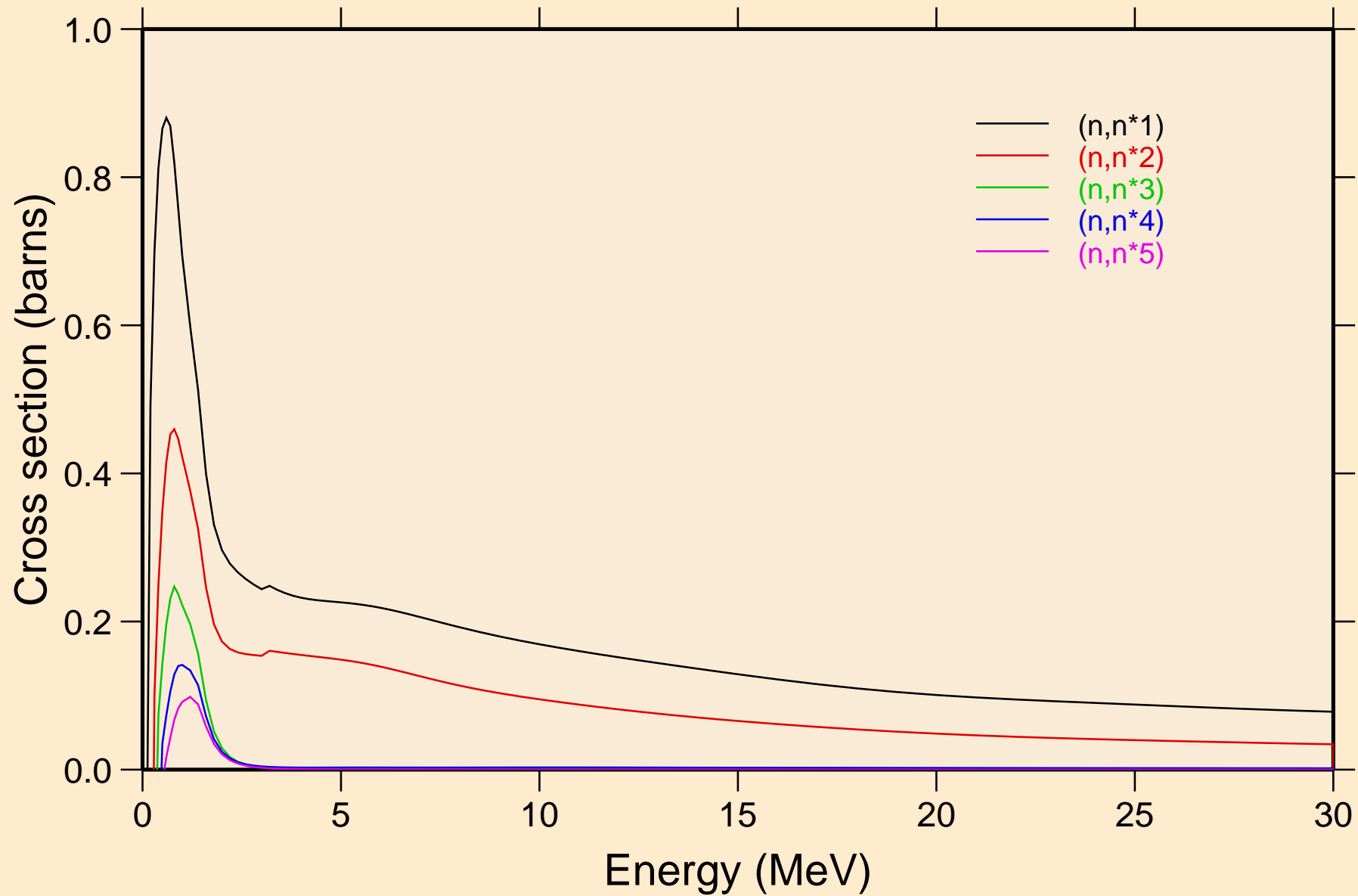

RE185 NEUTRON ACER TENDL-2024 LIBRARY; T=0.K
Inelastic levels

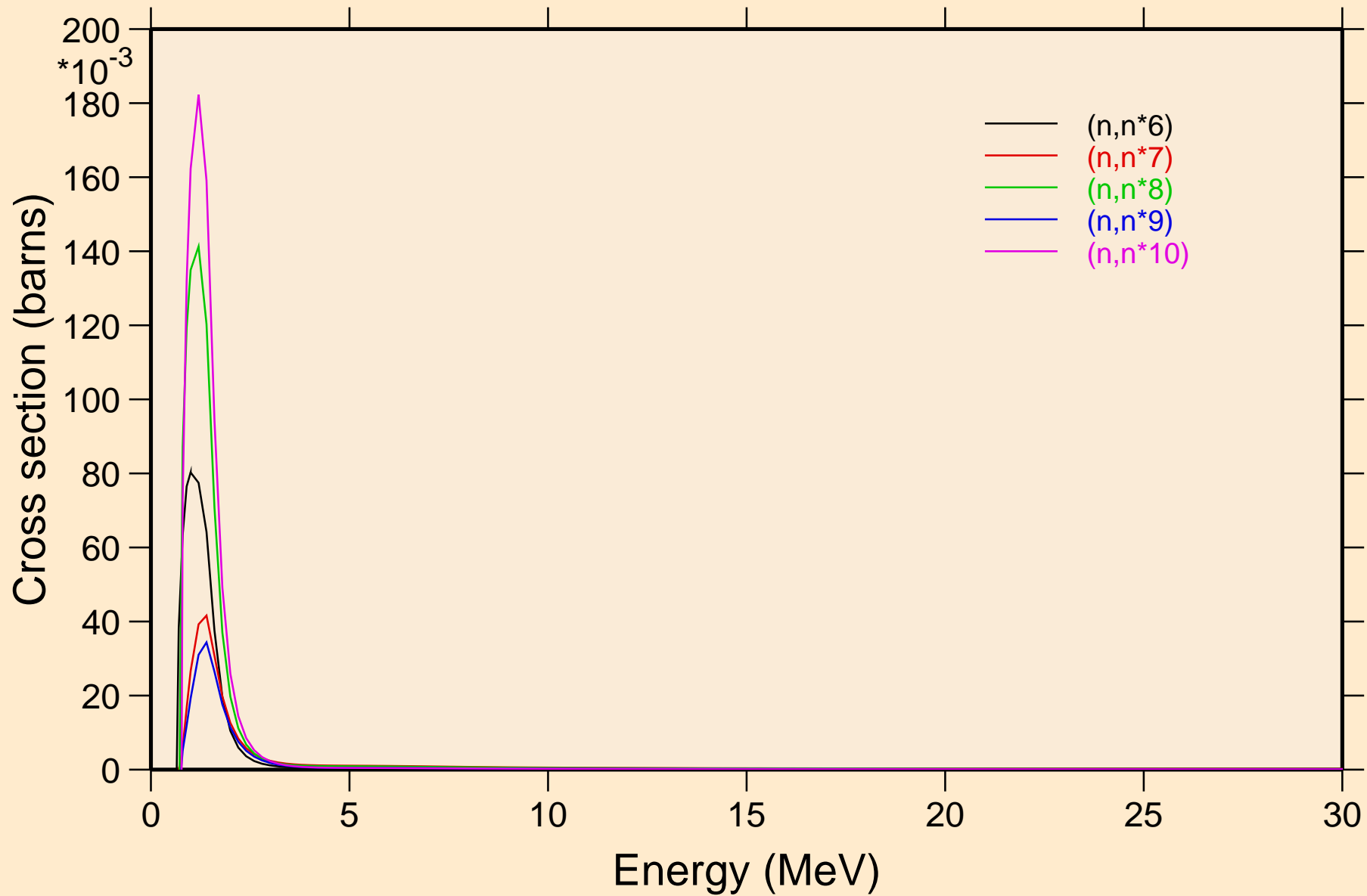

RE185 NEUTRON ACER TENDL-2024 LIBRARY; T=0.K
Inelastic levels

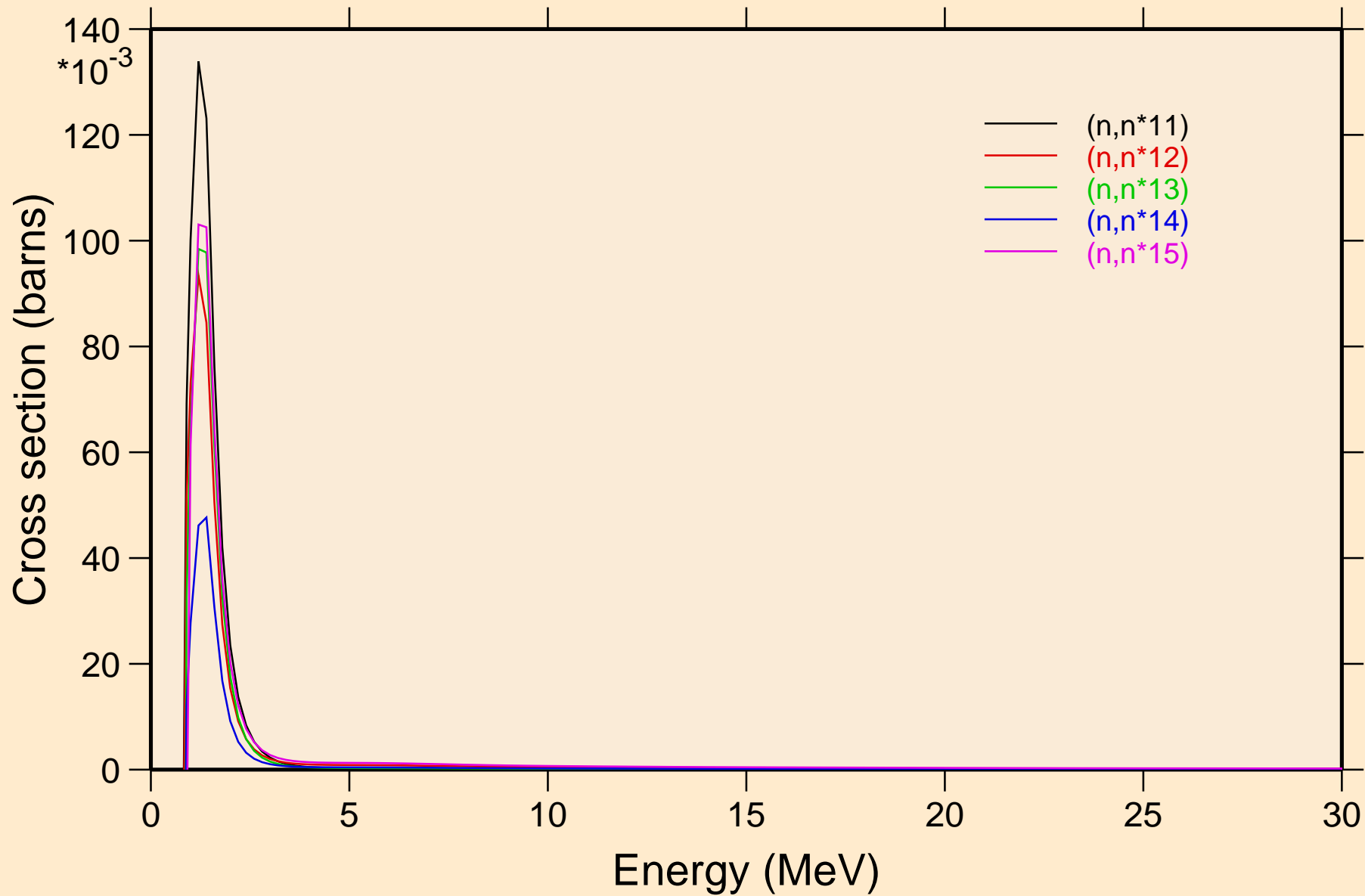

RE185 NEUTRON ACER TENDL-2024 LIBRARY; T=0.K
Inelastic levels

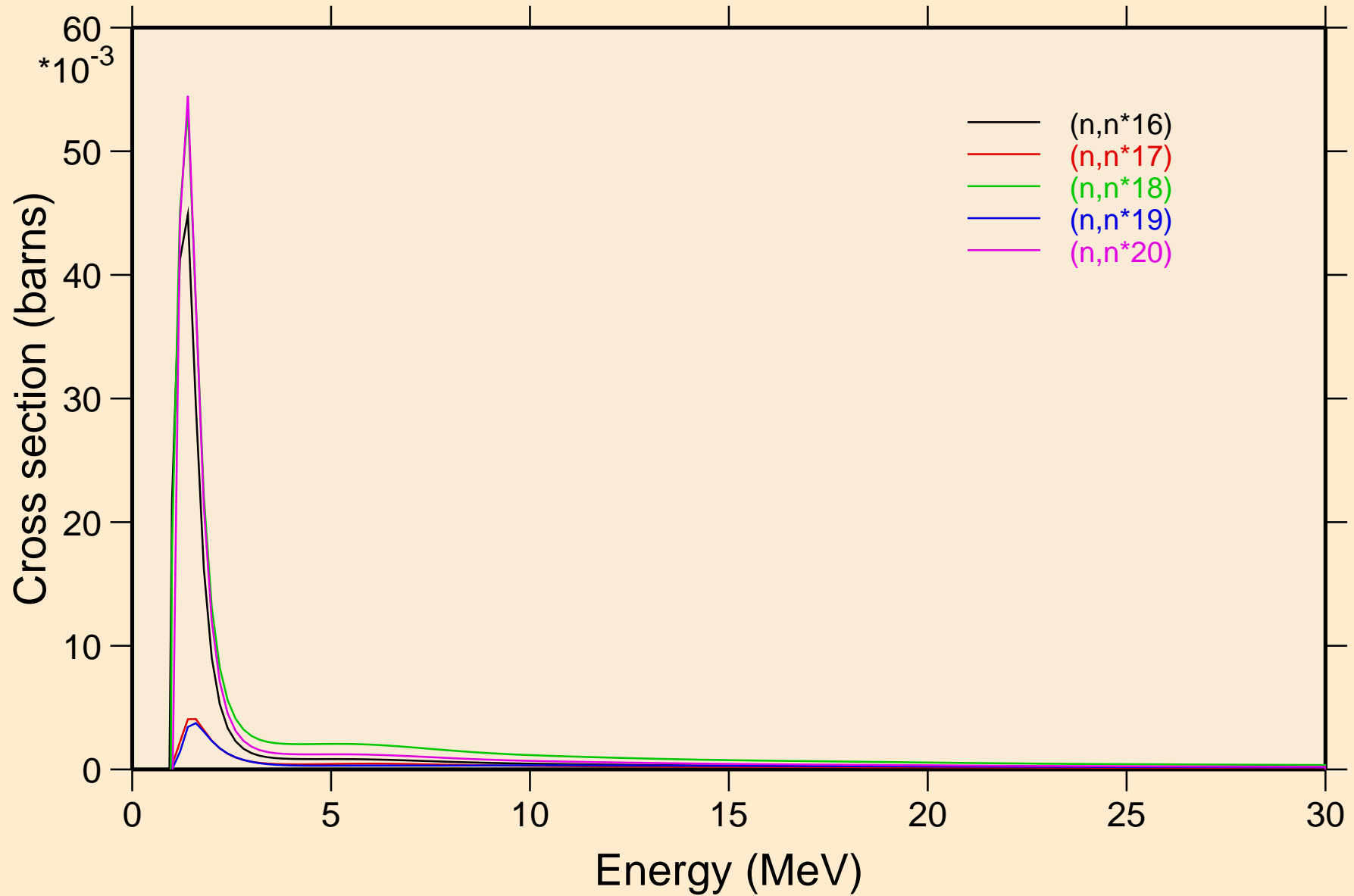

RE185 NEUTRON ACER TENDL-2024 LIBRARY; T=0.K
Inelastic levels

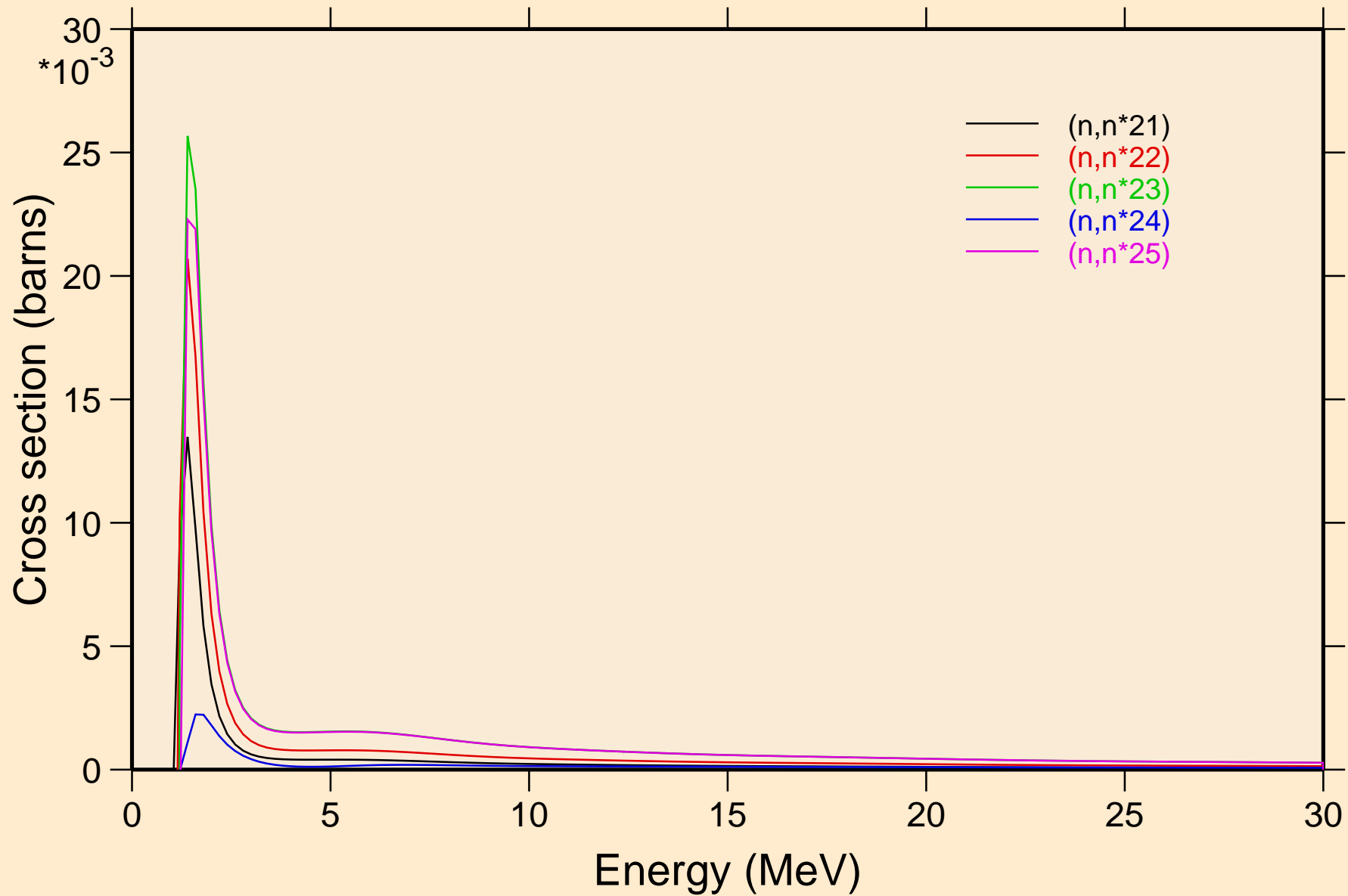

RE185 NEUTRON ACER TENDL-2024 LIBRARY; T=0.K
Inelastic levels

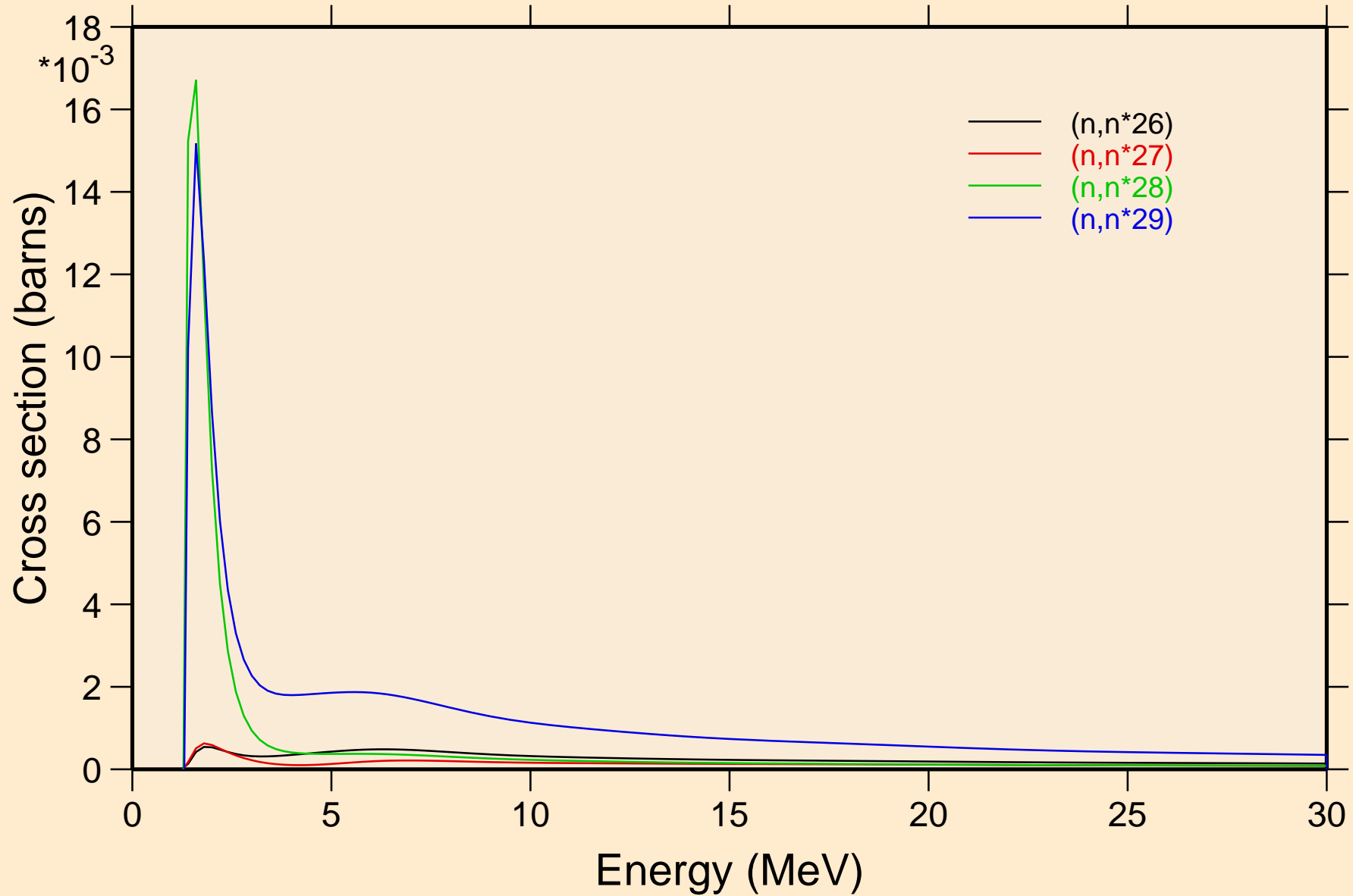

RE185 NEUTRON ACER TENDL-2024 LIBRARY; T=0.K
Threshold reactions

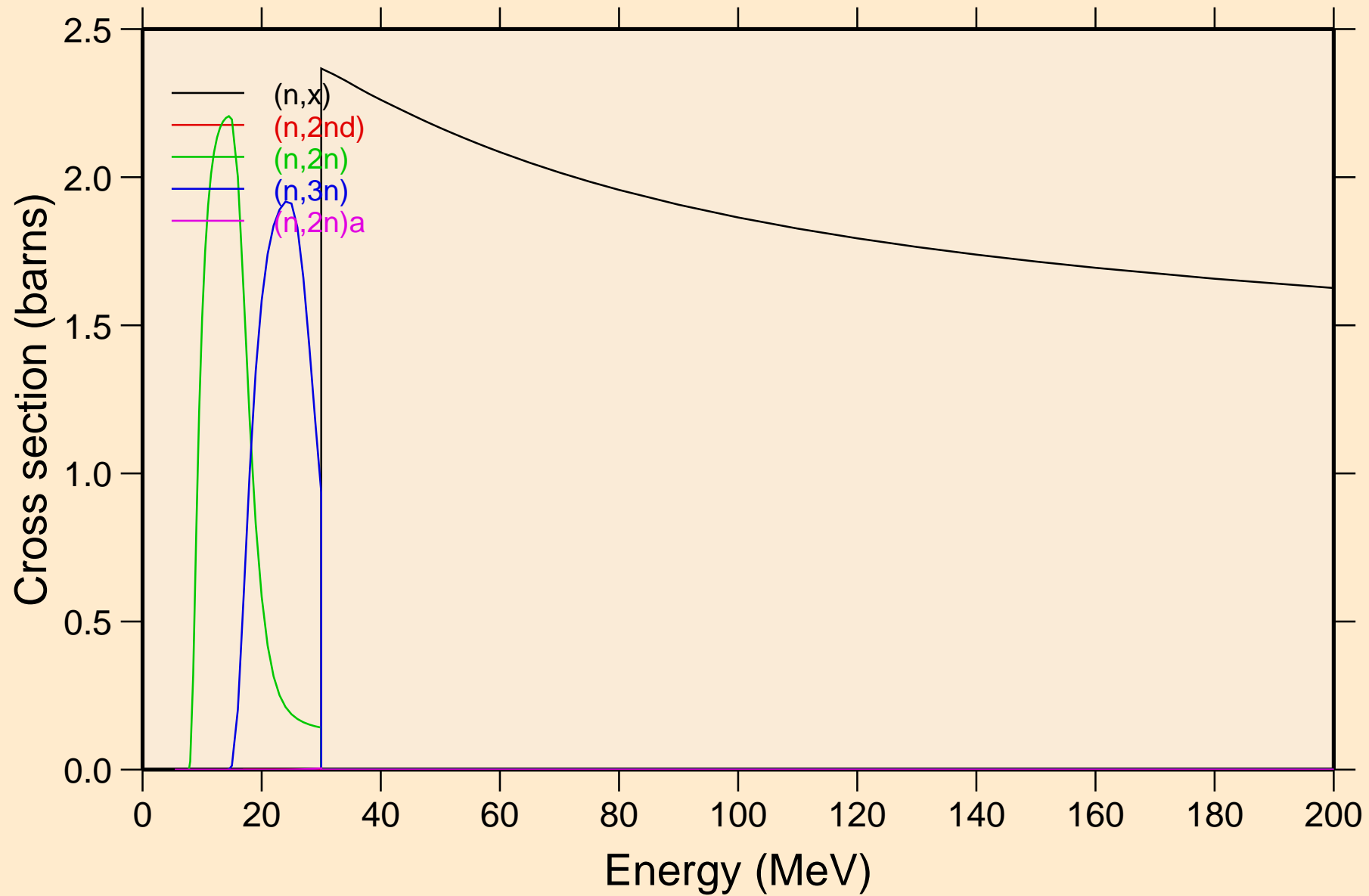

RE185 NEUTRON ACER TENDL-2024 LIBRARY; T=0.K
Threshold reactions

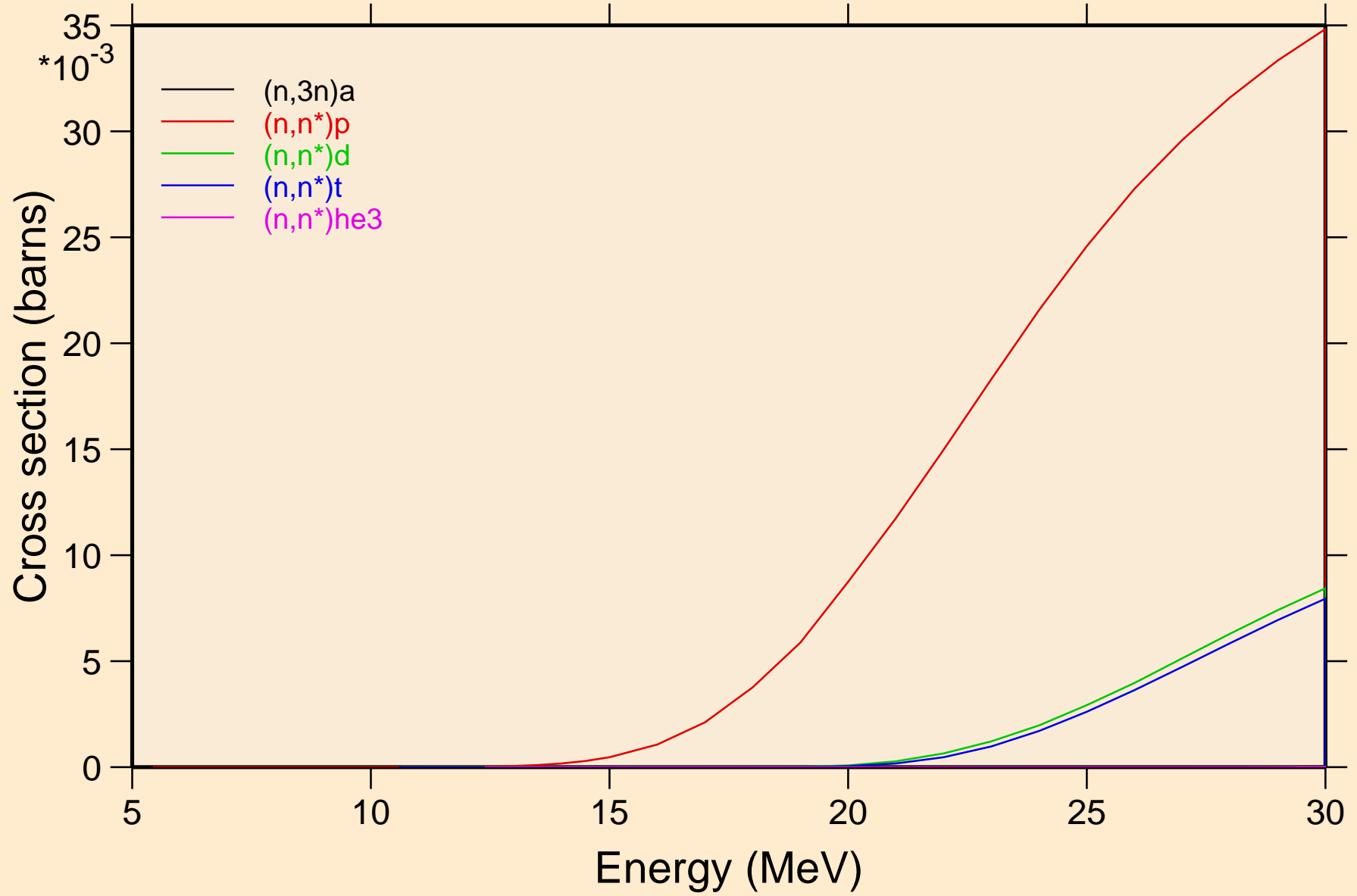

RE185 NEUTRON ACER TENDL-2024 LIBRARY; T=0.K
Threshold reactions

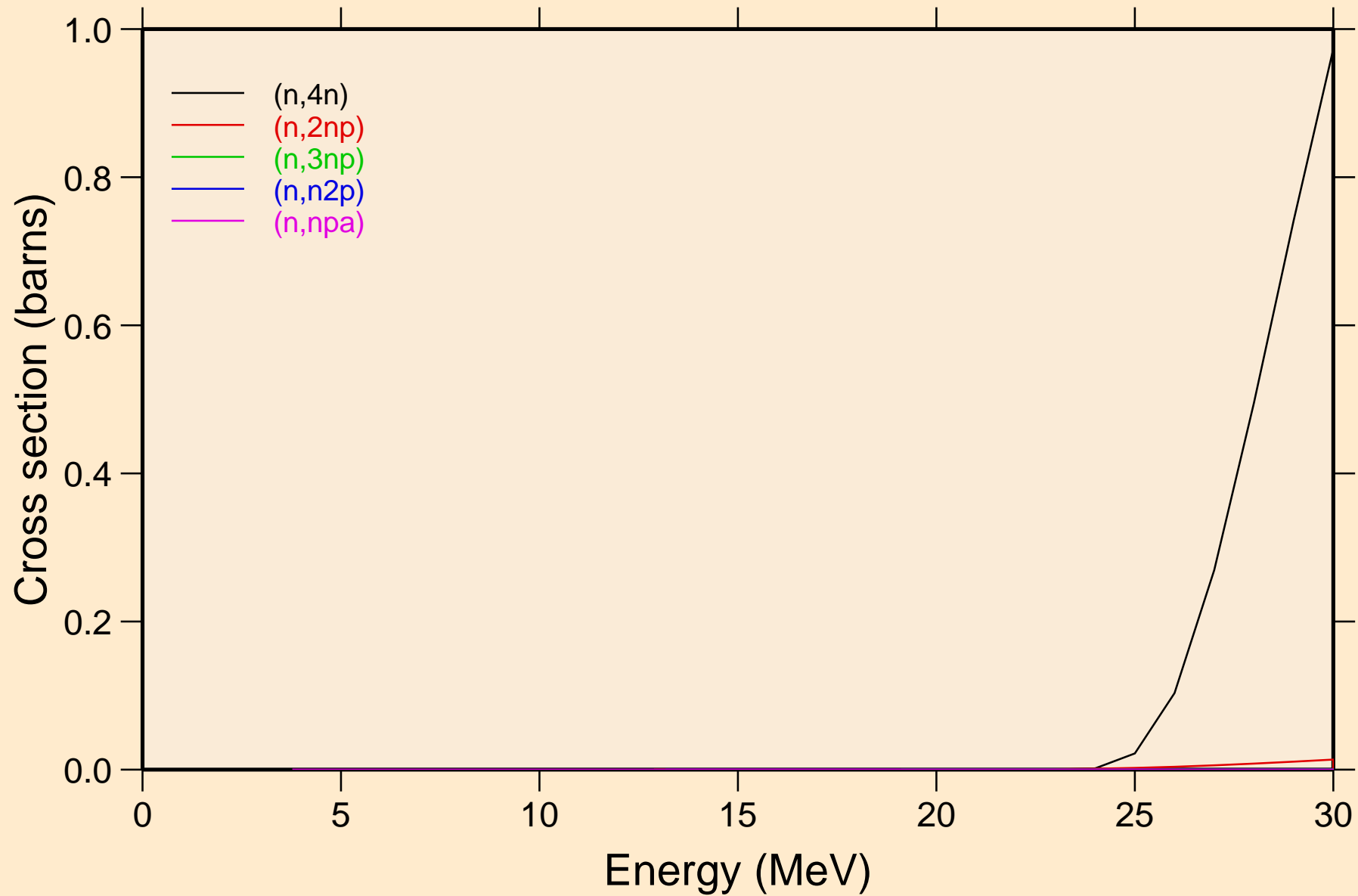

RE185 NEUTRON ACER TENDL-2024 LIBRARY; T=0.K
Threshold reactions

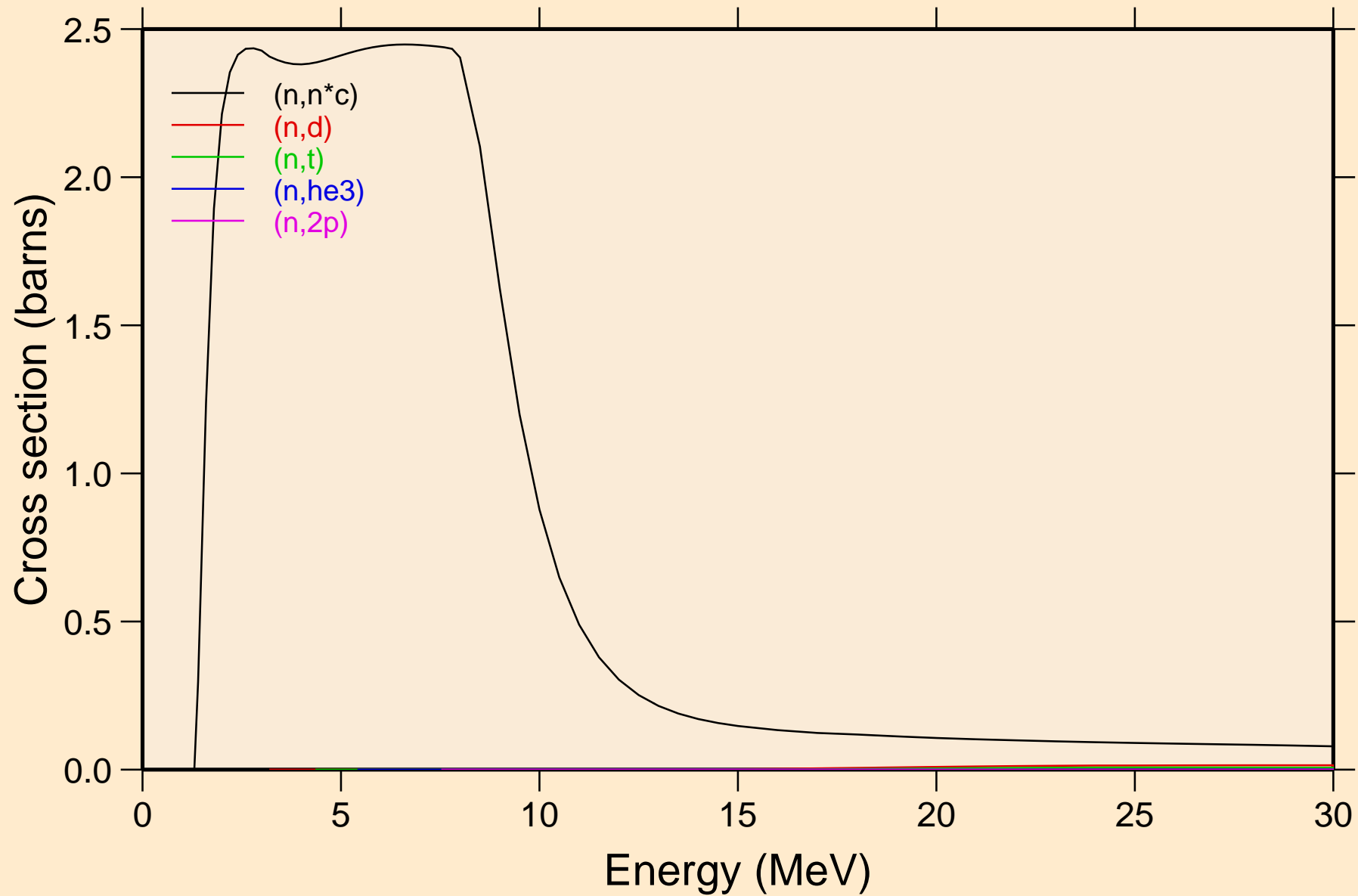

RE185 NEUTRON ACER TENDL-2024 LIBRARY; T=0.K
Threshold reactions

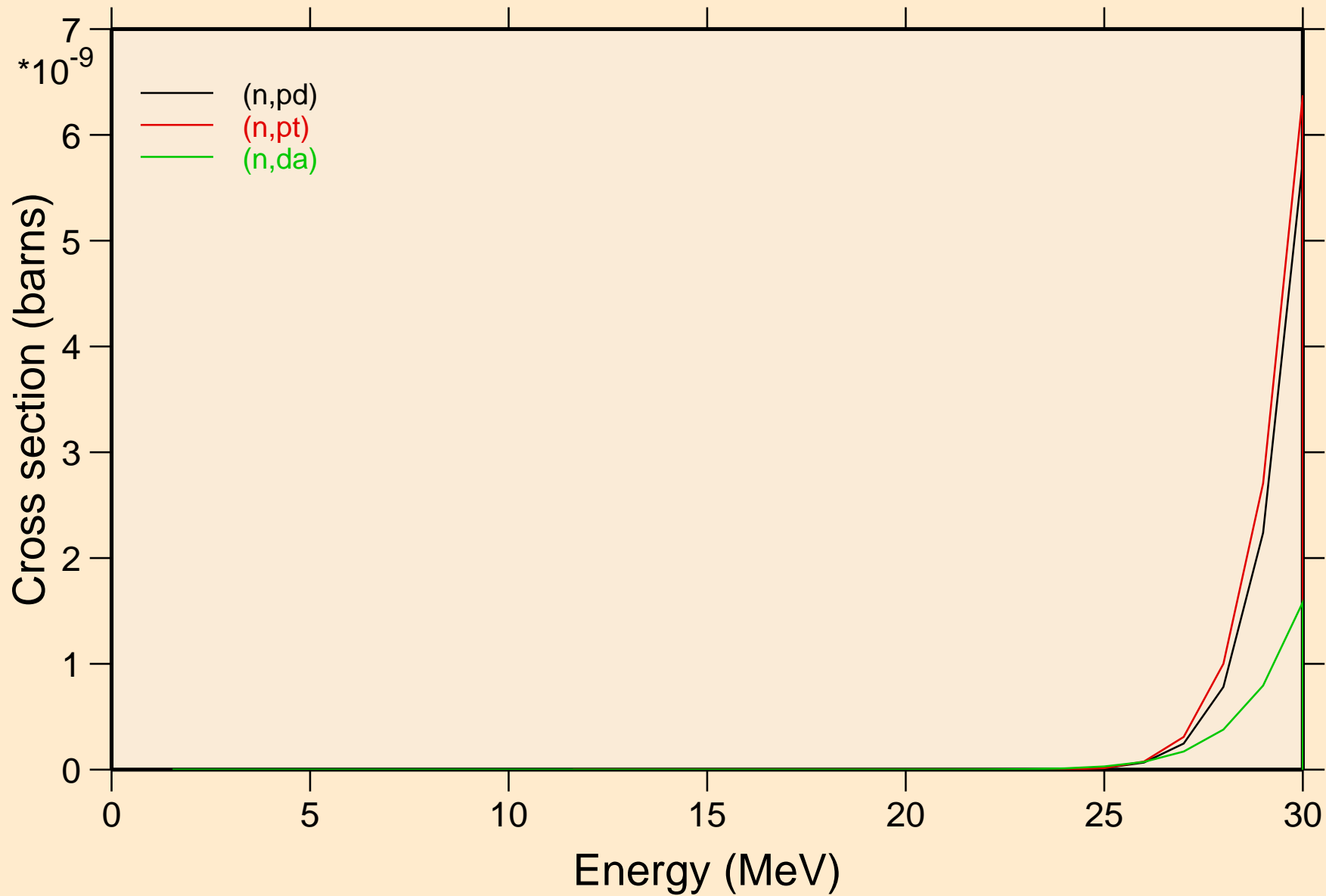

RE185 NEUTRON ACER TENDL-2024 LIBRARY; T=0.K
Threshold reactions

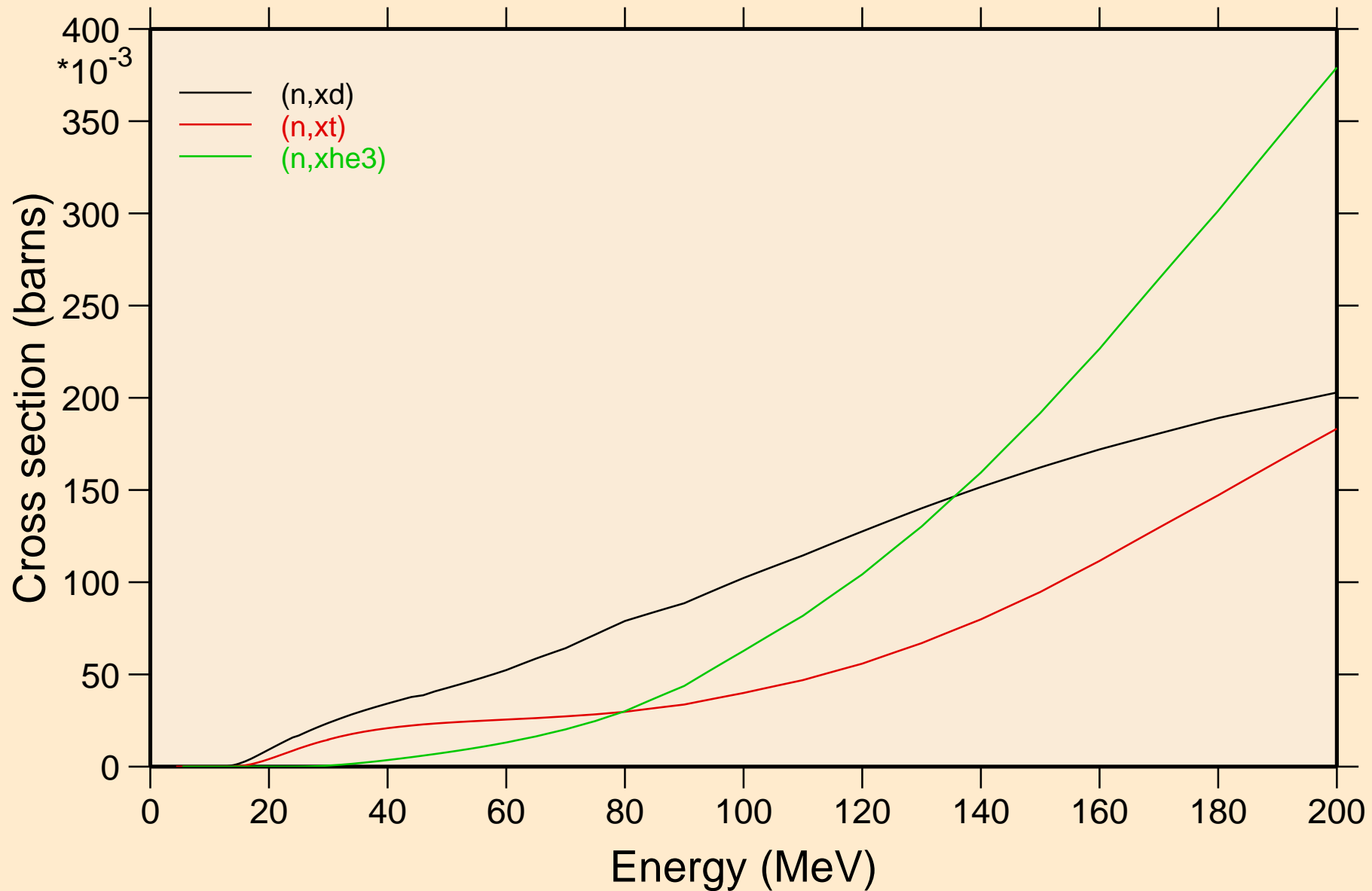

RE185 NEUTRON ACER TENDL-2024 LIBRARY; T=0.K
angular distribution for elastic

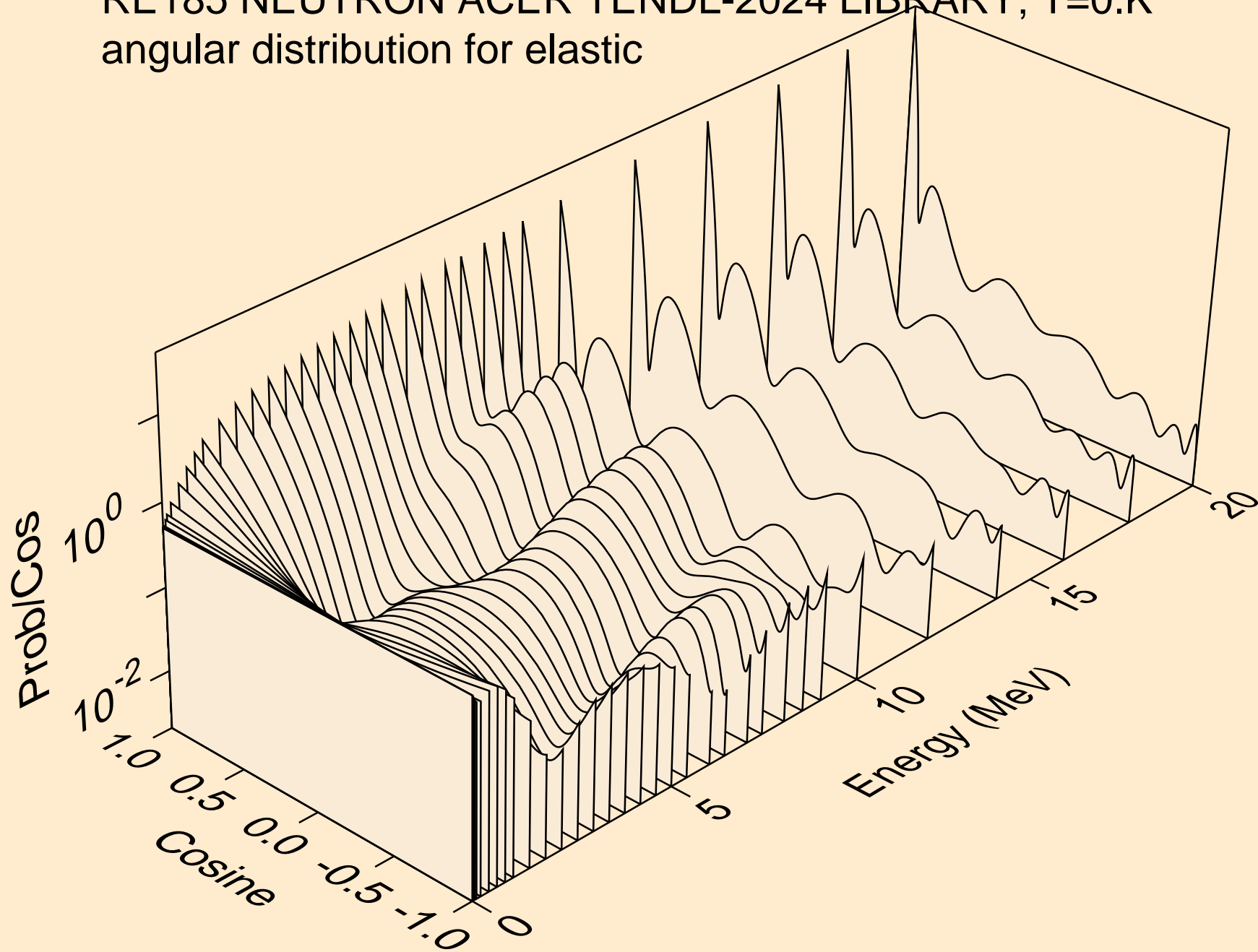

RE185 NEUTRON ACER TENDL-2024 LIBRARY; T=0.K
angular distribution for elastic

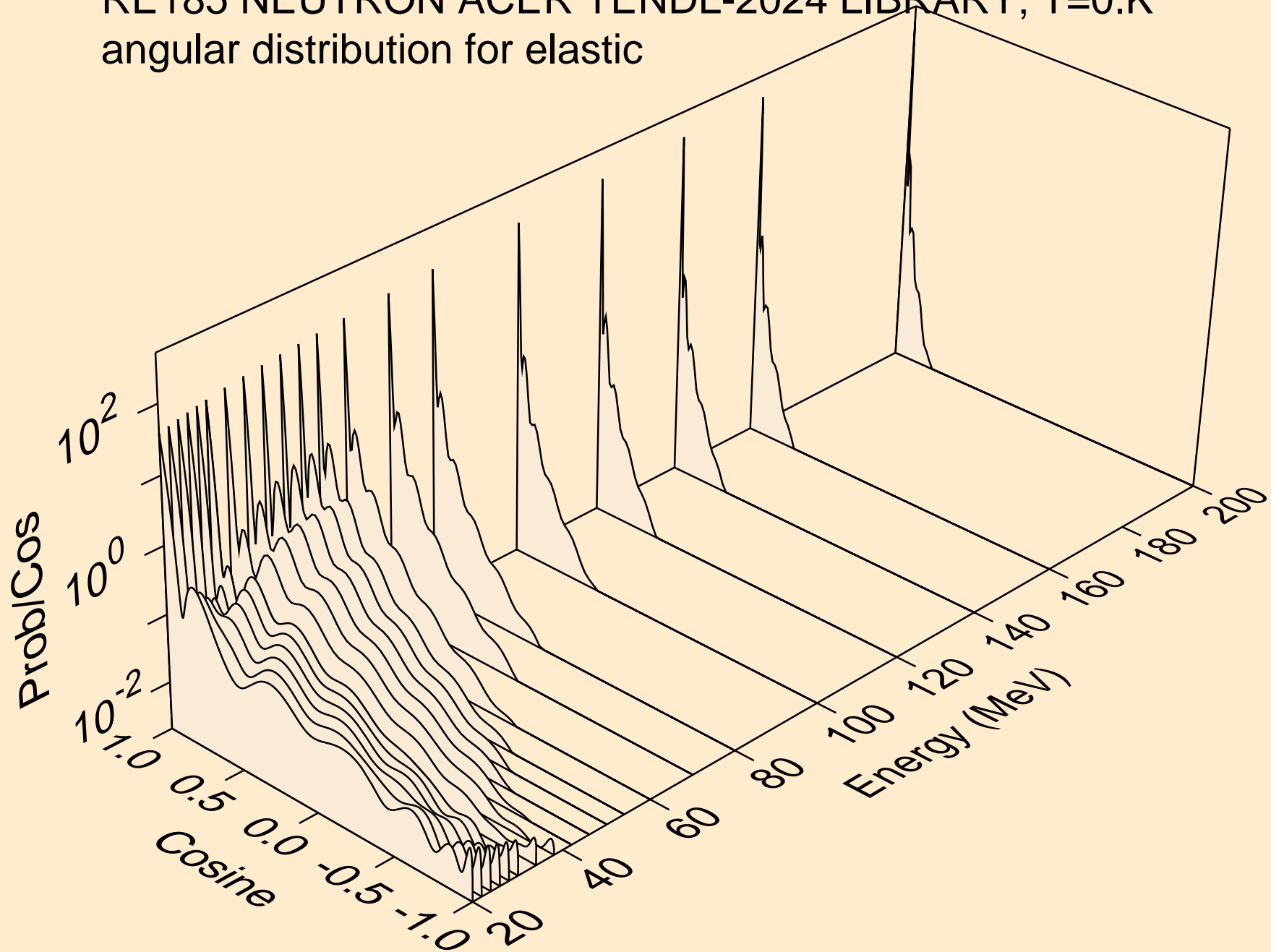

RE185 NEUTRON ACER TENDL-2024 LIBRARY; T=0.K
angular distribution for (n,n*1)

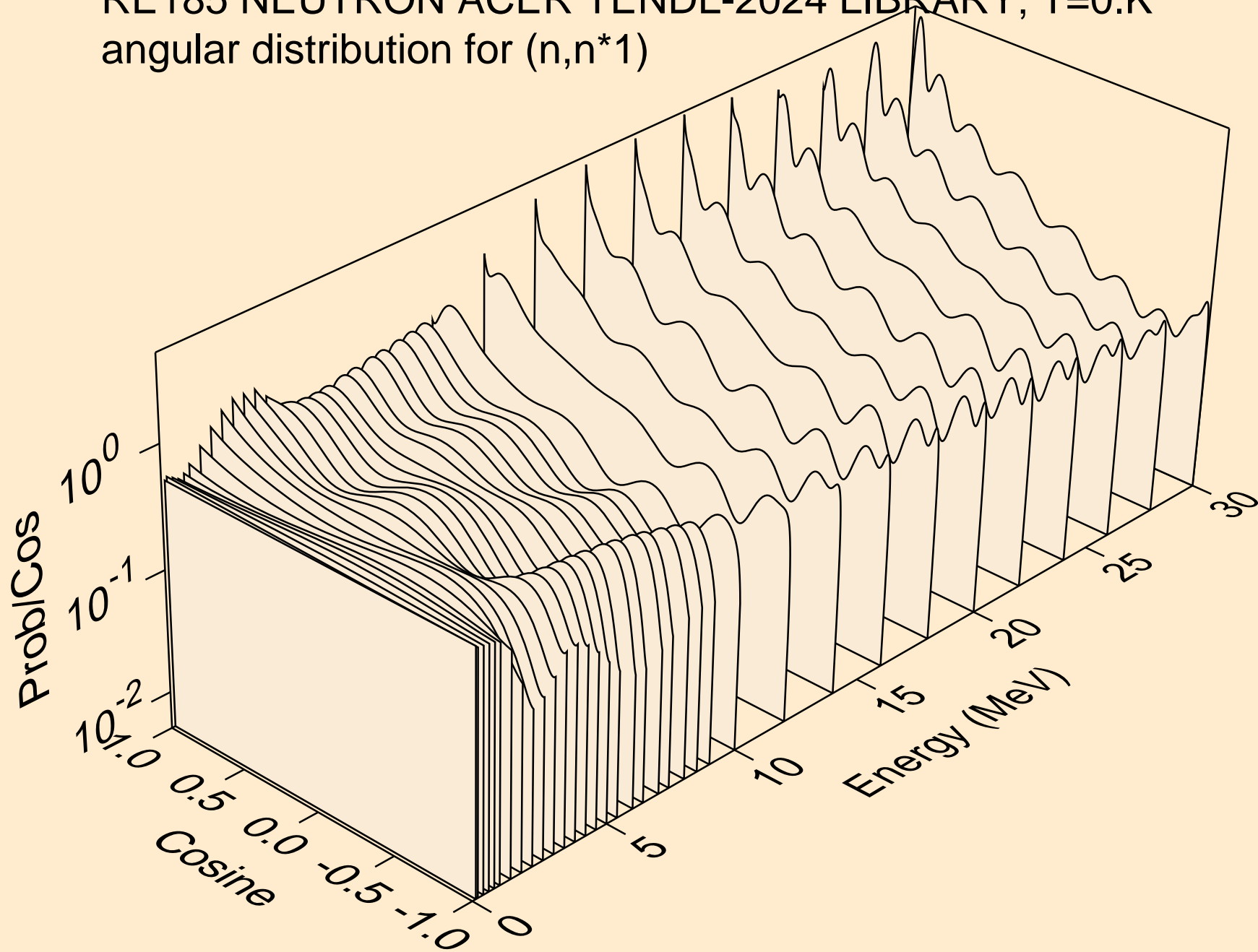

RE185 NEUTRON ACER TENDL-2024 LIBRARY; T=0.K
angular distribution for (n,n*2)

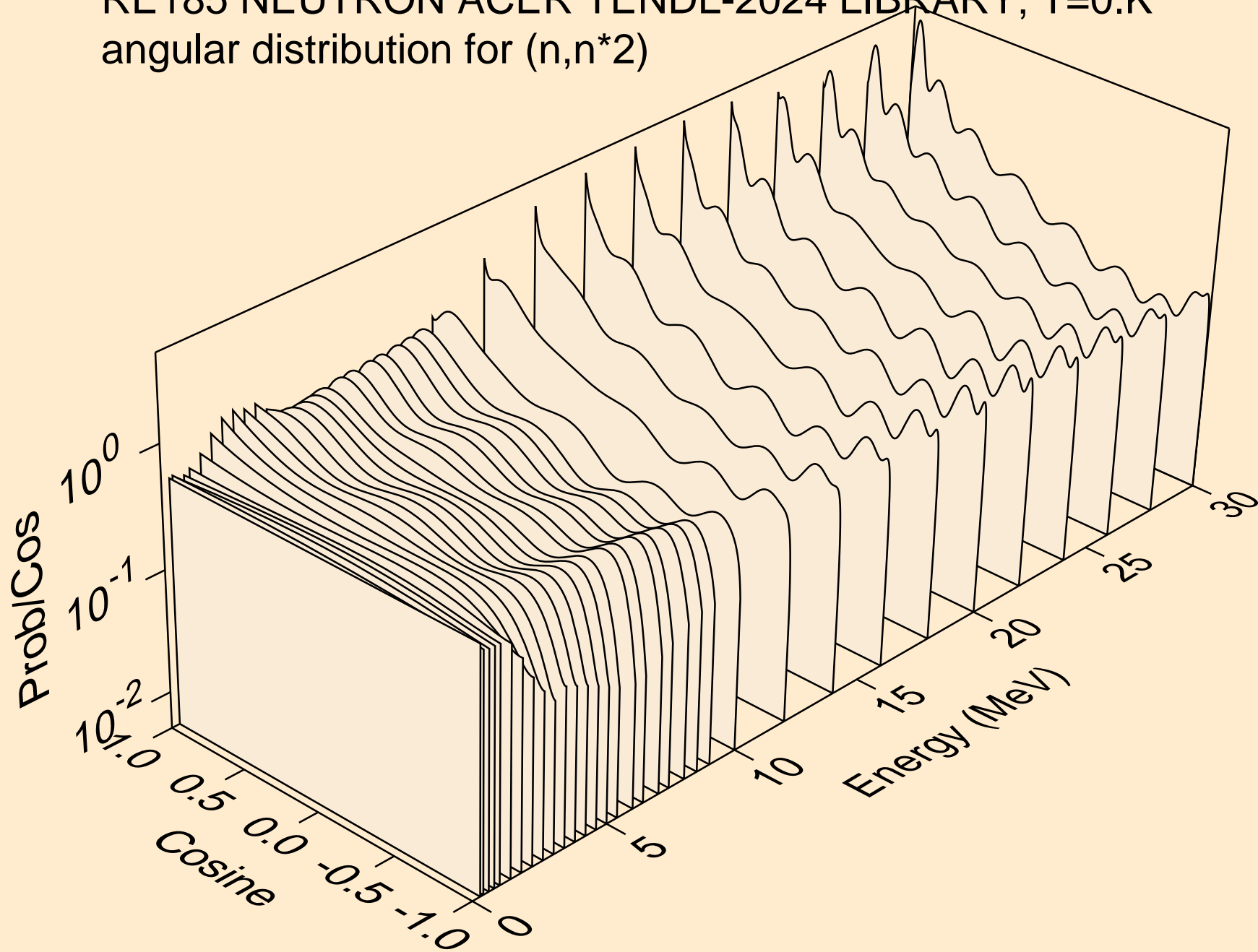

RE185 NEUTRON ACER TENDL-2024 LIBRARY; T=0.K
angular distribution for (n,n*3)

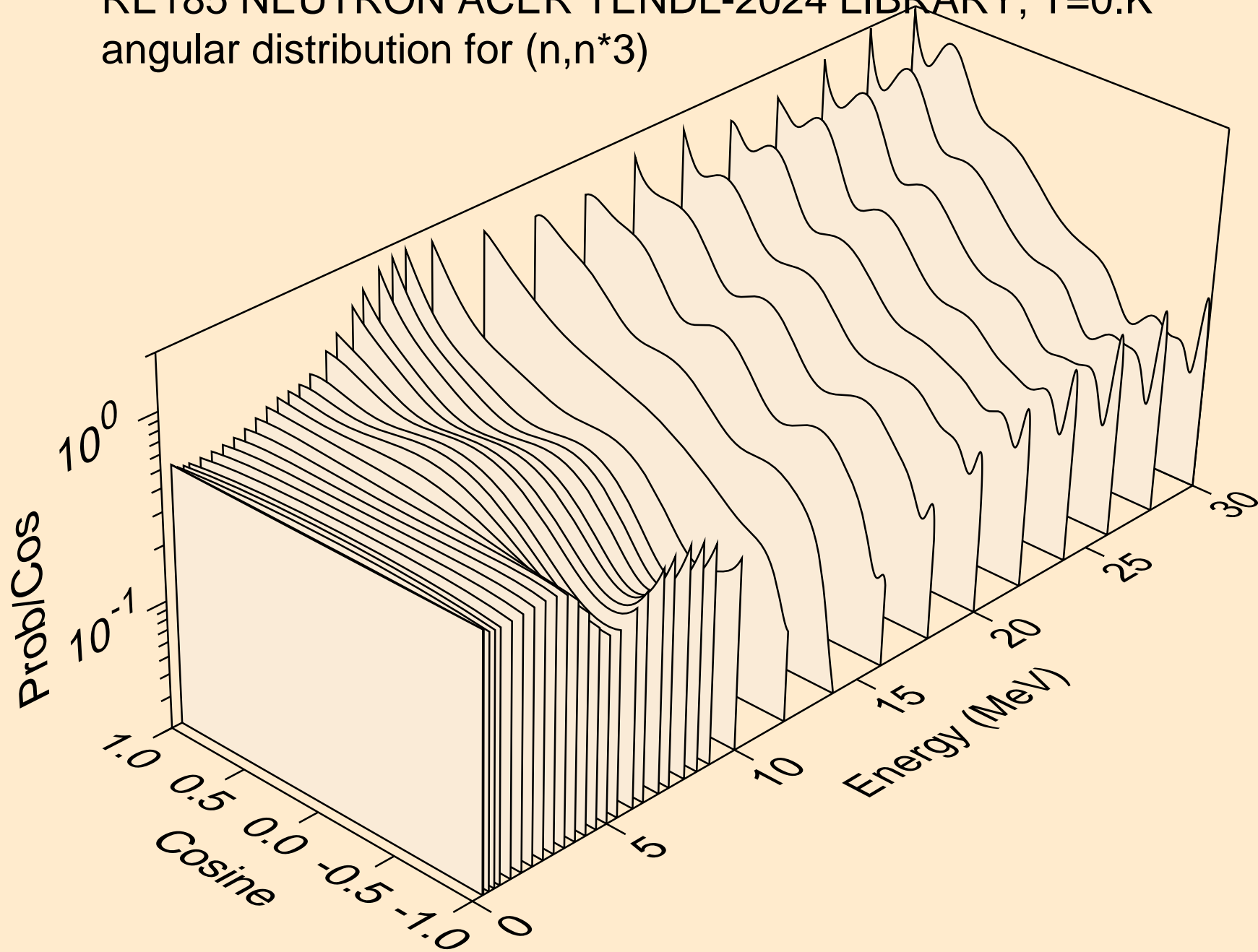

RE185 NEUTRON ACER TENDL-2024 LIBRARY; T=0.K
angular distribution for (n,n*4)

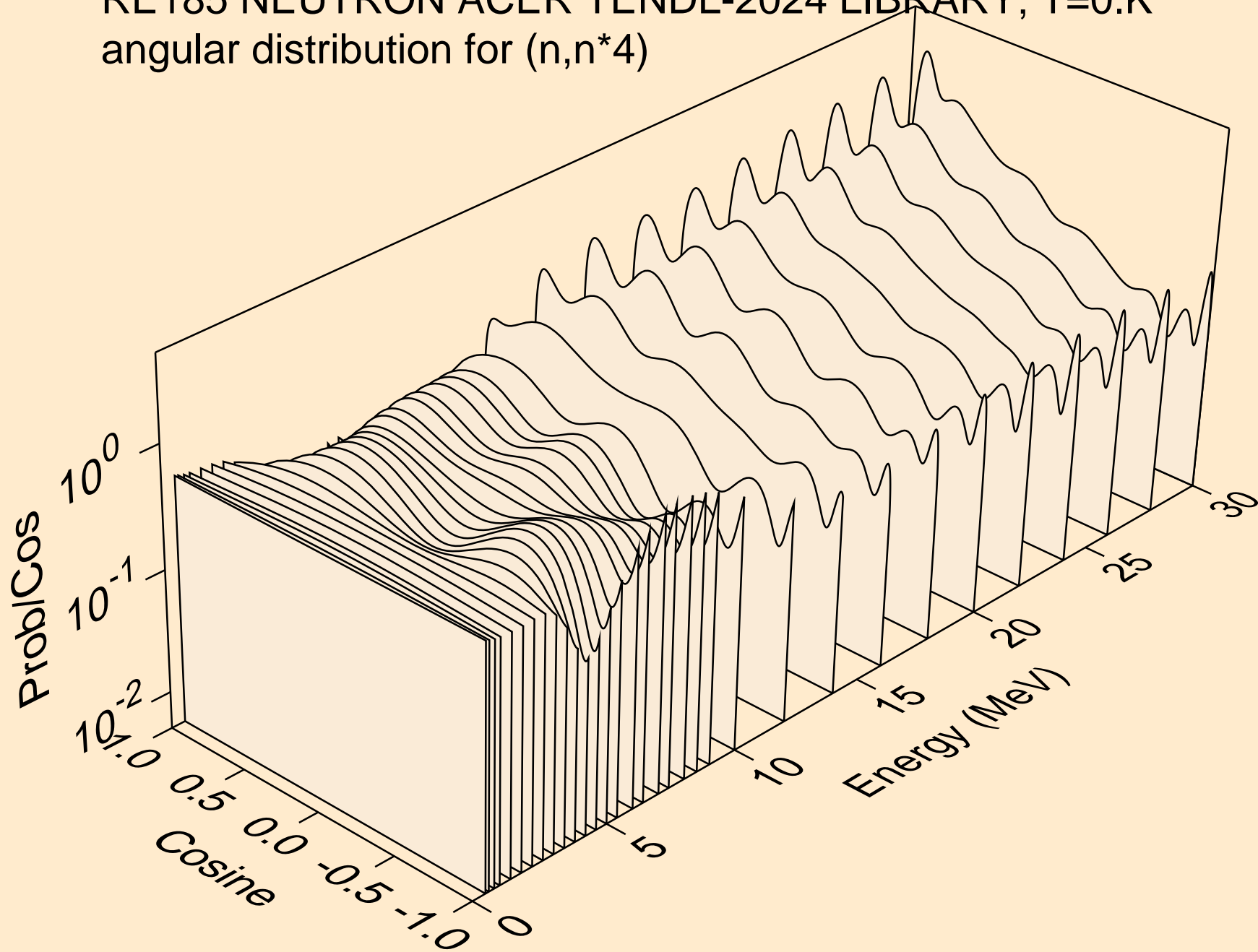

RE185 NEUTRON ACER TENDL-2024 LIBRARY; T=0.K
angular distribution for (n,n*5)

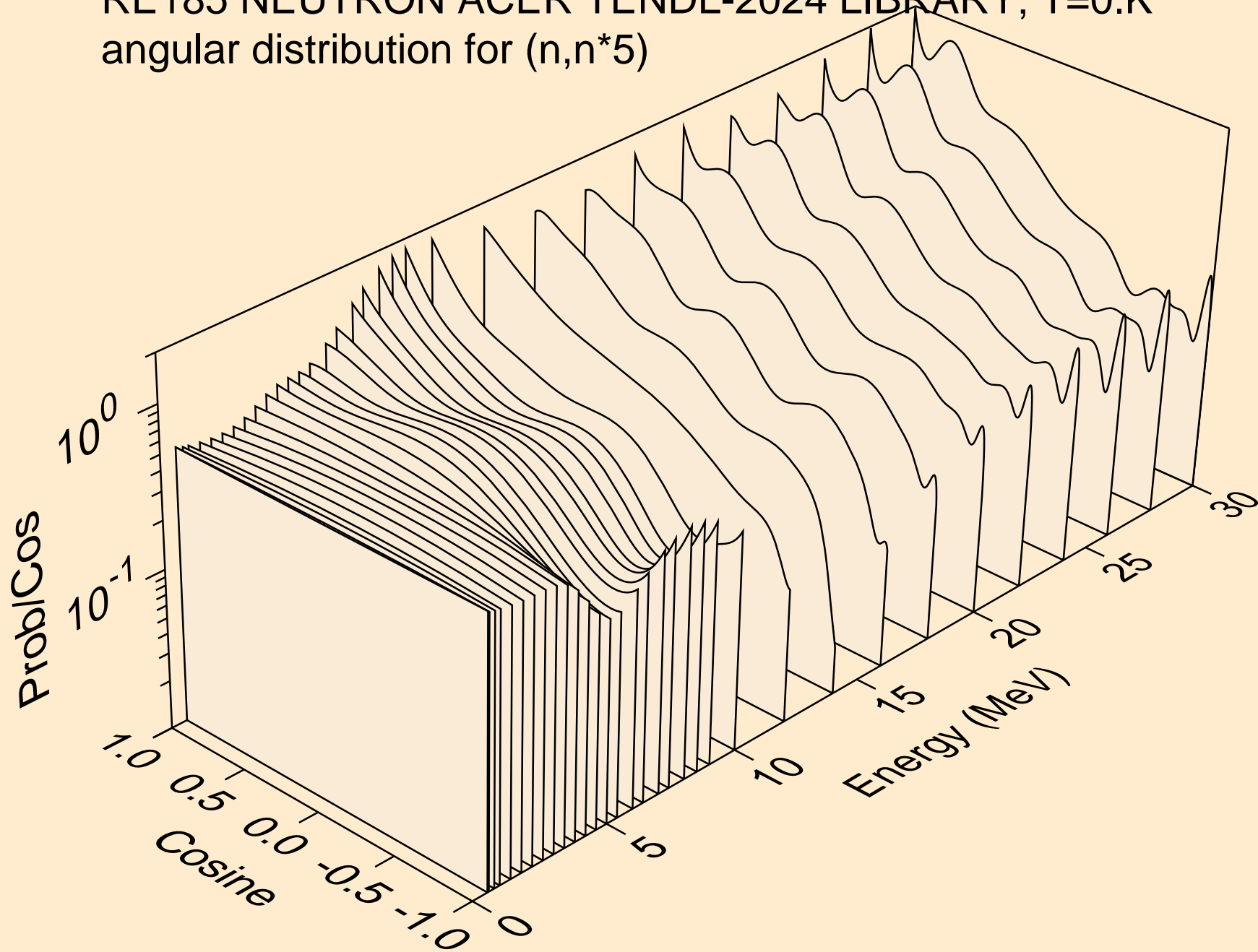

RE185 NEUTRON ACER TENDL-2024 LIBRARY; T=0.K
angular distribution for (n,n*6)

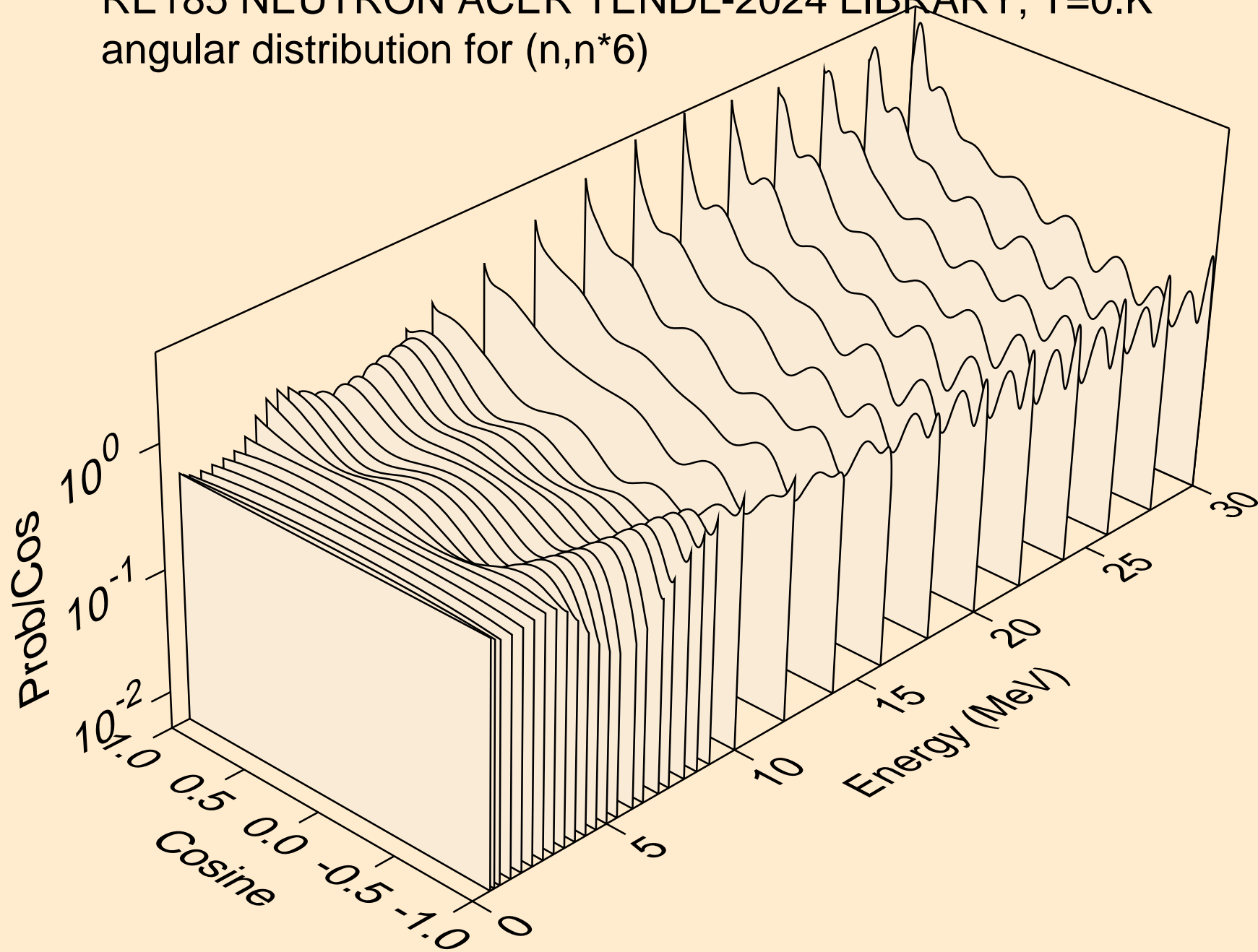

RE185 NEUTRON ACER TENDL-2024 LIBRARY; T=0.K
angular distribution for (n,n*7)

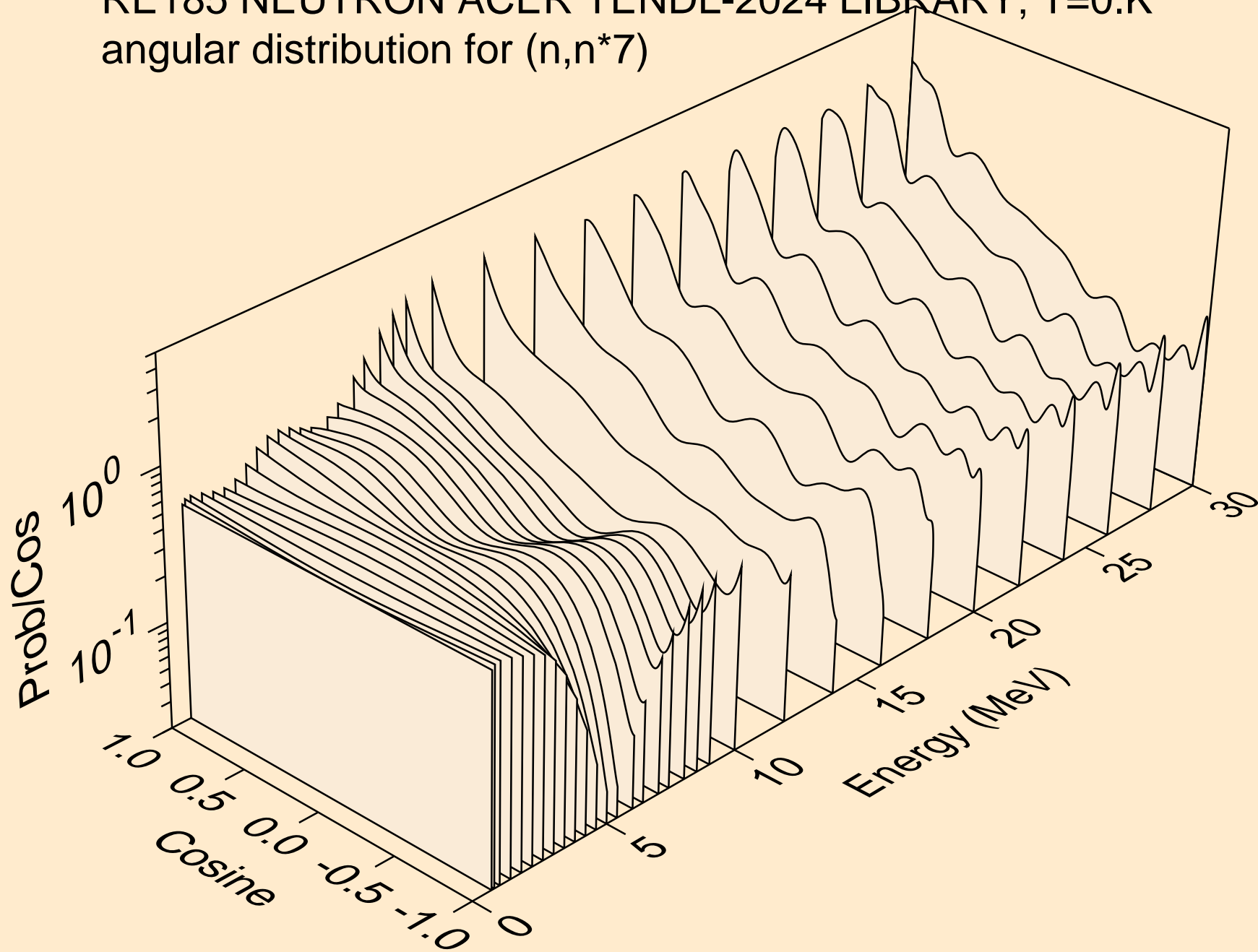

RE185 NEUTRON ACER TENDL-2024 LIBRARY; T=0.K
angular distribution for (n,n*8)

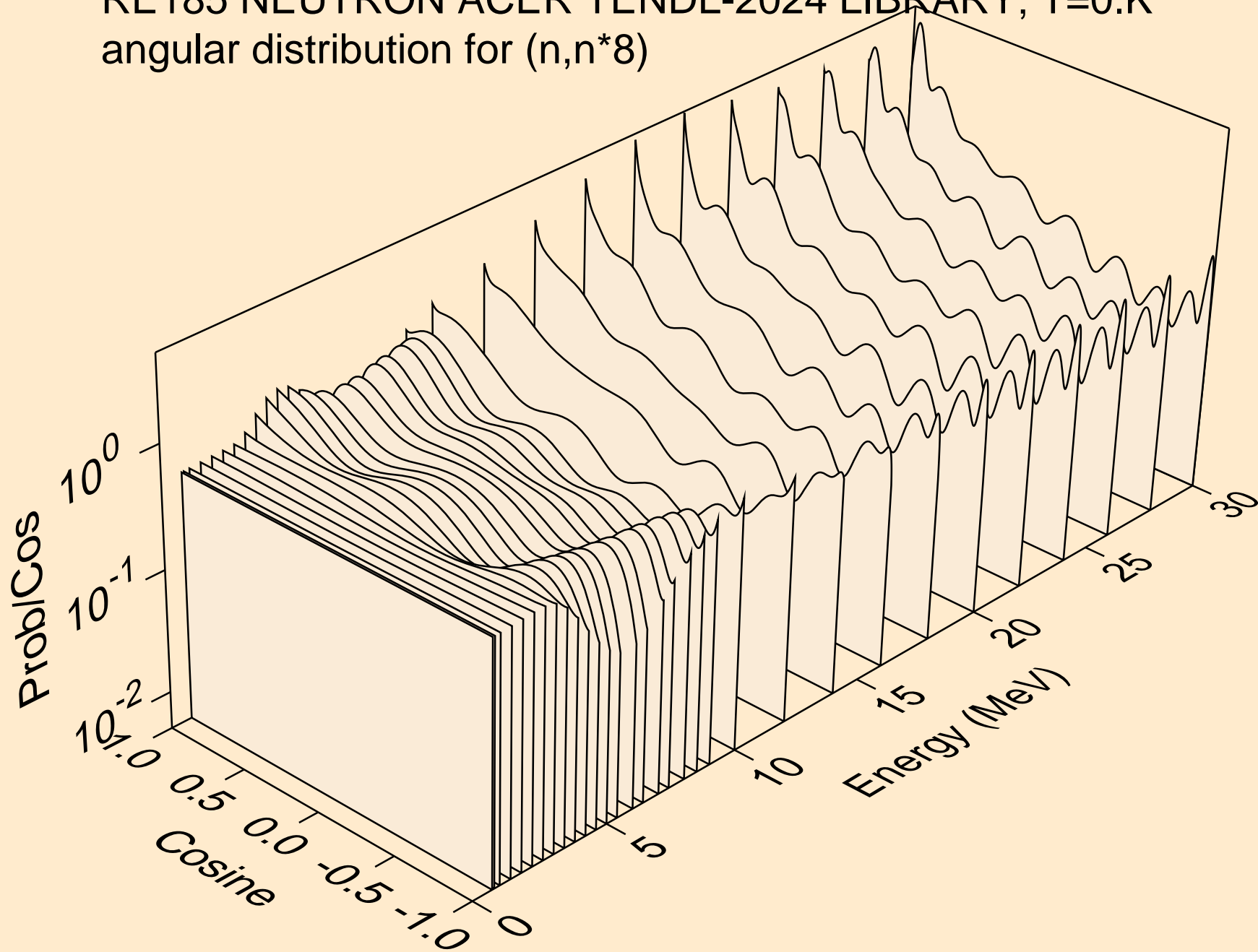

RE185 NEUTRON ACER TENDL-2024 LIBRARY; T=0.K
angular distribution for (n,n*9)

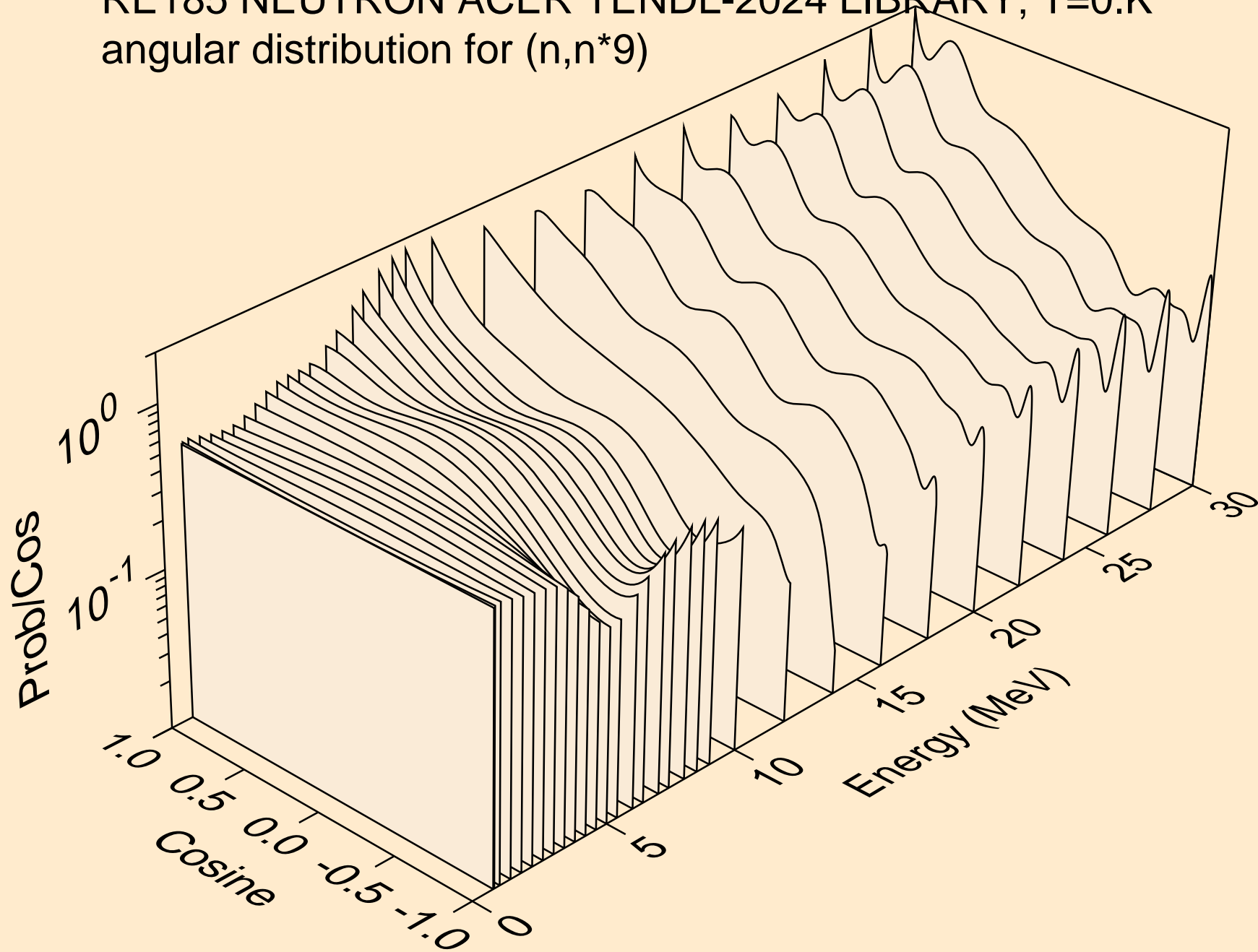

RE185 NEUTRON ACER TENDL-2024 LIBRARY; T=0.K
angular distribution for (n,n*10)

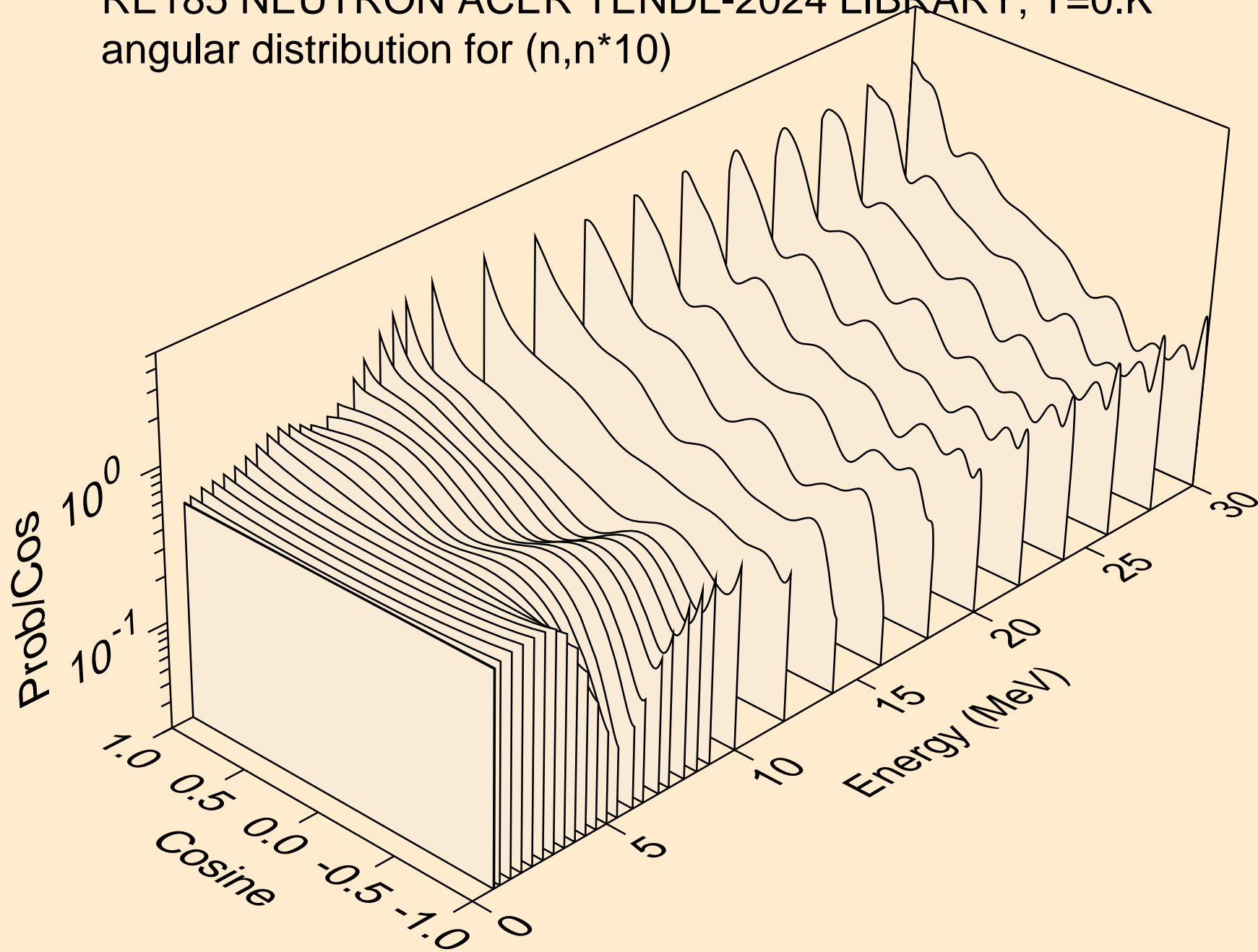

RE185 NEUTRON ACER TENDL-2024 LIBRARY; T=0.K
angular distribution for (n,n*11)

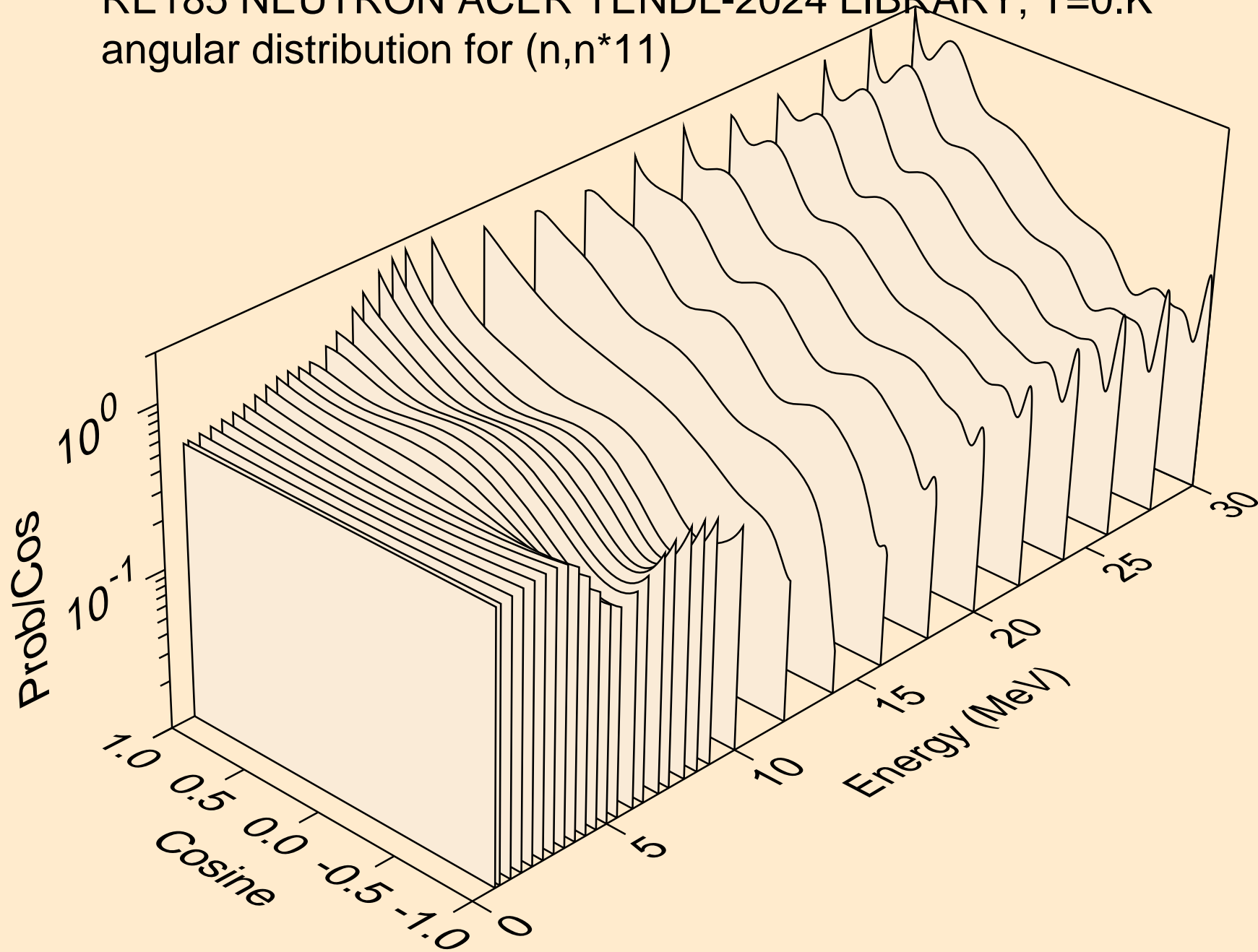

RE185 NEUTRON ACER TENDL-2024 LIBRARY; T=0.K
angular distribution for (n,n*12)

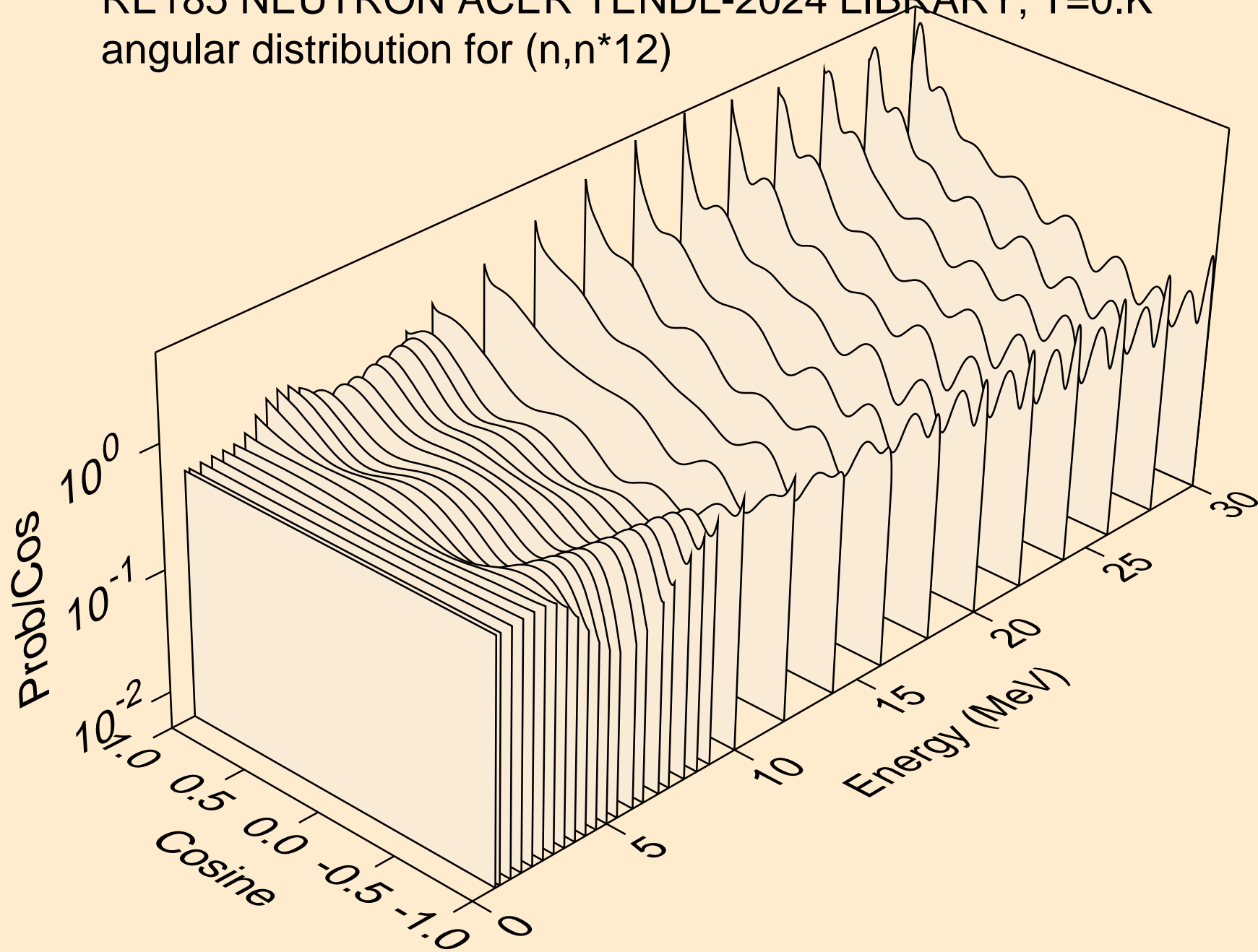

RE185 NEUTRON ACER TENDL-2024 LIBRARY; T=0.K
angular distribution for (n,n*13)

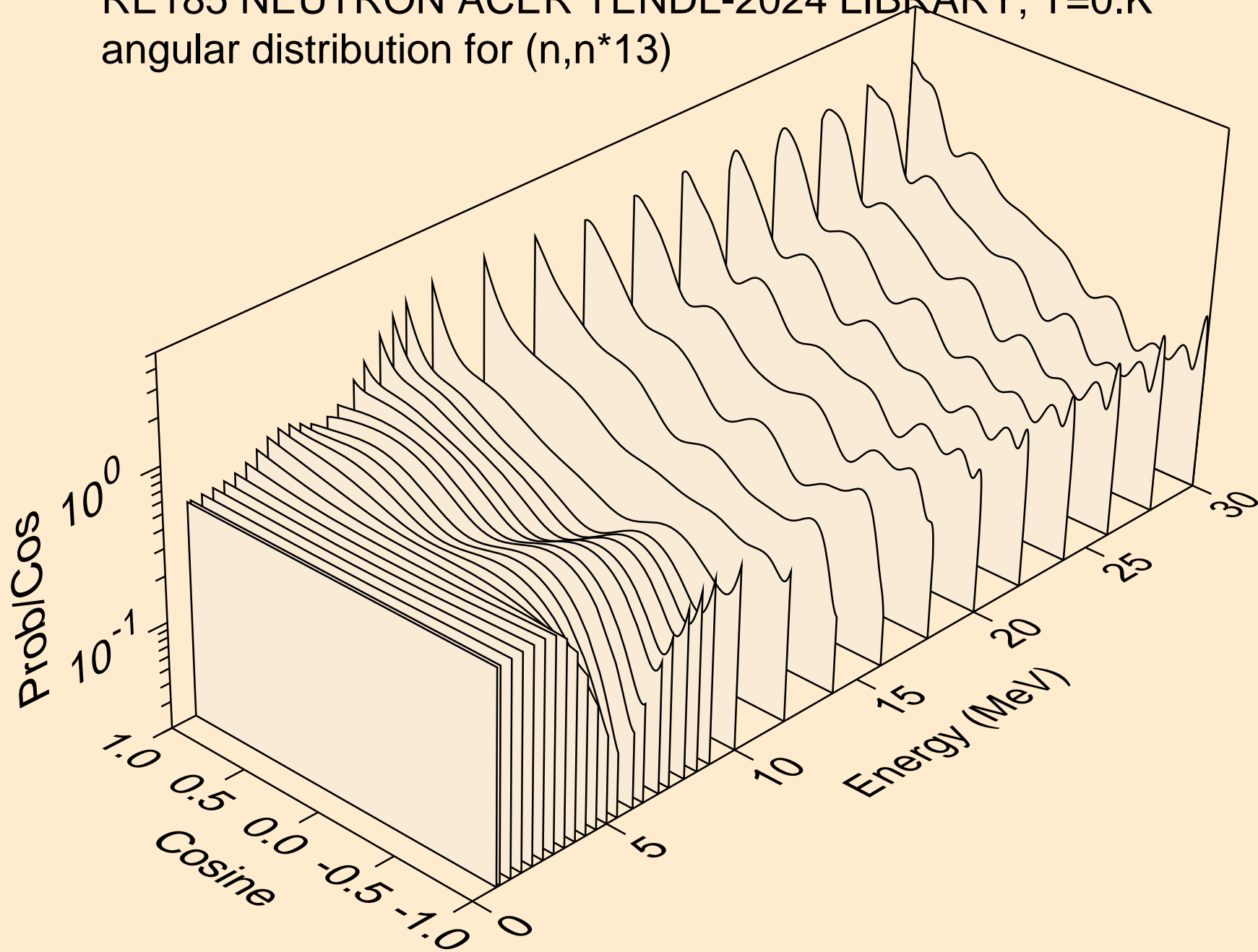

RE185 NEUTRON ACER TENDL-2024 LIBRARY; T=0.K
angular distribution for (n,n*14)

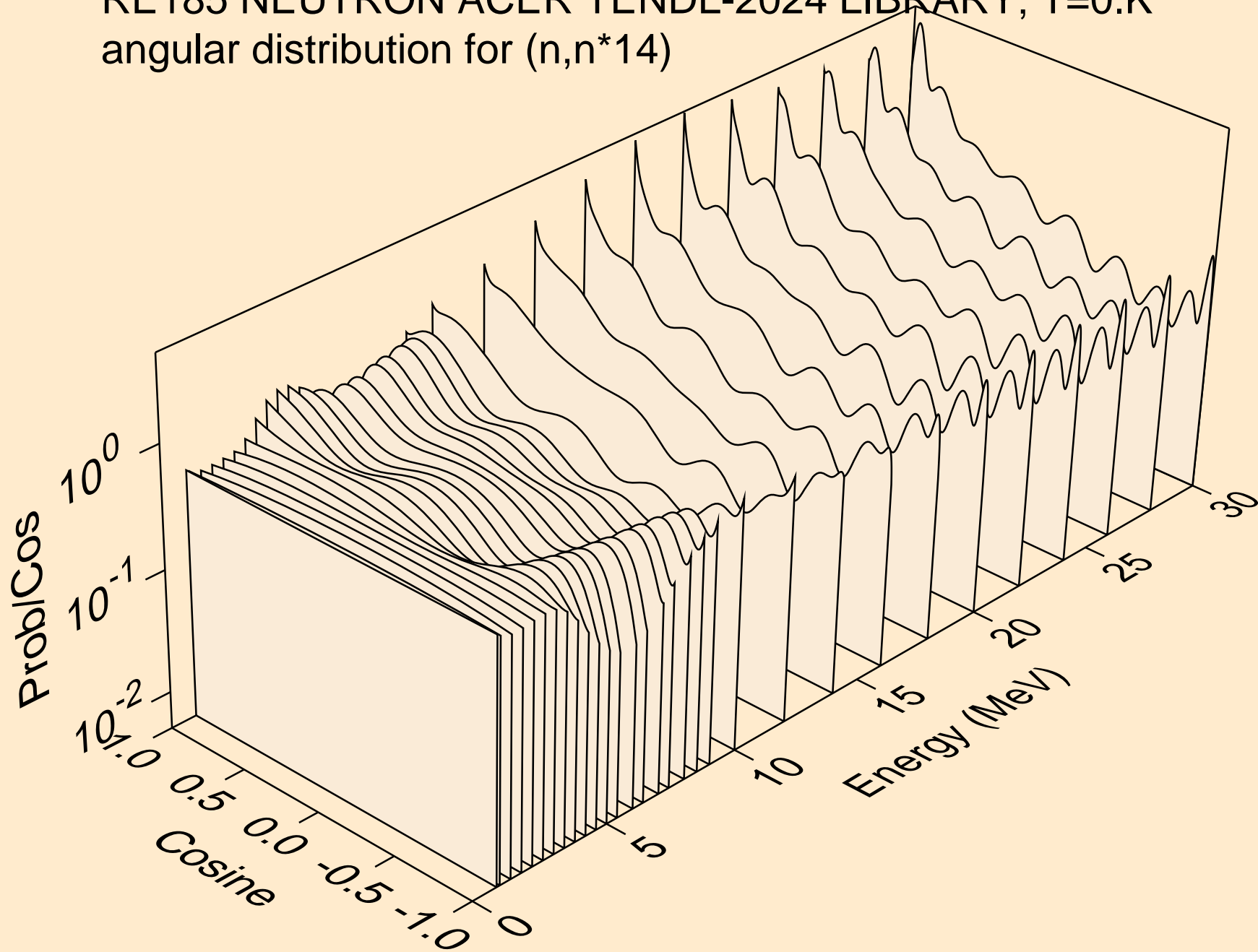

RE185 NEUTRON ACER TENDL-2024 LIBRARY; T=0.K
angular distribution for (n,n*15)

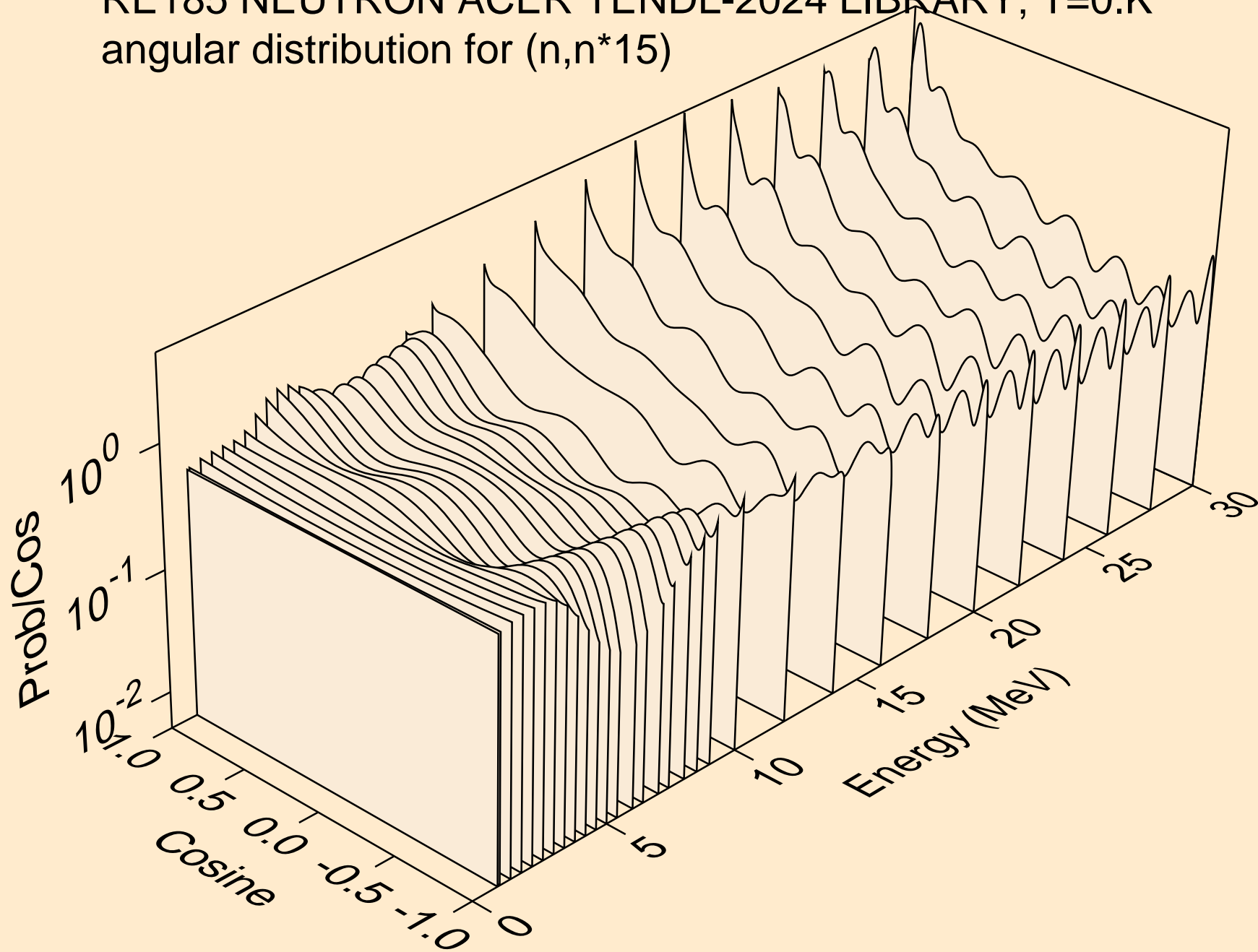

RE185 NEUTRON ACER TENDL-2024 LIBRARY; T=0.K
angular distribution for (n,n*16)

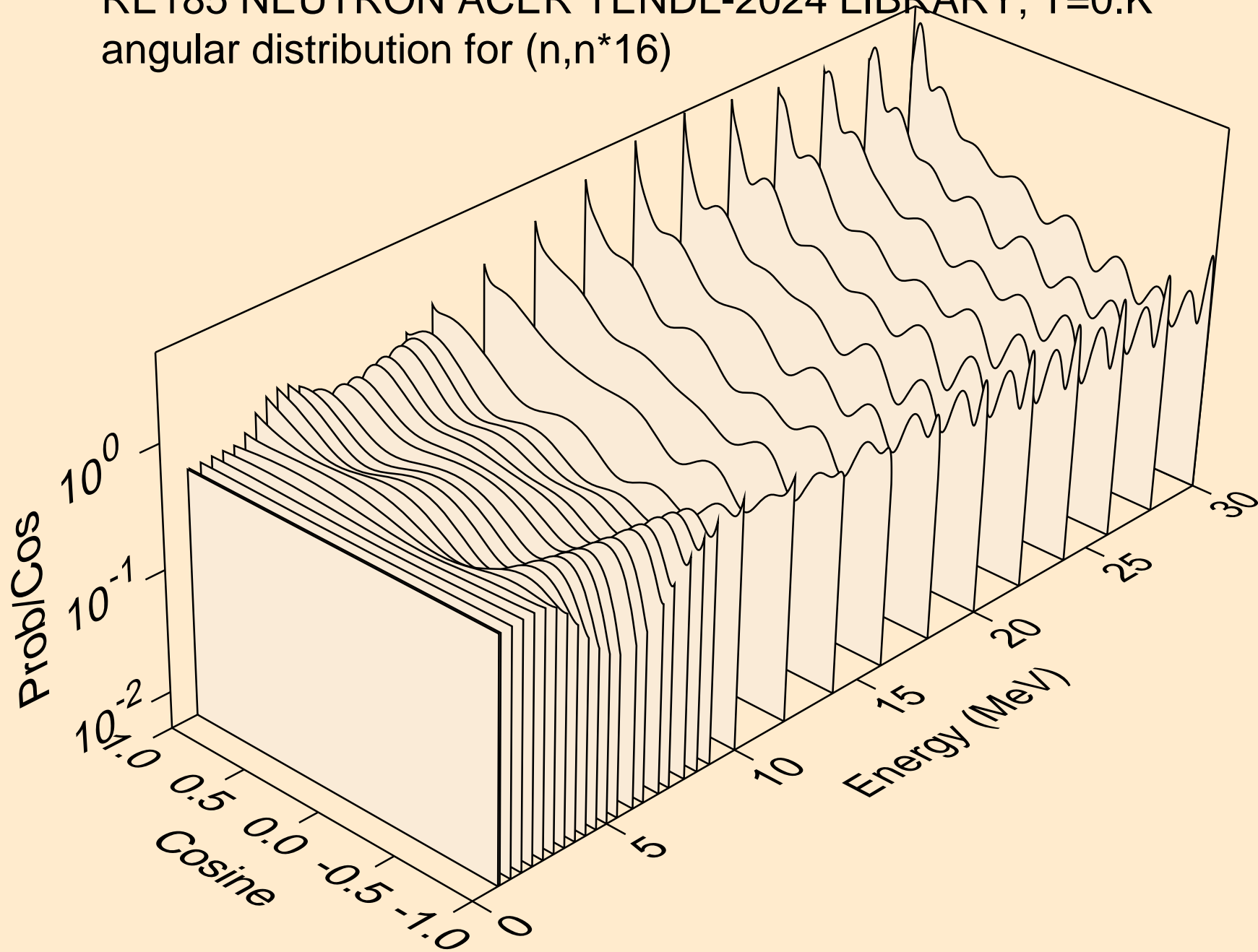

RE185 NEUTRON ACER TENDL-2024 LIBRARY; T=0.K
angular distribution for (n,n*17)

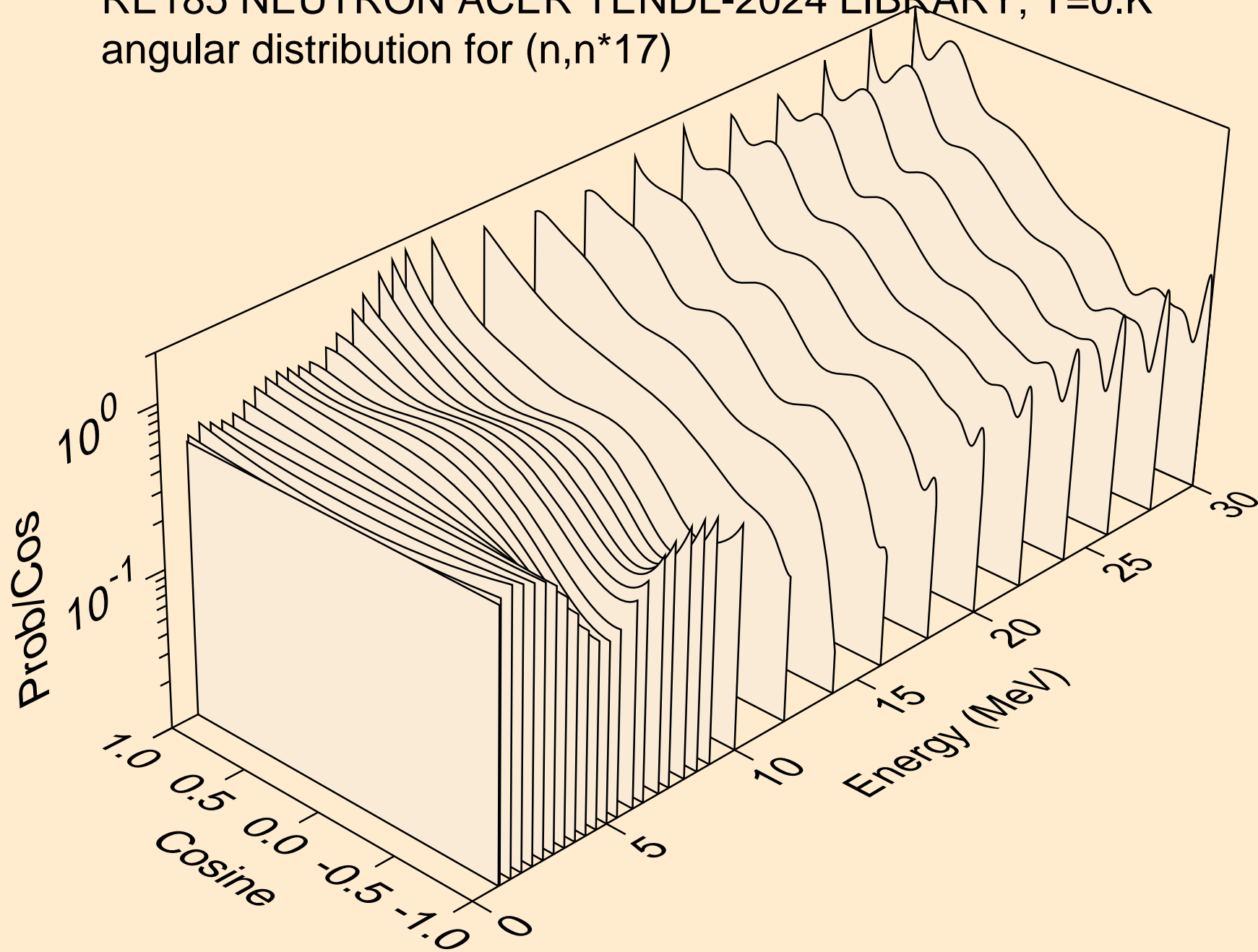

RE185 NEUTRON ACER TENDL-2024 LIBRARY; T=0.K
angular distribution for (n,n*18)

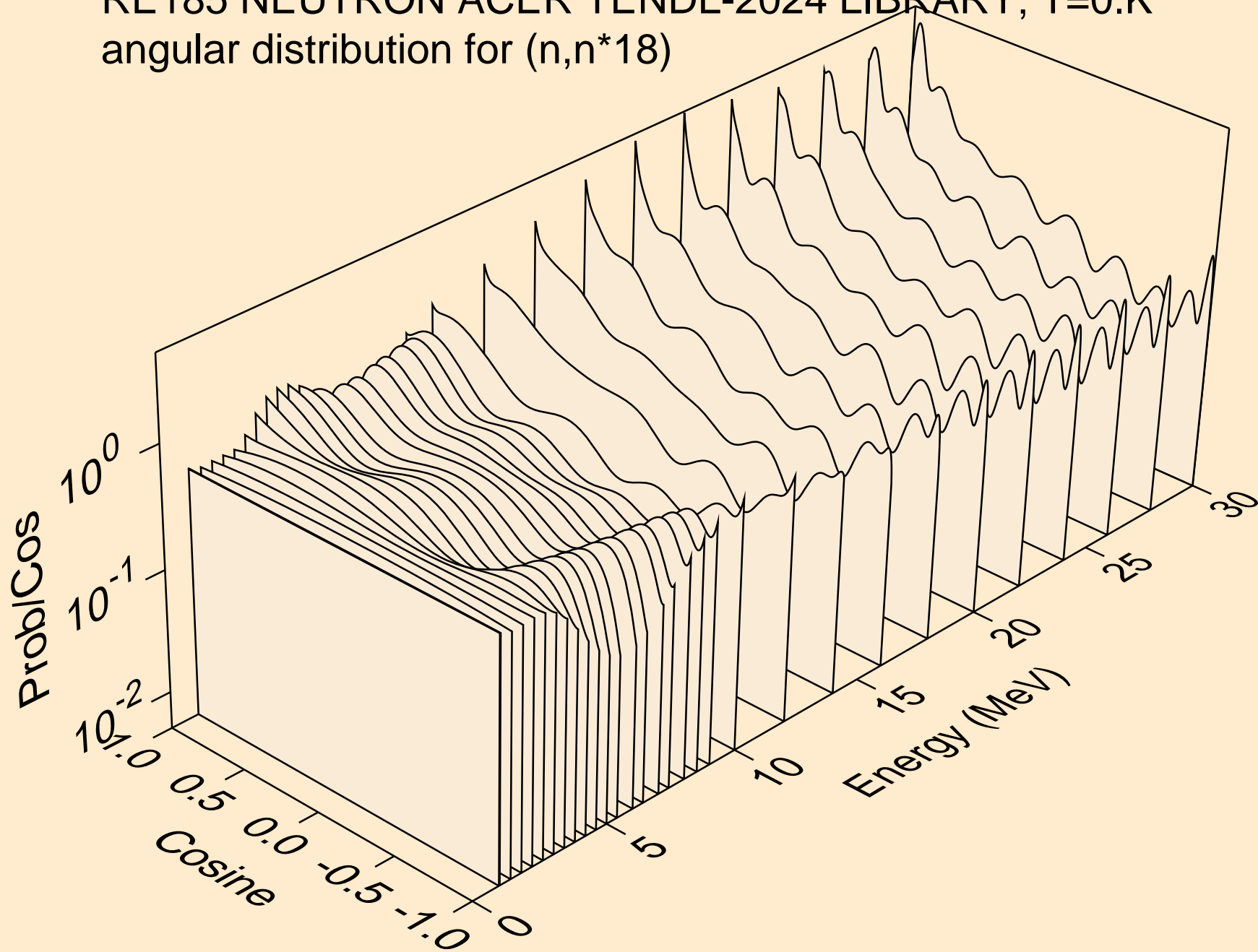

RE185 NEUTRON ACER TENDL-2024 LIBRARY; T=0.K
angular distribution for (n,n*19)

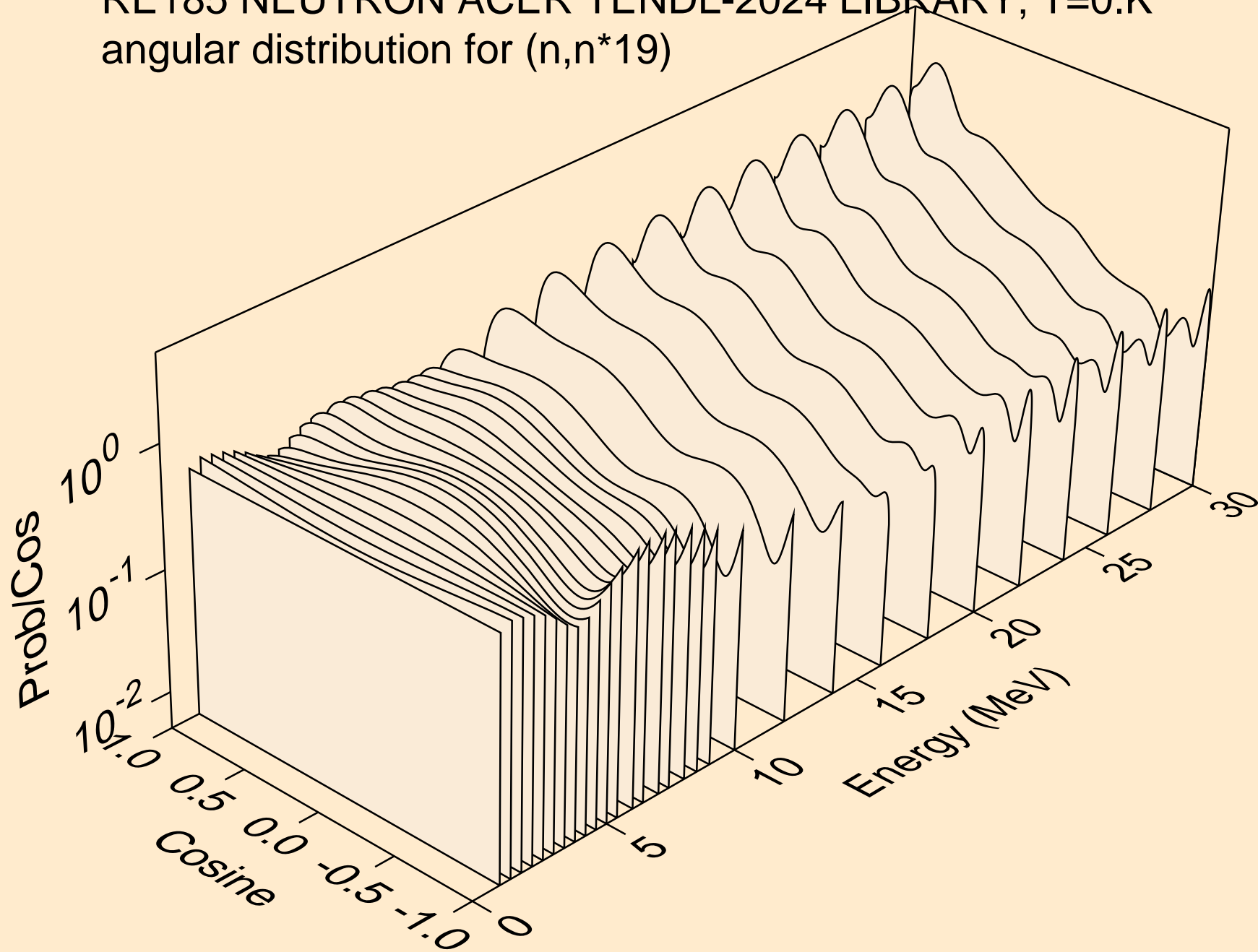

RE185 NEUTRON ACER TENDL-2024 LIBRARY; T=0.K
angular distribution for (n,n*20)

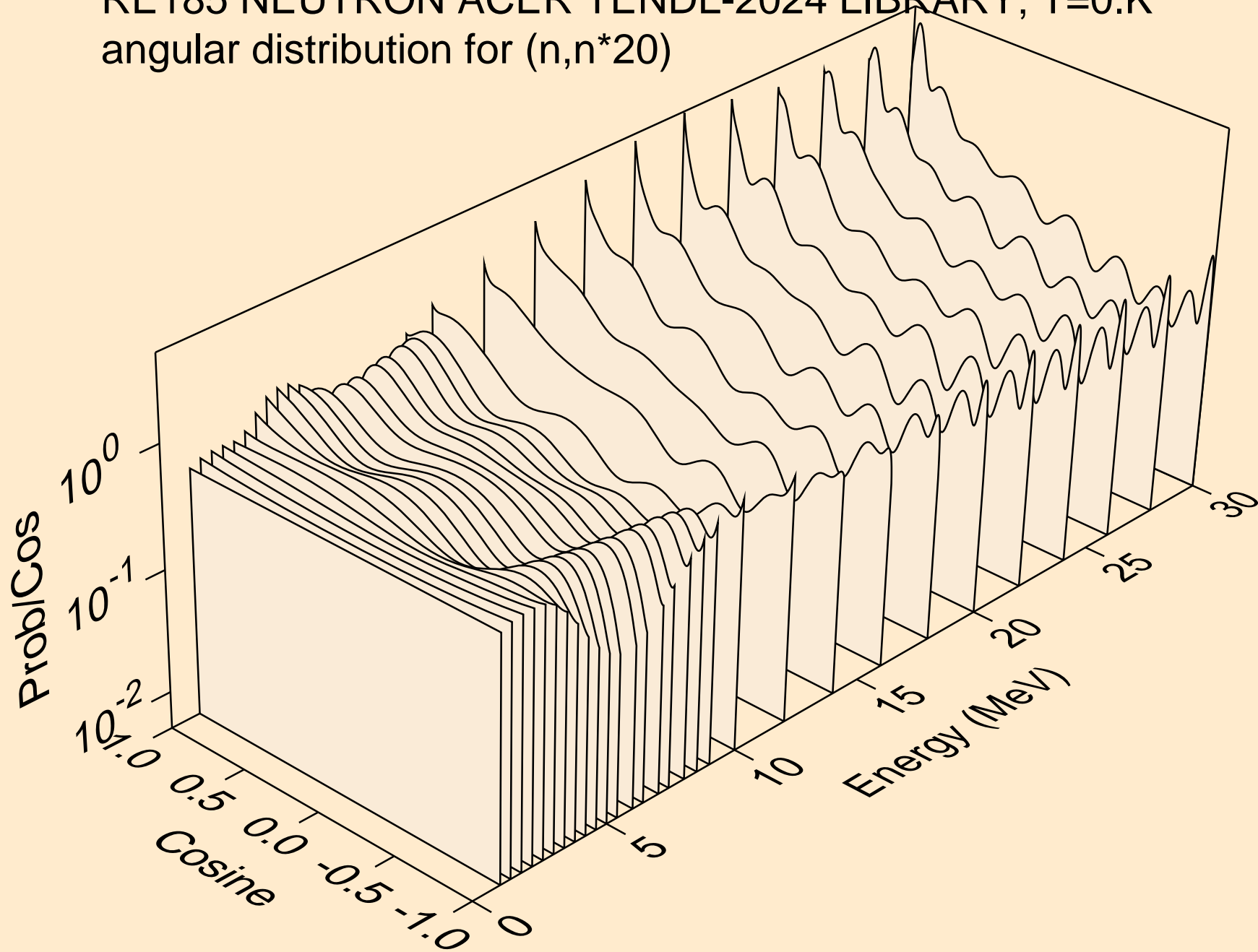

RE185 NEUTRON ACER TENDL-2024 LIBRARY; T=0.K
angular distribution for (n,n*21)

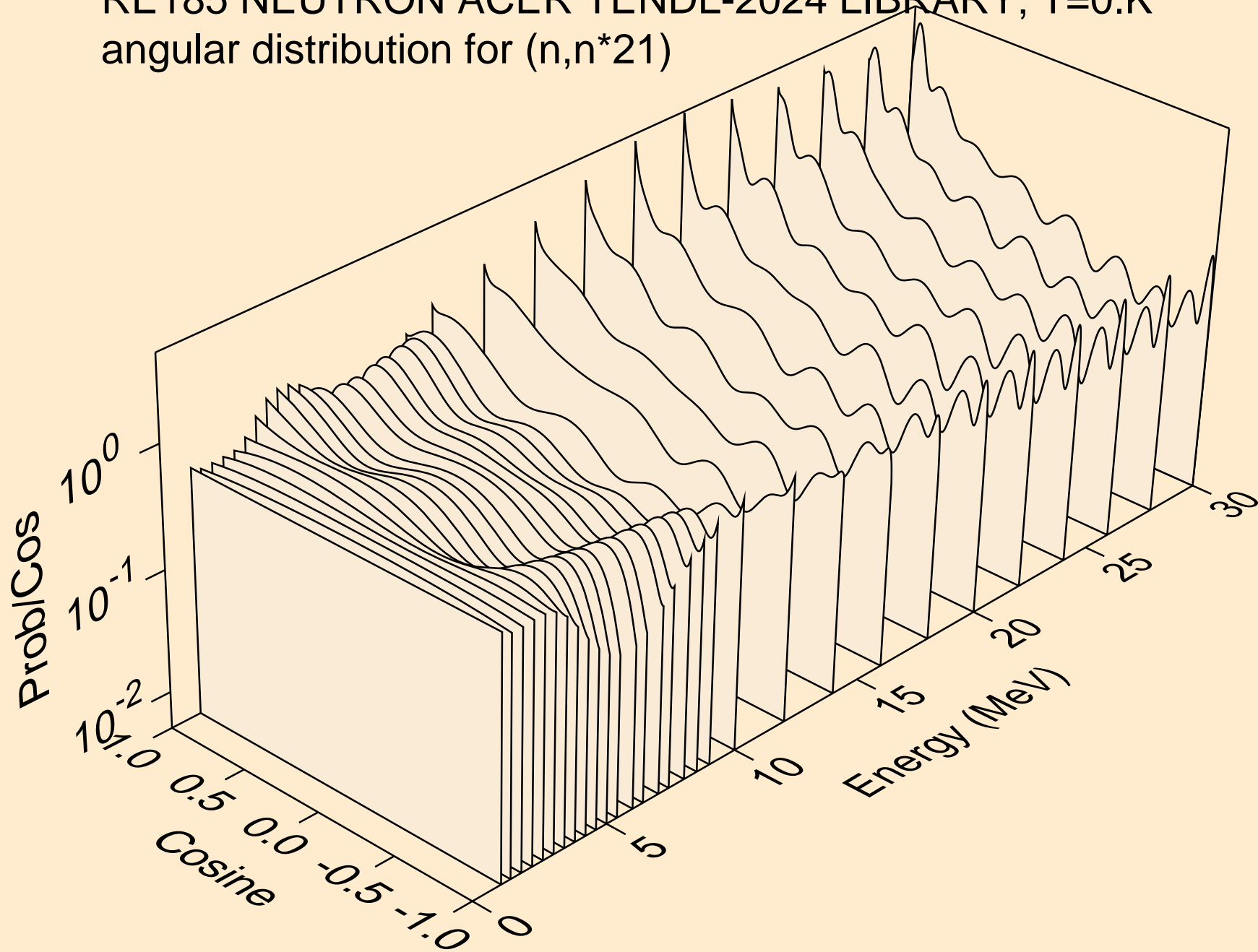

RE185 NEUTRON ACER TENDL-2024 LIBRARY; T=0.K
angular distribution for (n,n*22)

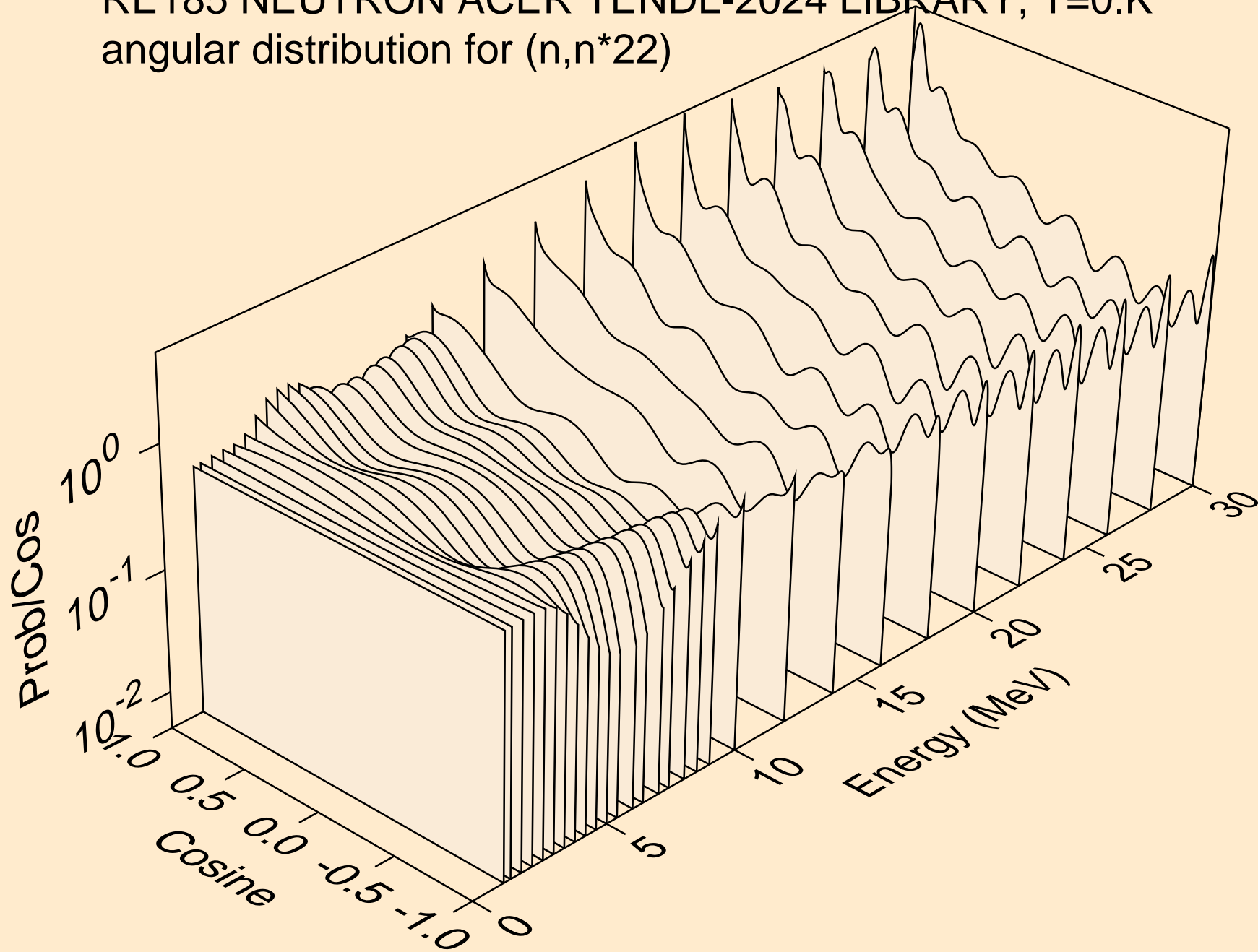

RE185 NEUTRON ACER TENDL-2024 LIBRARY; T=0.K
angular distribution for (n,n*23)

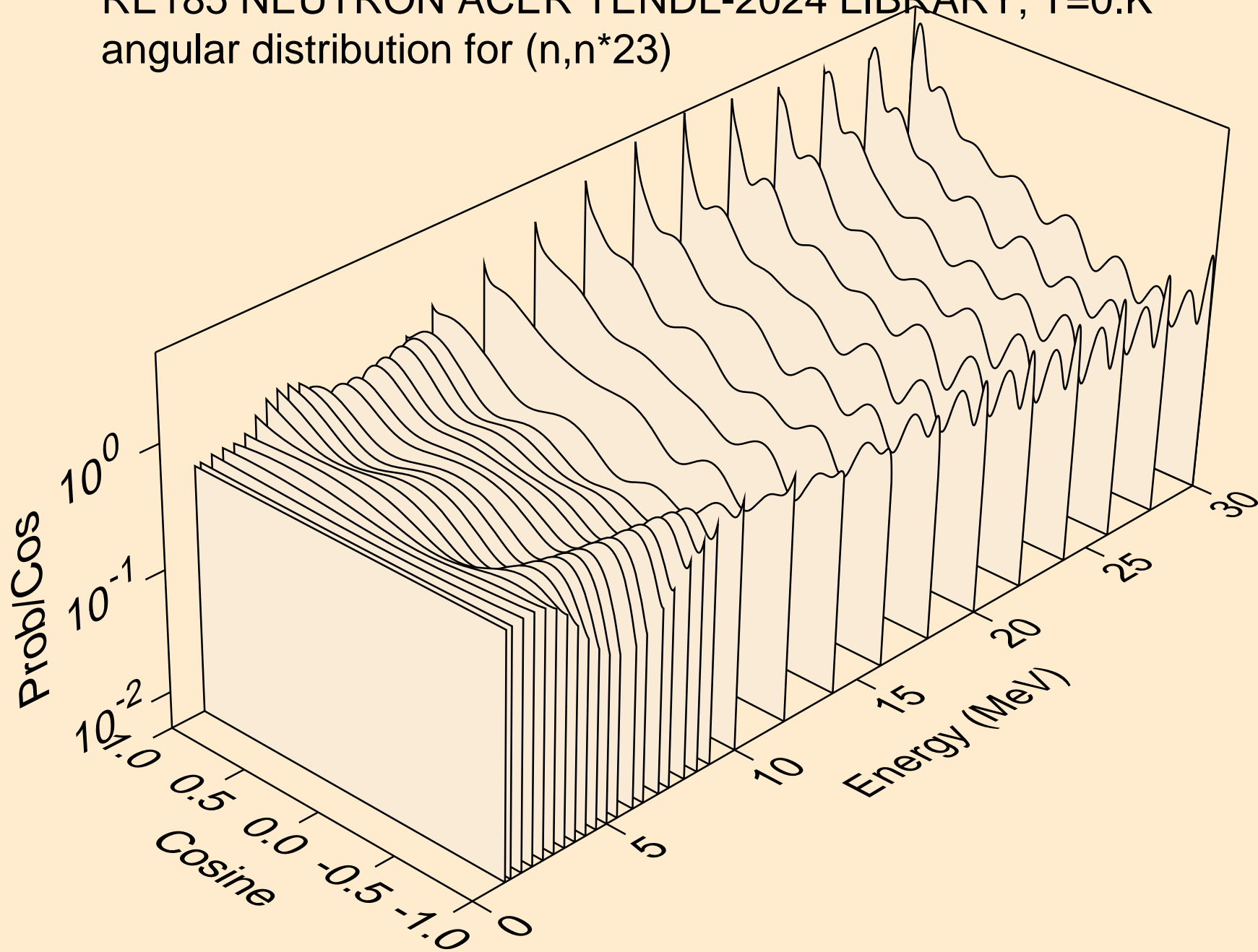

RE185 NEUTRON ACER TENDL-2024 LIBRARY; T=0.K
angular distribution for (n,n*24)

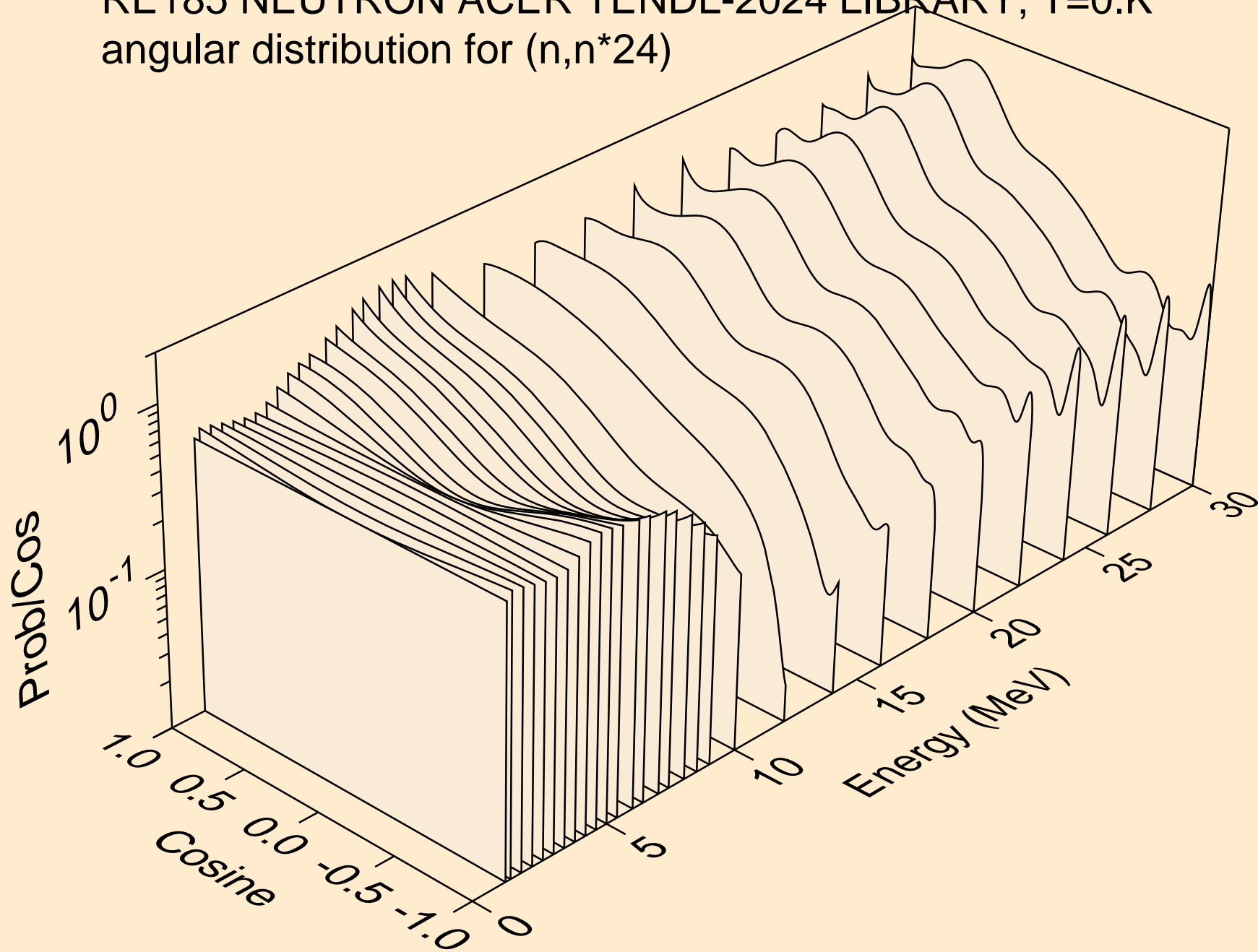

RE185 NEUTRON ACER TENDL-2024 LIBRARY; T=0.K
angular distribution for (n,n*25)

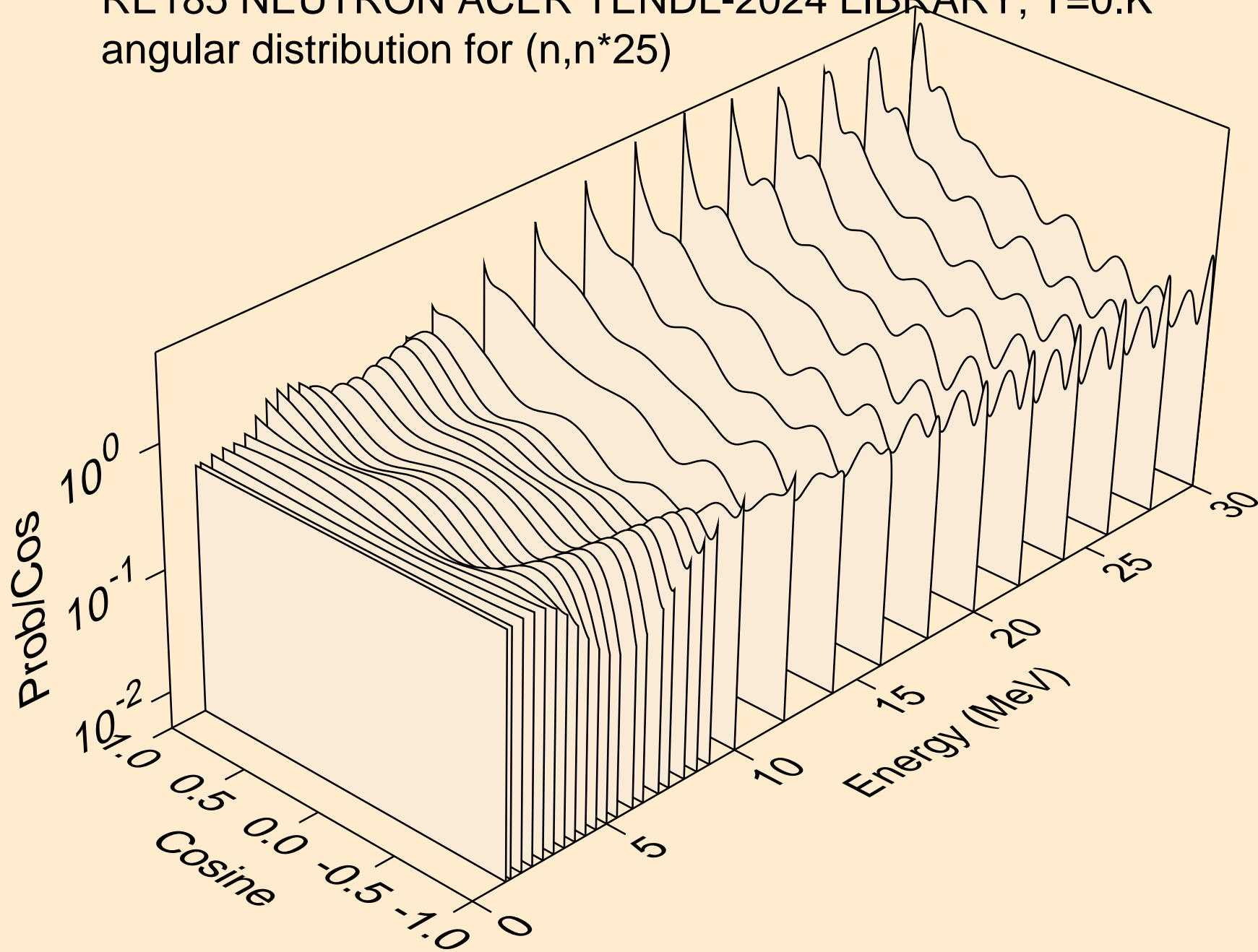

RE185 NEUTRON ACER TENDL-2024 LIBRARY; T=0.K
angular distribution for (n,n*26)

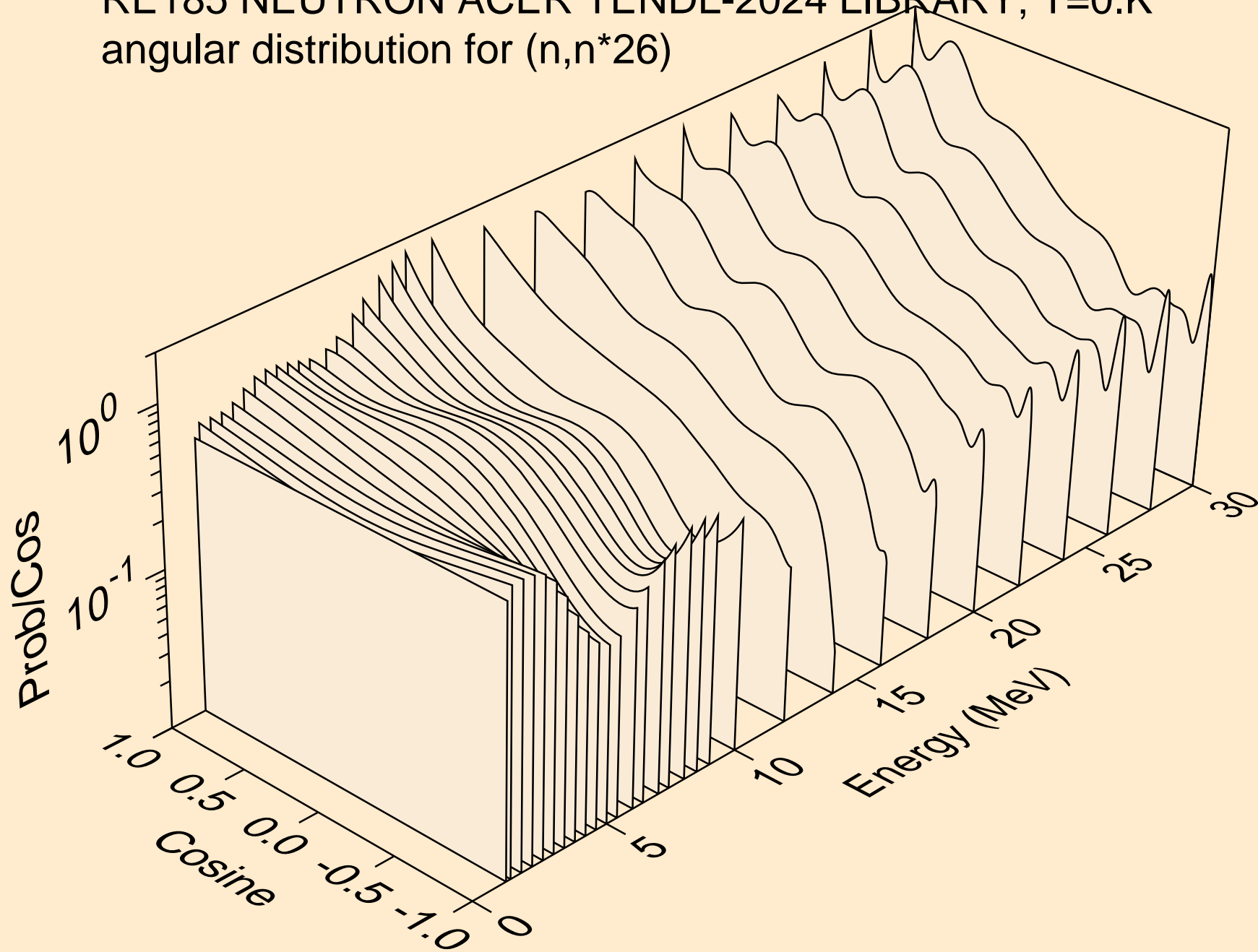

RE185 NEUTRON ACER TENDL-2024 LIBRARY; T=0.K
angular distribution for (n,n*27)

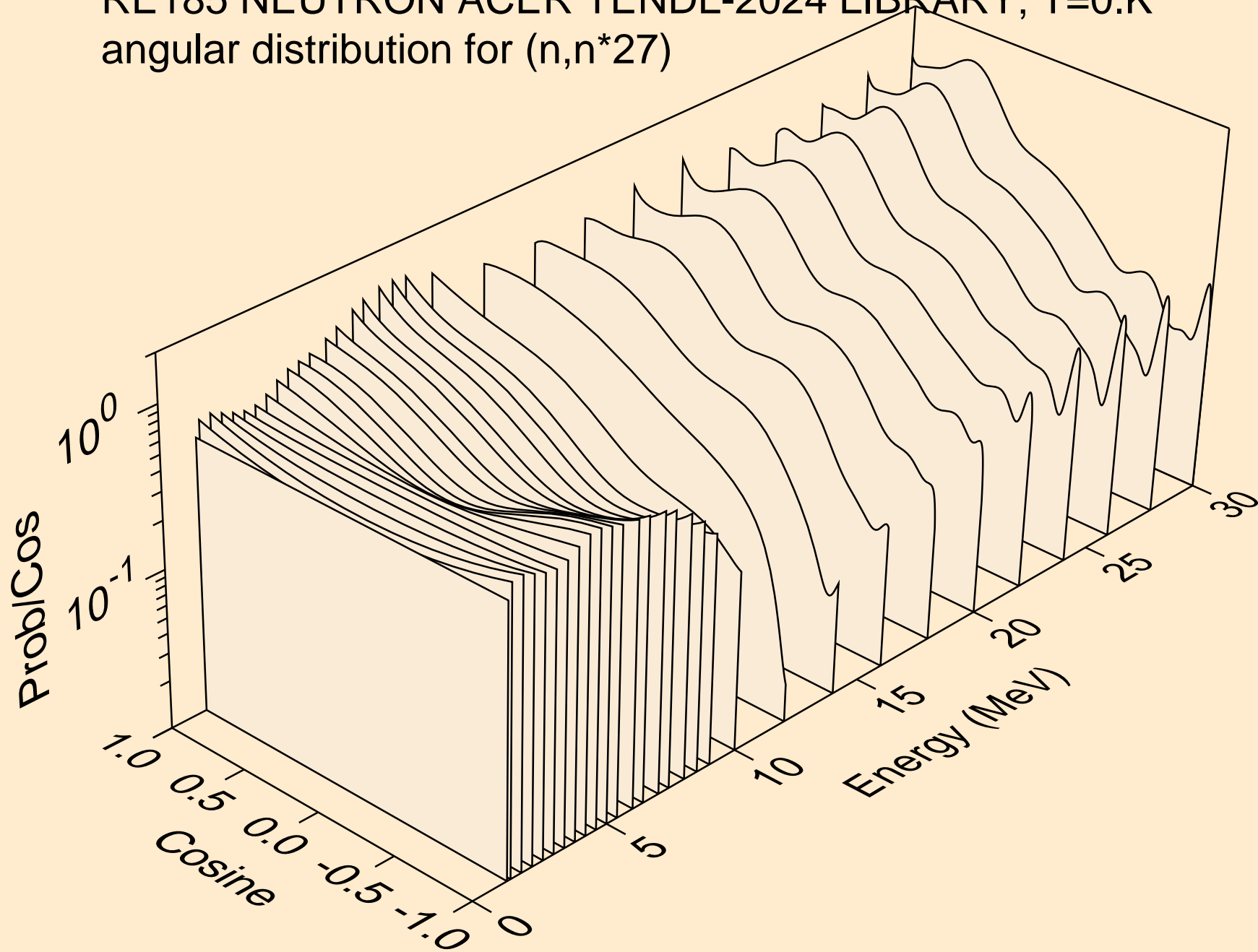

RE185 NEUTRON ACER TENDL-2024 LIBRARY; T=0.K
angular distribution for (n,n*28)

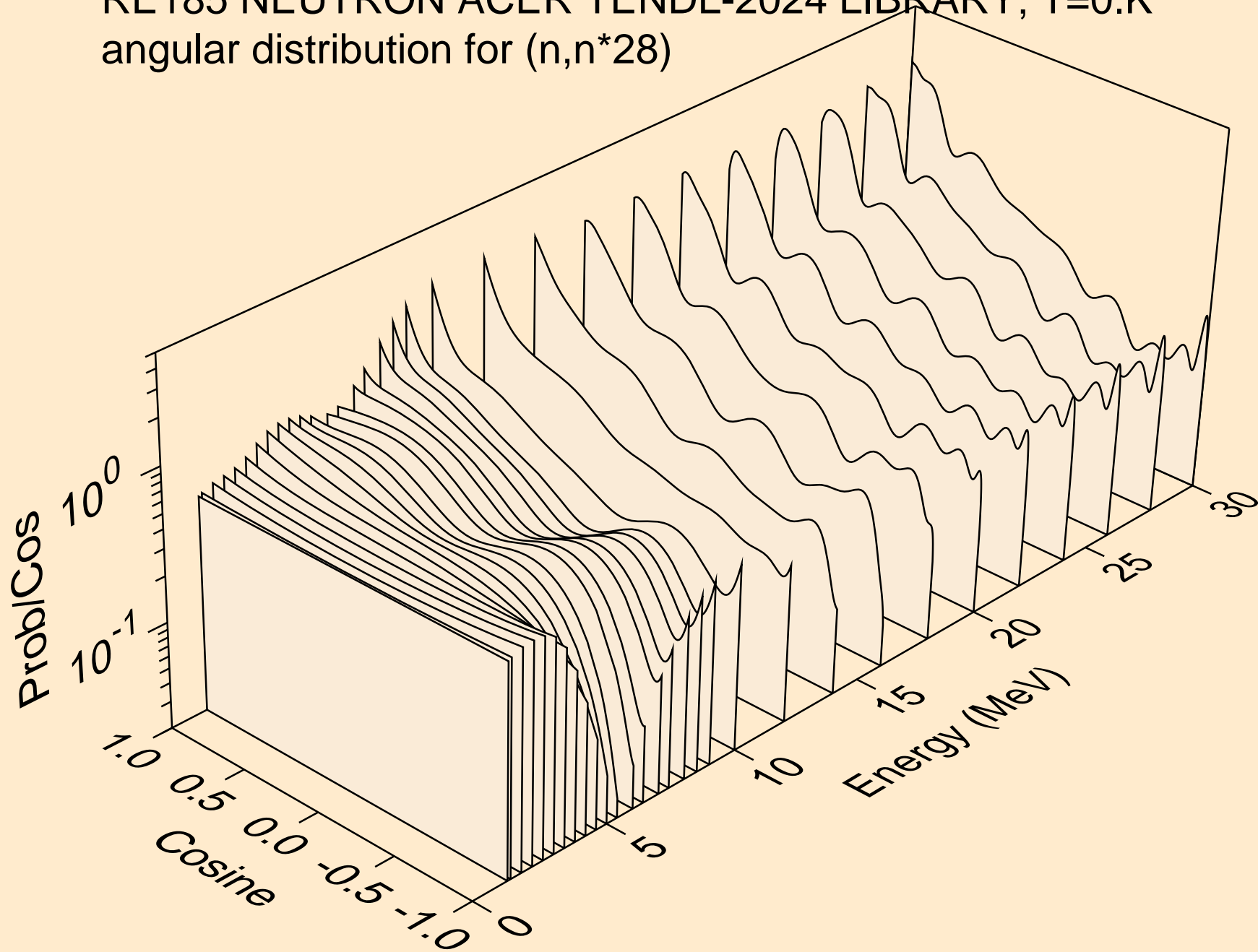

RE185 NEUTRON ACER TENDL-2024 LIBRARY; T=0.K
angular distribution for (n,n*29)

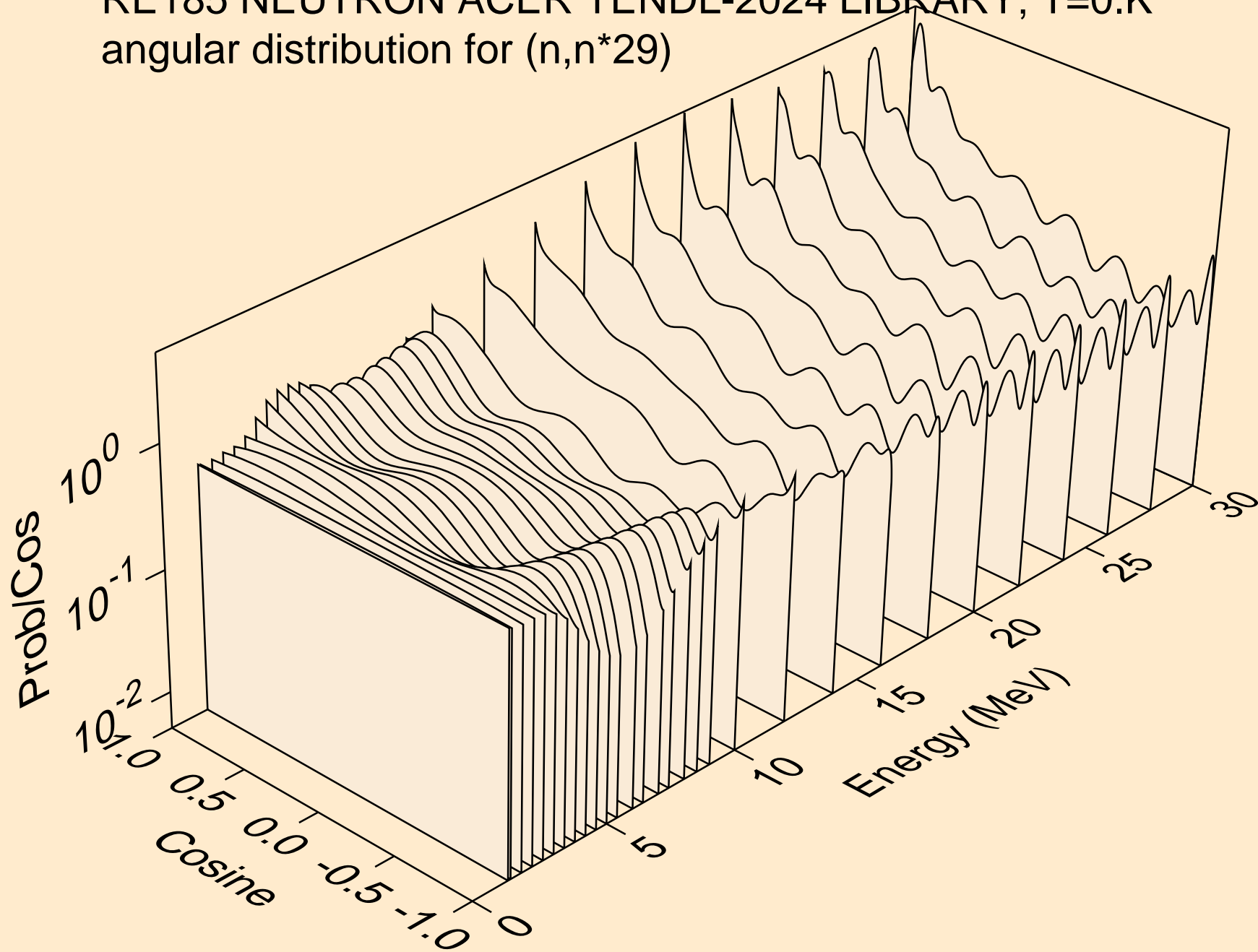

RE185 NEUTRON ACER TENDL-2024 LIBRARY; T=0.K
Neutron emission for (n,x)

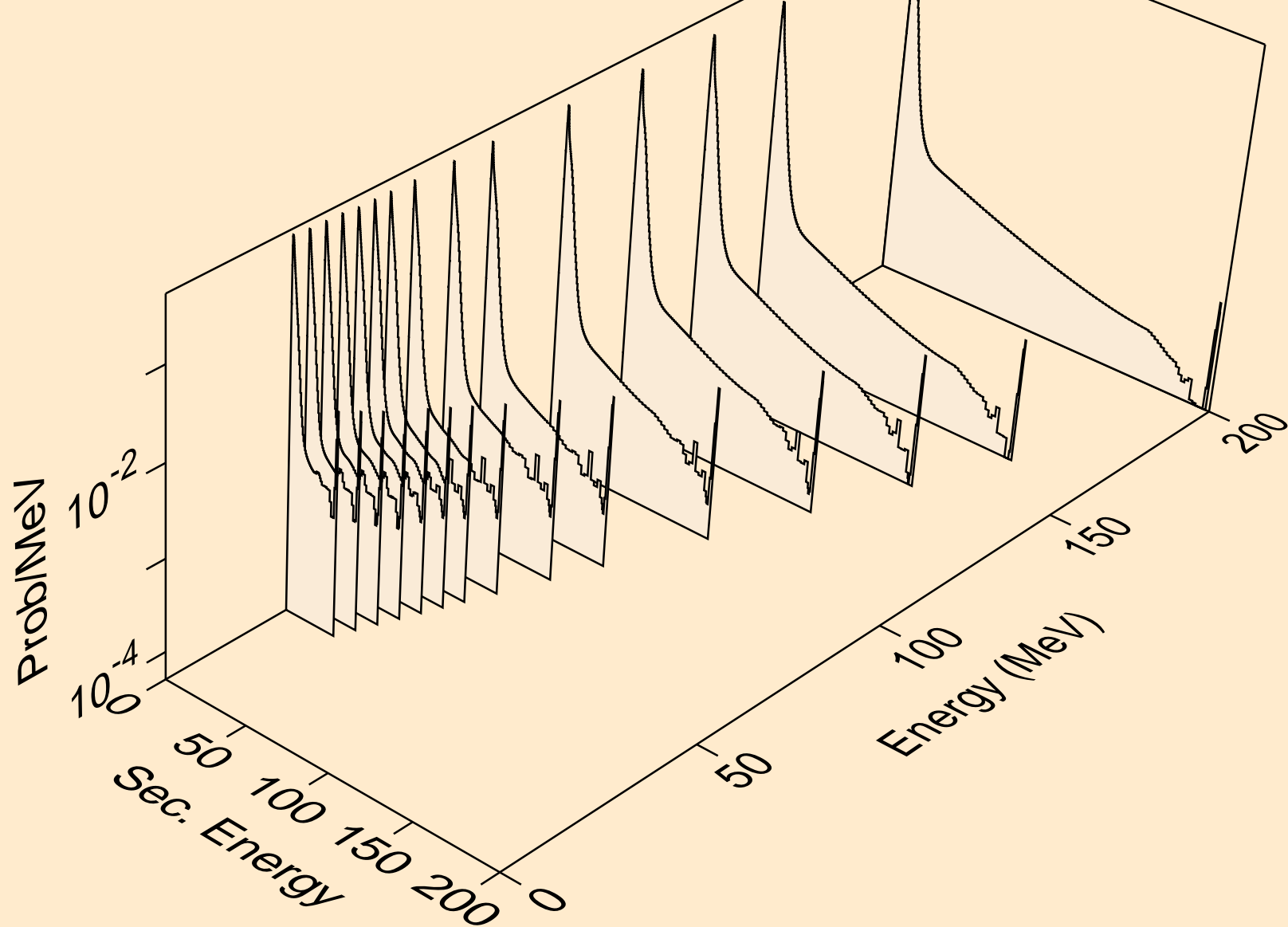

RE185 NEUTRON ACER TENDL-2024 LIBRARY; T=0.K
Neutron emission for (n,2nd)

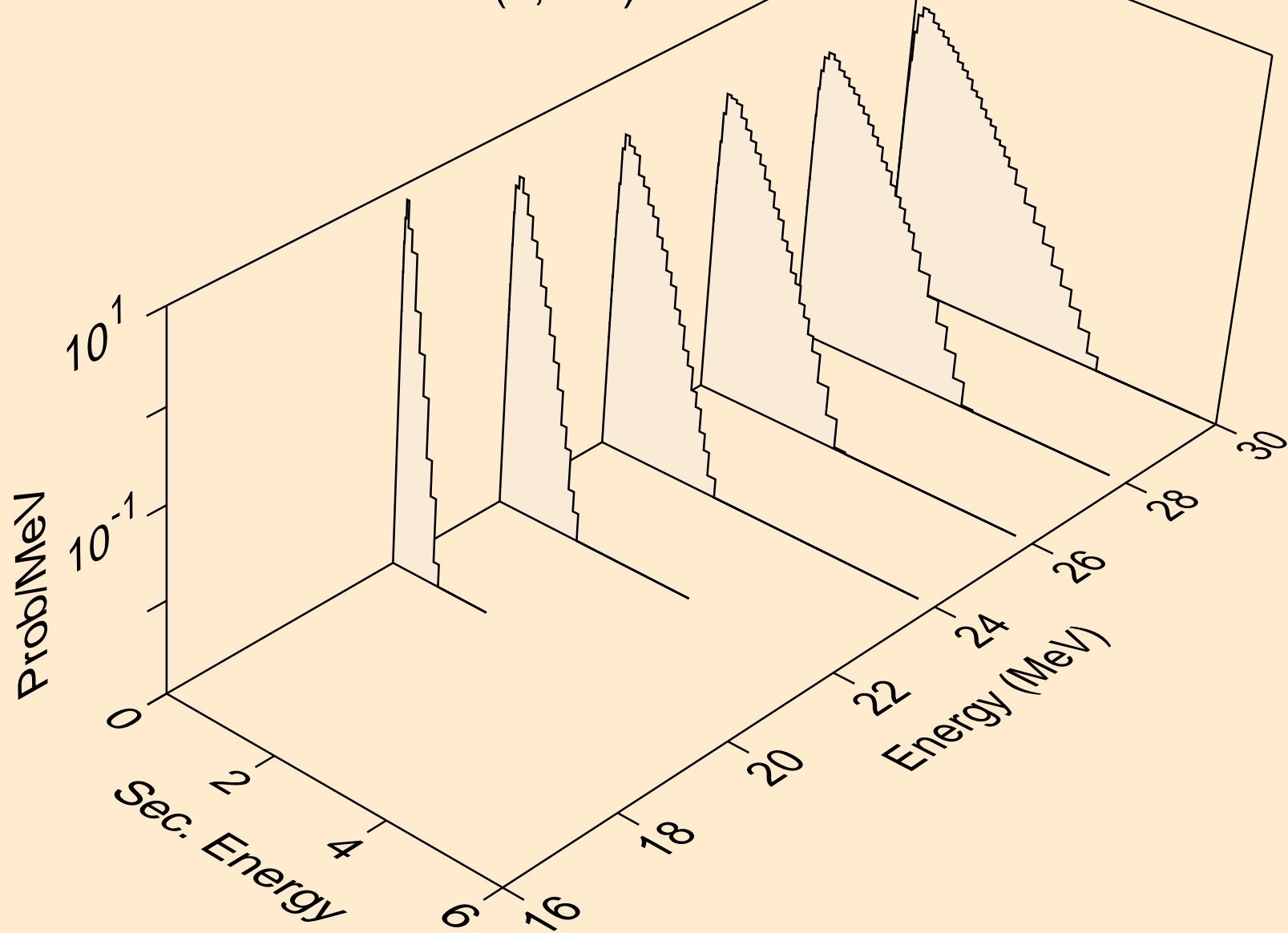

RE185 NEUTRON ACER TENDL-2024 LIBRARY; T=0.K
Neutron emission for (n,2n)

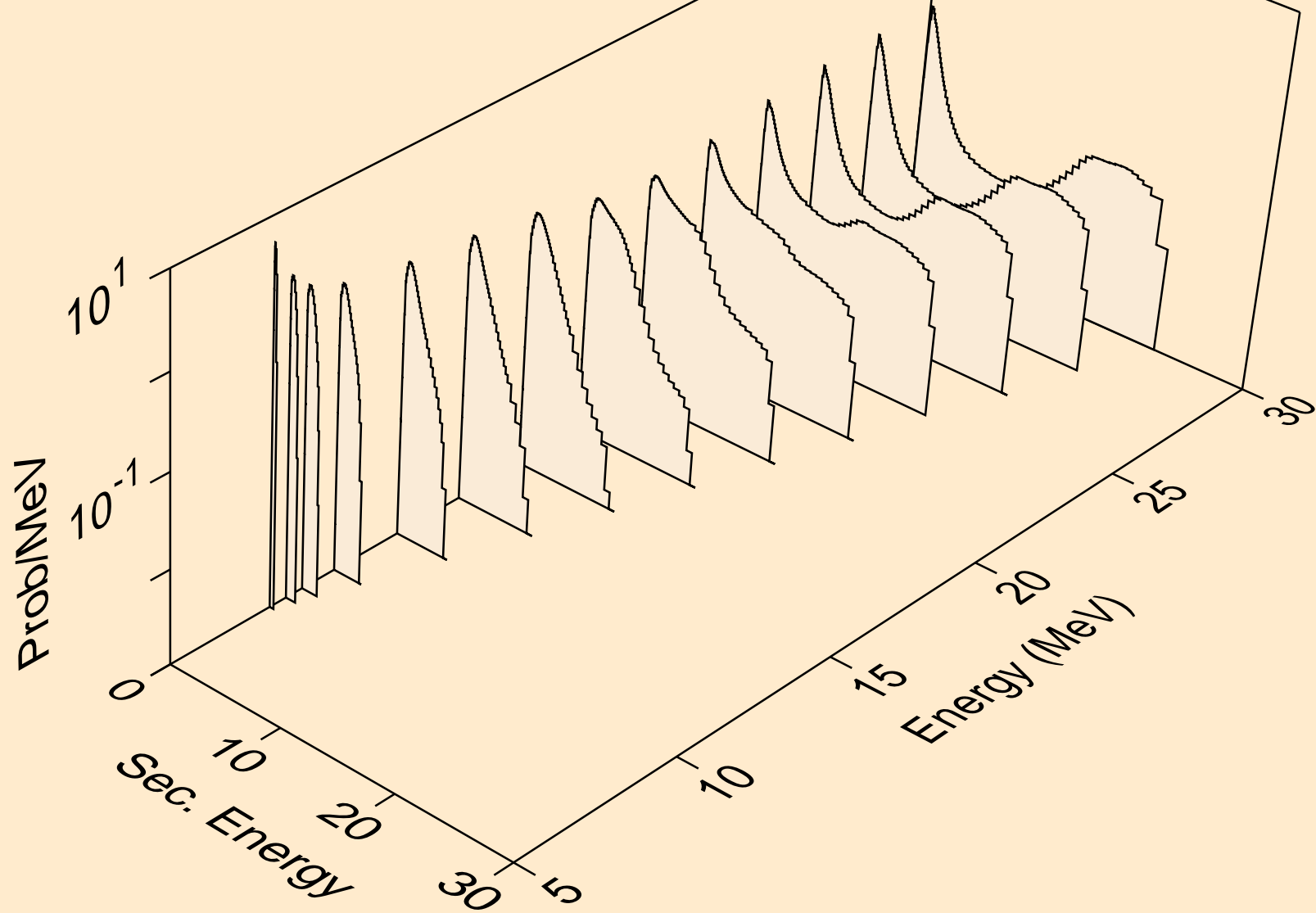

RE185 NEUTRON ACER TENDL-2024 LIBRARY; T=0.K
Neutron emission for (n,3n)

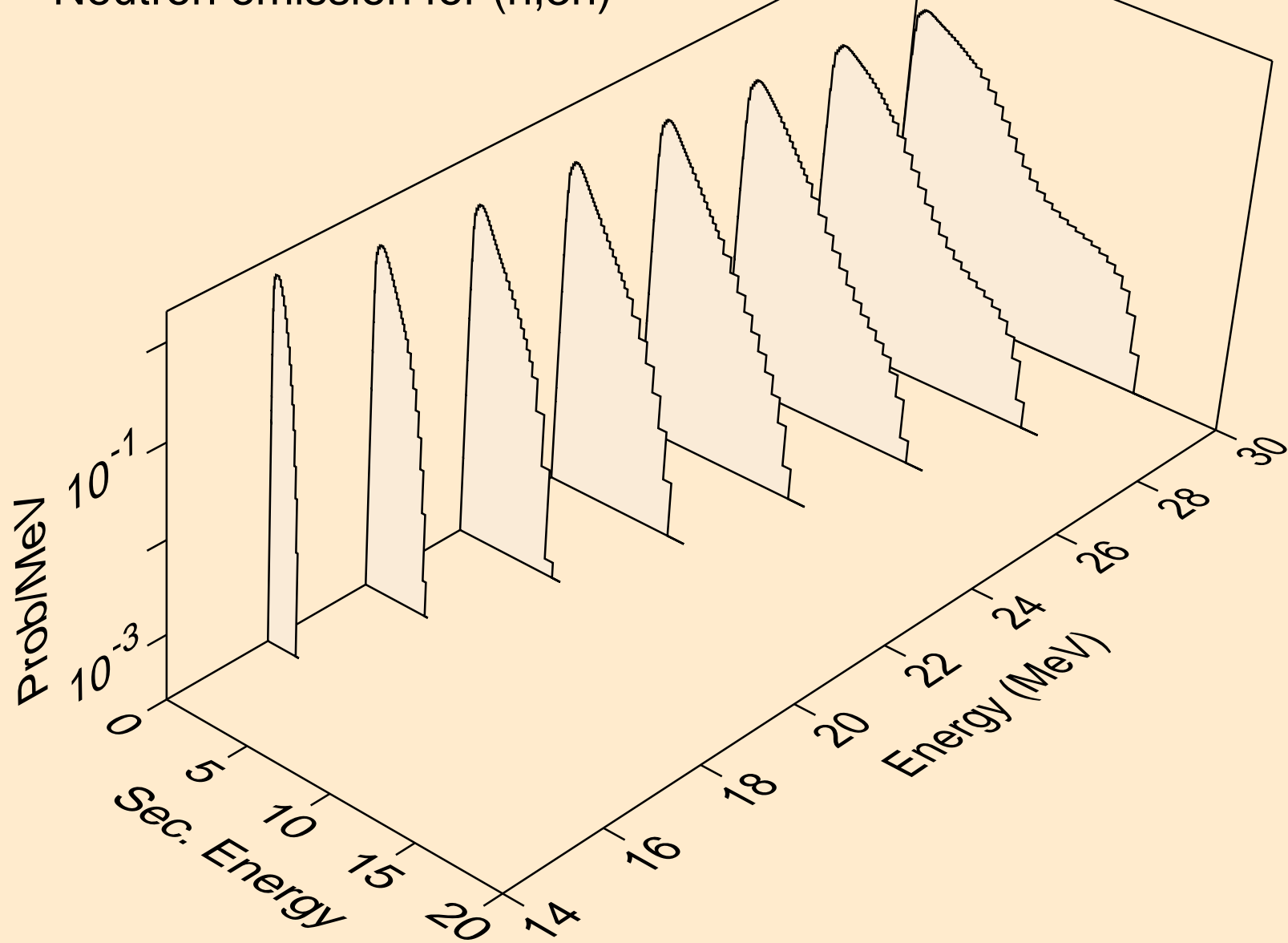

RE185 NEUTRON ACER TENDL-2024 LIBRARY; T=0.K
Neutron emission for (n,n*)a

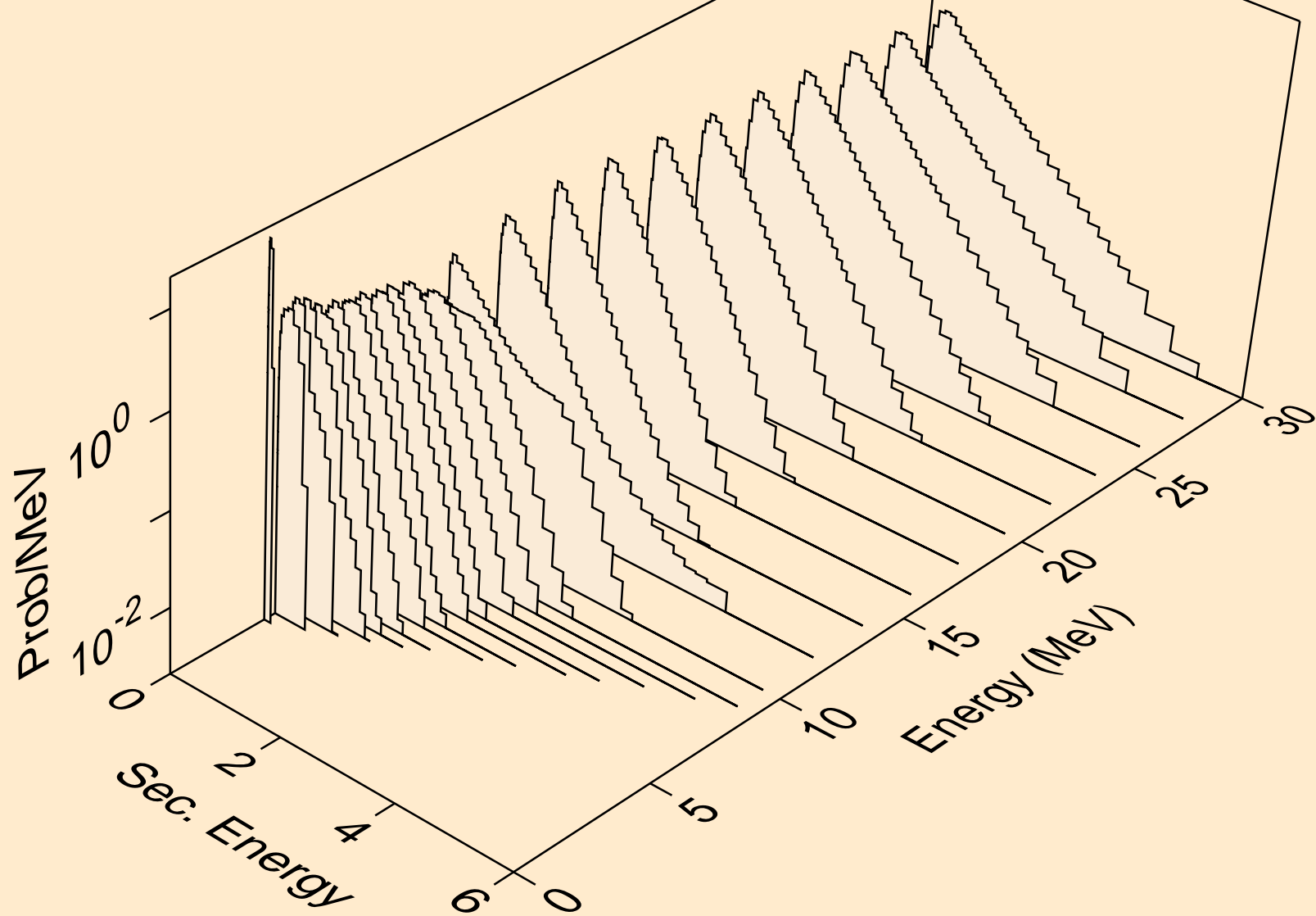

RE185 NEUTRON ACER TENDL-2024 LIBRARY; T=0.K
Neutron emission for (n,2n)a

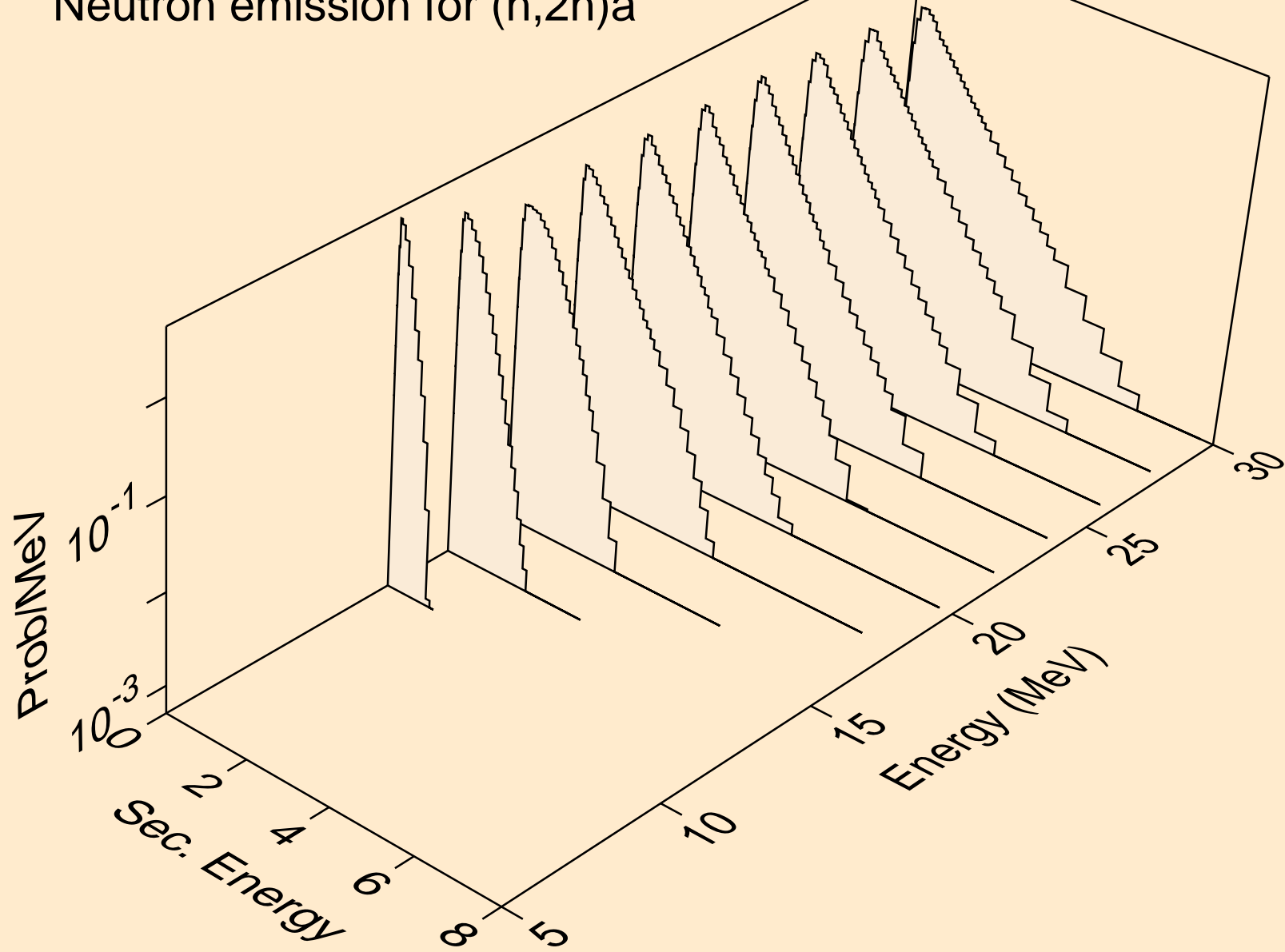

RE185 NEUTRON ACER TENDL-2024 LIBRARY; T=0.K
Neutron emission for (n,3n)a

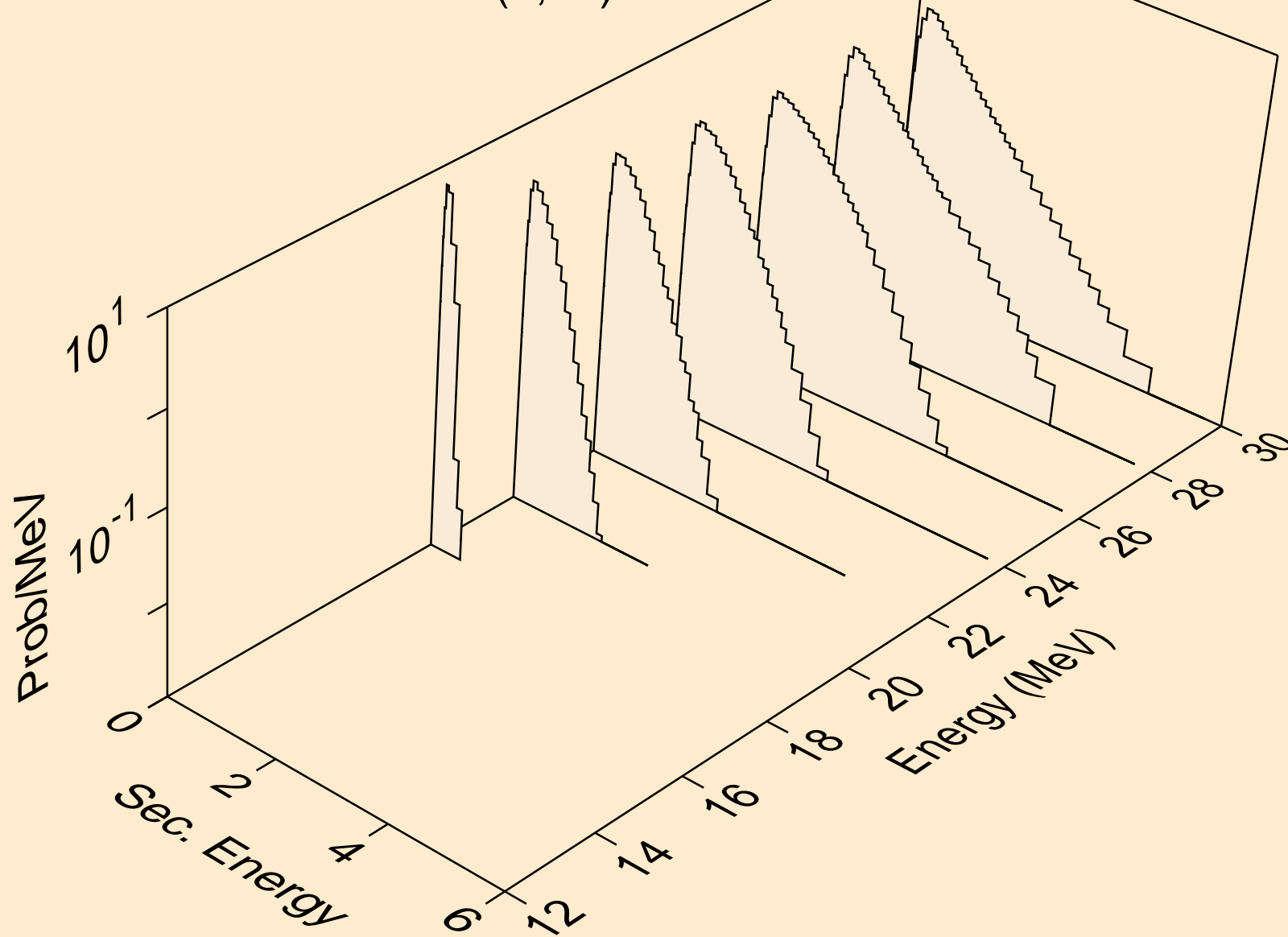

RE185 NEUTRON ACER TENDL-2024 LIBRARY; T=0.K
Neutron emission for (n,n*)p

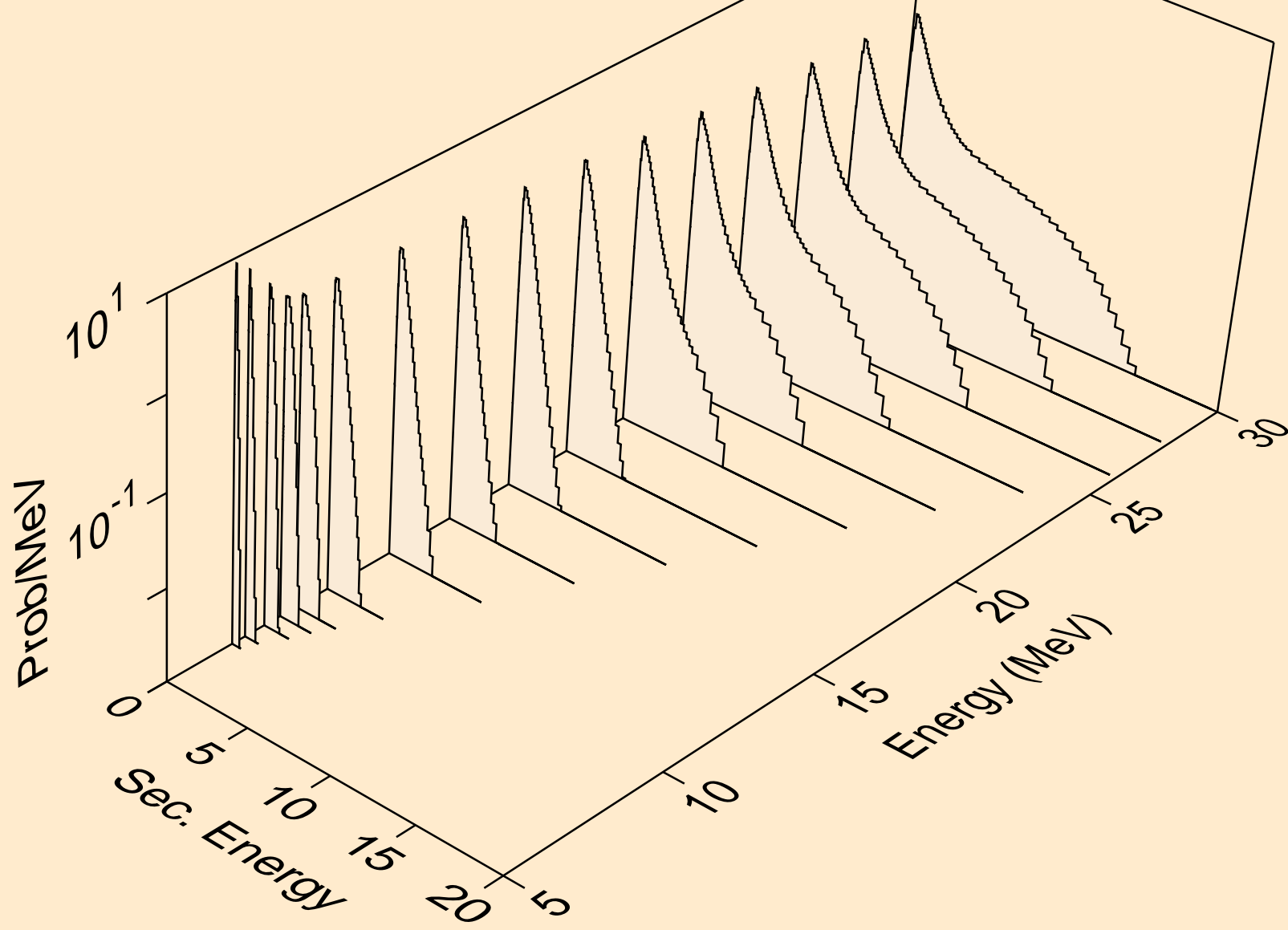

RE185 NEUTRON ACER TENDL-2024 LIBRARY; T=0.K
Neutron emission for (n,n*)2a

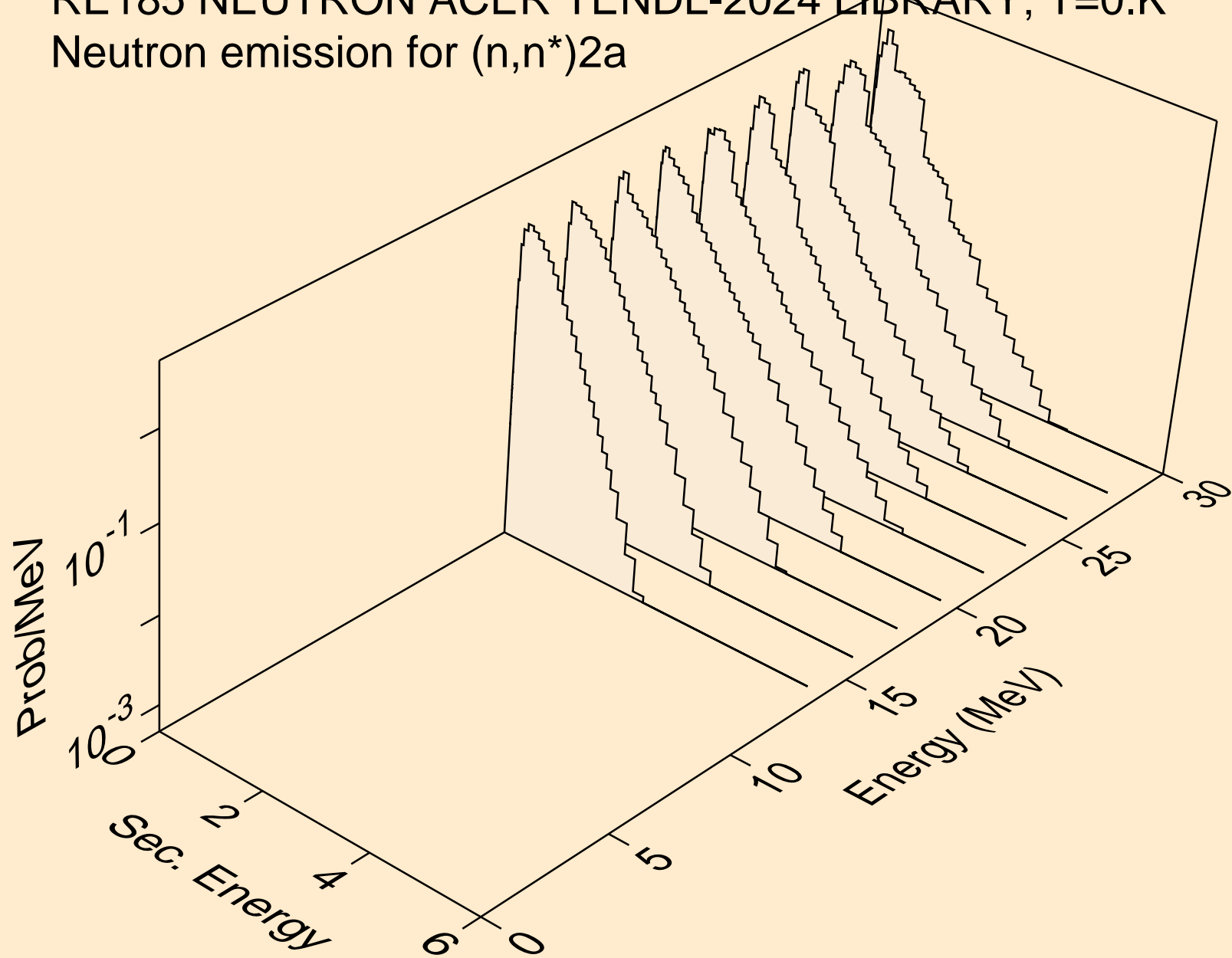

RE185 NEUTRON ACER TENDL-2024 LIBRARY; T=0.K
Neutron emission for (n,n*)d

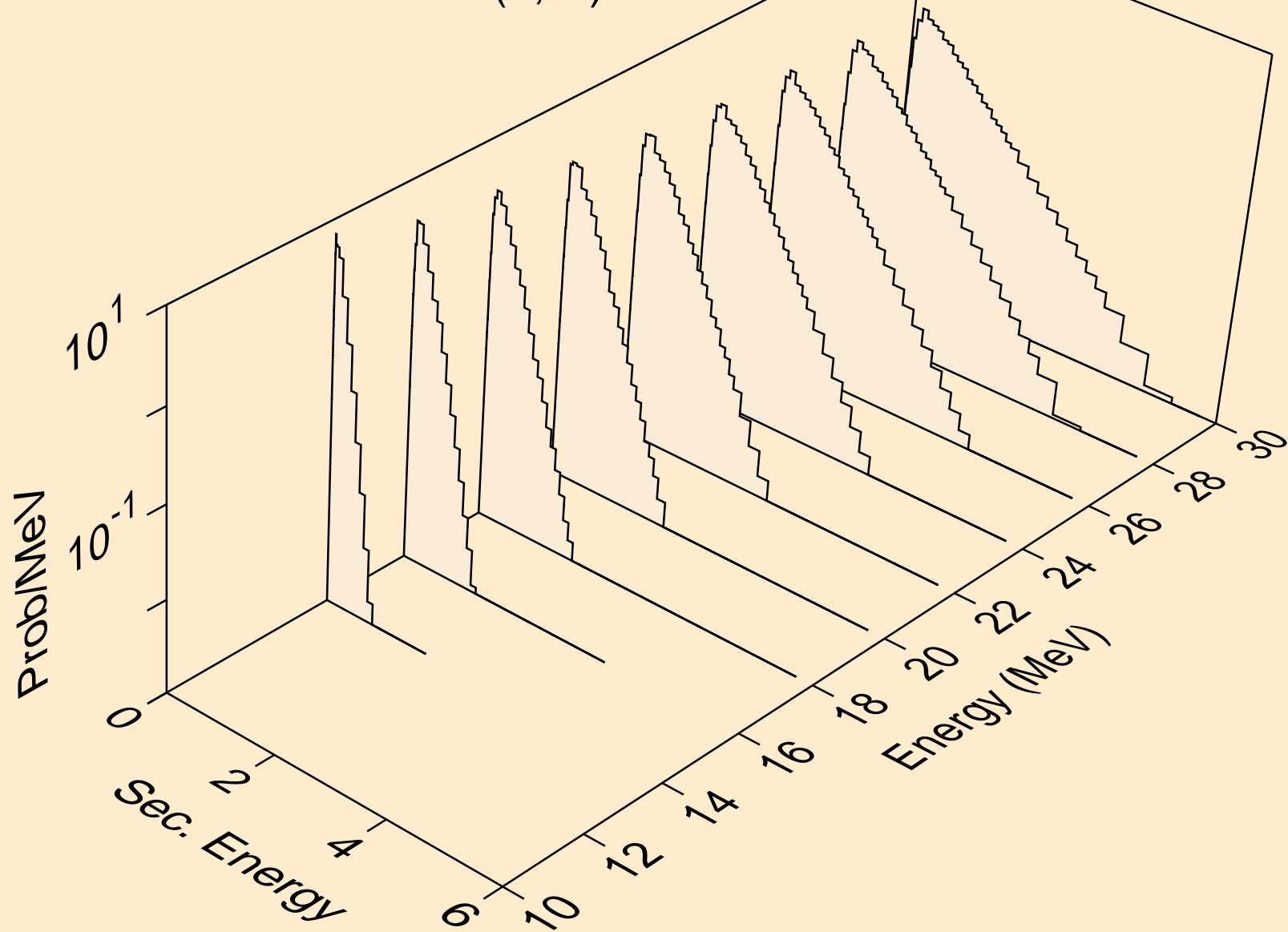

RE185 NEUTRON ACER TENDL-2024 LIBRARY; T=0.K
Neutron emission for (n,n*)t

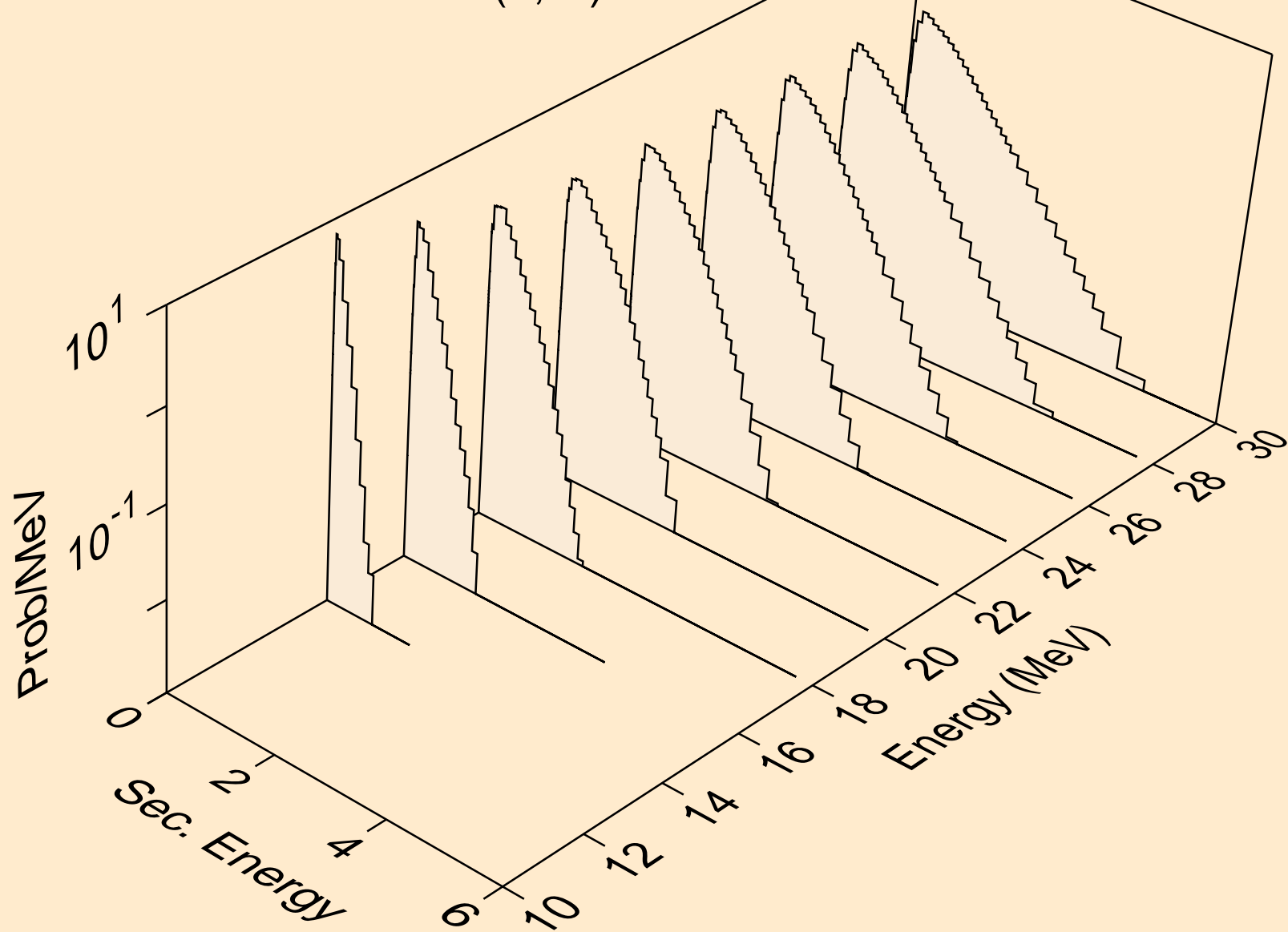

RE185 NEUTRON ACER TENDL-2024 LIBRARY; T=0.K
Neutron emission for (n,n*)he3

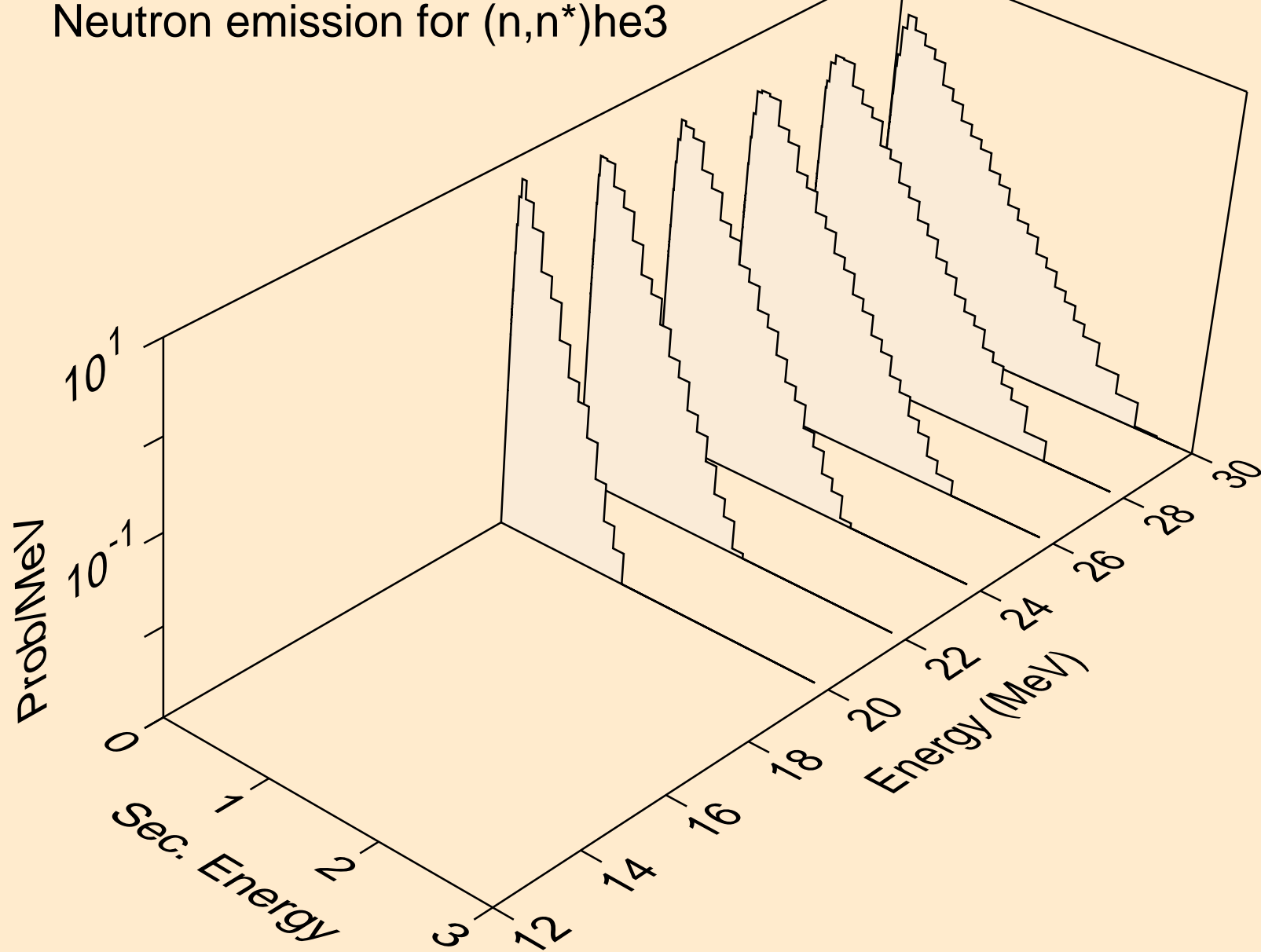

RE185 NEUTRON ACER TENDL-2024 LIBRARY; T=0.K
Neutron emission for (n,4n)

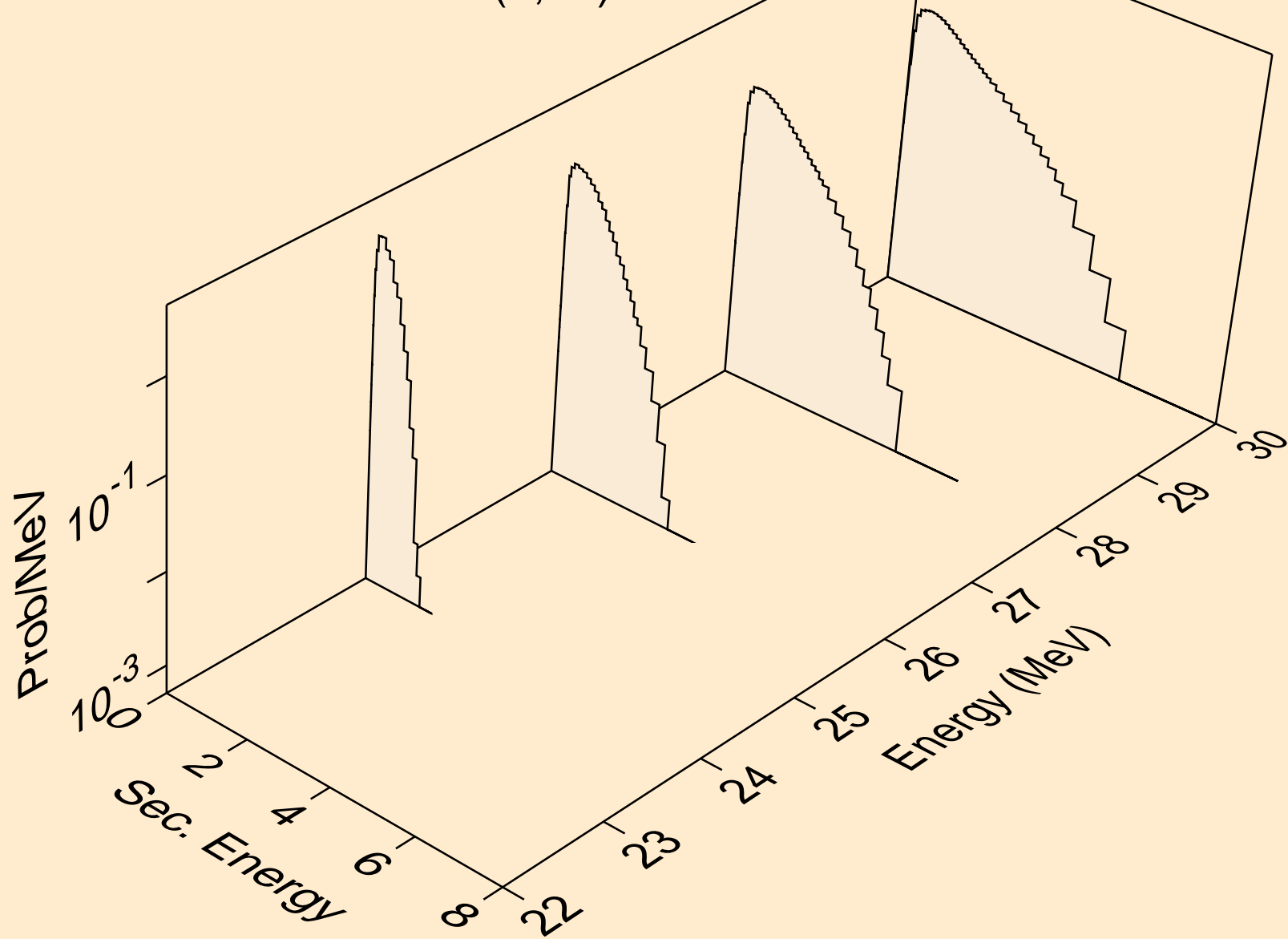

RE185 NEUTRON ACER TENDL-2024 LIBRARY; T=0.K
Neutron emission for (n,2np)

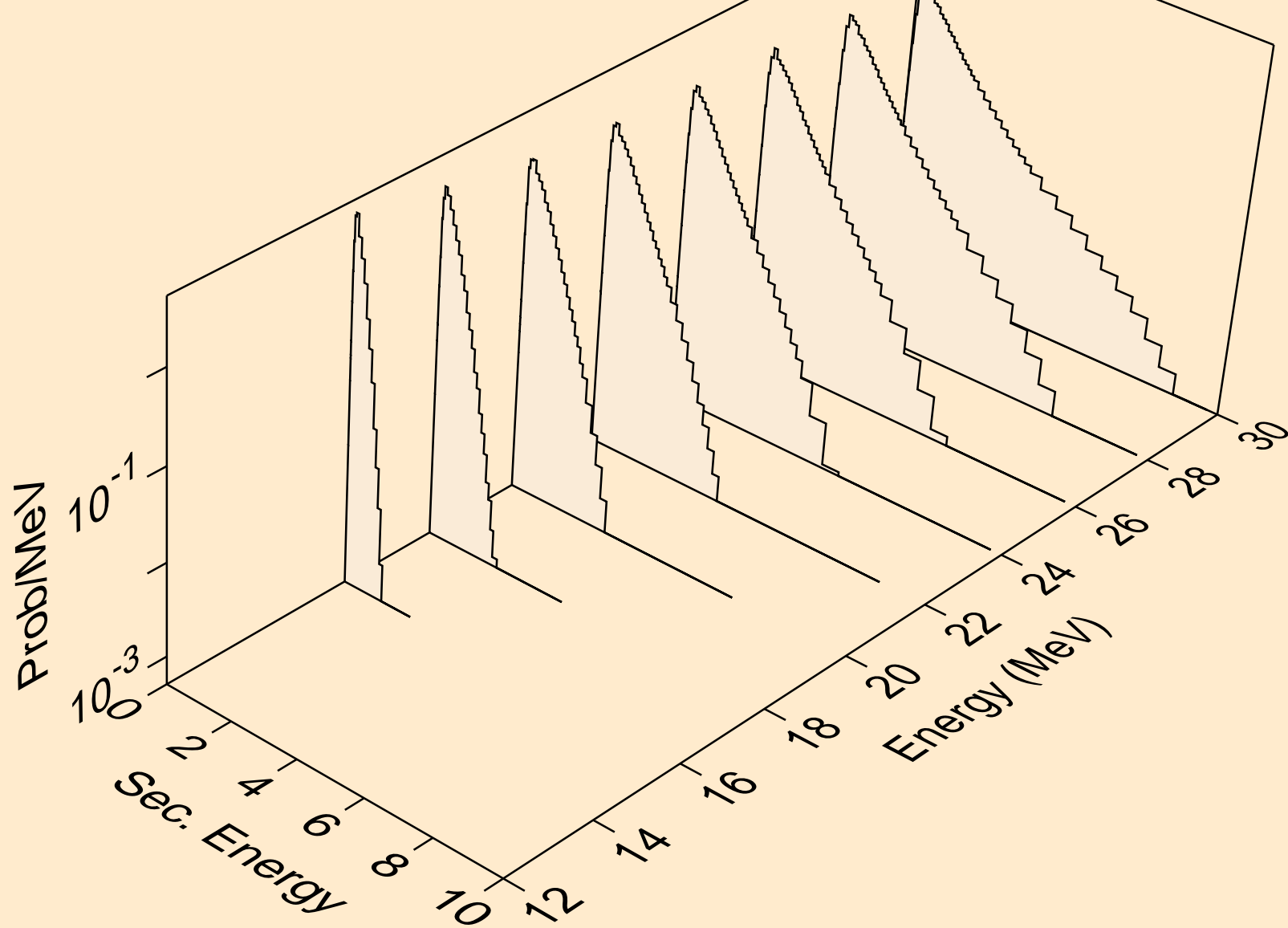

RE185 NEUTRON ACER TENDL-2024 LIBRARY; T=0.K
Neutron emission for (n,3np)

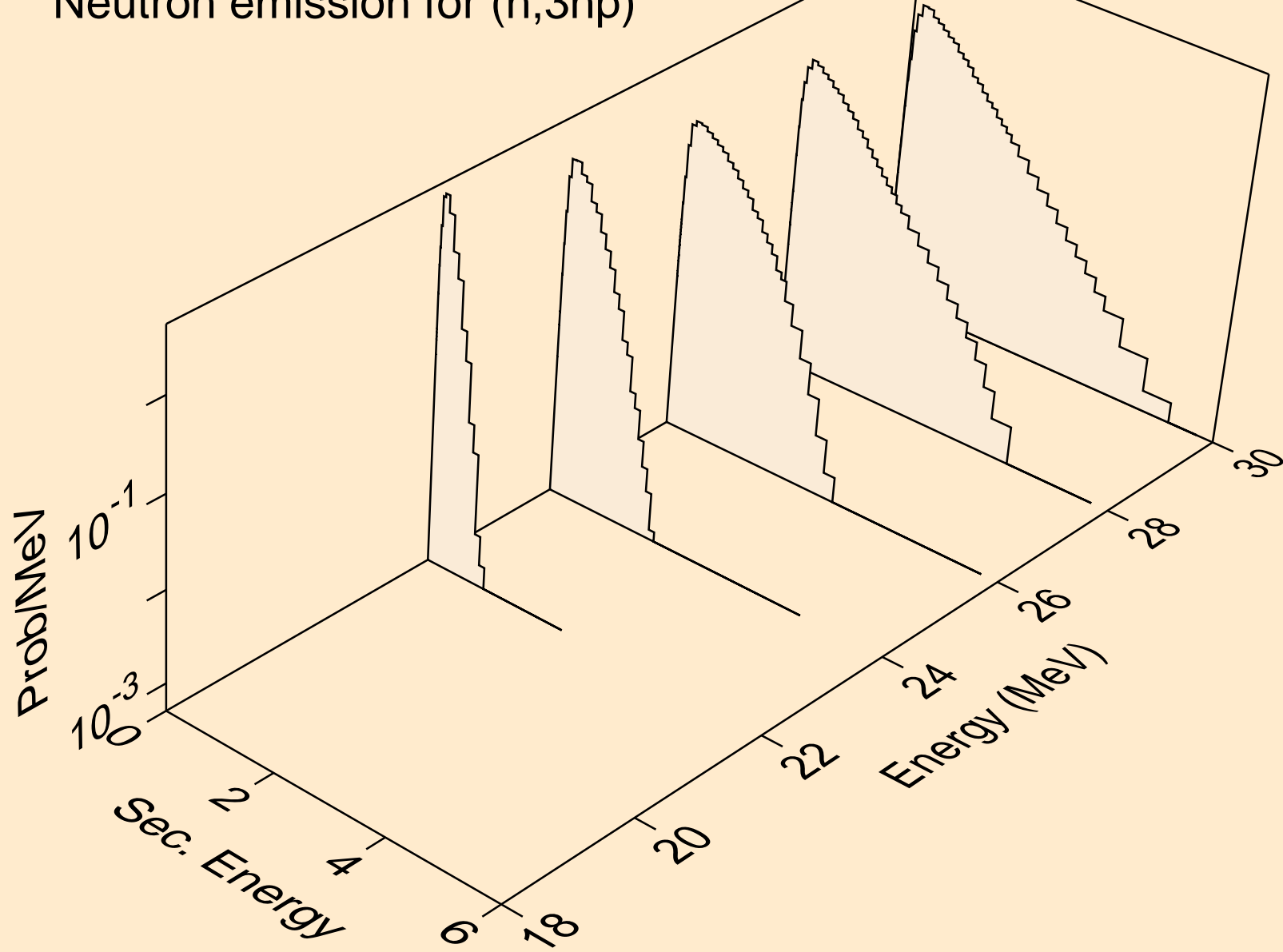

RE185 NEUTRON ACER TENDL-2024 LIBRARY; T=0.K
Neutron emission for (n,n2p)

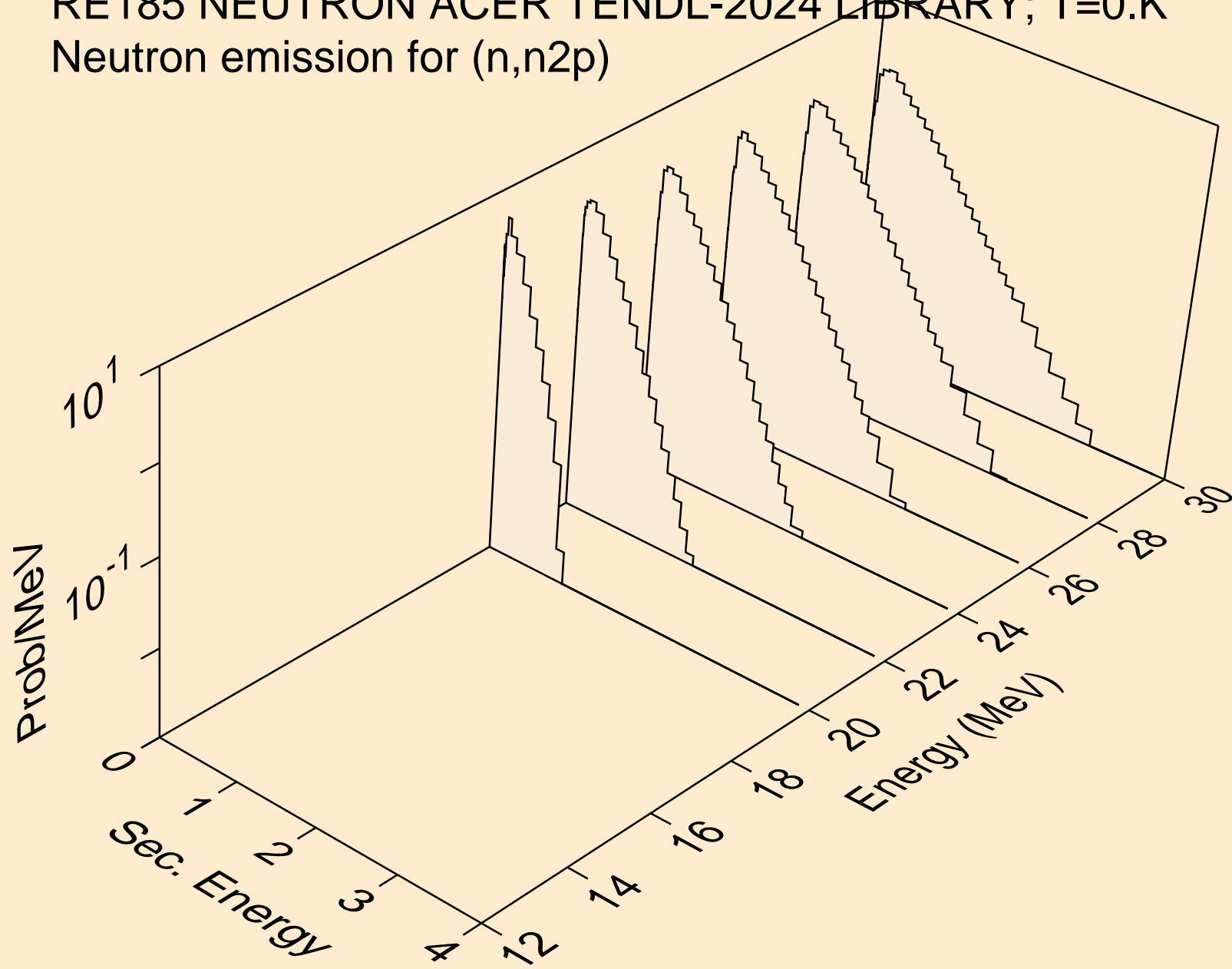

RE185 NEUTRON ACER TENDL-2024 LIBRARY; T=0.K
Neutron emission for (n,npa)

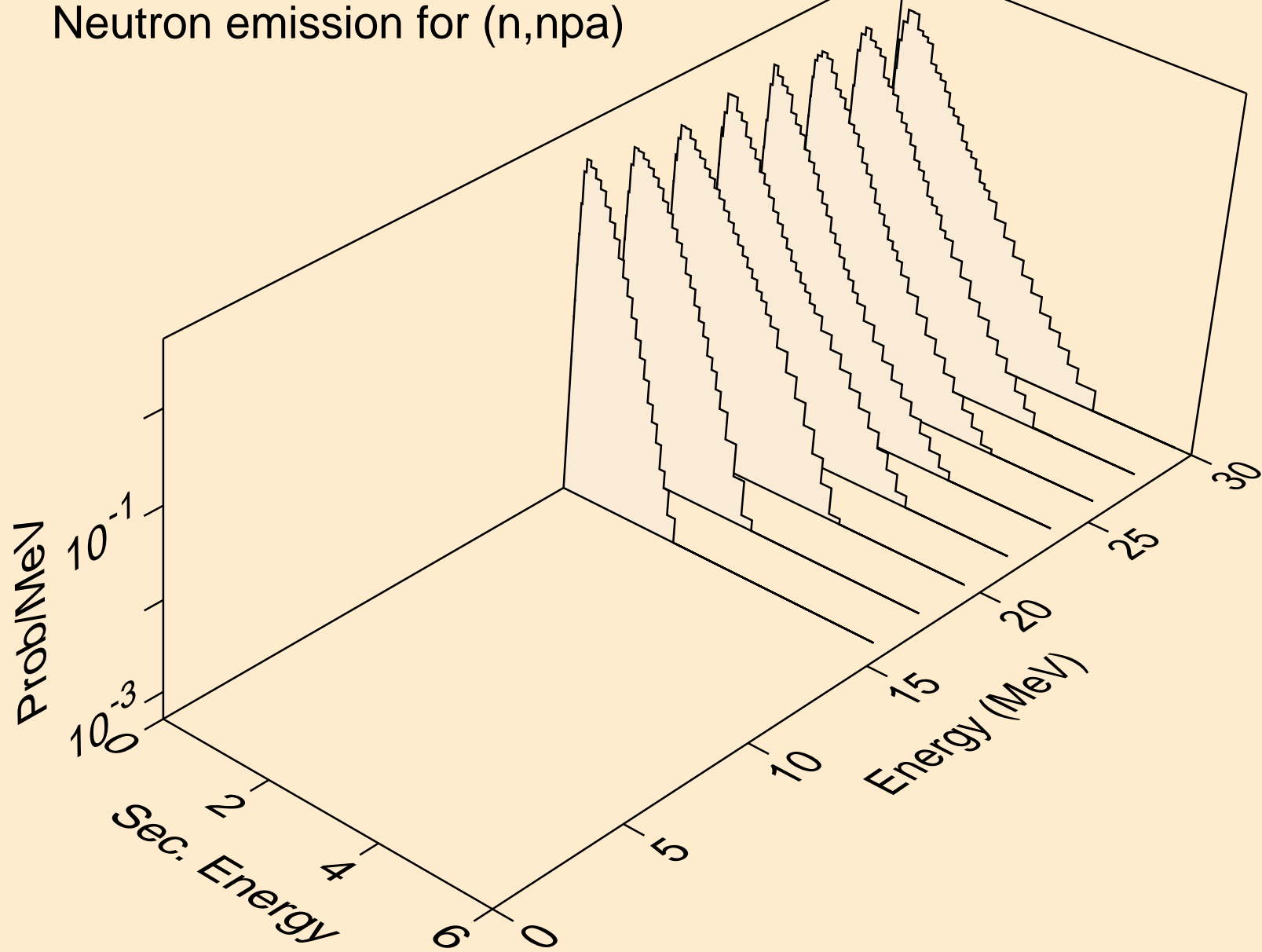

RE185 NEUTRON ACER TENDL-2024 LIBRARY; T=0.K
Neutron emission for (n,n*c)

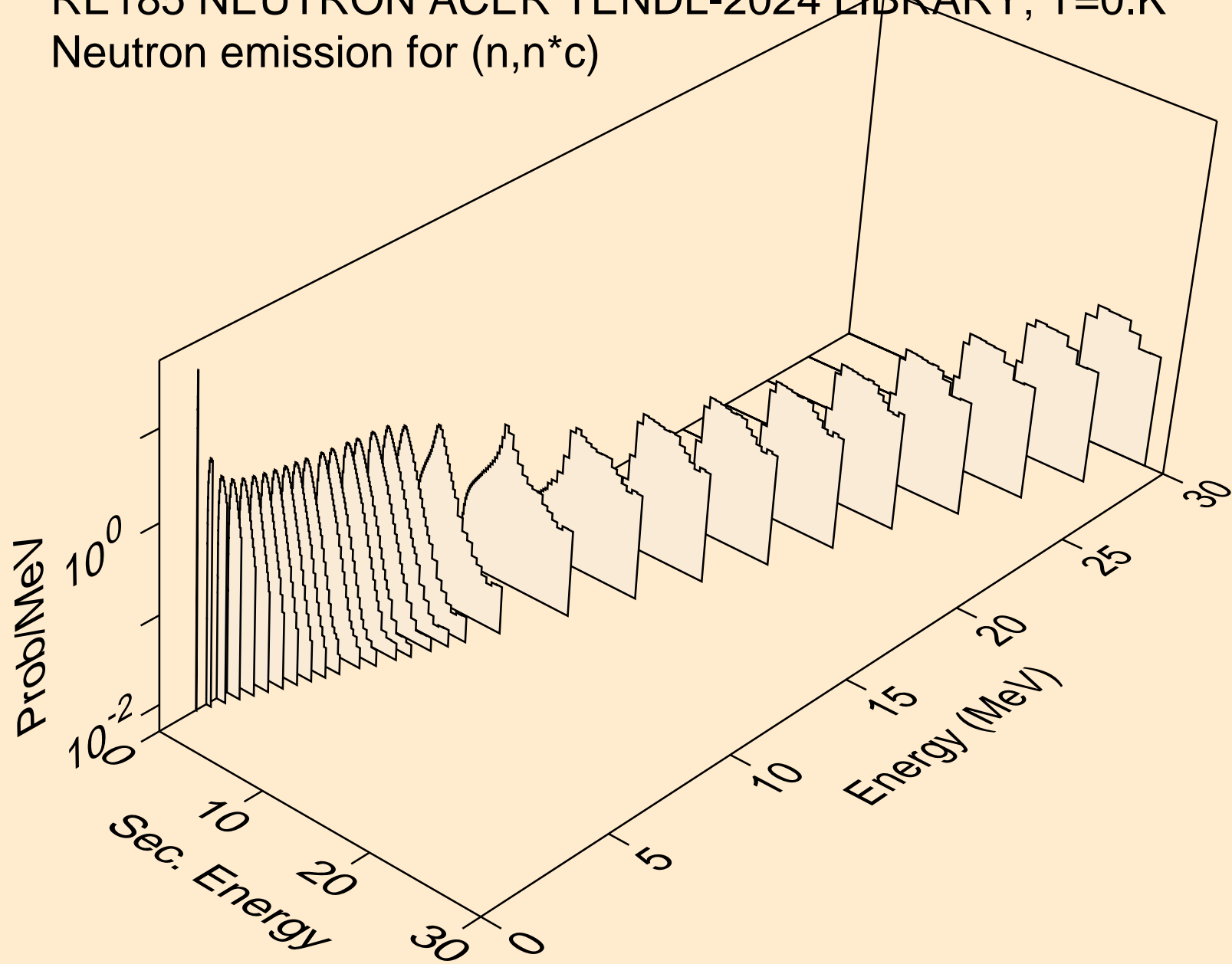

RE185 NEUTRON ACER TENDL-2024 LIBRARY; T=0.K
Photon emission for (n,x)

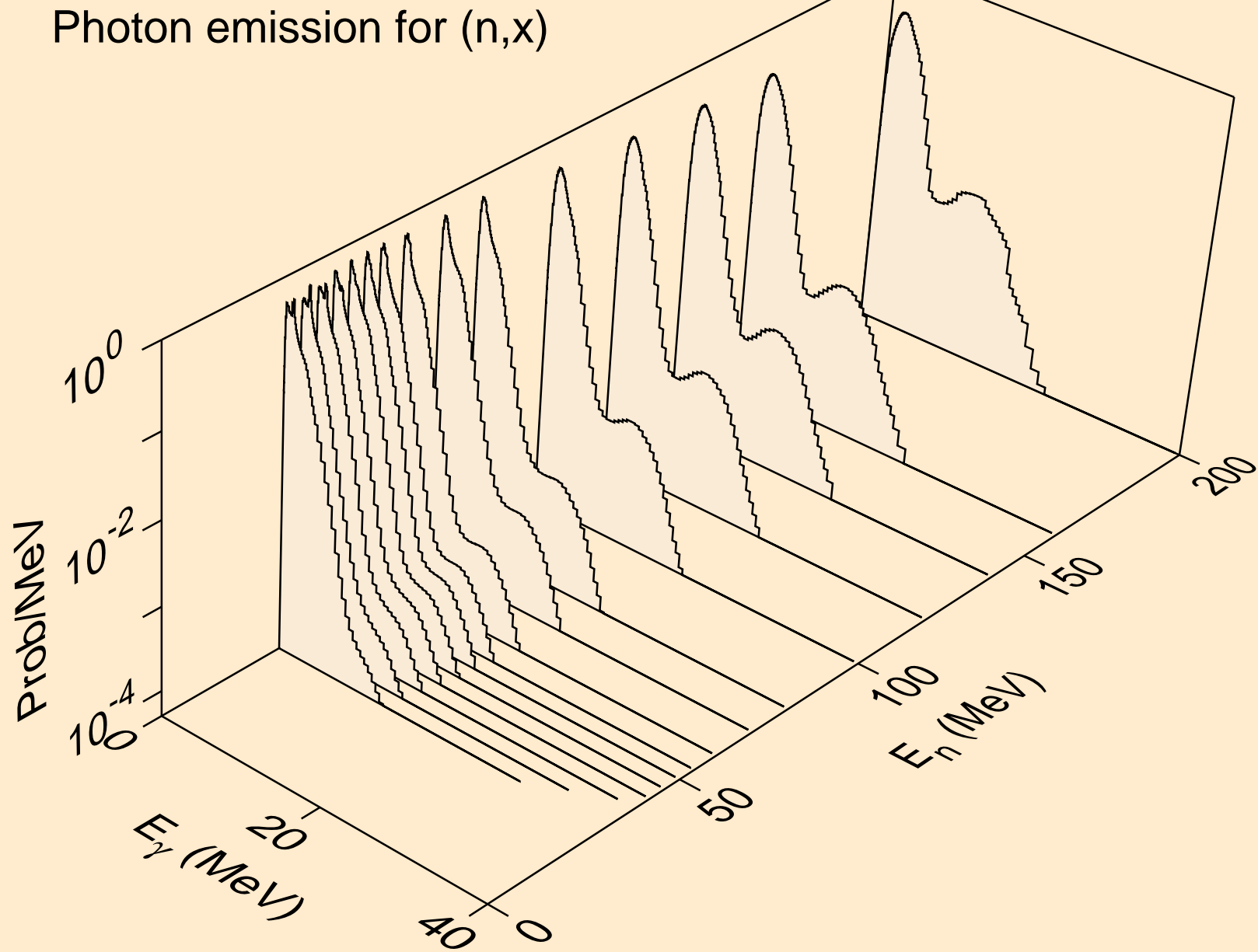

RE185 NEUTRON ACER TENDL-2024 LIBRARY; T=0.K
Photon emission for (n,2nd)

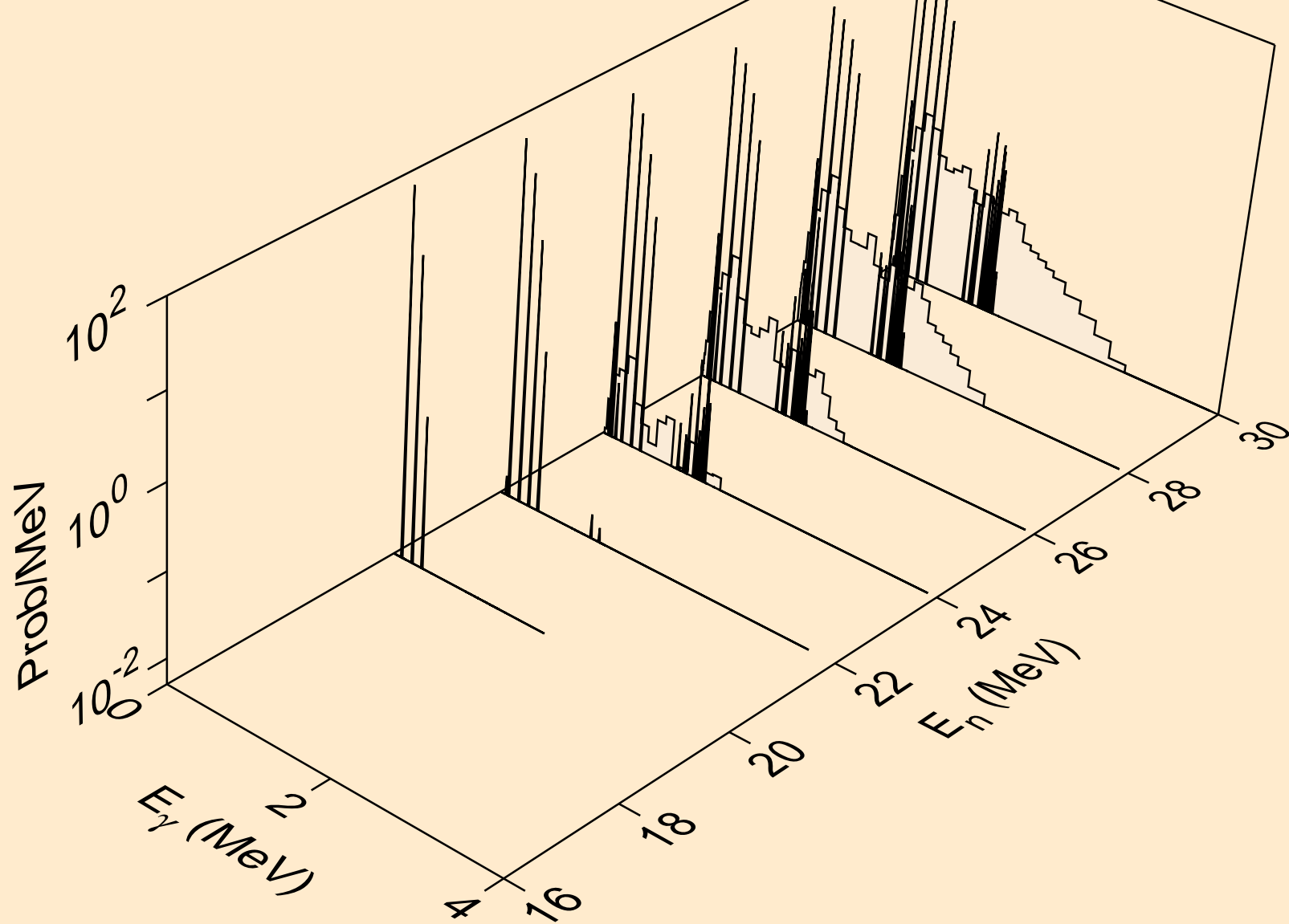

RE185 NEUTRON ACER TENDL-2024 LIBRARY; T=0.K
Photon emission for (n,2n)

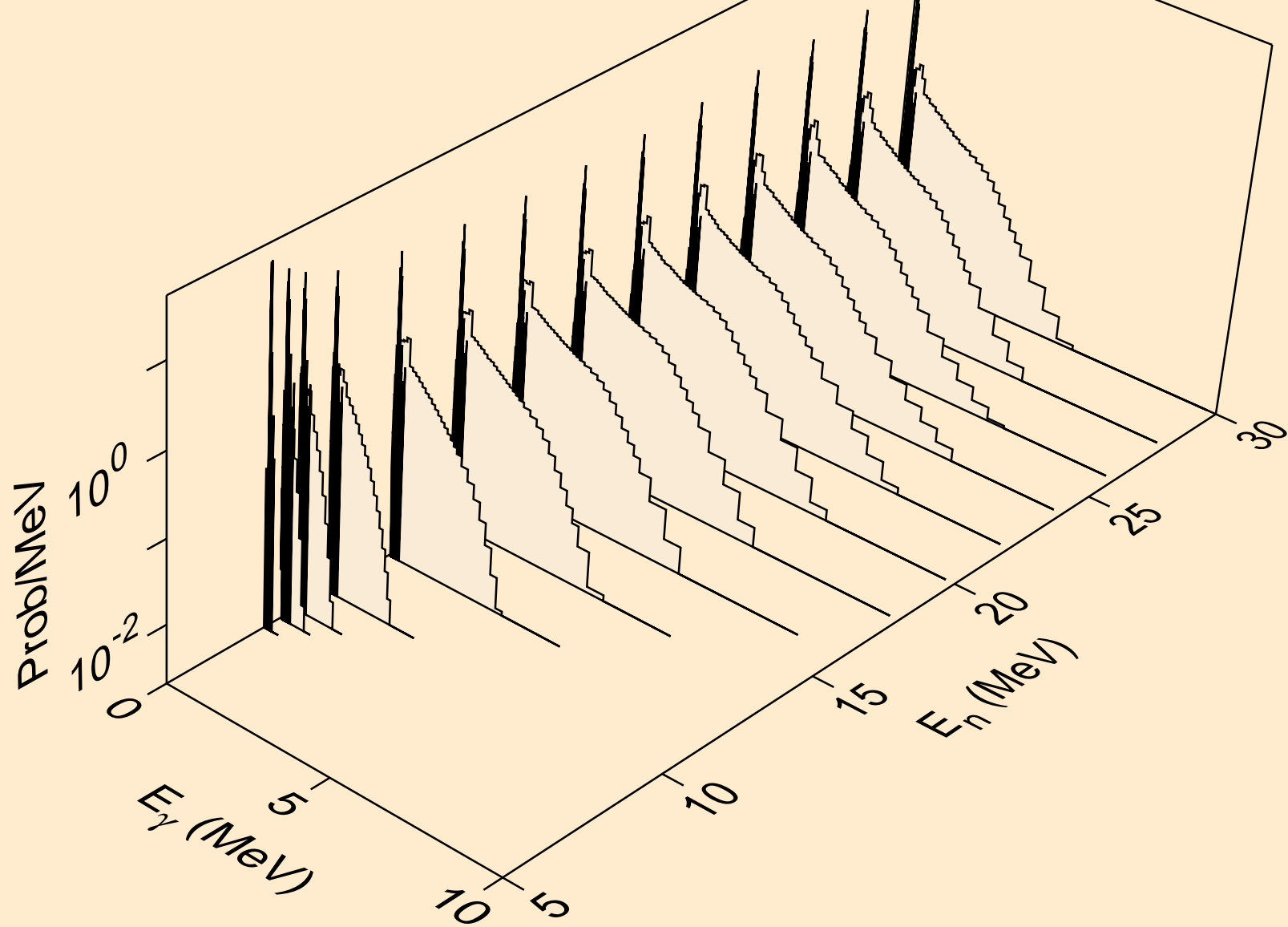

RE185 NEUTRON ACER TENDL-2024 LIBRARY; T=0.K
Photon emission for (n,3n)

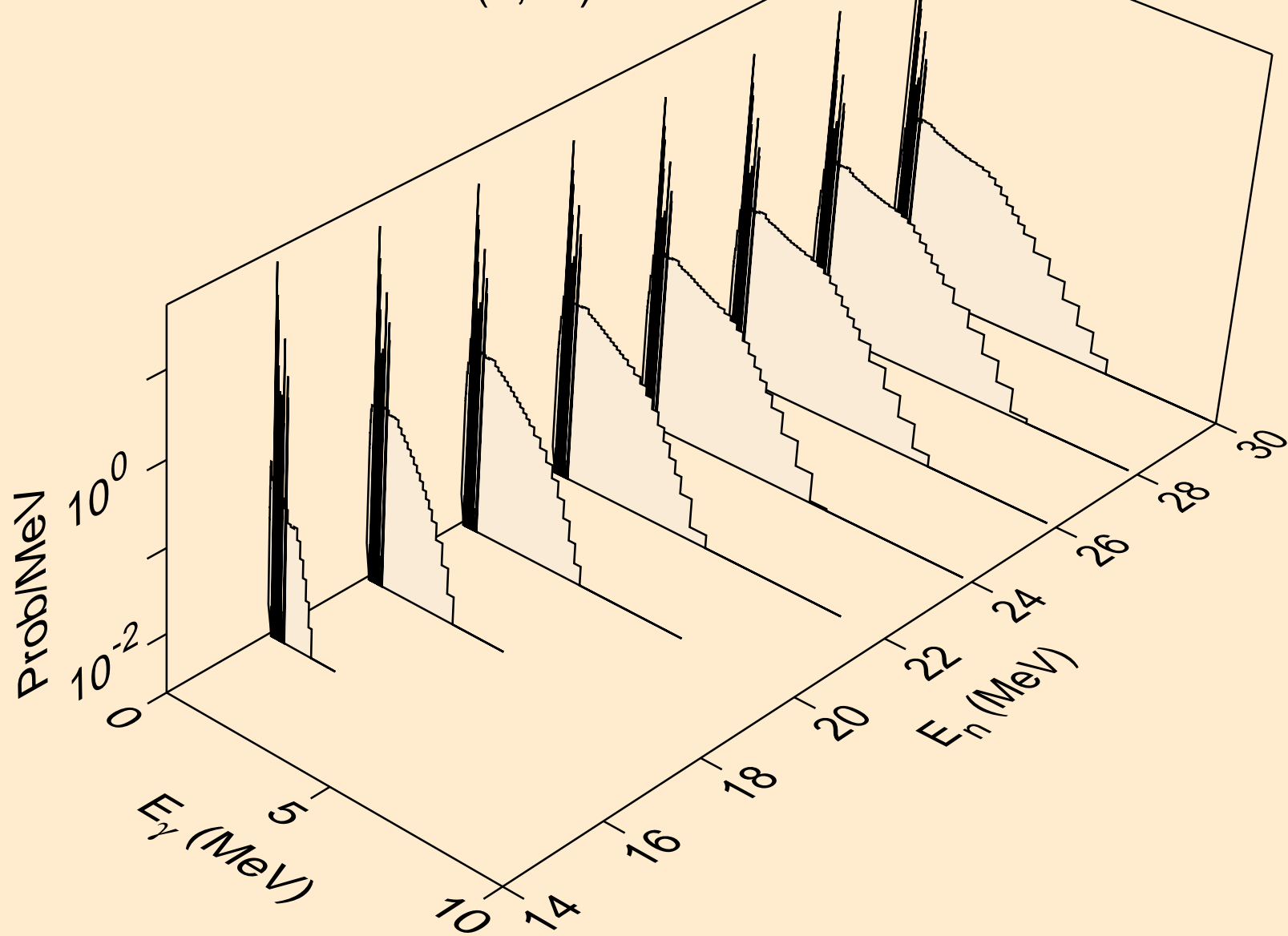

RE185 NEUTRON ACER TENDL-2024 LIBRARY; T=0.K
Photon emission for (n,n*)a

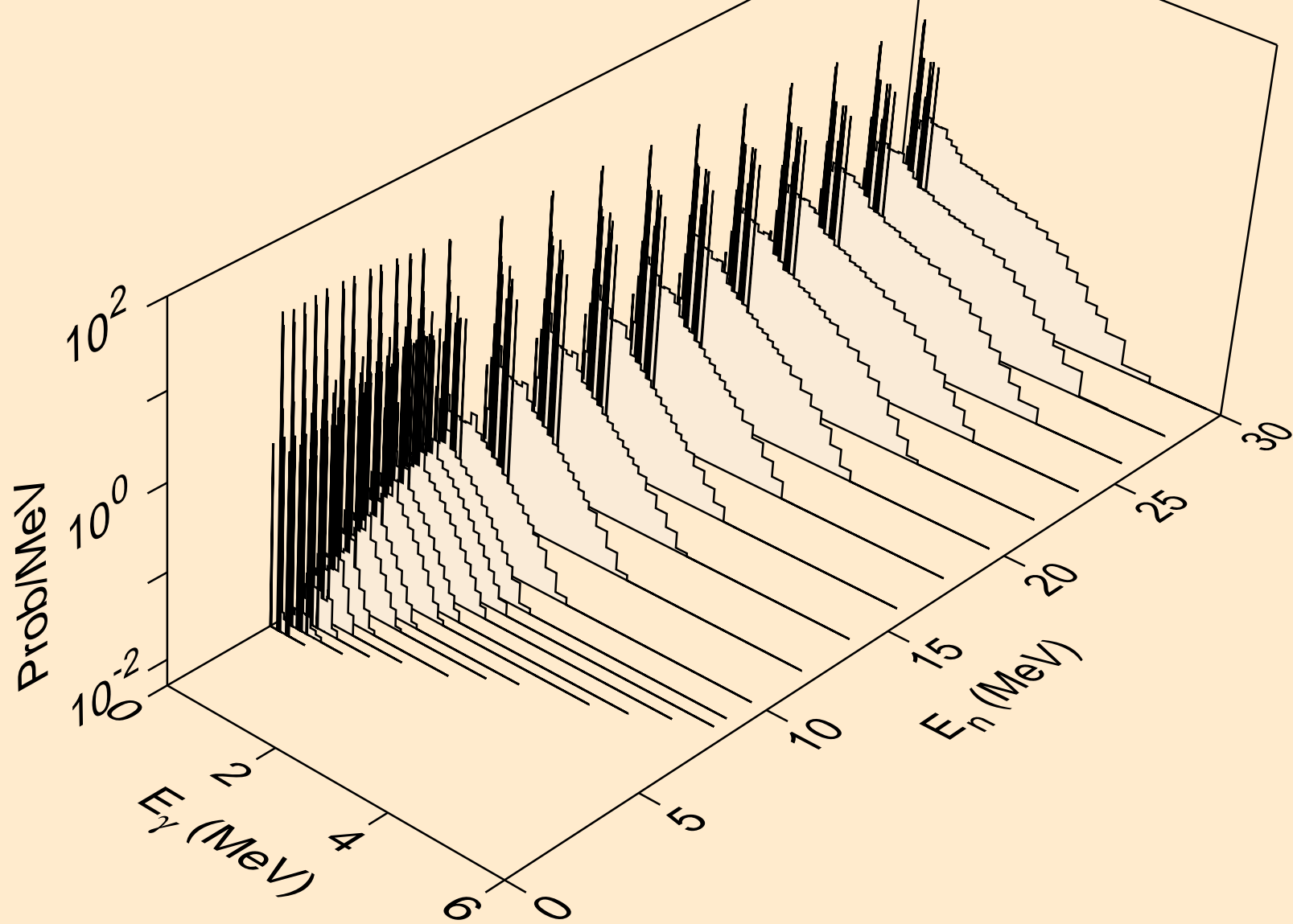

RE185 NEUTRON ACER TENDL-2024 LIBRARY; T=0.K
Photon emission for (n,2n)a

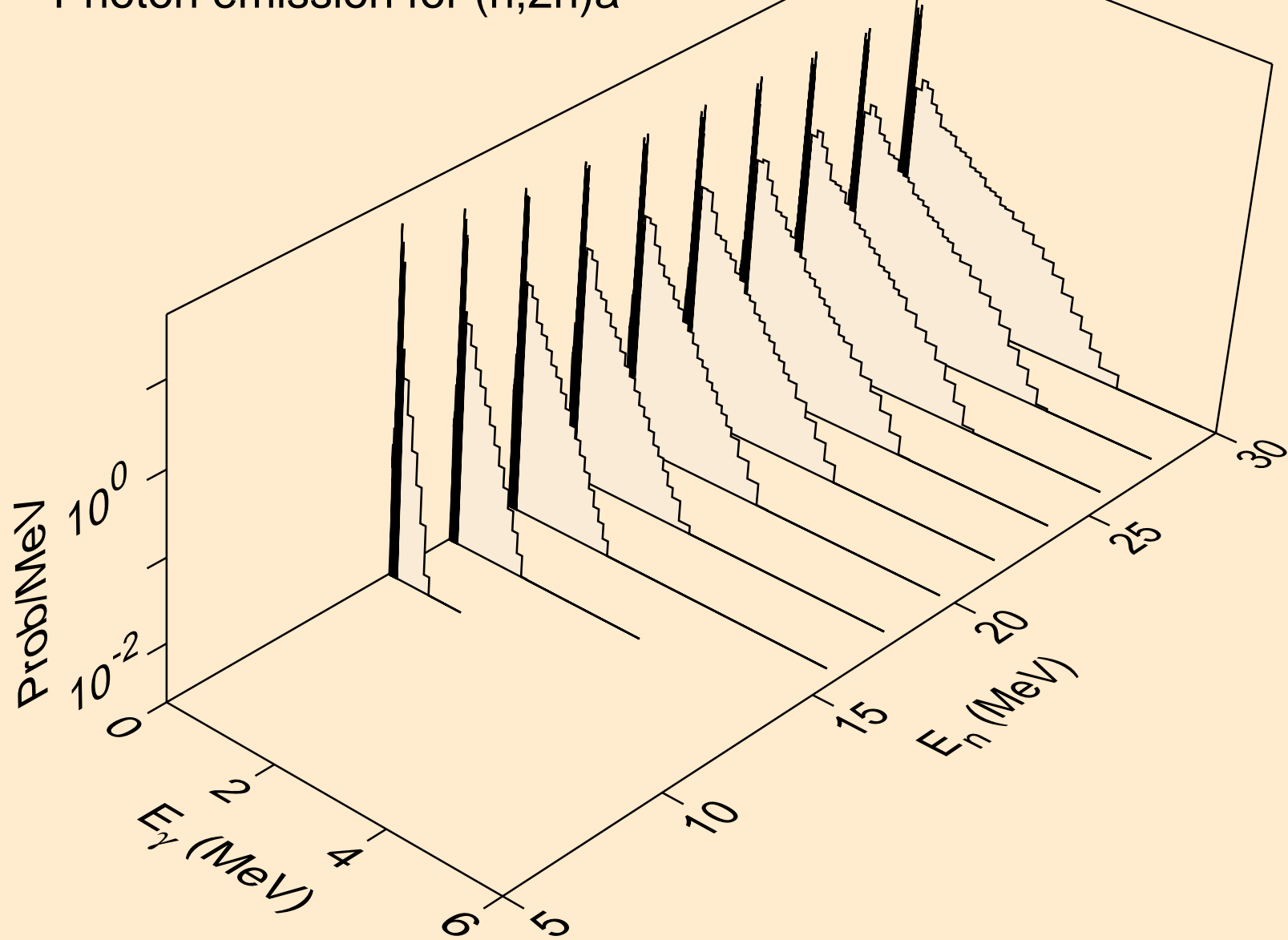

RE185 NEUTRON ACER TENDL-2024 LIBRARY; T=0.K
Photon emission for (n,3n)a

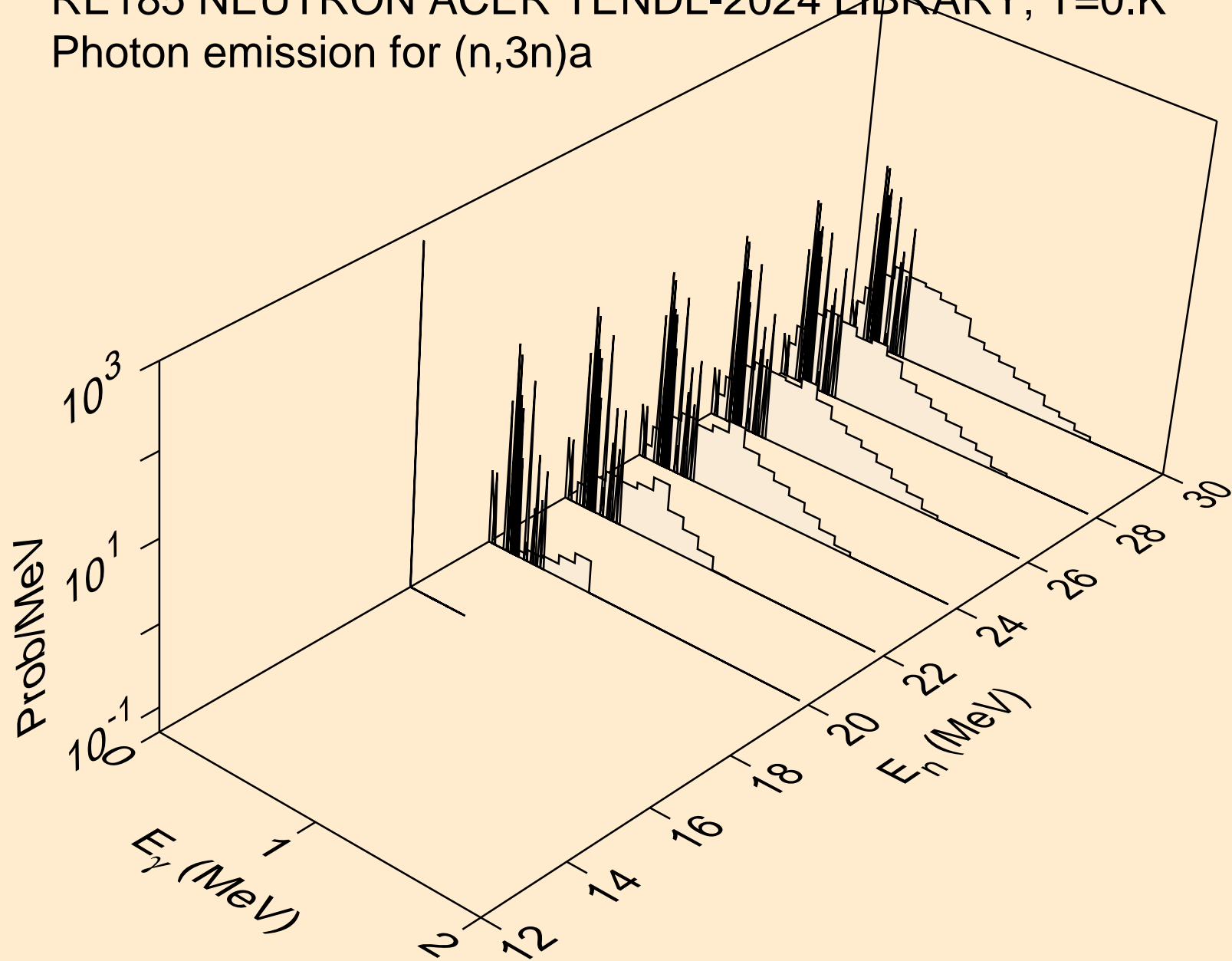

RE185 NEUTRON ACER TENDL-2024 LIBRARY; T=0.K
Photon emission for (n,n*)p

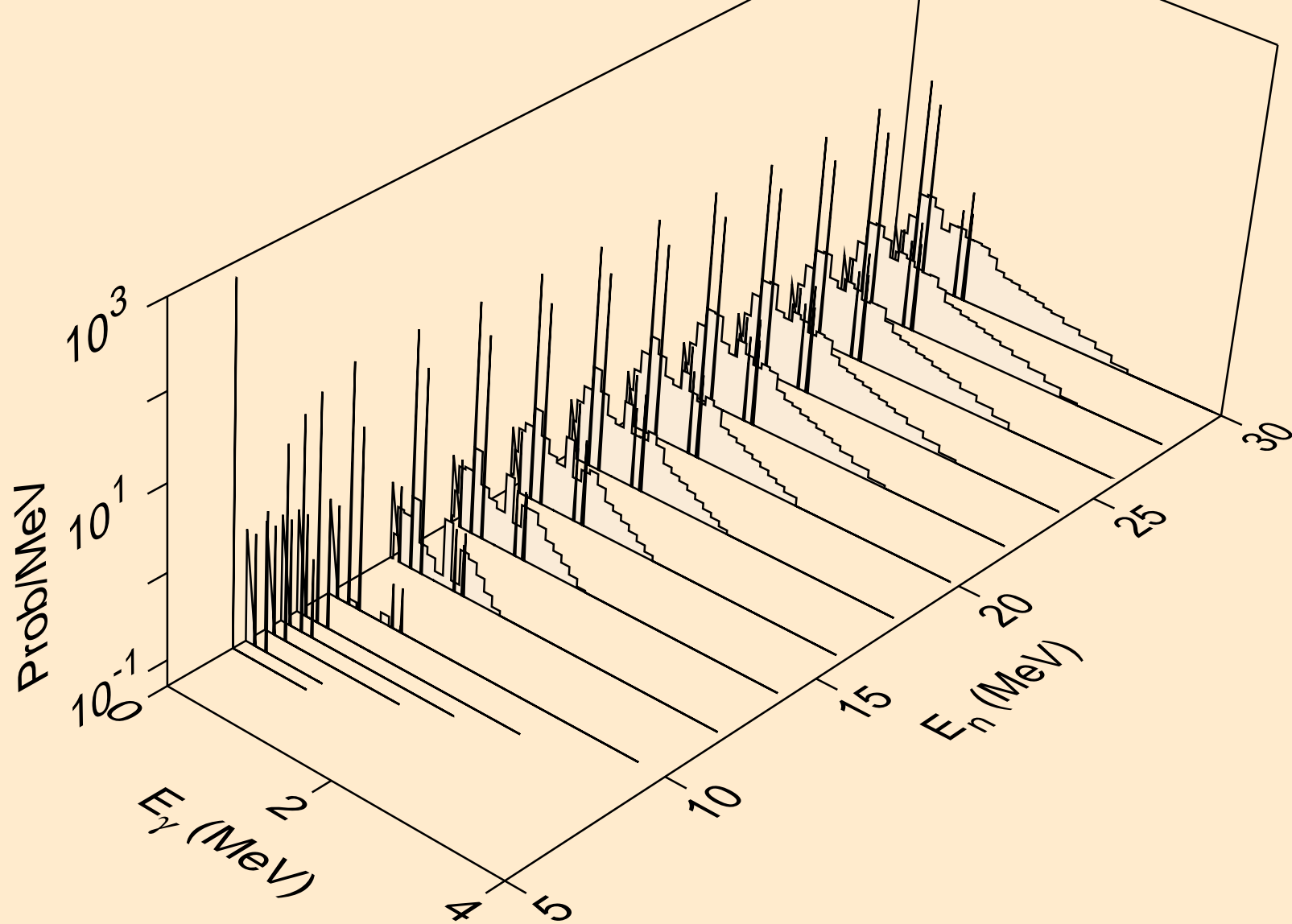

RE185 NEUTRON ACER TENDL-2024 LIBRARY; T=0.K
Photon emission for (n,n*)2a

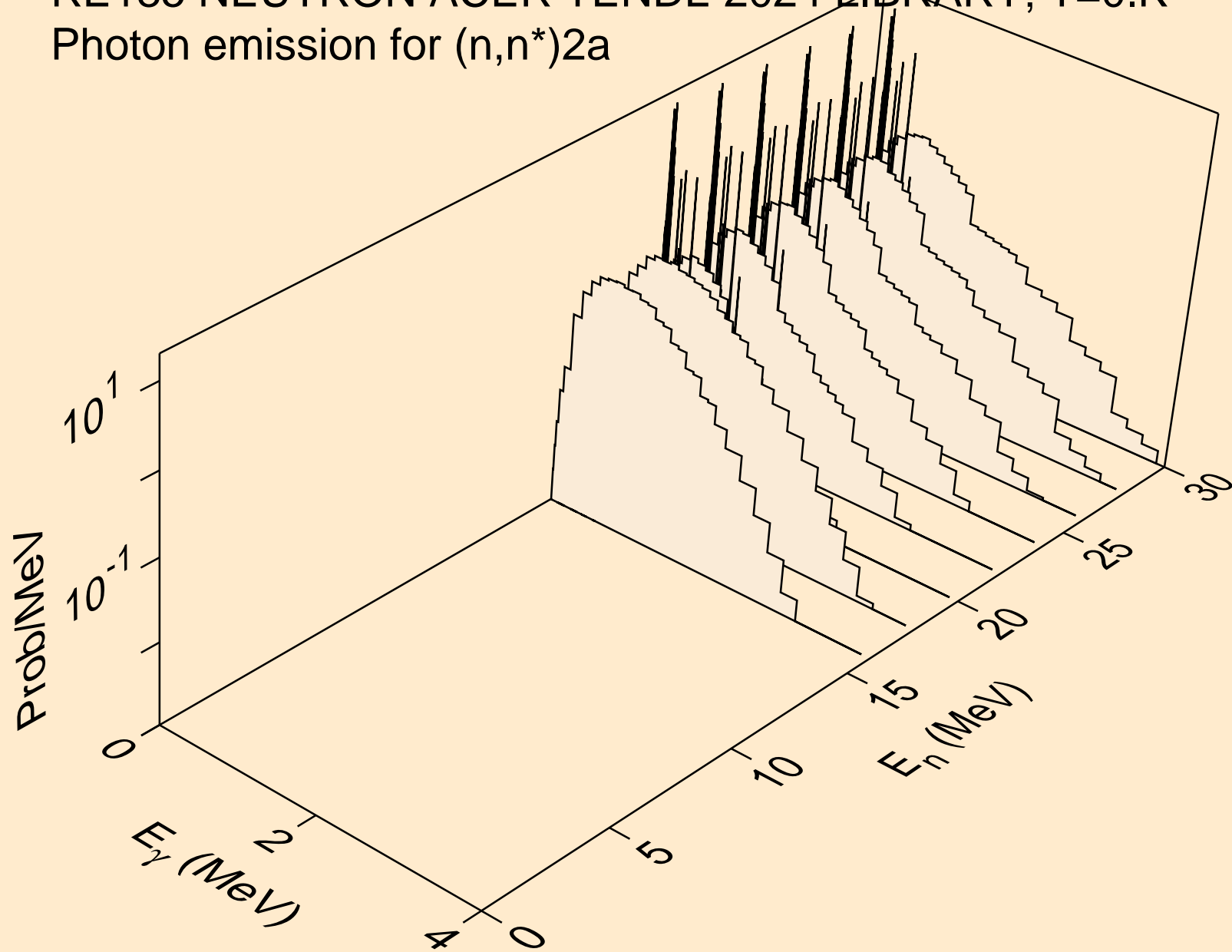

RE185 NEUTRON ACER TENDL-2024 LIBRARY; T=0.K
Photon emission for (n,n*)d

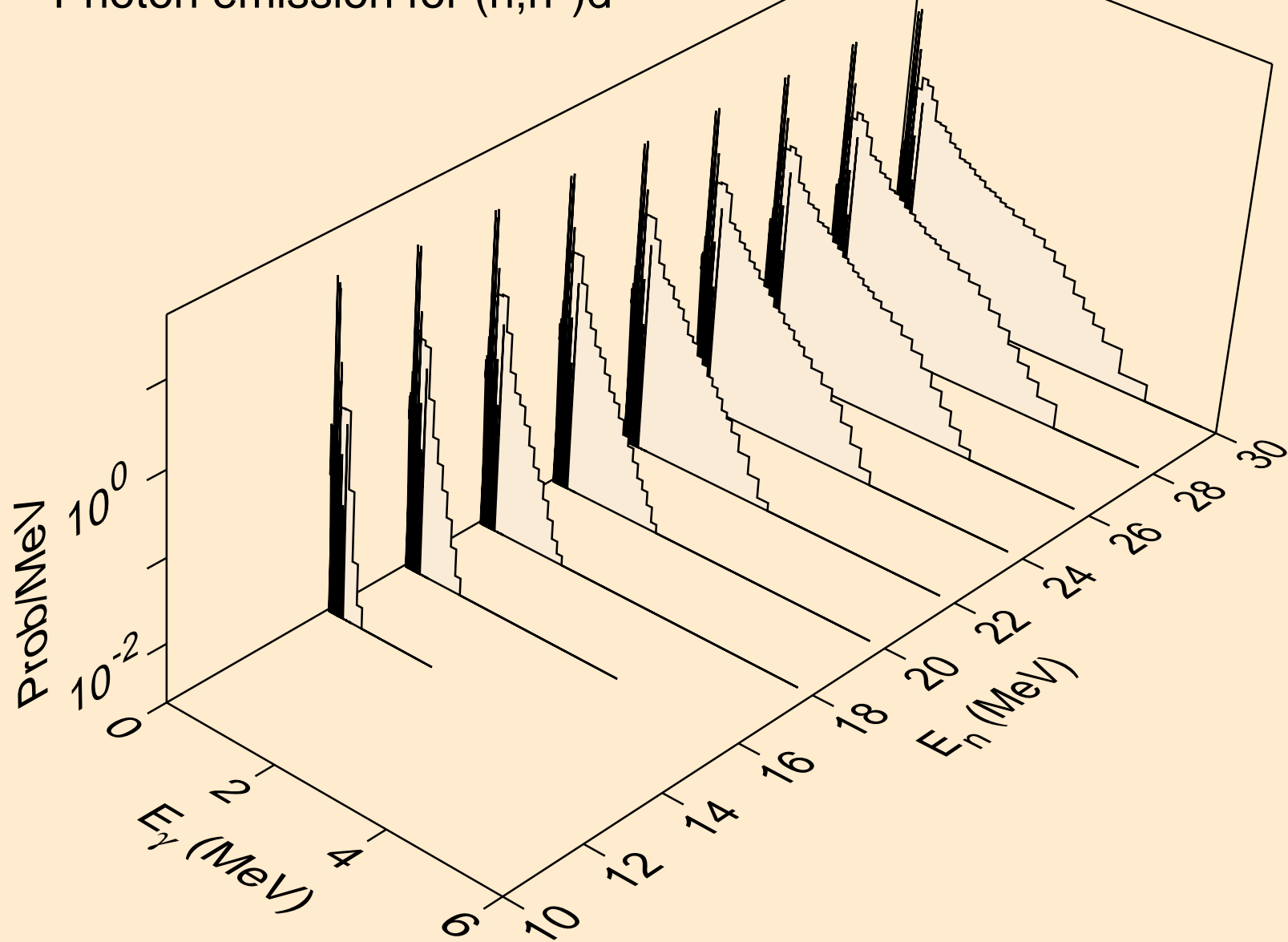

RE185 NEUTRON ACER TENDL-2024 LIBRARY; T=0.K
Photon emission for (n,n*)t

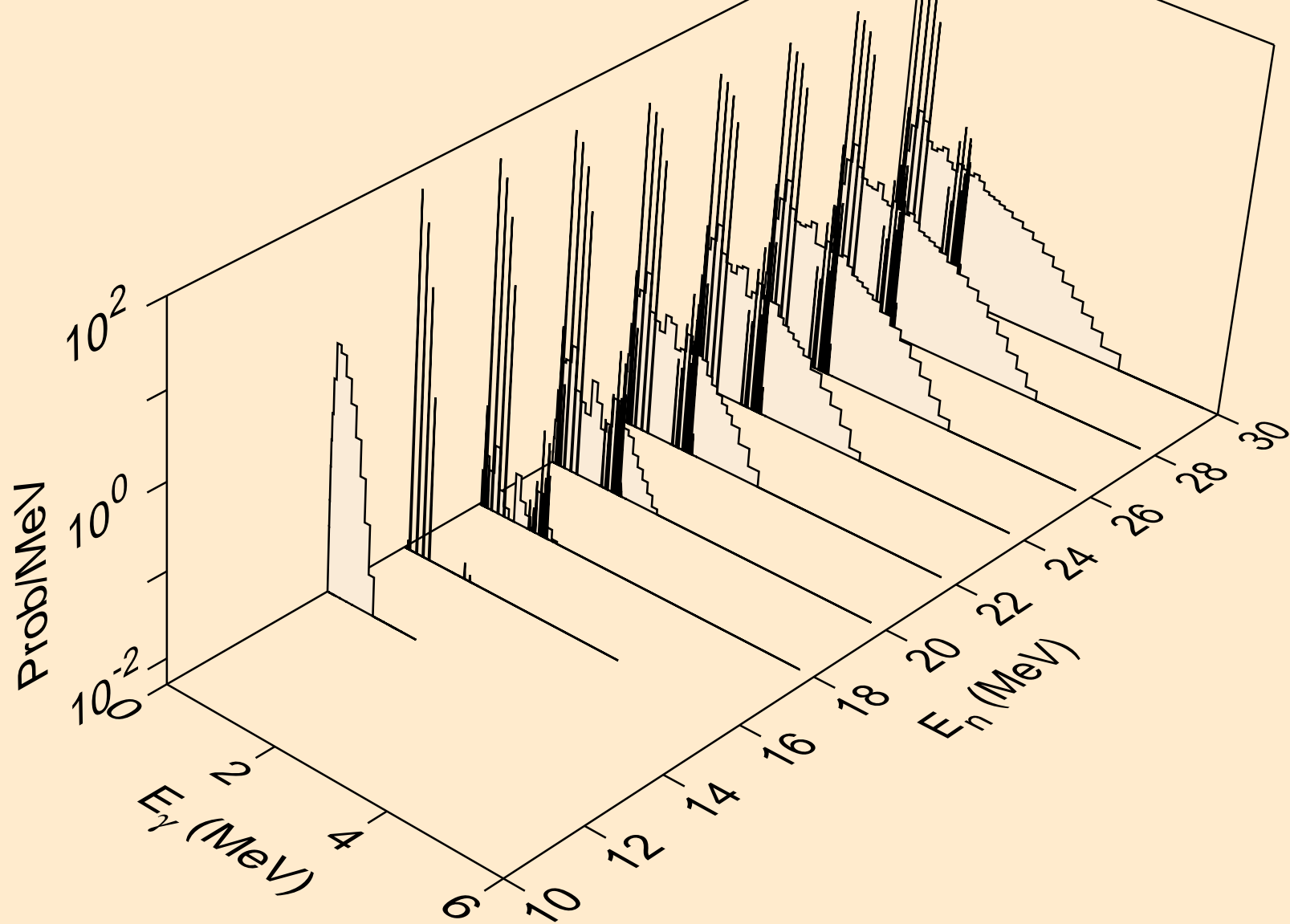

RE185 NEUTRON ACER TENDL-2024 LIBRARY; T=0.K
Photon emission for (n,n*)he3

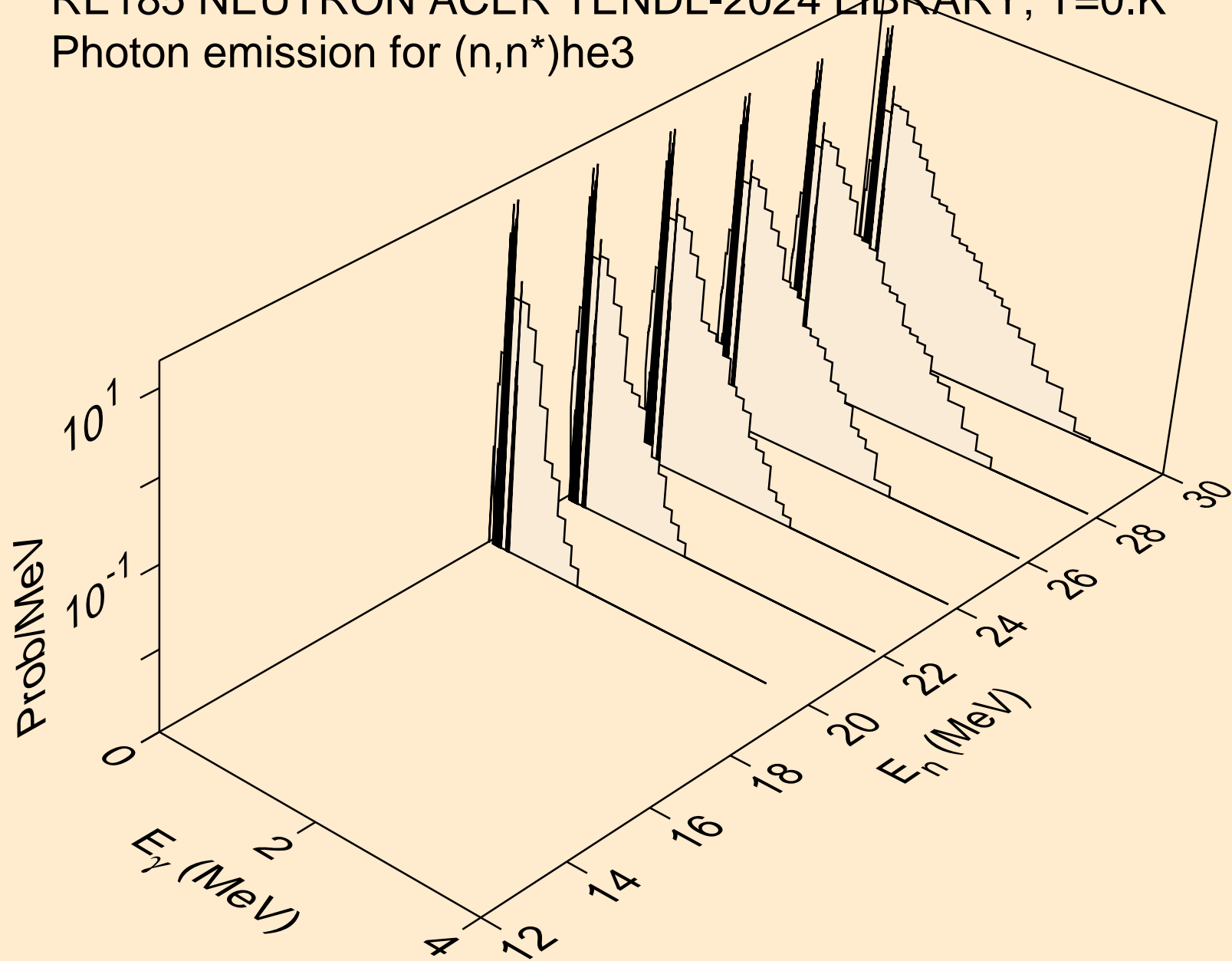

RE185 NEUTRON ACER TENDL-2024 LIBRARY; T=0.K
Photon emission for (n,4n)

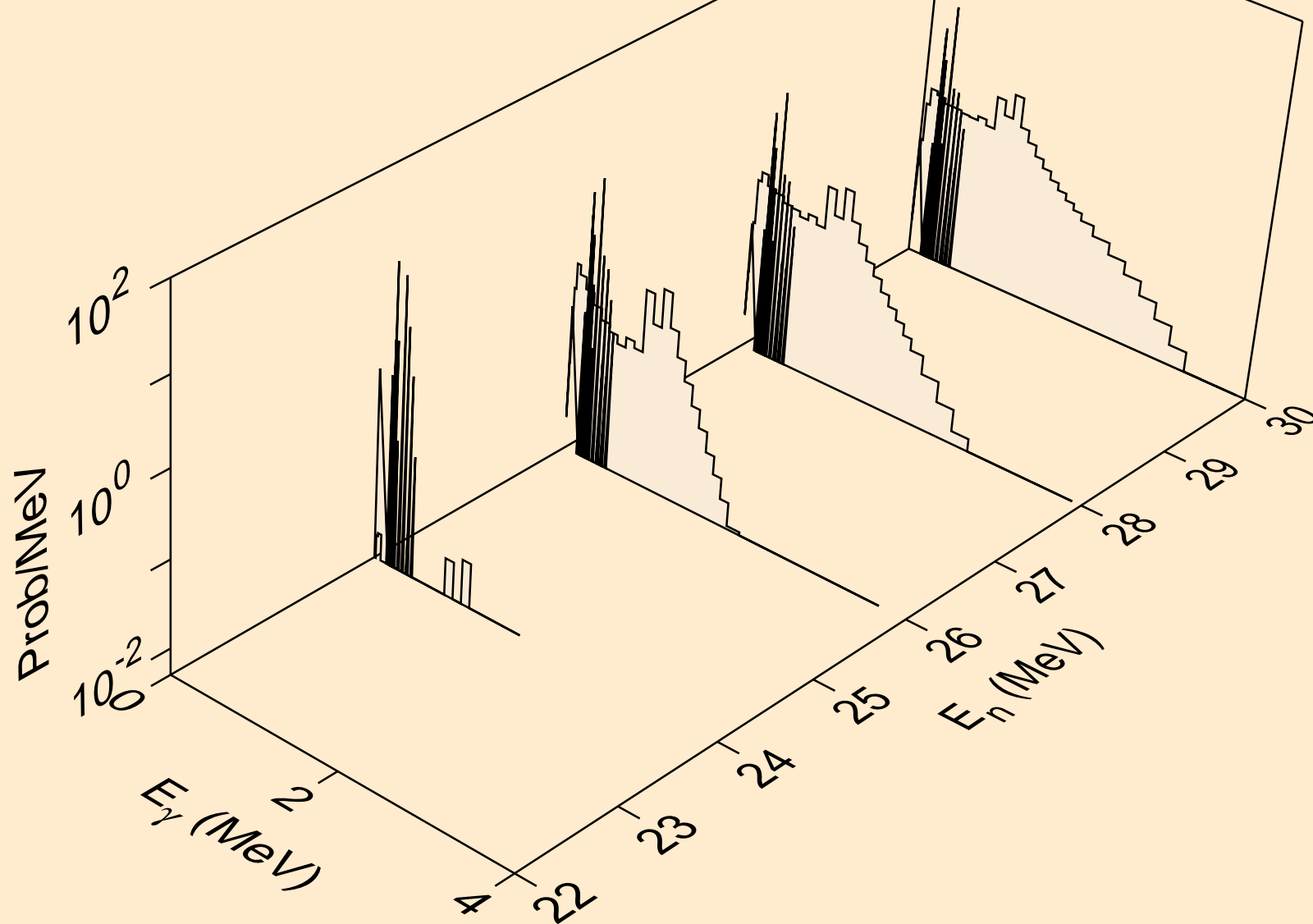

RE185 NEUTRON ACER TENDL-2024 LIBRARY; T=0.K
Photon emission for (n,2np)

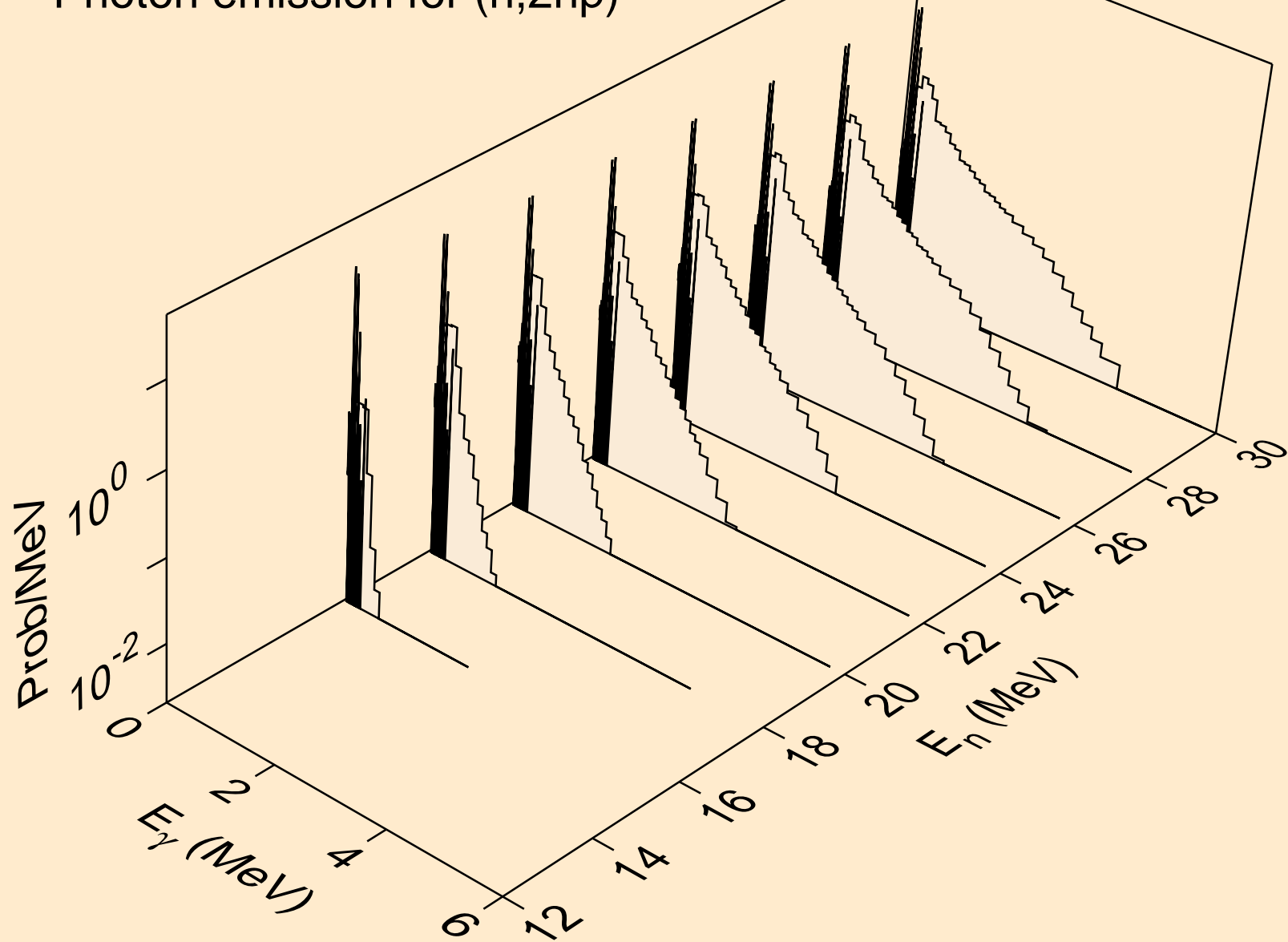

RE185 NEUTRON ACER TENDL-2024 LIBRARY; T=0.K
Photon emission for (n,3np)

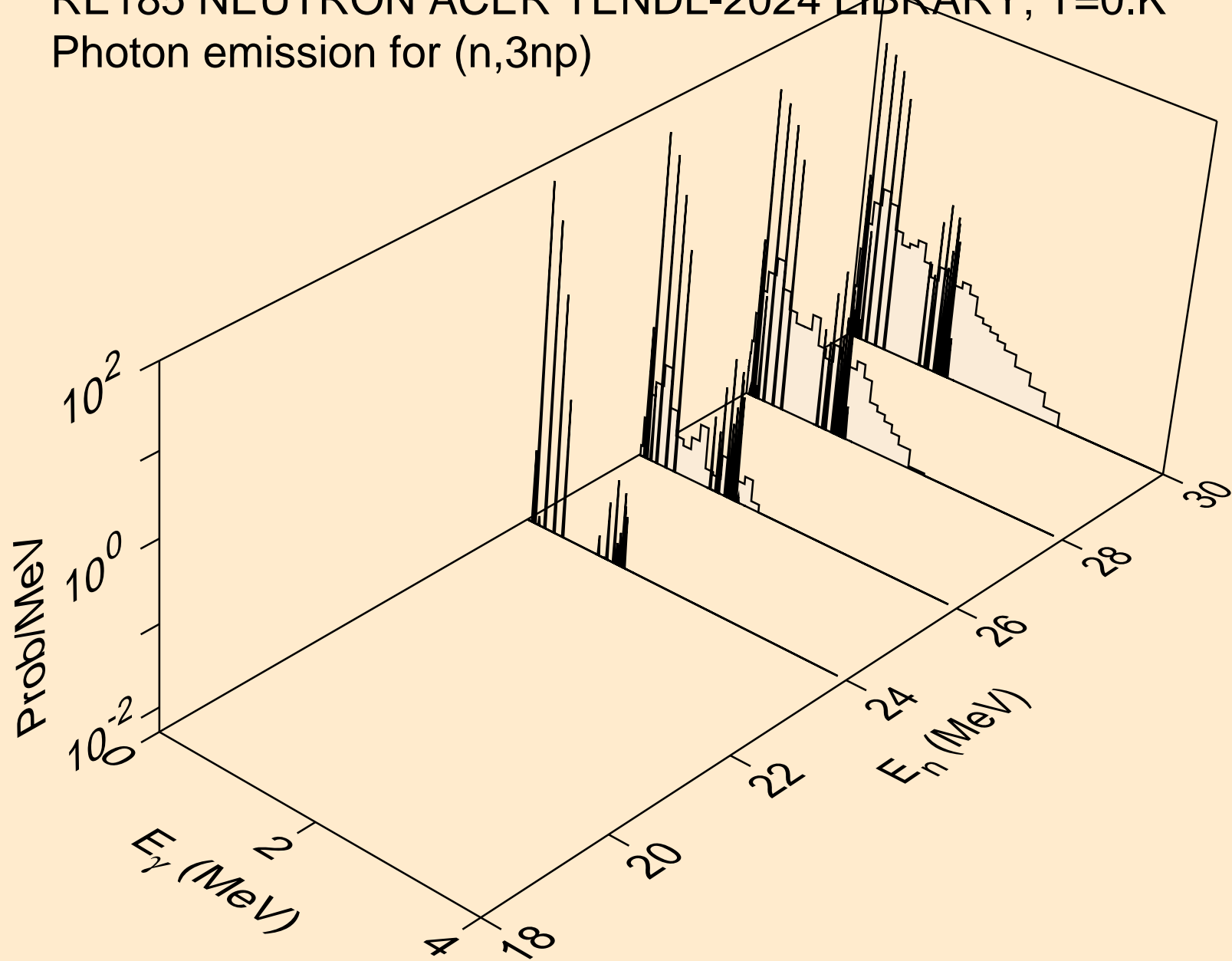

RE185 NEUTRON ACER TENDL-2024 LIBRARY; T=0.K
Photon emission for (n,n2p)

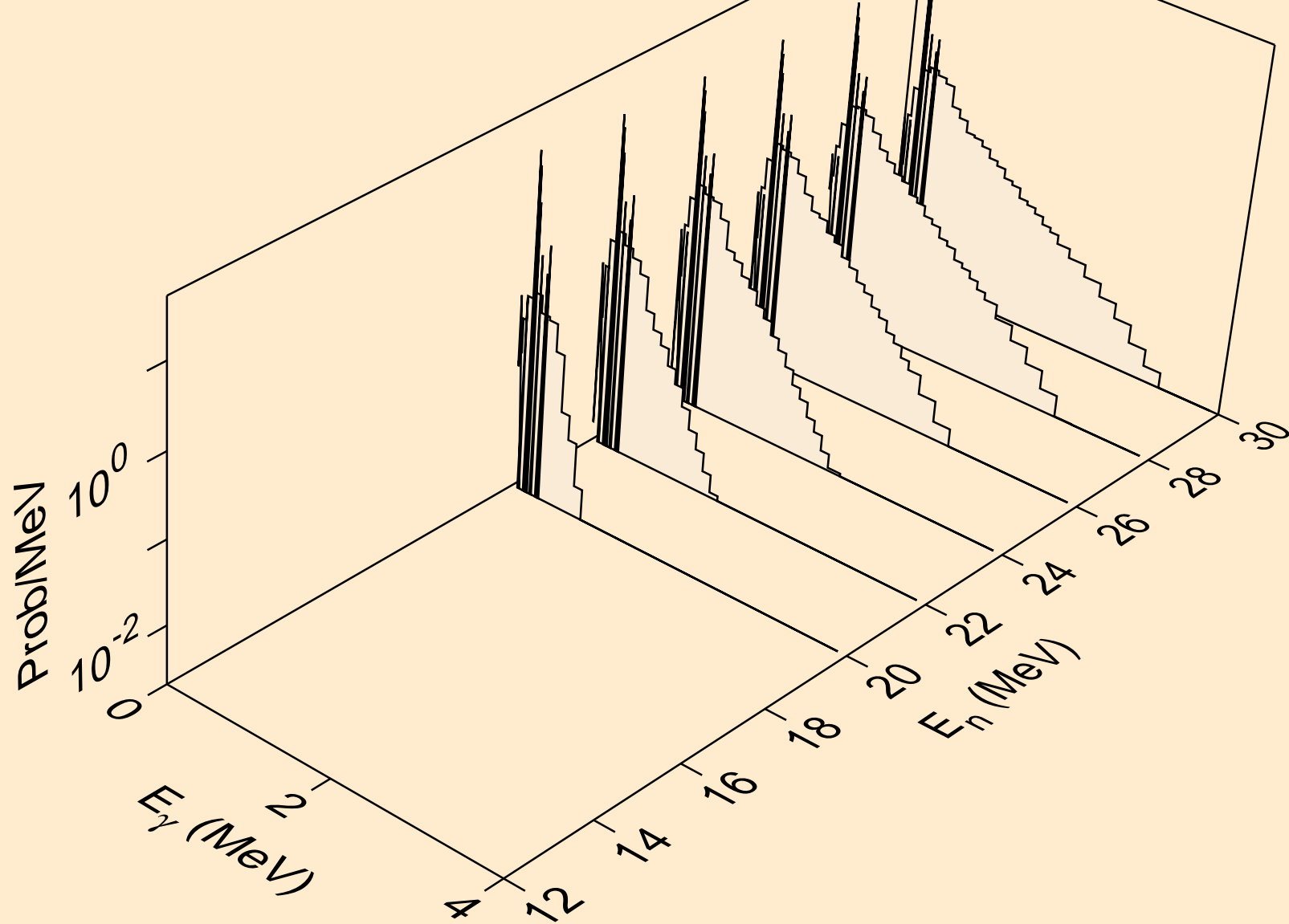

RE185 NEUTRON ACER TENDL-2024 LIBRARY; T=0.K
Photon emission for (n,npa)

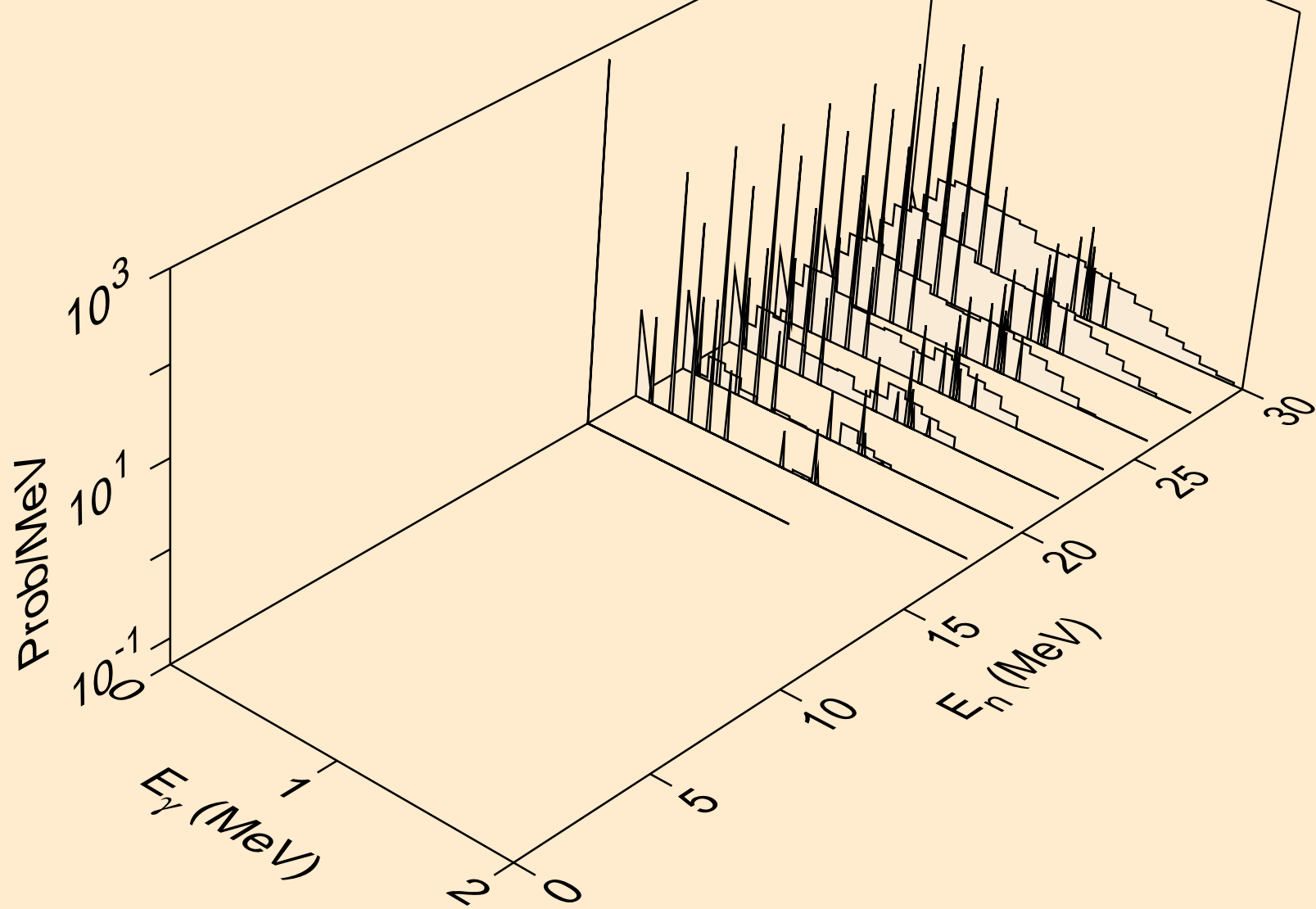

RE185 NEUTRON ACER TENDL-2024 LIBRARY; T=0.K
Photon emission for (n,n*c)

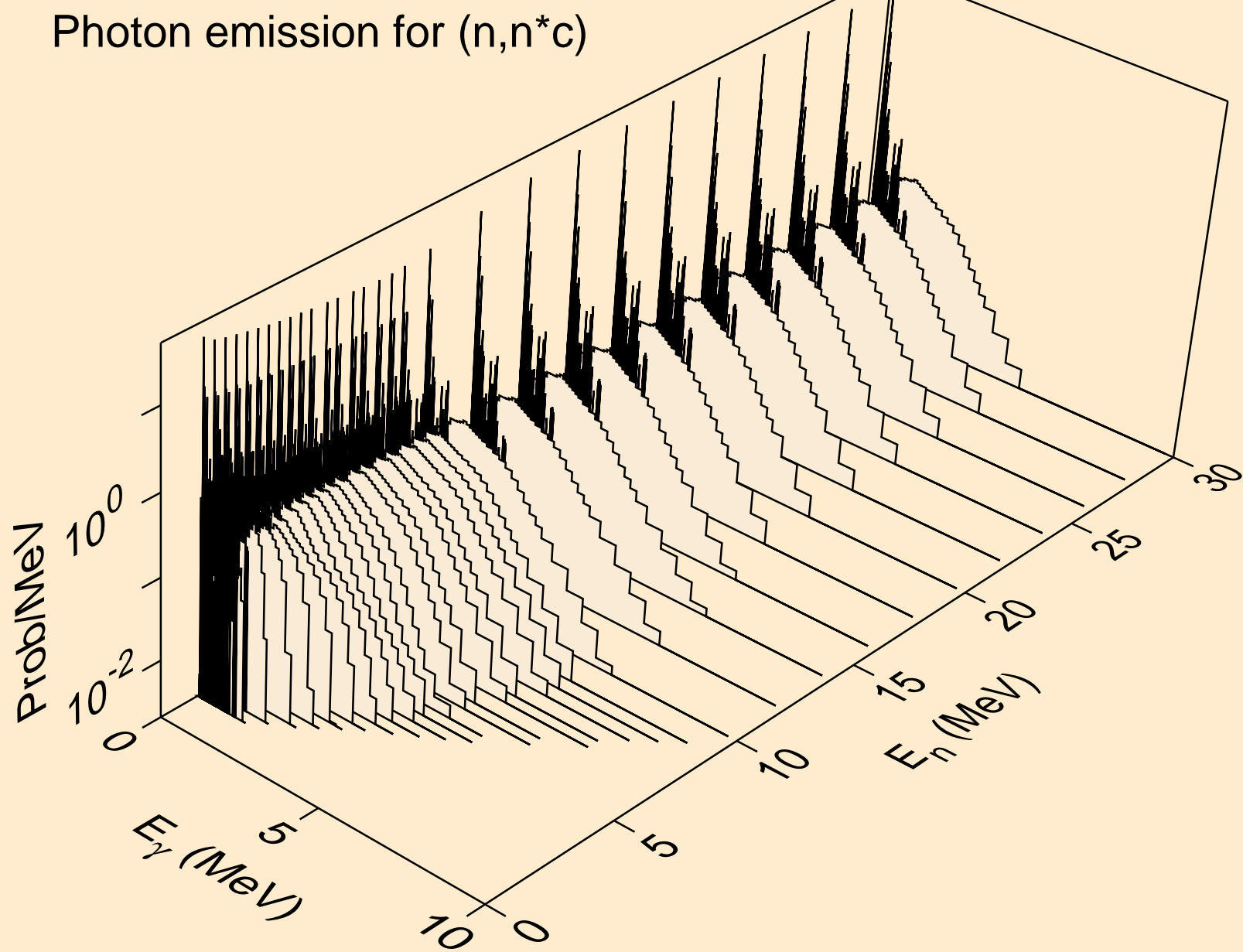

RE185 NEUTRON ACER TENDL-2024 LIBRARY; T=0.K
Photon emission for (n,gma)

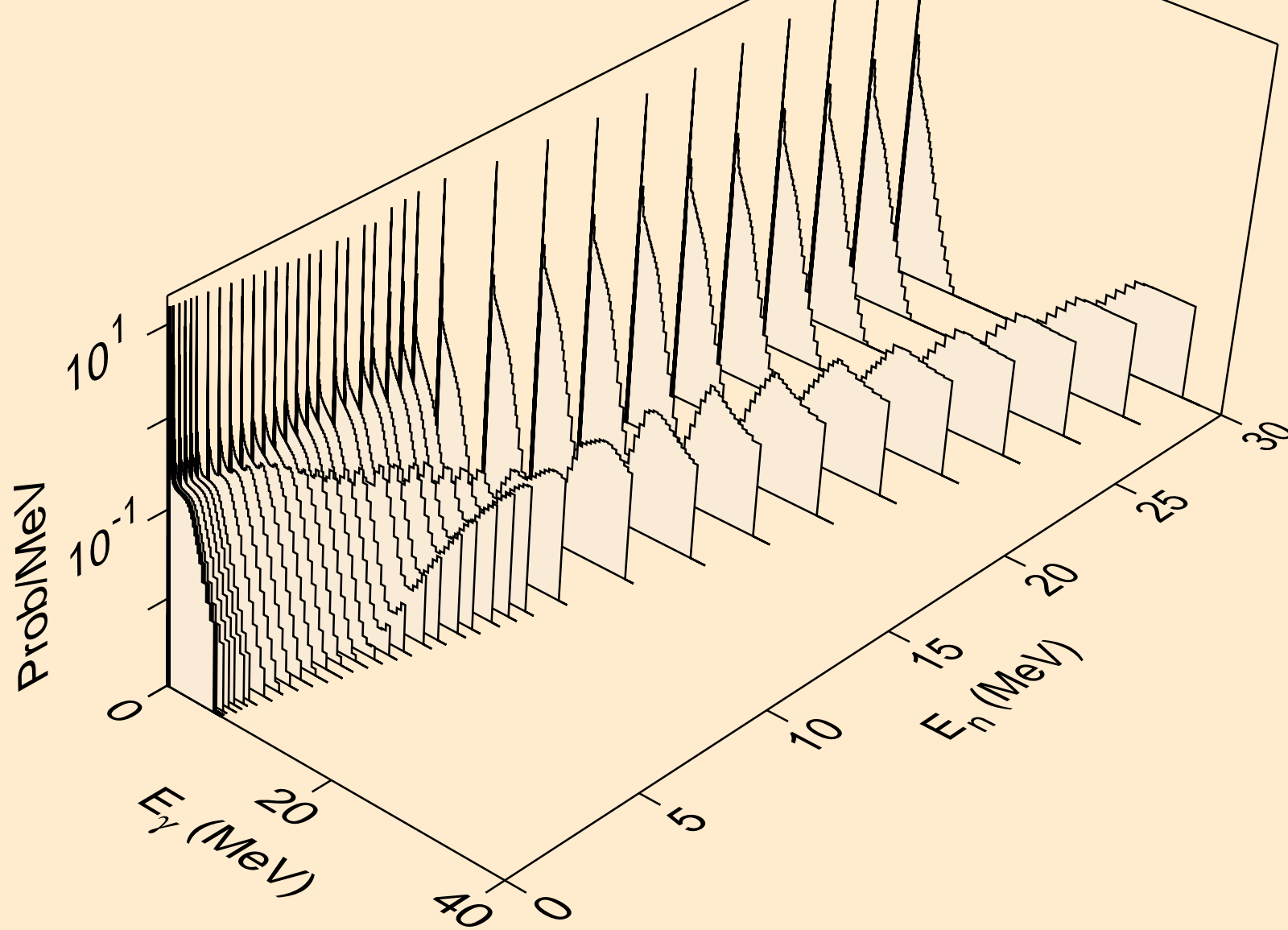

RE185 NEUTRON ACER TENDL-2024 LIBRARY; T=0.K
Photon emission for (n,p)

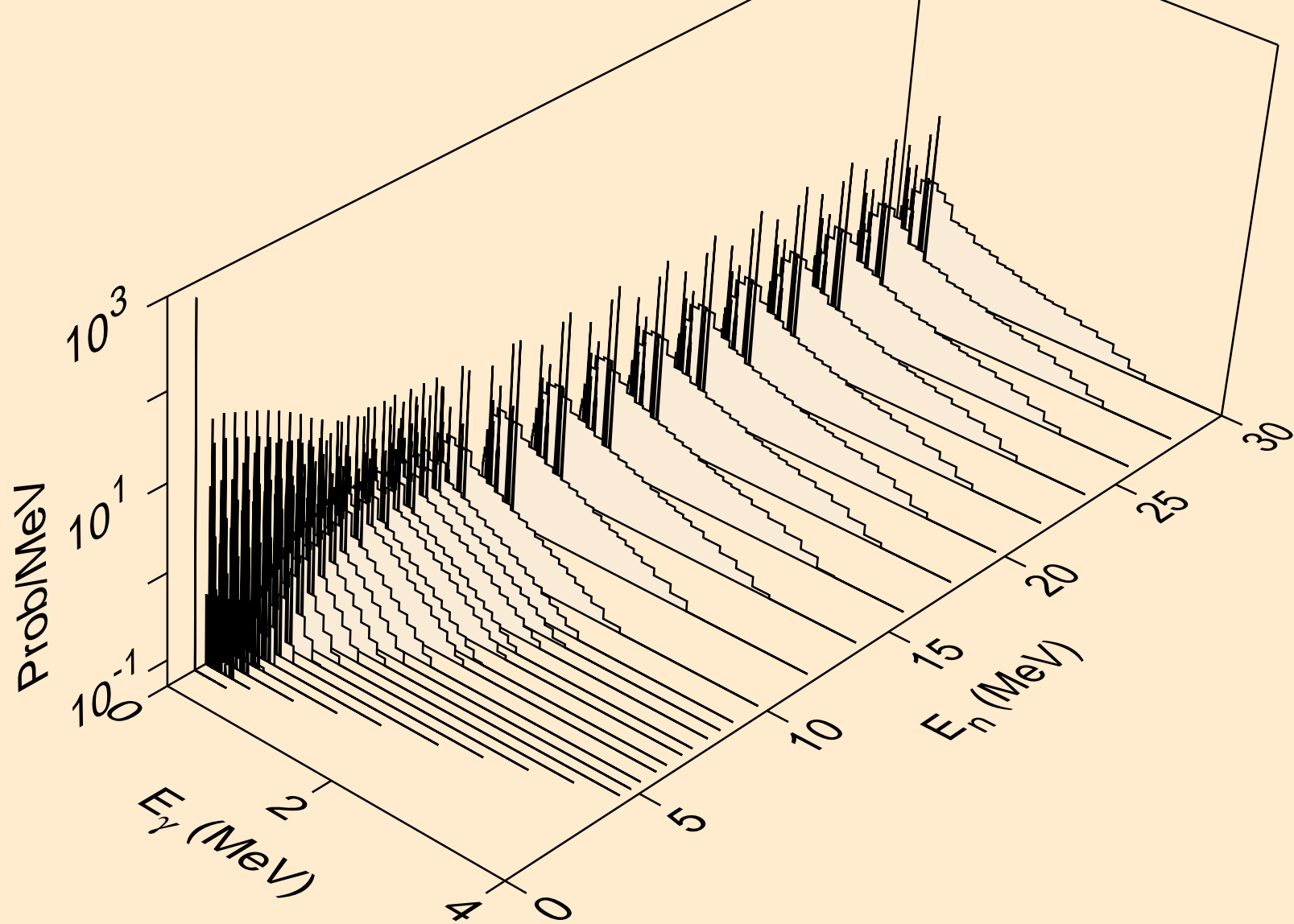

RE185 NEUTRON ACER TENDL-2024 LIBRARY; T=0.K
Photon emission for (n,d)

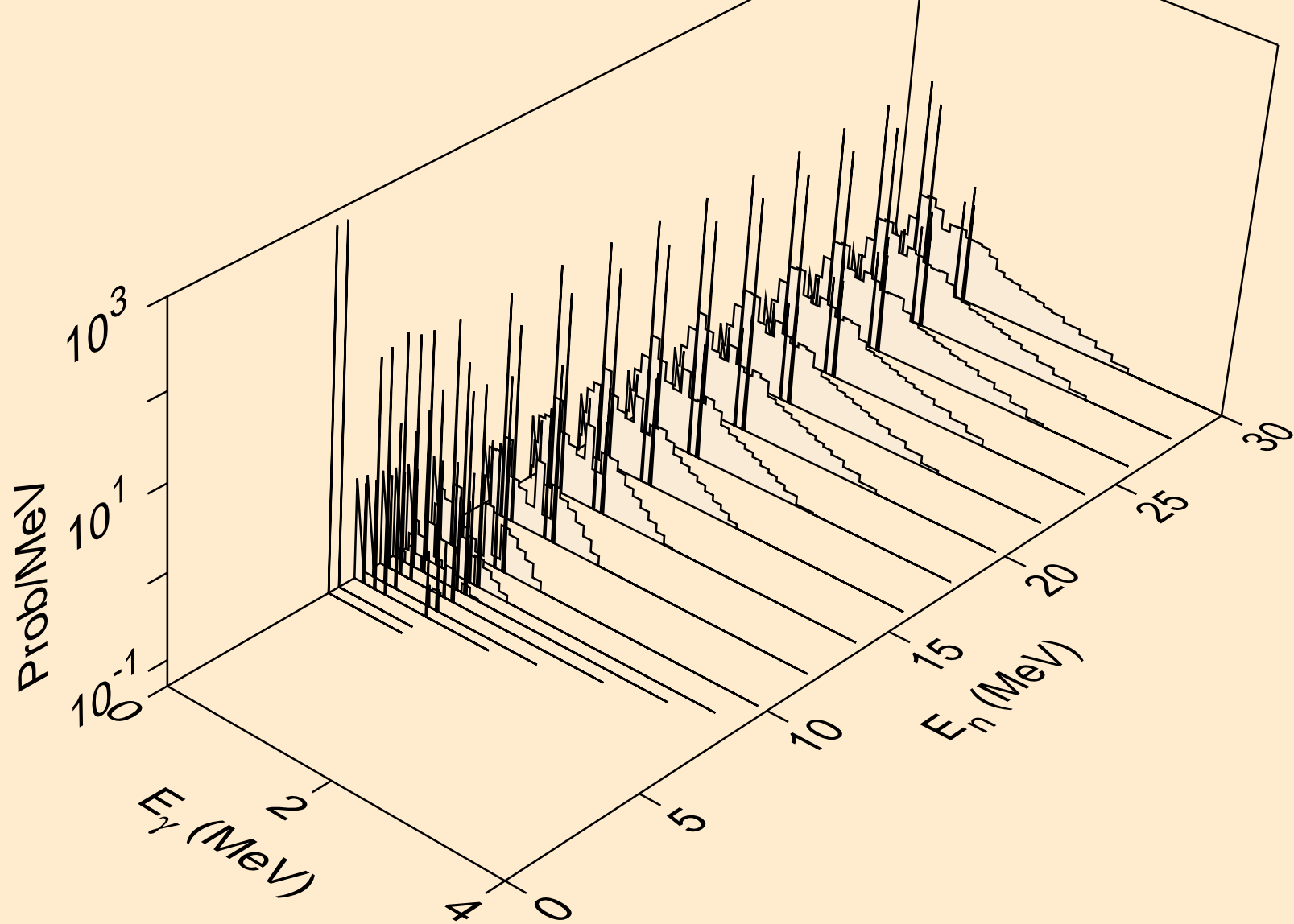

RE185 NEUTRON ACER TENDL-2024 LIBRARY; T=0.K
Photon emission for (n,t)

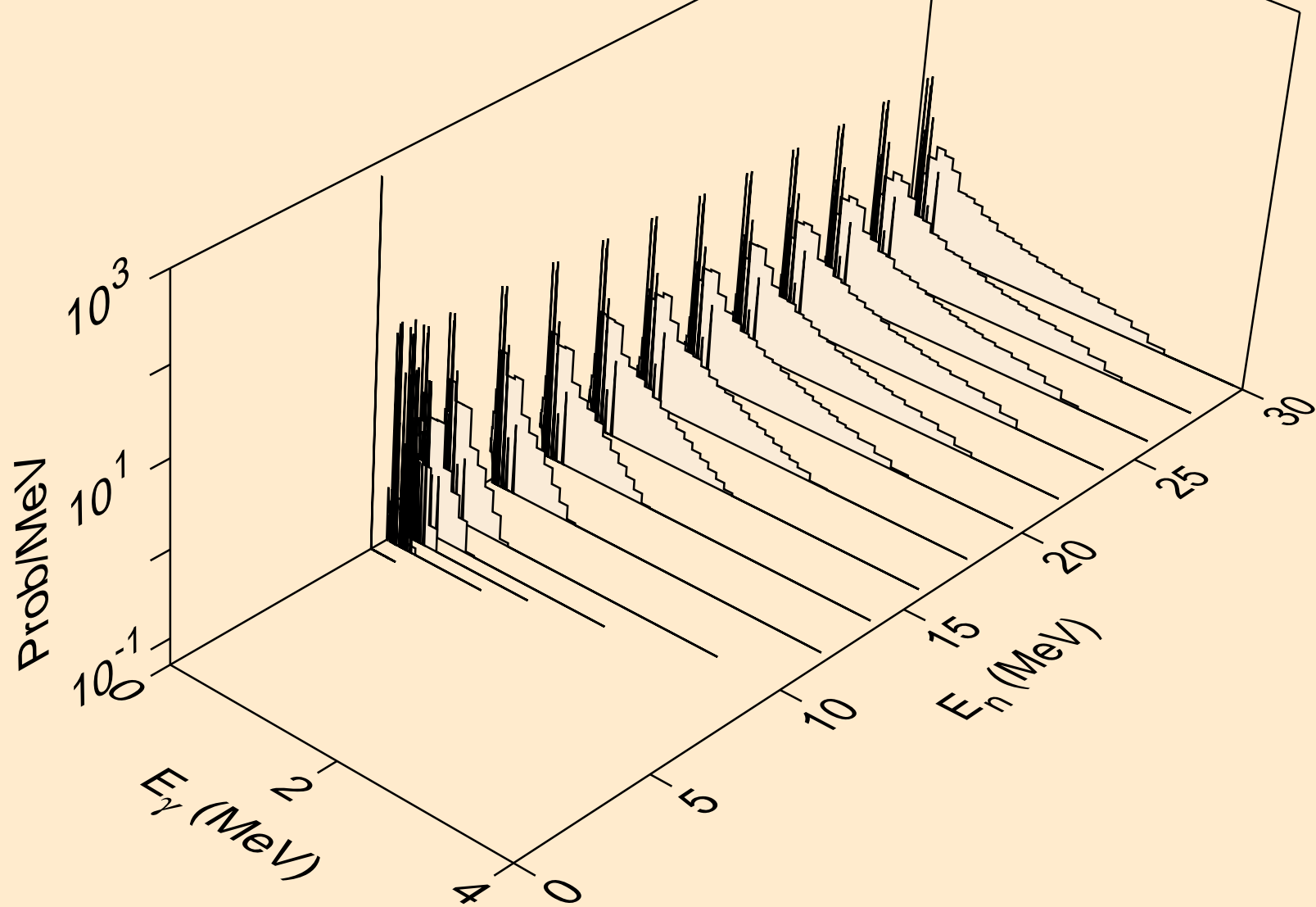

RE185 NEUTRON ACER TENDL-2024 LIBRARY; T=0.K
Photon emission for (n,he3)

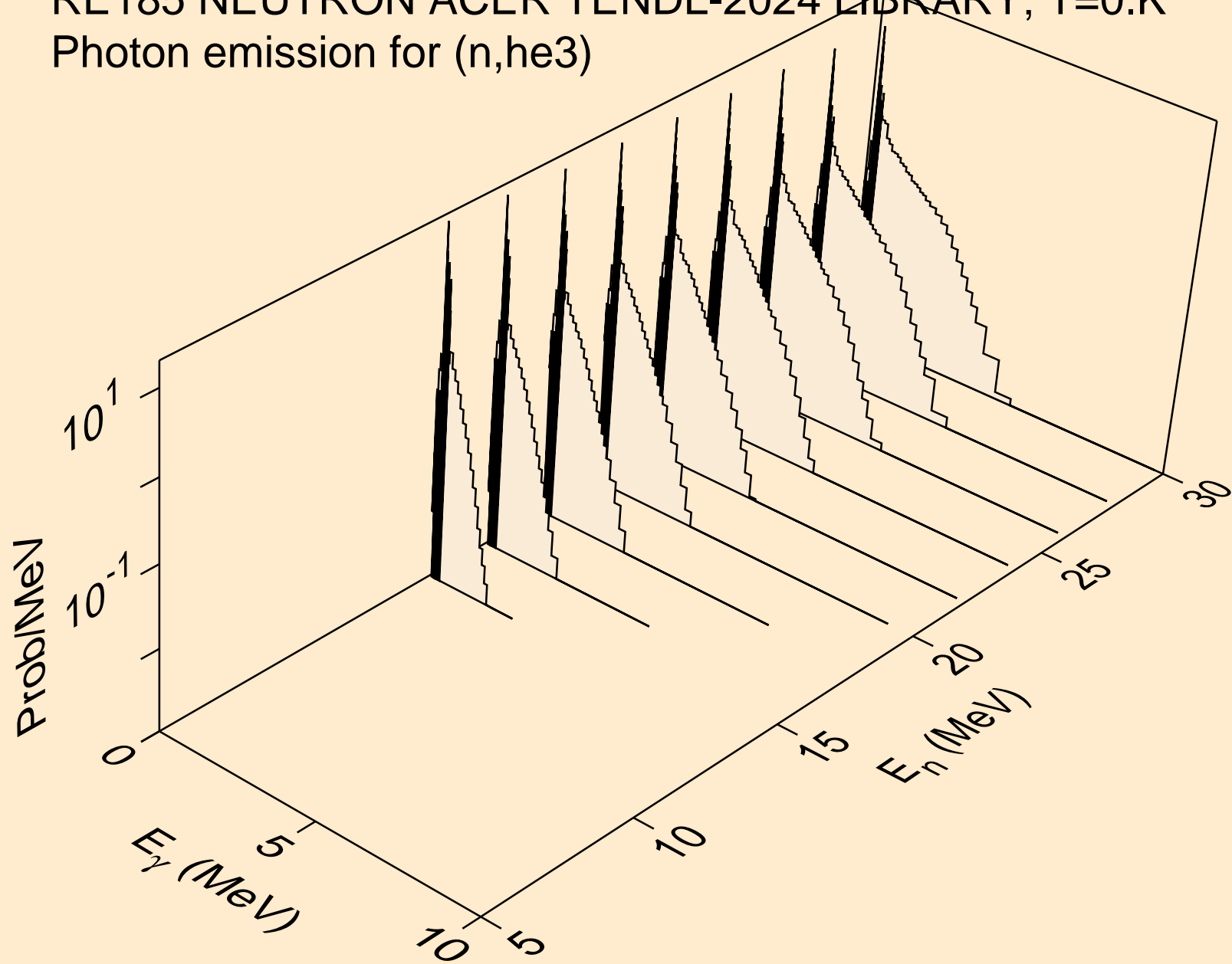

RE185 NEUTRON ACER TENDL-2024 LIBRARY; T=0.K
Photon emission for (n,a)

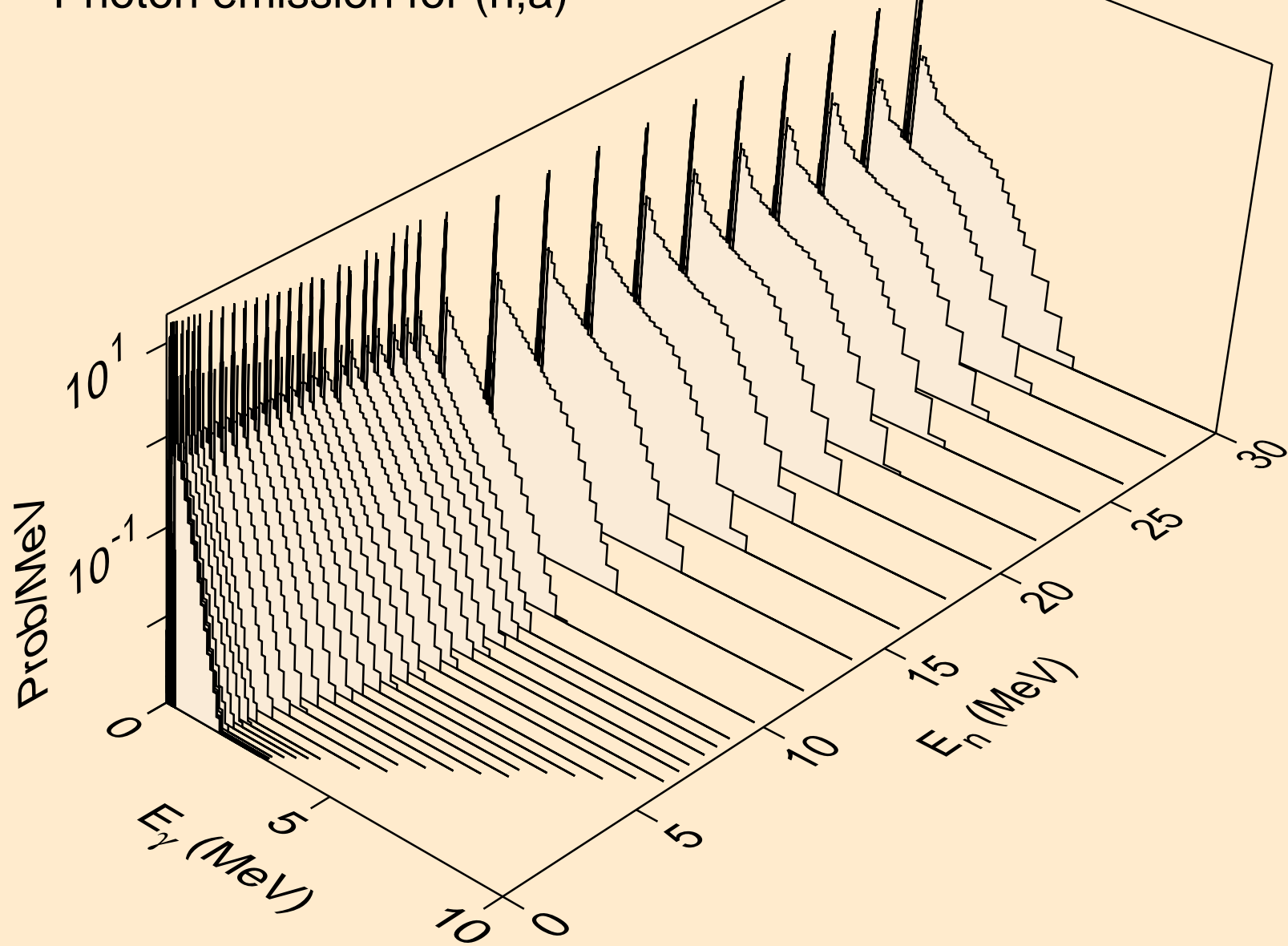

RE185 NEUTRON ACER TENDL-2024 LIBRARY; T=0.K
Photon emission for (n,2a)

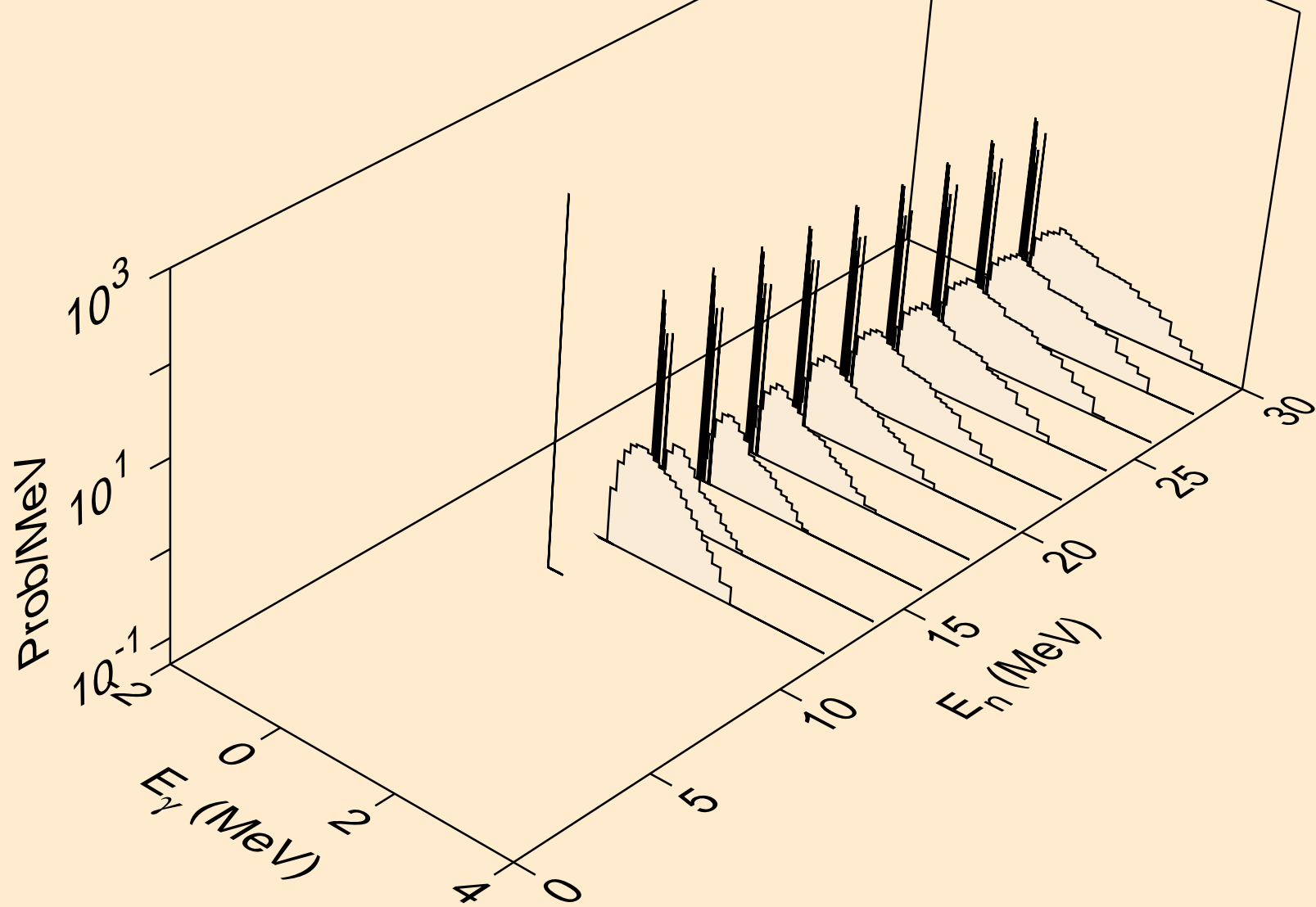

RE185 NEUTRON ACER TENDL-2024 LIBRARY; T=0.K
Photon emission for (n,2p)

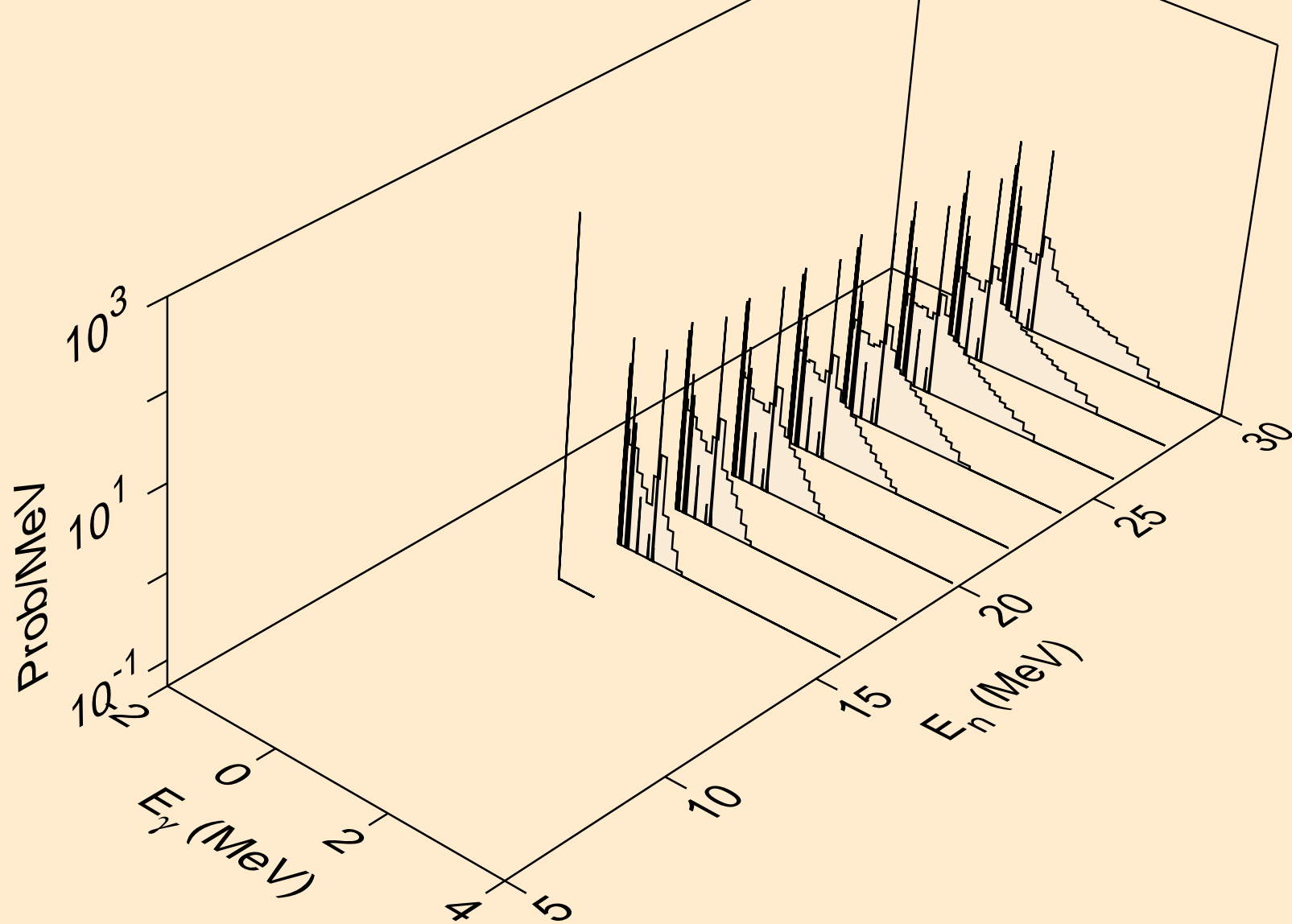

RE185 NEUTRON ACER TENDL-2024 LIBRARY; T=0.K
Photon emission for (n,p α)

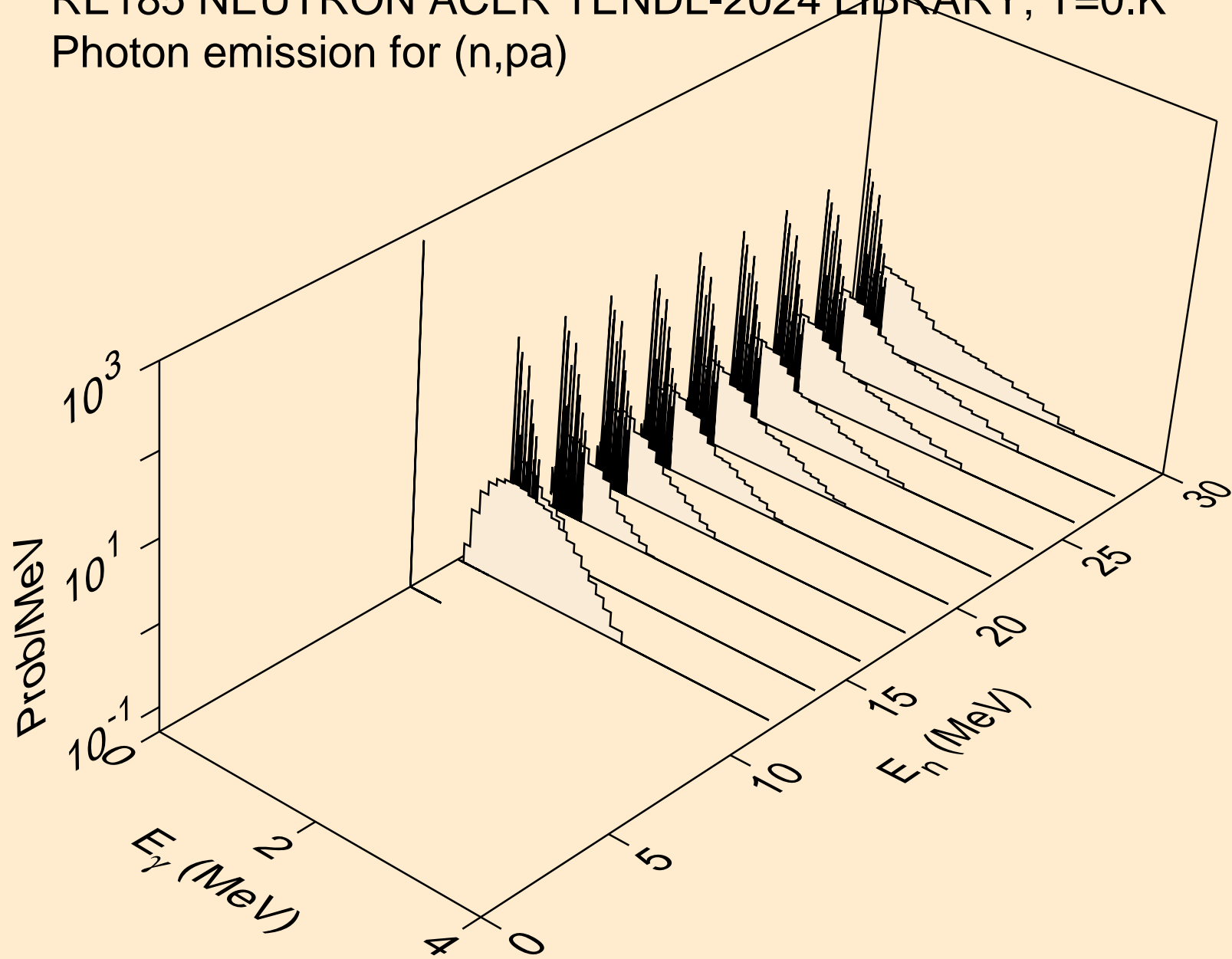

RE185 NEUTRON ACER TENDL-2024 LIBRARY; T=0.K
Photon emission for (n,pd)

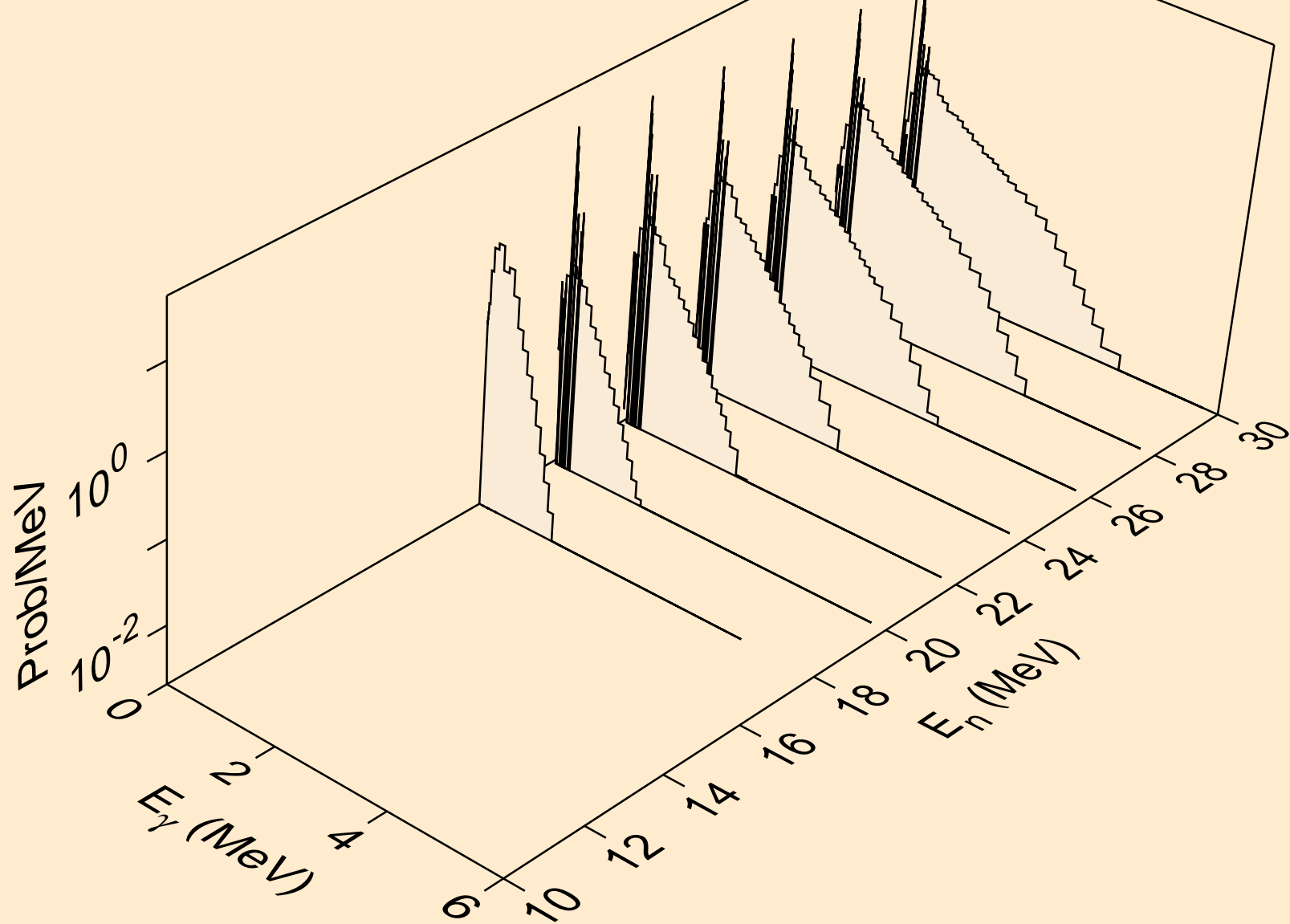

RE185 NEUTRON ACER TENDL-2024 LIBRARY; T=0.K
Photon emission for (n,pt)

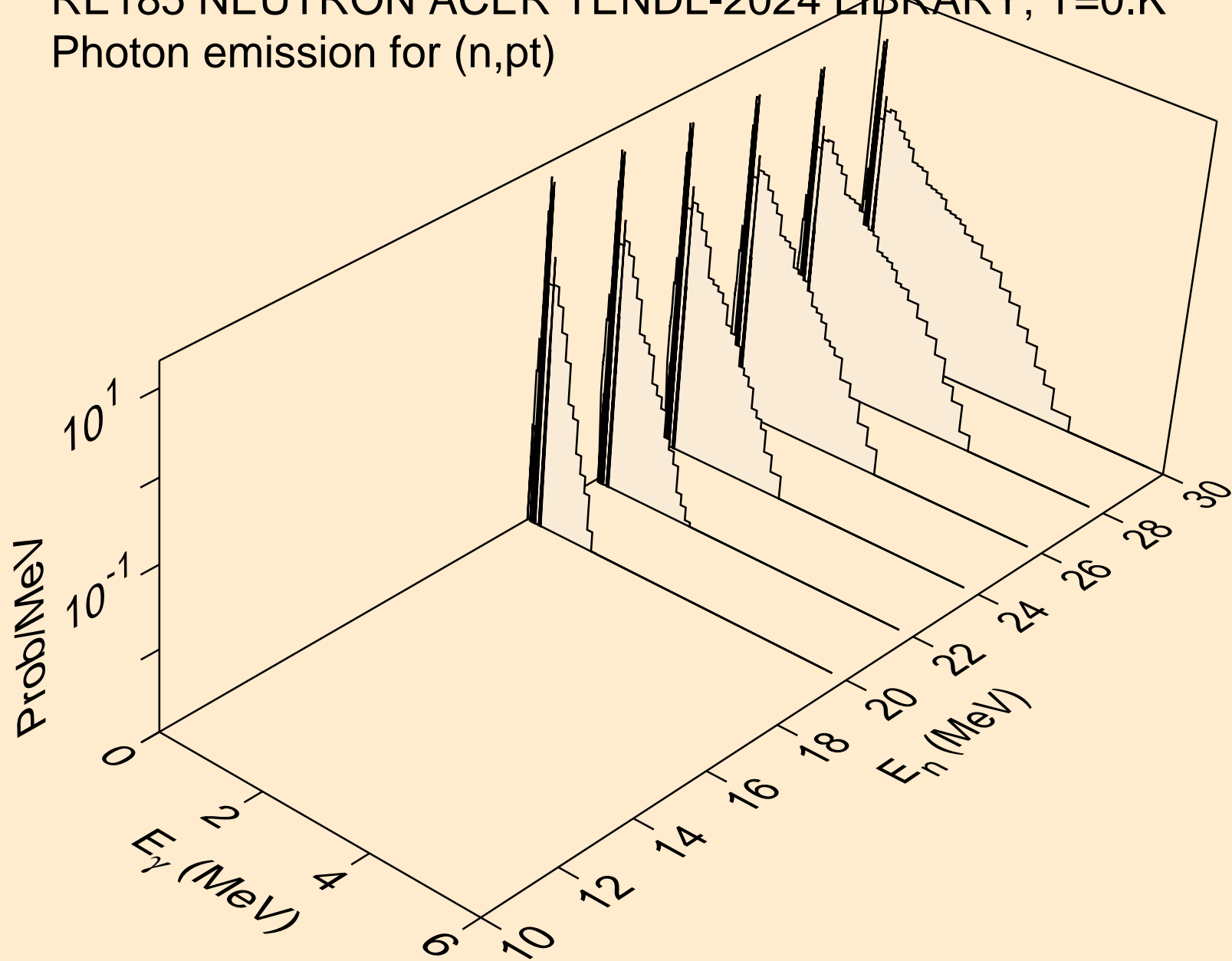

RE185 NEUTRON ACER TENDL-2024 LIBRARY; T=0.K
Photon emission for (n,da)

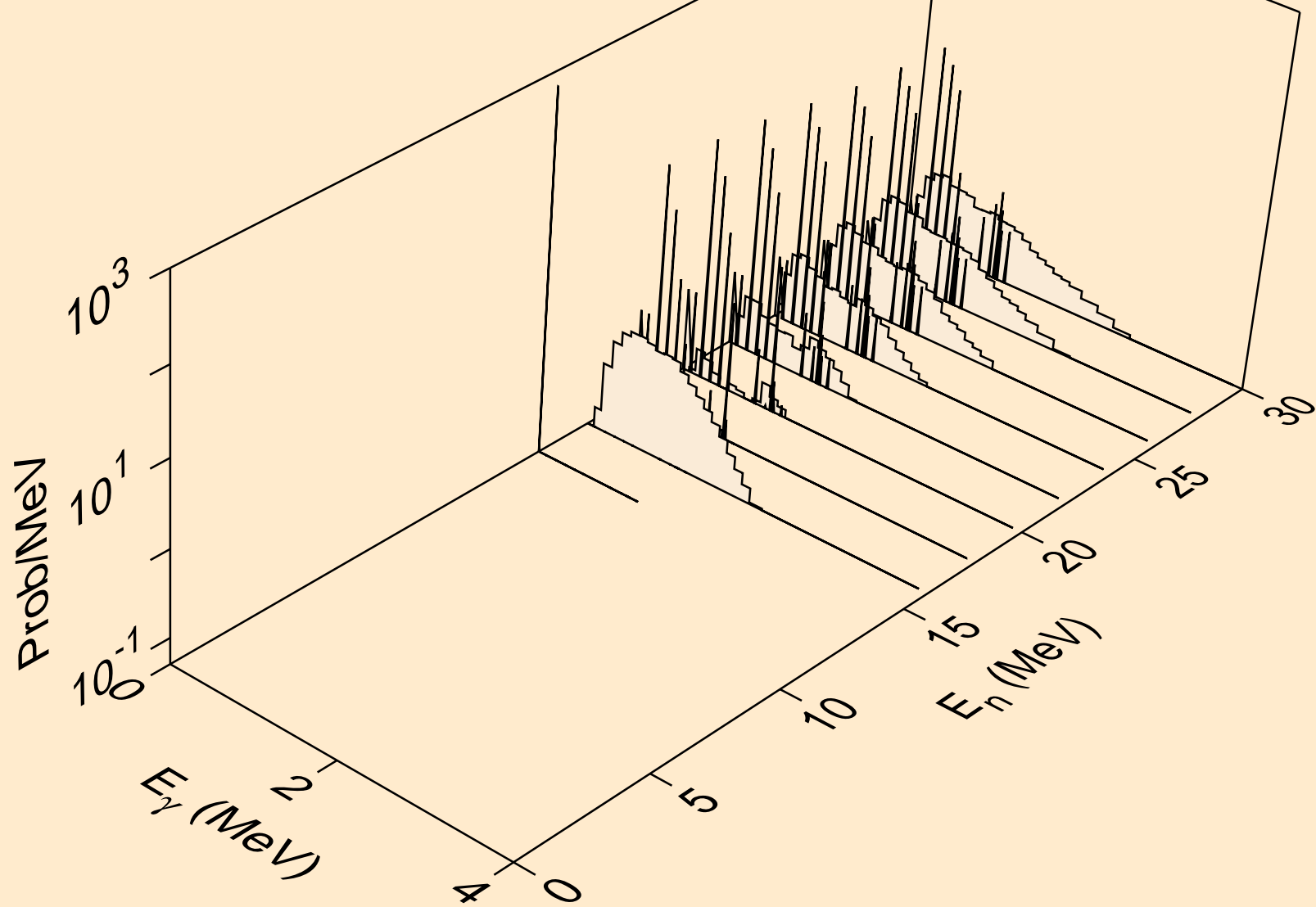

RE185 NEUTRON ACER TENDL-2024 LIBRARY; T=0.K
thermal capture photon spectrum

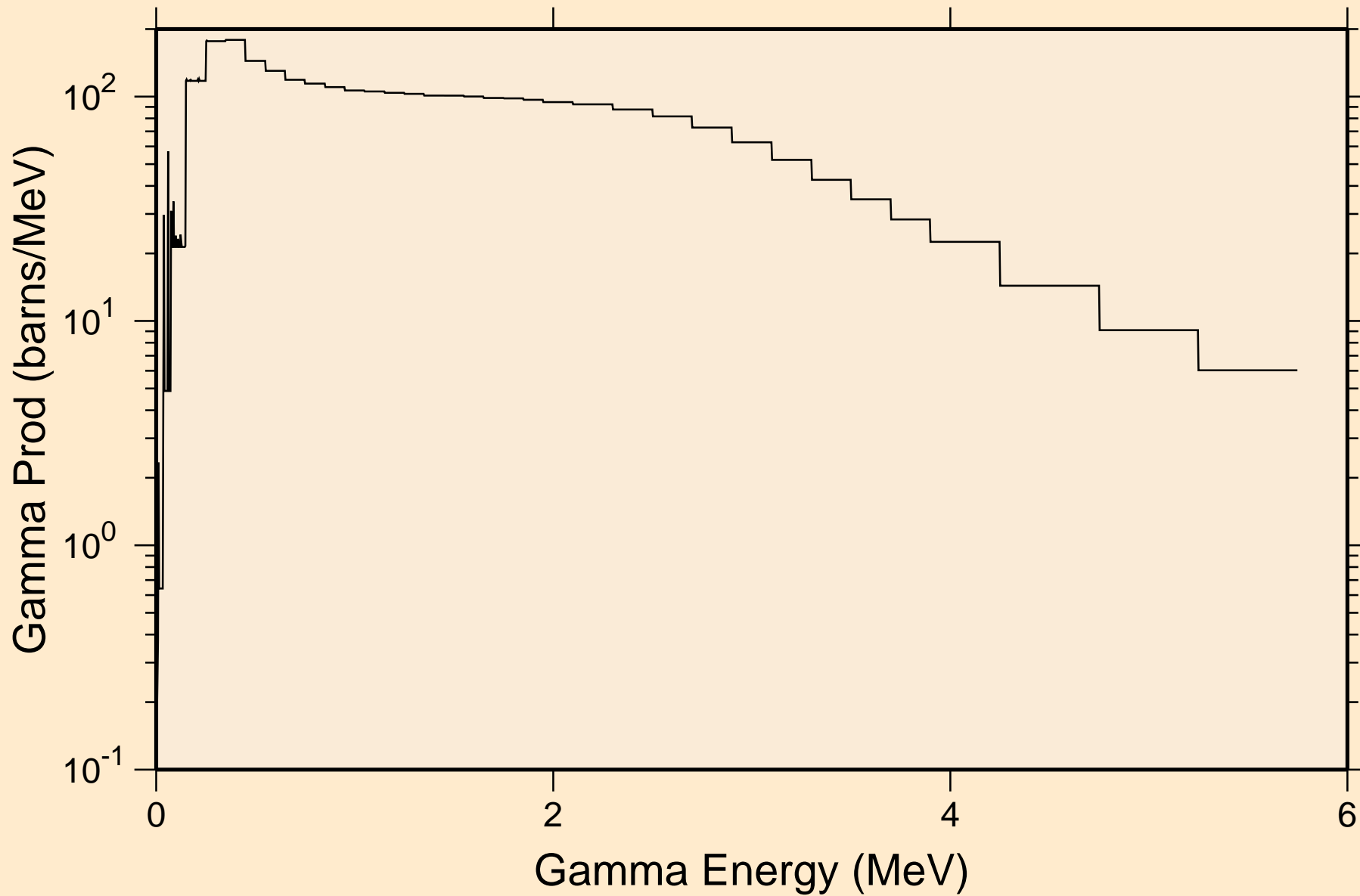

RE185 NEUTRON ACER TENDL-2024 LIBRARY; T=0.K
14 MeV photon spectrum

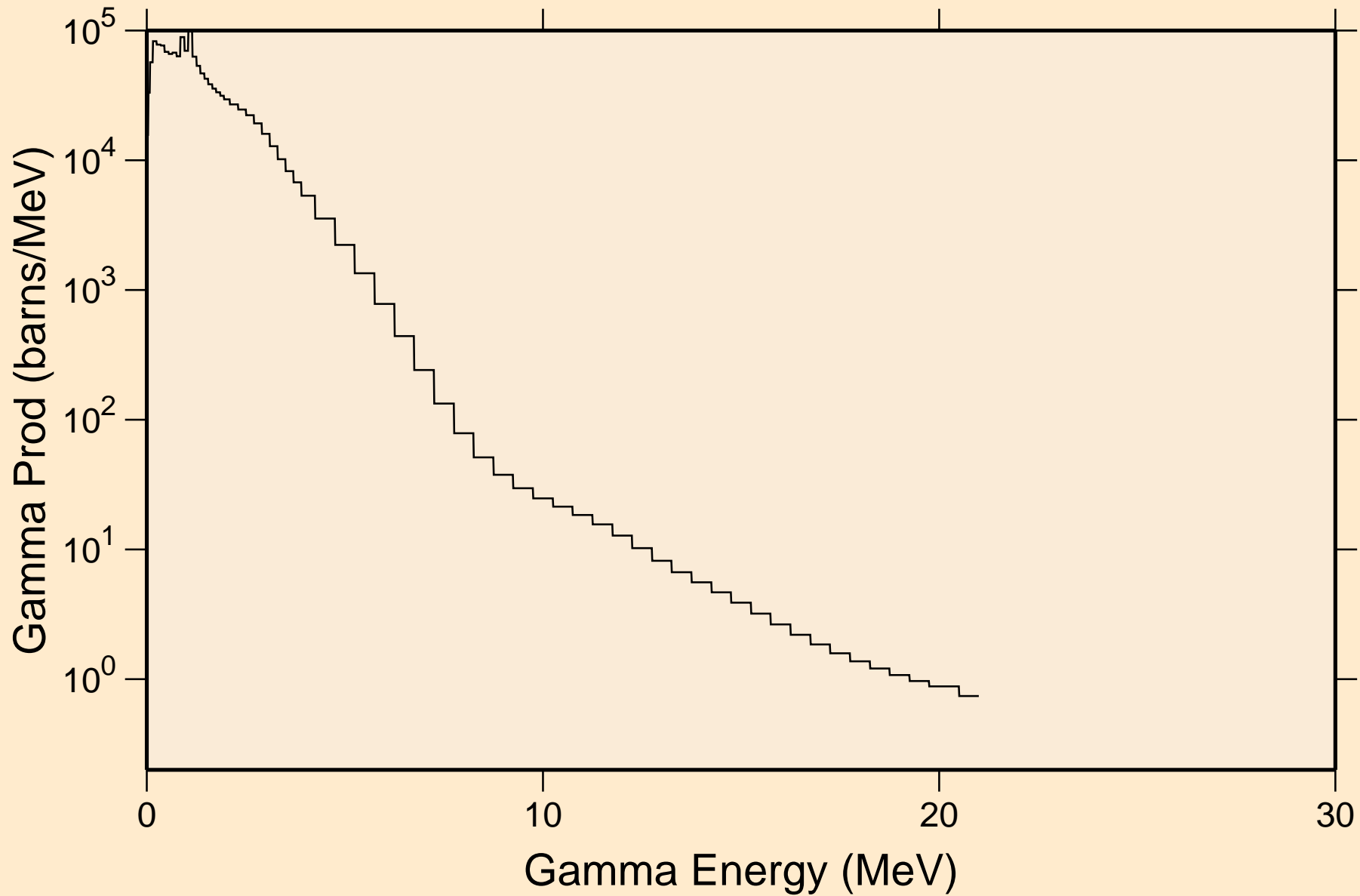

RE185 NEUTRON ACER TENDL-2024 LIBRARY; T=0.K
Particle heating contributions

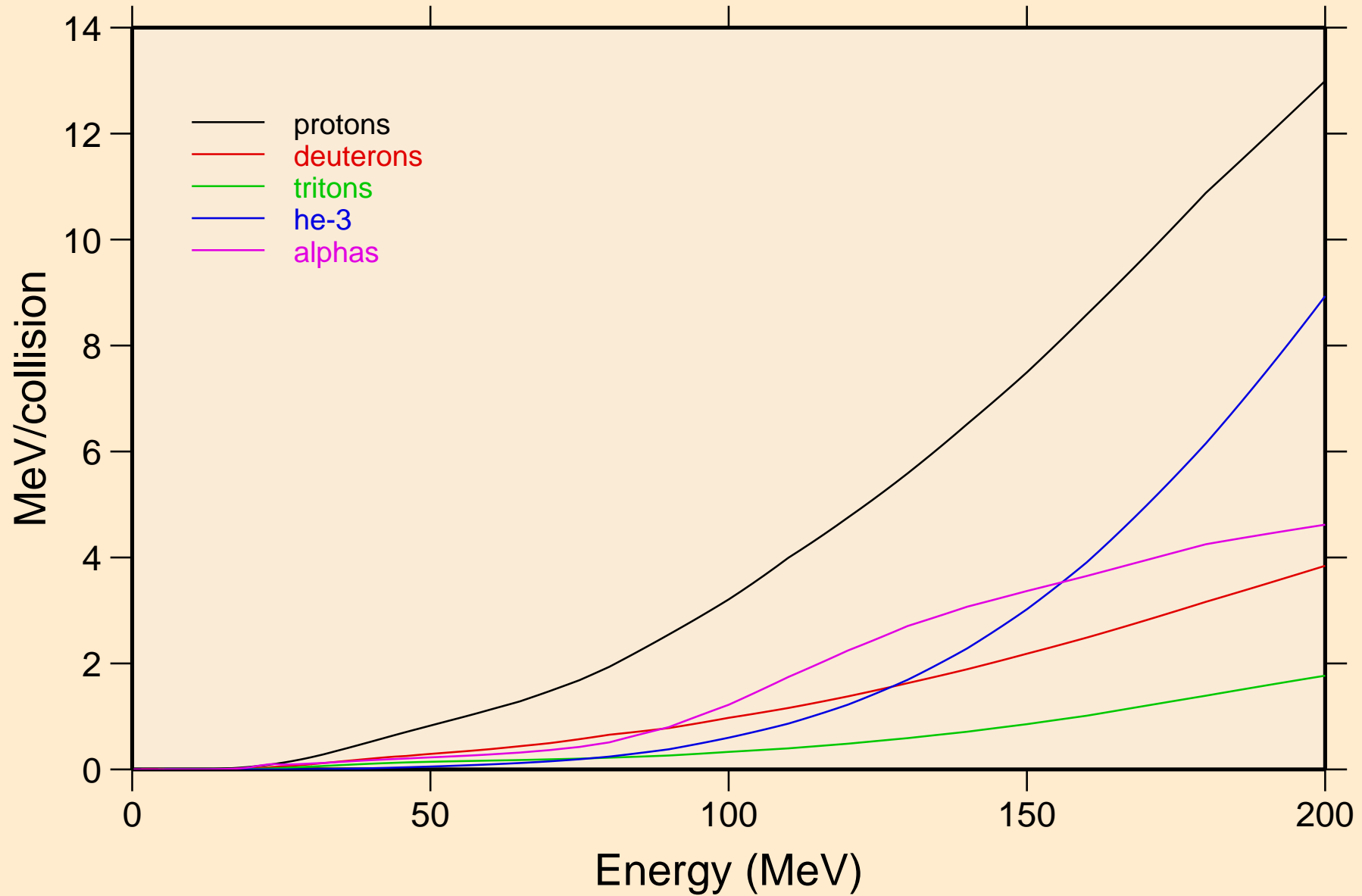

RE185 NEUTRON ACER TENDL-2024 LIBRARY; T=0.K
Recoil Heating

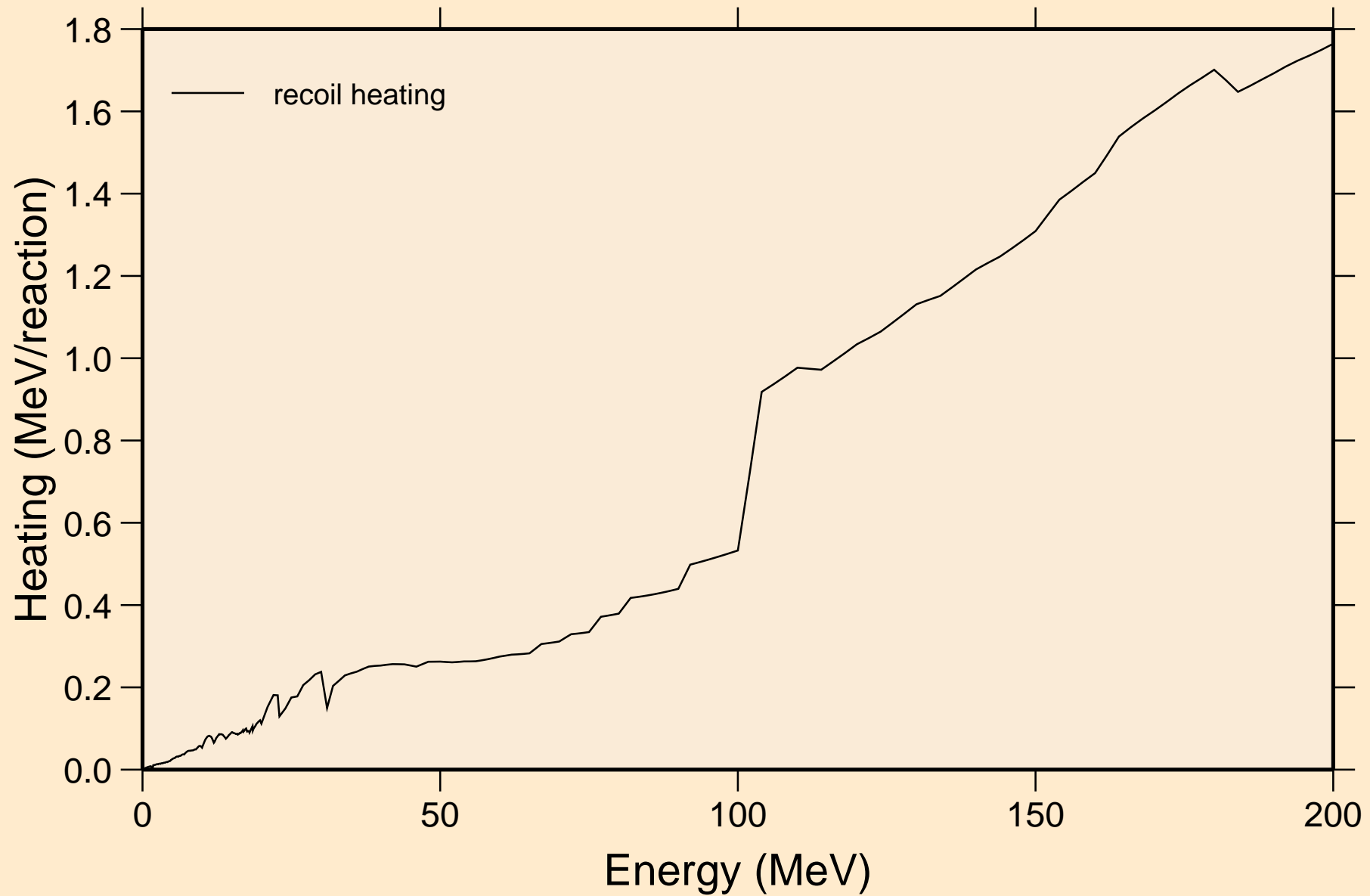

RE185 NEUTRON ACER TENDL-2024 LIBRARY; T=0.K
Particle production cross sections

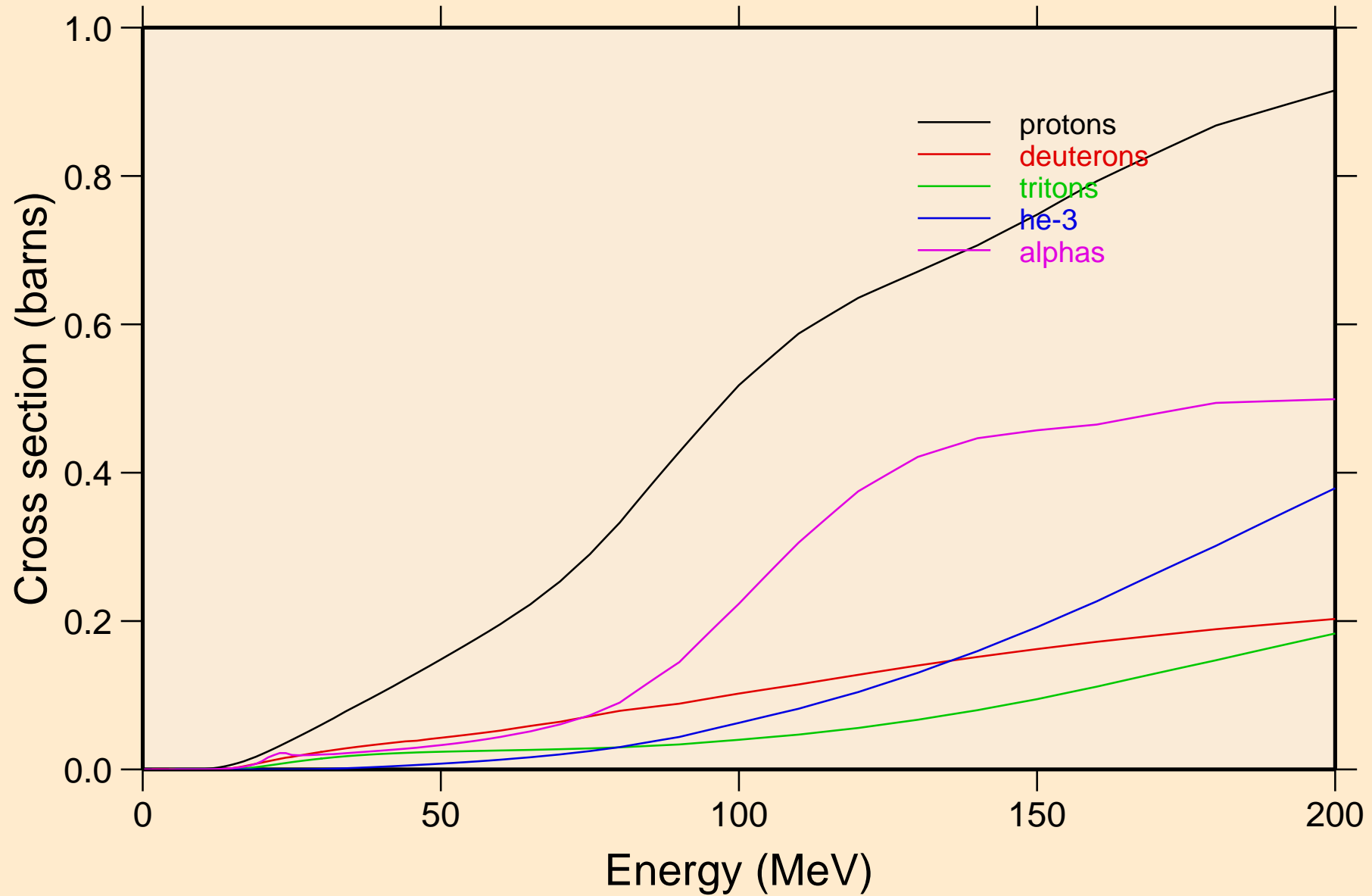

RE185 NEUTRON ACER TENDL-2024 LIBRARY; T=0.K
protons from (n,x)

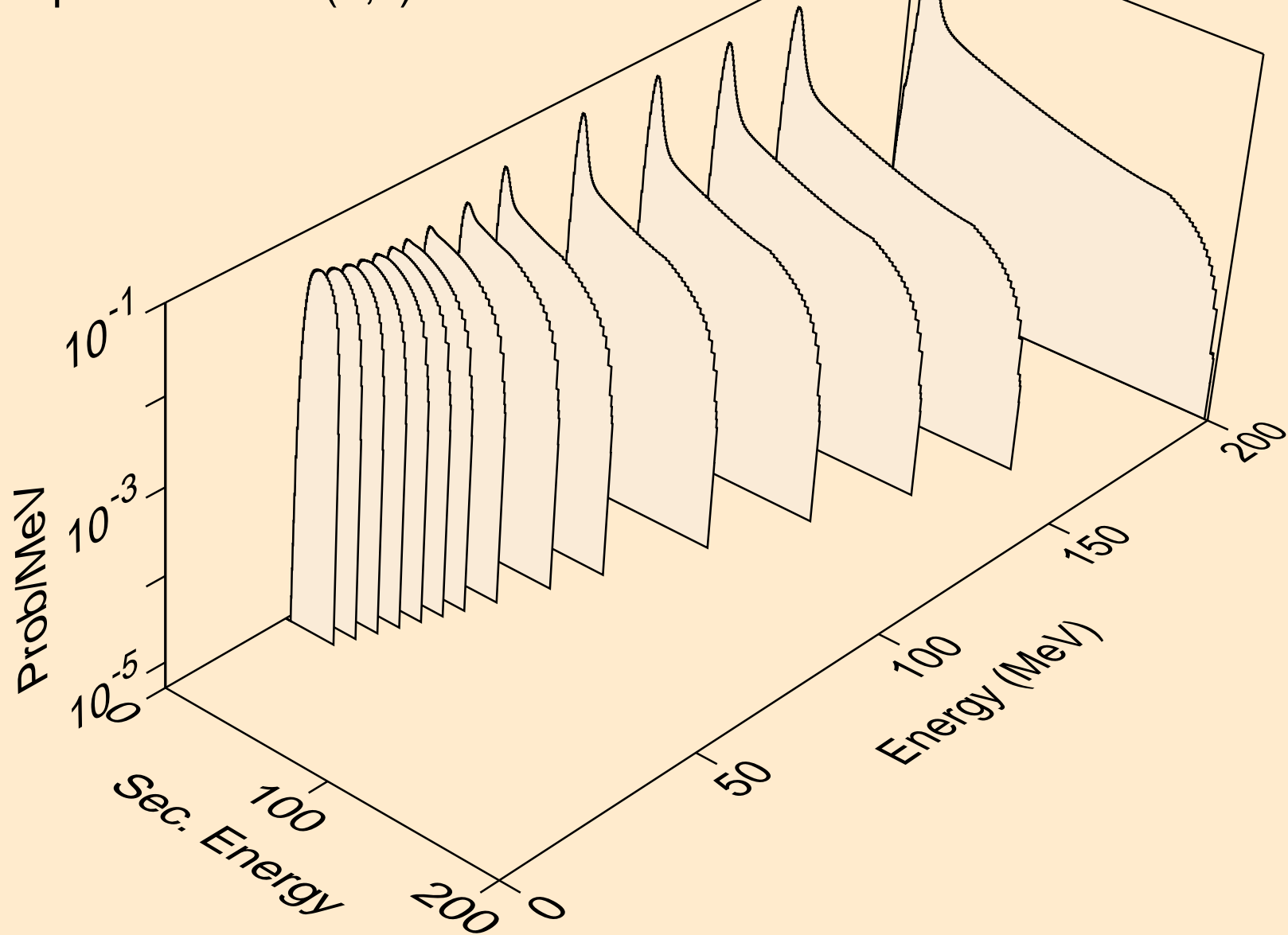

RE185 NEUTRON ACER TENDL-2024 LIBRARY; T=0.K
protons from (n,n*)p

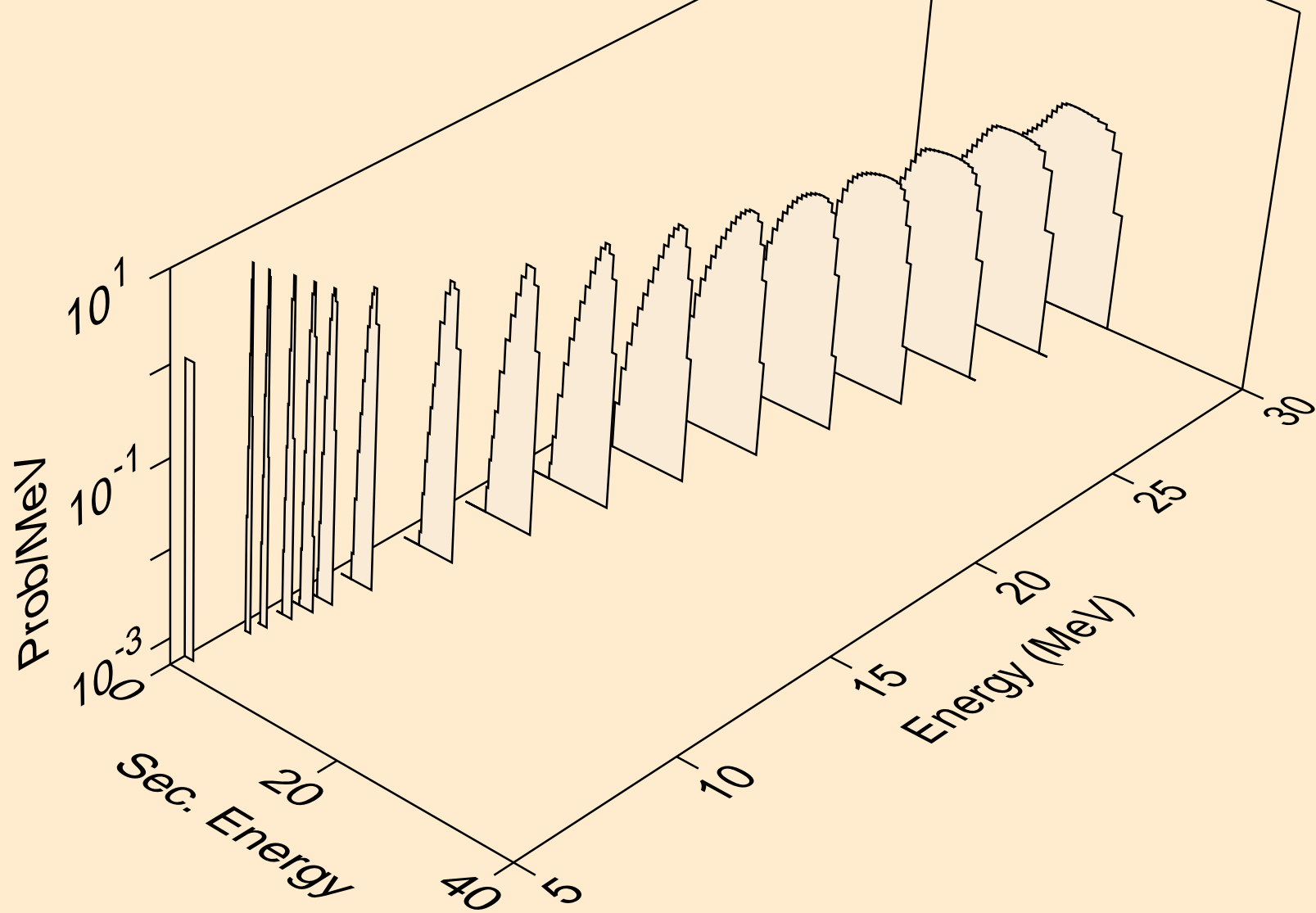

RE185 NEUTRON ACER TENDL-2024 LIBRARY; T=0.K
protons from (n,2np)

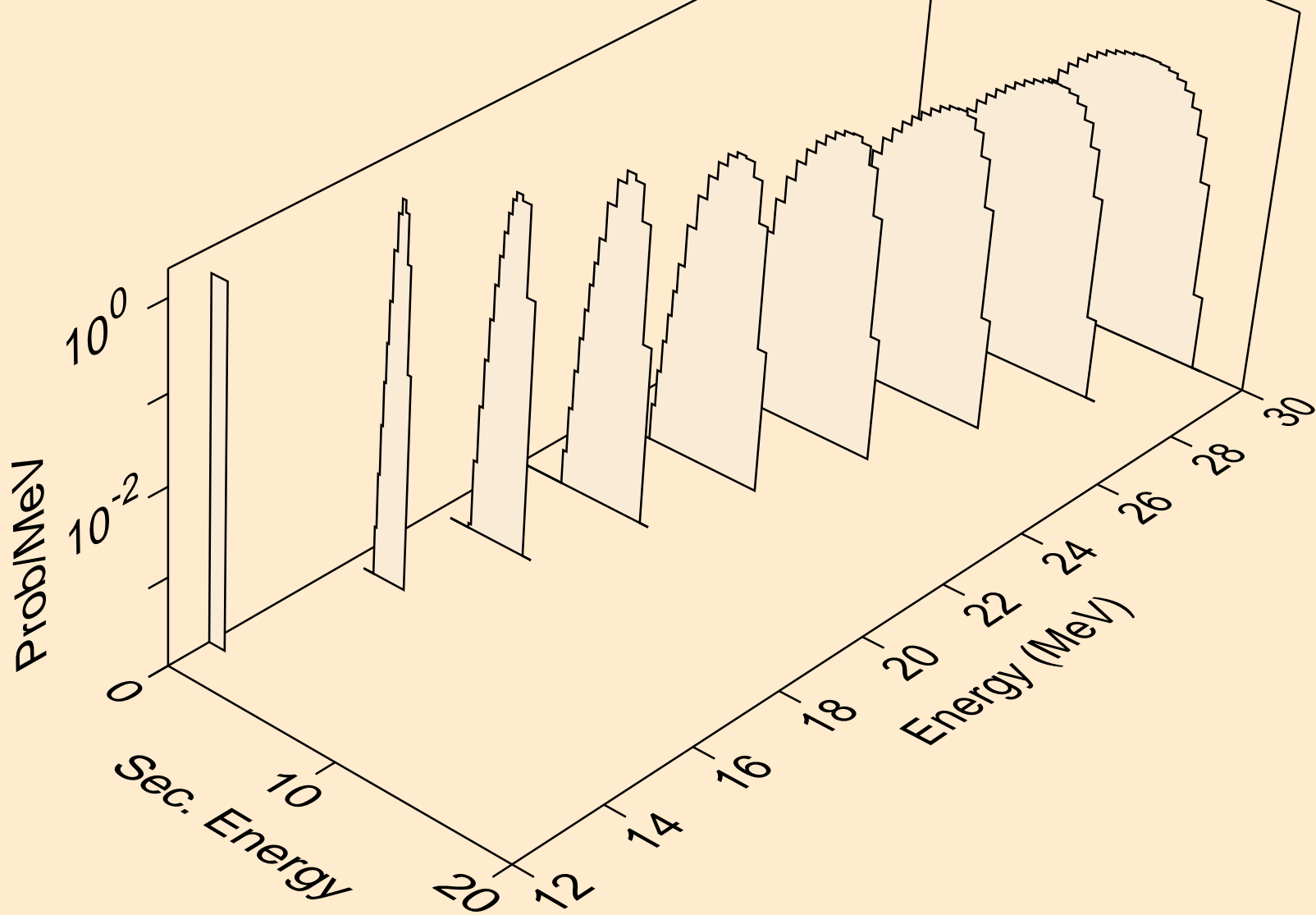

RE185 NEUTRON ACER TENDL-2024 LIBRARY; T=0.K
protons from (n,3np)

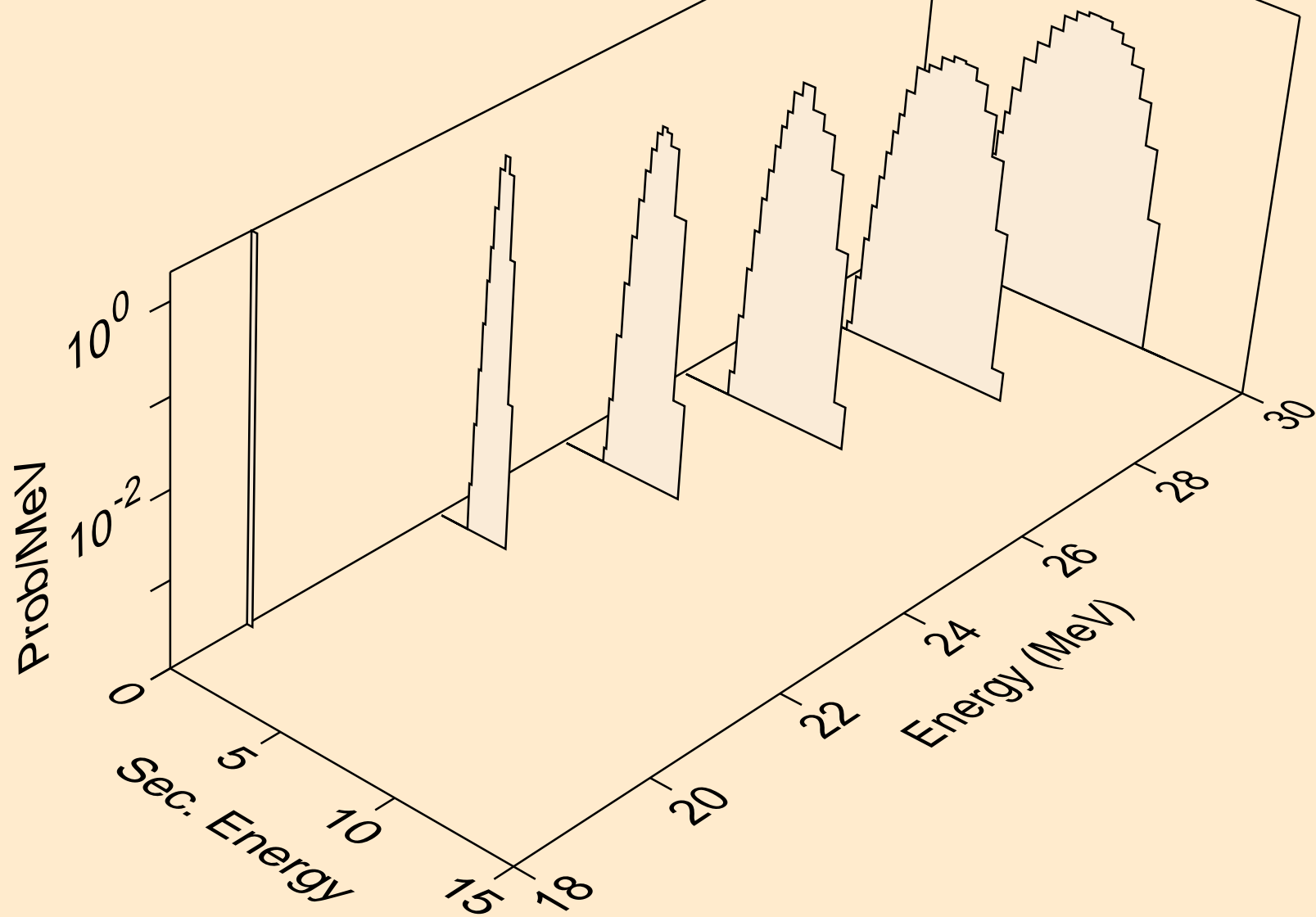

RE185 NEUTRON ACER TENDL-2024 LIBRARY; T=0.K
protons from (n,n2p)

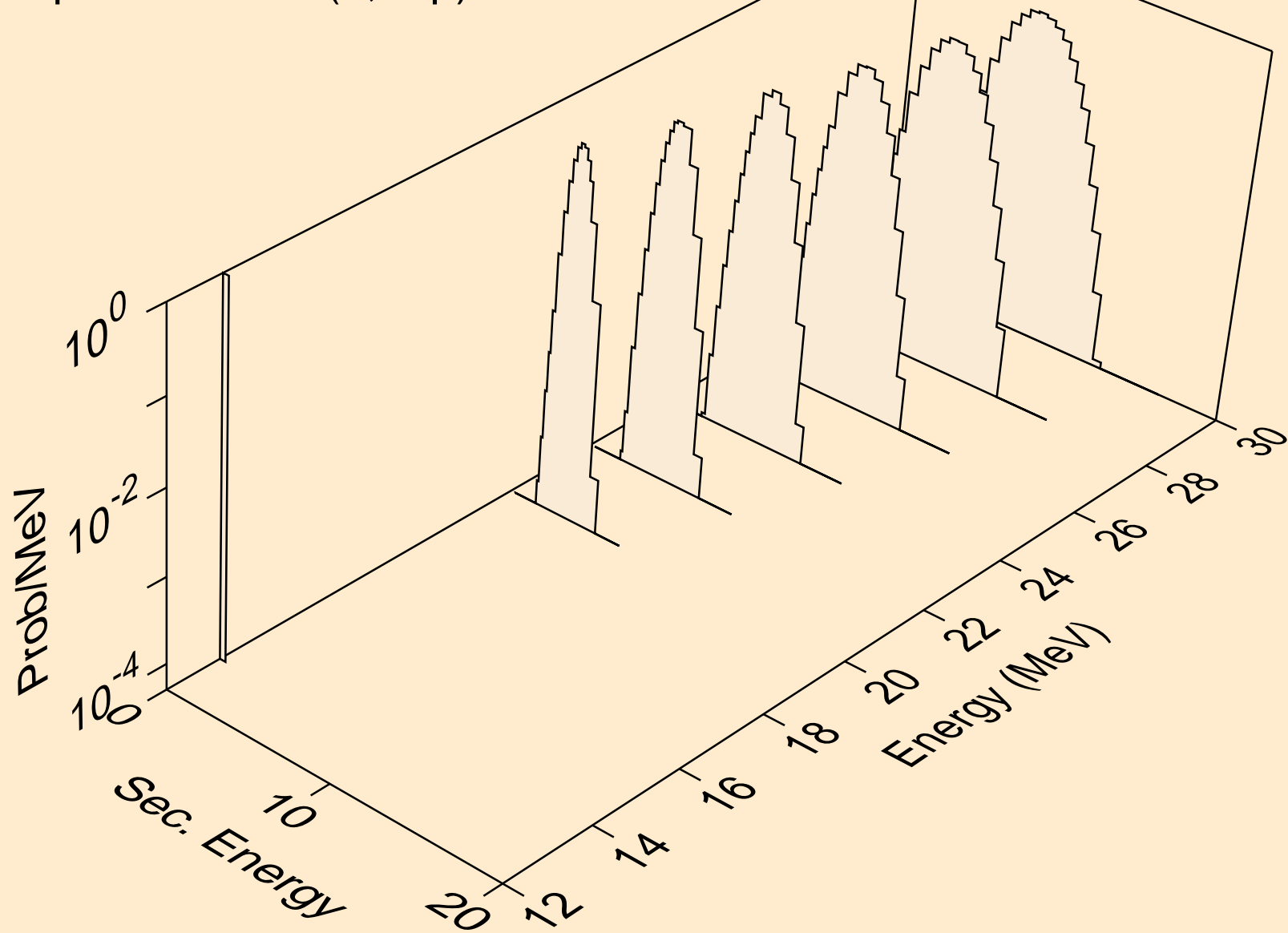

RE185 NEUTRON ACER TENDL-2024 LIBRARY; T=0.K
protons from (n,npa)

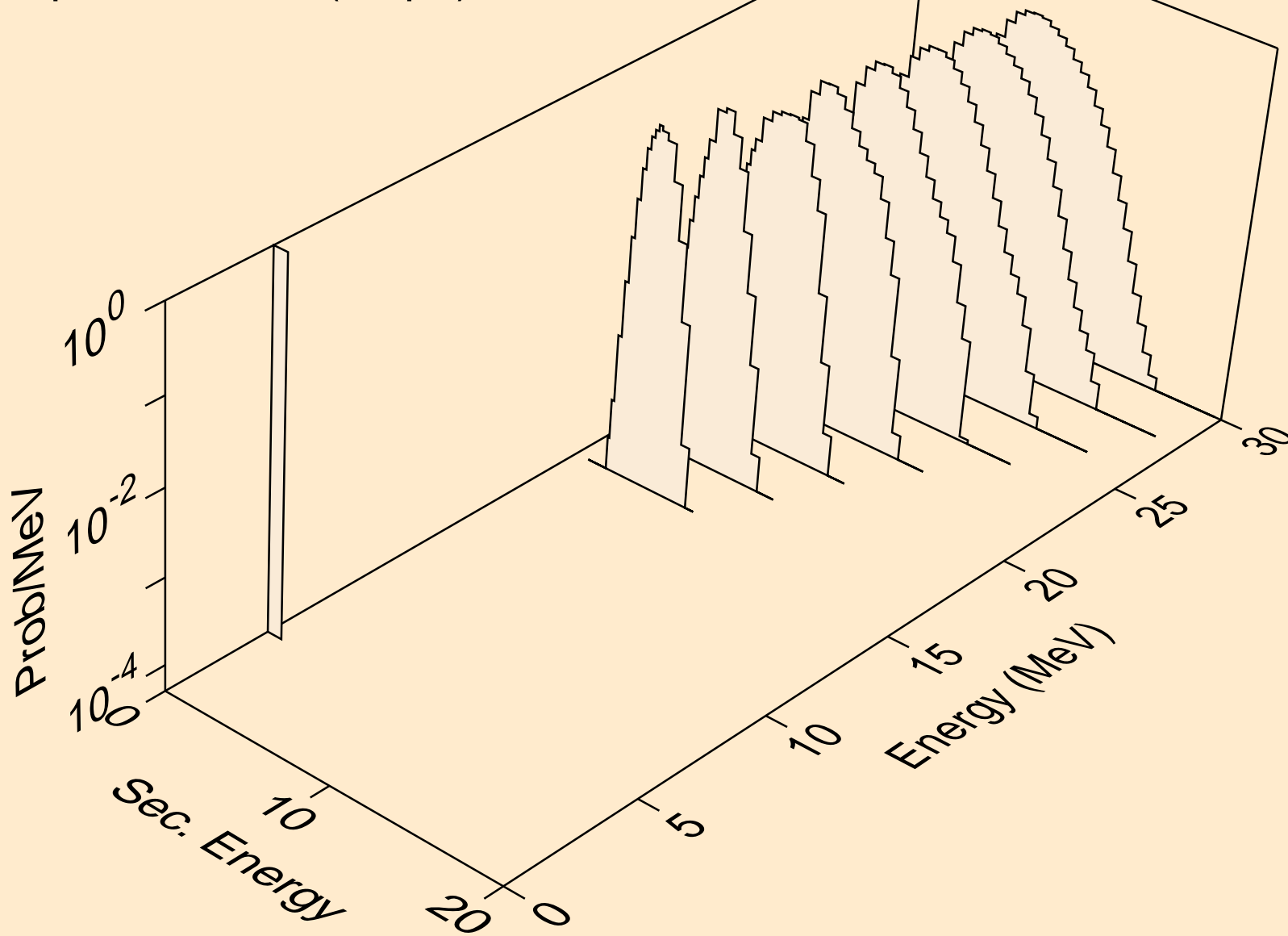

RE185 NEUTRON ACER TENDL-2024 LIBRARY; T=0.K
protons from (n,p)

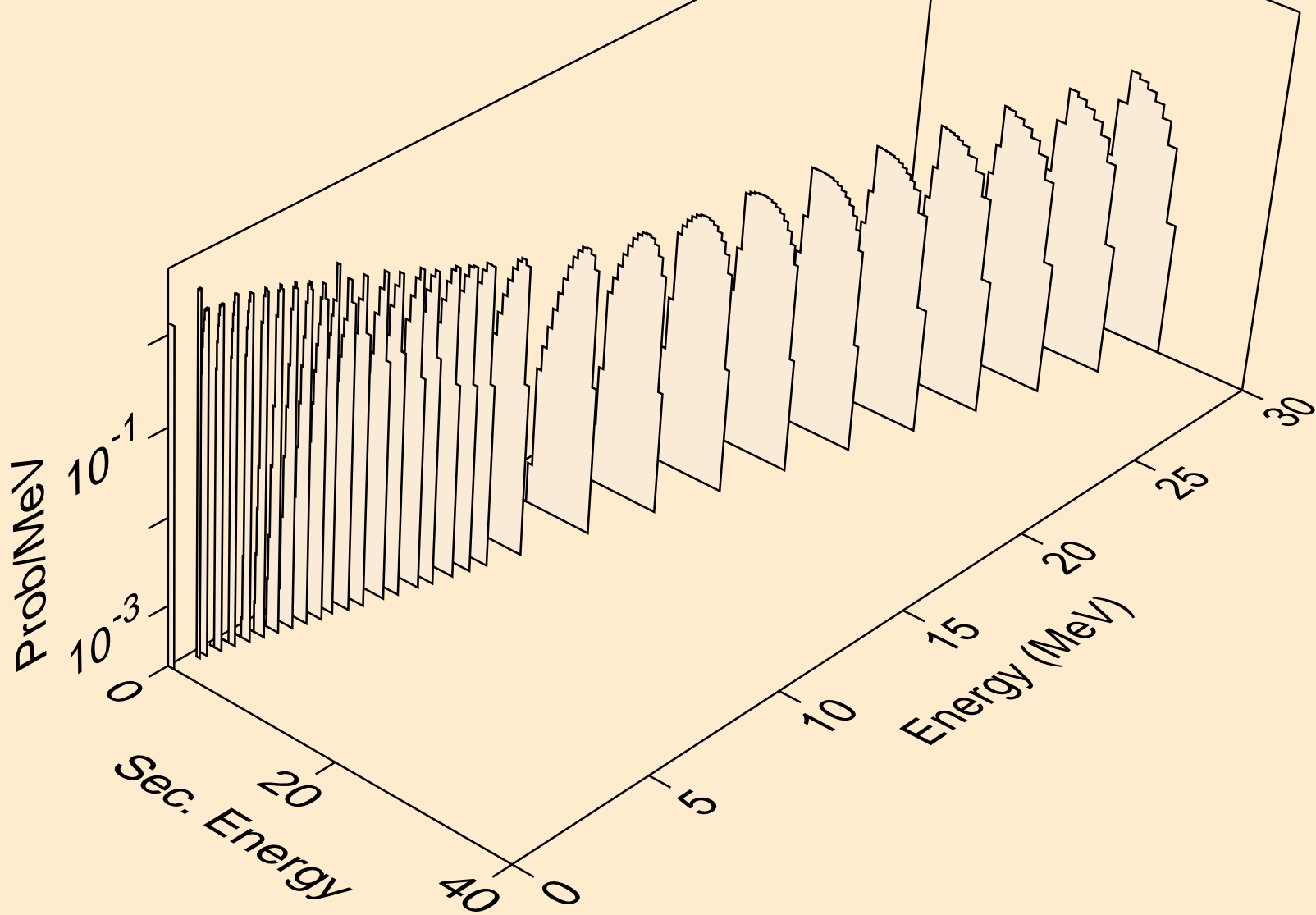

RE185 NEUTRON ACER TENDL-2024 LIBRARY; T=0.K
protons from (n,2p)

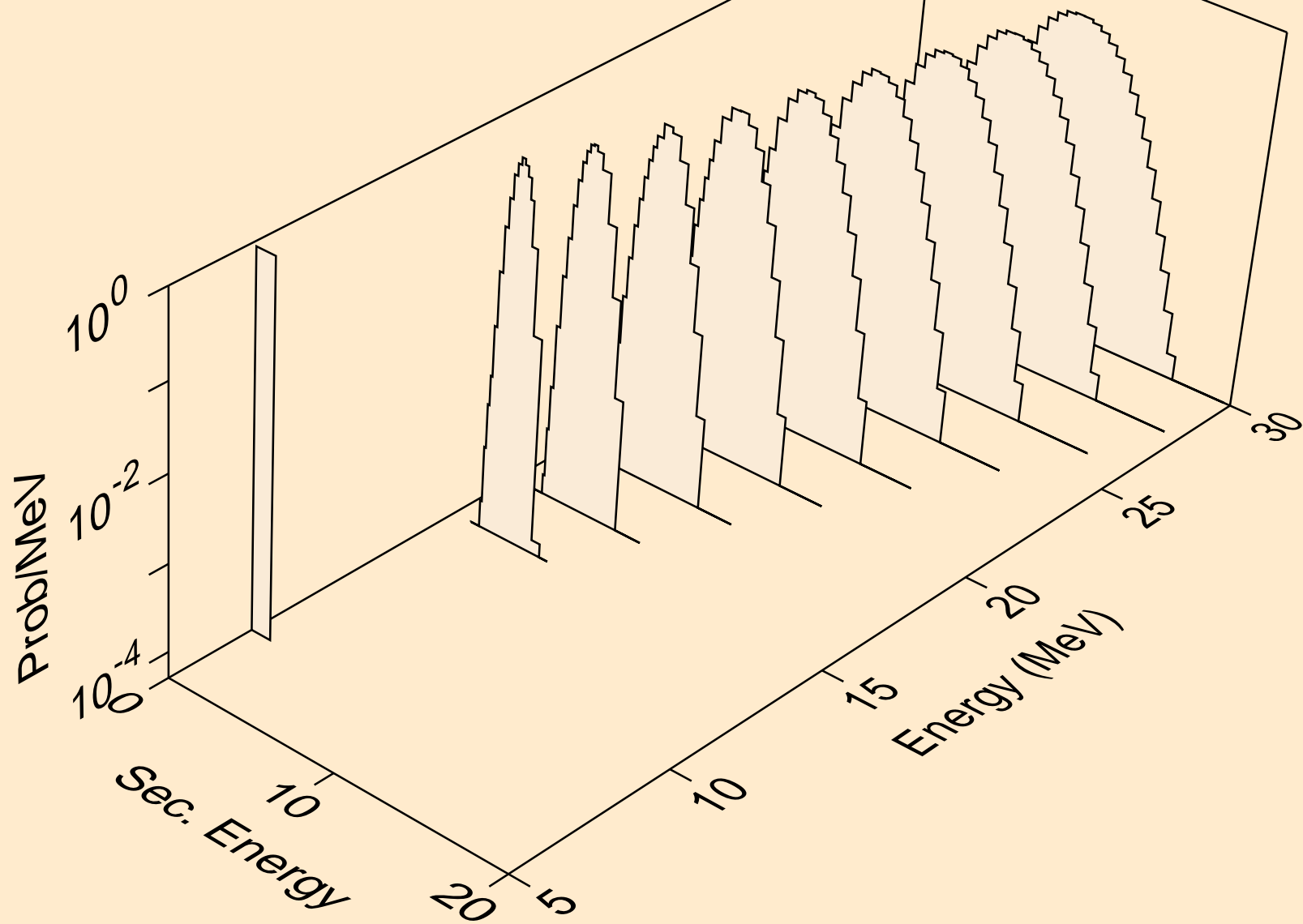

RE185 NEUTRON ACER TENDL-2024 LIBRARY; T=0.K
protons from (n,pa)

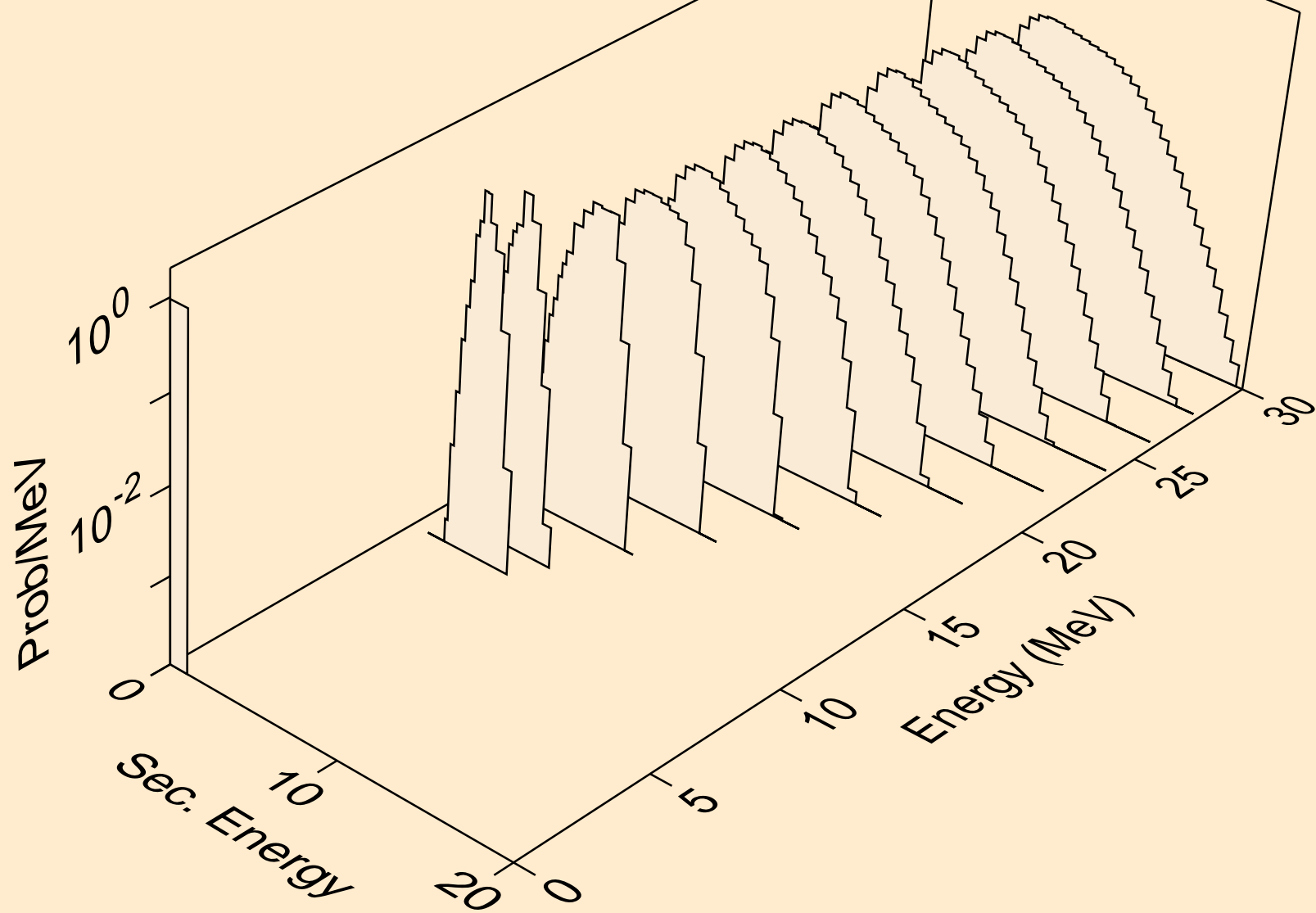

RE185 NEUTRON ACER TENDL-2024 LIBRARY; T=0.K
protons from (n,pd)

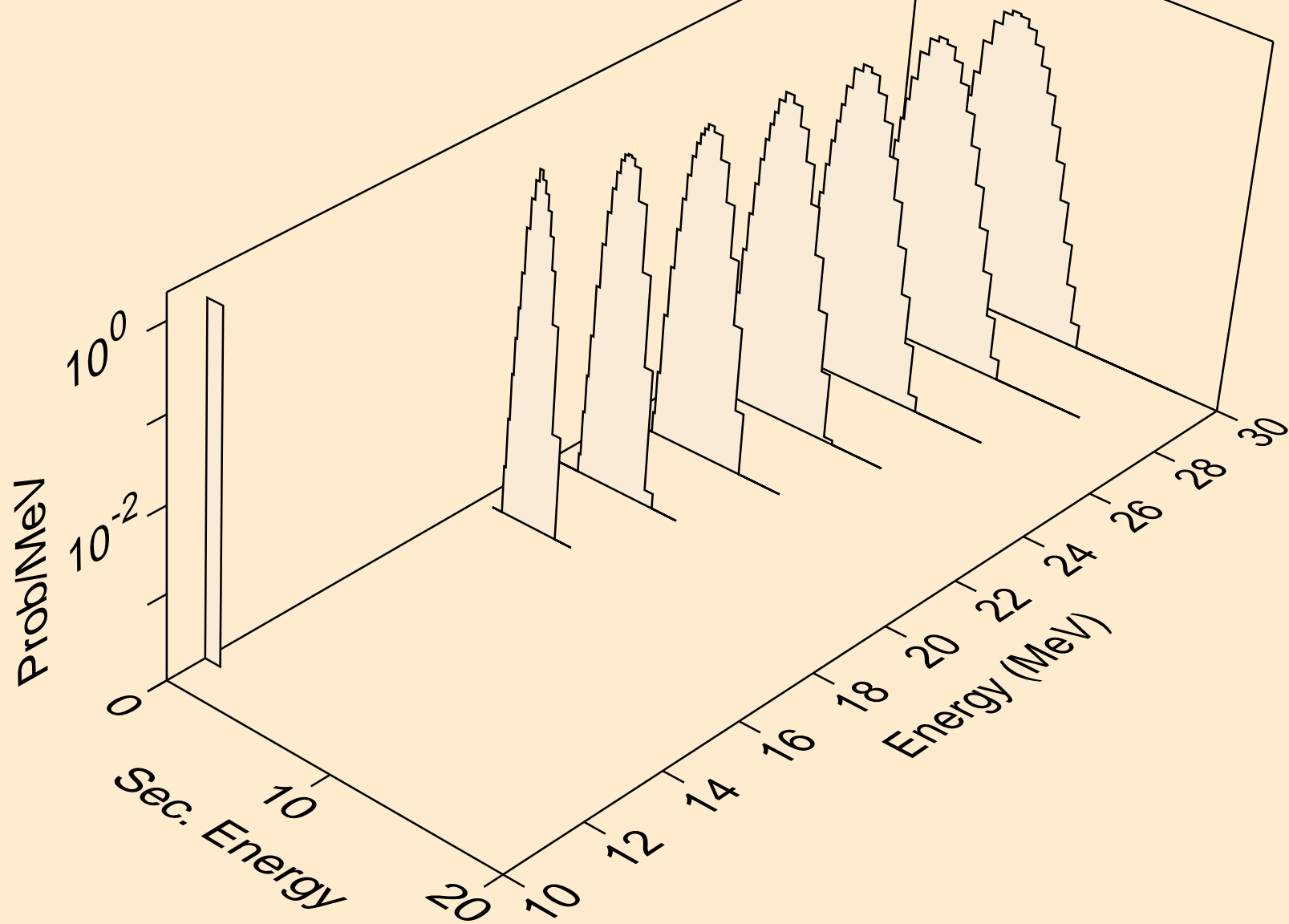

RE185 NEUTRON ACER TENDL-2024 LIBRARY; T=0.K
protons from (n,pt)

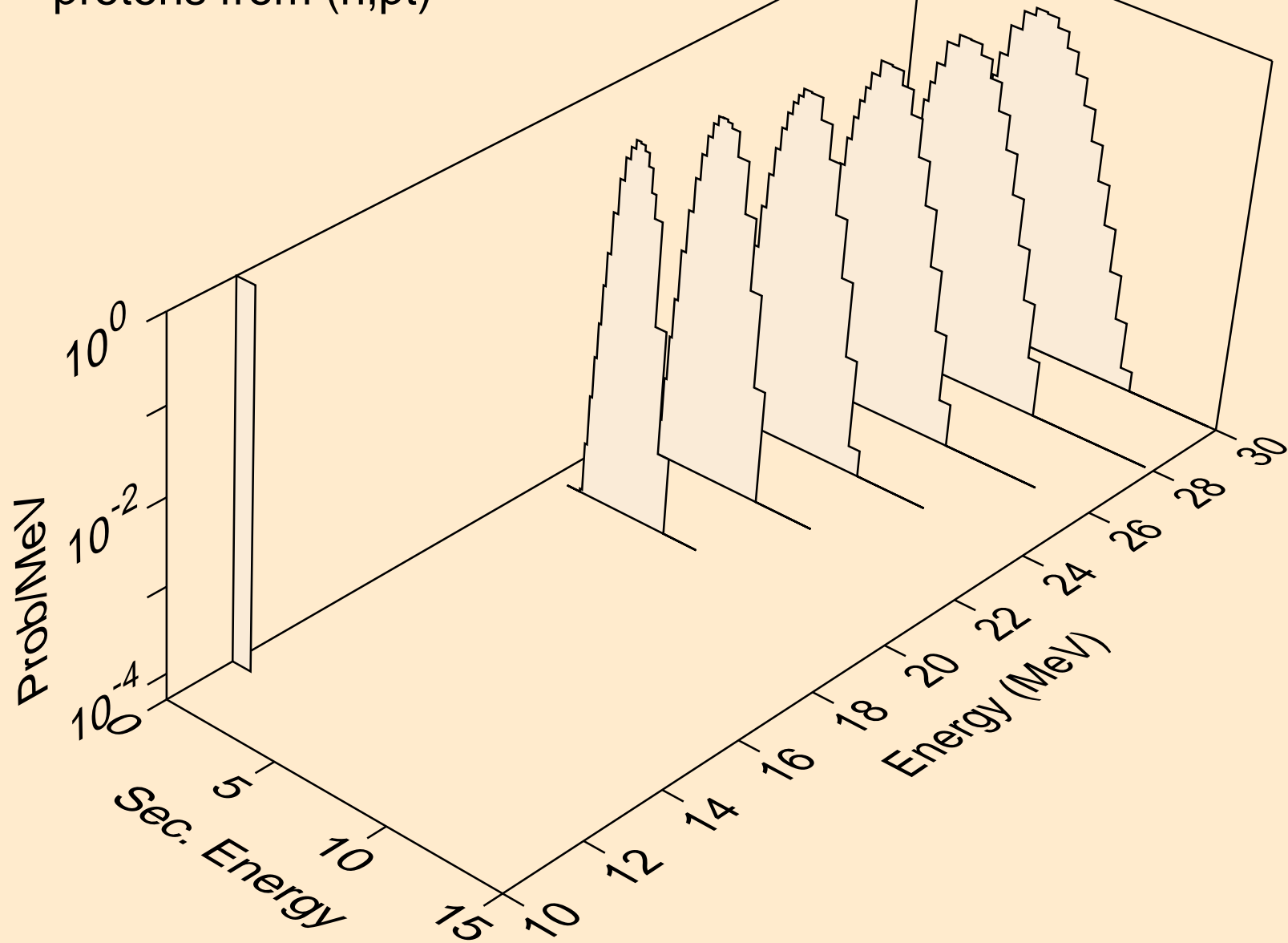

RE185 NEUTRON ACER TENDL-2024 LIBRARY; T=0.K
deuterons from (n,x)

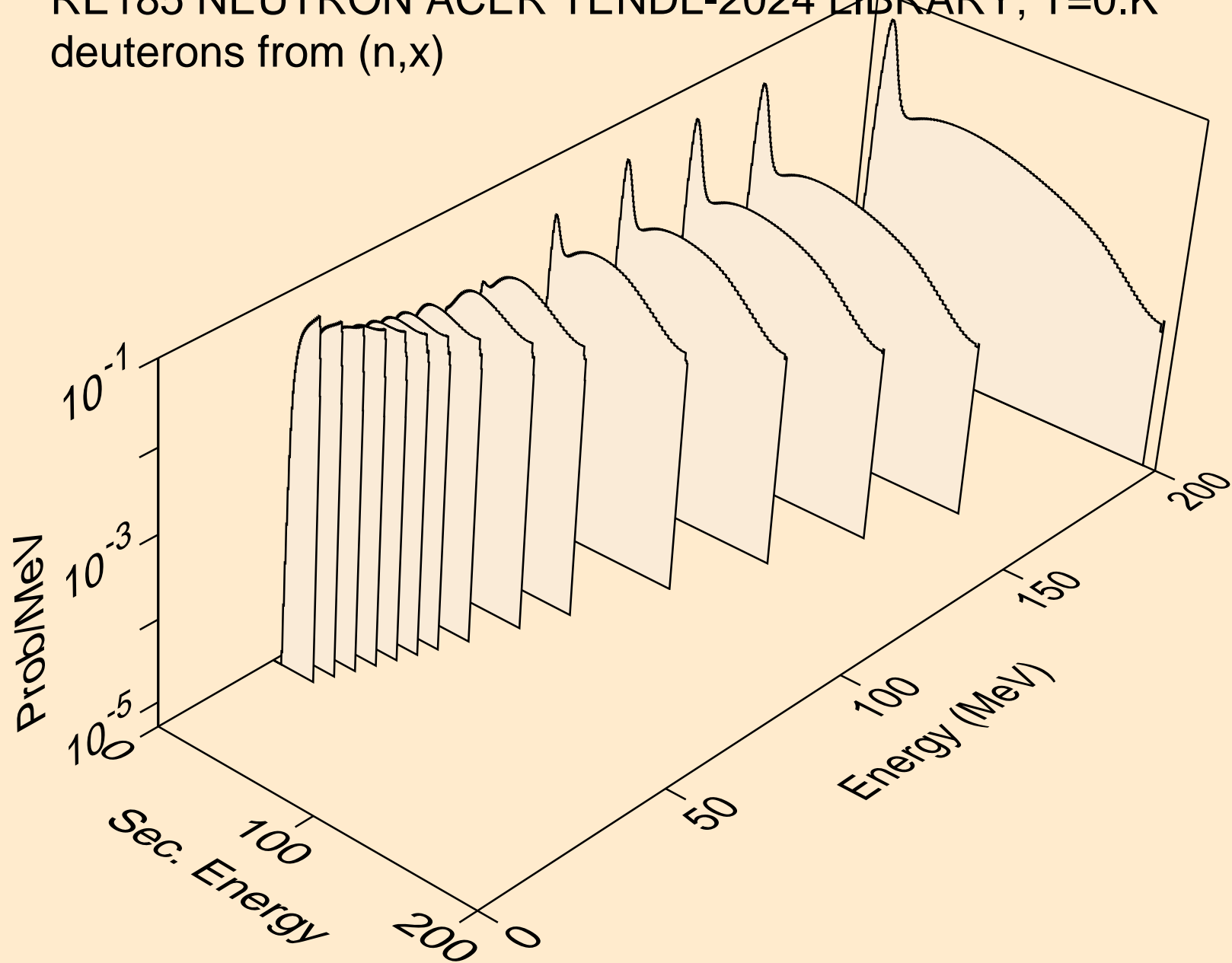

RE185 NEUTRON ACER TENDL-2024 LIBRARY; T=0.K
deuterons from (n,2nd)

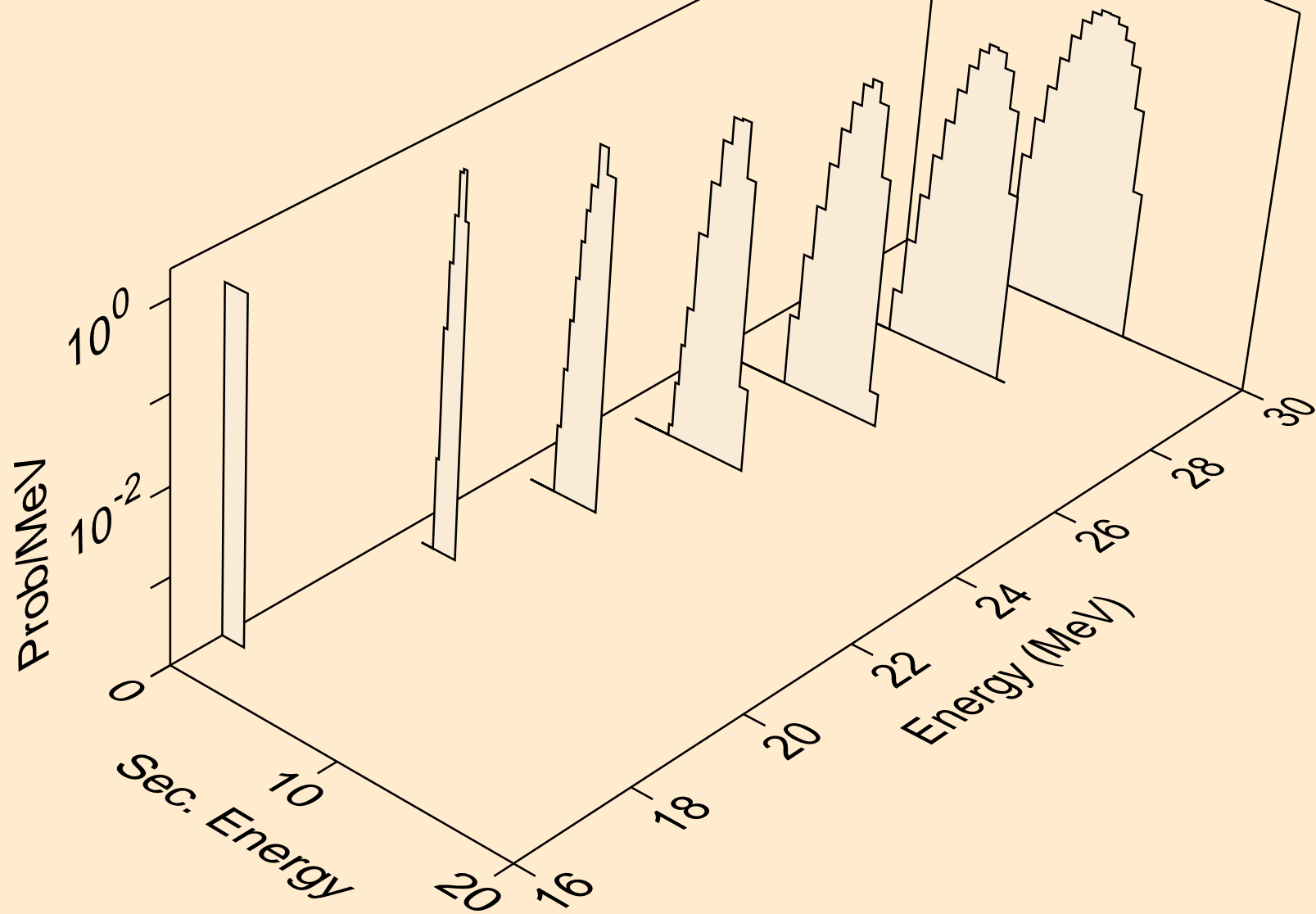

RE185 NEUTRON ACER TENDL-2024 LIBRARY; T=0.K
deuterons from (n,n*)d

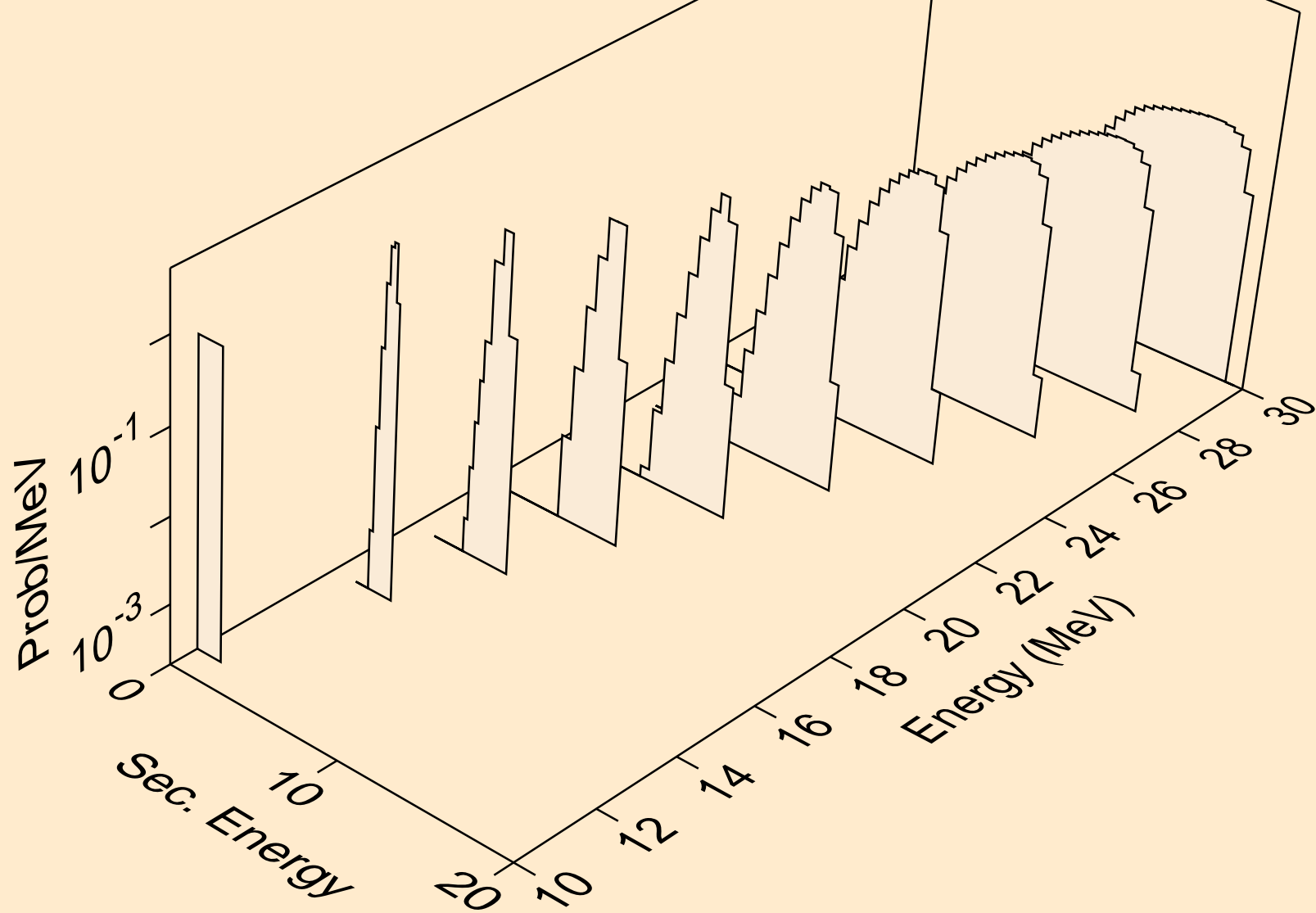

RE185 NEUTRON ACER TENDL-2024 LIBRARY; T=0.K
deuterons from (n,d)

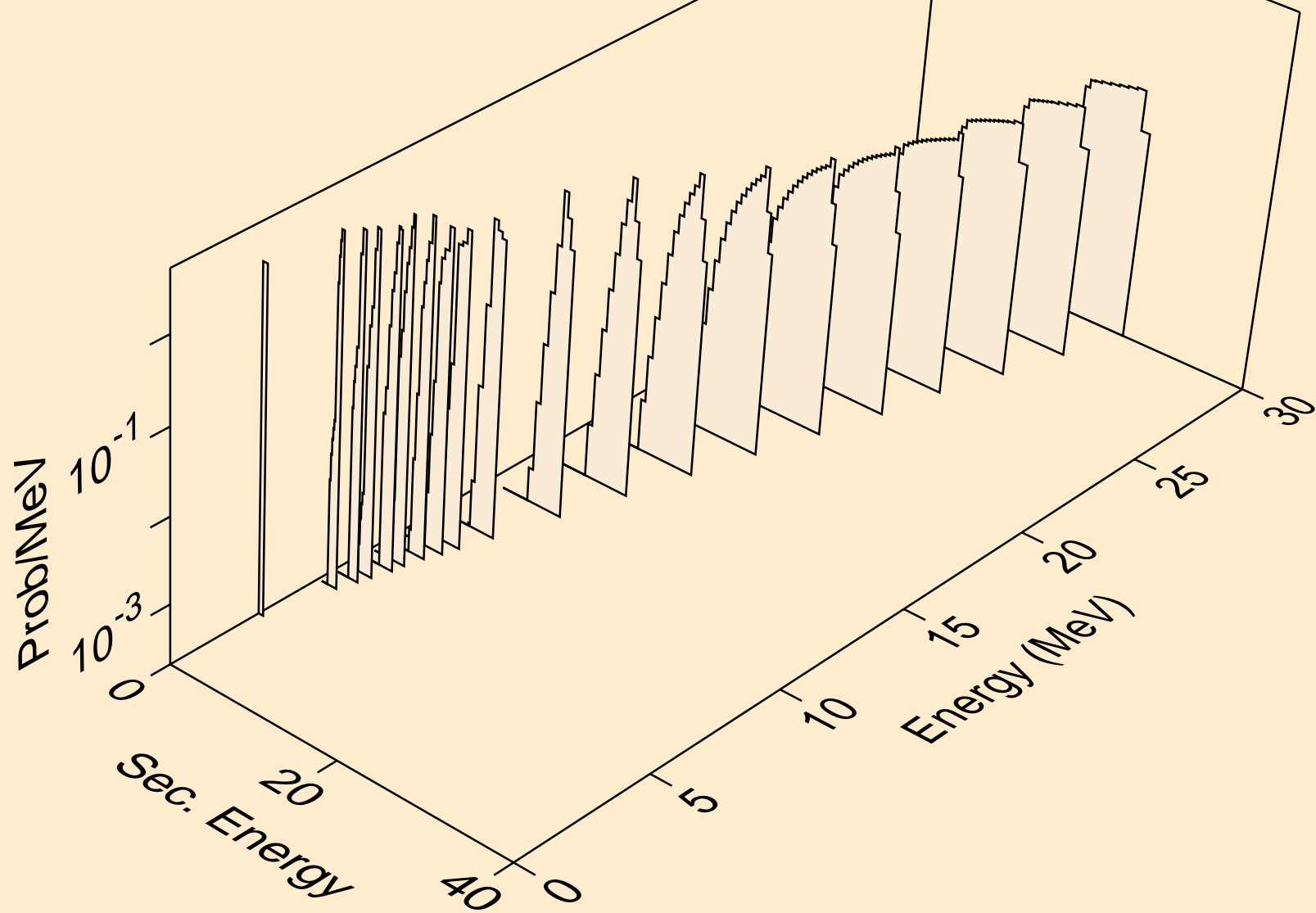

RE185 NEUTRON ACER TENDL-2024 LIBRARY; T=0.K
deuterons from (n,pd)

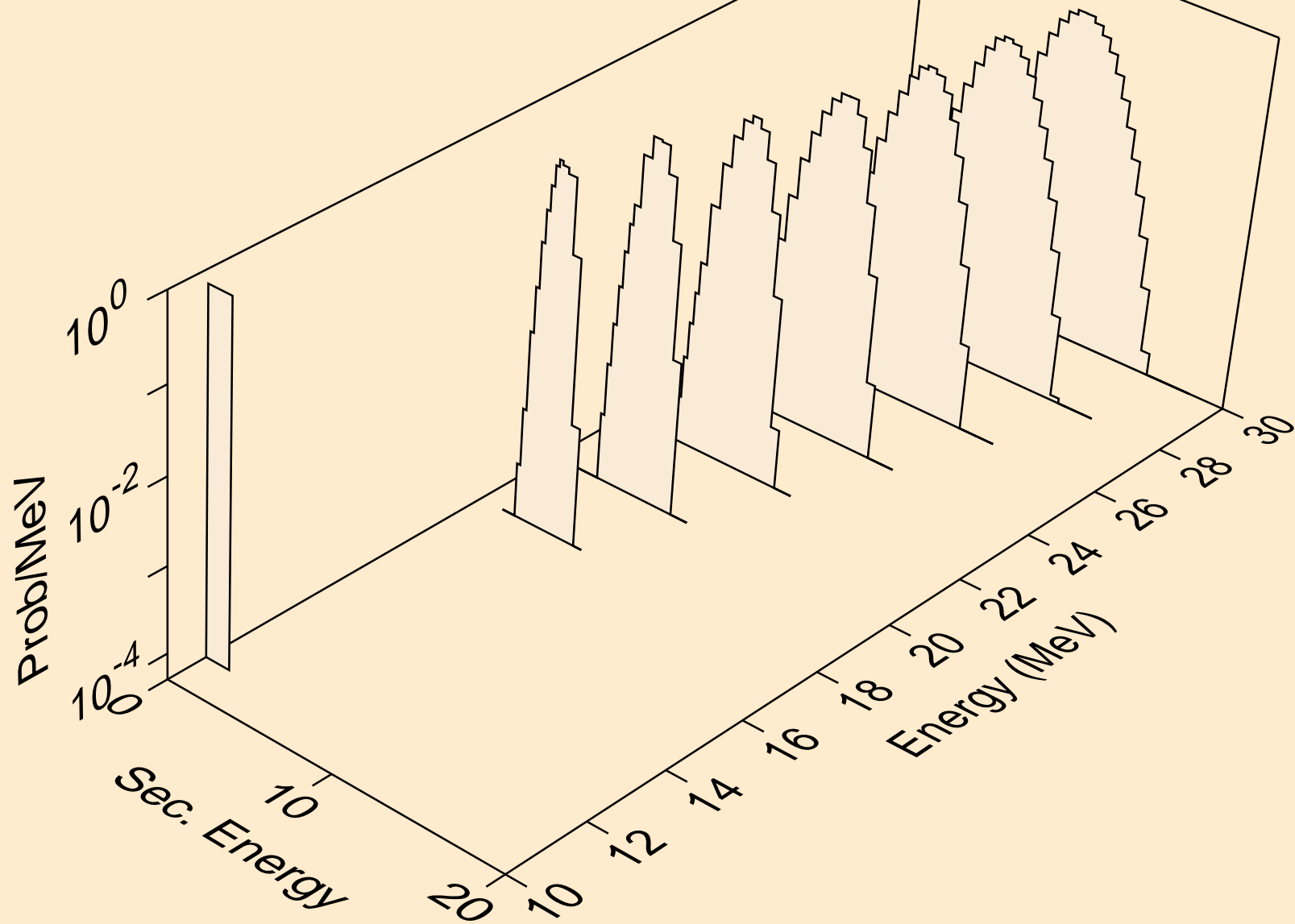

RE185 NEUTRON ACER TENDL-2024 LIBRARY; T=0.K
deuterons from (n,da)

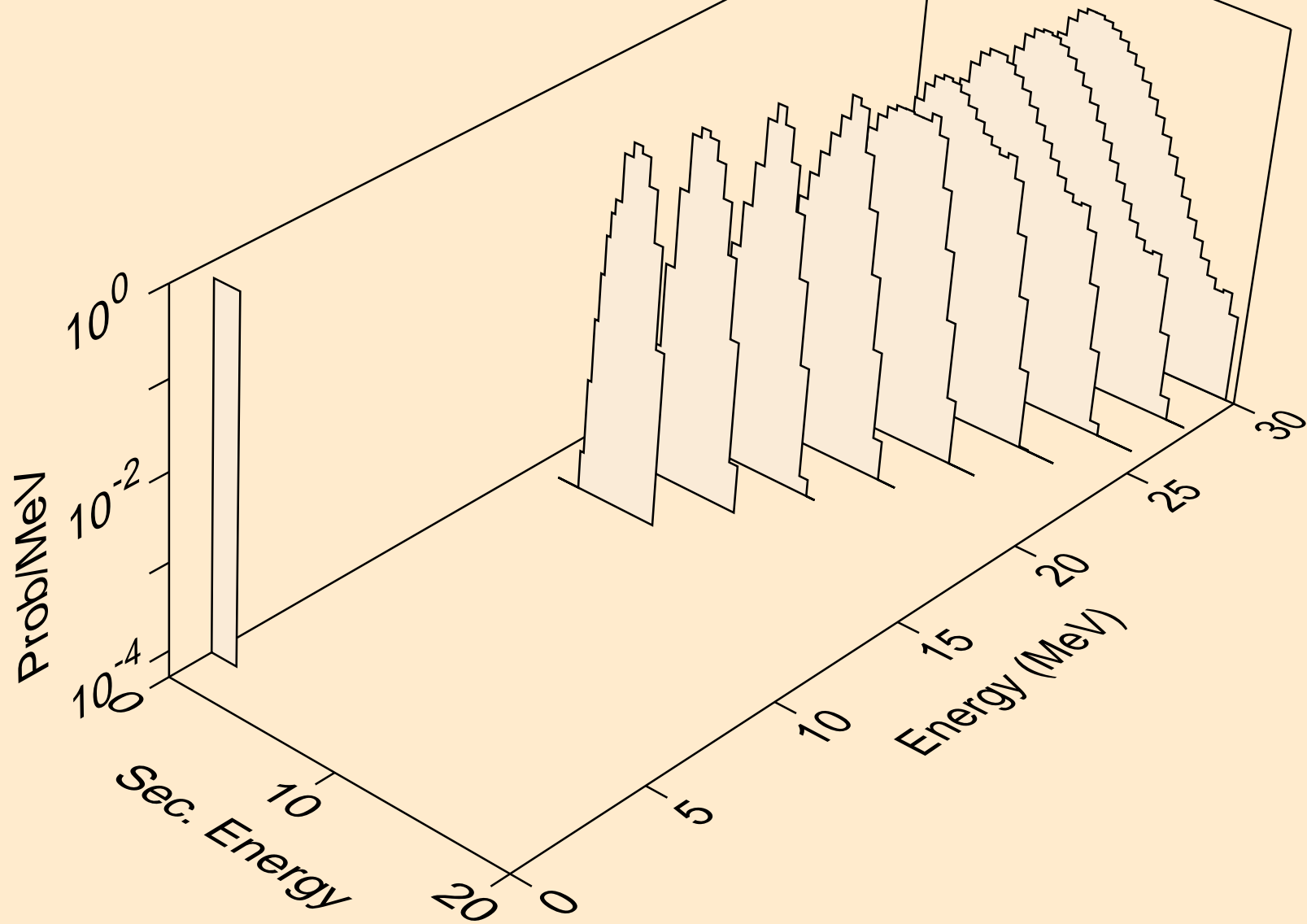

RE185 NEUTRON ACER TENDL-2024 LIBRARY; T=0.K
tritons from (n,x)

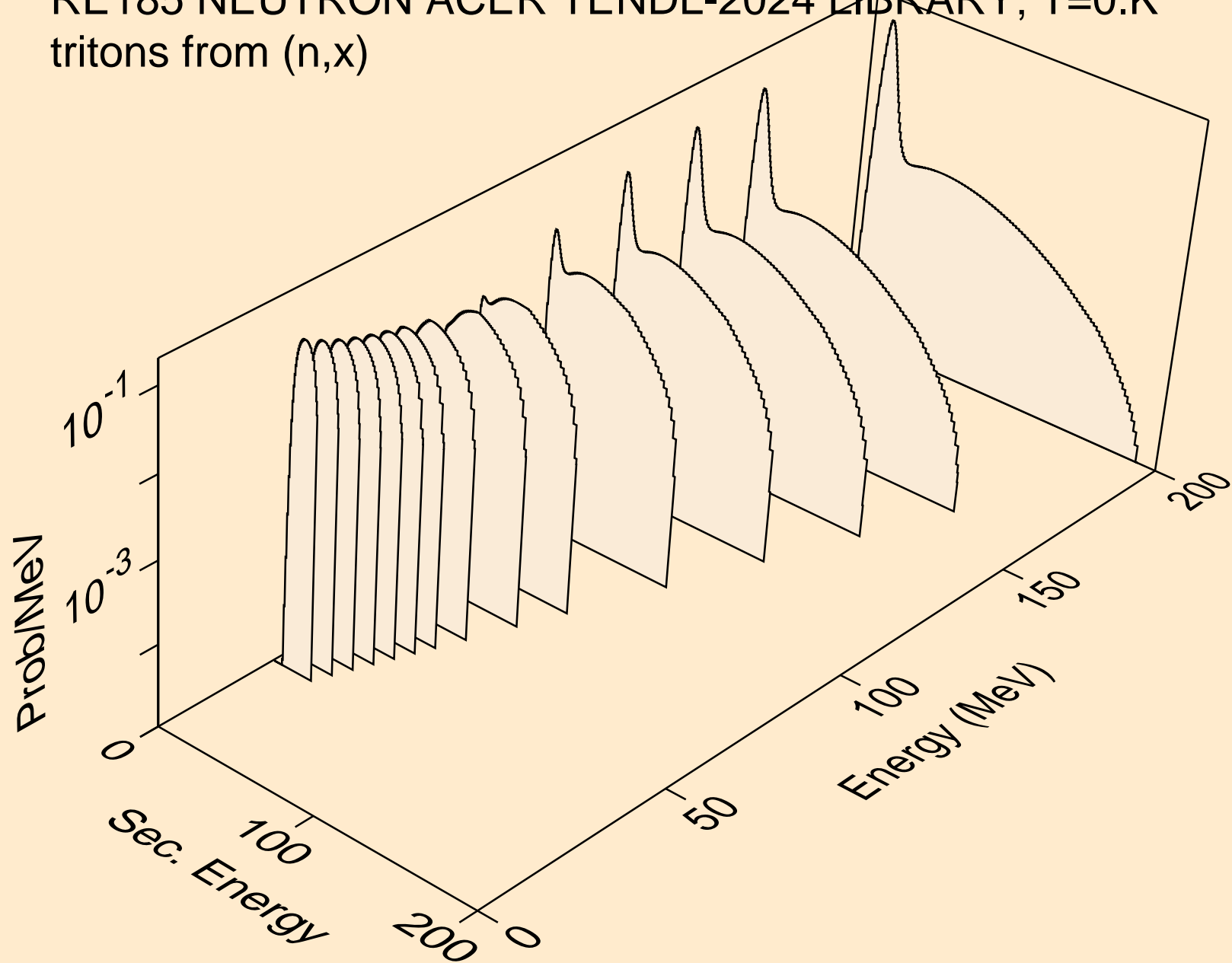

RE185 NEUTRON ACER TENDL-2024 LIBRARY; T=0.K
tritons from (n,n*)t

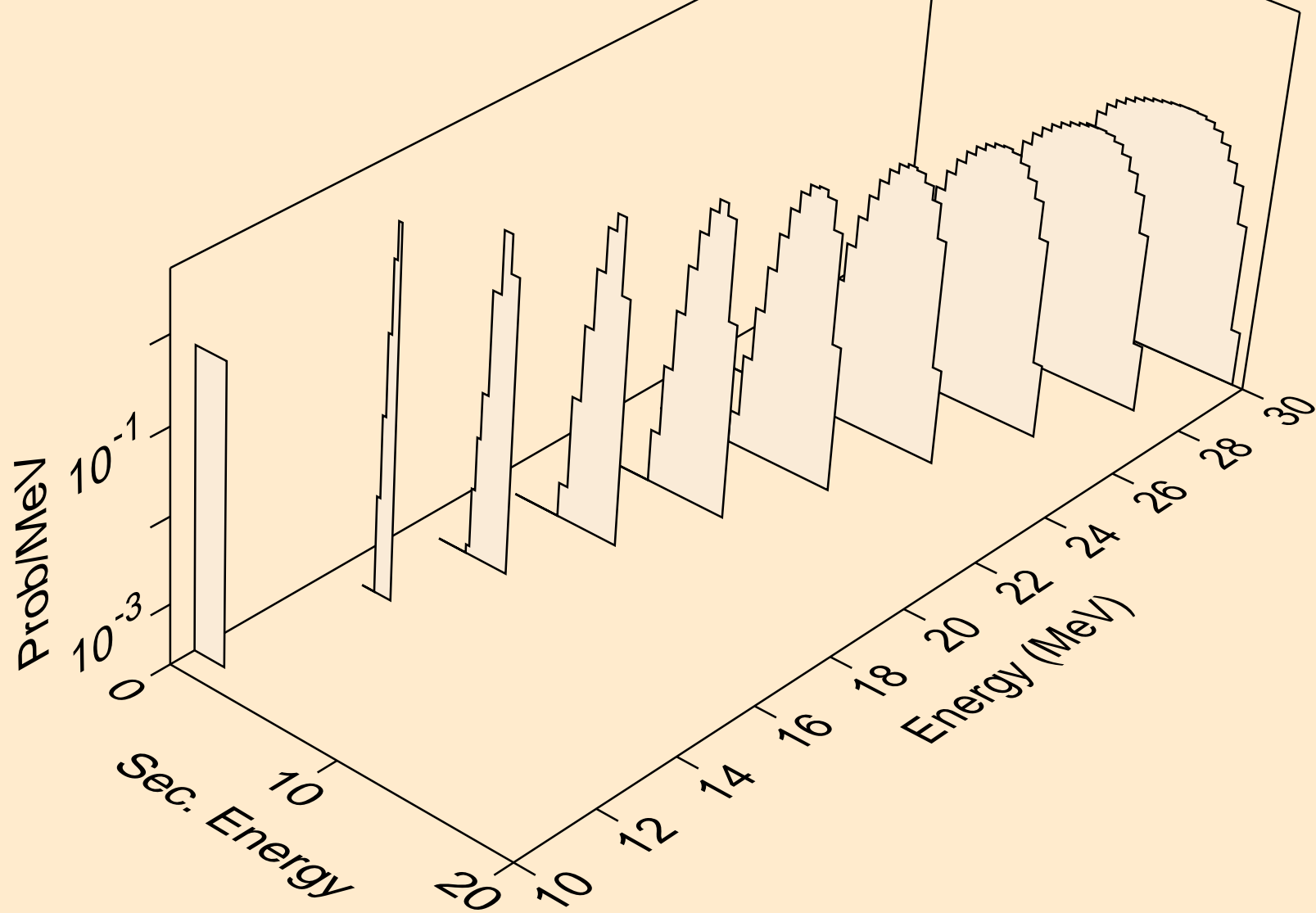

RE185 NEUTRON ACER TENDL-2024 LIBRARY; T=0.K
tritons from (n,t)

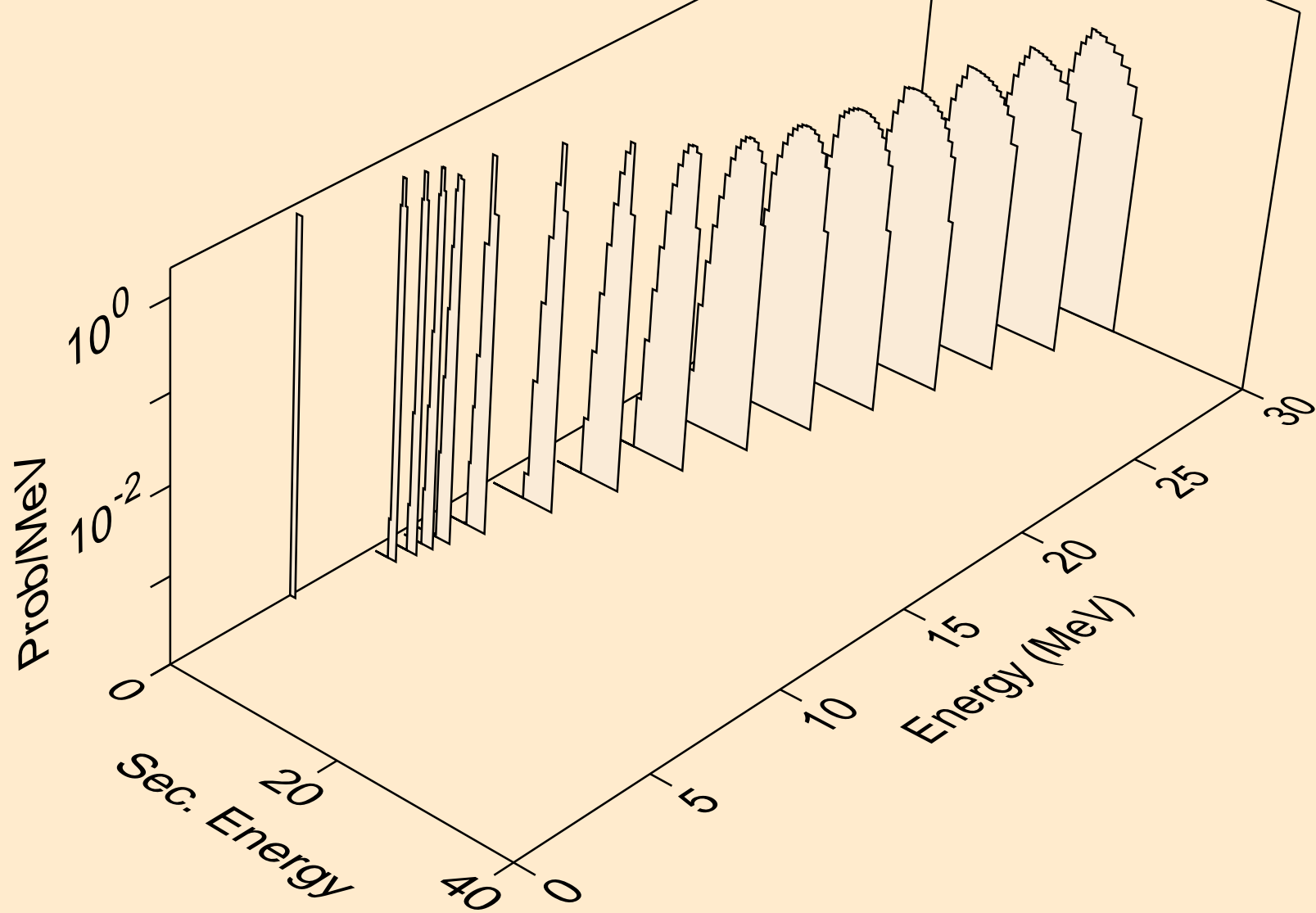

RE185 NEUTRON ACER TENDL-2024 LIBRARY; T=0.K
tritons from (n,pt)

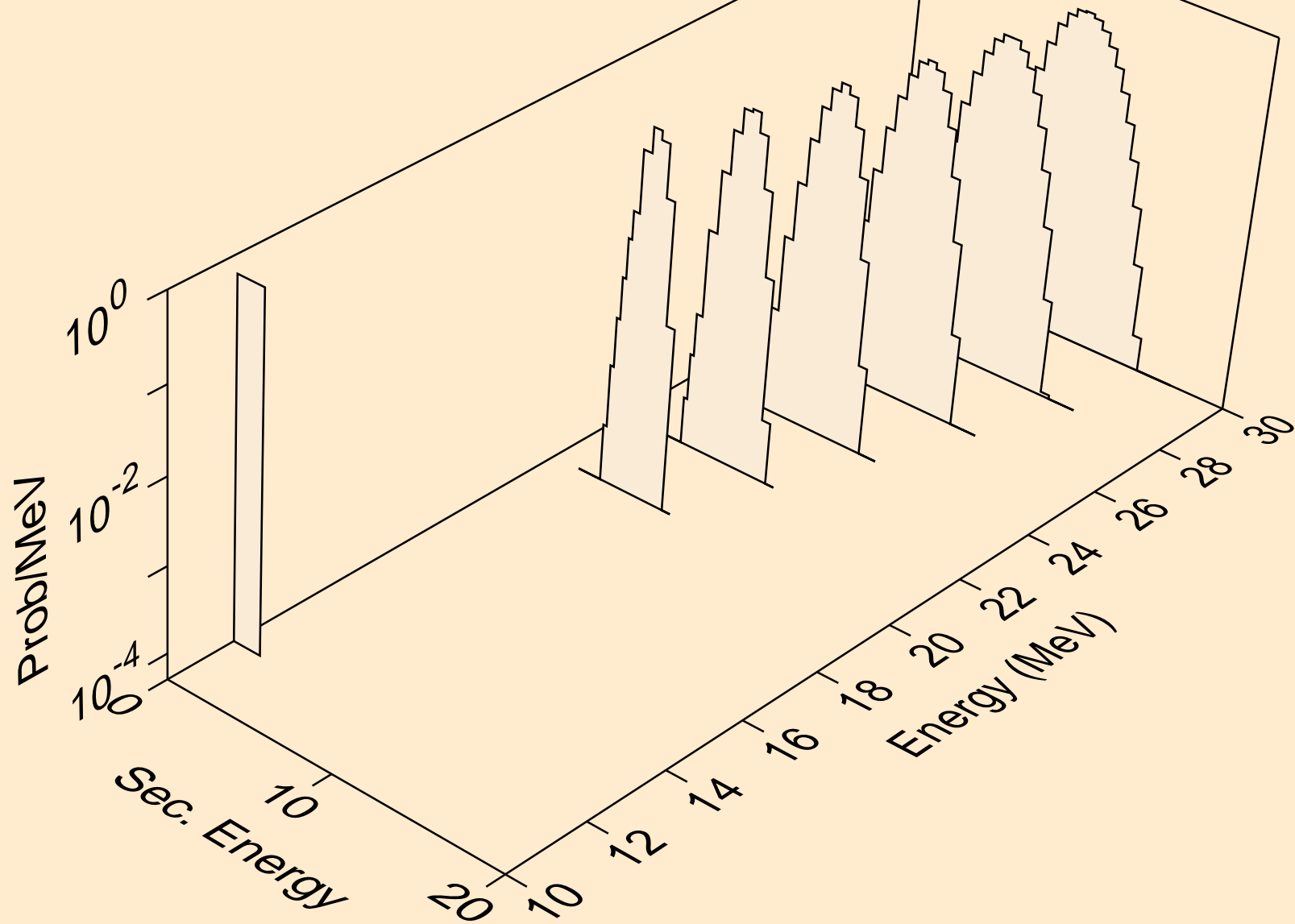

RE185 NEUTRON ACER TENDL-2024 LIBRARY; T=0.K
he3s from (n,x)

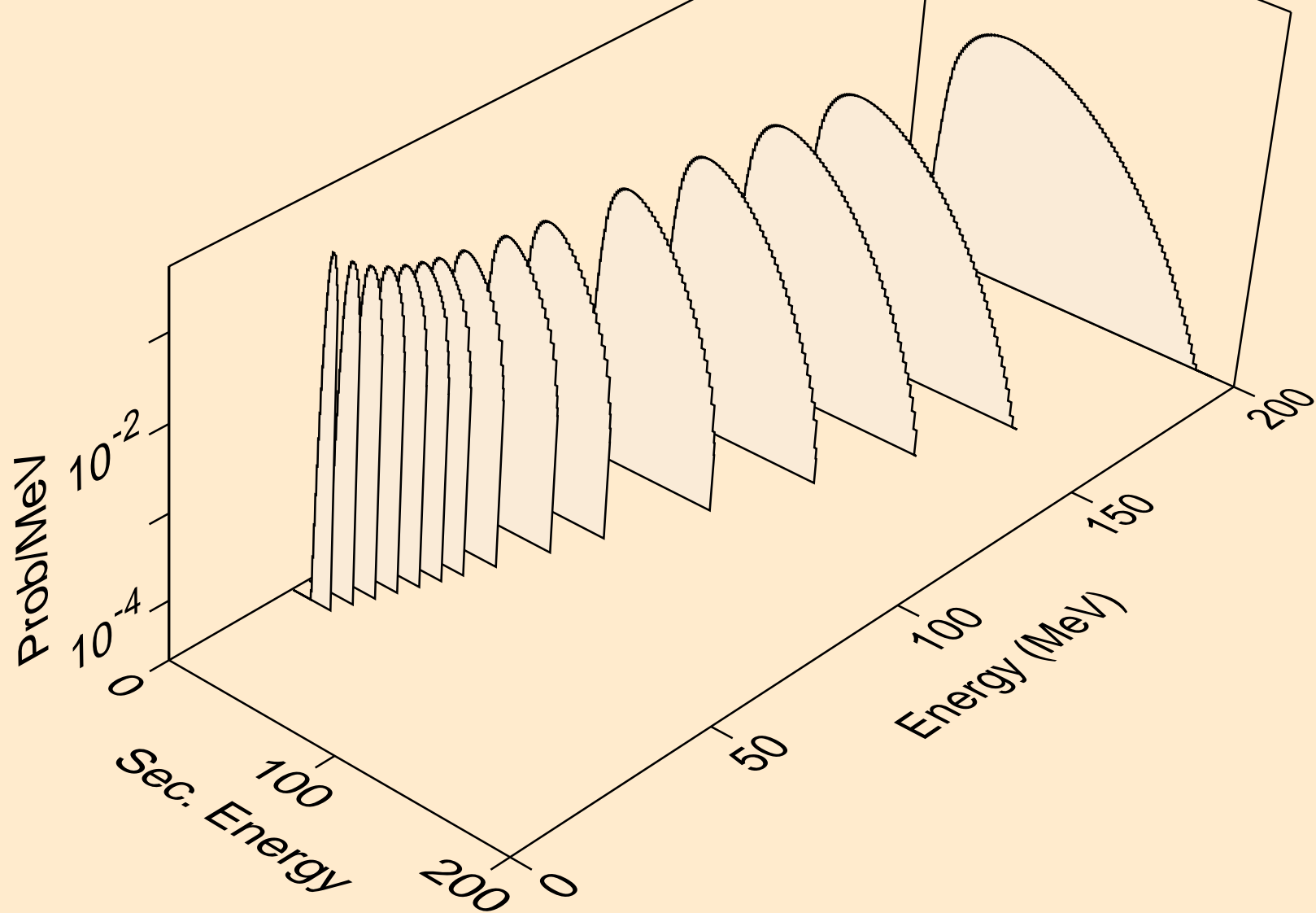

RE185 NEUTRON ACER TENDL-2024 LIBRARY; T=0.K
he3s from (n,n*)he3

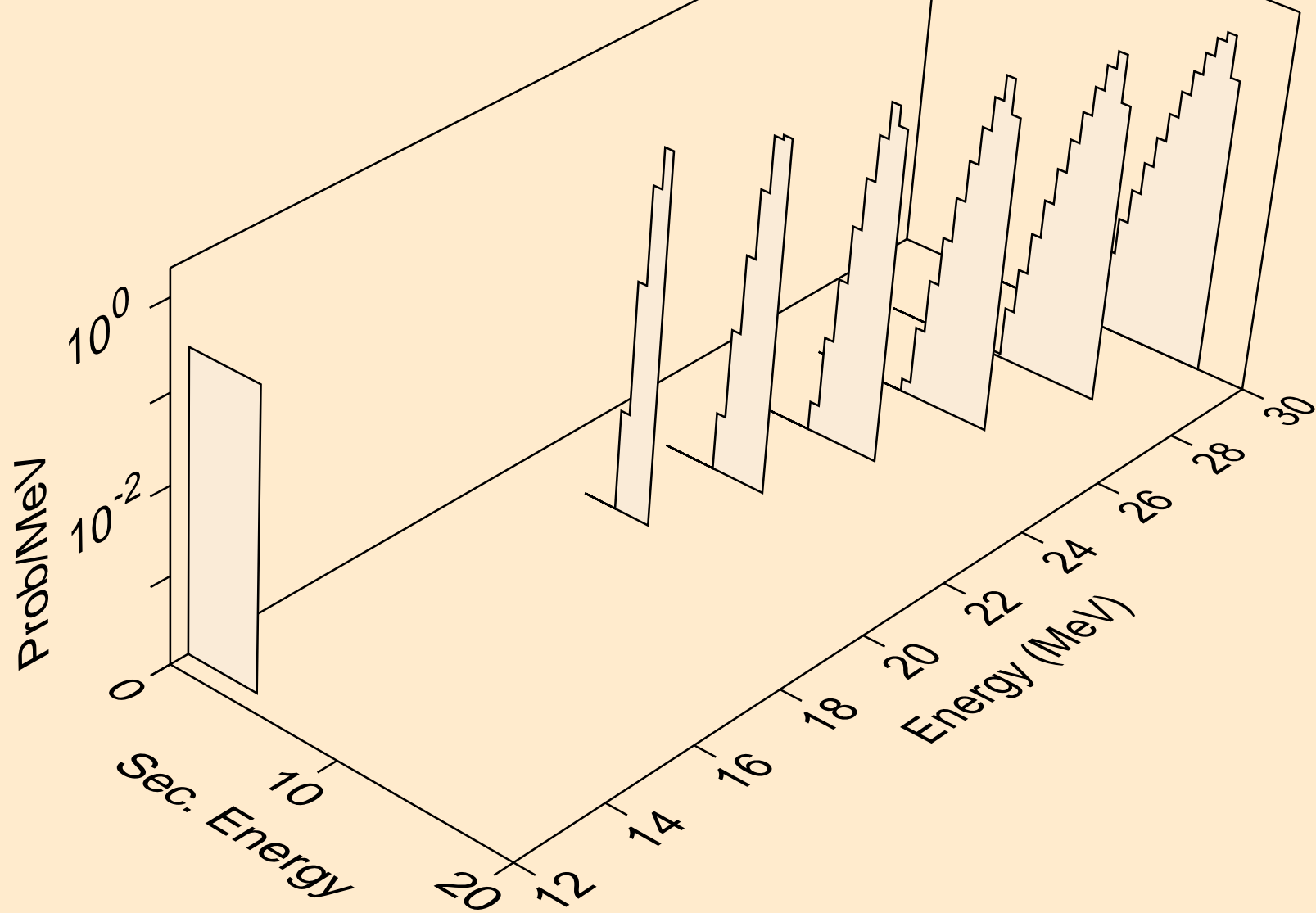

RE185 NEUTRON ACER TENDL-2024 LIBRARY; T=0.K
he3s from (n,he3)

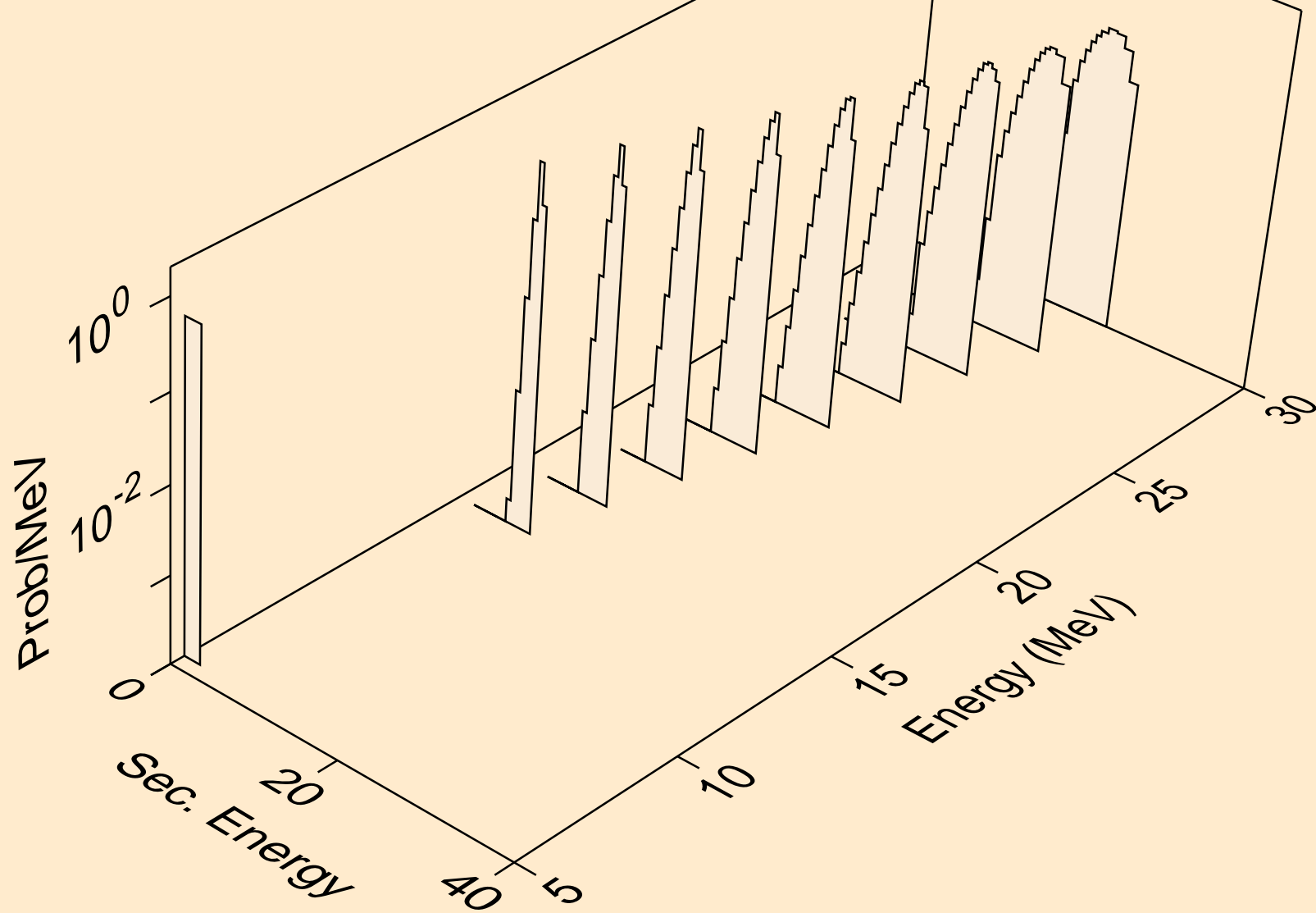

RE185 NEUTRON ACER TENDL-2024 LIBRARY; T=0.K
alphas from (n,x)

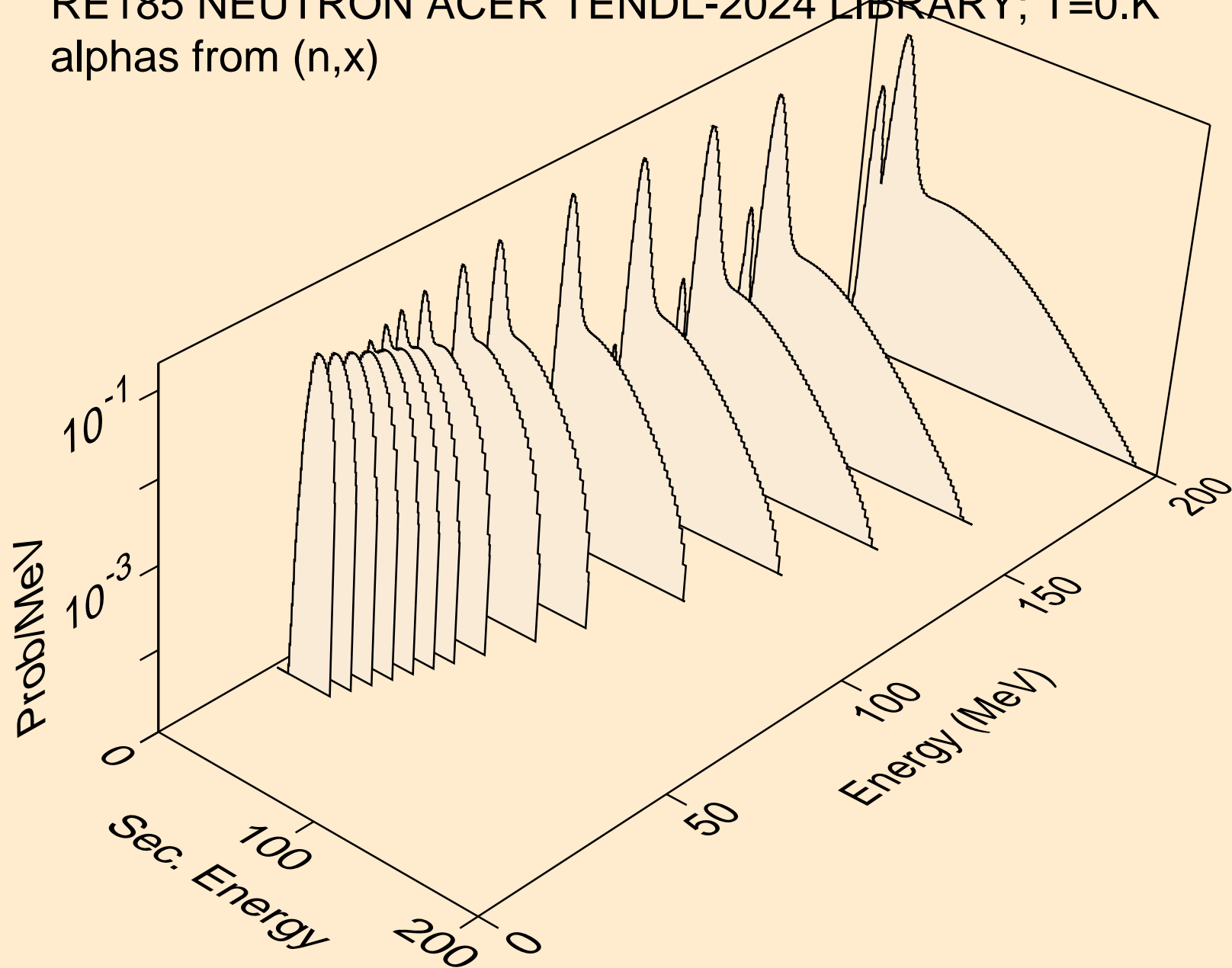

RE185 NEUTRON ACER TENDL-2024 LIBRARY; T=0.K
alphas from (n,n*)a

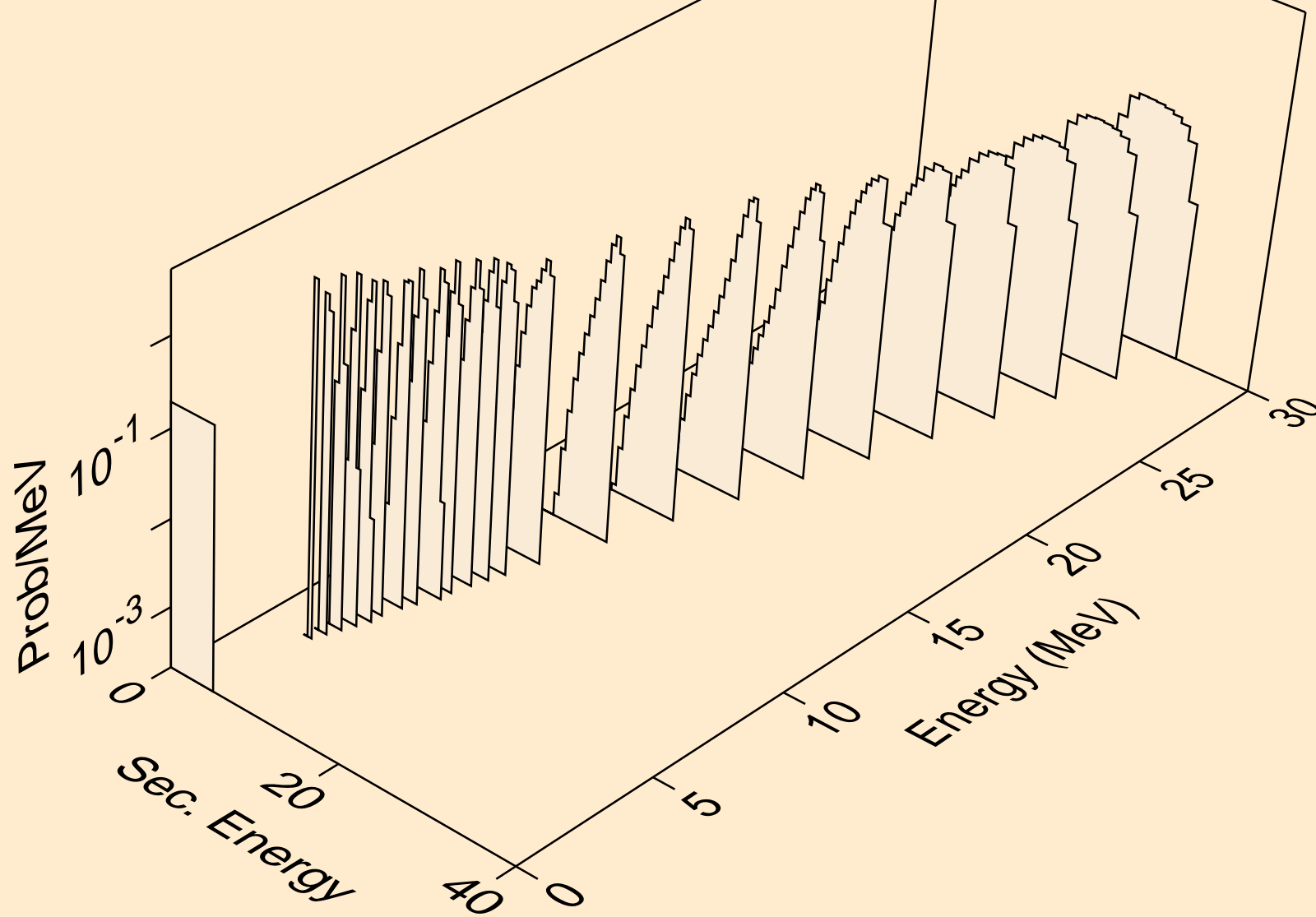

RE185 NEUTRON ACER TENDL-2024 LIBRARY; T=0.K
alphas from (n,2n)a

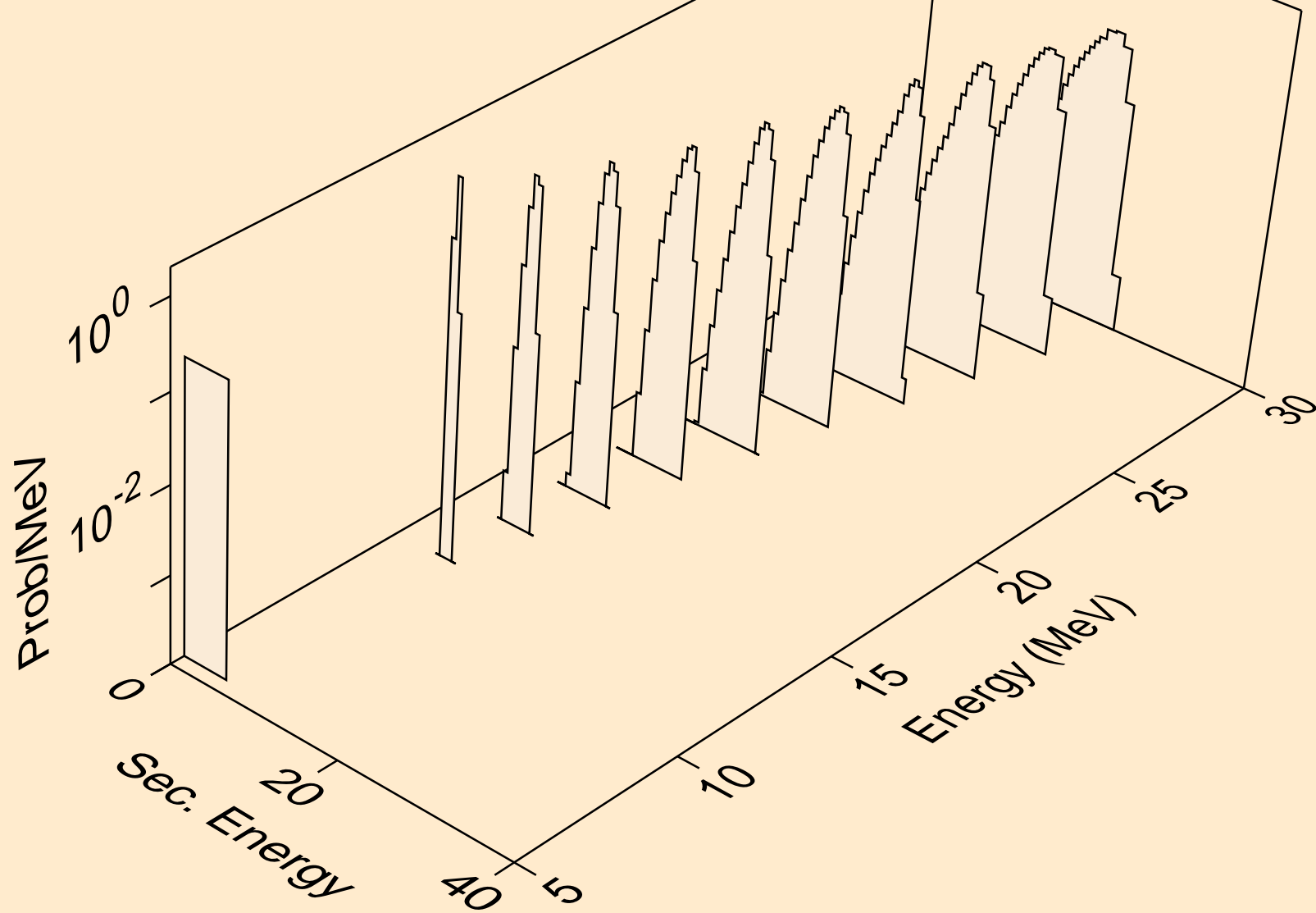

RE185 NEUTRON ACER TENDL-2024 LIBRARY; T=0.K
alphas from (n,3n)a

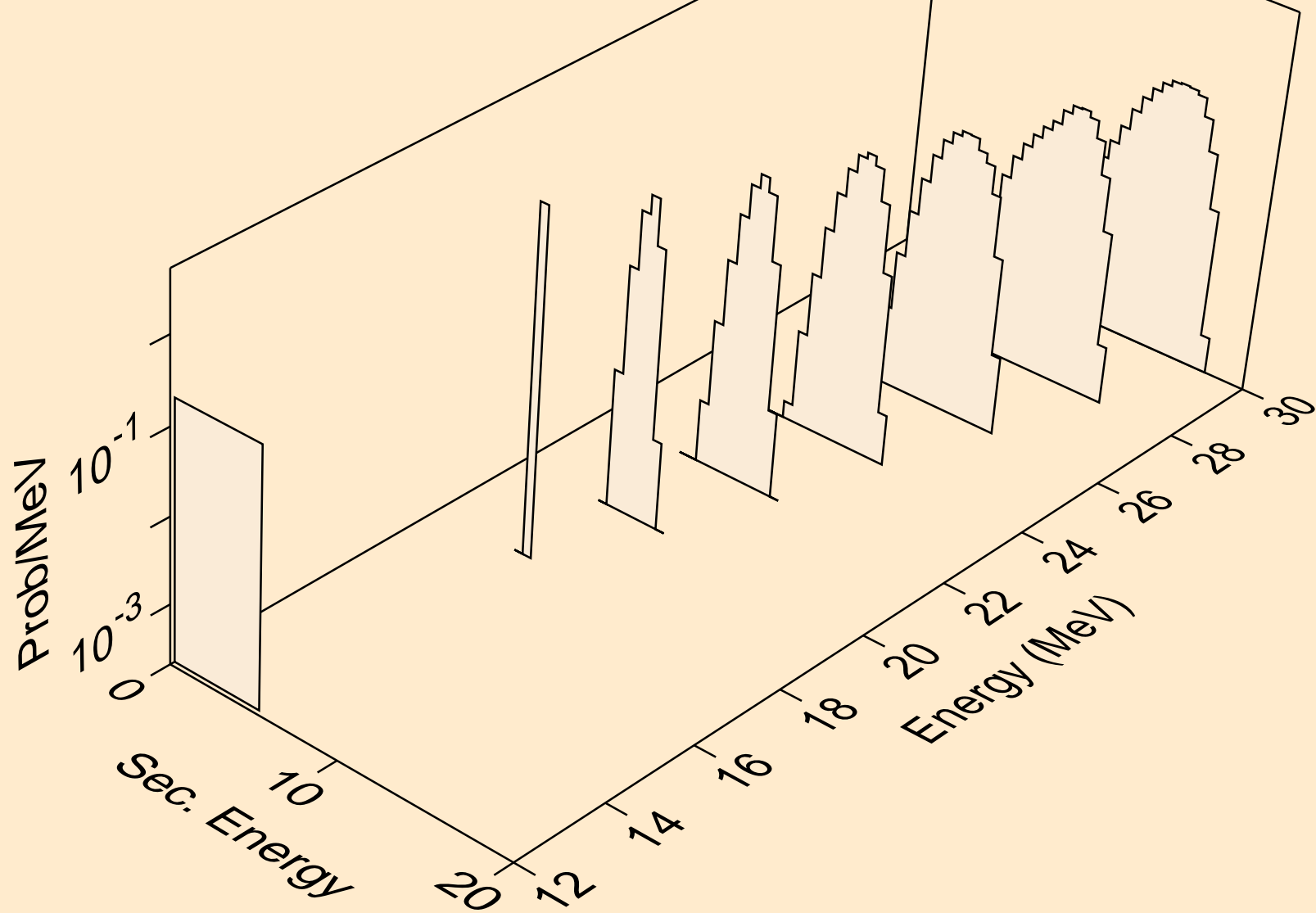

RE185 NEUTRON ACER TENDL-2024 LIBRARY; T=0.K
alphas from (n,n*)2a

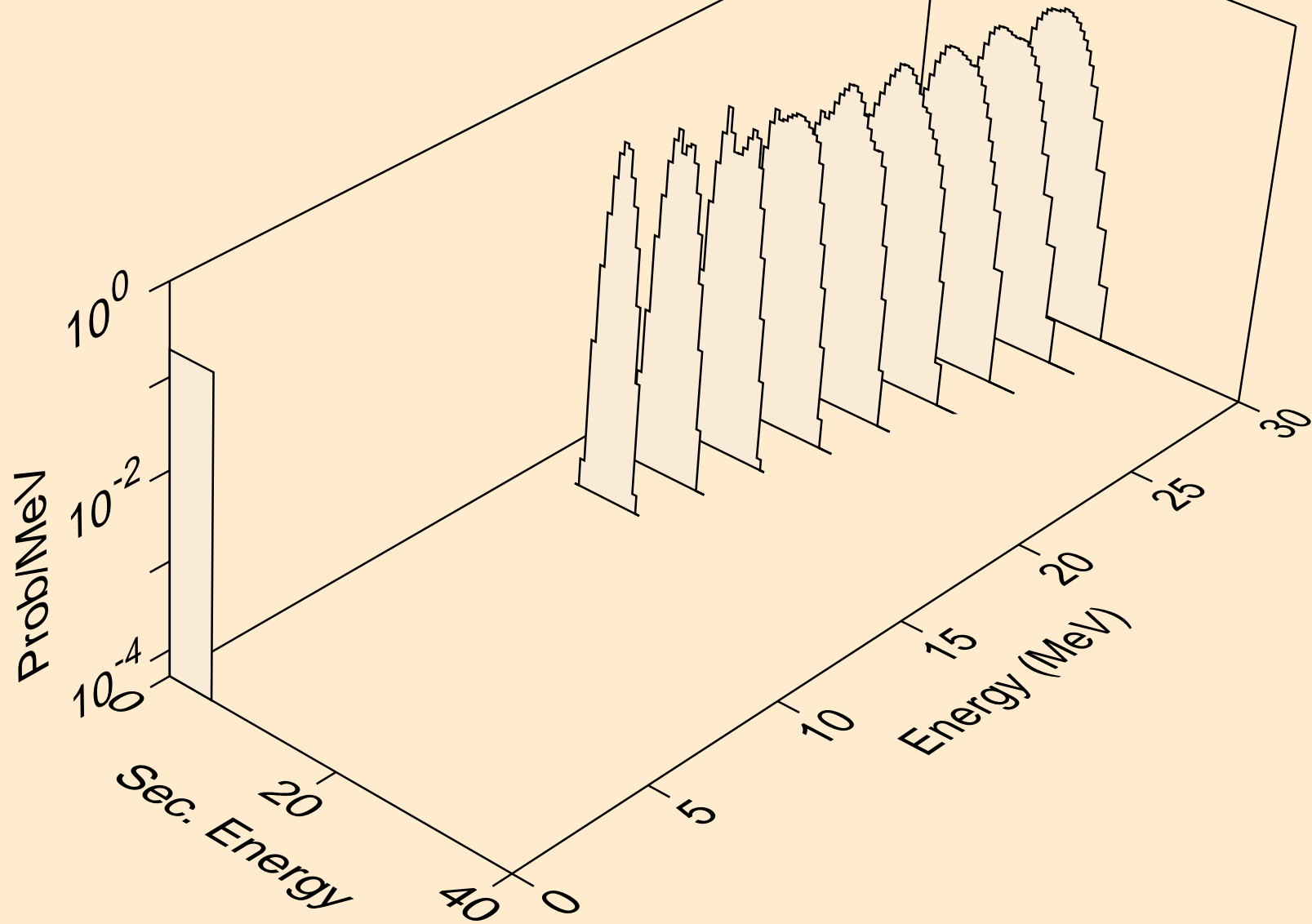

RE185 NEUTRON ACER TENDL-2024 LIBRARY; T=0.K
alphas from (n,npa)

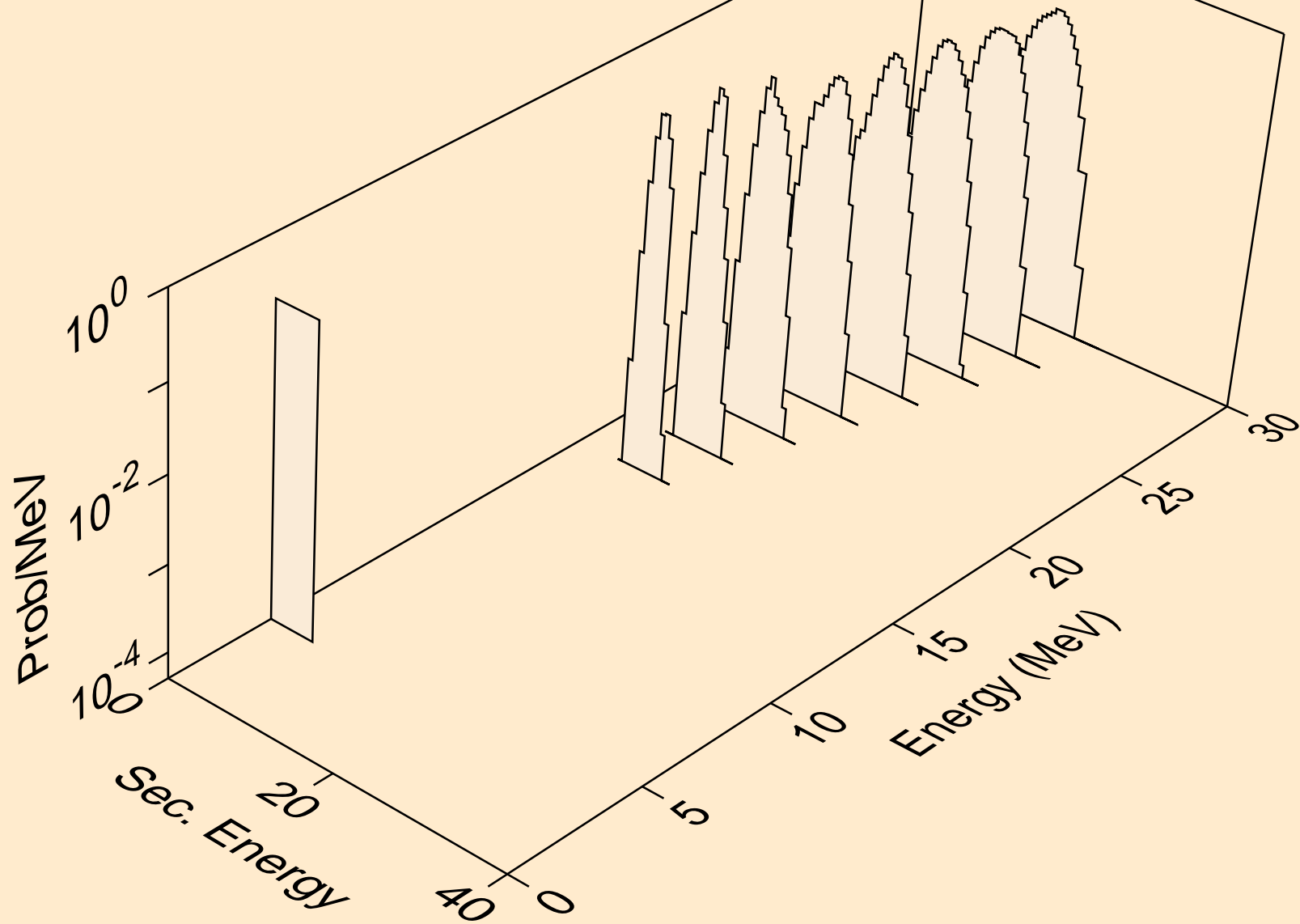

RE185 NEUTRON ACER TENDL-2024 LIBRARY; T=0.K
alphas from (n,a)

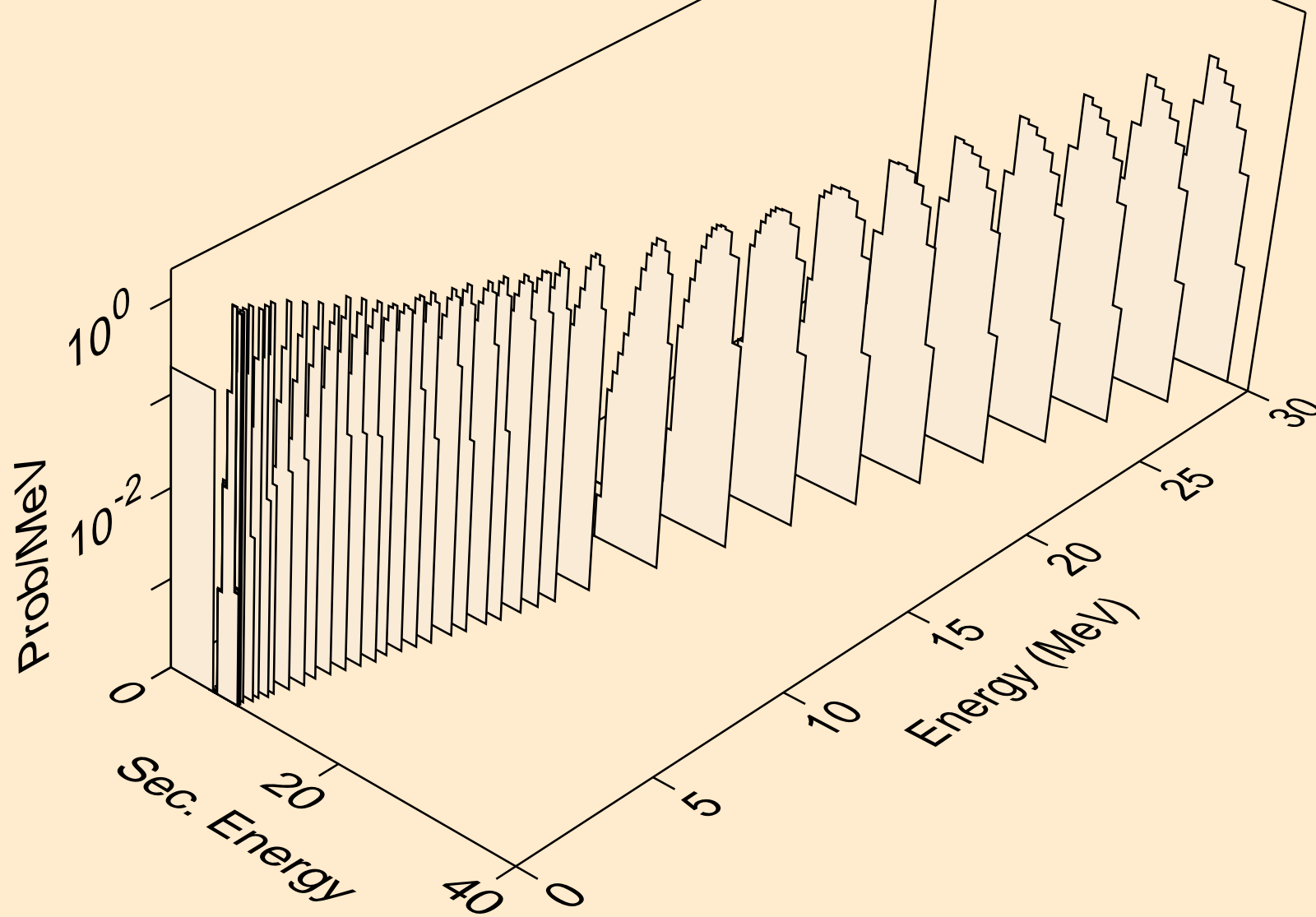

RE185 NEUTRON ACER TENDL-2024 LIBRARY; T=0.K
alphas from (n,2a)

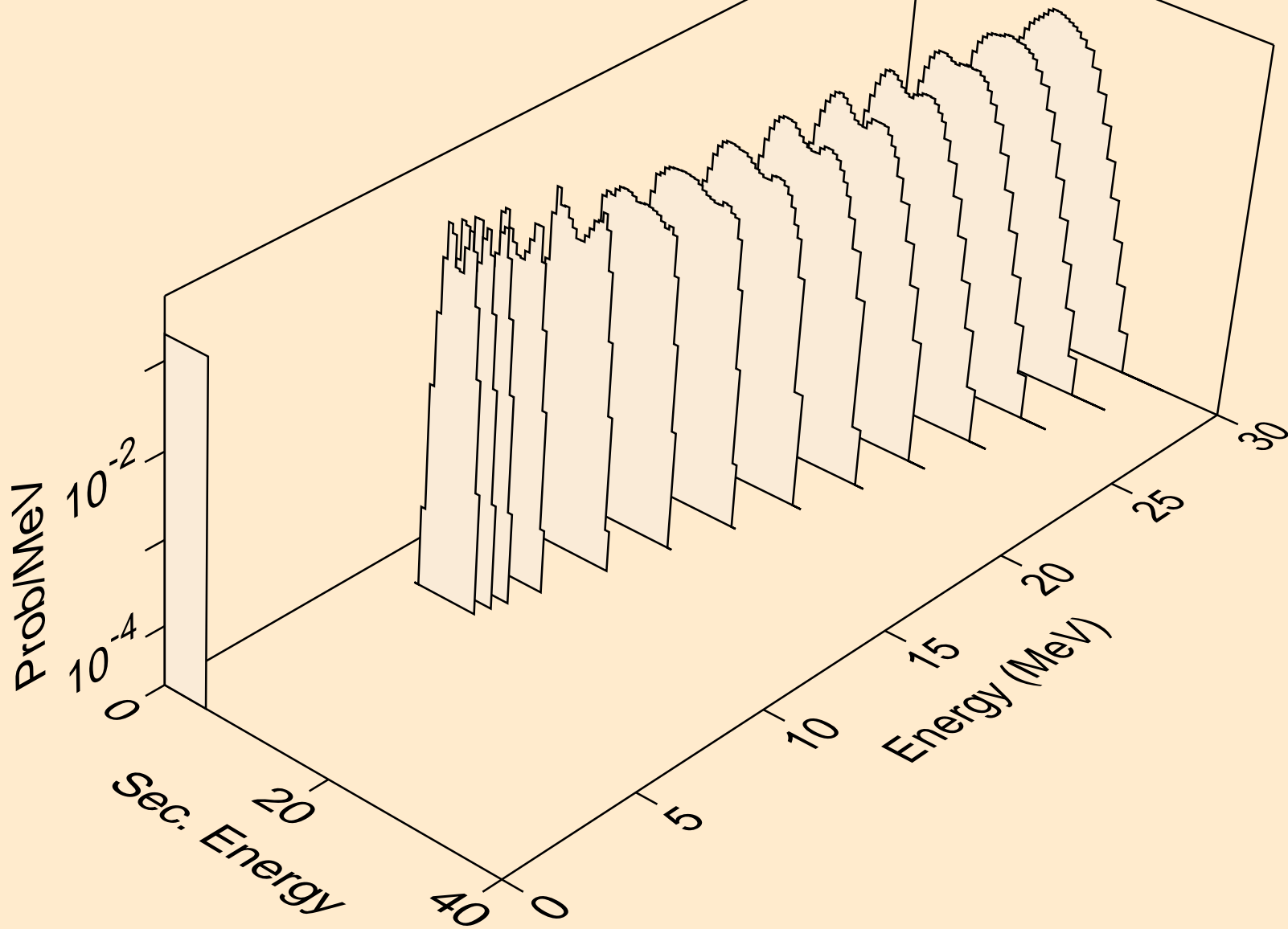

RE185 NEUTRON ACER TENDL-2024 LIBRARY; T=0.K
alphas from (n,pa)

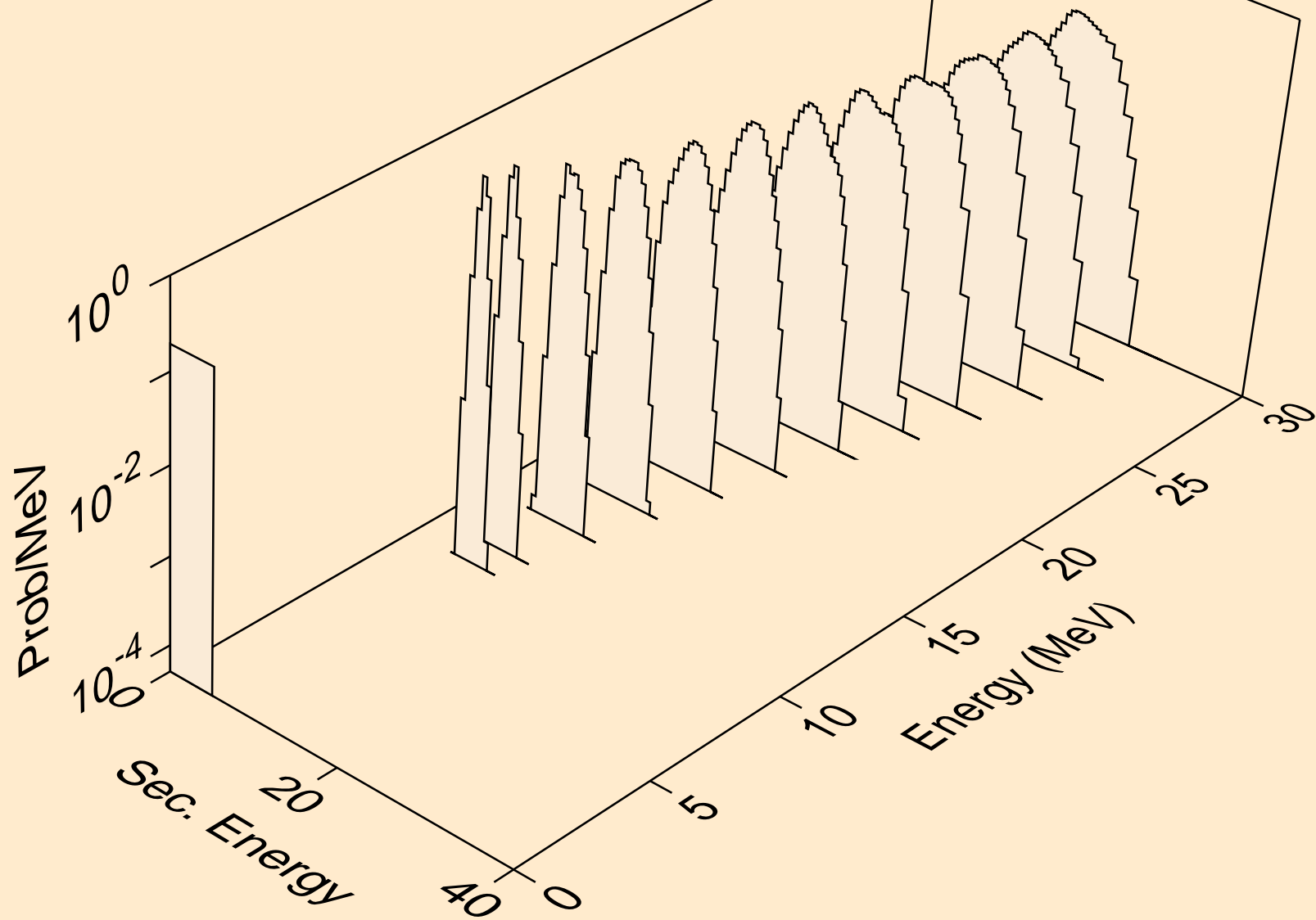

RE185 NEUTRON ACER TENDL-2024 LIBRARY; T=0.K
alphas from (n,da)

