

SE075 NEUTRON ACER TENDL-2024 LIBRARY; T=0.K

Principal cross sections

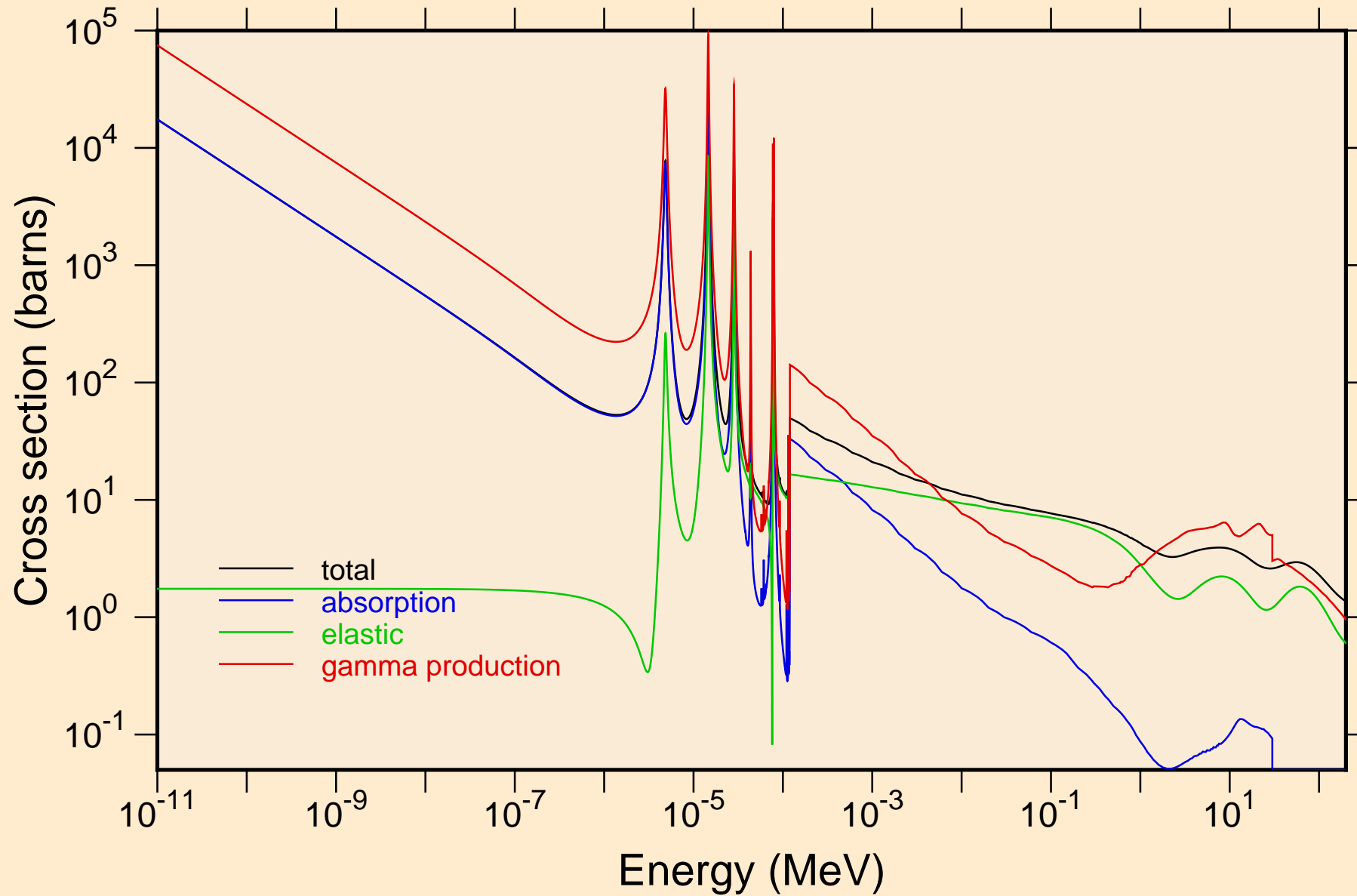

SE075 NEUTRON ACER TENDL-2024 LIBRARY; T=0.K
resonance total cross section

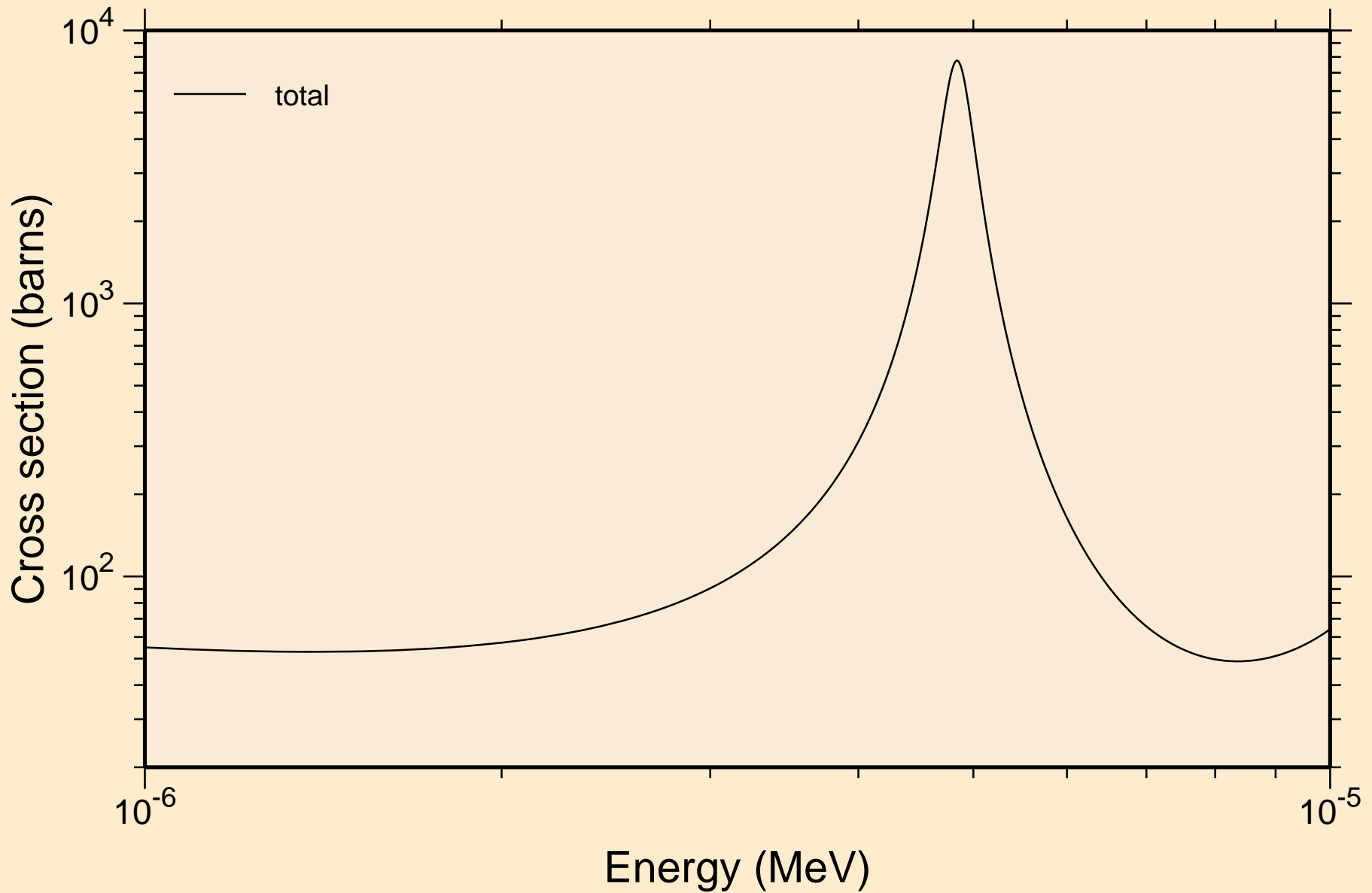

SE075 NEUTRON ACER TENDL-2024 LIBRARY; T=0.K
resonance total cross section

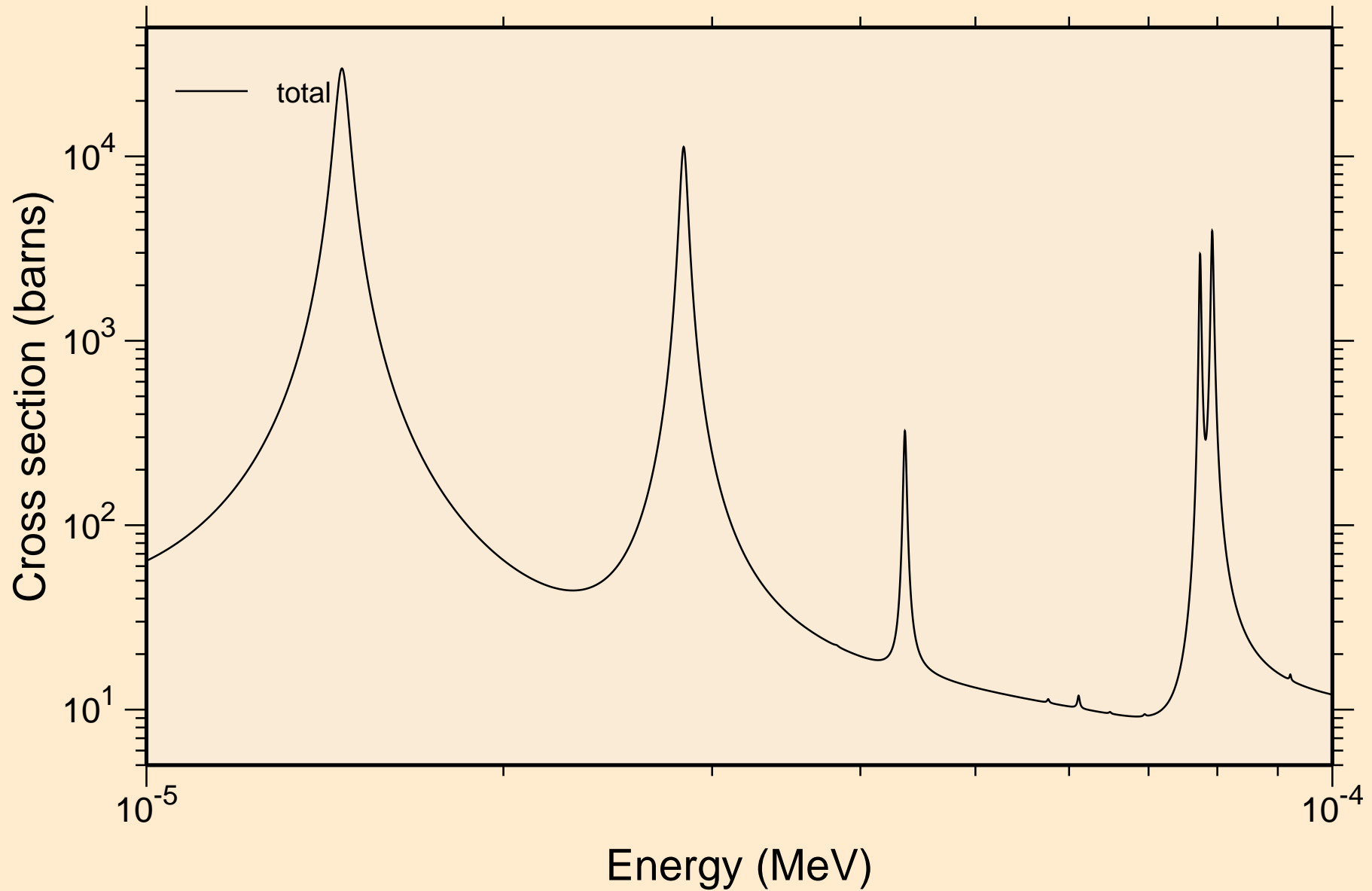

SE075 NEUTRON ACER TENDL-2024 LIBRARY; T=0.K
resonance total cross section

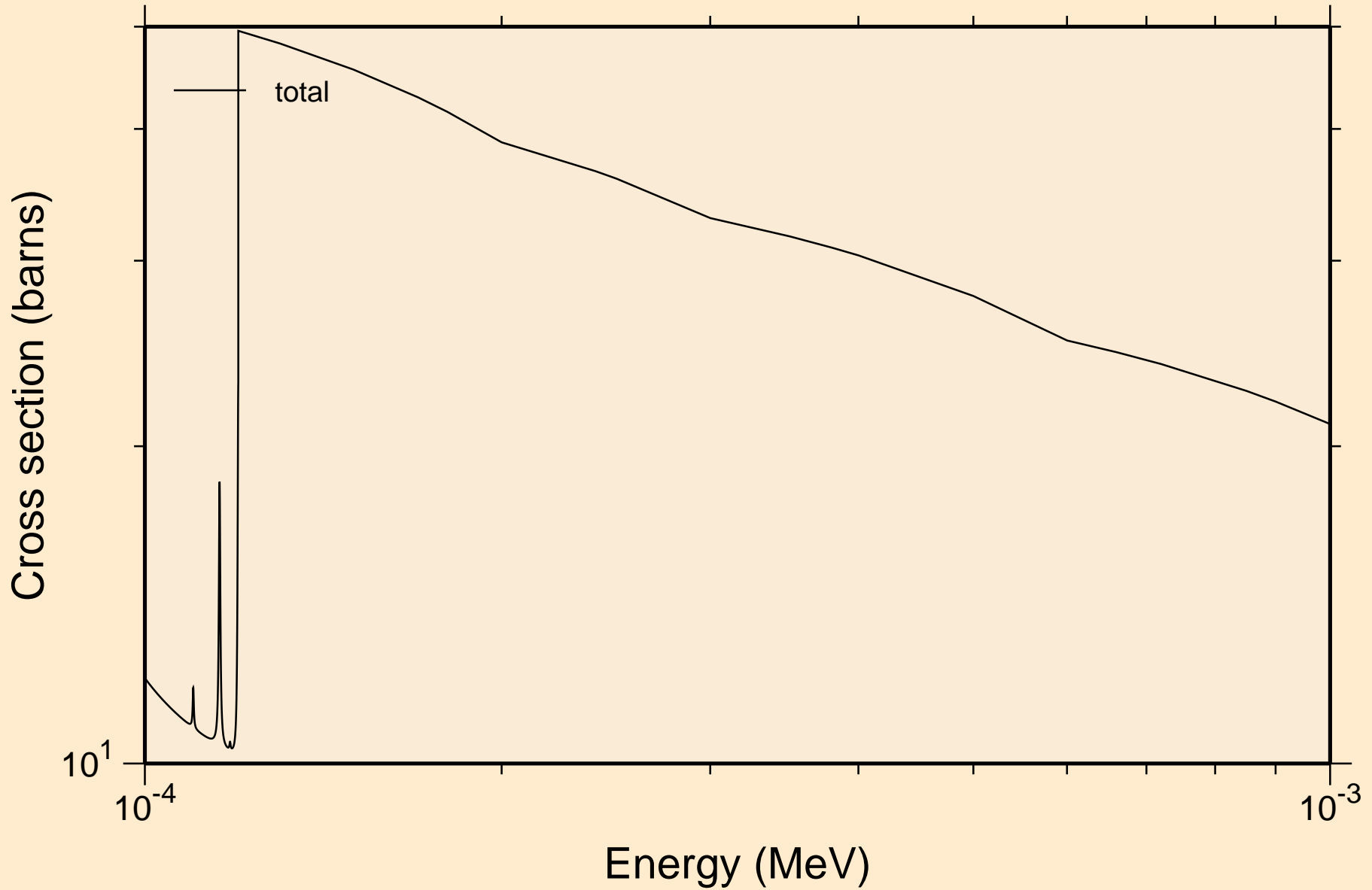

S \bar{E} 075 NEUTRON ACER TENDL-2024 LIBRARY; T=0.K
resonance total cross section

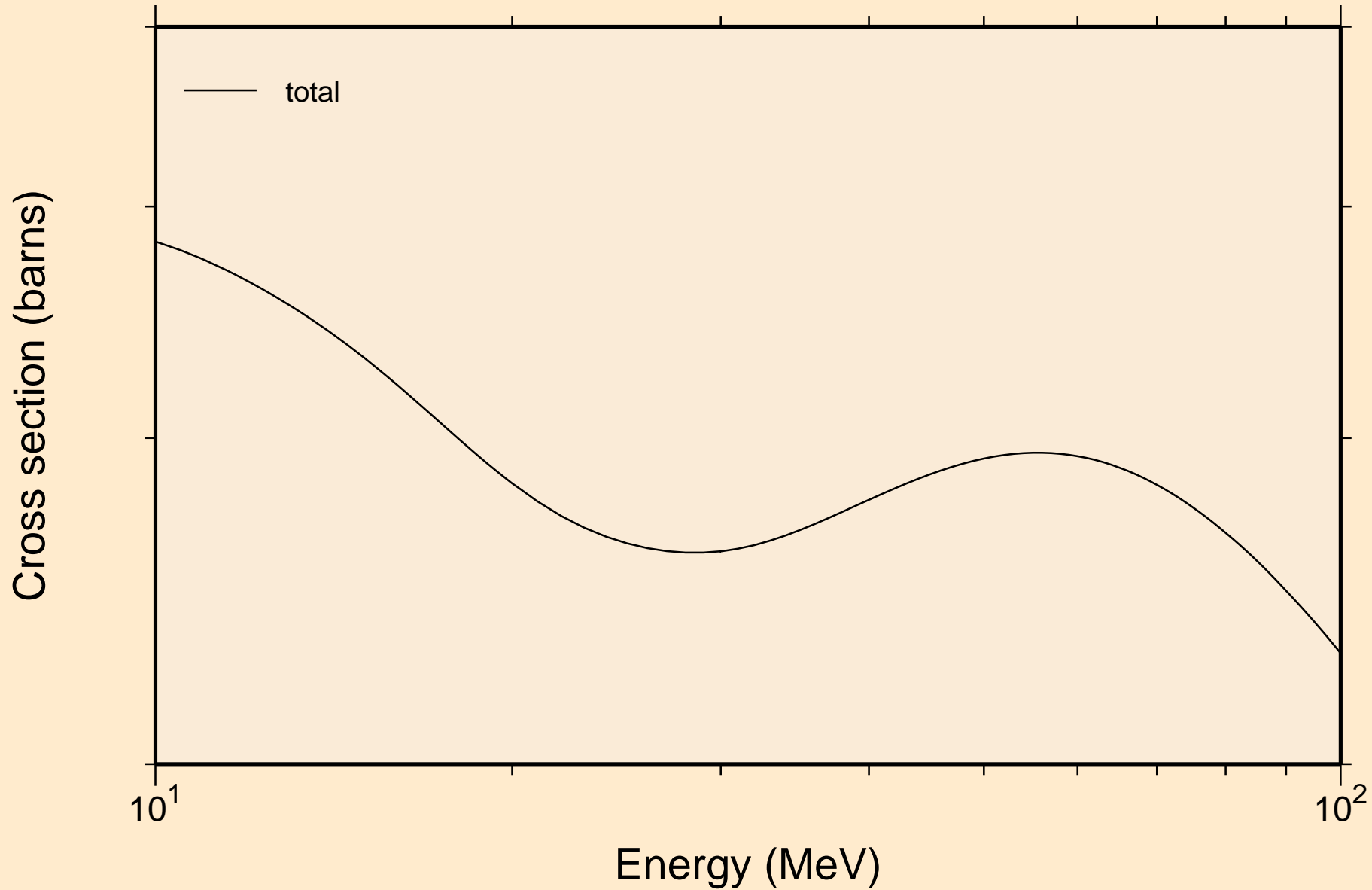

SE075 NEUTRON ACER TENDL-2024 LIBRARY; T=0.K
resonance absorption cross sections

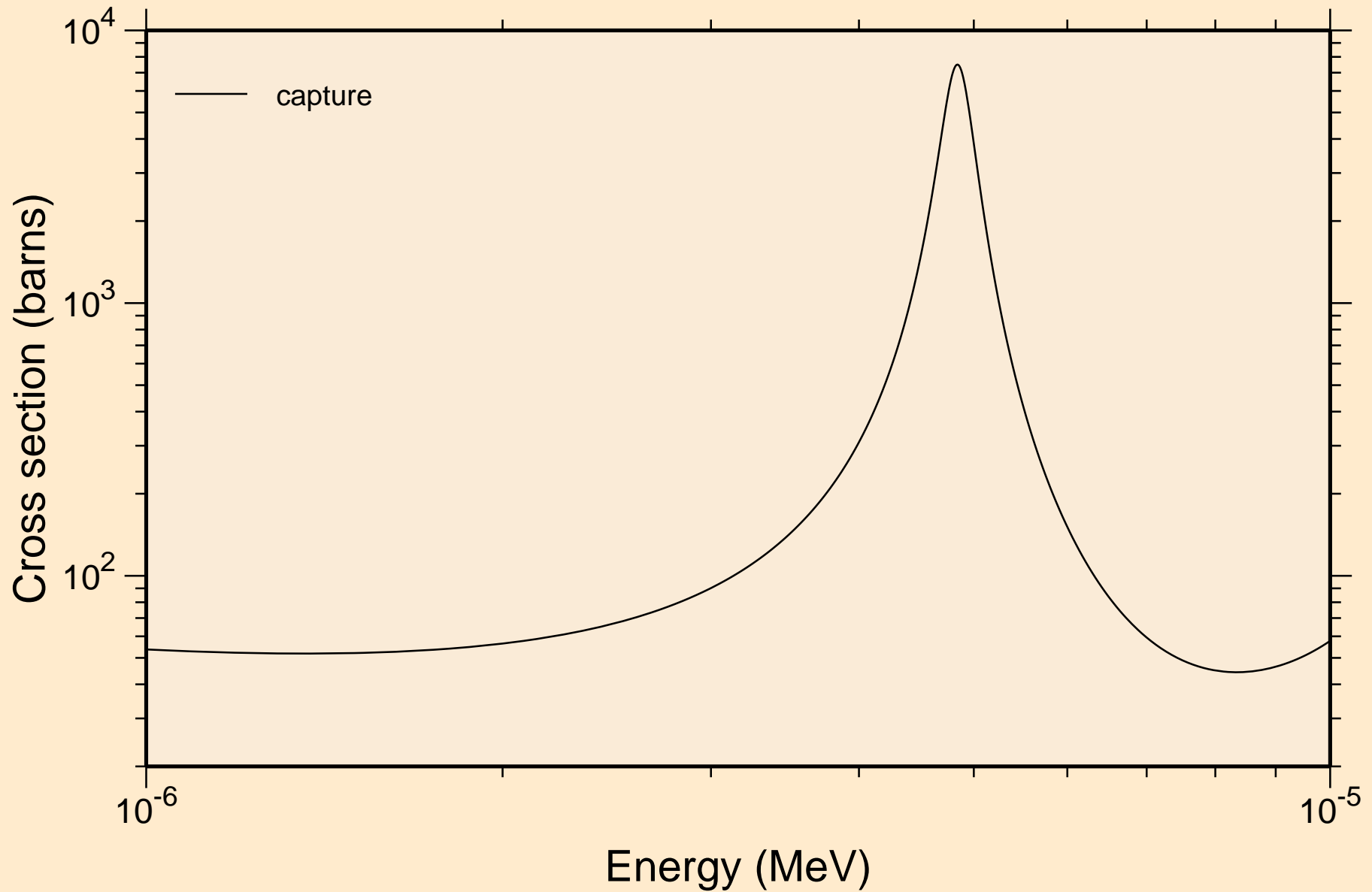

SE075 NEUTRON ACER TENDL-2024 LIBRARY; T=0.K
resonance absorption cross sections

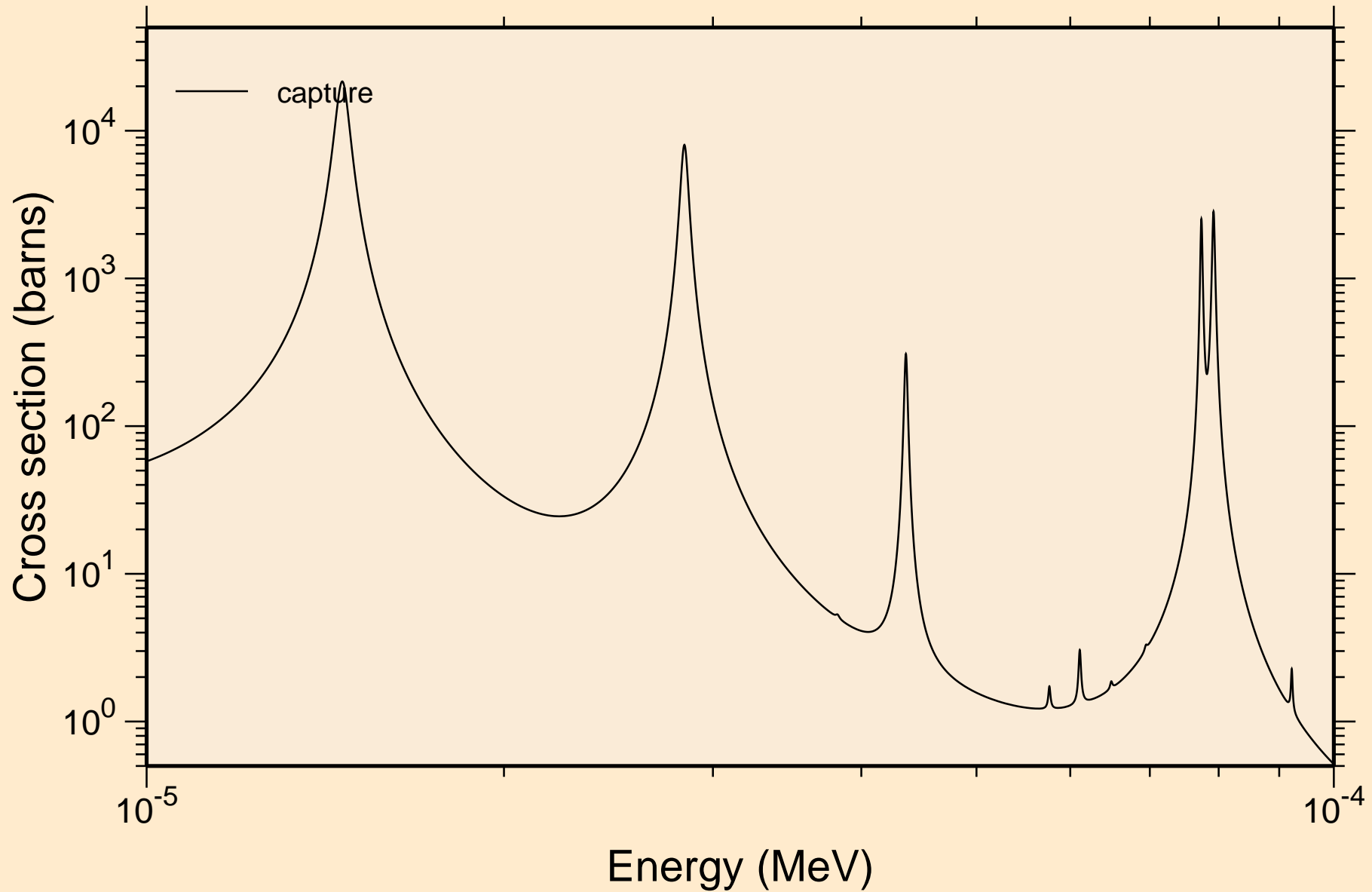

SE075 NEUTRON ACER TENDL-2024 LIBRARY; T=0.K
resonance absorption cross sections

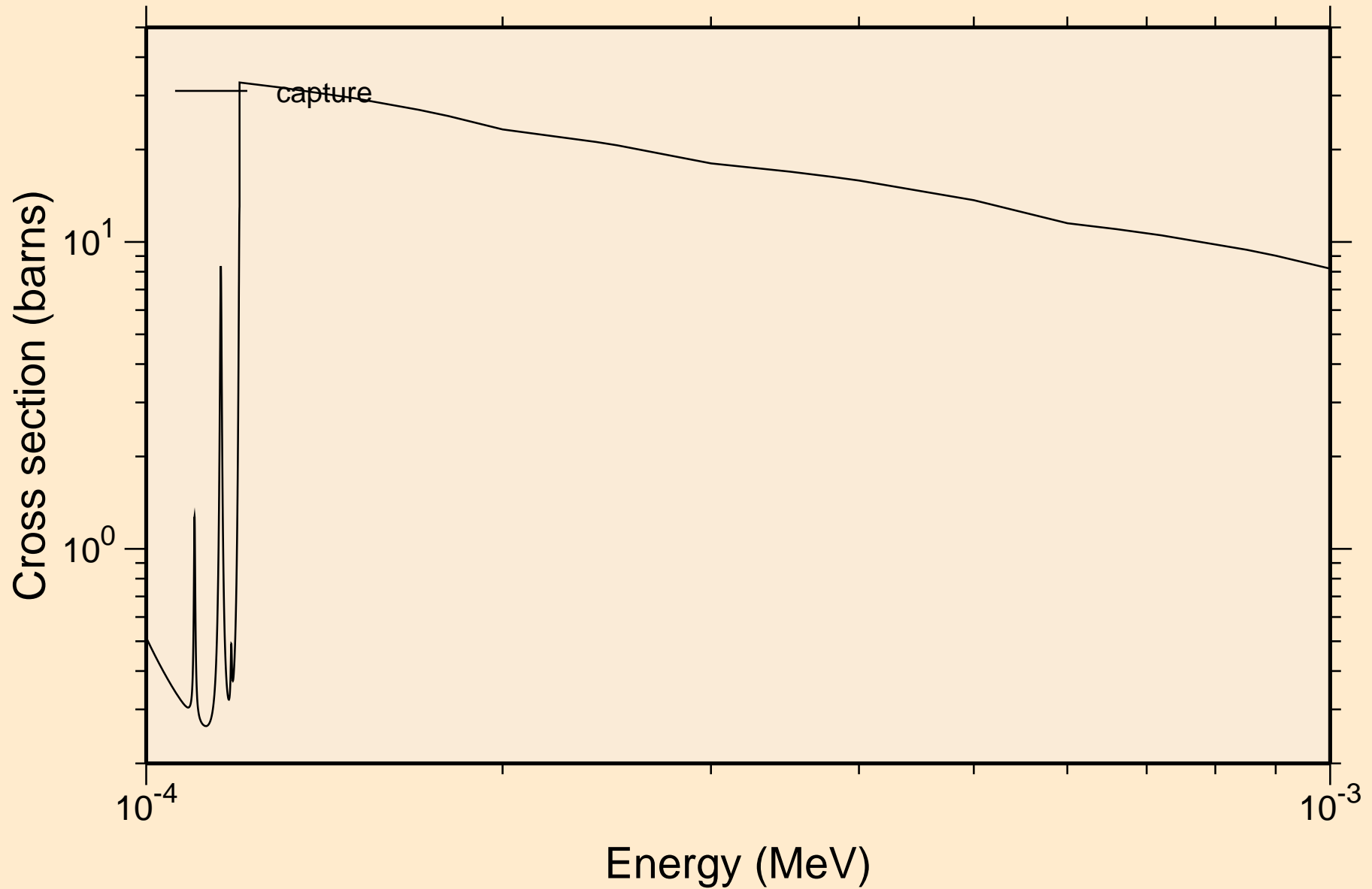

SE075 NEUTRON ACER TENDL-2024 LIBRARY; T=0.K
resonance absorption cross sections

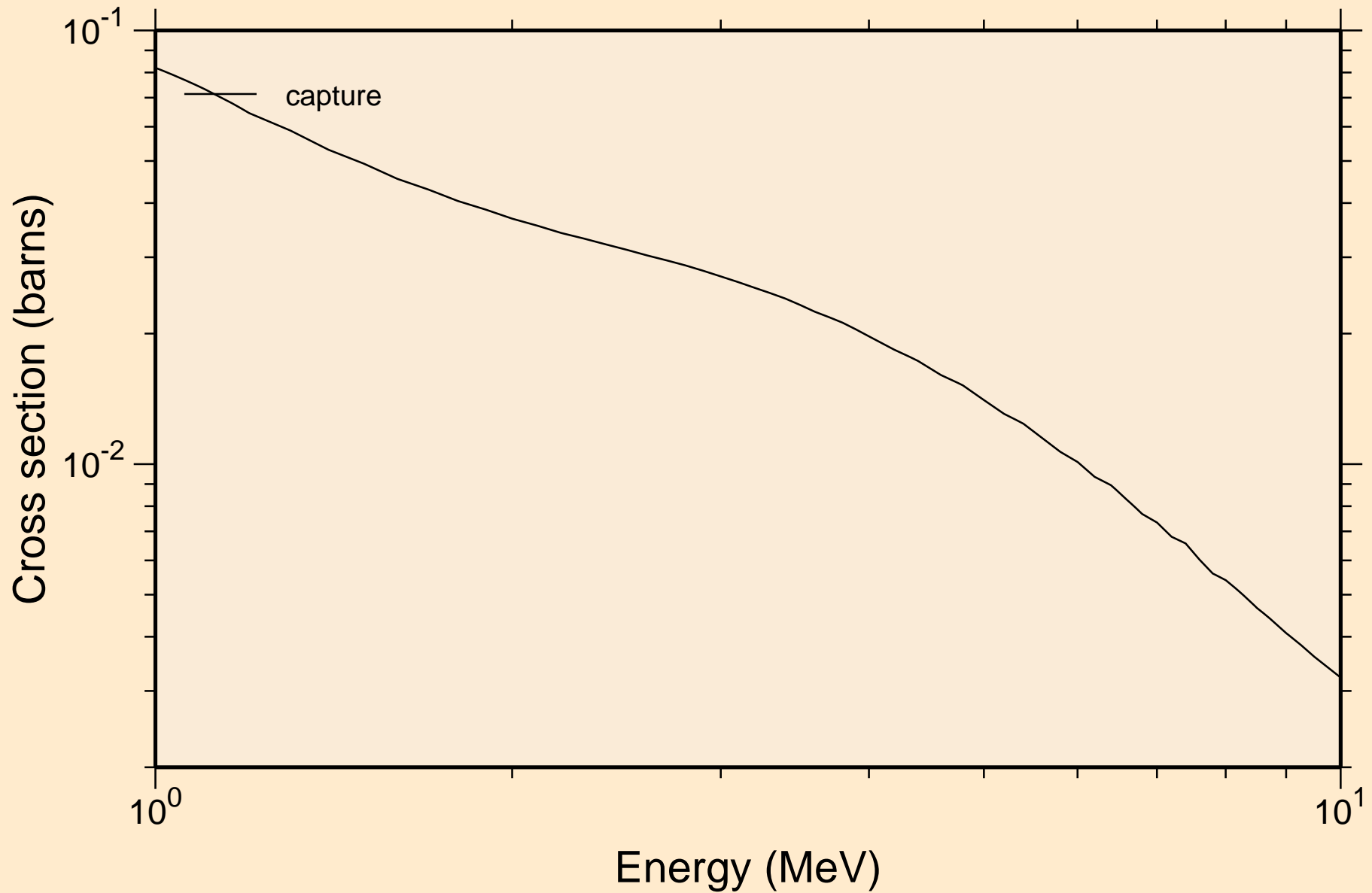

SE075 NEUTRON ACER TENDL-2024 LIBRARY; T=0.K

Heating

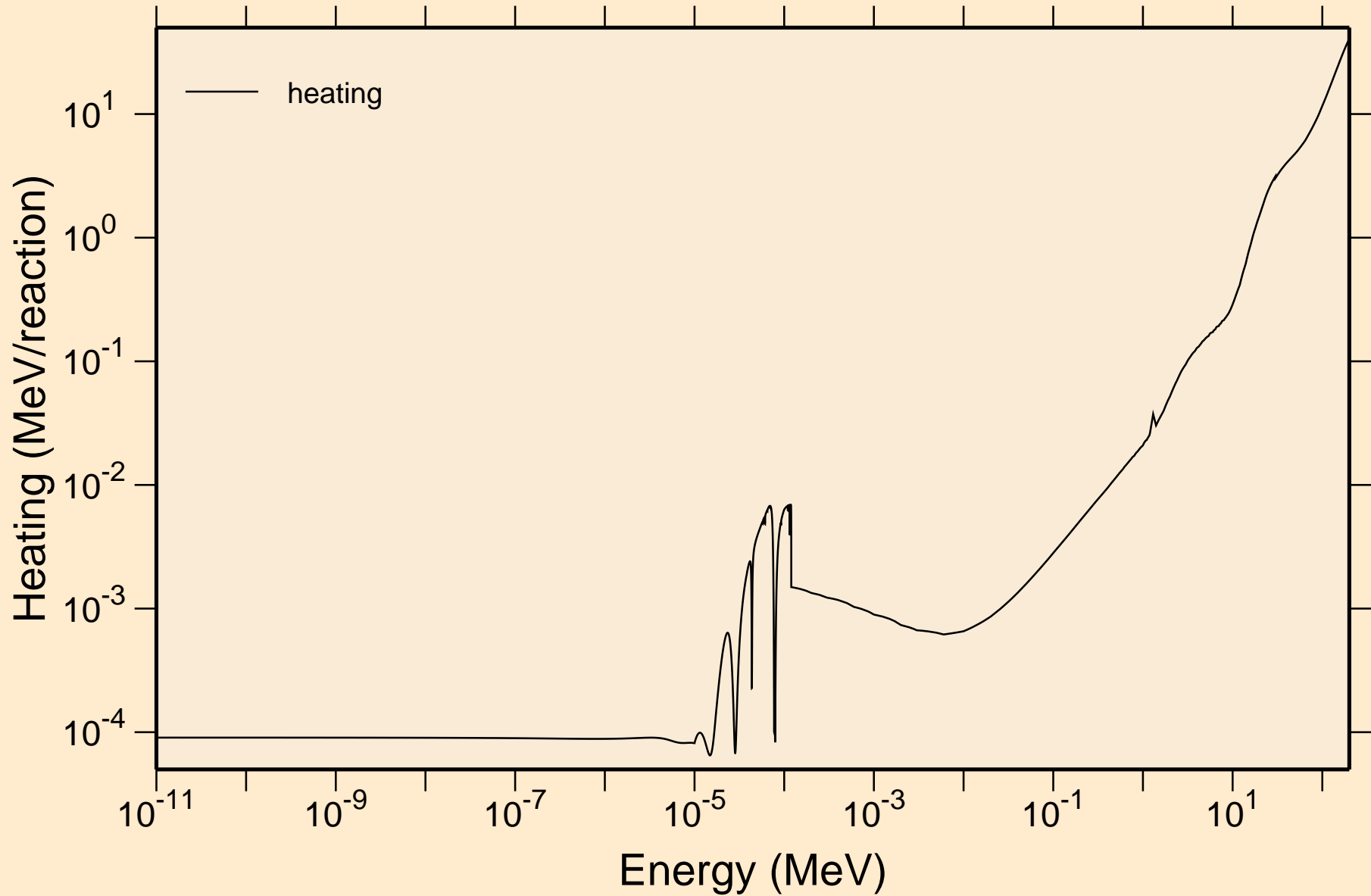

SE075 NEUTRON ACER TENDL-2024 LIBRARY; T=0.K
Damage

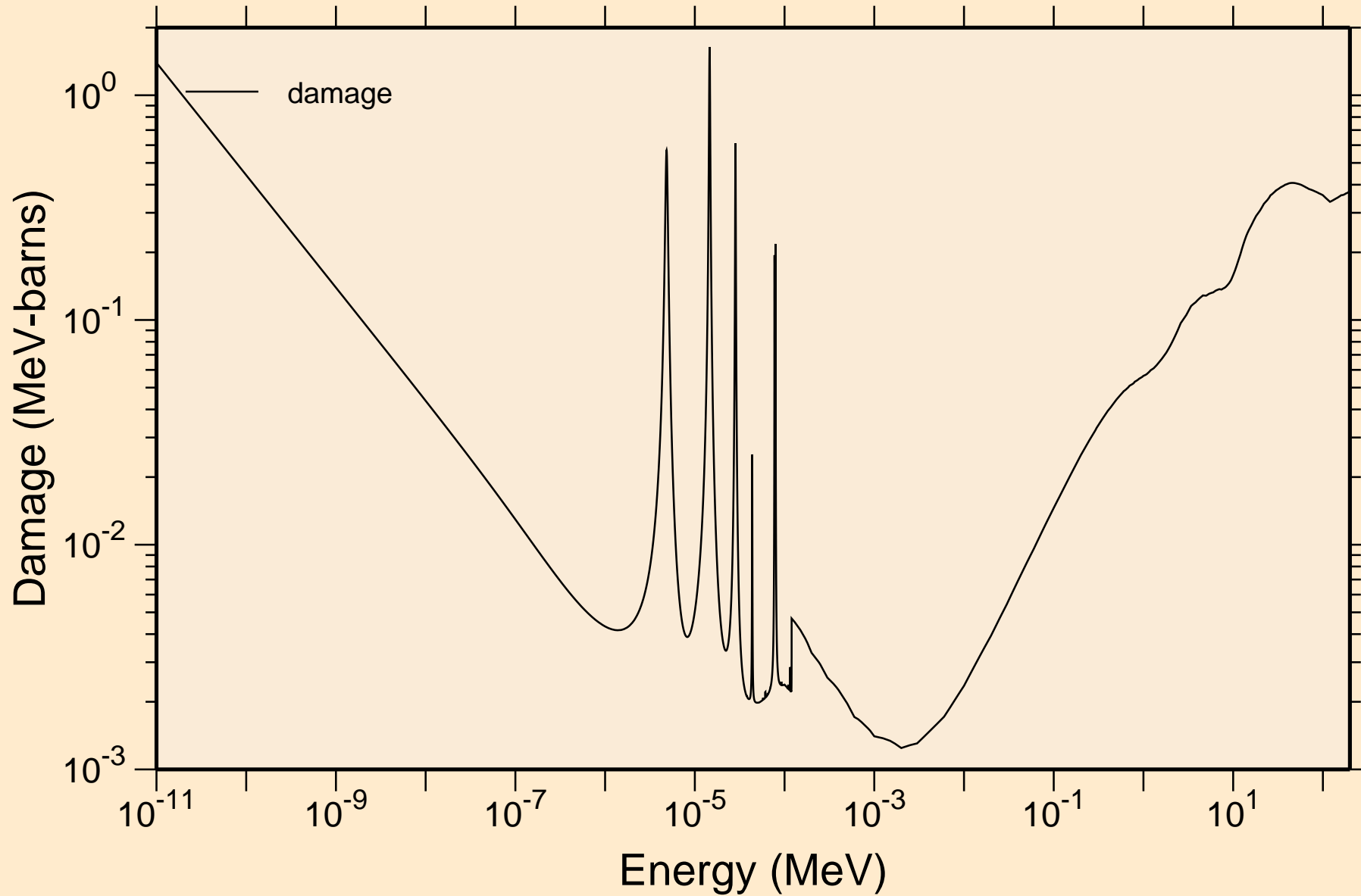

SE075 NEUTRON ACER TENDL-2024 LIBRARY; T=0.K
Non-threshold reactions

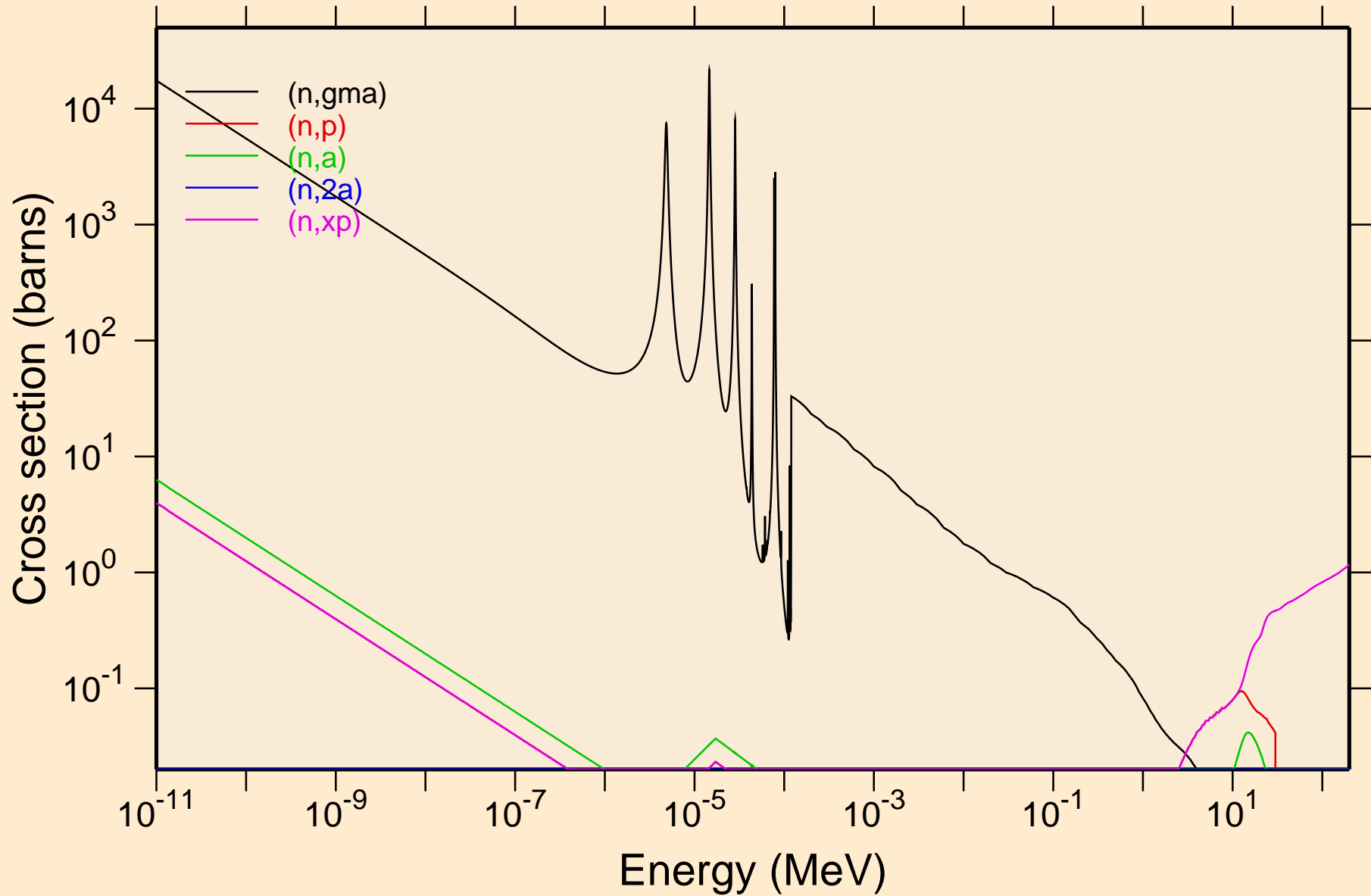

SE075 NEUTRON ACER TENDL-2024 LIBRARY; T=0.K
Non-threshold reactions

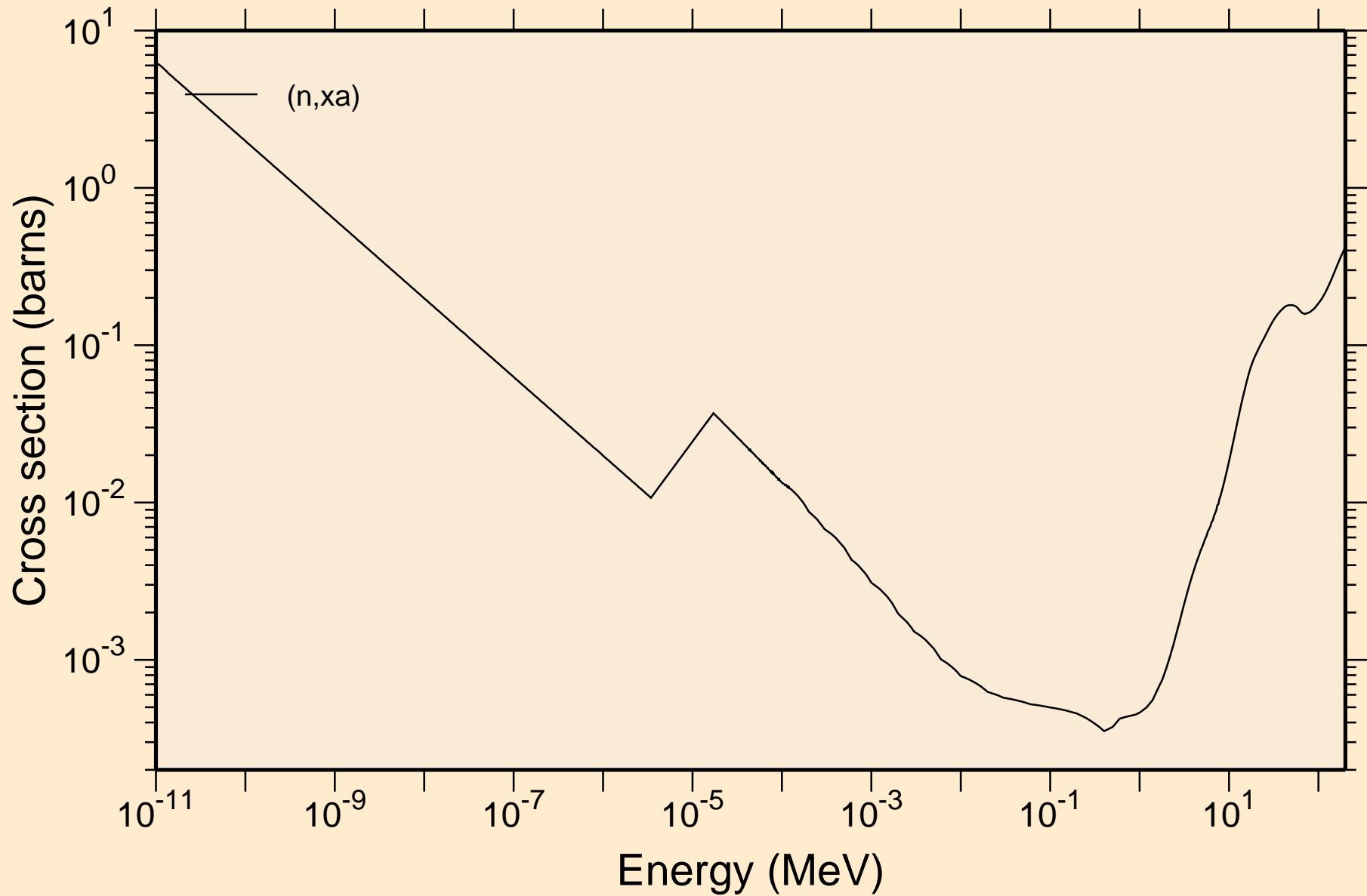

SE075 NEUTRON ACER TENDL-2024 LIBRARY; T=0.K

Principal cross sections

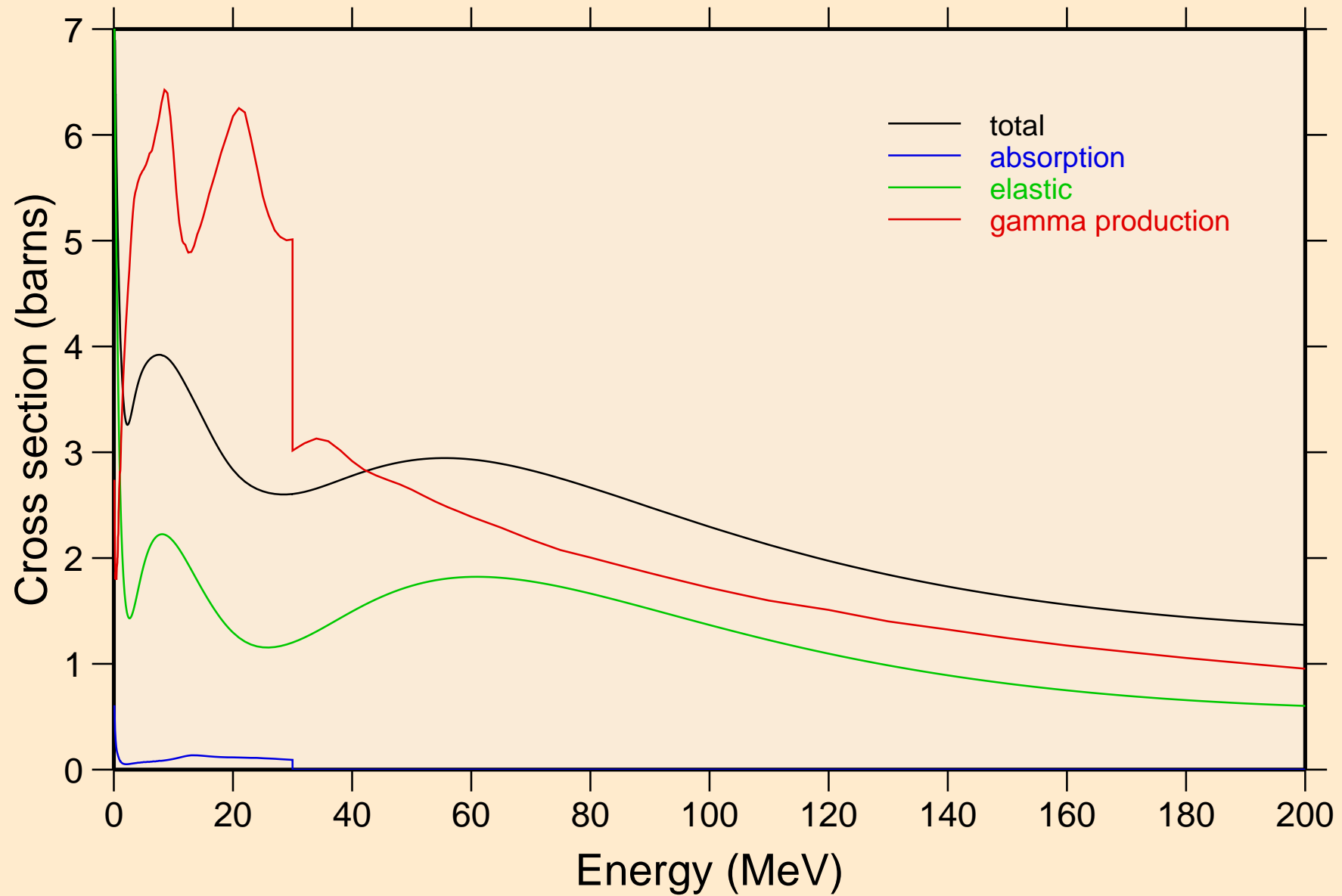

SE075 NEUTRON ACER TENDL-2024 LIBRARY; T=0.K

Heating

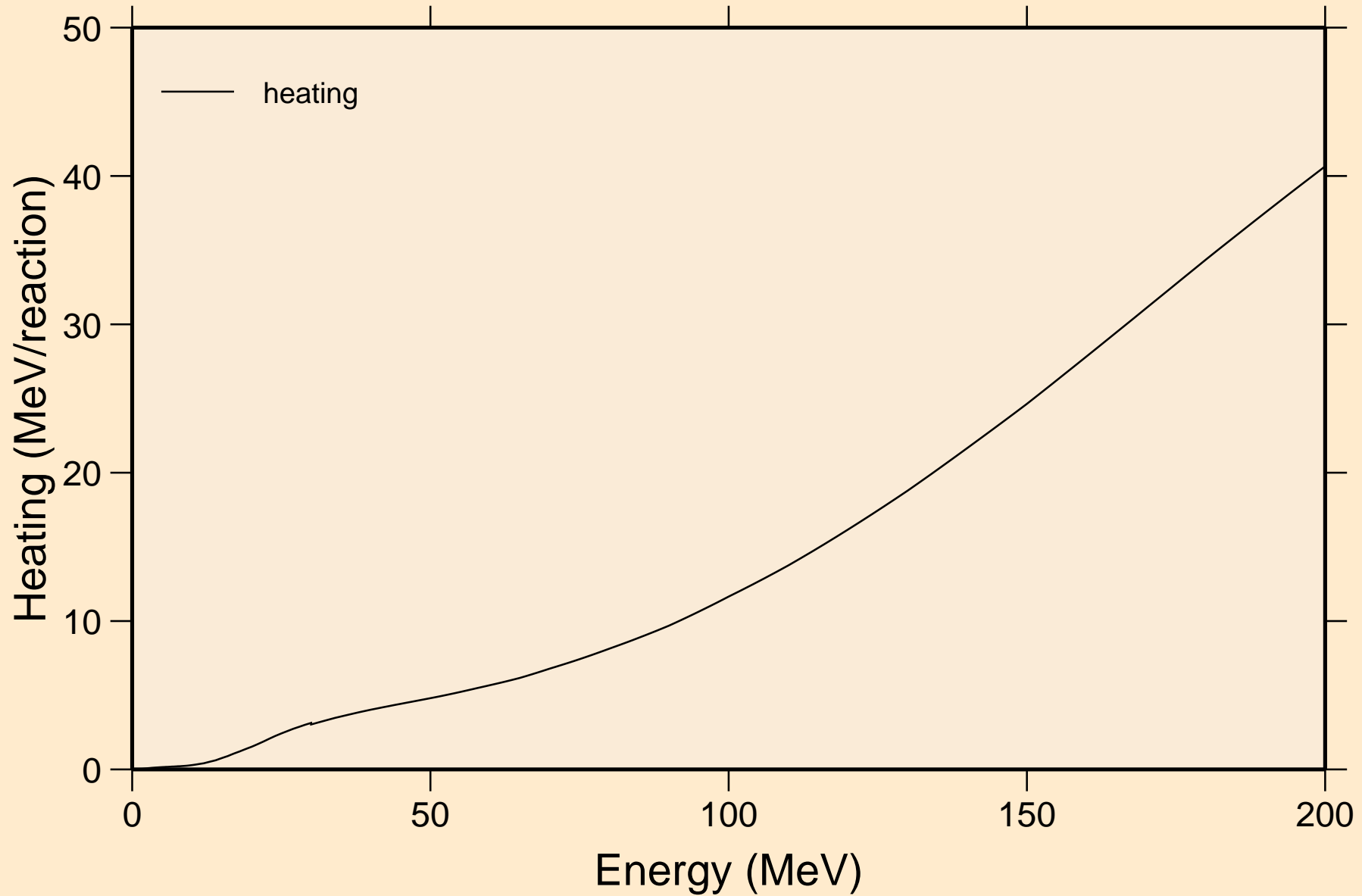

SE075 NEUTRON ACER TENDL-2024 LIBRARY; T=0.K

Damage

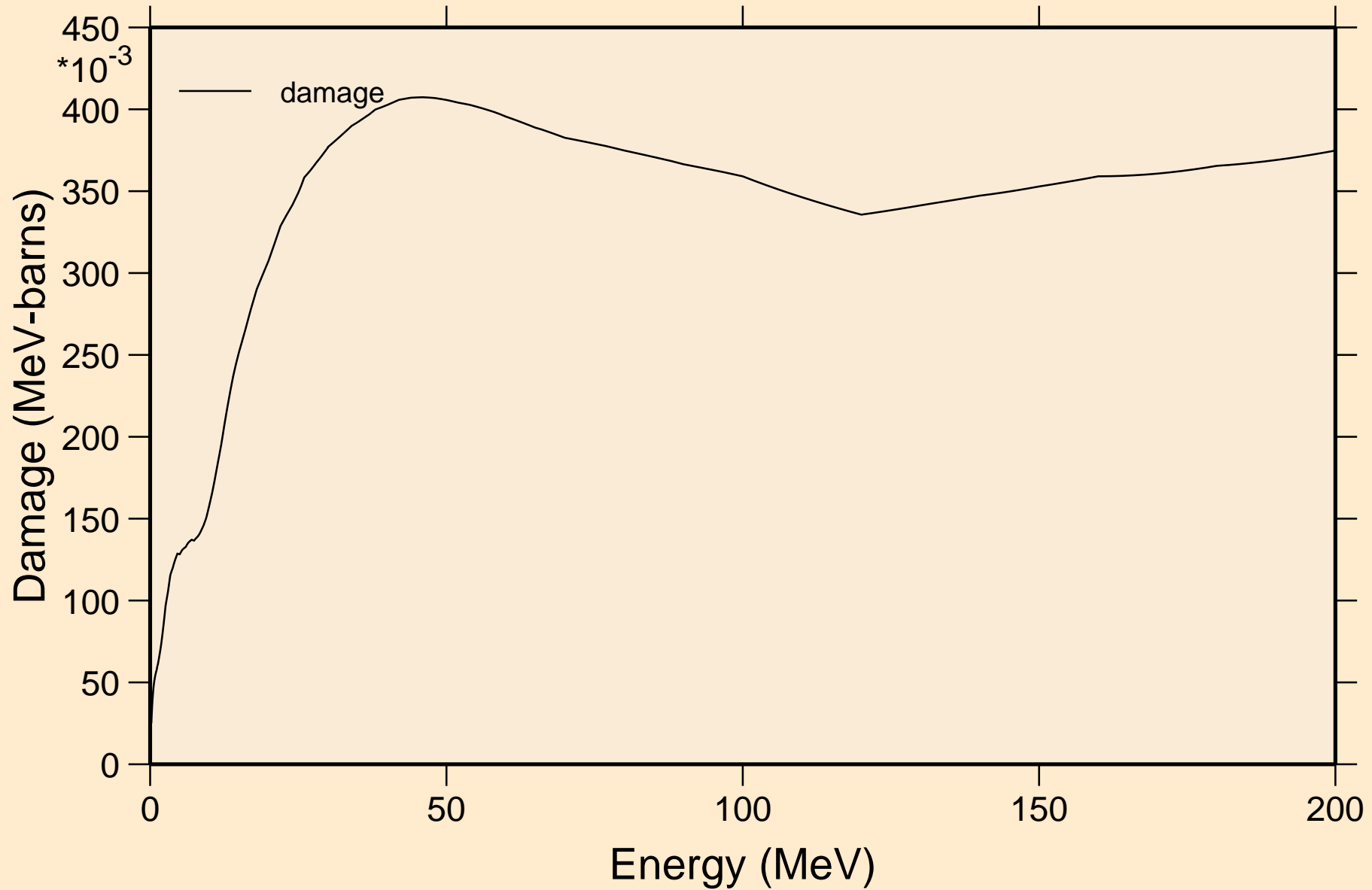

SE075 NEUTRON ACER TENDL-2024 LIBRARY; T=0.K
Non-threshold reactions

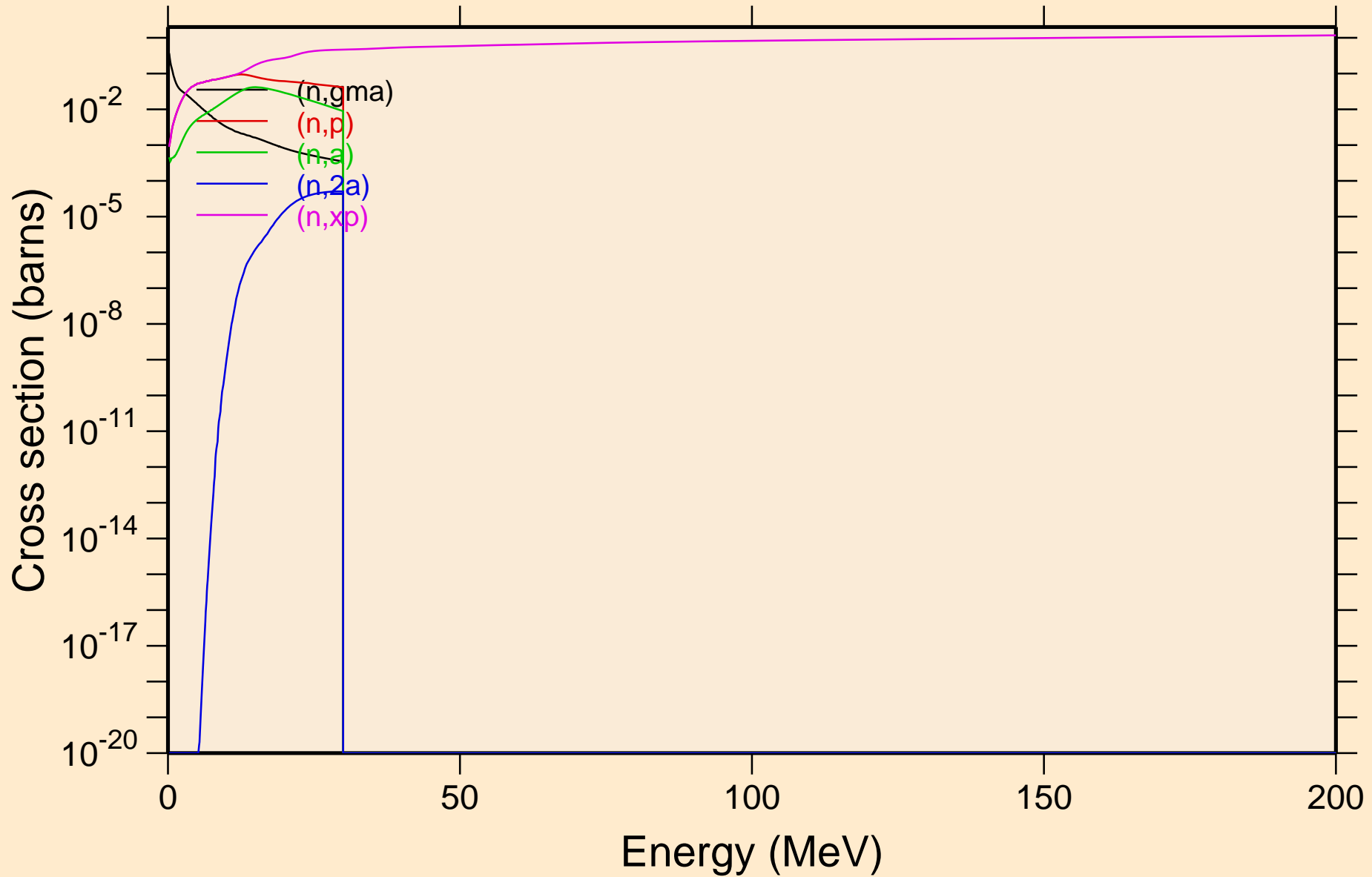

SE075 NEUTRON ACER TENDL-2024 LIBRARY; T=0.K
Non-threshold reactions

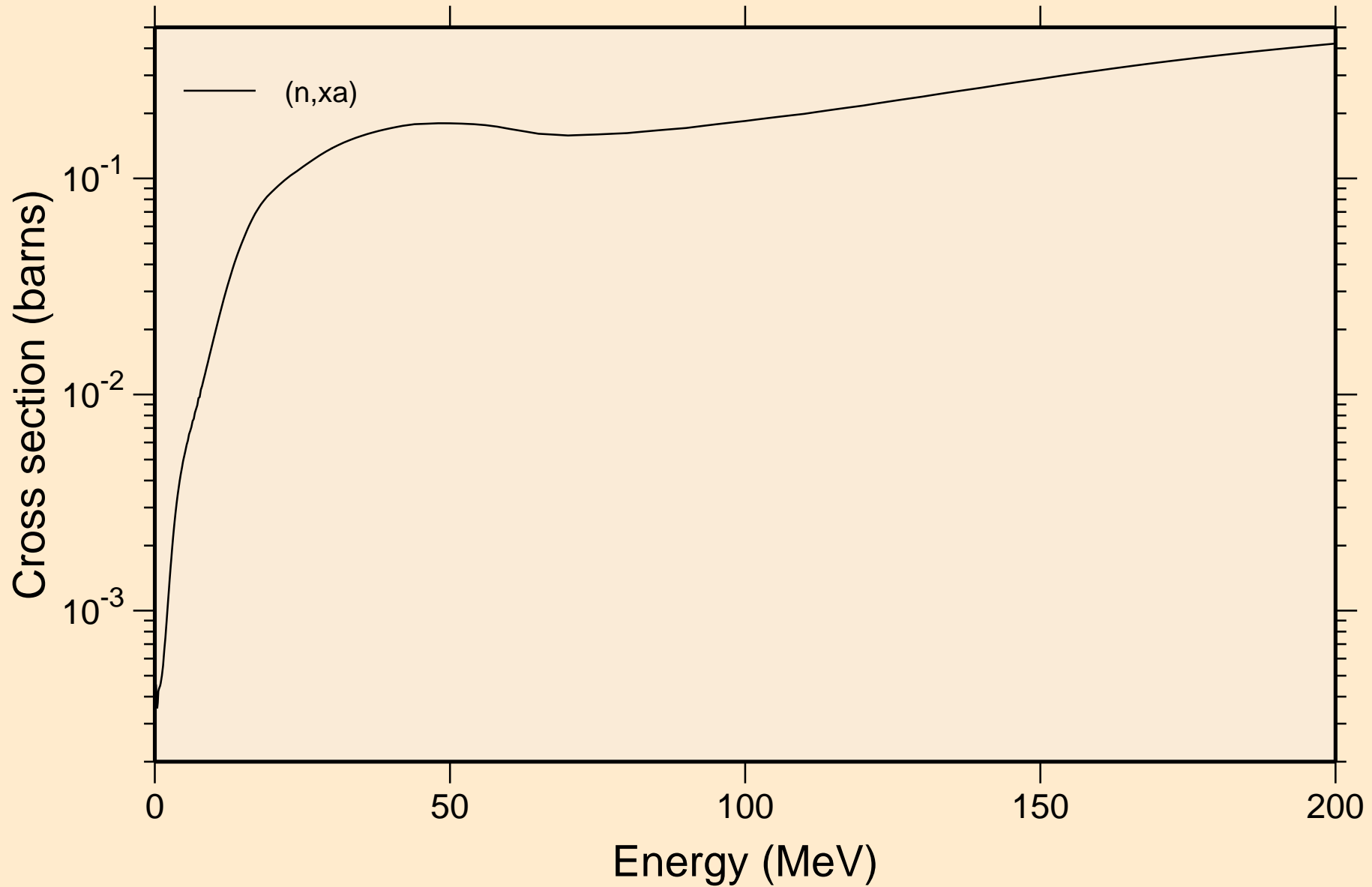

SE075 NEUTRON ACER TENDL-2024 LIBRARY; T=0.K
Inelastic levels

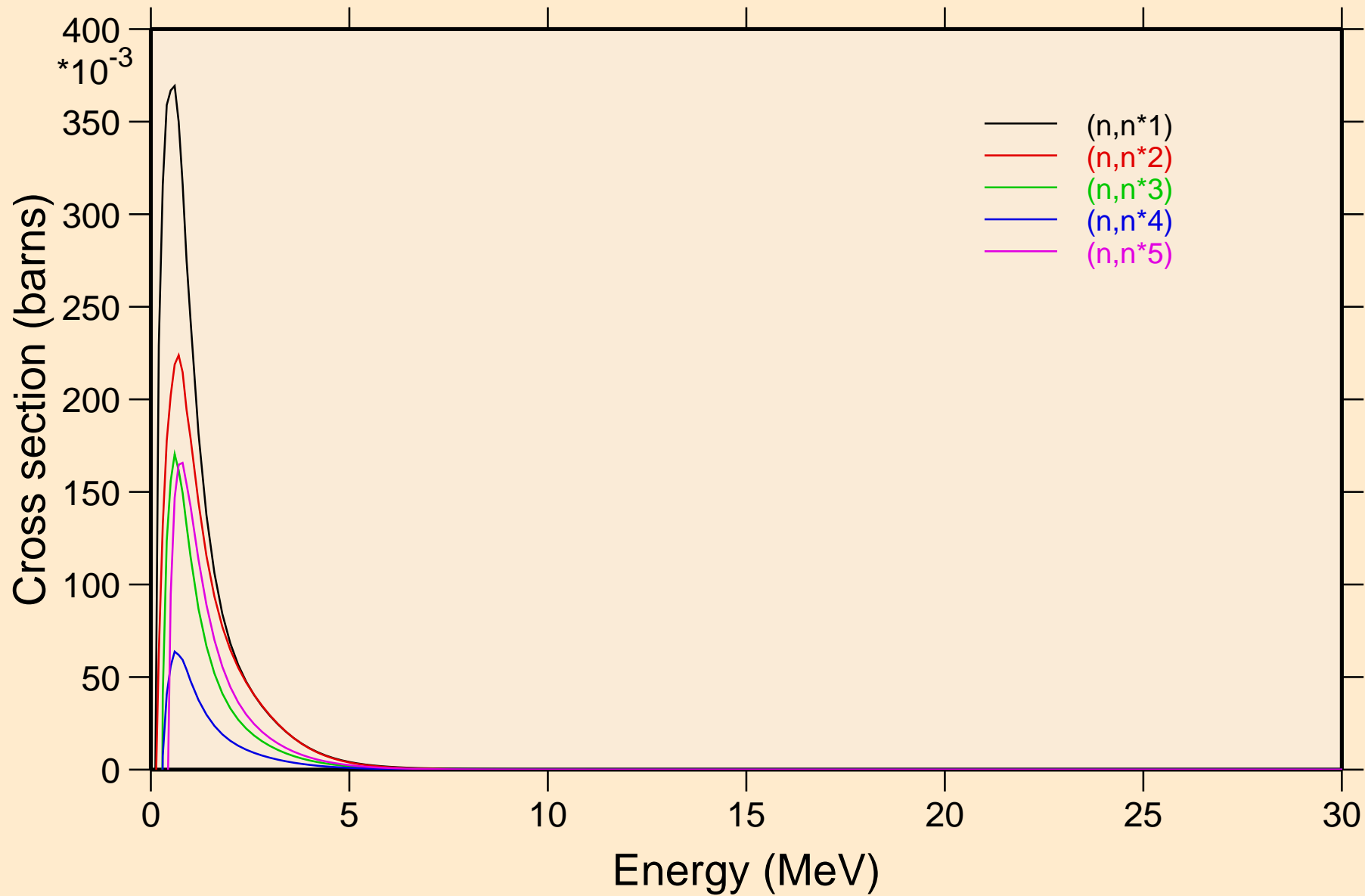

SE075 NEUTRON ACER TENDL-2024 LIBRARY; T=0.K
Inelastic levels

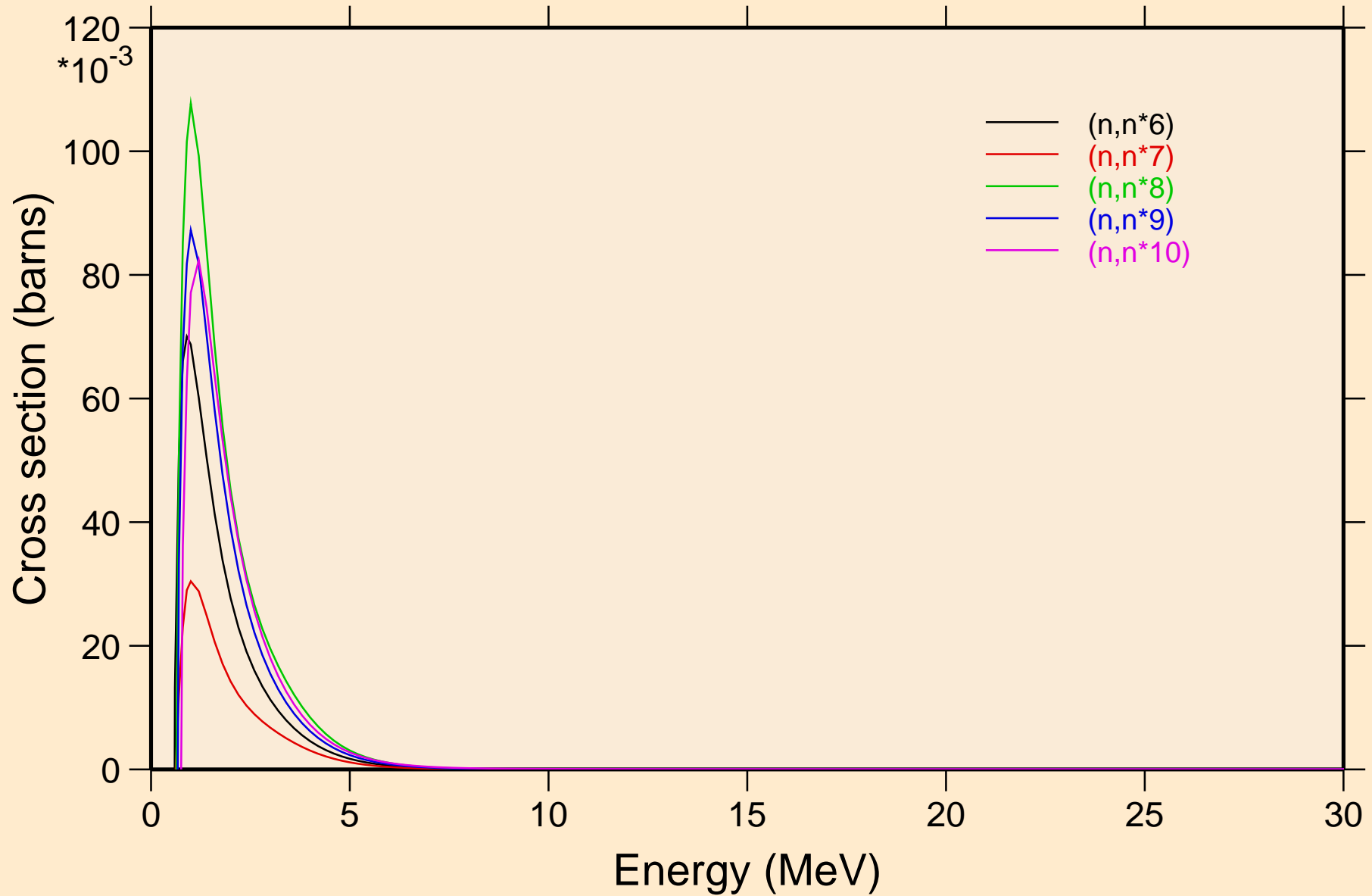

SE075 NEUTRON ACER TENDL-2024 LIBRARY; T=0.K
Inelastic levels

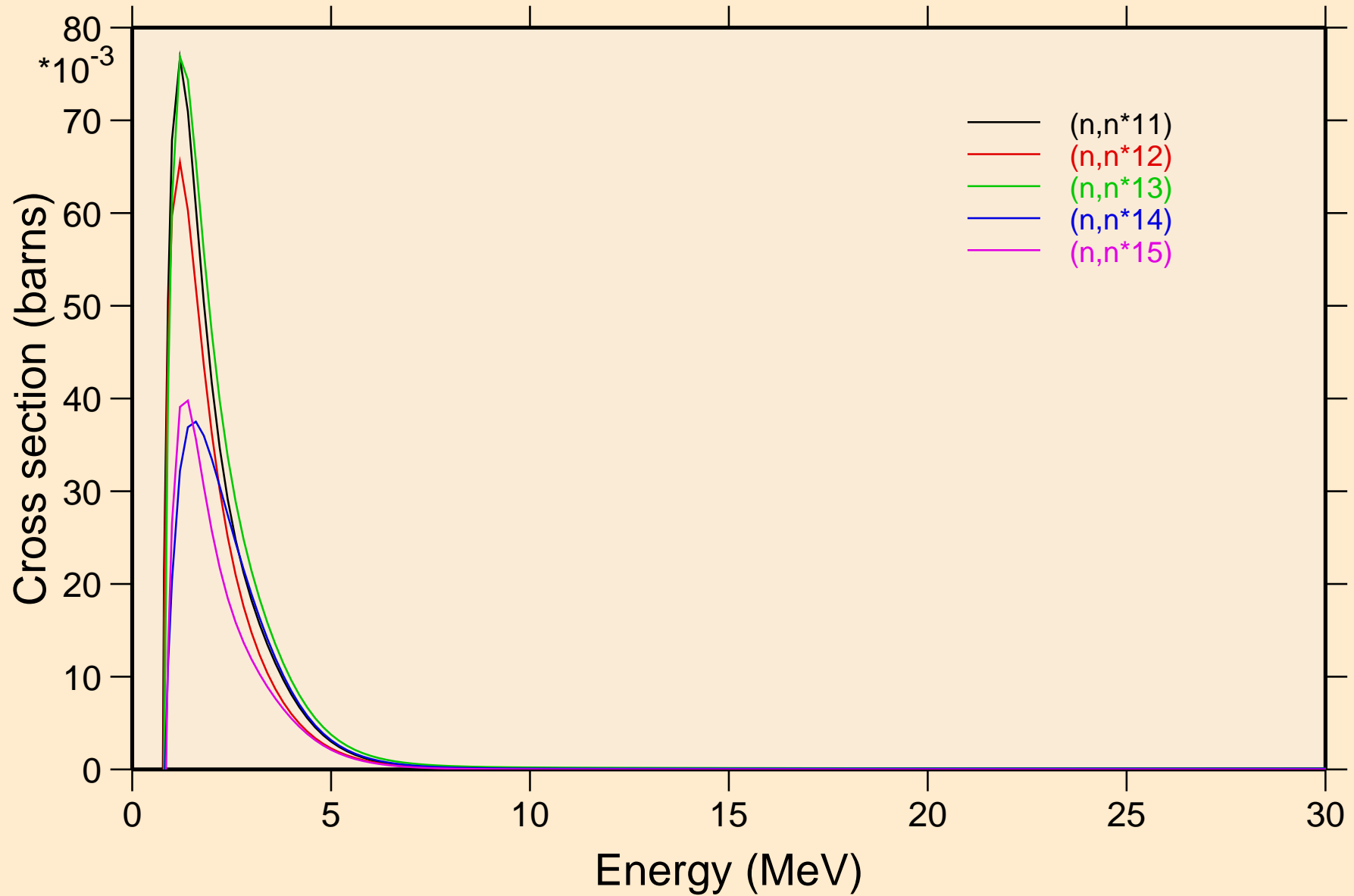

SE075 NEUTRON ACER TENDL-2024 LIBRARY; T=0.K
Inelastic levels

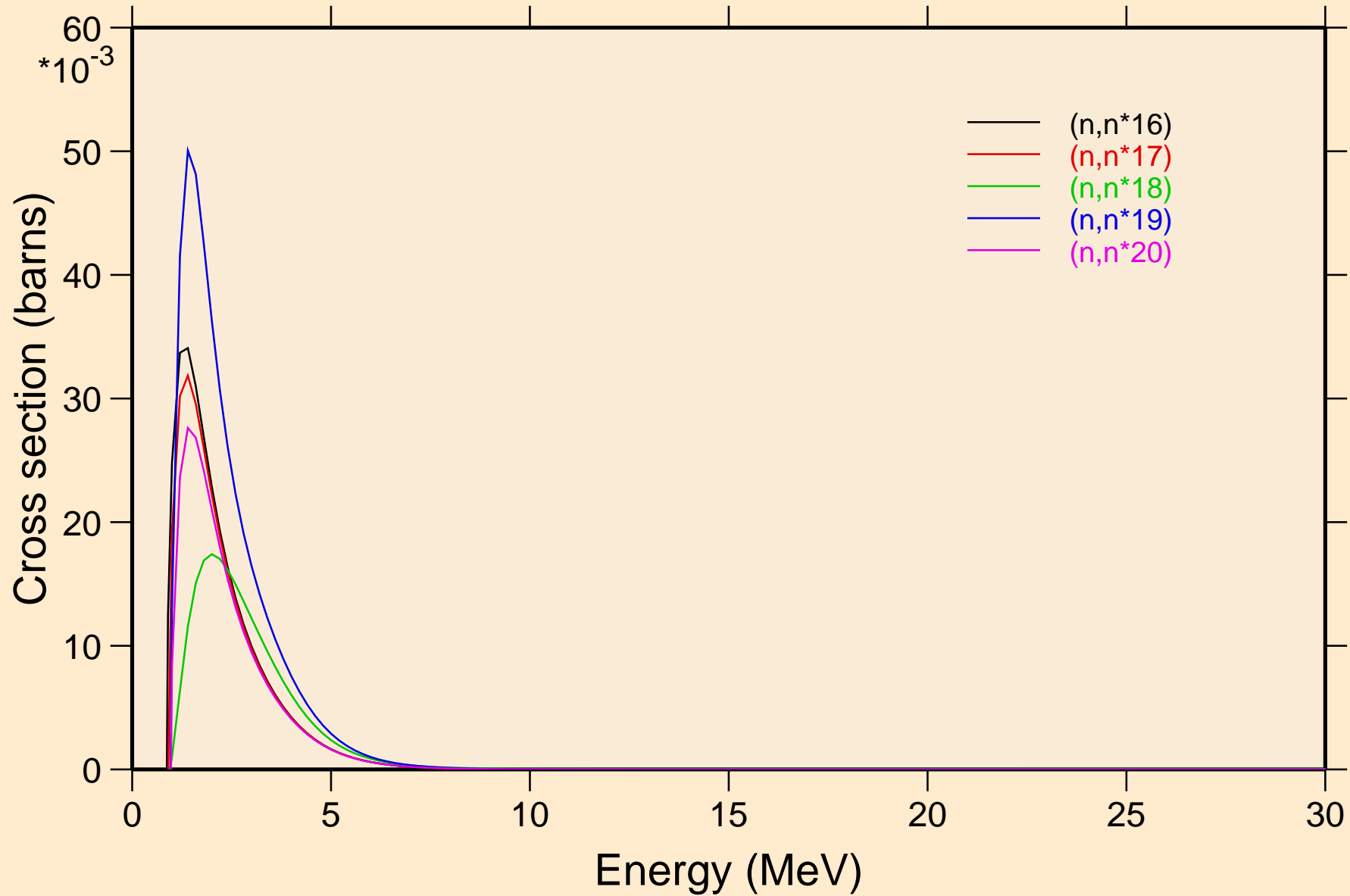

SE075 NEUTRON ACER TENDL-2024 LIBRARY; T=0.K
Inelastic levels

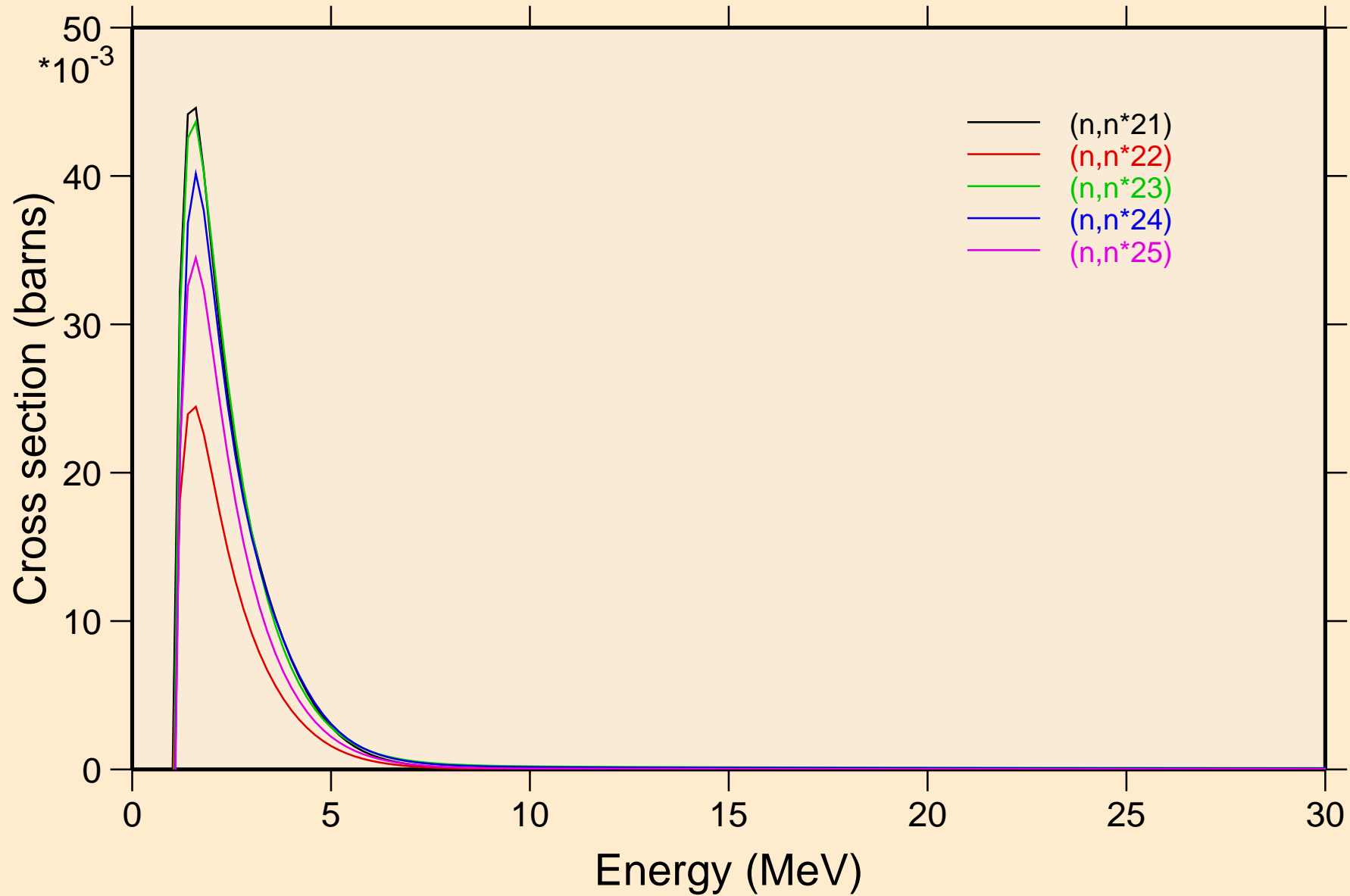

SE075 NEUTRON ACER TENDL-2024 LIBRARY; T=0.K
Inelastic levels

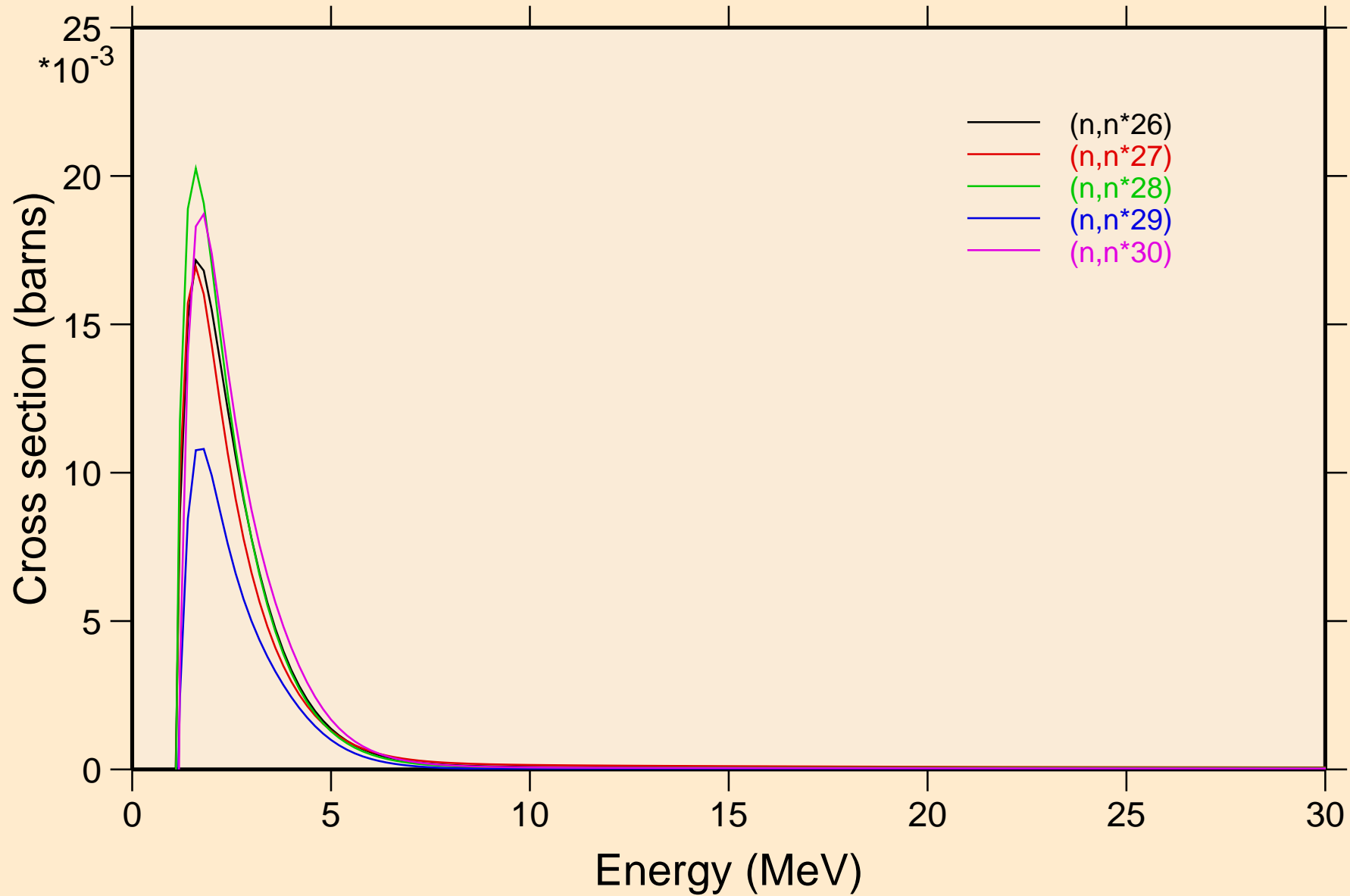

SE075 NEUTRON ACER TENDL-2024 LIBRARY; T=0.K
Threshold reactions

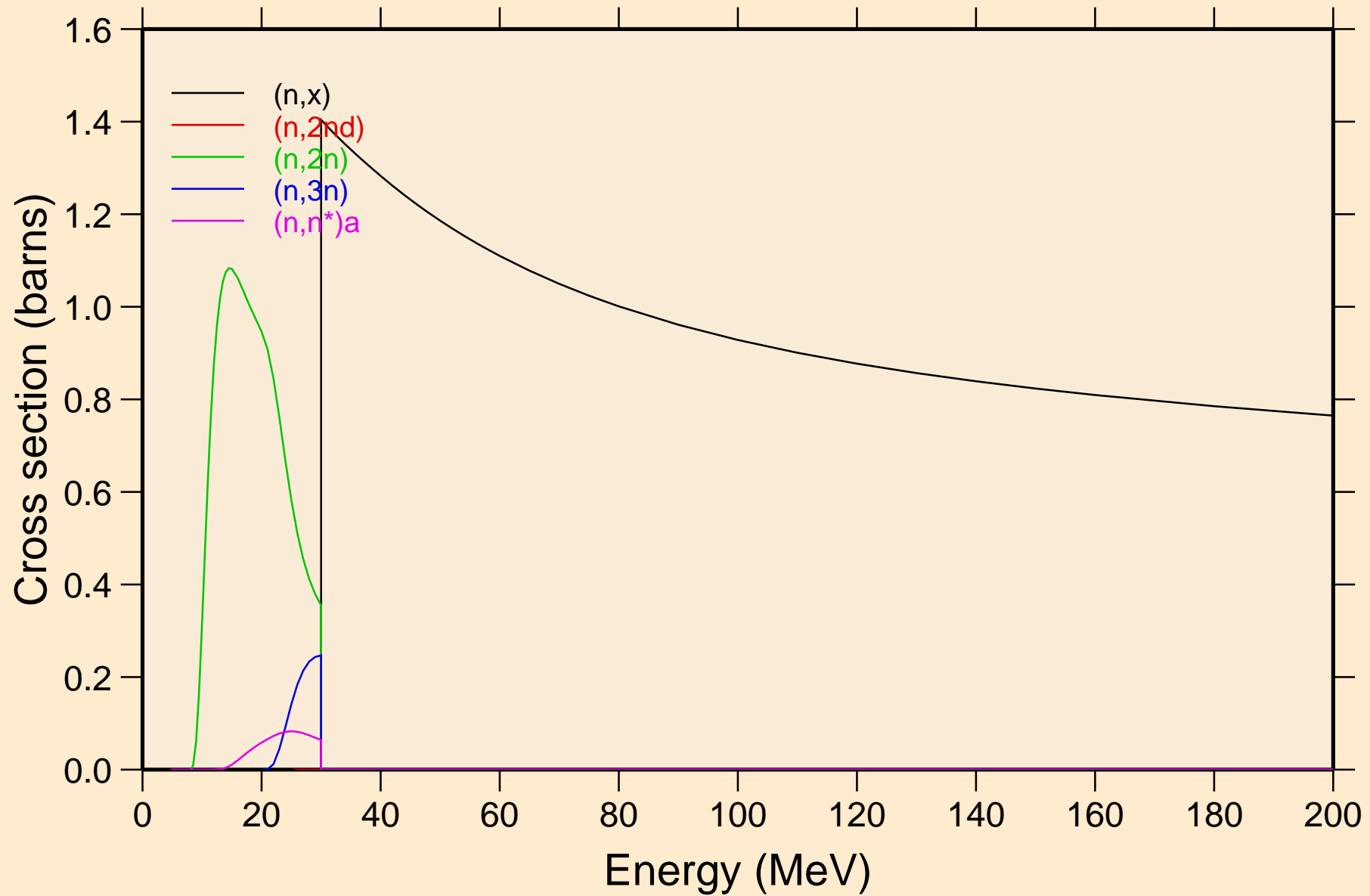

SE075 NEUTRON ACER TENDL-2024 LIBRARY; T=0.K

Threshold reactions

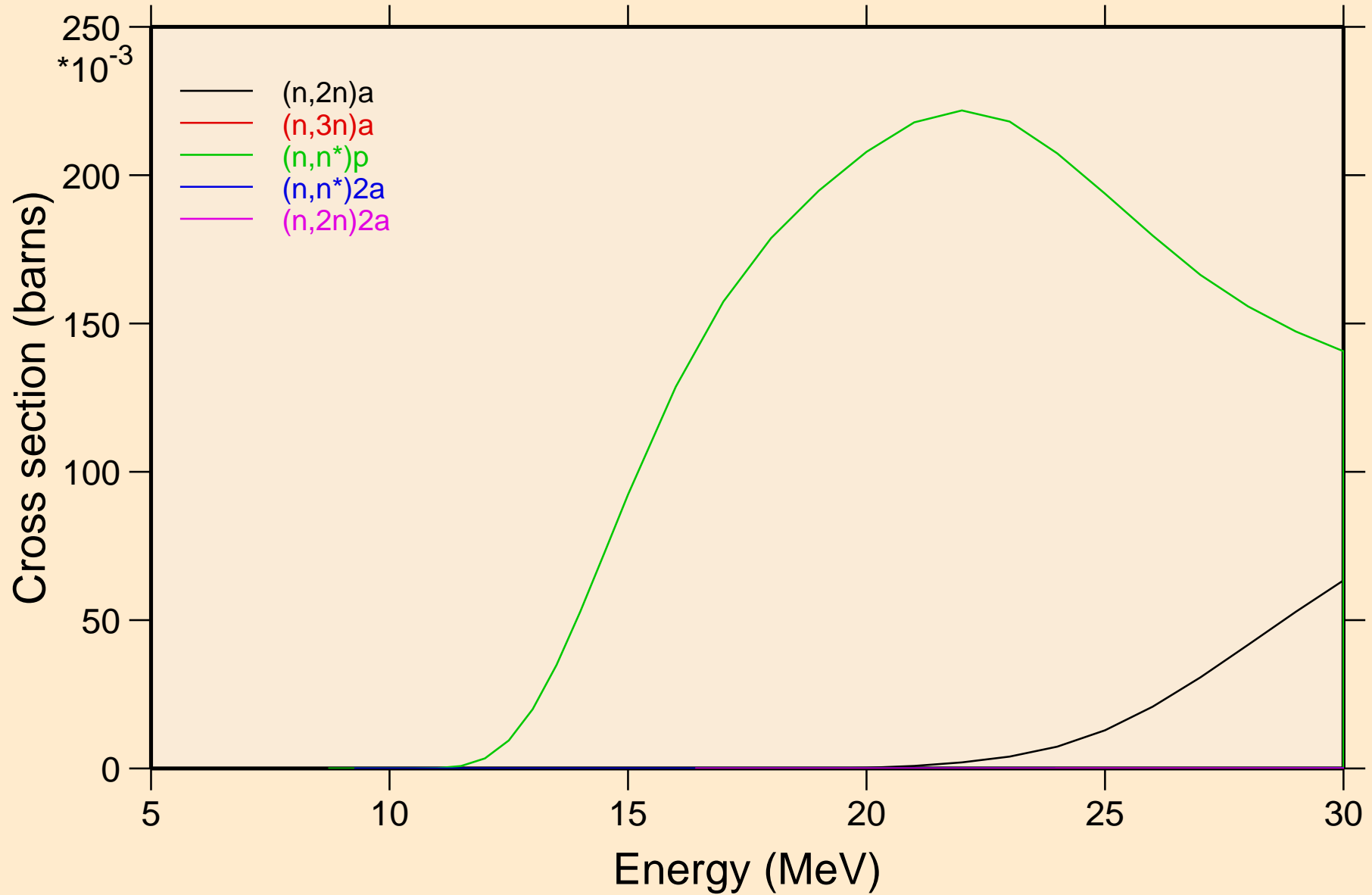

SE075 NEUTRON ACER TENDL-2024 LIBRARY; T=0.K

Threshold reactions

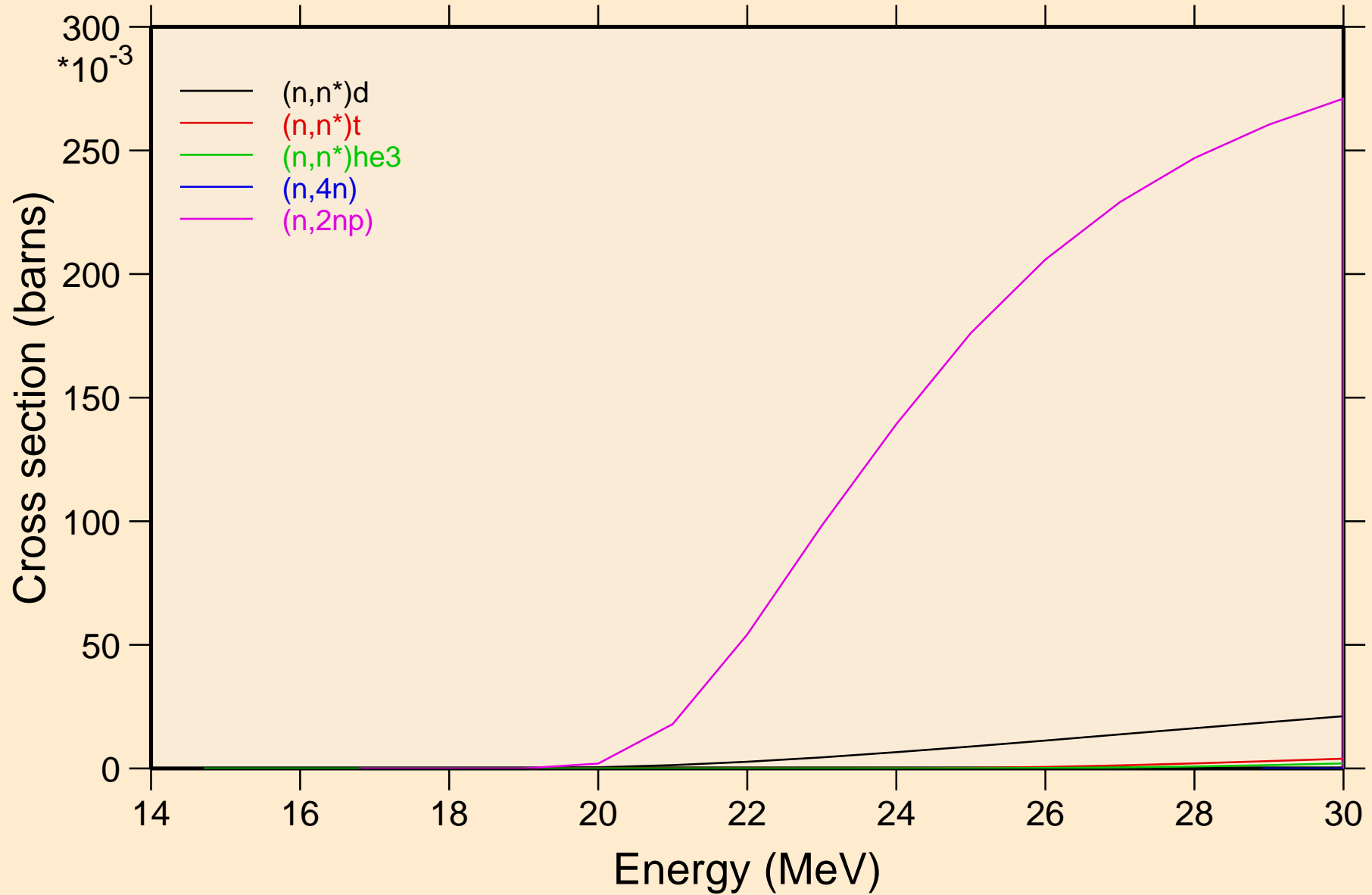

SE075 NEUTRON ACER TENDL-2024 LIBRARY; T=0.K
Threshold reactions

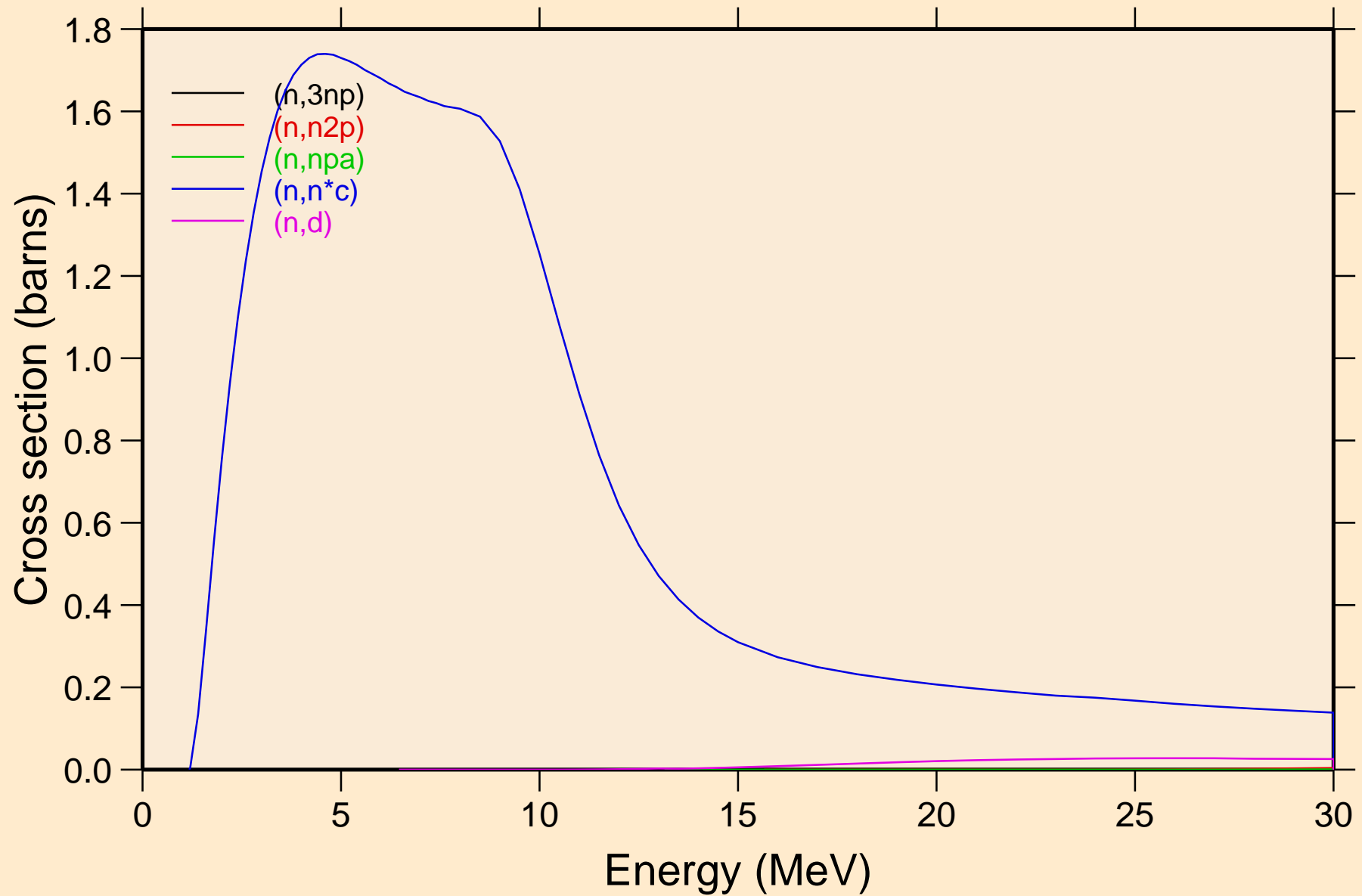

SE075 NEUTRON ACER TENDL-2024 LIBRARY; T=0.K

Threshold reactions

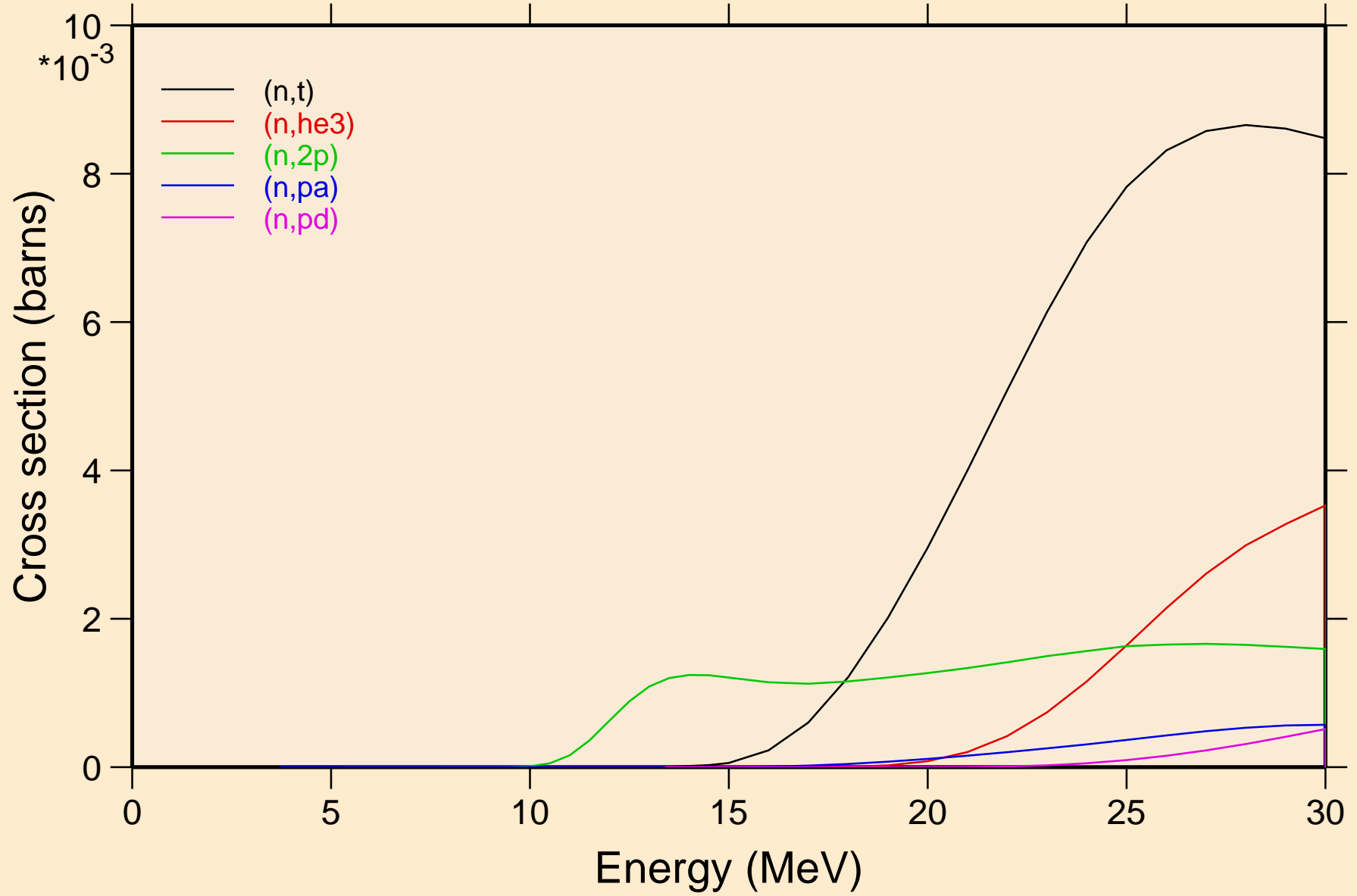

SE075 NEUTRON ACER TENDL-2024 LIBRARY; T=0.K
Threshold reactions

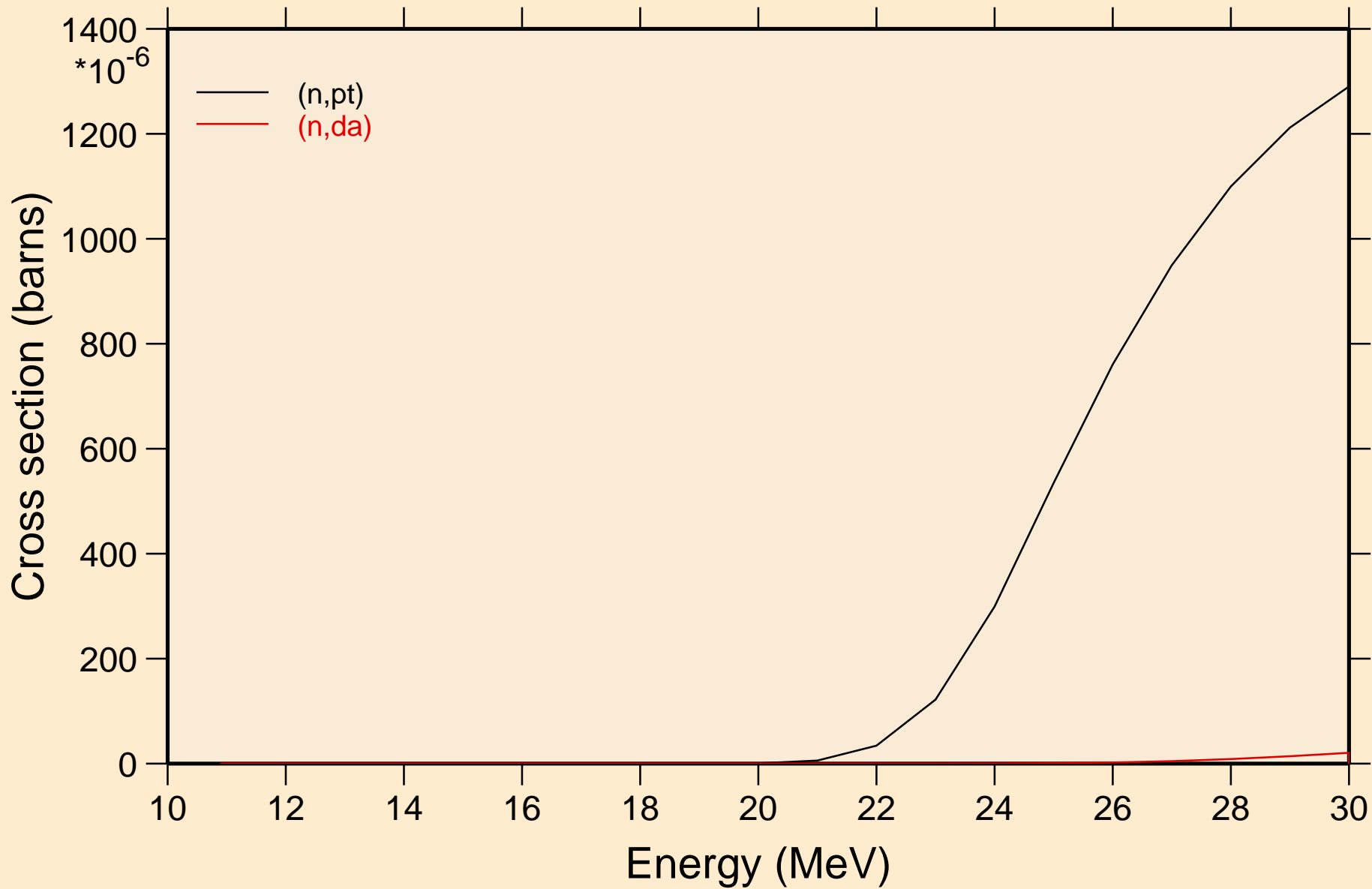

SE075 NEUTRON ACER TENDL-2024 LIBRARY; T=0.K

Threshold reactions

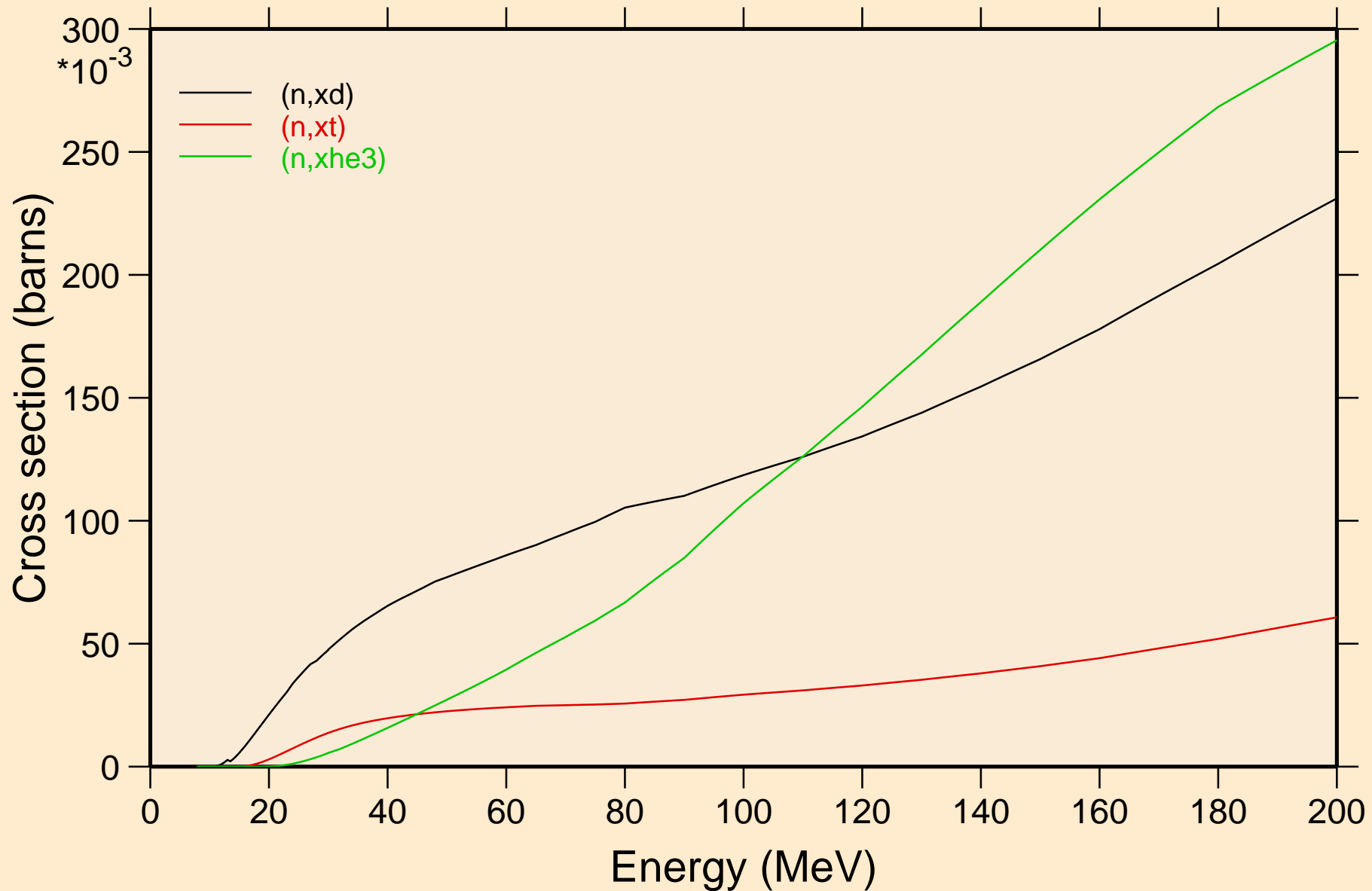

SE075 NEUTRON ACER TENDL-2024 LIBRARY; T=0.K
angular distribution for elastic

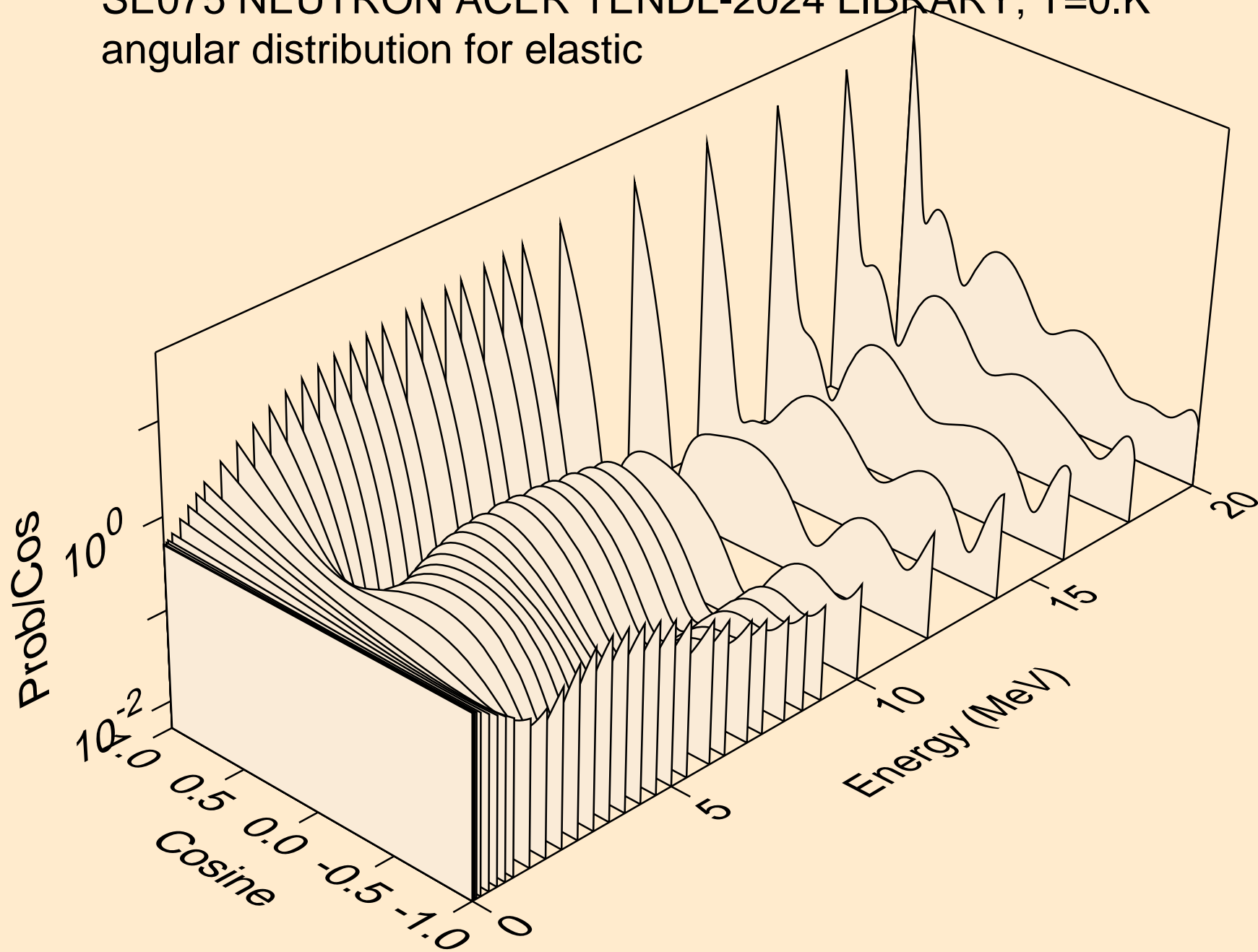

SE075 NEUTRON ACER TENDL-2024 LIBRARY; T=0.K
angular distribution for elastic

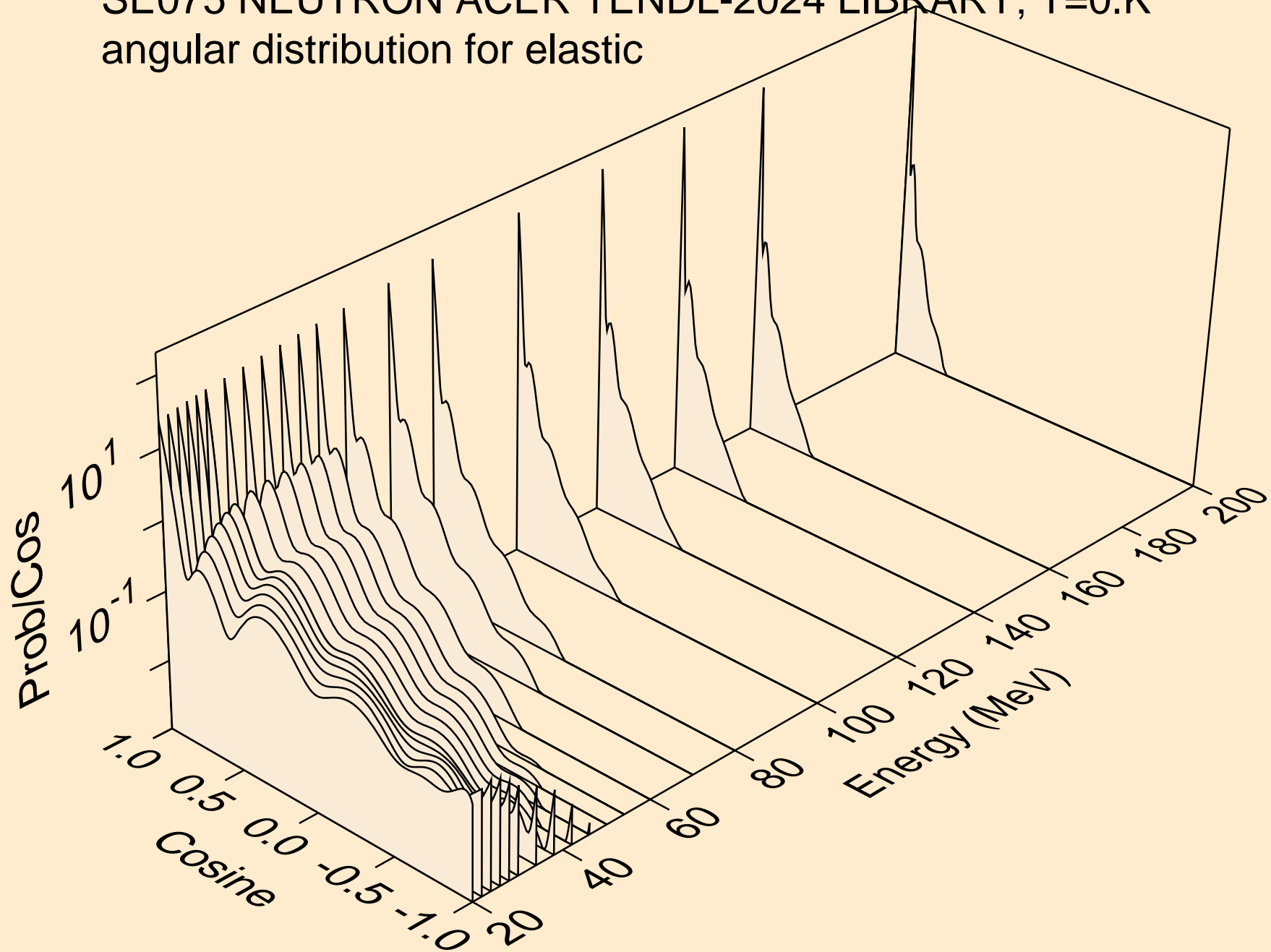

SE075 NEUTRON ACER TENDL-2024 LIBRARY; T=0.K
angular distribution for (n,n*1)

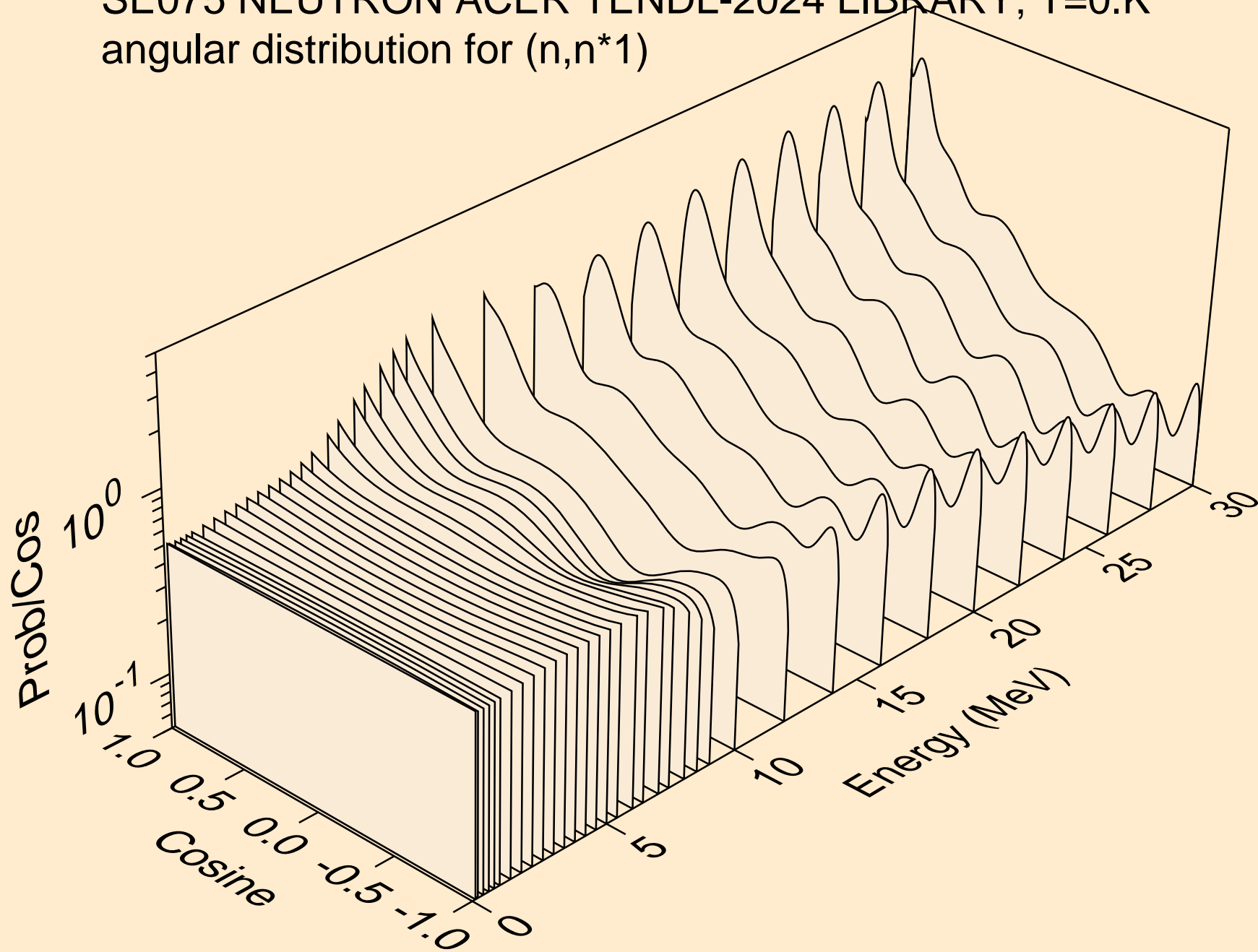

SE075 NEUTRON ACER TENDL-2024 LIBRARY; T=0.K
angular distribution for (n,n*2)

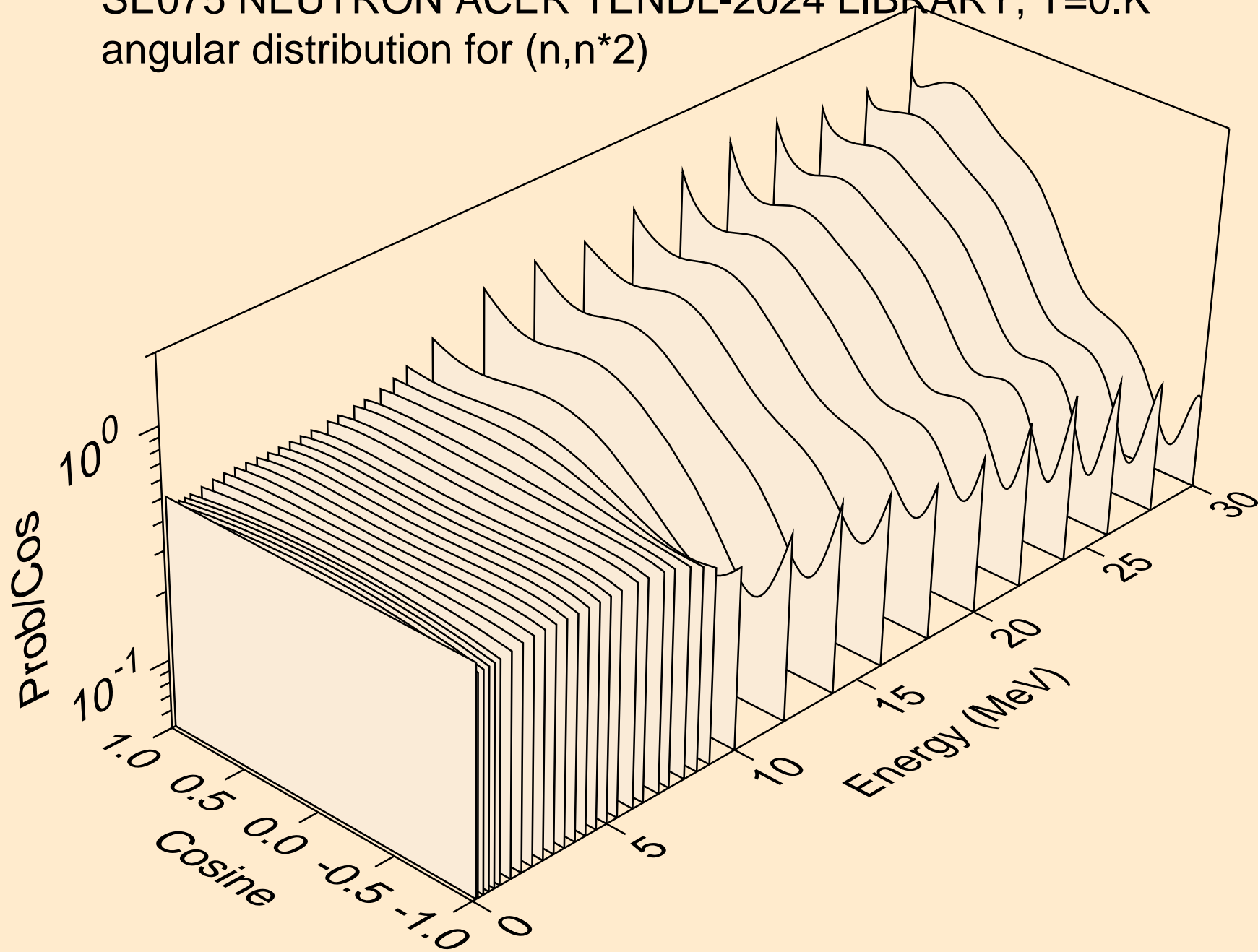

SE075 NEUTRON ACER TENDL-2024 LIBRARY; T=0.K
angular distribution for (n,n*3)

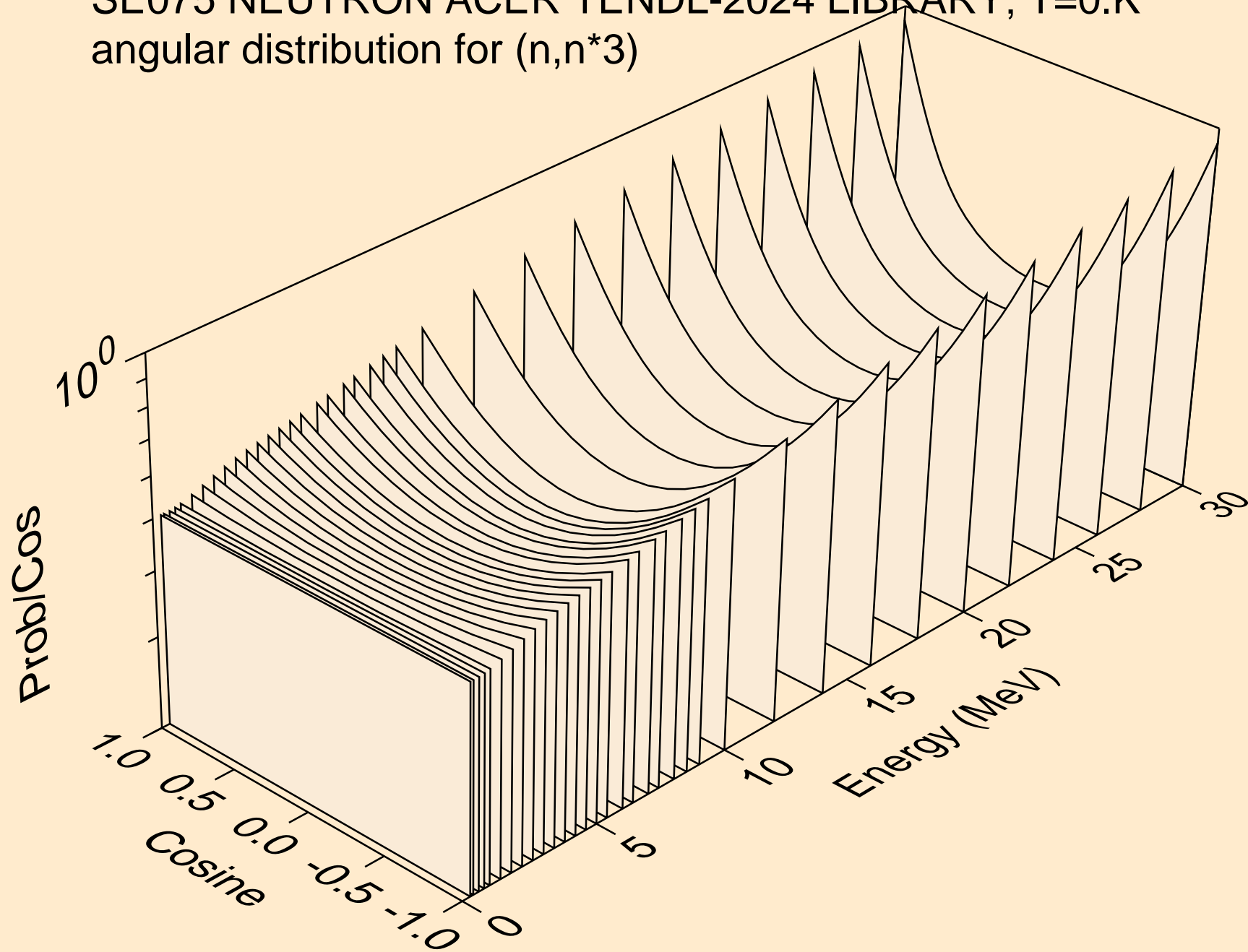

SE075 NEUTRON ACER TENDL-2024 LIBRARY; T=0.K
angular distribution for (n,n*4)

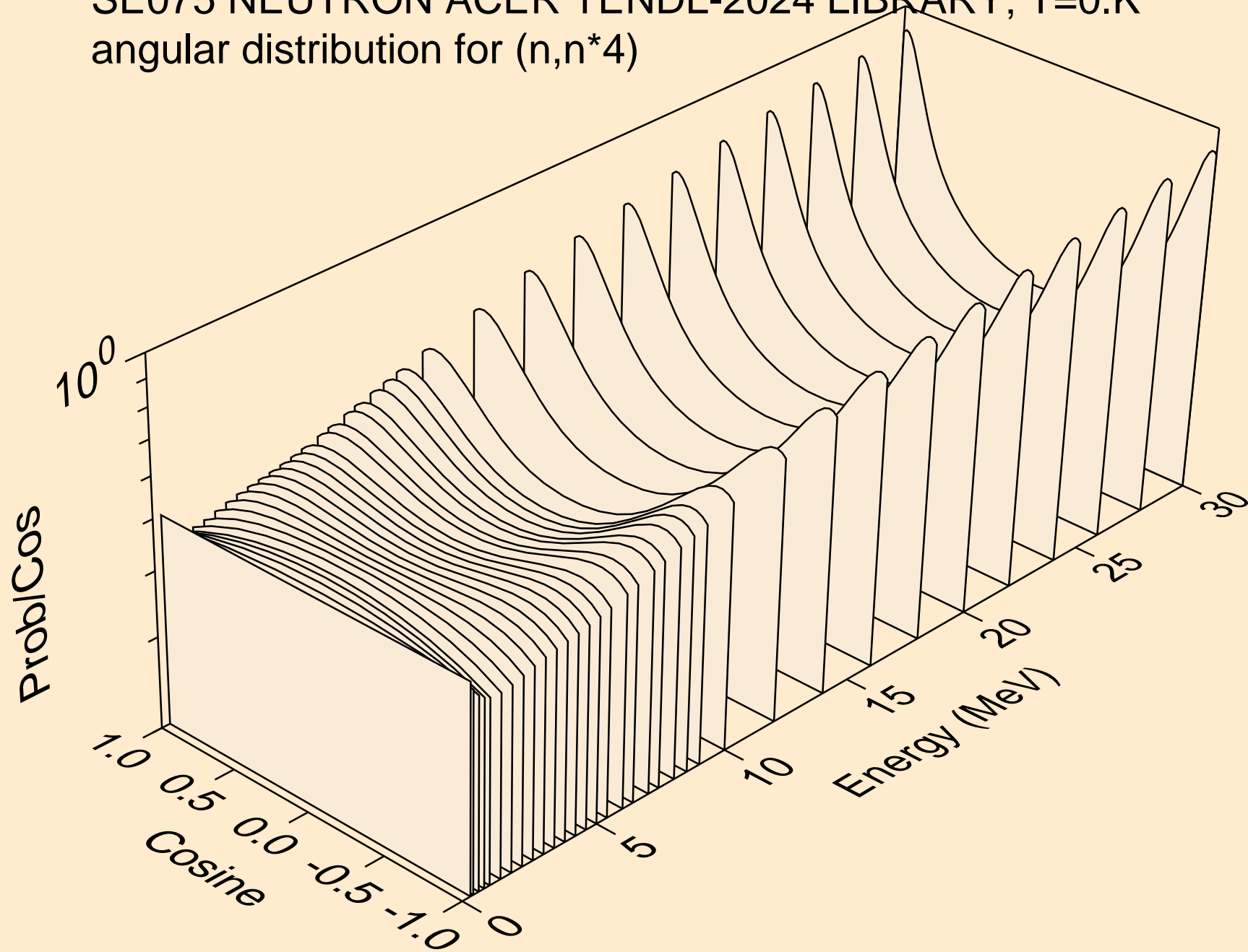

SE075 NEUTRON ACER TENDL-2024 LIBRARY; T=0.K
angular distribution for (n,n*5)

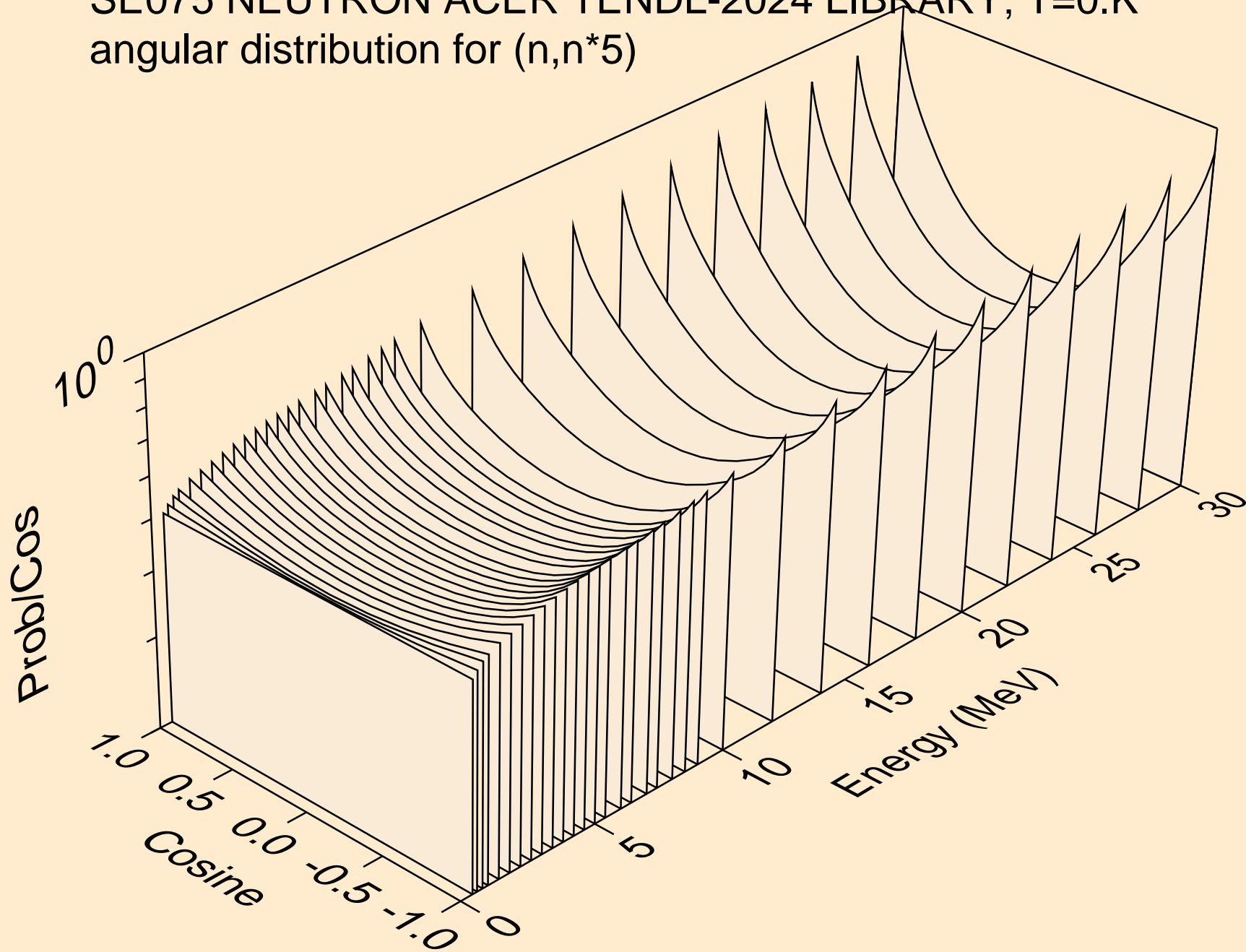

SE075 NEUTRON ACER TENDL-2024 LIBRARY; T=0.K
angular distribution for (n,n*6)

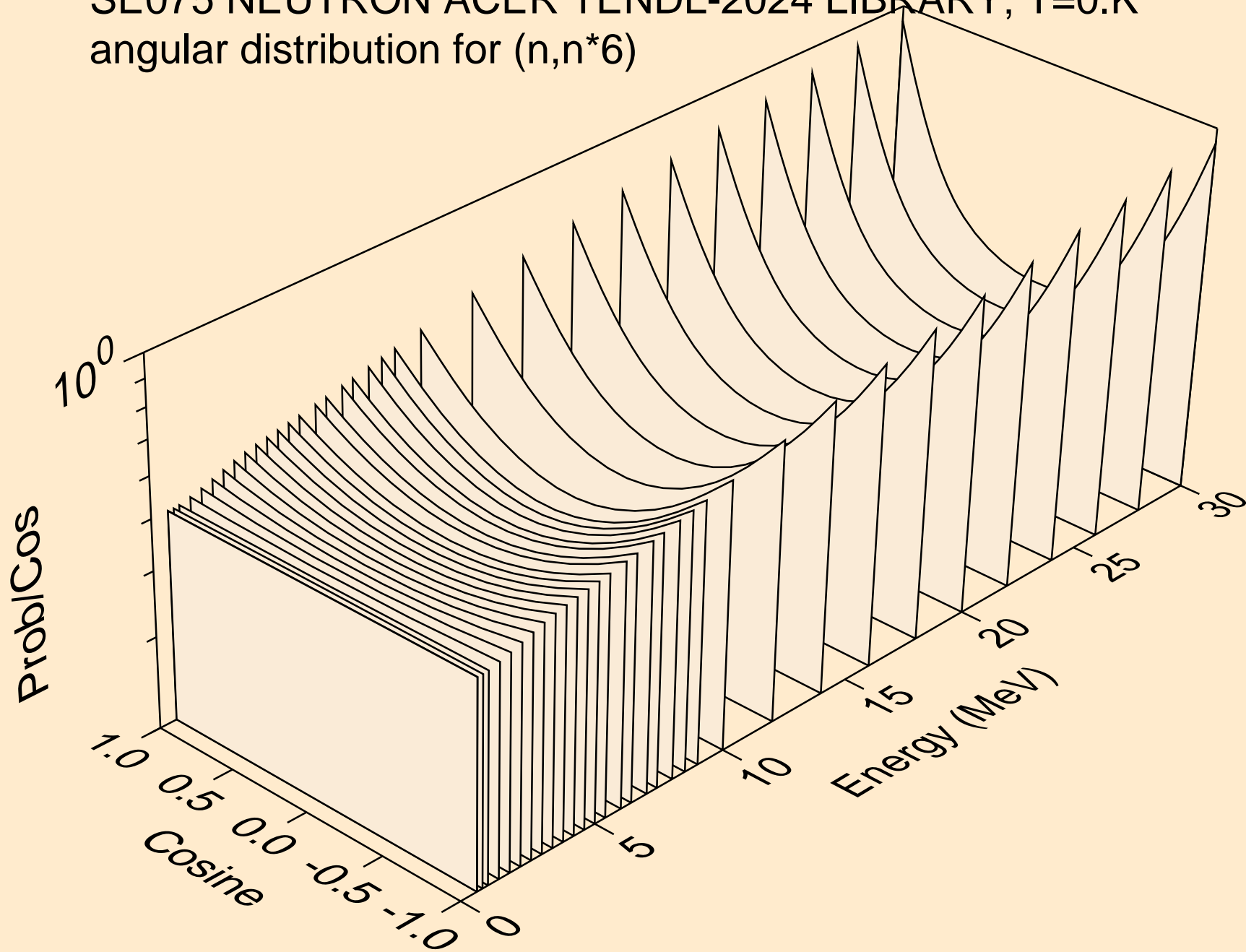

SE075 NEUTRON ACER TENDL-2024 LIBRARY; T=0.K
angular distribution for (n,n*7)

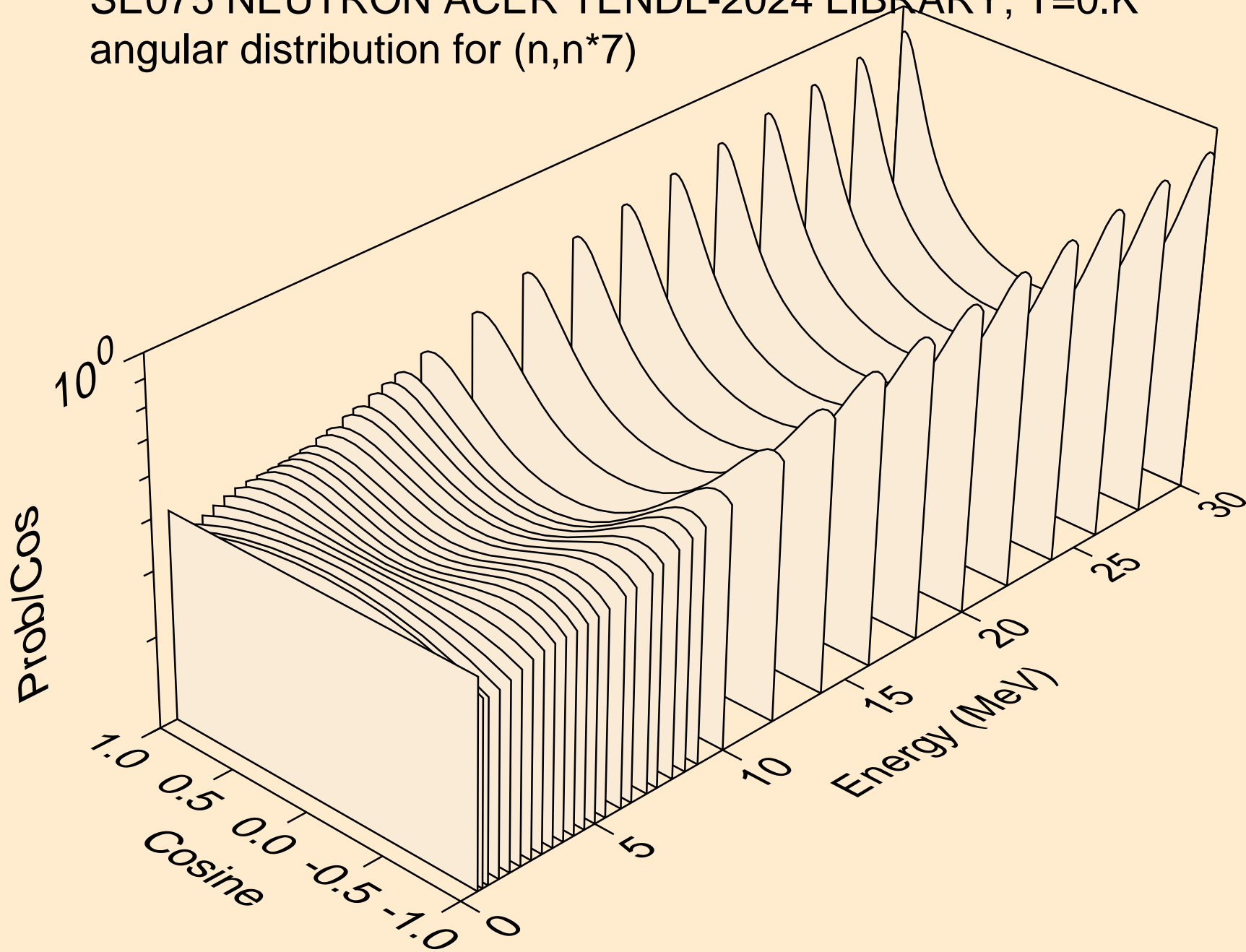

SE075 NEUTRON ACER TENDL-2024 LIBRARY; T=0.K
angular distribution for (n,n*8)

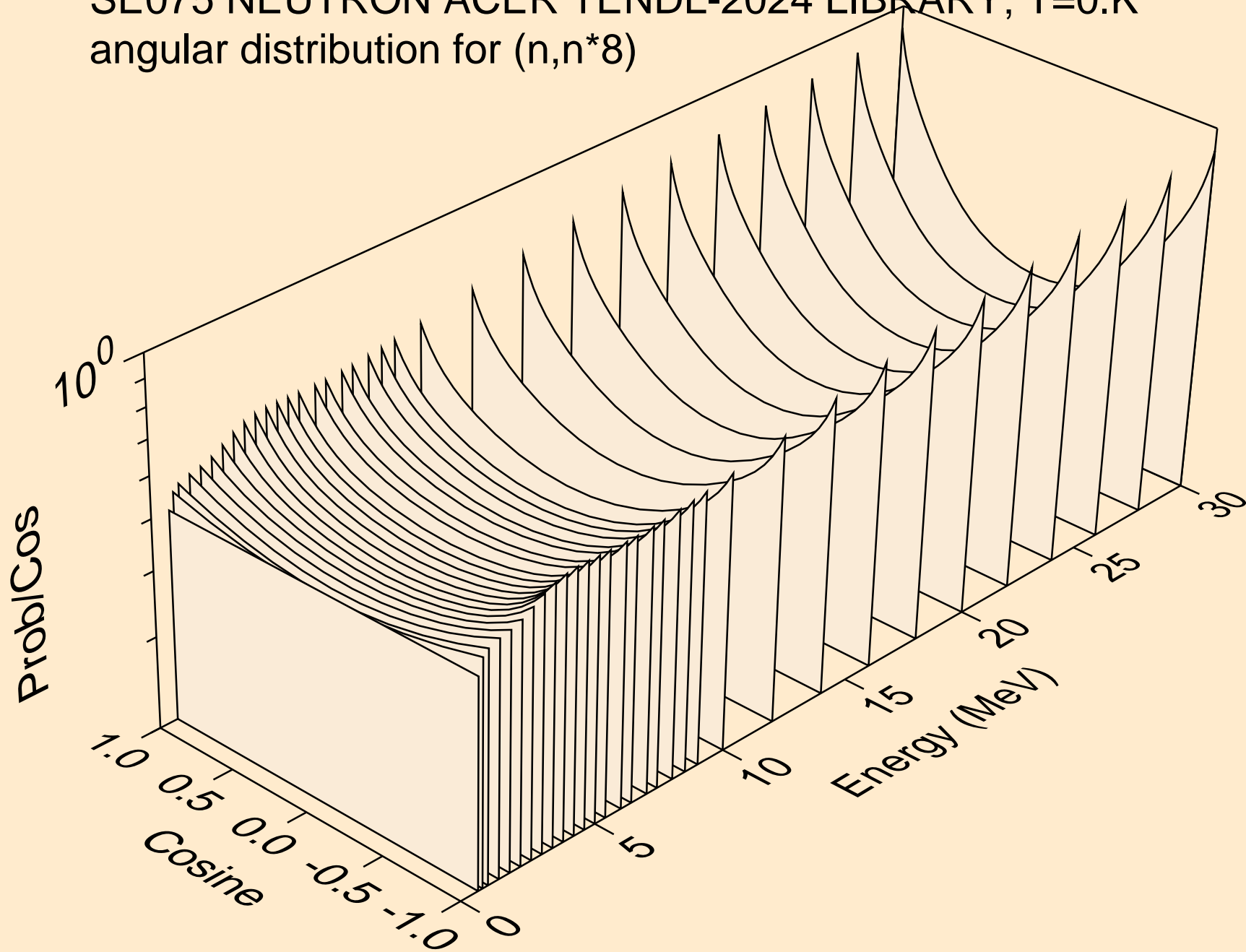

SE075 NEUTRON ACER TENDL-2024 LIBRARY; T=0.K
angular distribution for (n,n*9)

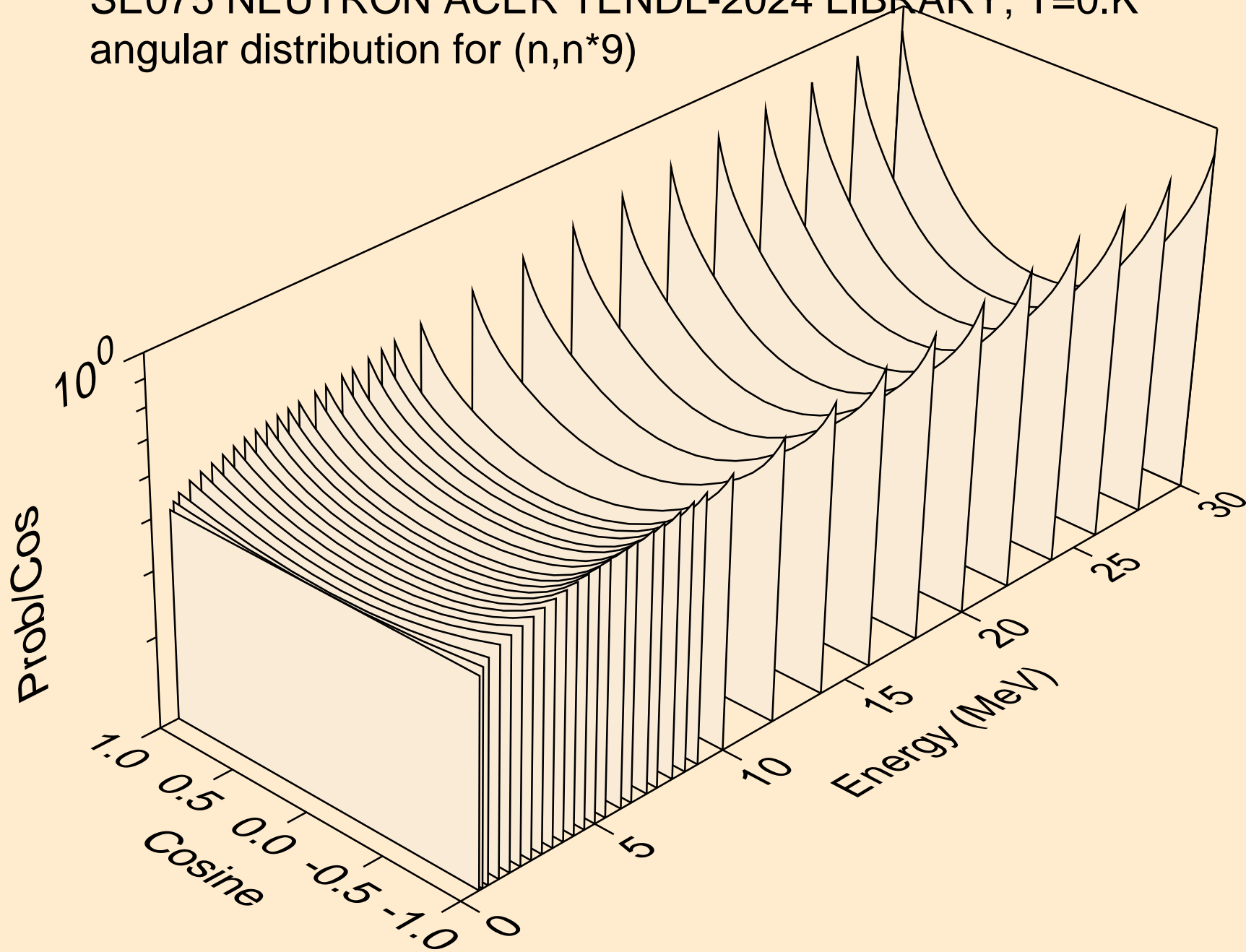

SE075 NEUTRON ACER TENDL-2024 LIBRARY; T=0.K
angular distribution for (n,n*10)

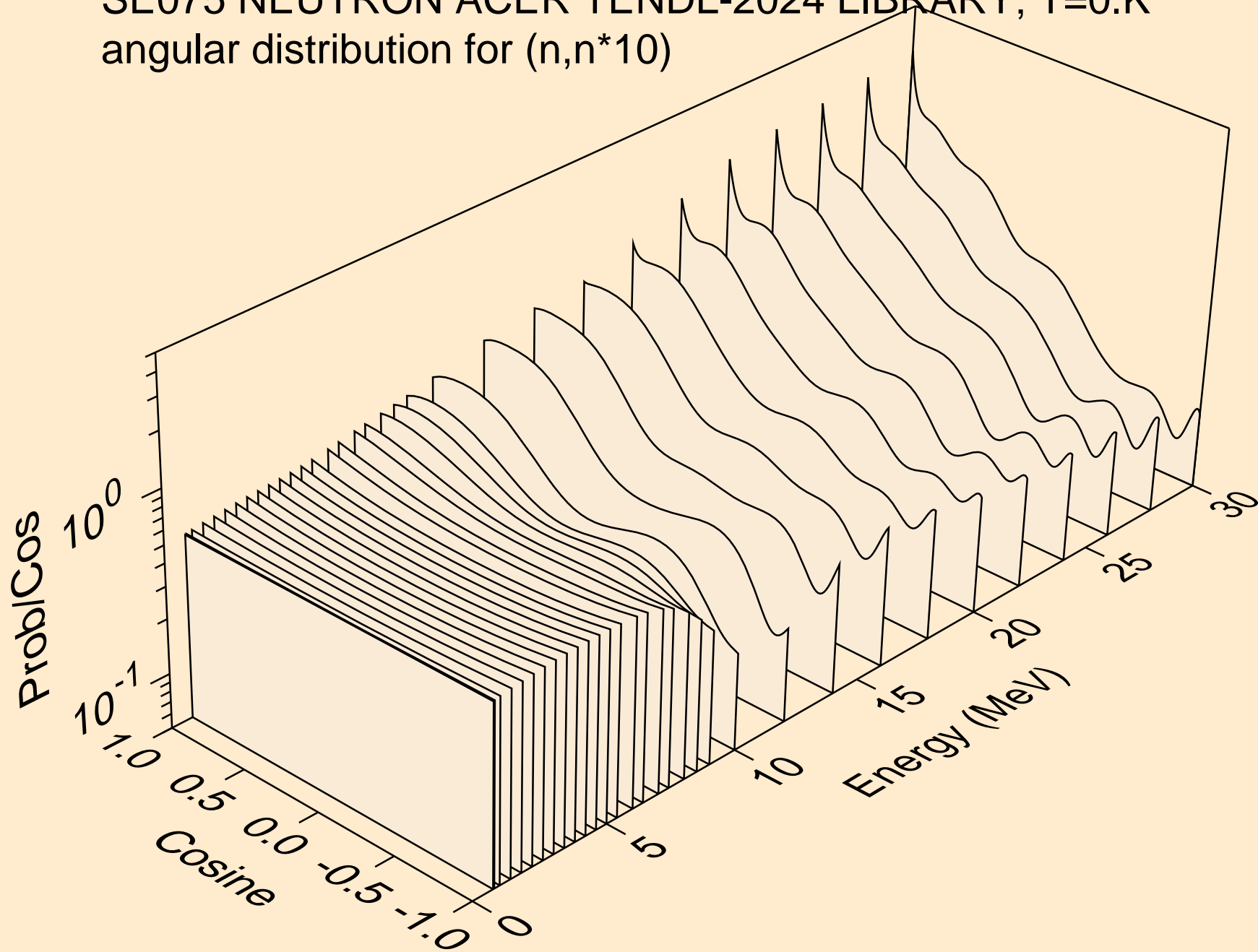

SE075 NEUTRON ACER TENDL-2024 LIBRARY; T=0.K
angular distribution for (n,n*11)

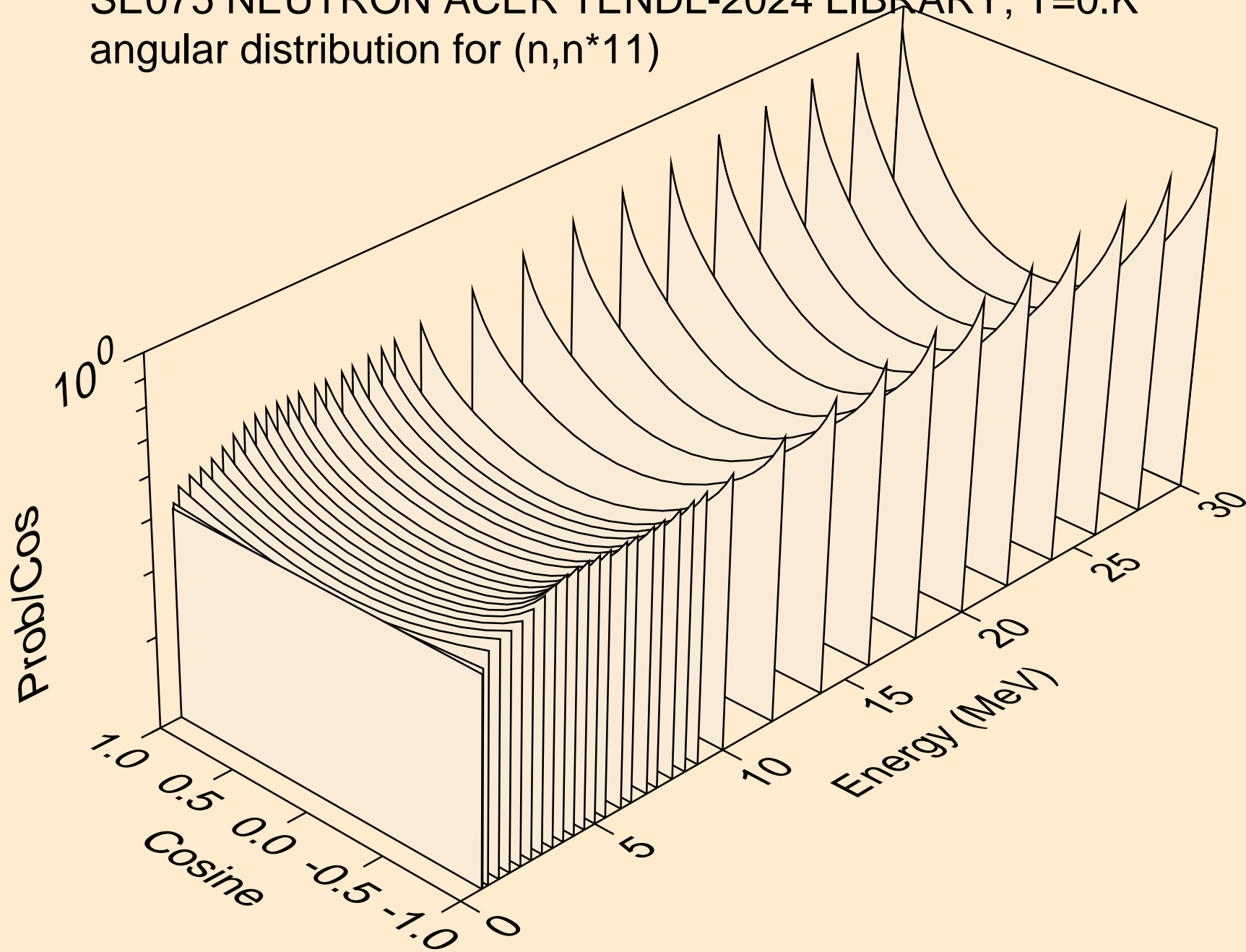

SE075 NEUTRON ACER TENDL-2024 LIBRARY; T=0.K
angular distribution for (n,n*12)

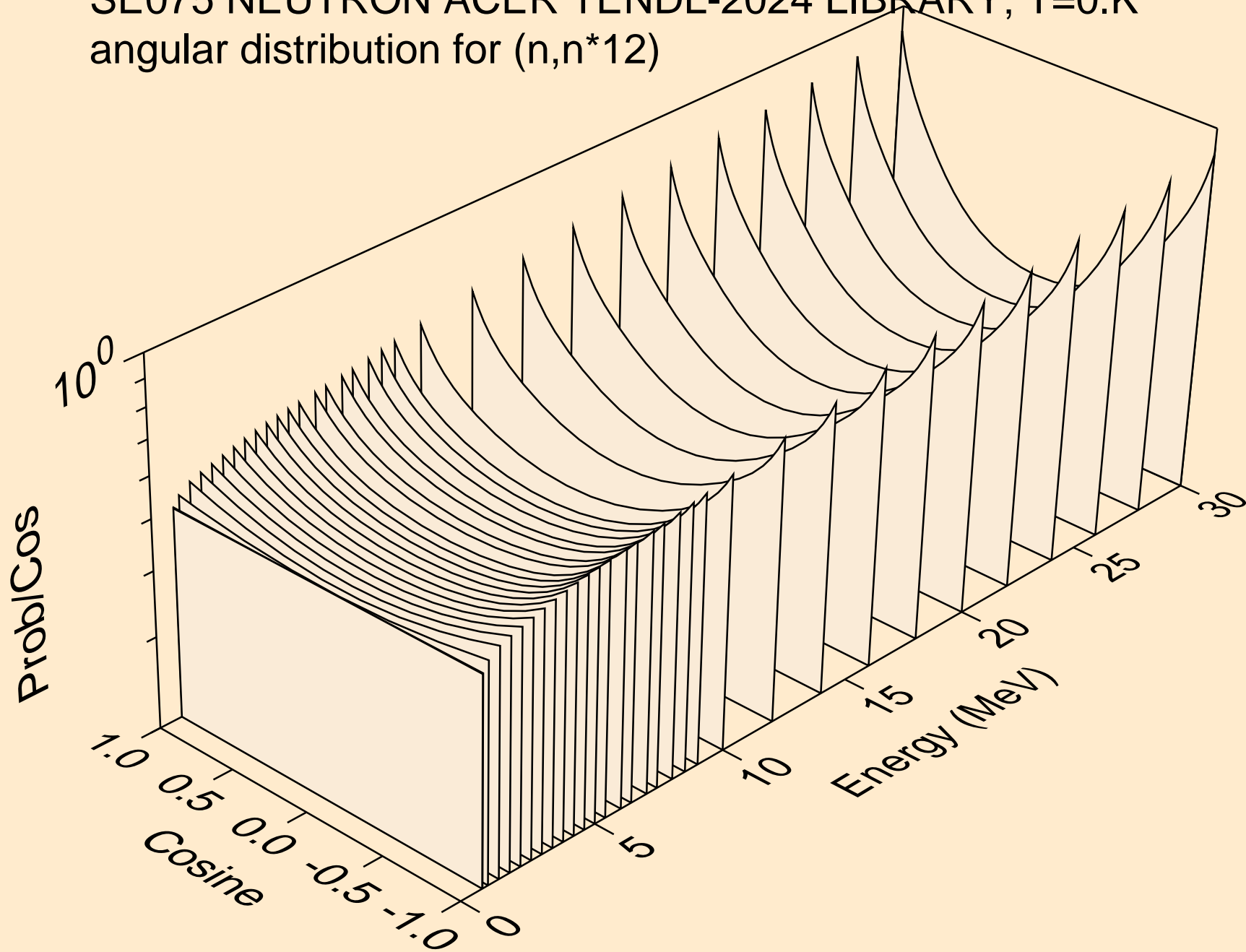

SE075 NEUTRON ACER TENDL-2024 LIBRARY; T=0.K
angular distribution for (n,n*13)

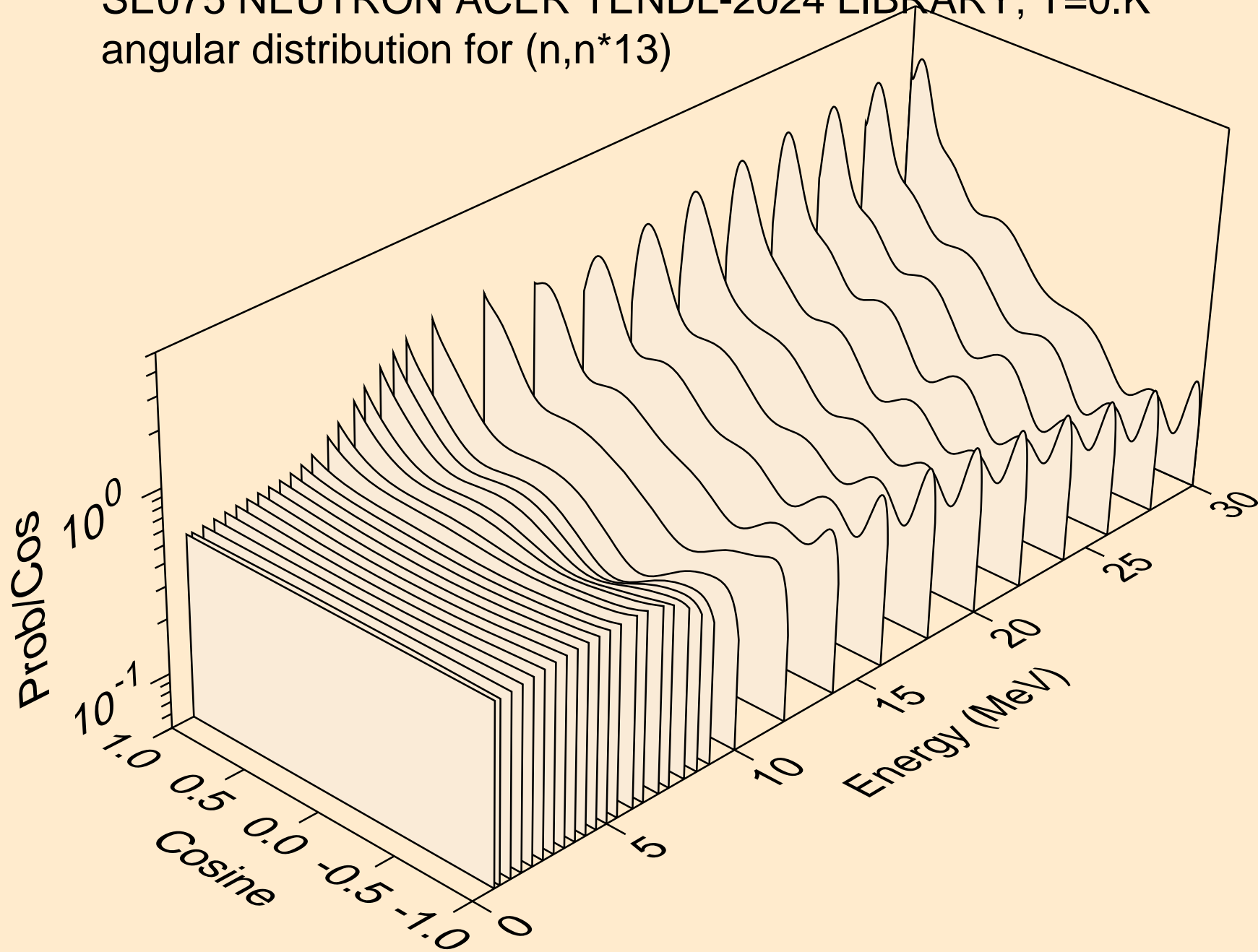

SE075 NEUTRON ACER TENDL-2024 LIBRARY; T=0.K
angular distribution for (n,n*14)

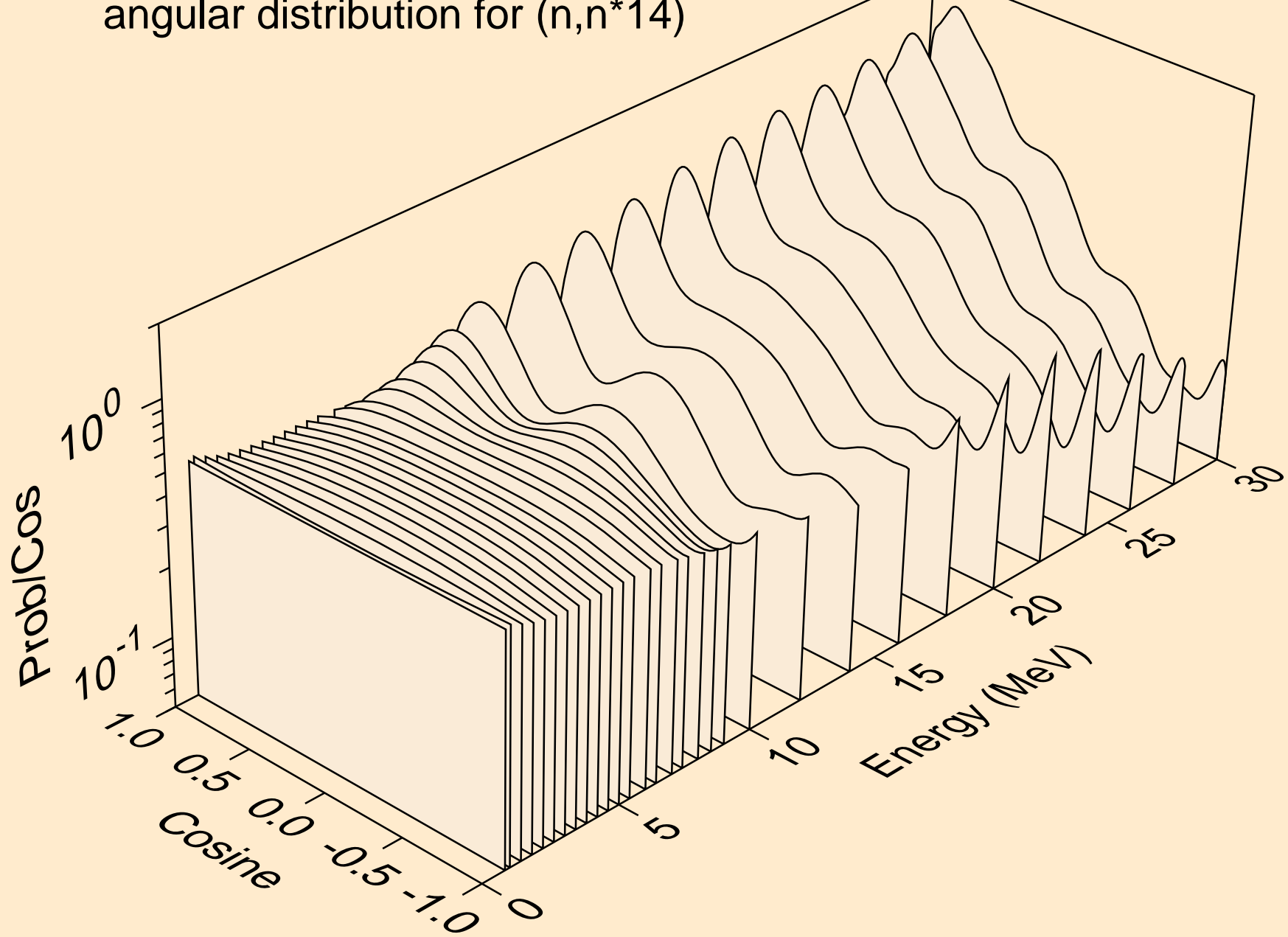

SE075 NEUTRON ACER TENDL-2024 LIBRARY; T=0.K
angular distribution for (n,n*15)

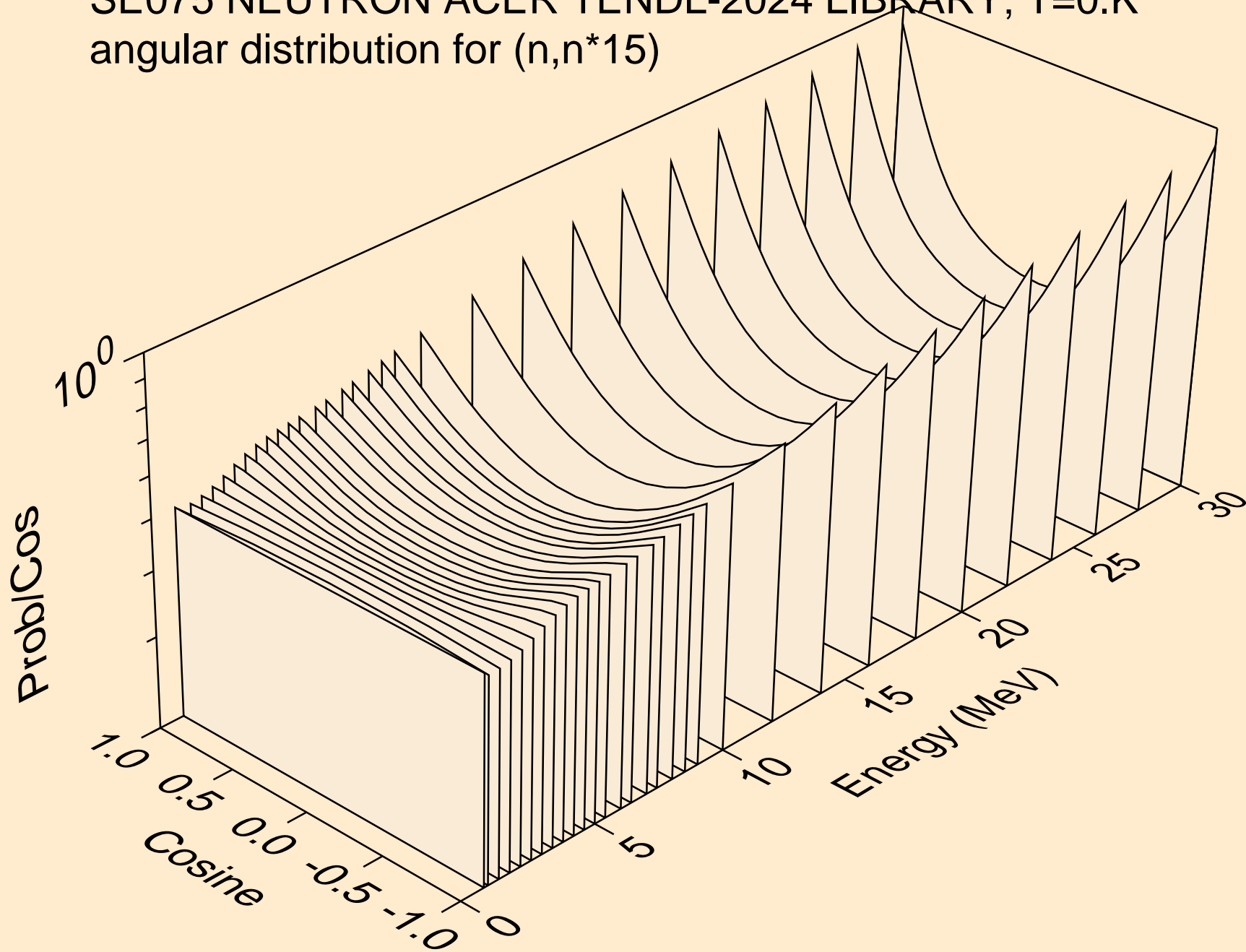

SE075 NEUTRON ACER TENDL-2024 LIBRARY; T=0.K
angular distribution for (n,n*16)

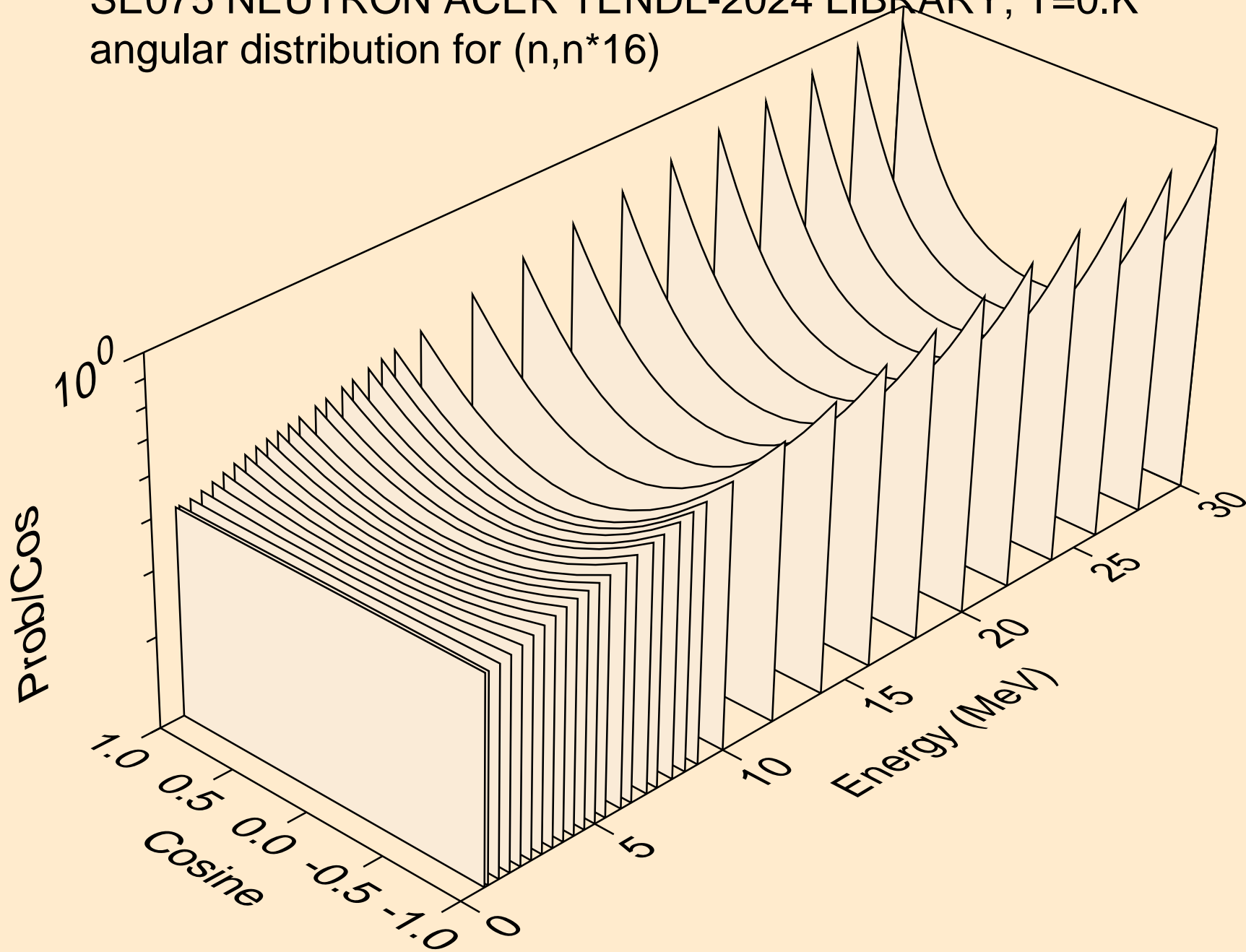

SE075 NEUTRON ACER TENDL-2024 LIBRARY; T=0.K
angular distribution for (n,n*17)

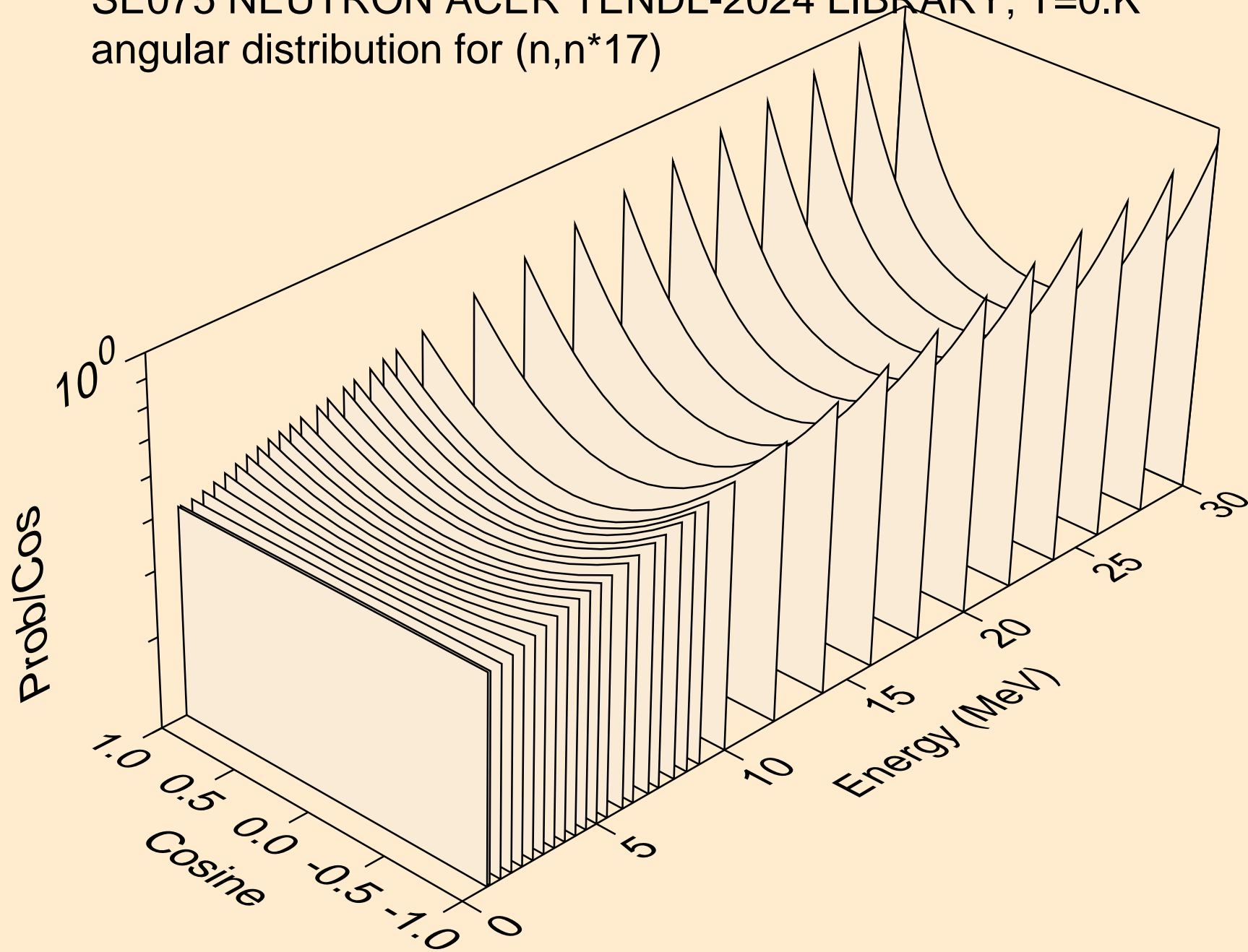

SE075 NEUTRON ACER TENDL-2024 LIBRARY; T=0.K
angular distribution for (n,n*18)

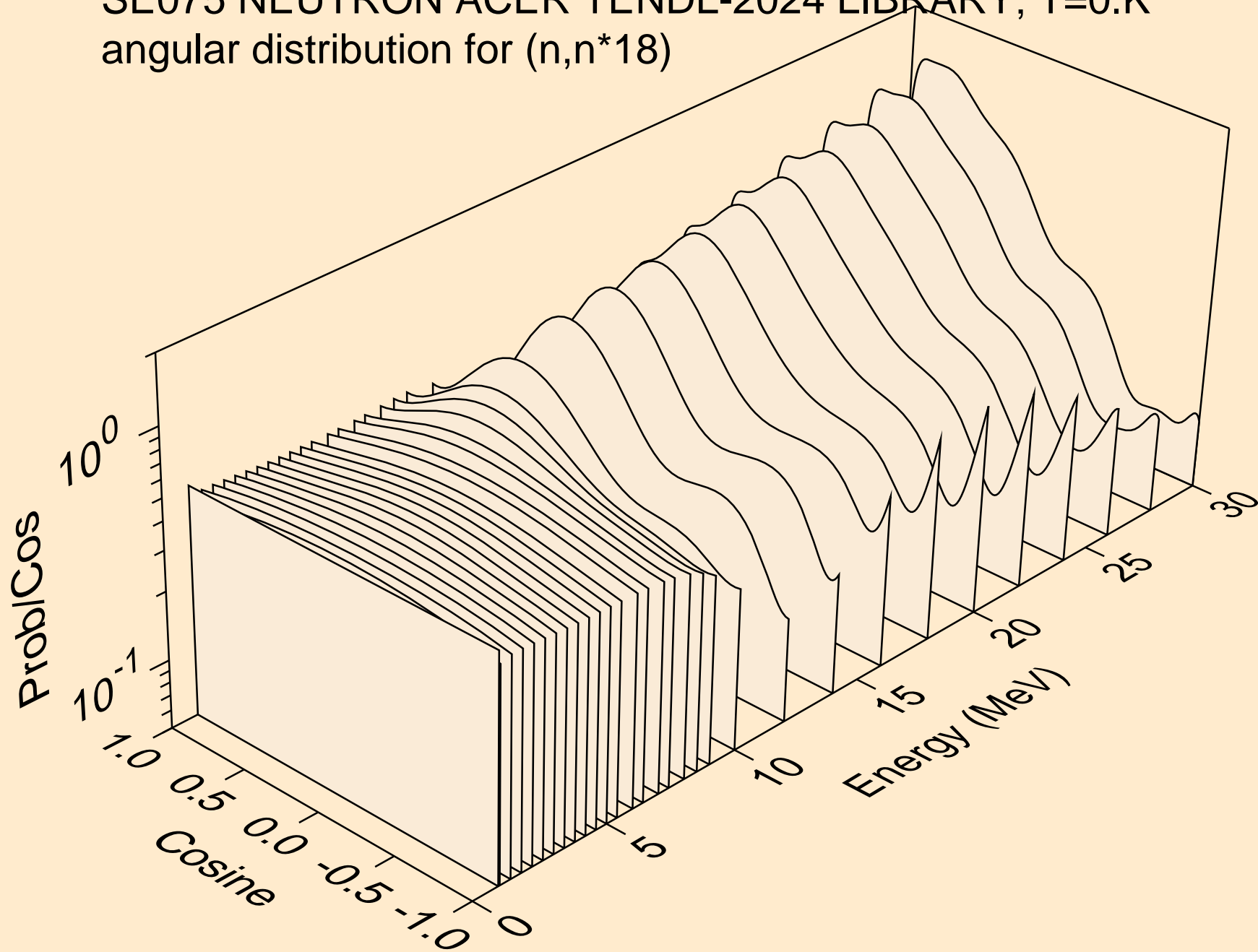

SE075 NEUTRON ACER TENDL-2024 LIBRARY; T=0.K
angular distribution for (n,n*19)

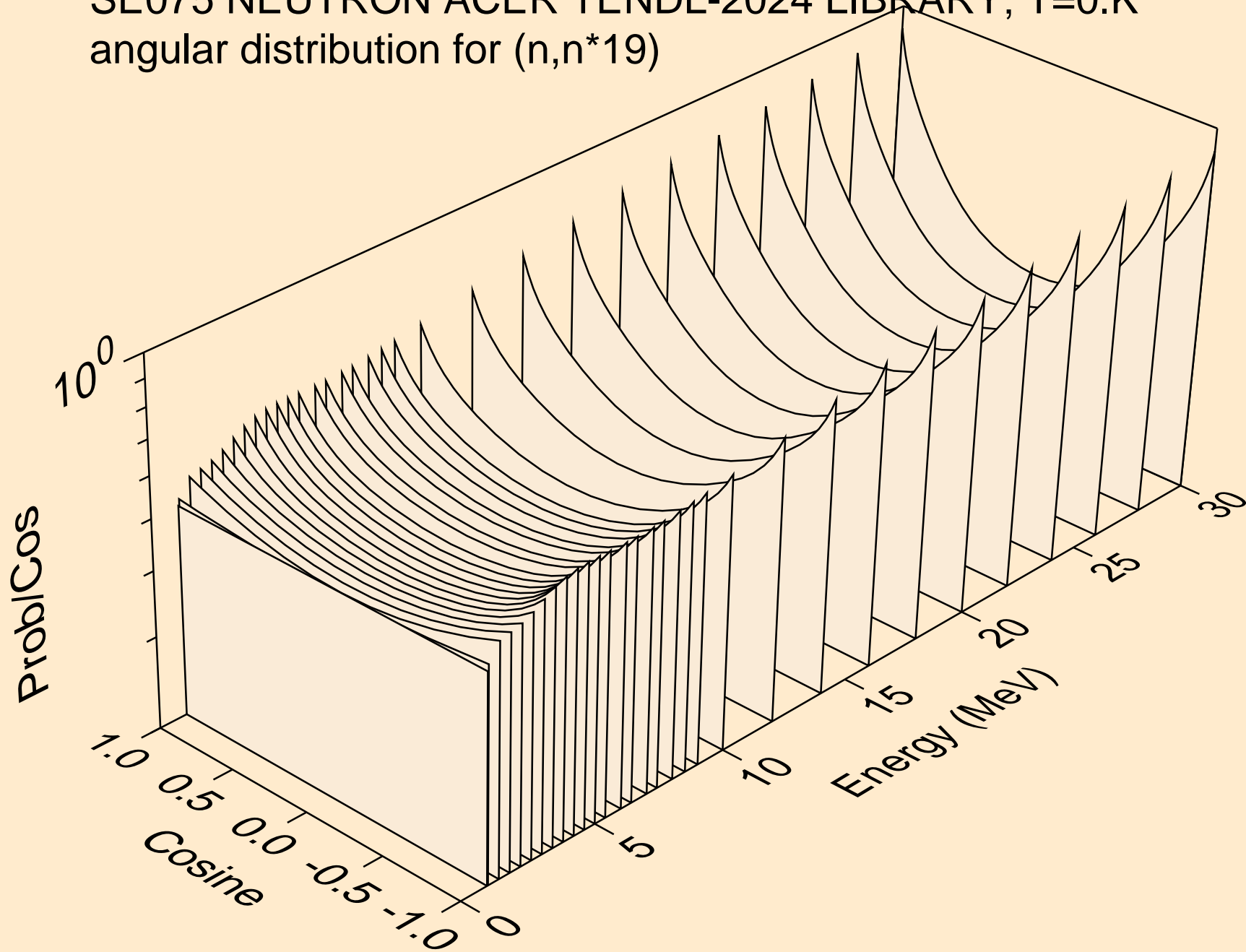

SE075 NEUTRON ACER TENDL-2024 LIBRARY; T=0.K
angular distribution for (n,n*20)

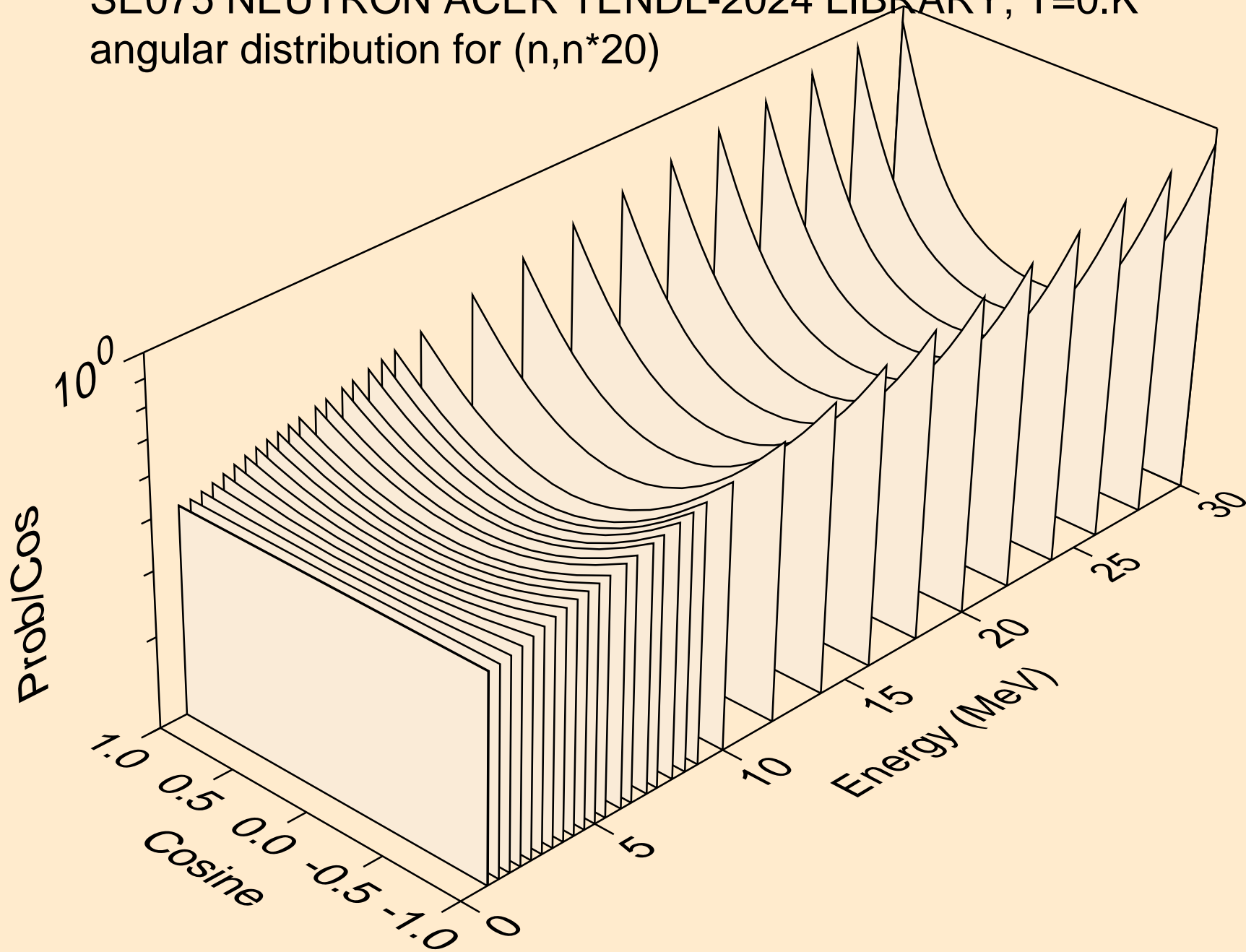

SE075 NEUTRON ACER TENDL-2024 LIBRARY; T=0.K
angular distribution for (n,n*21)

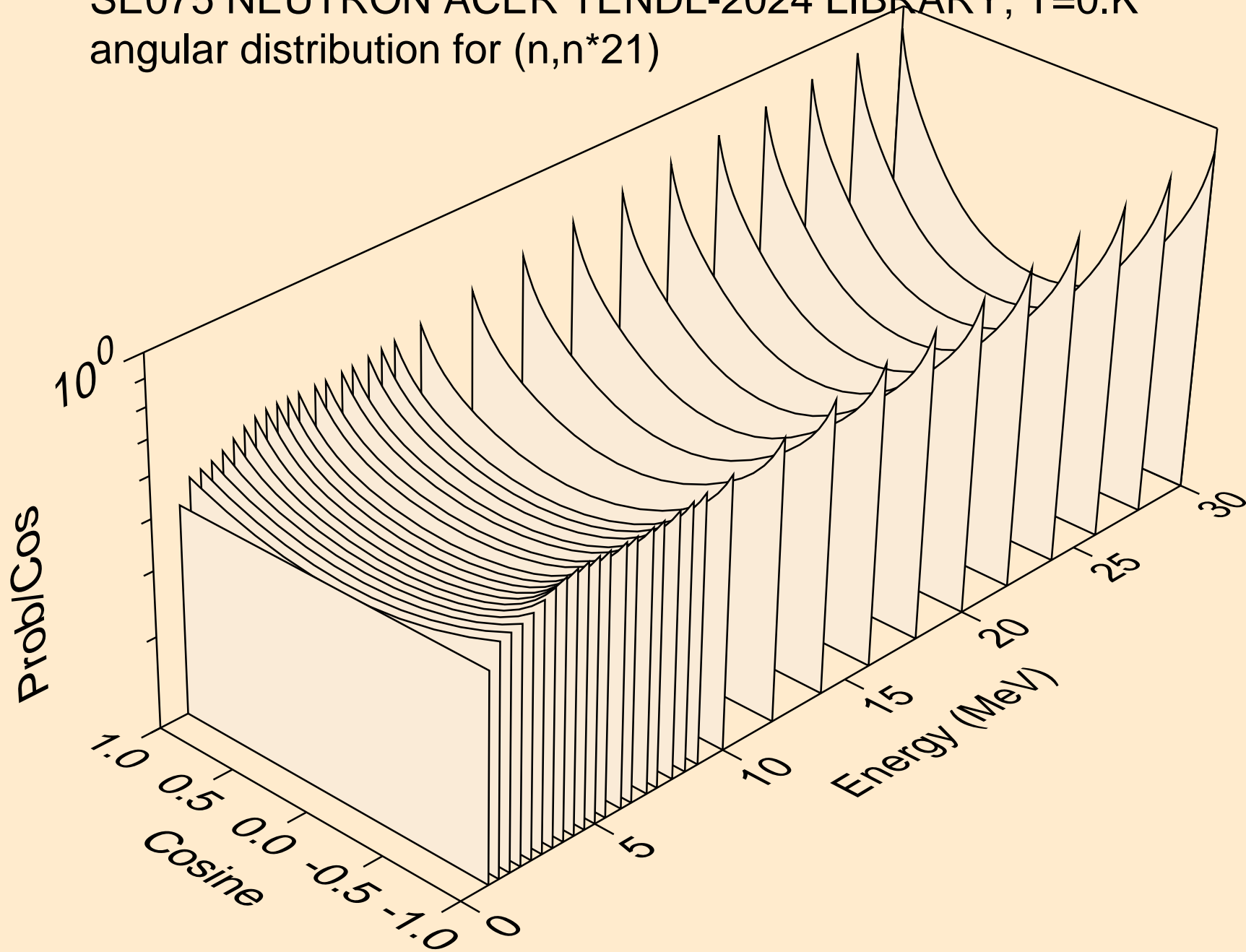

SE075 NEUTRON ACER TENDL-2024 LIBRARY; T=0.K
angular distribution for (n,n*22)

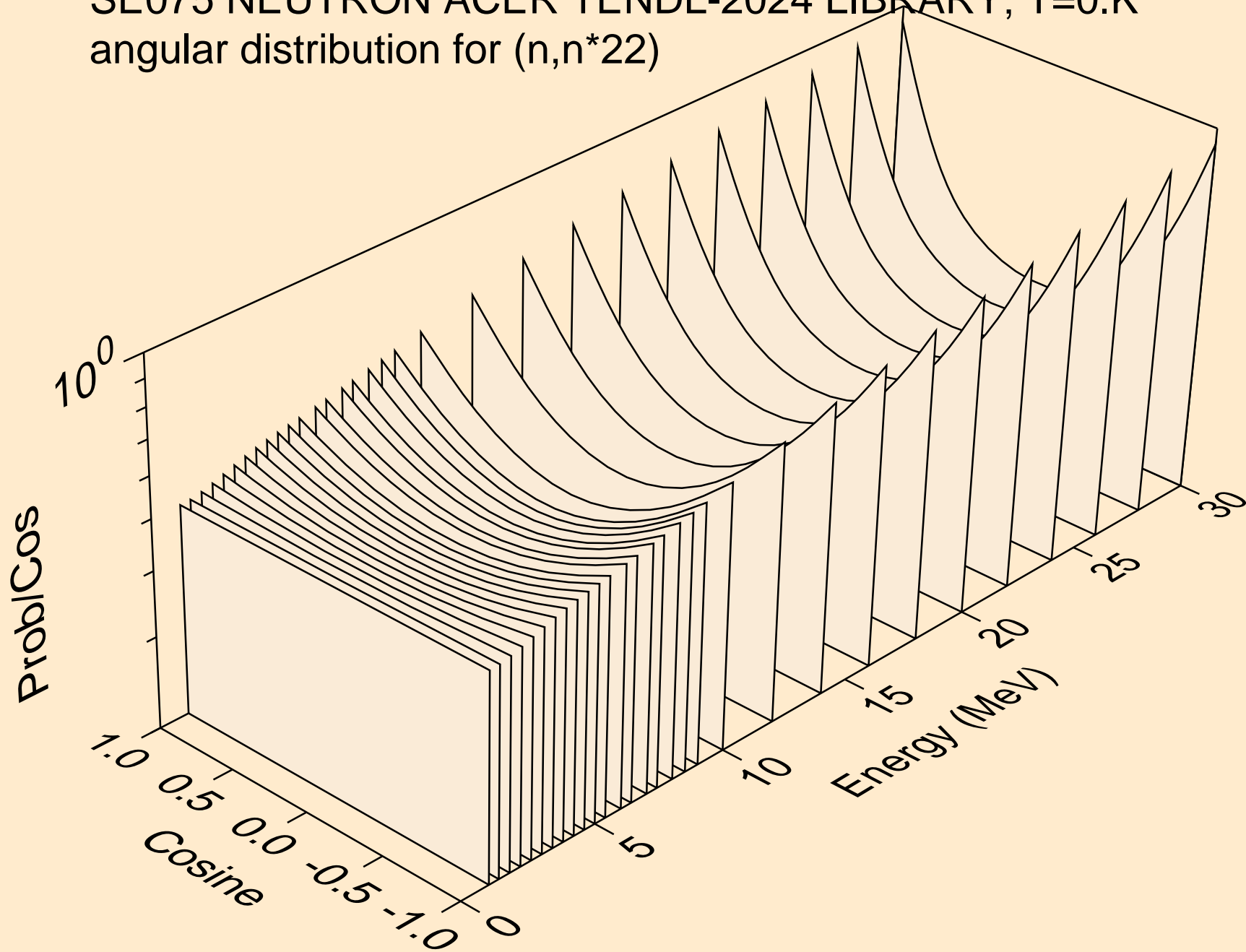

SE075 NEUTRON ACER TENDL-2024 LIBRARY; T=0.K
angular distribution for (n,n*23)

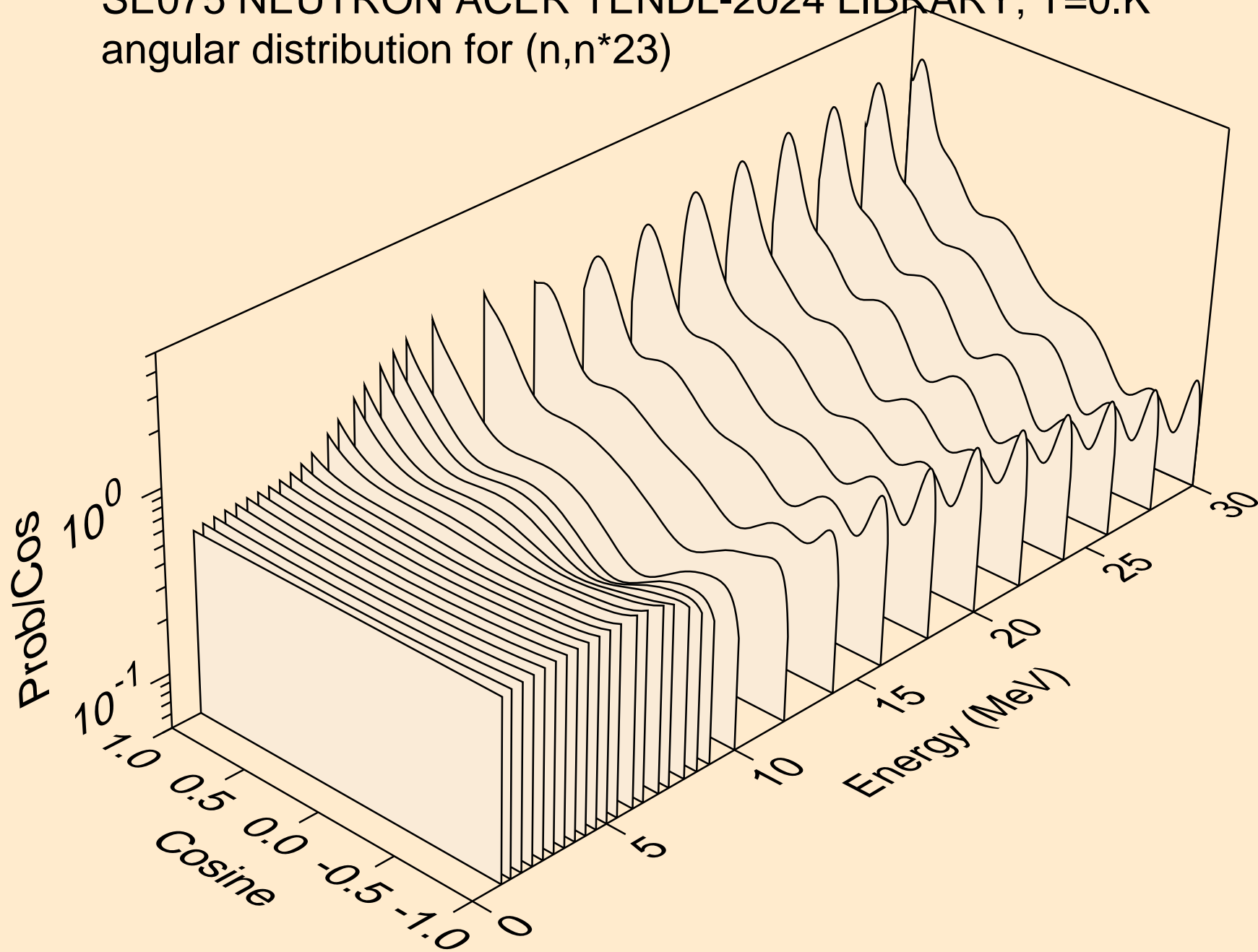

SE075 NEUTRON ACER TENDL-2024 LIBRARY; T=0.K
angular distribution for (n,n*24)

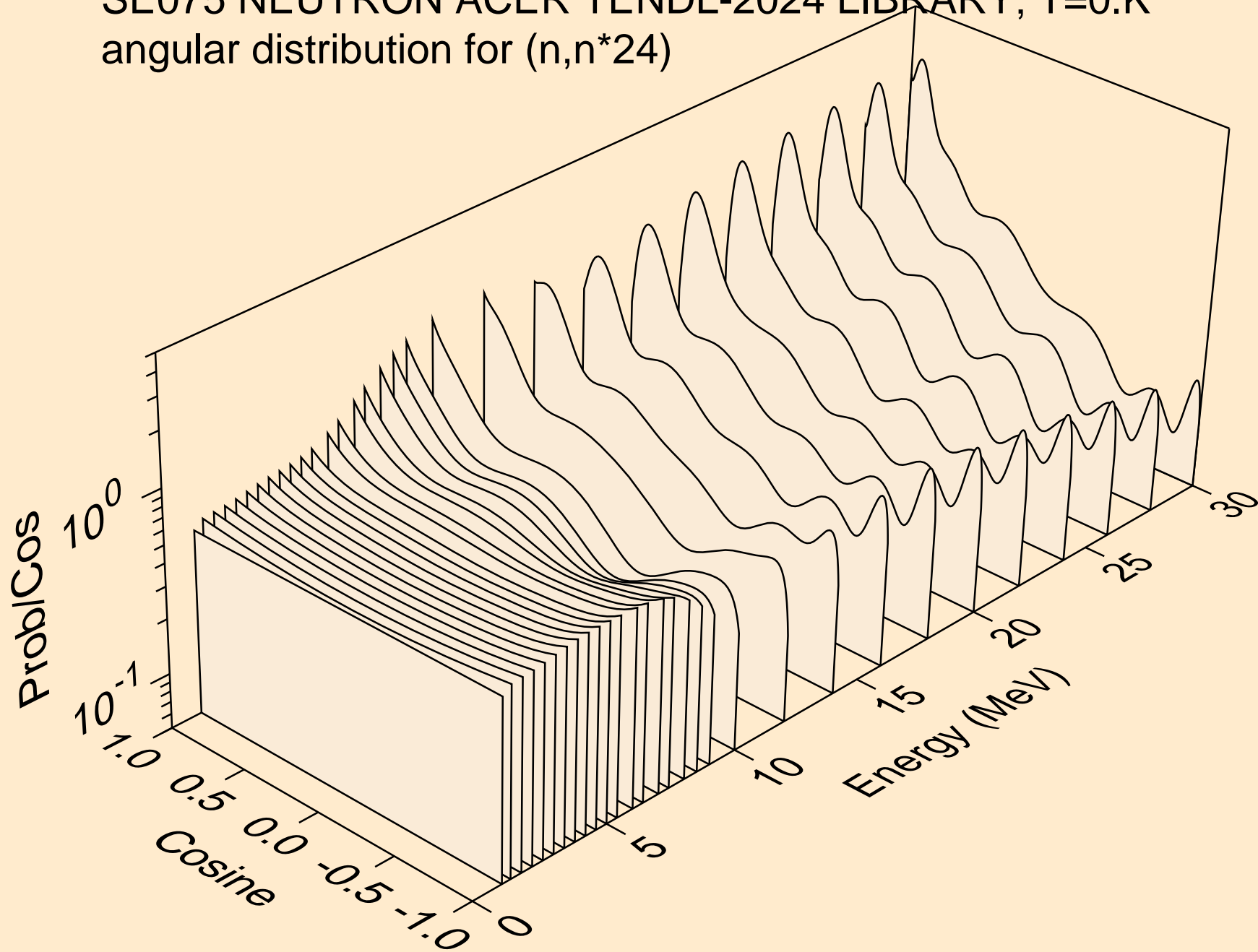

SE075 NEUTRON ACER TENDL-2024 LIBRARY; T=0.K
angular distribution for (n,n*25)

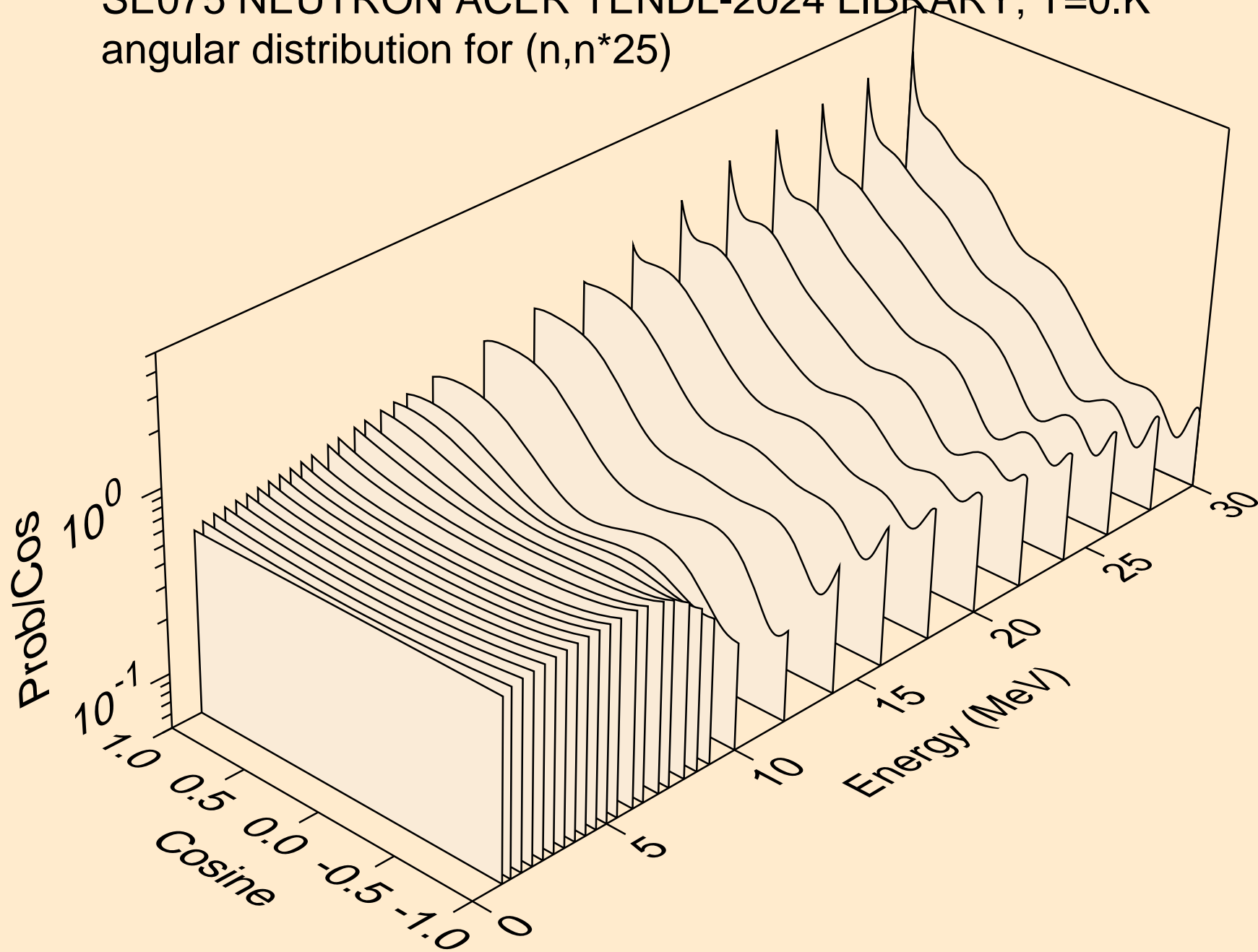

SE075 NEUTRON ACER TENDL-2024 LIBRARY; T=0.K
angular distribution for (n,n*26)

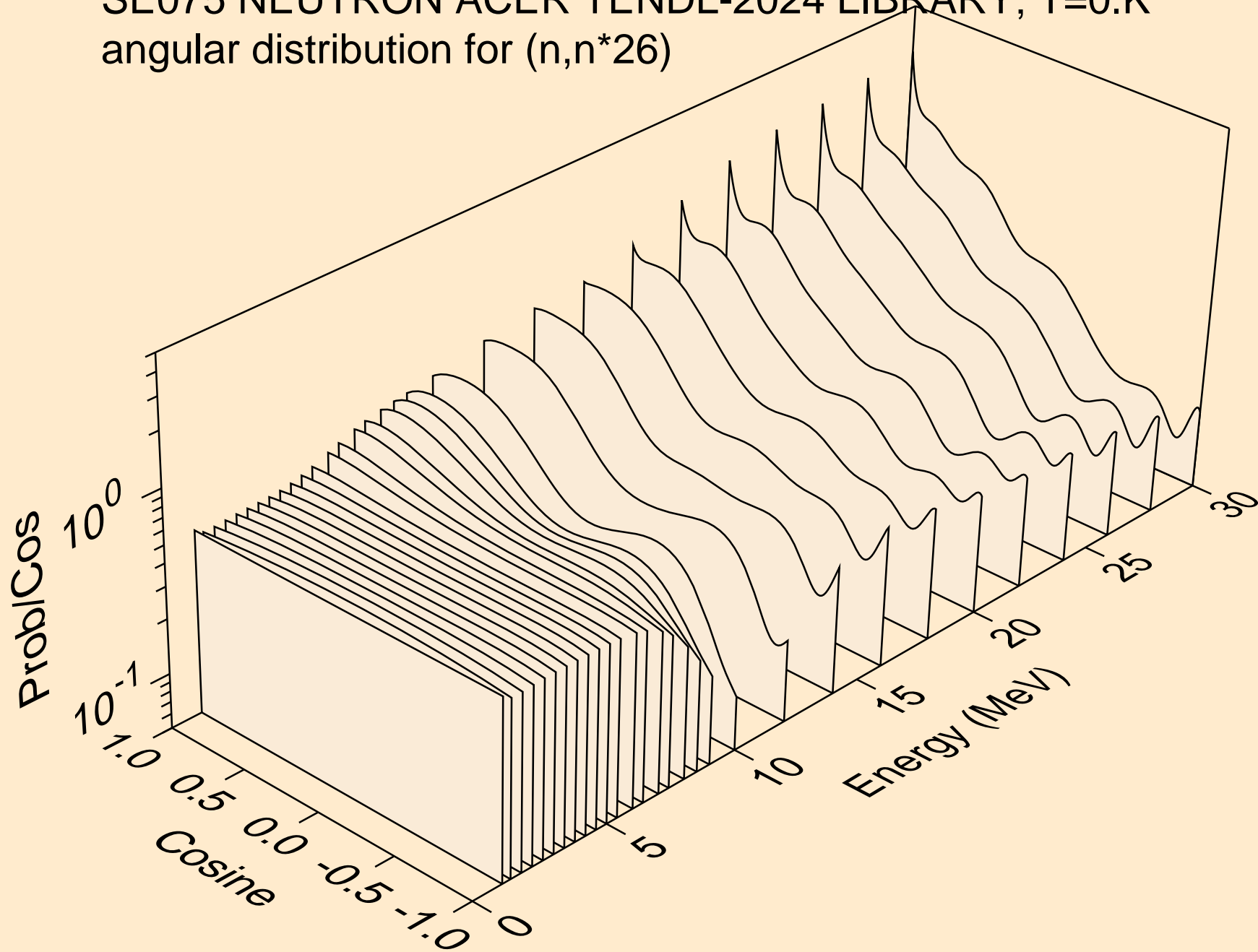

SE075 NEUTRON ACER TENDL-2024 LIBRARY; T=0.K
angular distribution for (n,n*27)

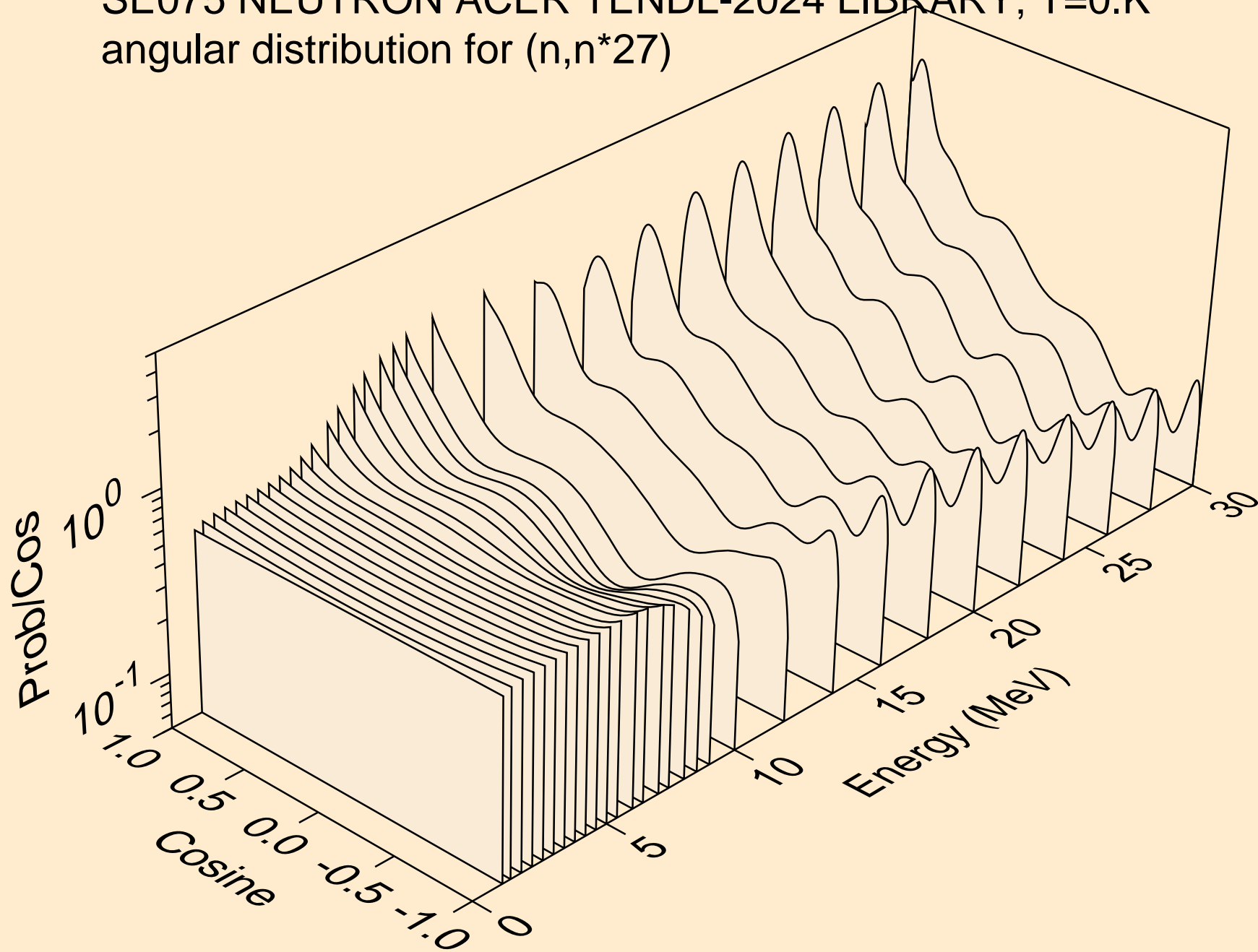

SE075 NEUTRON ACER TENDL-2024 LIBRARY; T=0.K
angular distribution for (n,n*28)

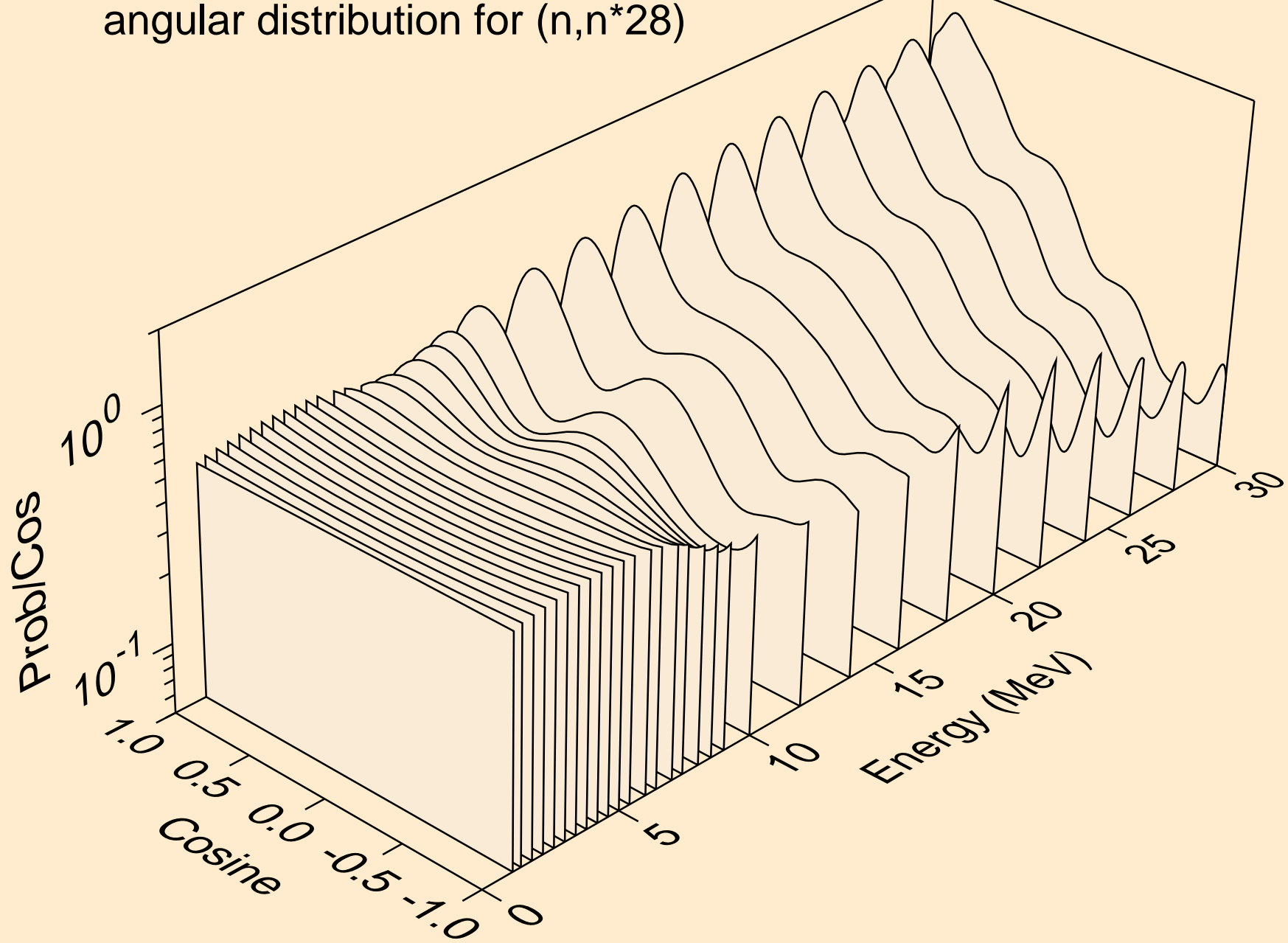

SE075 NEUTRON ACER TENDL-2024 LIBRARY; T=0.K
angular distribution for (n,n*29)

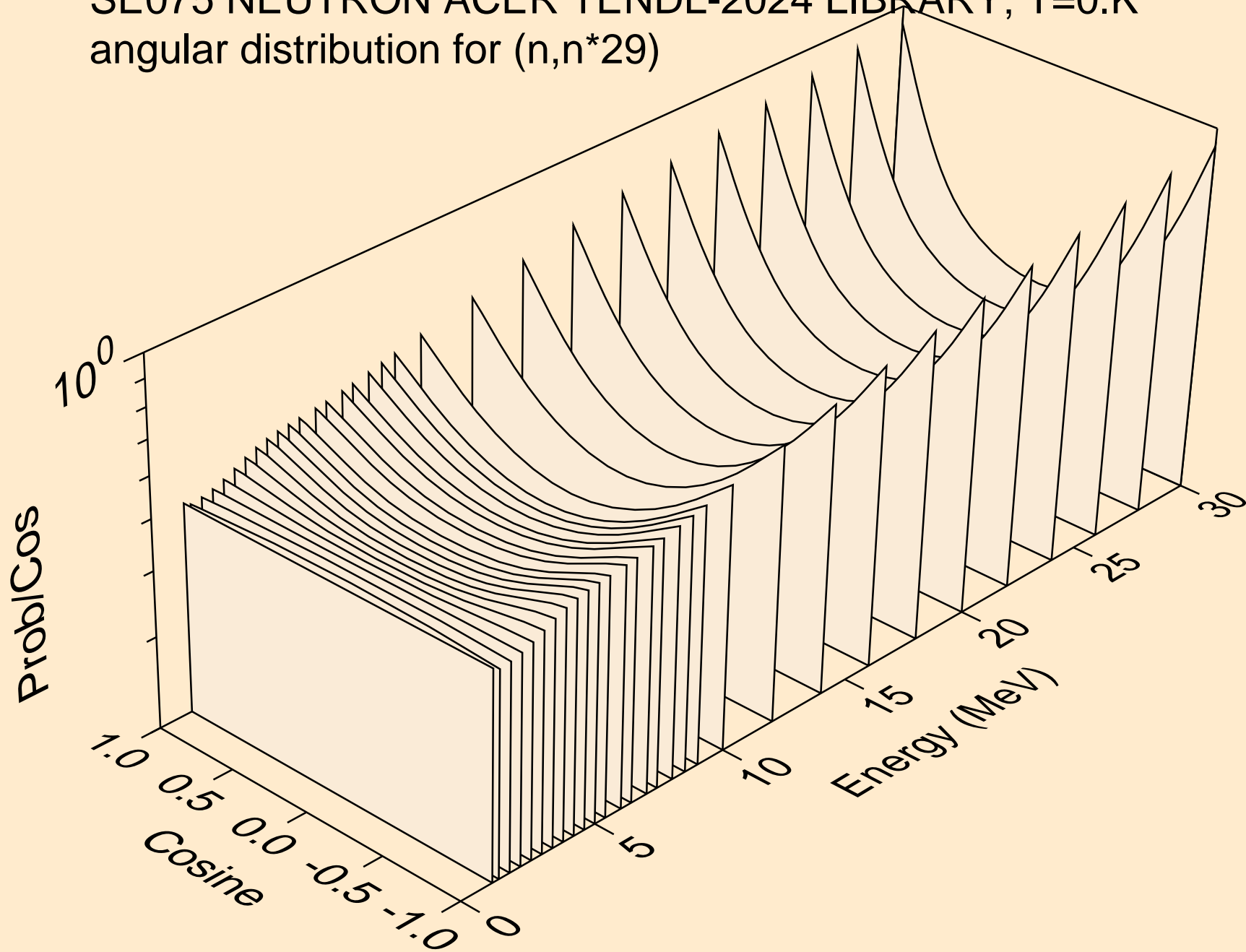

SE075 NEUTRON ACER TENDL-2024 LIBRARY; T=0.K
angular distribution for (n,n*30)

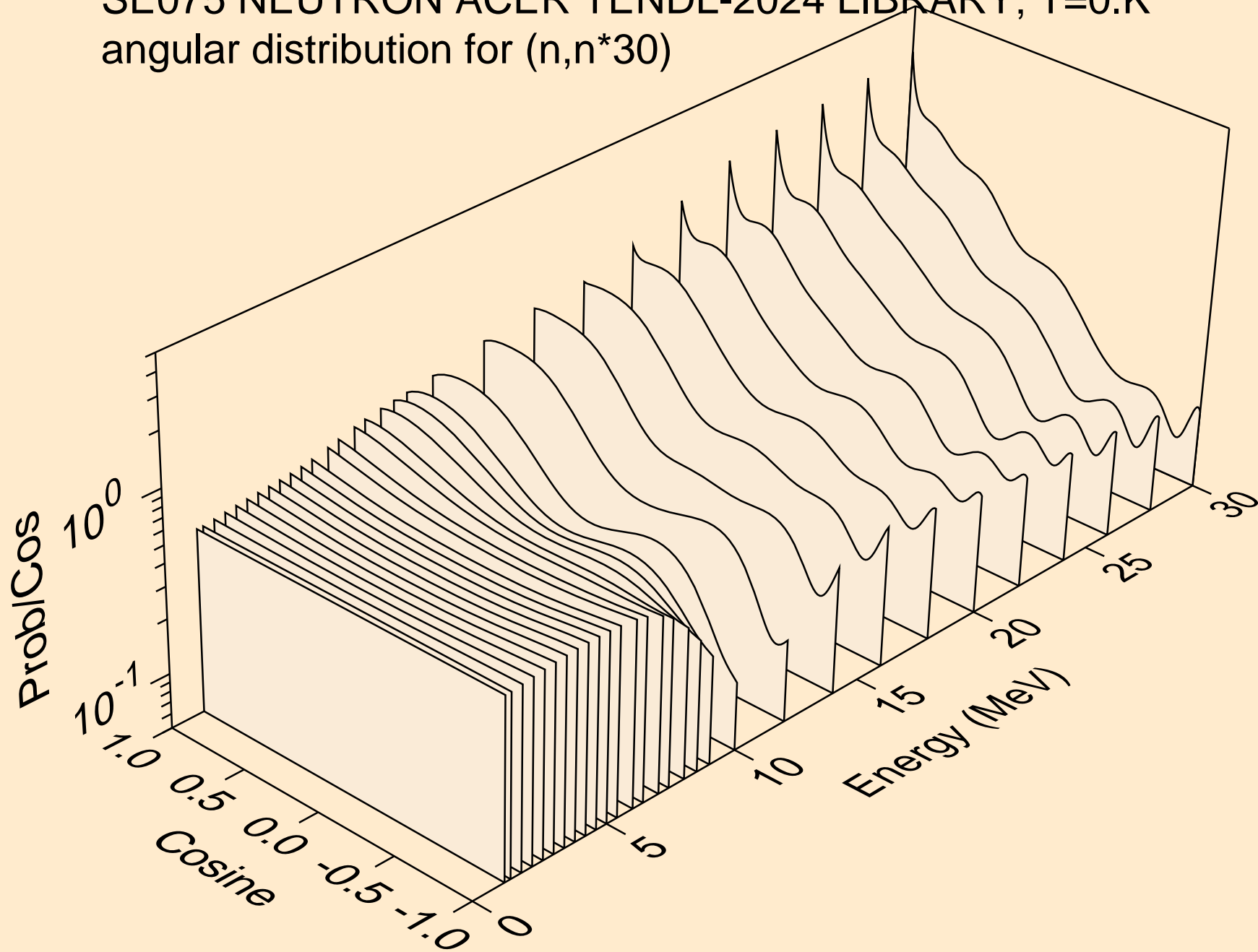

SE075 NEUTRON ACER TENDL-2024 LIBRARY; T=0.K
Neutron emission for (n,x)

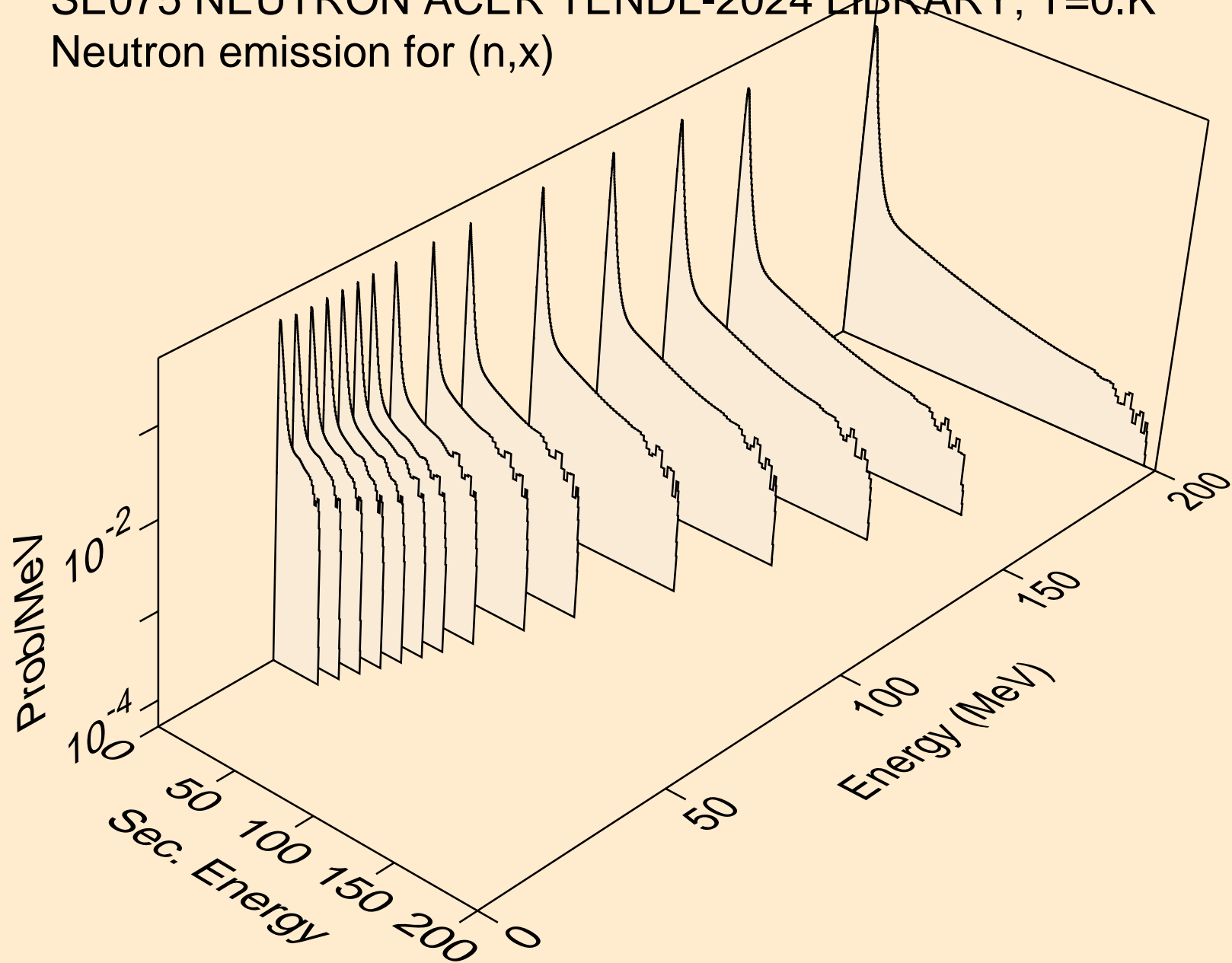

SE075 NEUTRON ACER TENDL-2024 LIBRARY; T=0.K
Neutron emission for (n,2nd)

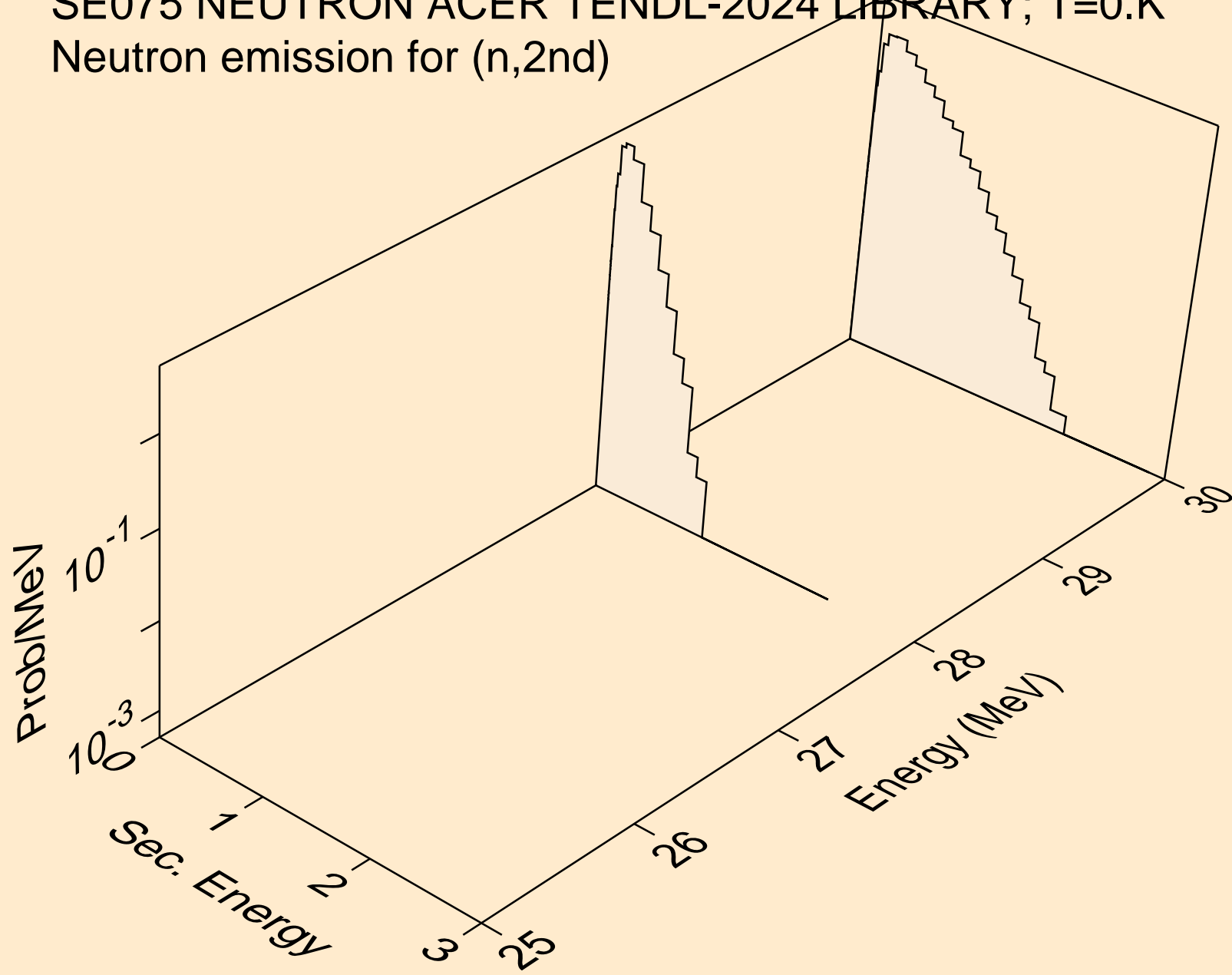

SE075 NEUTRON ACER TENDL-2024 LIBRARY; T=0.K
Neutron emission for (n,2n)

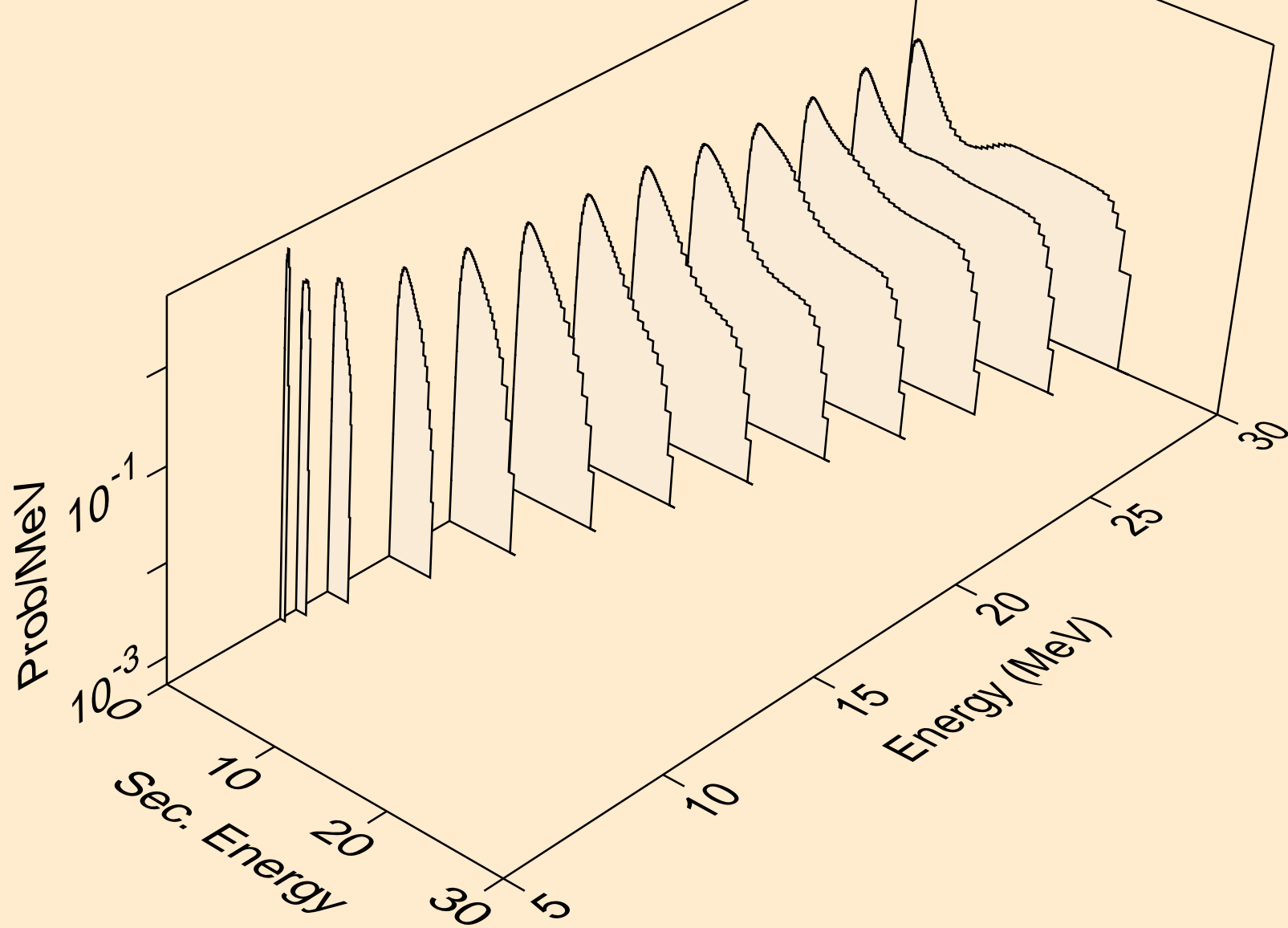

SE075 NEUTRON ACER TENDL-2024 LIBRARY; T=0.K
Neutron emission for (n,3n)

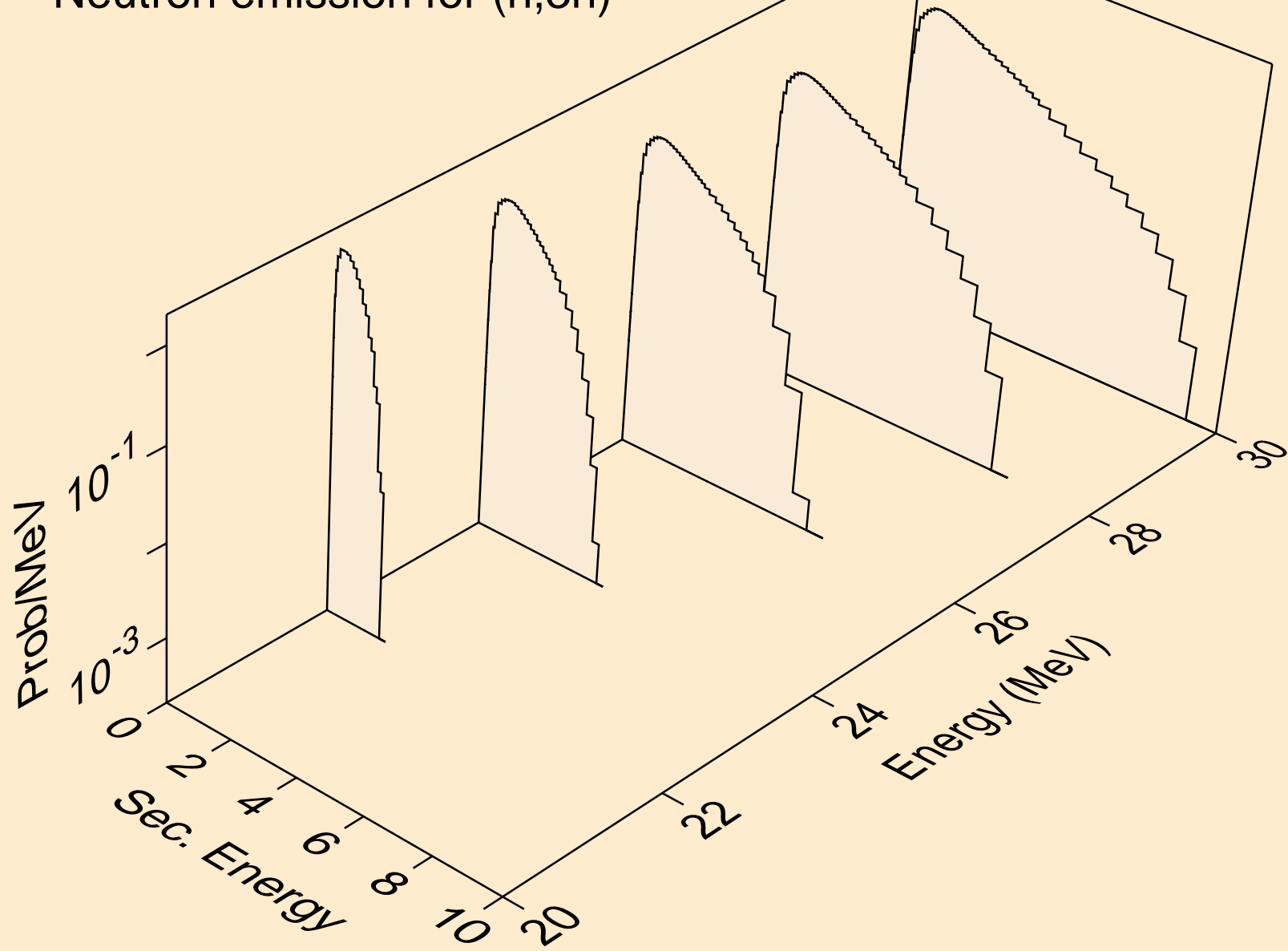

SE075 NEUTRON ACER TENDL-2024 LIBRARY; T=0.K
Neutron emission for (n,n*)a

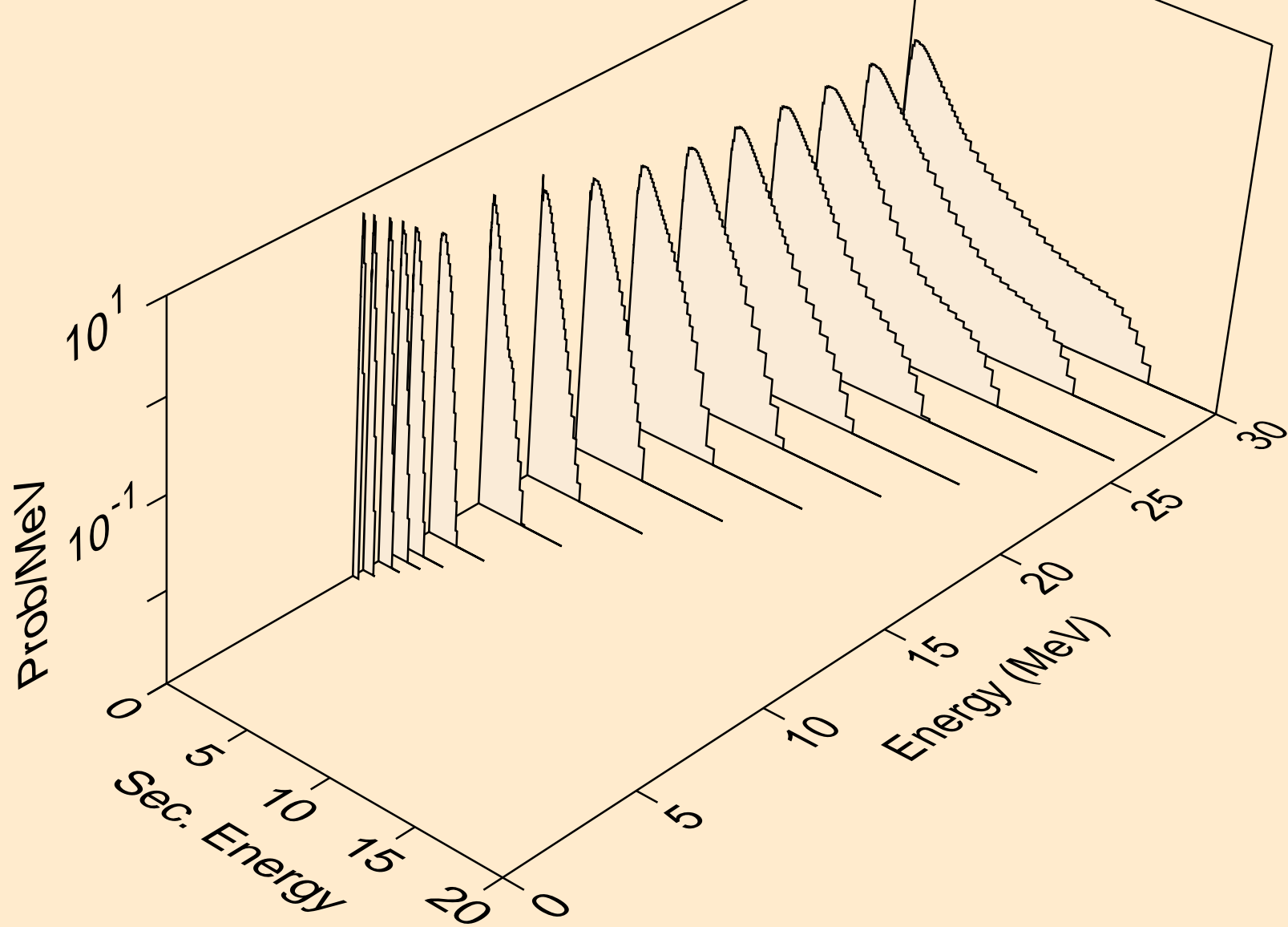

SE075 NEUTRON ACER TENDL-2024 LIBRARY; T=0.K
Neutron emission for (n,2n)a

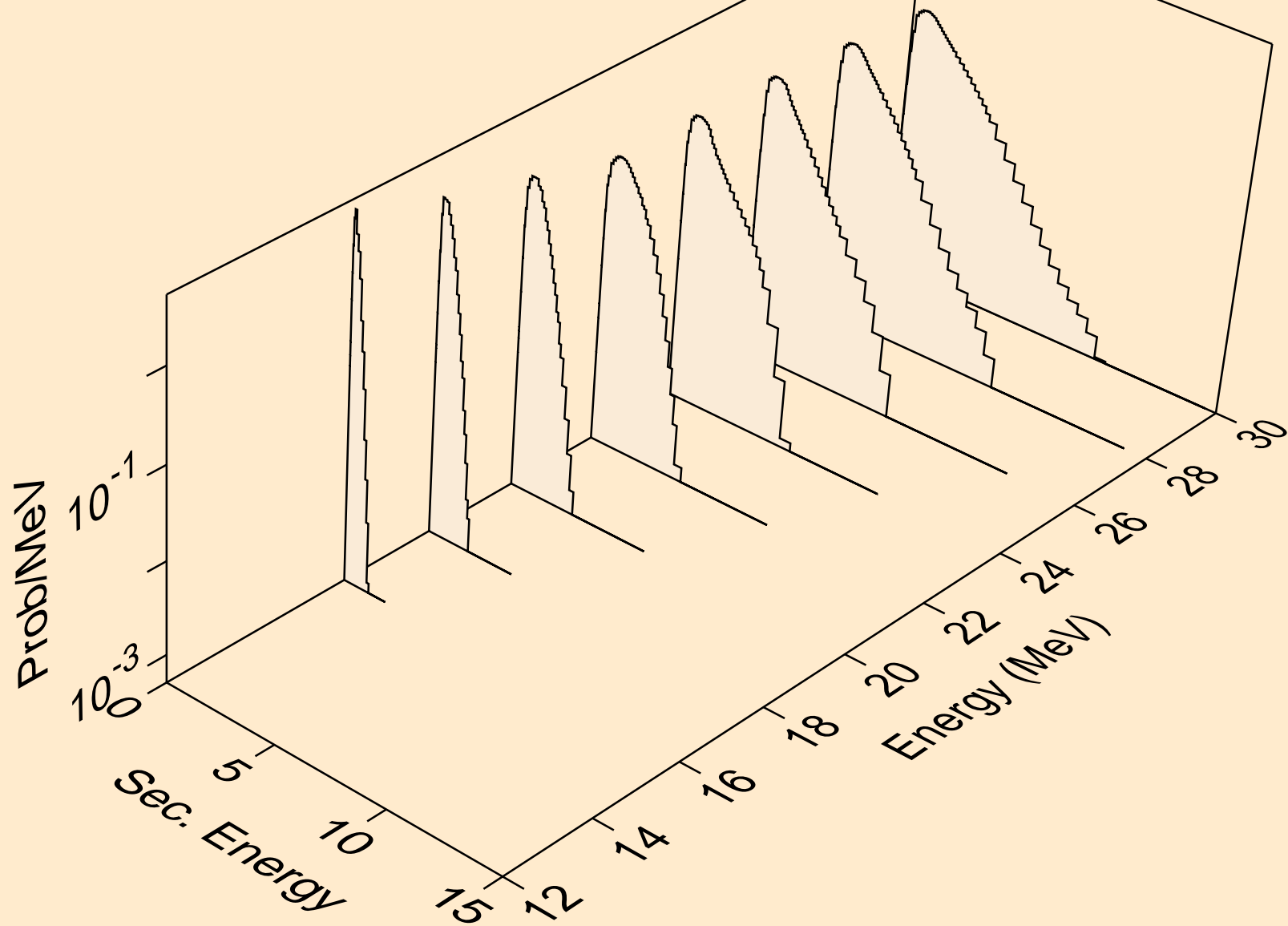

SE075 NEUTRON ACER TENDL-2024 LIBRARY; T=0.K
Neutron emission for (n,3n)a

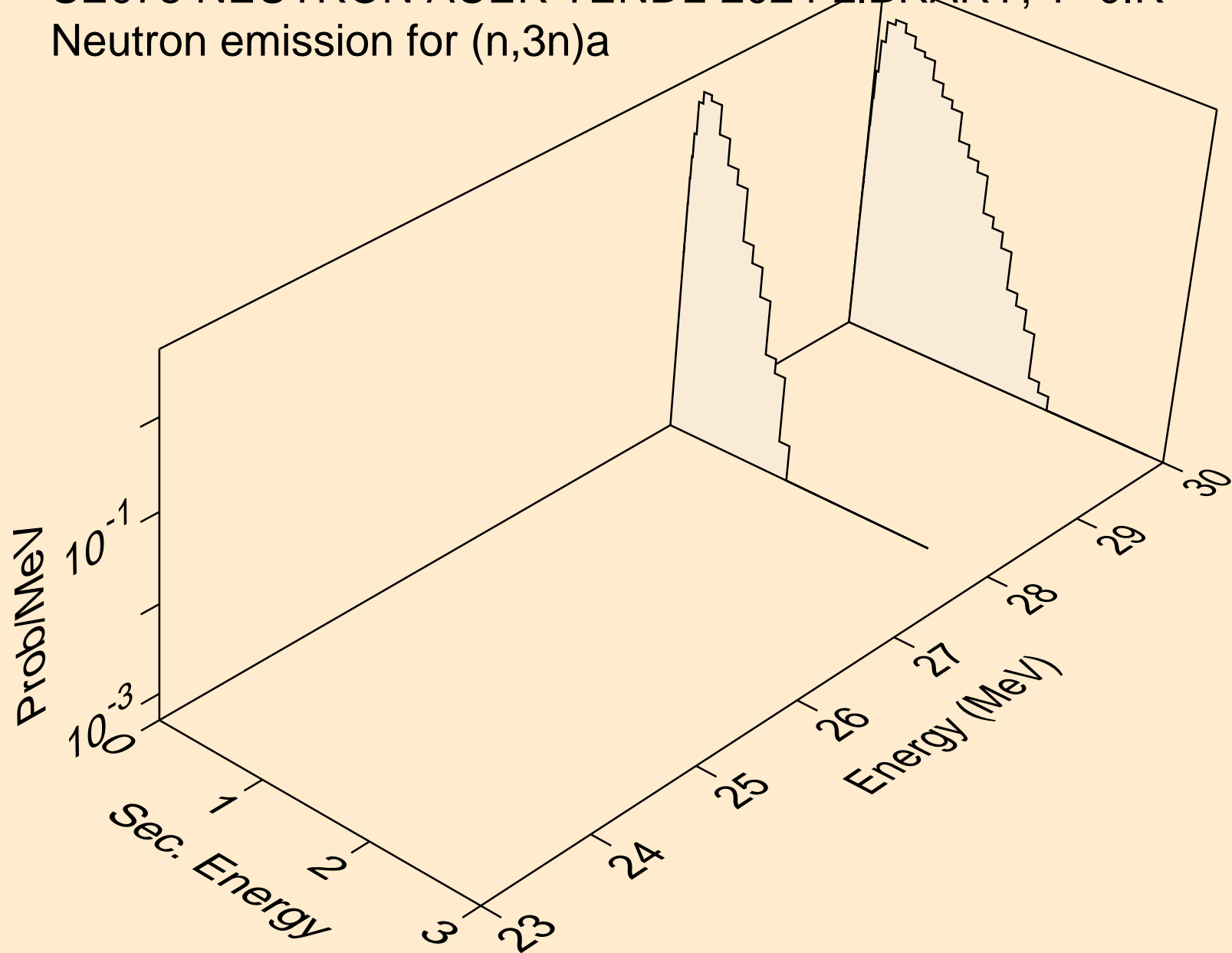

SE075 NEUTRON ACER TENDL-2024 LIBRARY; T=0.K
Neutron emission for (n,n*)p

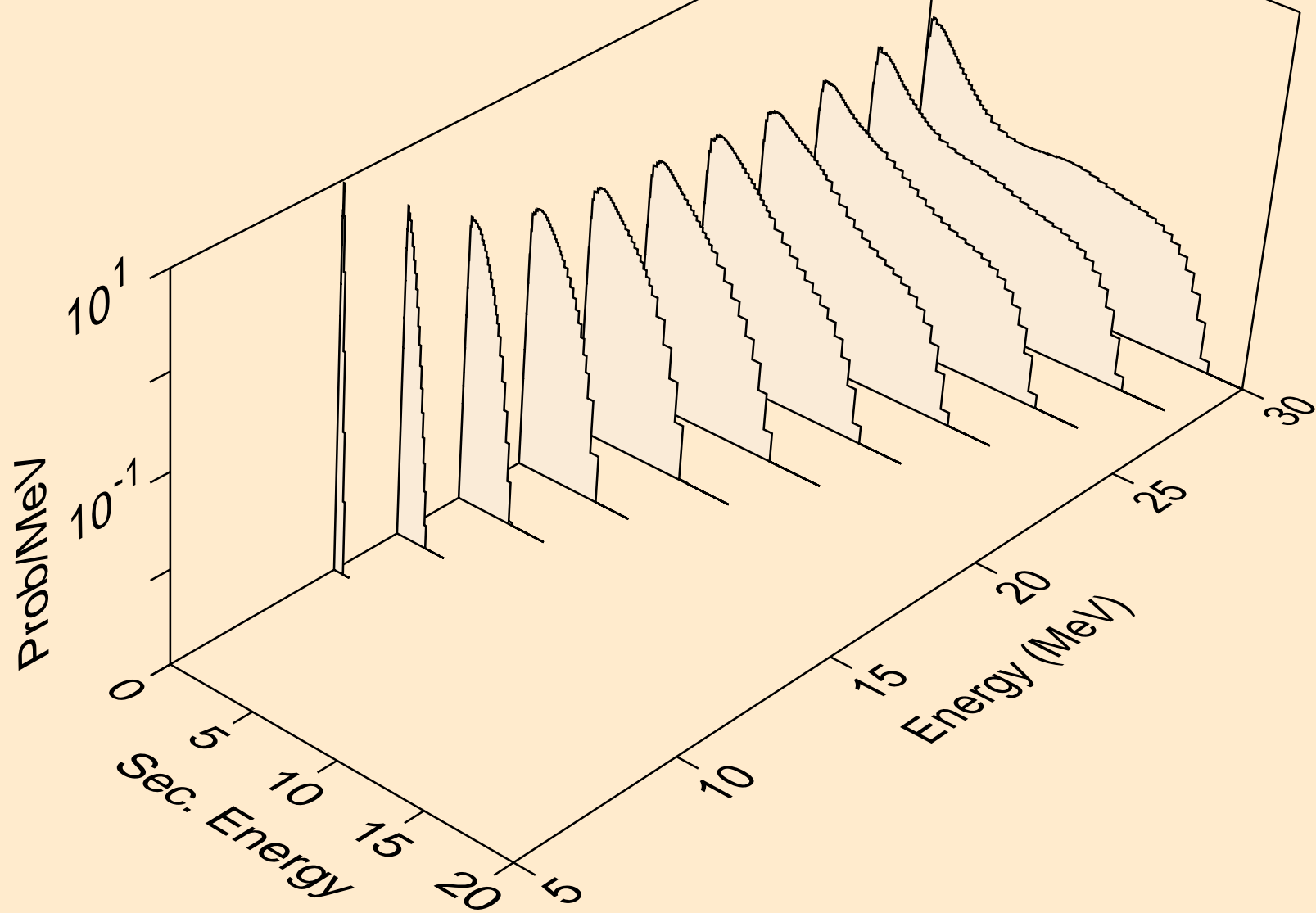

SE075 NEUTRON ACER TENDL-2024 LIBRARY; T=0.K
Neutron emission for (n,n*)2a

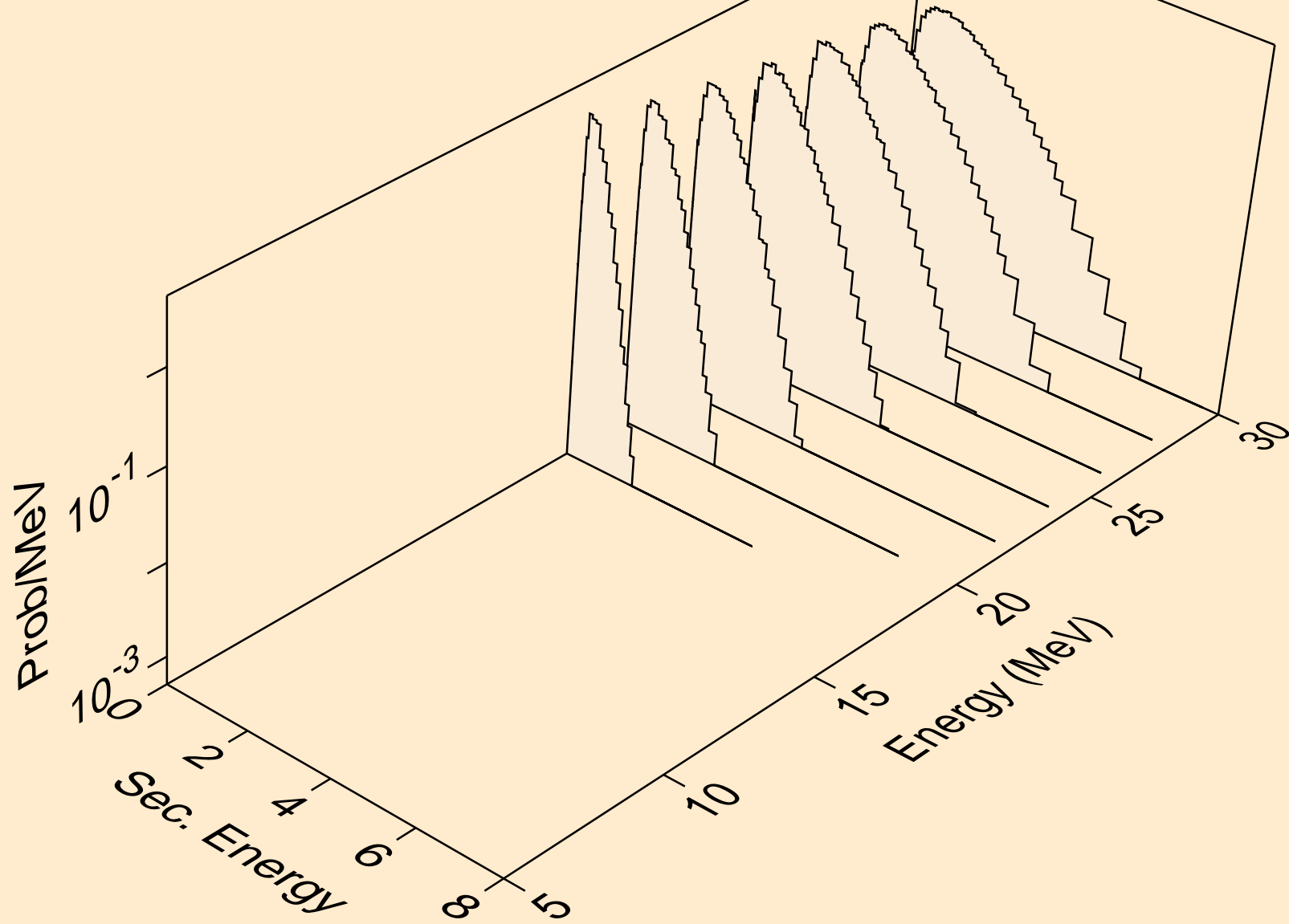

SE075 NEUTRON ACER TENDL-2024 LIBRARY; T=0.K
Neutron emission for (n,2n)2a

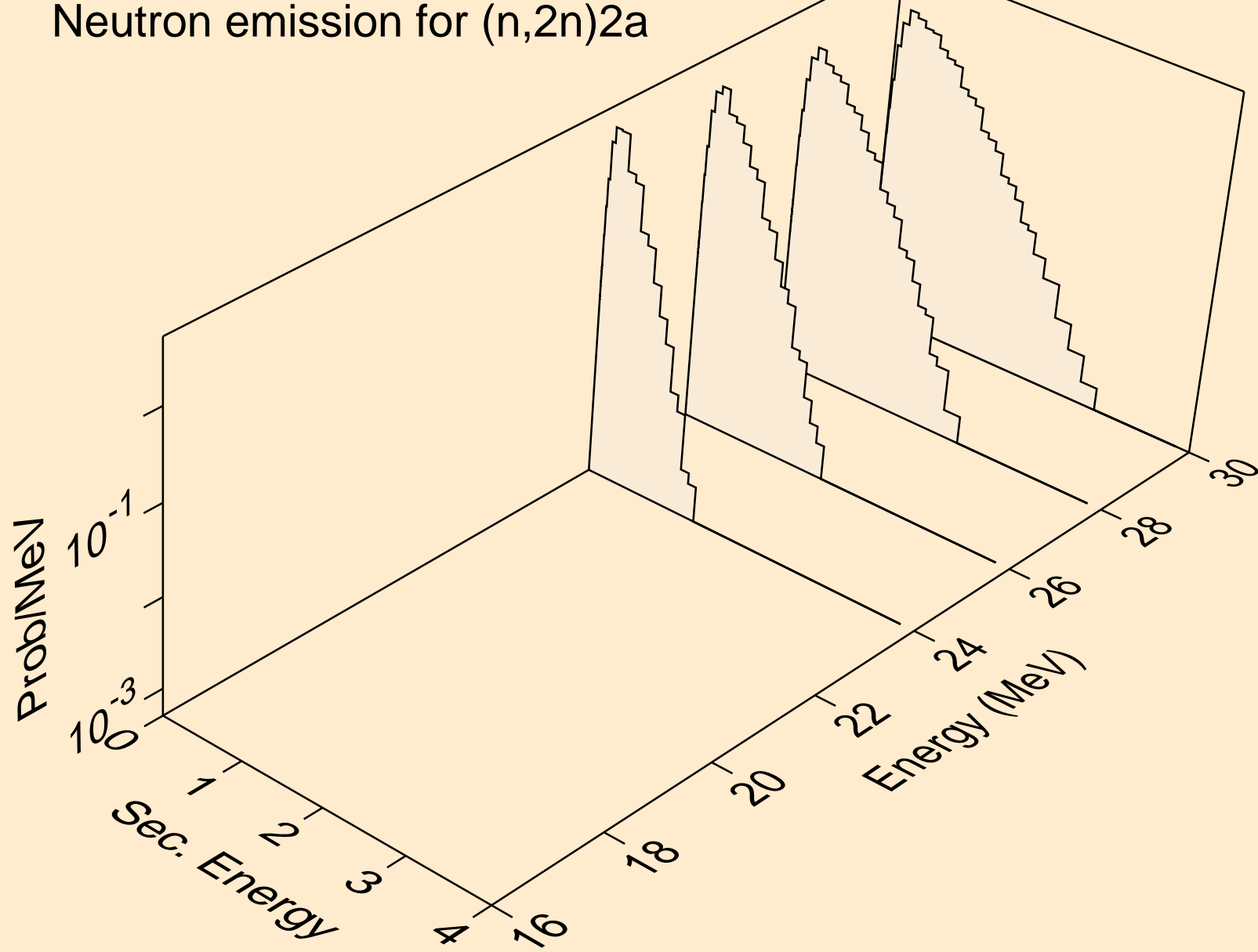

SE075 NEUTRON ACER TENDL-2024 LIBRARY; T=0.K
Neutron emission for (n,n*)d

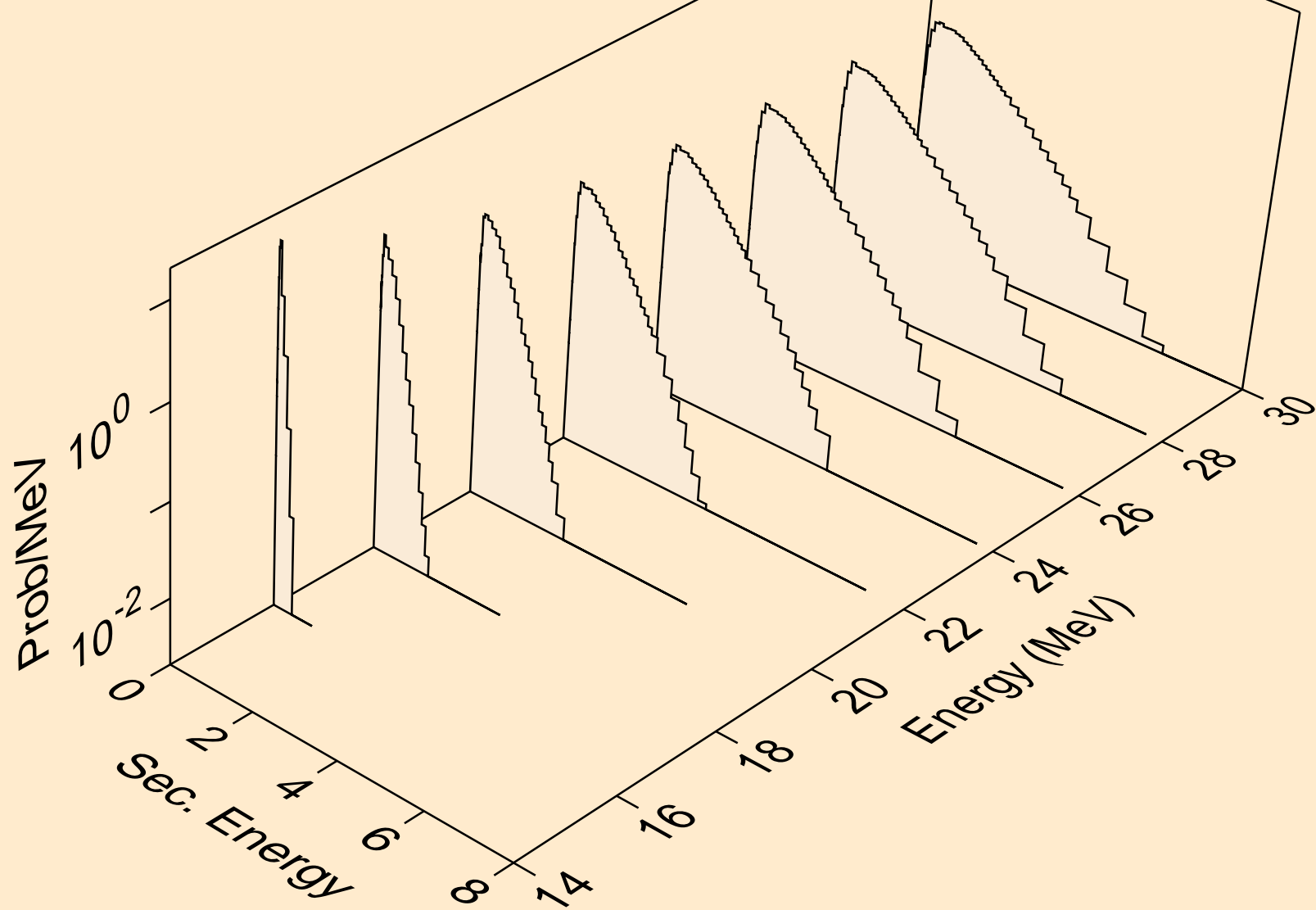

SE075 NEUTRON ACER TENDL-2024 LIBRARY; T=0.K
Neutron emission for (n,n*)t

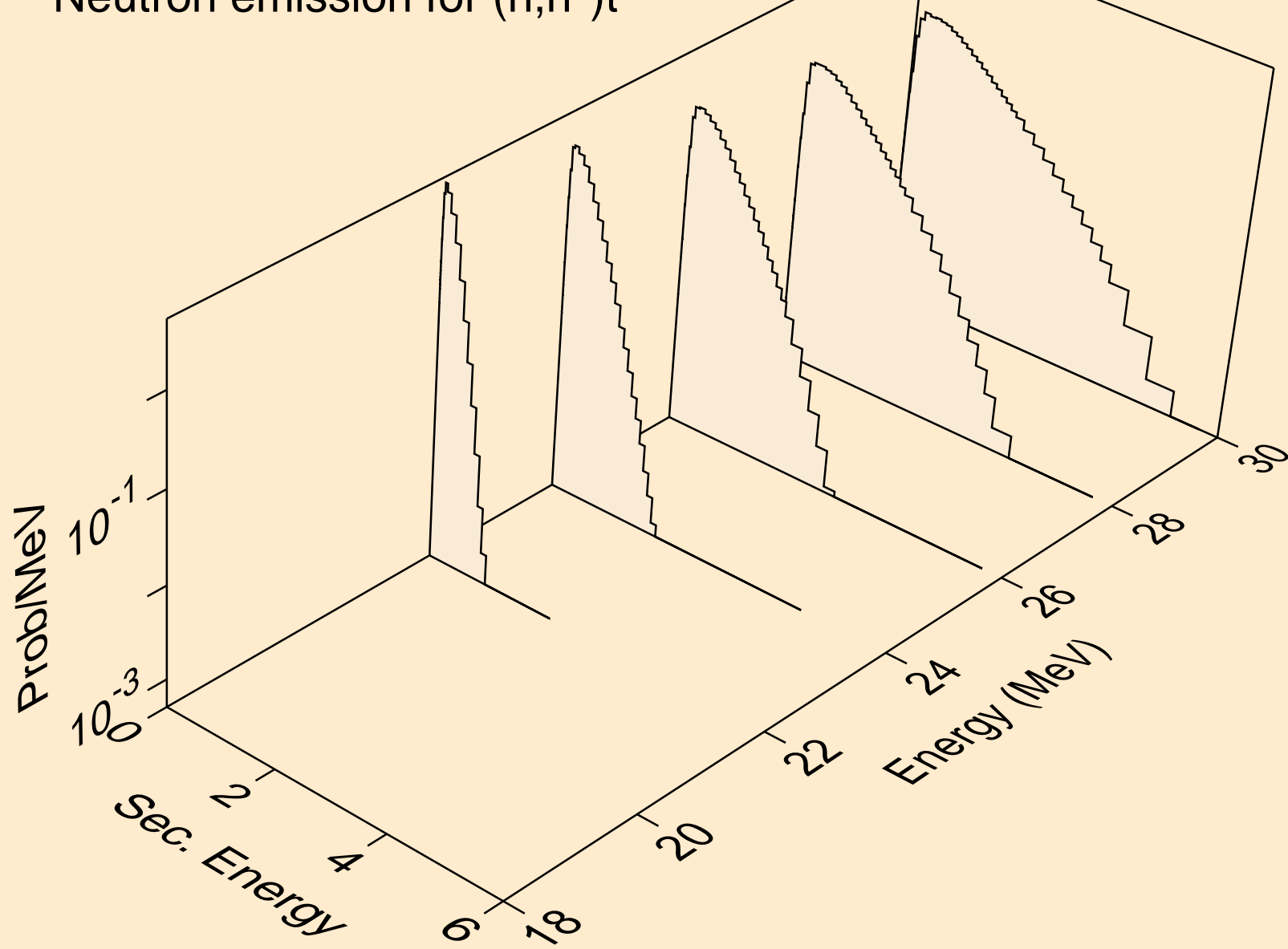

SE075 NEUTRON ACER TENDL-2024 LIBRARY; T=0.K
Neutron emission for (n,n*)he3

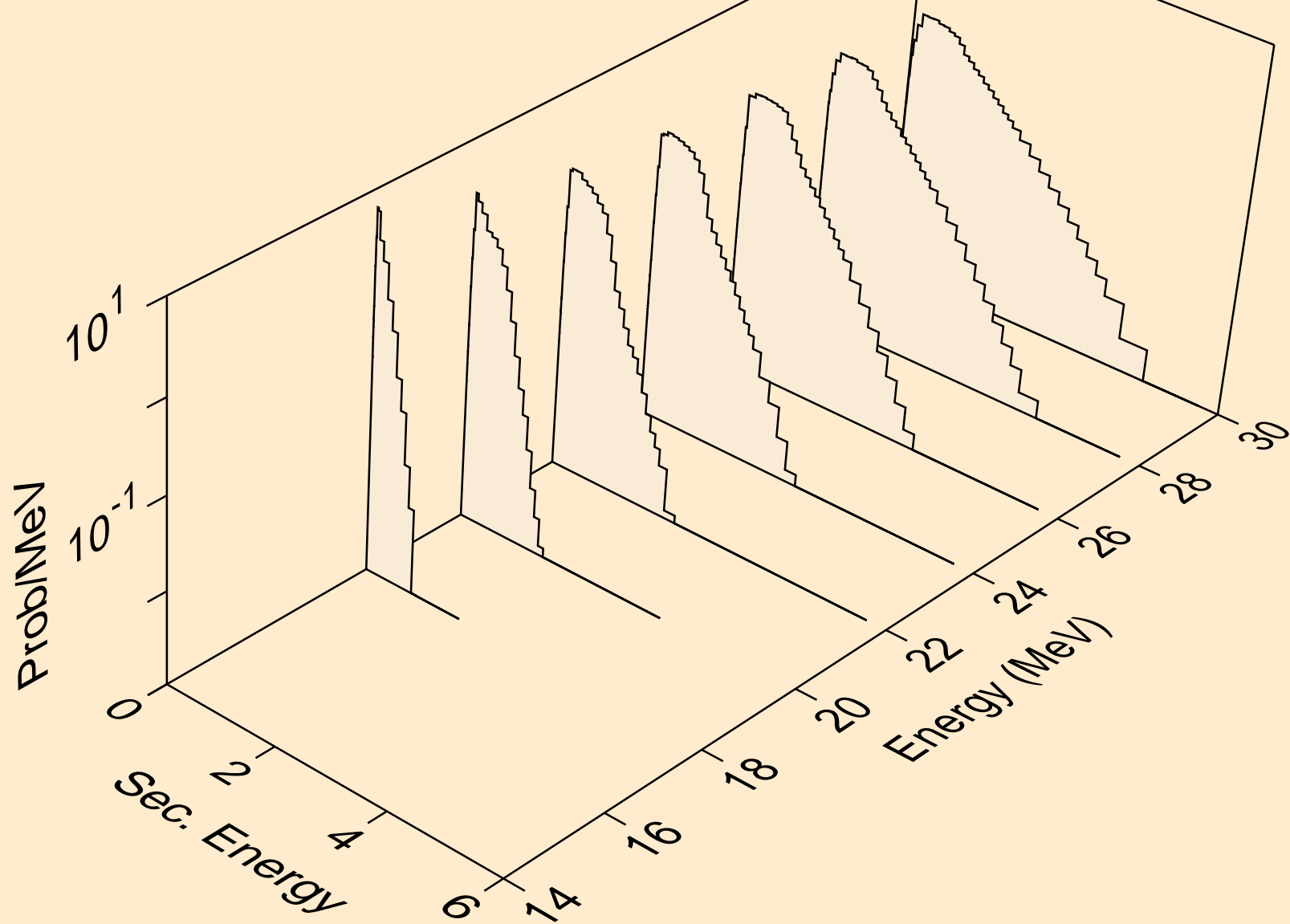

SE075 NEUTRON ACER TENDL-2024 LIBRARY; T=0.K
Neutron emission for (n,4n)

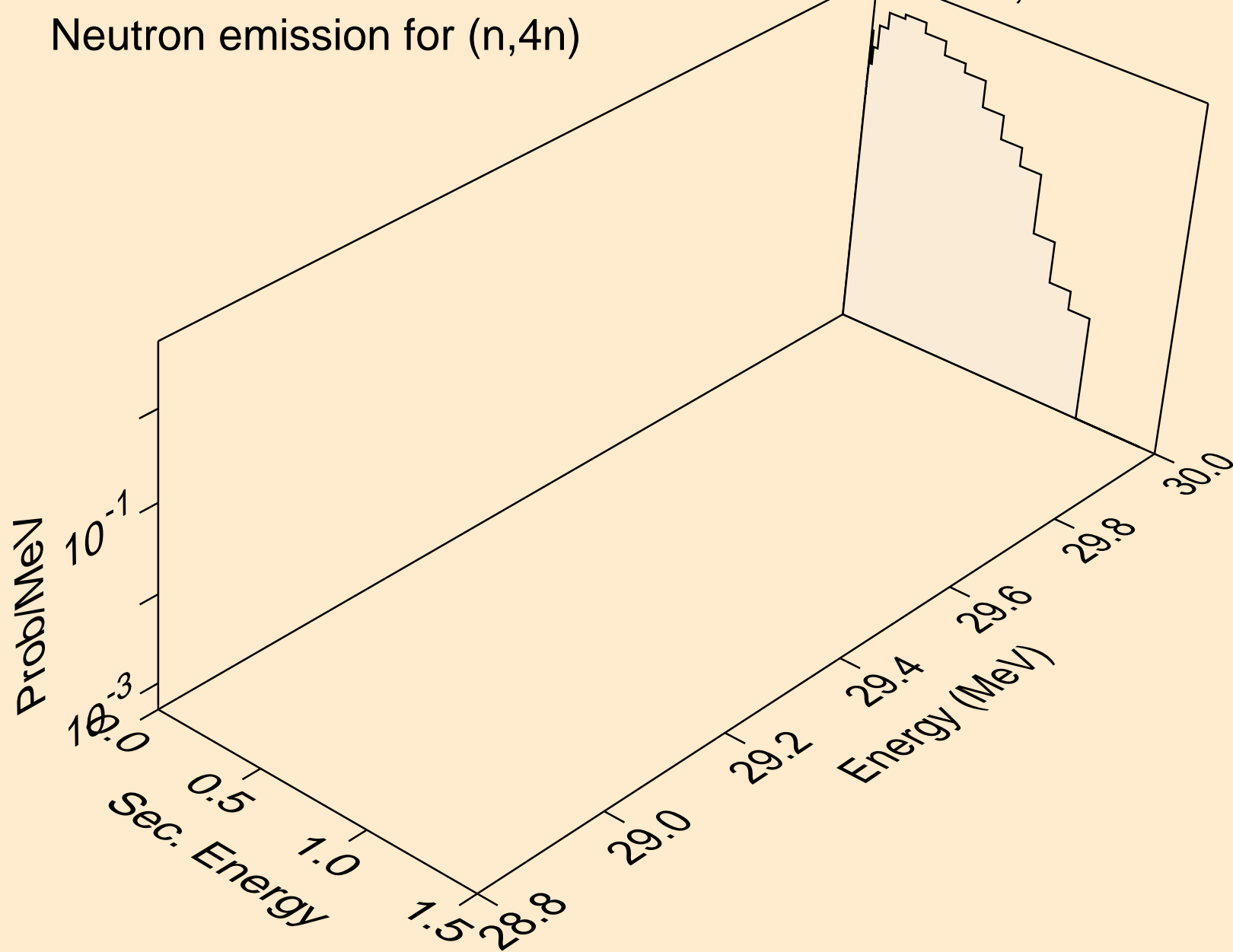

SE075 NEUTRON ACER TENDL-2024 LIBRARY; T=0.K
Neutron emission for (n,2np)

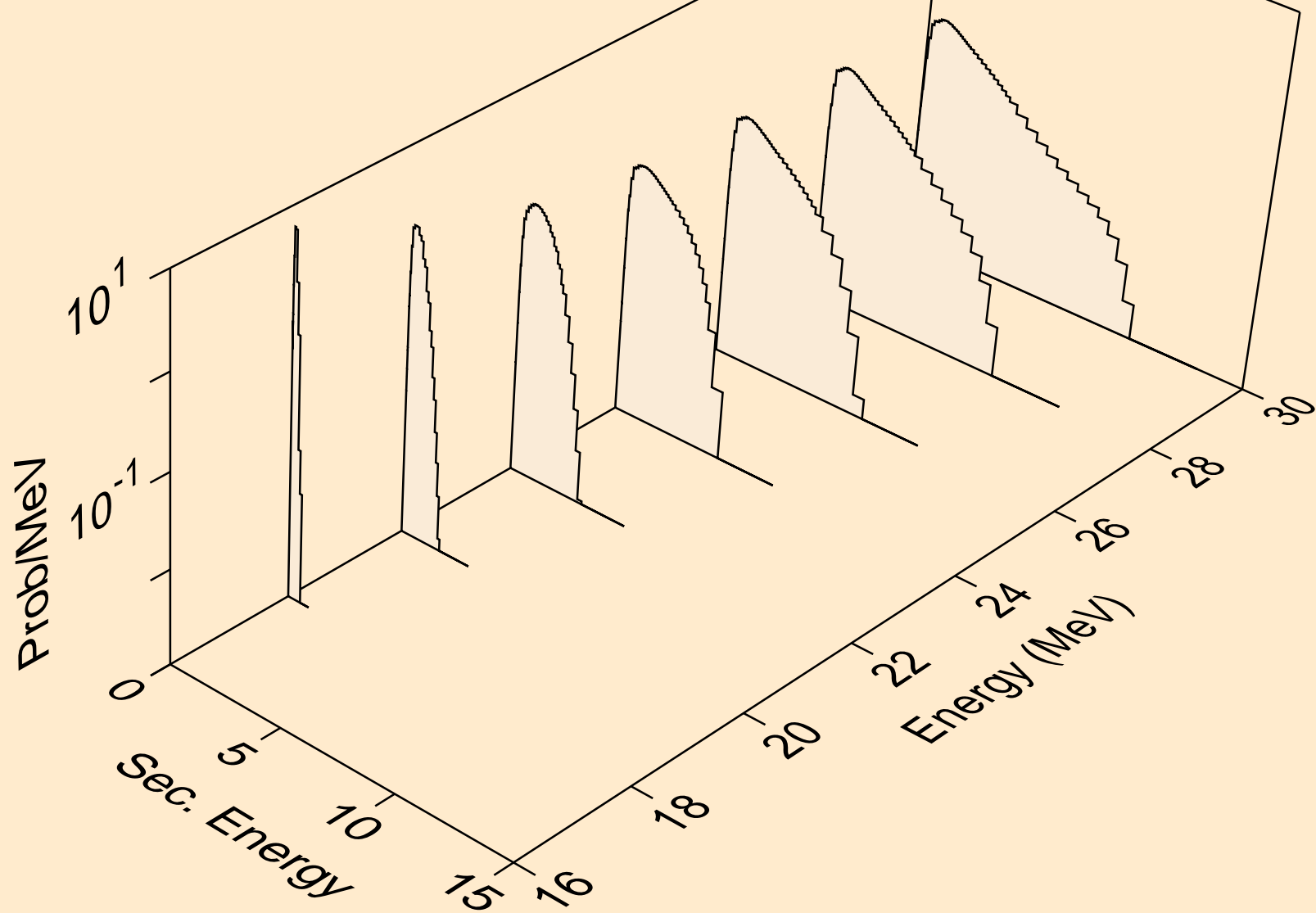

SE075 NEUTRON ACER TENDL-2024 LIBRARY; T=0.K
Neutron emission for (n,3np)

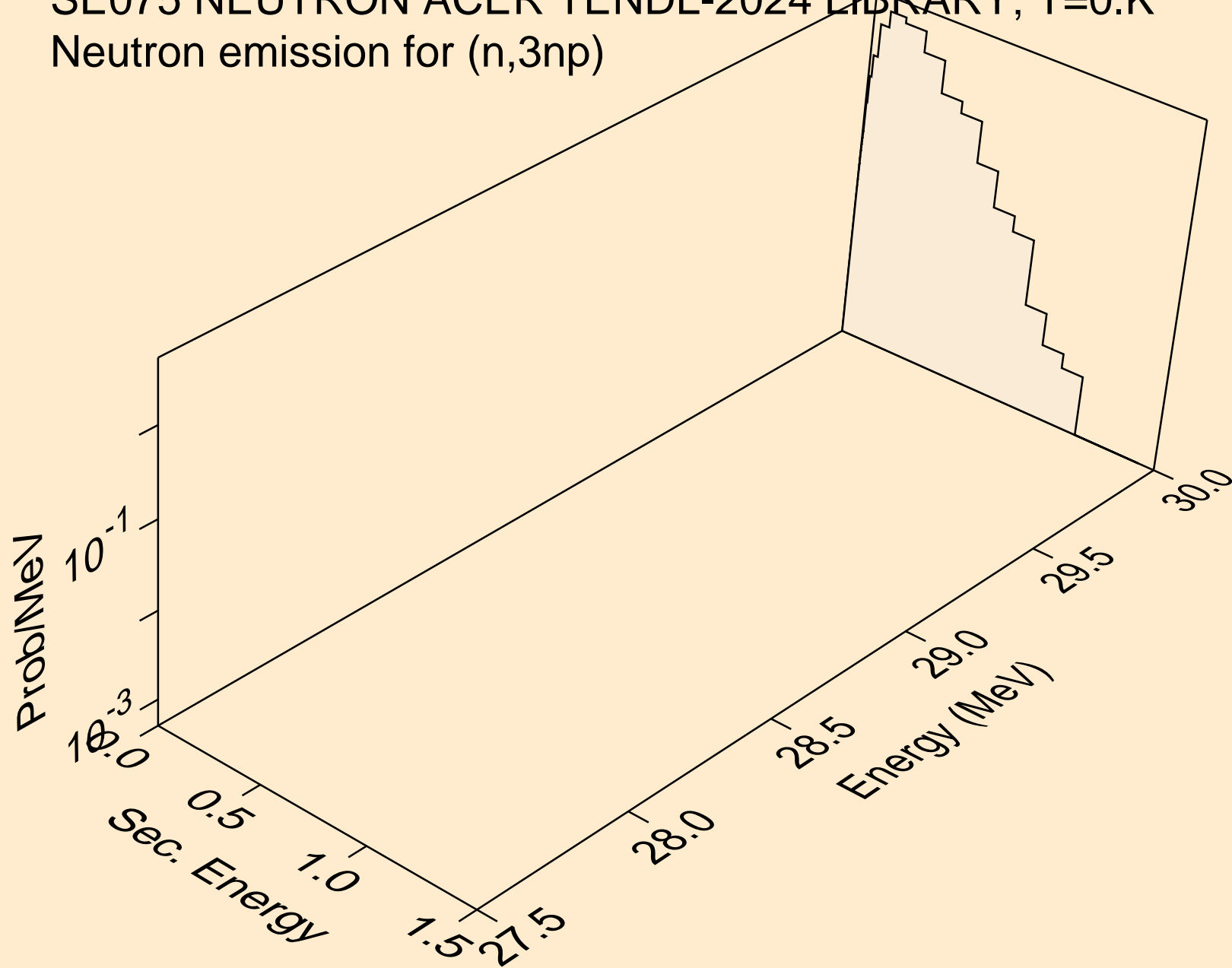

SE075 NEUTRON ACER TENDL-2024 LIBRARY; T=0.K
Neutron emission for (n,n2p)

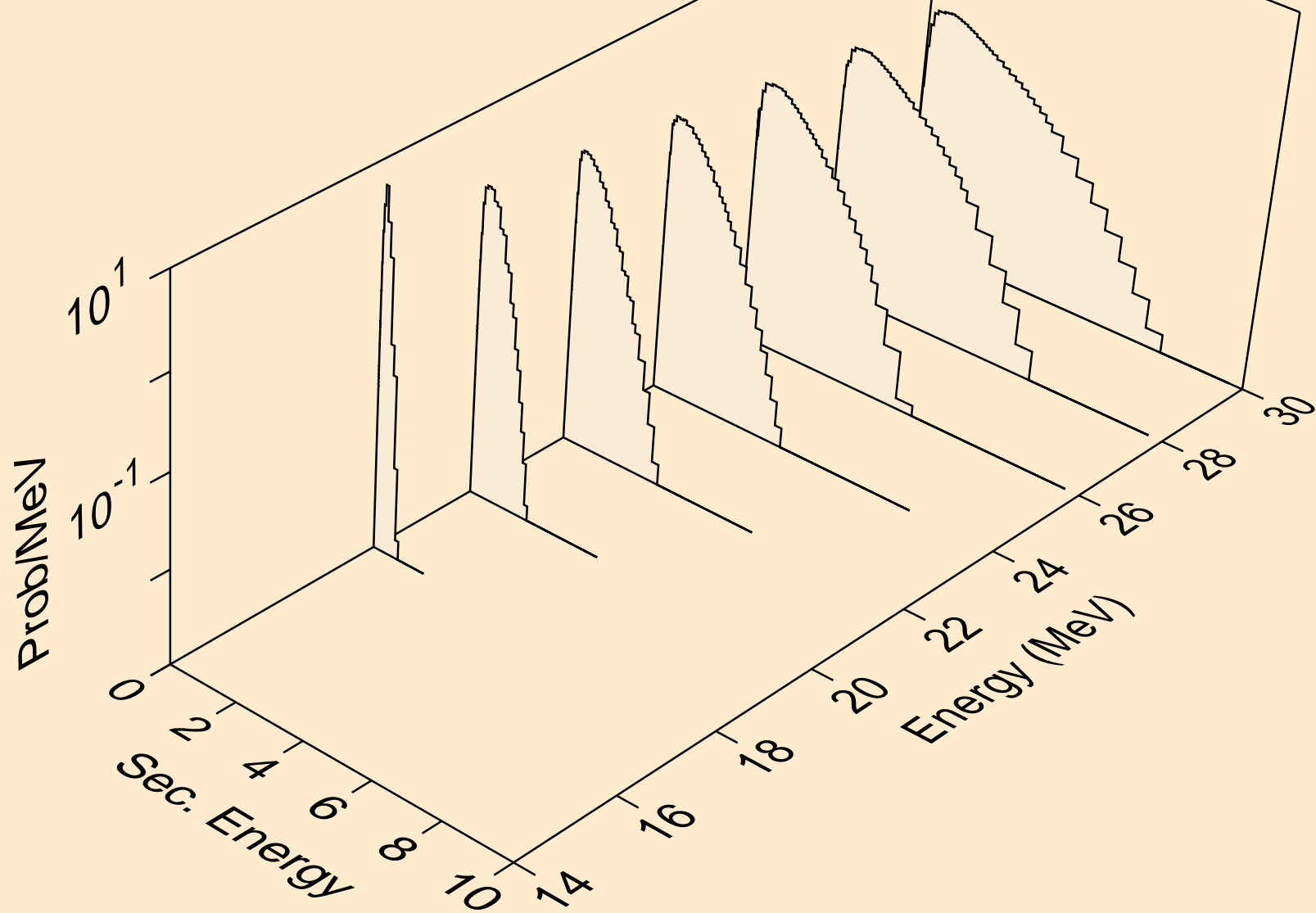

SE075 NEUTRON ACER TENDL-2024 LIBRARY; T=0.K
Neutron emission for (n,npa)

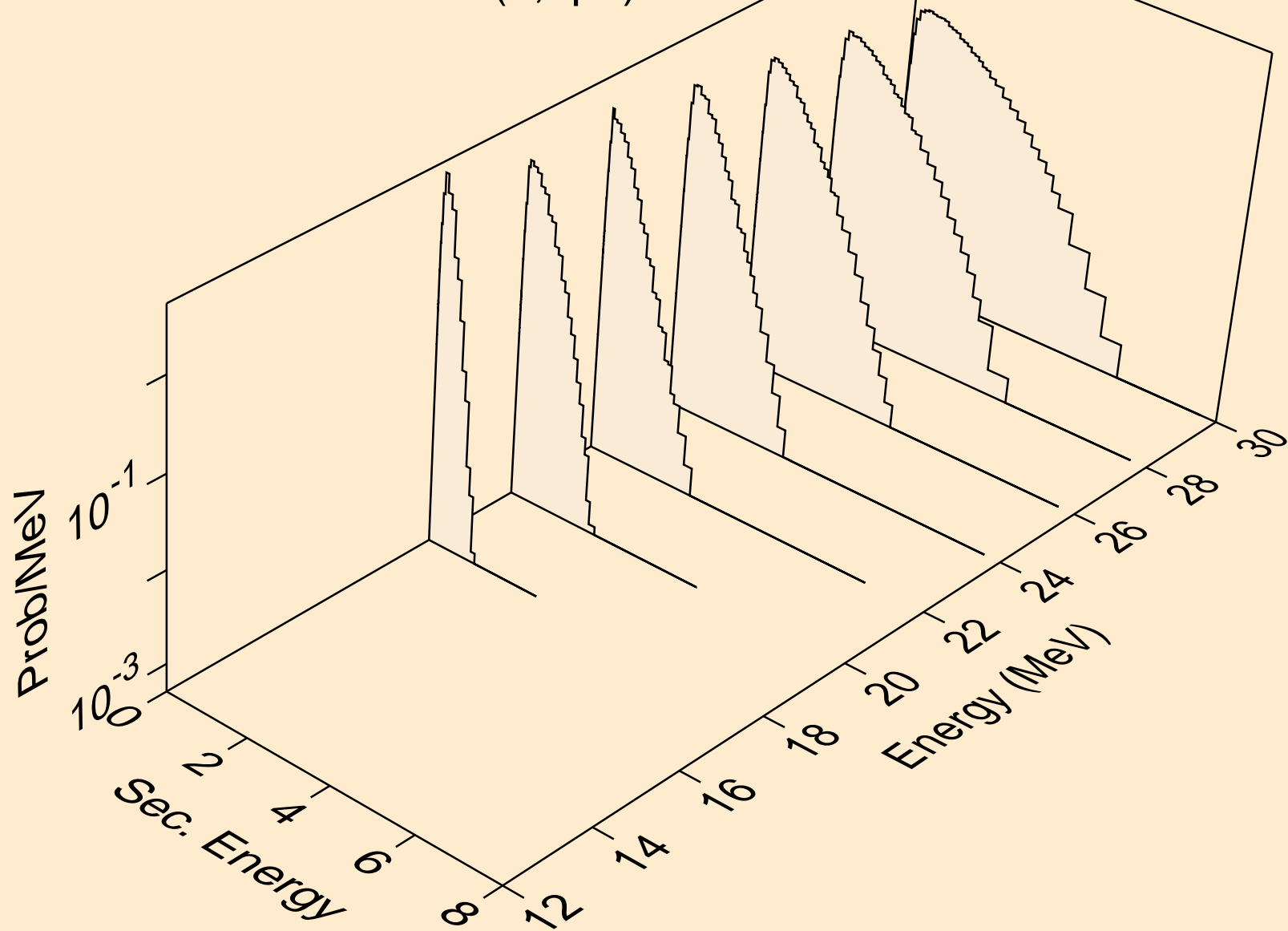

SE075 NEUTRON ACER TENDL-2024 LIBRARY; T=0.K
Neutron emission for (n,n*c)

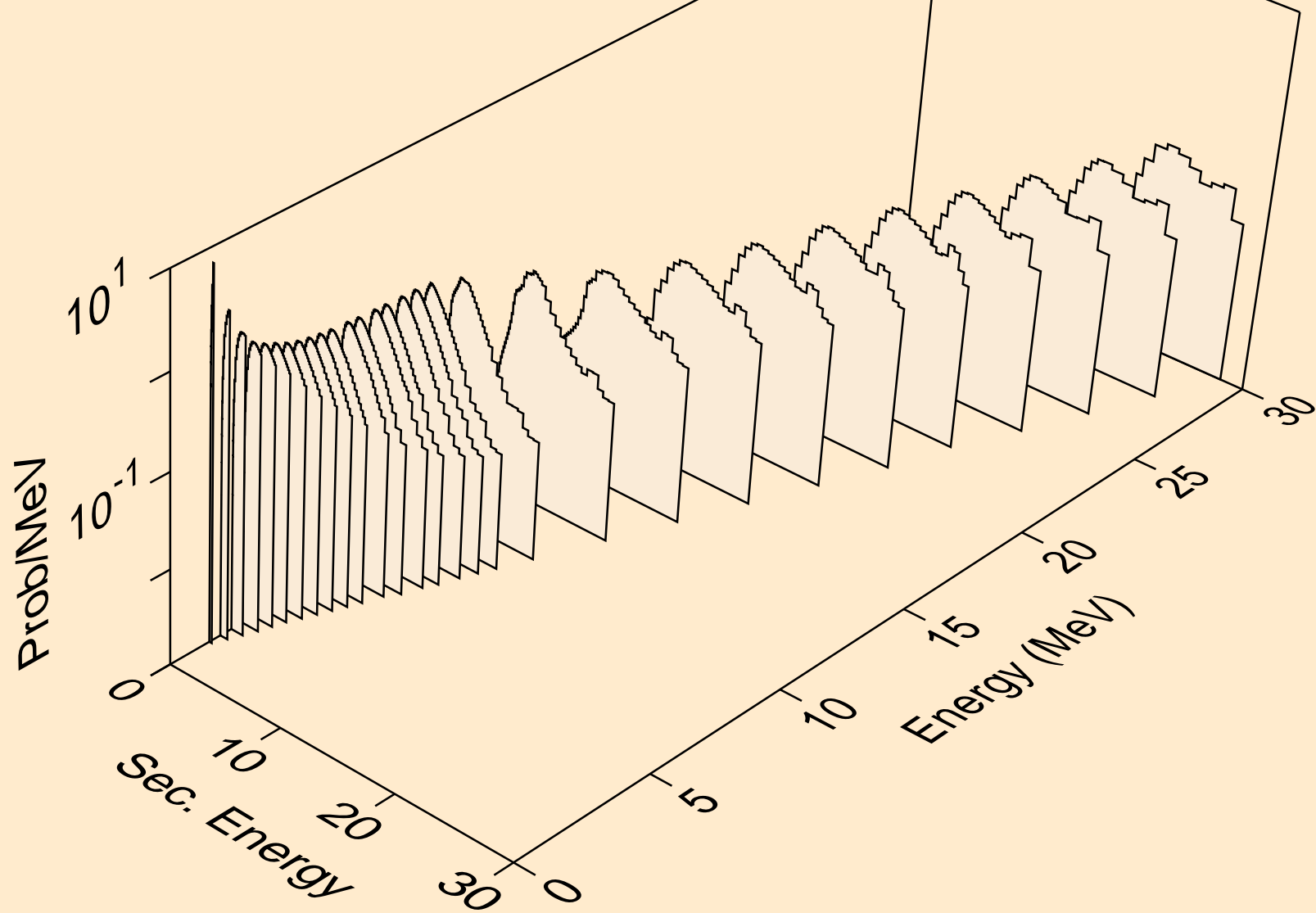

SE075 NEUTRON ACER TENDL-2024 LIBRARY; T=0.K
Photon emission for (n,x)

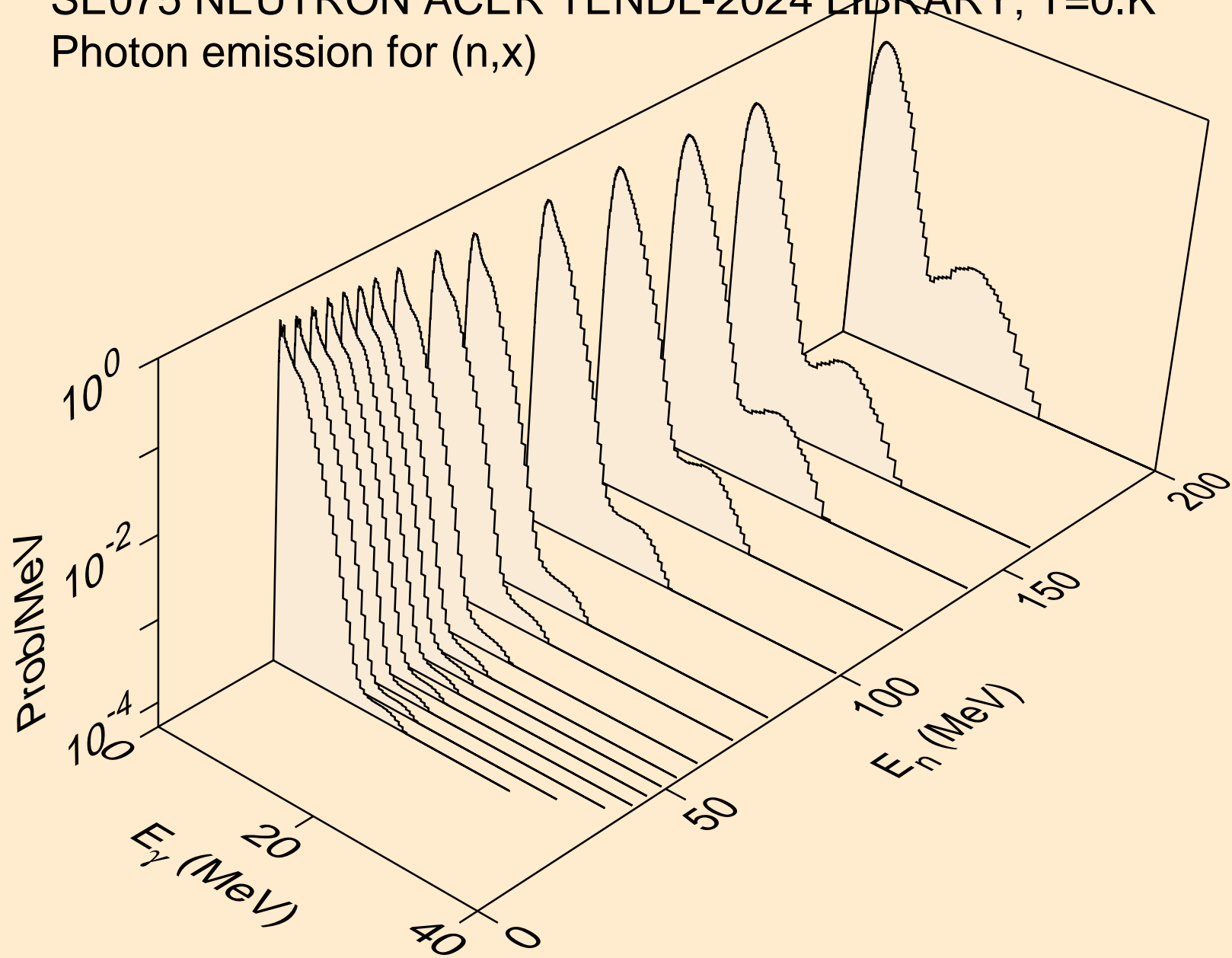

SE075 NEUTRON ACER TENDL-2024 LIBRARY; T=0.K
Photon emission for (n,2nd)

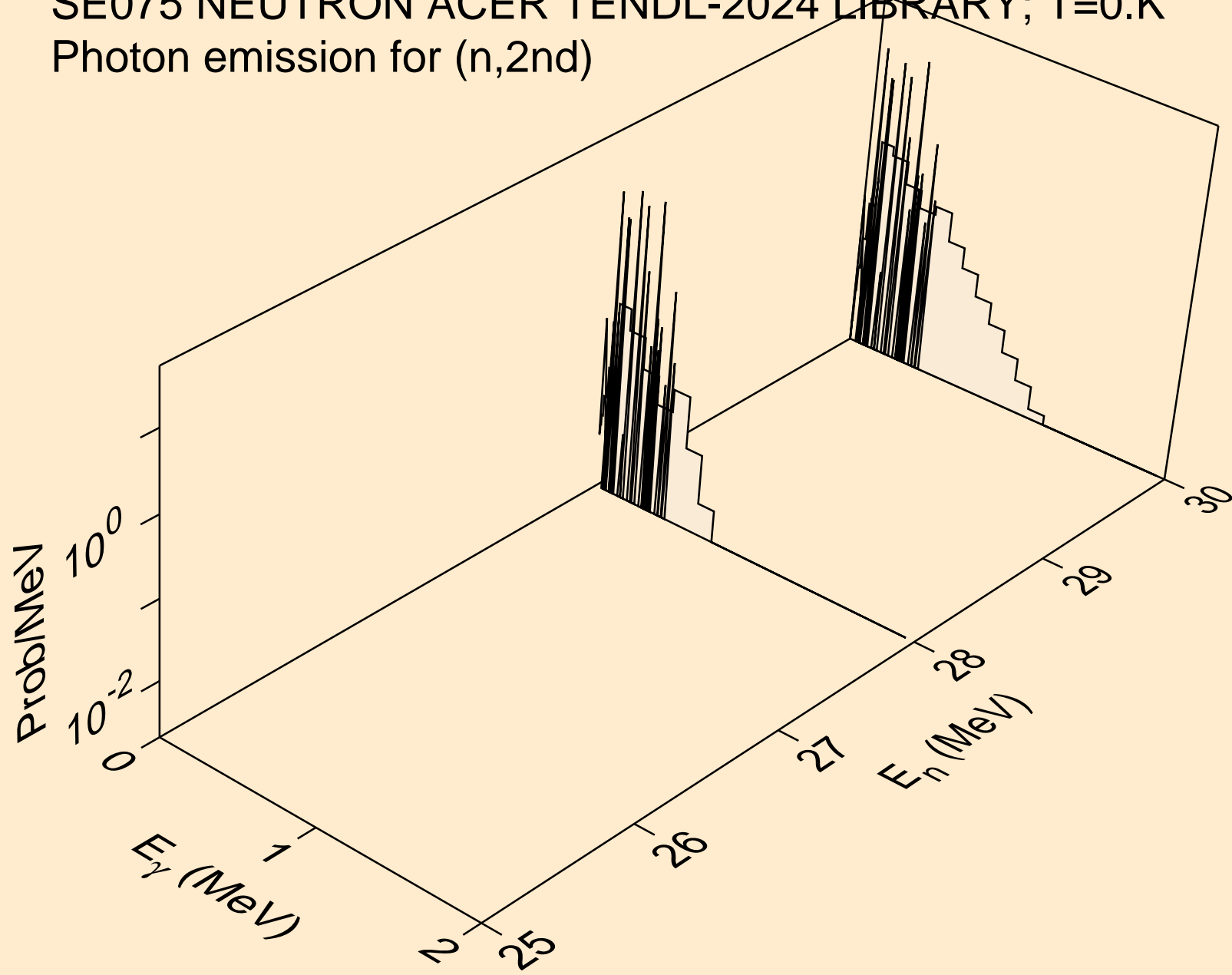

SE075 NEUTRON ACER TENDL-2024 LIBRARY; T=0.K
Photon emission for (n,2n)

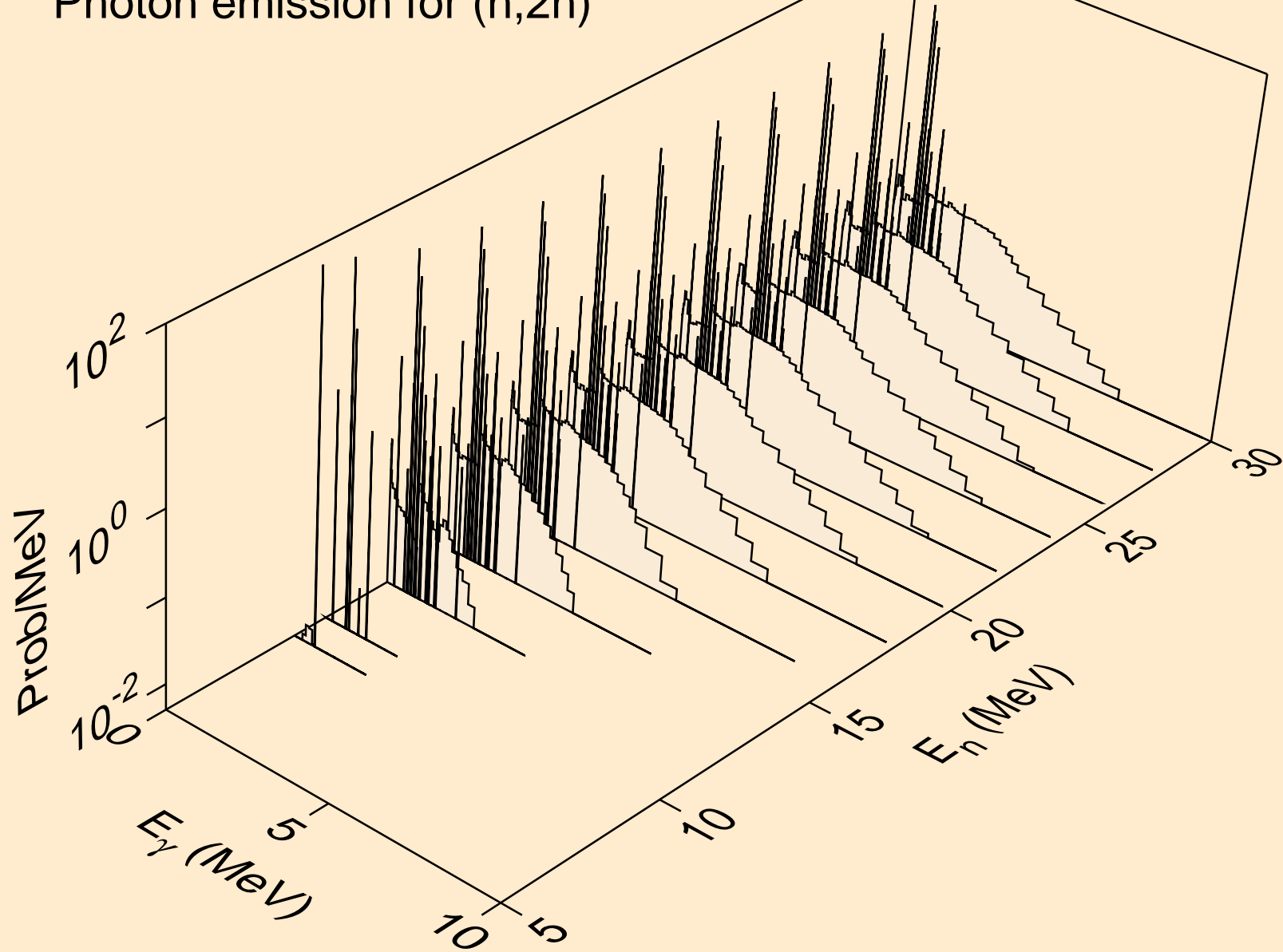

SE075 NEUTRON ACER TENDL-2024 LIBRARY; T=0.K
Photon emission for (n,3n)

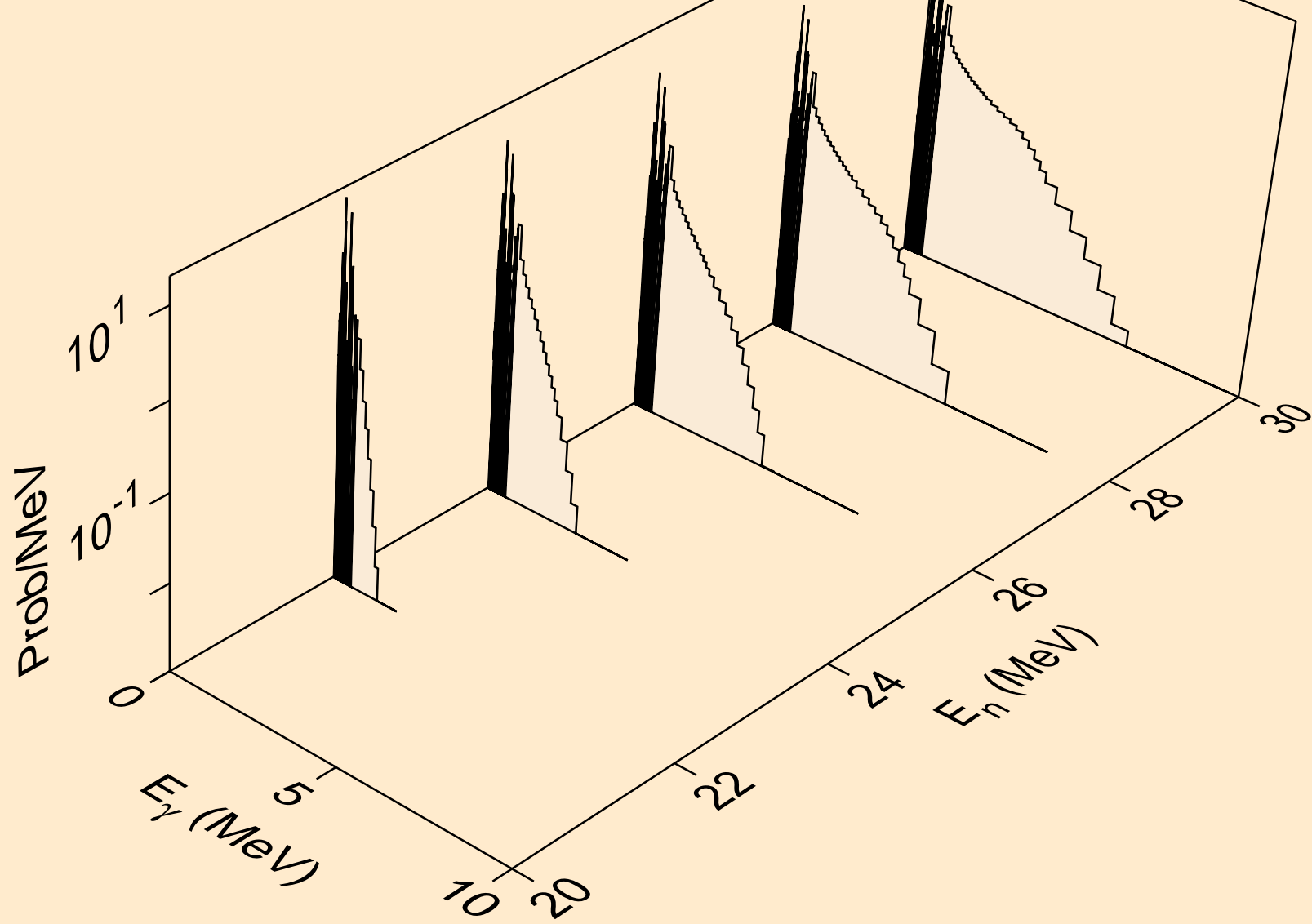

SE075 NEUTRON ACER TENDL-2024 LIBRARY; T=0.K
Photon emission for (n,n*)a

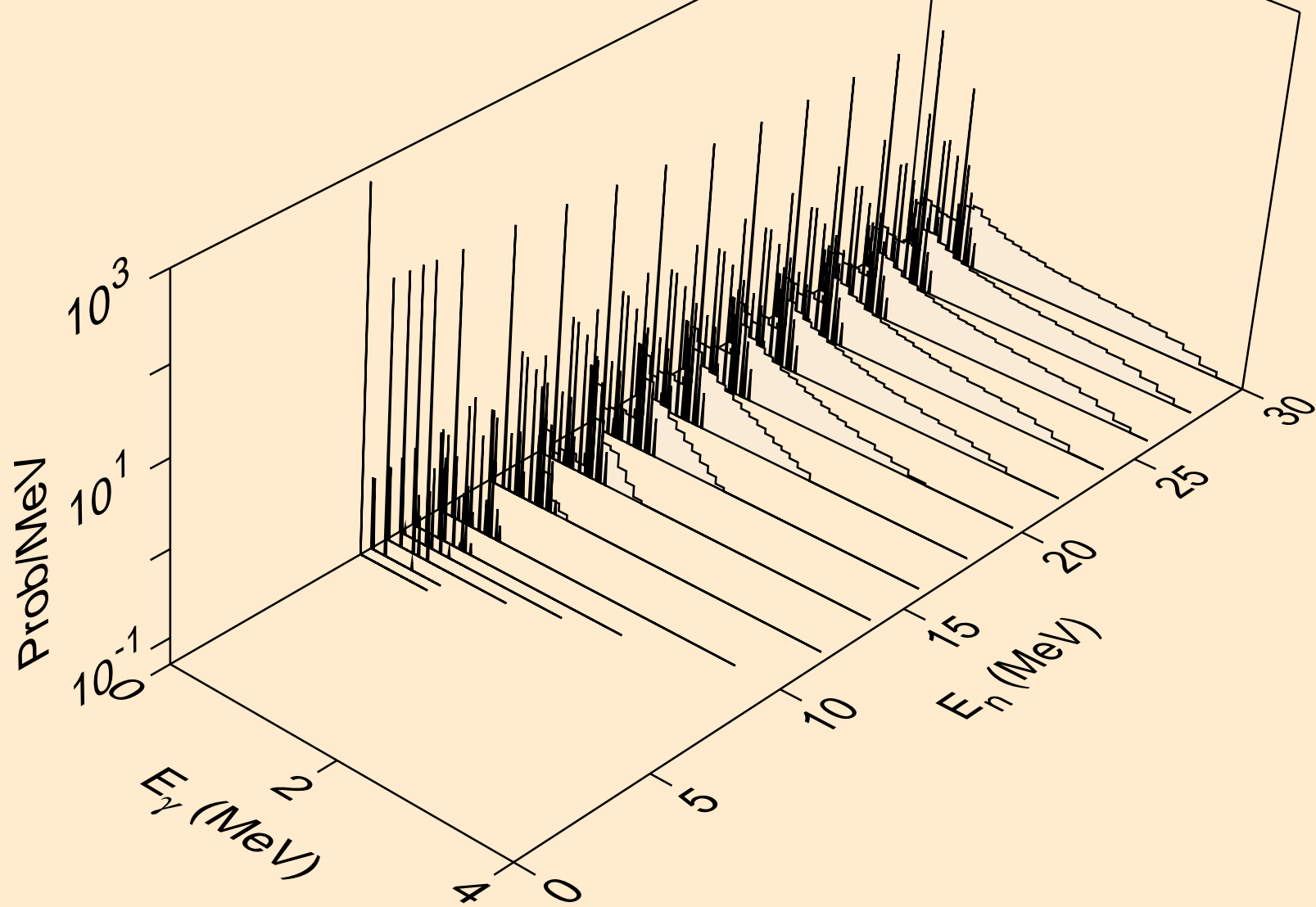

SE075 NEUTRON ACER TENDL-2024 LIBRARY; T=0.K
Photon emission for (n,2n)a

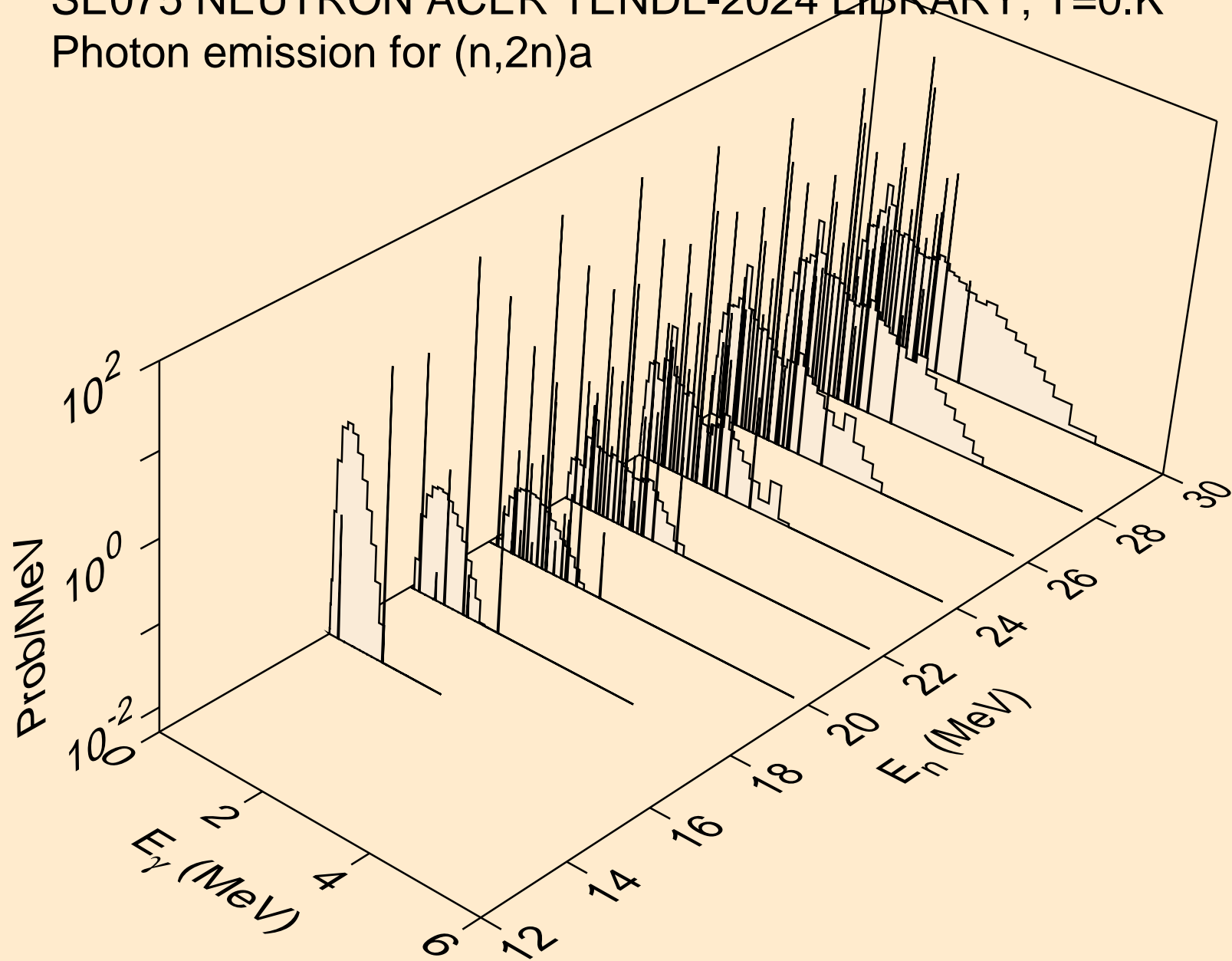

SE075 NEUTRON ACER TENDL-2024 LIBRARY; T=0.K
Photon emission for (n,3n)a

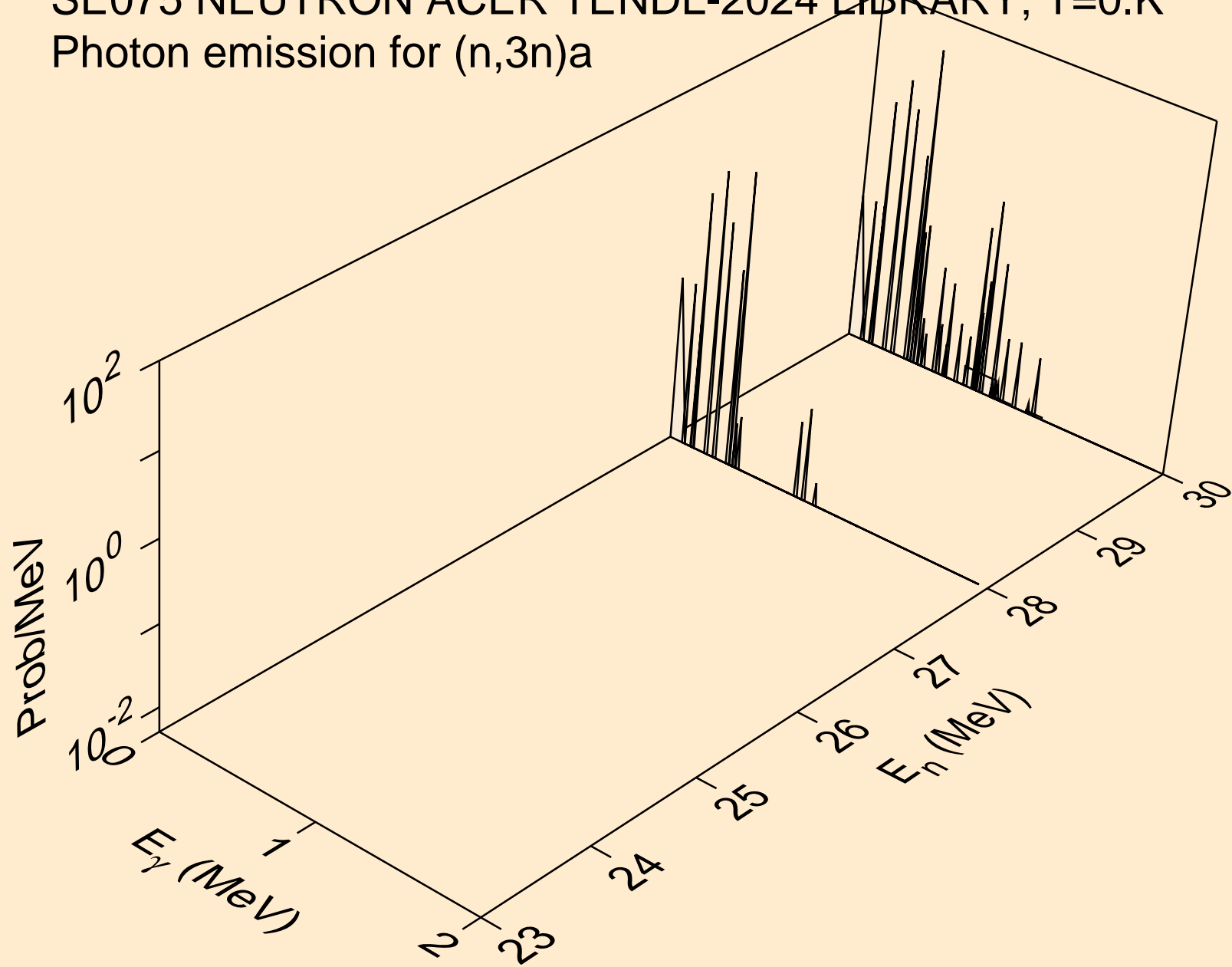

SE075 NEUTRON ACER TENDL-2024 LIBRARY; T=0.K
Photon emission for (n,n*)p

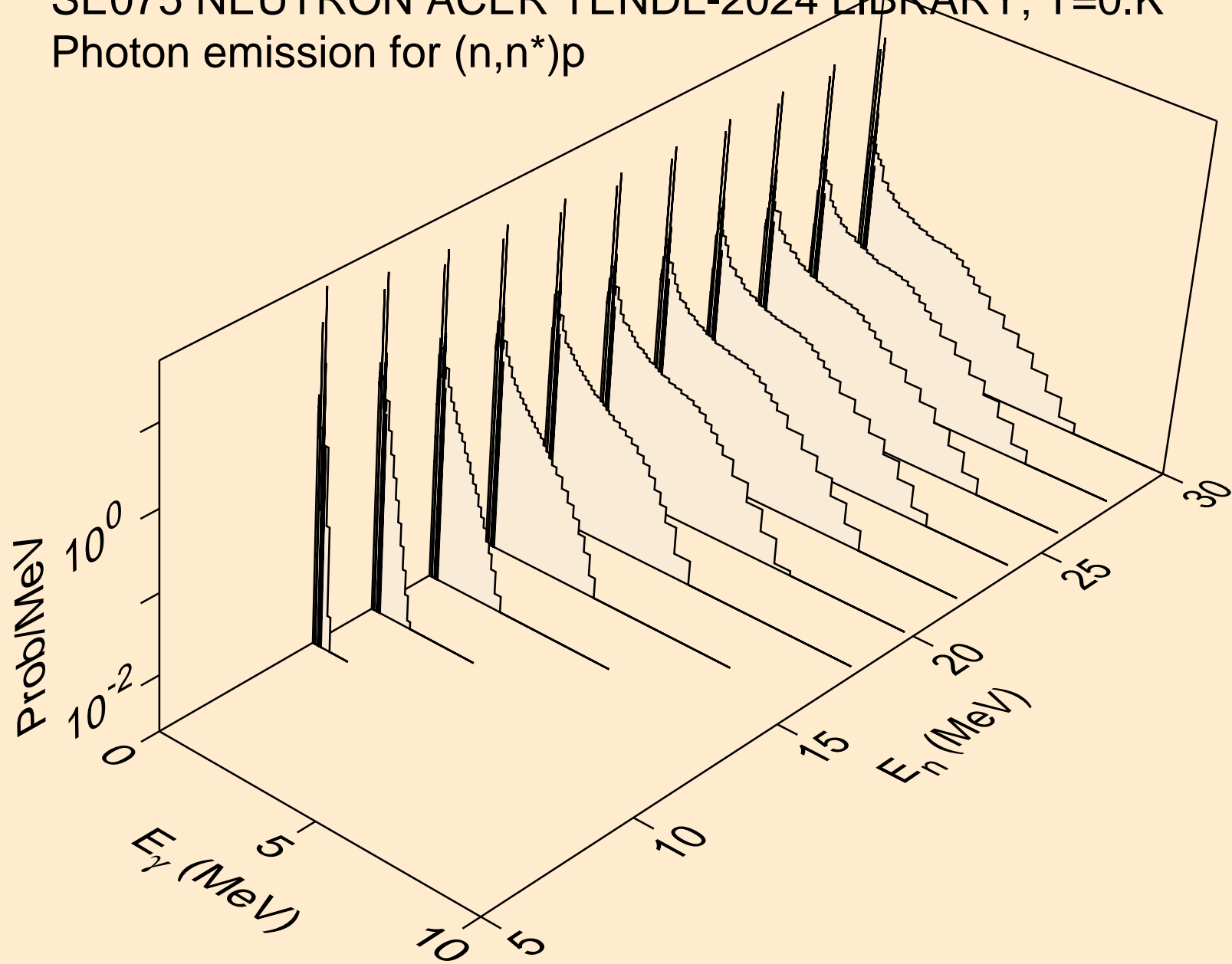

SE075 NEUTRON ACER TENDL-2024 LIBRARY; T=0.K
Photon emission for (n,n*)2a

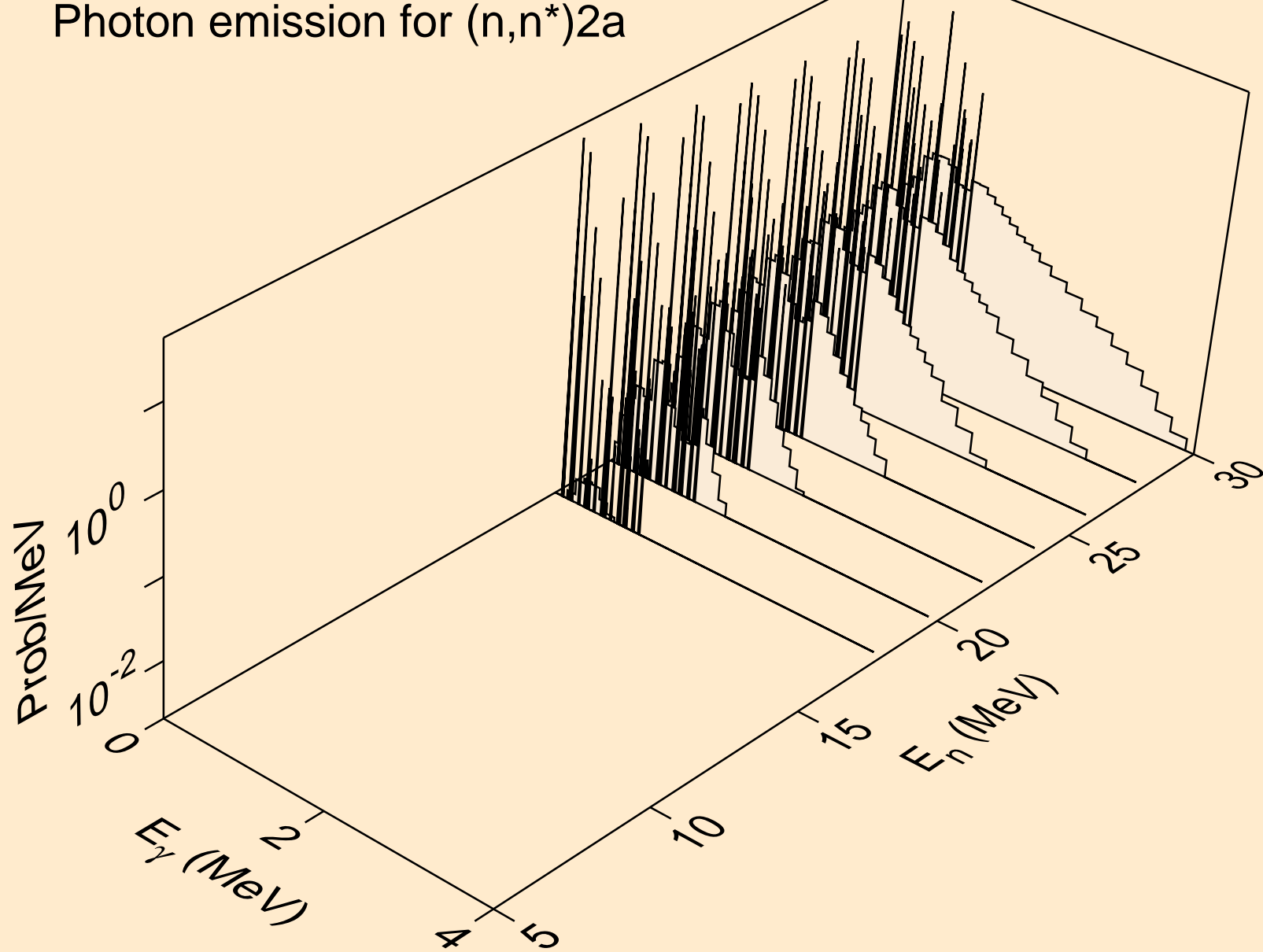

SE075 NEUTRON ACER TENDL-2024 LIBRARY; T=0.K
Photon emission for (n,2n)2a

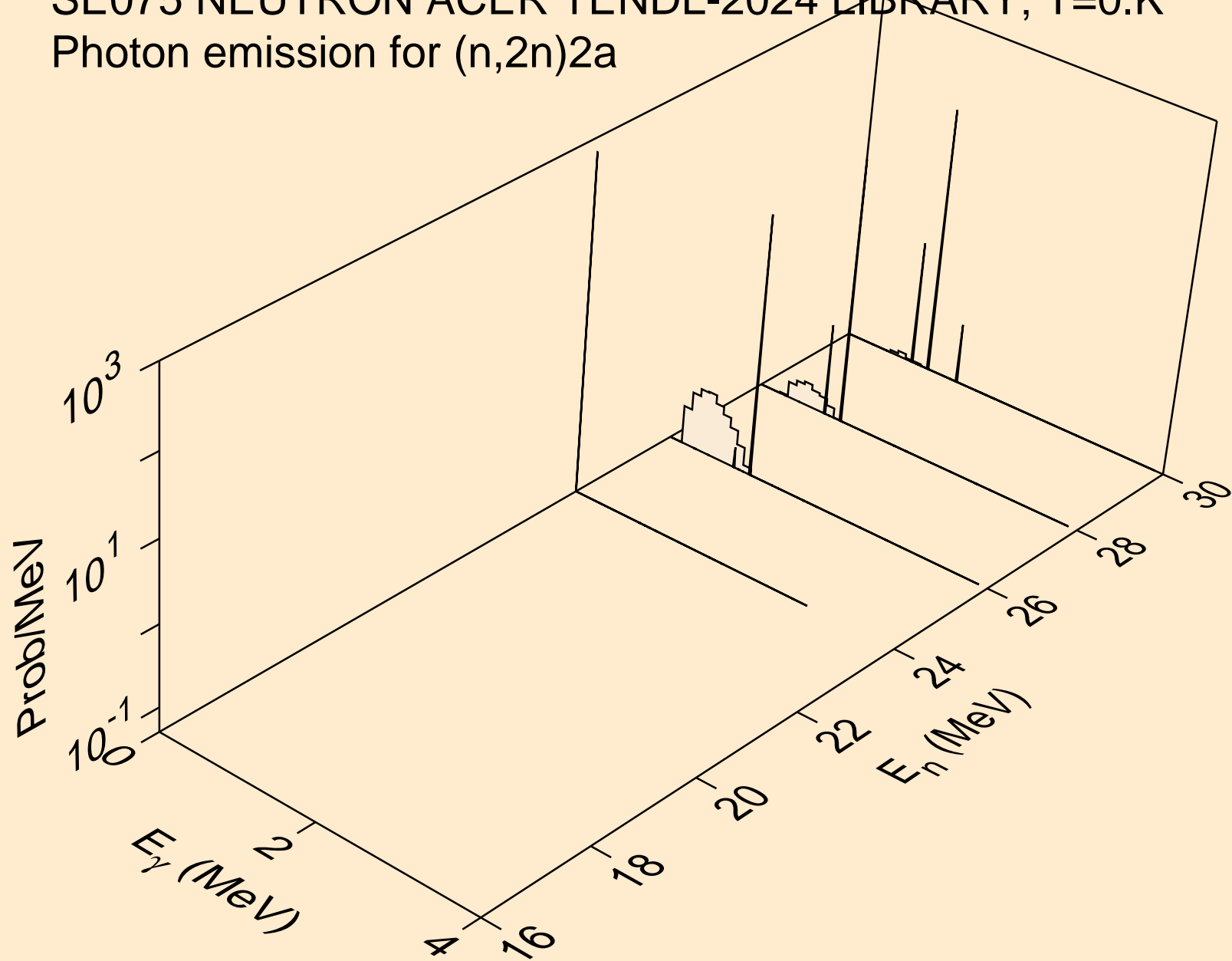

SE075 NEUTRON ACER TENDL-2024 LIBRARY; T=0.K
Photon emission for (n,n*)d

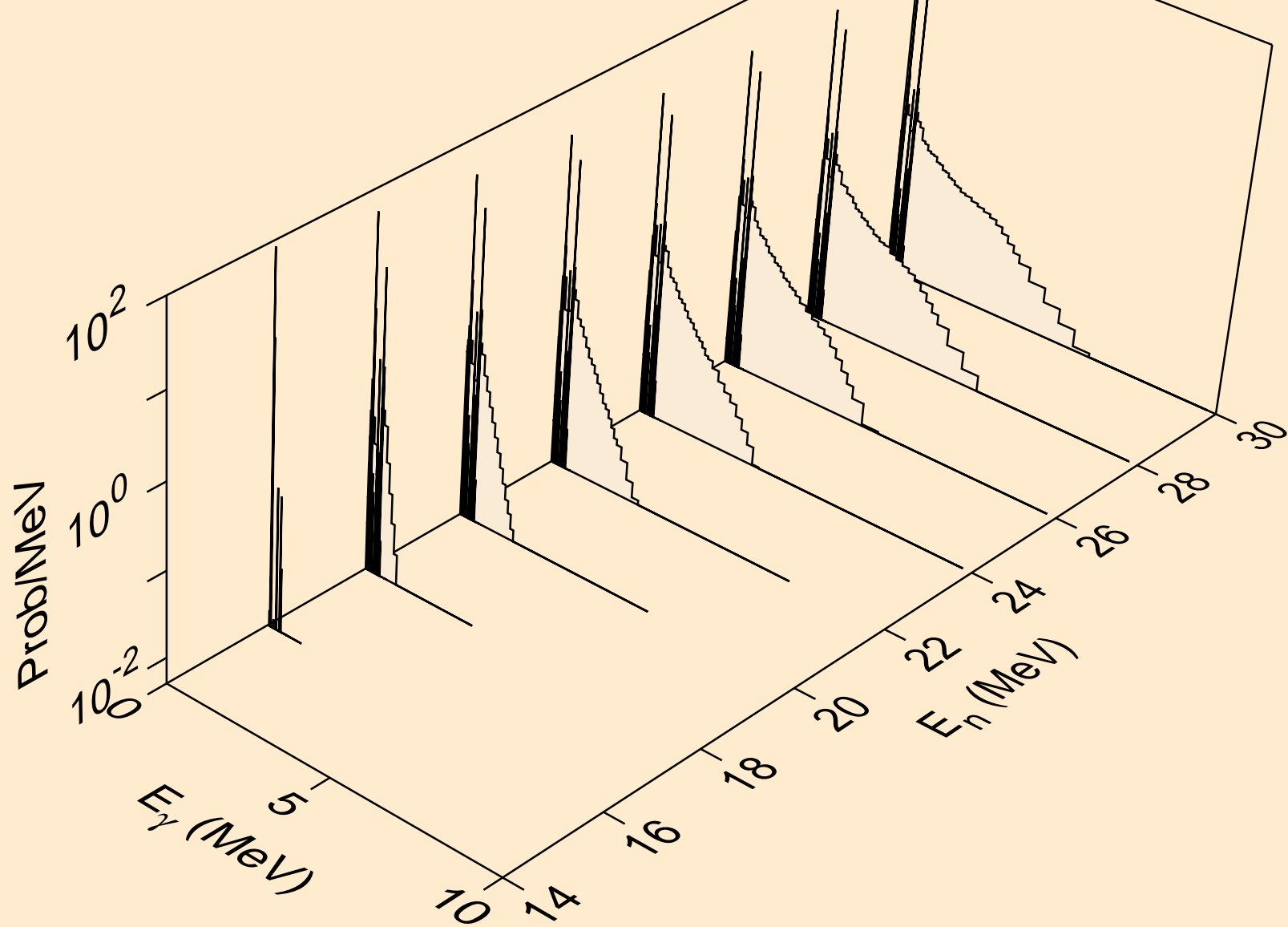

SE075 NEUTRON ACER TENDL-2024 LIBRARY; T=0.K
Photon emission for (n,n*)t

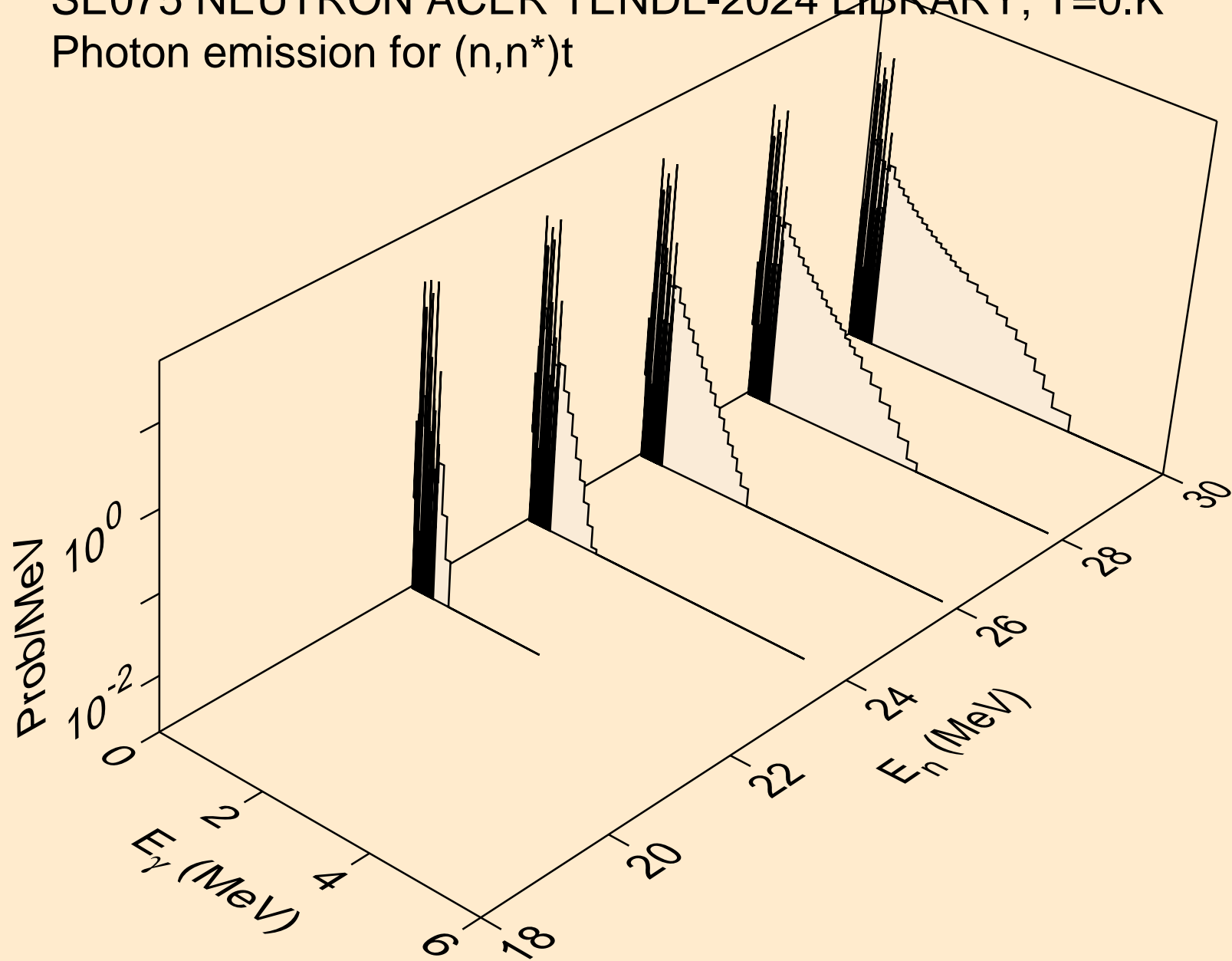

SE075 NEUTRON ACER TENDL-2024 LIBRARY; T=0.K
Photon emission for (n,n*)he3

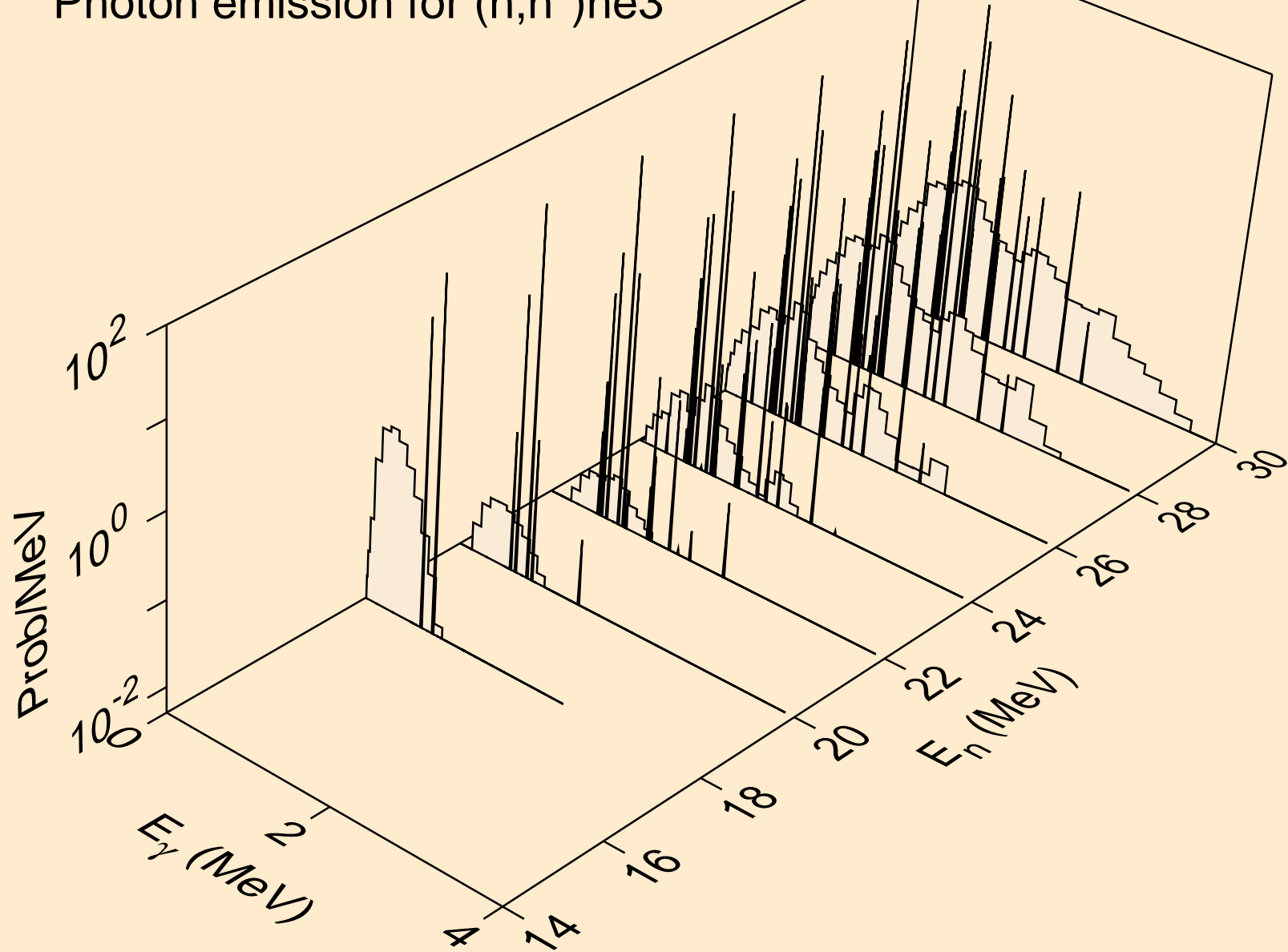

SE075 NEUTRON ACER TENDL-2024 LIBRARY; T=0.K
Photon emission for (n,4n)

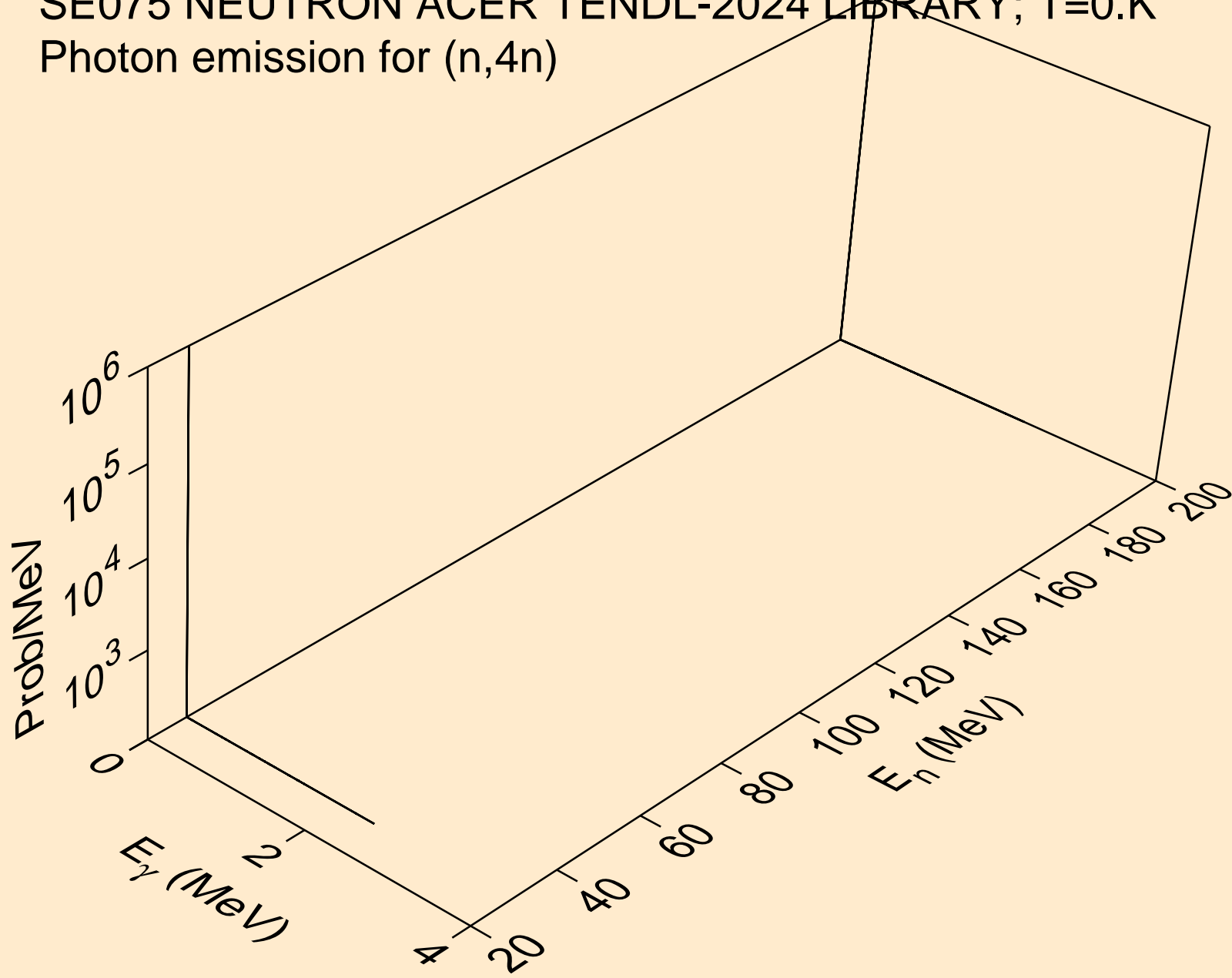

SE075 NEUTRON ACER TENDL-2024 LIBRARY; T=0.K
Photon emission for (n,2np)

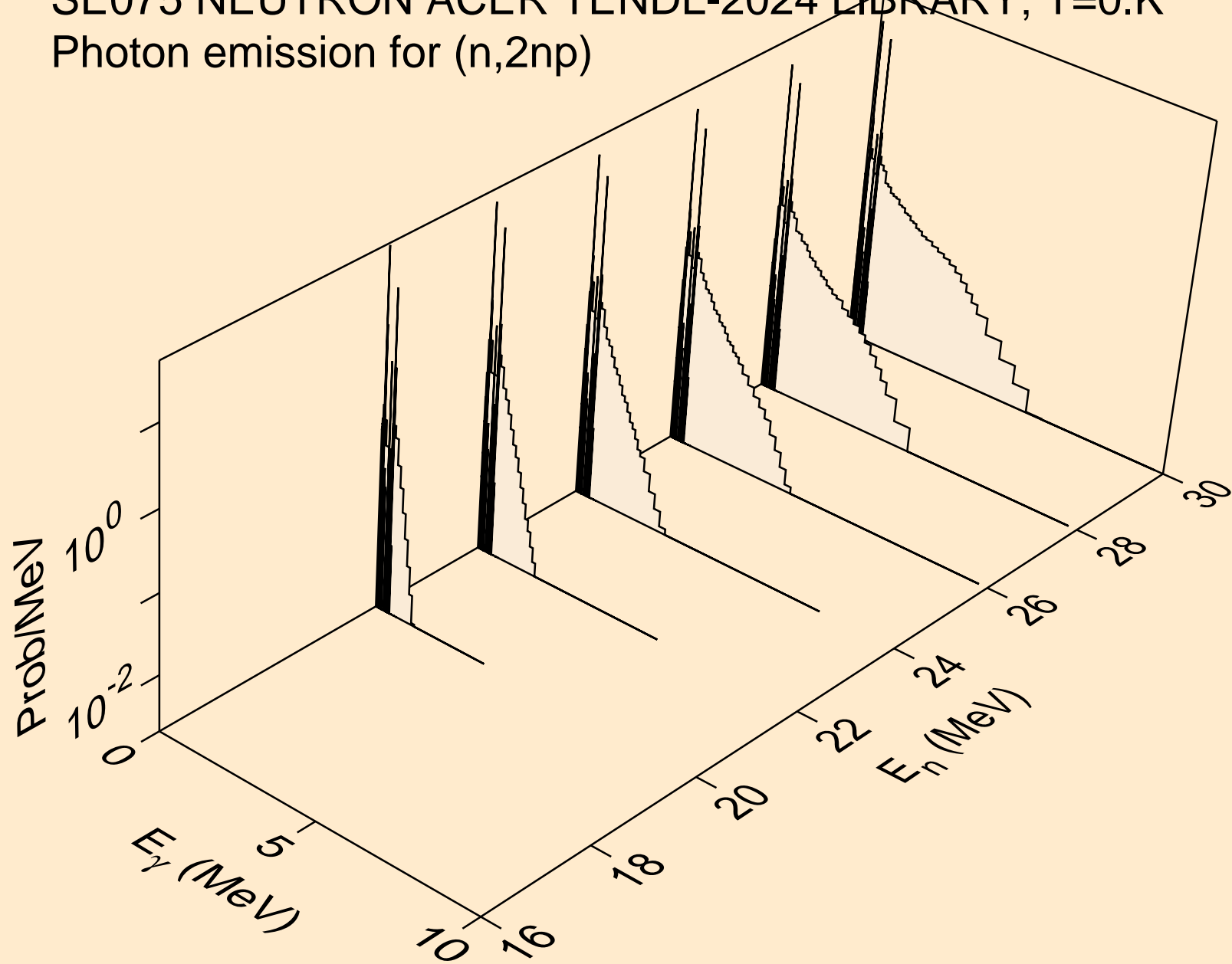

SE075 NEUTRON ACER TENDL-2024 LIBRARY; T=0.K
Photon emission for (n,3np)

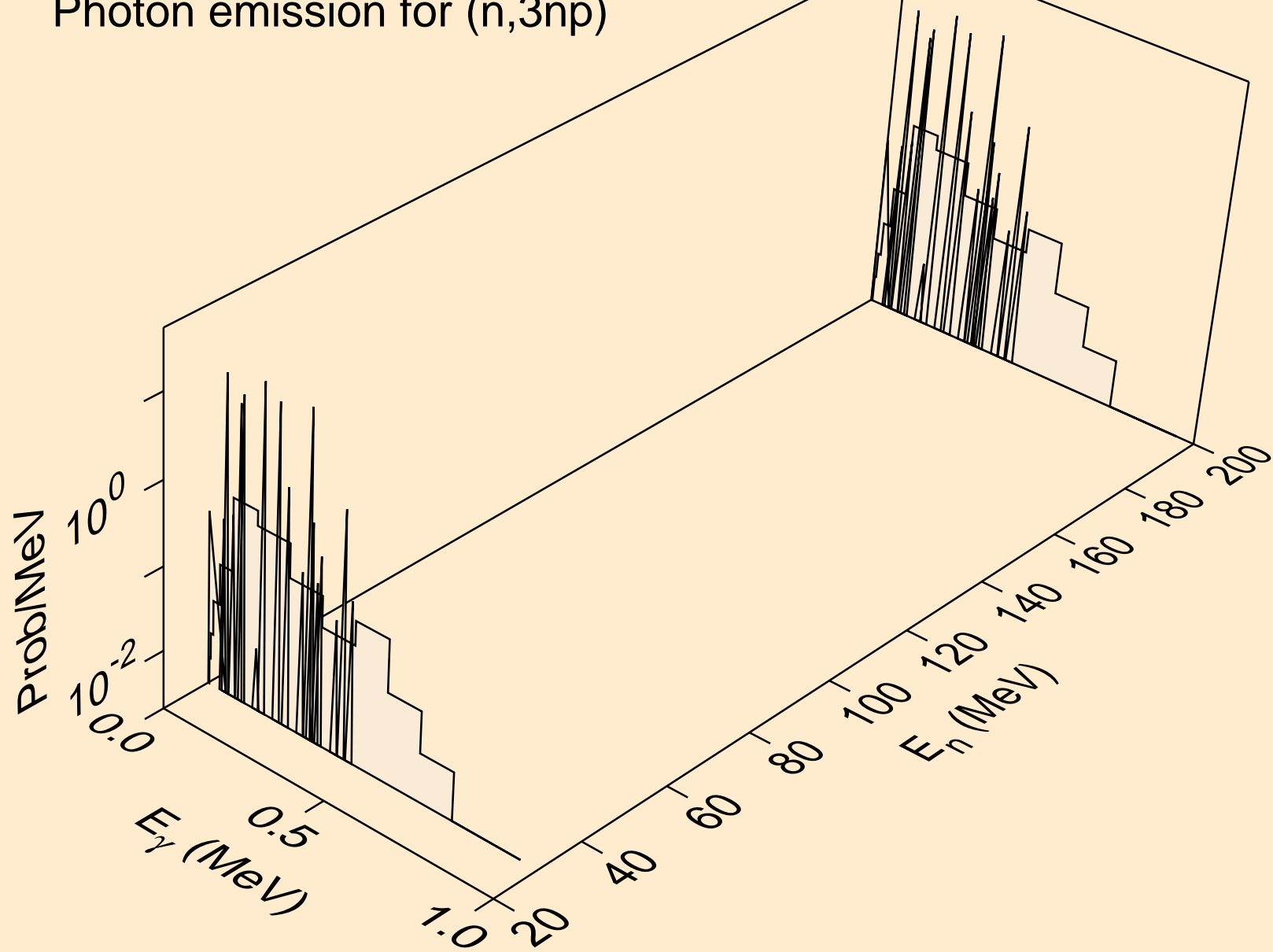

SE075 NEUTRON ACER TENDL-2024 LIBRARY; T=0.K
Photon emission for (n,n2p)

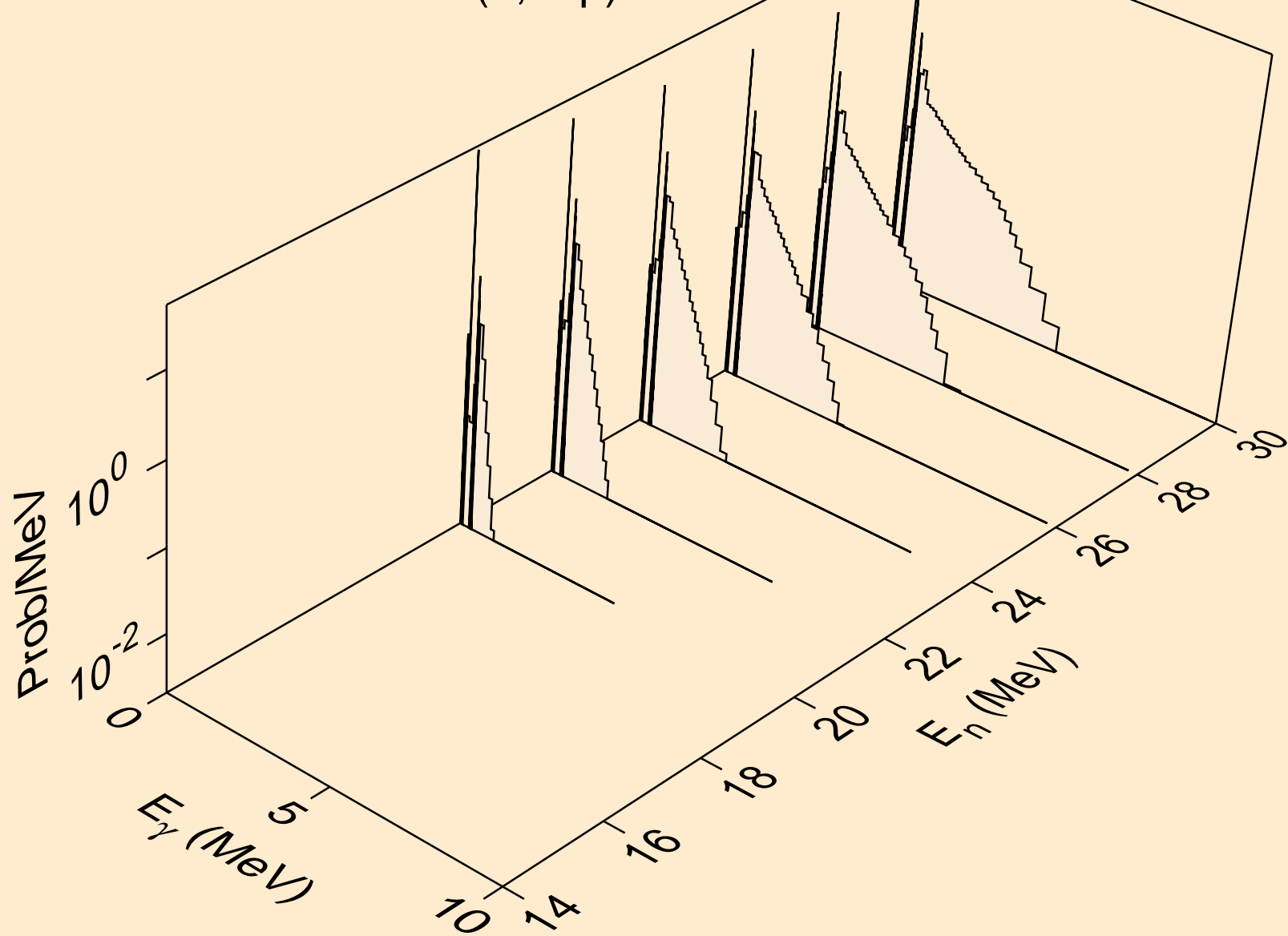

SE075 NEUTRON ACER TENDL-2024 LIBRARY; T=0.K
Photon emission for (n,npa)

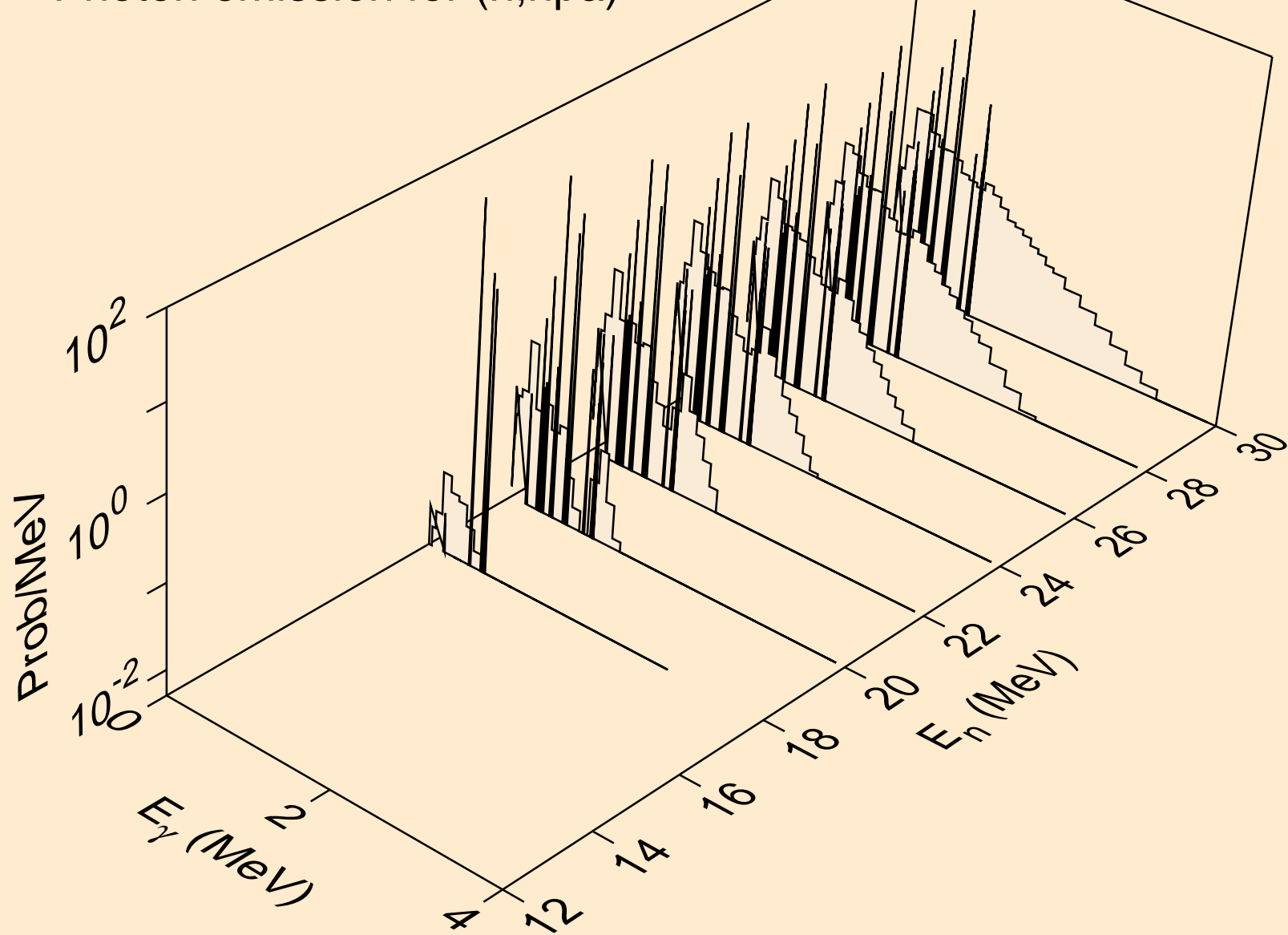

SE075 NEUTRON ACER TENDL-2024 LIBRARY; T=0.K
Photon emission for (n,n*c)

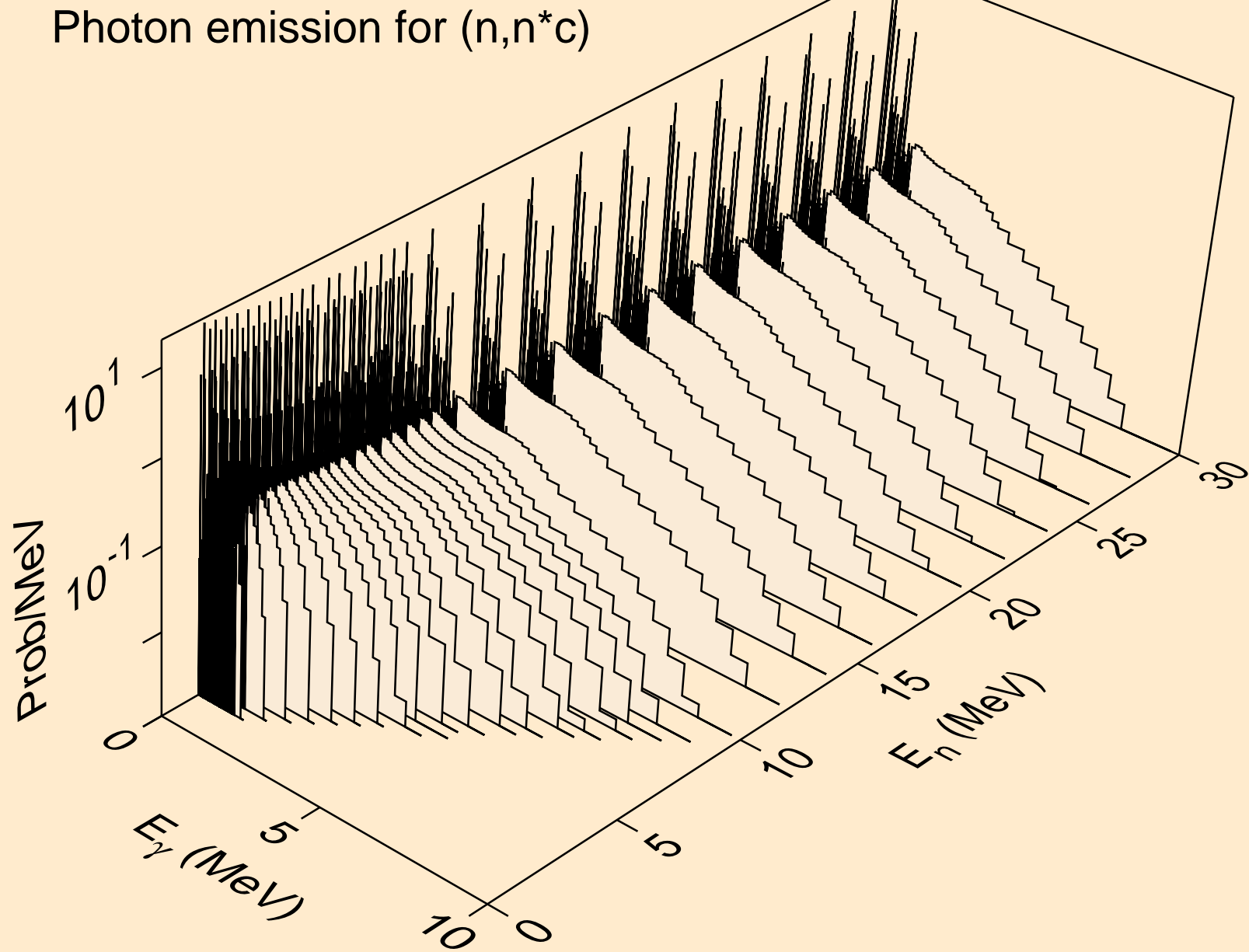

SE075 NEUTRON ACER TENDL-2024 LIBRARY; T=0.K
Photon emission for (n,gma)

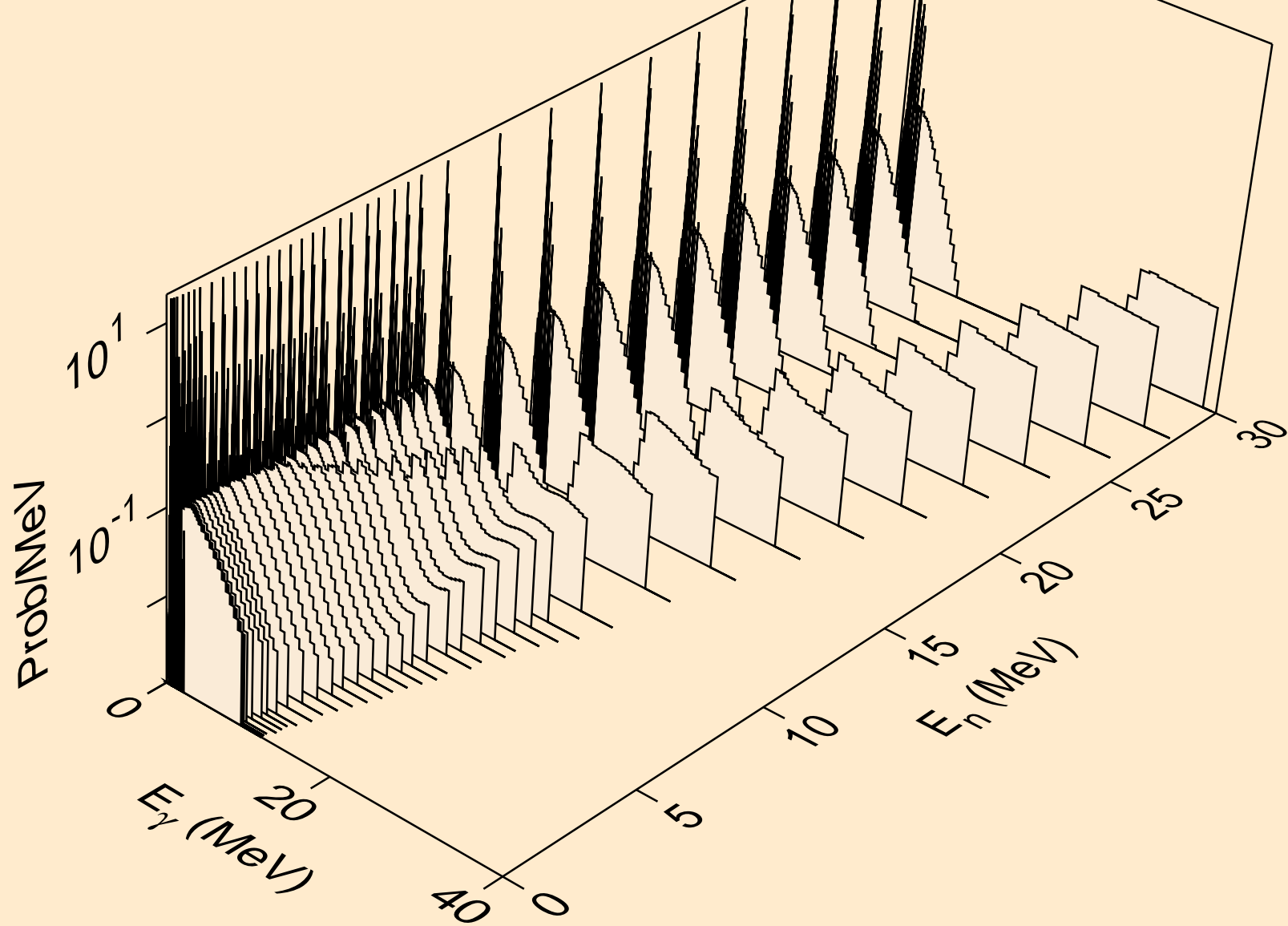

SE075 NEUTRON ACER TENDL-2024 LIBRARY; T=0.K
Photon emission for (n,p)

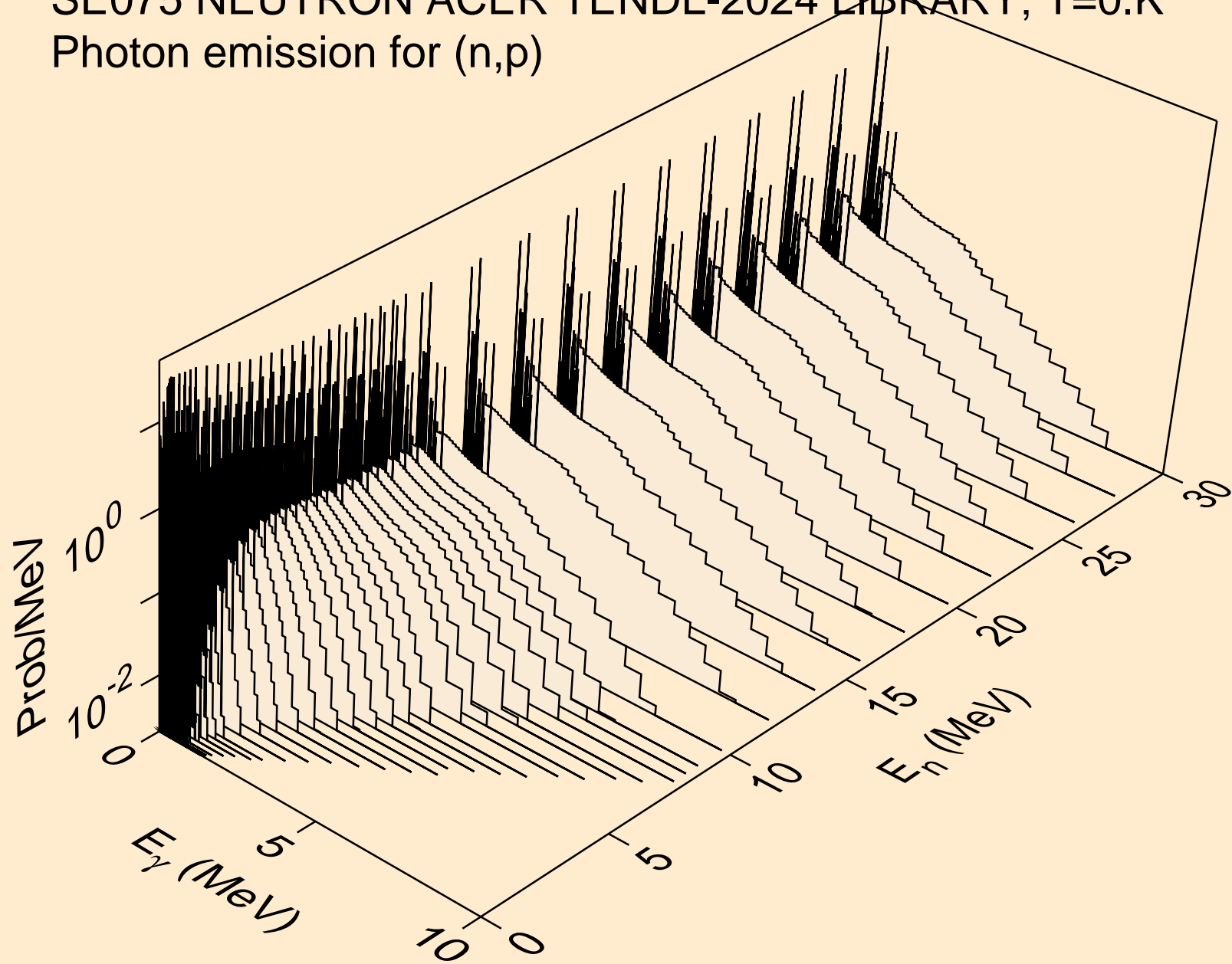

SE075 NEUTRON ACER TENDL-2024 LIBRARY; T=0.K
Photon emission for (n,d)

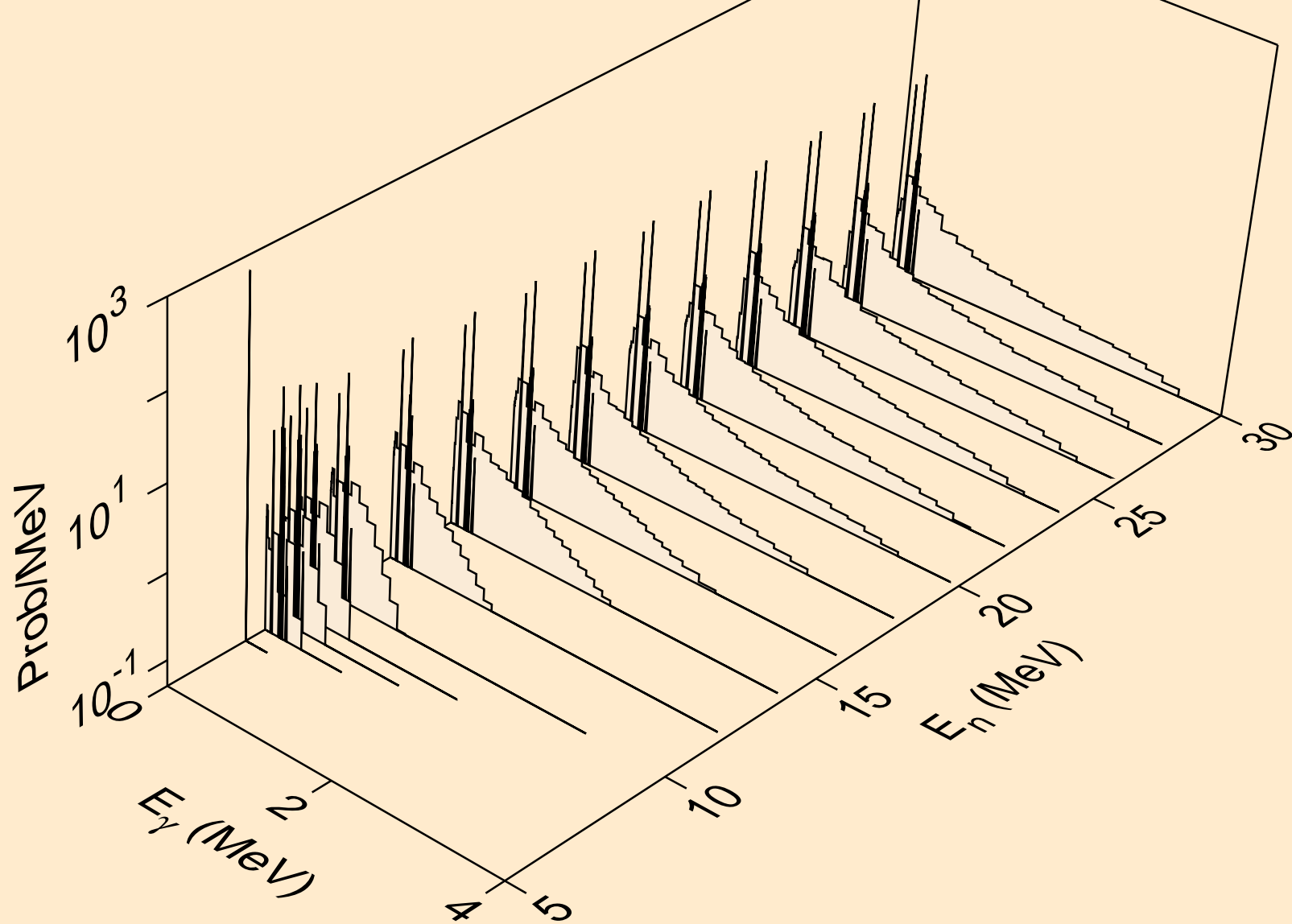

SE075 NEUTRON ACER TENDL-2024 LIBRARY; T=0.K
Photon emission for (n,t)

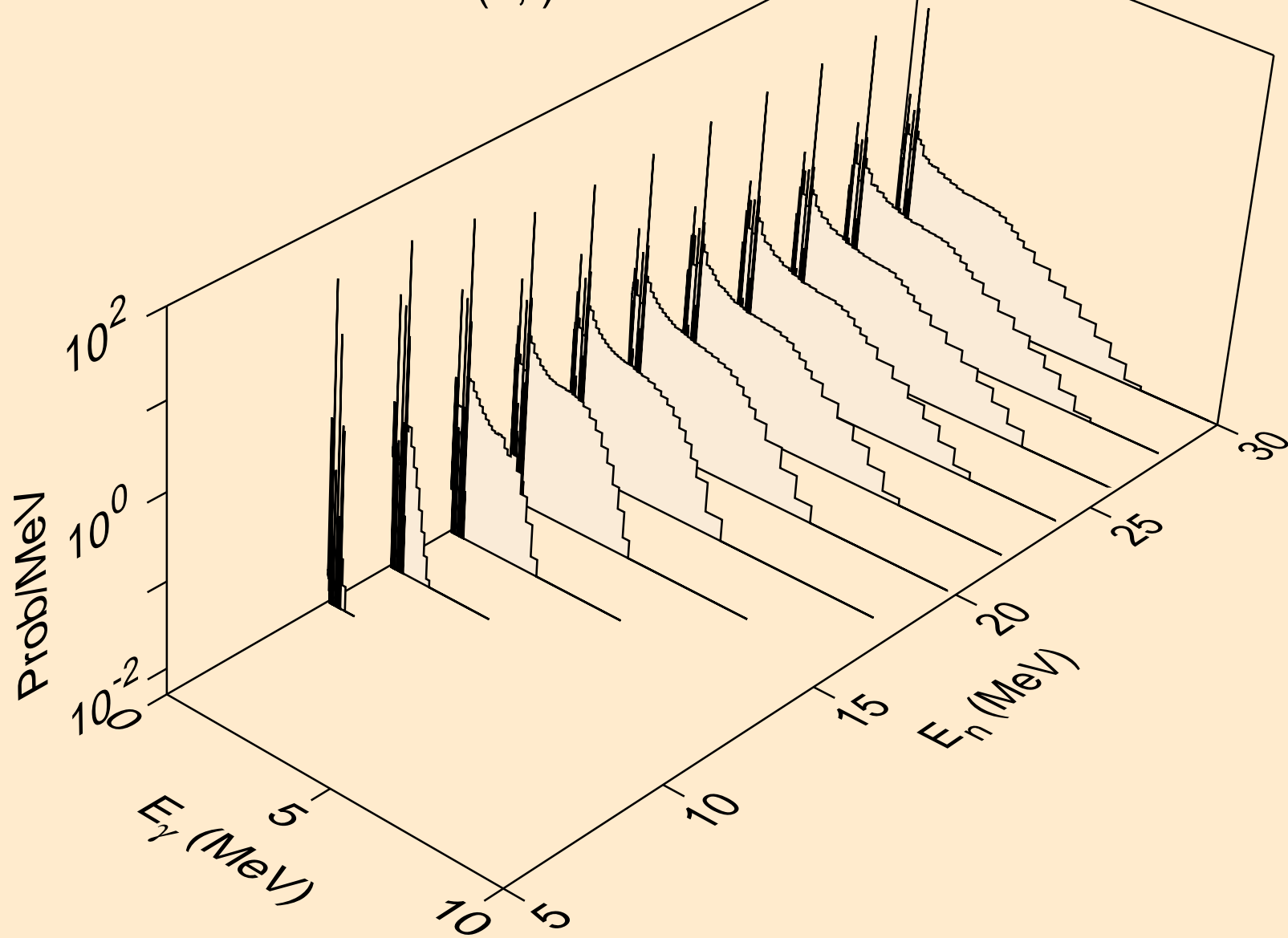

SE075 NEUTRON ACER TENDL-2024 LIBRARY; T=0.K
Photon emission for (n,he3)

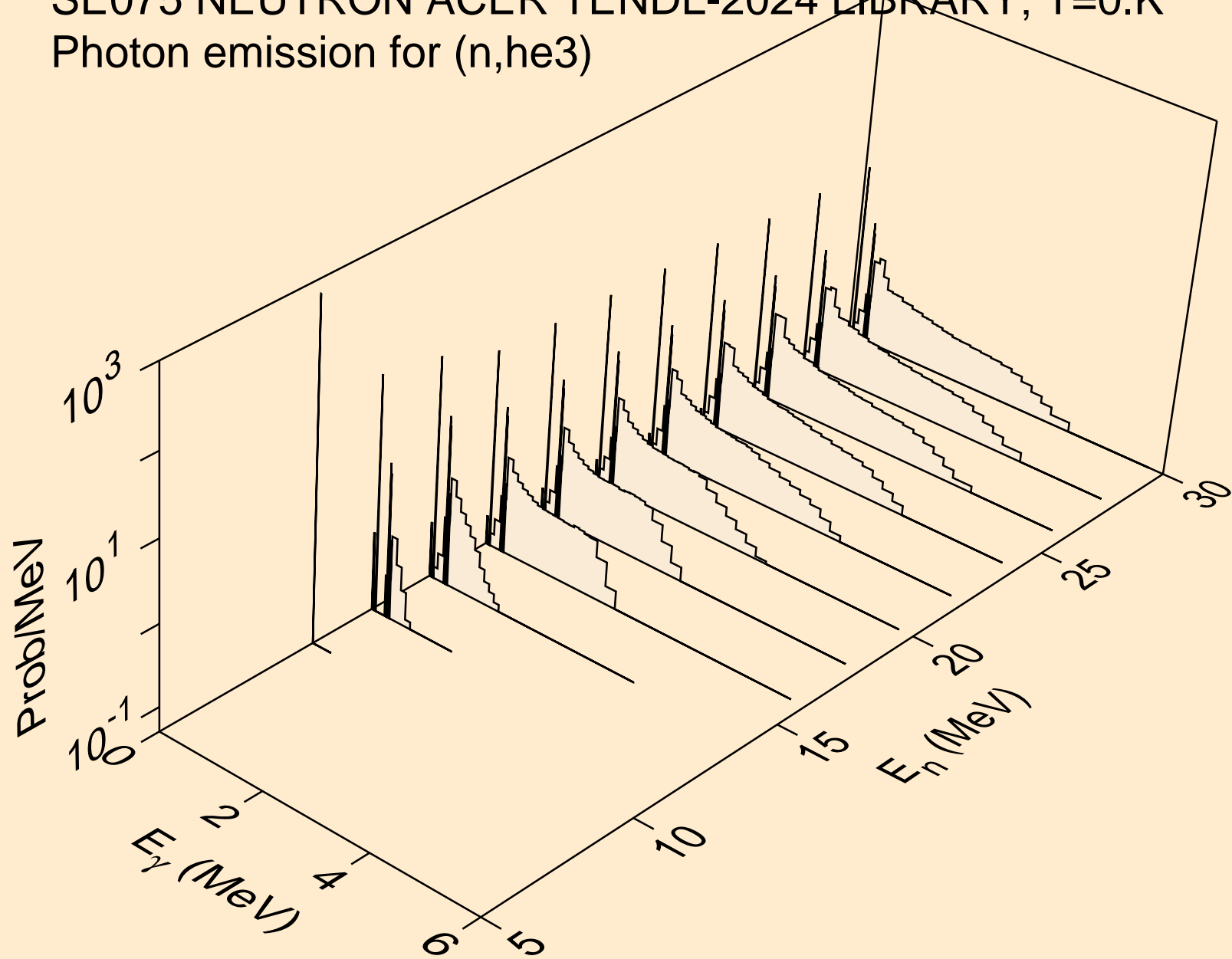

SE075 NEUTRON ACER TENDL-2024 LIBRARY; T=0.K
Photon emission for (n,a)

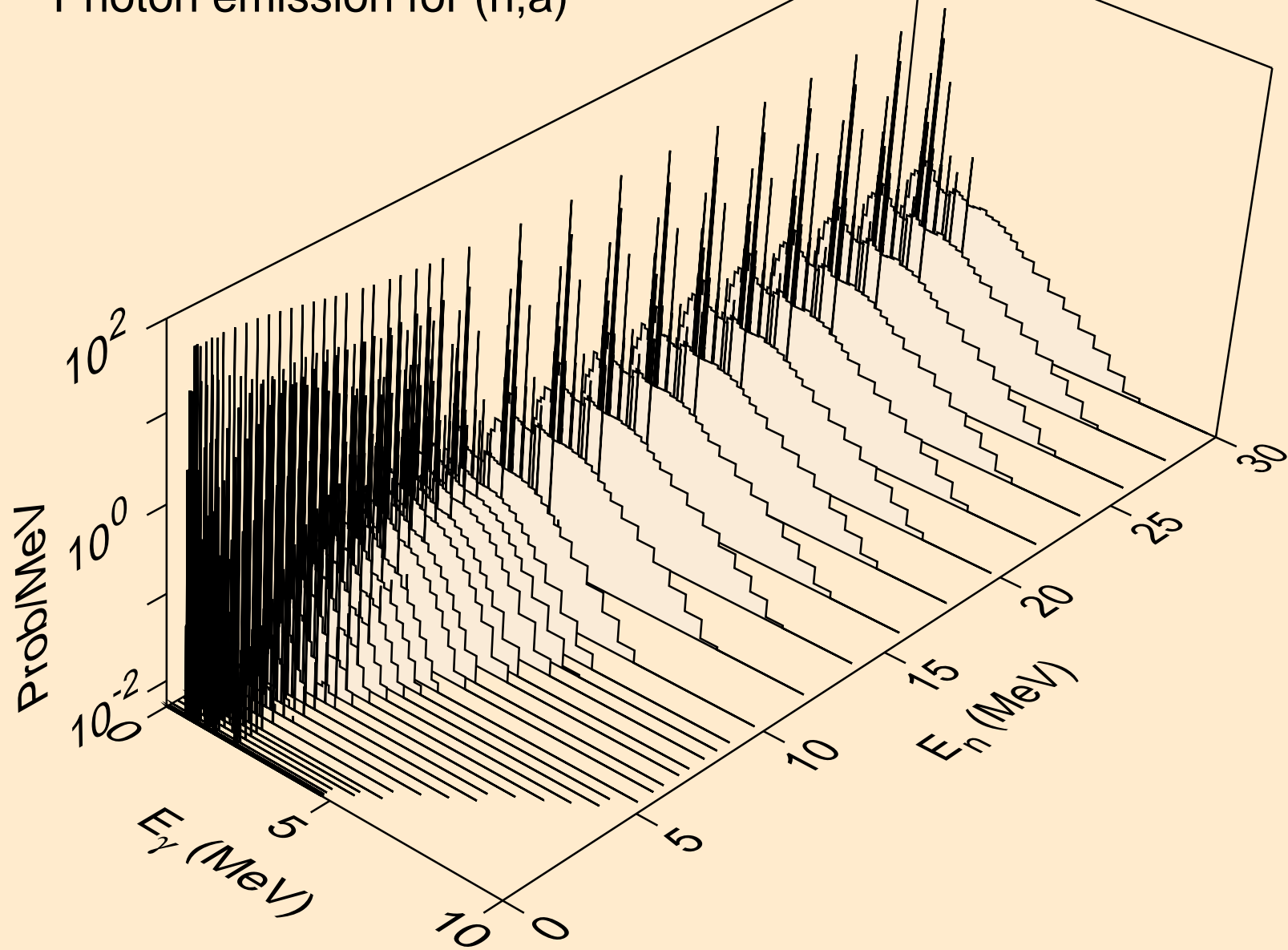

SE075 NEUTRON ACER TENDL-2024 LIBRARY; T=0.K
Photon emission for (n,2a)

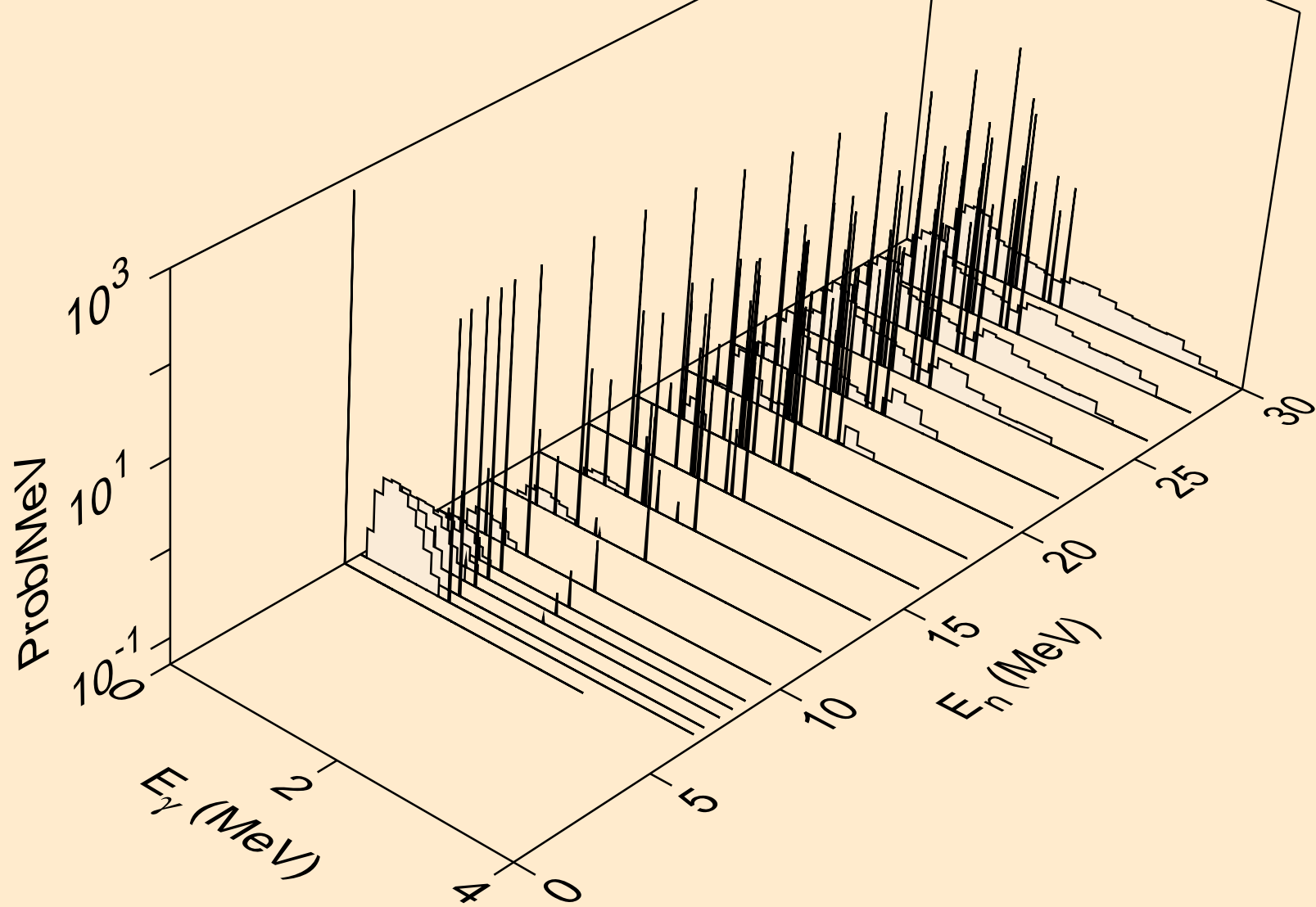

SE075 NEUTRON ACER TENDL-2024 LIBRARY; T=0.K
Photon emission for (n,2p)

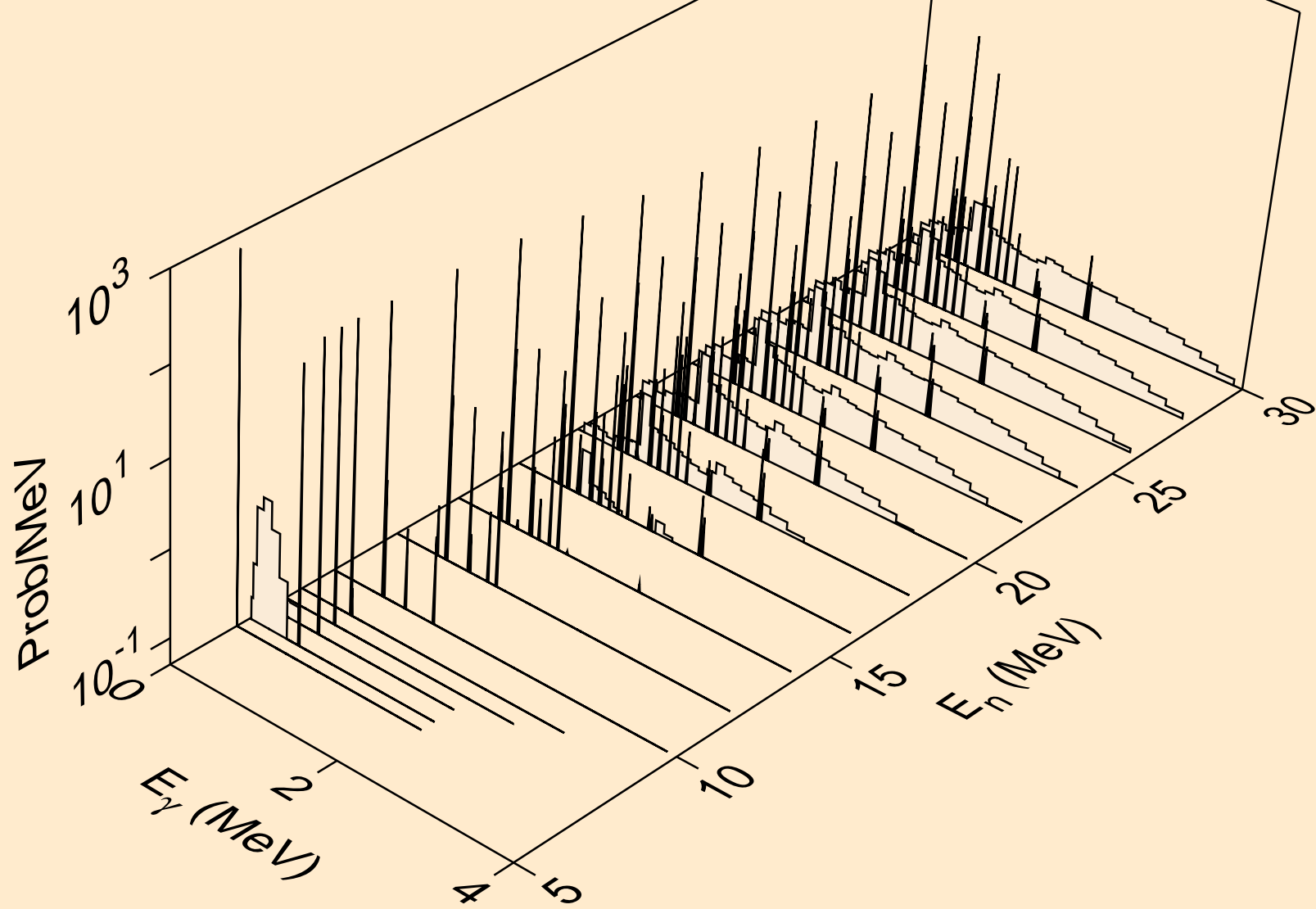

SE075 NEUTRON ACER TENDL-2024 LIBRARY; T=0.K
Photon emission for (n,p α)

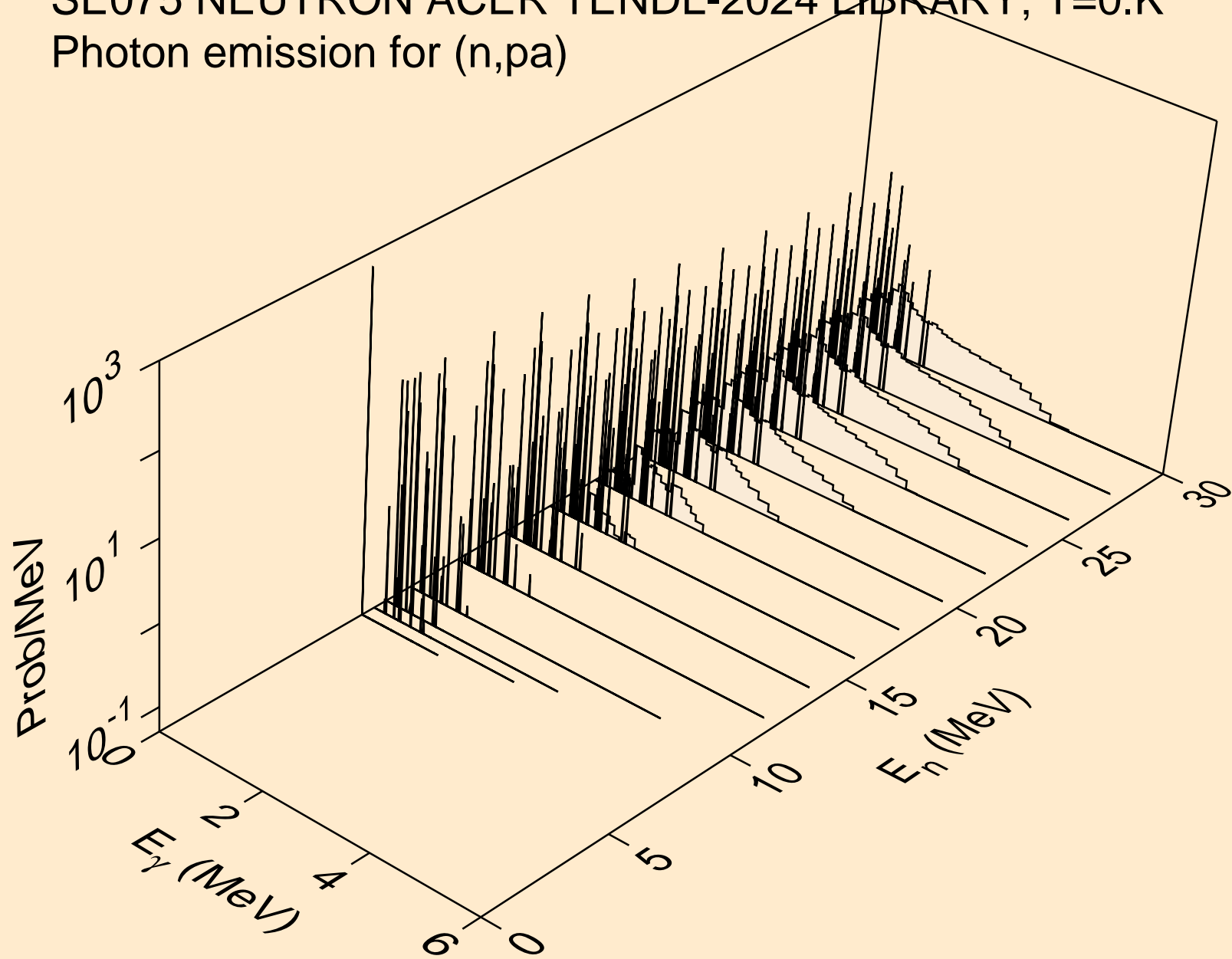

SE075 NEUTRON ACER TENDL-2024 LIBRARY; T=0.K
Photon emission for (n,pd)

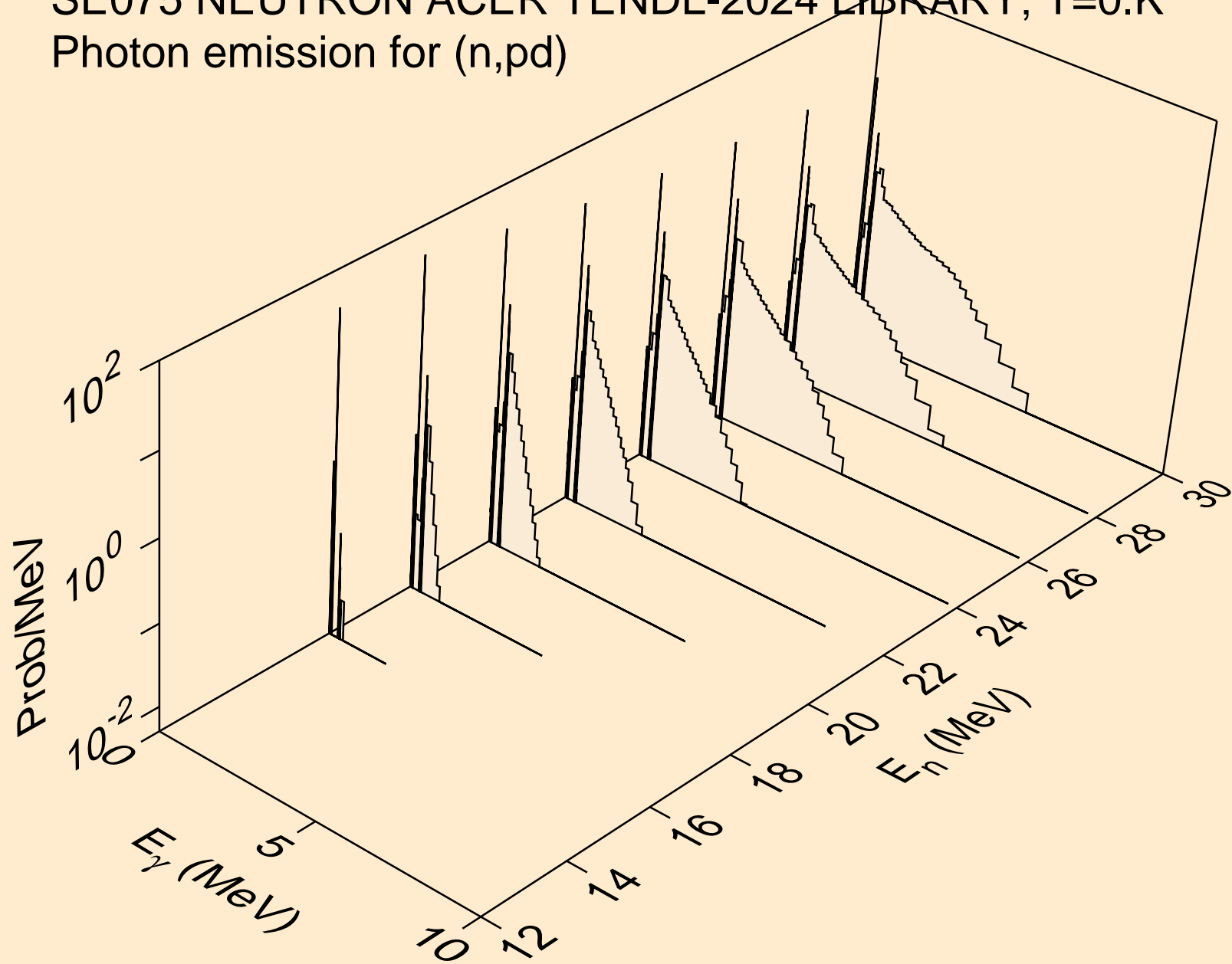

SE075 NEUTRON ACER TENDL-2024 LIBRARY; T=0.K
Photon emission for (n,pt)

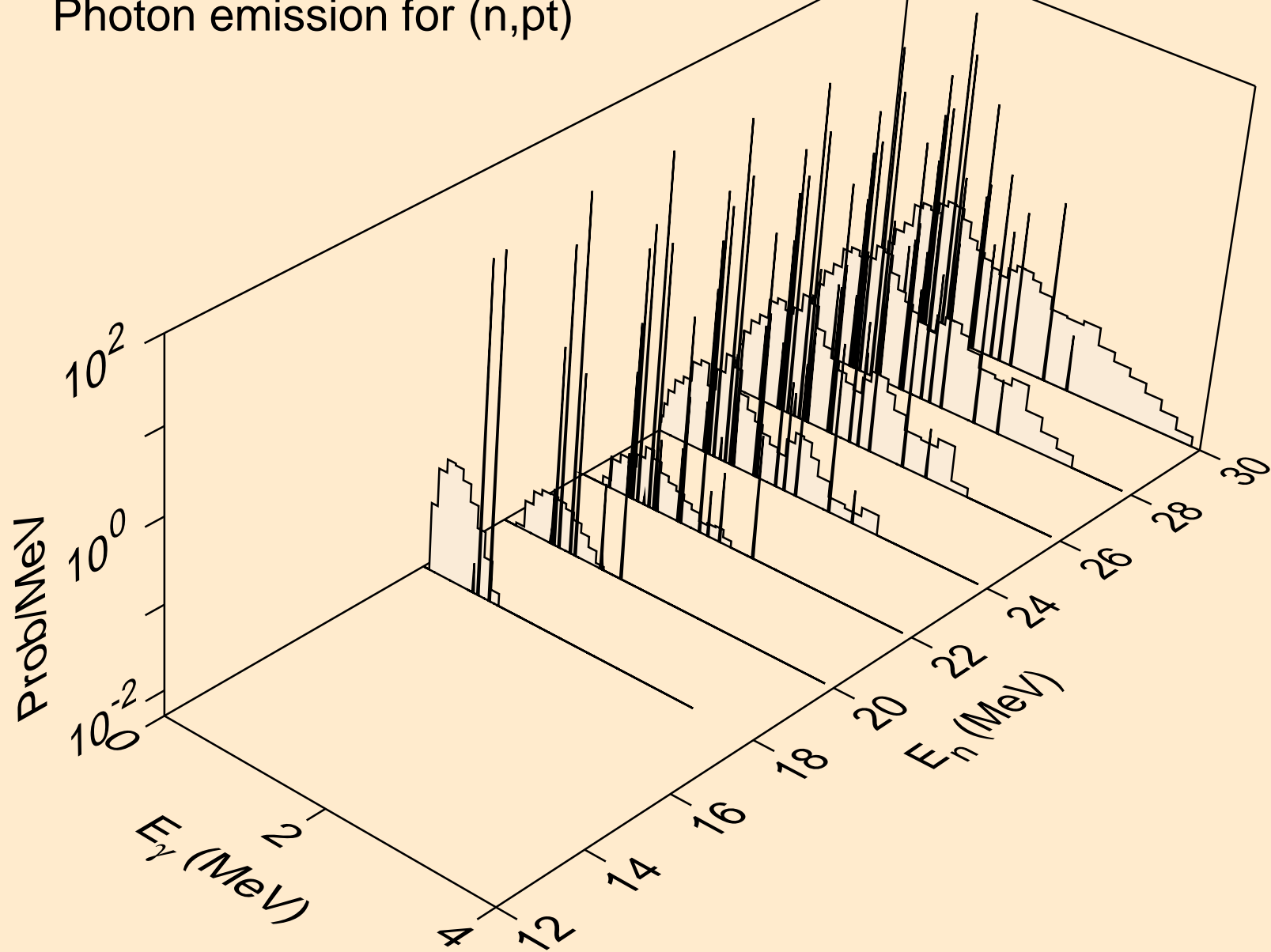

SE075 NEUTRON ACER TENDL-2024 LIBRARY; T=0.K
Photon emission for (n,da)

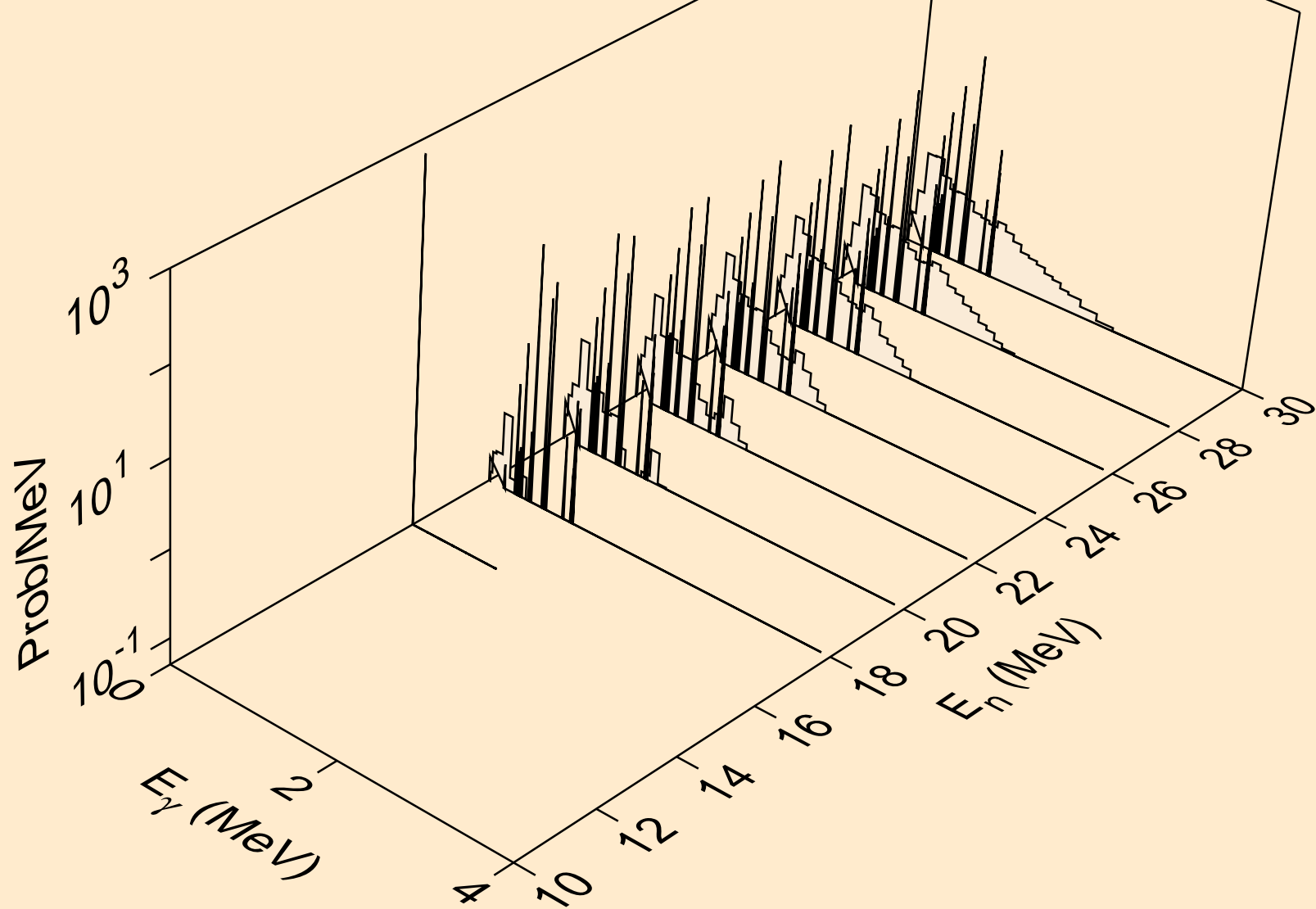

SE075 NEUTRON ACER TENDL-2024 LIBRARY; T=0.K
thermal capture photon spectrum

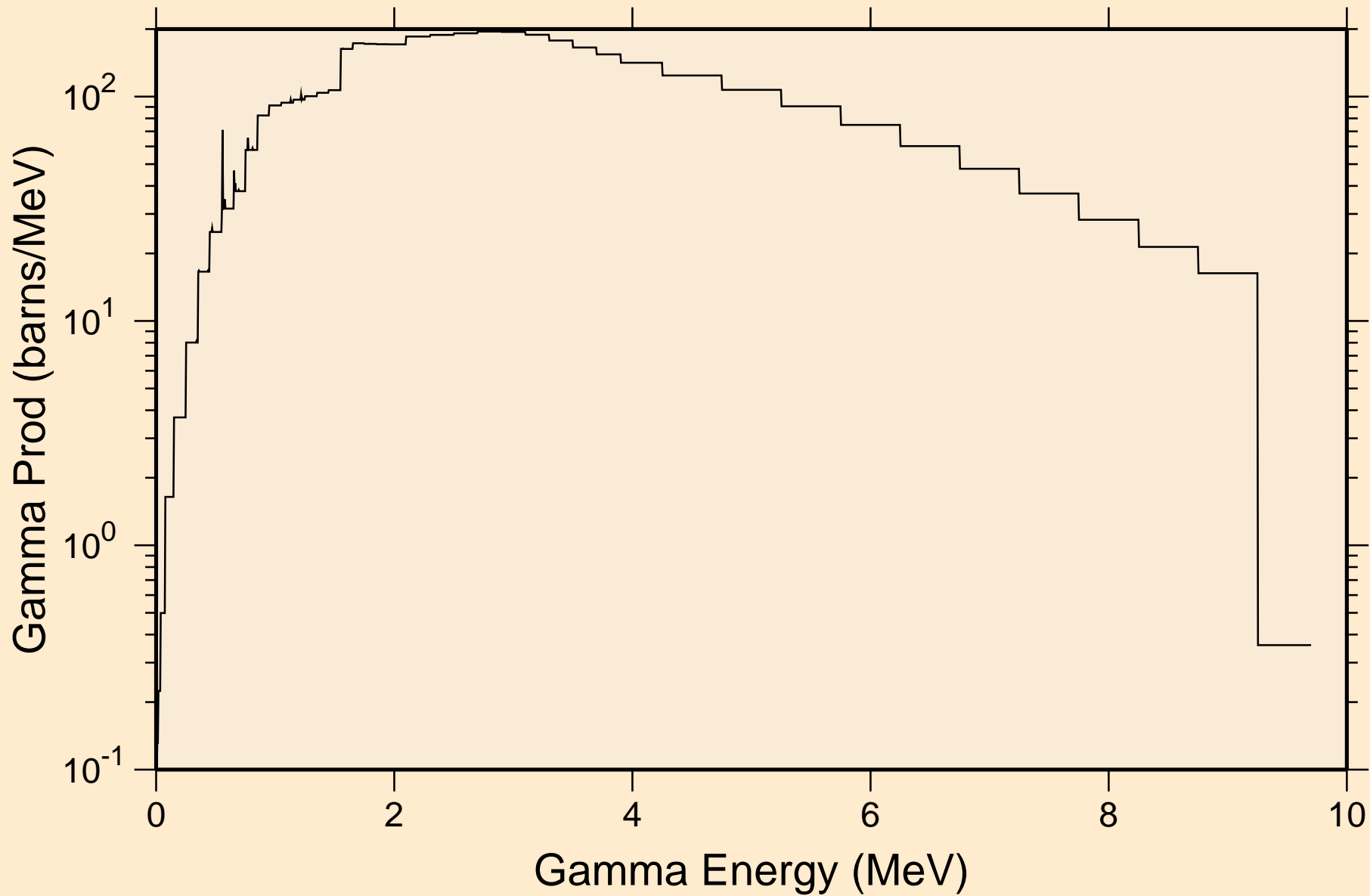

SE075 NEUTRON ACER TENDL-2024 LIBRARY; T=0.K
14 MeV photon spectrum

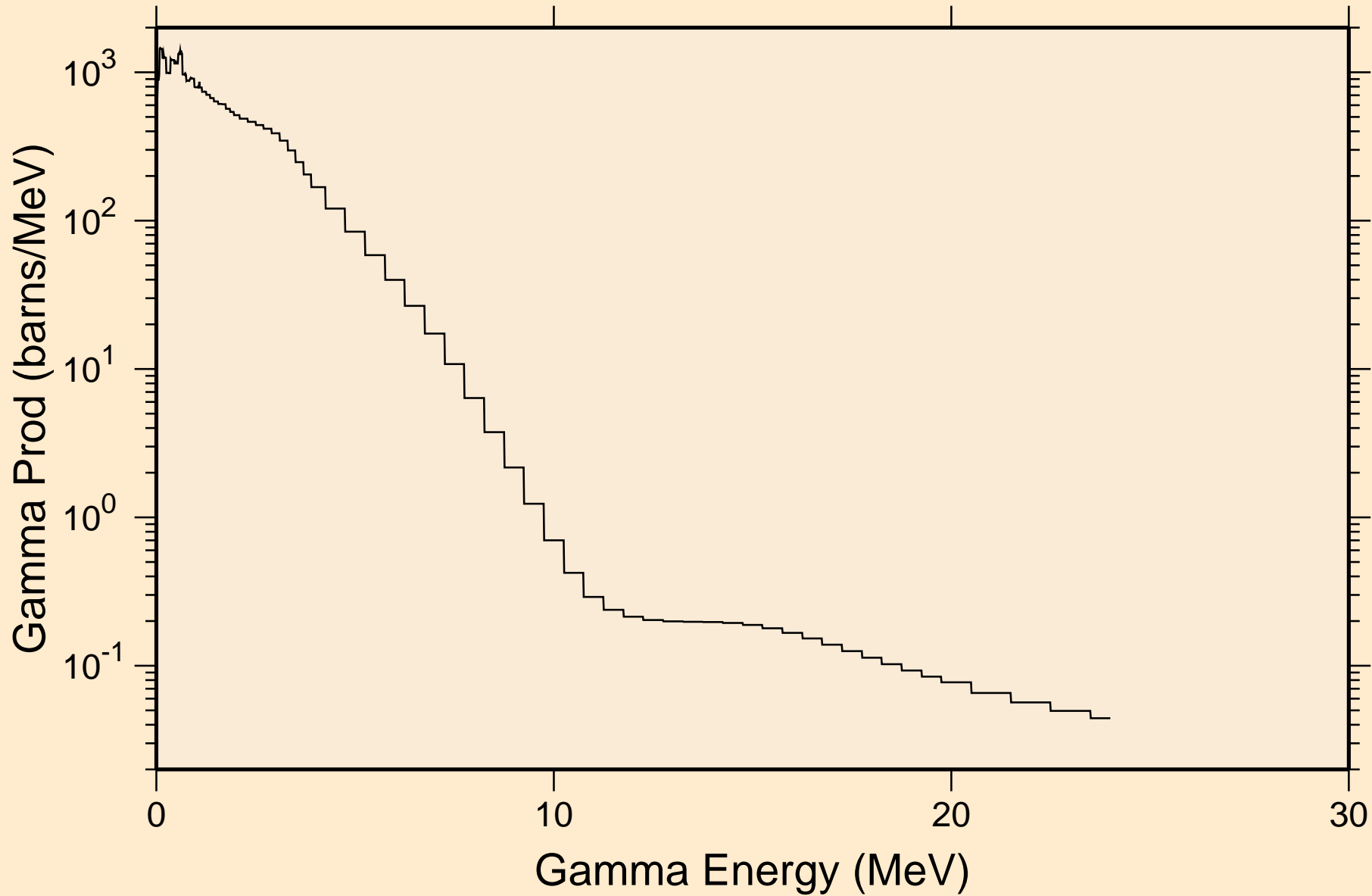

SE075 NEUTRON ACER TENDL-2024 LIBRARY; T=0.K

Particle heating contributions

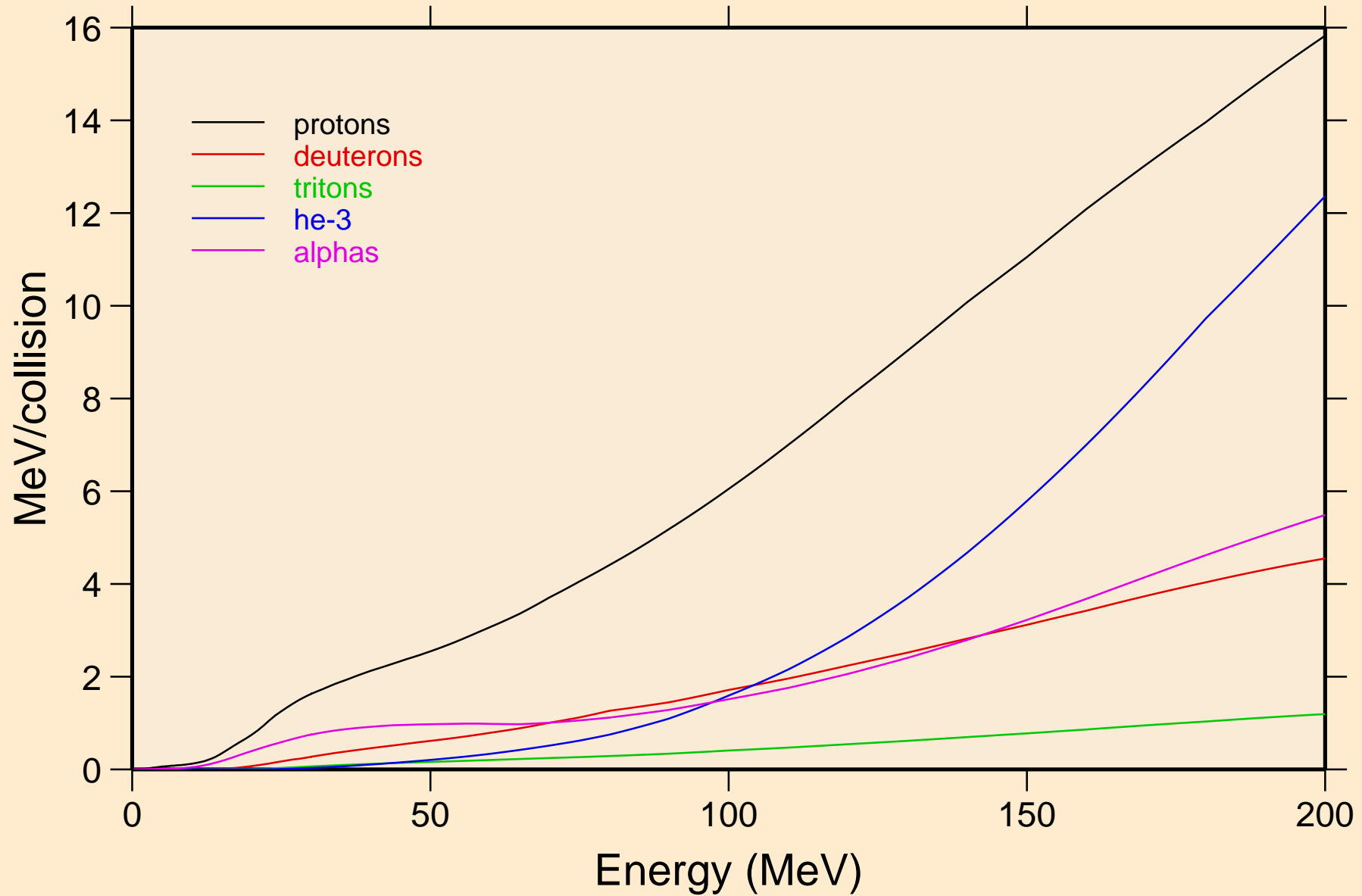

SE075 NEUTRON ACER TENDL-2024 LIBRARY; T=0.K

Recoil Heating

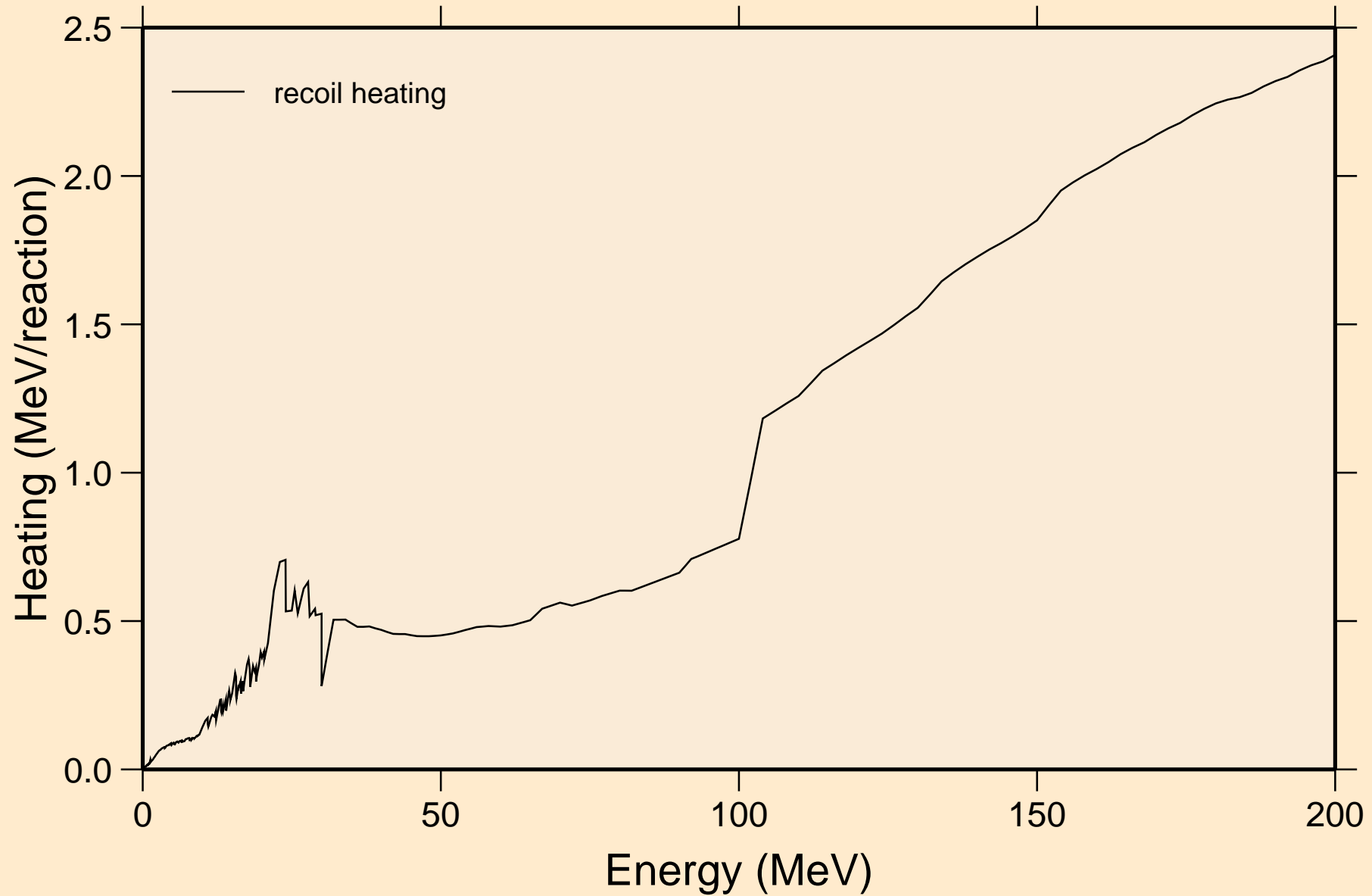

SE075 NEUTRON ACER TENDL-2024 LIBRARY; T=0.K
Particle production cross sections

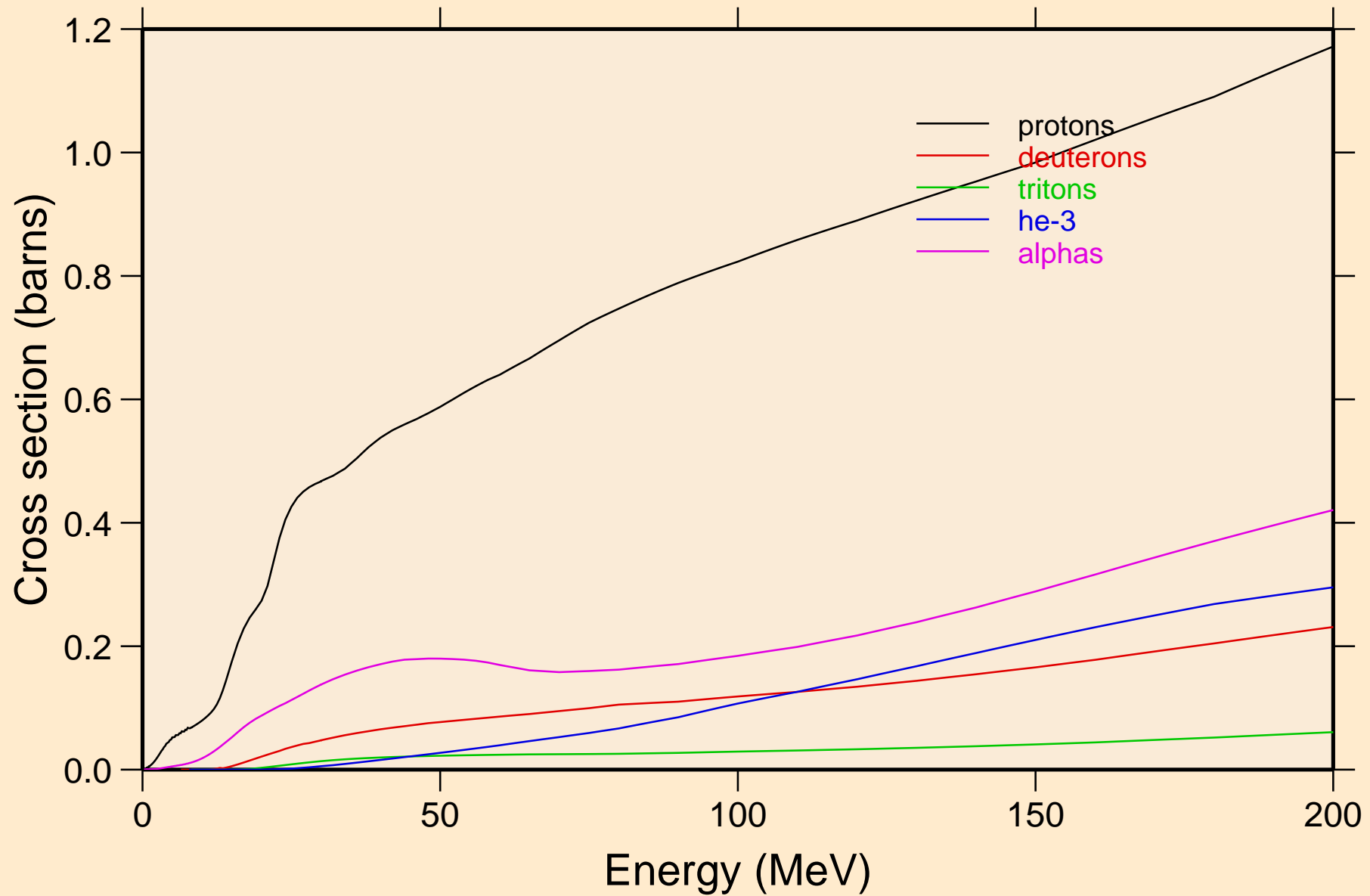

SE075 NEUTRON ACER TENDL-2024 LIBRARY; T=0.K
protons from (n,x)

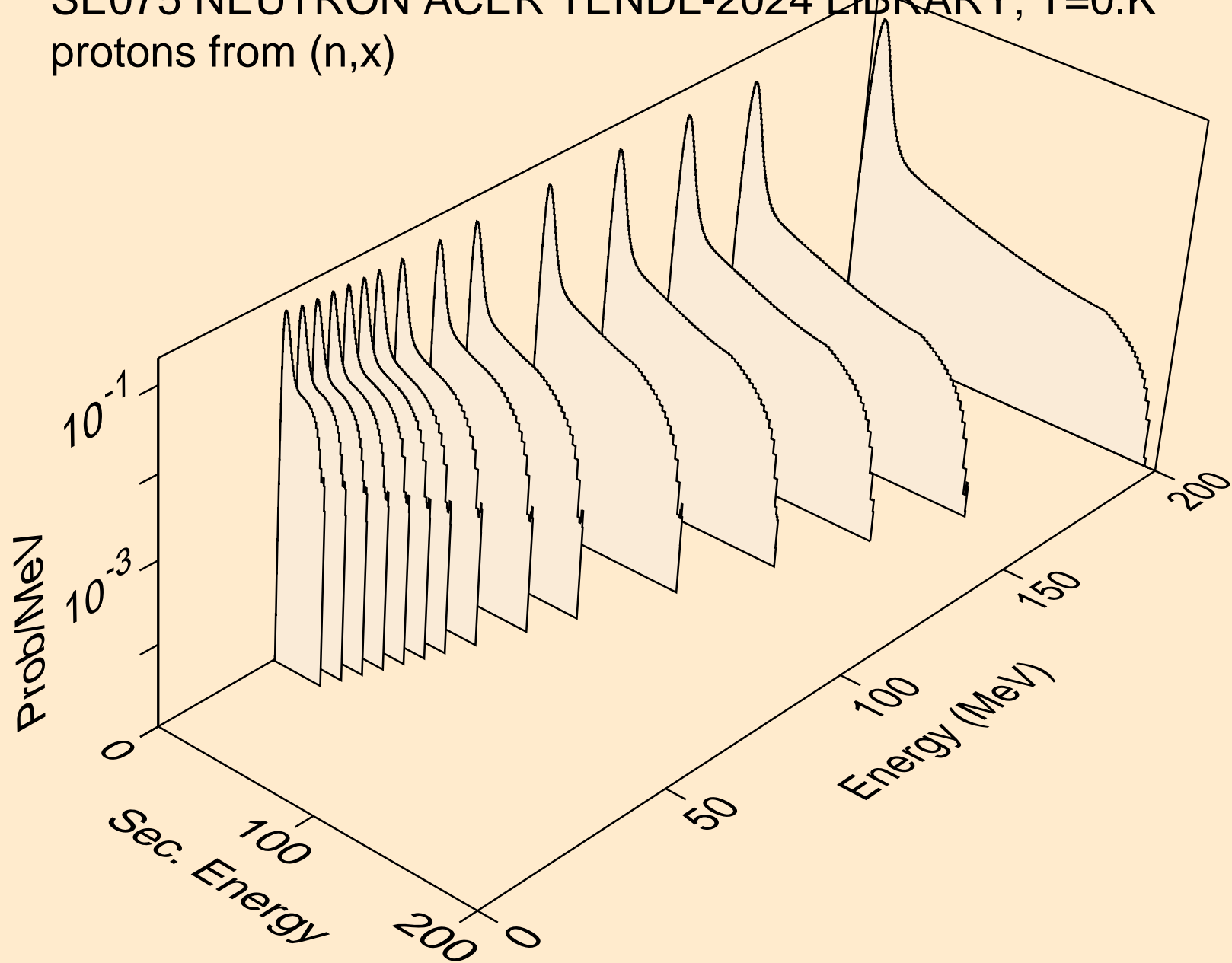

SE075 NEUTRON ACER TENDL-2024 LIBRARY; T=0.K
protons from (n,n*)p

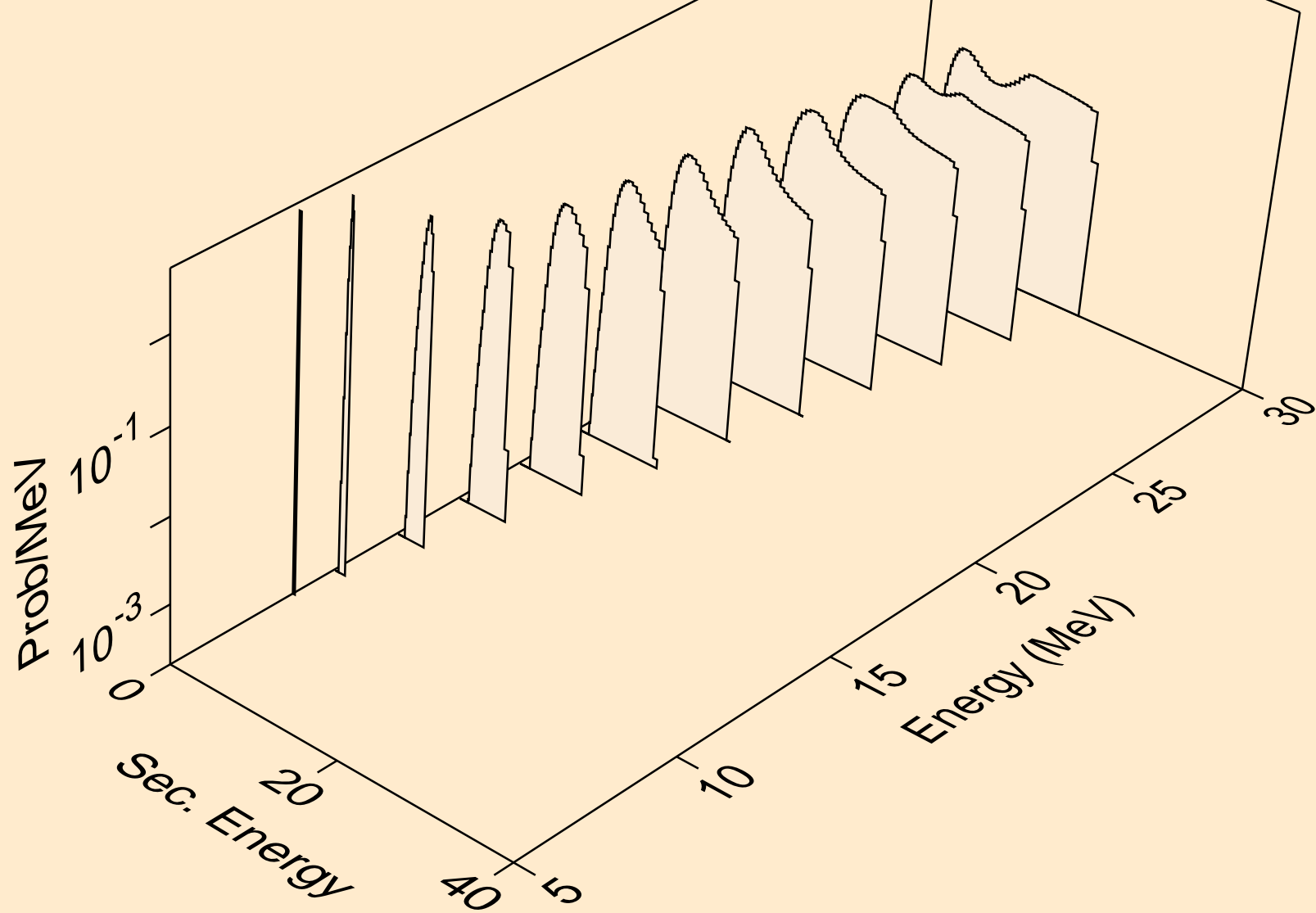

SE075 NEUTRON ACER TENDL-2024 LIBRARY; T=0.K
protons from (n,2np)

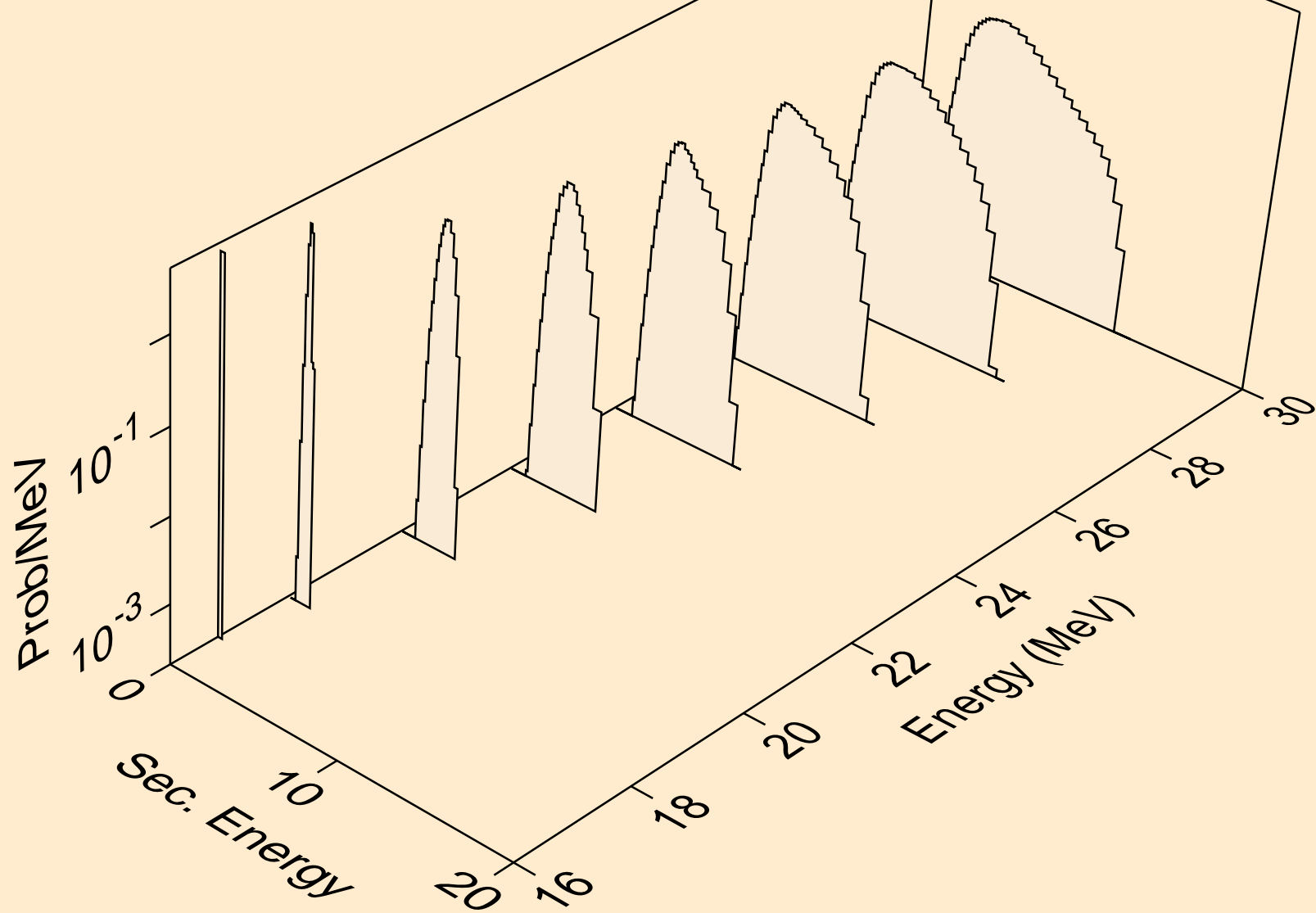

SE075 NEUTRON ACER TENDL-2024 LIBRARY; T=0.K
protons from (n,3np)

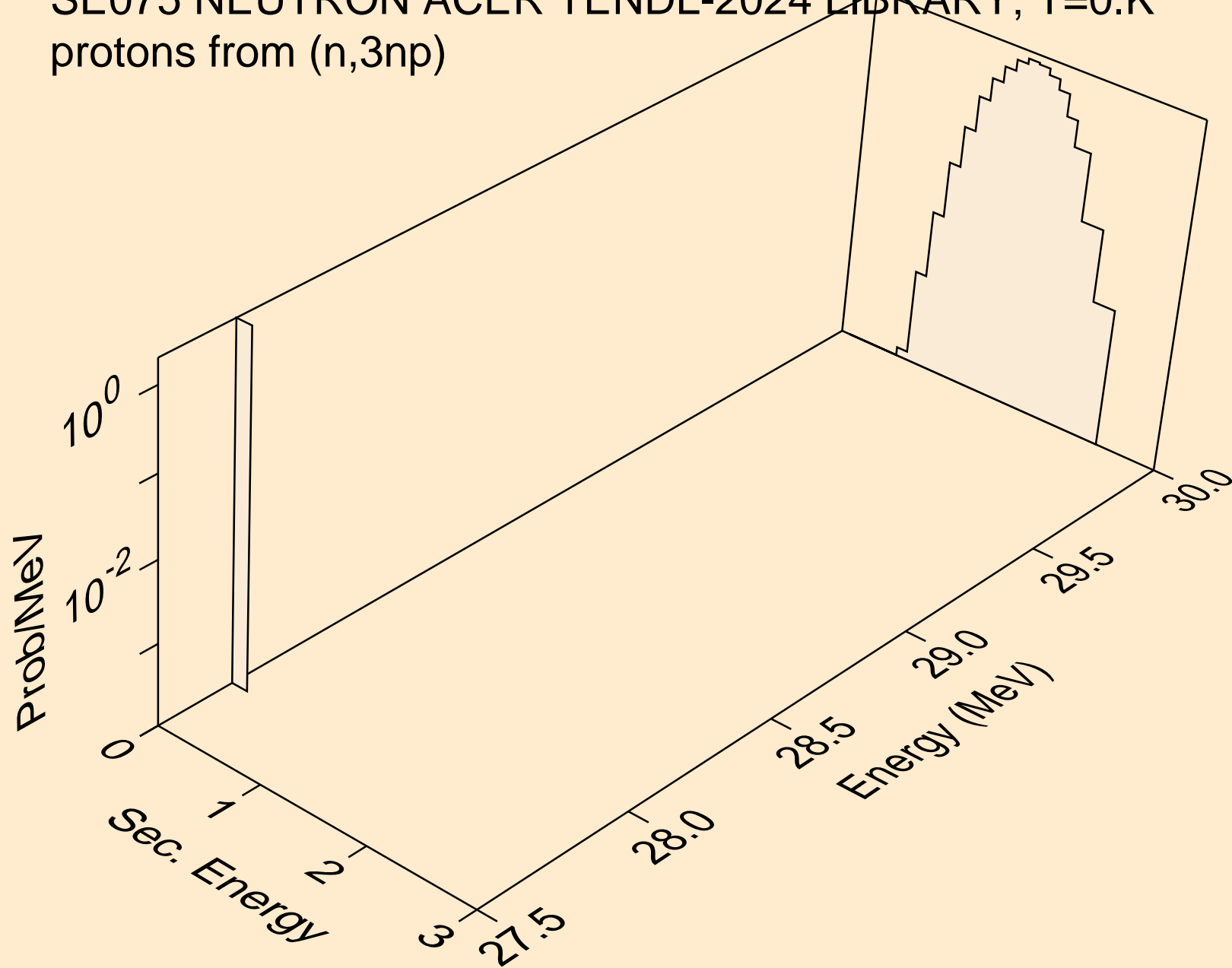

SE075 NEUTRON ACER TENDL-2024 LIBRARY; T=0.K
protons from (n,n2p)

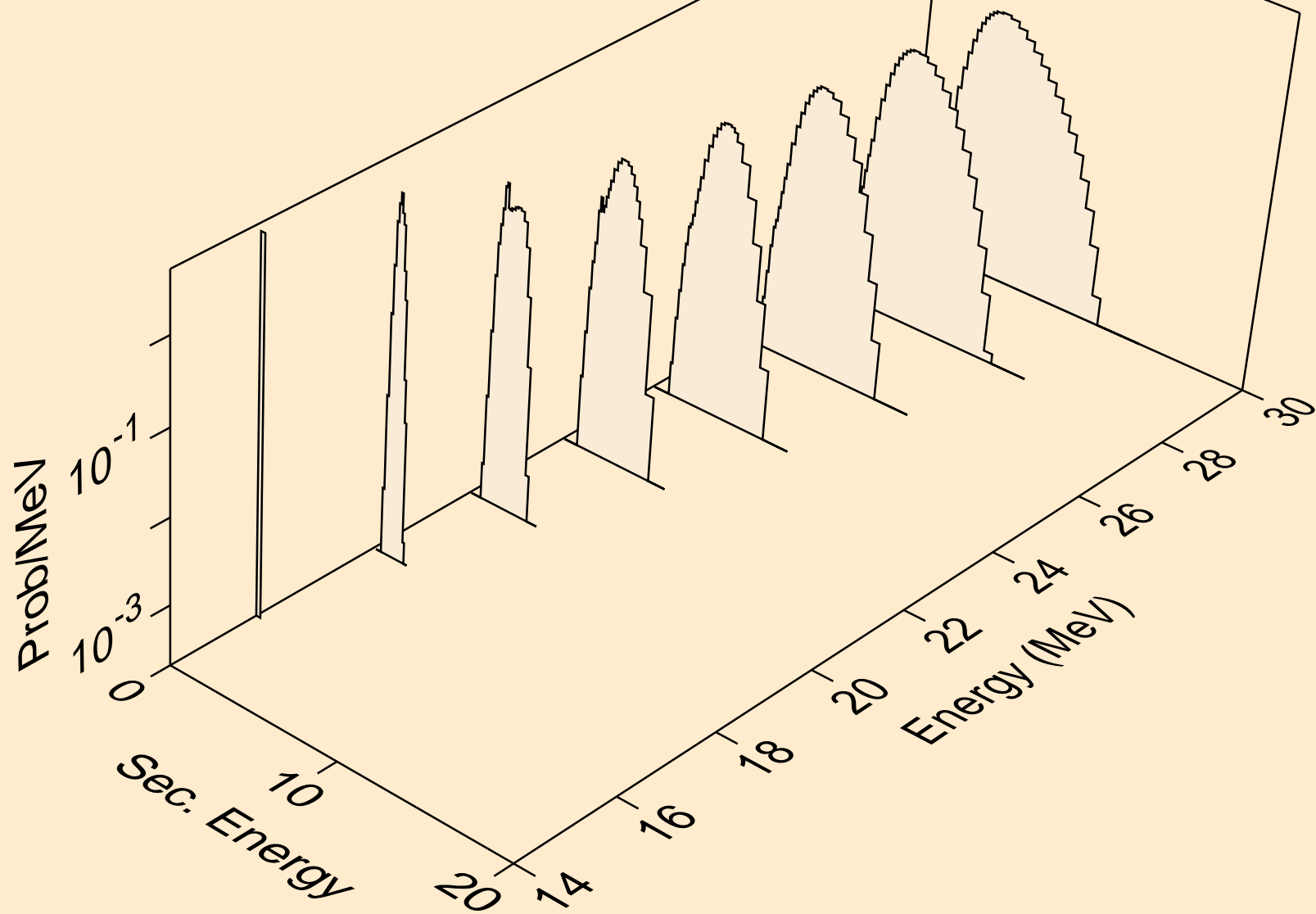

SE075 NEUTRON ACER TENDL-2024 LIBRARY; T=0.K
protons from (n,npa)

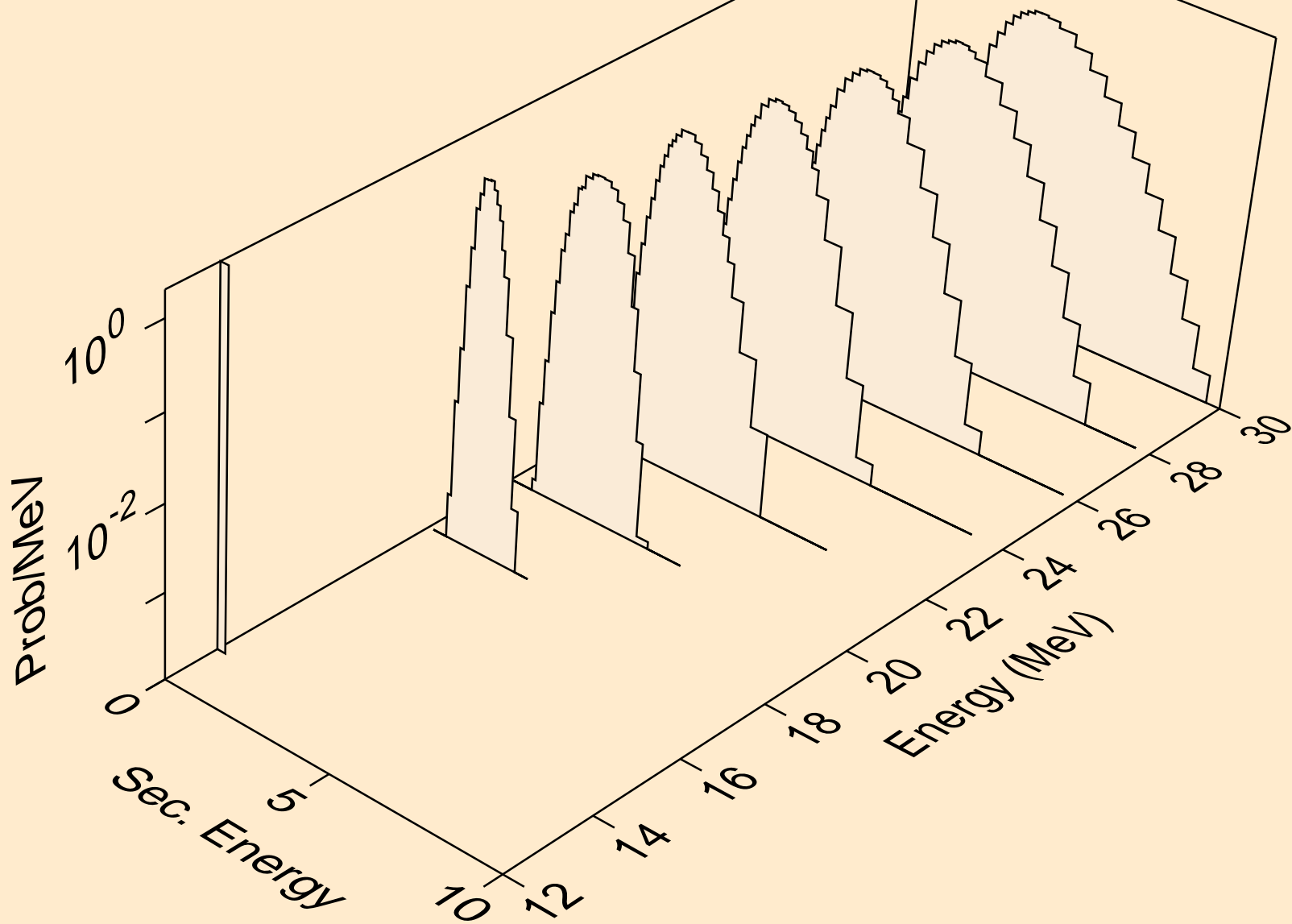

SE075 NEUTRON ACER TENDL-2024 LIBRARY; T=0.K
protons from (n,p)

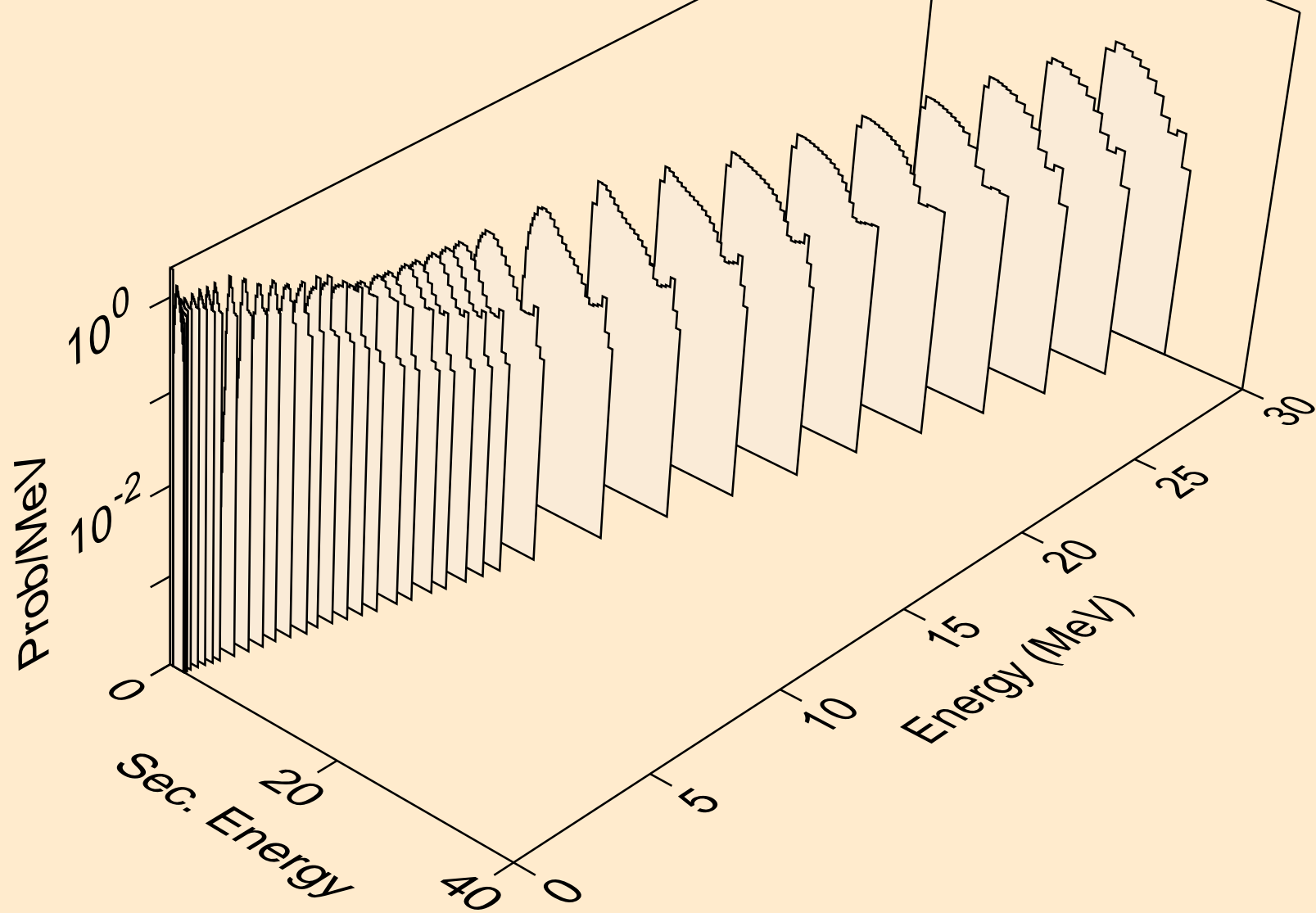

SE075 NEUTRON ACER TENDL-2024 LIBRARY; T=0.K
protons from (n,2p)

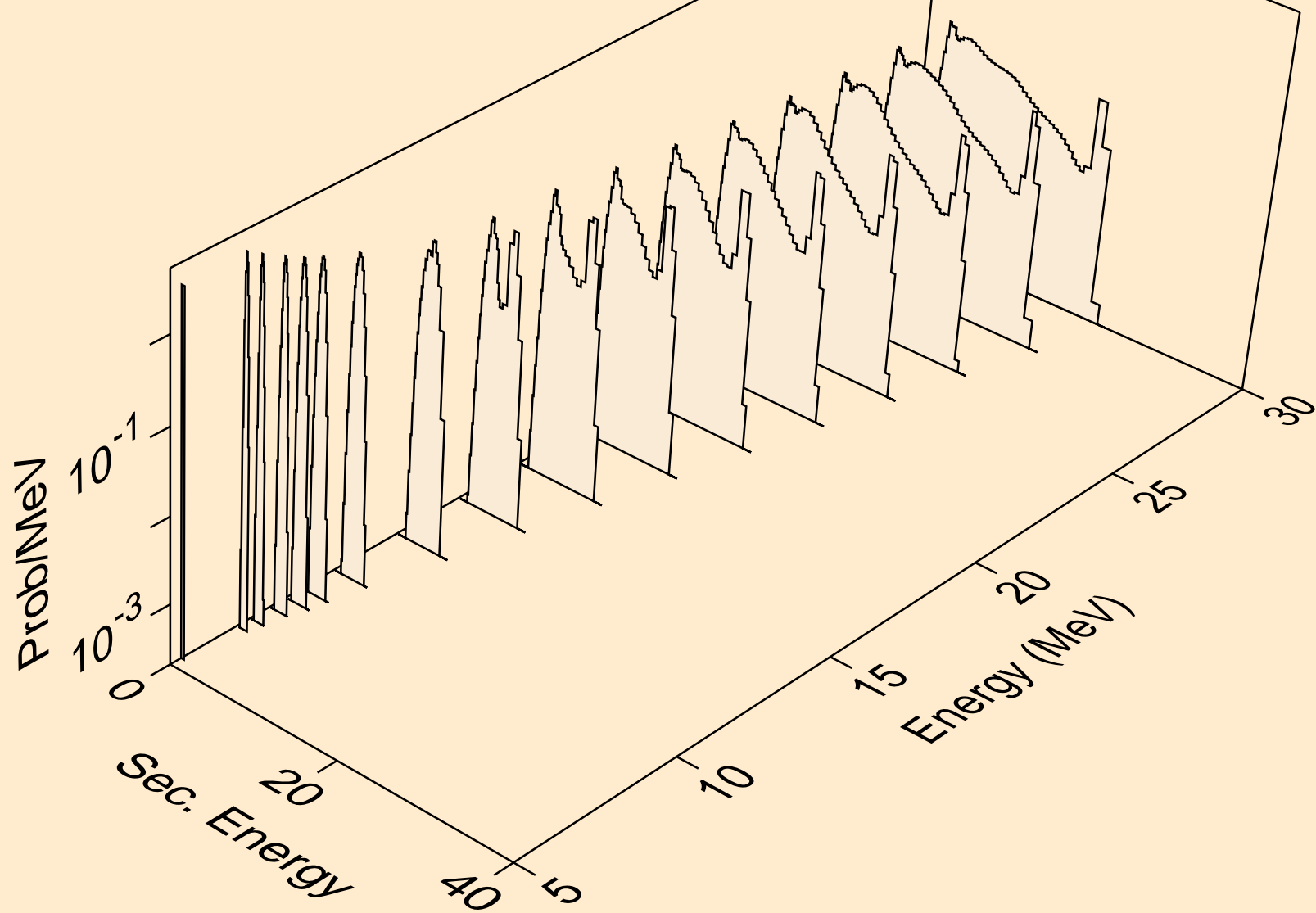

SE075 NEUTRON ACER TENDL-2024 LIBRARY; T=0.K
protons from (n,p)

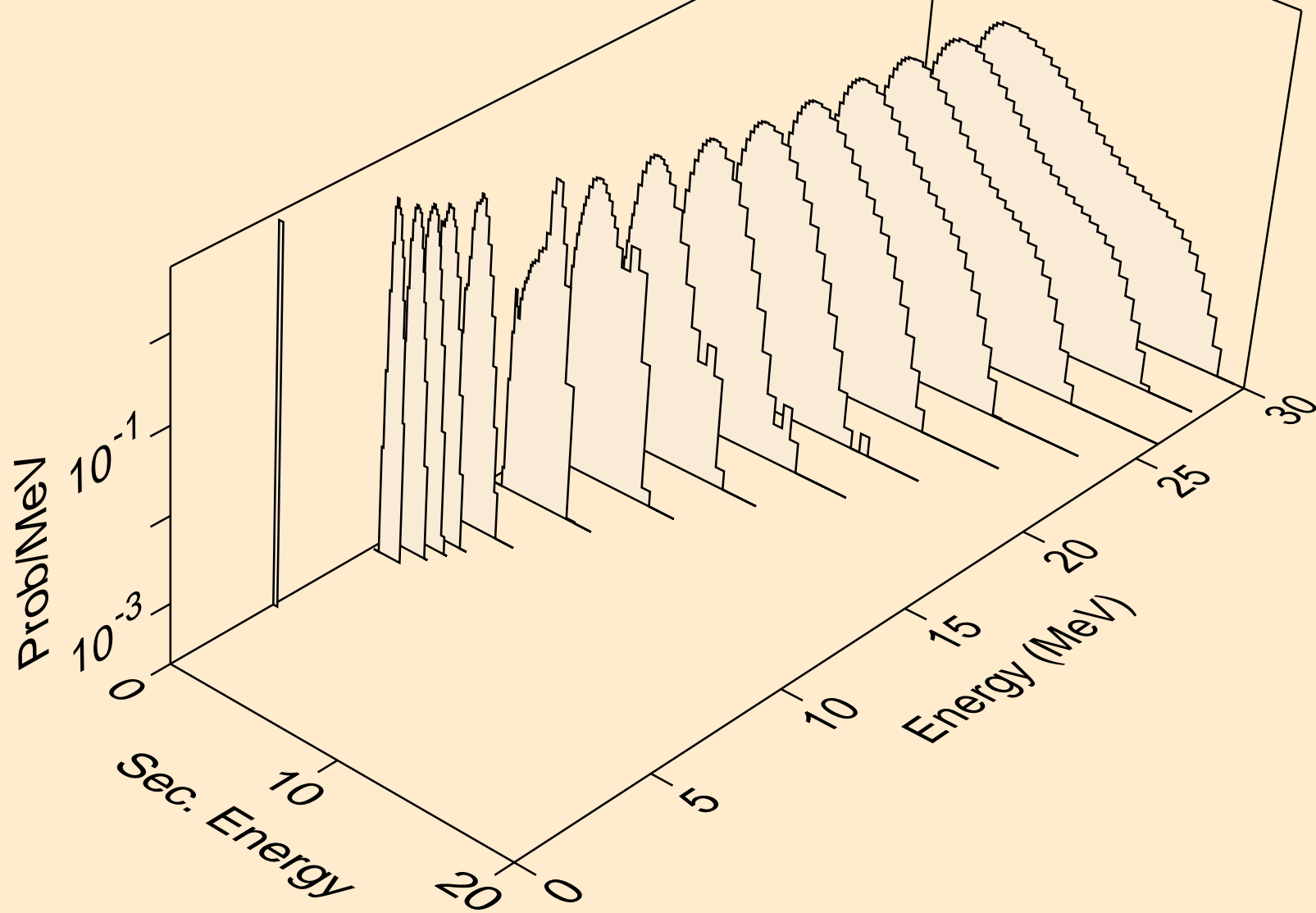

SE075 NEUTRON ACER TENDL-2024 LIBRARY; T=0.K
protons from (n,pd)

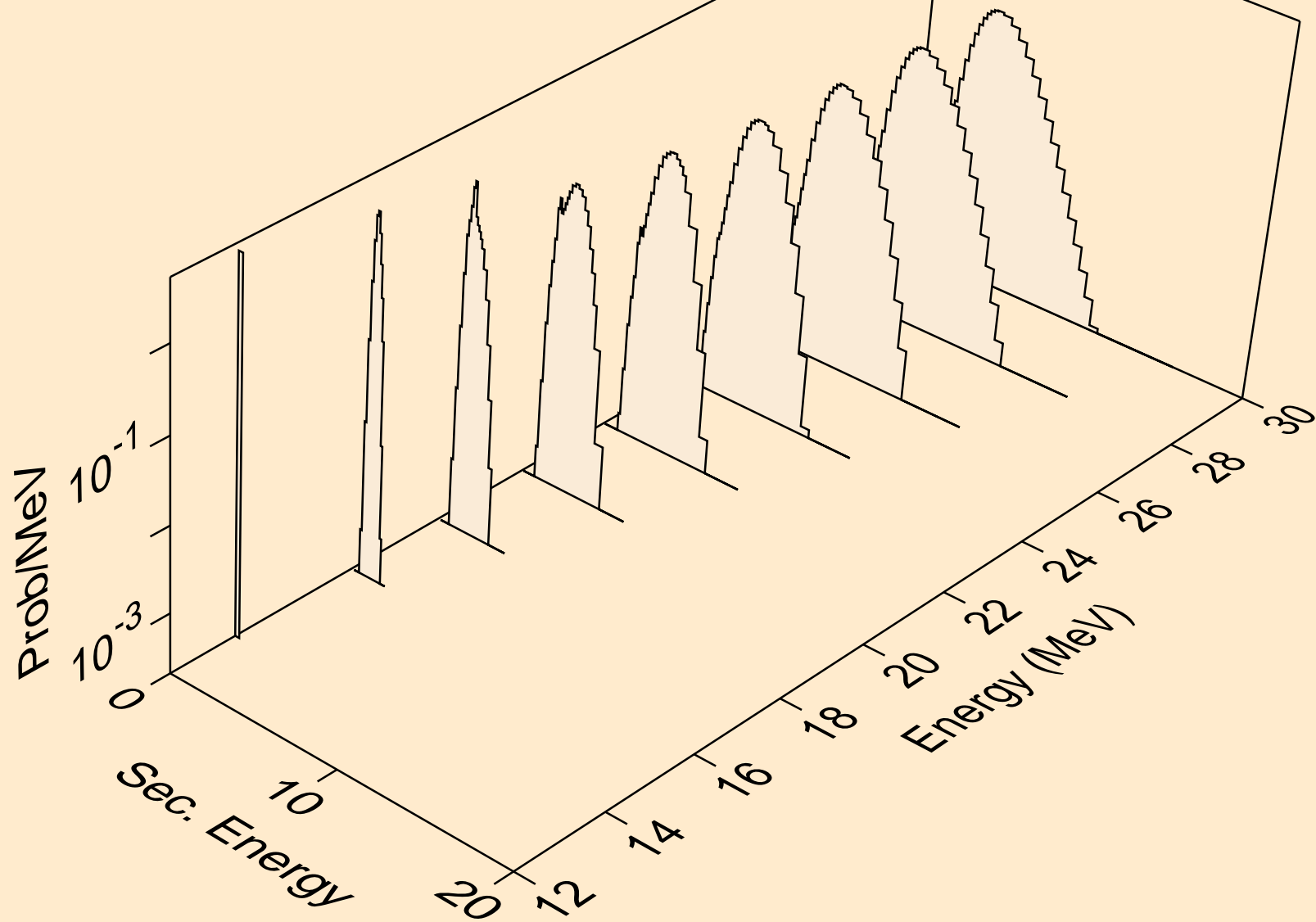

SE075 NEUTRON ACER TENDL-2024 LIBRARY; T=0.K
protons from (n,pt)

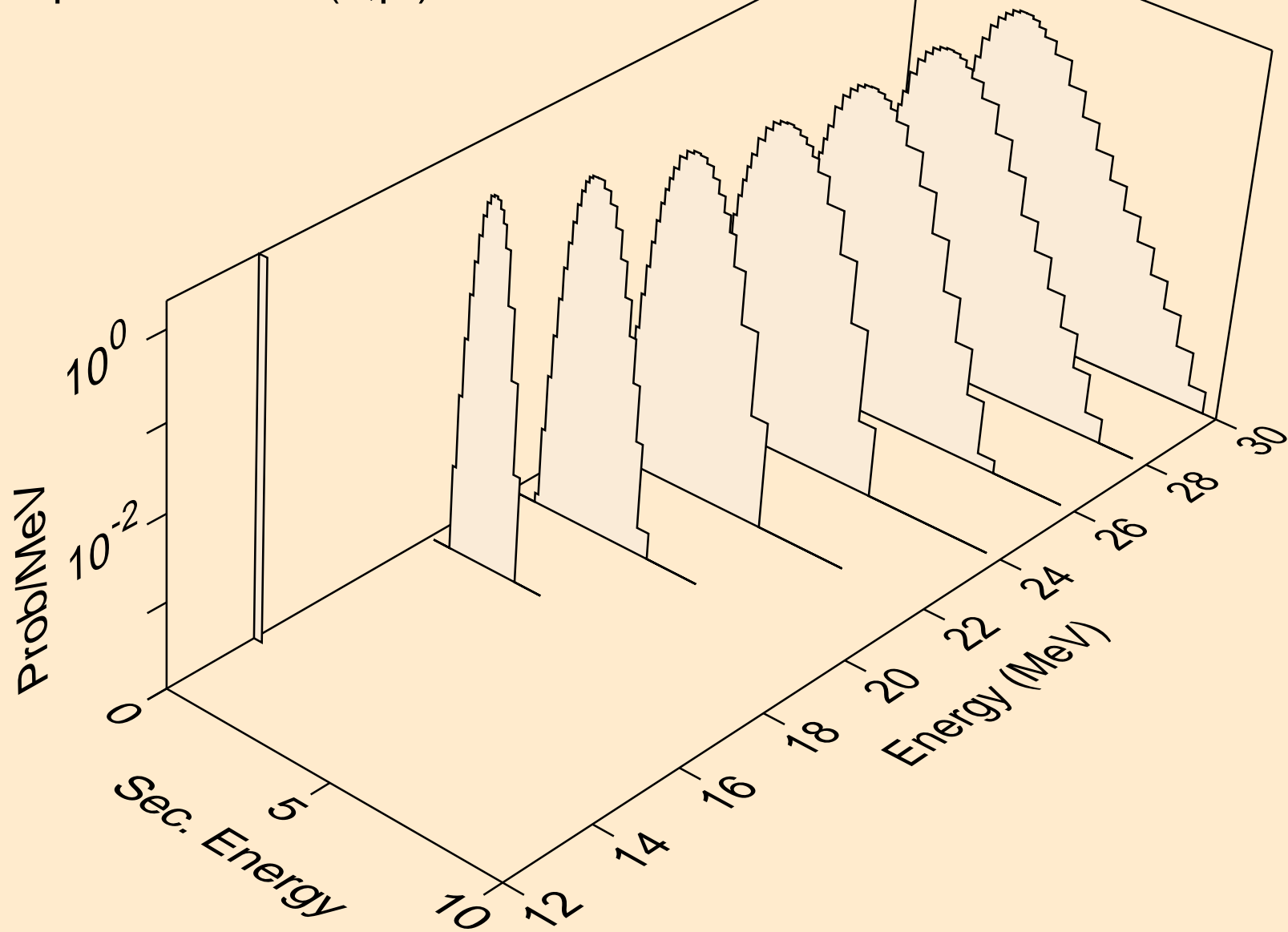

SE075 NEUTRON ACER TENDL-2024 LIBRARY; T=0.K
deuterons from (n,x)

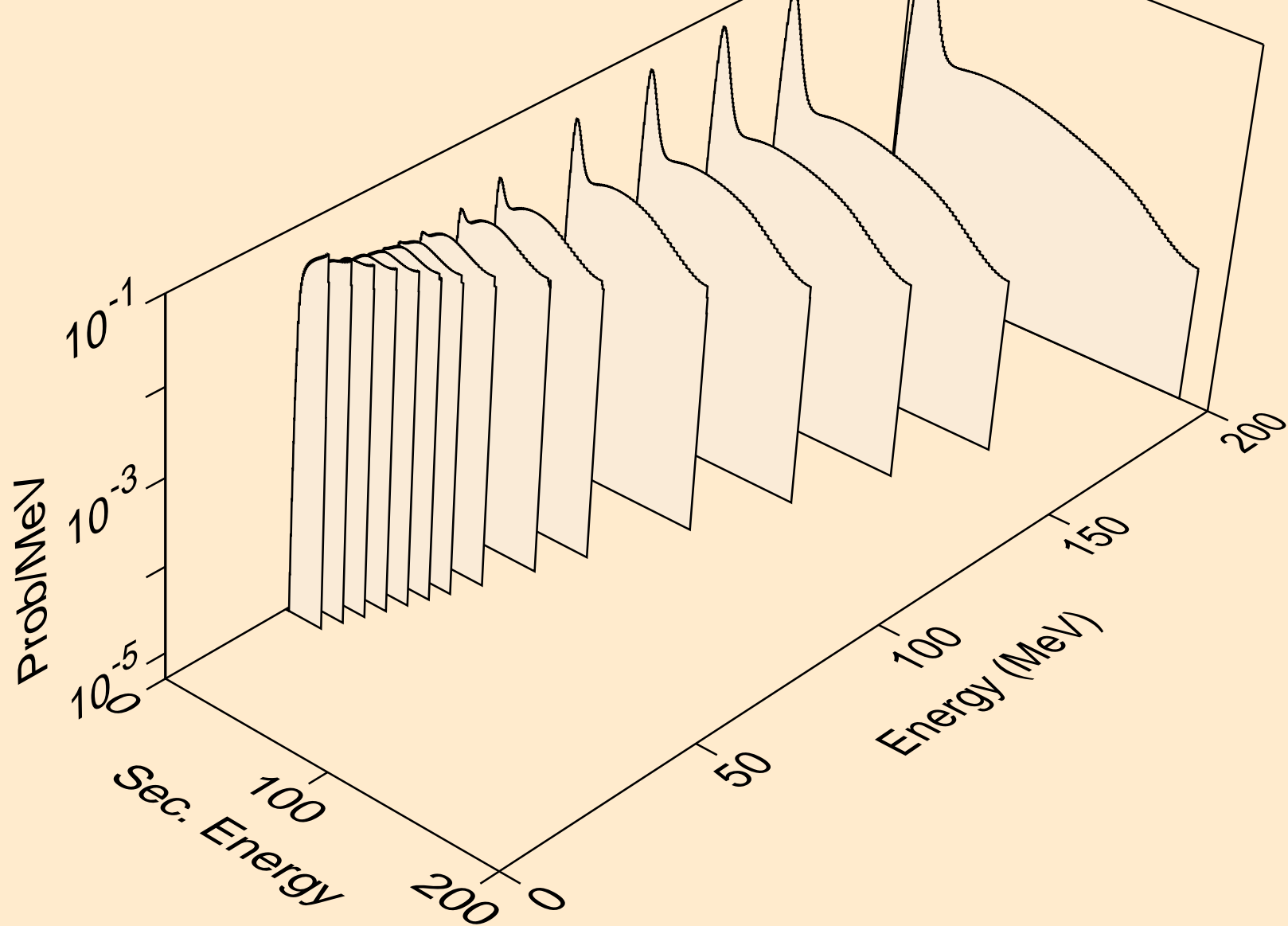

SE075 NEUTRON ACER TENDL-2024 LIBRARY; T=0.K
deuterons from (n,2nd)

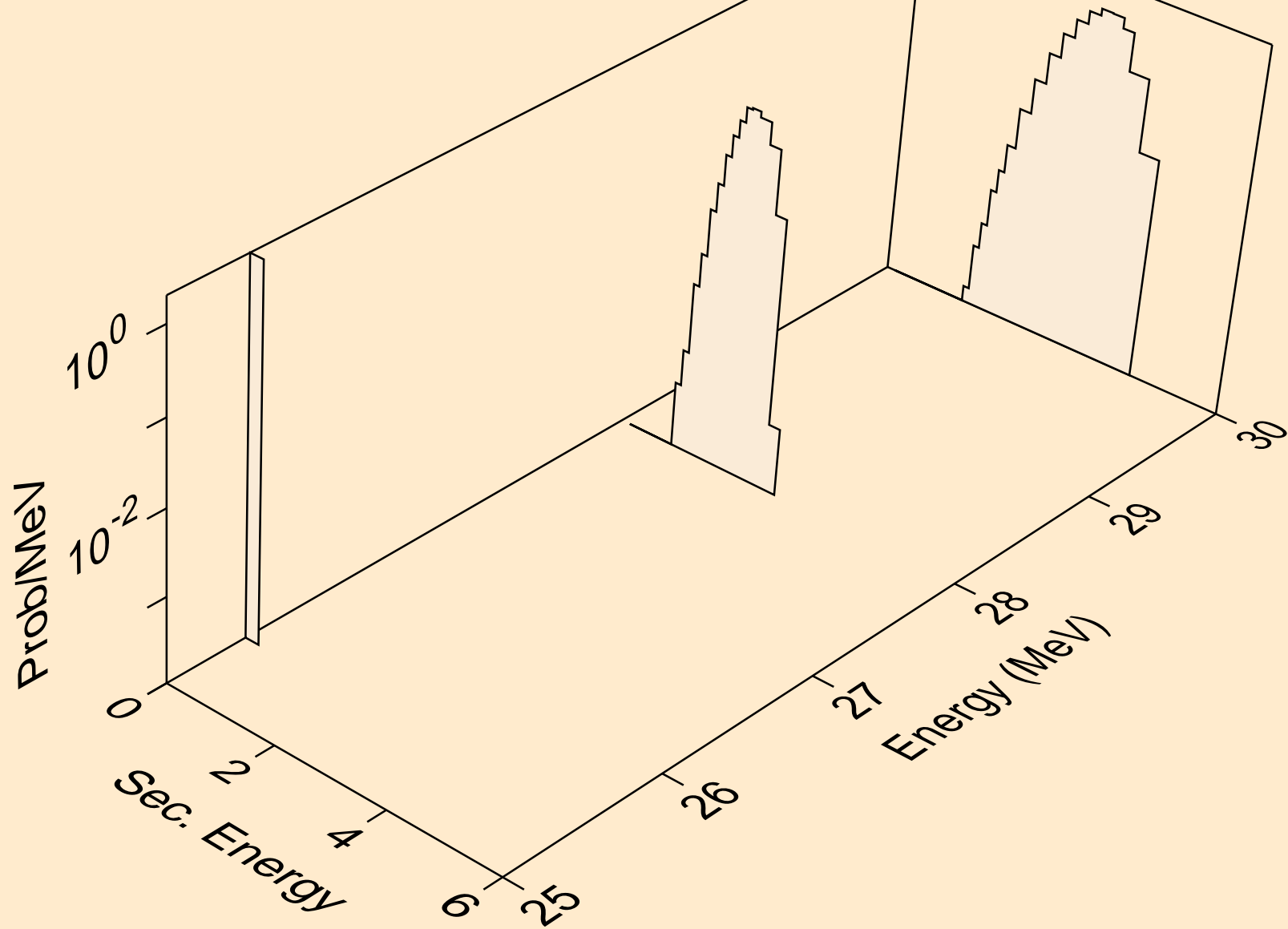

SE075 NEUTRON ACER TENDL-2024 LIBRARY; T=0.K
deuterons from (n,n*)d

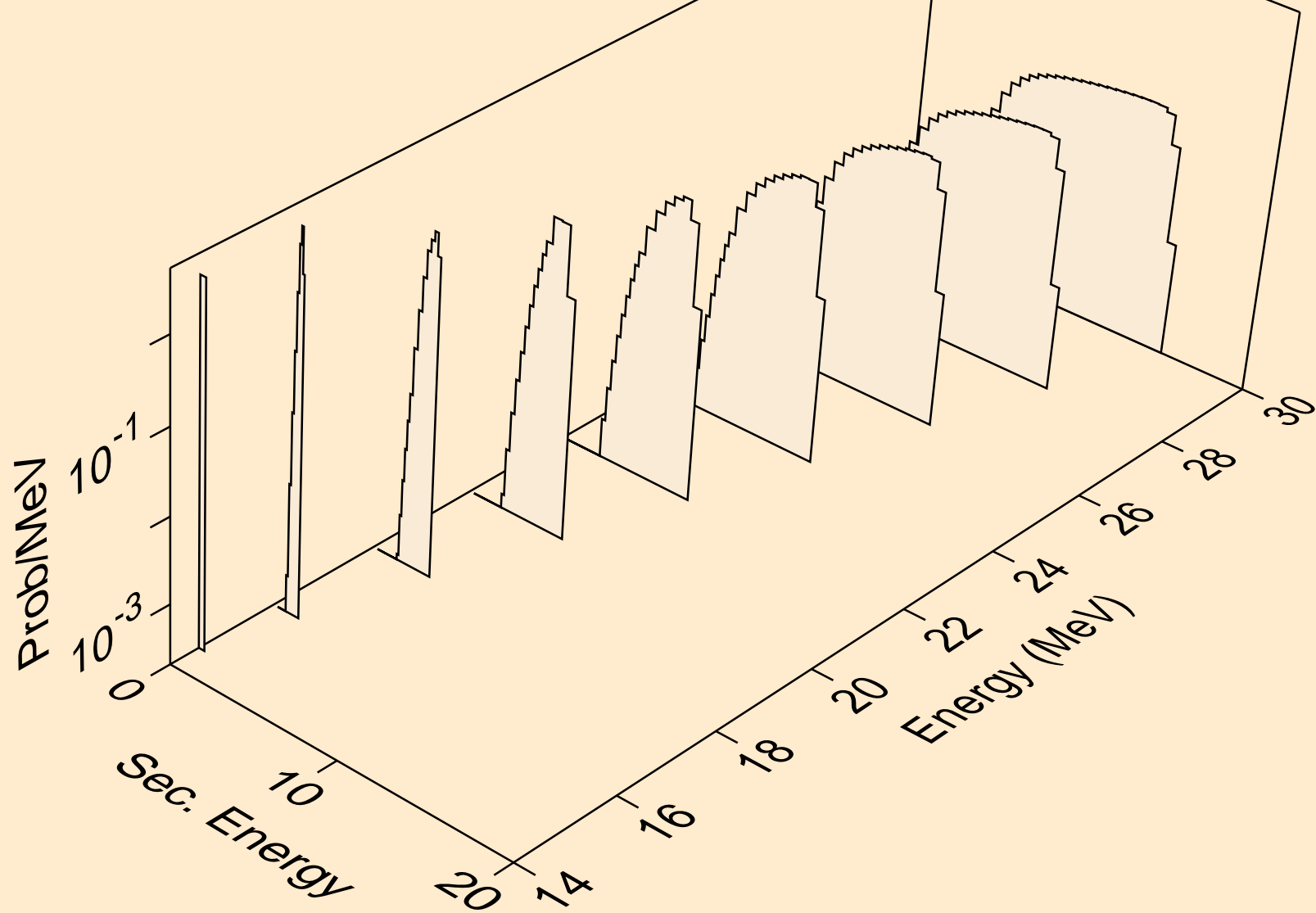

SE075 NEUTRON ACER TENDL-2024 LIBRARY; T=0.K
deuterons from (n,d)

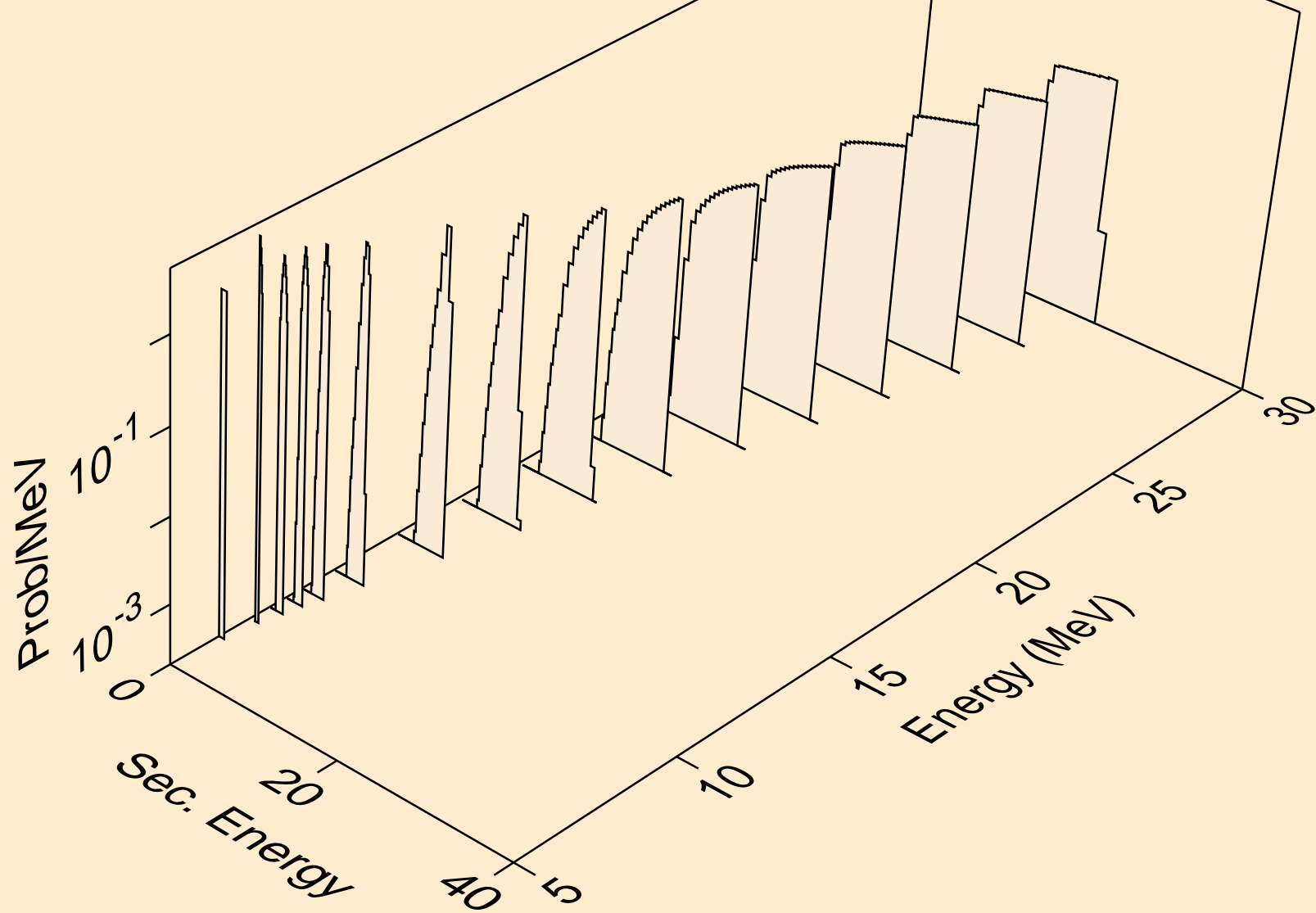

SE075 NEUTRON ACER TENDL-2024 LIBRARY; T=0.K
deuterons from (n,pd)

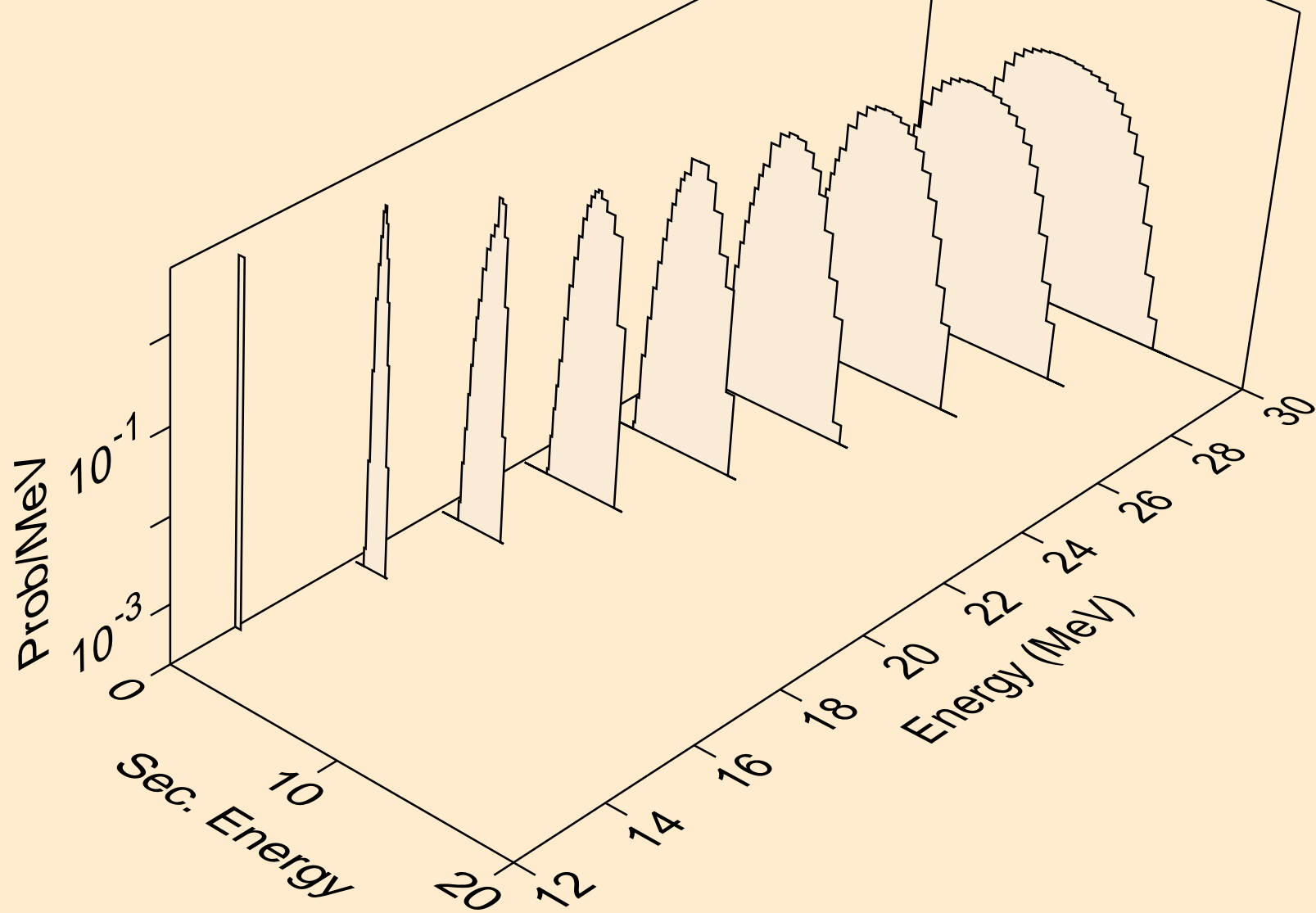

SE075 NEUTRON ACER TENDL-2024 LIBRARY; T=0.K
deuterons from (n,da)

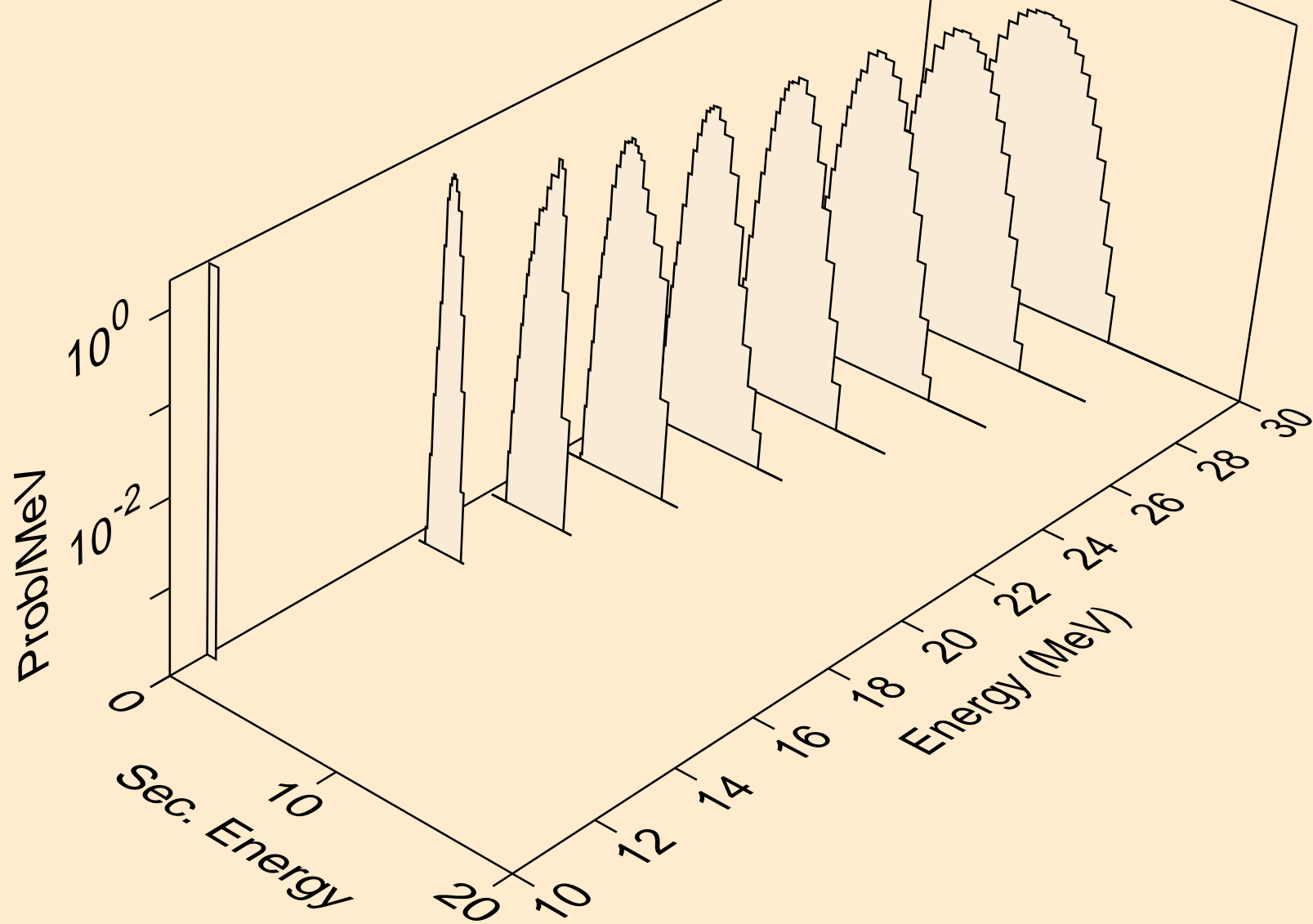

SE075 NEUTRON ACER TENDL-2024 LIBRARY; T=0.K
tritons from (n,x)

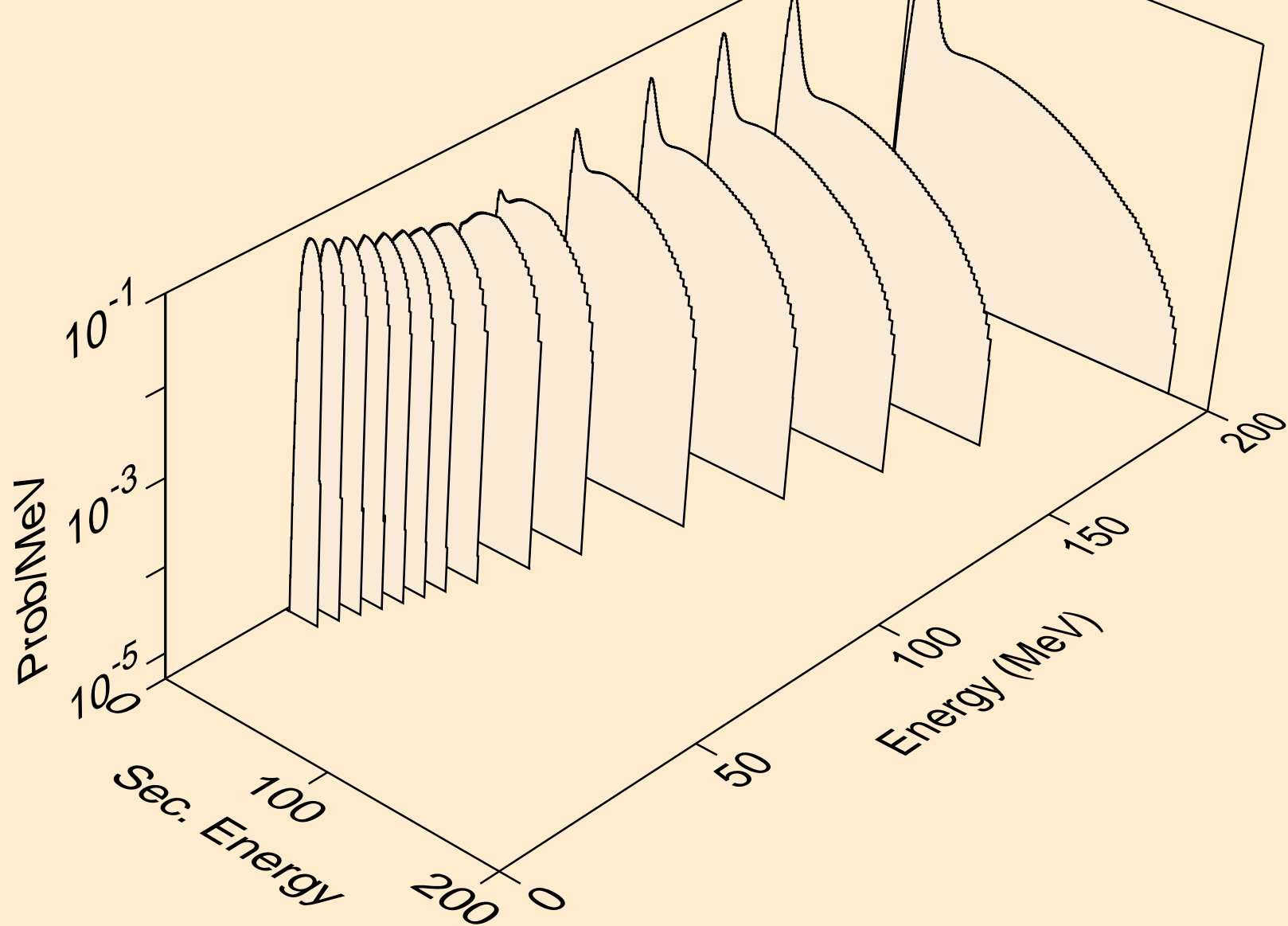

SE075 NEUTRON ACER TENDL-2024 LIBRARY; T=0.K
tritons from (n,n*)t

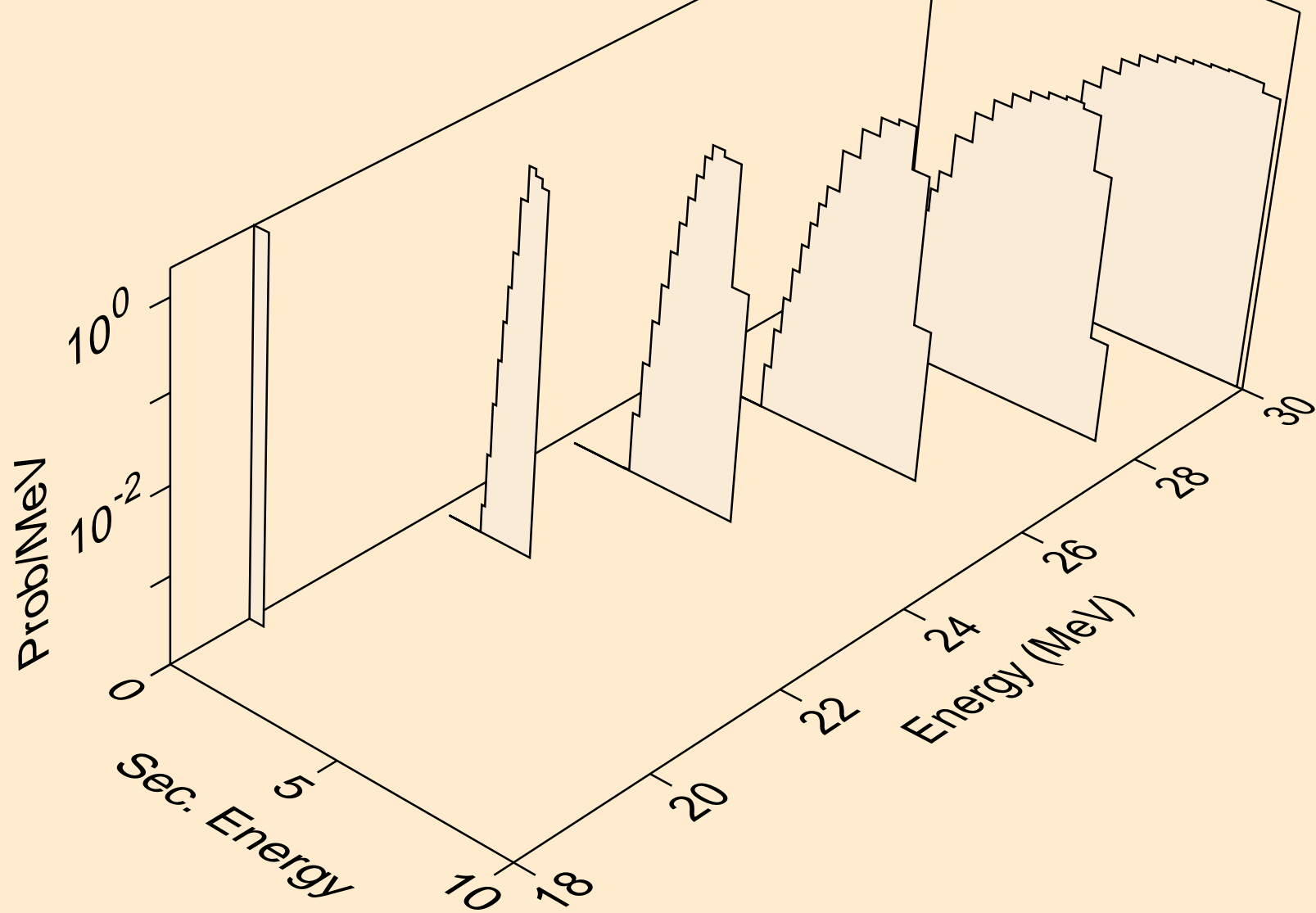

SE075 NEUTRON ACER TENDL-2024 LIBRARY; T=0.K
tritons from (n,t)

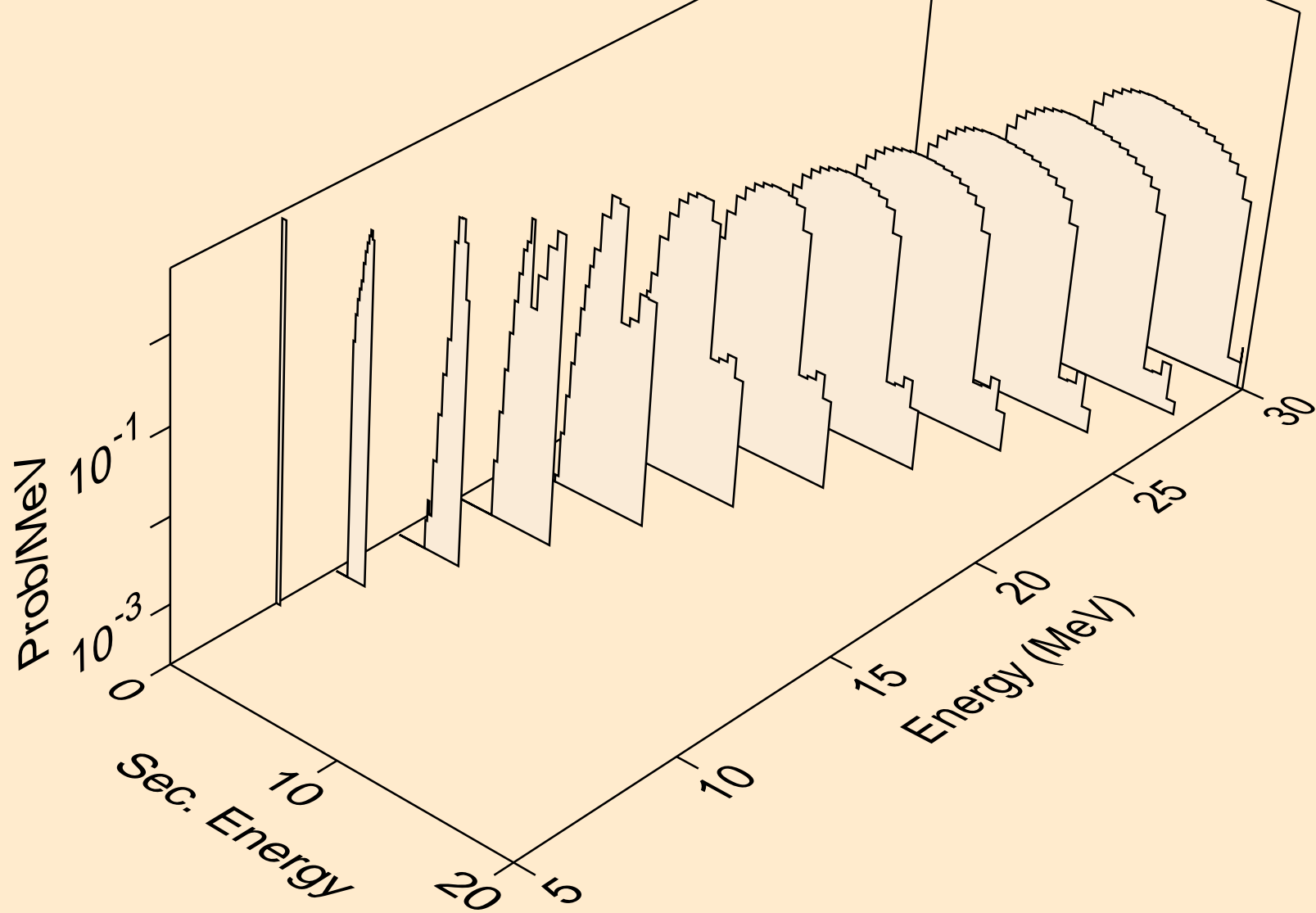

SE075 NEUTRON ACER TENDL-2024 LIBRARY; T=0.K
tritons from (n,pt)

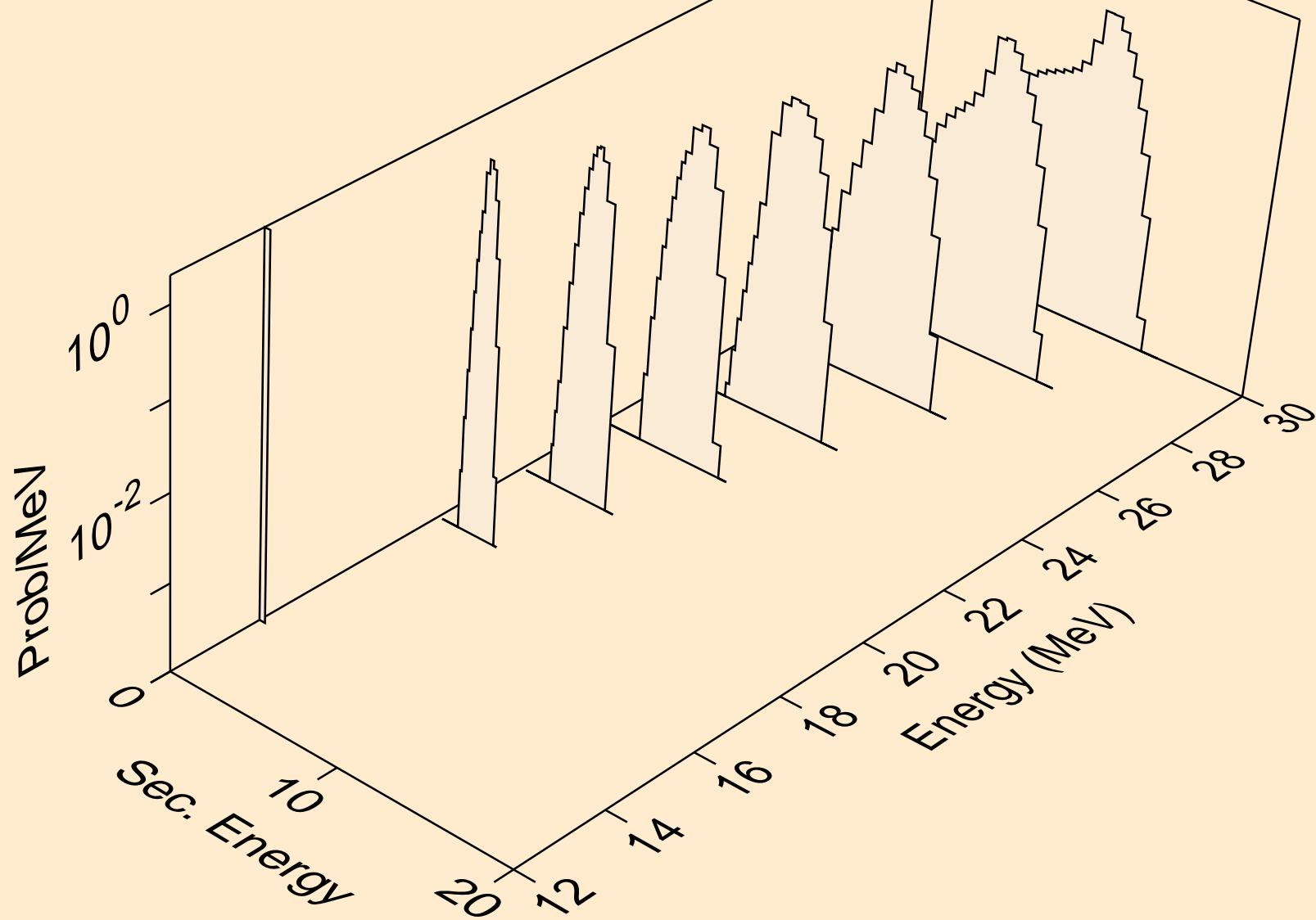

SE075 NEUTRON ACER TENDL-2024 LIBRARY; T=0.K
he3s from (n,x)

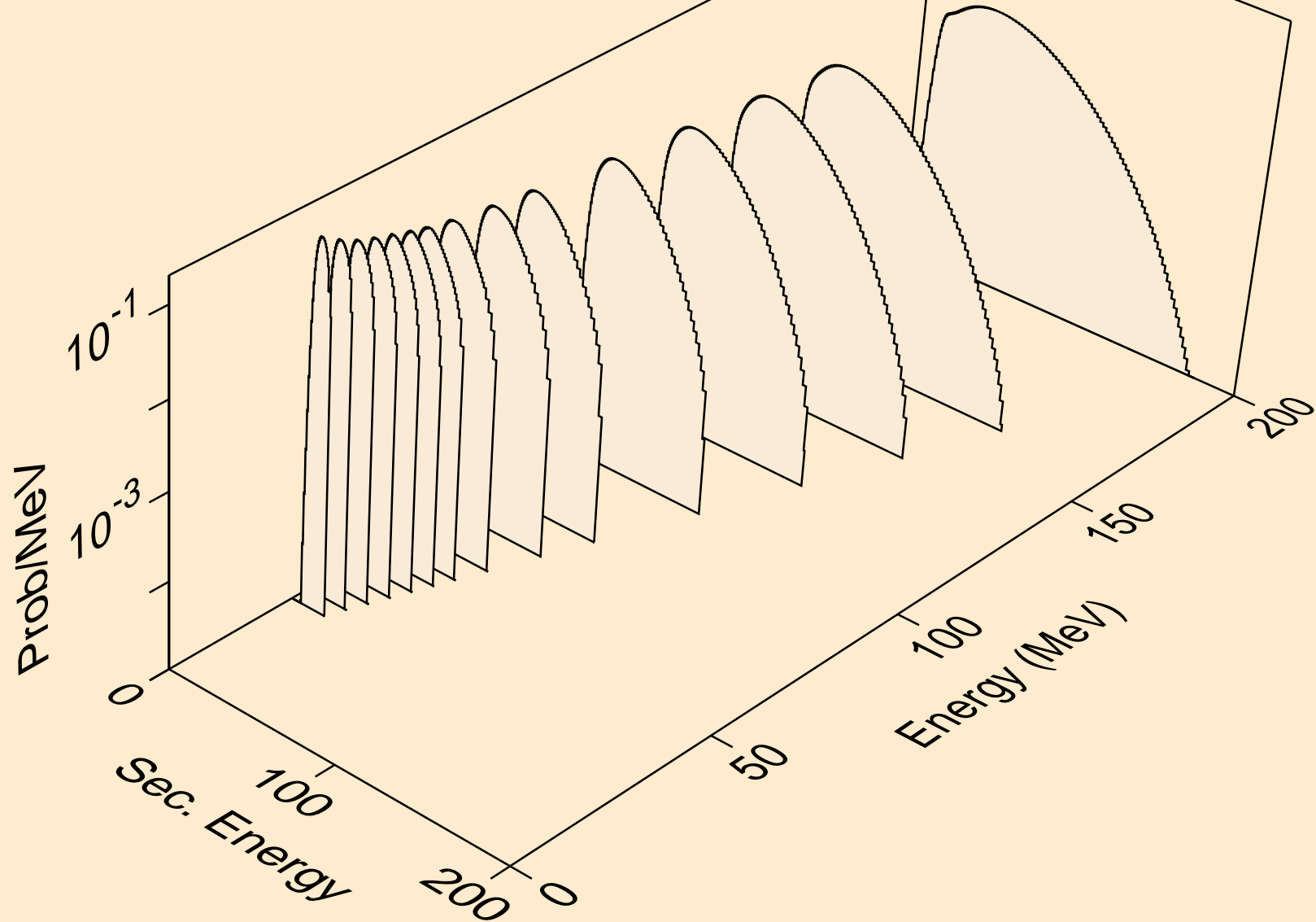

SE075 NEUTRON ACER TENDL-2024 LIBRARY; T=0.K
he3s from (n,n*)he3

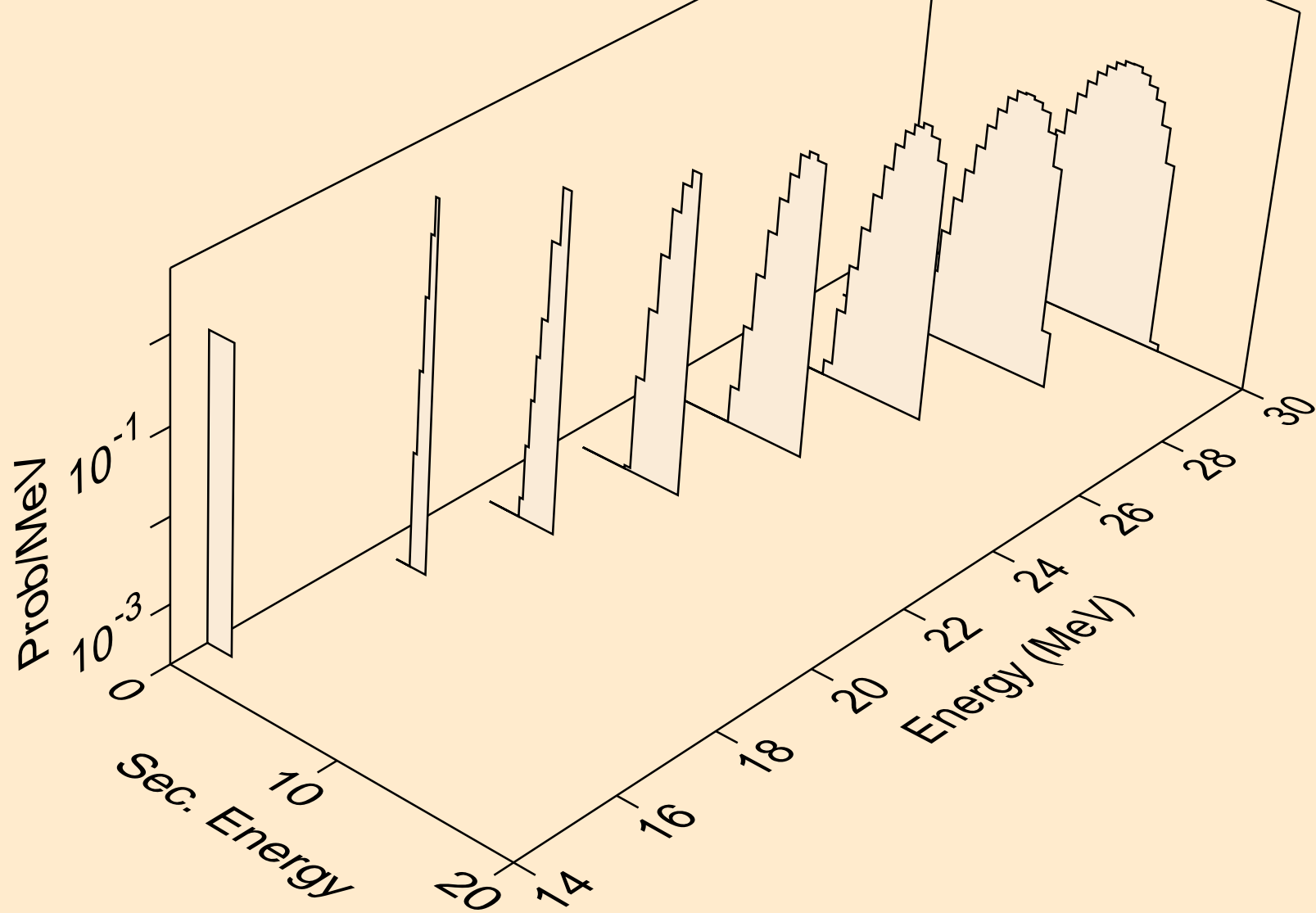

SE075 NEUTRON ACER TENDL-2024 LIBRARY; T=0.K
he3s from (n,he3)

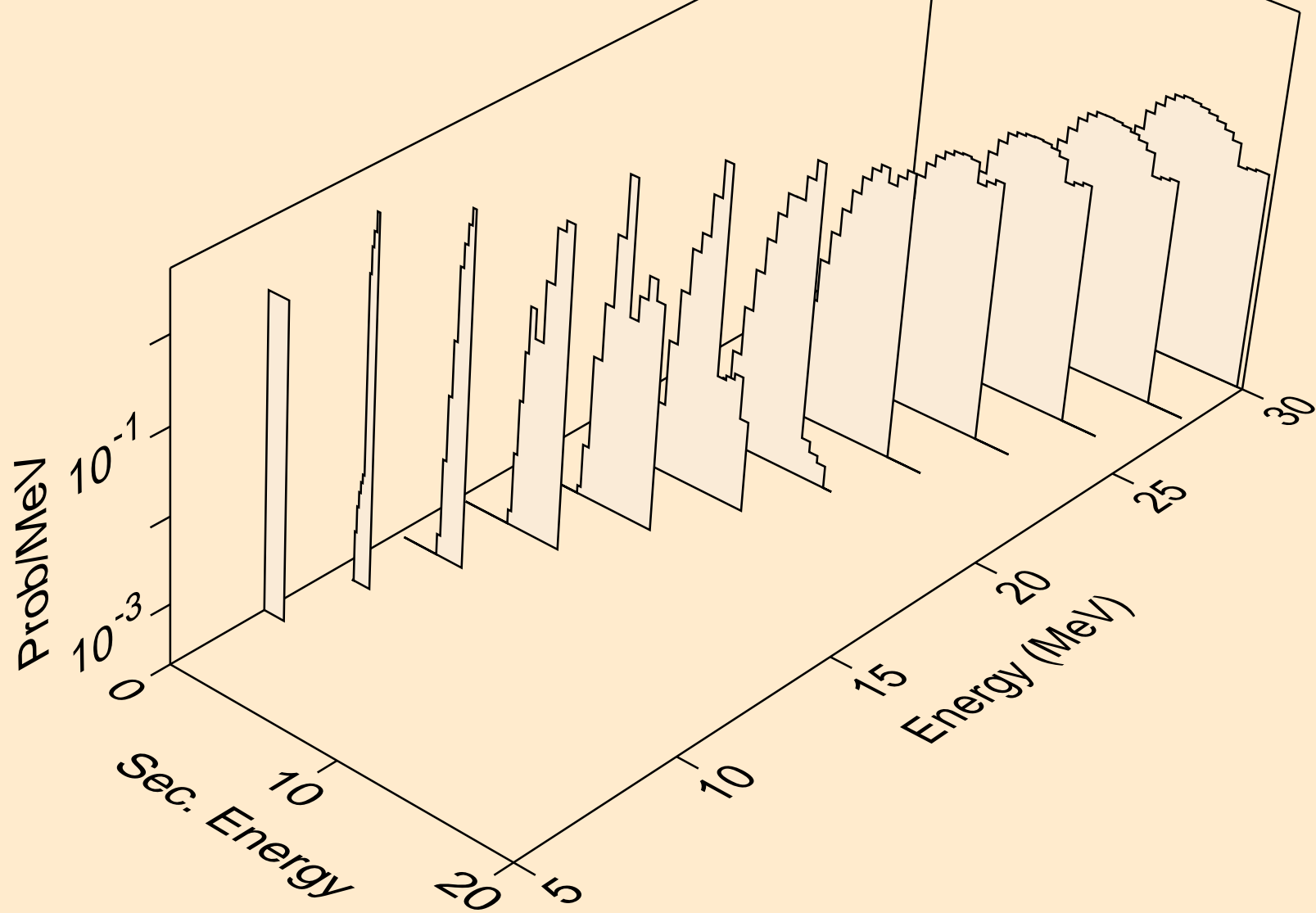

SE075 NEUTRON ACER TENDL-2024 LIBRARY; T=0.K
alphas from (n,x)

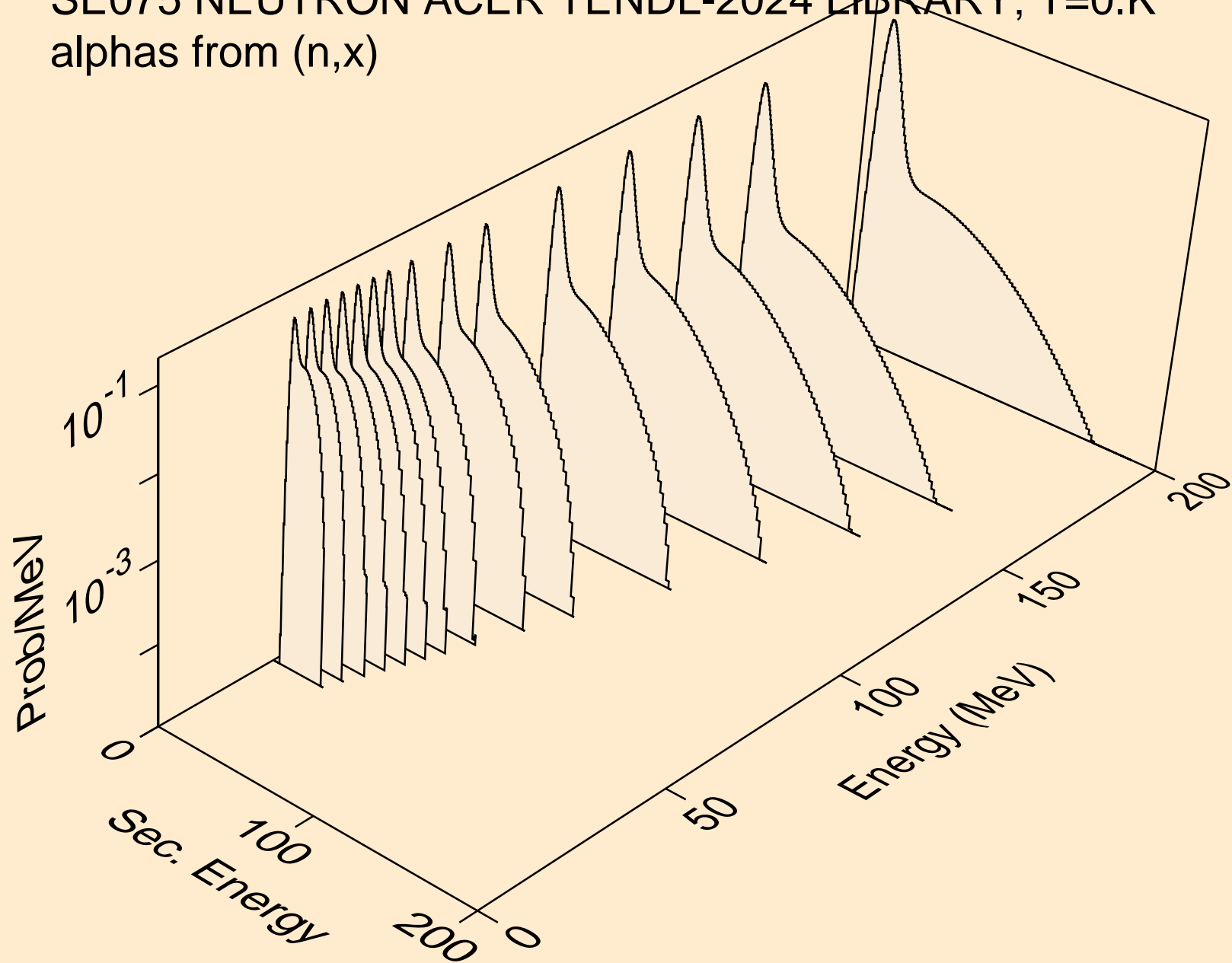

SE075 NEUTRON ACER TENDL-2024 LIBRARY; T=0.K
alphas from (n,n*)a

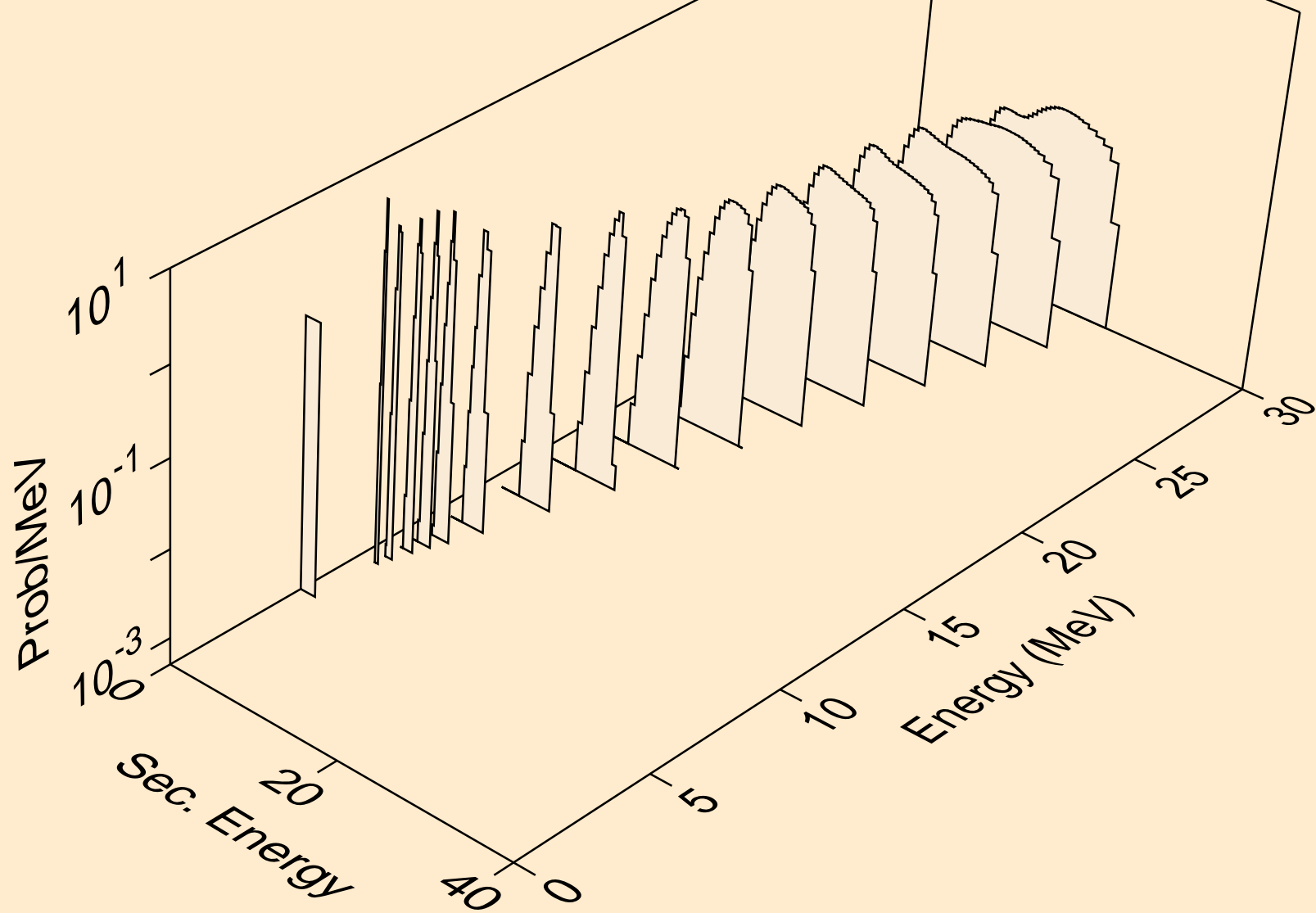

SE075 NEUTRON ACER TENDL-2024 LIBRARY; T=0.K
alphas from (n,2n)a

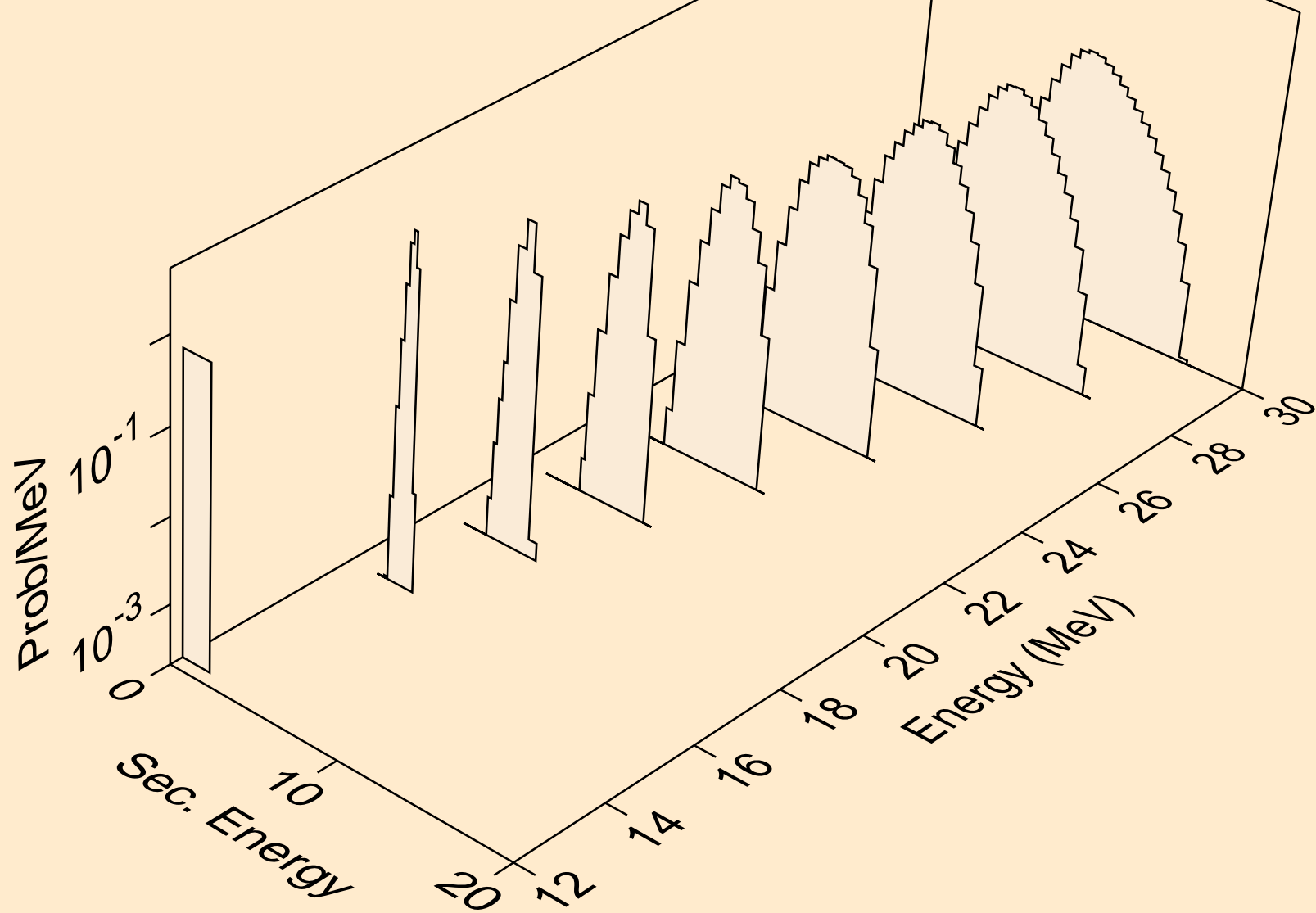

SE075 NEUTRON ACER TENDL-2024 LIBRARY; T=0.K
alphas from (n,3n)a

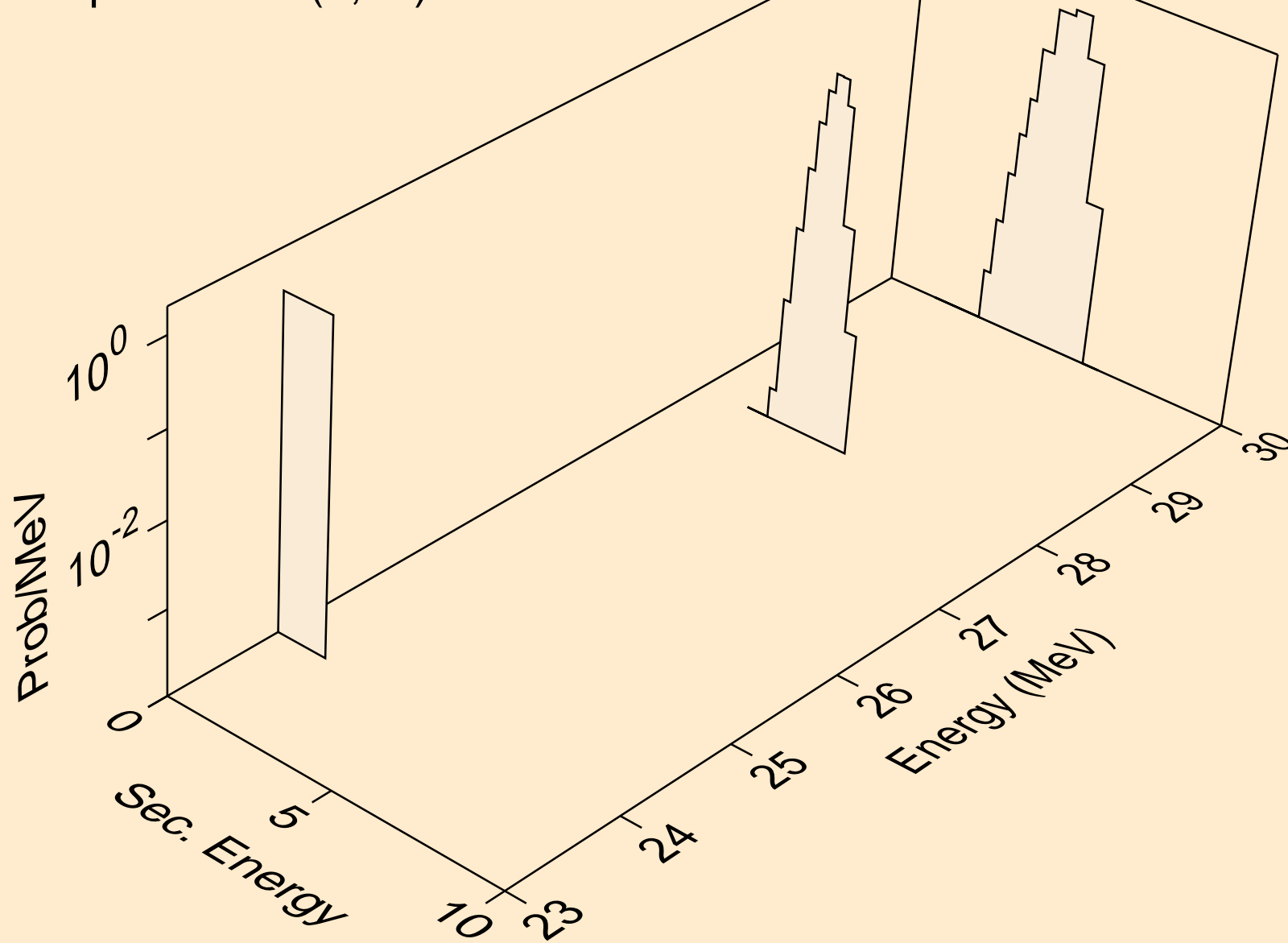

SE075 NEUTRON ACER TENDL-2024 LIBRARY; T=0.K
alphas from (n,n*)2a

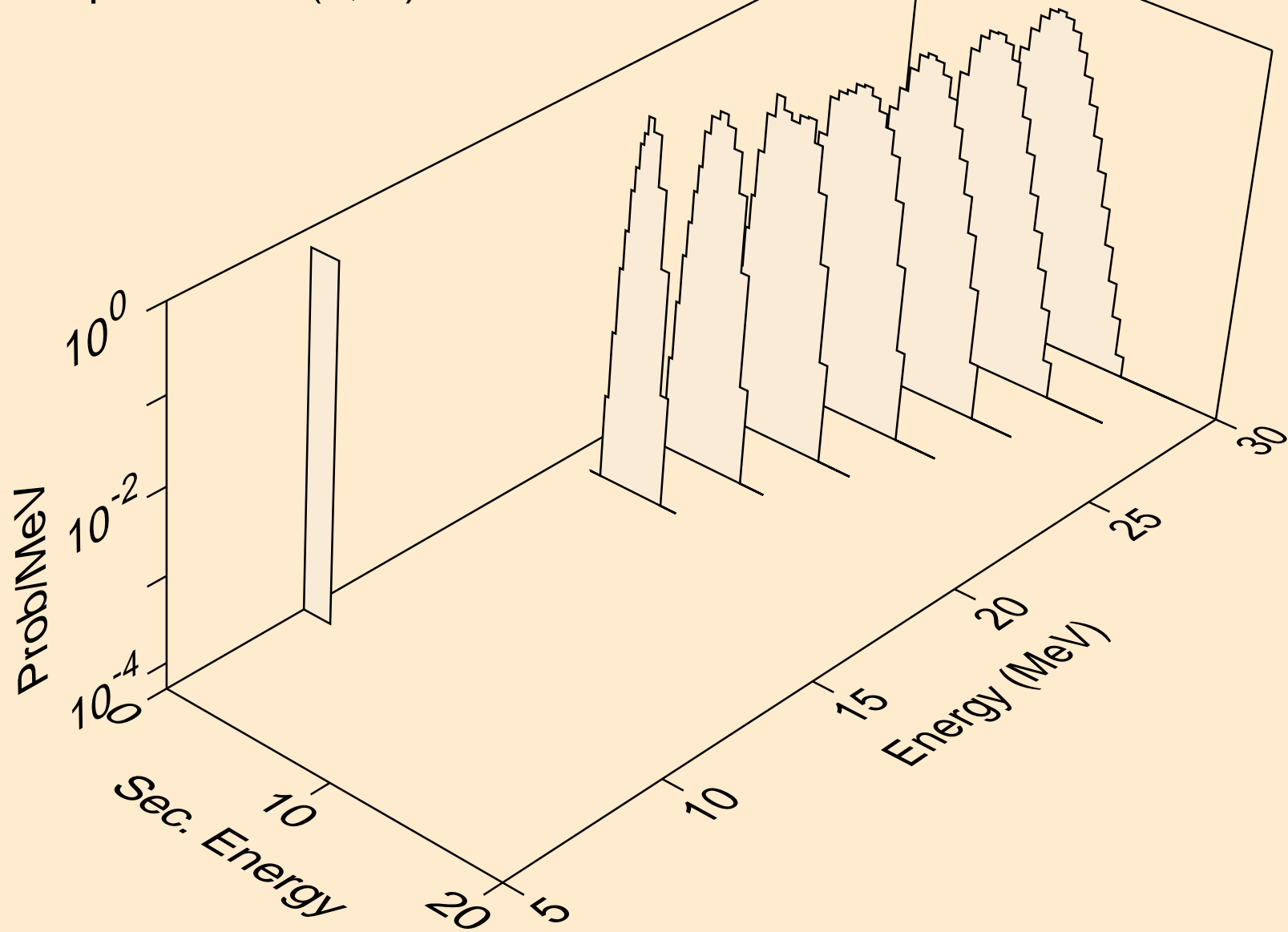

SE075 NEUTRON ACER TENDL-2024 LIBRARY; T=0.K
alphas from (n,2n)2a

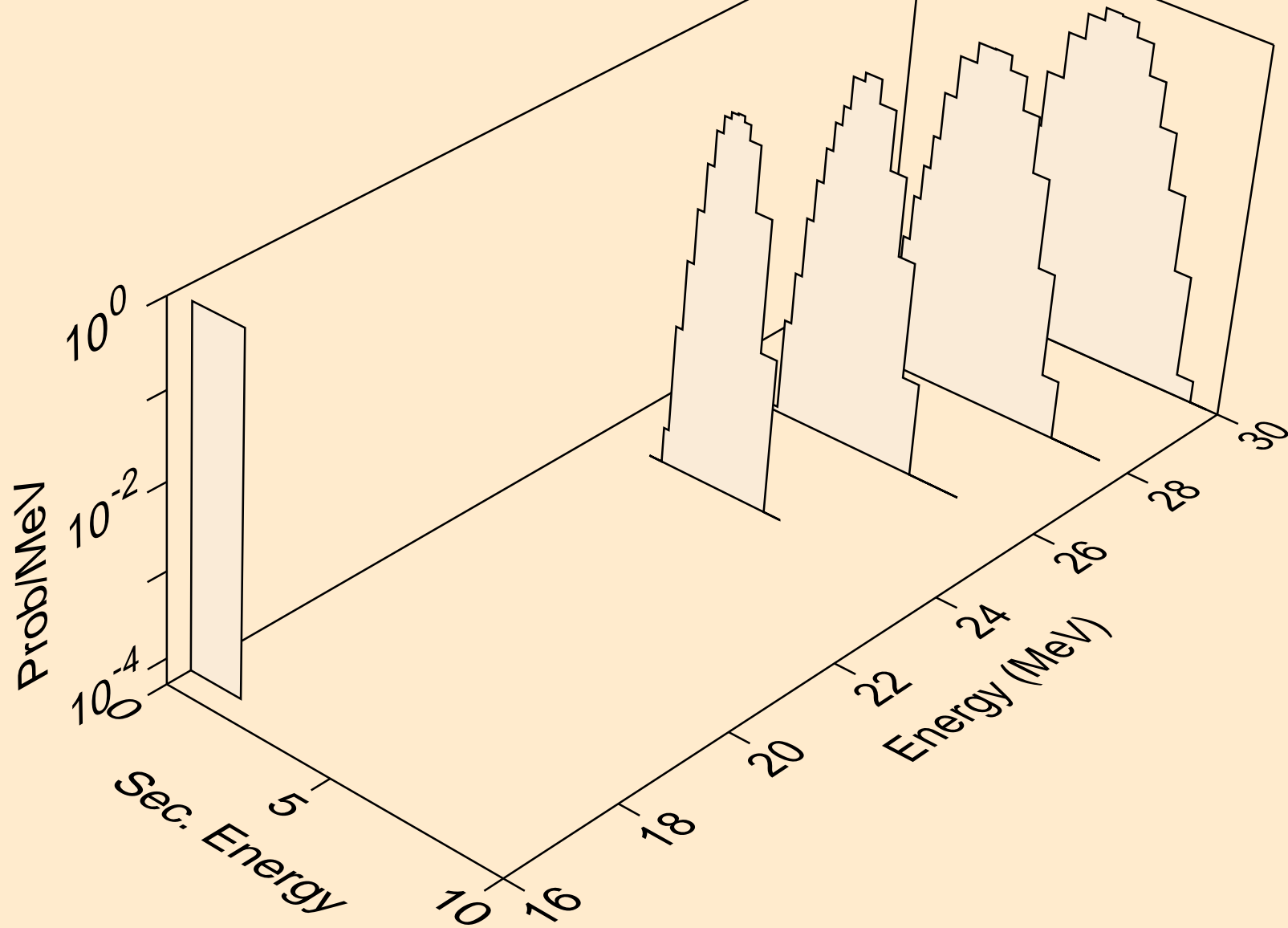

SE075 NEUTRON ACER TENDL-2024 LIBRARY; T=0.K
alphas from (n,npa)

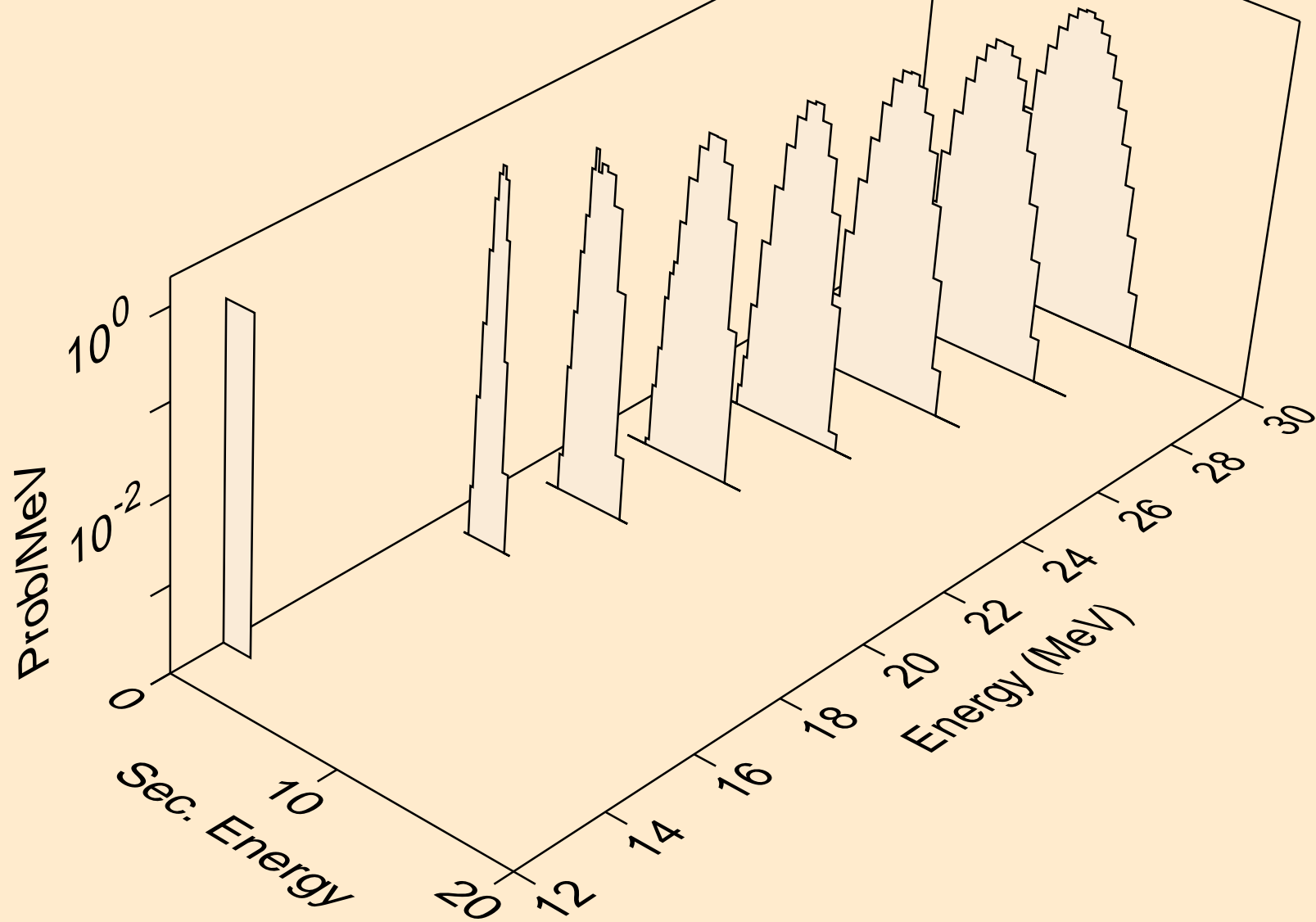

SE075 NEUTRON ACER TENDL-2024 LIBRARY; T=0.K
alphas from (n,a)

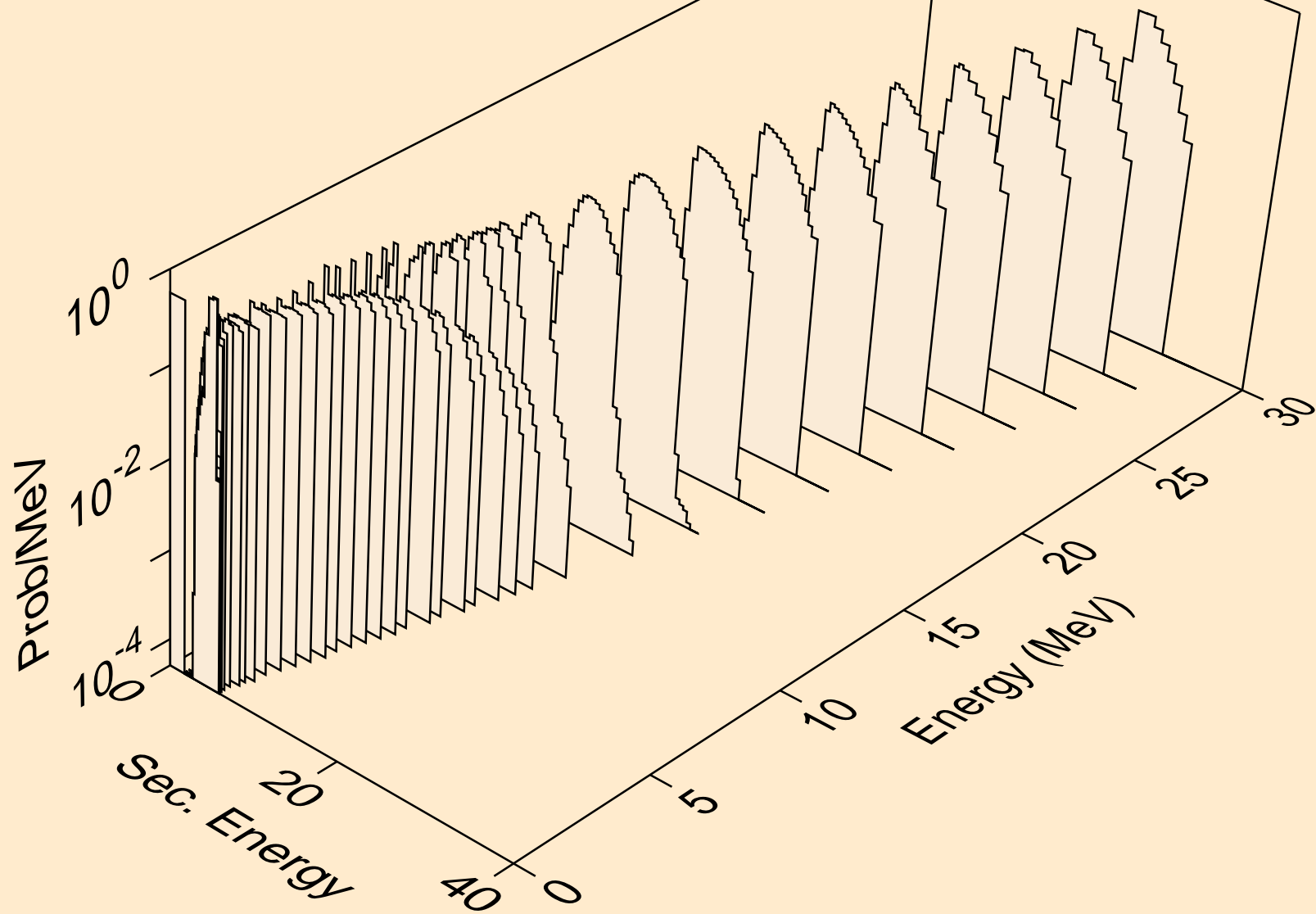

SE075 NEUTRON ACER TENDL-2024 LIBRARY; T=0.K
alphas from (n,2a)

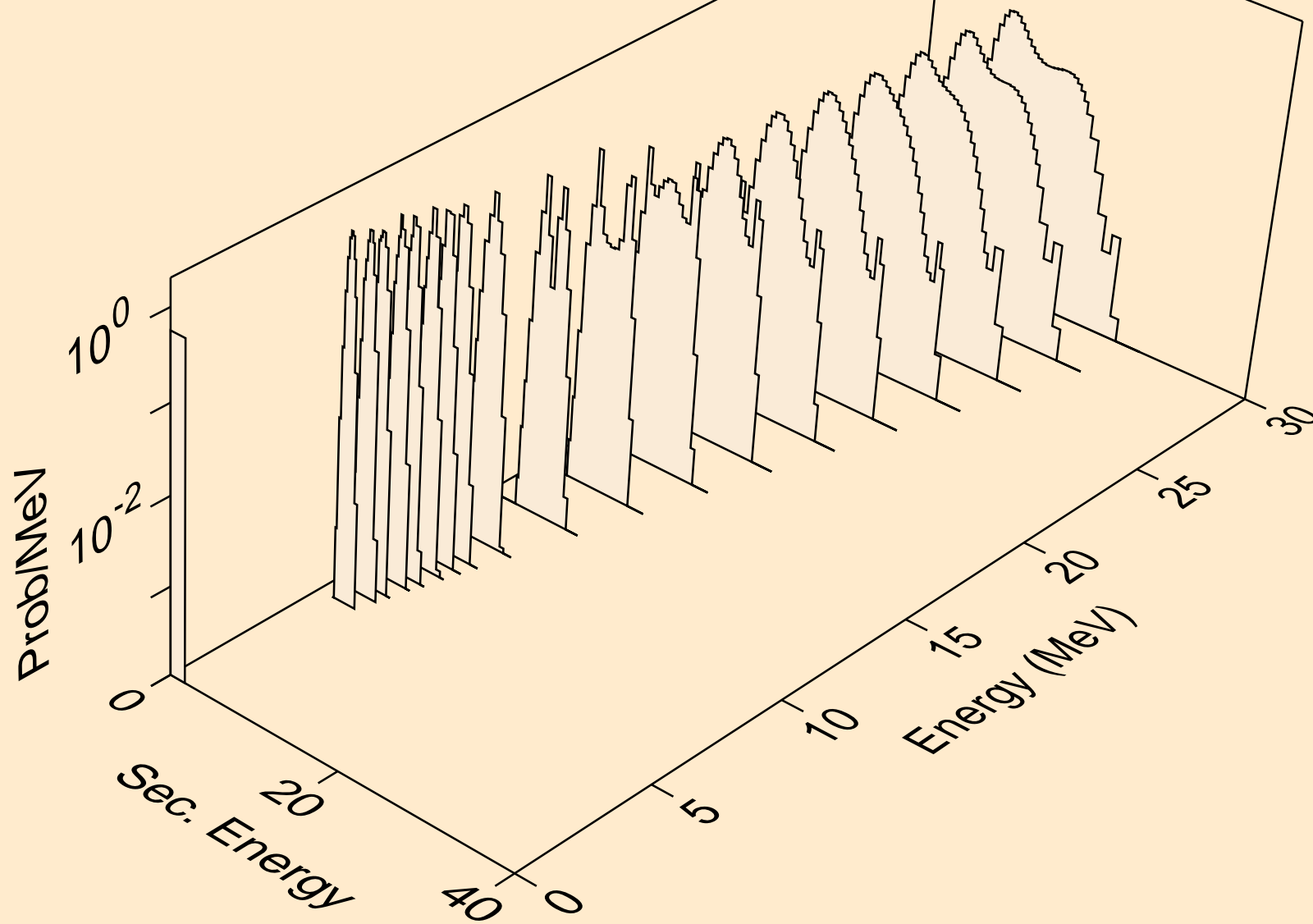

SE075 NEUTRON ACER TENDL-2024 LIBRARY; T=0.K
alphas from (n,pa)

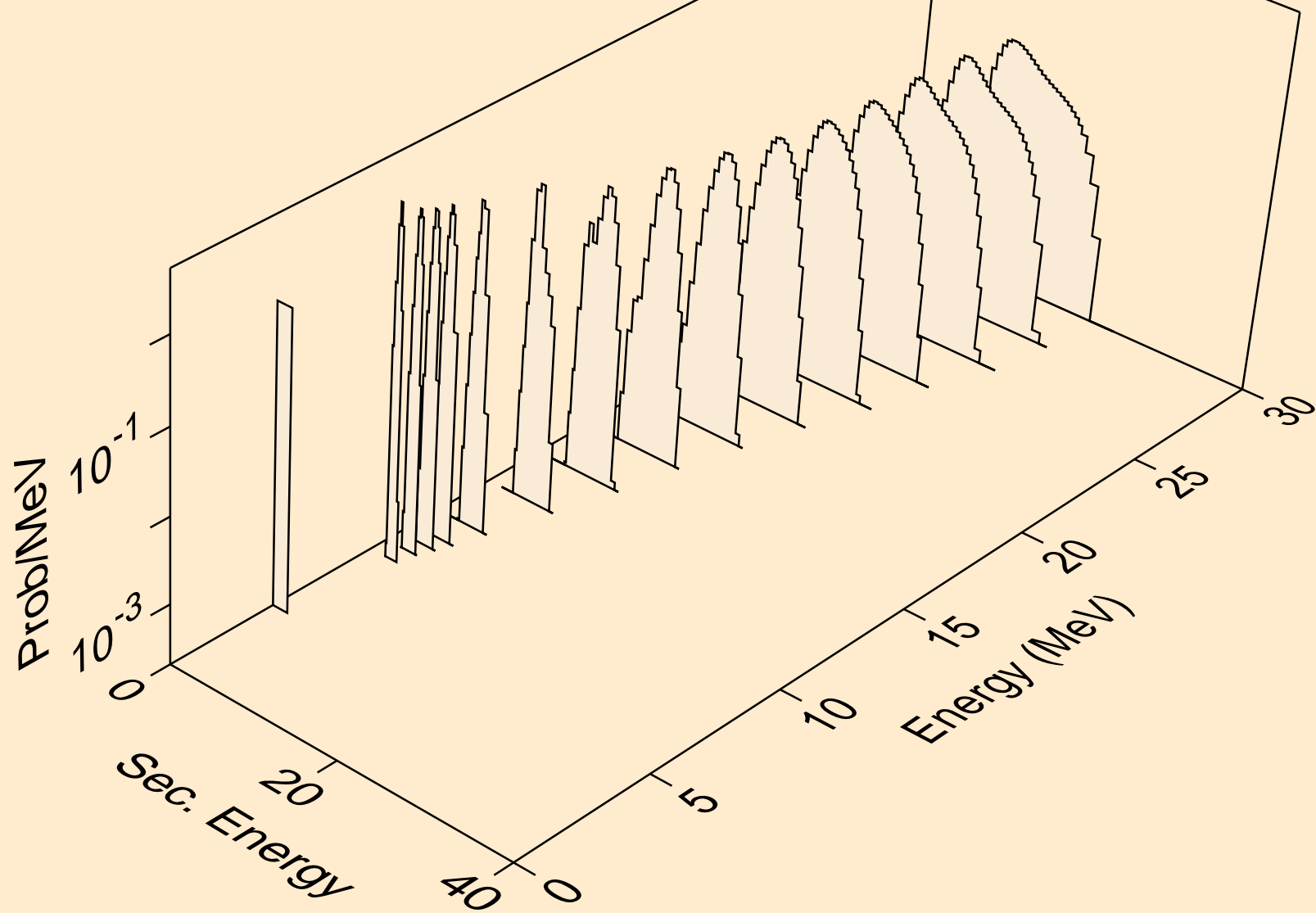

SE075 NEUTRON ACER TENDL-2024 LIBRARY; T=0.K
alphas from (n,da)

