

TA164 NEUTRON ACER TENDL-2024 LIBRARY; T=0.K
Principal cross sections

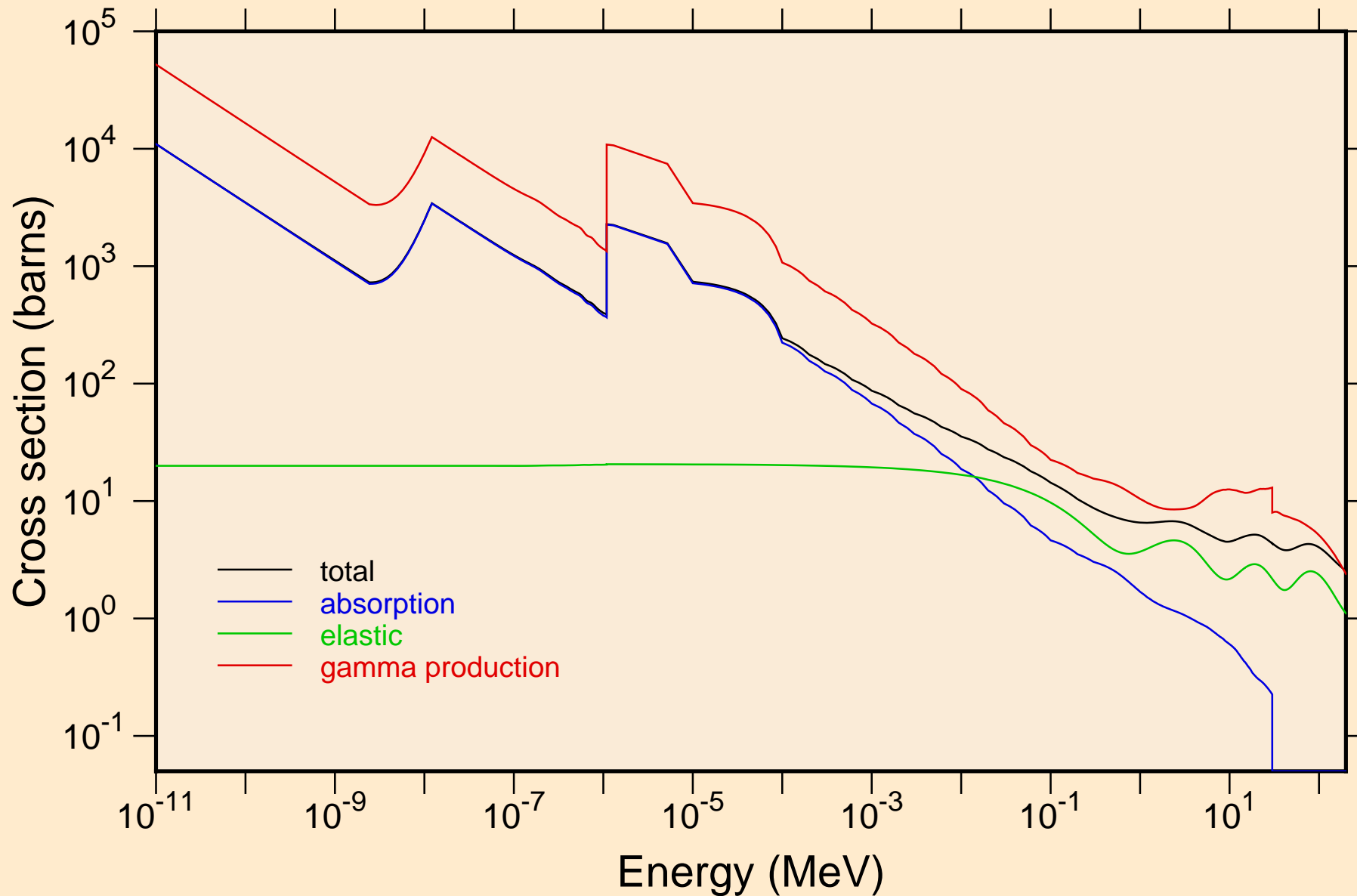

TA164 NEUTRON ACER TENDL-2024 LIBRARY; T=0.K

Heating

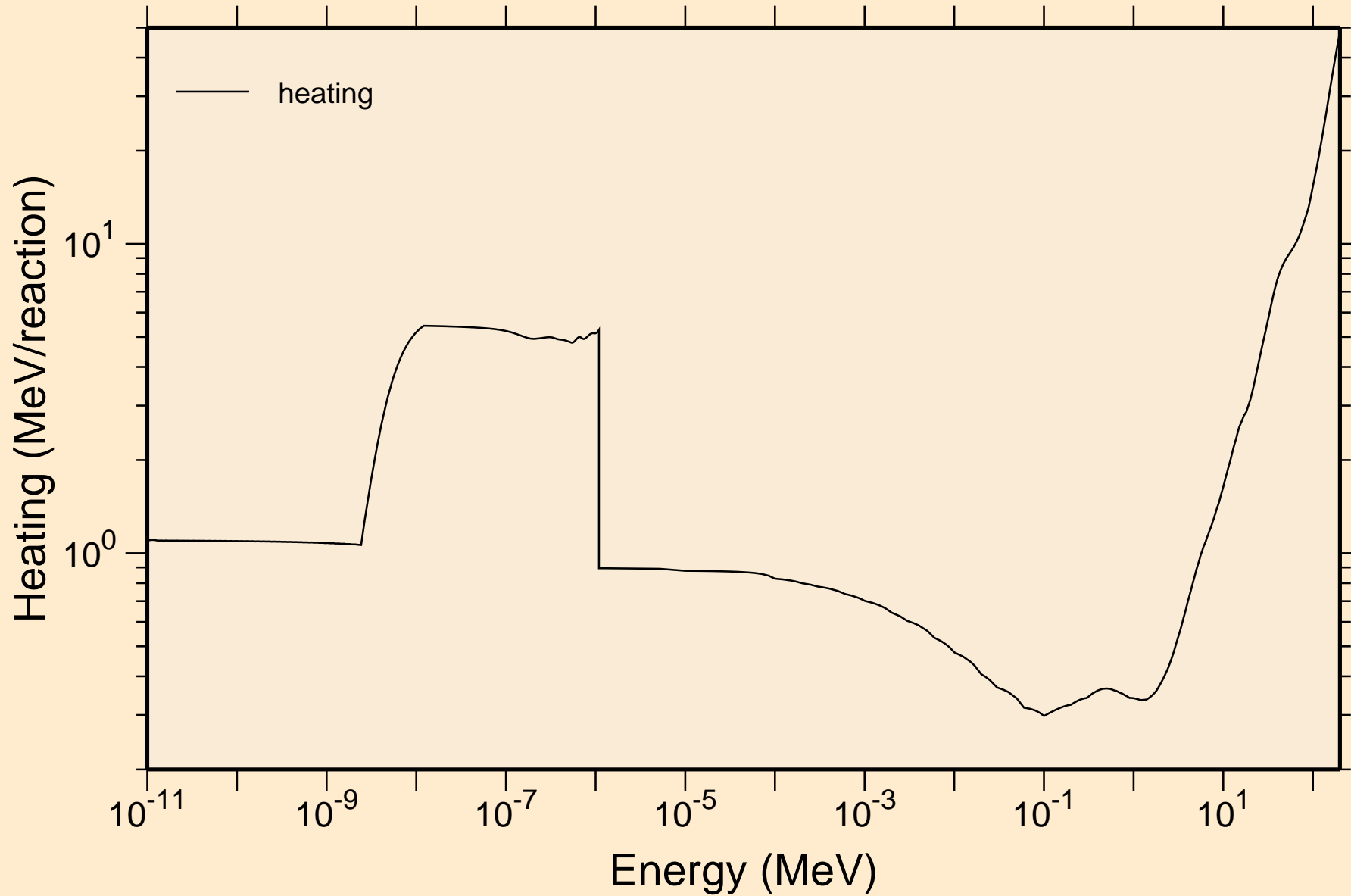

TA164 NEUTRON ACER TENDL-2024 LIBRARY; T=0.K
Damage

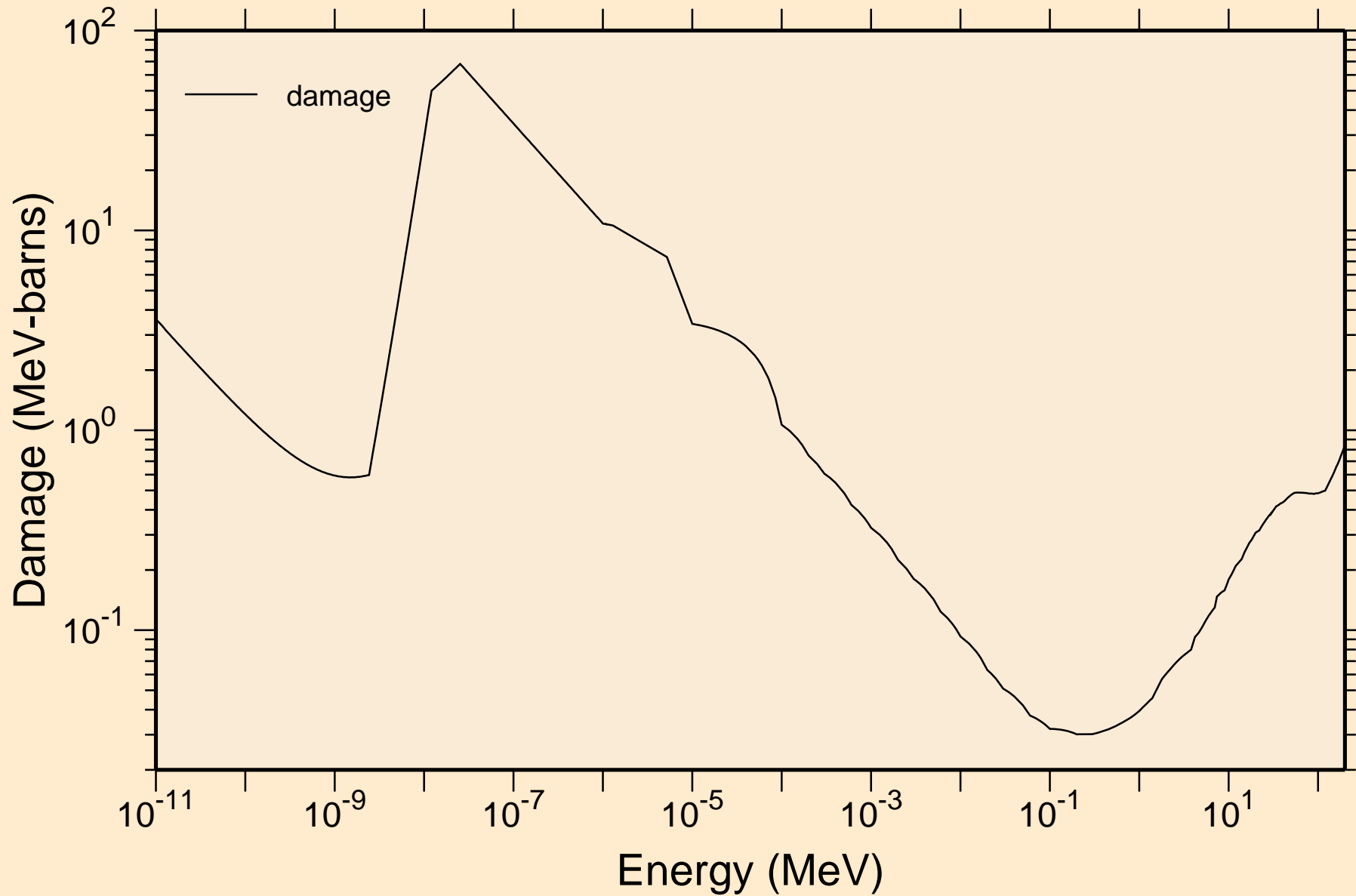

TA164 NEUTRON ACER TENDL-2024 LIBRARY; T=0.K
Non-threshold reactions

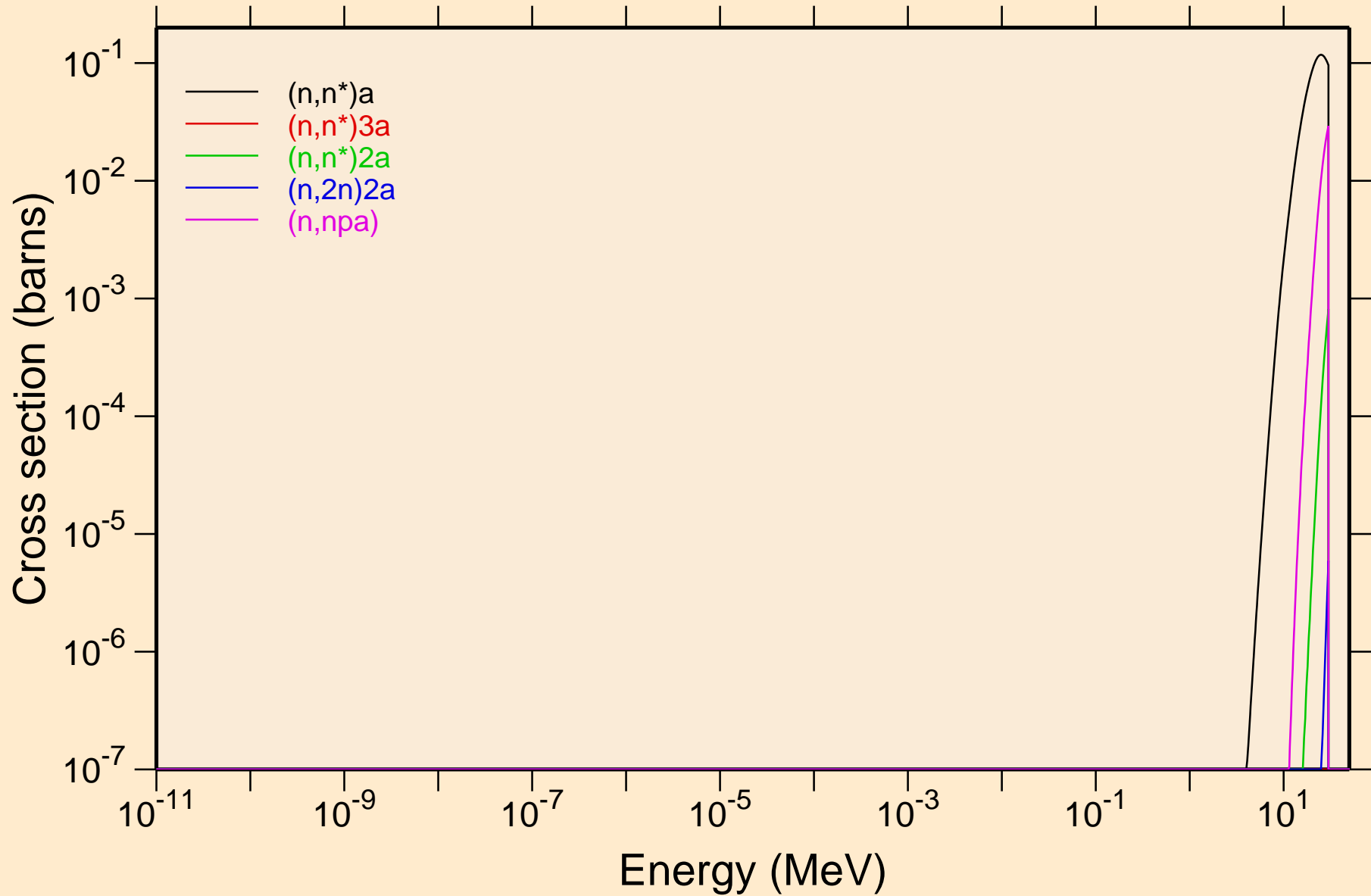

TA164 NEUTRON ACER TENDL-2024 LIBRARY; T=0.K
Non-threshold reactions

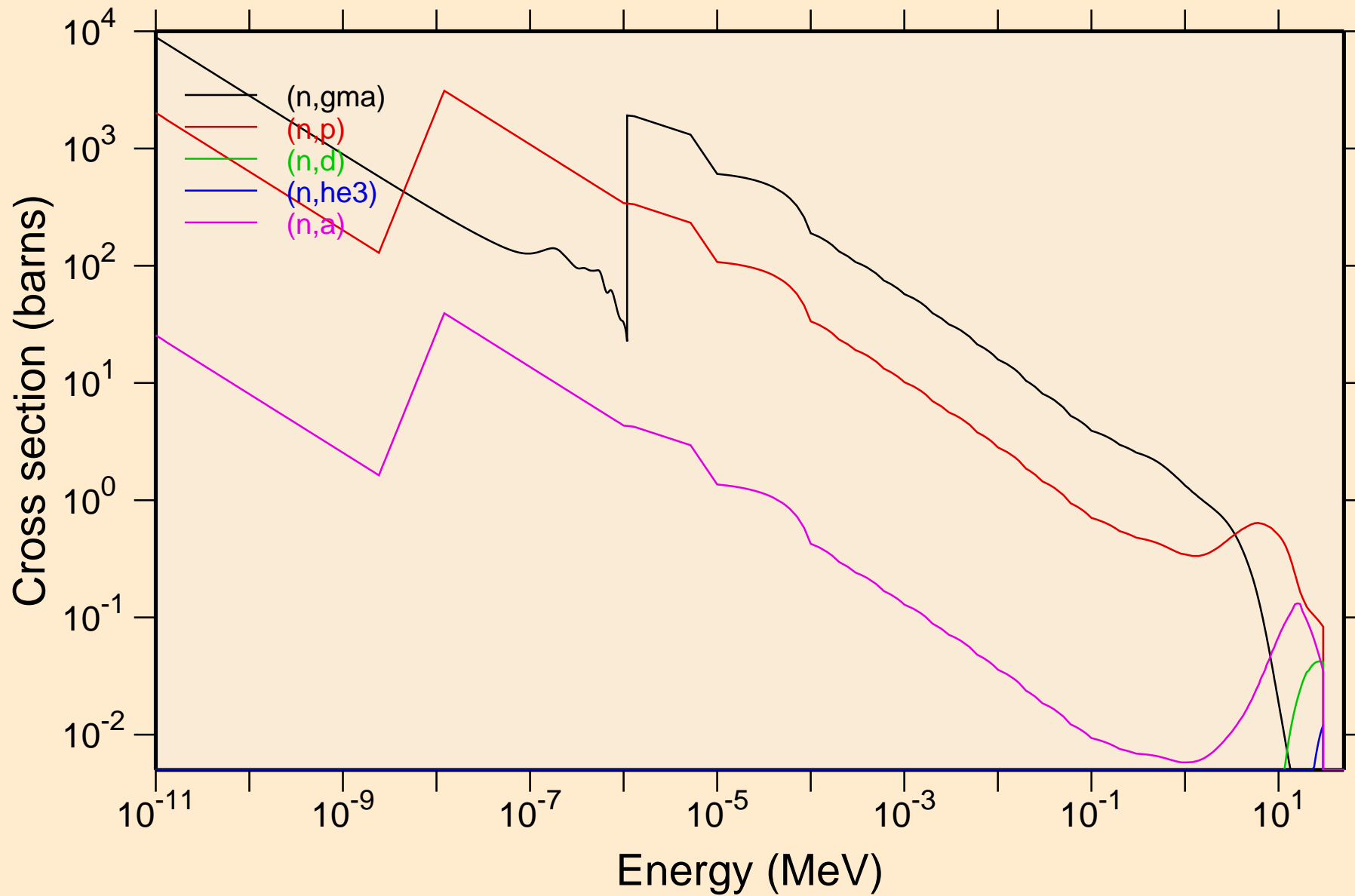

TA164 NEUTRON ACER TENDL-2024 LIBRARY; T=0.K
Non-threshold reactions

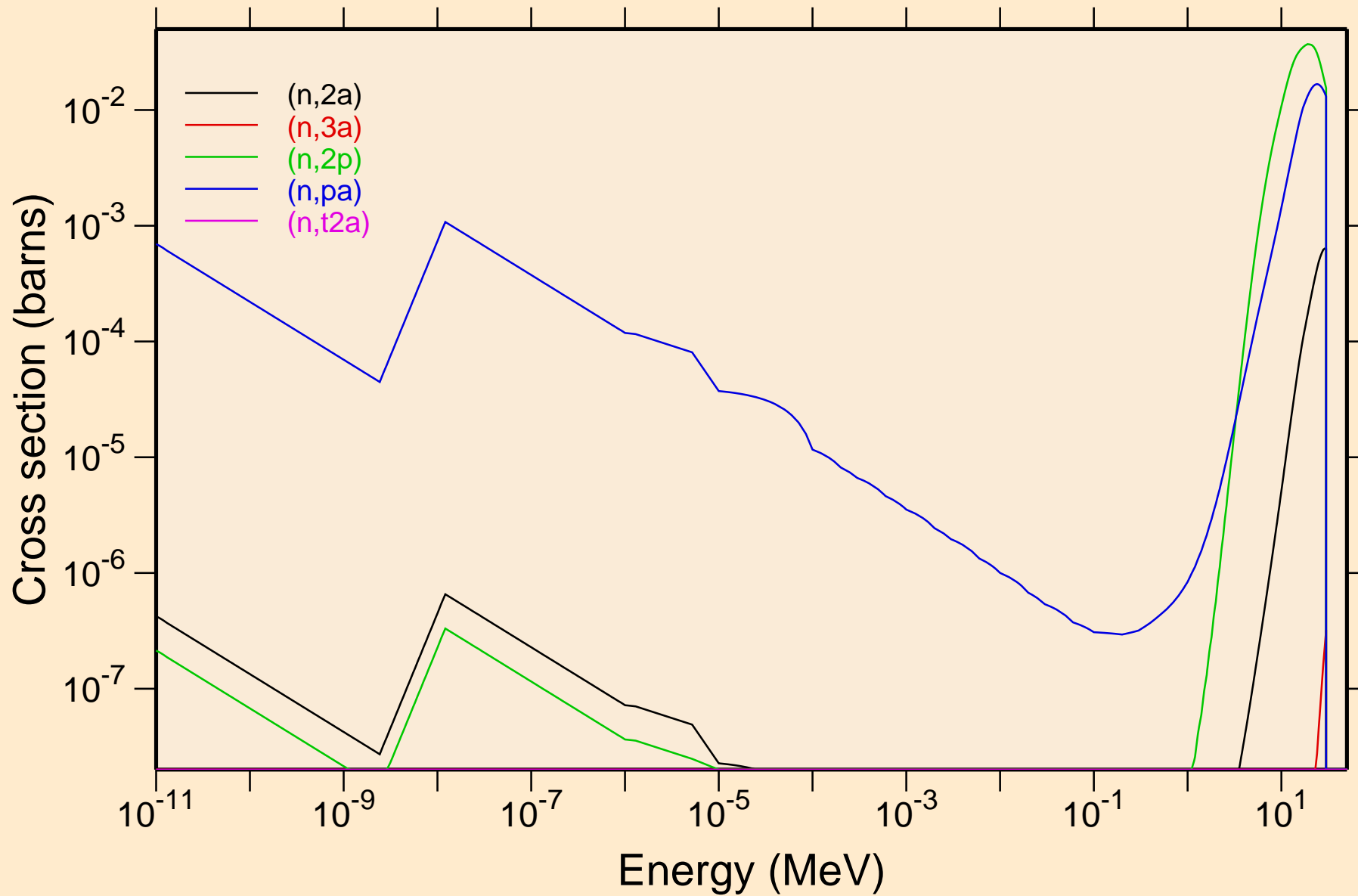

TA164 NEUTRON ACER TENDL-2024 LIBRARY; T=0.K
Non-threshold reactions

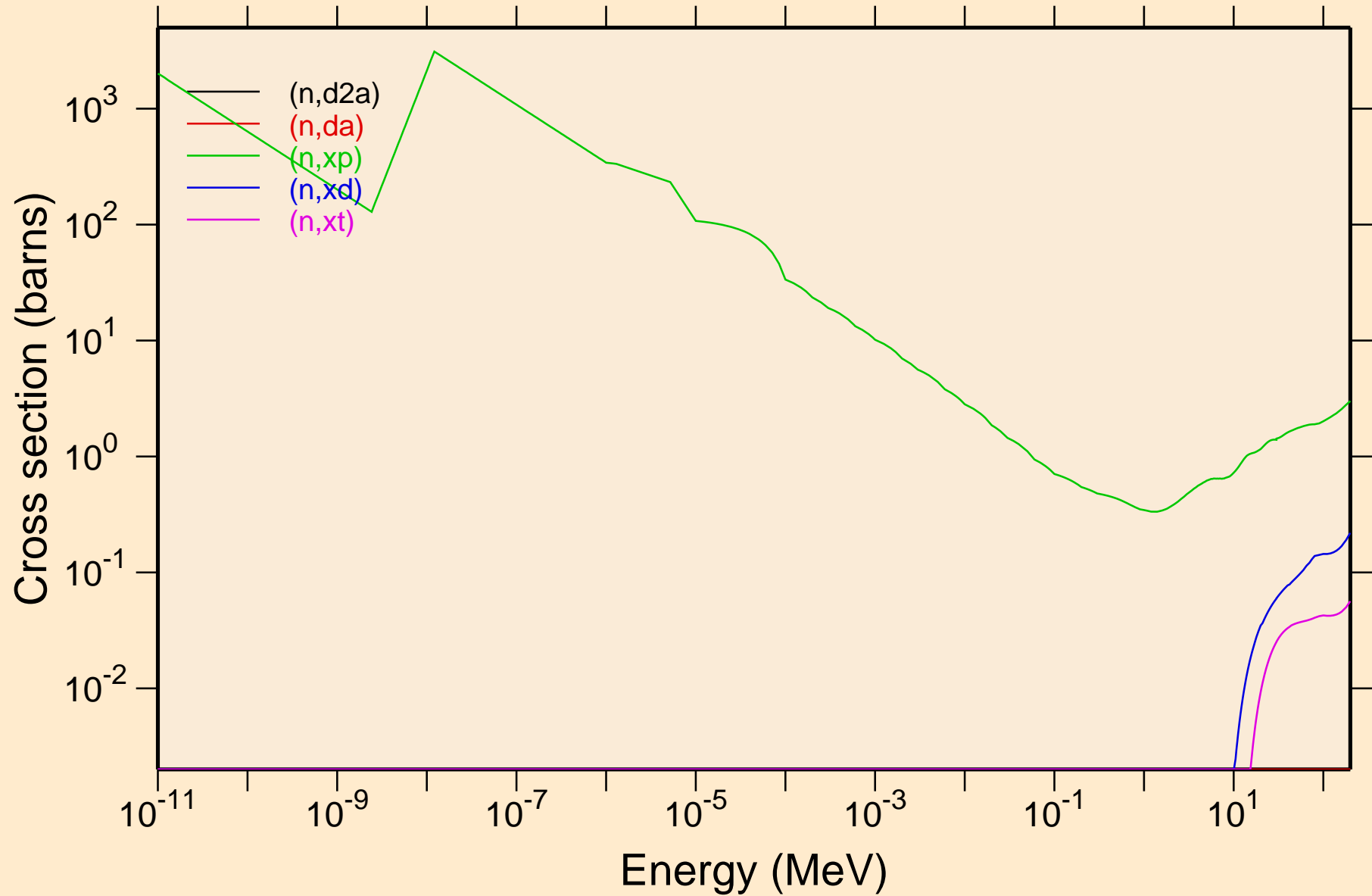

TA164 NEUTRON ACER TENDL-2024 LIBRARY; T=0.K
Non-threshold reactions

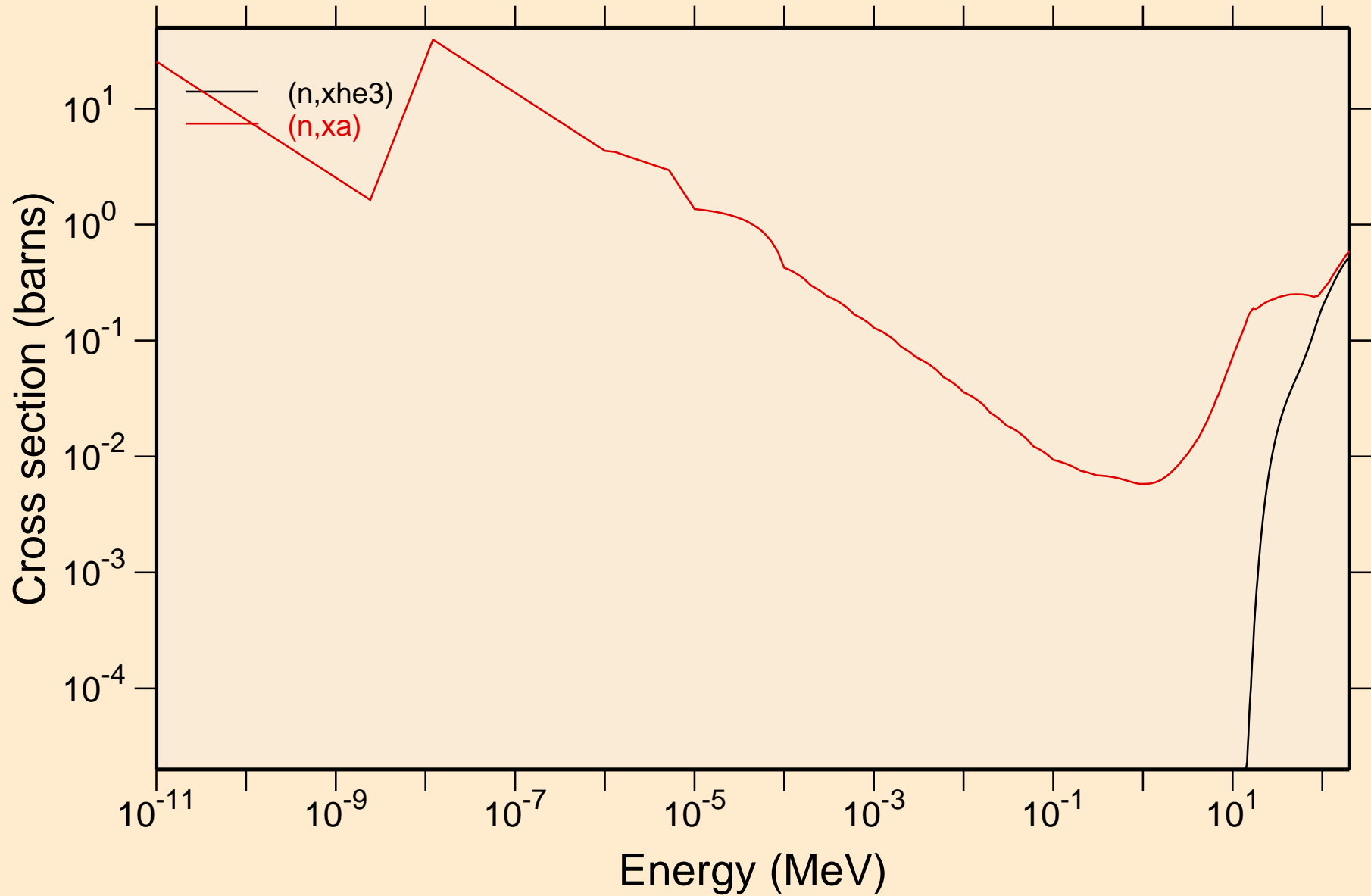

TA164 NEUTRON ACER TENDL-2024 LIBRARY; T=0.K
Principal cross sections

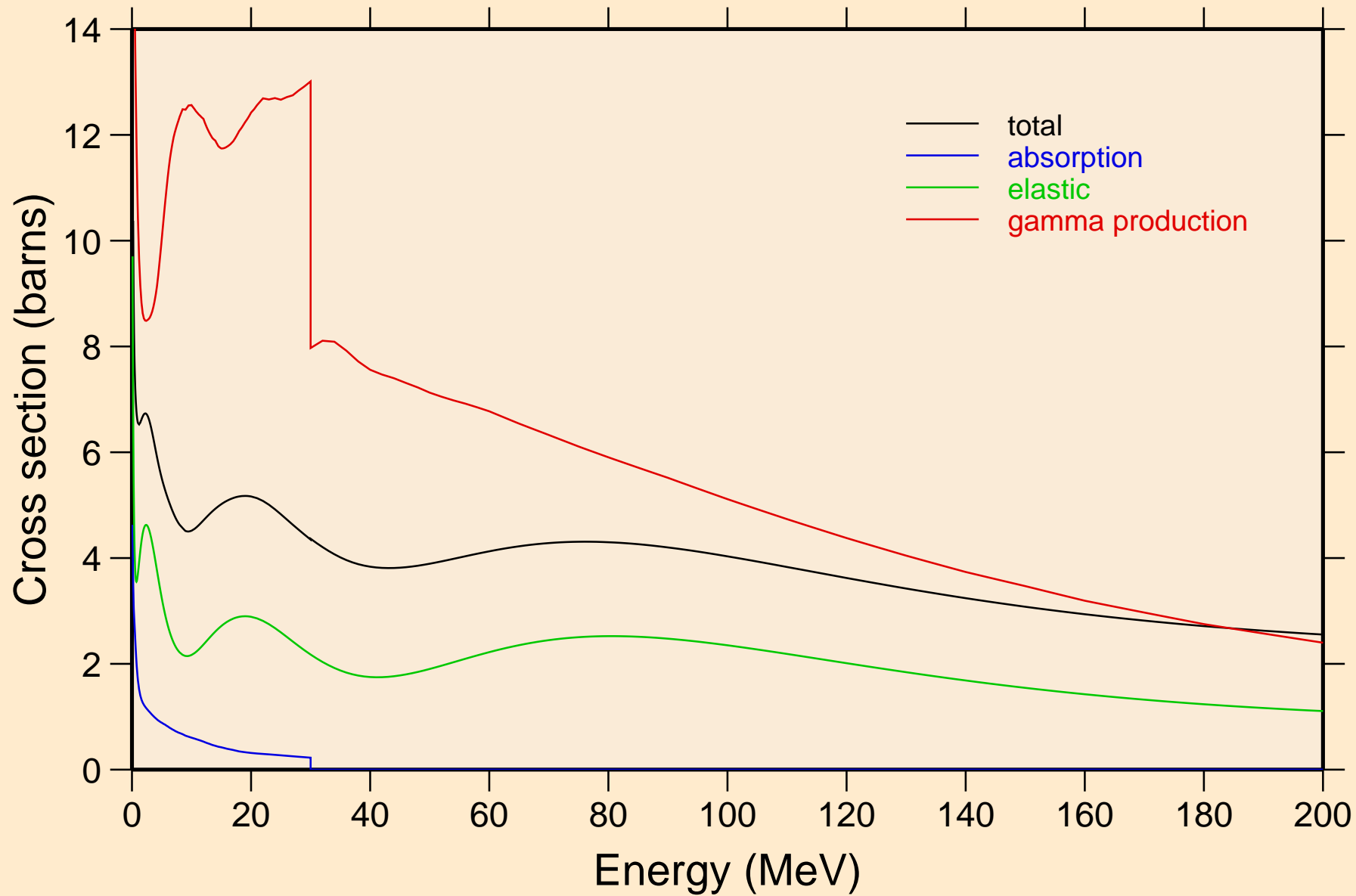

TA164 NEUTRON ACER TENDL-2024 LIBRARY; T=0.K

Heating

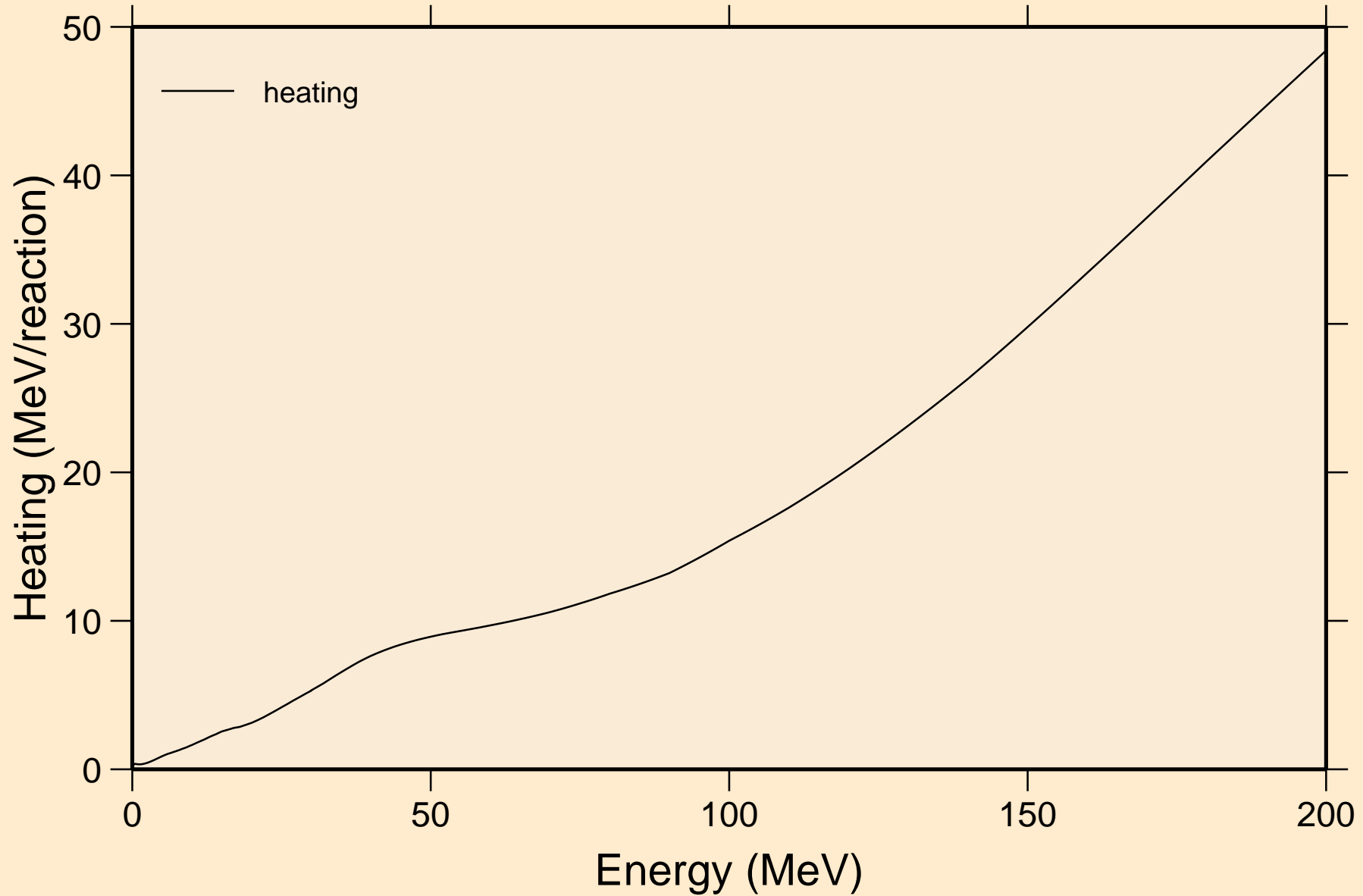

TA164 NEUTRON ACER TENDL-2024 LIBRARY; T=0.K
Damage

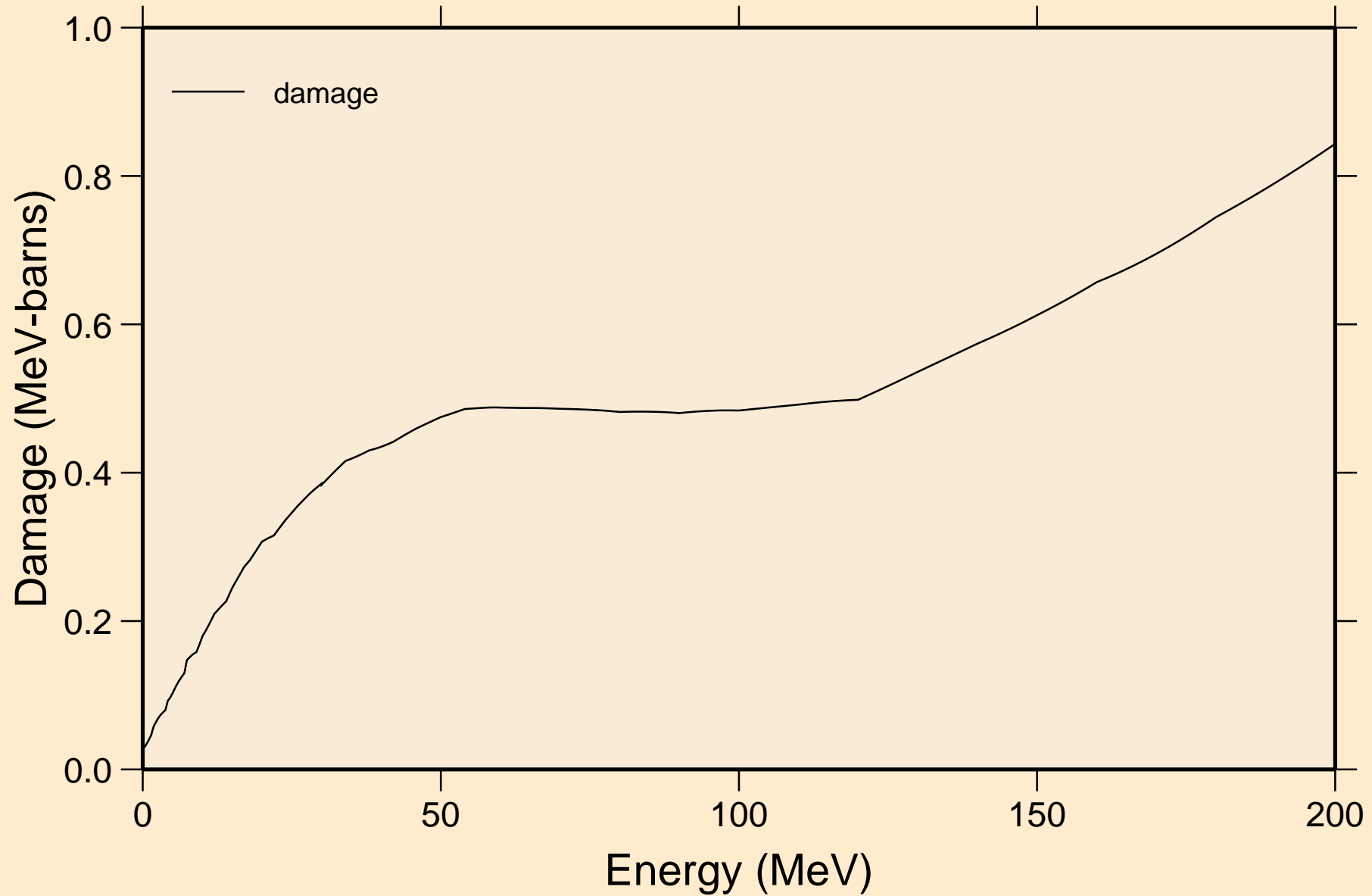

TA164 NEUTRON ACER TENDL-2024 LIBRARY; T=0.K
Non-threshold reactions

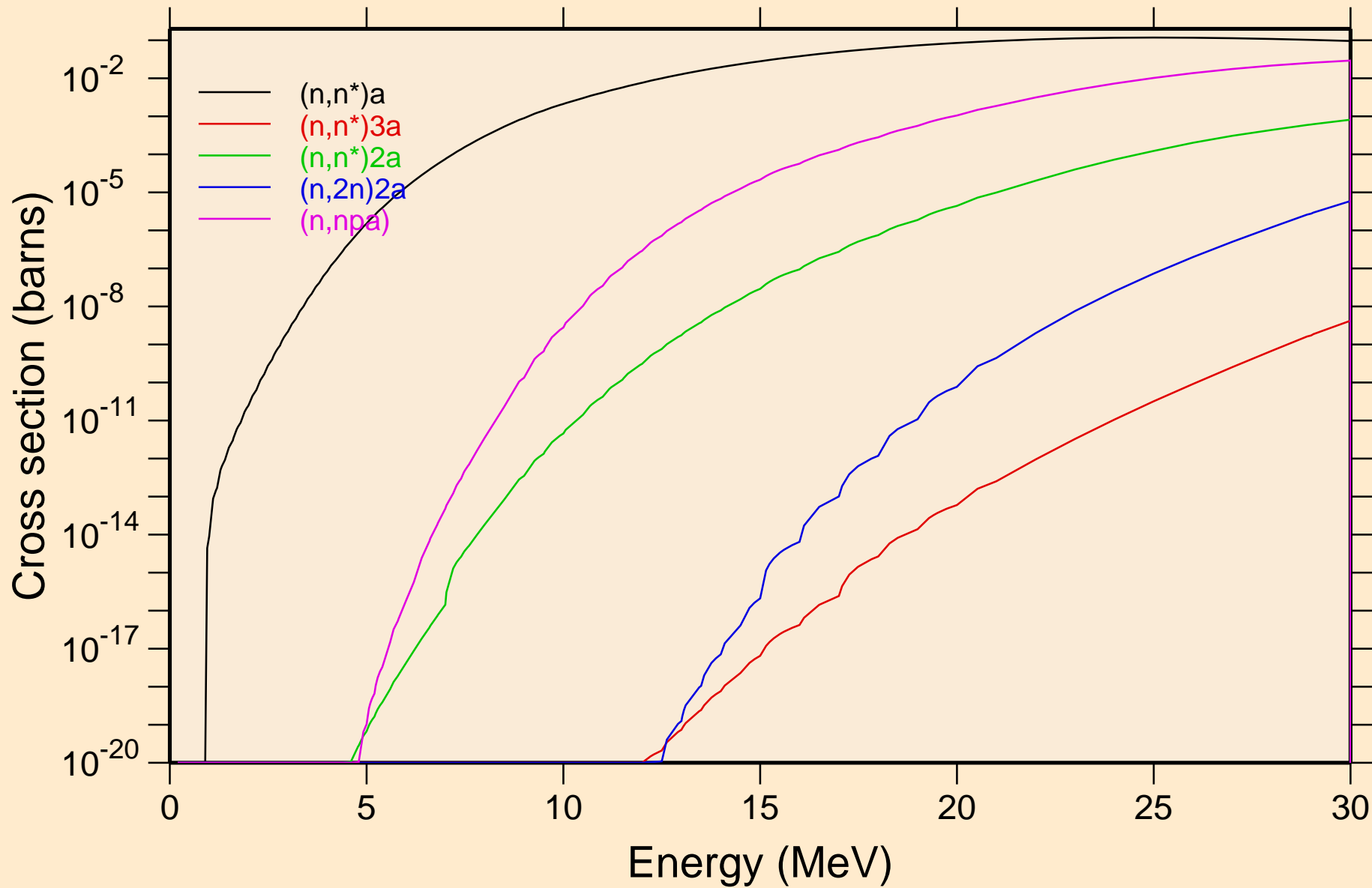

TA164 NEUTRON ACER TENDL-2024 LIBRARY; T=0.K
Non-threshold reactions

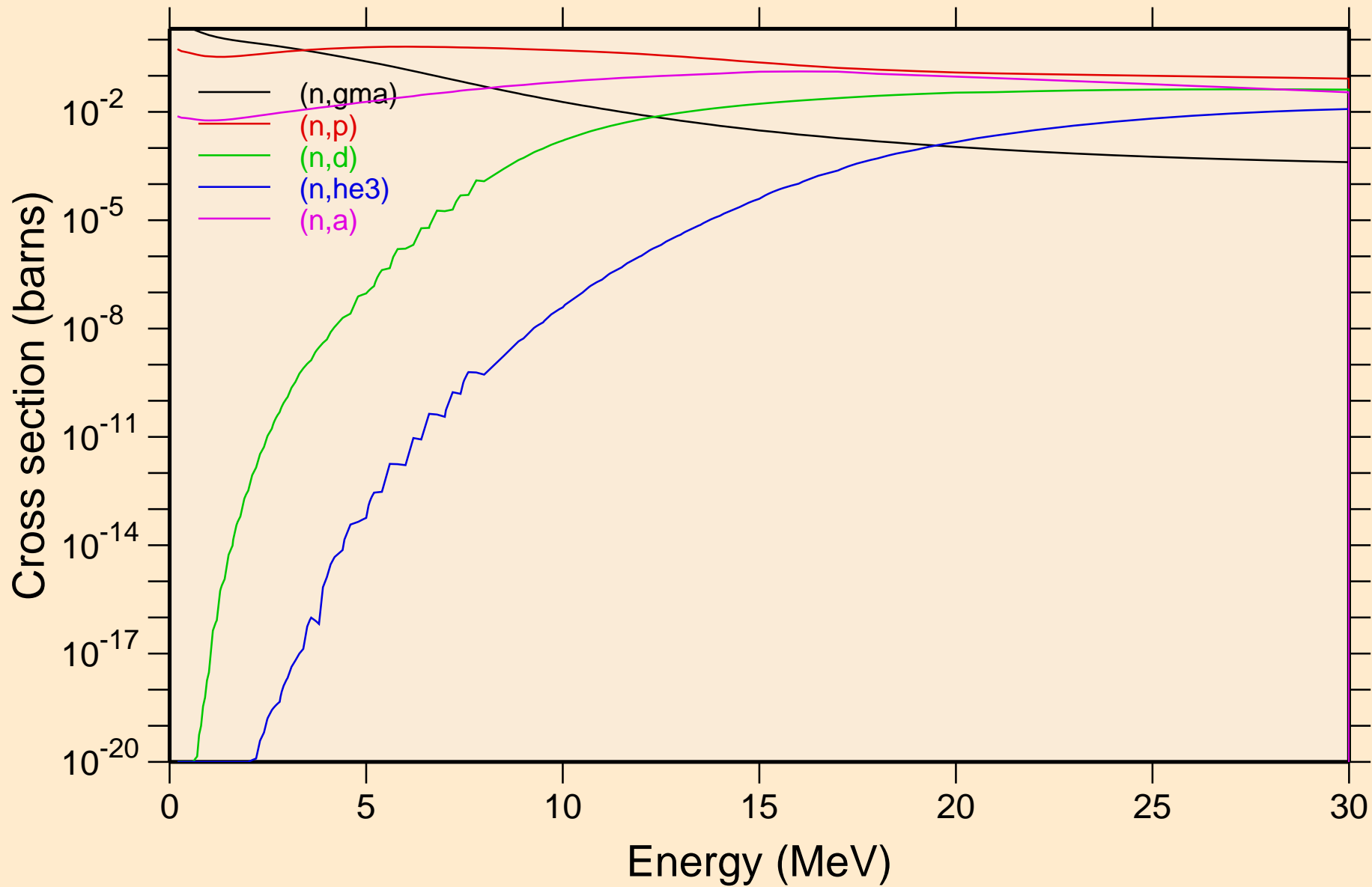

TA164 NEUTRON ACER TENDL-2024 LIBRARY; T=0.K
Non-threshold reactions

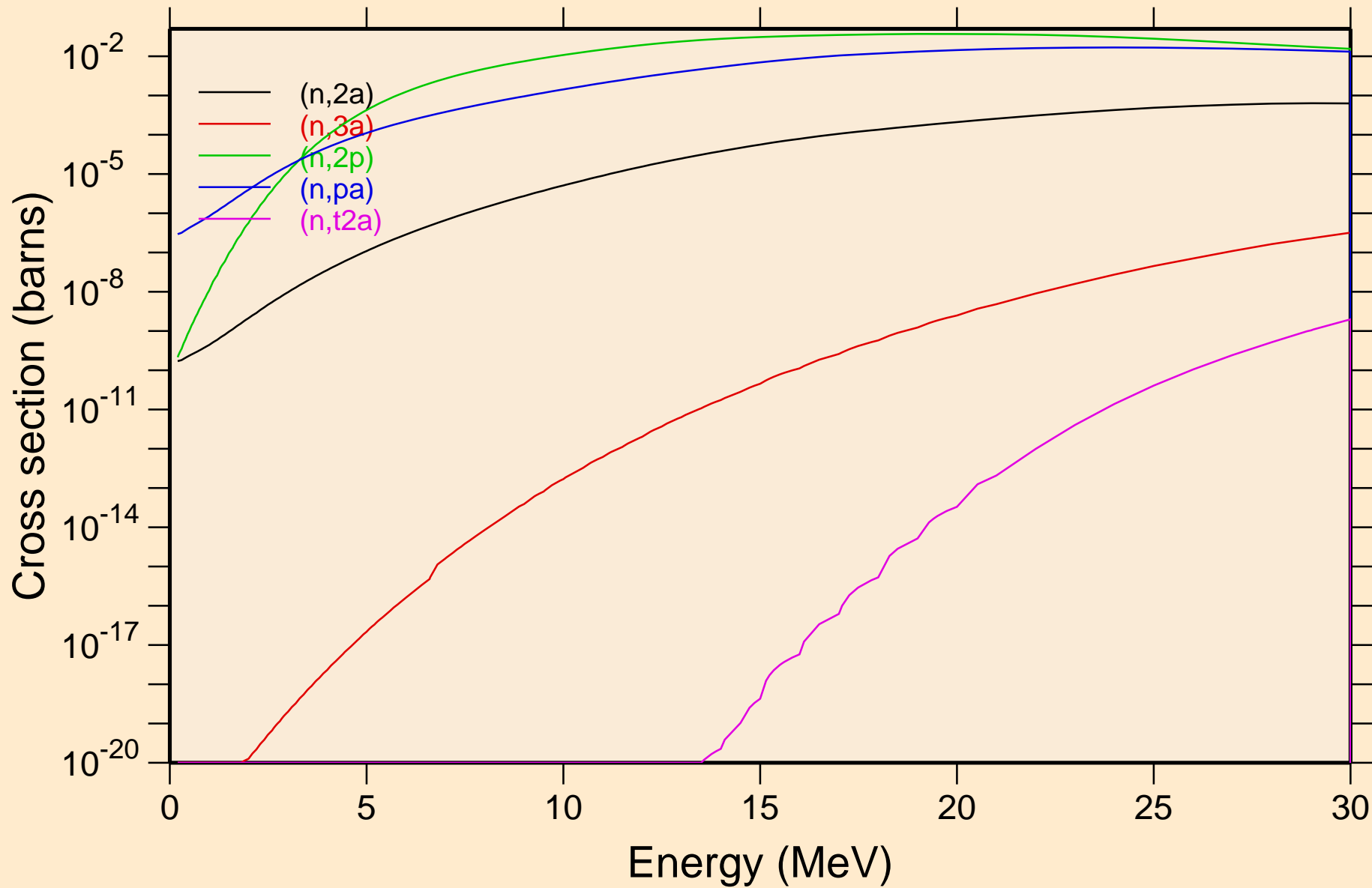

TA164 NEUTRON ACER TENDL-2024 LIBRARY; T=0.K
Non-threshold reactions

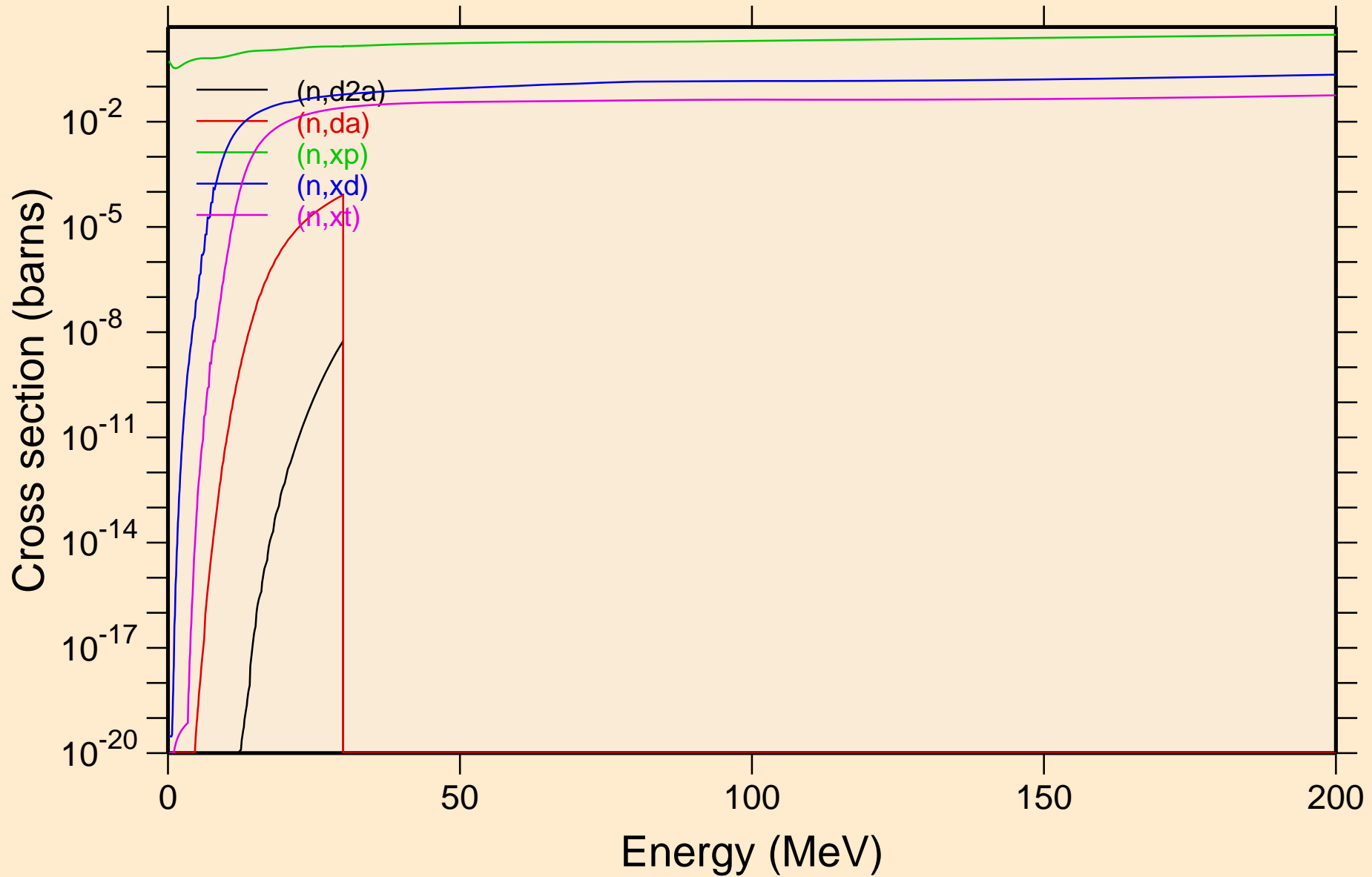

TA164 NEUTRON ACER TENDL-2024 LIBRARY; T=0.K
Non-threshold reactions

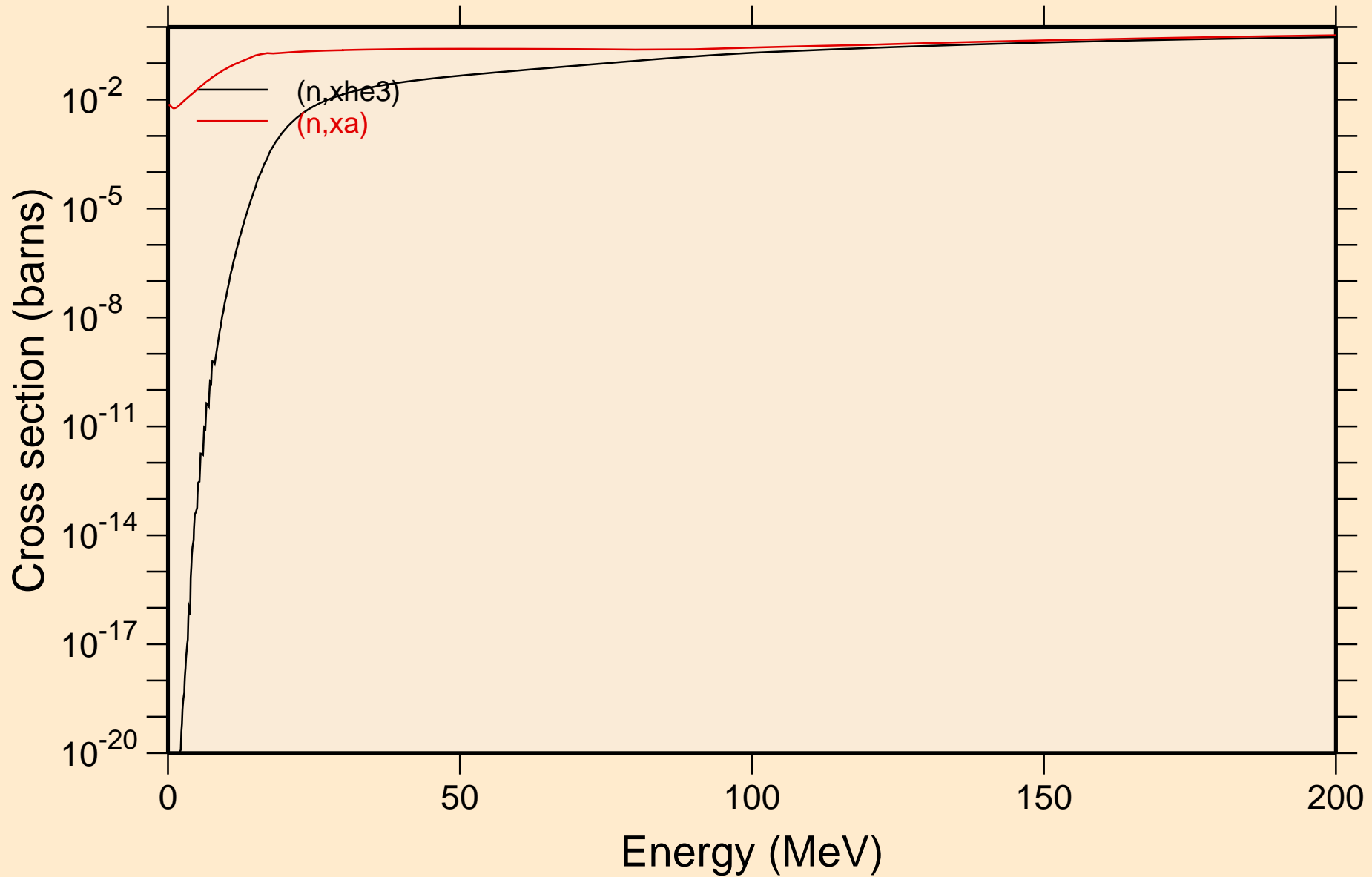

TA164 NEUTRON ACER TENDL-2024 LIBRARY; T=0.K
Inelastic levels

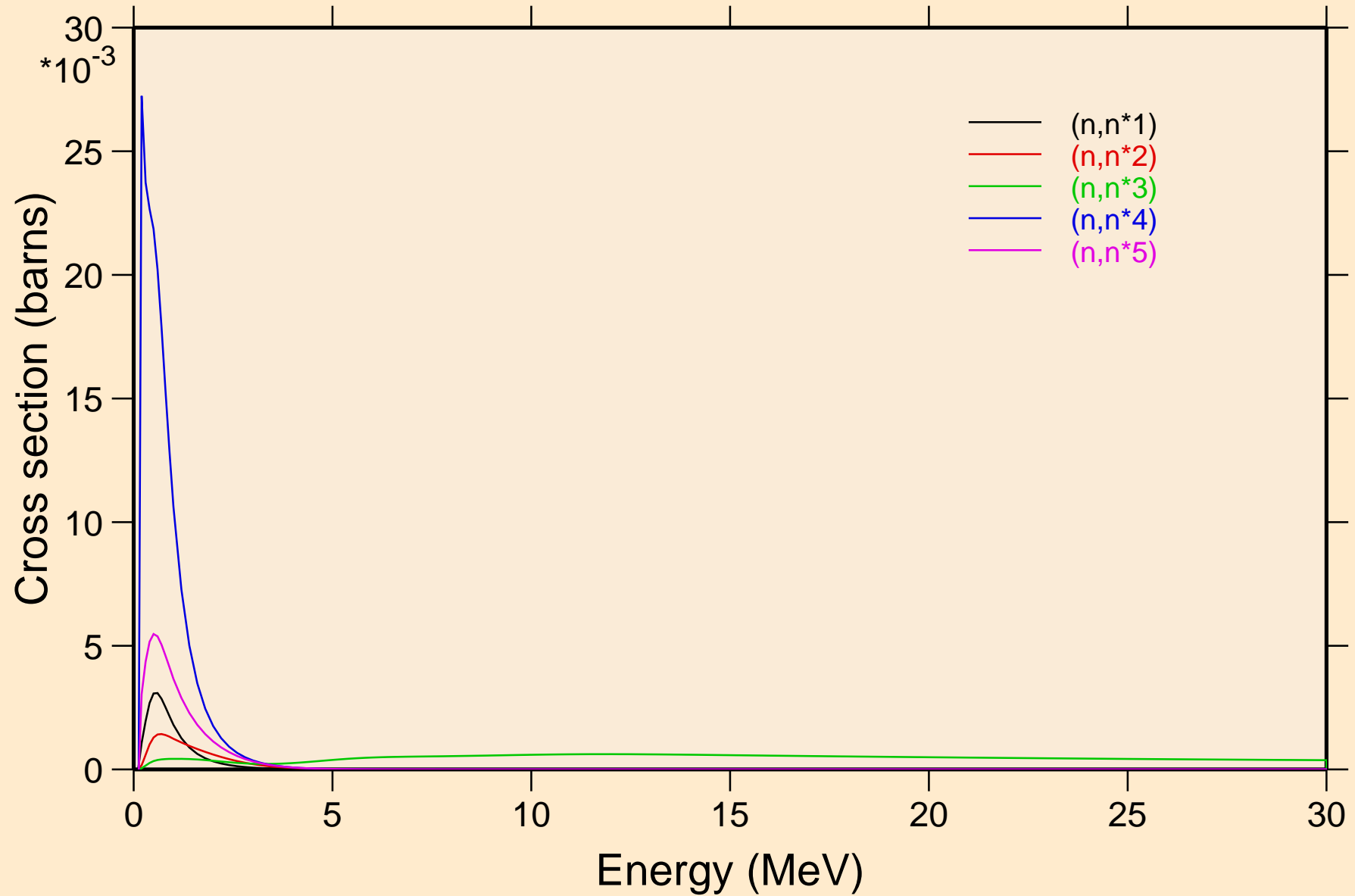

TA164 NEUTRON ACER TENDL-2024 LIBRARY; T=0.K
Inelastic levels

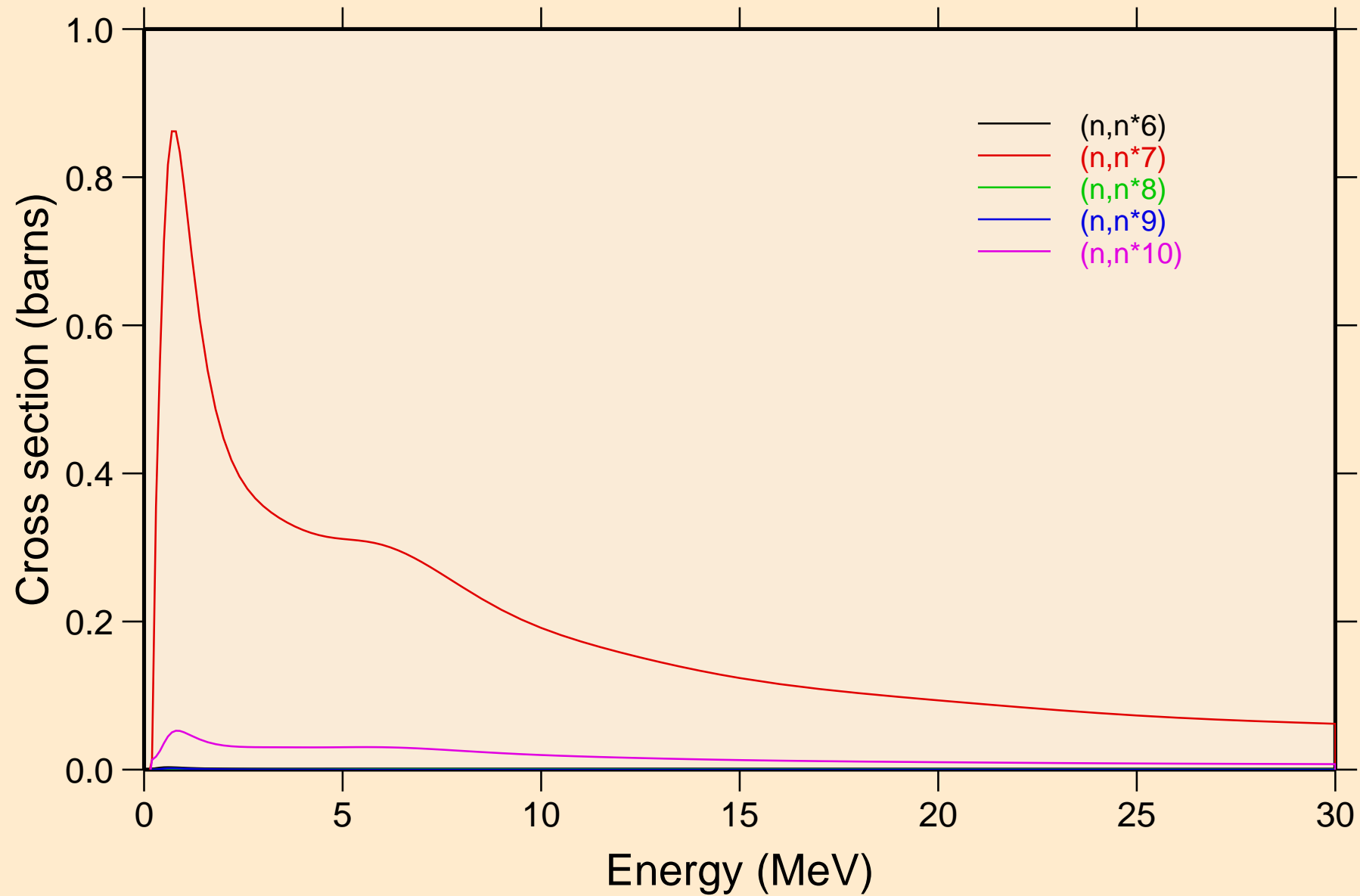

TA164 NEUTRON ACER TENDL-2024 LIBRARY; T=0.K
Inelastic levels

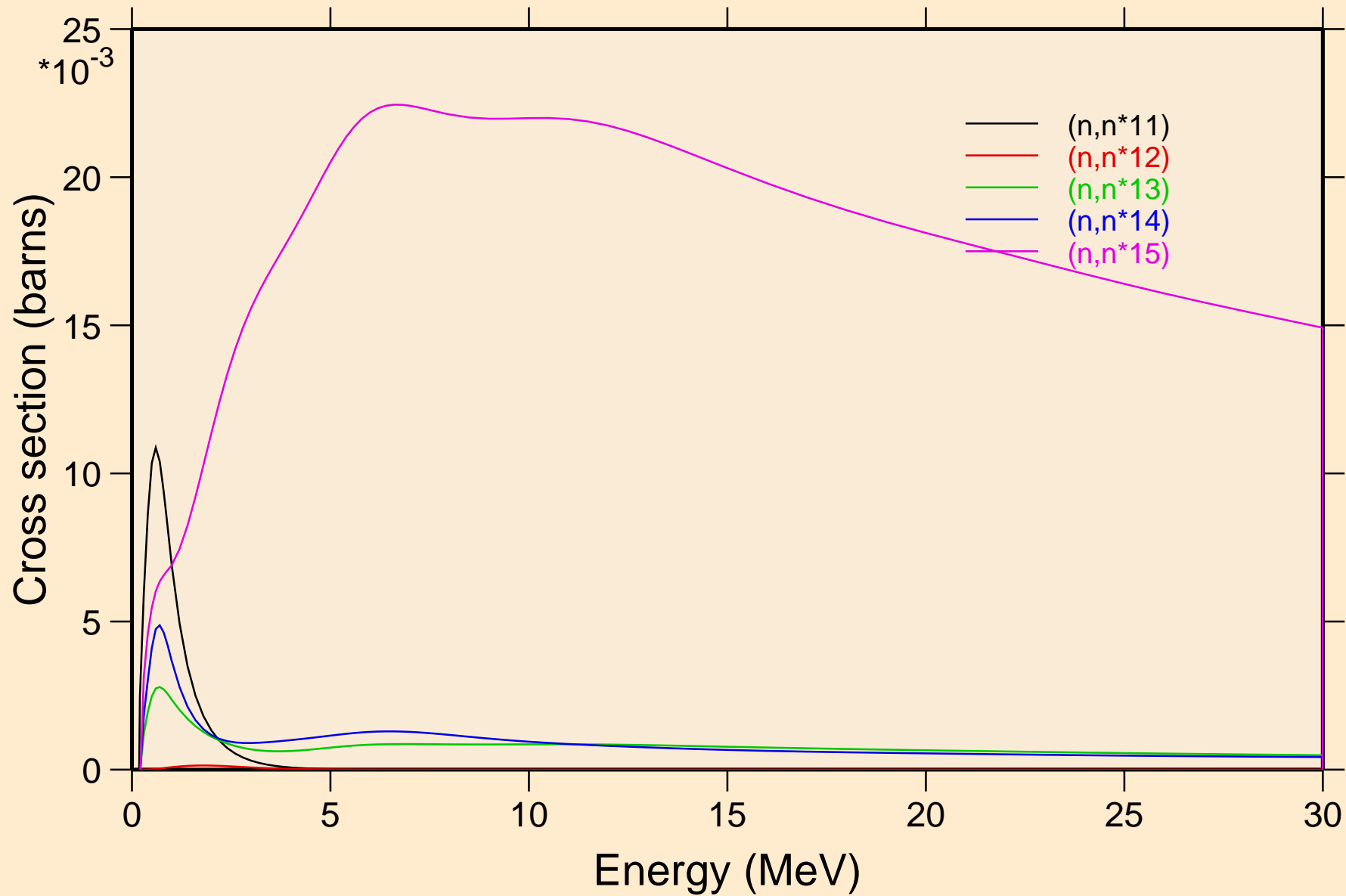

TA164 NEUTRON ACER TENDL-2024 LIBRARY; T=0.K
Inelastic levels

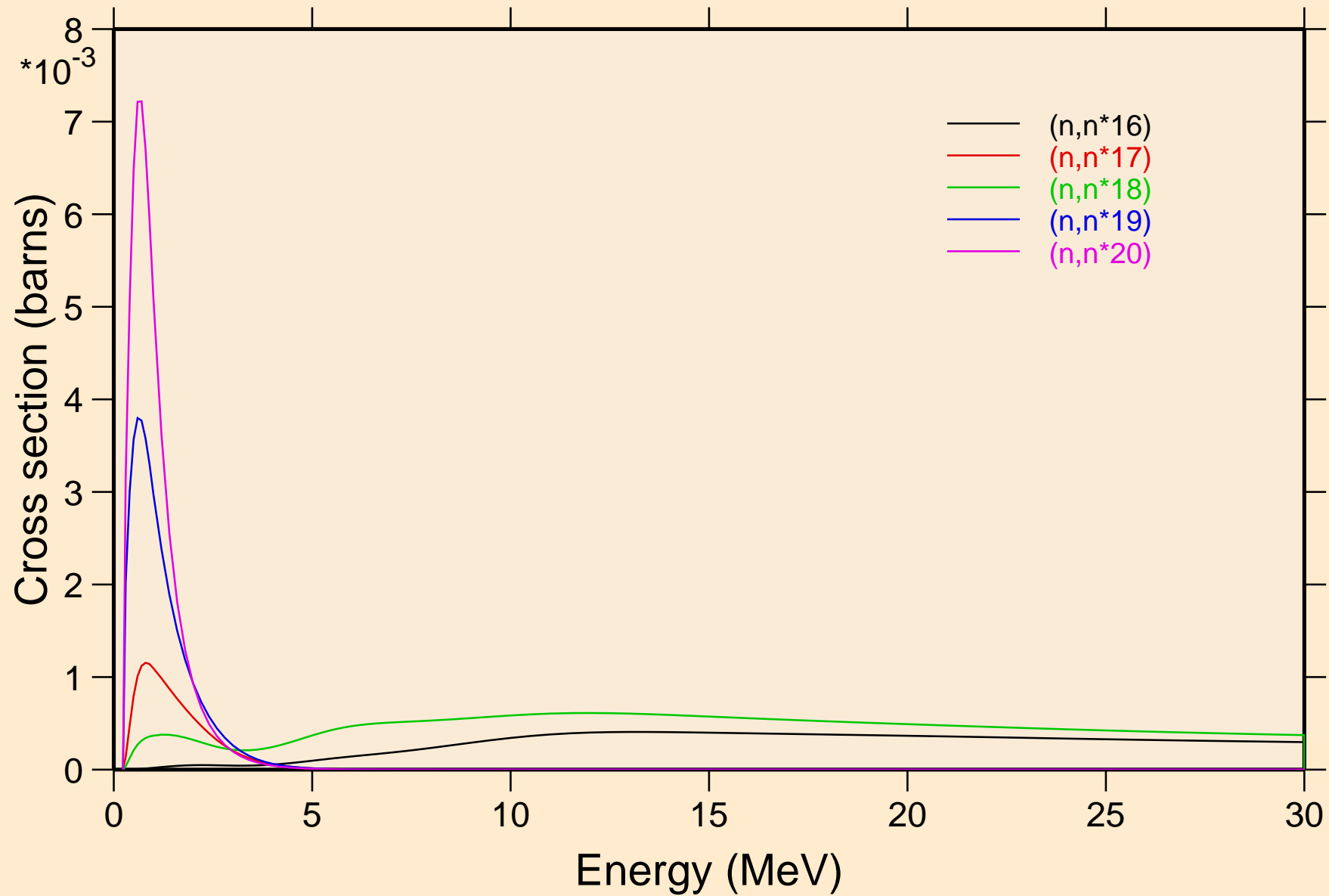

TA164 NEUTRON ACER TENDL-2024 LIBRARY; T=0.K
Inelastic levels

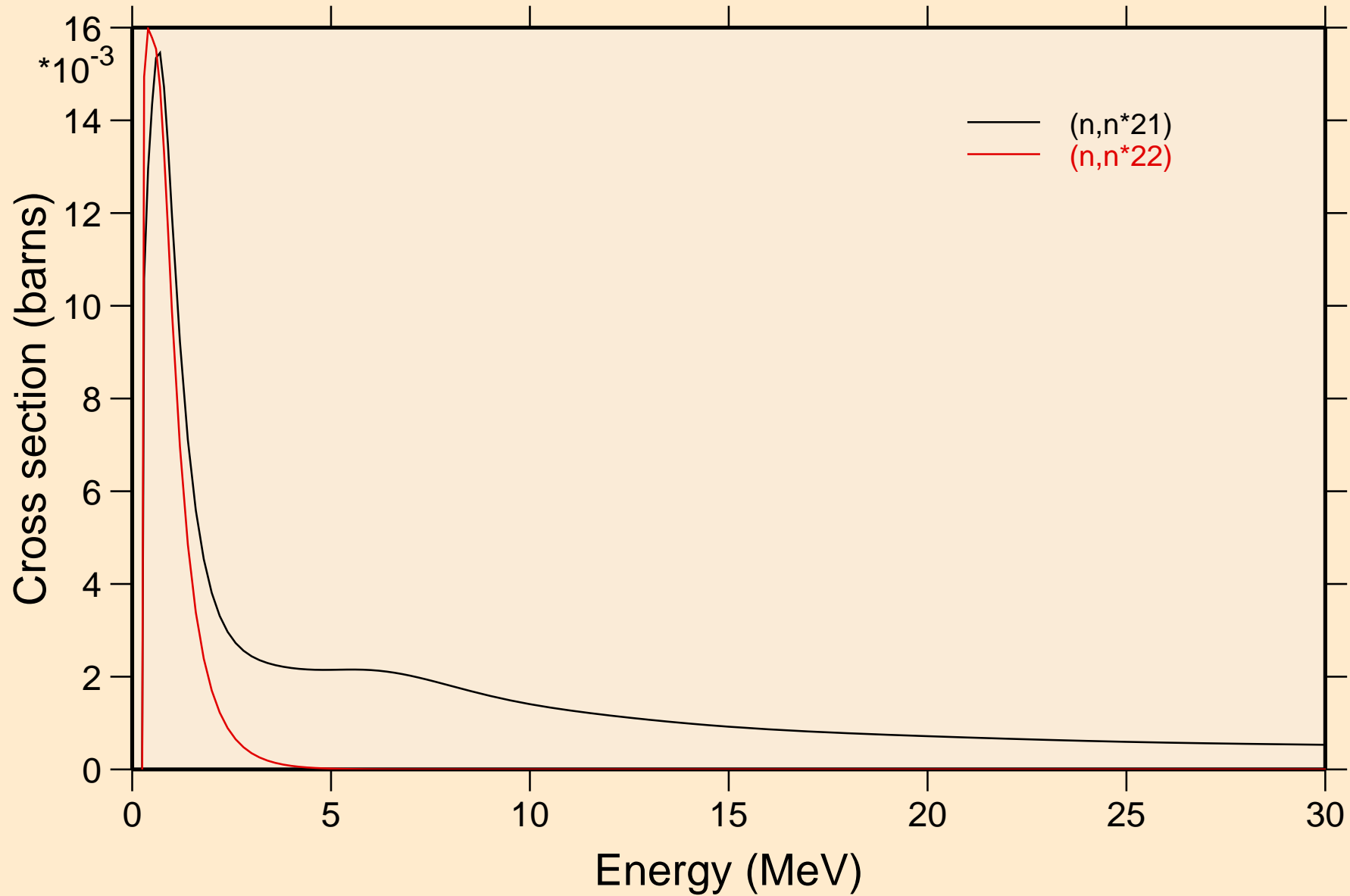

TA164 NEUTRON ACER TENDL-2024 LIBRARY; T=0.K
Threshold reactions

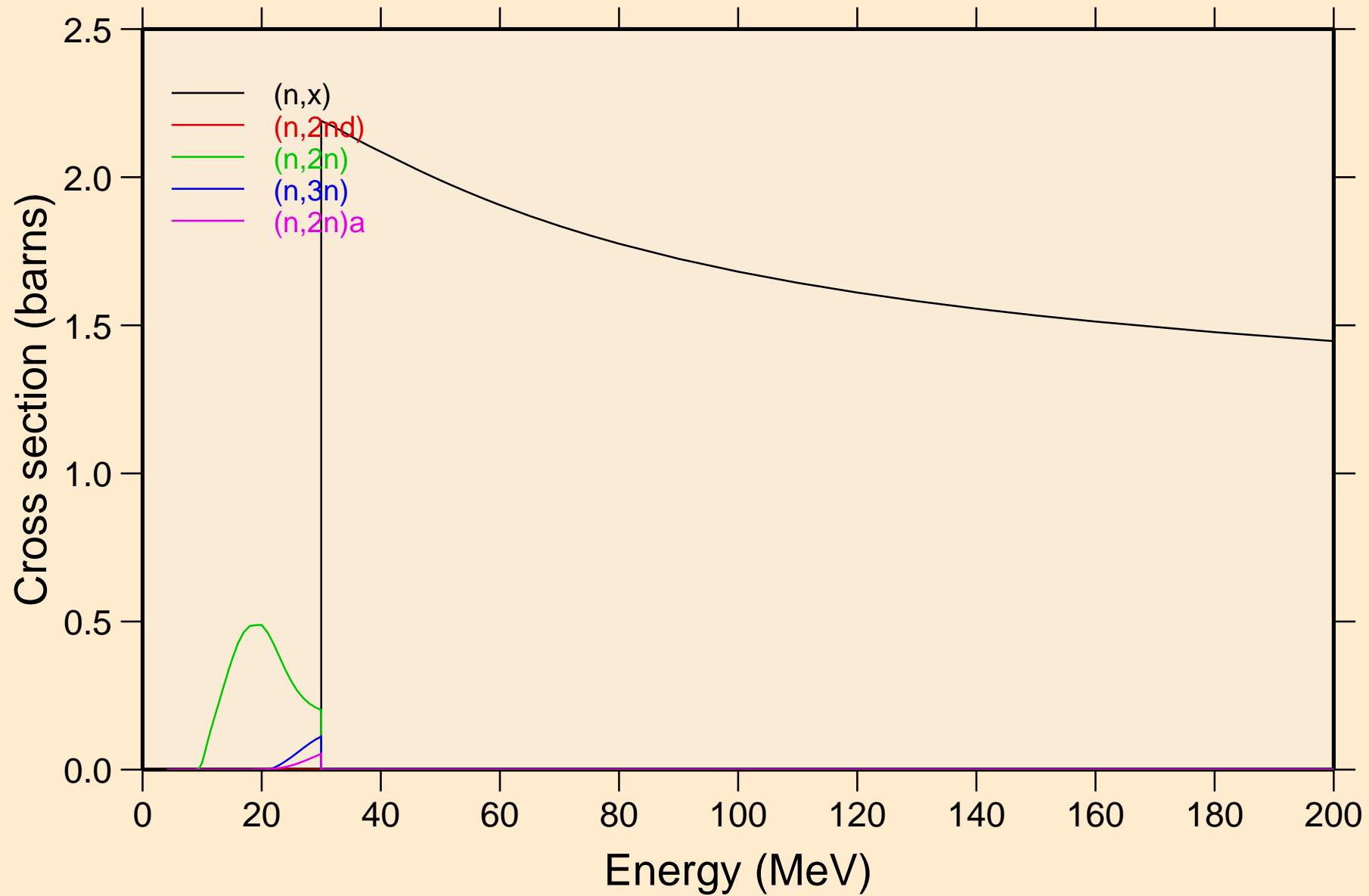

TA164 NEUTRON ACER TENDL-2024 LIBRARY; T=0.K
Threshold reactions

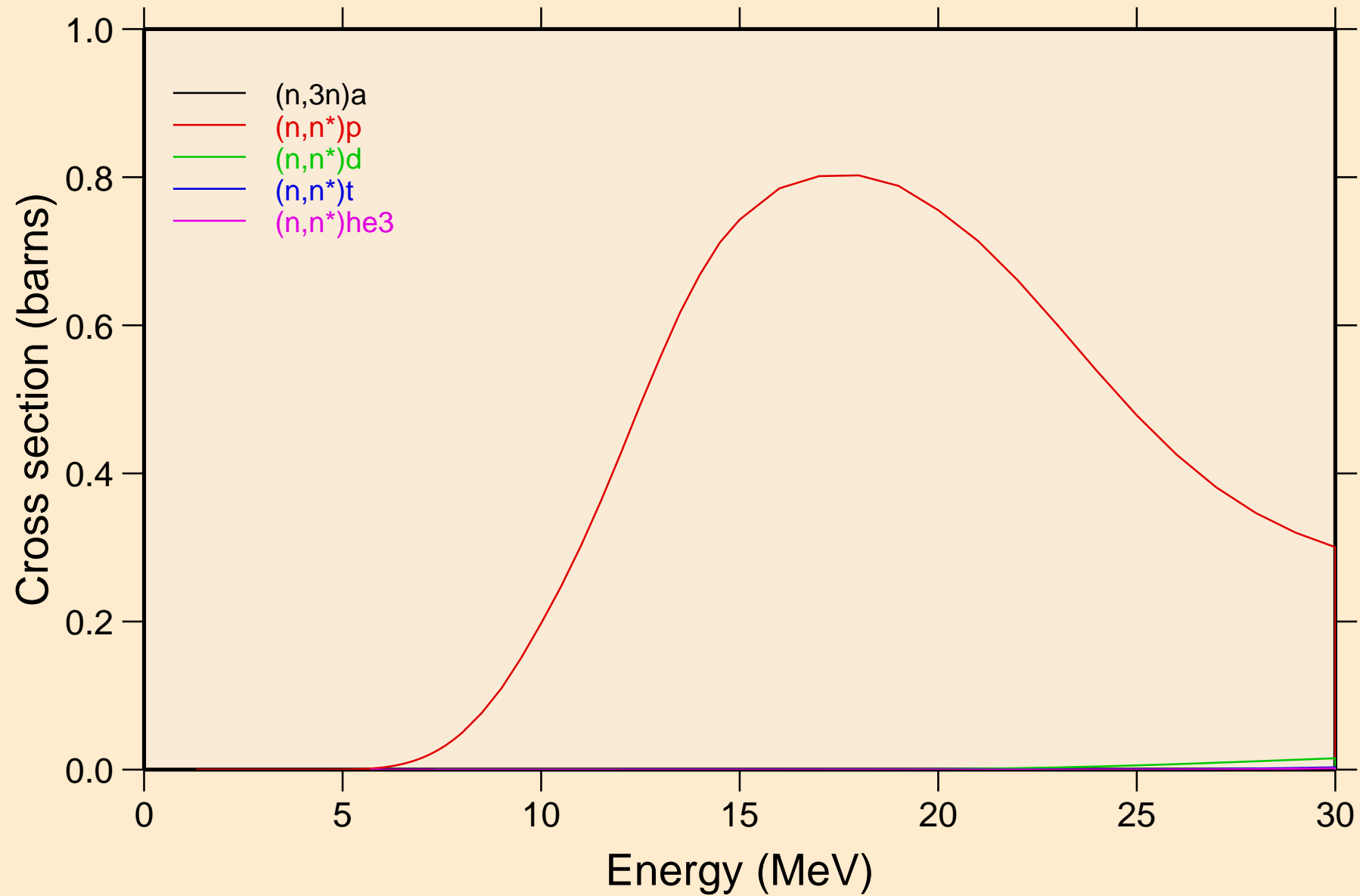

TA164 NEUTRON ACER TENDL-2024 LIBRARY; T=0.K
Threshold reactions

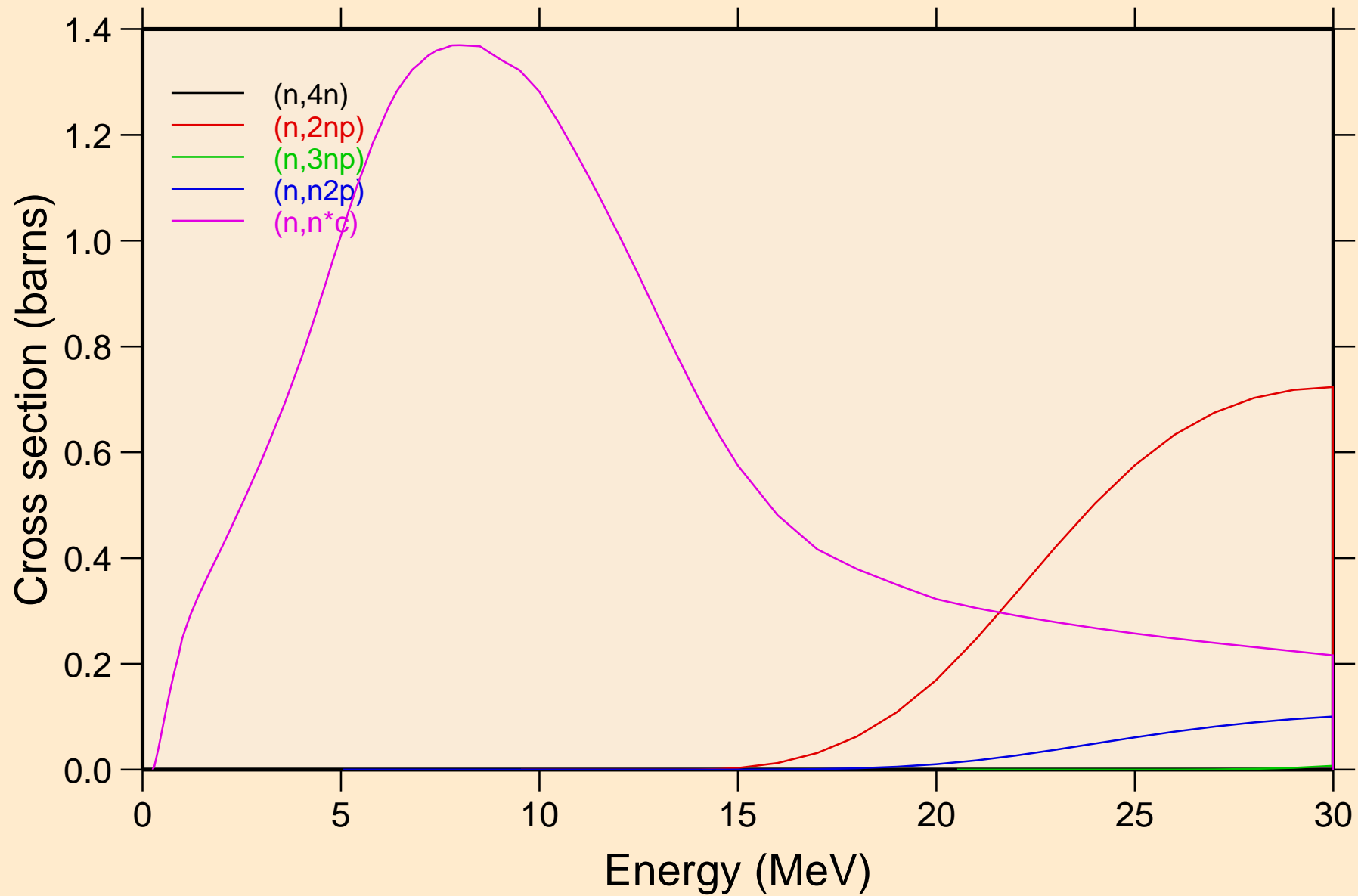

TA164 NEUTRON ACER TENDL-2024 LIBRARY; T=0.K
Threshold reactions

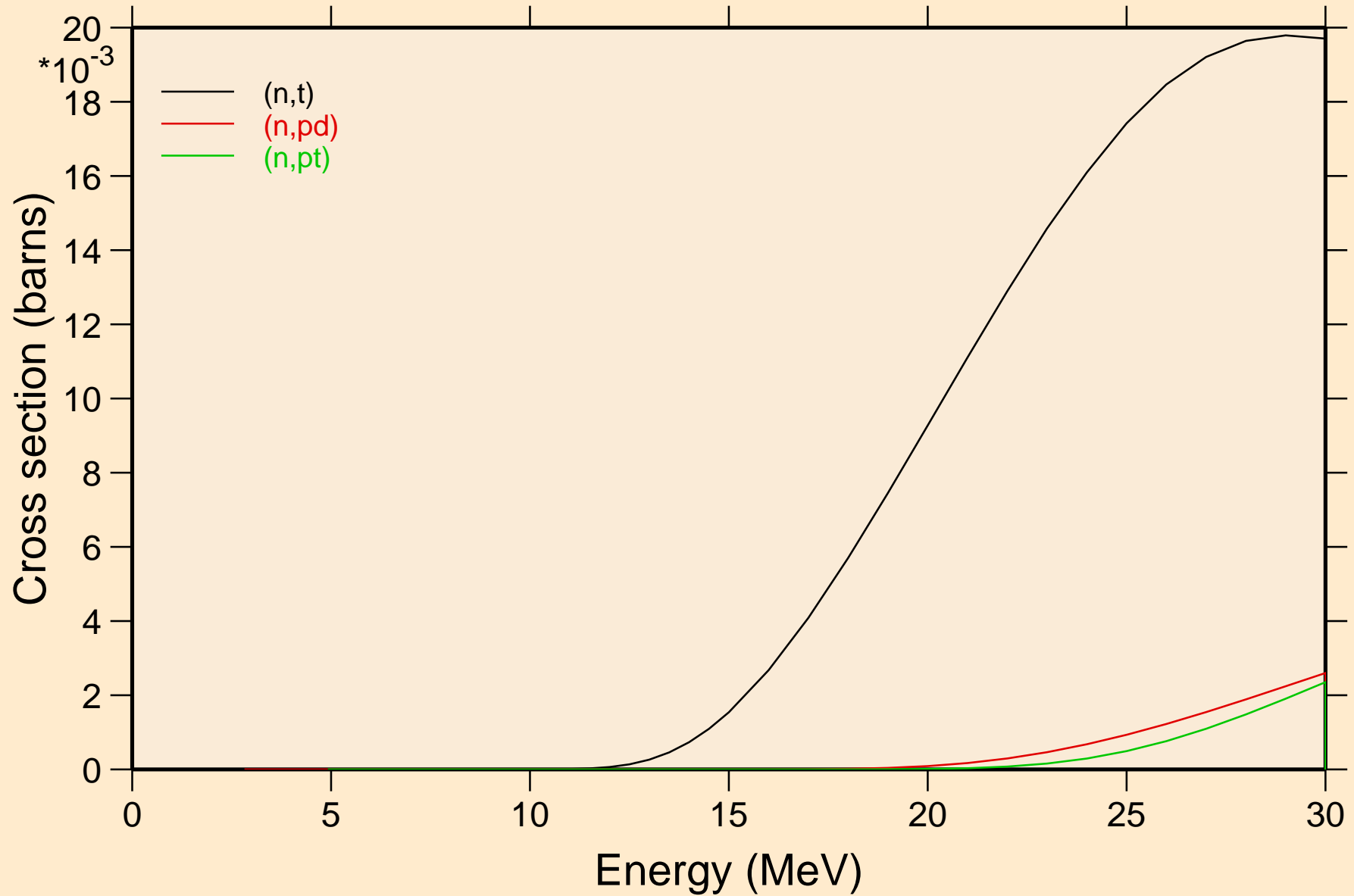

TA164 NEUTRON ACER TENDL-2024 LIBRARY; T=0.K
angular distribution for elastic

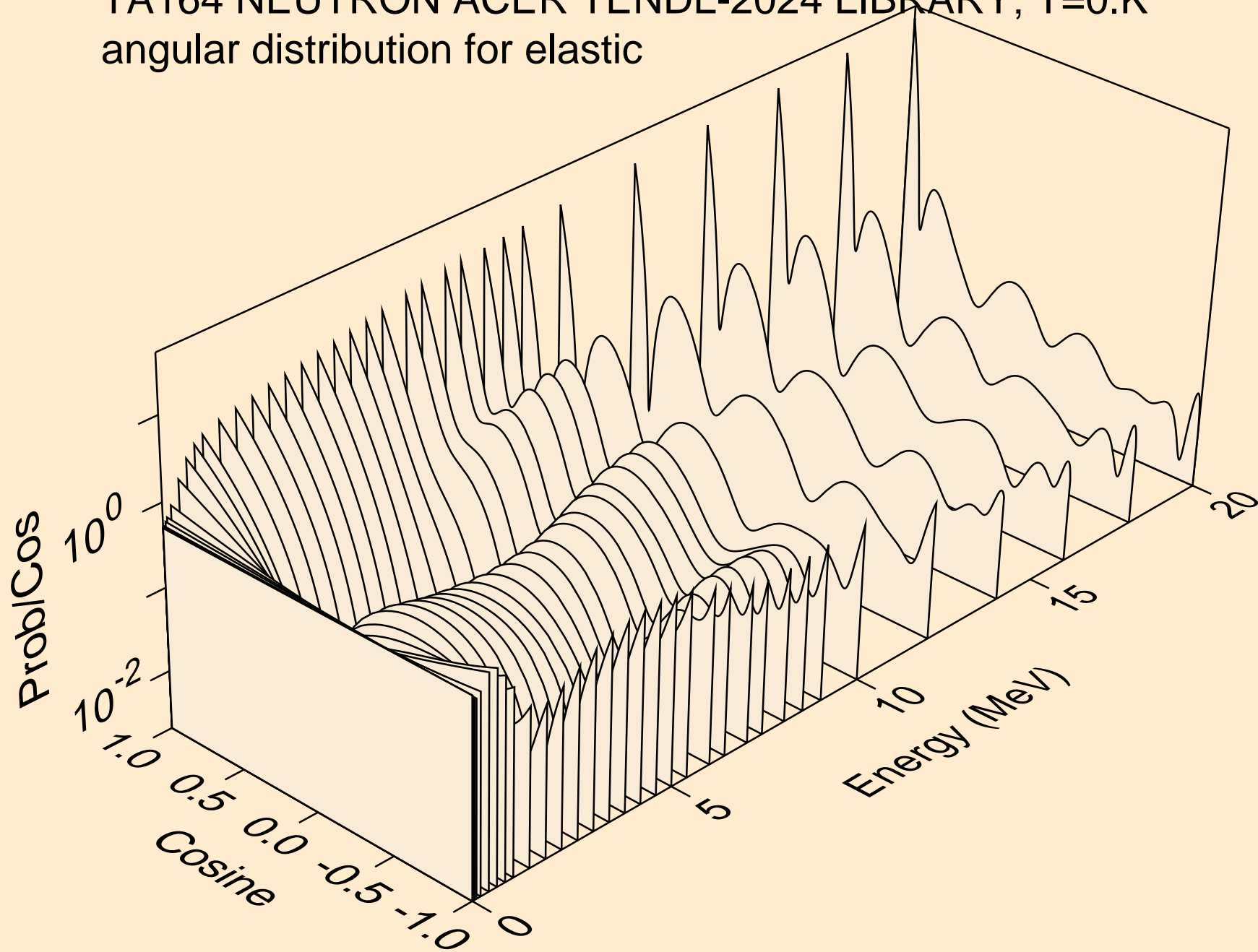

TA164 NEUTRON ACER TENDL-2024 LIBRARY; T=0.K
angular distribution for elastic

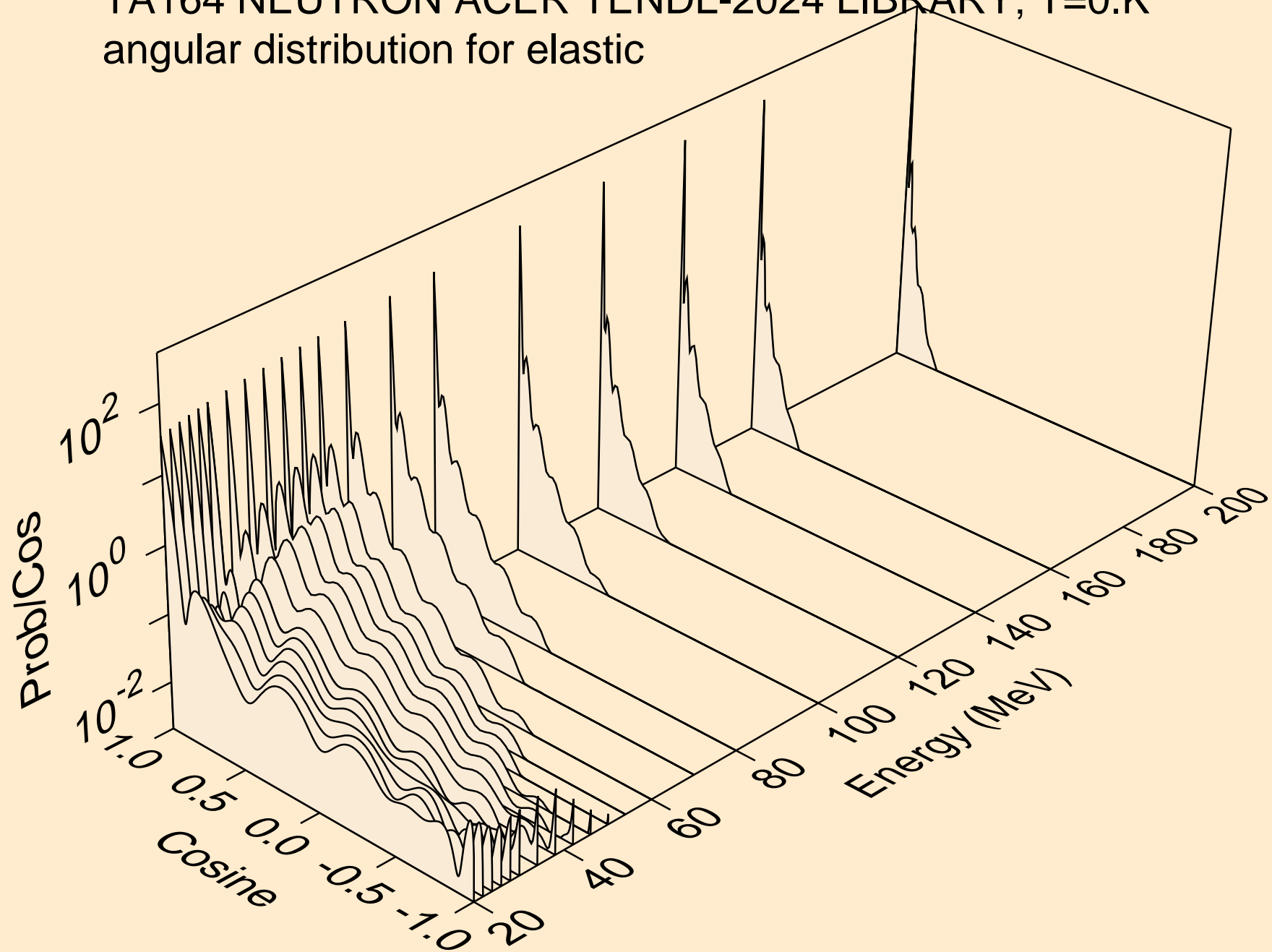

TA164 NEUTRON ACER TENDL-2024 LIBRARY; T=0.K
angular distribution for (n,n*1)

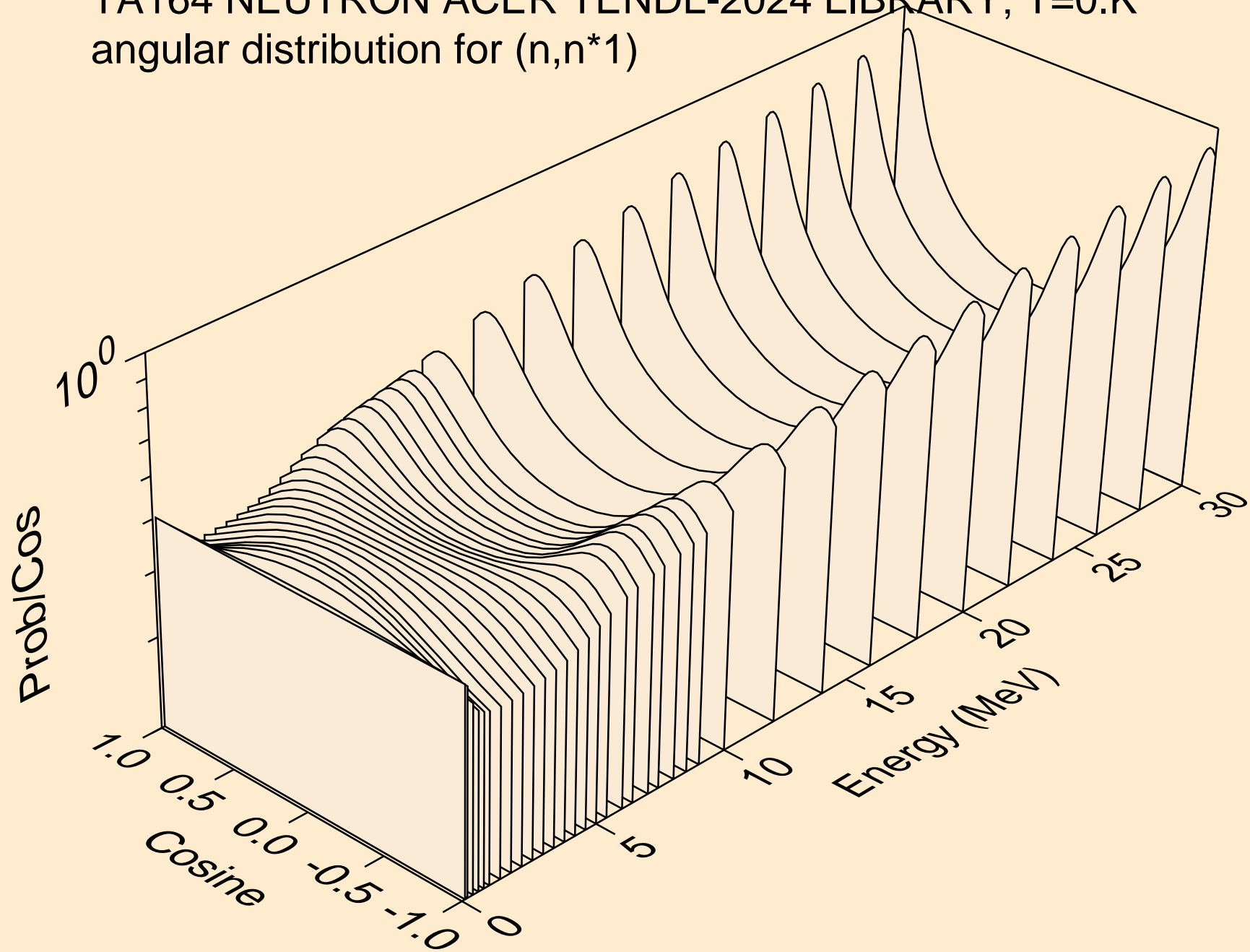

TA164 NEUTRON ACER TENDL-2024 LIBRARY; T=0.K
angular distribution for (n,n*2)

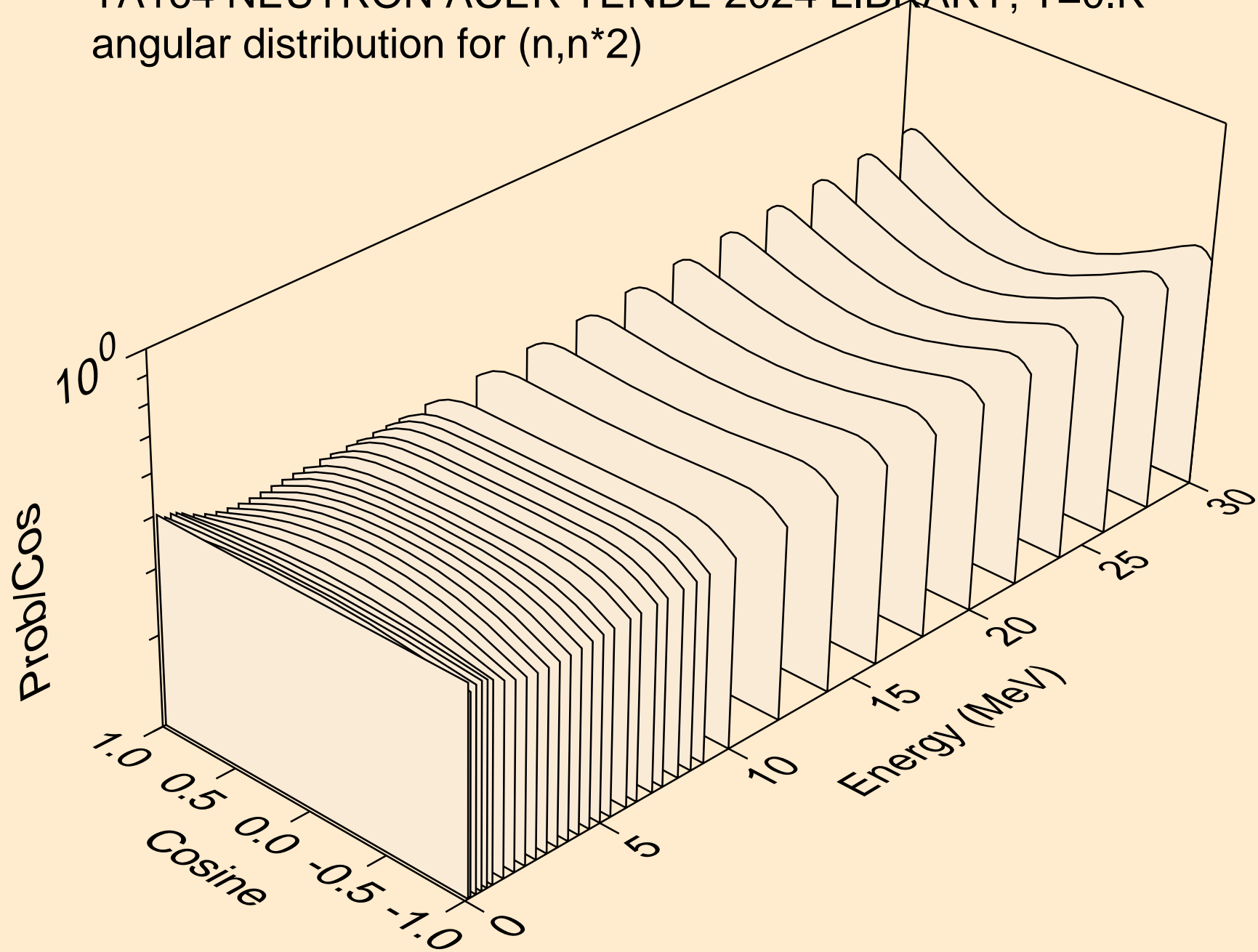

TA164 NEUTRON ACER TENDL-2024 LIBRARY; T=0.K
angular distribution for (n,n*3)

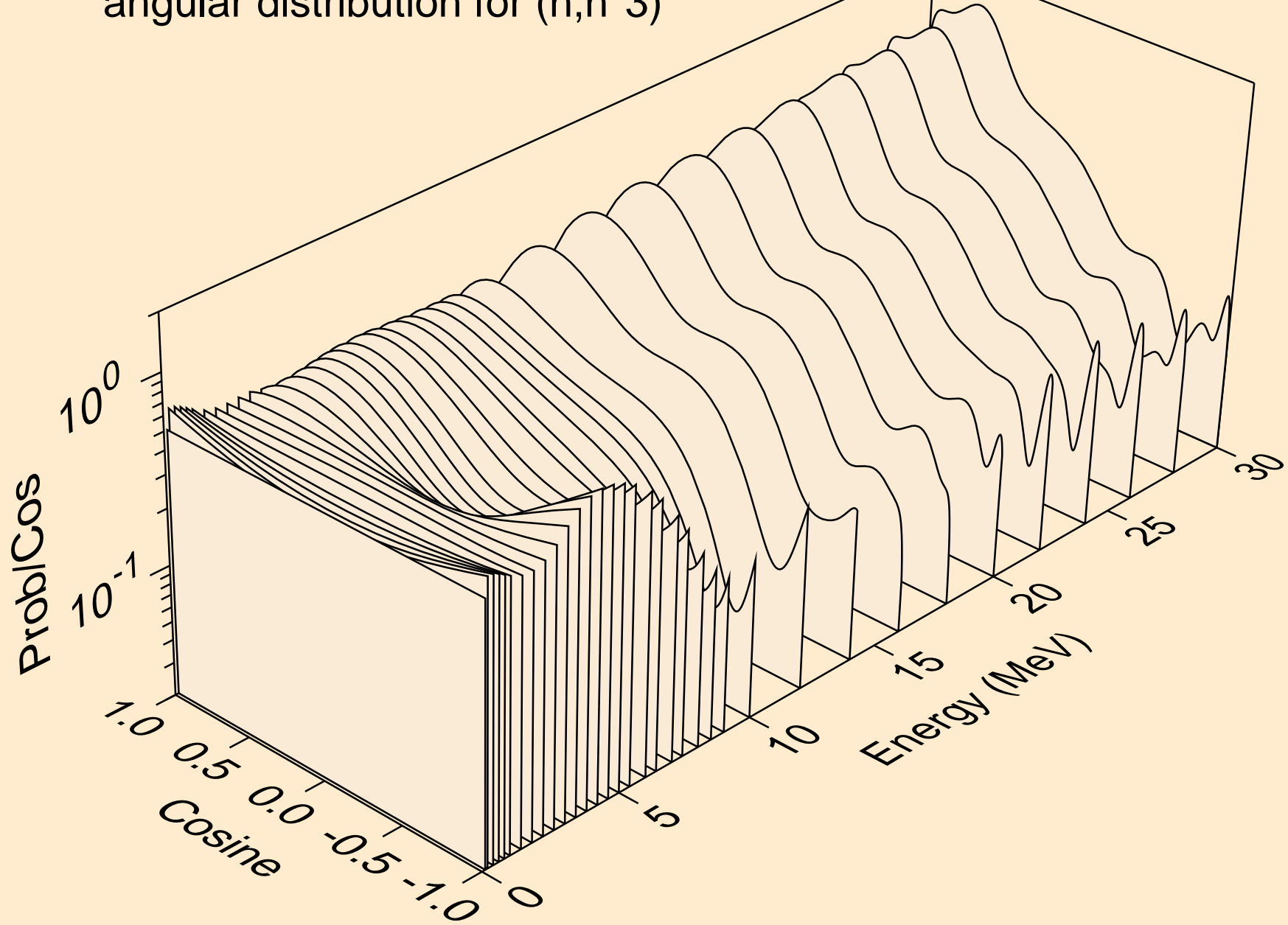

TA164 NEUTRON ACER TENDL-2024 LIBRARY; T=0.K
angular distribution for (n,n*4)

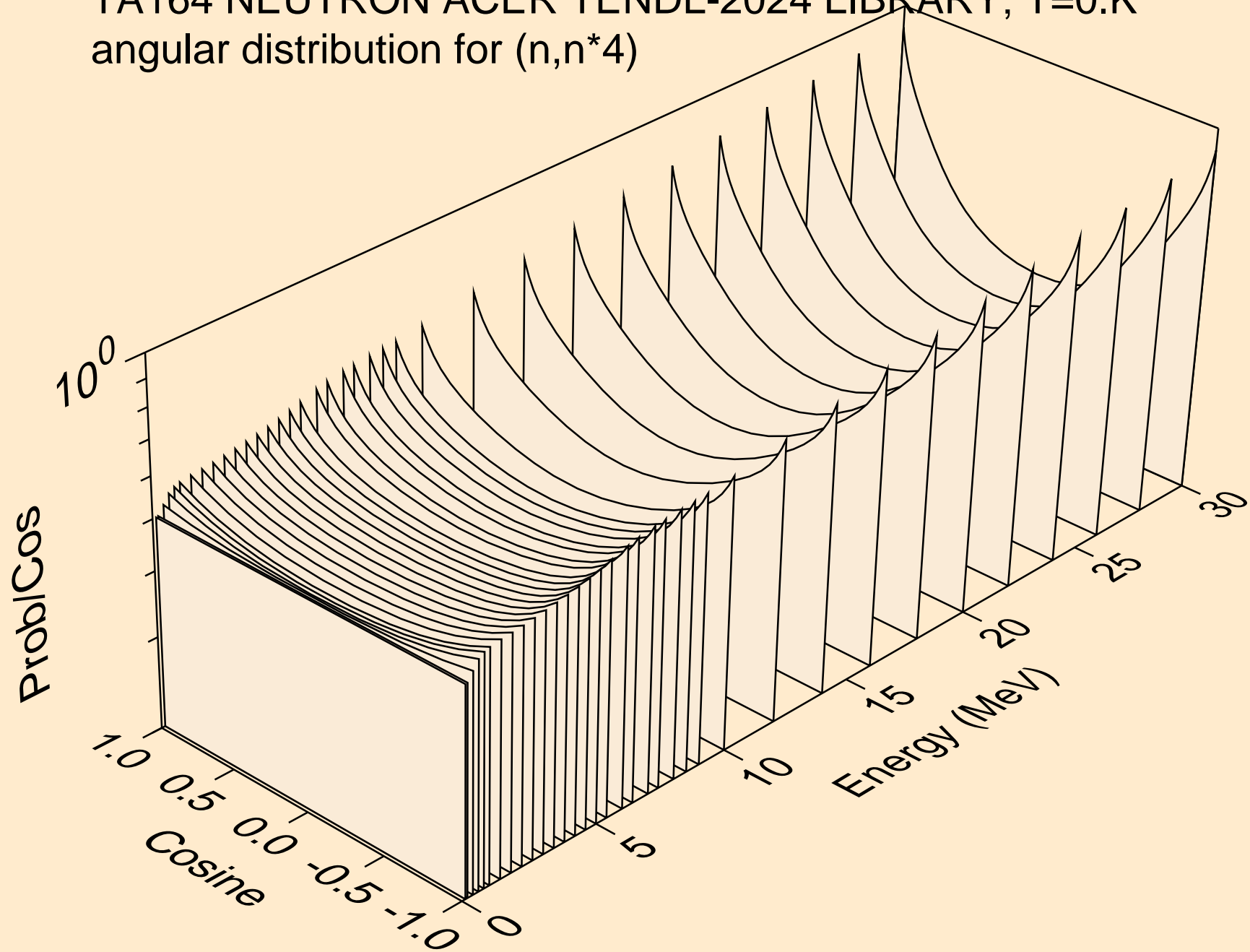

TA164 NEUTRON ACER TENDL-2024 LIBRARY; T=0.K
angular distribution for (n,n*5)

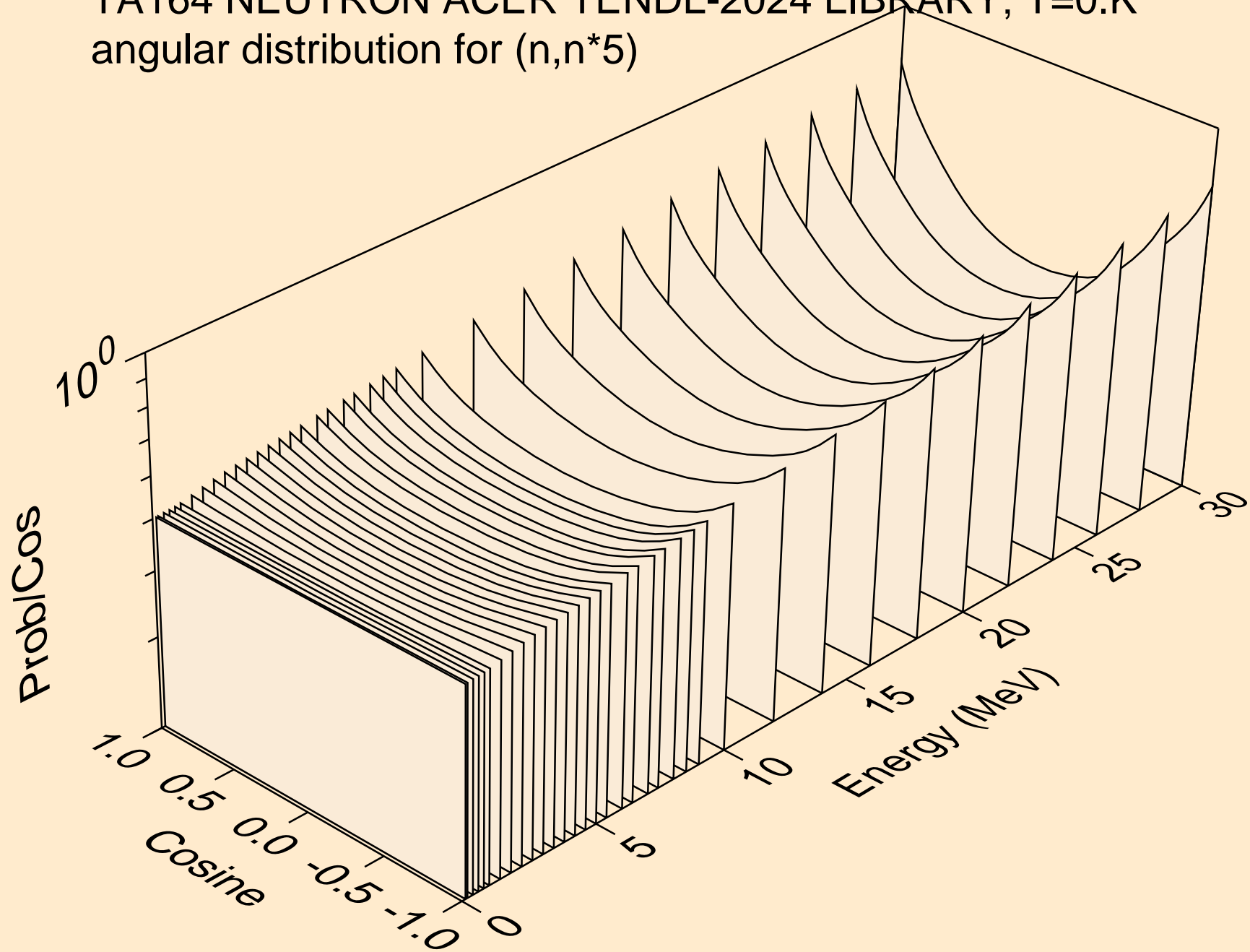

TA164 NEUTRON ACER TENDL-2024 LIBRARY; T=0.K
angular distribution for (n,n*6)

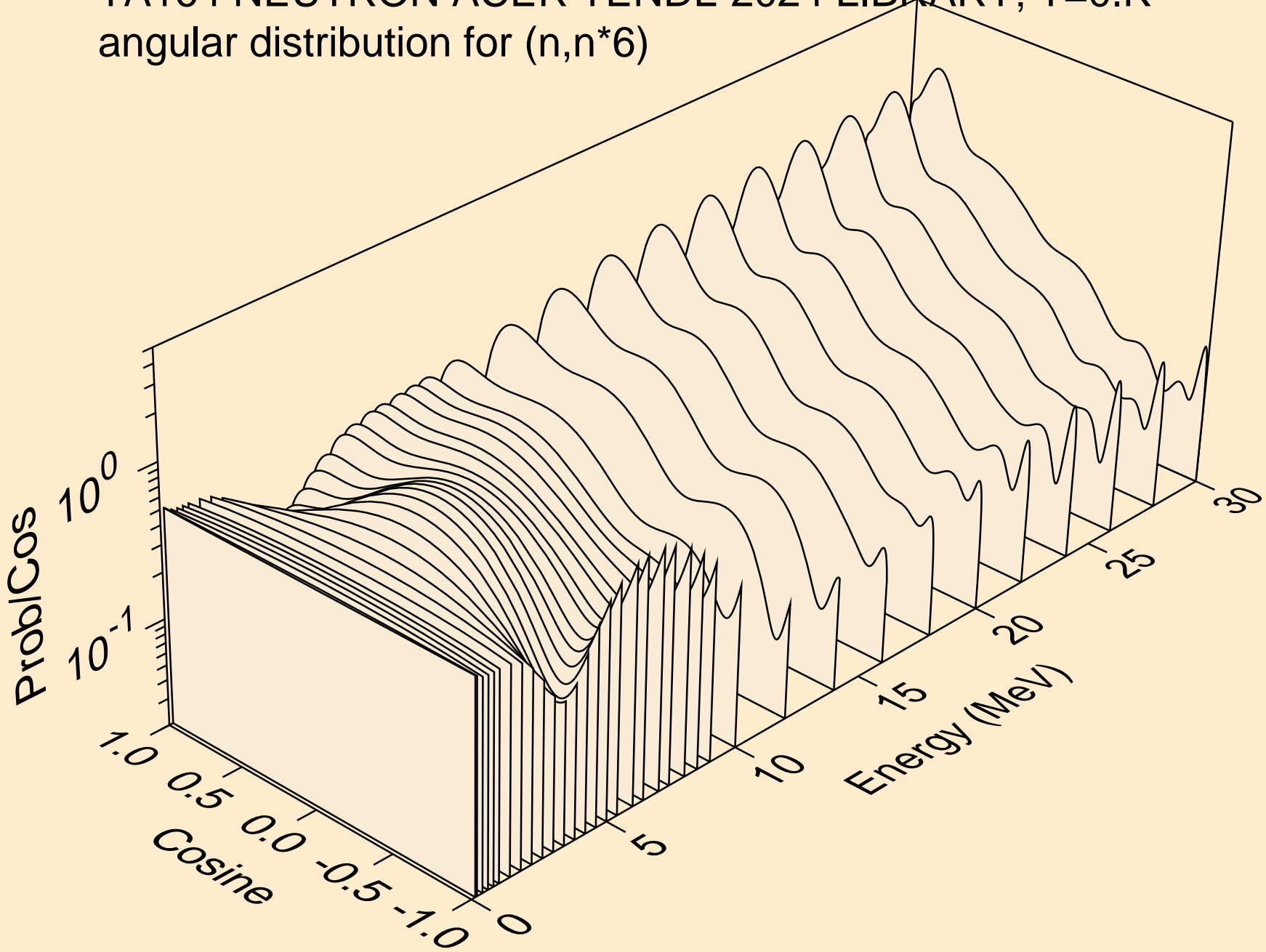

TA164 NEUTRON ACER TENDL-2024 LIBRARY; T=0.K
angular distribution for (n,n*7)

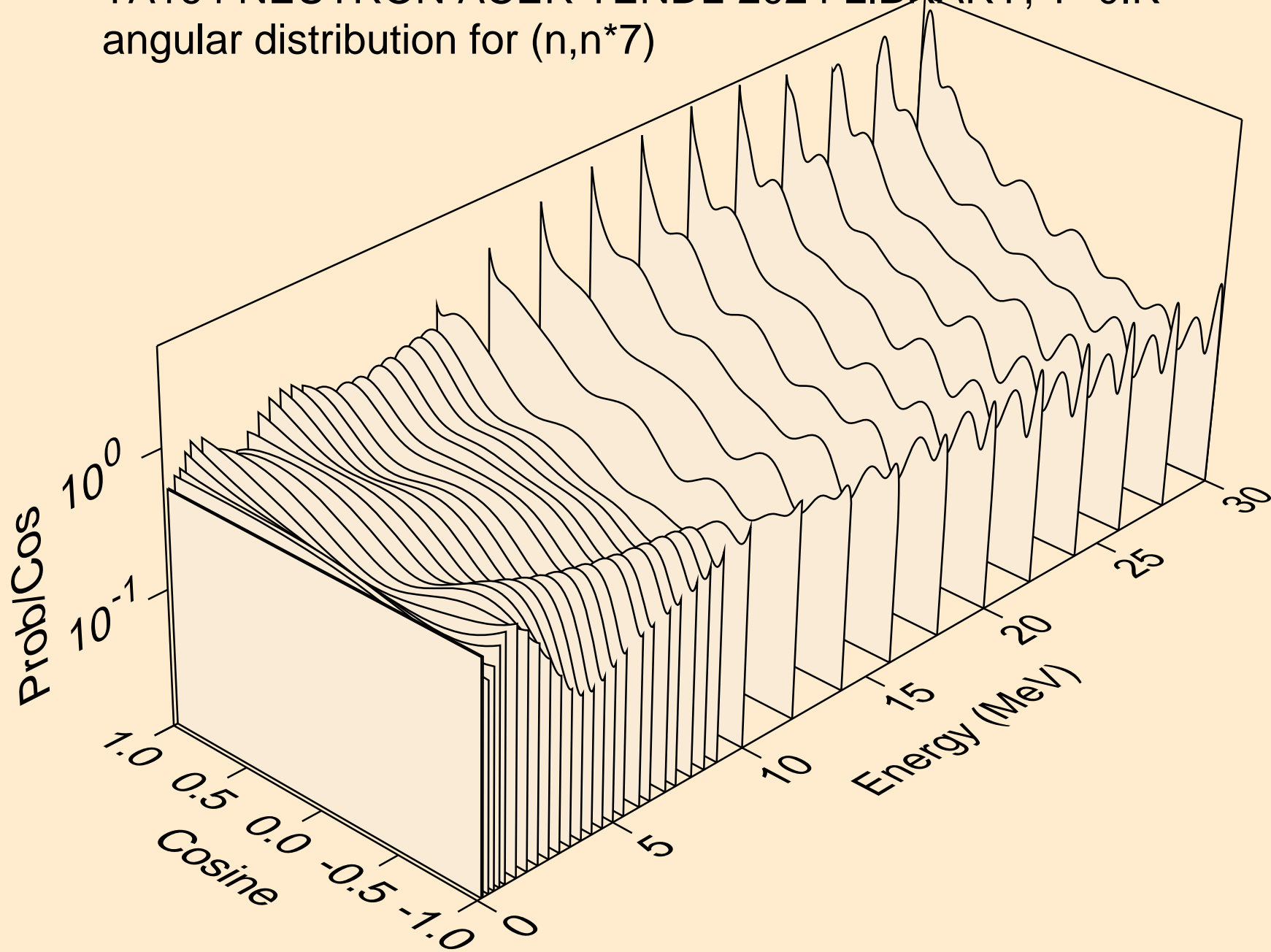

TA164 NEUTRON ACER TENDL-2024 LIBRARY; T=0.K
angular distribution for (n,n*8)

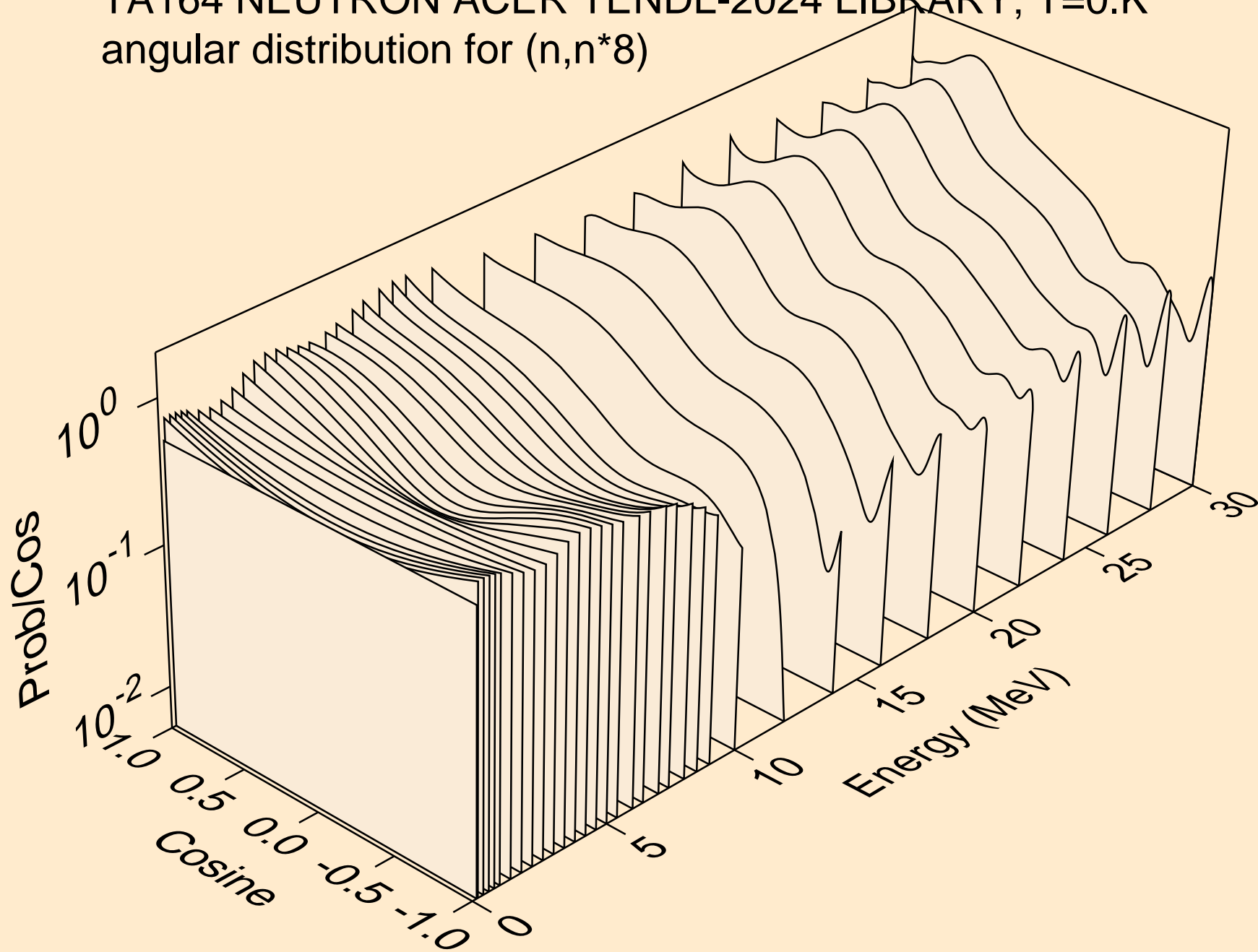

TA164 NEUTRON ACER TENDL-2024 LIBRARY; T=0.K
angular distribution for (n,n*9)

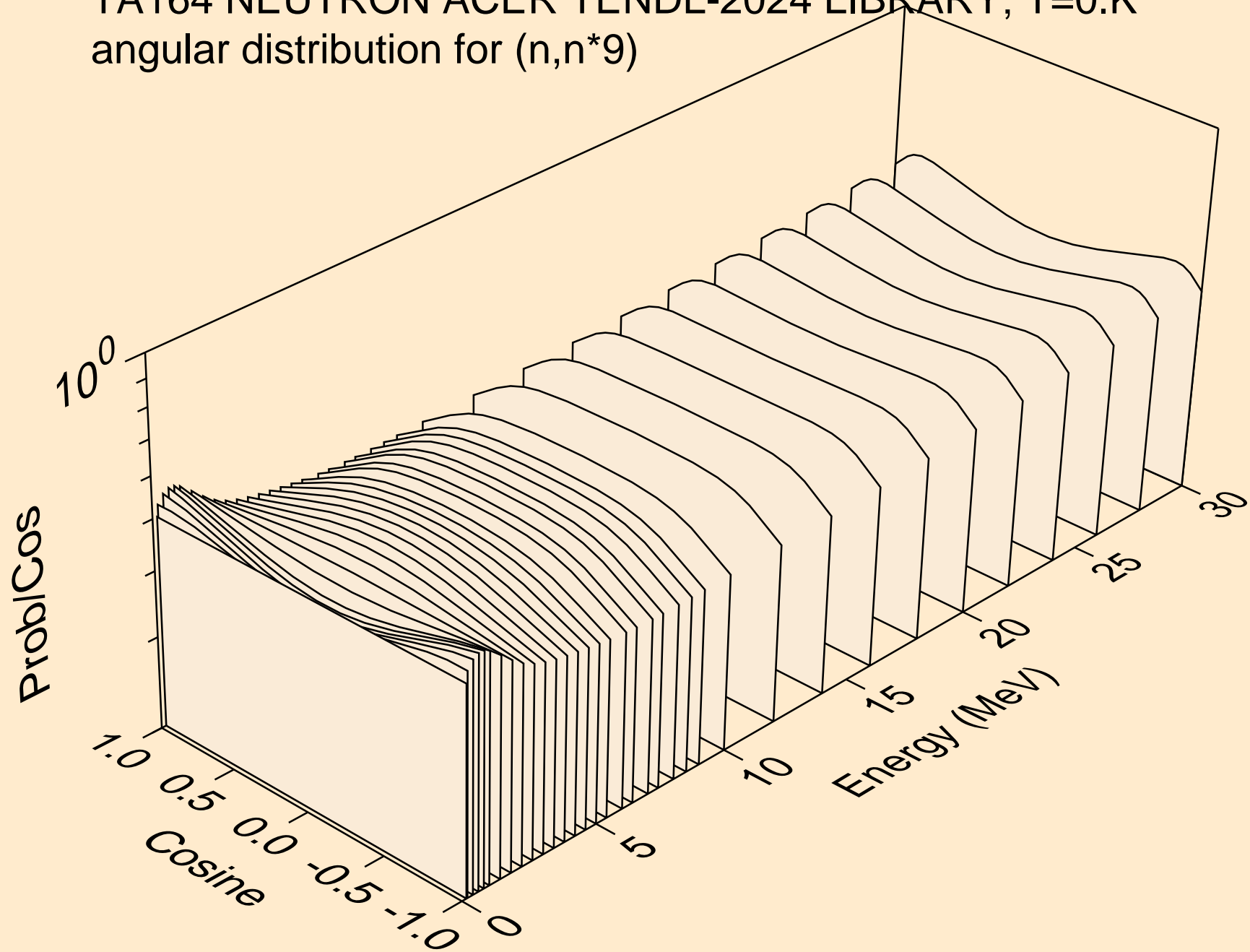

TA164 NEUTRON ACER TENDL-2024 LIBRARY; T=0.K
angular distribution for (n,n*10)

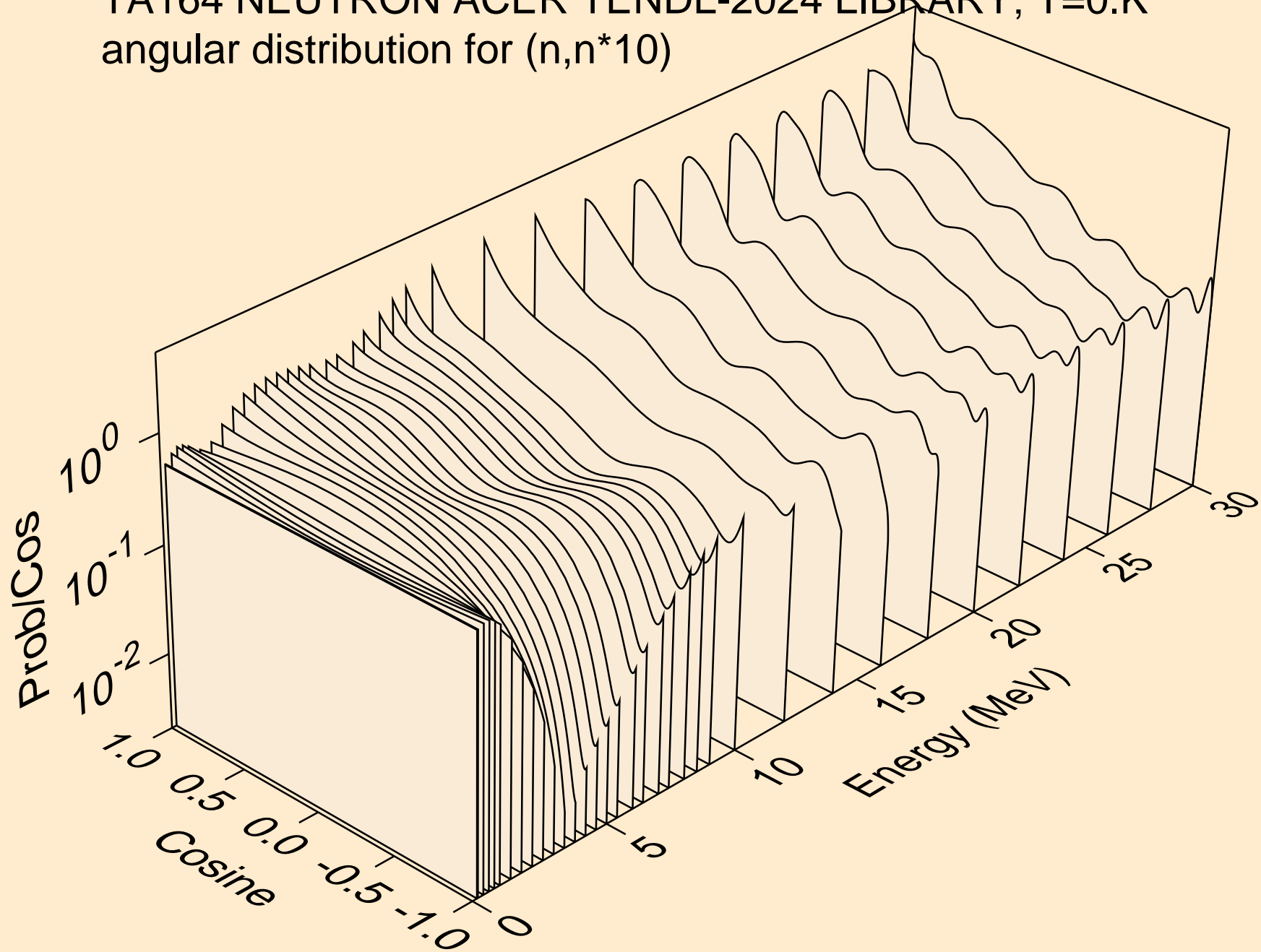

TA164 NEUTRON ACER TENDL-2024 LIBRARY; T=0.K
angular distribution for (n,n*11)

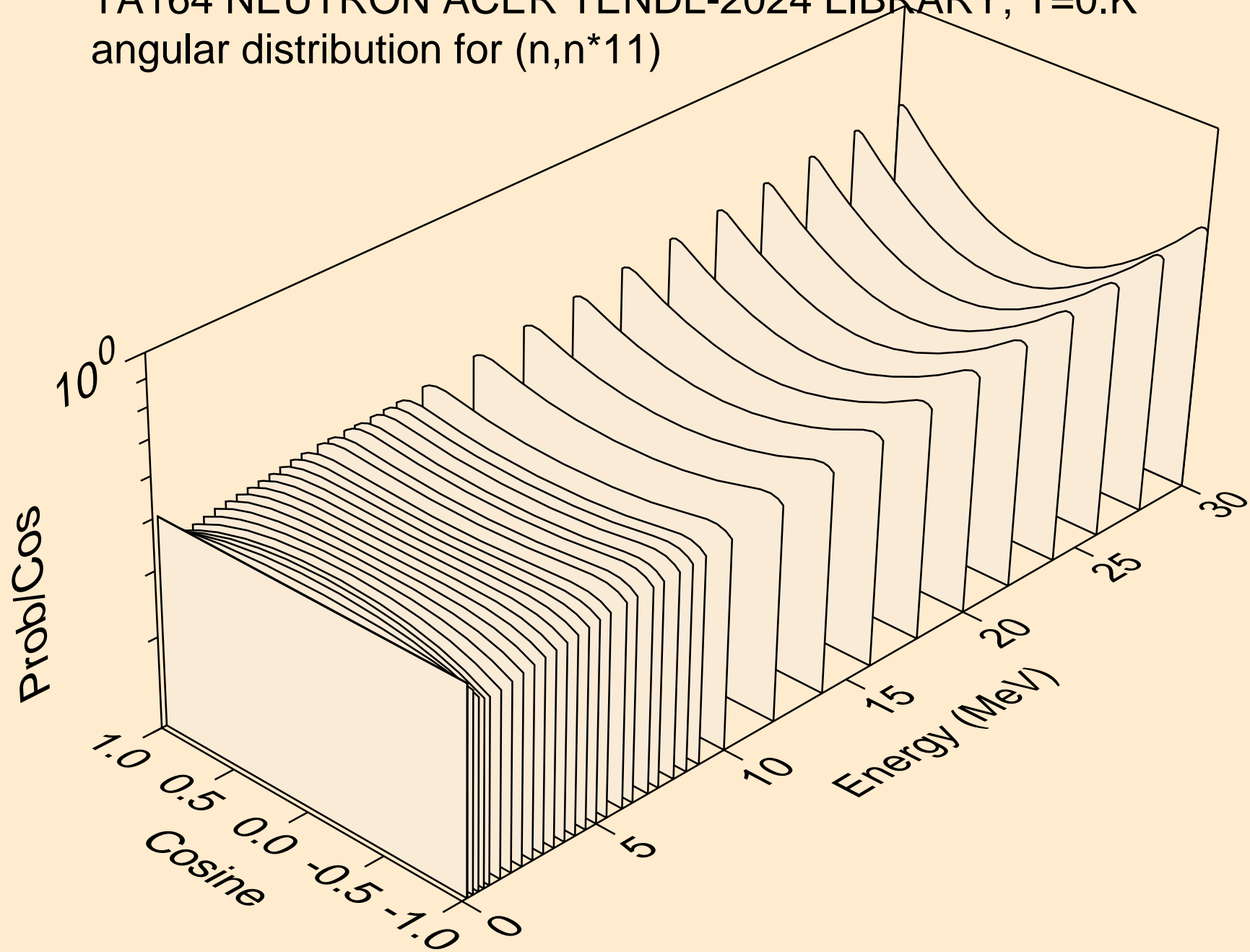

TA164 NEUTRON ACER TENDL-2024 LIBRARY; T=0.K
angular distribution for (n,n*12)

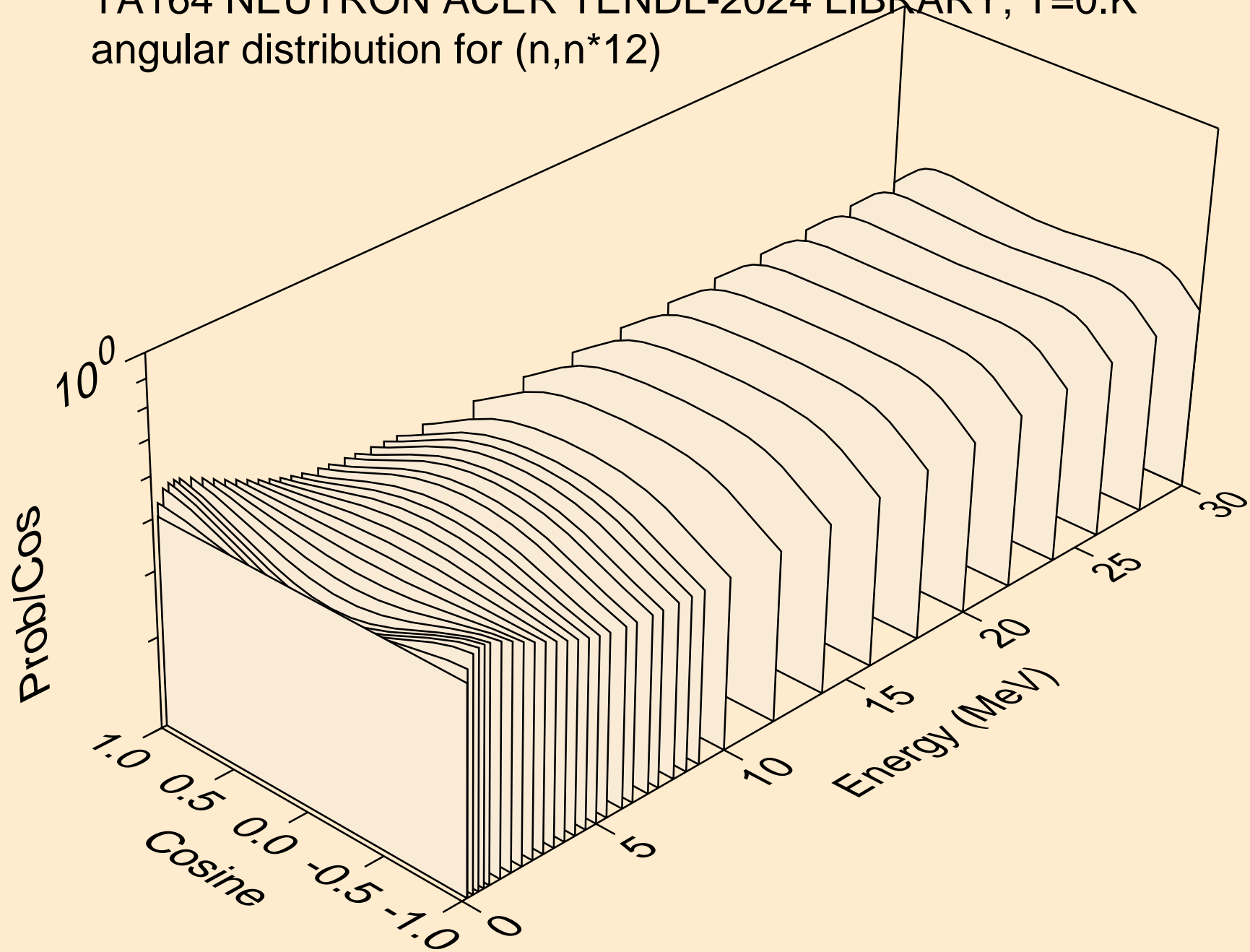

TA164 NEUTRON ACER TENDL-2024 LIBRARY; T=0.K
angular distribution for (n,n*13)

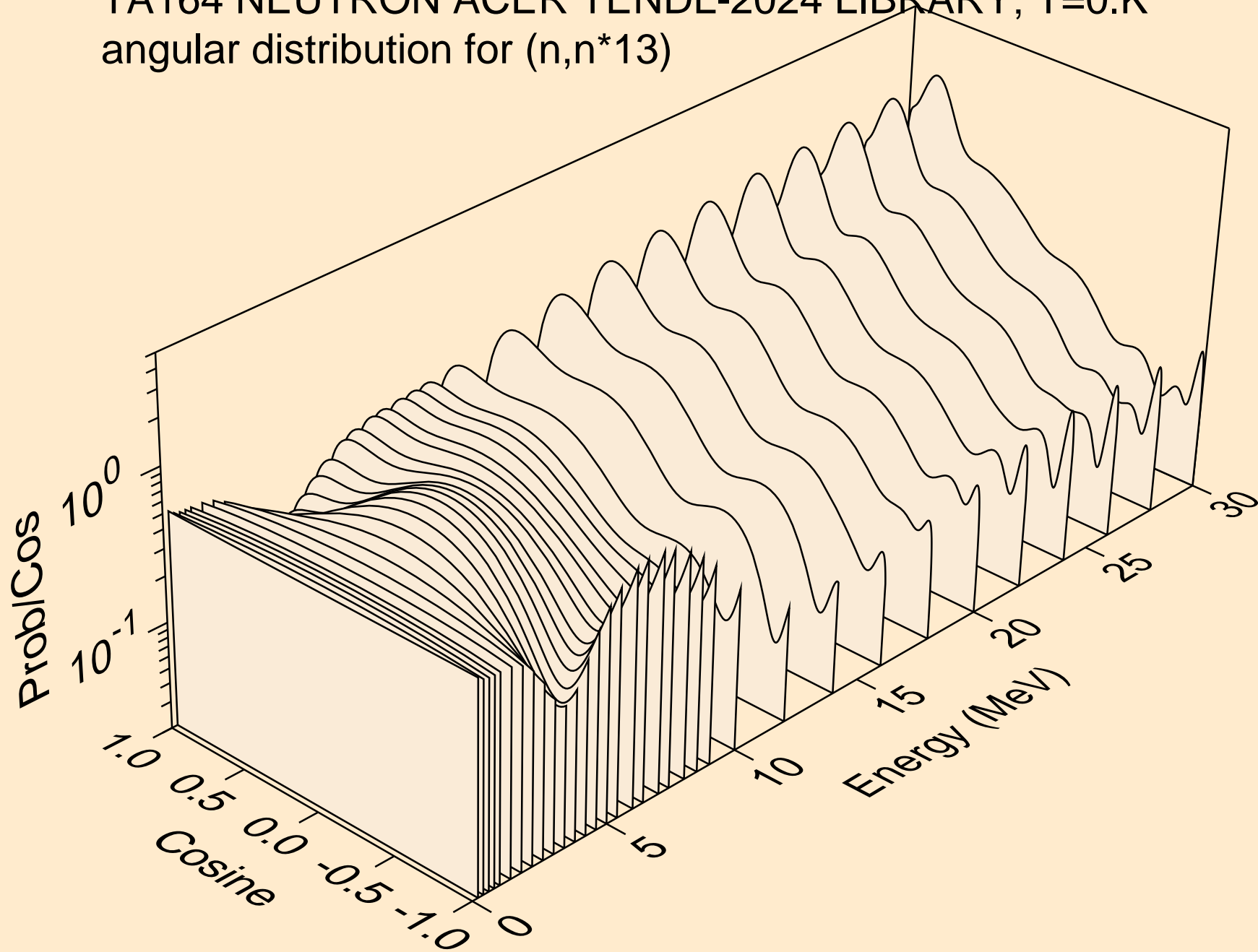

TA164 NEUTRON ACER TENDL-2024 LIBRARY; T=0.K
angular distribution for (n,n*14)

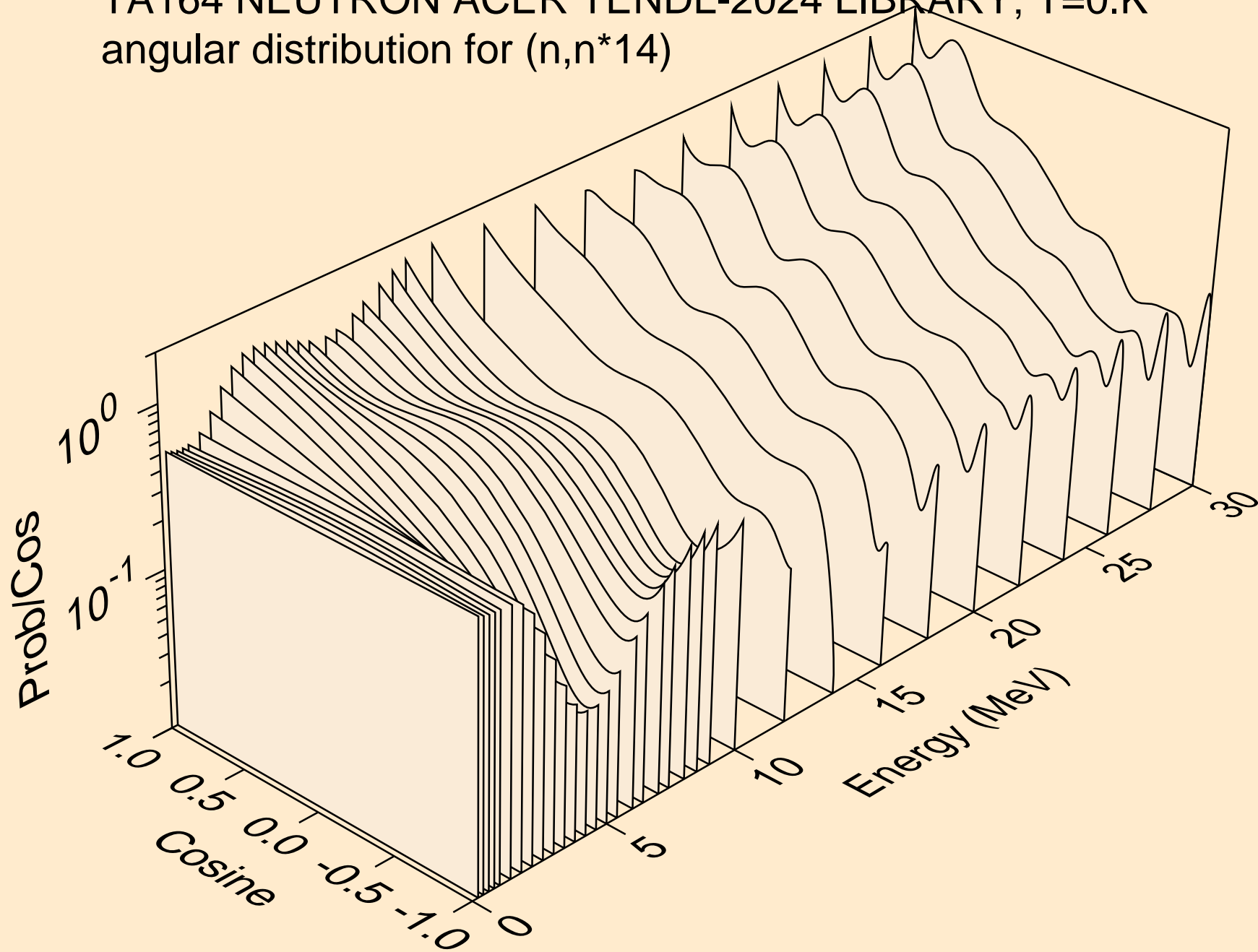

TA164 NEUTRON ACER TENDL-2024 LIBRARY; T=0.K
angular distribution for (n,n*15)

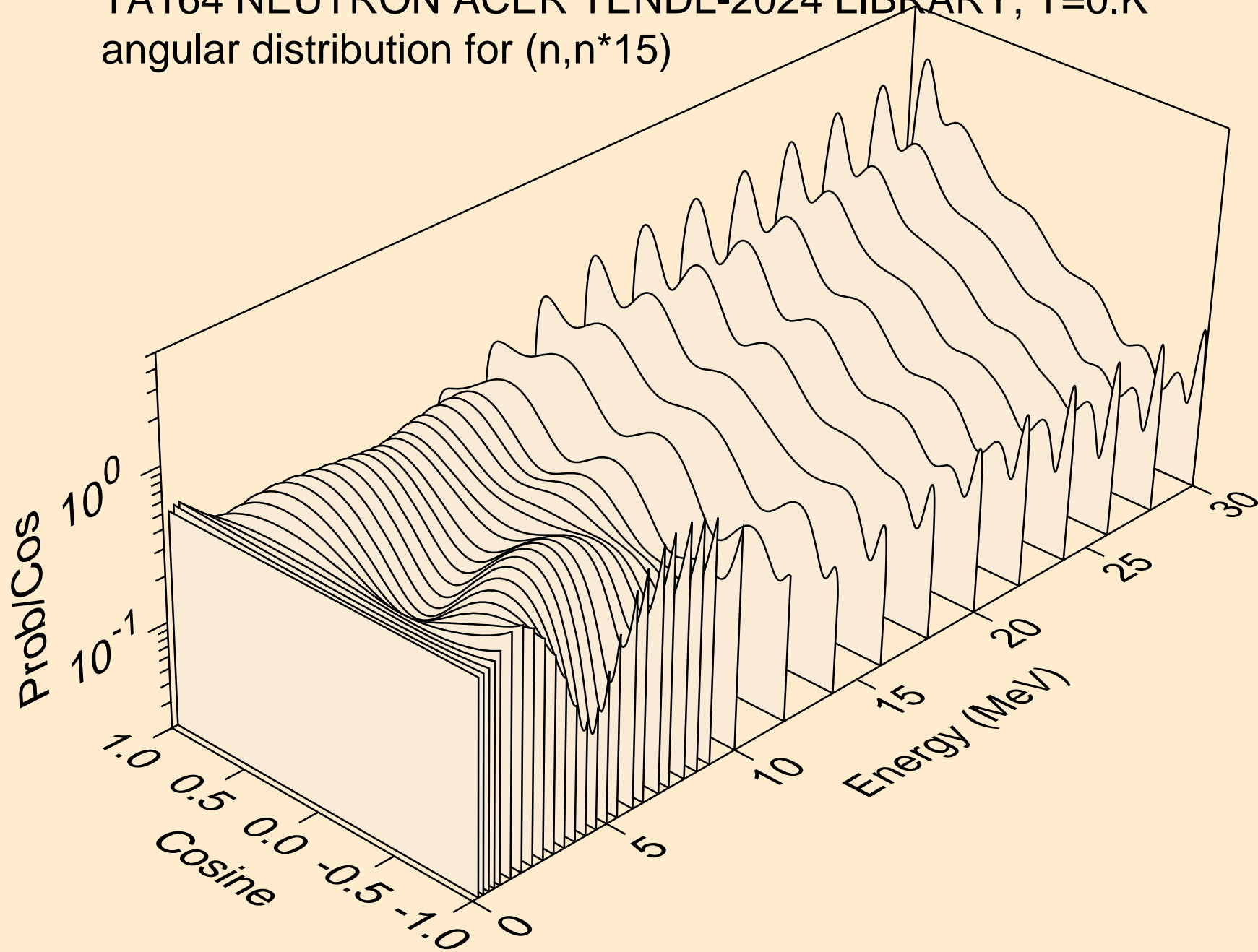

TA164 NEUTRON ACER TENDL-2024 LIBRARY; T=0.K
angular distribution for (n,n*16)

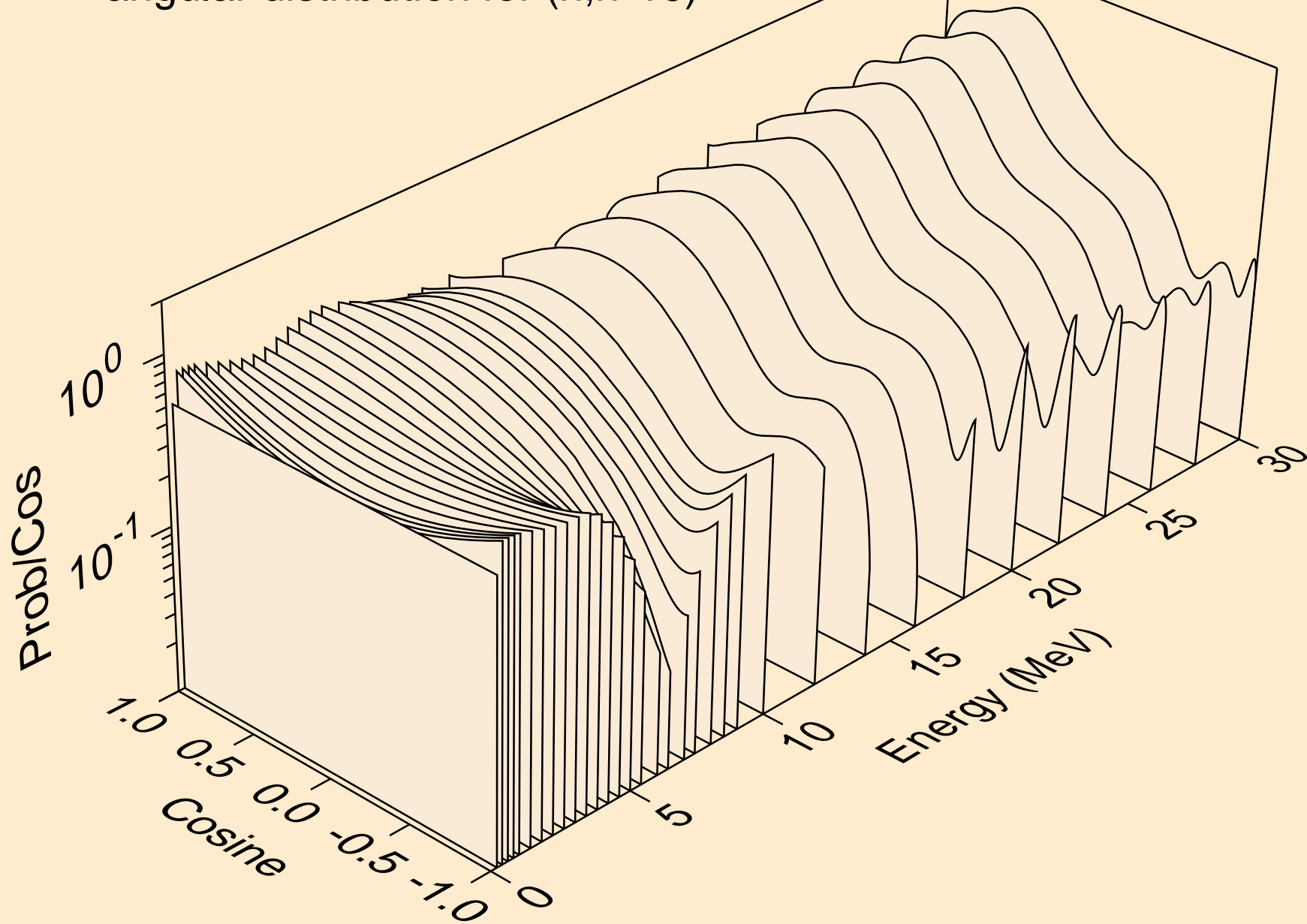

TA164 NEUTRON ACER TENDL-2024 LIBRARY; T=0.K
angular distribution for (n,n*17)

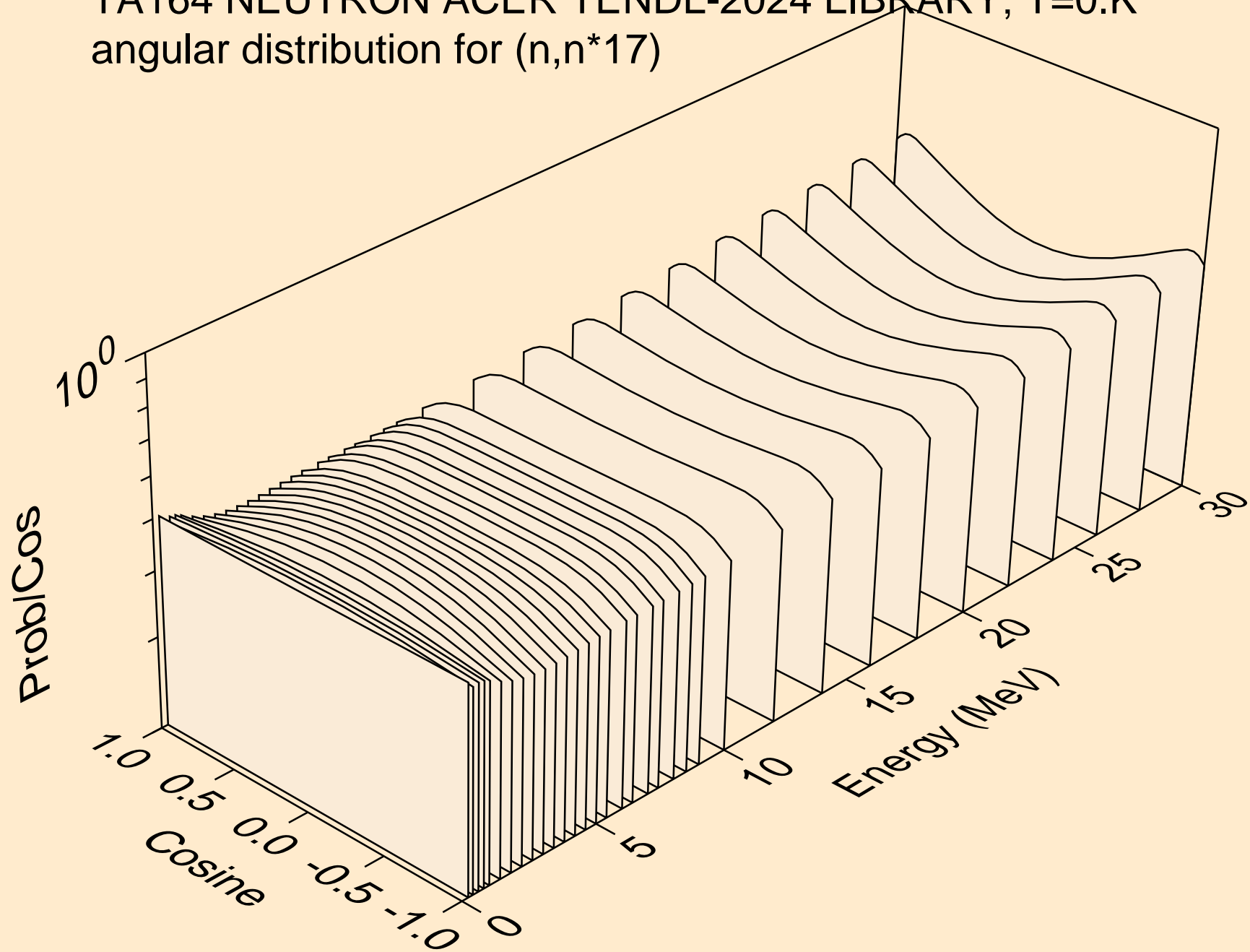

TA164 NEUTRON ACER TENDL-2024 LIBRARY; T=0.K
angular distribution for (n,n*18)

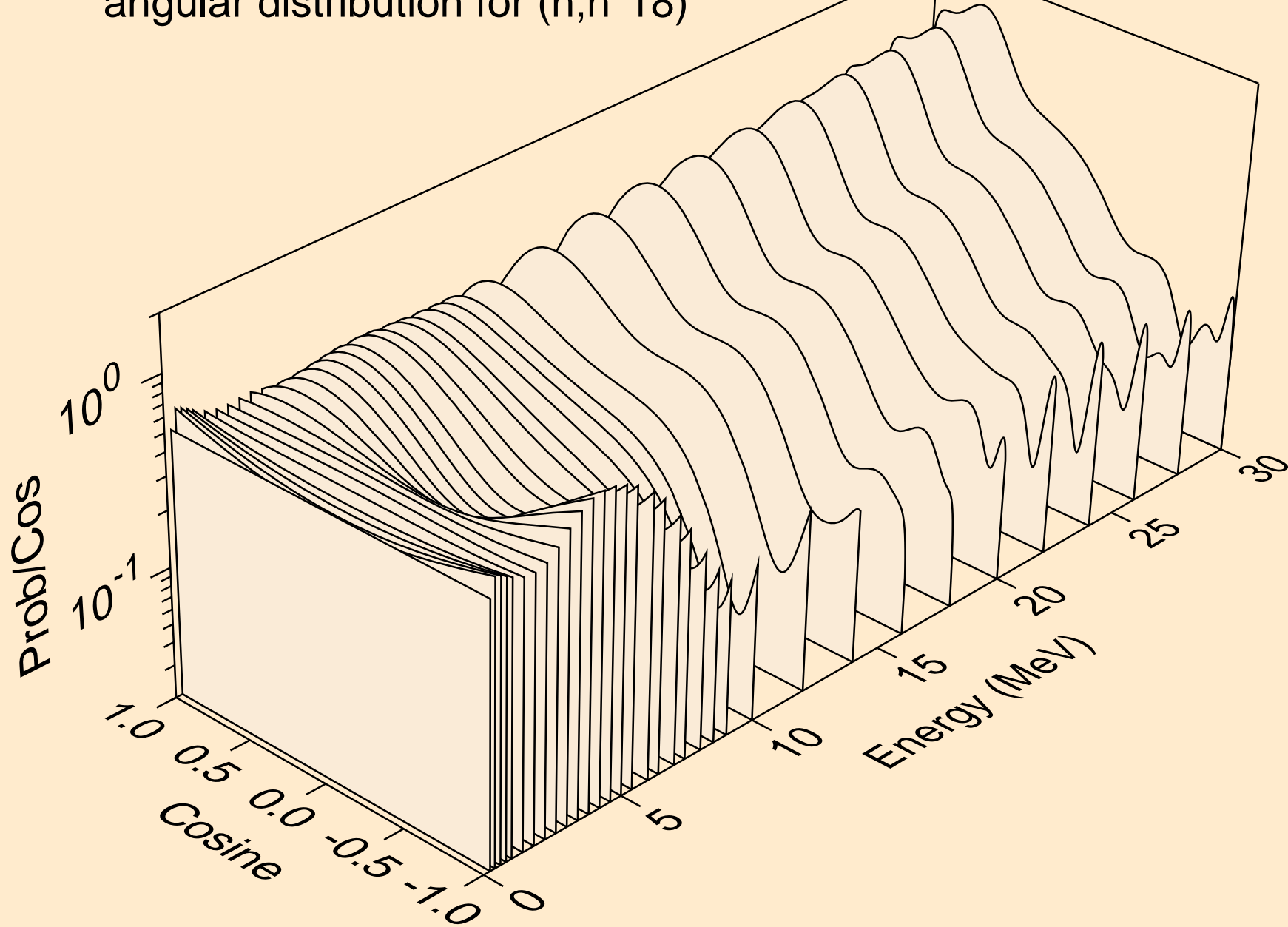

TA164 NEUTRON ACER TENDL-2024 LIBRARY; T=0.K
angular distribution for (n,n*19)

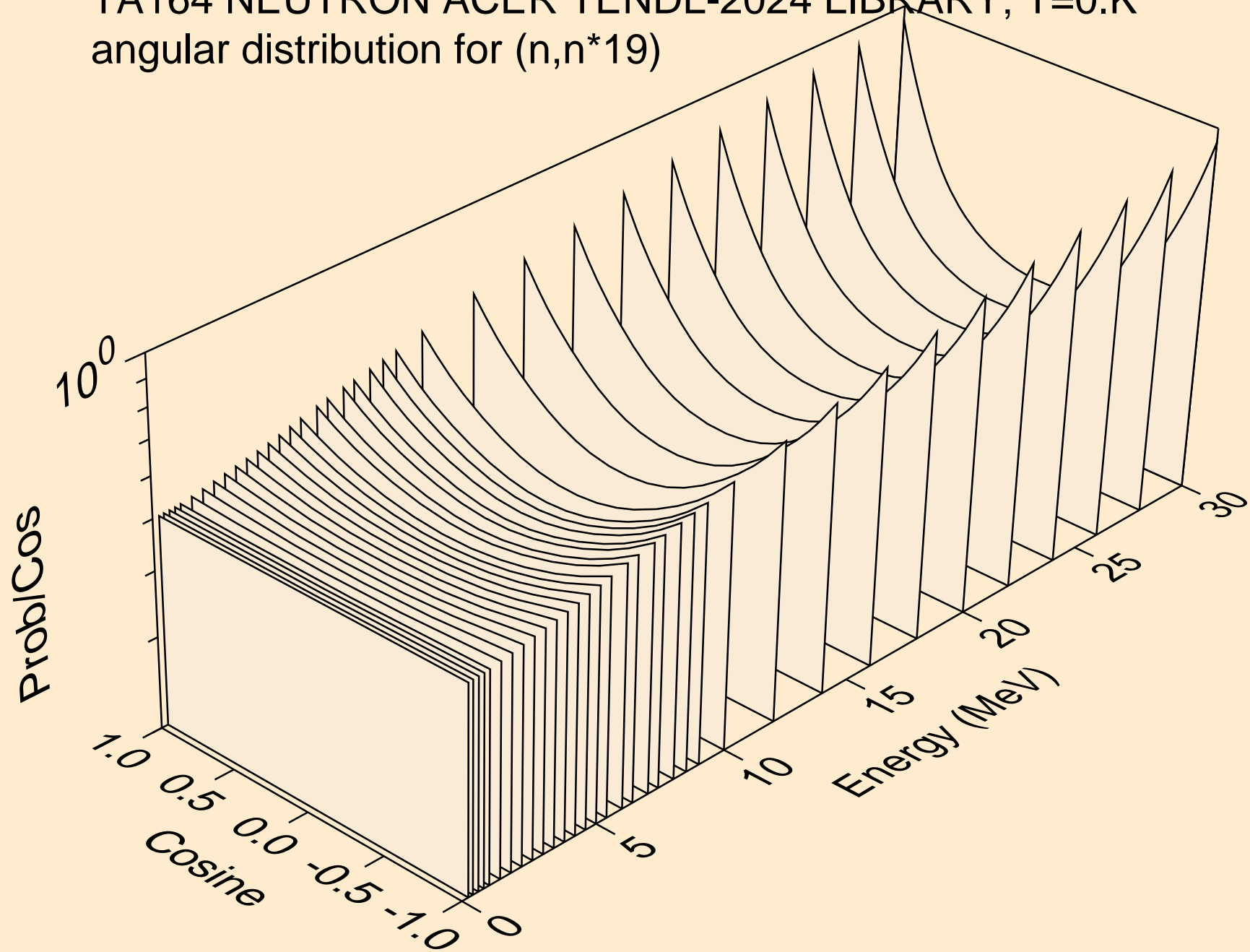

TA164 NEUTRON ACER TENDL-2024 LIBRARY; T=0.K
angular distribution for (n,n*20)

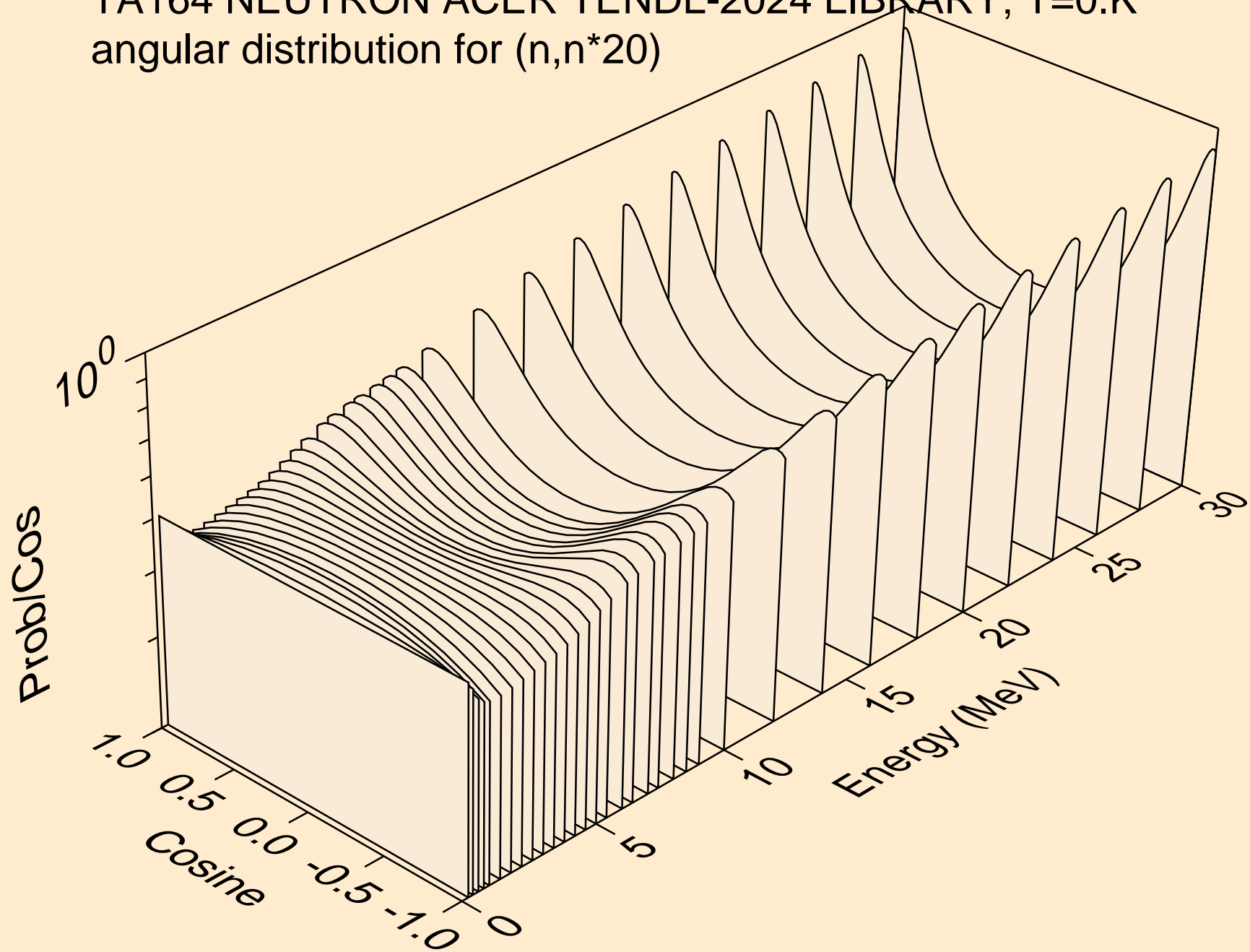

TA164 NEUTRON ACER TENDL-2024 LIBRARY; T=0.K
angular distribution for (n,n*21)

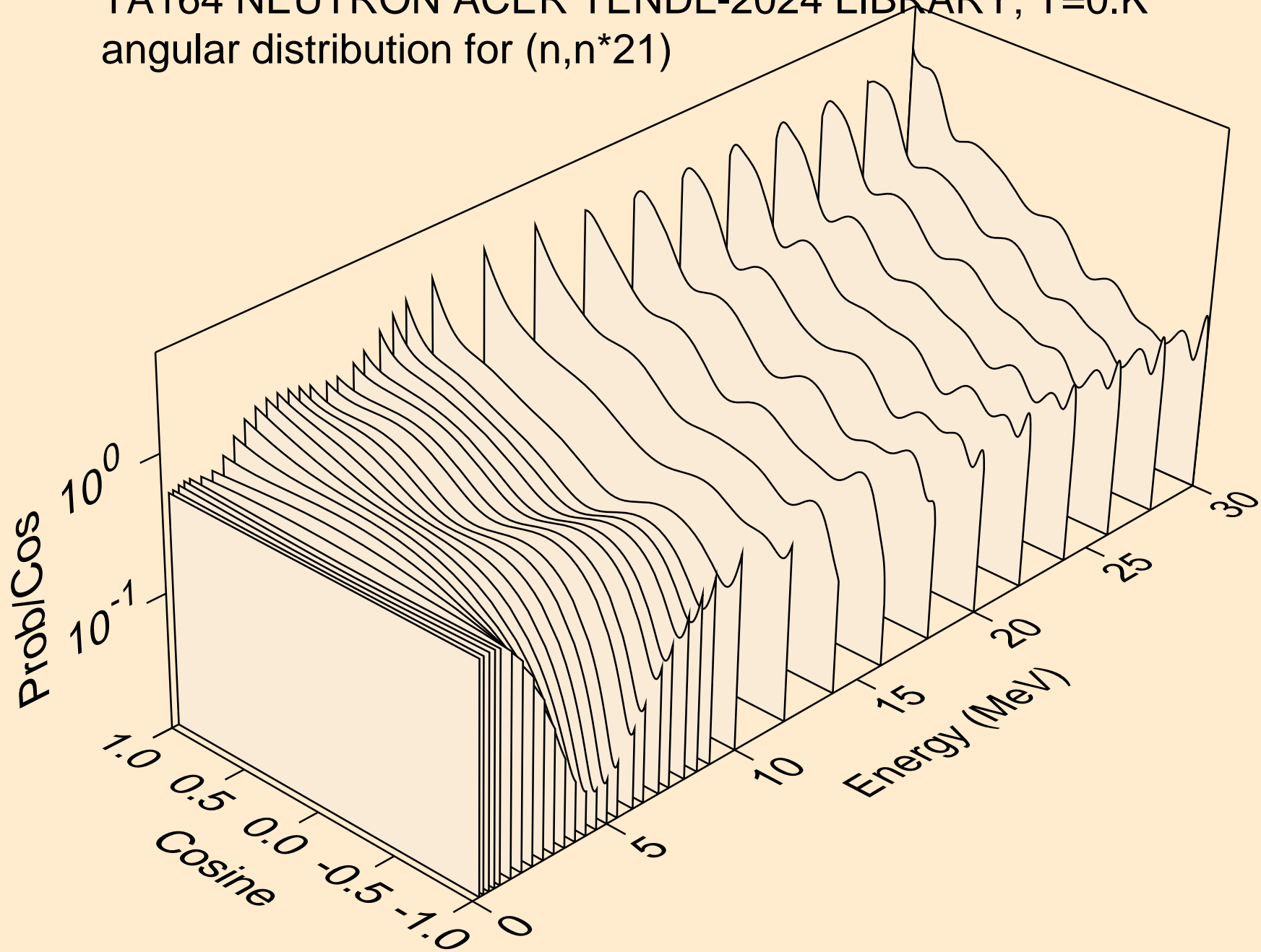

TA164 NEUTRON ACER TENDL-2024 LIBRARY; T=0.K
angular distribution for (n,n*22)

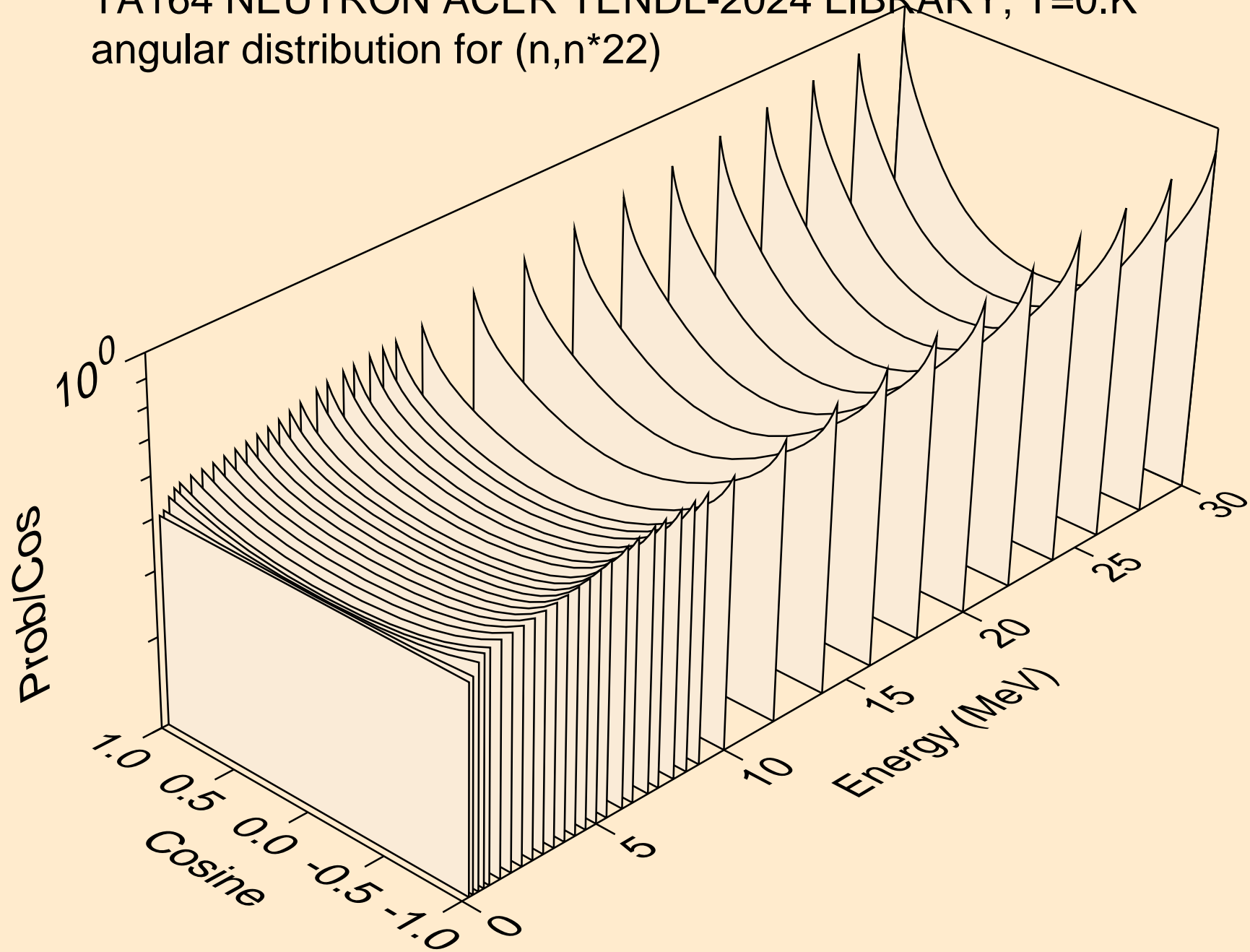

TA164 NEUTRON ACER TENDL-2024 LIBRARY; T=0.K
Neutron emission for (n,x)

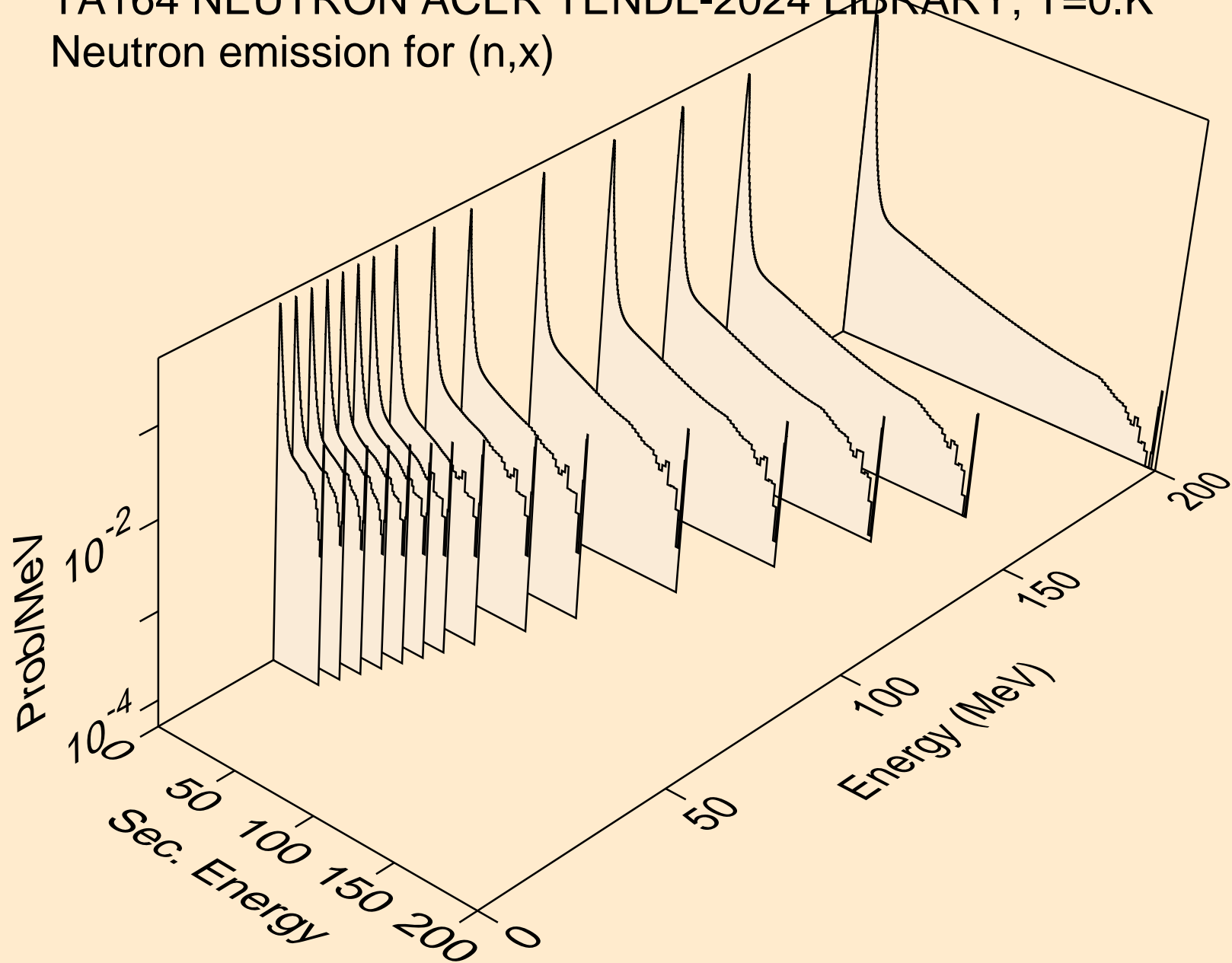

TA164 NEUTRON ACER TENDL-2024 LIBRARY; T=0.K
Neutron emission for (n,2nd)

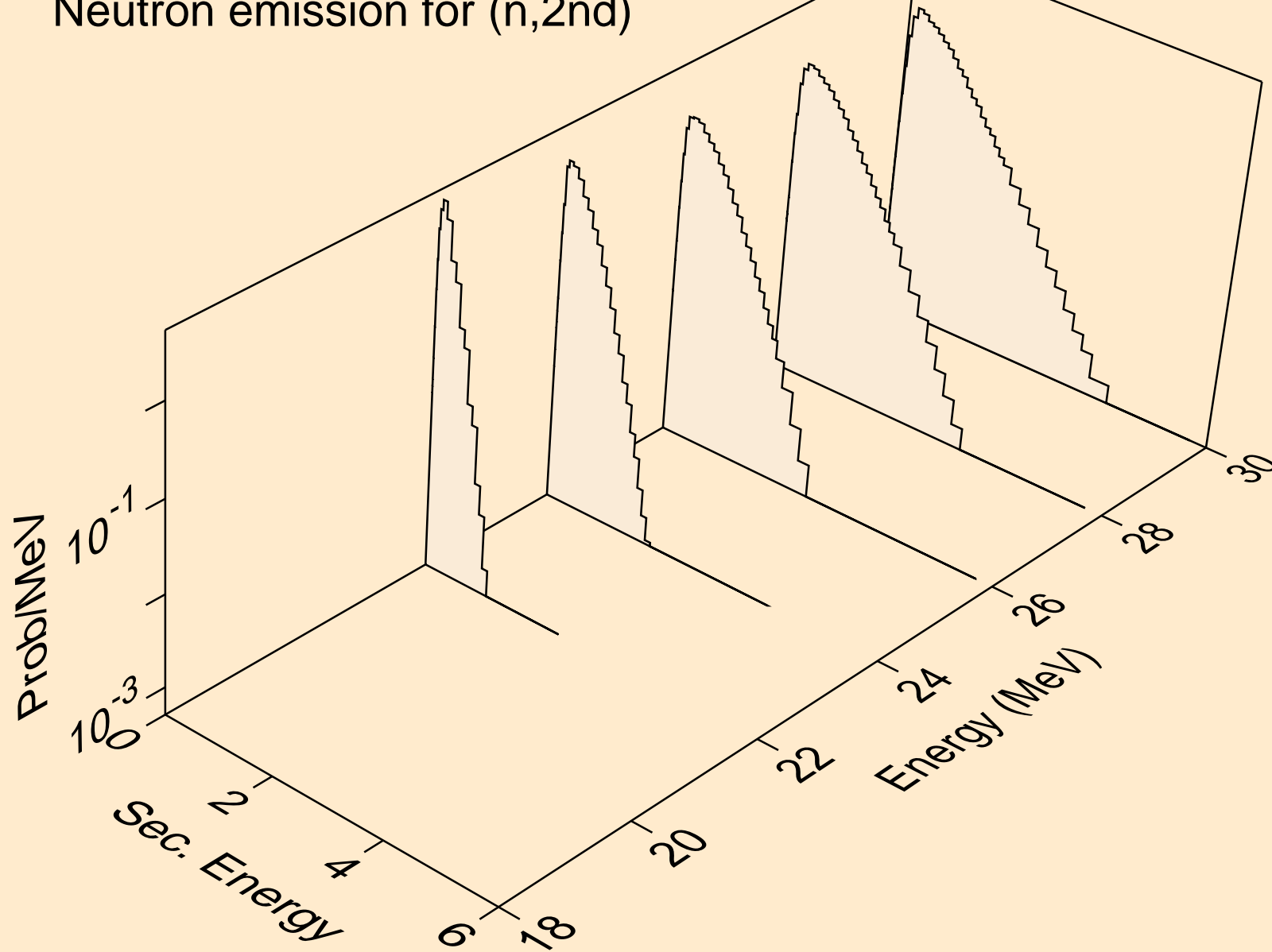

TA164 NEUTRON ACER TENDL-2024 LIBRARY; T=0.K
Neutron emission for (n,2n)

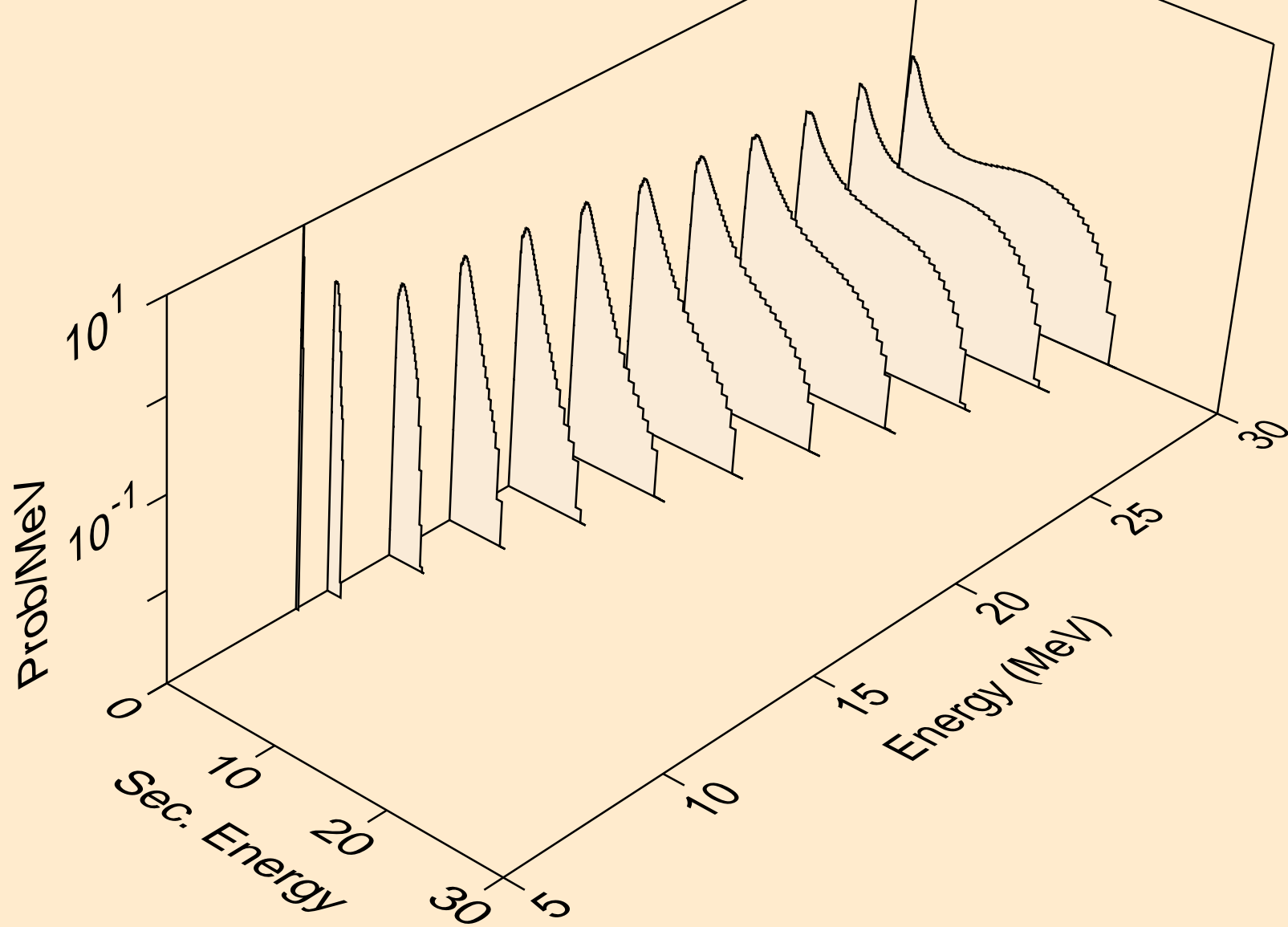

TA164 NEUTRON ACER TENDL-2024 LIBRARY; T=0.K
Neutron emission for (n,3n)

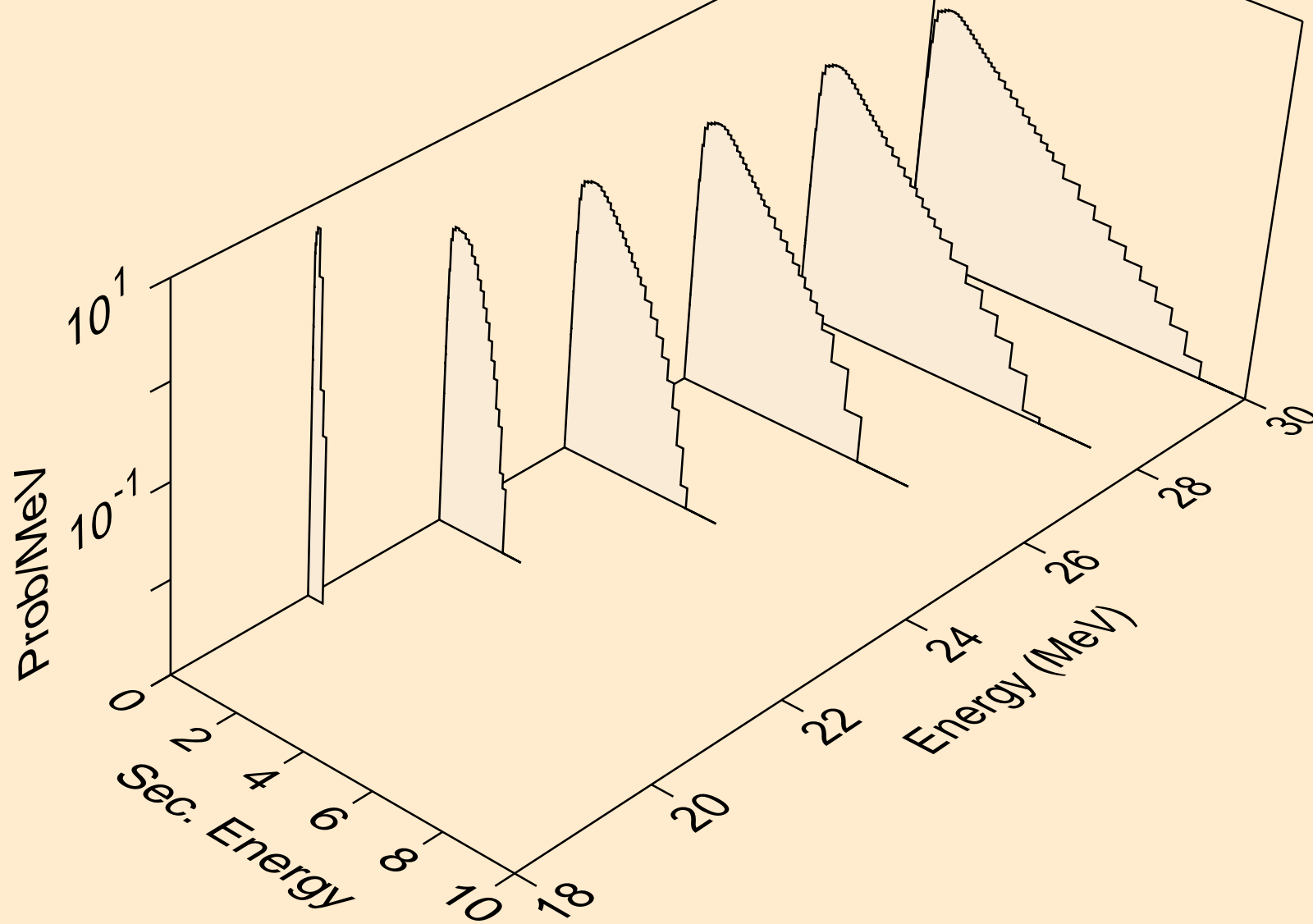

TA164 NEUTRON ACER TENDL-2024 LIBRARY; T=0.K
Neutron emission for (n,n*)a

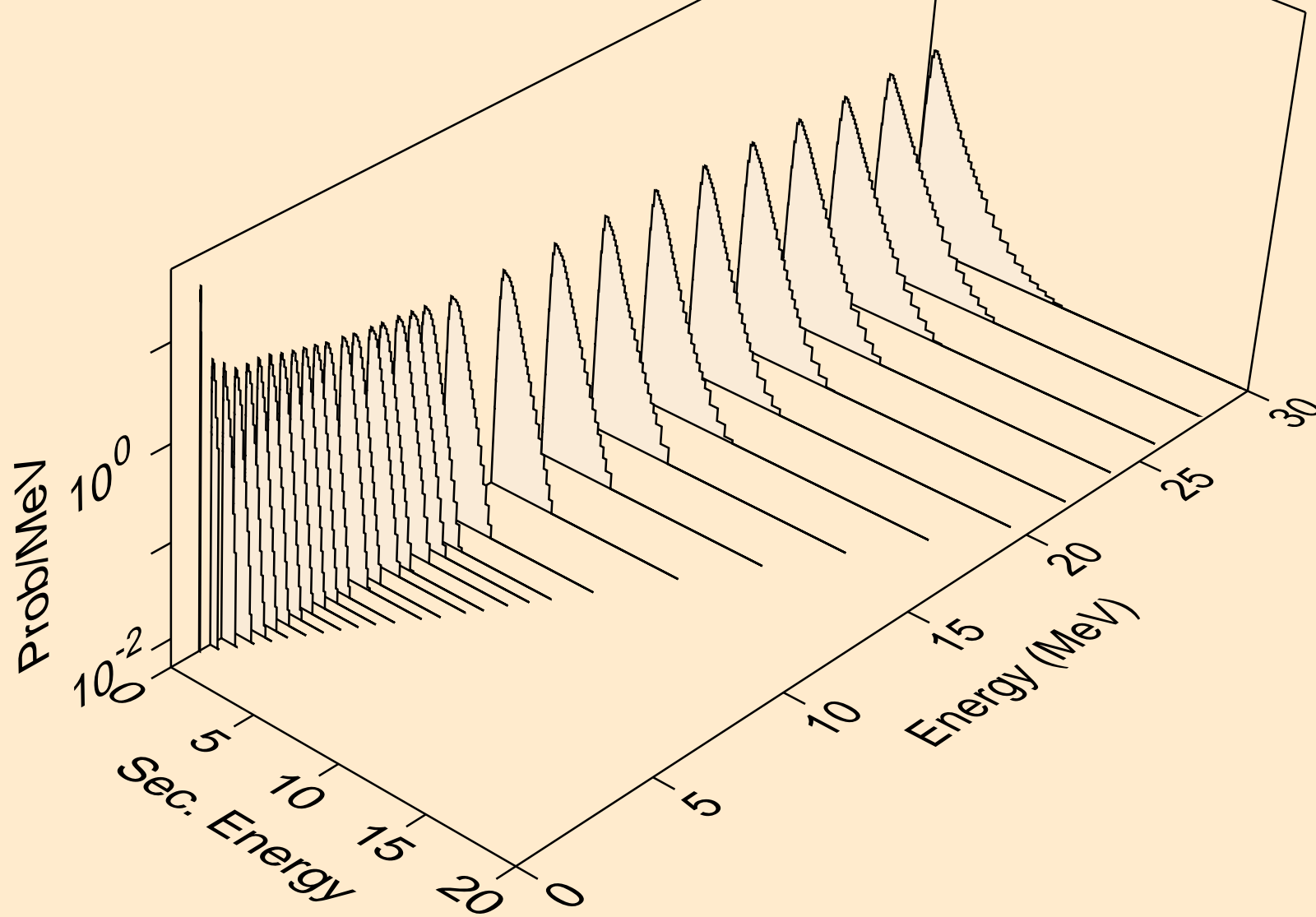

TA164 NEUTRON ACER TENDL-2024 LIBRARY; T=0.K
Neutron emission for (n,n*)3a

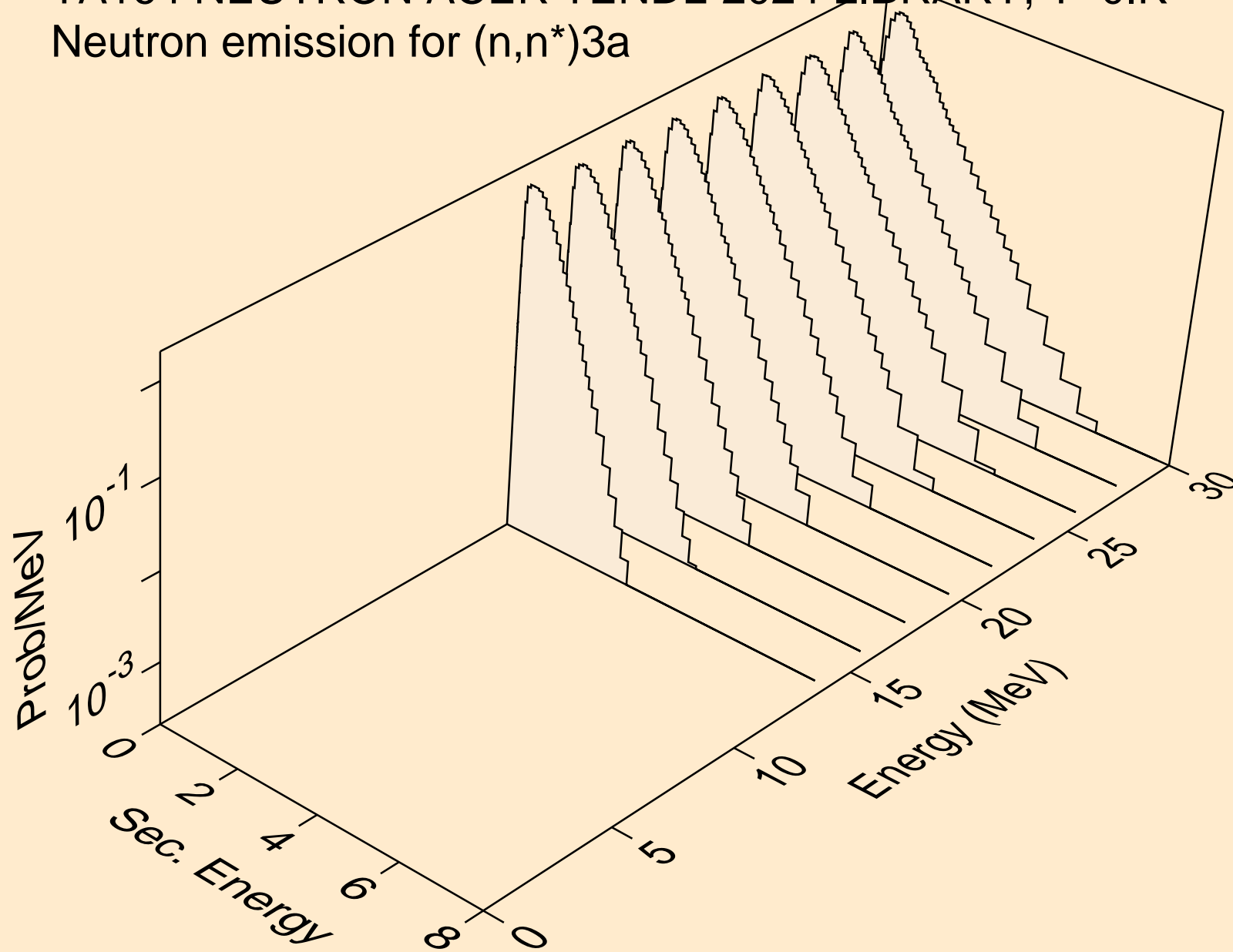

TA164 NEUTRON ACER TENDL-2024 LIBRARY; T=0.K
Neutron emission for (n,2n)a

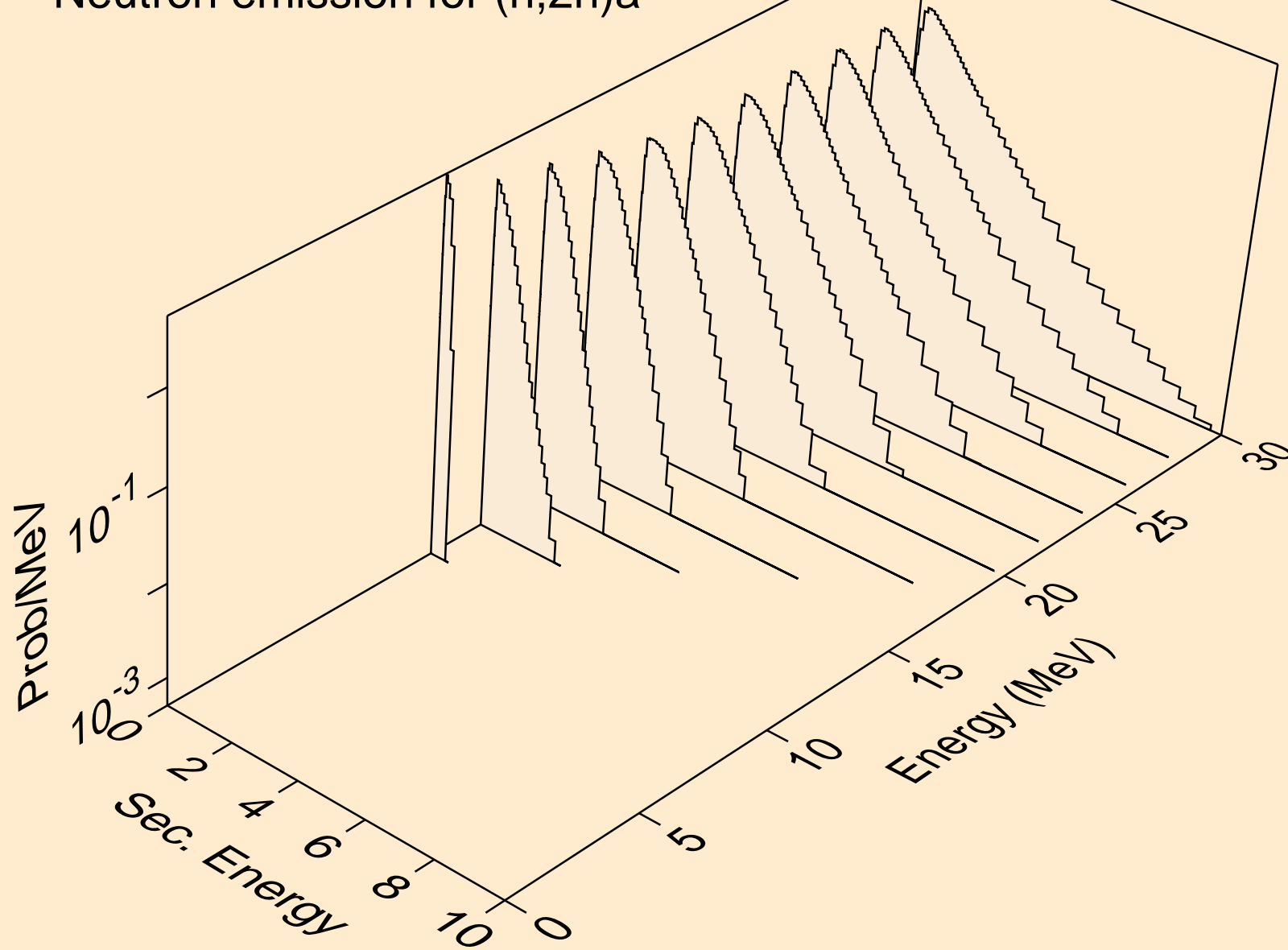

TA164 NEUTRON ACER TENDL-2024 LIBRARY; T=0.K
Neutron emission for (n,3n)_a

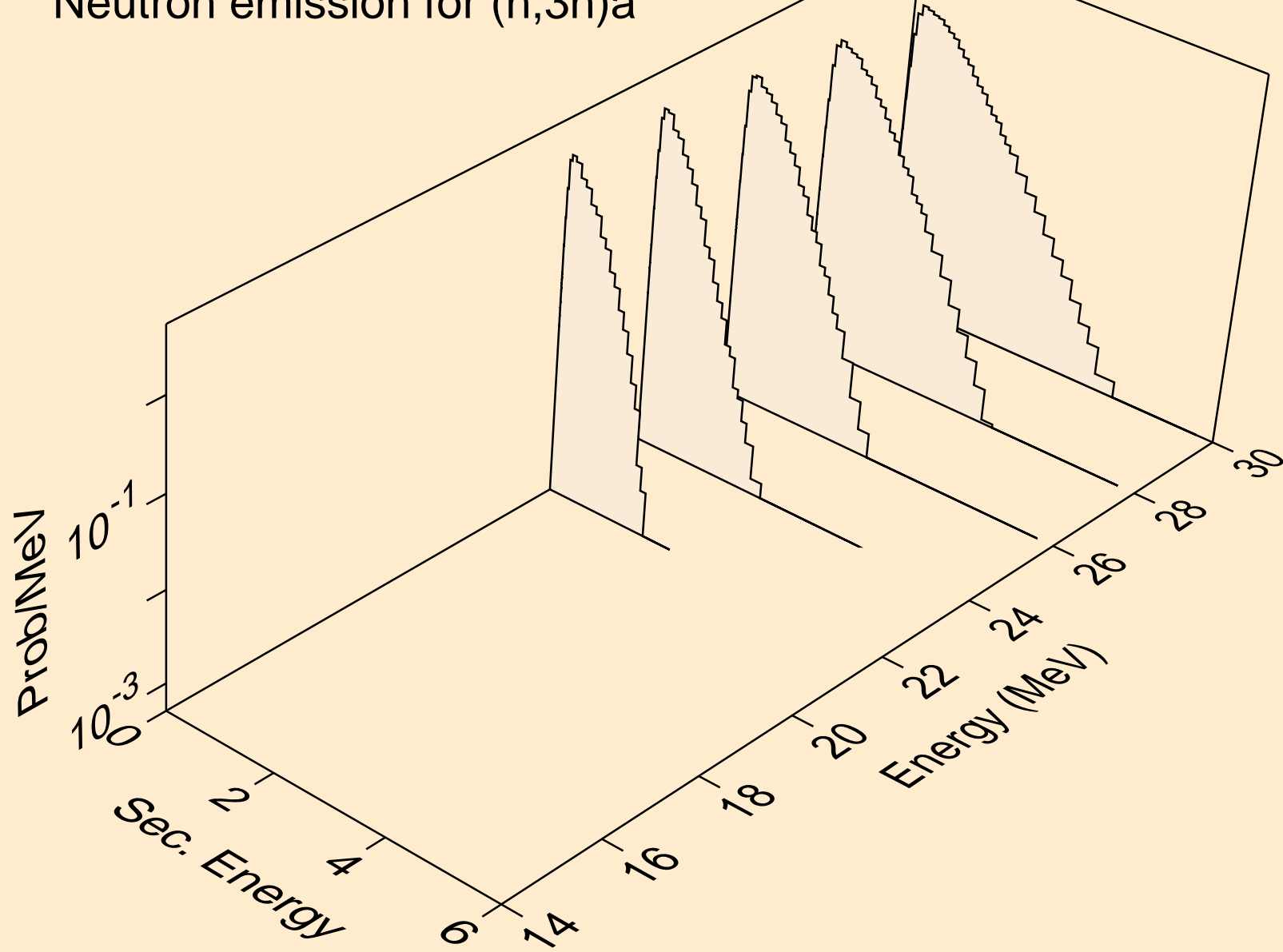

TA164 NEUTRON ACER TENDL-2024 LIBRARY; T=0.K
Neutron emission for (n,n*)p

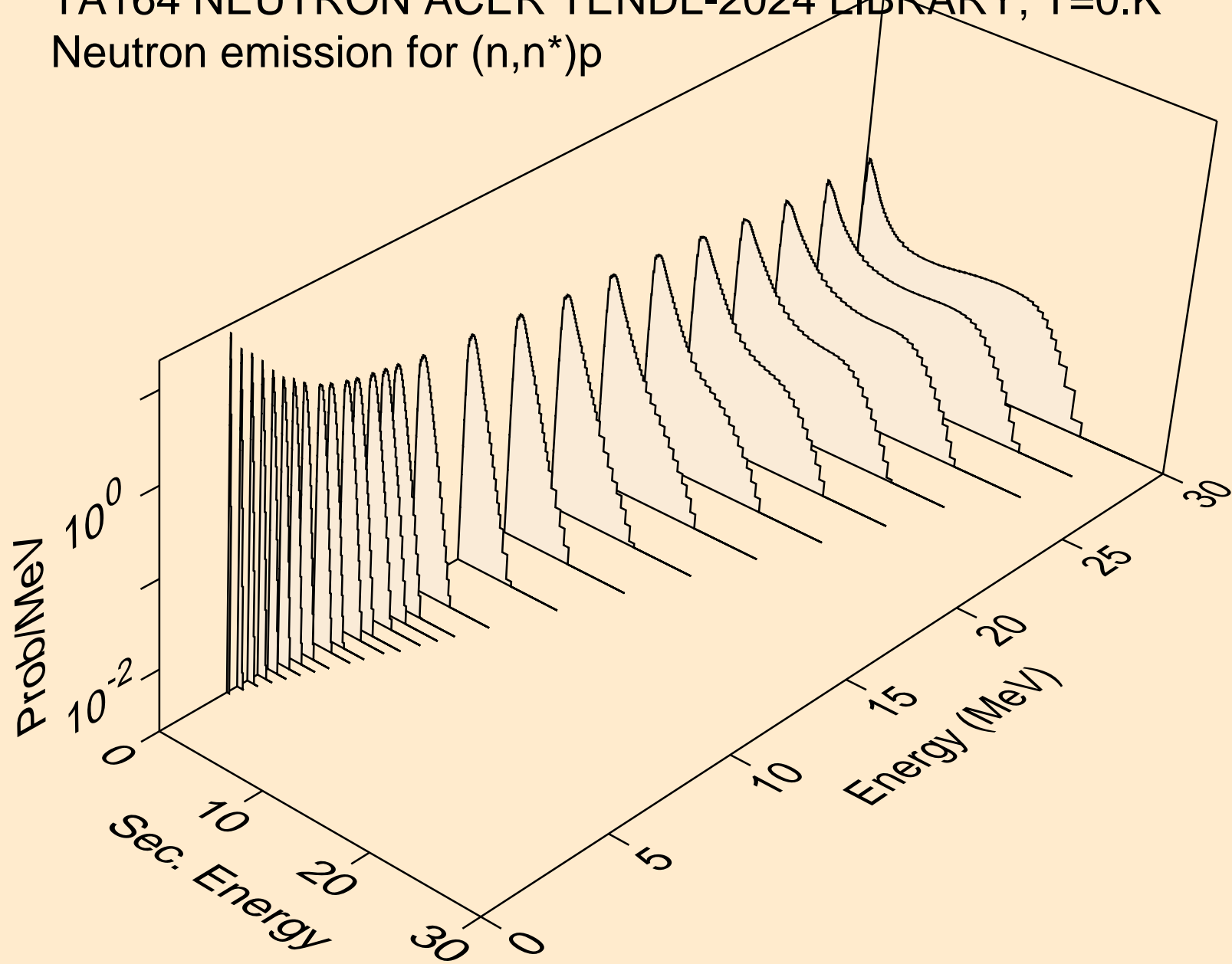

TA164 NEUTRON ACER TENDL-2024 LIBRARY; T=0.K
Neutron emission for (n,n*)2a

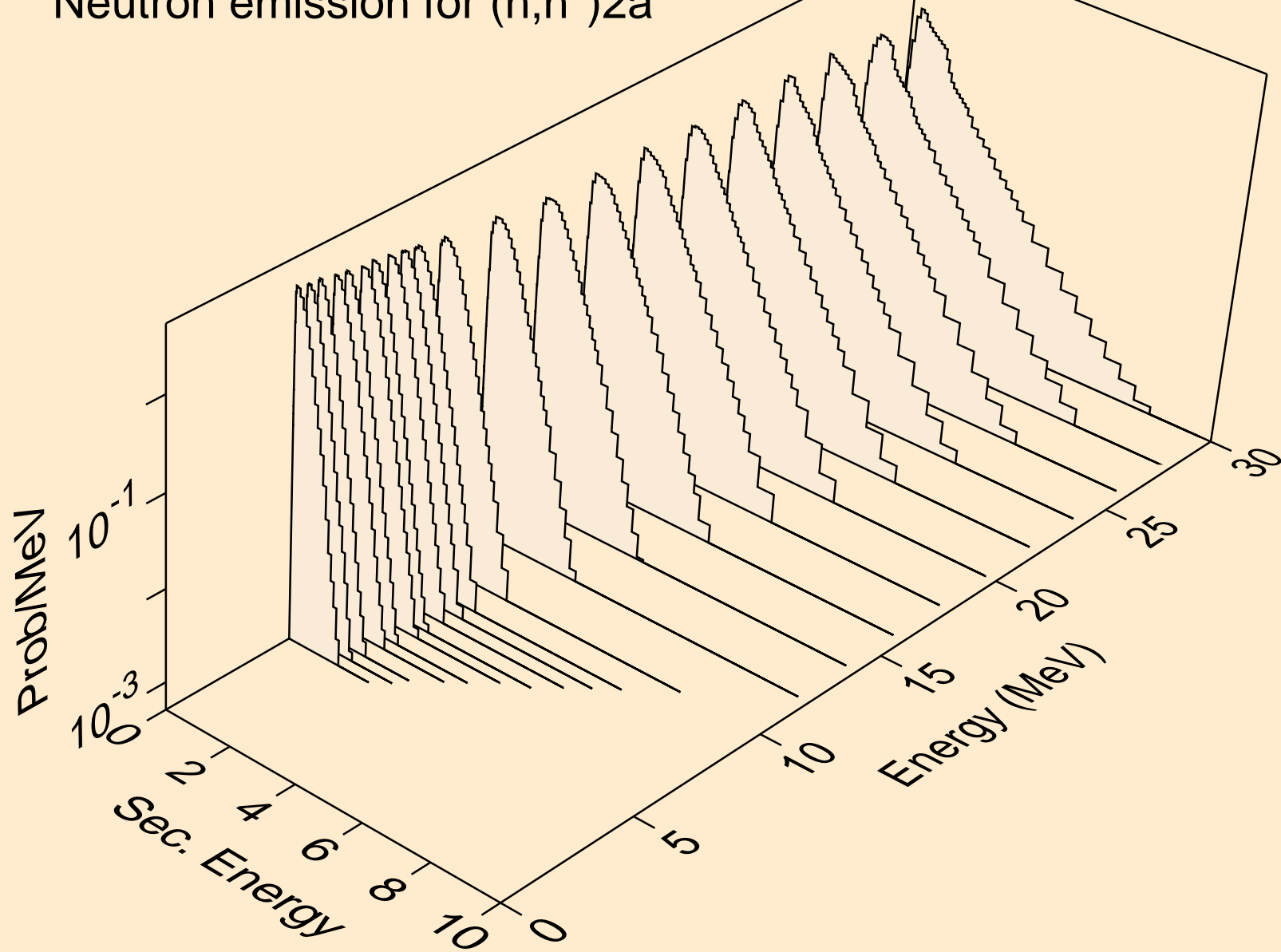

TA164 NEUTRON ACER TENDL-2024 LIBRARY; T=0.K
Neutron emission for (n,2n)2a

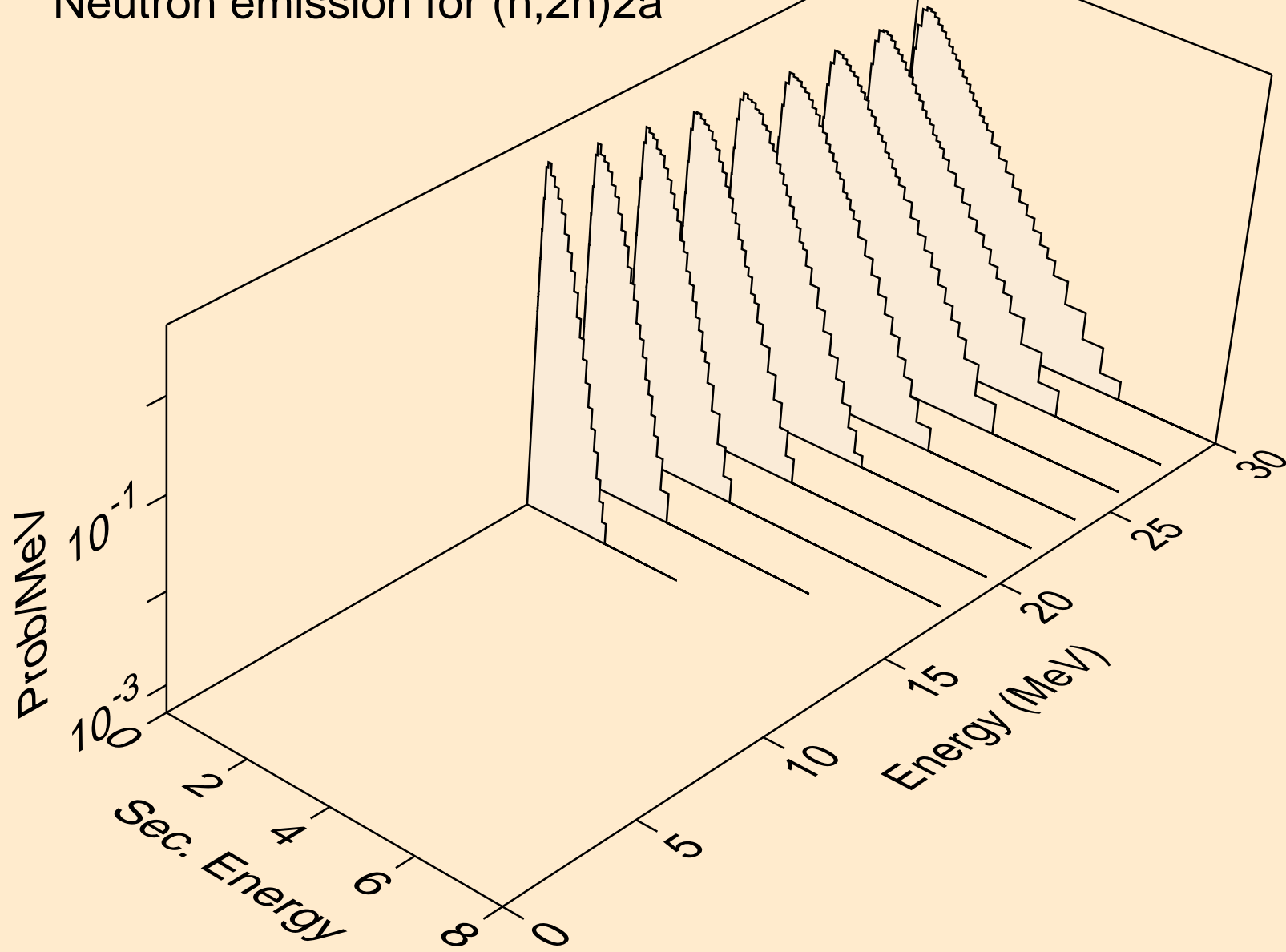

TA164 NEUTRON ACER TENDL-2024 LIBRARY; T=0.K
Neutron emission for (n,n*)d

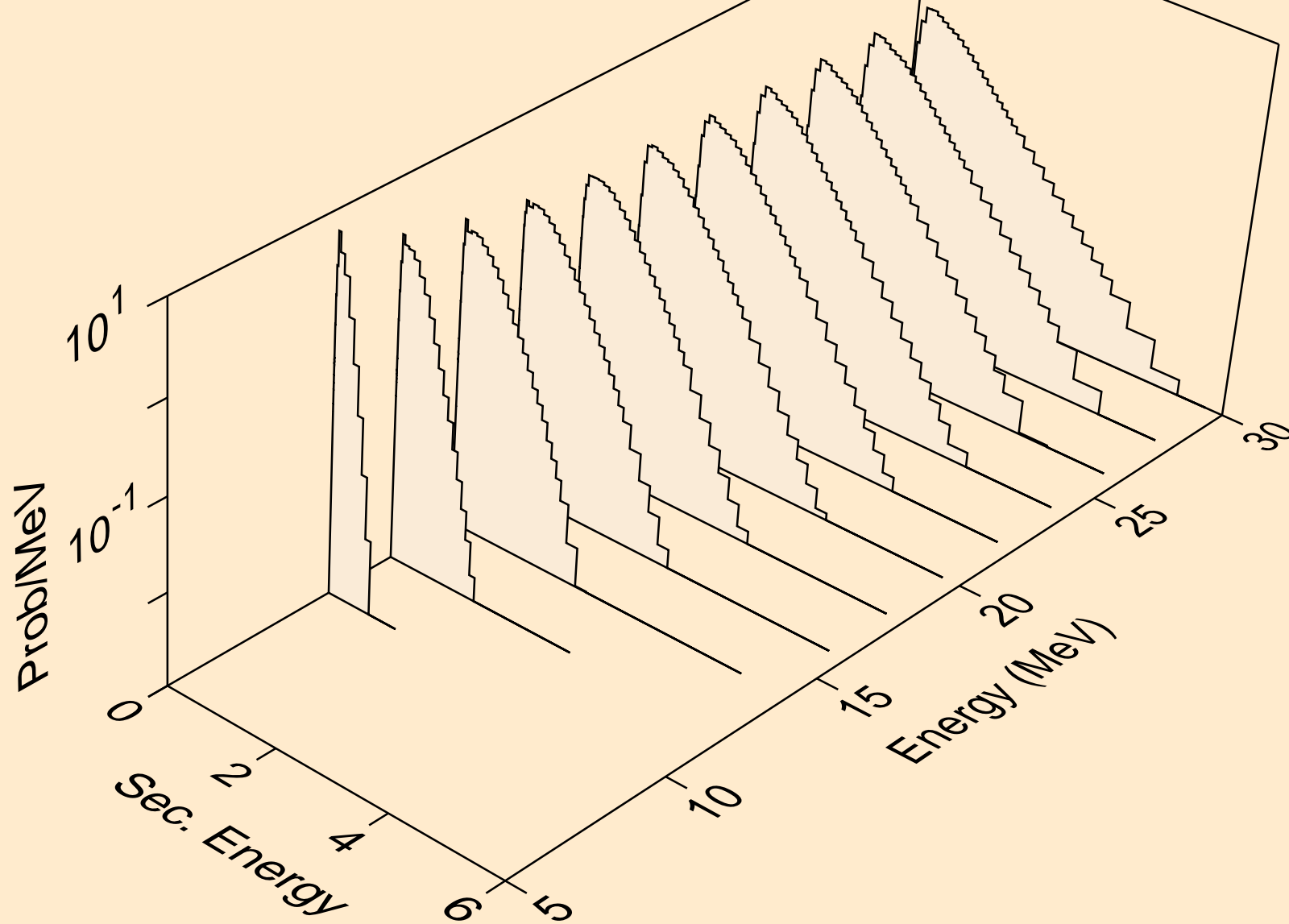

TA164 NEUTRON ACER TENDL-2024 LIBRARY; T=0.K
Neutron emission for (n,n*)t

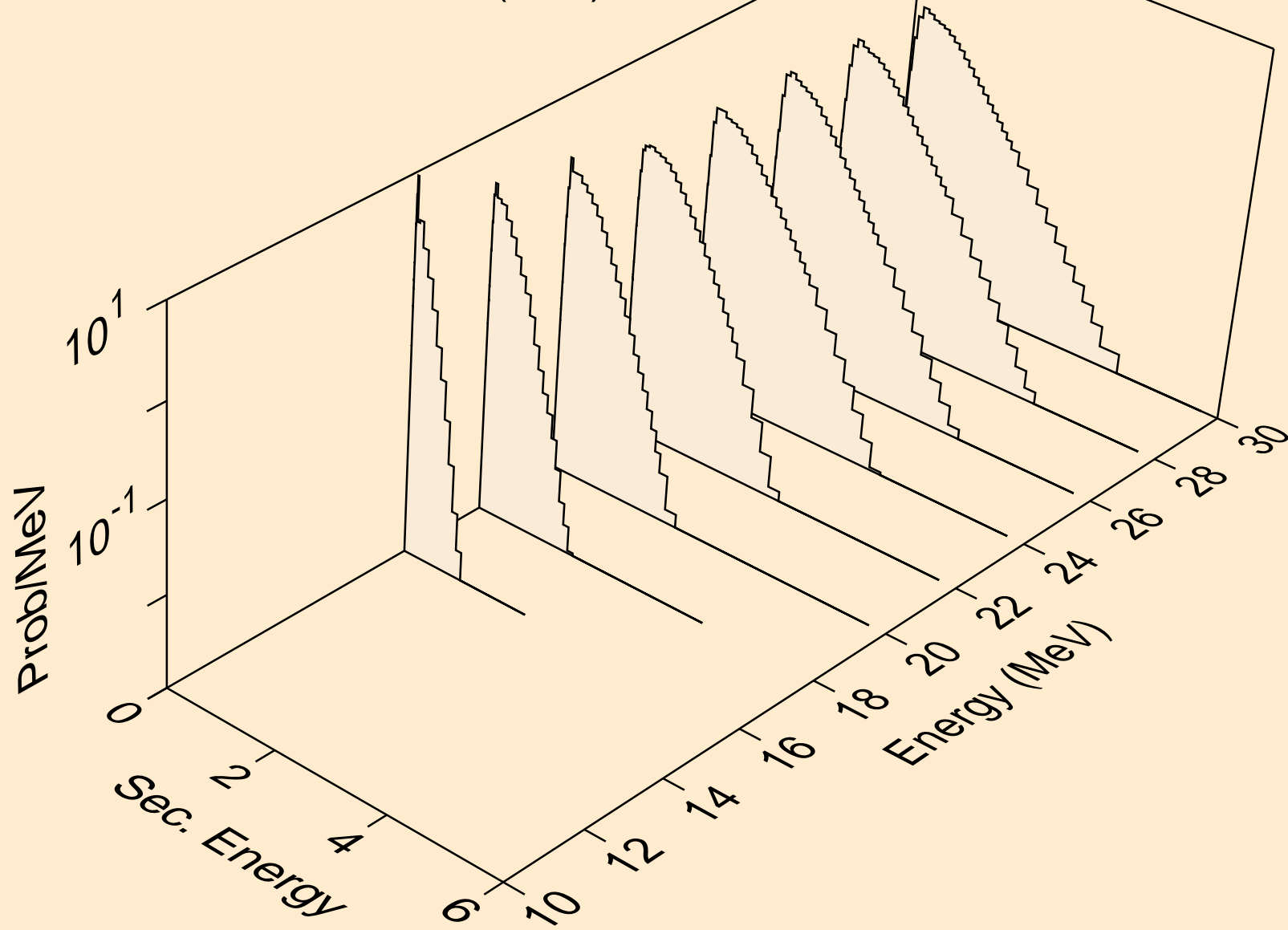

TA164 NEUTRON ACER TENDL-2024 LIBRARY; T=0.K
Neutron emission for (n,n*)he3

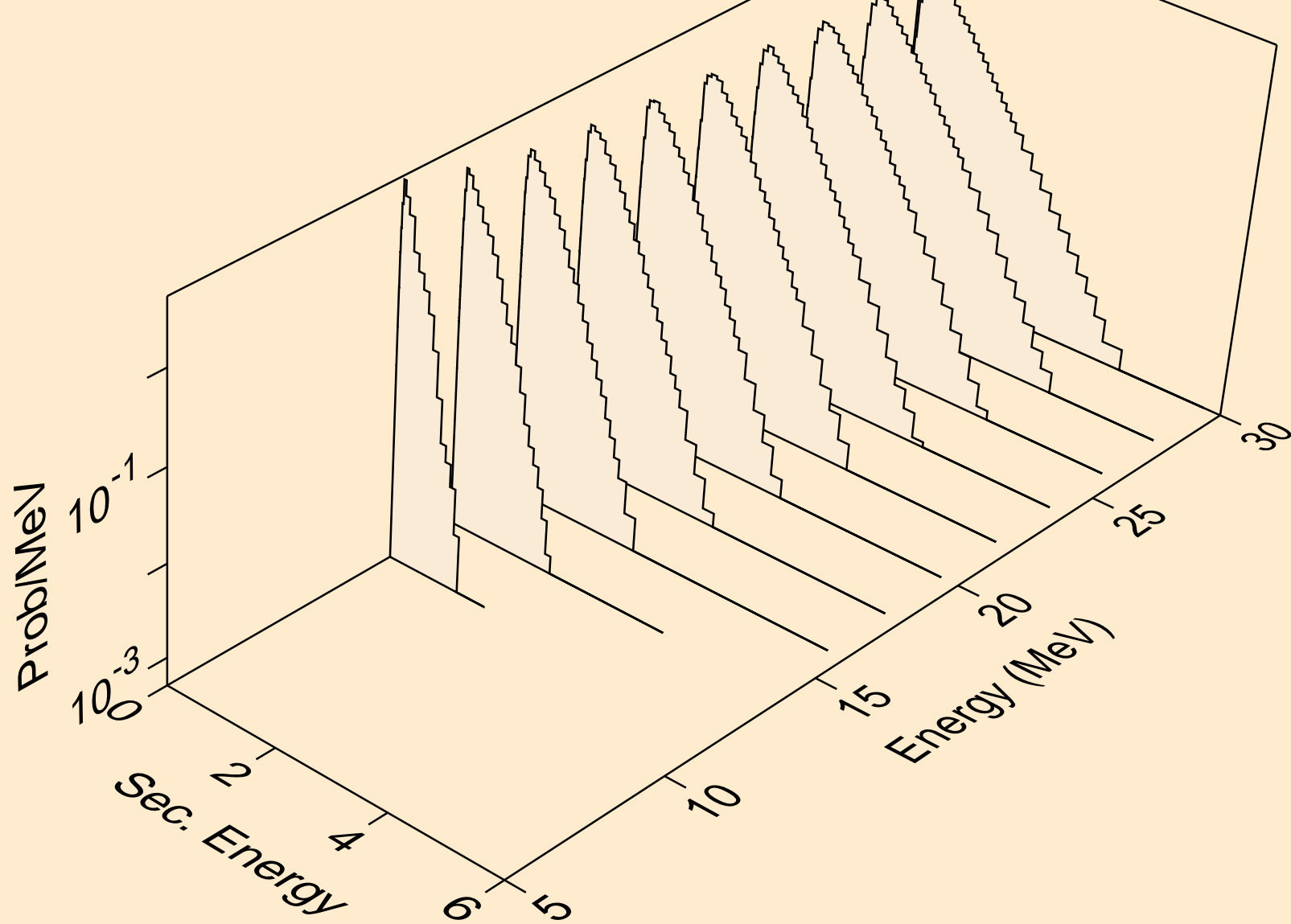

TA164 NEUTRON ACER TENDL-2024 LIBRARY; T=0.K
Neutron emission for (n,4n)

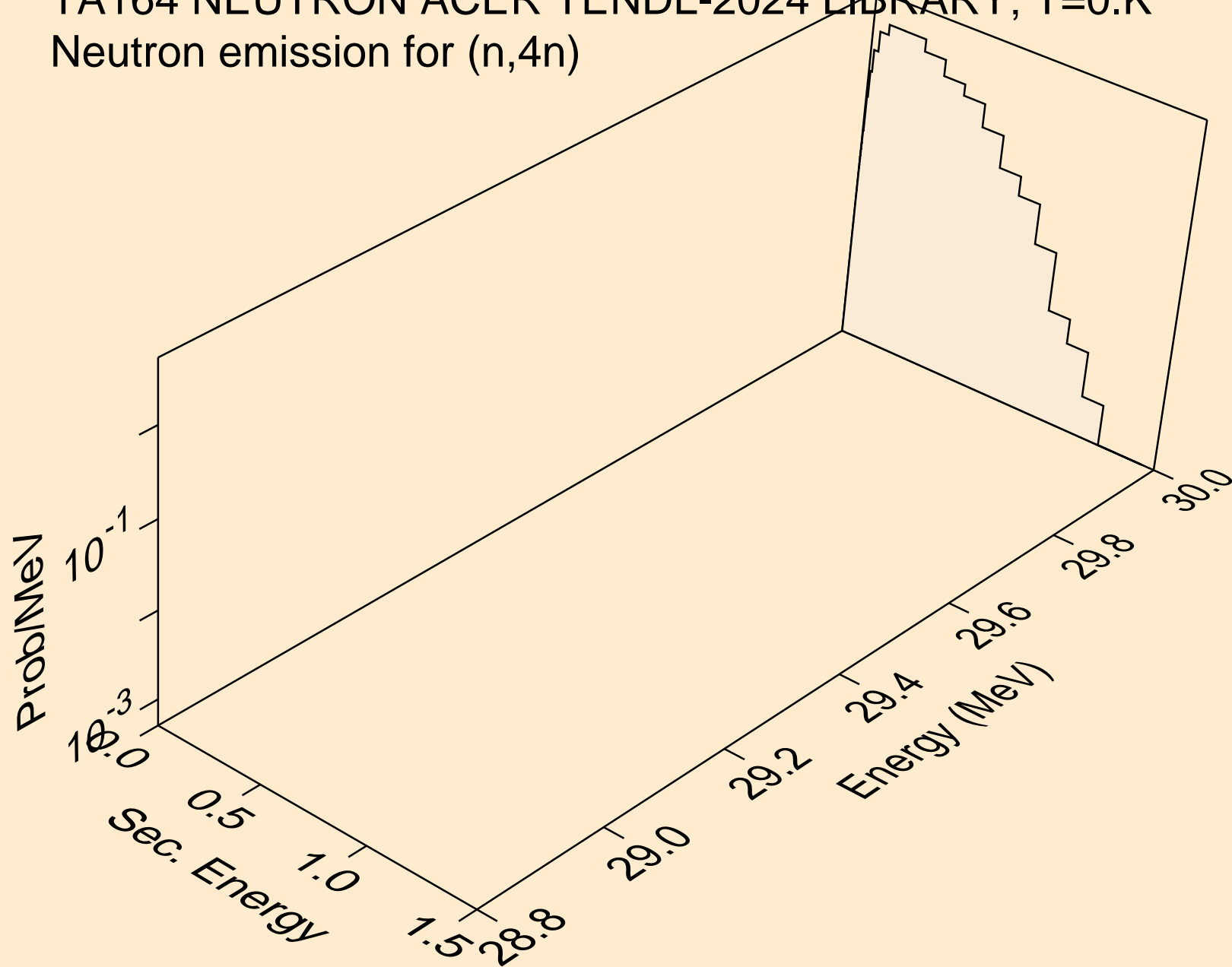

TA164 NEUTRON ACER TENDL-2024 LIBRARY; T=0.K
Neutron emission for (n,2np)

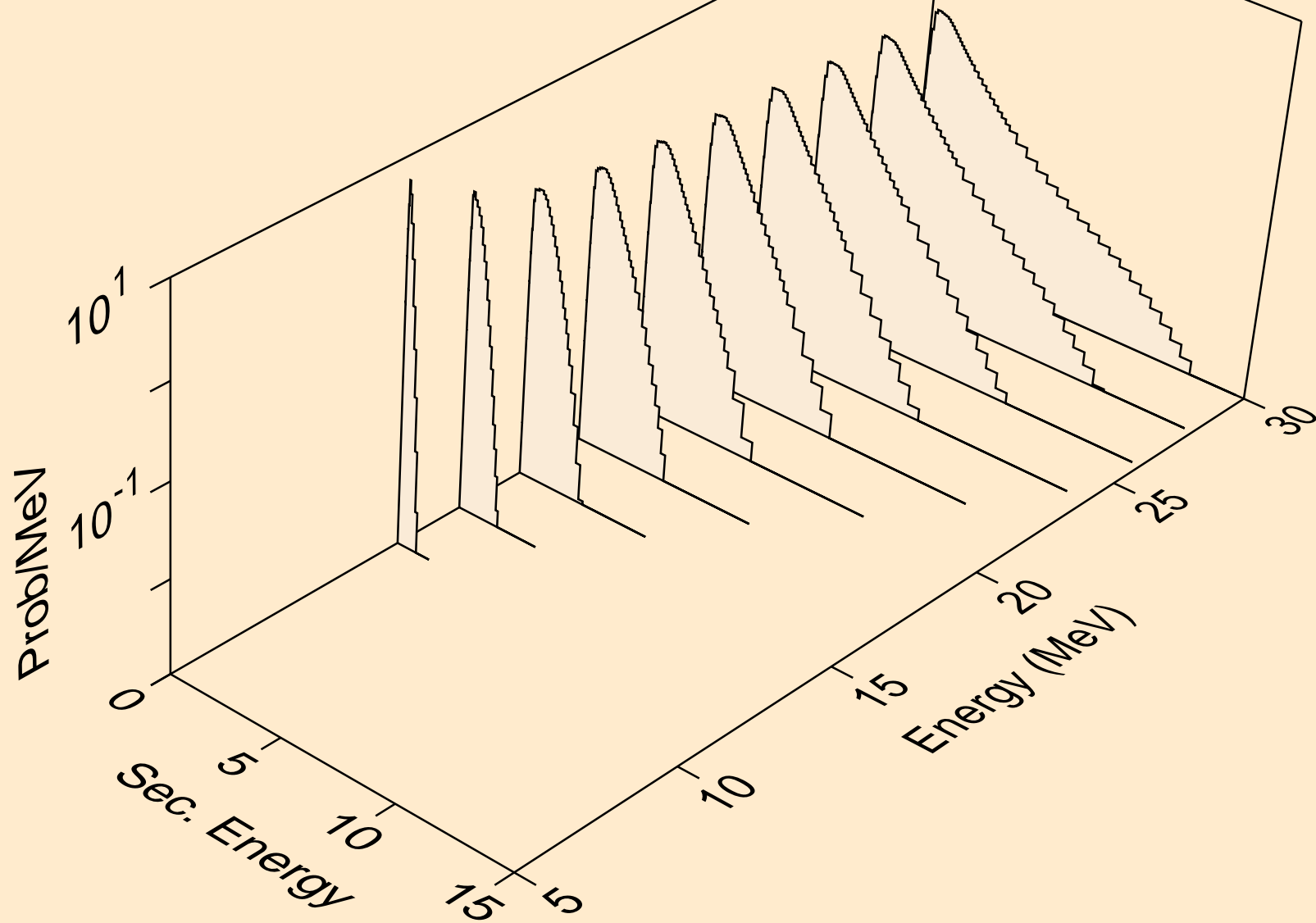

TA164 NEUTRON ACER TENDL-2024 LIBRARY; T=0.K
Neutron emission for (n,3np)

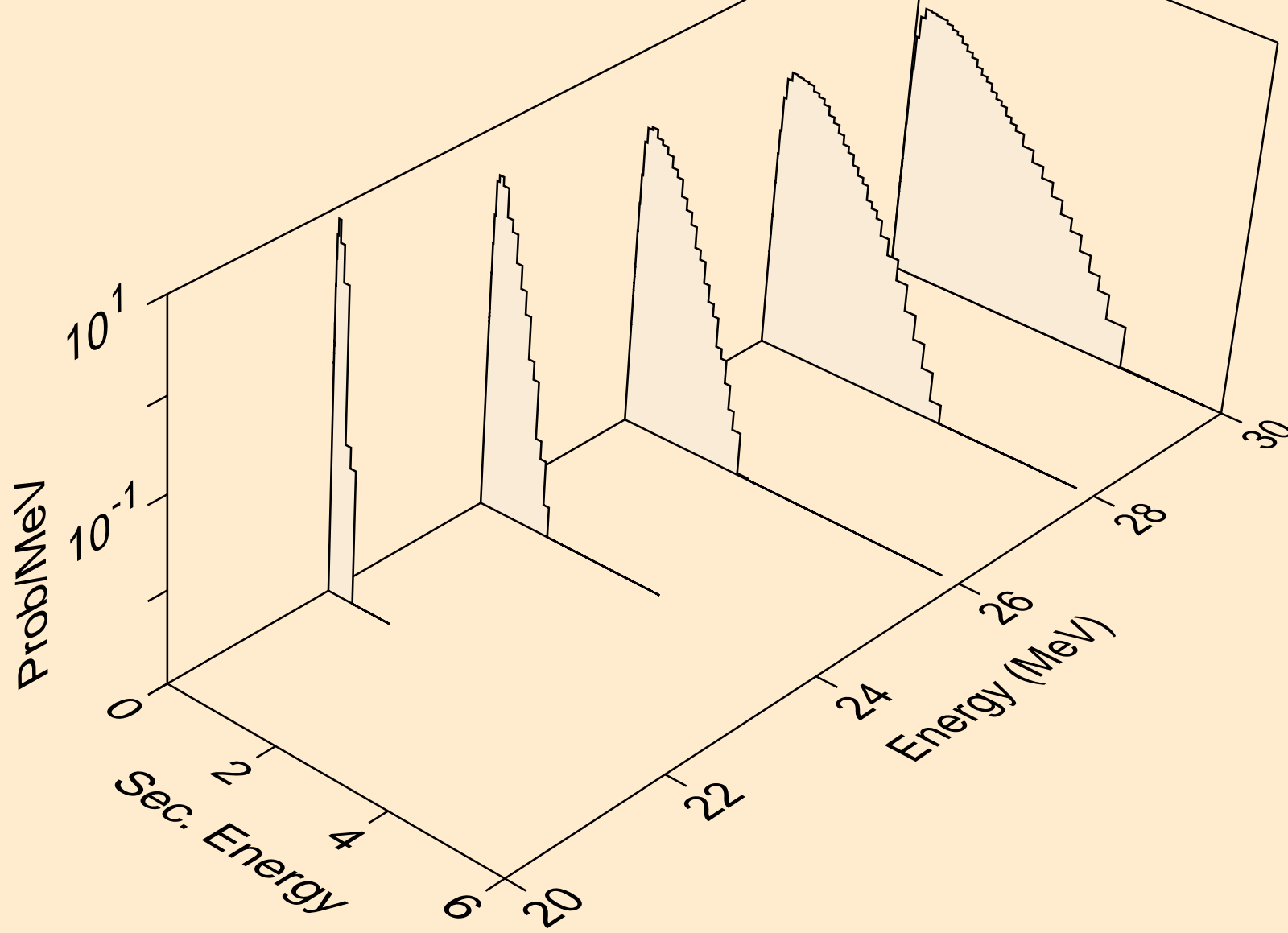

TA164 NEUTRON ACER TENDL-2024 LIBRARY; T=0.K
Neutron emission for (n,n2p)

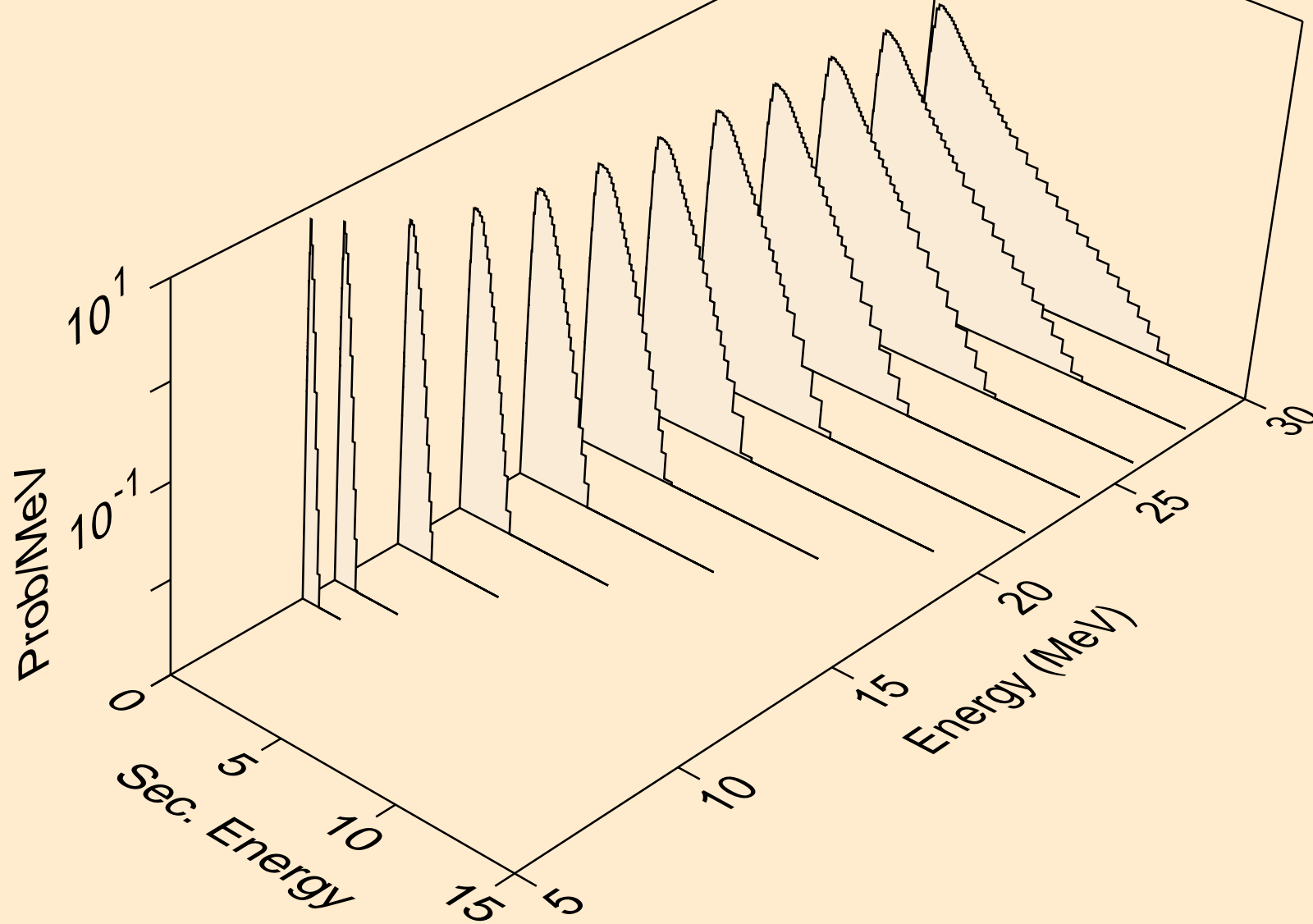

TA164 NEUTRON ACER TENDL-2024 LIBRARY; T=0.K
Neutron emission for (n,npa)

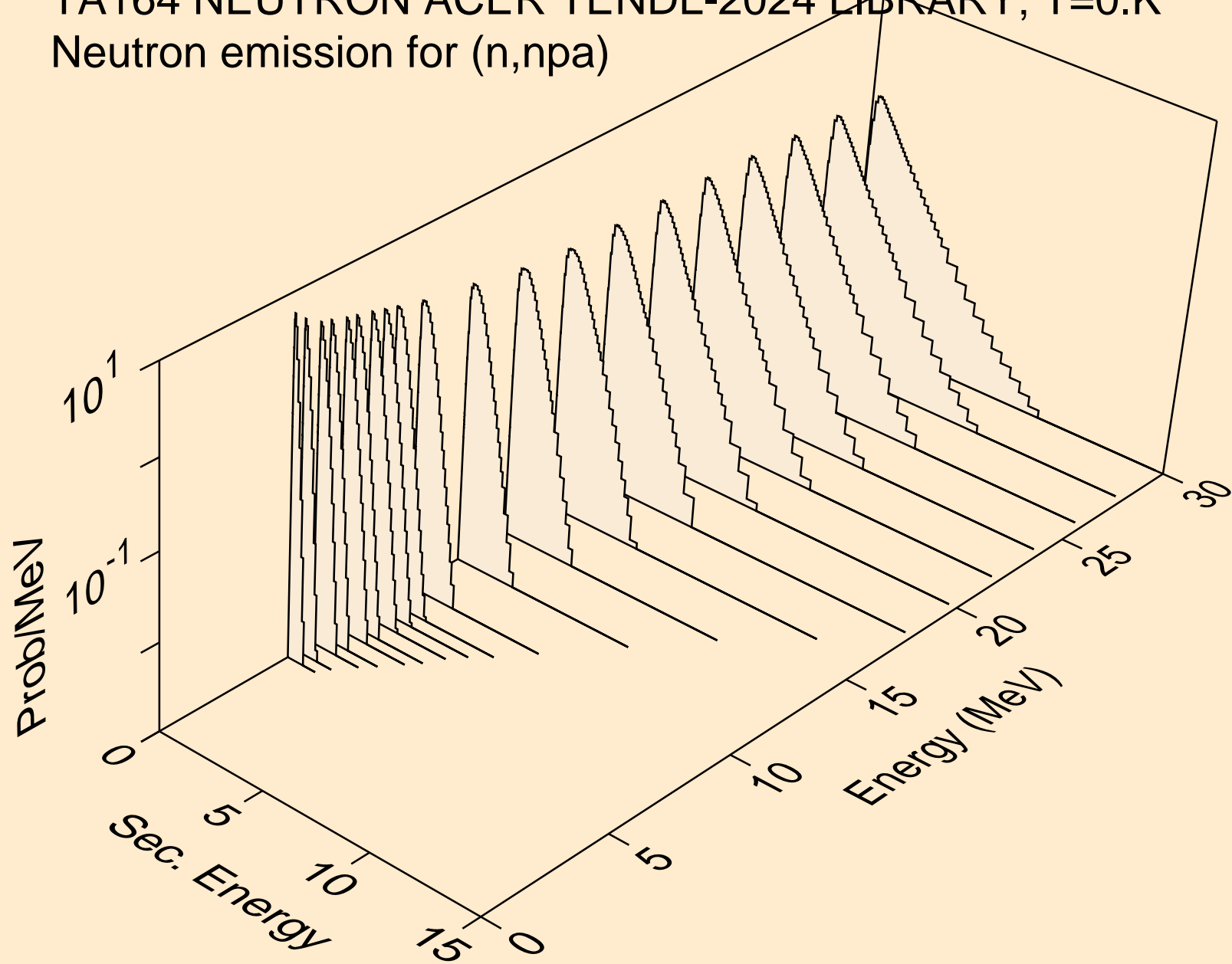

TA164 NEUTRON ACER TENDL-2024 LIBRARY; T=0.K
Neutron emission for (n,n*c)

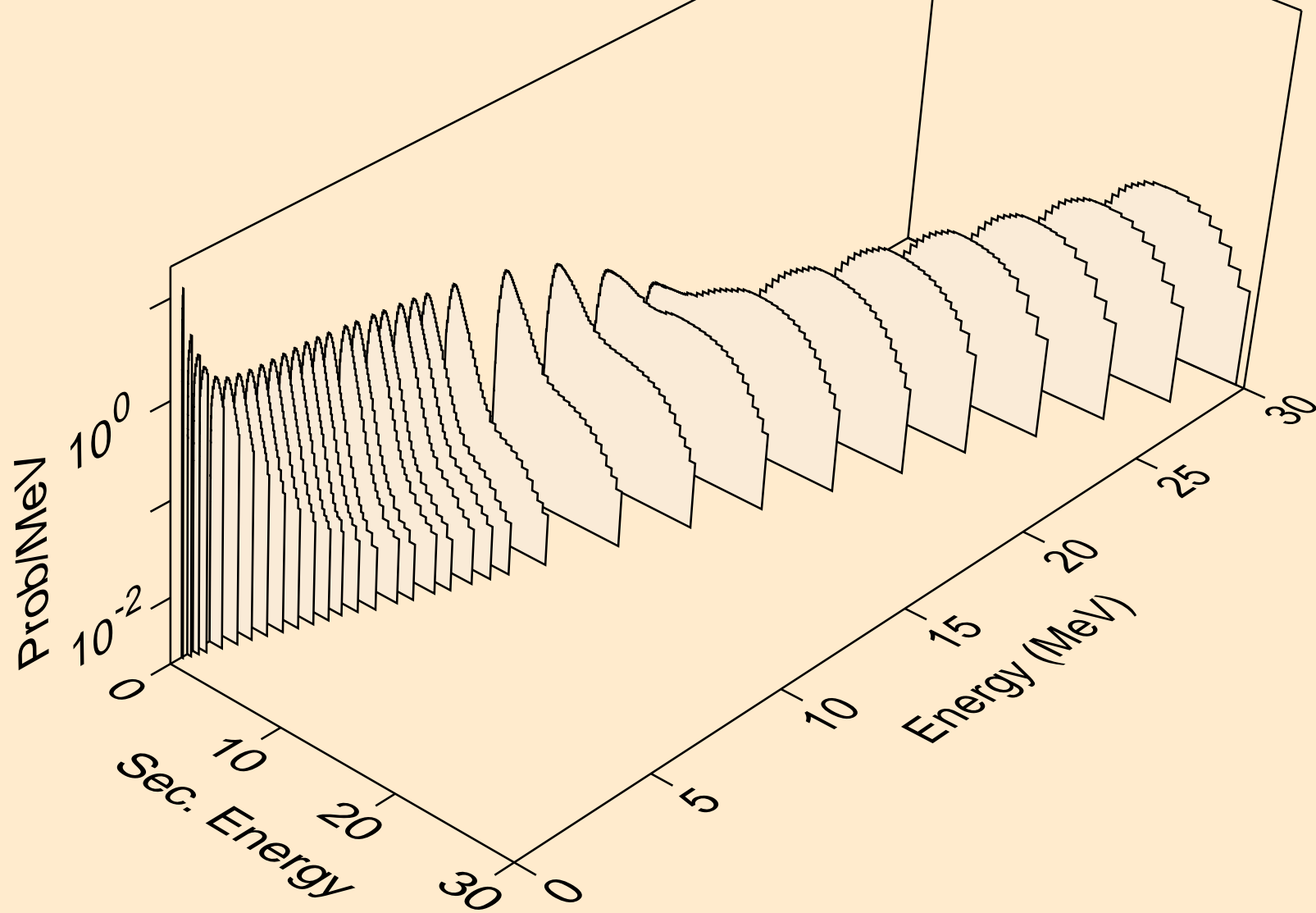

TA164 NEUTRON ACER TENDL-2024 LIBRARY; T=0.K
Photon emission for (n,x)

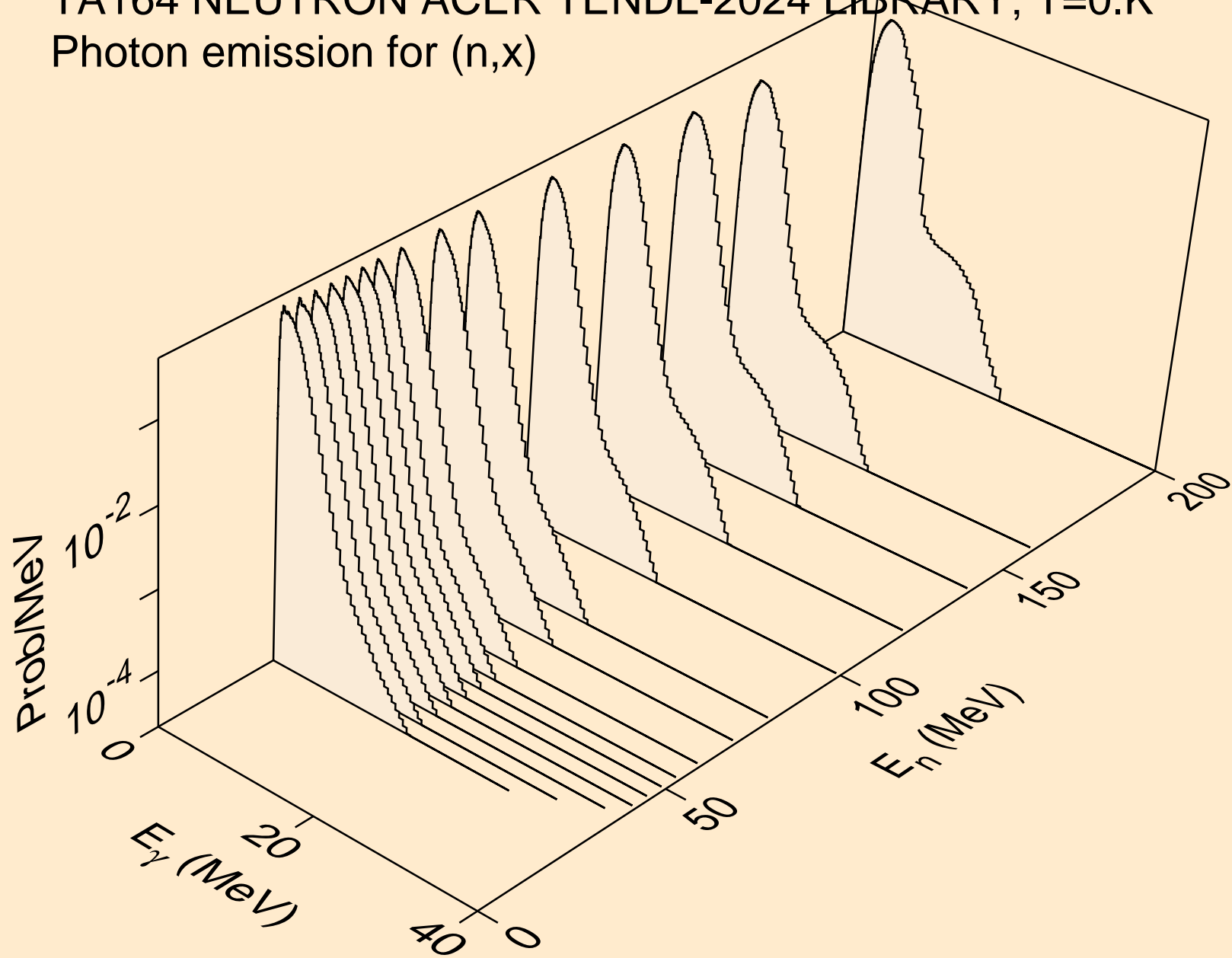

TA164 NEUTRON ACER TENDL-2024 LIBRARY; T=0.K
Photon emission for (n,2nd)

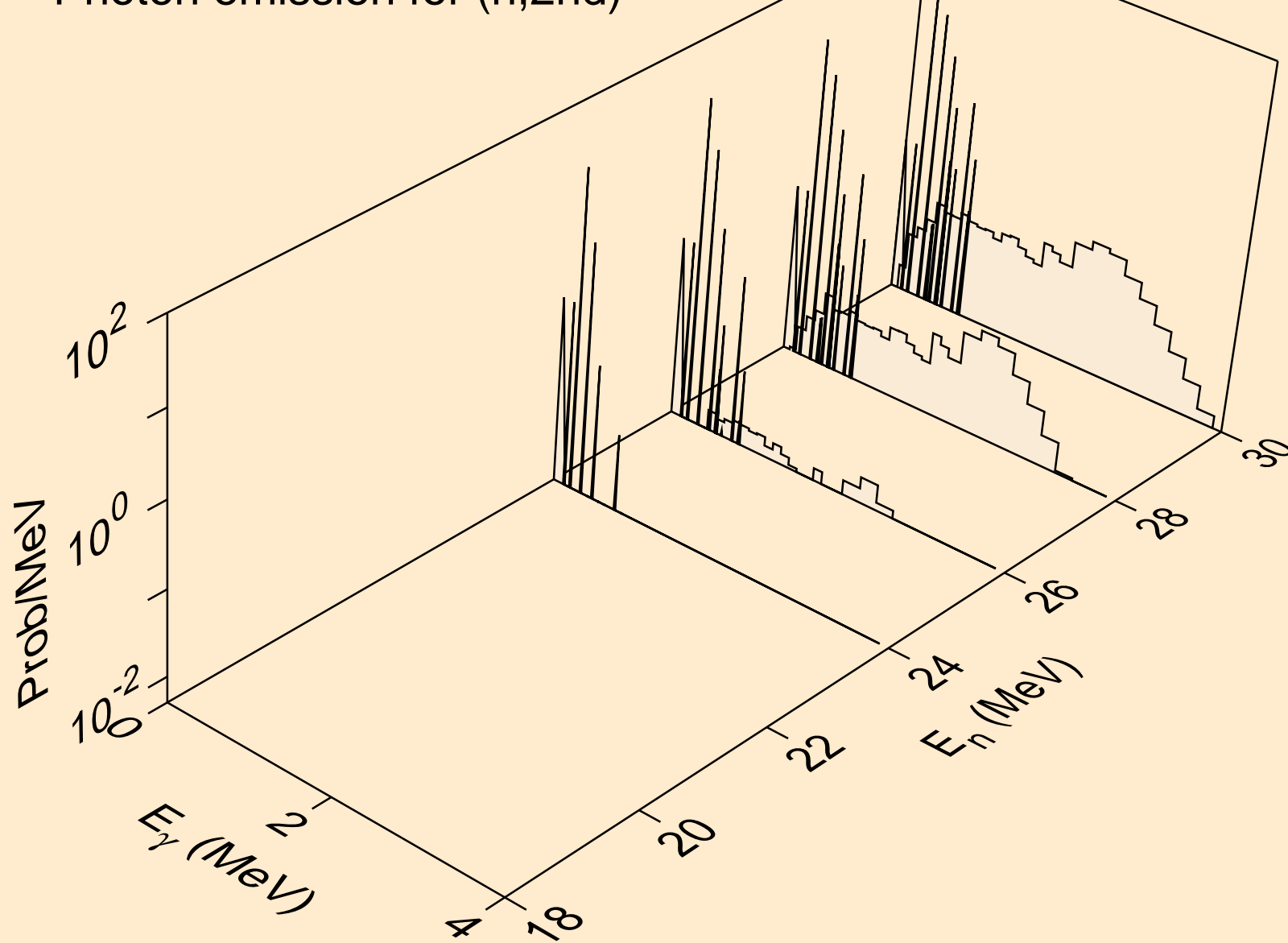

TA164 NEUTRON ACER TENDL-2024 LIBRARY; T=0.K
Photon emission for (n,2n)

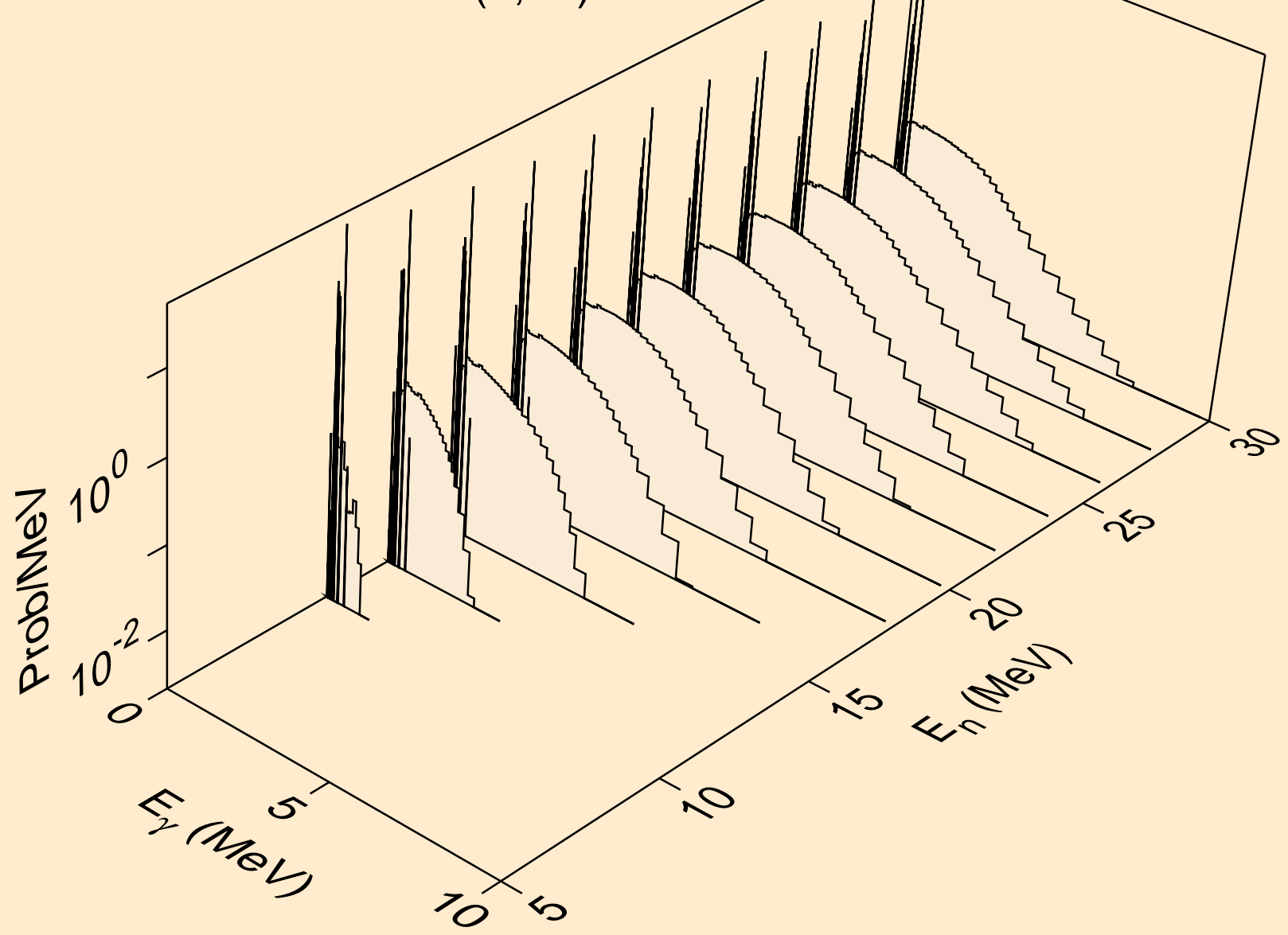

TA164 NEUTRON ACER TENDL-2024 LIBRARY; T=0.K
Photon emission for (n,3n)

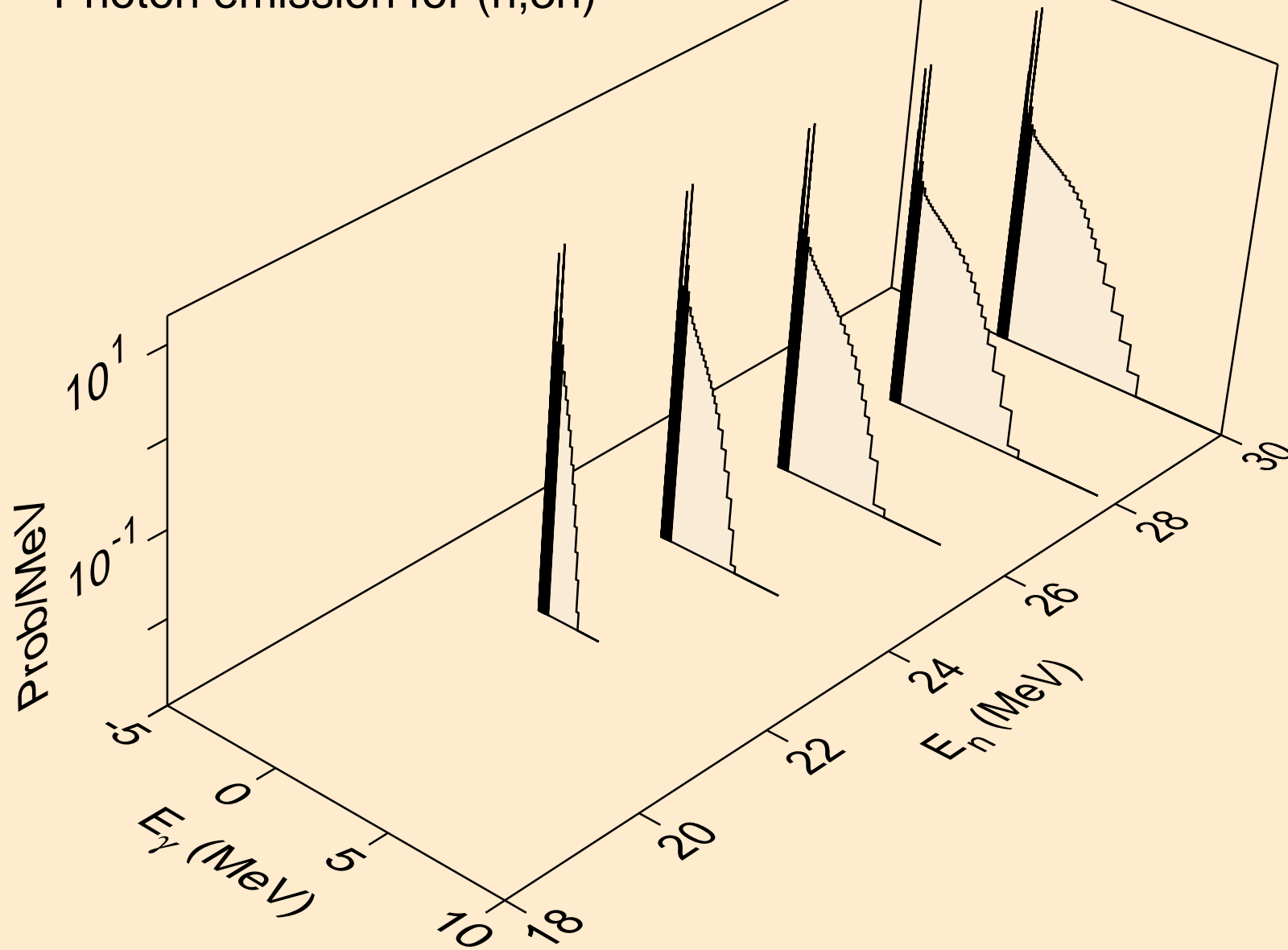

TA164 NEUTRON ACER TENDL-2024 LIBRARY; T=0.K
Photon emission for (n,n*)a

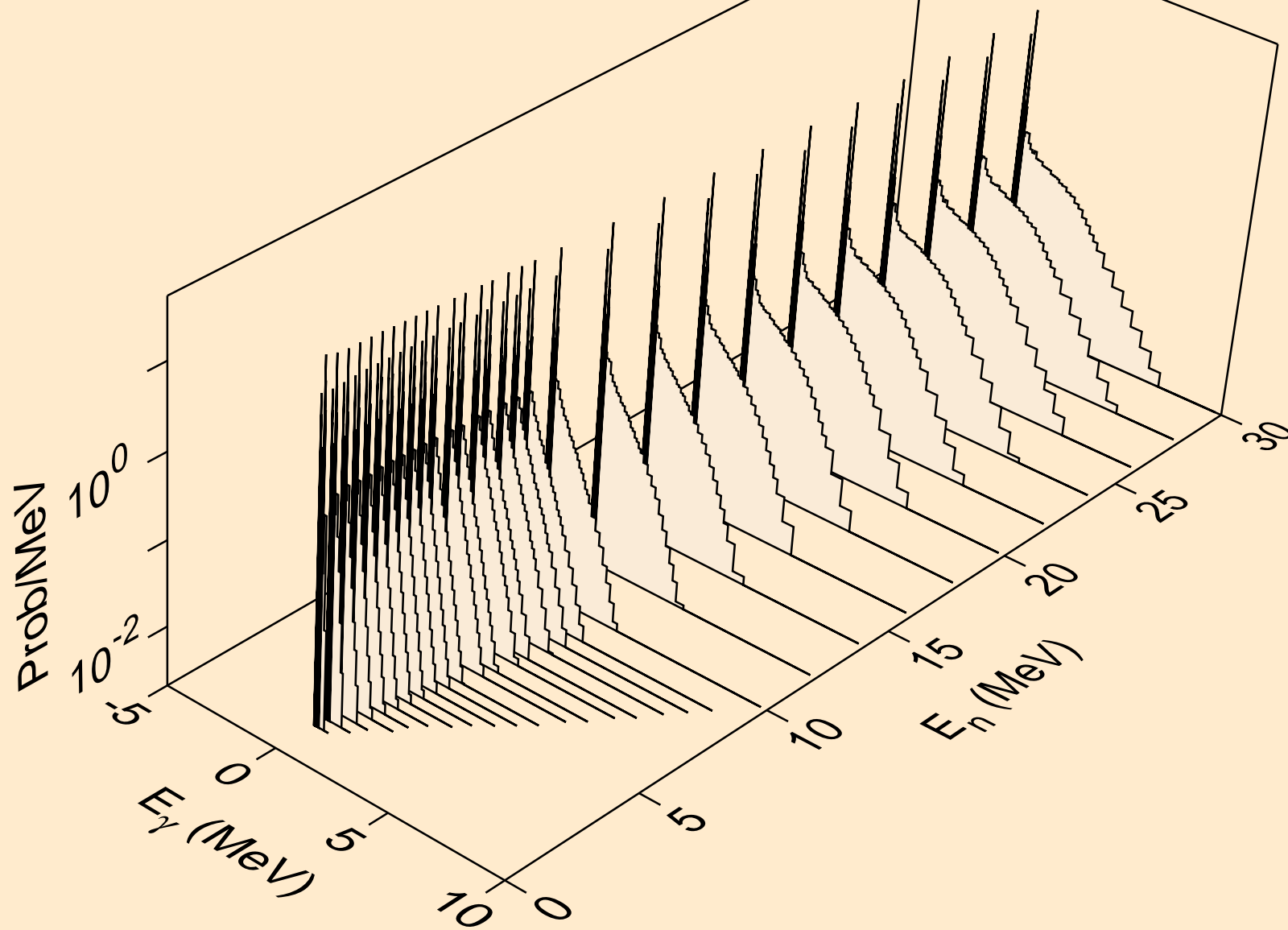

TA164 NEUTRON ACER TENDL-2024 LIBRARY; T=0.K
Photon emission for (n,n*)3a

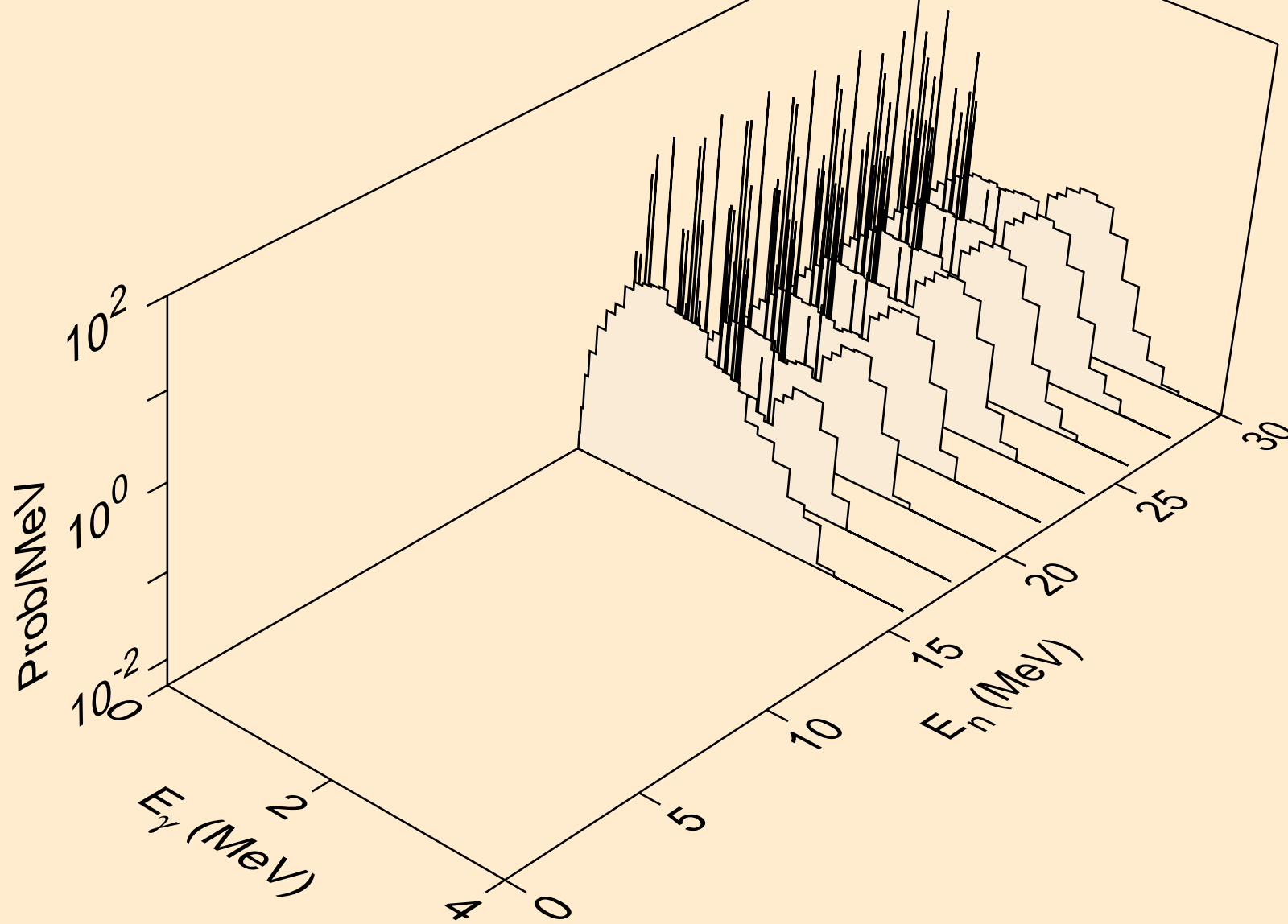

TA164 NEUTRON ACER TENDL-2024 LIBRARY; T=0.K
Photon emission for (n,2n)a

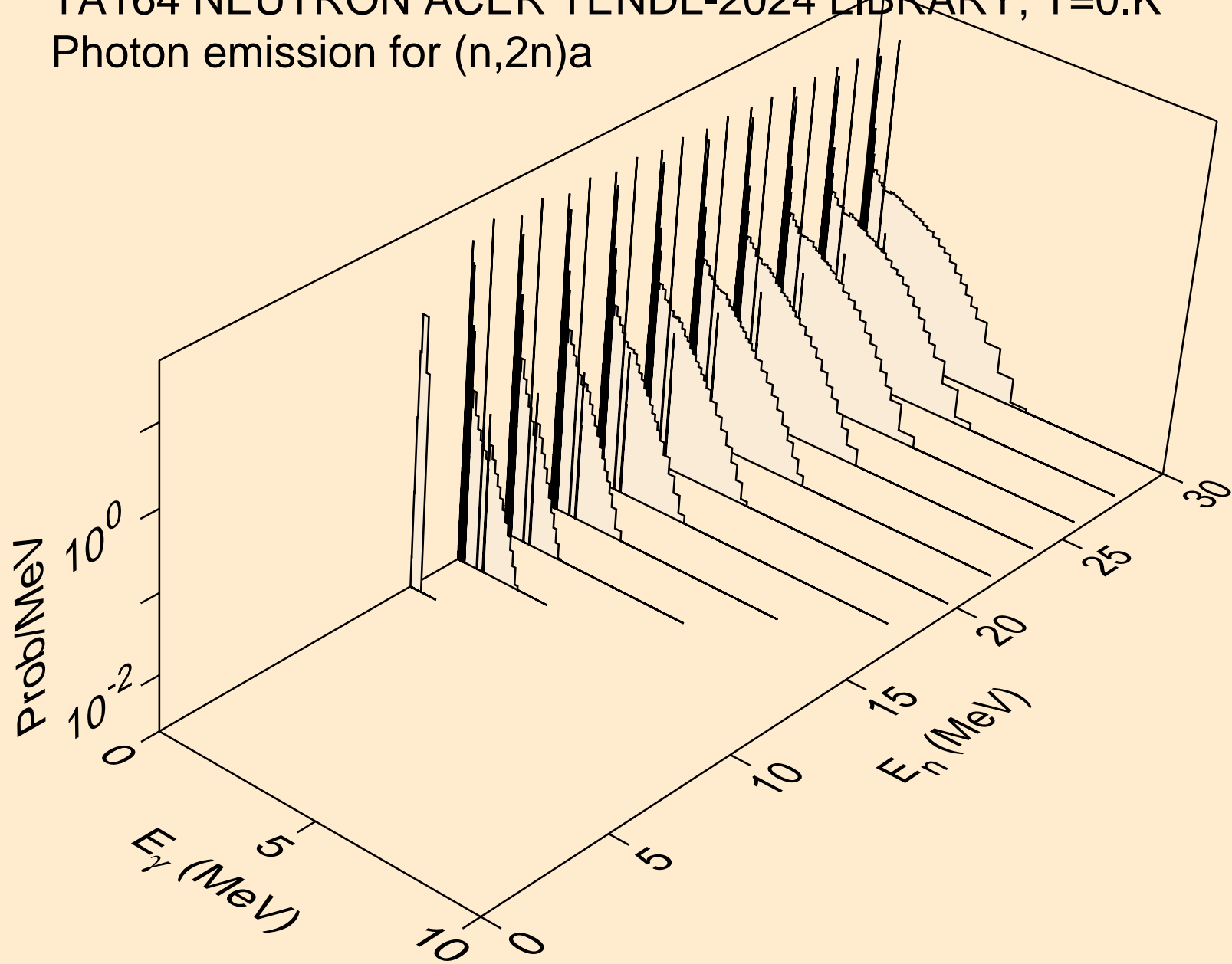

TA164 NEUTRON ACER TENDL-2024 LIBRARY; T=0.K
Photon emission for (n,3n)a

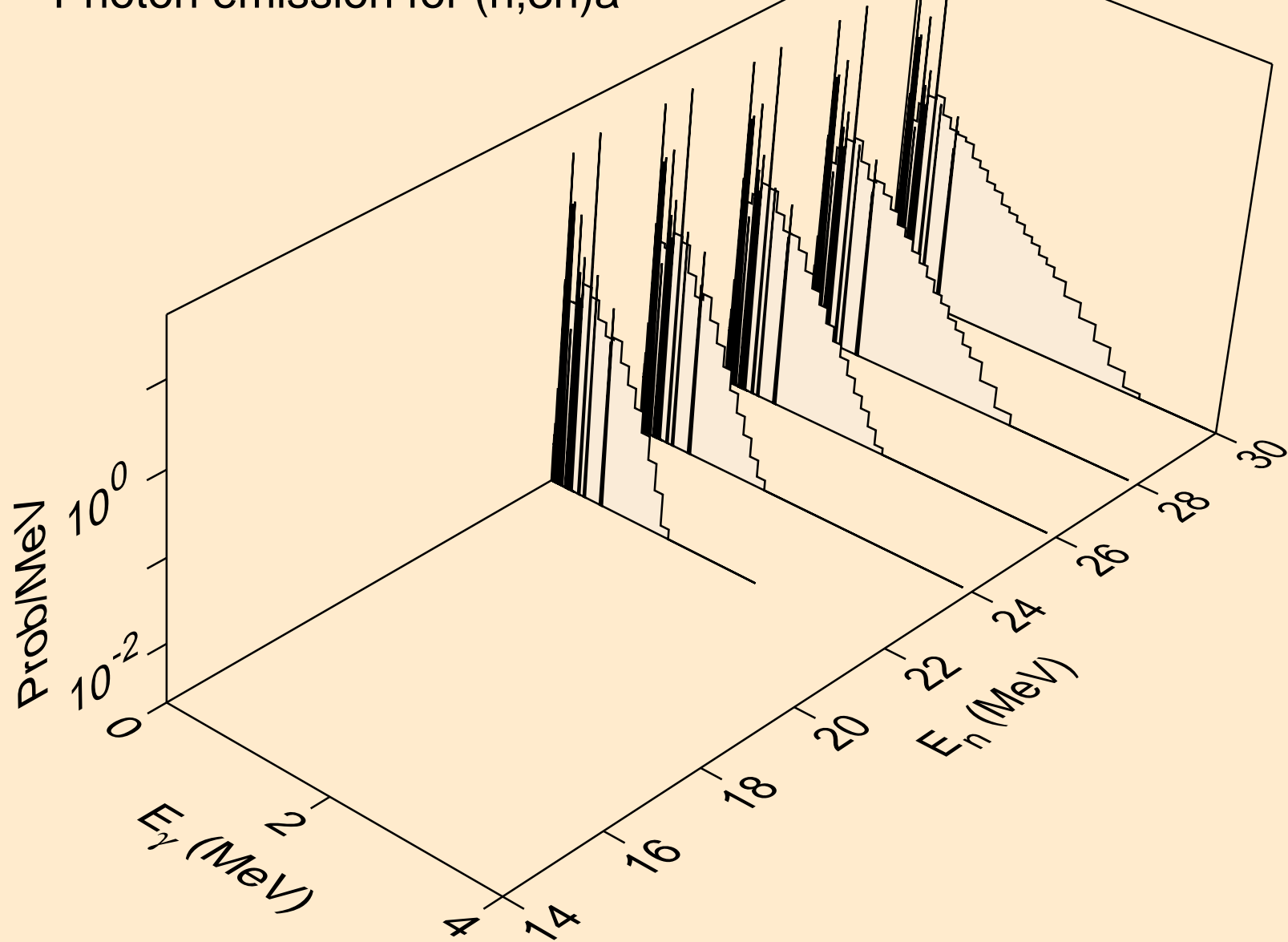

TA164 NEUTRON ACER TENDL-2024 LIBRARY; T=0.K
Photon emission for (n,n*)p

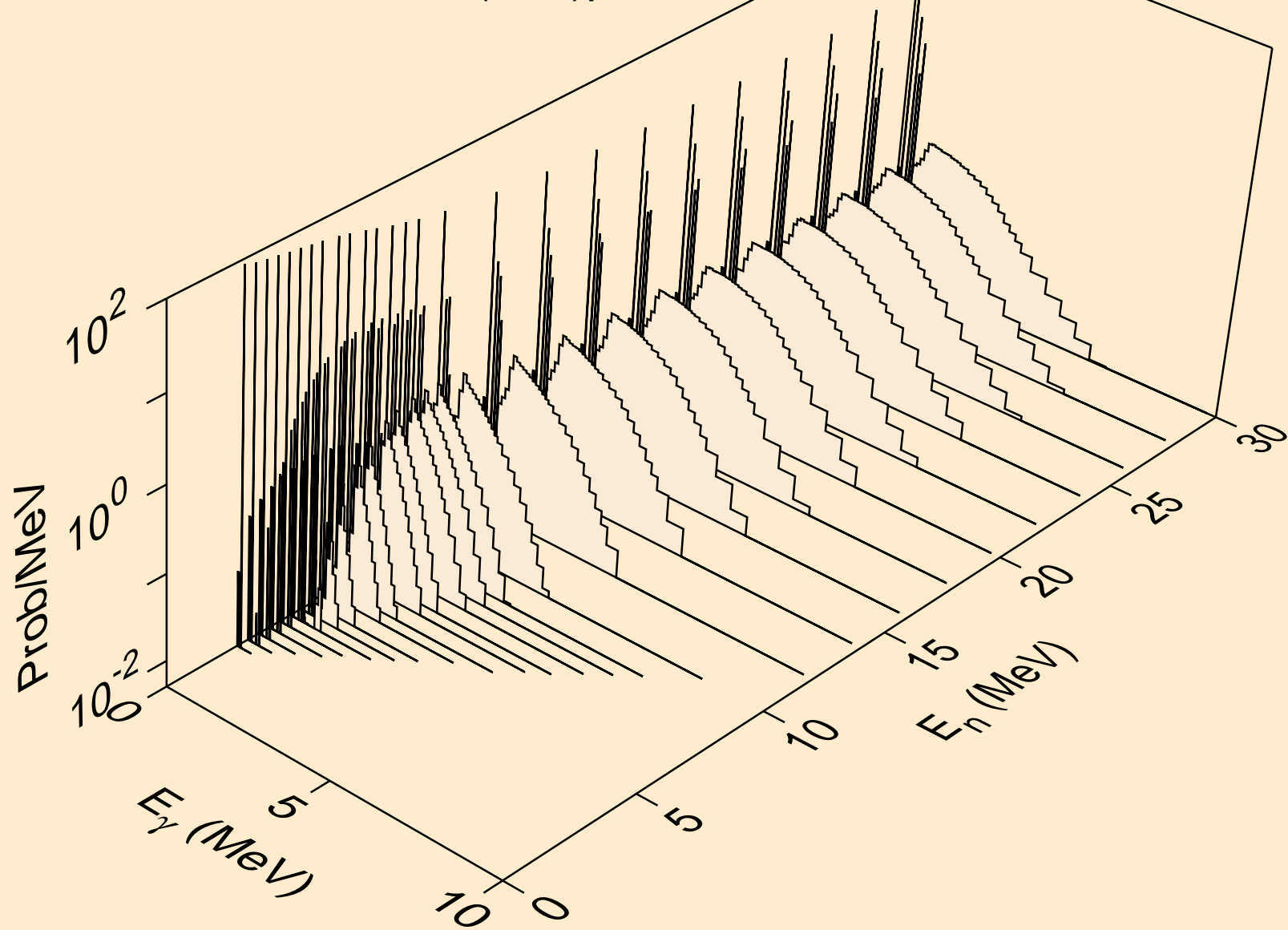

TA164 NEUTRON ACER TENDL-2024 LIBRARY; T=0.K
Photon emission for (n,n*)2a

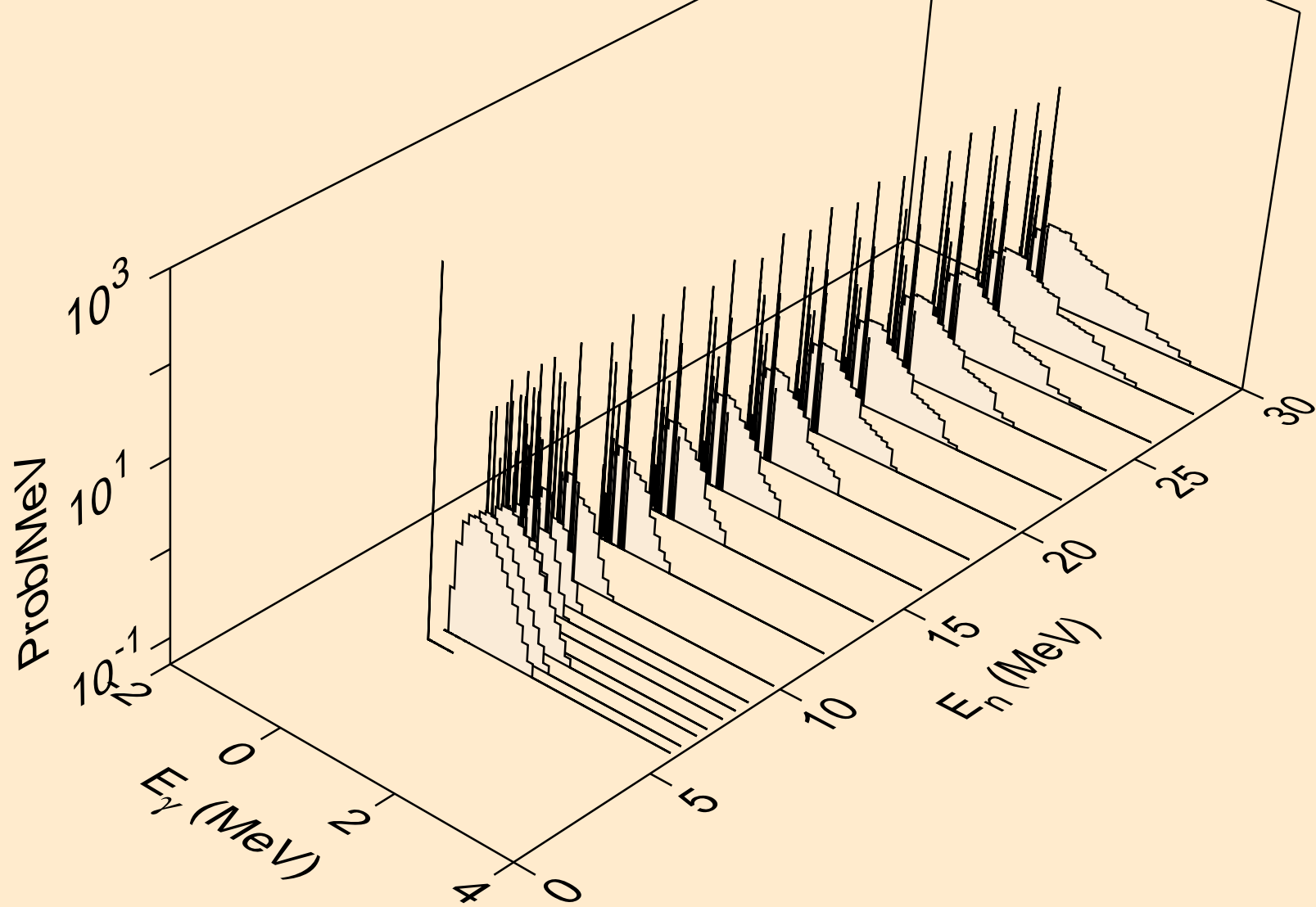

TA164 NEUTRON ACER TENDL-2024 LIBRARY; T=0.K
Photon emission for (n,2n)2a

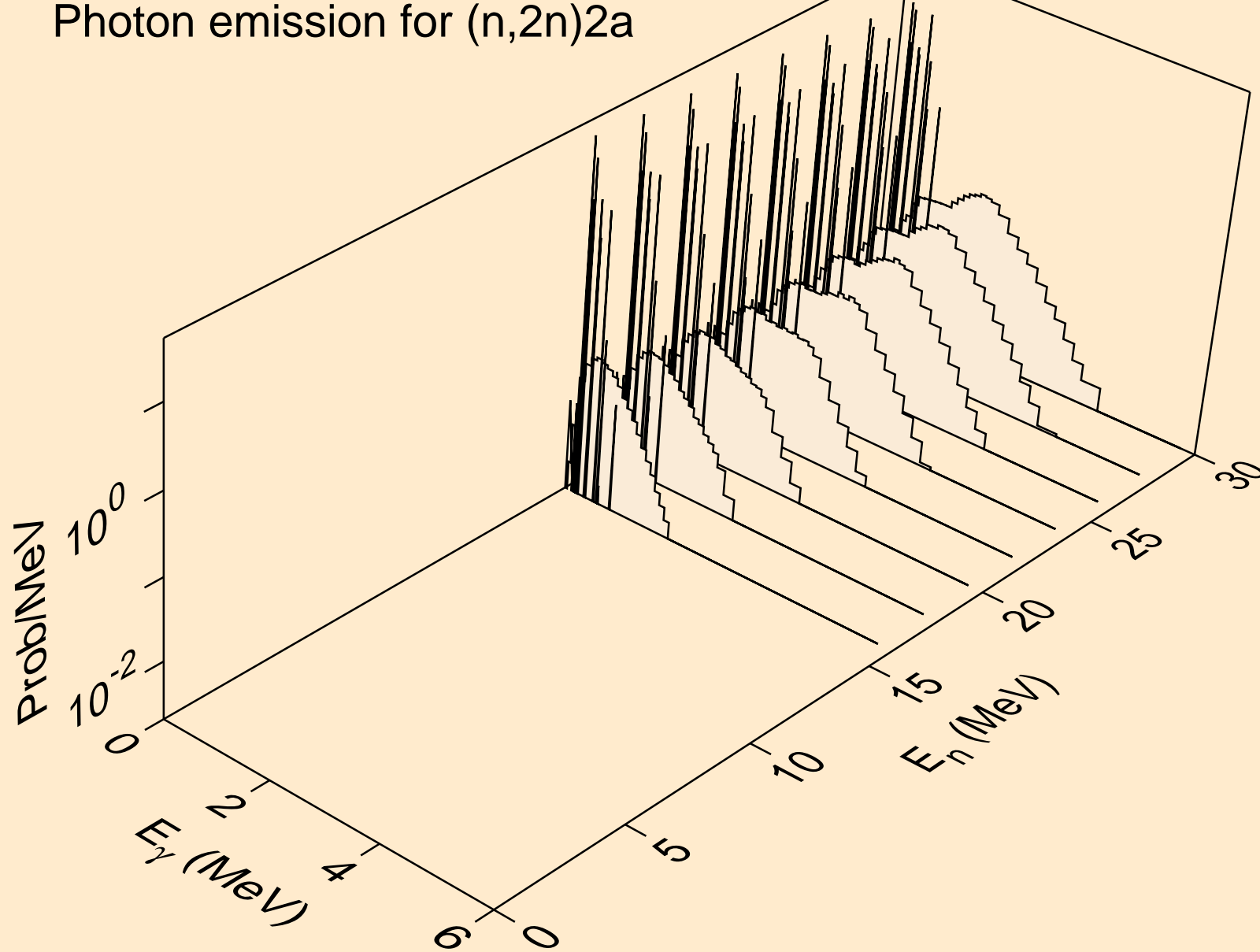

TA164 NEUTRON ACER TENDL-2024 LIBRARY; T=0.K
Photon emission for (n,n*)d

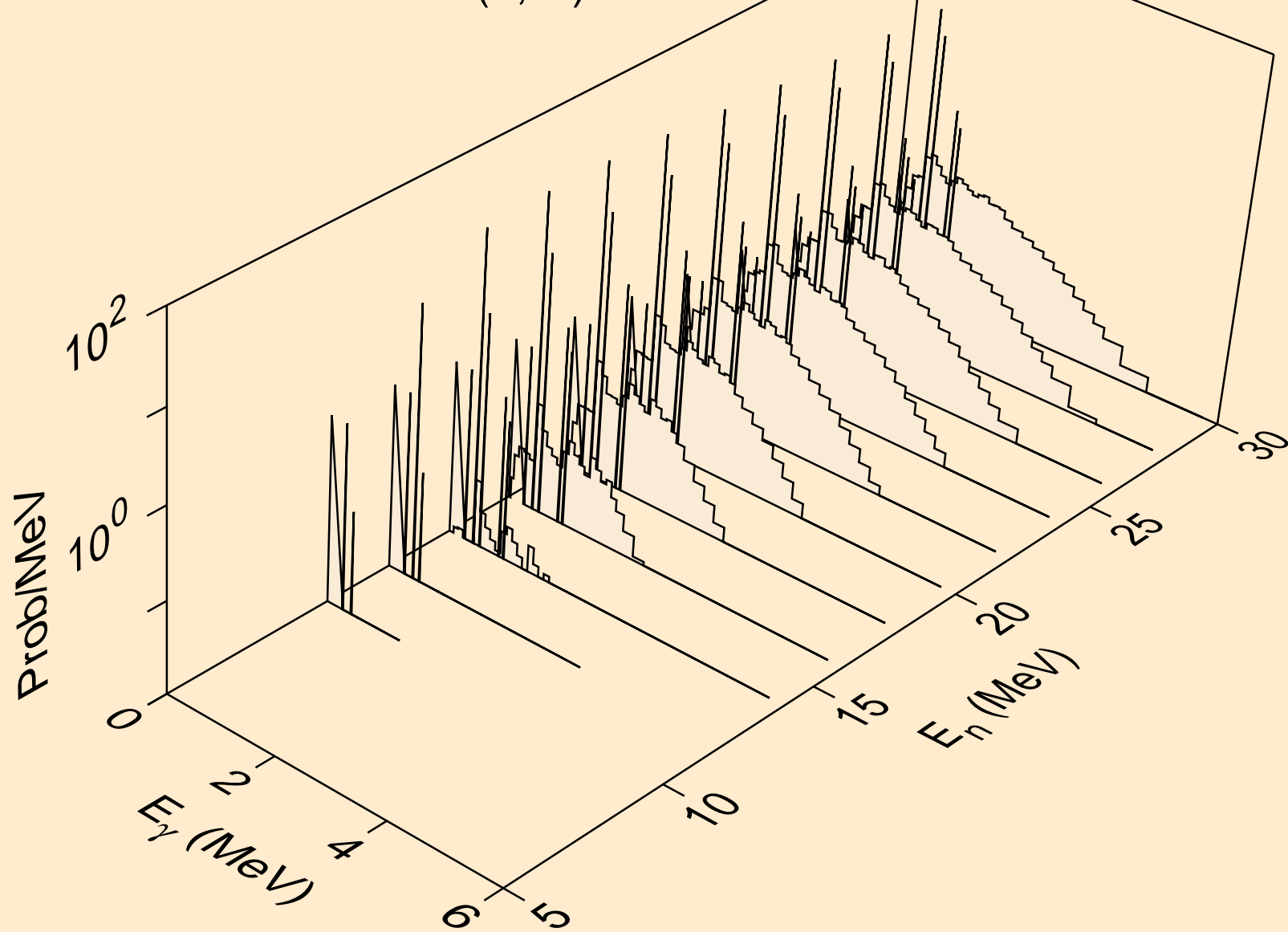

TA164 NEUTRON ACER TENDL-2024 LIBRARY; T=0.K
Photon emission for (n,n*)t

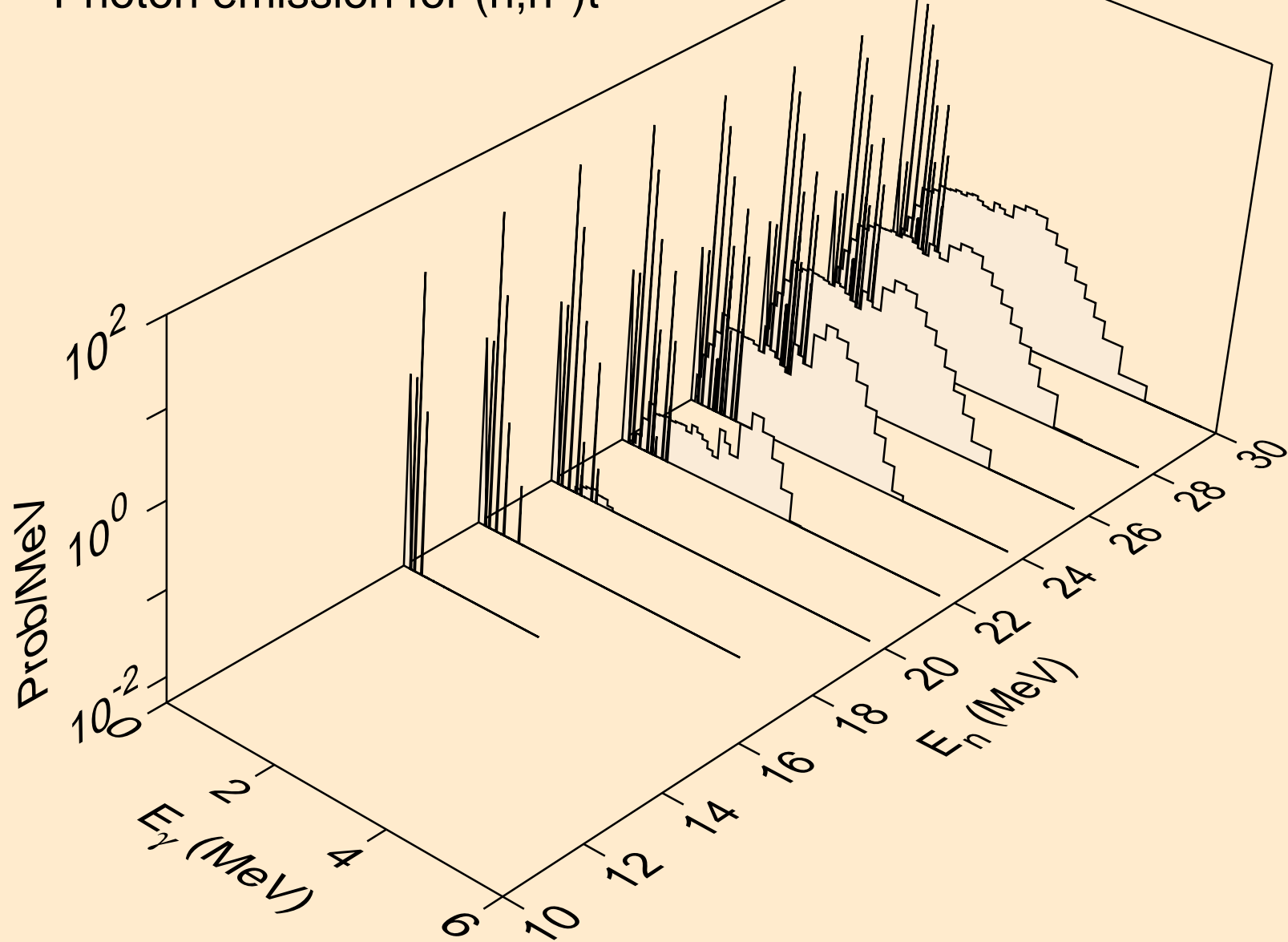

TA164 NEUTRON ACER TENDL-2024 LIBRARY; T=0.K
Photon emission for (n,n*)he3

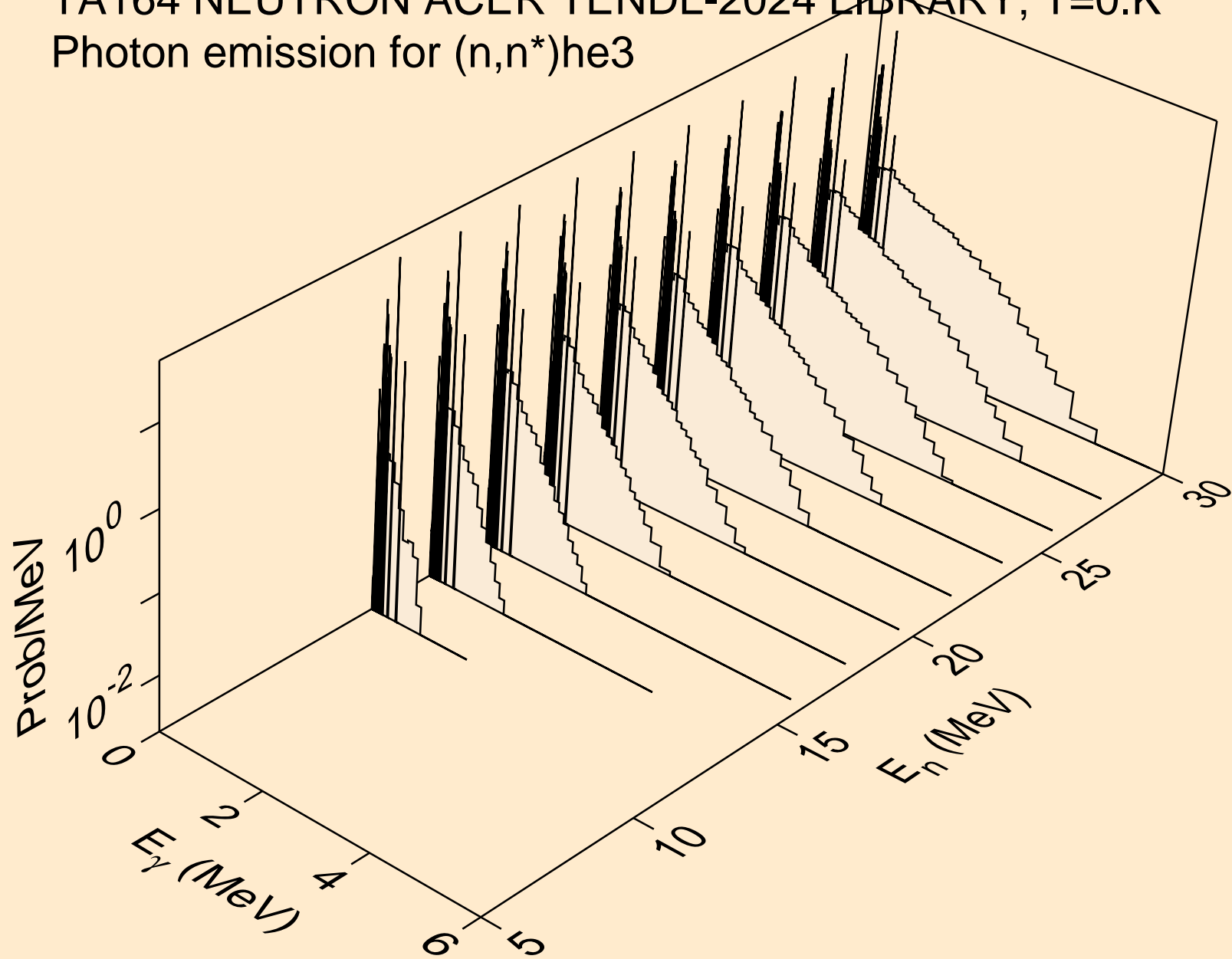

TA164 NEUTRON ACER TENDL-2024 LIBRARY; T=0.K
Photon emission for (n,4n)

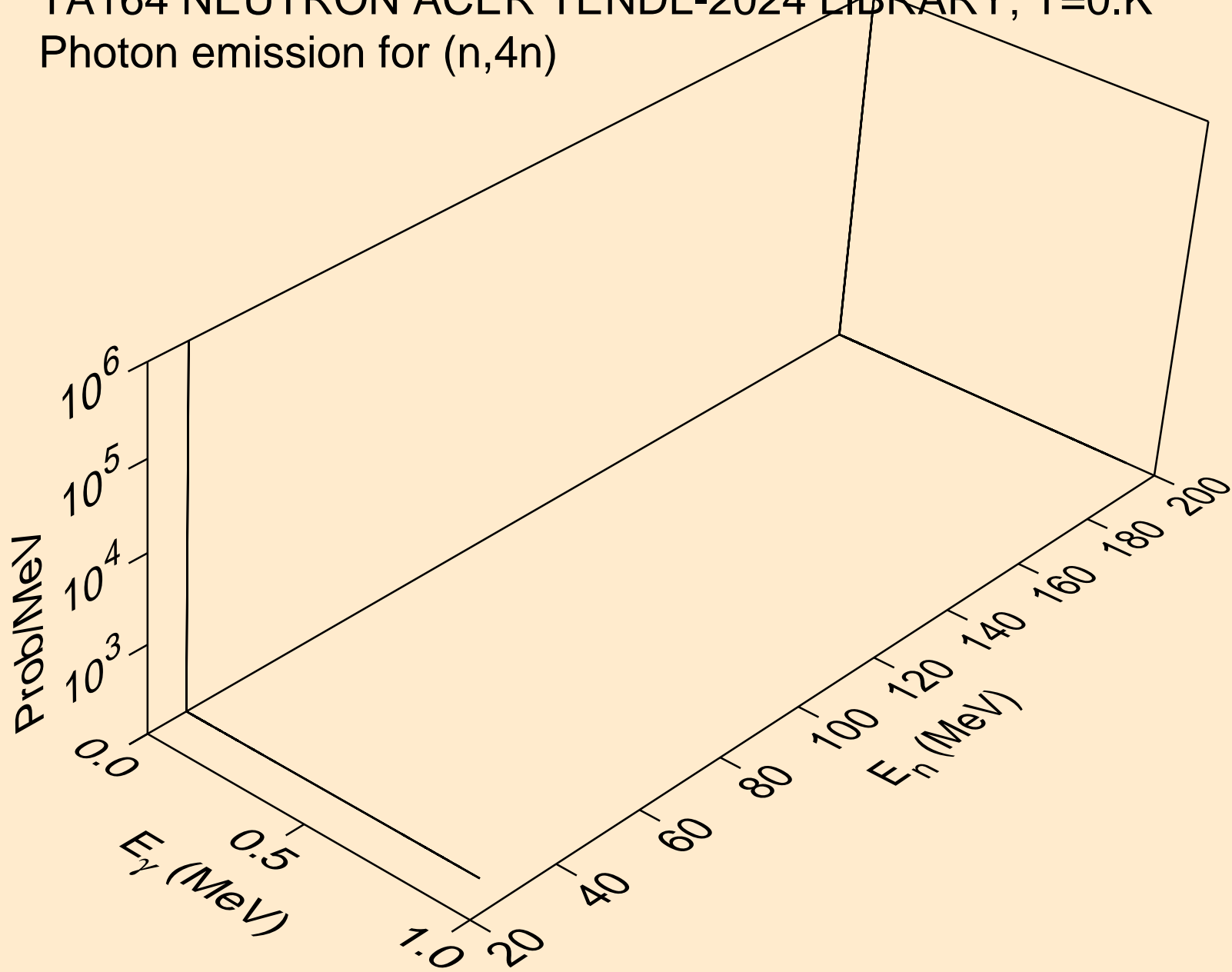

TA164 NEUTRON ACER TENDL-2024 LIBRARY; T=0.K
Photon emission for (n,2np)

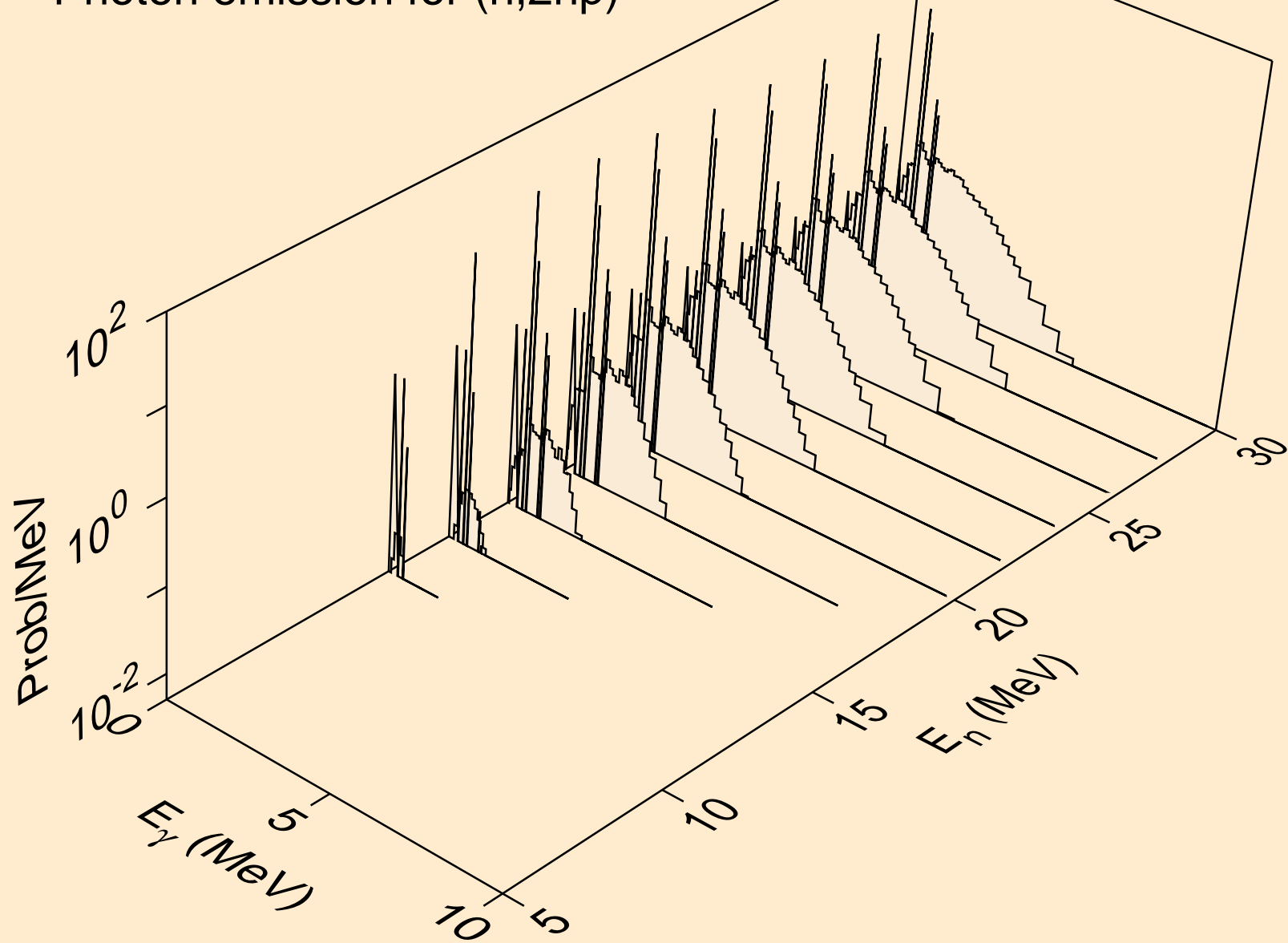

TA164 NEUTRON ACER TENDL-2024 LIBRARY; T=0.K
Photon emission for (n,3np)

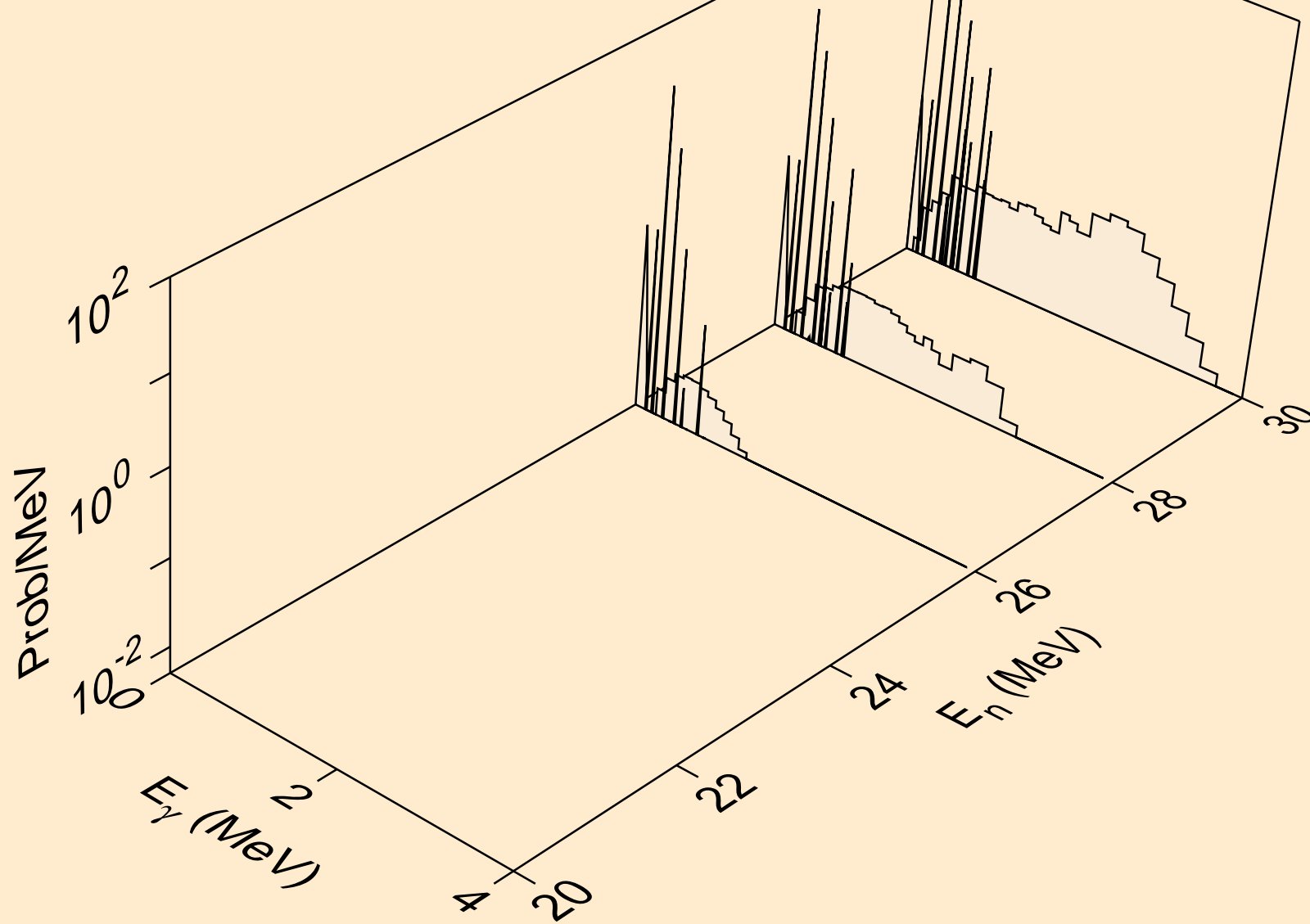

TA164 NEUTRON ACER TENDL-2024 LIBRARY; T=0.K
Photon emission for (n,n2p)

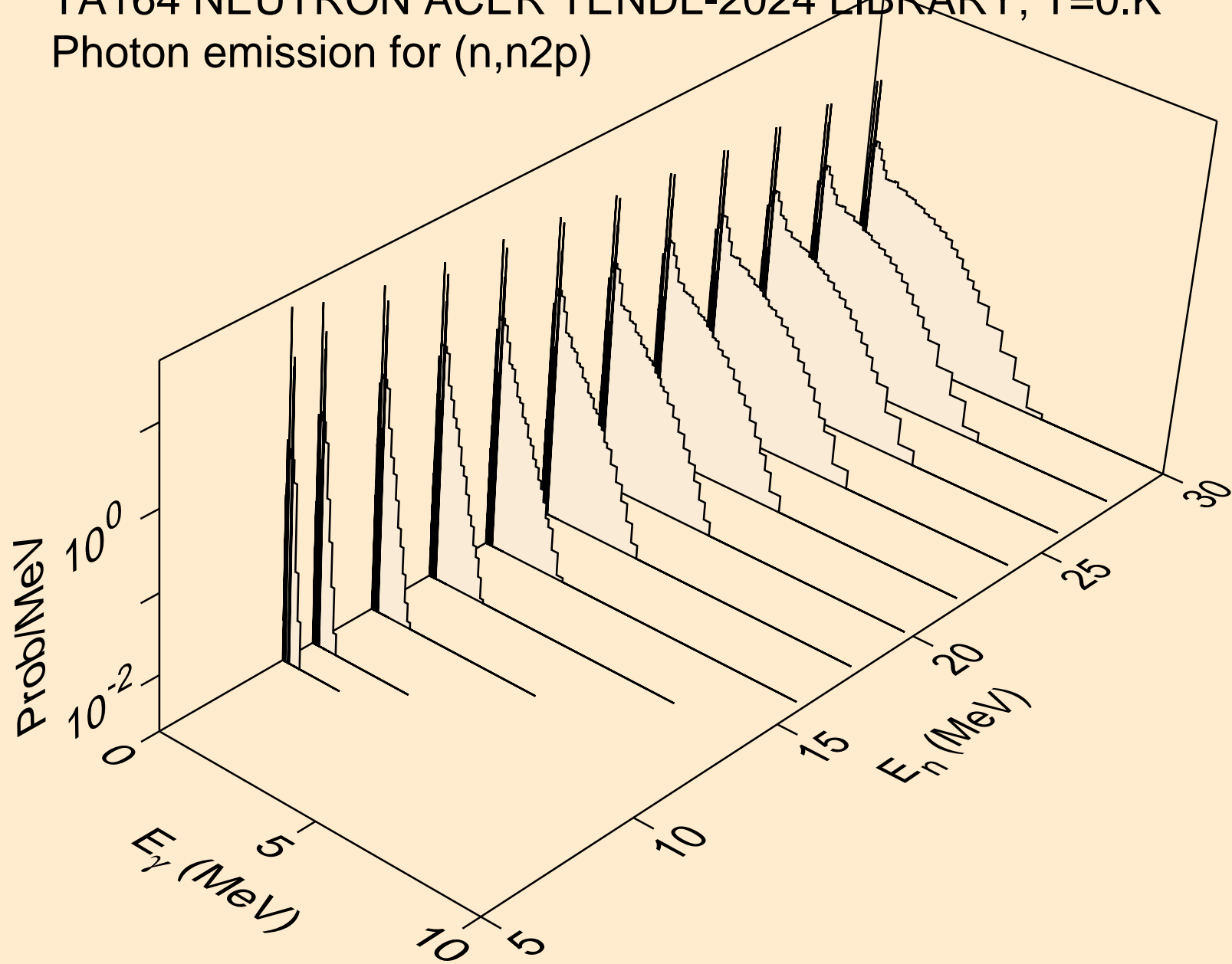

TA164 NEUTRON ACER TENDL-2024 LIBRARY; T=0.K
Photon emission for (n,npa)

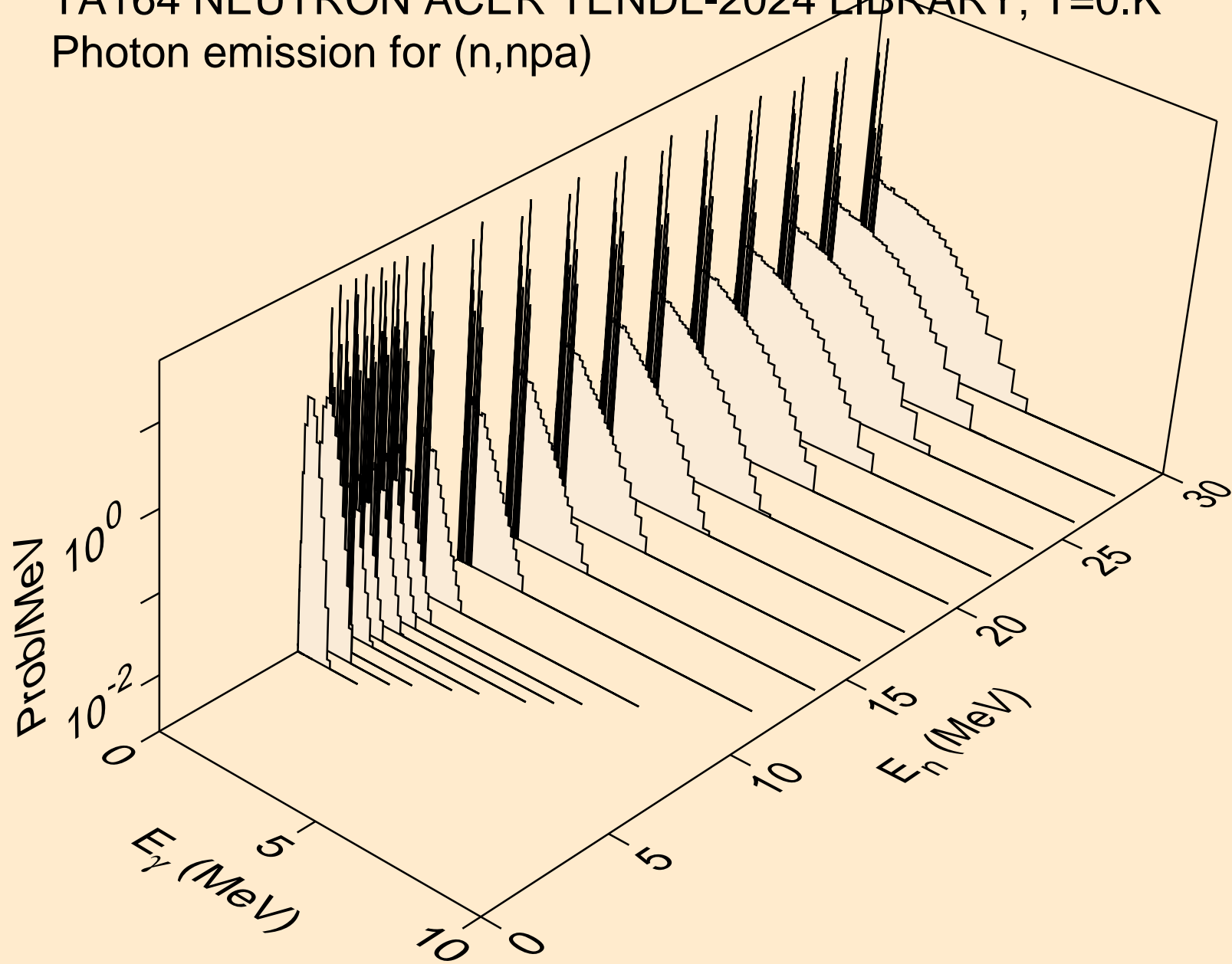

TA164 NEUTRON ACER TENDL-2024 LIBRARY; T=0.K
Photon emission for (n,n*c)

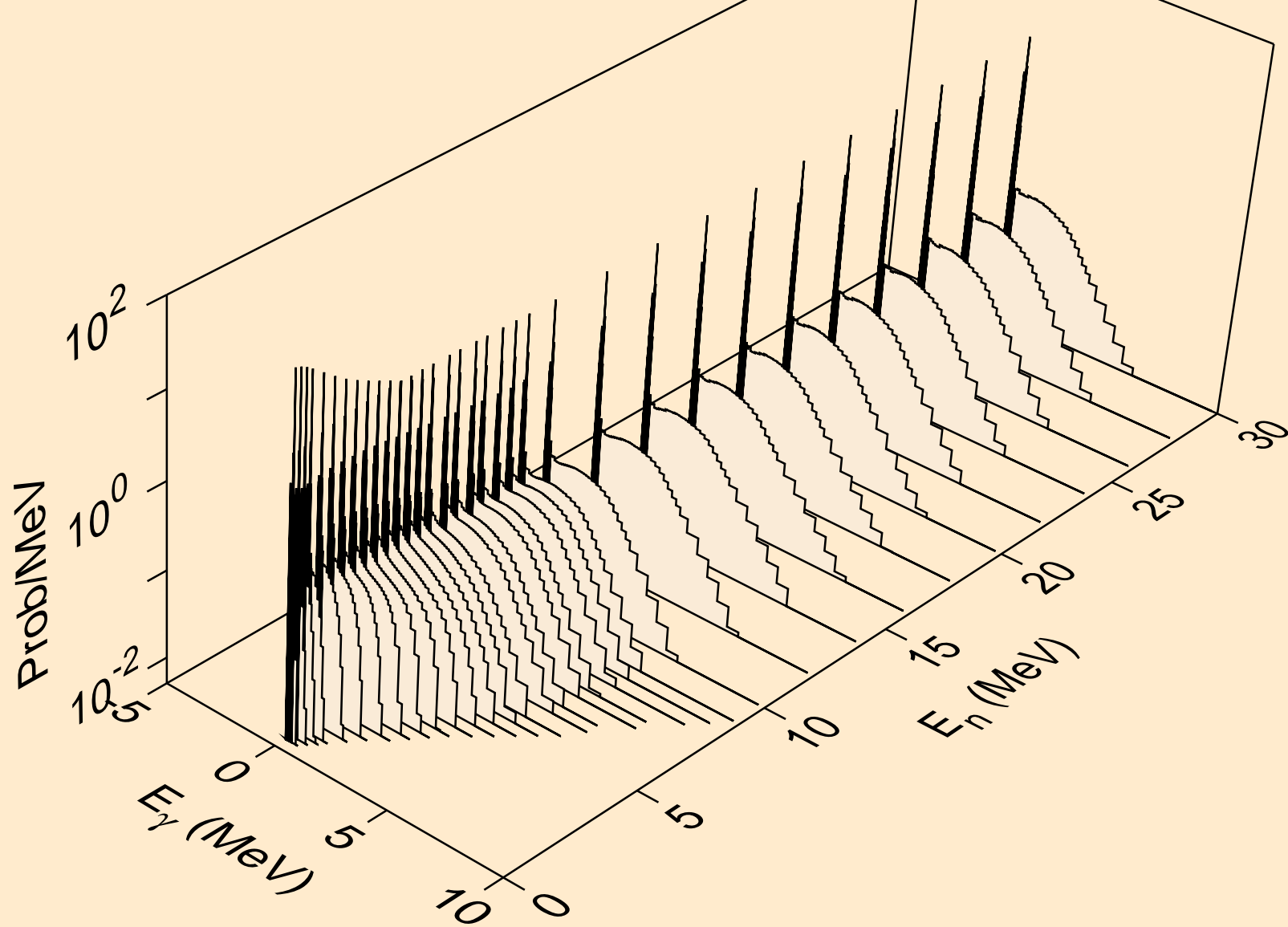

TA164 NEUTRON ACER TENDL-2024 LIBRARY; T=0.K
Photon emission for (n,gma)

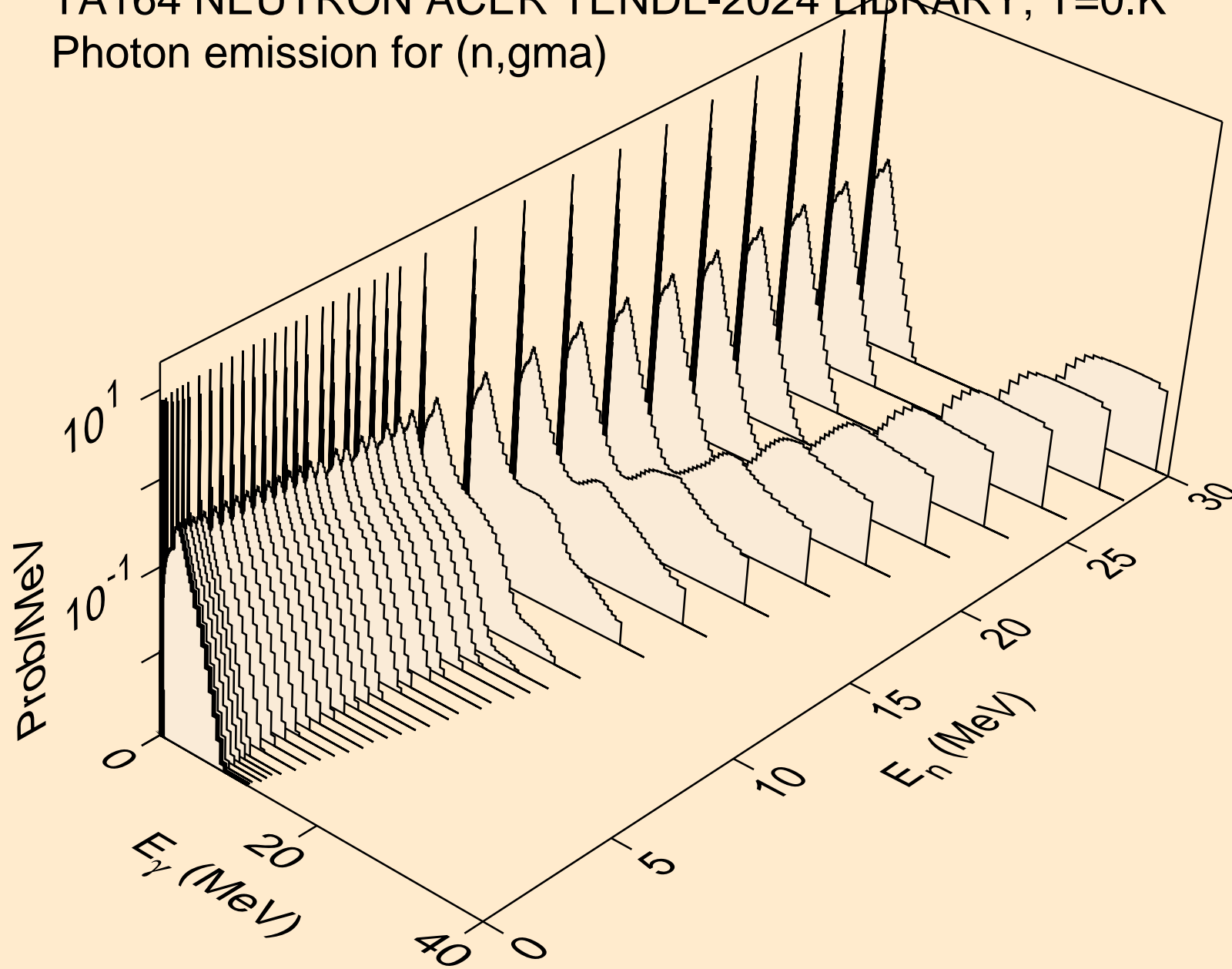

TA164 NEUTRON ACER TENDL-2024 LIBRARY; T=0.K
Photon emission for (n,p)

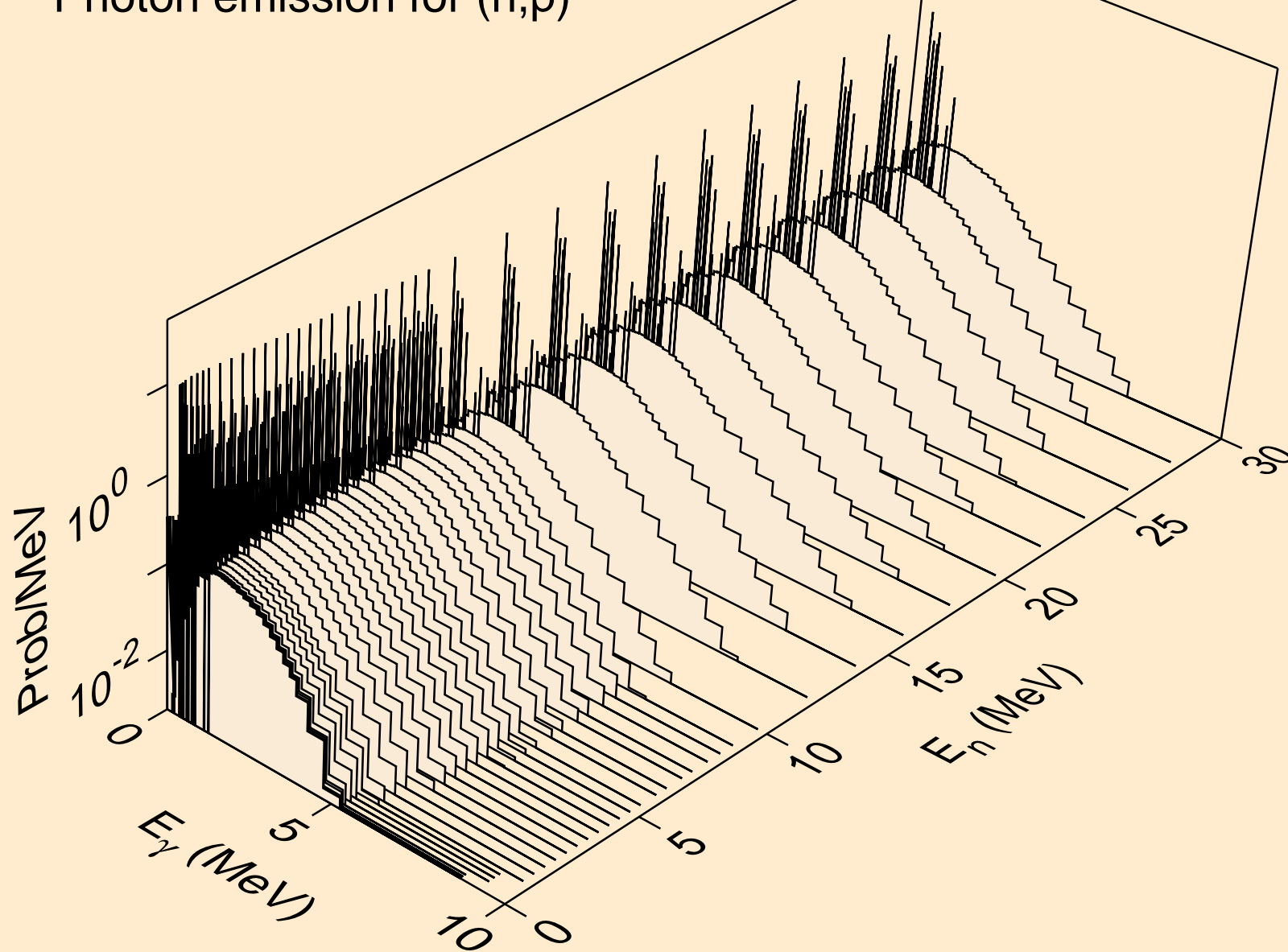

TA164 NEUTRON ACER TENDL-2024 LIBRARY; T=0.K
Photon emission for (n,d)

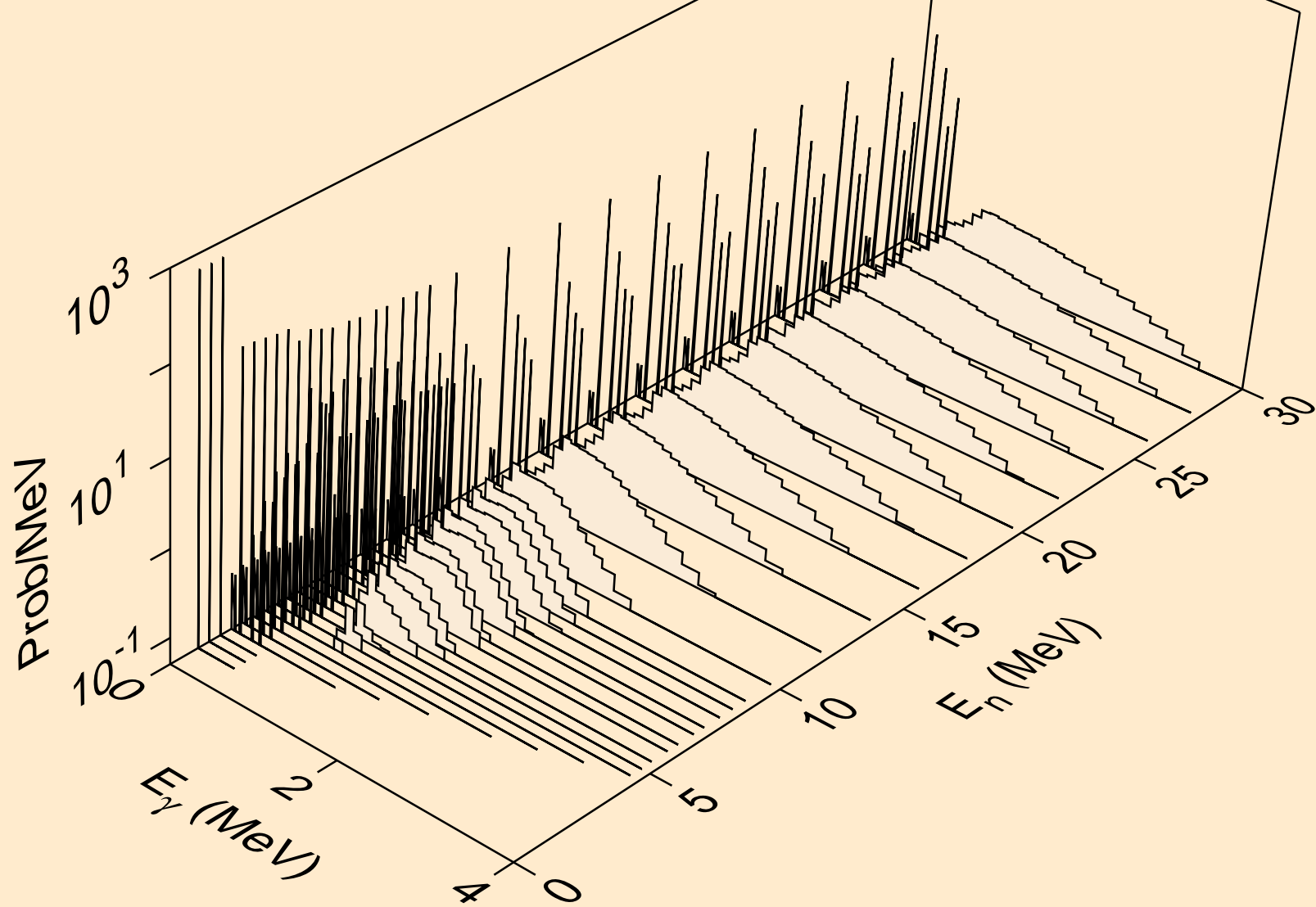

TA164 NEUTRON ACER TENDL-2024 LIBRARY; T=0.K
Photon emission for (n,t)

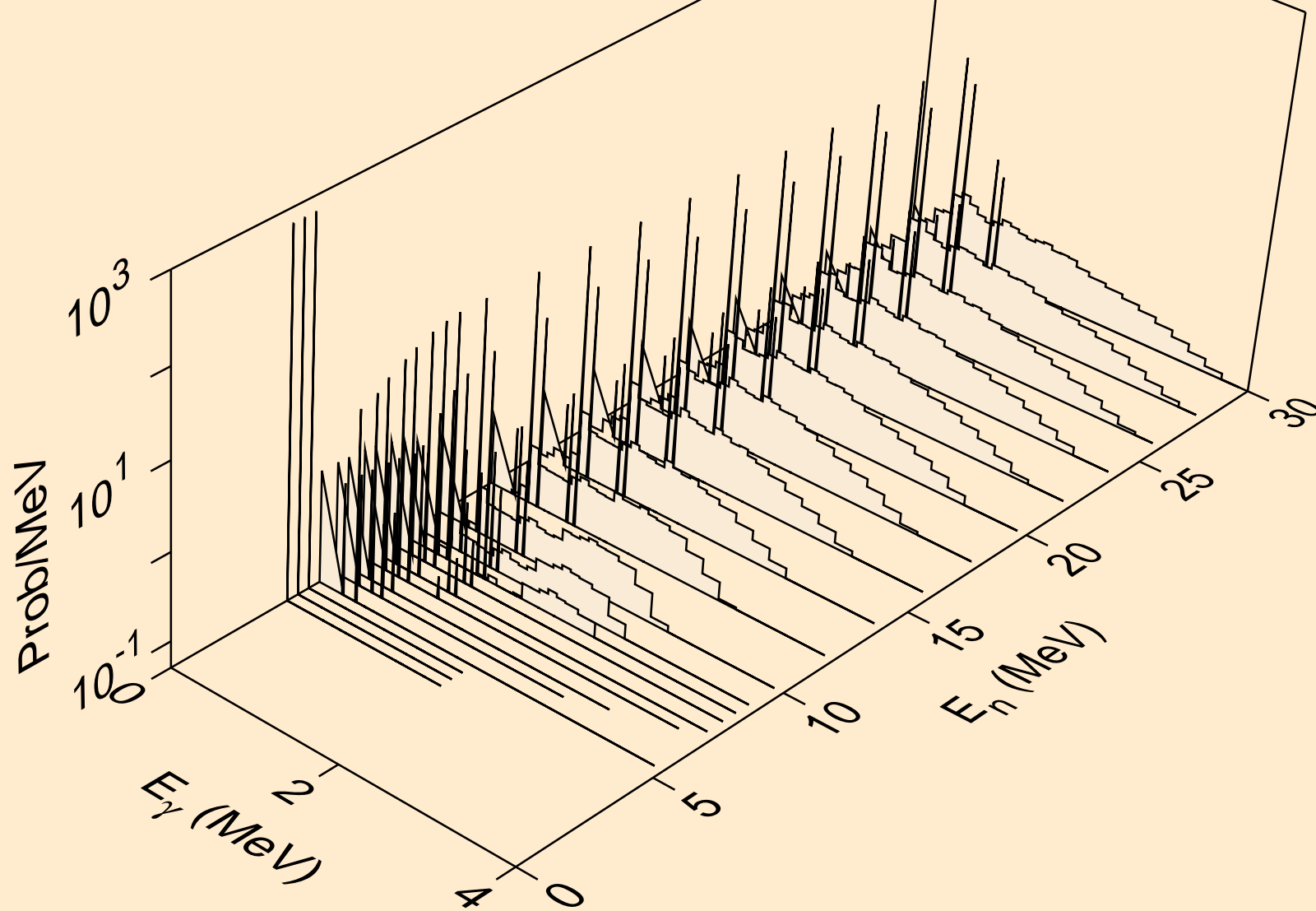

TA164 NEUTRON ACER TENDL-2024 LIBRARY; T=0.K
Photon emission for (n,he3)

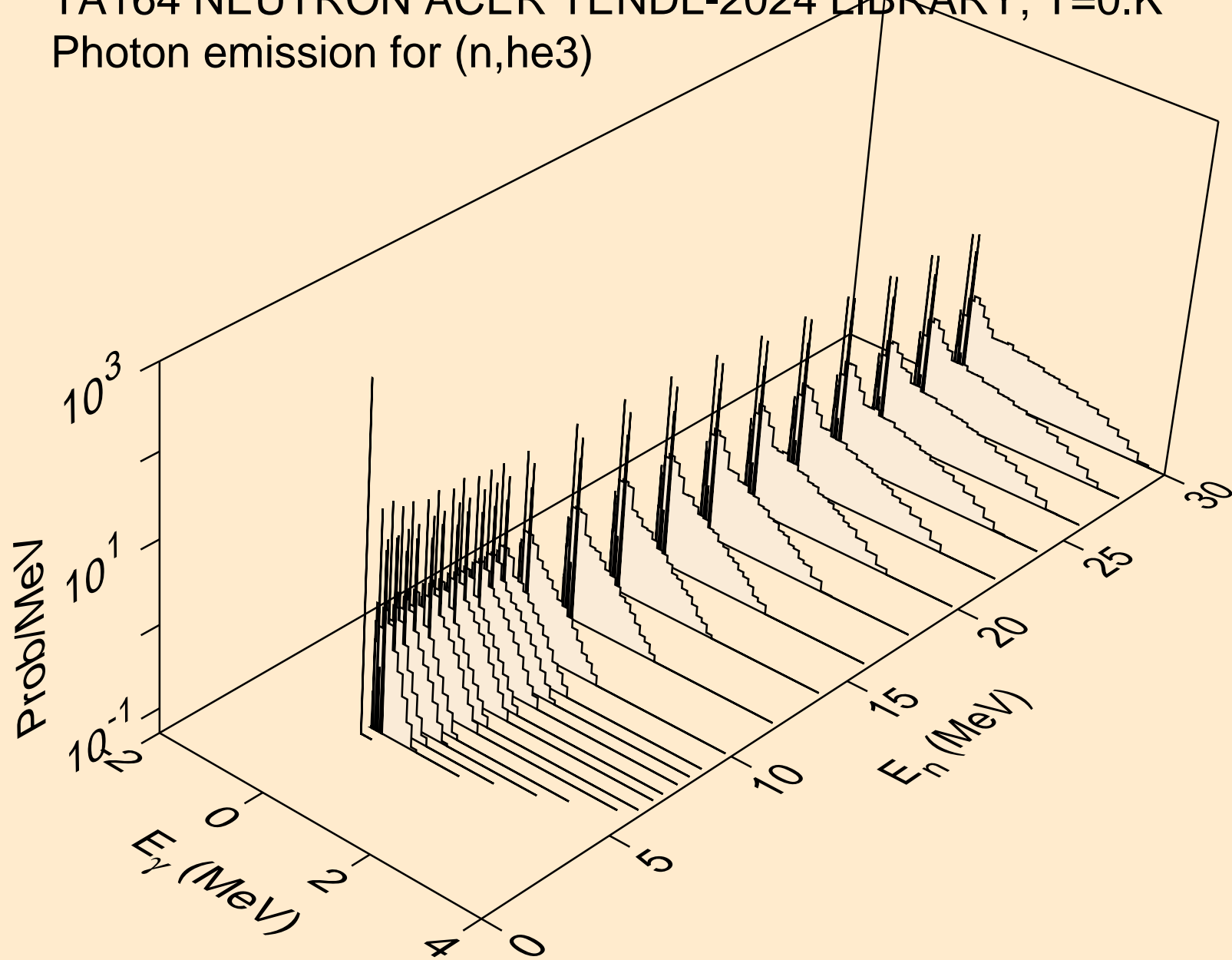

TA164 NEUTRON ACER TENDL-2024 LIBRARY; T=0.K
Photon emission for (n,a)

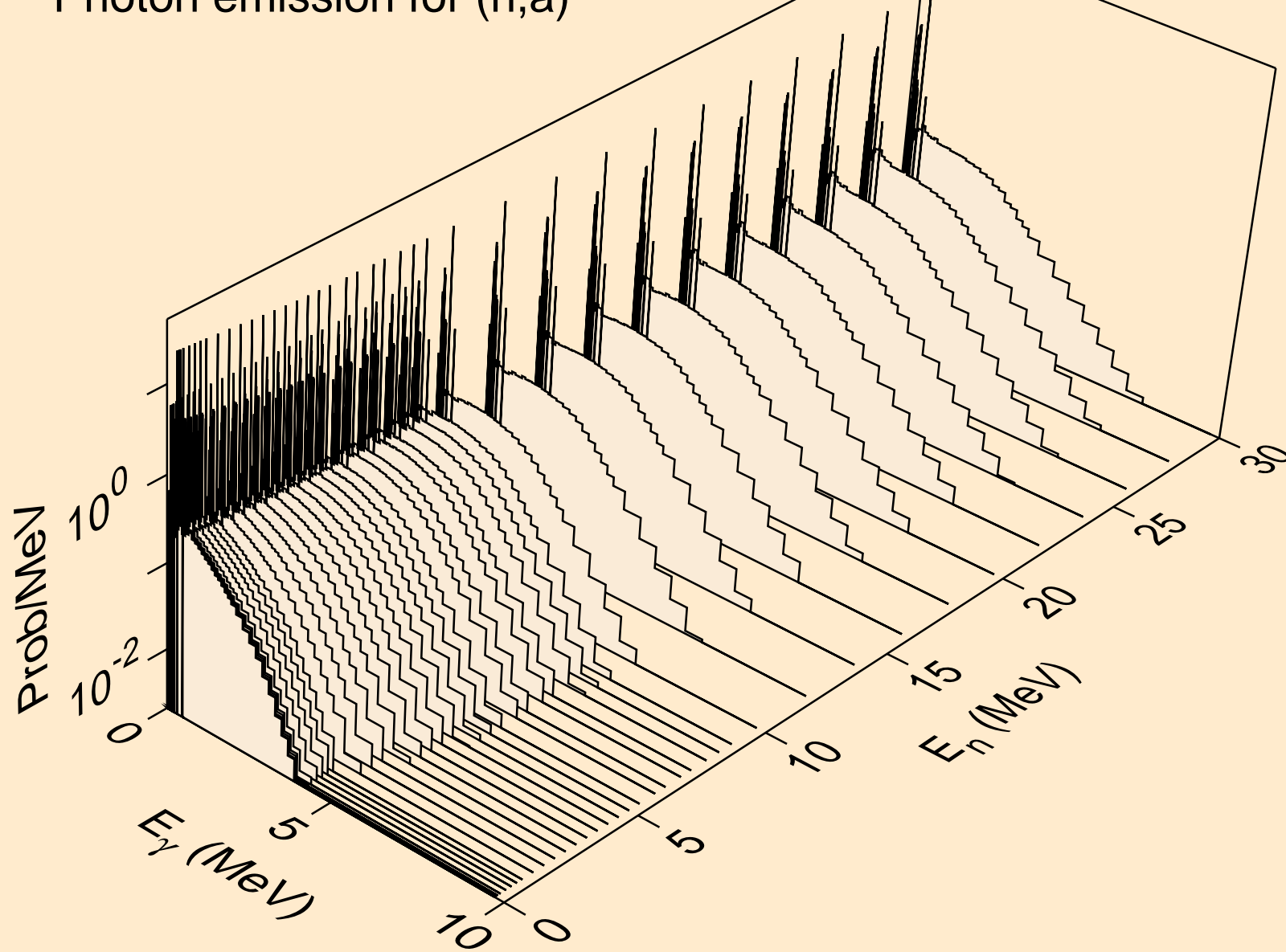

TA164 NEUTRON ACER TENDL-2024 LIBRARY; T=0.K
Photon emission for (n,2a)

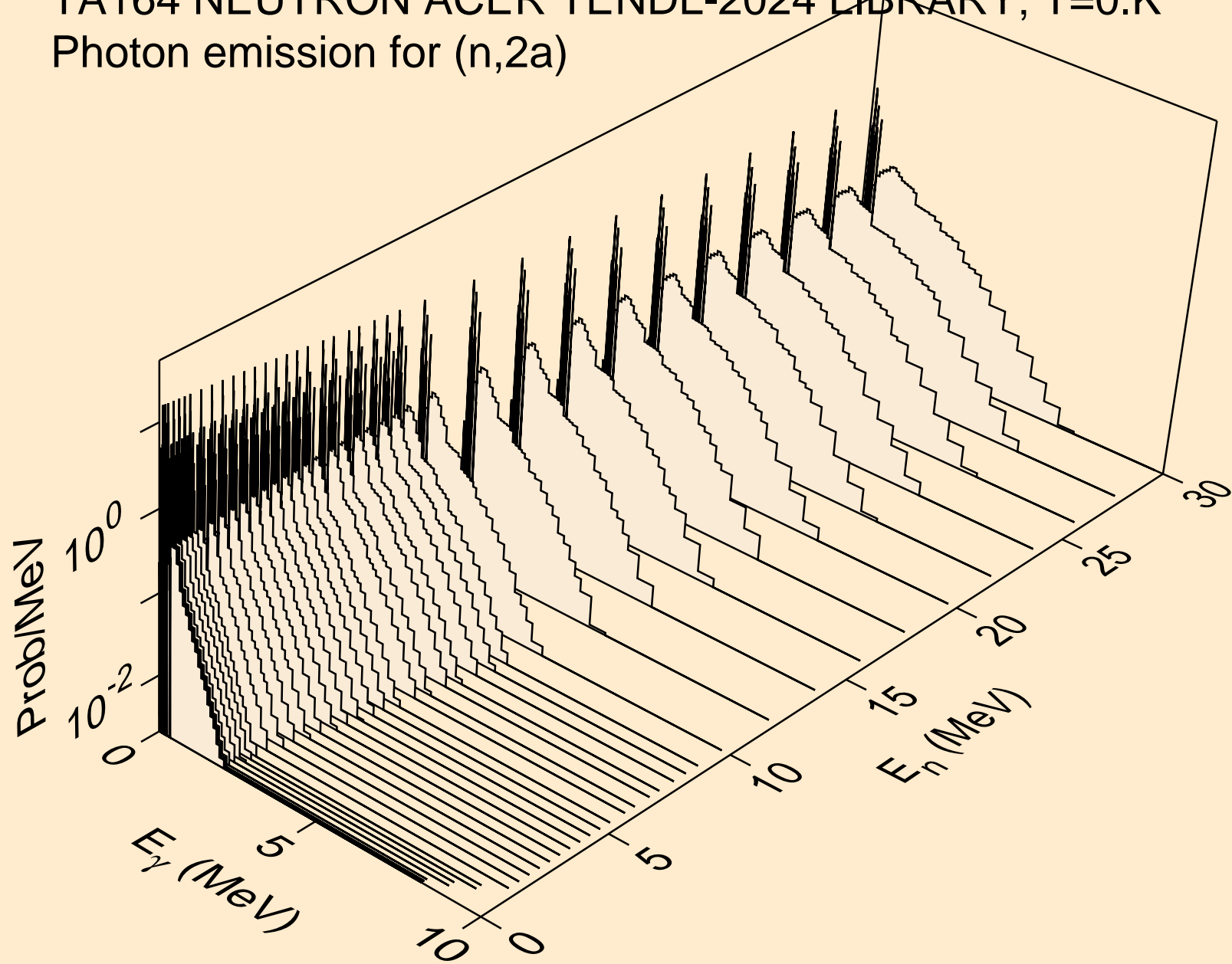

TA164 NEUTRON ACER TENDL-2024 LIBRARY; T=0.K
Photon emission for (n,3a)

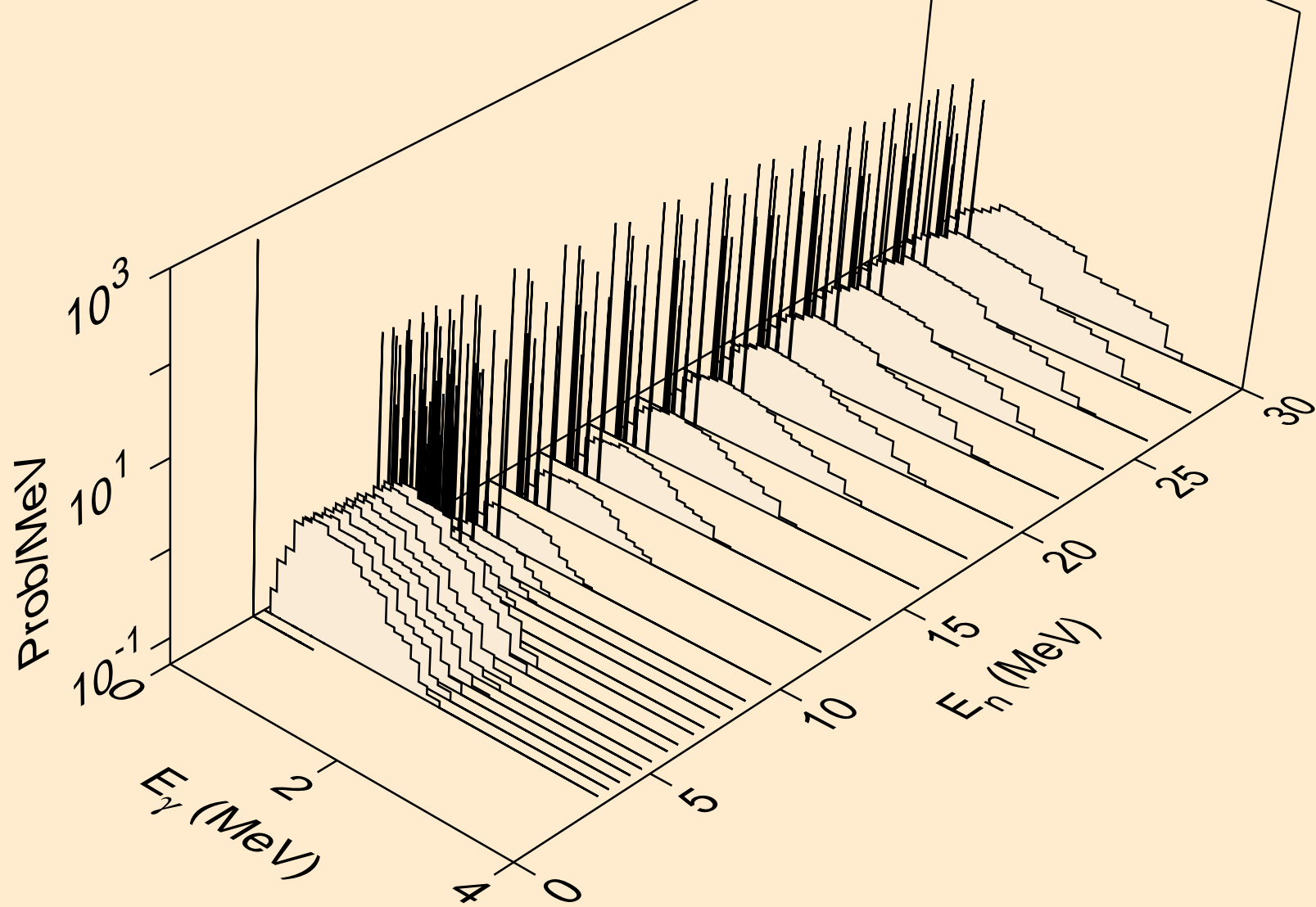

TA164 NEUTRON ACER TENDL-2024 LIBRARY; T=0.K
Photon emission for (n,2p)

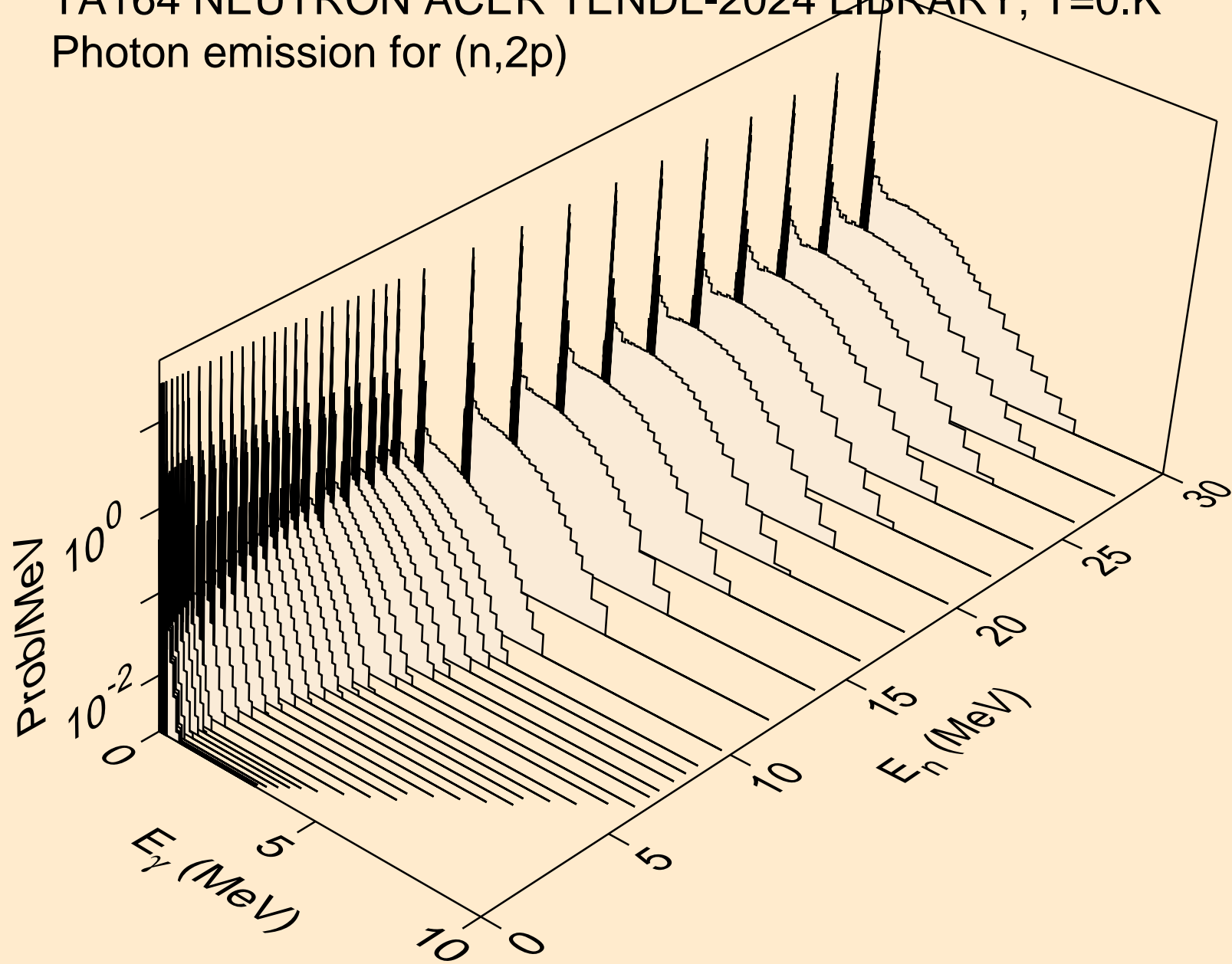

TA164 NEUTRON ACER TENDL-2024 LIBRARY; T=0.K
Photon emission for (n,p α)

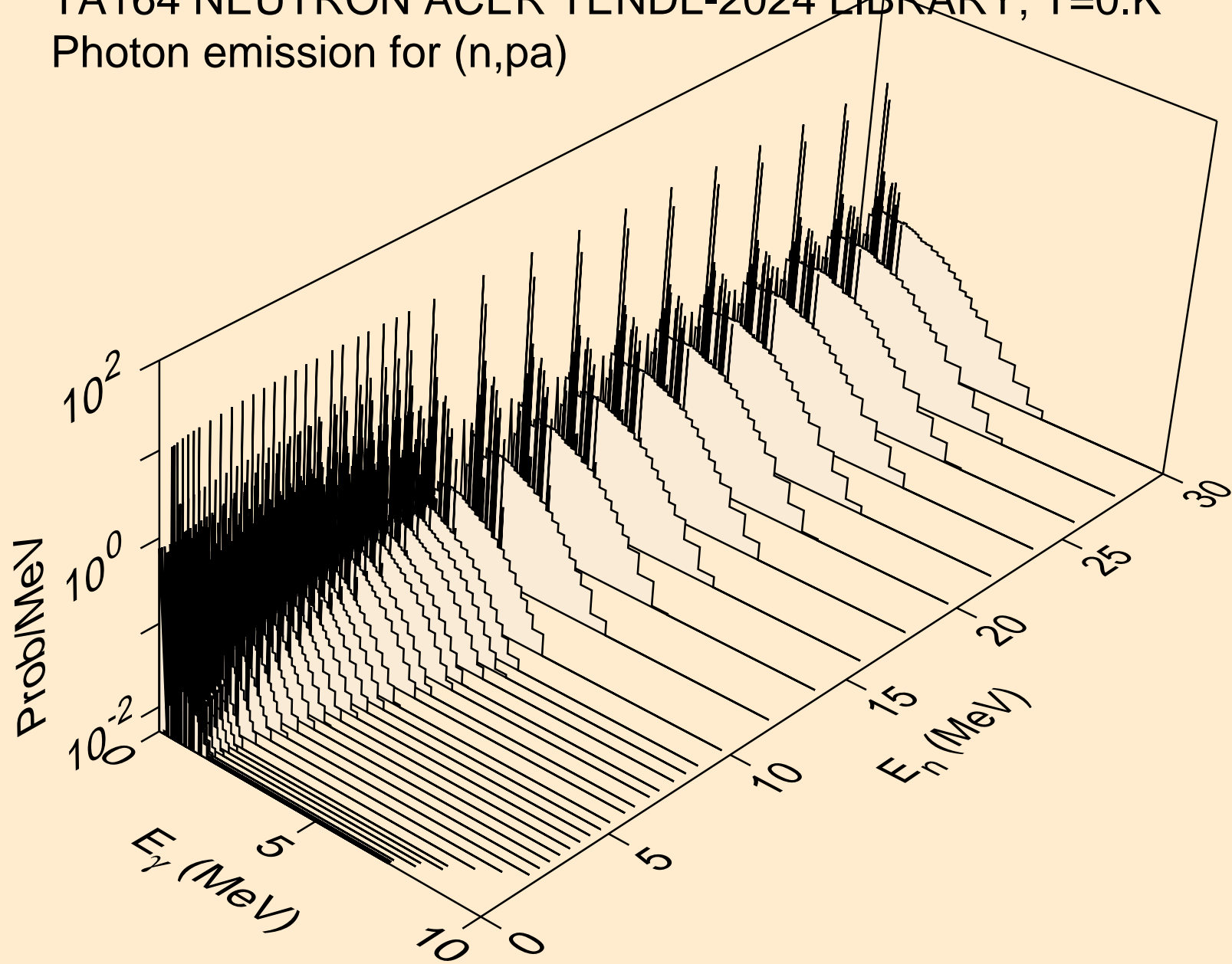

TA164 NEUTRON ACER TENDL-2024 LIBRARY; T=0.K
Photon emission for (n,t2a)

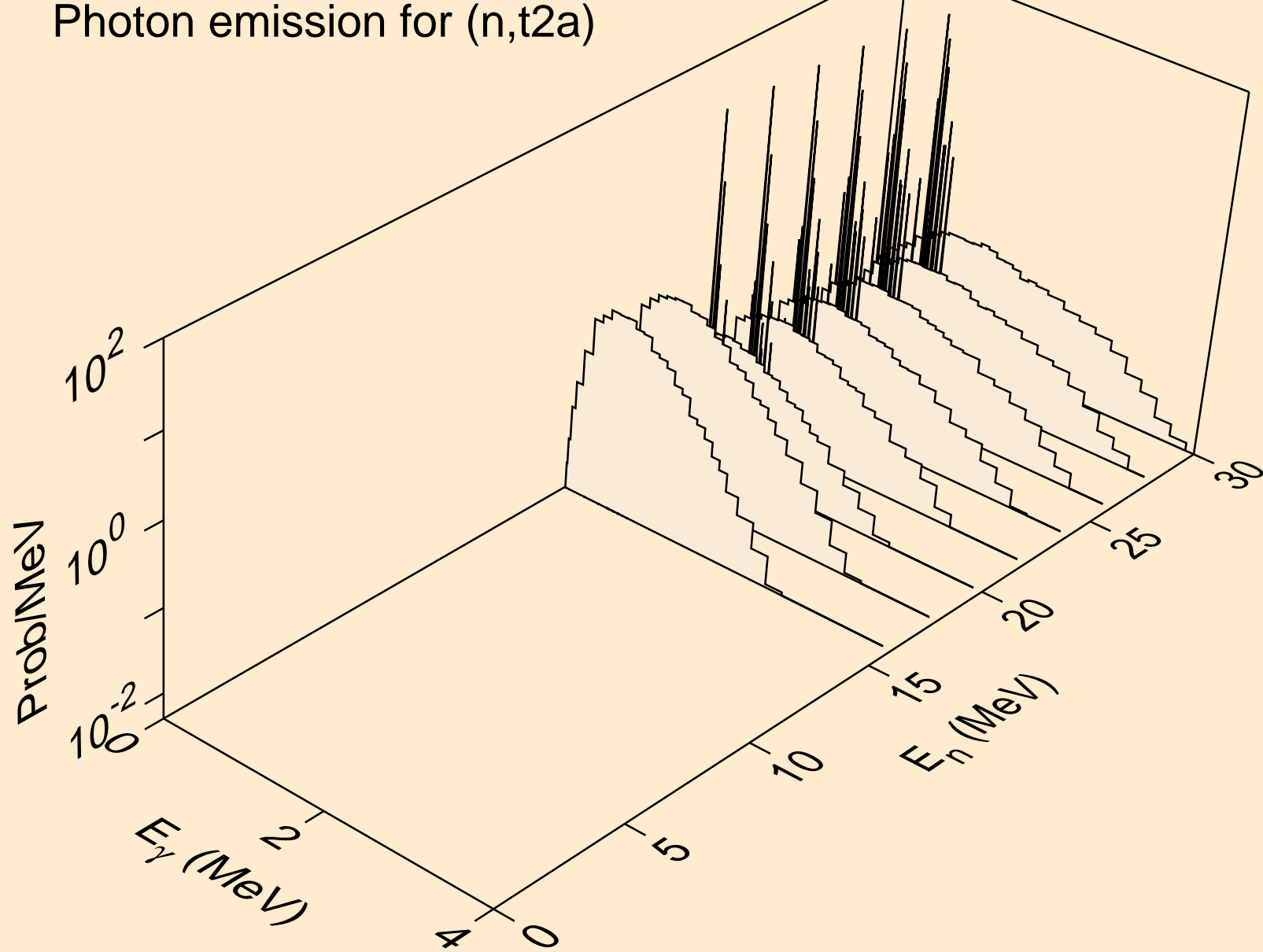

TA164 NEUTRON ACER TENDL-2024 LIBRARY; T=0.K
Photon emission for (n,d2a)

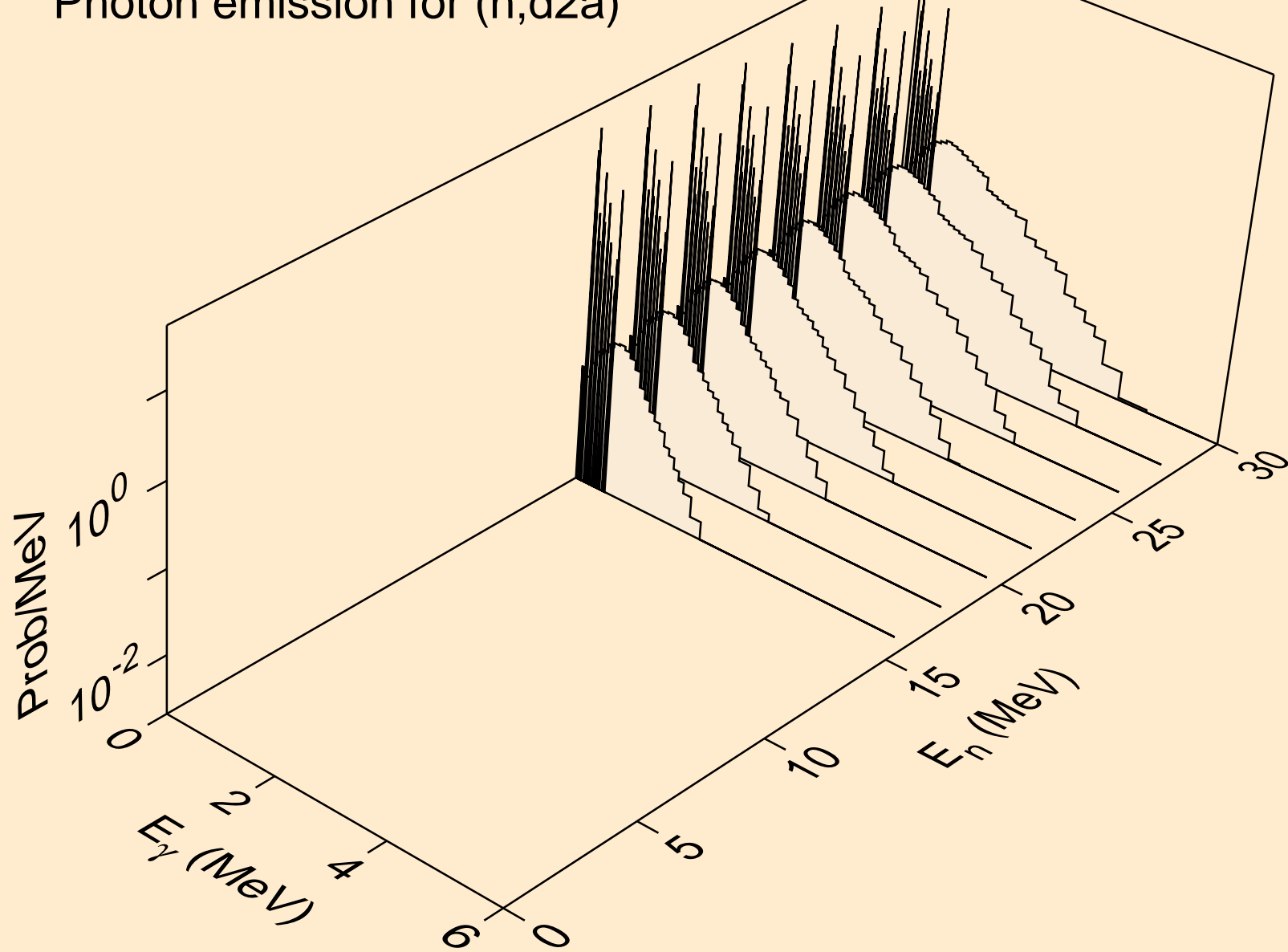

TA164 NEUTRON ACER TENDL-2024 LIBRARY; T=0.K
Photon emission for (n,pd)

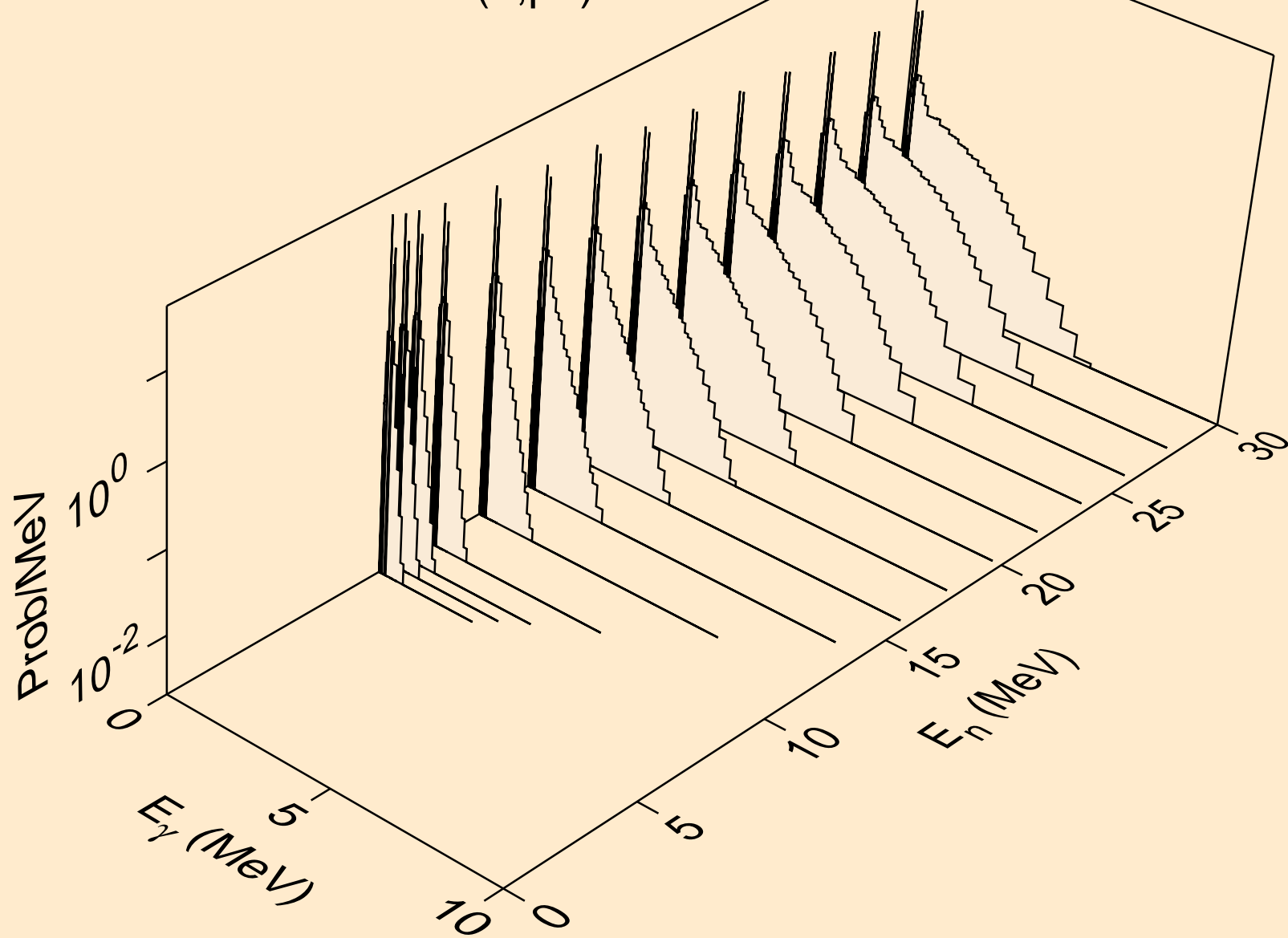

TA164 NEUTRON ACER TENDL-2024 LIBRARY; T=0.K
Photon emission for (n,pt)

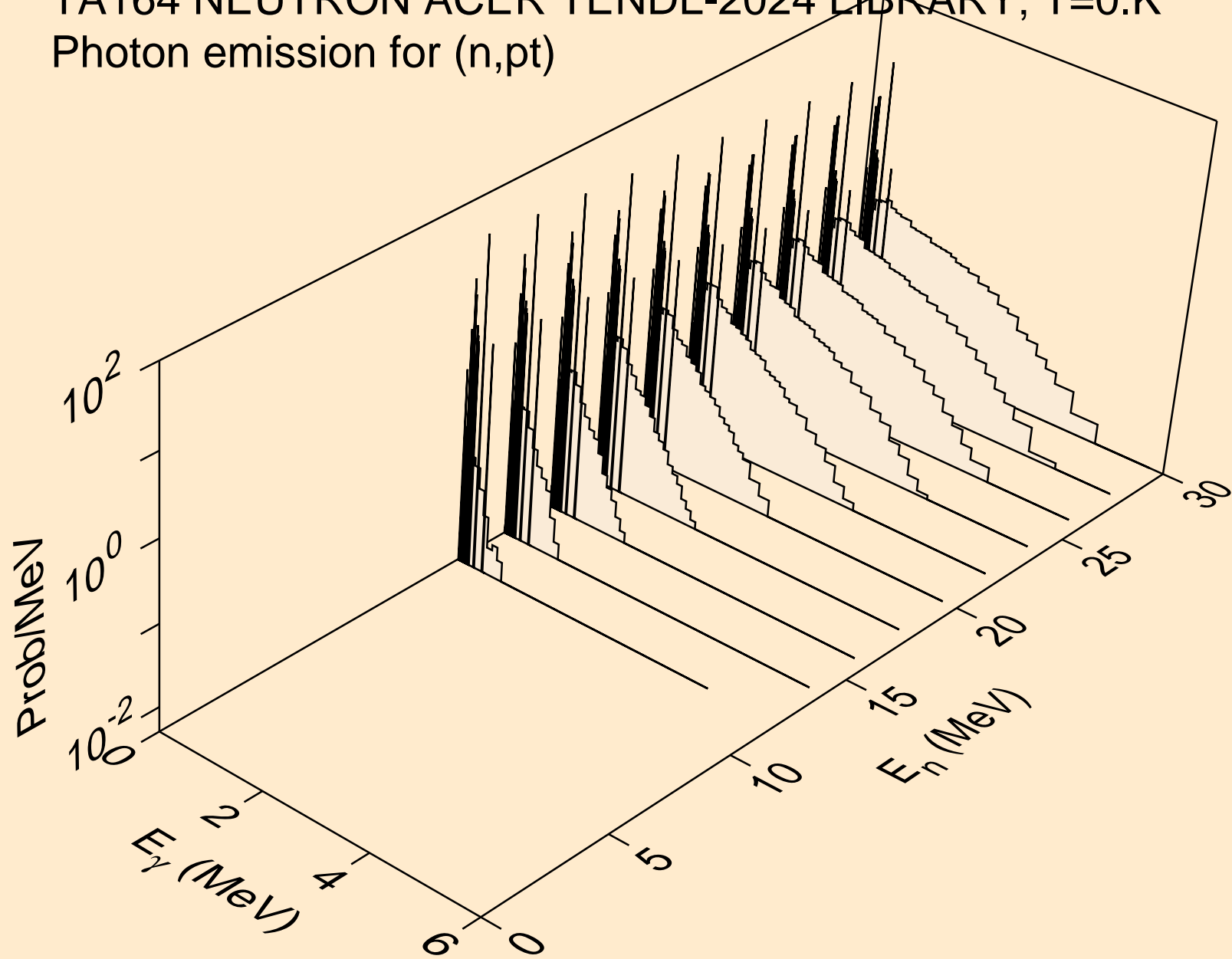

TA164 NEUTRON ACER TENDL-2024 LIBRARY; T=0.K
Photon emission for (n,da)

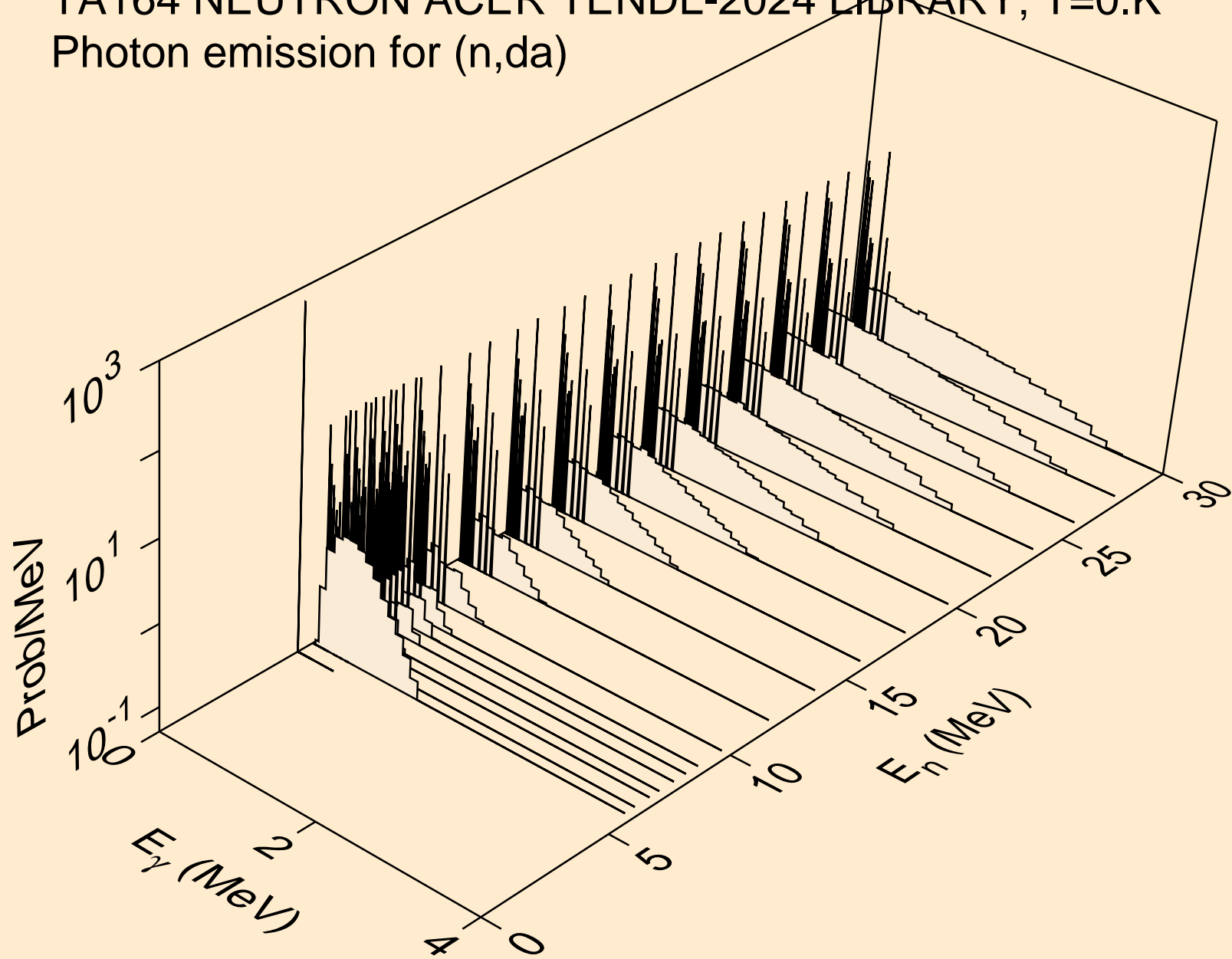

TA164 NEUTRON ACER TENDL-2024 LIBRARY; T=0.K
thermal capture photon spectrum

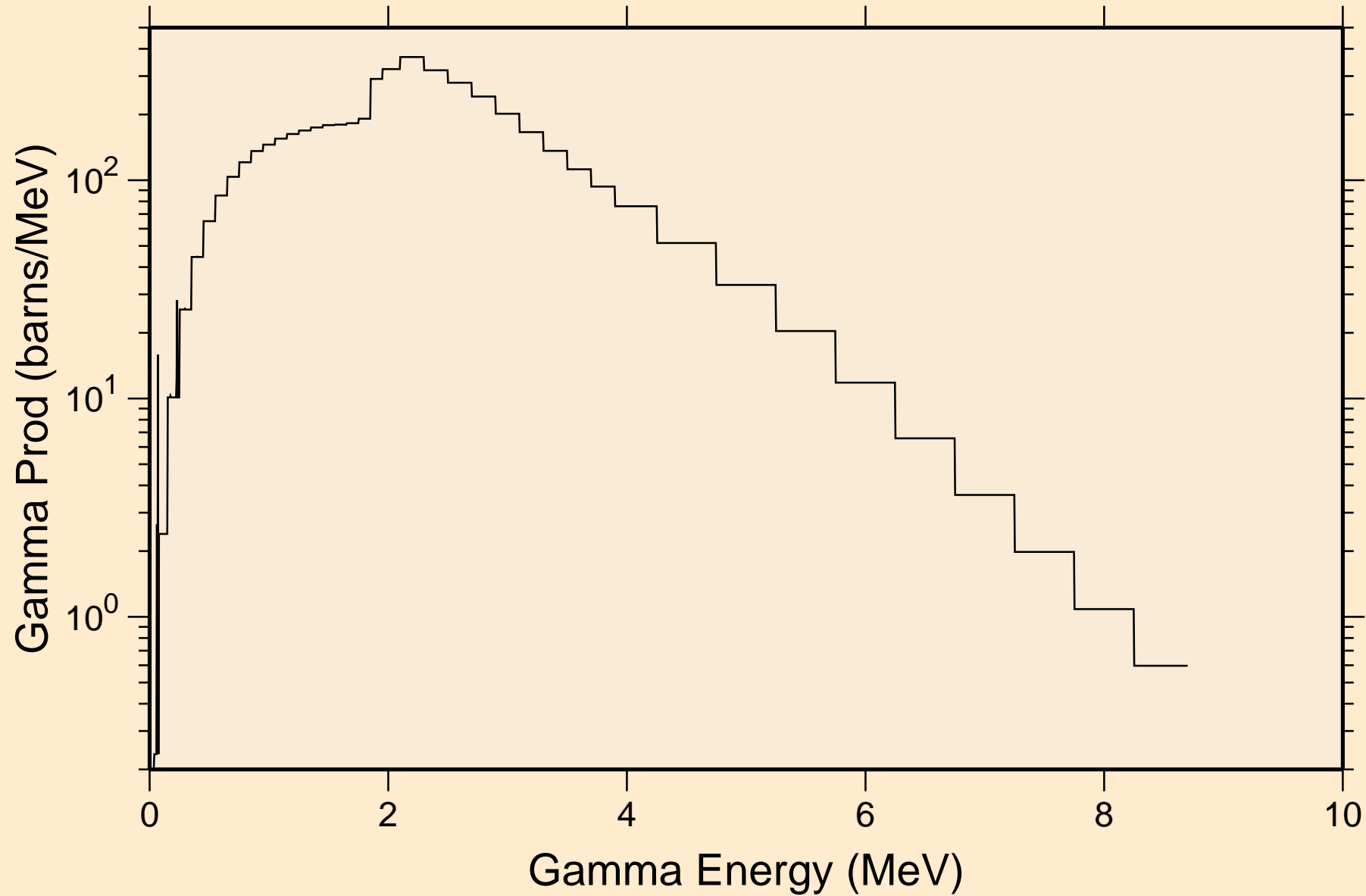

TA164 NEUTRON ACER TENDL-2024 LIBRARY; T=0.K
14 MeV photon spectrum

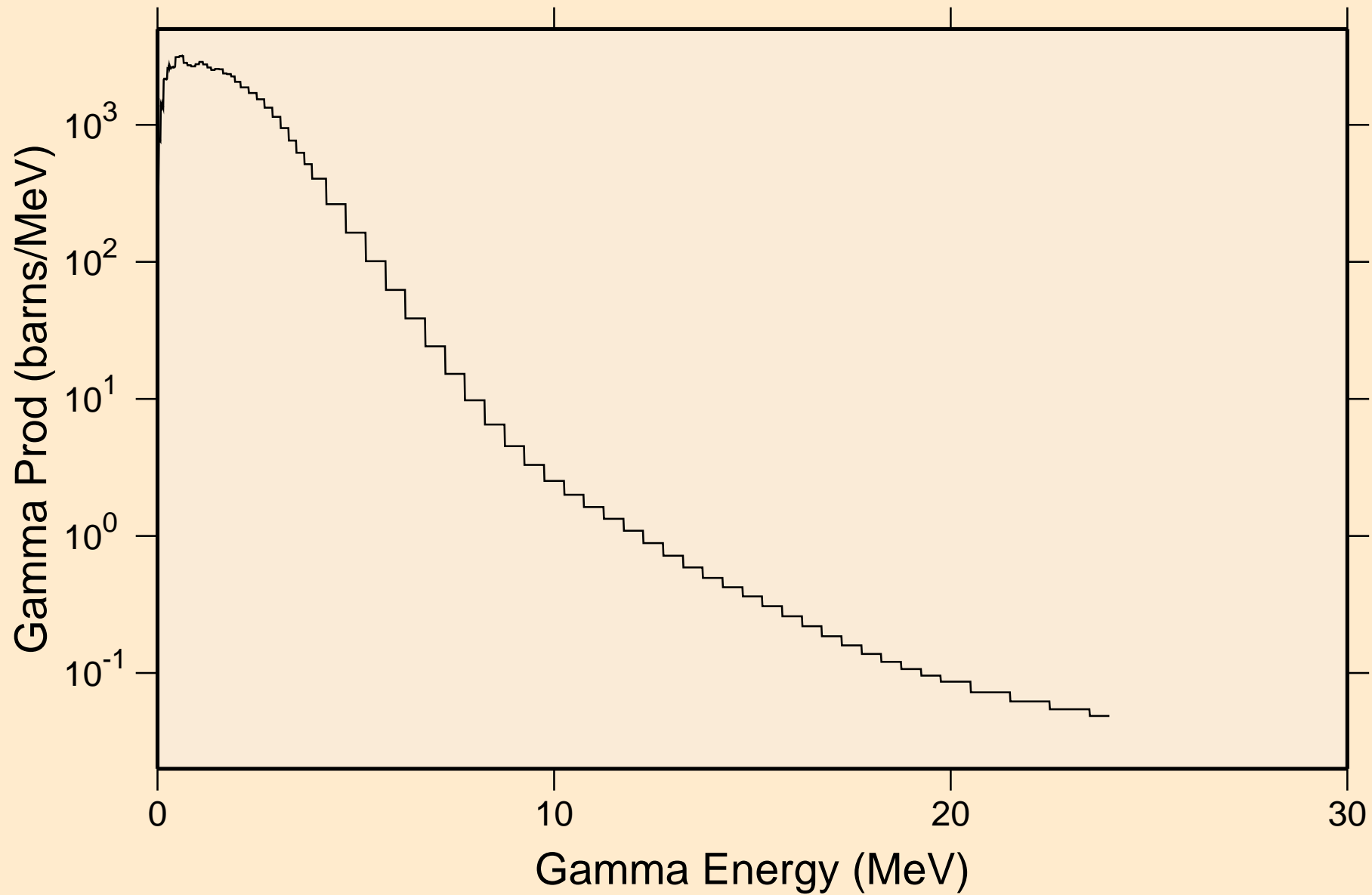

TA164 NEUTRON ACER TENDL-2024 LIBRARY; T=0.K

Particle heating contributions

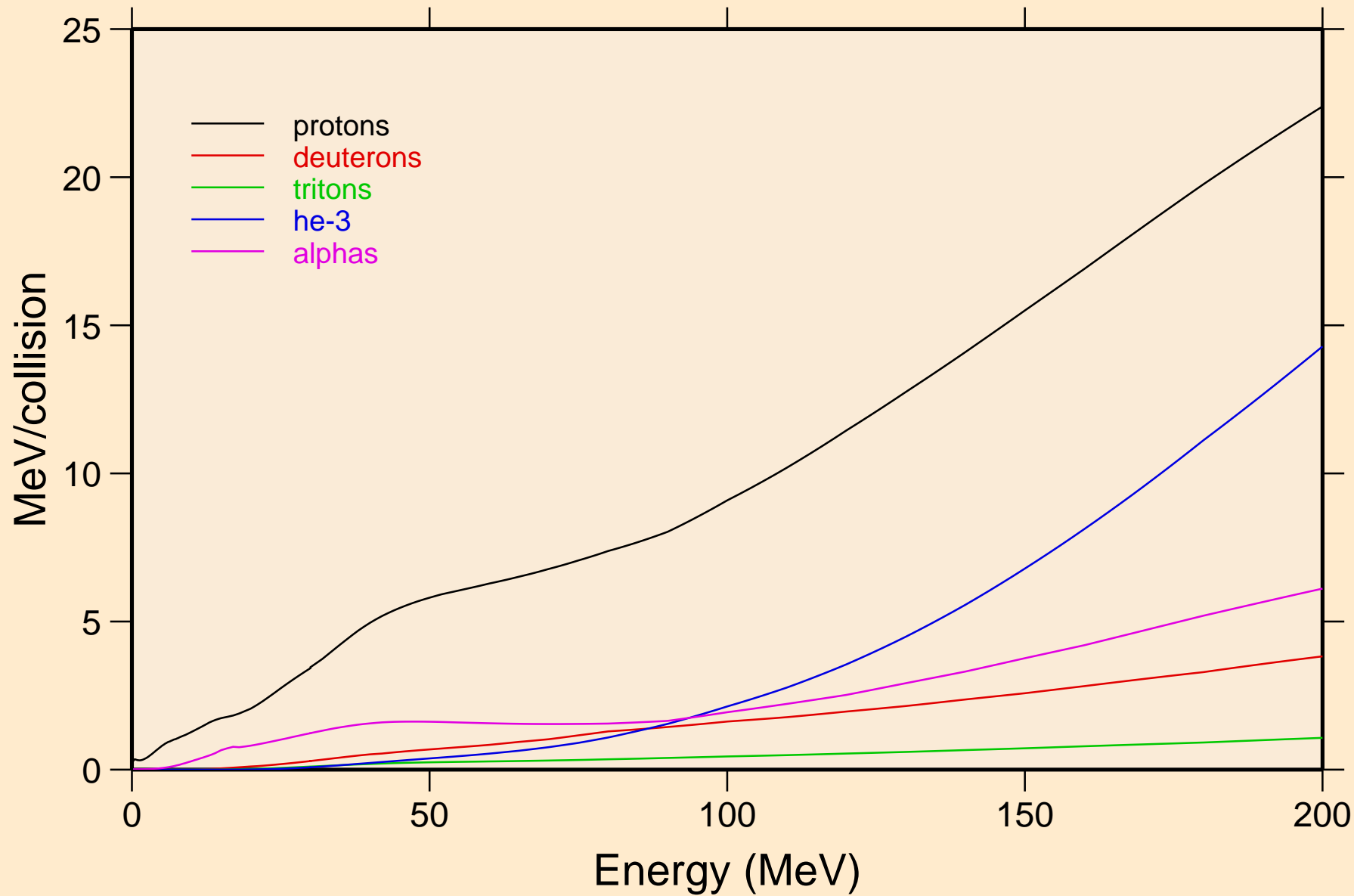

TA164 NEUTRON ACER TENDL-2024 LIBRARY; T=0.K
Recoil Heating

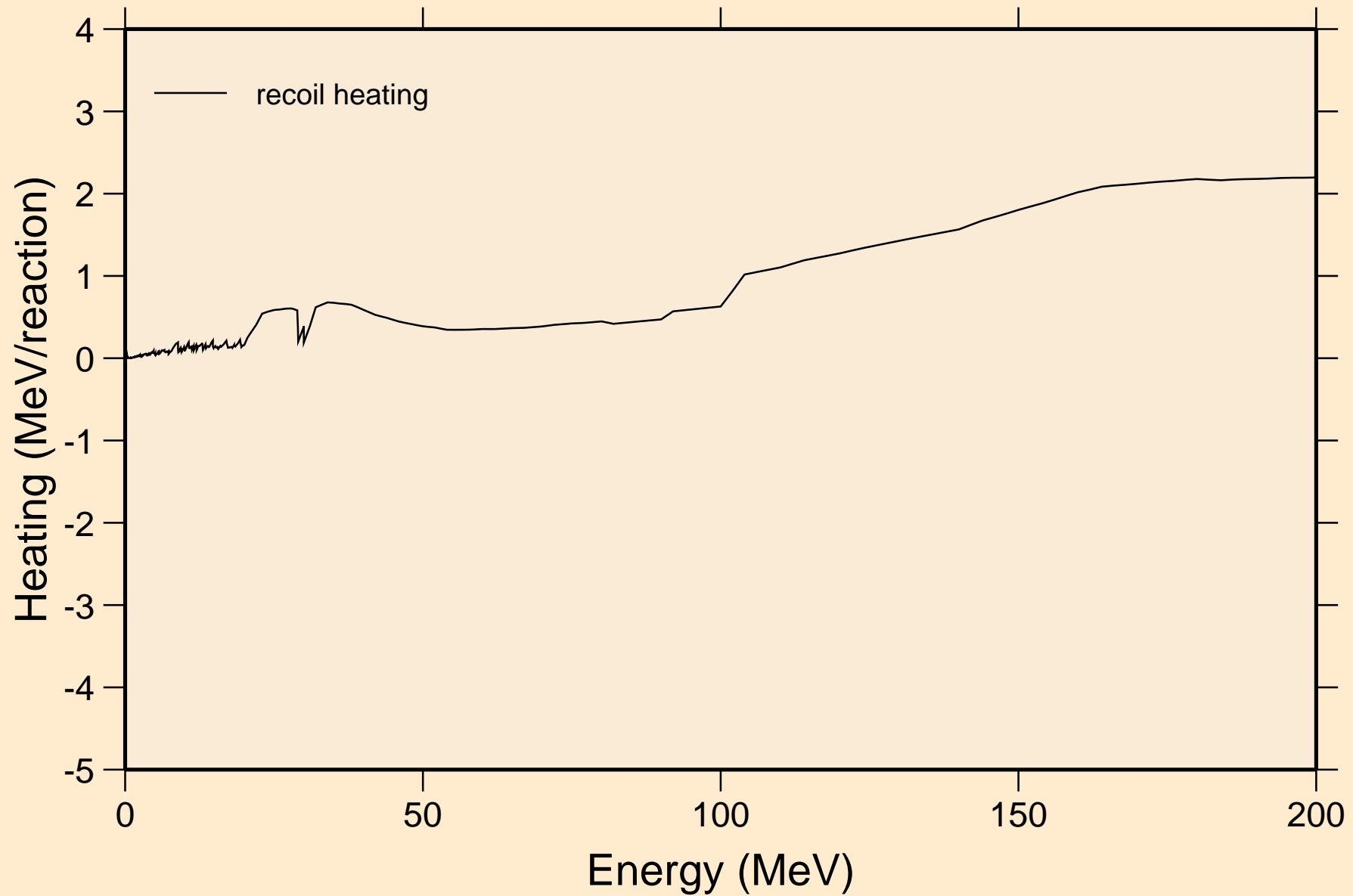

TA164 NEUTRON ACER TENDL-2024 LIBRARY; T=0.K

Particle production cross sections

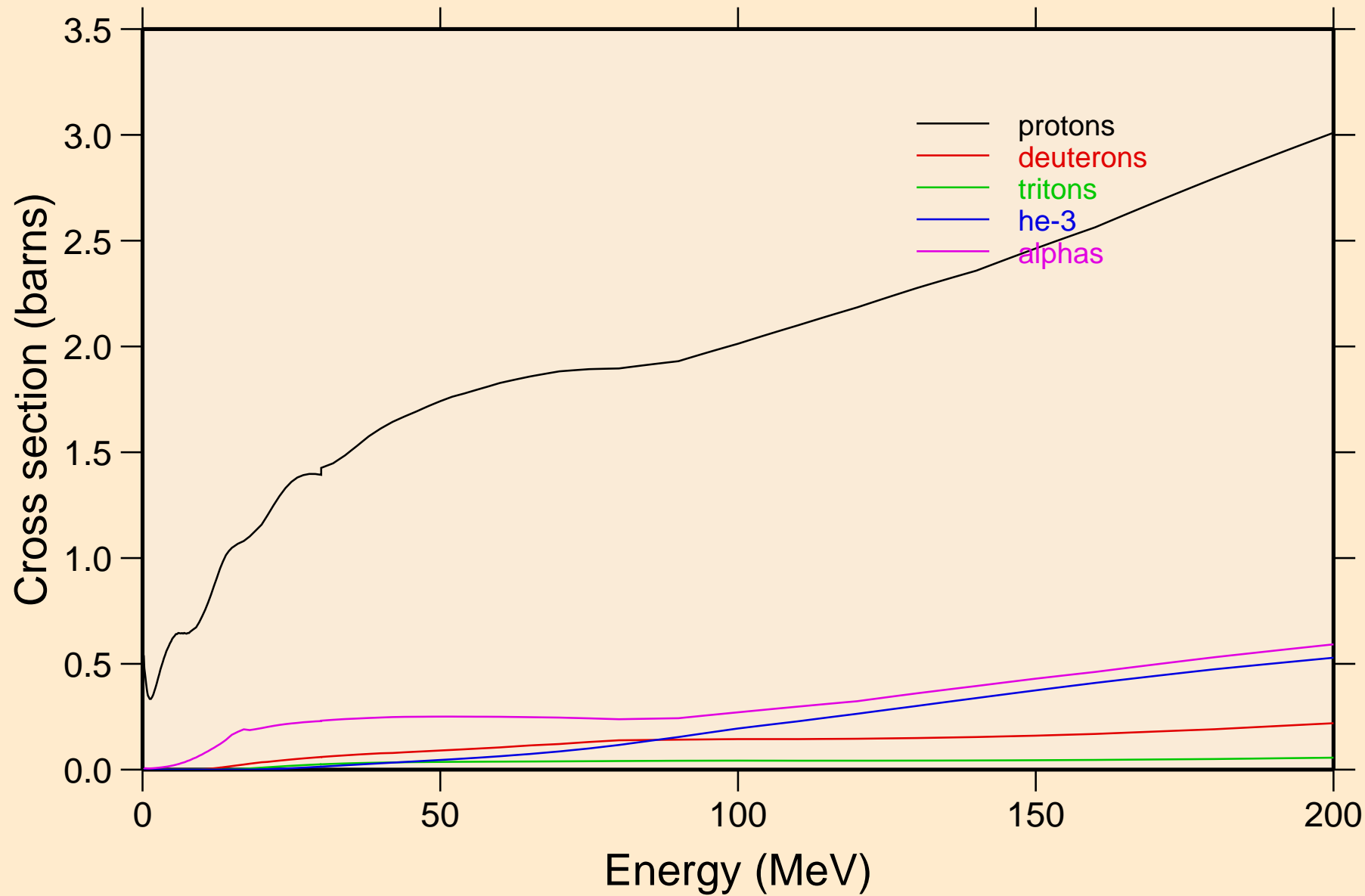

TA164 NEUTRON ACER TENDL-2024 LIBRARY; T=0.K
protons from (n,x)

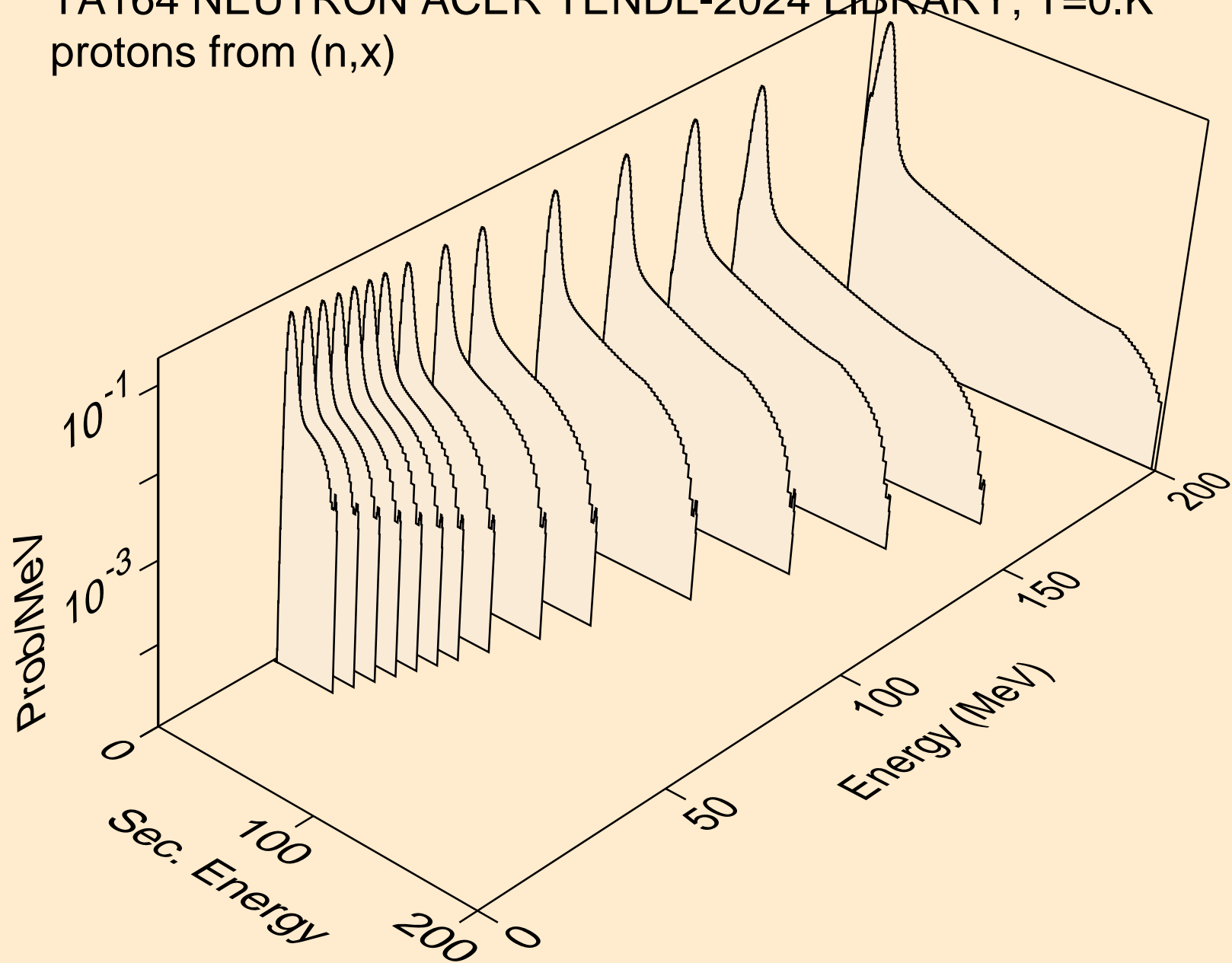

TA164 NEUTRON ACER TENDL-2024 LIBRARY; T=0.K
protons from (n,n*)p

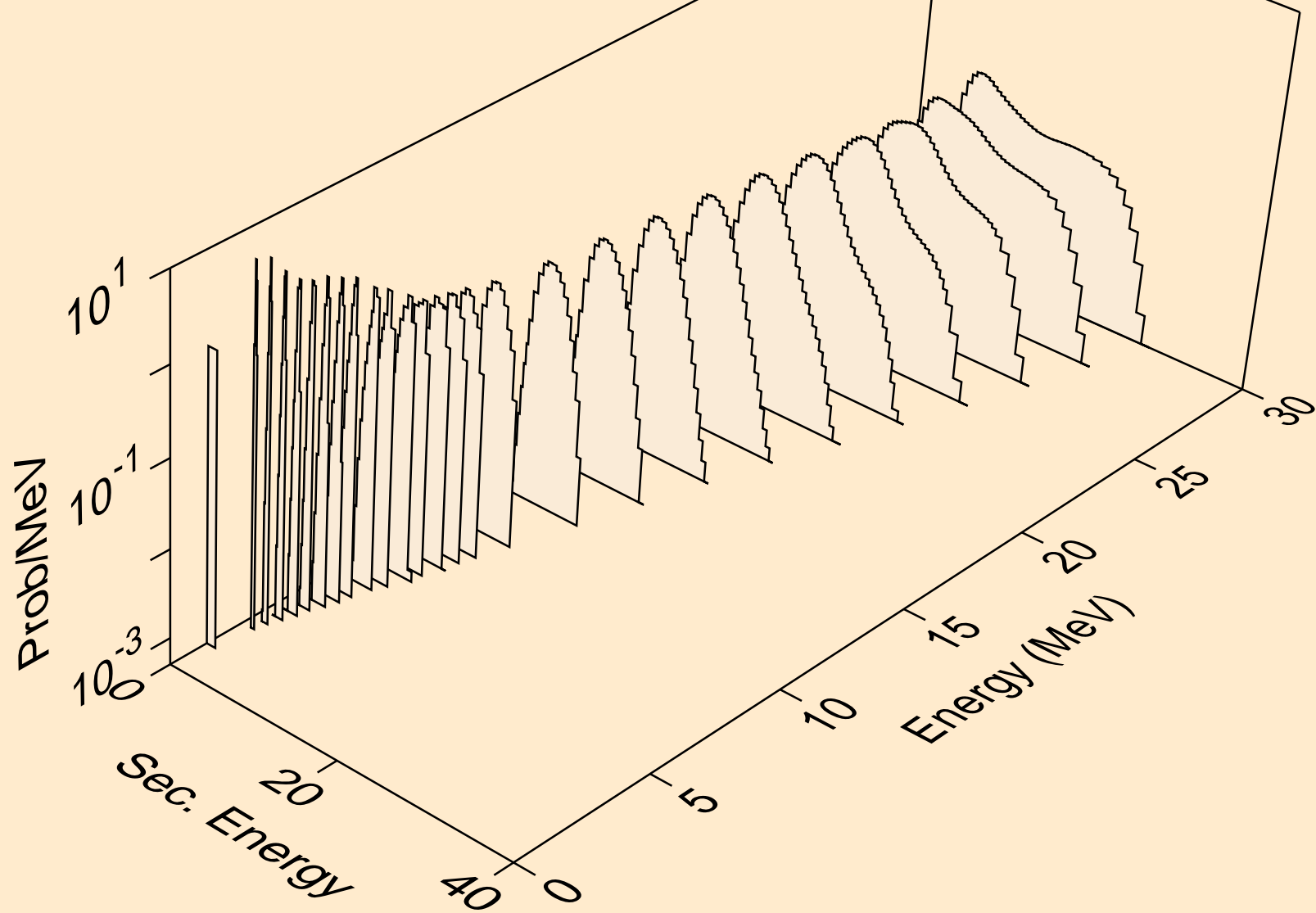

TA164 NEUTRON ACER TENDL-2024 LIBRARY; T=0.K
protons from (n,2np)

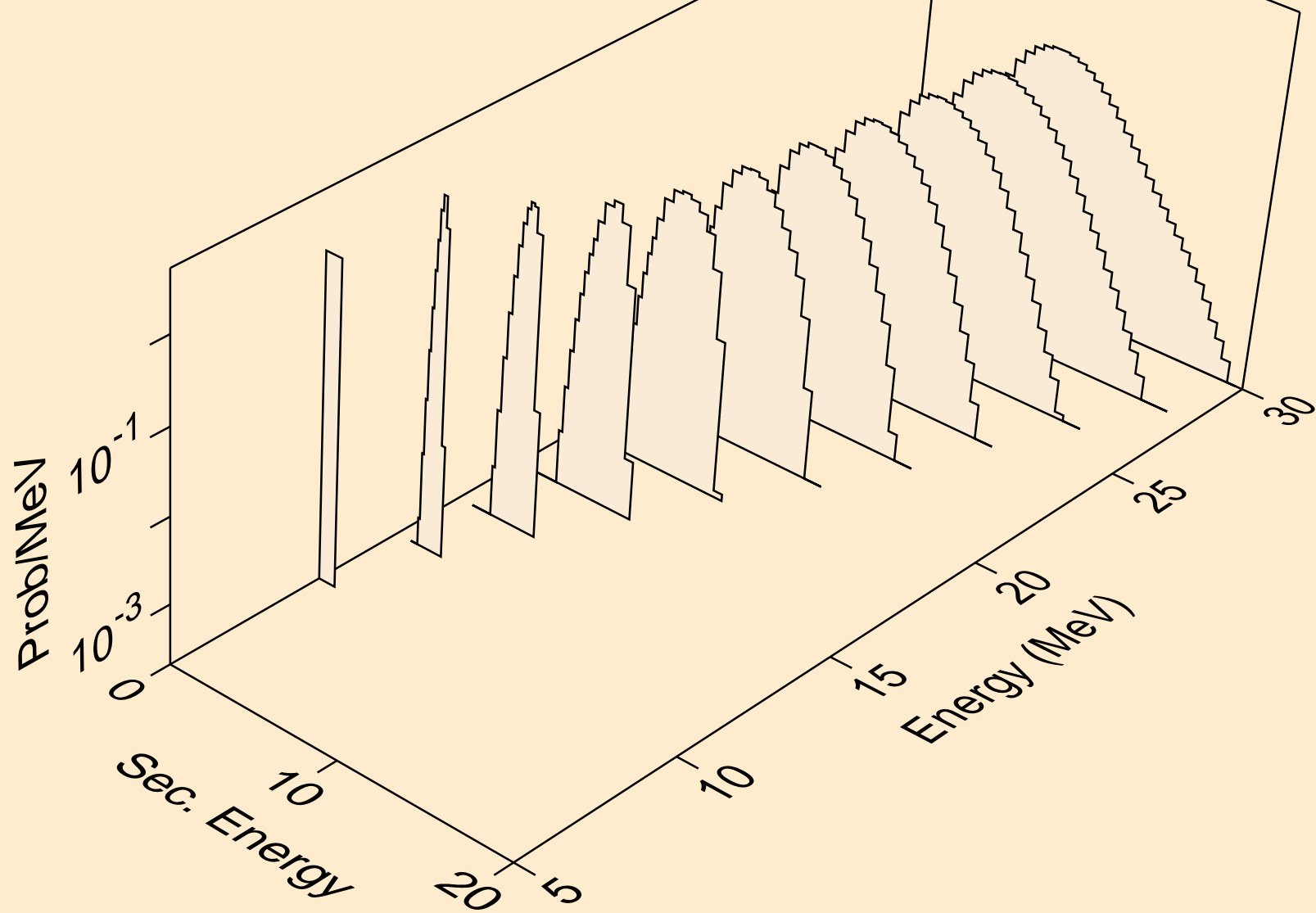

TA164 NEUTRON ACER TENDL-2024 LIBRARY; T=0.K
protons from (n,3np)

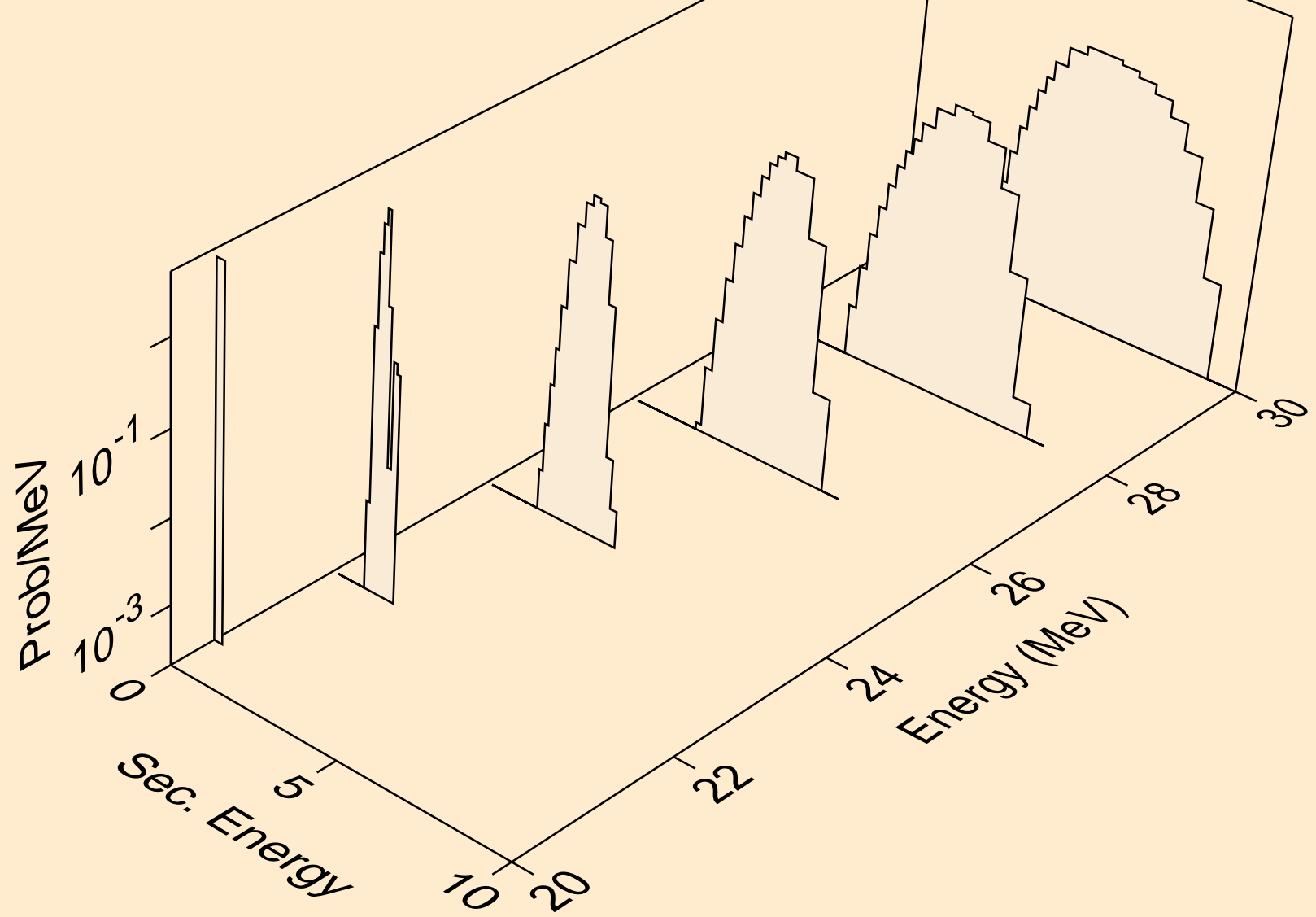

TA164 NEUTRON ACER TENDL-2024 LIBRARY; T=0.K
protons from (n,n2p)

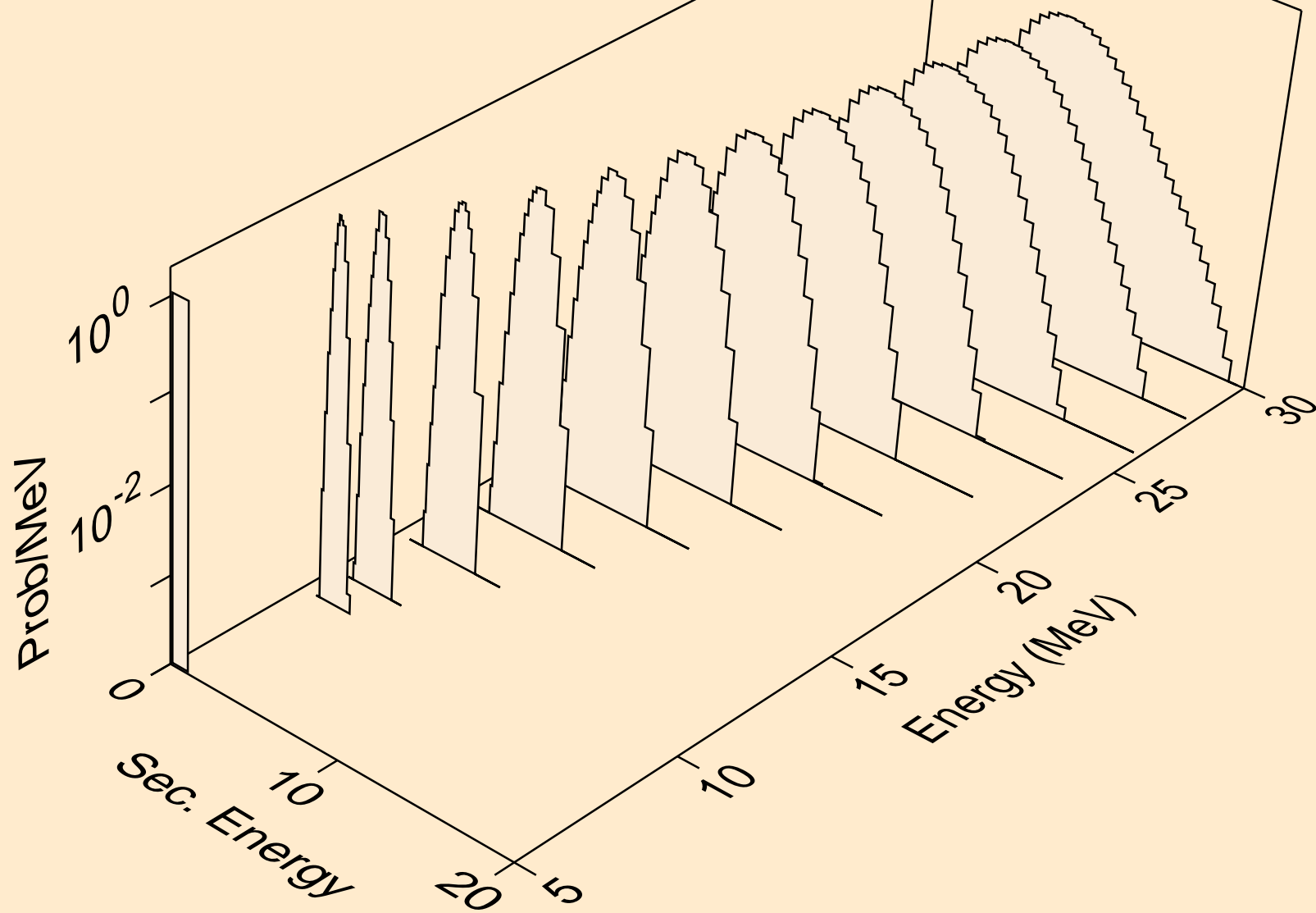

TA164 NEUTRON ACER TENDL-2024 LIBRARY; T=0.K
protons from (n,npa)

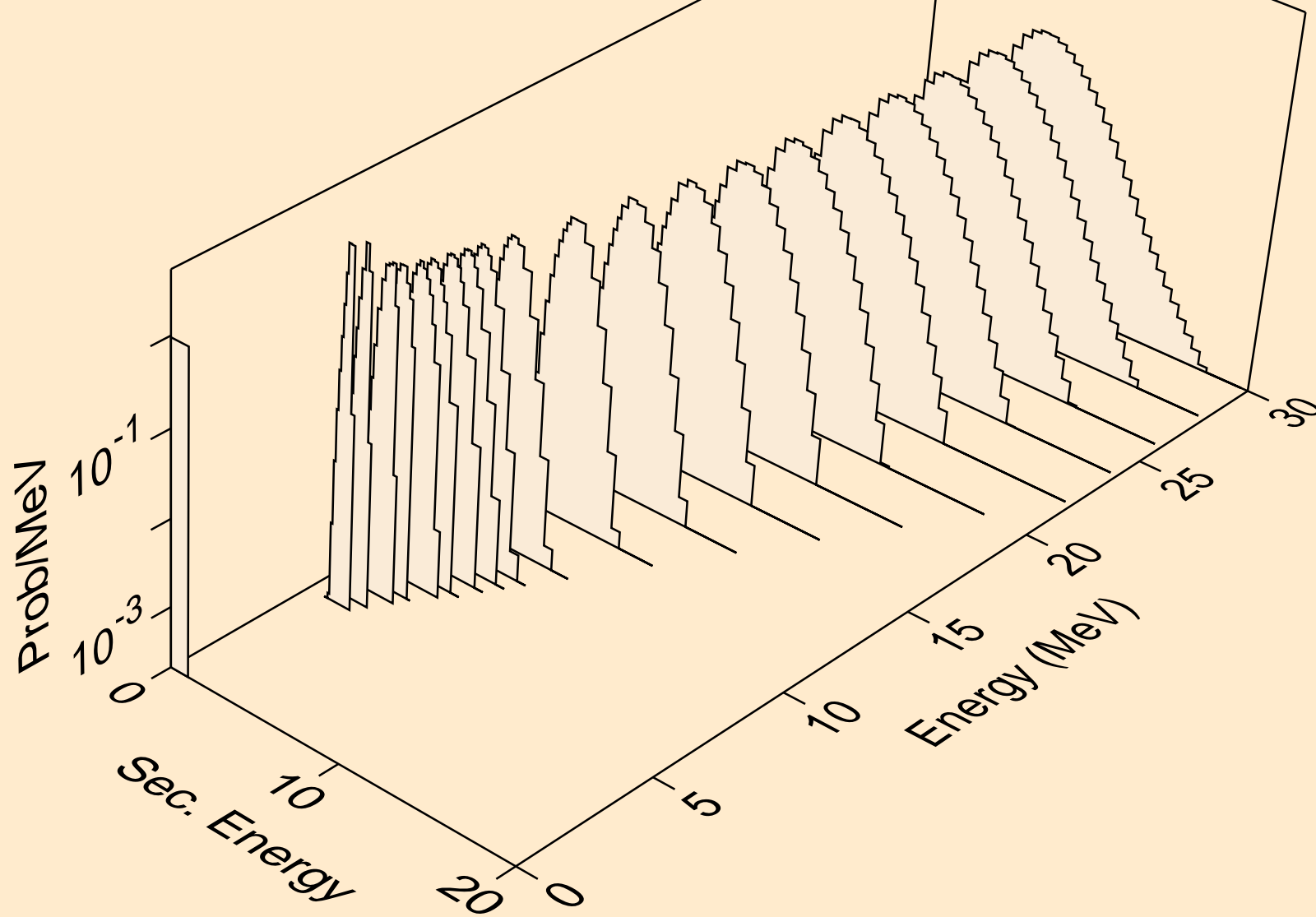

TA164 NEUTRON ACER TENDL-2024 LIBRARY; T=0.K
protons from (n,p)

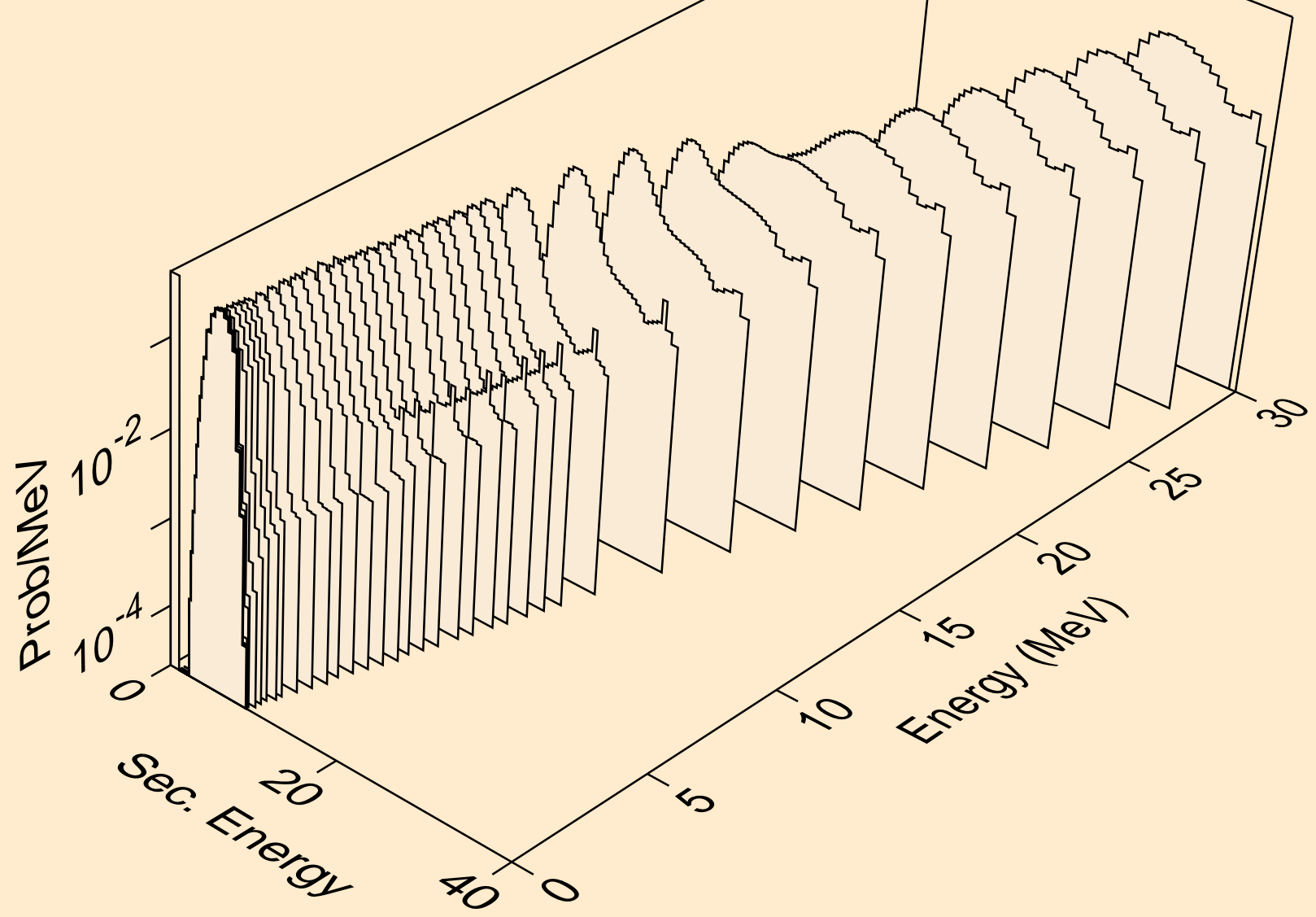

TA164 NEUTRON ACER TENDL-2024 LIBRARY; T=0.K
protons from (n,2p)

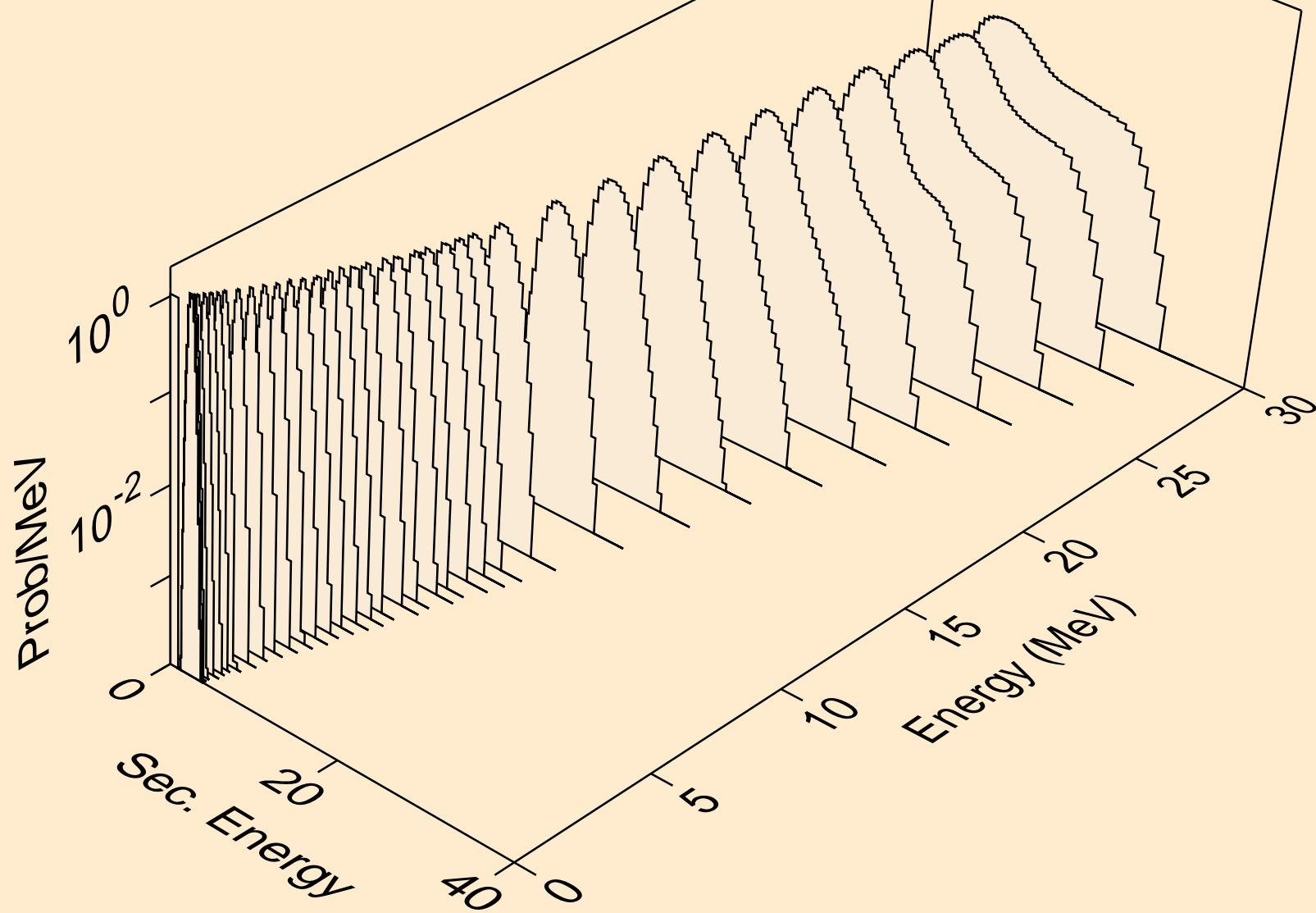

TA164 NEUTRON ACER TENDL-2024 LIBRARY; T=0.K
protons from (n,p)

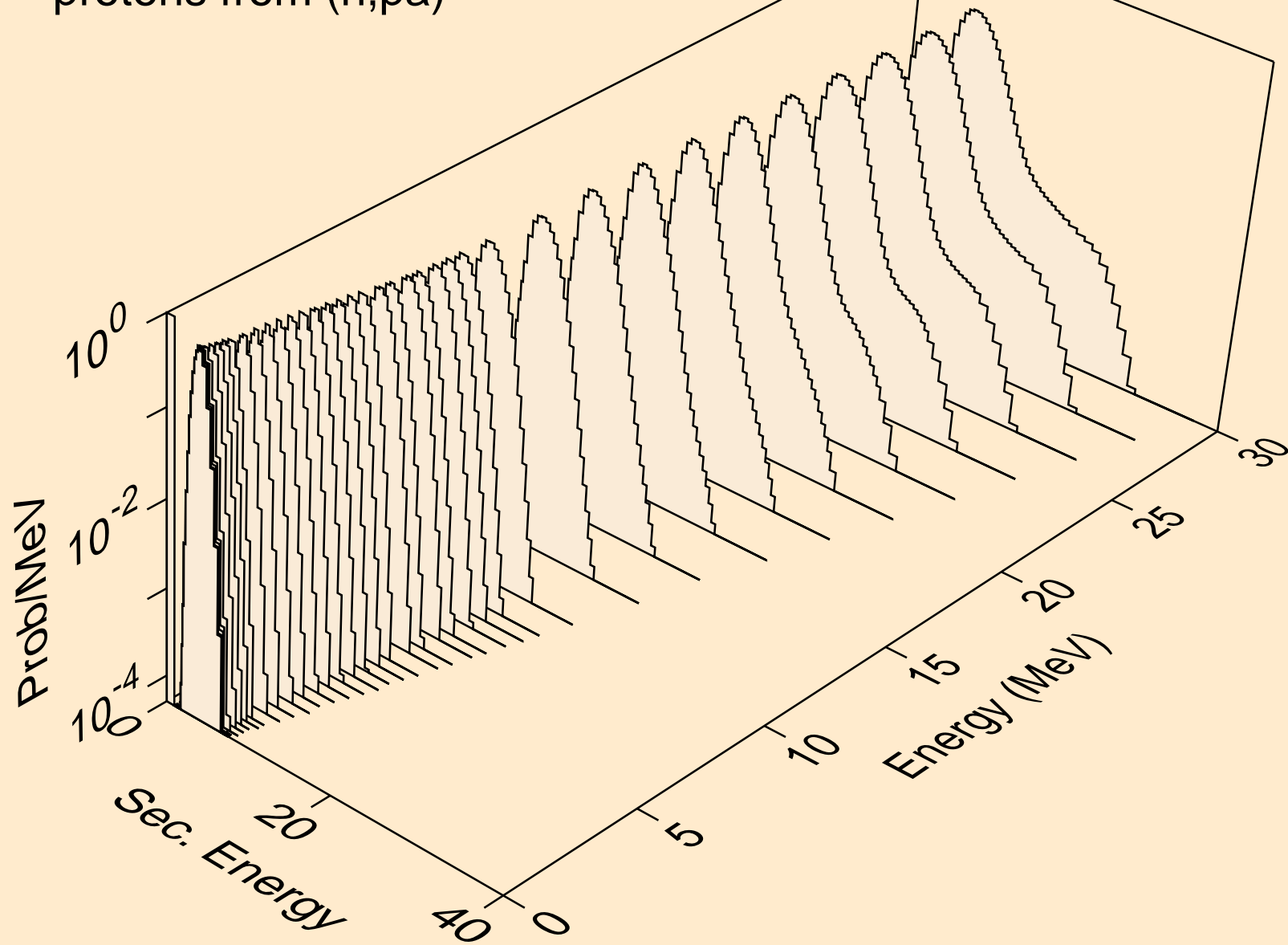

TA164 NEUTRON ACER TENDL-2024 LIBRARY; T=0.K
protons from (n,pd)

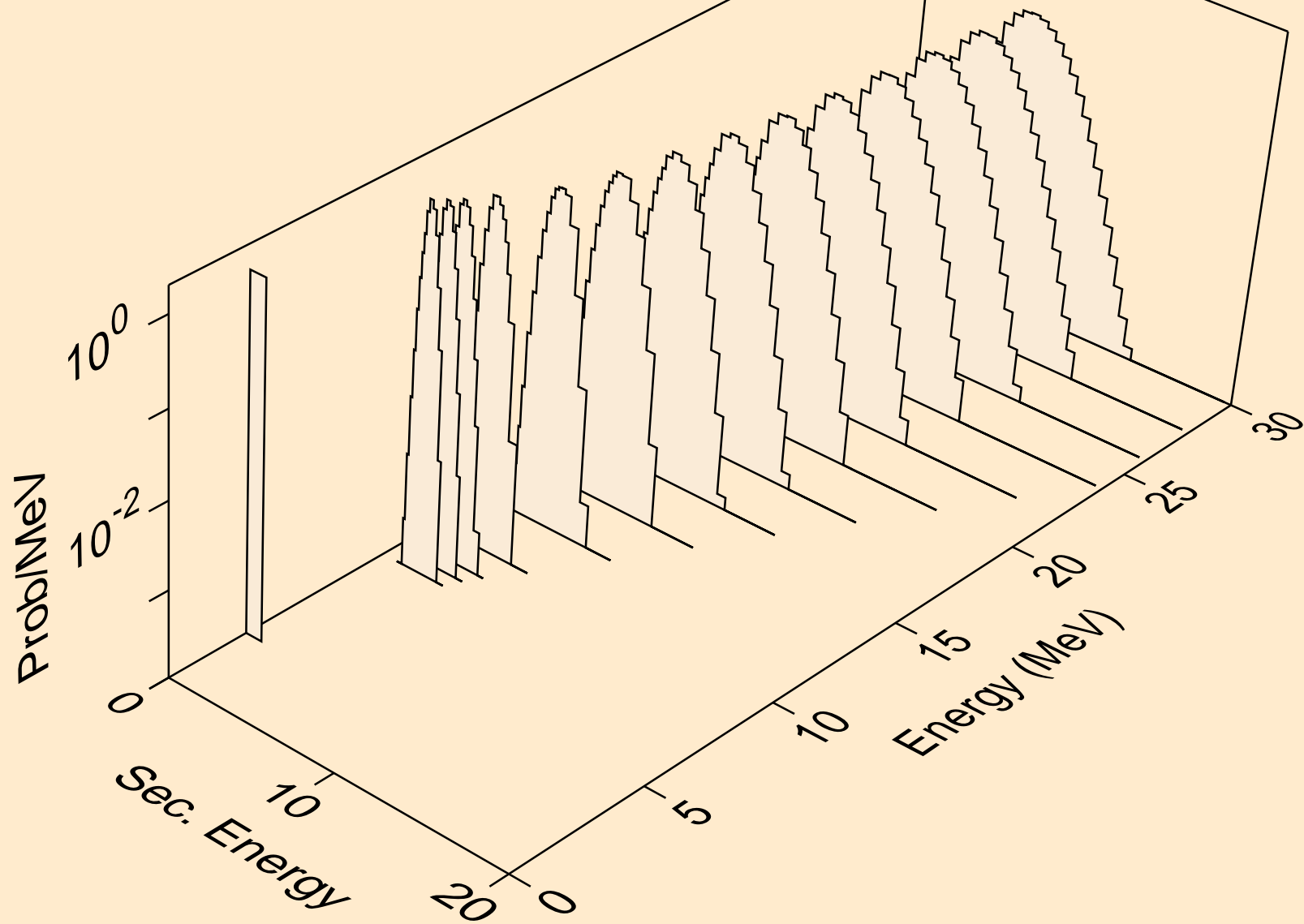

TA164 NEUTRON ACER TENDL-2024 LIBRARY; T=0.K
protons from (n,pt)

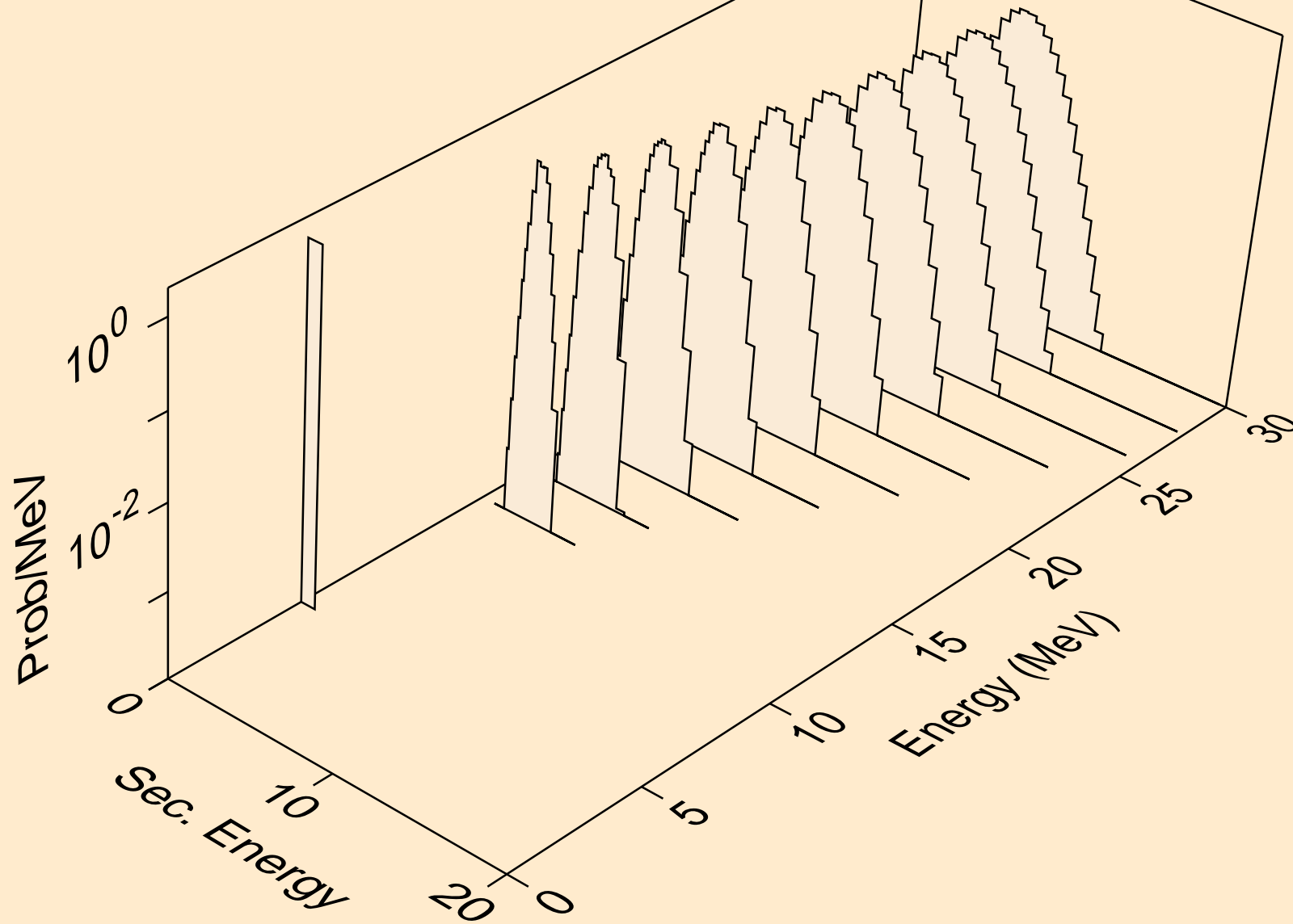

TA164 NEUTRON ACER TENDL-2024 LIBRARY; T=0.K
deuterons from (n,x)

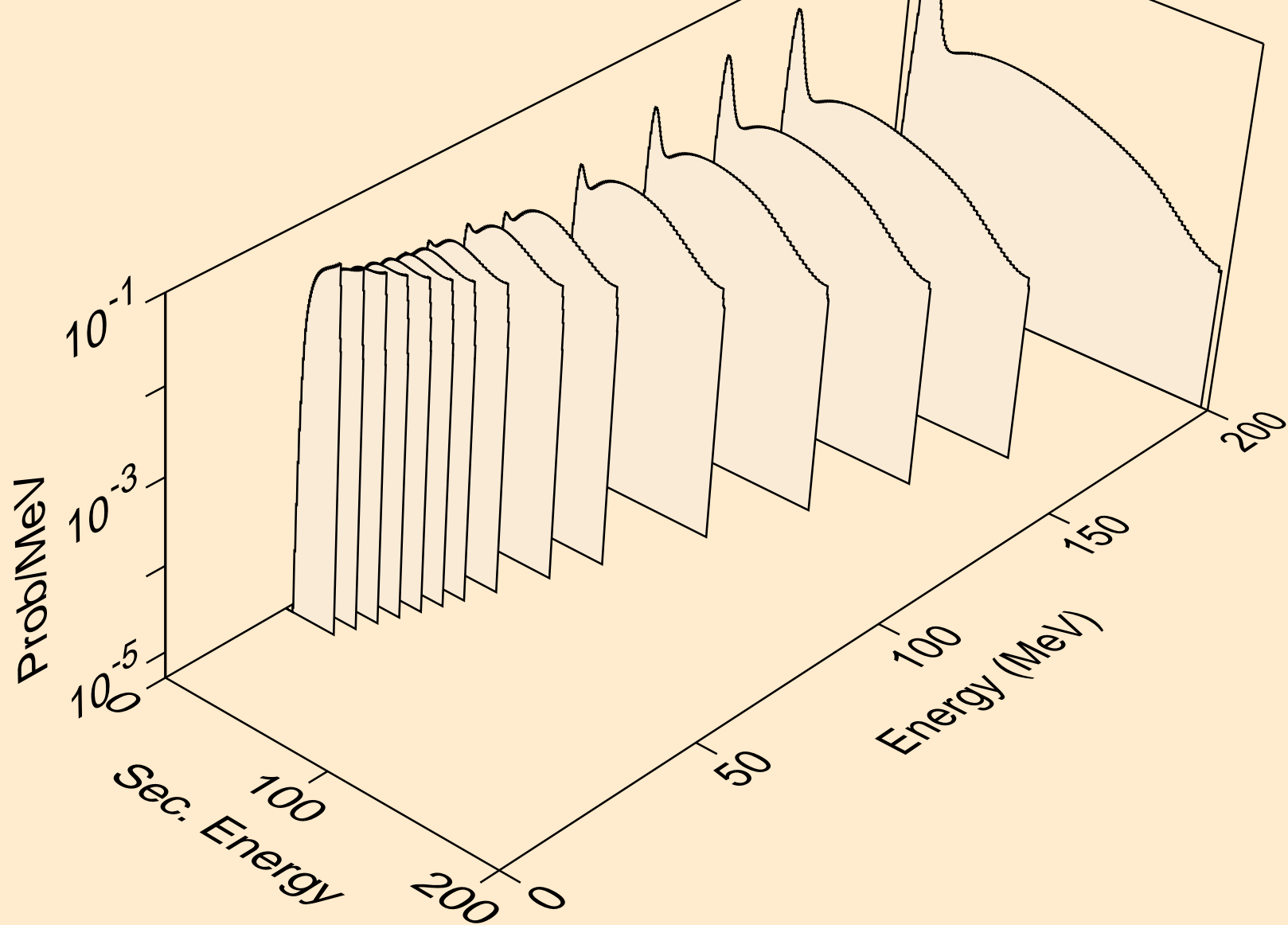

TA164 NEUTRON ACER TENDL-2024 LIBRARY; T=0.K
deuterons from (n,2nd)

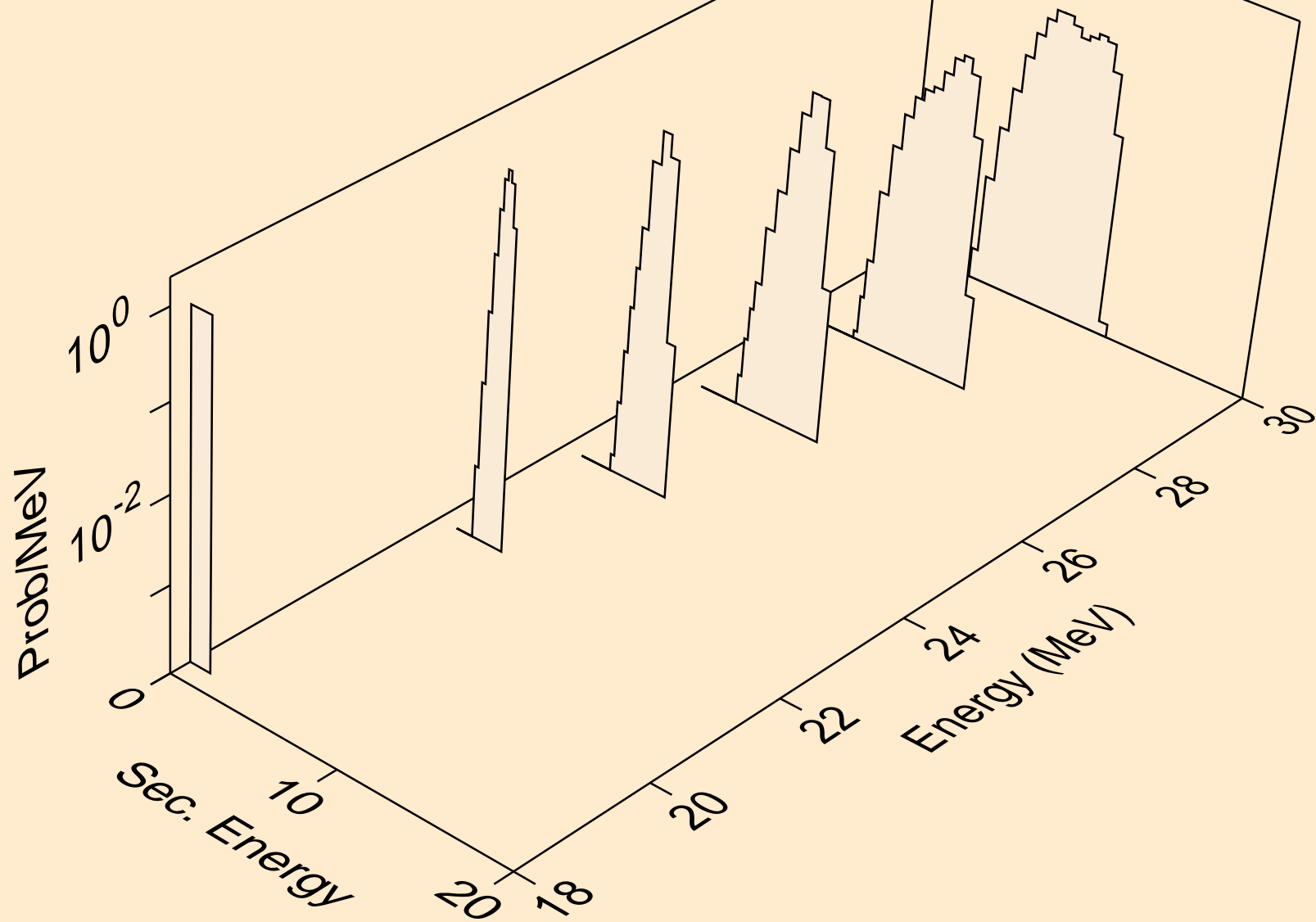

TA164 NEUTRON ACER TENDL-2024 LIBRARY; T=0.K
deuterons from (n,n*)d

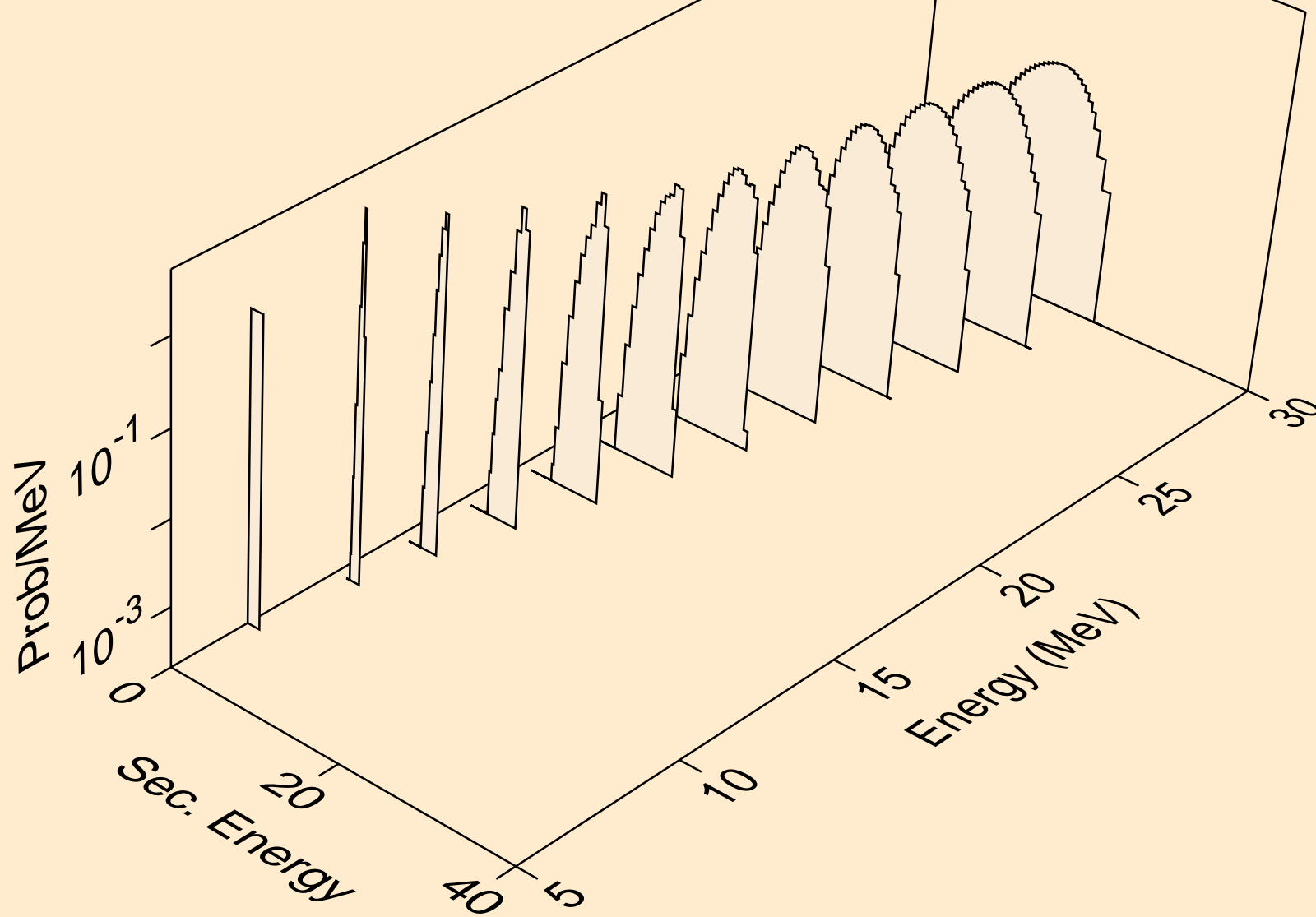

TA164 NEUTRON ACER TENDL-2024 LIBRARY; T=0.K
deuterons from (n,d)

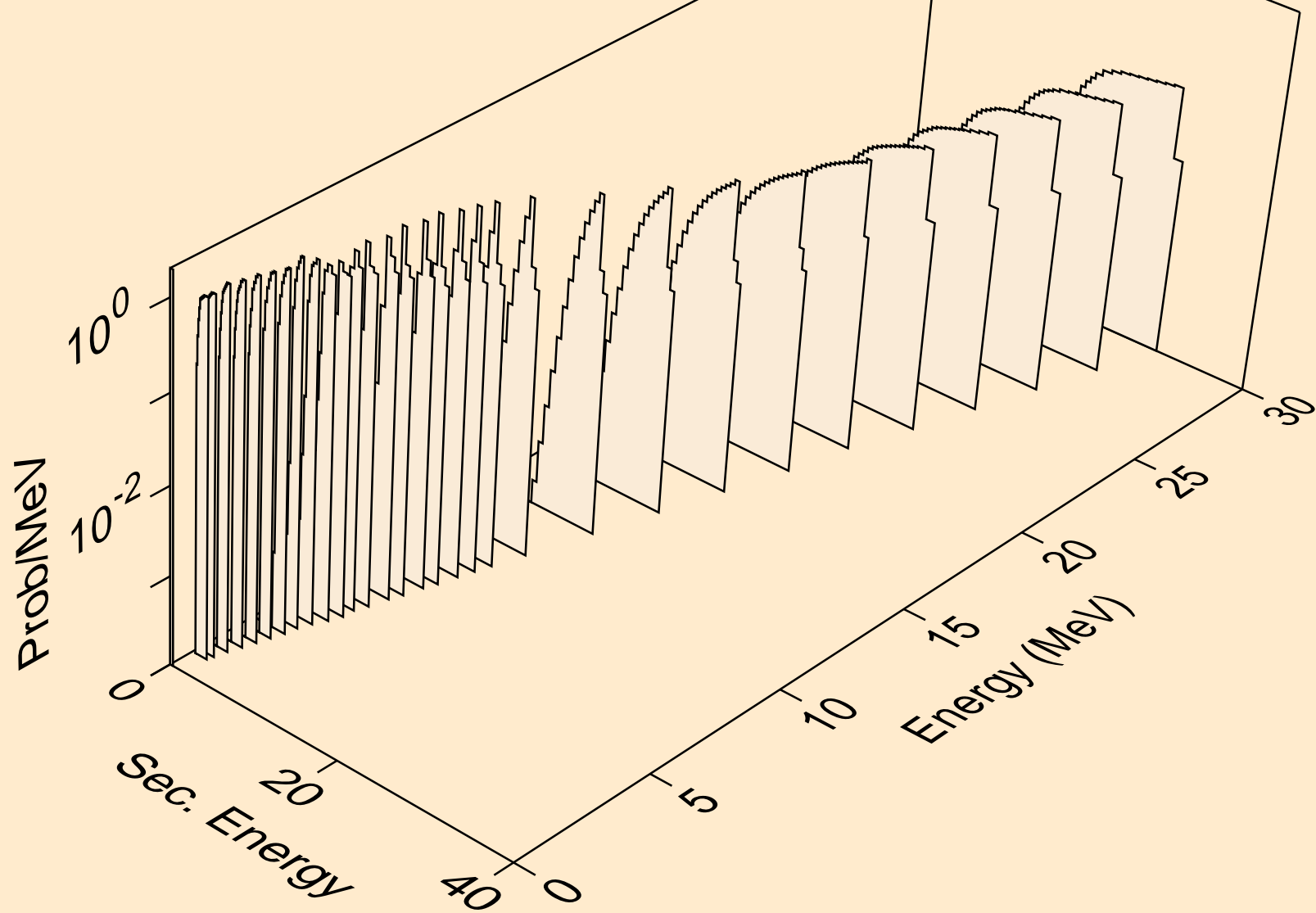

TA164 NEUTRON ACER TENDL-2024 LIBRARY; T=0.K
deuterons from (n,d2a)

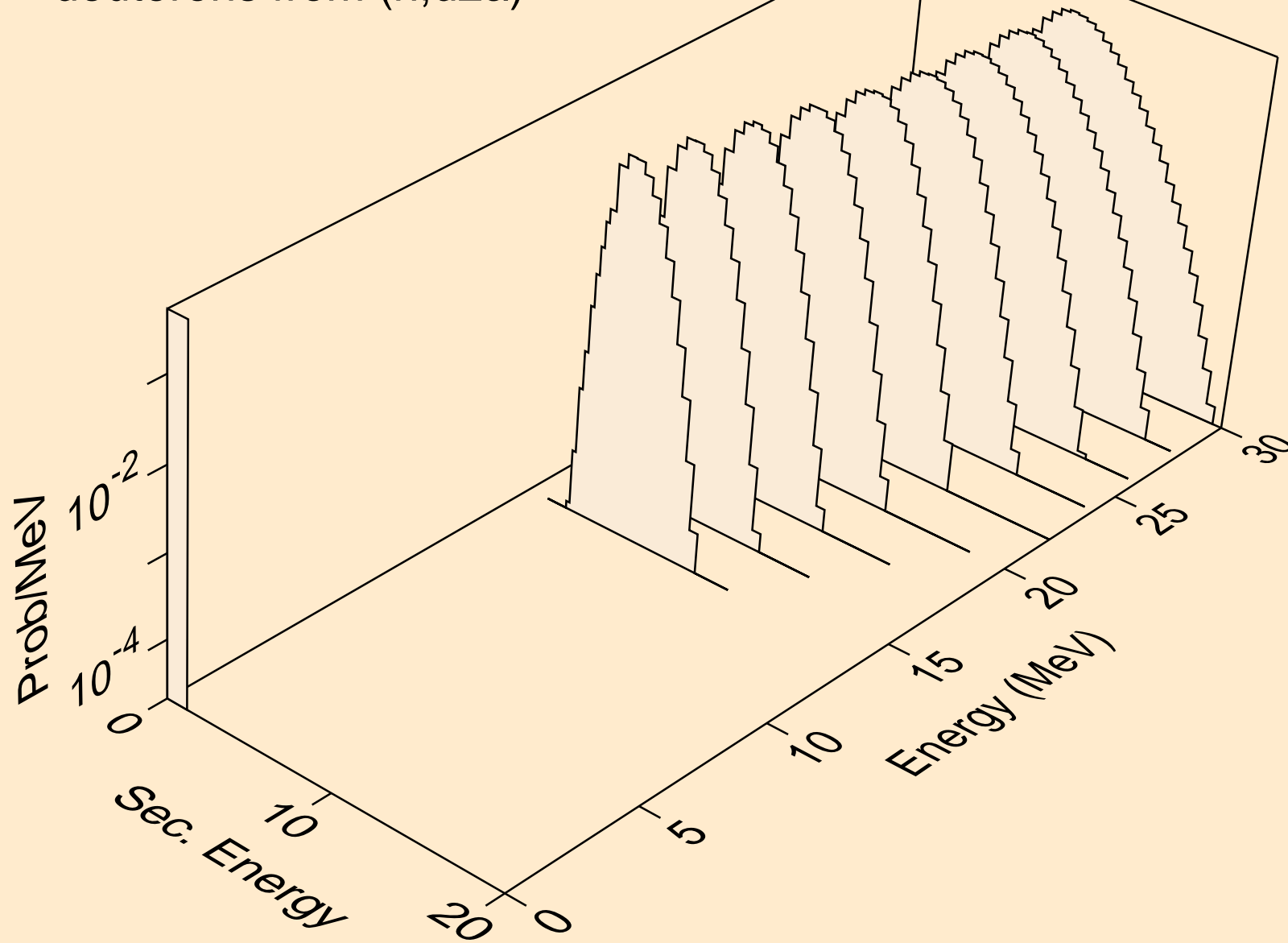

TA164 NEUTRON ACER TENDL-2024 LIBRARY; T=0.K
deuterons from (n,pd)

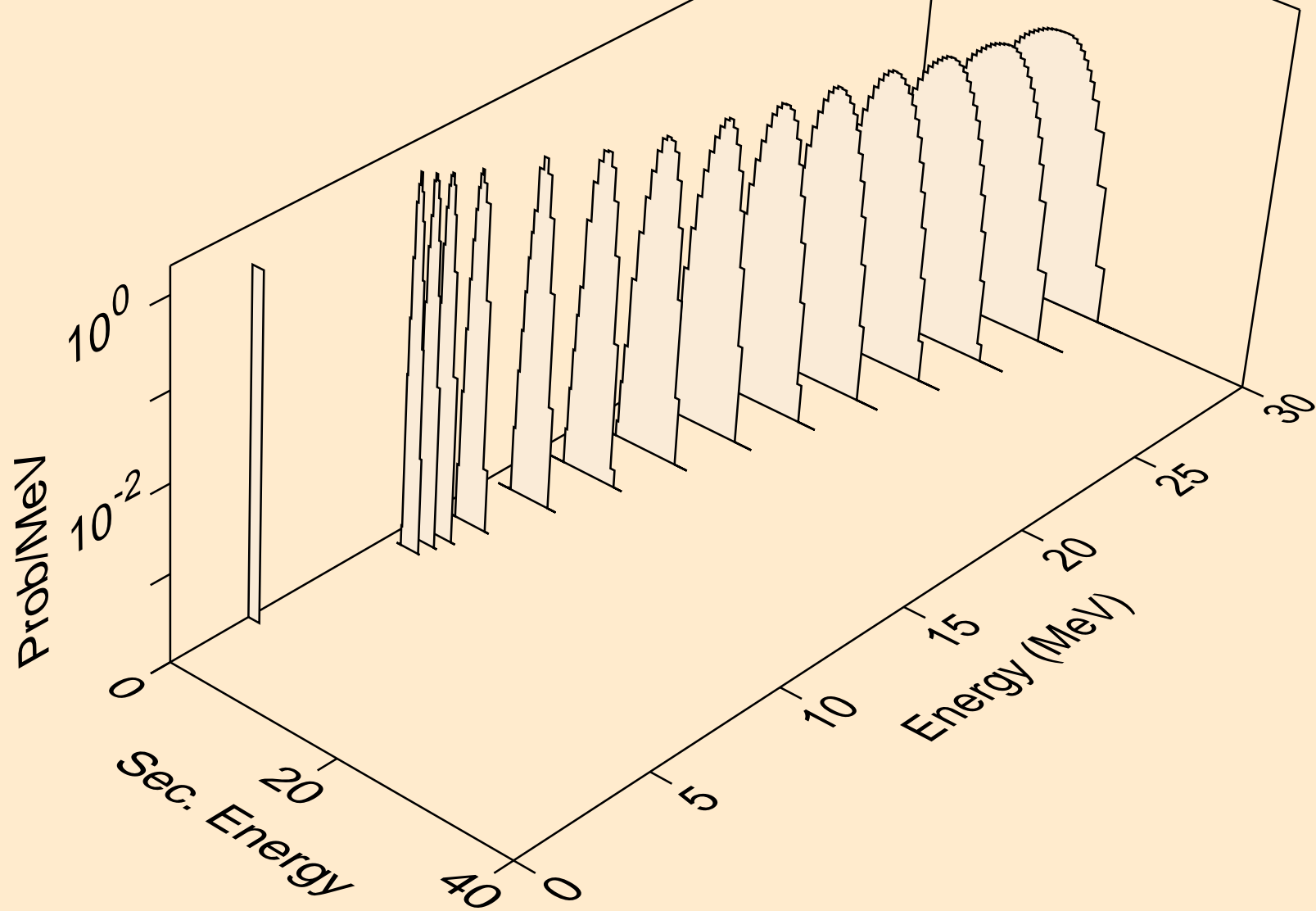

TA164 NEUTRON ACER TENDL-2024 LIBRARY; T=0.K
deuterons from (n,da)

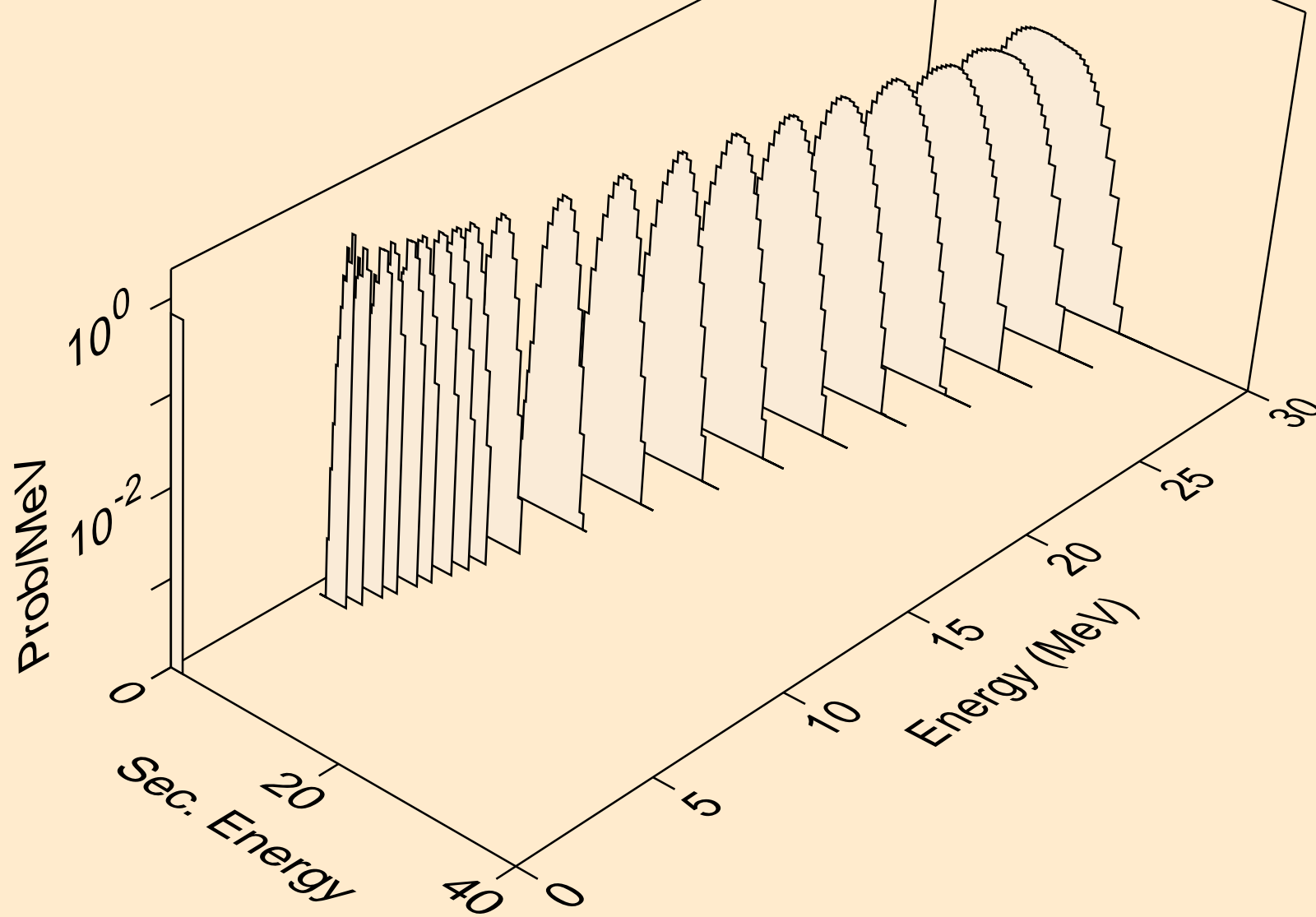

TA164 NEUTRON ACER TENDL-2024 LIBRARY; T=0.K
tritons from (n,x)

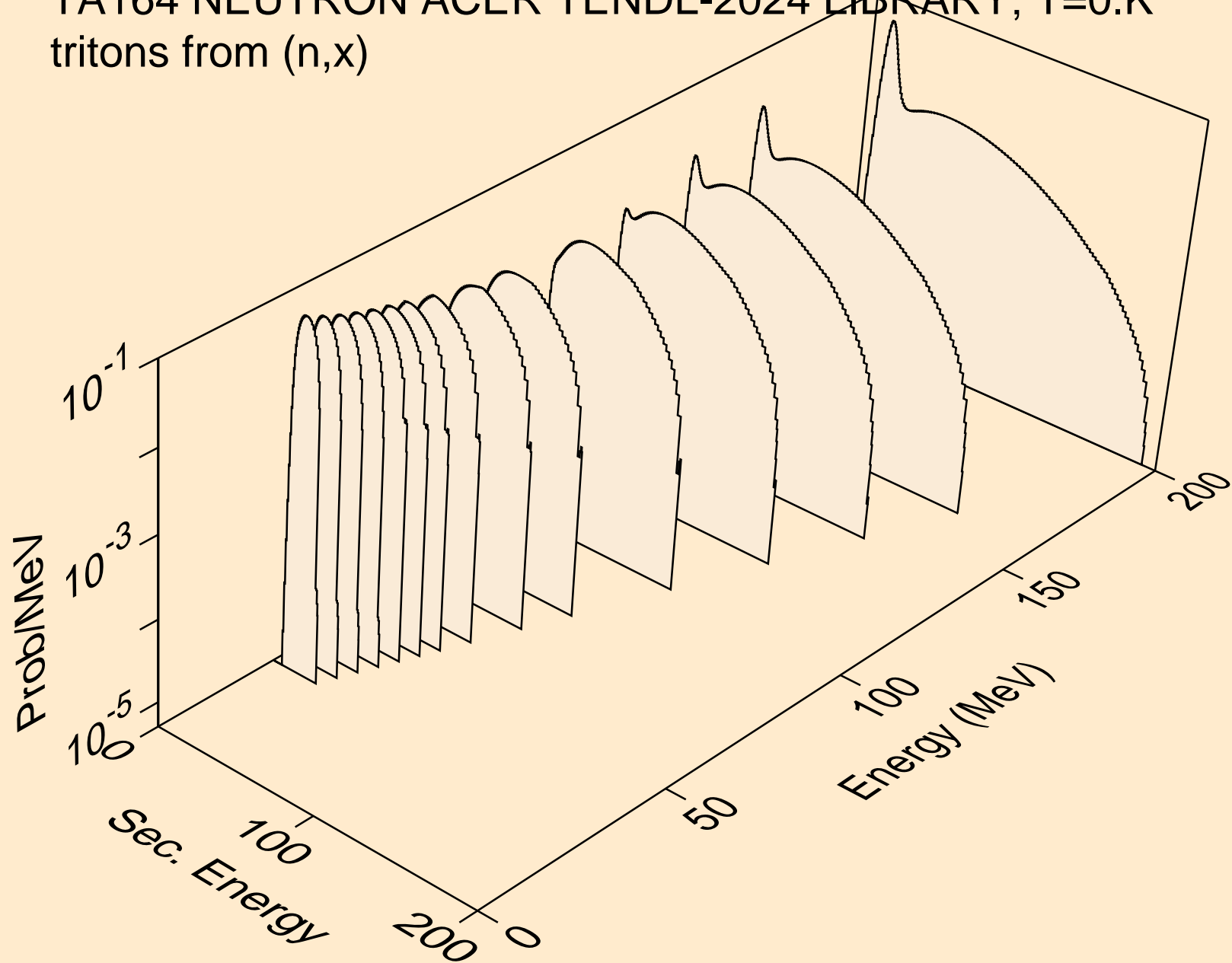

TA164 NEUTRON ACER TENDL-2024 LIBRARY; T=0.K
tritons from (n,n*)t

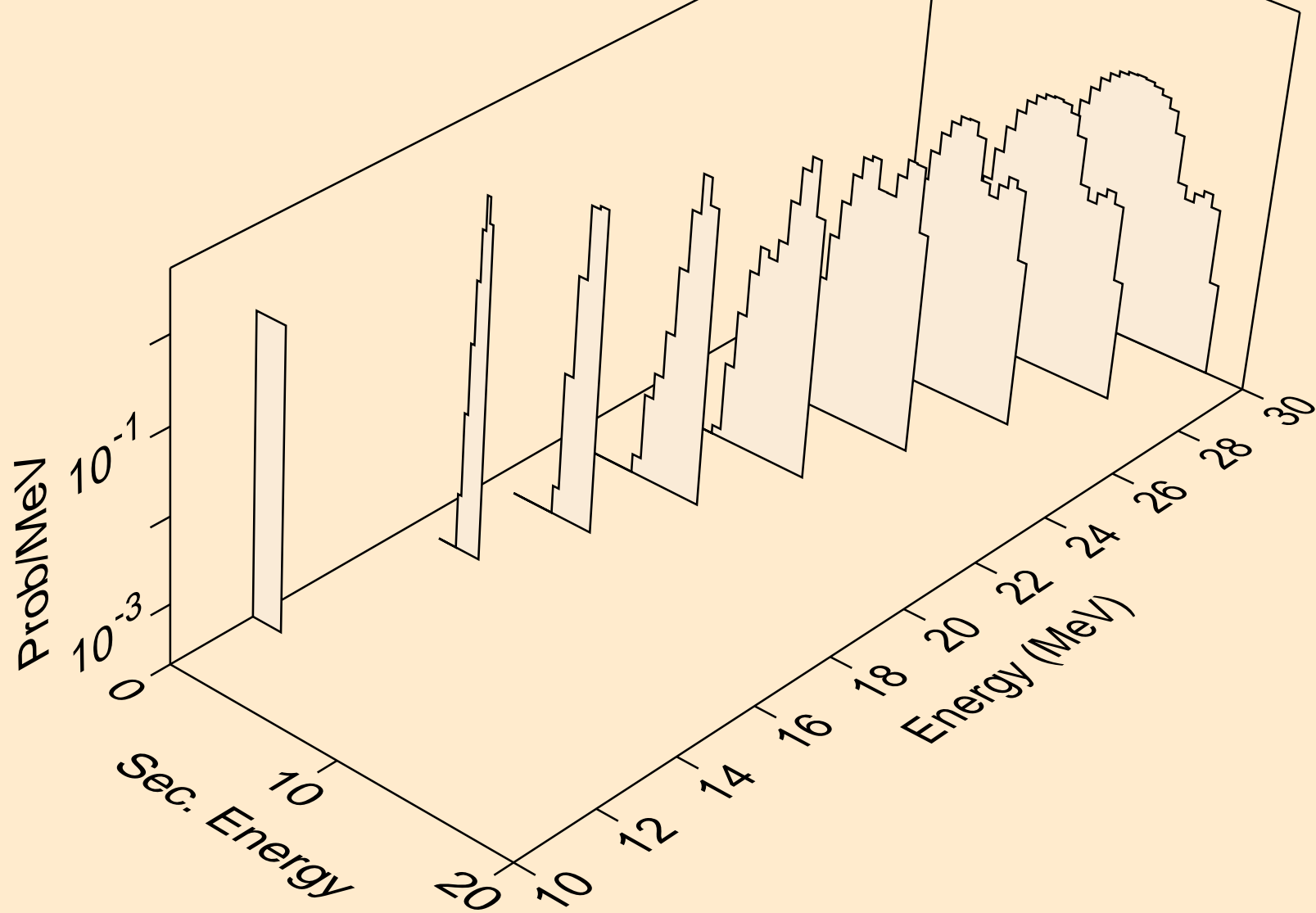

TA164 NEUTRON ACER TENDL-2024 LIBRARY; T=0.K
tritons from (n,t)

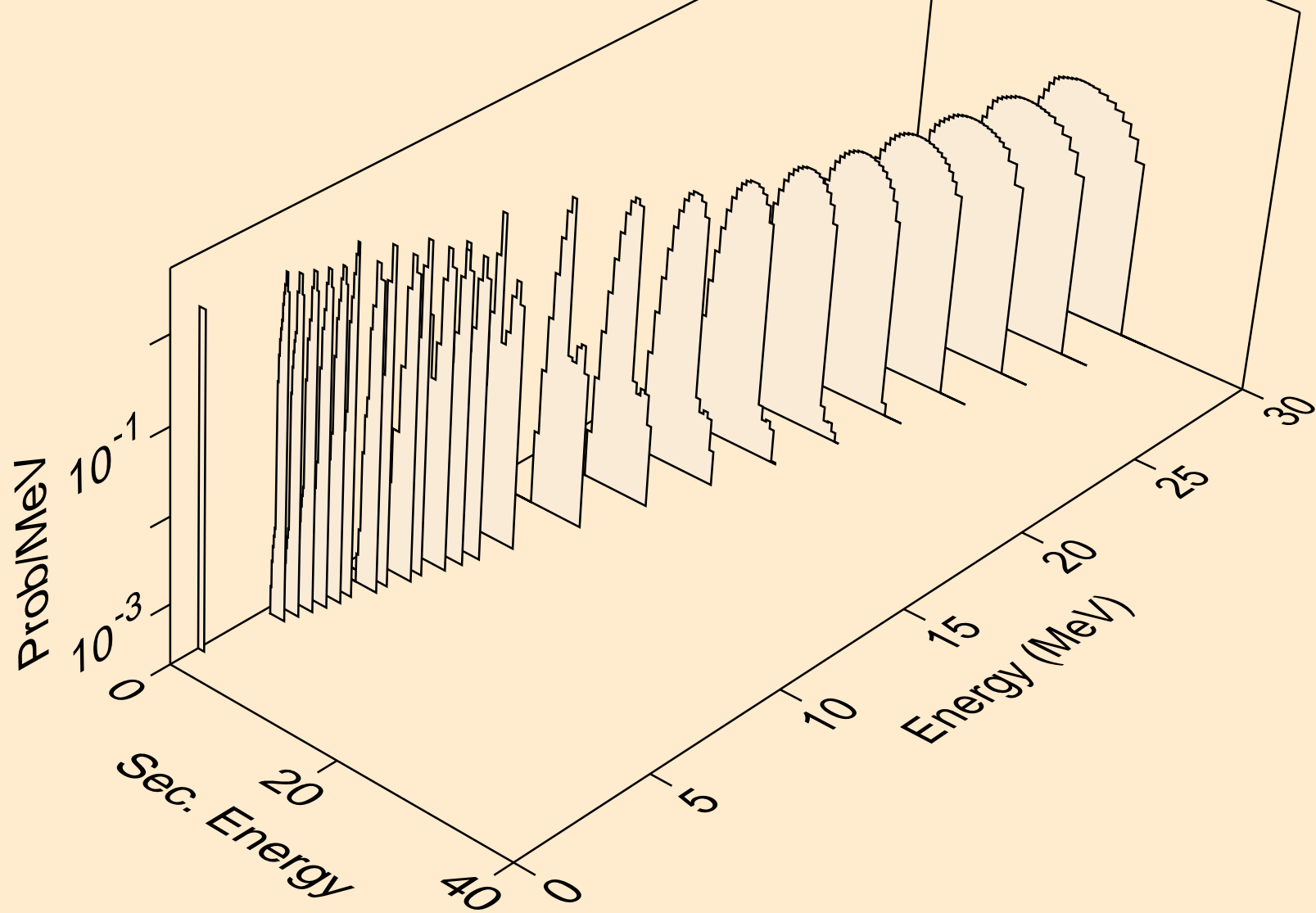

TA164 NEUTRON ACER TENDL-2024 LIBRARY; T=0.K
tritons from (n,t2a)

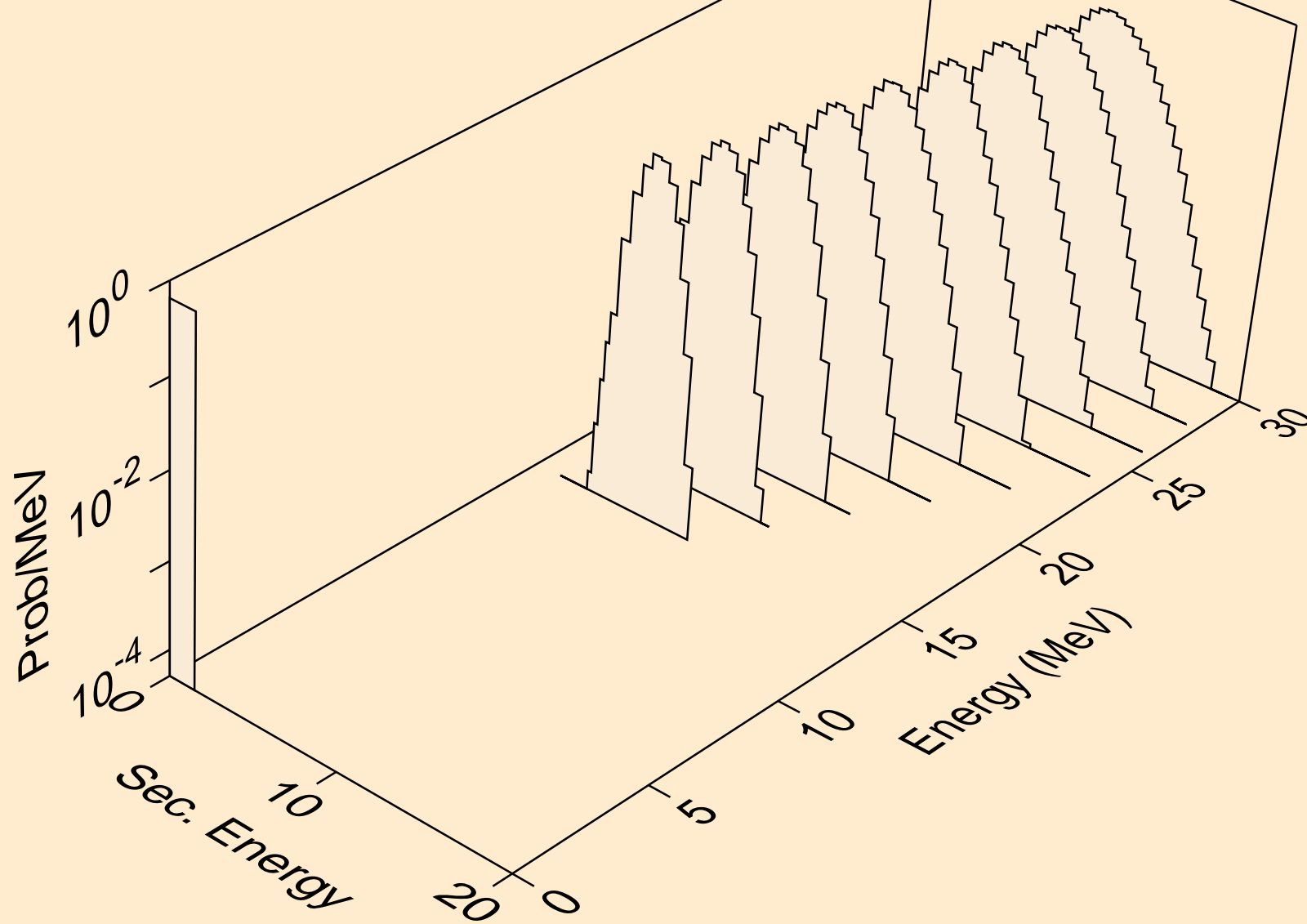

TA164 NEUTRON ACER TENDL-2024 LIBRARY; T=0.K
tritons from (n,pt)

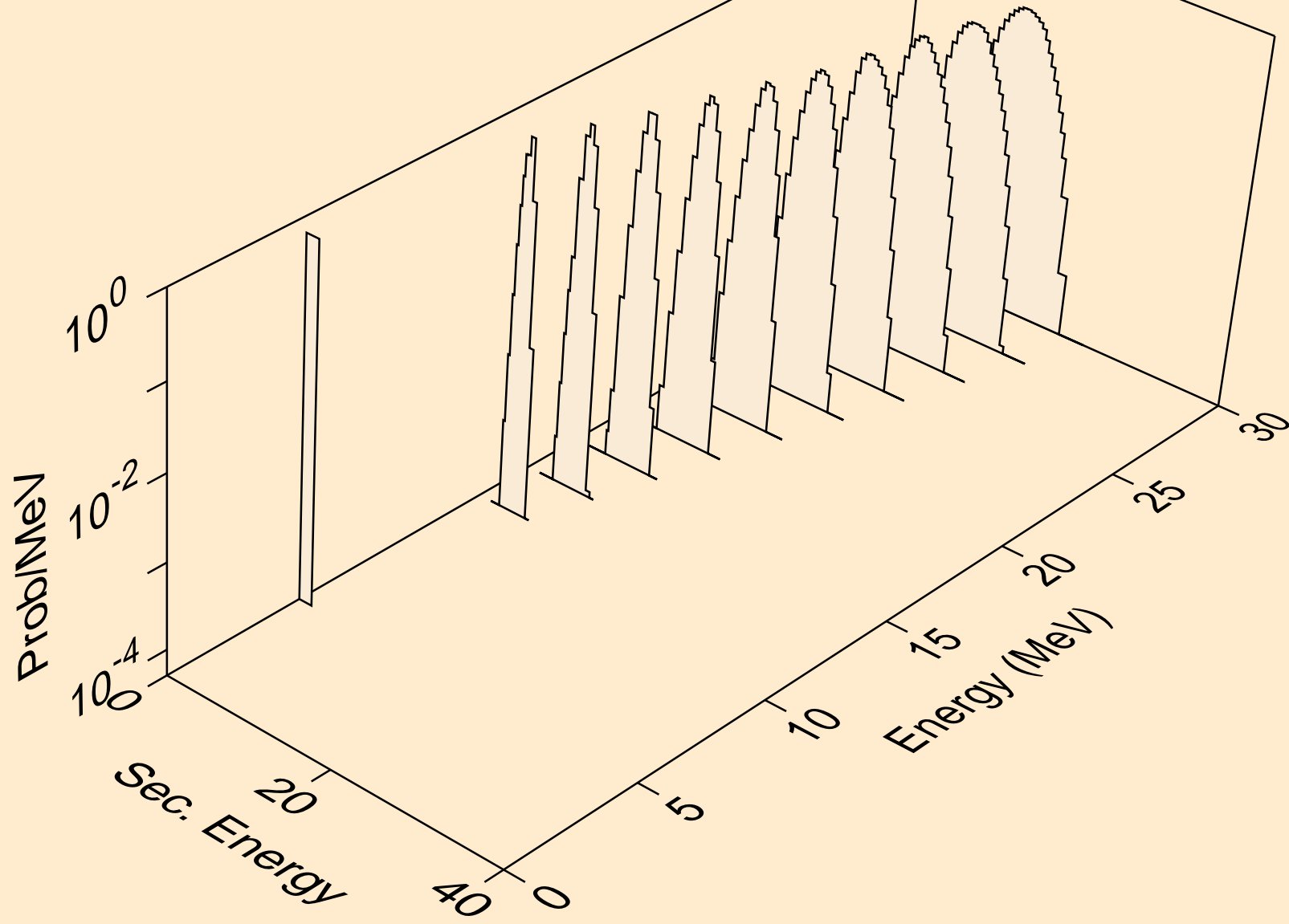

TA164 NEUTRON ACER TENDL-2024 LIBRARY; T=0.K
he3s from (n,x)

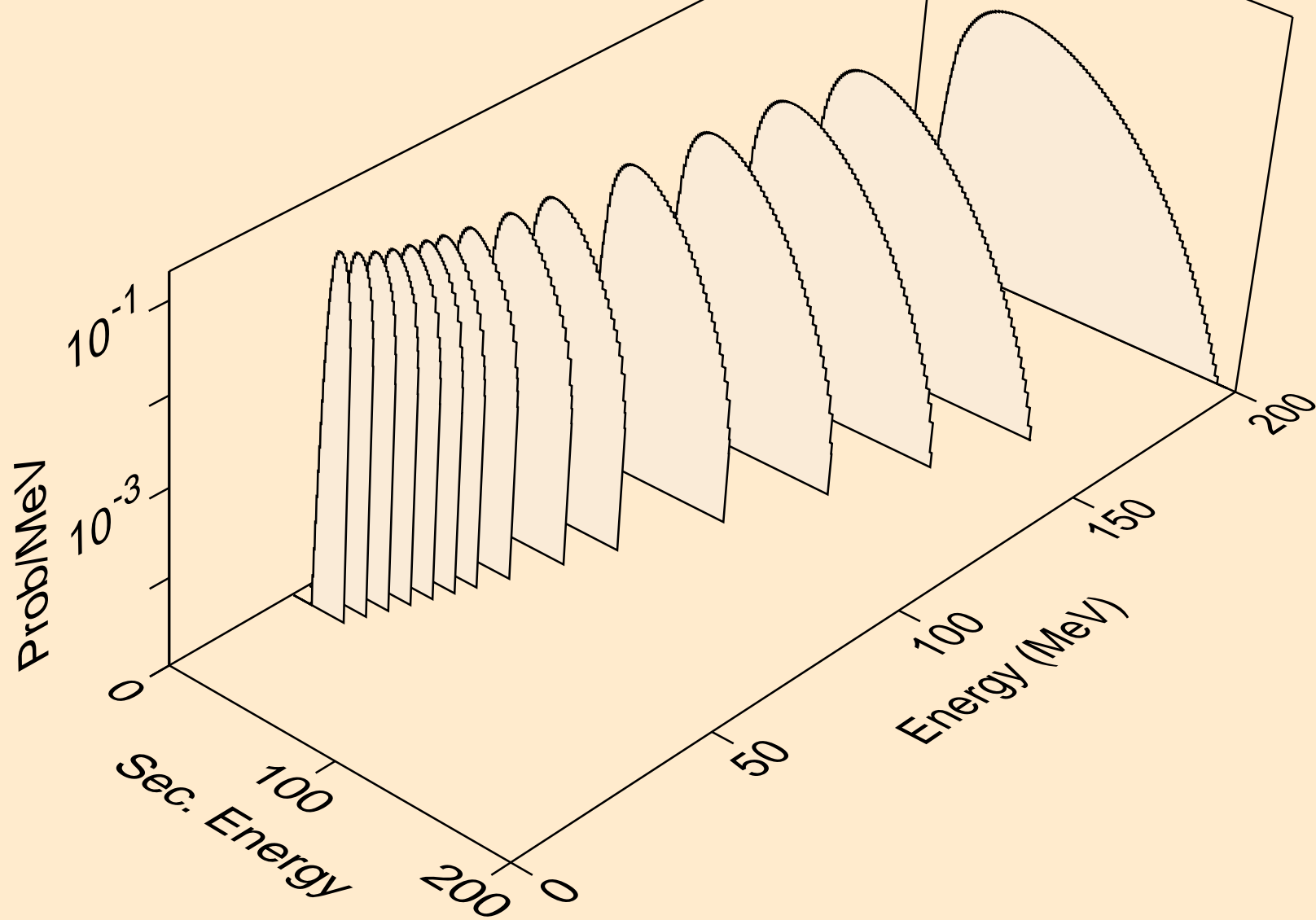

TA164 NEUTRON ACER TENDL-2024 LIBRARY; T=0.K
he3s from (n,n*)he3

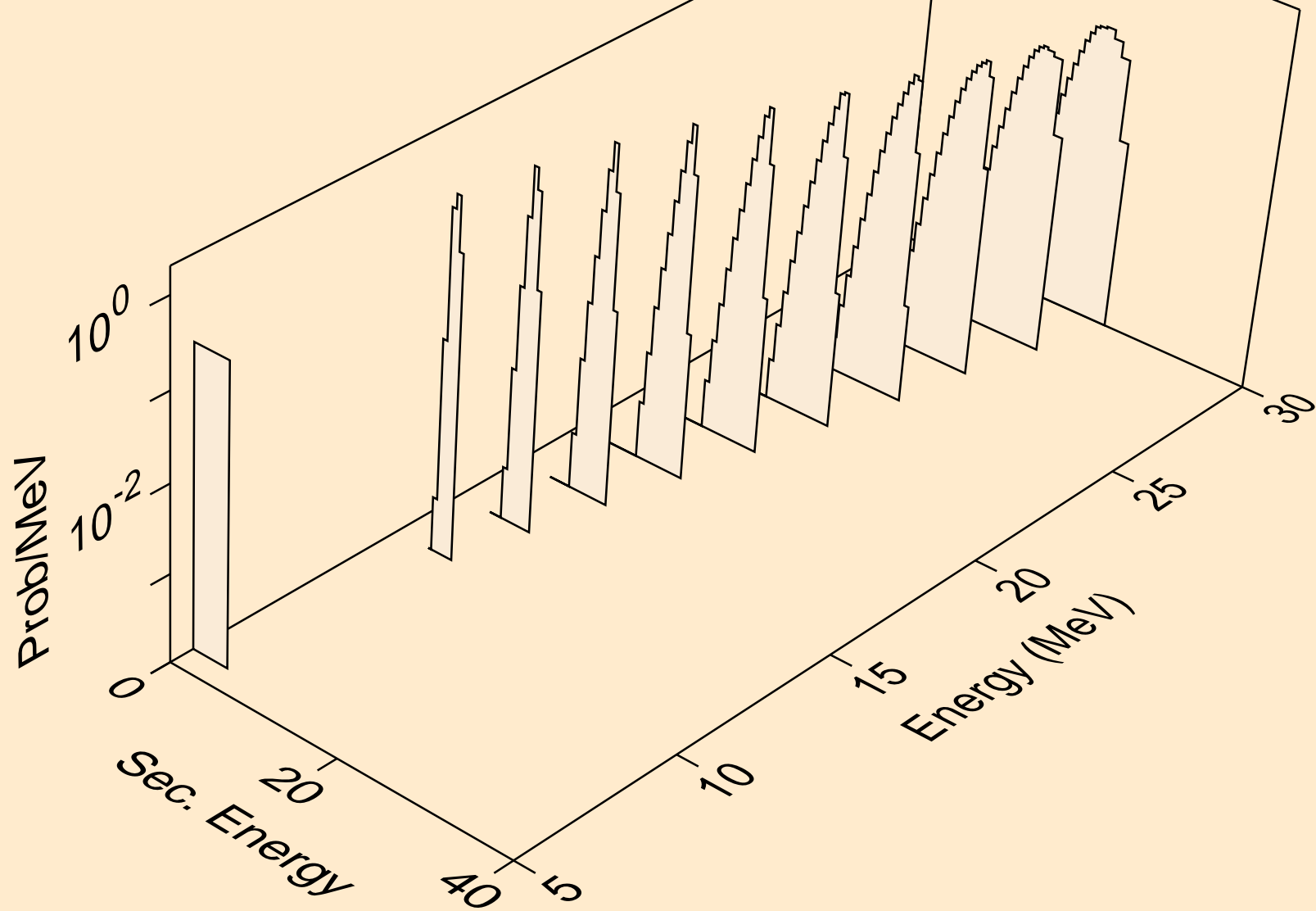

TA164 NEUTRON ACER TENDL-2024 LIBRARY; T=0.K
he3s from (n,he3)

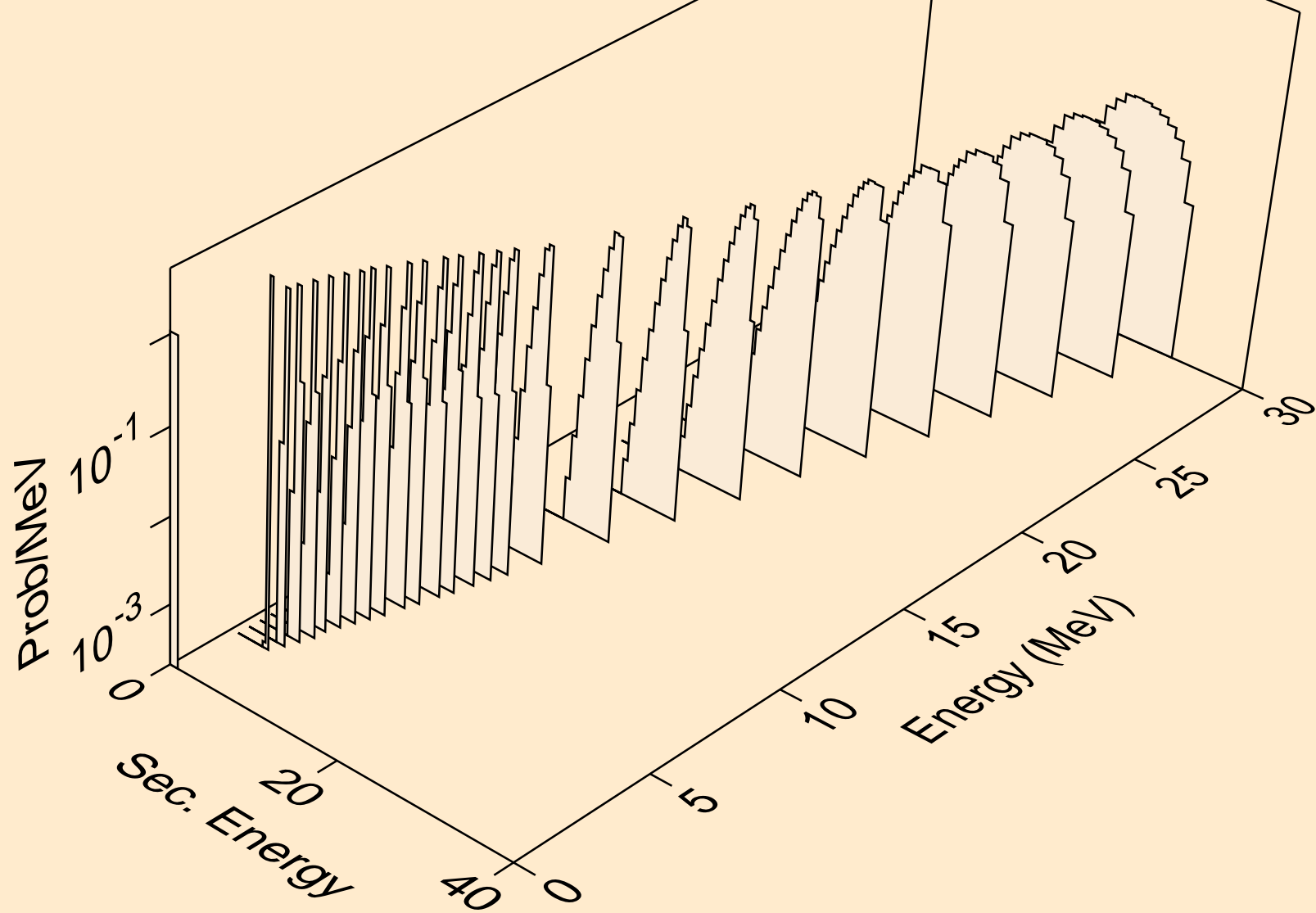

TA164 NEUTRON ACER TENDL-2024 LIBRARY; T=0.K
alphas from (n,x)

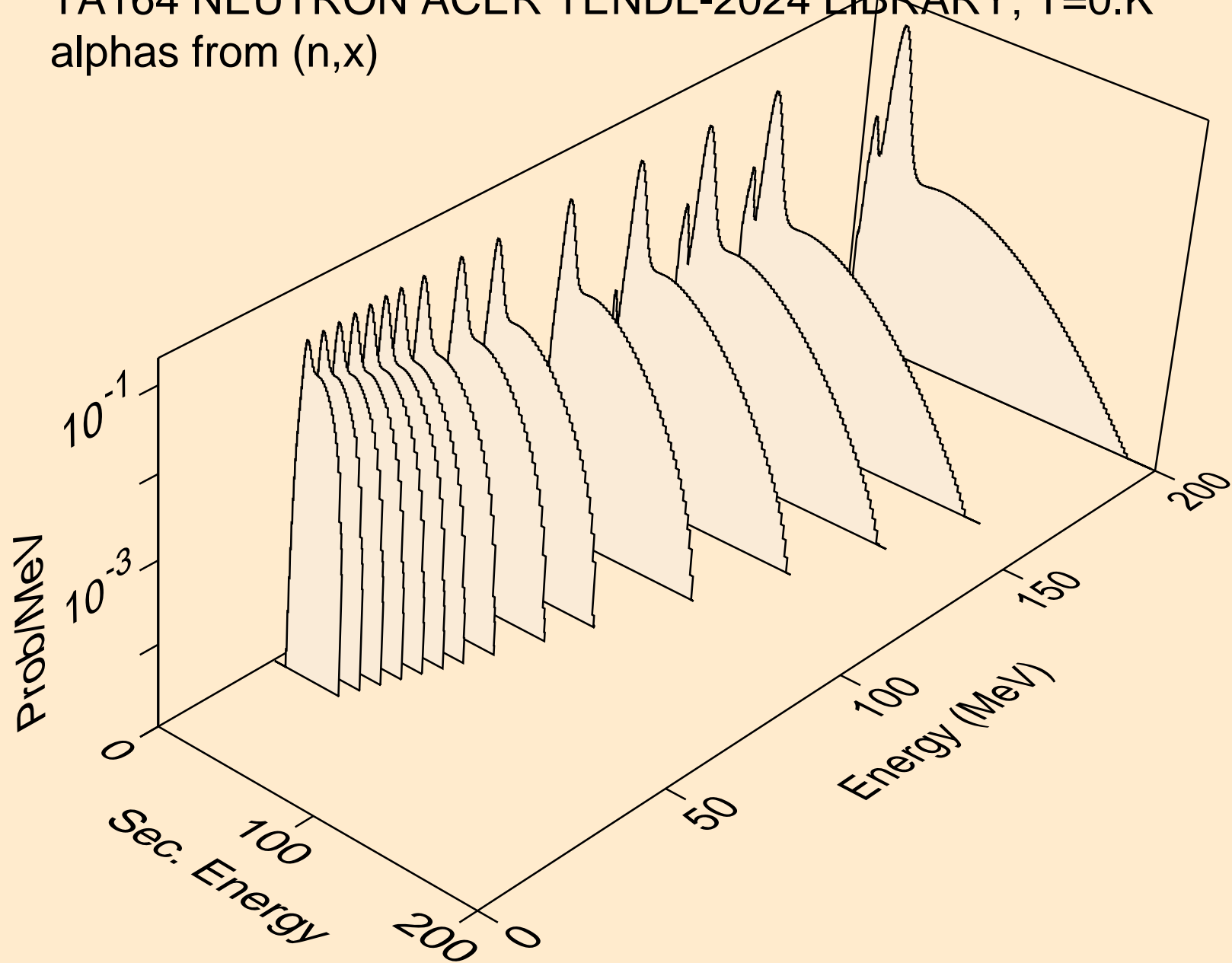

TA164 NEUTRON ACER TENDL-2024 LIBRARY; T=0.K
alphas from (n,n*)a

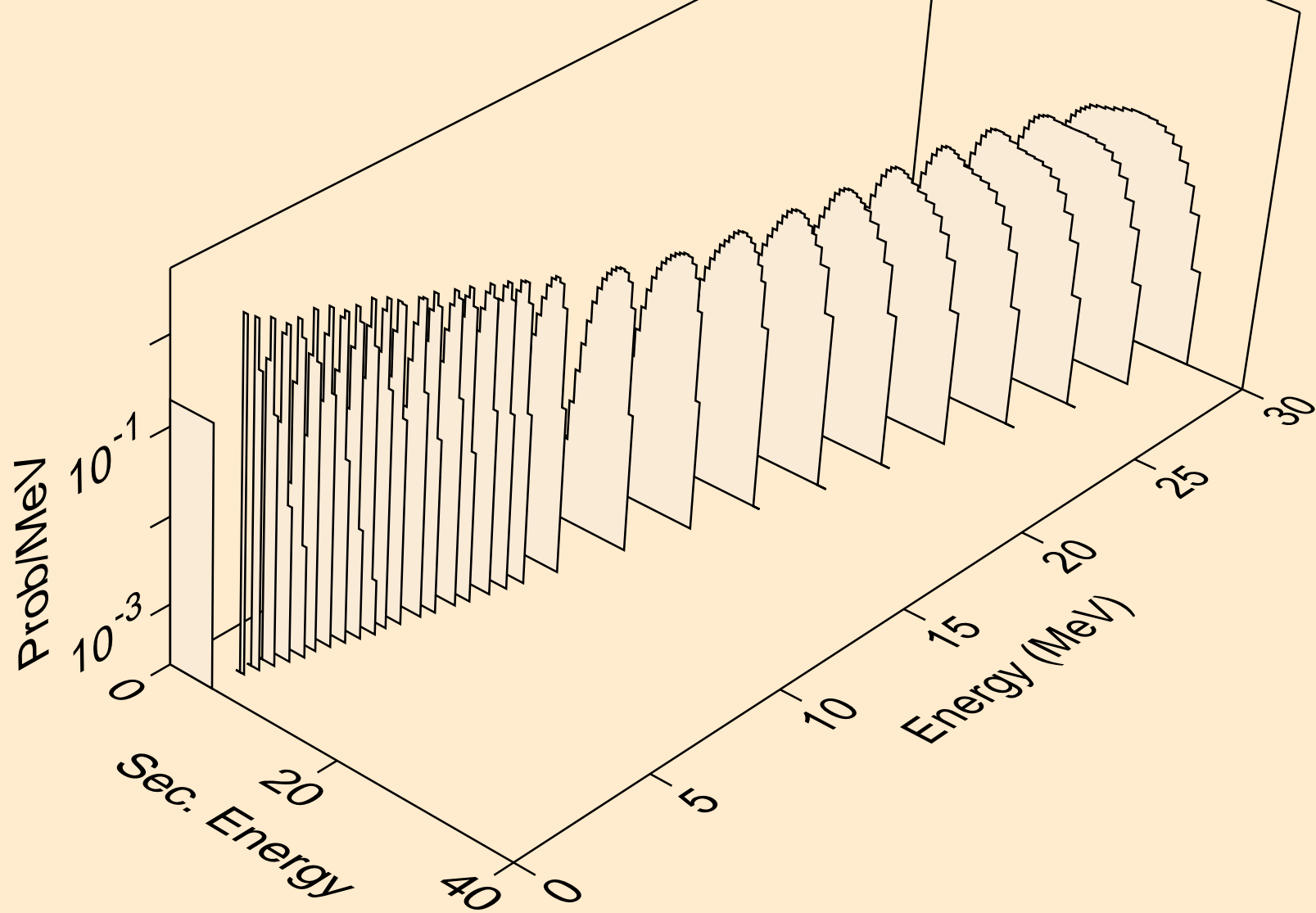

TA164 NEUTRON ACER TENDL-2024 LIBRARY; T=0.K
alphas from (n,n*)3a

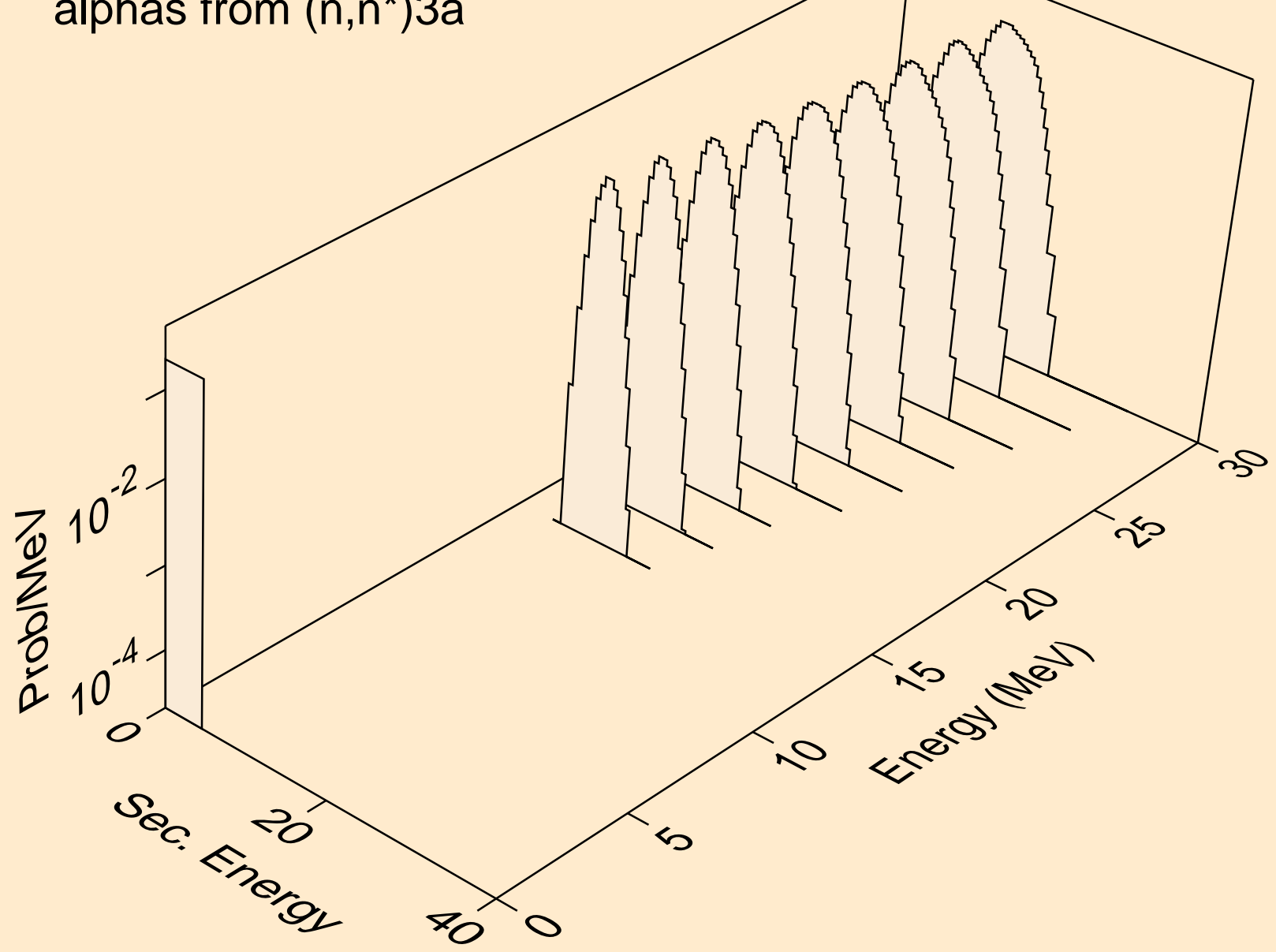

TA164 NEUTRON ACER TENDL-2024 LIBRARY; T=0.K
alphas from (n,2n)a

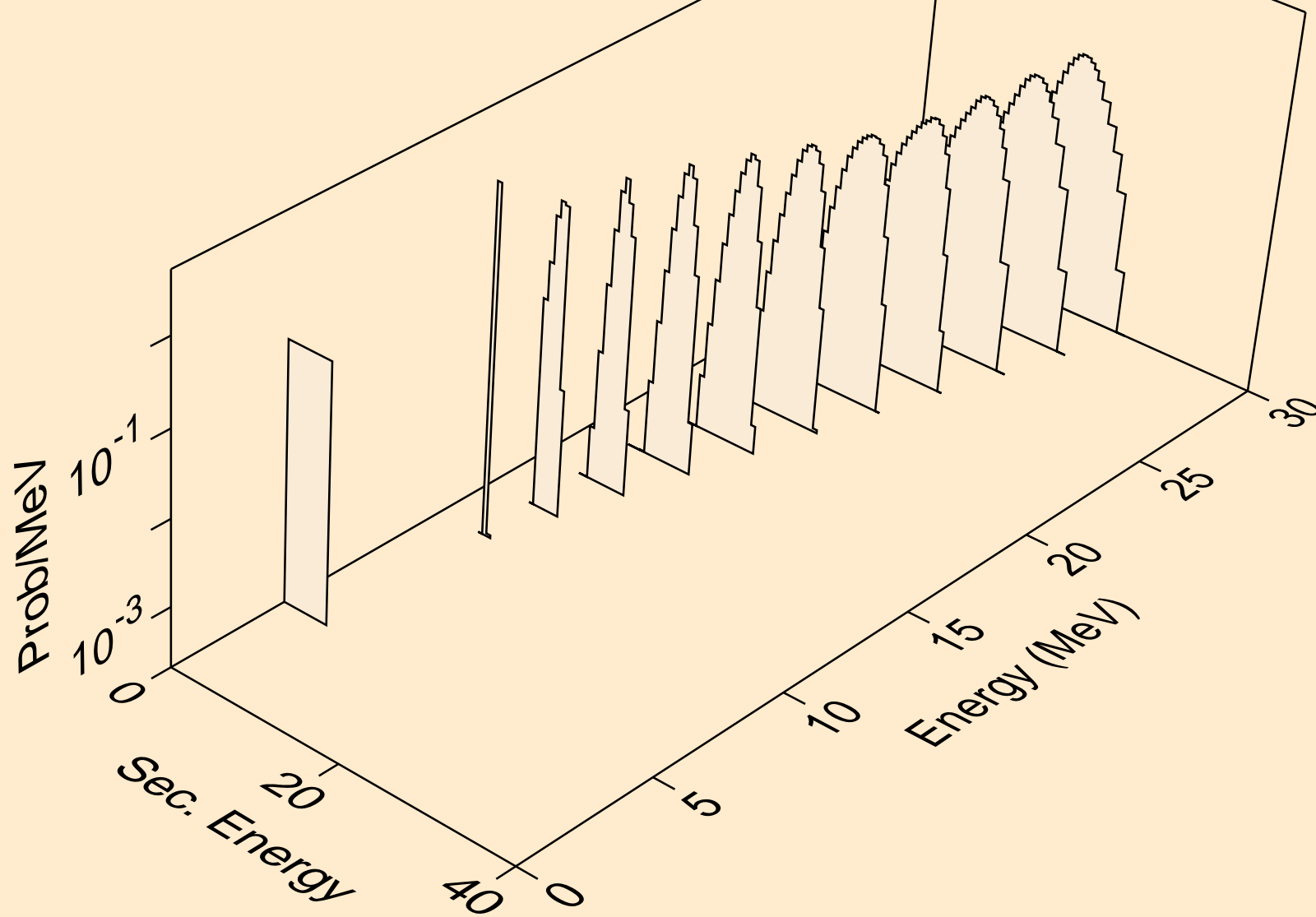

TA164 NEUTRON ACER TENDL-2024 LIBRARY; T=0.K
alphas from (n,3n)a

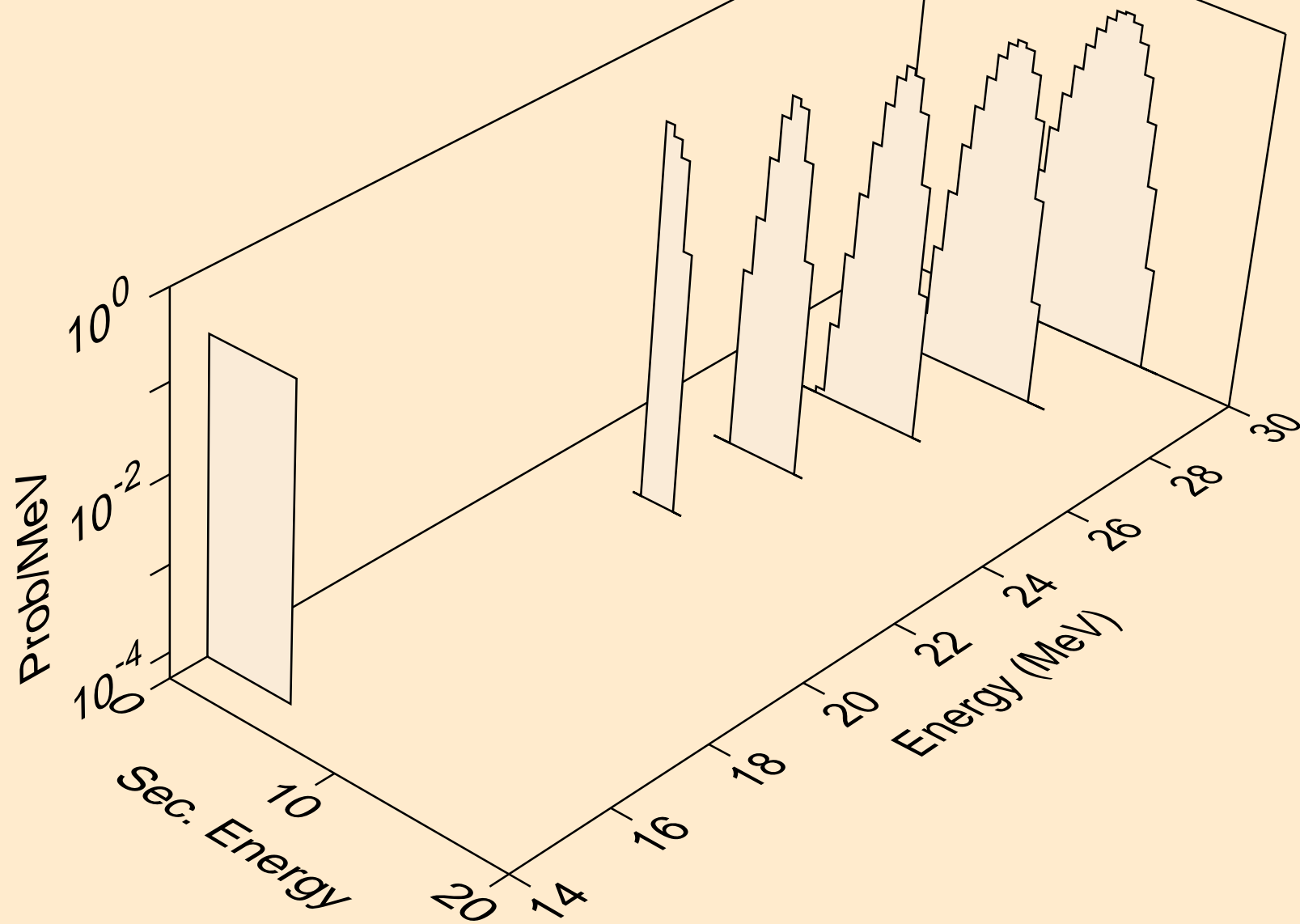

TA164 NEUTRON ACER TENDL-2024 LIBRARY; T=0.K
alphas from (n,n*)2a

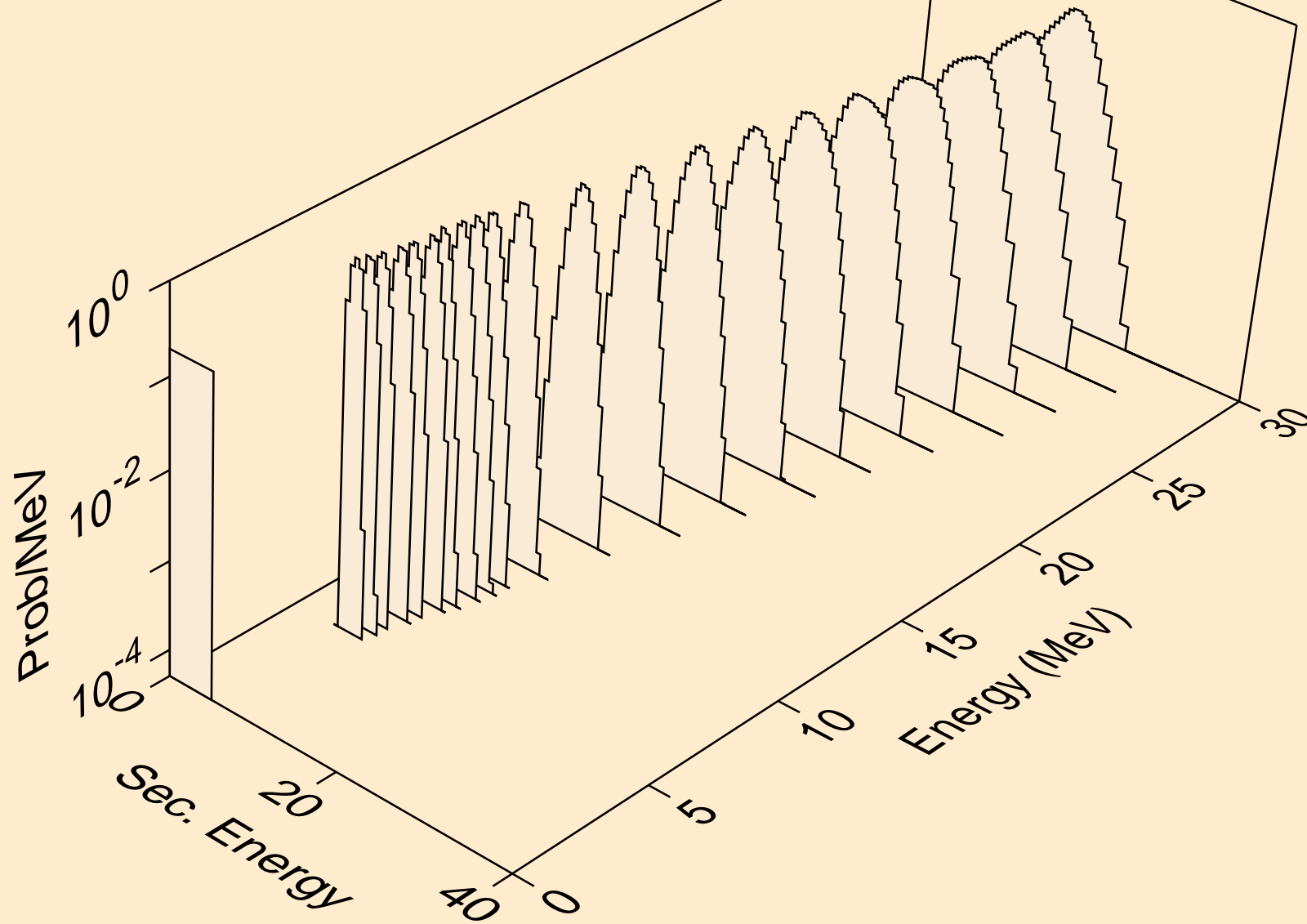

TA164 NEUTRON ACER TENDL-2024 LIBRARY; T=0.K
alphas from (n,2n)2a

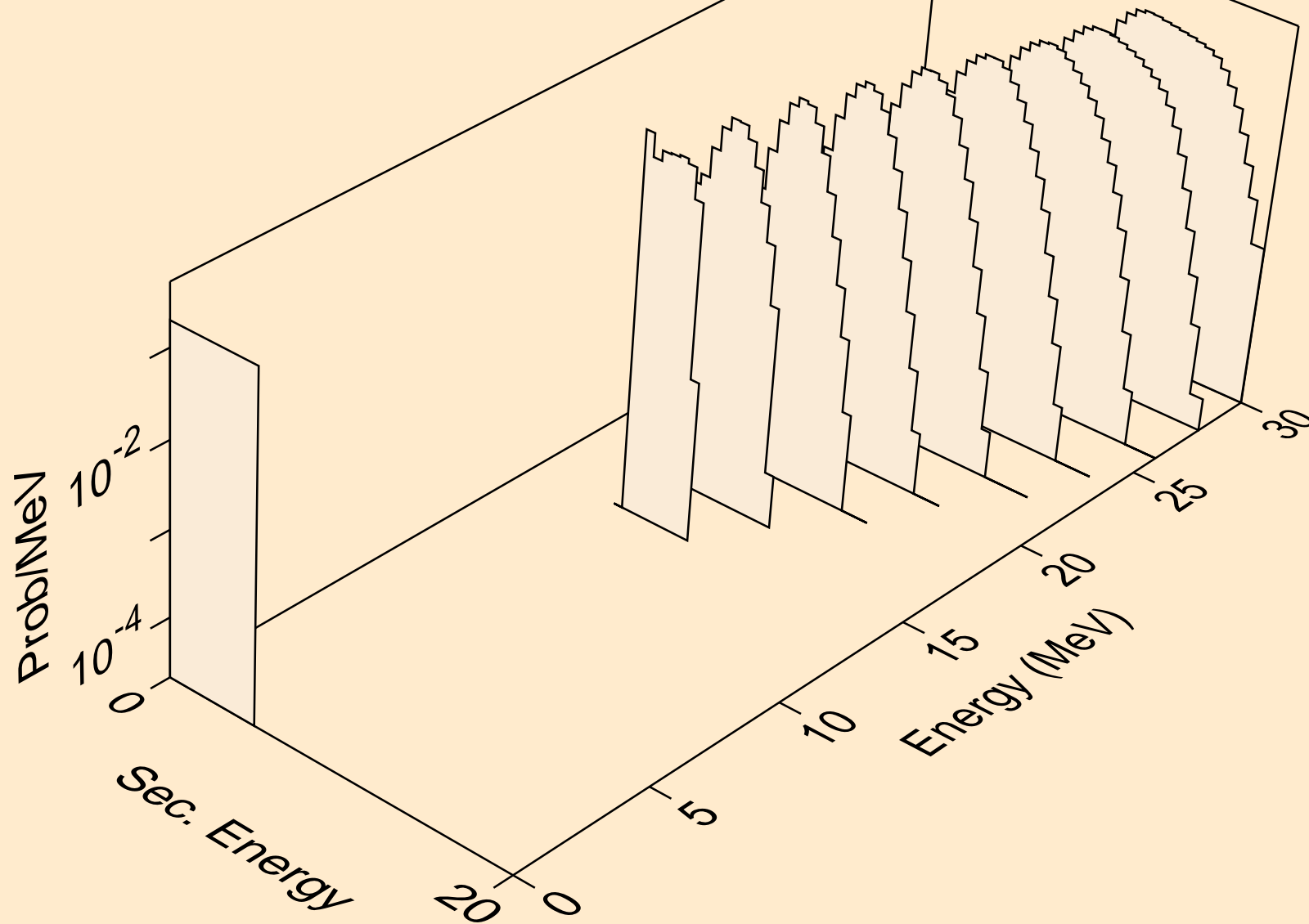

TA164 NEUTRON ACER TENDL-2024 LIBRARY; T=0.K
alphas from (n,npa)

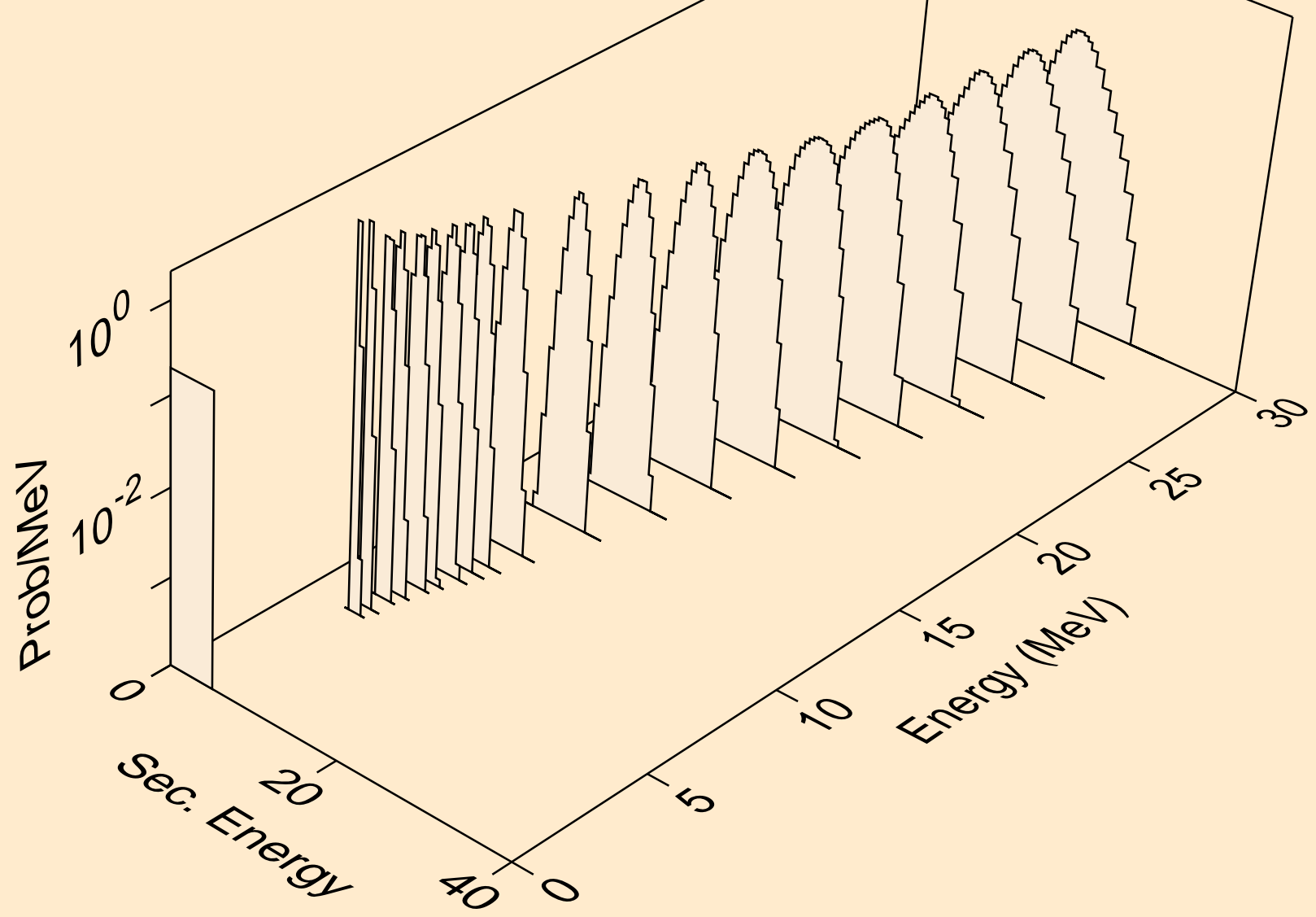

TA164 NEUTRON ACER TENDL-2024 LIBRARY; T=0.K
alphas from (n,a)

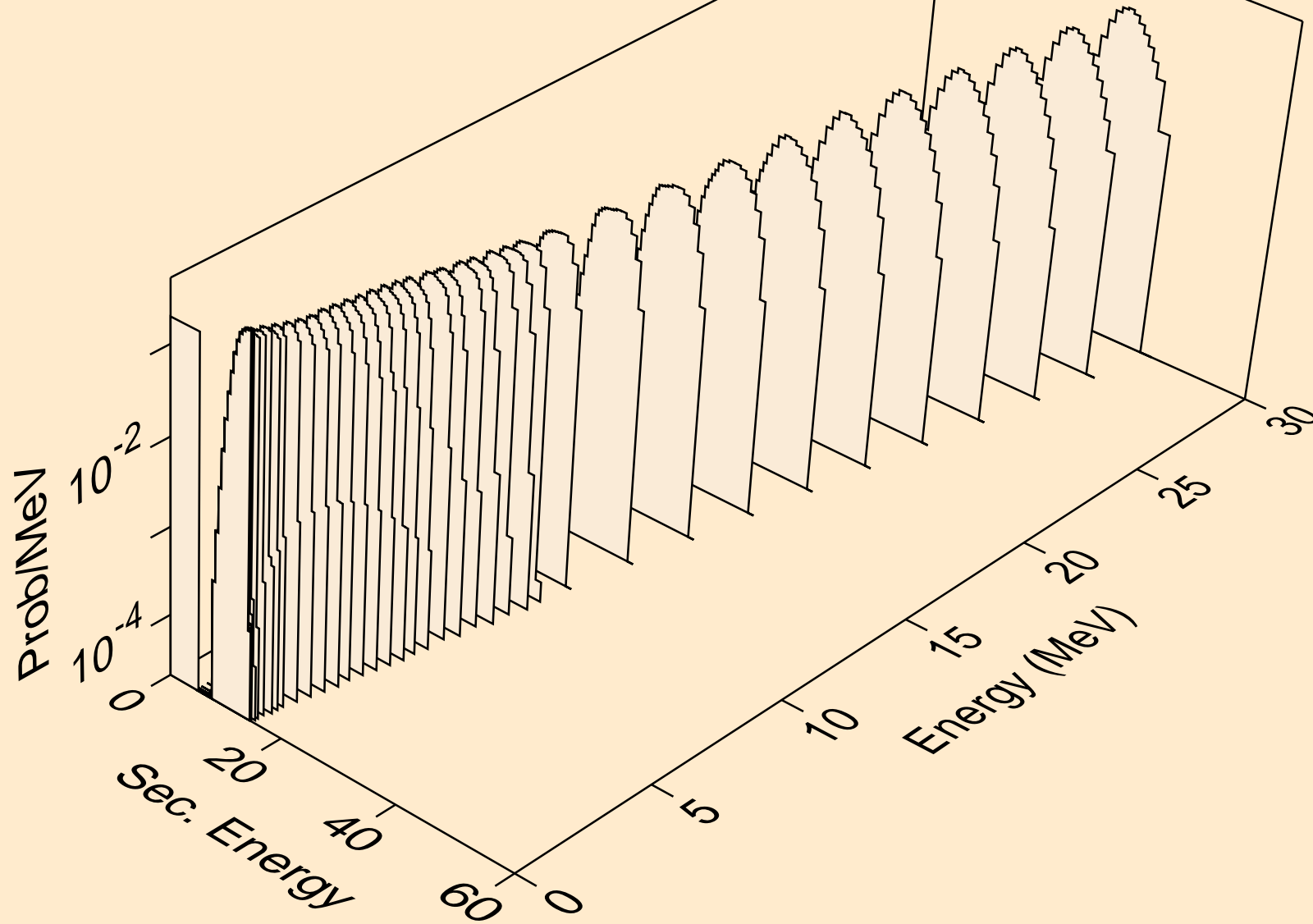

TA164 NEUTRON ACER TENDL-2024 LIBRARY; T=0.K
alphas from (n,2a)

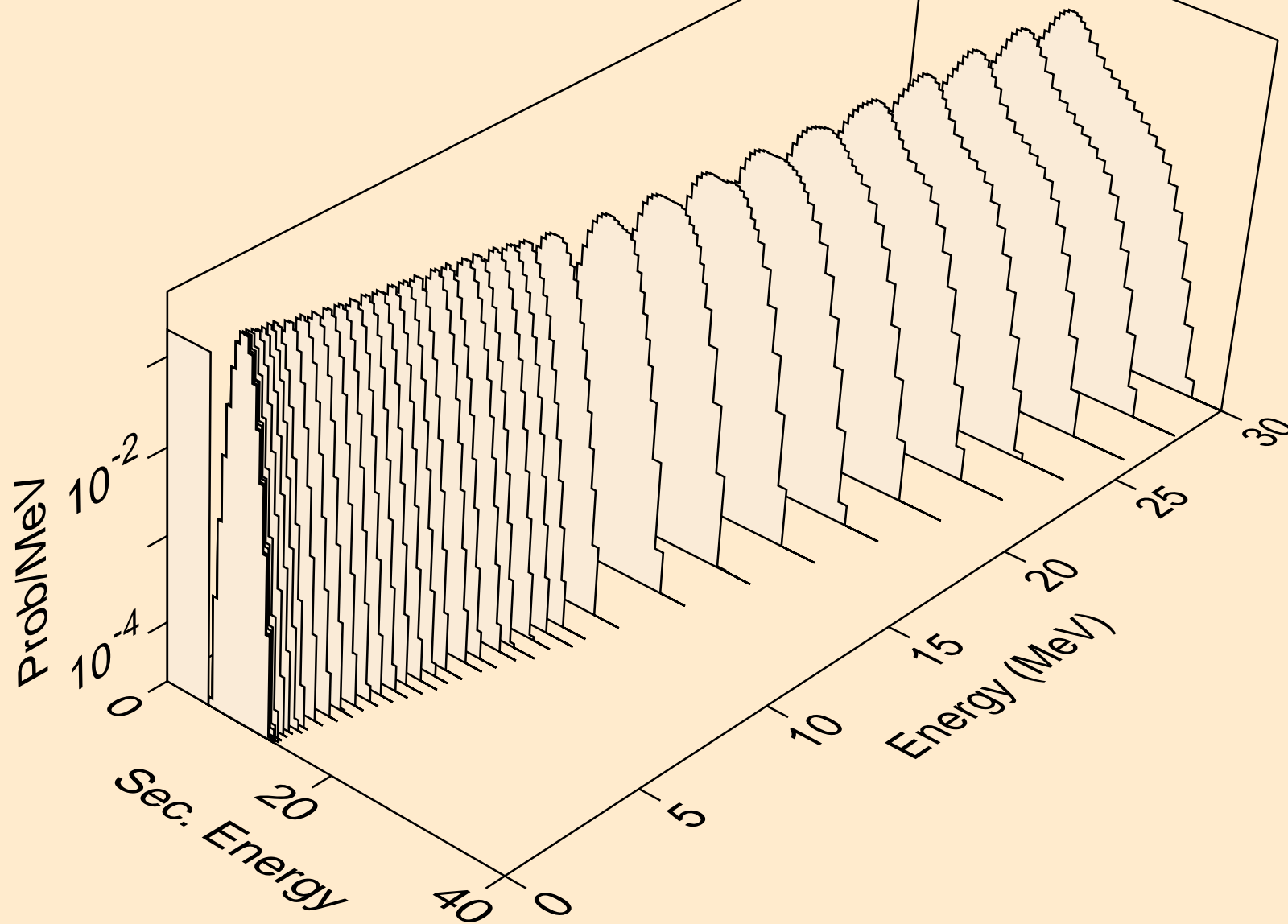

TA164 NEUTRON ACER TENDL-2024 LIBRARY; T=0.K
alphas from (n,3a)

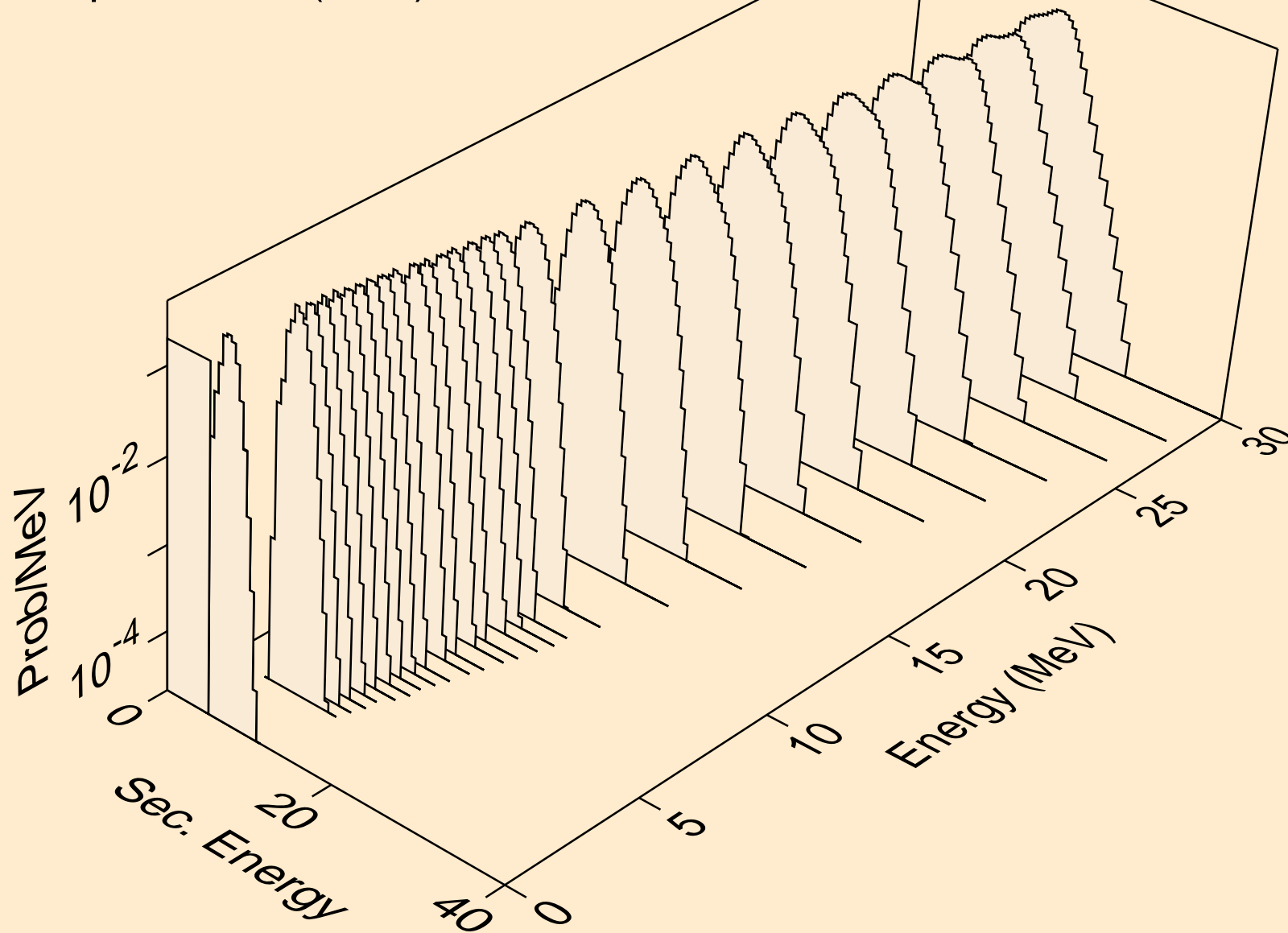

TA164 NEUTRON ACER TENDL-2024 LIBRARY; T=0.K
alphas from (n,pa)

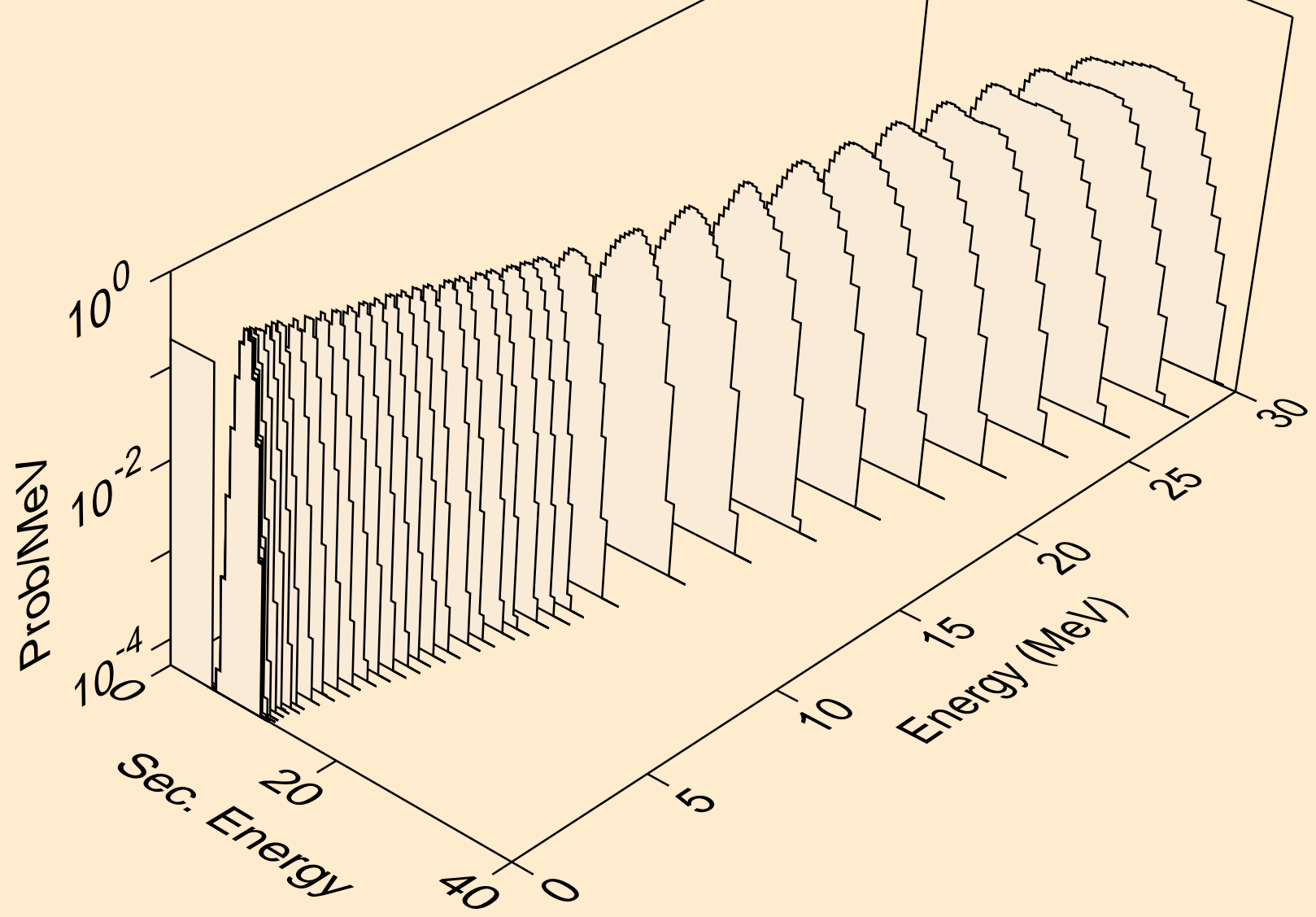

TA164 NEUTRON ACER TENDL-2024 LIBRARY; T=0.K
alphas from (n,t2a)

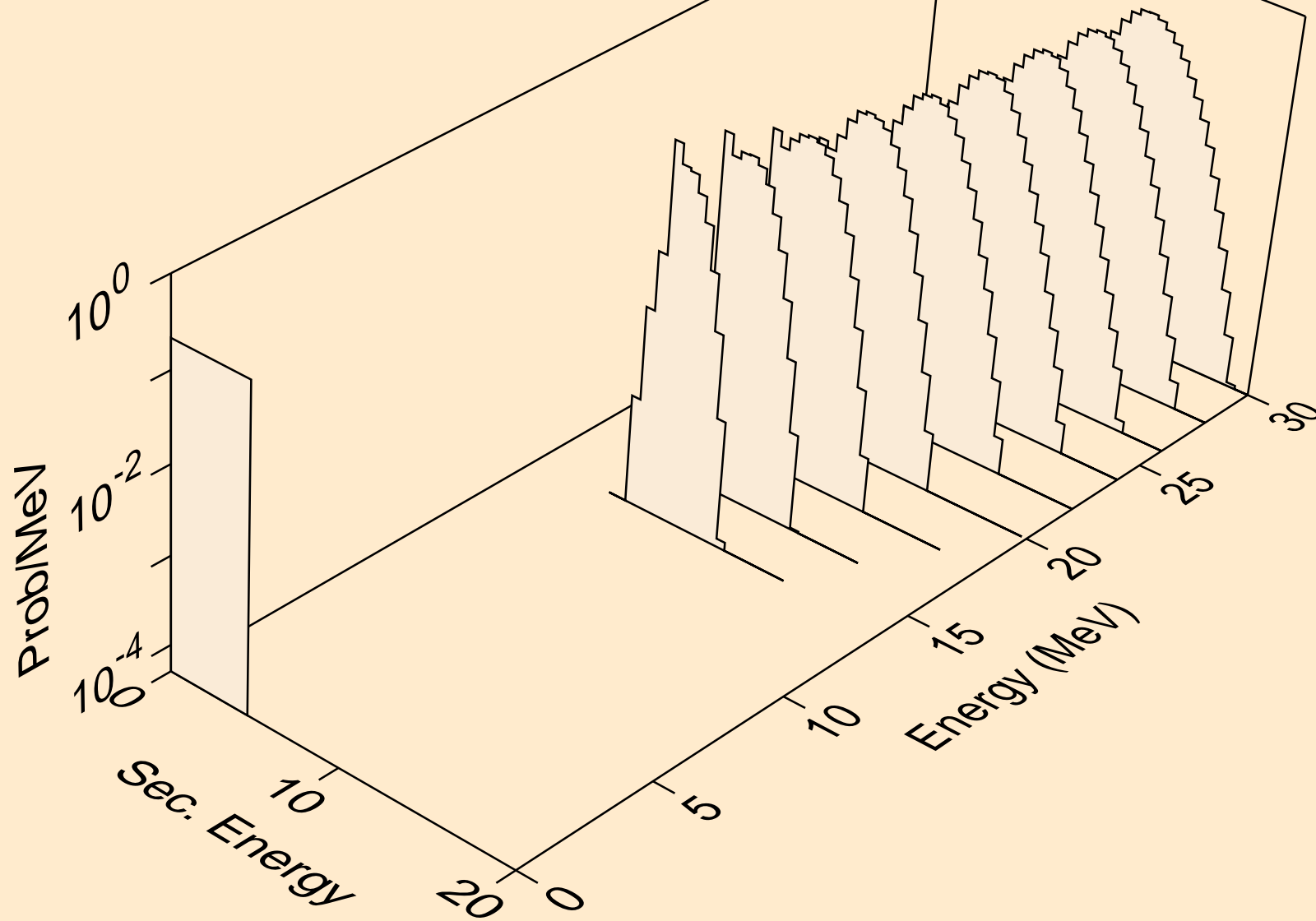

TA164 NEUTRON ACER TENDL-2024 LIBRARY; T=0.K
alphas from (n,d2a)

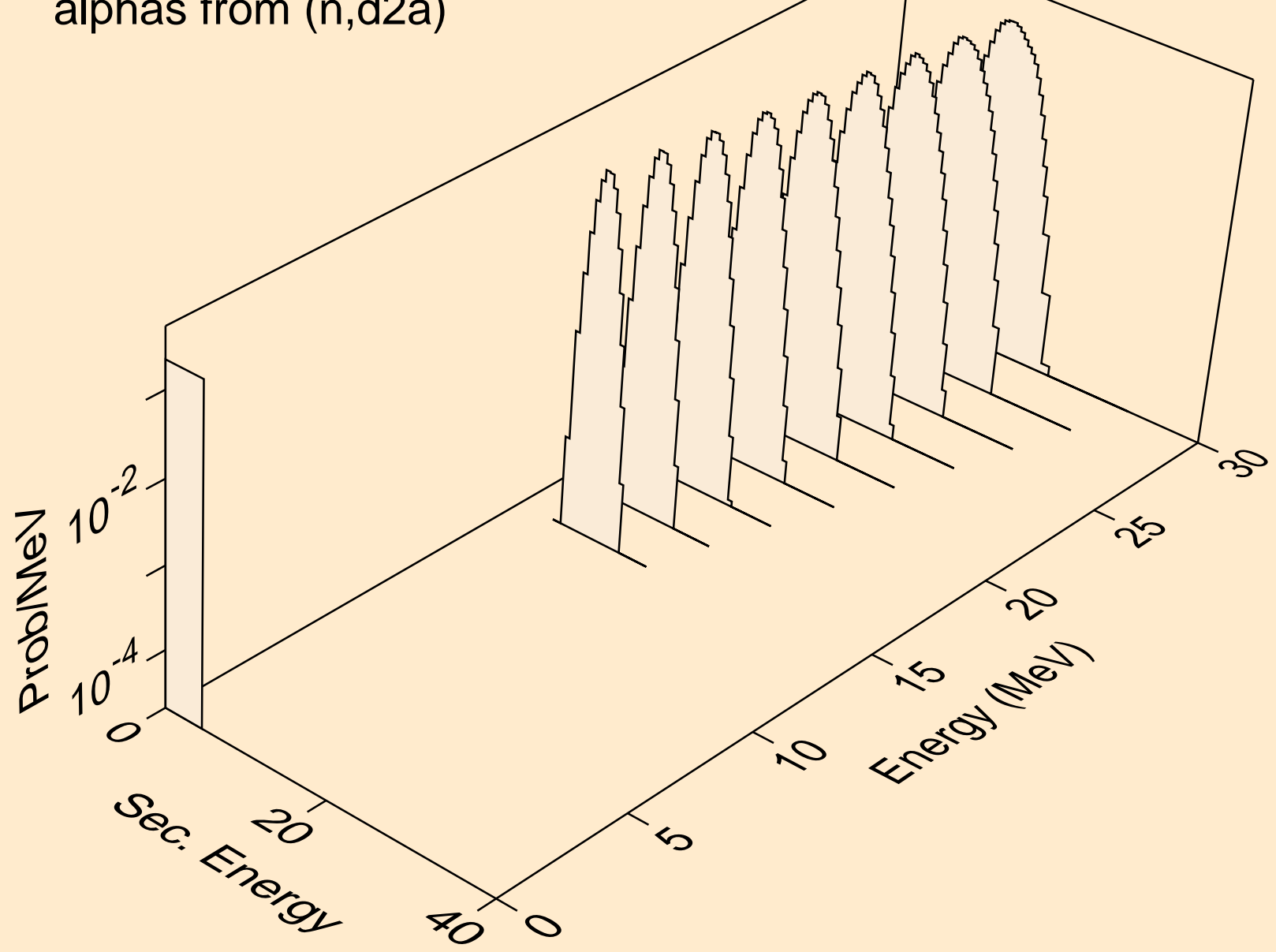

TA164 NEUTRON ACER TENDL-2024 LIBRARY; T=0.K
alphas from (n,da)

