

TL193M NEUTRON ACER TENDL-2024 LIBRARY; T=0.K  
Principal cross sections

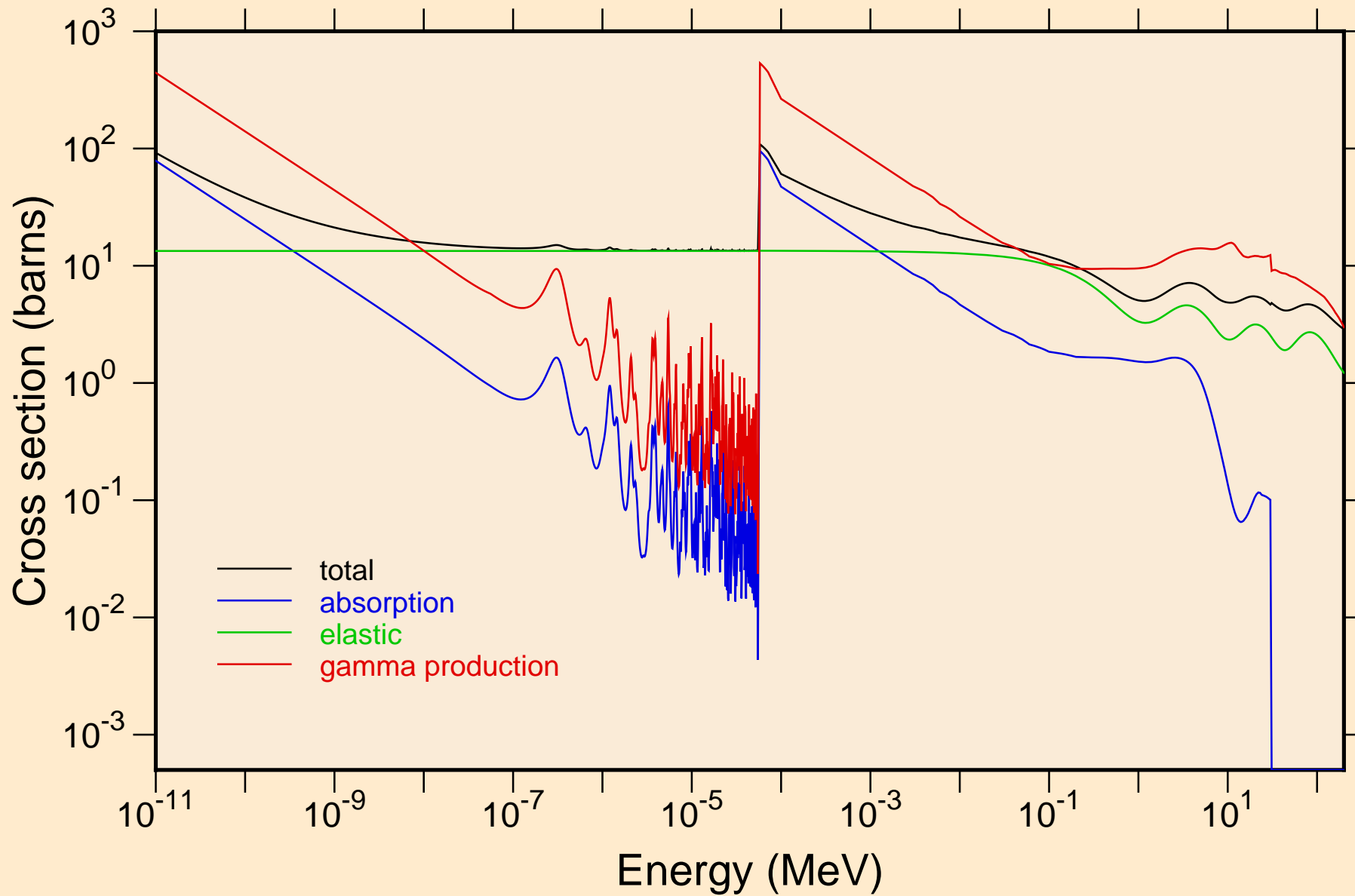

TL193M NEUTRON ACER TENDL-2024 LIBRARY; T=0.K  
resonance total cross section

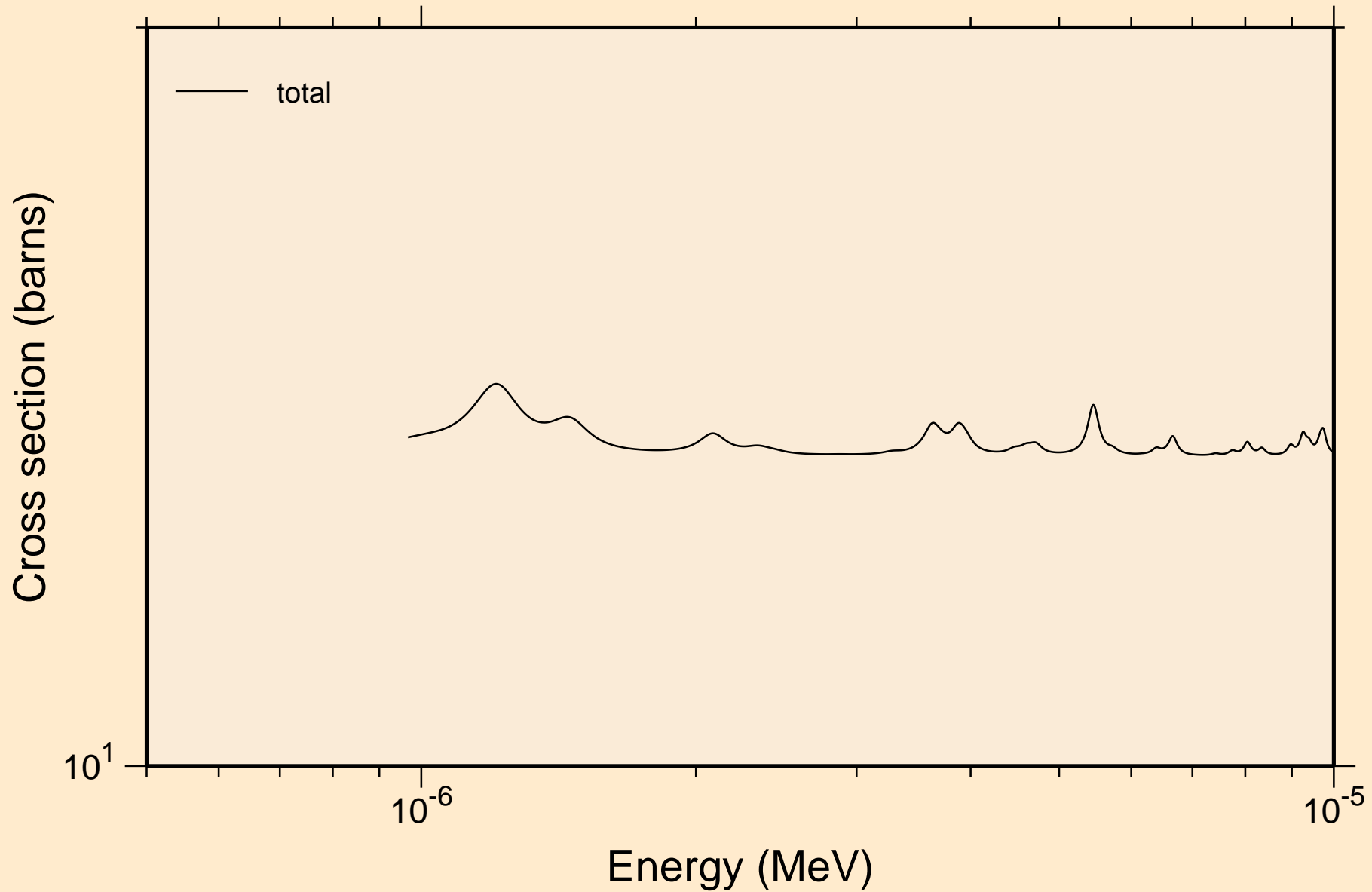

TL193M NEUTRON ACER TENDL-2024 LIBRARY; T=0.K  
resonance total cross section

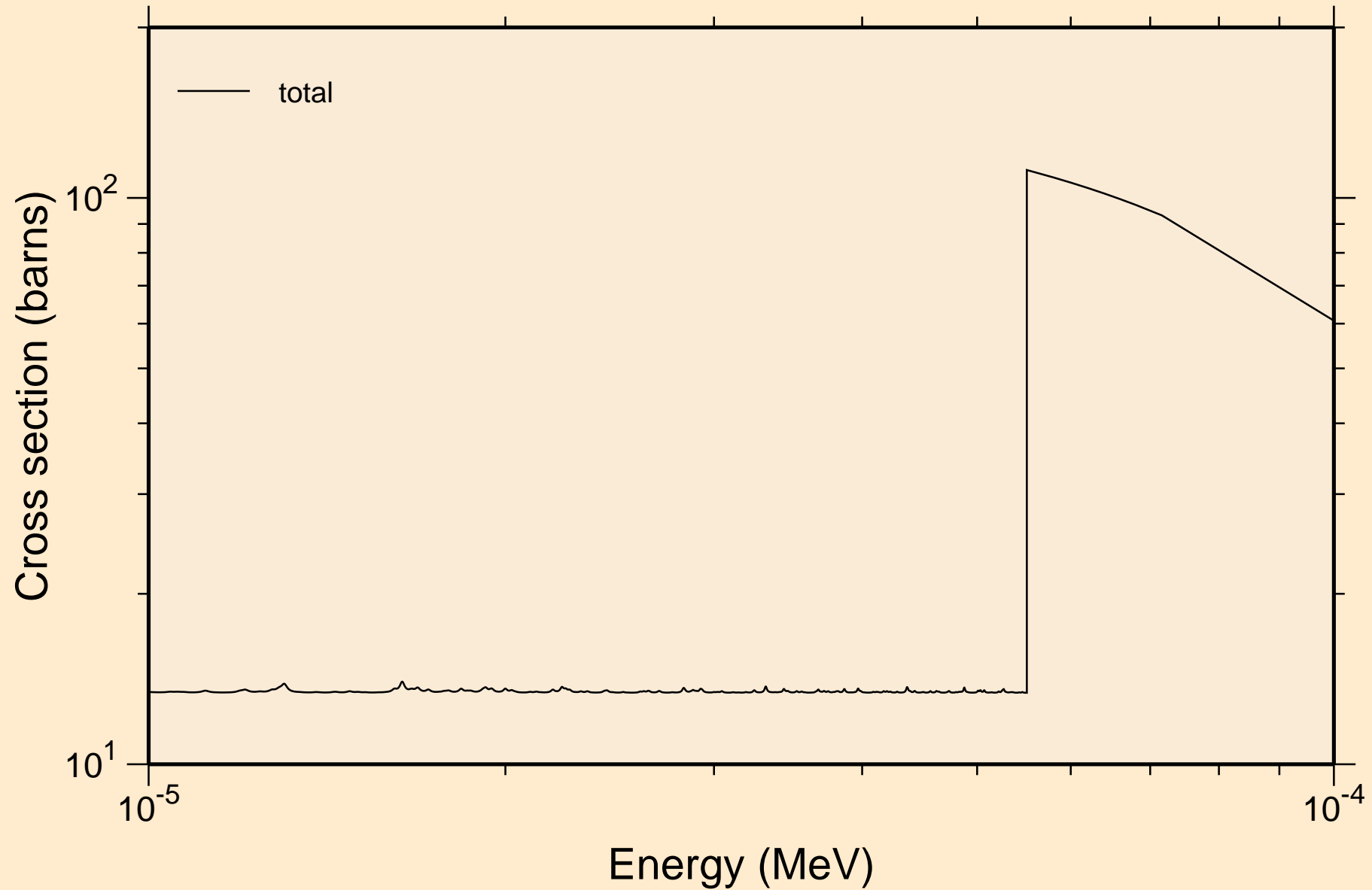

TL193M NEUTRON ACER TENDL-2024 LIBRARY; T=0.K  
resonance total cross section

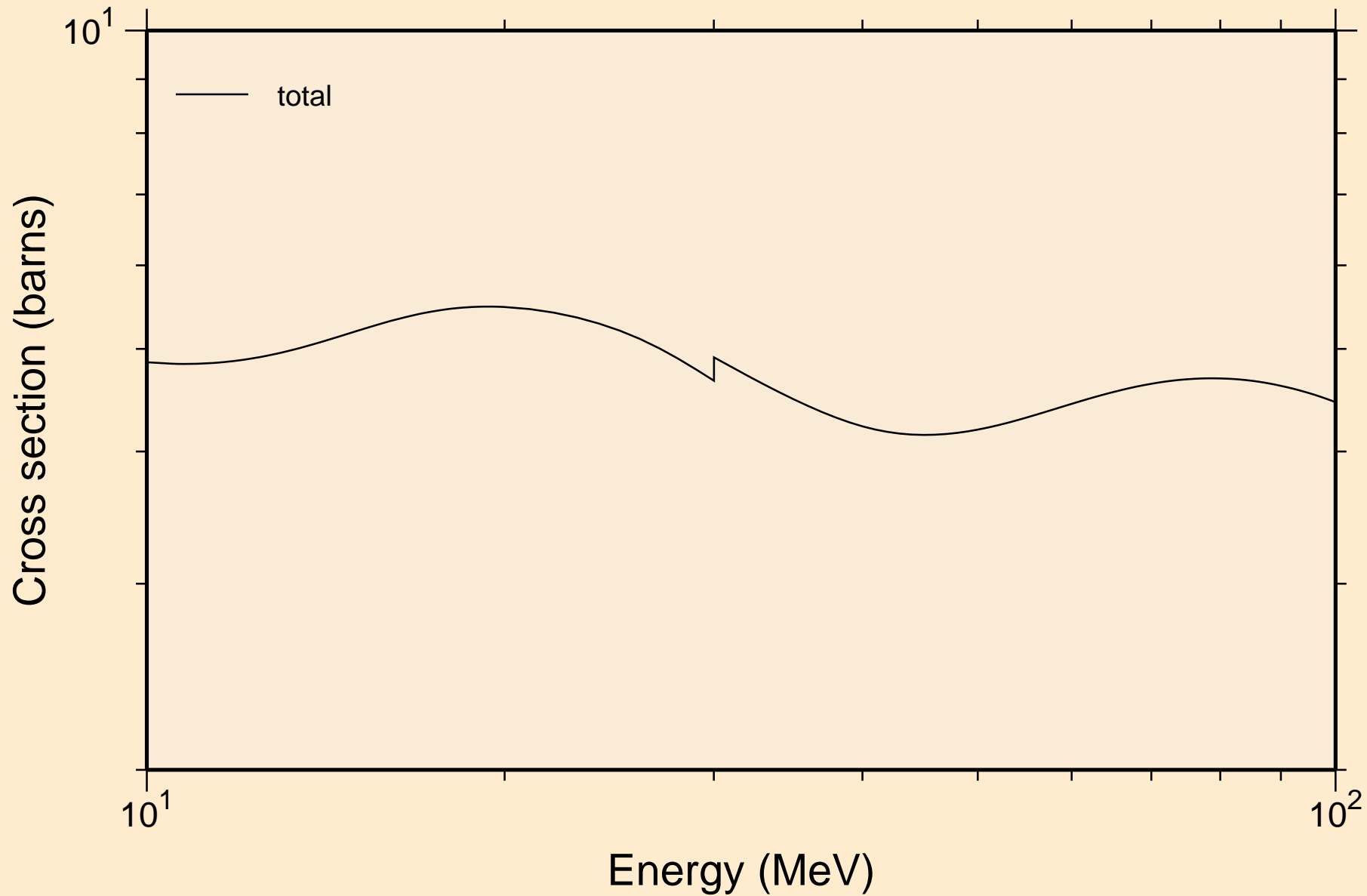

TL193M NEUTRON ACER TENDL-2024 LIBRARY; T=0.K  
resonance absorption cross sections

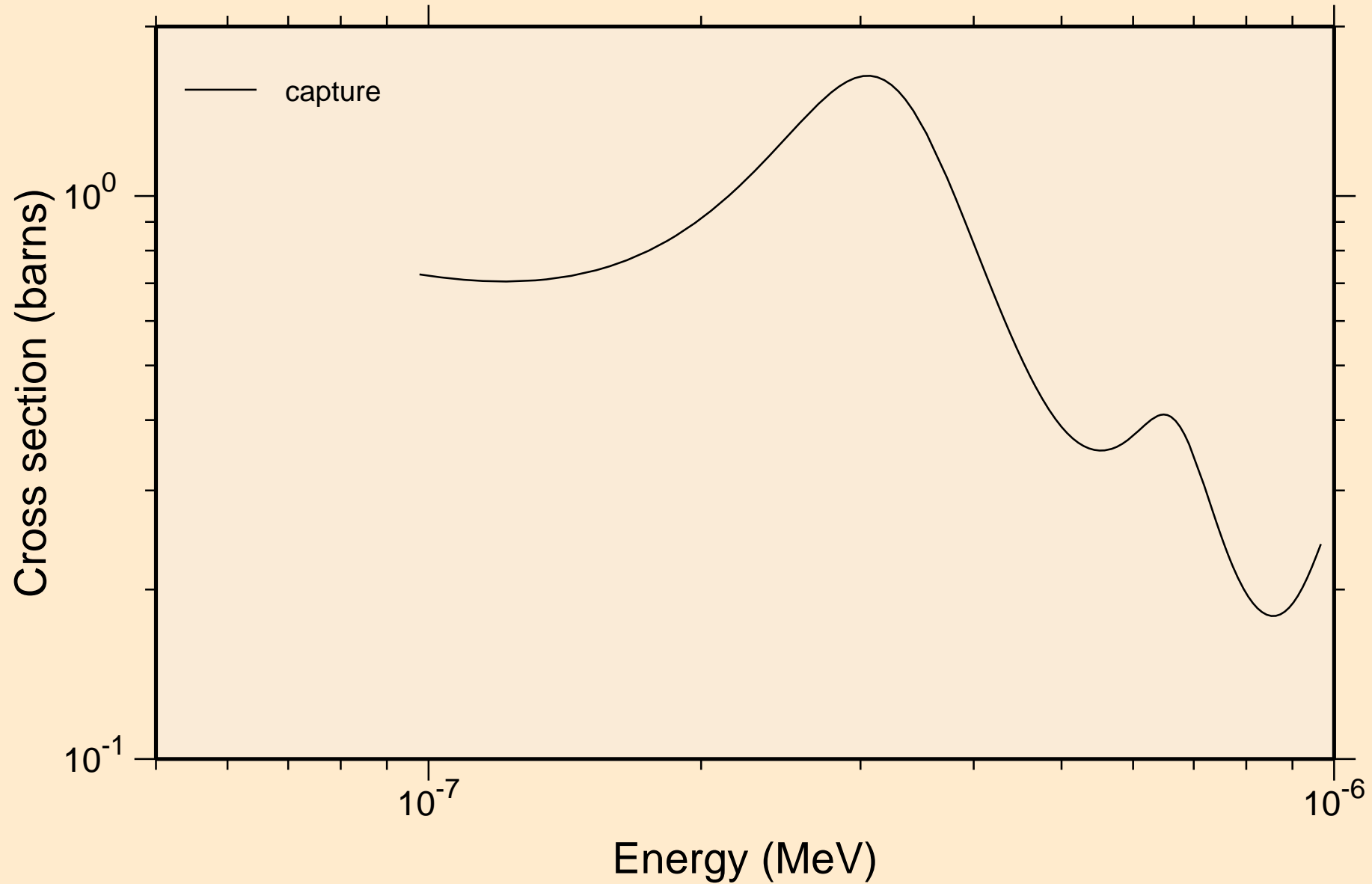

TL193M NEUTRON ACER TENDL-2024 LIBRARY; T=0.K  
resonance absorption cross sections

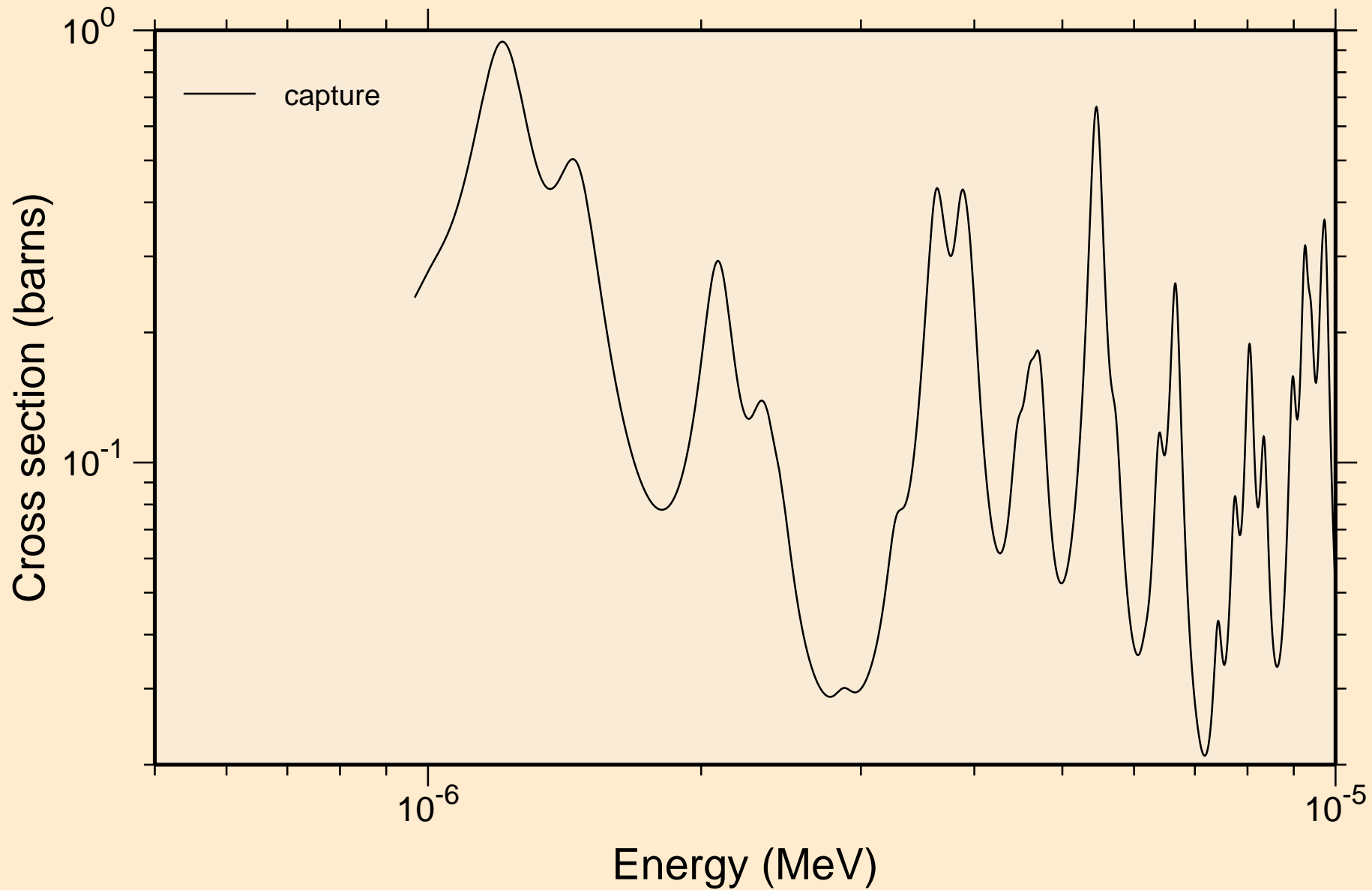

TL193M NEUTRON ACER TENDL-2024 LIBRARY; T=0.K  
resonance absorption cross sections

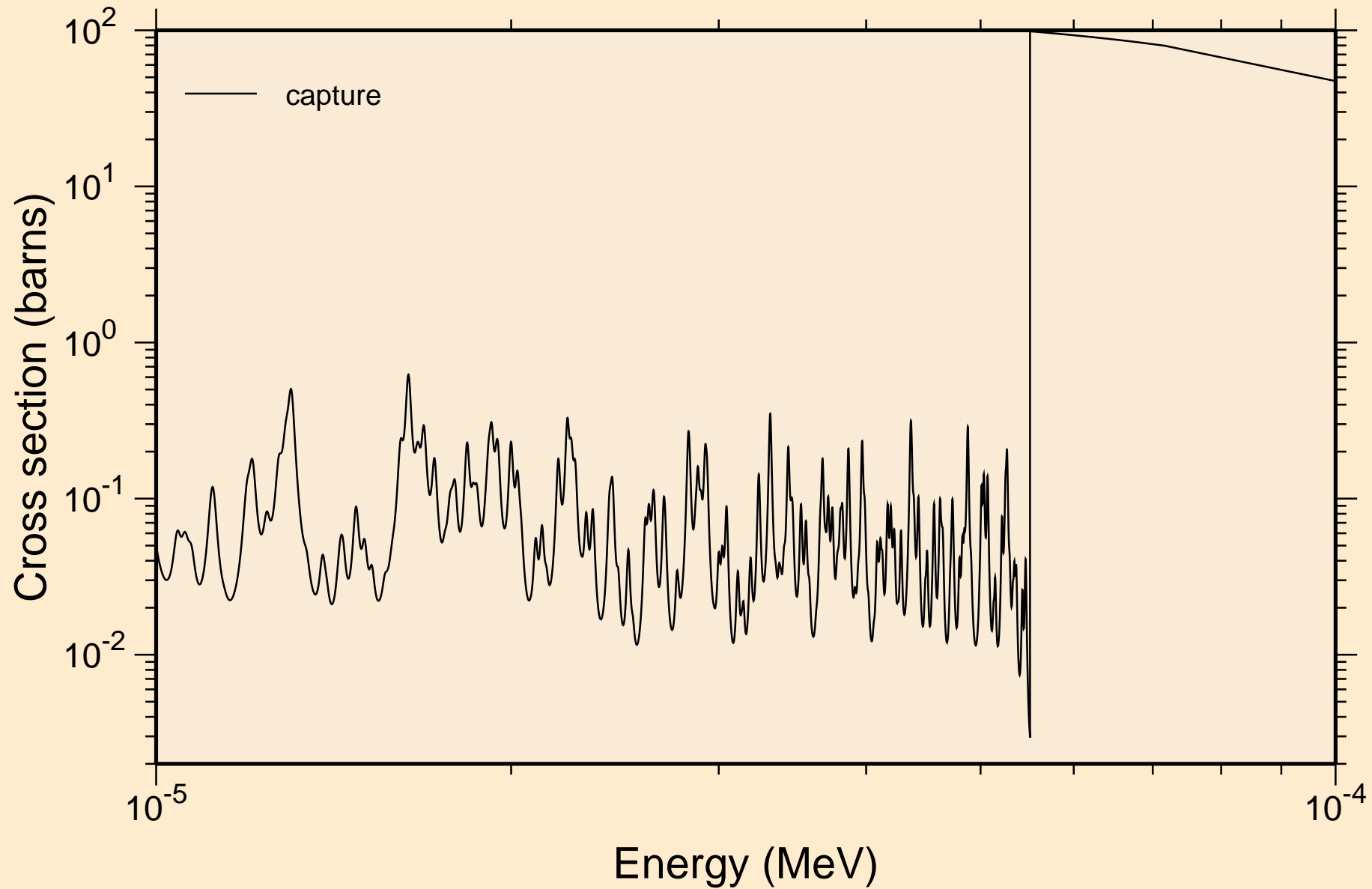

TL193M NEUTRON ACER TENDL-2024 LIBRARY; T=0.K  
resonance absorption cross sections

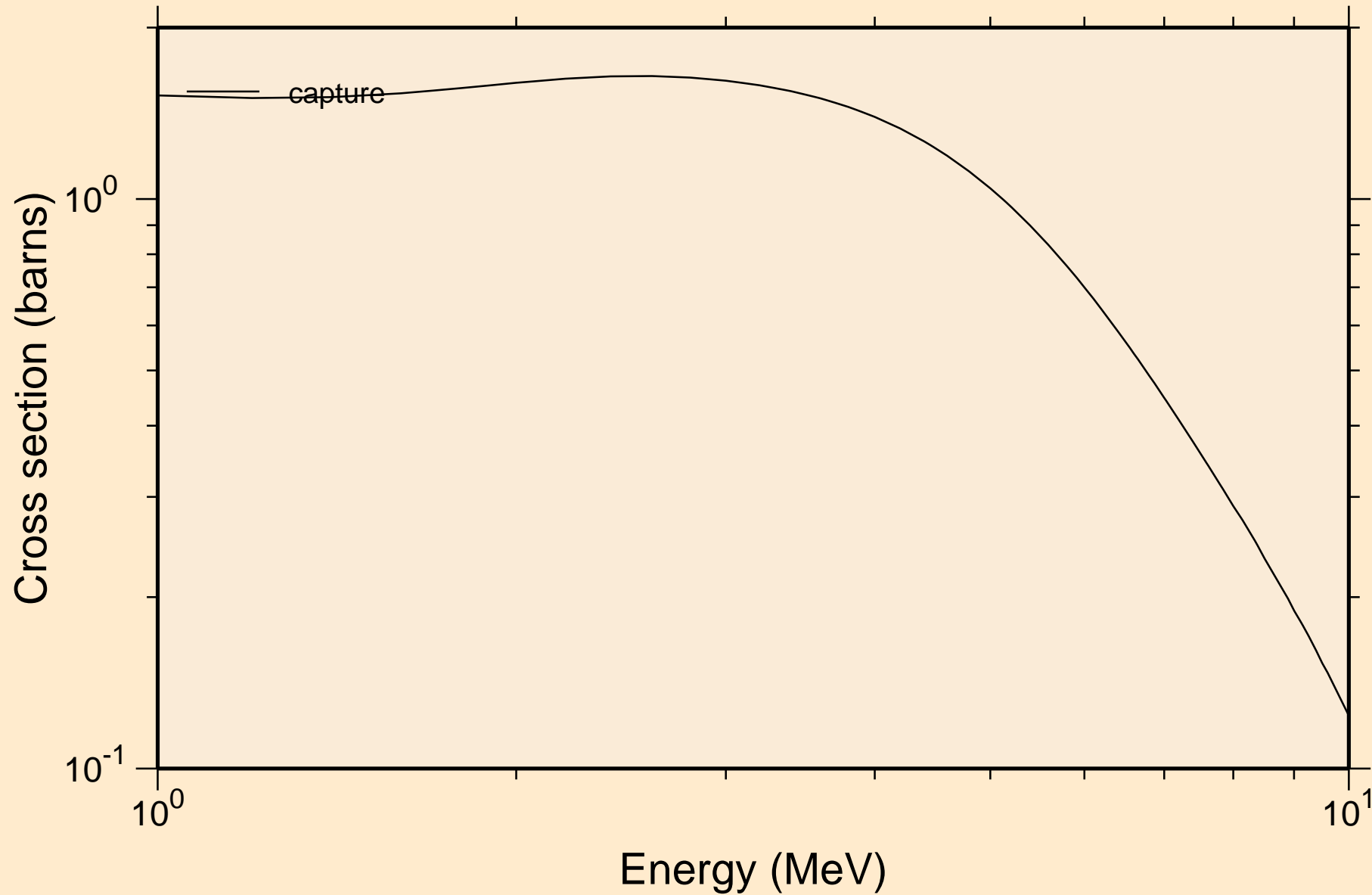



TL193M NEUTRON ACER TENDL-2024 LIBRARY; T=0.K  
Heating

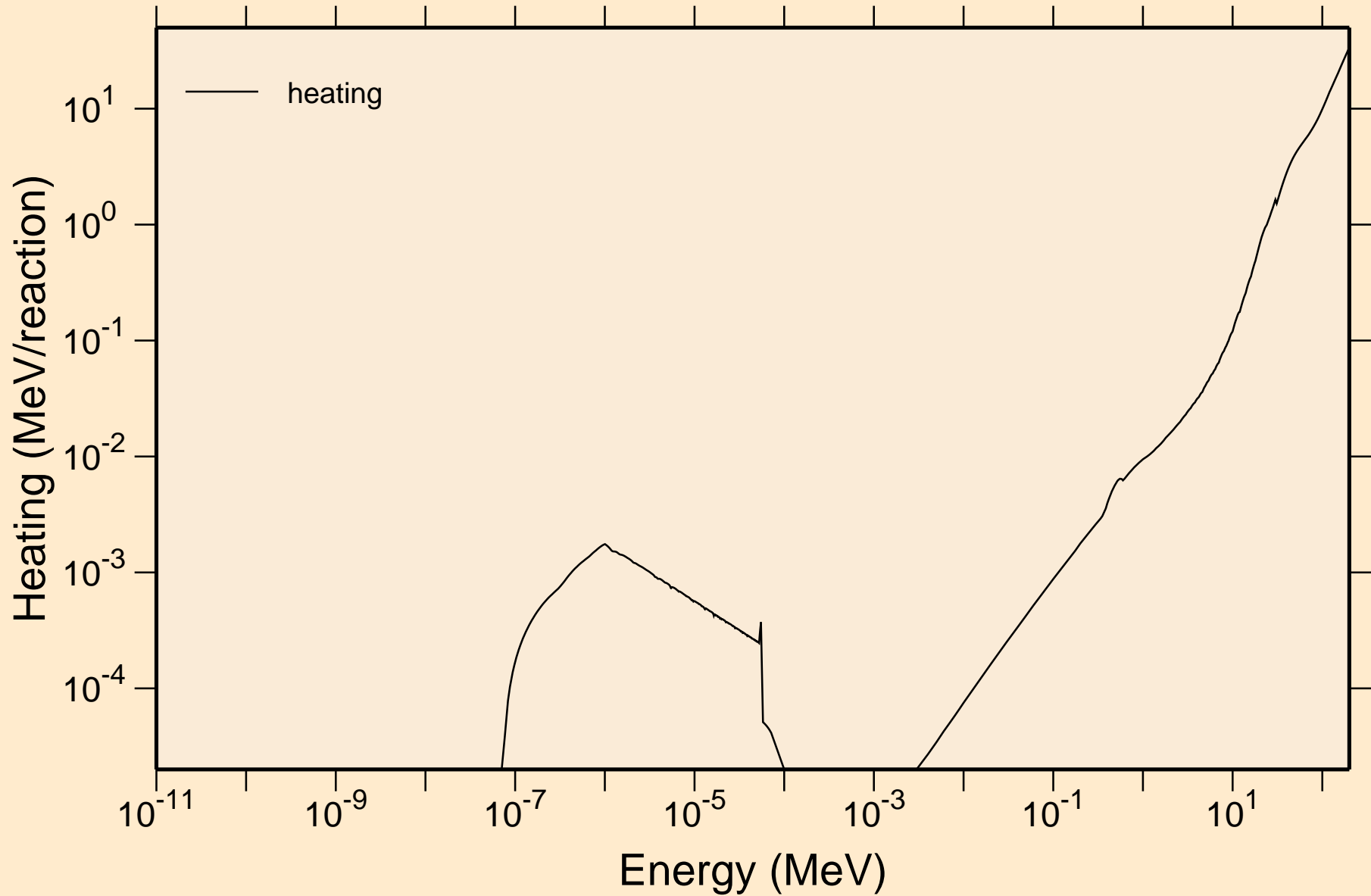

TL193M NEUTRON ACER TENDL-2024 LIBRARY; T=0.K  
Damage

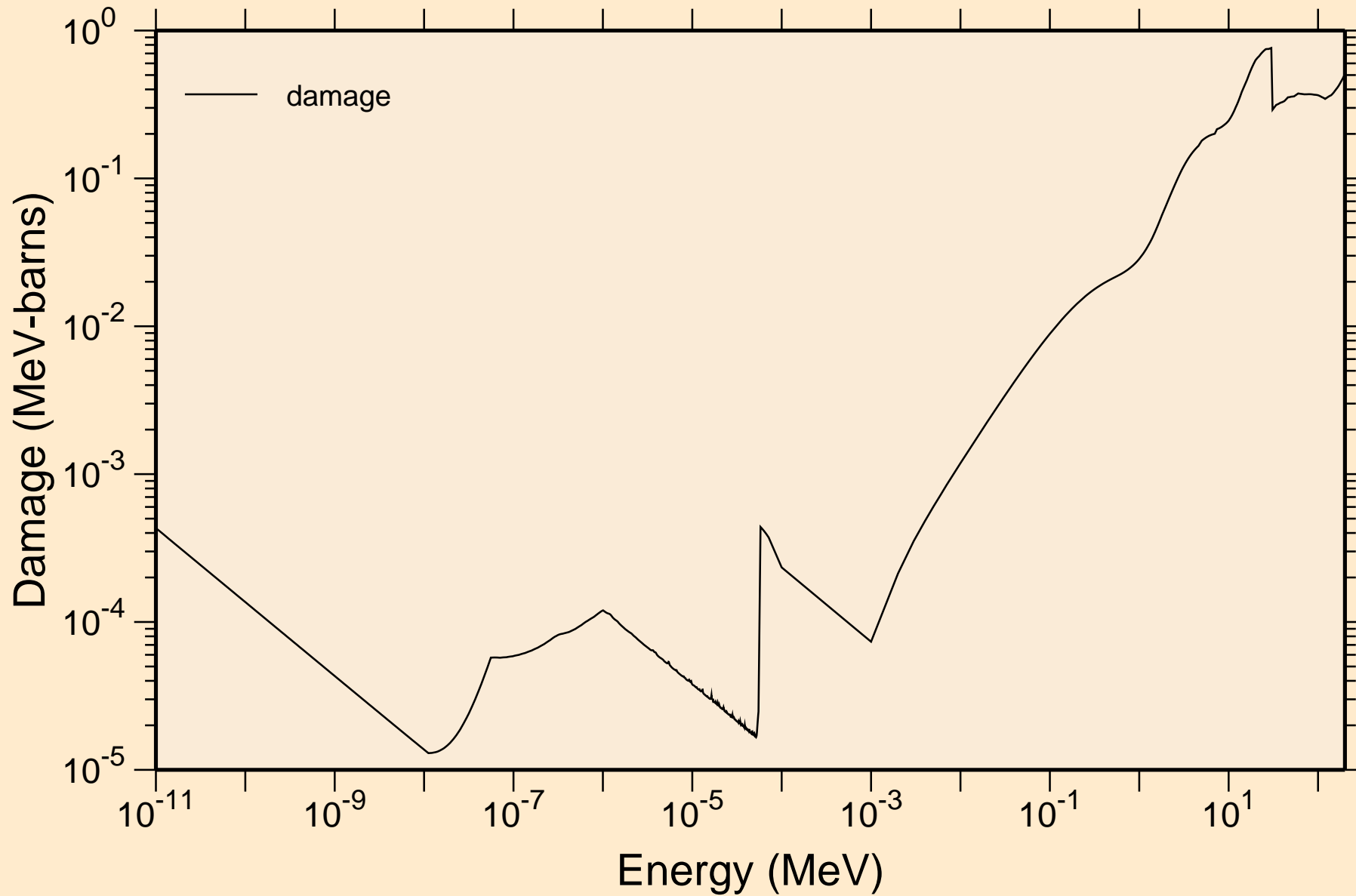

TL193M NEUTRON ACER TENDL-2024 LIBRARY; T=0.K  
Non-threshold reactions

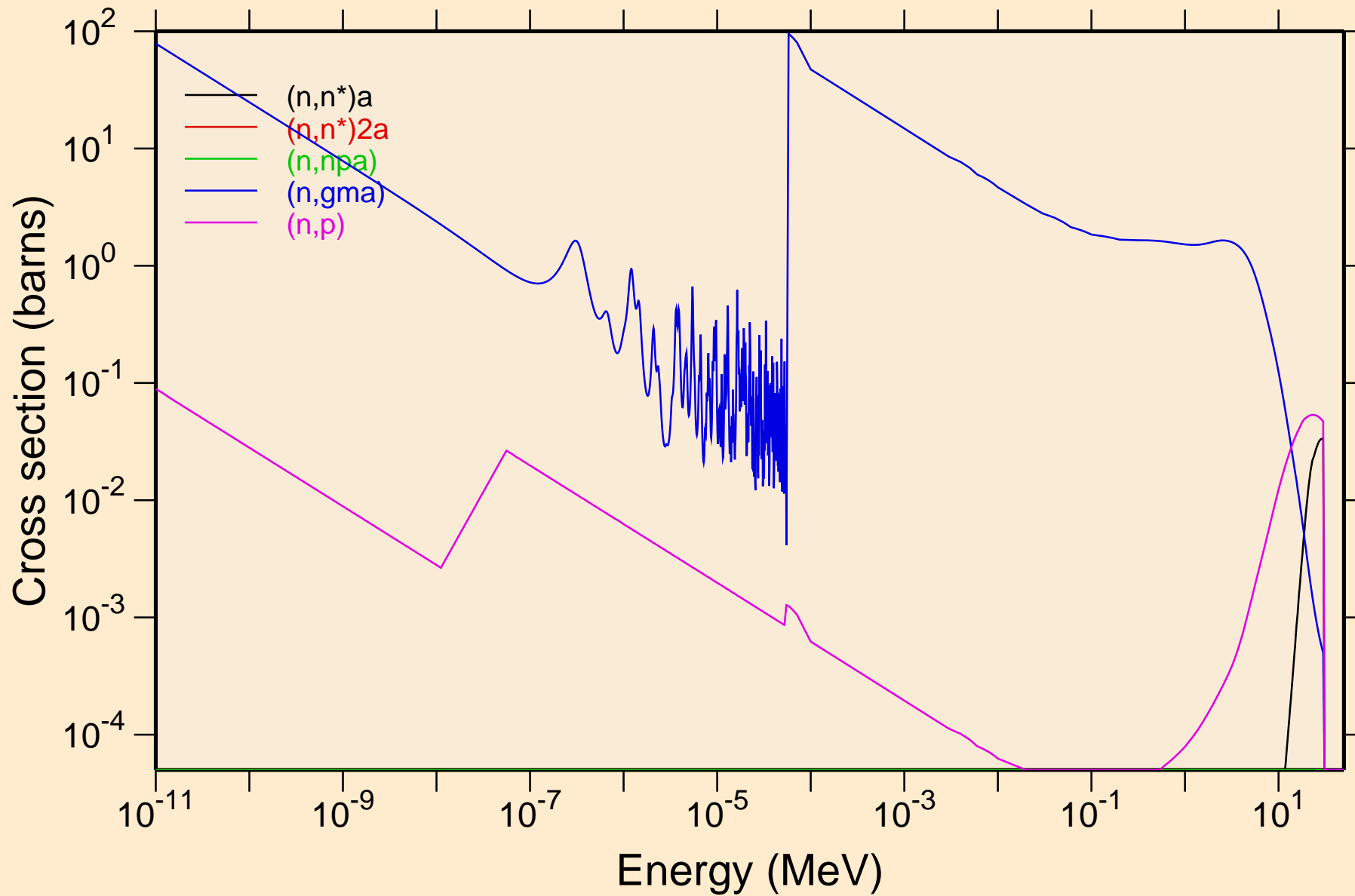

TL193M NEUTRON ACER TENDL-2024 LIBRARY; T=0.K  
Non-threshold reactions

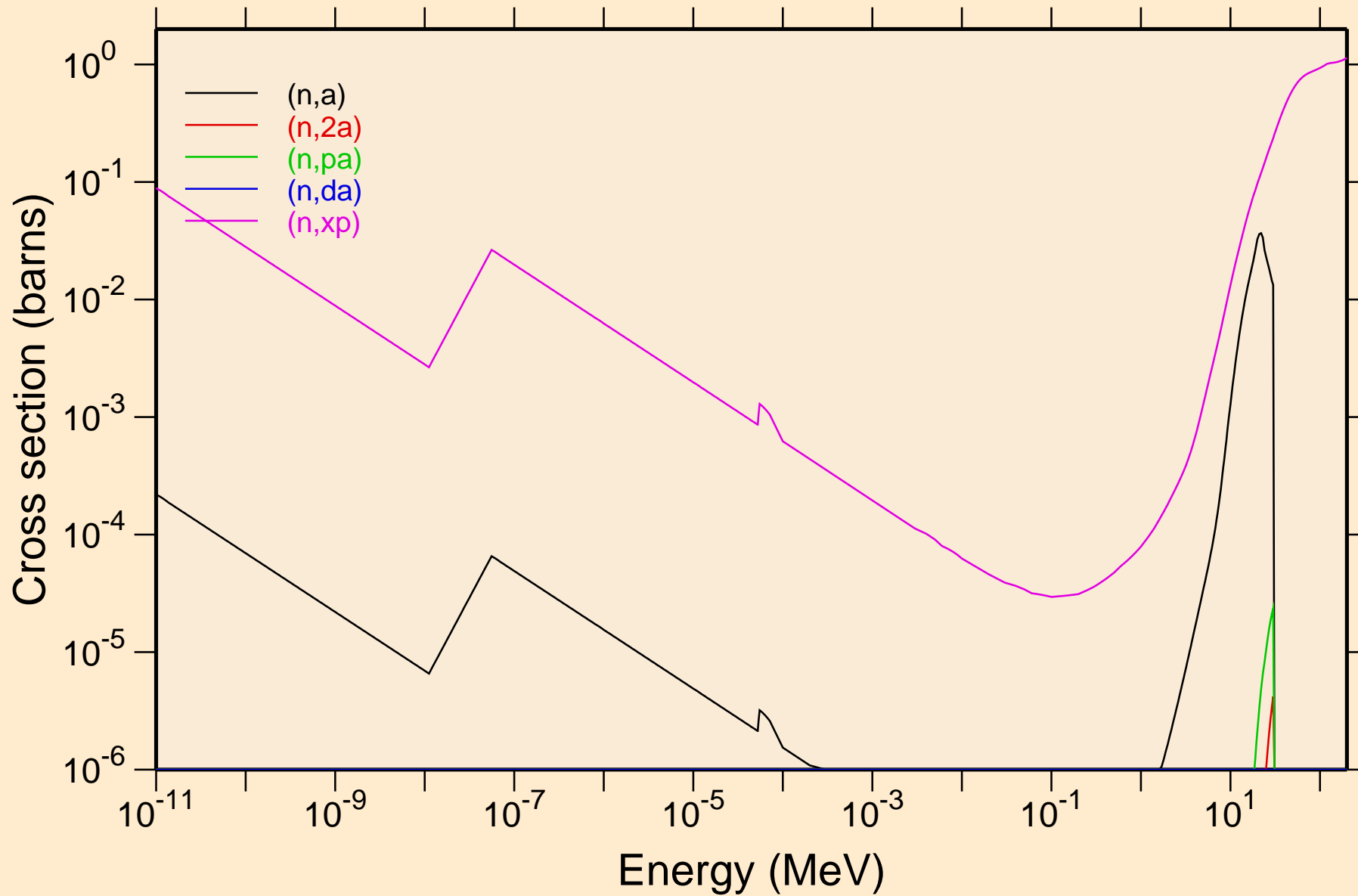

TL193M NEUTRON ACER TENDL-2024 LIBRARY; T=0.K  
Non-threshold reactions

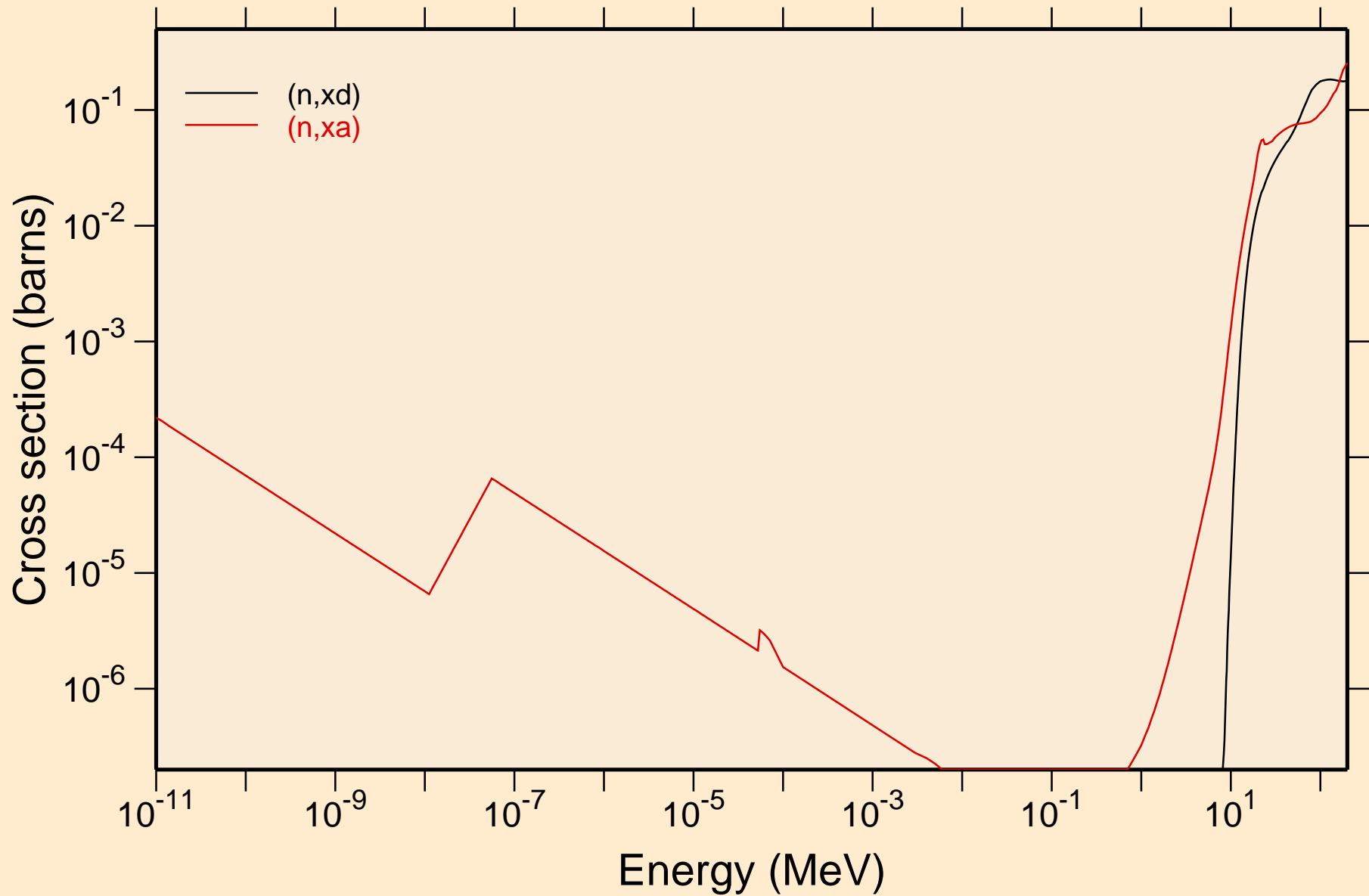

# TL193M NEUTRON ACER TENDL-2024 LIBRARY; T=0.K

## Principal cross sections

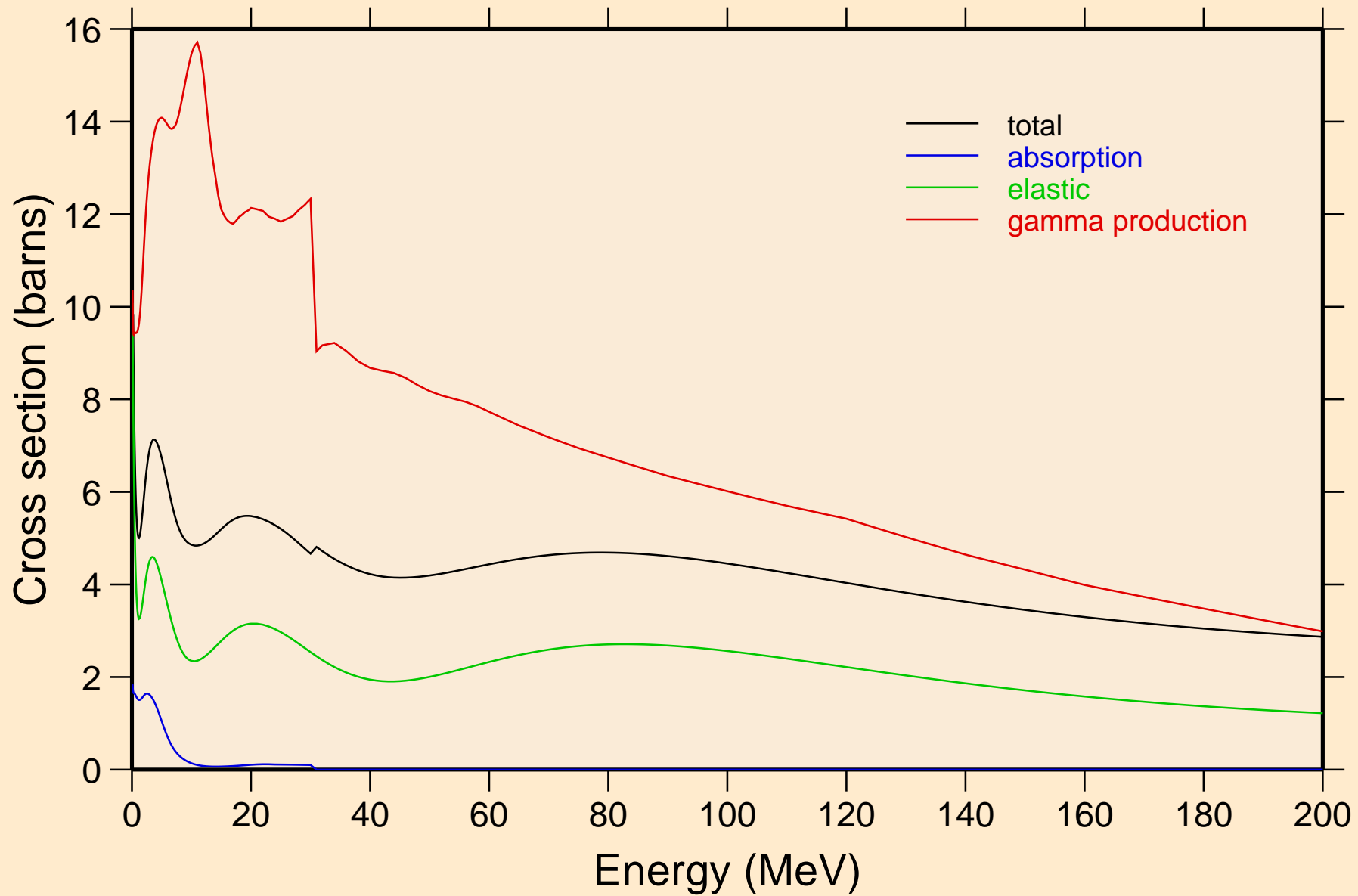

TL193M NEUTRON ACER TENDL-2024 LIBRARY; T=0.K  
Heating

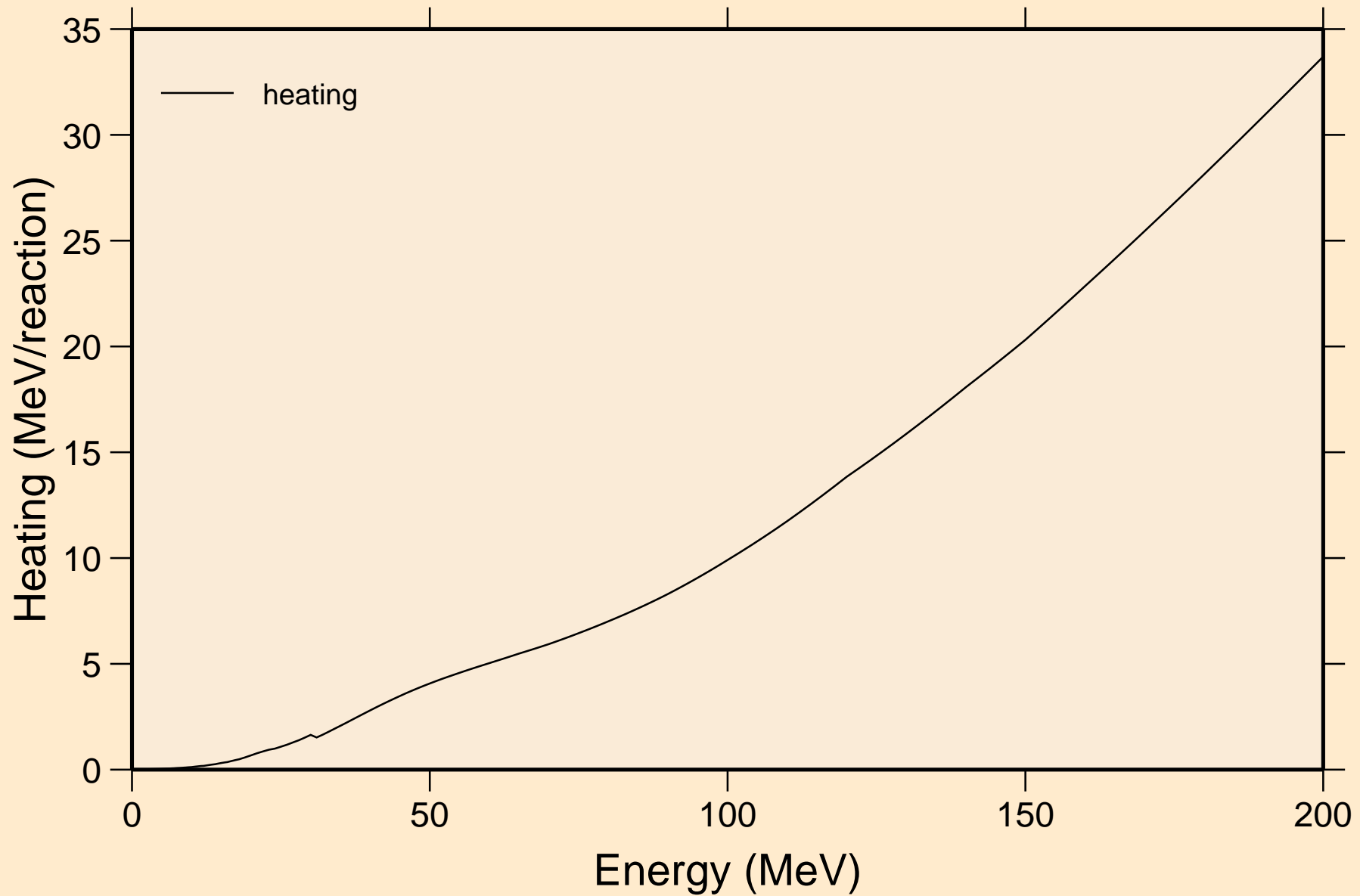

TL193M NEUTRON ACER TENDL-2024 LIBRARY; T=0.K  
Damage

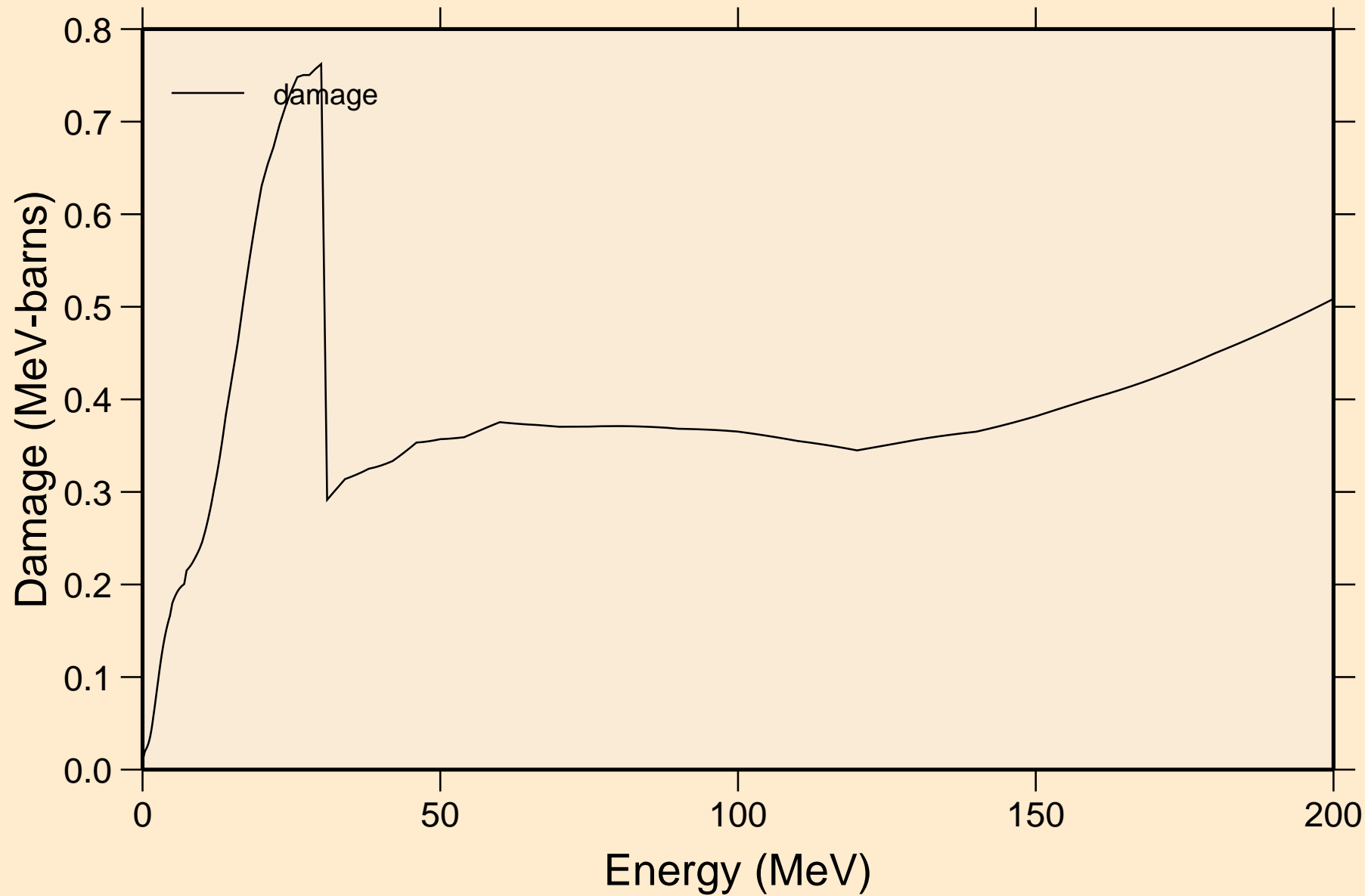



TL193M NEUTRON ACER TENDL-2024 LIBRARY; T=0.K  
Non-threshold reactions

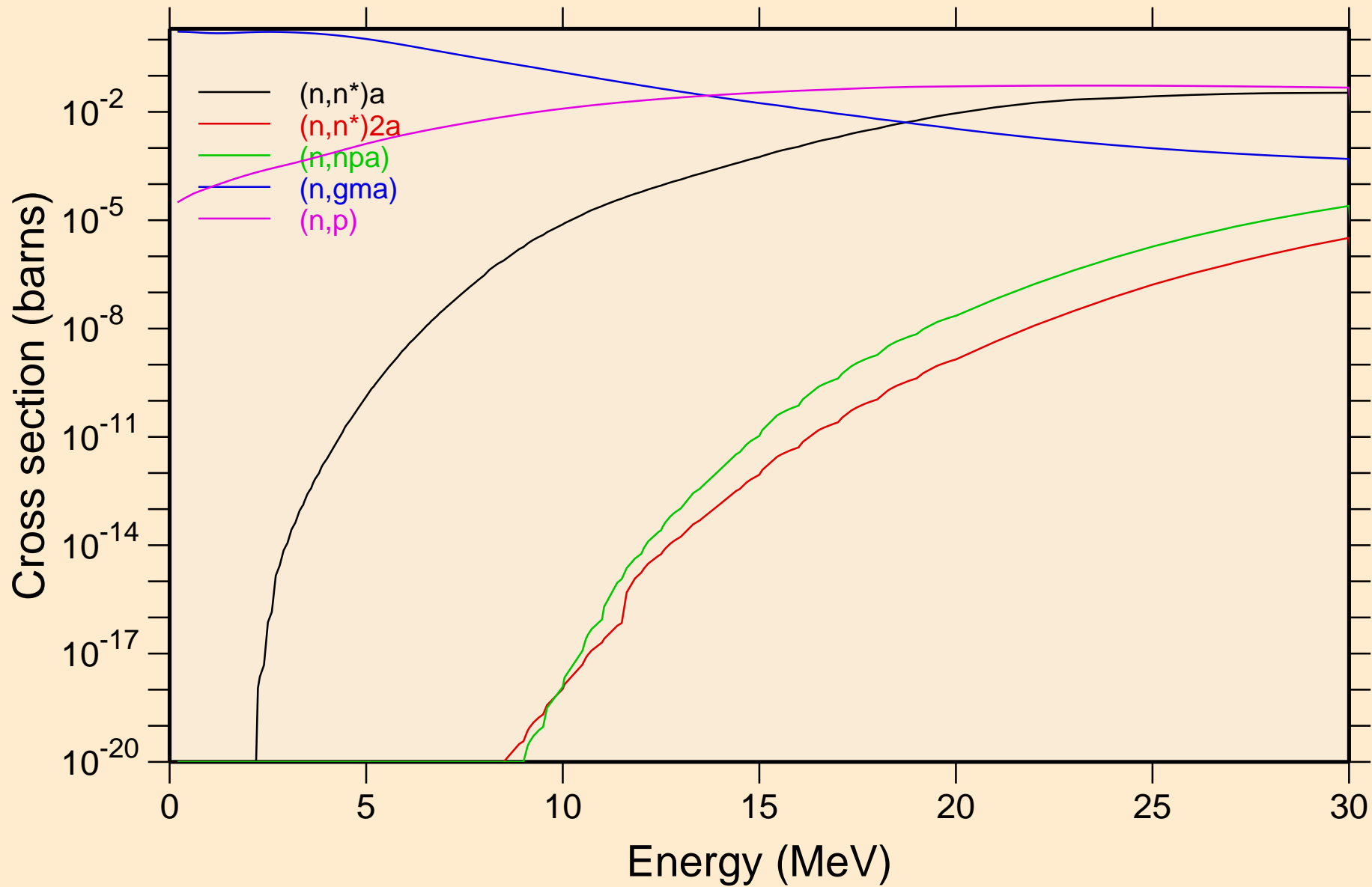

TL193M NEUTRON ACER TENDL-2024 LIBRARY; T=0.K  
Non-threshold reactions

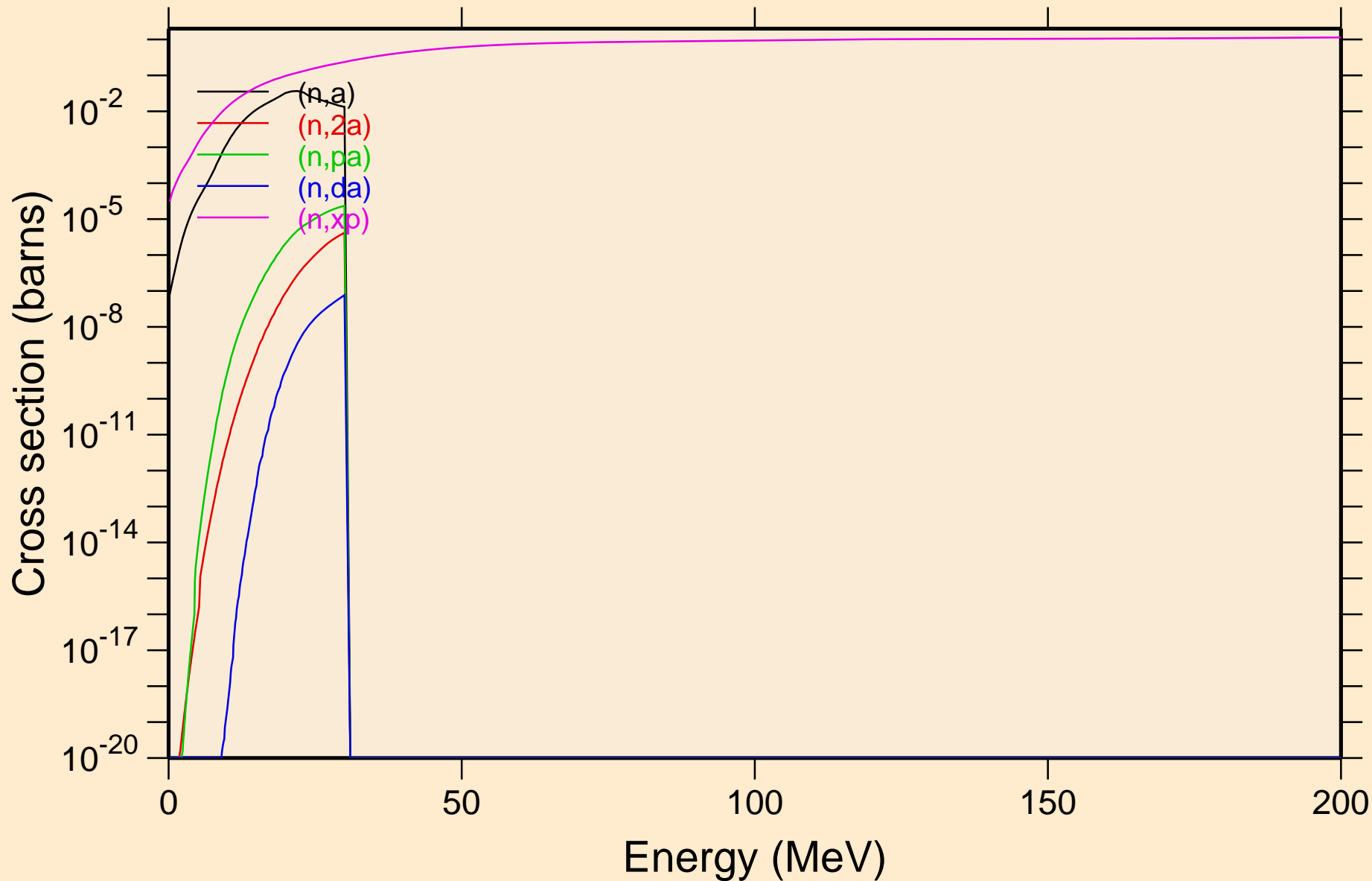

TL193M NEUTRON ACER TENDL-2024 LIBRARY; T=0.K  
Non-threshold reactions

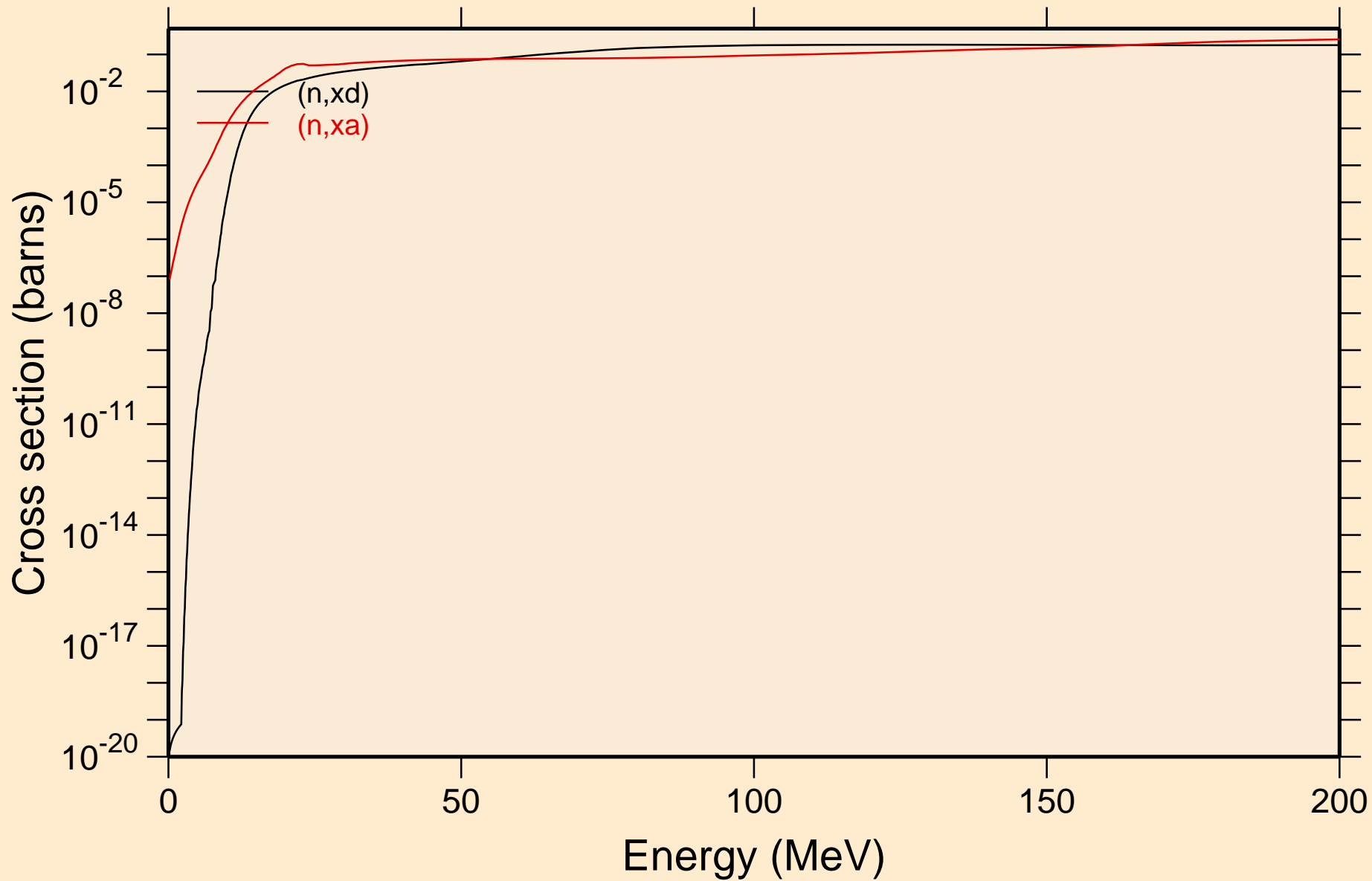

TL193M NEUTRON ACER TENDL-2024 LIBRARY; T=0.K  
Inelastic levels

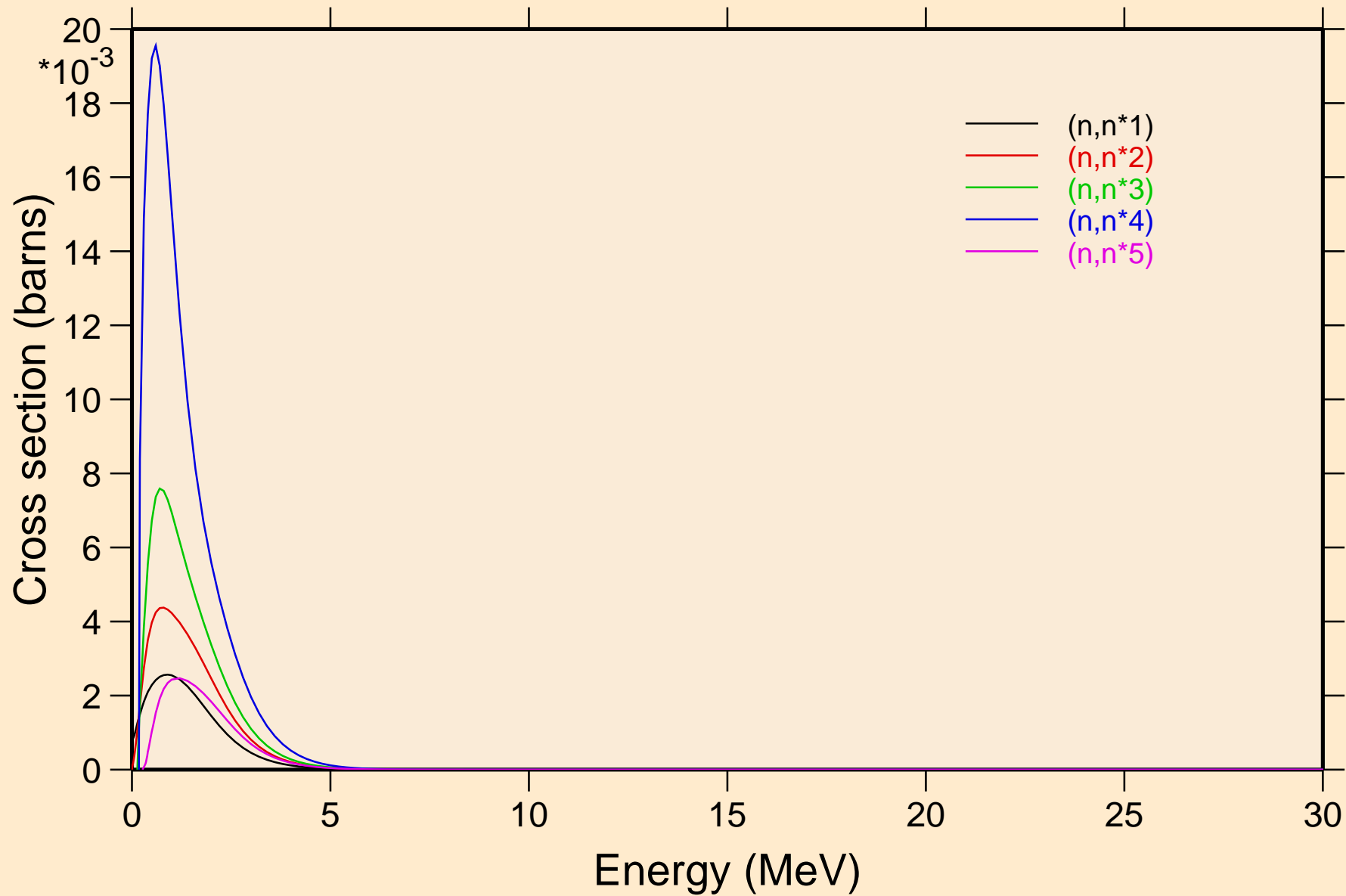

TL193M NEUTRON ACER TENDL-2024 LIBRARY; T=0.K  
Inelastic levels

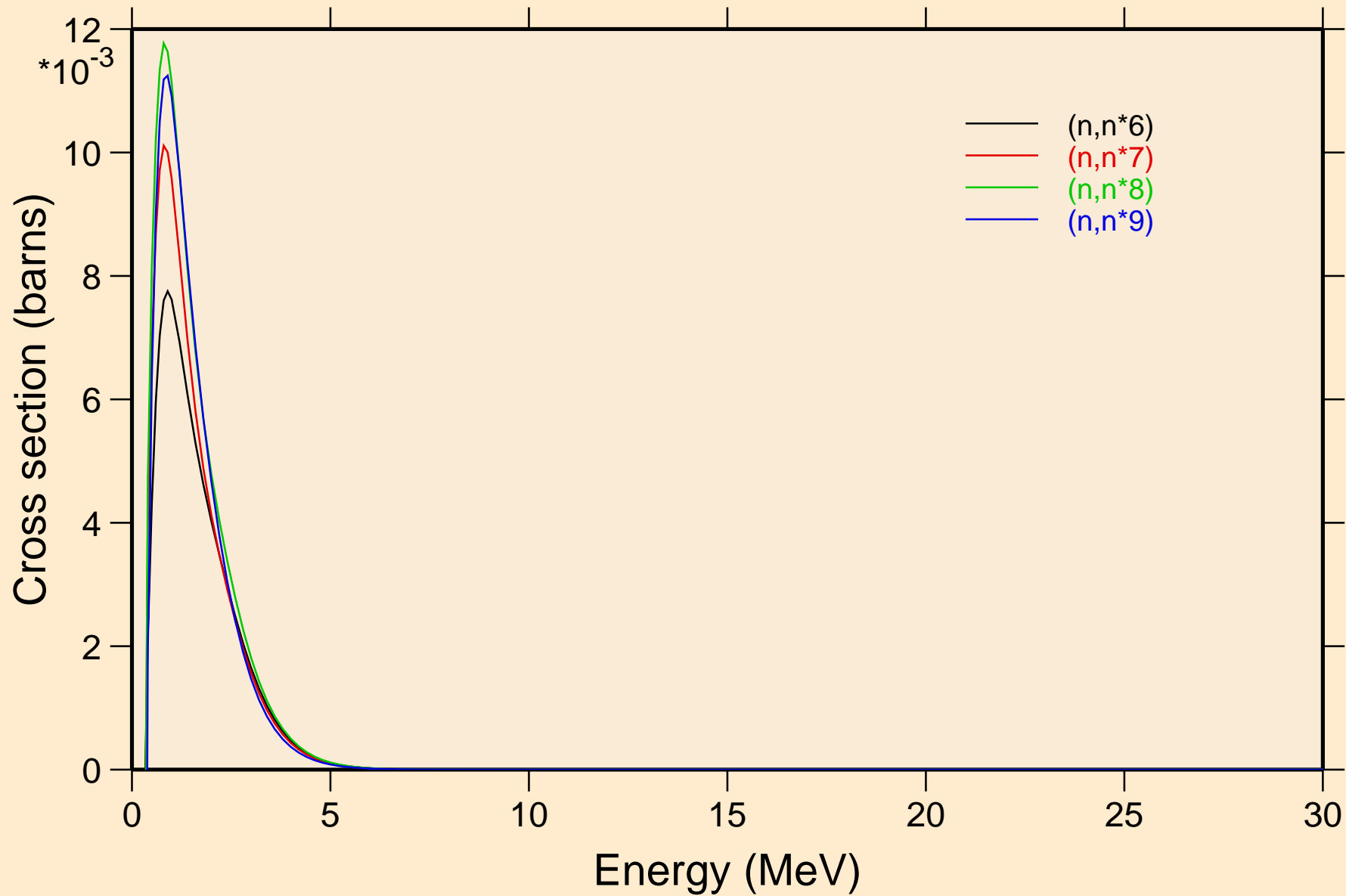

TL193M NEUTRON ACER TENDL-2024 LIBRARY; T=0.K  
Threshold reactions

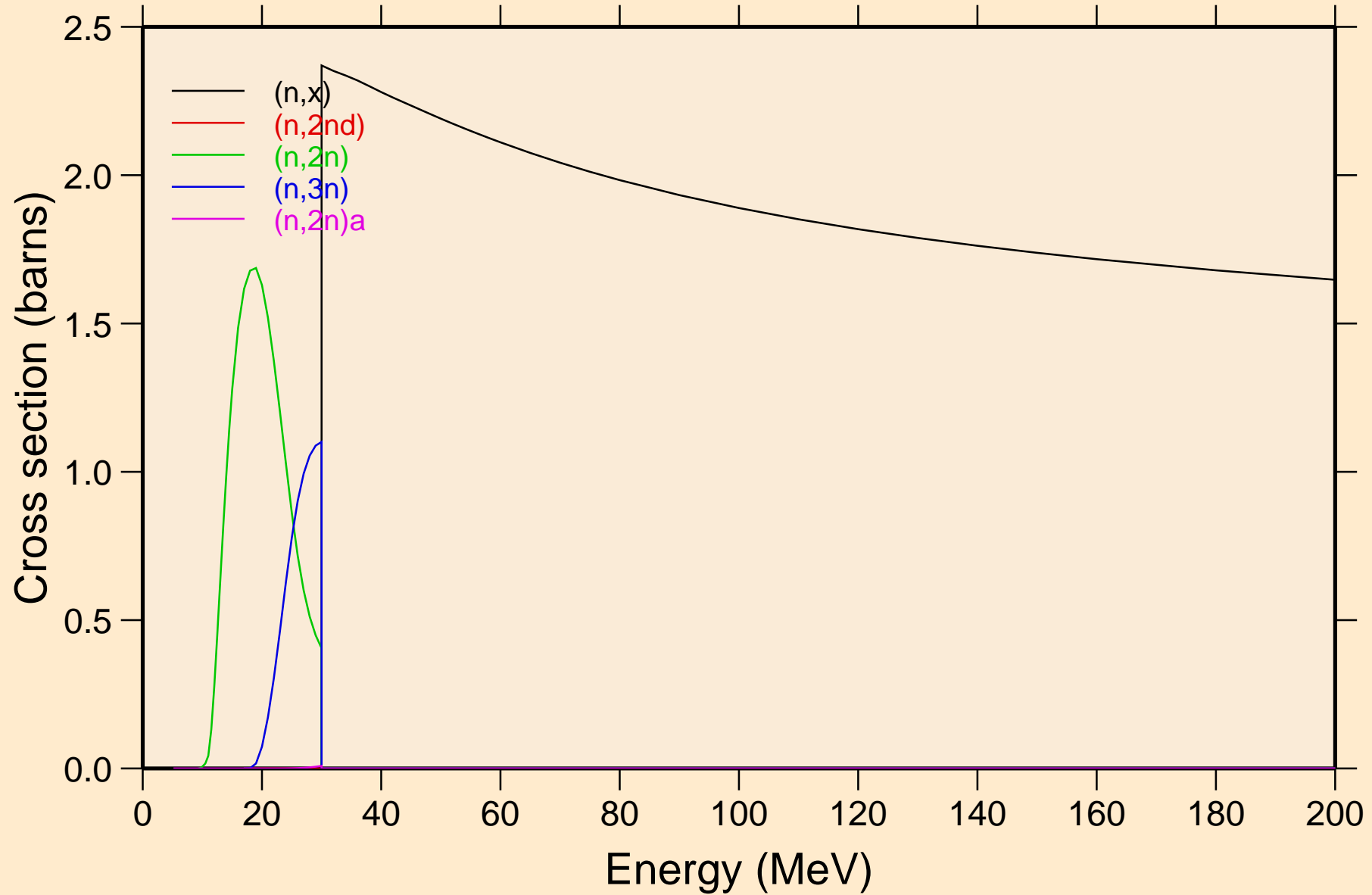

TL193M NEUTRON ACER TENDL-2024 LIBRARY; T=0.K  
Threshold reactions

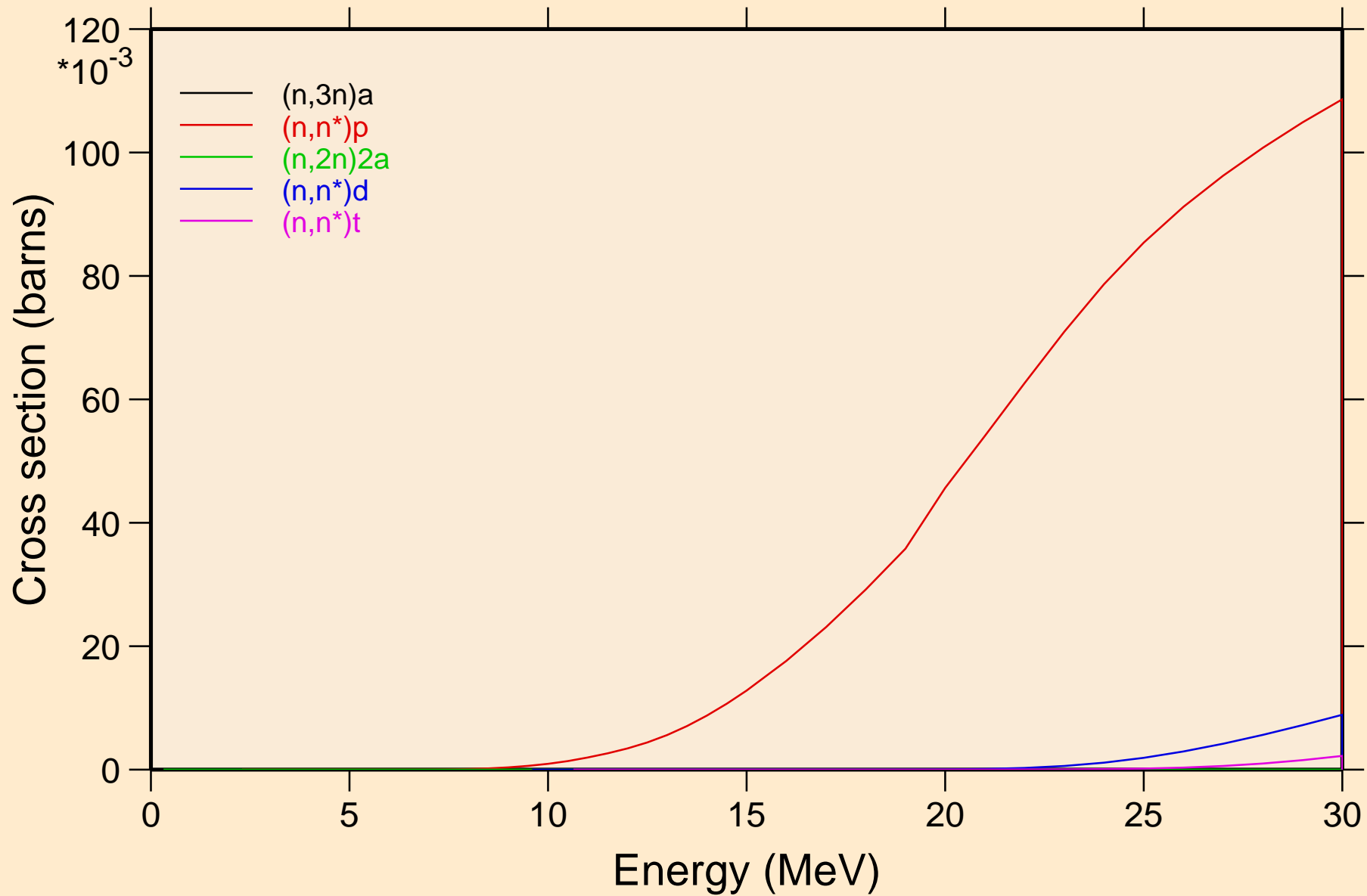

TL193M NEUTRON ACER TENDL-2024 LIBRARY; T=0.K  
Threshold reactions

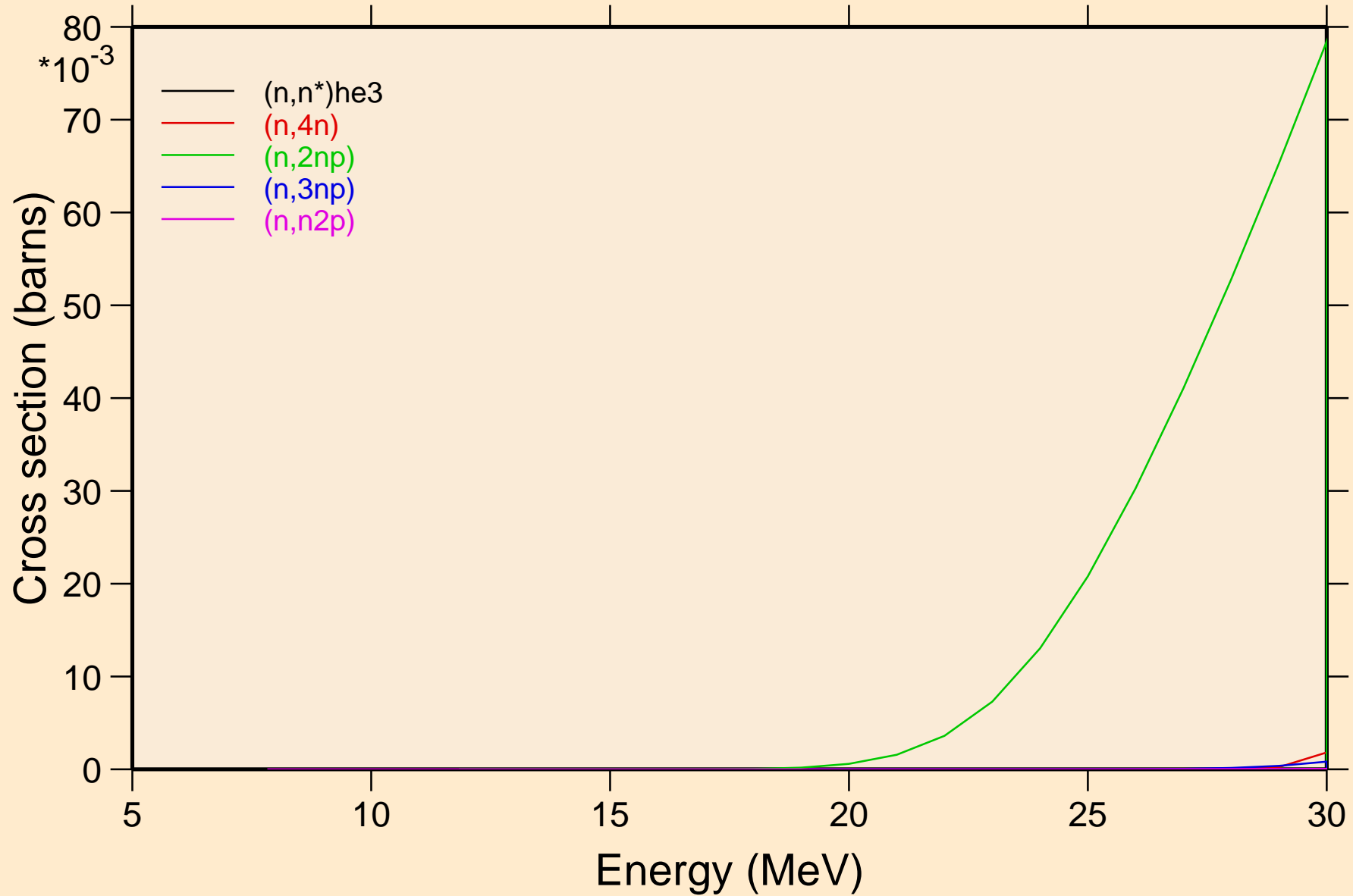



TL193M NEUTRON ACER TENDL-2024 LIBRARY; T=0.K  
Threshold reactions

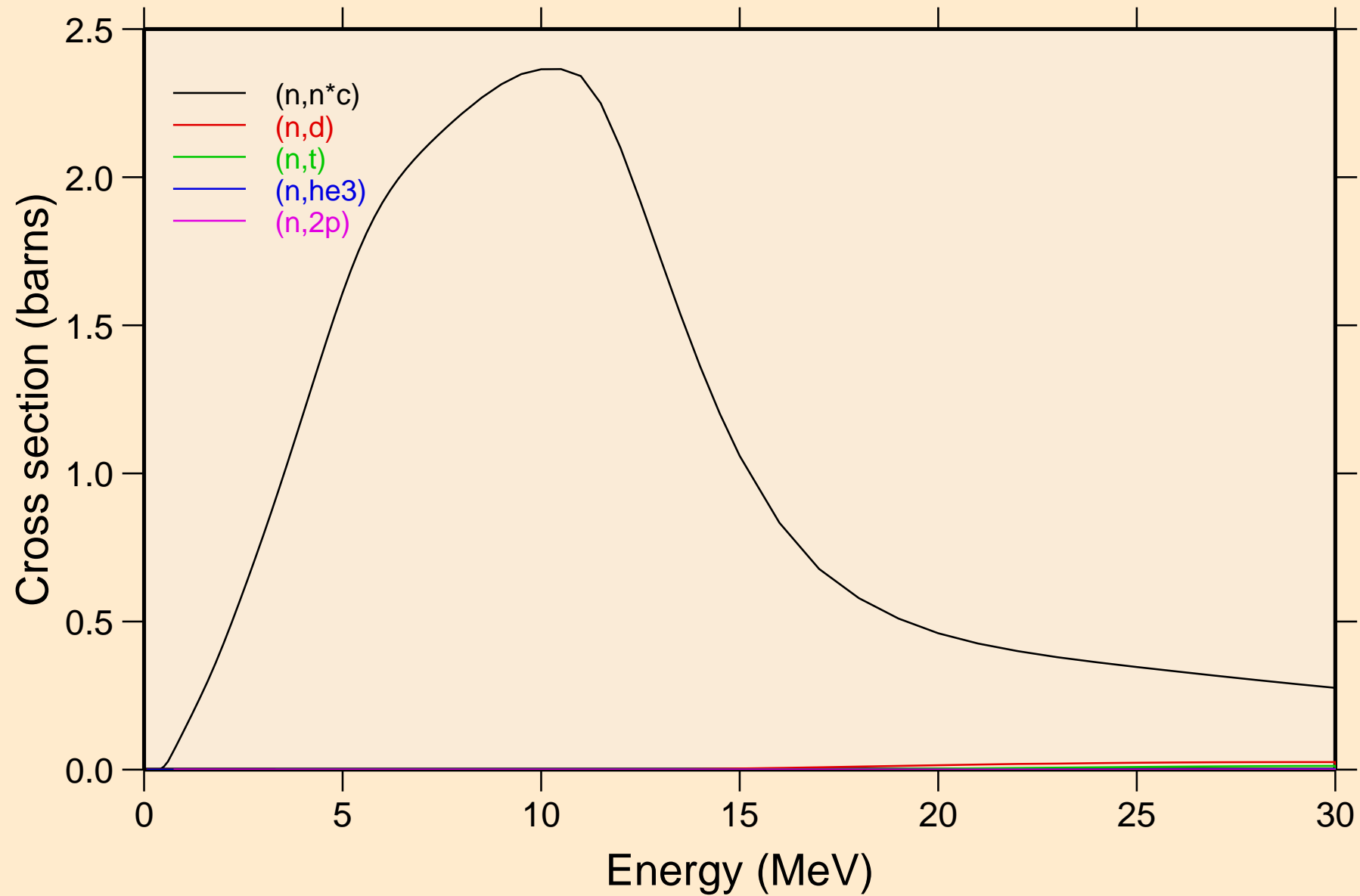

TL193M NEUTRON ACER TENDL-2024 LIBRARY; T=0.K  
Threshold reactions

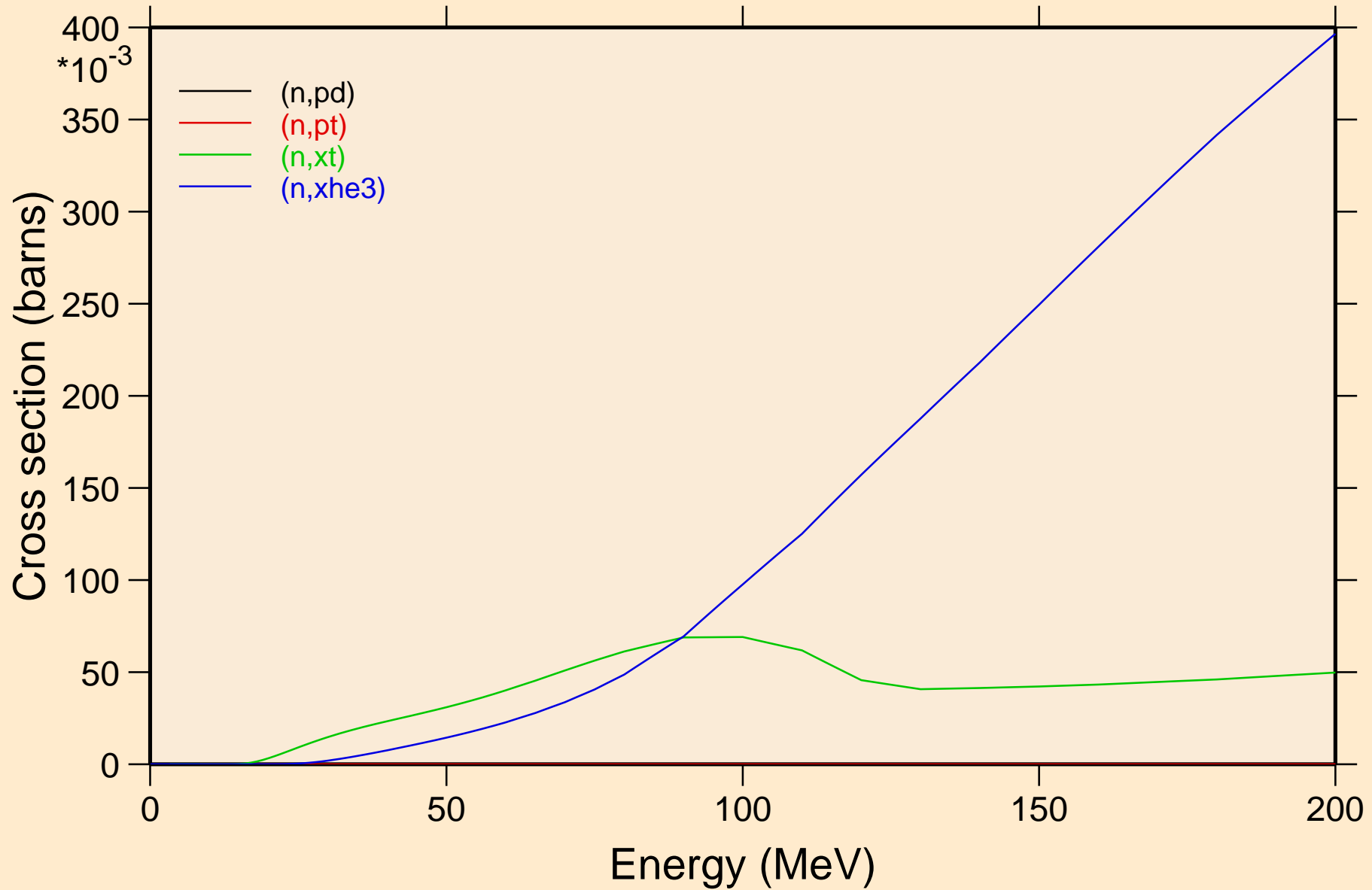

TL193M NEUTRON ACER TENDL-2024 LIBRARY; T=0.K  
angular distribution for elastic

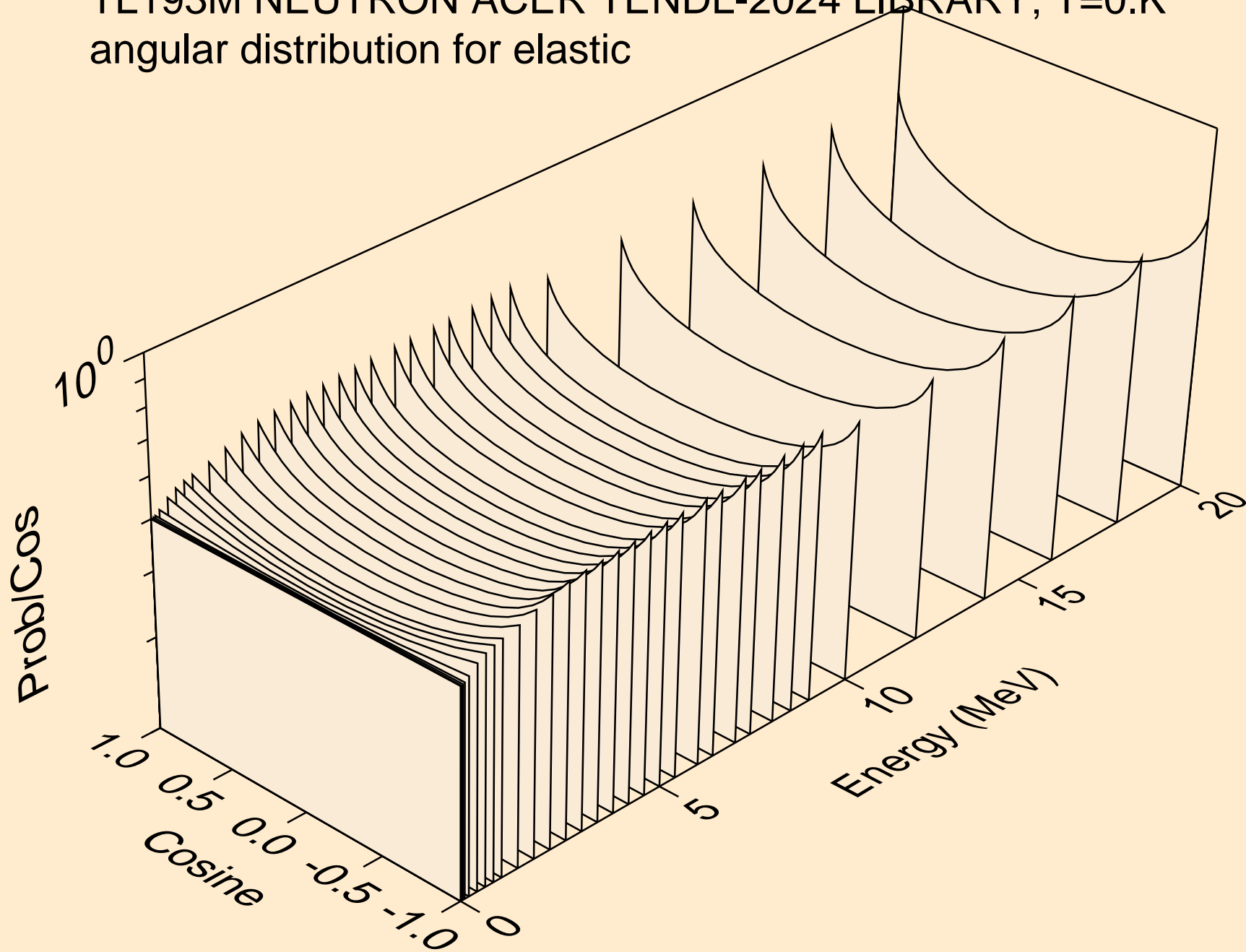

TL193M NEUTRON ACER TENDL-2024 LIBRARY; T=0.K  
angular distribution for elastic

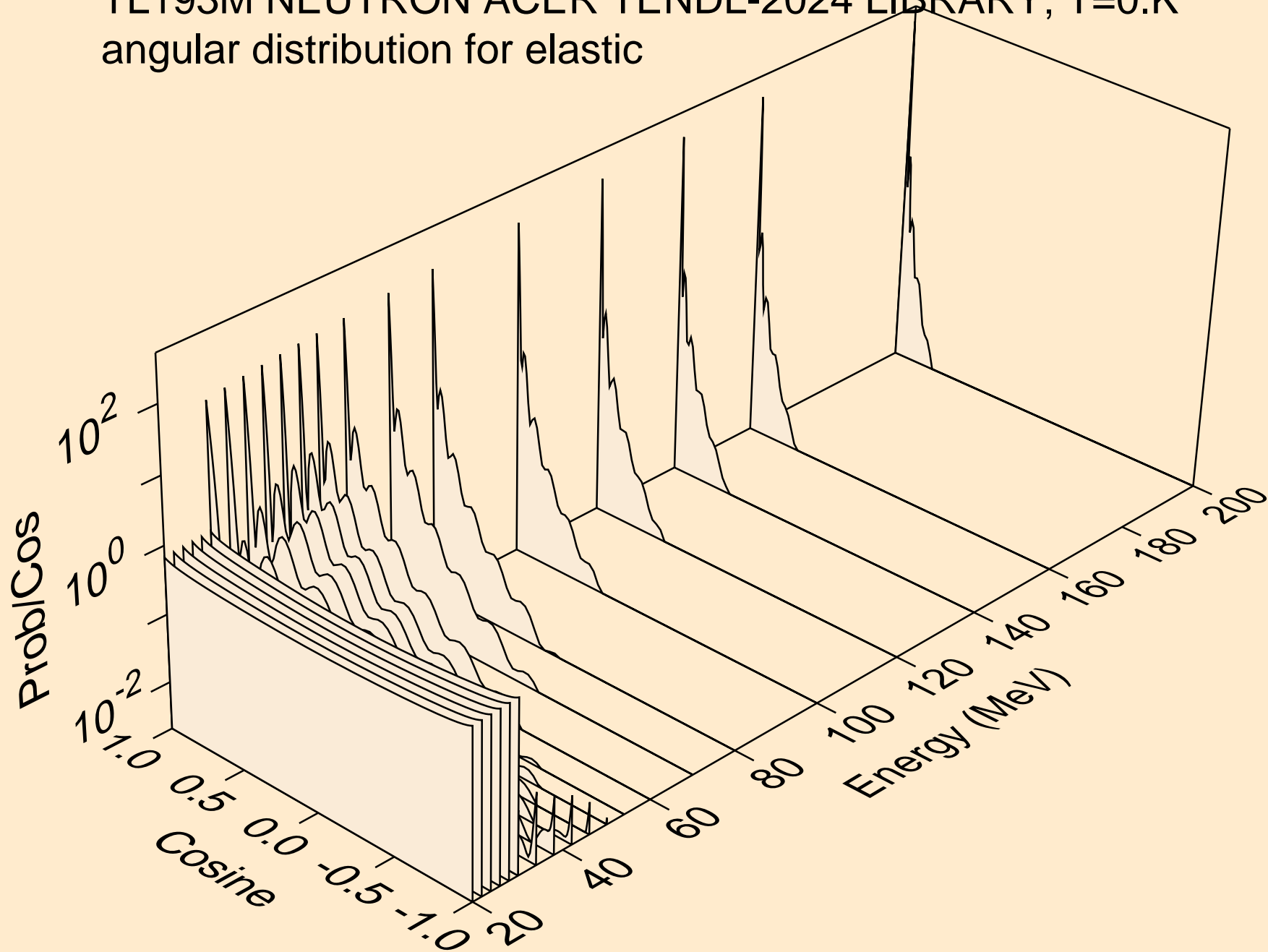

TL193M NEUTRON ACER TENDL-2024 LIBRARY; T=0.K  
angular distribution for (n,n\*1)

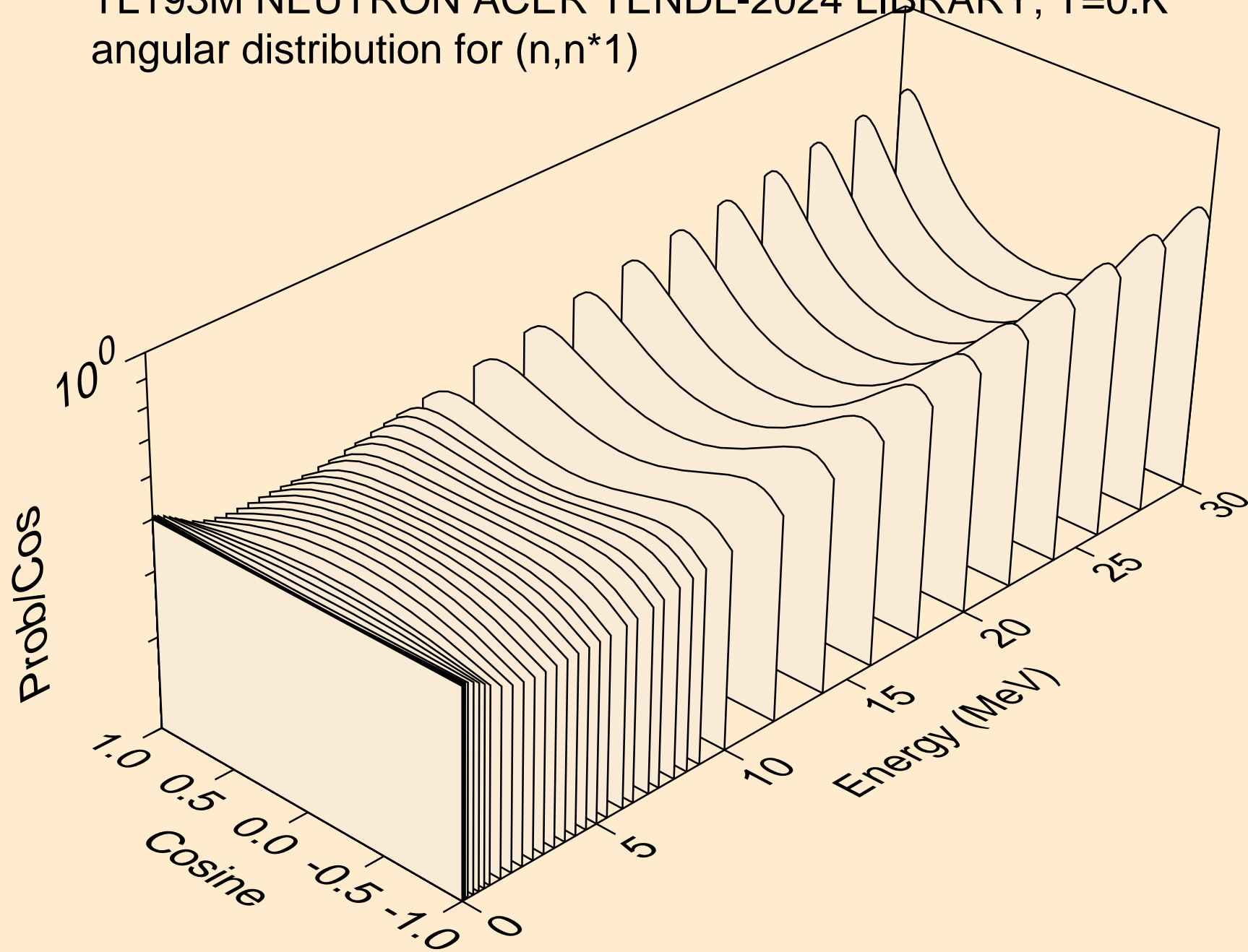

TL193M NEUTRON ACER TENDL-2024 LIBRARY; T=0.K  
angular distribution for (n,n\*2)

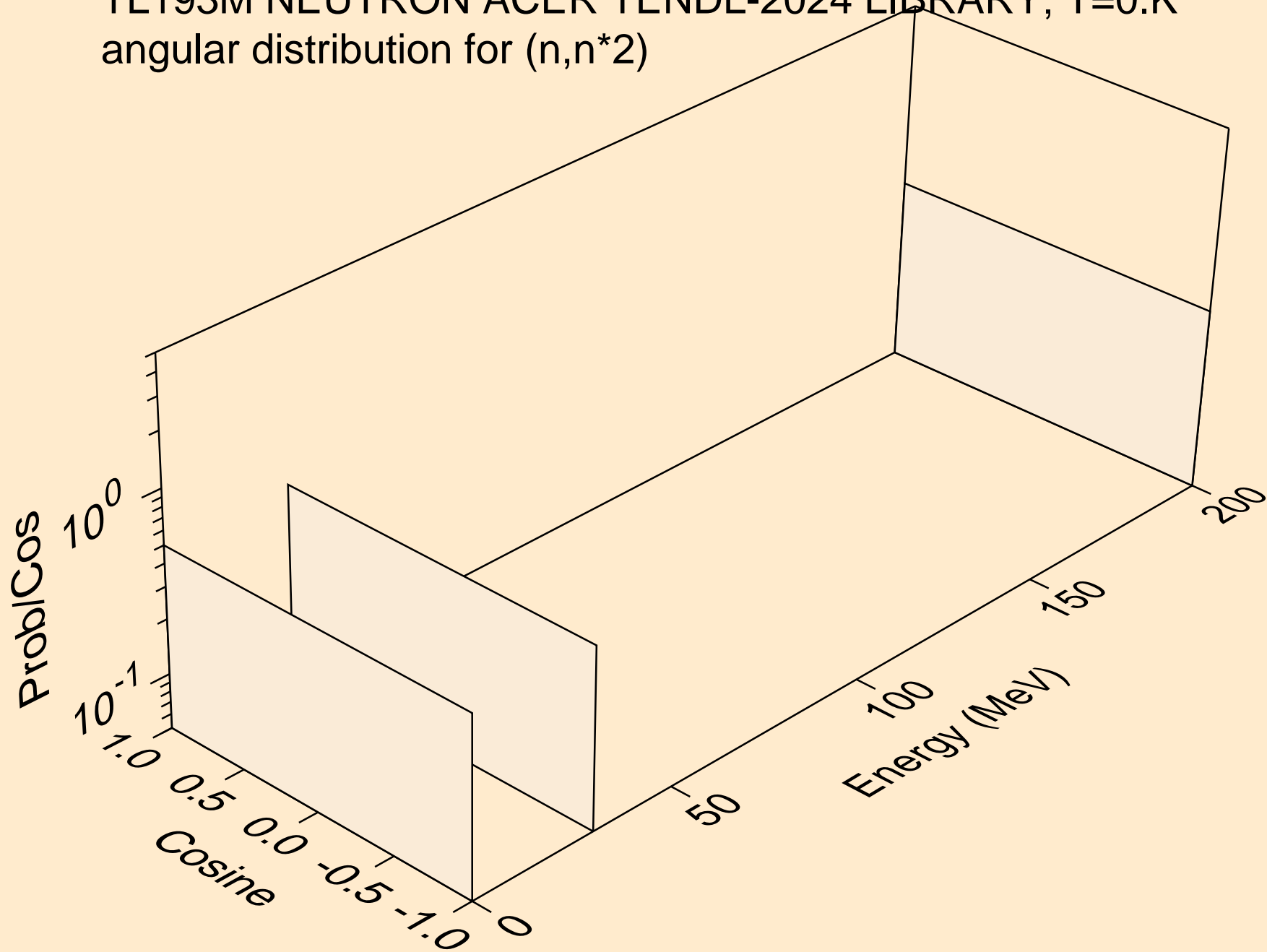

TL193M NEUTRON ACER TENDL-2024 LIBRARY; T=0.K  
angular distribution for (n,n\*3)

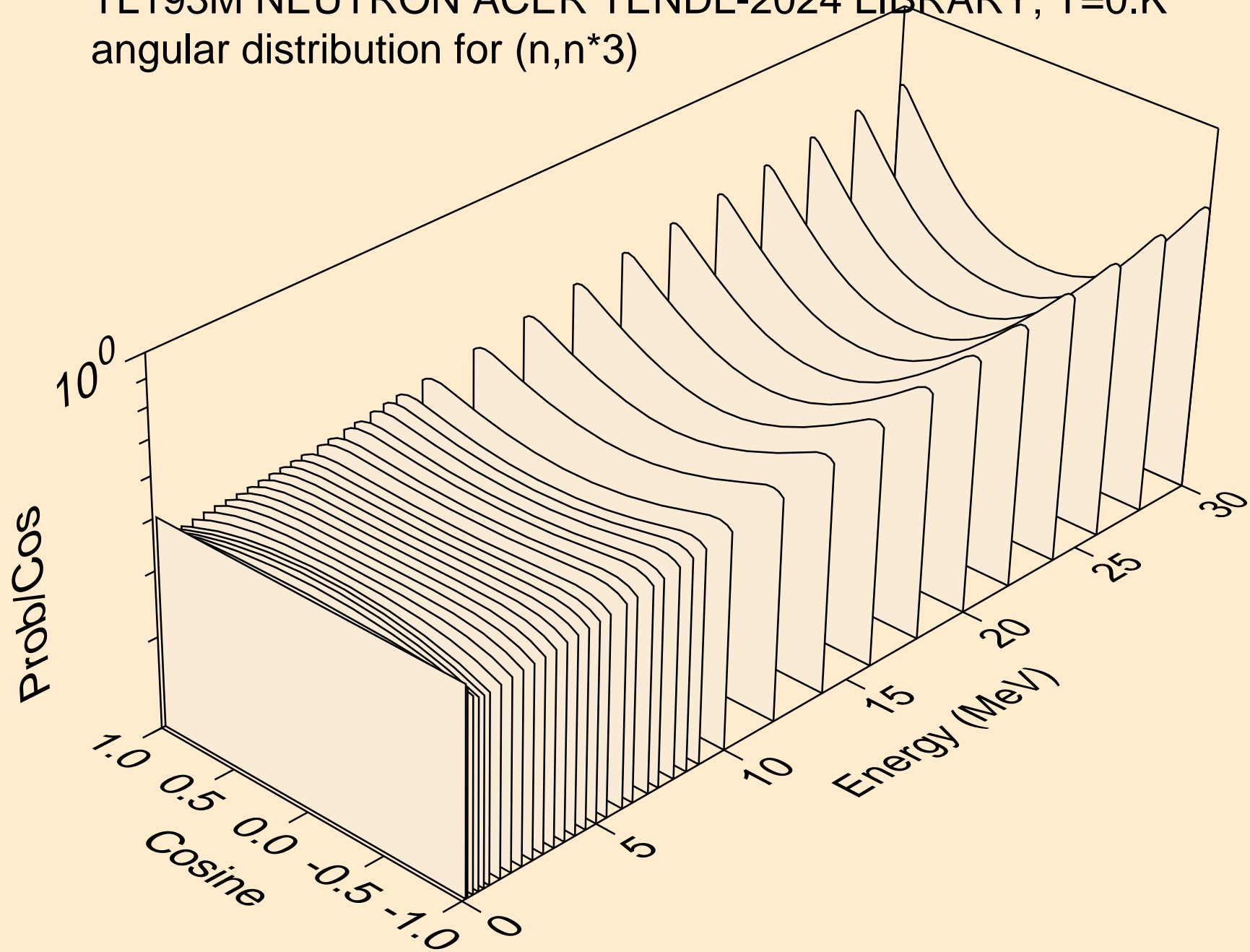

TL193M NEUTRON ACER TENDL-2024 LIBRARY; T=0.K  
angular distribution for (n,n\*4)

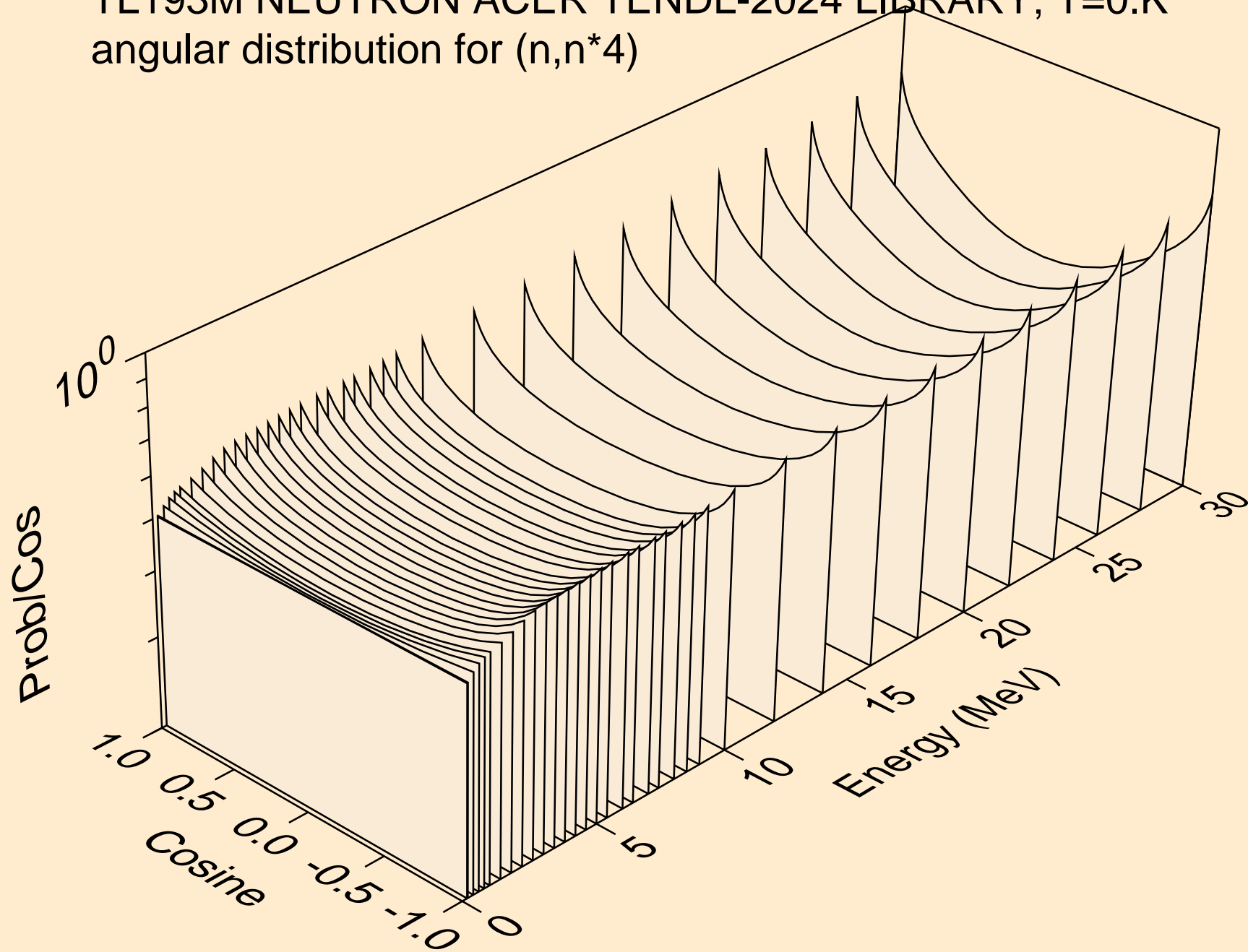



TL193M NEUTRON ACER TENDL-2024 LIBRARY; T=0.K  
angular distribution for (n,n\*5)

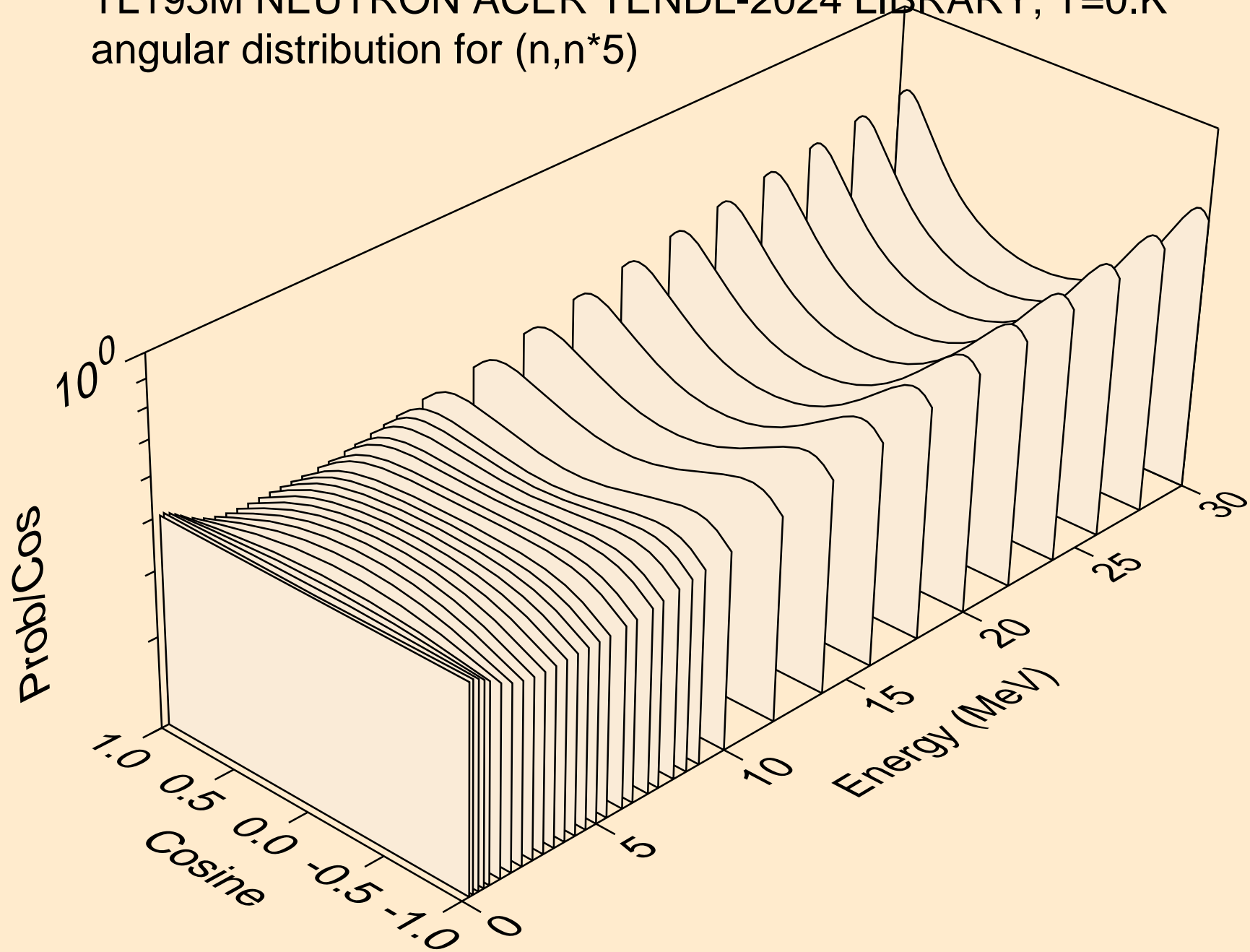

TL193M NEUTRON ACER TENDL-2024 LIBRARY; T=0.K  
angular distribution for (n,n\*6)

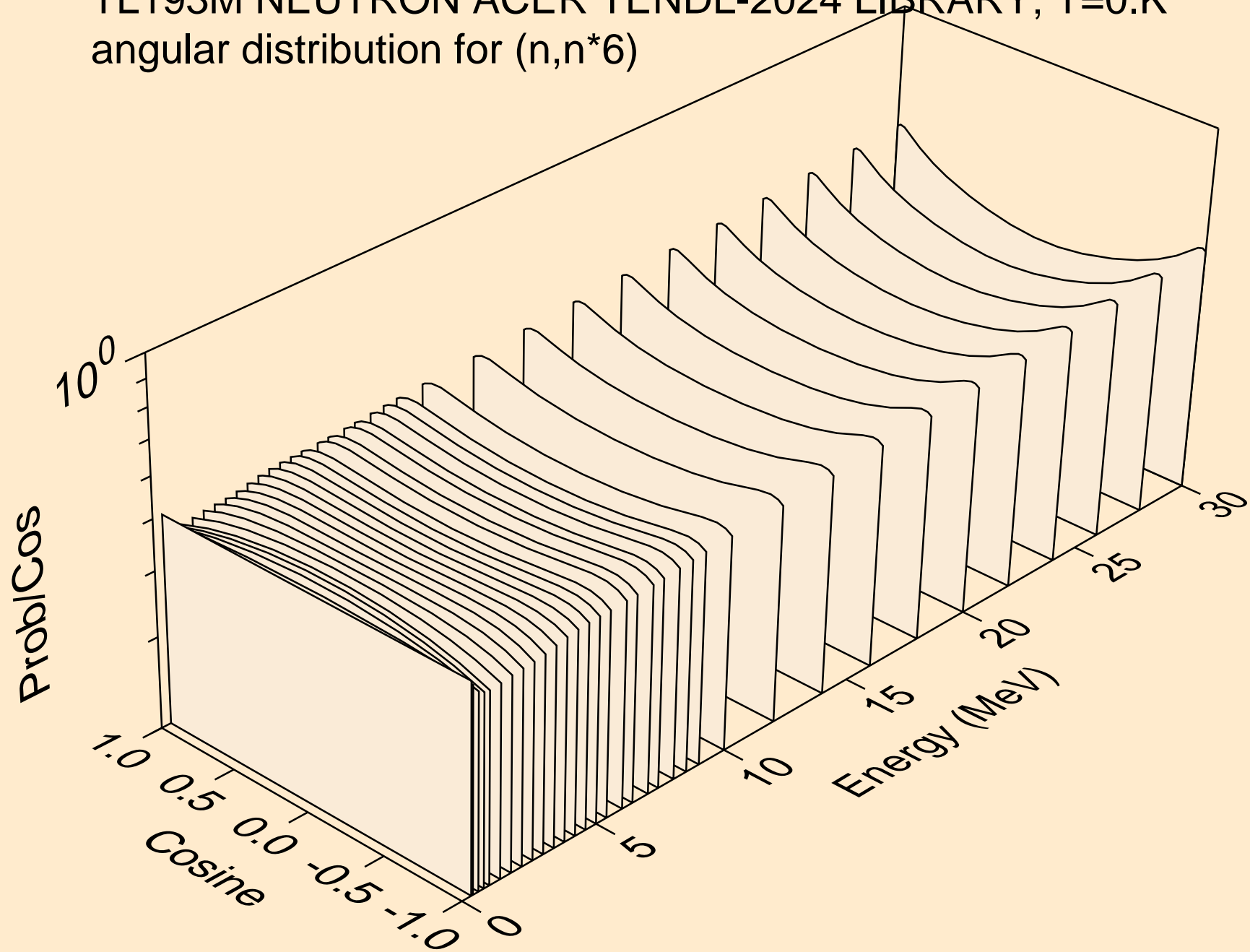

TL193M NEUTRON ACER TENDL-2024 LIBRARY; T=0.K  
angular distribution for (n,n\*7)

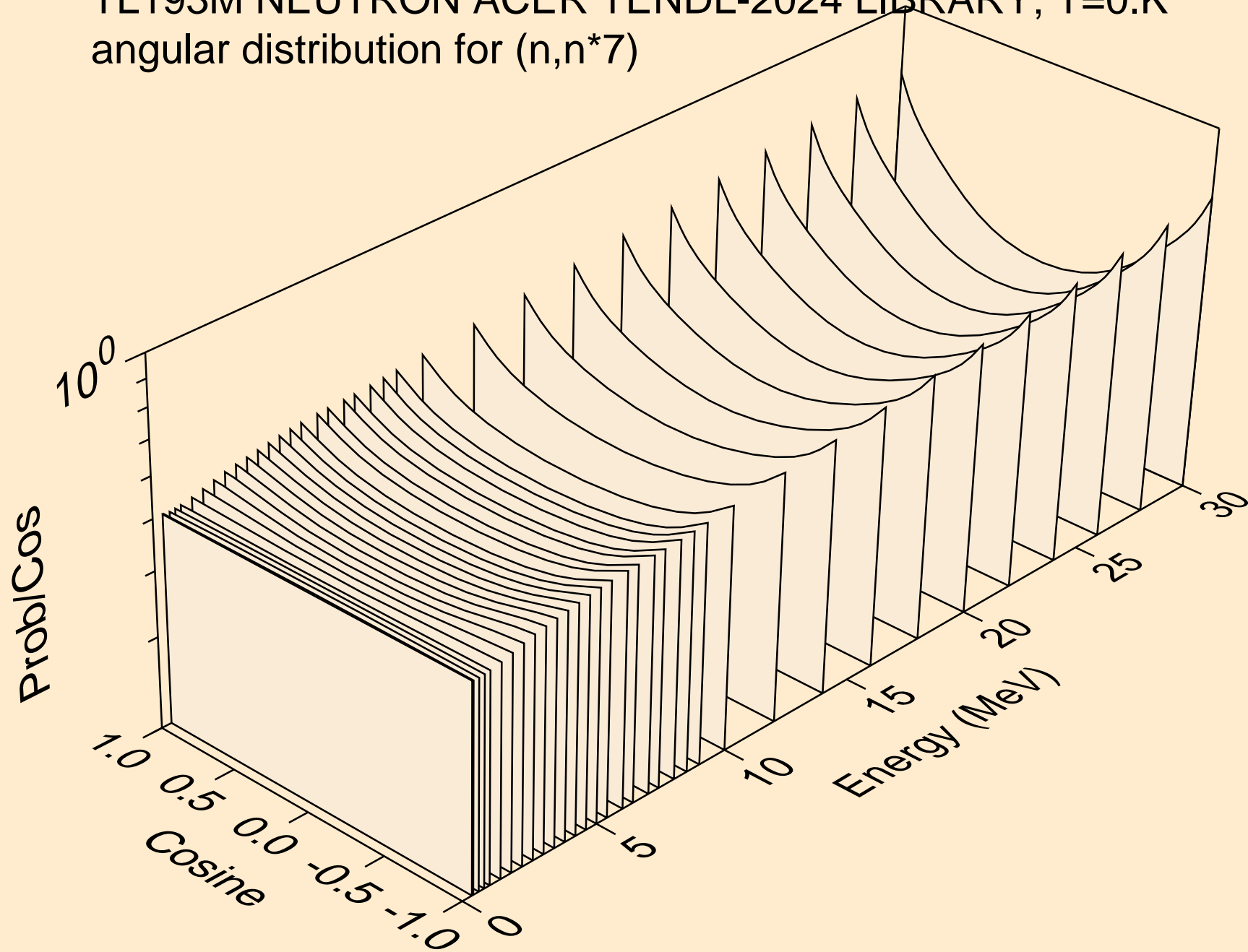

TL193M NEUTRON ACER TENDL-2024 LIBRARY; T=0.K  
angular distribution for (n,n\*8)

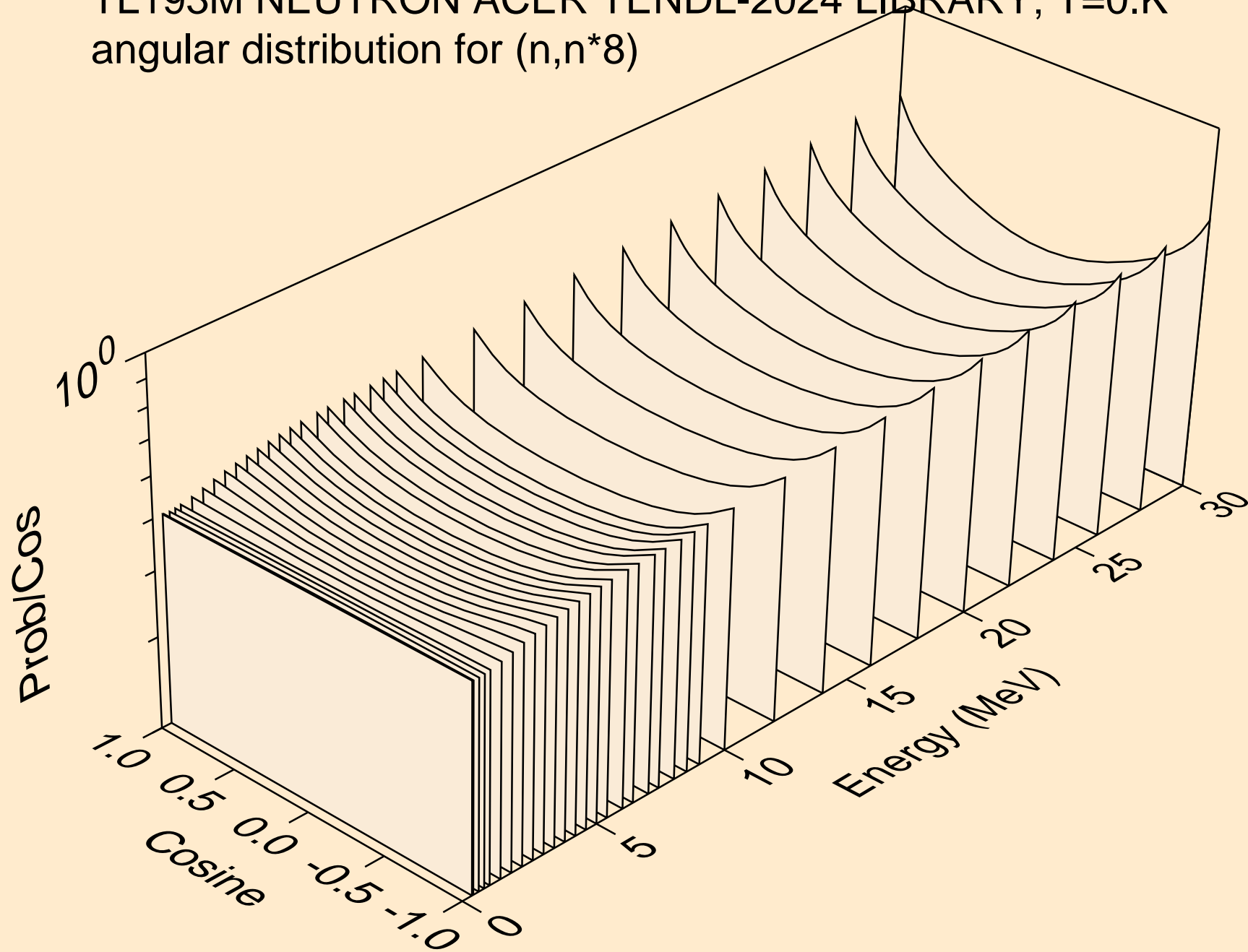

TL193M NEUTRON ACER TENDL-2024 LIBRARY; T=0.K  
angular distribution for (n,n\*9)

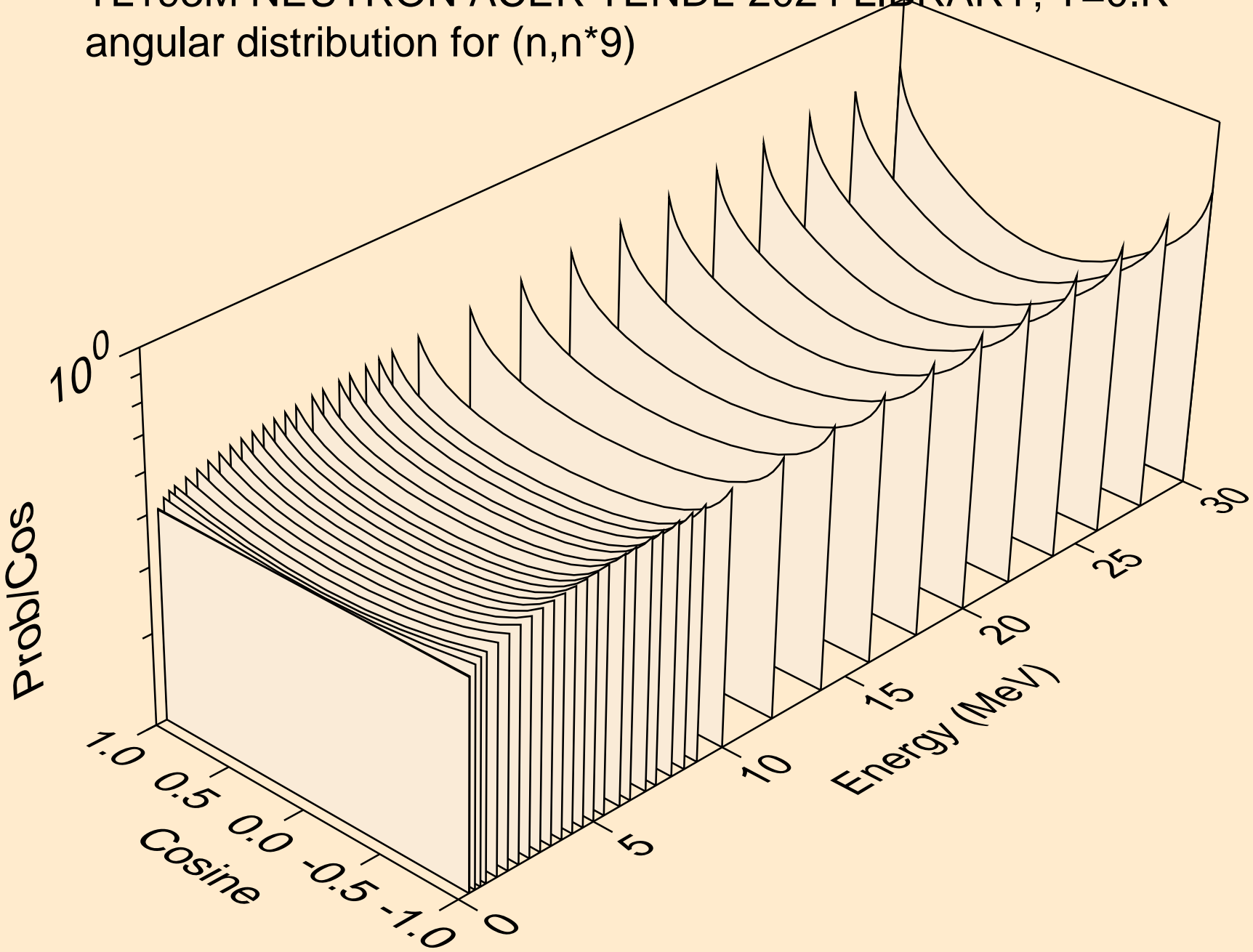

TL193M NEUTRON ACER TENDL-2024 LIBRARY; T=0.K  
Neutron emission for (n,x)

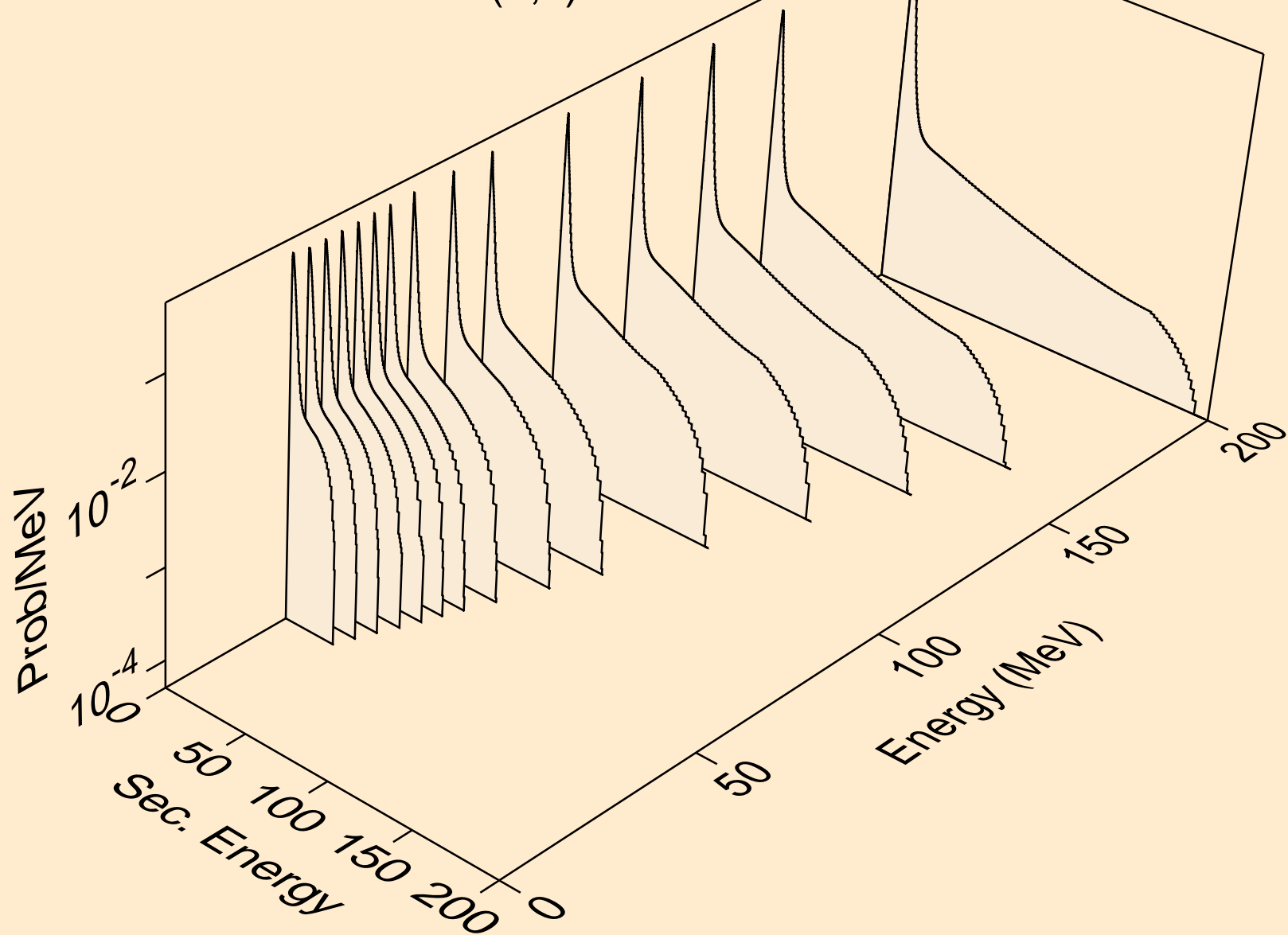

TL193M NEUTRON ACER TENDL-2024 LIBRARY; T=0.K  
Neutron emission for (n,2nd)

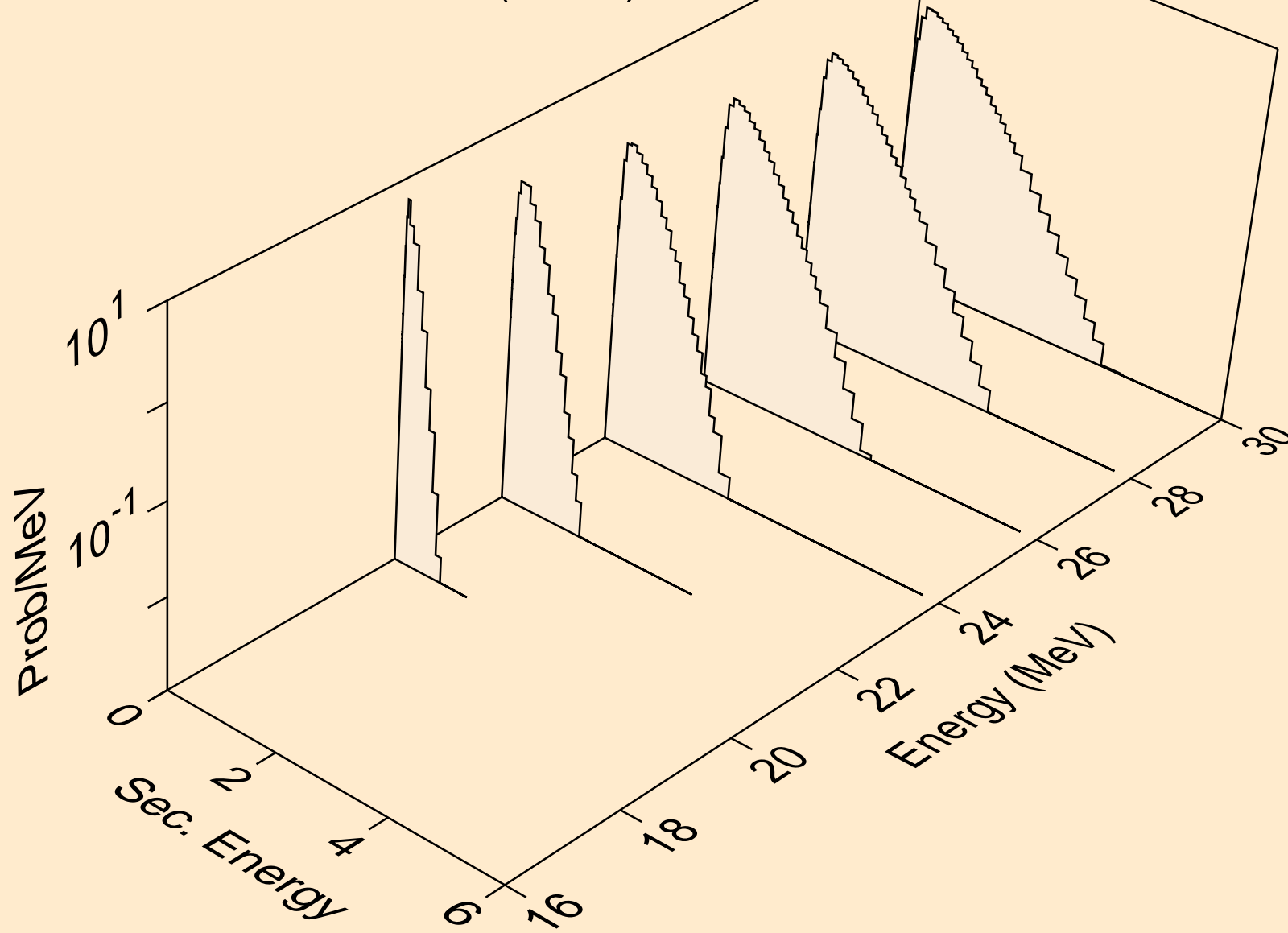

TL193M NEUTRON ACER TENDL-2024 LIBRARY; T=0.K  
Neutron emission for (n,2n)

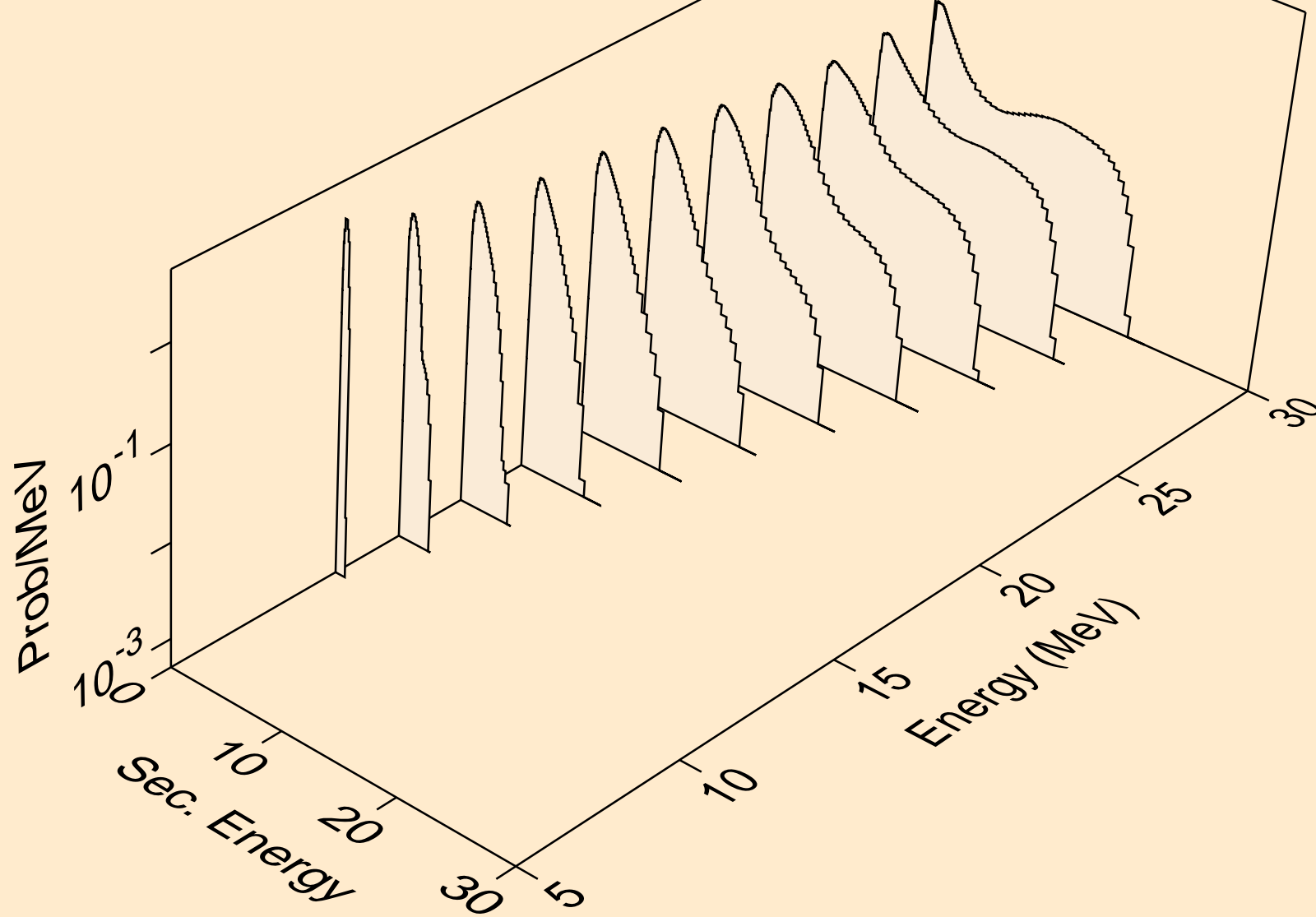



TL193M NEUTRON ACER TENDL-2024 LIBRARY; T=0.K  
Neutron emission for (n,3n)

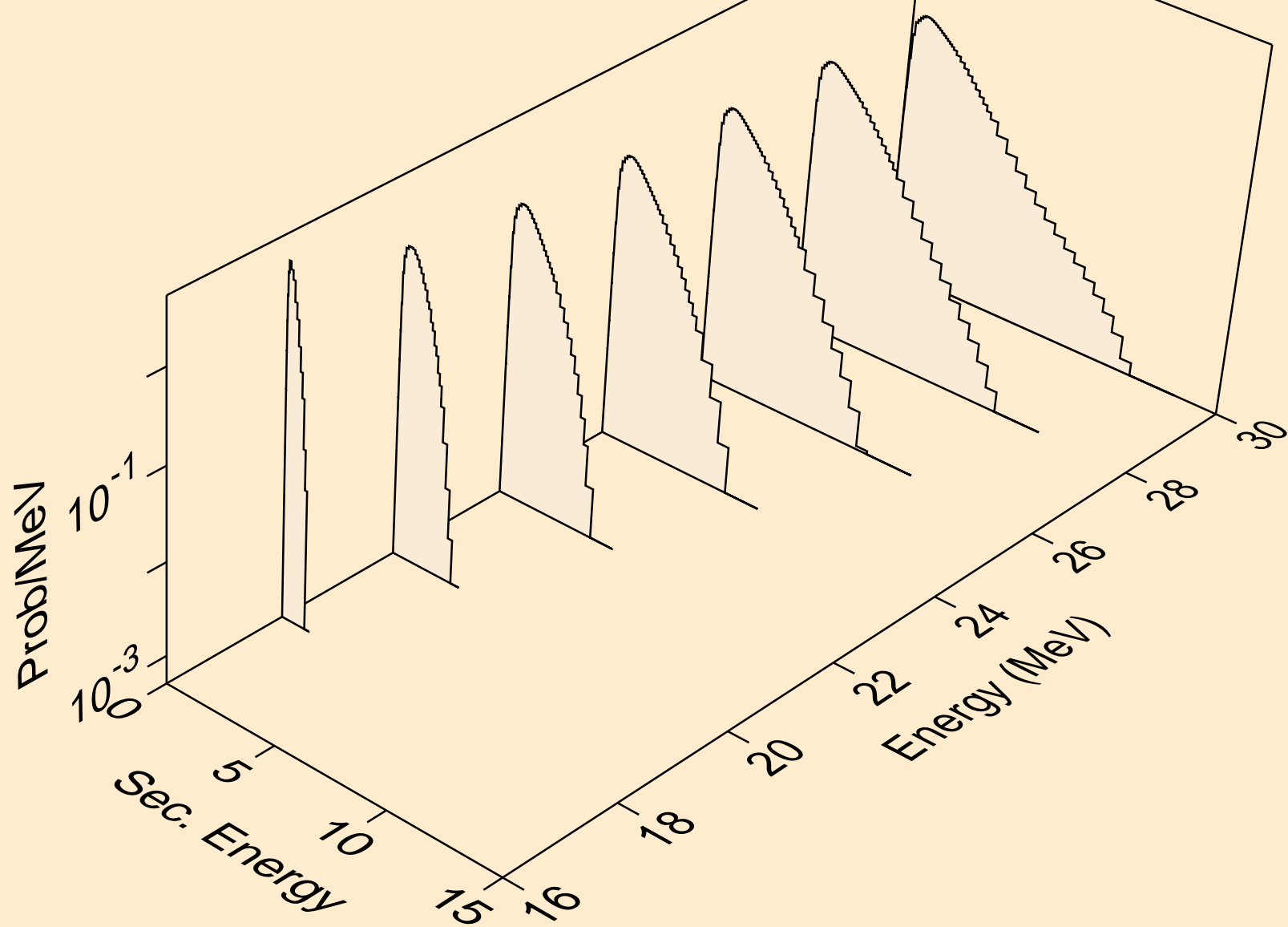

TL193M NEUTRON ACER TENDL-2024 LIBRARY; T=0.K  
Neutron emission for (n,n\*)a

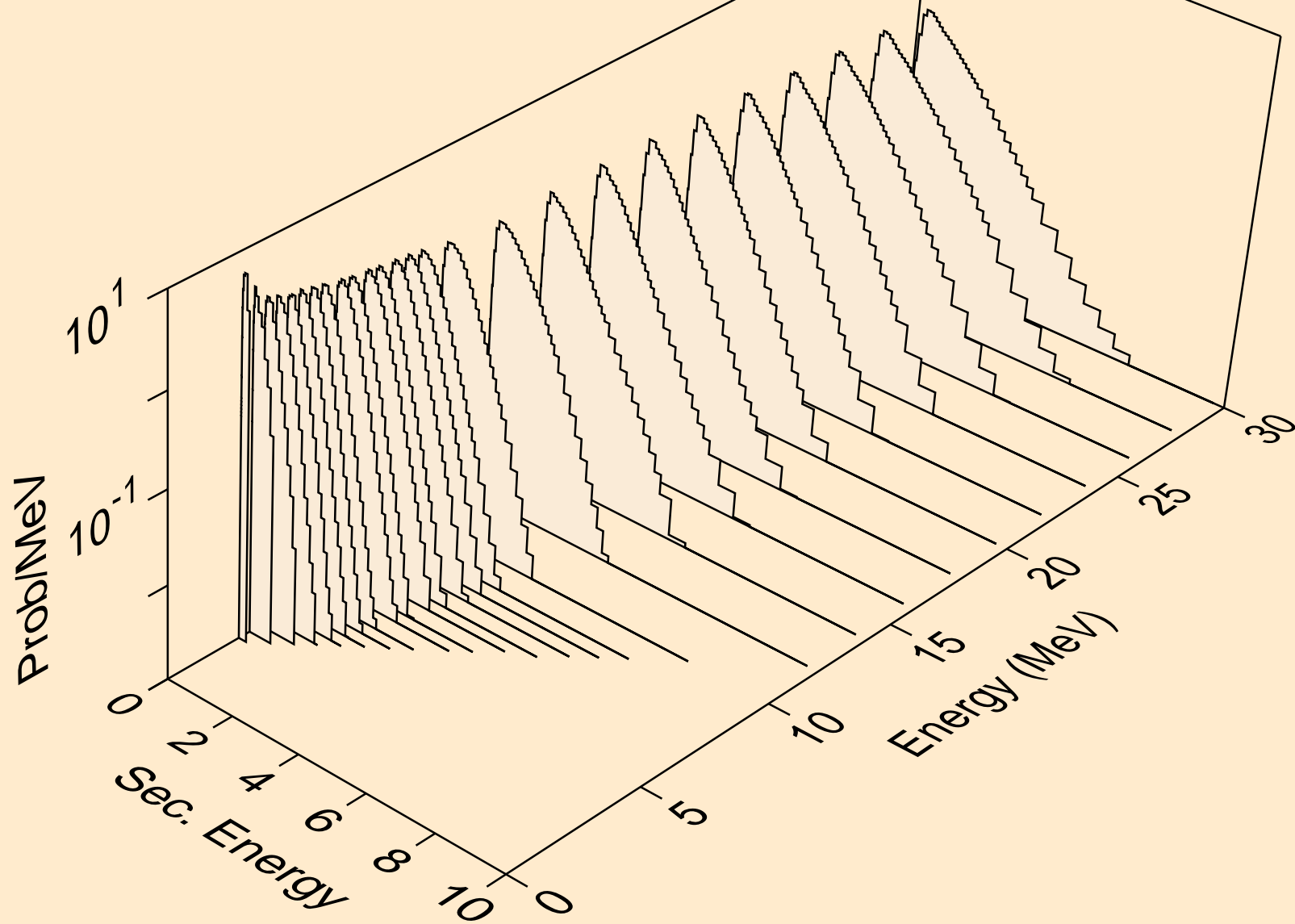

TL193M NEUTRON ACER TENDL-2024 LIBRARY; T=0.K  
Neutron emission for (n,2n)a

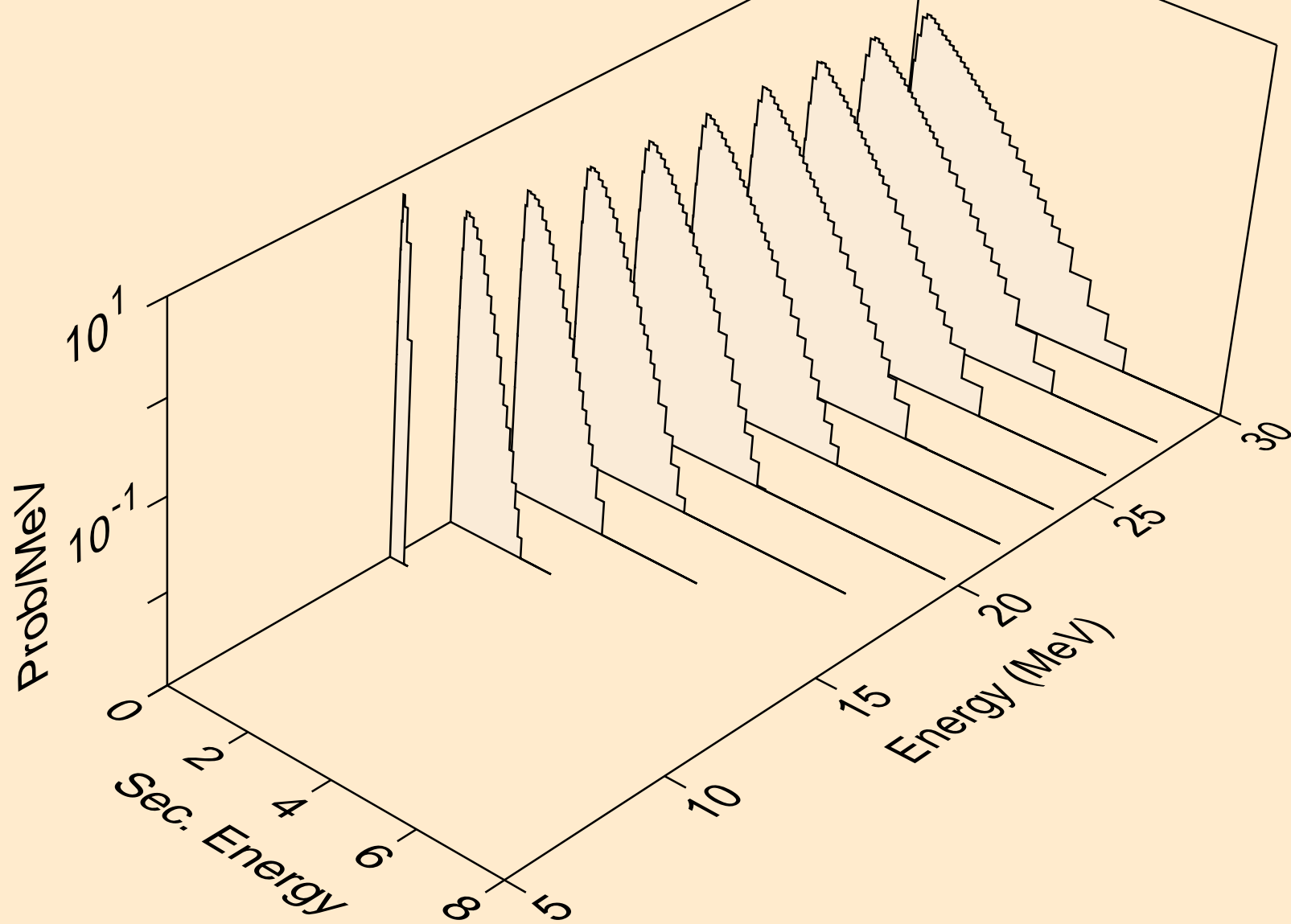

TL193M NEUTRON ACER TENDL-2024 LIBRARY; T=0.K  
Neutron emission for (n,3n)a

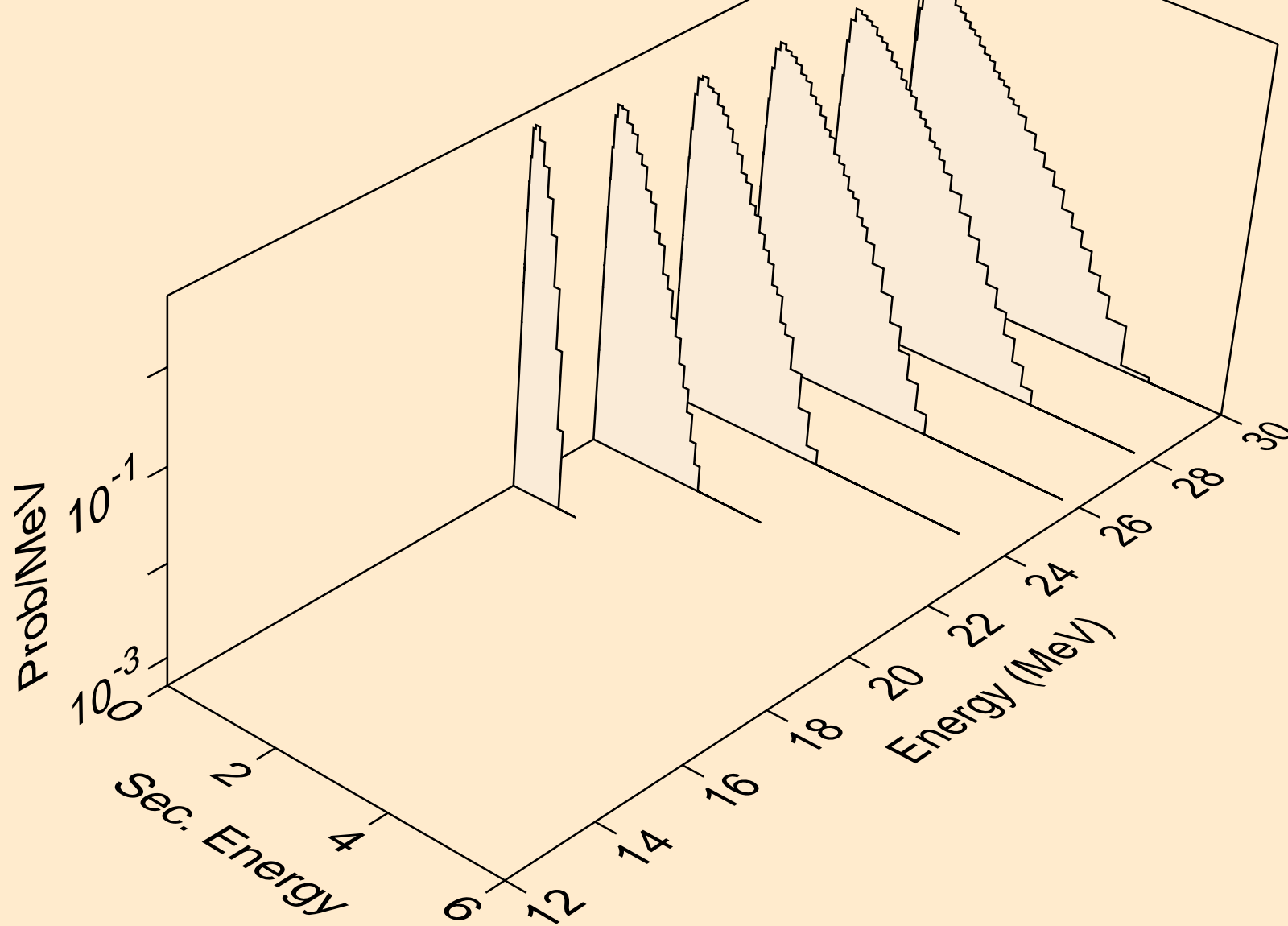

TL193M NEUTRON ACER TENDL-2024 LIBRARY; T=0.K  
Neutron emission for (n,n\*)p

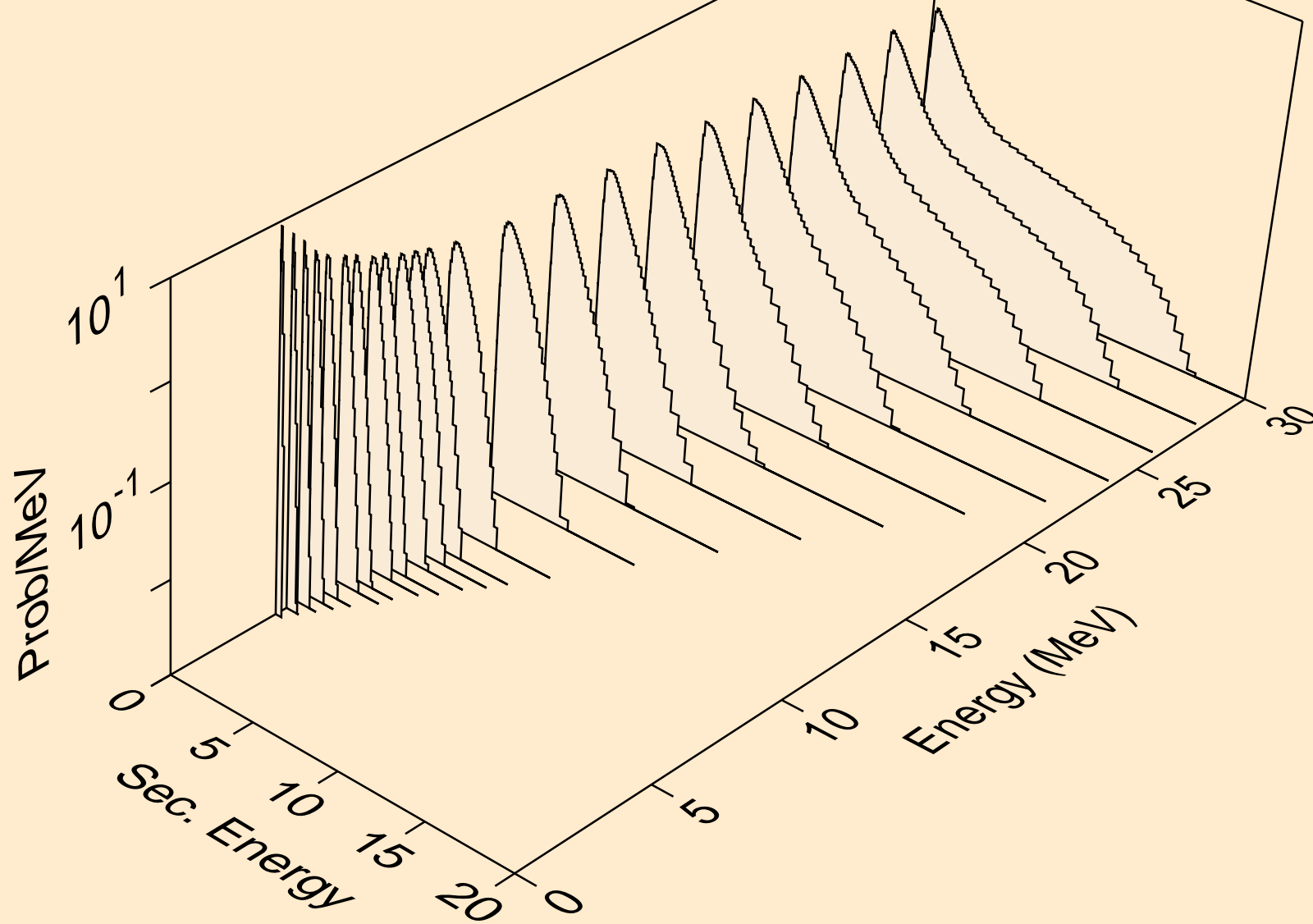

TL193M NEUTRON ACER TENDL-2024 LIBRARY; T=0.K  
Neutron emission for (n,n\*)2a

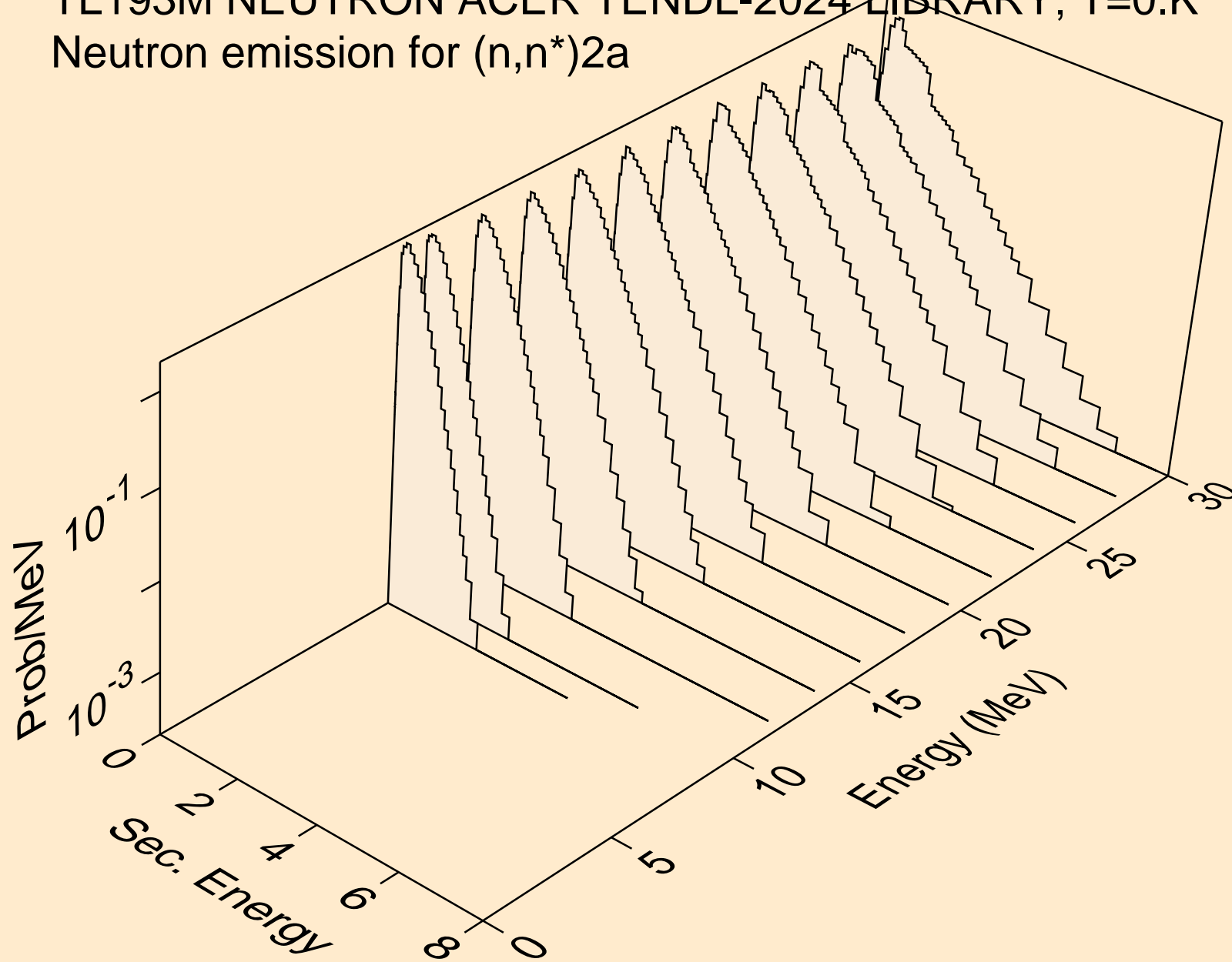

TL193M NEUTRON ACER TENDL-2024 LIBRARY; T=0.K  
Neutron emission for (n,2n)2a

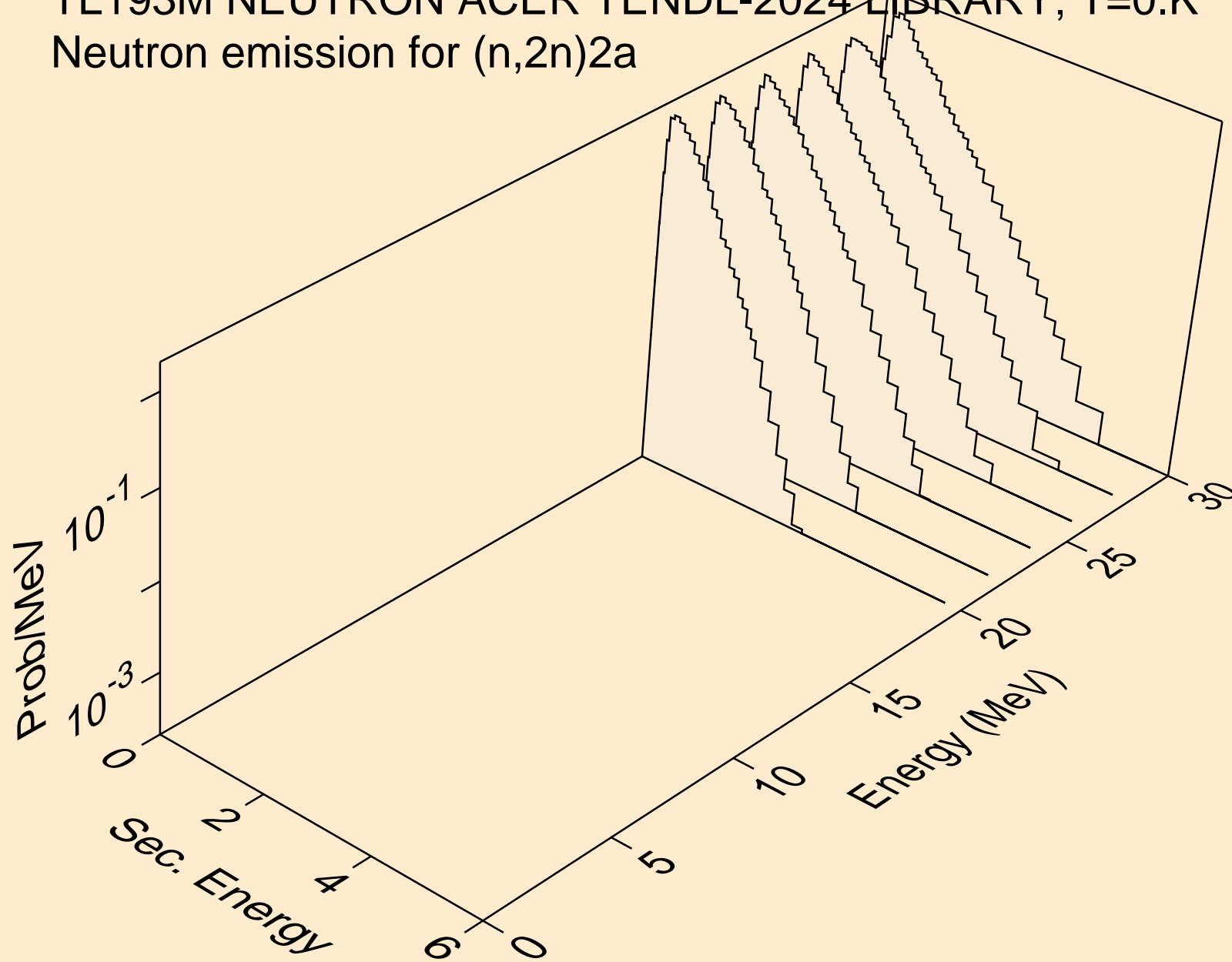

TL193M NEUTRON ACER TENDL-2024 LIBRARY; T=0.K  
Neutron emission for (n,n\*)d

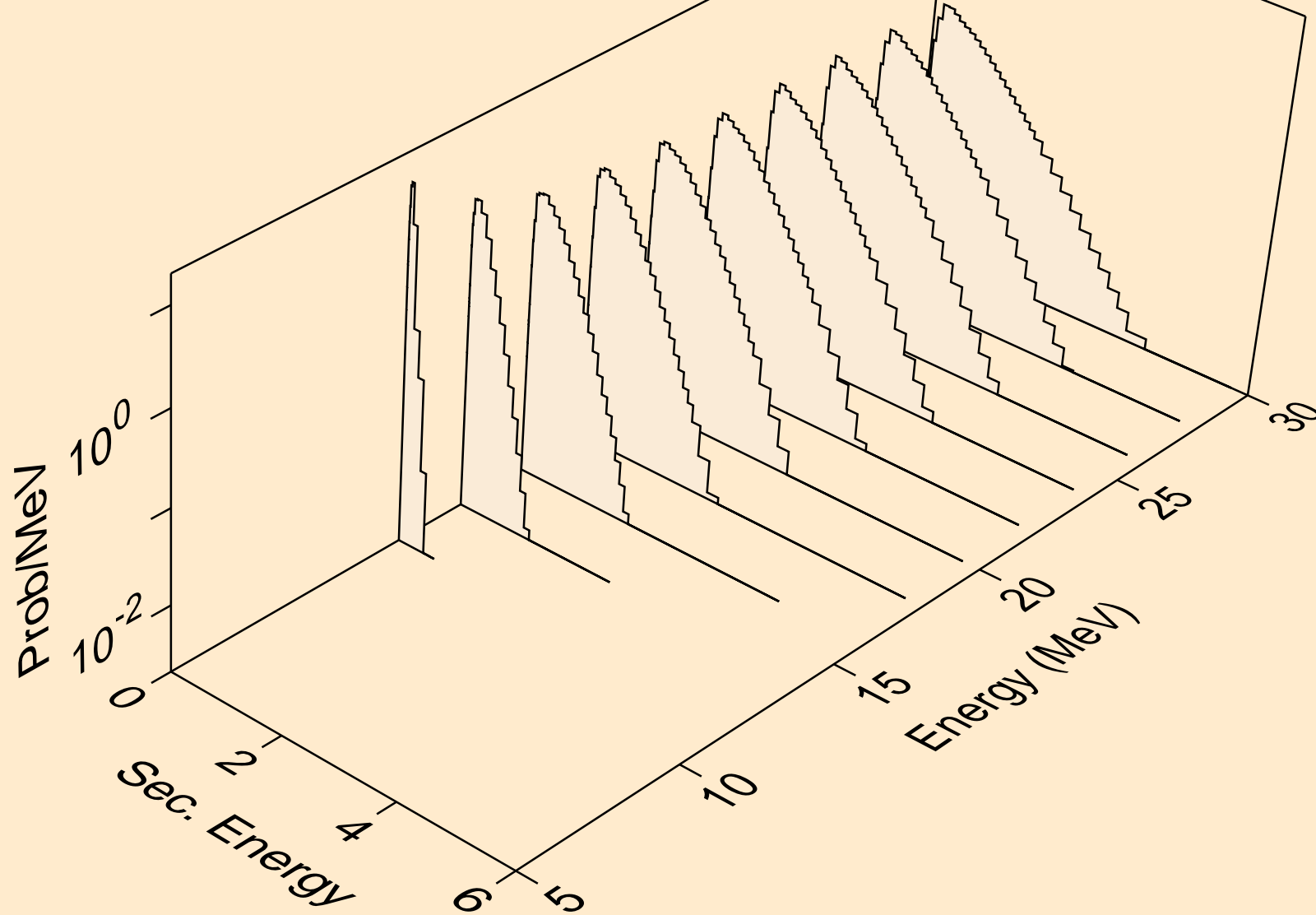



TL193M NEUTRON ACER TENDL-2024 LIBRARY; T=0.K  
Neutron emission for (n,n\*)t

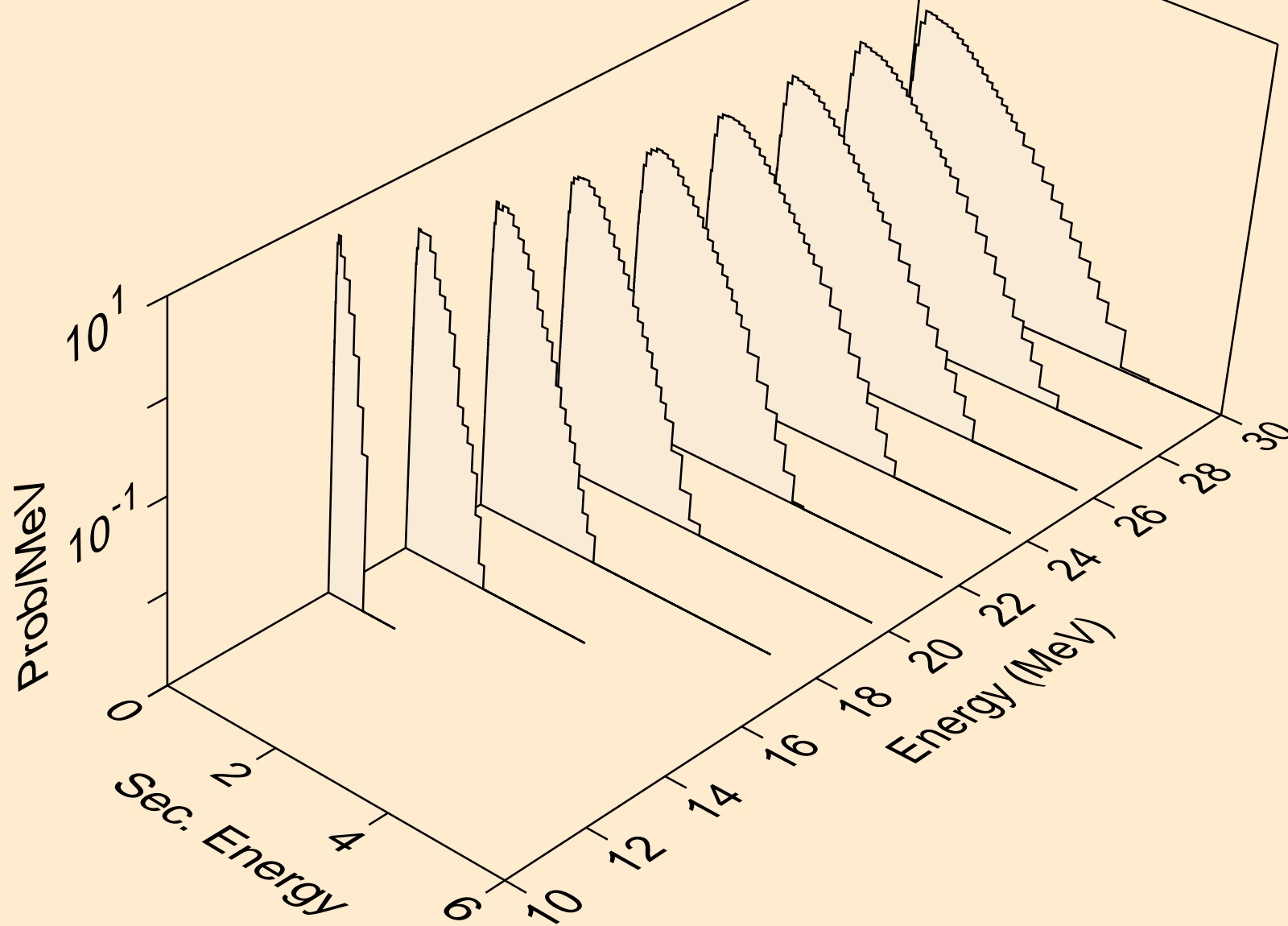

TL193M NEUTRON ACER TENDL-2024 LIBRARY; T=0.K  
Neutron emission for (n,n\*)he3

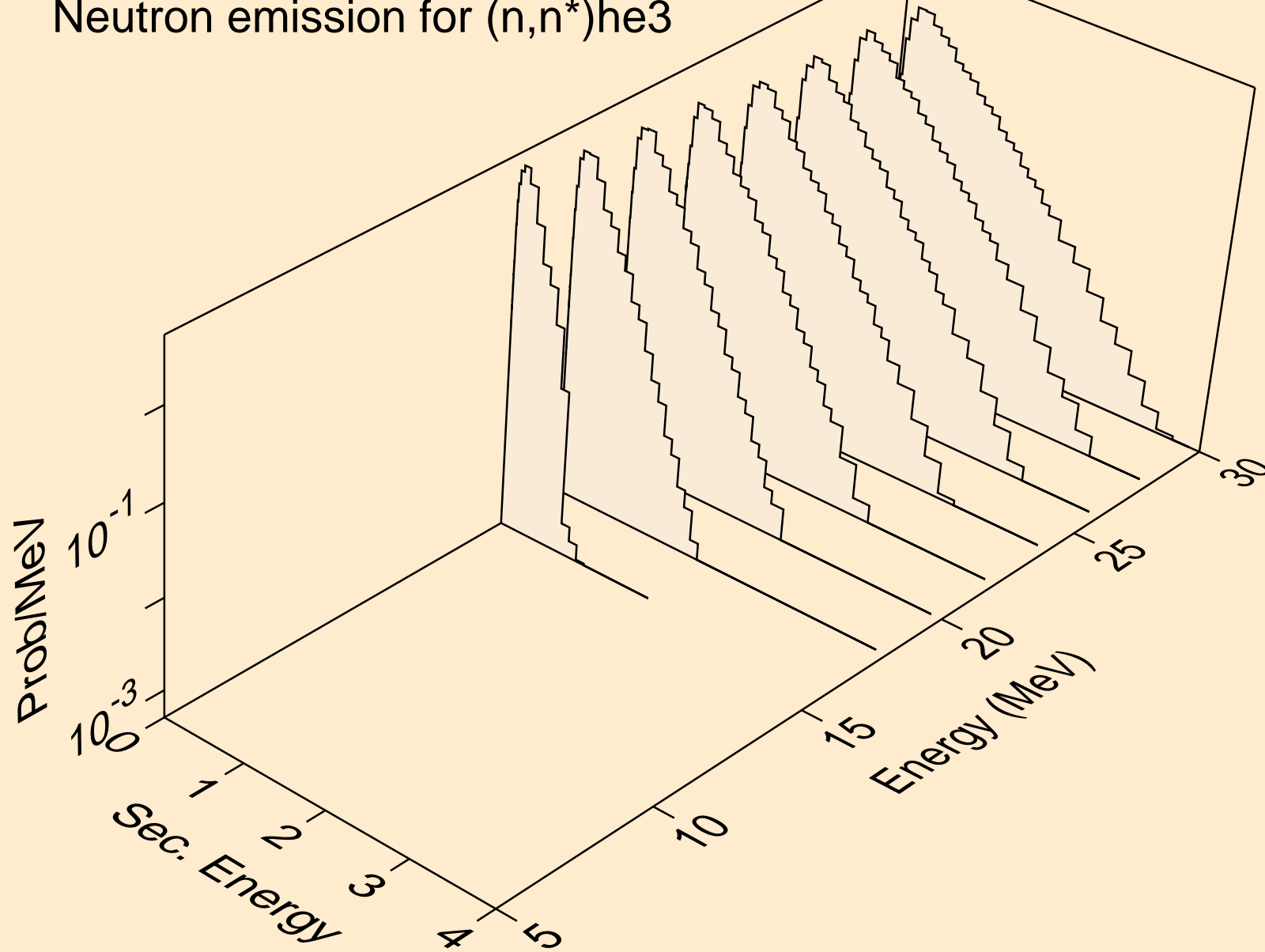

TL193M NEUTRON ACER TENDL-2024 LIBRARY; T=0.K  
Neutron emission for (n,4n)

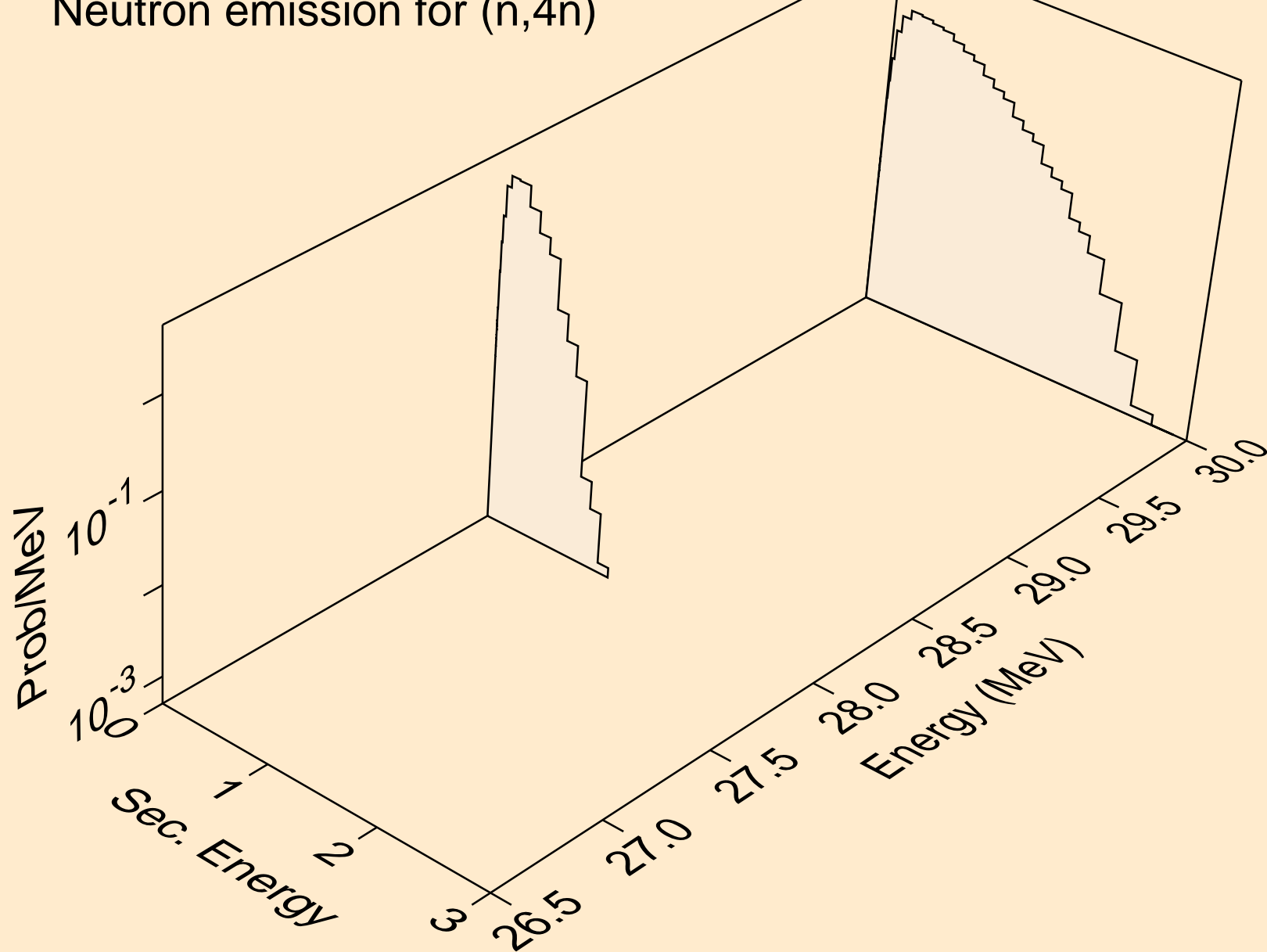

TL193M NEUTRON ACER TENDL-2024 LIBRARY; T=0.K  
Neutron emission for (n,2np)

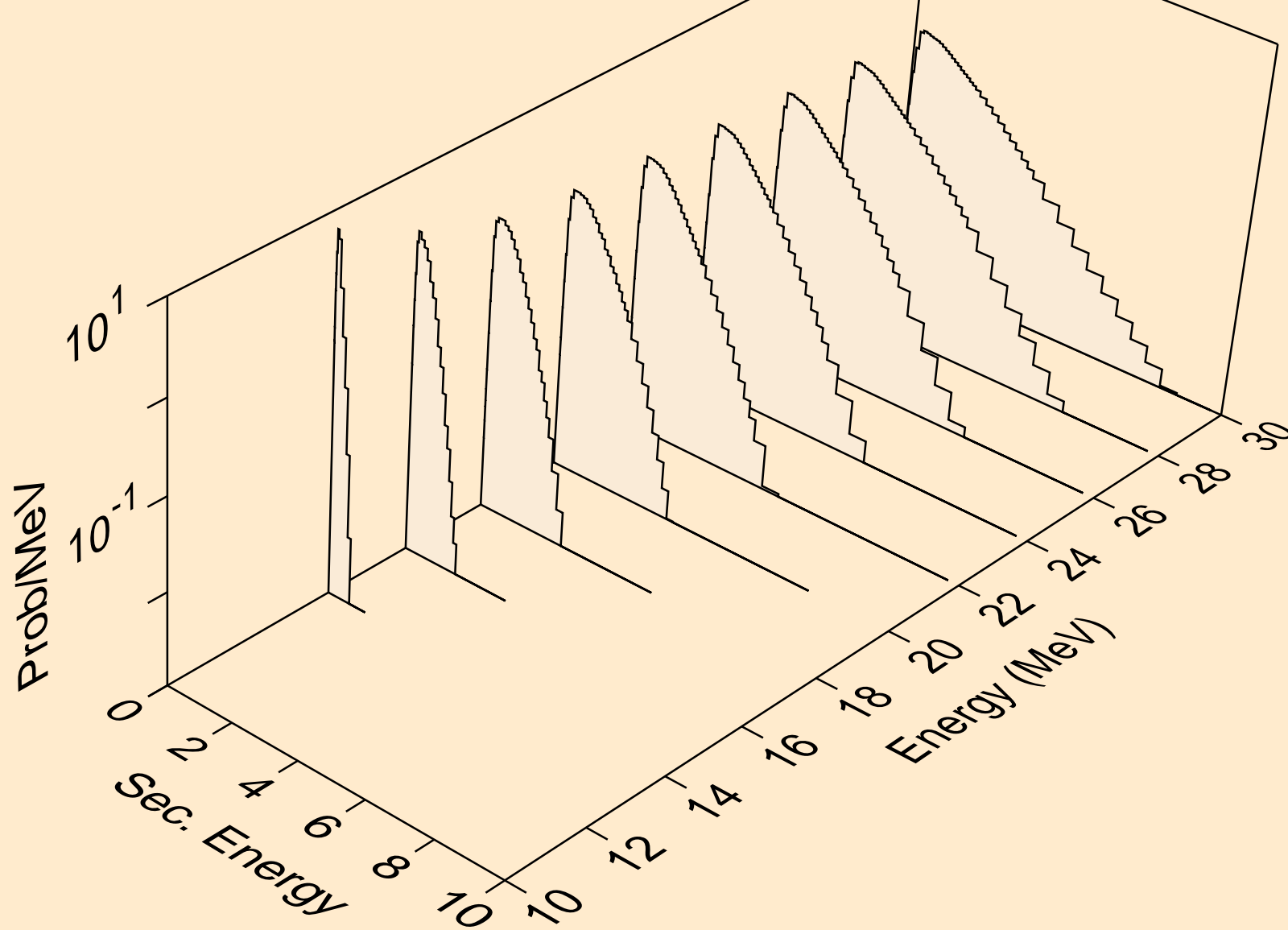

TL193M NEUTRON ACER TENDL-2024 LIBRARY; T=0.K  
Neutron emission for (n,3np)

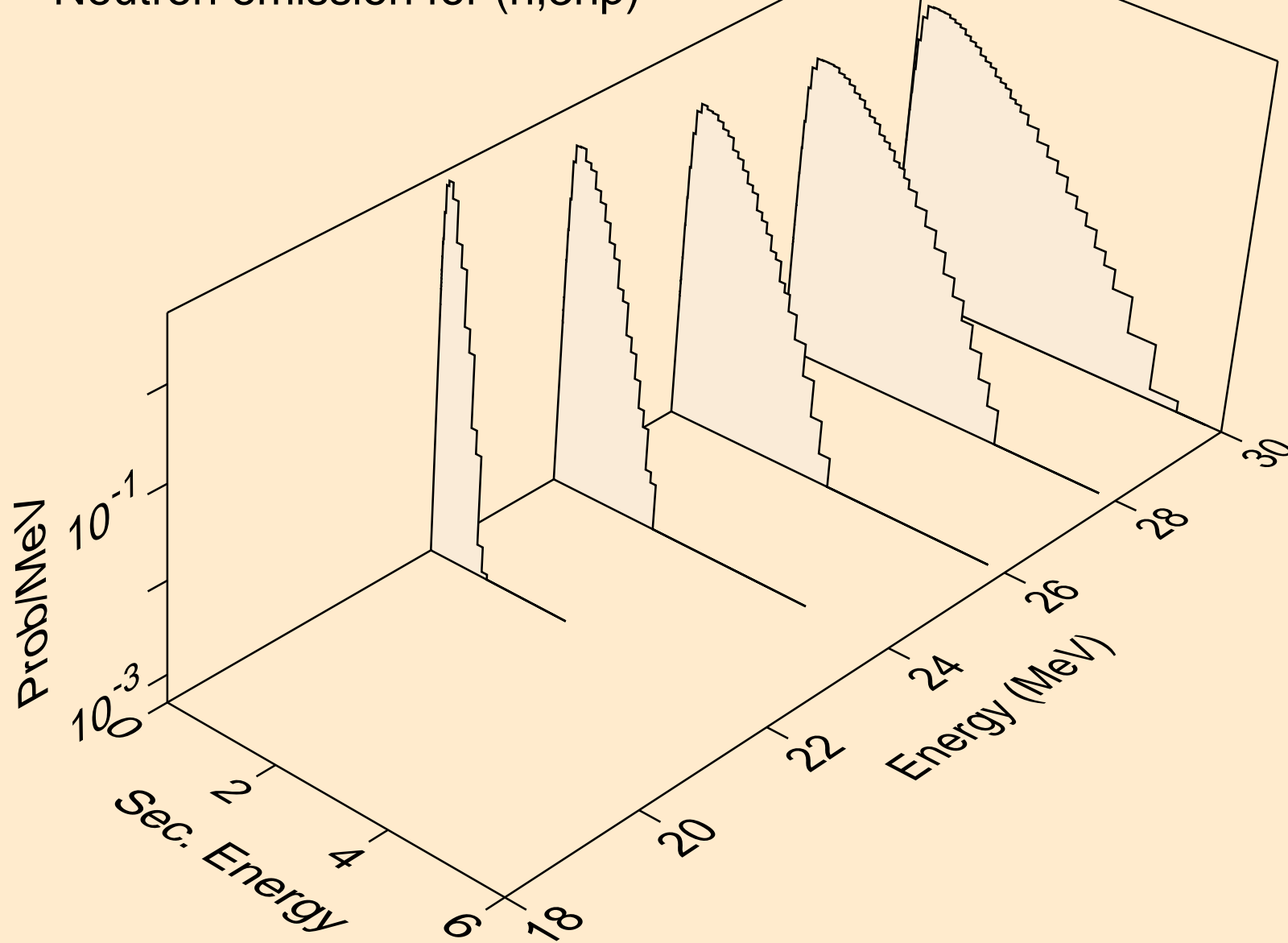

TL193M NEUTRON ACER TENDL-2024 LIBRARY; T=0.K  
Neutron emission for (n,n2p)

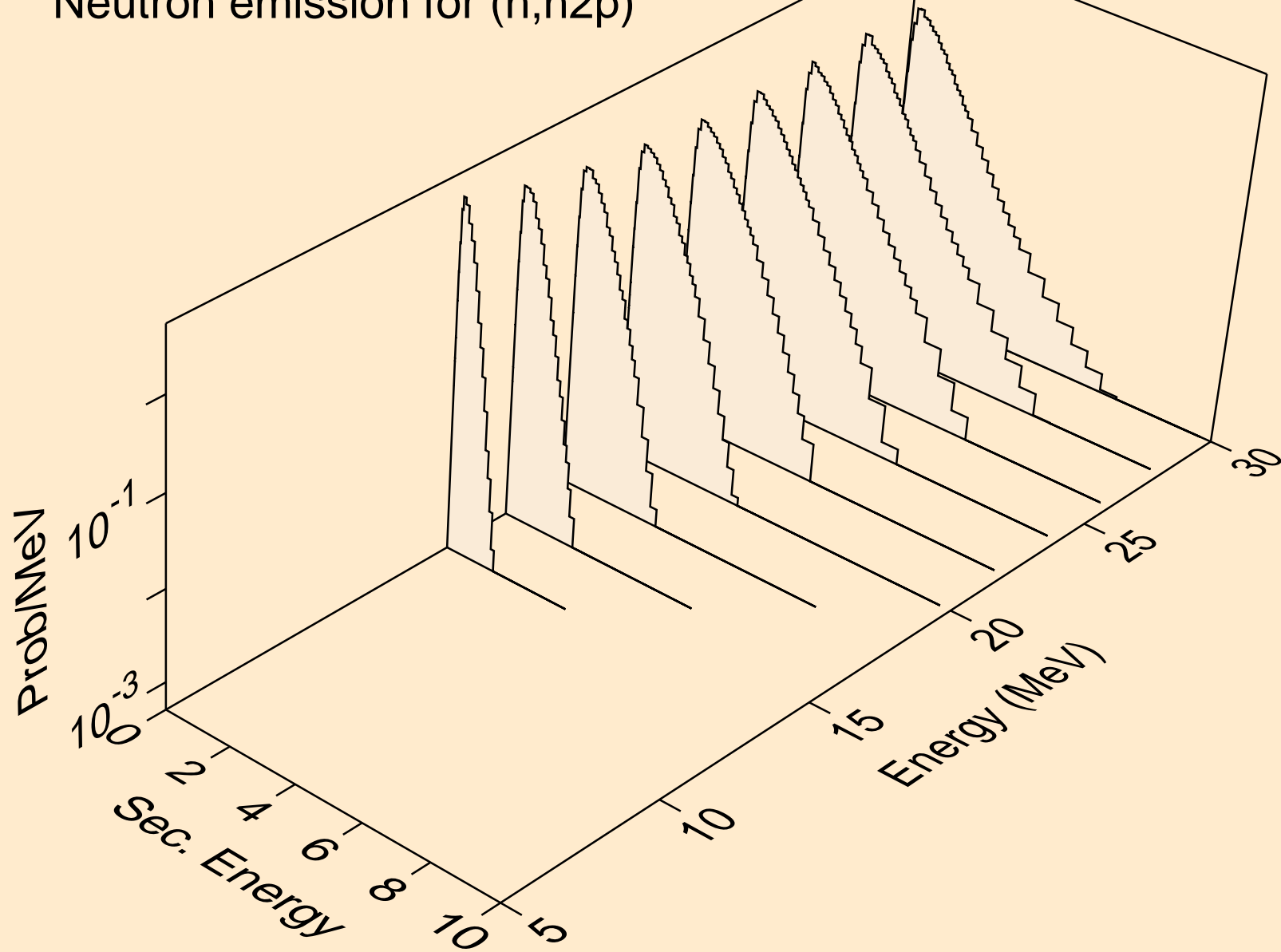

TL193M NEUTRON ACER TENDL-2024 LIBRARY; T=0.K  
Neutron emission for (n,npa)

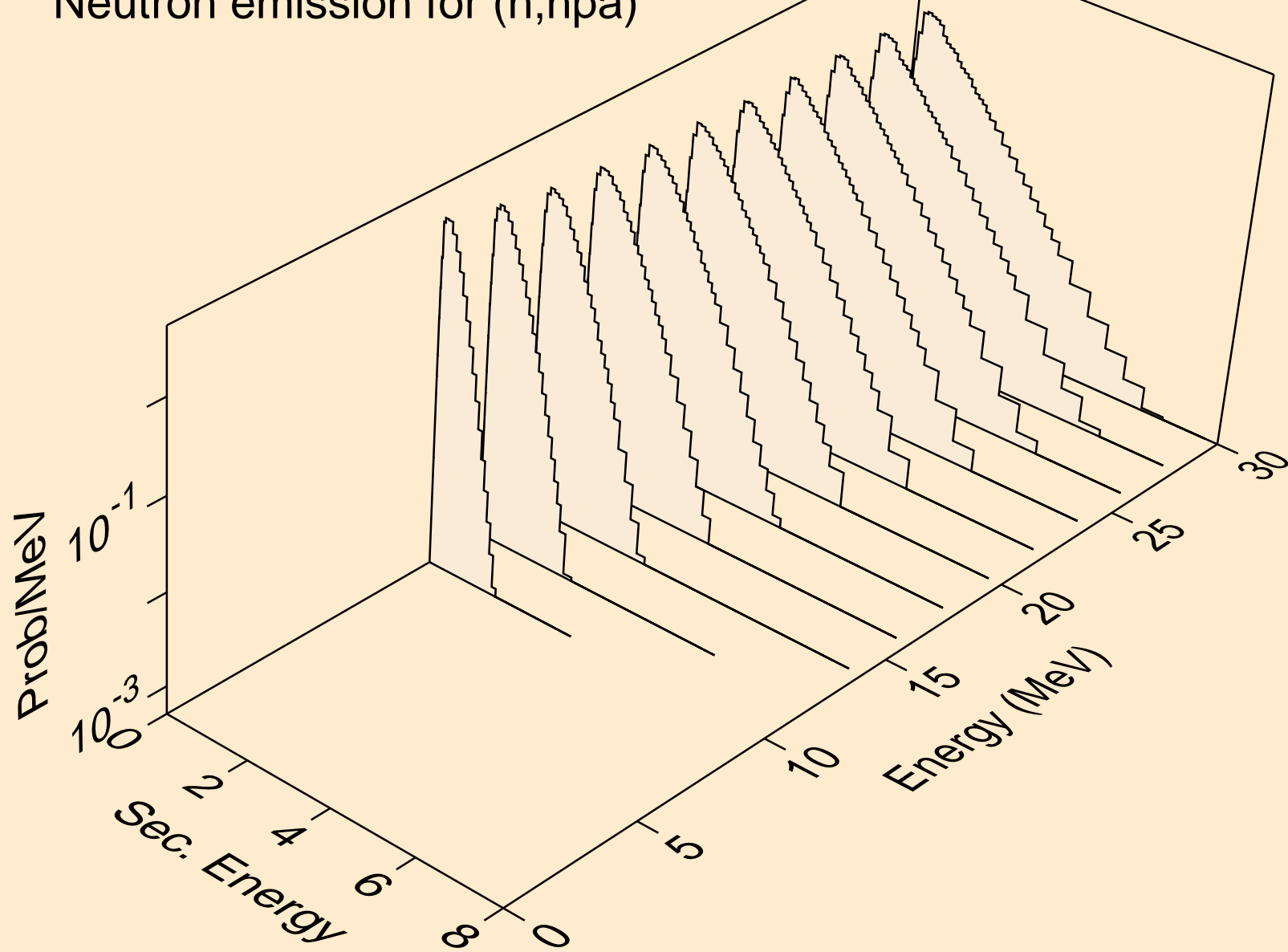

TL193M NEUTRON ACER TENDL-2024 LIBRARY; T=0.K  
Neutron emission for (n,n\*c)

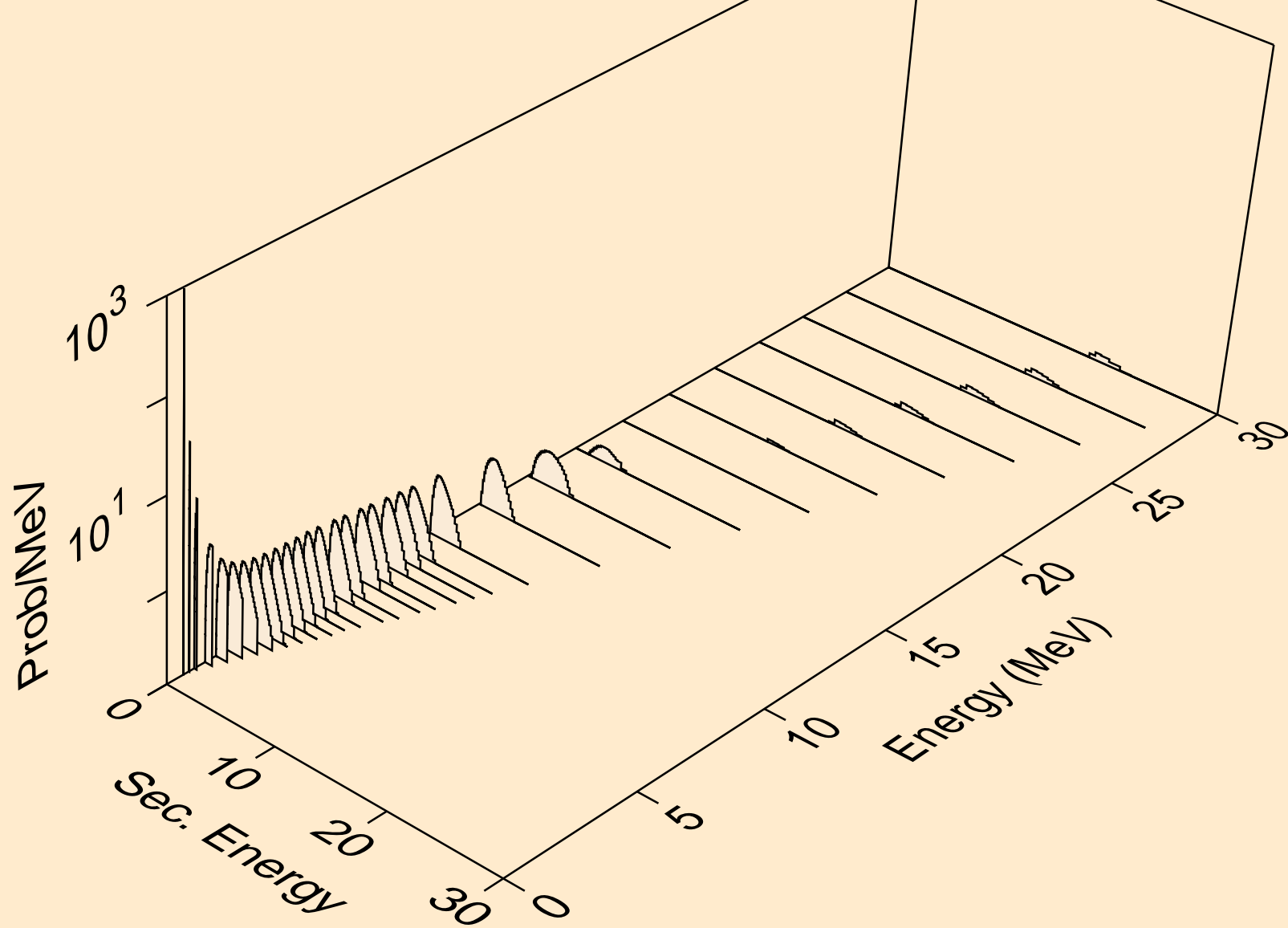



TL193M NEUTRON ACER TENDL-2024 LIBRARY; T=0.K  
Photon emission for (n,x)

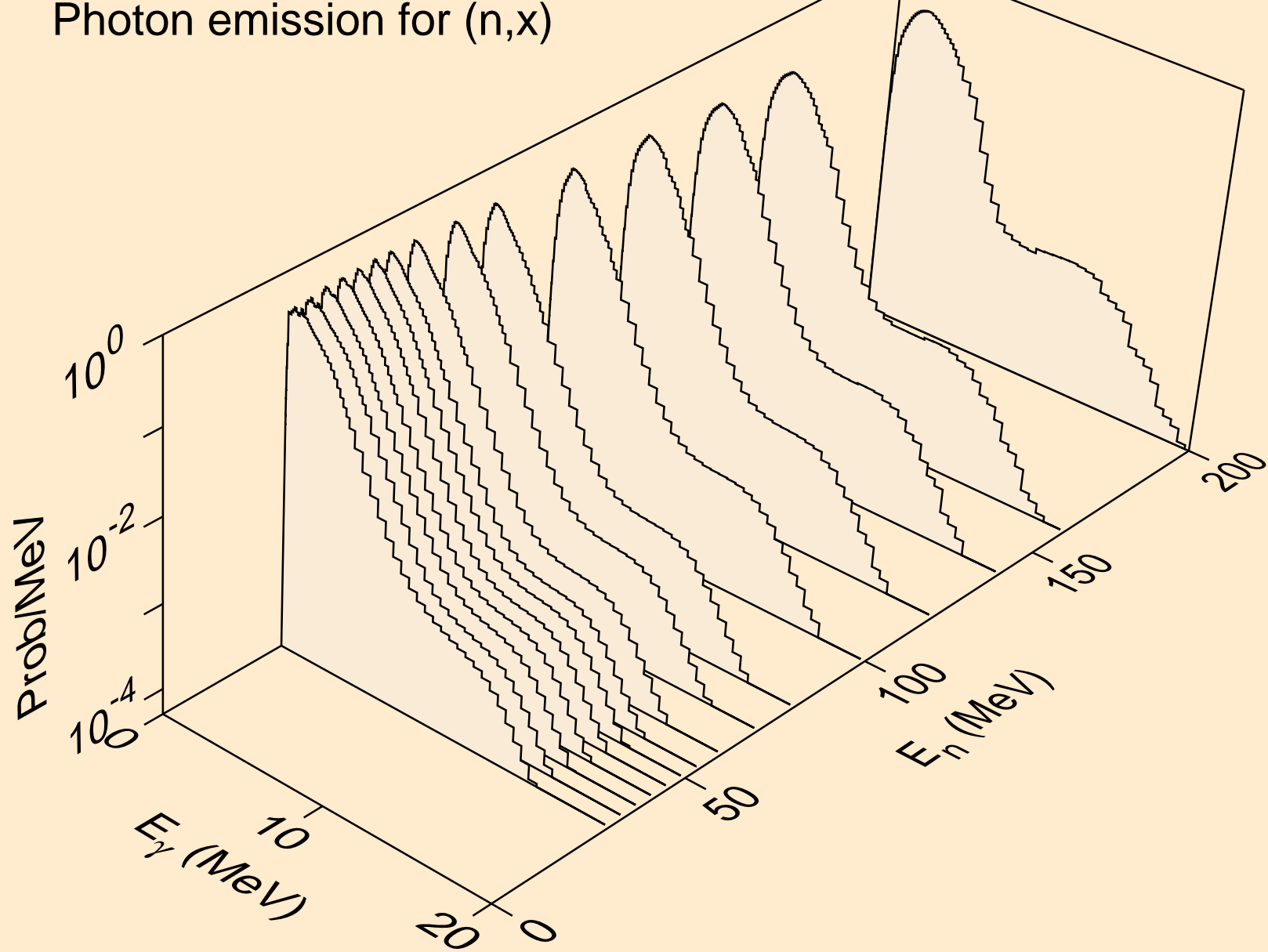

TL193M NEUTRON ACER TENDL-2024 LIBRARY; T=0.K  
Photon emission for (n,2nd)

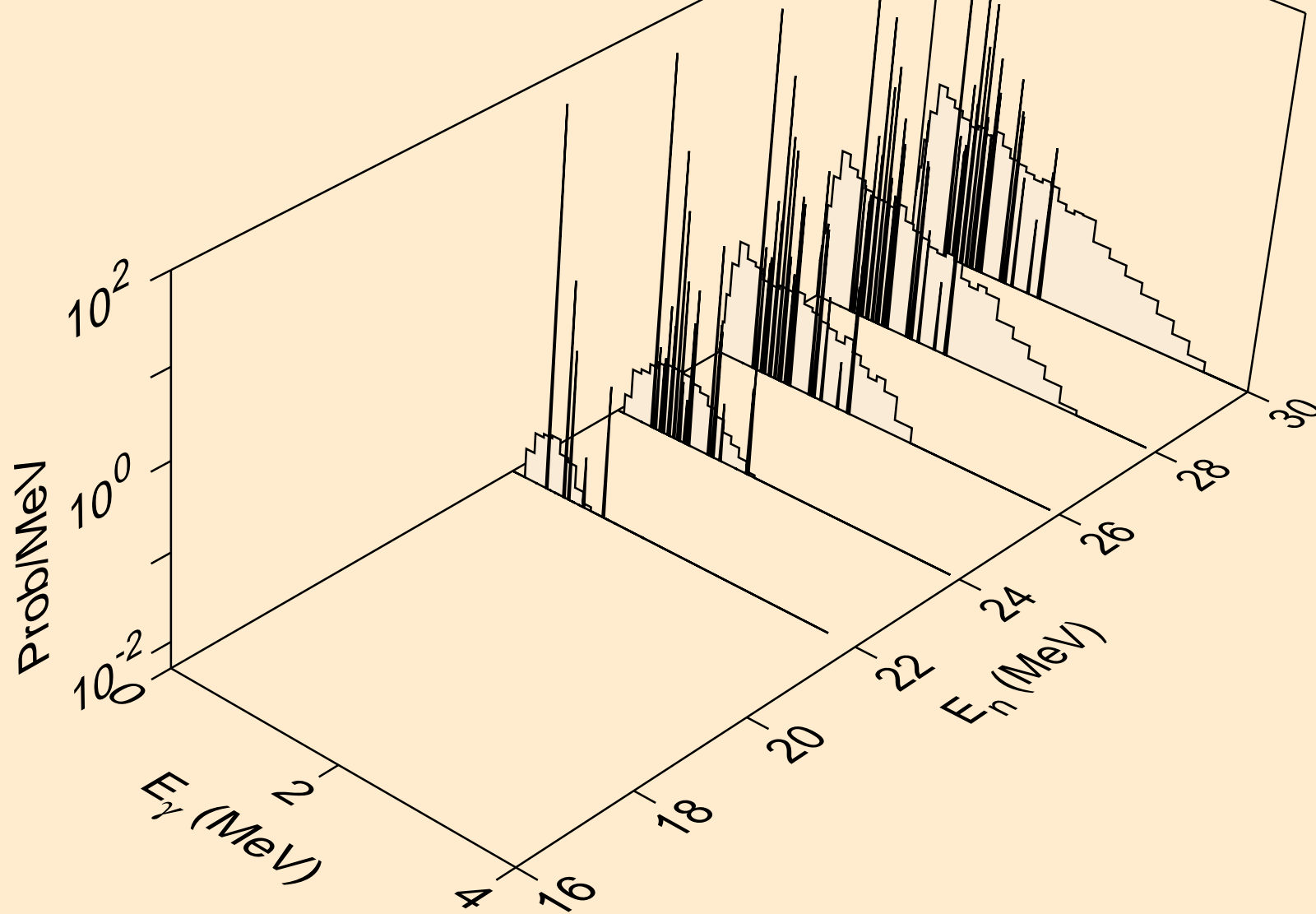

TL193M NEUTRON ACER TENDL-2024 LIBRARY; T=0.K  
Photon emission for (n,2n)

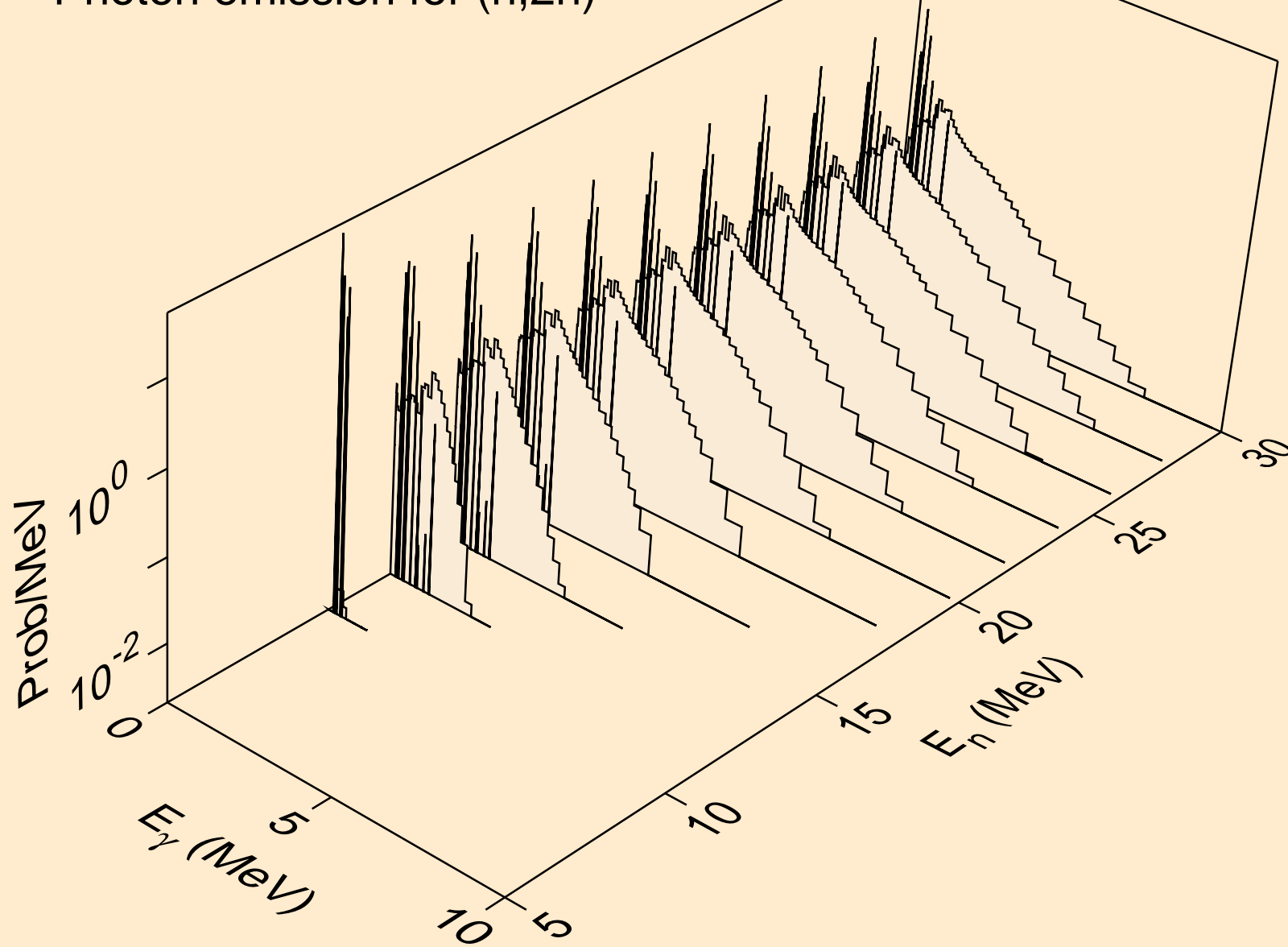

TL193M NEUTRON ACER TENDL-2024 LIBRARY; T=0.K  
Photon emission for (n,3n)

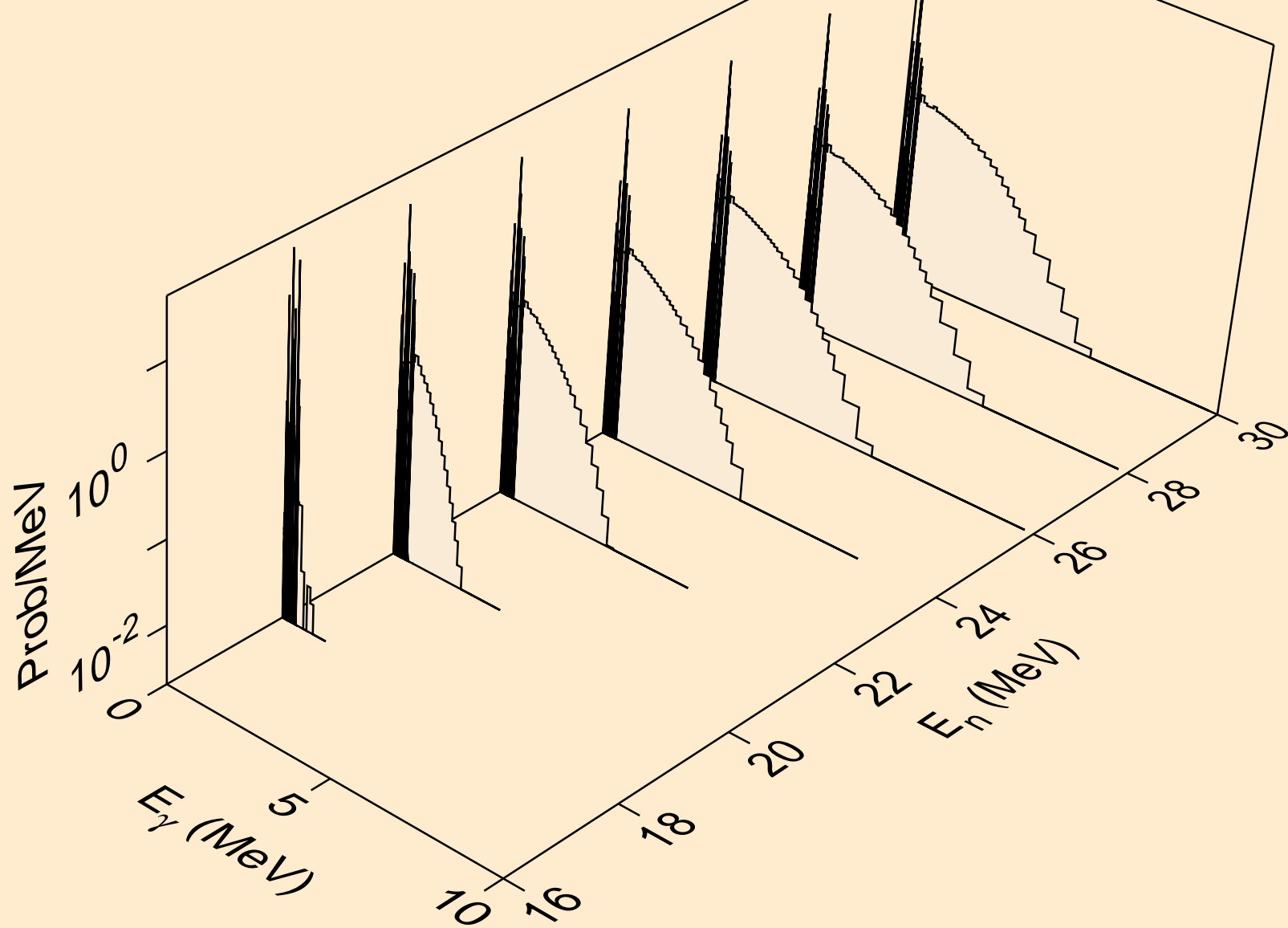

TL193M NEUTRON ACER TENDL-2024 LIBRARY; T=0.K  
Photon emission for (n,n\*)a

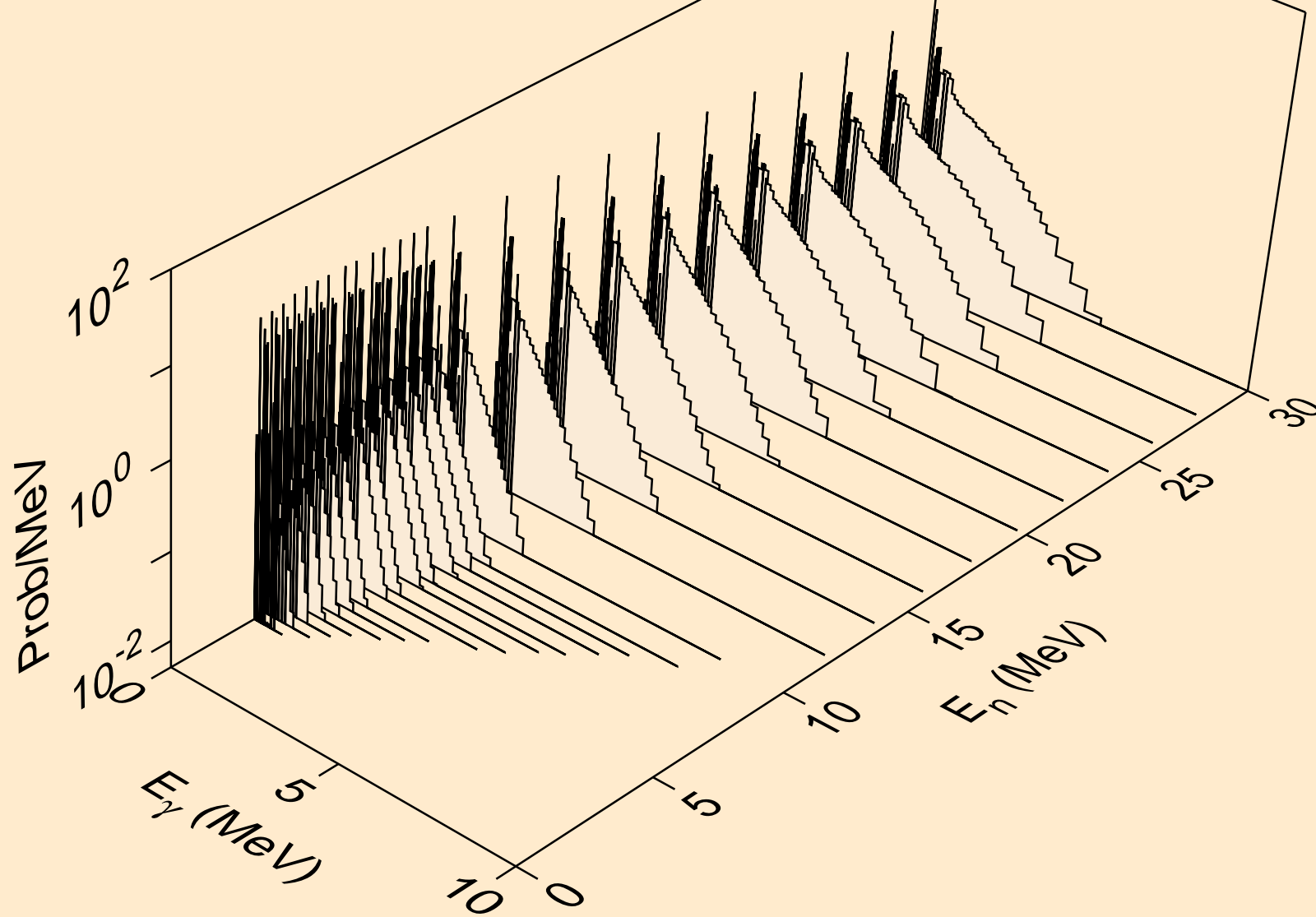

TL193M NEUTRON ACER TENDL-2024 LIBRARY; T=0.K  
Photon emission for (n,2n)a

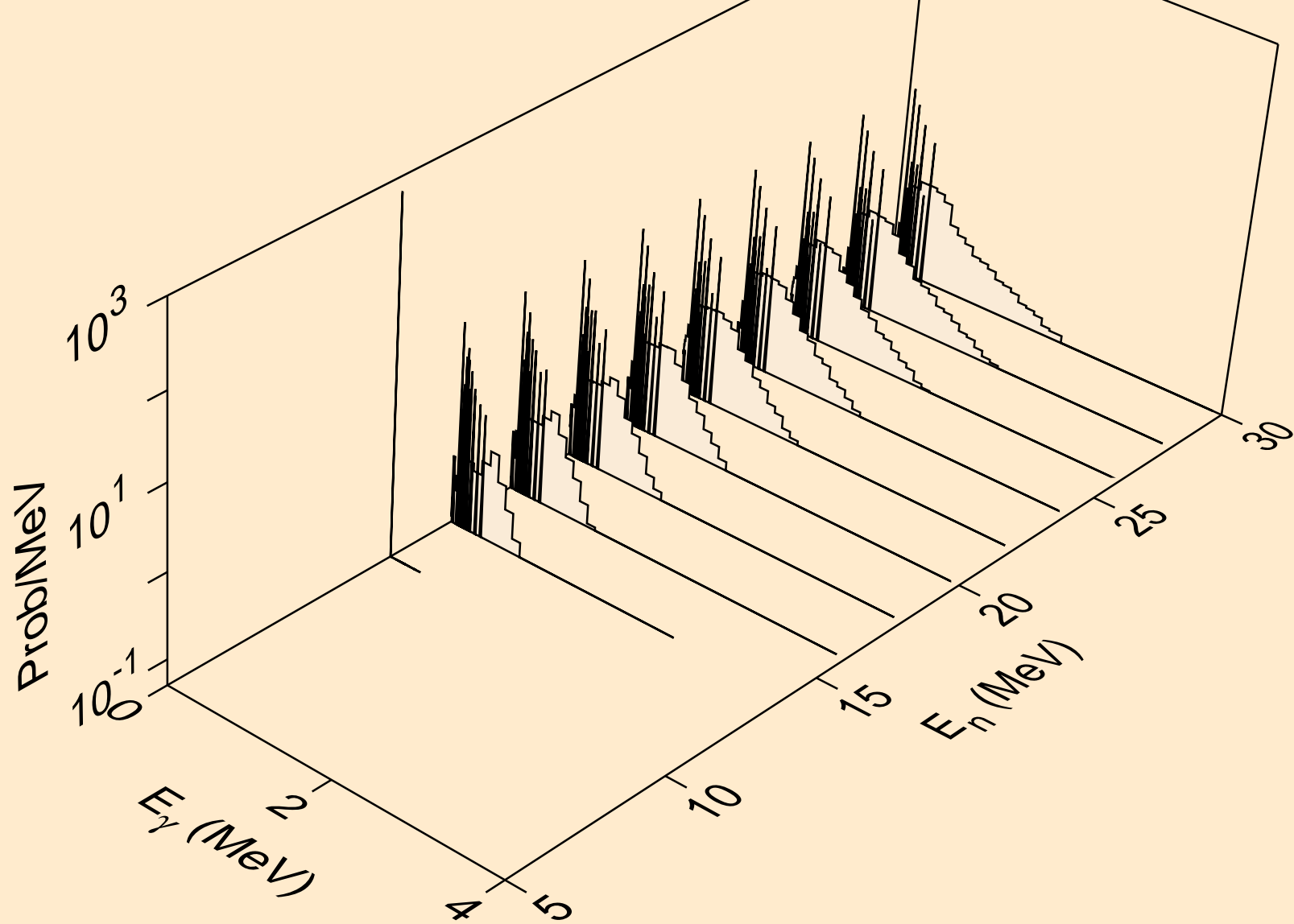

TL193M NEUTRON ACER TENDL-2024 LIBRARY; T=0.K  
Photon emission for (n,3n)a

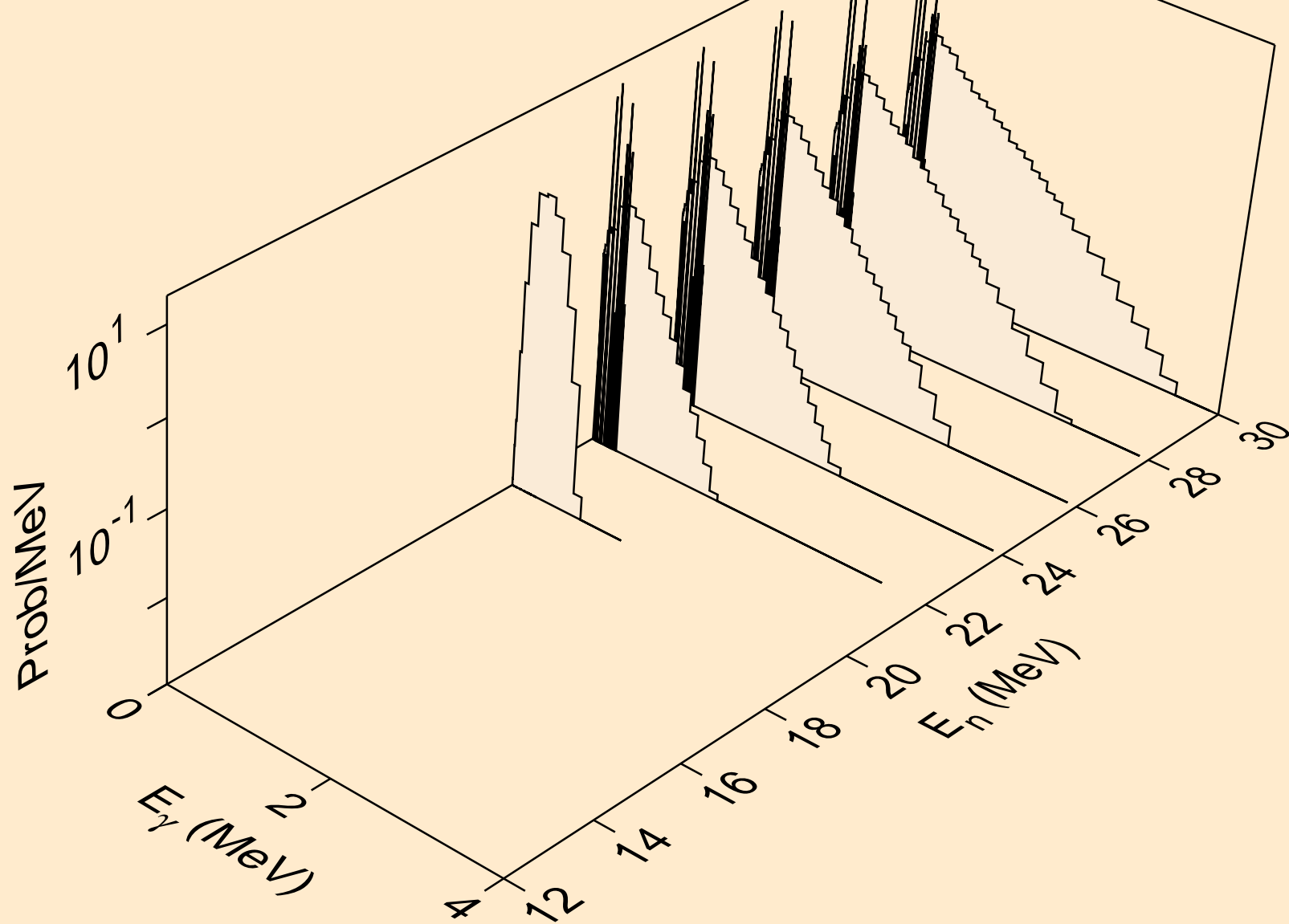

TL193M NEUTRON ACER TENDL-2024 LIBRARY; T=0.K  
Photon emission for (n,n\*)p

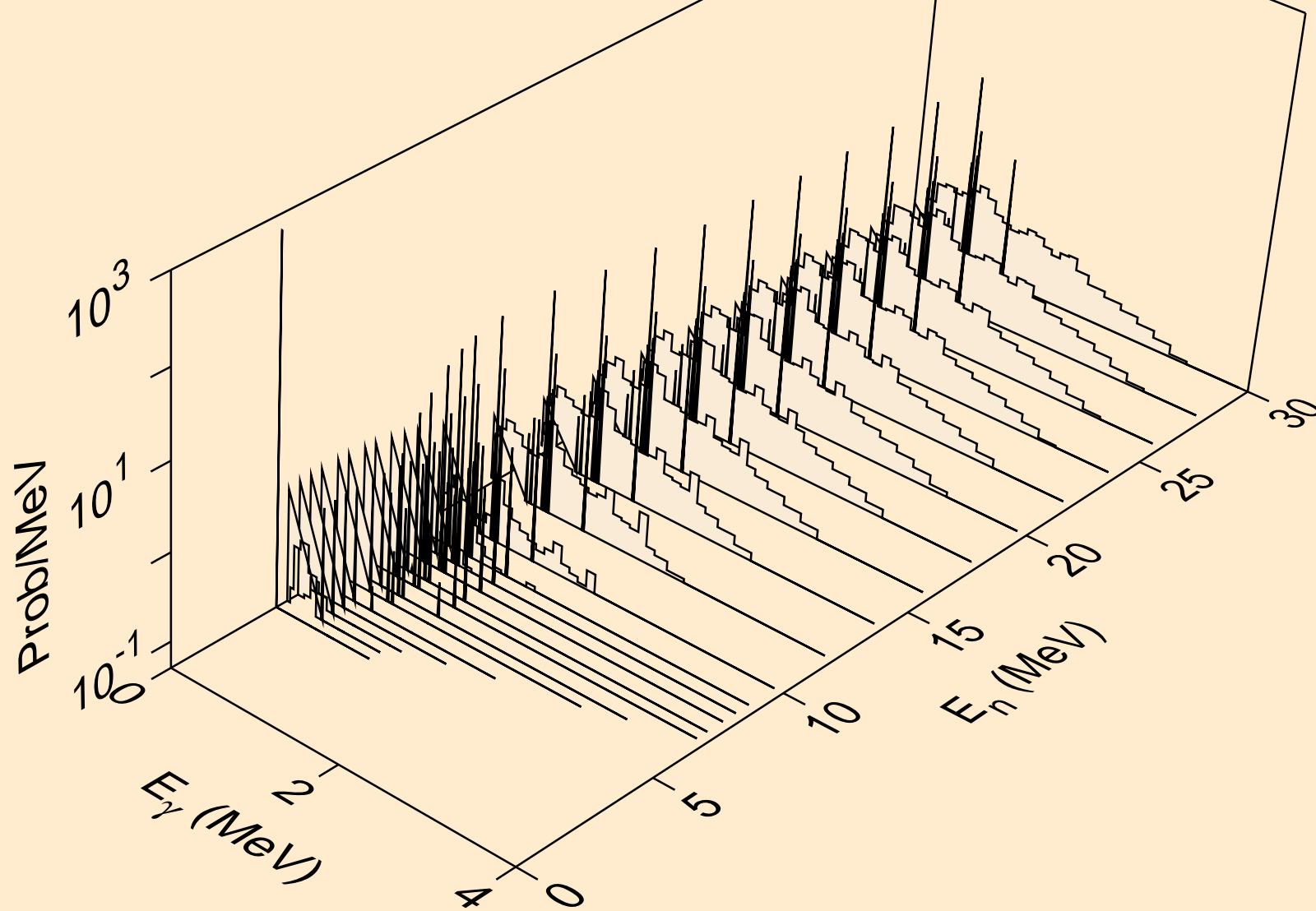



TL193M NEUTRON ACER TENDL-2024 LIBRARY; T=0.K  
Photon emission for (n,n\*)2a

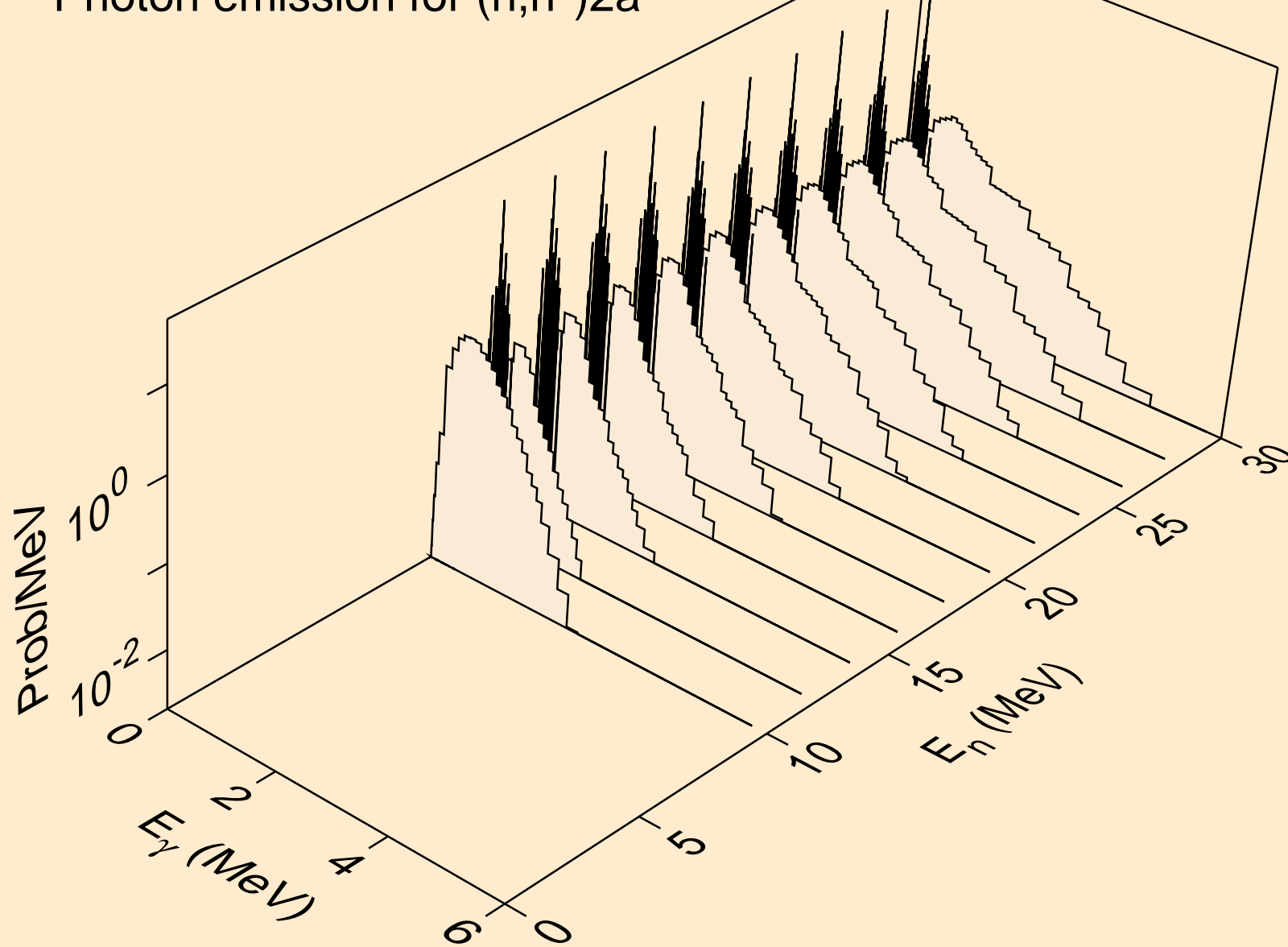

TL193M NEUTRON ACER TENDL-2024 LIBRARY; T=0.K  
Photon emission for (n,2n)2a

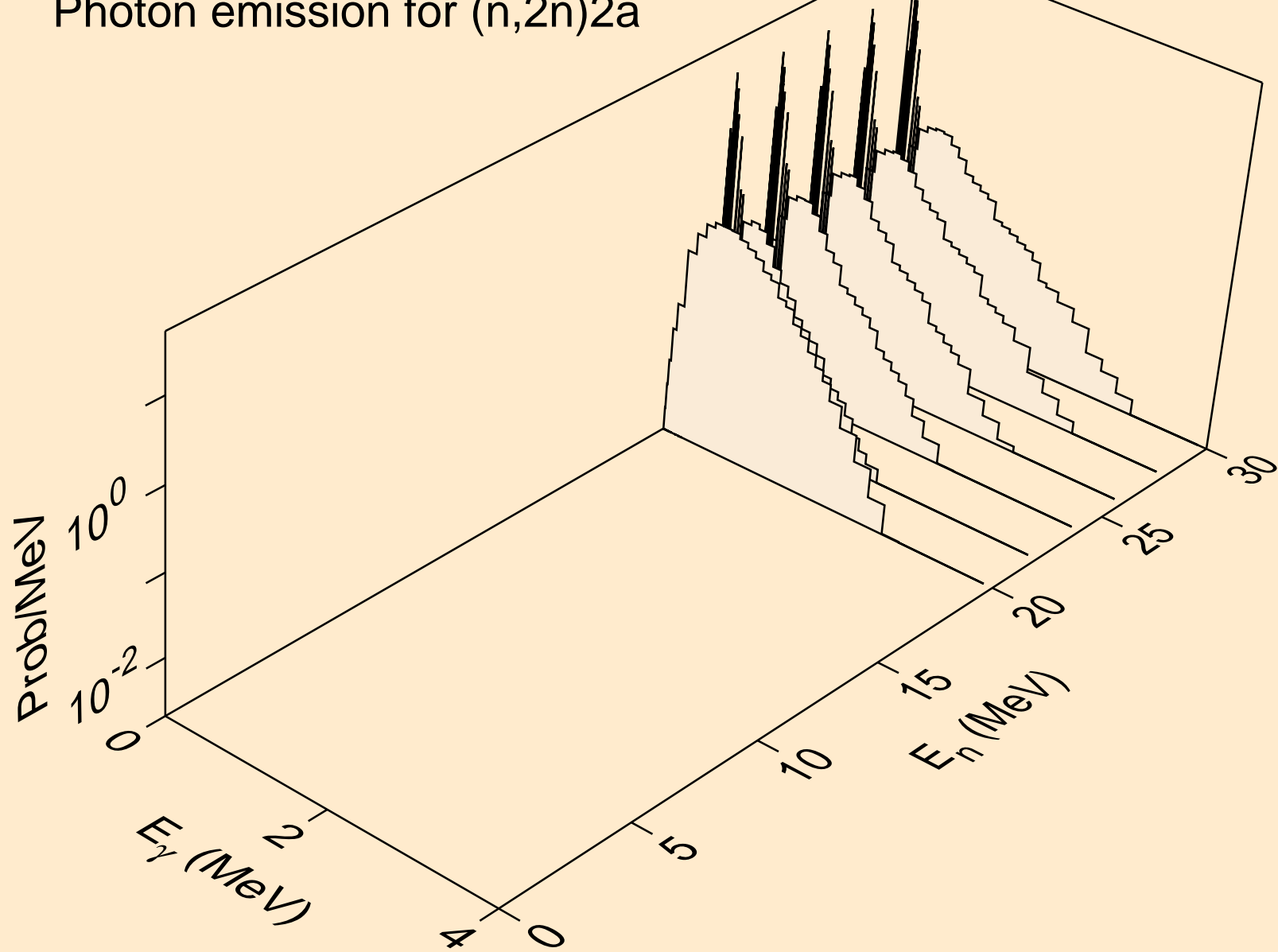

TL193M NEUTRON ACER TENDL-2024 LIBRARY; T=0.K  
Photon emission for (n,n\*)d

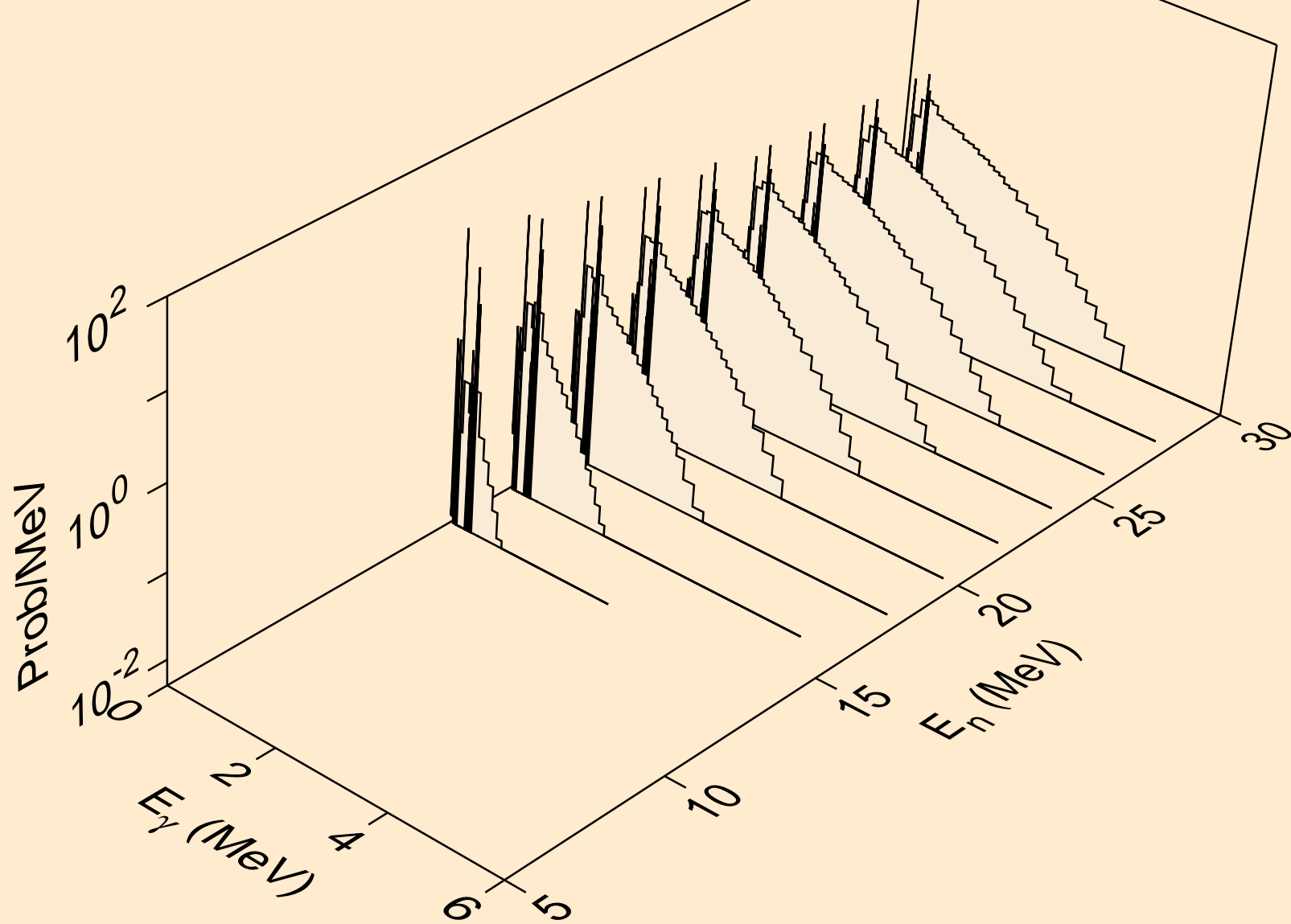

TL193M NEUTRON ACER TENDL-2024 LIBRARY; T=0.K  
Photon emission for (n,n\*)t

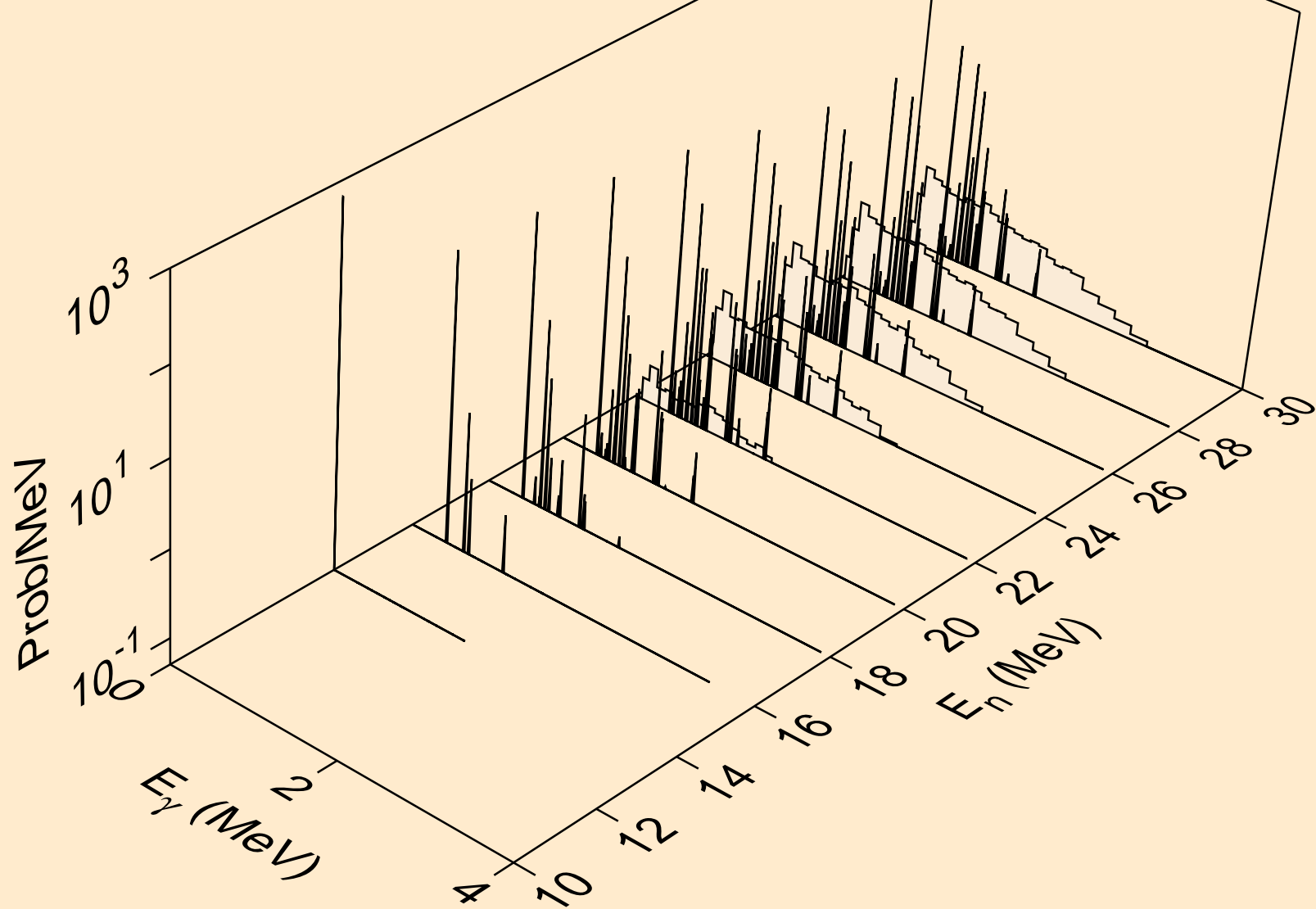

TL193M NEUTRON ACER TENDL-2024 LIBRARY; T=0.K  
Photon emission for (n,n\*)he3

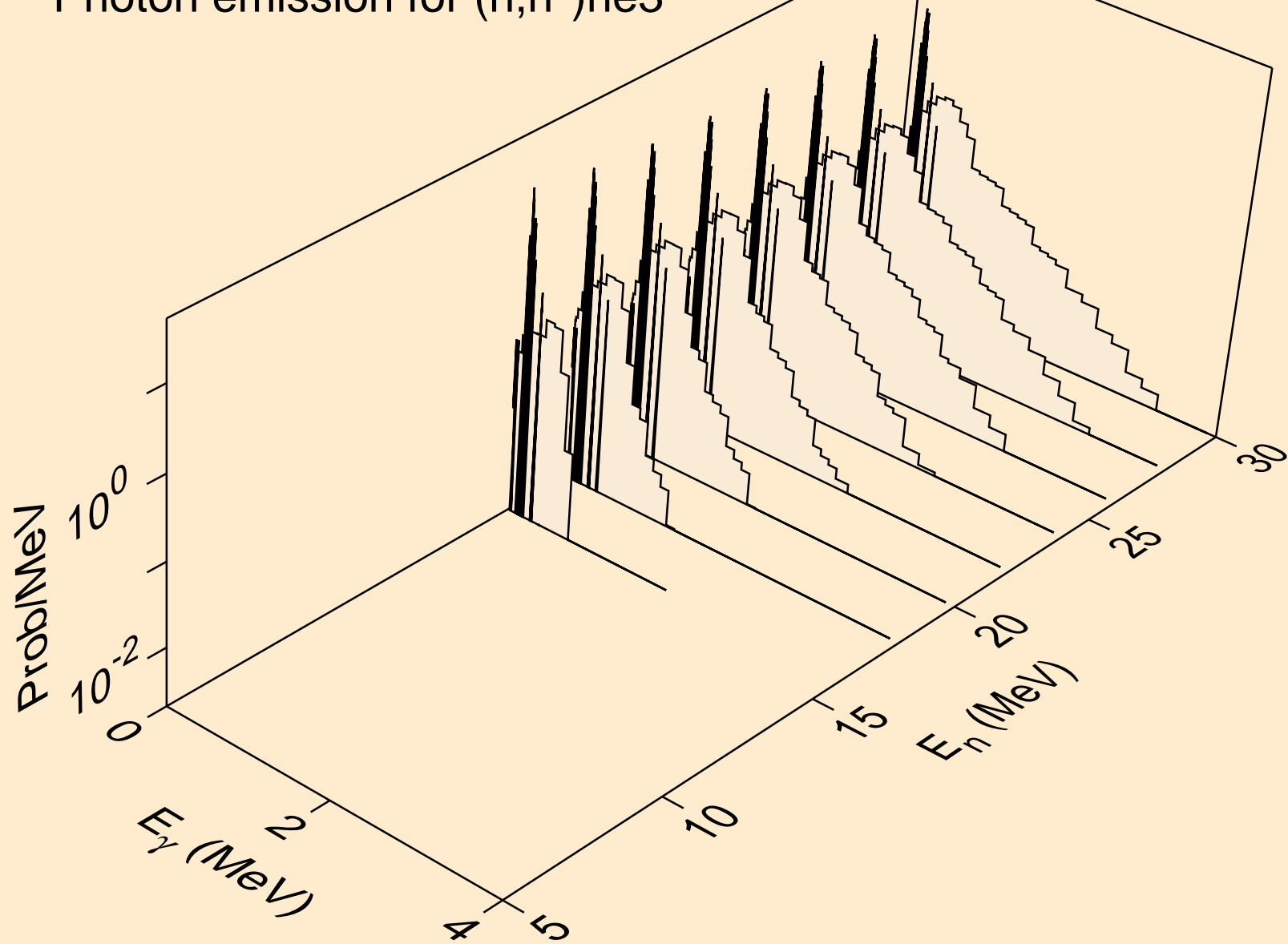

TL193M NEUTRON ACER TENDL-2024 LIBRARY; T=0.K  
Photon emission for (n,4n)

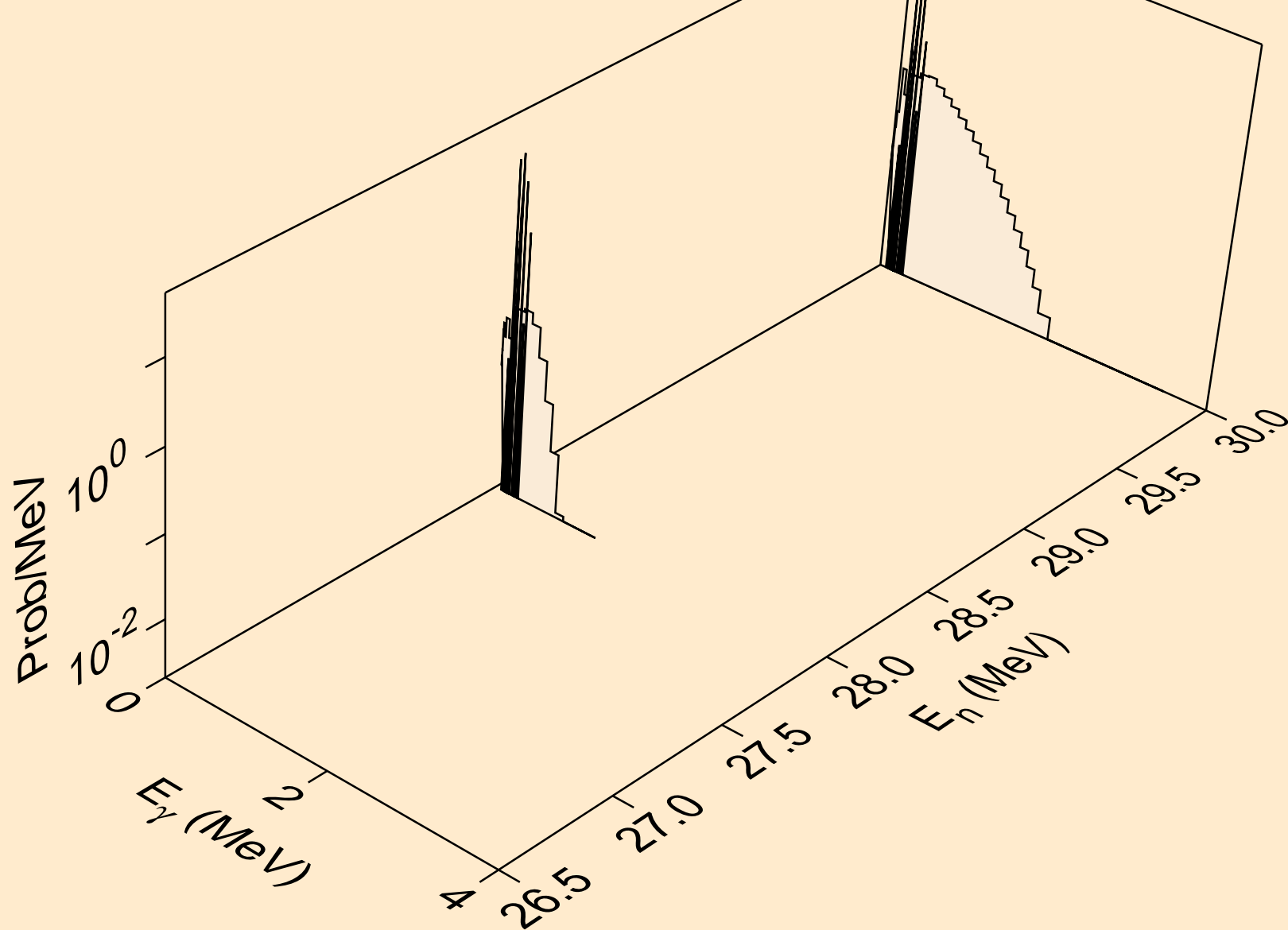

TL193M NEUTRON ACER TENDL-2024 LIBRARY; T=0.K  
Photon emission for (n,2np)

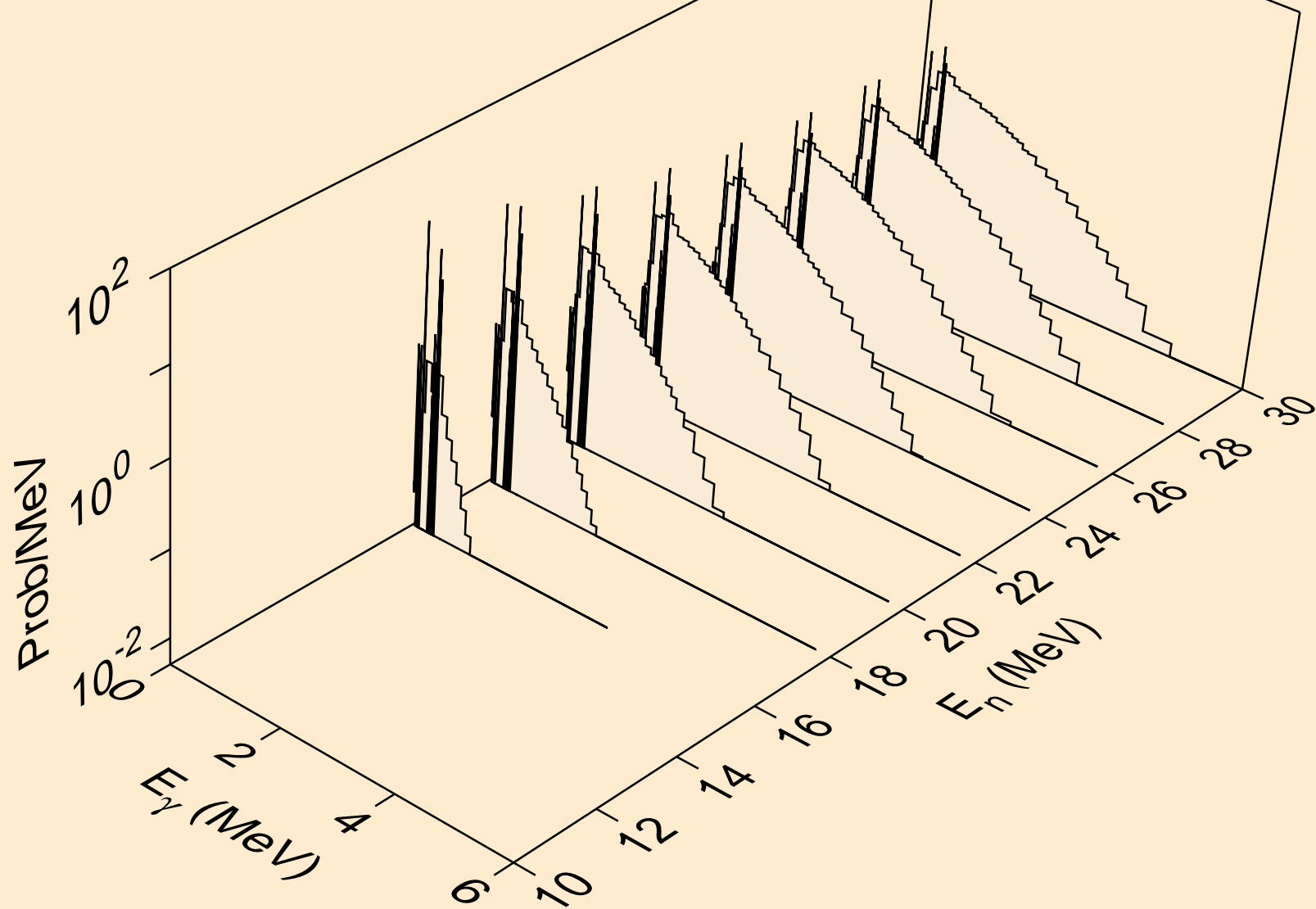

TL193M NEUTRON ACER TENDL-2024 LIBRARY; T=0.K  
Photon emission for (n,3np)

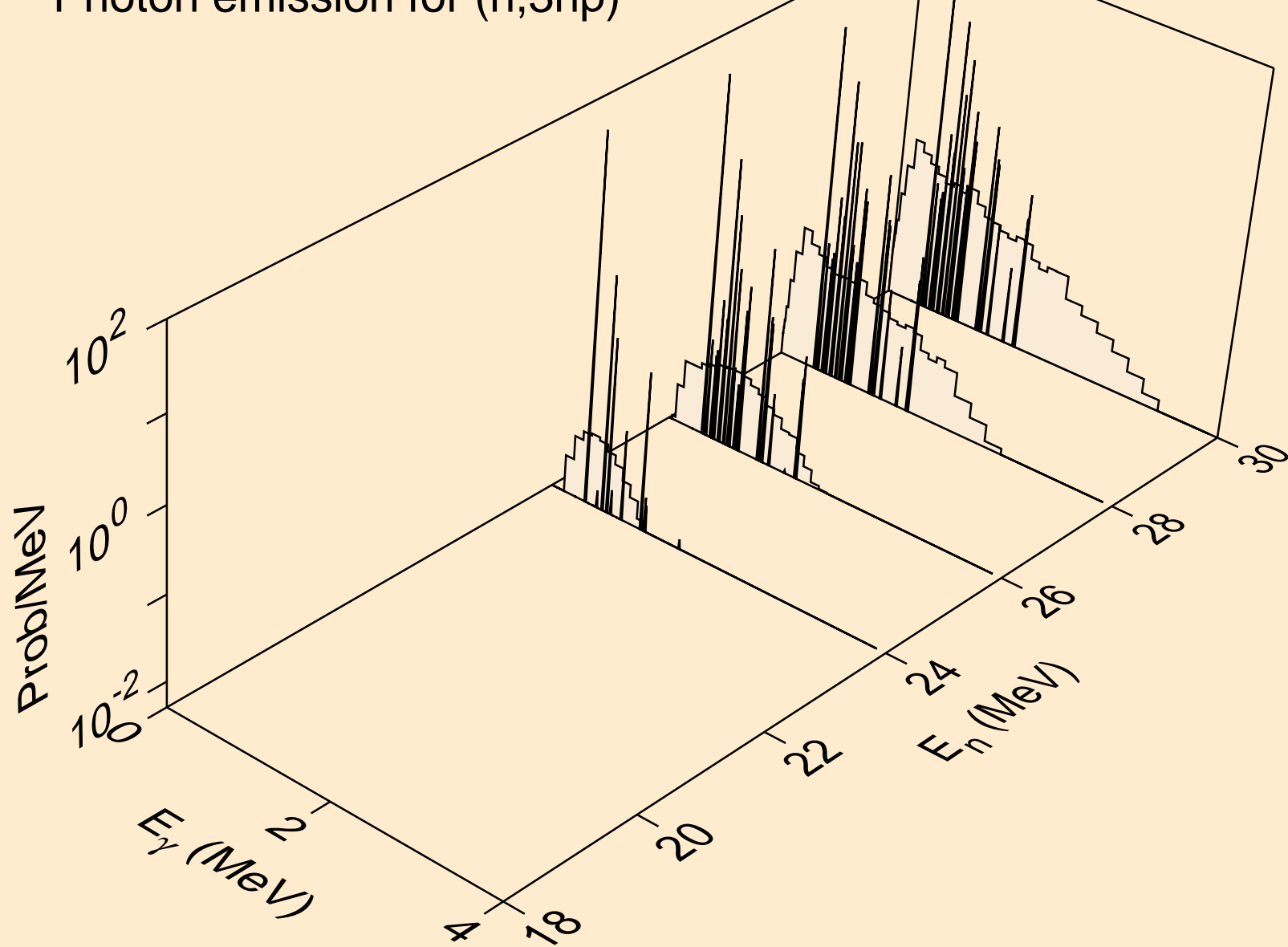



TL193M NEUTRON ACER TENDL-2024 LIBRARY; T=0.K  
Photon emission for (n,n2p)

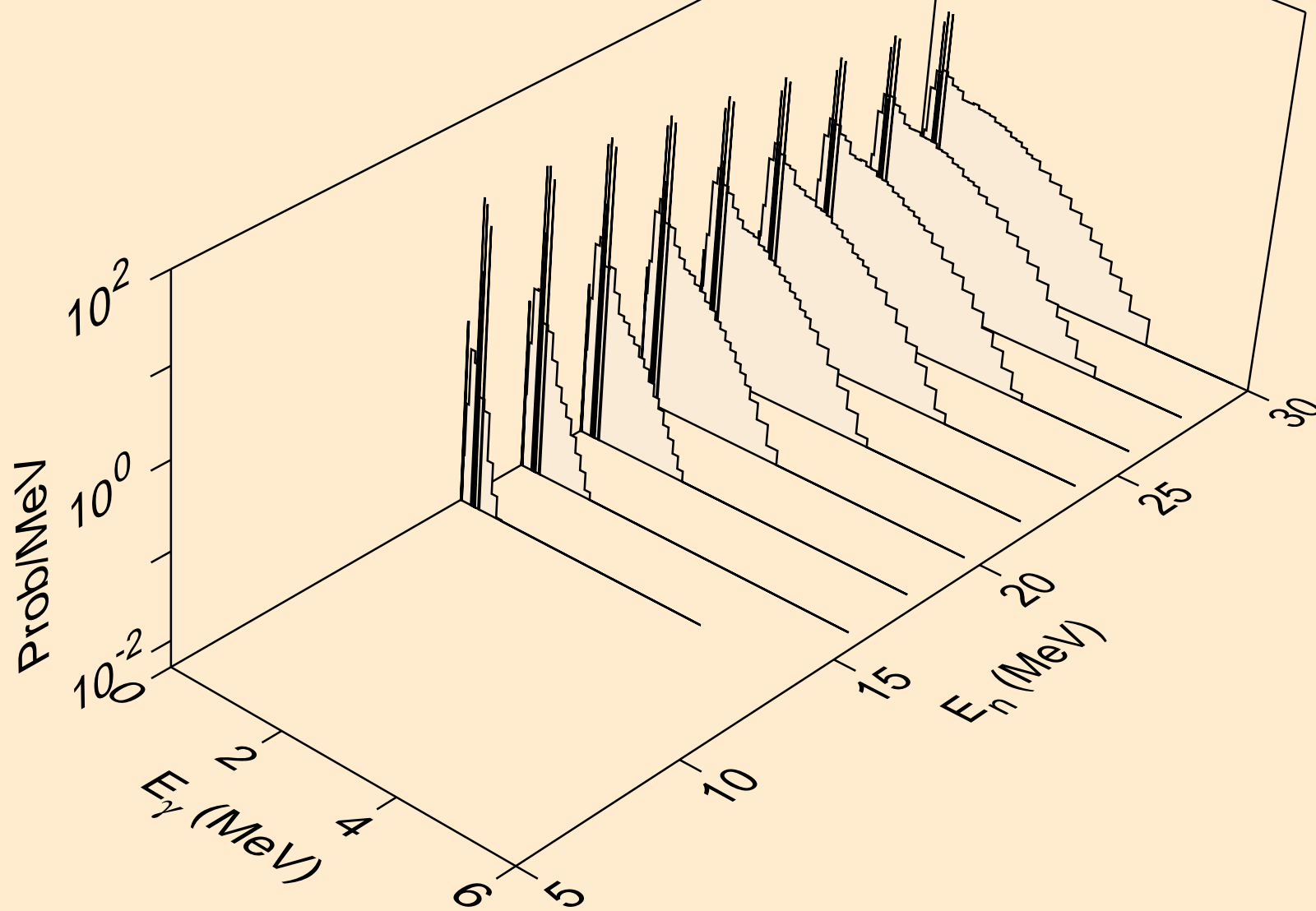

TL193M NEUTRON ACER TENDL-2024 LIBRARY; T=0.K  
Photon emission for (n,npa)

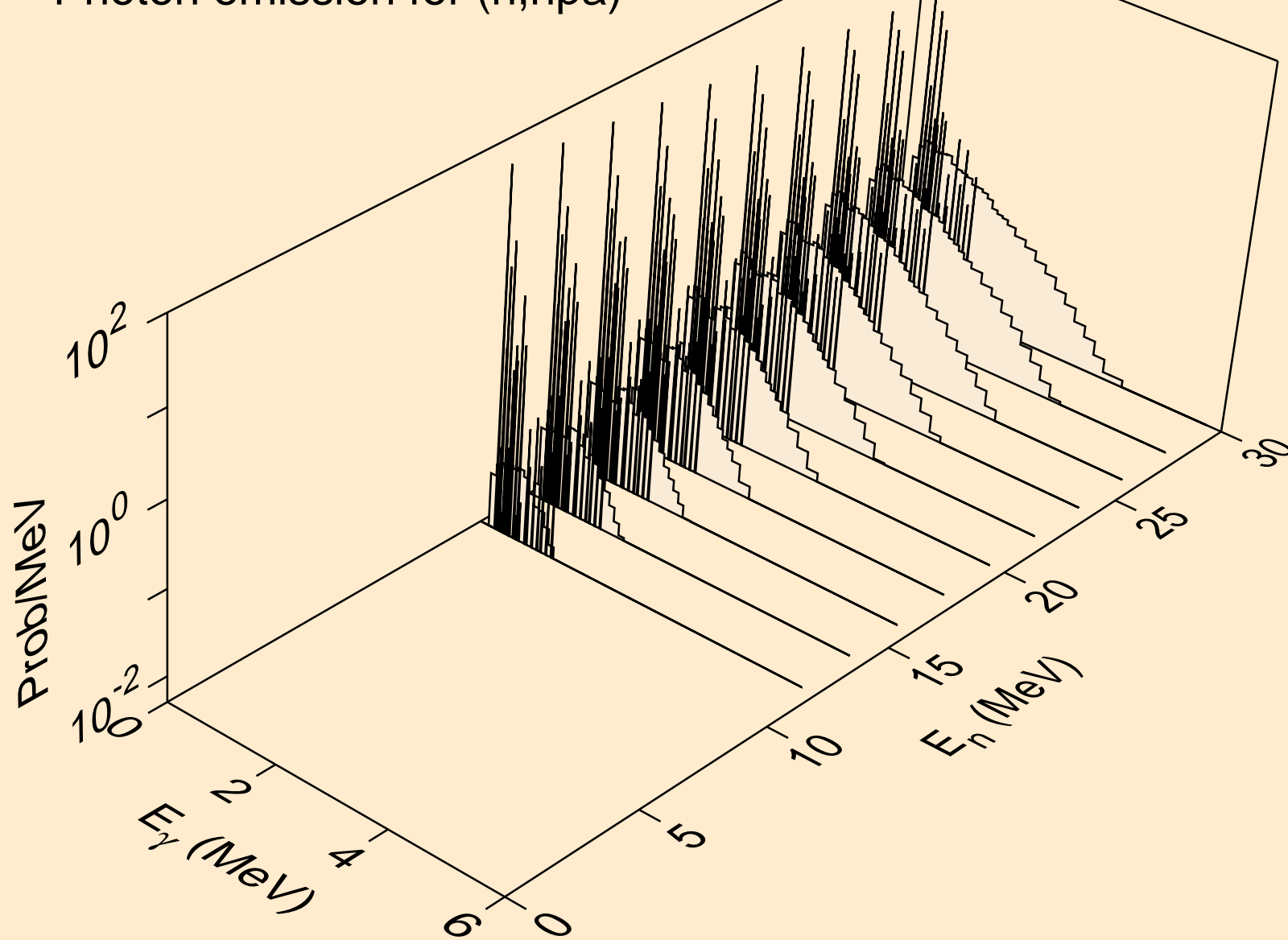

TL193M NEUTRON ACER TENDL-2024 LIBRARY; T=0.K  
Photon emission for (n,n\*1)

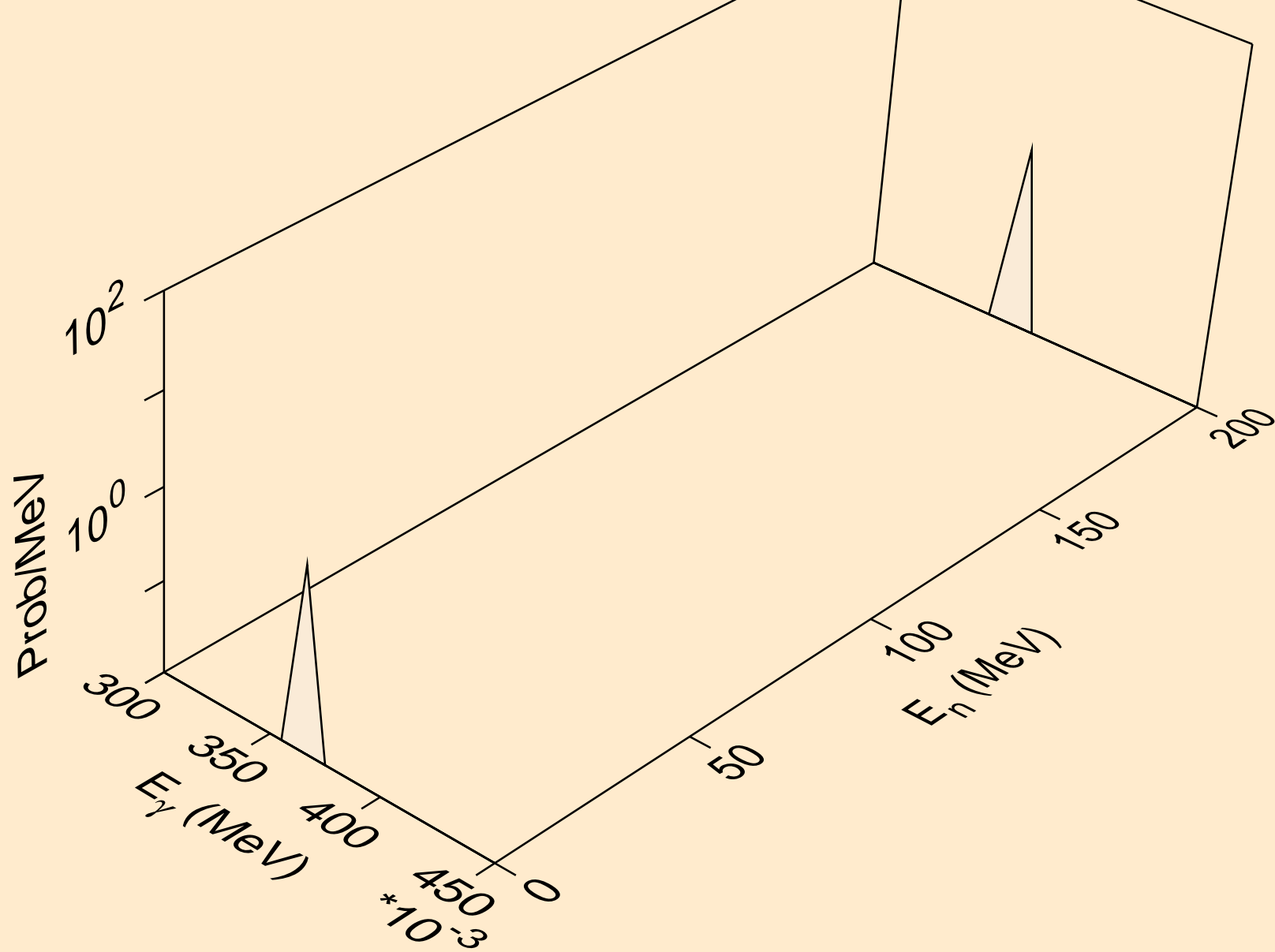

TL193M NEUTRON ACER TENDL-2024 LIBRARY; T=0.K  
Photon emission for (n,n\*3)

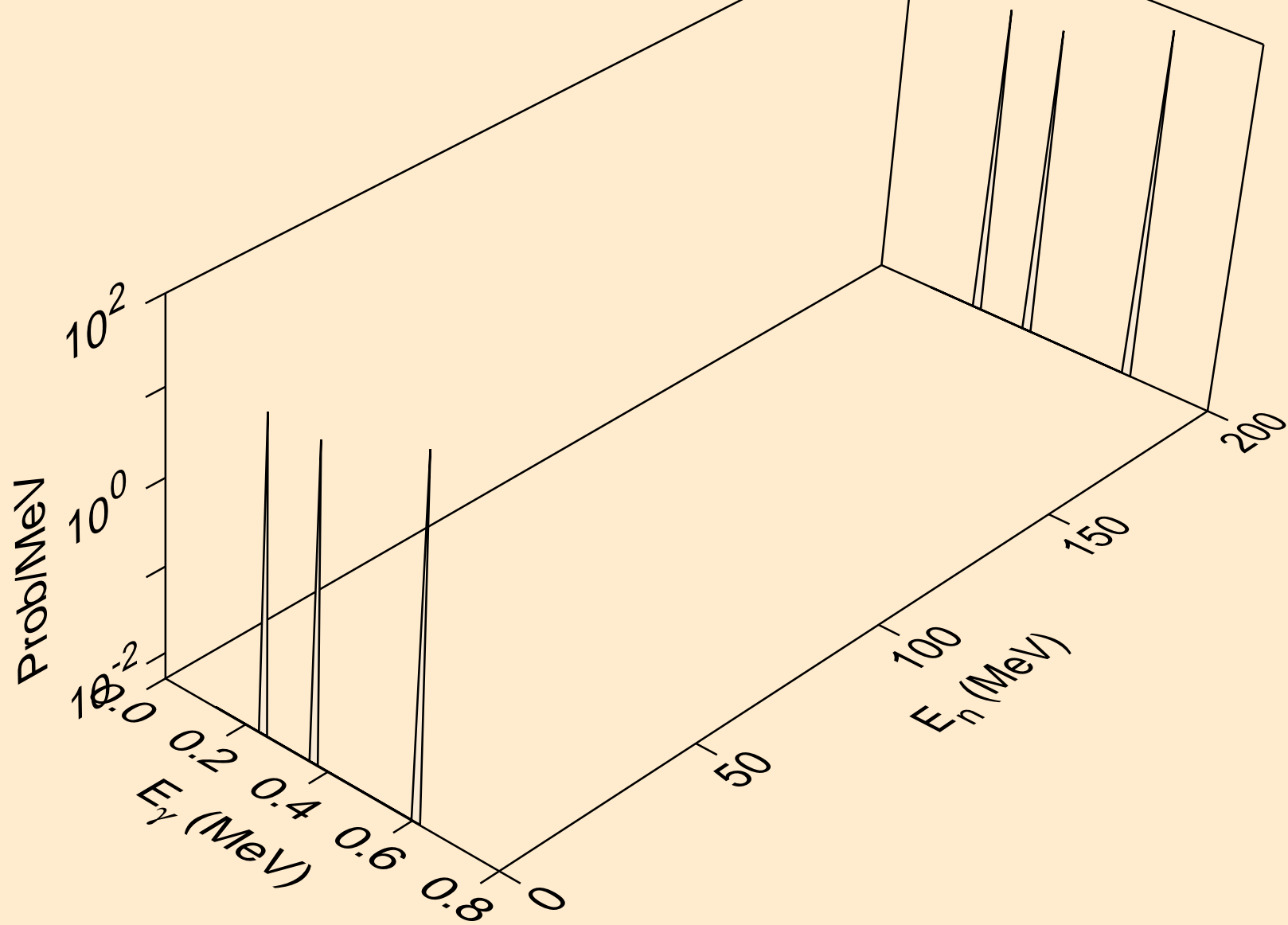

TL193M NEUTRON ACER TENDL-2024 LIBRARY; T=0.K  
Photon emission for (n,n\*4)

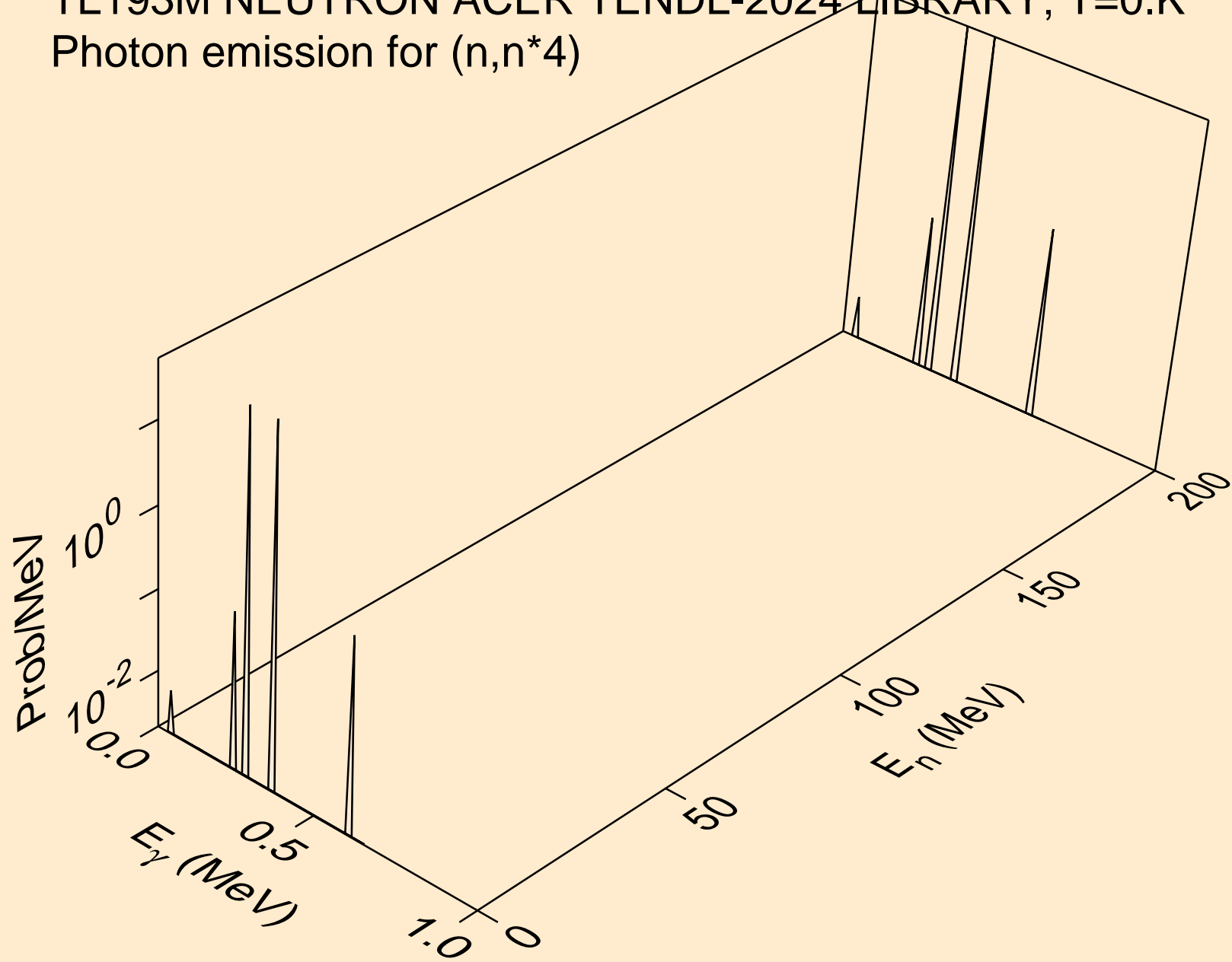

TL193M NEUTRON ACER TENDL-2024 LIBRARY; T=0.K  
Photon emission for (n,n\*5)

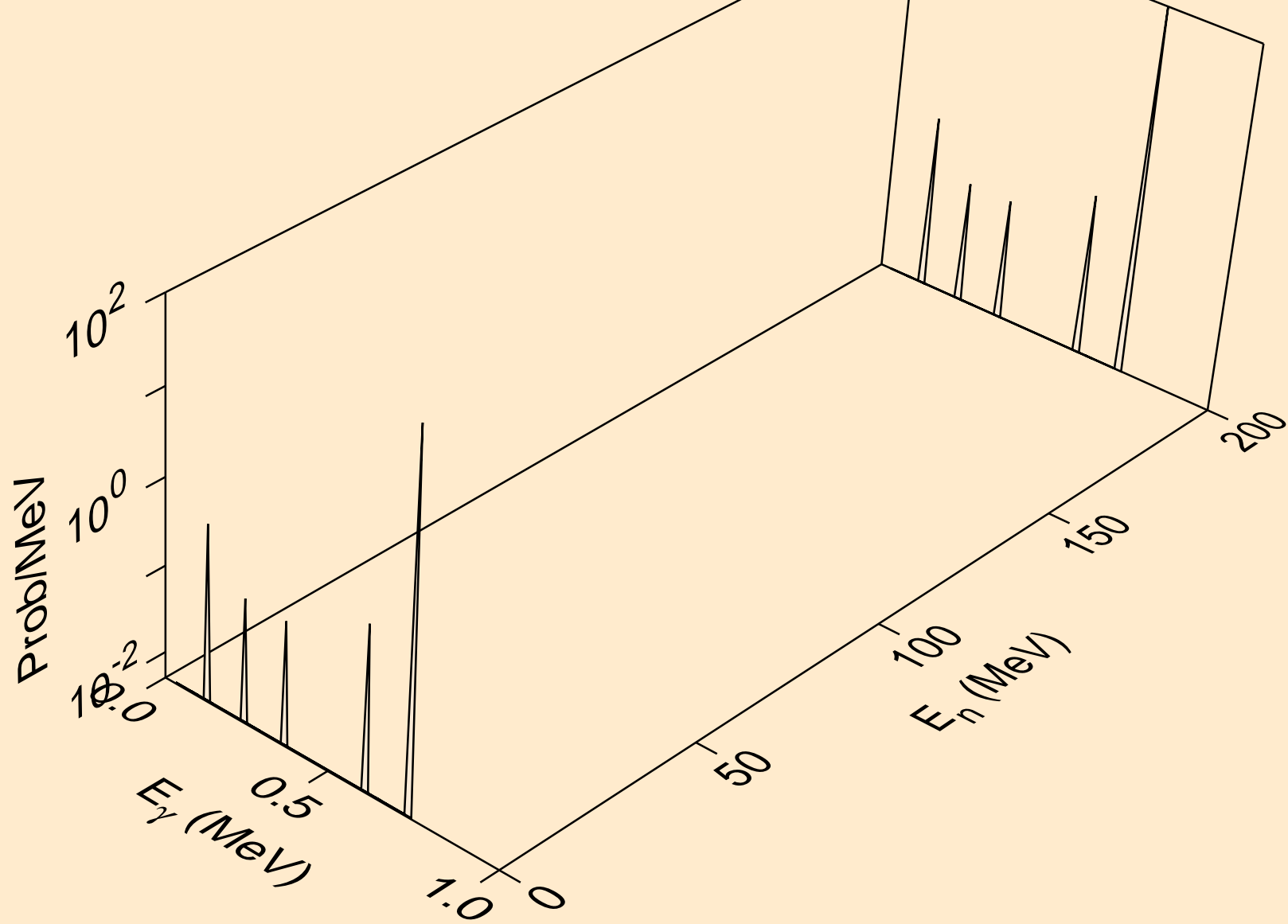

TL193M NEUTRON ACER TENDL-2024 LIBRARY; T=0.K  
Photon emission for (n,n\*6)

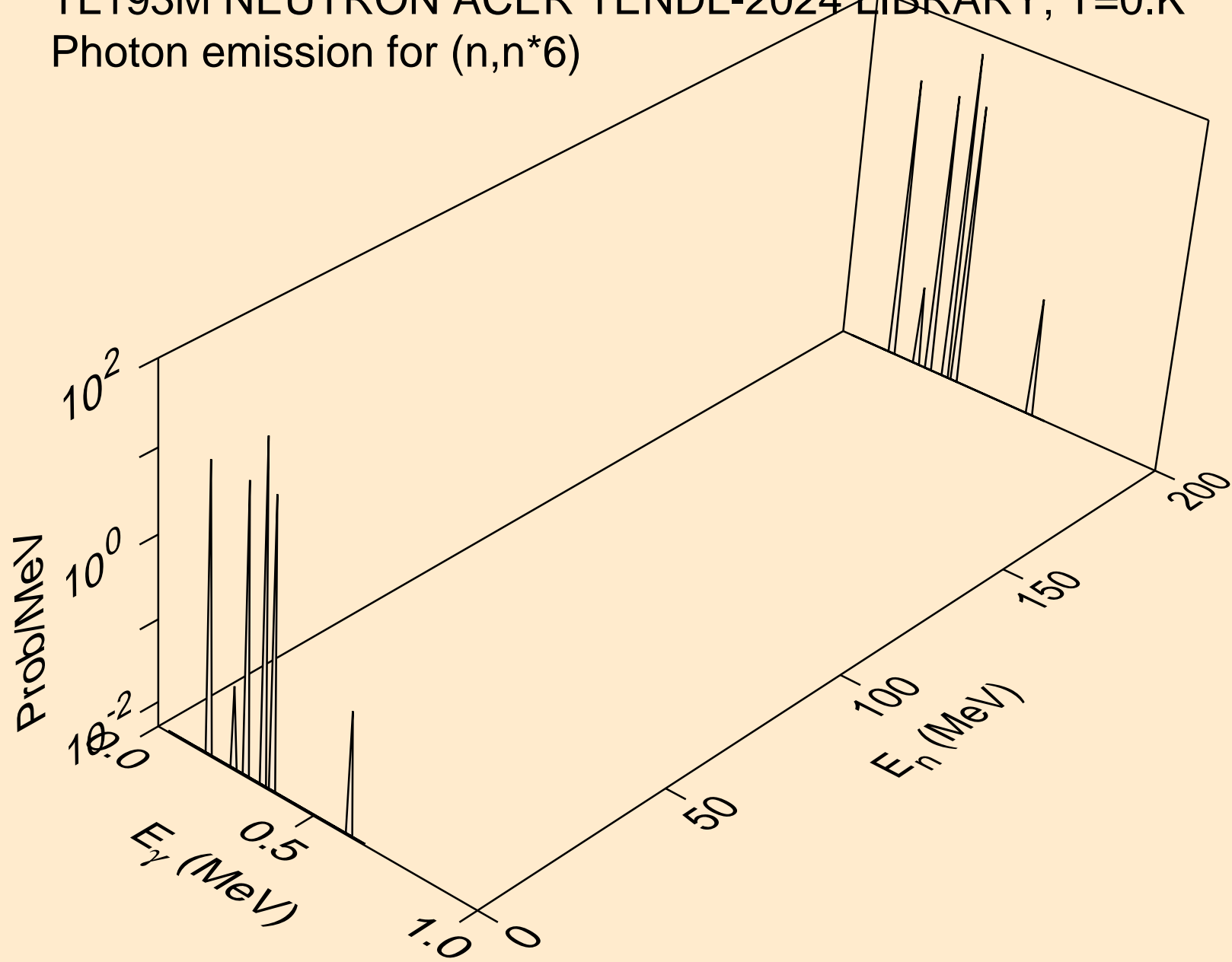

TL193M NEUTRON ACER TENDL-2024 LIBRARY; T=0.K  
Photon emission for (n,n\*7)

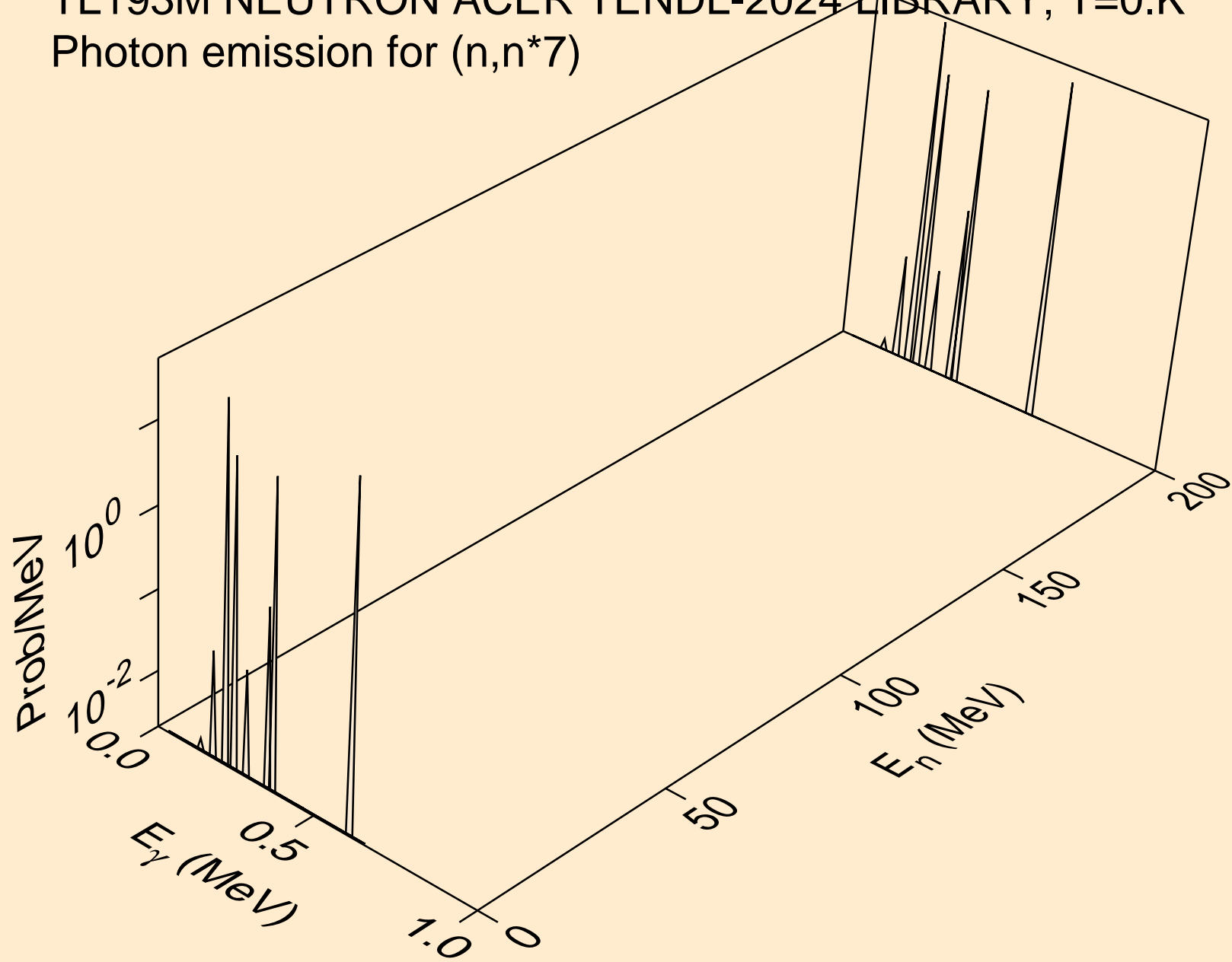



TL193M NEUTRON ACER TENDL-2024 LIBRARY; T=0.K  
Photon emission for (n,n\*8)

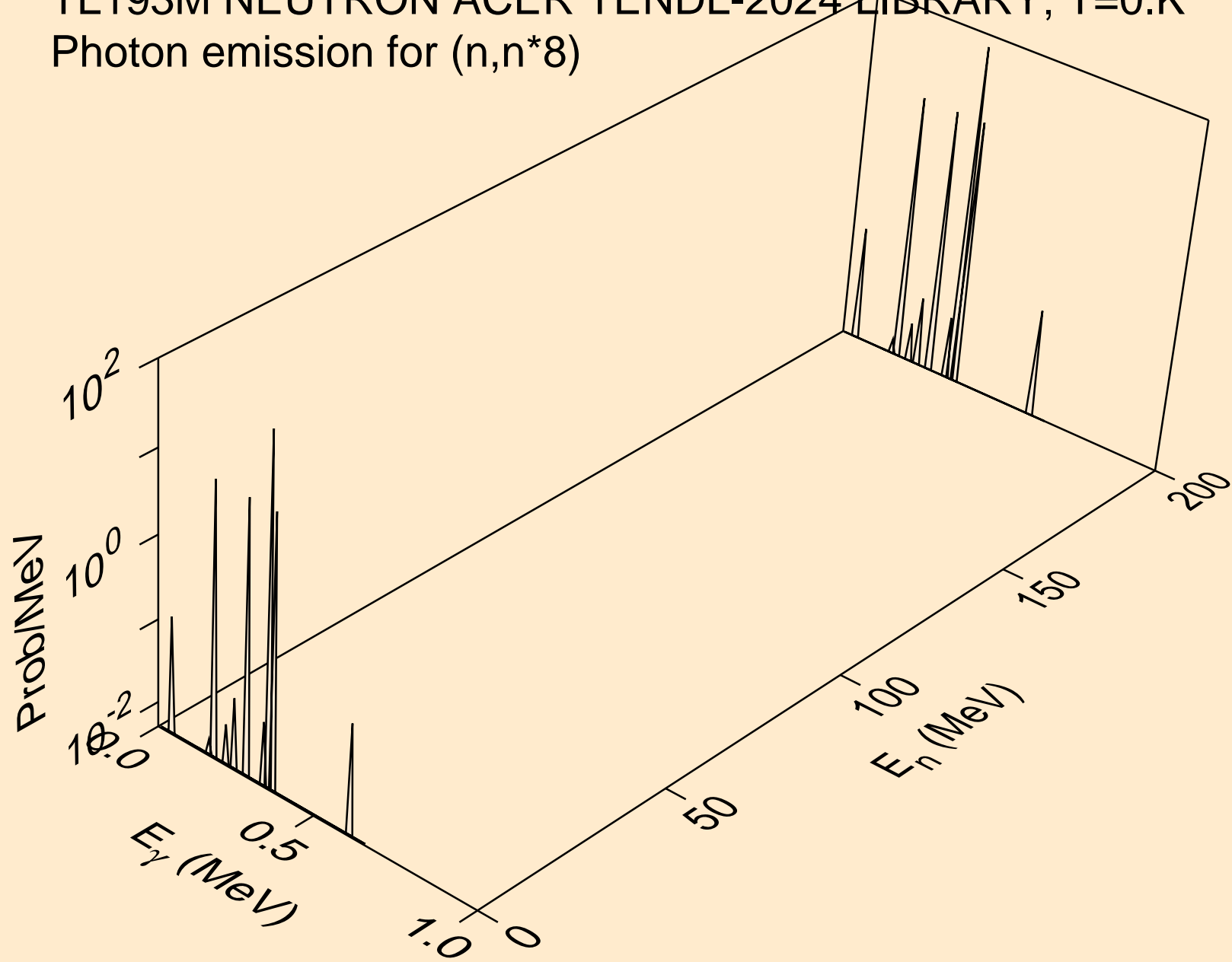

TL193M NEUTRON ACER TENDL-2024 LIBRARY; T=0.K  
Photon emission for (n,n\*9)

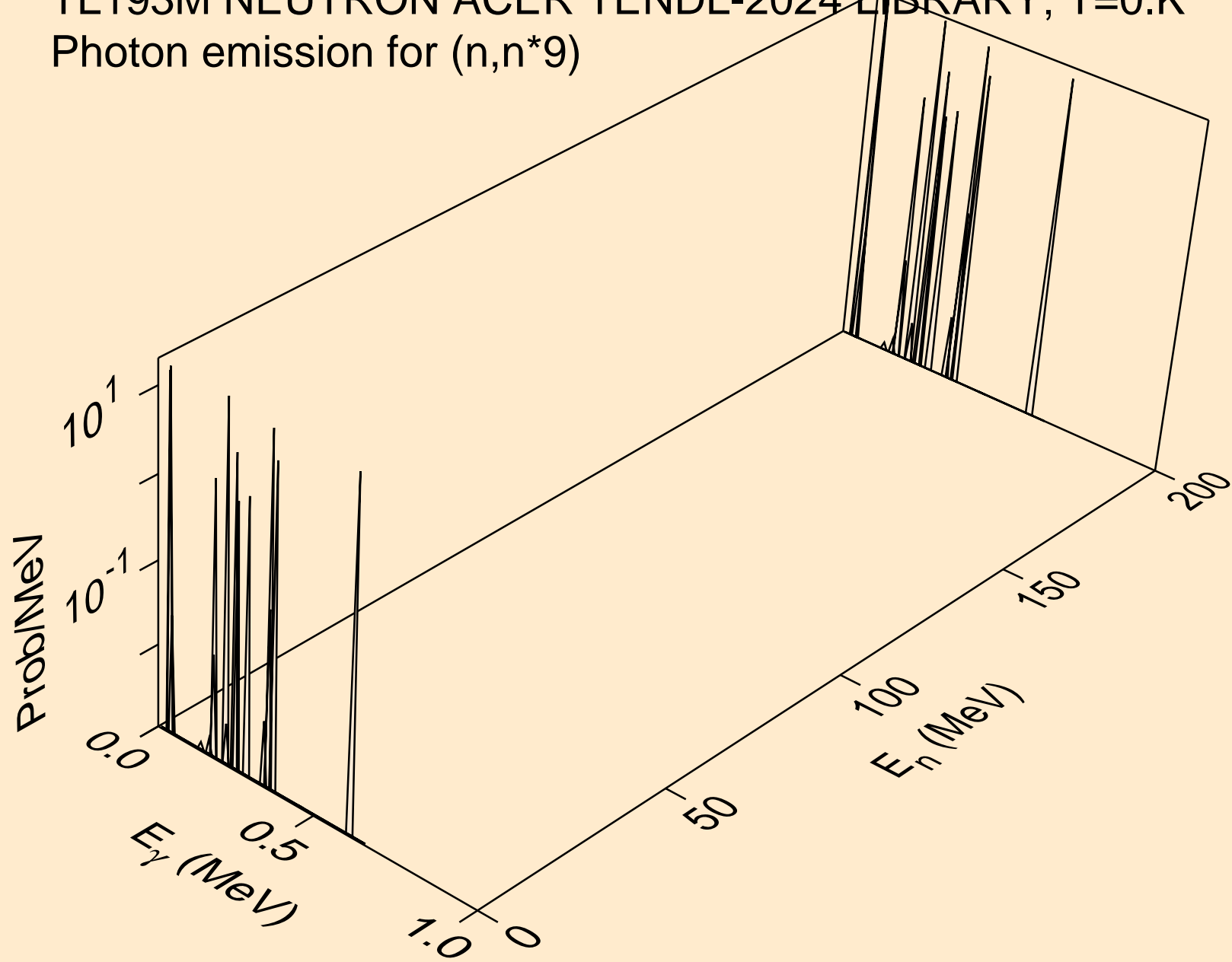

TL193M NEUTRON ACER TENDL-2024 LIBRARY; T=0.K  
Photon emission for (n,n\*c)

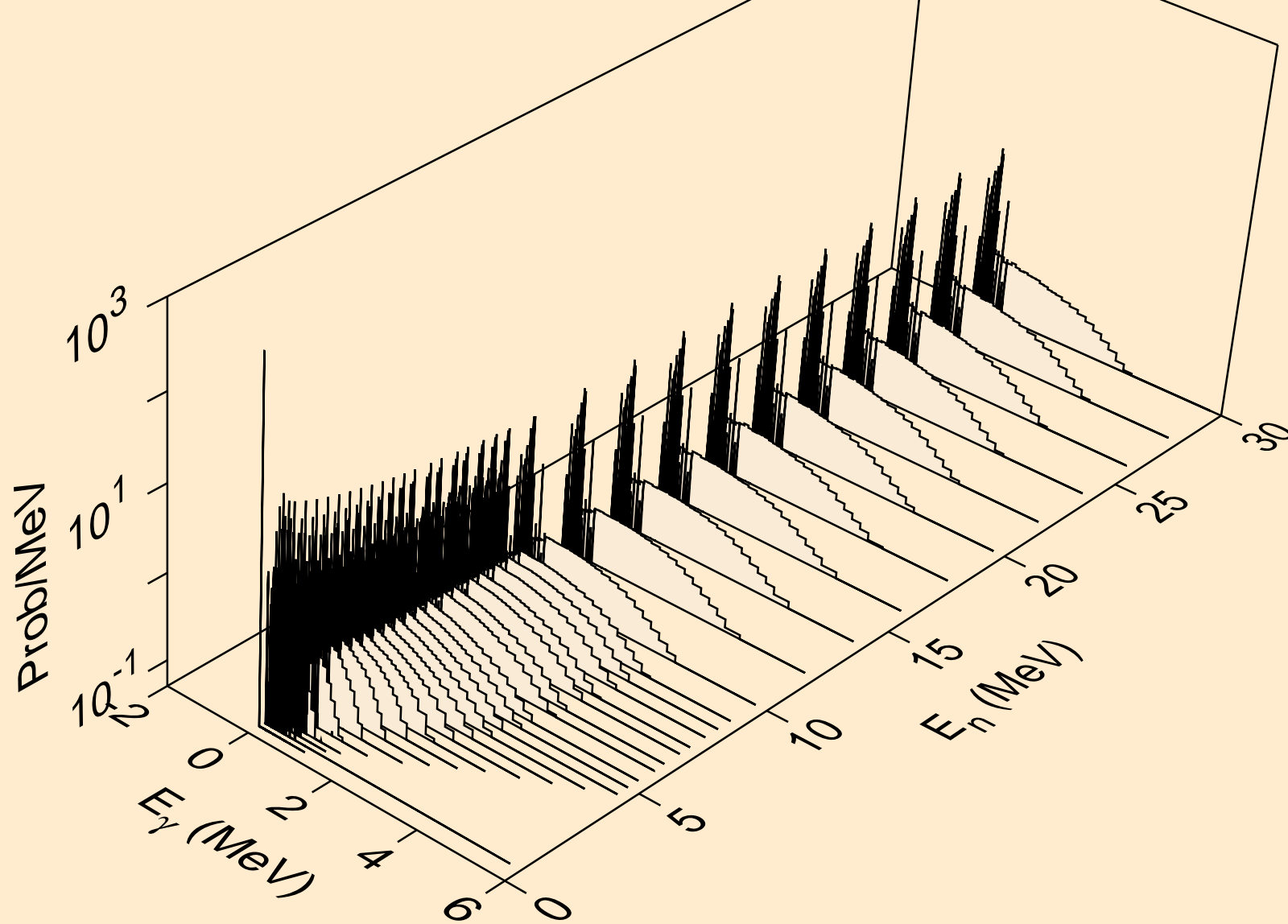

TL193M NEUTRON ACER TENDL-2024 LIBRARY; T=0.K  
Photon emission for (n,gma)

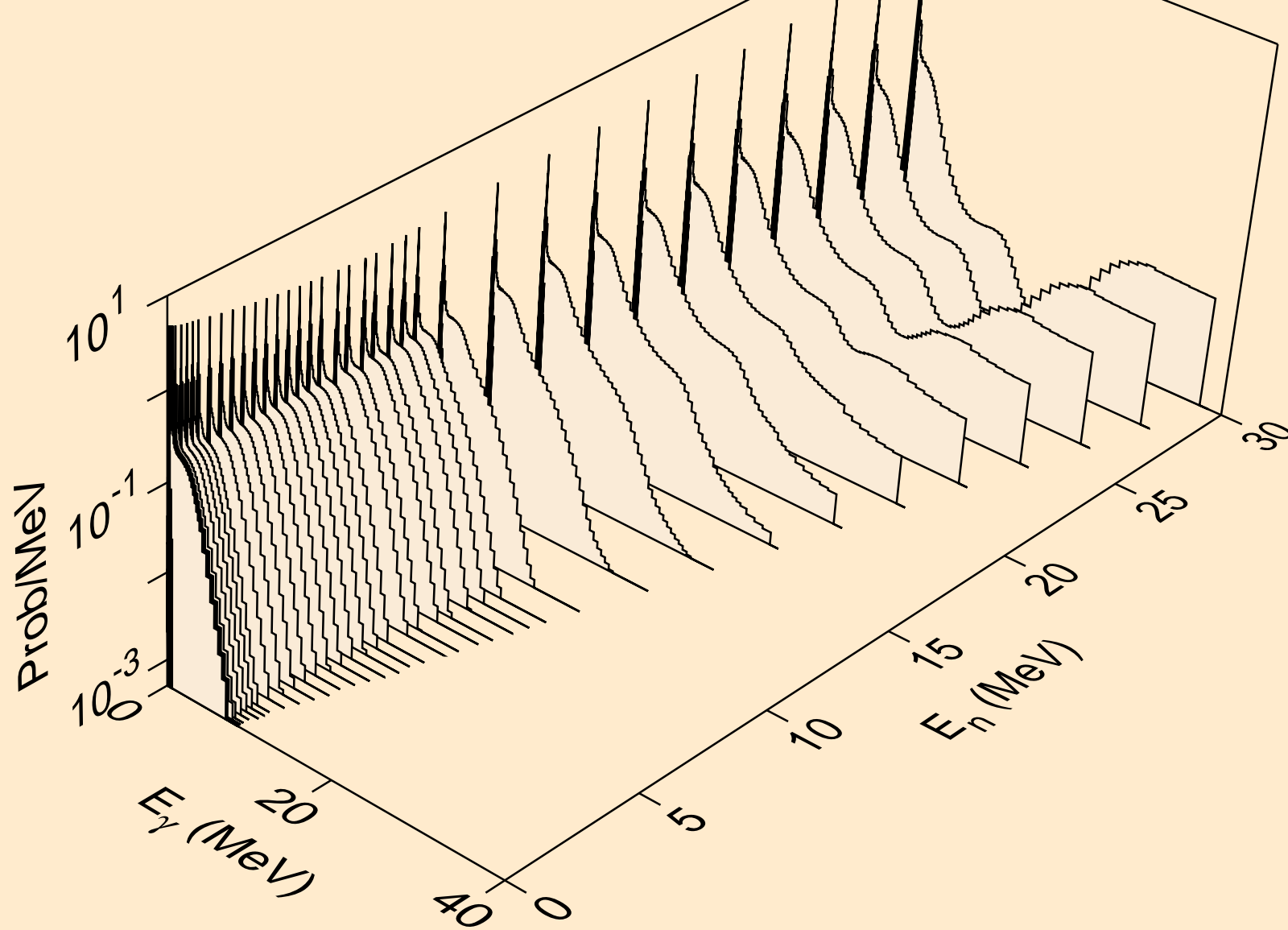

TL193M NEUTRON ACER TENDL-2024 LIBRARY; T=0.K  
Photon emission for (n,p)

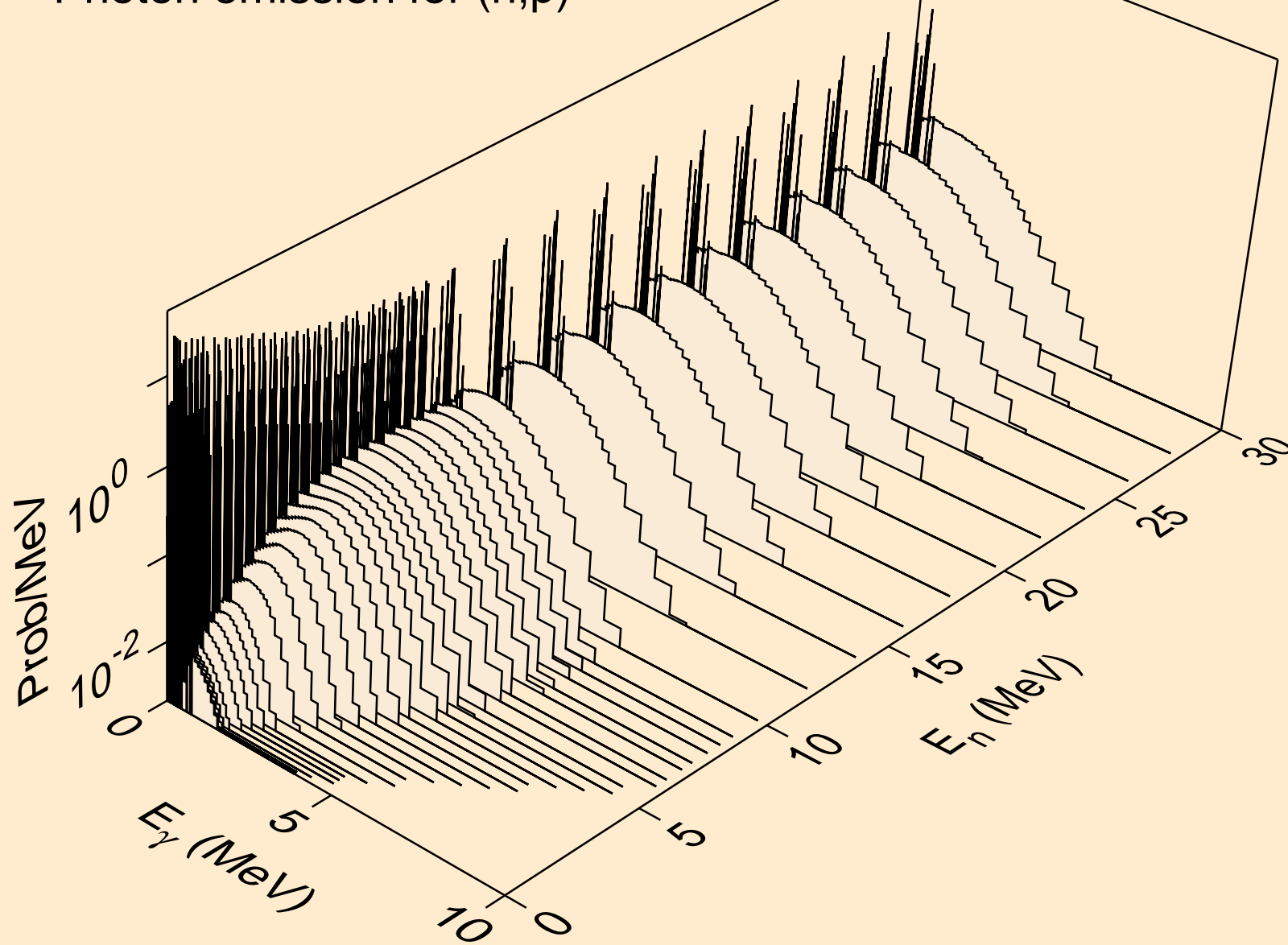

TL193M NEUTRON ACER TENDL-2024 LIBRARY; T=0.K  
Photon emission for (n,d)

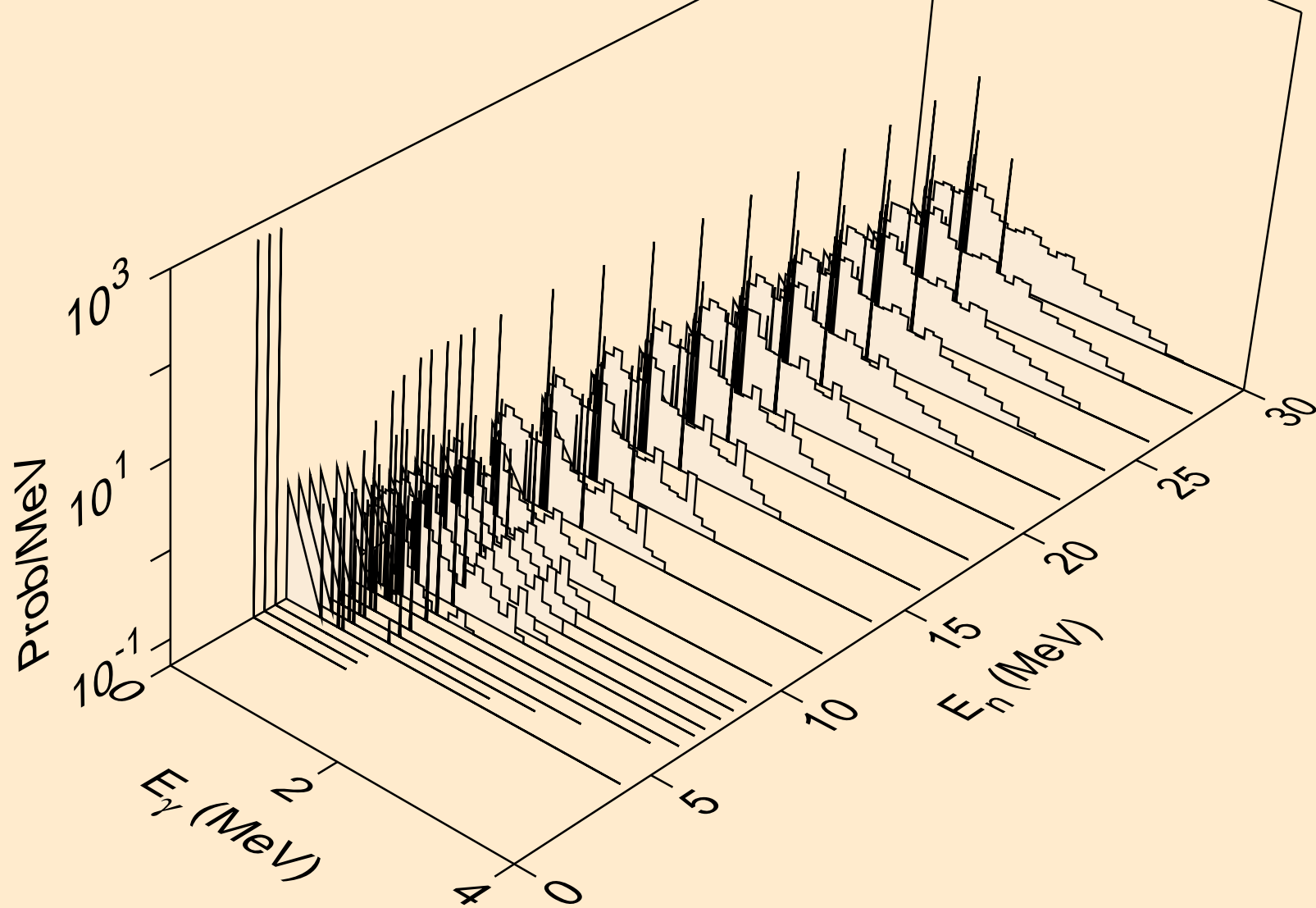

TL193M NEUTRON ACER TENDL-2024 LIBRARY; T=0.K  
Photon emission for (n,t)

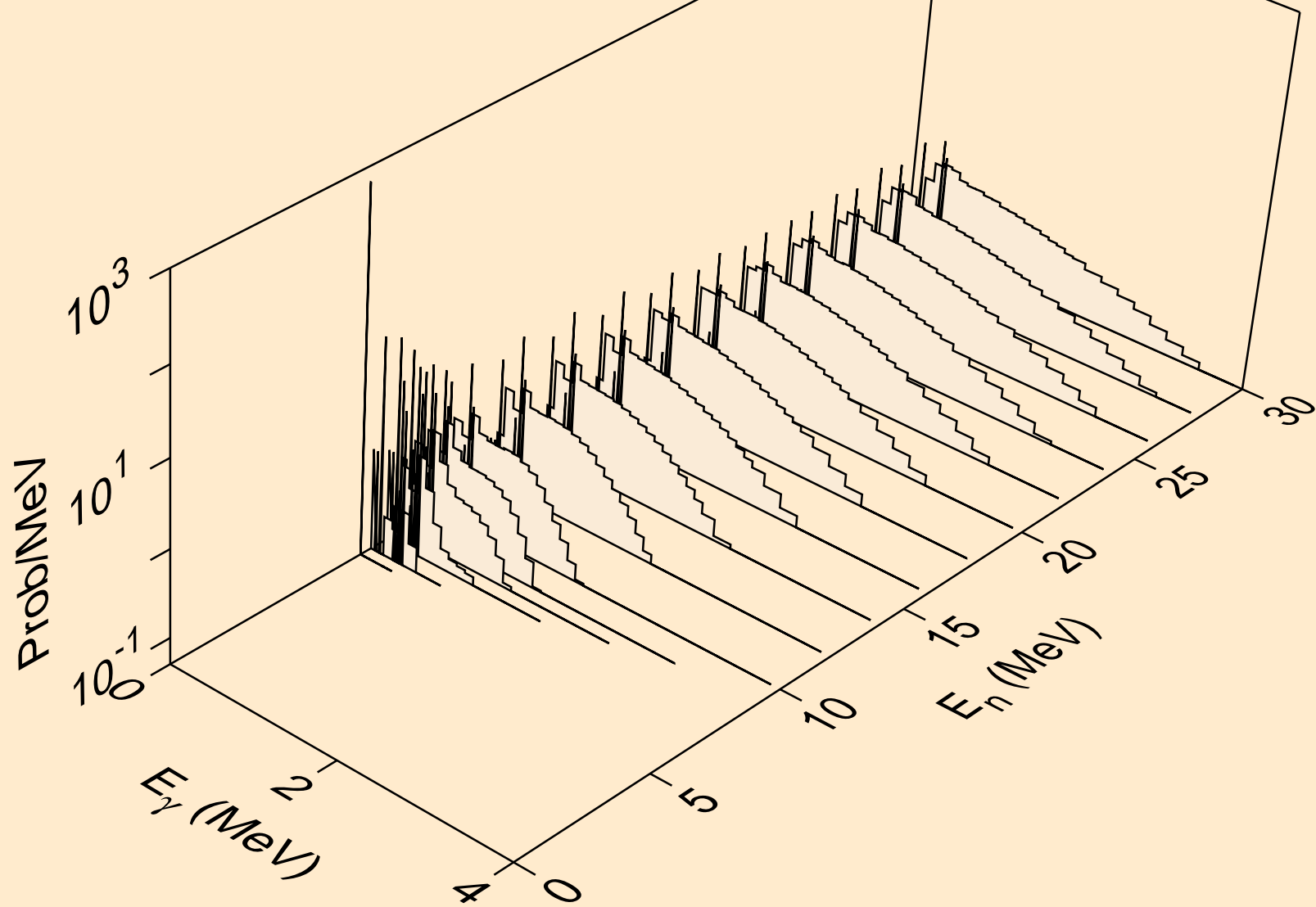

TL193M NEUTRON ACER TENDL-2024 LIBRARY; T=0.K  
Photon emission for (n,he3)

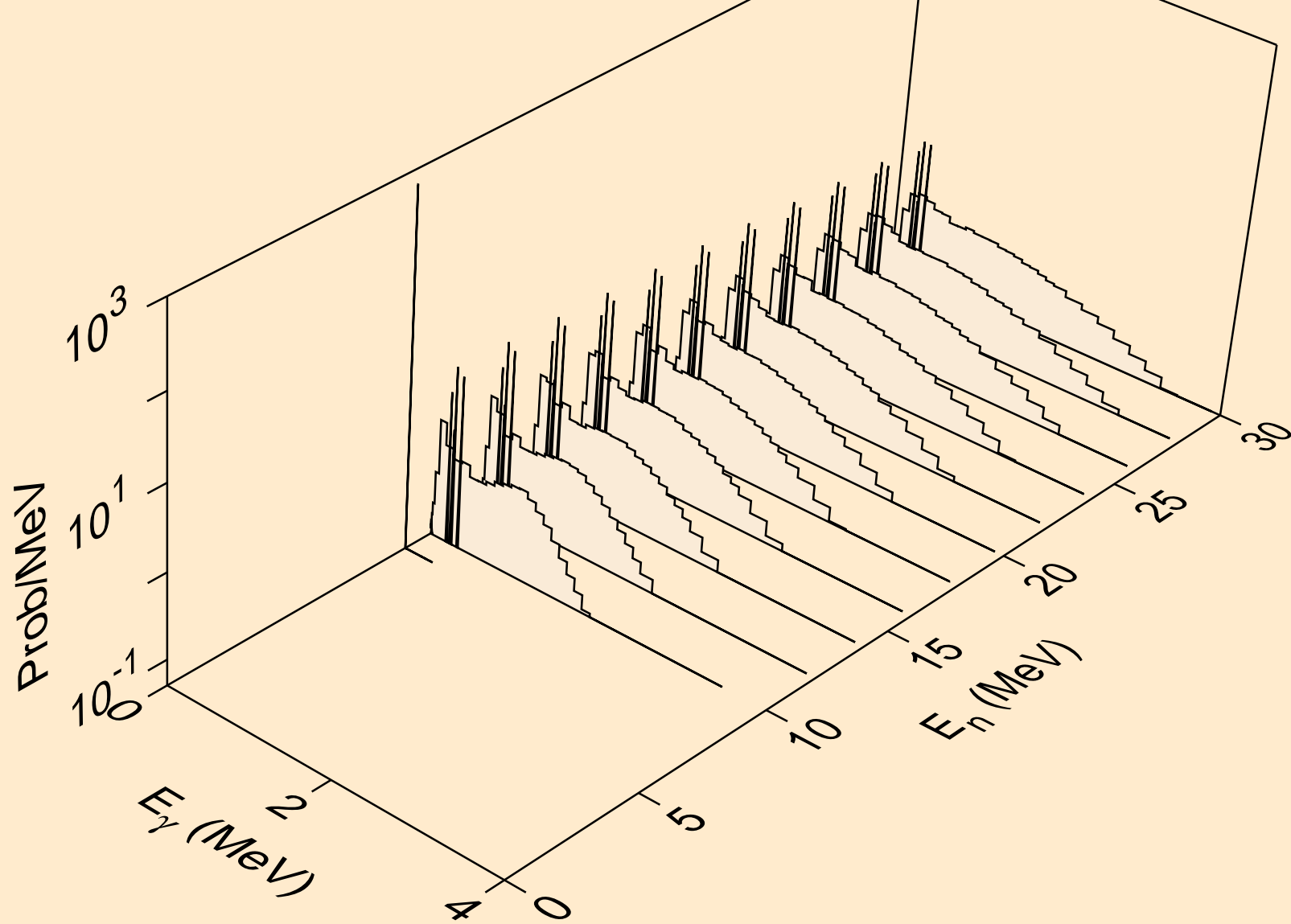



TL193M NEUTRON ACER TENDL-2024 LIBRARY; T=0.K  
Photon emission for (n,a)

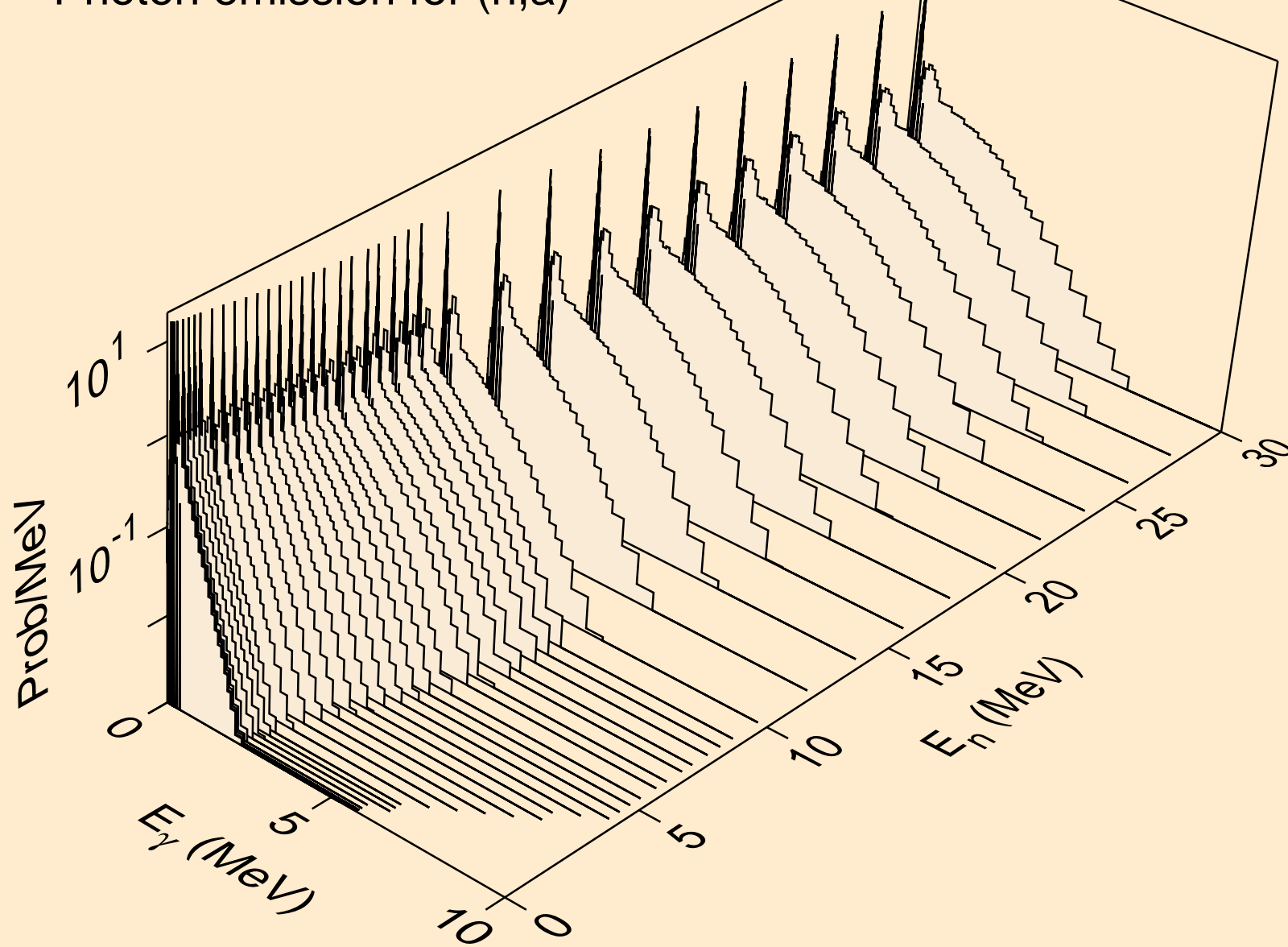

TL193M NEUTRON ACER TENDL-2024 LIBRARY; T=0.K  
Photon emission for (n,2a)

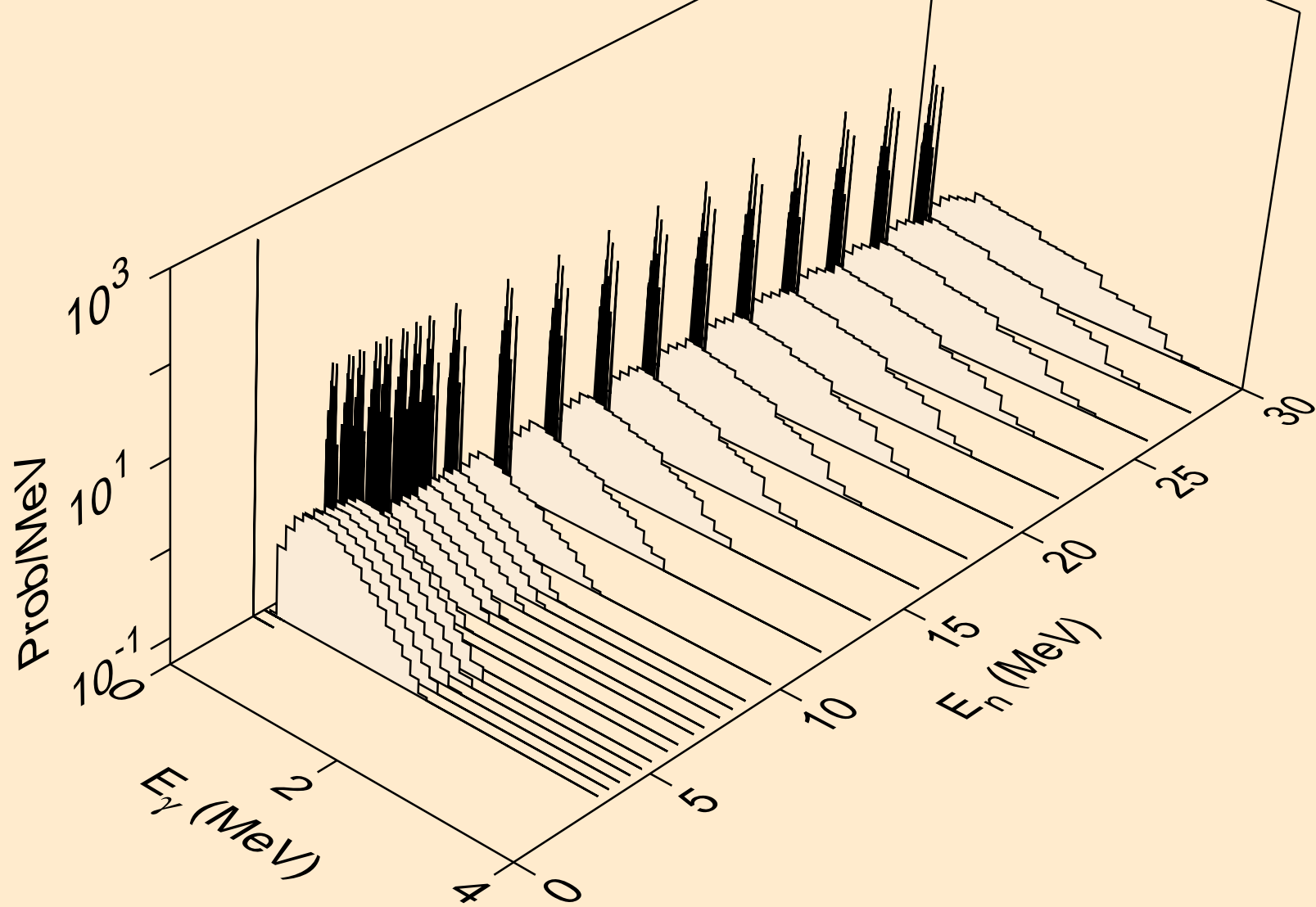

TL193M NEUTRON ACER TENDL-2024 LIBRARY; T=0.K  
Photon emission for (n,2p)

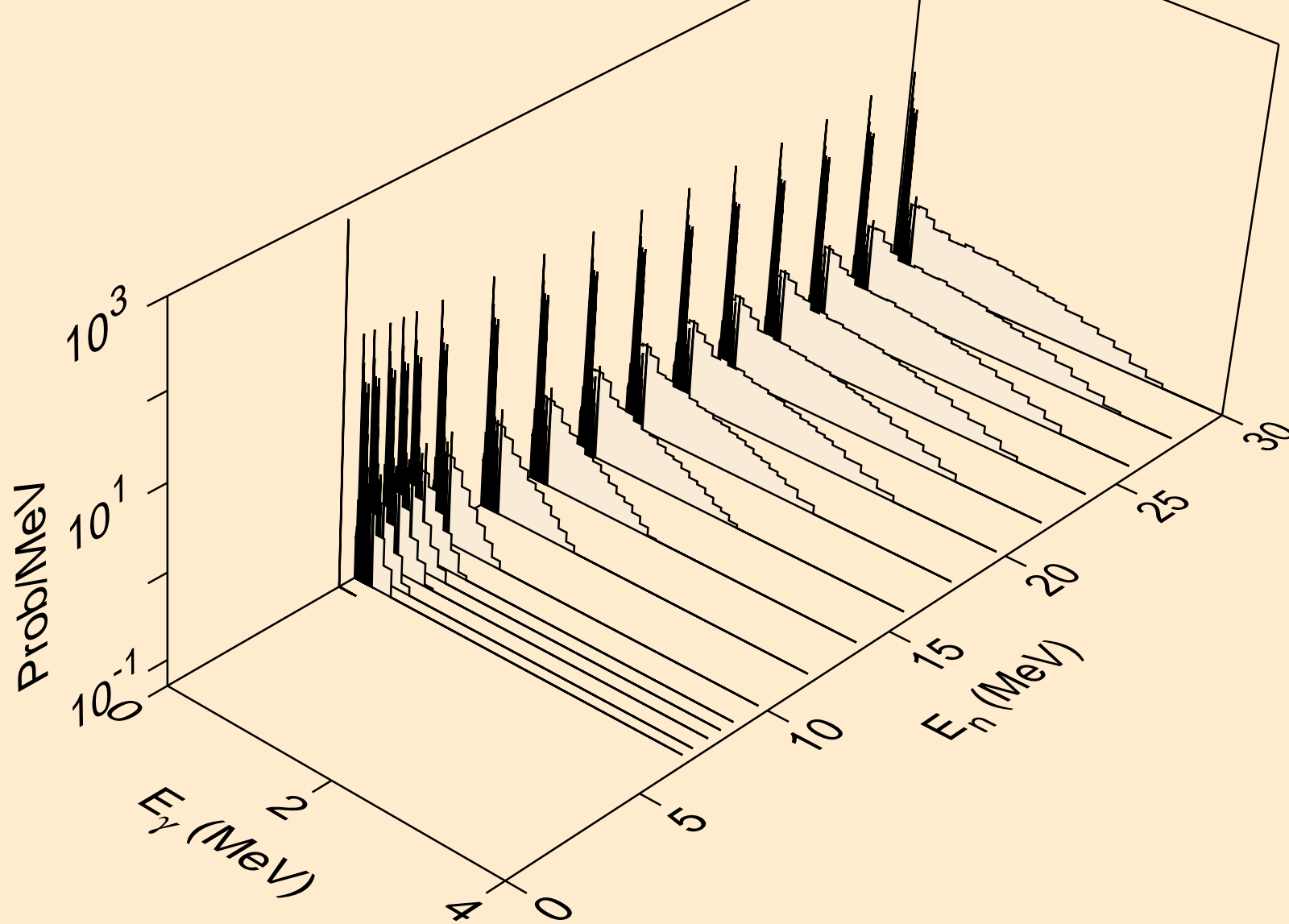

TL193M NEUTRON ACER TENDL-2024 LIBRARY; T=0.K  
Photon emission for (n,p $\alpha$ )

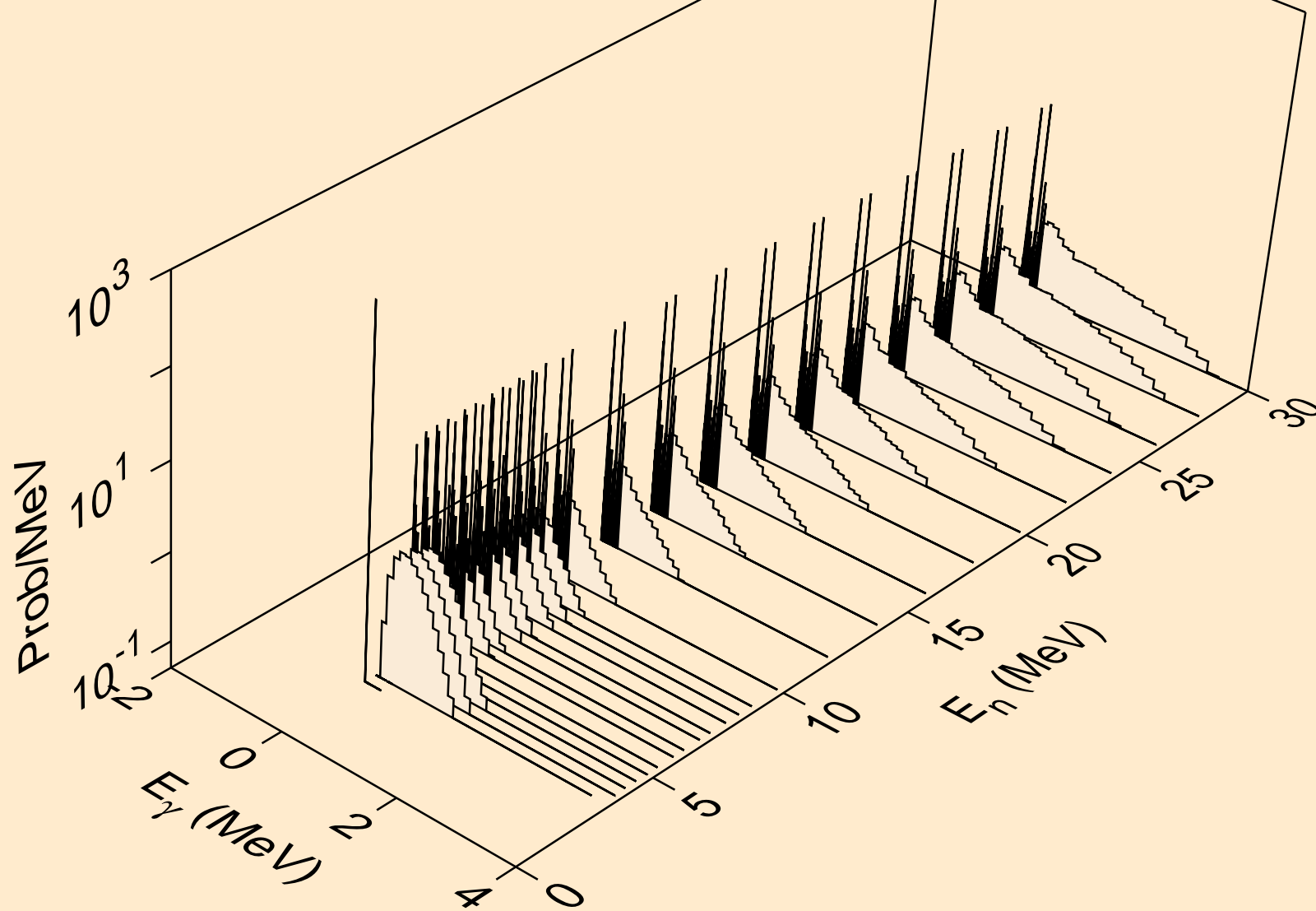

TL193M NEUTRON ACER TENDL-2024 LIBRARY; T=0.K  
Photon emission for (n,pd)

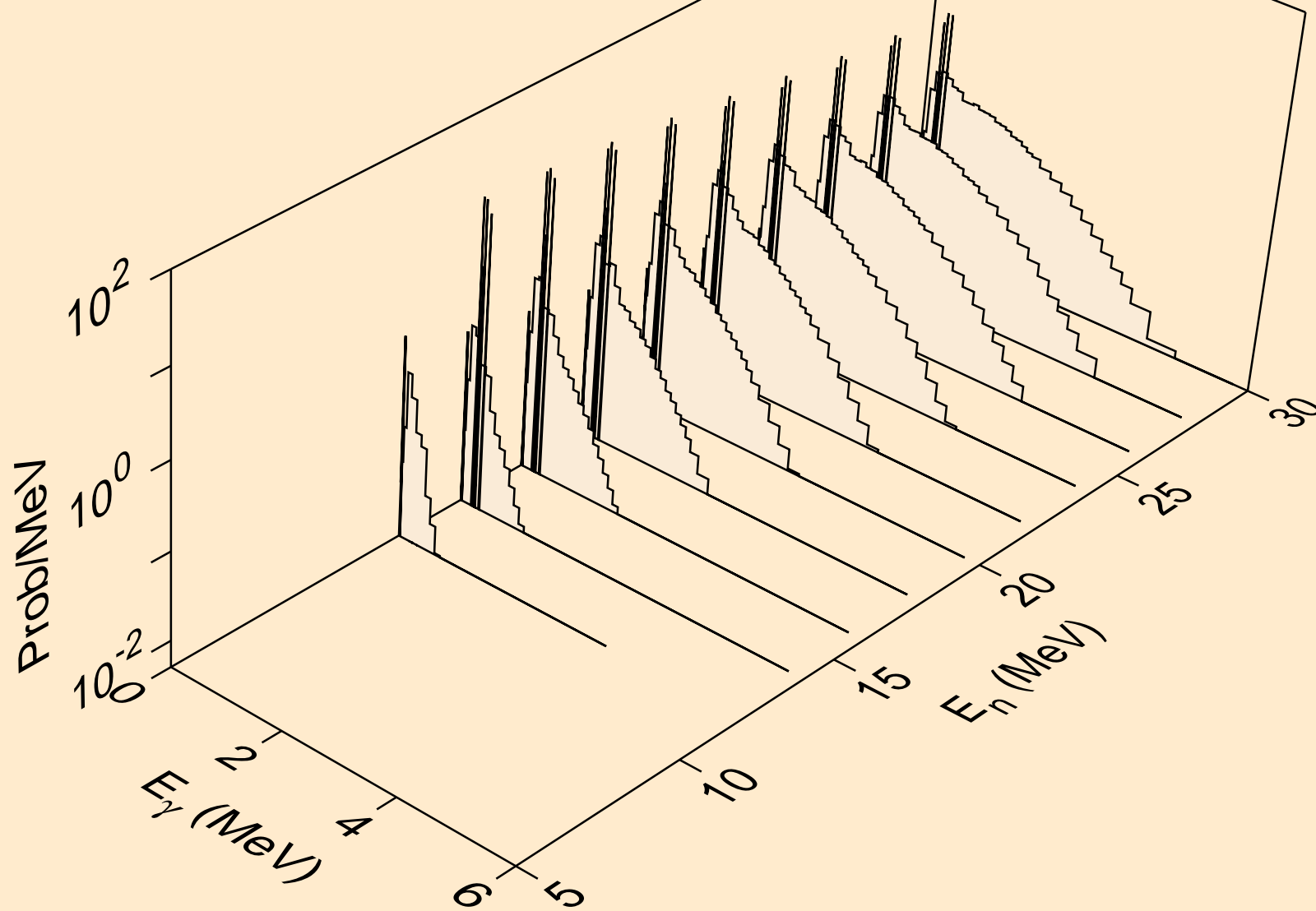

TL193M NEUTRON ACER TENDL-2024 LIBRARY; T=0.K  
Photon emission for (n,pt)

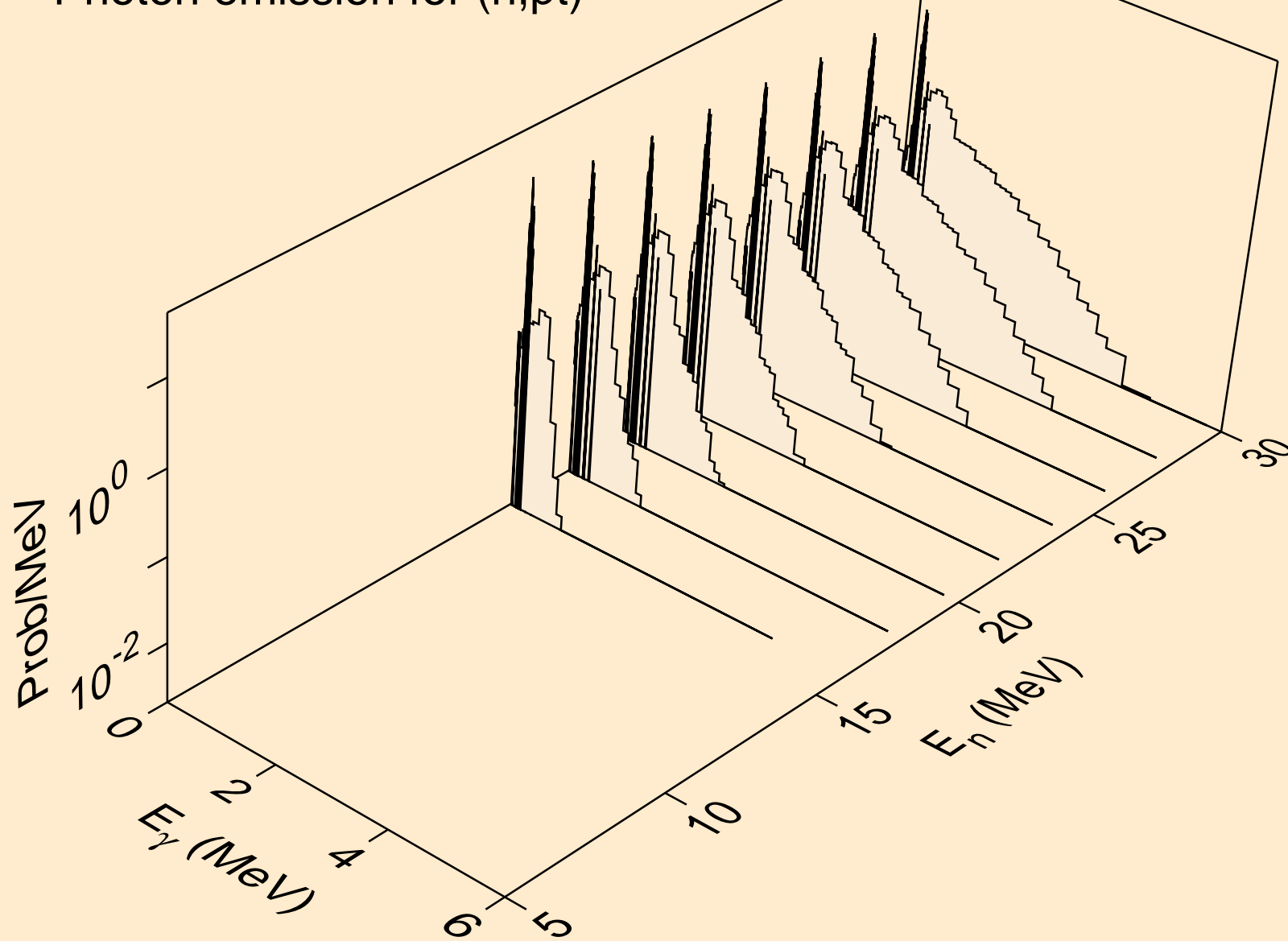

TL193M NEUTRON ACER TENDL-2024 LIBRARY; T=0.K  
Photon emission for (n,da)

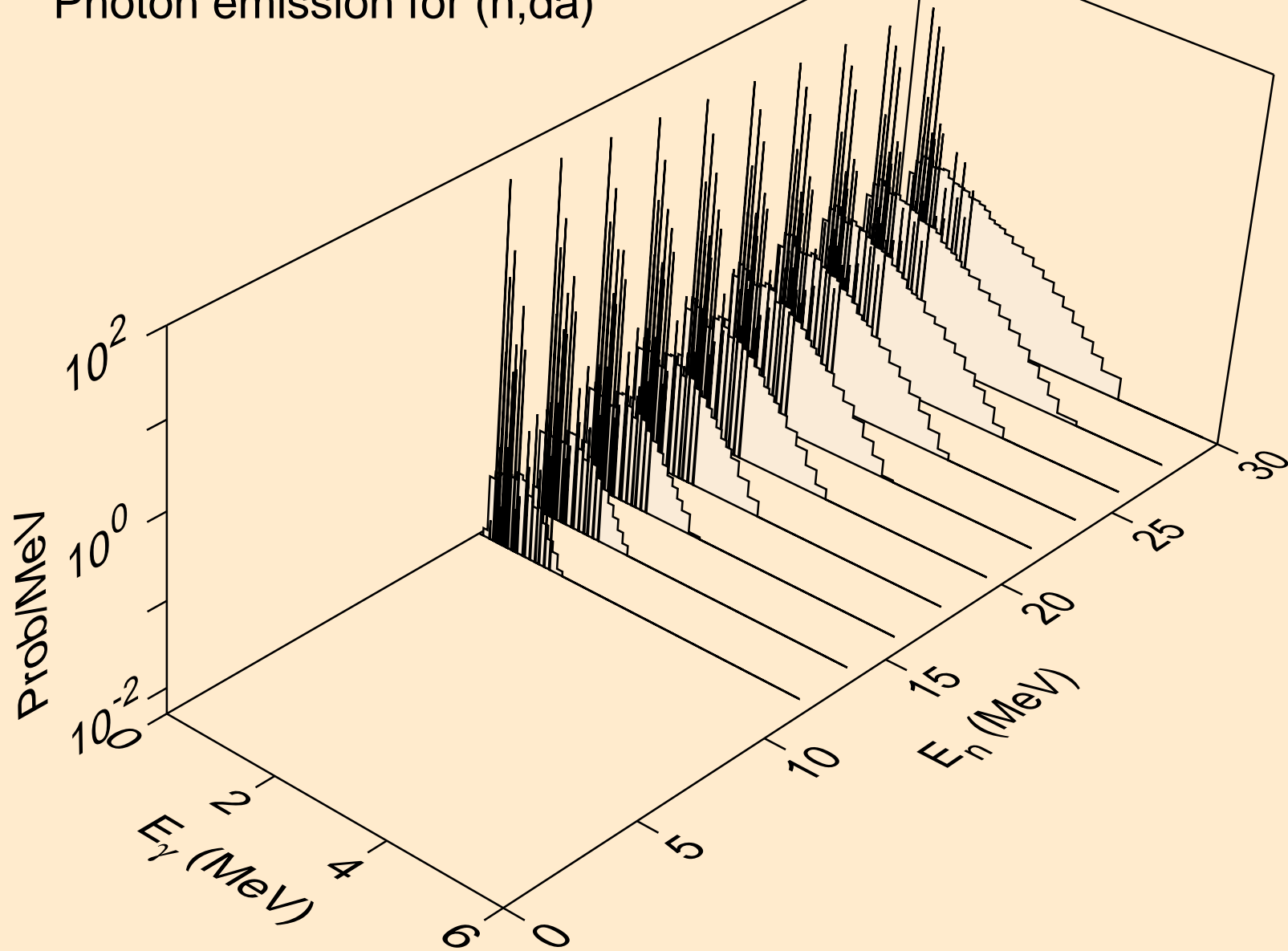

TL193M NEUTRON ACER TENDL-2024 LIBRARY; T=0.K  
thermal capture photon spectrum

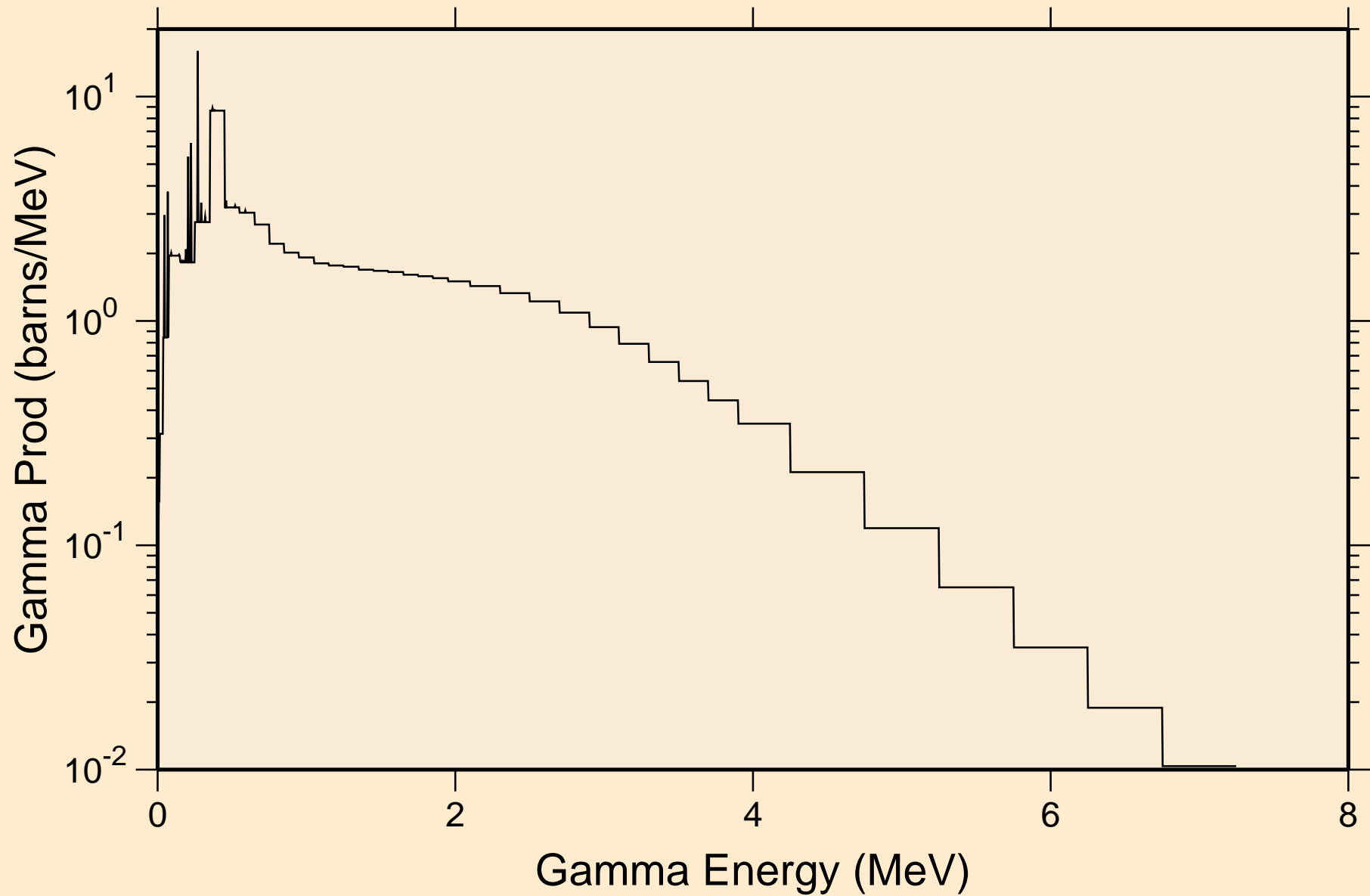



TL193M NEUTRON ACER TENDL-2024 LIBRARY; T=0.K  
14 MeV photon spectrum

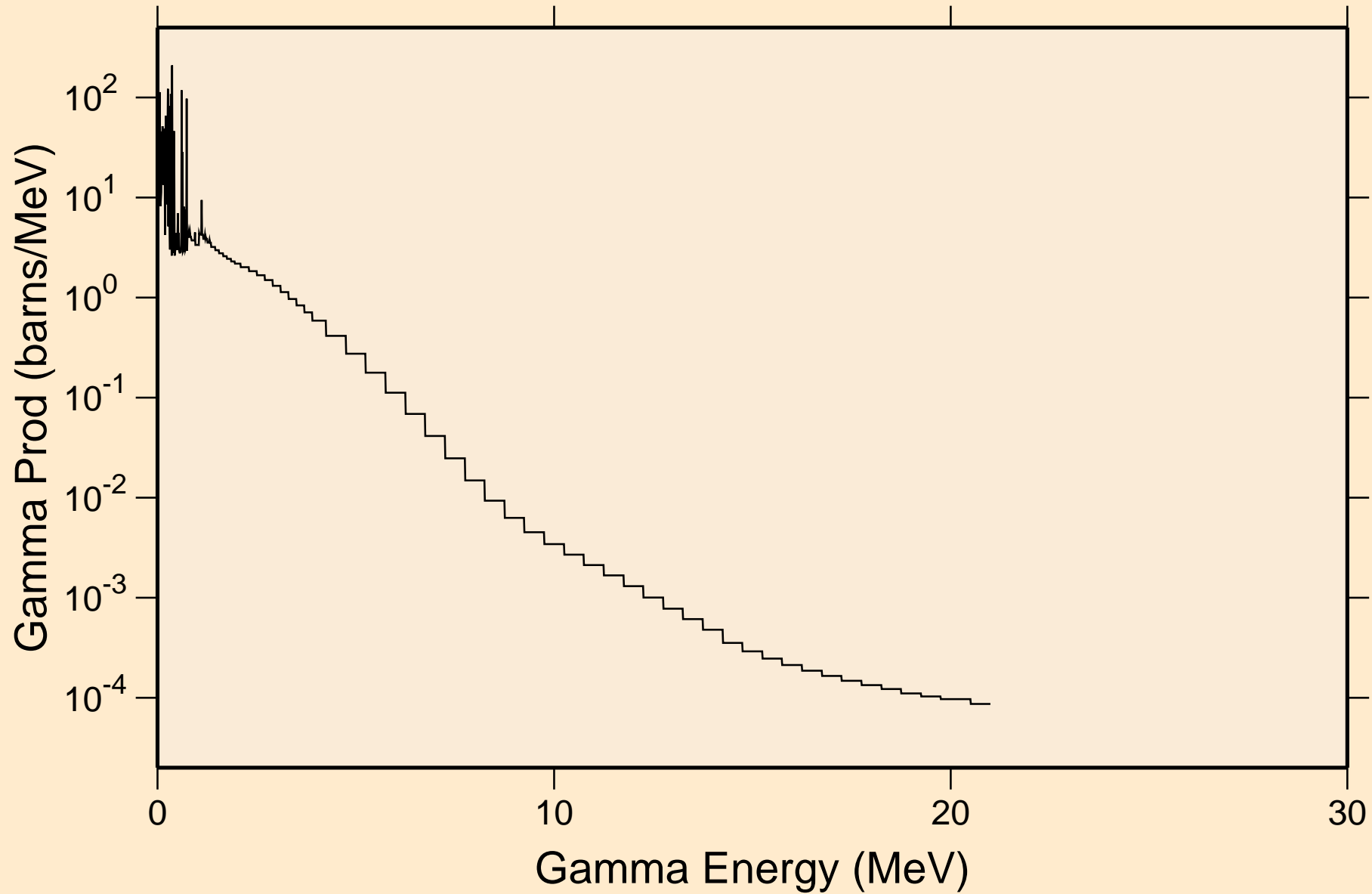

TL193M NEUTRON ACER TENDL-2024 LIBRARY; T=0.K  
Particle heating contributions

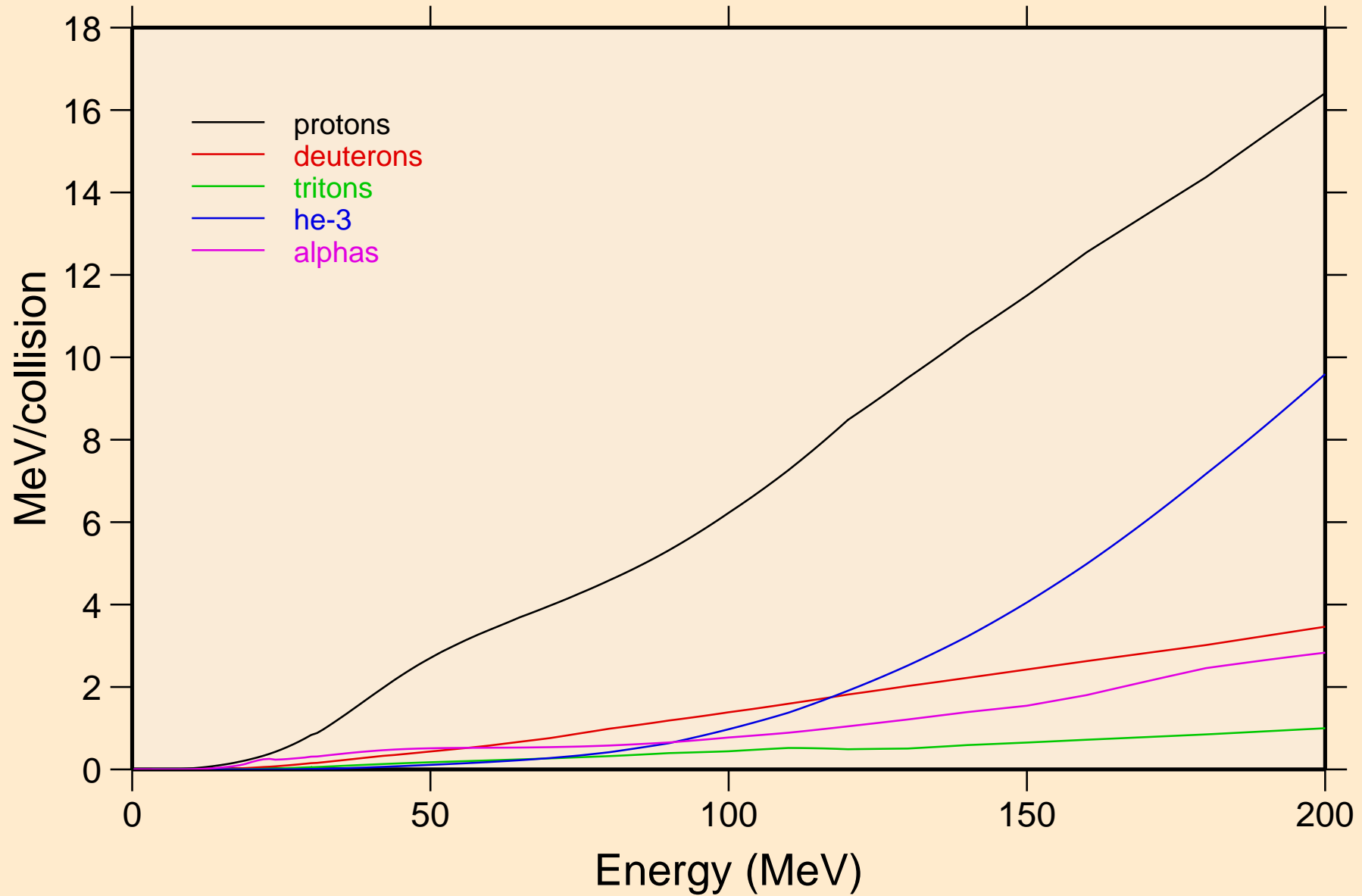

TL193M NEUTRON ACER TENDL-2024 LIBRARY; T=0.K  
Recoil Heating

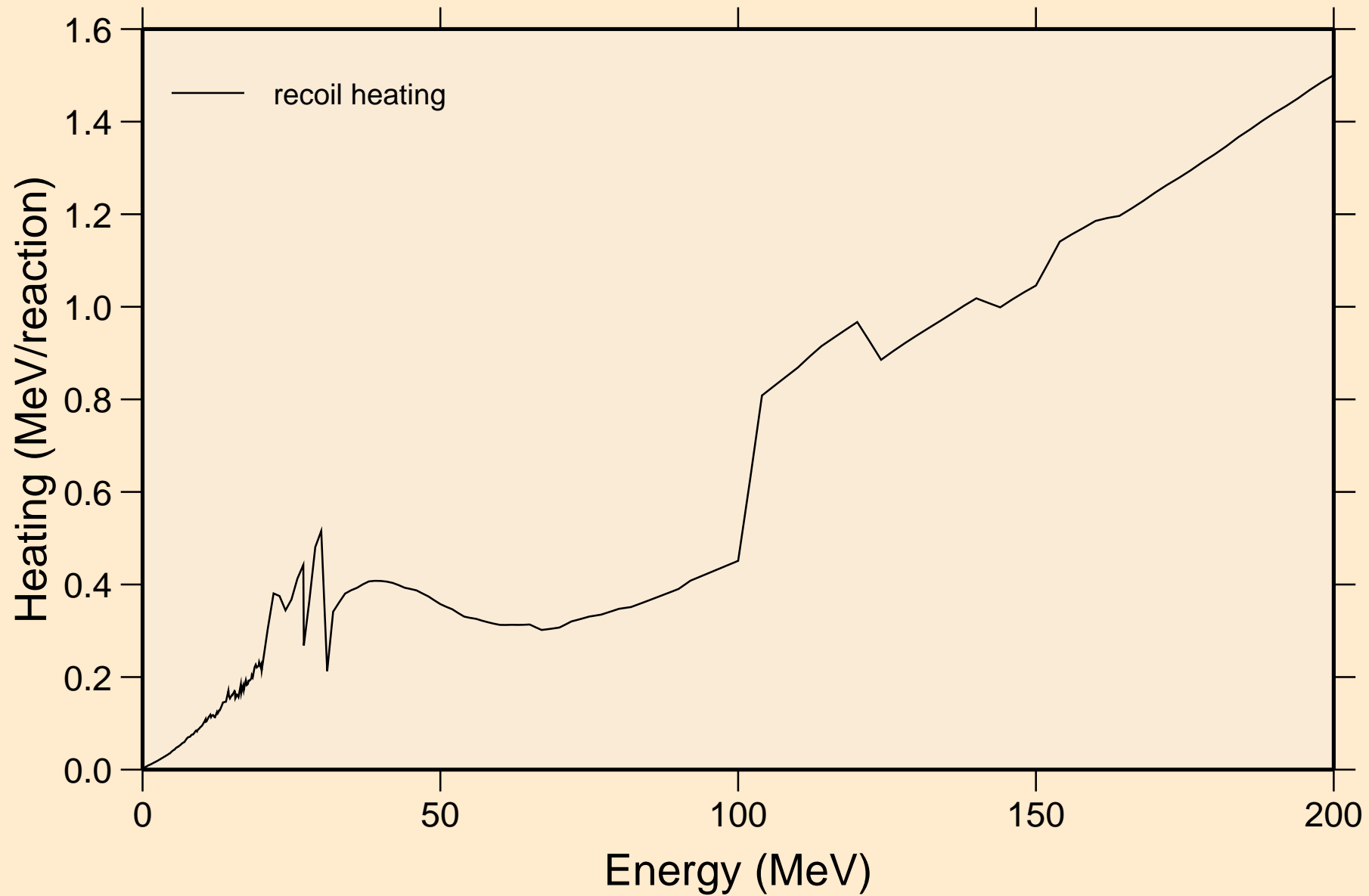

TL193M NEUTRON ACER TENDL-2024 LIBRARY; T=0.K  
Particle production cross sections

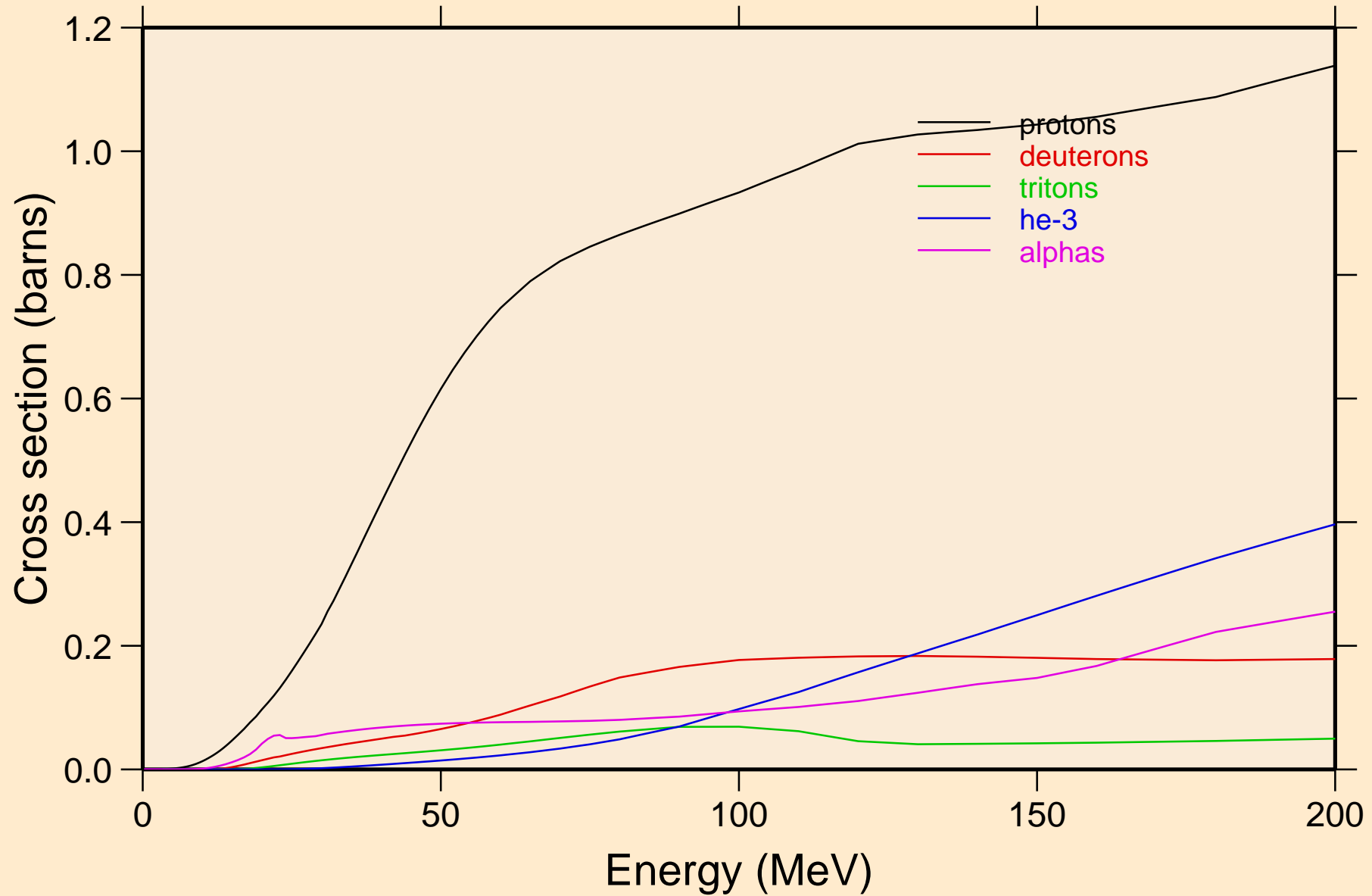

TL193M NEUTRON ACER TENDL-2024 LIBRARY; T=0.K  
protons from (n,x)

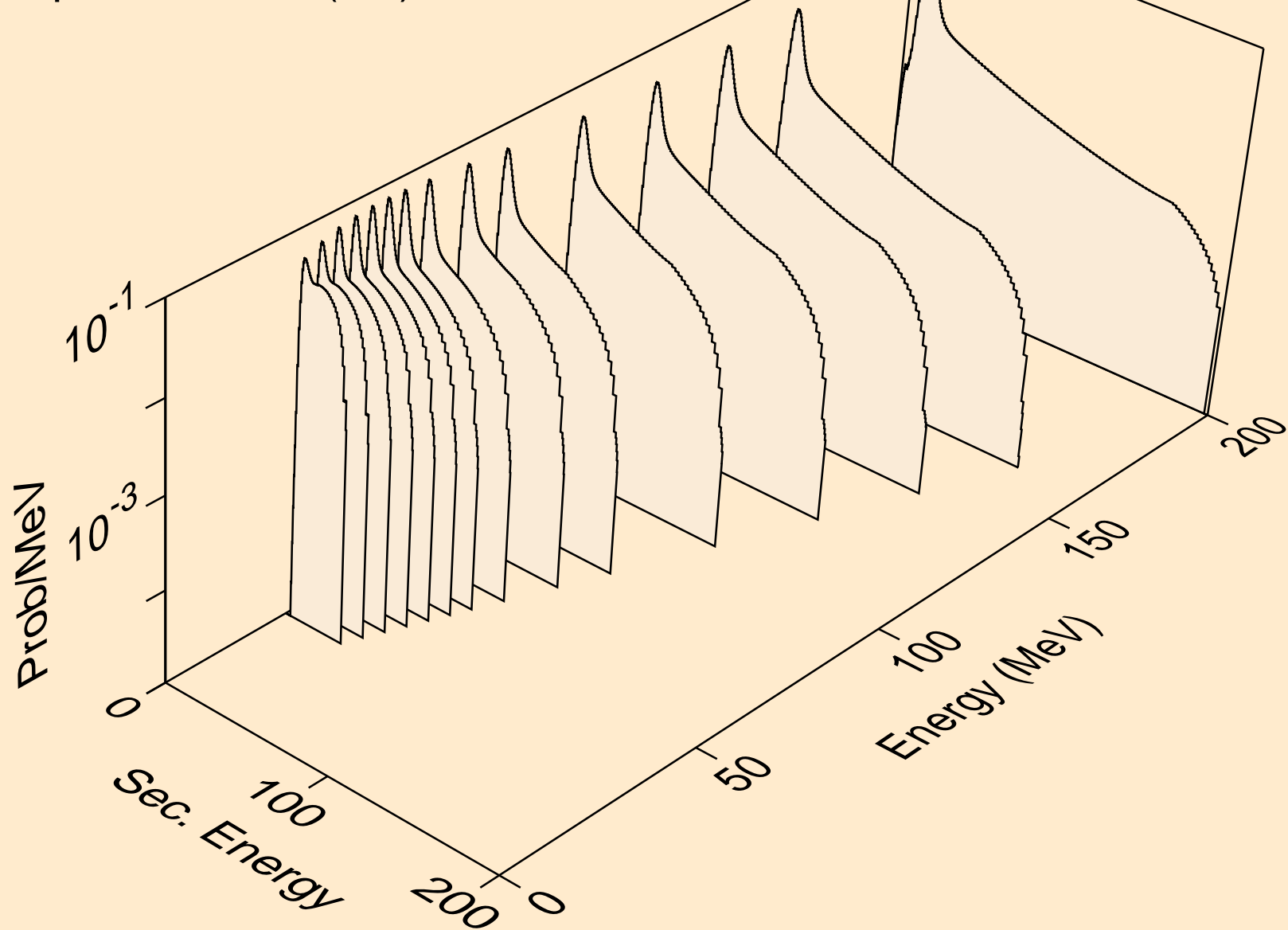

TL193M NEUTRON ACER TENDL-2024 LIBRARY; T=0.K  
protons from (n,n\*)p

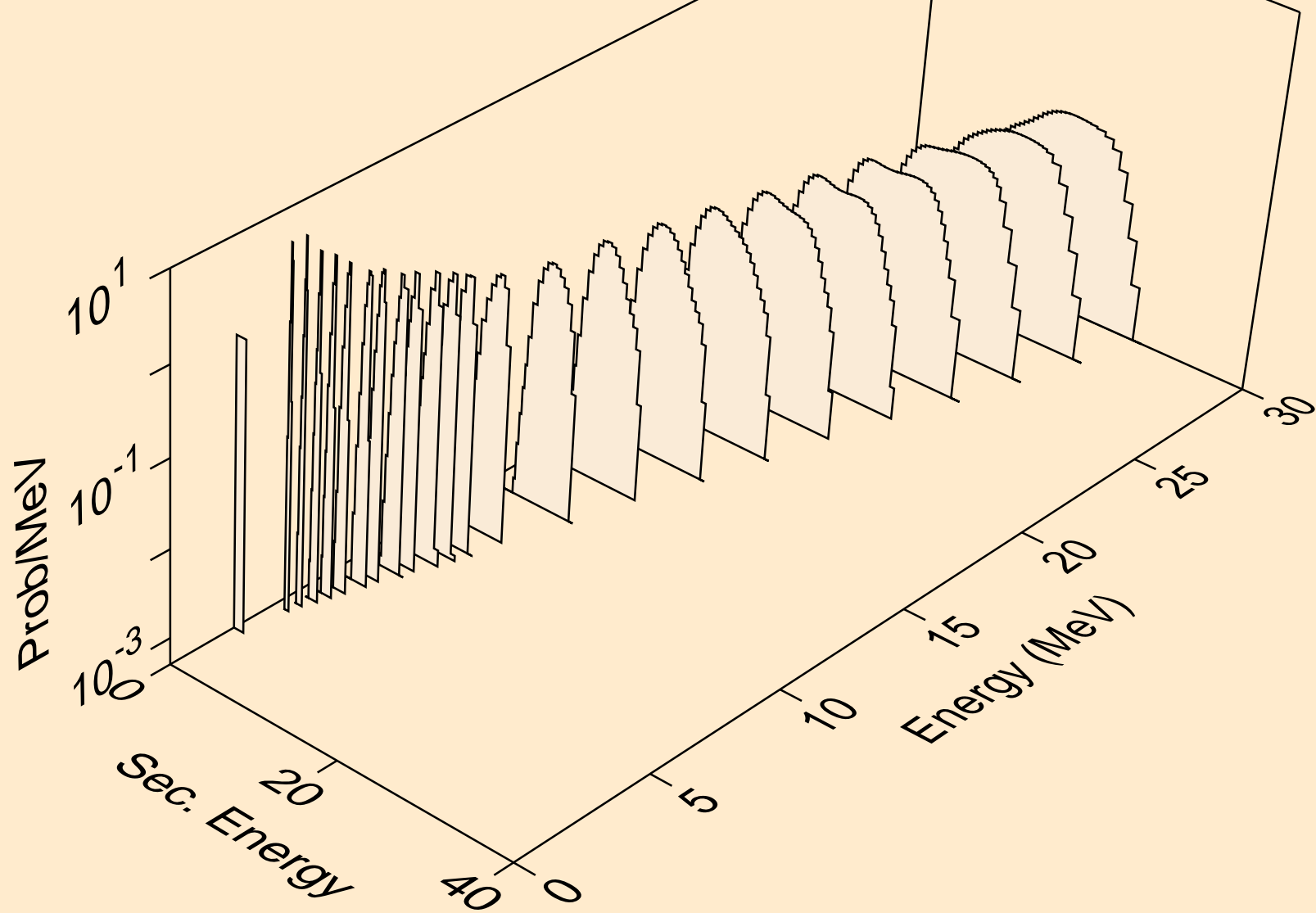

TL193M NEUTRON ACER TENDL-2024 LIBRARY; T=0.K  
protons from (n,2np)

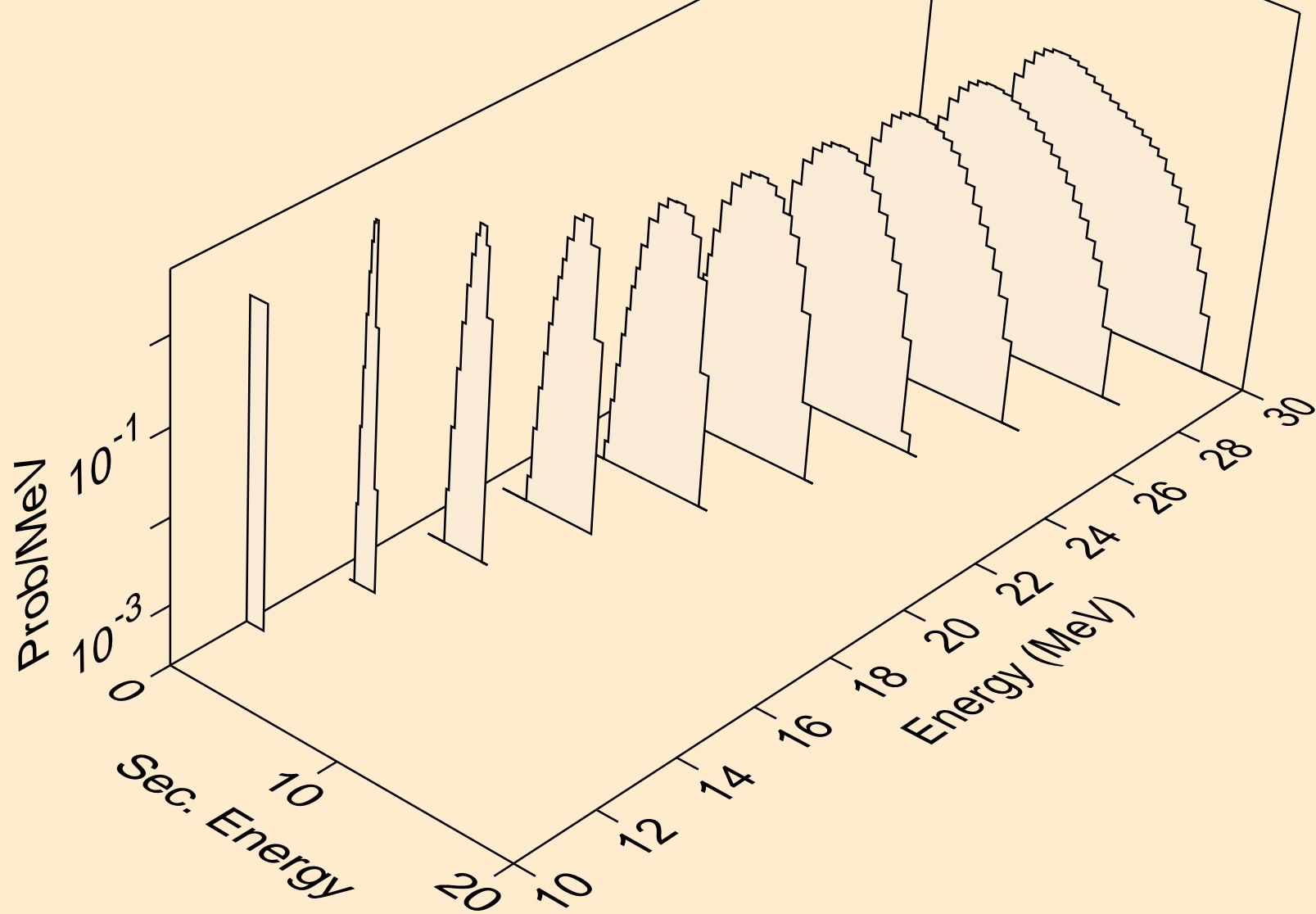

TL193M NEUTRON ACER TENDL-2024 LIBRARY; T=0.K  
protons from (n,3np)

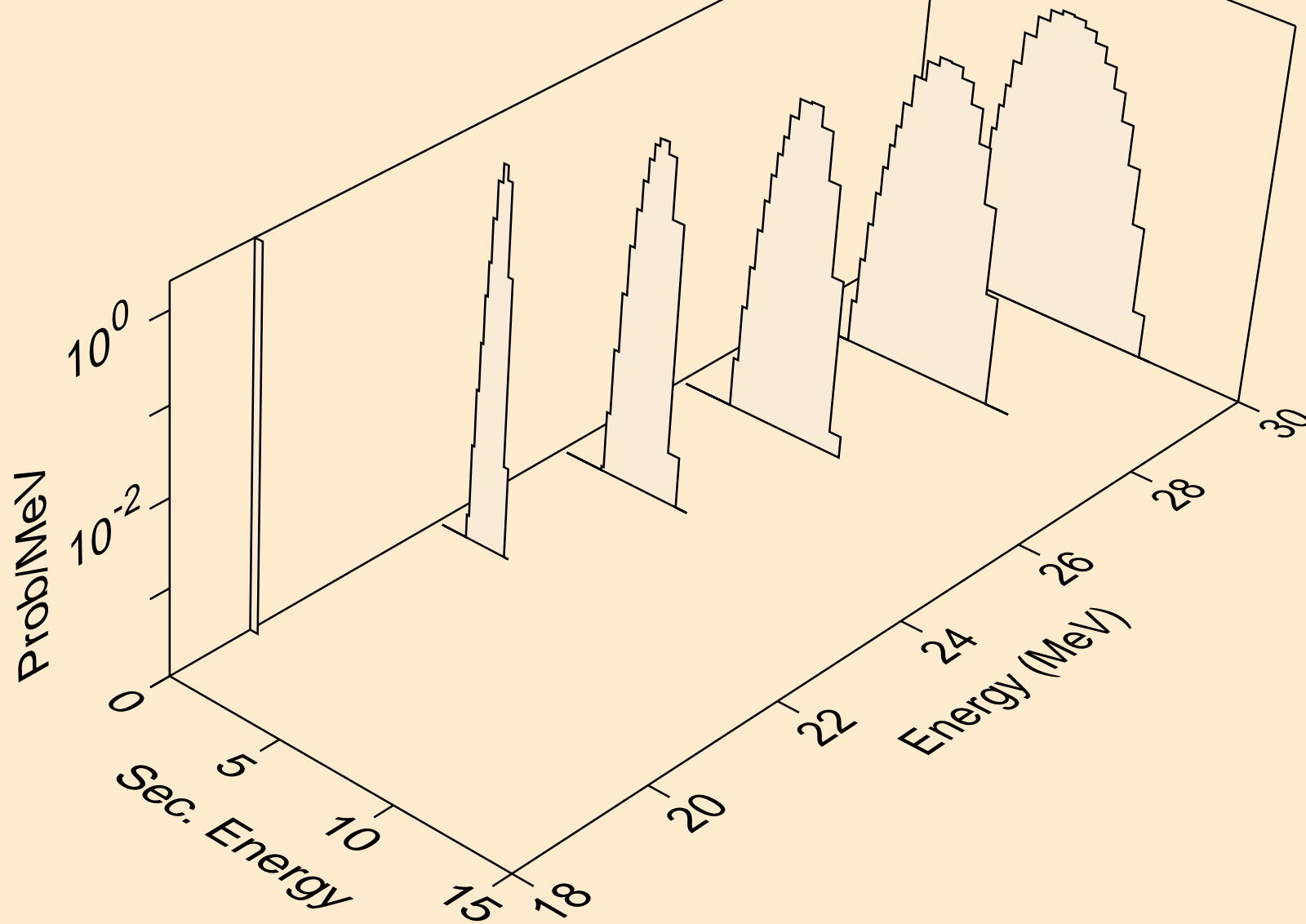



TL193M NEUTRON ACER TENDL-2024 LIBRARY; T=0.K  
protons from (n,n2p)

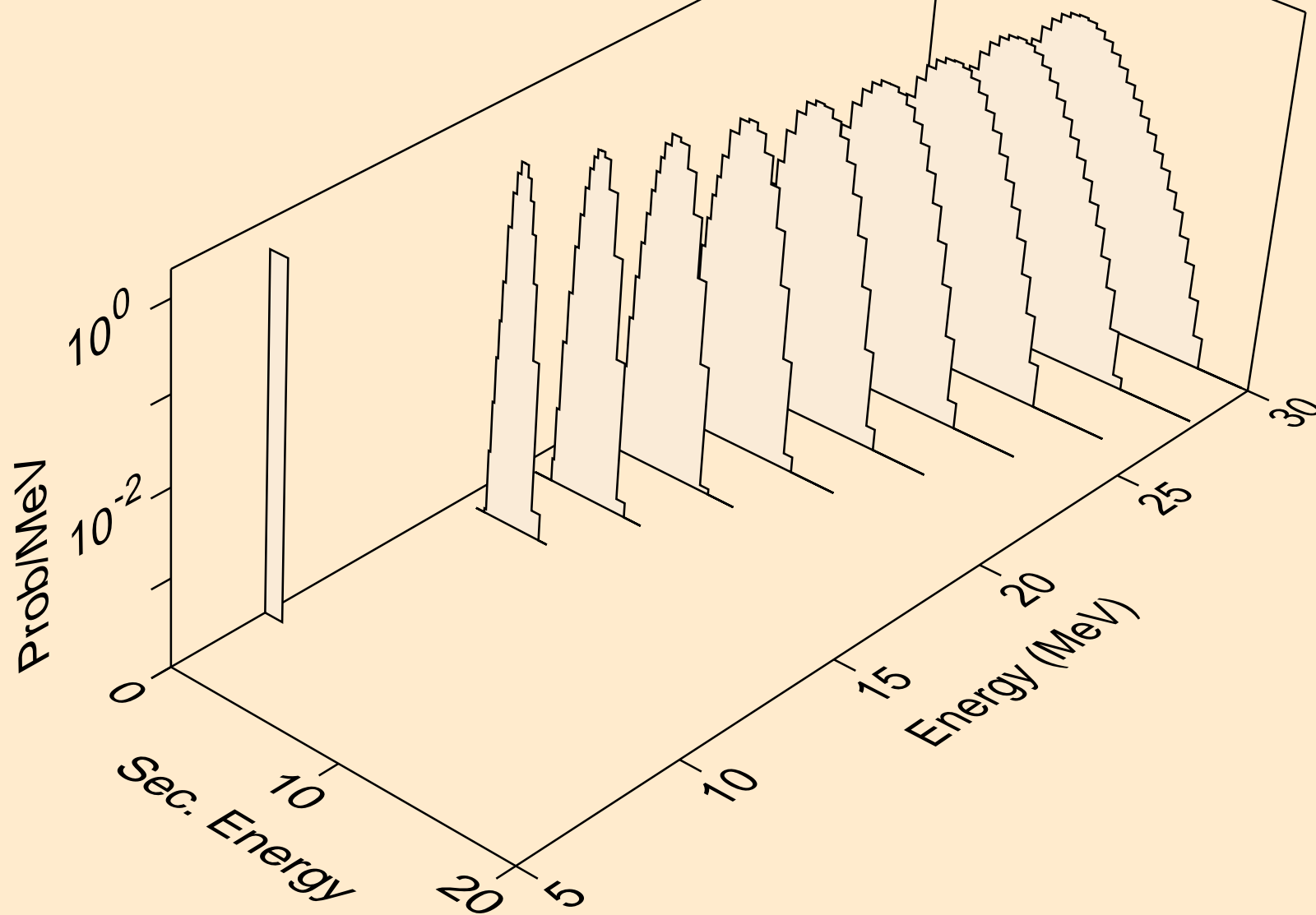

TL193M NEUTRON ACER TENDL-2024 LIBRARY; T=0.K  
protons from (n,npa)

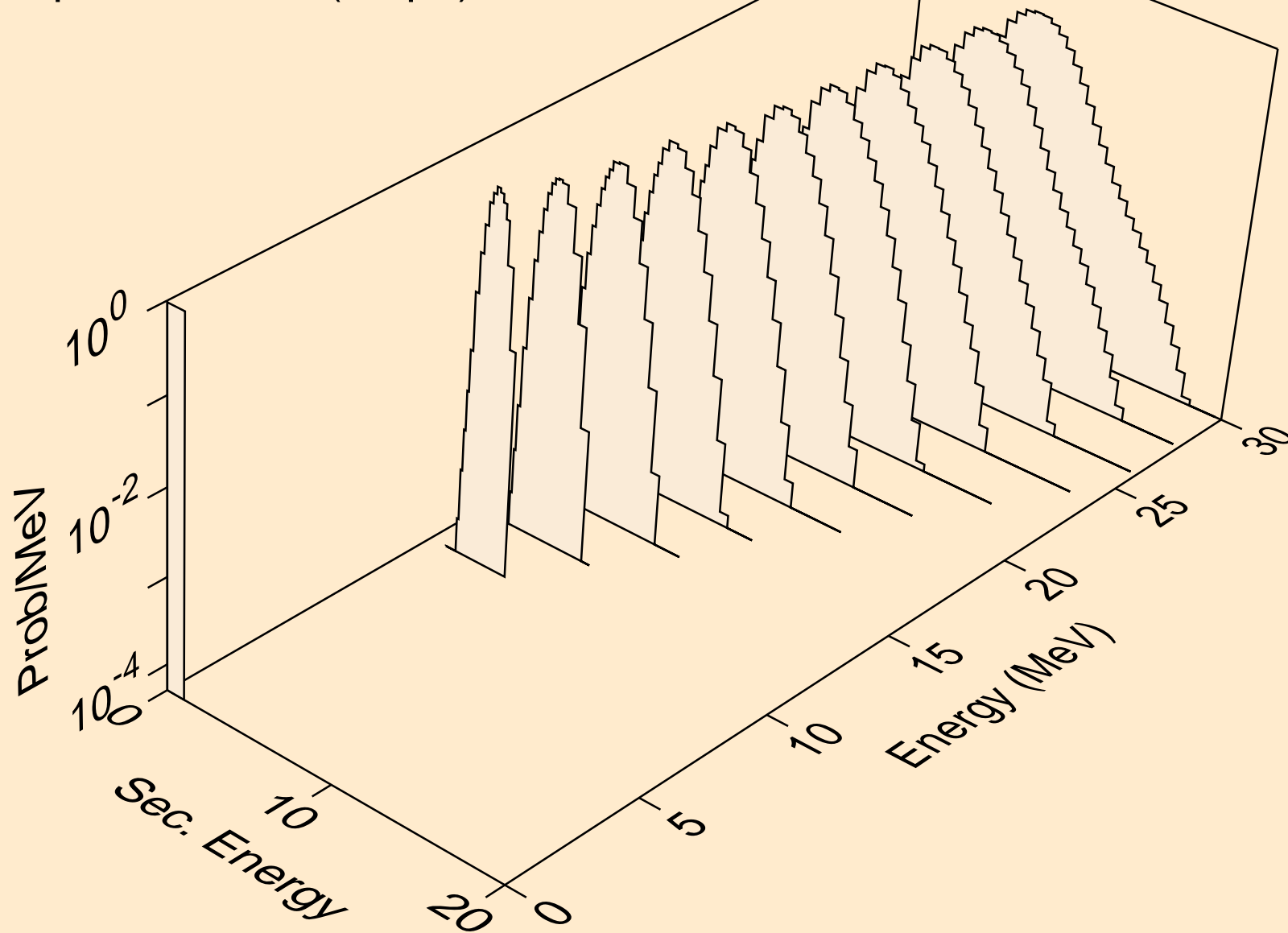

TL193M NEUTRON ACER TENDL-2024 LIBRARY; T=0.K  
protons from (n,p)

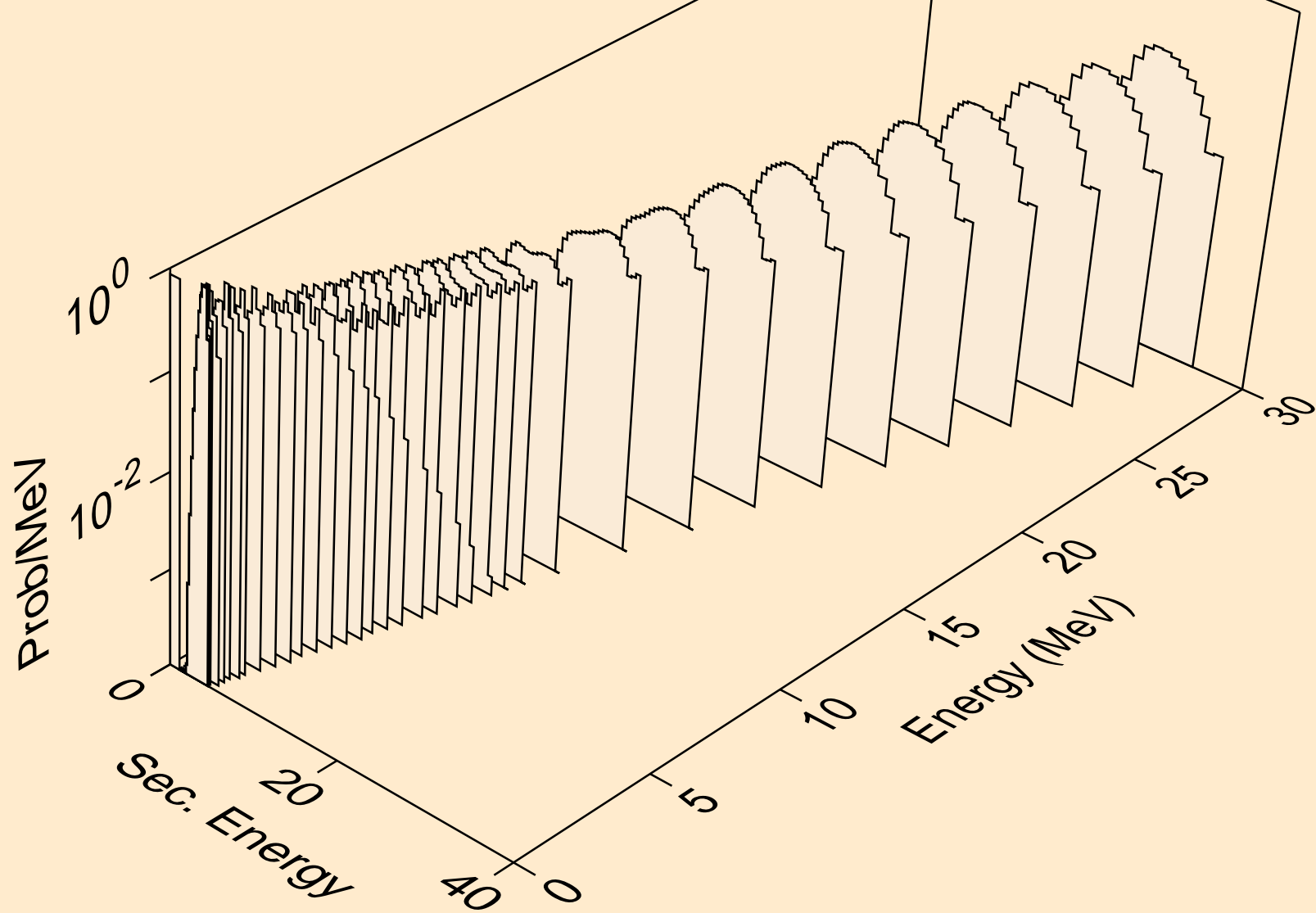

TL193M NEUTRON ACER TENDL-2024 LIBRARY; T=0.K  
protons from (n,2p)

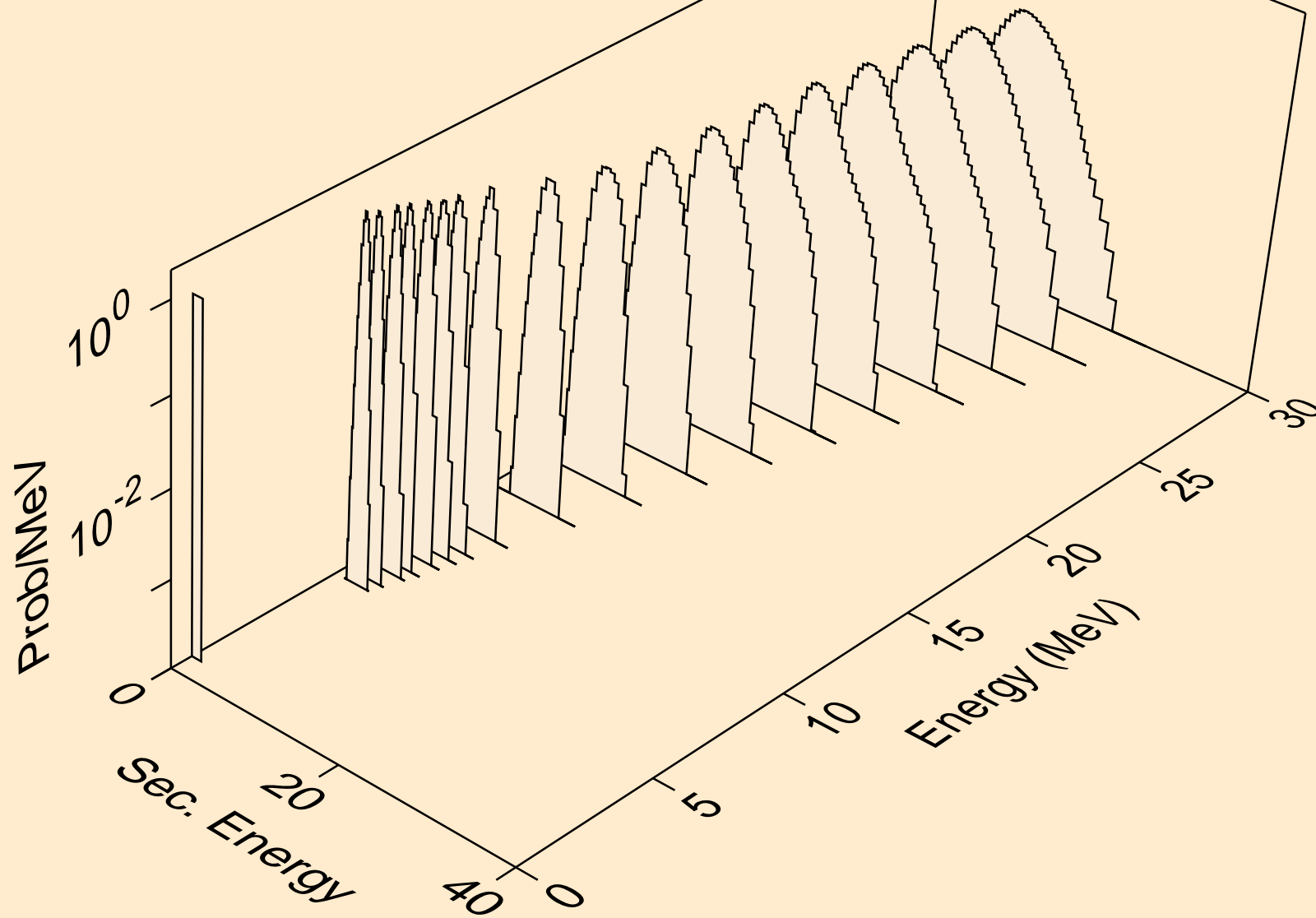

TL193M NEUTRON ACER TENDL-2024 LIBRARY; T=0.K  
protons from (n,p)

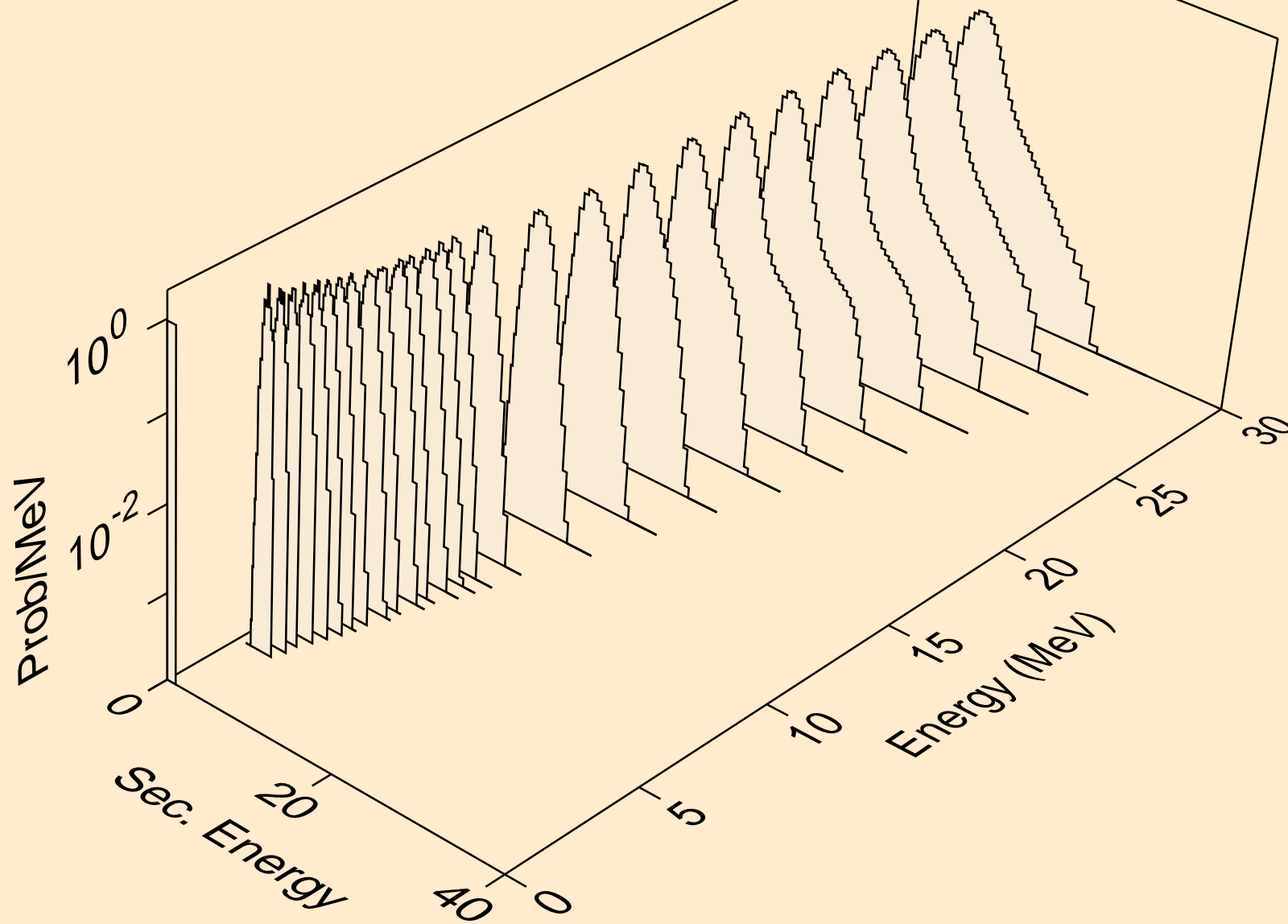

TL193M NEUTRON ACER TENDL-2024 LIBRARY; T=0.K  
protons from (n,pd)

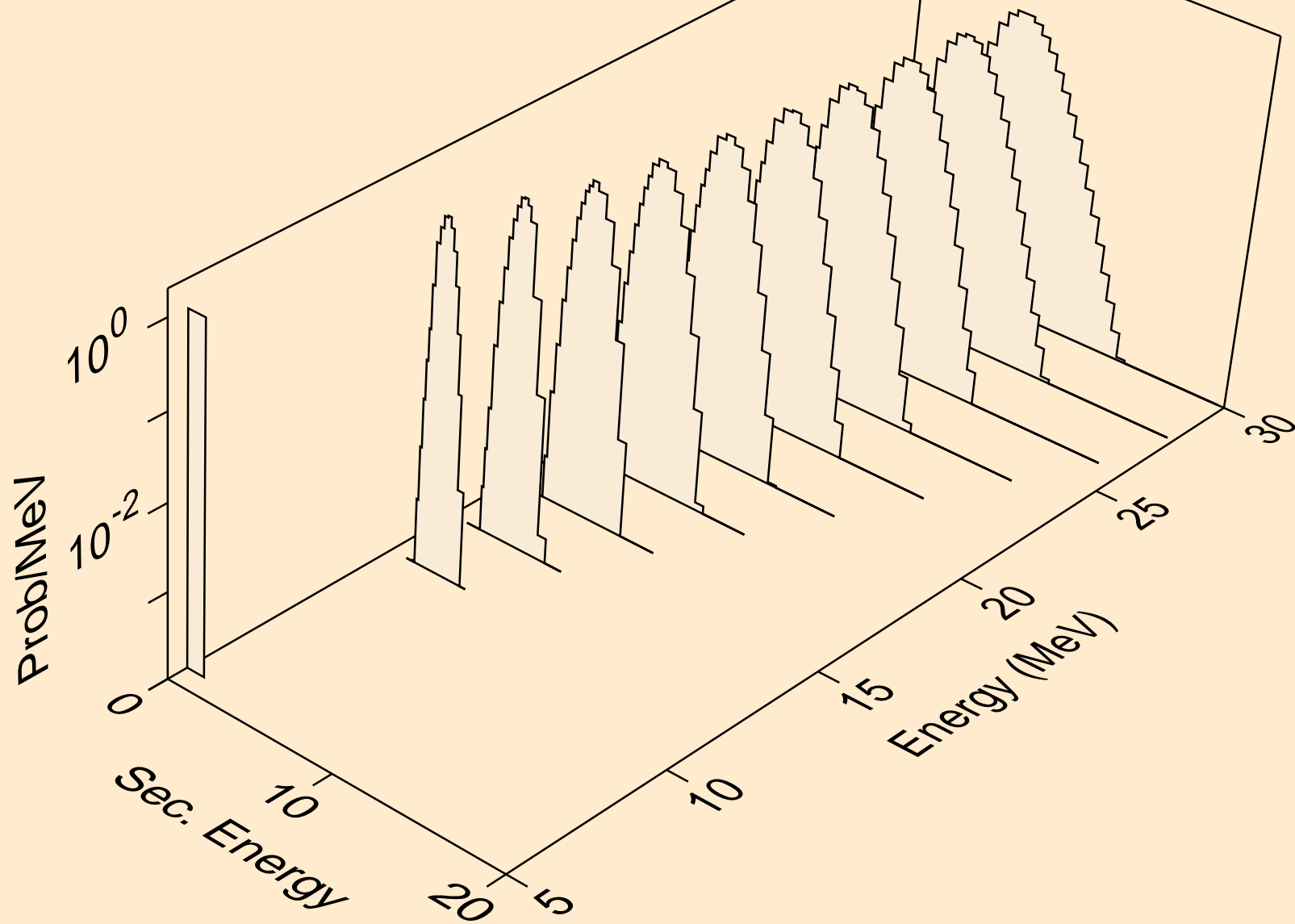

TL193M NEUTRON ACER TENDL-2024 LIBRARY; T=0.K  
protons from (n,pt)

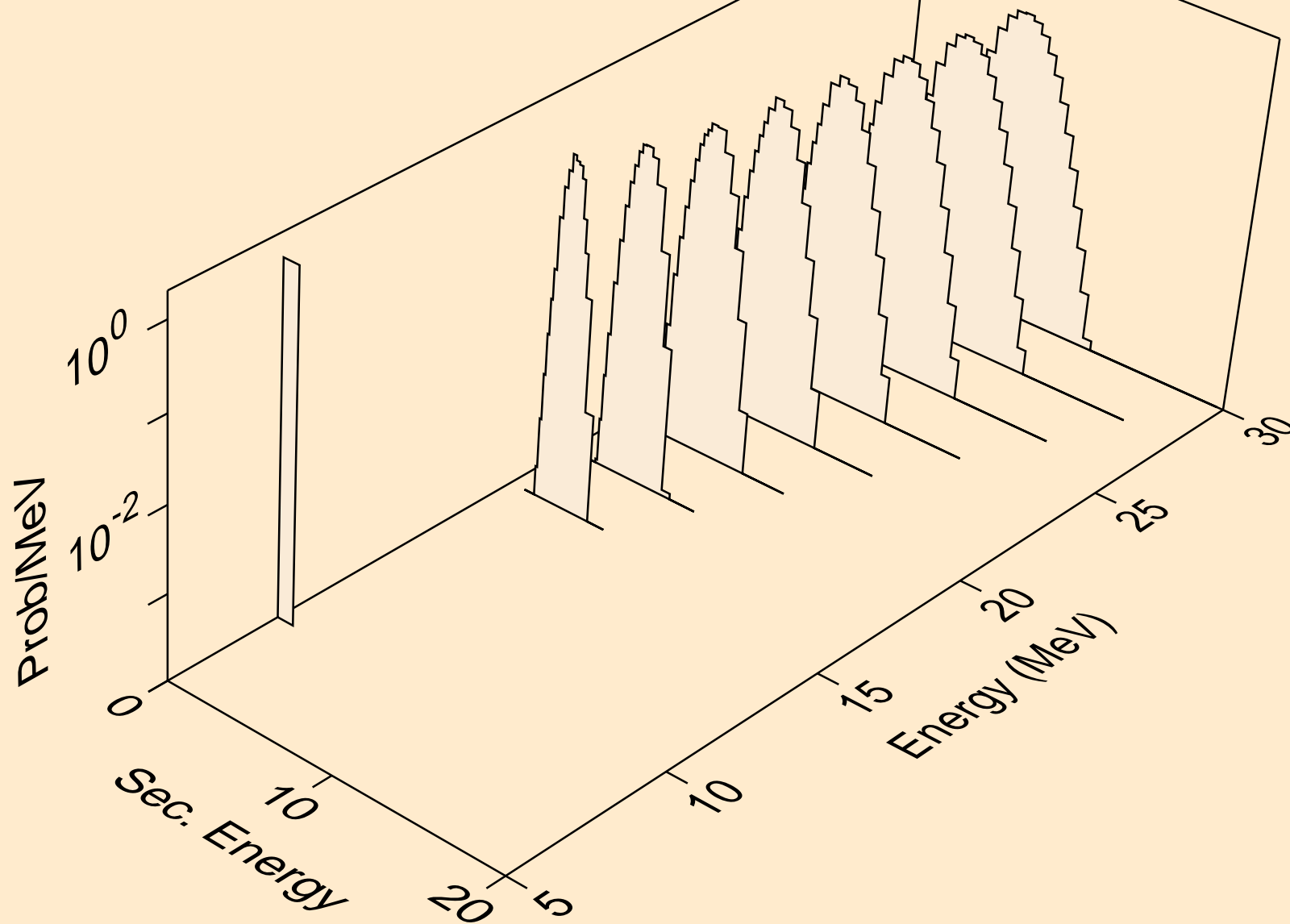

TL193M NEUTRON ACER TENDL-2024 LIBRARY; T=0.K  
deuterons from (n,x)

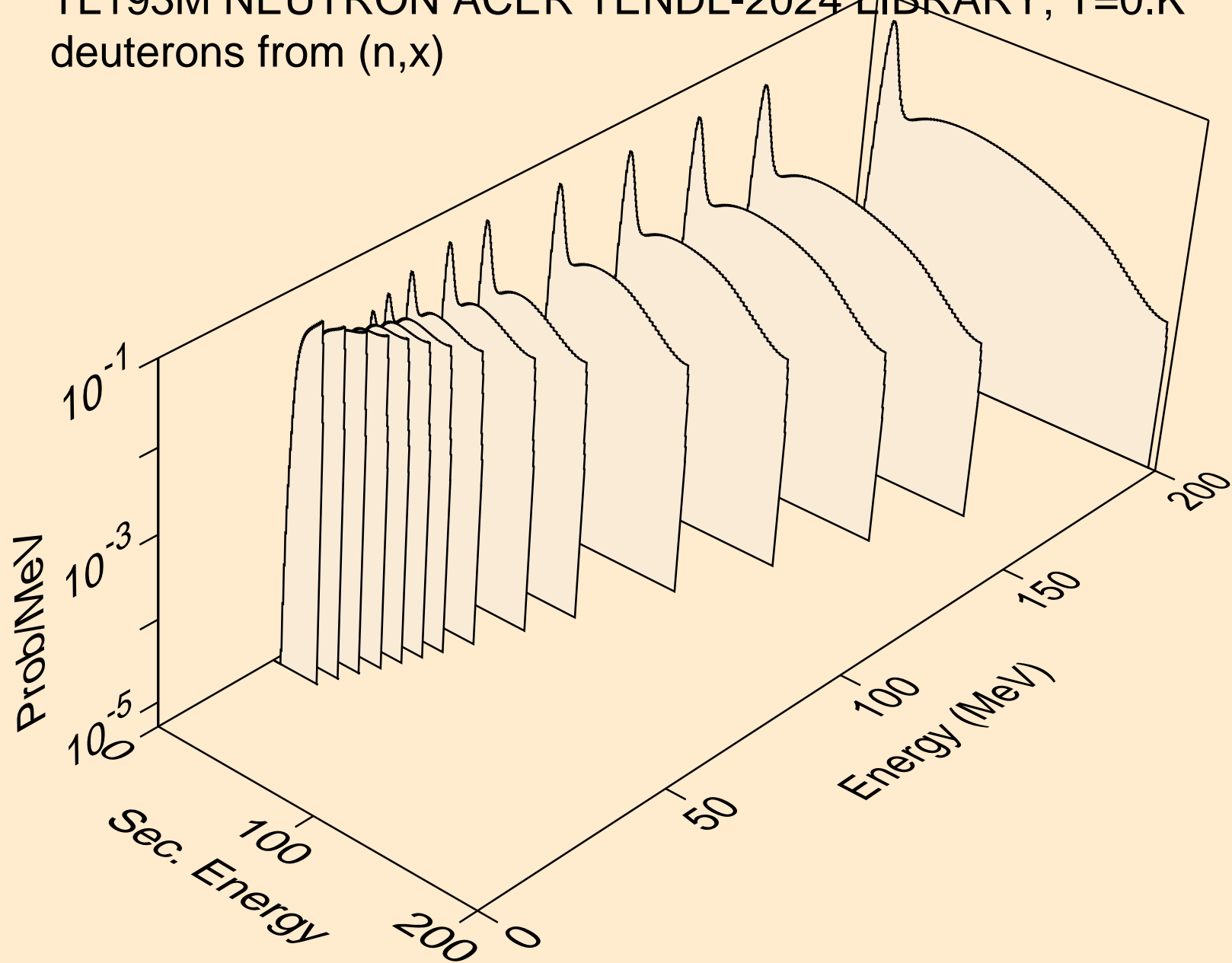



TL193M NEUTRON ACER TENDL-2024 LIBRARY; T=0.K  
deuterons from (n,2nd)

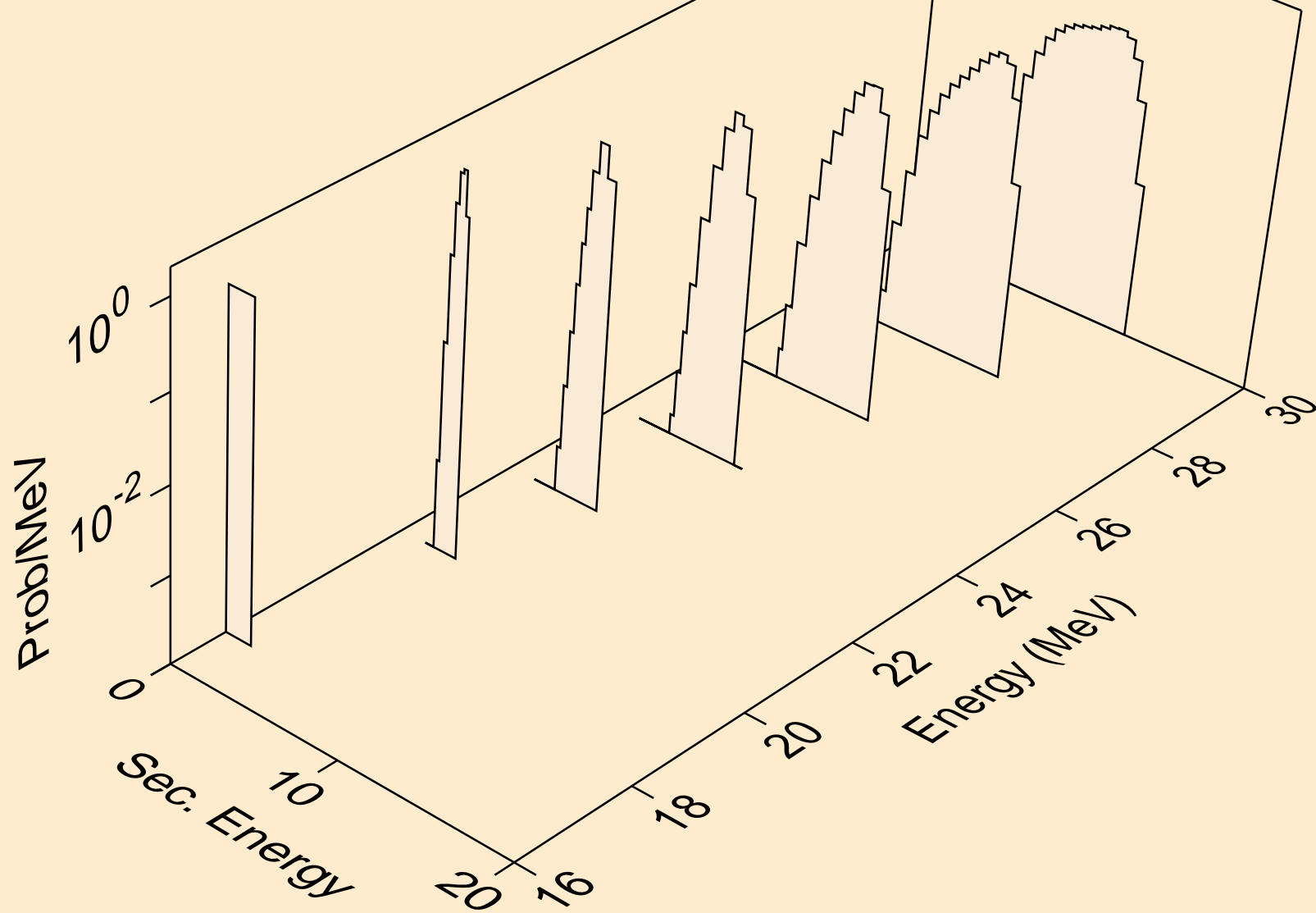

TL193M NEUTRON ACER TENDL-2024 LIBRARY; T=0.K  
deuterons from (n,n\*)d

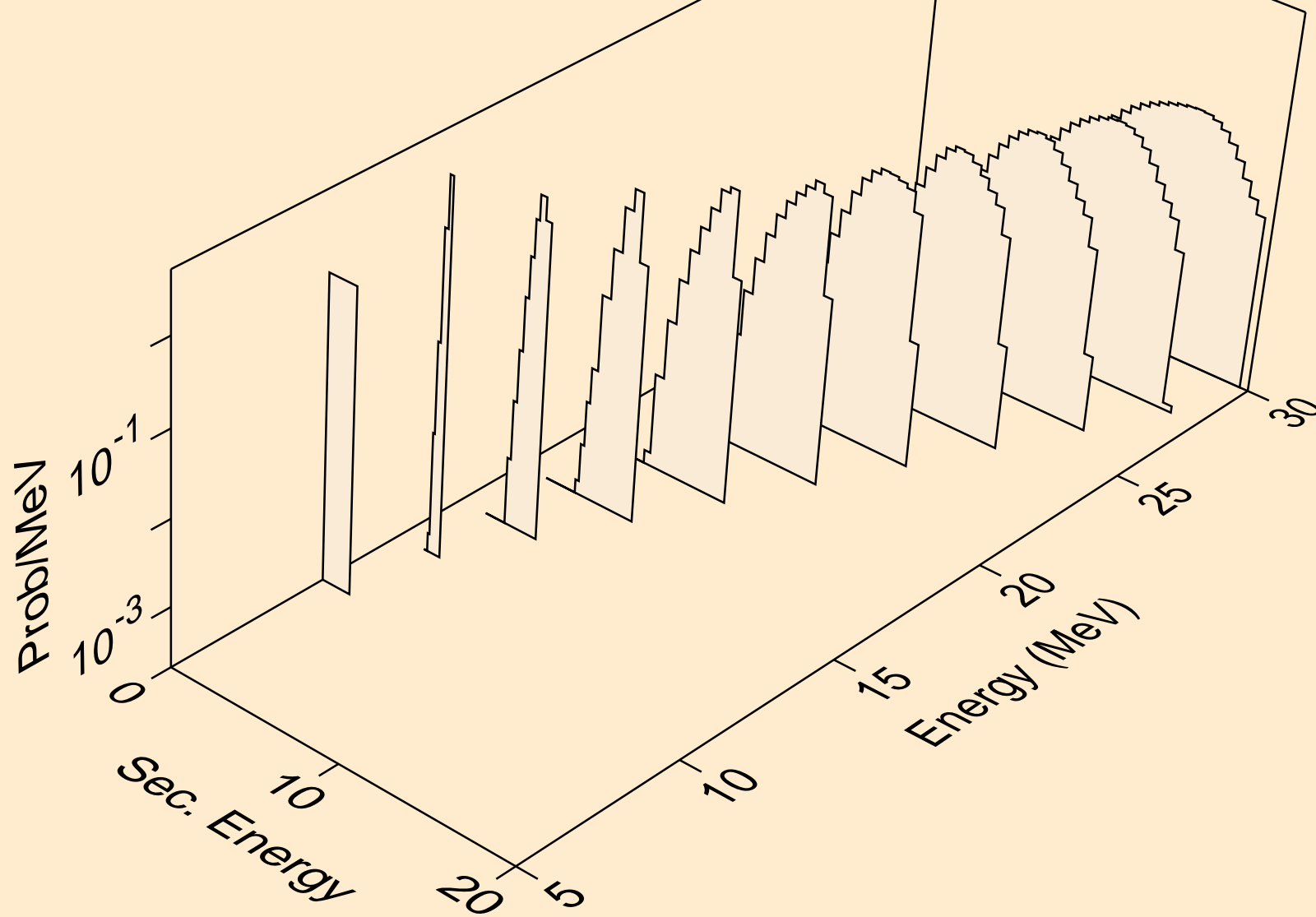

TL193M NEUTRON ACER TENDL-2024 LIBRARY; T=0.K  
deuterons from (n,d)

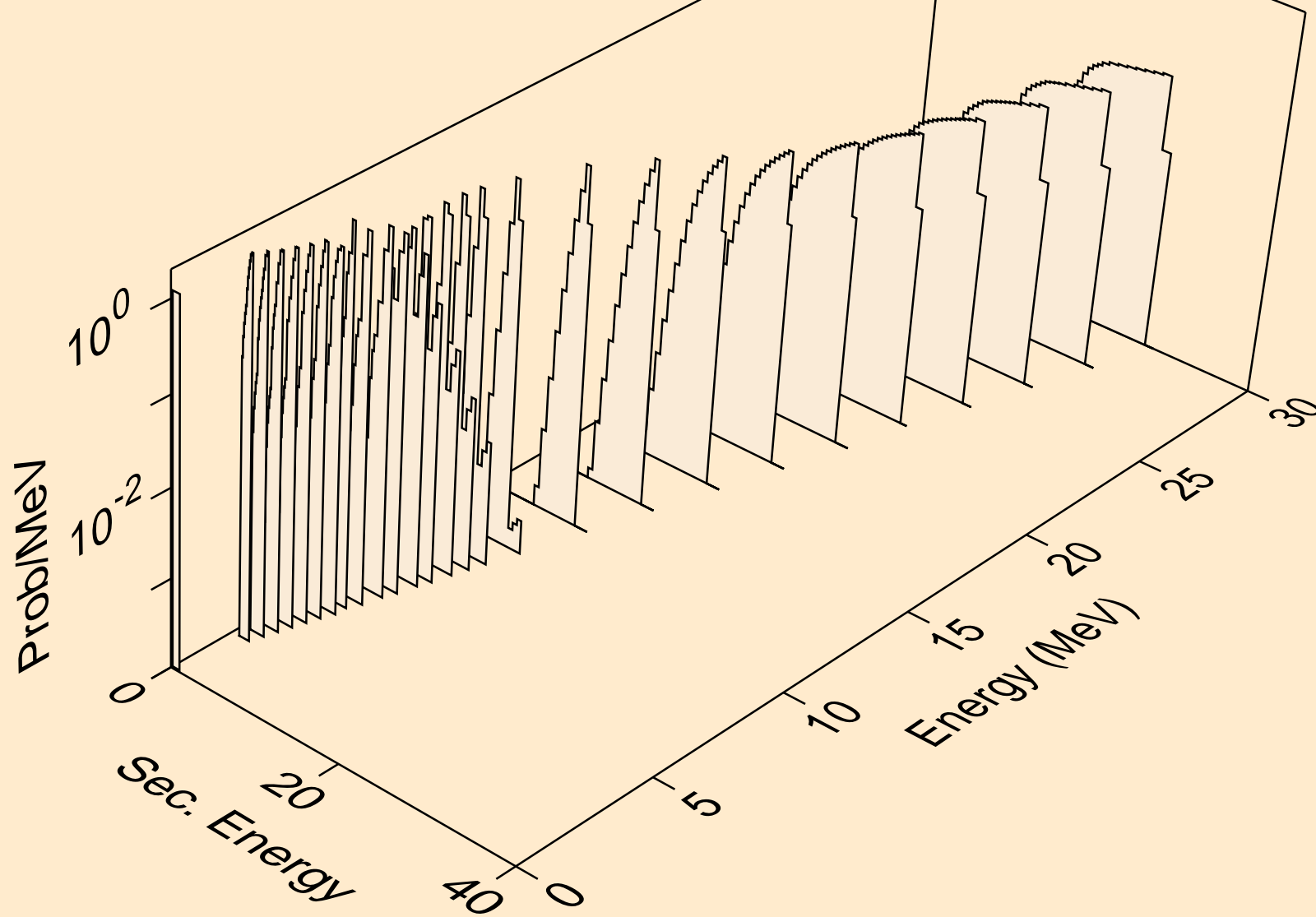

TL193M NEUTRON ACER TENDL-2024 LIBRARY; T=0.K  
deuterons from (n,pd)

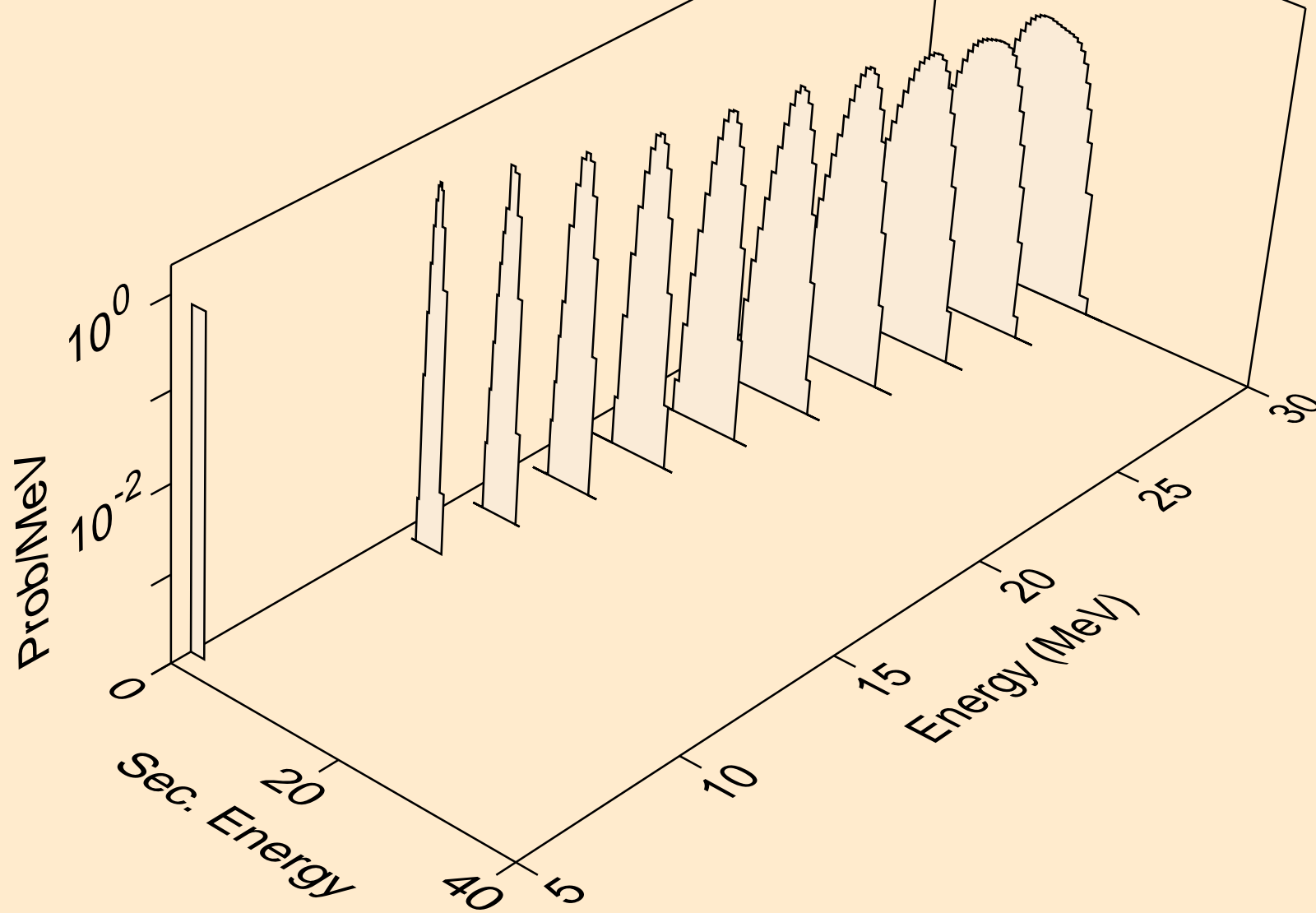

TL193M NEUTRON ACER TENDL-2024 LIBRARY; T=0.K  
deuterons from (n,da)

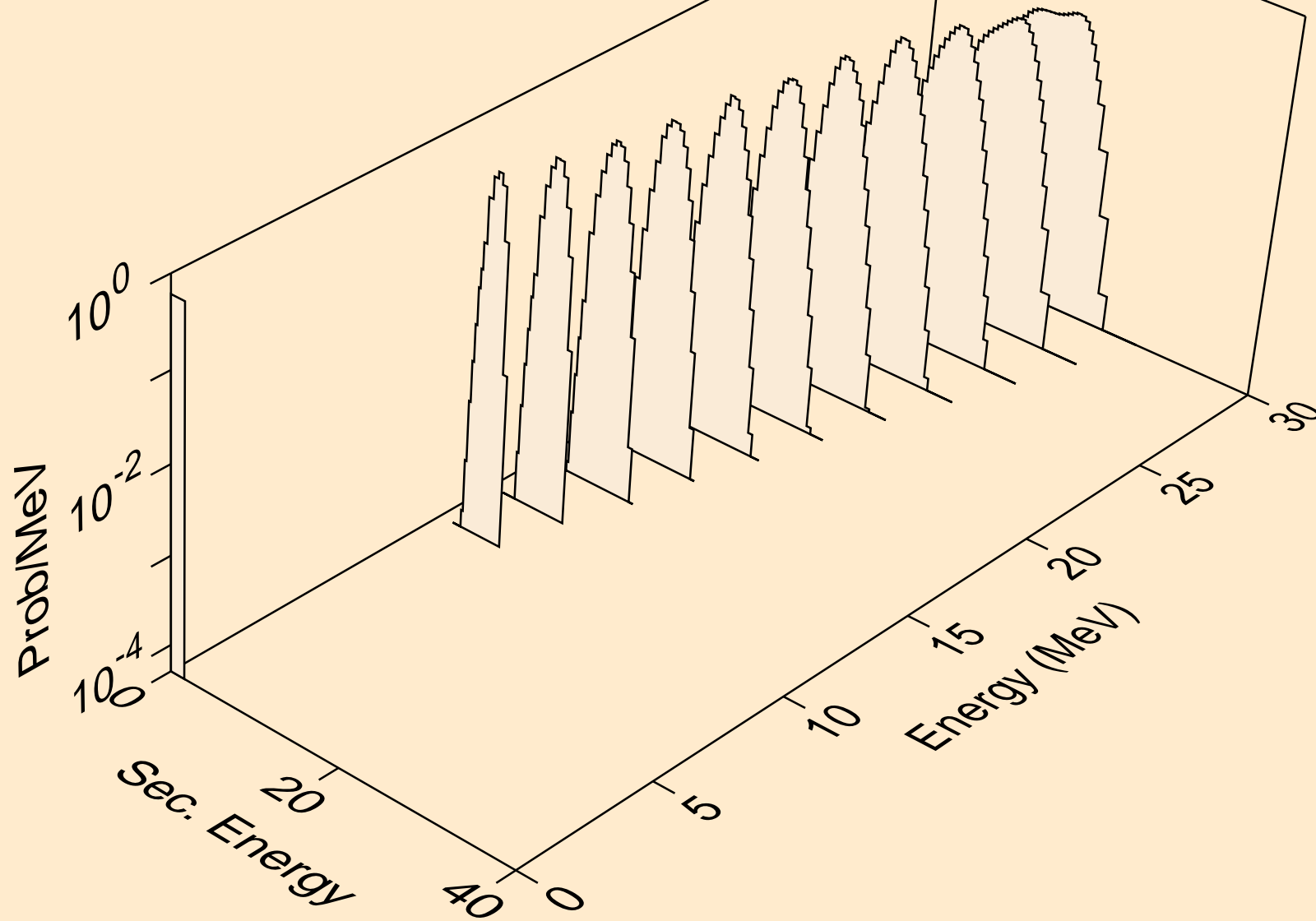

TL193M NEUTRON ACER TENDL-2024 LIBRARY; T=0.K  
tritons from (n,x)

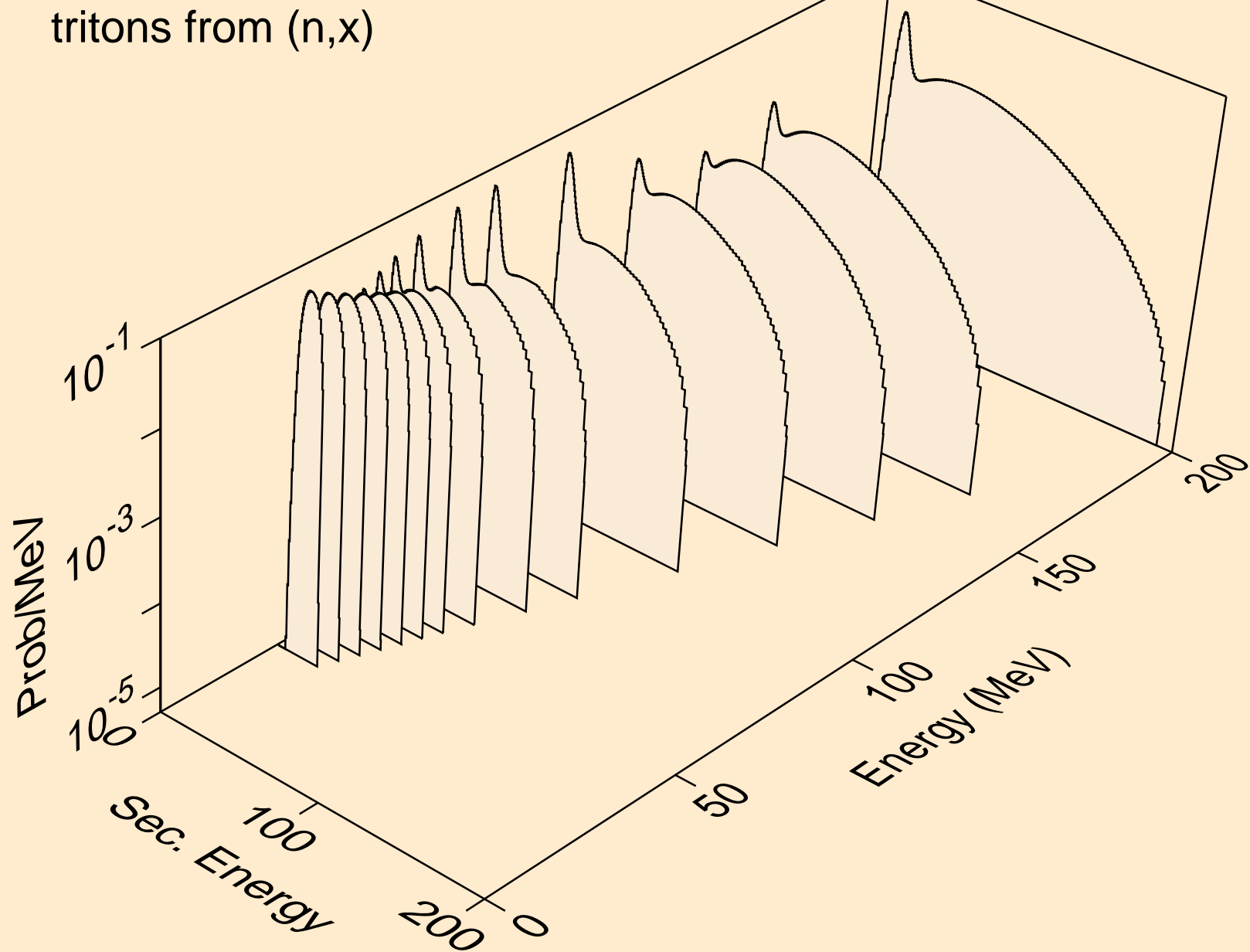

TL193M NEUTRON ACER TENDL-2024 LIBRARY; T=0.K  
tritons from (n,n\*)t

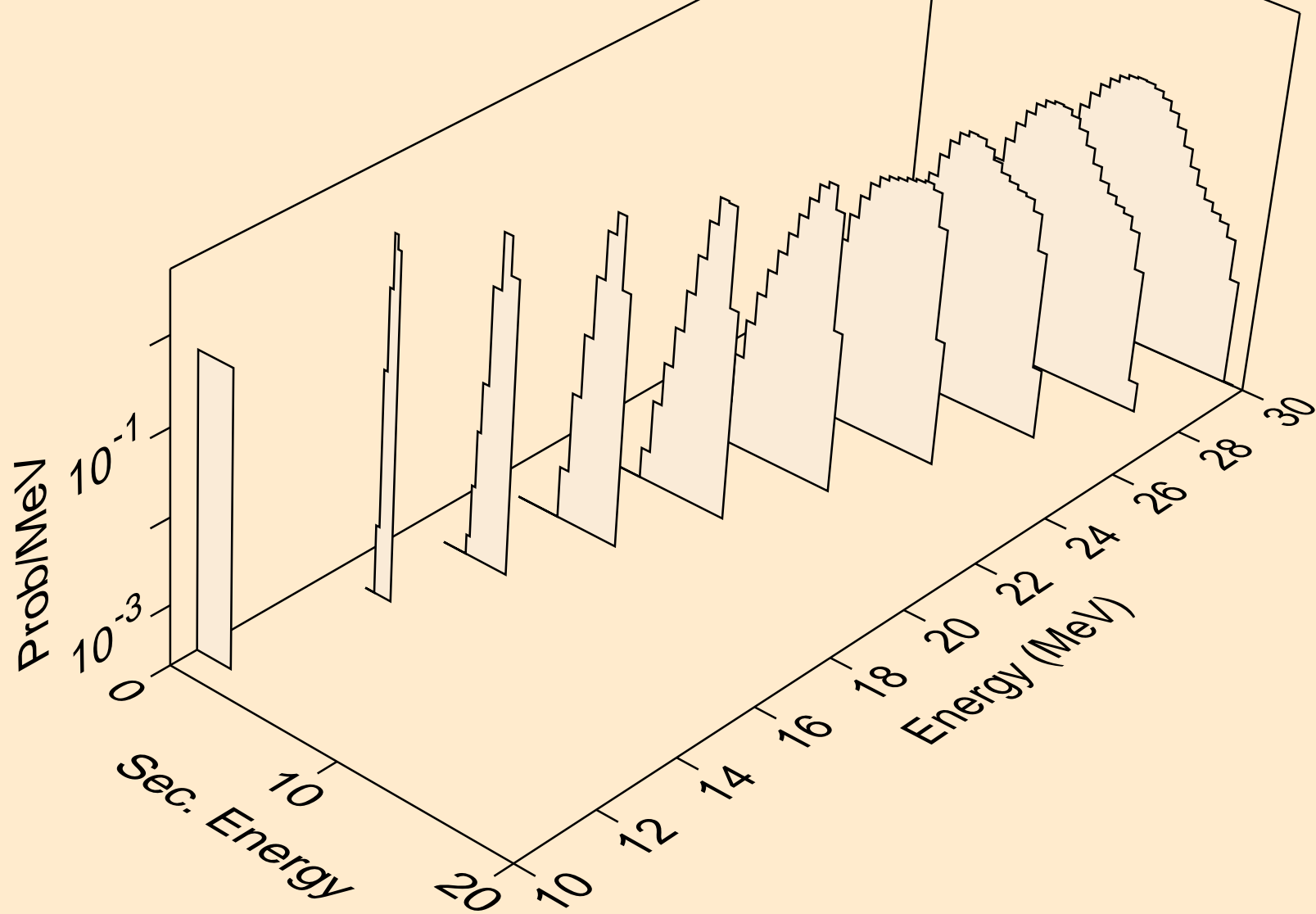

TL193M NEUTRON ACER TENDL-2024 LIBRARY; T=0.K  
tritons from (n,t)

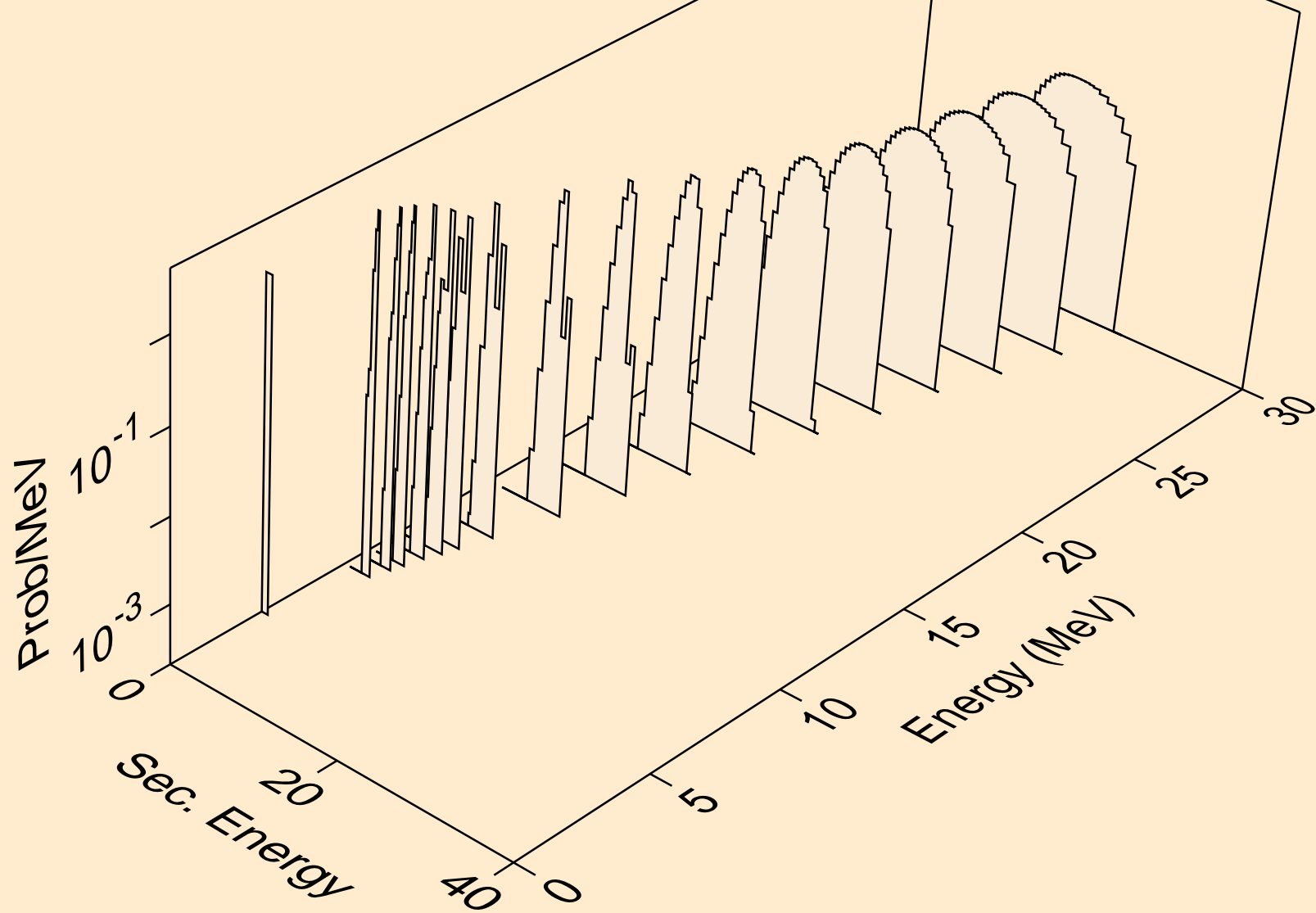



TL193M NEUTRON ACER TENDL-2024 LIBRARY; T=0.K  
tritons from (n,pt)

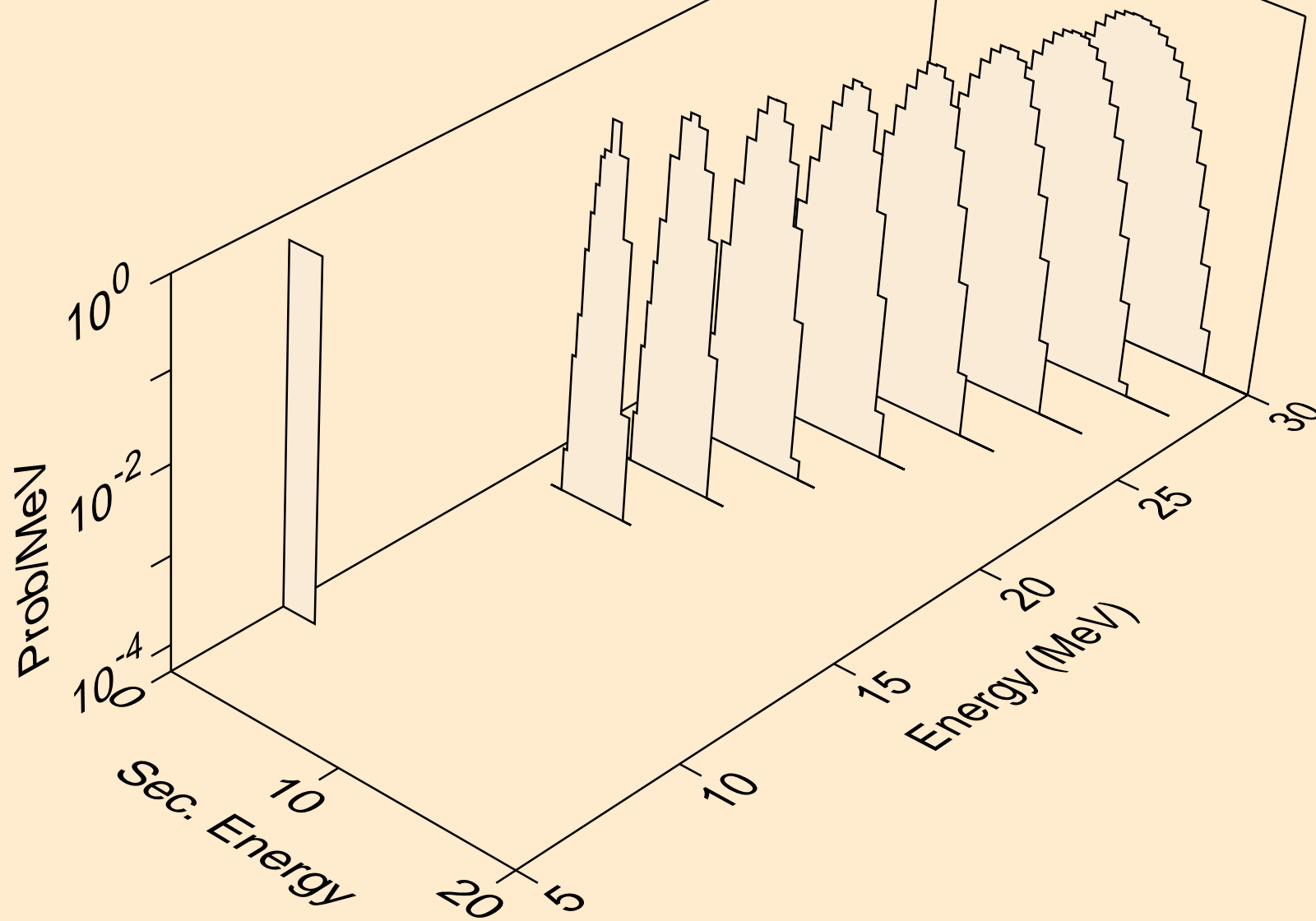

TL193M NEUTRON ACER TENDL-2024 LIBRARY; T=0.K  
he3s from (n,x)

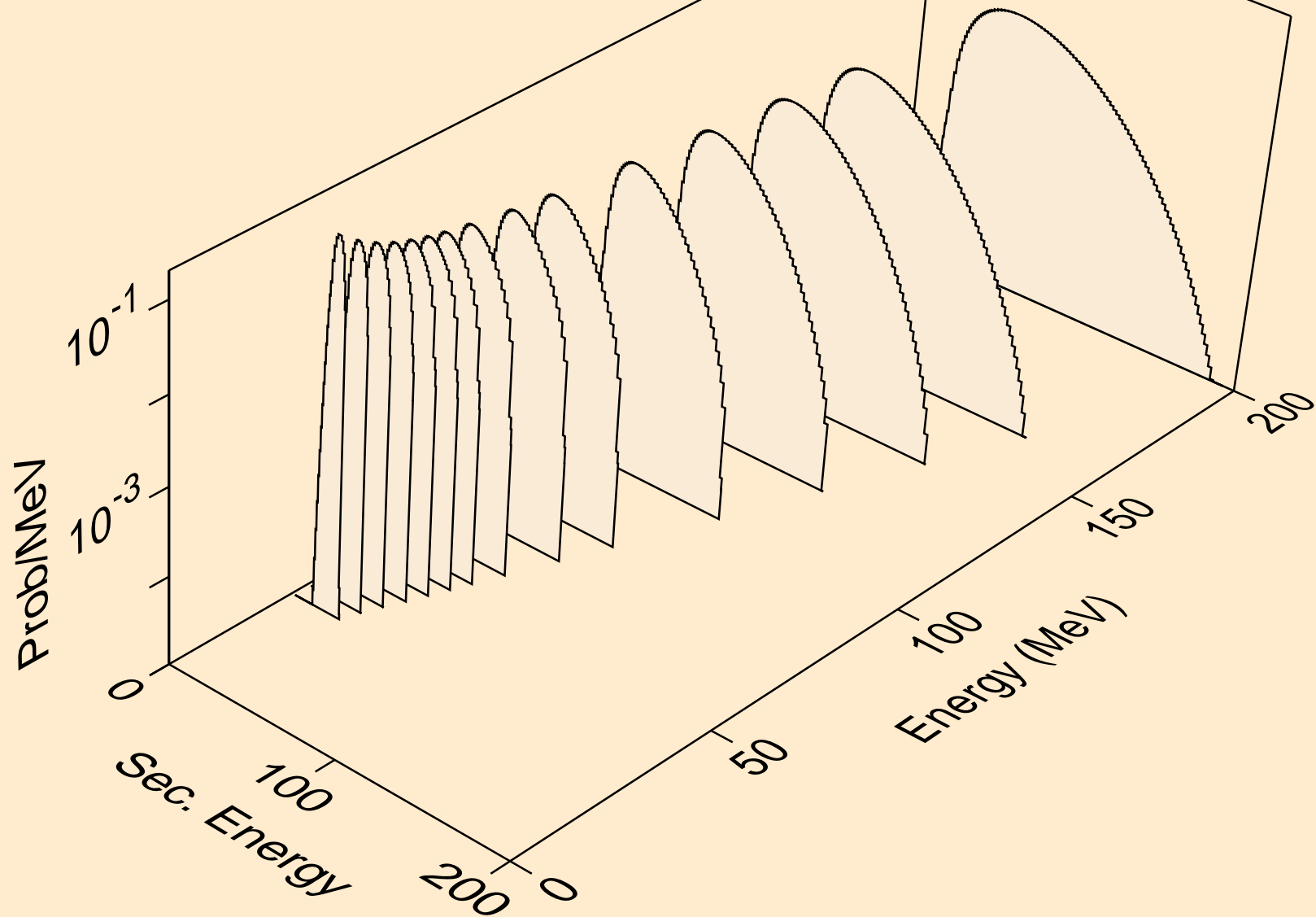

TL193M NEUTRON ACER TENDL-2024 LIBRARY; T=0.K  
he3s from (n,n\*)he3

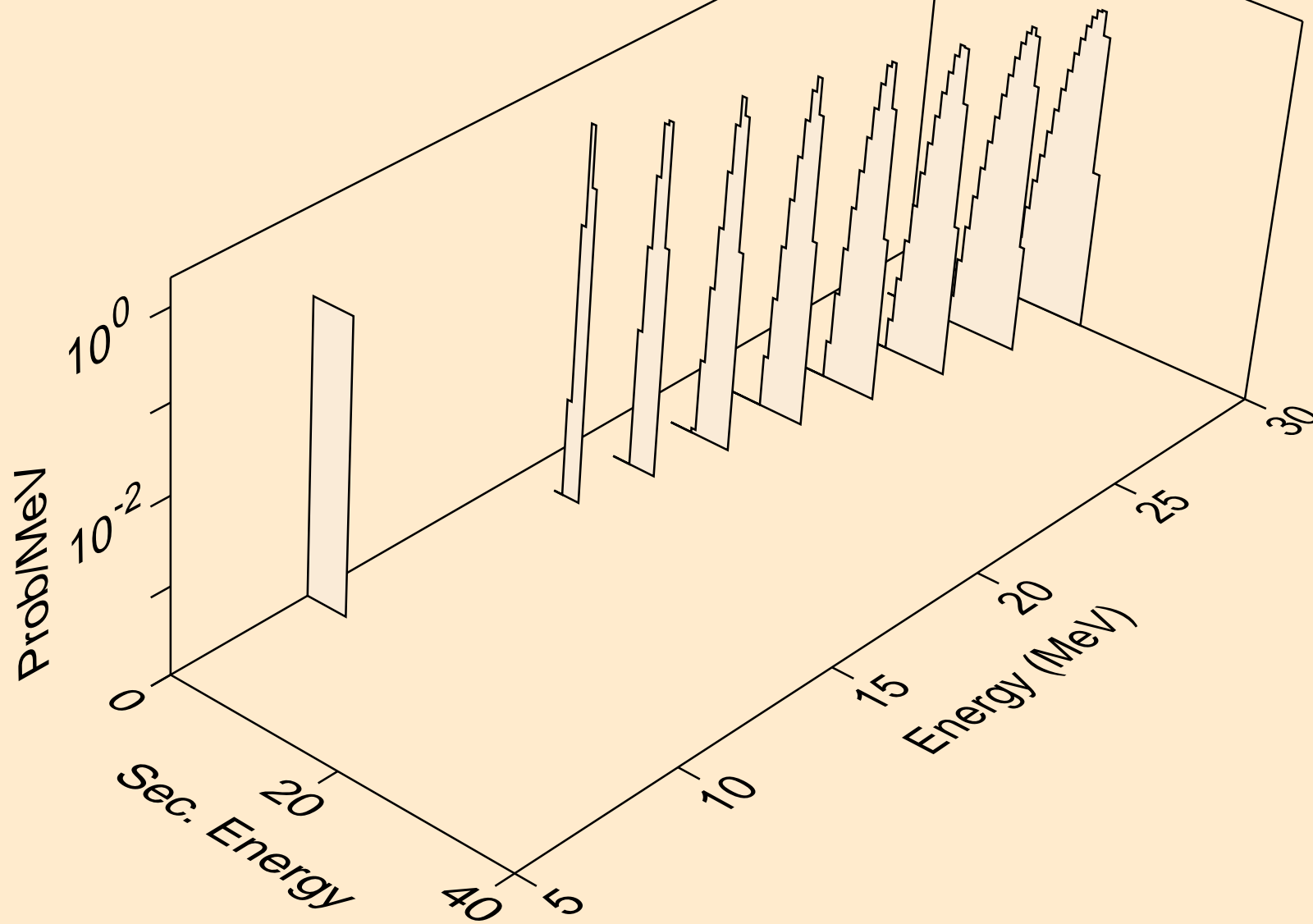

TL193M NEUTRON ACER TENDL-2024 LIBRARY; T=0.K  
he3s from (n,he3)

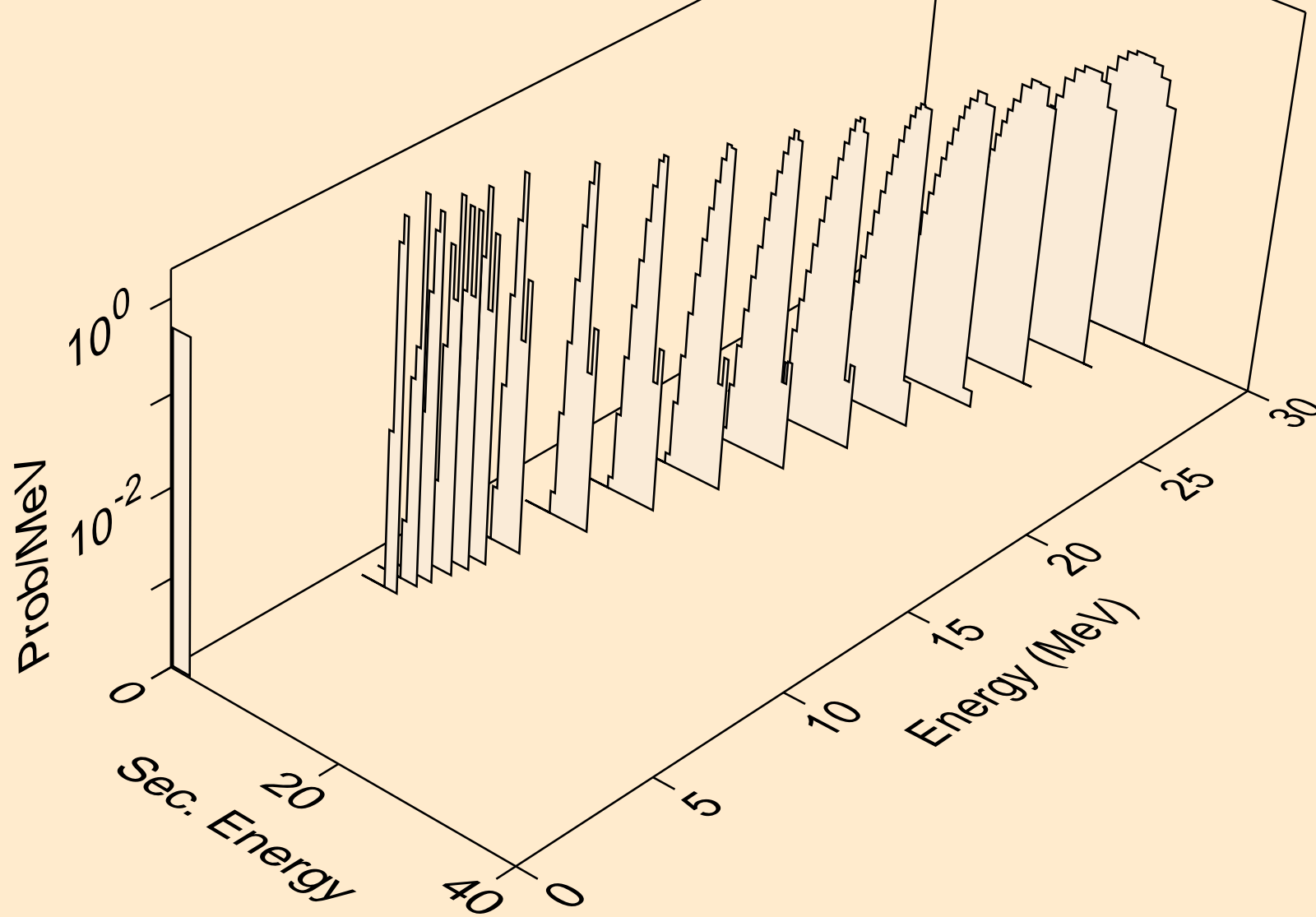

TL193M NEUTRON ACER TENDL-2024 LIBRARY; T=0.K  
alphas from (n,x)

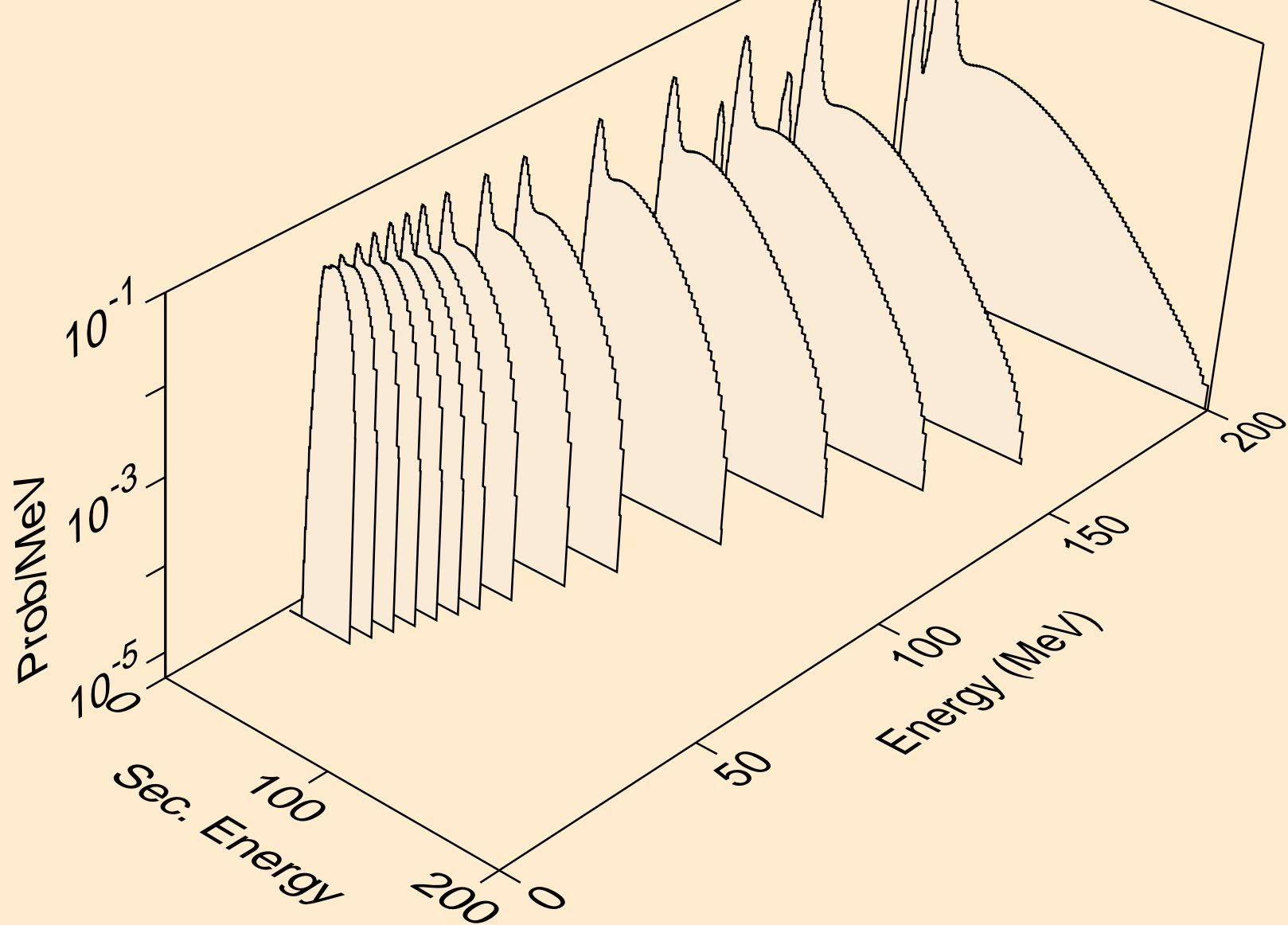

TL193M NEUTRON ACER TENDL-2024 LIBRARY; T=0.K  
alphas from (n,n\*)a

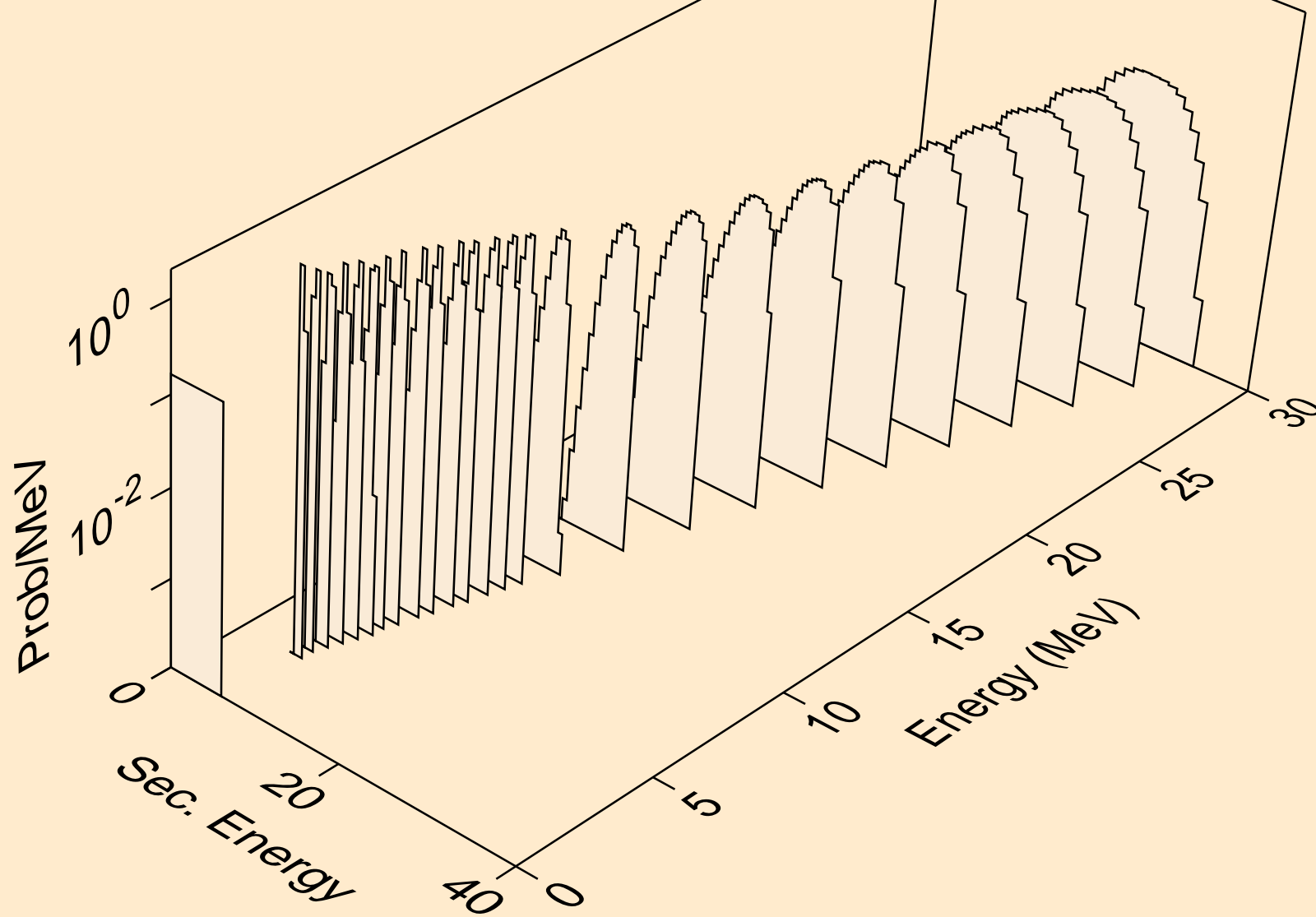

TL193M NEUTRON ACER TENDL-2024 LIBRARY; T=0.K  
alphas from (n,2n)a

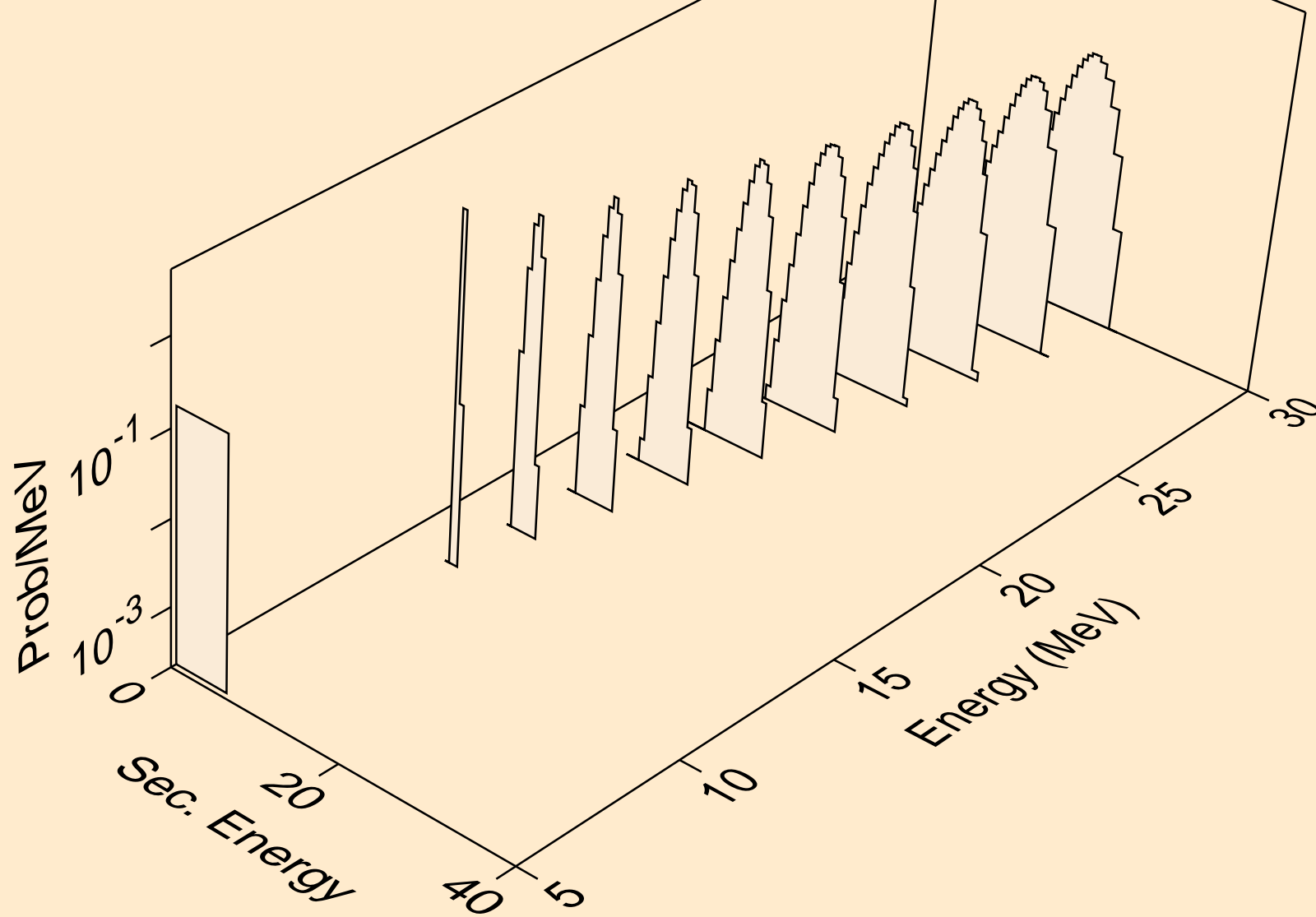

TL193M NEUTRON ACER TENDL-2024 LIBRARY; T=0.K  
alphas from (n,3n)a

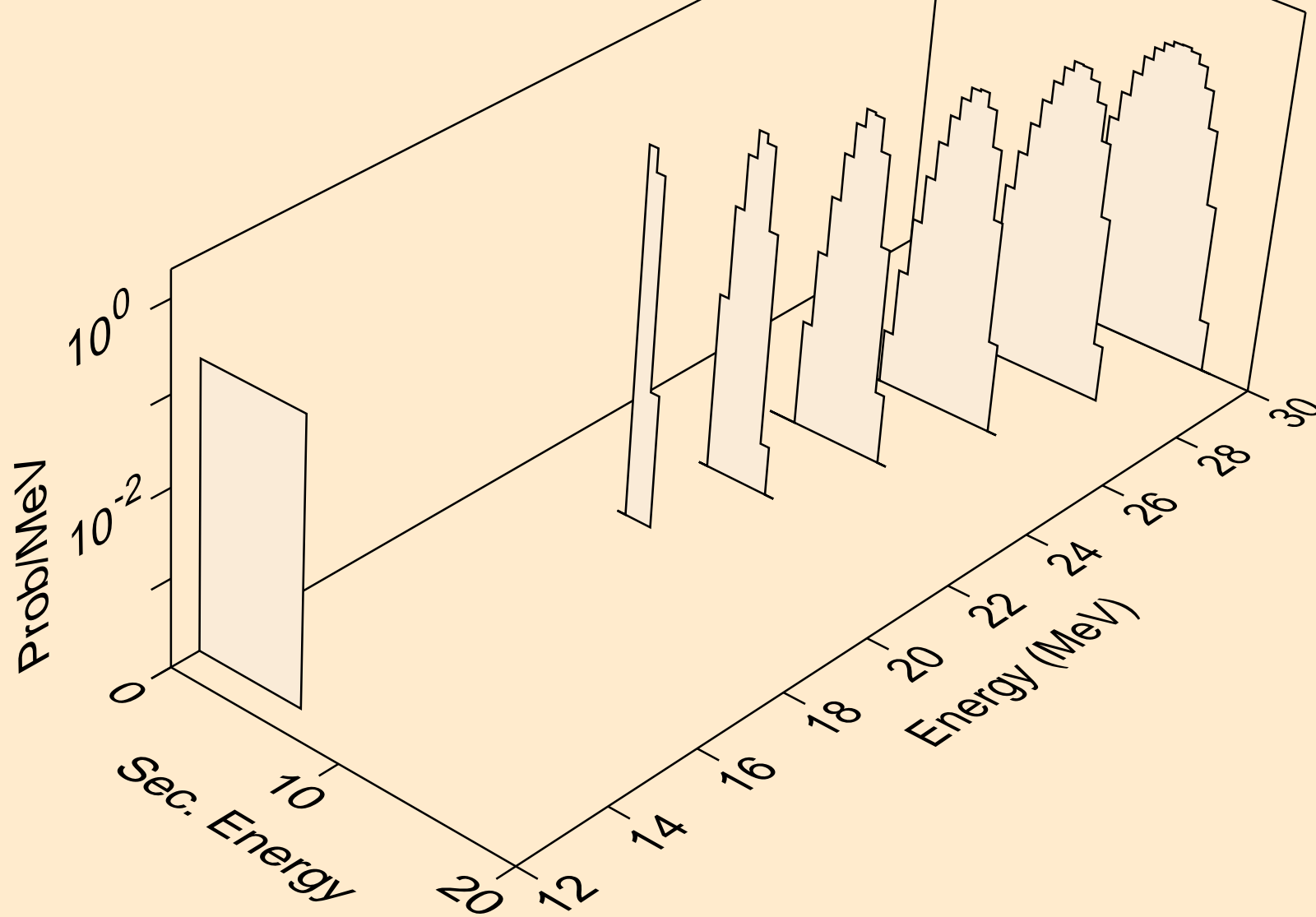



TL193M NEUTRON ACER TENDL-2024 LIBRARY; T=0.K  
alphas from (n,n\*)2a

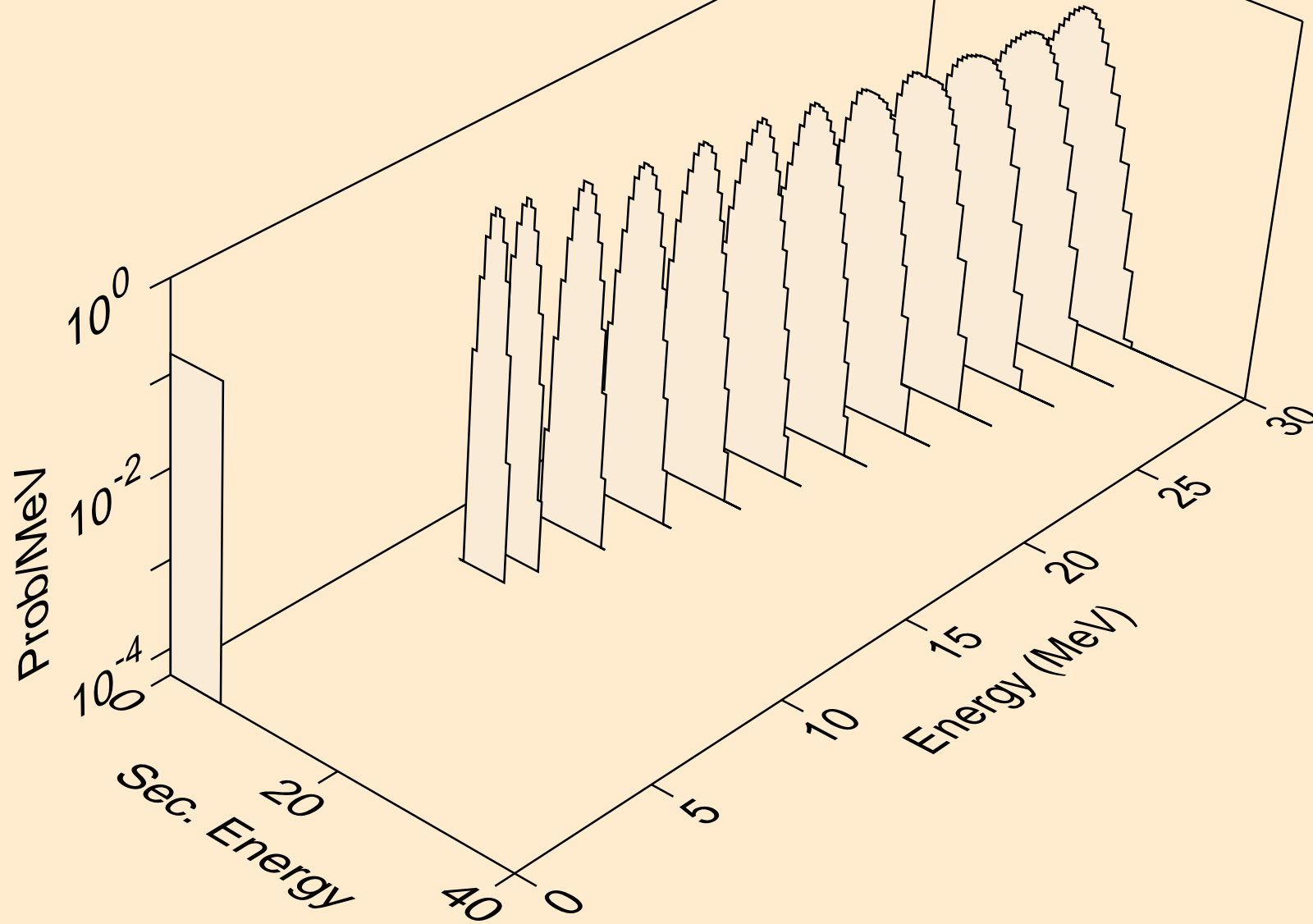

TL193M NEUTRON ACER TENDL-2024 LIBRARY; T=0.K  
alphas from (n,2n)2a

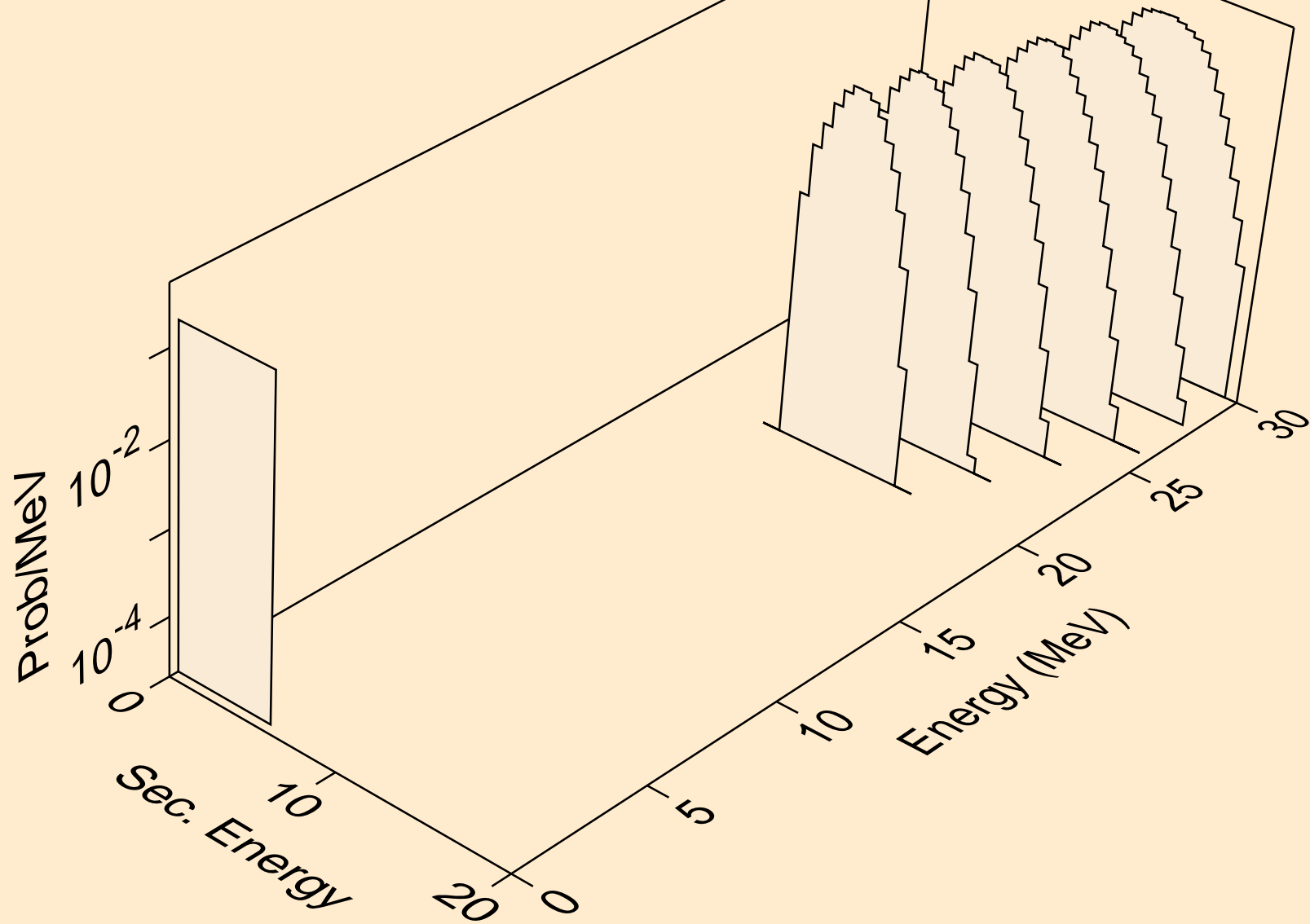

TL193M NEUTRON ACER TENDL-2024 LIBRARY; T=0.K  
alphas from (n,npa)

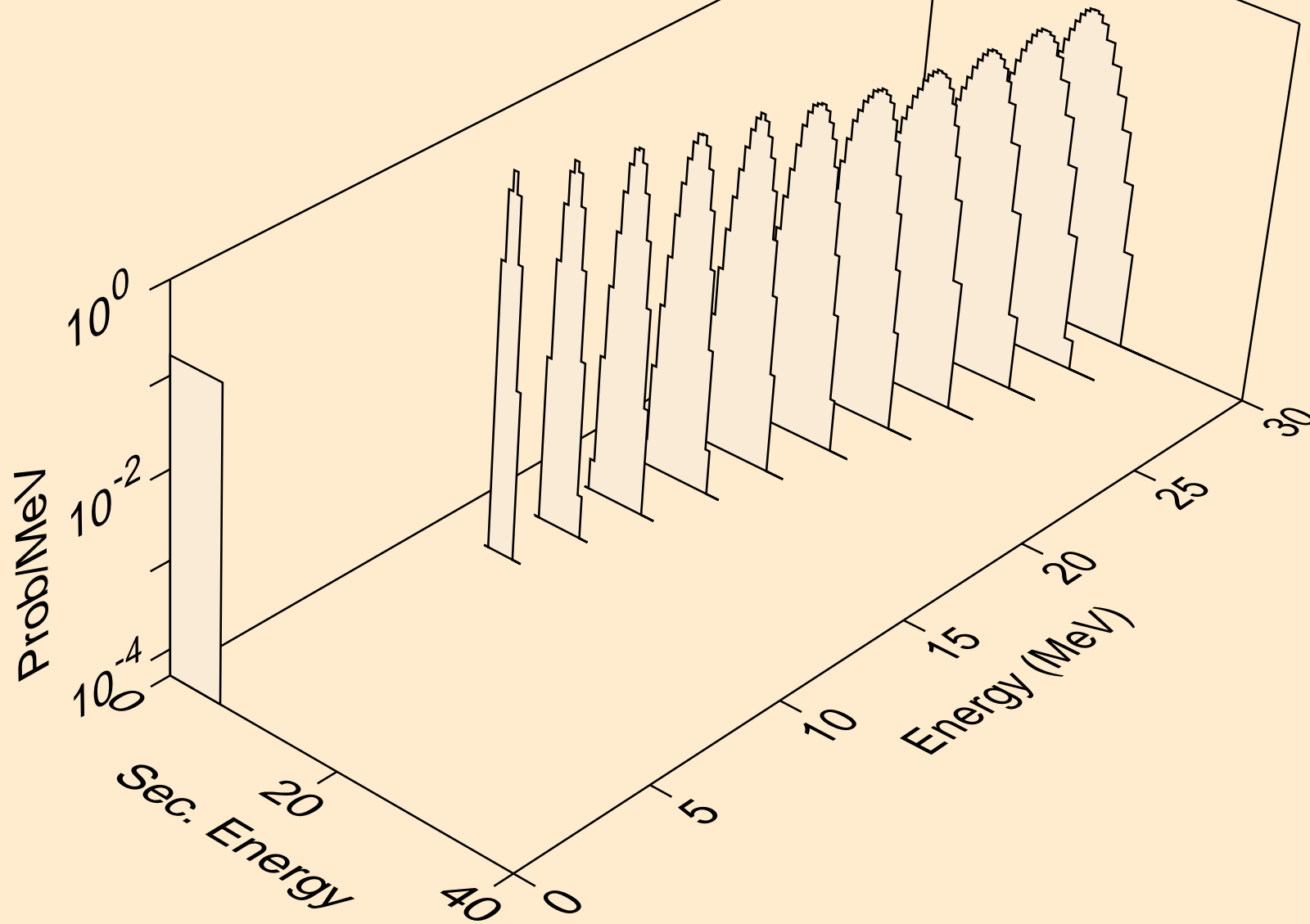

TL193M NEUTRON ACER TENDL-2024 LIBRARY; T=0.K  
alphas from (n,a)

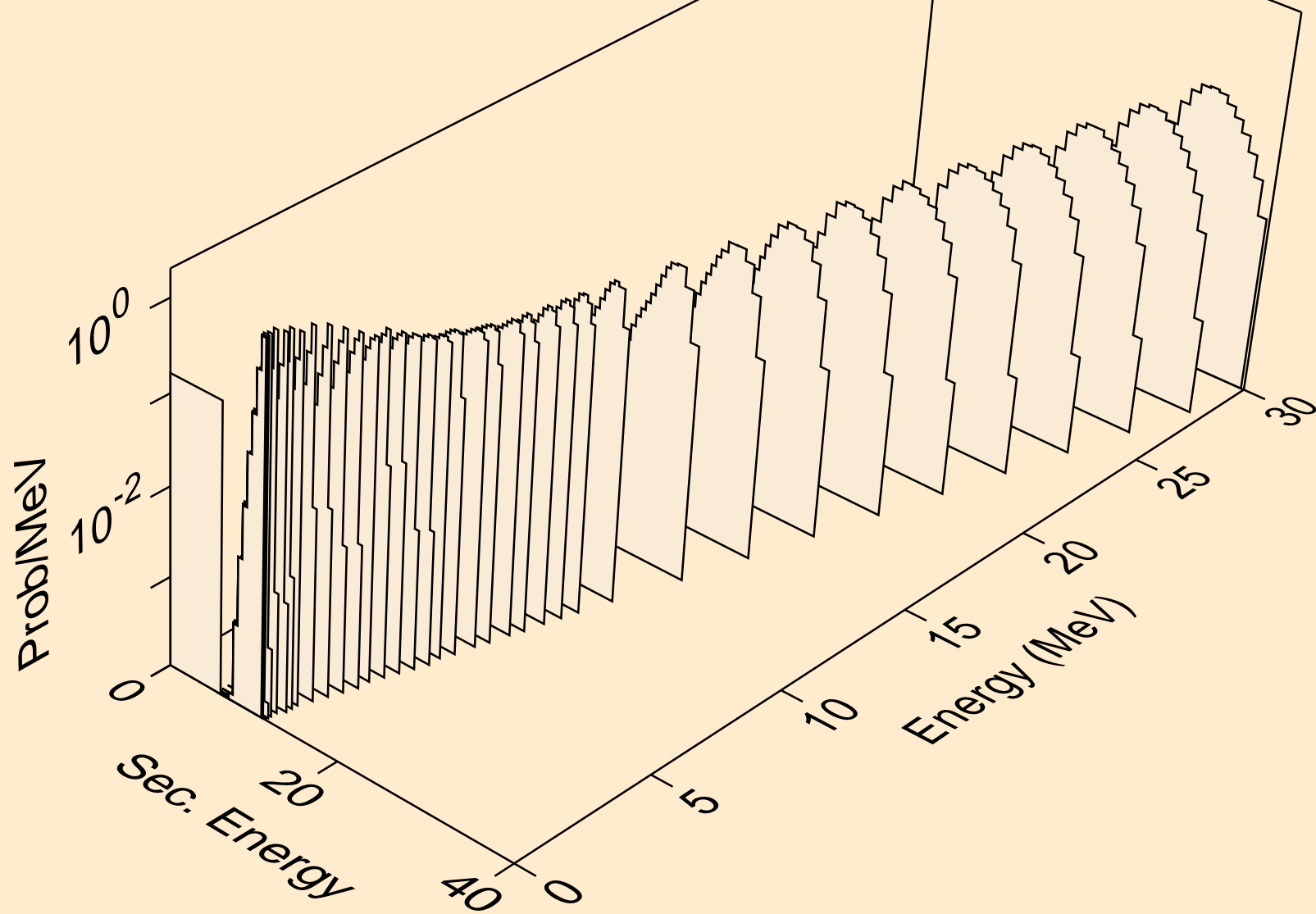

TL193M NEUTRON ACER TENDL-2024 LIBRARY; T=0.K  
alphas from (n,2a)

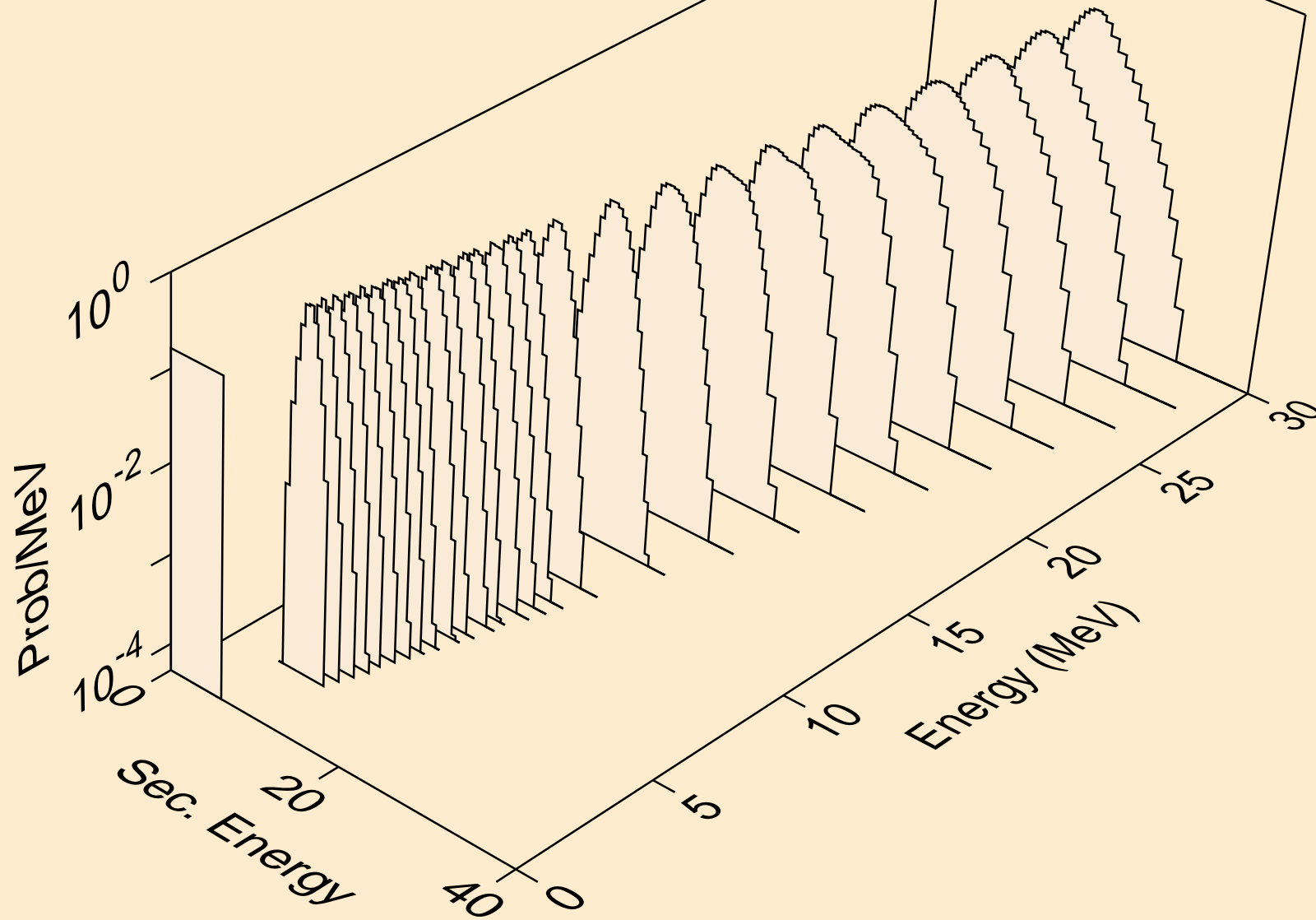

TL193M NEUTRON ACER TENDL-2024 LIBRARY; T=0.K  
alphas from (n,p)

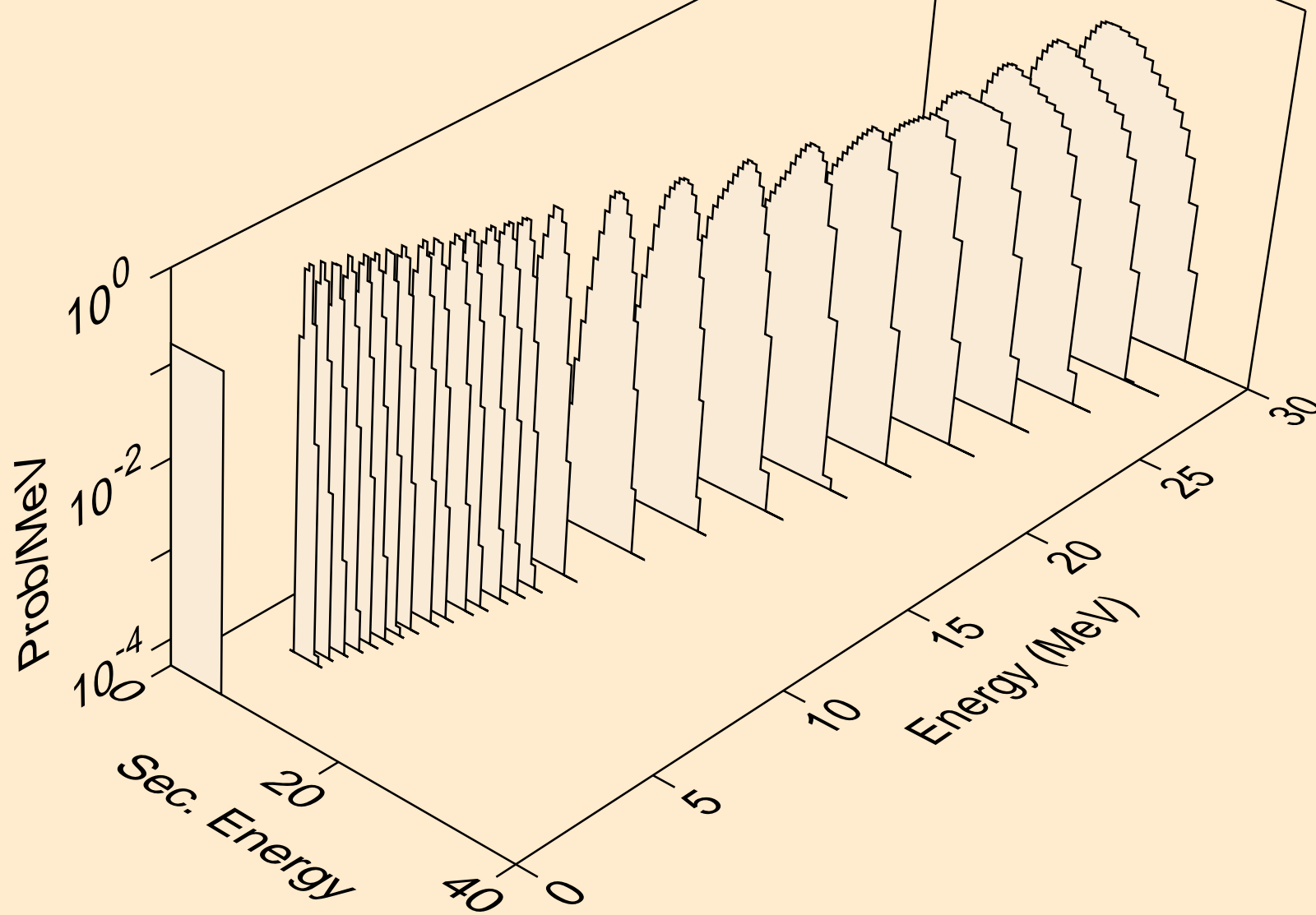

TL193M NEUTRON ACER TENDL-2024 LIBRARY; T=0.K  
alphas from (n,da)

