

TM160M NEUTRON ACER TENDL-2024 LIBRARY; T=0.K

Principal cross sections

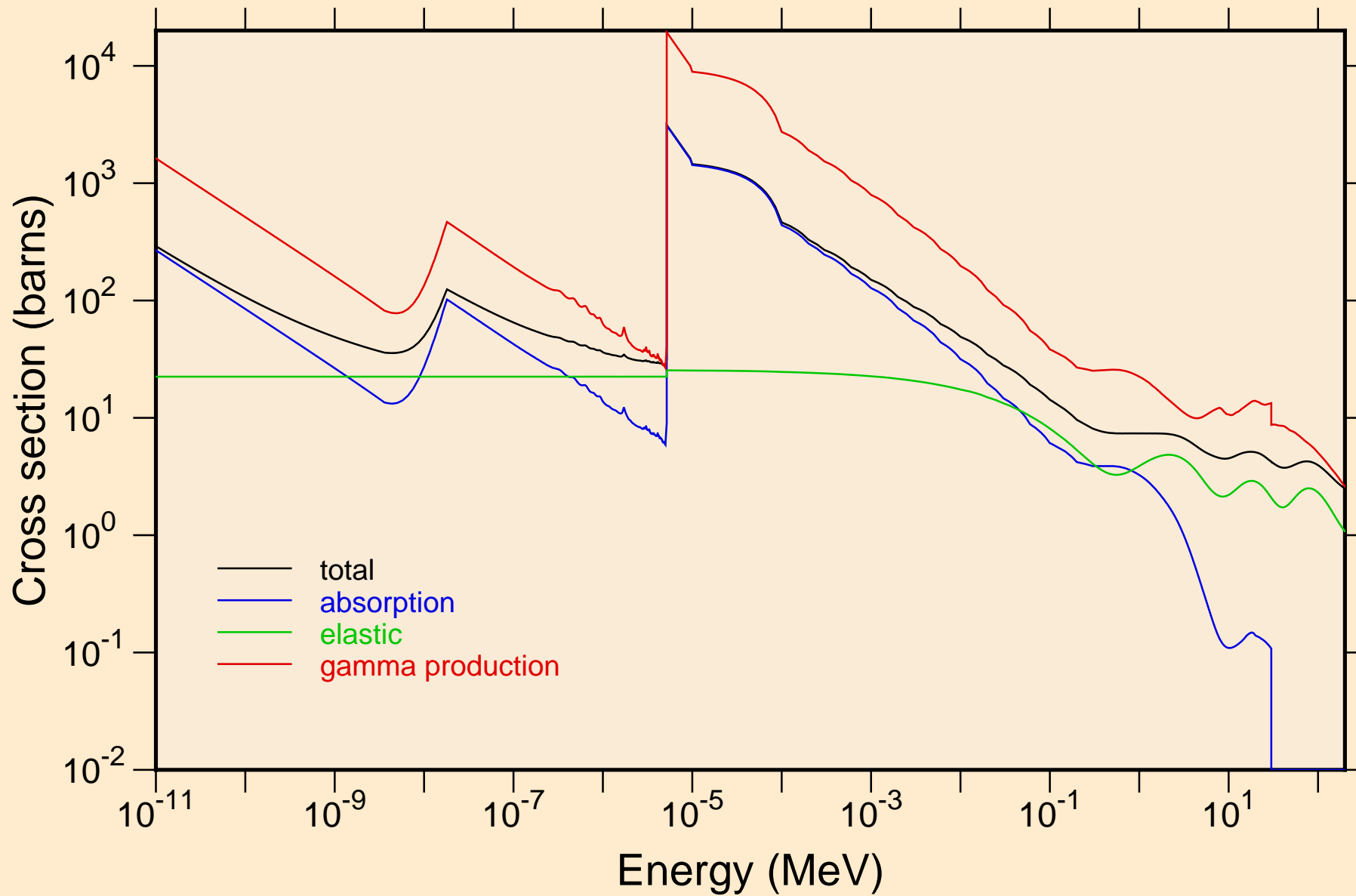

TM160M NEUTRON ACER TENDL-2024 LIBRARY; T=0.K

Heating

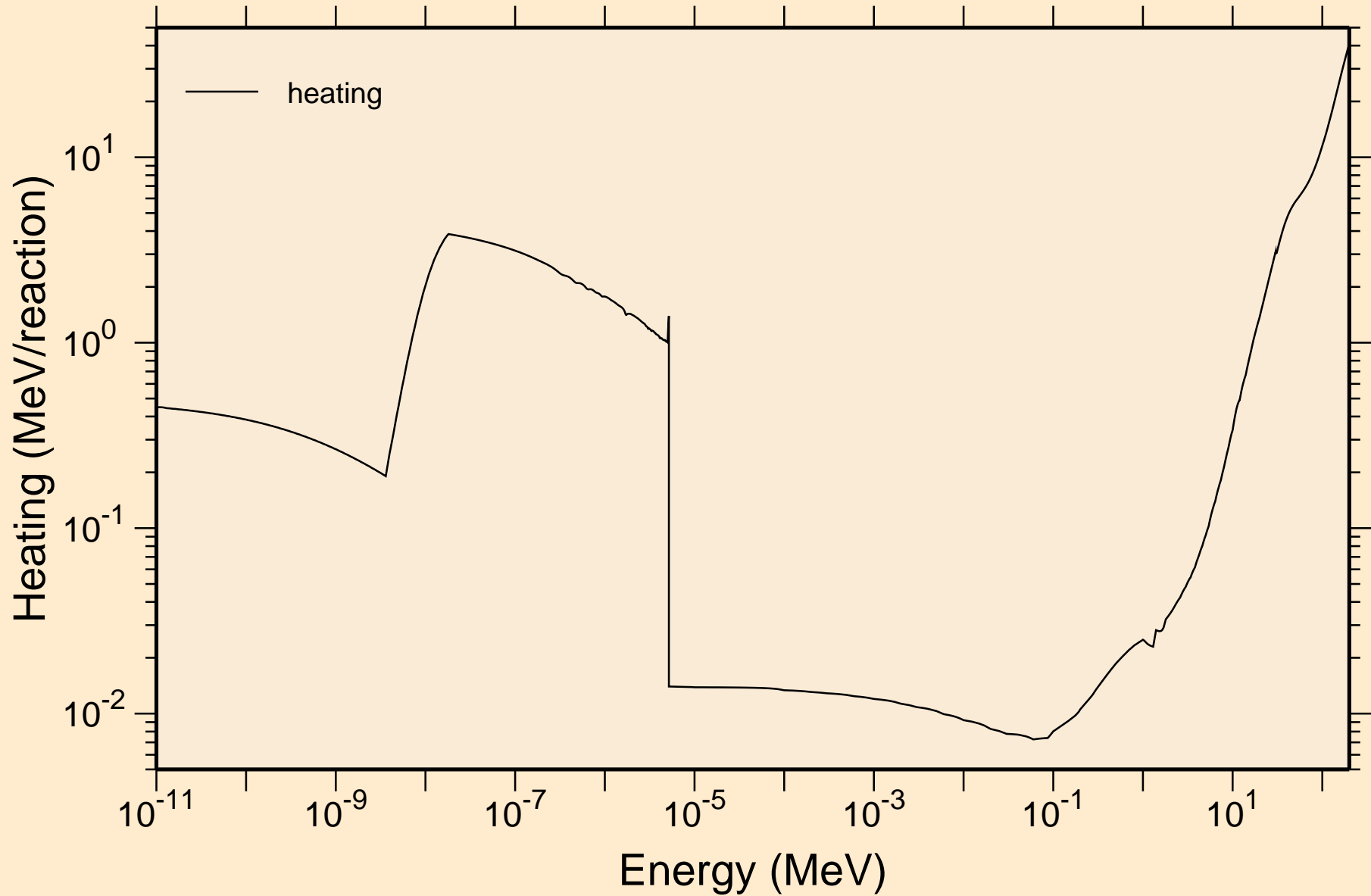

TM160M NEUTRON ACER TENDL-2024 LIBRARY; T=0.K
Damage

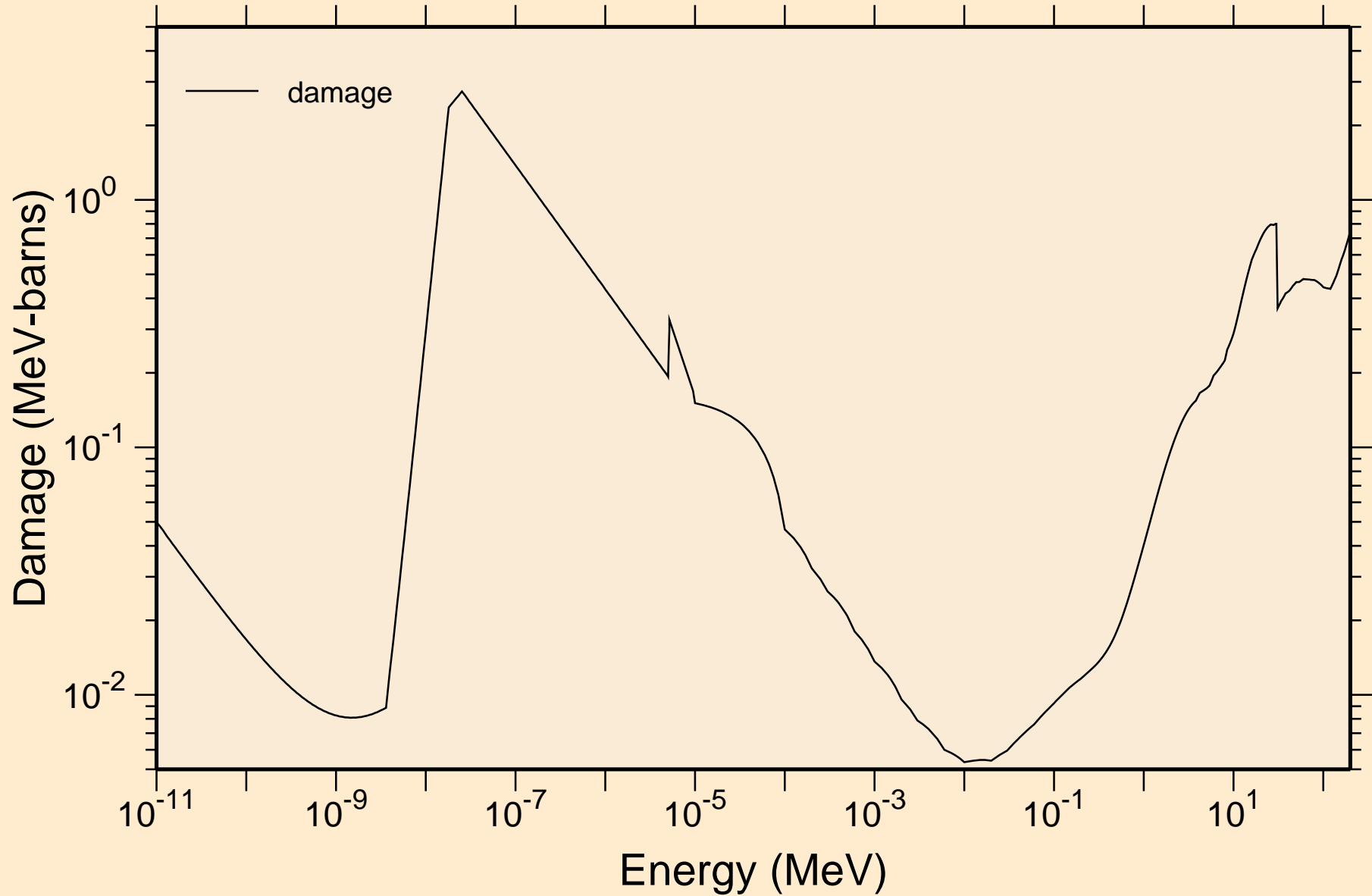

TM160M NEUTRON ACER TENDL-2024 LIBRARY; T=0.K

Non-threshold reactions

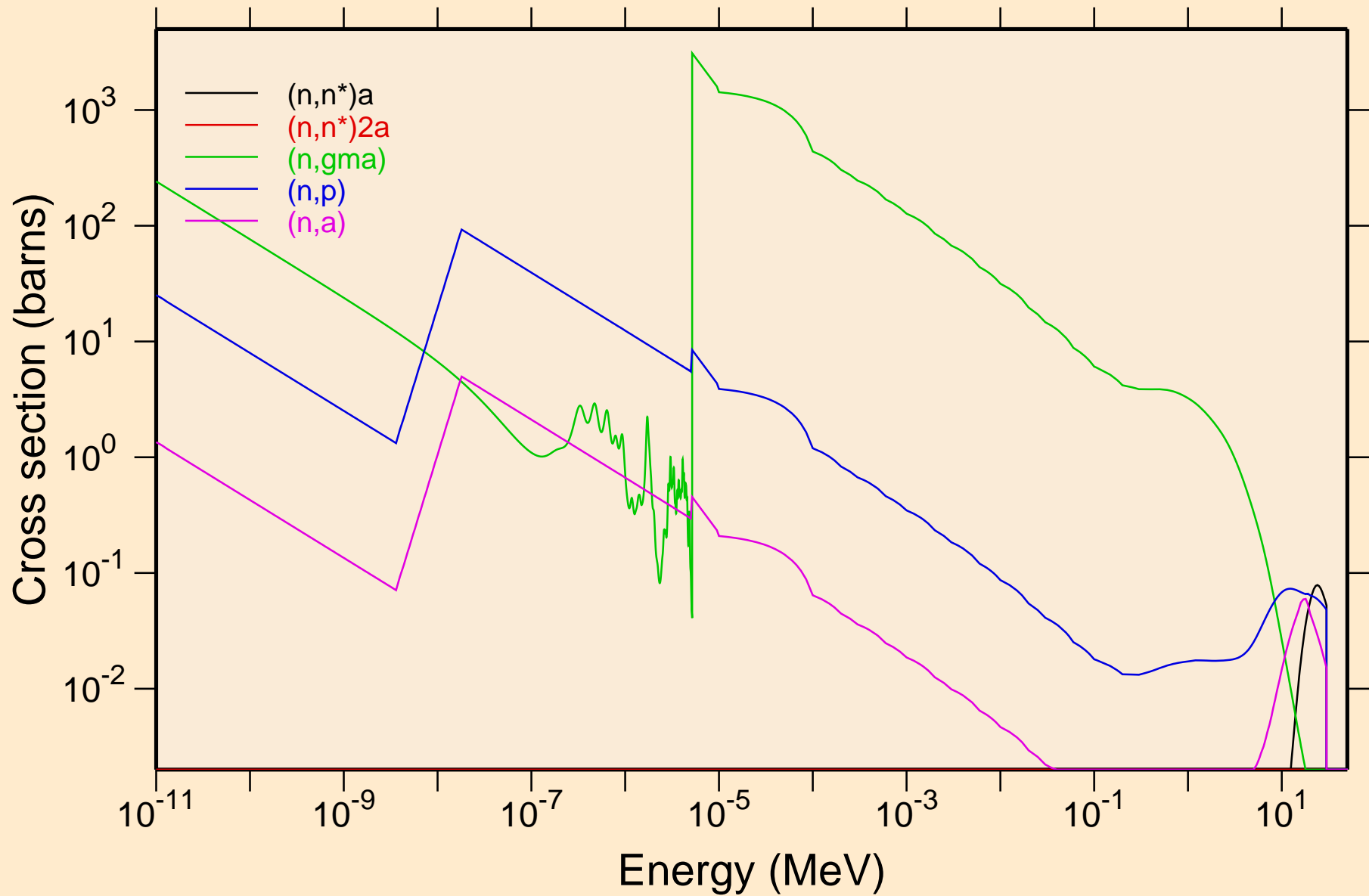

TM160M NEUTRON ACER TENDL-2024 LIBRARY; T=0.K
Non-threshold reactions

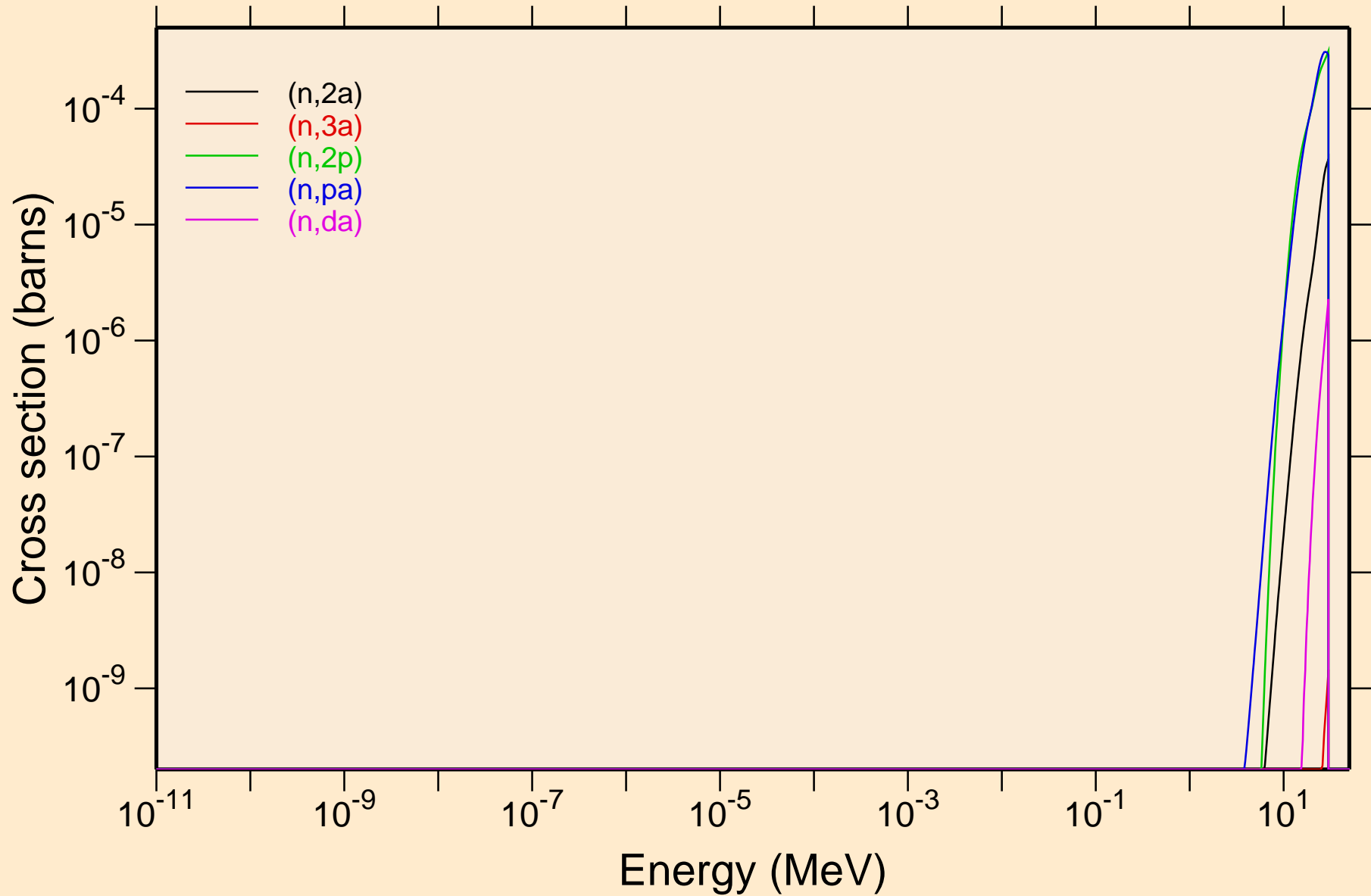

TM160M NEUTRON ACER TENDL-2024 LIBRARY; T=0.K
Non-threshold reactions

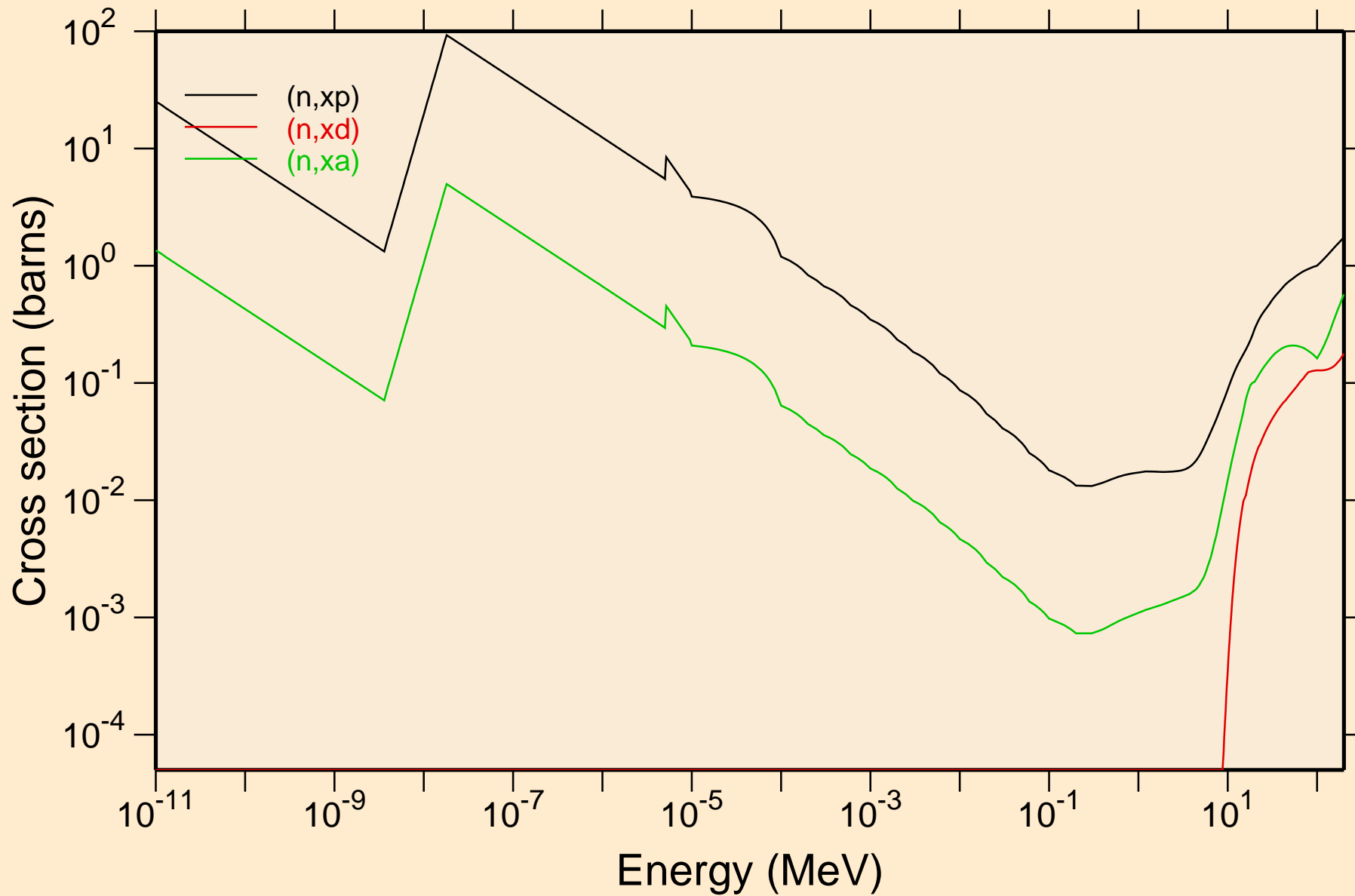

TM160M NEUTRON ACER TENDL-2024 LIBRARY; T=0.K

Principal cross sections

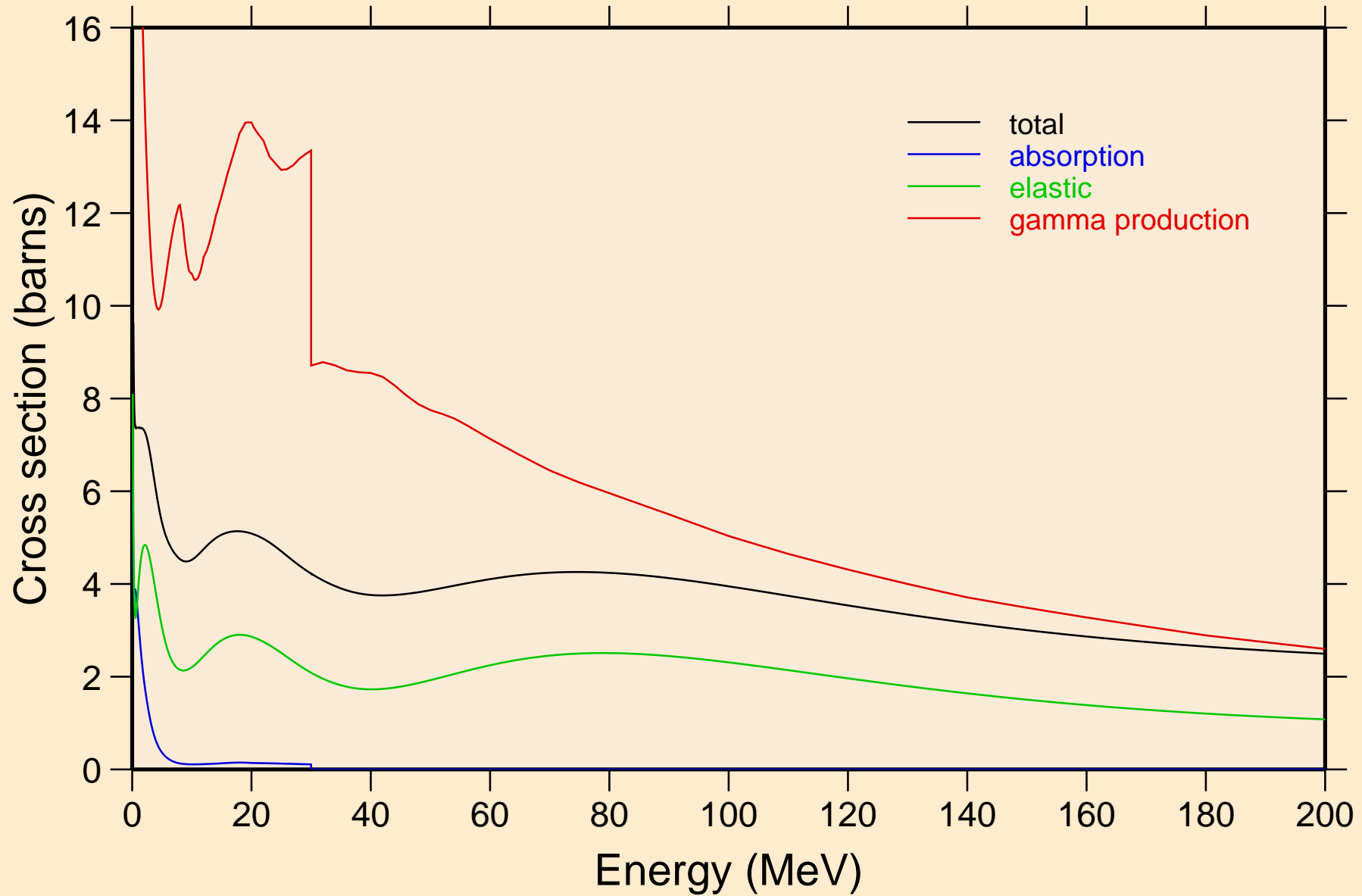

TM160M NEUTRON ACER TENDL-2024 LIBRARY; T=0.K

Heating

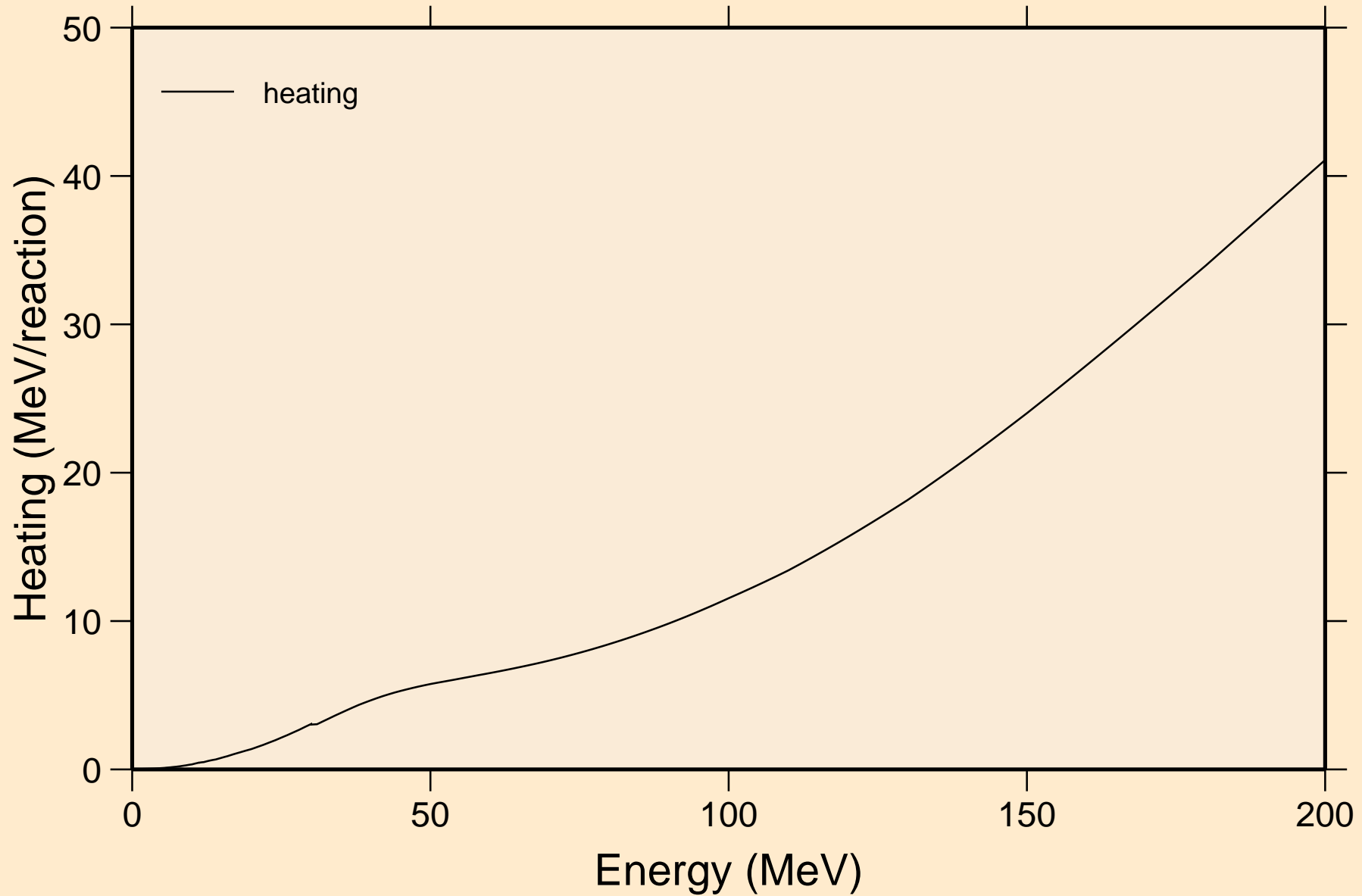

TM160M NEUTRON ACER TENDL-2024 LIBRARY; T=0.K
Damage

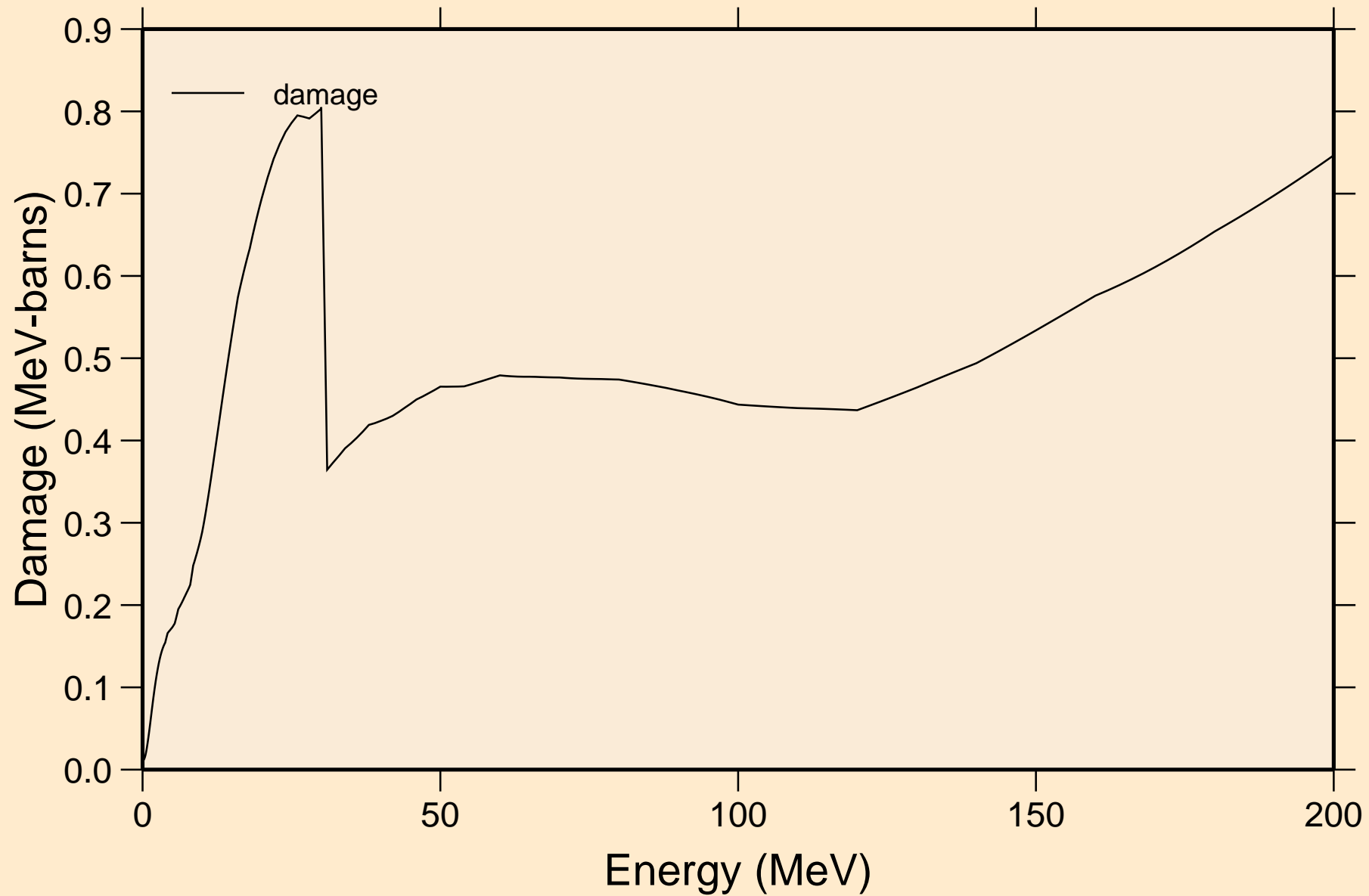

TM160M NEUTRON ACER TENDL-2024 LIBRARY; T=0.K
Non-threshold reactions

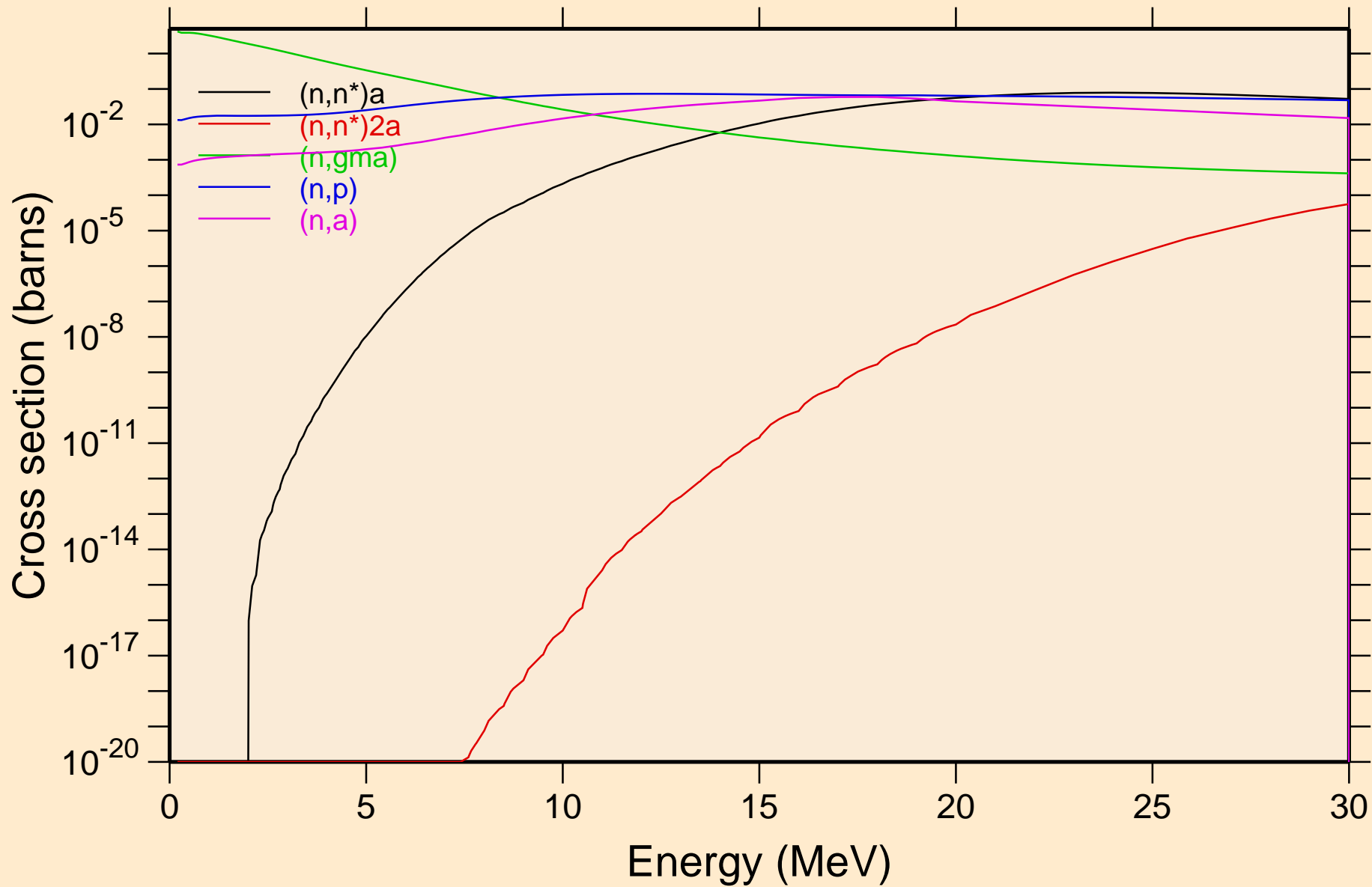

TM160M NEUTRON ACER TENDL-2024 LIBRARY; T=0.K
Non-threshold reactions

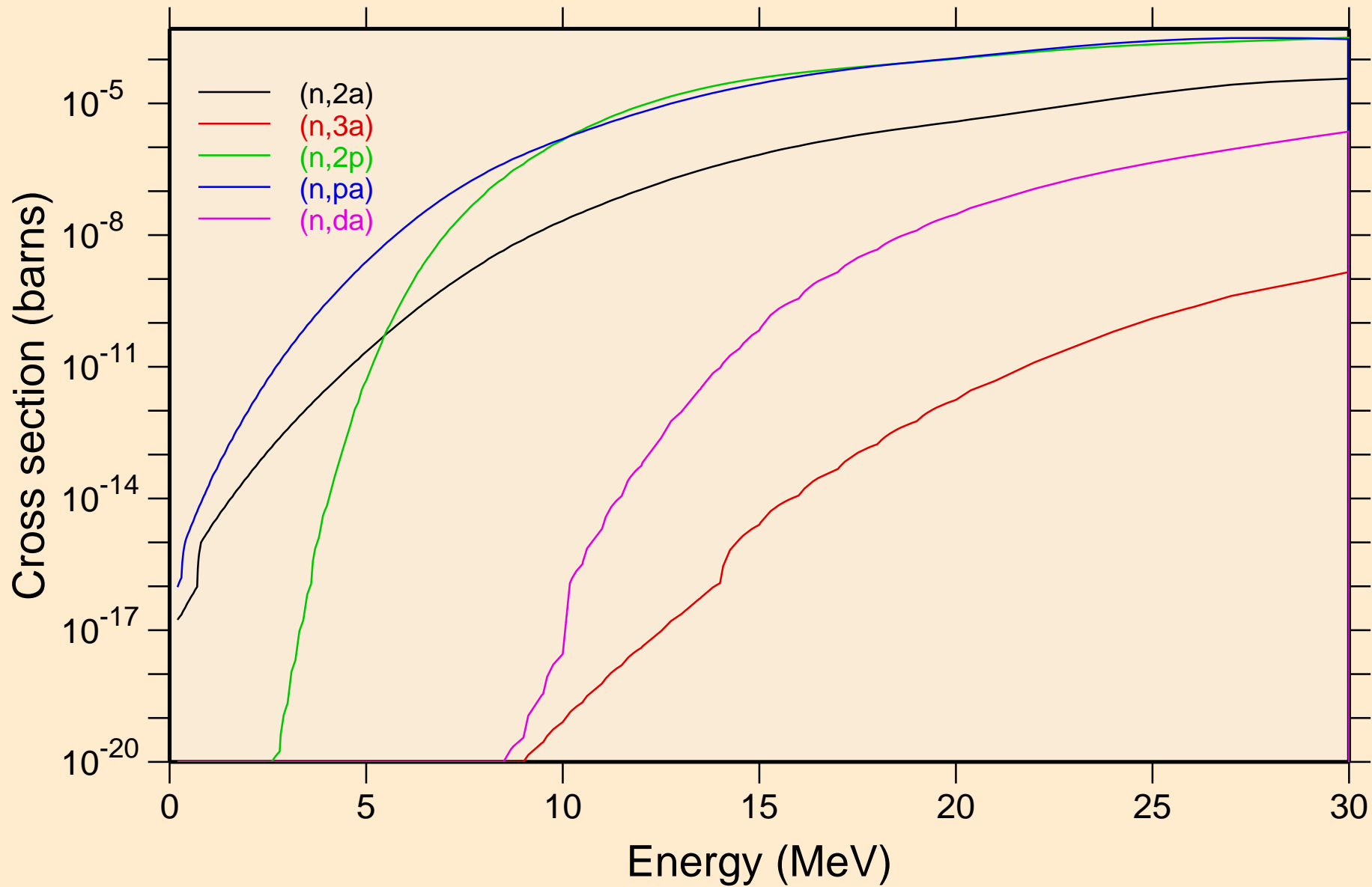

TM160M NEUTRON ACER TENDL-2024 LIBRARY; T=0.K

Non-threshold reactions

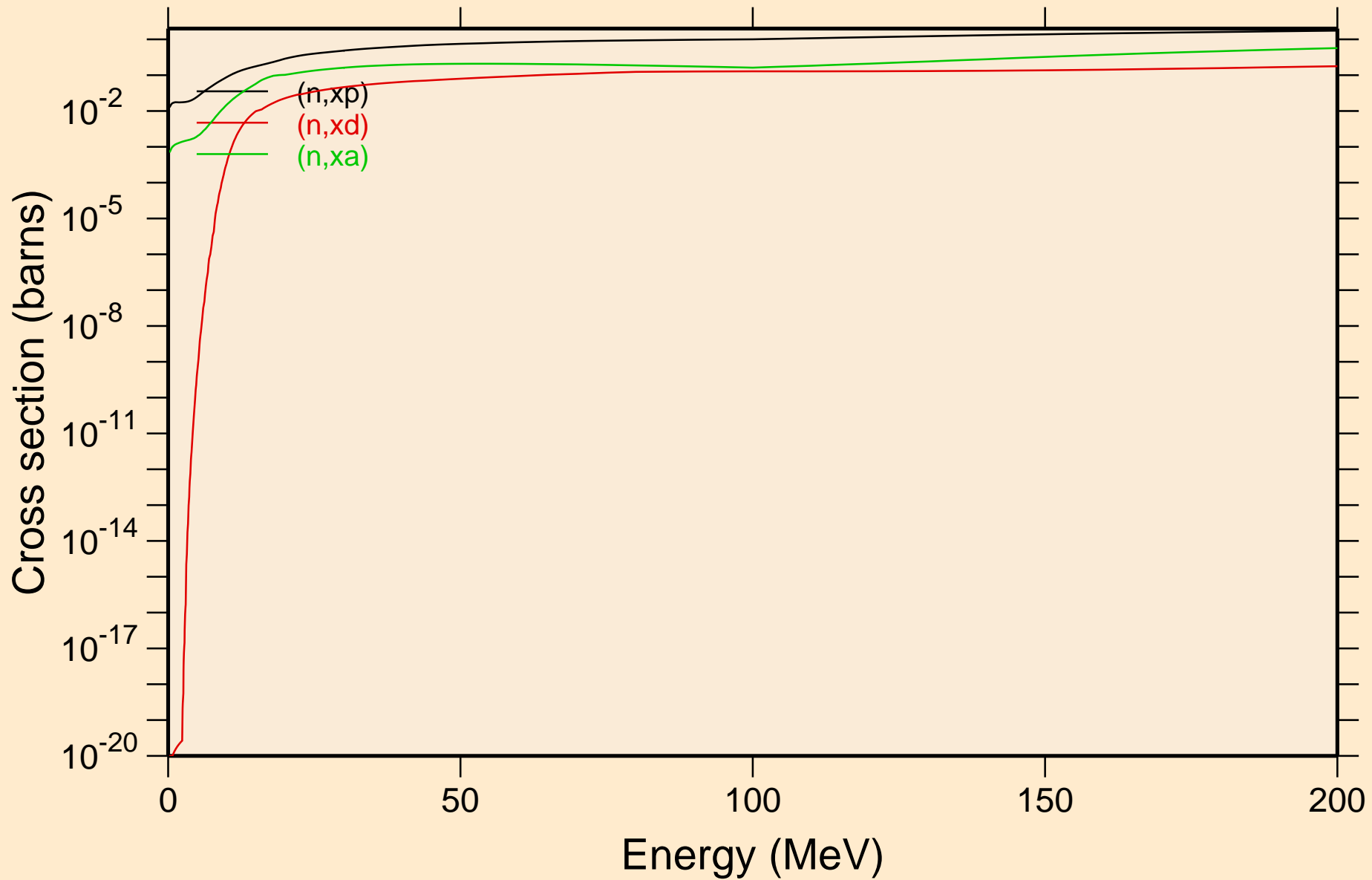

TM160M NEUTRON ACER TENDL-2024 LIBRARY; T=0.K
Inelastic levels

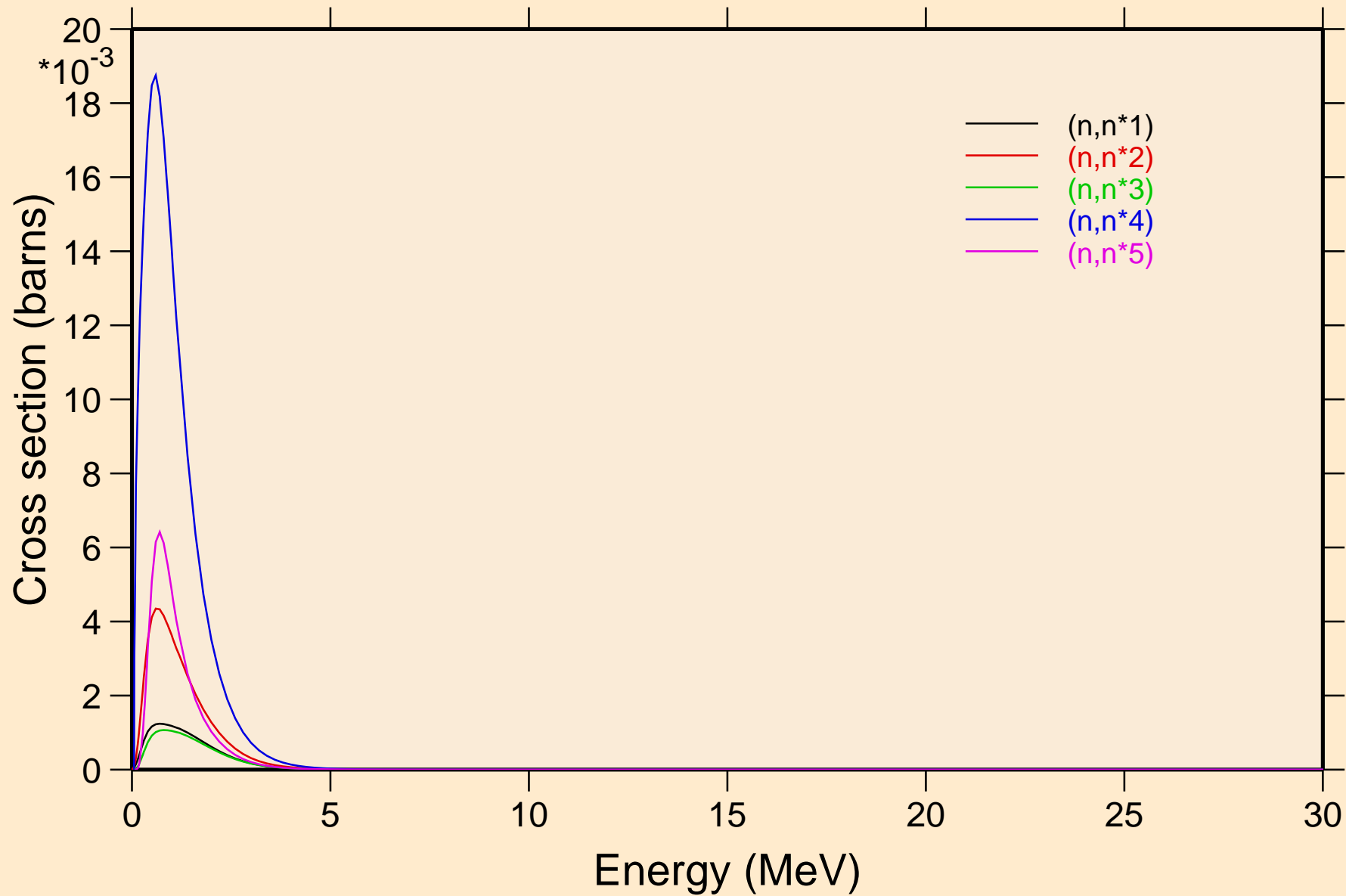

TM160M NEUTRON ACER TENDL-2024 LIBRARY; T=0.K
Inelastic levels

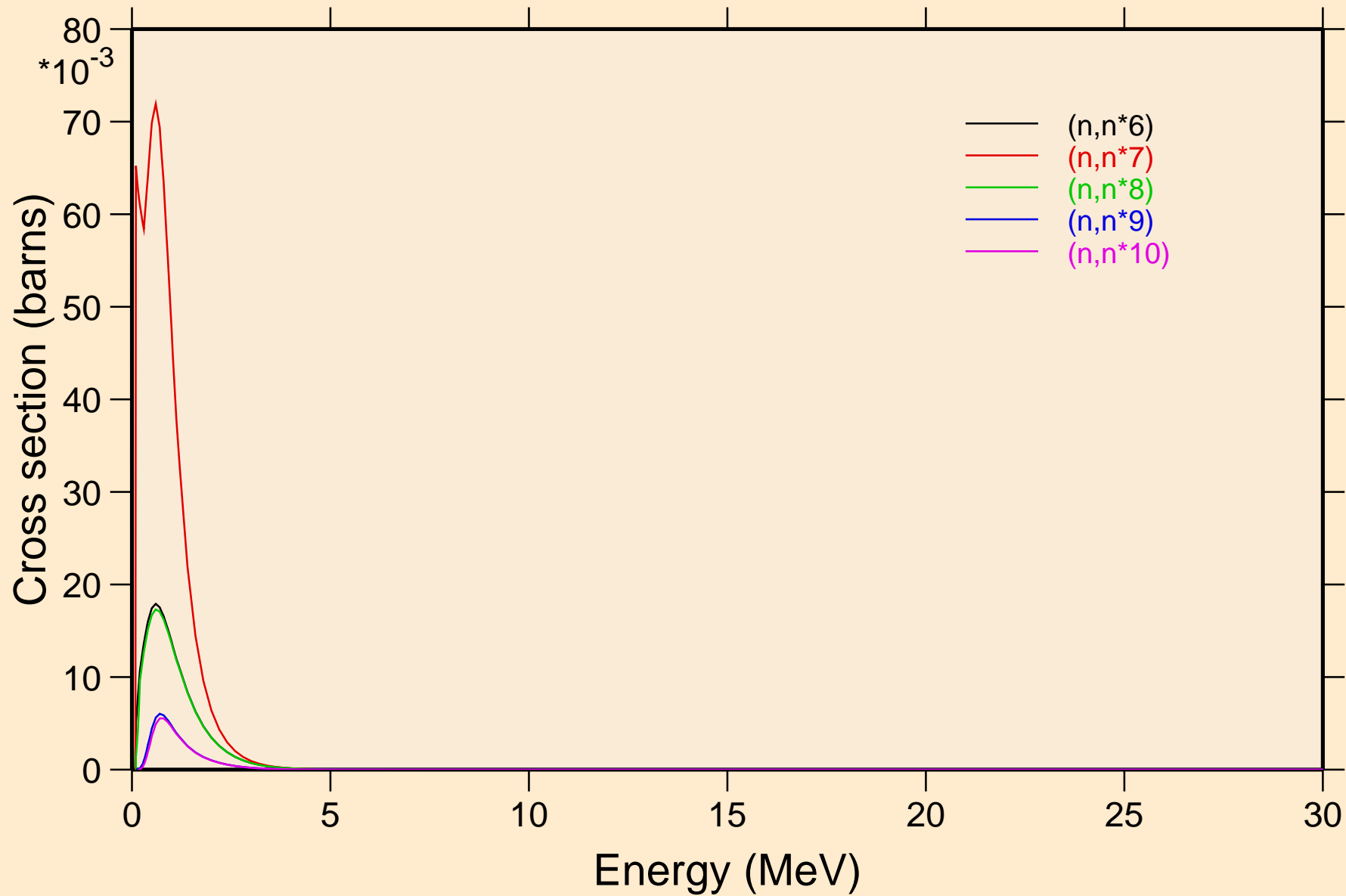

TM160M NEUTRON ACER TENDL-2024 LIBRARY; T=0.K
Inelastic levels

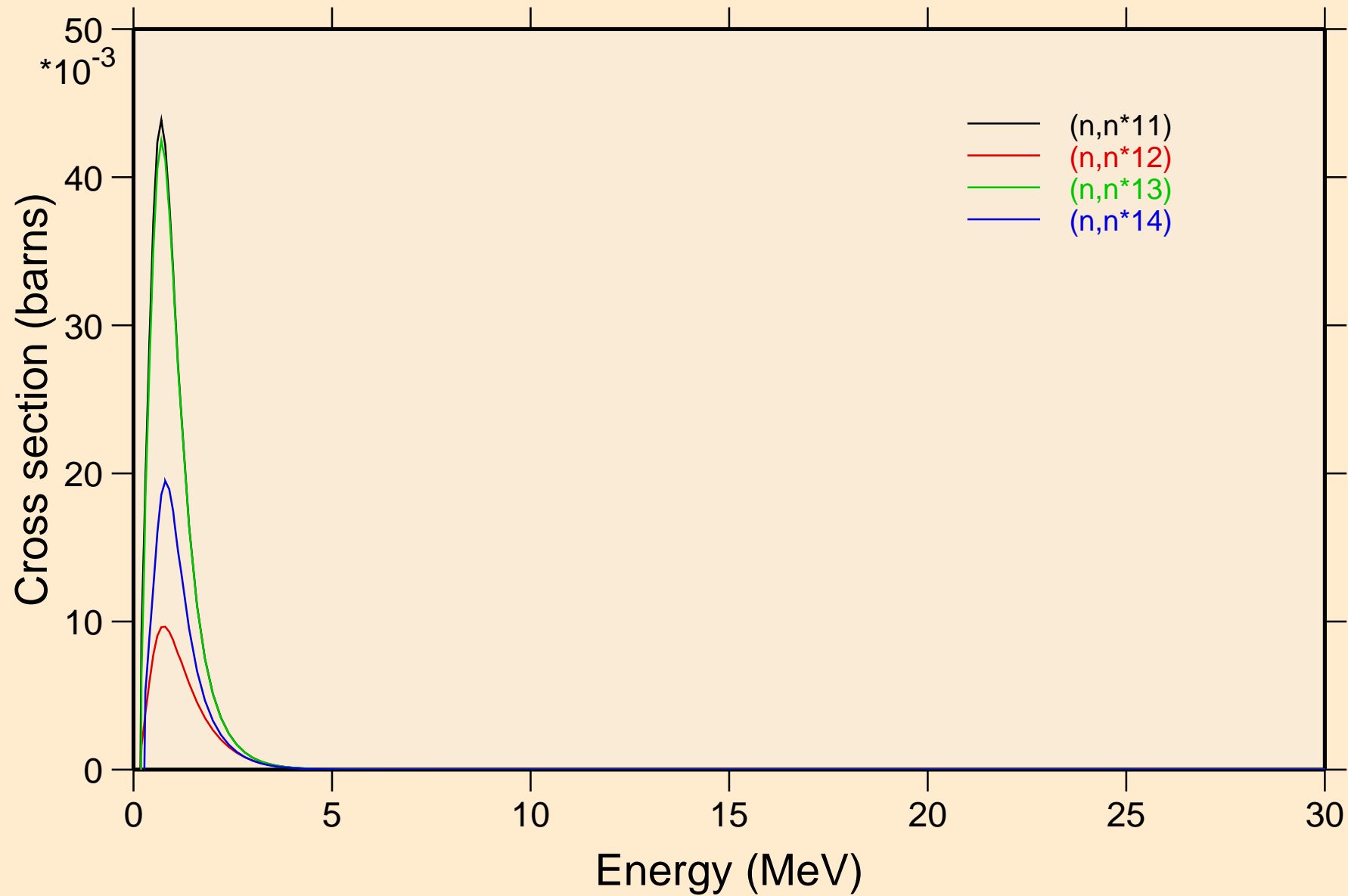

TM160M NEUTRON ACER TENDL-2024 LIBRARY; T=0.K

Threshold reactions

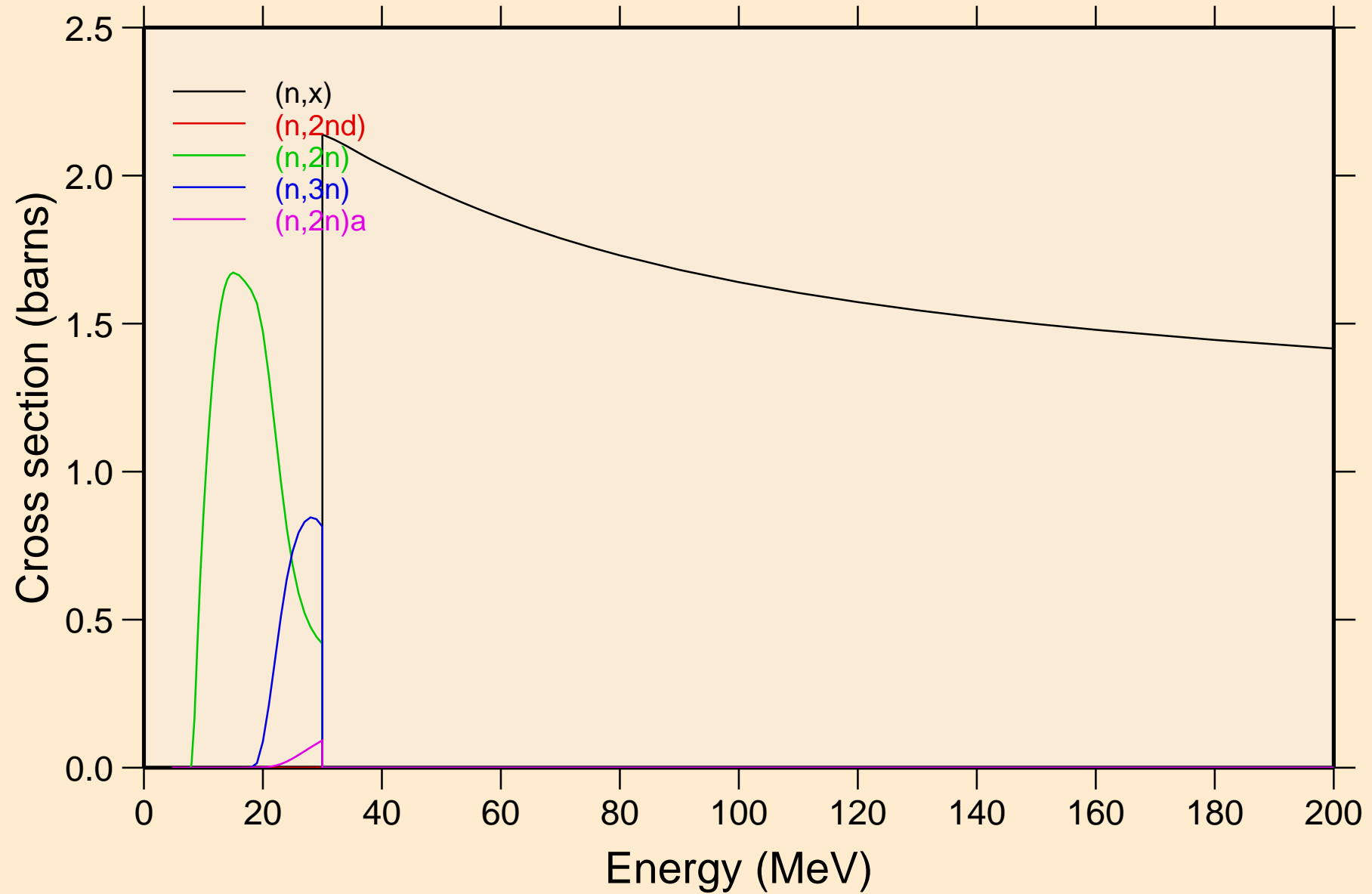

TM160M NEUTRON ACER TENDL-2024 LIBRARY; T=0.K

Threshold reactions

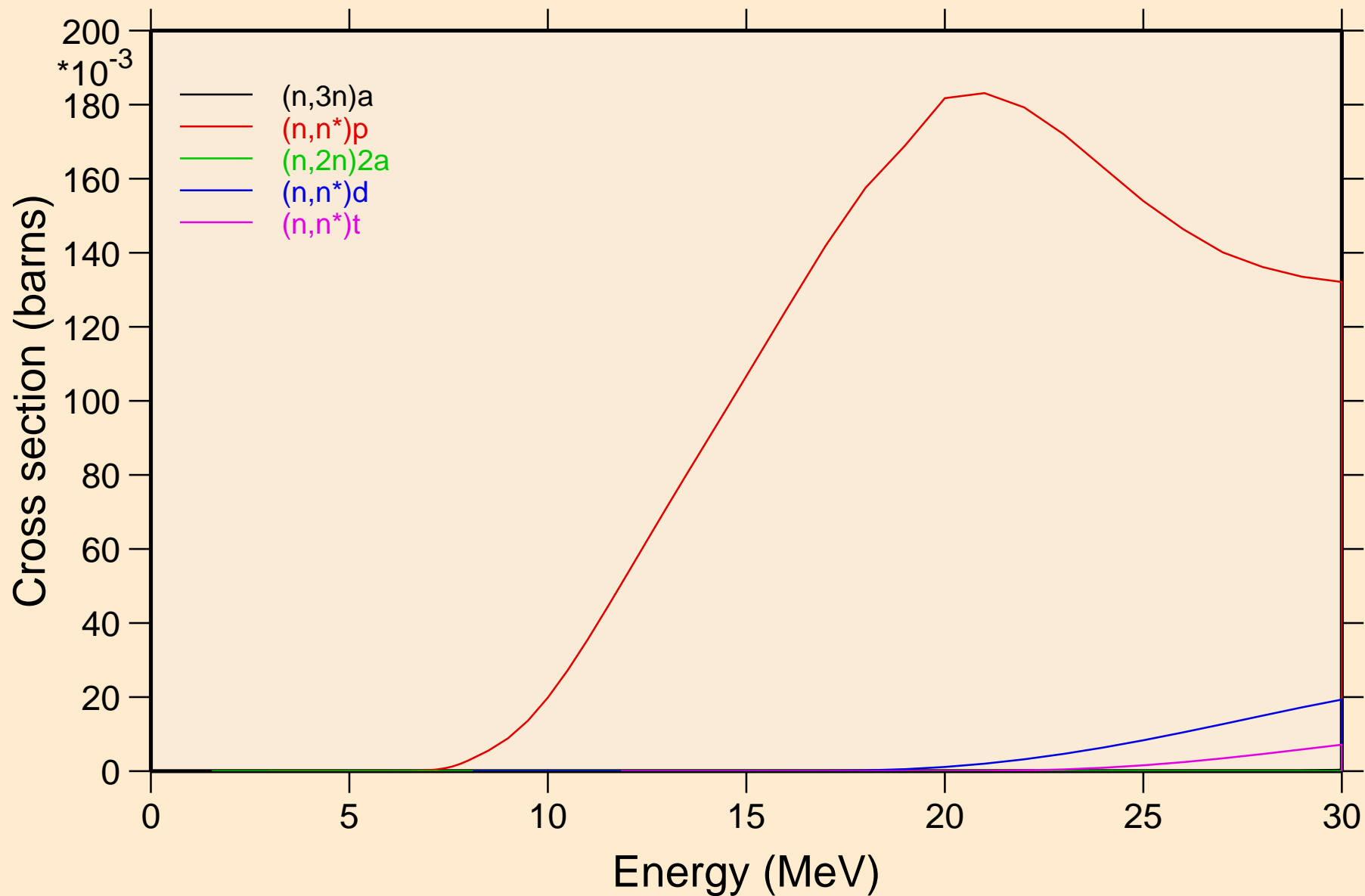

TM160M NEUTRON ACER TENDL-2024 LIBRARY; T=0.K

Threshold reactions

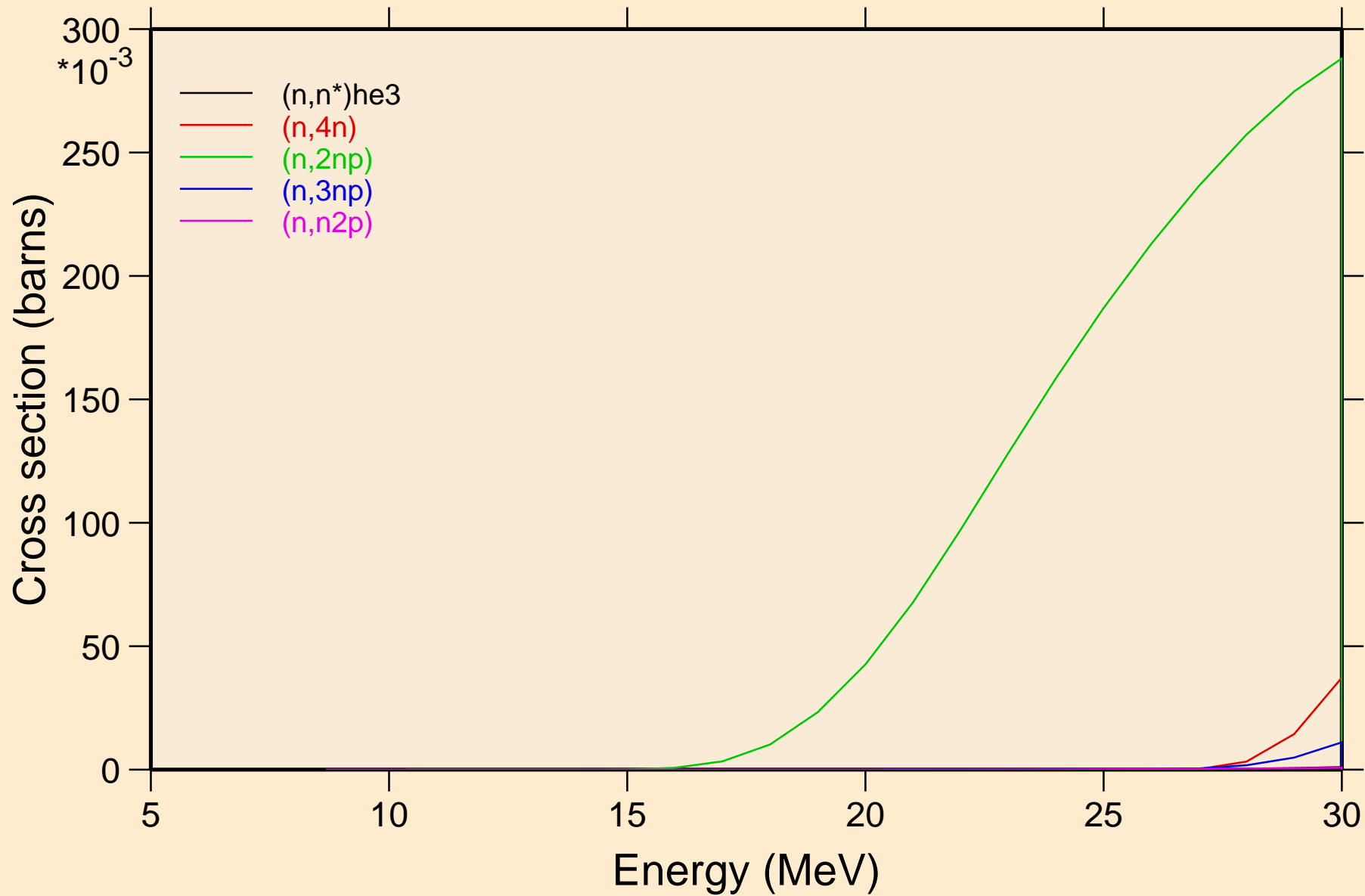

TM160M NEUTRON ACER TENDL-2024 LIBRARY; T=0.K
Threshold reactions

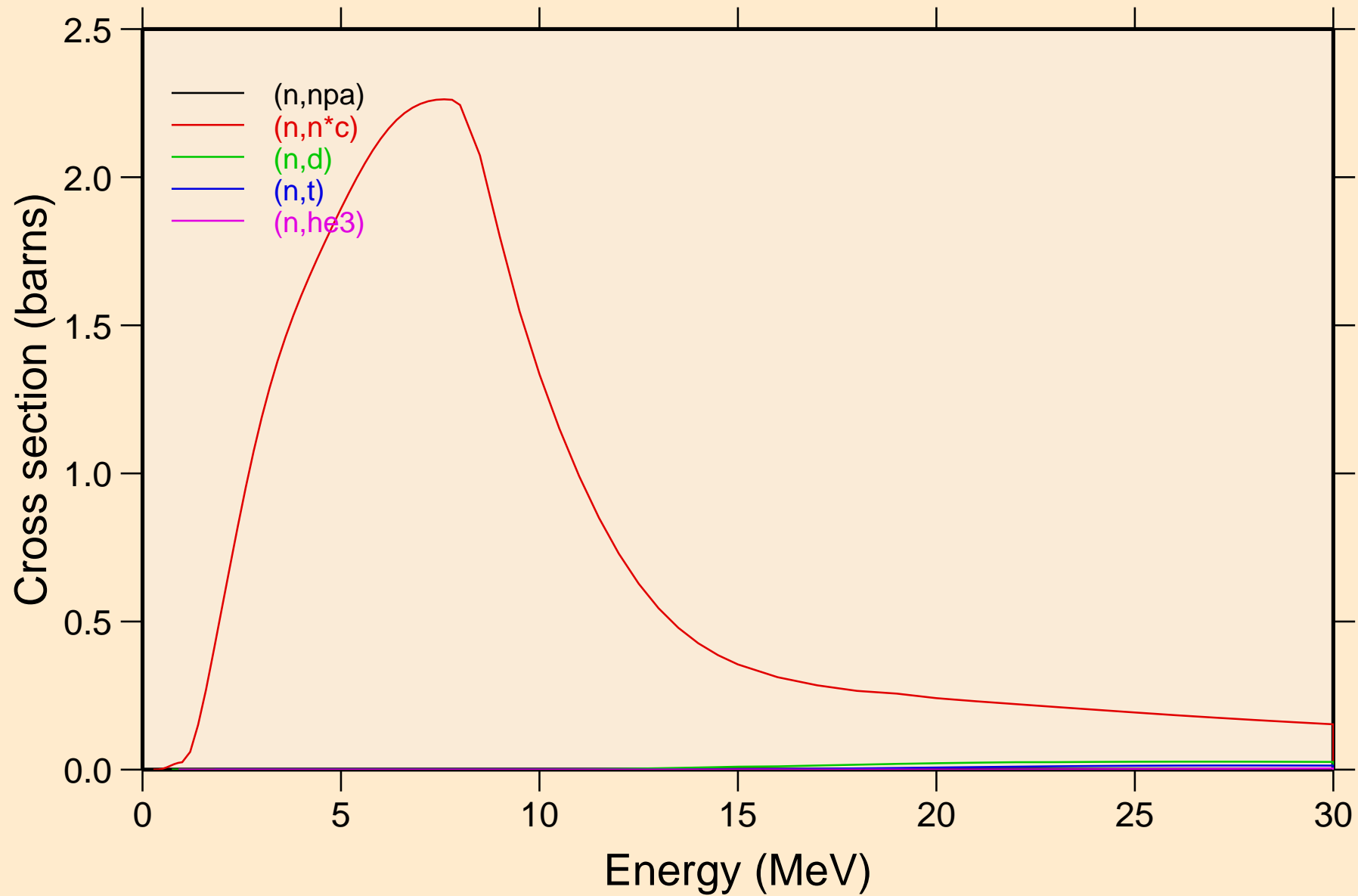

TM160M NEUTRON ACER TENDL-2024 LIBRARY; T=0.K
Threshold reactions

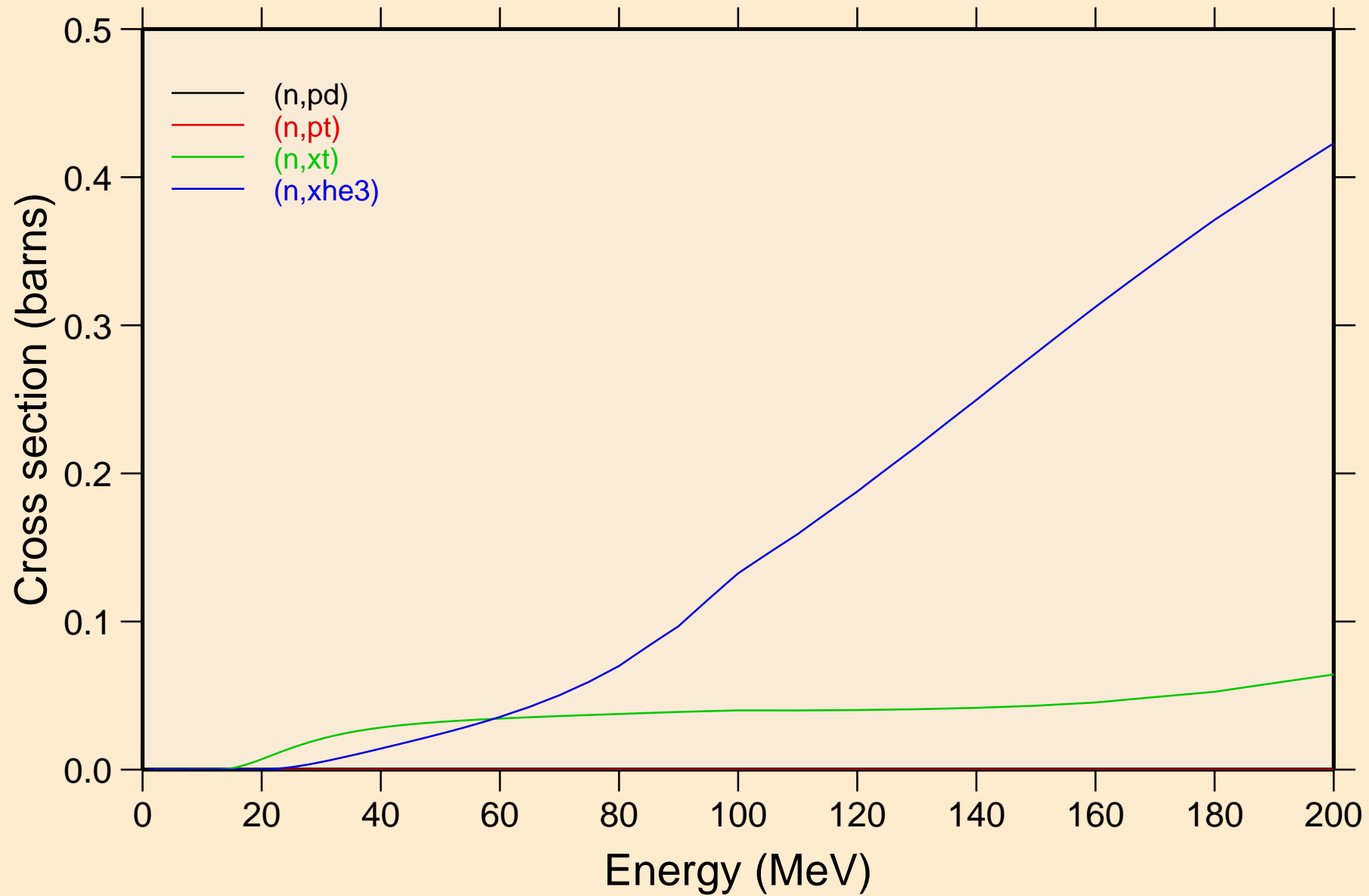

TM160M NEUTRON ACER TENDL-2024 LIBRARY; T=0.K
angular distribution for elastic

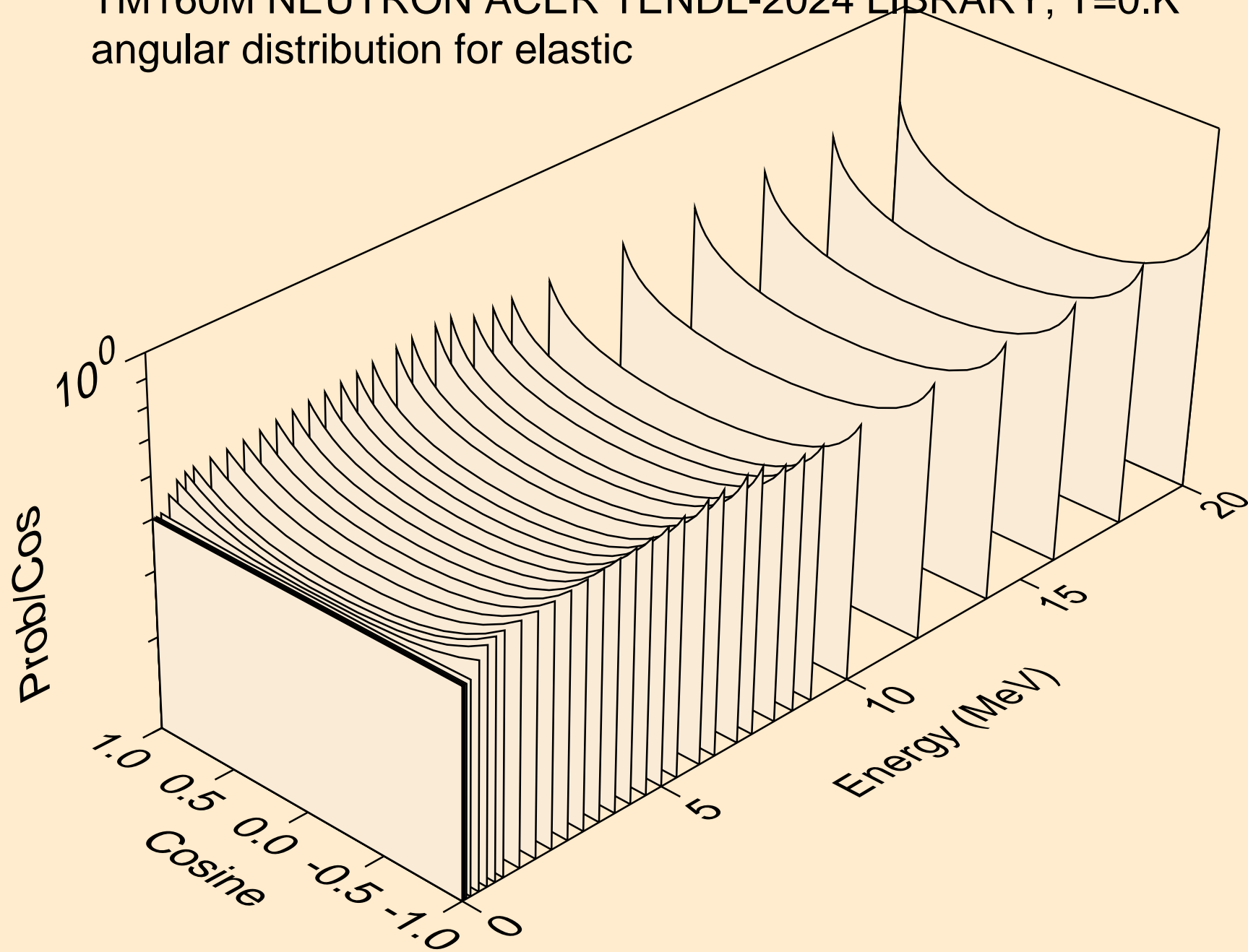

TM160M NEUTRON ACER TENDL-2024 LIBRARY; T=0.K
angular distribution for elastic

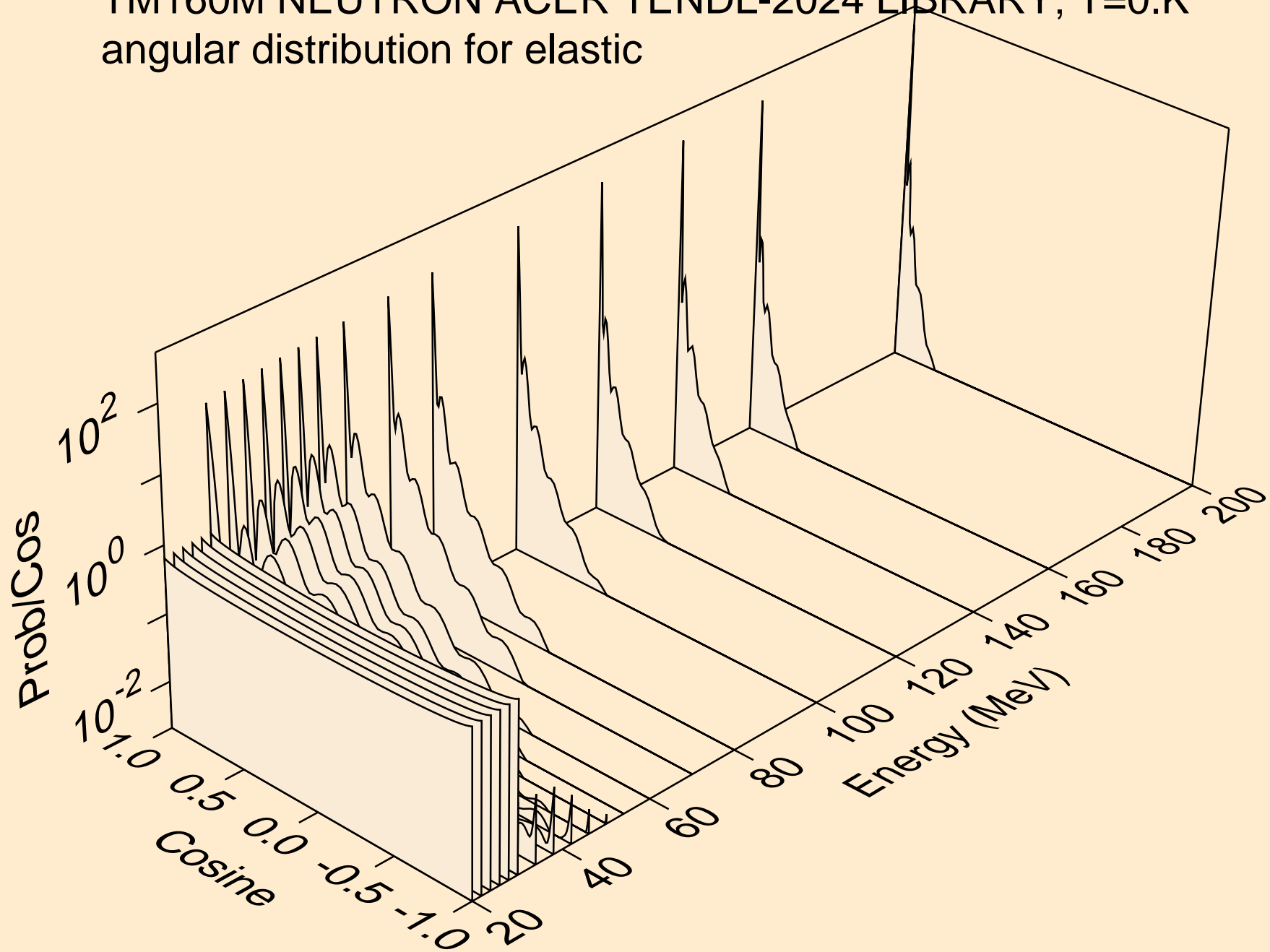

TM160M NEUTRON ACER TENDL-2024 LIBRARY; T=0.K
angular distribution for (n,n*1)

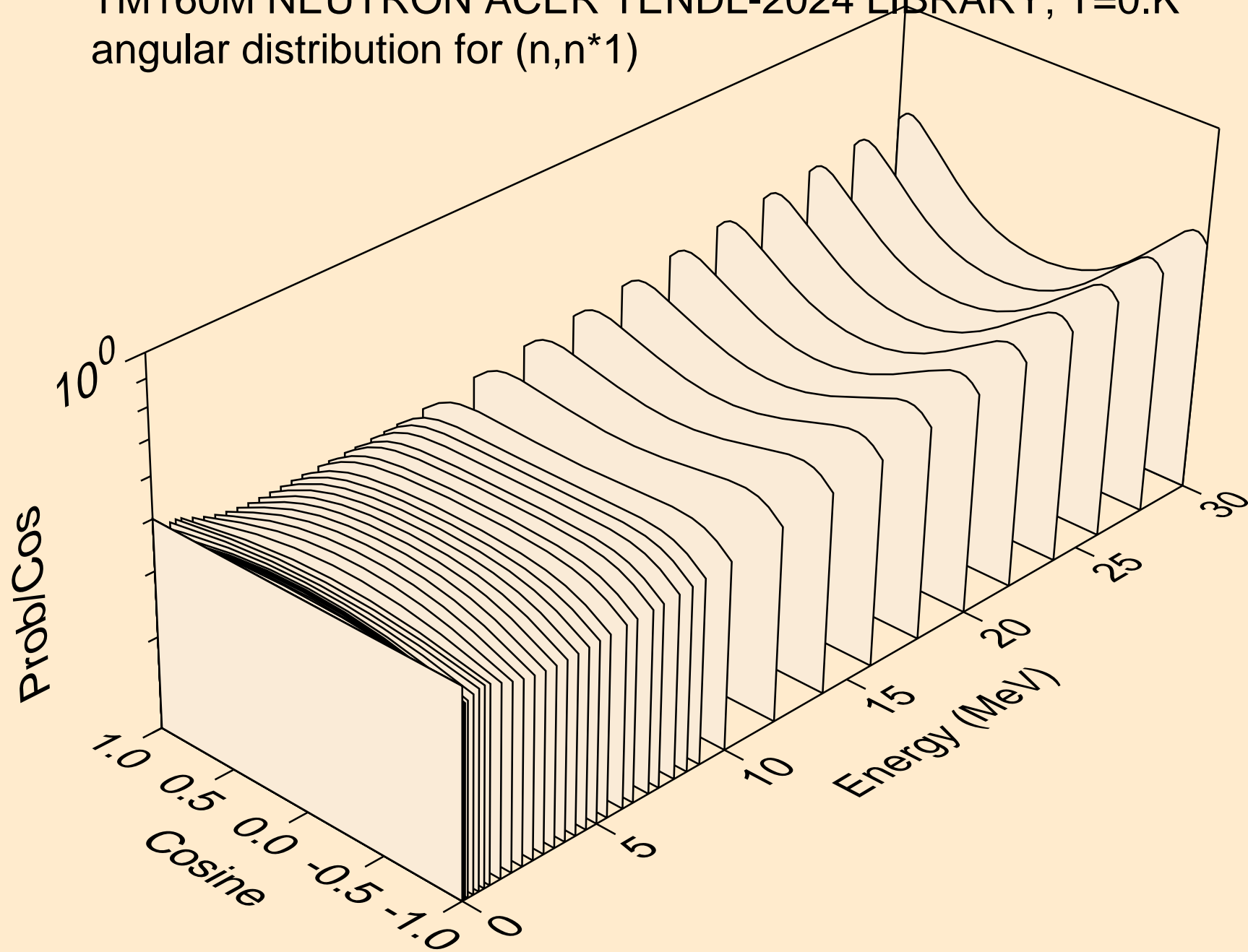

TM160M NEUTRON ACER TENDL-2024 LIBRARY; T=0.K
angular distribution for (n,n*2)

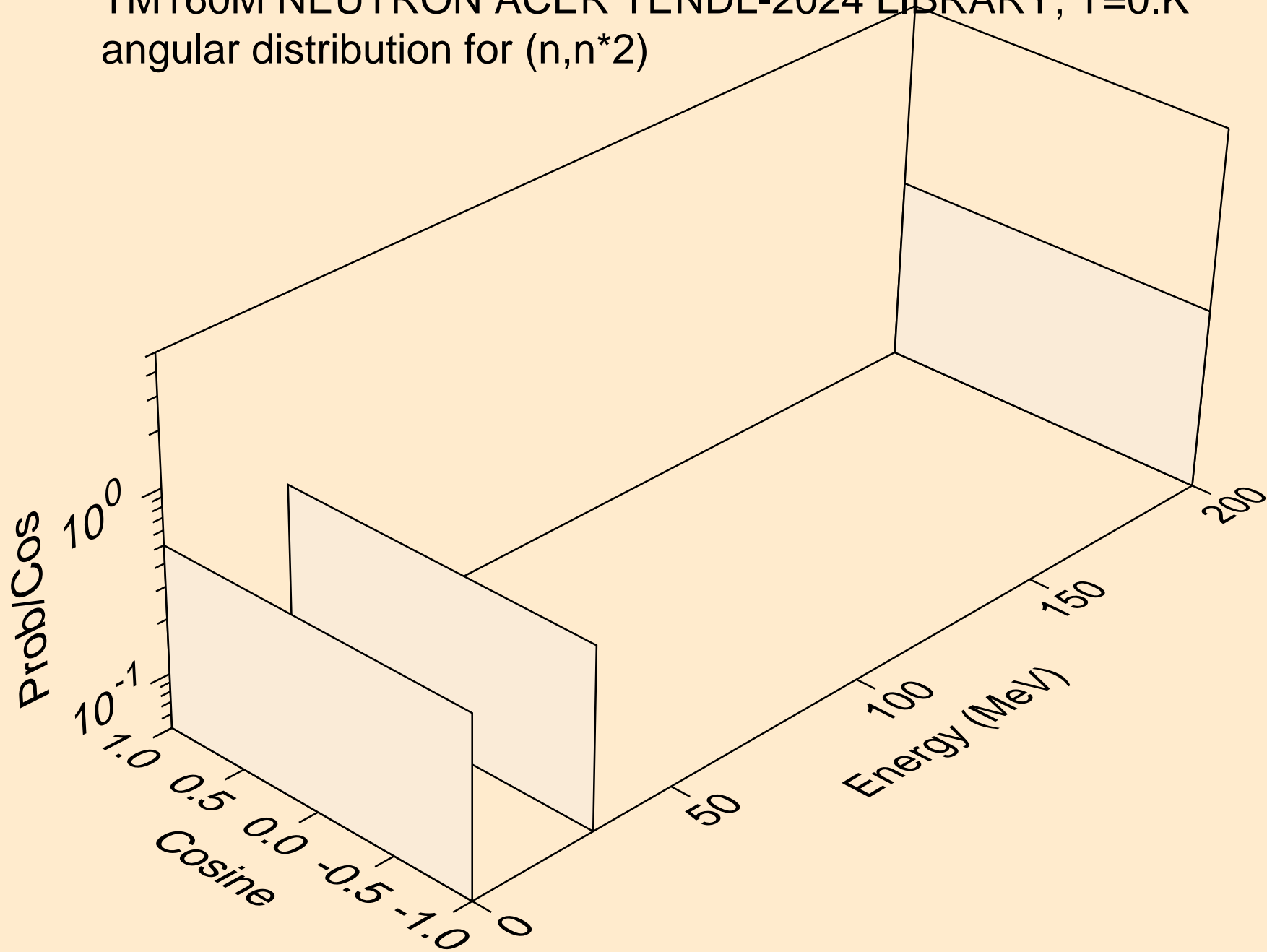

TM160M NEUTRON ACER TENDL-2024 LIBRARY; T=0.K
angular distribution for (n,n*3)

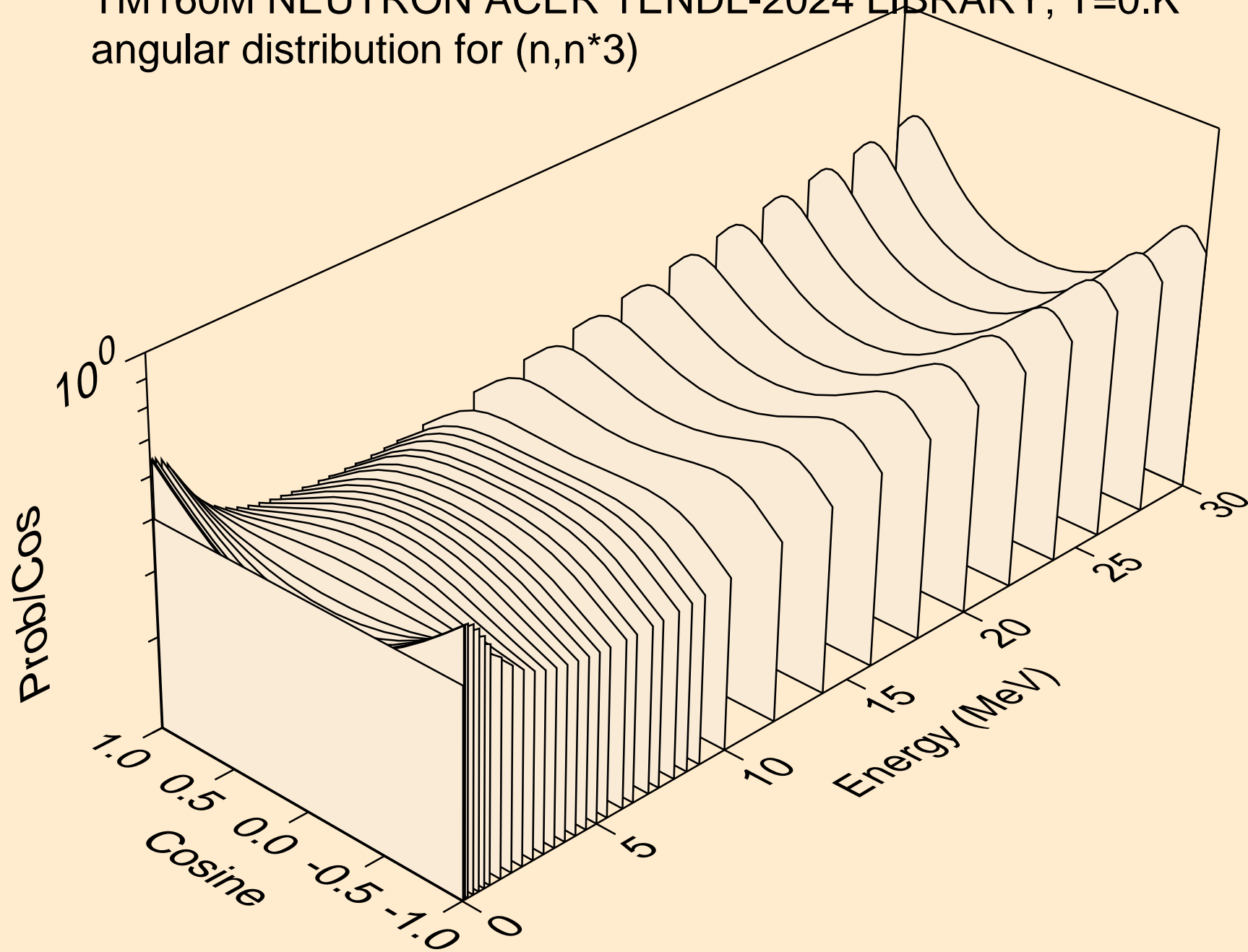

TM160M NEUTRON ACER TENDL-2024 LIBRARY; T=0.K
angular distribution for (n,n*4)

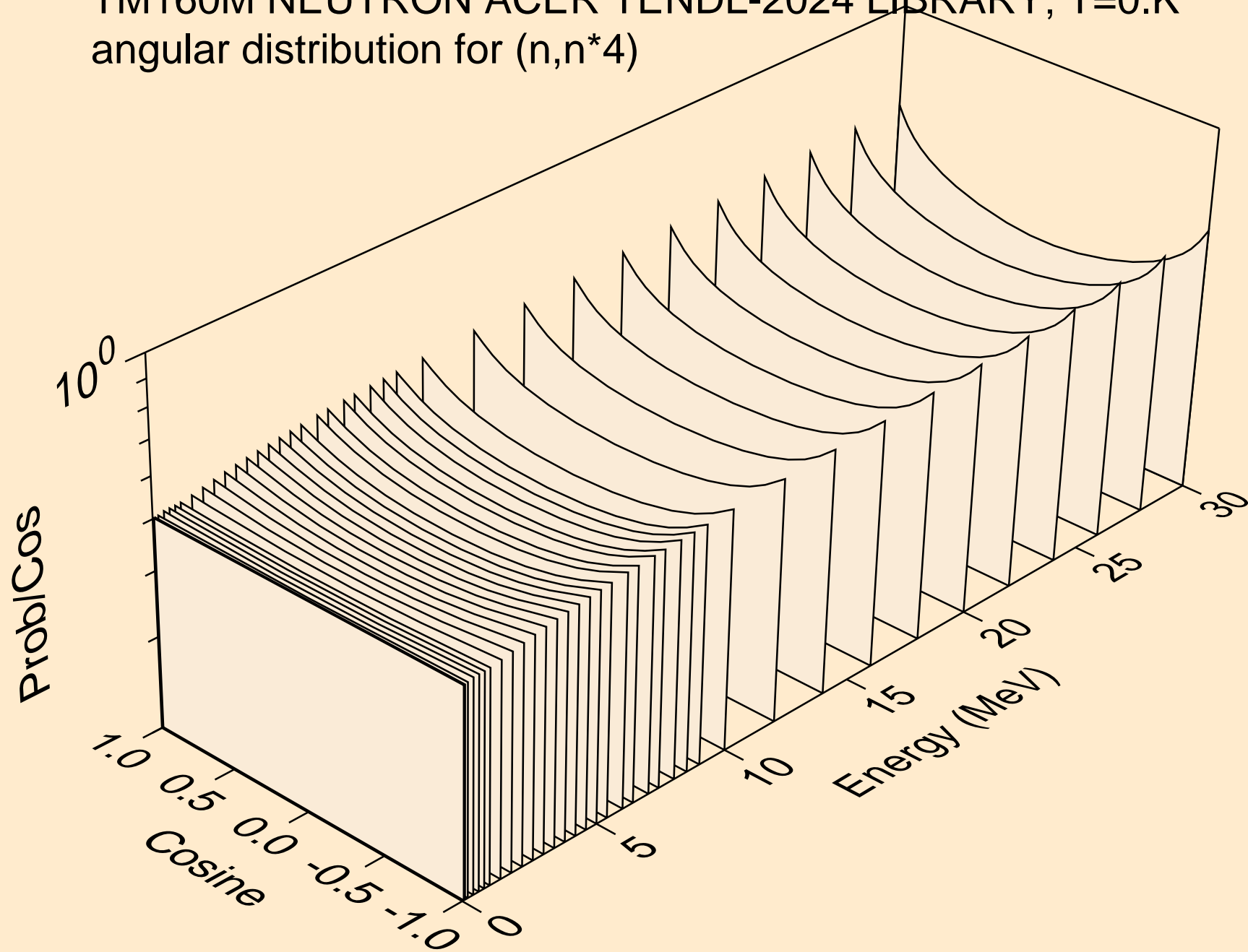

TM160M NEUTRON ACER TENDL-2024 LIBRARY; T=0.K
angular distribution for (n,n*5)

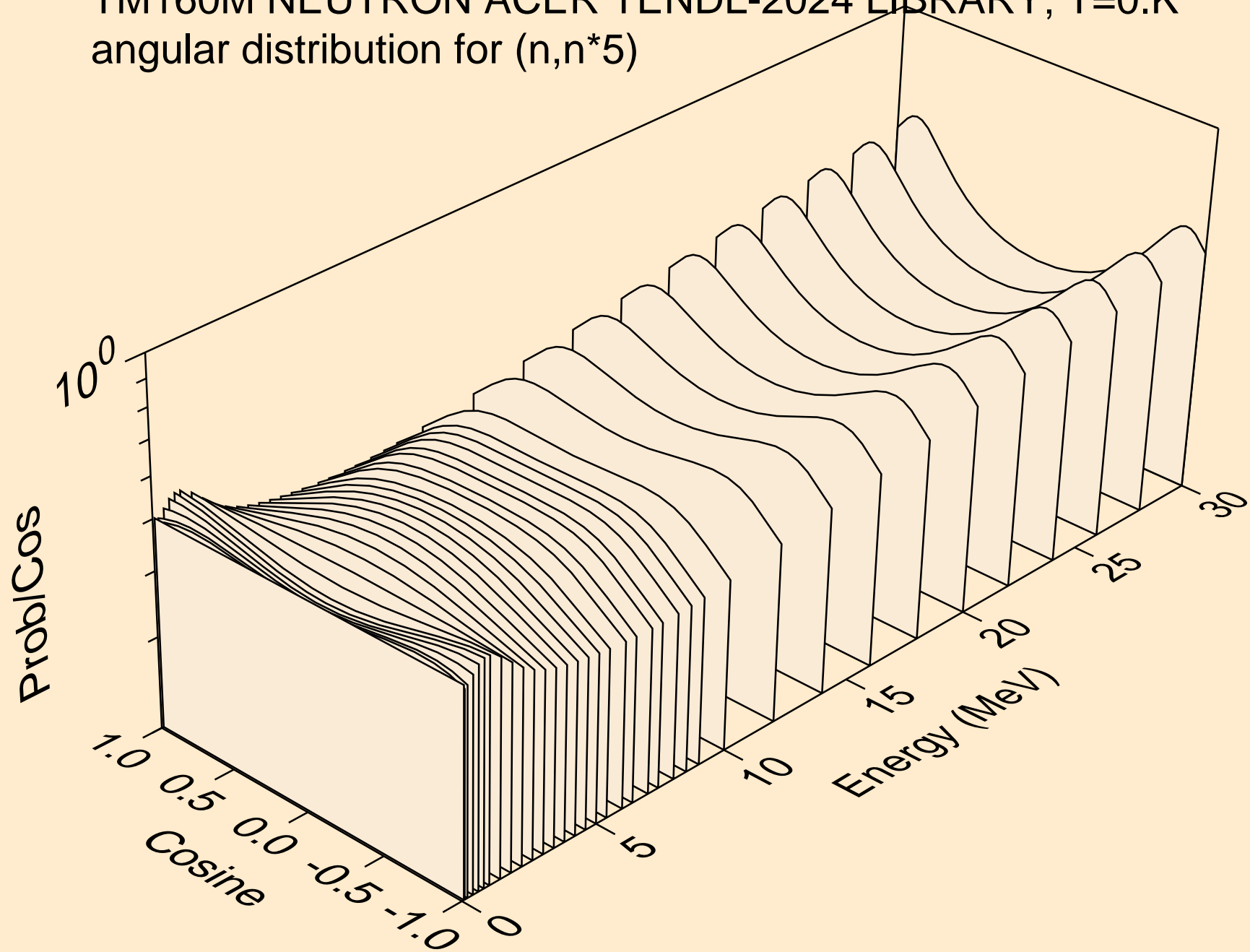

TM160M NEUTRON ACER TENDL-2024 LIBRARY; T=0.K
angular distribution for (n,n*6)

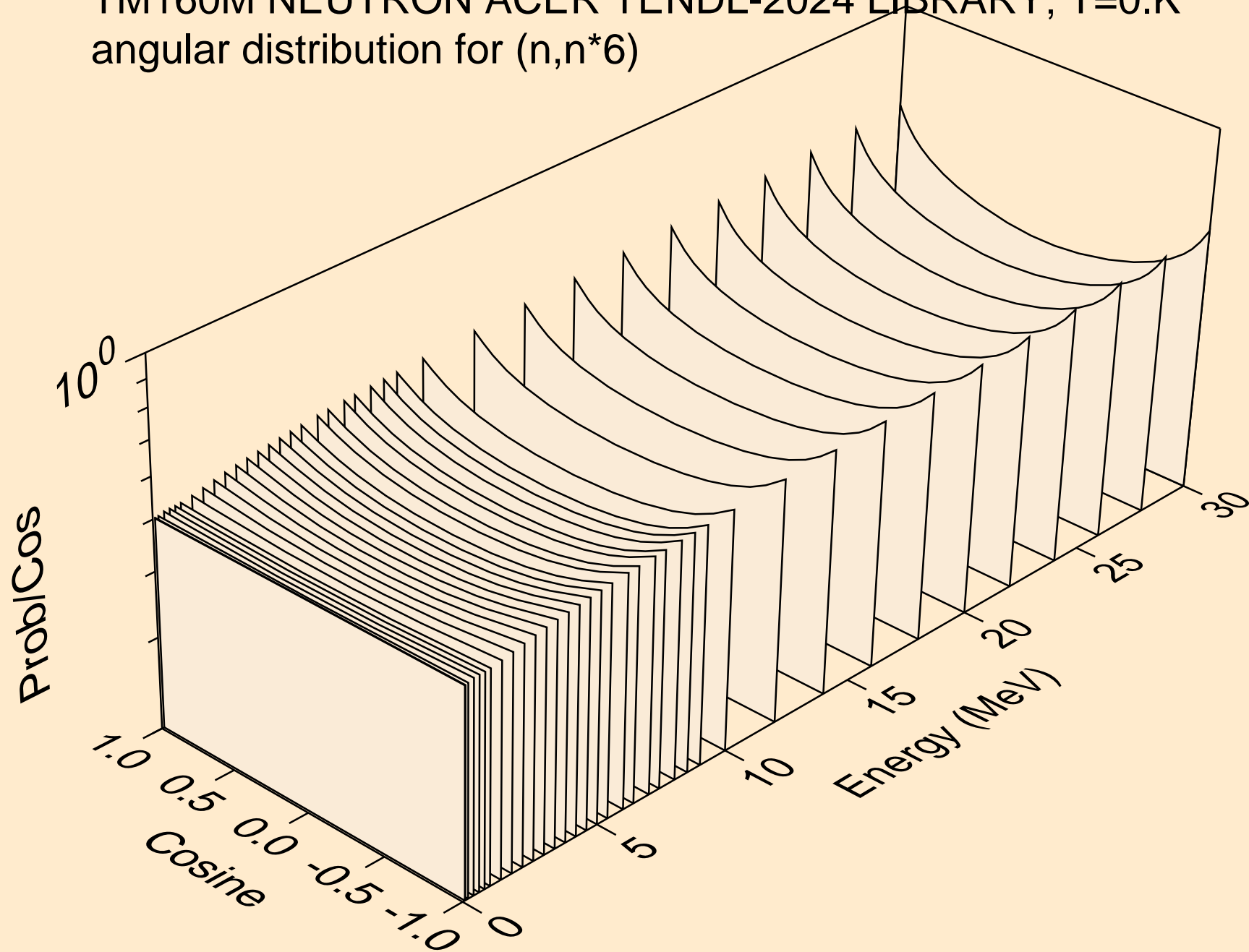

TM160M NEUTRON ACER TENDL-2024 LIBRARY; T=0.K
angular distribution for (n,n*7)

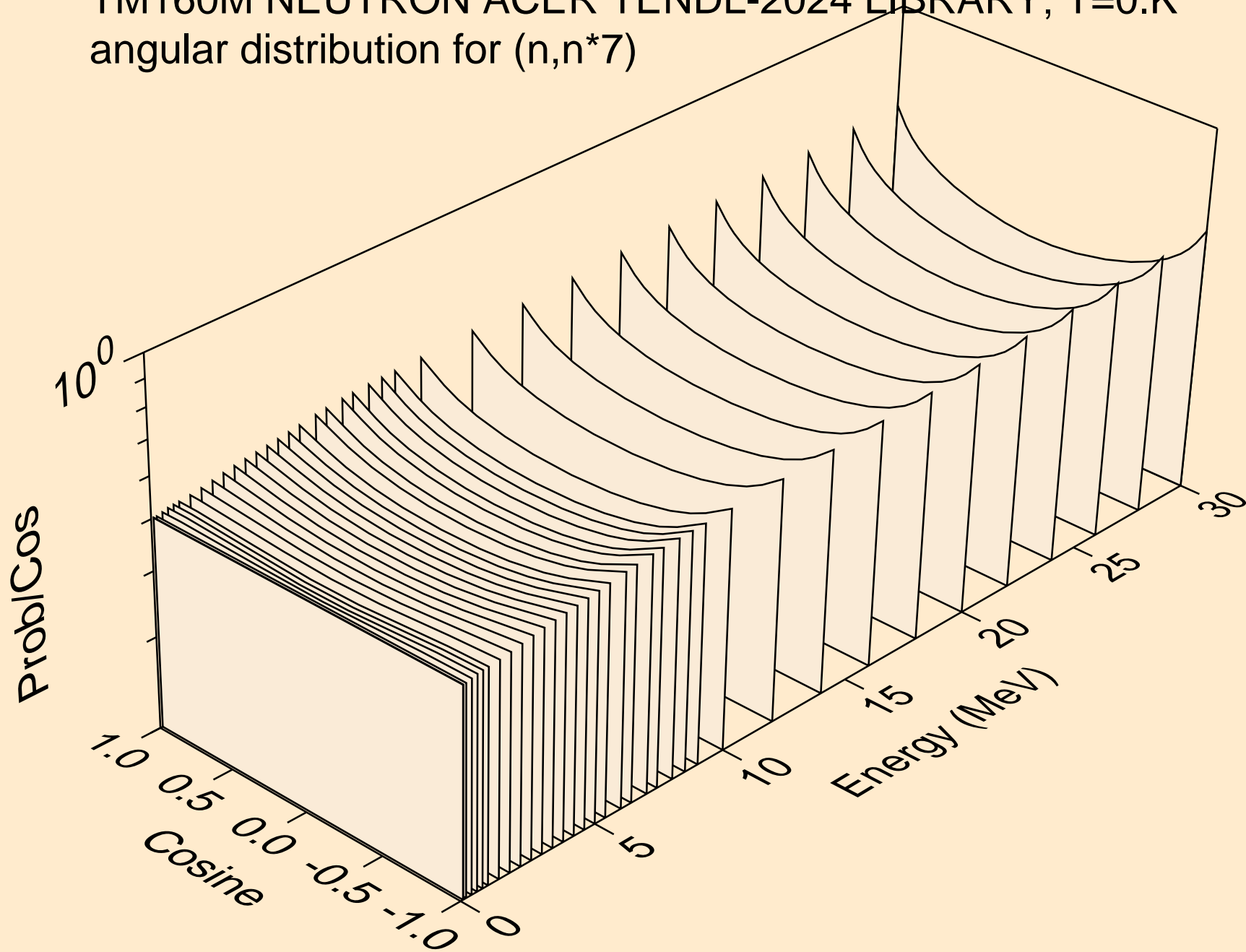

TM160M NEUTRON ACER TENDL-2024 LIBRARY; T=0.K
angular distribution for (n,n*8)

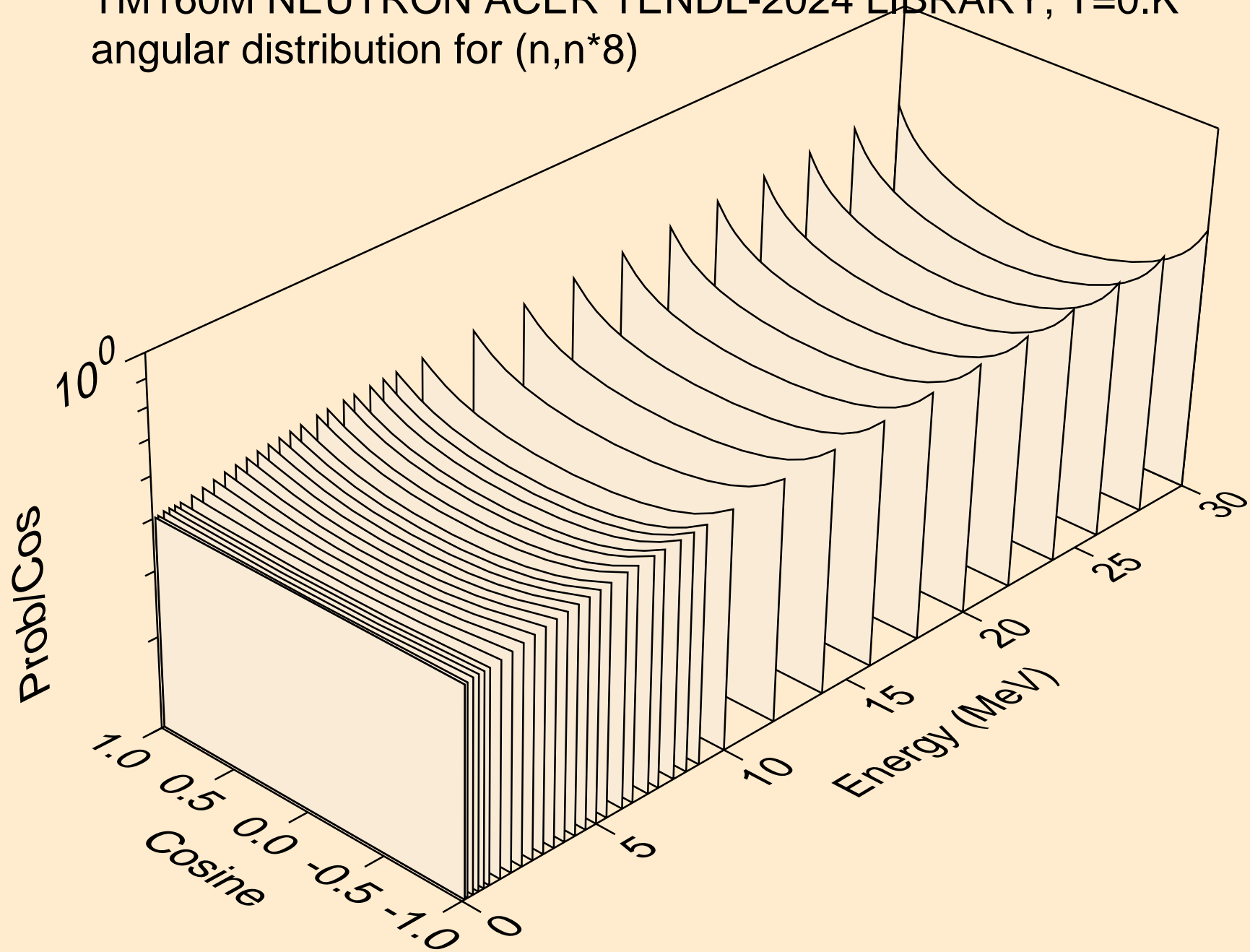

TM160M NEUTRON ACER TENDL-2024 LIBRARY; T=0.K
angular distribution for (n,n*9)

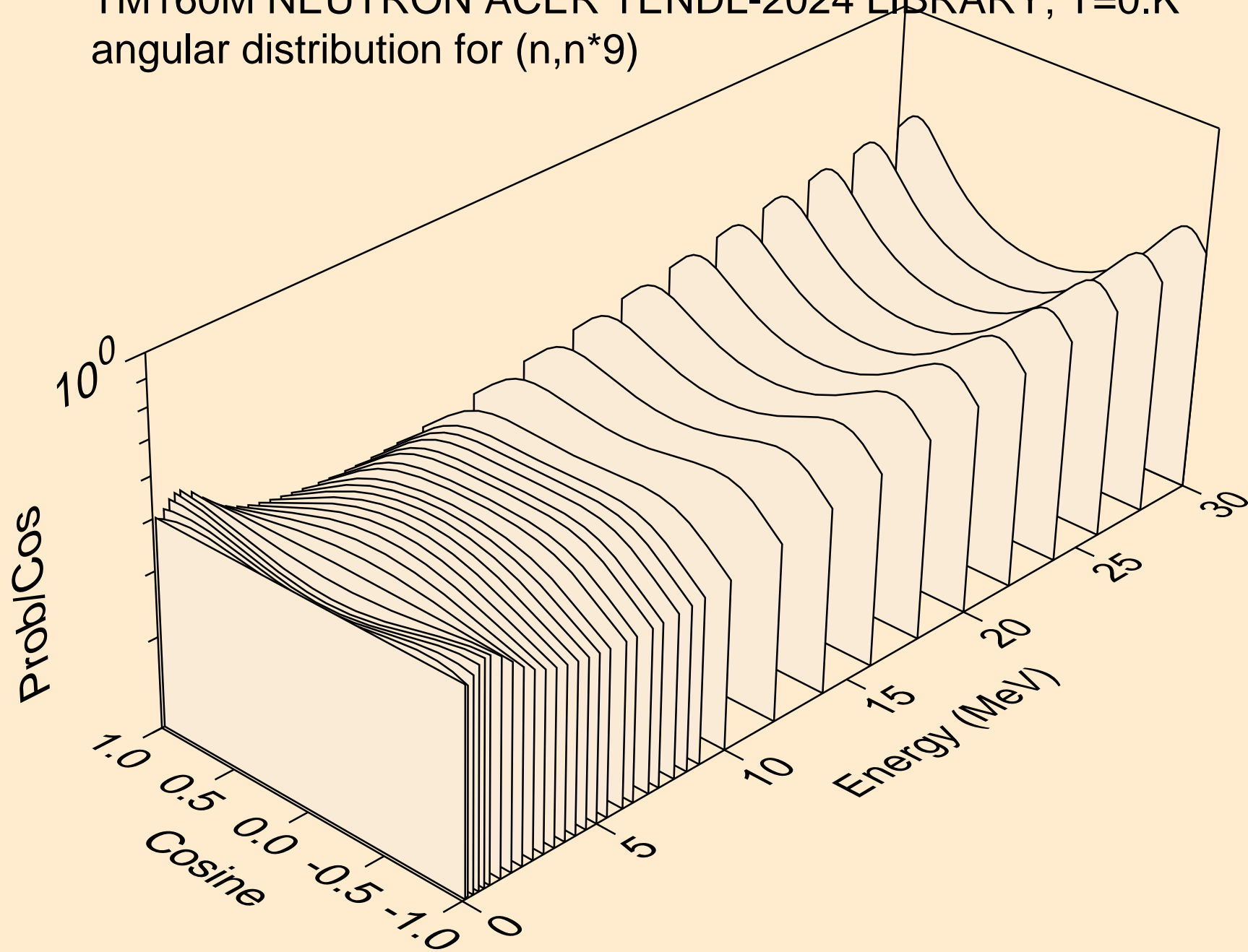

TM160M NEUTRON ACER TENDL-2024 LIBRARY; T=0.K
angular distribution for (n,n*10)

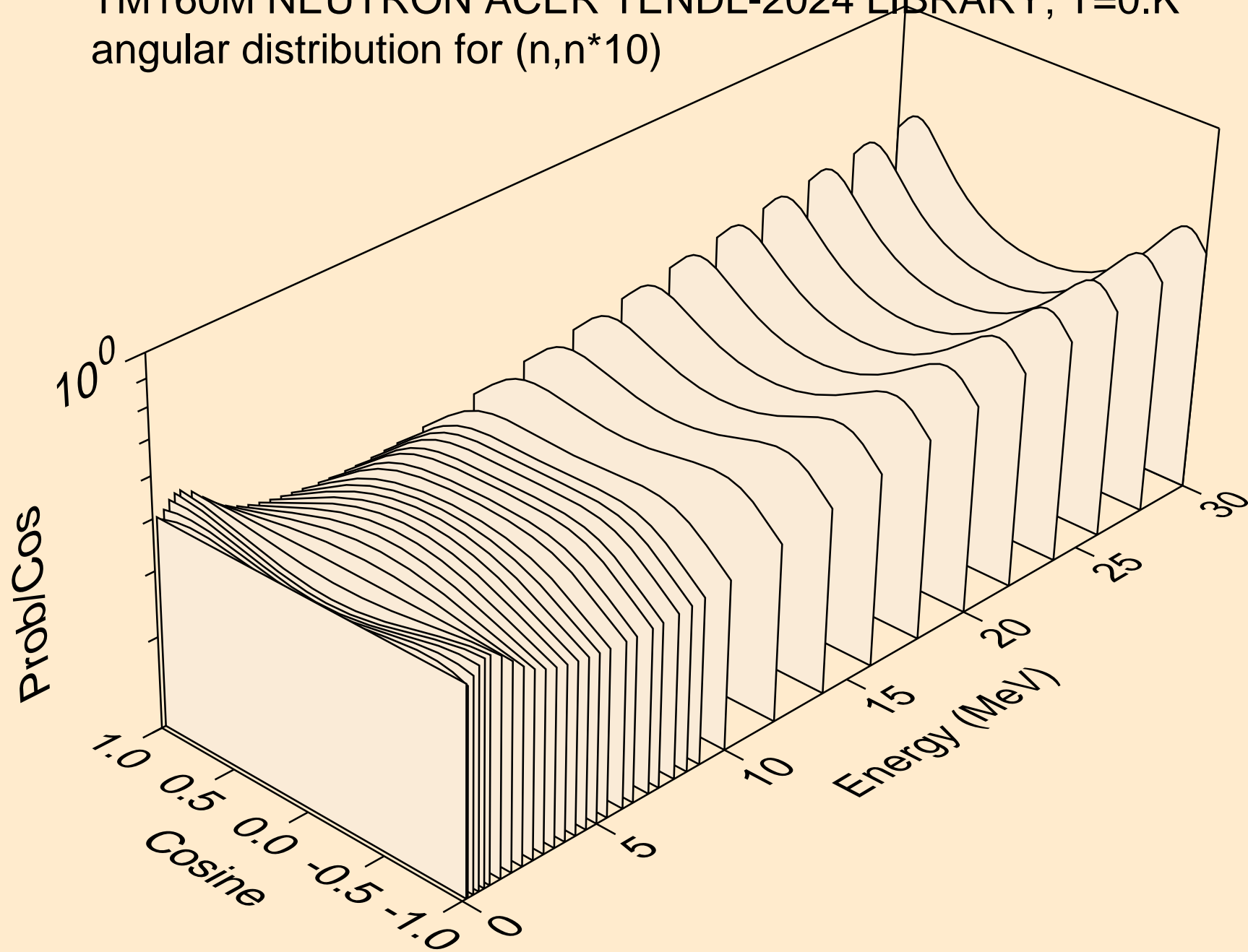

TM160M NEUTRON ACER TENDL-2024 LIBRARY; T=0.K
angular distribution for (n,n*11)

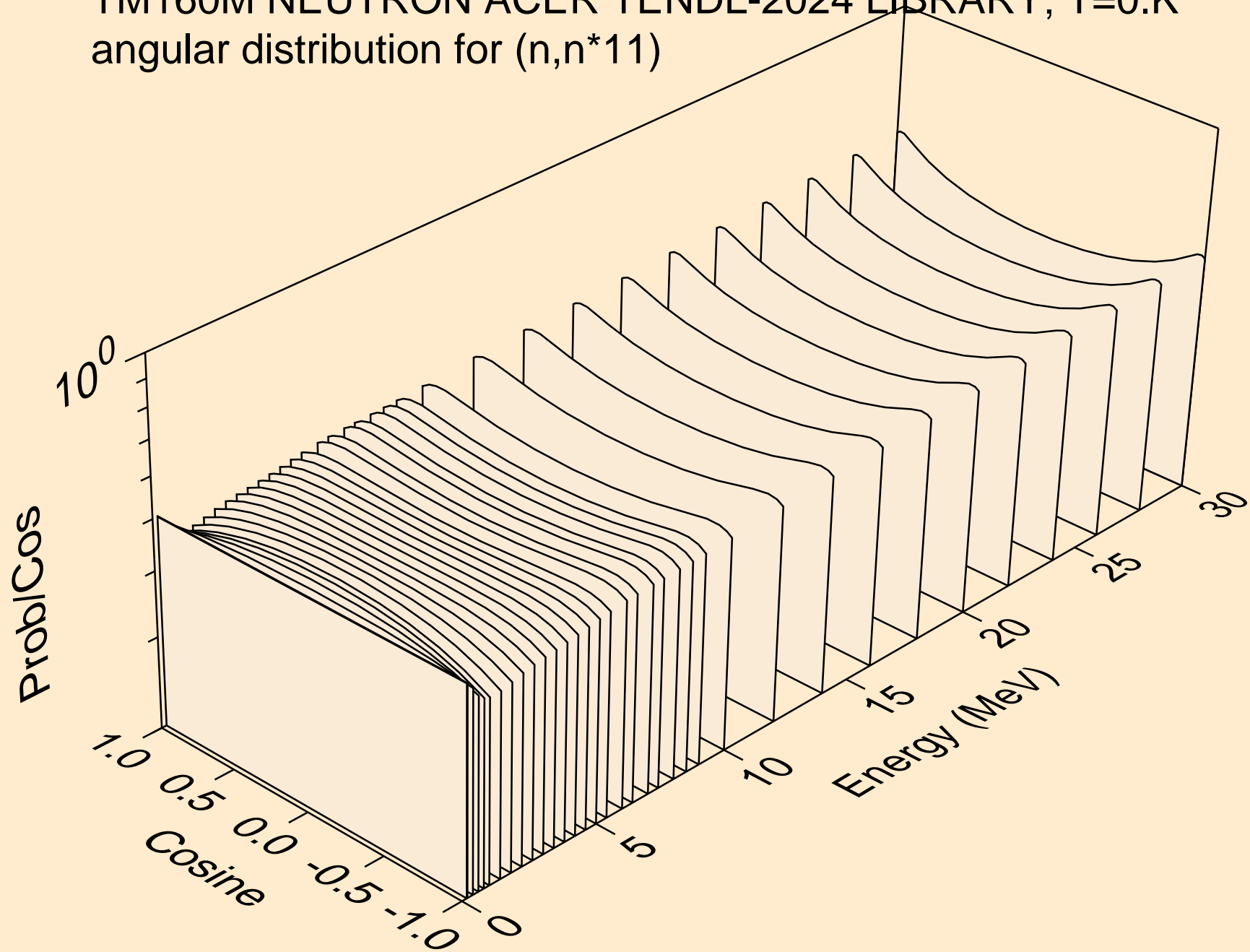

TM160M NEUTRON ACER TENDL-2024 LIBRARY; T=0.K
angular distribution for (n,n*12)

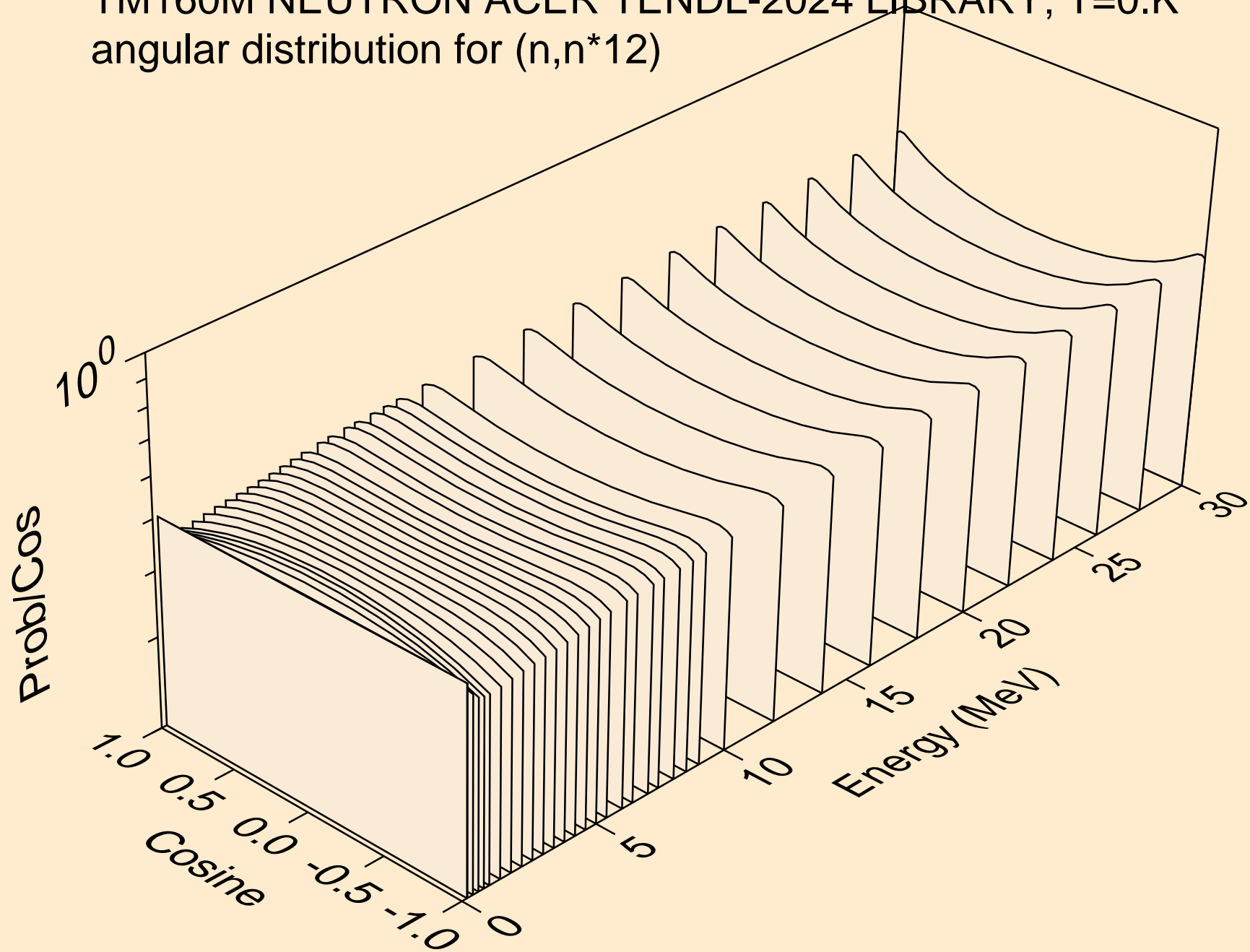

TM160M NEUTRON ACER TENDL-2024 LIBRARY; T=0.K
angular distribution for (n,n*13)

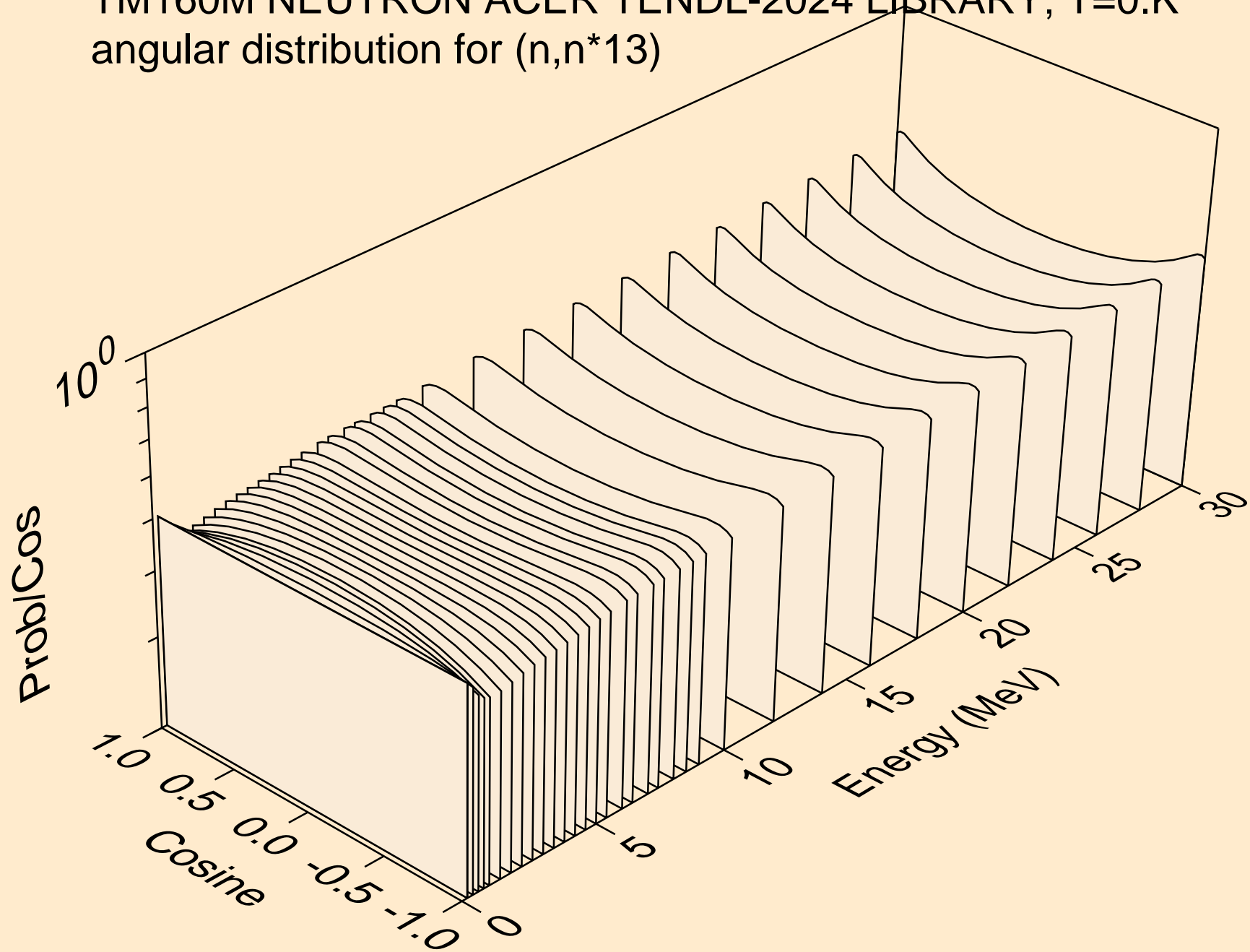

TM160M NEUTRON ACER TENDL-2024 LIBRARY; T=0.K
angular distribution for (n,n*14)

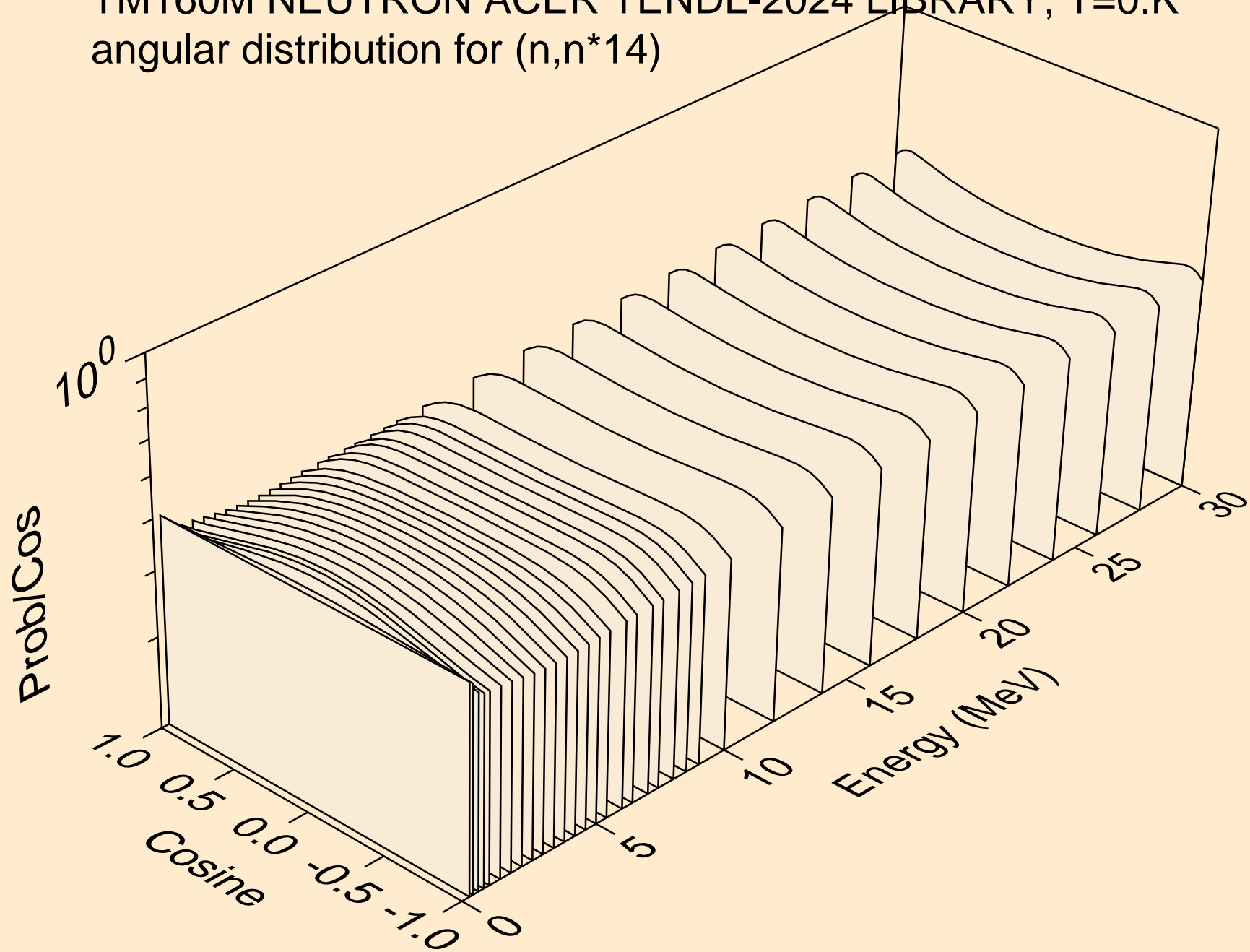

TM160M NEUTRON ACER TENDL-2024 LIBRARY; T=0.K
Neutron emission for (n,x)

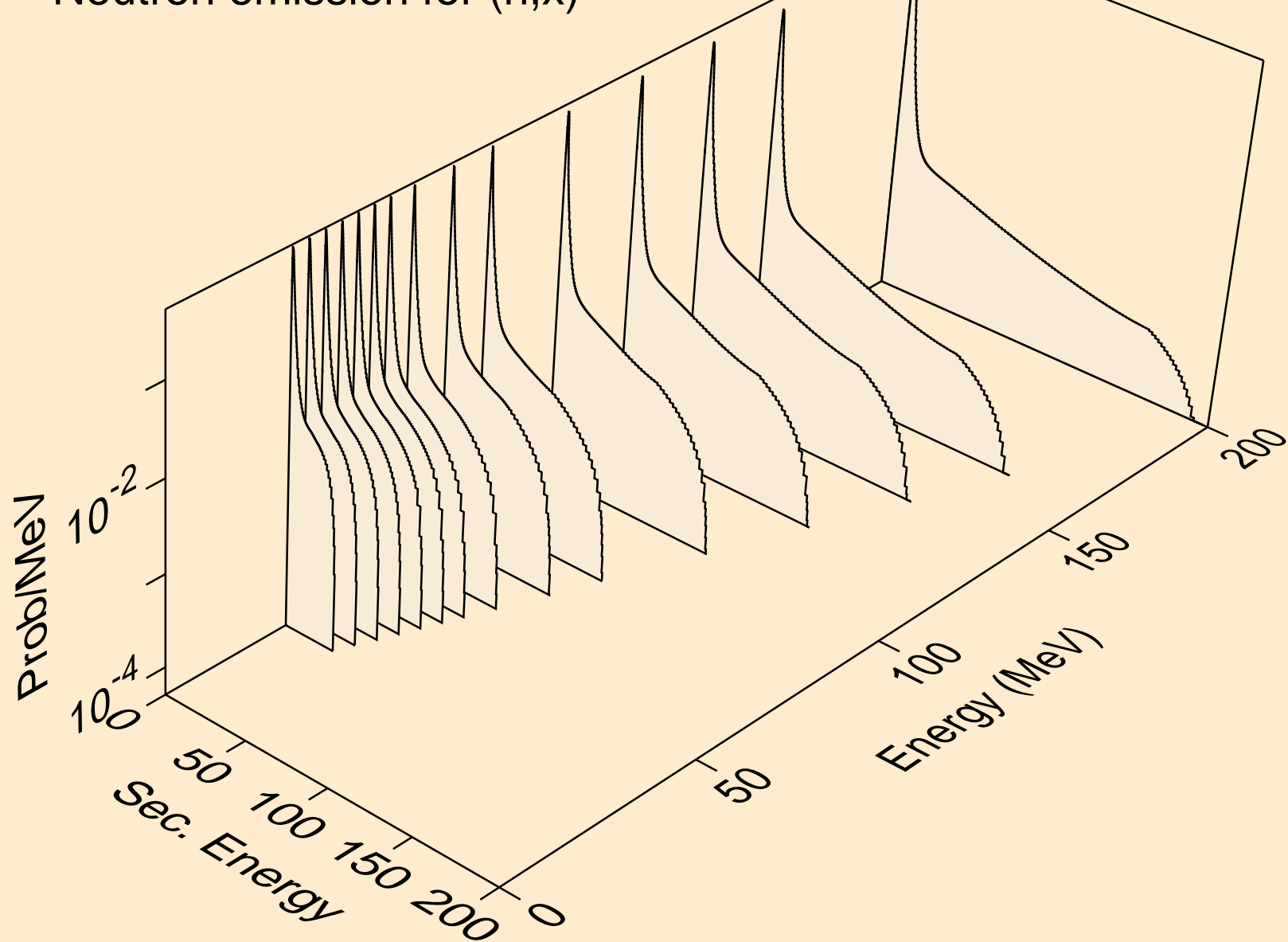

TM160M NEUTRON ACER TENDL-2024 LIBRARY; T=0.K
Neutron emission for (n,2nd)

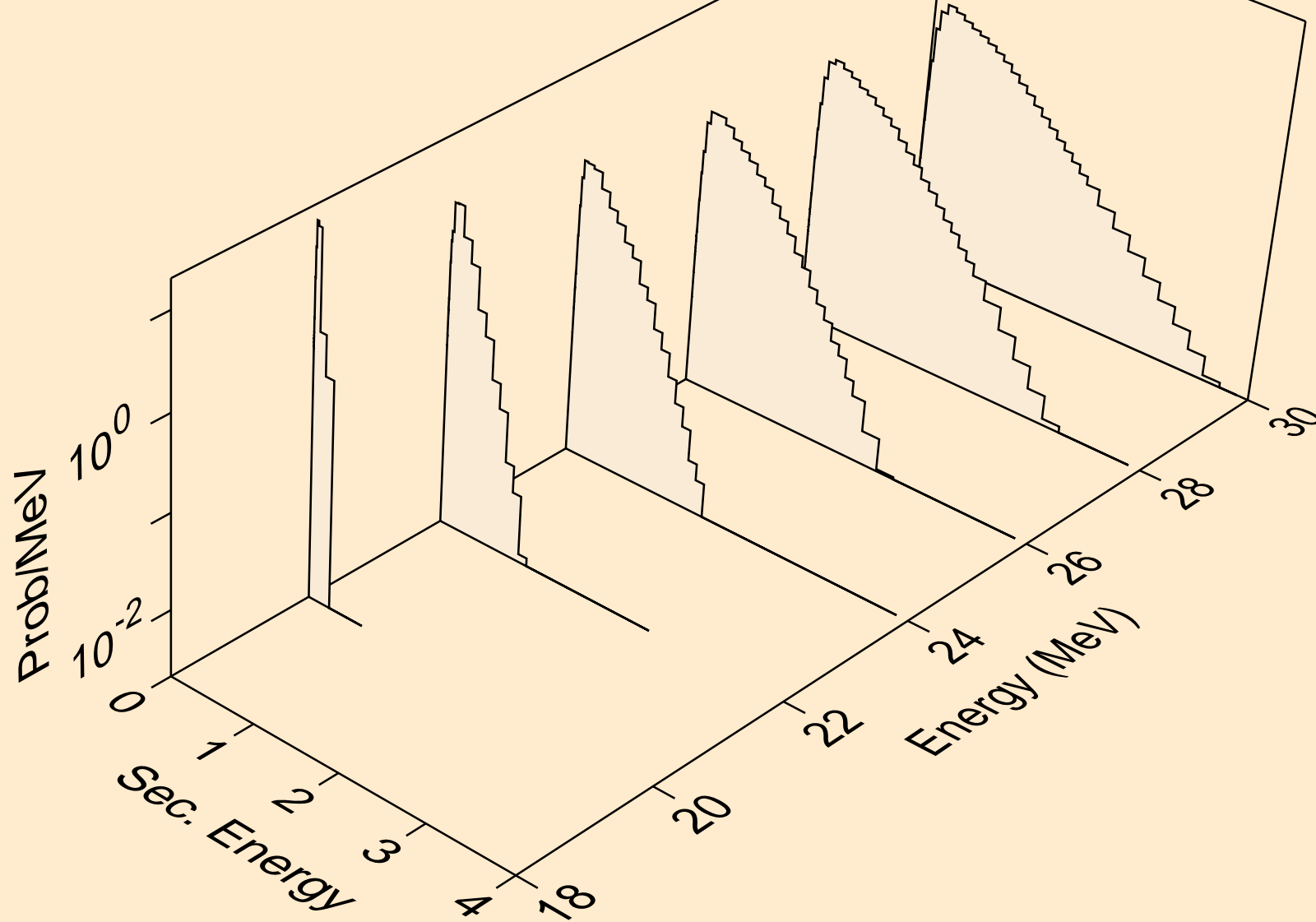

TM160M NEUTRON ACER TENDL-2024 LIBRARY; T=0.K
Neutron emission for (n,2n)

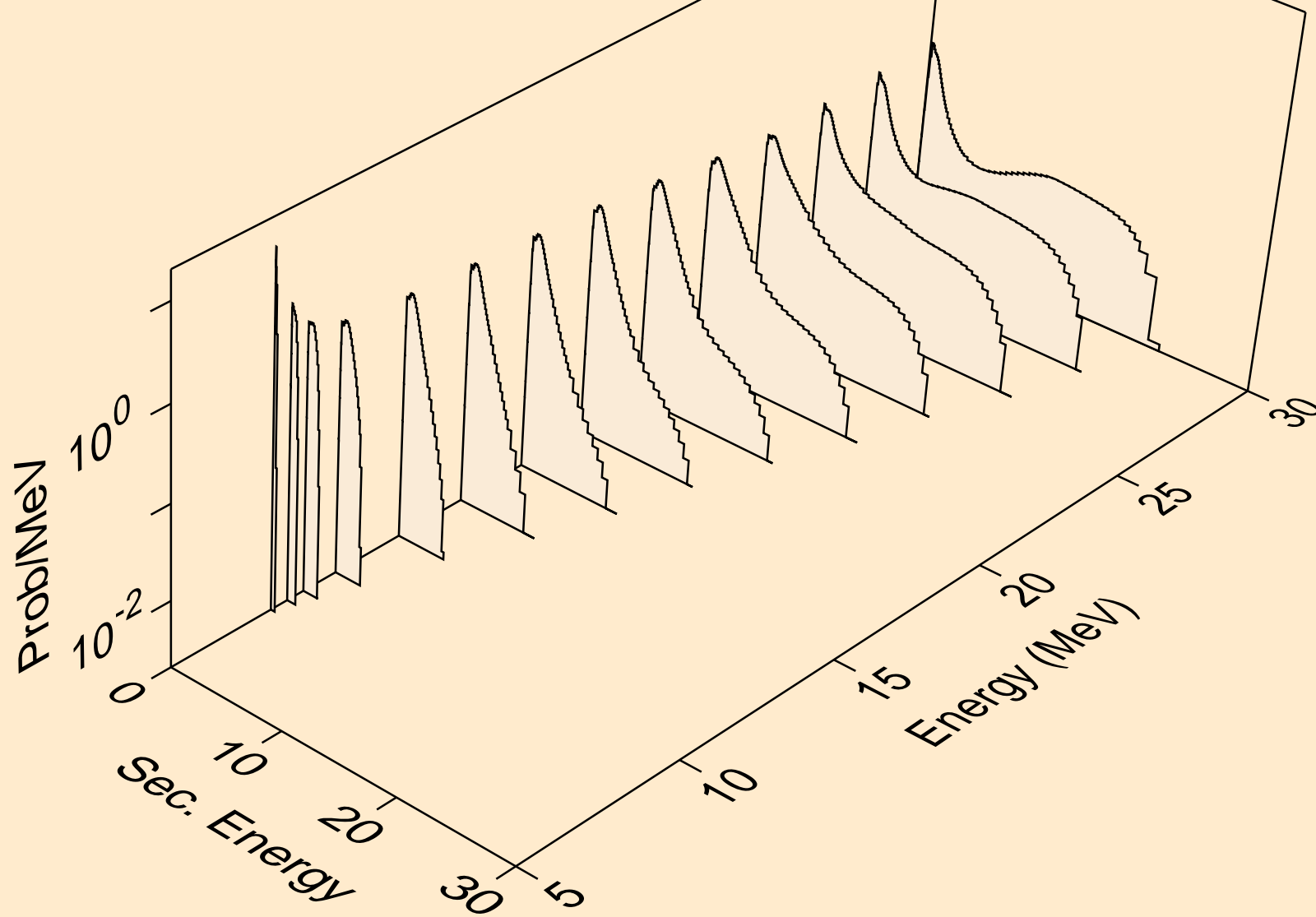

TM160M NEUTRON ACER TENDL-2024 LIBRARY; T=0.K
Neutron emission for (n,3n)

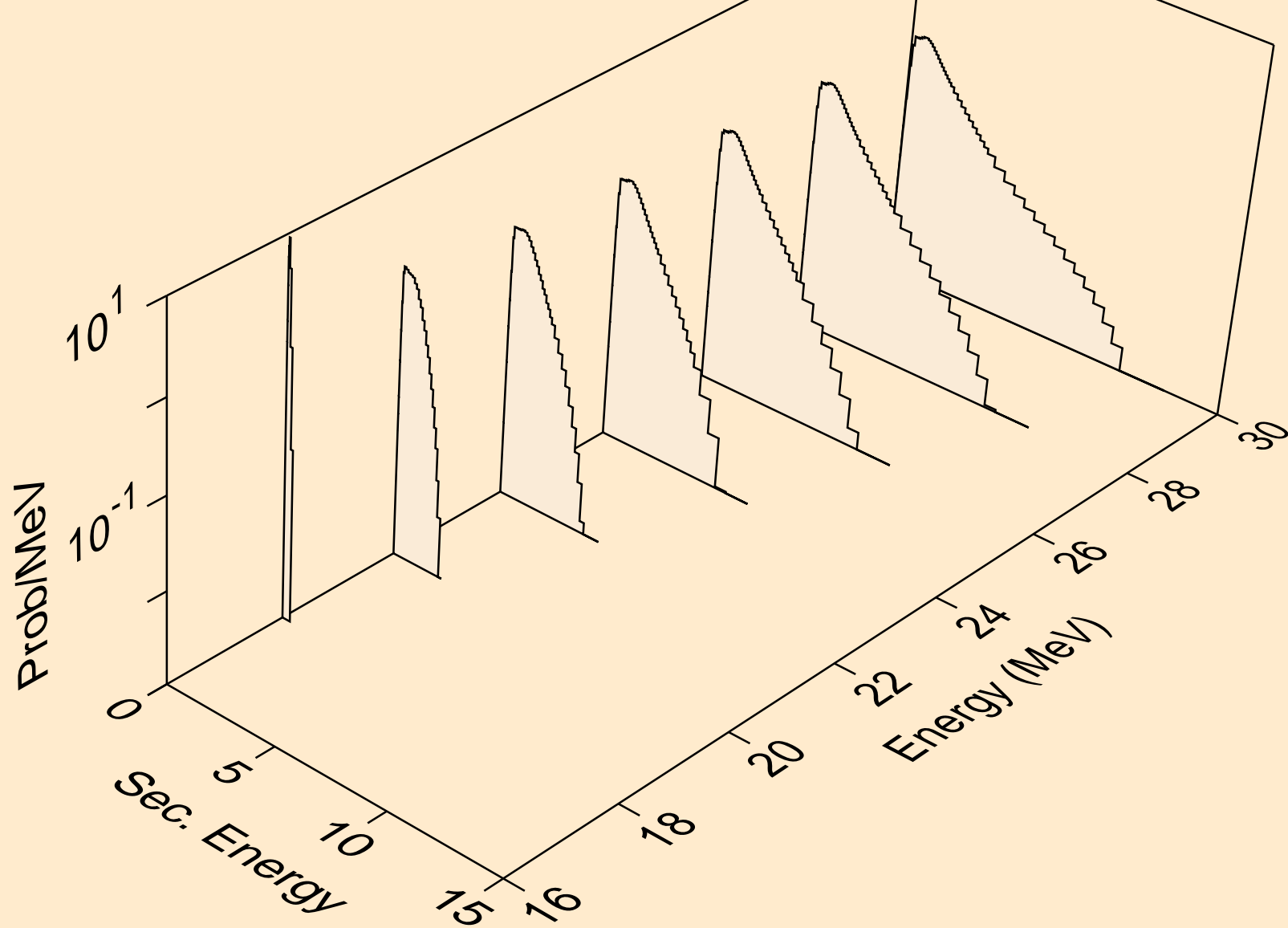

TM160M NEUTRON ACER TENDL-2024 LIBRARY; T=0.K
Neutron emission for (n,n*)a

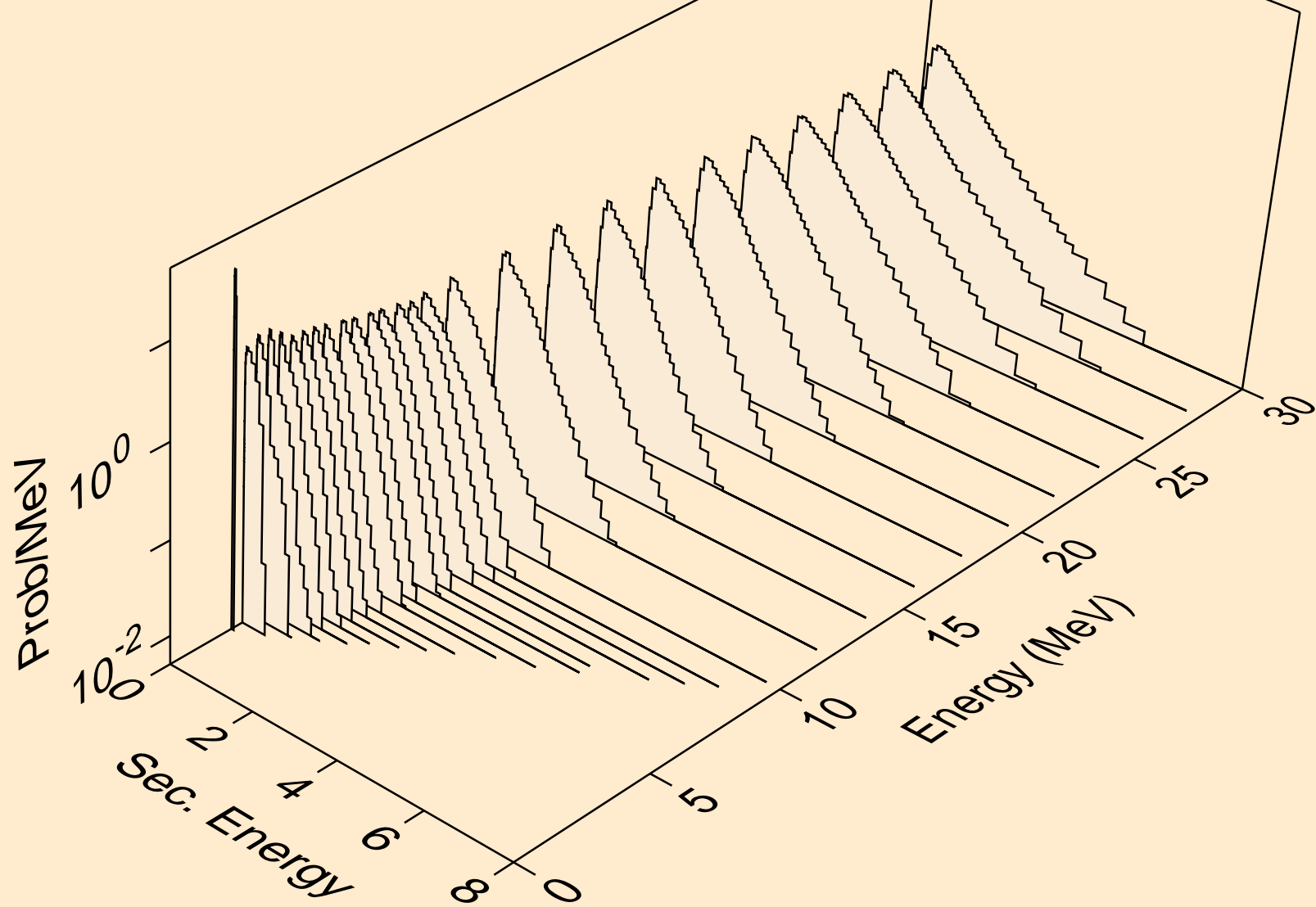

TM160M NEUTRON ACER TENDL-2024 LIBRARY; T=0.K
Neutron emission for (n,2n)a

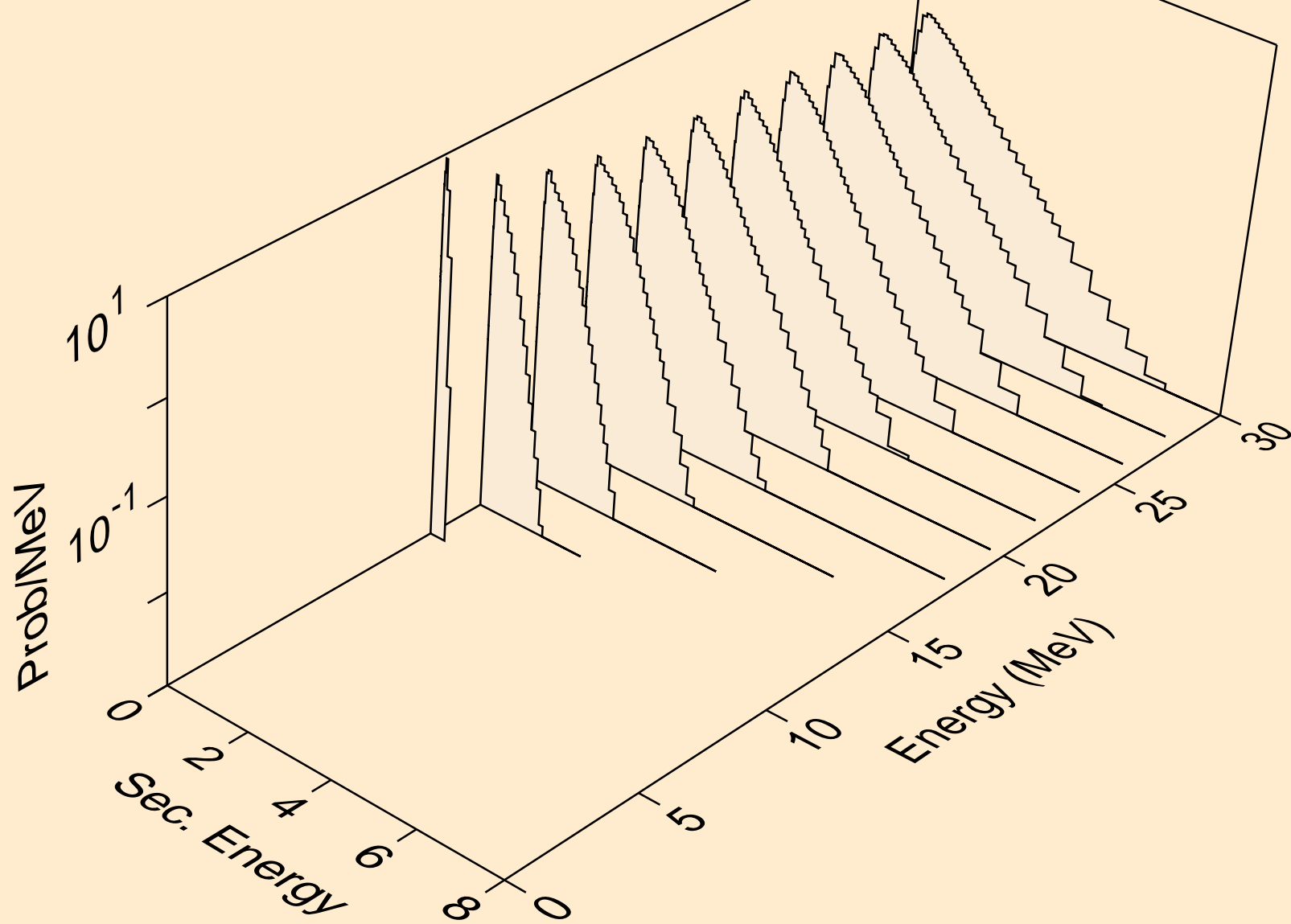

TM160M NEUTRON ACER TENDL-2024 LIBRARY; T=0.K
Neutron emission for (n,3n)a

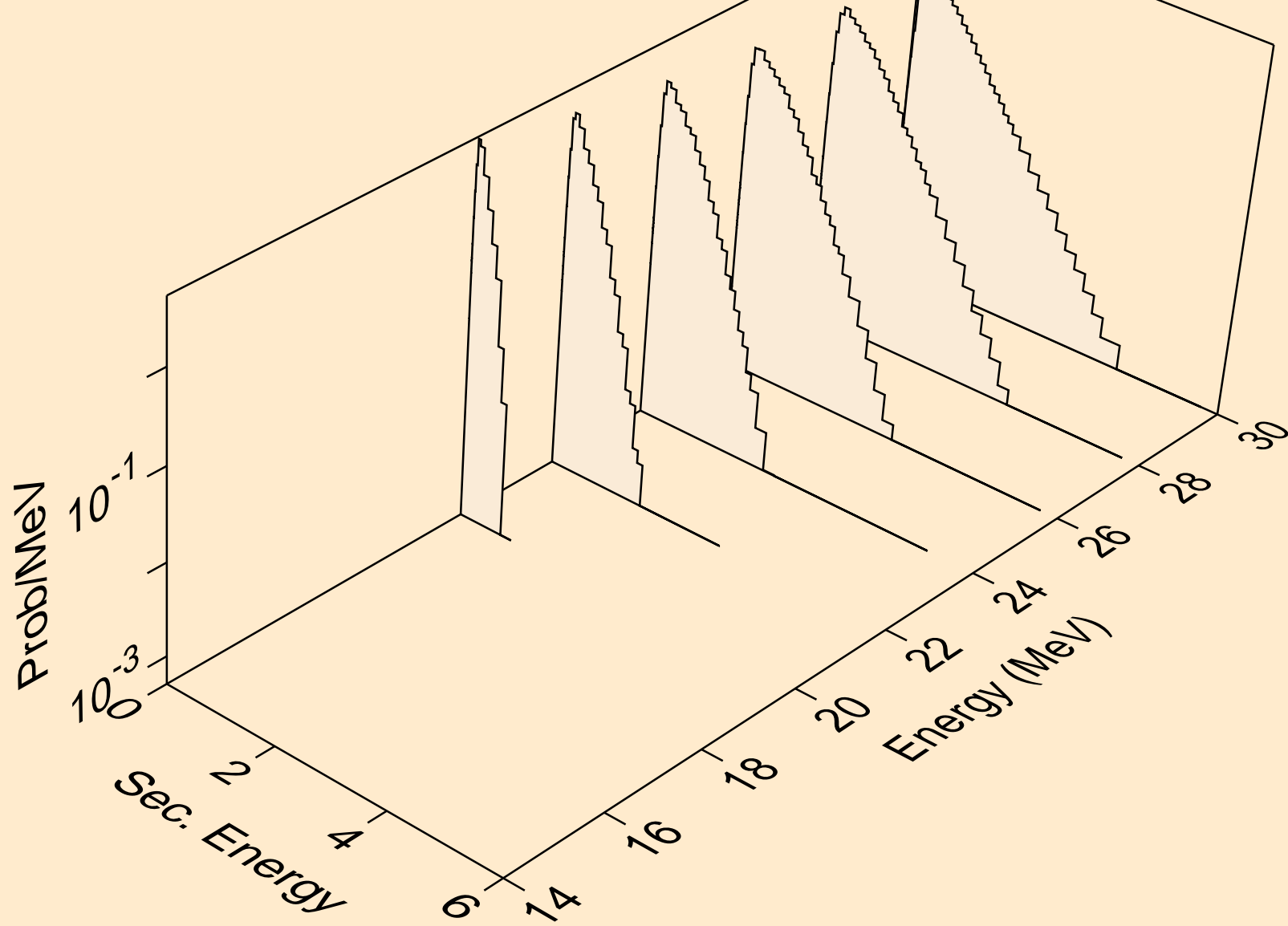

TM160M NEUTRON ACER TENDL-2024 LIBRARY; T=0.K
Neutron emission for (n,n*)p

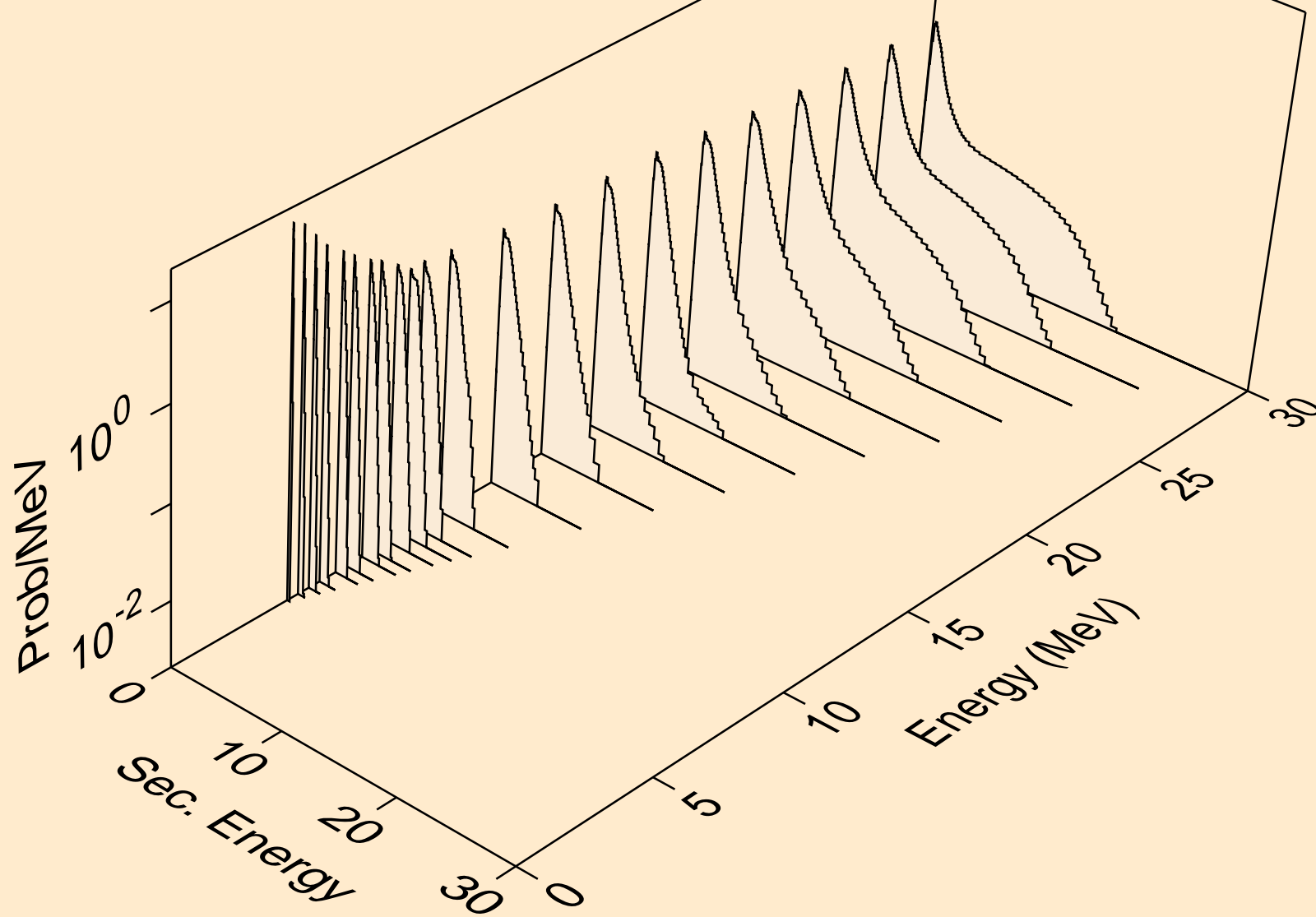

TM160M NEUTRON ACER TENDL-2024 LIBRARY; T=0.K
Neutron emission for (n,n*)2a

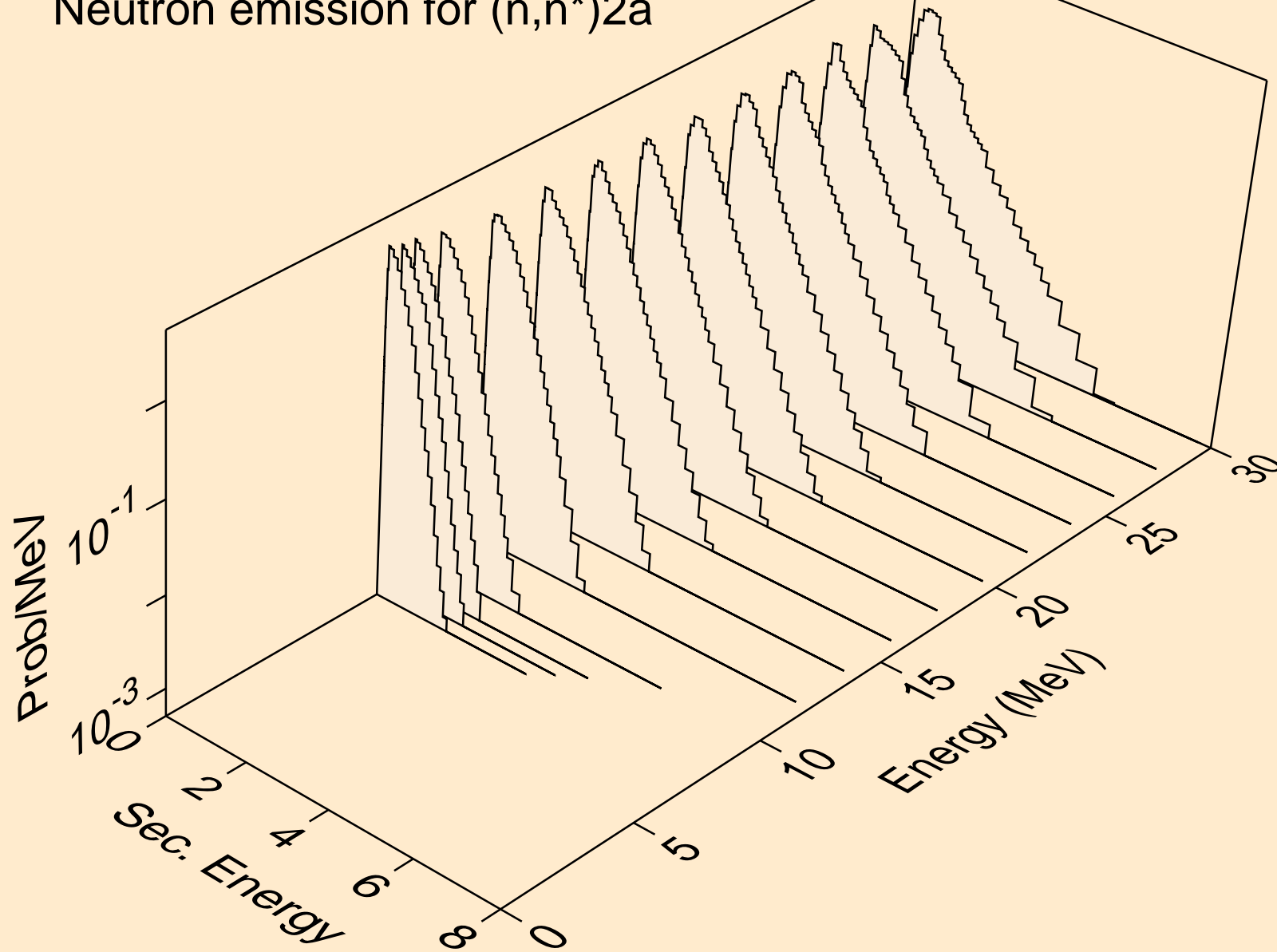

TM160M NEUTRON ACER TENDL-2024 LIBRARY; T=0.K
Neutron emission for (n,2n)2a

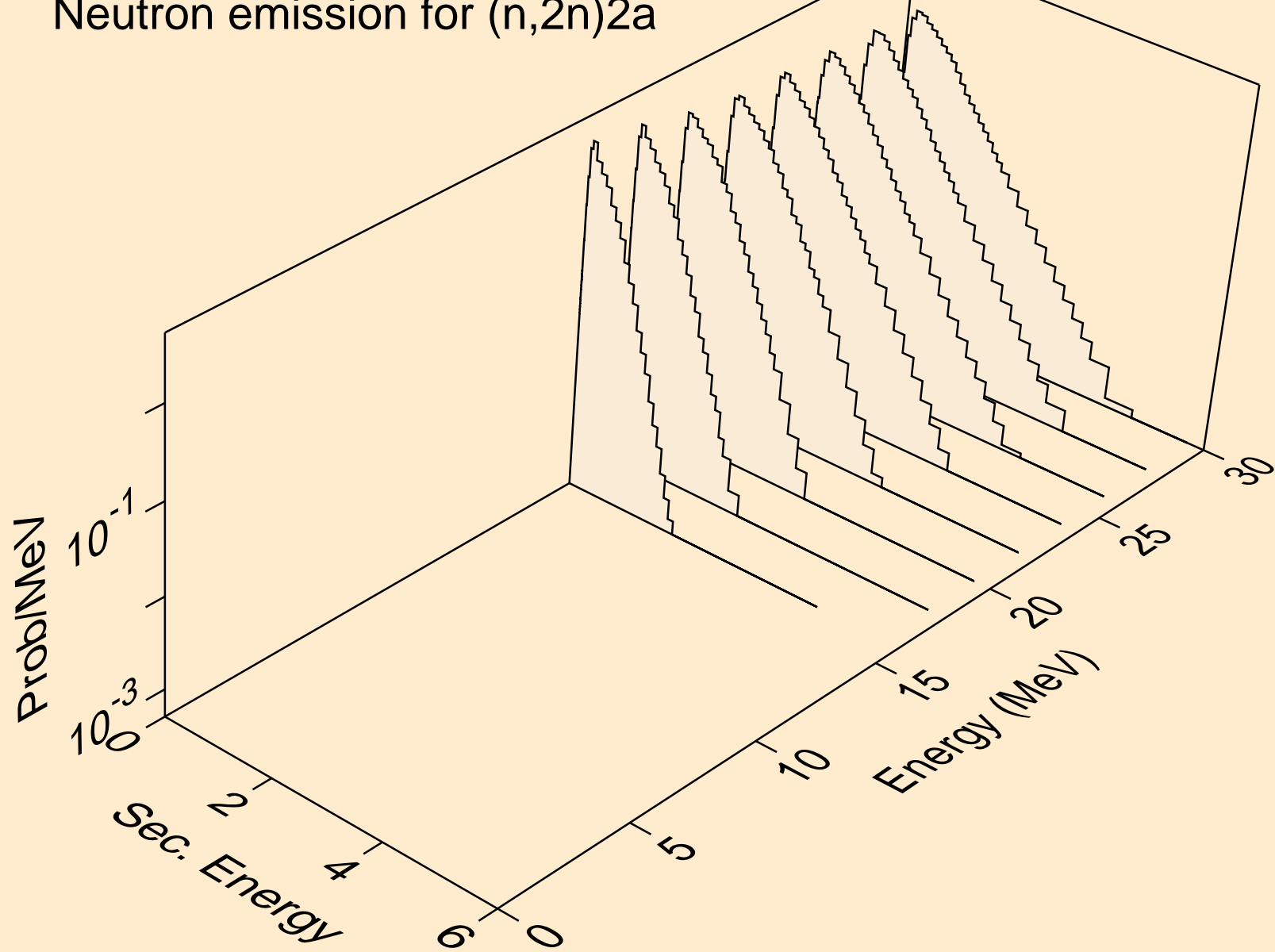

TM160M NEUTRON ACER TENDL-2024 LIBRARY; T=0.K
Neutron emission for (n,n*)d

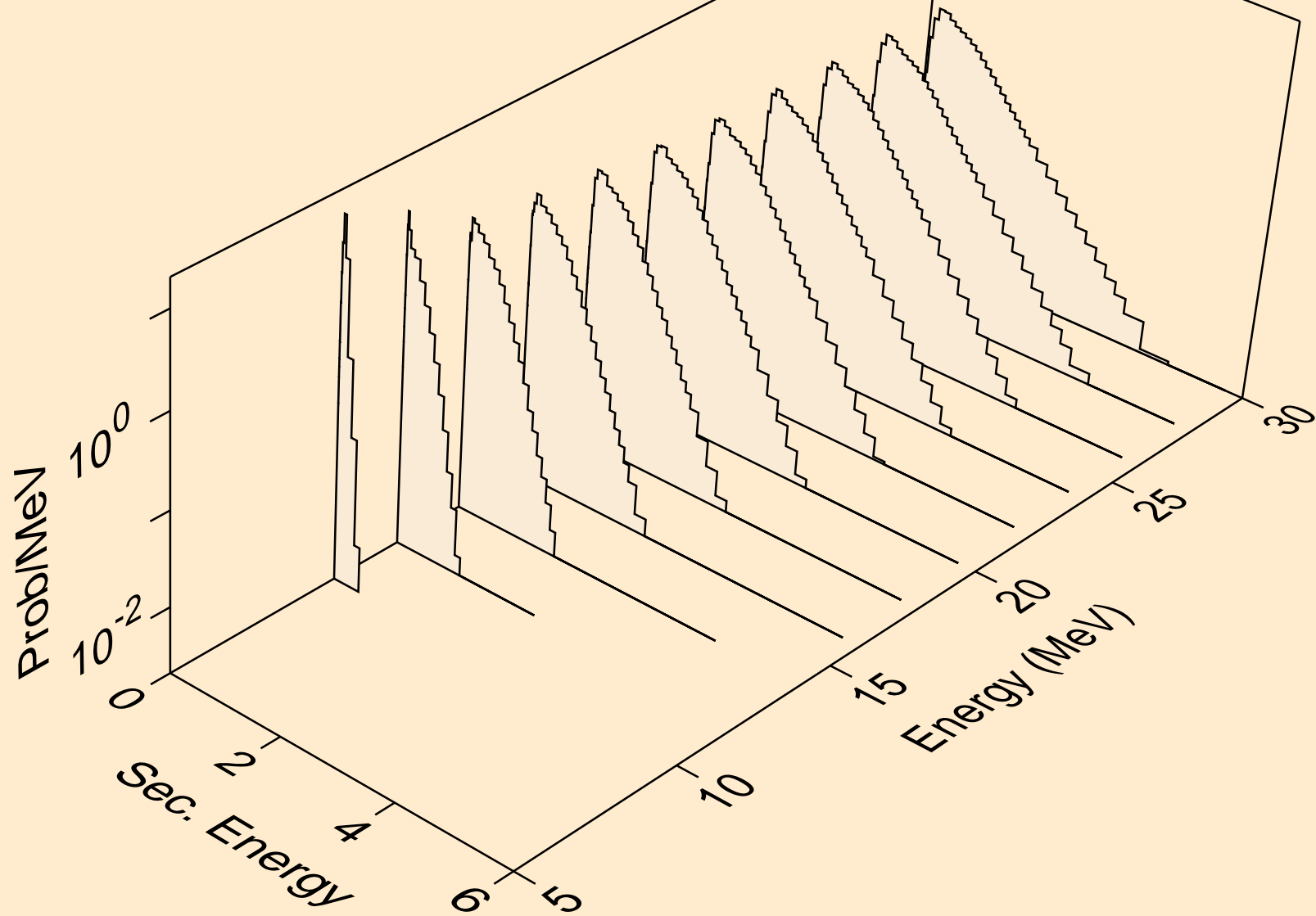

TM160M NEUTRON ACER TENDL-2024 LIBRARY; T=0.K
Neutron emission for (n,n*)t

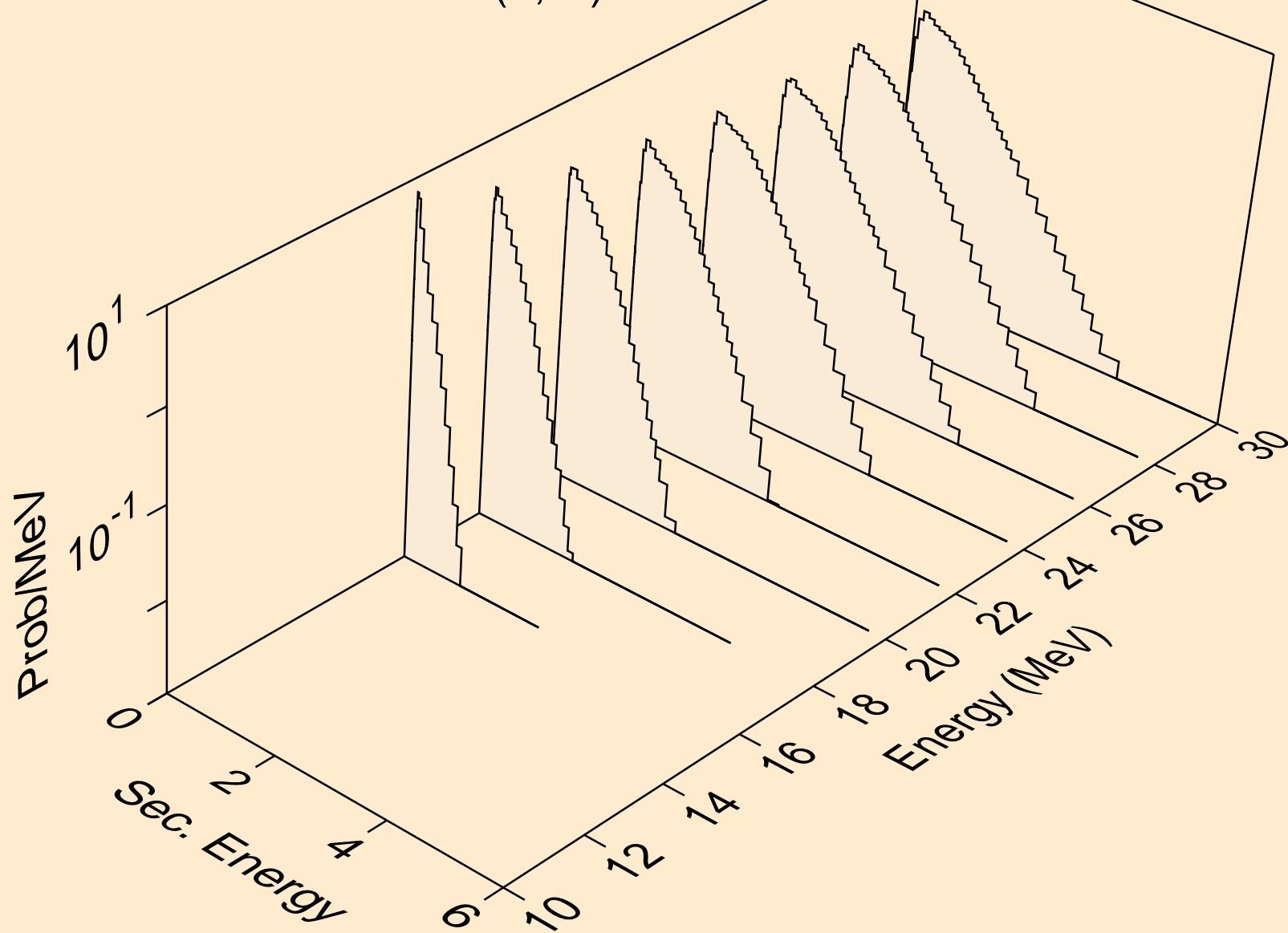

TM160M NEUTRON ACER TENDL-2024 LIBRARY; T=0.K
Neutron emission for (n,n*)he3

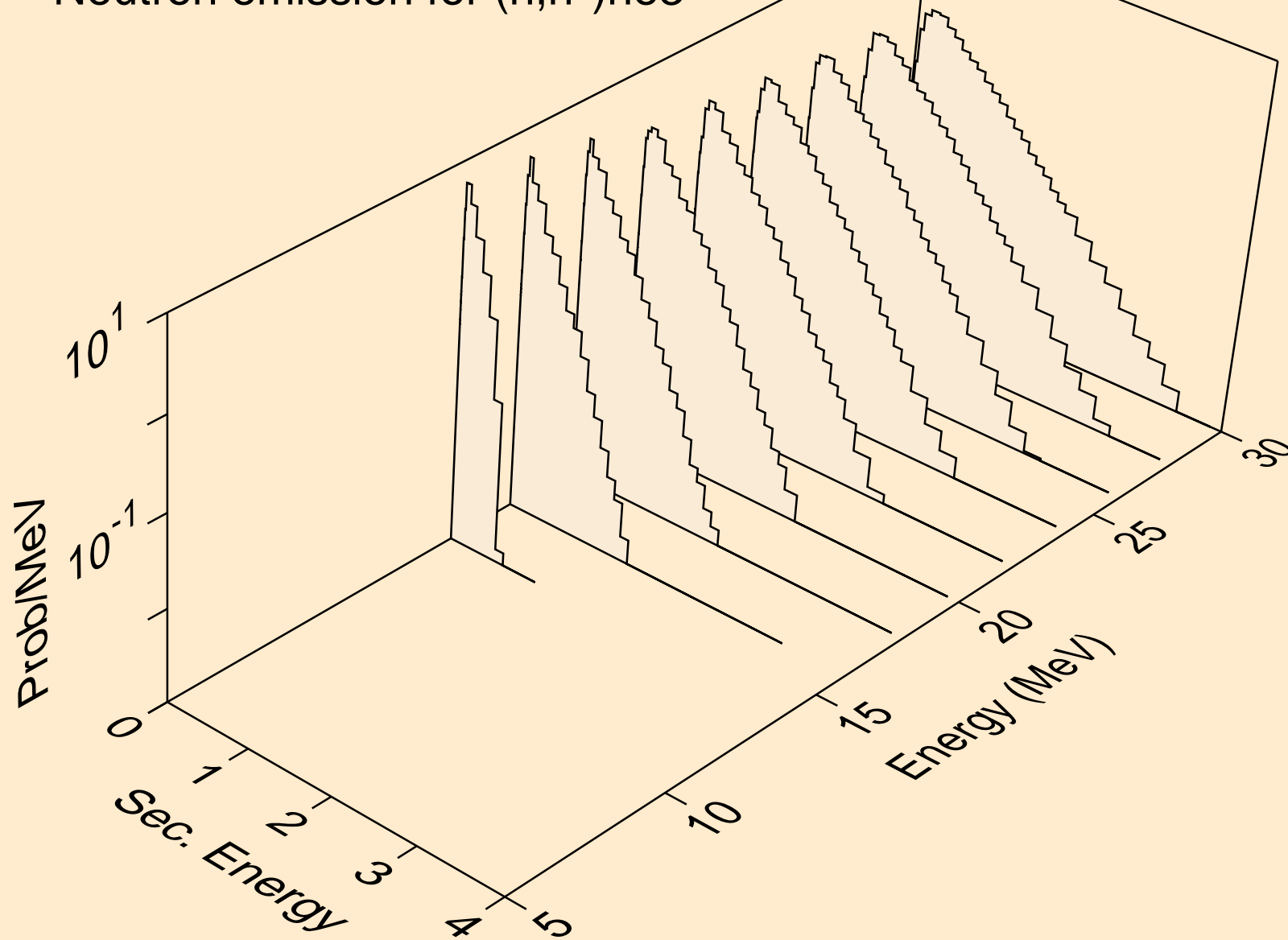

TM160M NEUTRON ACER TENDL-2024 LIBRARY; T=0.K
Neutron emission for (n,4n)

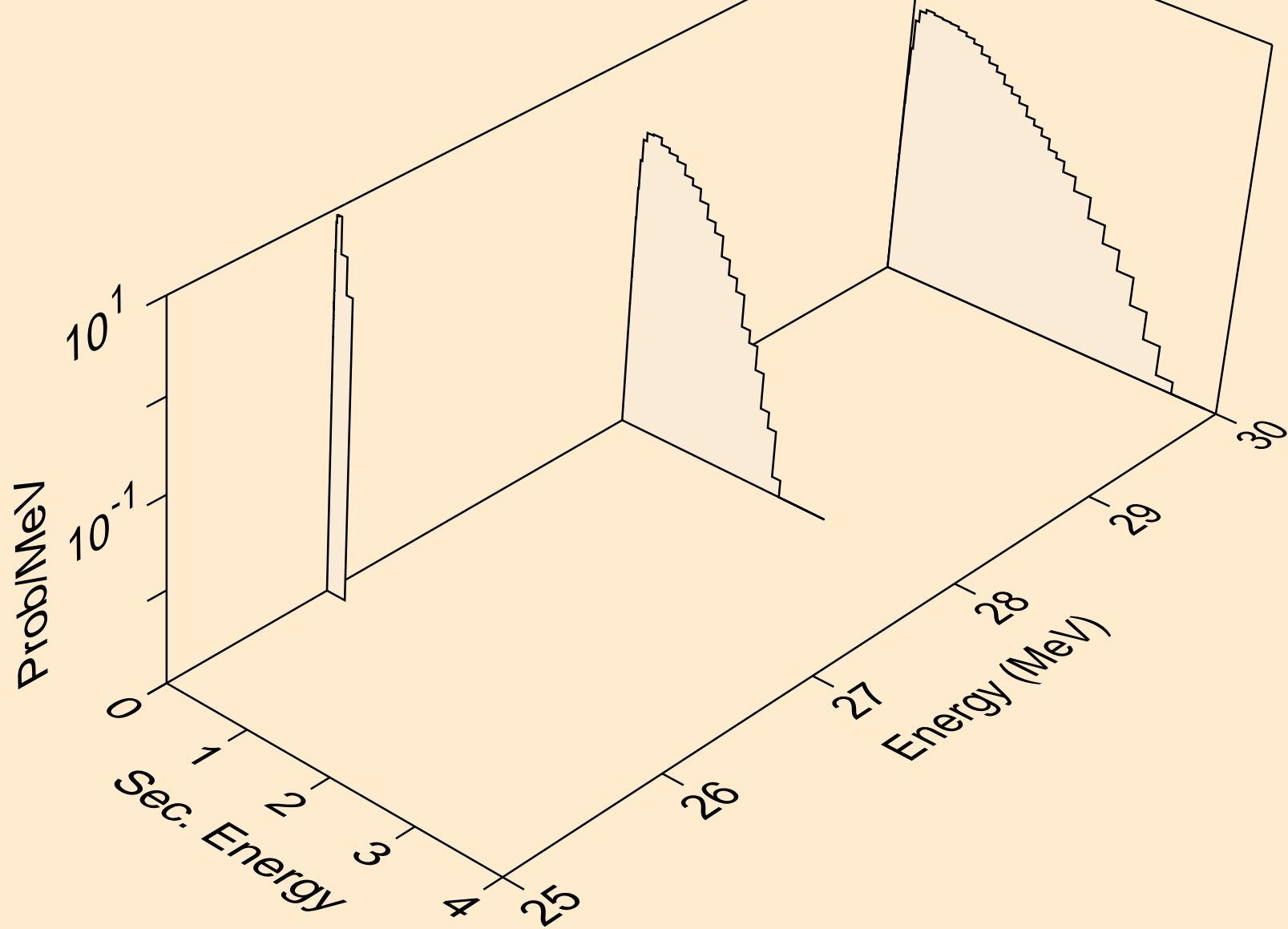

TM160M NEUTRON ACER TENDL-2024 LIBRARY; T=0.K
Neutron emission for (n,2np)

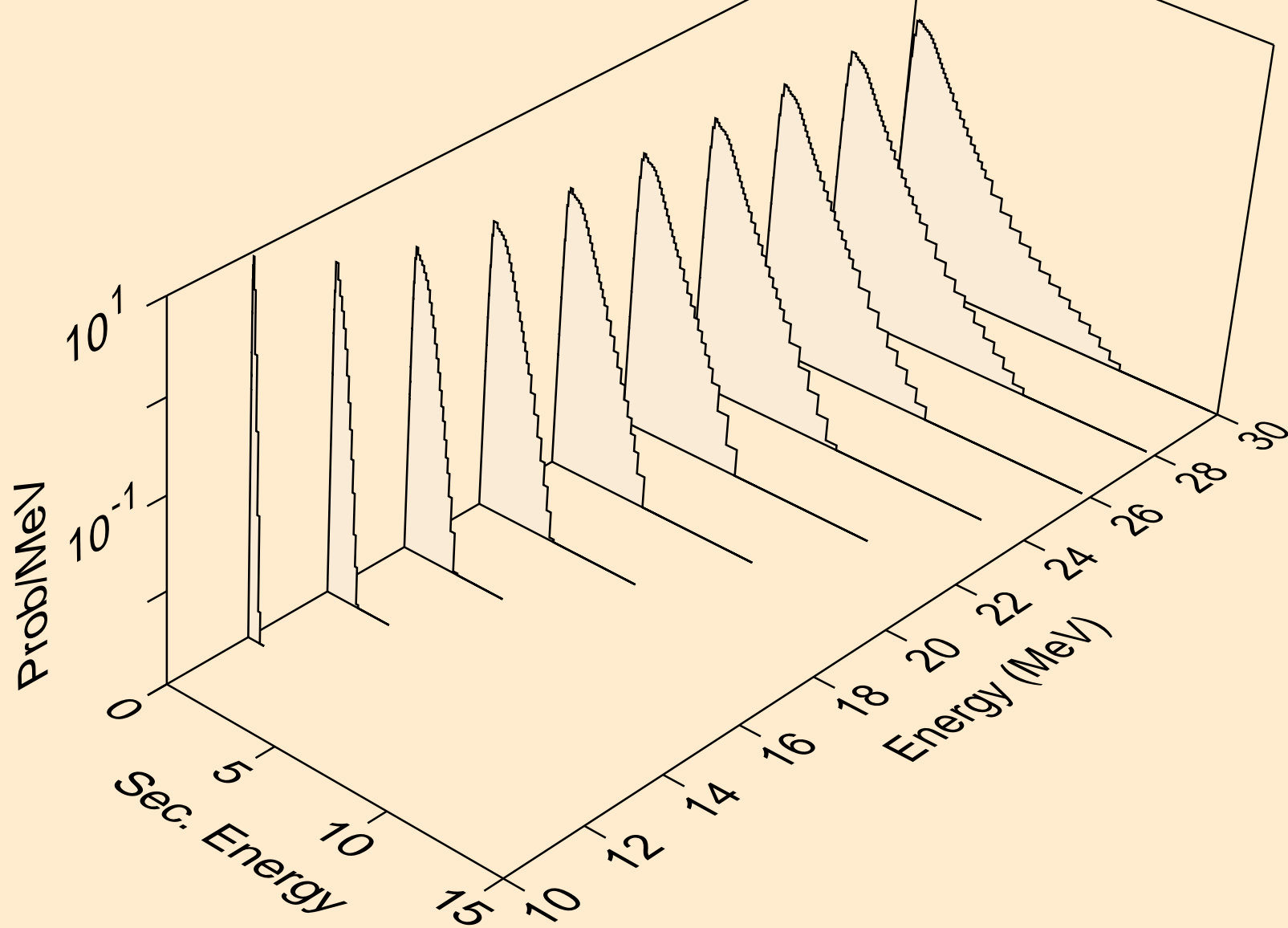

TM160M NEUTRON ACER TENDL-2024 LIBRARY; T=0.K
Neutron emission for (n,3np)

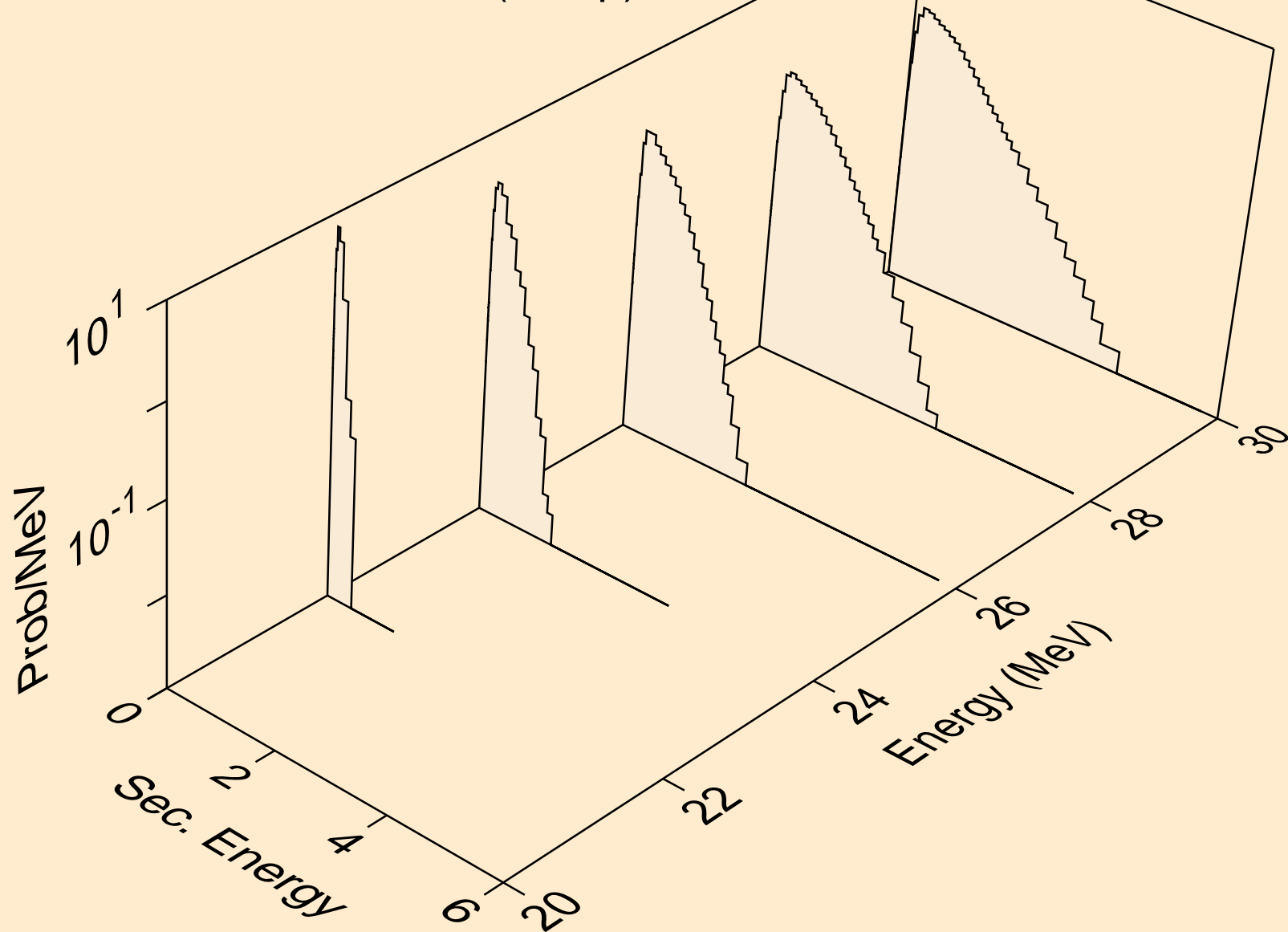

TM160M NEUTRON ACER TENDL-2024 LIBRARY; T=0.K
Neutron emission for (n,n2p)

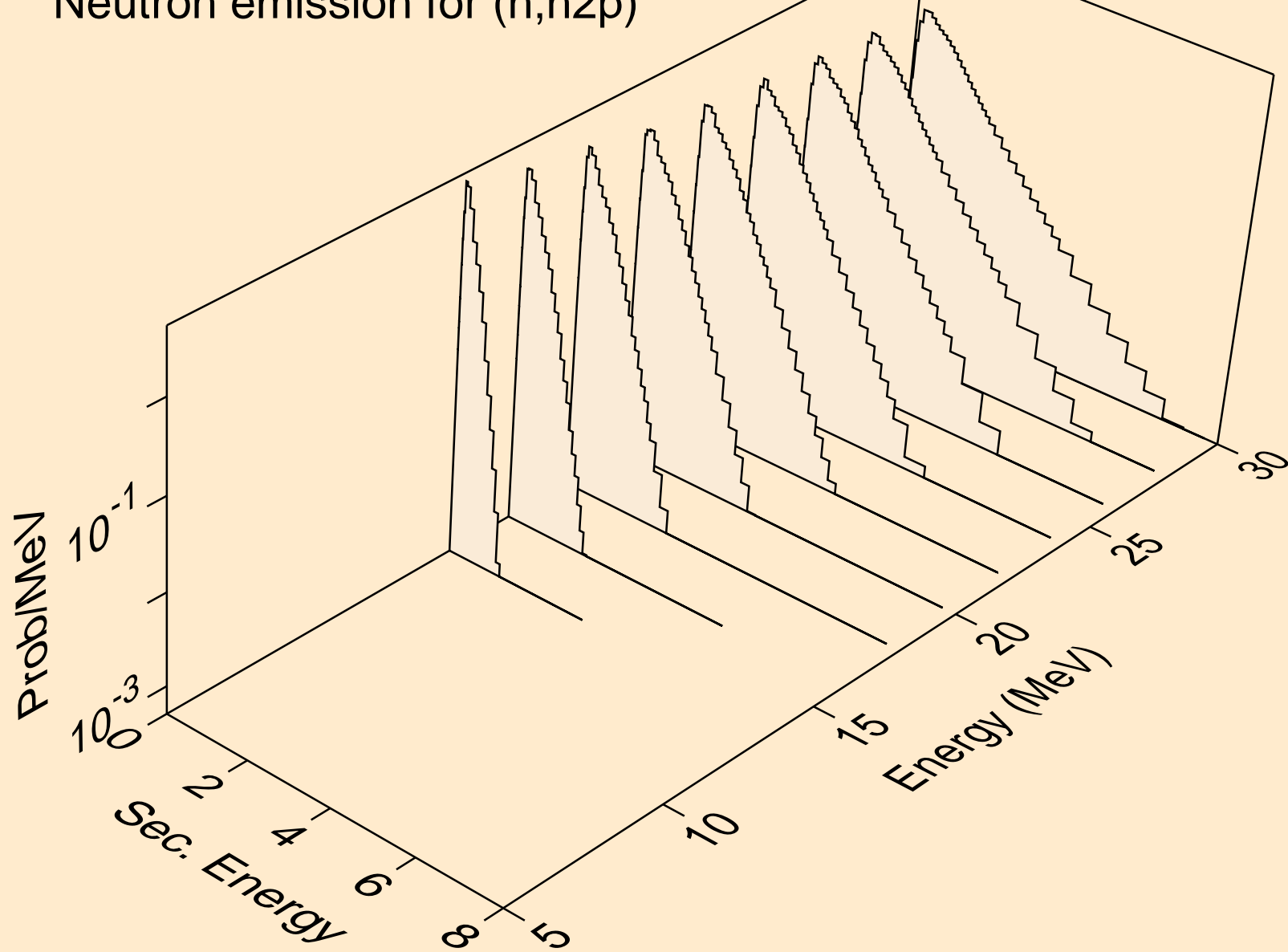

TM160M NEUTRON ACER TENDL-2024 LIBRARY; T=0.K
Neutron emission for (n,npa)

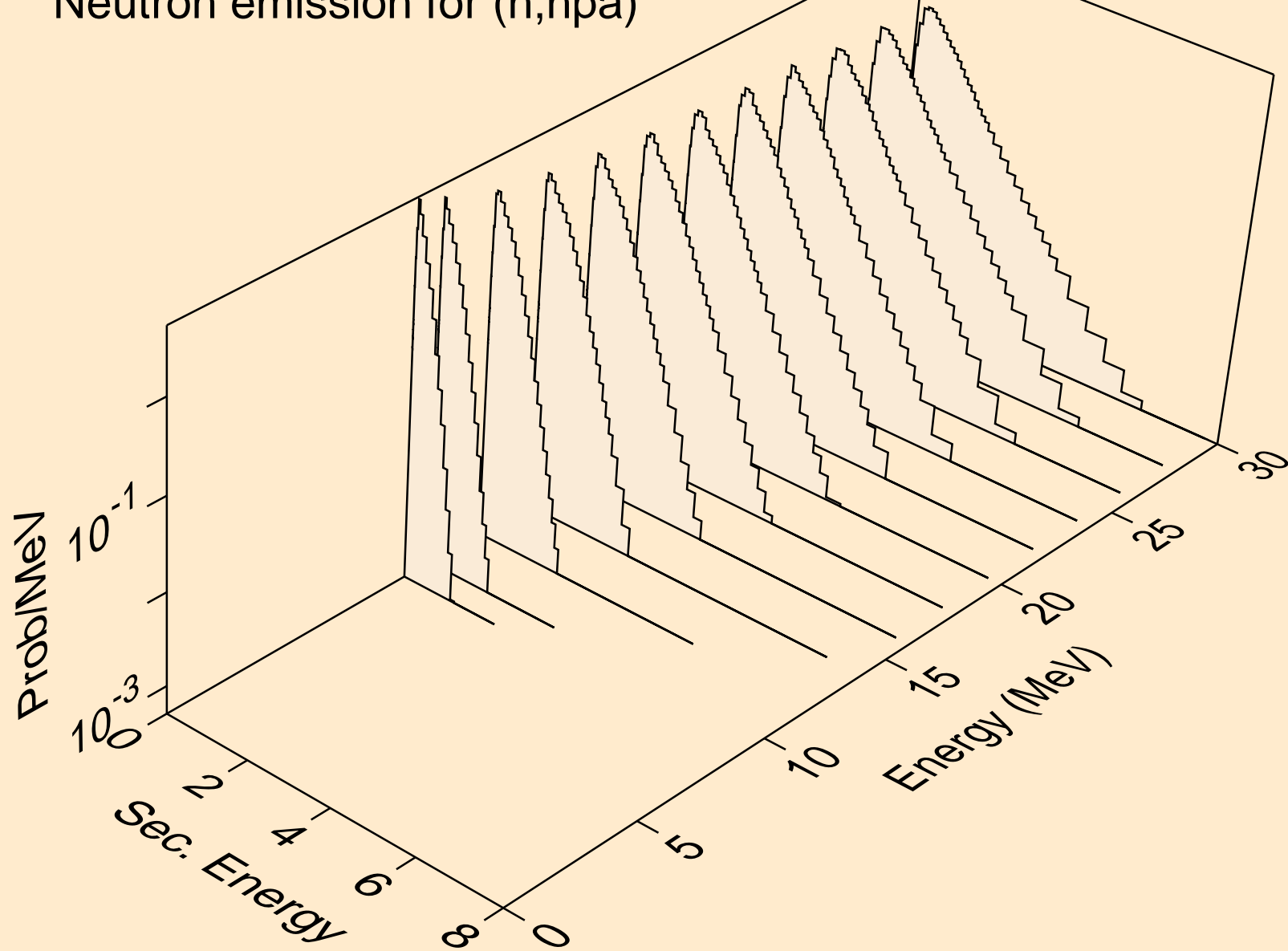

TM160M NEUTRON ACER TENDL-2024 LIBRARY; T=0.K
Neutron emission for (n,n*c)

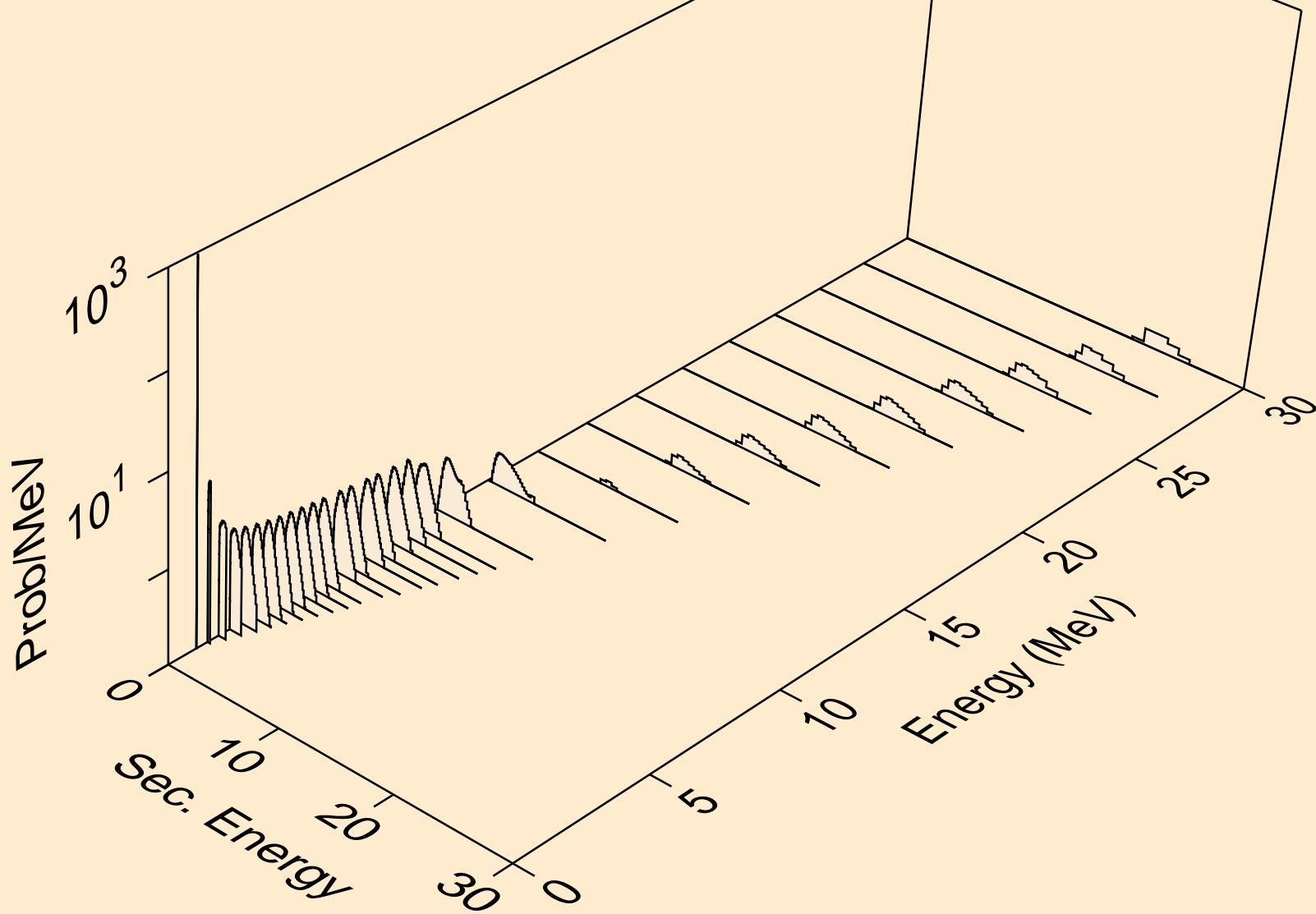

TM160M NEUTRON ACER TENDL-2024 LIBRARY; T=0.K
Photon emission for (n,x)

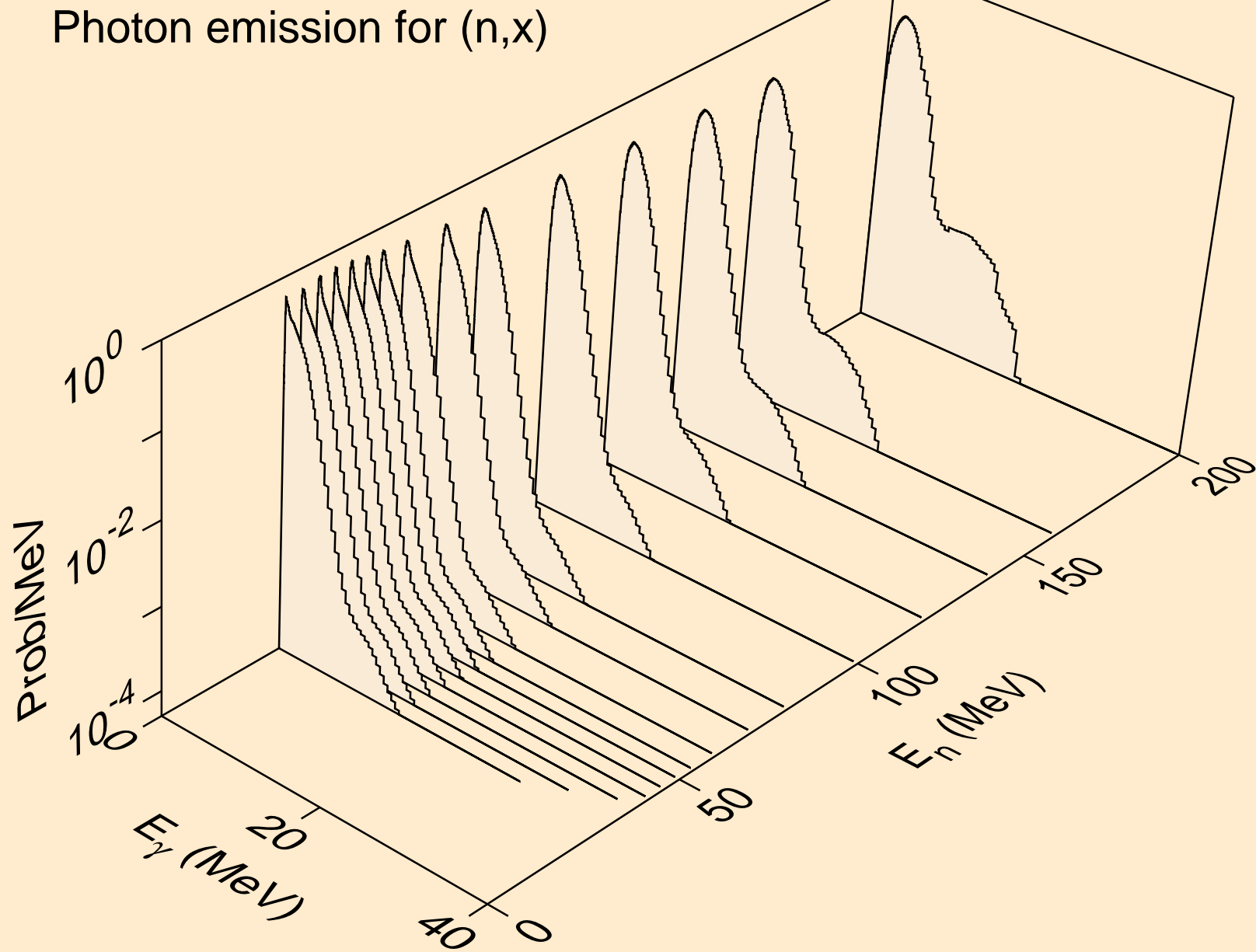

TM160M NEUTRON ACER TENDL-2024 LIBRARY; T=0.K
Photon emission for (n,2nd)

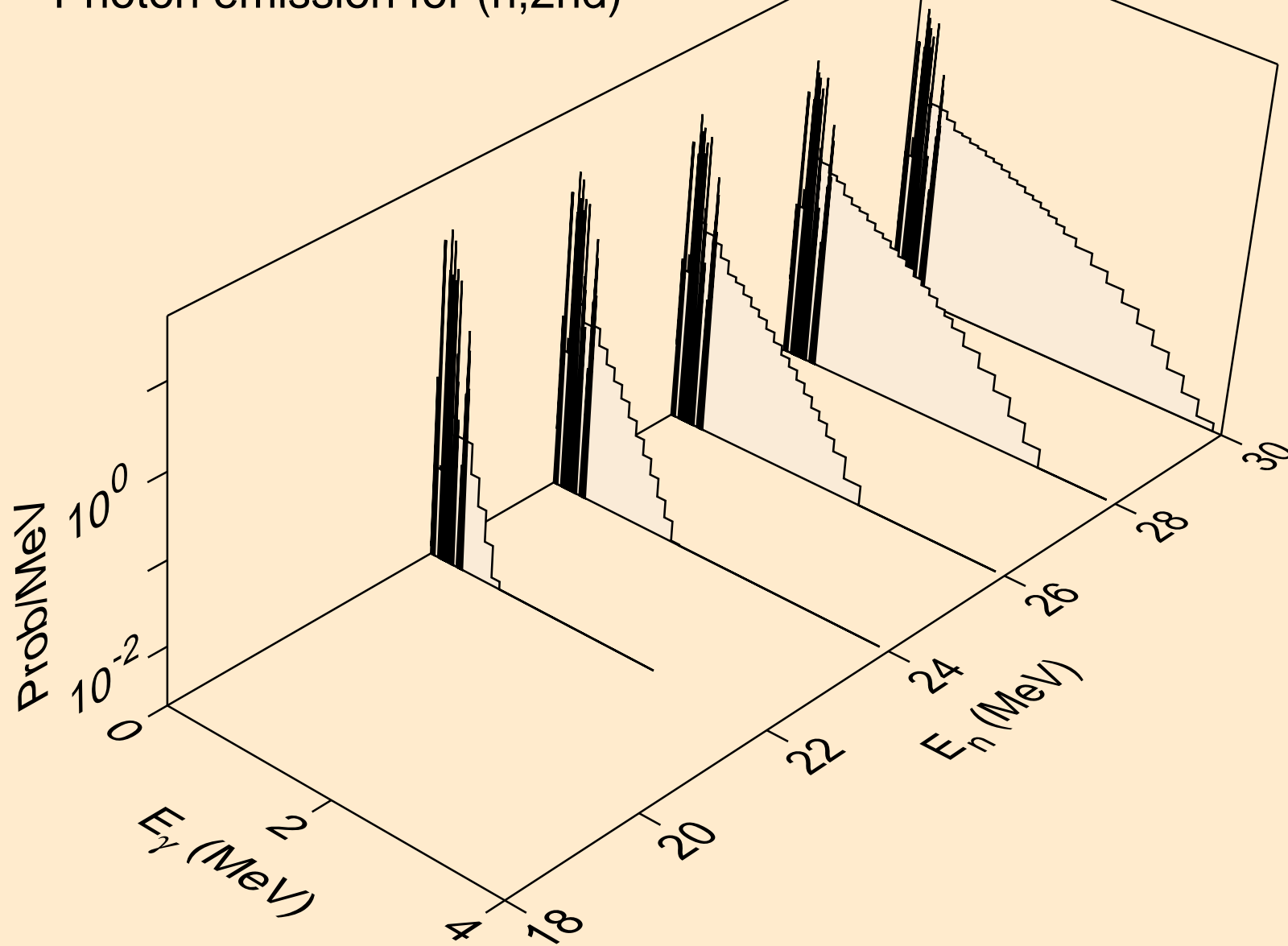

TM160M NEUTRON ACER TENDL-2024 LIBRARY; T=0.K
Photon emission for (n,2n)

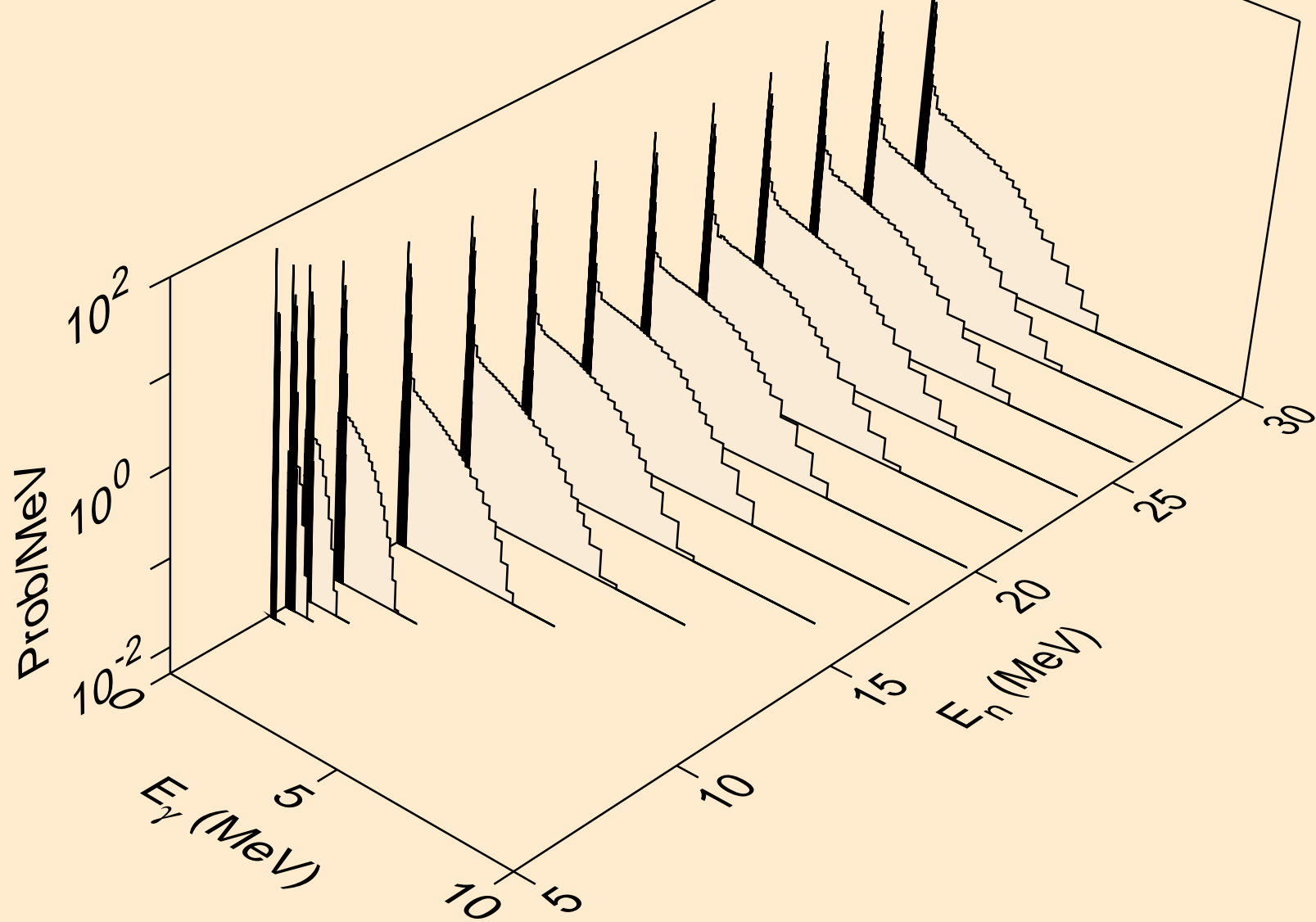

TM160M NEUTRON ACER TENDL-2024 LIBRARY; T=0.K
Photon emission for (n,3n)

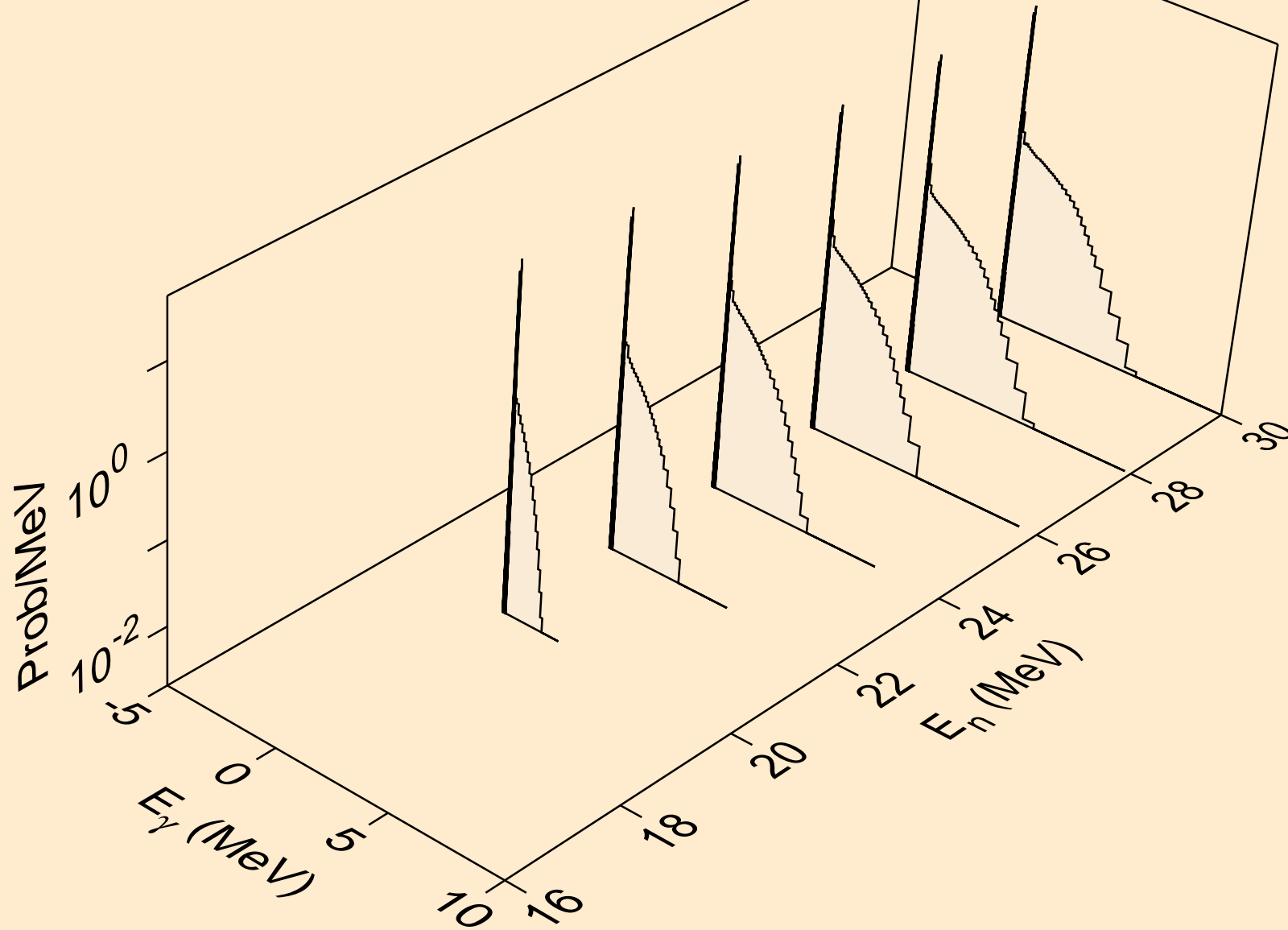

TM160M NEUTRON ACER TENDL-2024 LIBRARY; T=0.K
Photon emission for (n,n*)a

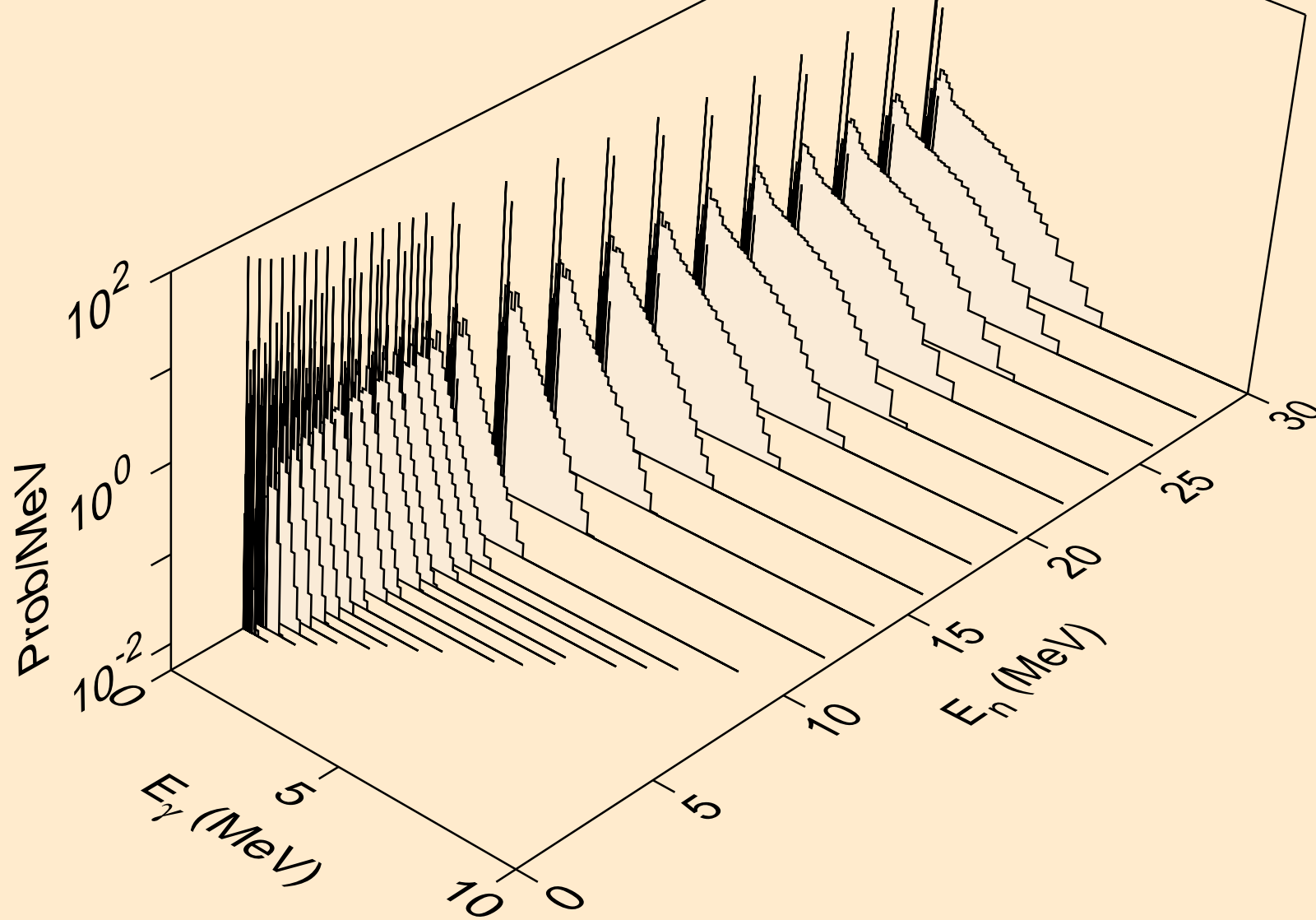

TM160M NEUTRON ACER TENDL-2024 LIBRARY; T=0.K
Photon emission for (n,2n)a

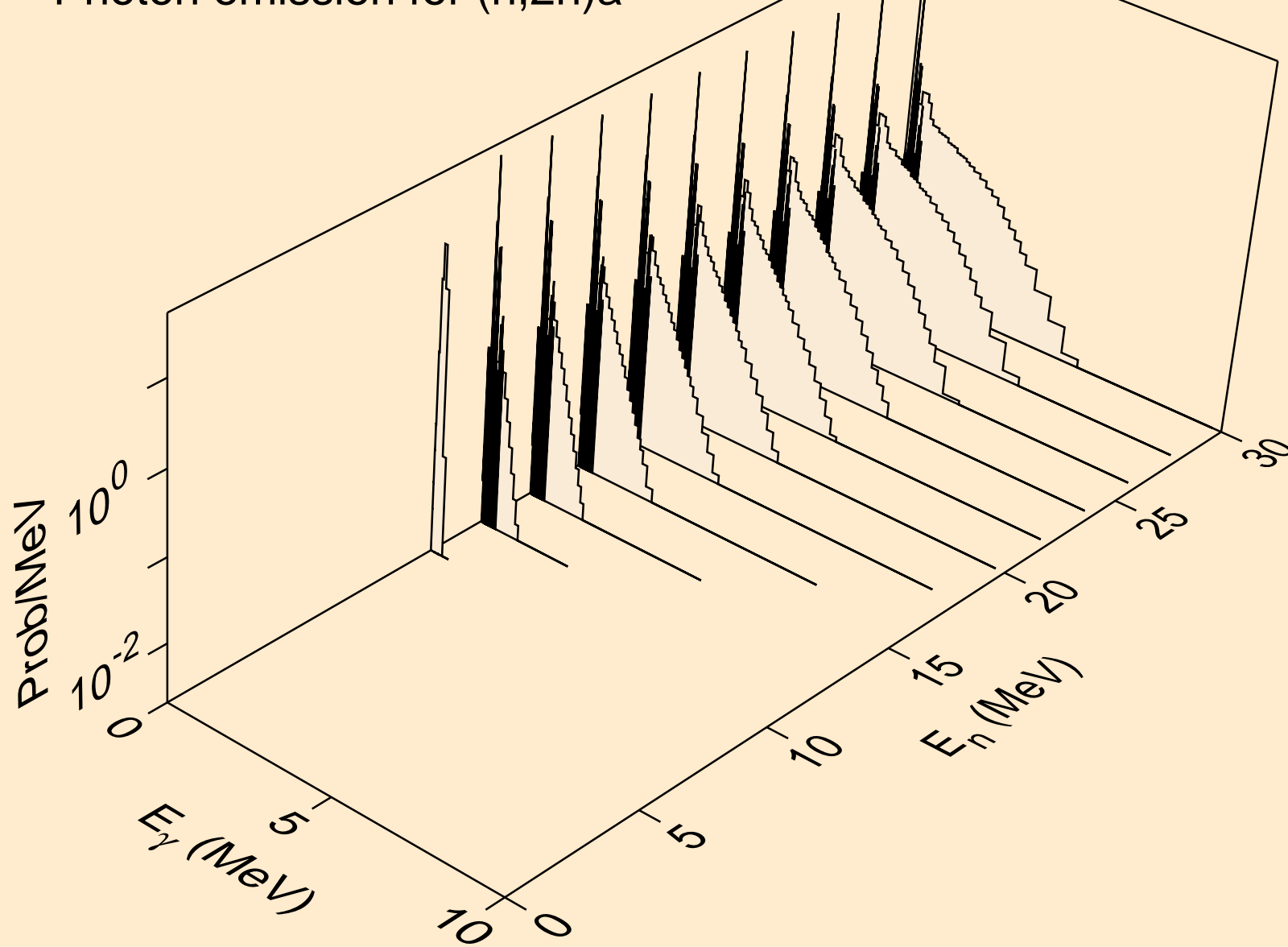

TM160M NEUTRON ACER TENDL-2024 LIBRARY; T=0.K
Photon emission for (n,3n)a

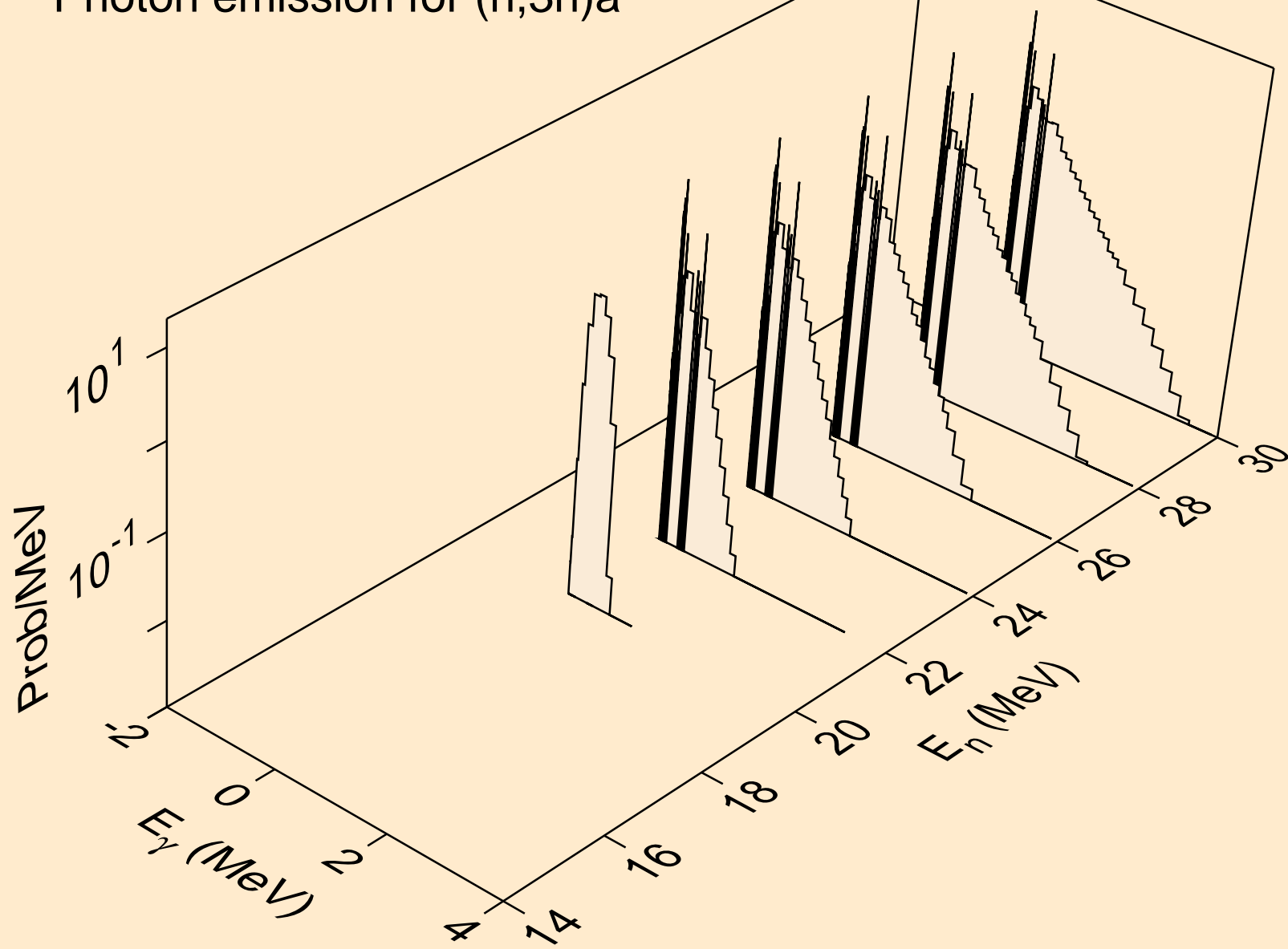

TM160M NEUTRON ACER TENDL-2024 LIBRARY; T=0.K
Photon emission for (n,n*)p

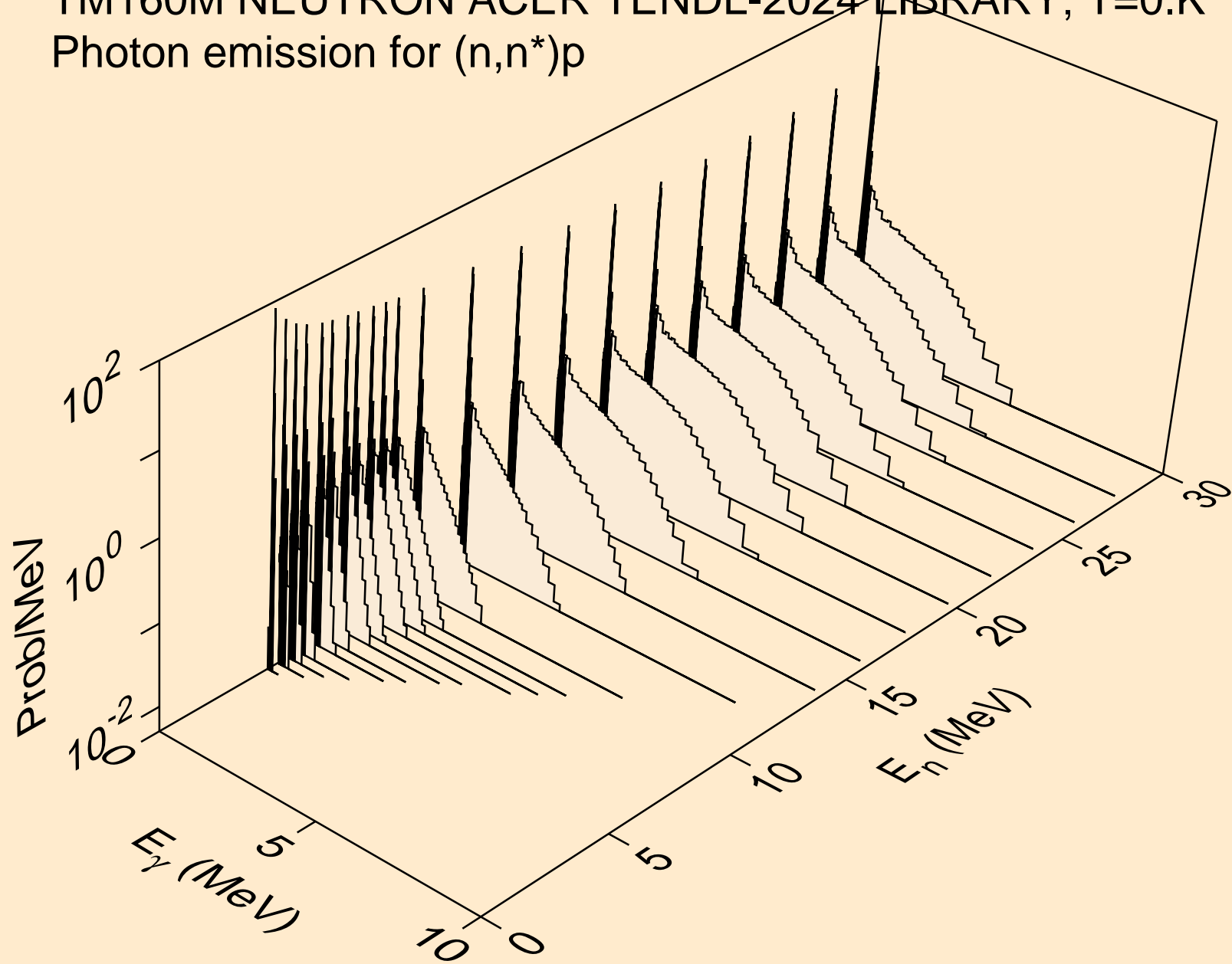

TM160M NEUTRON ACER TENDL-2024 LIBRARY; T=0.K
Photon emission for (n,n*)2a

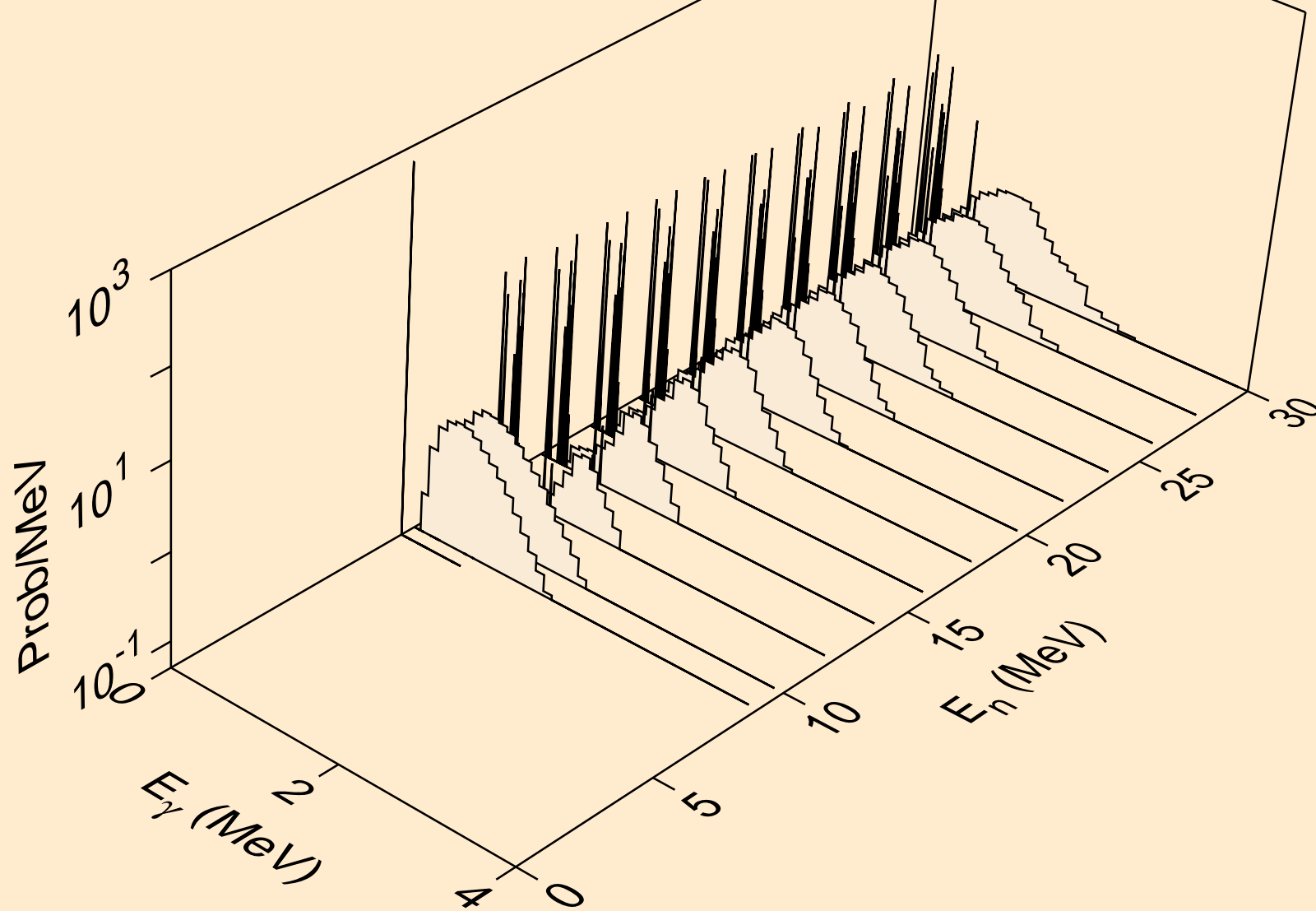

TM160M NEUTRON ACER TENDL-2024 LIBRARY; T=0.K
Photon emission for (n,2n)2a

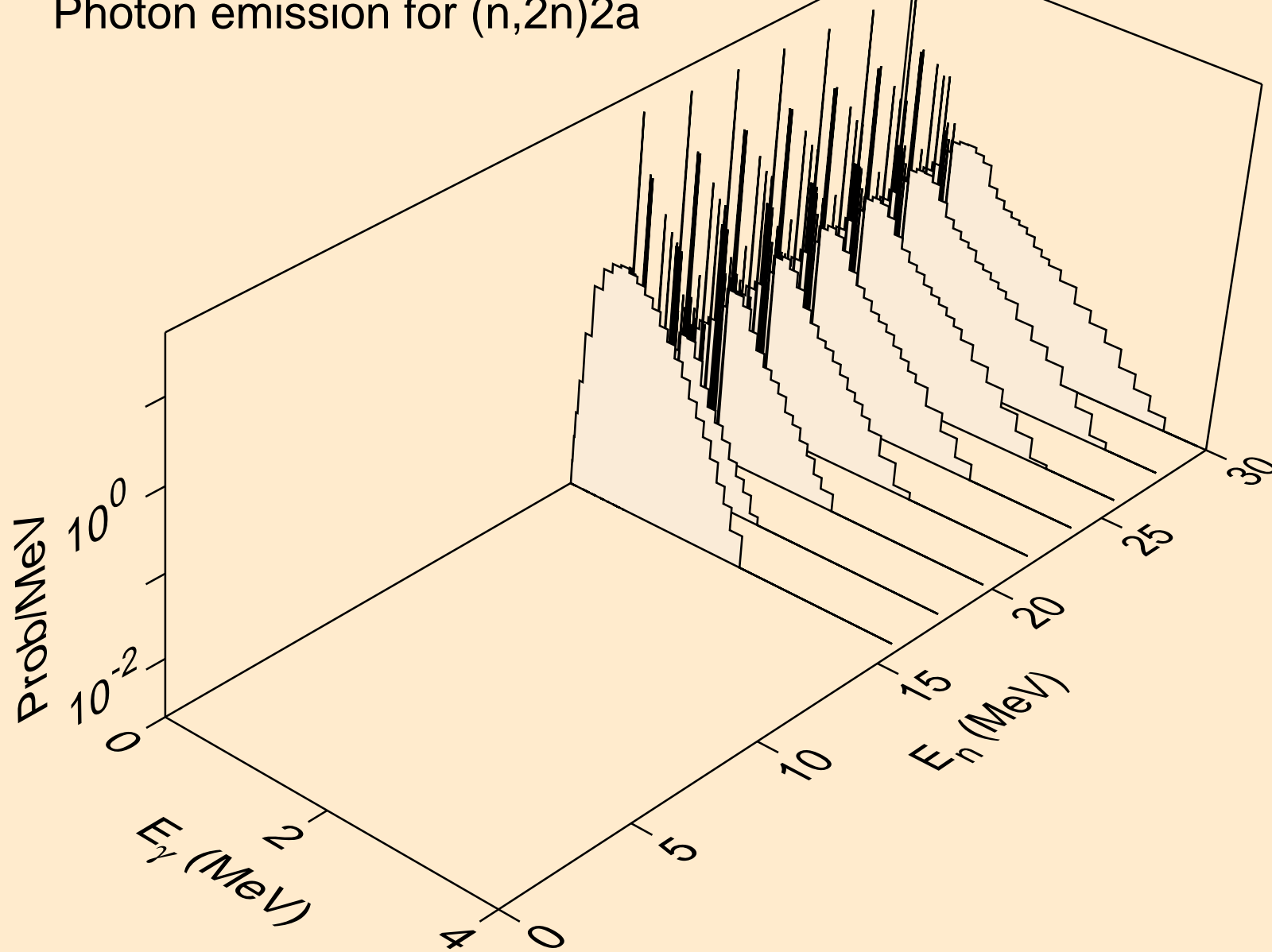

TM160M NEUTRON ACER TENDL-2024 LIBRARY; T=0.K
Photon emission for (n,n*)d

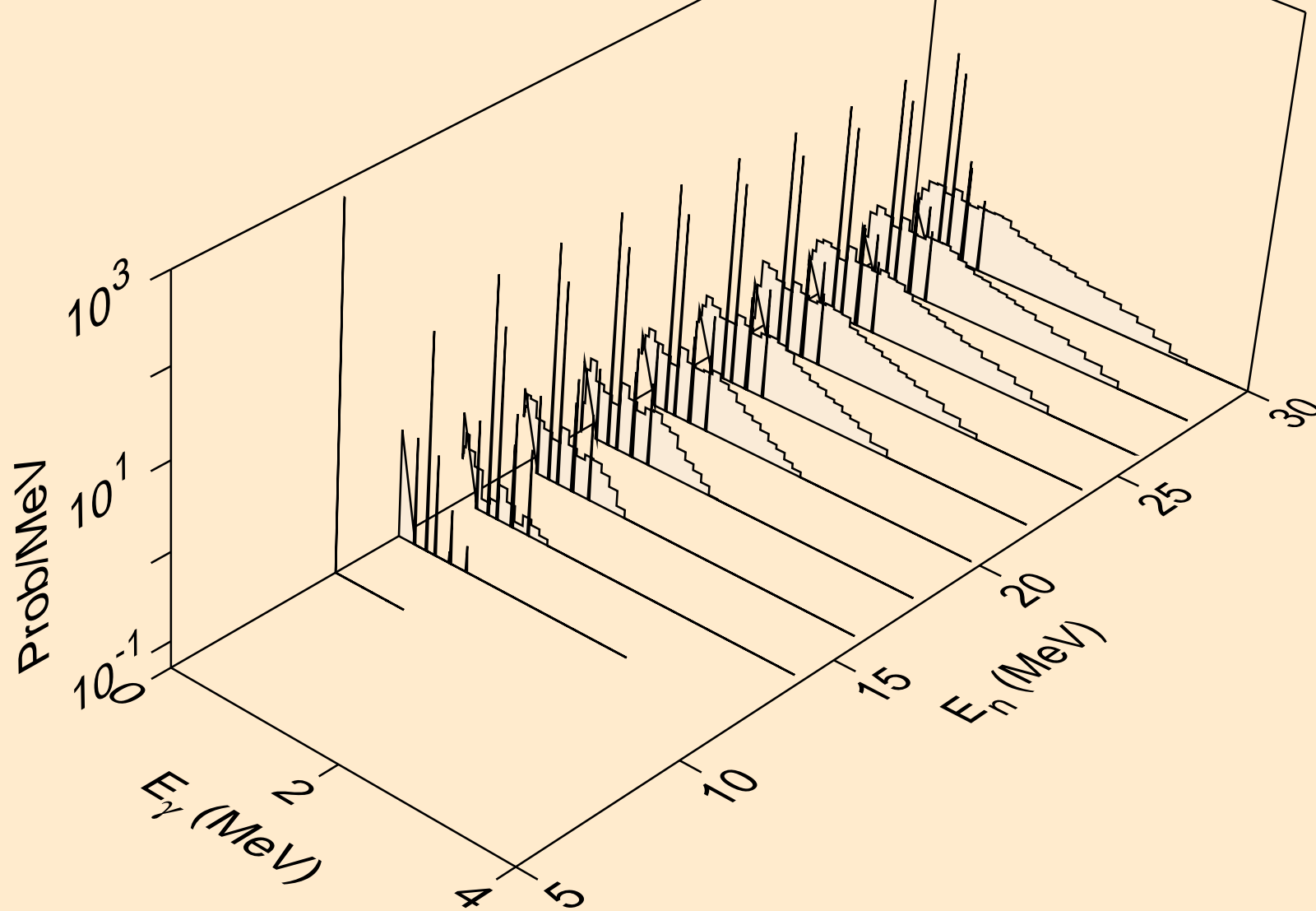

TM160M NEUTRON ACER TENDL-2024 LIBRARY; T=0.K
Photon emission for (n,n*)t

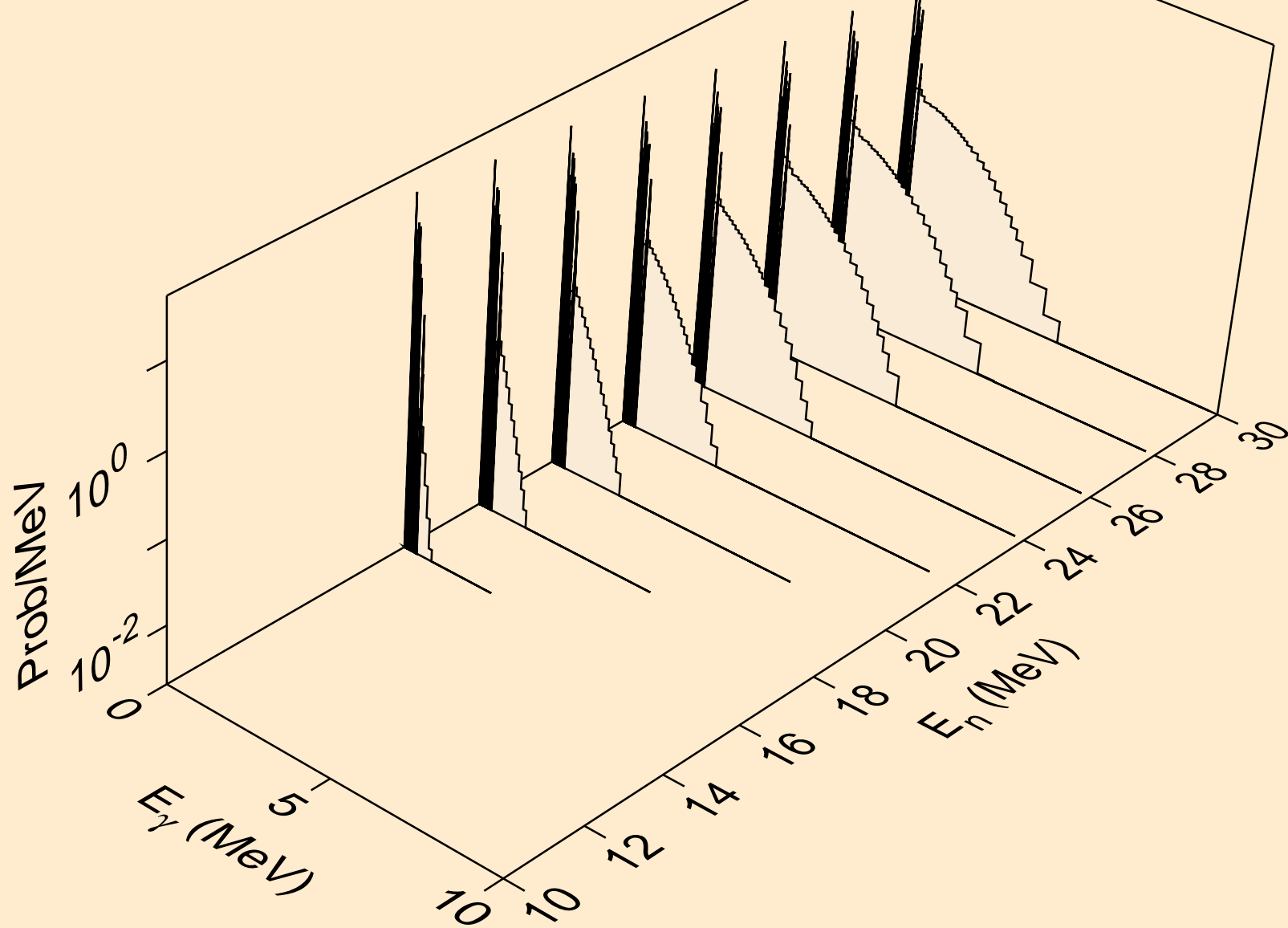

TM160M NEUTRON ACER TENDL-2024 LIBRARY; T=0.K
Photon emission for (n,n*)he3

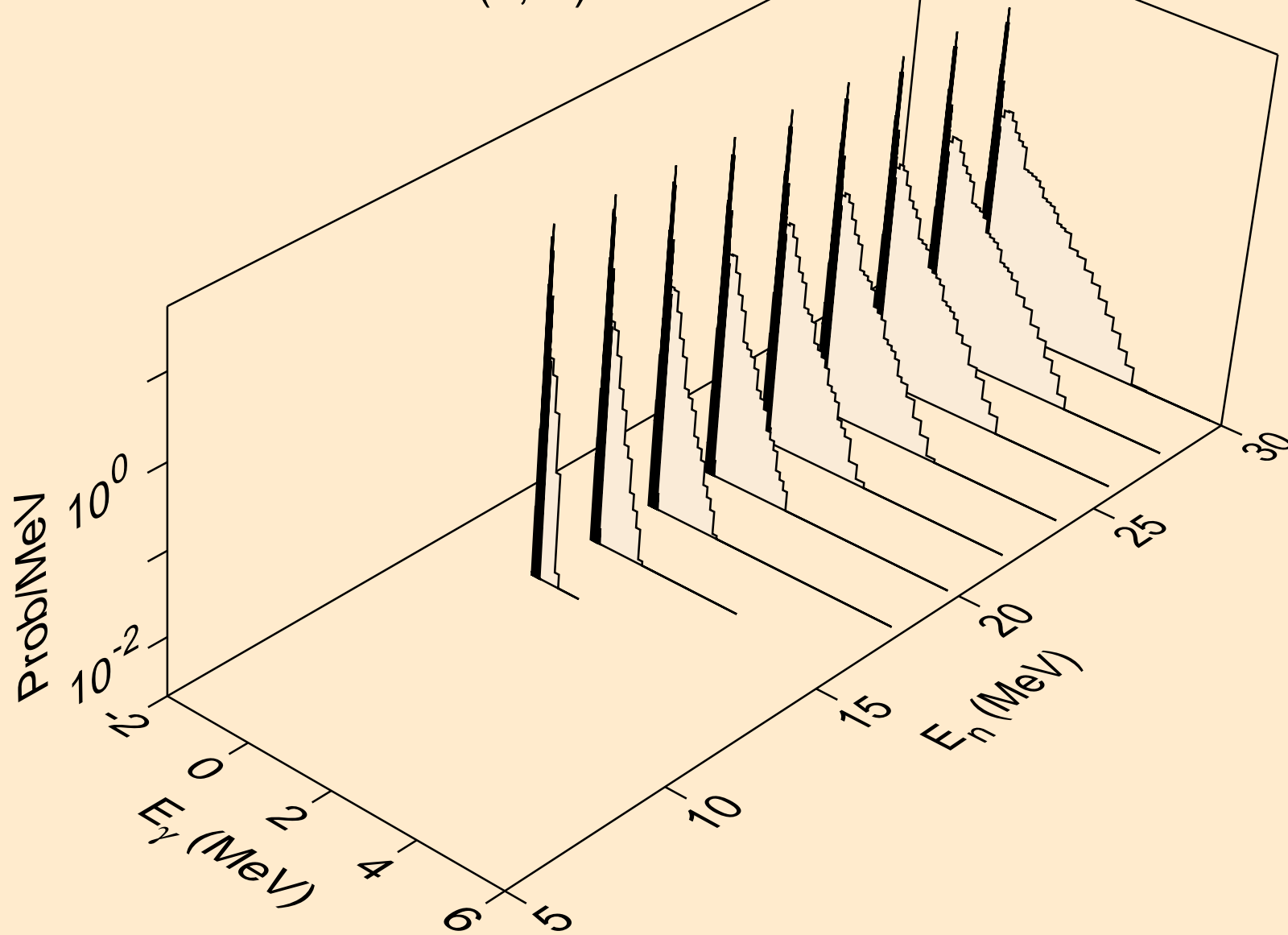

TM160M NEUTRON ACER TENDL-2024 LIBRARY; T=0.K
Photon emission for (n,4n)

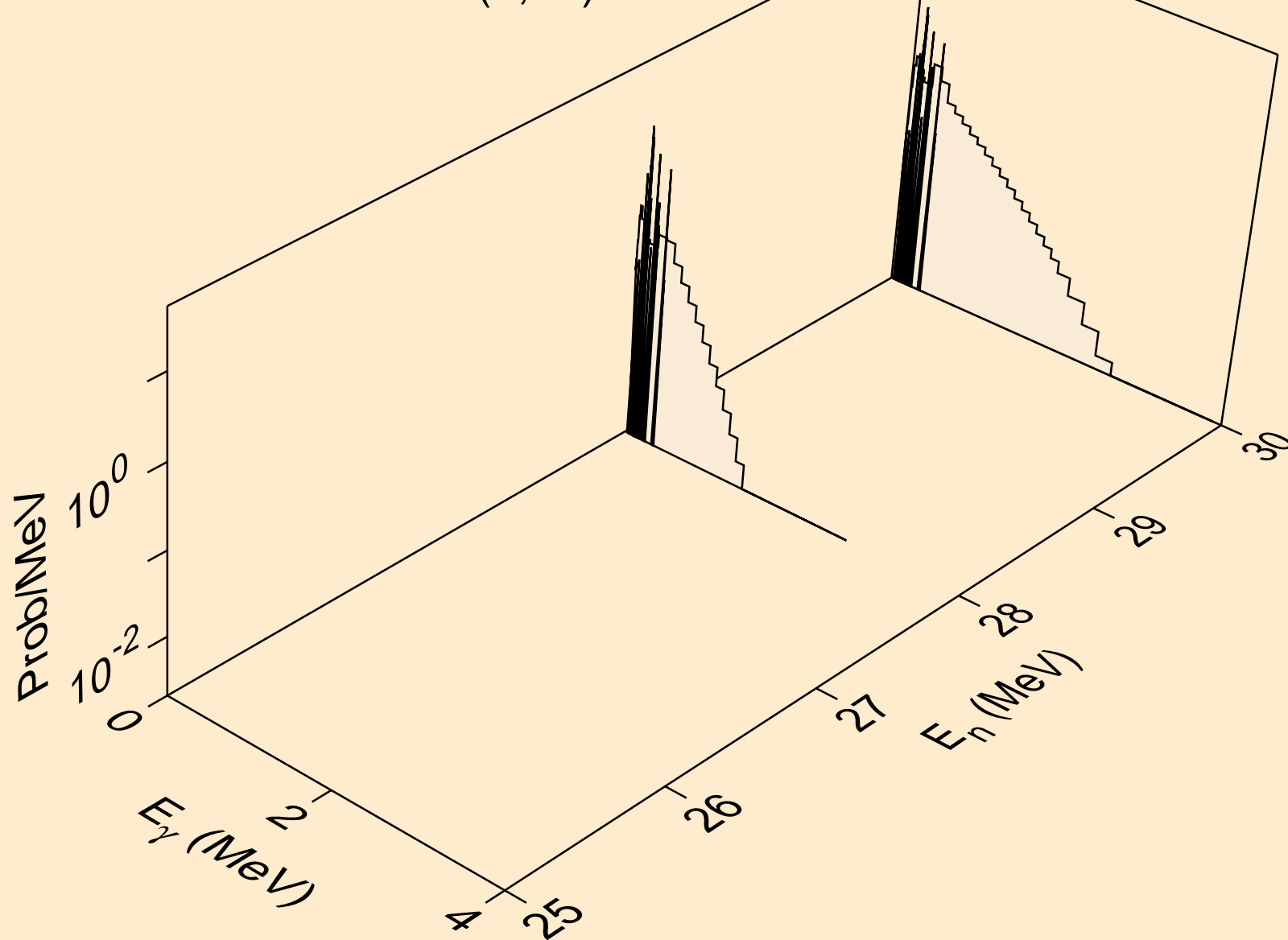

TM160M NEUTRON ACER TENDL-2024 LIBRARY; T=0.K
Photon emission for (n,2np)

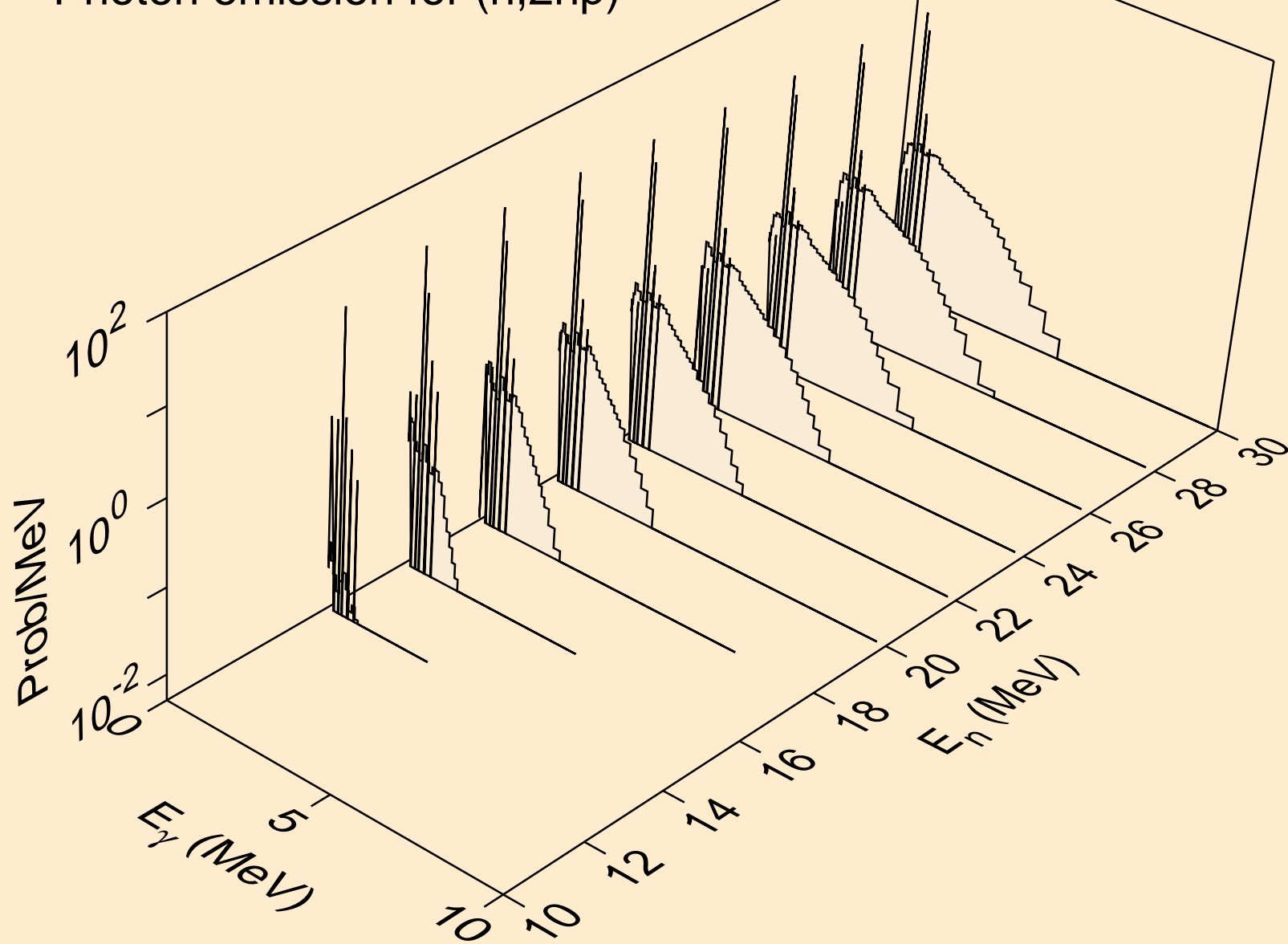

TM160M NEUTRON ACER TENDL-2024 LIBRARY; T=0.K
Photon emission for (n,3np)

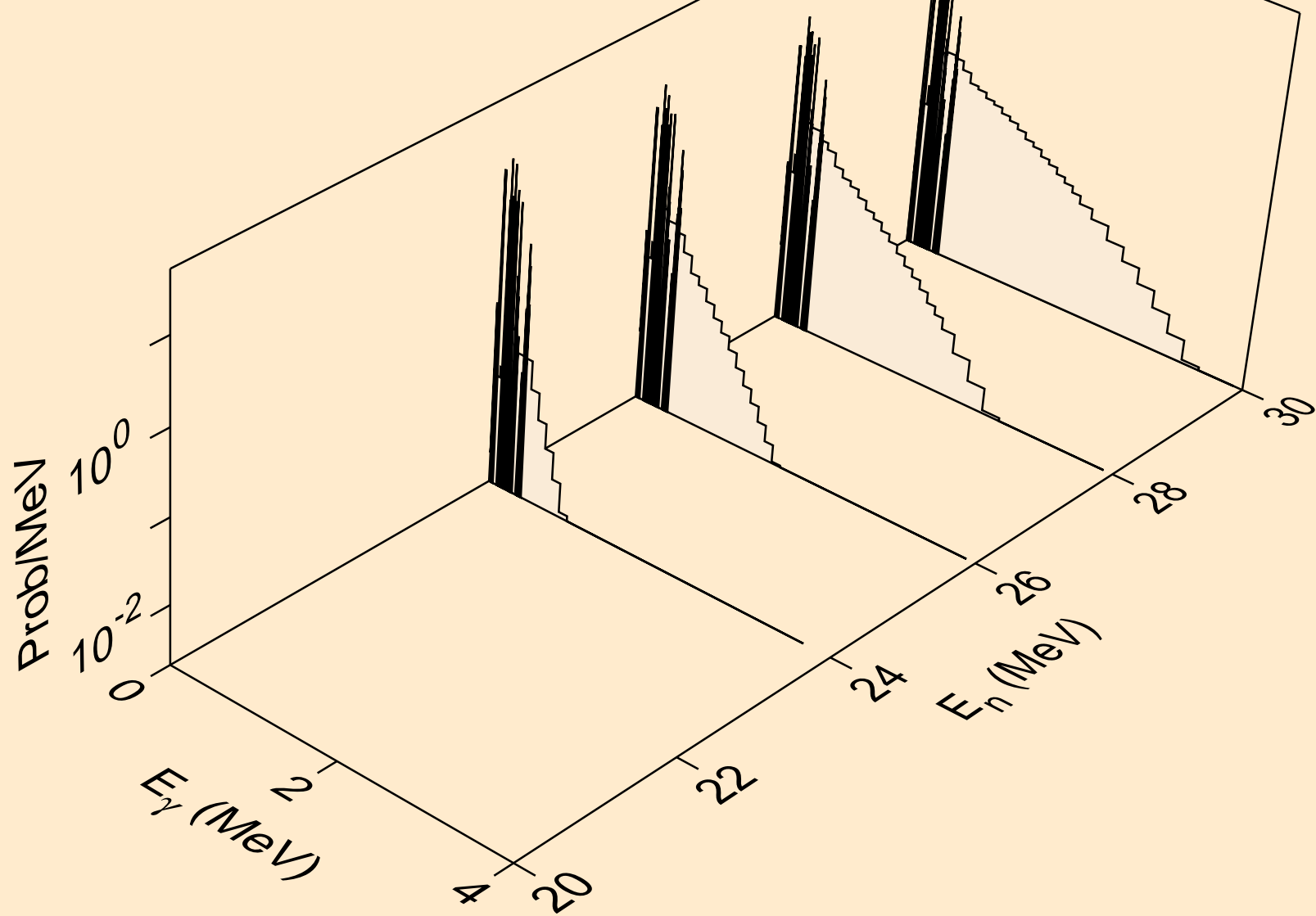

TM160M NEUTRON ACER TENDL-2024 LIBRARY; T=0.K
Photon emission for (n,n2p)

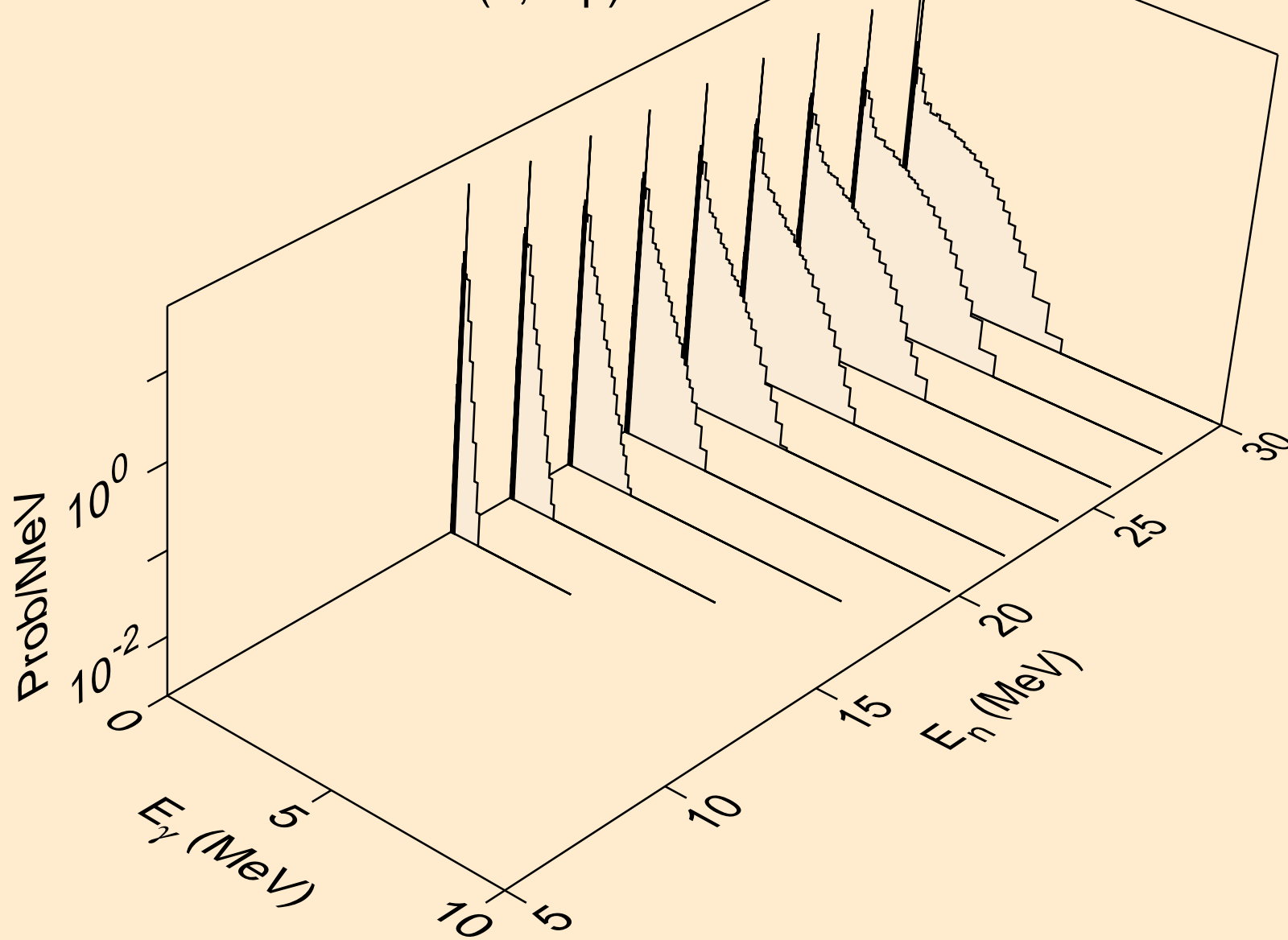

TM160M NEUTRON ACER TENDL-2024 LIBRARY; T=0.K
Photon emission for (n,npa)

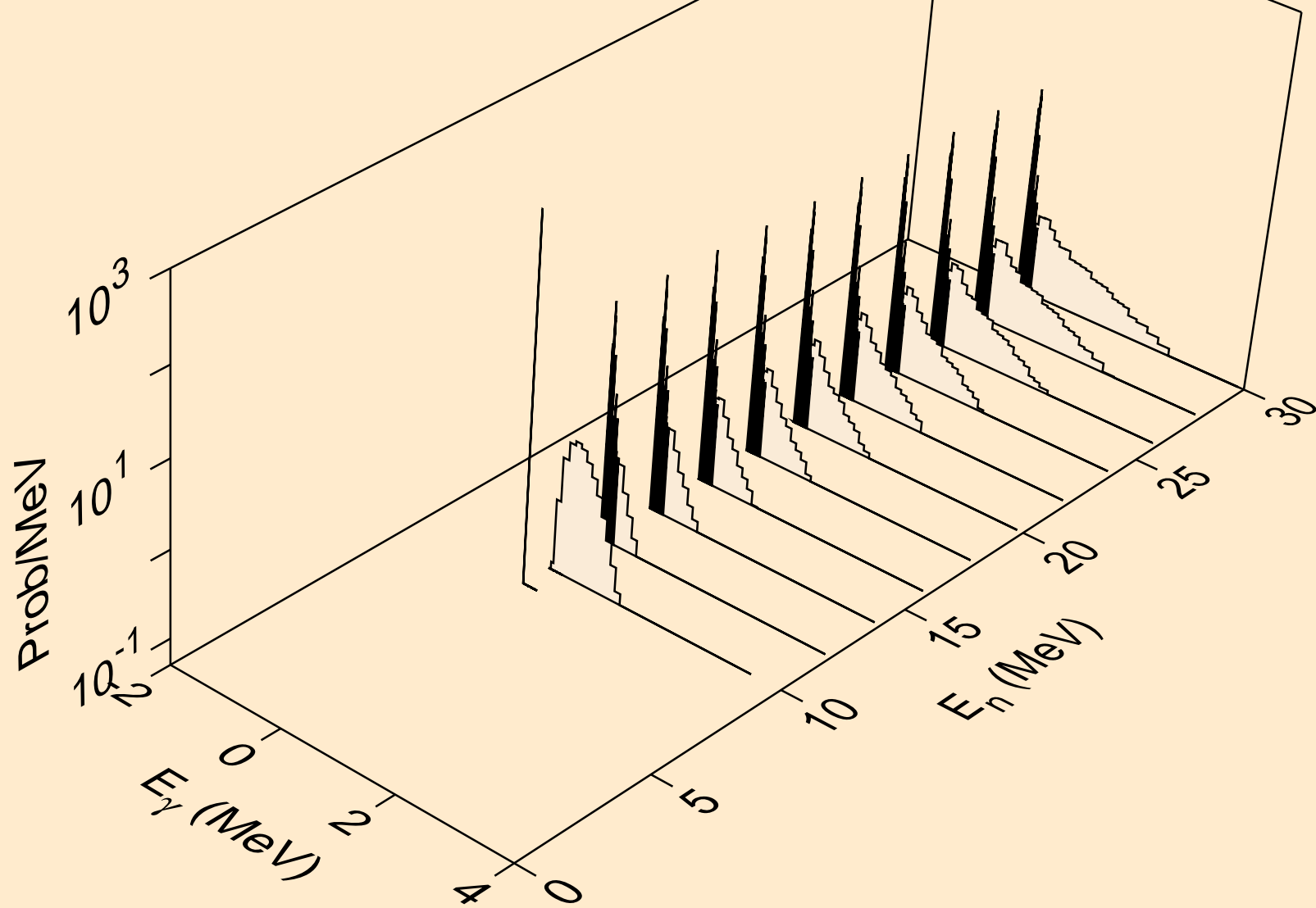

TM160M NEUTRON ACER TENDL-2024 LIBRARY; T=0.K
Photon emission for (n,n*1)

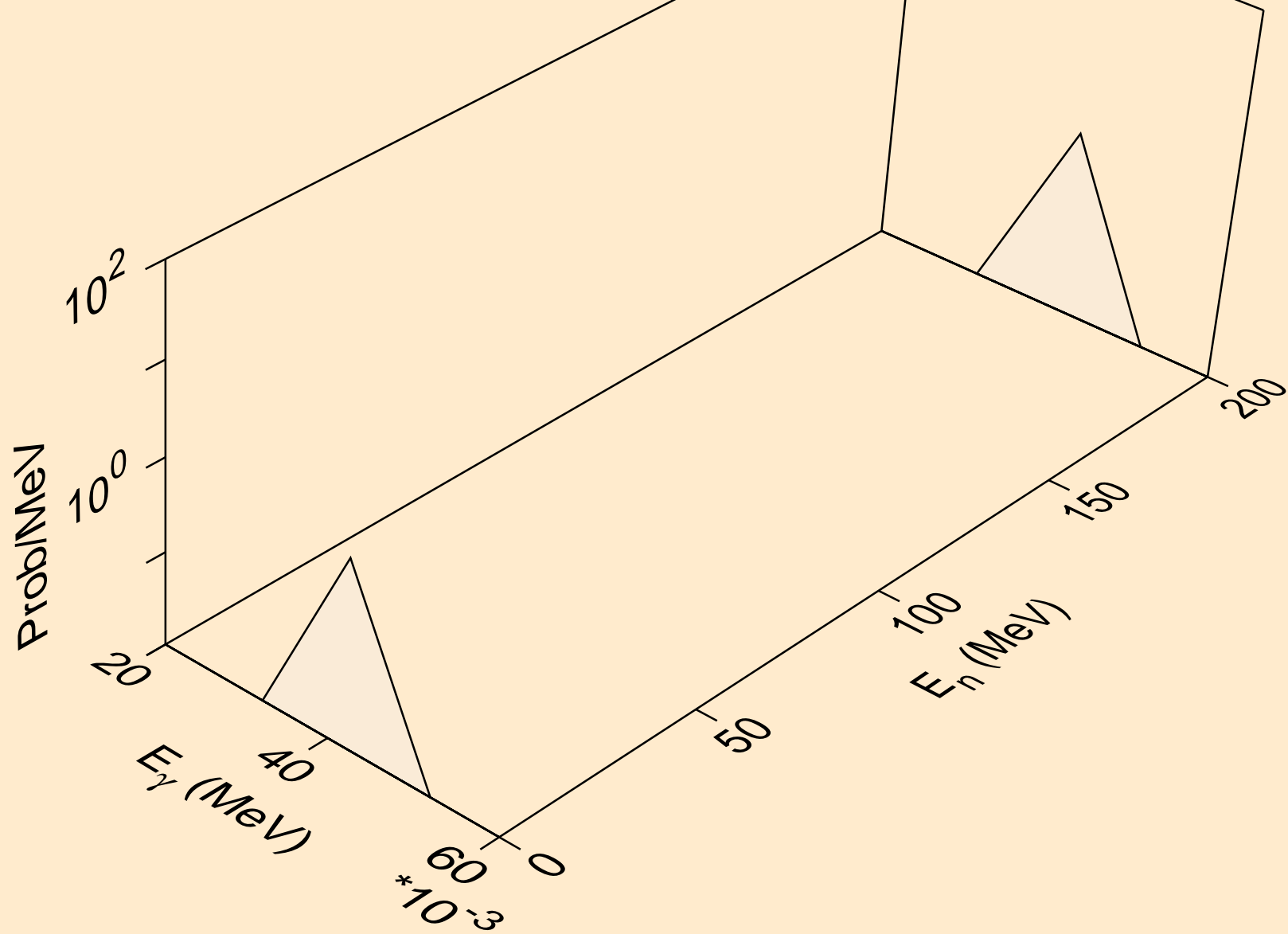

TM160M NEUTRON ACER TENDL-2024 LIBRARY; T=0.K
Photon emission for (n,n*3)

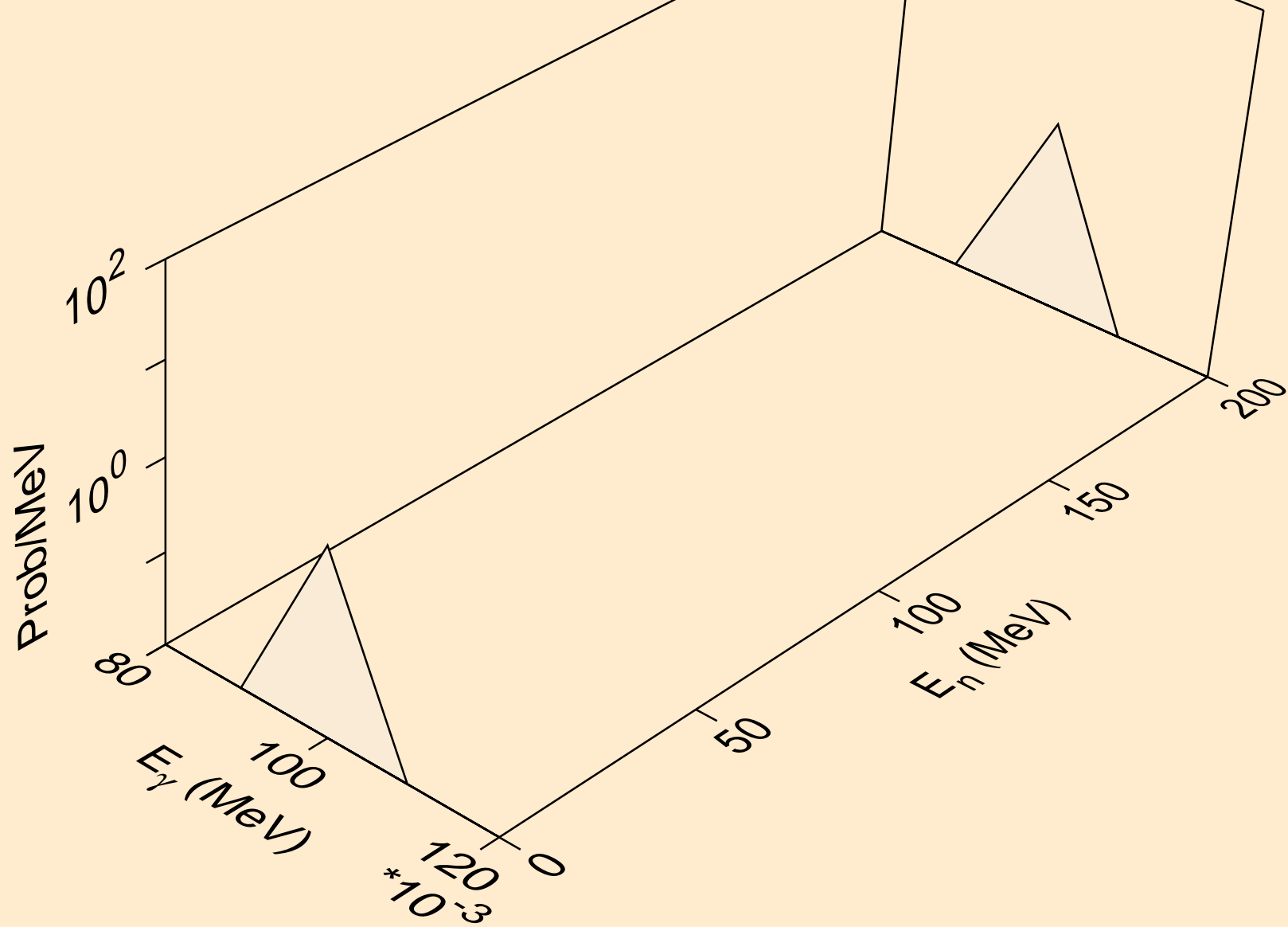

TM160M NEUTRON ACER TENDL-2024 LIBRARY; T=0.K
Photon emission for (n,n*4)

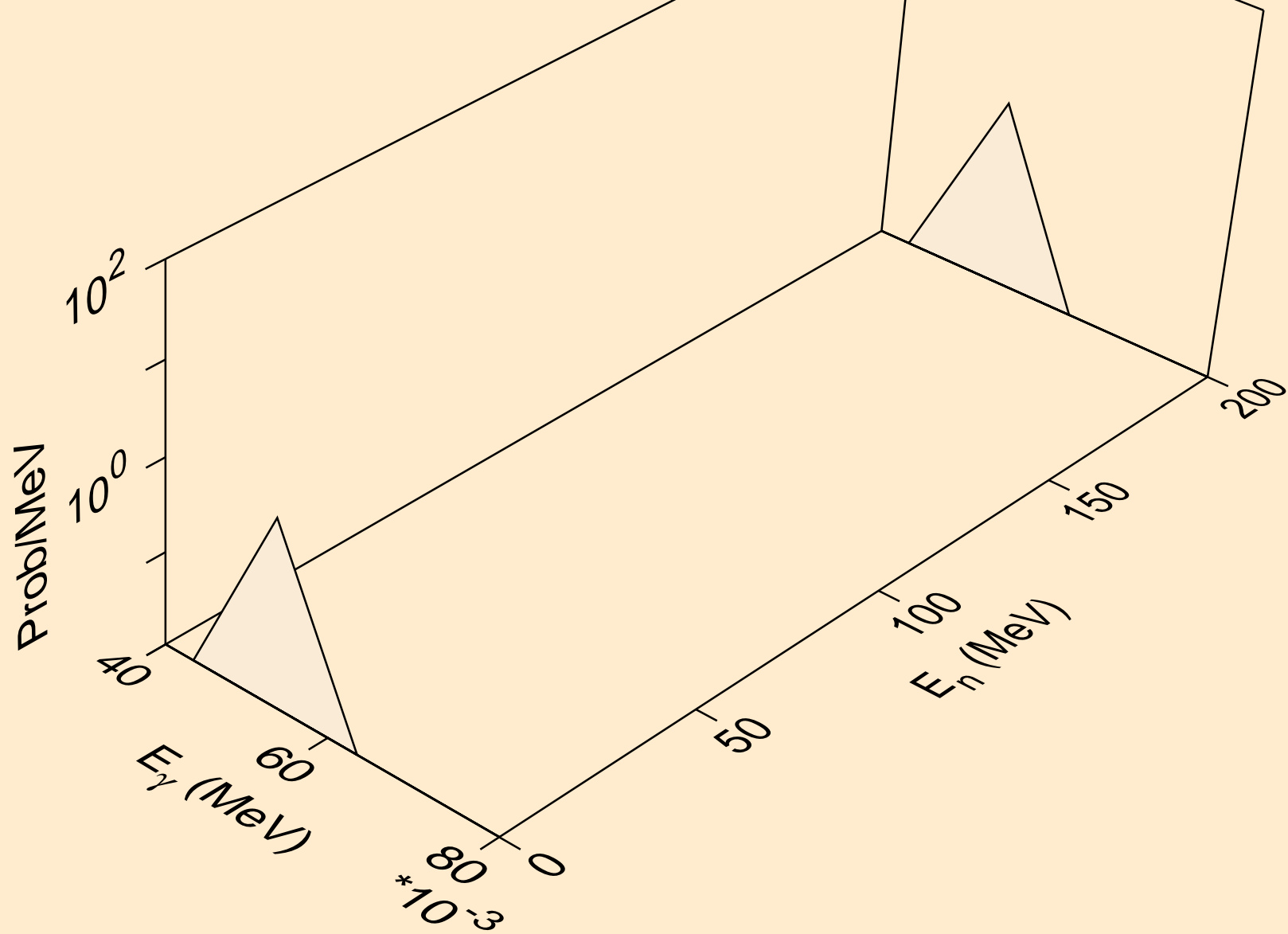

TM160M NEUTRON ACER TENDL-2024 LIBRARY; T=0.K
Photon emission for (n,n*5)

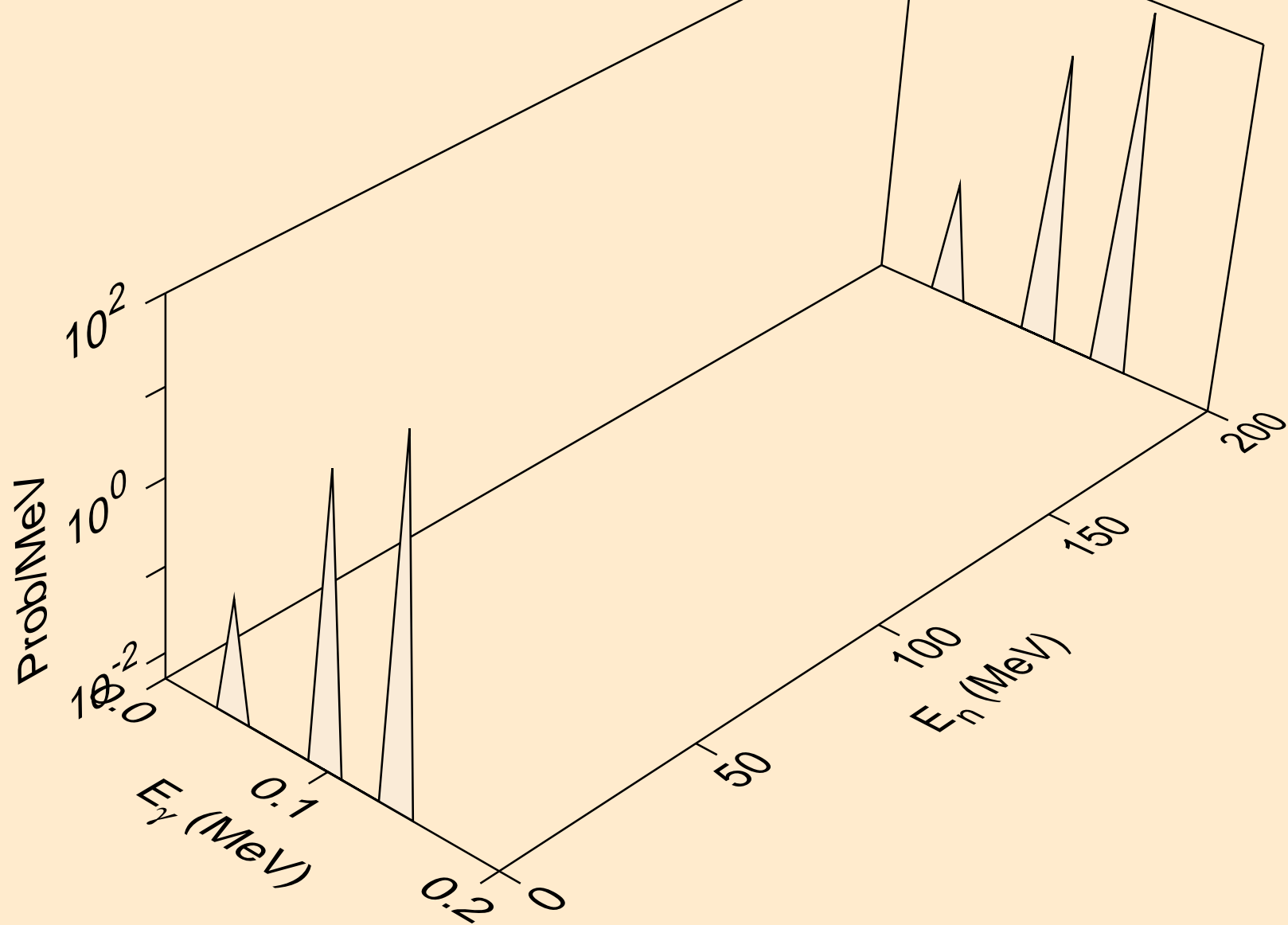

TM160M NEUTRON ACER TENDL-2024 LIBRARY; T=0.K
Photon emission for (n,n*6)

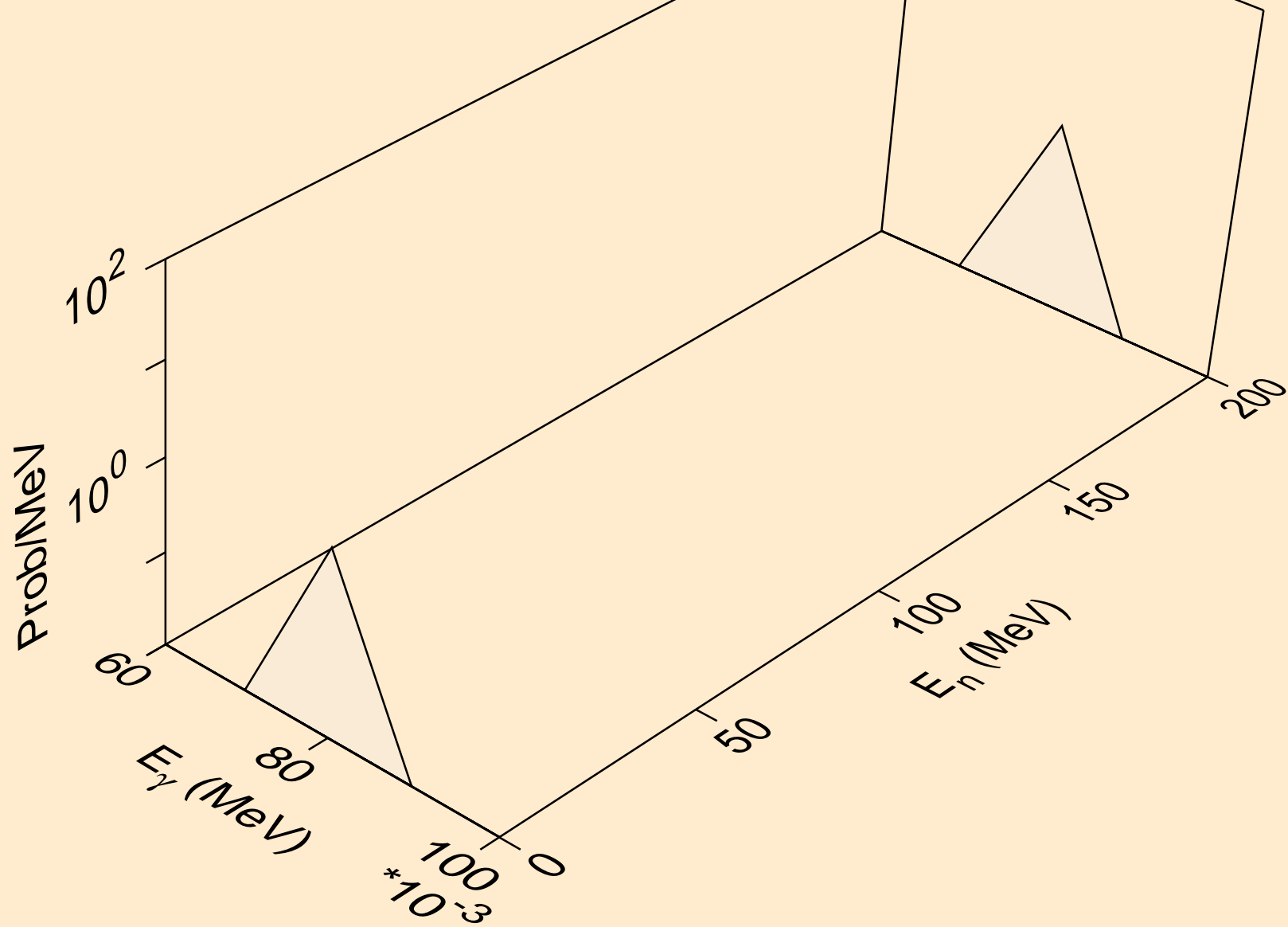

TM160M NEUTRON ACER TENDL-2024 LIBRARY; T=0.K
Photon emission for (n,n*7)

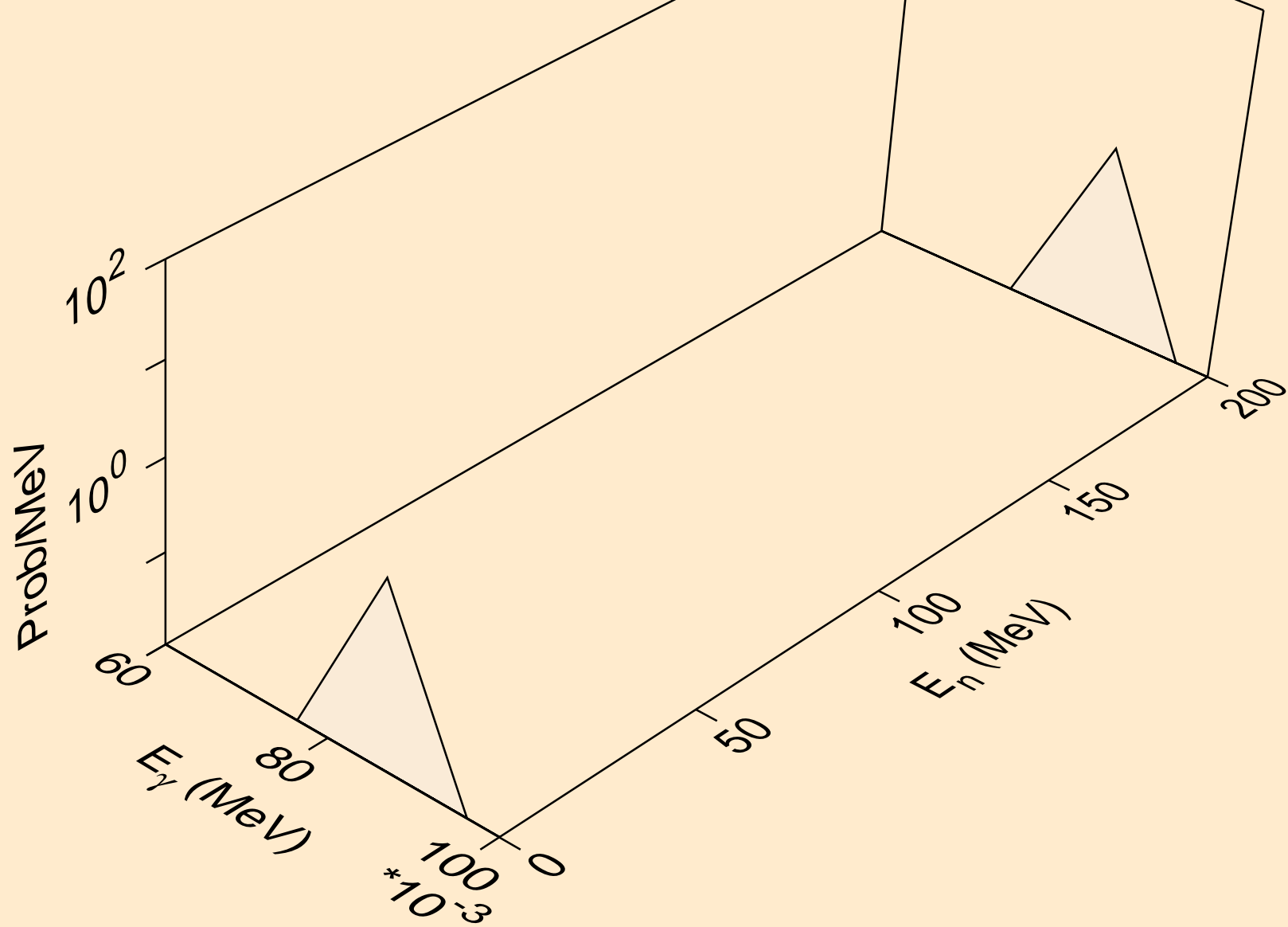

TM160M NEUTRON ACER TENDL-2024 LIBRARY; T=0.K
Photon emission for (n,n*8)

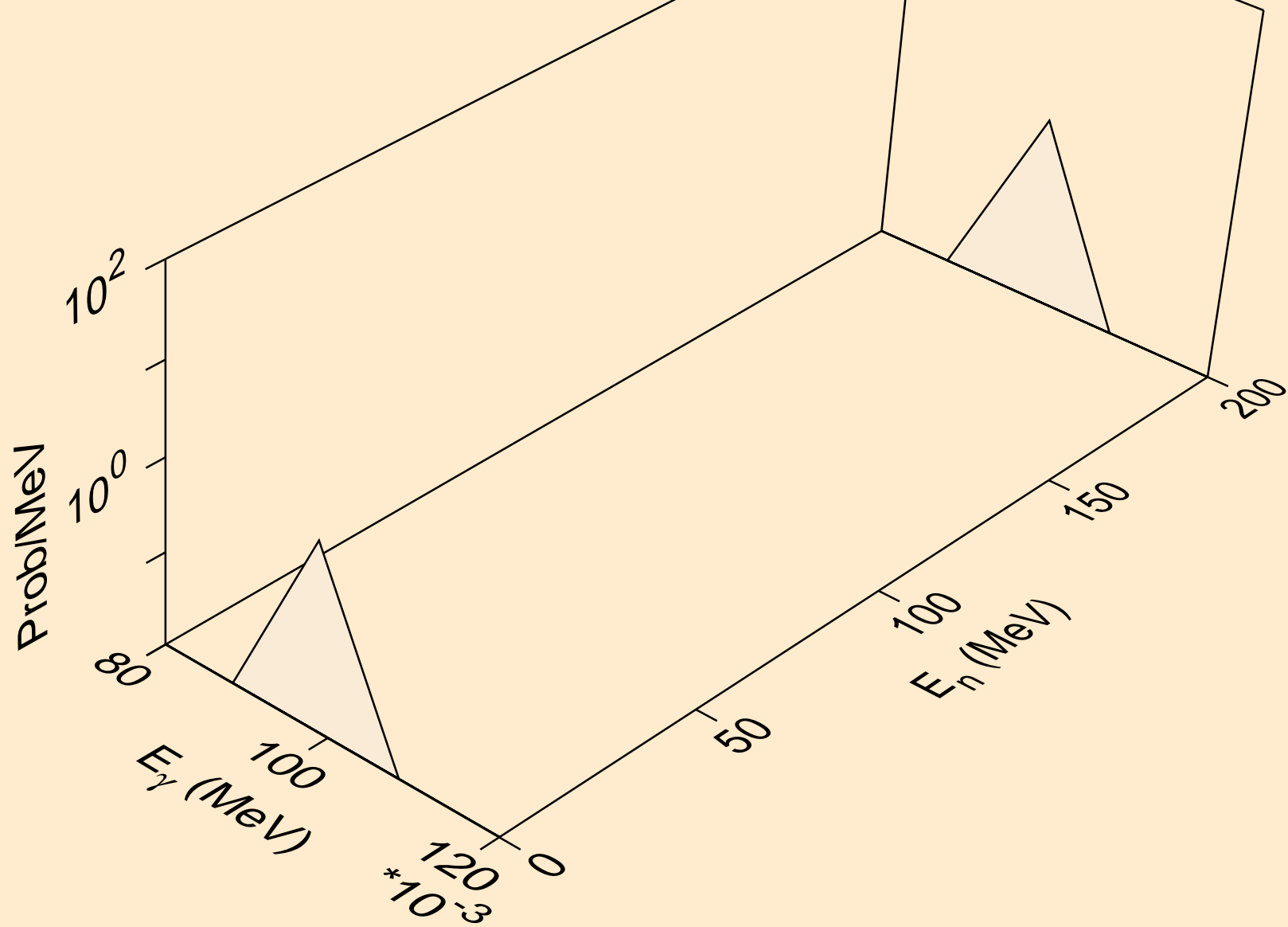

TM160M NEUTRON ACER TENDL-2024 LIBRARY; T=0.K
Photon emission for (n,n*9)

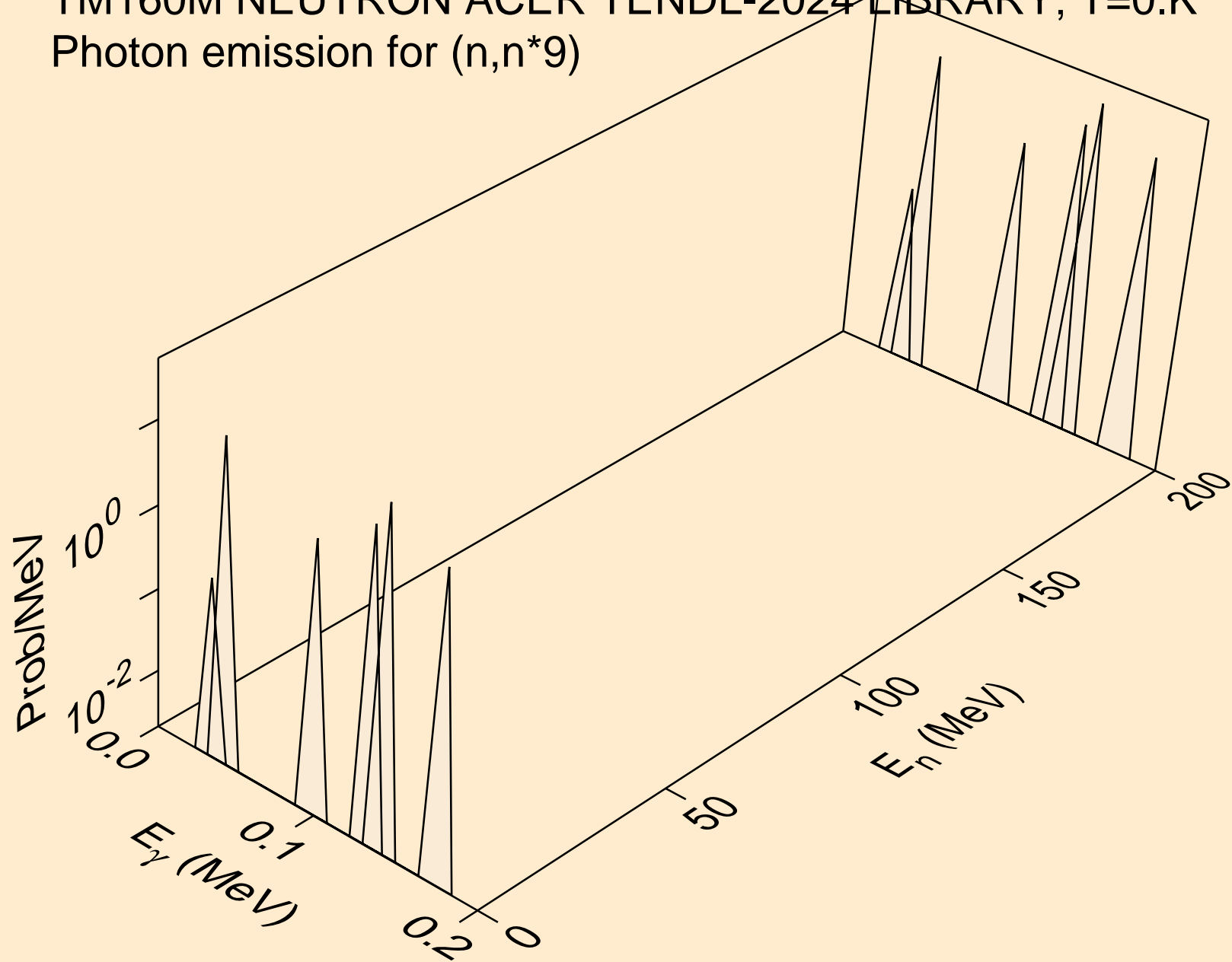

TM160M NEUTRON ACER TENDL-2024 LIBRARY; T=0.K
Photon emission for (n,n*10)

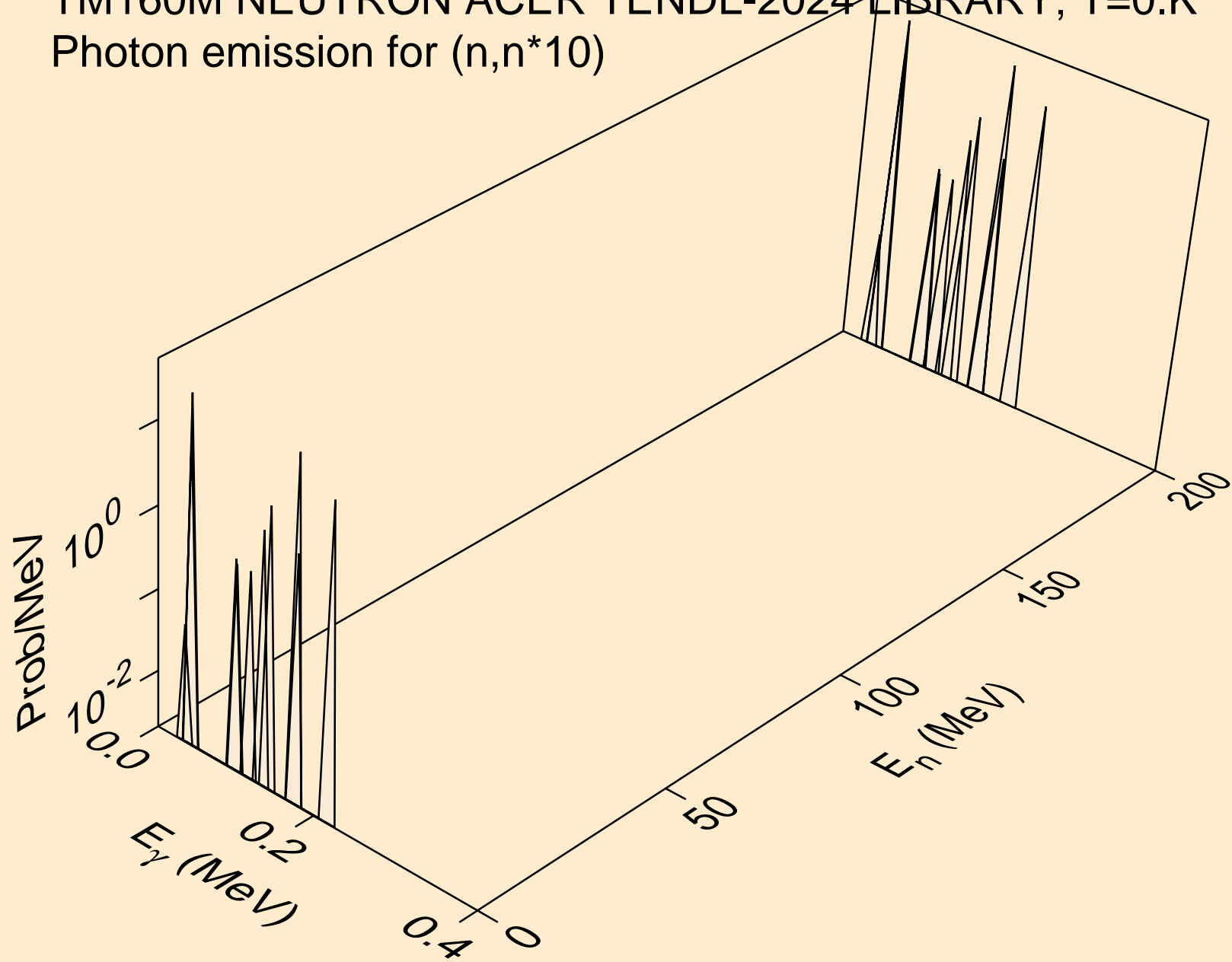

TM160M NEUTRON ACER TENDL-2024 LIBRARY; T=0.K
Photon emission for (n,n*11)

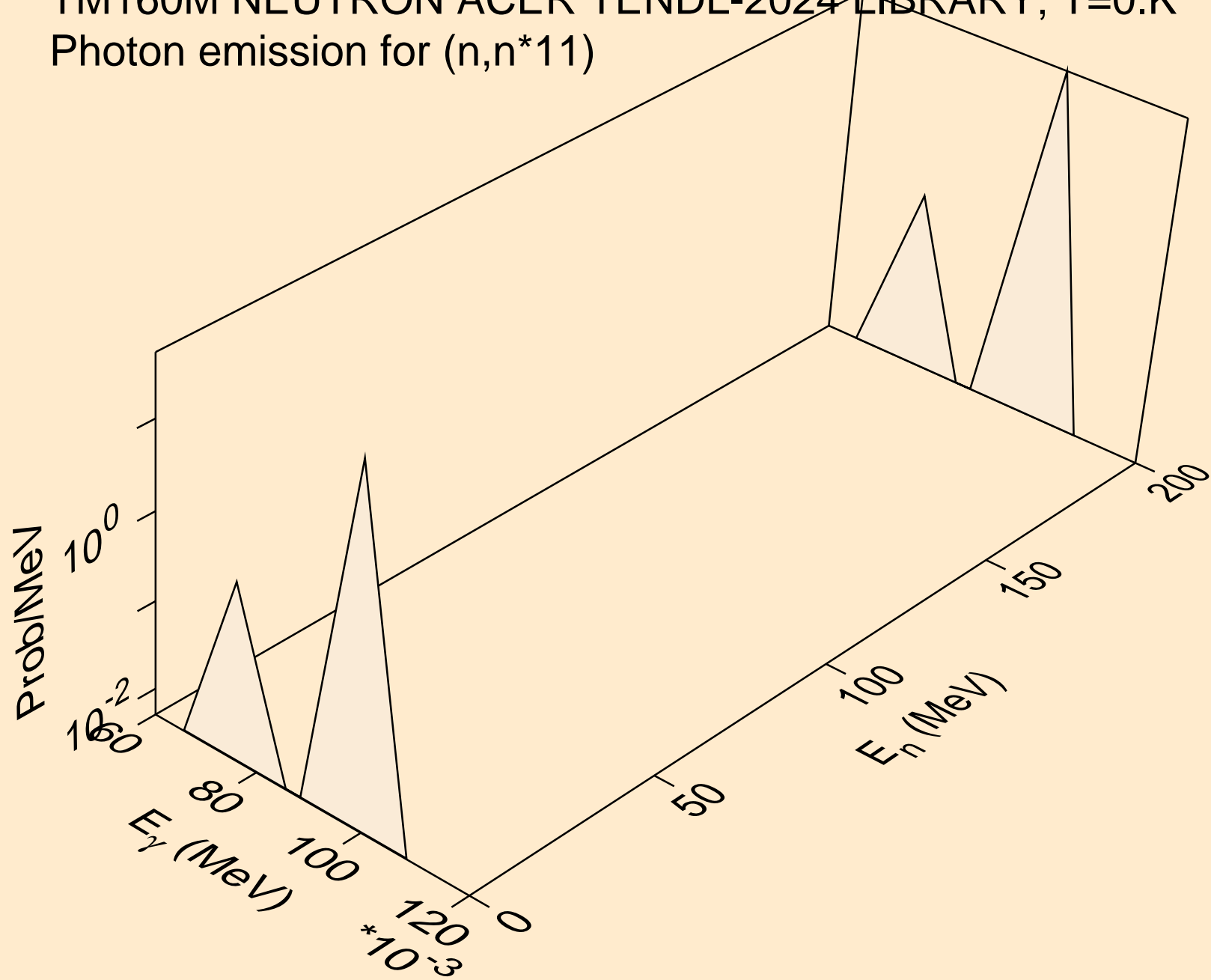

TM160M NEUTRON ACER TENDL-2024 LIBRARY; T=0.K
Photon emission for (n,n*12)

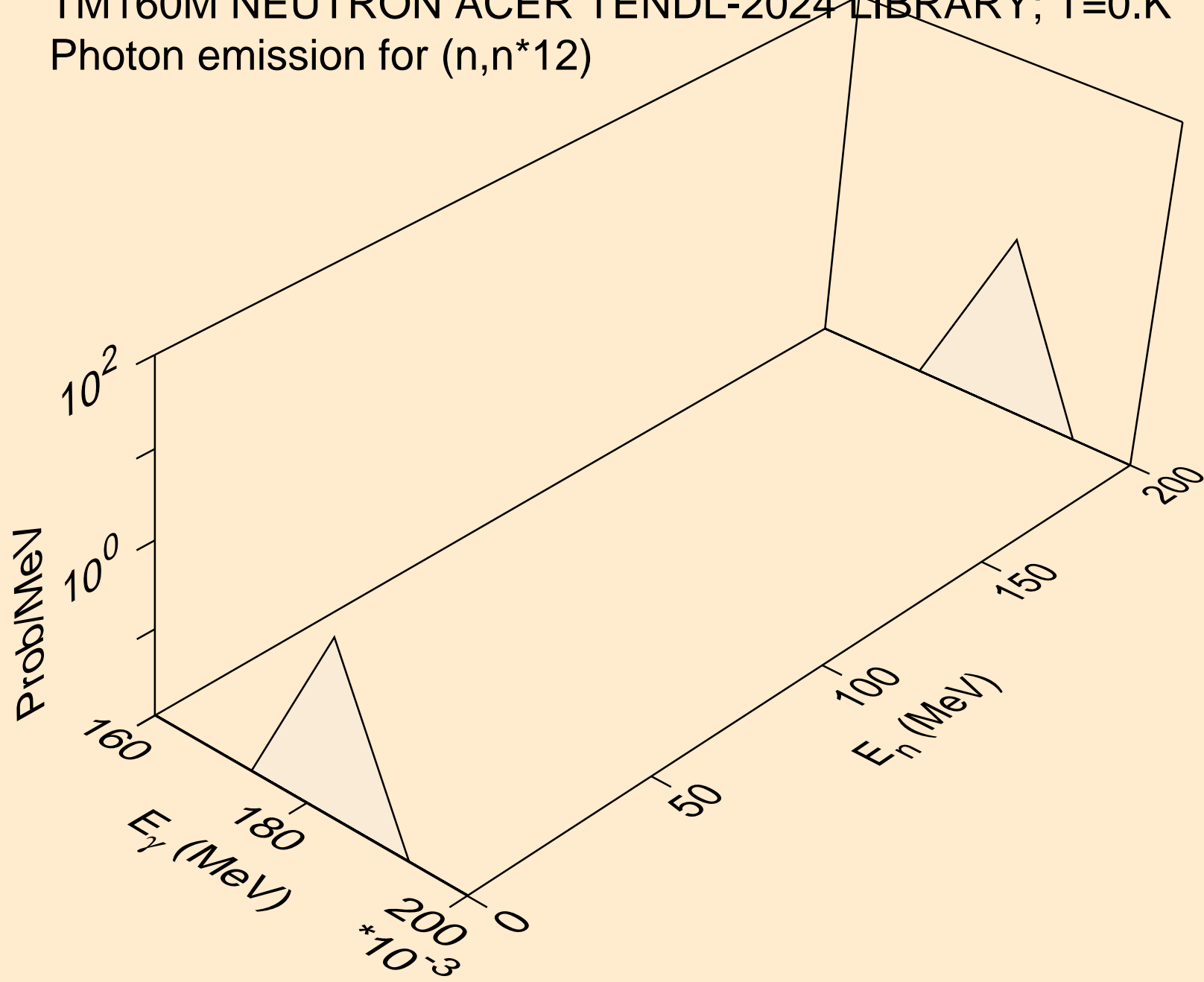

TM160M NEUTRON ACER TENDL-2024 LIBRARY; T=0.K
Photon emission for (n,n*13)

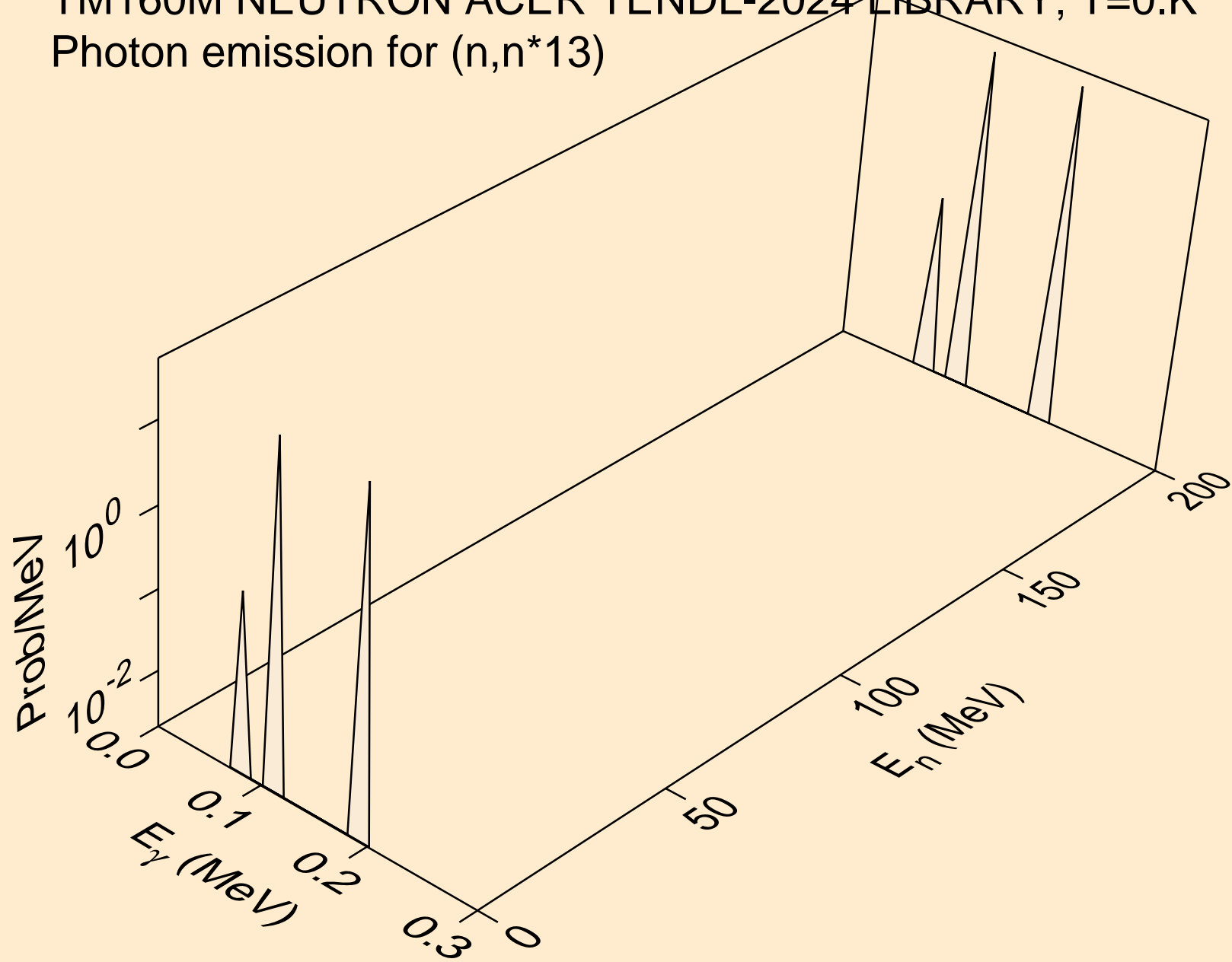

TM160M NEUTRON ACER TENDL-2024 LIBRARY; T=0.K
Photon emission for (n,n*14)

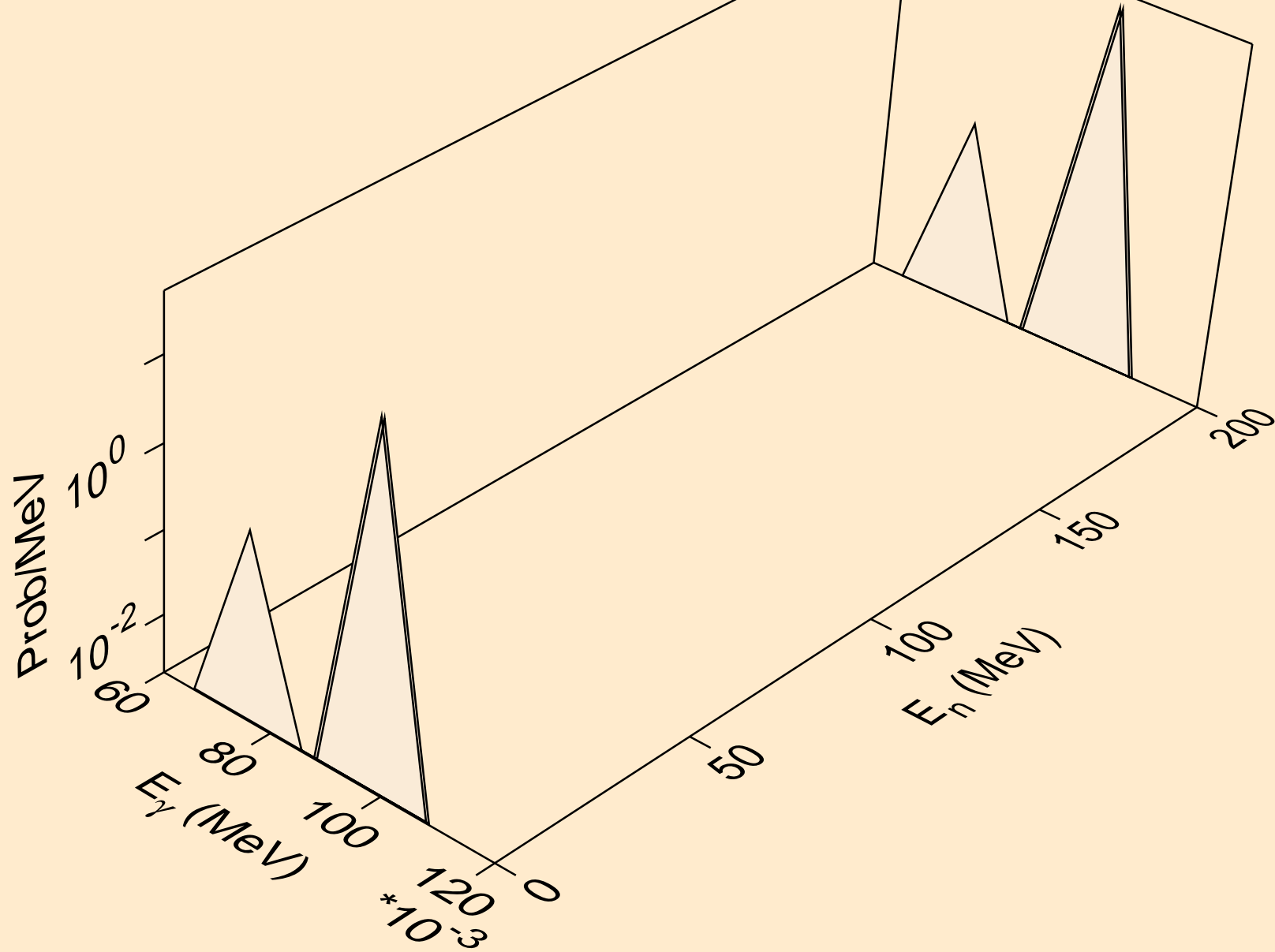

TM160M NEUTRON ACER TENDL-2024 LIBRARY; T=0.K
Photon emission for (n,n*c)

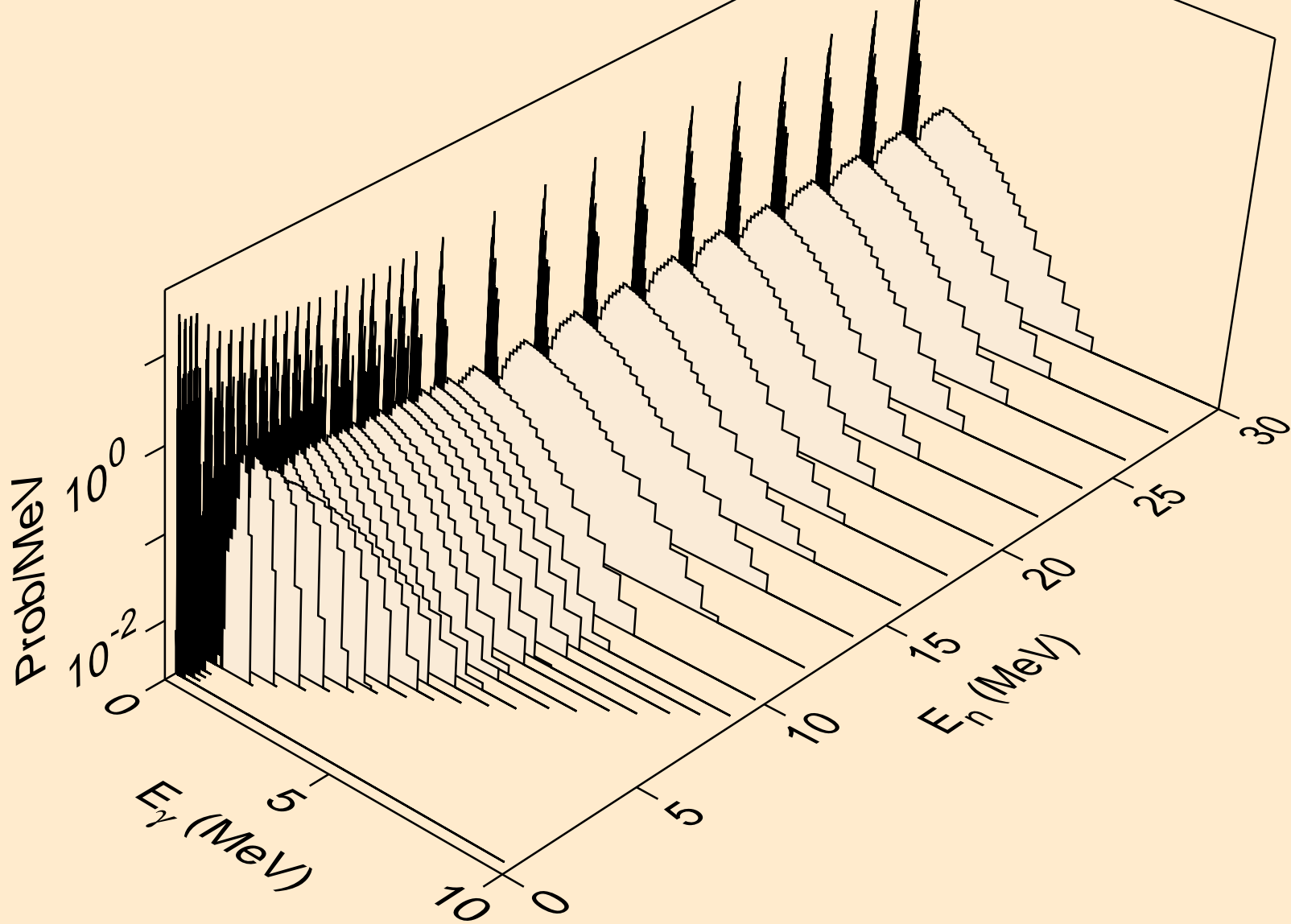

TM160M NEUTRON ACER TENDL-2024 LIBRARY; T=0.K
Photon emission for (n,gma)

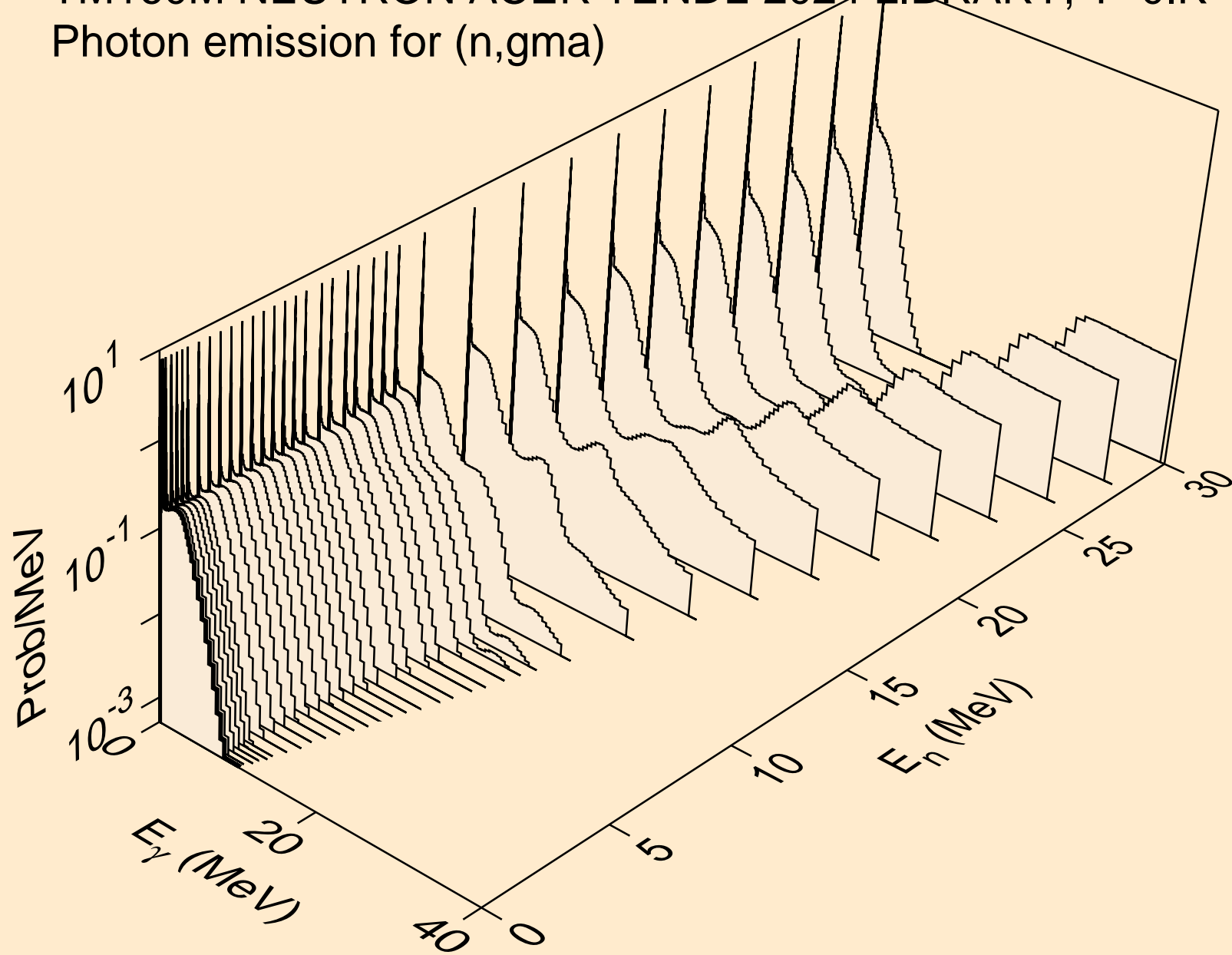

TM160M NEUTRON ACER TENDL-2024 LIBRARY; T=0.K
Photon emission for (n,p)

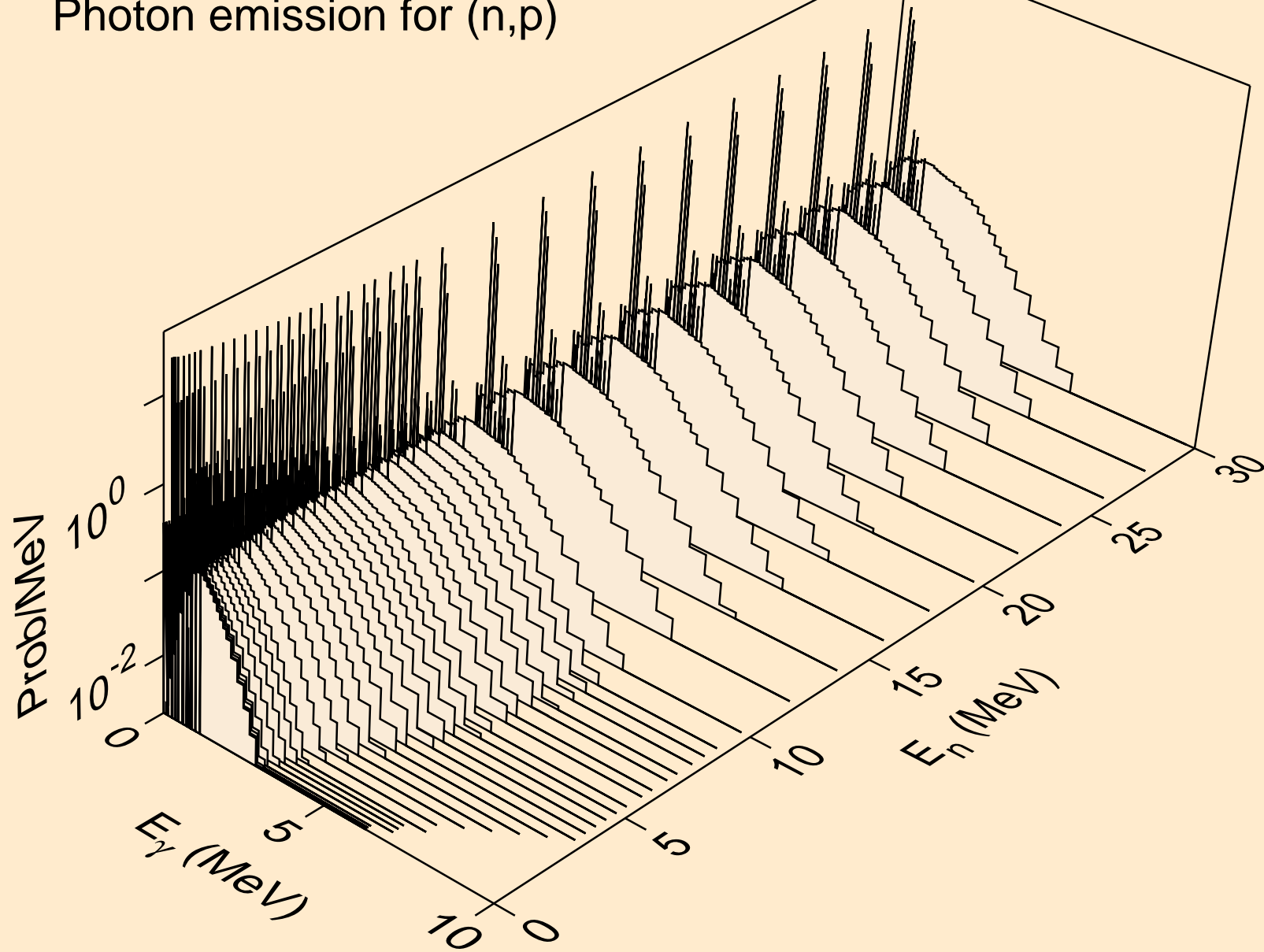

TM160M NEUTRON ACER TENDL-2024 LIBRARY; T=0.K
Photon emission for (n,d)

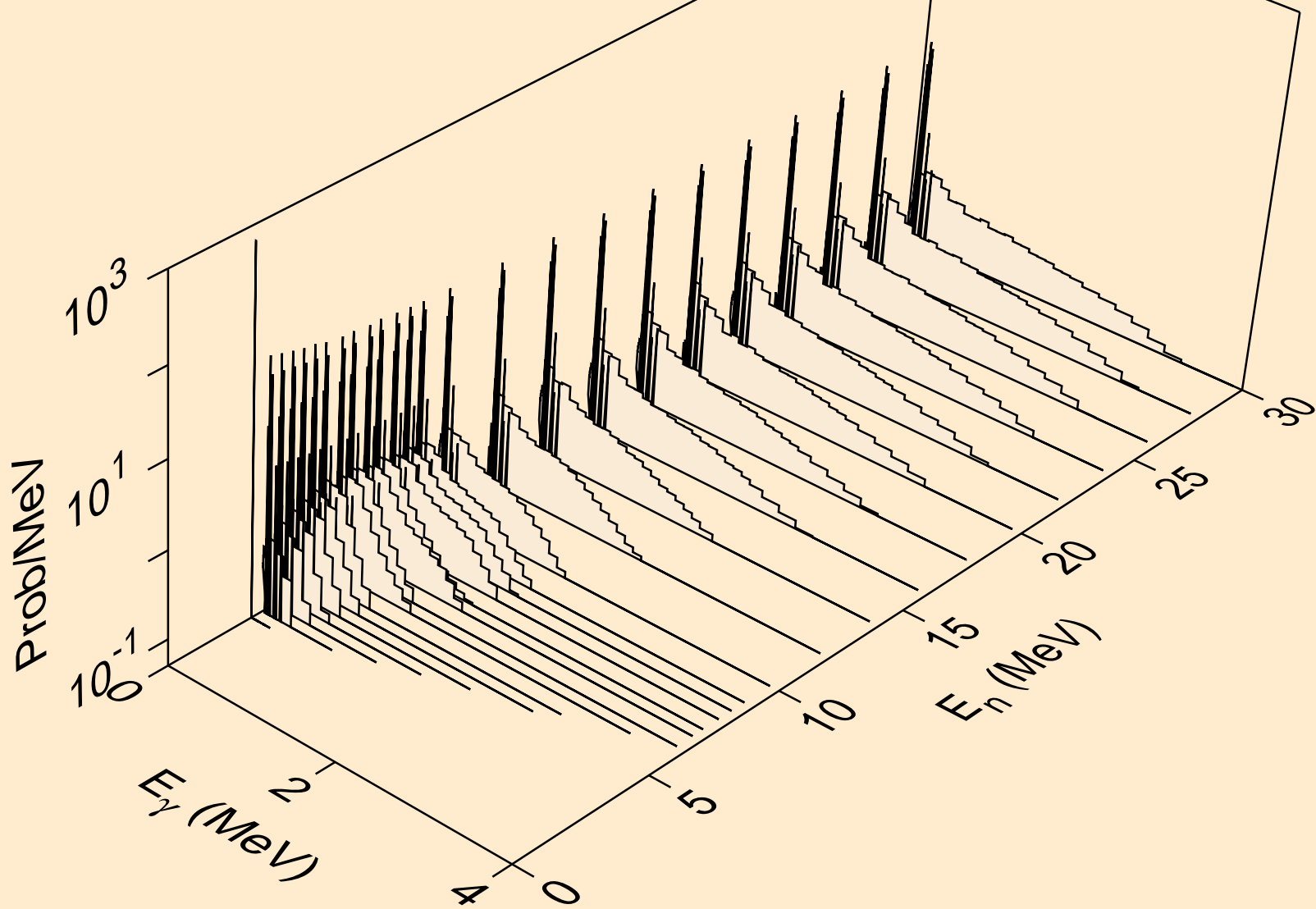

TM160M NEUTRON ACER TENDL-2024 LIBRARY; T=0.K
Photon emission for (n,t)

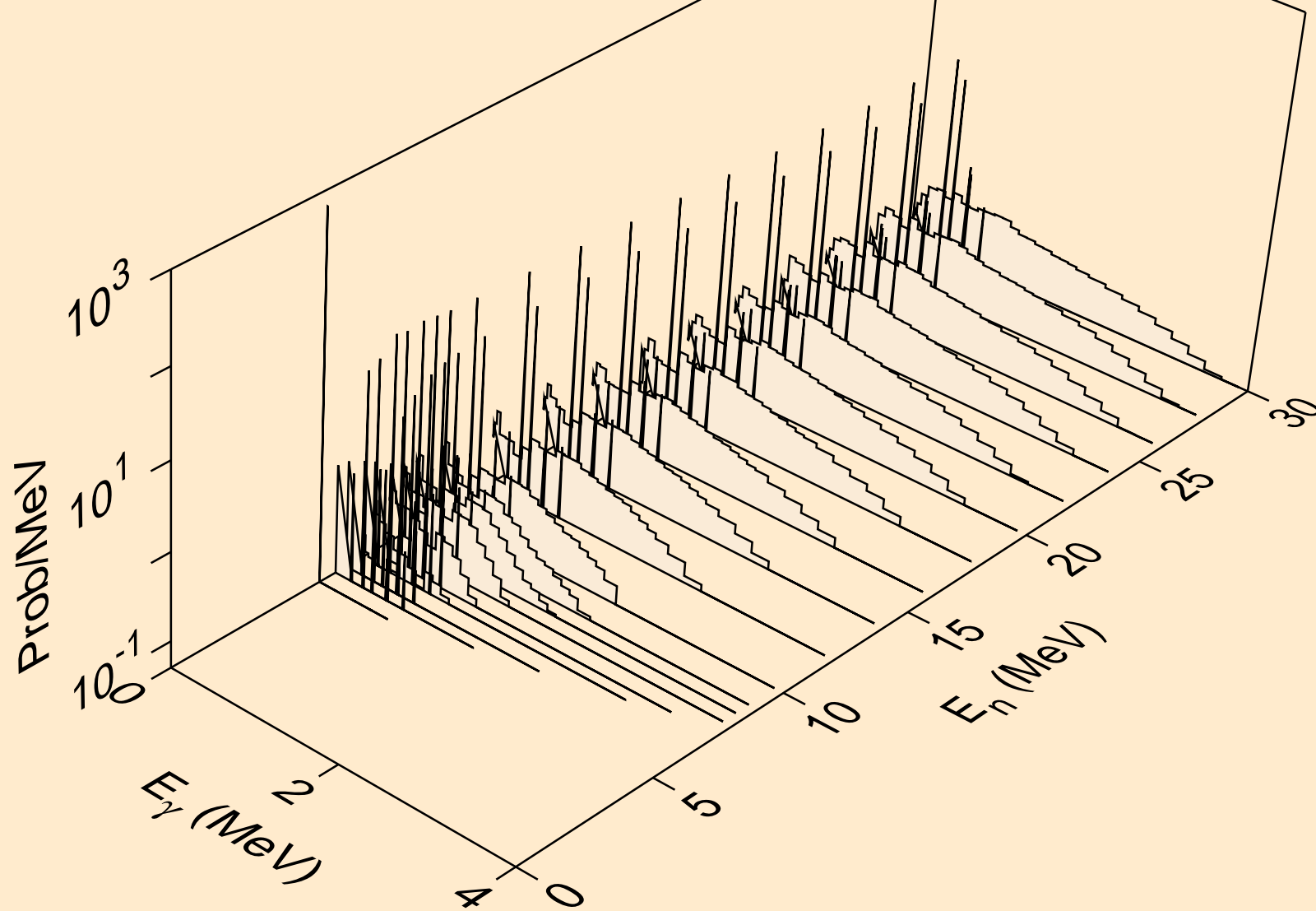

TM160M NEUTRON ACER TENDL-2024 LIBRARY; T=0.K
Photon emission for (n,he3)

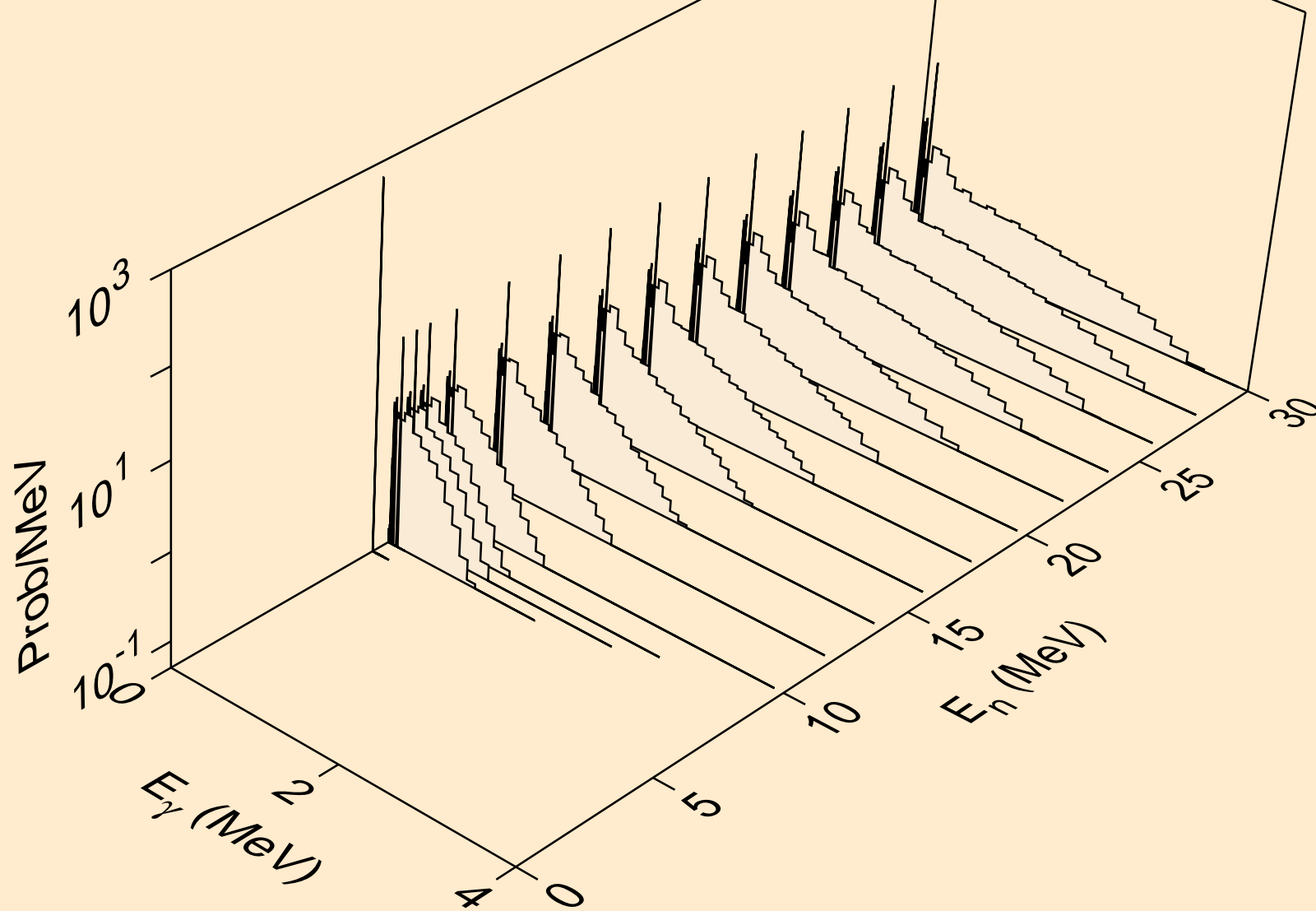

TM160M NEUTRON ACER TENDL-2024 LIBRARY; T=0.K
Photon emission for (n,a)

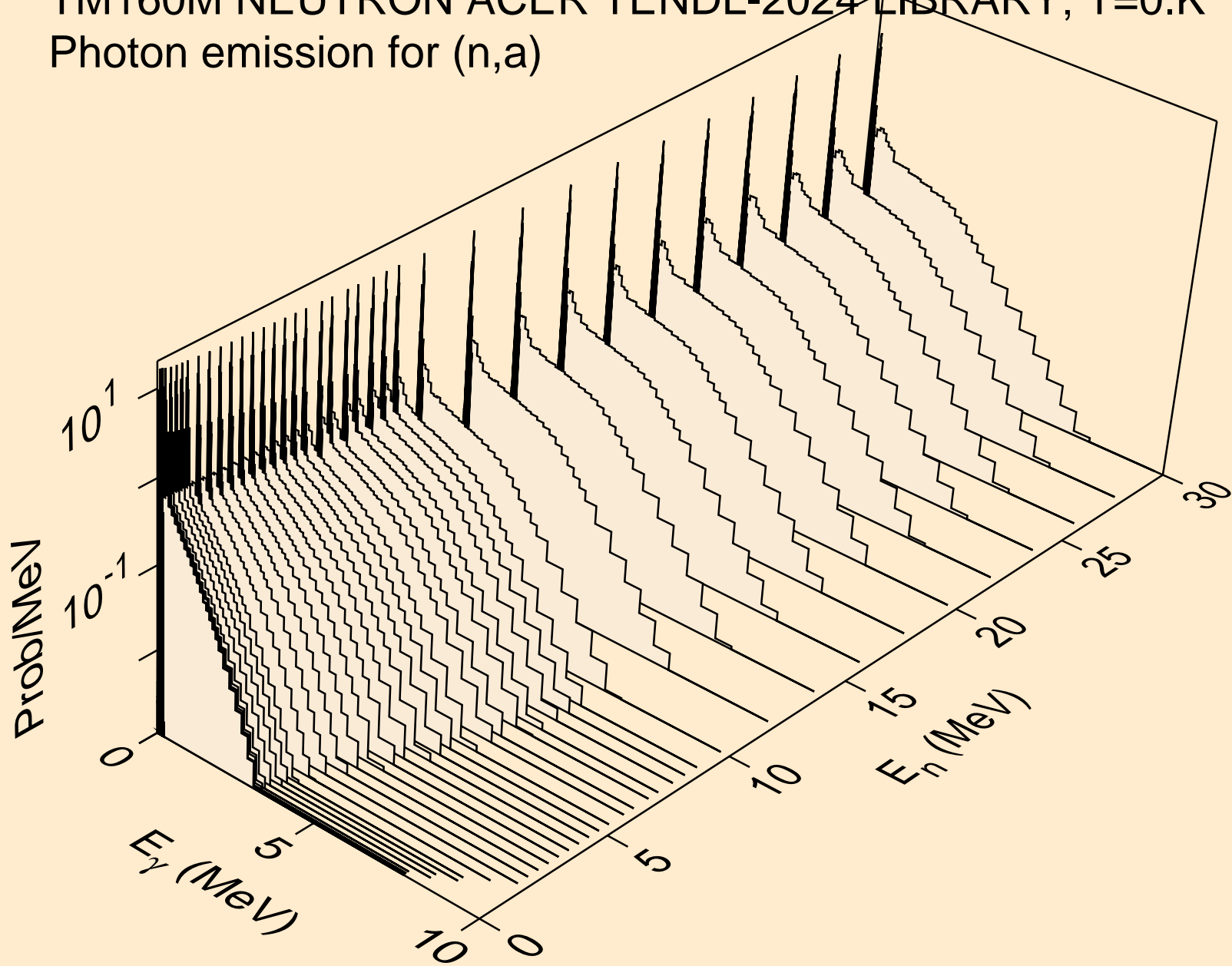

TM160M NEUTRON ACER TENDL-2024 LIBRARY; T=0.K
Photon emission for (n,2a)

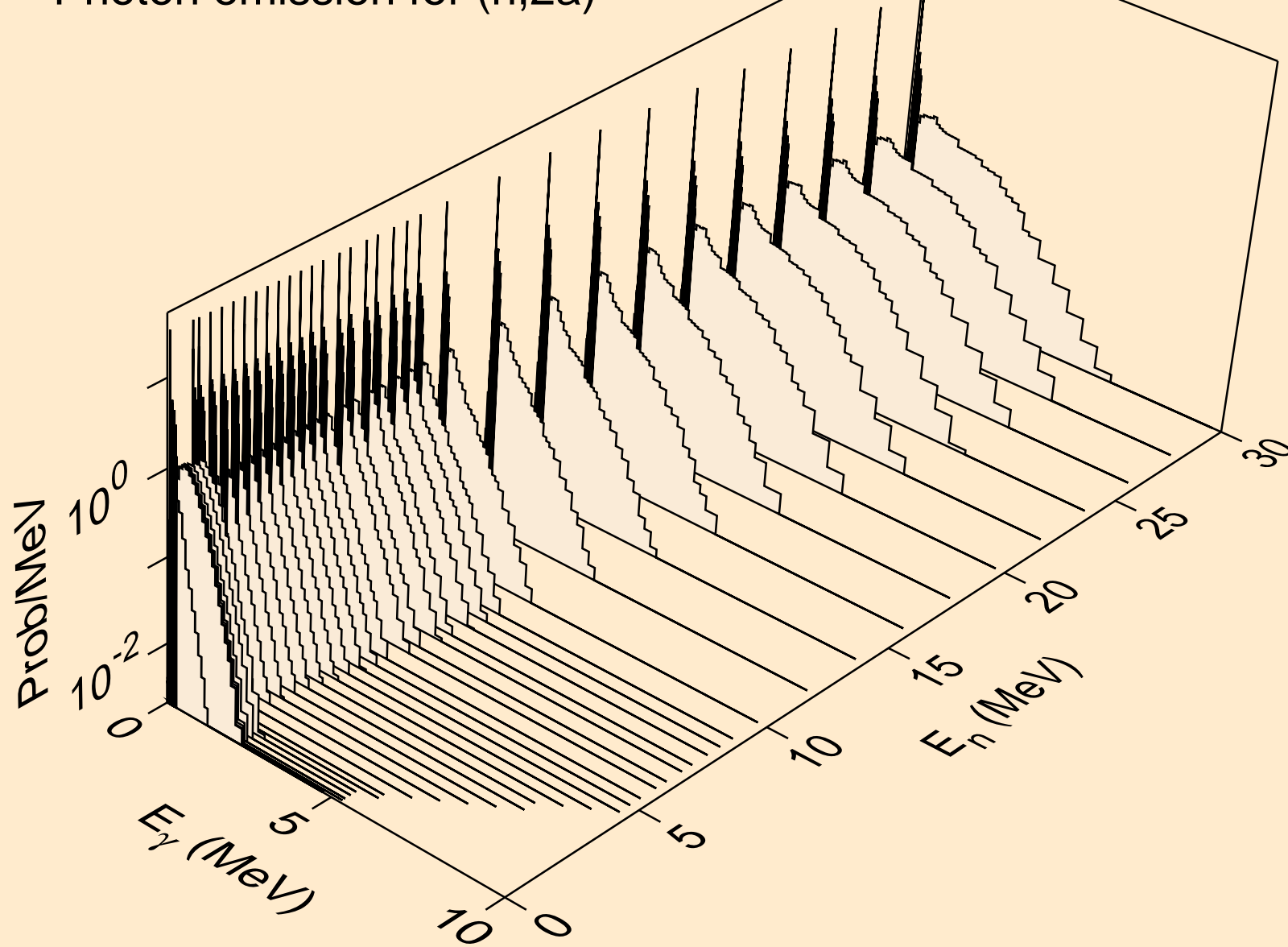

TM160M NEUTRON ACER TENDL-2024 LIBRARY; T=0.K
Photon emission for (n,3a)

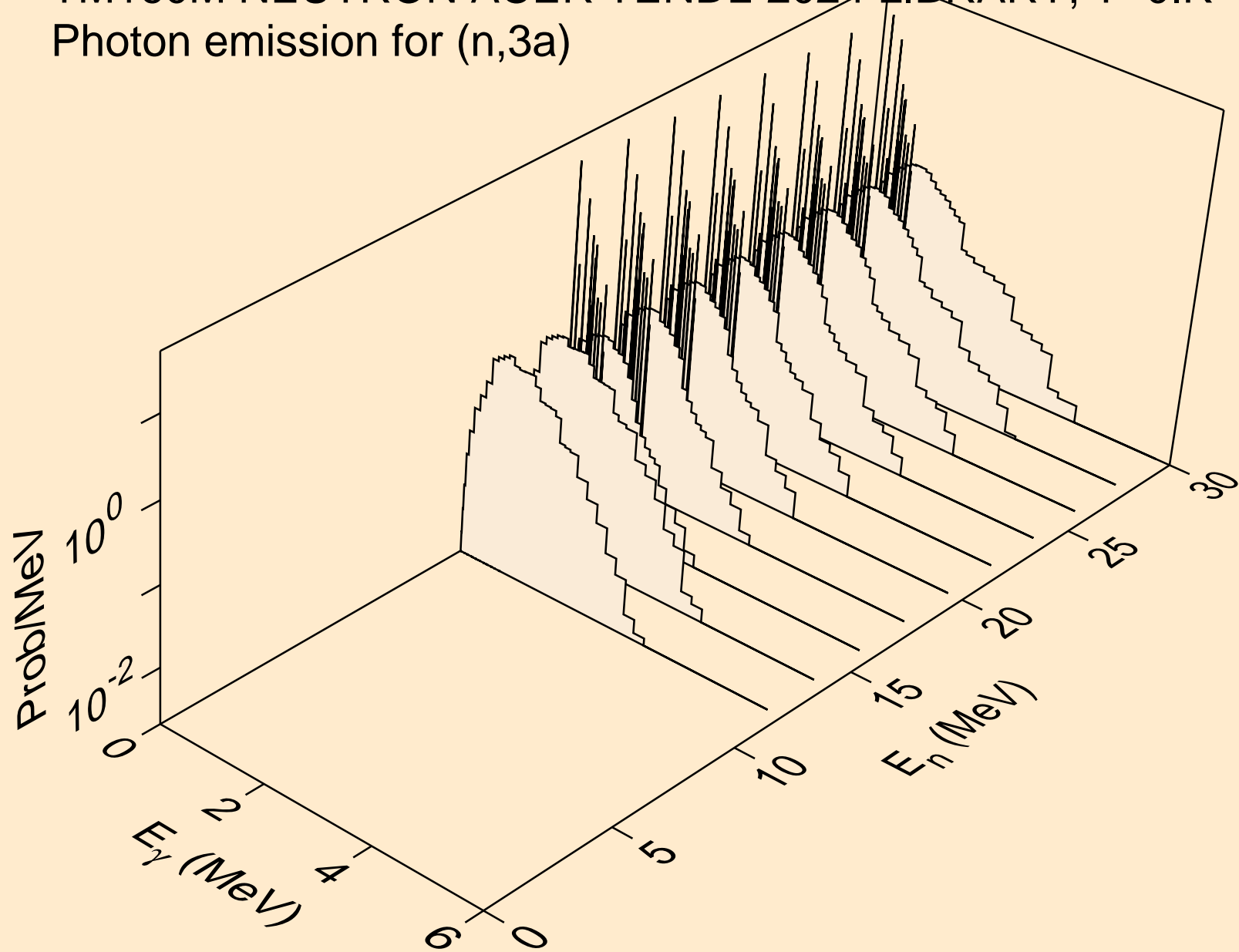

TM160M NEUTRON ACER TENDL-2024 LIBRARY; T=0.K
Photon emission for (n,2p)

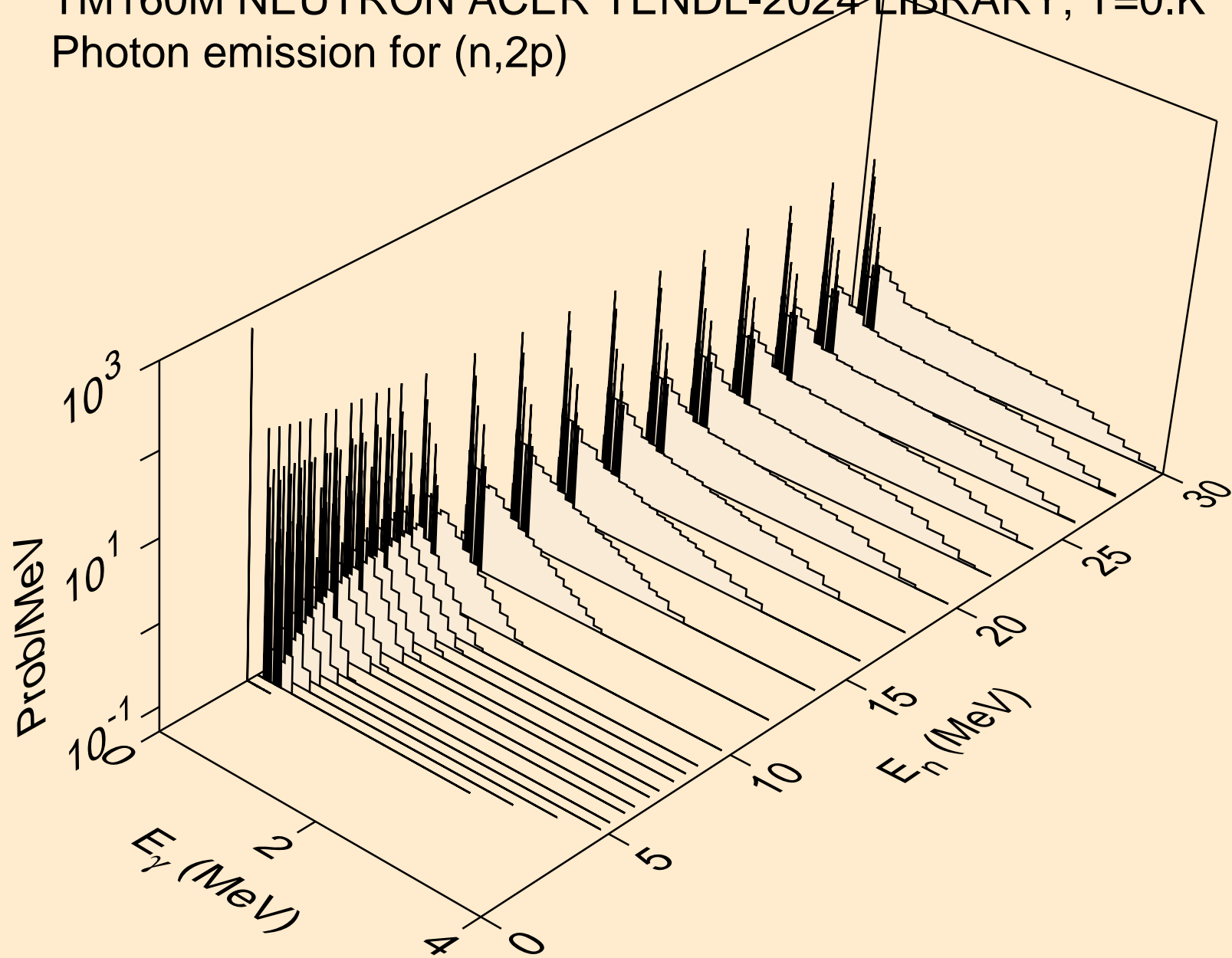

TM160M NEUTRON ACER TENDL-2024 LIBRARY; T=0.K
Photon emission for (n,p)

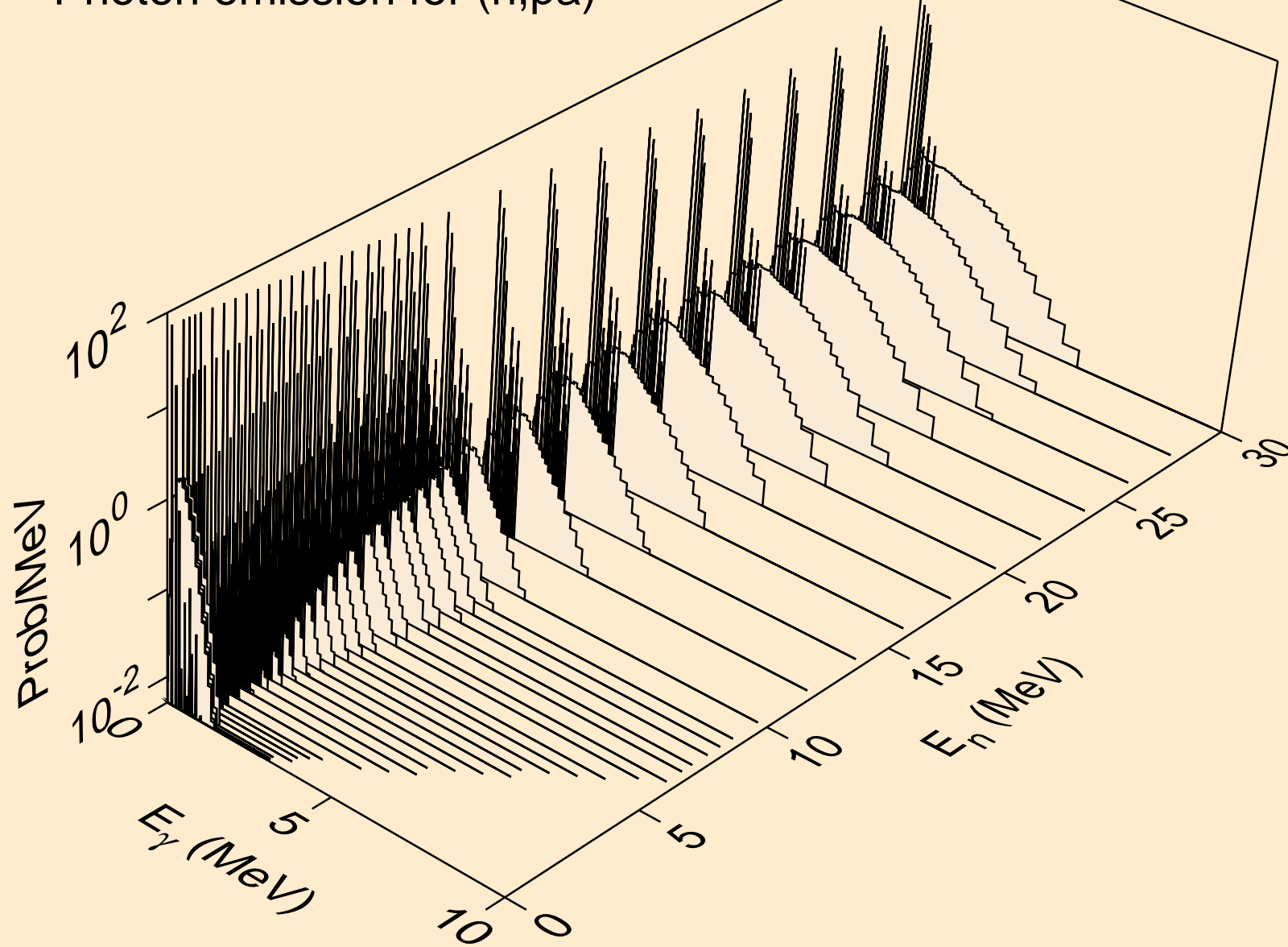

TM160M NEUTRON ACER TENDL-2024 LIBRARY; T=0.K
Photon emission for (n,pd)

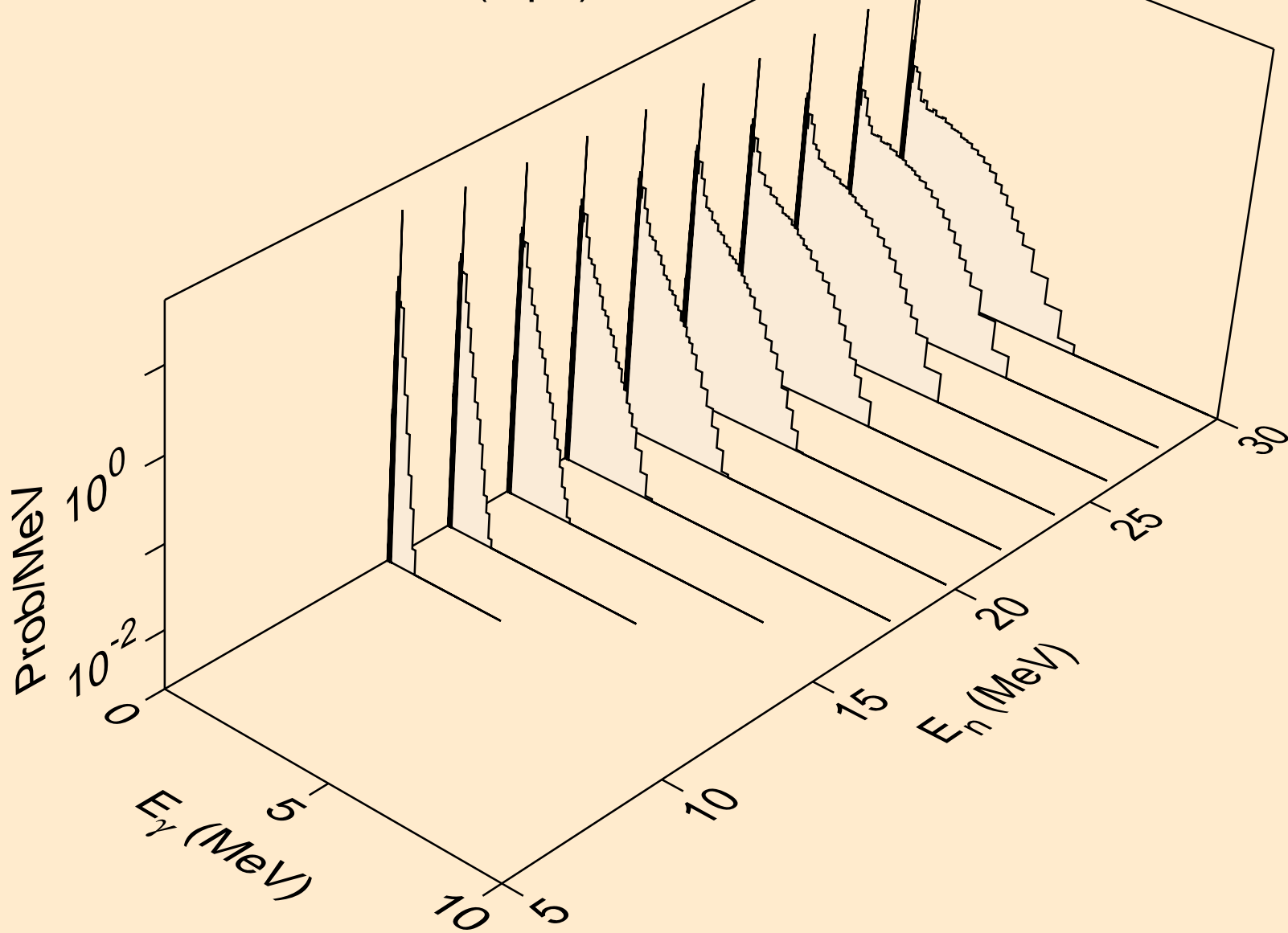

TM160M NEUTRON ACER TENDL-2024 LIBRARY; T=0.K
Photon emission for (n,pt)

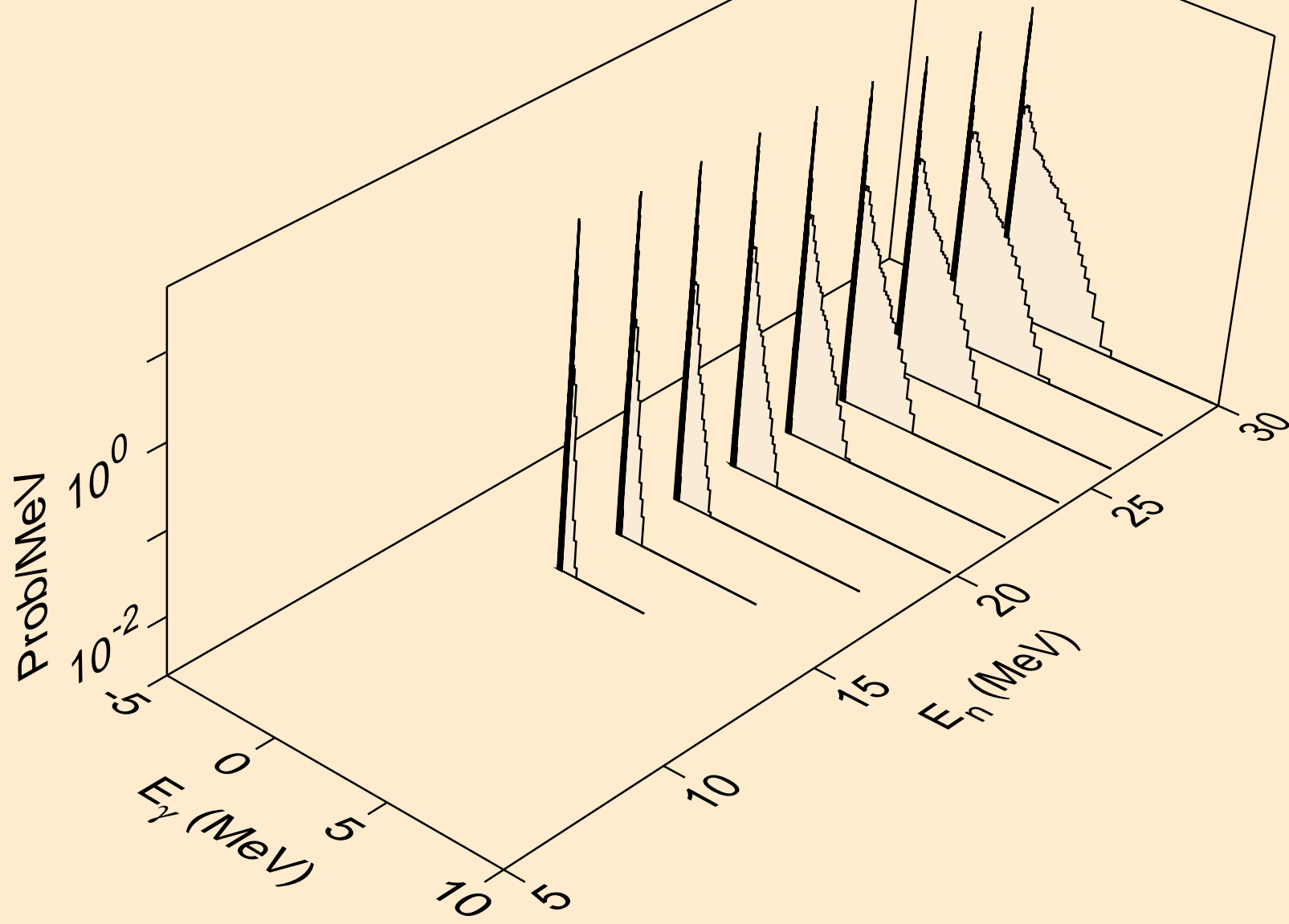

TM160M NEUTRON ACER TENDL-2024 LIBRARY; T=0.K
Photon emission for (n,da)

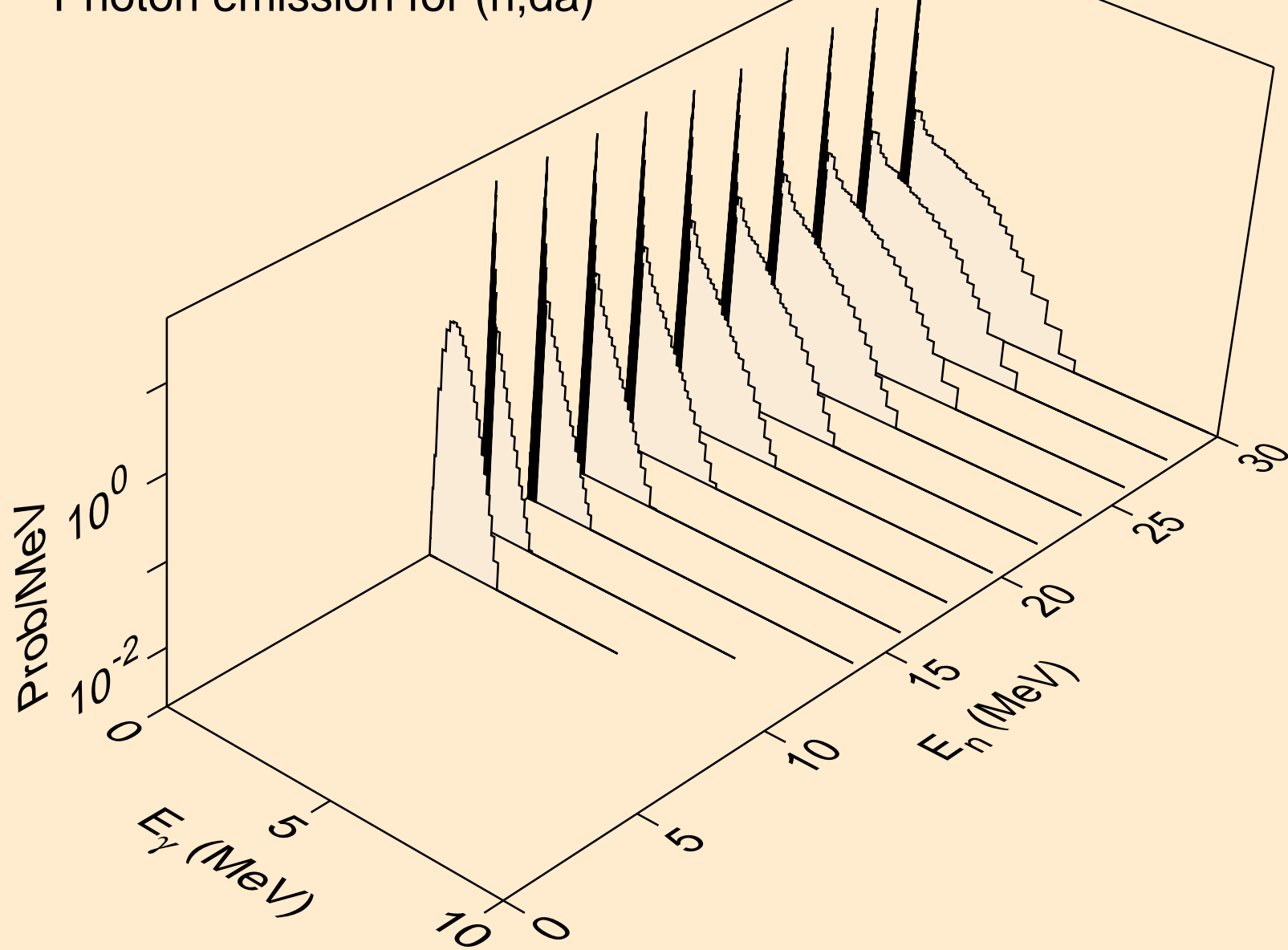

TM160M NEUTRON ACER TENDL-2024 LIBRARY; T=0.K
thermal capture photon spectrum

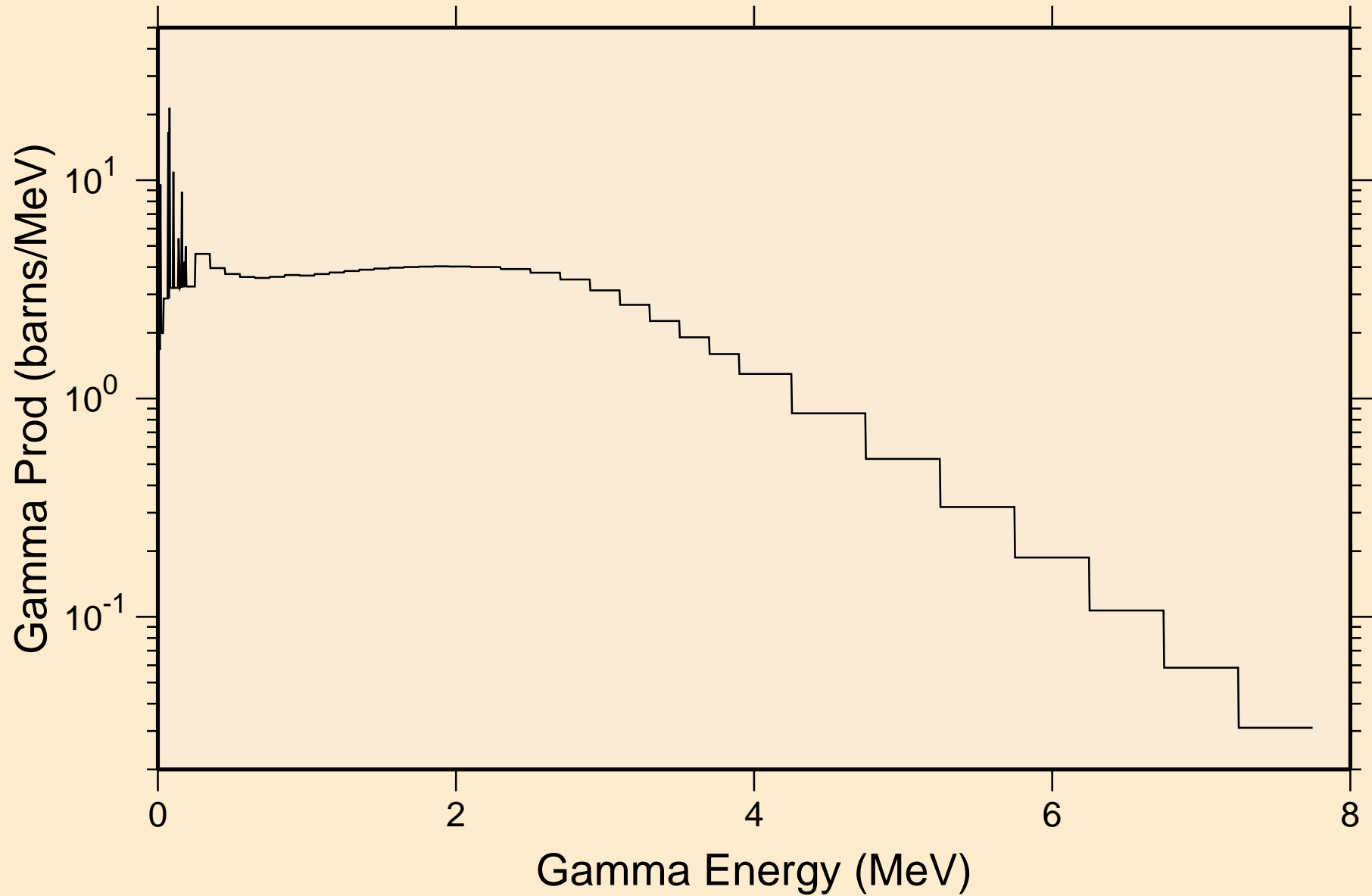

TM160M NEUTRON ACER TENDL-2024 LIBRARY; T=0.K
14 MeV photon spectrum

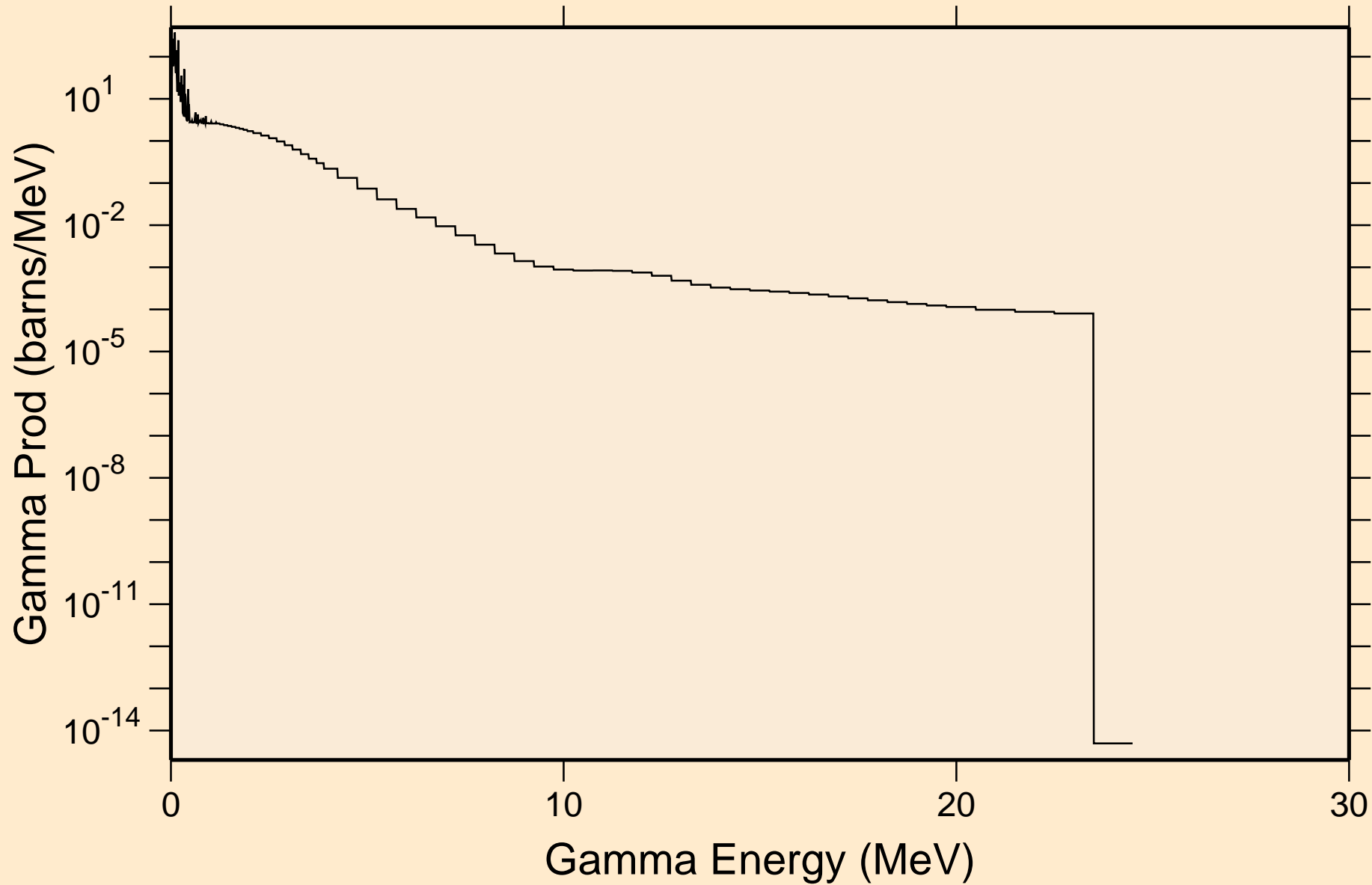

TM160M NEUTRON ACER TENDL-2024 LIBRARY; T=0.K

Particle heating contributions

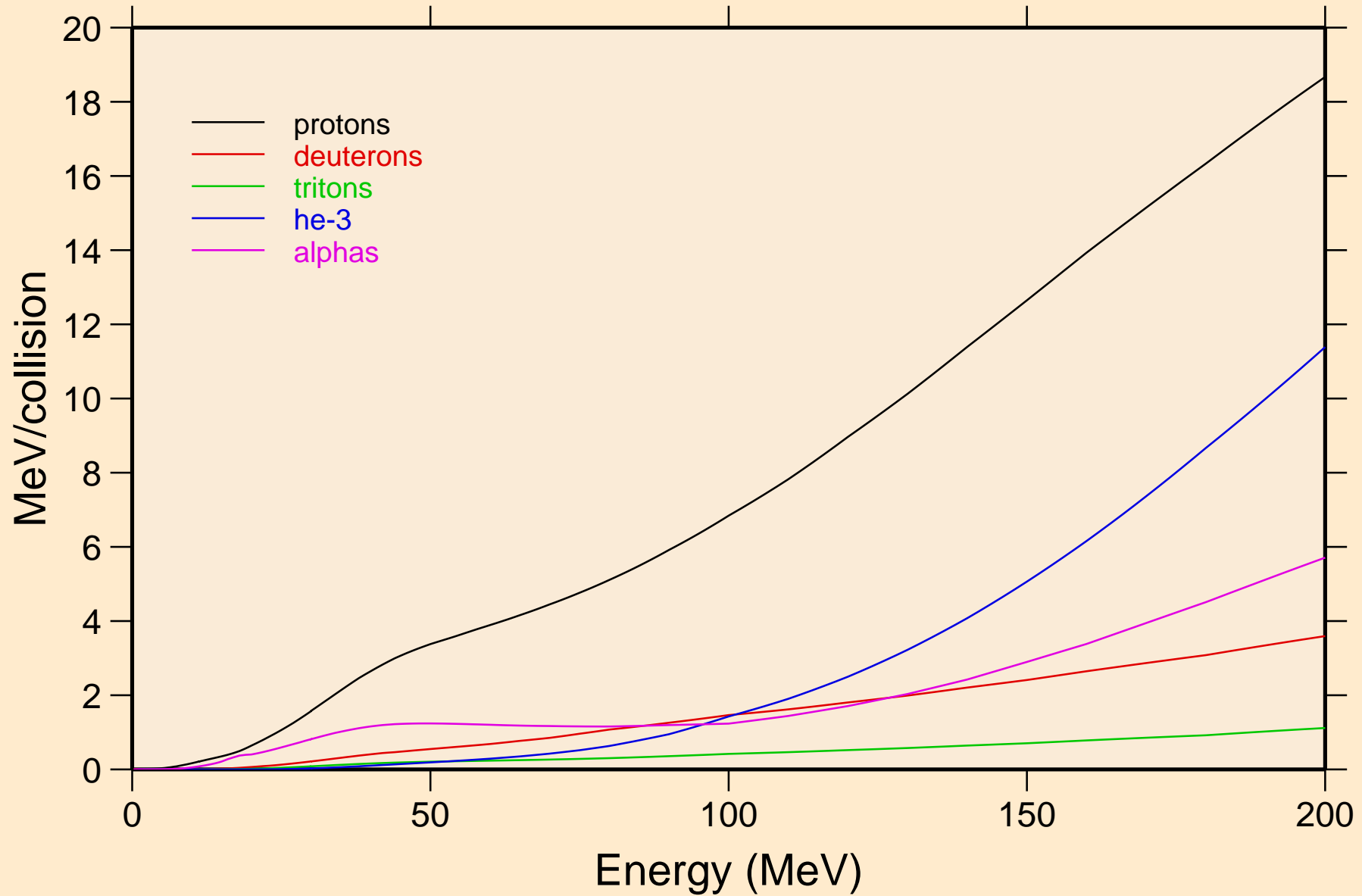

TM160M NEUTRON ACER TENDL-2024 LIBRARY; T=0.K
Recoil Heating

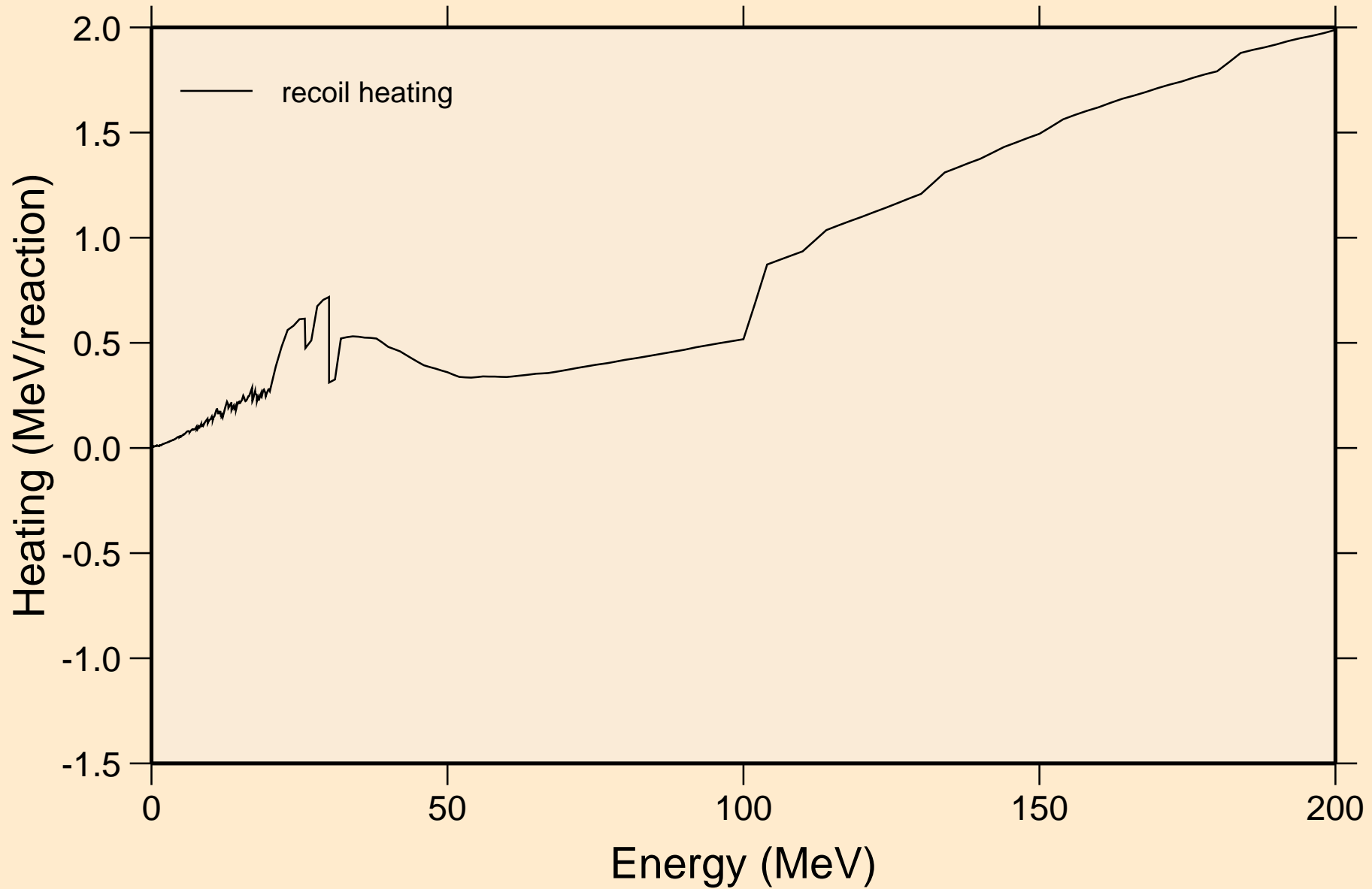

TM160M NEUTRON ACER TENDL-2024 LIBRARY; T=0.K
Particle production cross sections

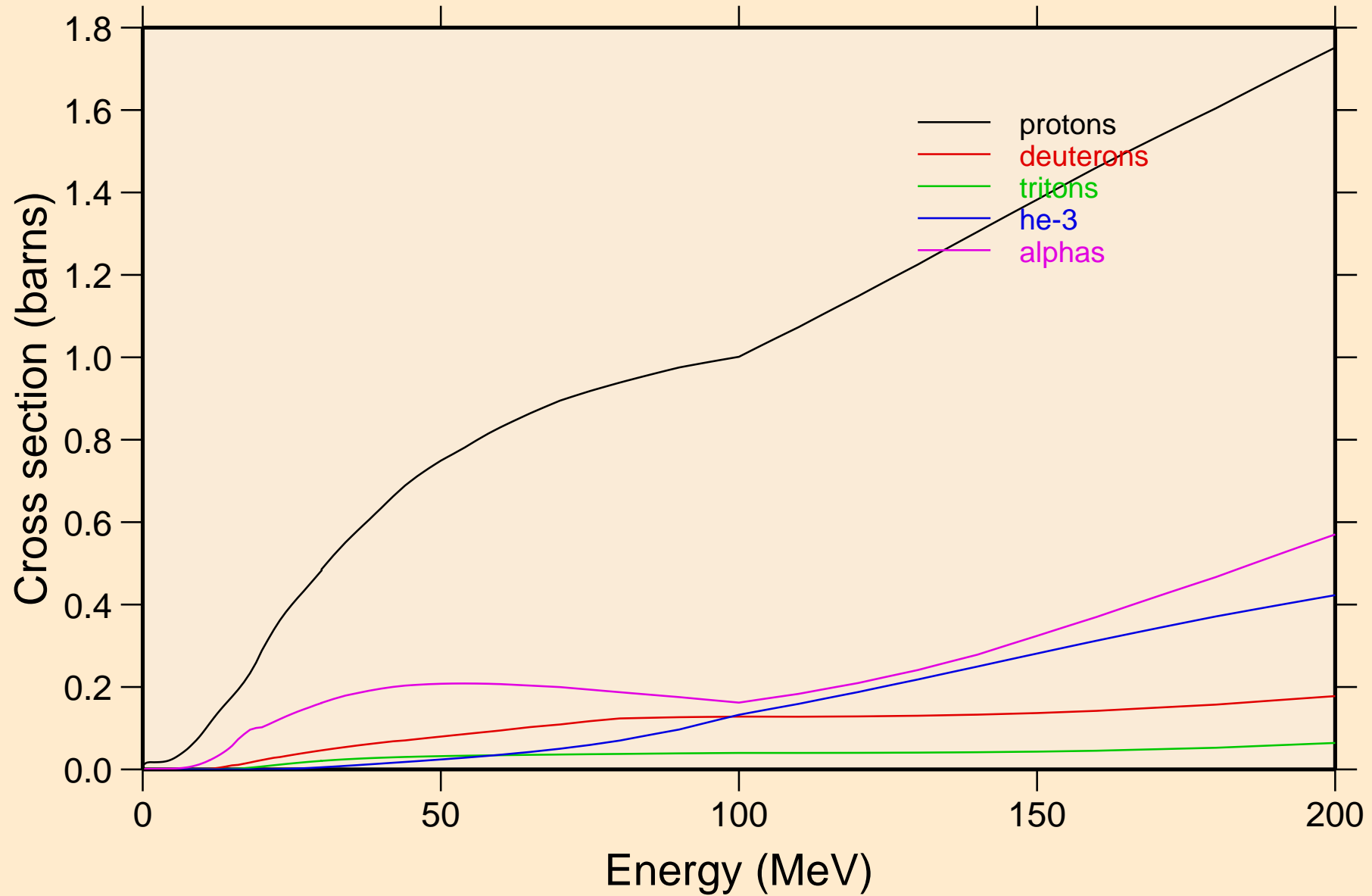

TM160M NEUTRON ACER TENDL-2024 LIBRARY; T=0.K
protons from (n,x)

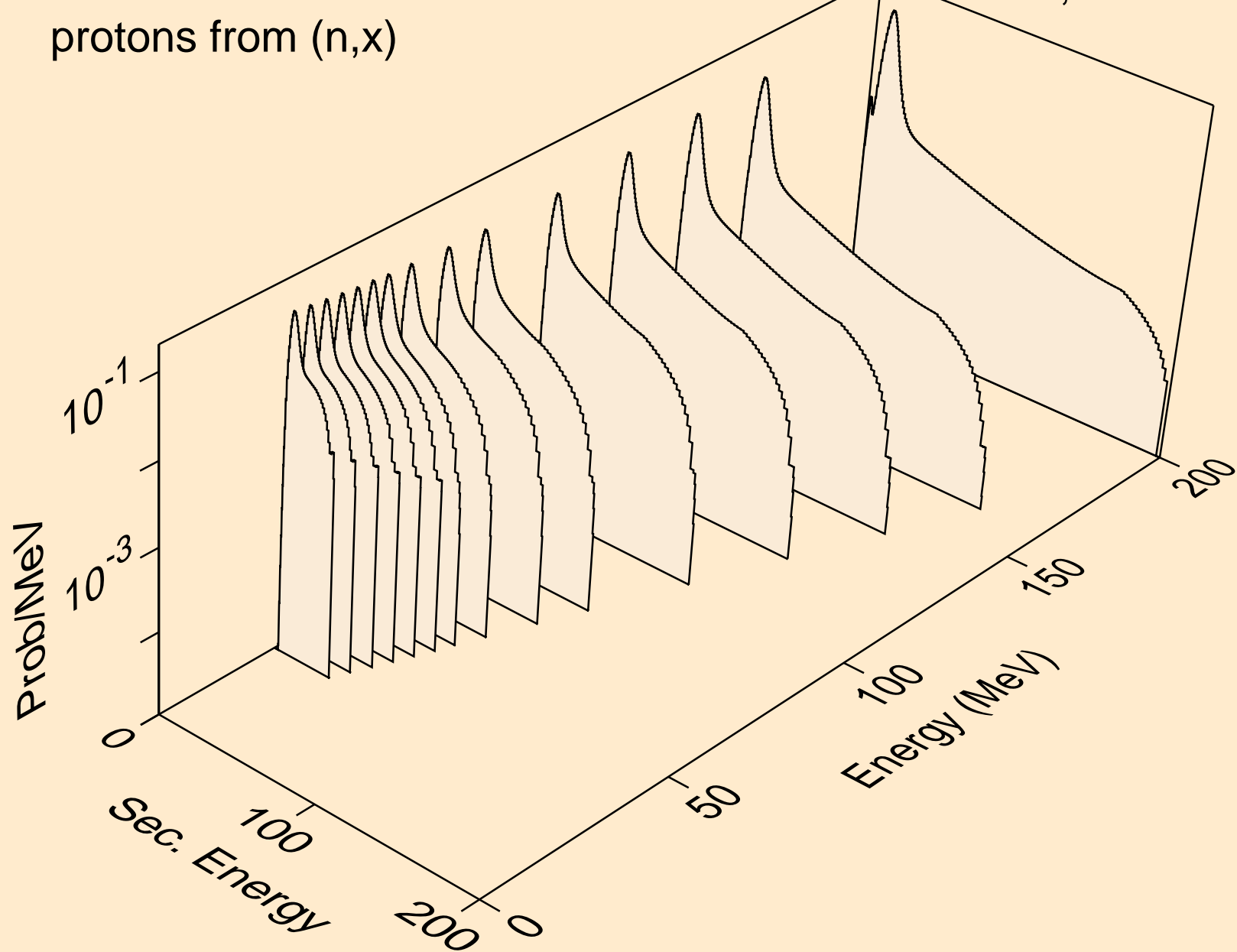

TM160M NEUTRON ACER TENDL-2024 LIBRARY; T=0.K
protons from (n,n*)p

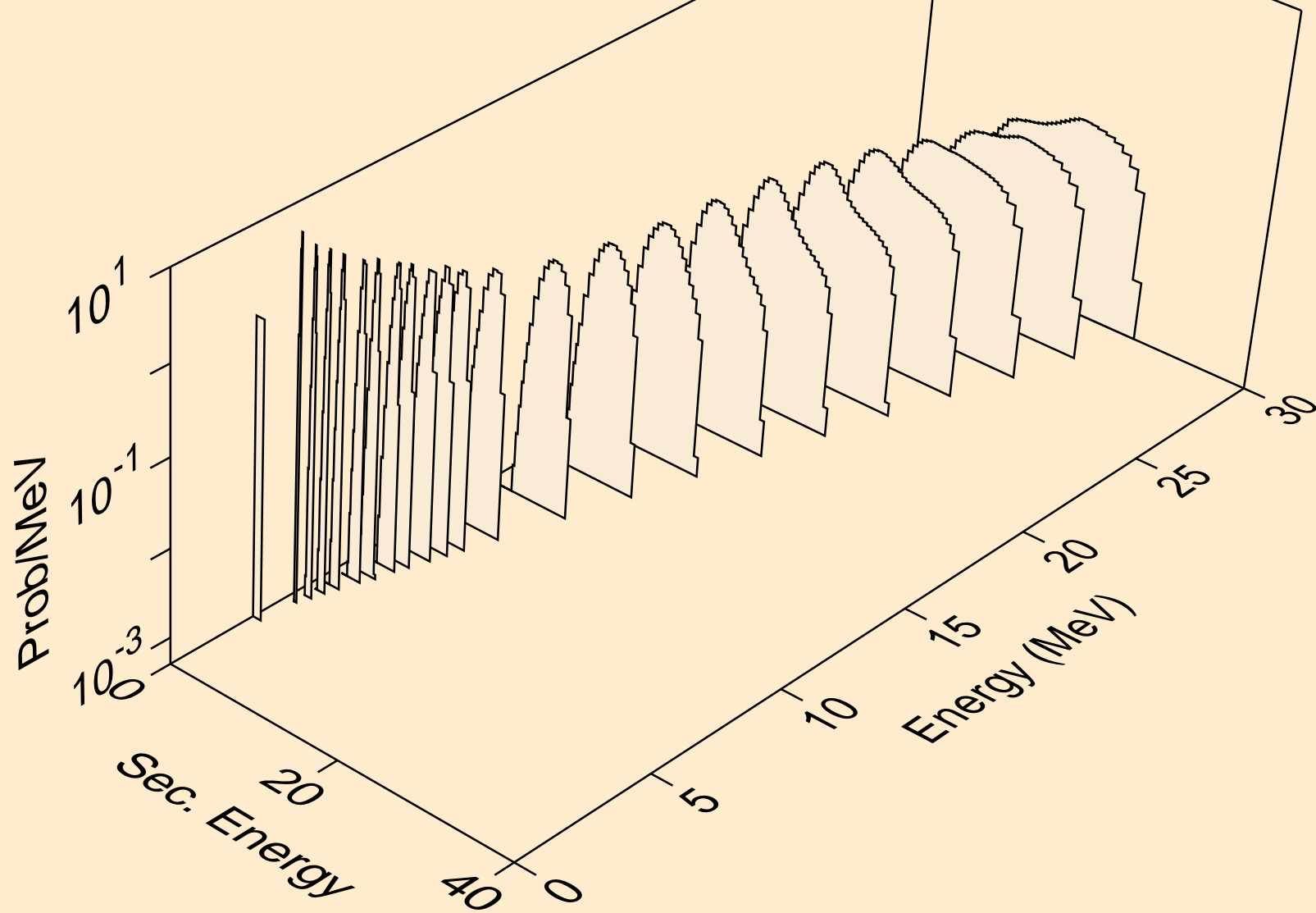

TM160M NEUTRON ACER TENDL-2024 LIBRARY; T=0.K
protons from (n,2np)

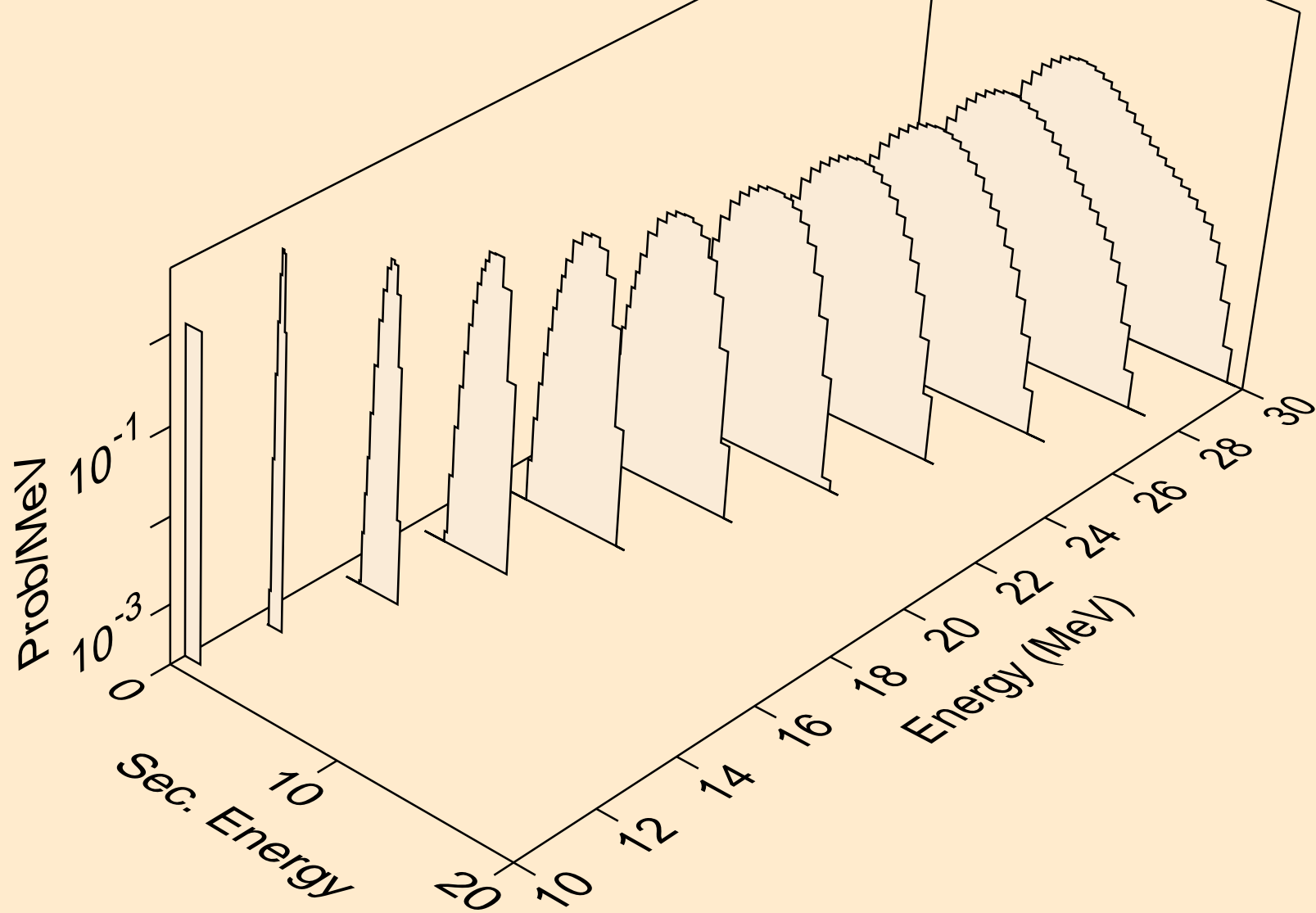

TM160M NEUTRON ACER TENDL-2024 LIBRARY; T=0.K
protons from (n,3np)

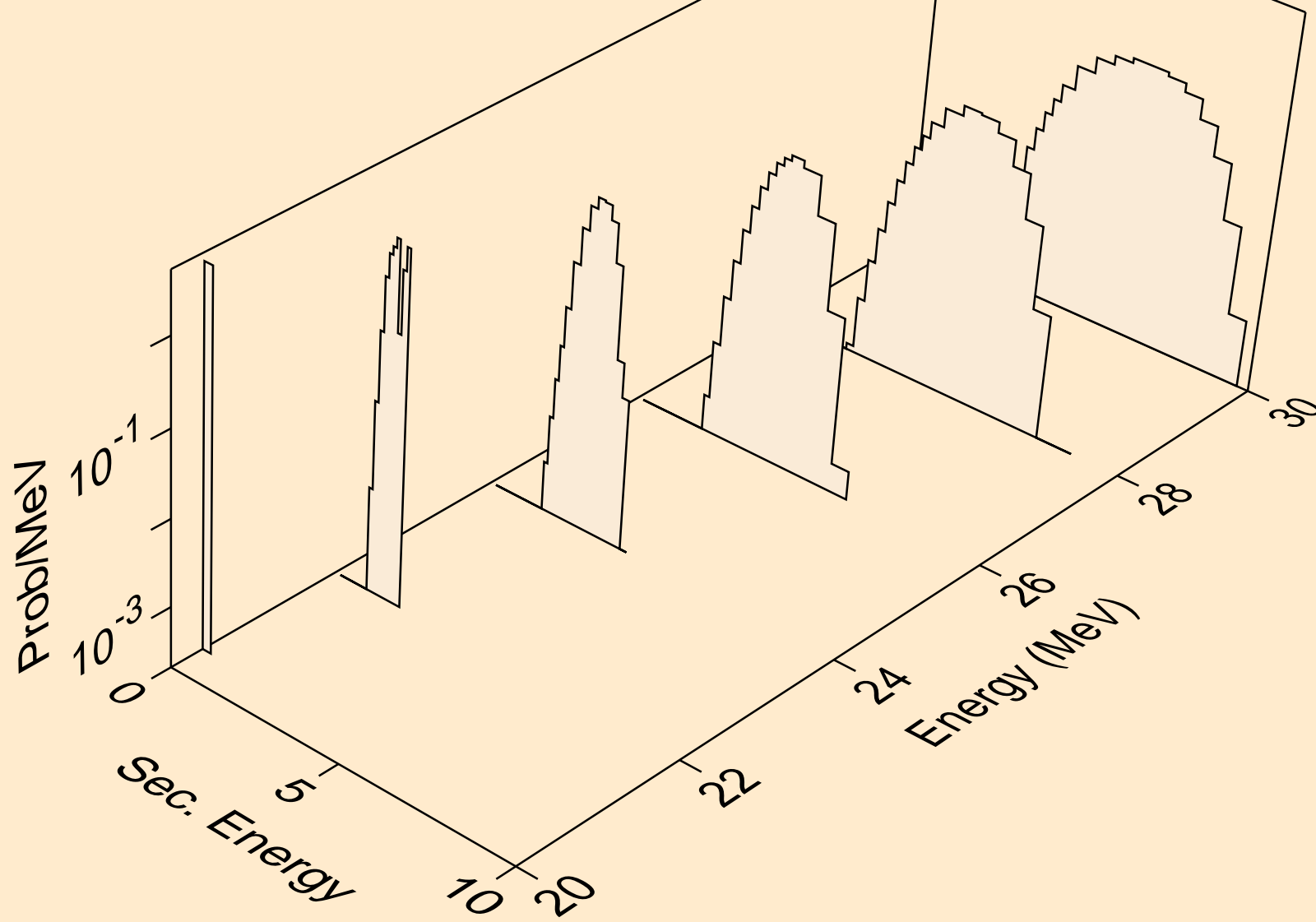

TM160M NEUTRON ACER TENDL-2024 LIBRARY; T=0.K
protons from (n,n2p)

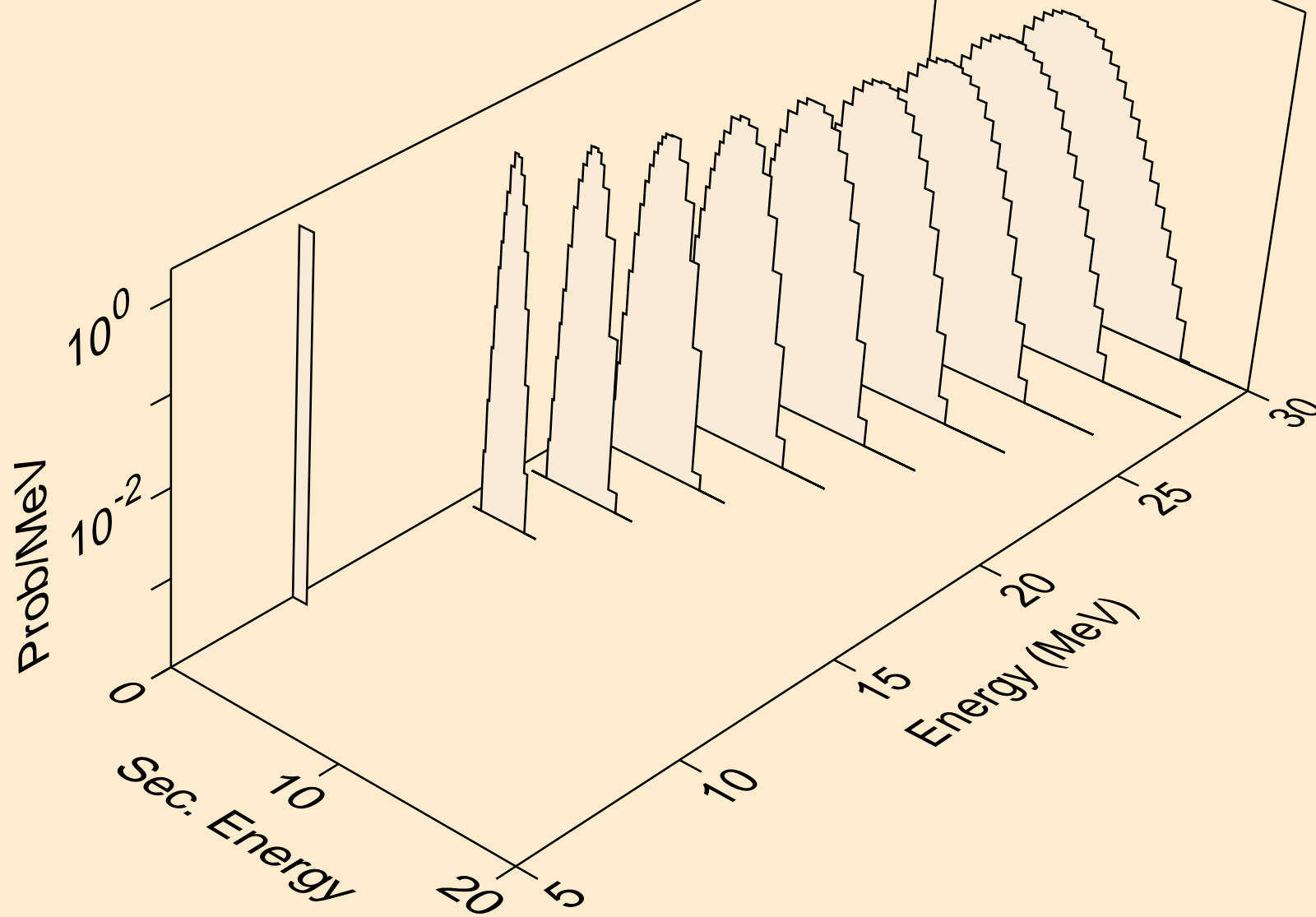

TM160M NEUTRON ACER TENDL-2024 LIBRARY; T=0.K
protons from (n,npa)

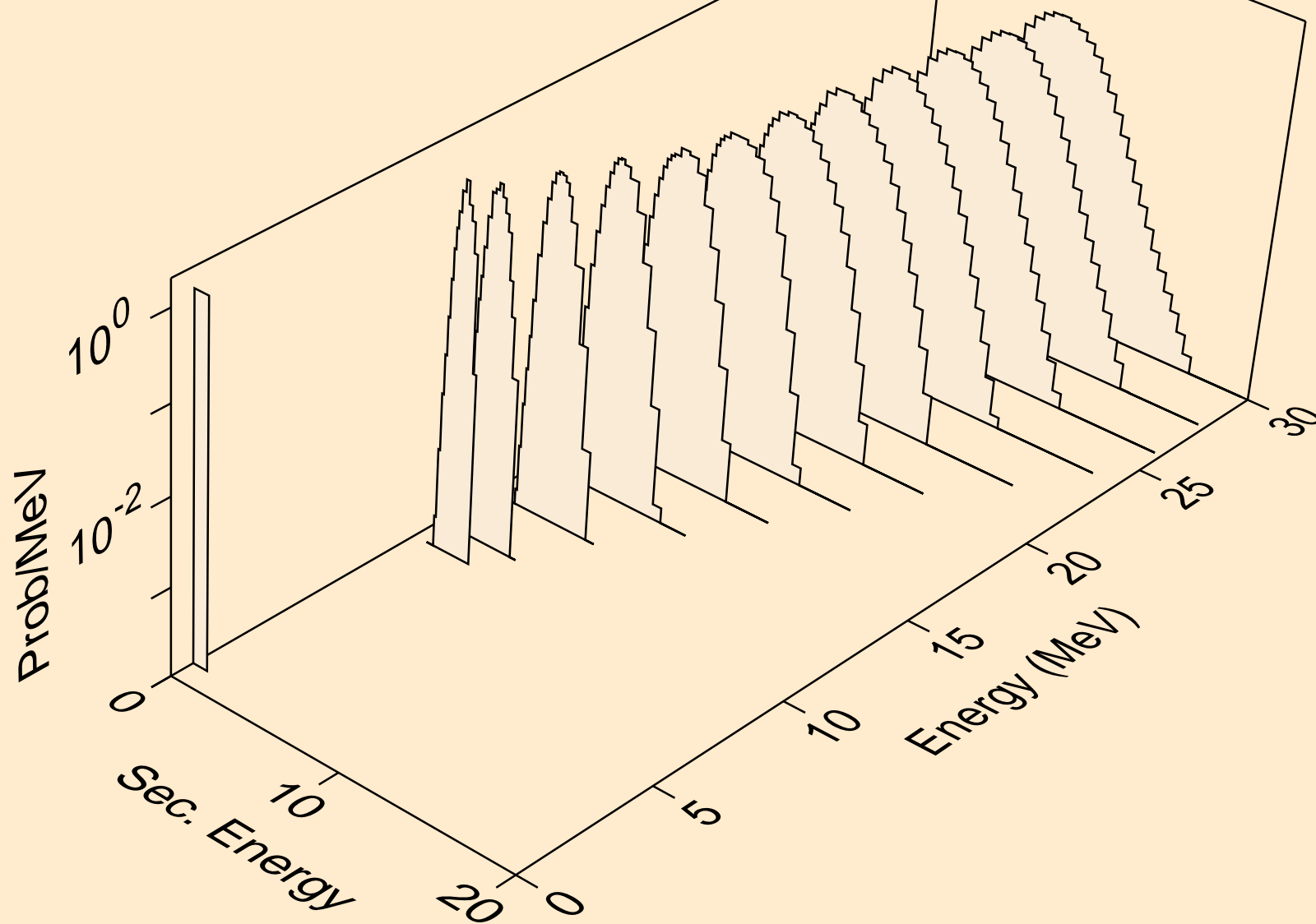

TM160M NEUTRON ACER TENDL-2024 LIBRARY; T=0.K
protons from (n,p)

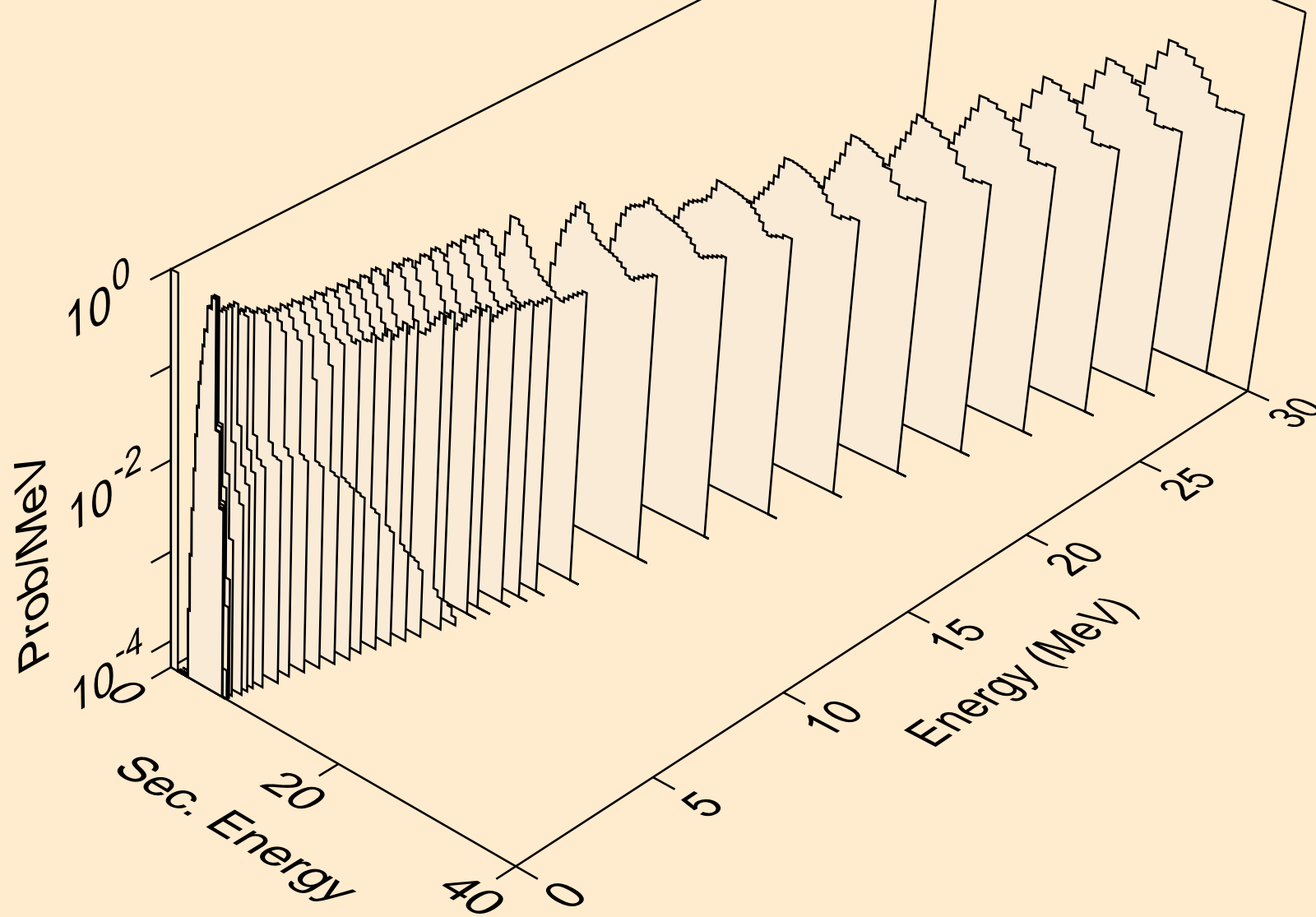

TM160M NEUTRON ACER TENDL-2024 LIBRARY; T=0.K
protons from (n,2p)

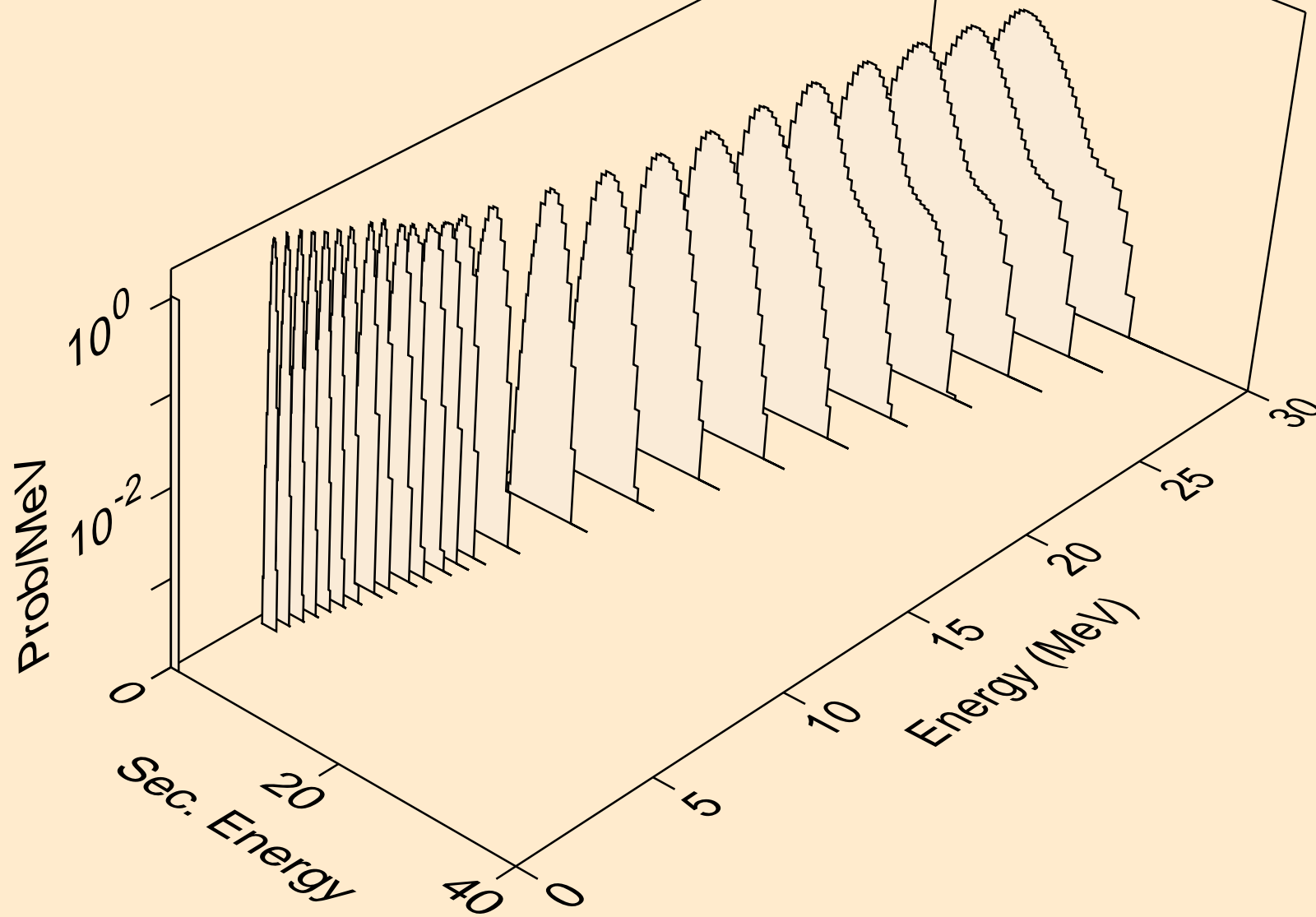

TM160M NEUTRON ACER TENDL-2024 LIBRARY; T=0.K
protons from (n,p)

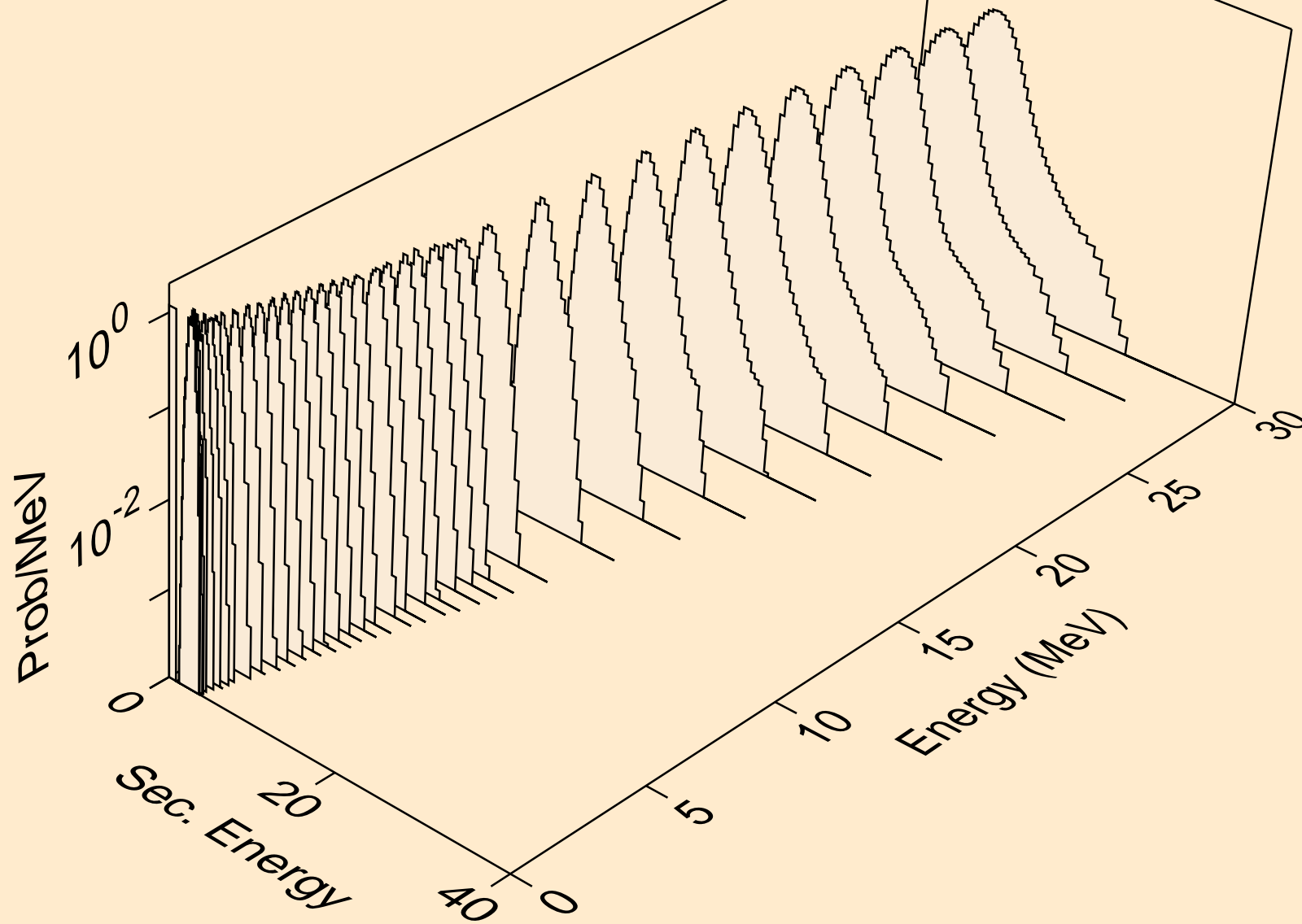

TM160M NEUTRON ACER TENDL-2024 LIBRARY; T=0.K
protons from (n,pd)

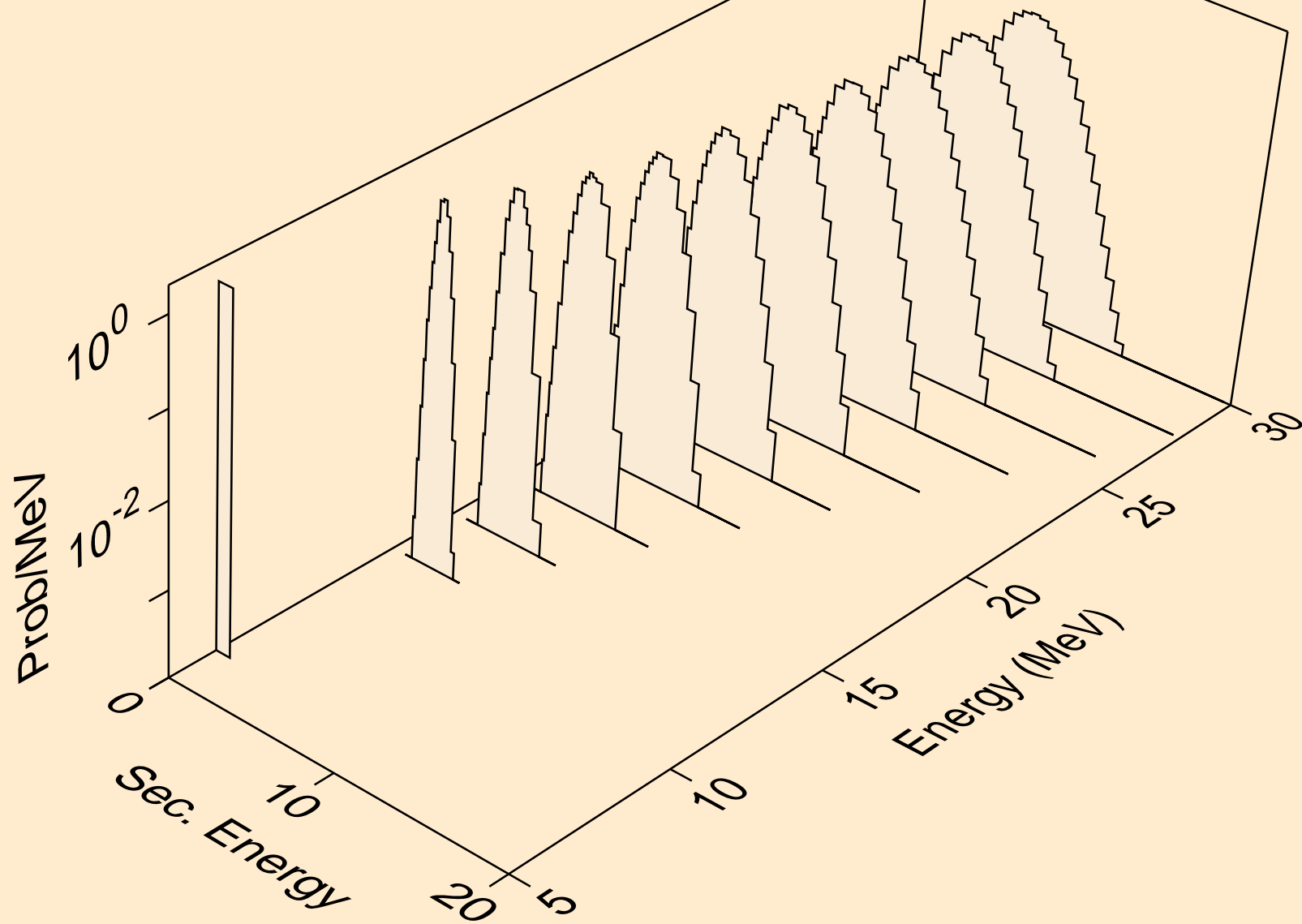

TM160M NEUTRON ACER TENDL-2024 LIBRARY; T=0.K
protons from (n,pt)

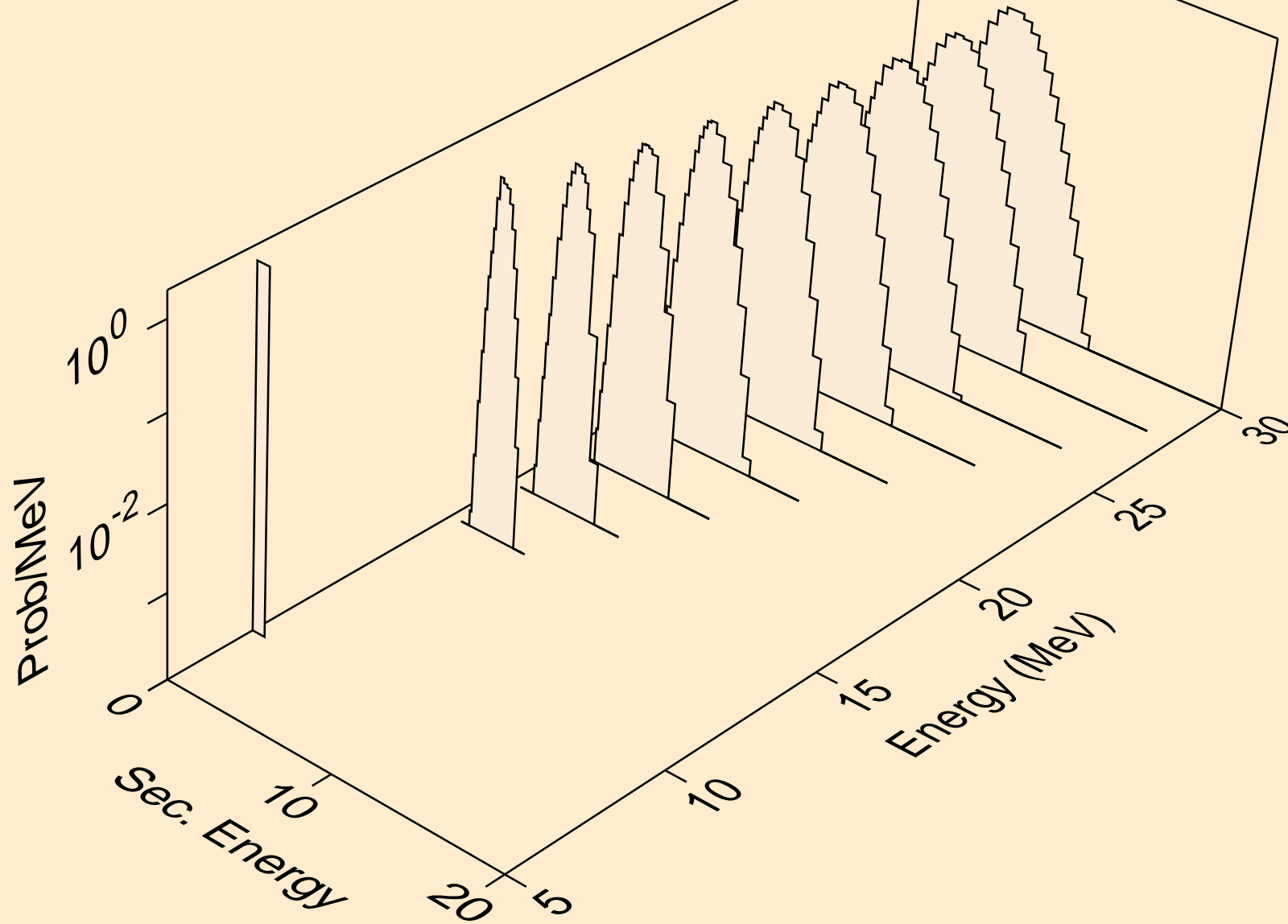

TM160M NEUTRON ACER TENDL-2024 LIBRARY; T=0.K
deuterons from (n,x)

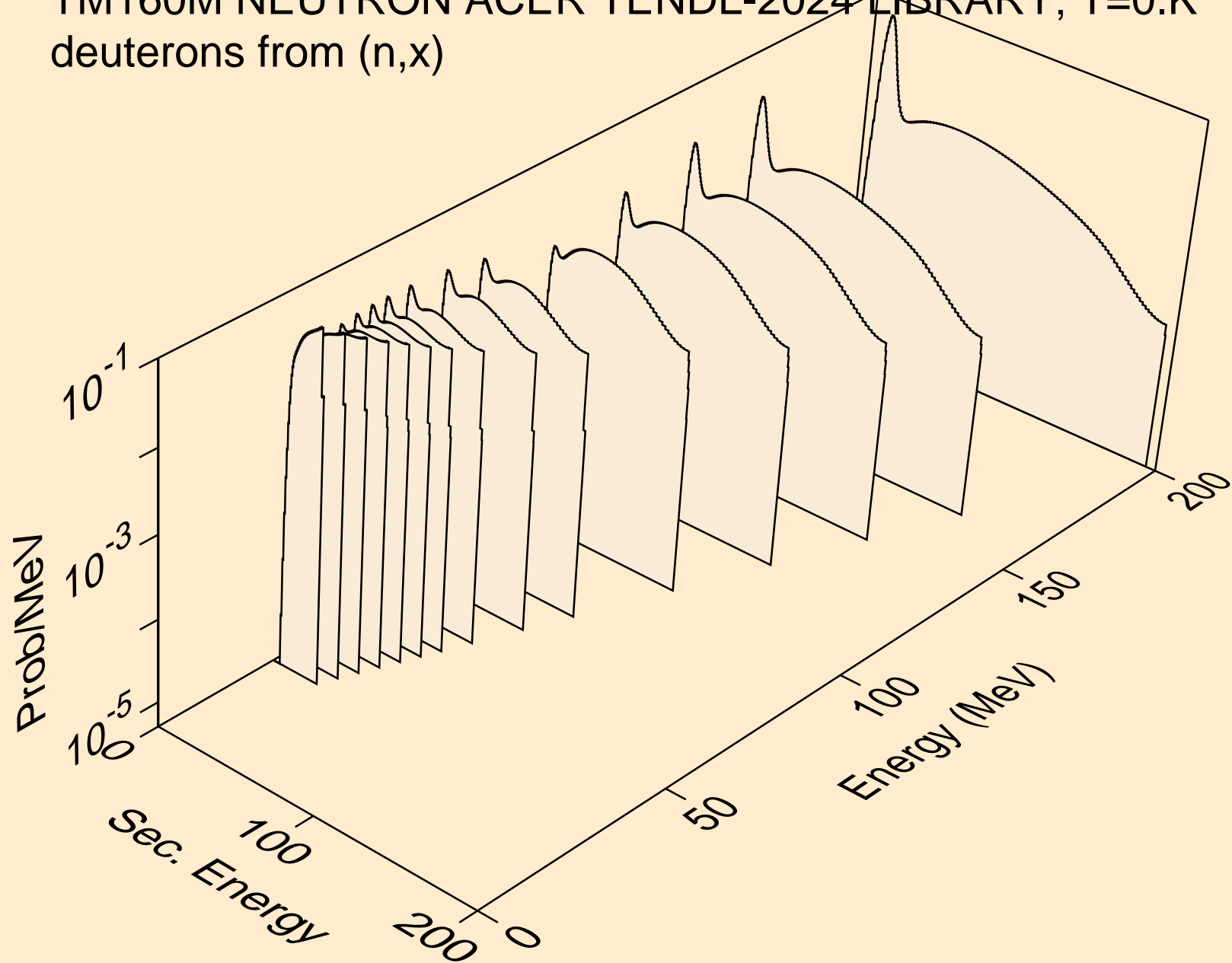

TM160M NEUTRON ACER TENDL-2024 LIBRARY; T=0.K
deuterons from (n,2nd)

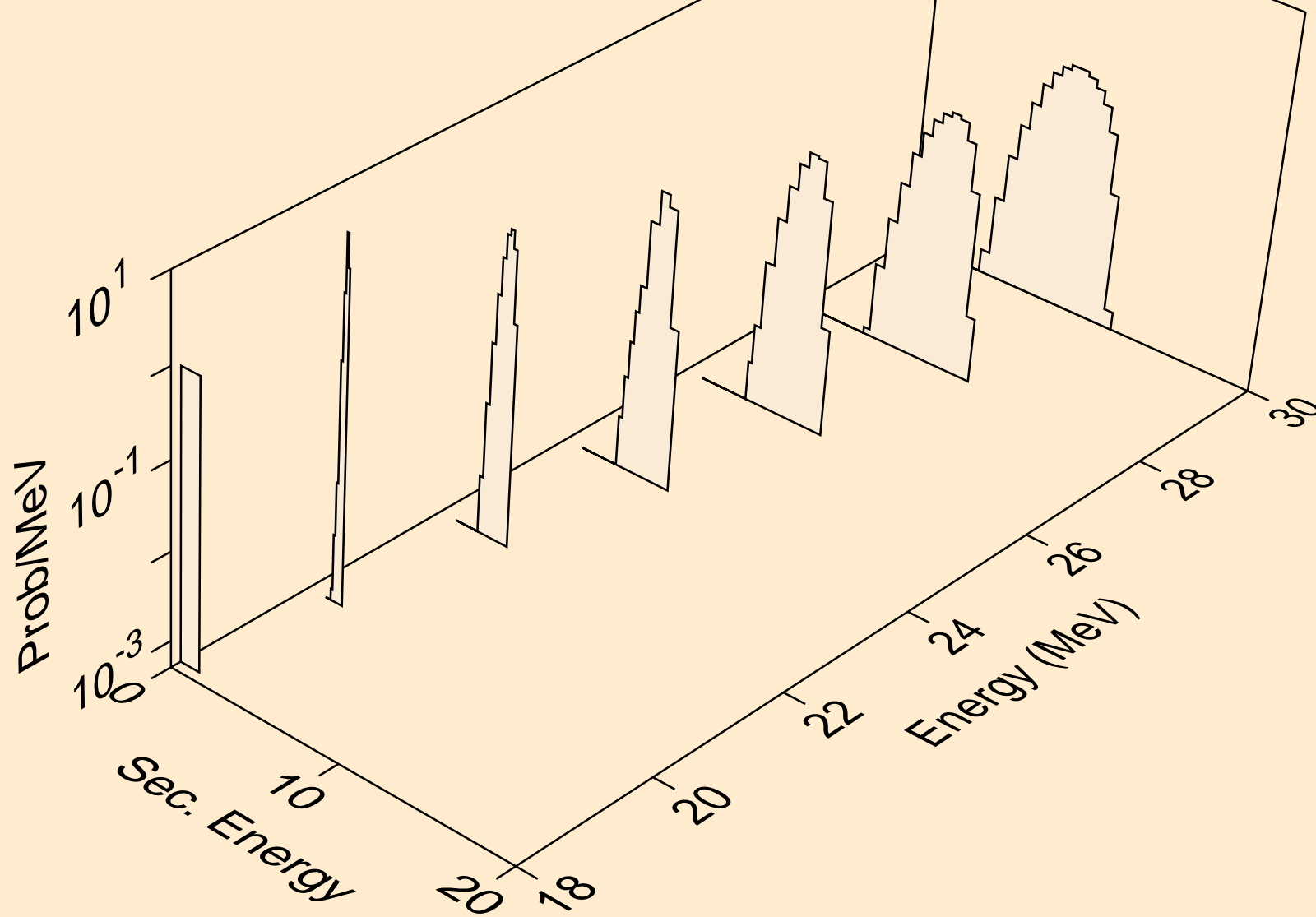

TM160M NEUTRON ACER TENDL-2024 LIBRARY; T=0.K
deuterons from (n,n*)d

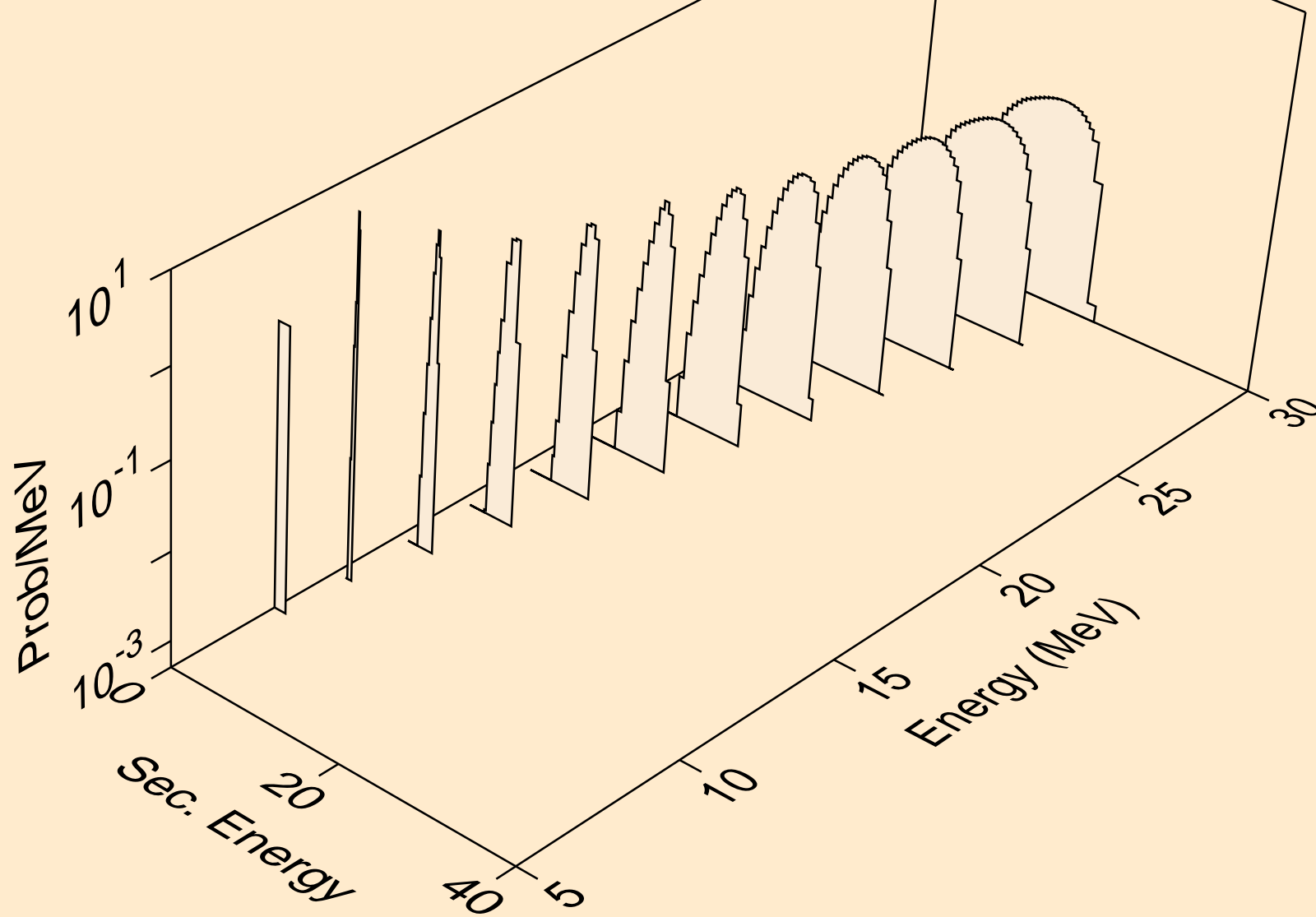

TM160M NEUTRON ACER TENDL-2024 LIBRARY; T=0.K
deuterons from (n,d)

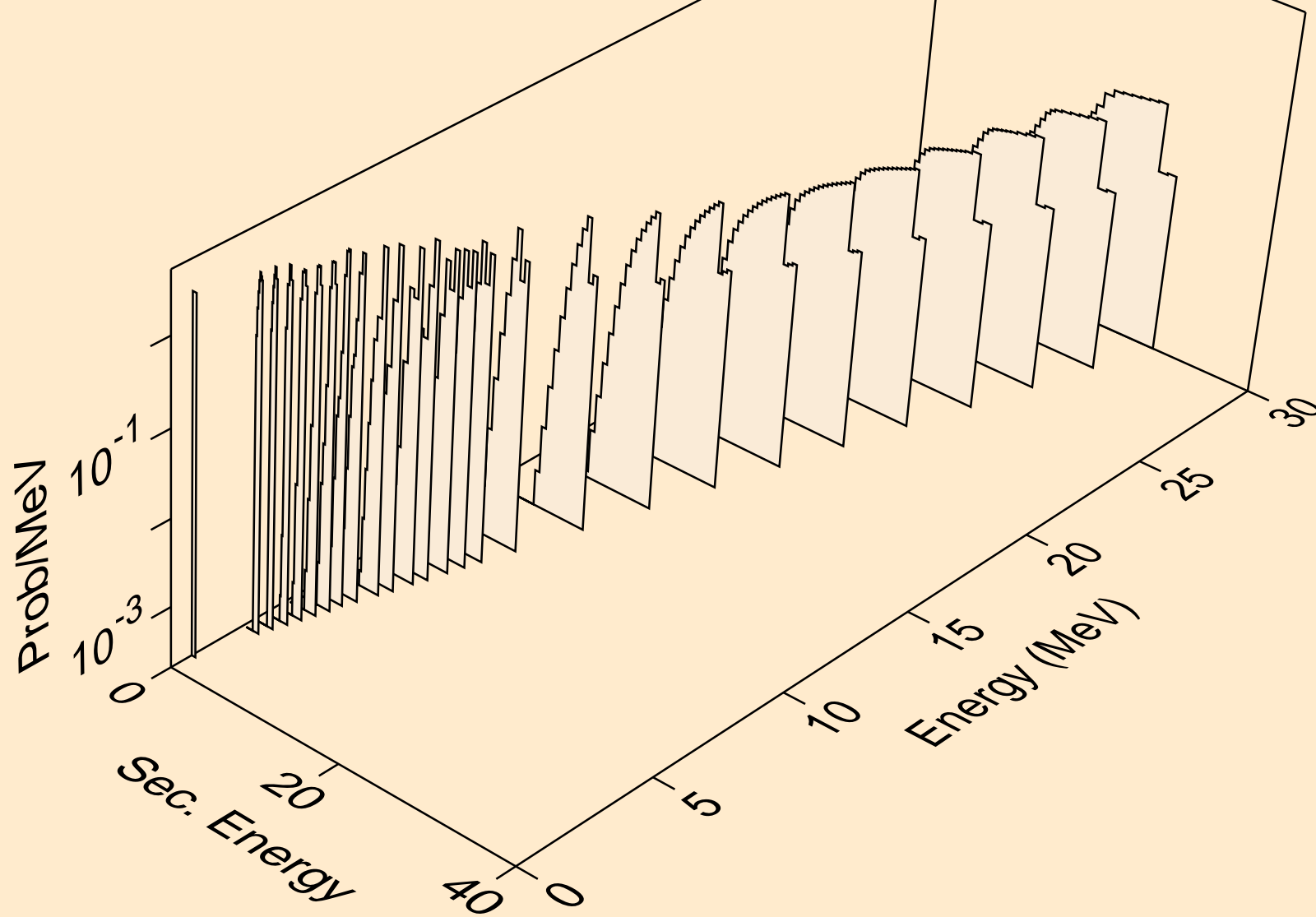

TM160M NEUTRON ACER TENDL-2024 LIBRARY; T=0.K
deuterons from (n,pd)

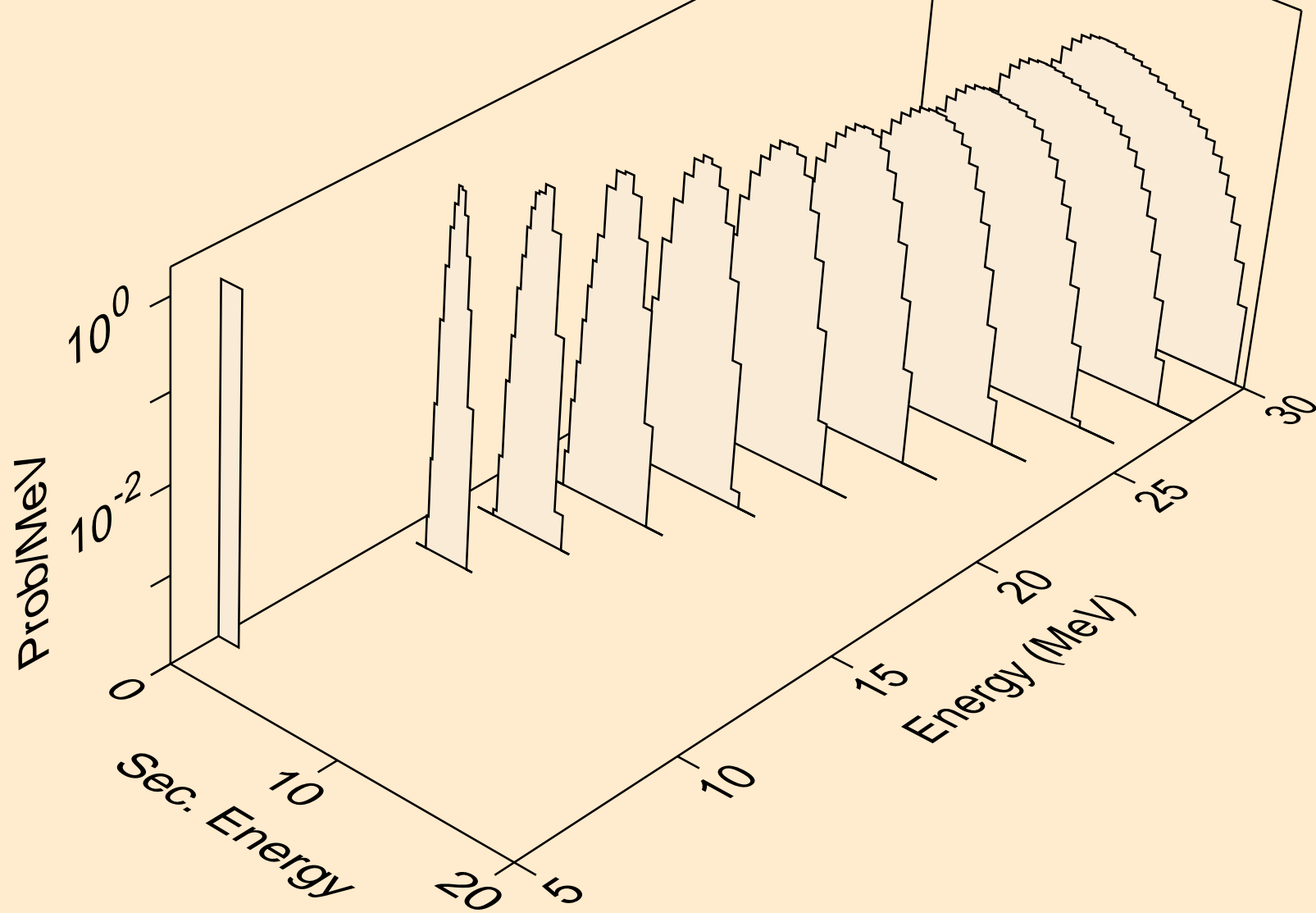

TM160M NEUTRON ACER TENDL-2024 LIBRARY; T=0.K
deuterons from (n,da)

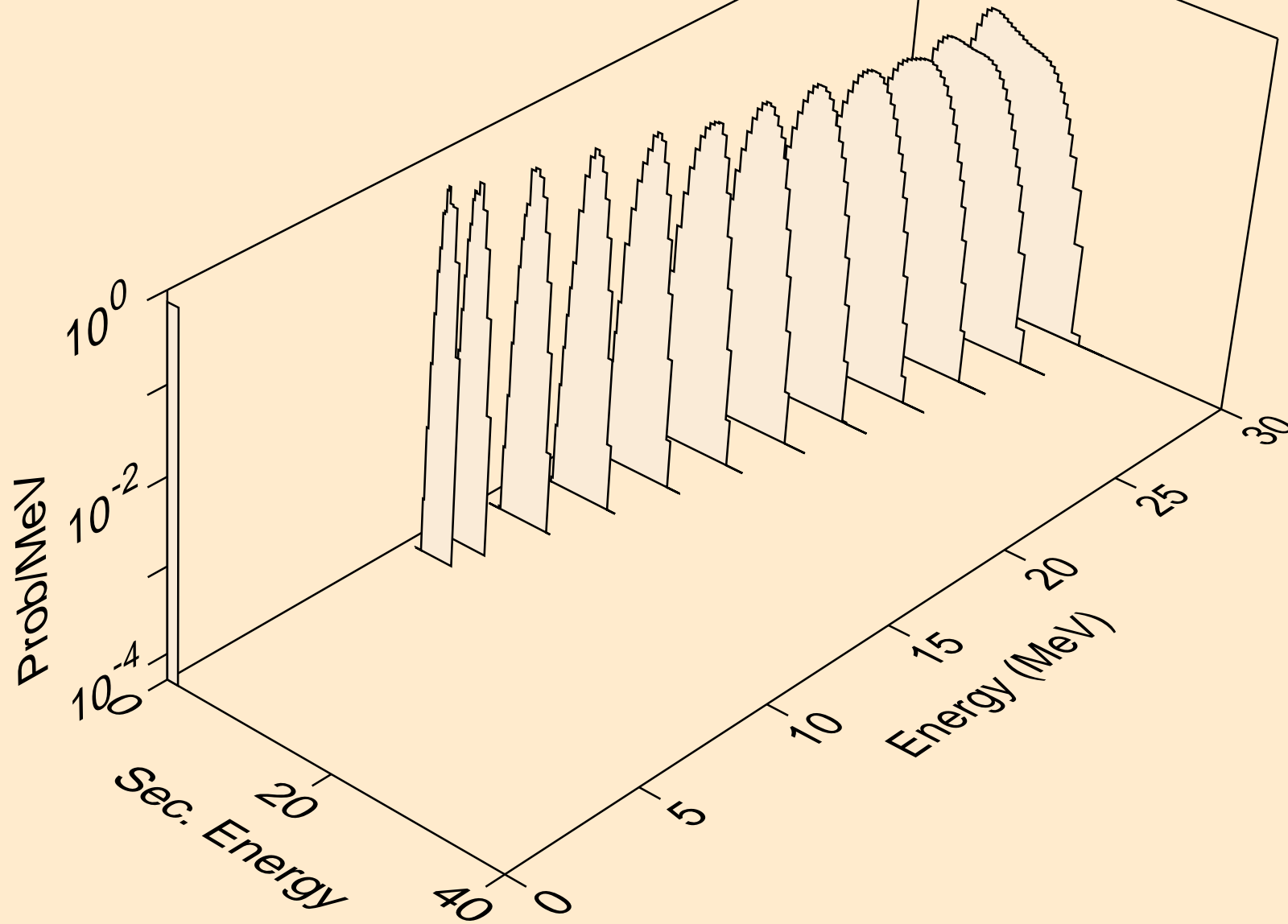

TM160M NEUTRON ACER TENDL-2024 LIBRARY; T=0.K
tritons from (n,x)

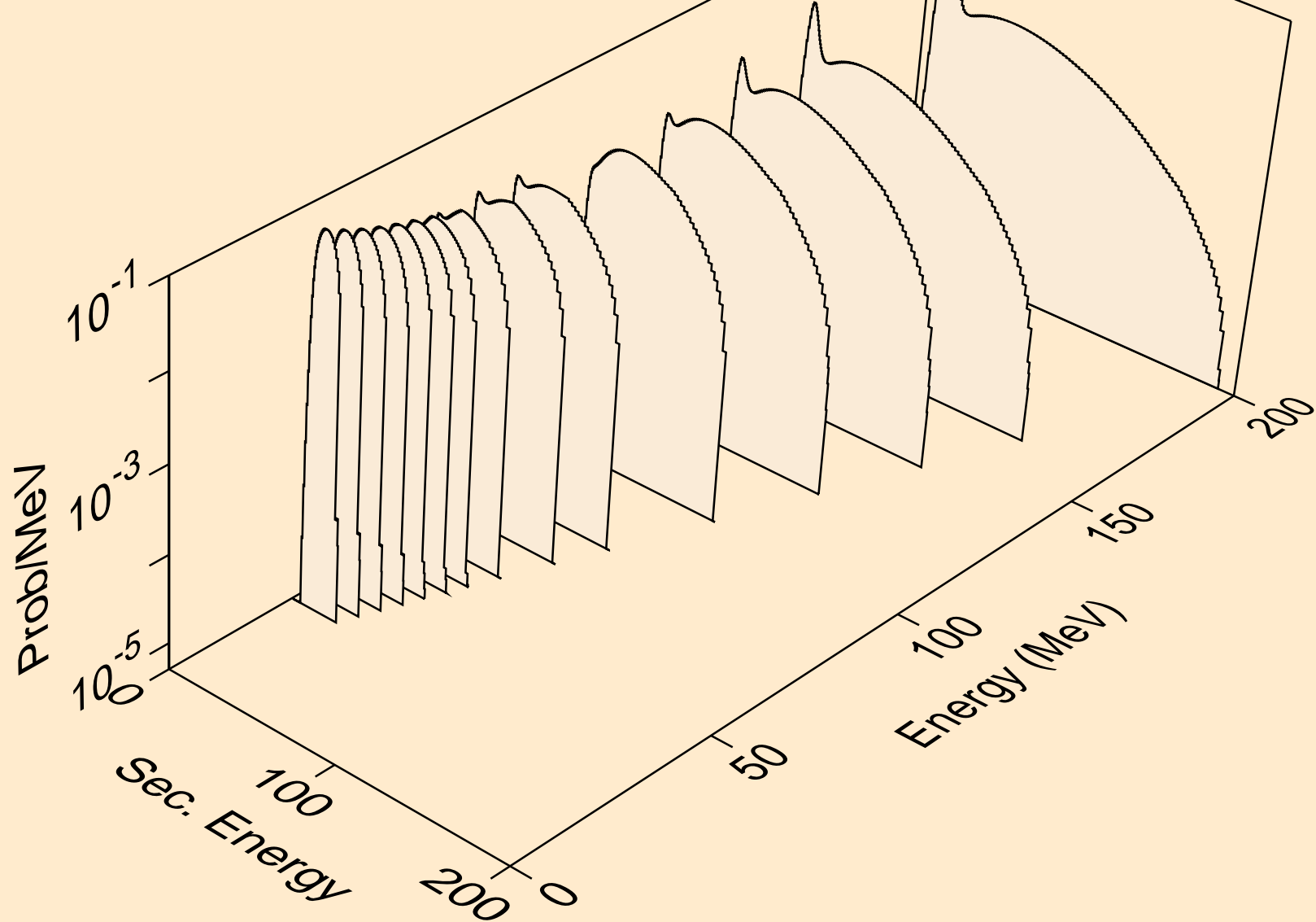

TM160M NEUTRON ACER TENDL-2024 LIBRARY; T=0.K
tritons from (n,n*)t

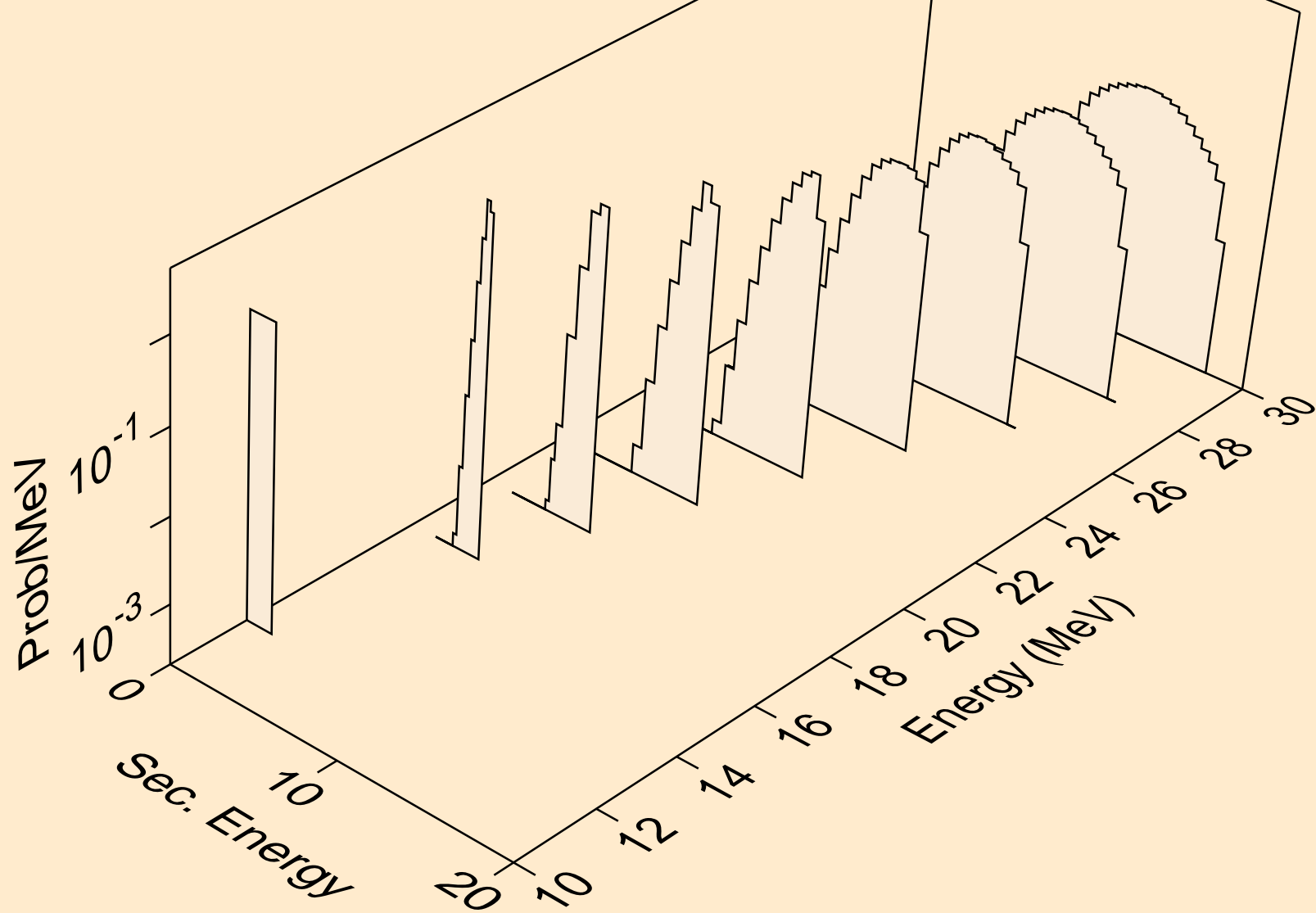

TM160M NEUTRON ACER TENDL-2024 LIBRARY; T=0.K
tritons from (n,t)

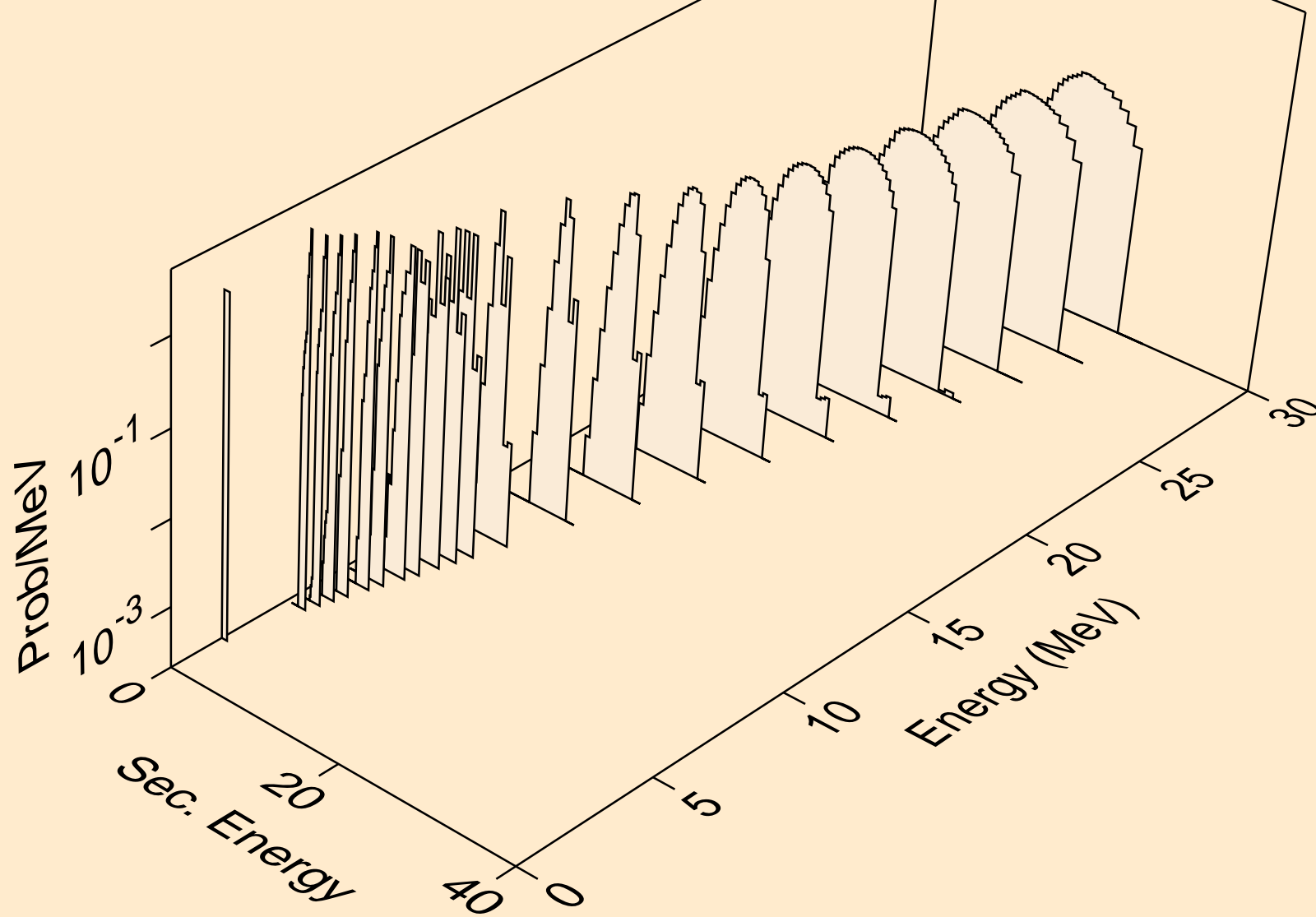

TM160M NEUTRON ACER TENDL-2024 LIBRARY; T=0.K
tritons from (n,pt)

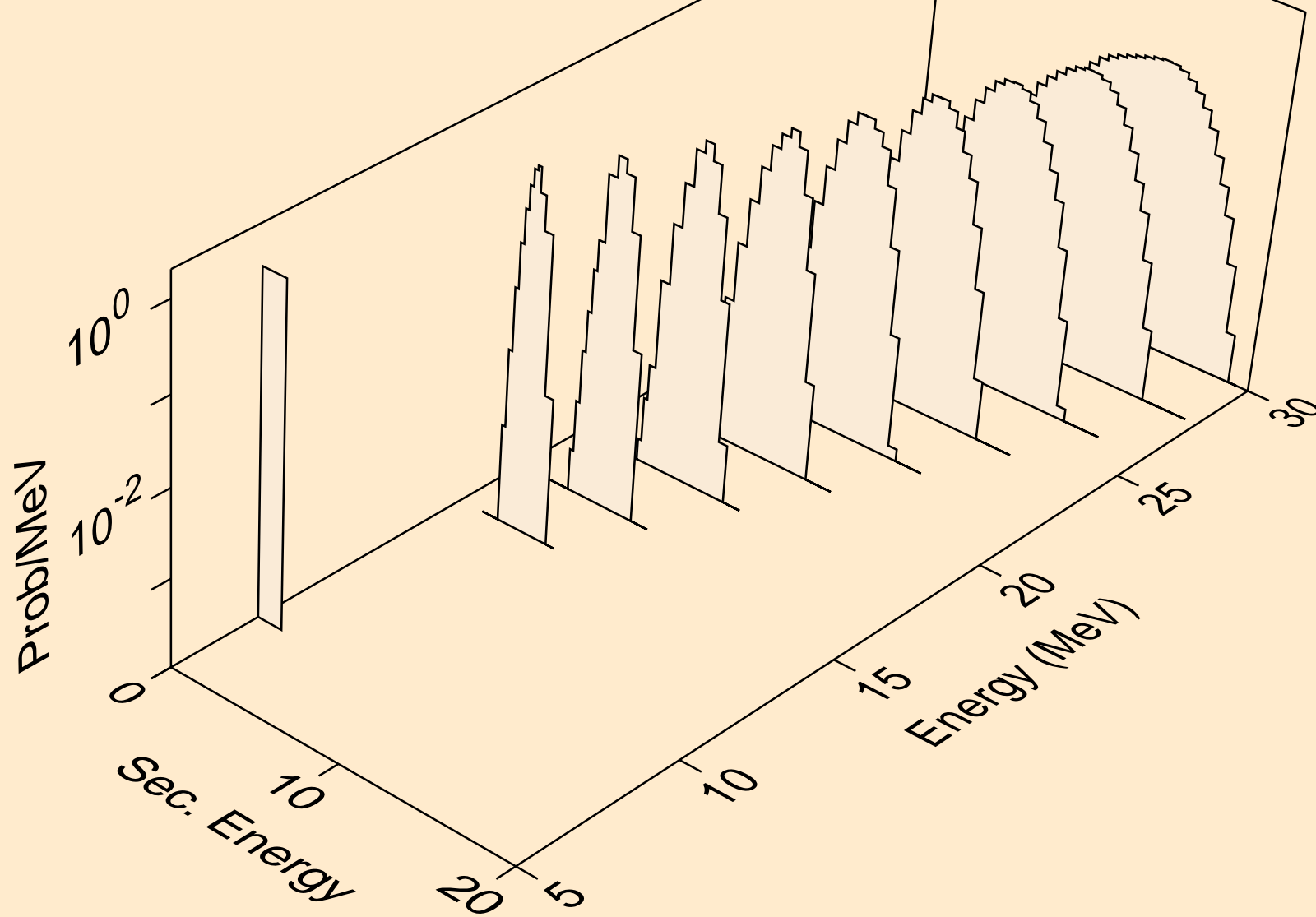

TM160M NEUTRON ACER TENDL-2024 LIBRARY; T=0.K
he3s from (n,x)

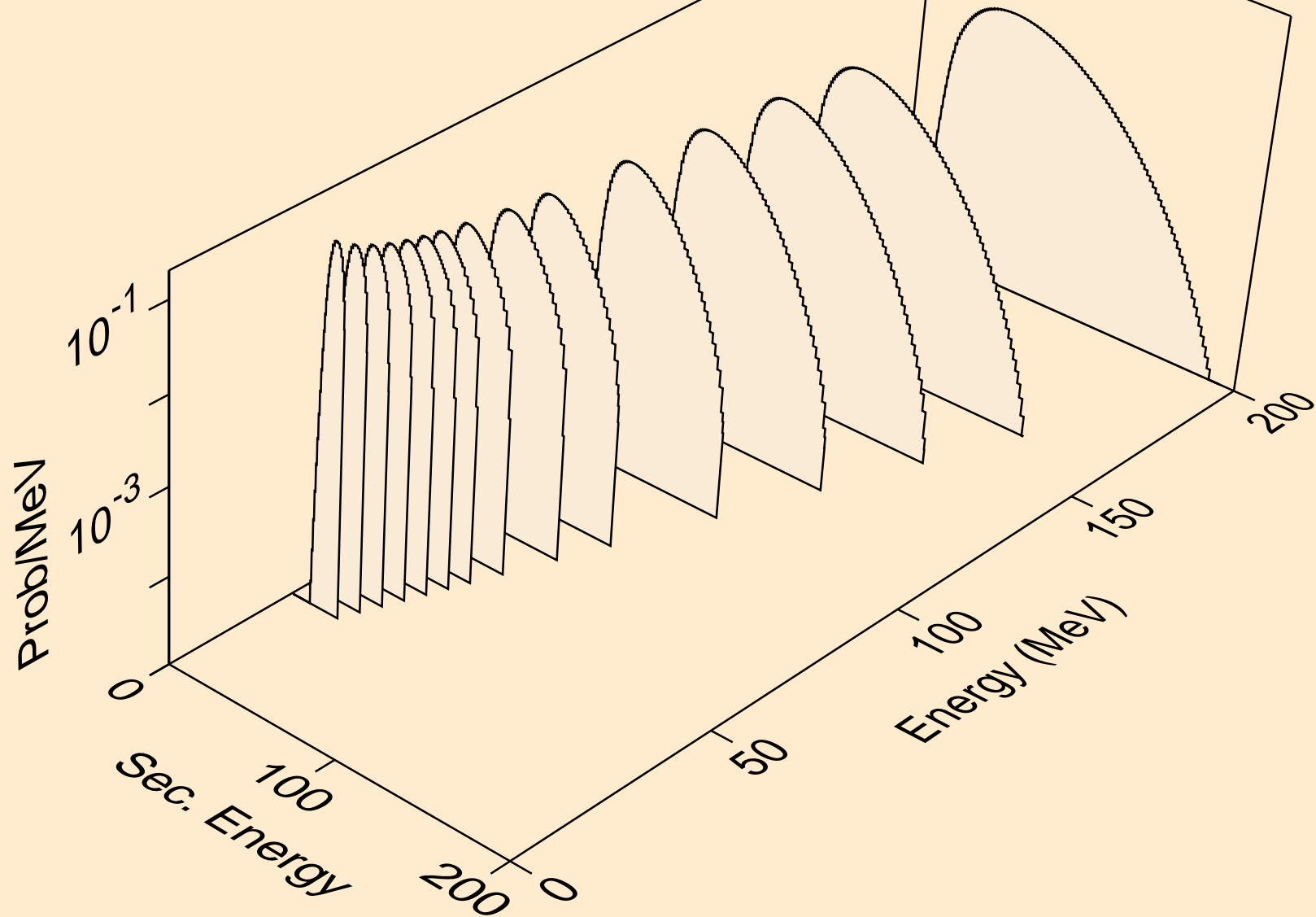

TM160M NEUTRON ACER TENDL-2024 LIBRARY; T=0.K
he3s from (n,n*)he3

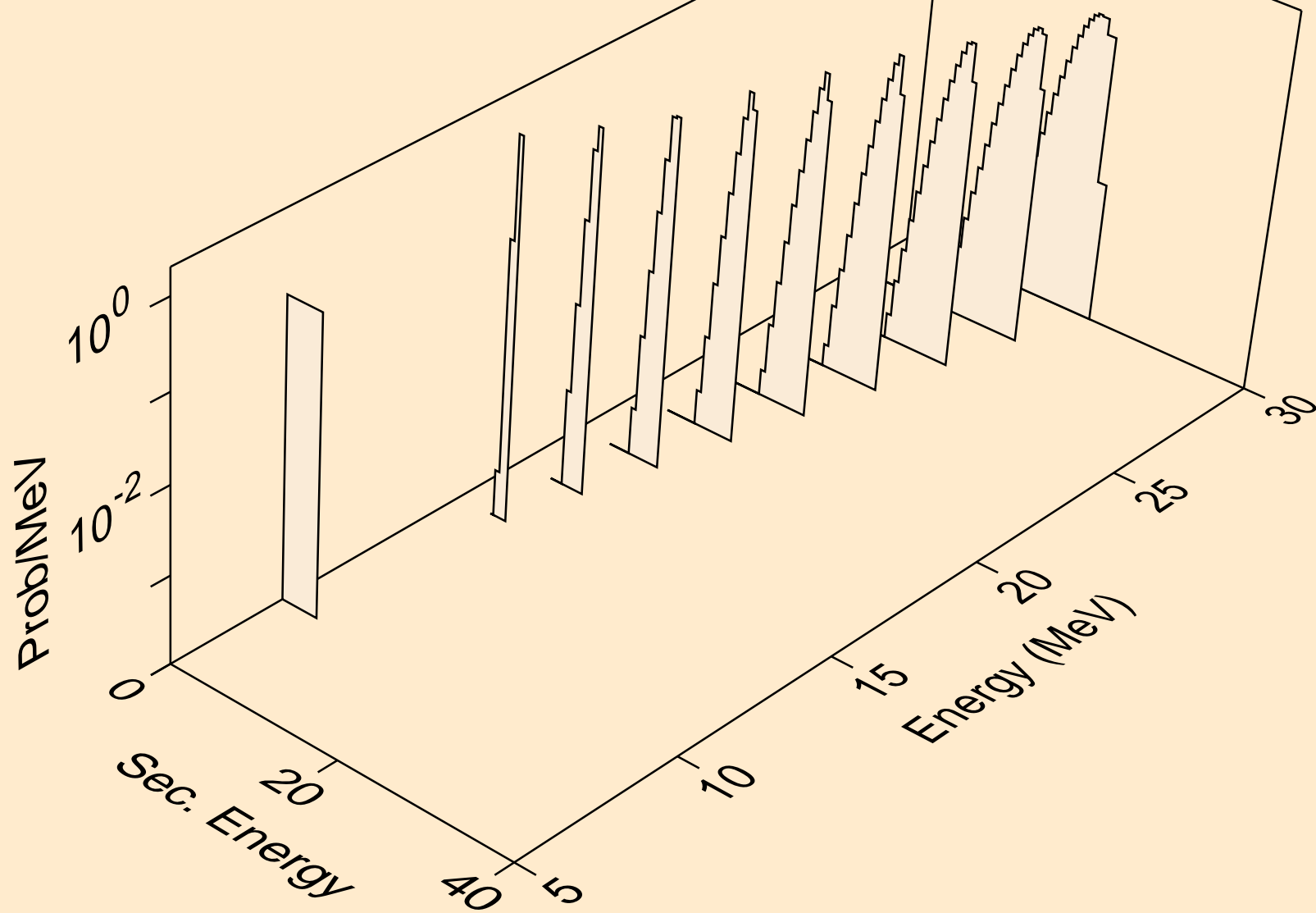

TM160M NEUTRON ACER TENDL-2024 LIBRARY; T=0.K
he3s from (n,he3)

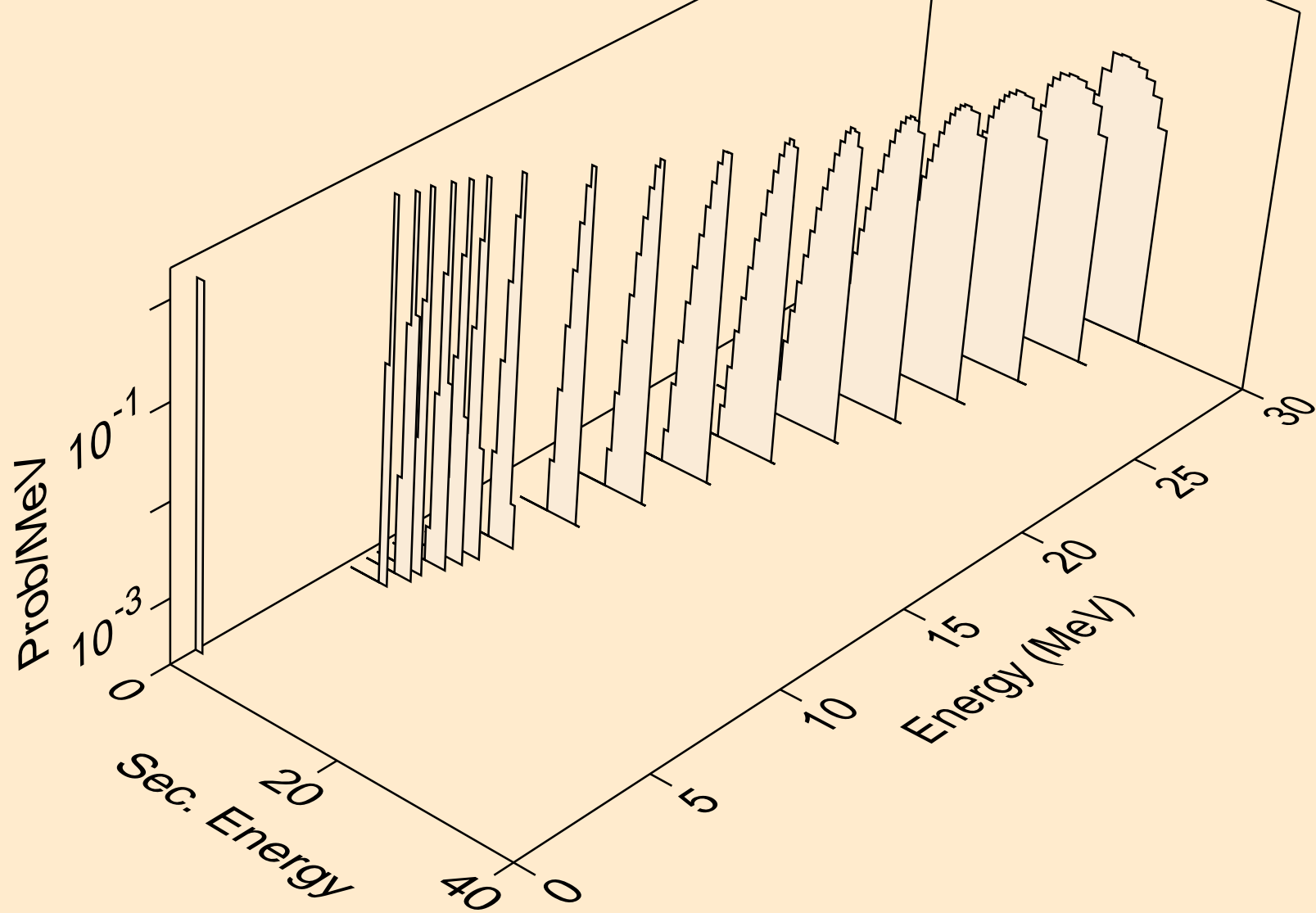

TM160M NEUTRON ACER TENDL-2024 LIBRARY; T=0.K
alphas from (n,x)

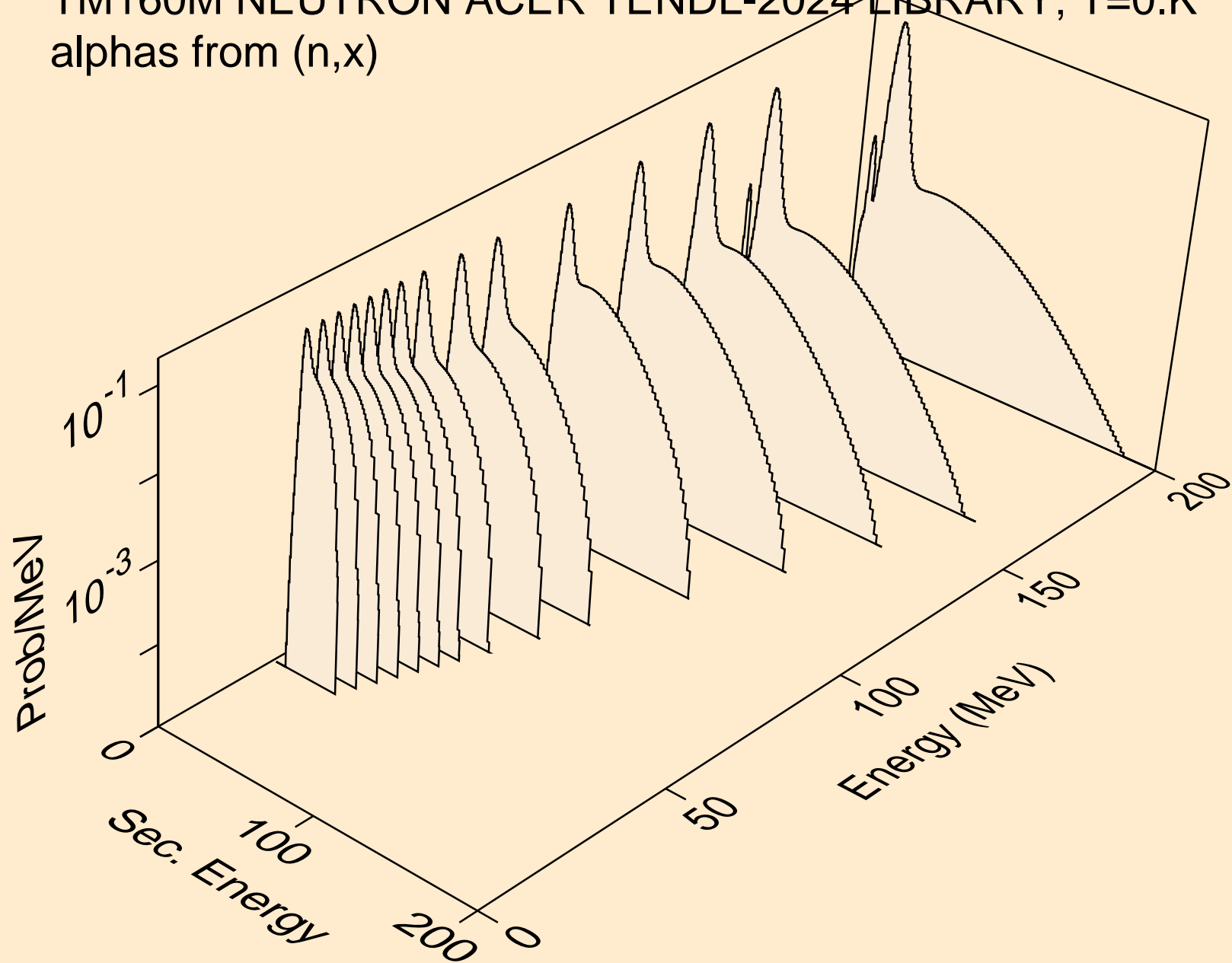

TM160M NEUTRON ACER TENDL-2024 LIBRARY; T=0.K
alphas from (n,n*)a

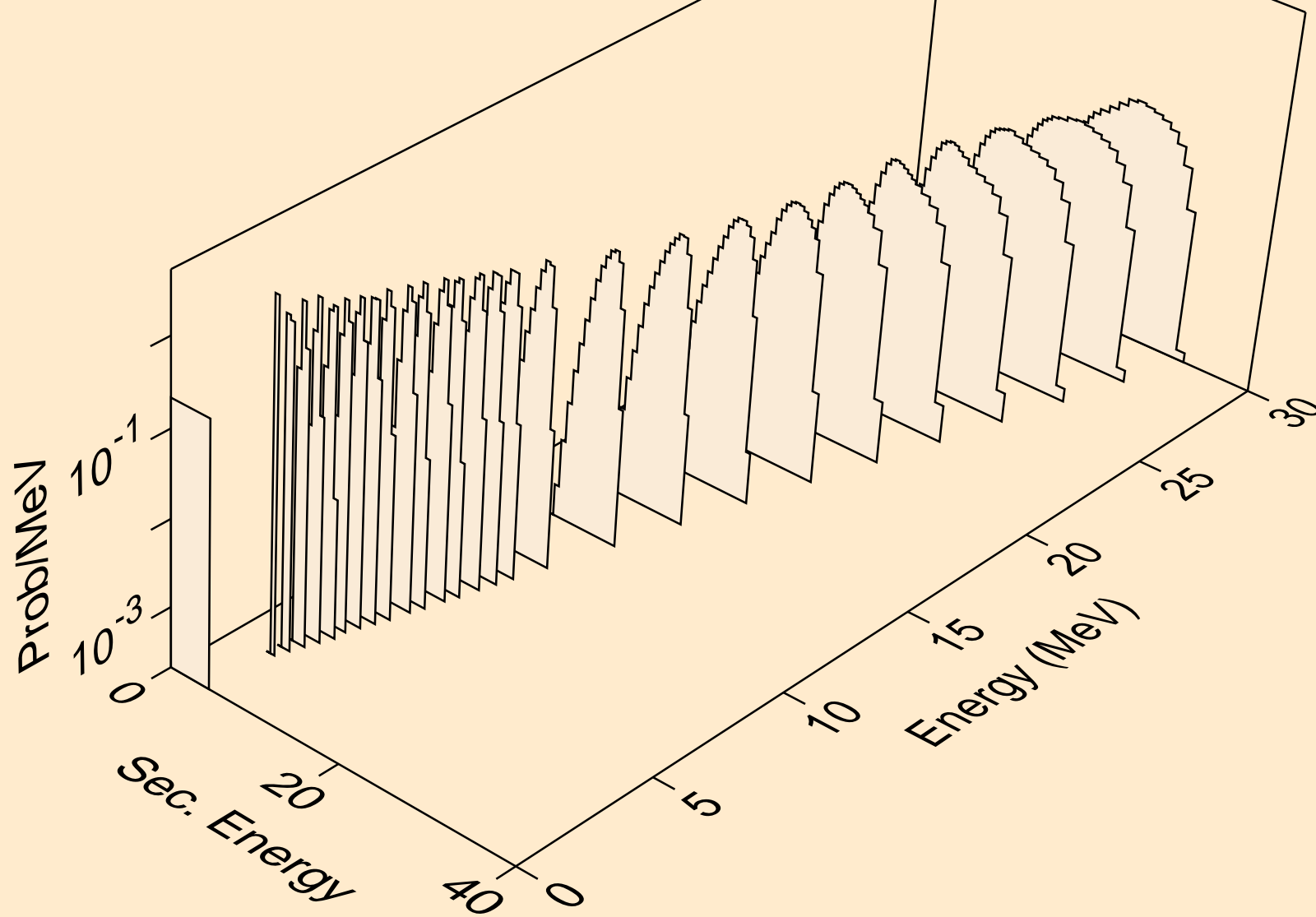

TM160M NEUTRON ACER TENDL-2024 LIBRARY; T=0.K
alphas from (n,2n)a

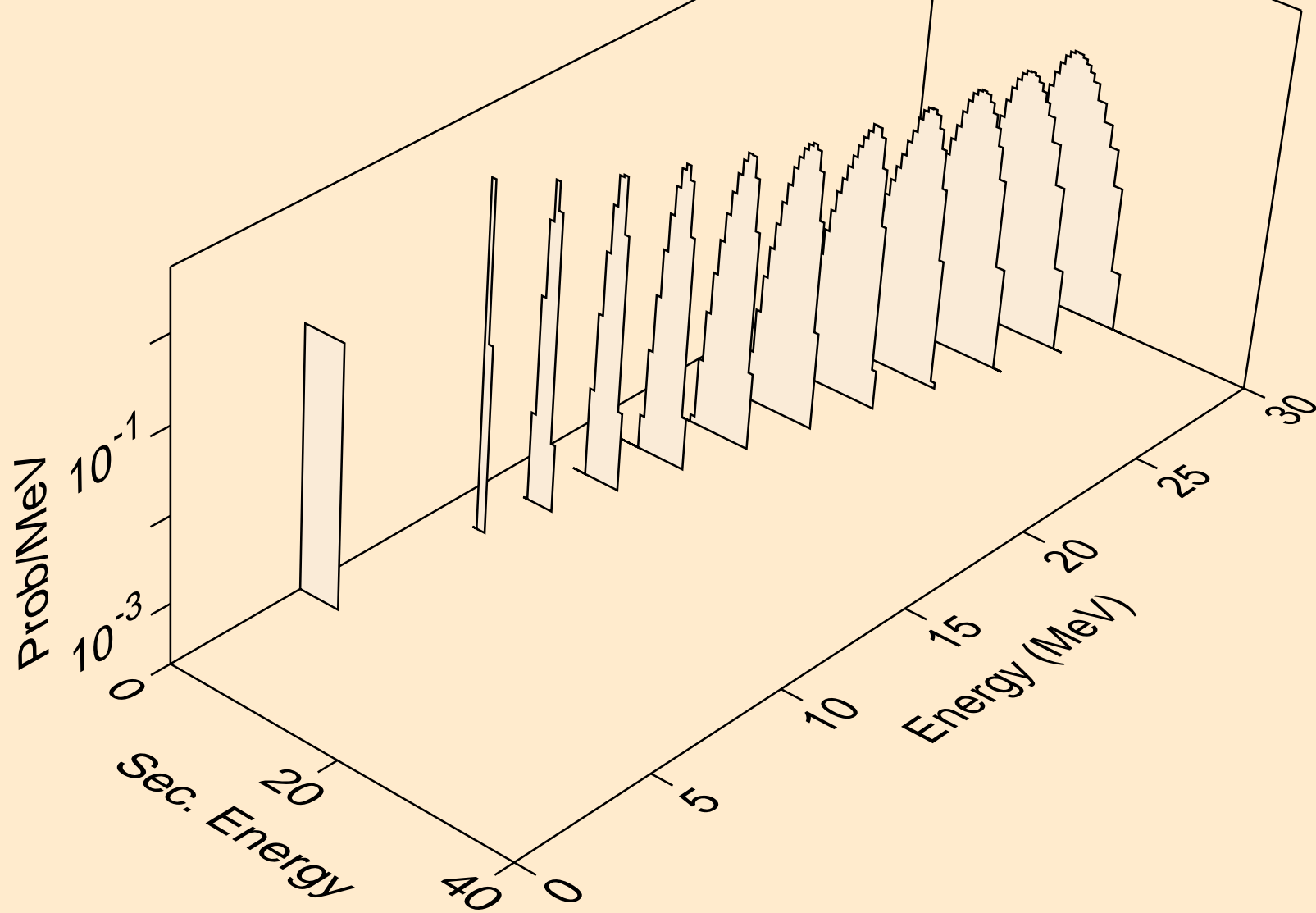

TM160M NEUTRON ACER TENDL-2024 LIBRARY; T=0.K
alphas from (n,3n)a

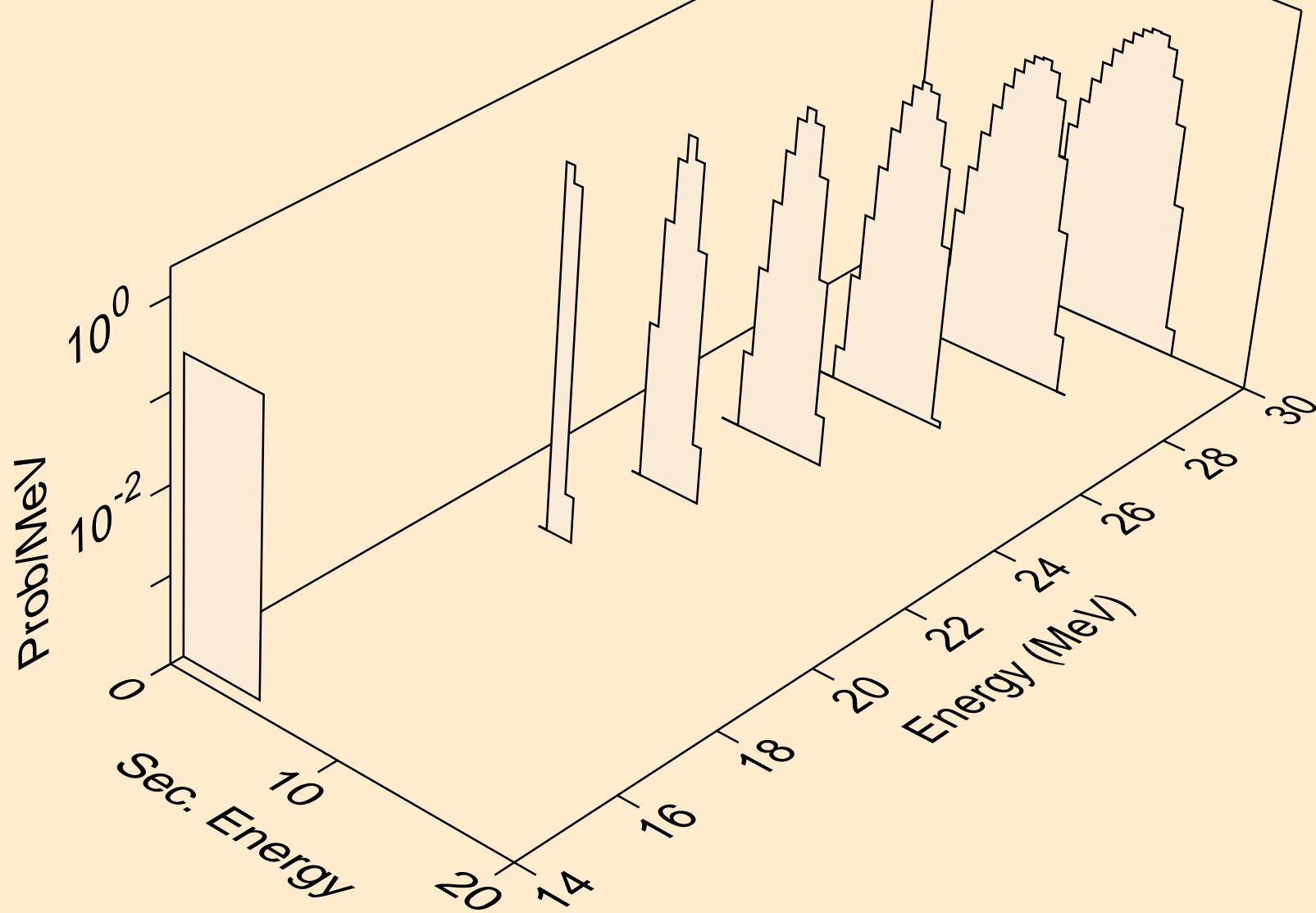

TM160M NEUTRON ACER TENDL-2024 LIBRARY; T=0.K
alphas from (n,n*)2a

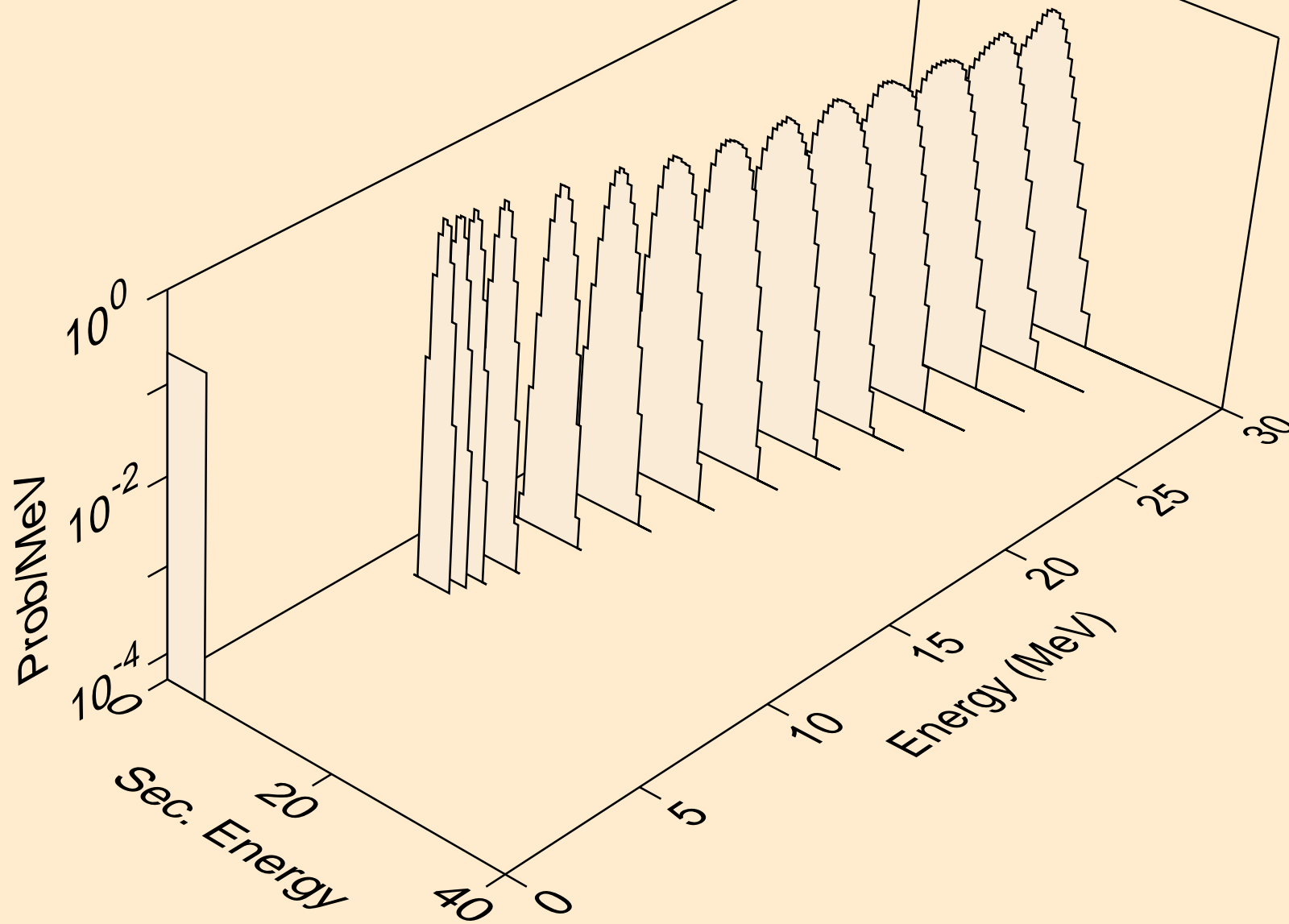

TM160M NEUTRON ACER TENDL-2024 LIBRARY; T=0.K
alphas from (n,2n)2a

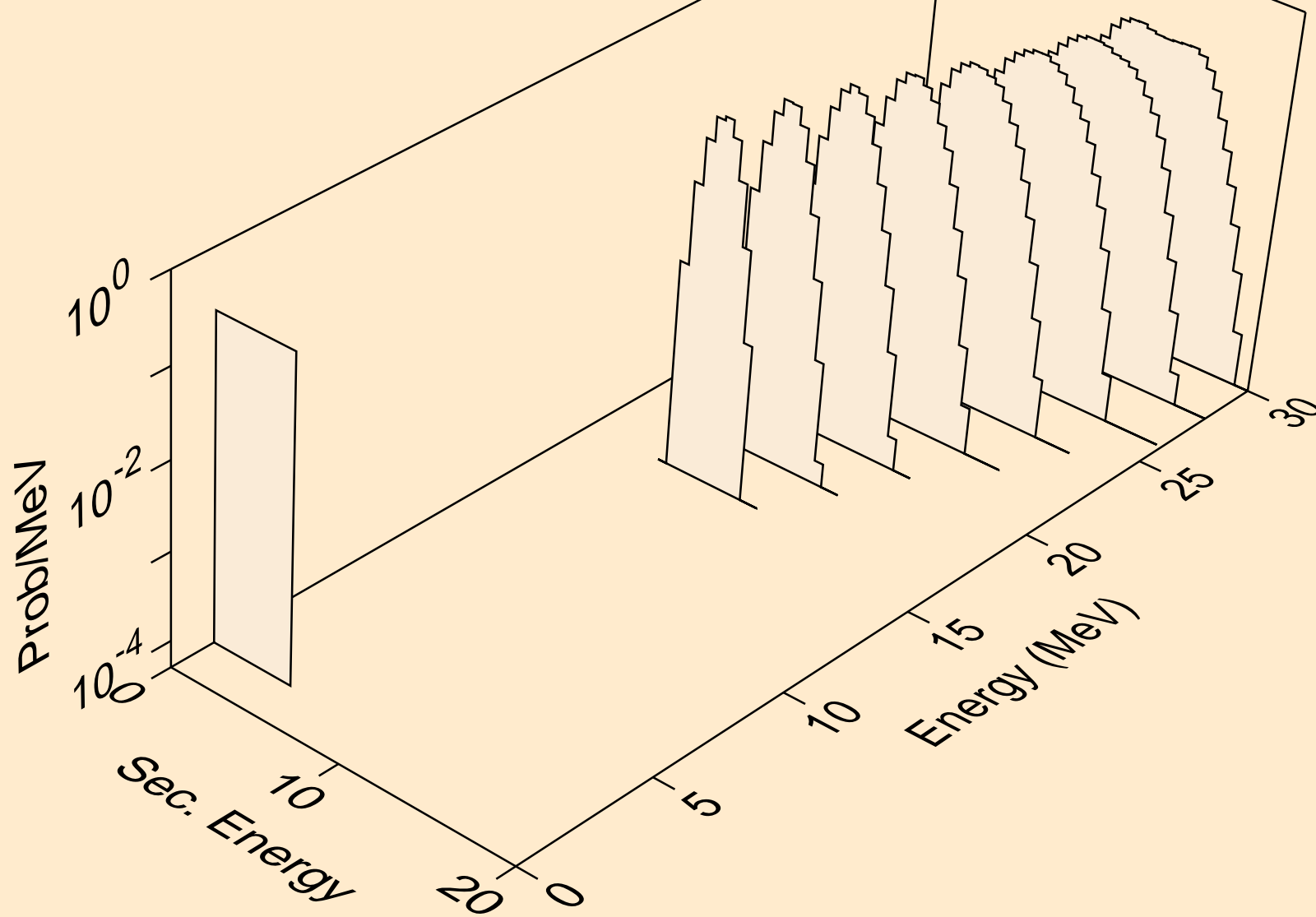

TM160M NEUTRON ACER TENDL-2024 LIBRARY; T=0.K
alphas from (n,npa)

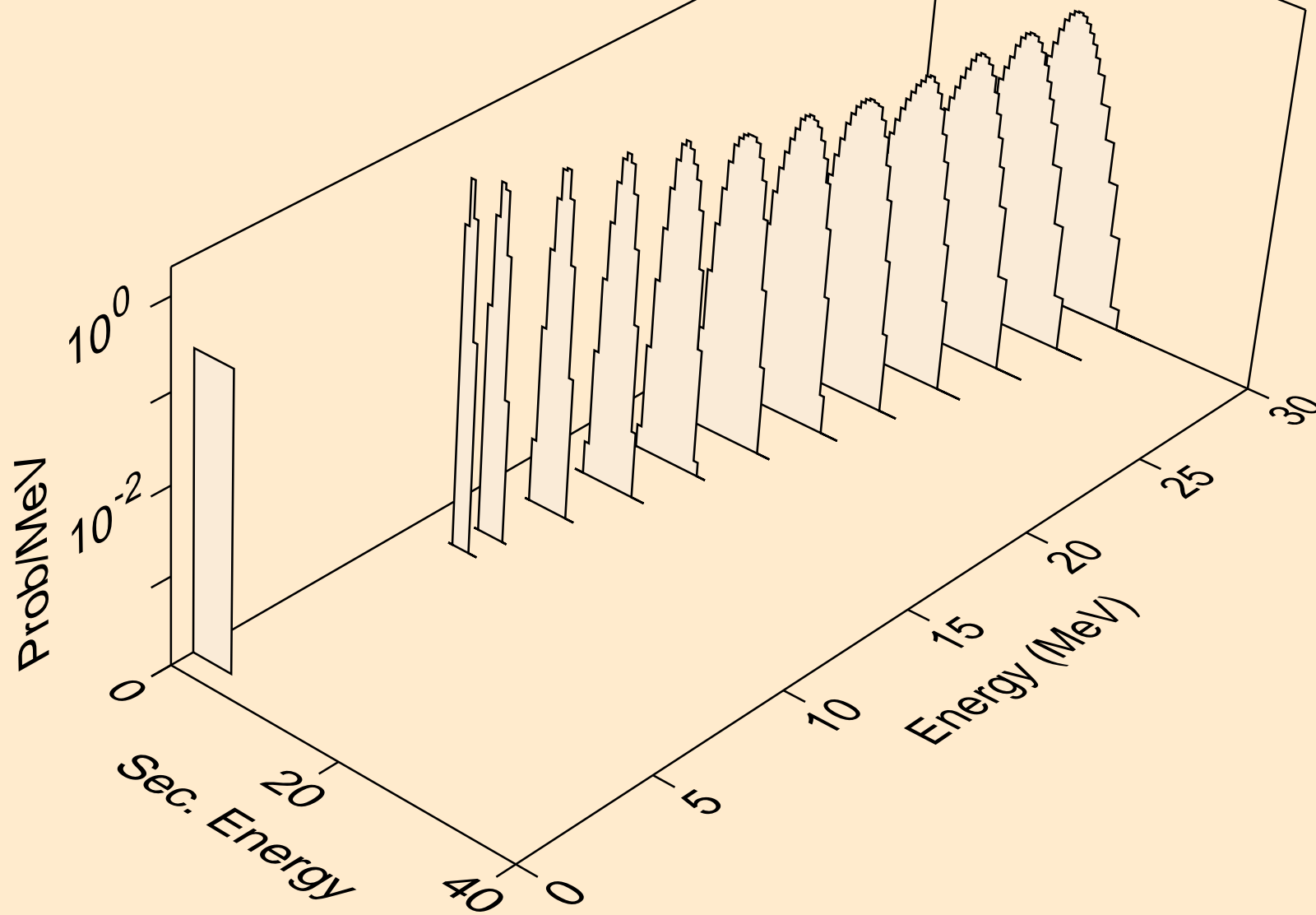

TM160M NEUTRON ACER TENDL-2024 LIBRARY; T=0.K
alphas from (n,a)

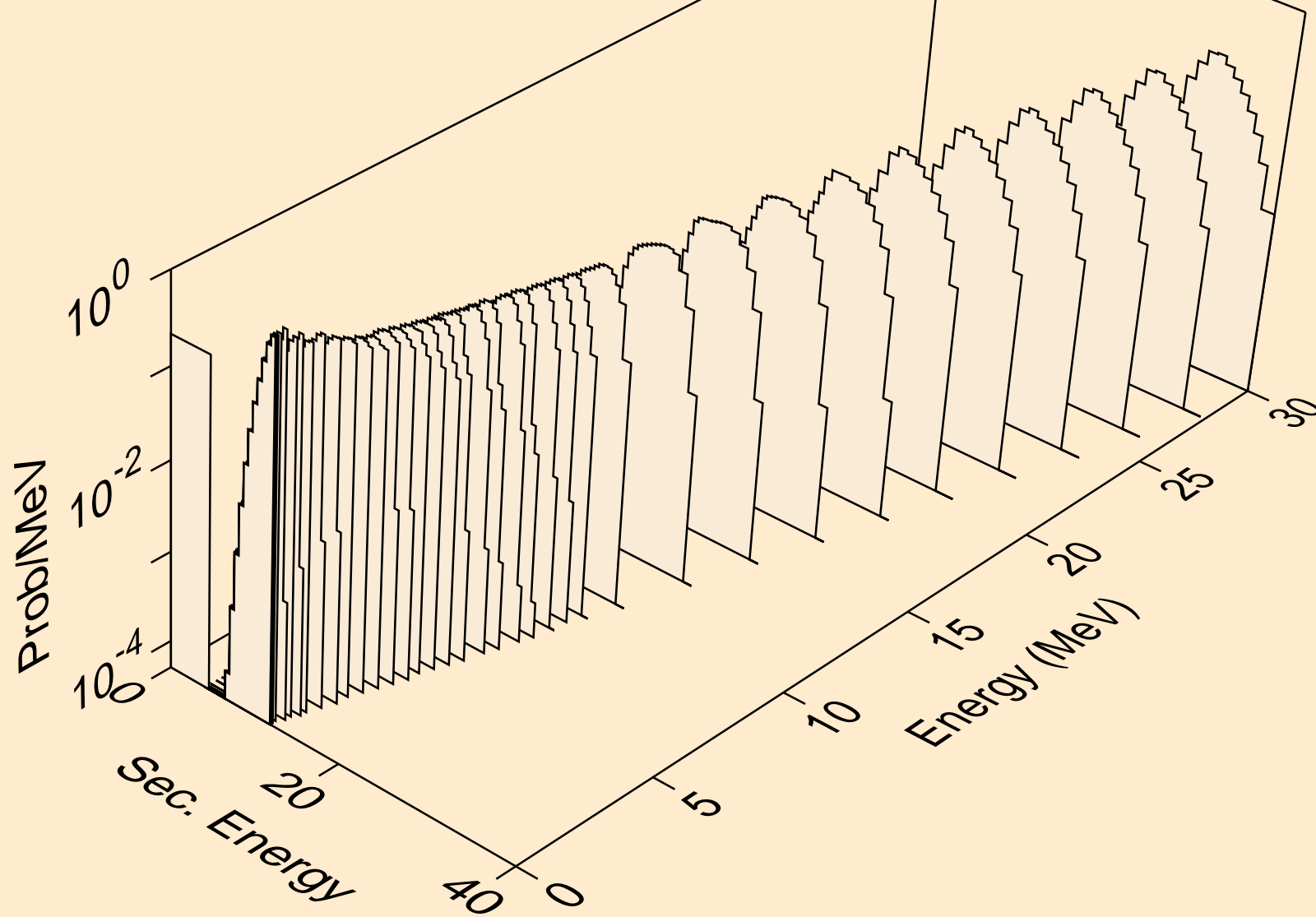

TM160M NEUTRON ACER TENDL-2024 LIBRARY; T=0.K
alphas from (n,2a)

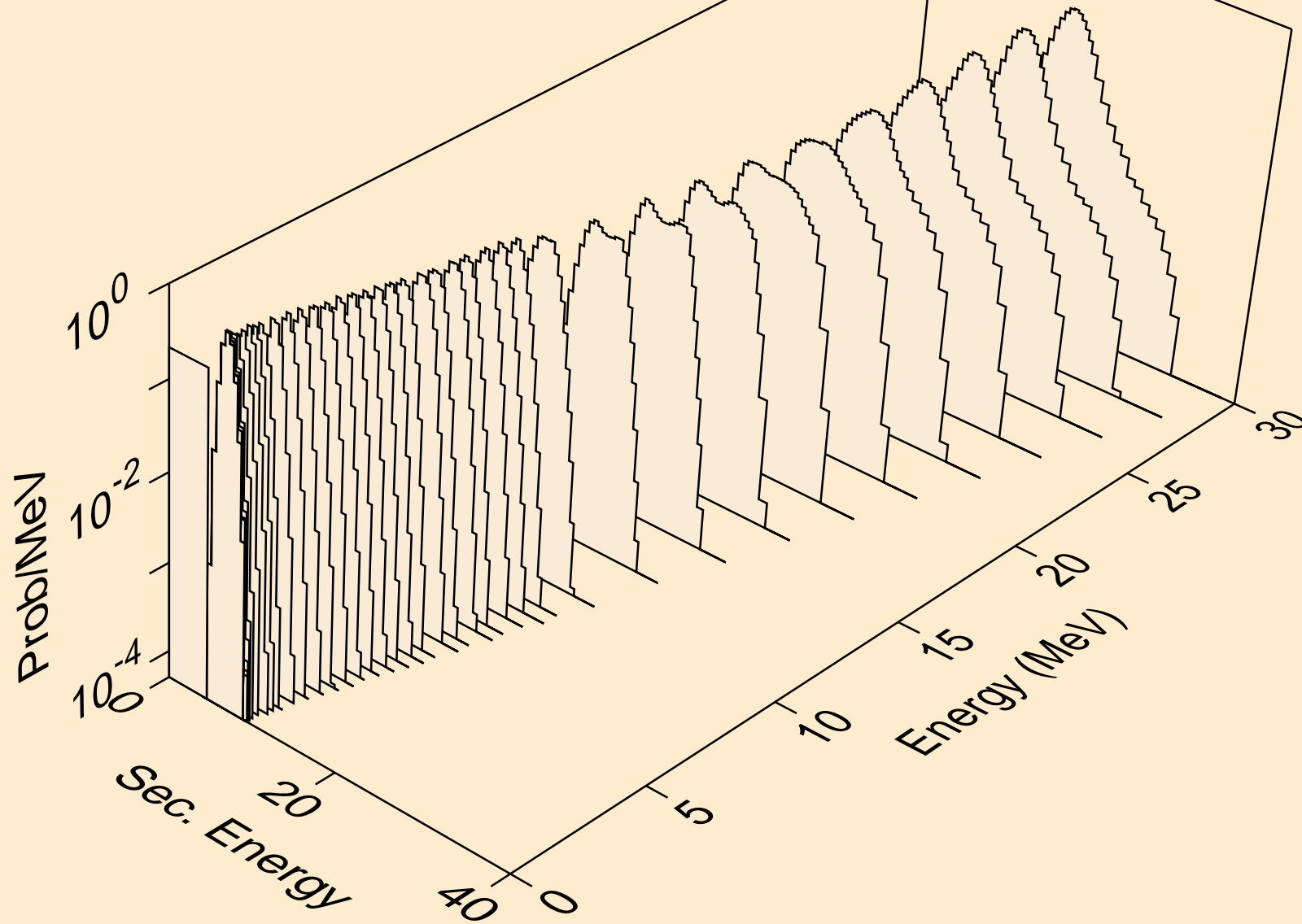

TM160M NEUTRON ACER TENDL-2024 LIBRARY; T=0.K
alphas from (n,3a)

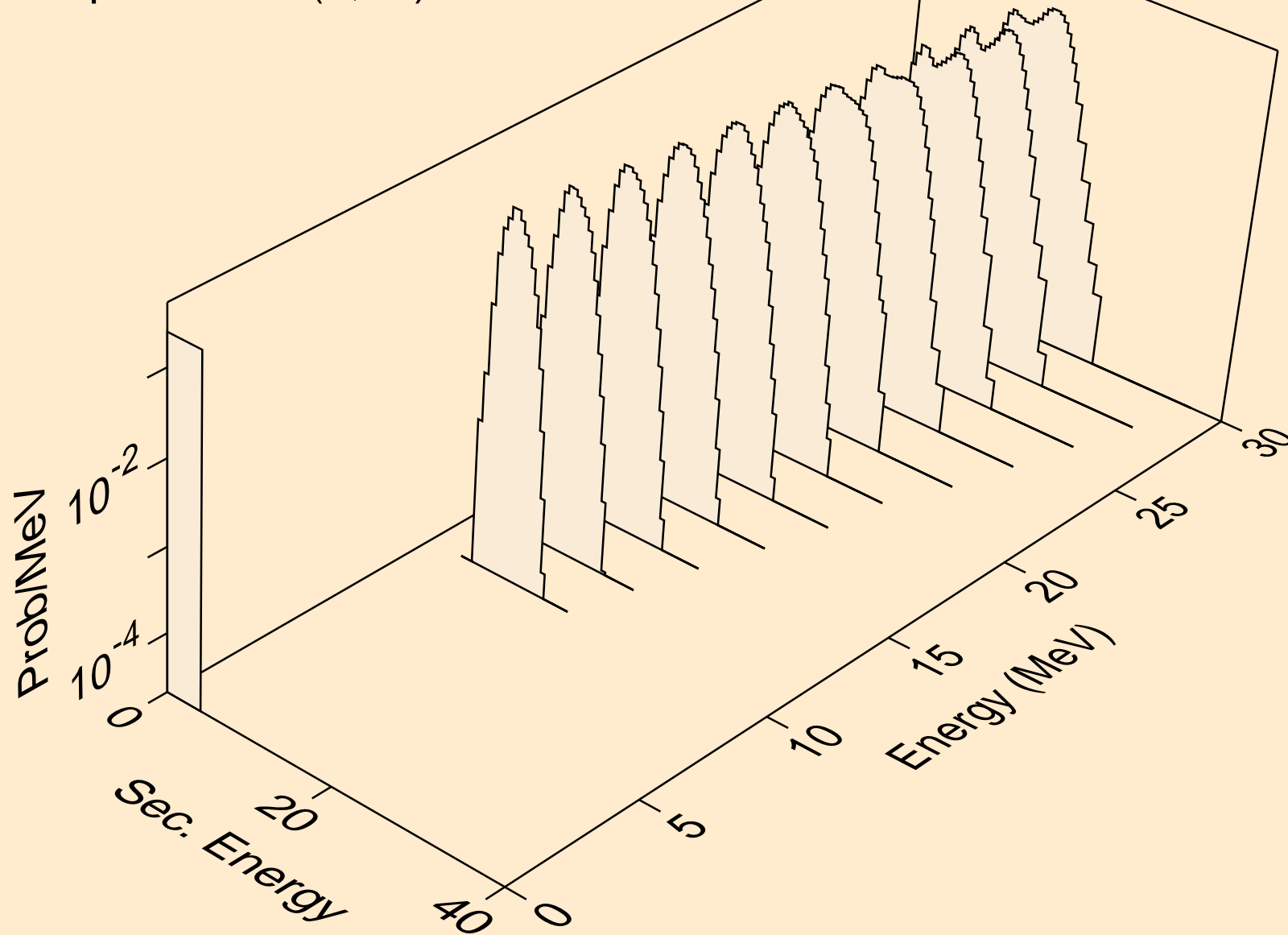

TM160M NEUTRON ACER TENDL-2024 LIBRARY; T=0.K
alphas from (n,pa)

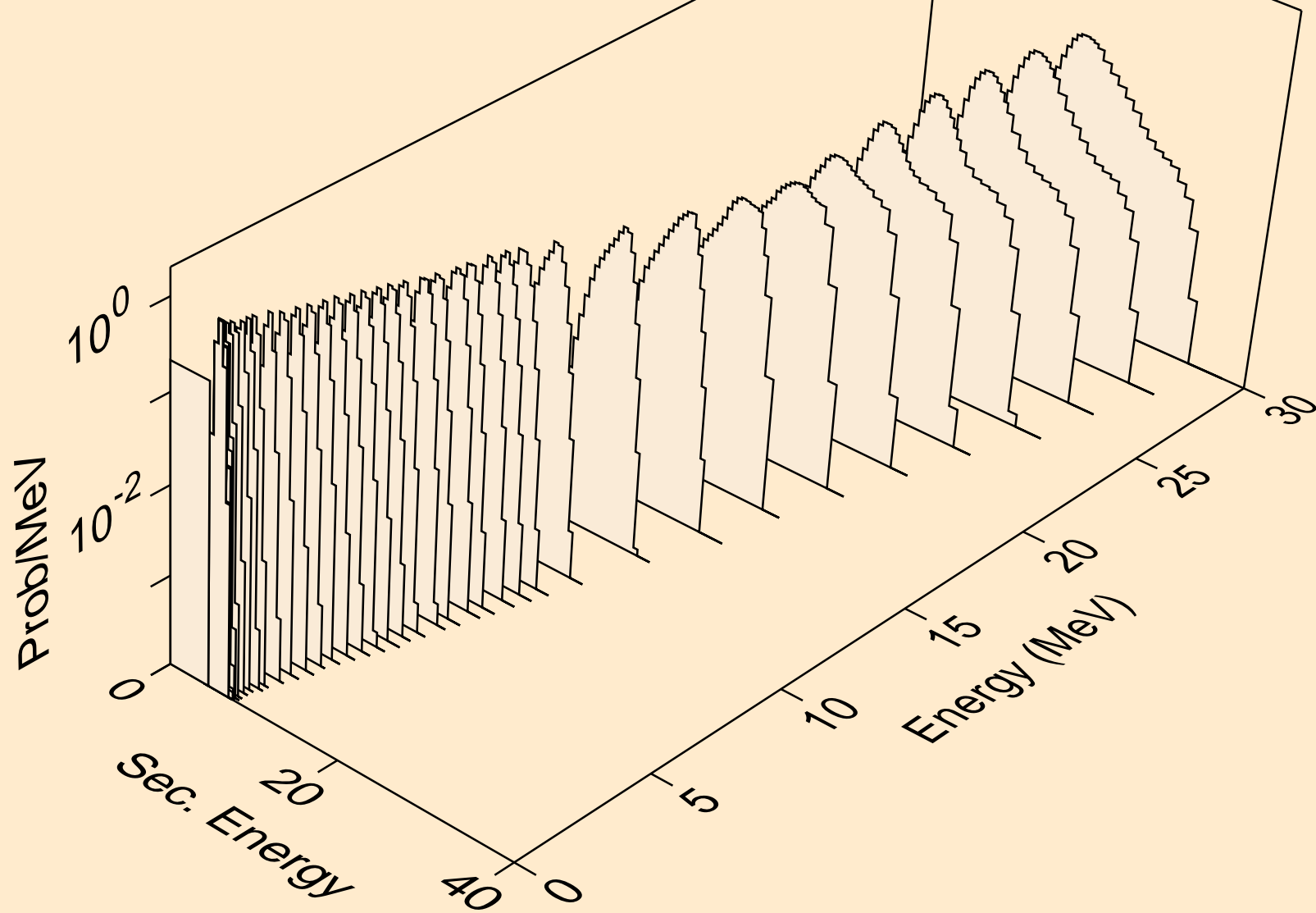

TM160M NEUTRON ACER TENDL-2024 LIBRARY; T=0.K
alphas from (n,da)

