

AR039 PROTON ACER TENDL-2023 LIBRARY; T=0.K  
Principal cross sections

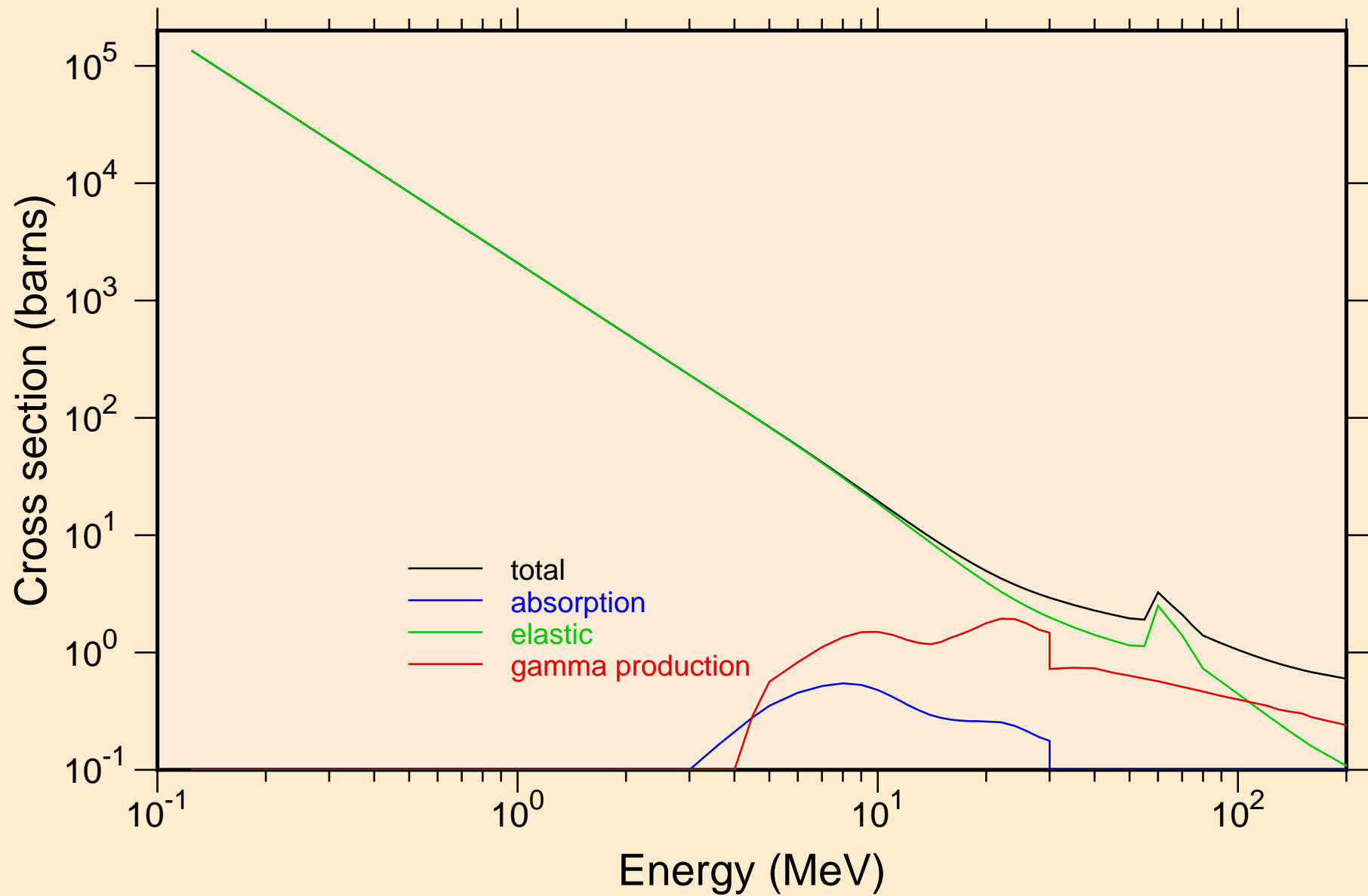

# AR039 PROTON ACER TENDL-2023 LIBRARY; T=0.K

## Heating

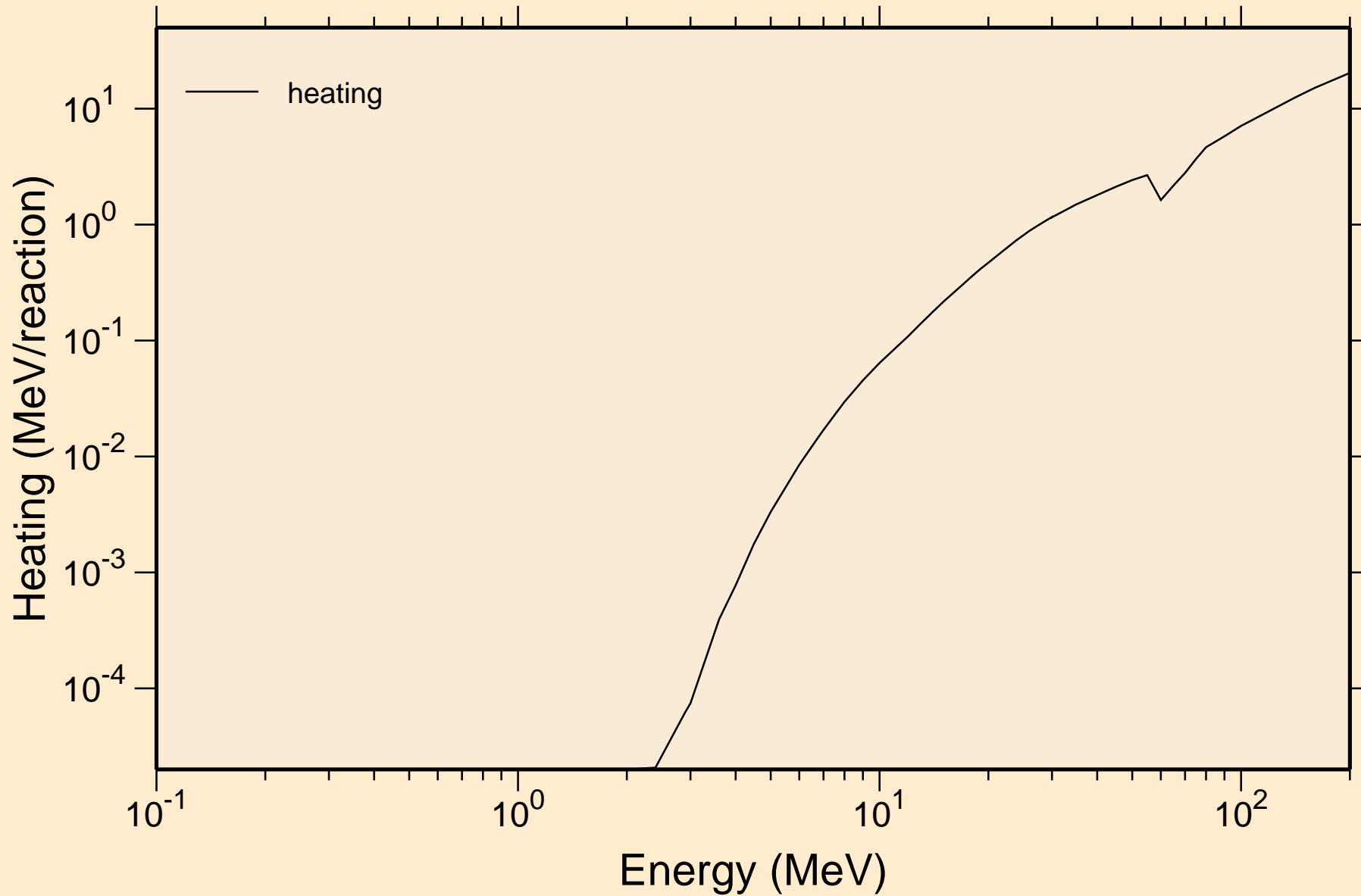

# AR039 PROTON ACER TENDL-2023 LIBRARY; T=0.K

## Principal cross sections

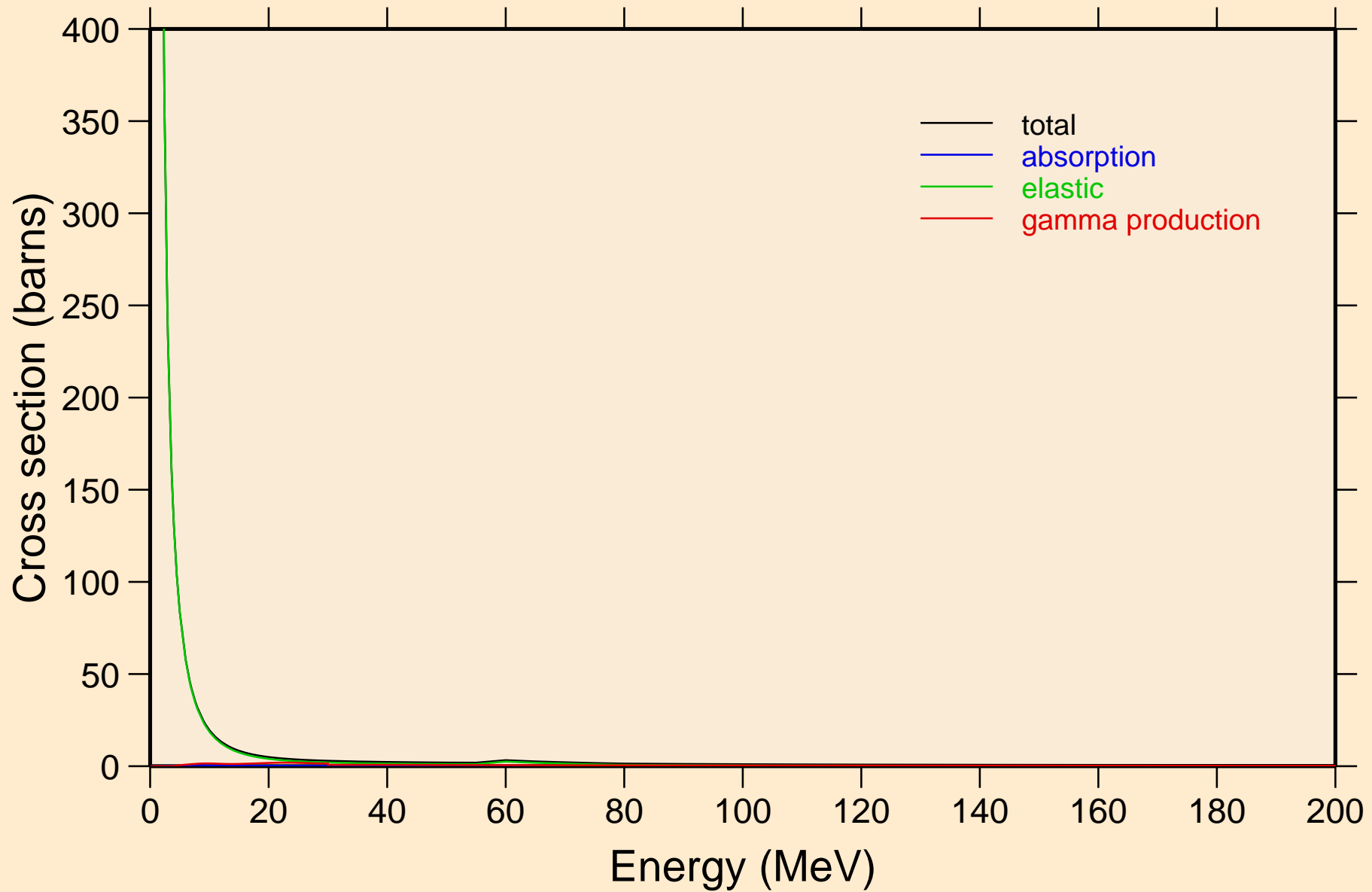

# AR039 PROTON ACER TENDL-2023 LIBRARY; T=0.K

## Heating

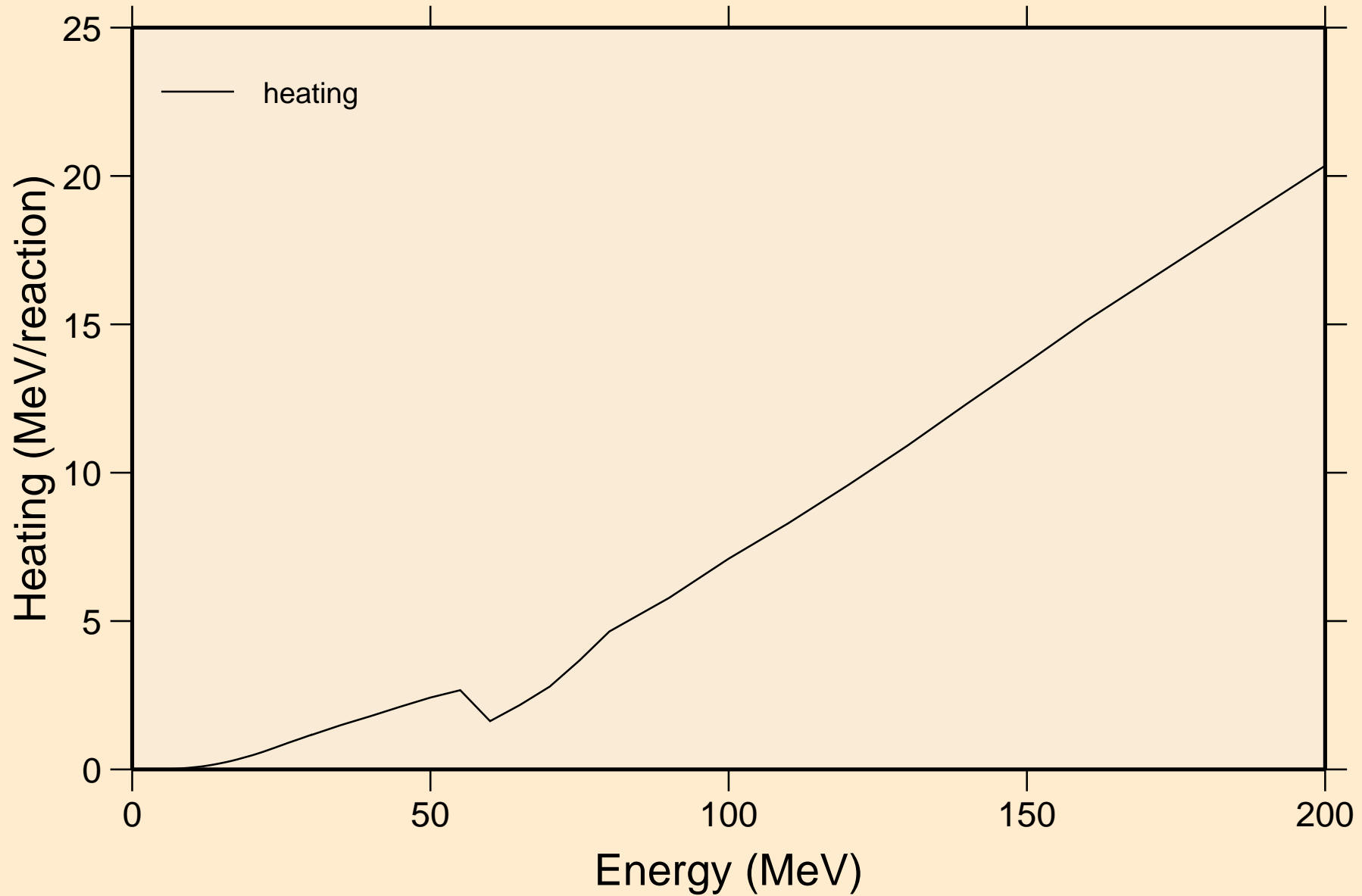

AR039 PROTON ACER TENDL-2023 LIBRARY; T=0.K  
Threshold reactions

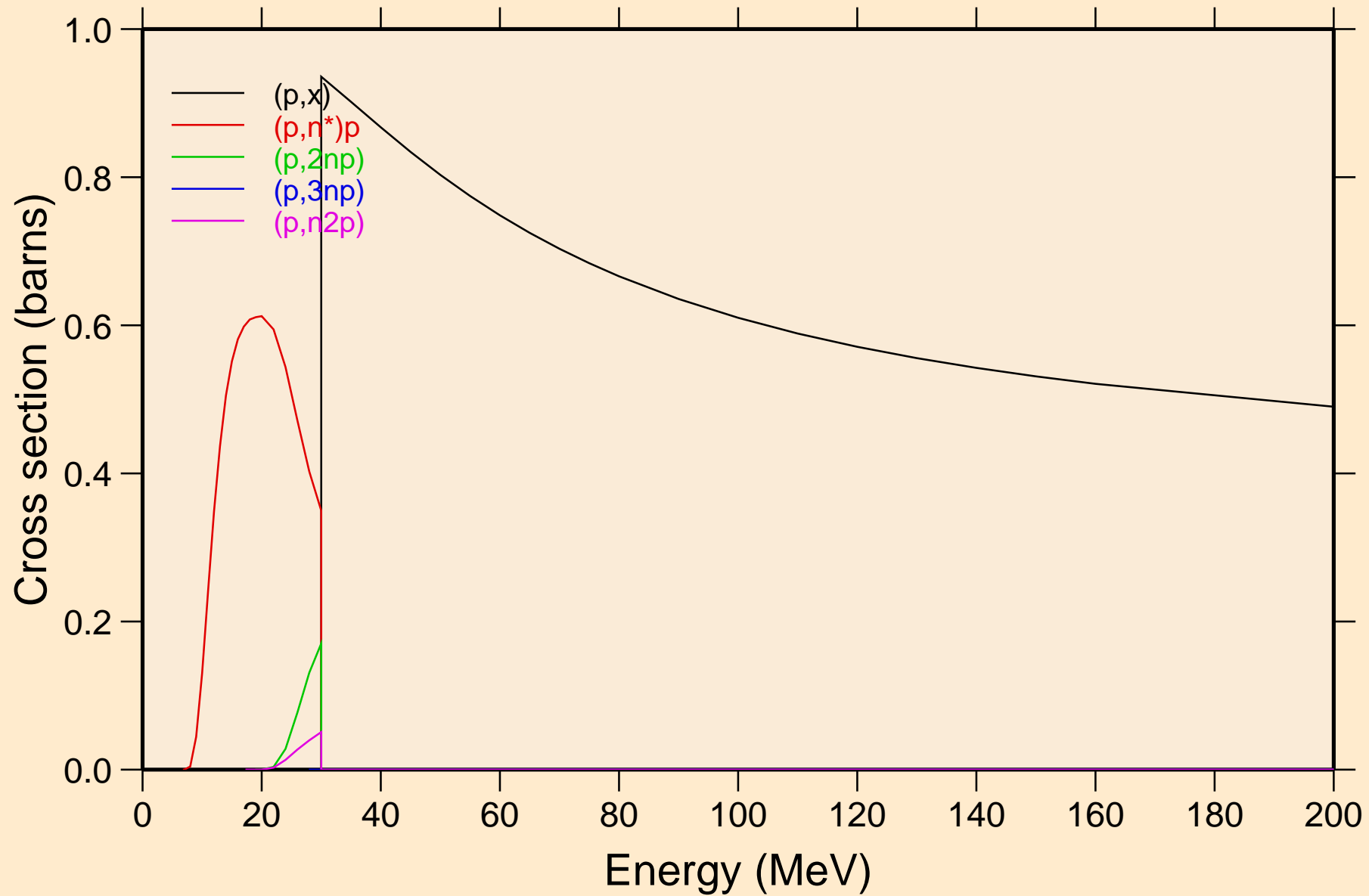

# AR039 PROTON ACER TENDL-2023 LIBRARY; T=0.K

## Threshold reactions

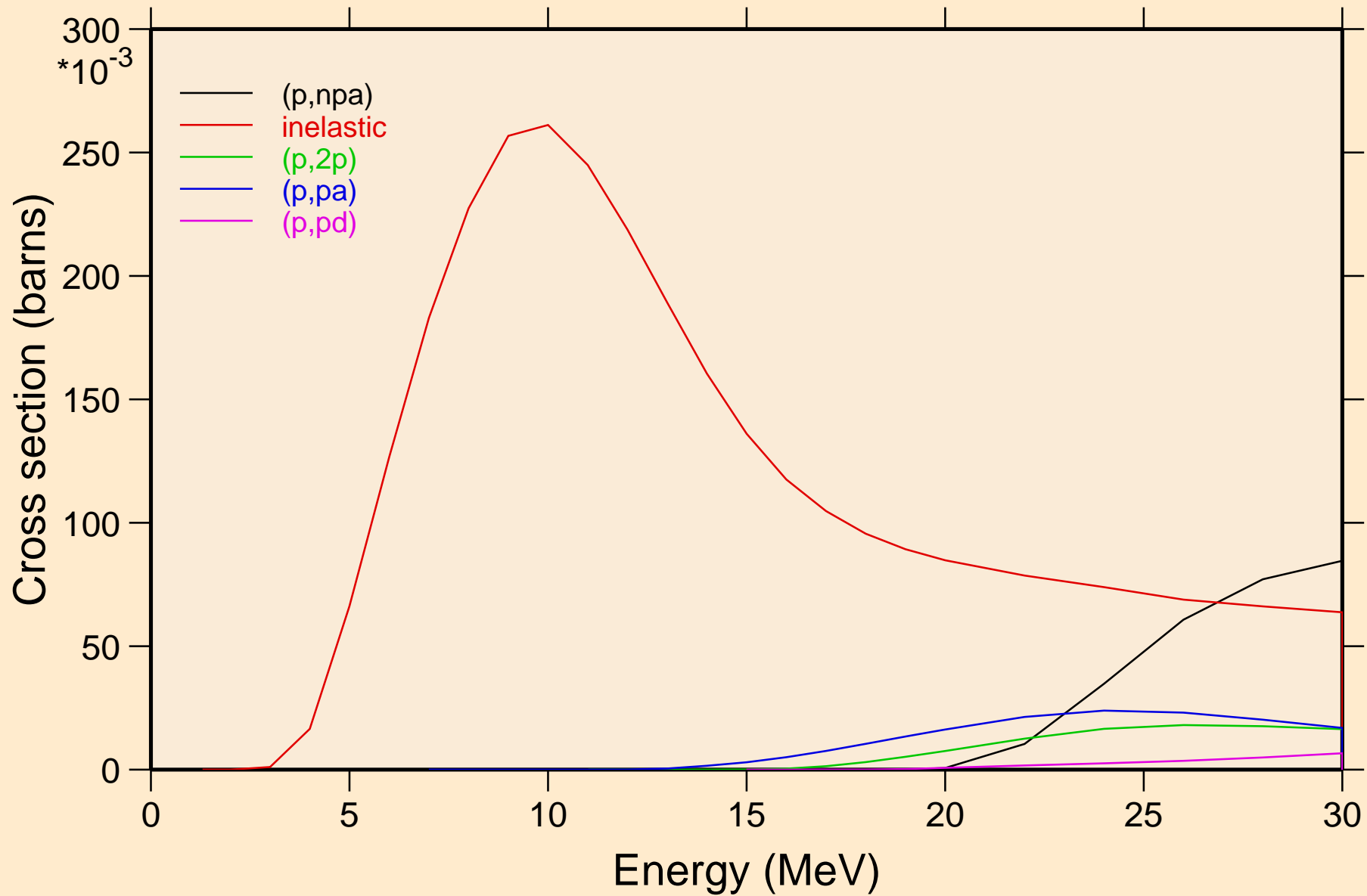

AR039 PROTON ACER TENDL-2023 LIBRARY; T=0.K  
Threshold reactions

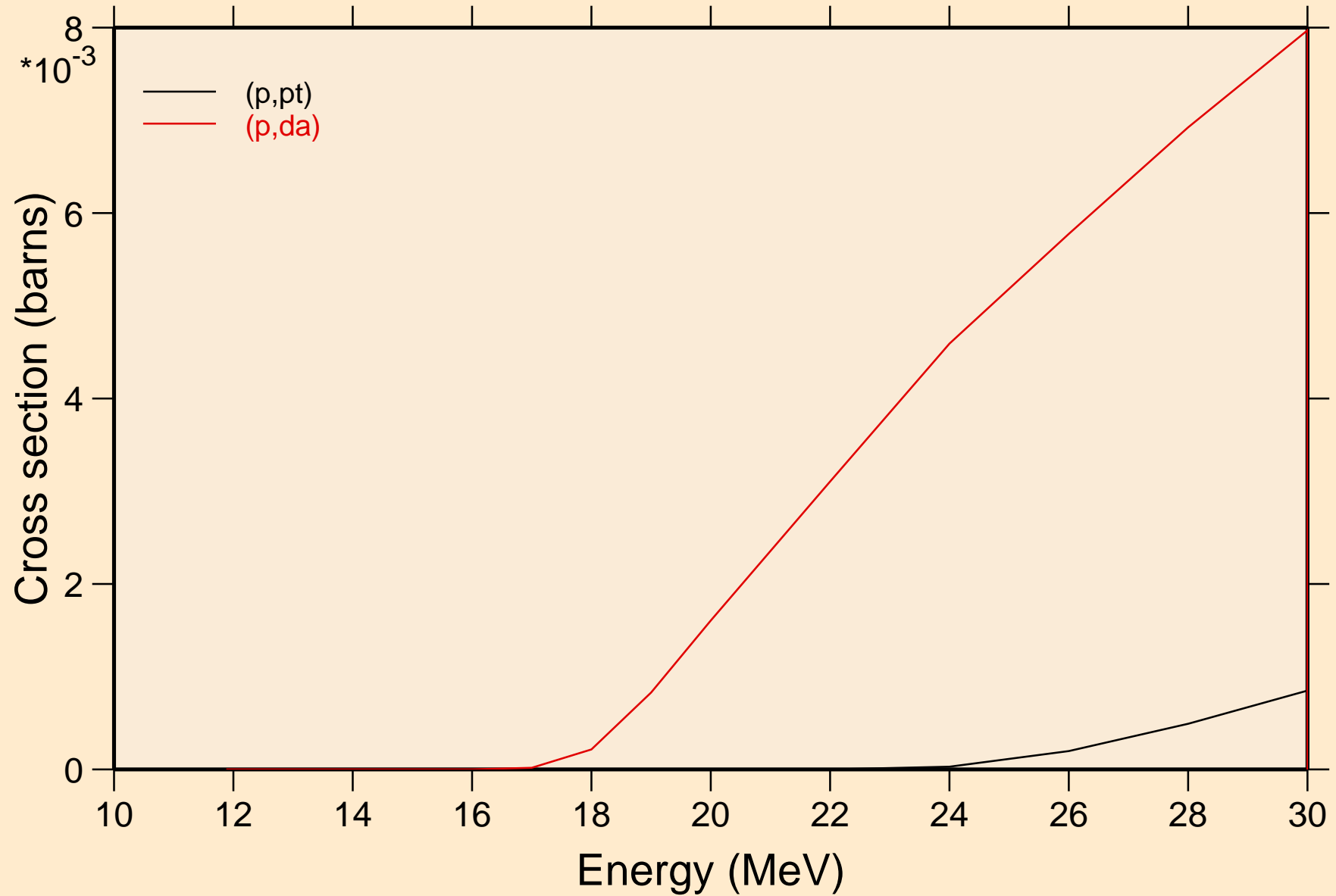

AR039 PROTON ACER TENDL-2023 LIBRARY; T=0.K  
angular distribution for elastic

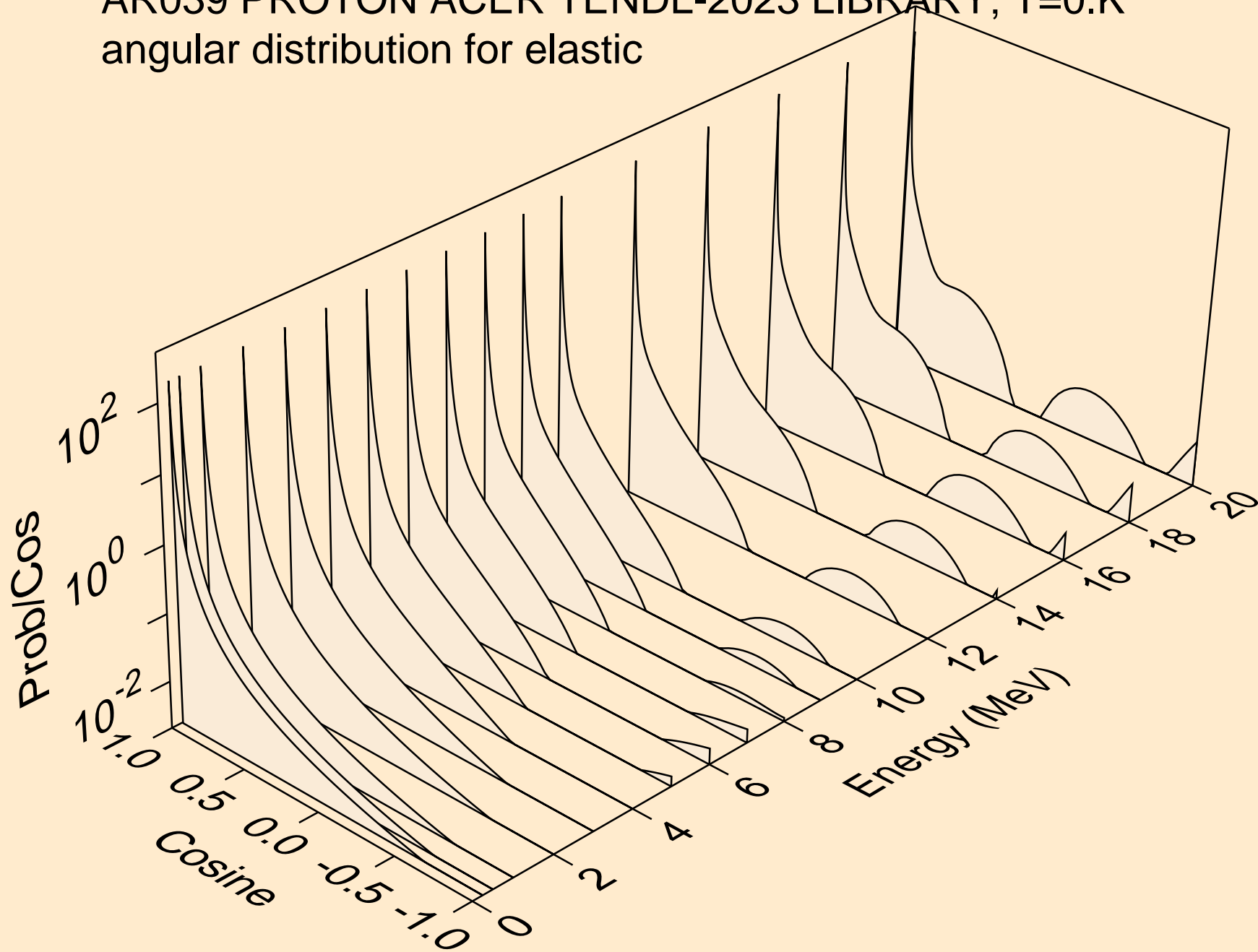



AR039 PROTON ACER TENDL-2023 LIBRARY; T=0.K  
angular distribution for elastic

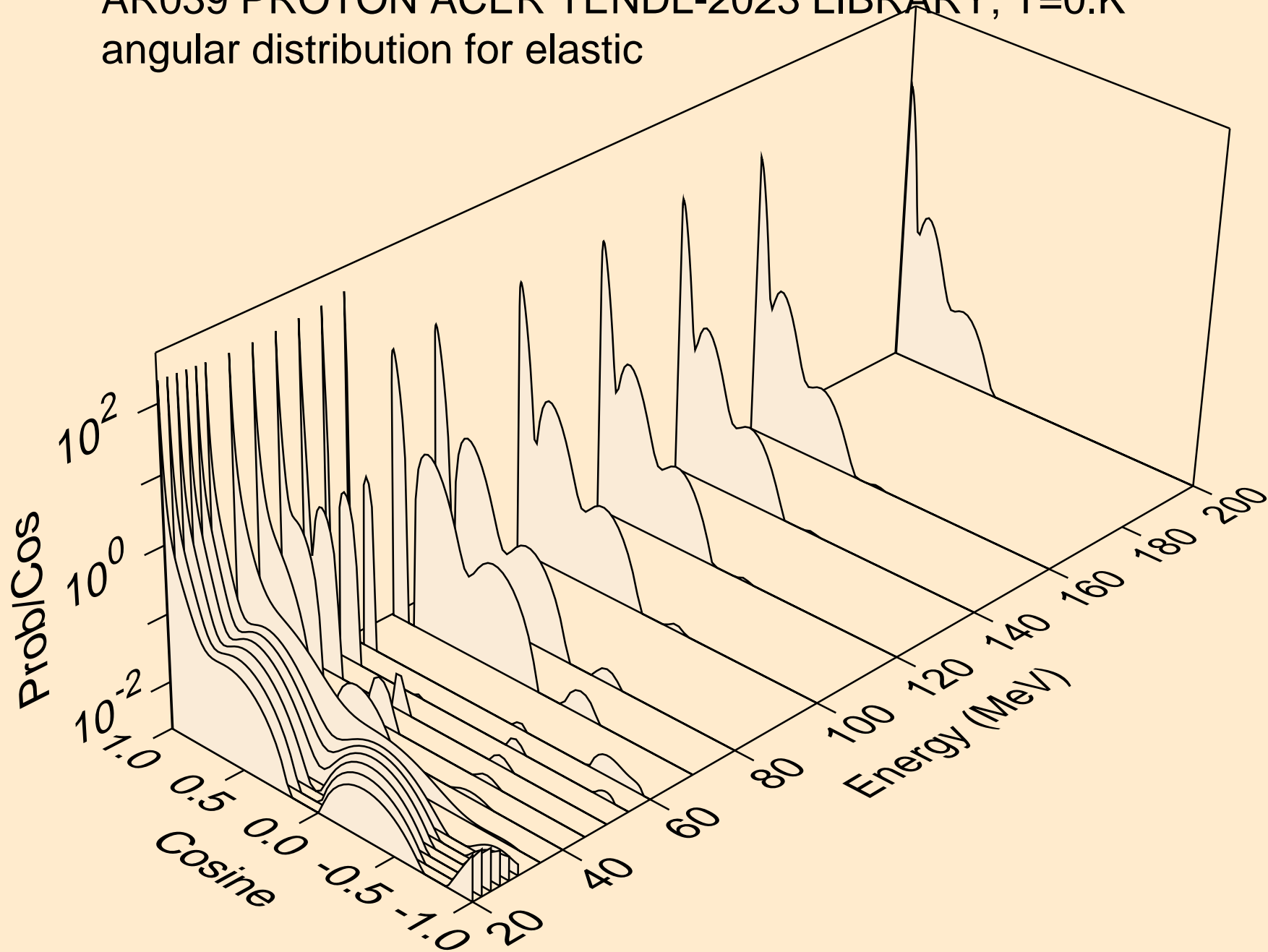

AR039 PROTON ACER TENDL-2023 LIBRARY; T=0.K  
Proton emission for (p,x)

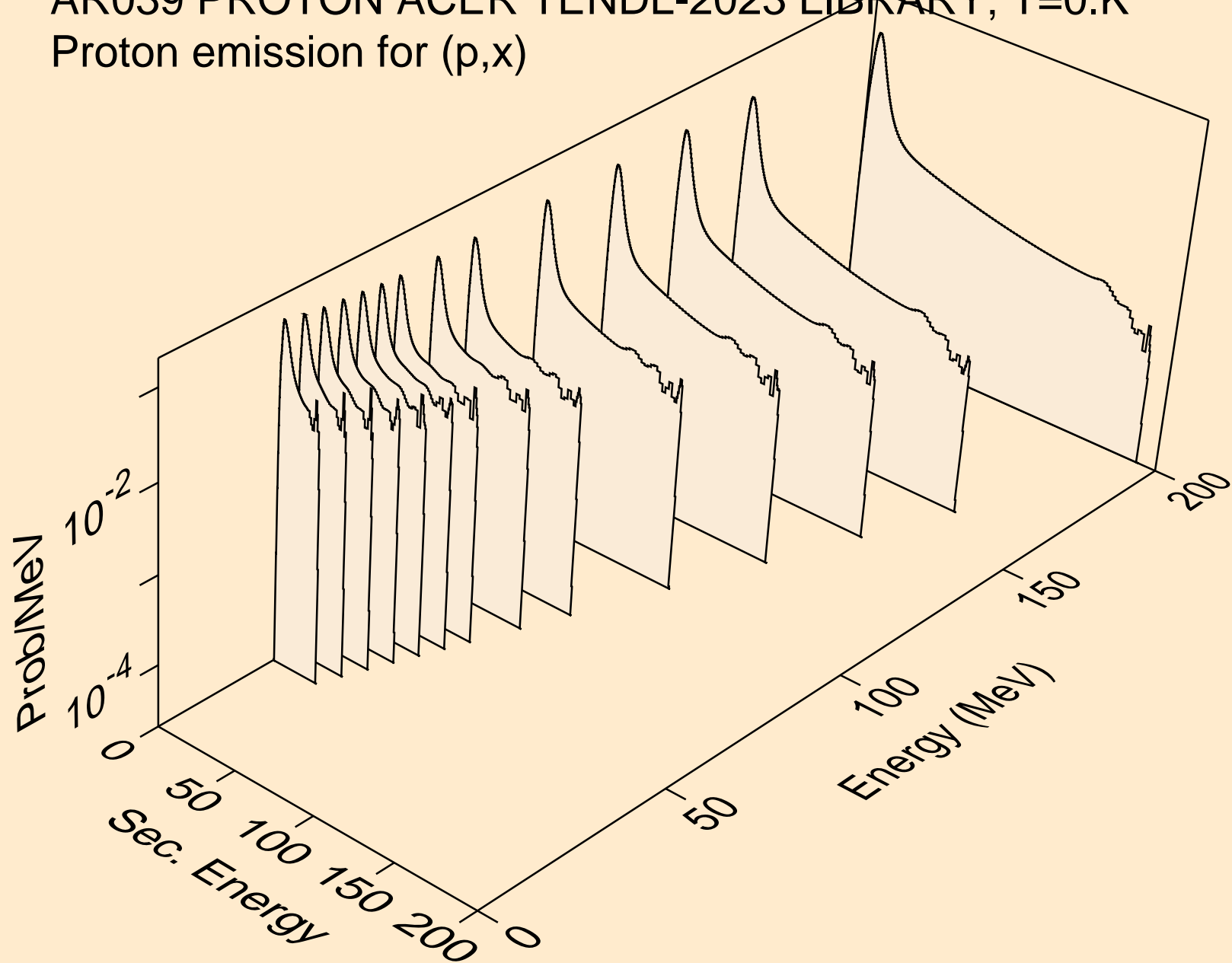

AR039 PROTON ACER TENDL-2023 LIBRARY; T=0.K  
Proton emission for (p,n\*)p

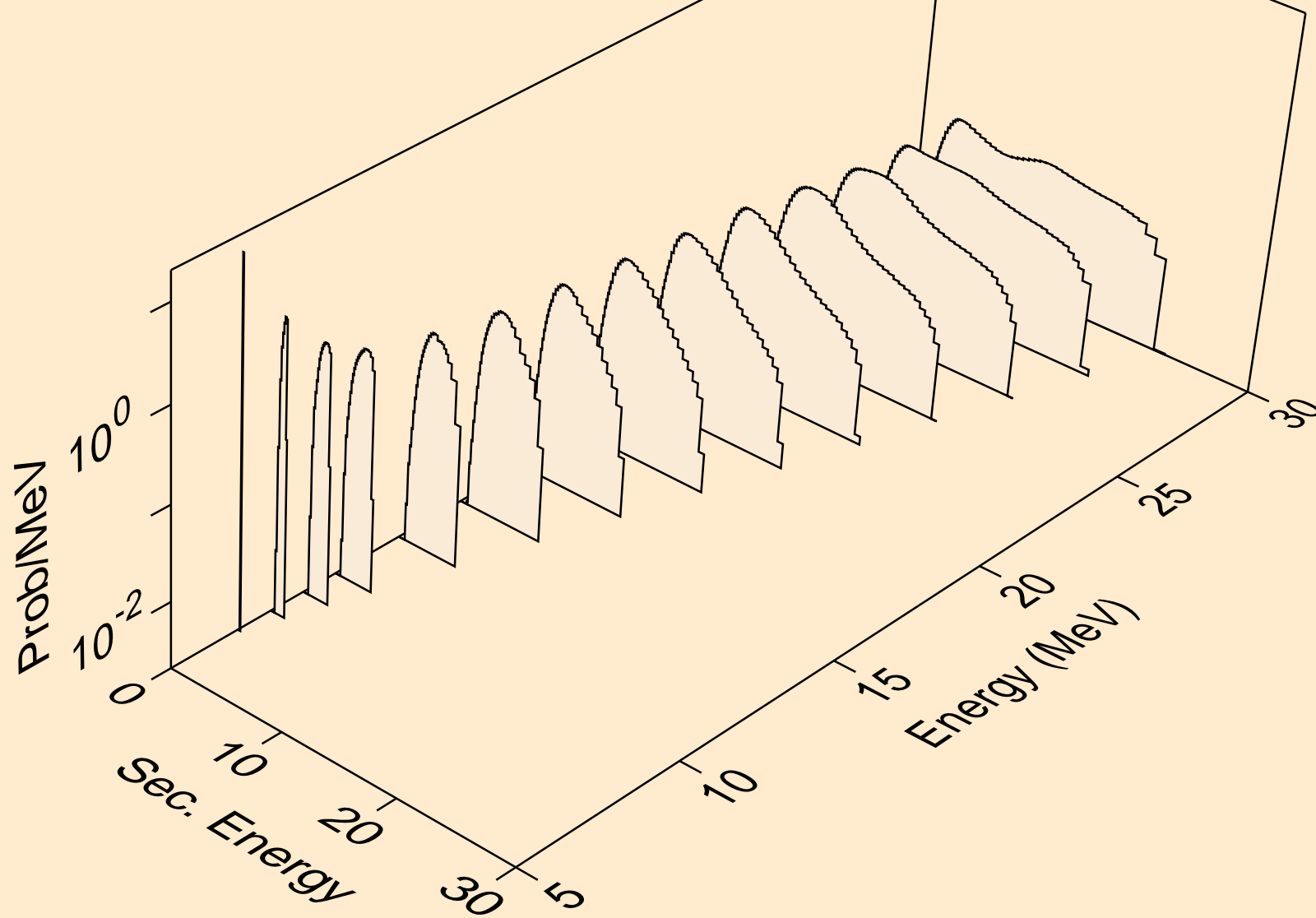

AR039 PROTON ACER TENDL-2023 LIBRARY; T=0.K  
Proton emission for (p,2np)

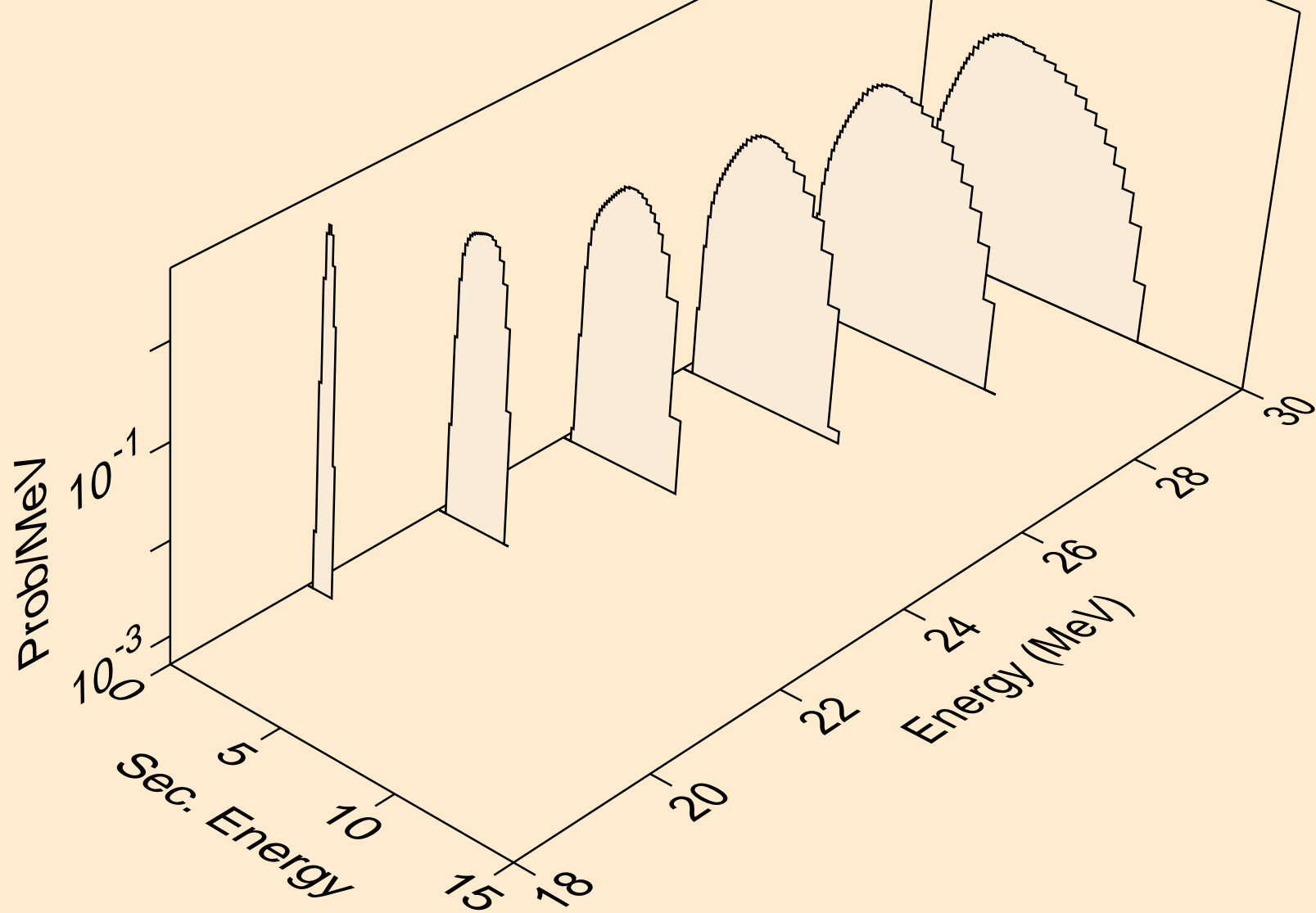

AR039 PROTON ACER TENDL-2023 LIBRARY; T=0.K  
Proton emission for (p,3np)

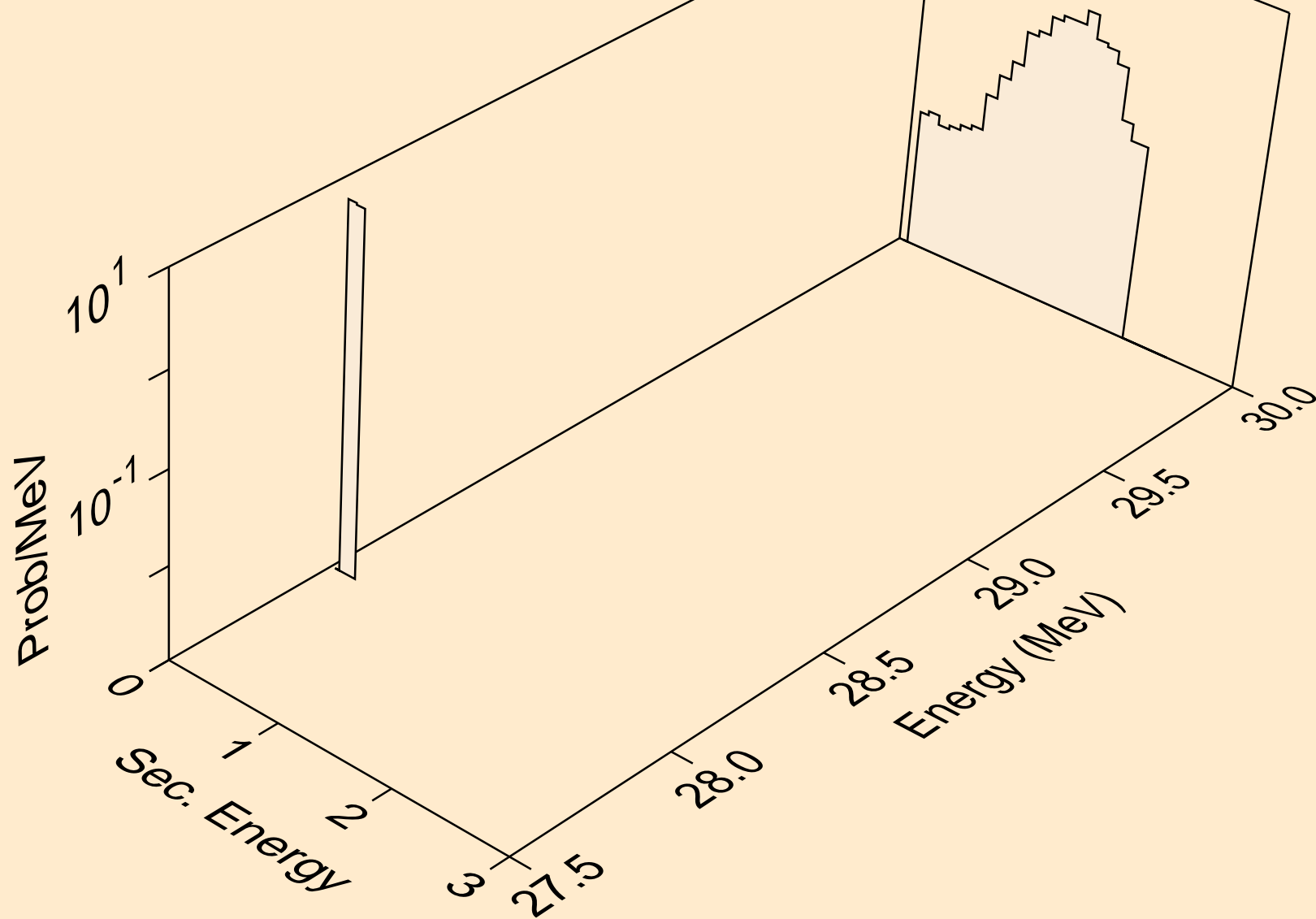

AR039 PROTON ACER TENDL-2023 LIBRARY; T=0.K  
Proton emission for (p,n2p)

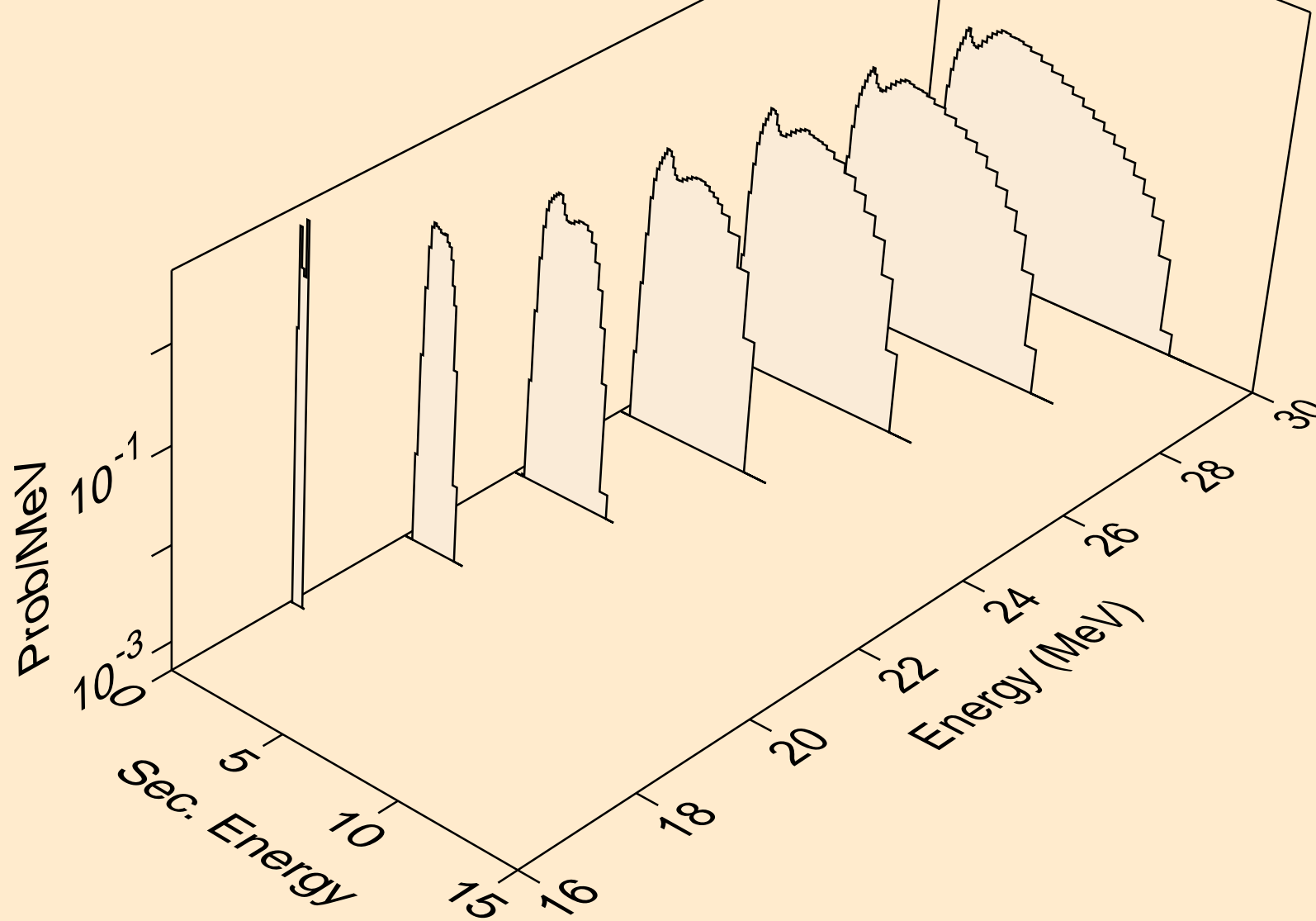

AR039 PROTON ACER TENDL-2023 LIBRARY; T=0.K  
Proton emission for (p,npa)

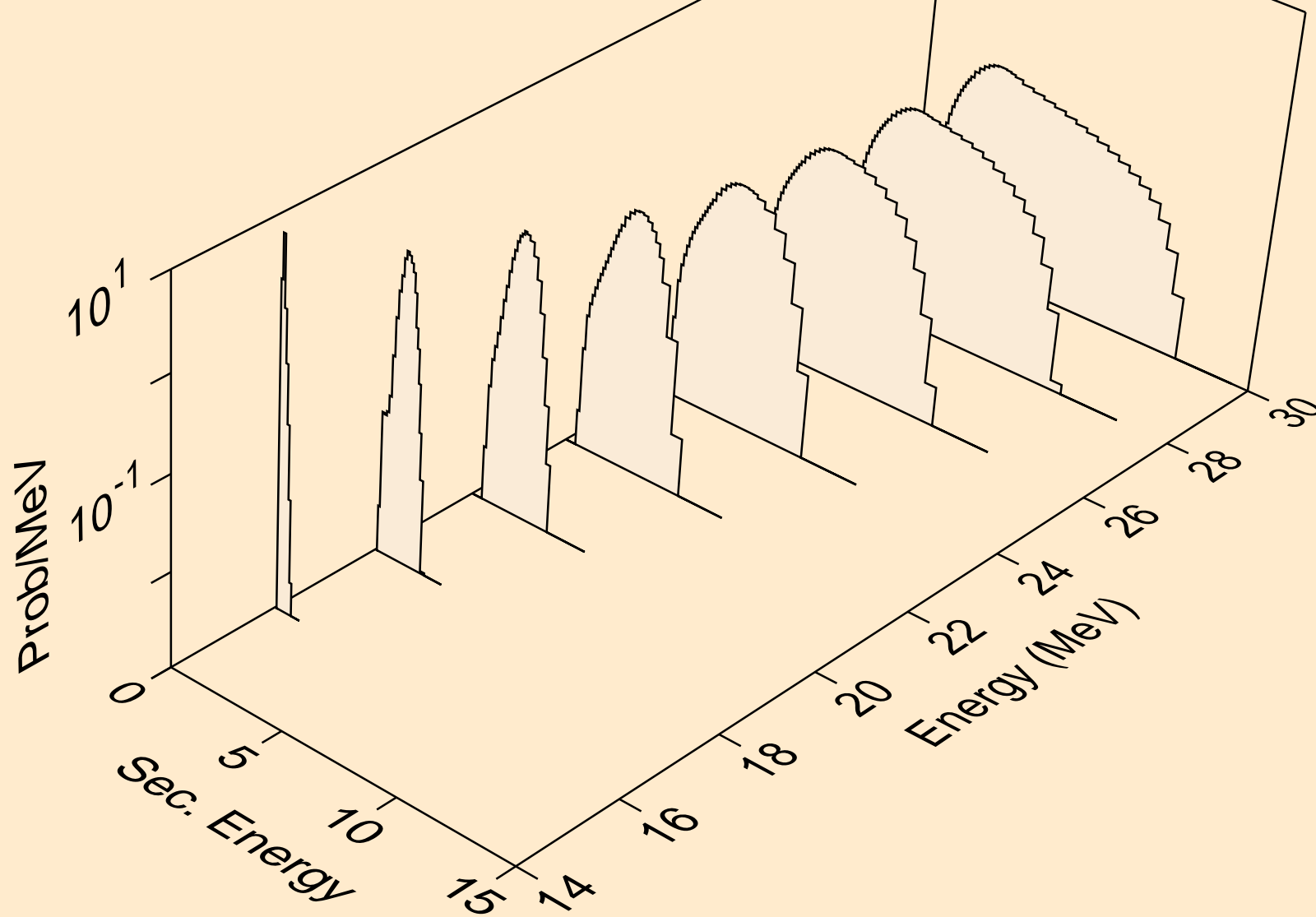

AR039 PROTON ACER TENDL-2023 LIBRARY; T=0.K  
Proton emission for inelastic

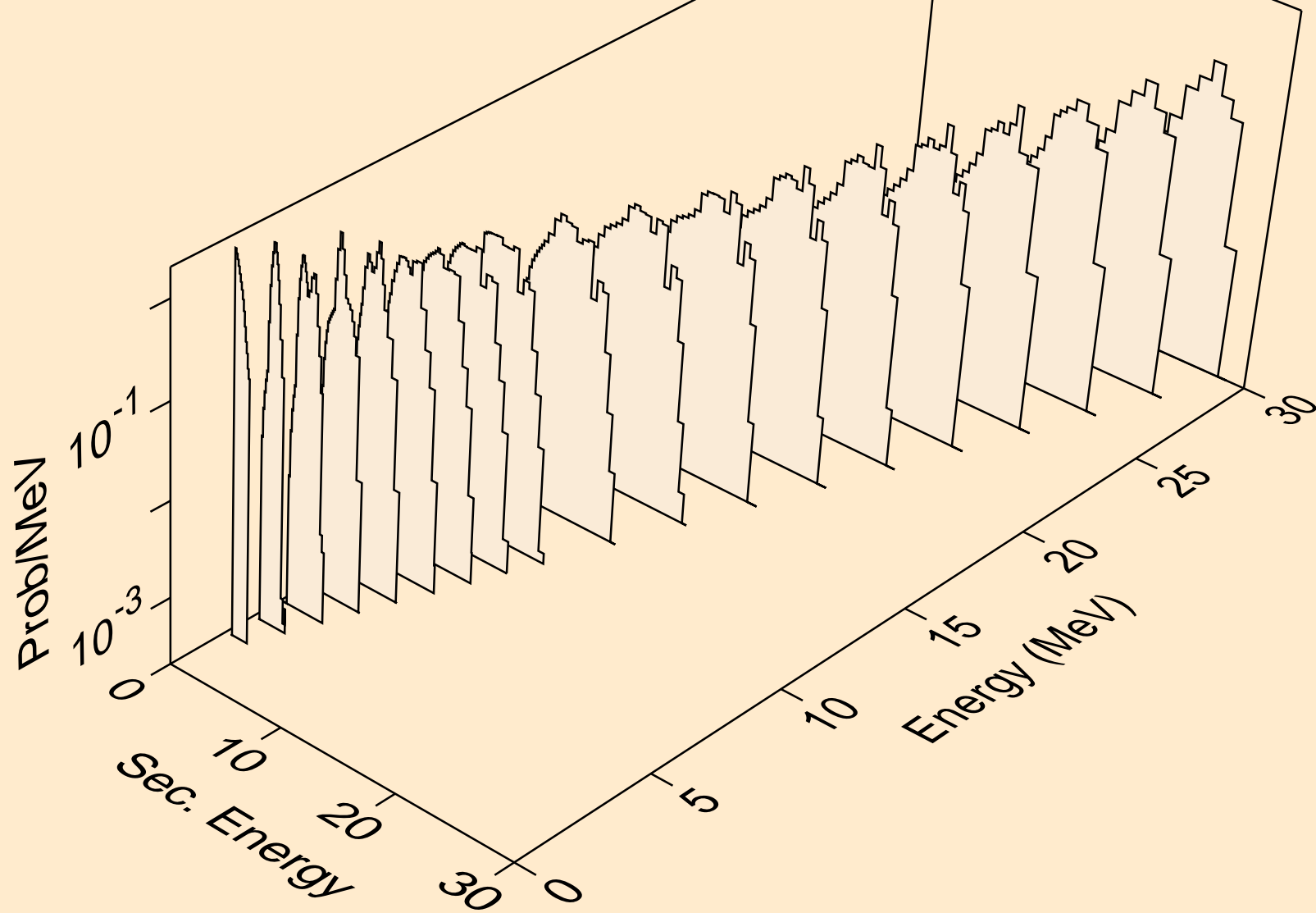



AR039 PROTON ACER TENDL-2023 LIBRARY; T=0.K  
Proton emission for (p,2p)

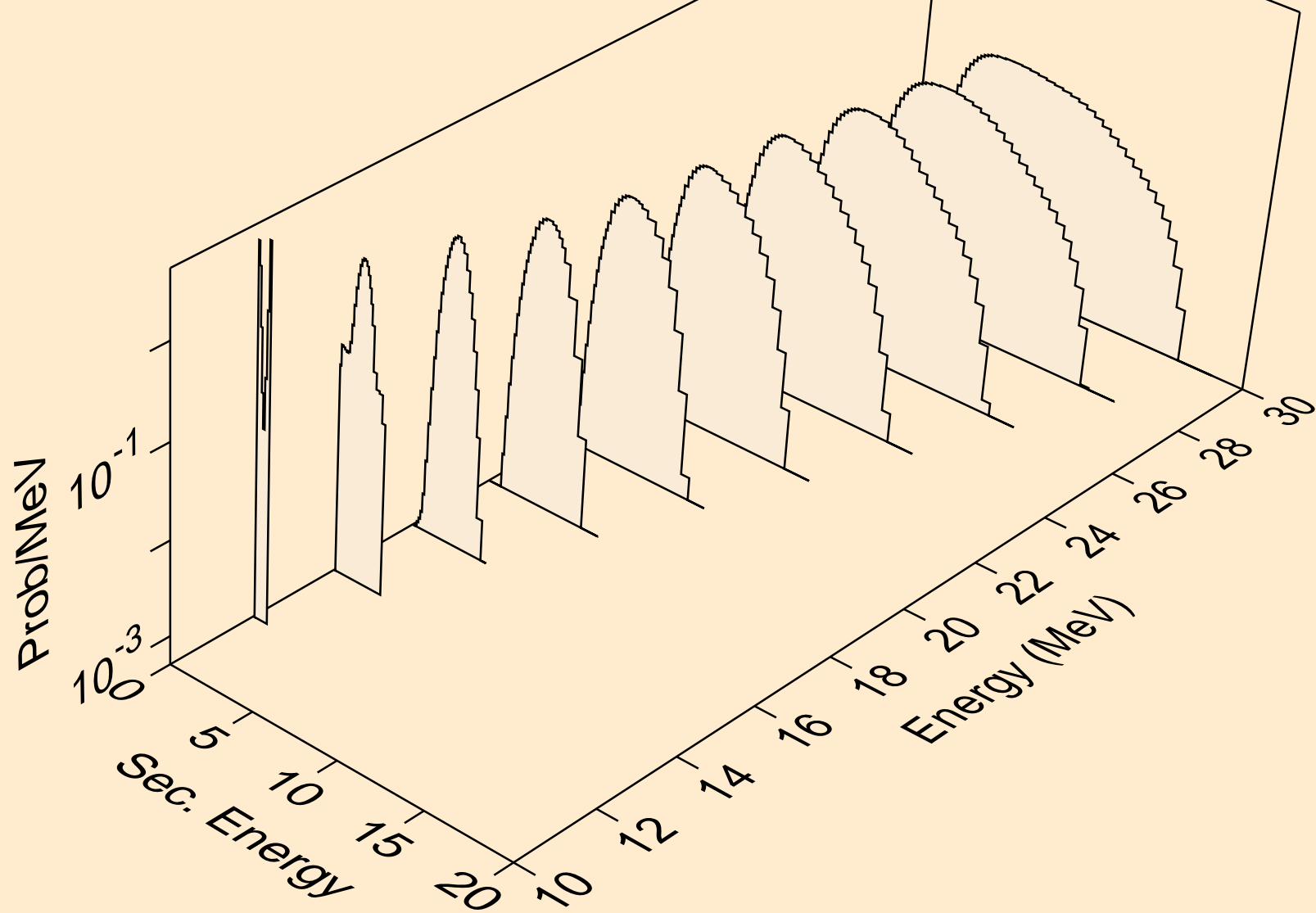

AR039 PROTON ACER TENDL-2023 LIBRARY; T=0.K  
Proton emission for (p,pa)

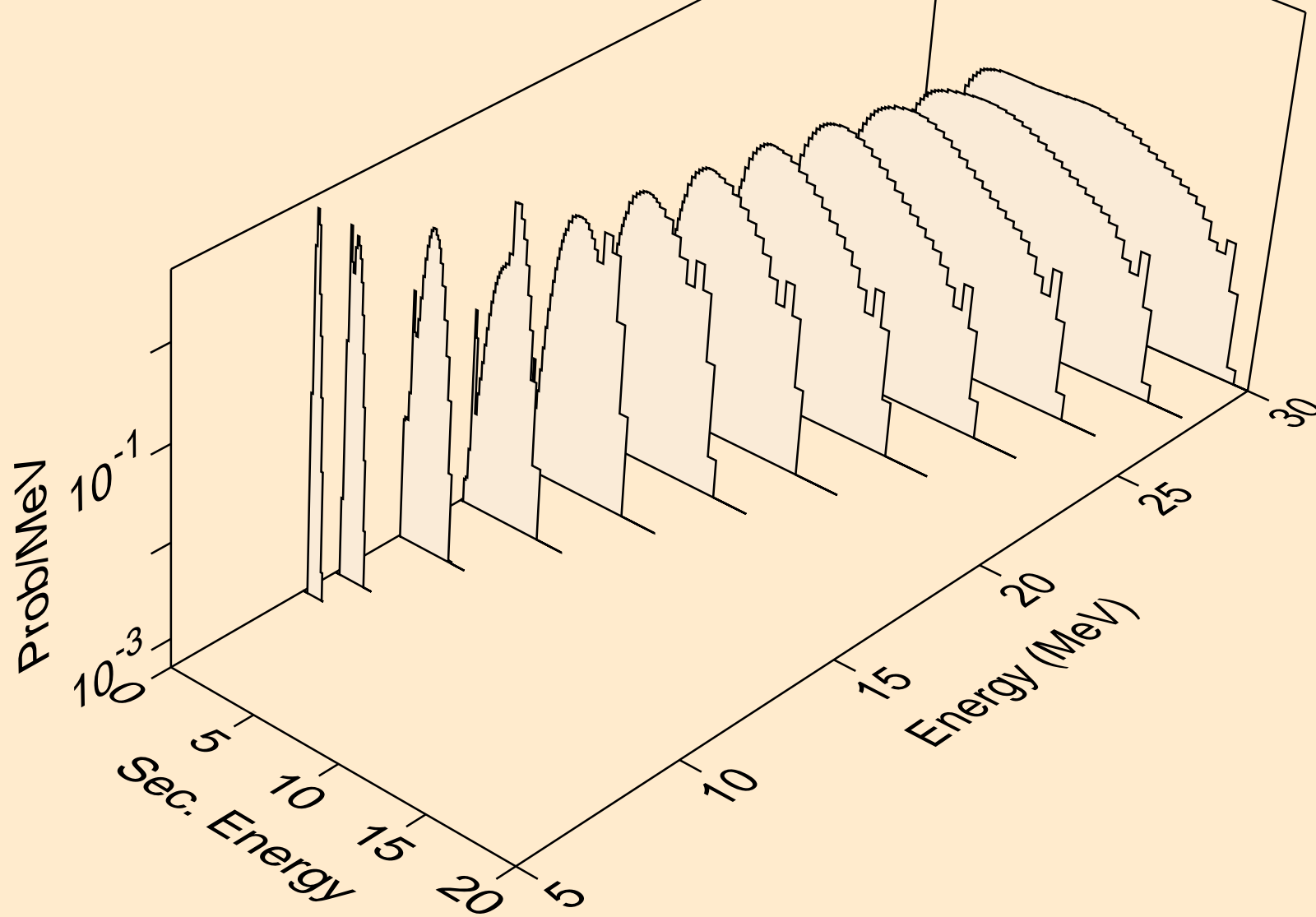

AR039 PROTON ACER TENDL-2023 LIBRARY; T=0.K  
Proton emission for (p,pd)

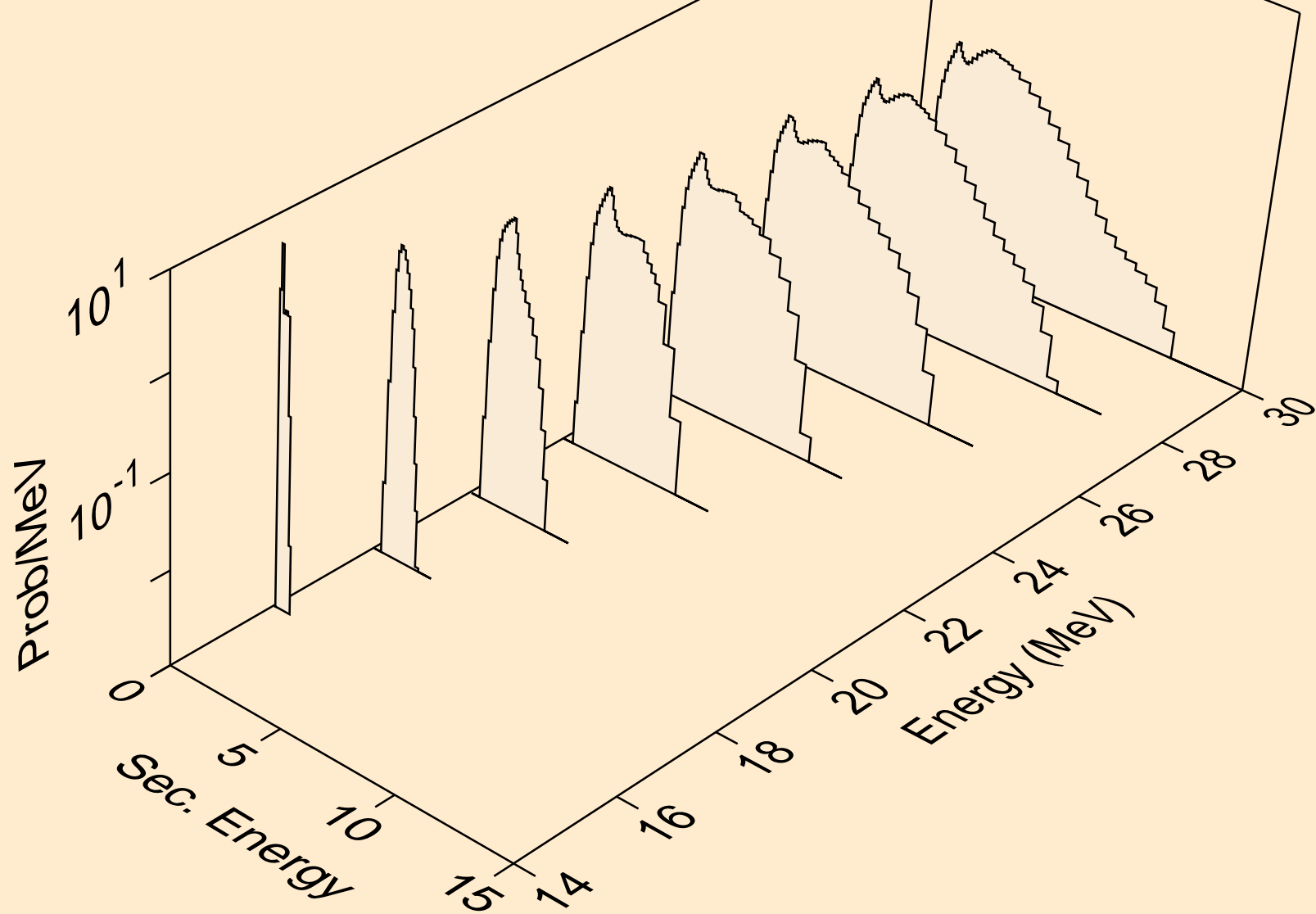

AR039 PROTON ACER TENDL-2023 LIBRARY; T=0.K  
Proton emission for (p,pt)

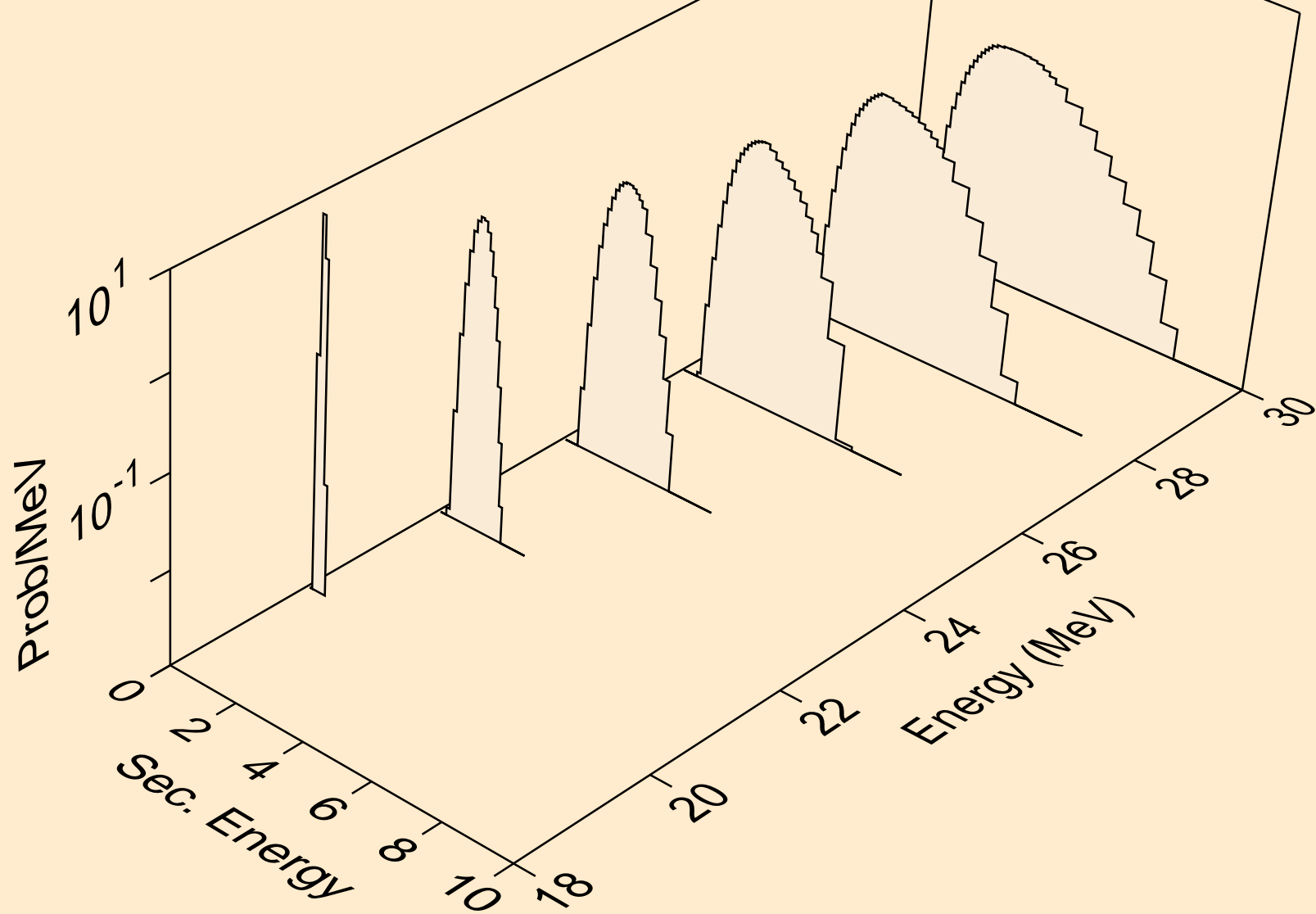

AR039 PROTON ACER TENDL-2023 LIBRARY; T=0.K  
Photon emission for (z,n)

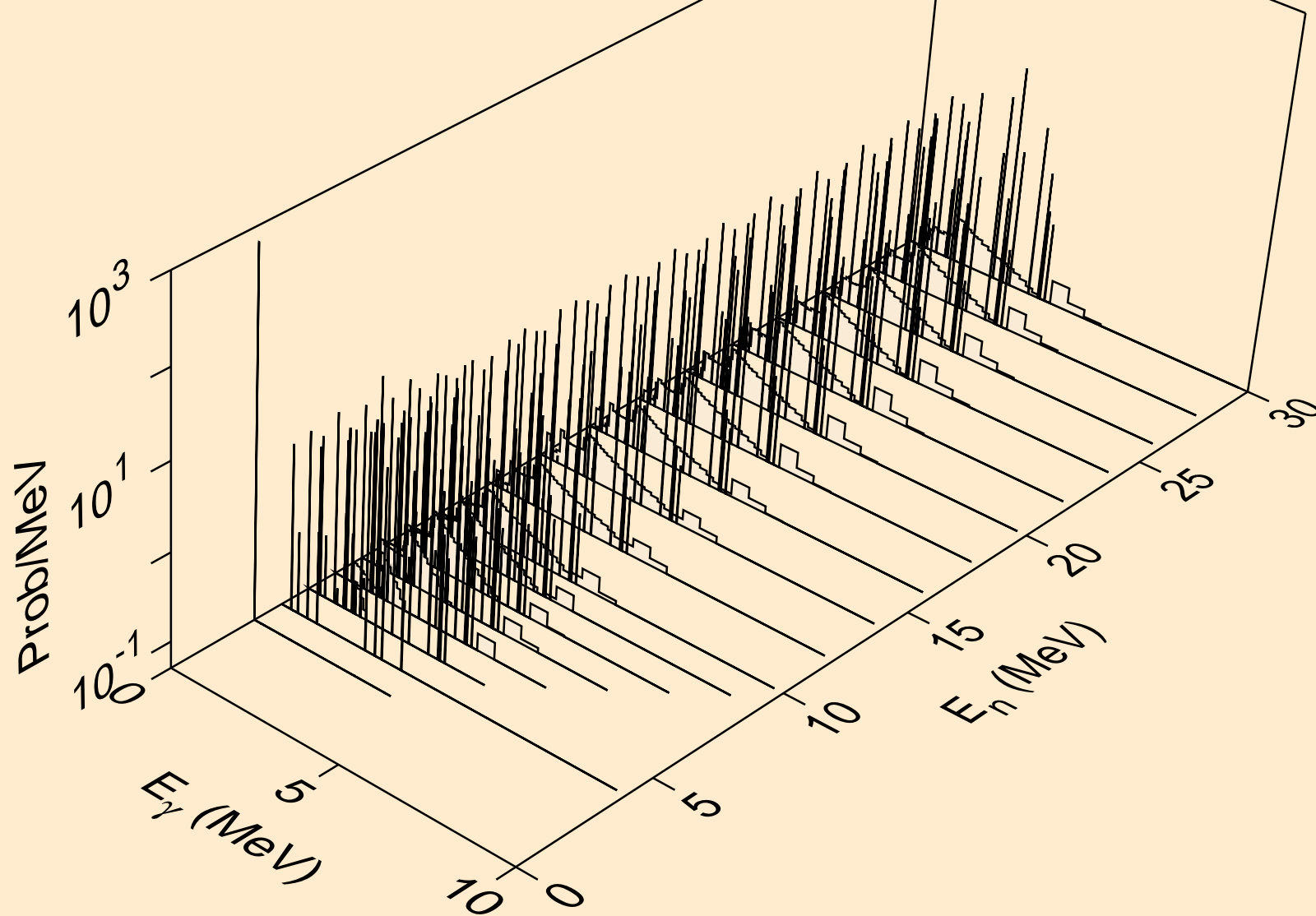

AR039 PROTON ACER TENDL-2023 LIBRARY; T=0.K  
Photon emission for (z,x)

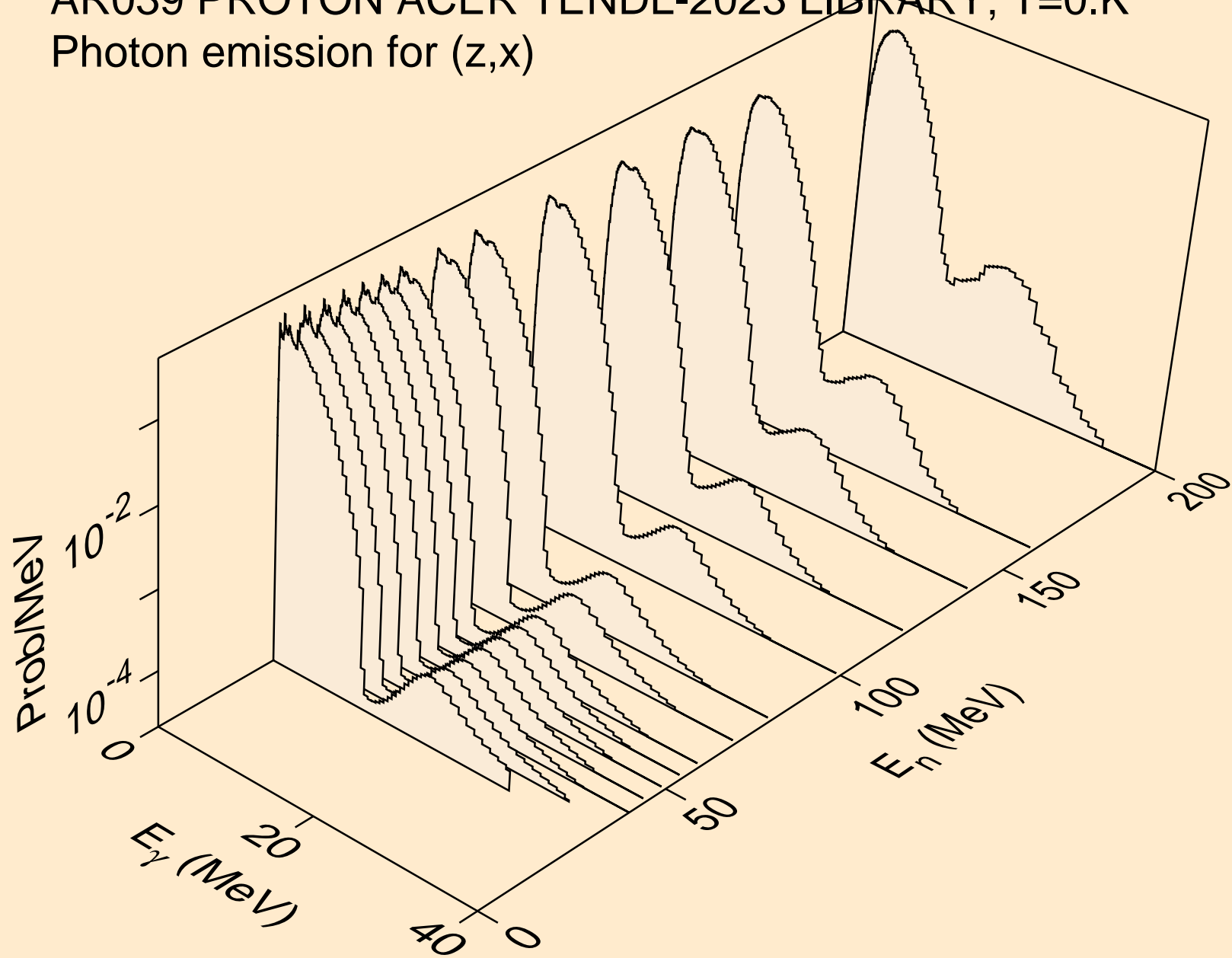

AR039 PROTON ACER TENDL-2023 LIBRARY; T=0.K  
Photon emission for (n,2nd)

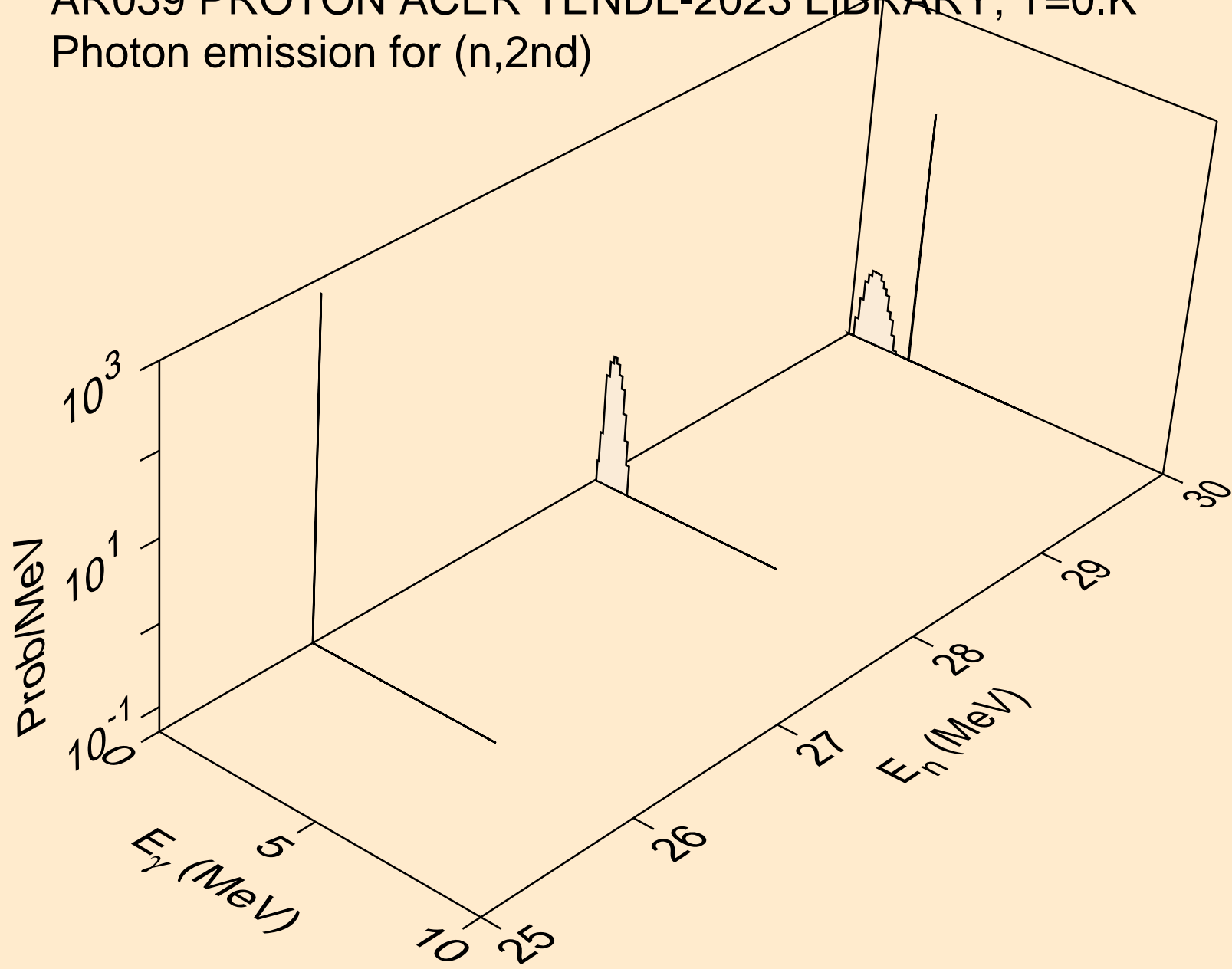

AR039 PROTON ACER TENDL-2023 LIBRARY; T=0.K  
Photon emission for (n,2n)

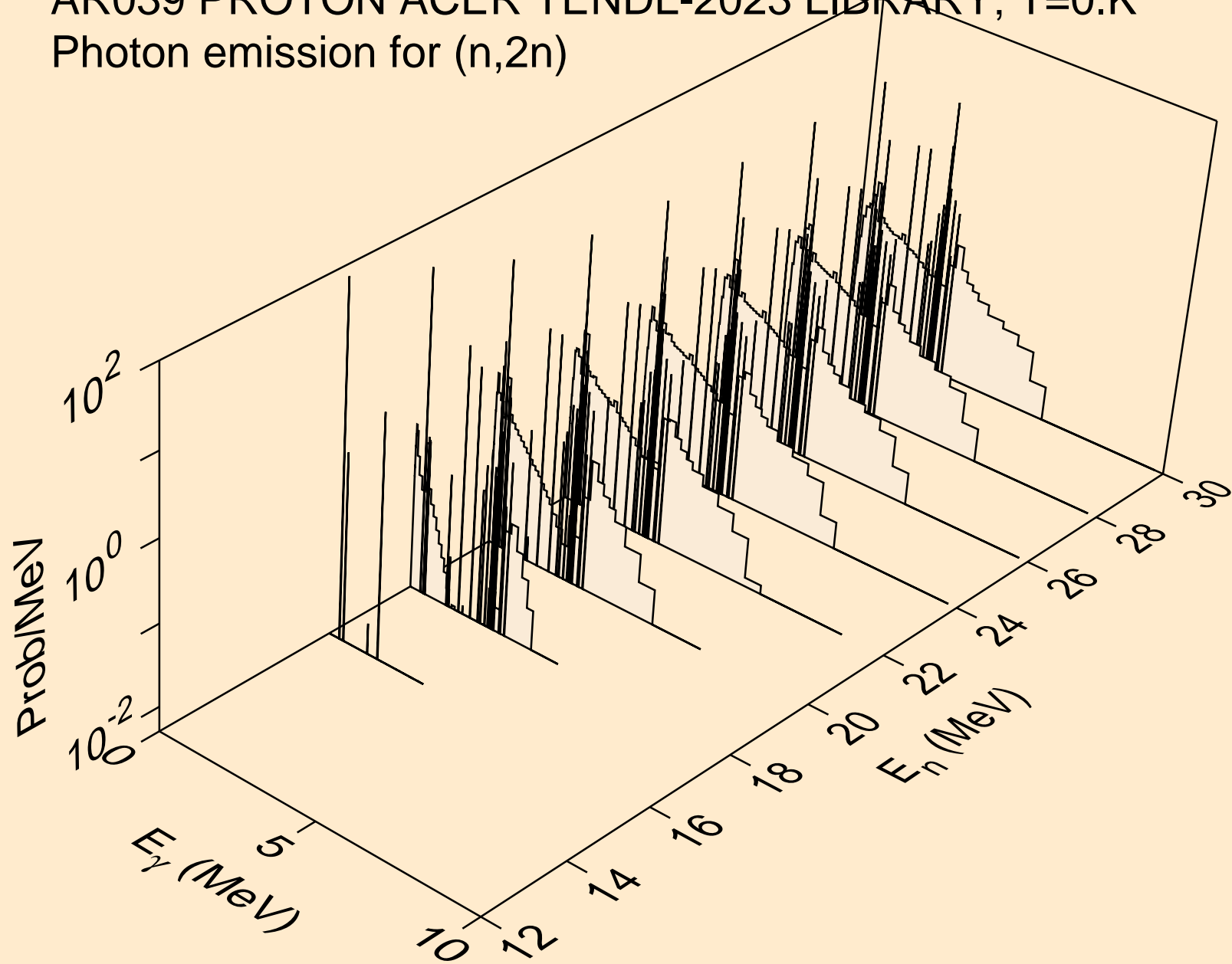



AR039 PROTON ACER TENDL-2023 LIBRARY; T=0.K  
Photon emission for (n,3n)

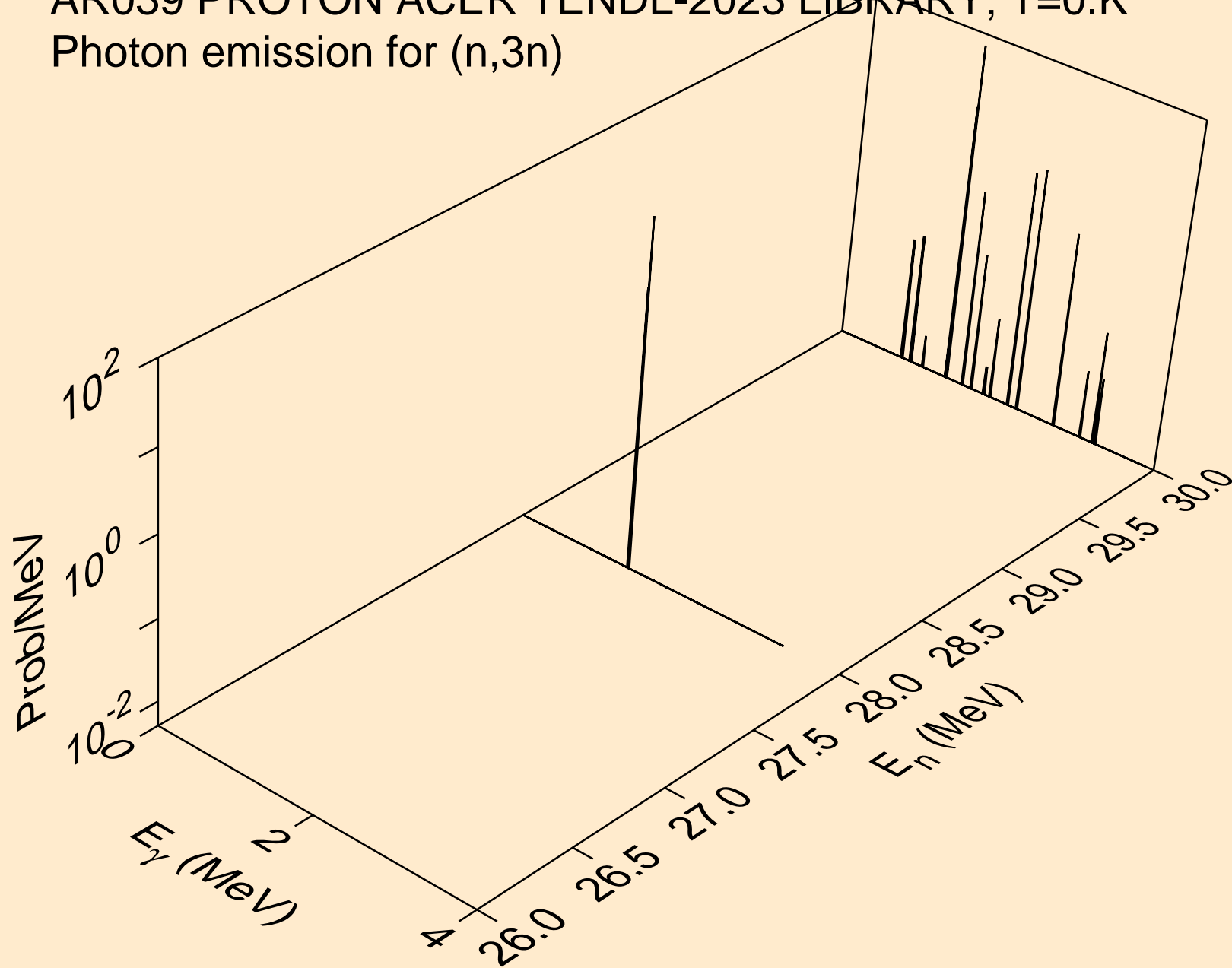

AR039 PROTON ACER TENDL-2023 LIBRARY; T=0.K  
Photon emission for (n,n\*)a

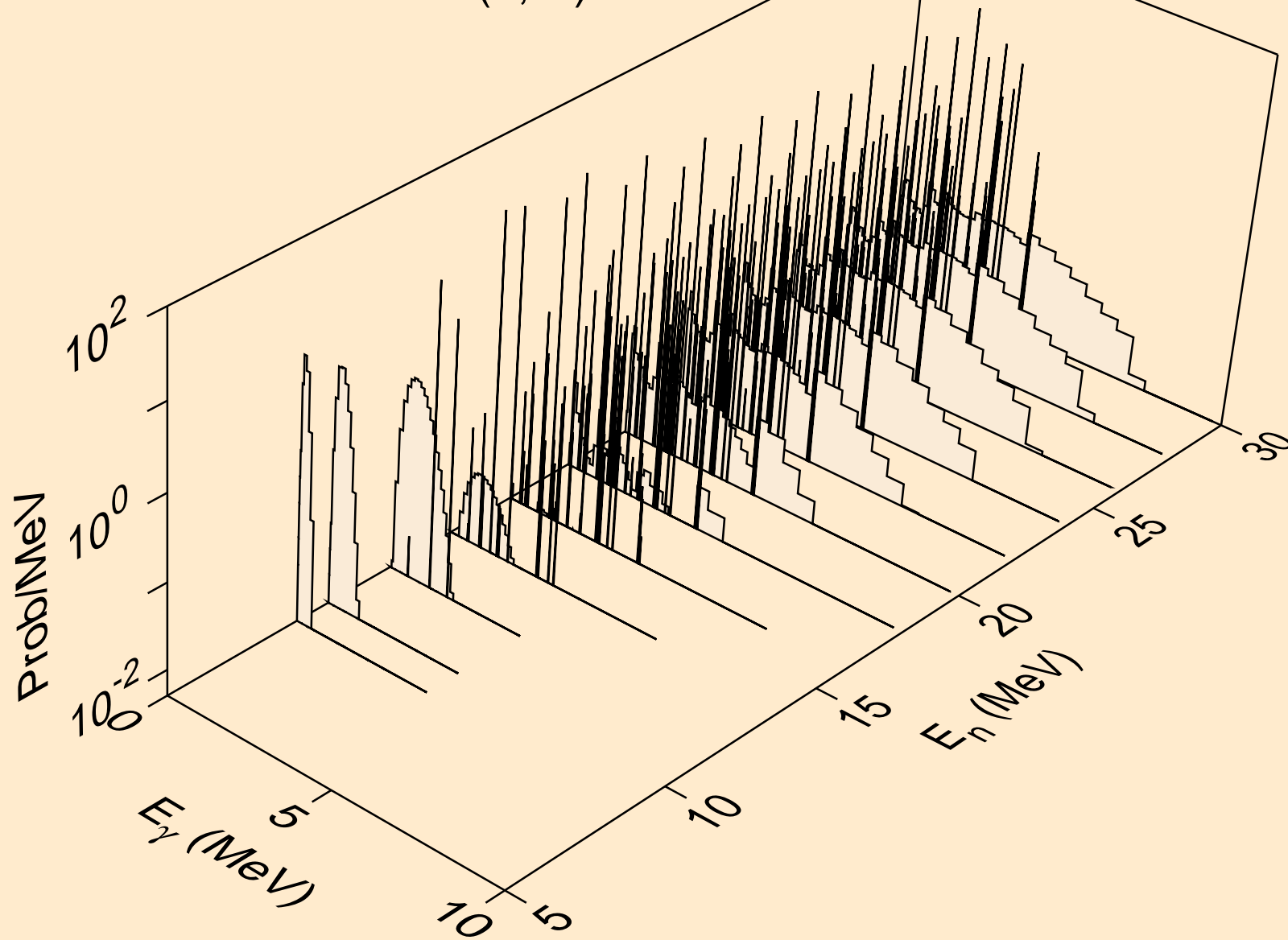

AR039 PROTON ACER TENDL-2023 LIBRARY; T=0.K  
Photon emission for (n,2n)a

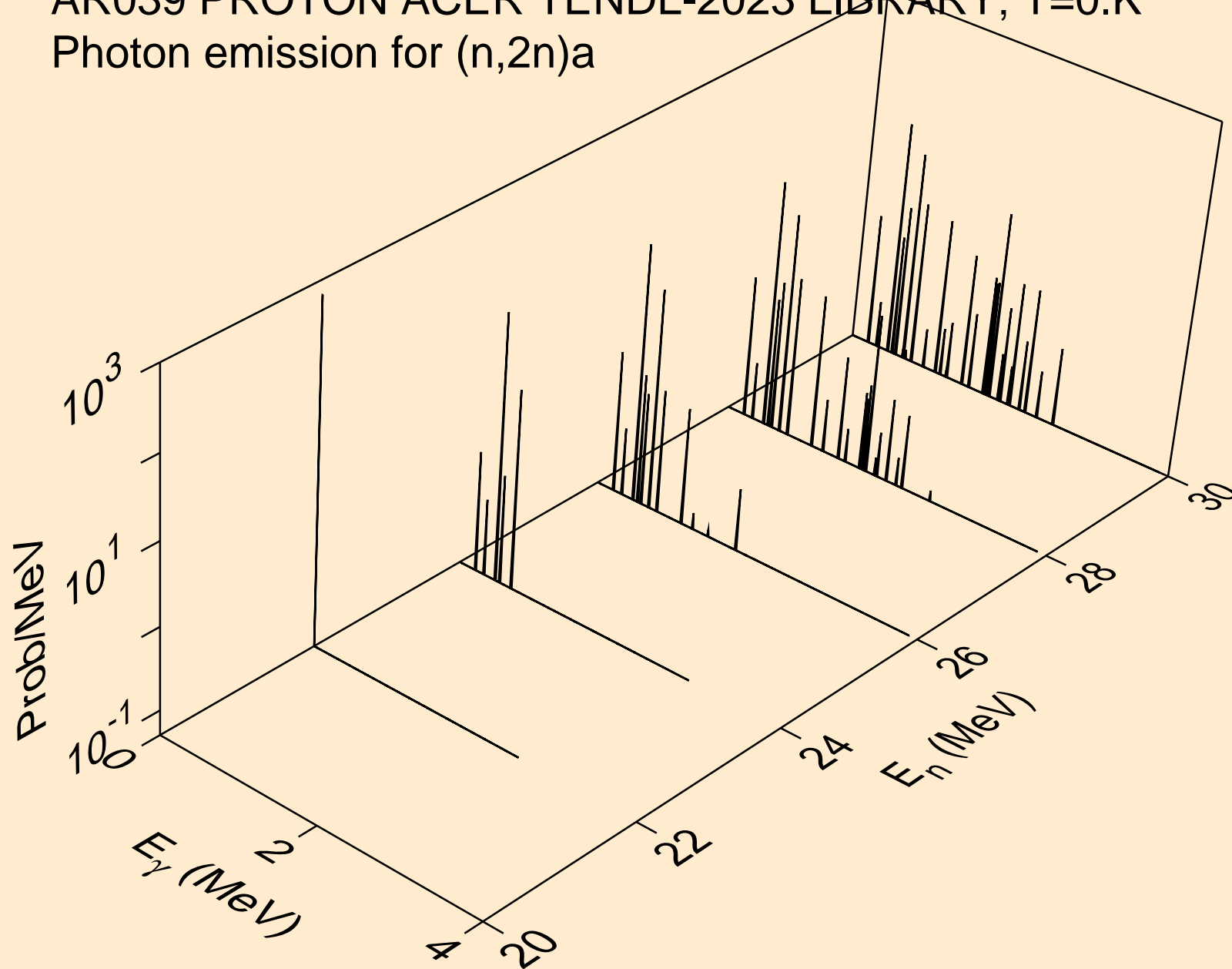

AR039 PROTON ACER TENDL-2023 LIBRARY; T=0.K  
Photon emission for (n,n\*)p

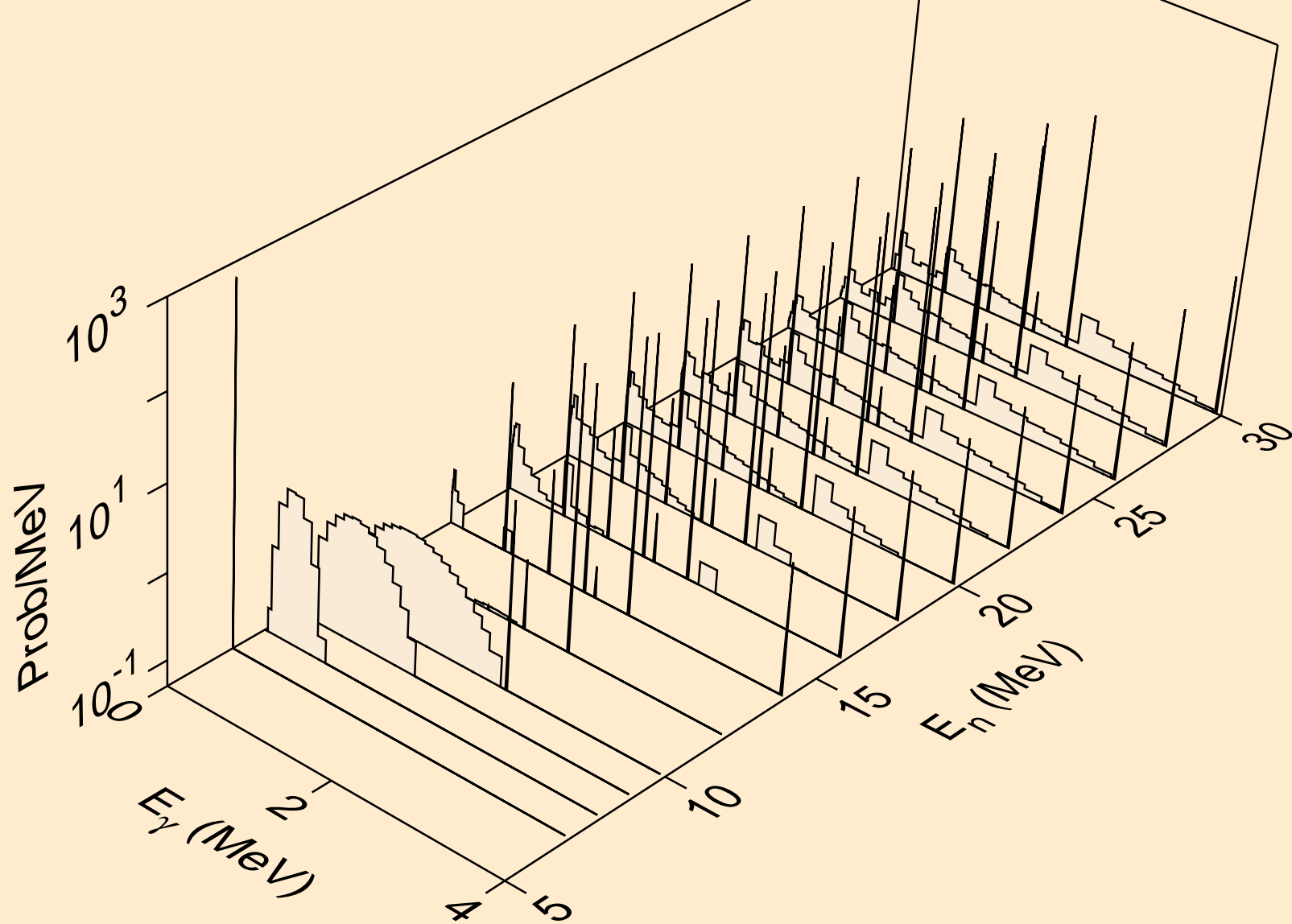

AR039 PROTON ACER TENDL-2023 LIBRARY; T=0.K  
Photon emission for (n,n\*)2a

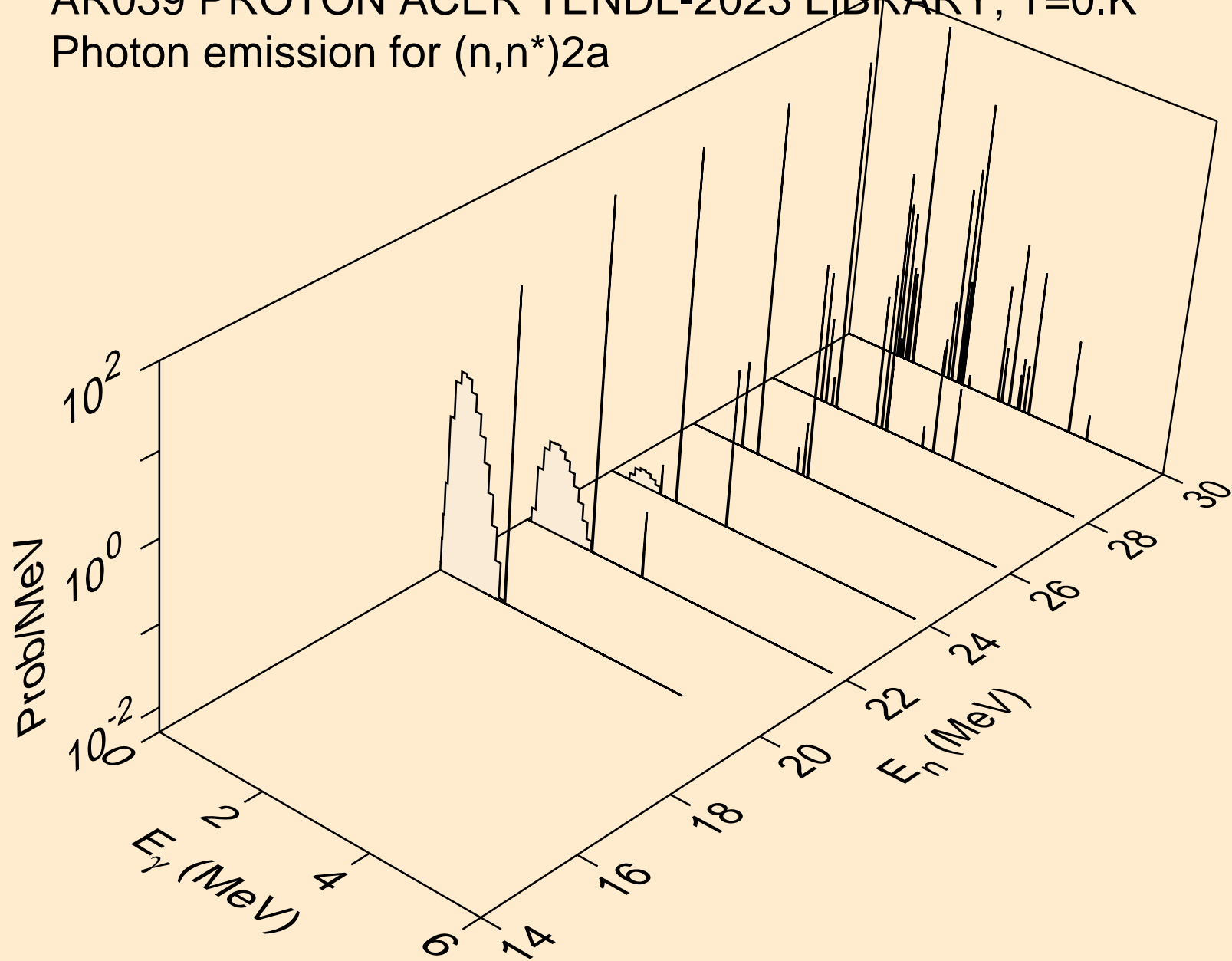

AR039 PROTON ACER TENDL-2023 LIBRARY; T=0.K  
Photon emission for (n,n\*)d

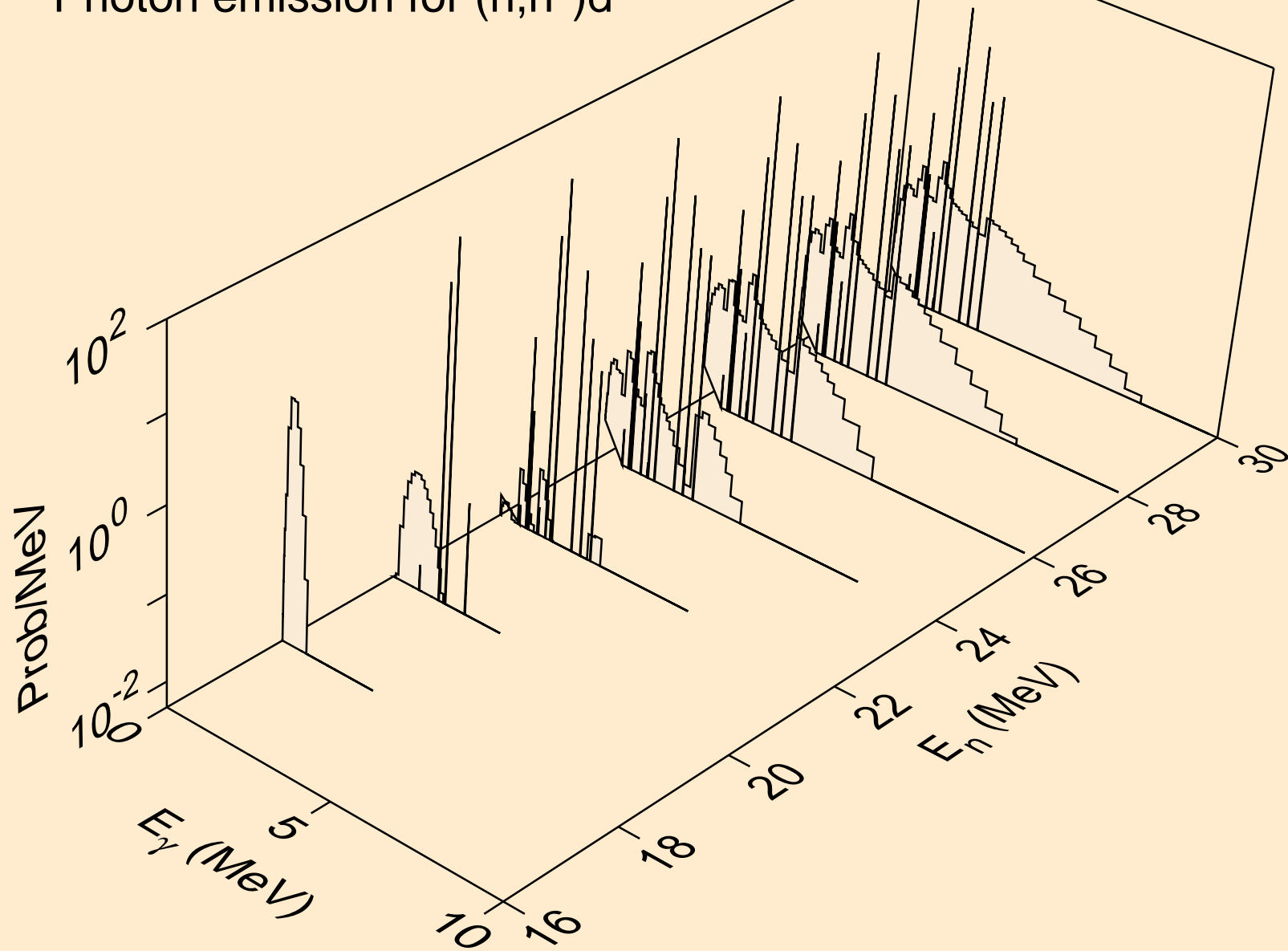

AR039 PROTON ACER TENDL-2023 LIBRARY; T=0.K  
Photon emission for (n,n\*)t

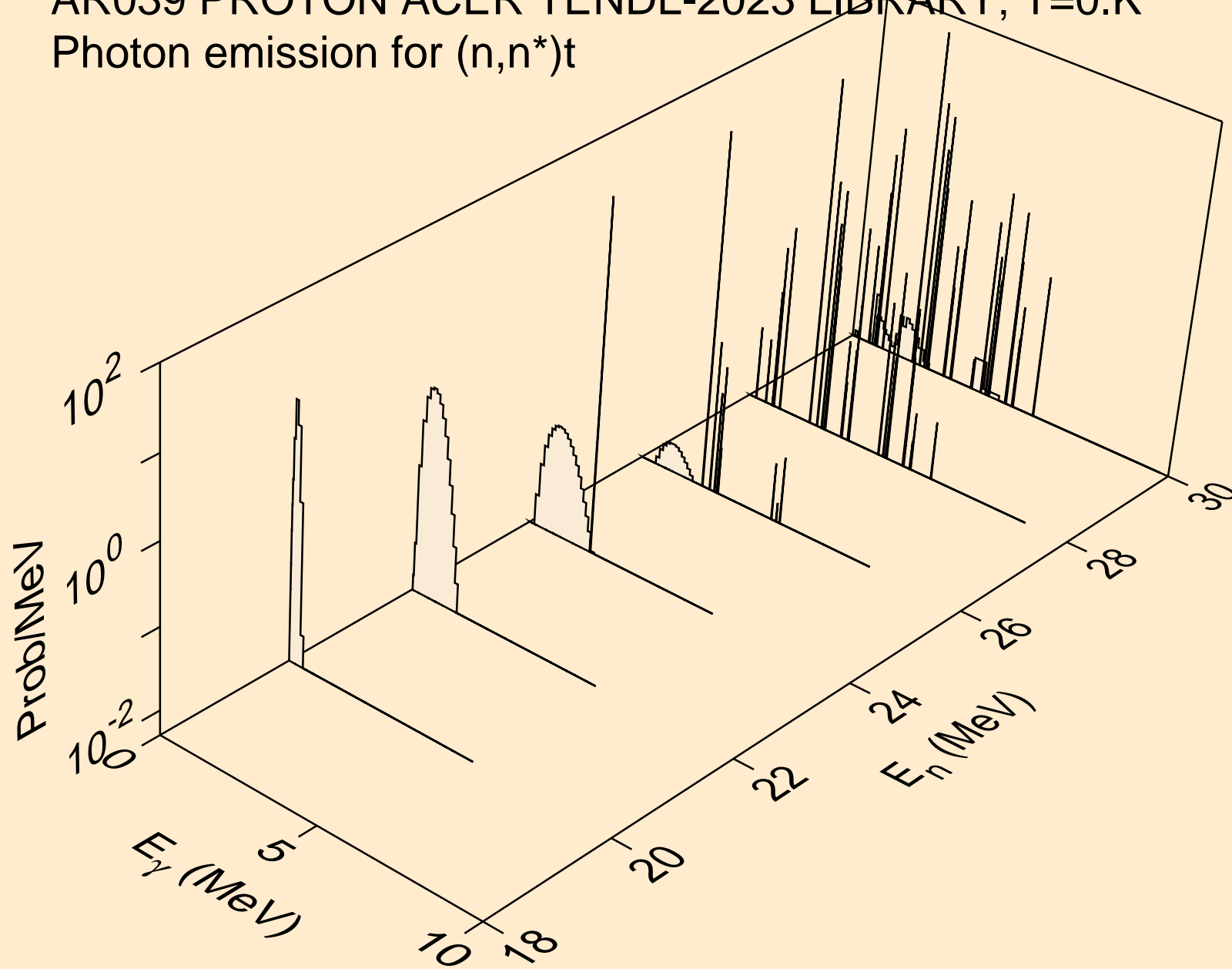

AR039 PROTON ACER TENDL-2023 LIBRARY; T=0.K  
Photon emission for (n,n\*)he3

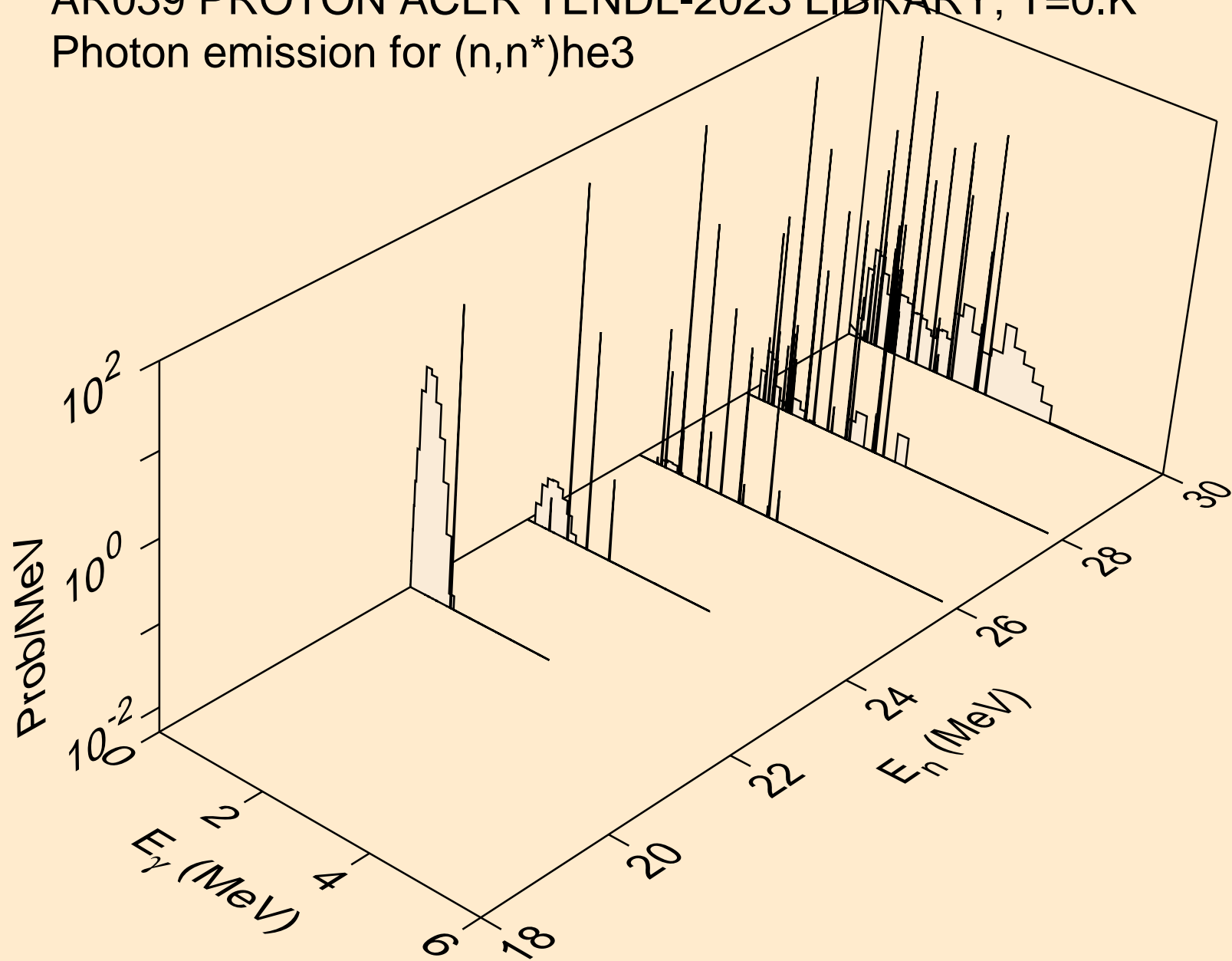



AR039 PROTON ACER TENDL-2023 LIBRARY; T=0.K  
Photon emission for (n,2np)

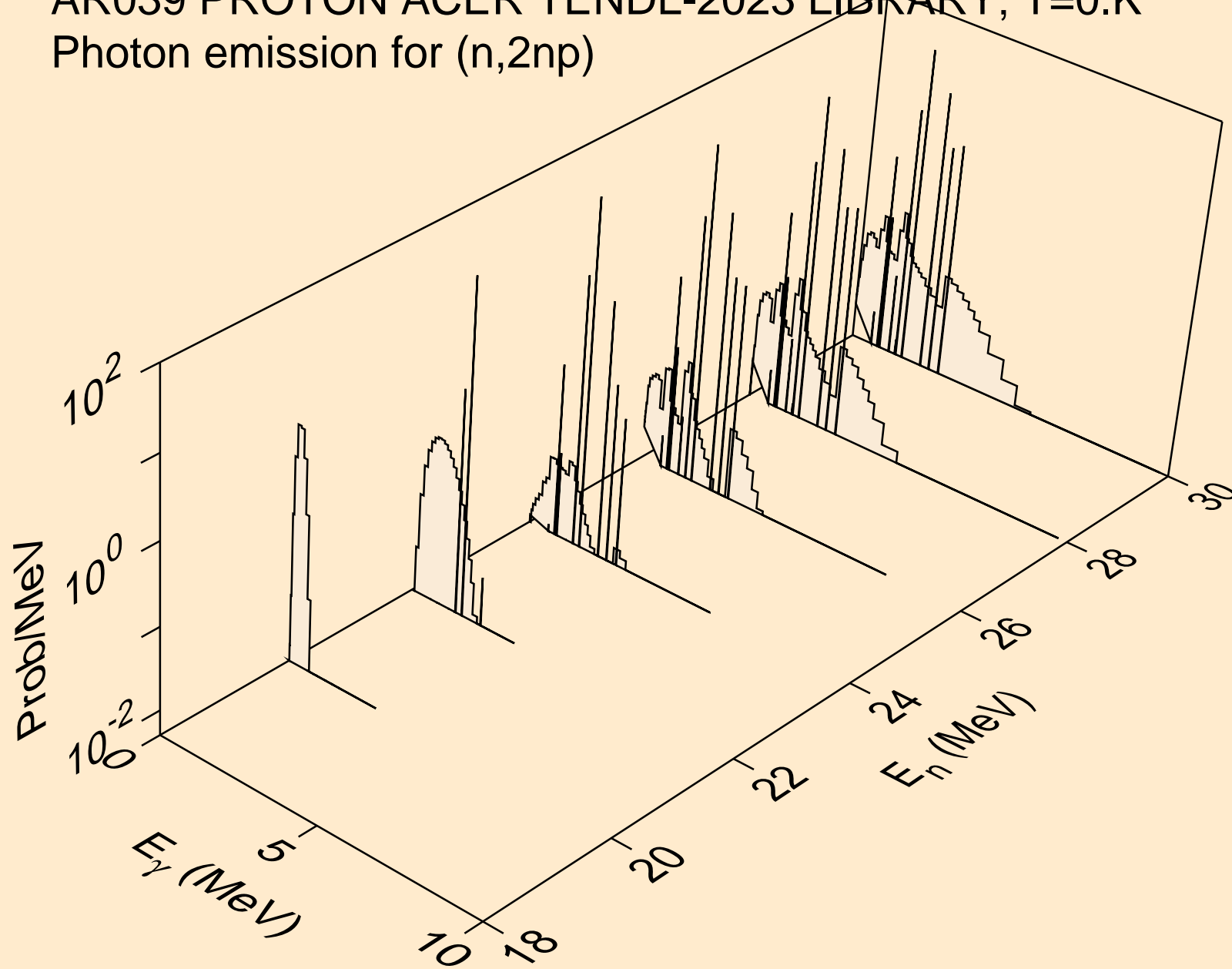

AR039 PROTON ACER TENDL-2023 LIBRARY; T=0.K  
Photon emission for (n,3np)

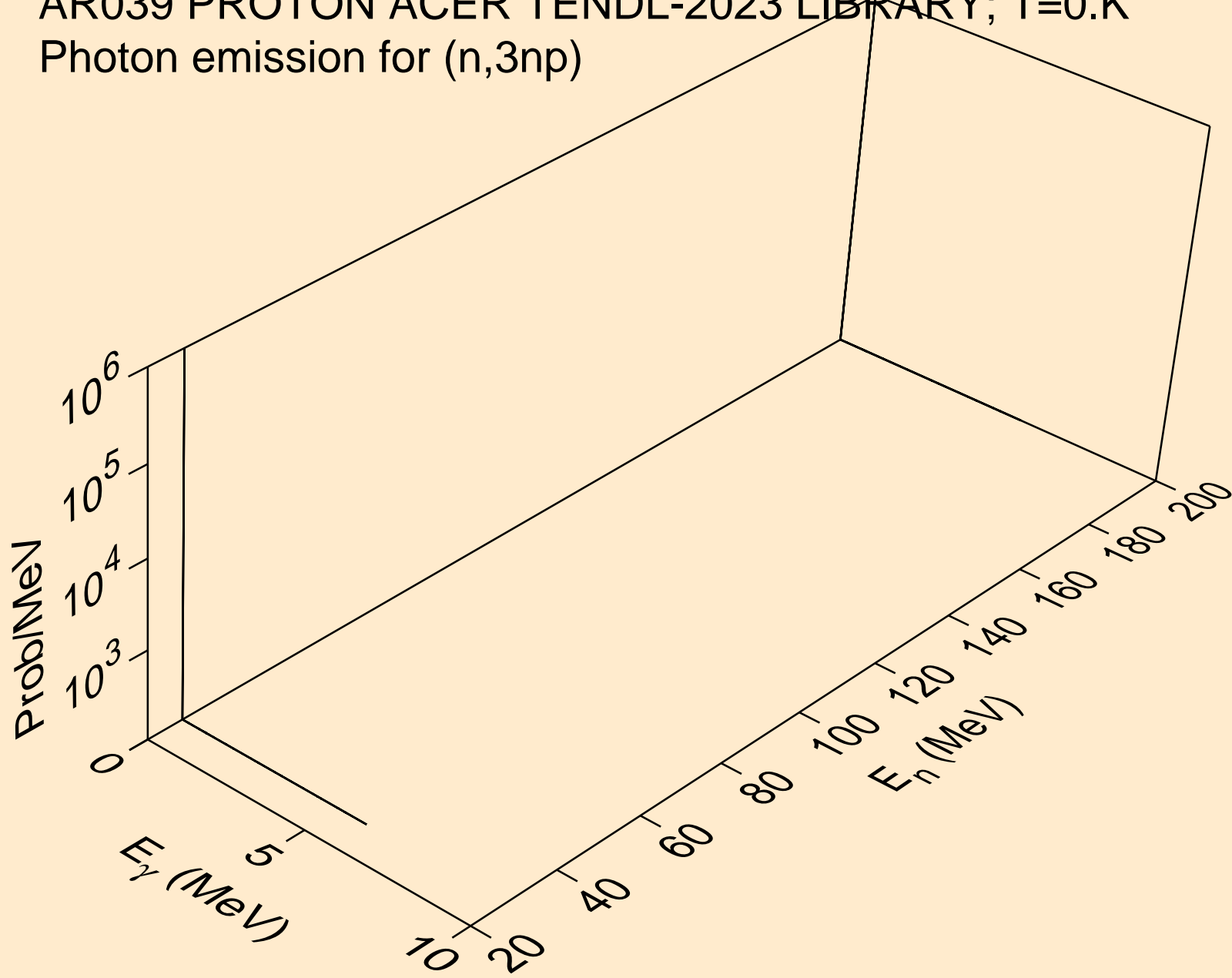

AR039 PROTON ACER TENDL-2023 LIBRARY; T=0.K  
Photon emission for (n,n2p)

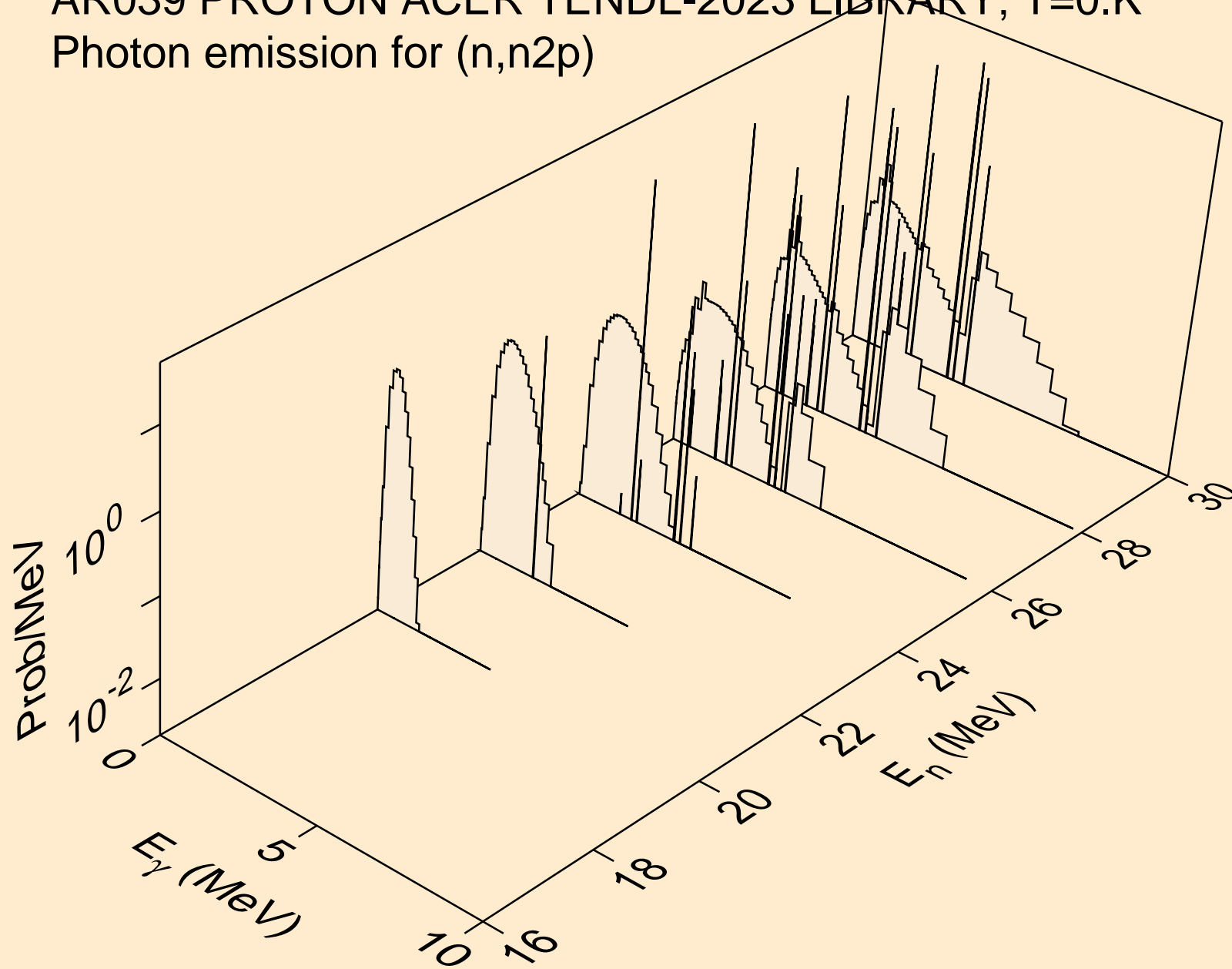

AR039 PROTON ACER TENDL-2023 LIBRARY; T=0.K  
Photon emission for (n,npa)

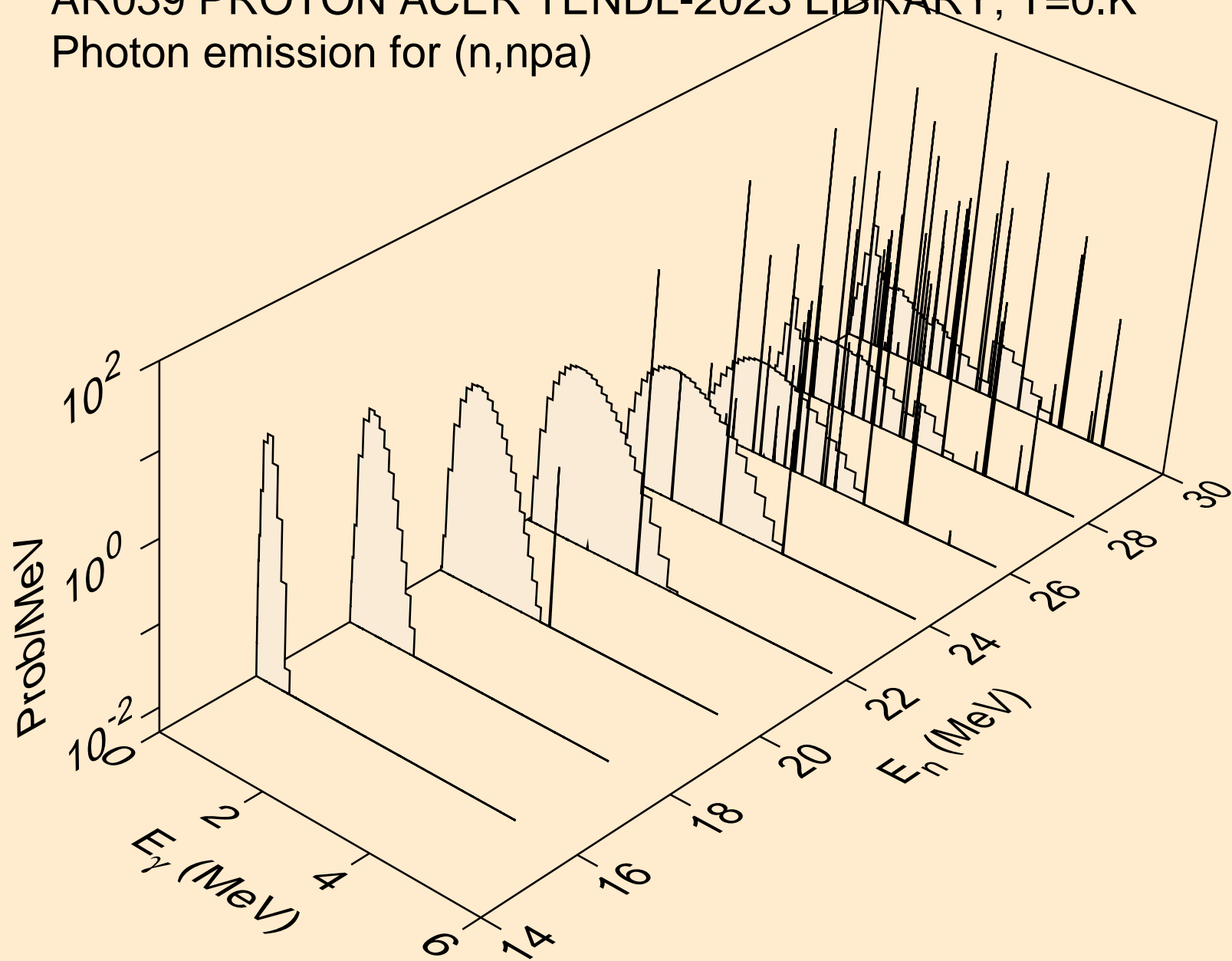

AR039 PROTON ACER TENDL-2023 LIBRARY; T=0.K  
Photon emission for (n,gma)

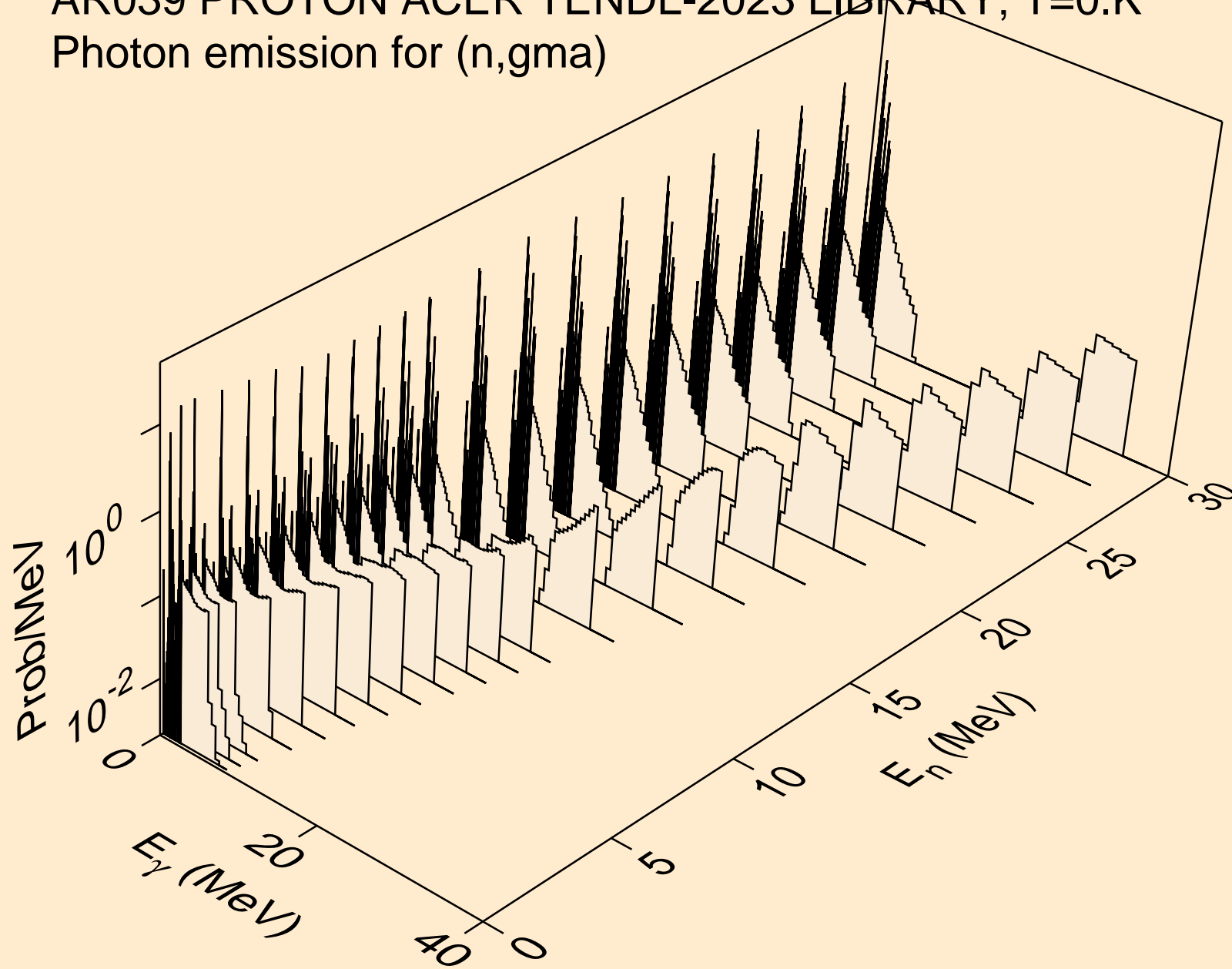

AR039 PROTON ACER TENDL-2023 LIBRARY; T=0.K  
Photon emission for inelastic

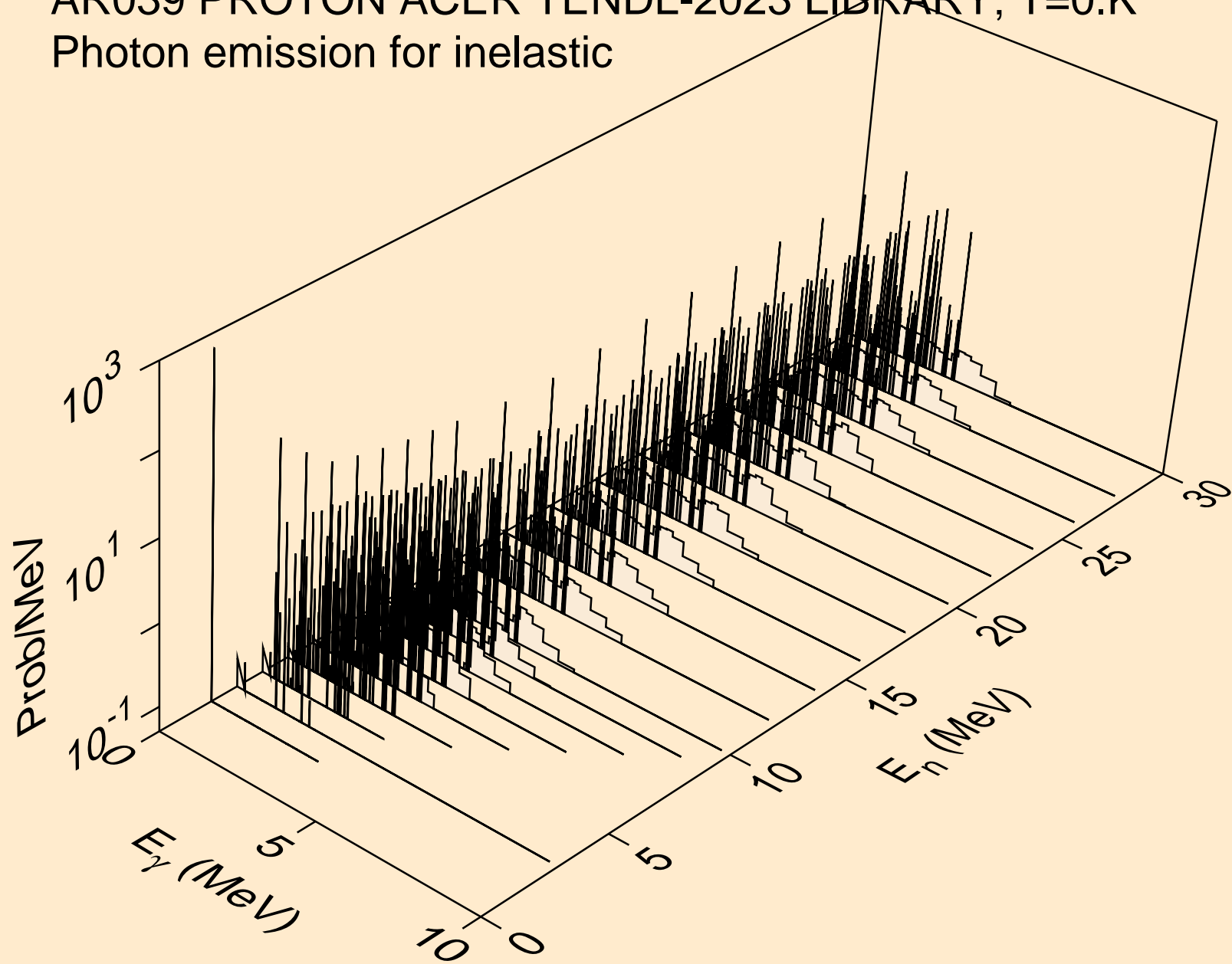

AR039 PROTON ACER TENDL-2023 LIBRARY; T=0.K  
Photon emission for (n,d)

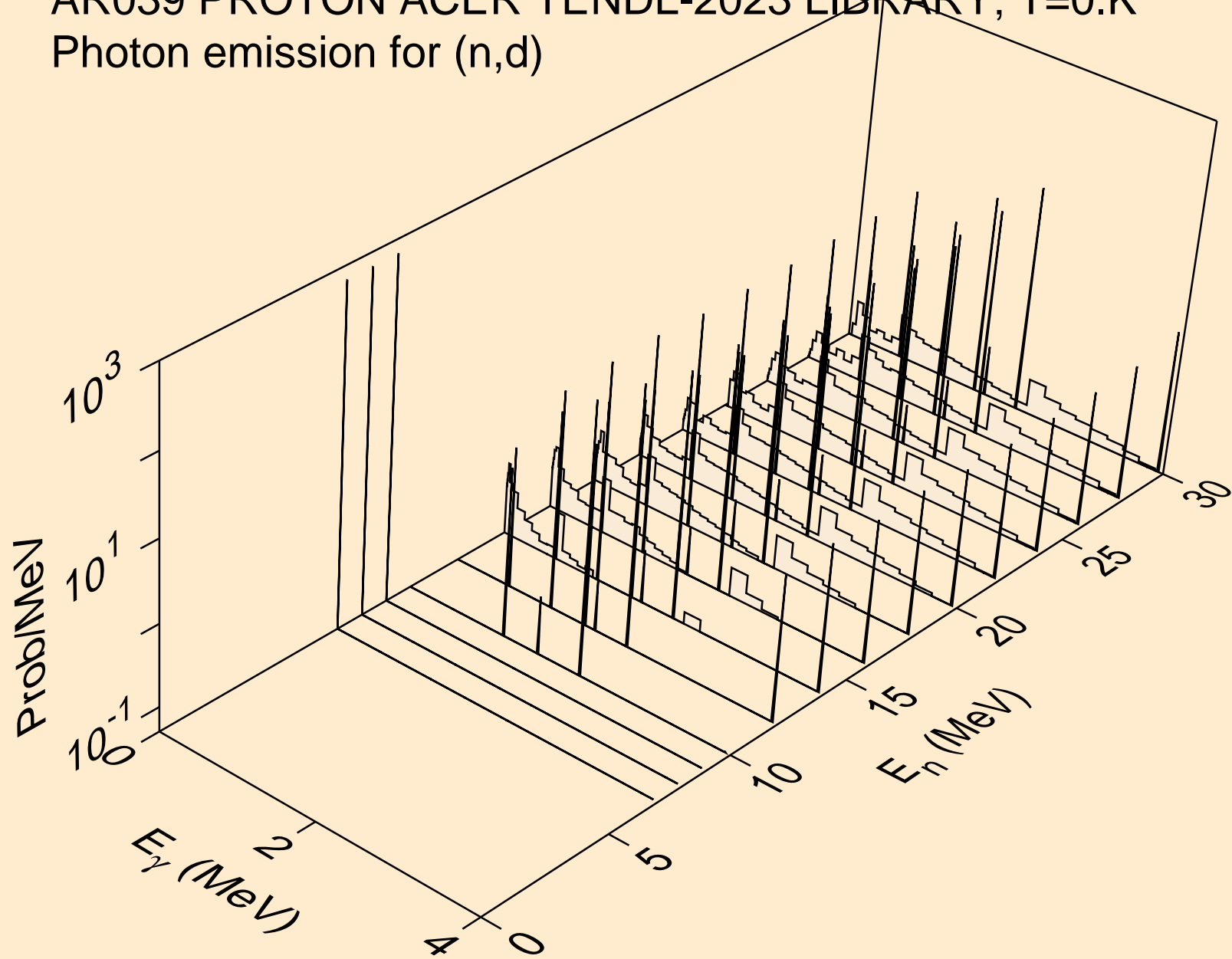

AR039 PROTON ACER TENDL-2023 LIBRARY; T=0.K  
Photon emission for (n,t)

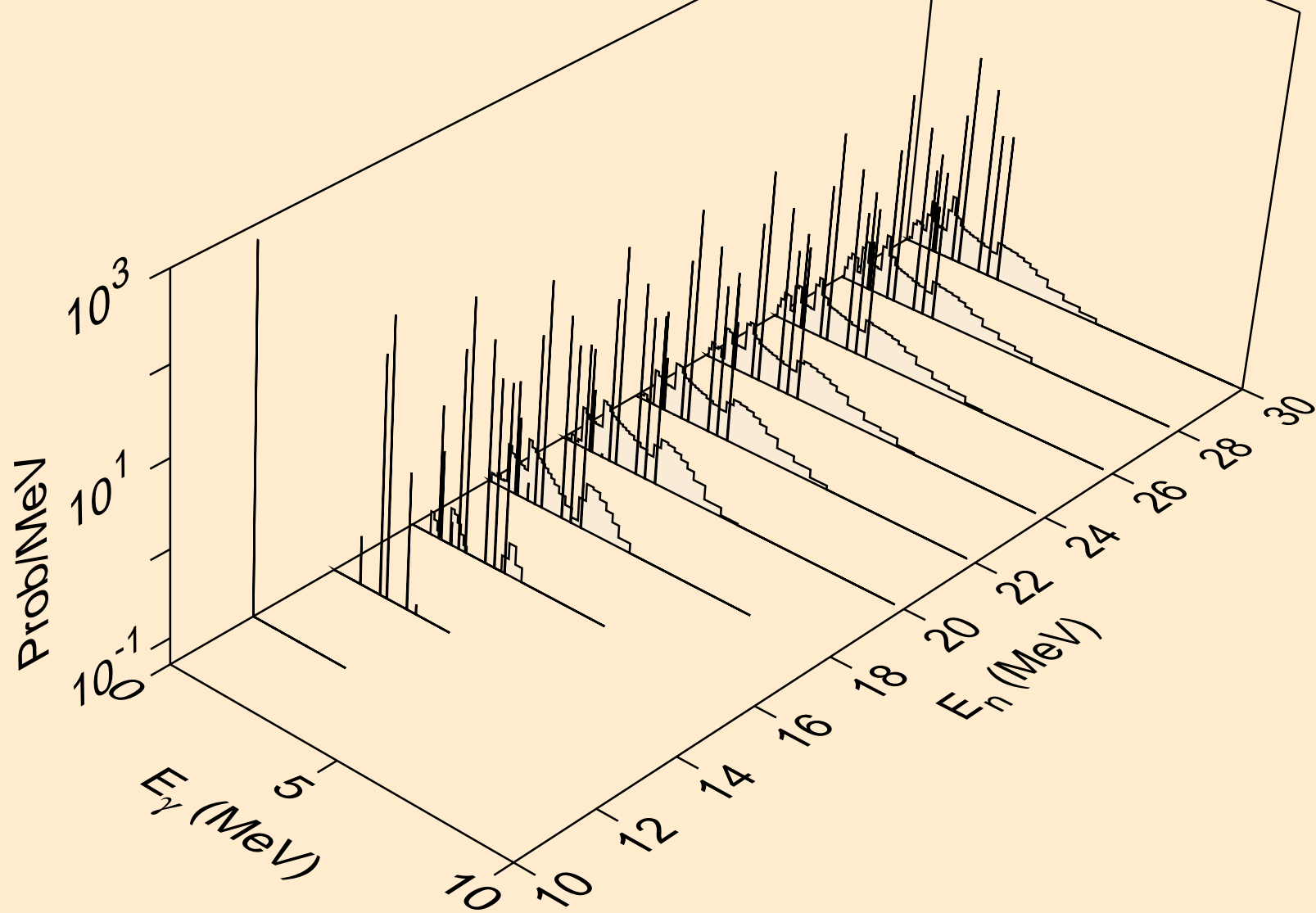



AR039 PROTON ACER TENDL-2023 LIBRARY; T=0.K  
Photon emission for (n,he3)

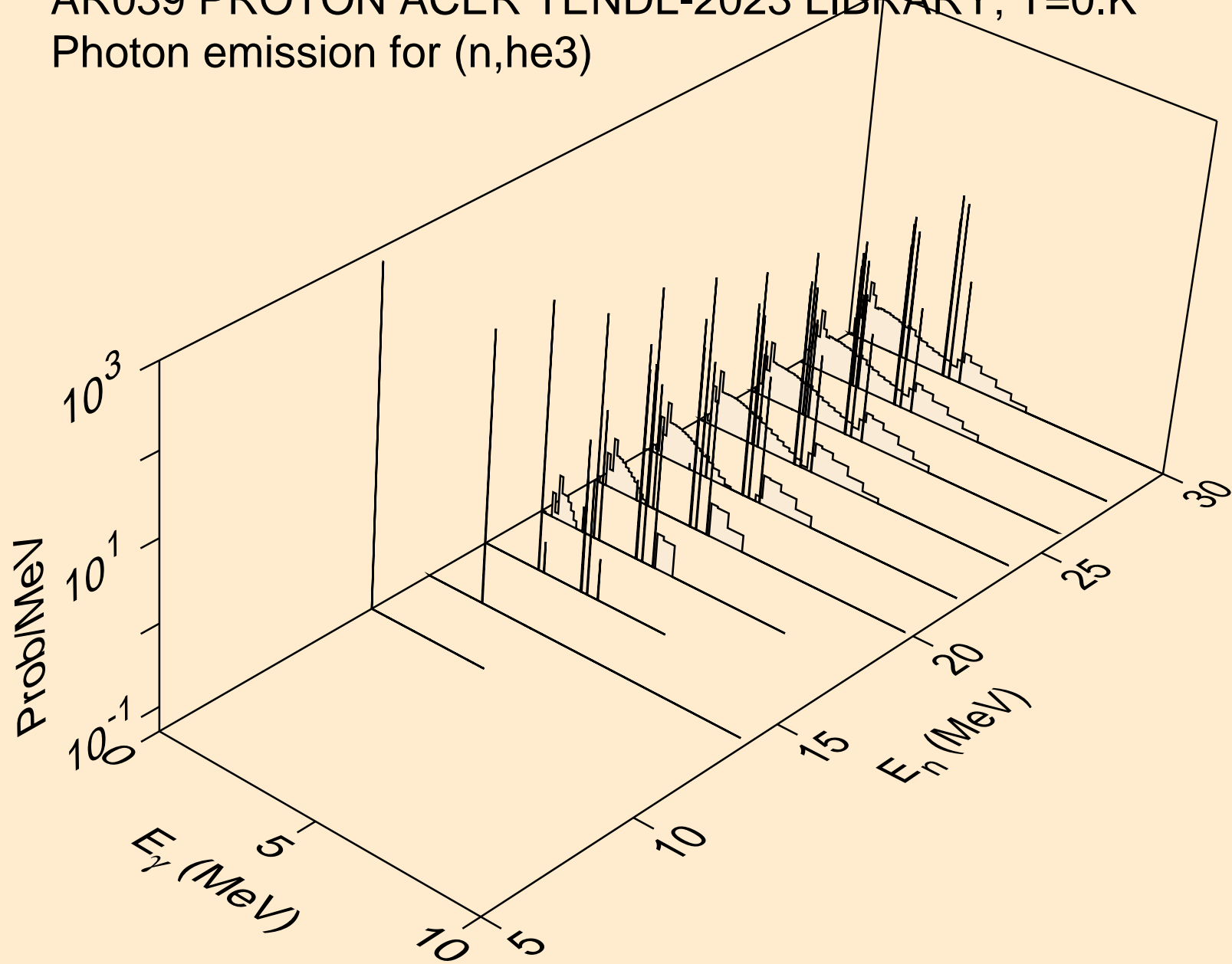

AR039 PROTON ACER TENDL-2023 LIBRARY; T=0.K  
Photon emission for (n,a)

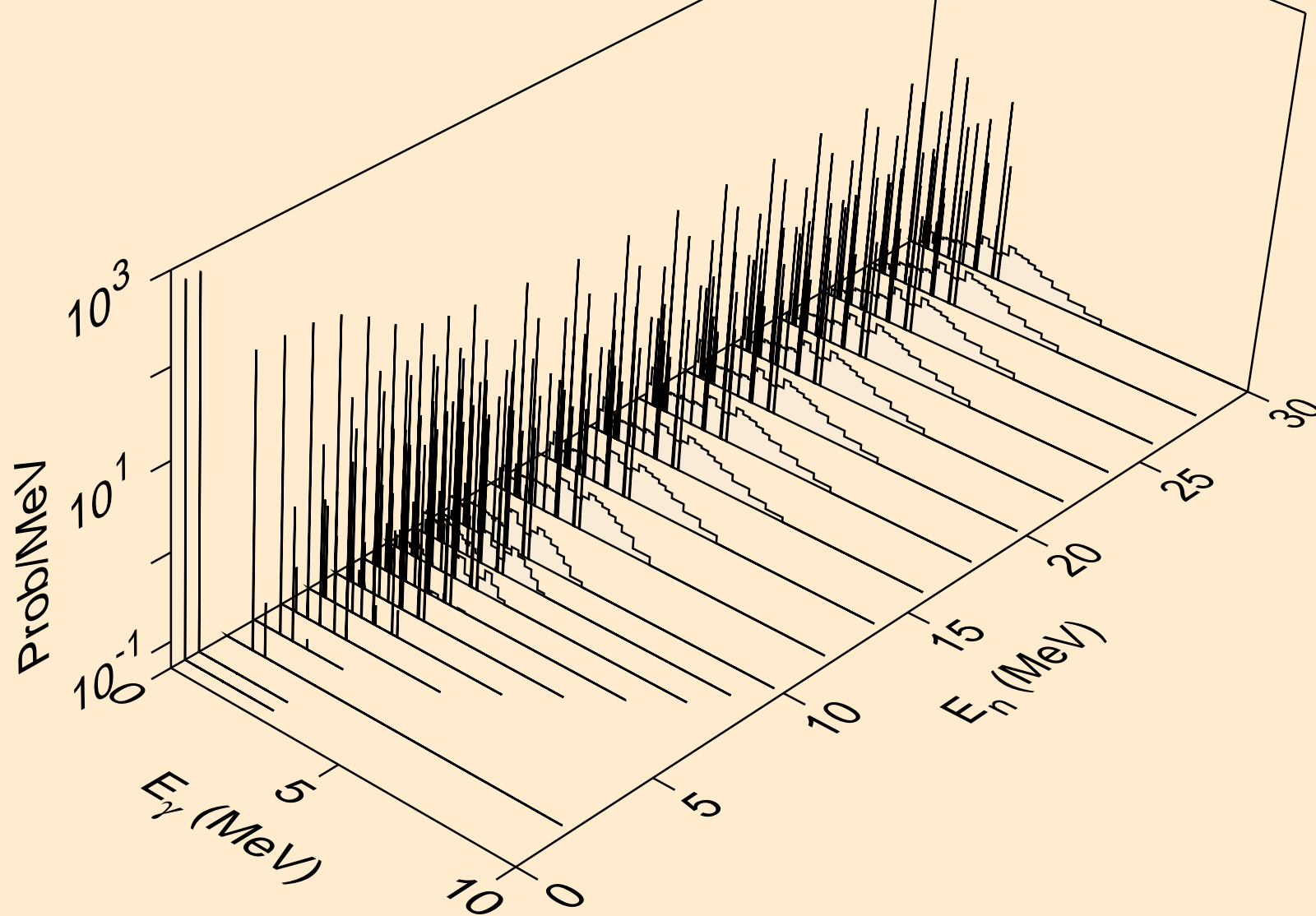

AR039 PROTON ACER TENDL-2023 LIBRARY; T=0.K  
Photon emission for (n,2a)

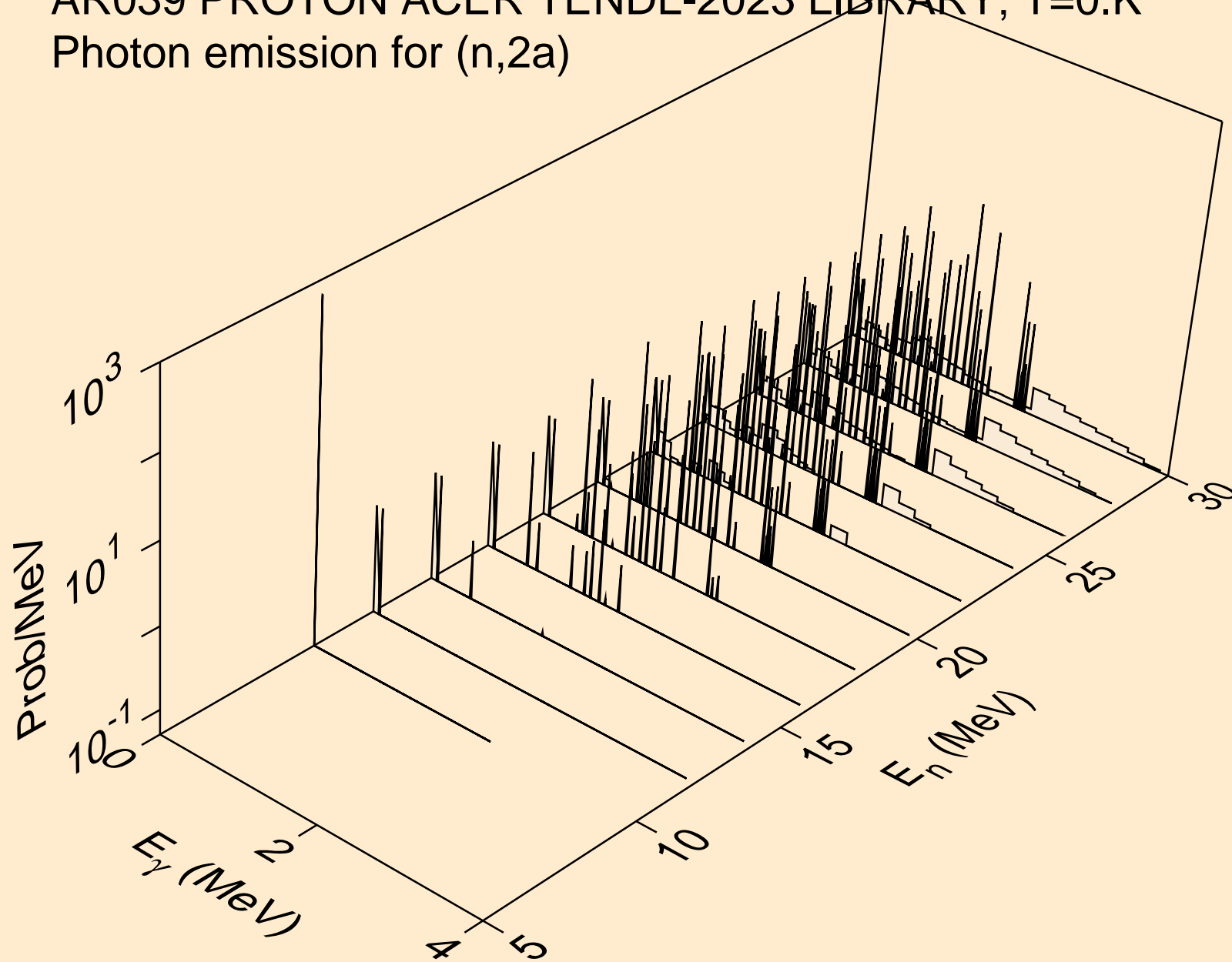

AR039 PROTON ACER TENDL-2023 LIBRARY; T=0.K  
Photon emission for (n,2p)

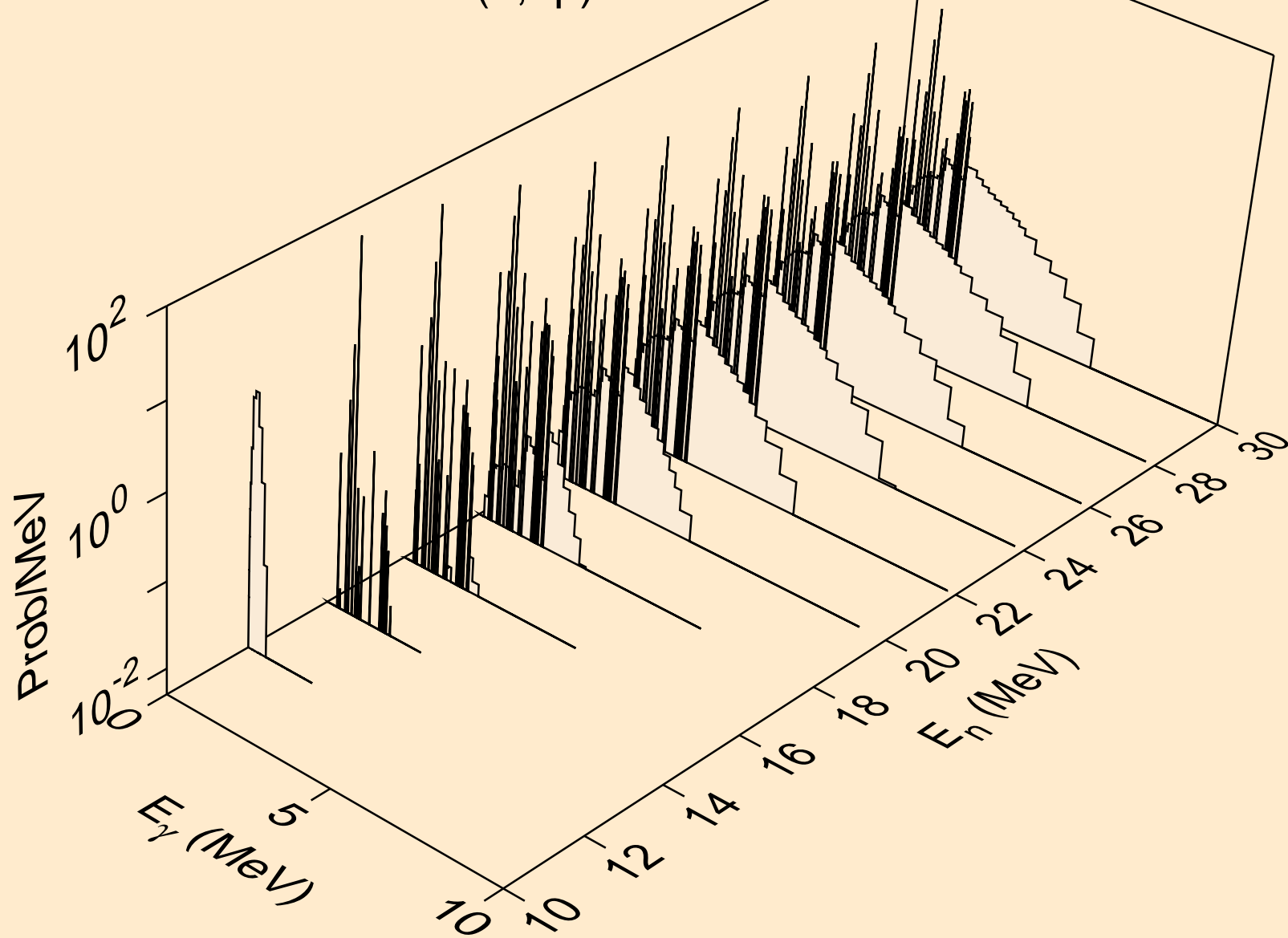

AR039 PROTON ACER TENDL-2023 LIBRARY; T=0.K  
Photon emission for (n,pa)

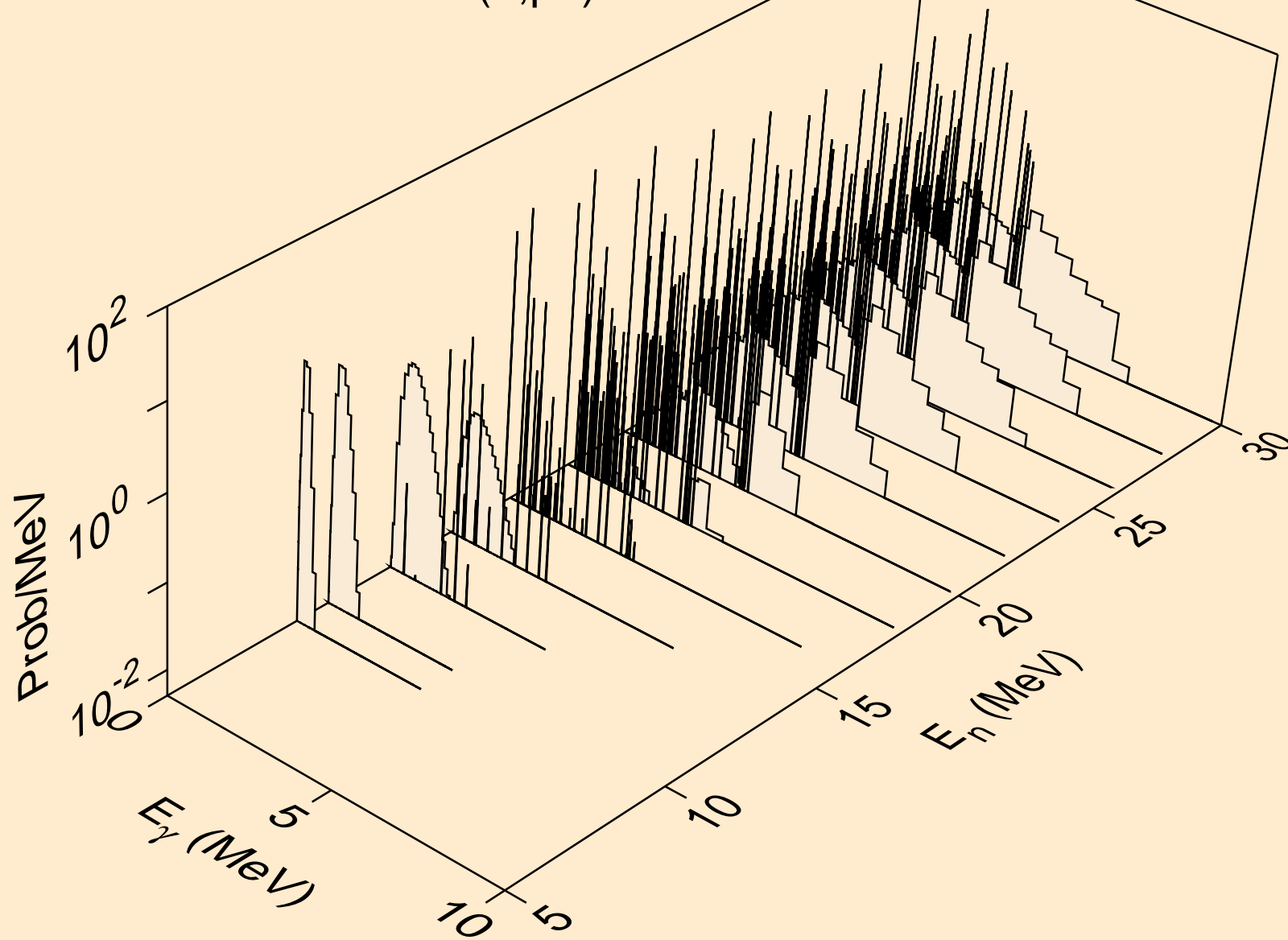

AR039 PROTON ACER TENDL-2023 LIBRARY; T=0.K  
Photon emission for (n,d2a)

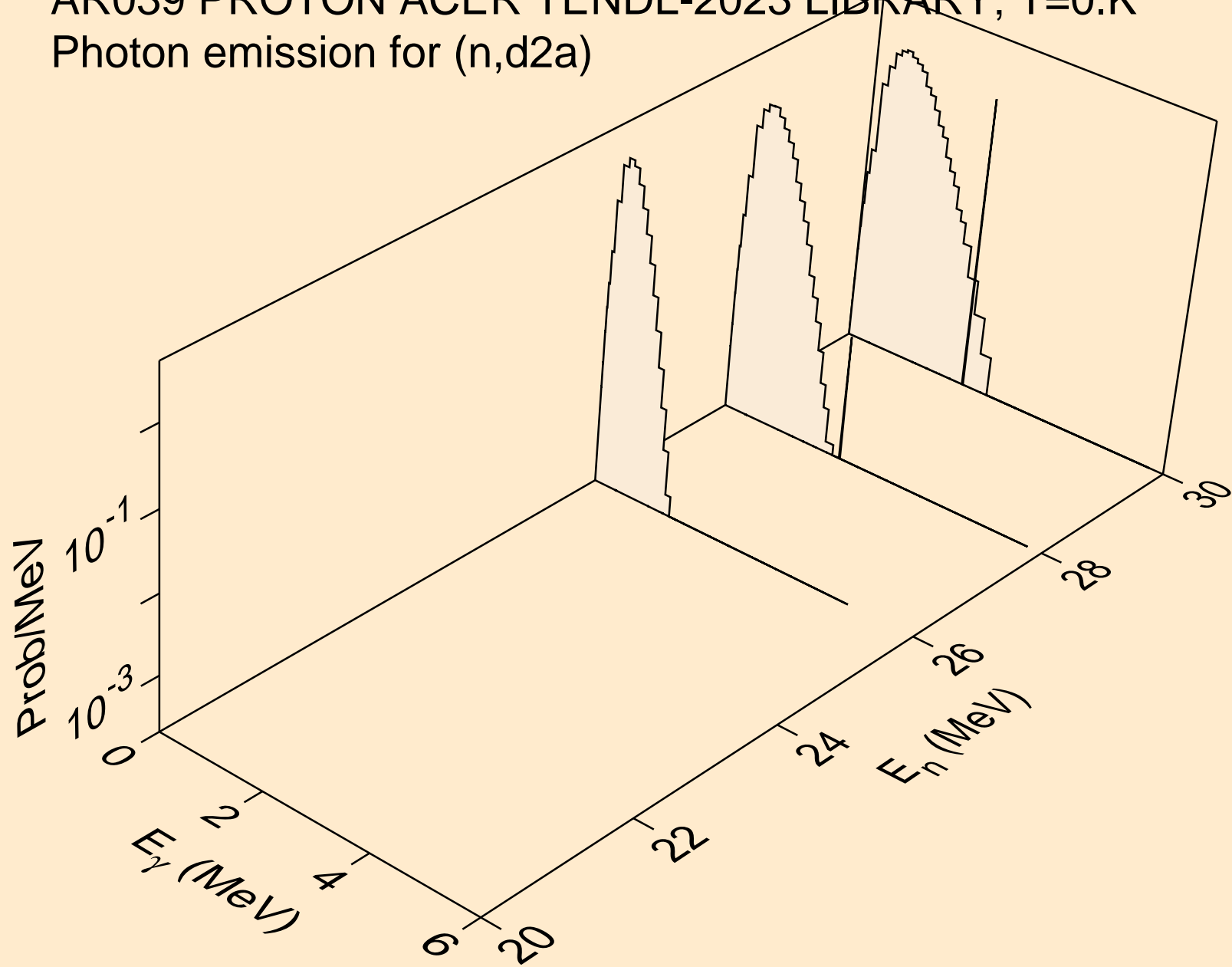

AR039 PROTON ACER TENDL-2023 LIBRARY; T=0.K  
Photon emission for (n,pd)

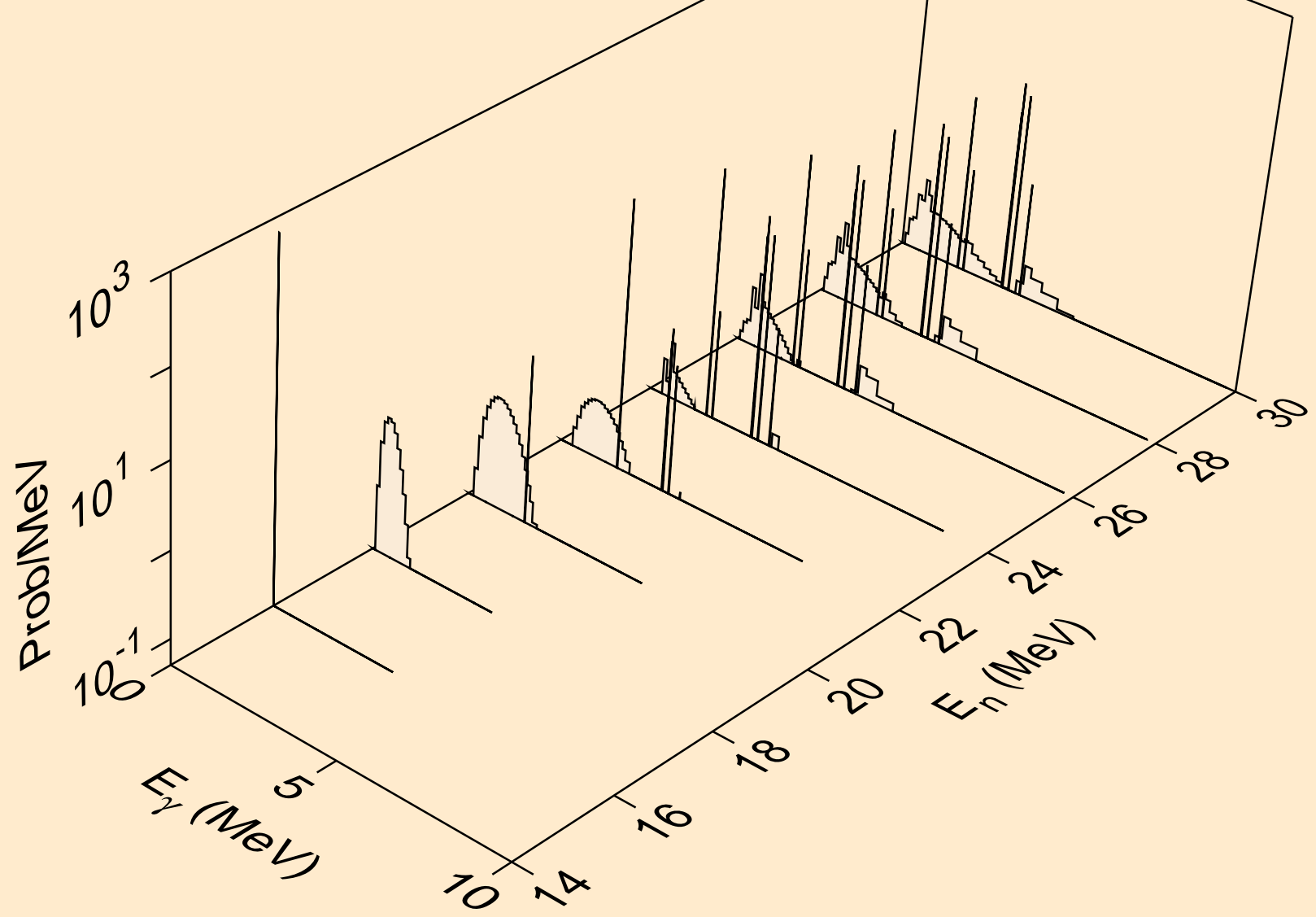

AR039 PROTON ACER TENDL-2023 LIBRARY; T=0.K  
Photon emission for (n,pt)

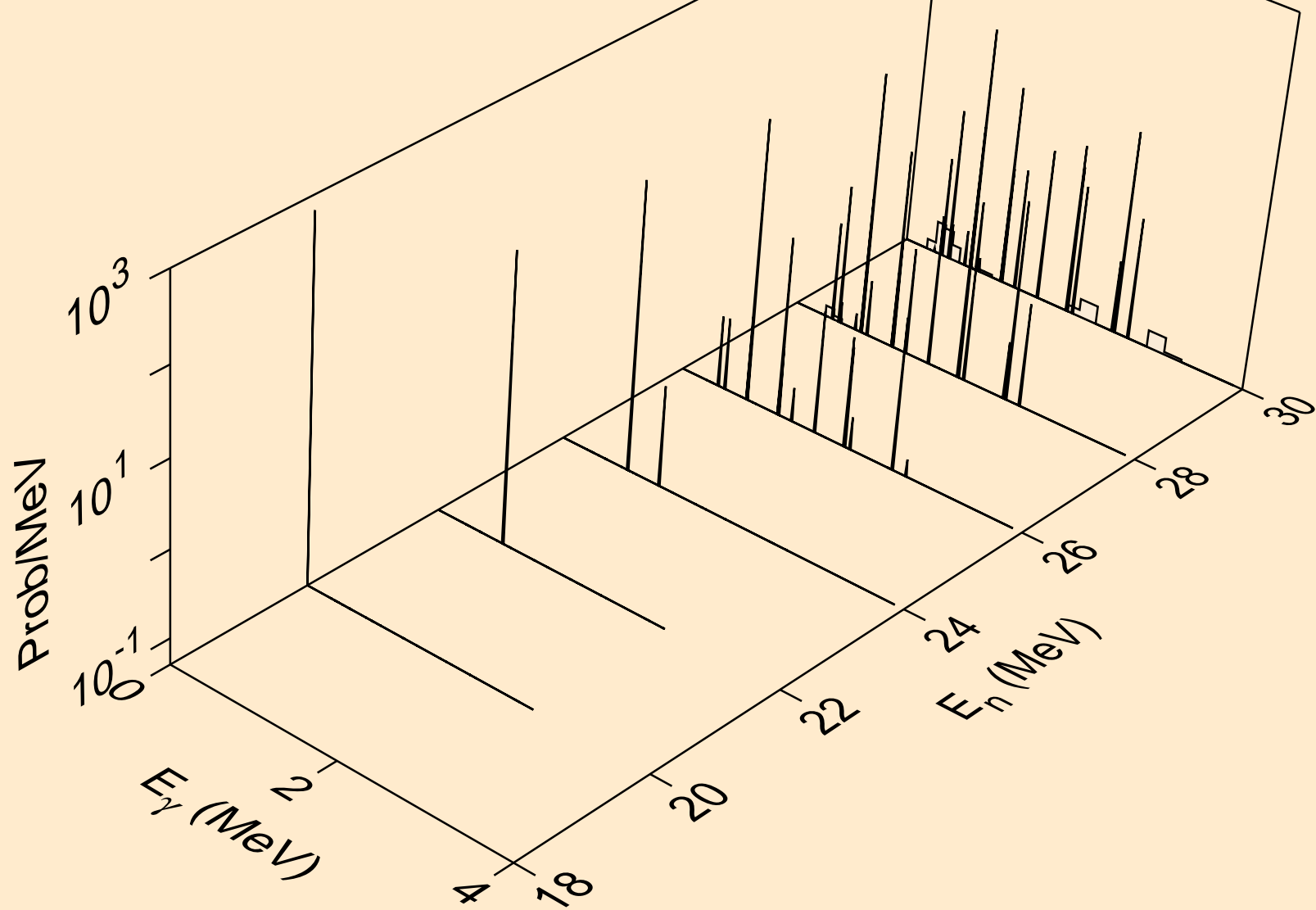



AR039 PROTON ACER TENDL-2023 LIBRARY; T=0.K  
Photon emission for (n,da)

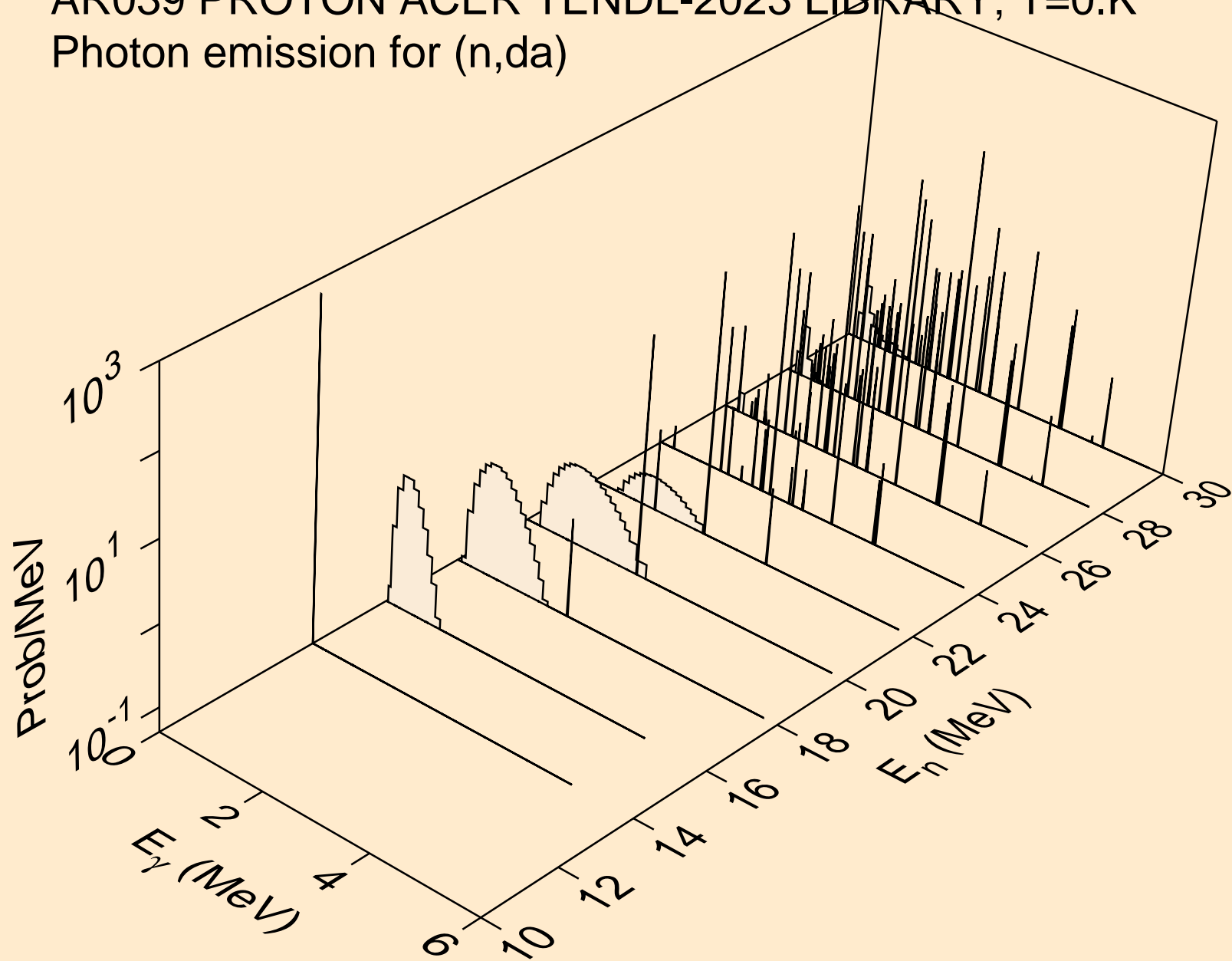

AR039 PROTON ACER TENDL-2023 LIBRARY; T=0.K  
Particle heating contributions

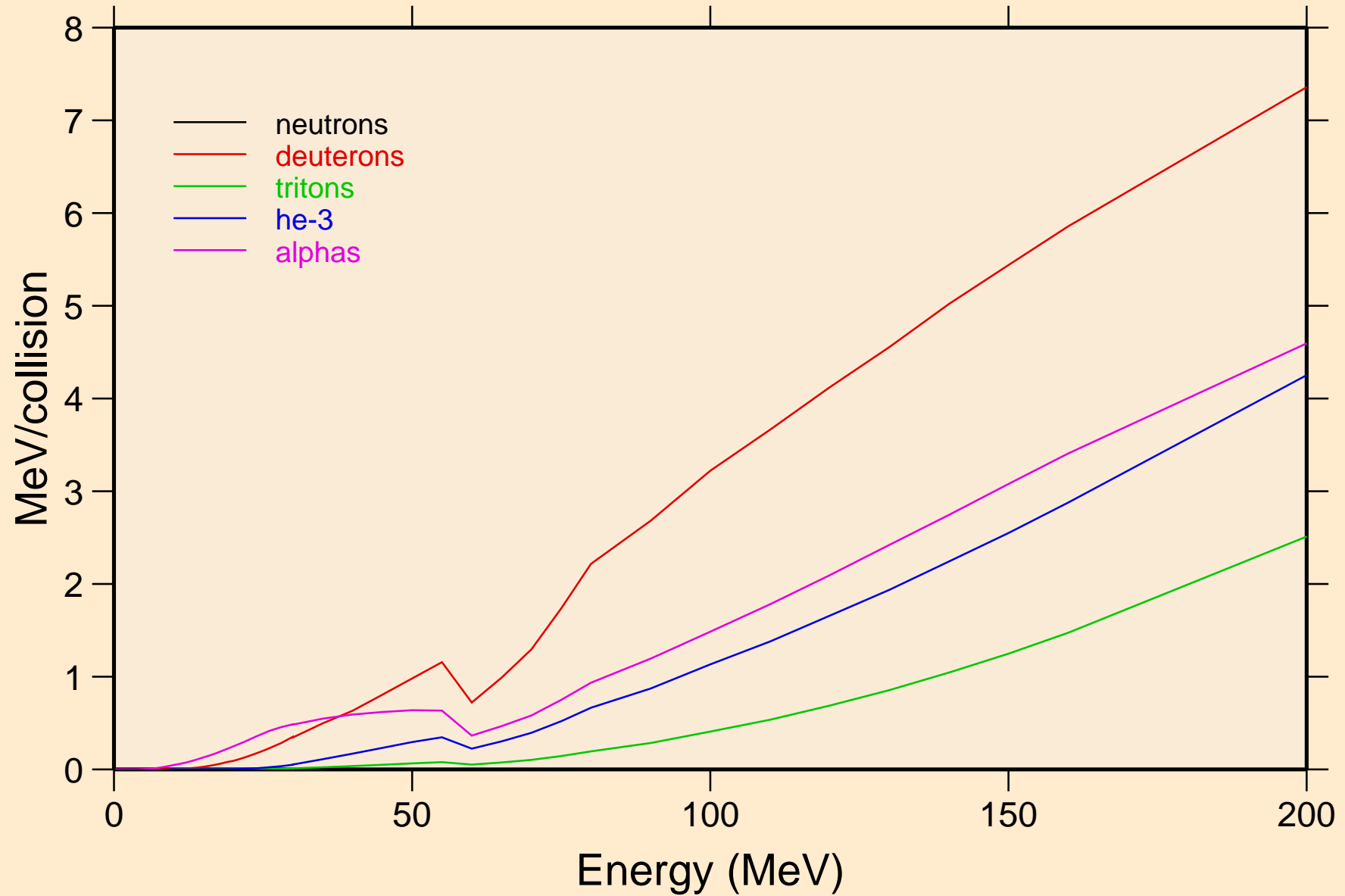

AR039 PROTON ACER TENDL-2023 LIBRARY; T=0.K  
Recoil Heating

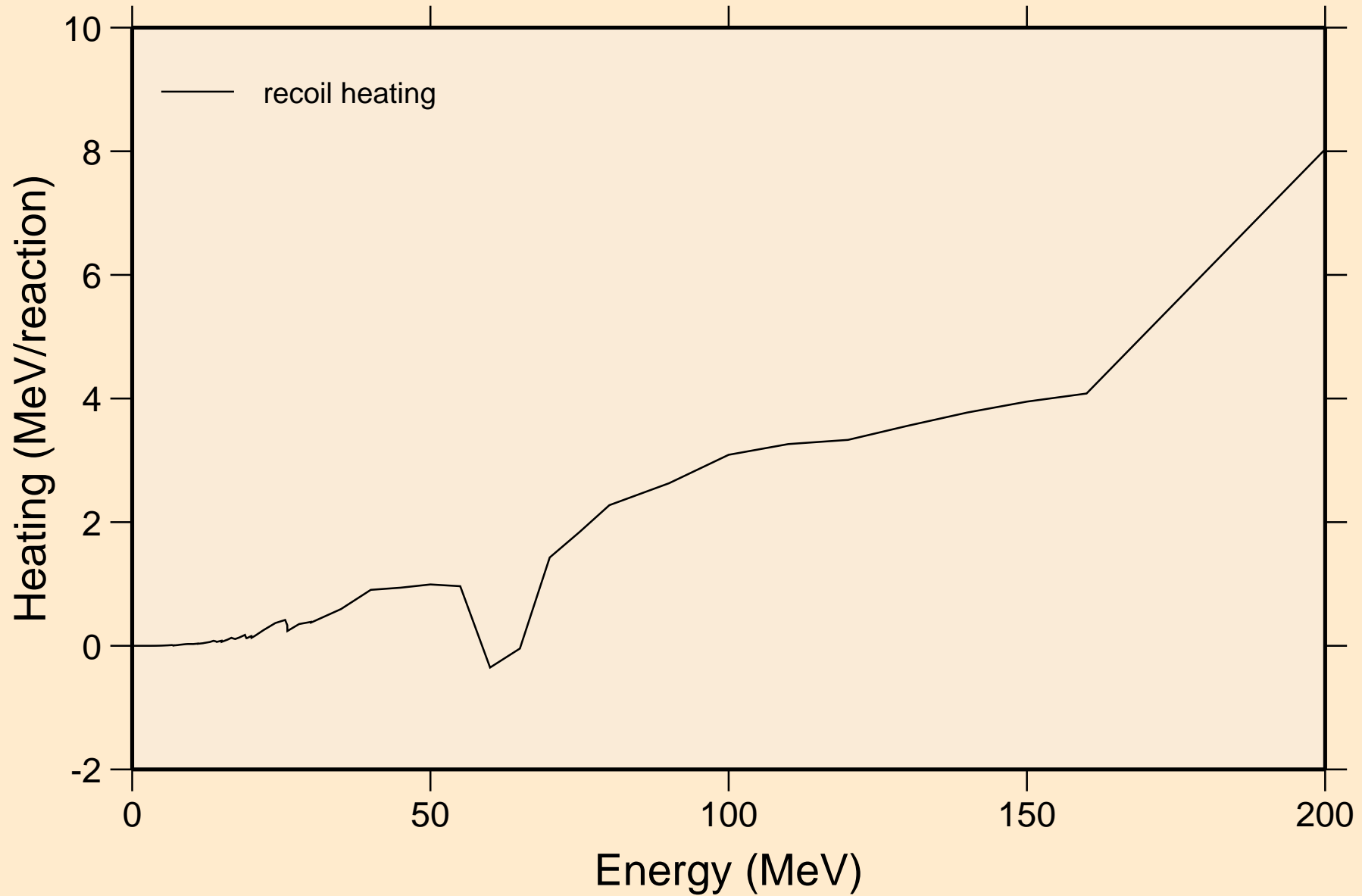

AR039 PROTON ACER TENDL-2023 LIBRARY; T=0.K  
Particle production cross sections

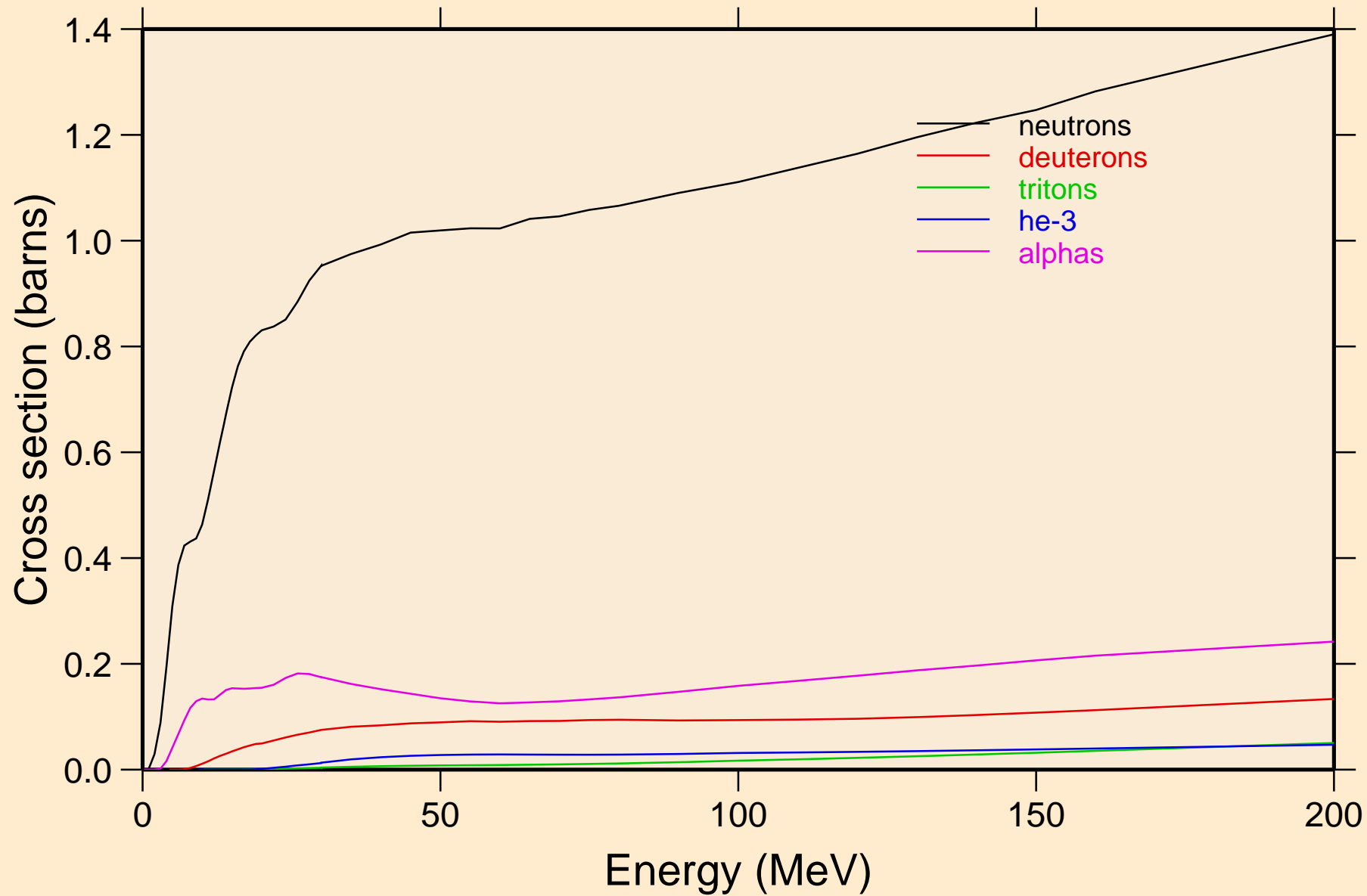

AR039 PROTON ACER TENDL-2023 LIBRARY; T=0.K  
neutrons from (p,n)

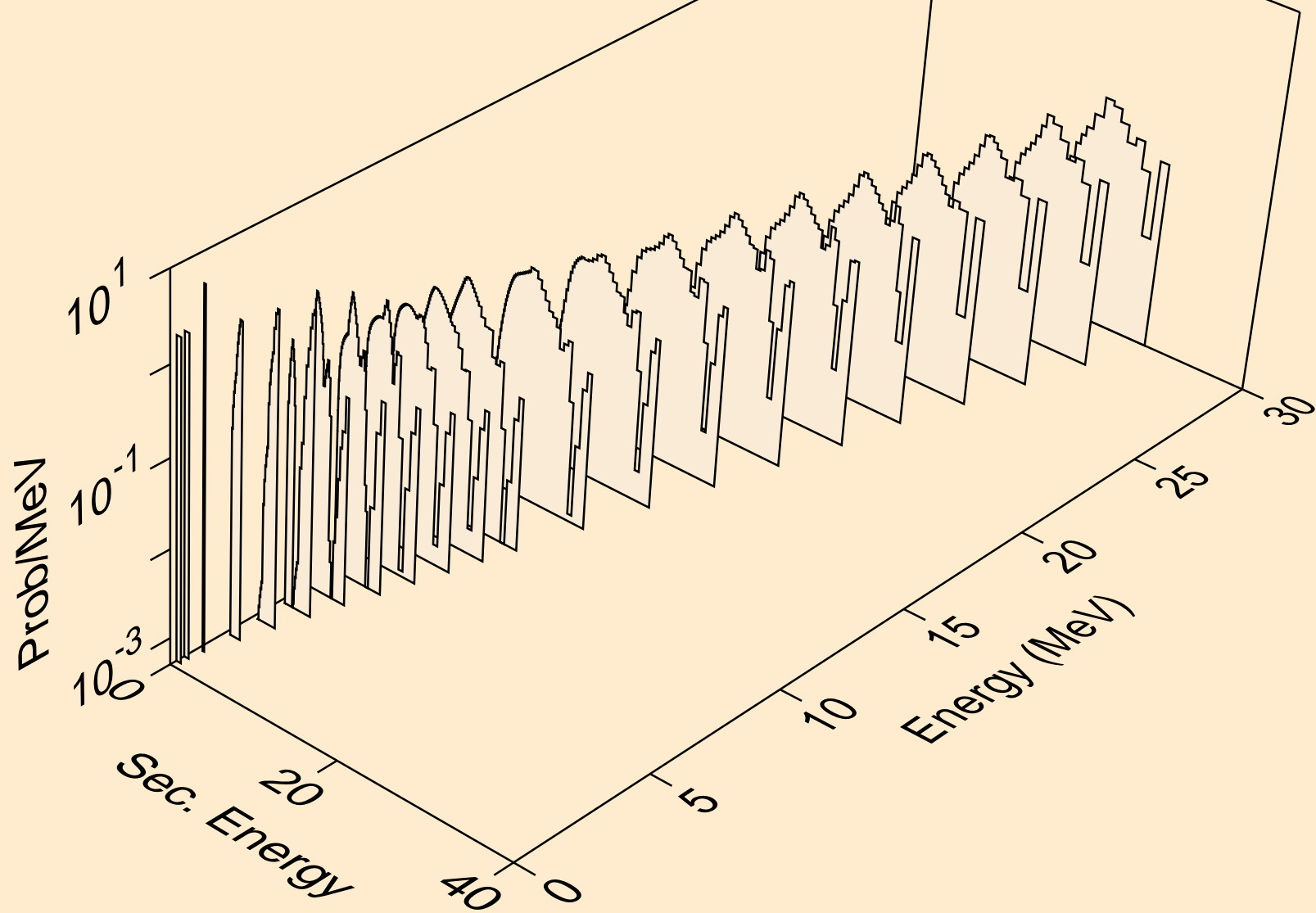

AR039 PROTON ACER TENDL-2023 LIBRARY; T=0.K  
neutrons from (p,x)

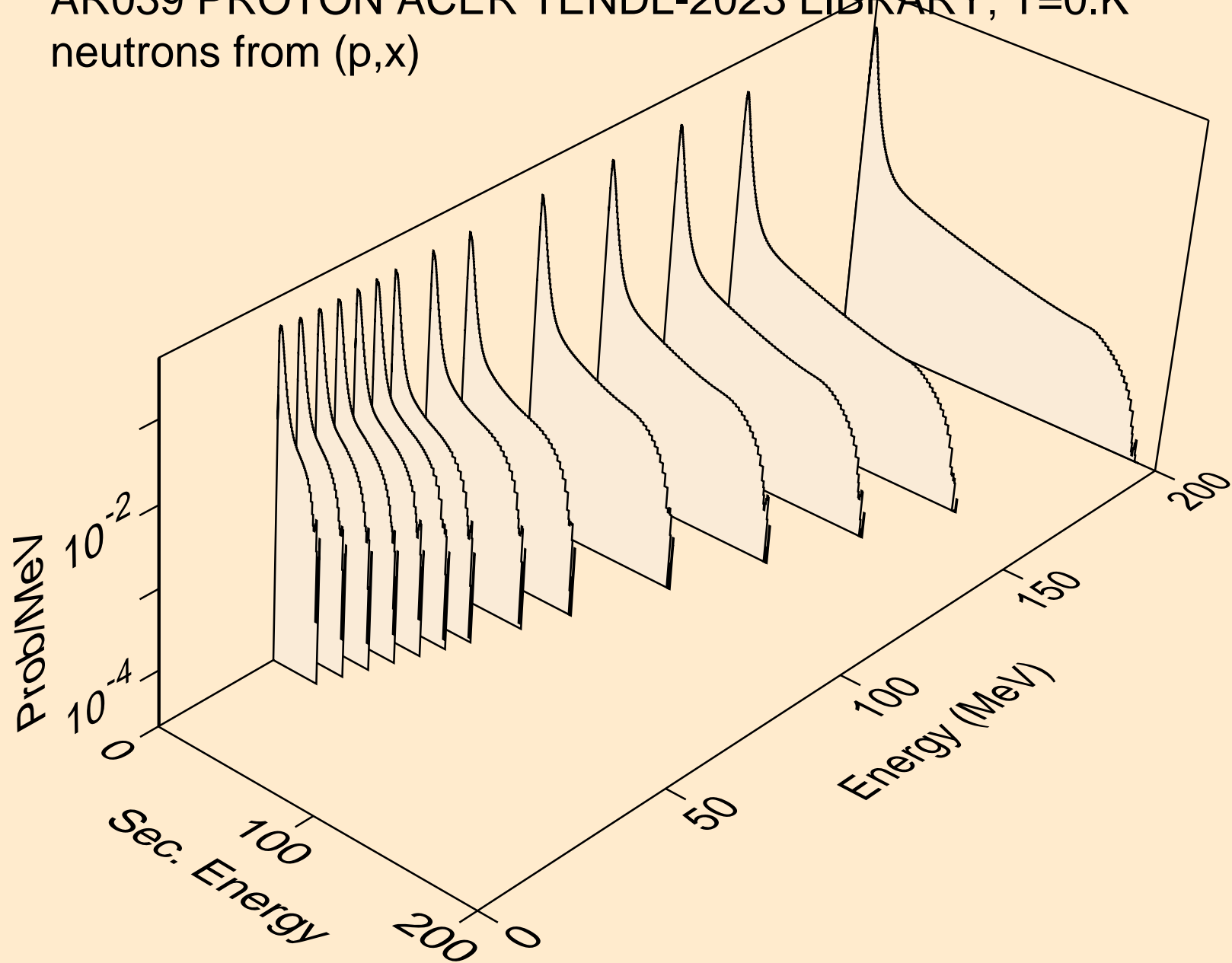

AR039 PROTON ACER TENDL-2023 LIBRARY; T=0.K  
neutrons from (p,2nd)

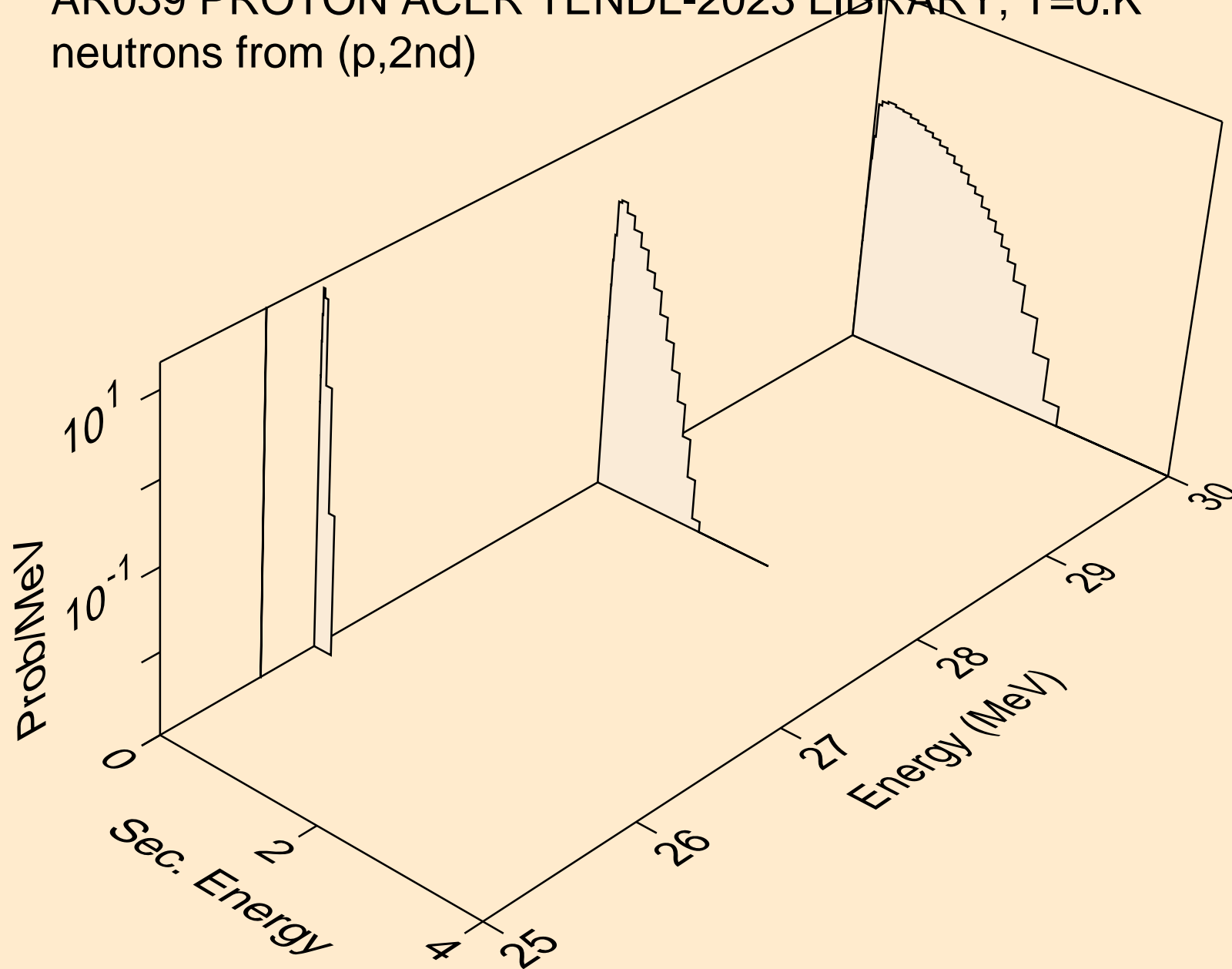

AR039 PROTON ACER TENDL-2023 LIBRARY; T=0.K  
neutrons from (p,2n)

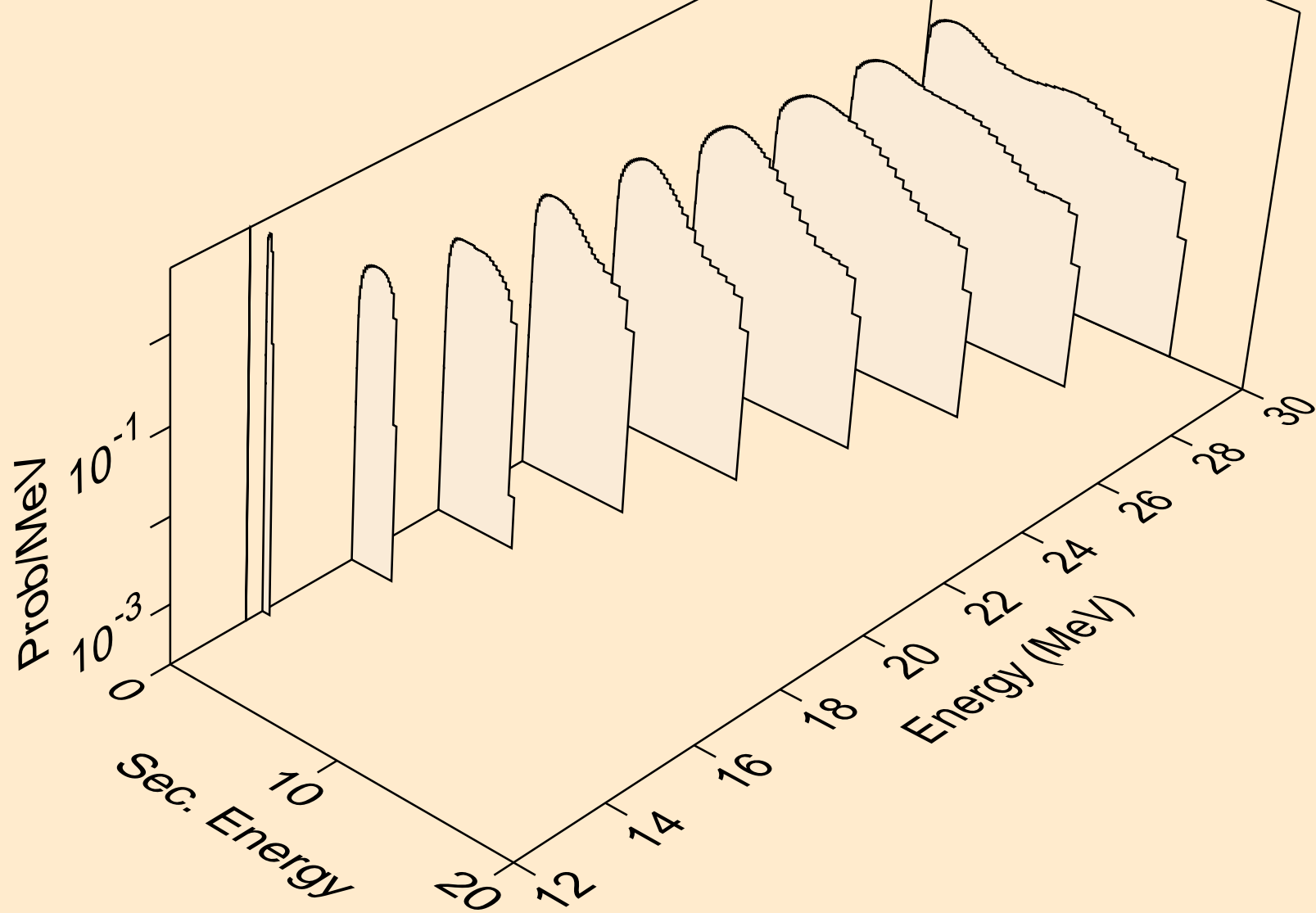



AR039 PROTON ACER TENDL-2023 LIBRARY; T=0.K  
neutrons from (p,3n)

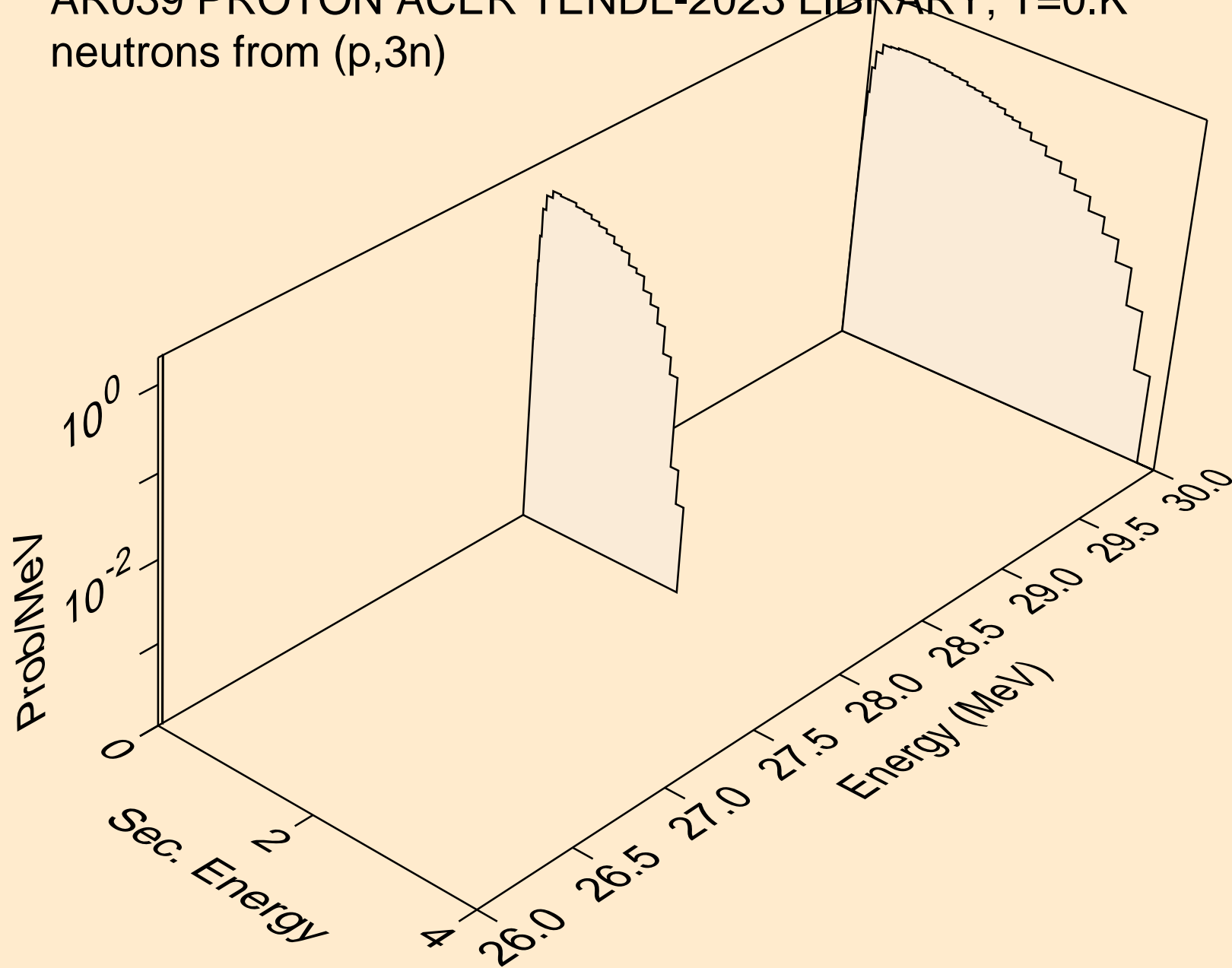

AR039 PROTON ACER TENDL-2023 LIBRARY; T=0.K  
neutrons from (p,n\*)a

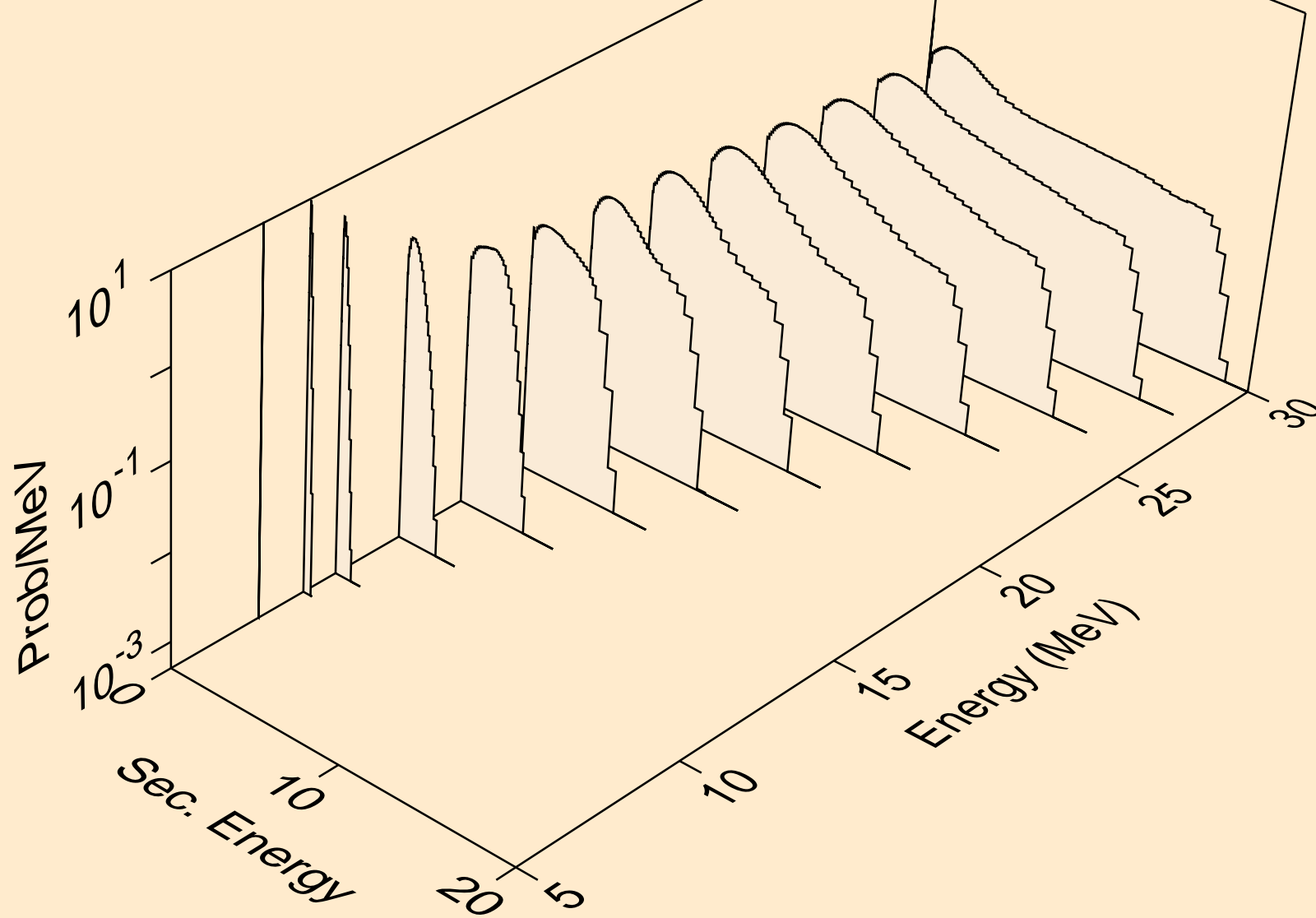

AR039 PROTON ACER TENDL-2023 LIBRARY; T=0.K  
neutrons from (p,2n)a

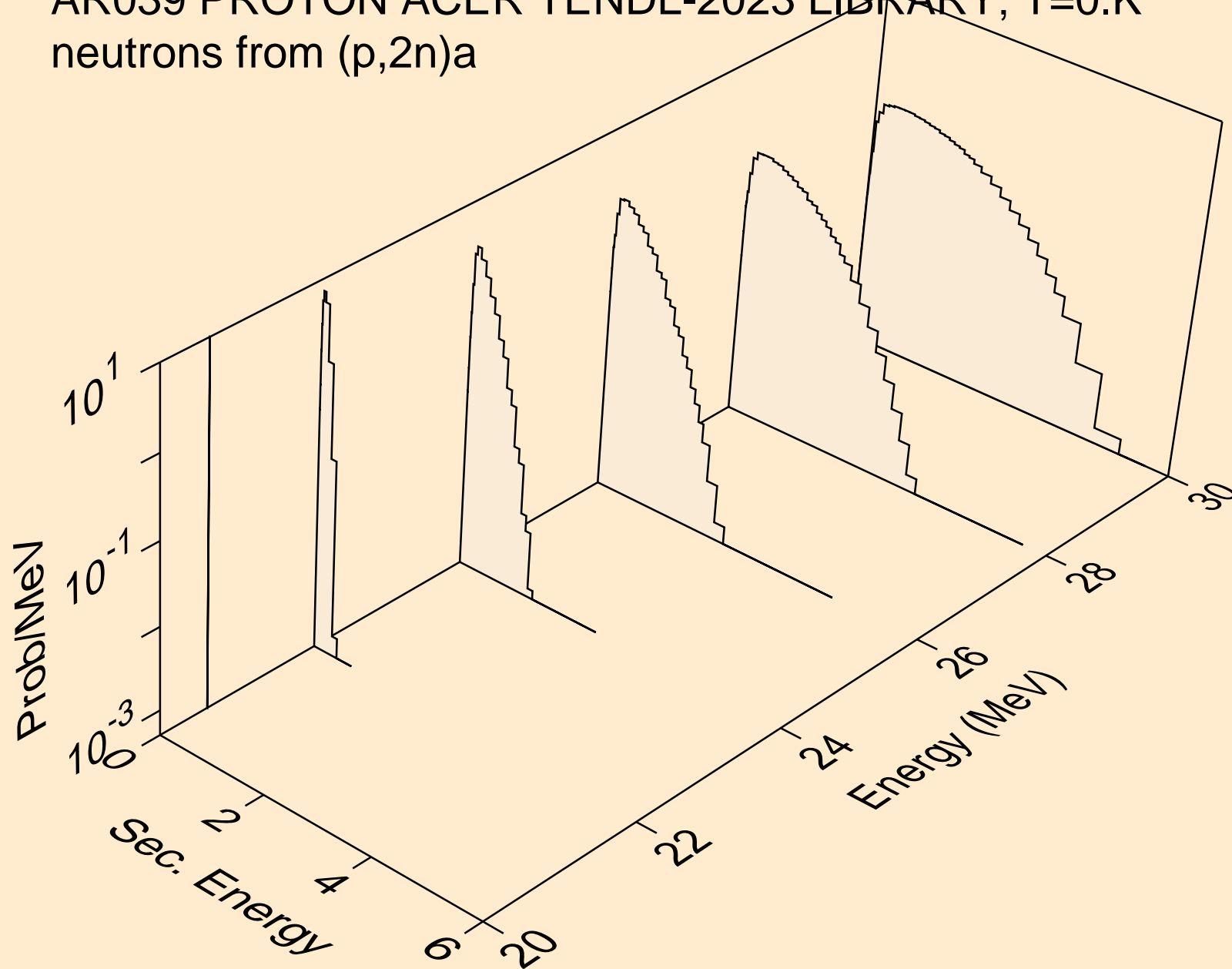

AR039 PROTON ACER TENDL-2023 LIBRARY; T=0.K  
neutrons from (p,n\*)p

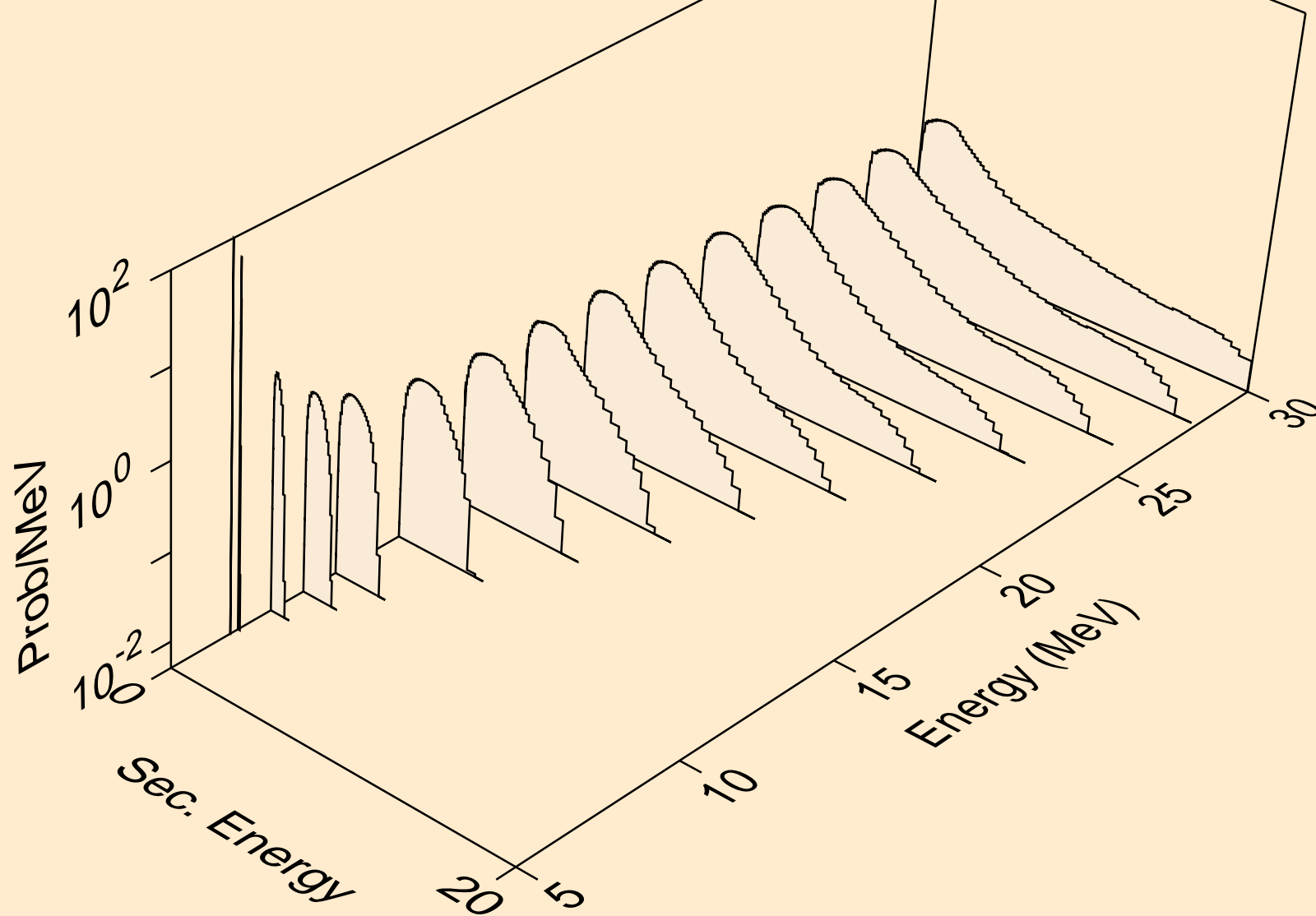

AR039 PROTON ACER TENDL-2023 LIBRARY; T=0.K  
neutrons from (p,n\*)2a

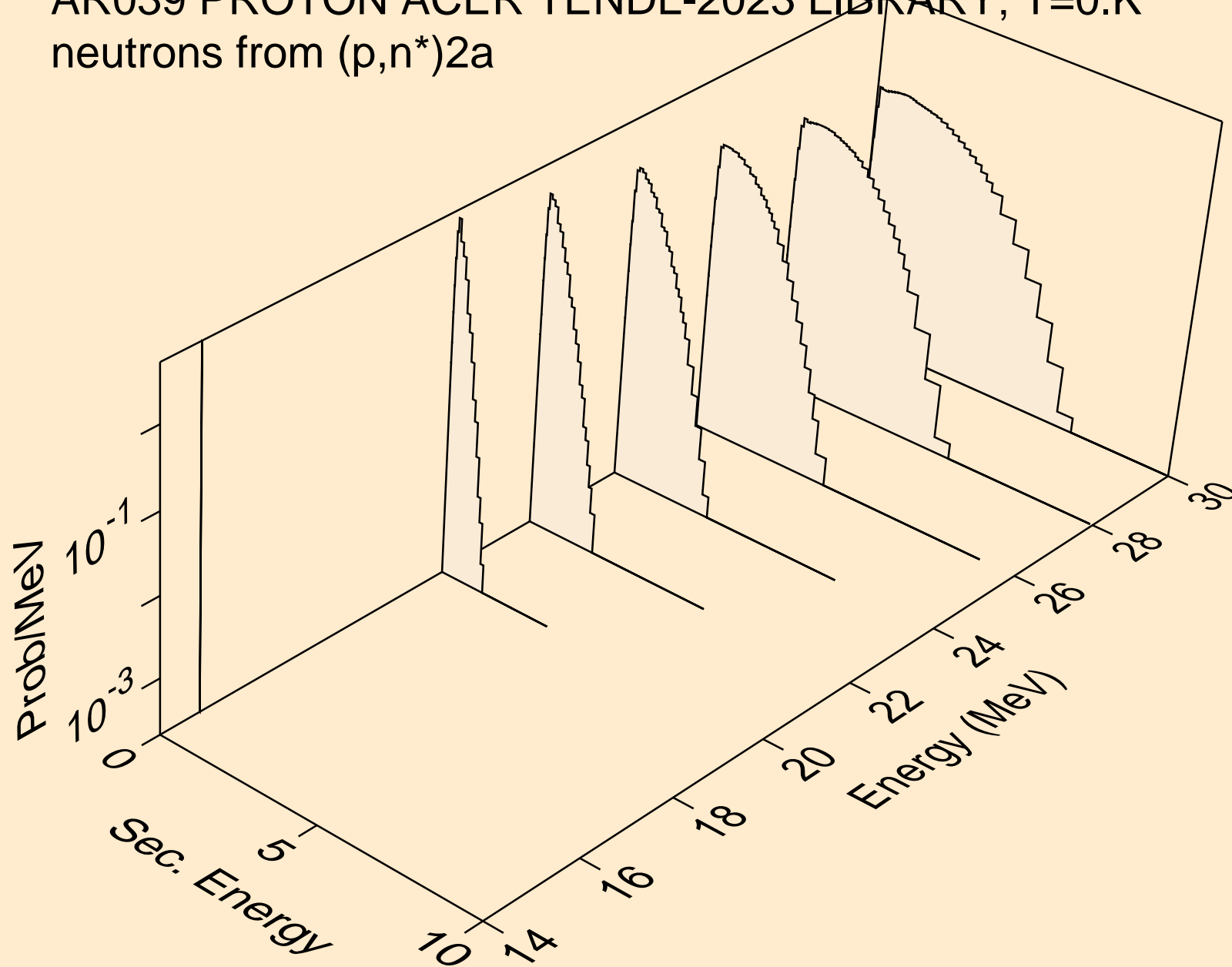

AR039 PROTON ACER TENDL-2023 LIBRARY; T=0.K  
neutrons from (p,n\*)d

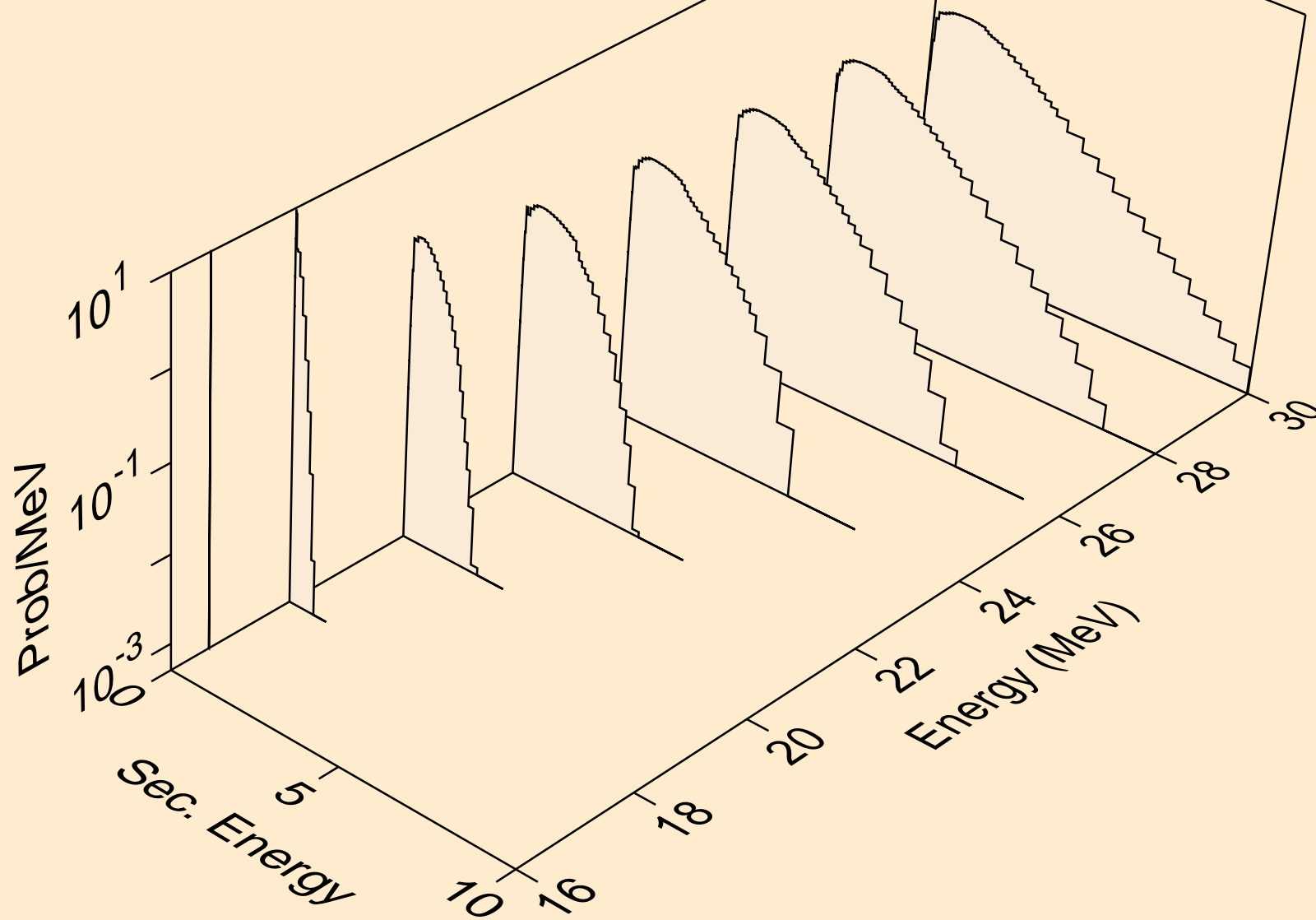

AR039 PROTON ACER TENDL-2023 LIBRARY; T=0.K  
neutrons from (p,n\*)t

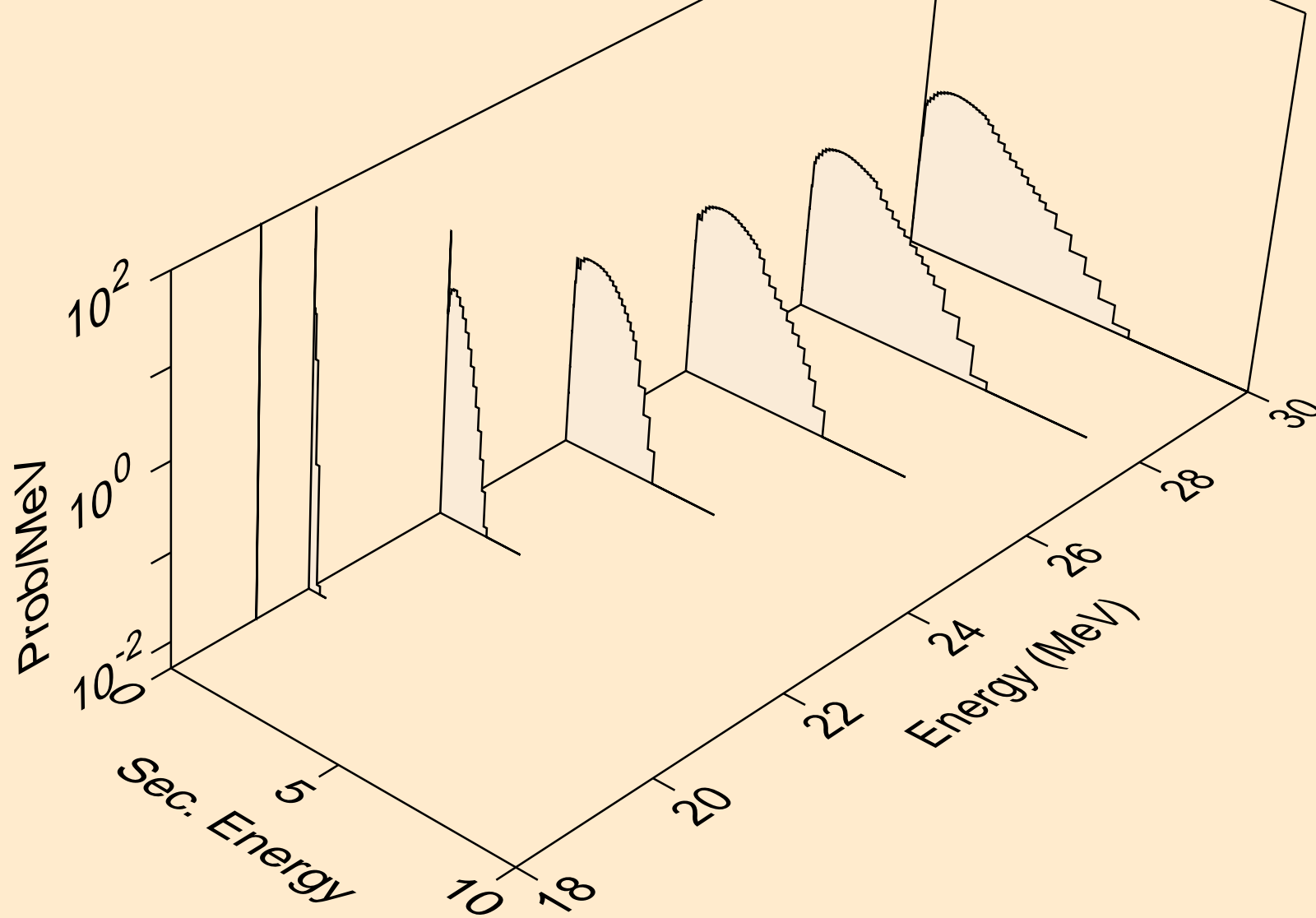

AR039 PROTON ACER TENDL-2023 LIBRARY; T=0.K  
neutrons from (p,n\*)he3

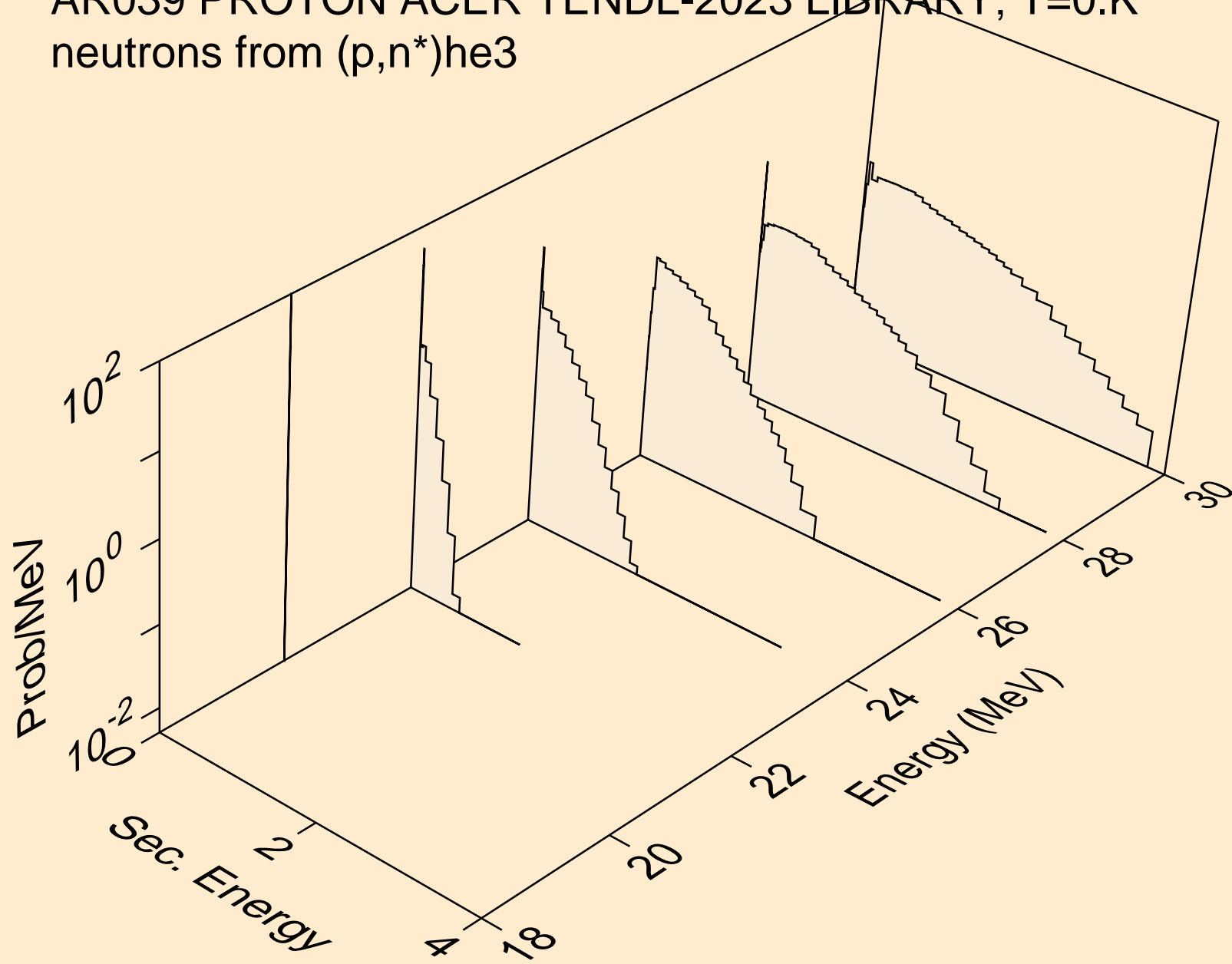



AR039 PROTON ACER TENDL-2023 LIBRARY; T=0.K  
neutrons from (p,2np)

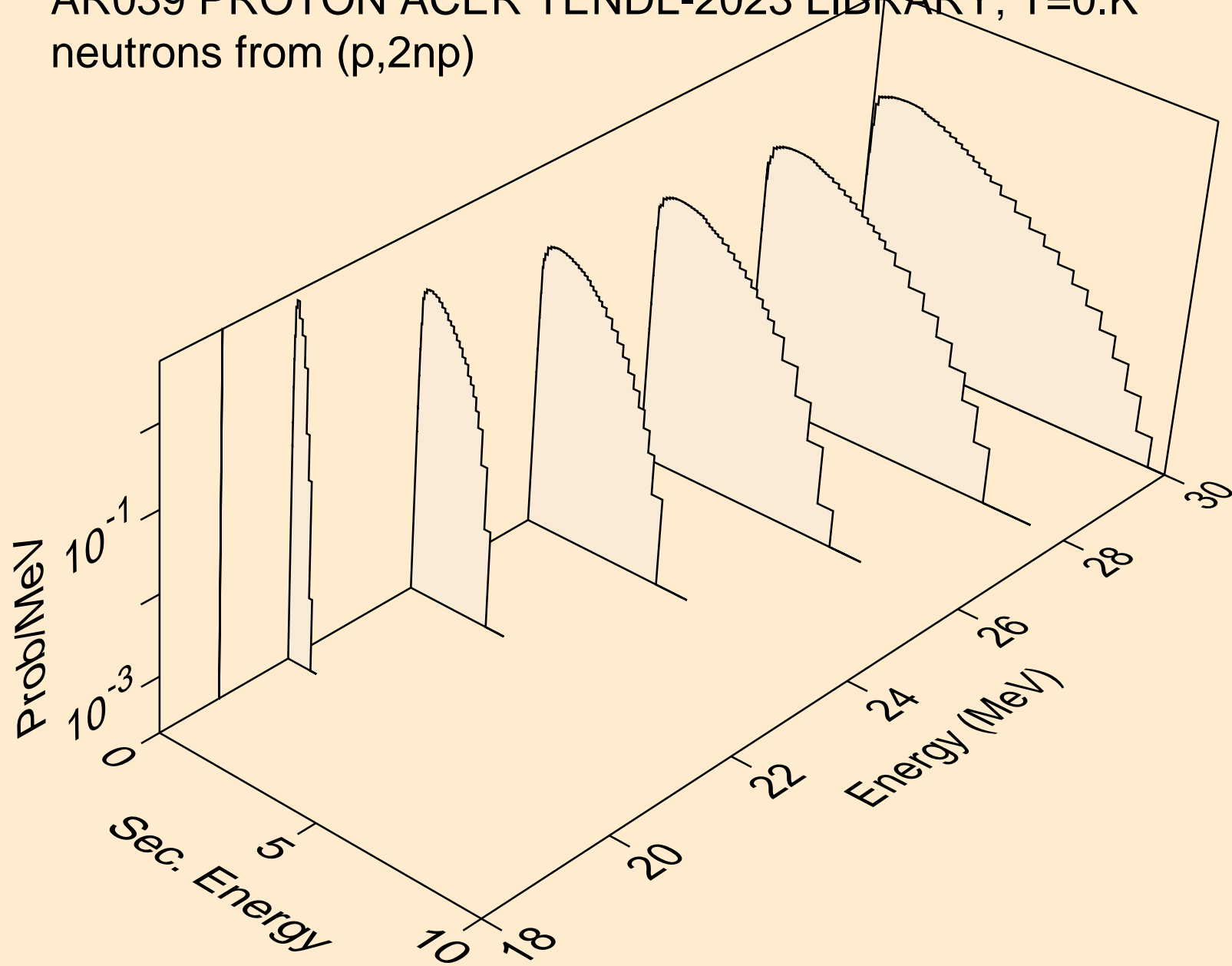

AR039 PROTON ACER TENDL-2023 LIBRARY; T=0.K  
neutrons from (p,3np)

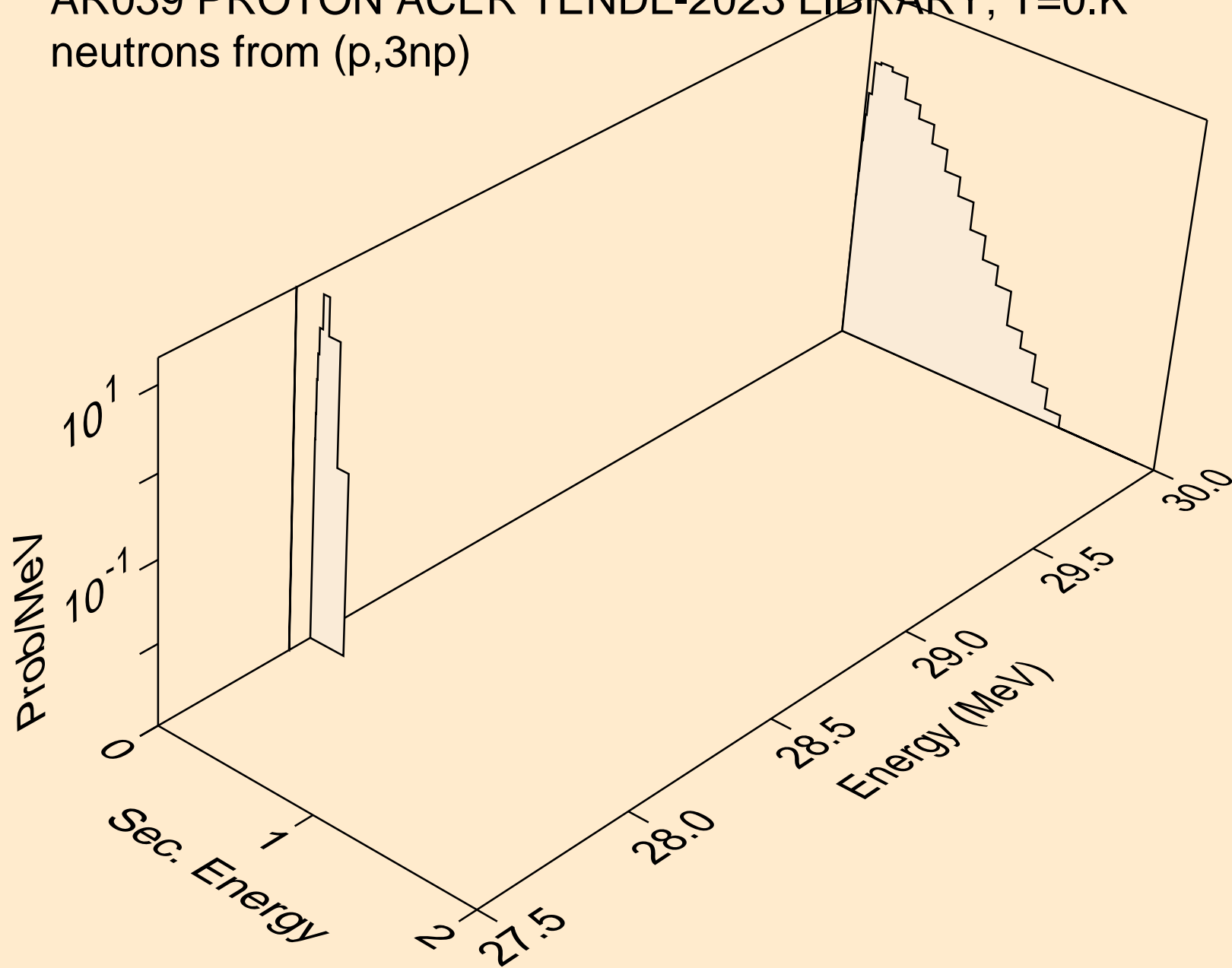

AR039 PROTON ACER TENDL-2023 LIBRARY; T=0.K  
neutrons from (p,n2p)

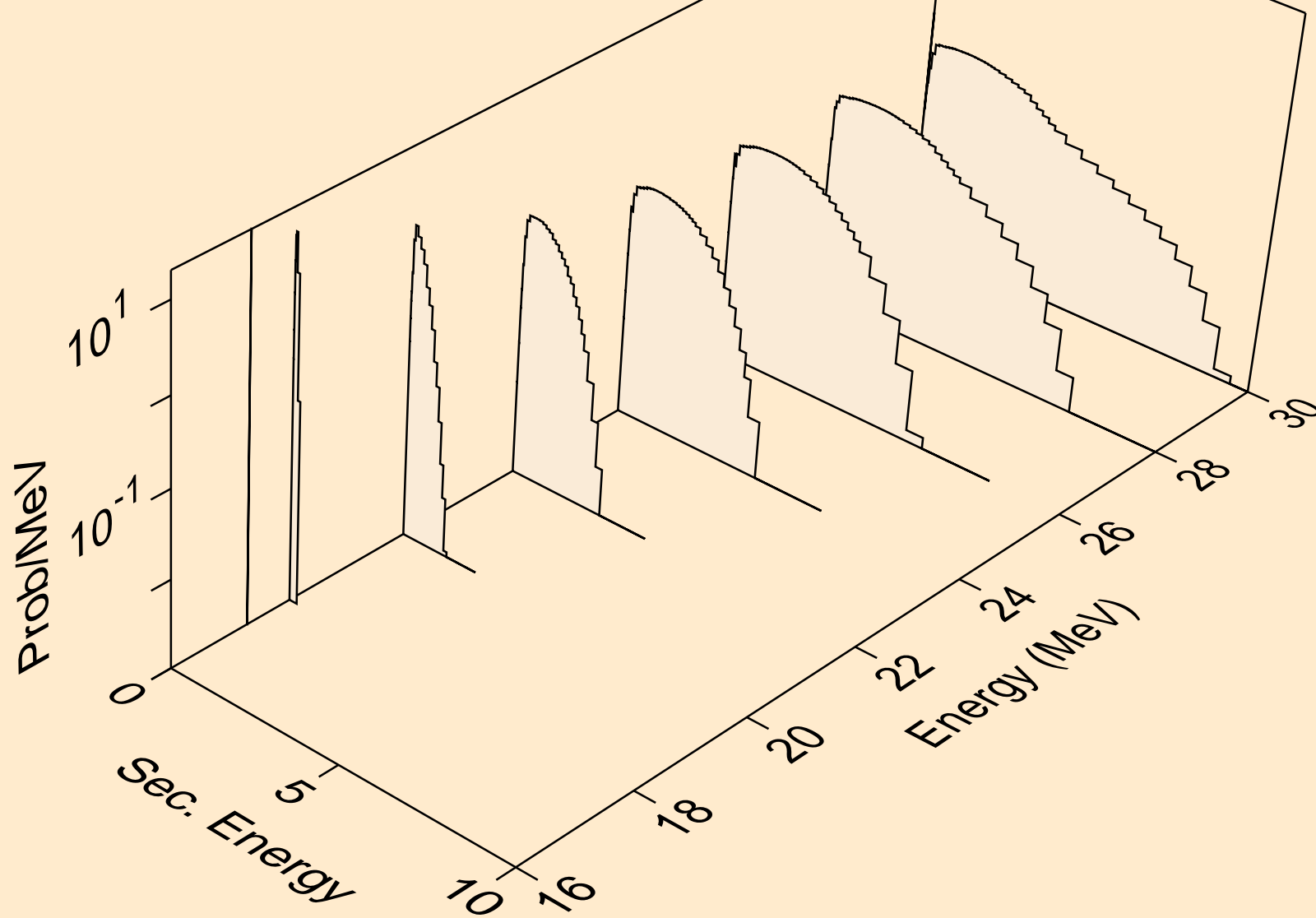

AR039 PROTON ACER TENDL-2023 LIBRARY; T=0.K  
neutrons from (p,npa)

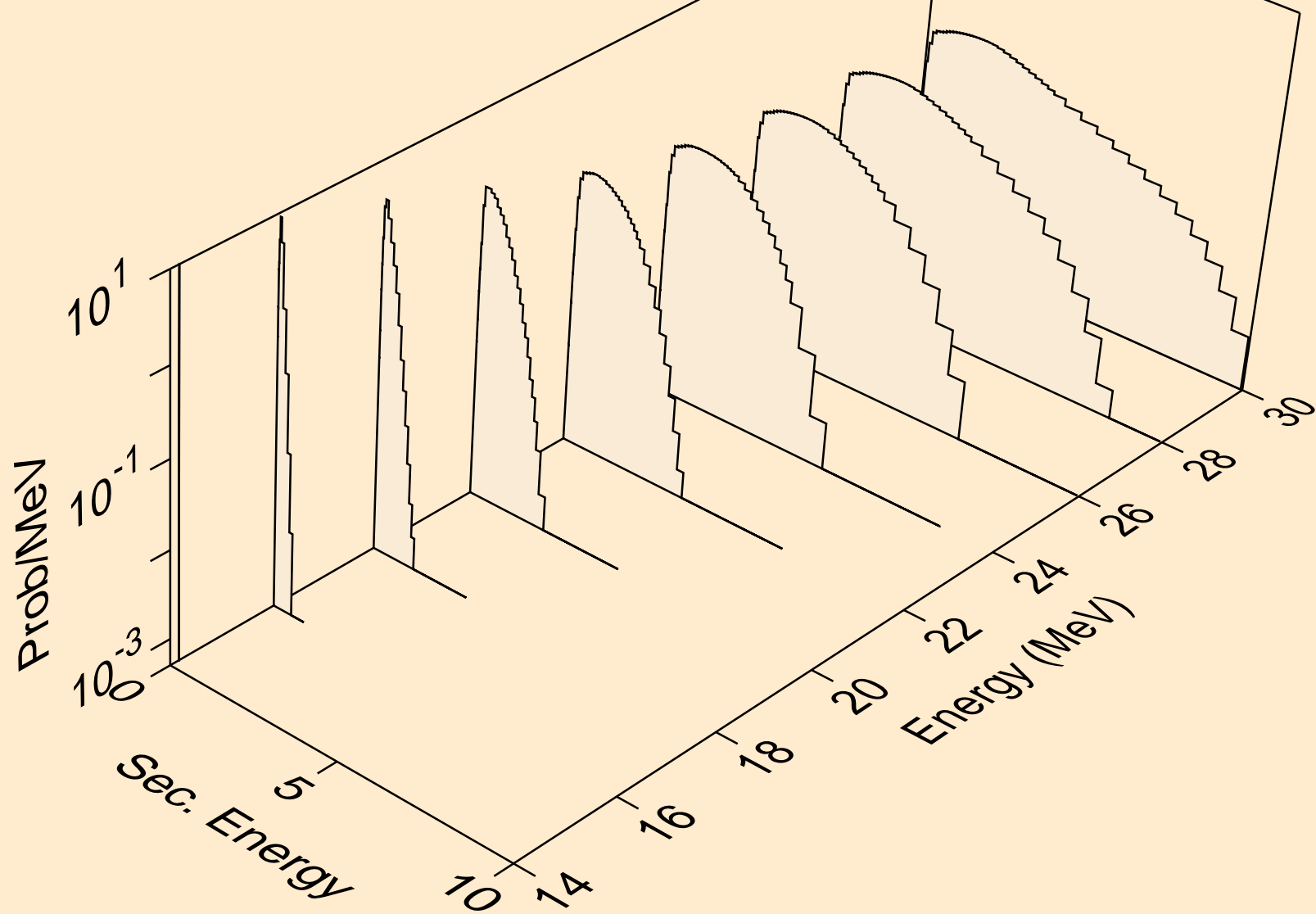

AR039 PROTON ACER TENDL-2023 LIBRARY; T=0.K  
deuterons from (p,x)

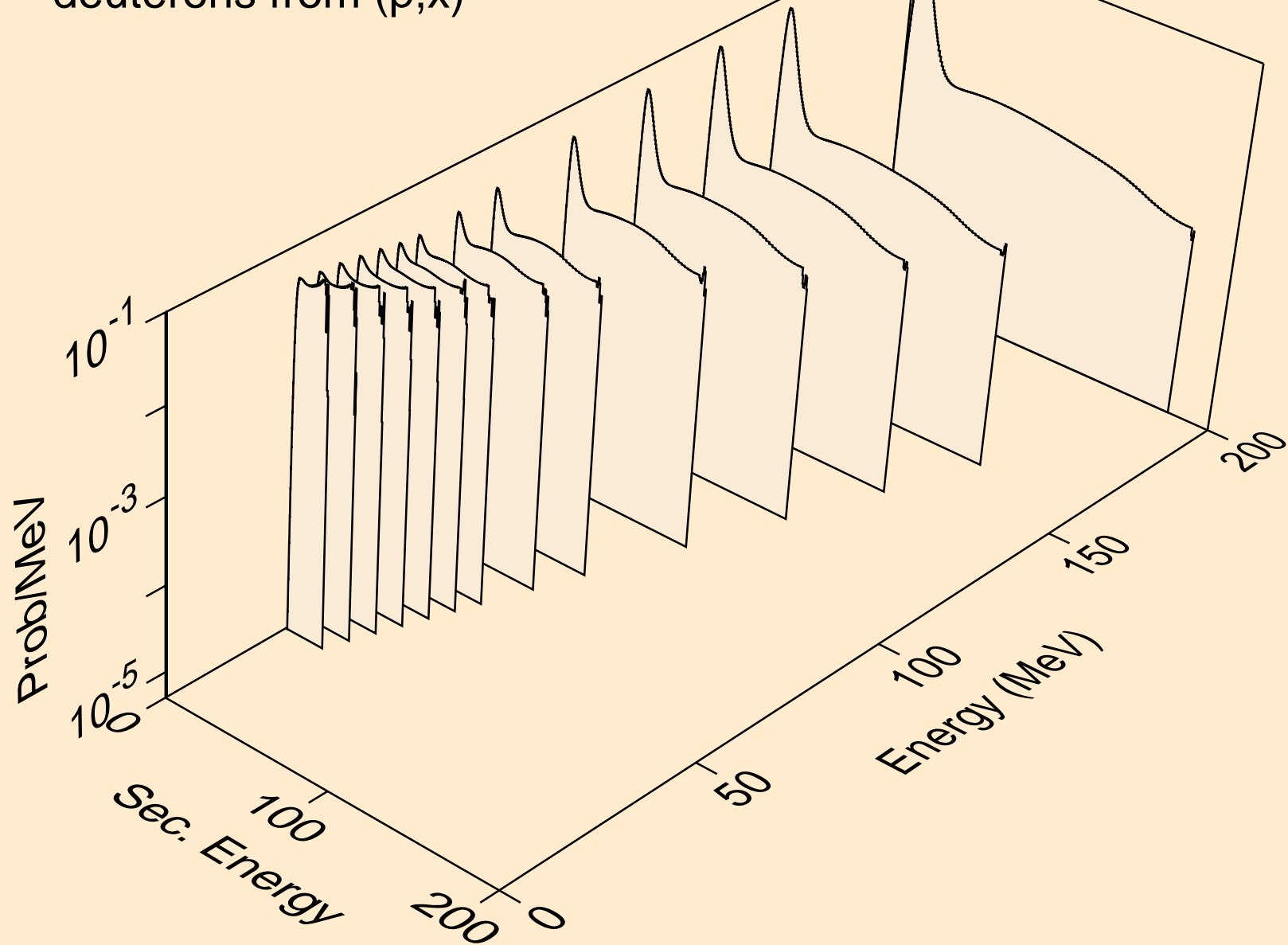

AR039 PROTON ACER TENDL-2023 LIBRARY; T=0.K  
deuterons from (p,2nd)

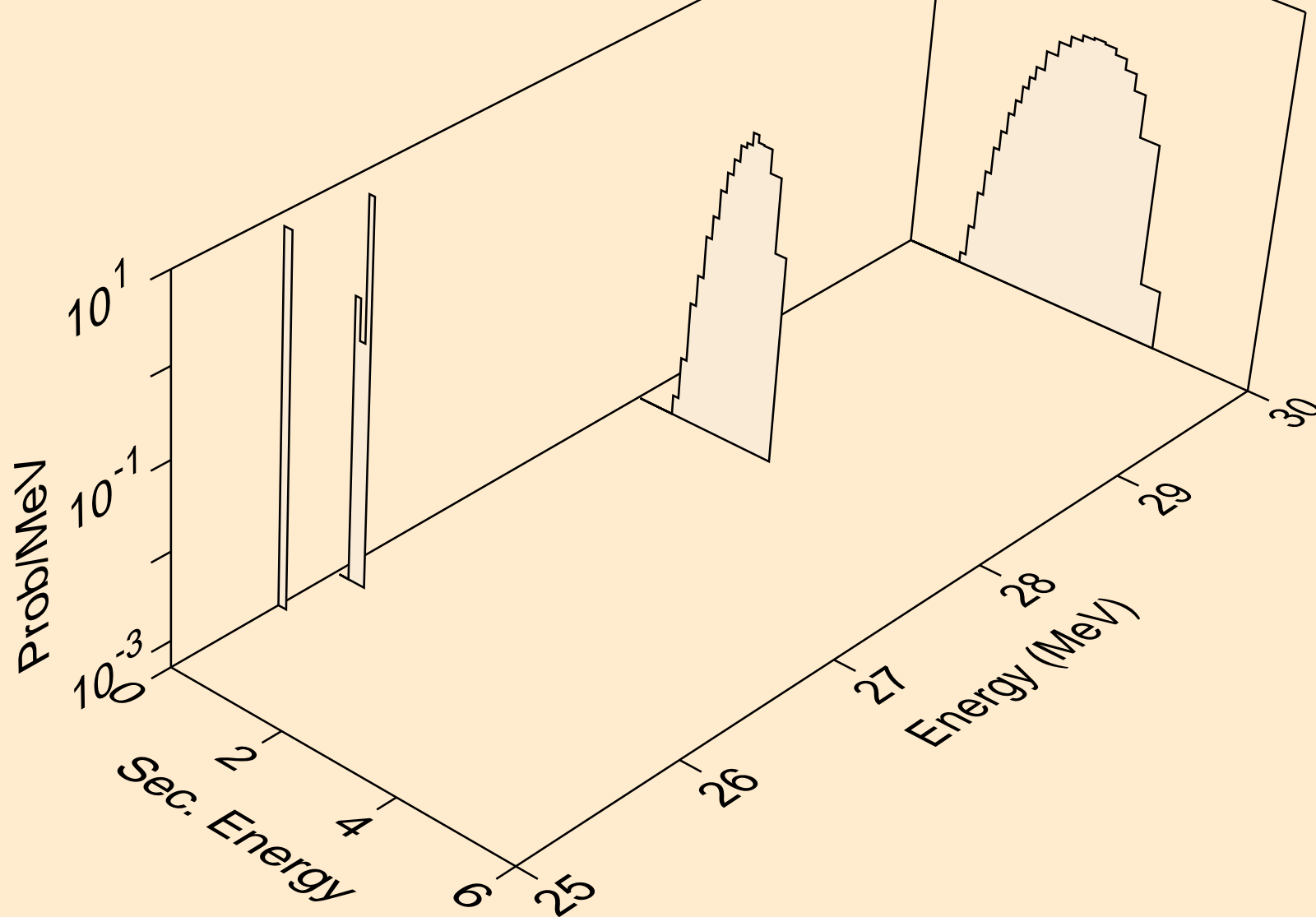

AR039 PROTON ACER TENDL-2023 LIBRARY; T=0.K  
deuterons from (p,n\*)d

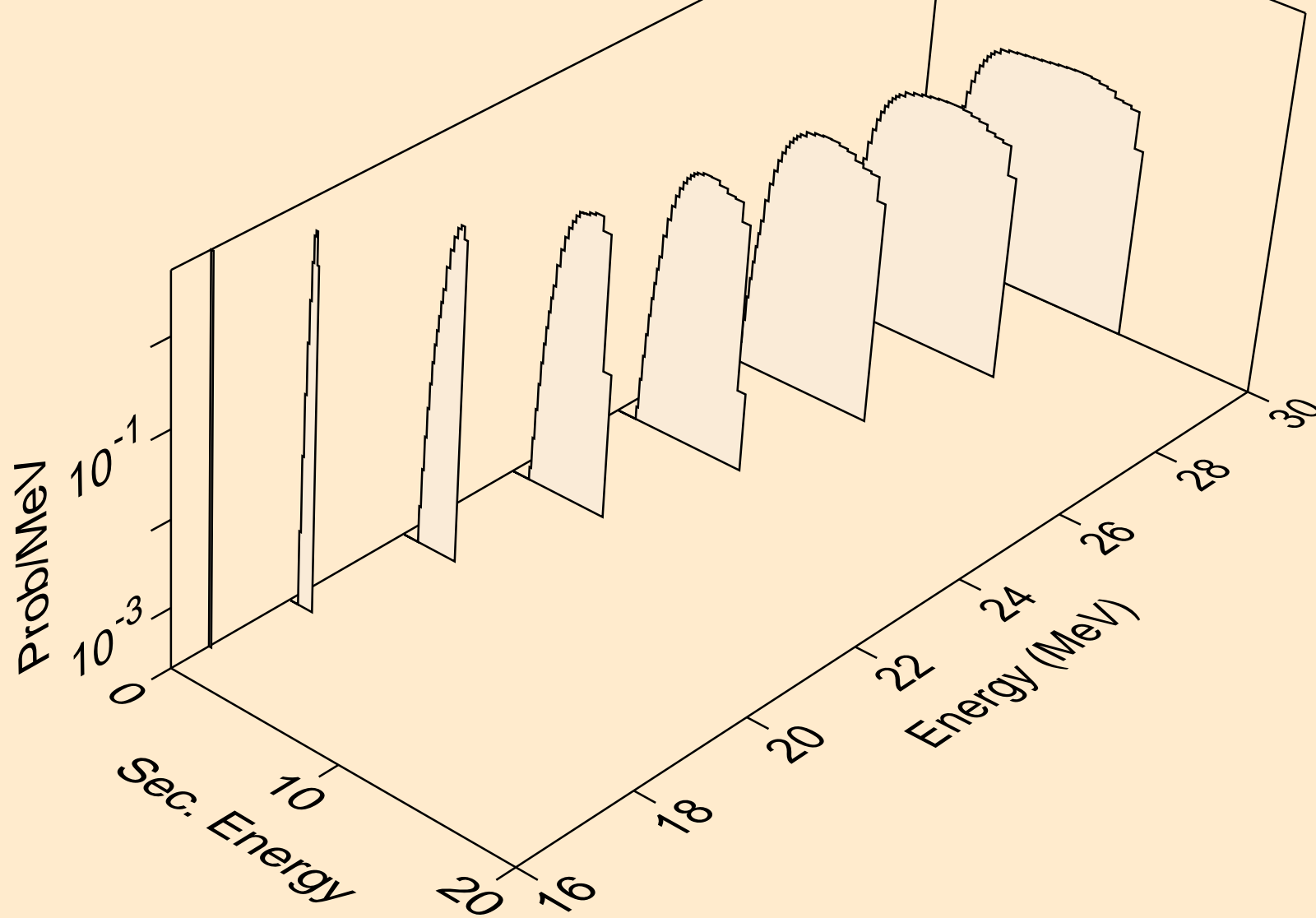

AR039 PROTON ACER TENDL-2023 LIBRARY; T=0.K  
deuterons from (p,d)

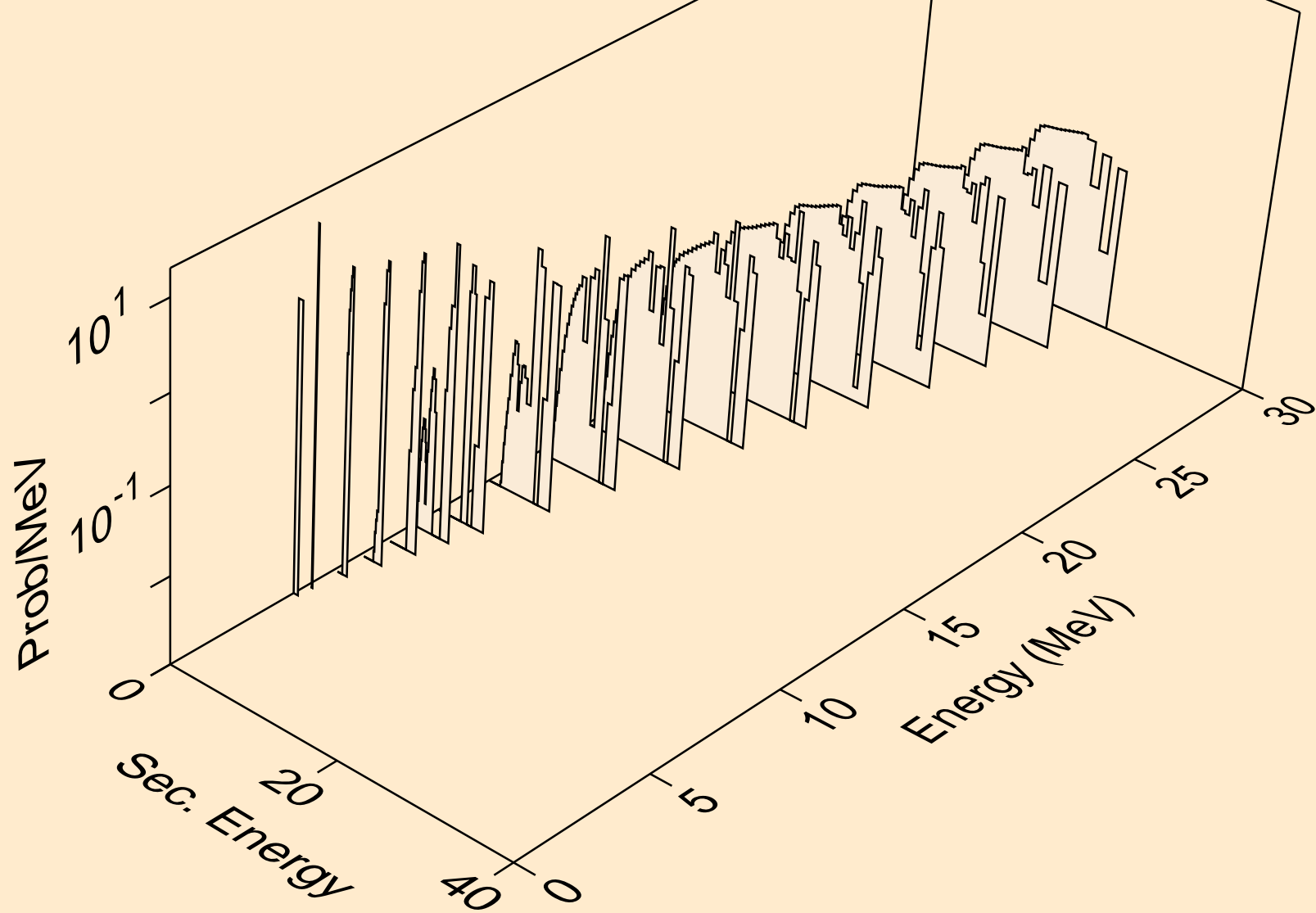



AR039 PROTON ACER TENDL-2023 LIBRARY; T=0.K  
deuterons from (p,d2a)

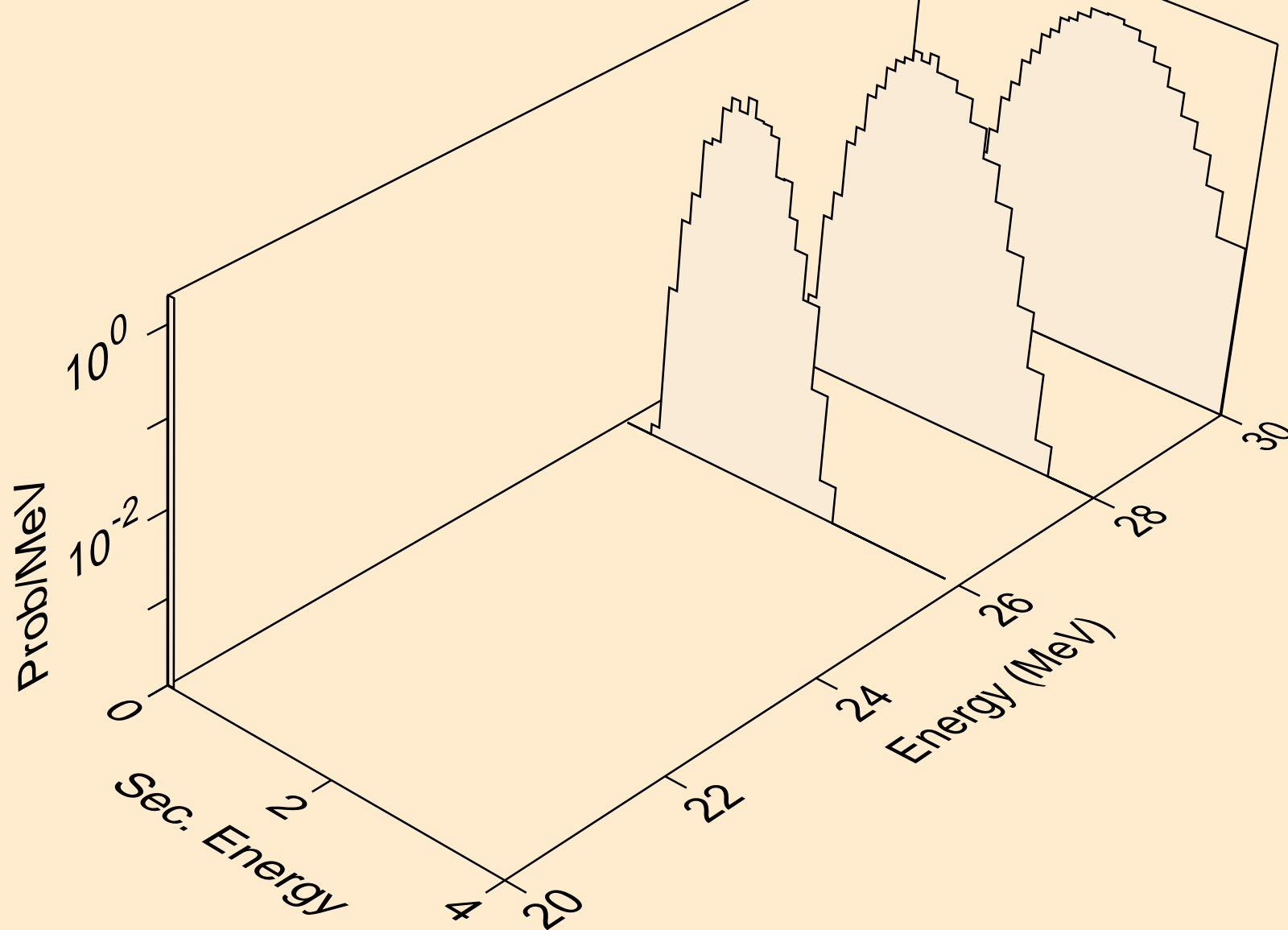

AR039 PROTON ACER TENDL-2023 LIBRARY; T=0.K  
deuterons from (p,pd)

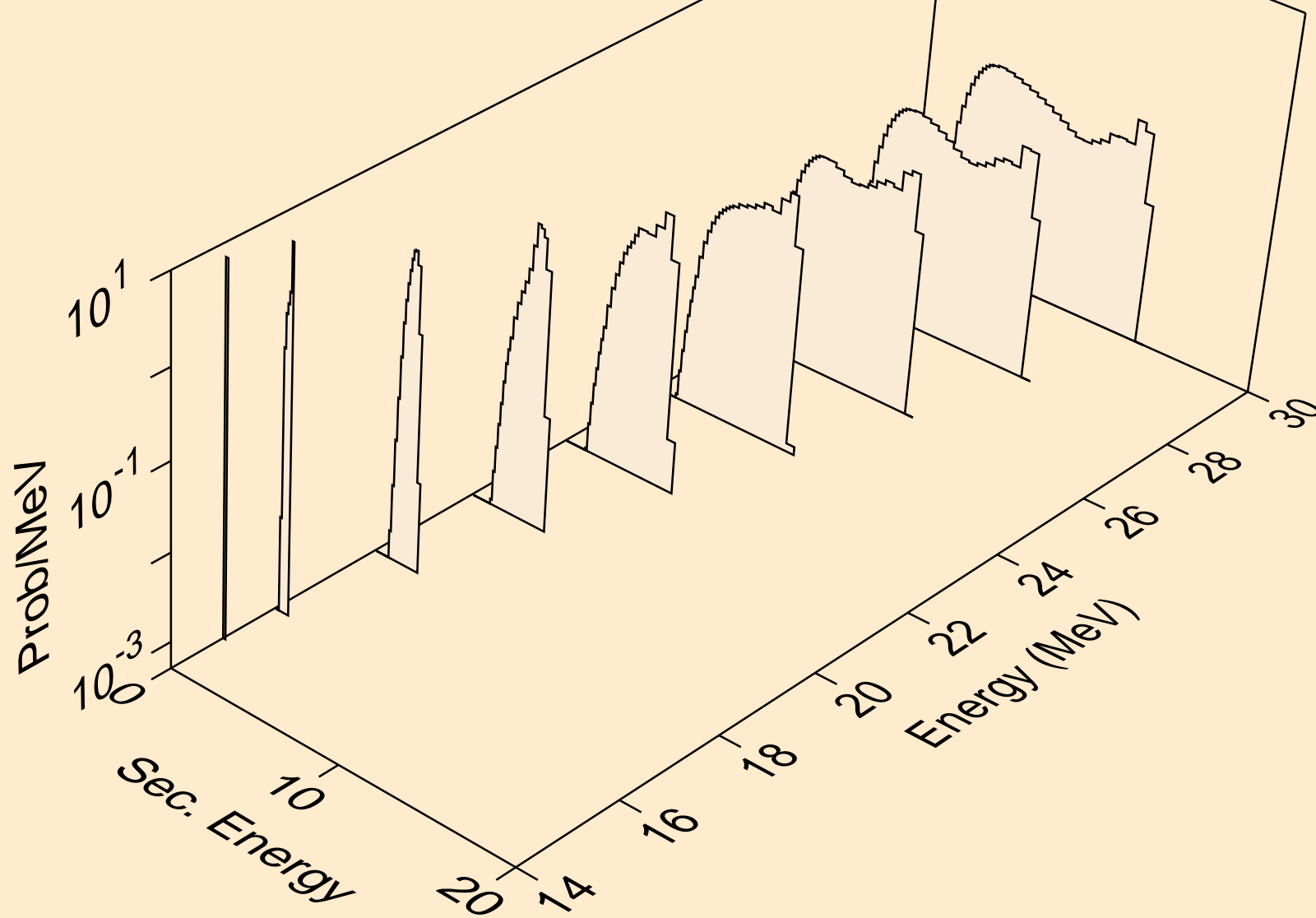

AR039 PROTON ACER TENDL-2023 LIBRARY; T=0.K  
deuterons from (p,da)

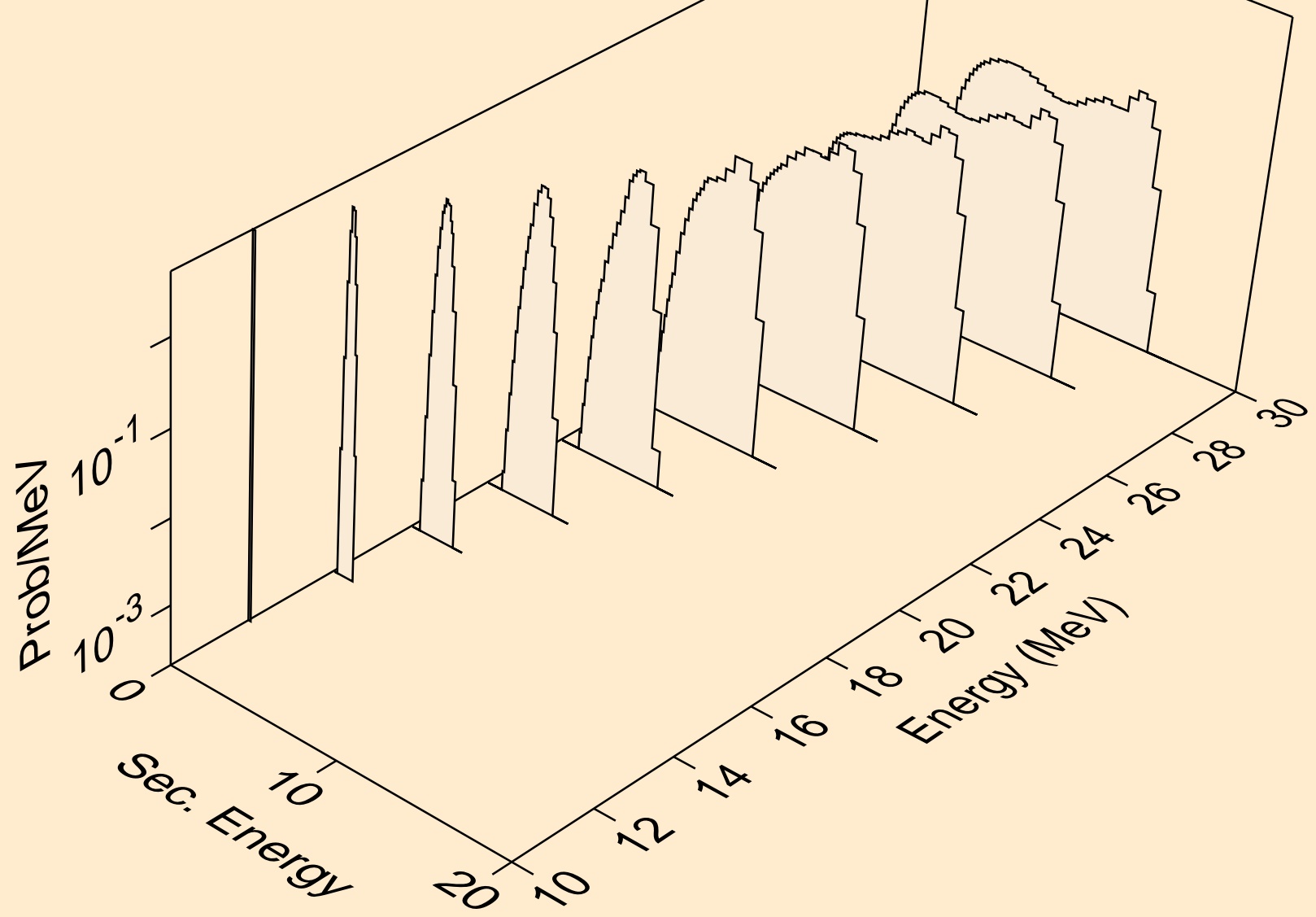

AR039 PROTON ACER TENDL-2023 LIBRARY; T=0.K  
tritons from (p,x)

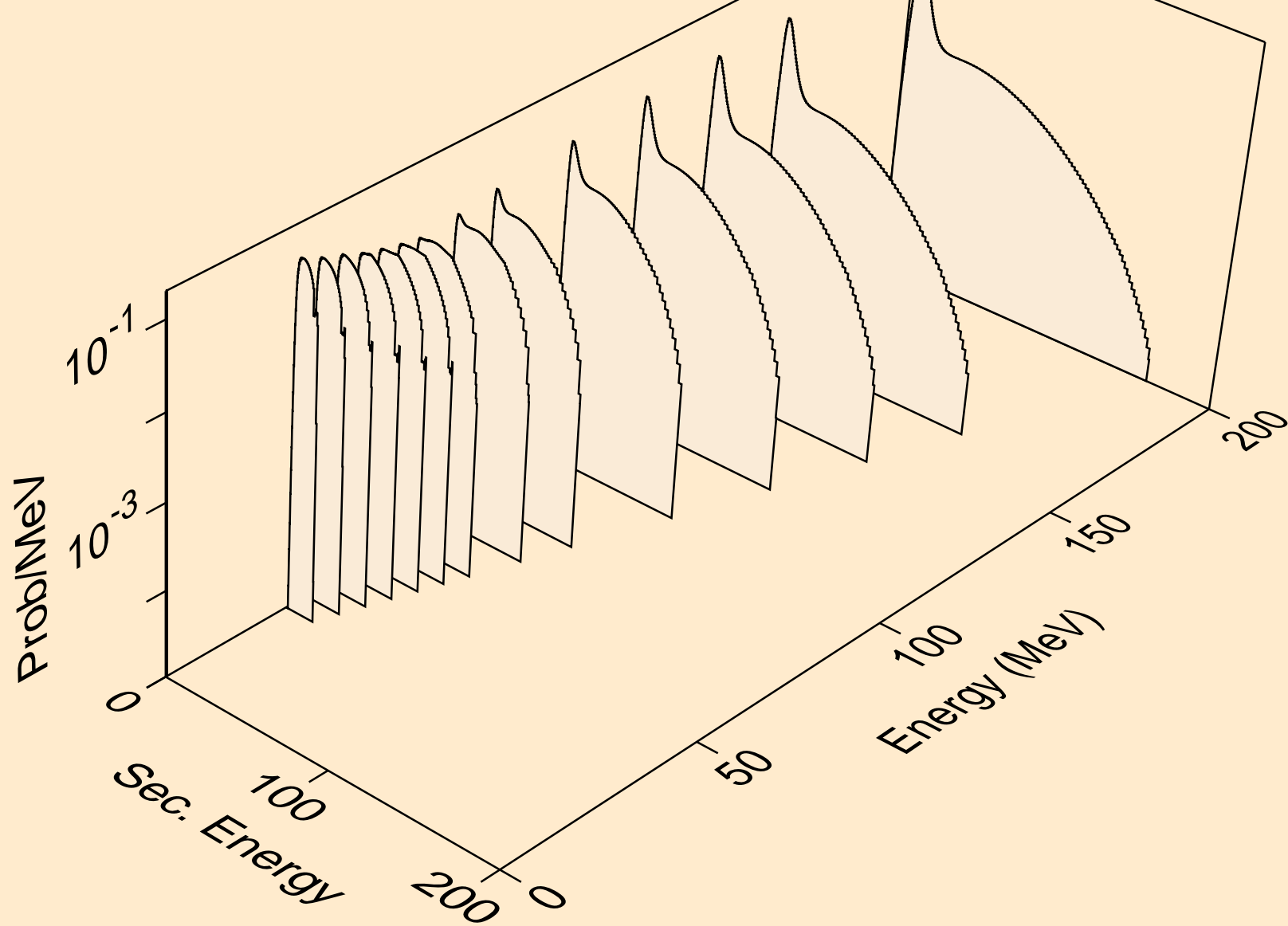

AR039 PROTON ACER TENDL-2023 LIBRARY; T=0.K  
tritons from (p,n\*)t

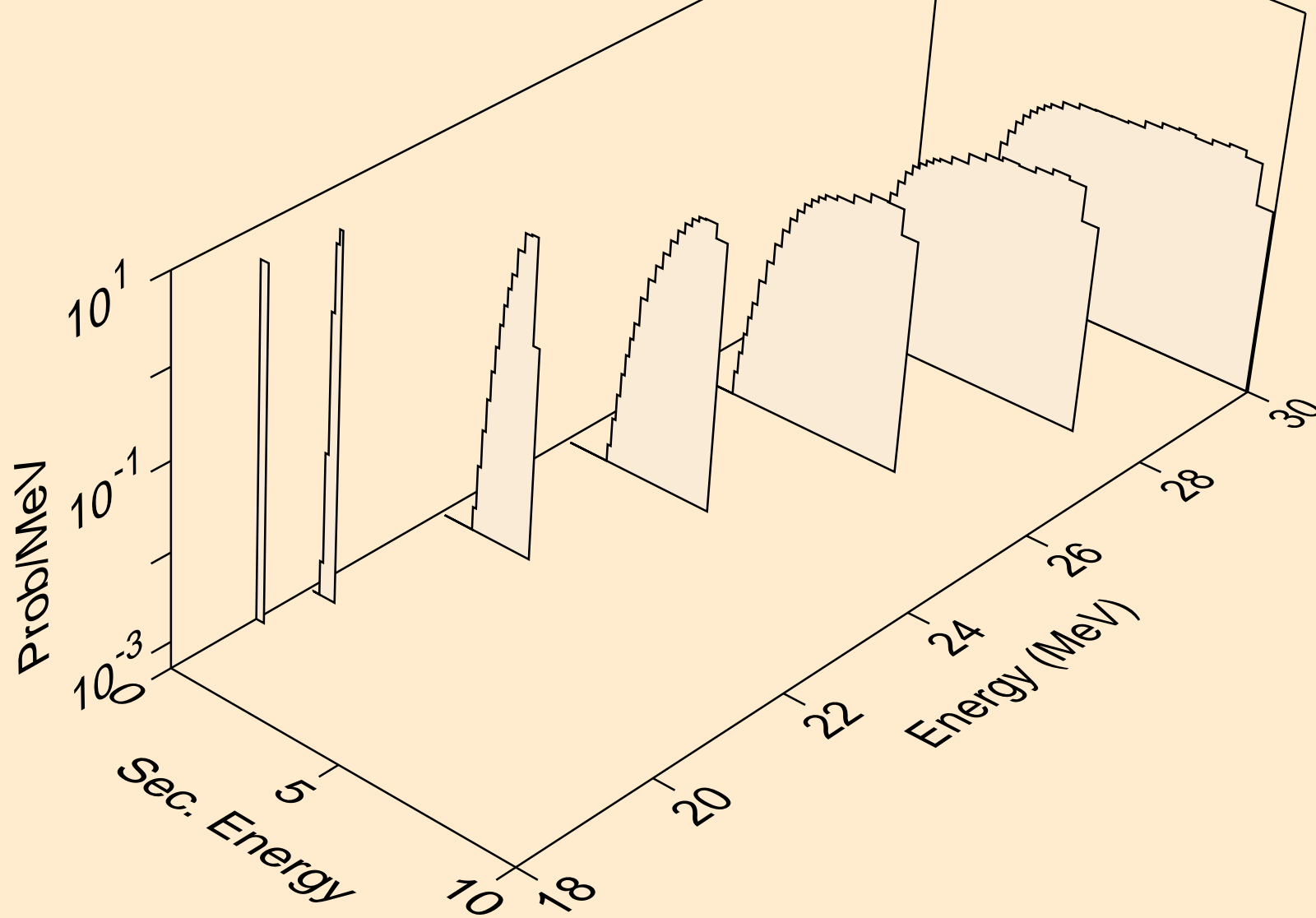

AR039 PROTON ACER TENDL-2023 LIBRARY; T=0.K  
tritons from (p,t)

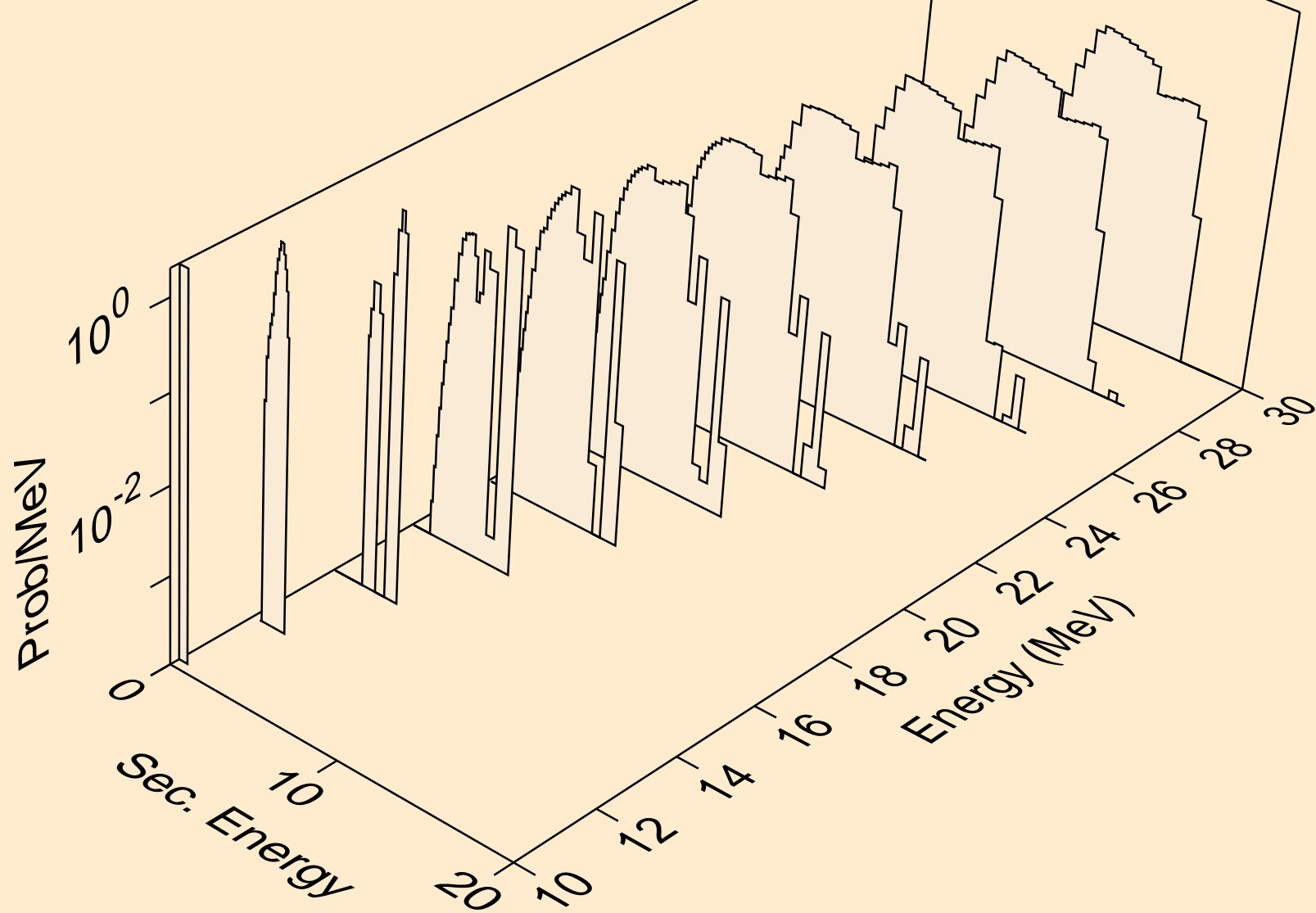

AR039 PROTON ACER TENDL-2023 LIBRARY; T=0.K  
tritons from (p,pt)

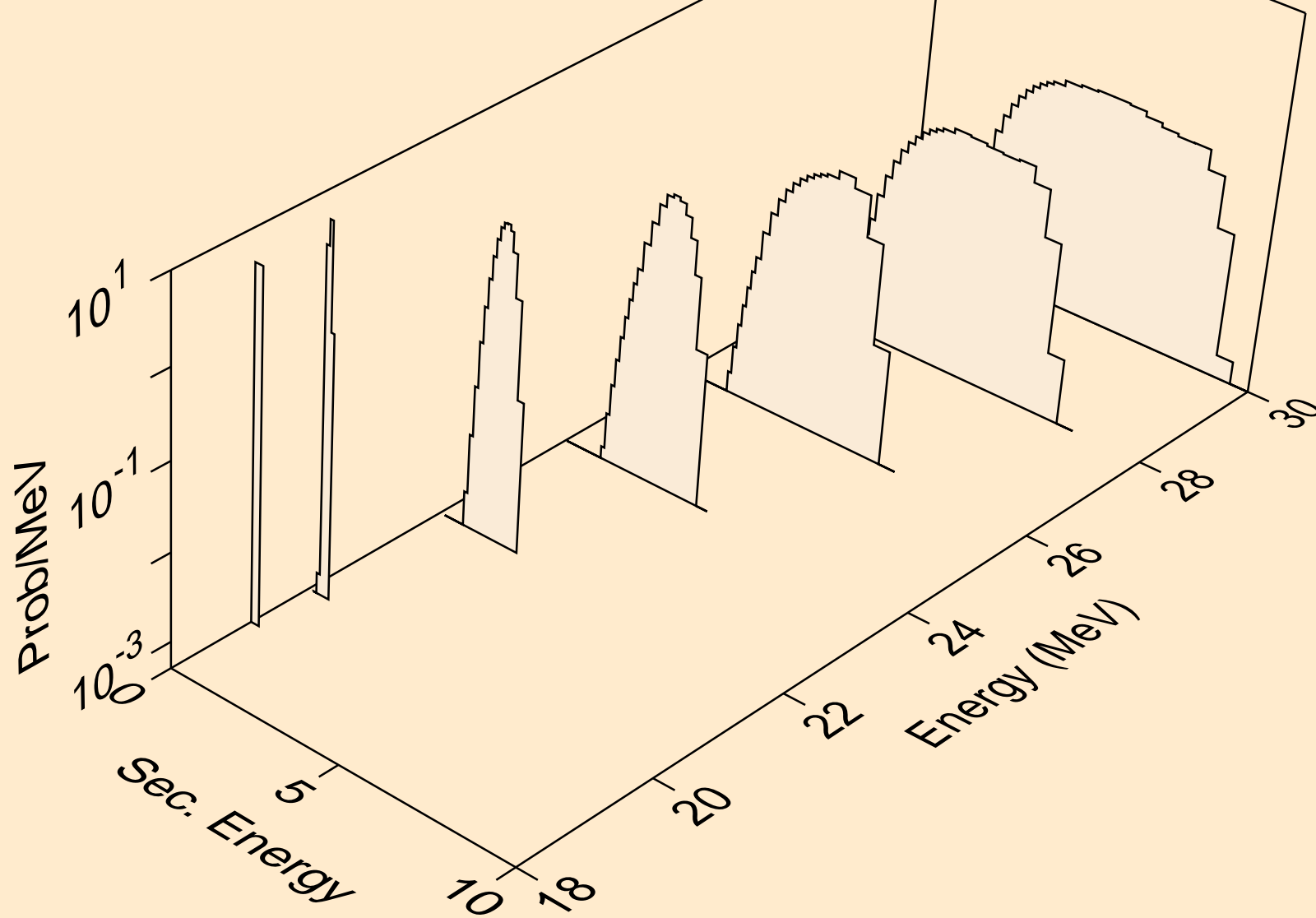

AR039 PROTON ACER TENDL-2023 LIBRARY; T=0.K  
he3s from (p,x)

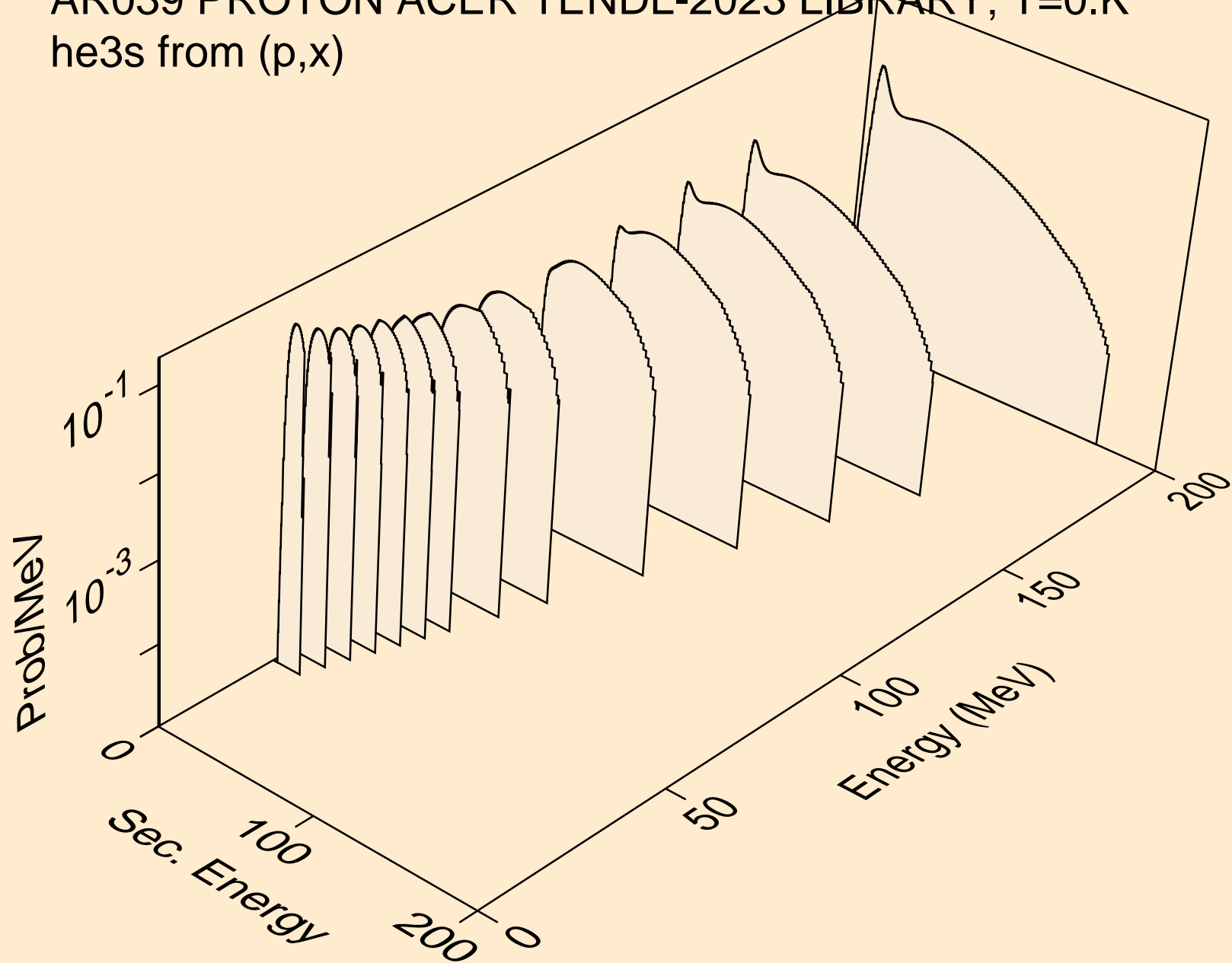



AR039 PROTON ACER TENDL-2023 LIBRARY; T=0.K  
he3s from (p,n\*)he3

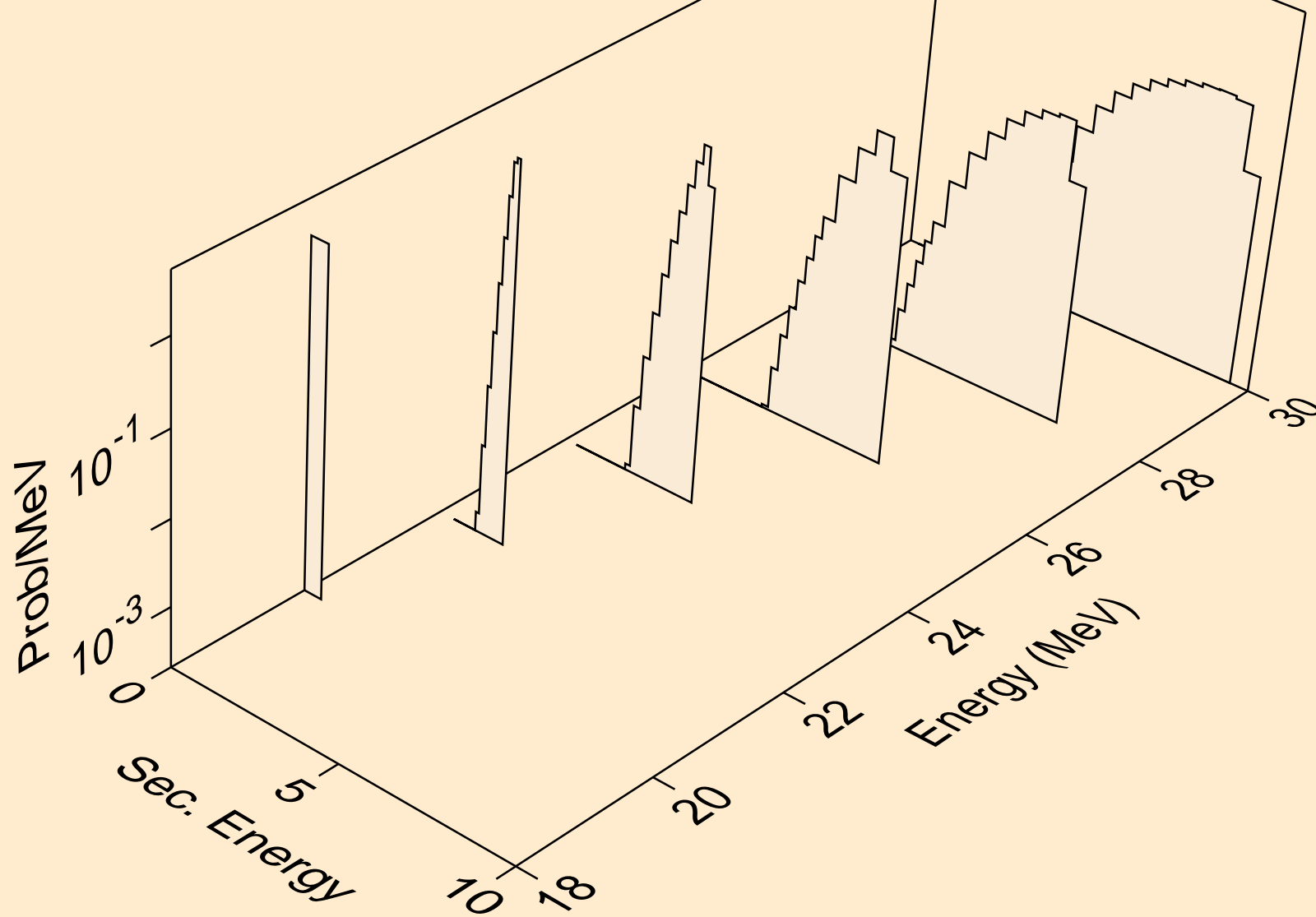

AR039 PROTON ACER TENDL-2023 LIBRARY; T=0.K  
he3s from (p,he3)

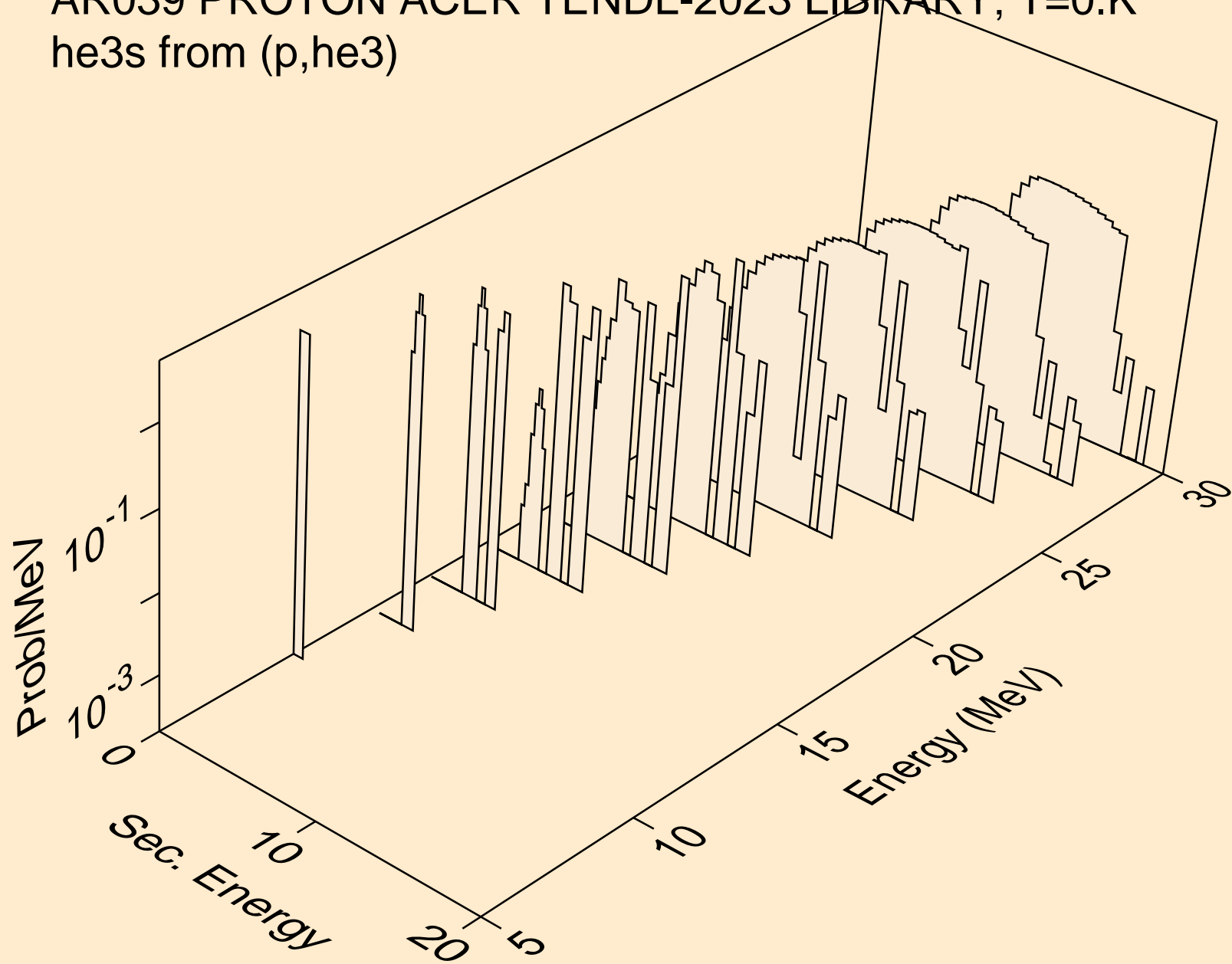

AR039 PROTON ACER TENDL-2023 LIBRARY; T=0.K  
alphas from (p,x)

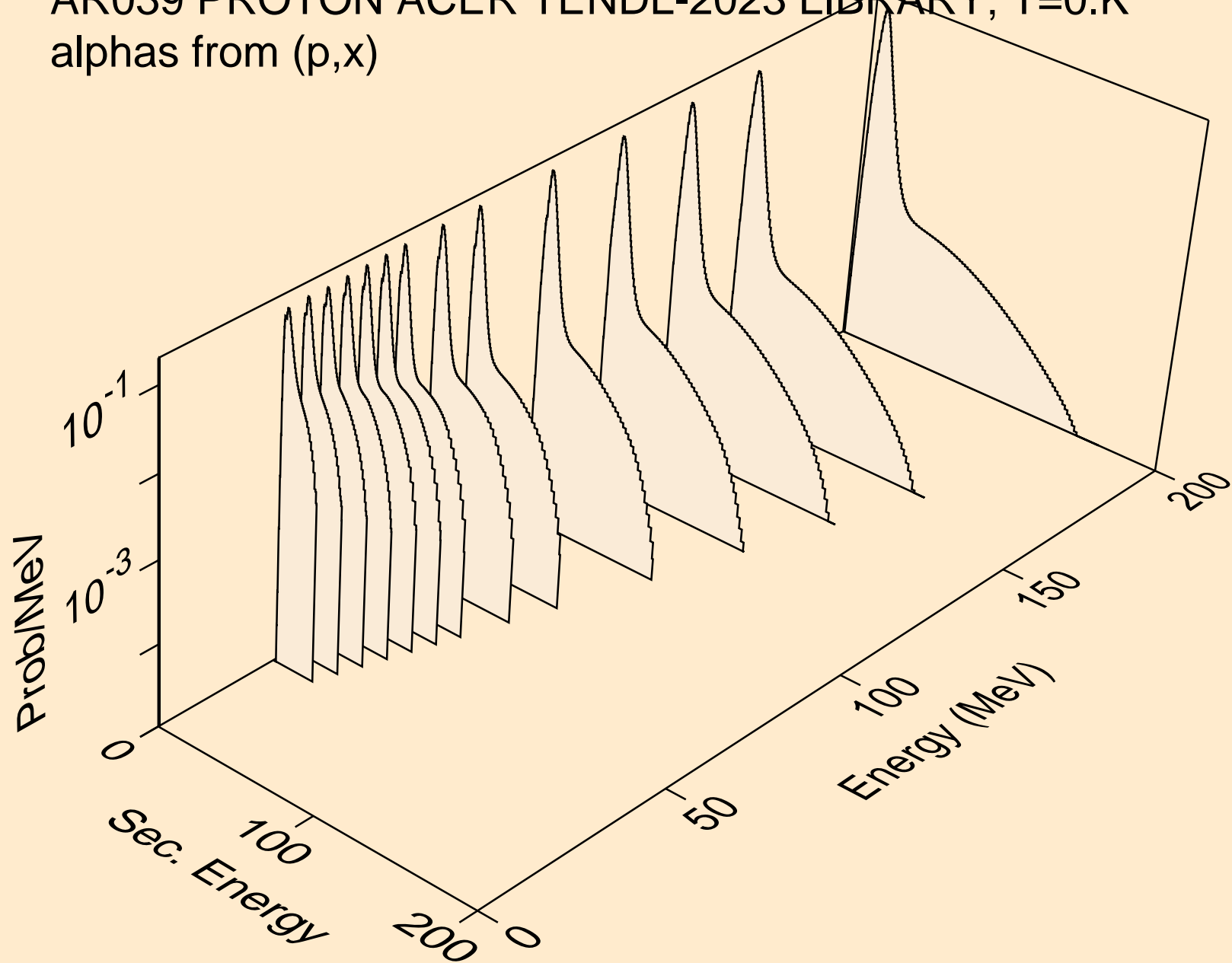

AR039 PROTON ACER TENDL-2023 LIBRARY; T=0.K  
alphas from (p,n\*)a

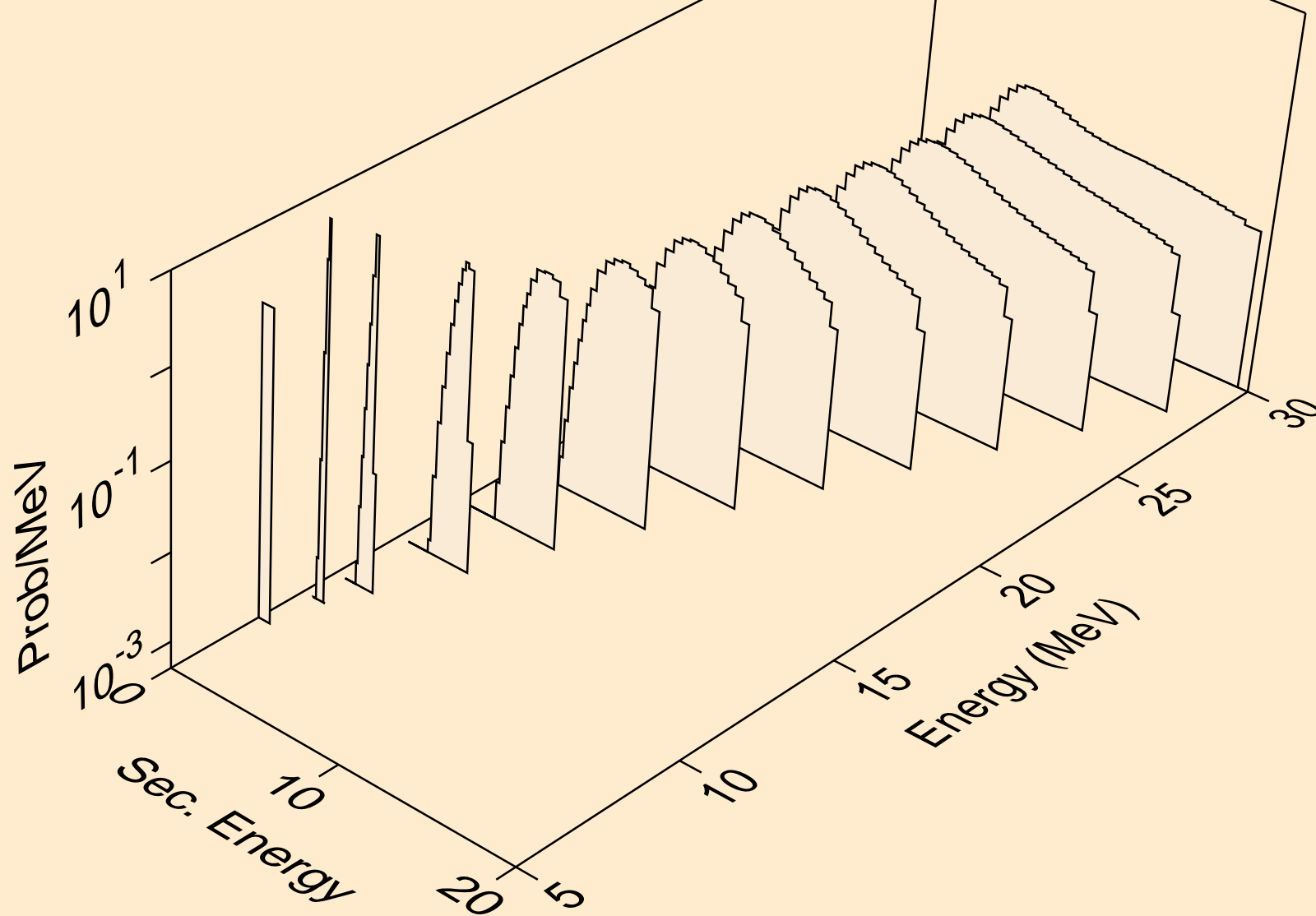

AR039 PROTON ACER TENDL-2023 LIBRARY; T=0.K  
alphas from (p,2n)a

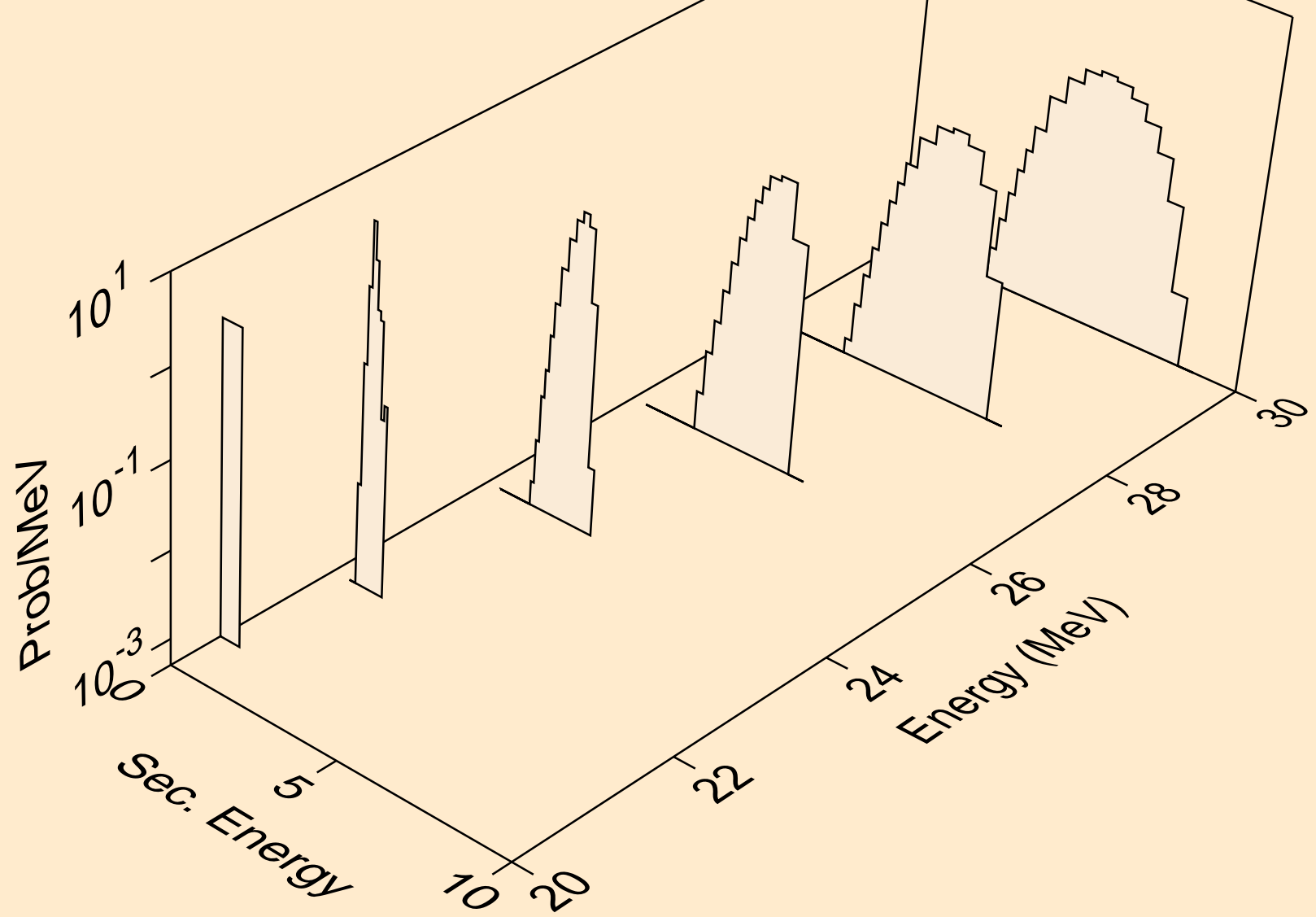

AR039 PROTON ACER TENDL-2023 LIBRARY; T=0.K  
alphas from (p,n\*)2a

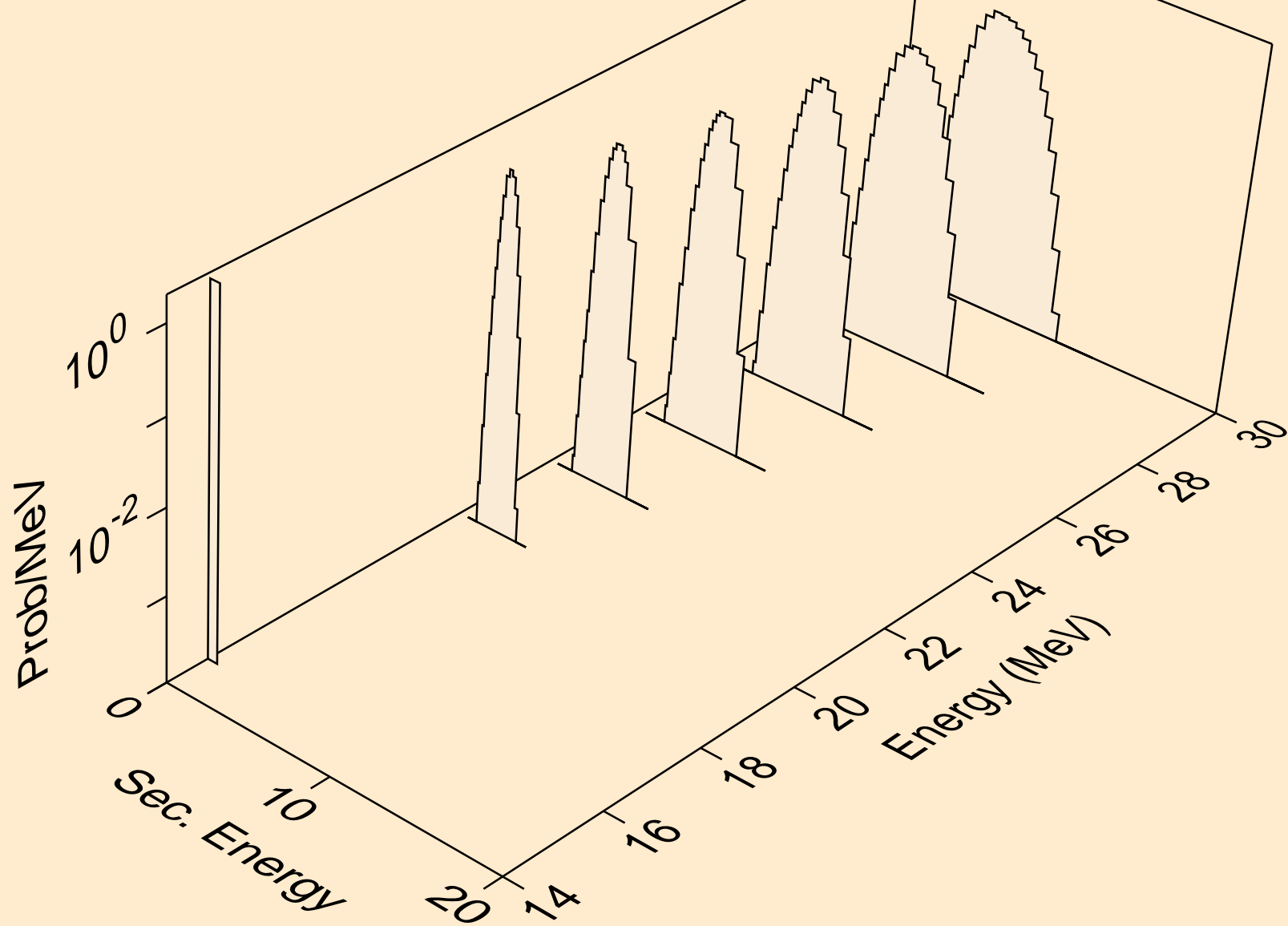

AR039 PROTON ACER TENDL-2023 LIBRARY; T=0.K  
alphas from (p,npa)

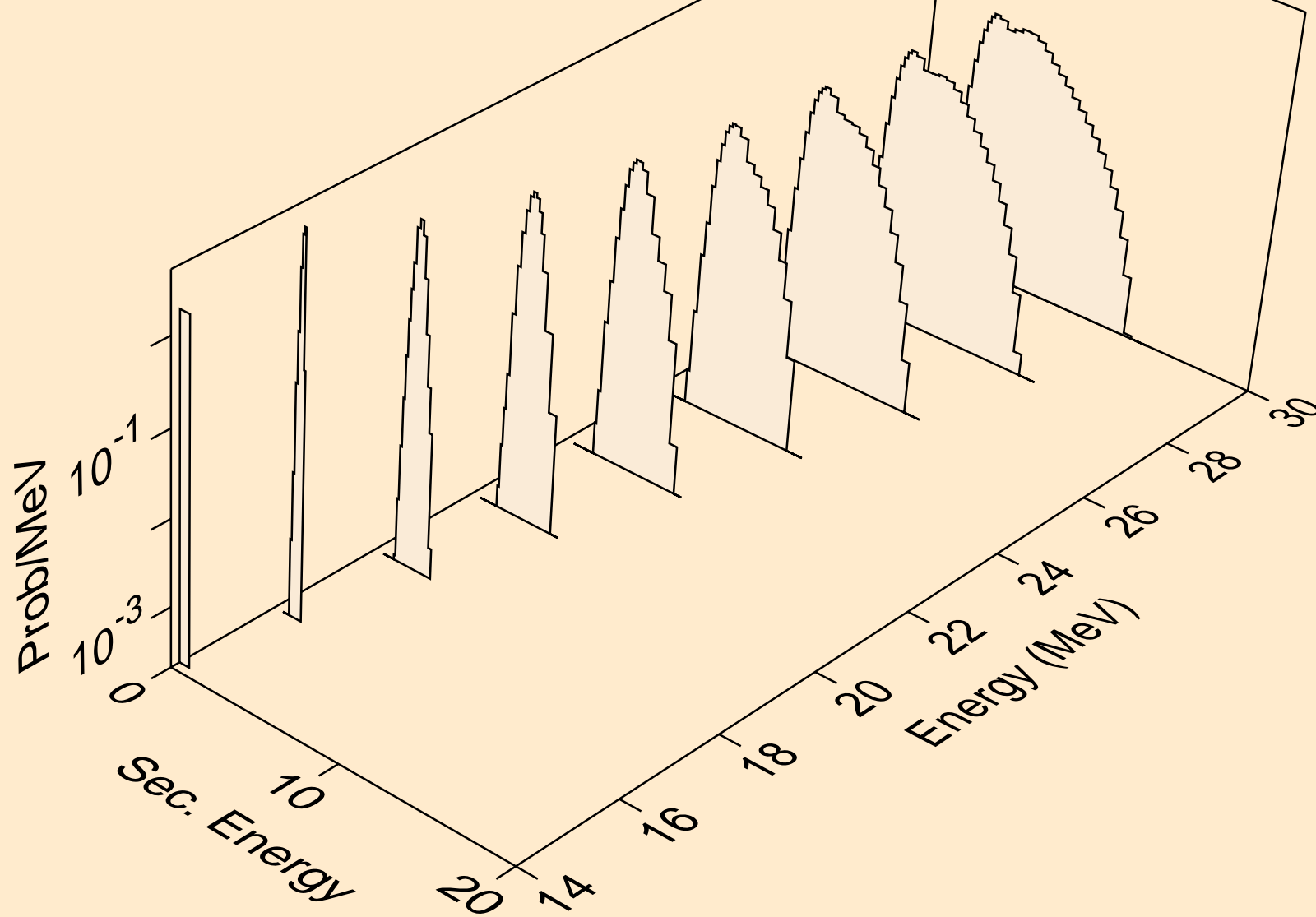

AR039 PROTON ACER TENDL-2023 LIBRARY; T=0.K  
alphas from (p,a)

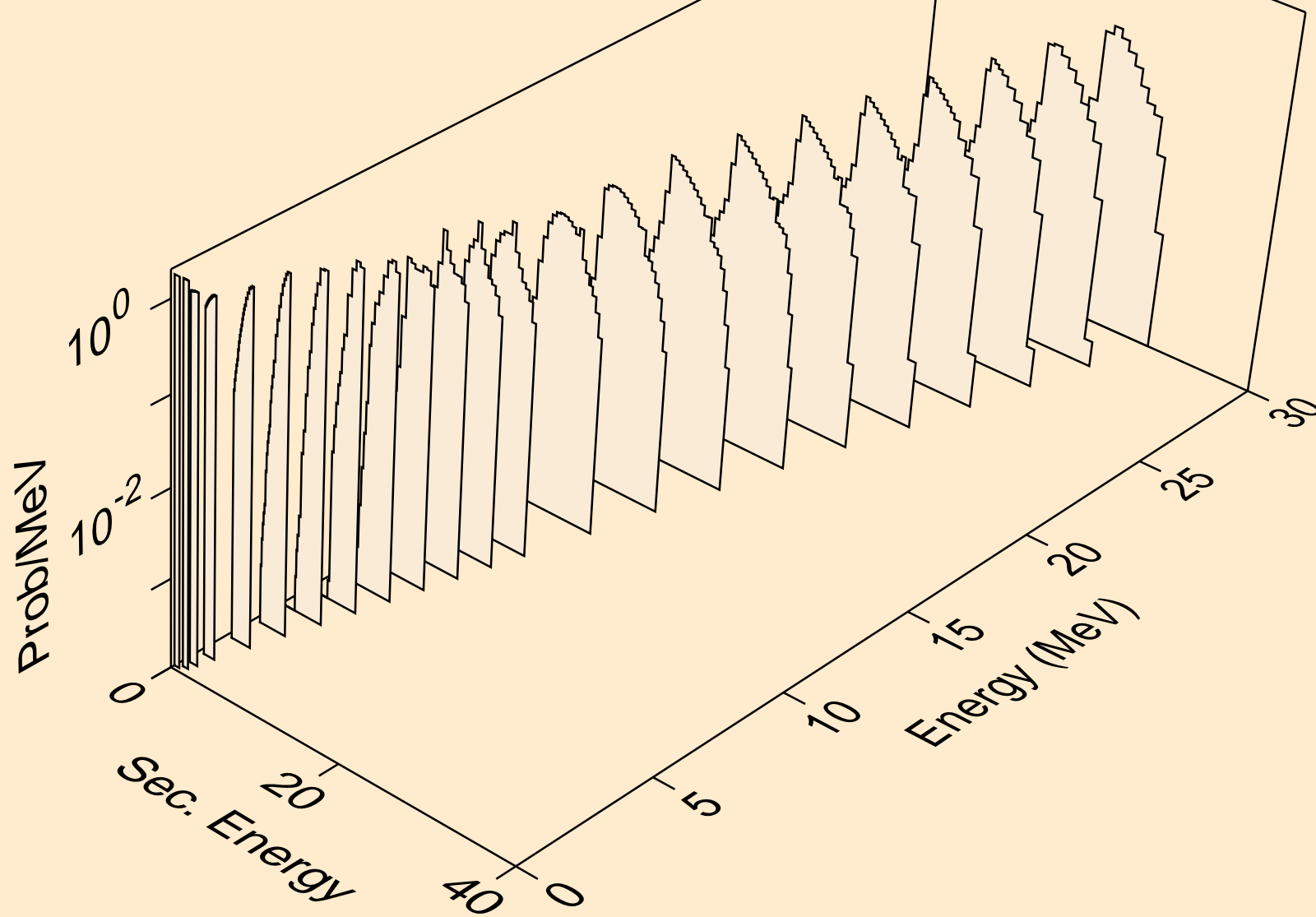



AR039 PROTON ACER TENDL-2023 LIBRARY; T=0.K  
alphas from (p,2a)

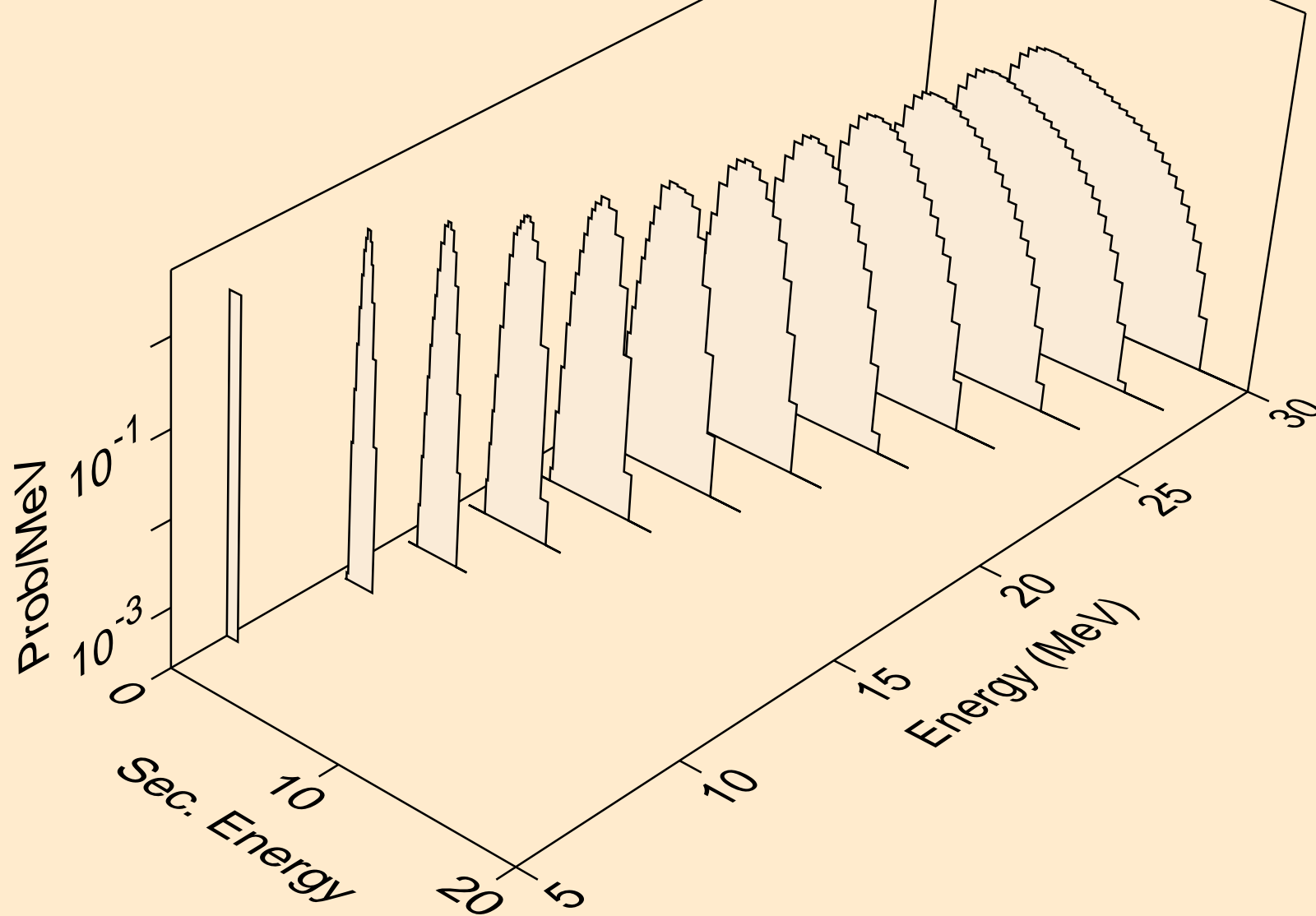

AR039 PROTON ACER TENDL-2023 LIBRARY; T=0.K  
alphas from (p,pa)

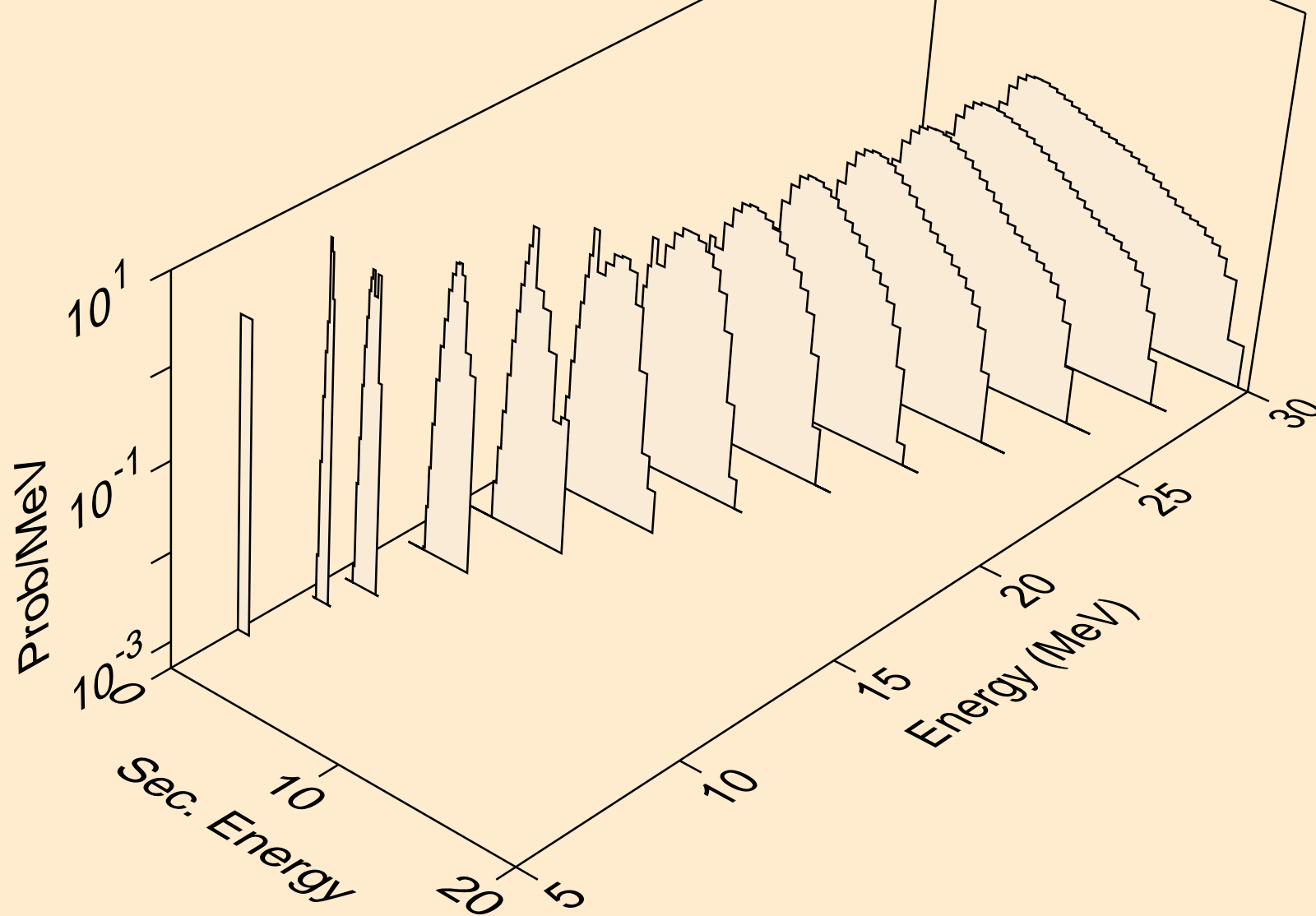

AR039 PROTON ACER TENDL-2023 LIBRARY; T=0.K  
alphas from (p,d2a)

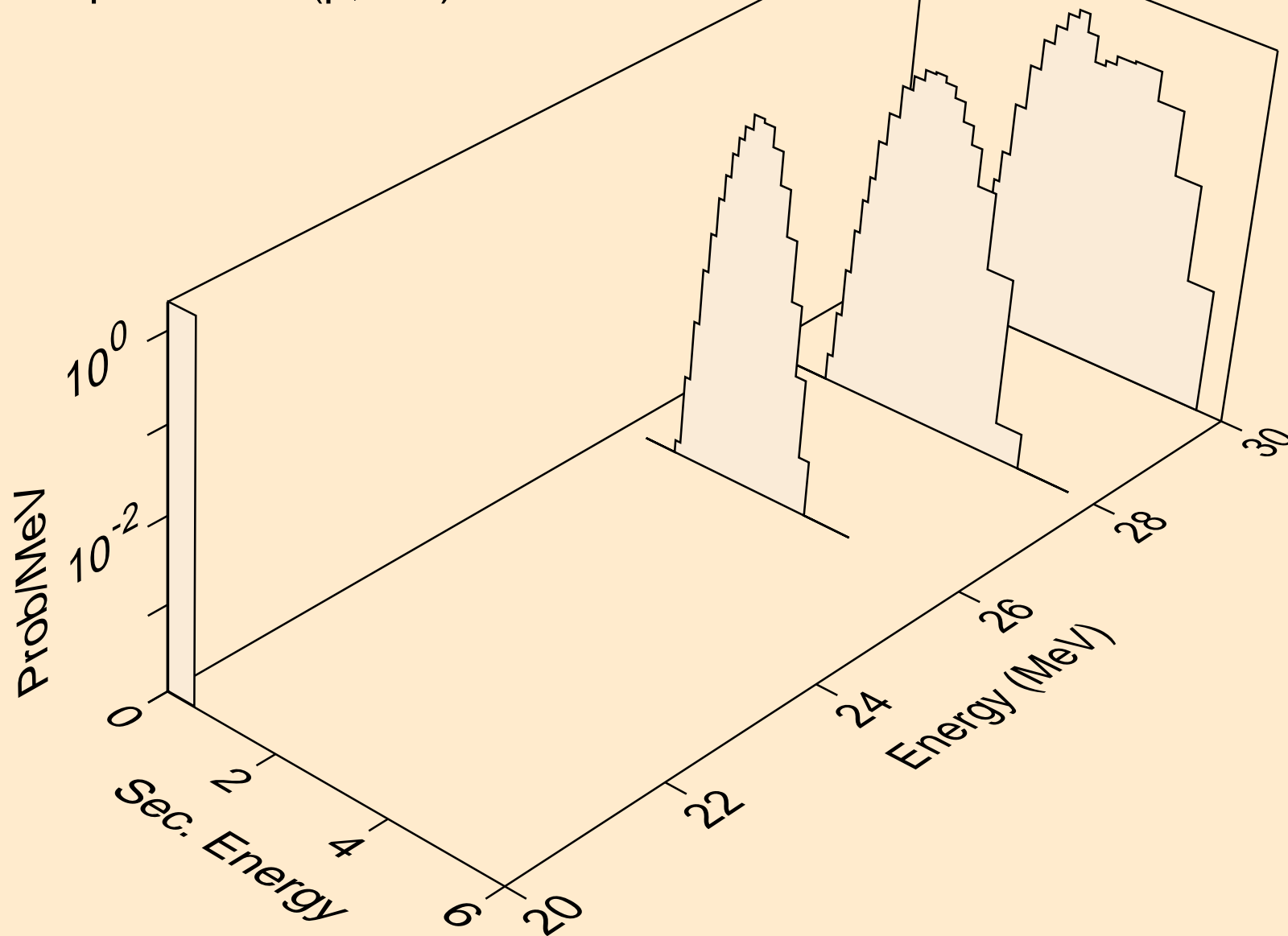

AR039 PROTON ACER TENDL-2023 LIBRARY; T=0.K  
alphas from (p,da)

