

# CD121M PROTON ACER TENDL-2023 LIBRARY; T=0.K

## Principal cross sections

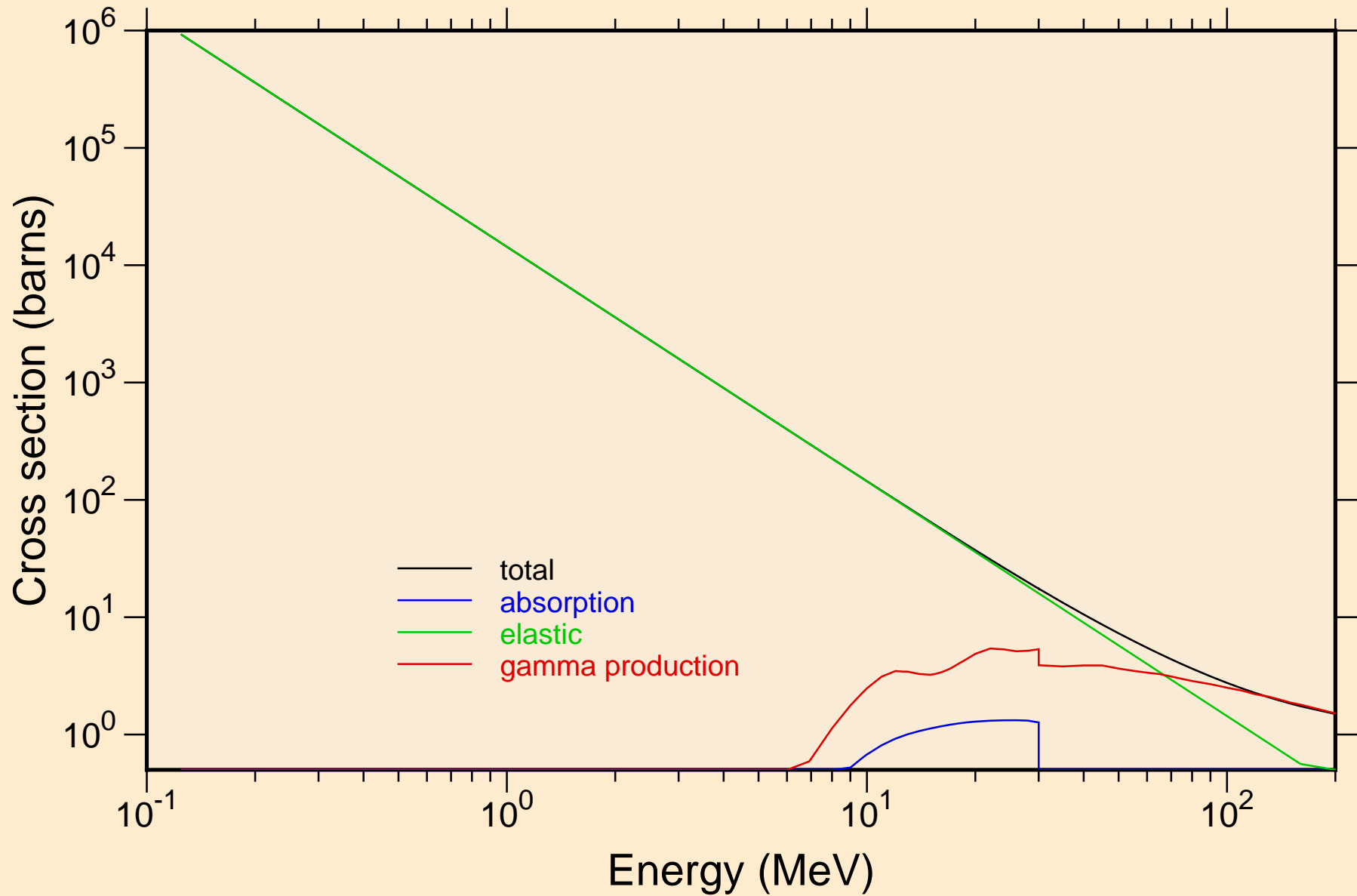

CD121M PROTON ACER TENDL-2023 LIBRARY; T=0.K  
Heating

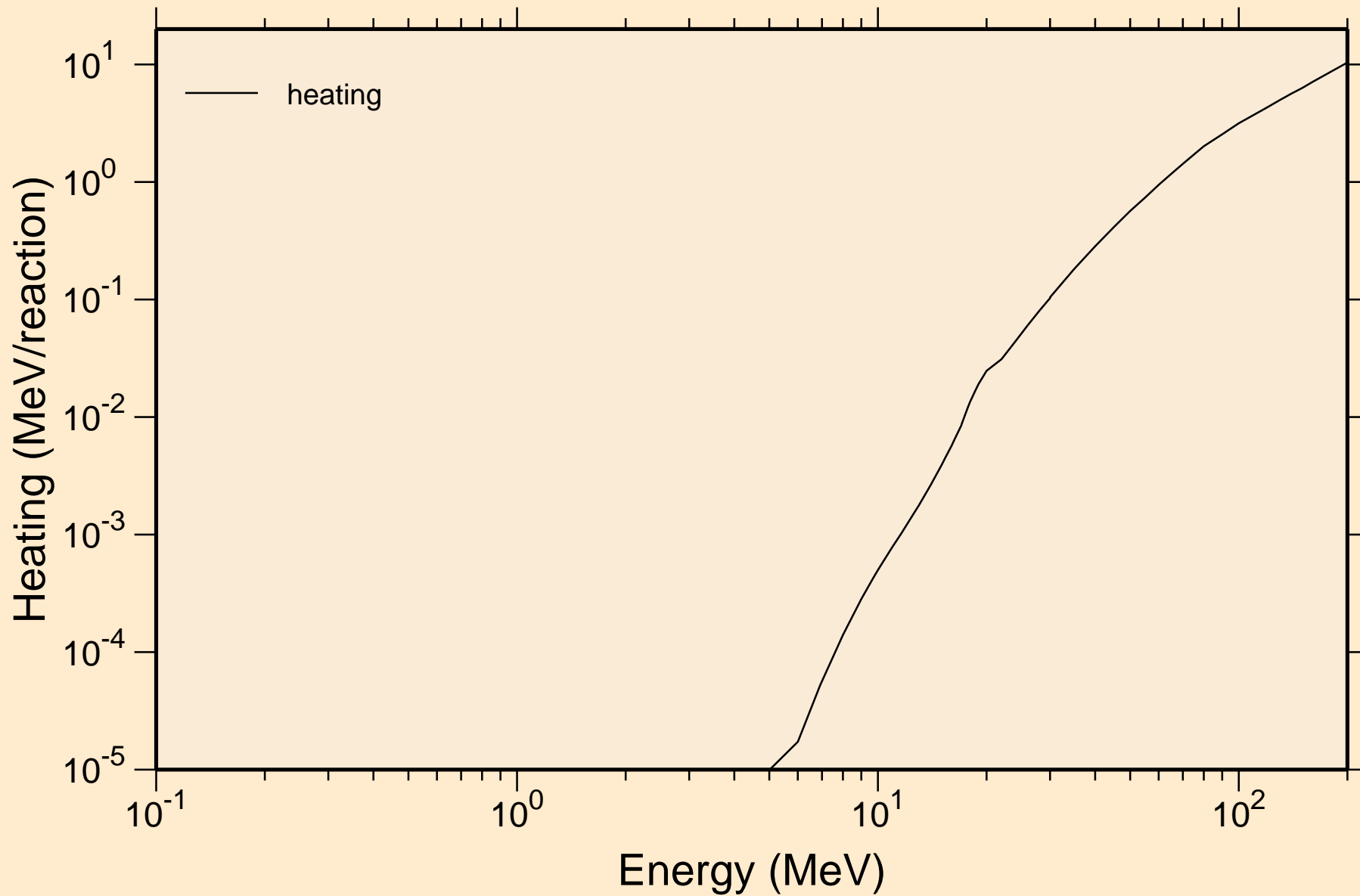

# CD121M PROTON ACER TENDL-2023 LIBRARY; T=0.K

## Principal cross sections

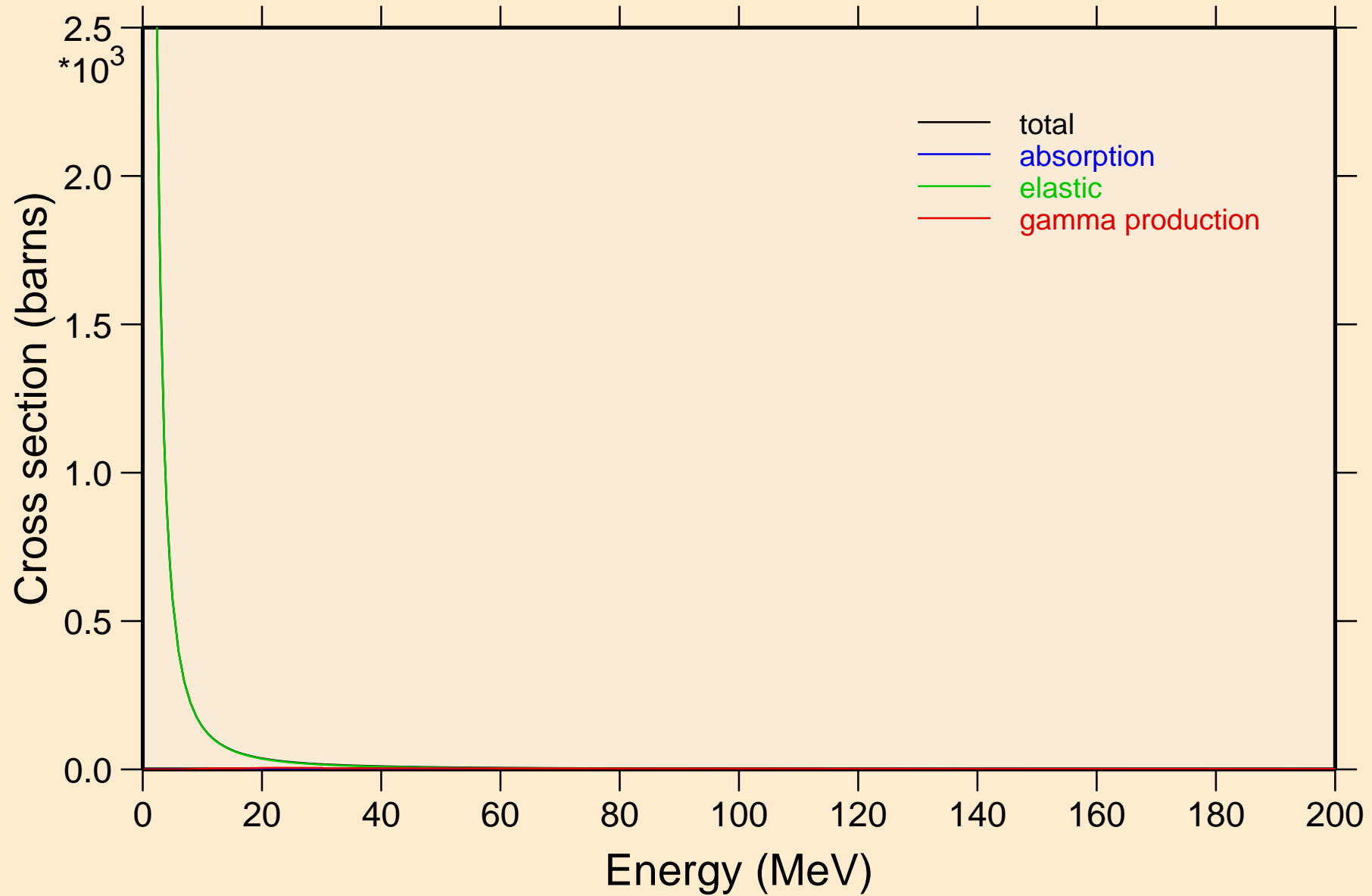

# CD121M PROTON ACER TENDL-2023 LIBRARY; T=0.K

## Heating

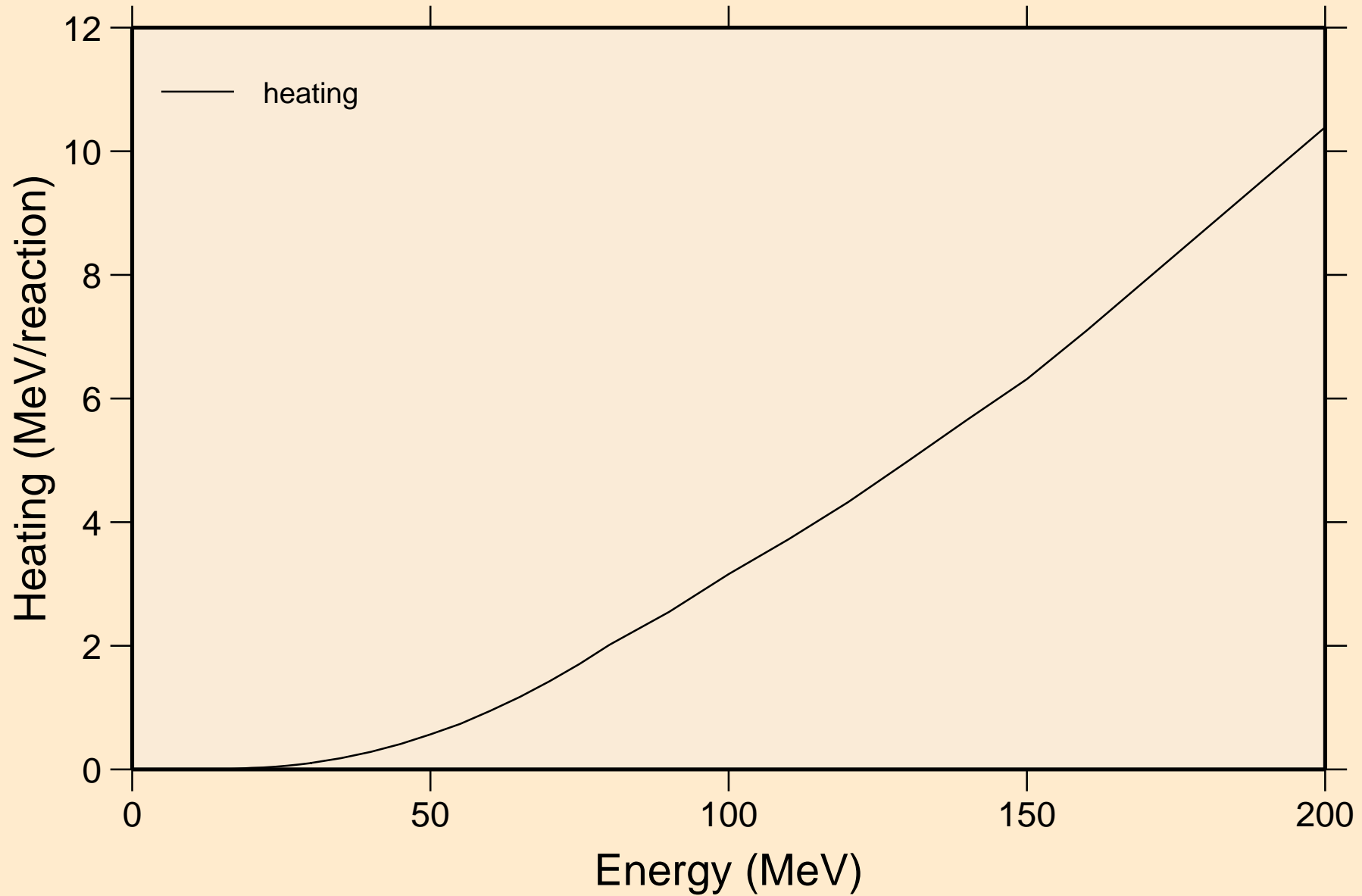

# CD121M PROTON ACER TENDL-2023 LIBRARY; T=0.K

## Threshold reactions

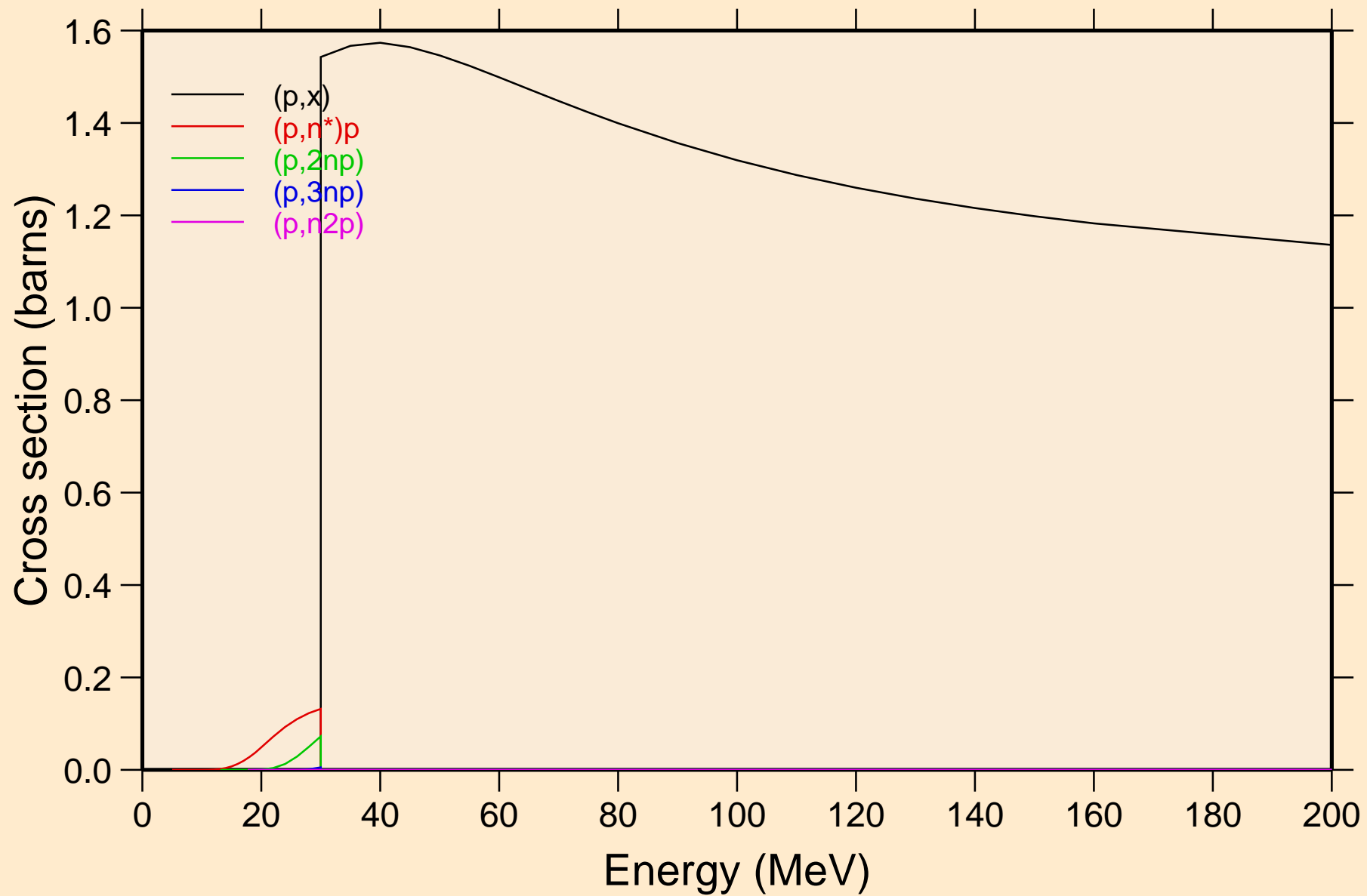

# CD121M PROTON ACER TENDL-2023 LIBRARY; T=0.K

## Threshold reactions

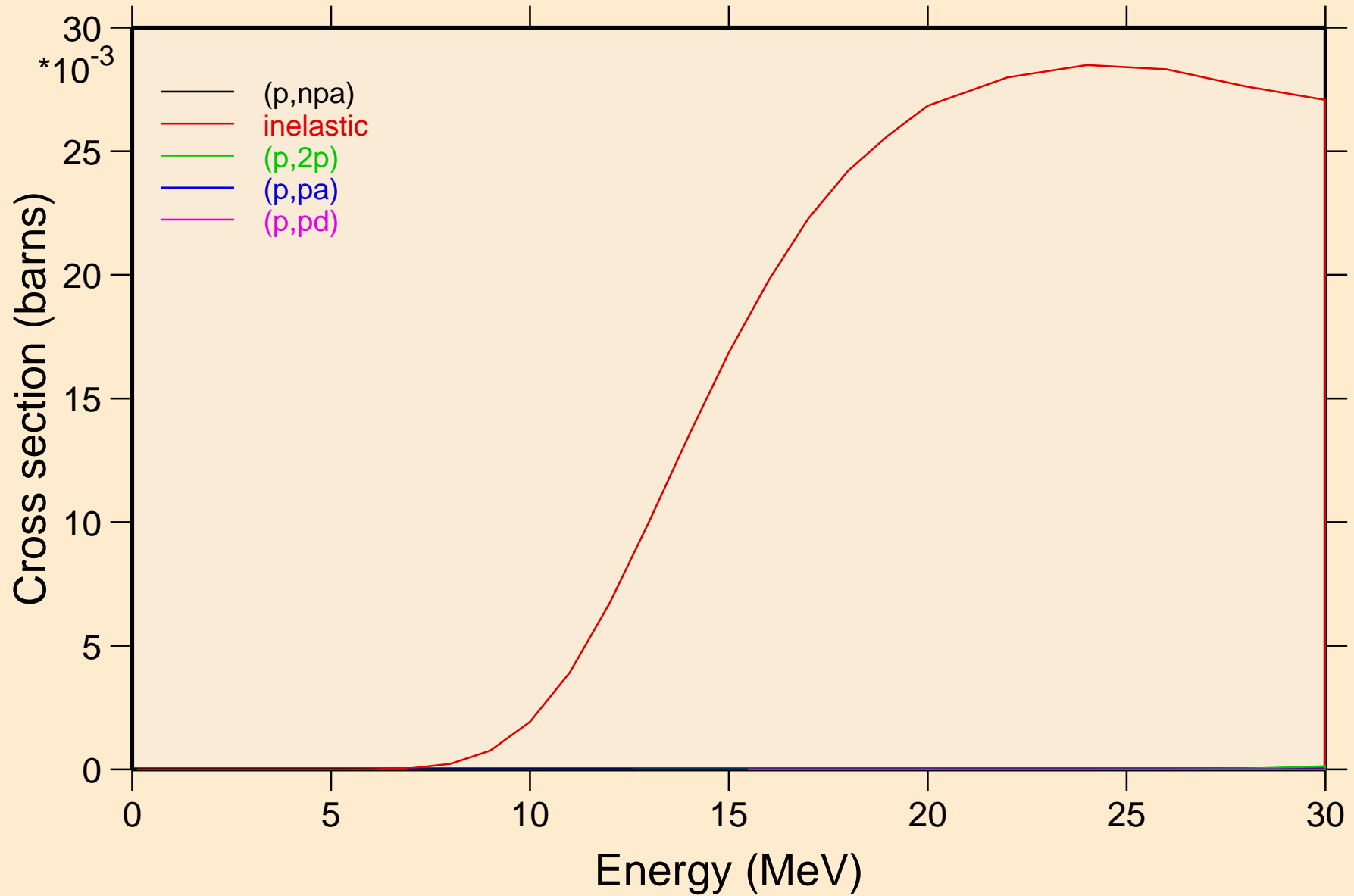

CD121M PROTON ACER TENDL-2023 LIBRARY; T=0.K  
angular distribution for elastic

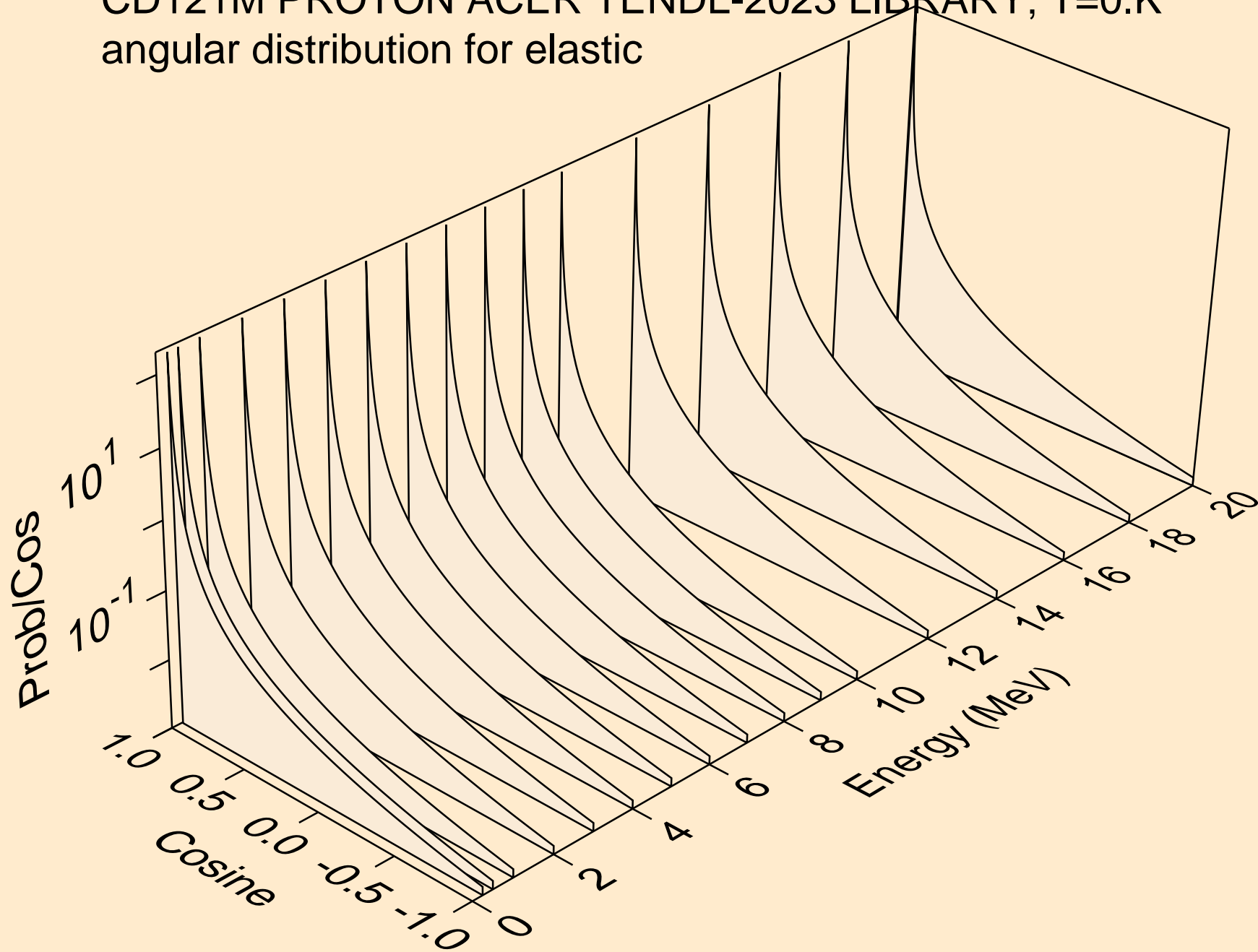

CD121M PROTON ACER TENDL-2023 LIBRARY; T=0.K  
angular distribution for elastic

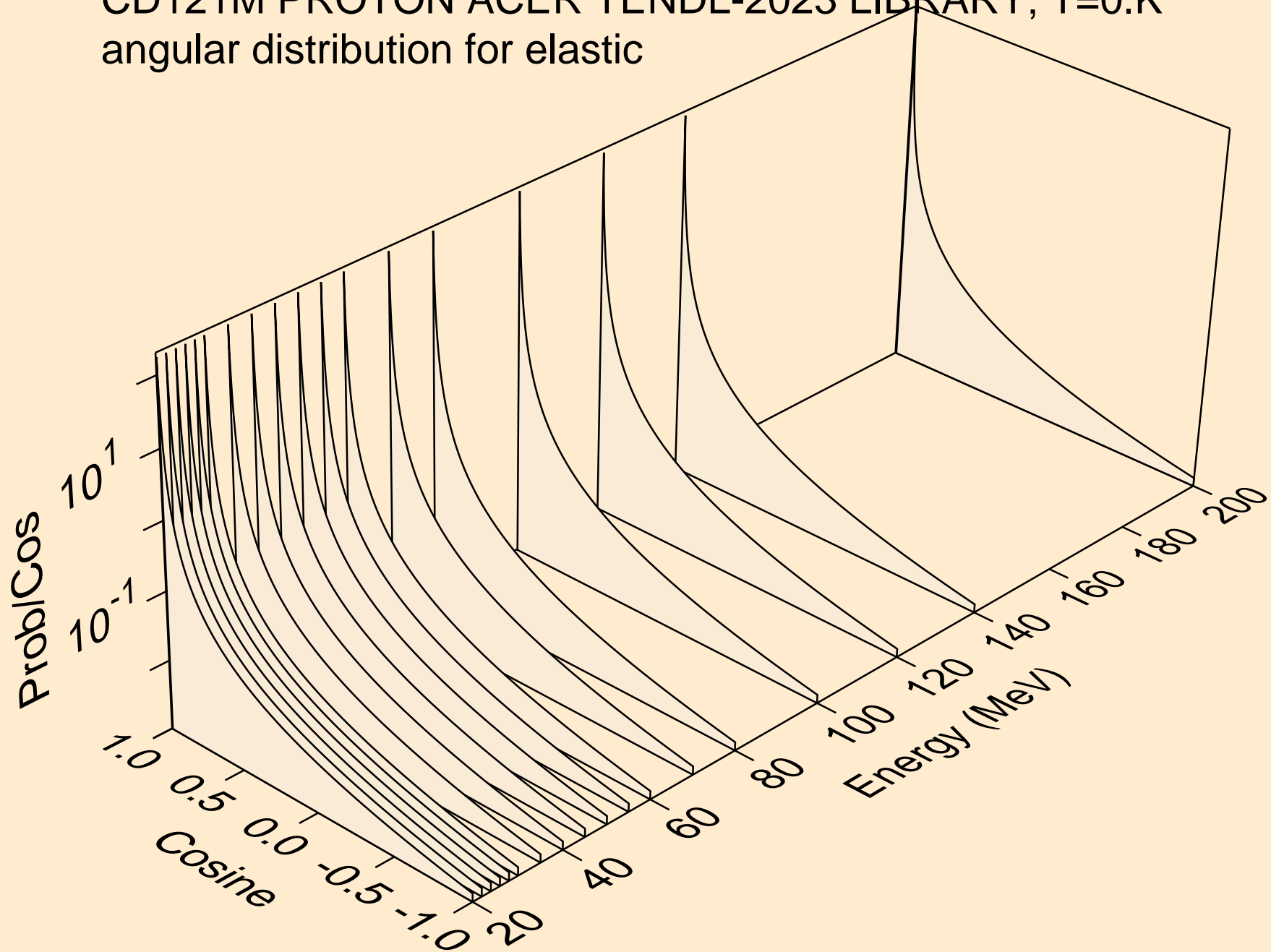



CD121M PROTON ACER TENDL-2023 LIBRARY; T=0.K  
Proton emission for (p,x)

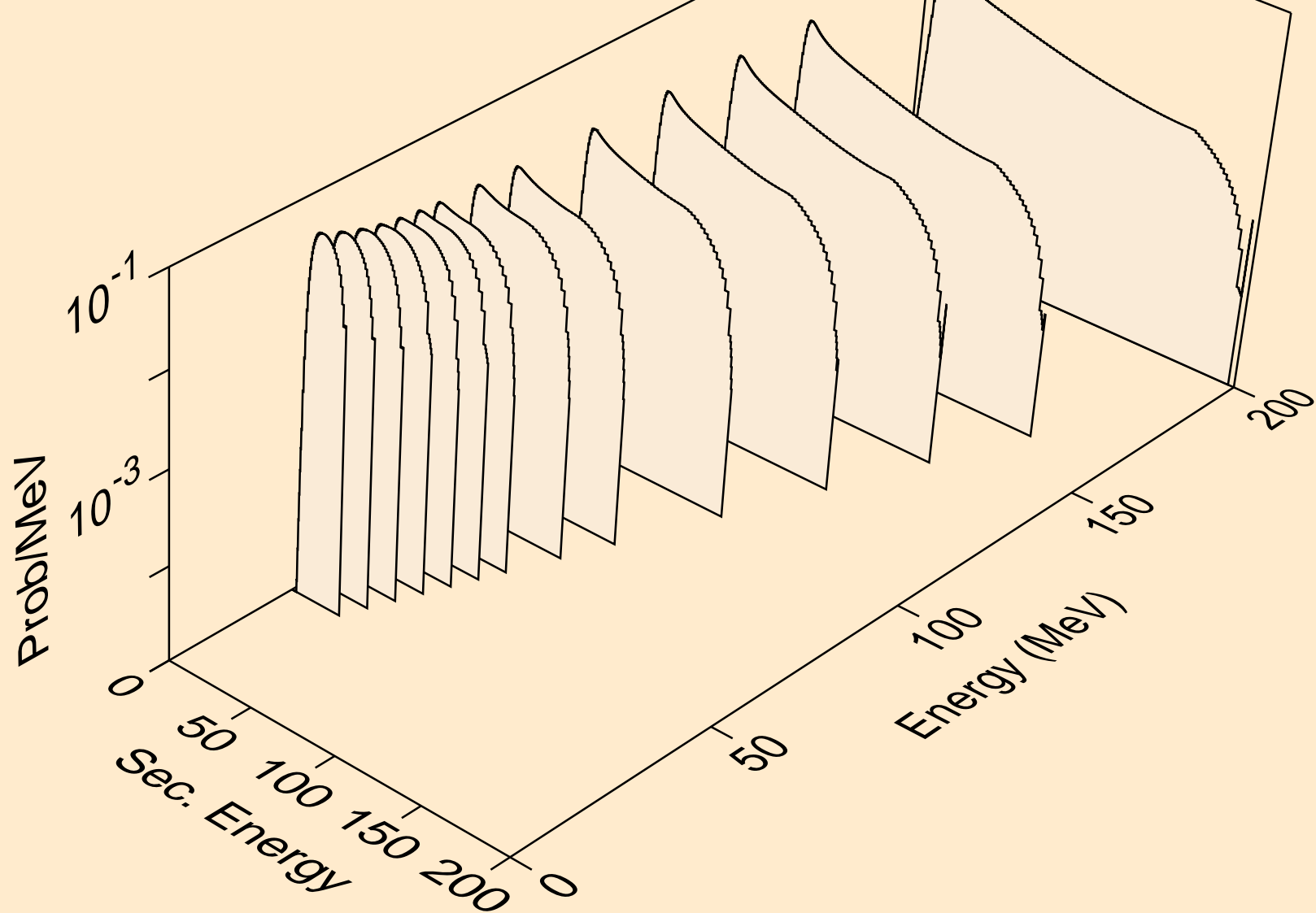

CD121M PROTON ACER TENDL-2023 LIBRARY; T=0.K  
Proton emission for (p,n\*)p

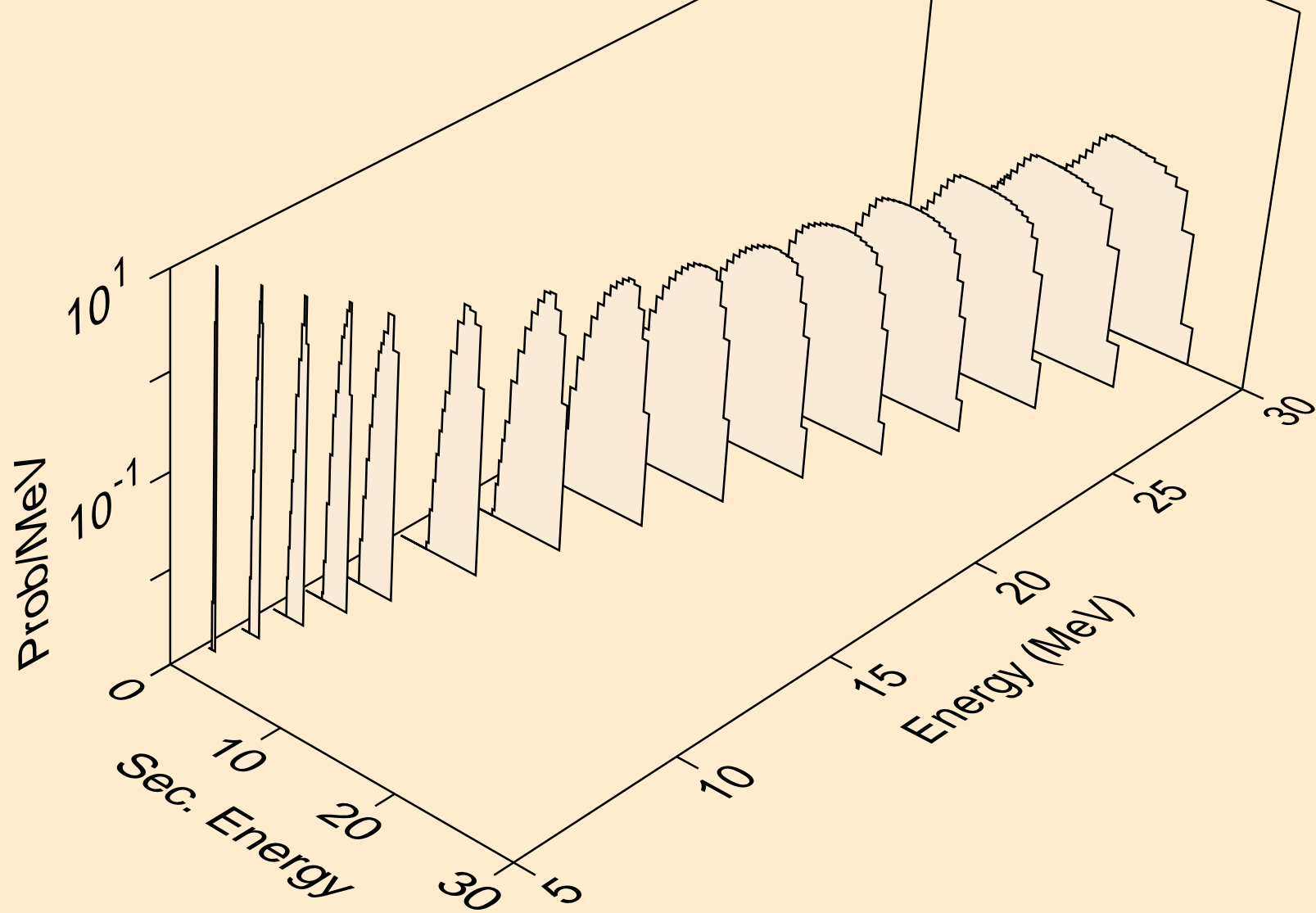

CD121M PROTON ACER TENDL-2023 LIBRARY; T=0.K  
Proton emission for (p,2np)

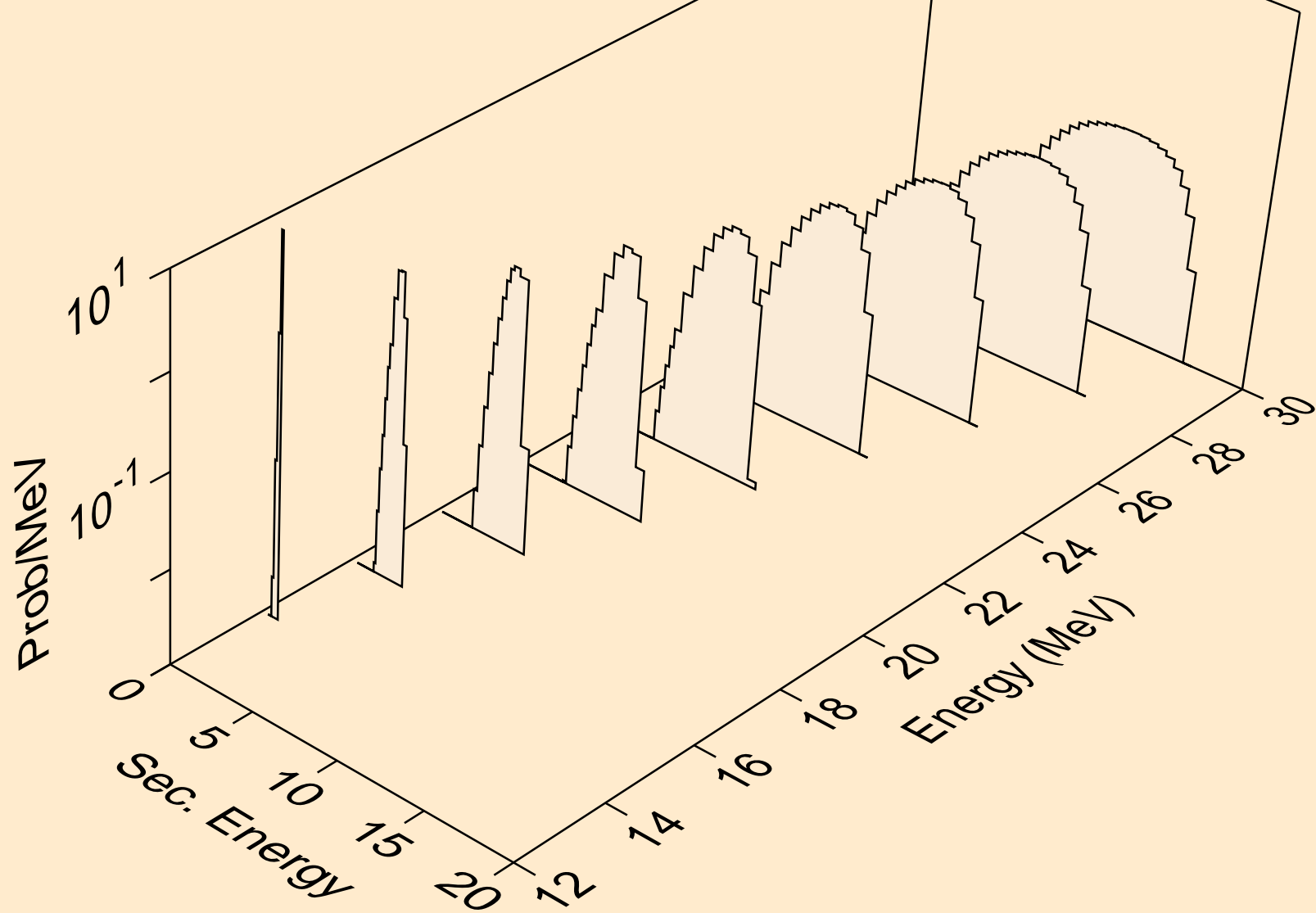

CD121M PROTON ACER TENDL-2023 LIBRARY; T=0.K  
Proton emission for (p,3np)

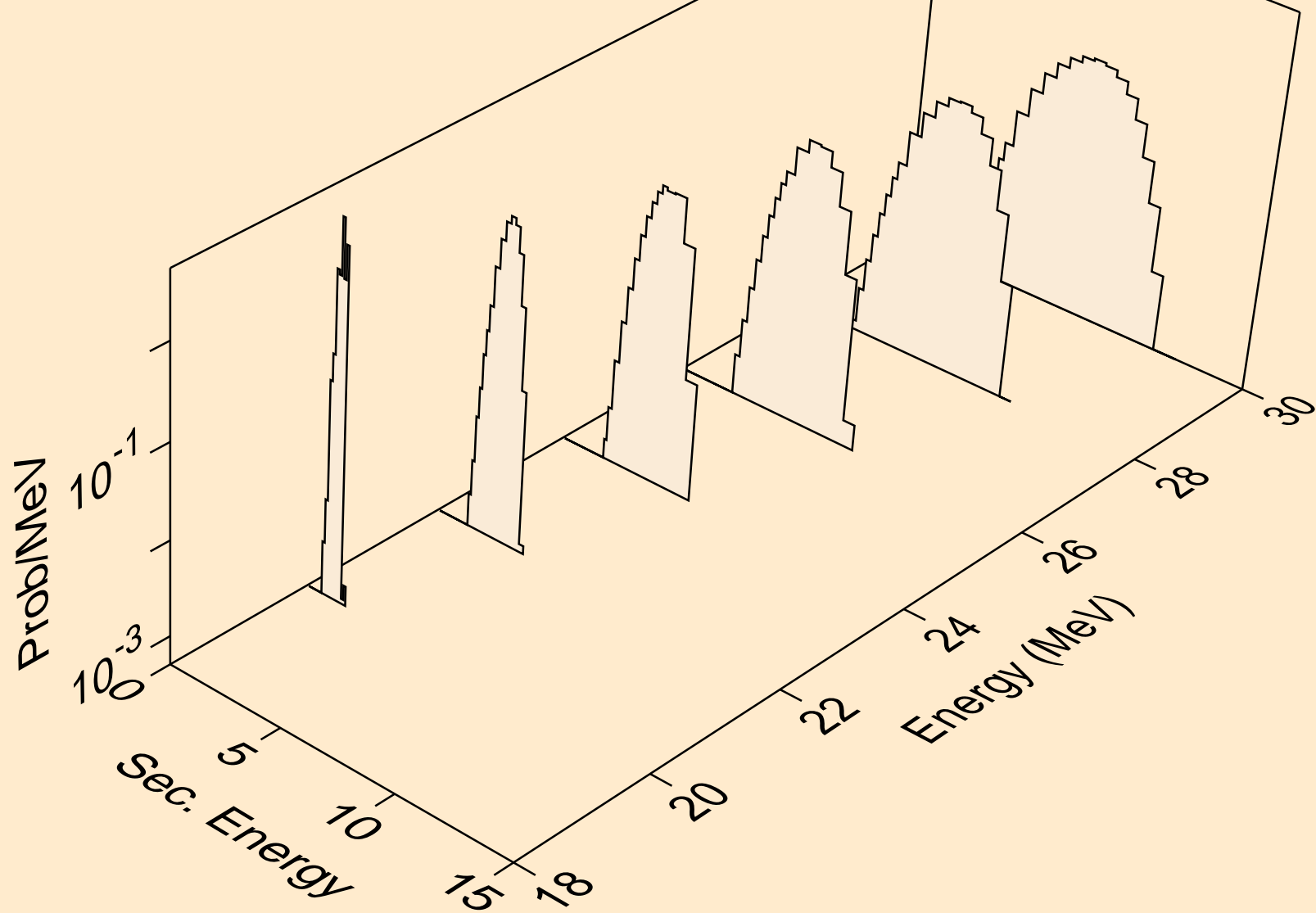

CD121M PROTON ACER TENDL-2023 LIBRARY; T=0.K  
Proton emission for (p,n2p)

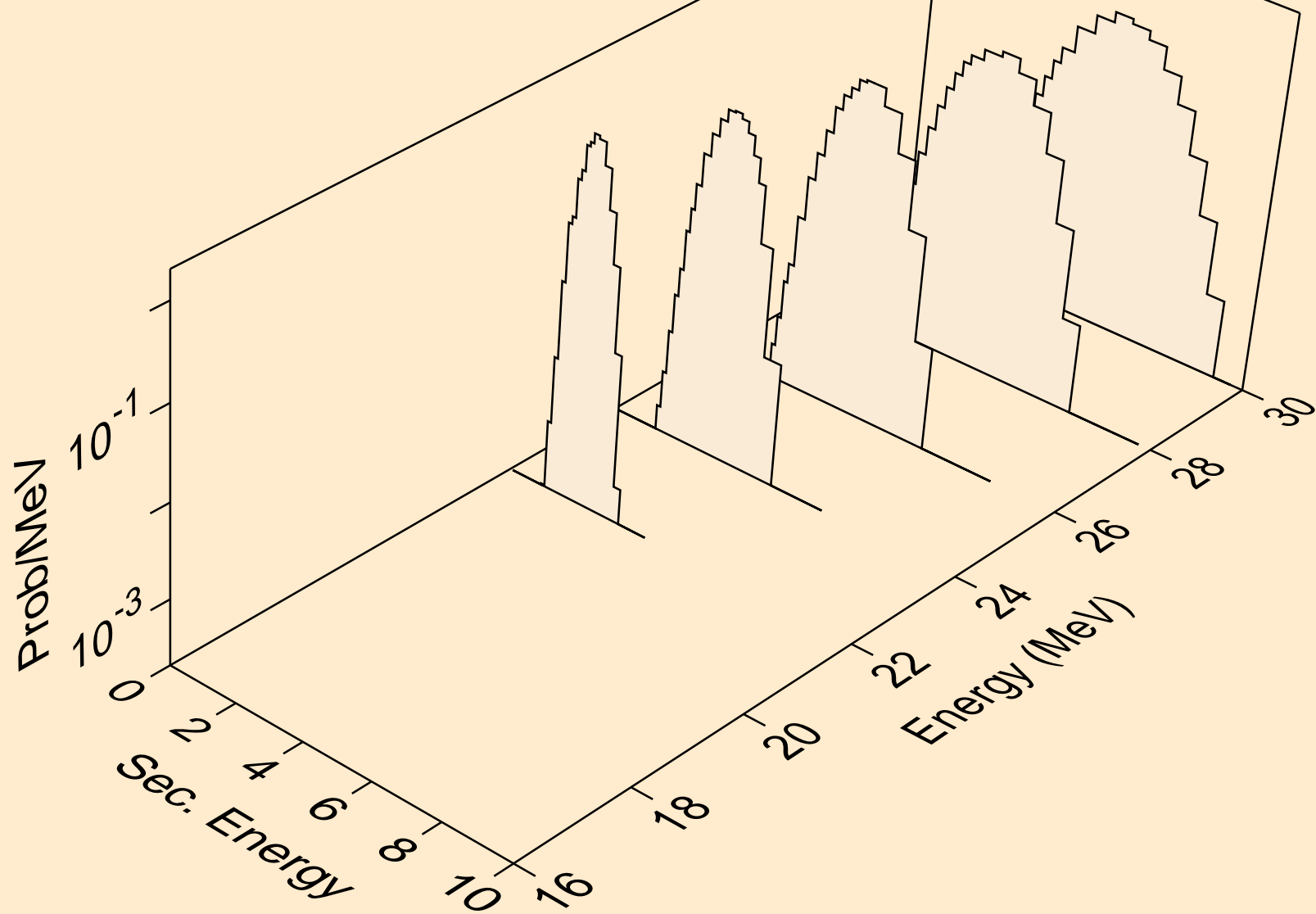

CD121M PROTON ACER TENDL-2023 LIBRARY; T=0.K  
Proton emission for (p,npa)

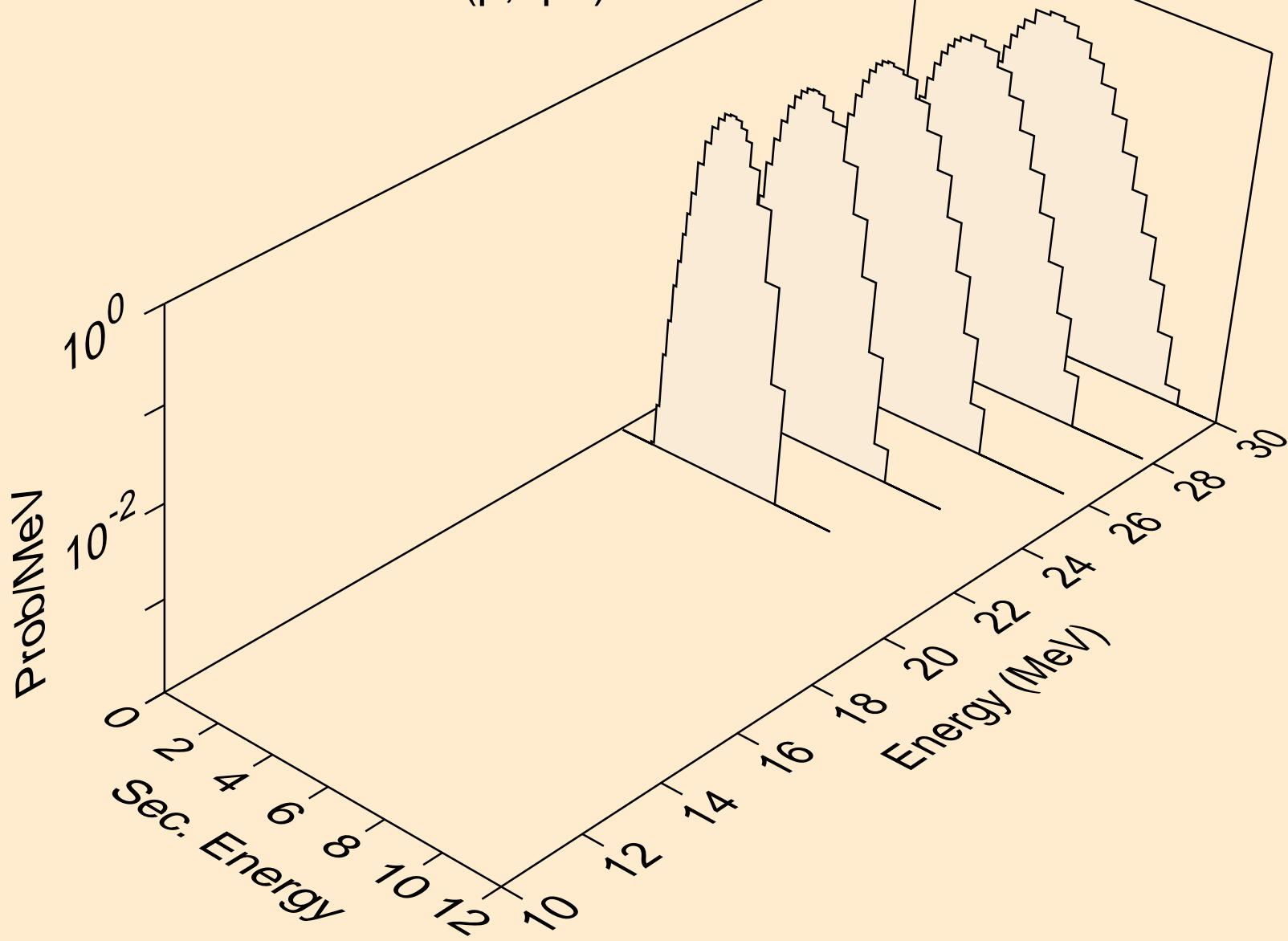

CD121M PROTON ACER TENDL-2023 LIBRARY; T=0.K  
Proton emission for inelastic

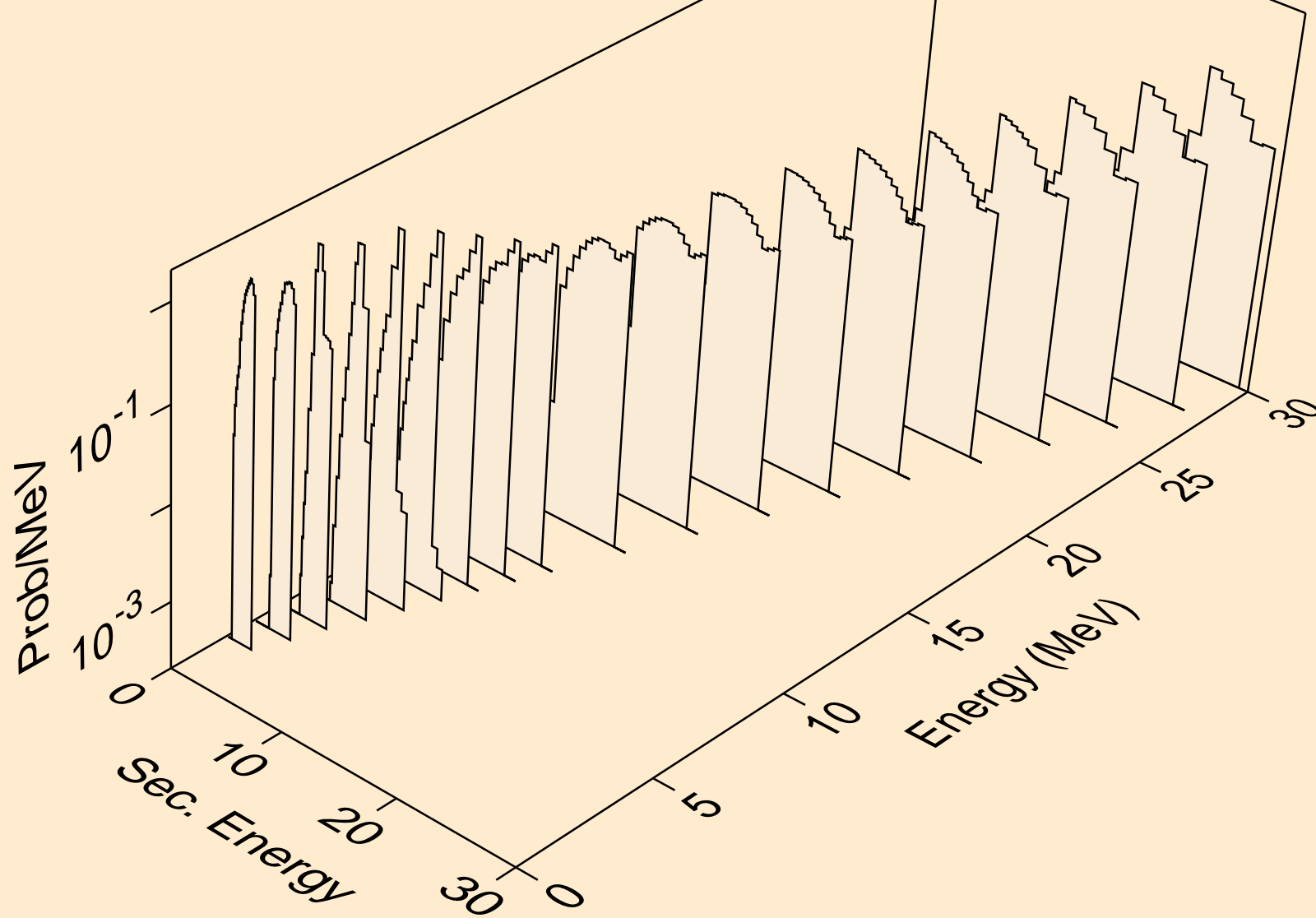

CD121M PROTON ACER TENDL-2023 LIBRARY; T=0.K  
Proton emission for (p,2p)

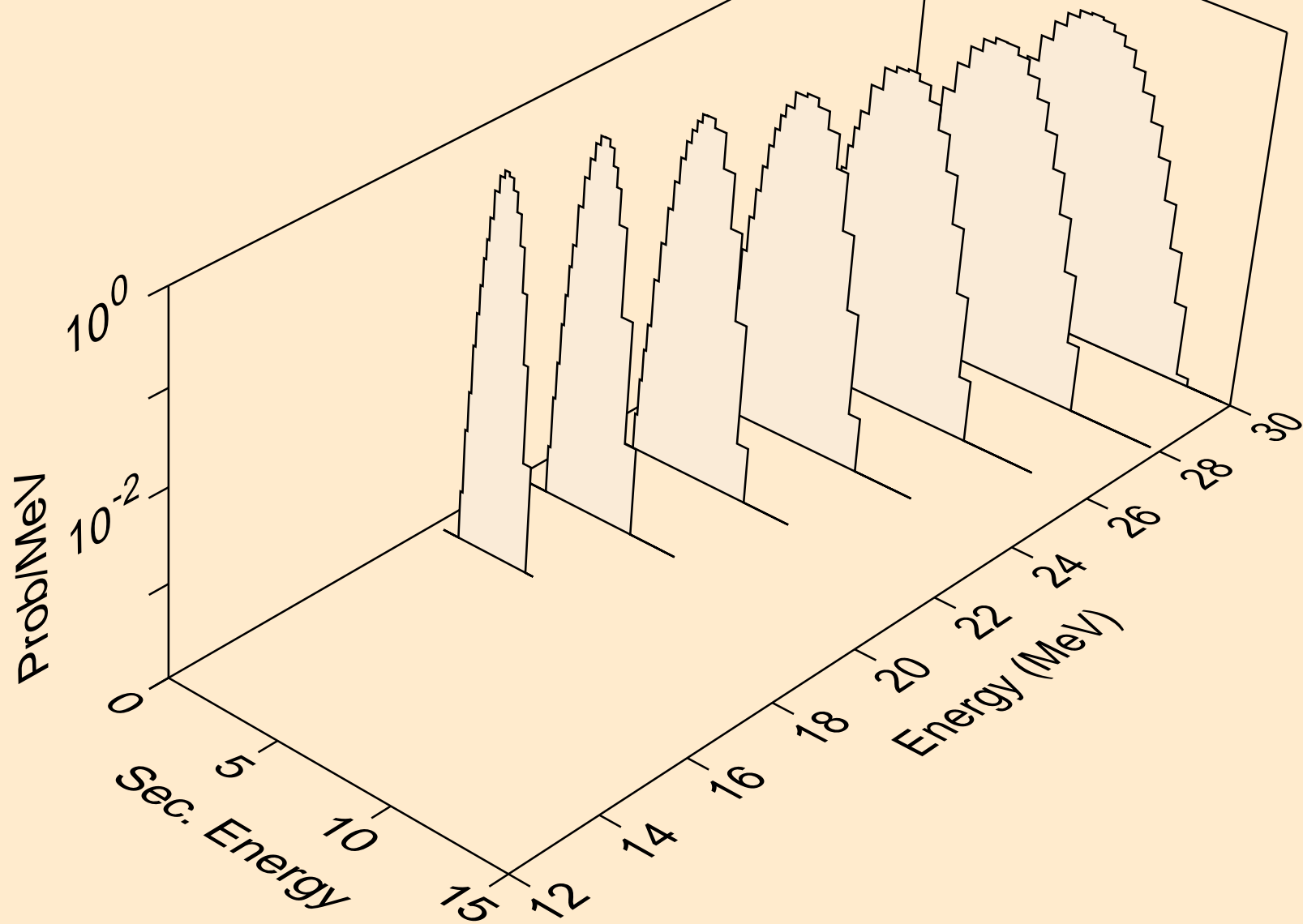



CD121M PROTON ACER TENDL-2023 LIBRARY; T=0.K  
Proton emission for (p,pa)

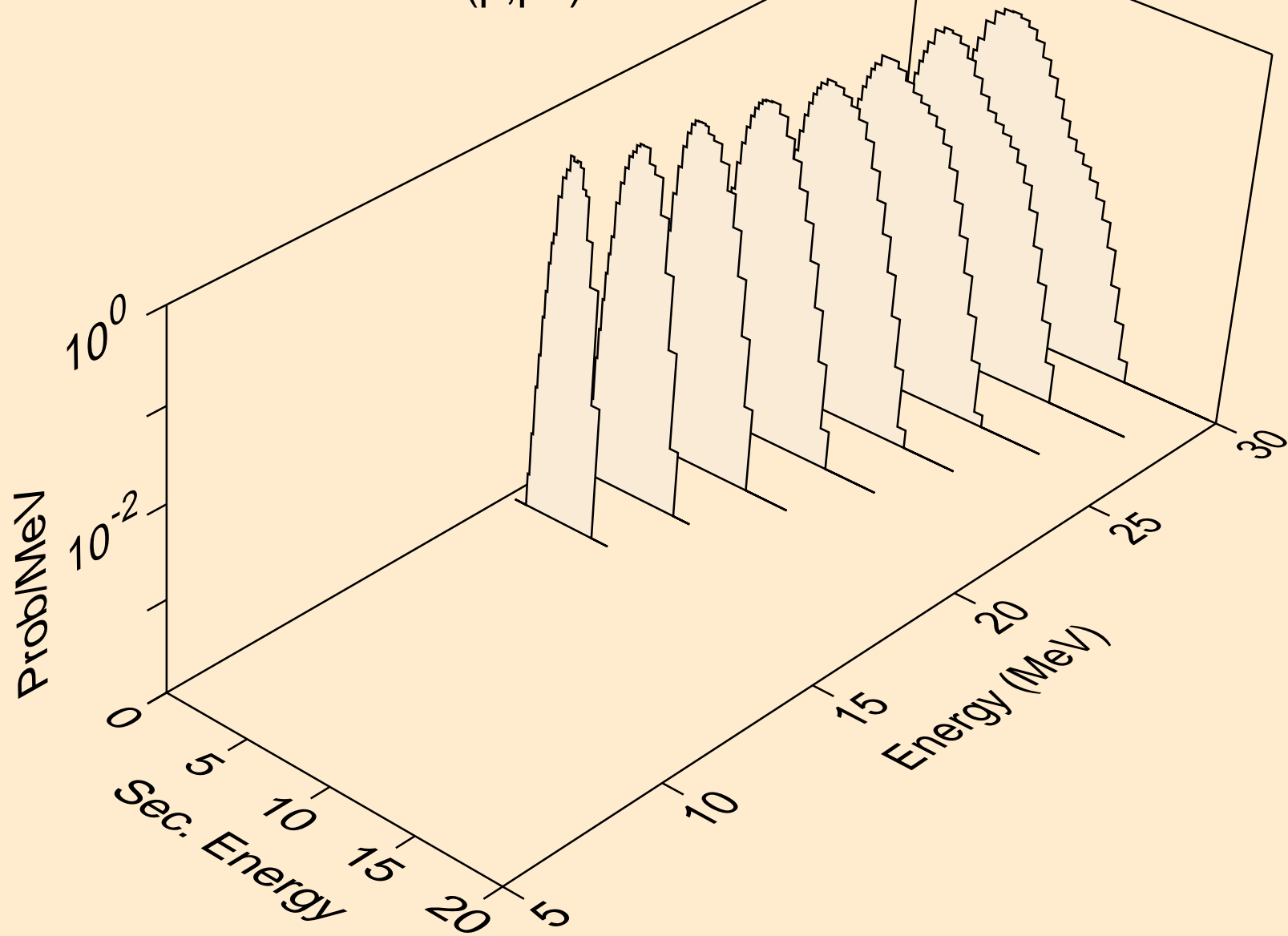

CD121M PROTON ACER TENDL-2023 LIBRARY; T=0.K  
Proton emission for (p,pd)

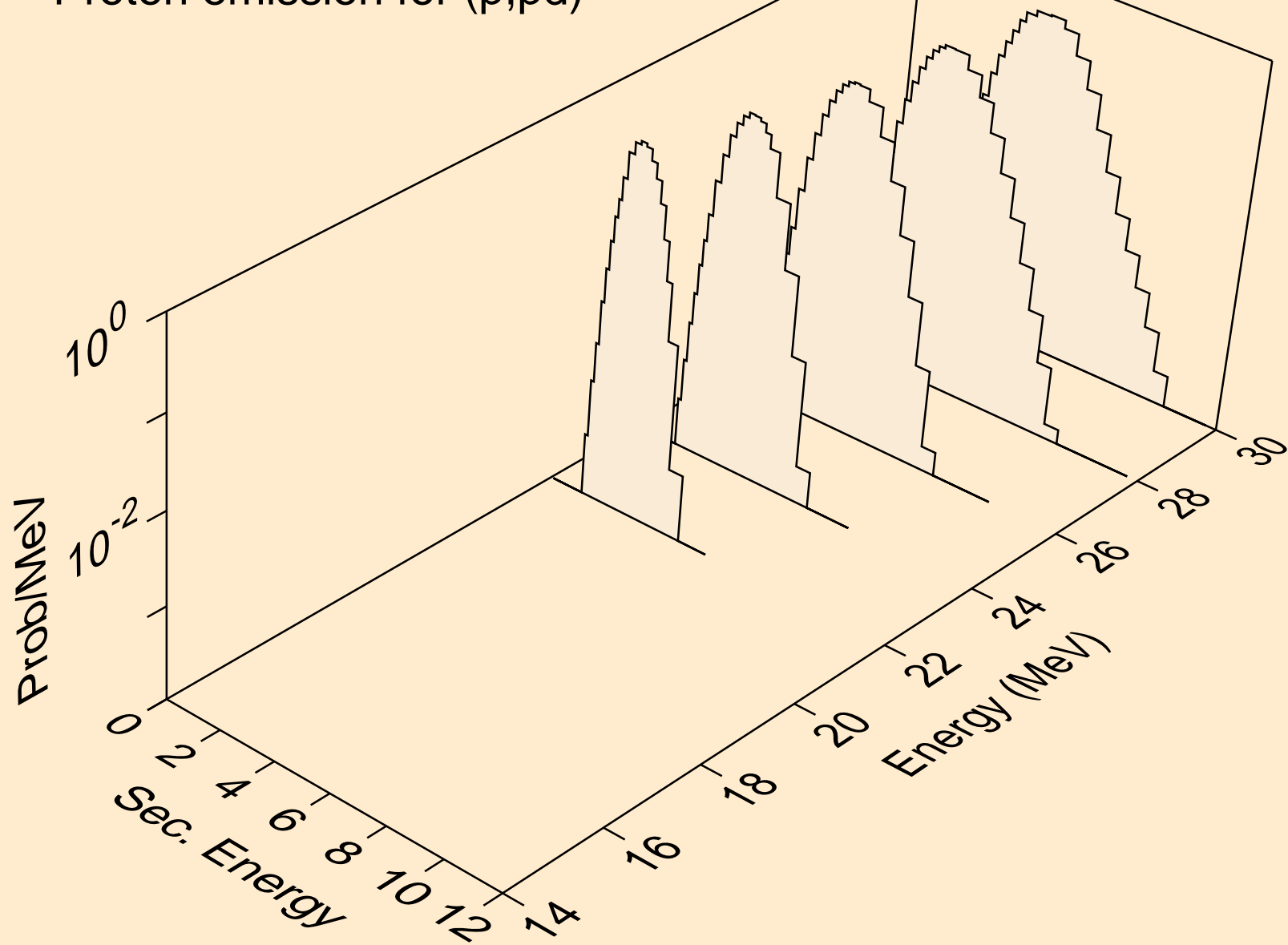

CD121M PROTON ACER TENDL-2023 LIBRARY; T=0.K  
Photon emission for (z,n)

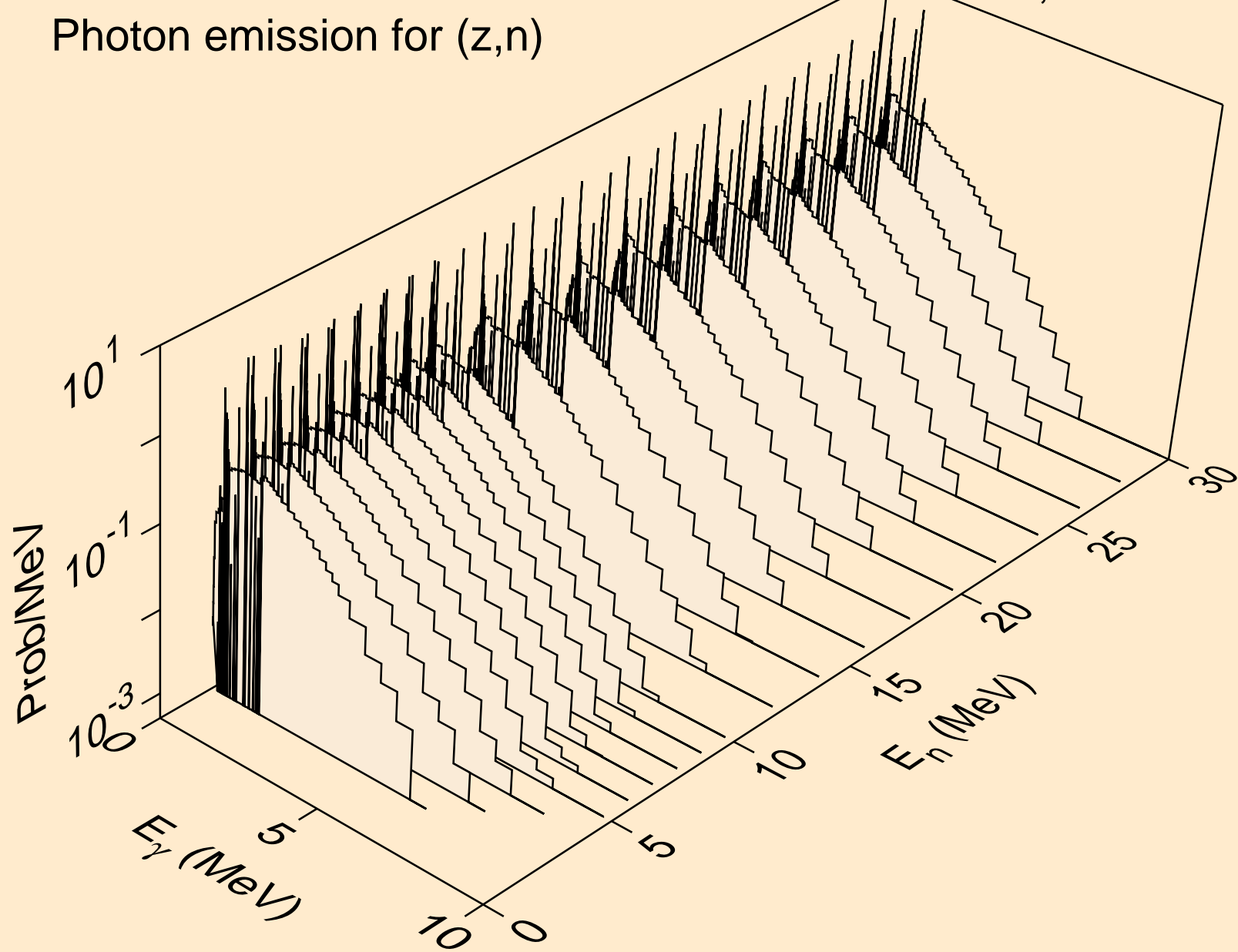

CD121M PROTON ACER TENDL-2023 LIBRARY; T=0.K  
Photon emission for (z,x)

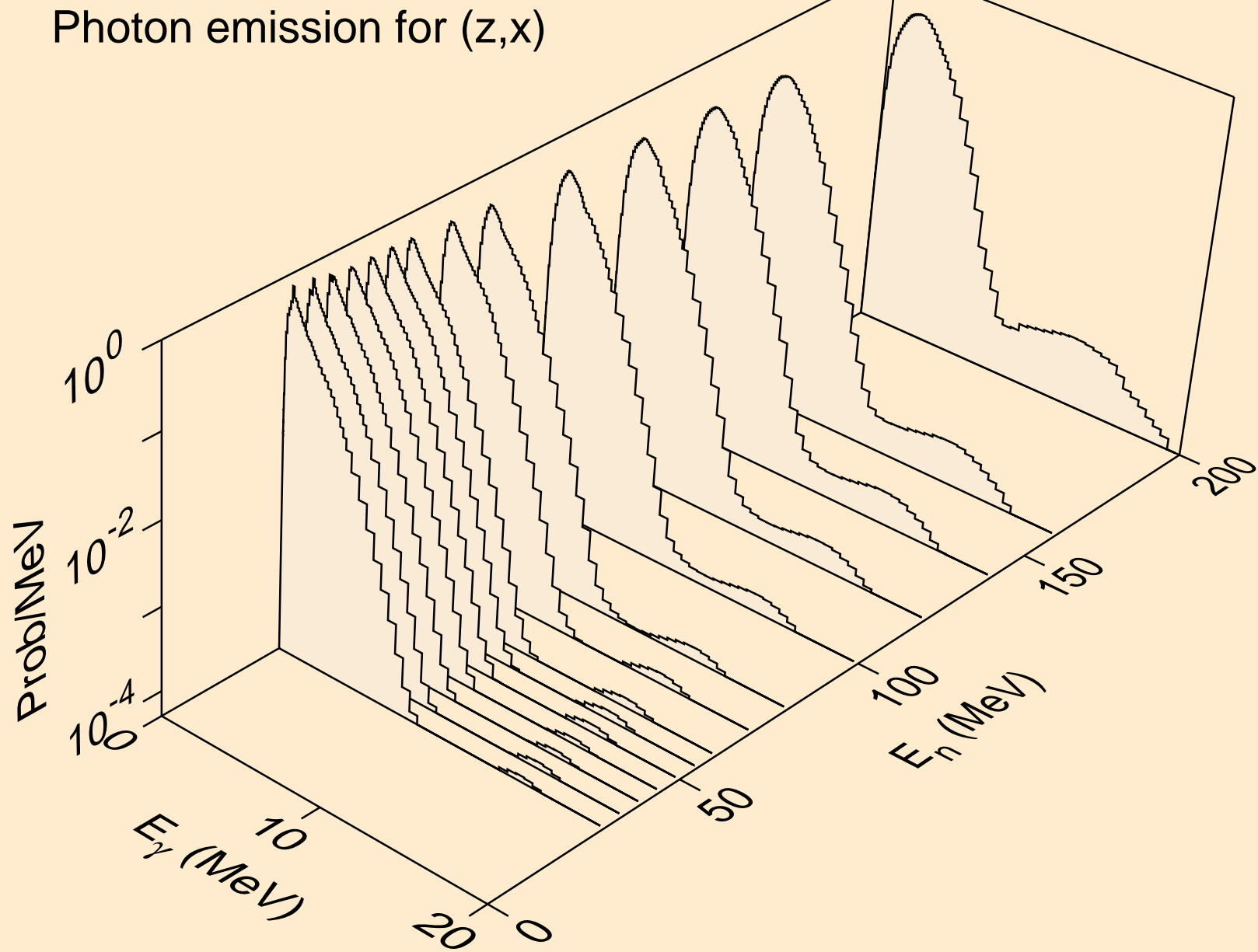

CD121M PROTON ACER TENDL-2023 LIBRARY; T=0.K  
Photon emission for (n,2nd)

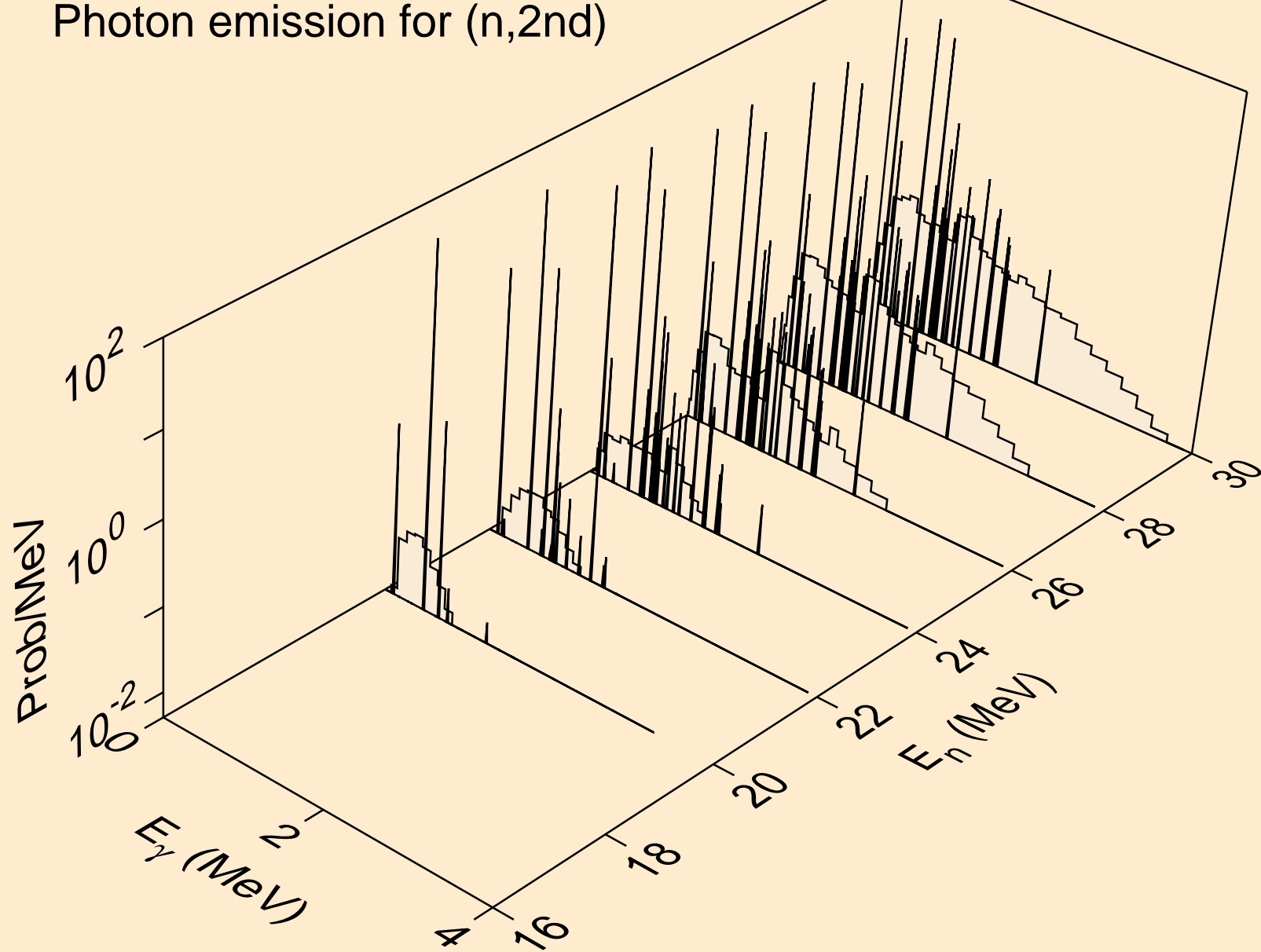

CD121M PROTON ACER TENDL-2023 LIBRARY; T=0.K  
Photon emission for (n,2n)

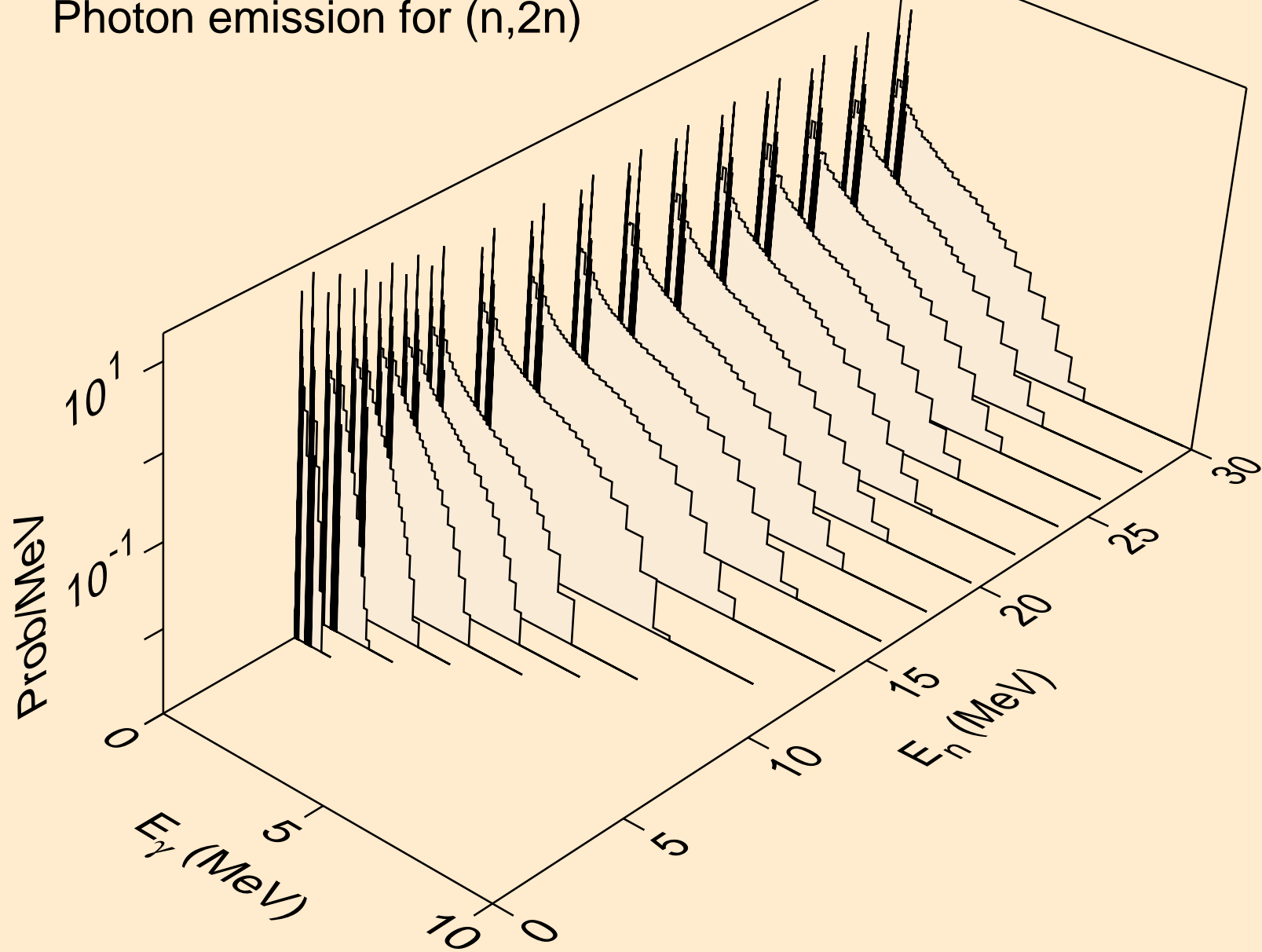

CD121M PROTON ACER TENDL-2023 LIBRARY; T=0.K  
Photon emission for (n,3n)

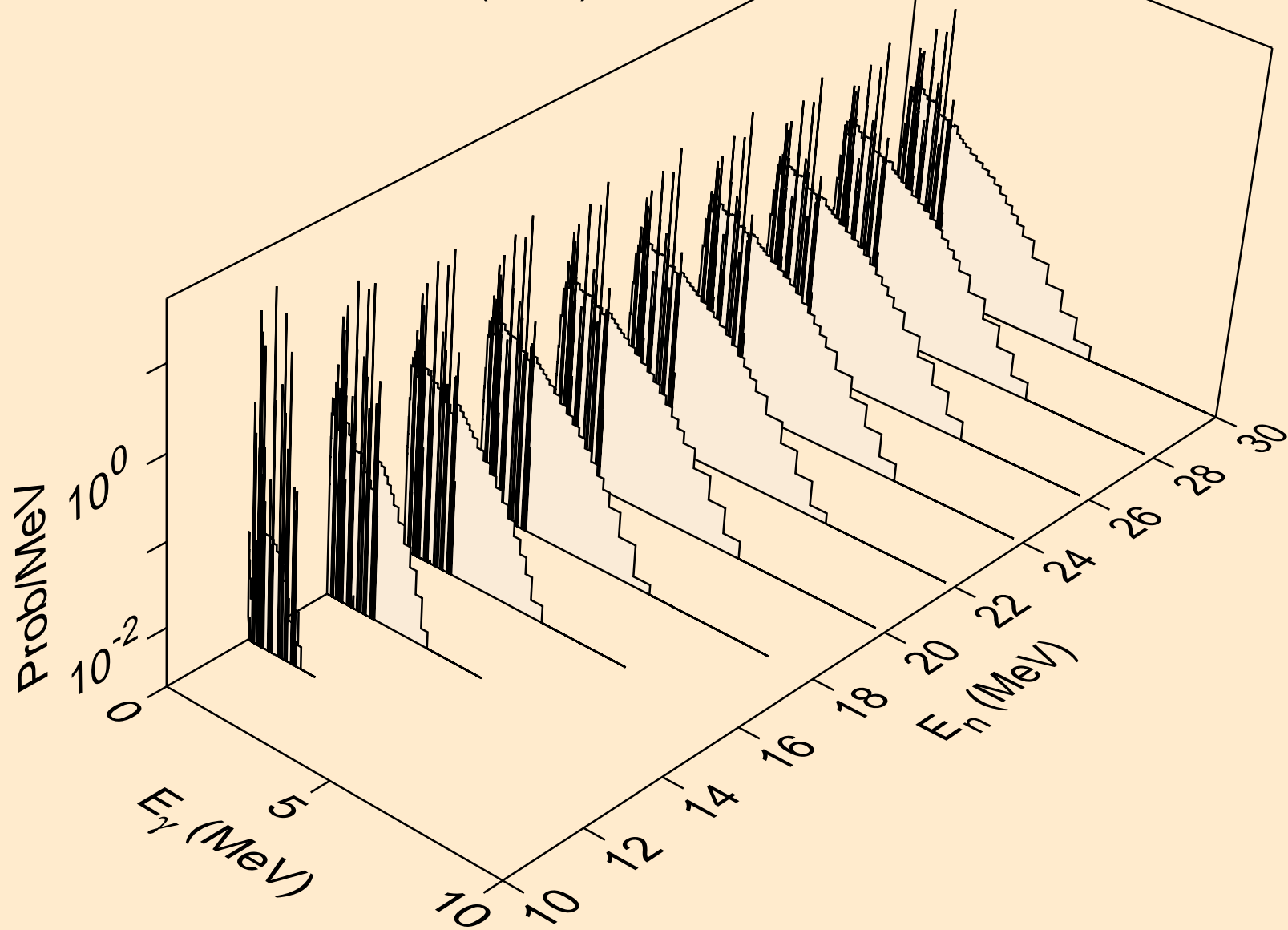

CD121M PROTON ACER TENDL-2023 LIBRARY; T=0.K  
Photon emission for (n,n\*)a

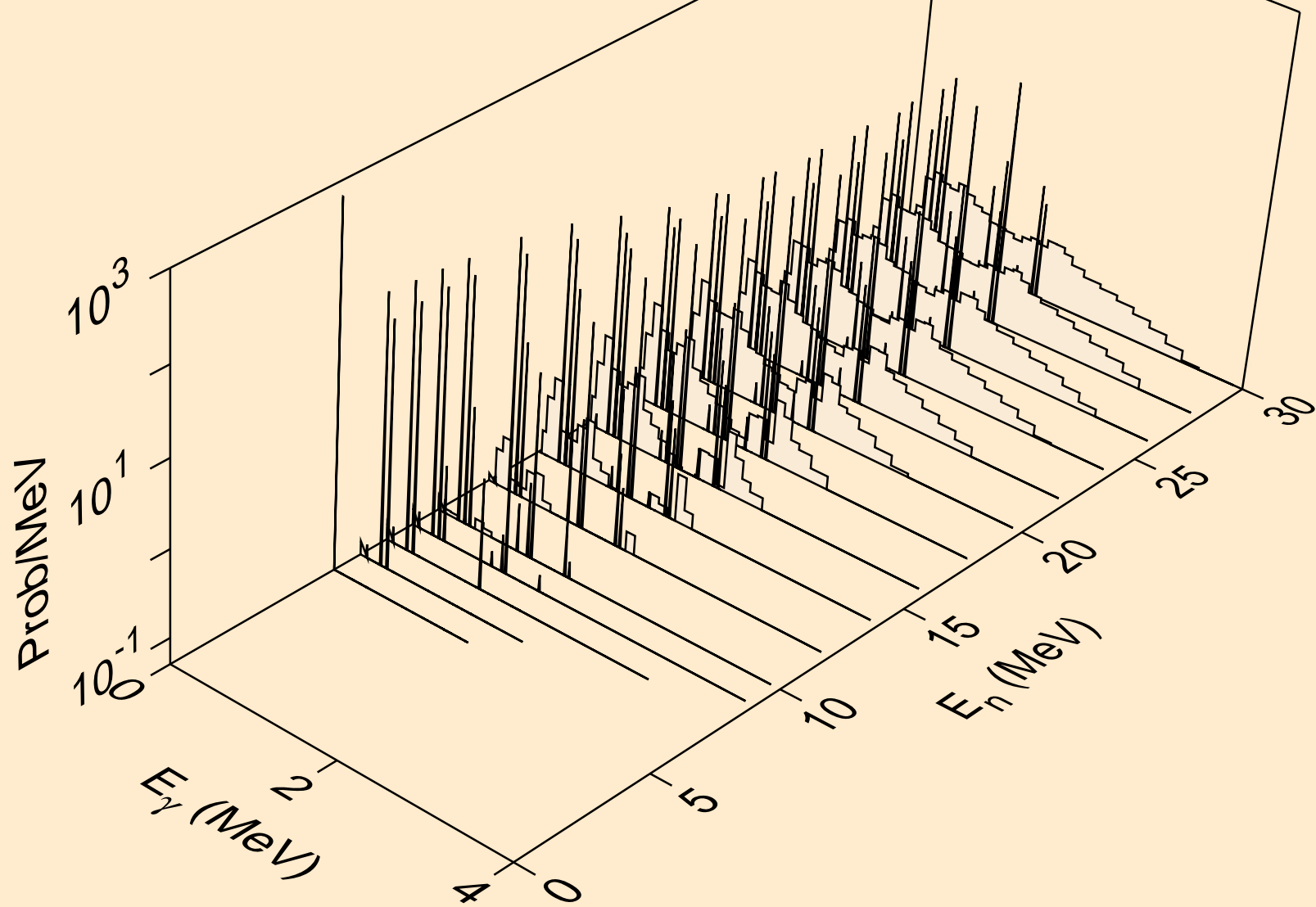



CD121M PROTON ACER TENDL-2023 LIBRARY; T=0.K  
Photon emission for (n,2n) $\alpha$

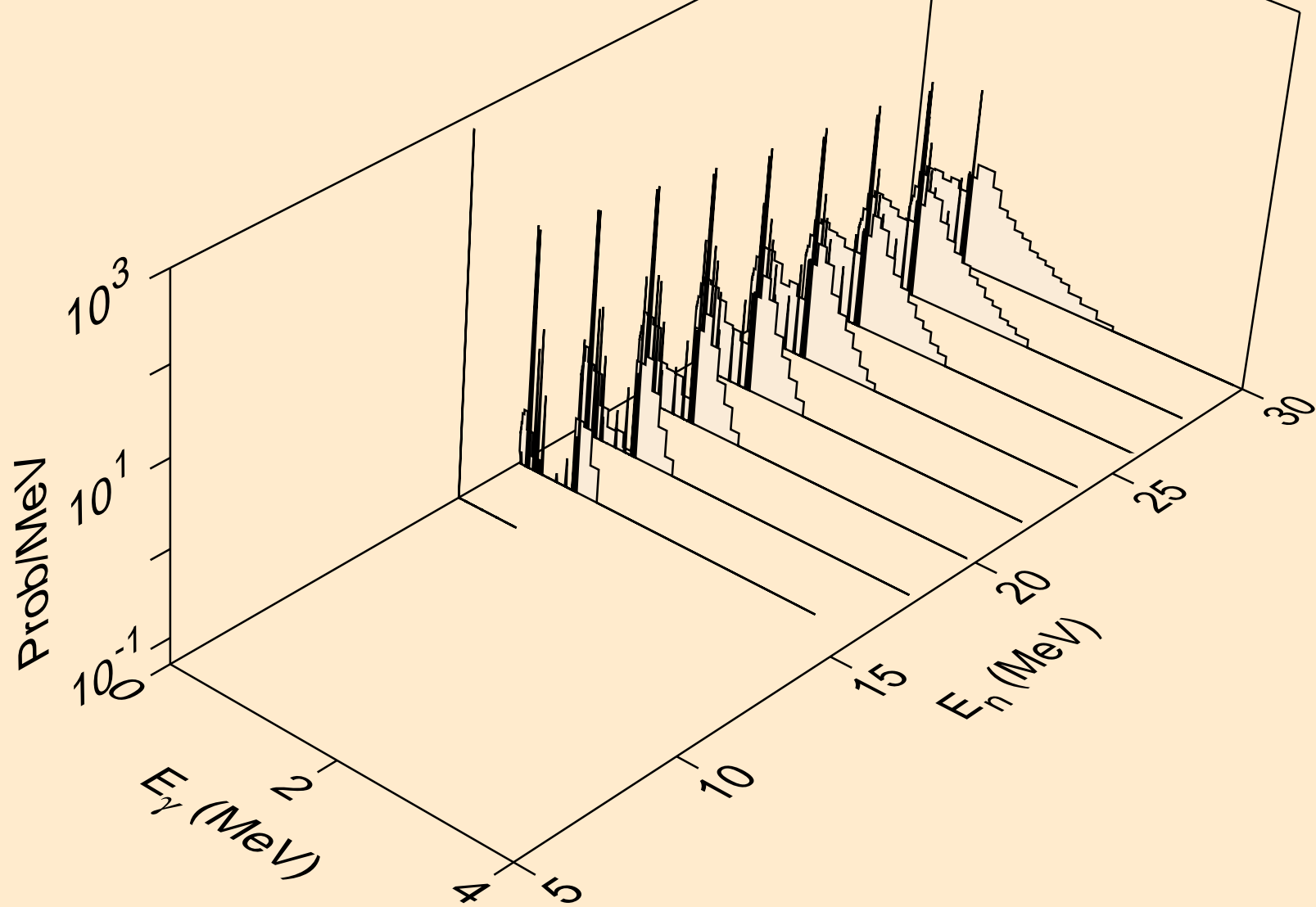

CD121M PROTON ACER TENDL-2023 LIBRARY; T=0.K  
Photon emission for (n,3n)a

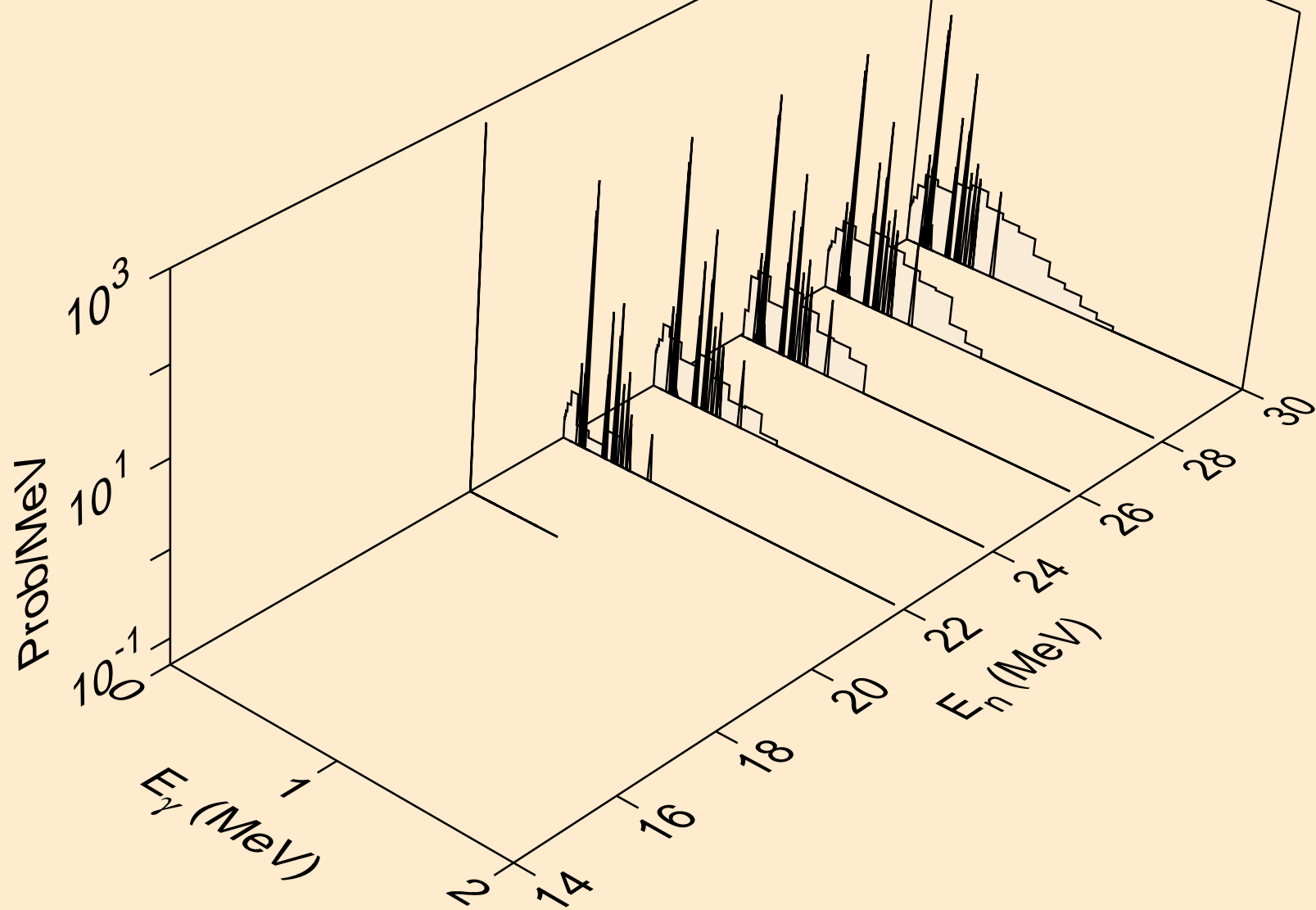

CD121M PROTON ACER TENDL-2023 LIBRARY; T=0.K  
Photon emission for (n,n\*)p

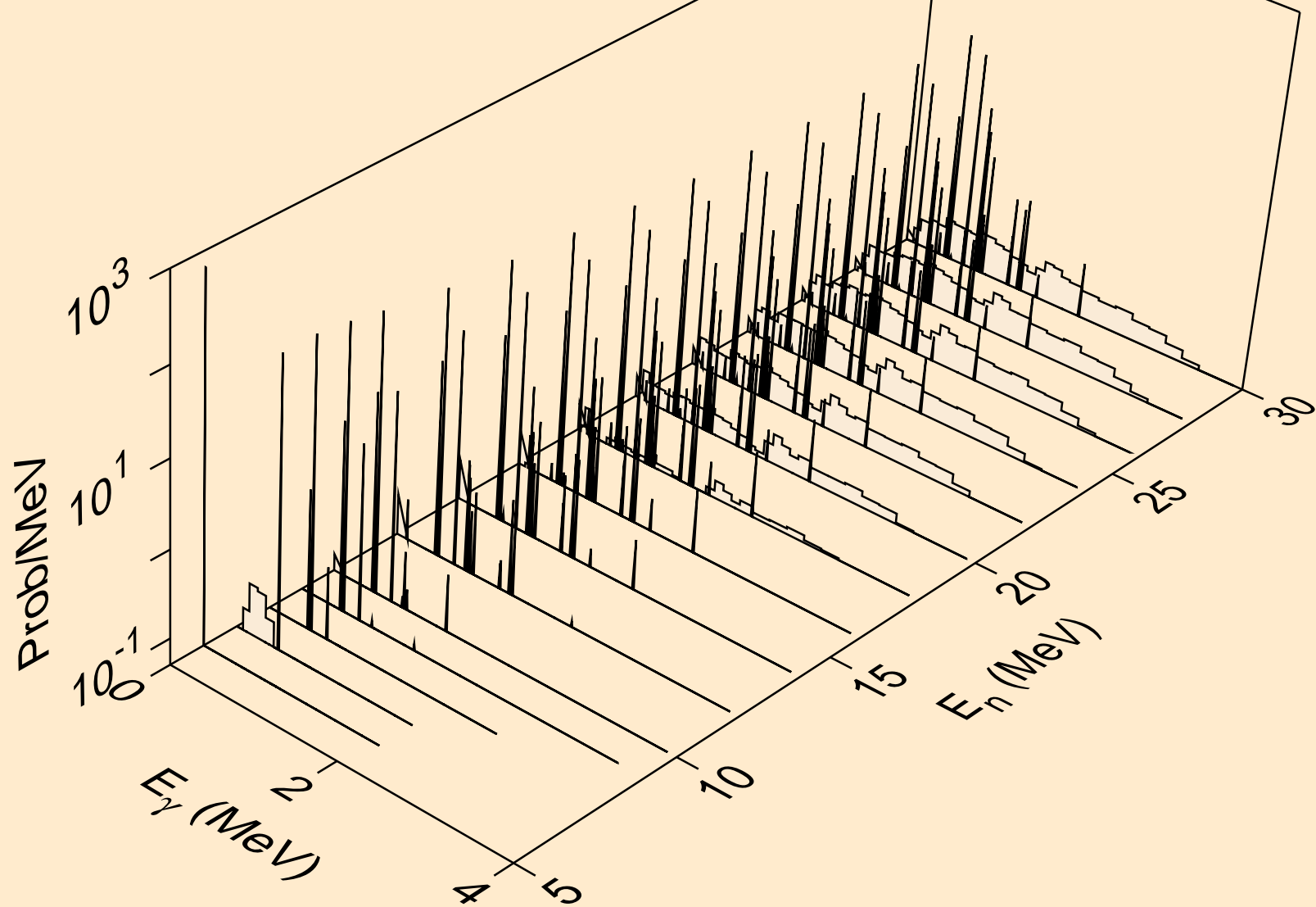

CD121M PROTON ACER TENDL-2023 LIBRARY; T=0.K  
Photon emission for (n,n\*)d

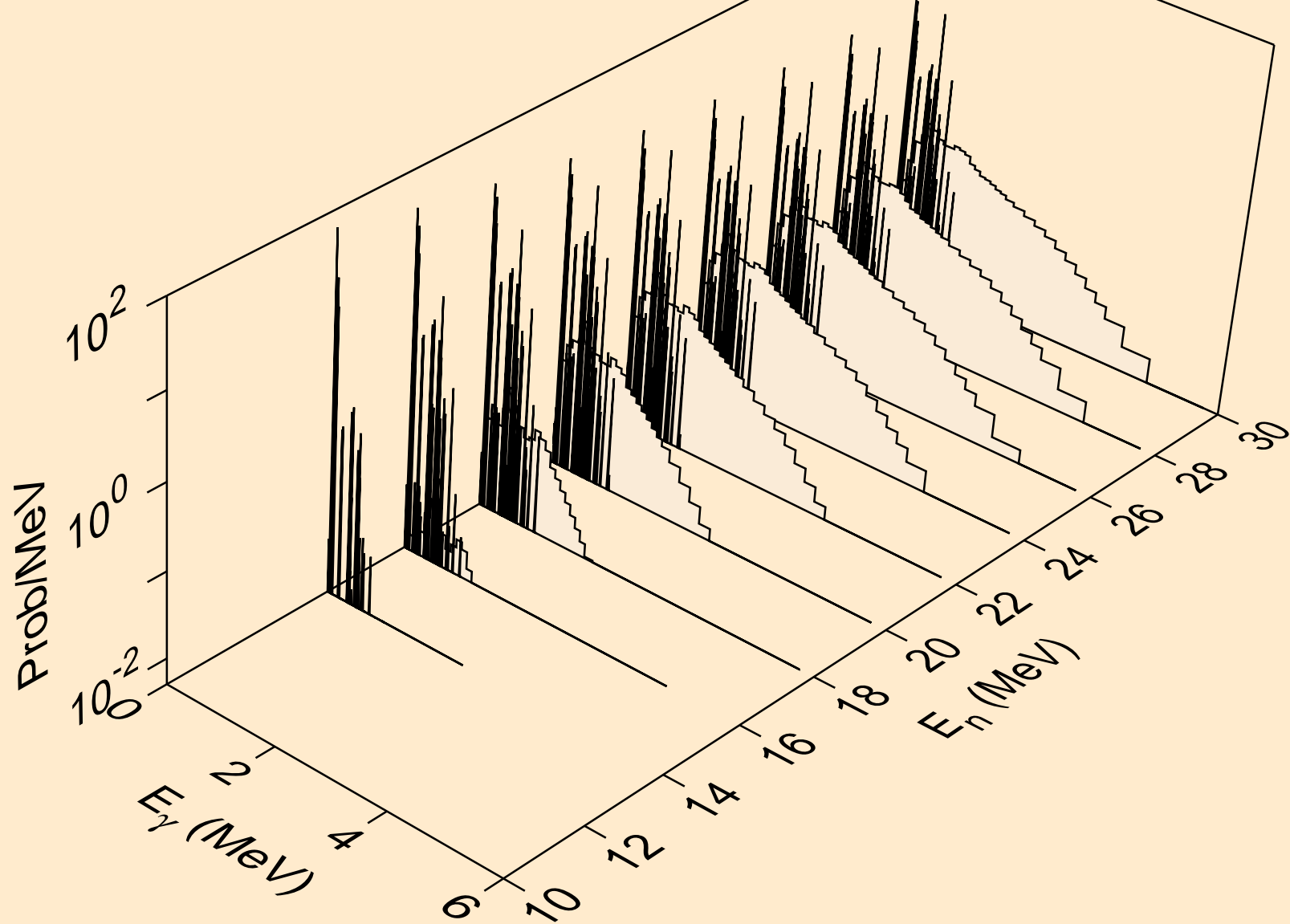

CD121M PROTON ACER TENDL-2023 LIBRARY; T=0.K  
Photon emission for (n,n\*)t

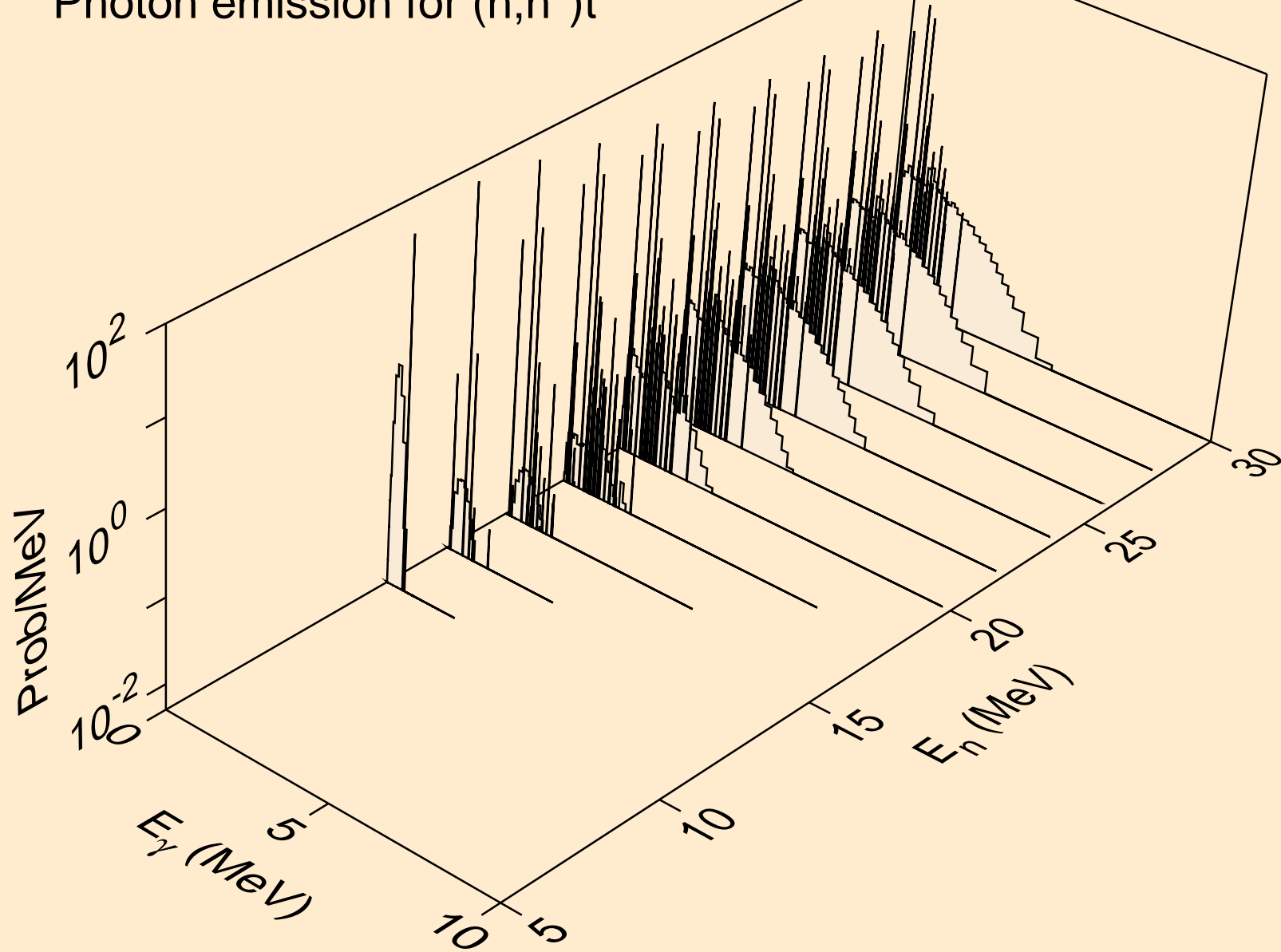

CD121M PROTON ACER TENDL-2023 LIBRARY; T=0.K  
Photon emission for (n,n\*)he3

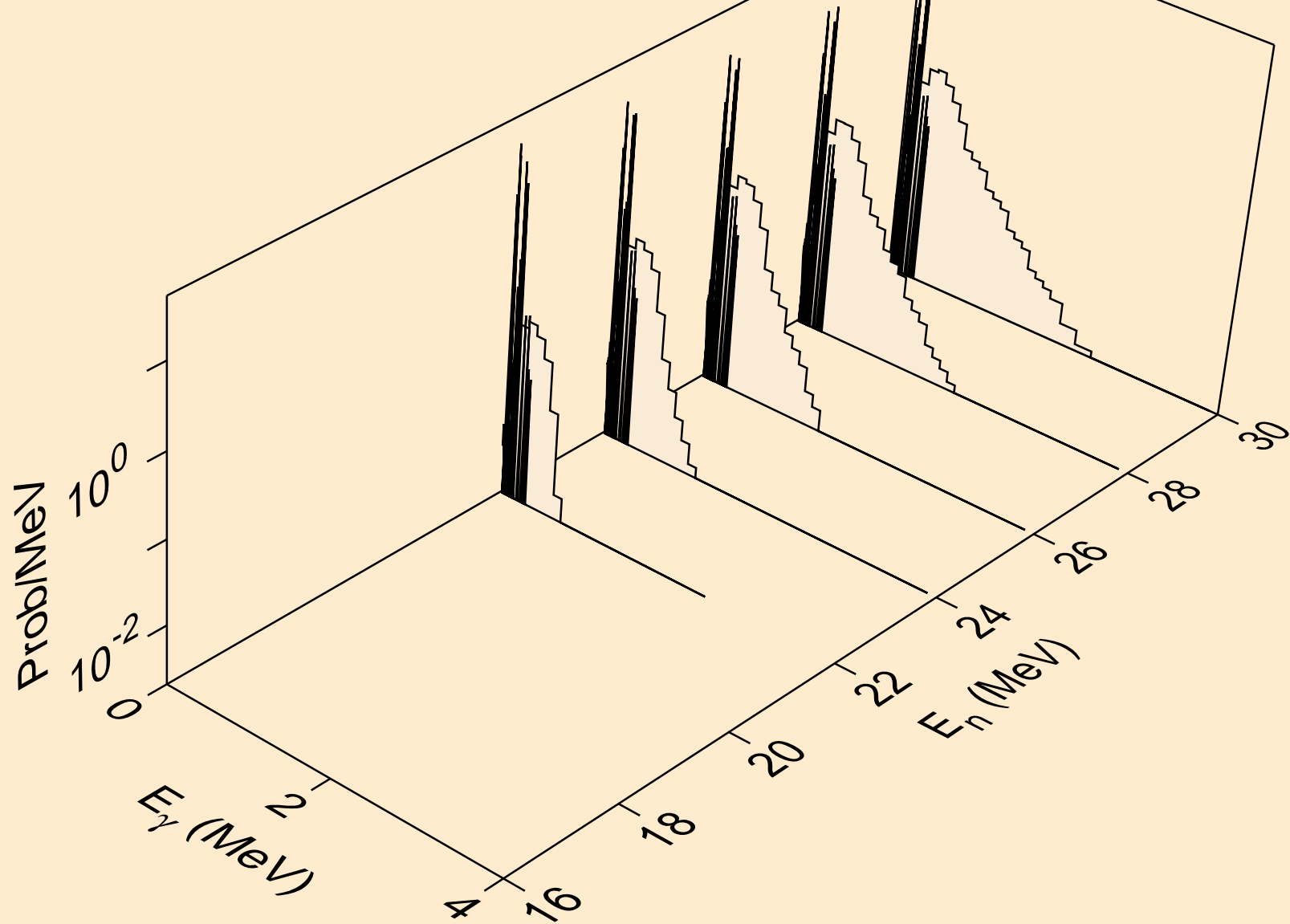

CD121M PROTON ACER TENDL-2023 LIBRARY; T=0.K  
Photon emission for (n,4n)

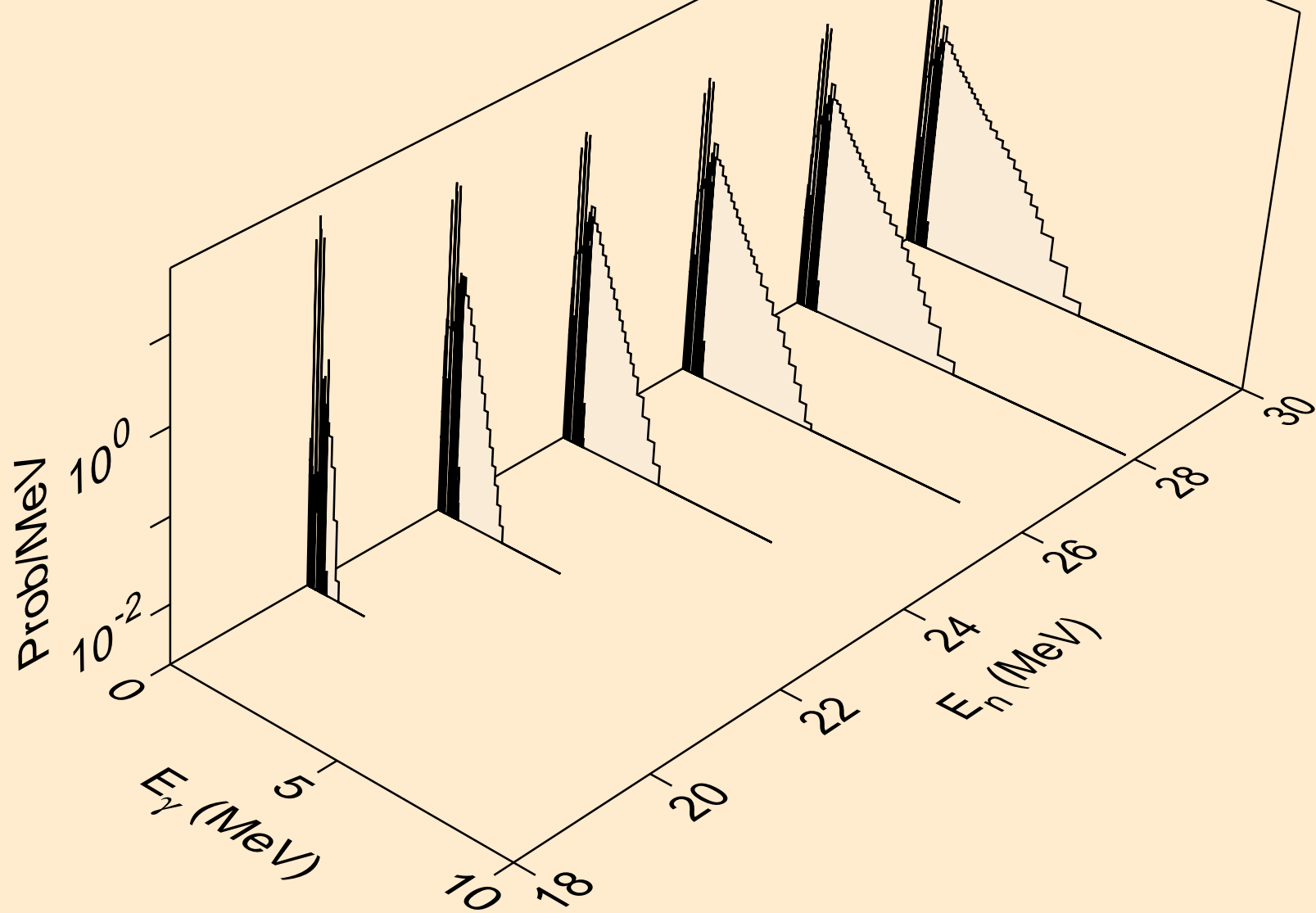

CD121M PROTON ACER TENDL-2023 LIBRARY; T=0.K  
Photon emission for (n,2np)

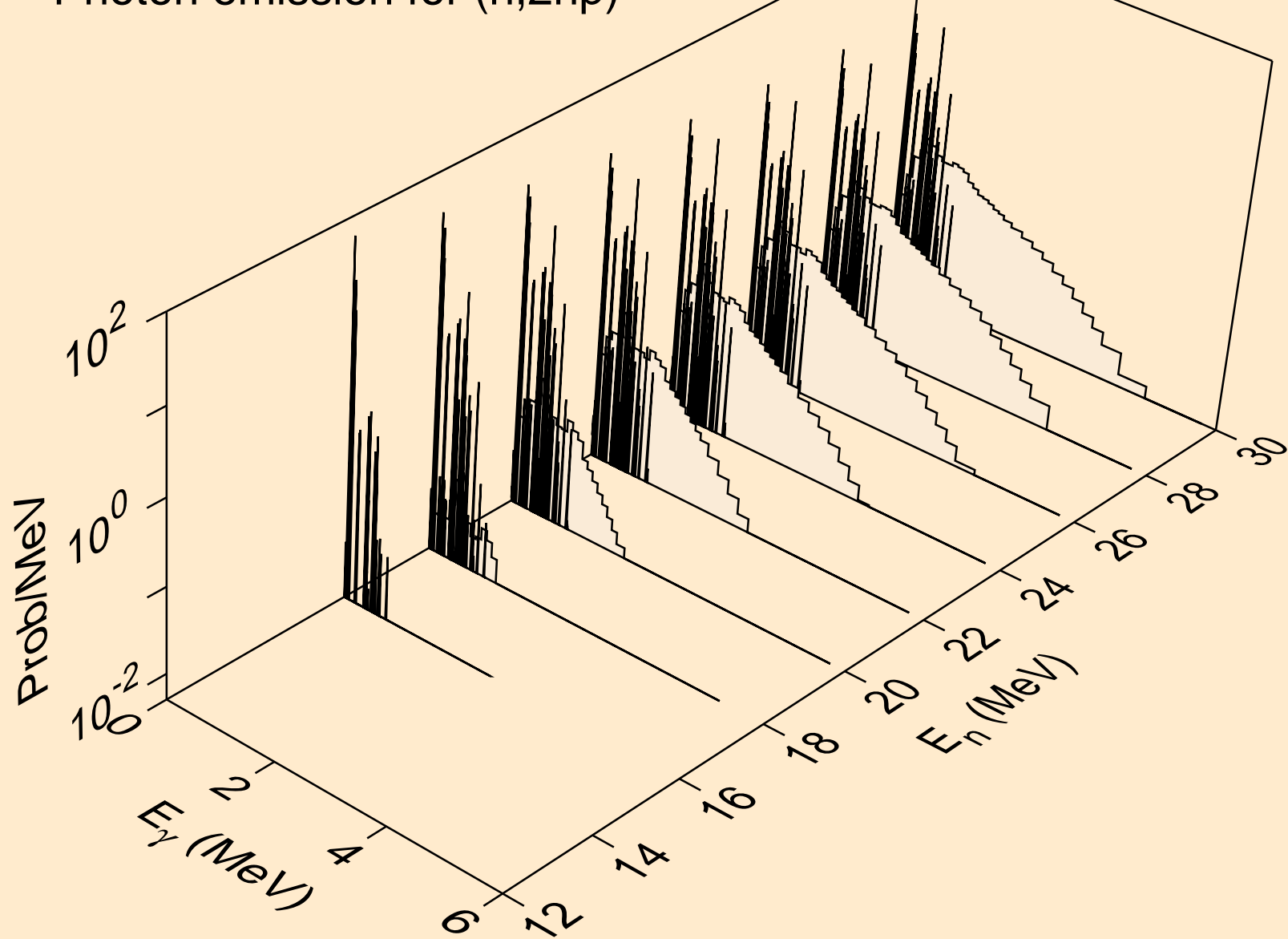



CD121M PROTON ACER TENDL-2023 LIBRARY; T=0.K  
Photon emission for (n,3np)

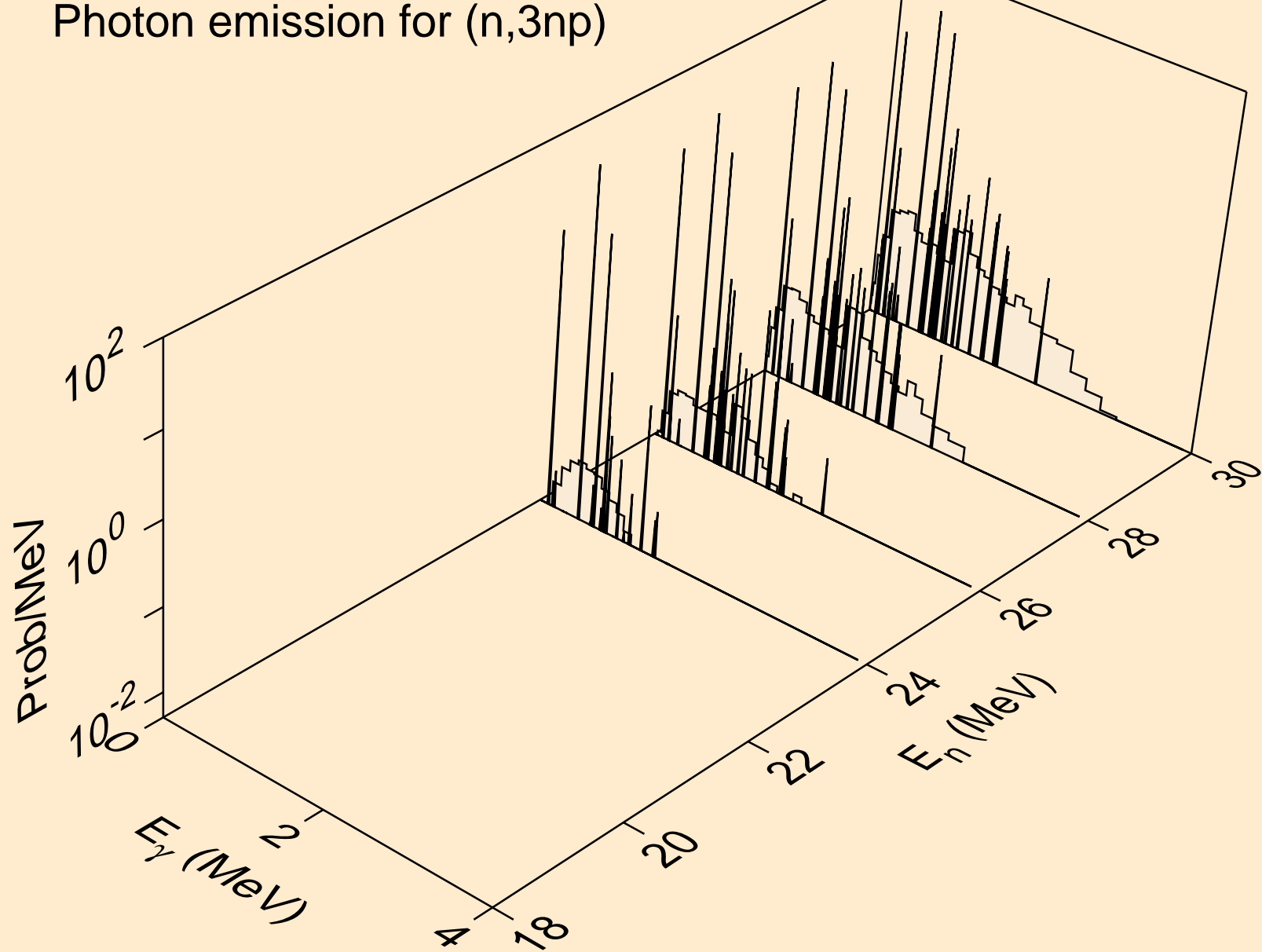

CD121M PROTON ACER TENDL-2023 LIBRARY; T=0.K  
Photon emission for (n,n2p)

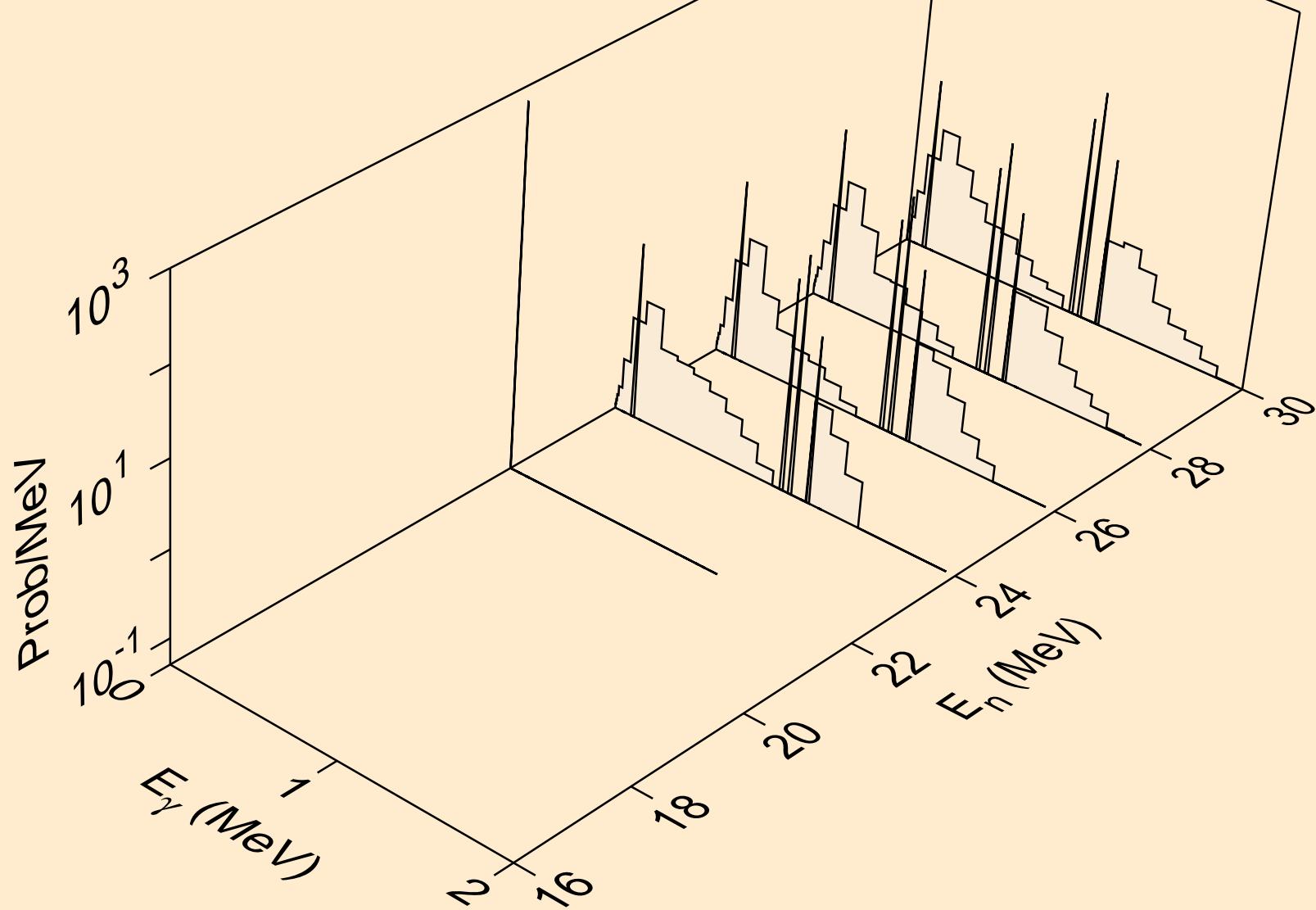

CD121M PROTON ACER TENDL-2023 LIBRARY; T=0.K  
Photon emission for (n,npa)

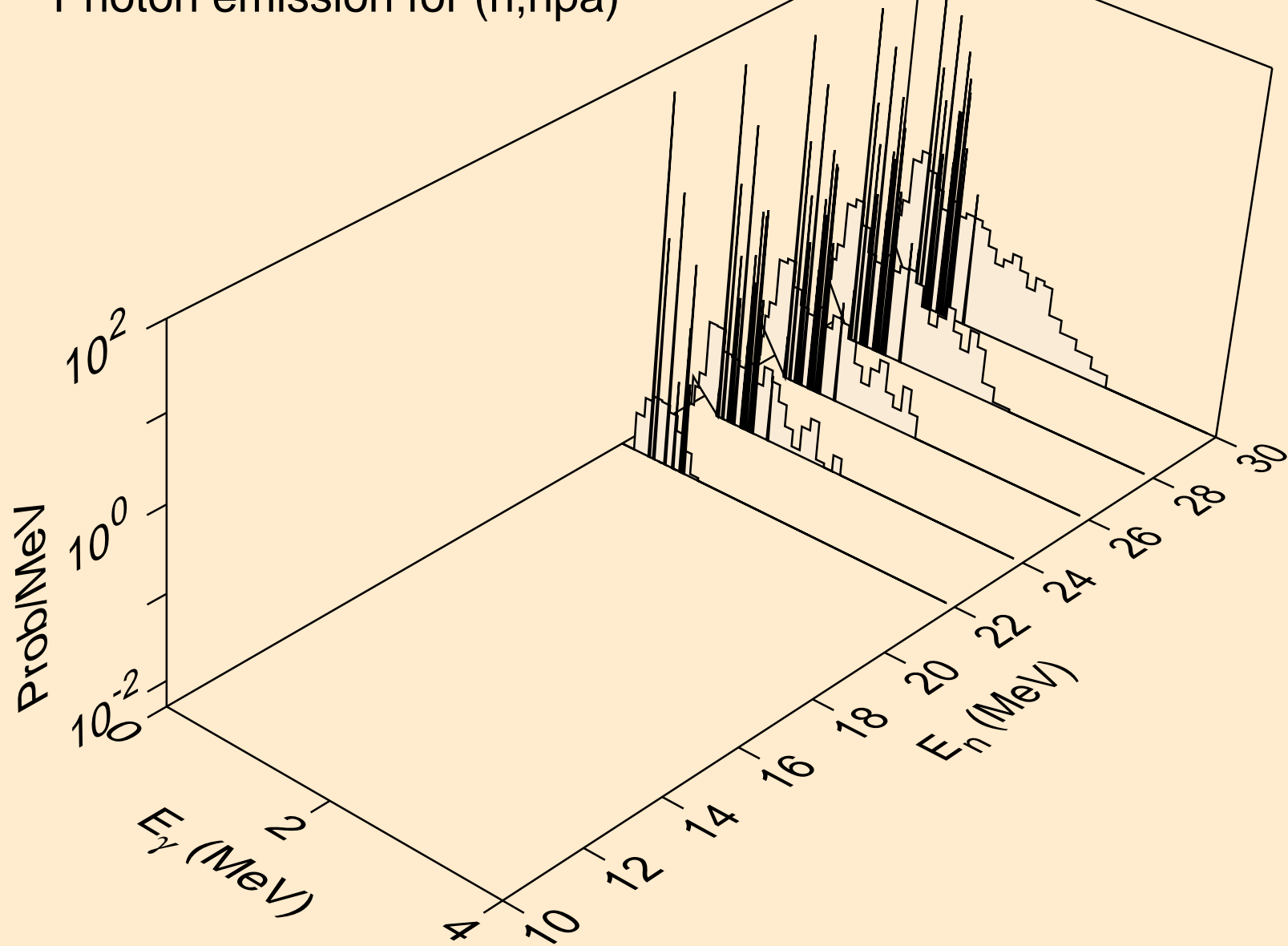

CD121M PROTON ACER TENDL-2023 LIBRARY; T=0.K  
Photon emission for (n,gma)

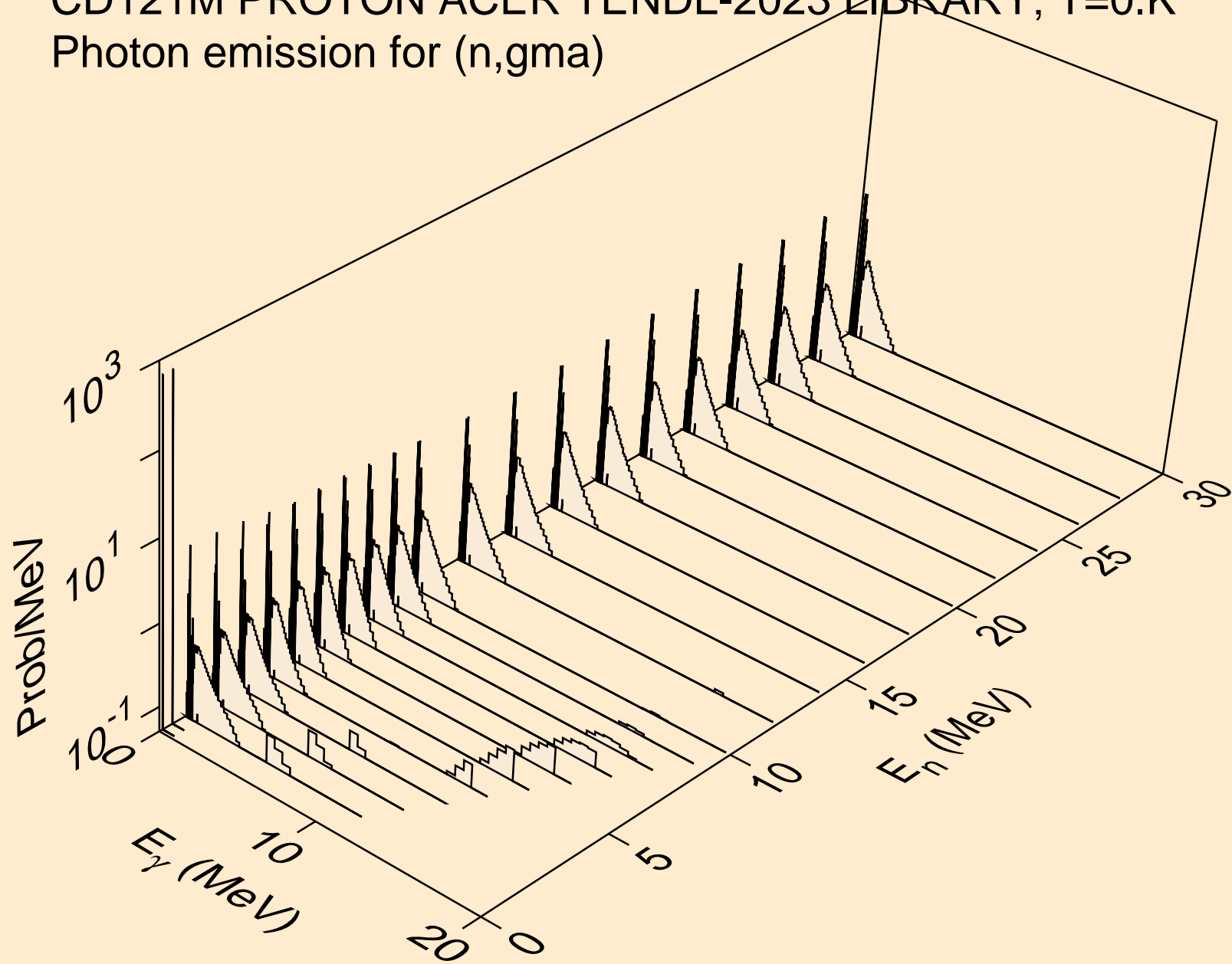

CD121M PROTON ACER TENDL-2023 LIBRARY; T=0.K  
Photon emission for inelastic

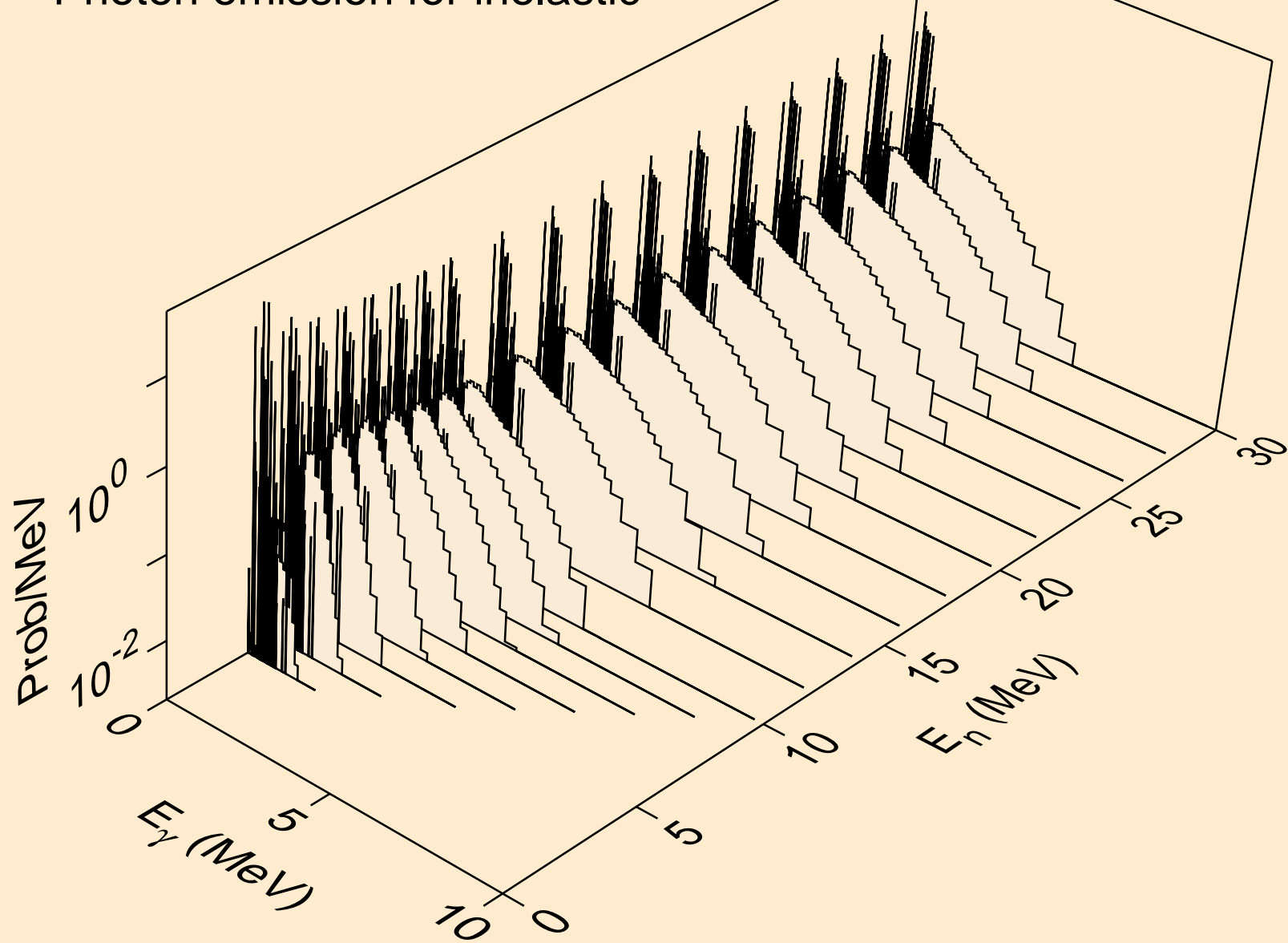

CD121M PROTON ACER TENDL-2023 LIBRARY; T=0.K  
Photon emission for (n,d)

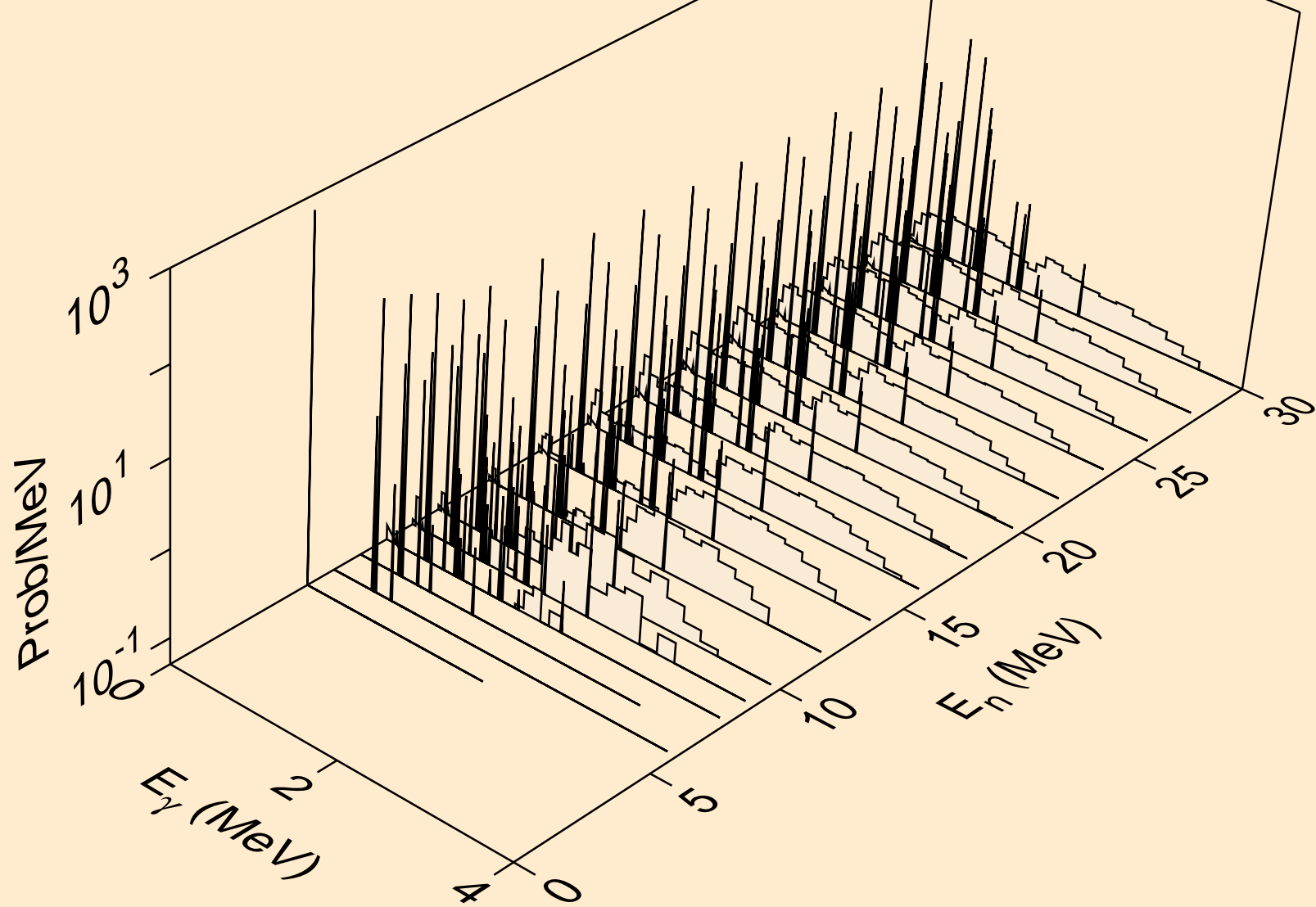

CD121M PROTON ACER TENDL-2023 LIBRARY; T=0.K  
Photon emission for (n,t)

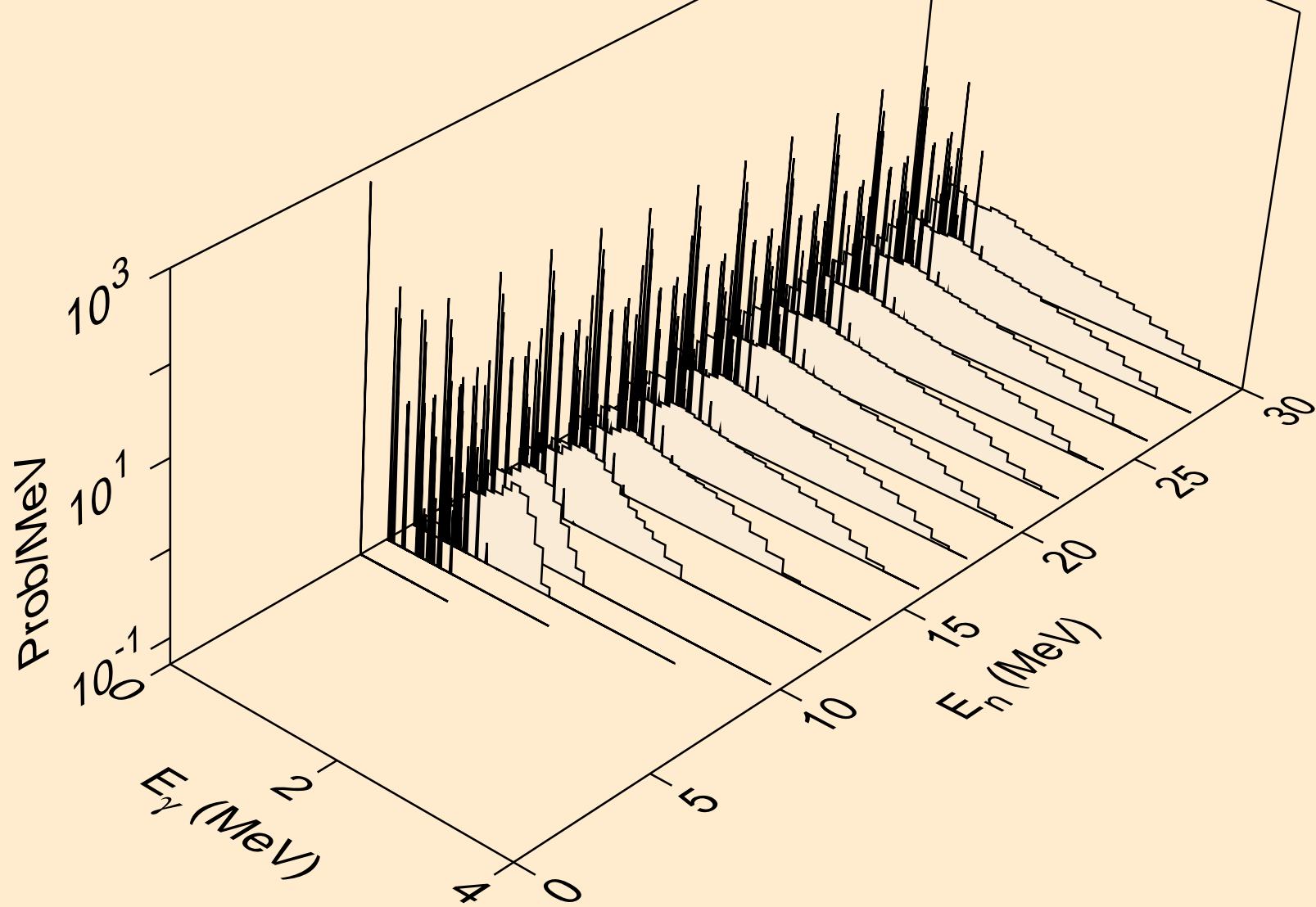

CD121M PROTON ACER TENDL-2023 LIBRARY; T=0.K  
Photon emission for (n,he3)

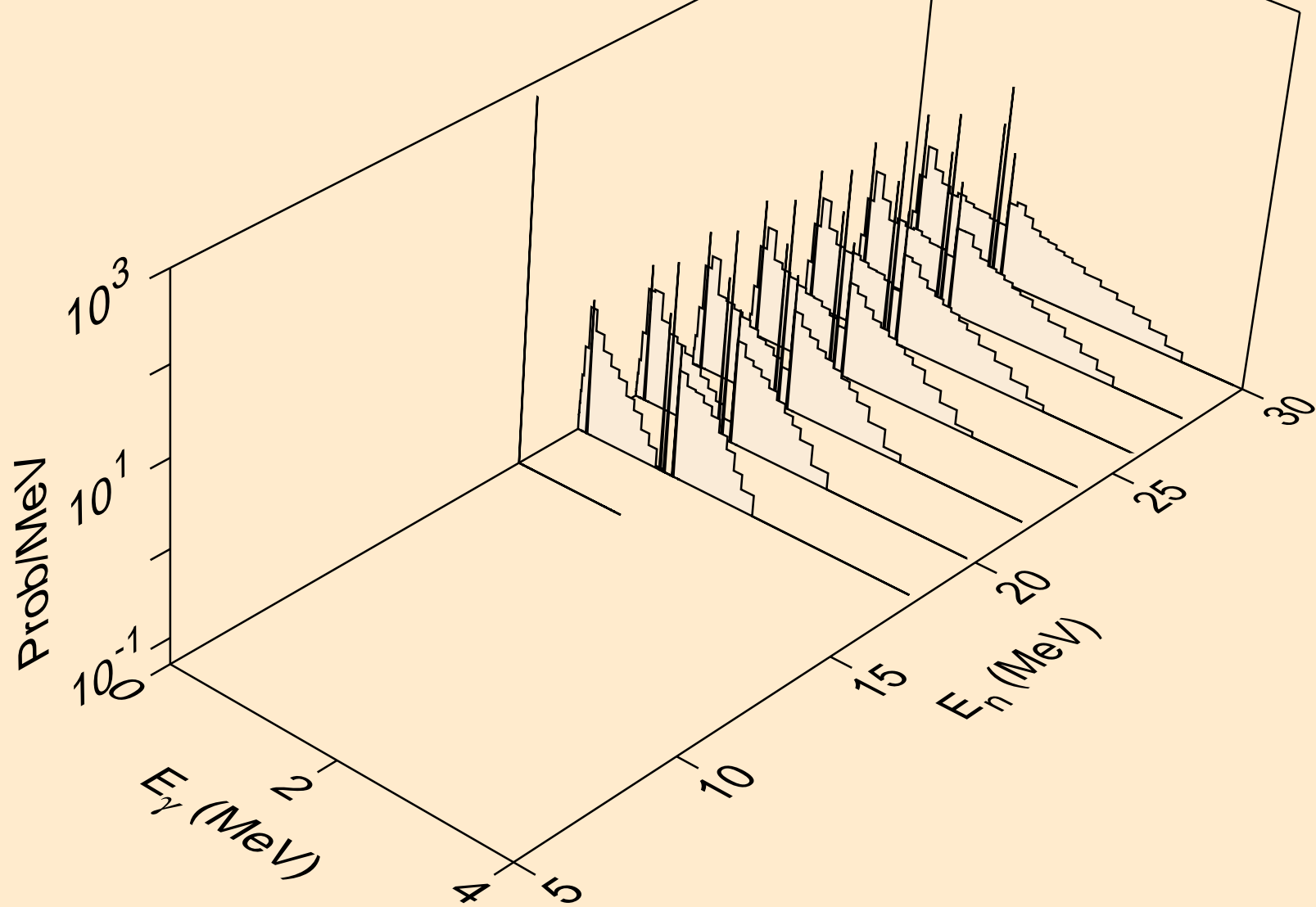



CD121M PROTON ACER TENDL-2023 LIBRARY; T=0.K  
Photon emission for (n,a)

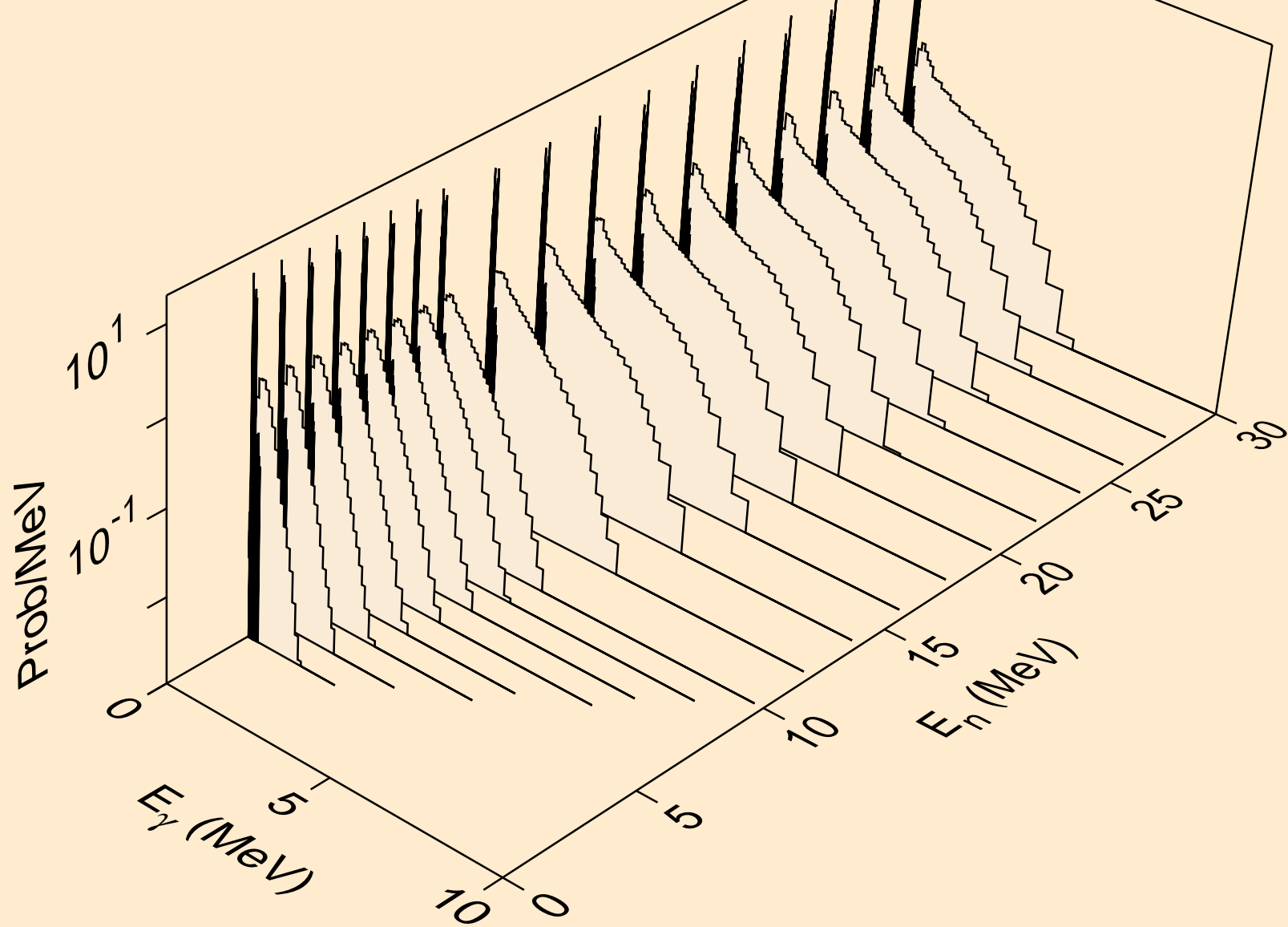

CD121M PROTON ACER TENDL-2023 LIBRARY; T=0.K  
Photon emission for (n,2p)

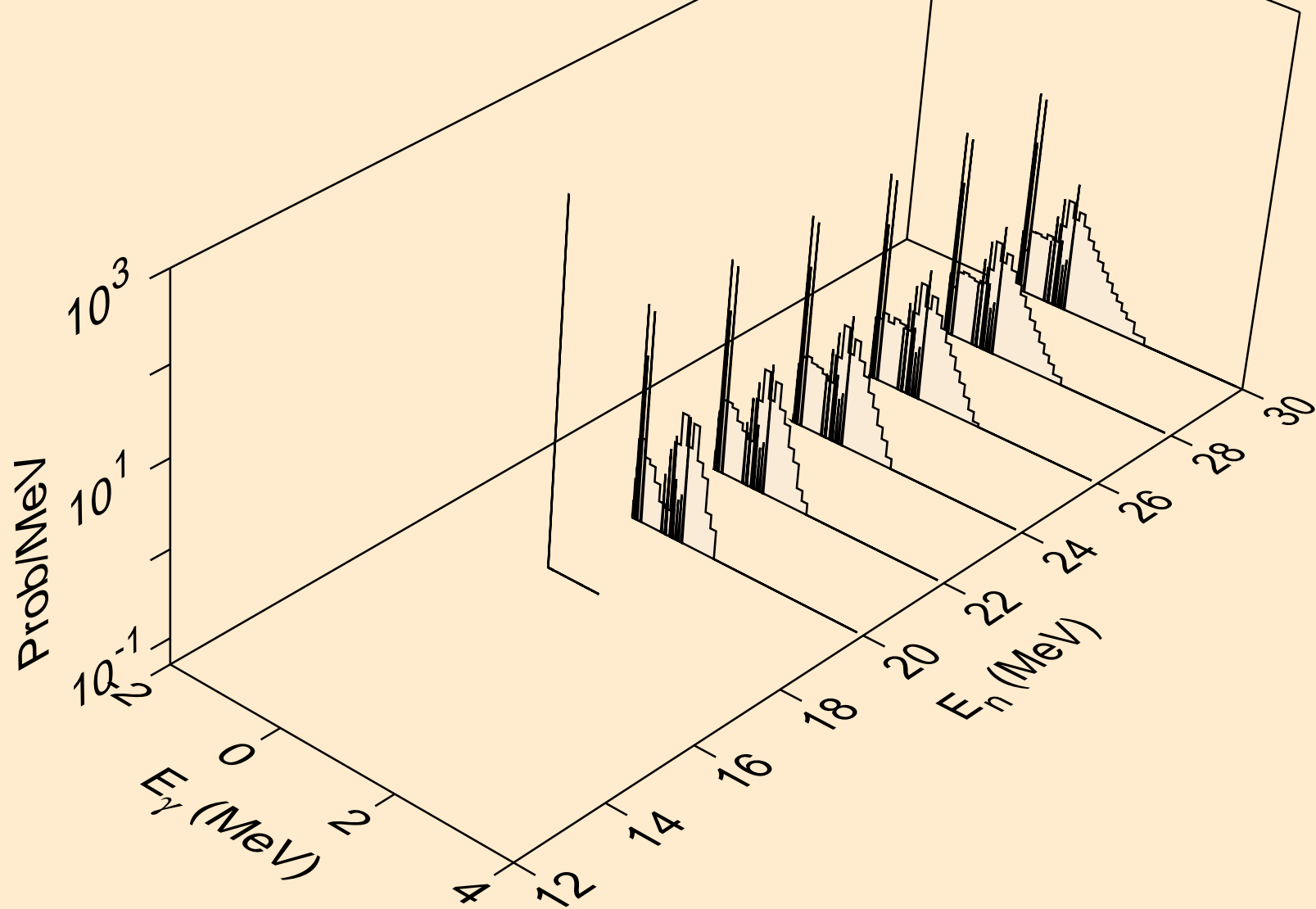

CD121M PROTON ACER TENDL-2023 LIBRARY; T=0.K  
Photon emission for (n,pa)

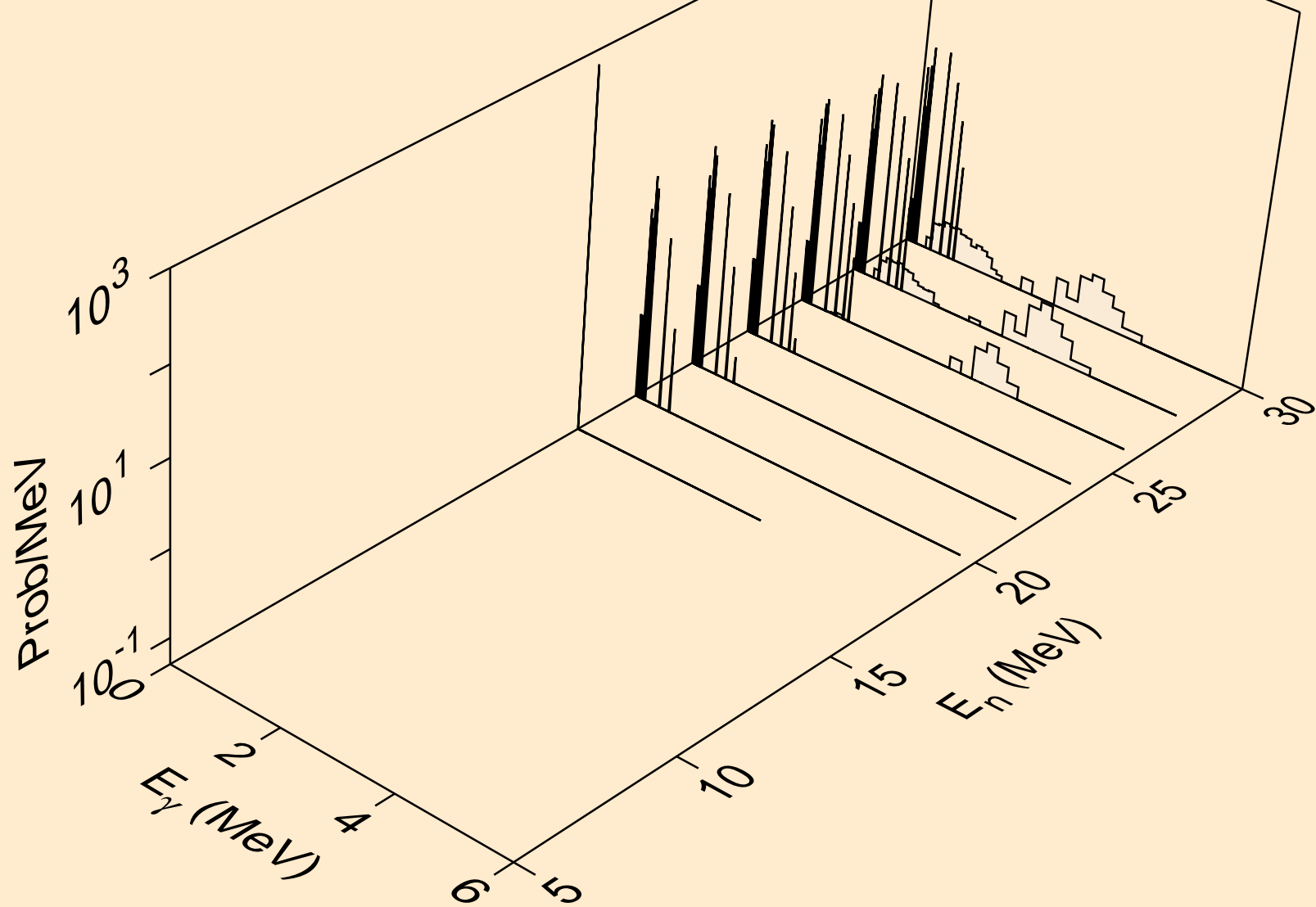

CD121M PROTON ACER TENDL-2023 LIBRARY; T=0.K  
Photon emission for (n,pd)

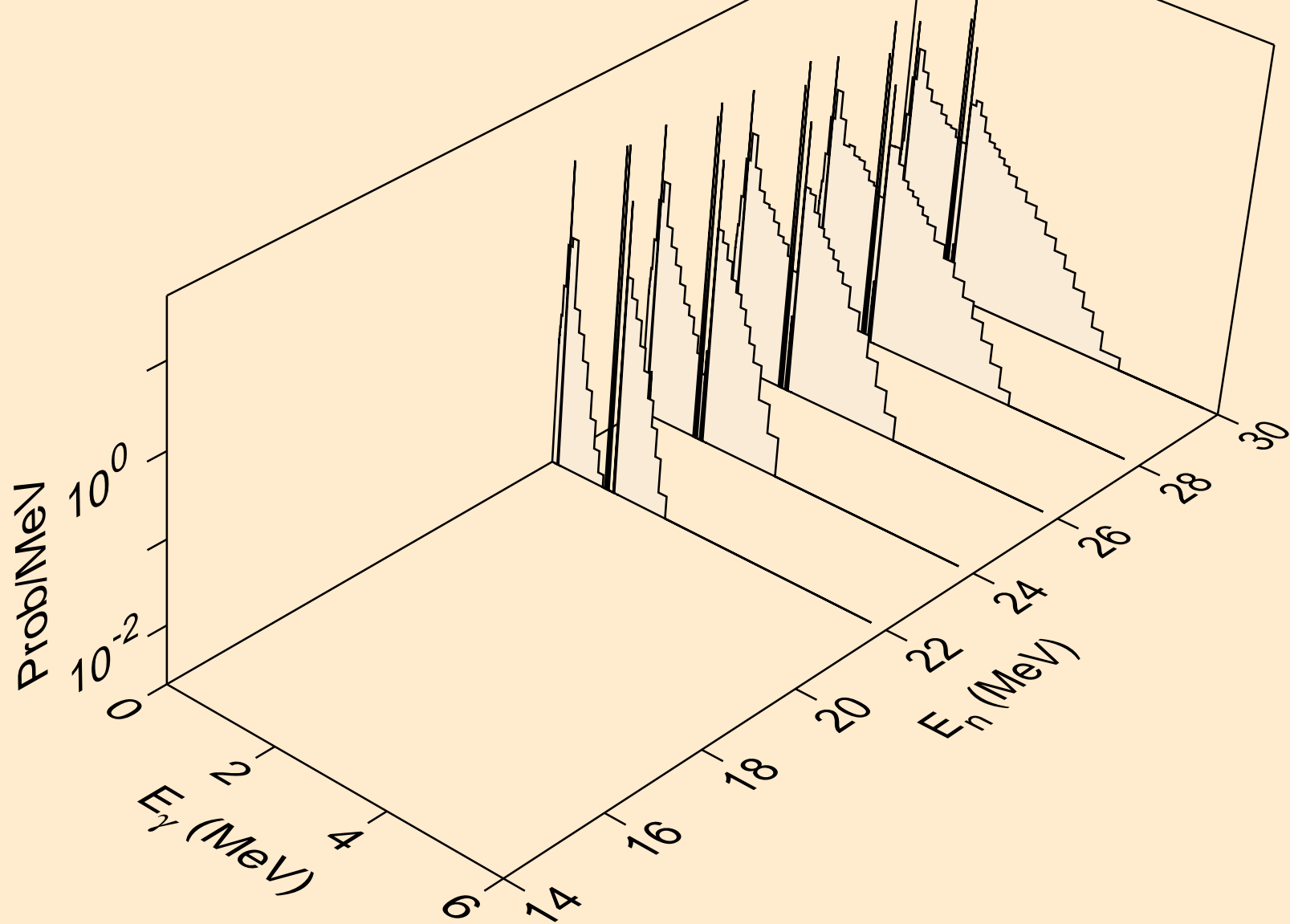

# CD121M PROTON ACER TENDL-2023 LIBRARY; T=0.K

## Particle heating contributions

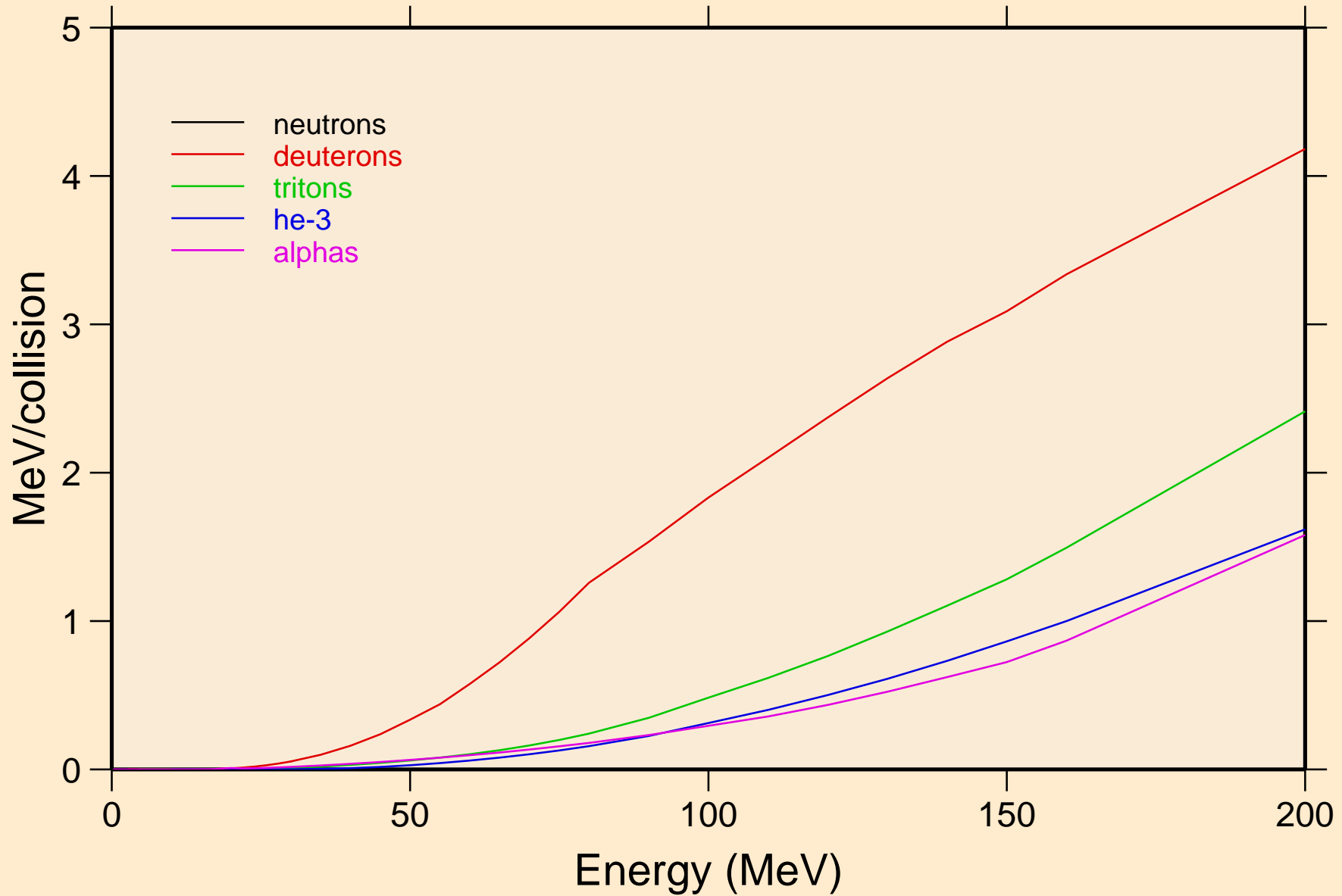

CD121M PROTON ACER TENDL-2023 LIBRARY; T=0.K  
Recoil Heating

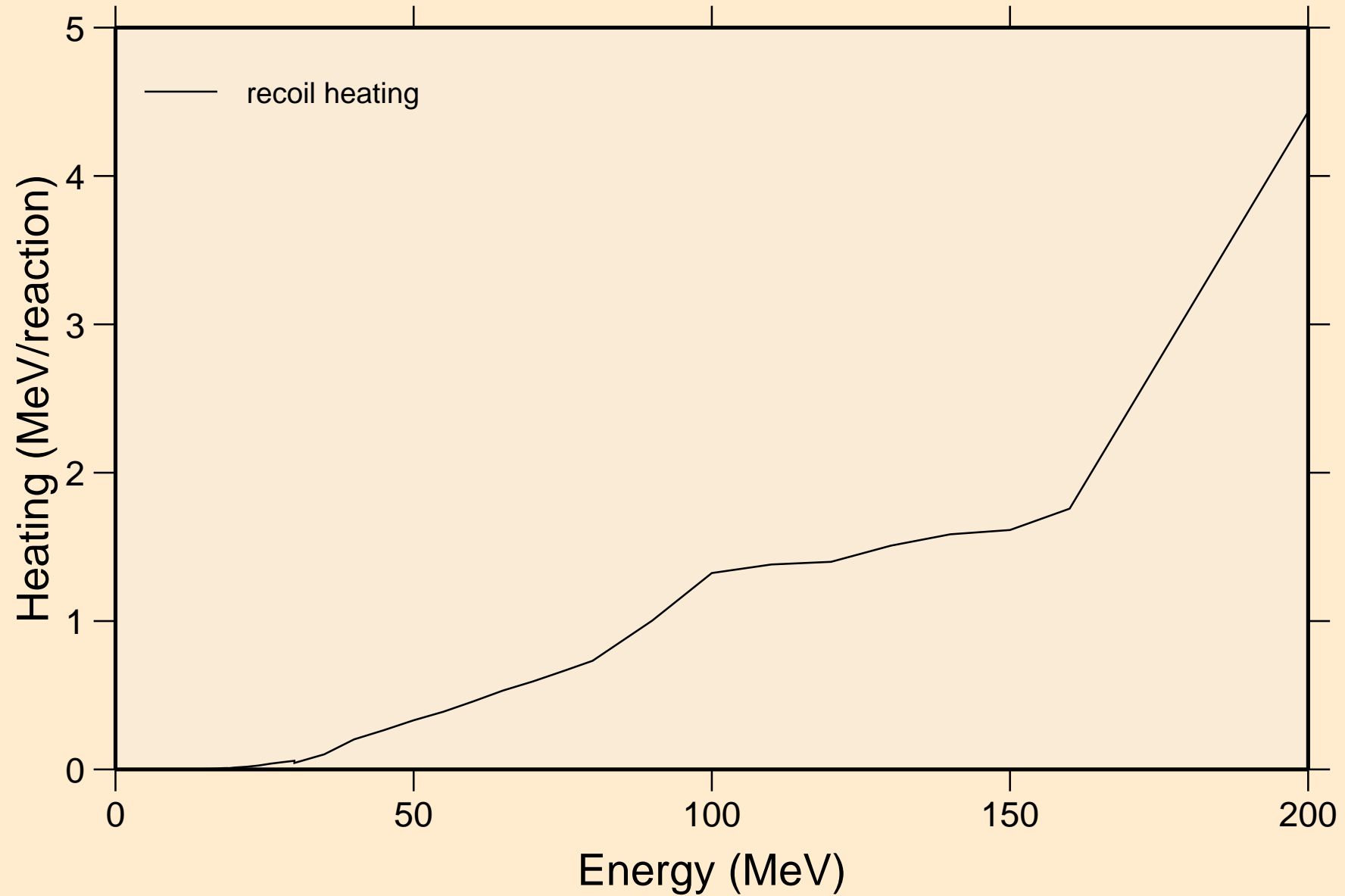

CD121M PROTON ACER TENDL-2023 LIBRARY; T=0.K  
Particle production cross sections

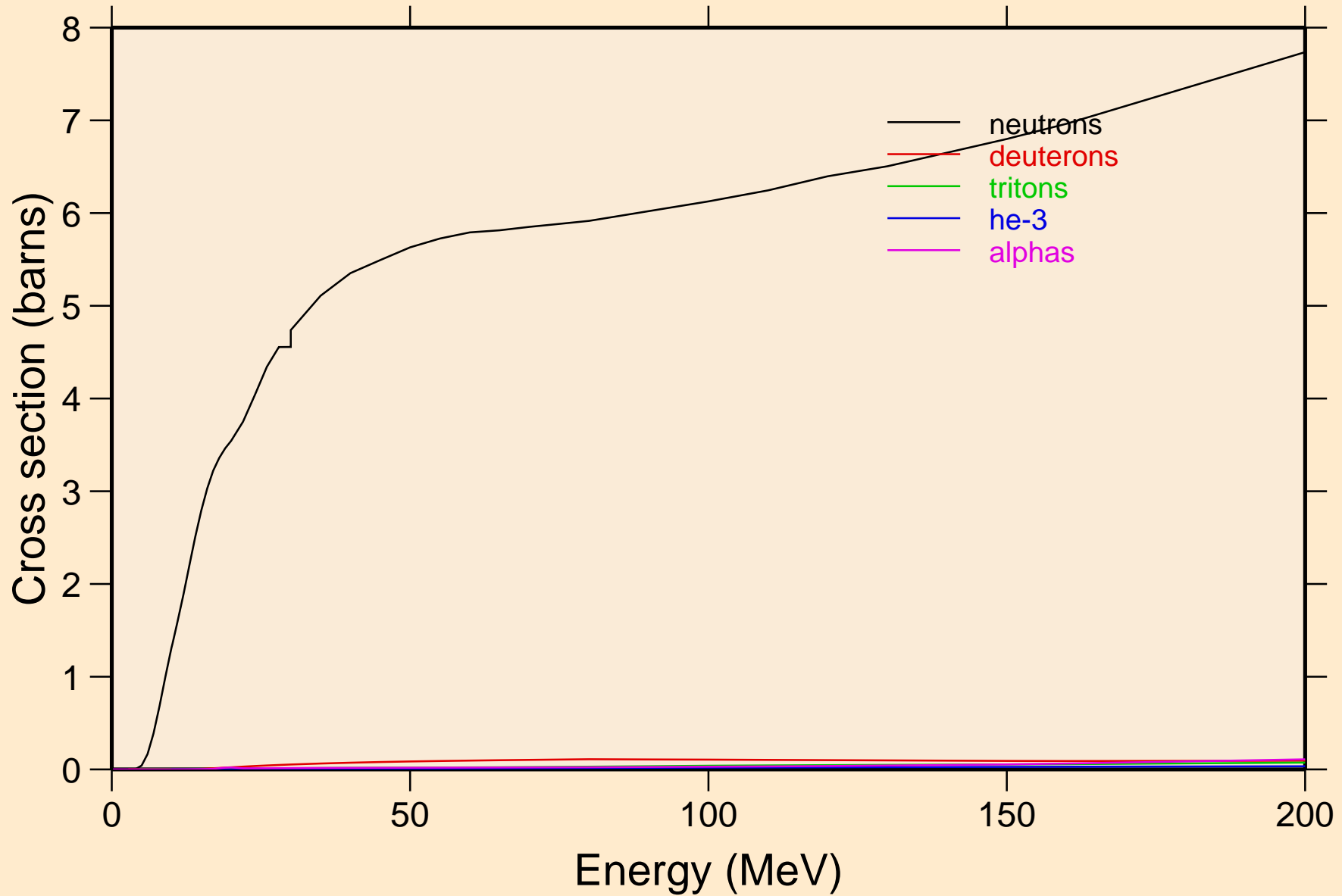

CD121M PROTON ACER TENDL-2023 LIBRARY; T=0.K  
neutrons from (p,n)

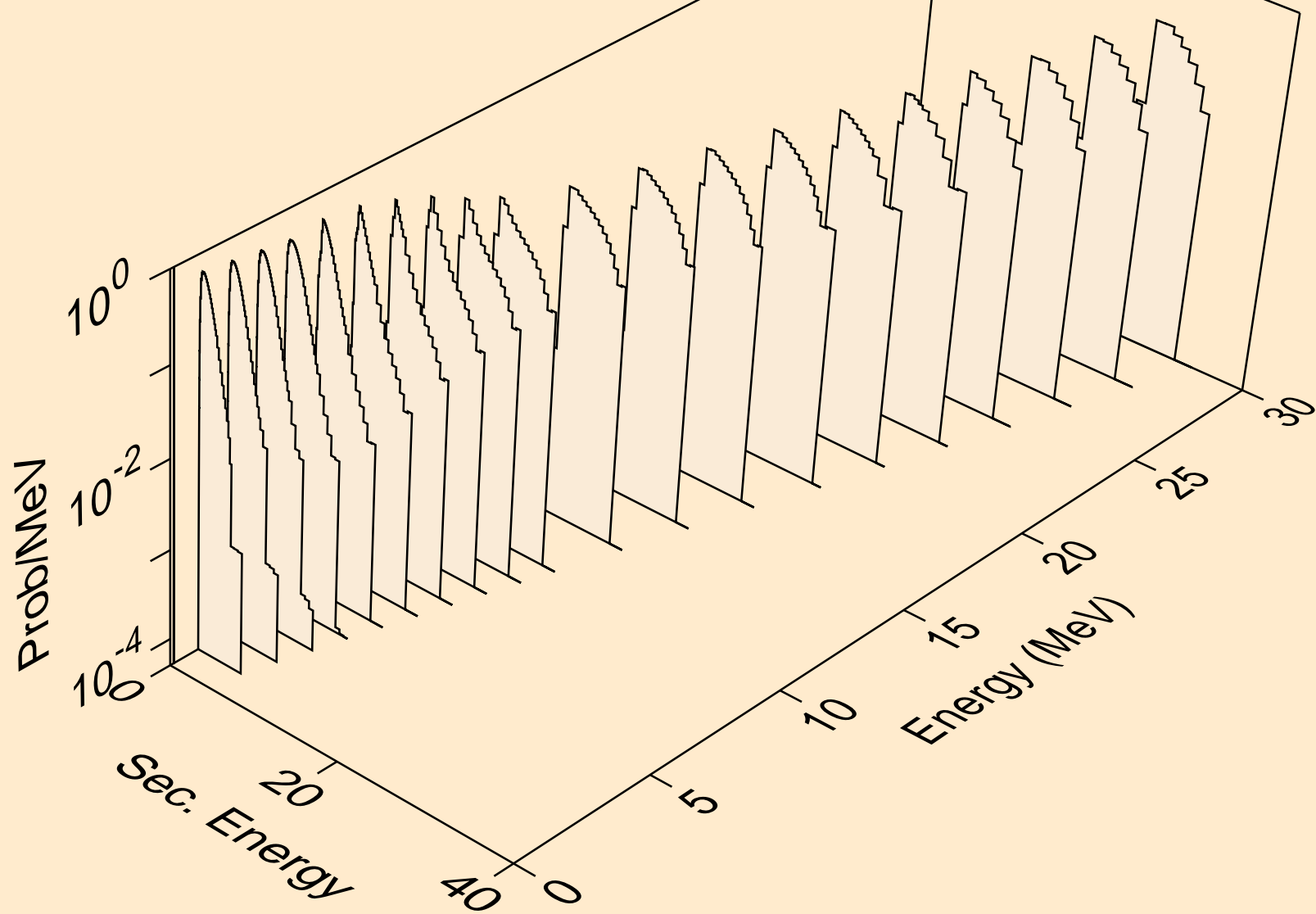



CD121M PROTON ACER TENDL-2023 LIBRARY; T=0.K  
neutrons from (p,x)

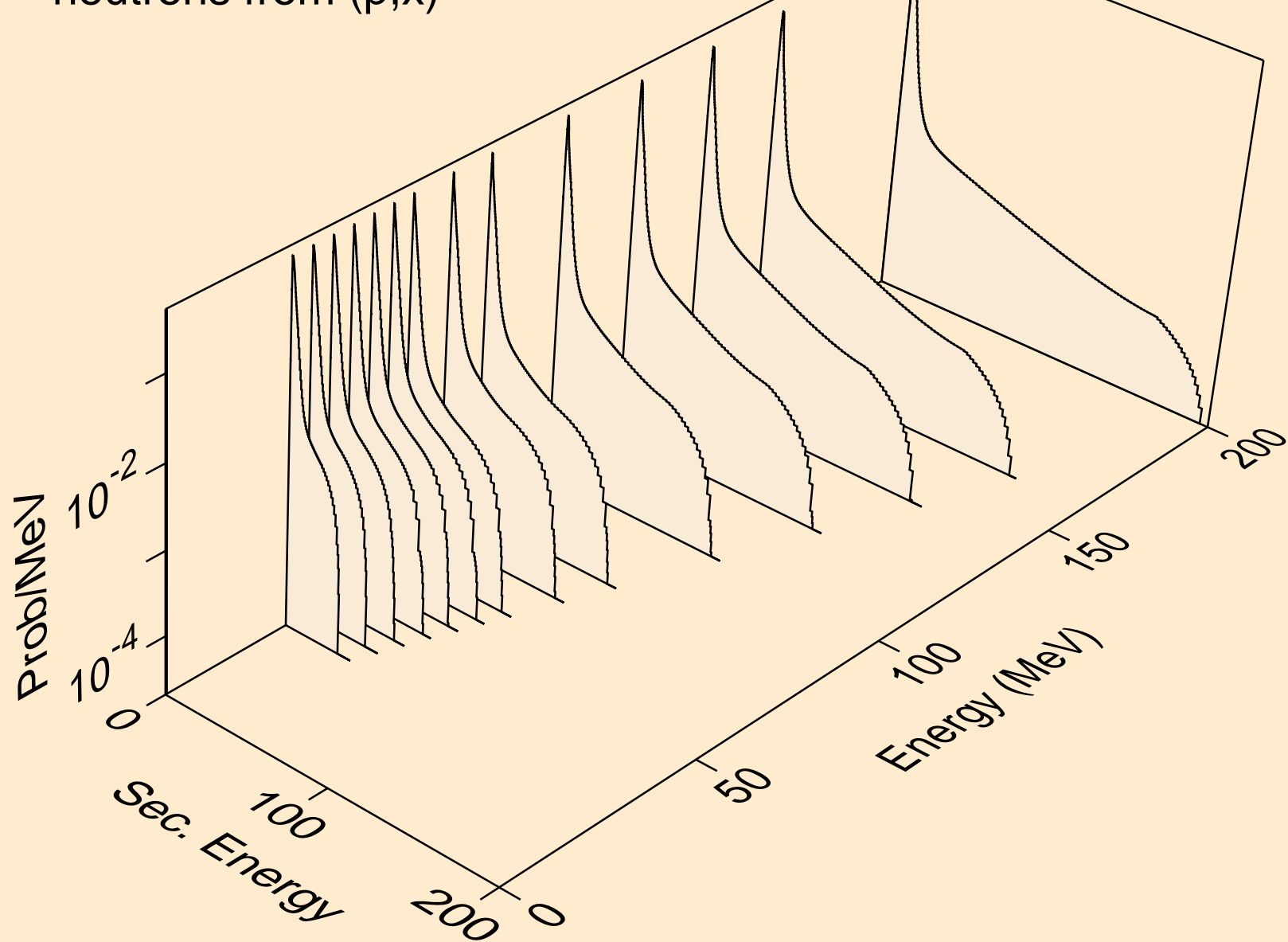

CD121M PROTON ACER TENDL-2023 LIBRARY; T=0.K  
neutrons from (p,2nd)

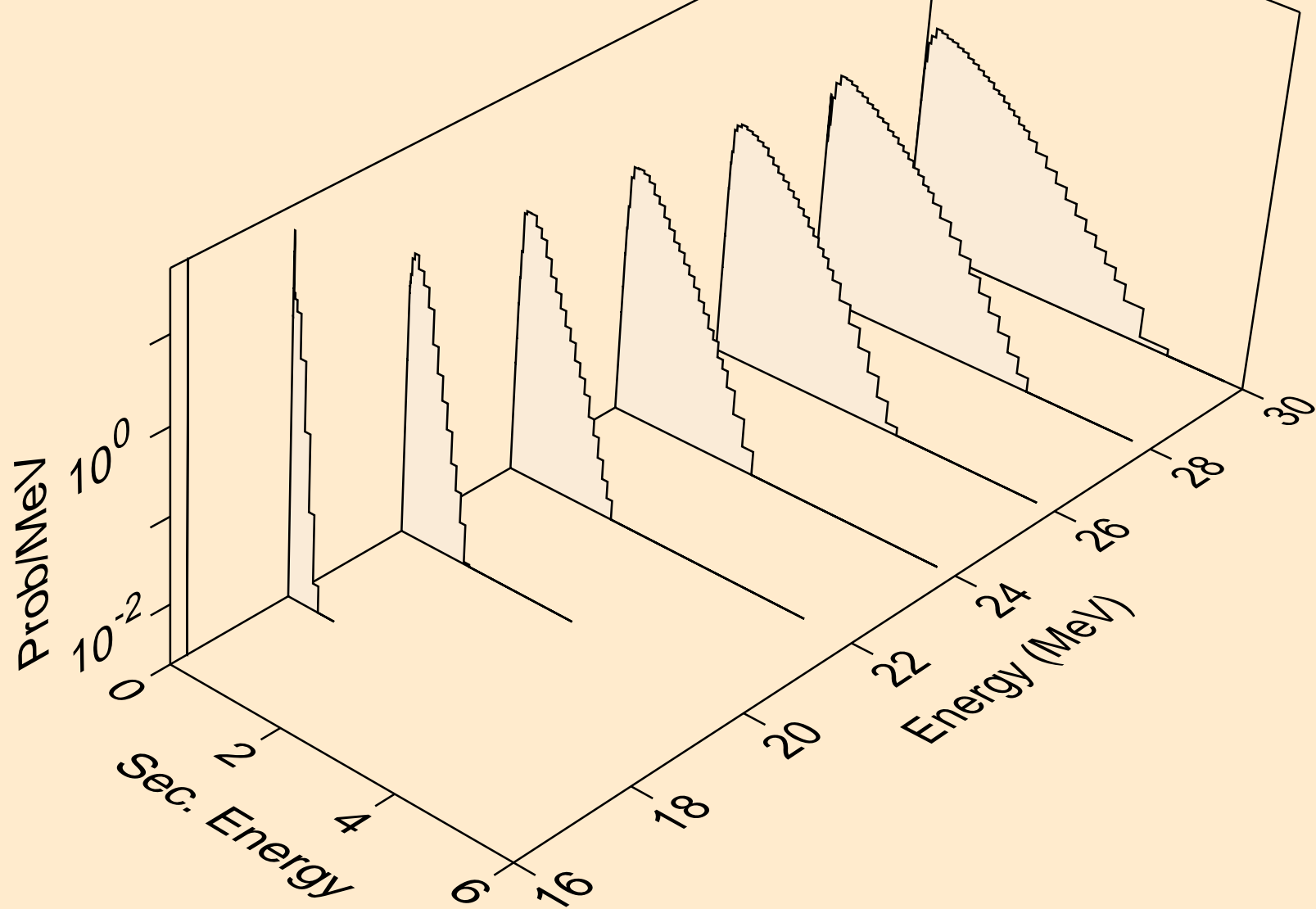

CD121M PROTON ACER TENDL-2023 LIBRARY; T=0.K  
neutrons from (p,2n)

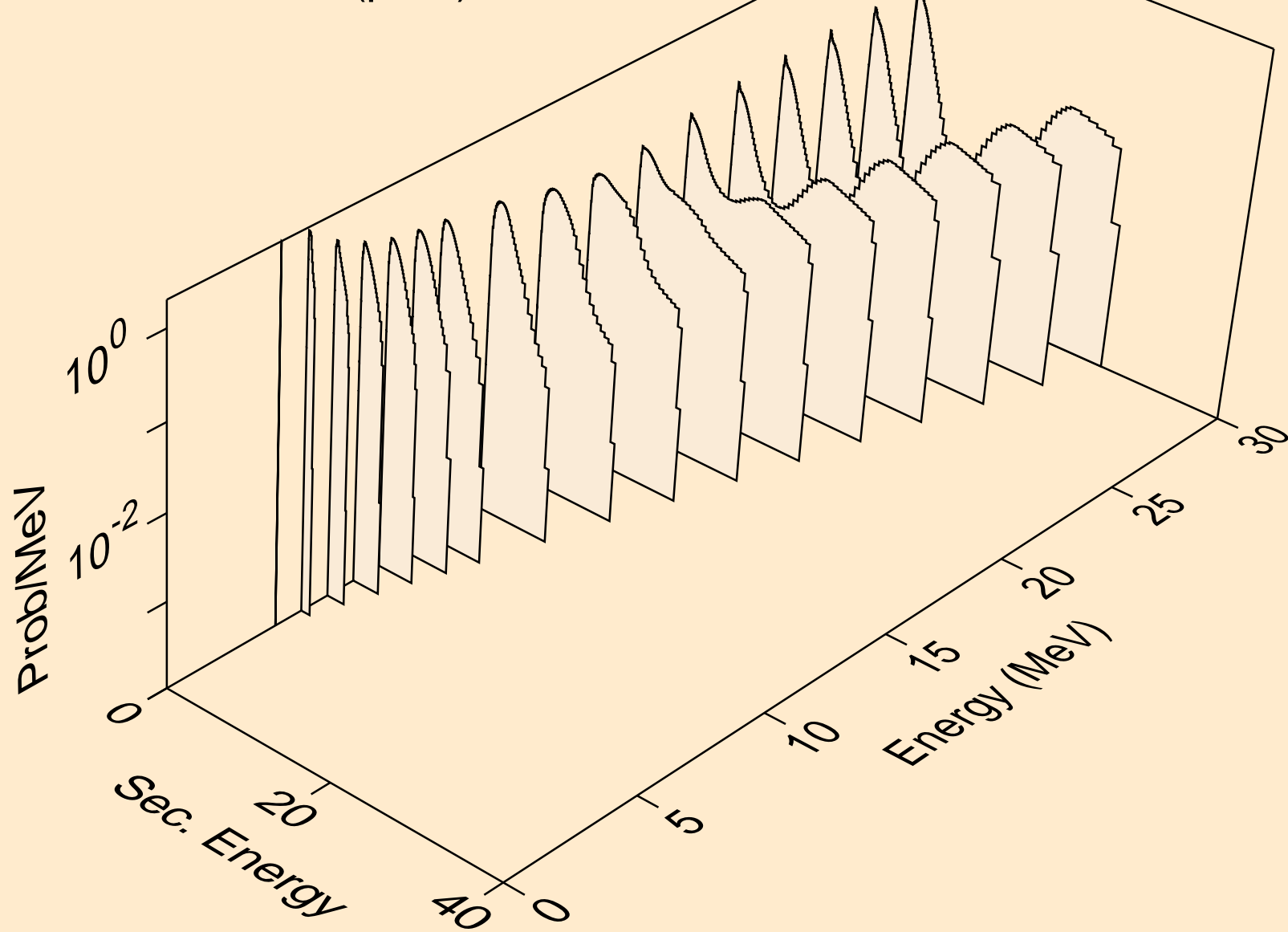

CD121M PROTON ACER TENDL-2023 LIBRARY; T=0.K  
neutrons from (p,3n)

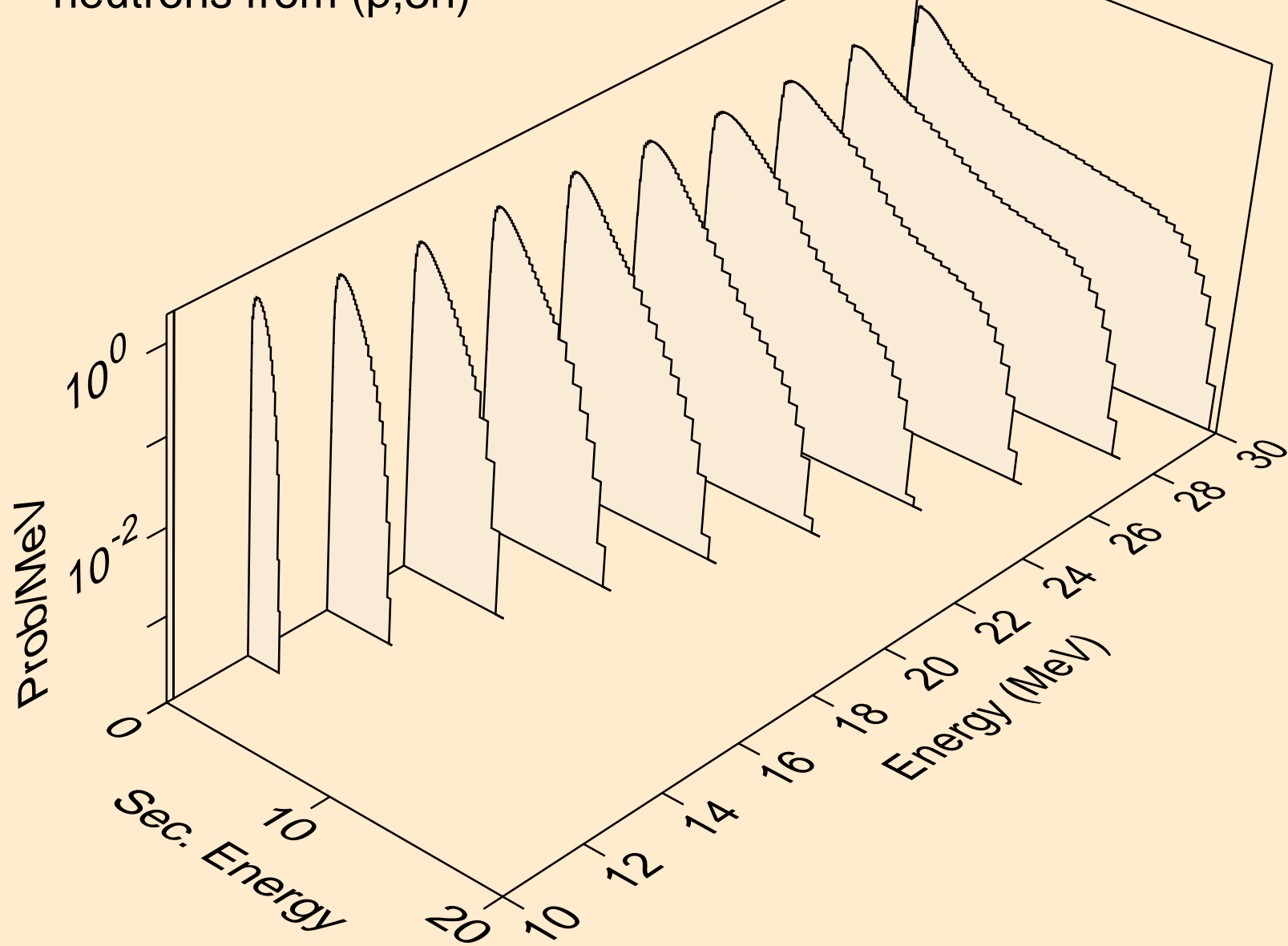

CD121M PROTON ACER TENDL-2023 LIBRARY; T=0.K  
neutrons from (p,n\*)a

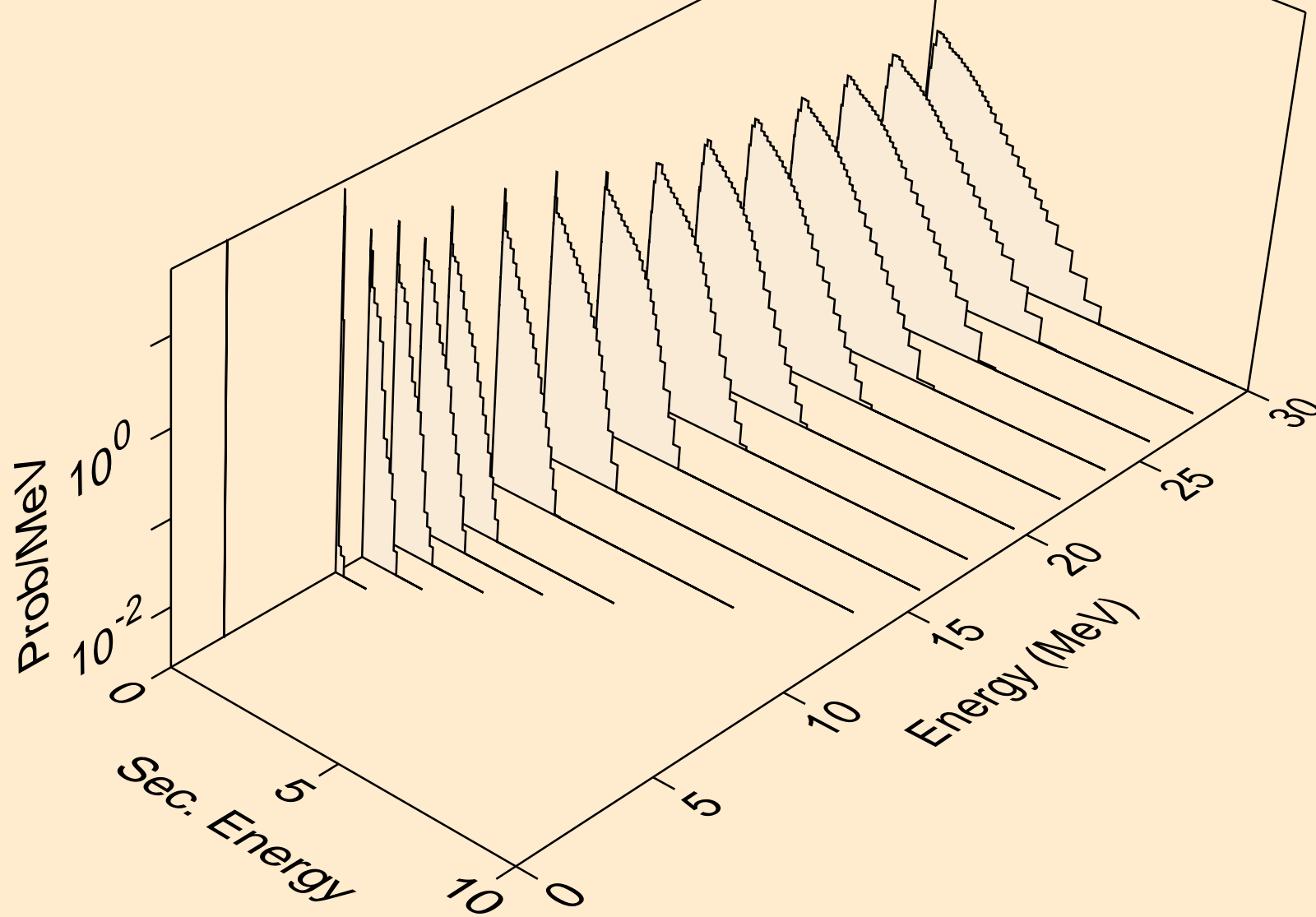

CD121M PROTON ACER TENDL-2023 LIBRARY; T=0.K  
neutrons from (p,2n)a

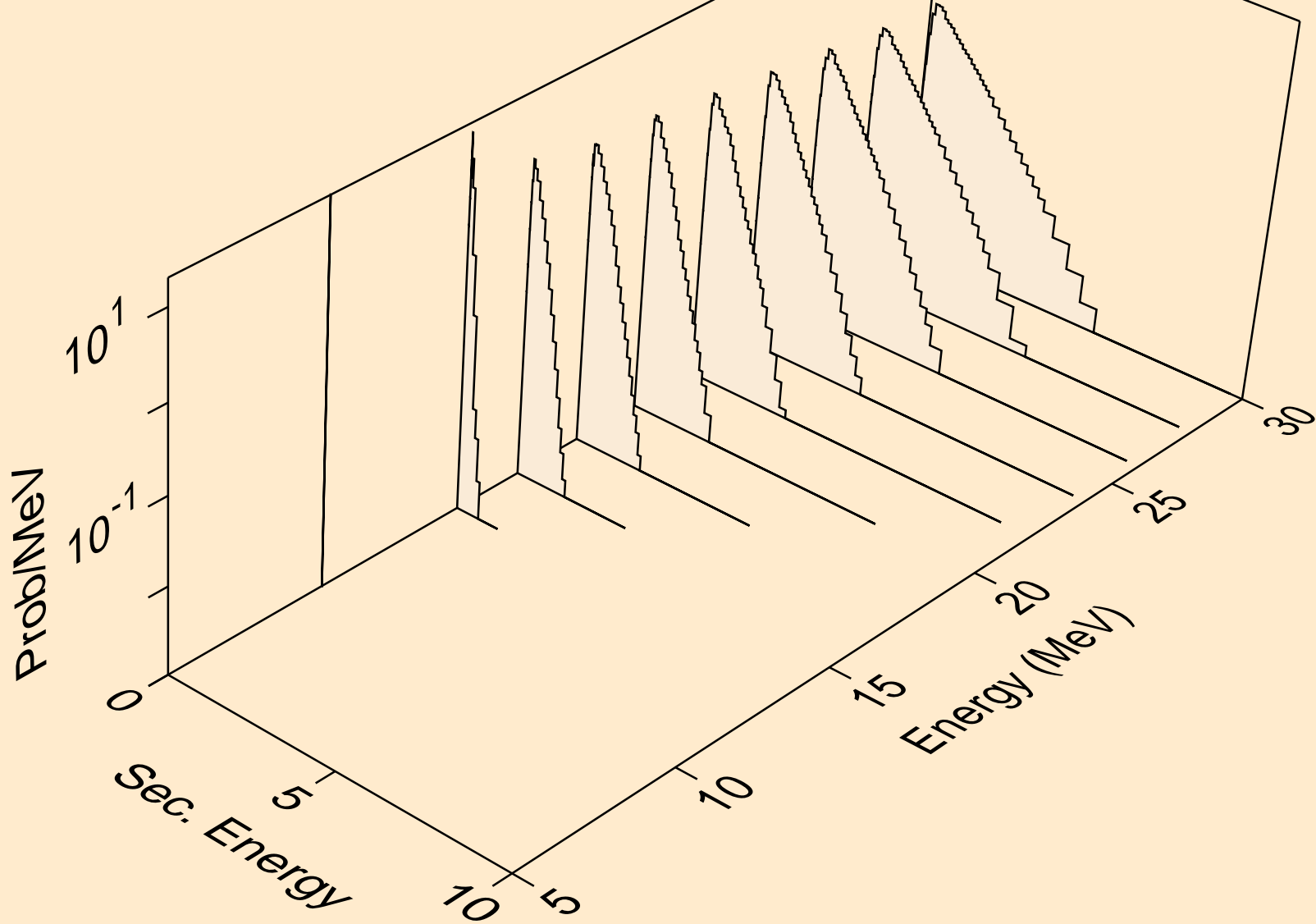

CD121M PROTON ACER TENDL-2023 LIBRARY; T=0.K  
neutrons from (p,3n)a

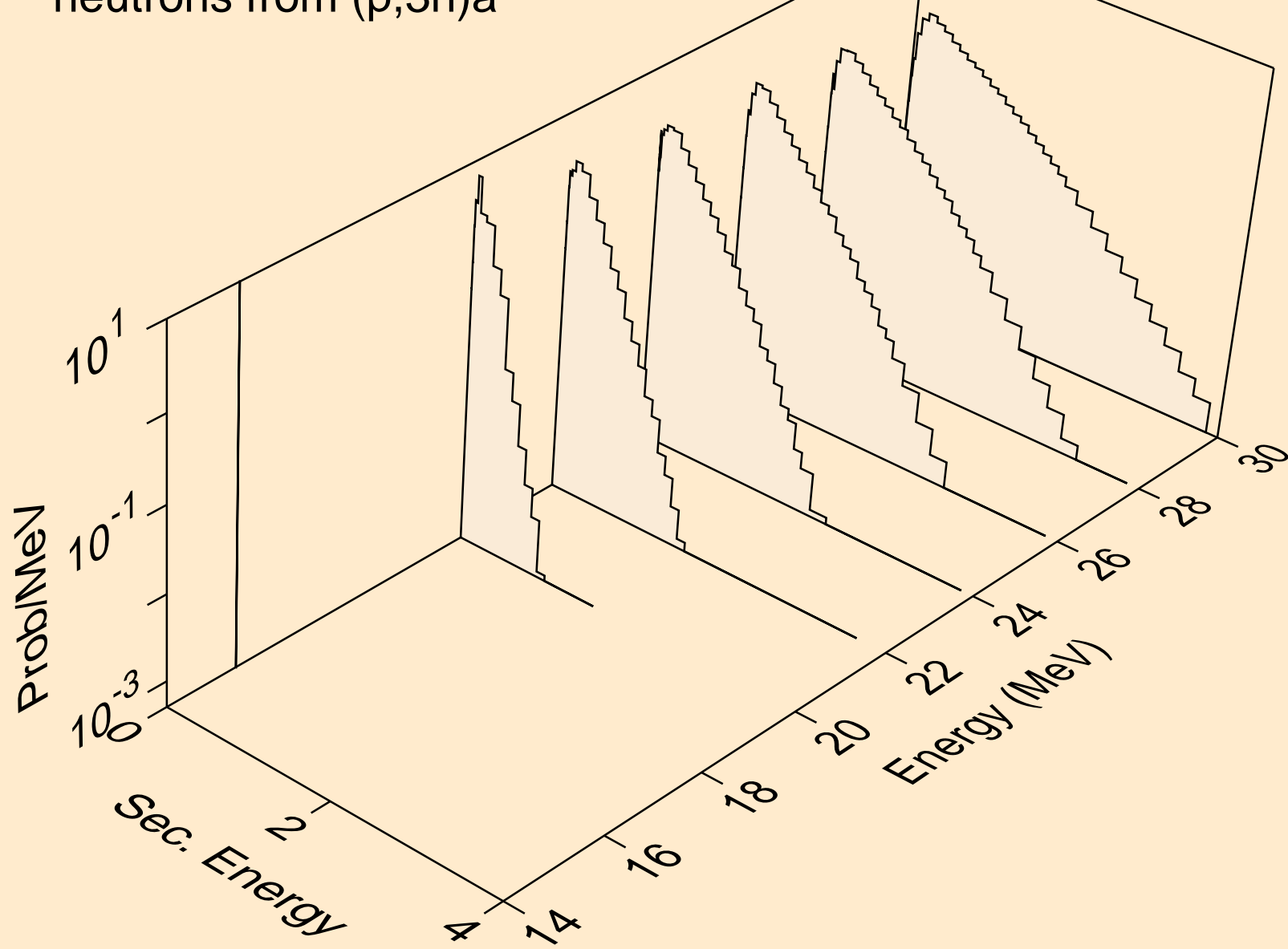

CD121M PROTON ACER TENDL-2023 LIBRARY; T=0.K  
neutrons from (p,n\*)p

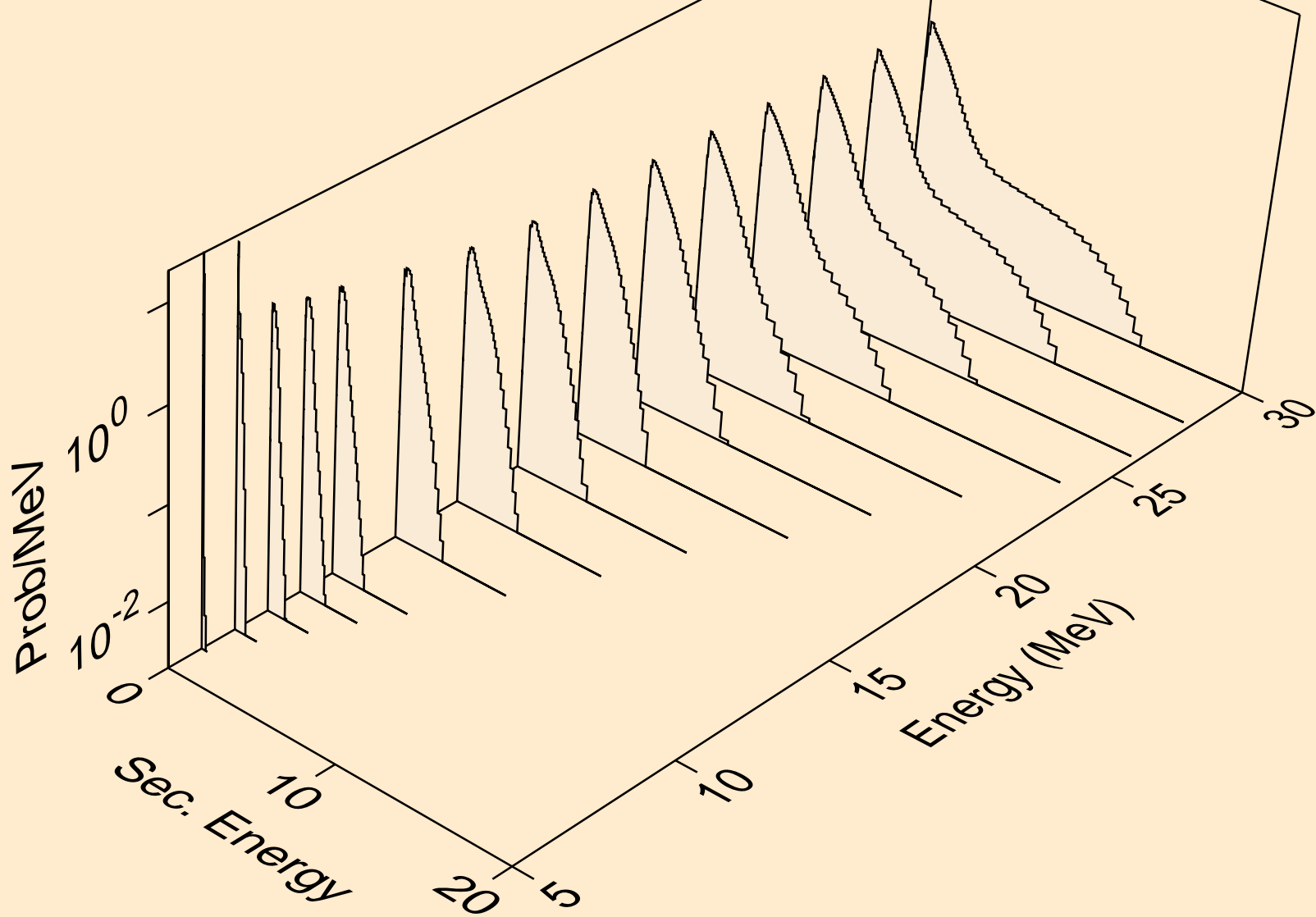



CD121M PROTON ACER TENDL-2023 LIBRARY; T=0.K  
neutrons from (p,n\*)d

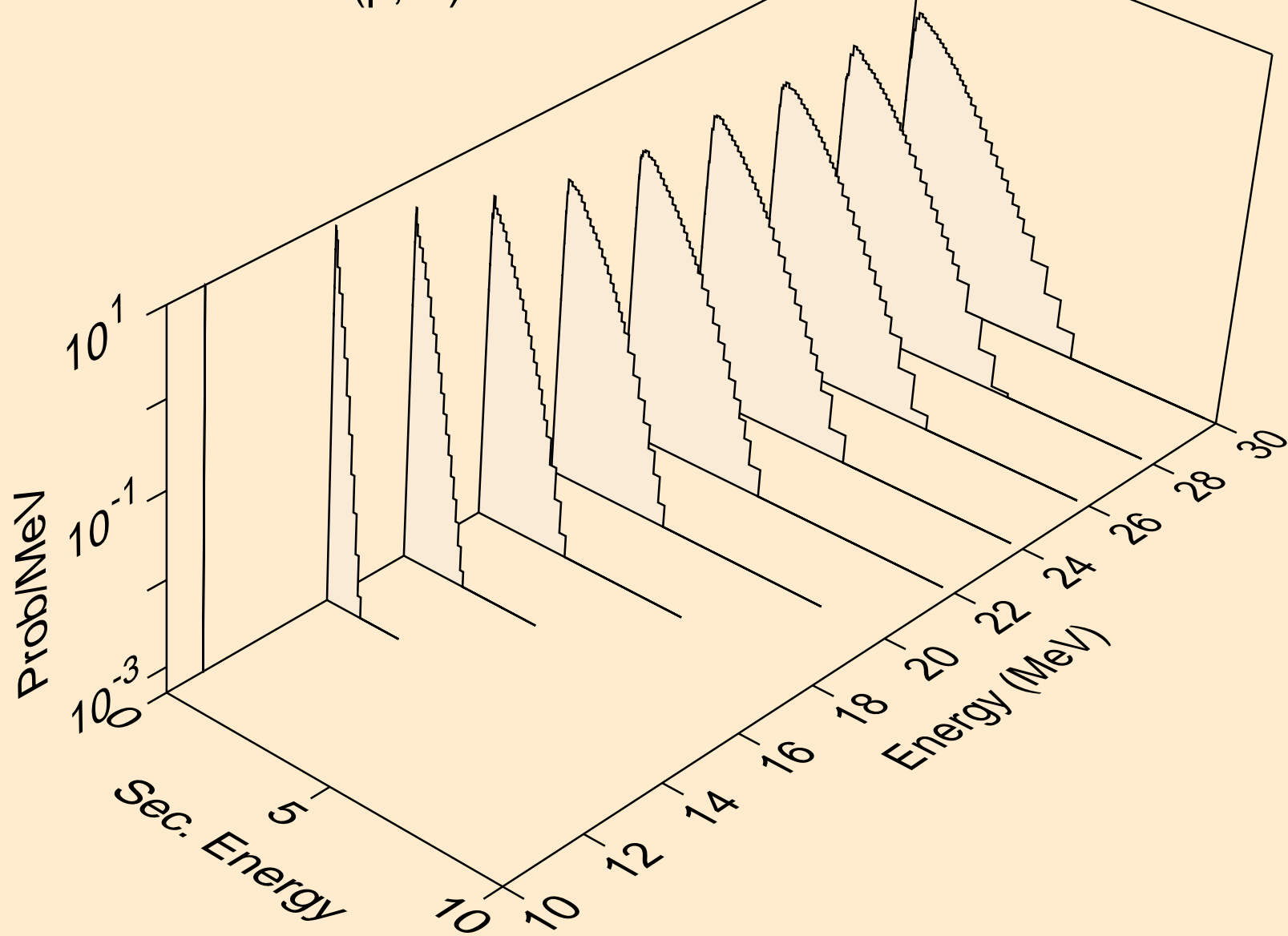

CD121M PROTON ACER TENDL-2023 LIBRARY; T=0.K  
neutrons from (p,n\*)t

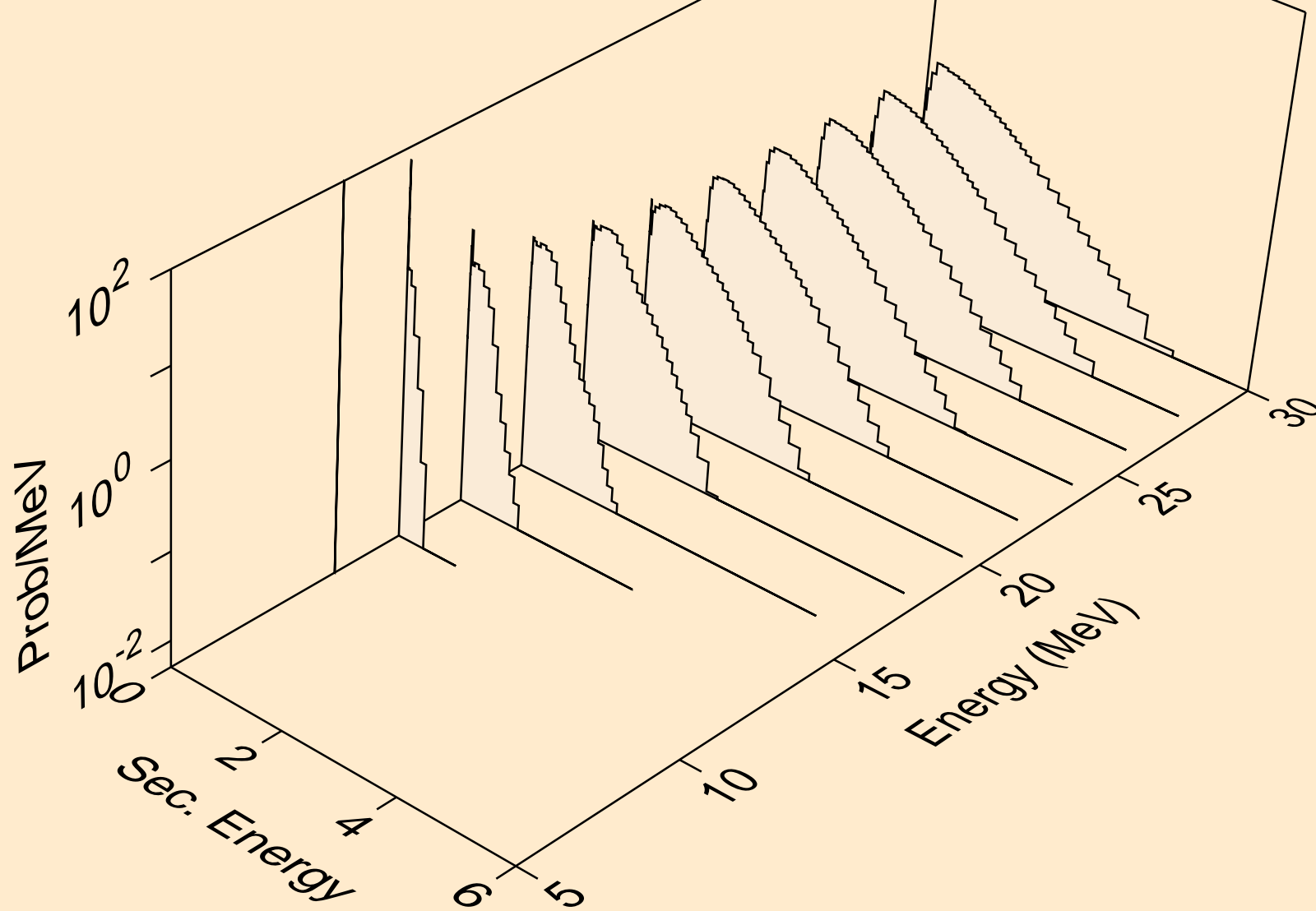

CD121M PROTON ACER TENDL-2023 LIBRARY; T=0.K  
neutrons from (p,n\*)he3

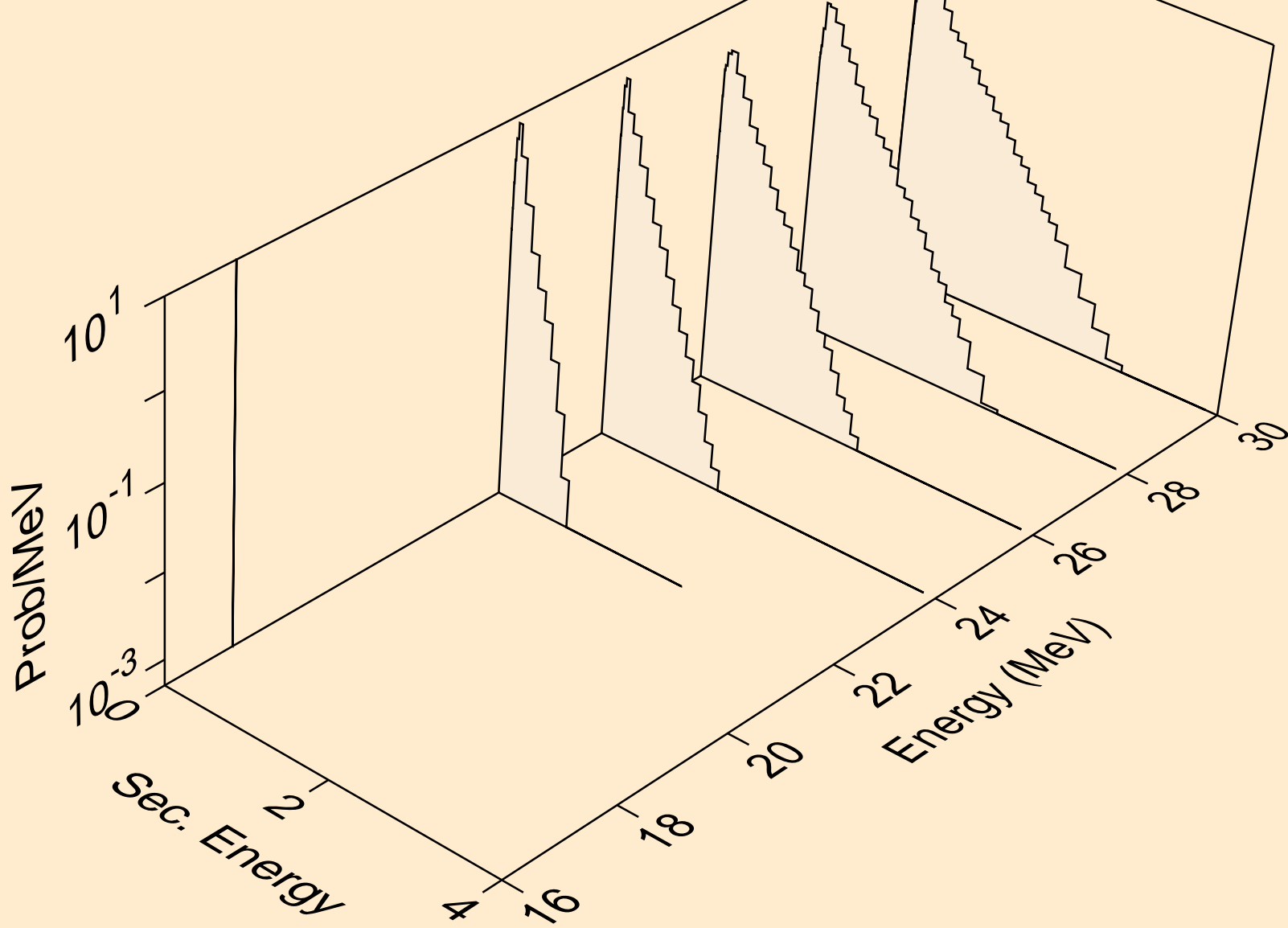

CD121M PROTON ACER TENDL-2023 LIBRARY; T=0.K  
neutrons from (p,4n)

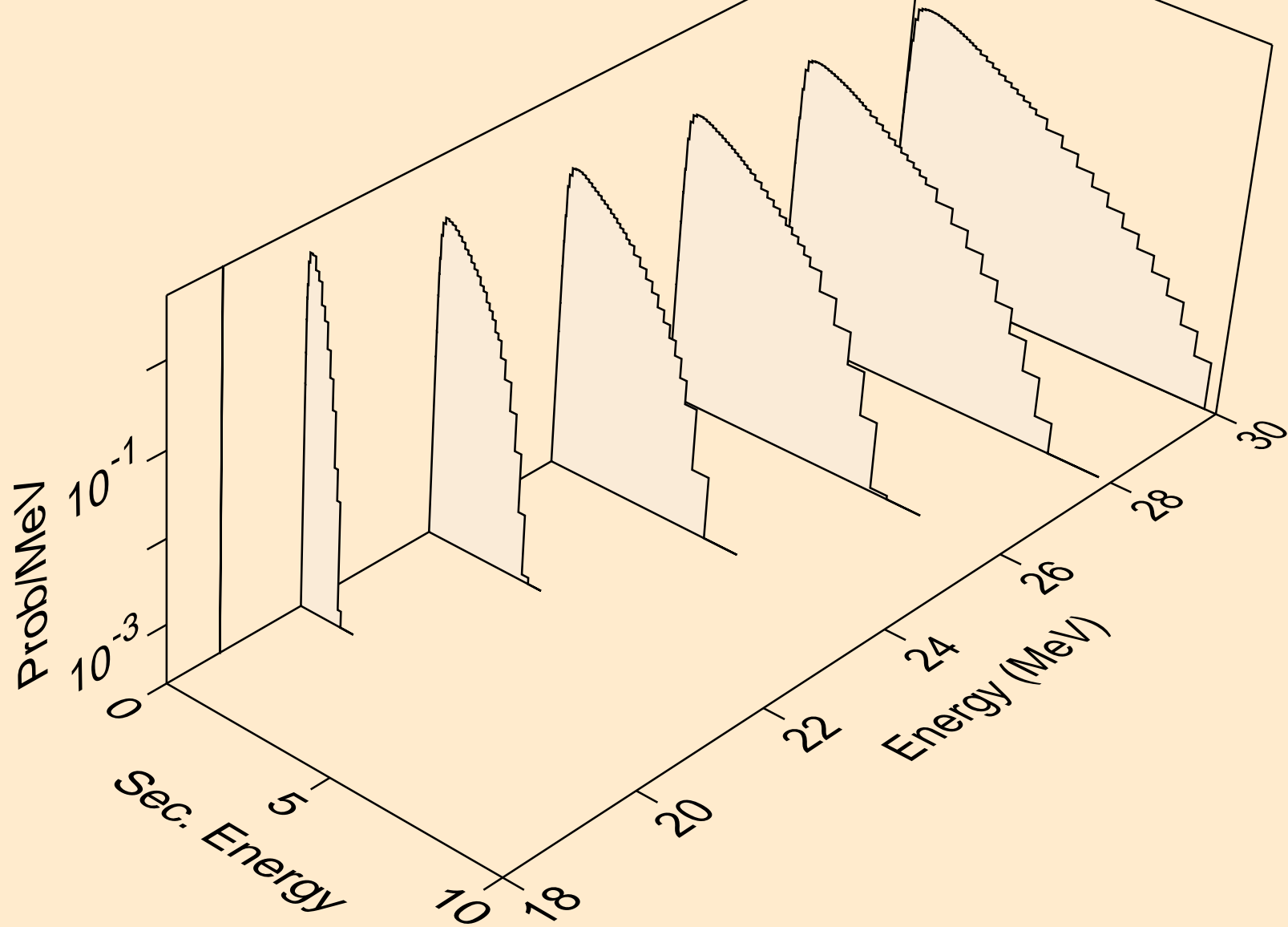

CD121M PROTON ACER TENDL-2023 LIBRARY; T=0.K  
neutrons from (p,2np)

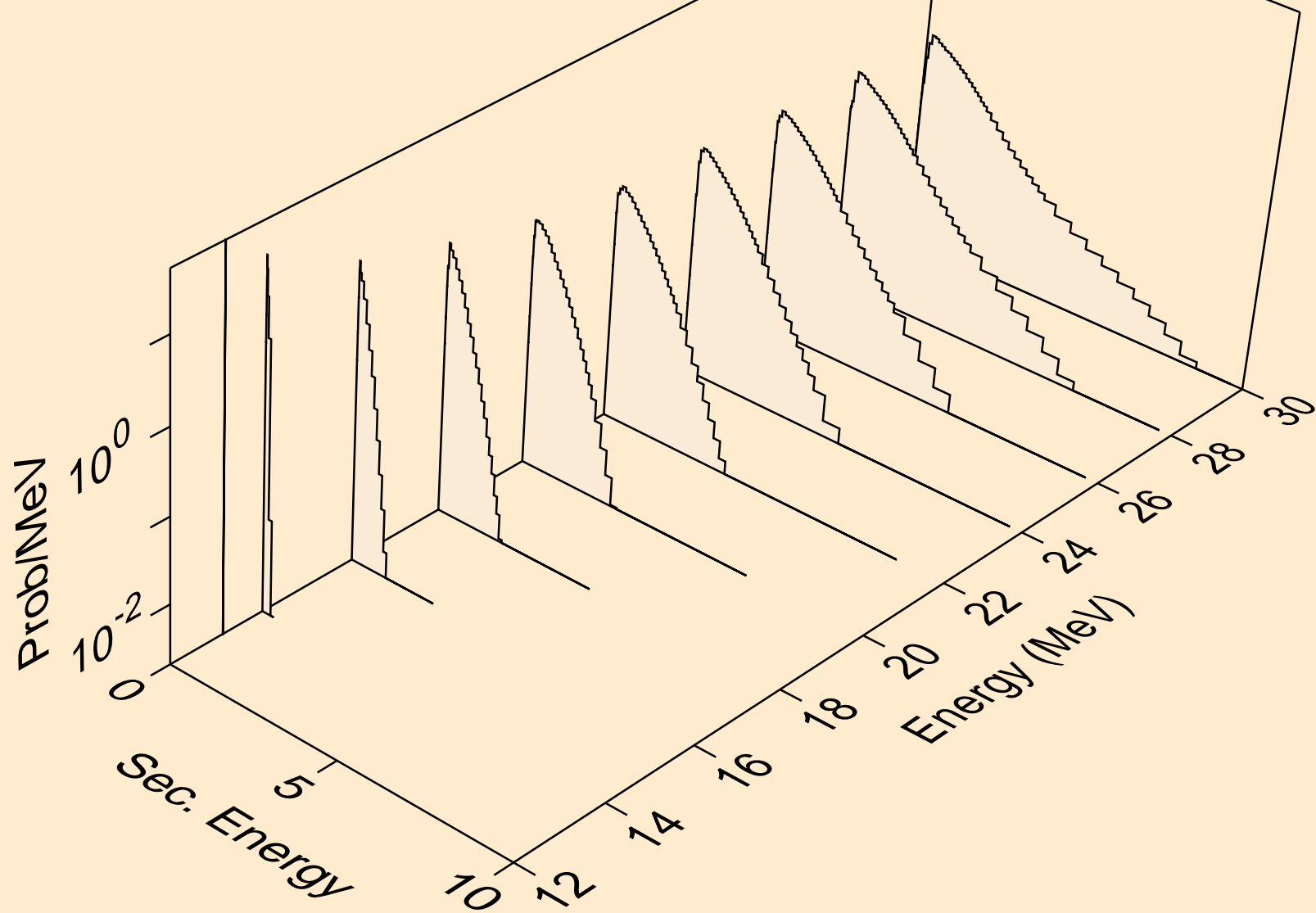

CD121M PROTON ACER TENDL-2023 LIBRARY; T=0.K  
neutrons from (p,3np)

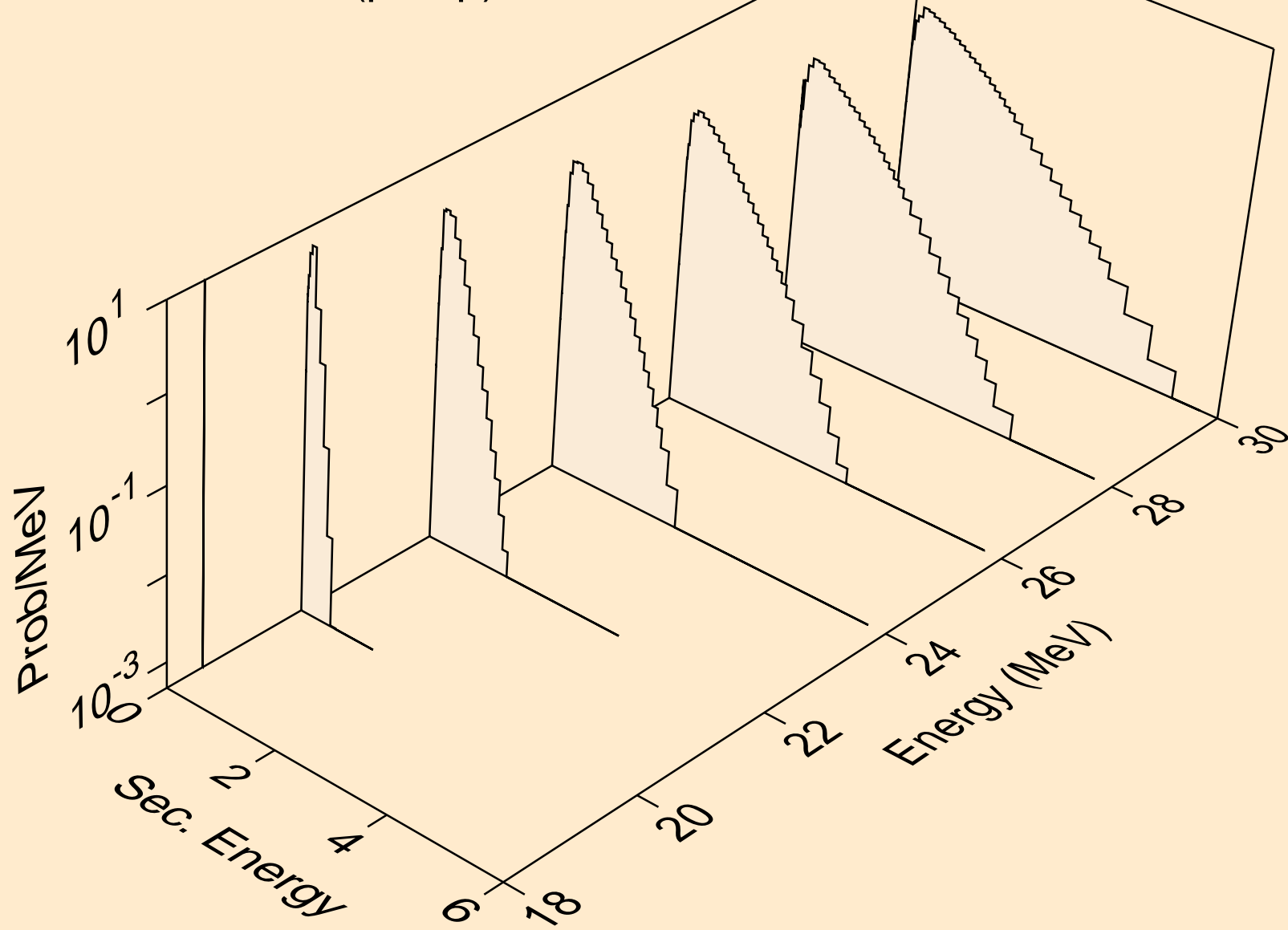

CD121M PROTON ACER TENDL-2023 LIBRARY; T=0.K  
neutrons from (p,n2p)

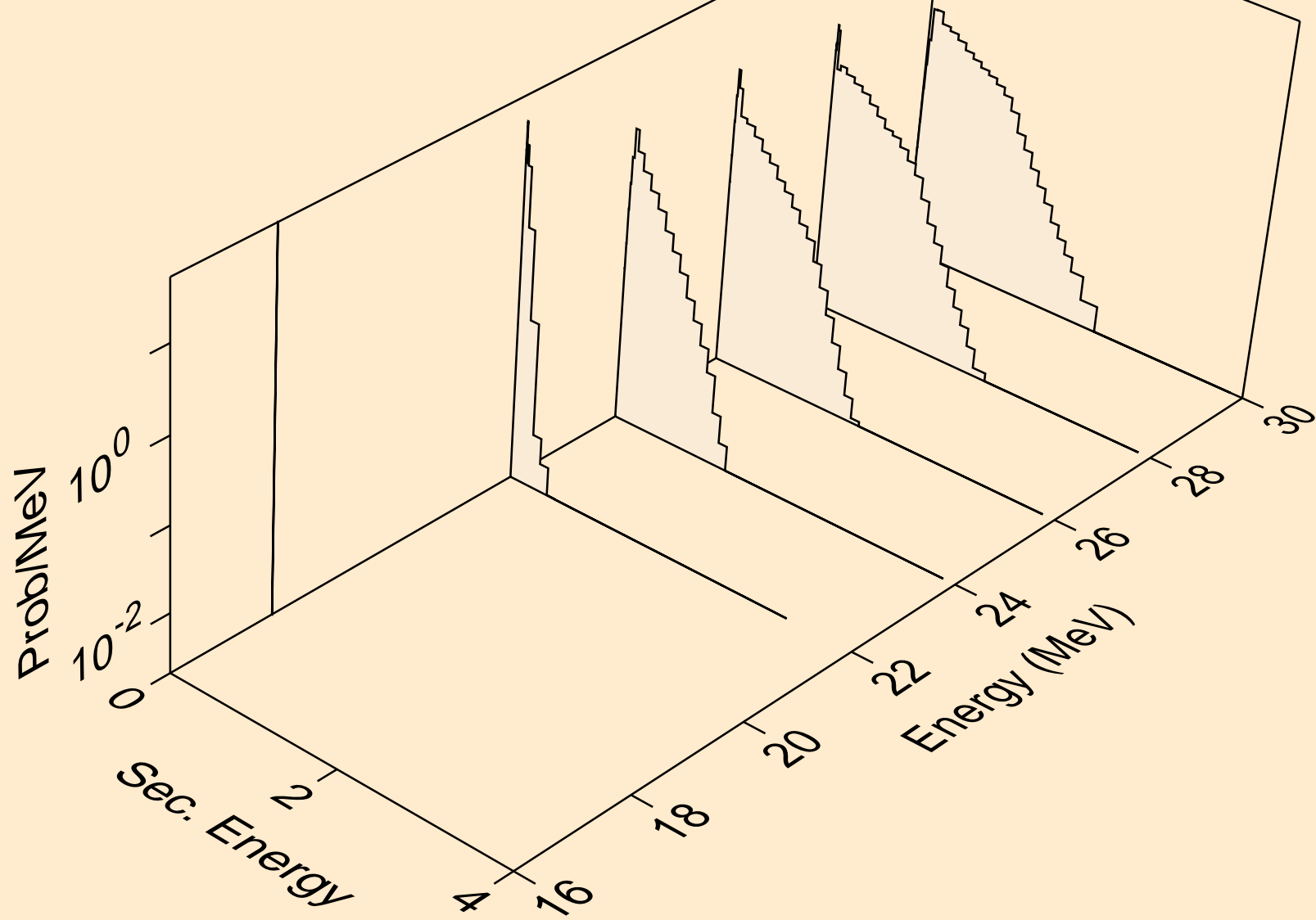

CD121M PROTON ACER TENDL-2023 LIBRARY; T=0.K  
neutrons from (p,npa)

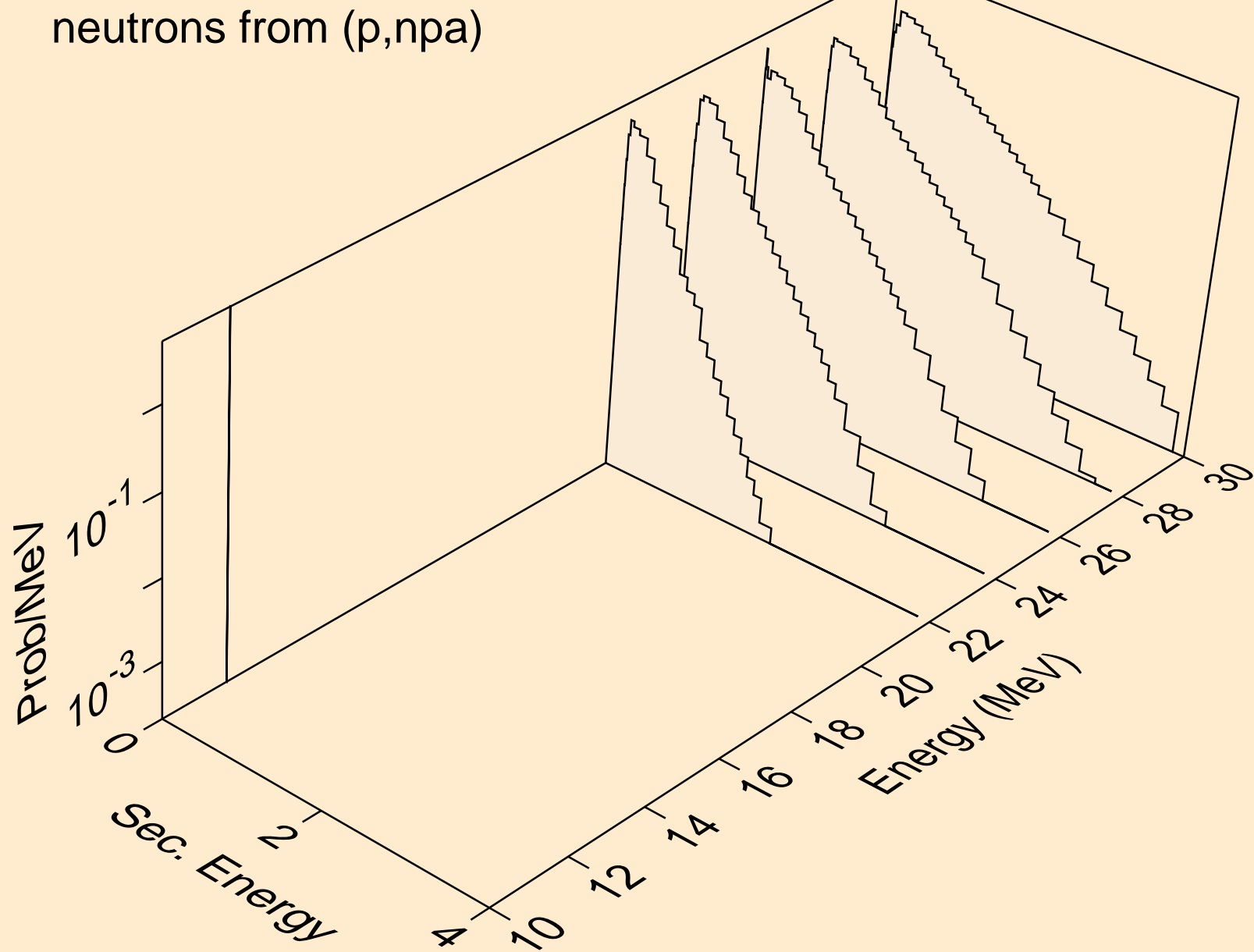



CD121M PROTON ACER TENDL-2023 LIBRARY; T=0.K  
deuterons from (p,x)

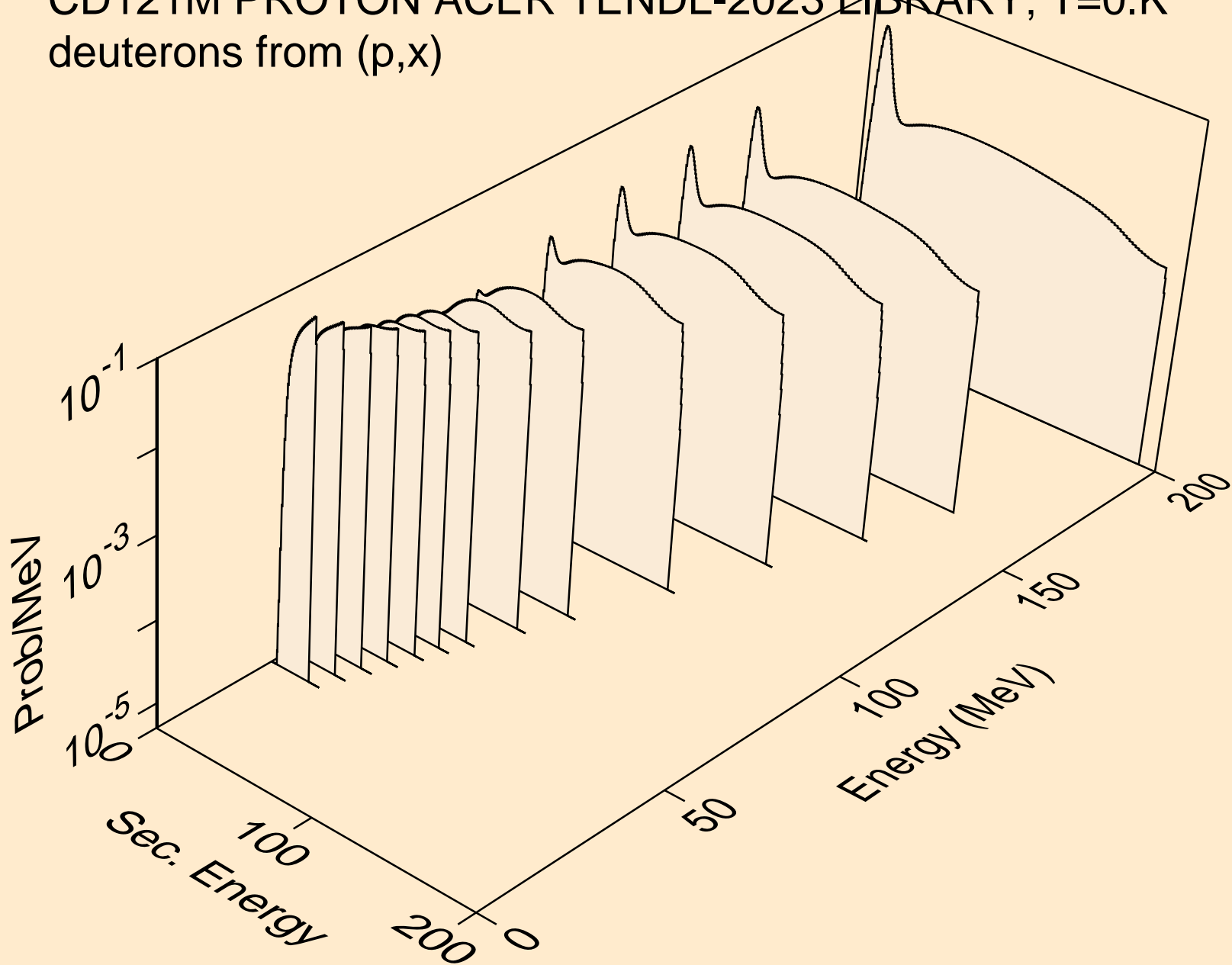

CD121M PROTON ACER TENDL-2023 LIBRARY; T=0.K  
deuterons from (p,2nd)

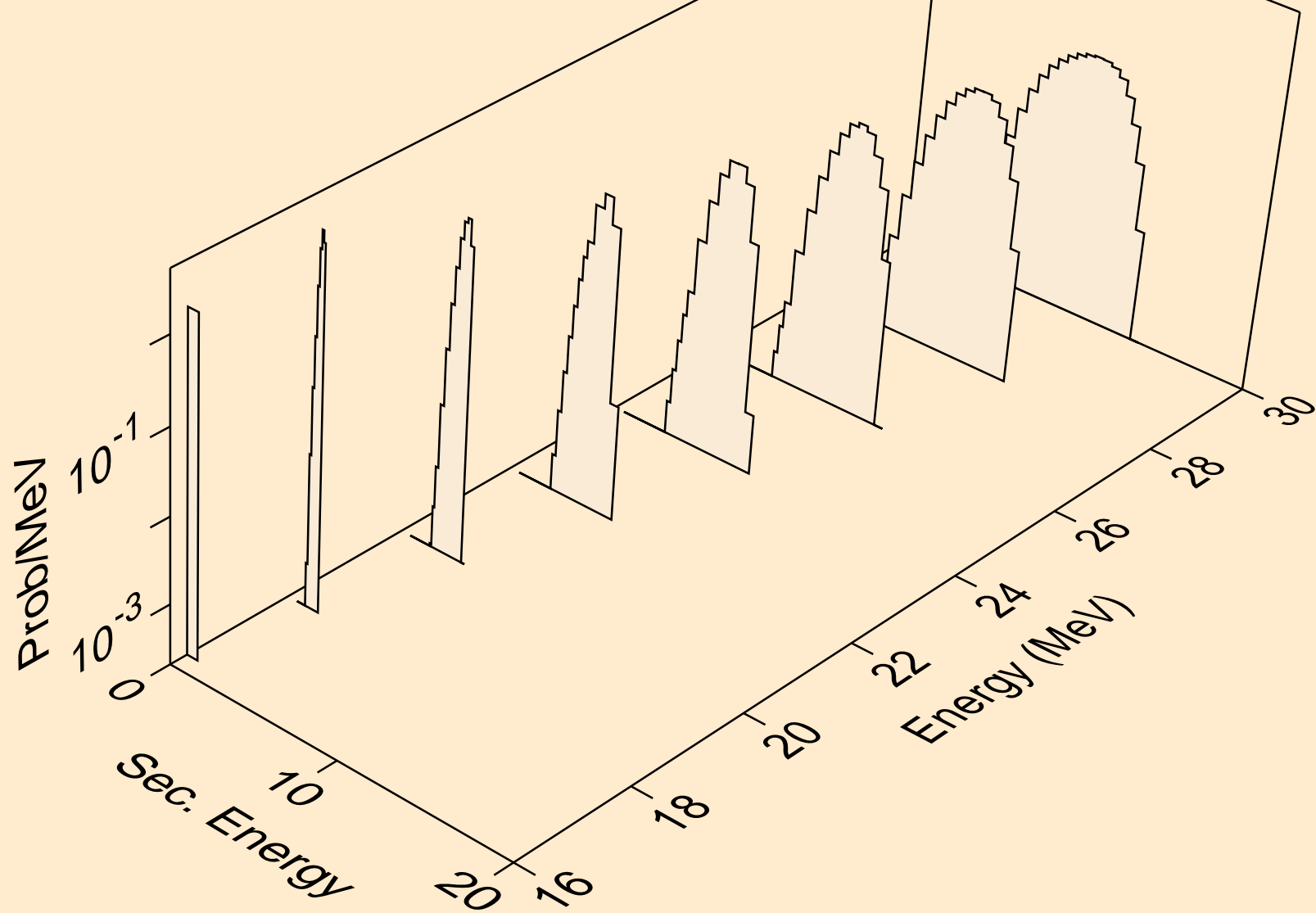

CD121M PROTON ACER TENDL-2023 LIBRARY; T=0.K  
deuterons from (p,n\*)d

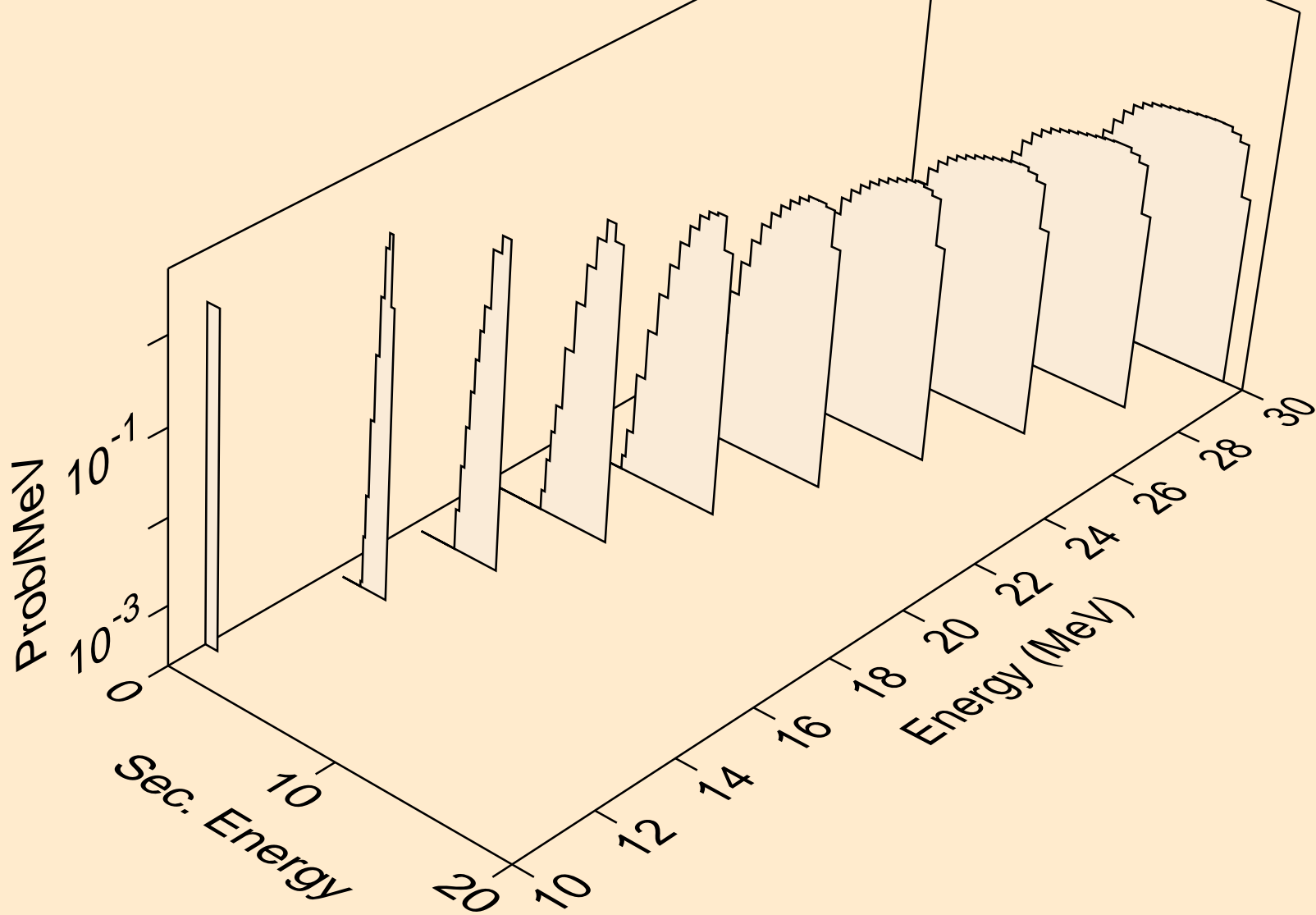

CD121M PROTON ACER TENDL-2023 LIBRARY; T=0.K  
deuterons from (p,d)

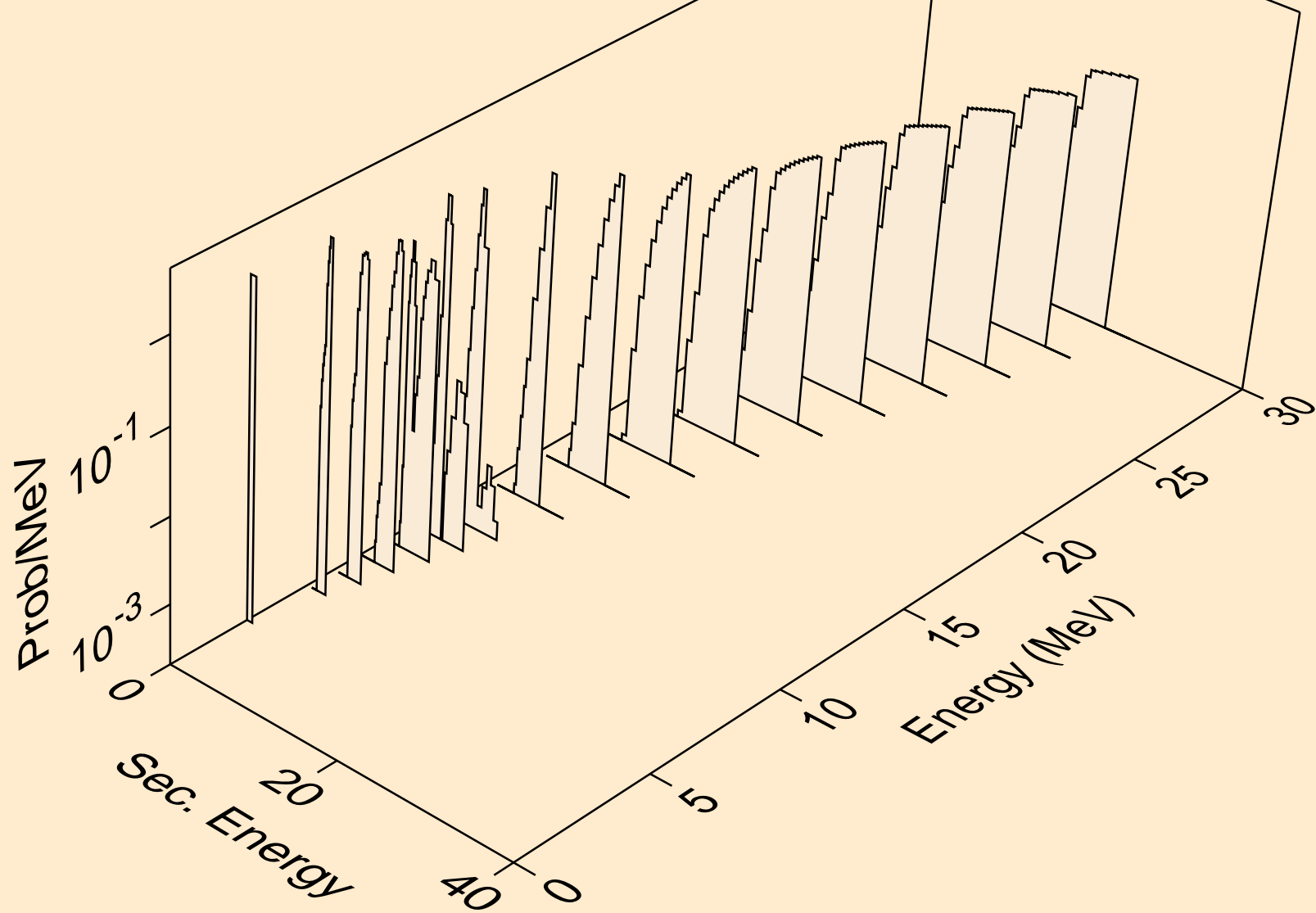

CD121M PROTON ACER TENDL-2023 LIBRARY; T=0.K  
deuterons from (p,pd)

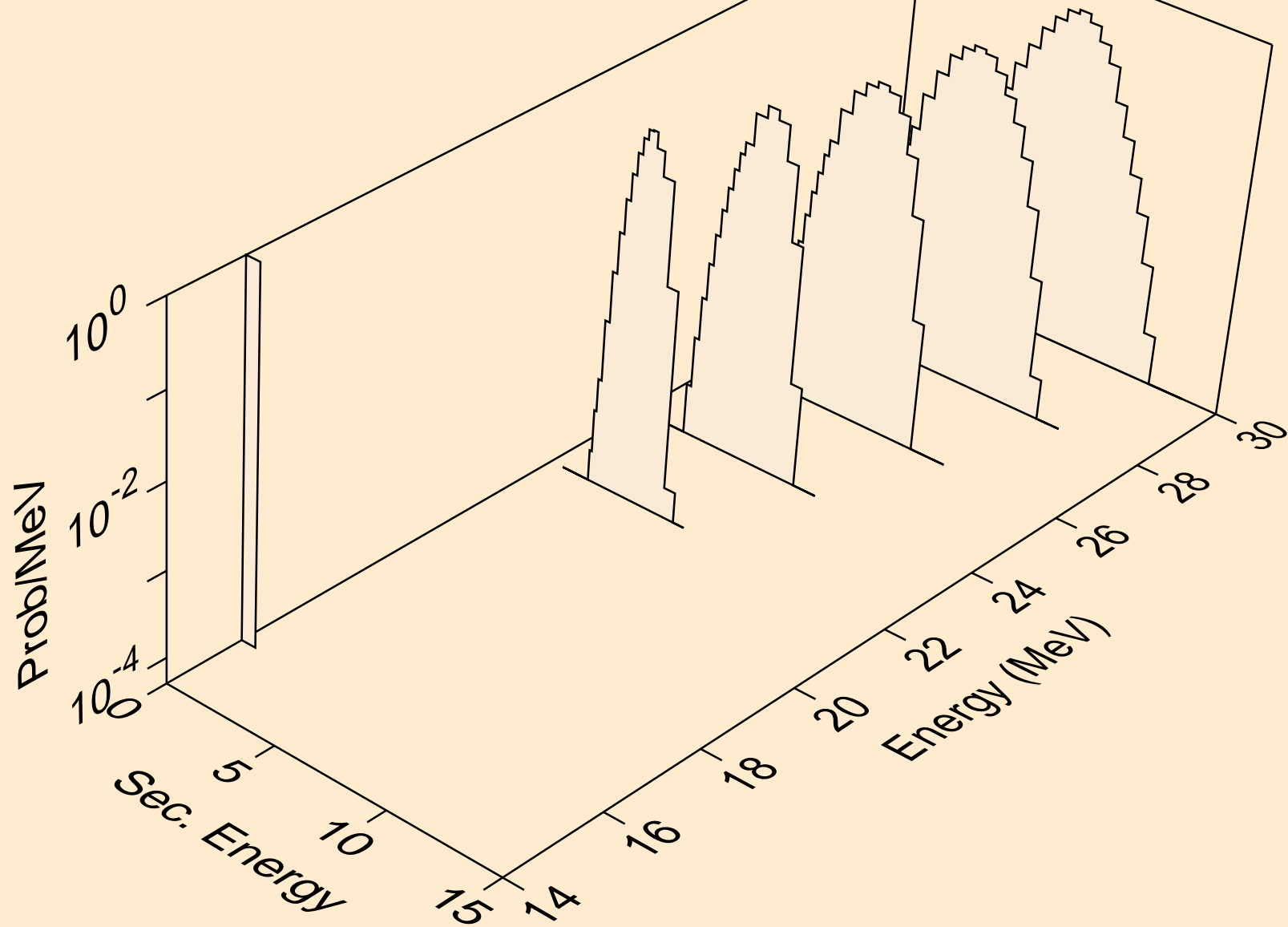

CD121M PROTON ACER TENDL-2023 LIBRARY; T=0.K  
tritons from (p,x)

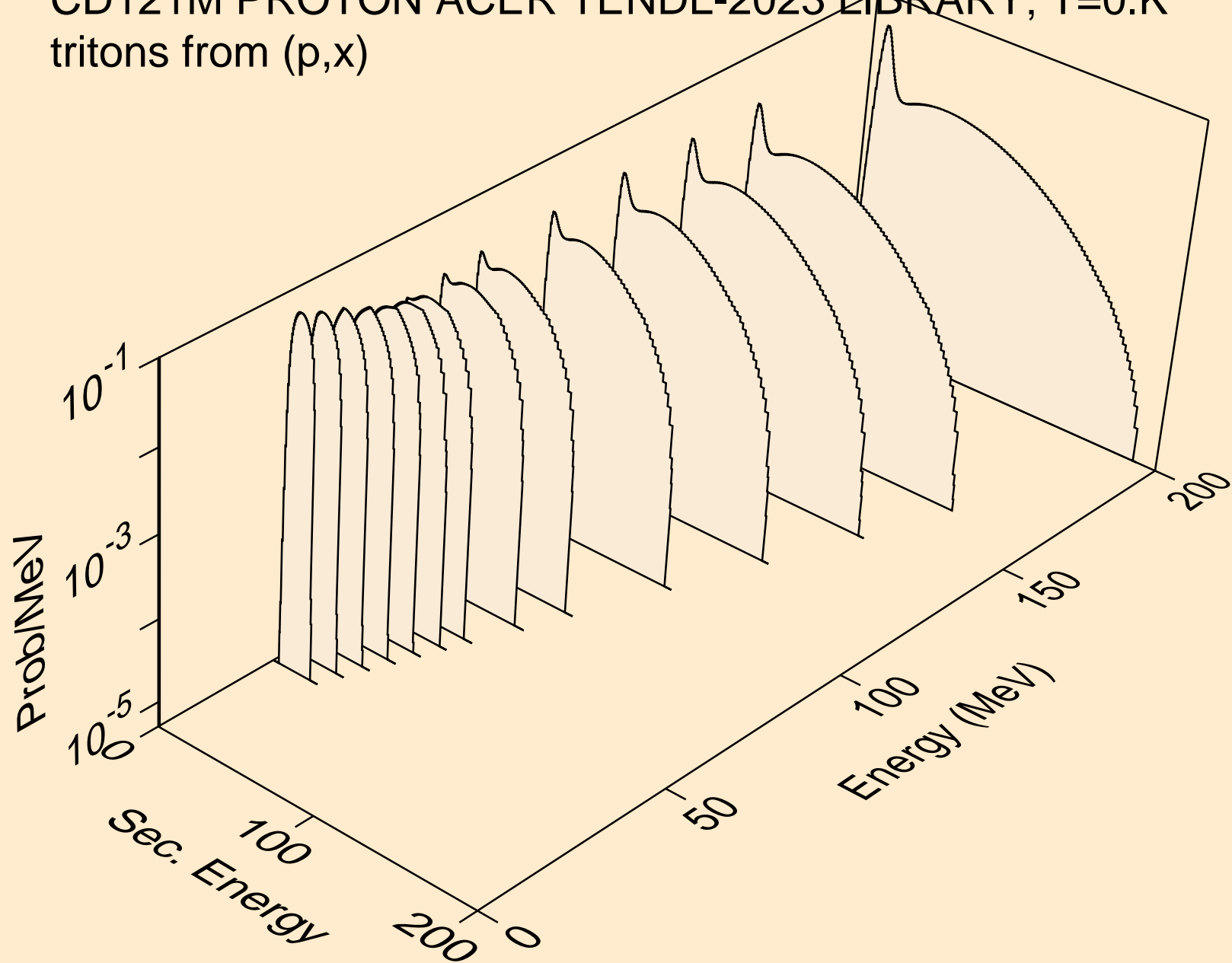

CD121M PROTON ACER TENDL-2023 LIBRARY; T=0.K  
tritons from (p,n\*)t

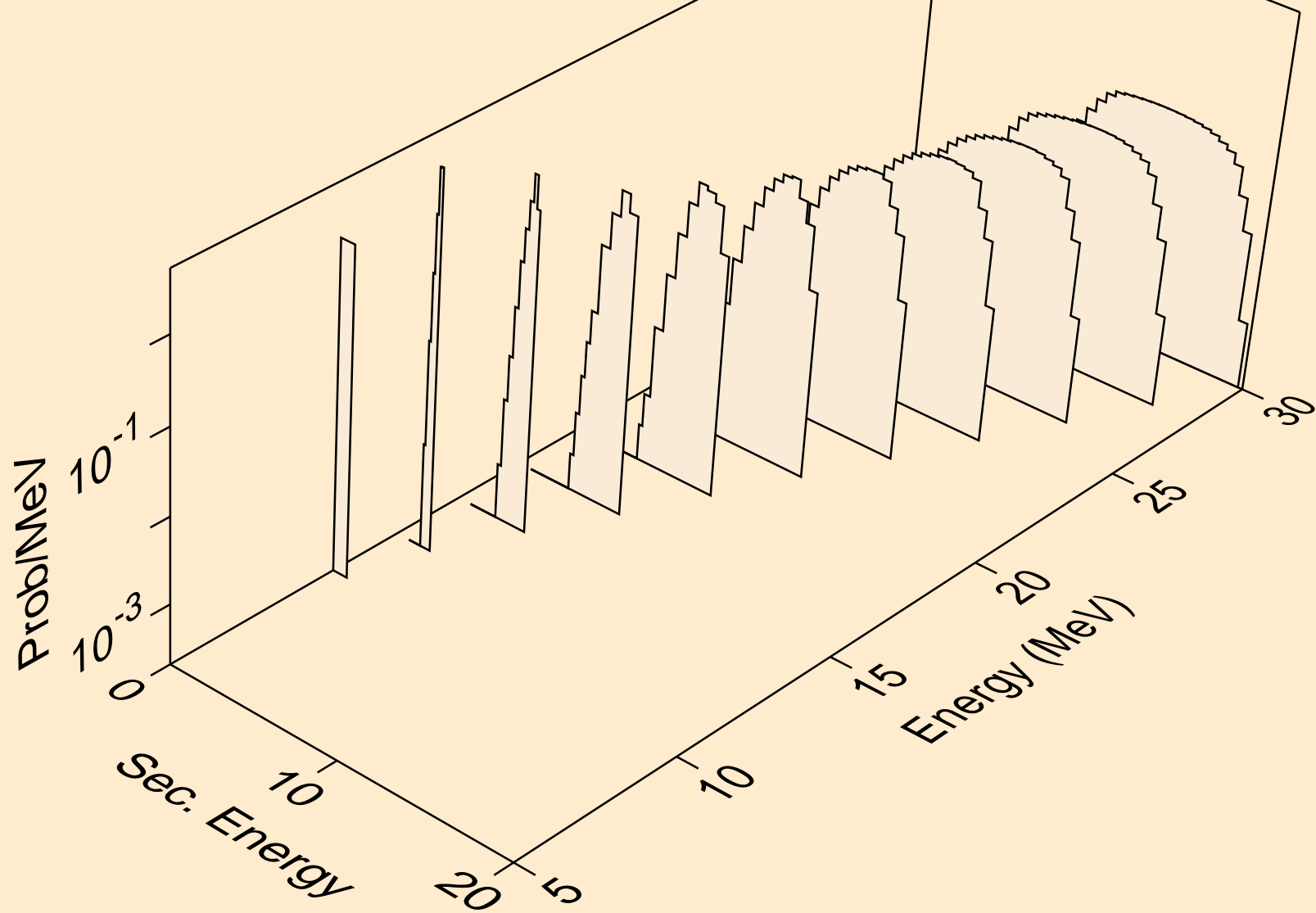

CD121M PROTON ACER TENDL-2023 LIBRARY; T=0.K  
tritons from (p,t)

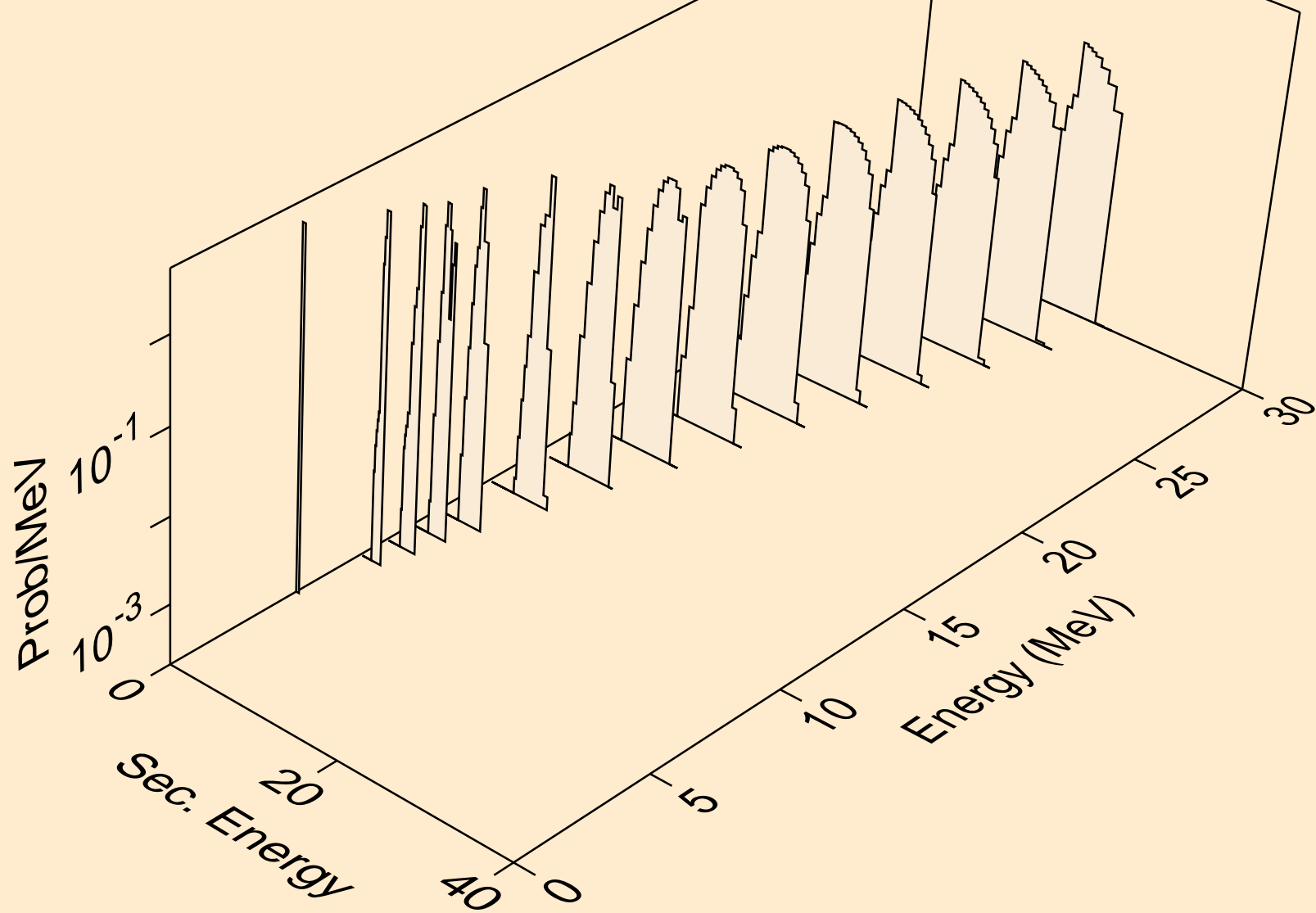



CD121M PROTON ACER TENDL-2023 LIBRARY; T=0.K  
he3s from (p,x)

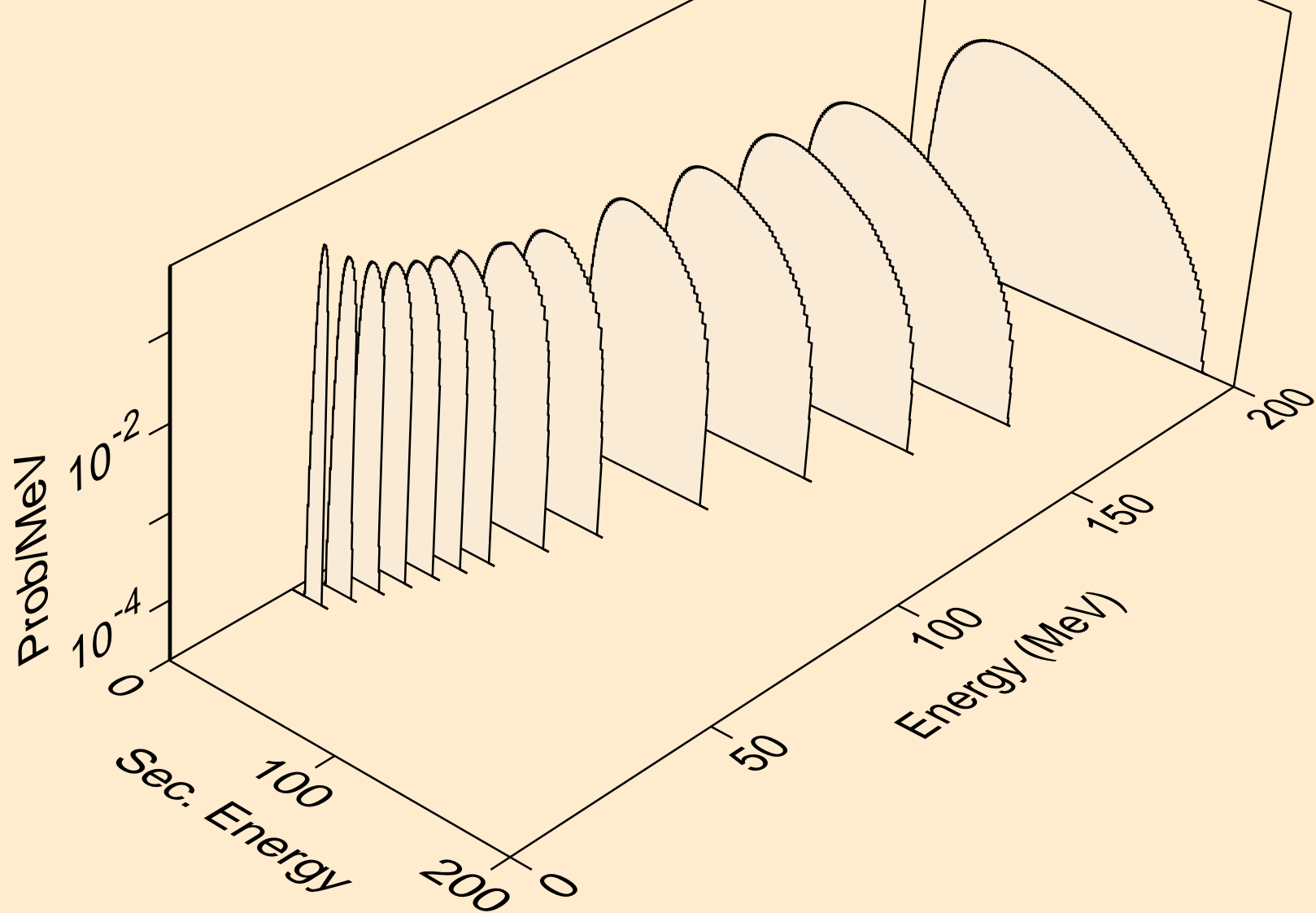

CD121M PROTON ACER TENDL-2023 LIBRARY; T=0.K  
he3s from (p,n\*)he3

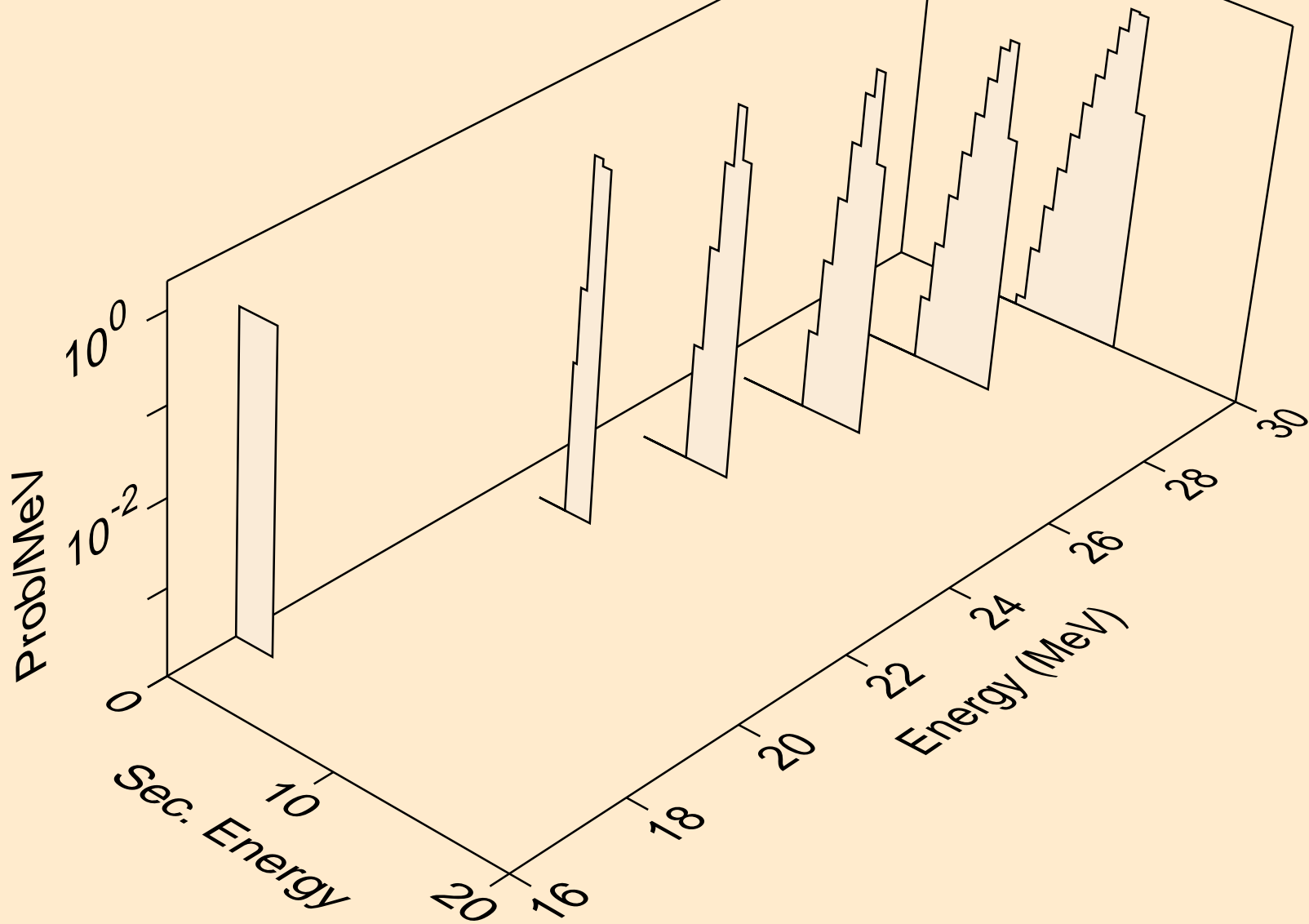

CD121M PROTON ACER TENDL-2023 LIBRARY; T=0.K  
he3s from (p,he3)

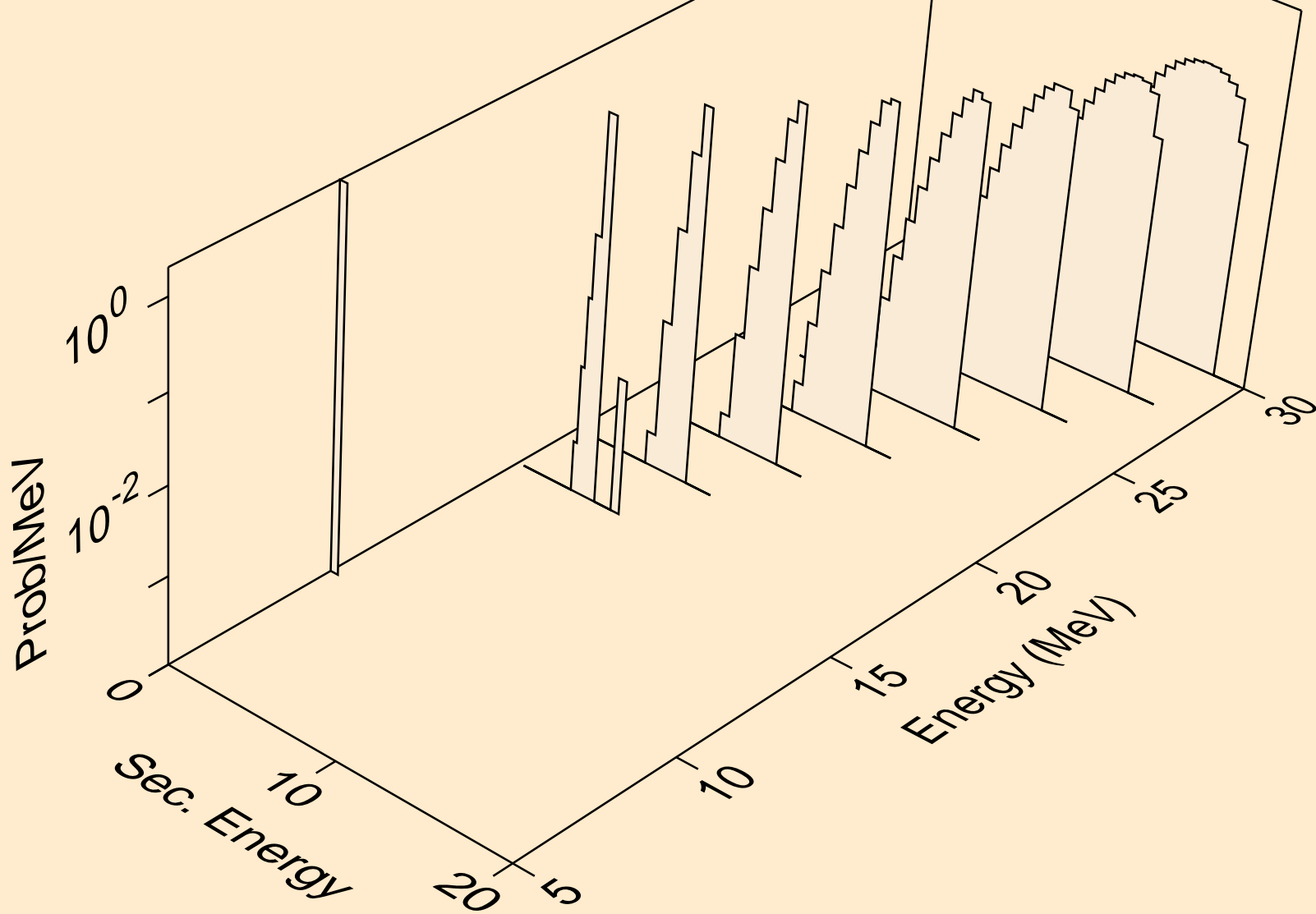

CD121M PROTON ACER TENDL-2023 LIBRARY; T=0.K  
alphas from (p,x)

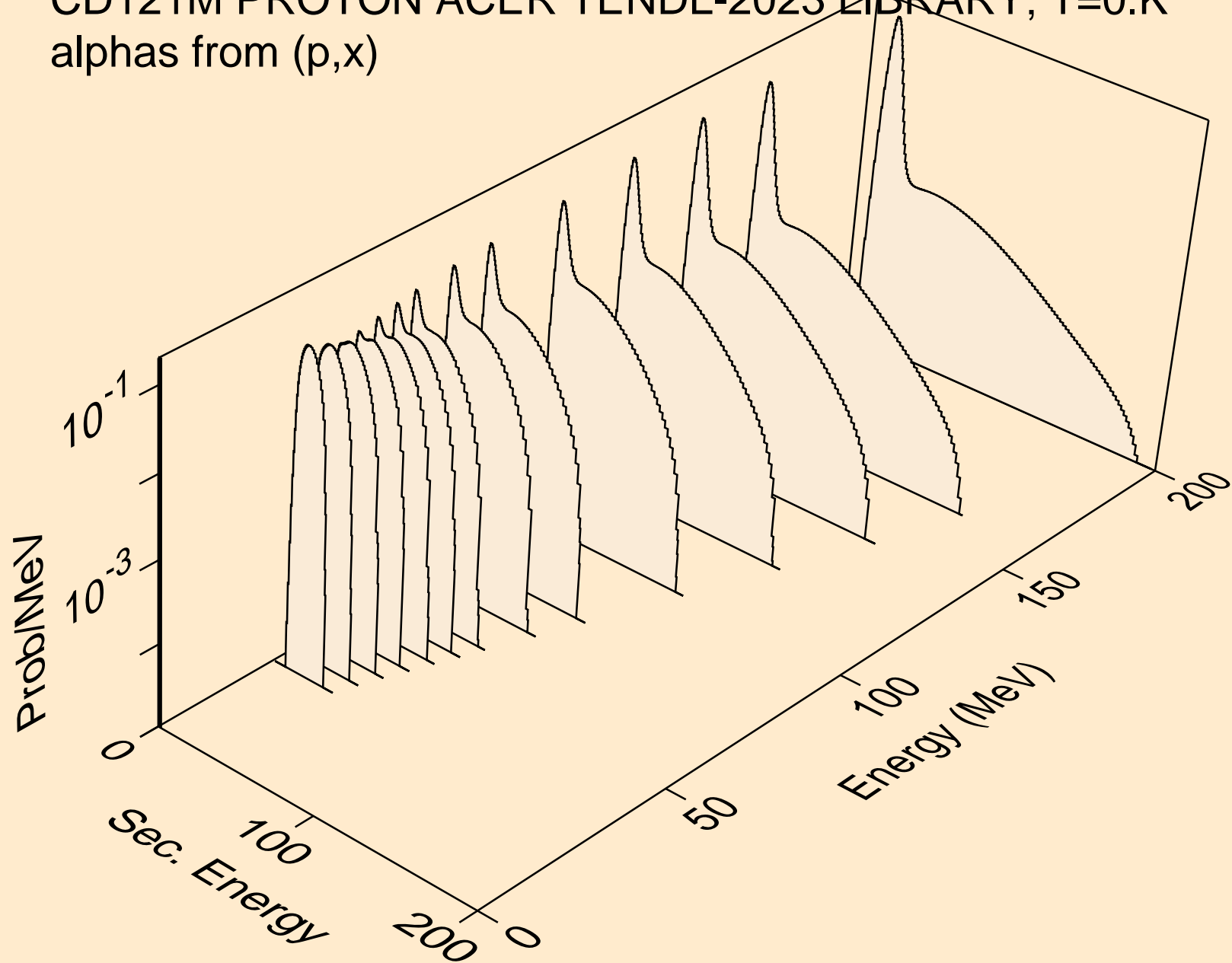

CD121M PROTON ACER TENDL-2023 LIBRARY; T=0.K  
alphas from (p,n\*)a

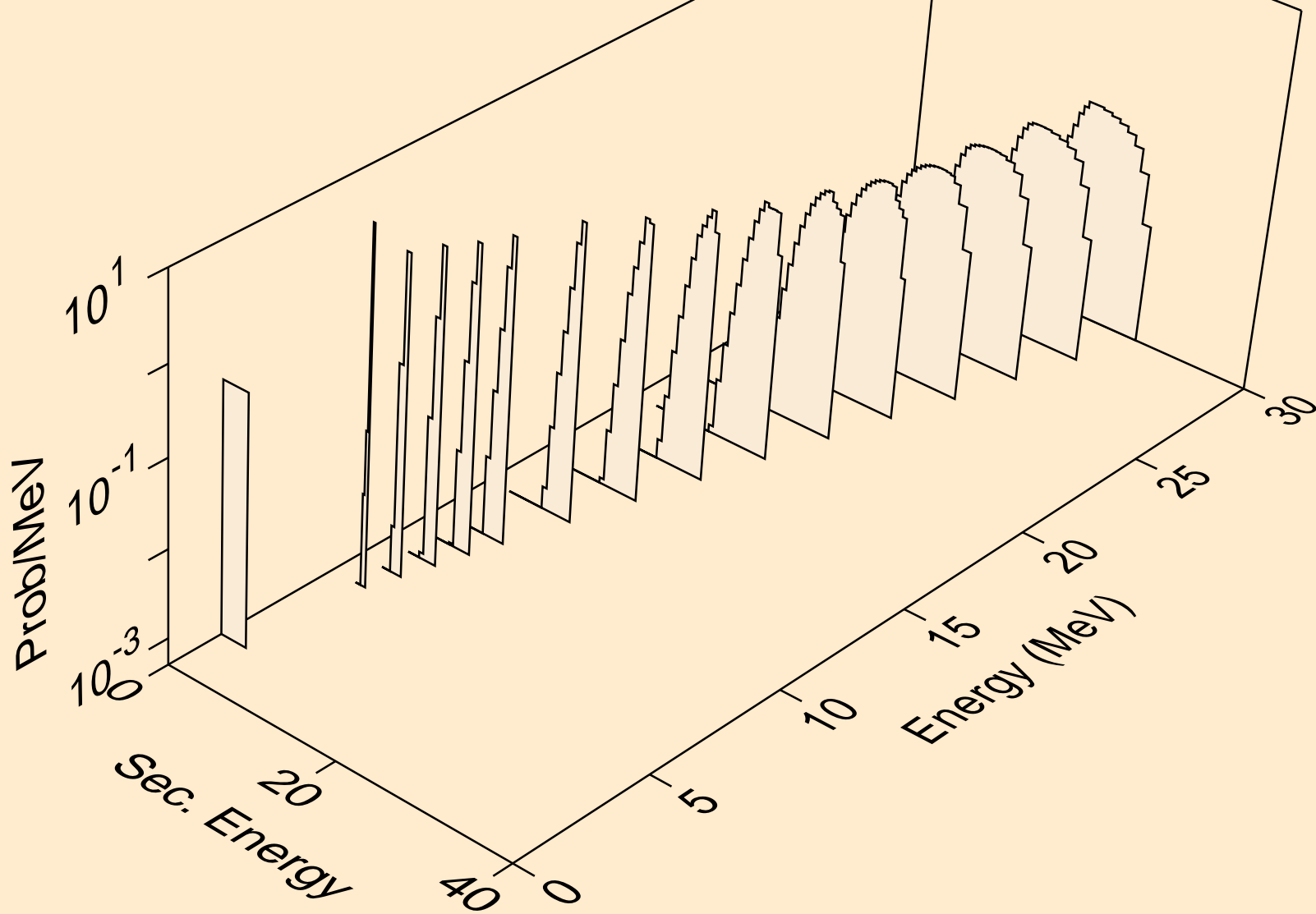

CD121M PROTON ACER TENDL-2023 LIBRARY; T=0.K  
alphas from (p,2n)a

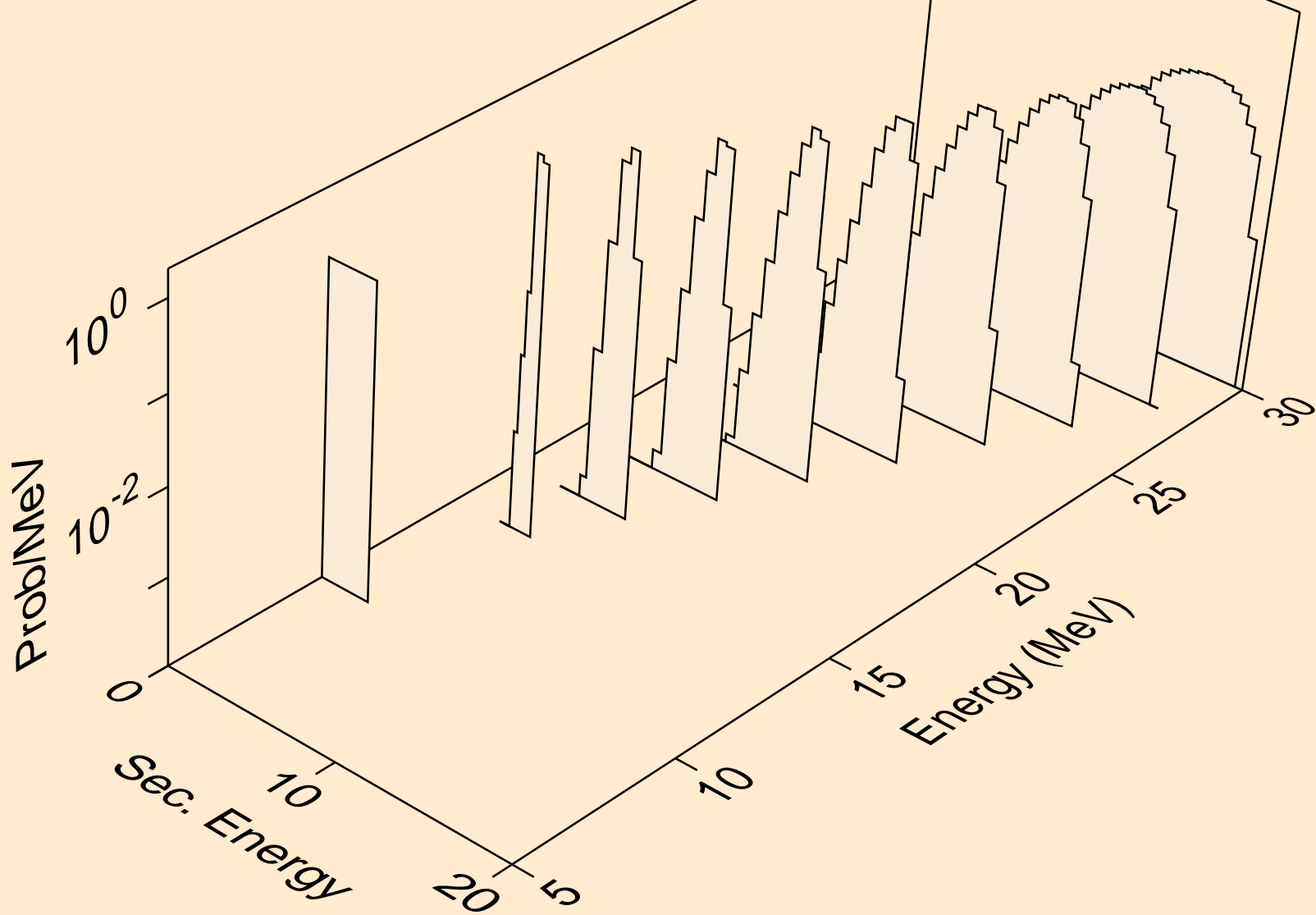

CD121M PROTON ACER TENDL-2023 LIBRARY; T=0.K  
alphas from (p,3n)a

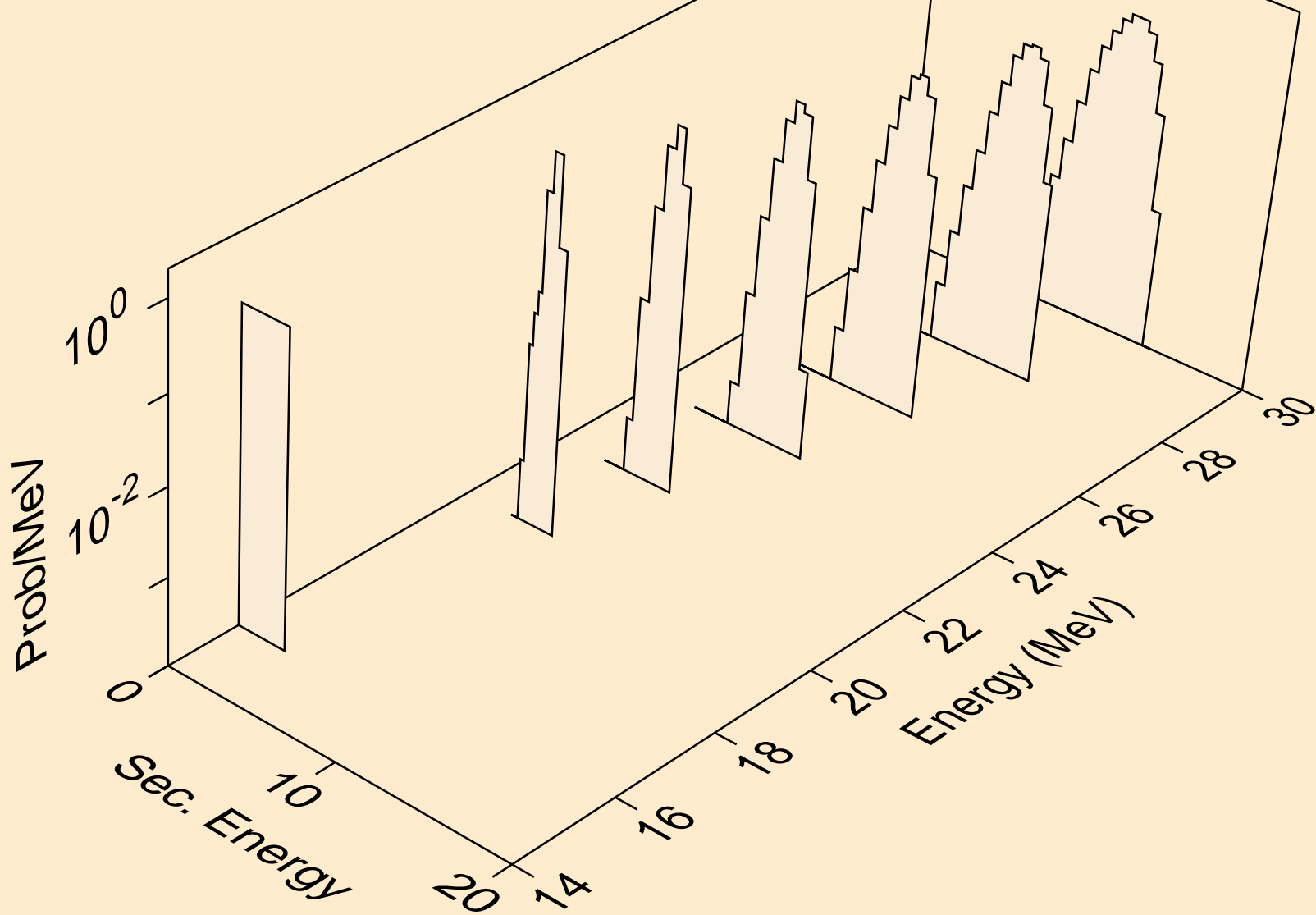

CD121M PROTON ACER TENDL-2023 LIBRARY; T=0.K  
alphas from (p,npa)

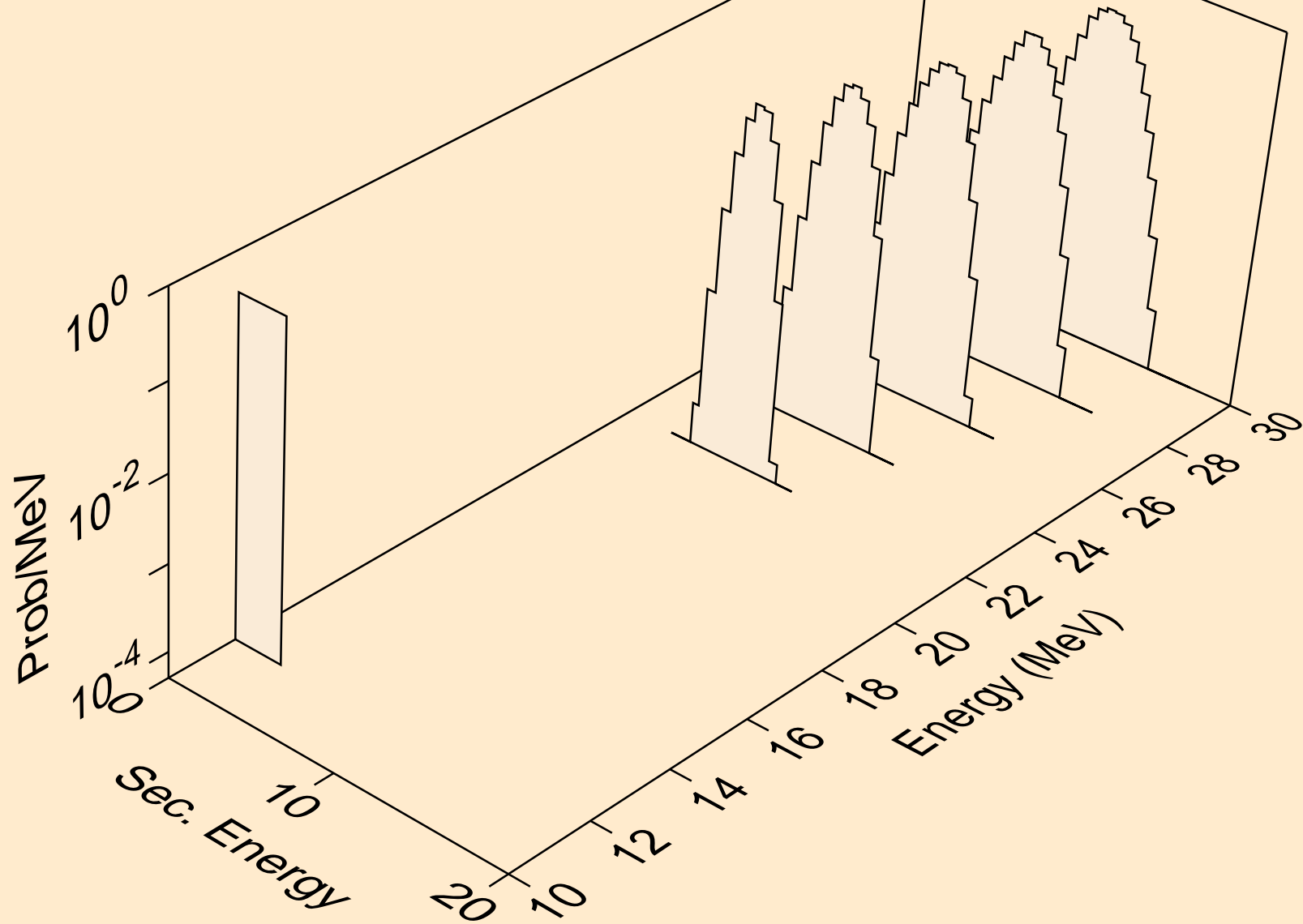



CD121M PROTON ACER TENDL-2023 LIBRARY; T=0.K  
alphas from (p,a)

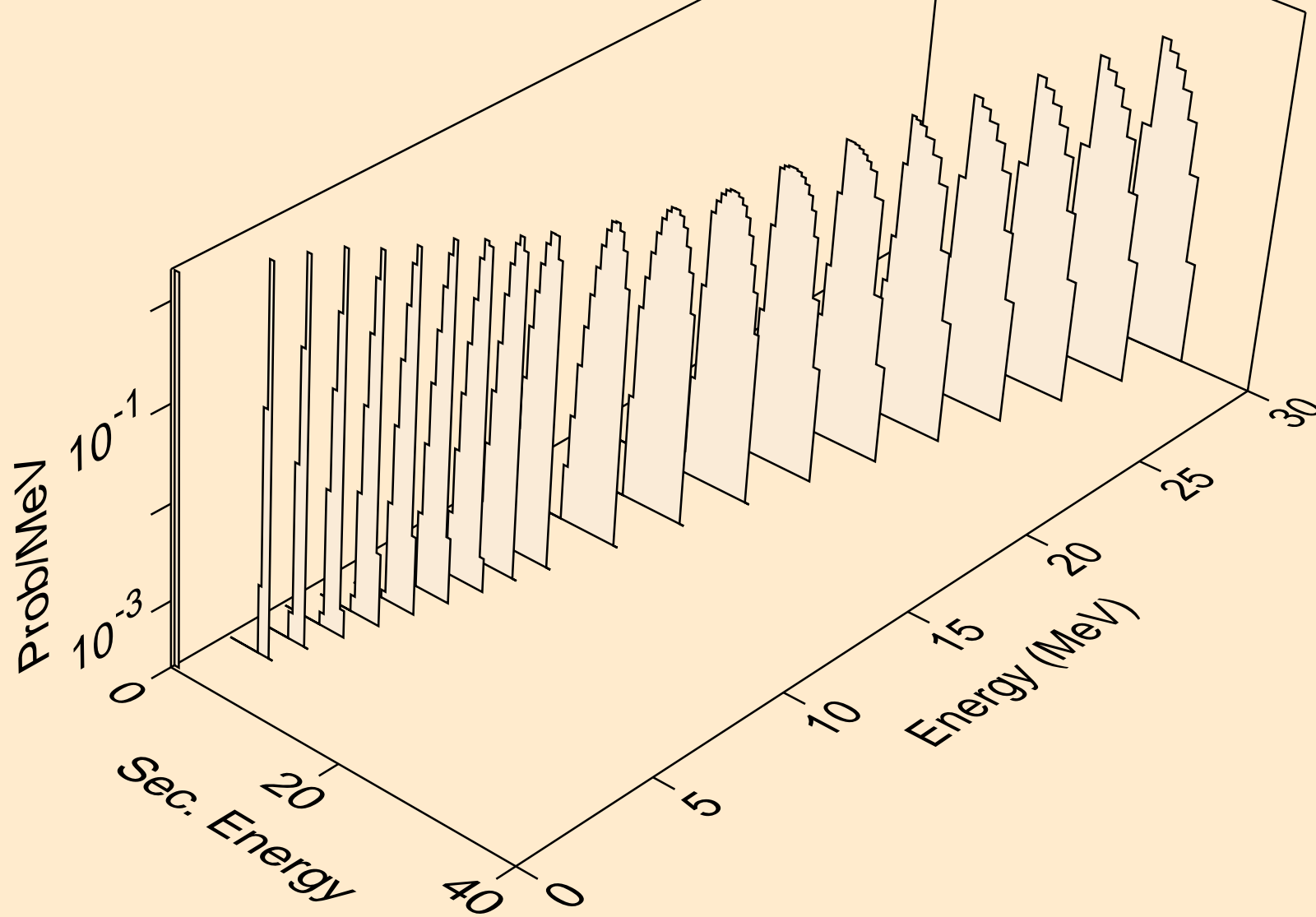

CD121M PROTON ACER TENDL-2023 LIBRARY; T=0.K  
alphas from (p,pa)

