

# CD123M PROTON ACER TENDL-2023 LIBRARY; T=0.K

## Principal cross sections

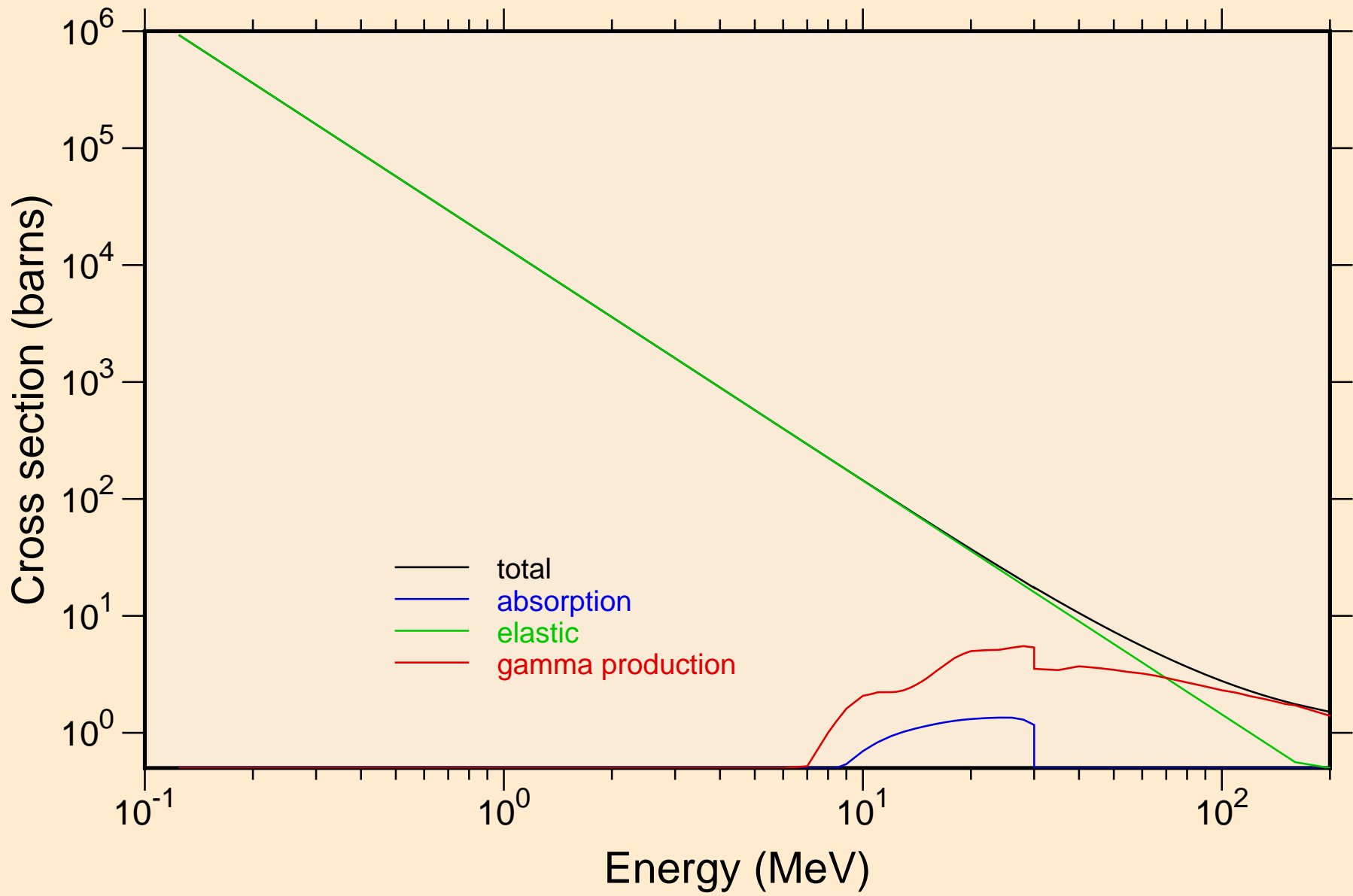

# CD123M PROTON ACER TENDL-2023 LIBRARY; T=0.K

## Heating

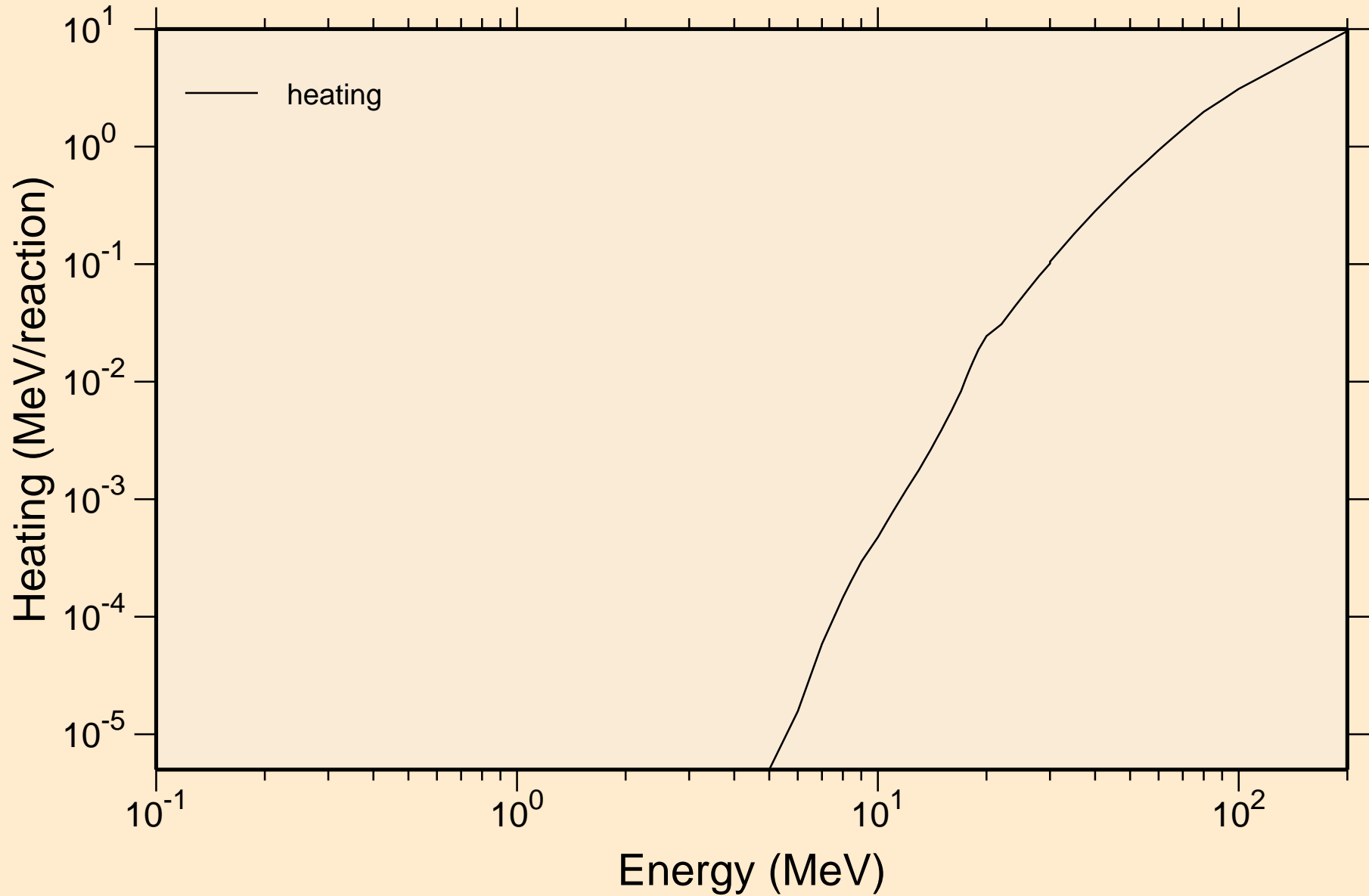

# CD123M PROTON ACER TENDL-2023 LIBRARY; T=0.K

## Principal cross sections

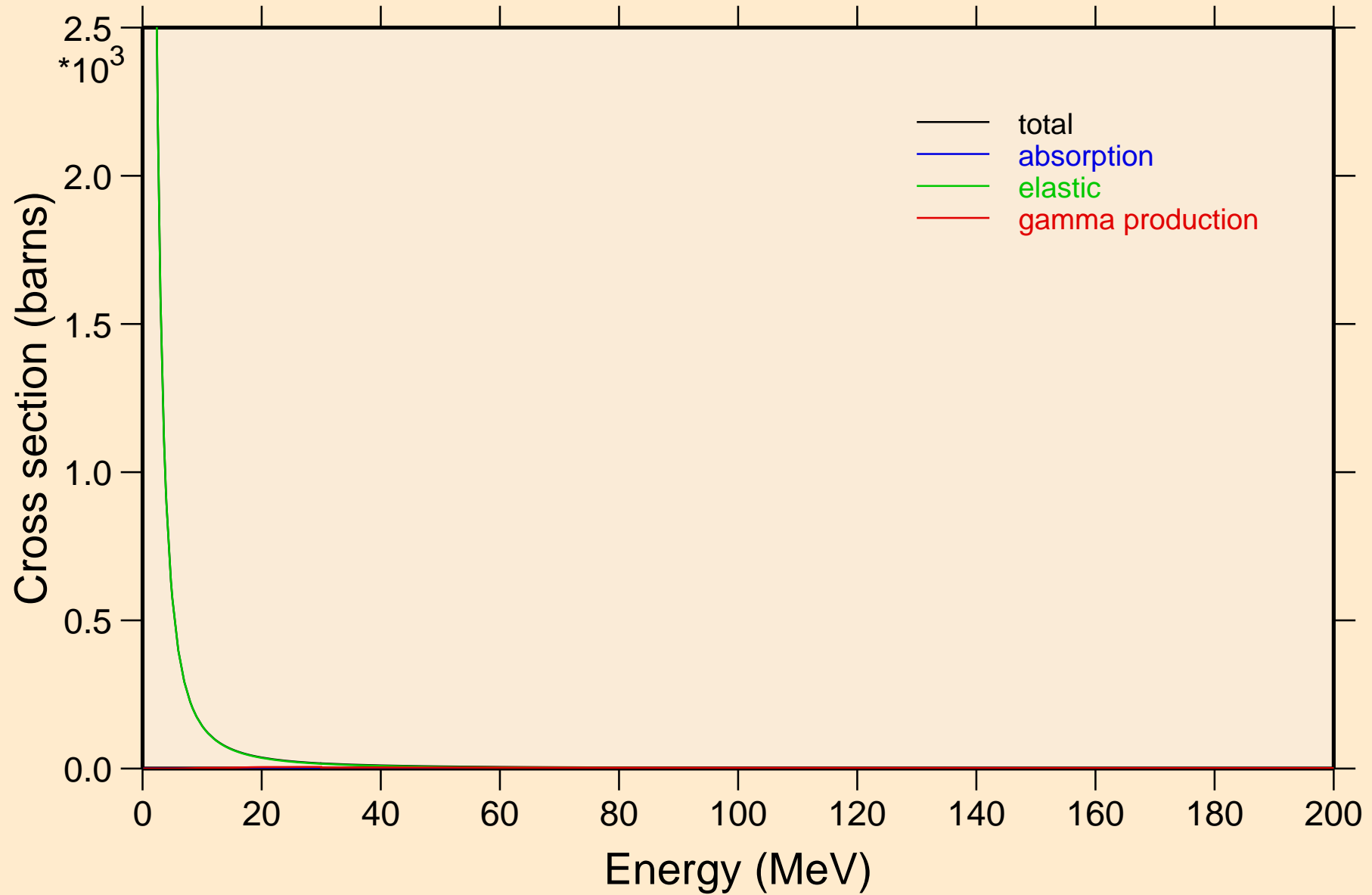

# CD123M PROTON ACER TENDL-2023 LIBRARY; T=0.K

## Heating

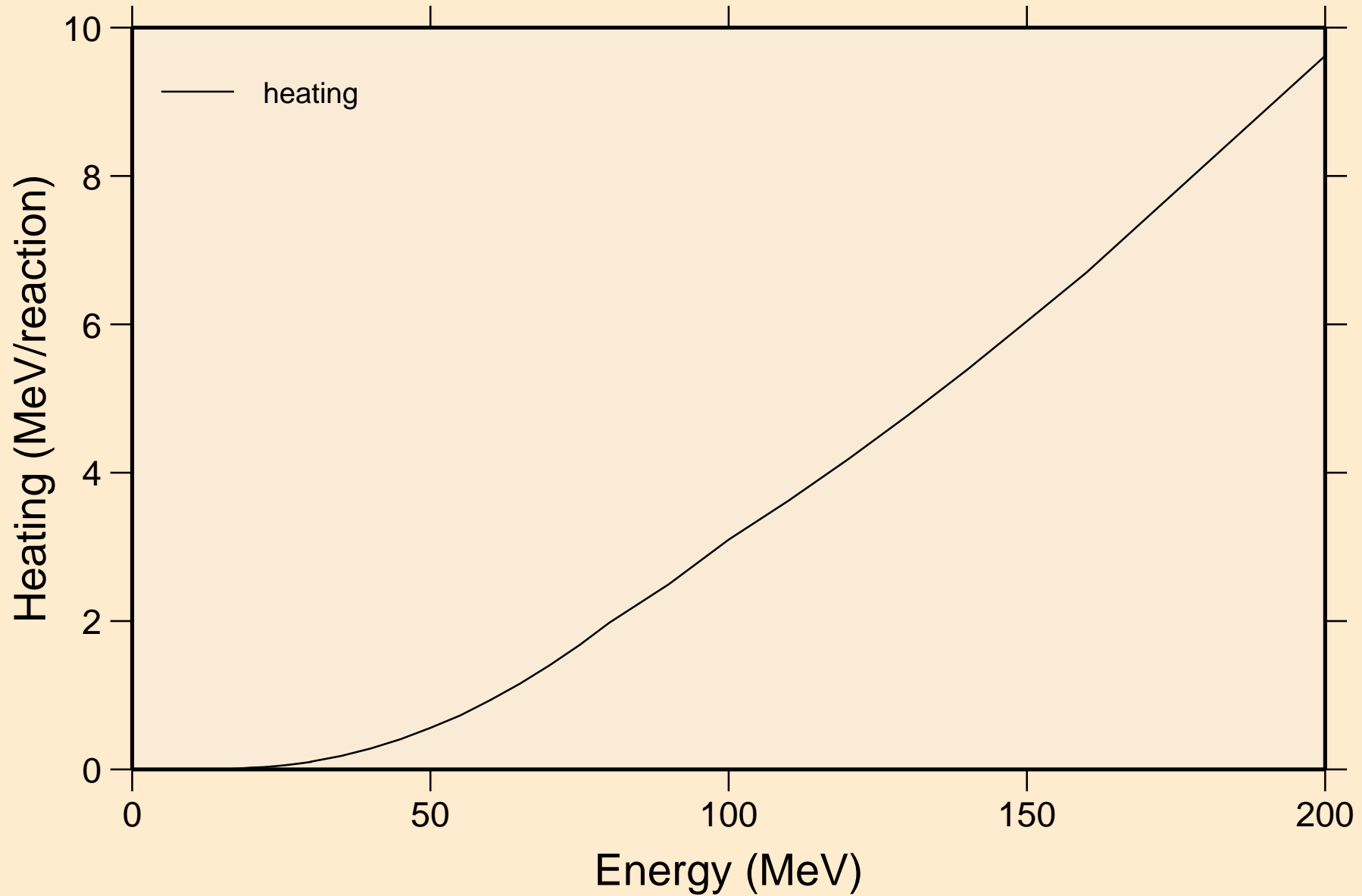

# CD123M PROTON ACER TENDL-2023 LIBRARY; T=0.K

## Threshold reactions

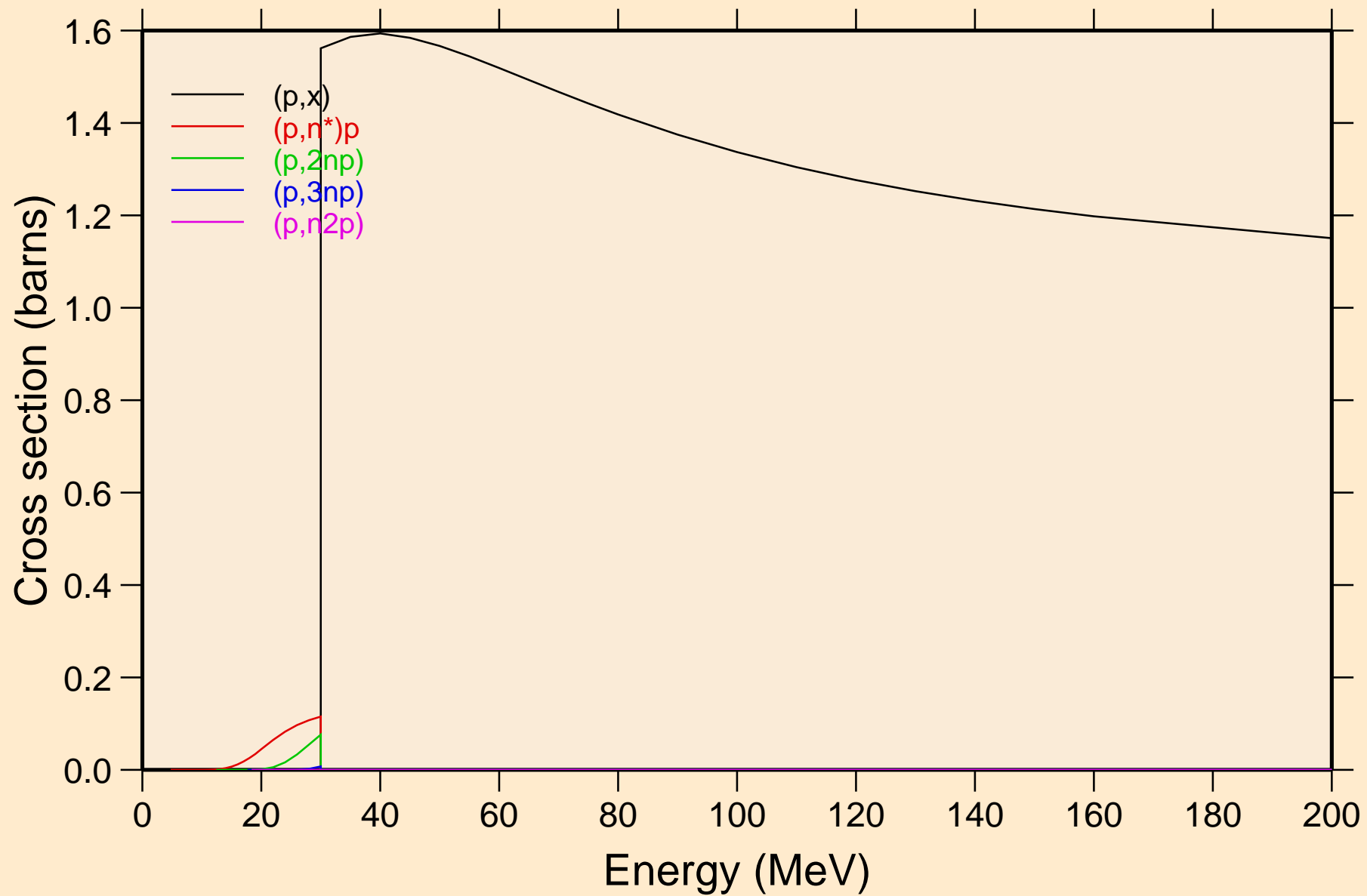

# CD123M PROTON ACER TENDL-2023 LIBRARY; T=0.K

## Threshold reactions

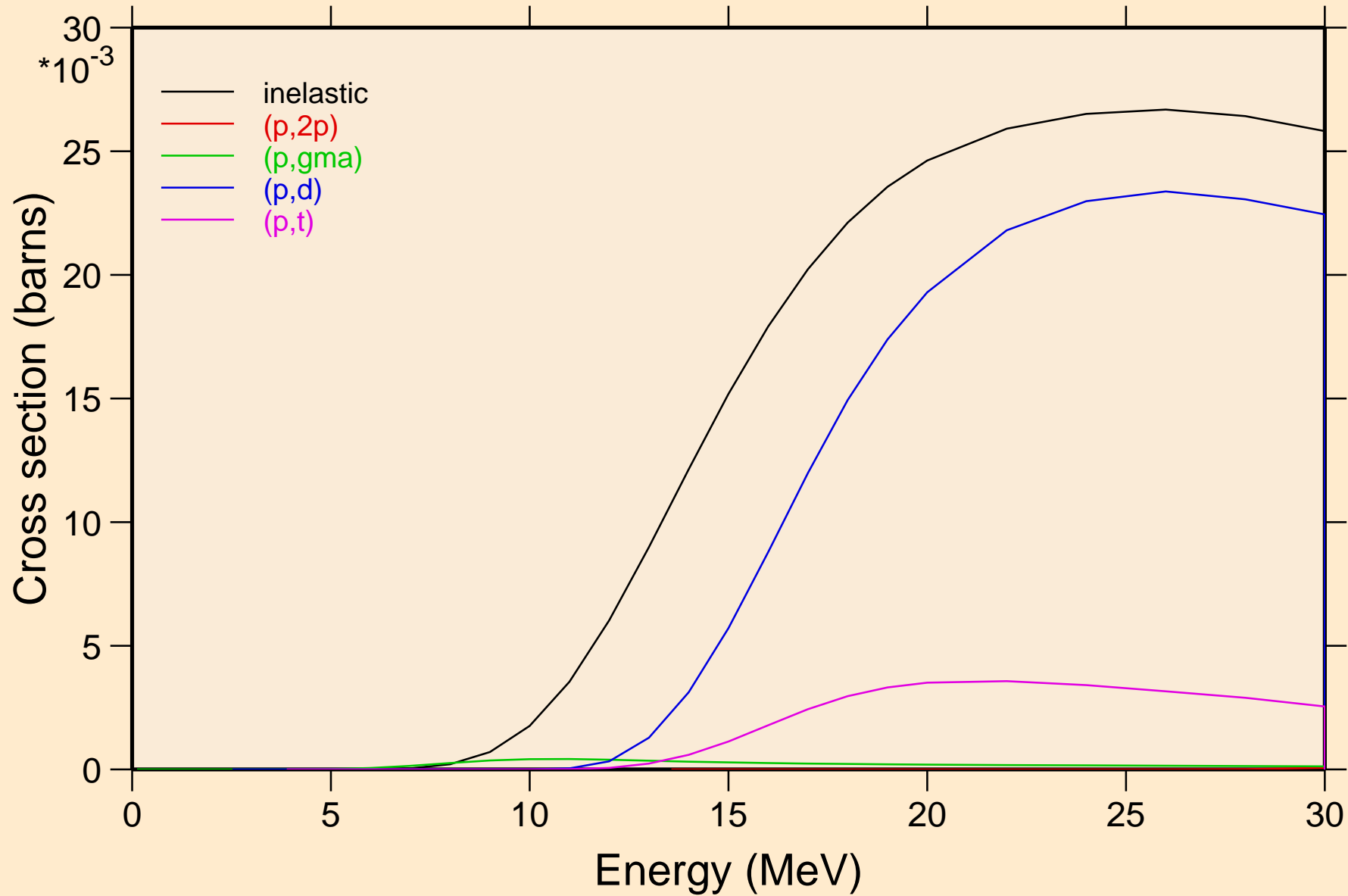

# CD123M PROTON ACER TENDL-2023 LIBRARY; T=0.K

## Threshold reactions

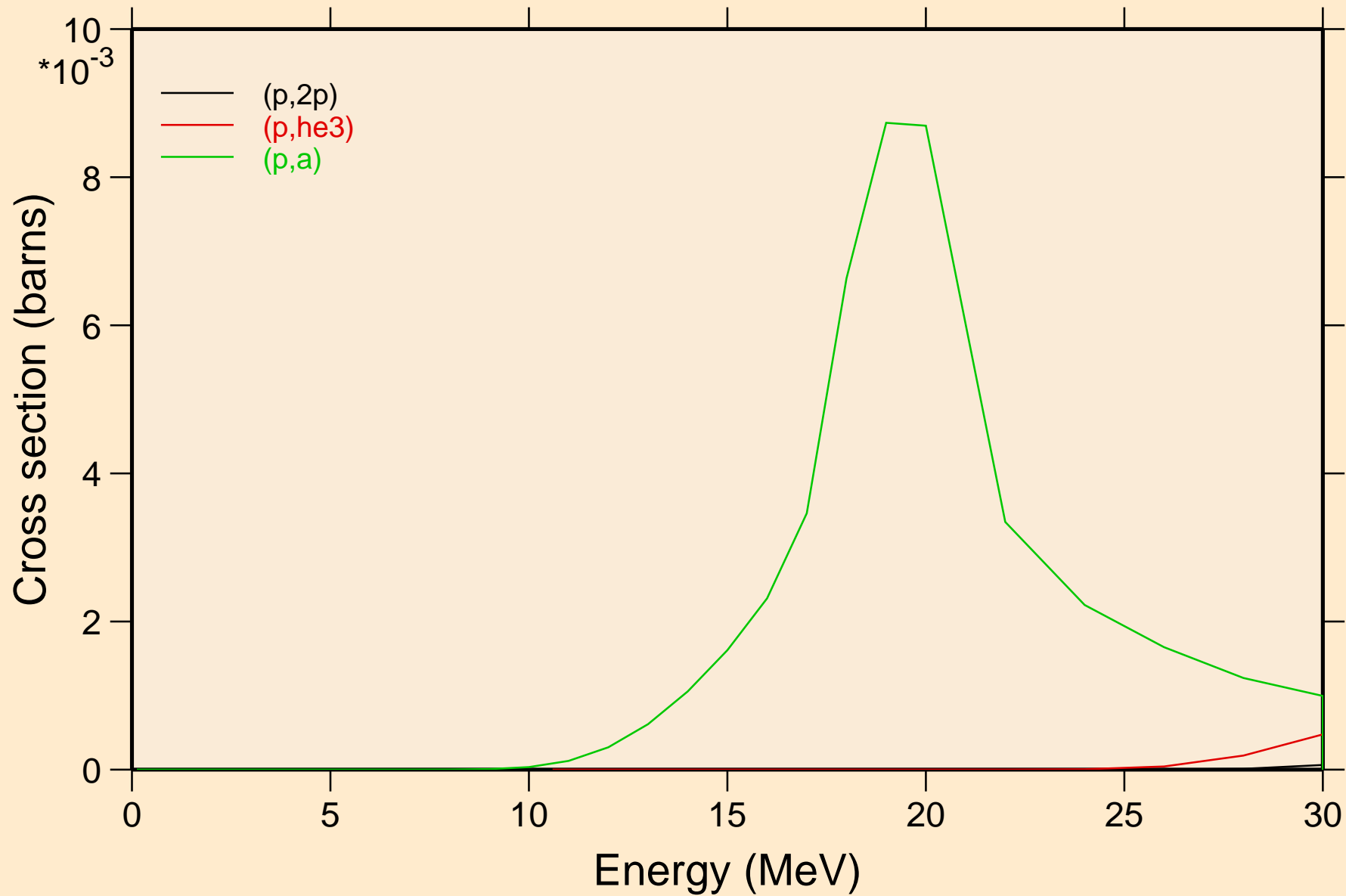

CD123M PROTON ACER TENDL-2023 LIBRARY; T=0.K  
Threshold reactions

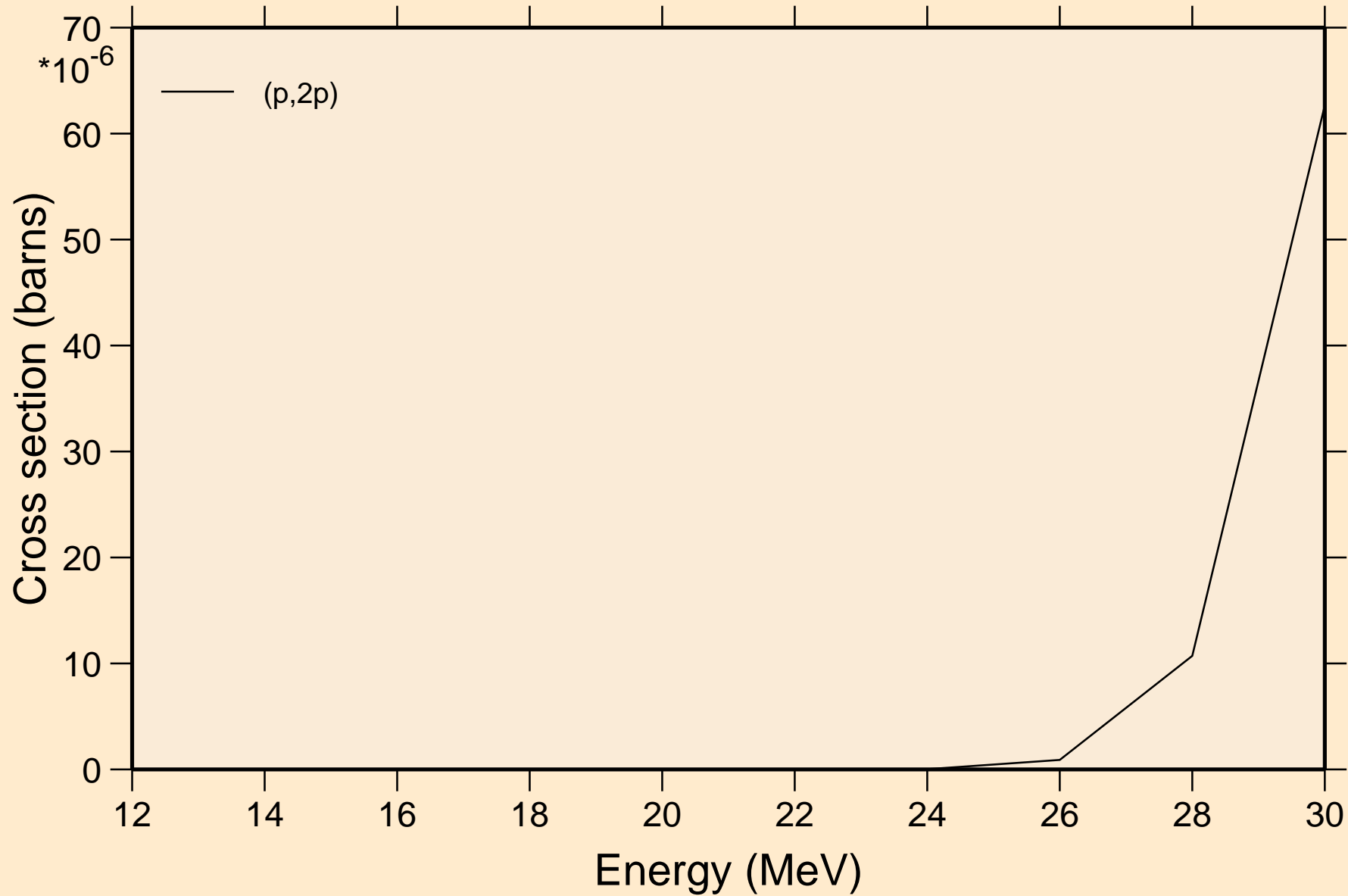



CD123M PROTON ACER TENDL-2023 LIBRARY; T=0.K  
angular distribution for elastic

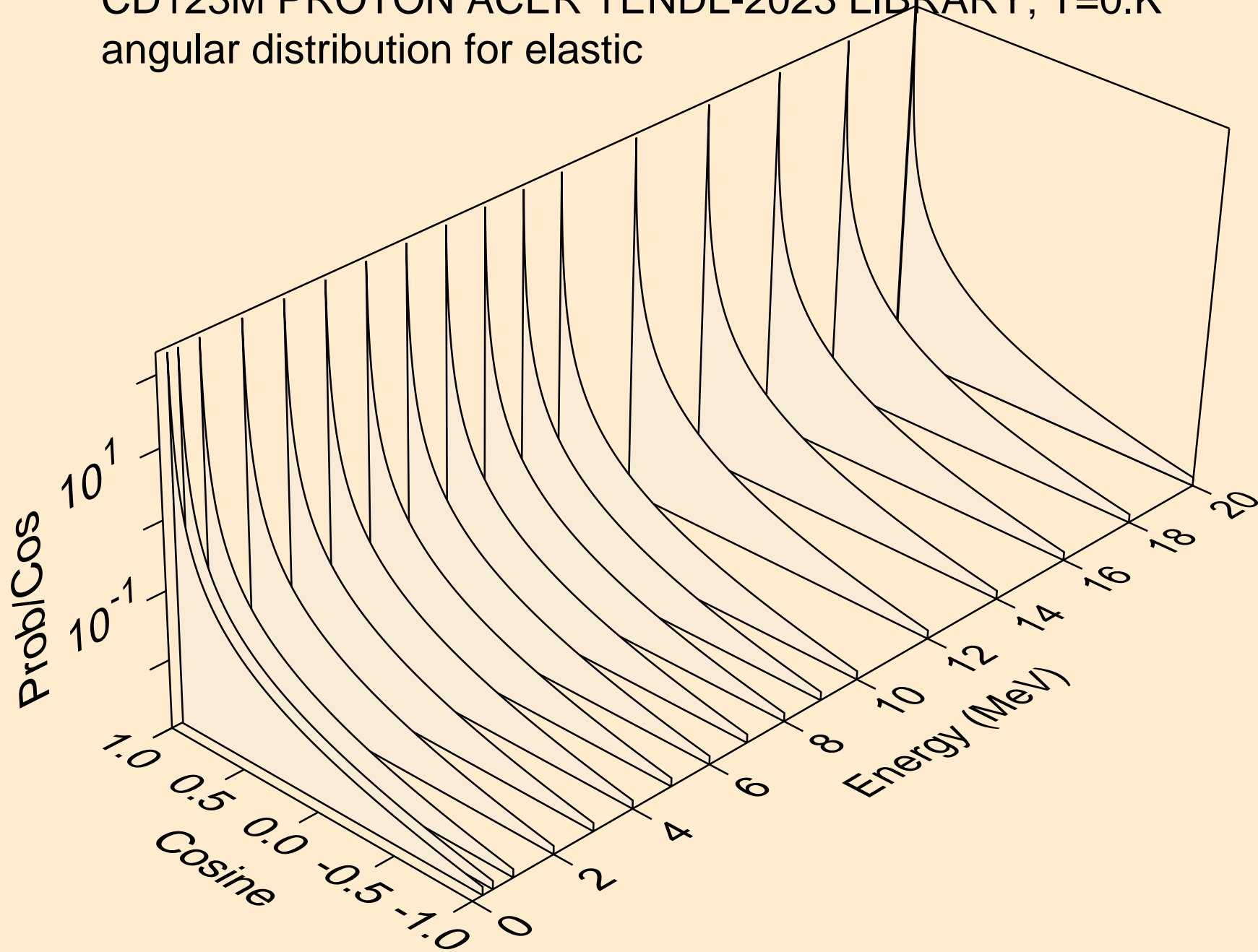

CD123M PROTON ACER TENDL-2023 LIBRARY; T=0.K  
angular distribution for elastic

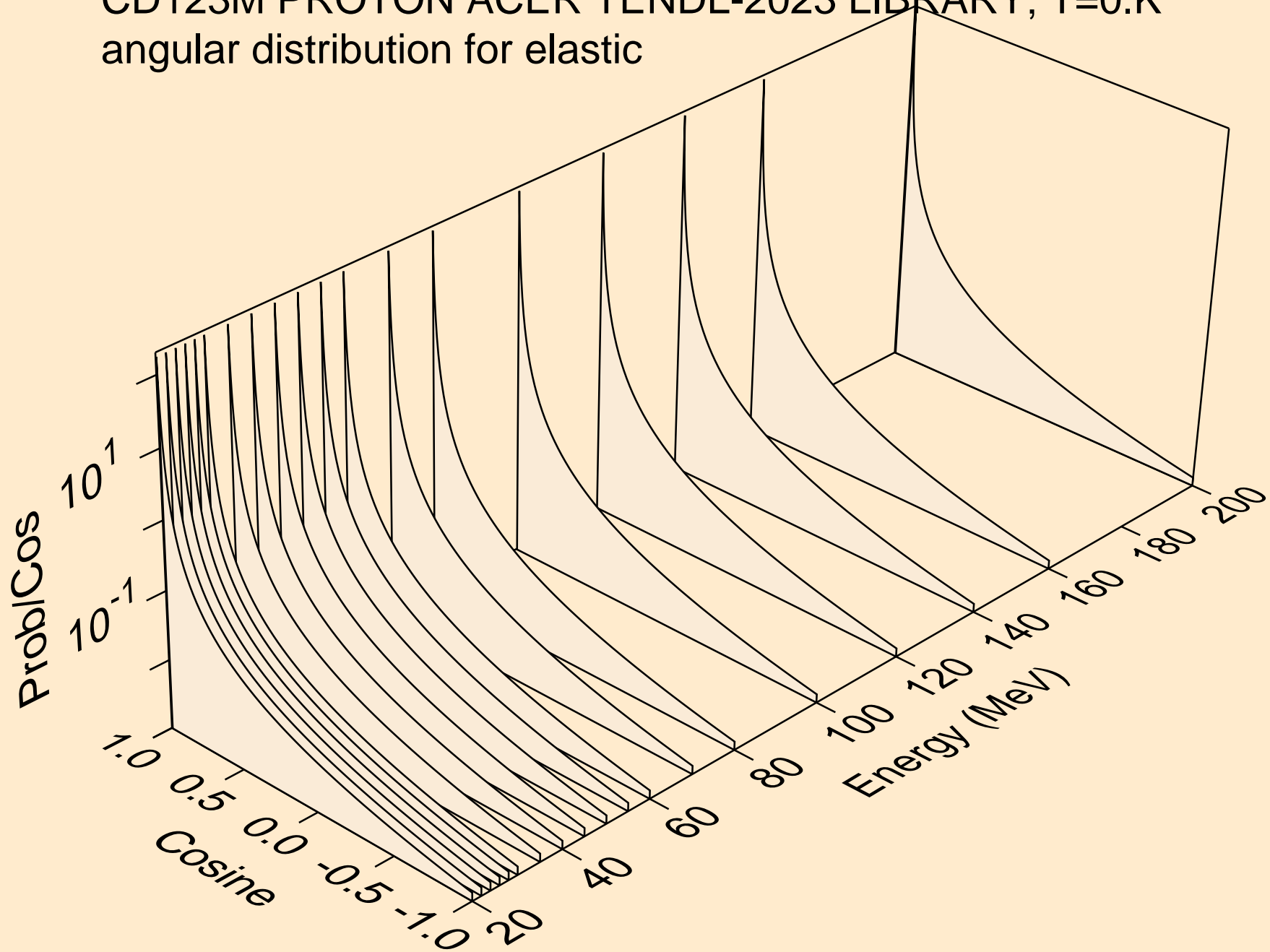

CD123M PROTON ACER TENDL-2023 LIBRARY; T=0.K  
Proton emission for (p,x)

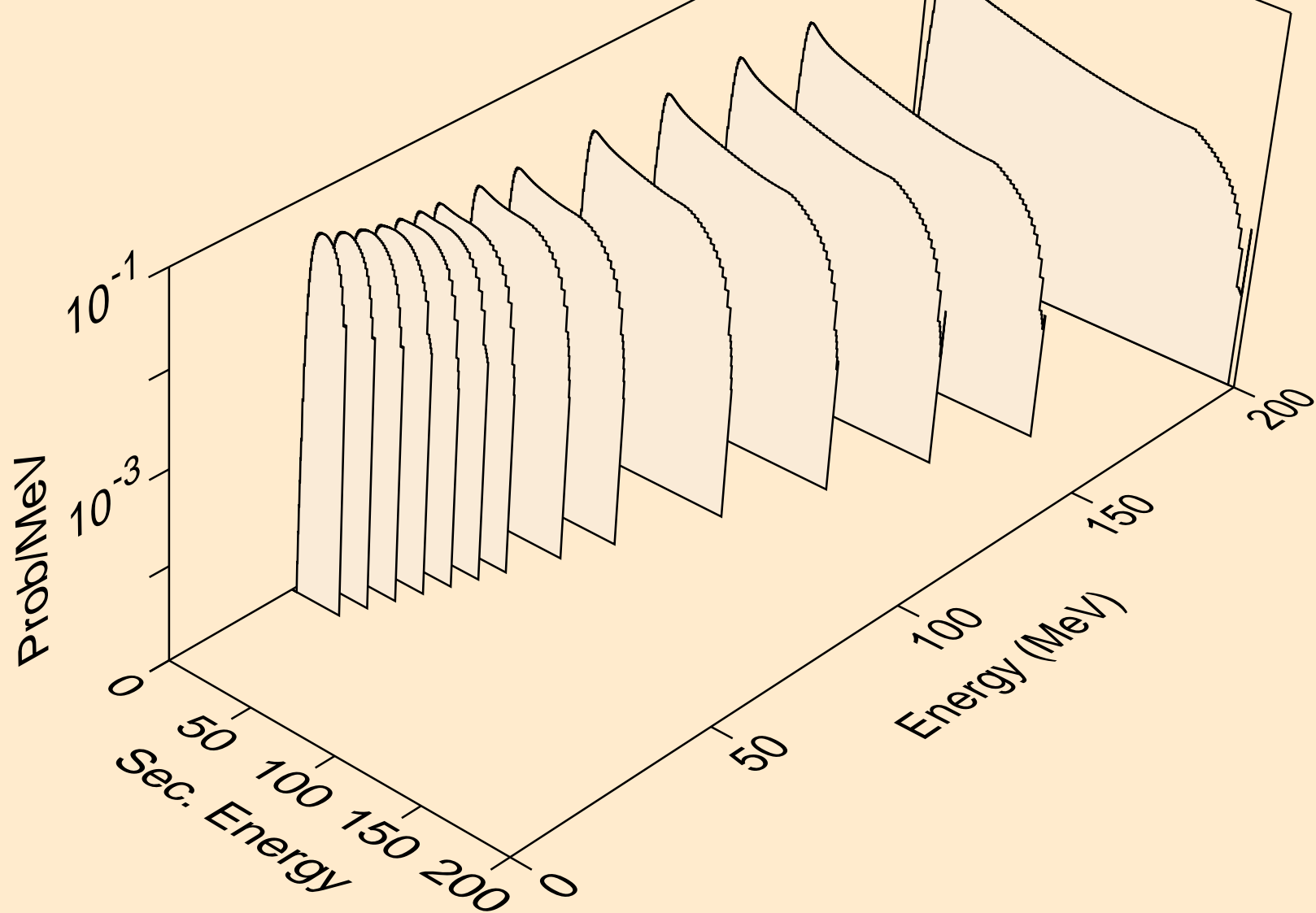

CD123M PROTON ACER TENDL-2023 LIBRARY; T=0.K  
Proton emission for (p,n\*)p

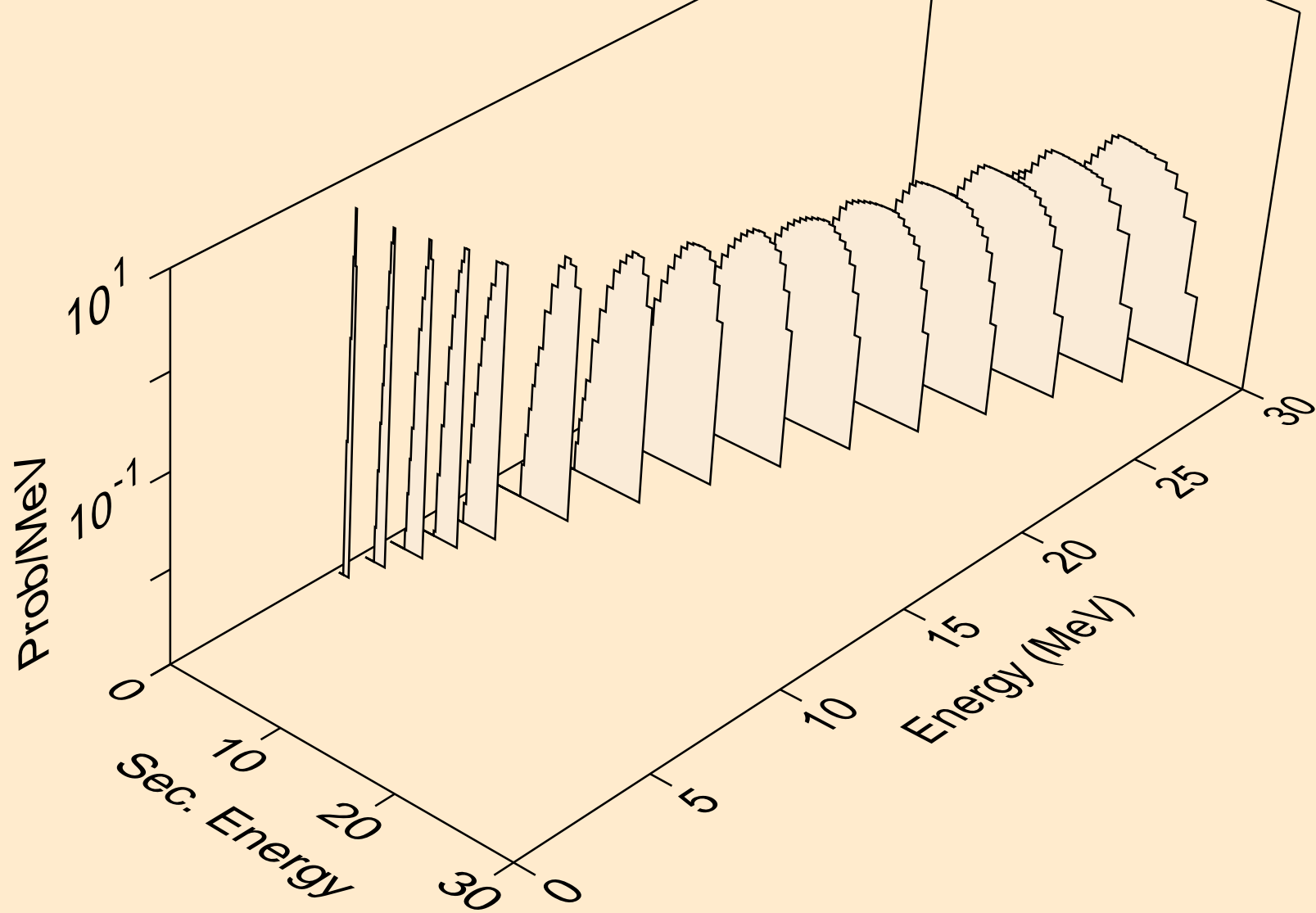

CD123M PROTON ACER TENDL-2023 LIBRARY; T=0.K  
Proton emission for (p,2np)

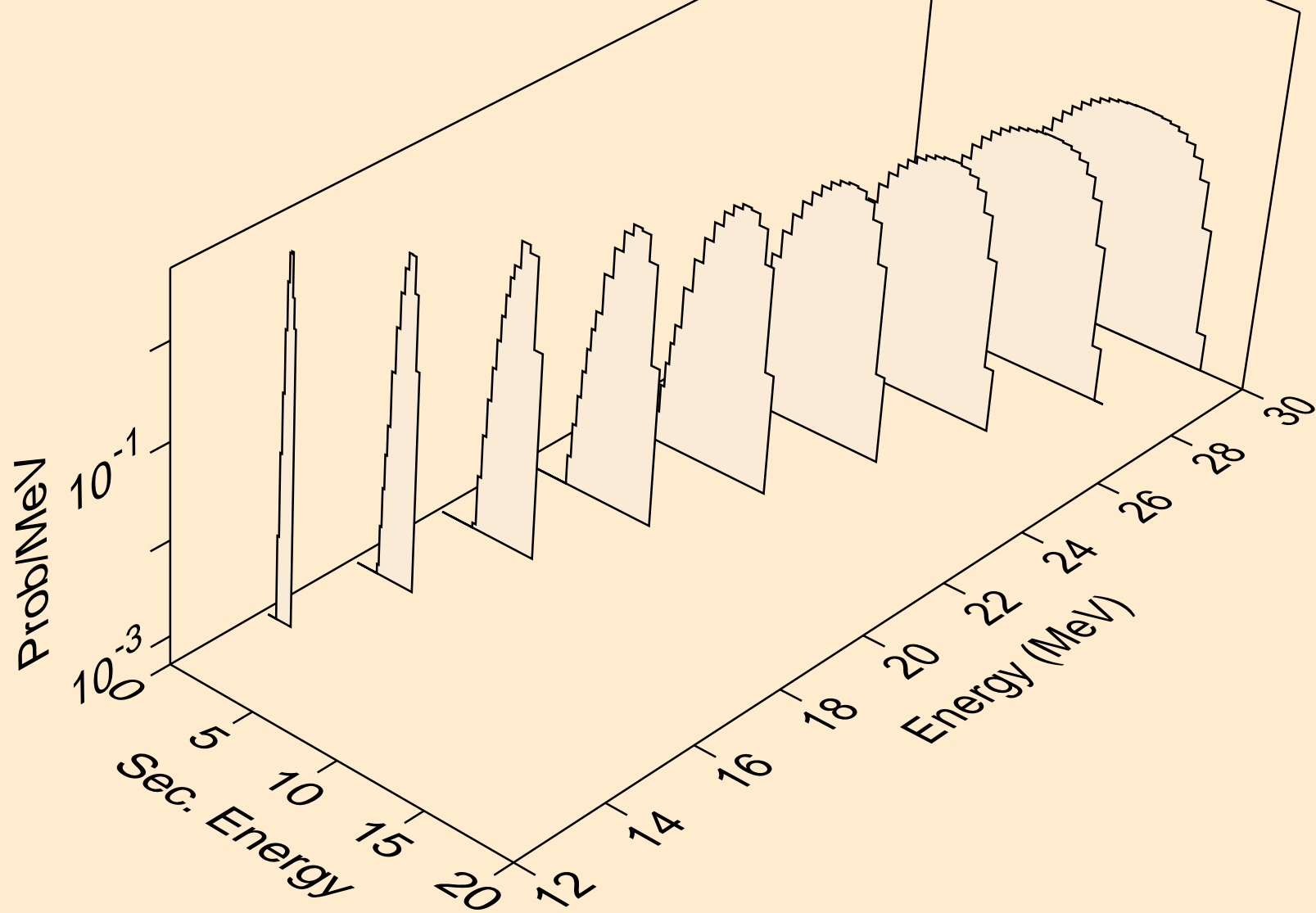

CD123M PROTON ACER TENDL-2023 LIBRARY; T=0.K  
Proton emission for (p,3np)

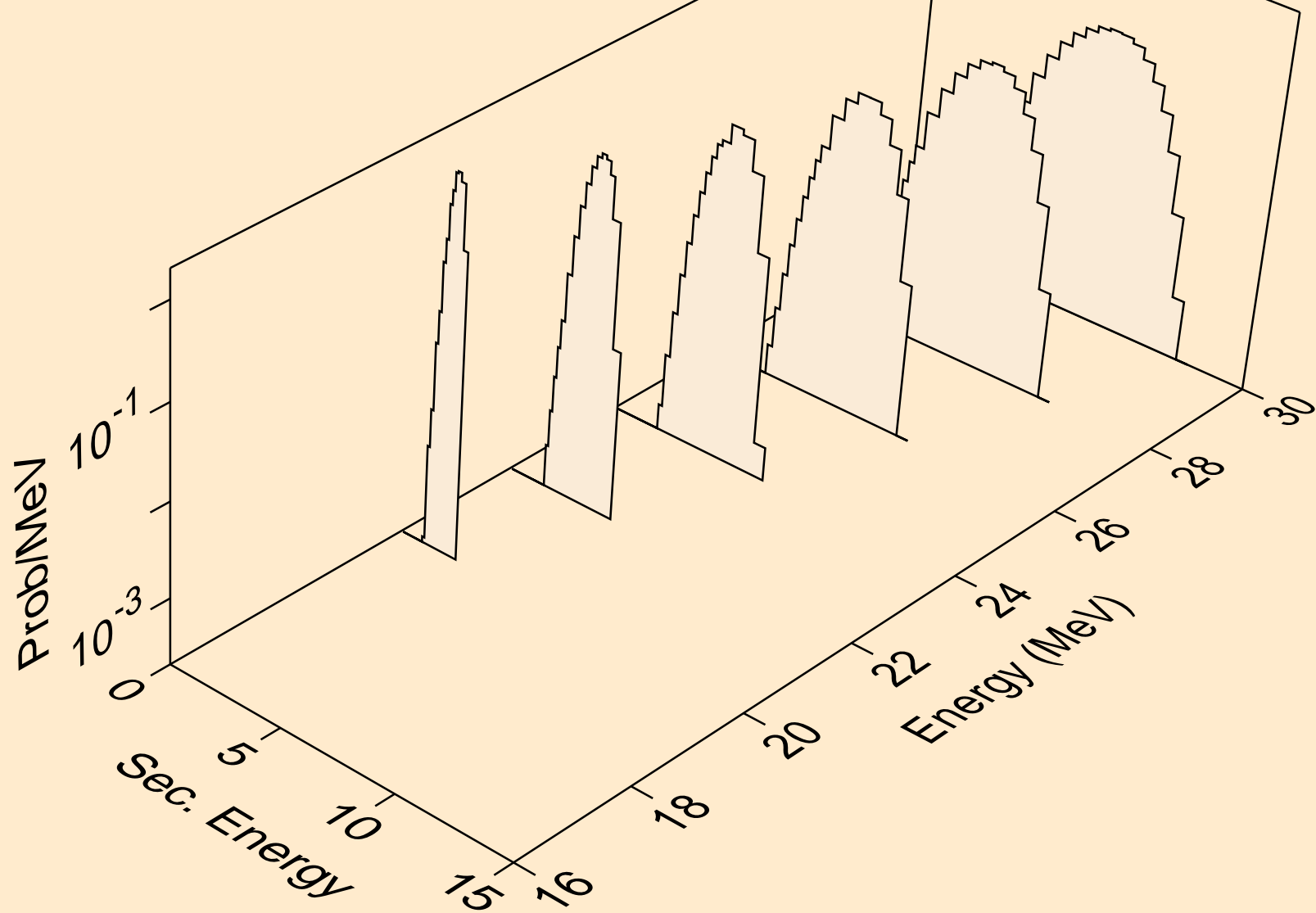

CD123M PROTON ACER TENDL-2023 LIBRARY; T=0.K  
Proton emission for (p,n2p)

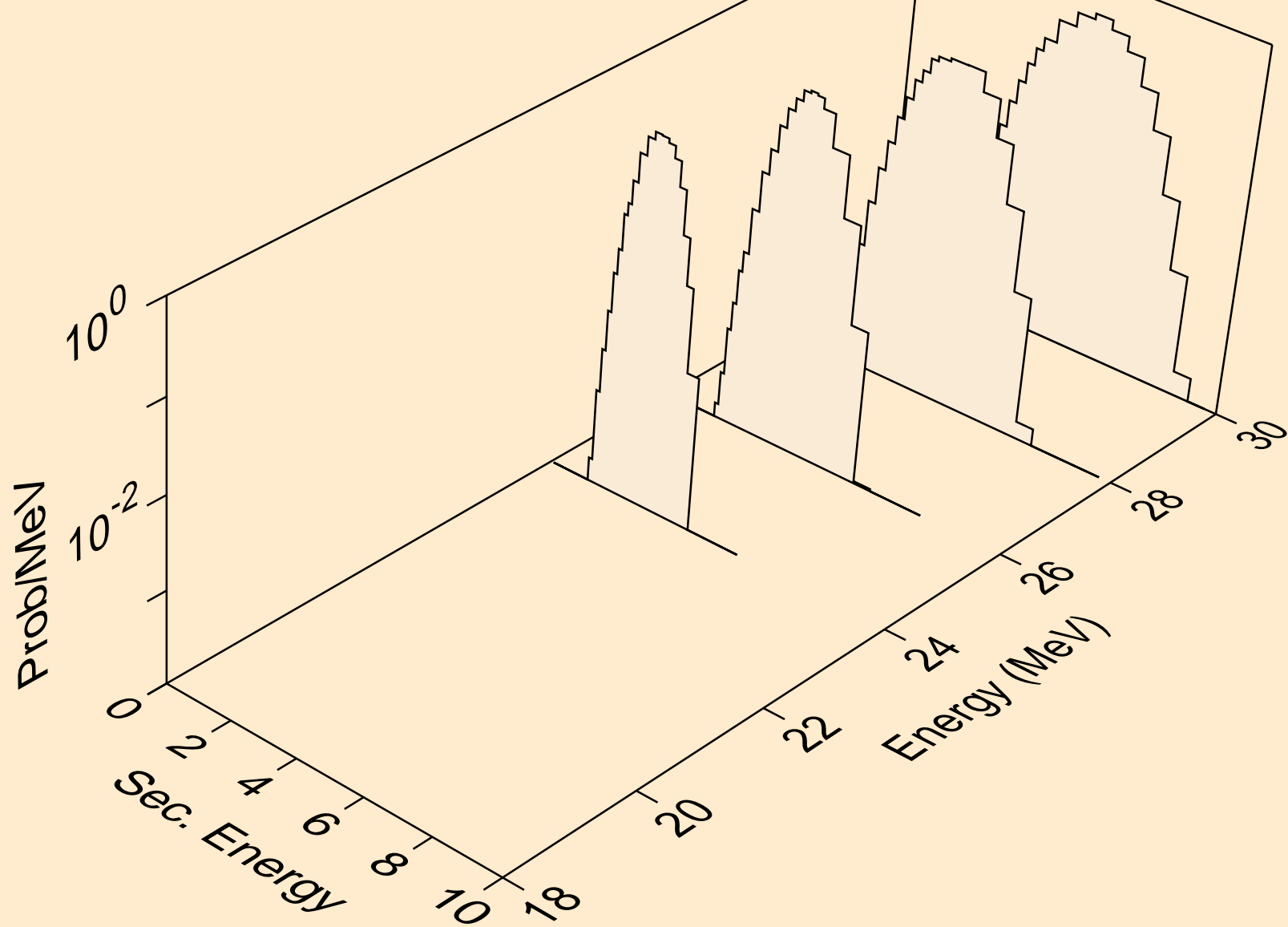

CD123M PROTON ACER TENDL-2023 LIBRARY; T=0.K  
Proton emission for inelastic

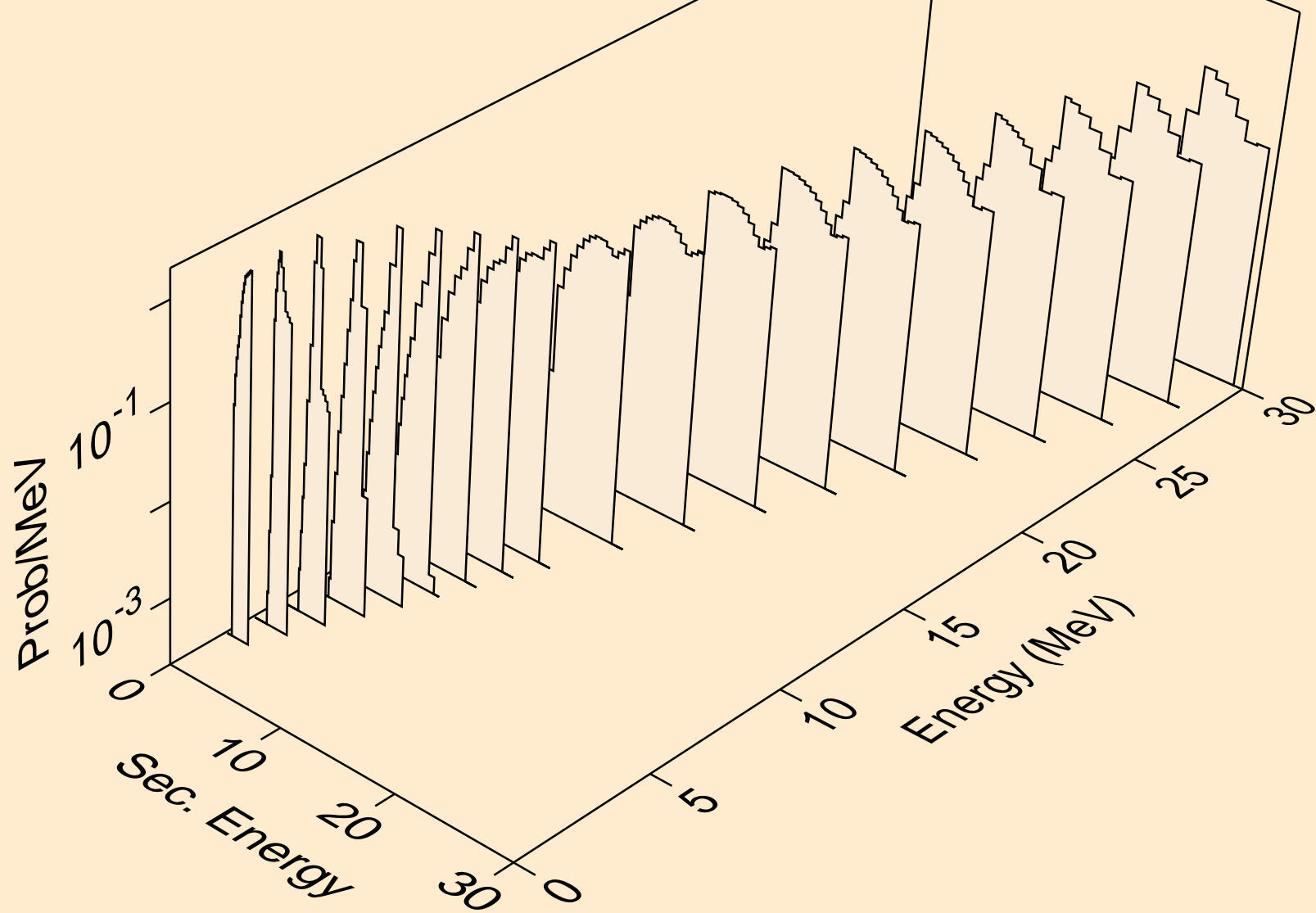



CD123M PROTON ACER TENDL-2023 LIBRARY; T=0.K  
Proton emission for (p,2p)

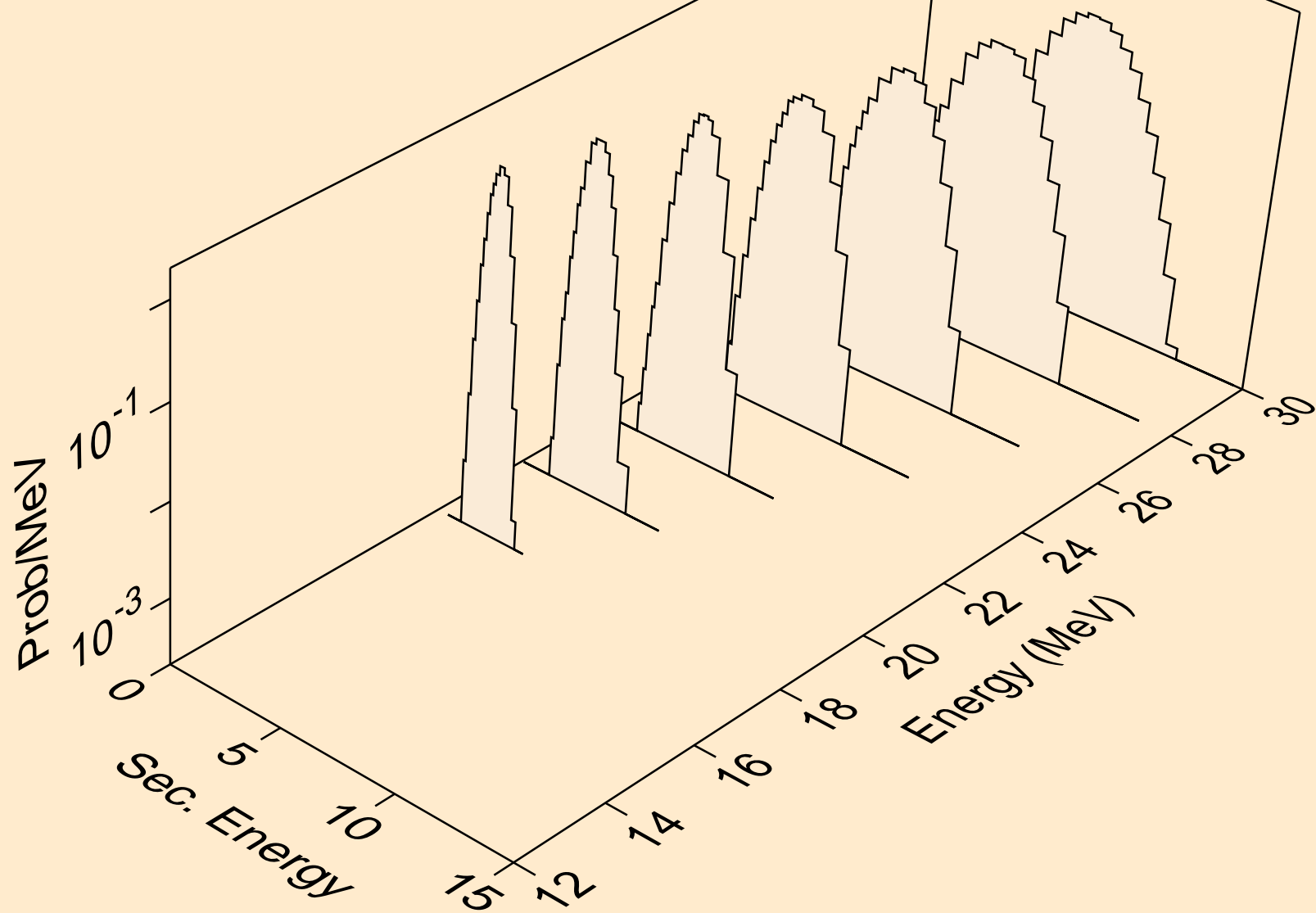

CD123M PROTON ACER TENDL-2023 LIBRARY; T=0.K  
Photon emission for (z,n)

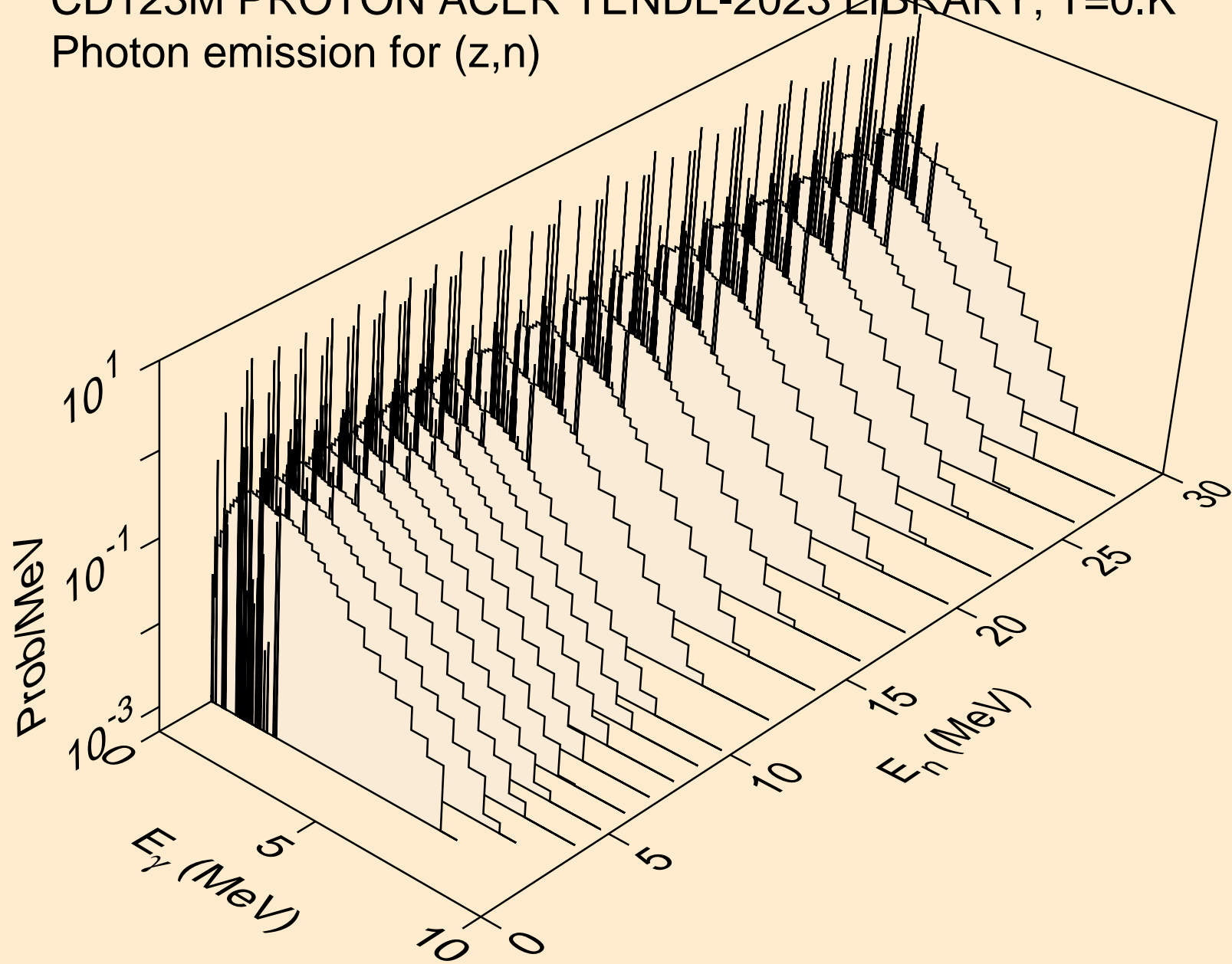

CD123M PROTON ACER TENDL-2023 LIBRARY; T=0.K  
Photon emission for (z,x)

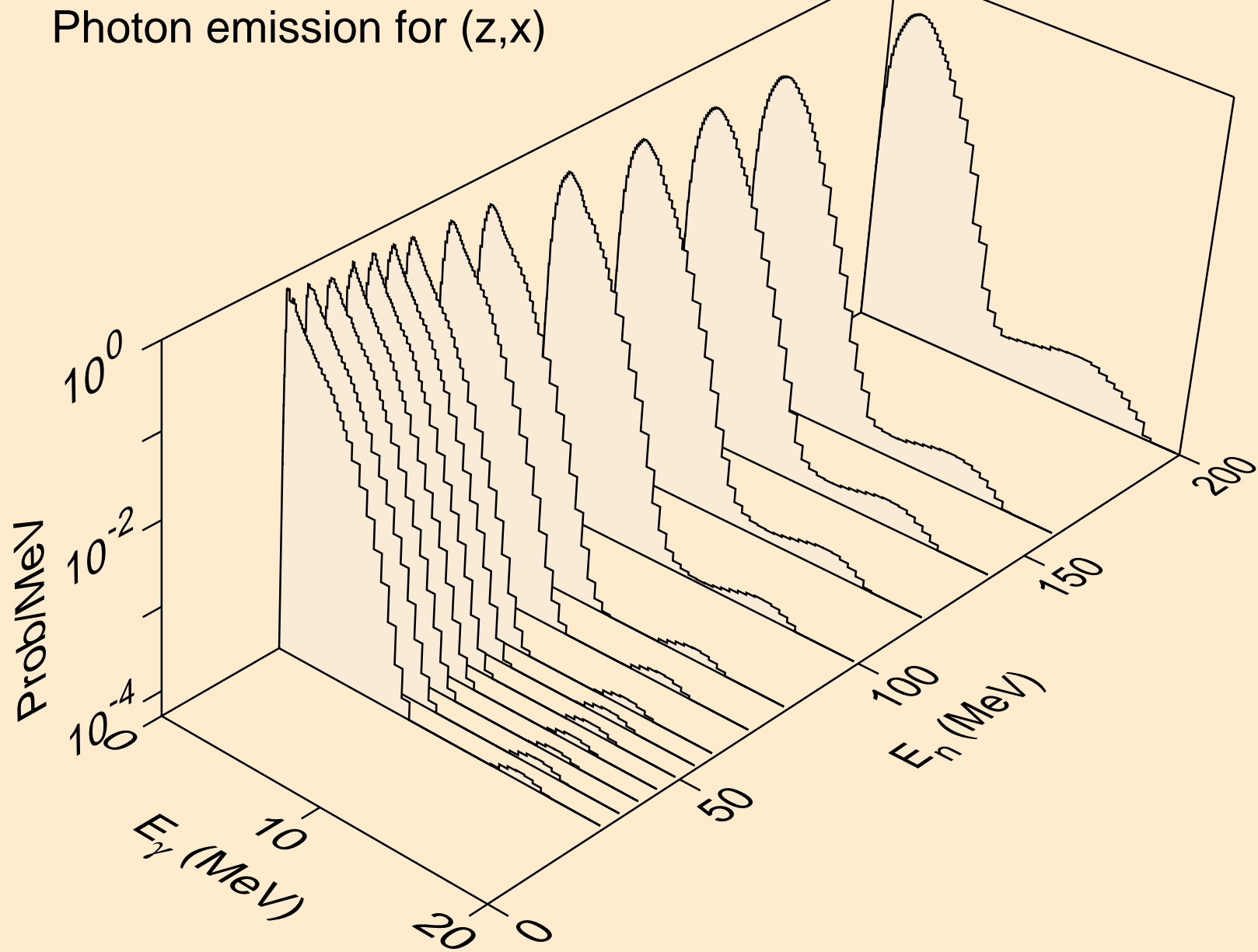

CD123M PROTON ACER TENDL-2023 LIBRARY; T=0.K  
Photon emission for (n,2nd)

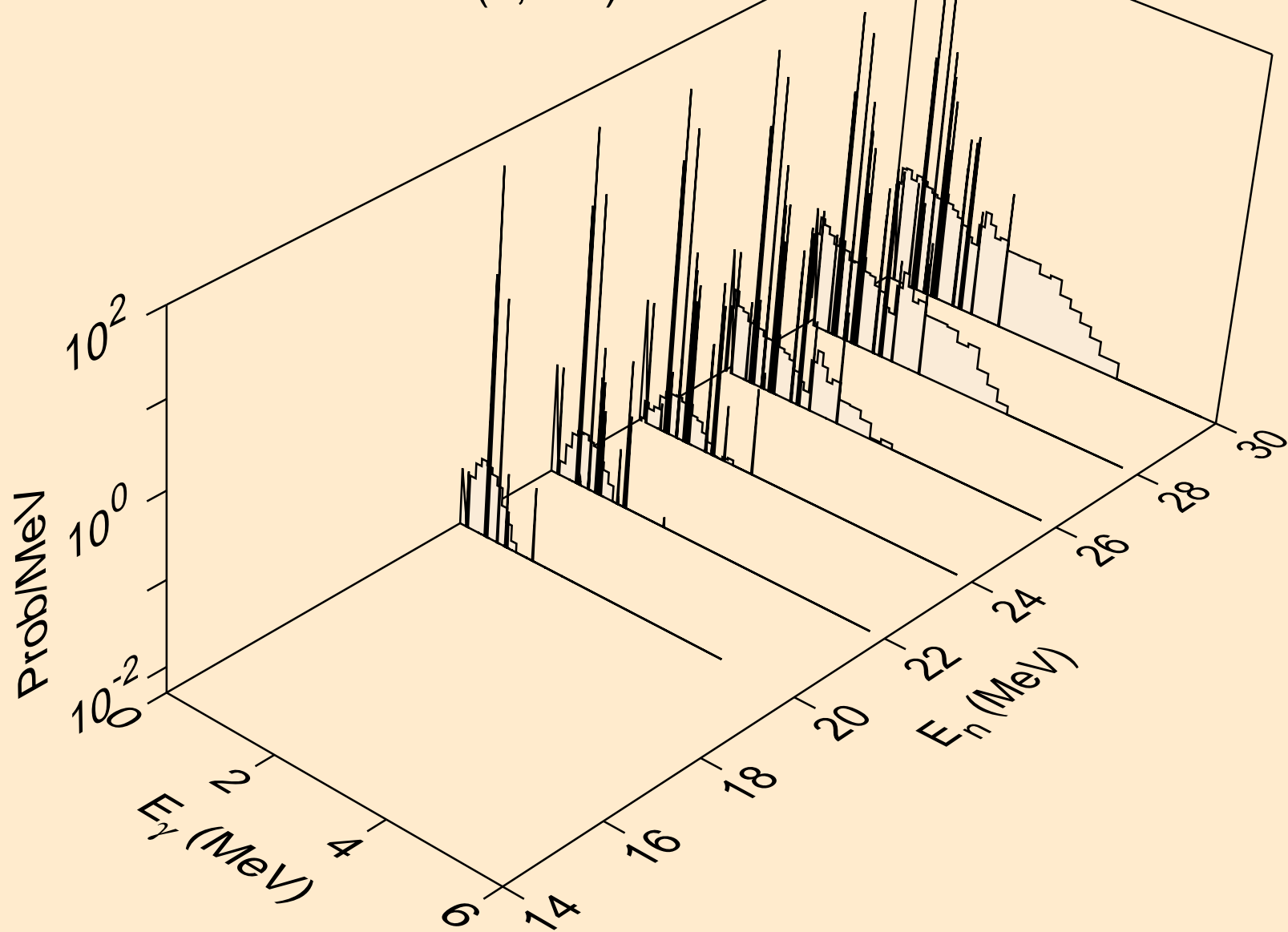

CD123M PROTON ACER TENDL-2023 LIBRARY; T=0.K  
Photon emission for (n,2n)

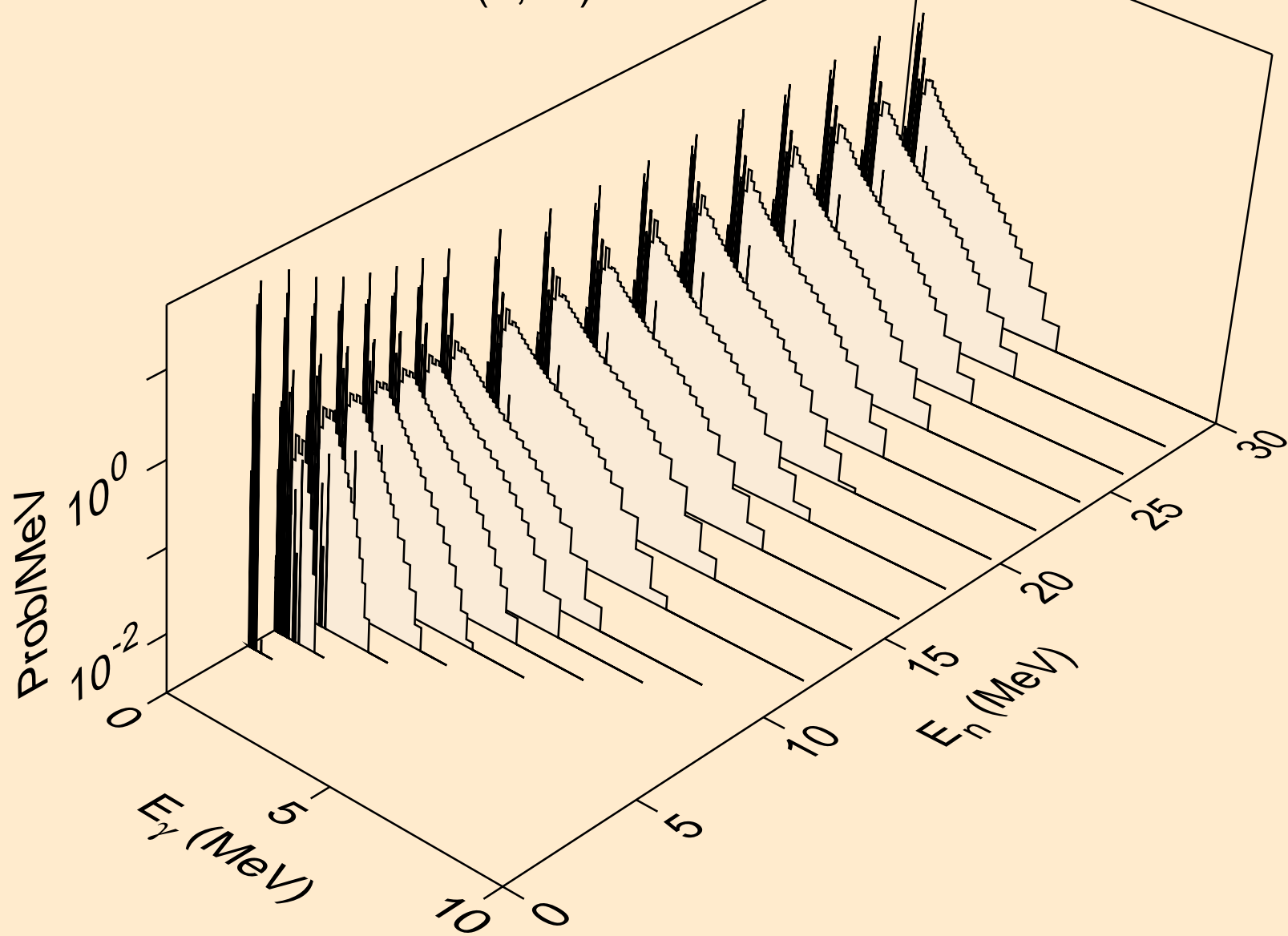

CD123M PROTON ACER TENDL-2023 LIBRARY; T=0.K  
Photon emission for (n,3n)

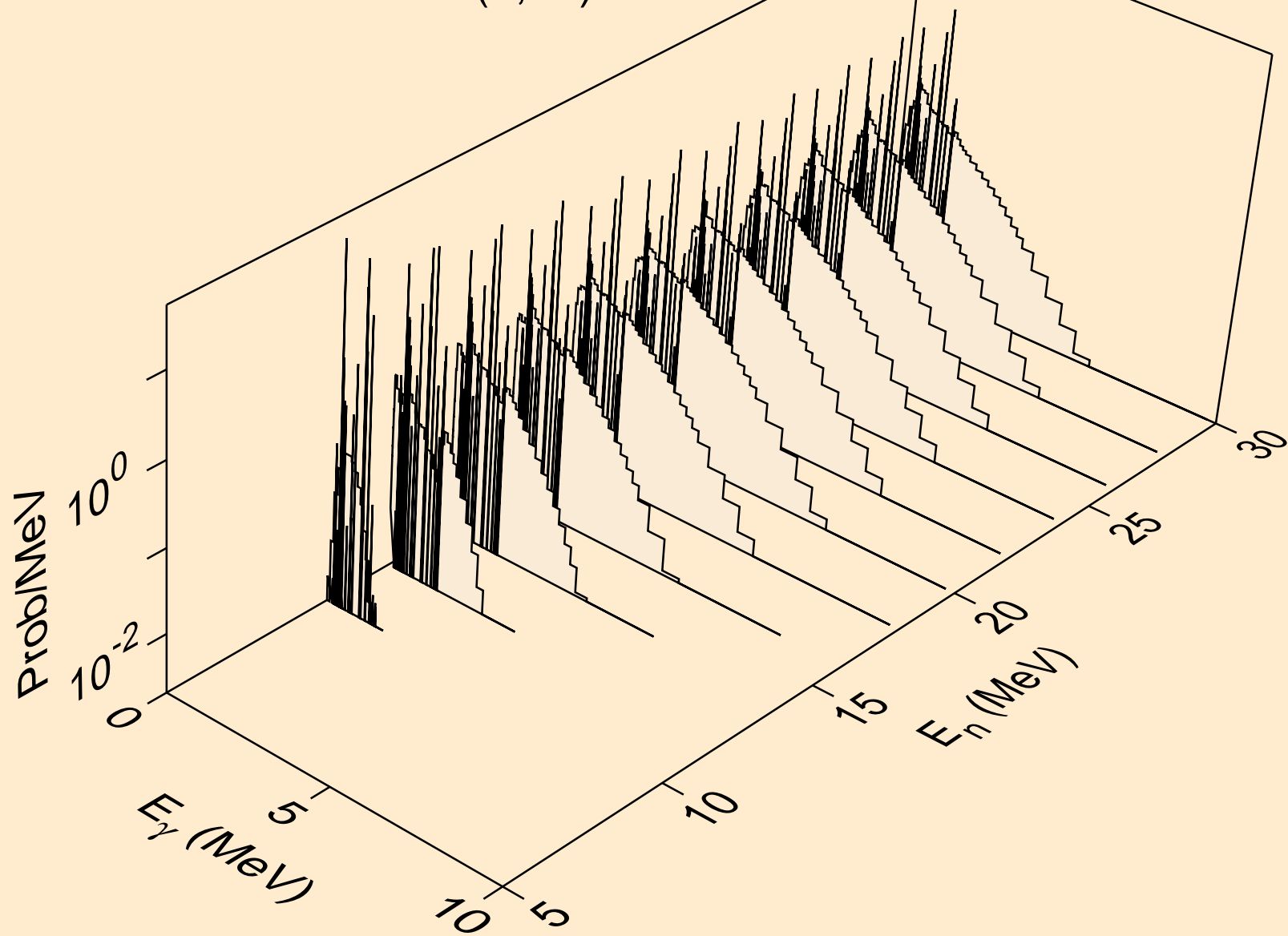

CD123M PROTON ACER TENDL-2023 LIBRARY; T=0.K  
Photon emission for (n,n\*)a

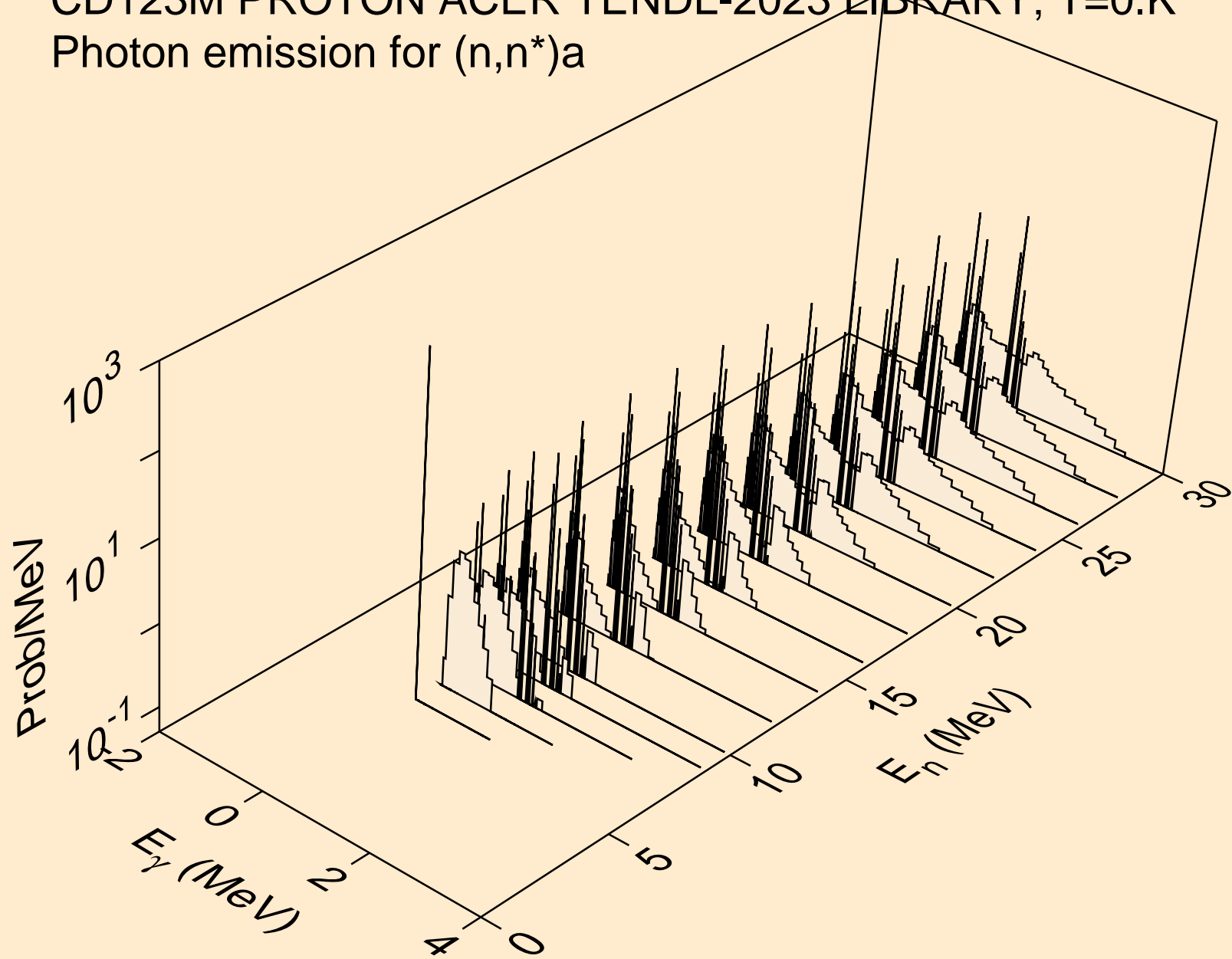

CD123M PROTON ACER TENDL-2023 LIBRARY; T=0.K  
Photon emission for (n,2n)a

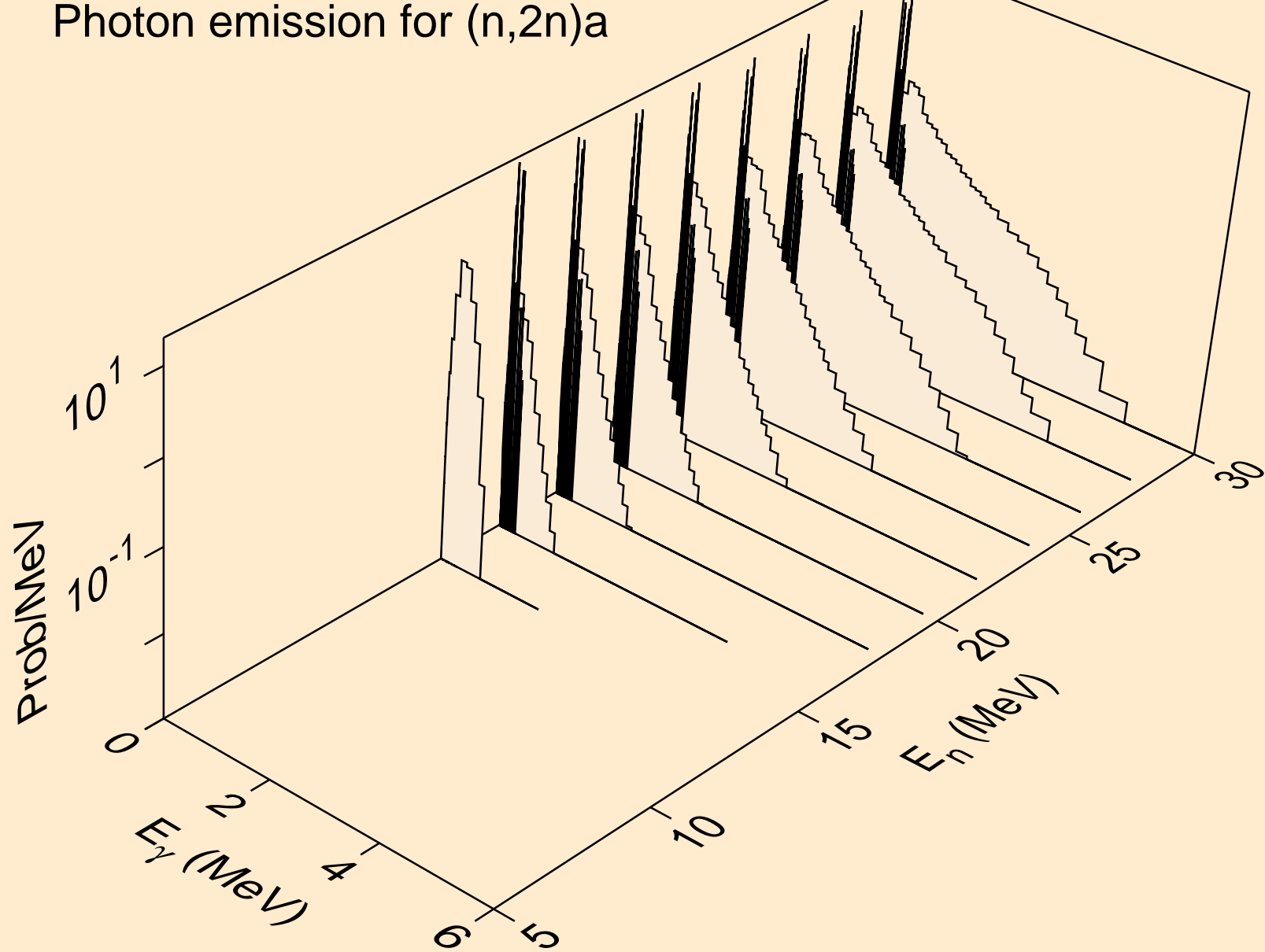



CD123M PROTON ACER TENDL-2023 LIBRARY; T=0.K  
Photon emission for (n,3n)a

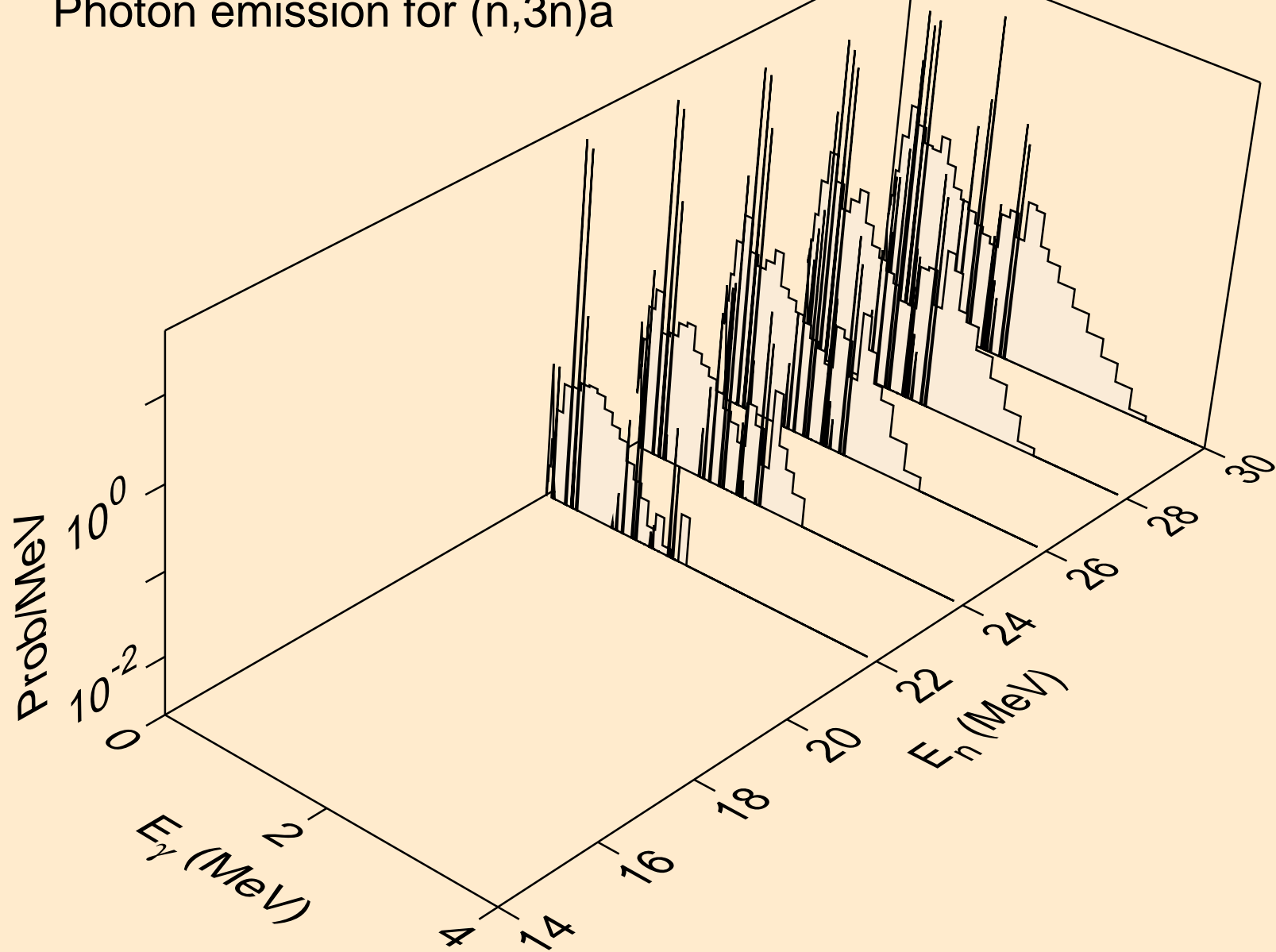

CD123M PROTON ACER TENDL-2023 LIBRARY; T=0.K  
Photon emission for (n,n\*)p

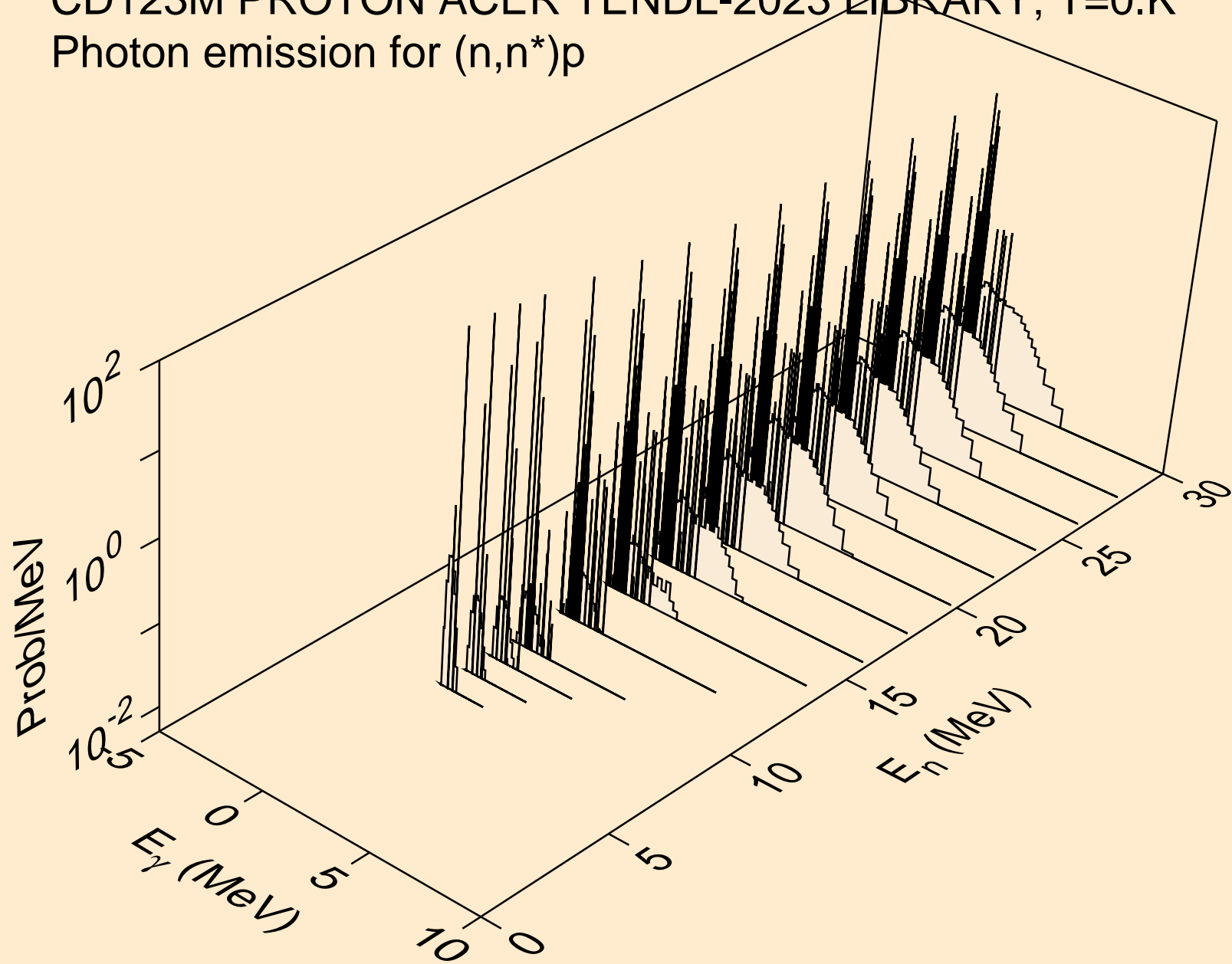

CD123M PROTON ACER TENDL-2023 LIBRARY; T=0.K  
Photon emission for (n,n\*)d

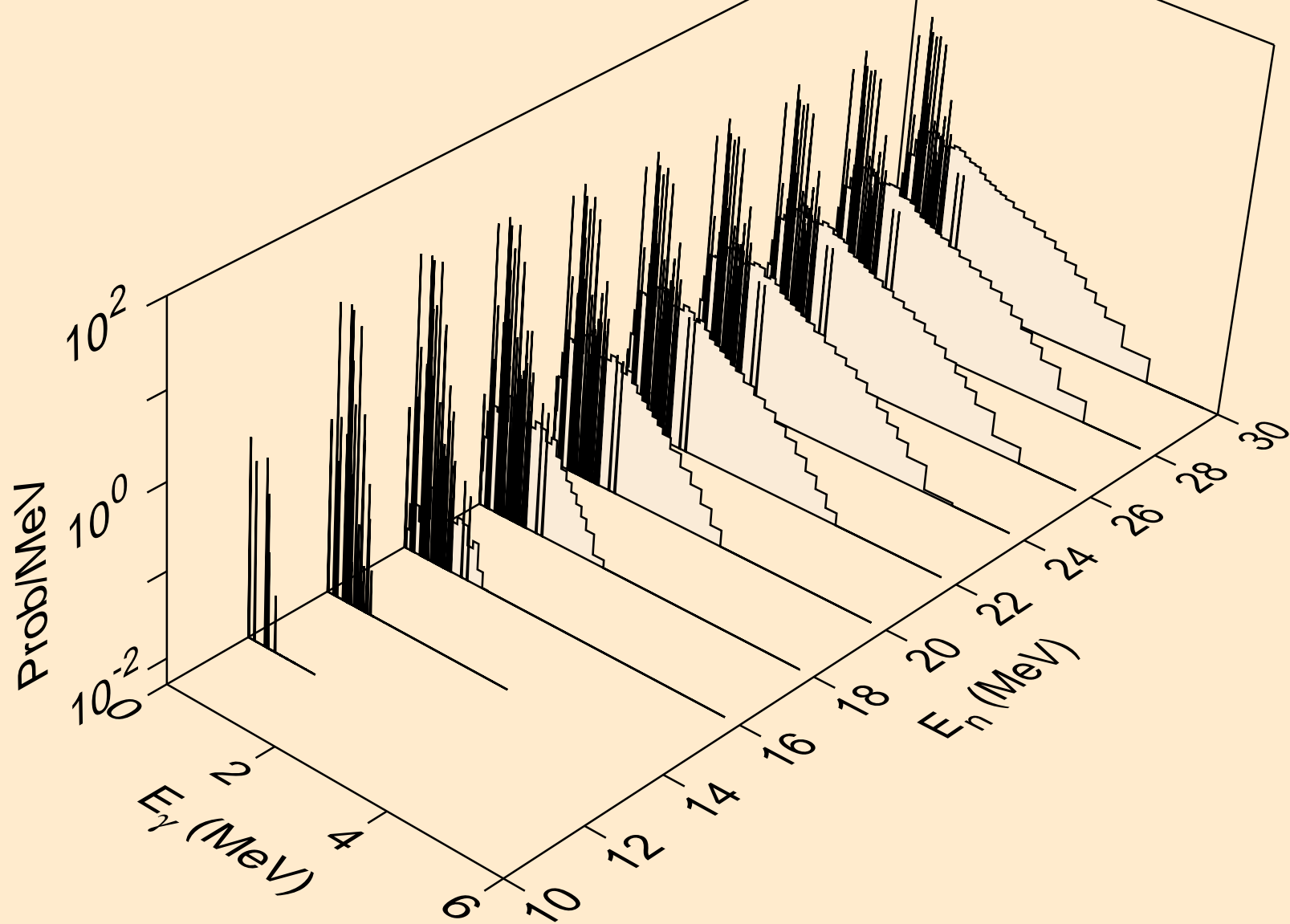

CD123M PROTON ACER TENDL-2023 LIBRARY; T=0.K  
Photon emission for (n,n\*)t

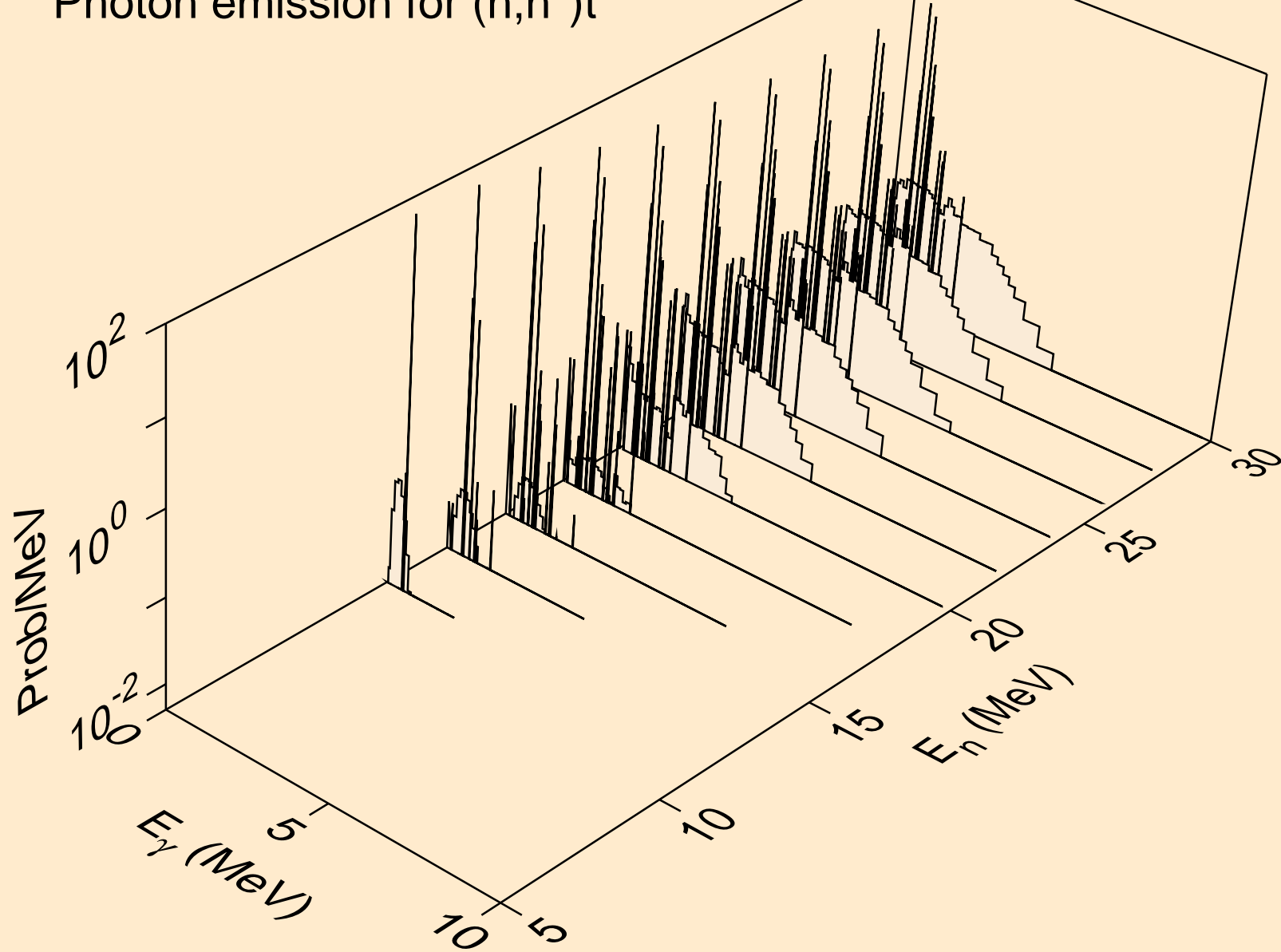

CD123M PROTON ACER TENDL-2023 LIBRARY; T=0.K  
Photon emission for (n,n\*)he3

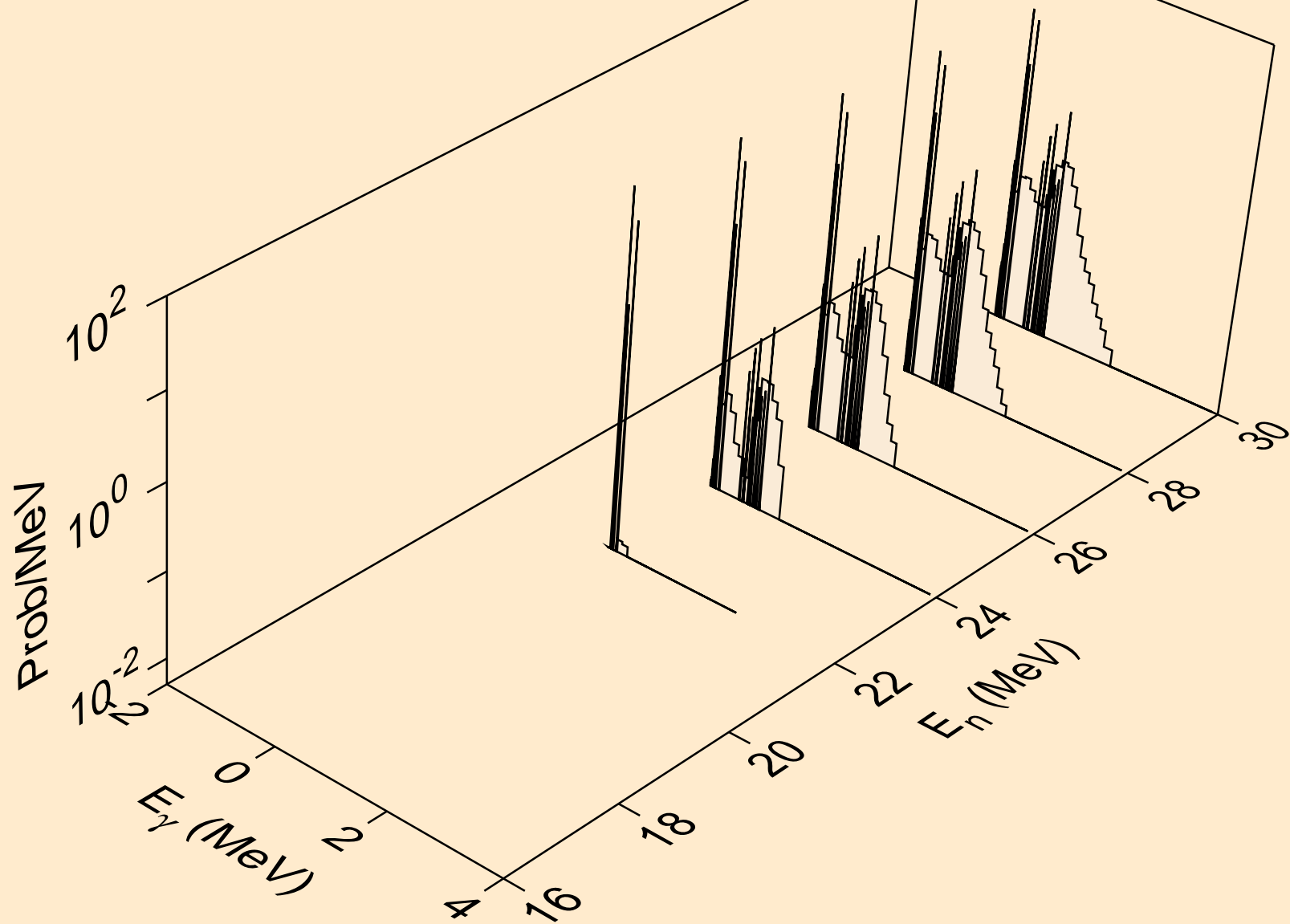

CD123M PROTON ACER TENDL-2023 LIBRARY; T=0.K  
Photon emission for (n,4n)

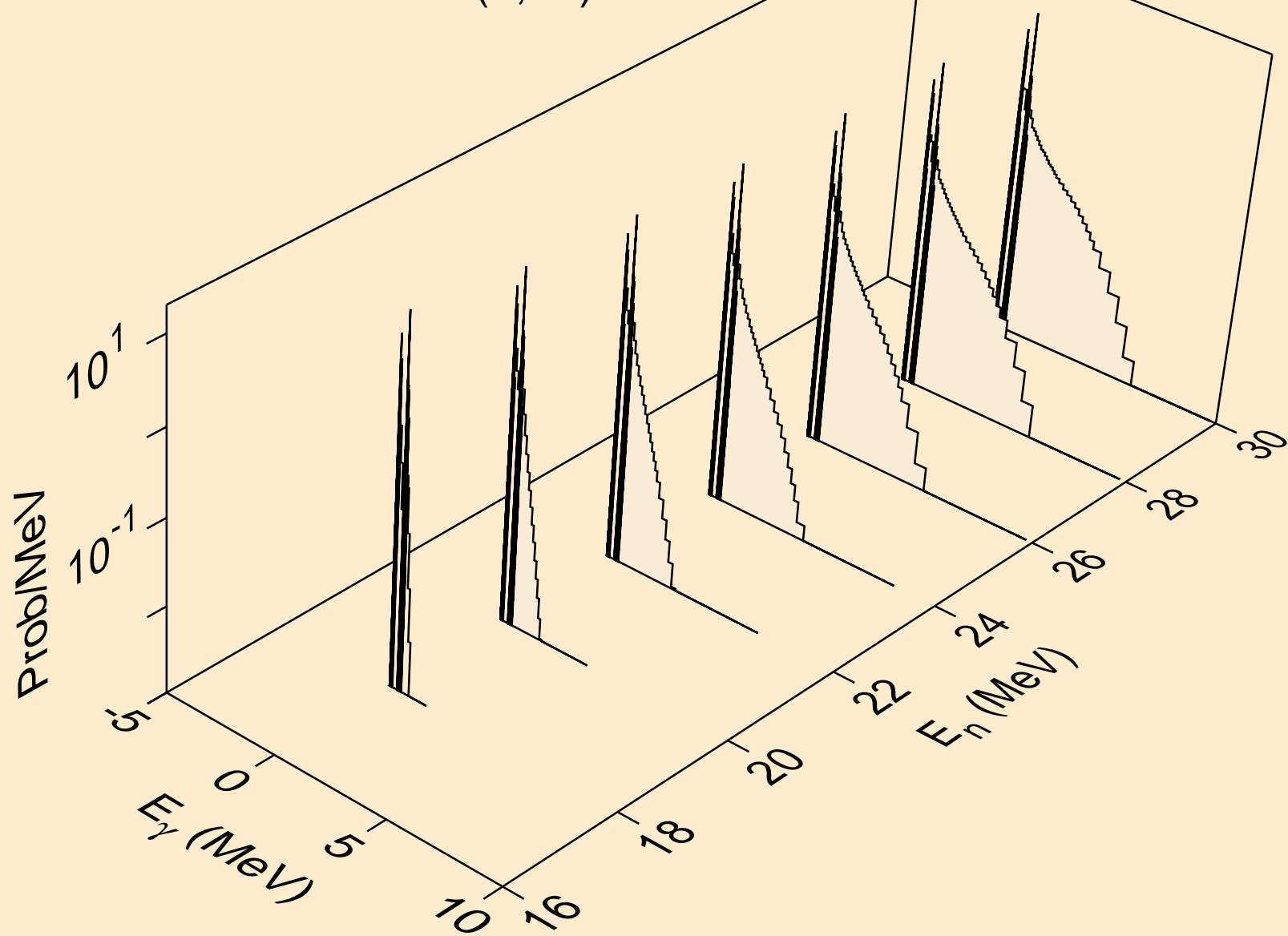

CD123M PROTON ACER TENDL-2023 LIBRARY; T=0.K  
Photon emission for (n,2np)

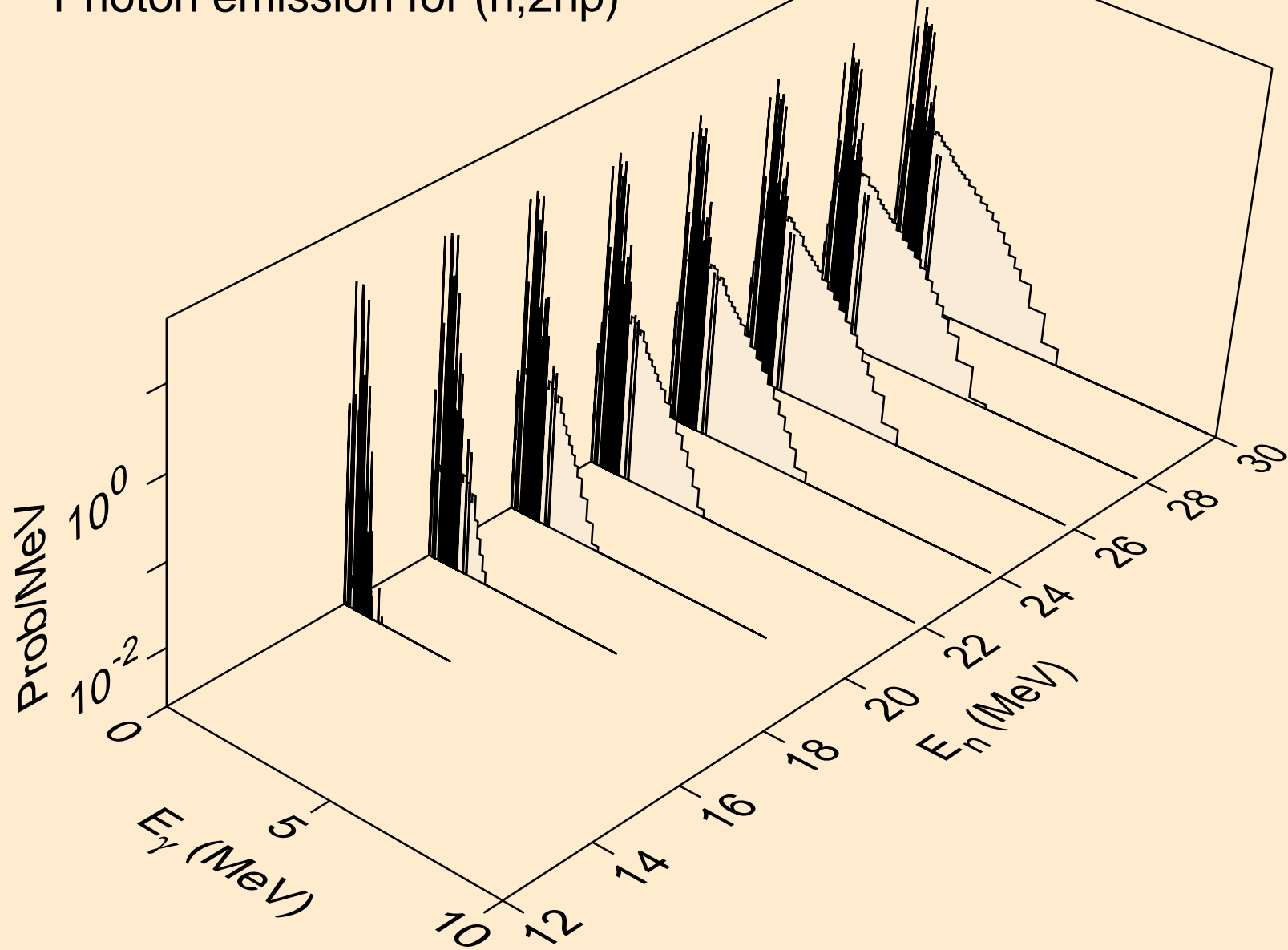

CD123M PROTON ACER TENDL-2023 LIBRARY; T=0.K  
Photon emission for (n,3np)

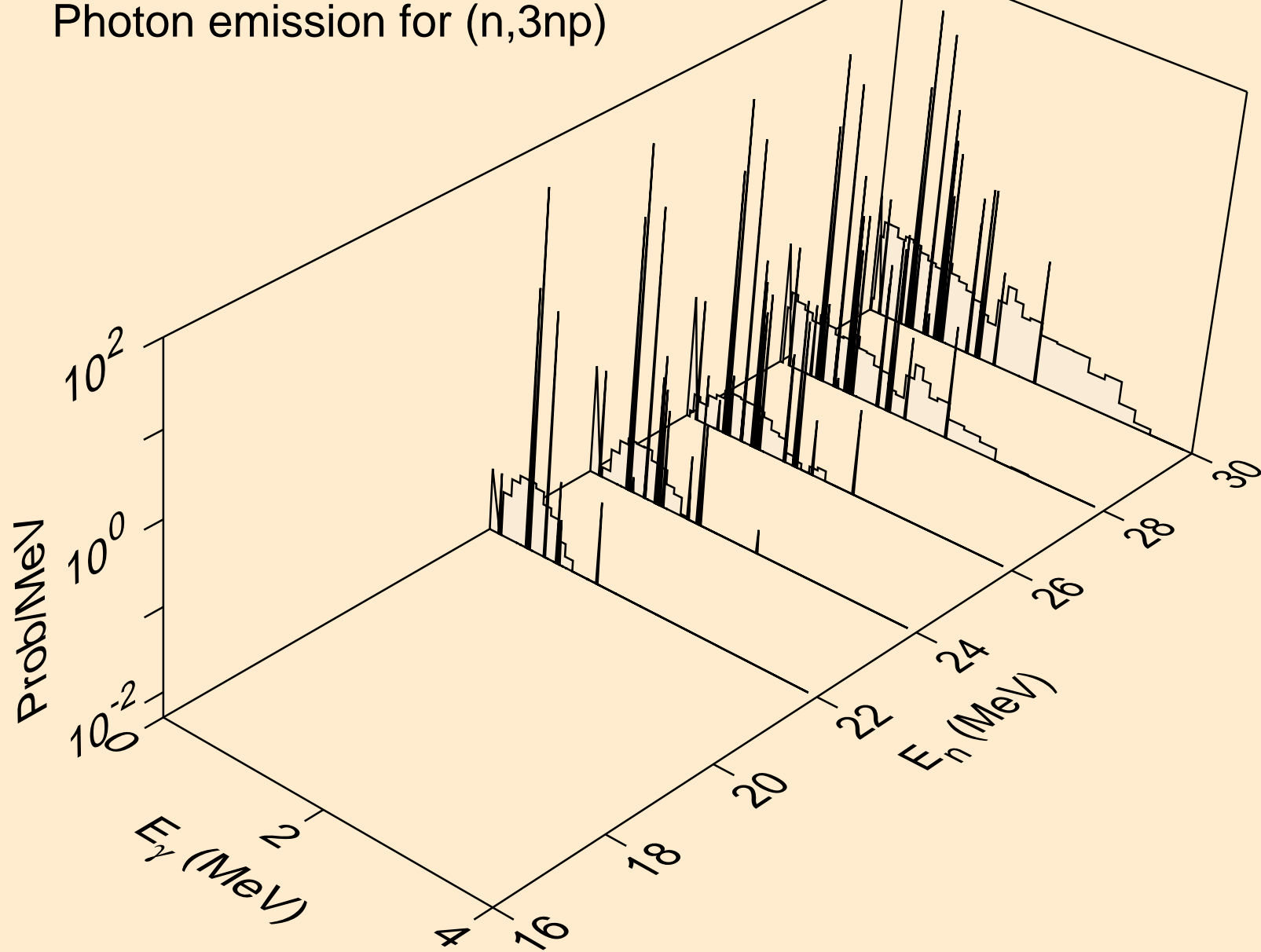



CD123M PROTON ACER TENDL-2023 LIBRARY; T=0.K  
Photon emission for (n,n2p)

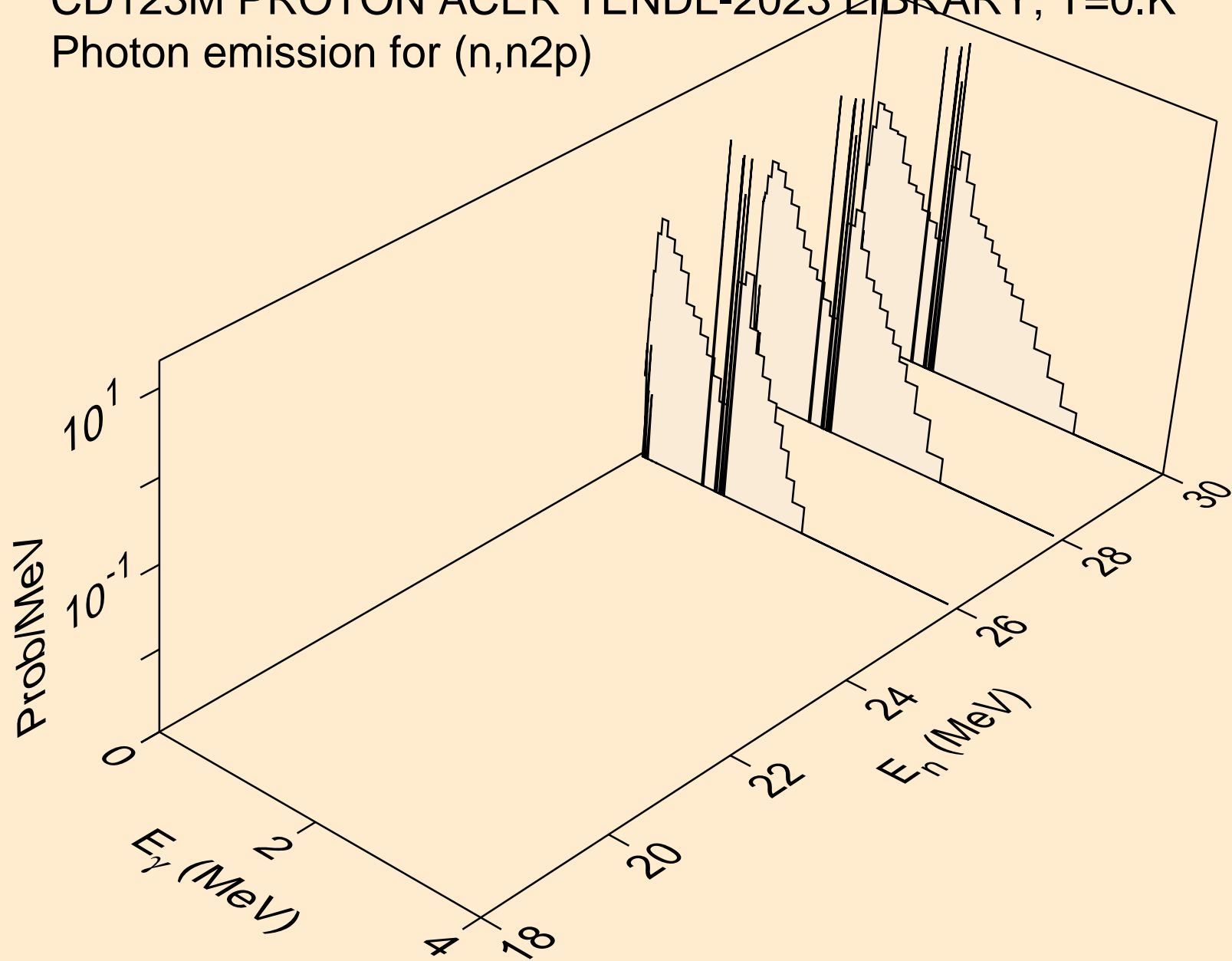

CD123M PROTON ACER TENDL-2023 LIBRARY; T=0.K  
Photon emission for (n,gma)

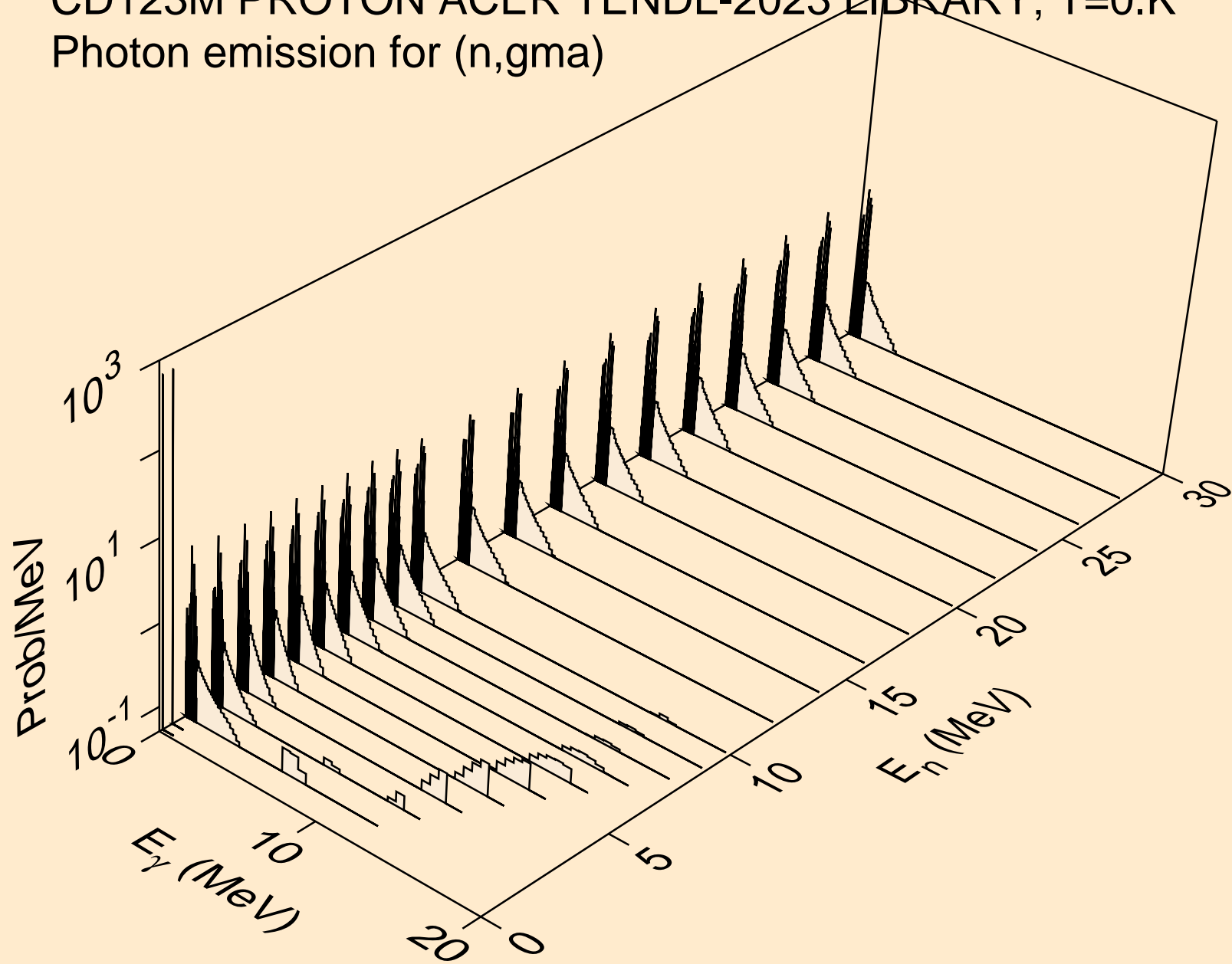

CD123M PROTON ACER TENDL-2023 LIBRARY; T=0.K  
Photon emission for inelastic

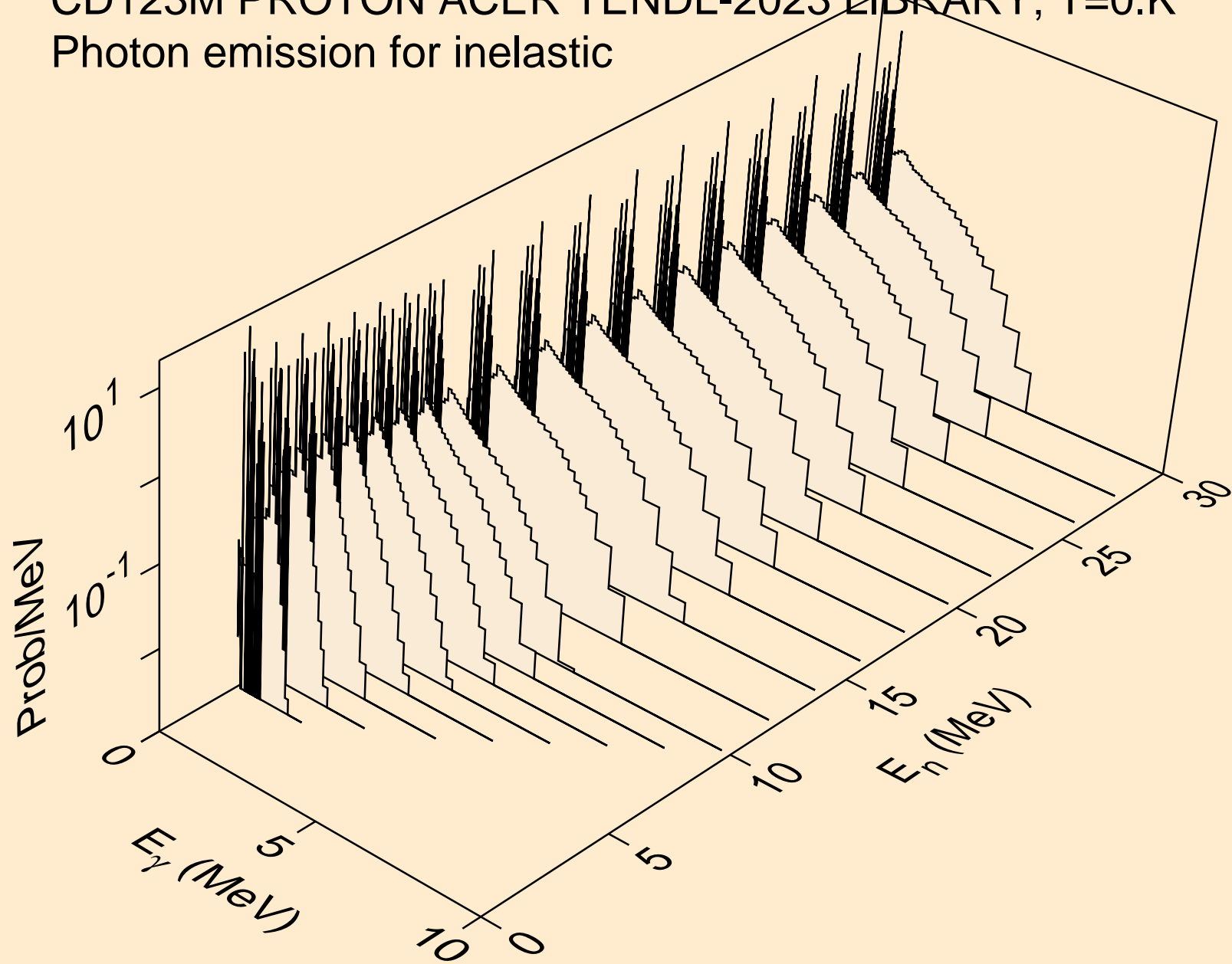

CD123M PROTON ACER TENDL-2023 LIBRARY; T=0.K  
Photon emission for (n,d)

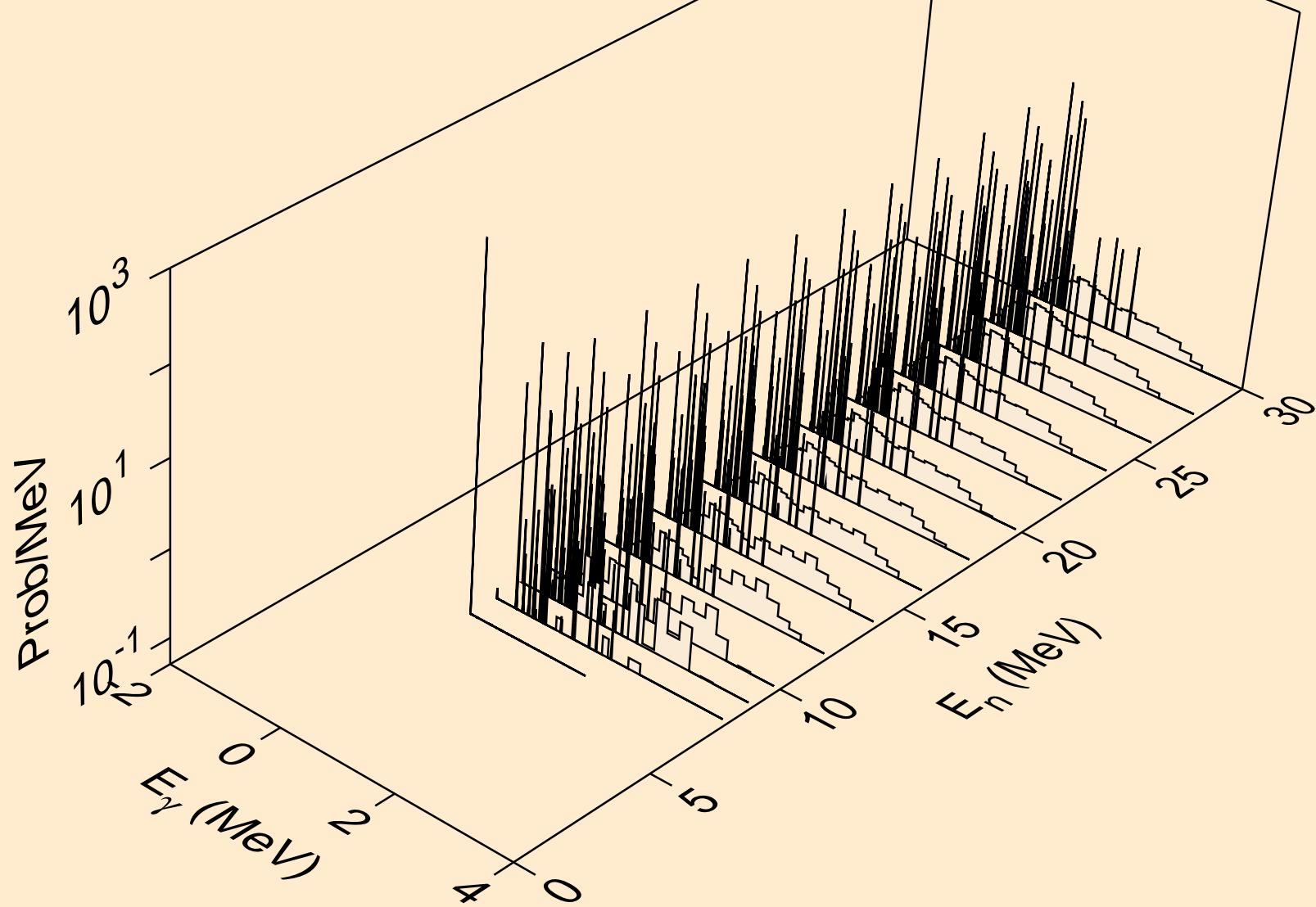

CD123M PROTON ACER TENDL-2023 LIBRARY; T=0.K  
Photon emission for (n,t)

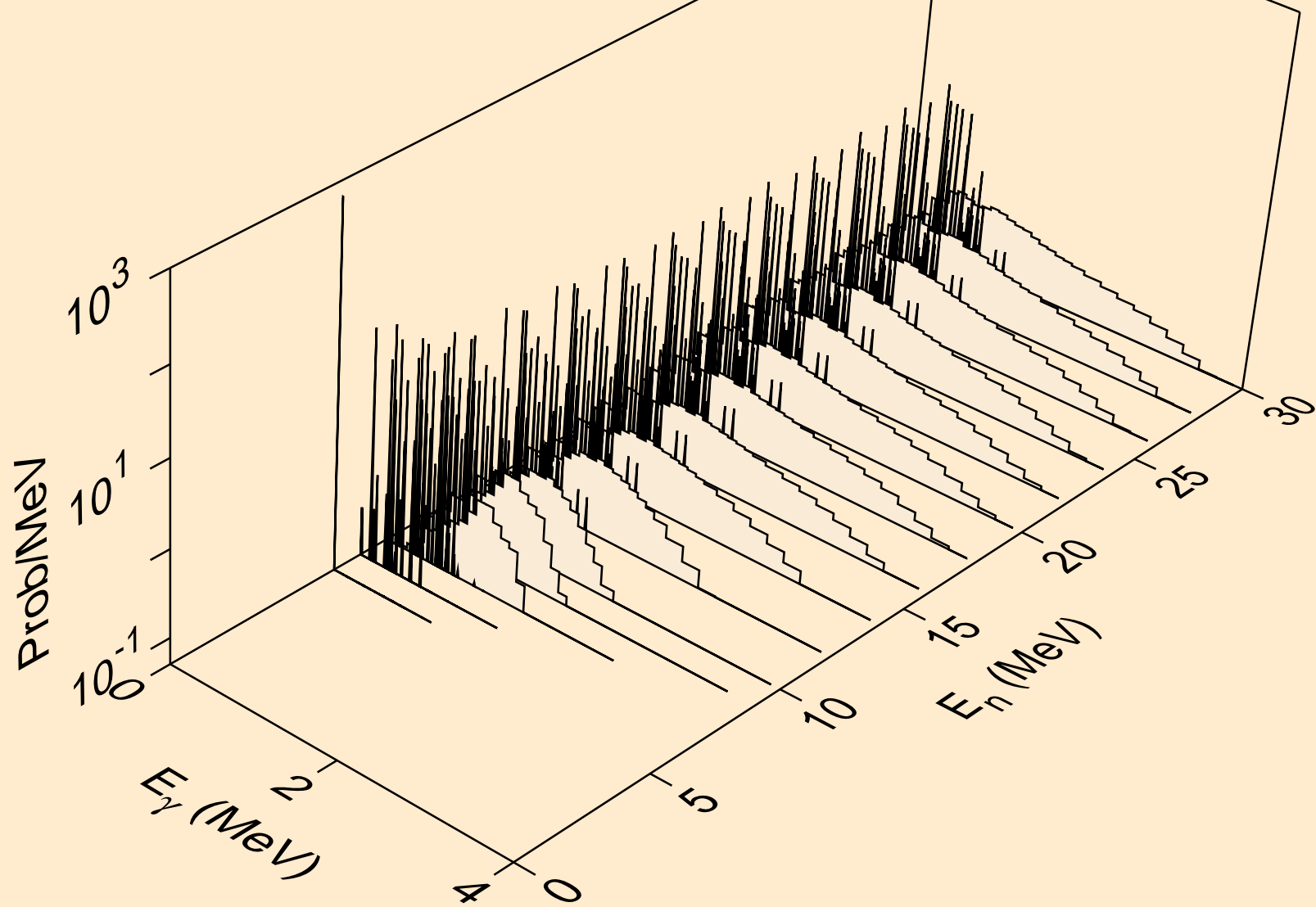

CD123M PROTON ACER TENDL-2023 LIBRARY; T=0.K  
Photon emission for (n,he3)

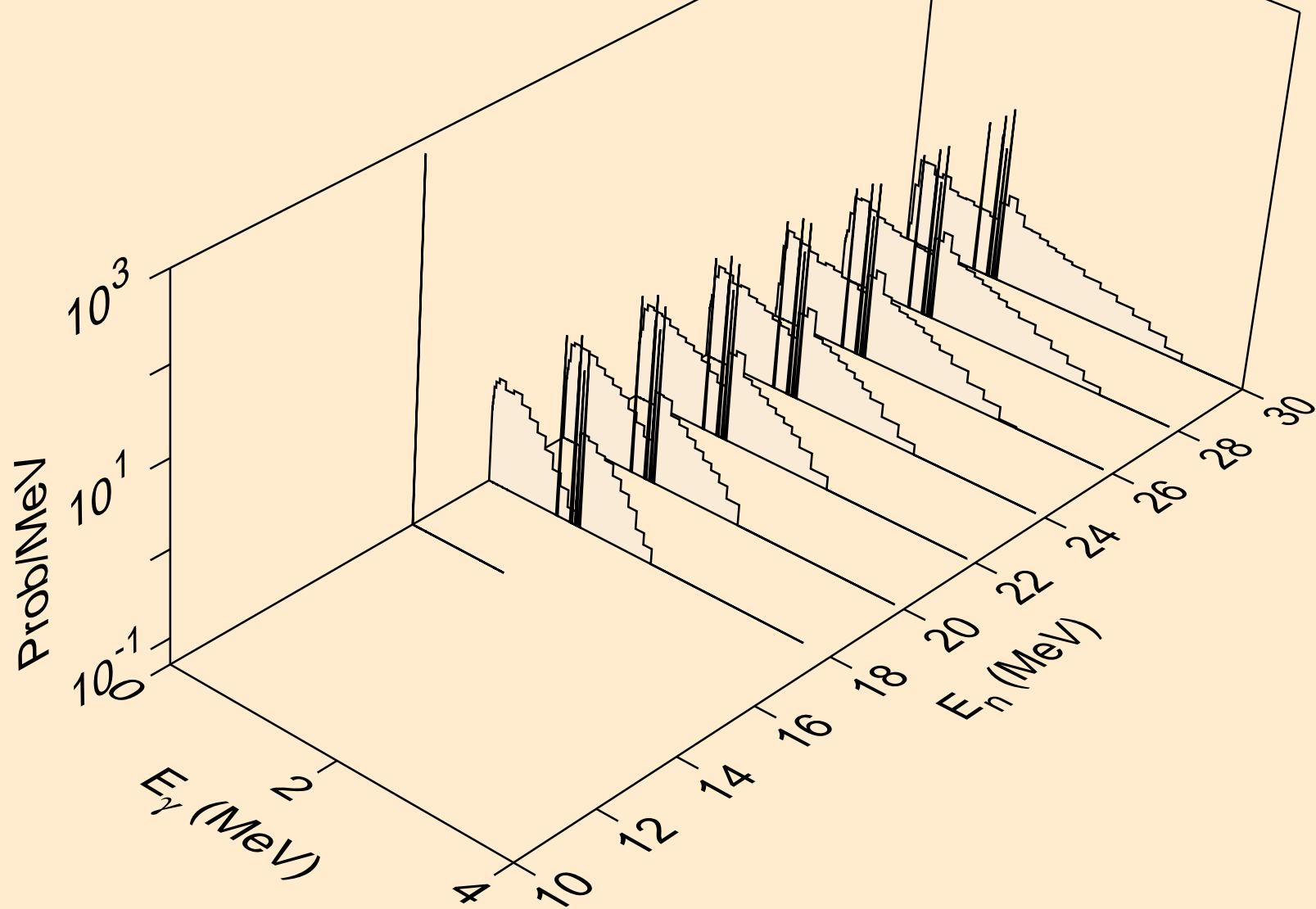

CD123M PROTON ACER TENDL-2023 LIBRARY; T=0.K  
Photon emission for (n,a)

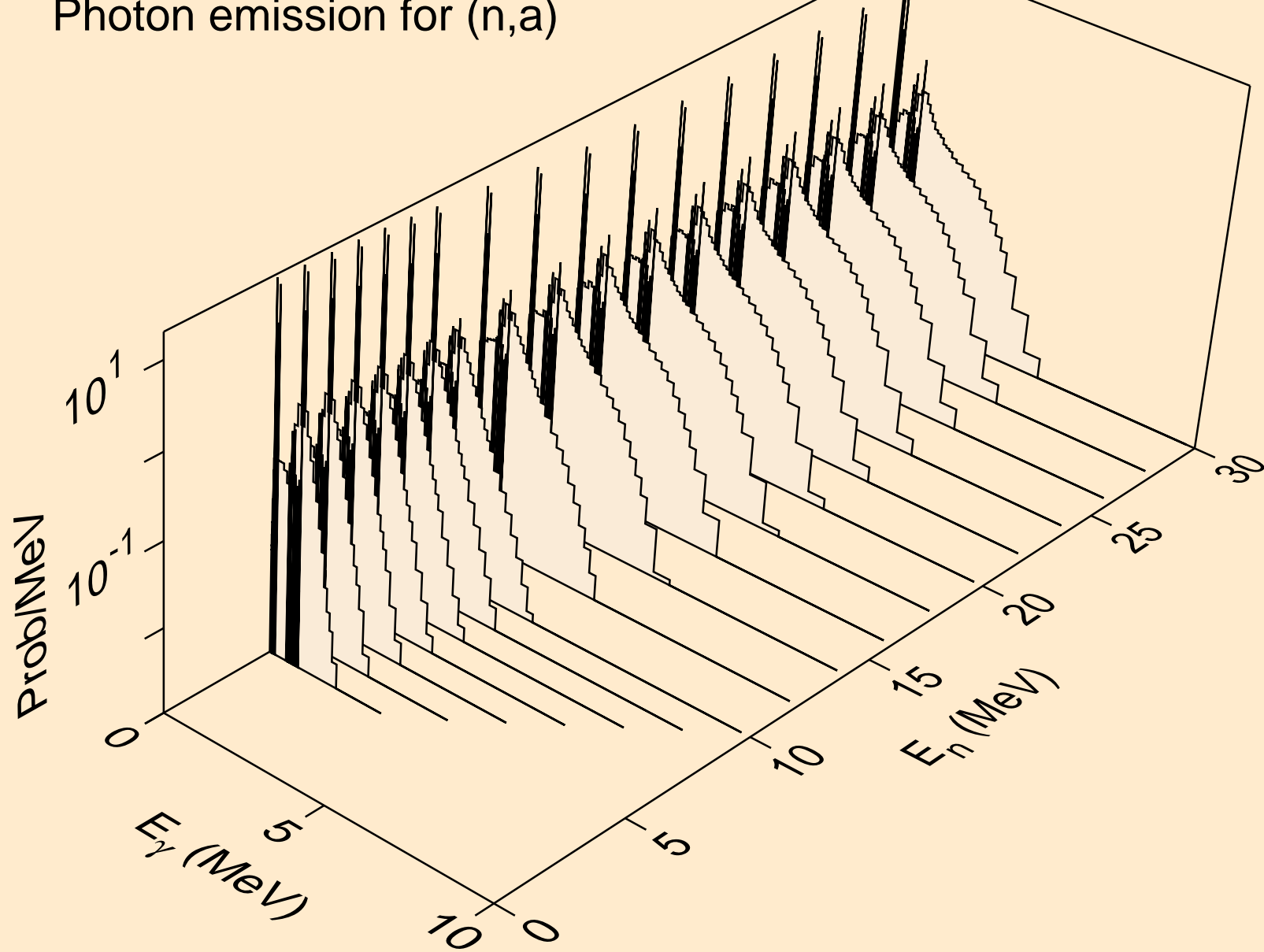

CD123M PROTON ACER TENDL-2023 LIBRARY; T=0.K  
Photon emission for (n,2p)

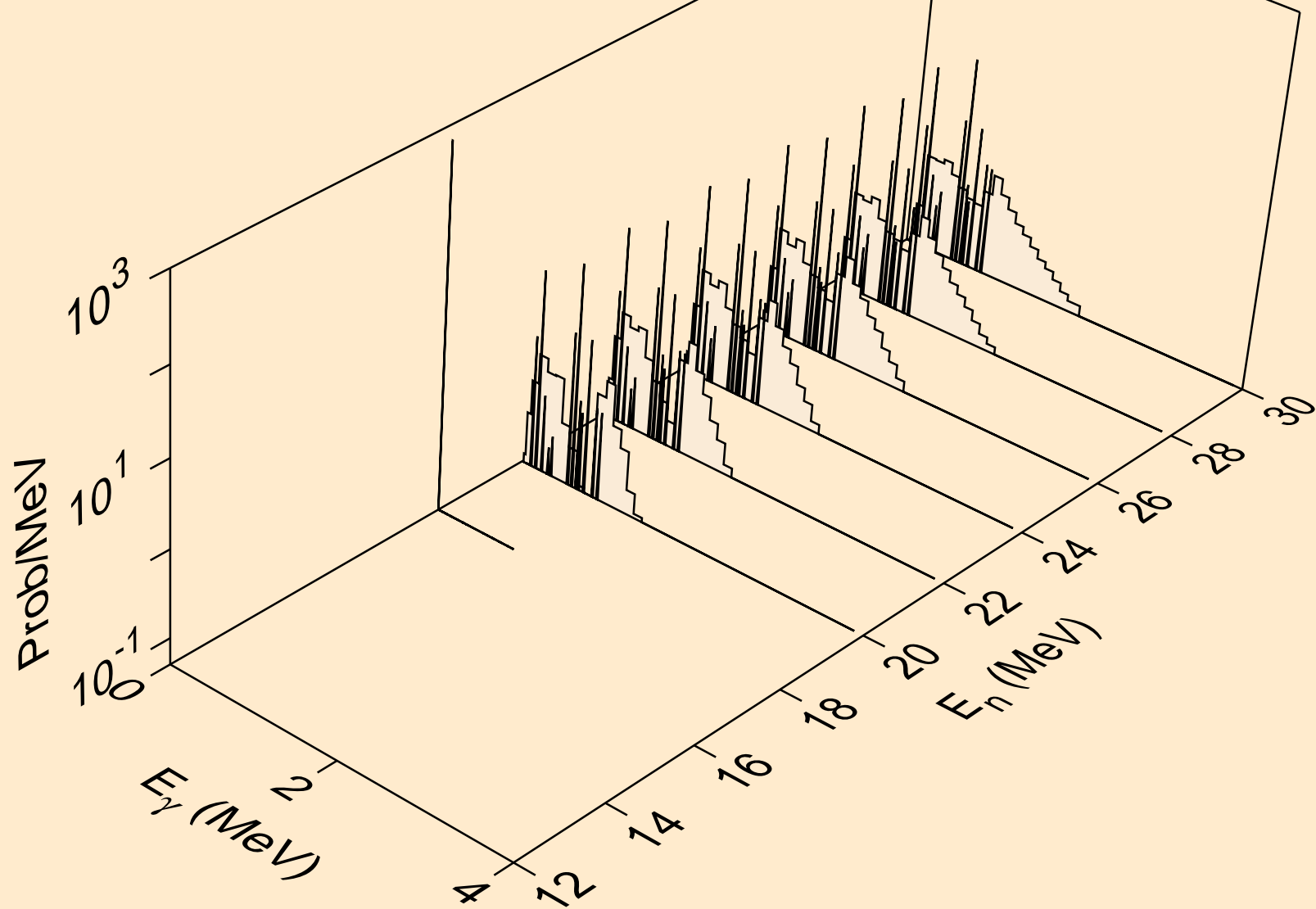



# CD123M PROTON ACER TENDL-2023 LIBRARY; T=0.K

## Particle heating contributions

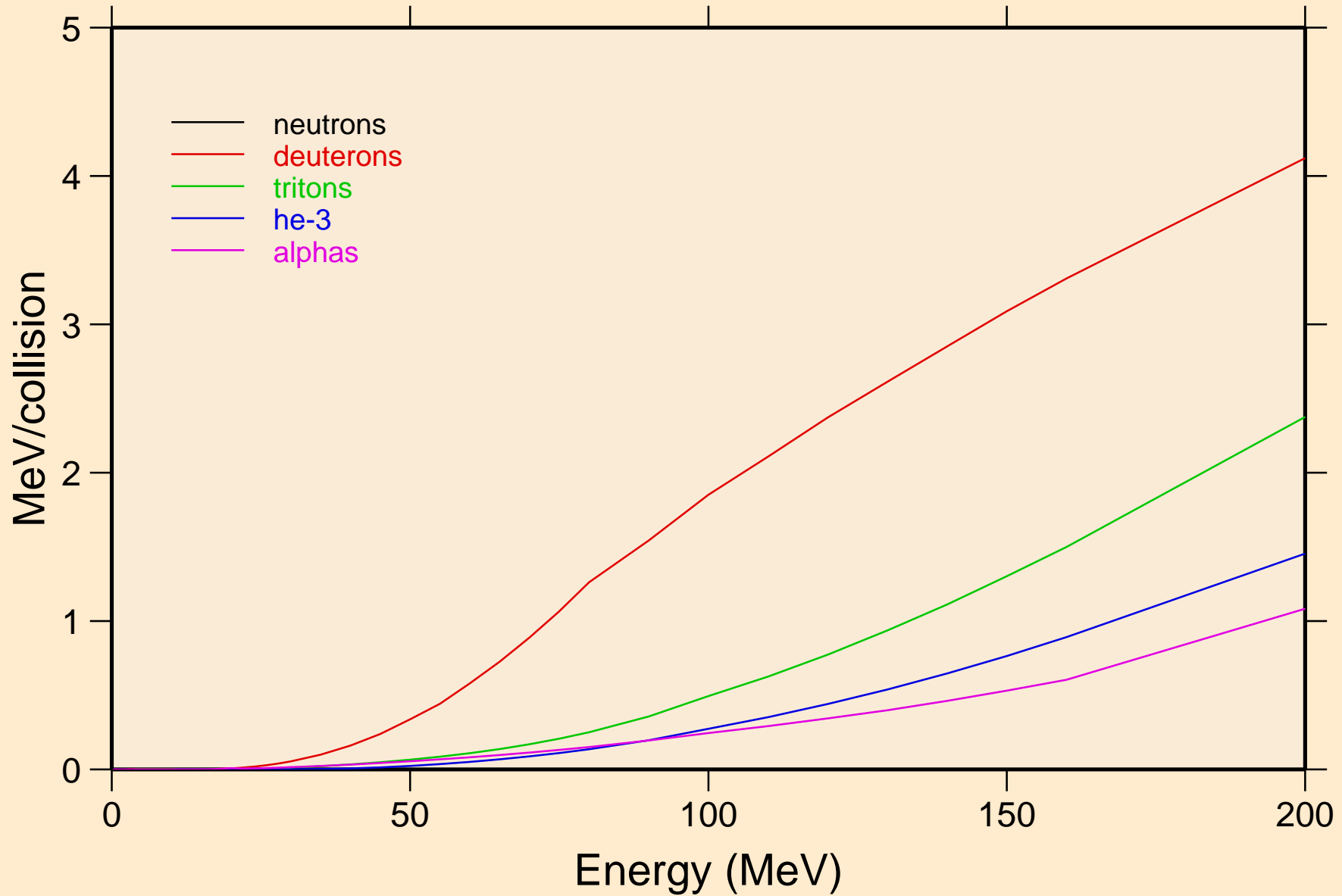

# CD123M PROTON ACER TENDL-2023 LIBRARY; T=0.K

## Recoil Heating

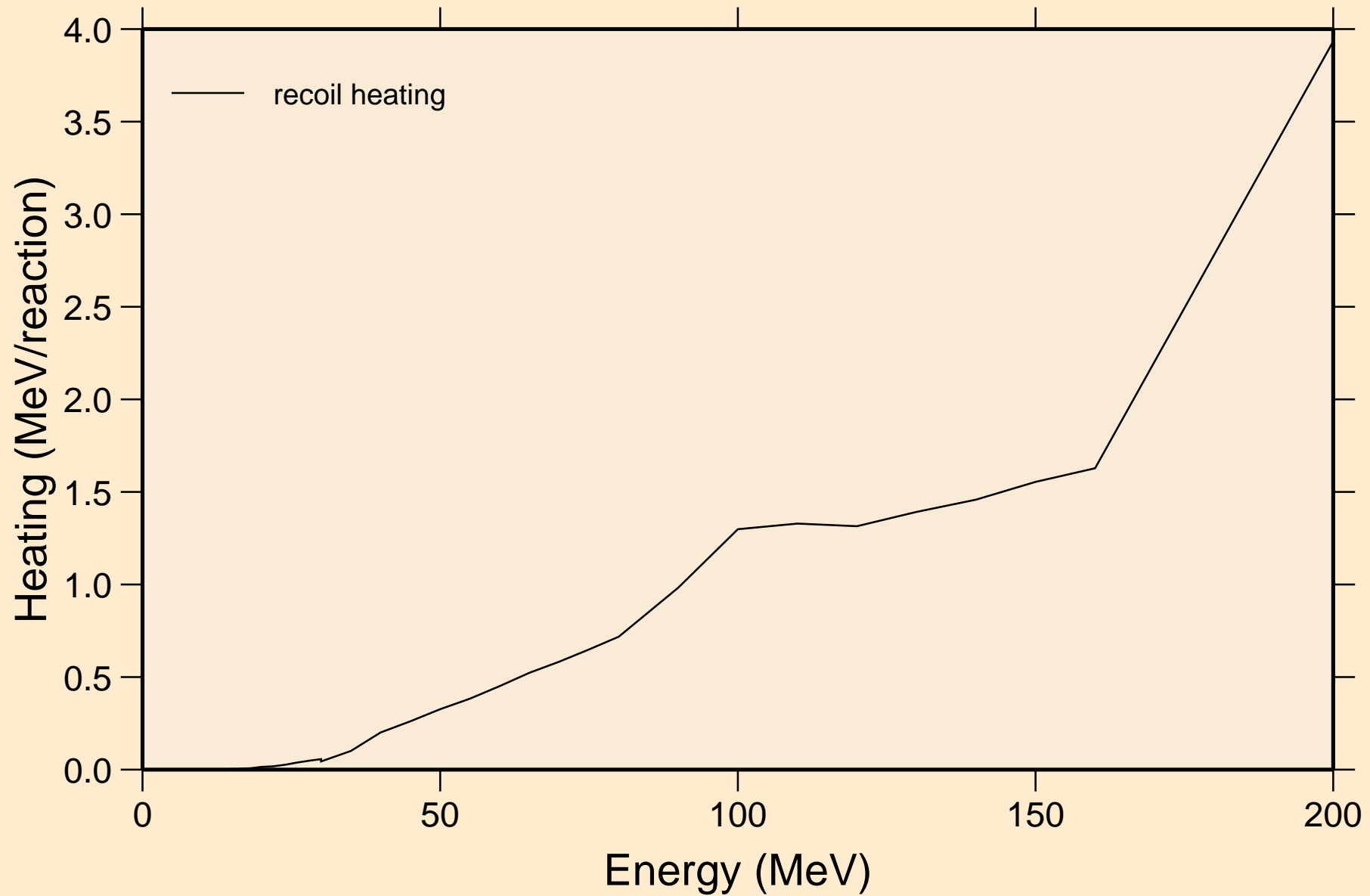

CD123M PROTON ACER TENDL-2023 LIBRARY; T=0.K  
Particle production cross sections

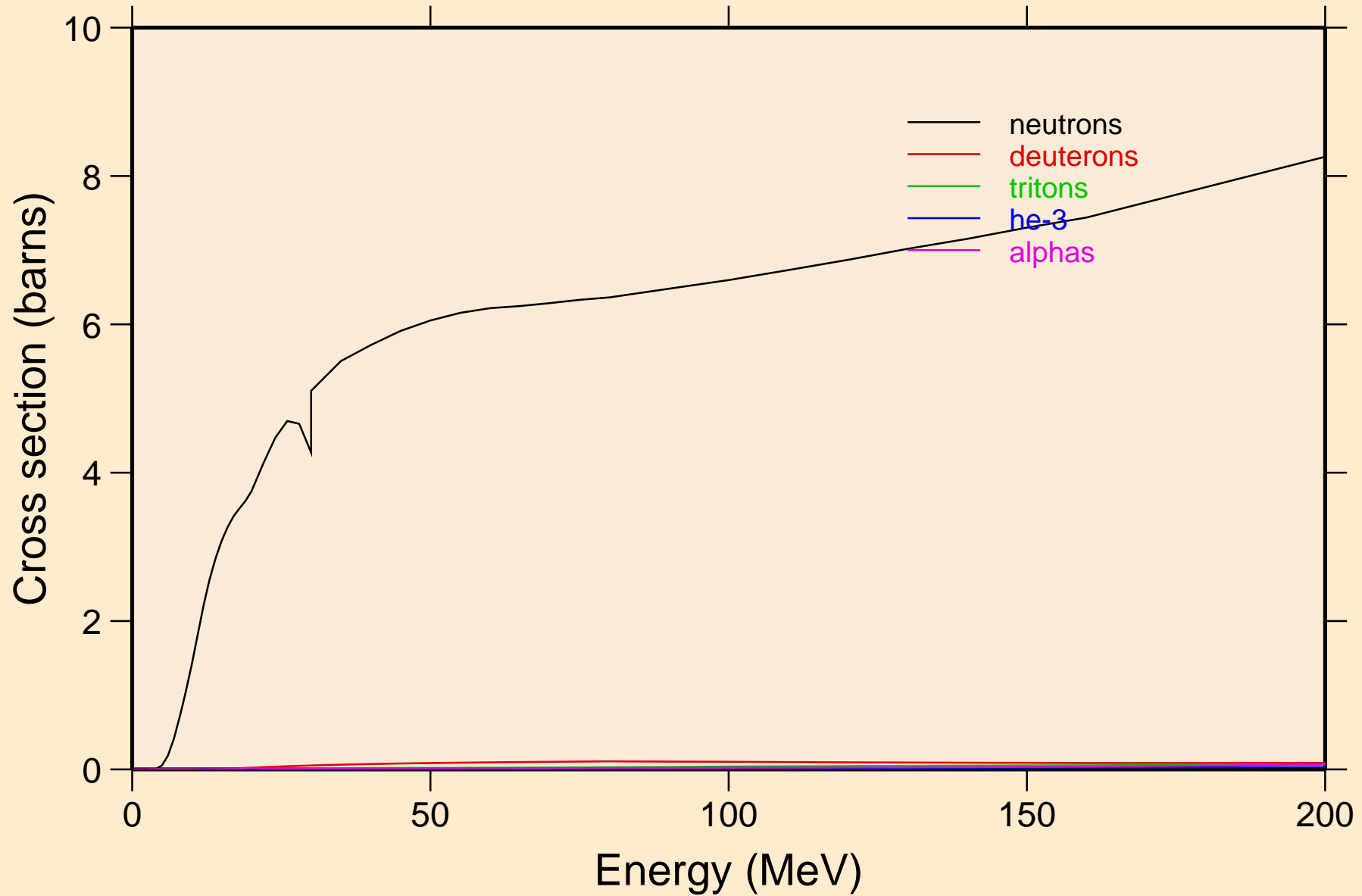

CD123M PROTON ACER TENDL-2023 LIBRARY; T=0.K  
neutrons from (p,n)

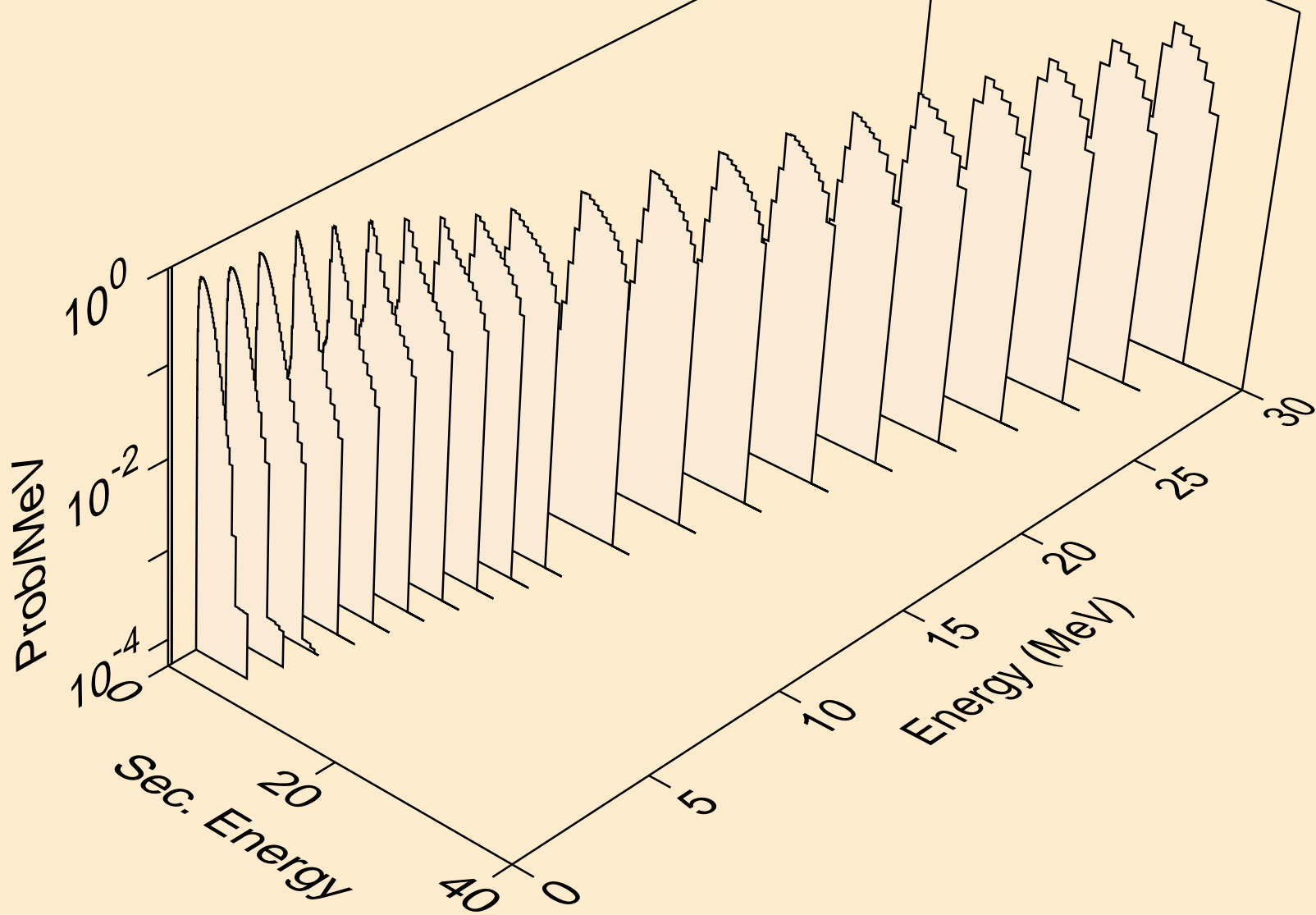

CD123M PROTON ACER TENDL-2023 LIBRARY; T=0.K  
neutrons from (p,x)

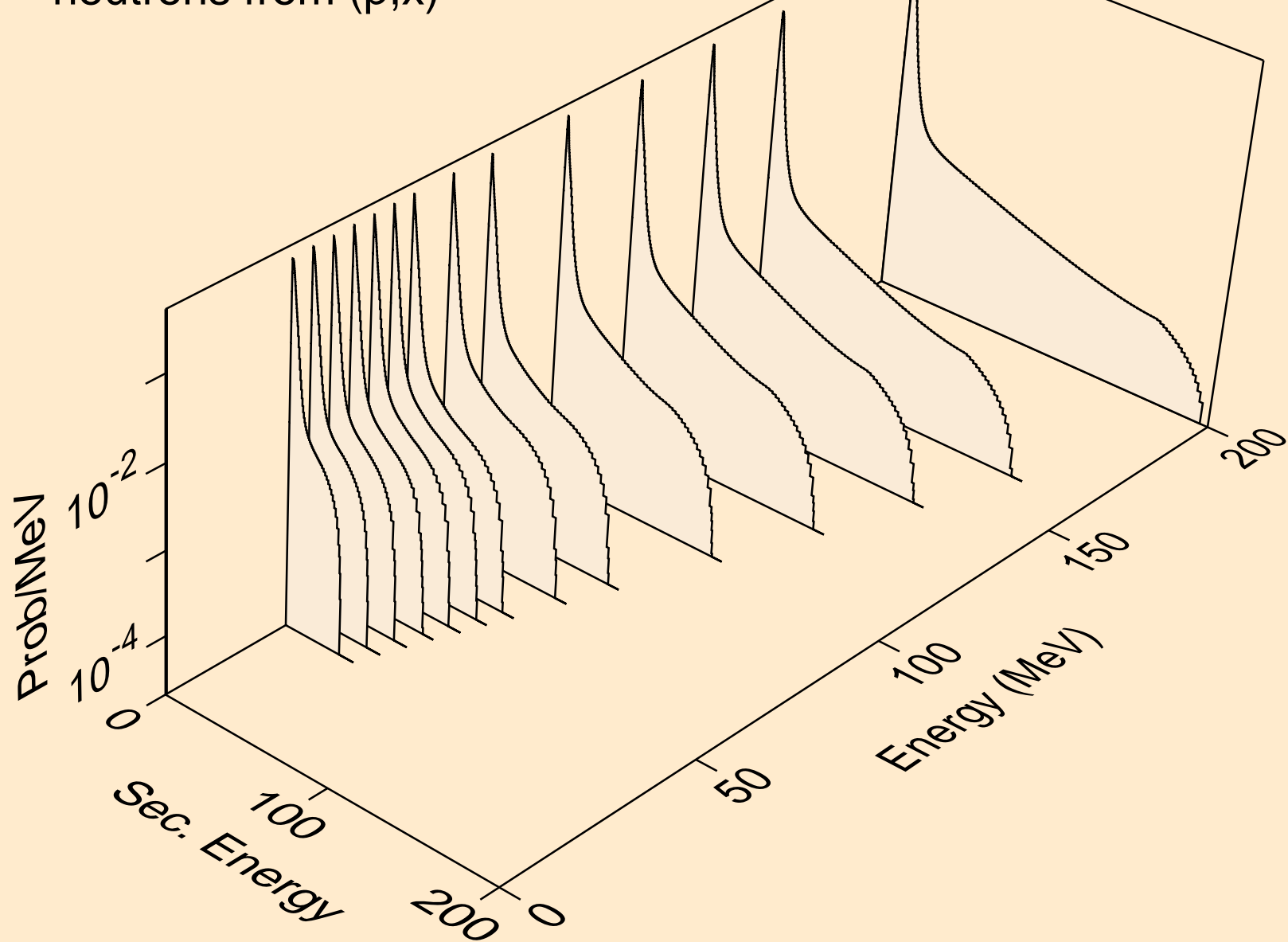

CD123M PROTON ACER TENDL-2023 LIBRARY; T=0.K  
neutrons from (p,2nd)

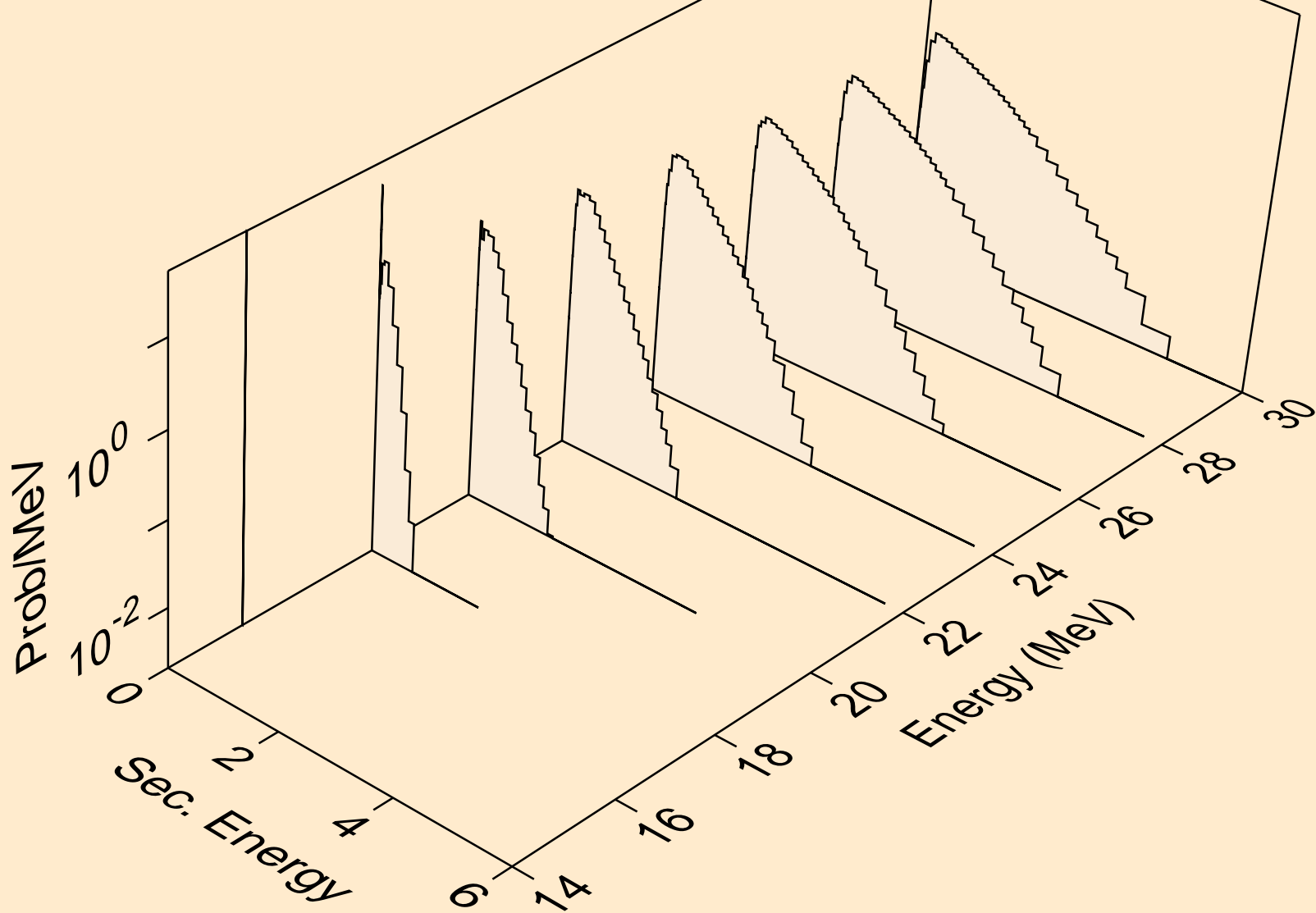

CD123M PROTON ACER TENDL-2023 LIBRARY; T=0.K  
neutrons from (p,2n)

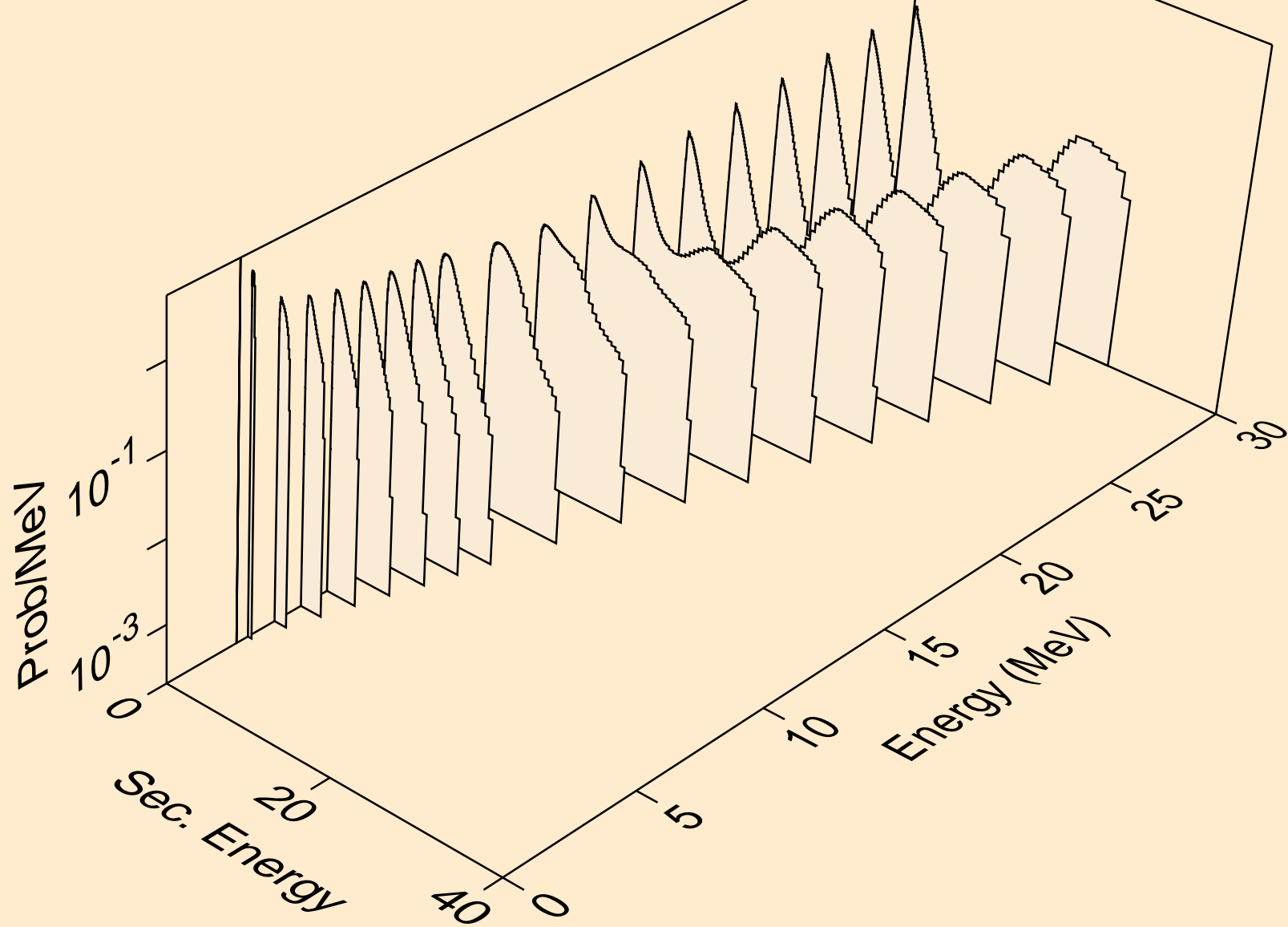

CD123M PROTON ACER TENDL-2023 LIBRARY; T=0.K  
neutrons from (p,3n)

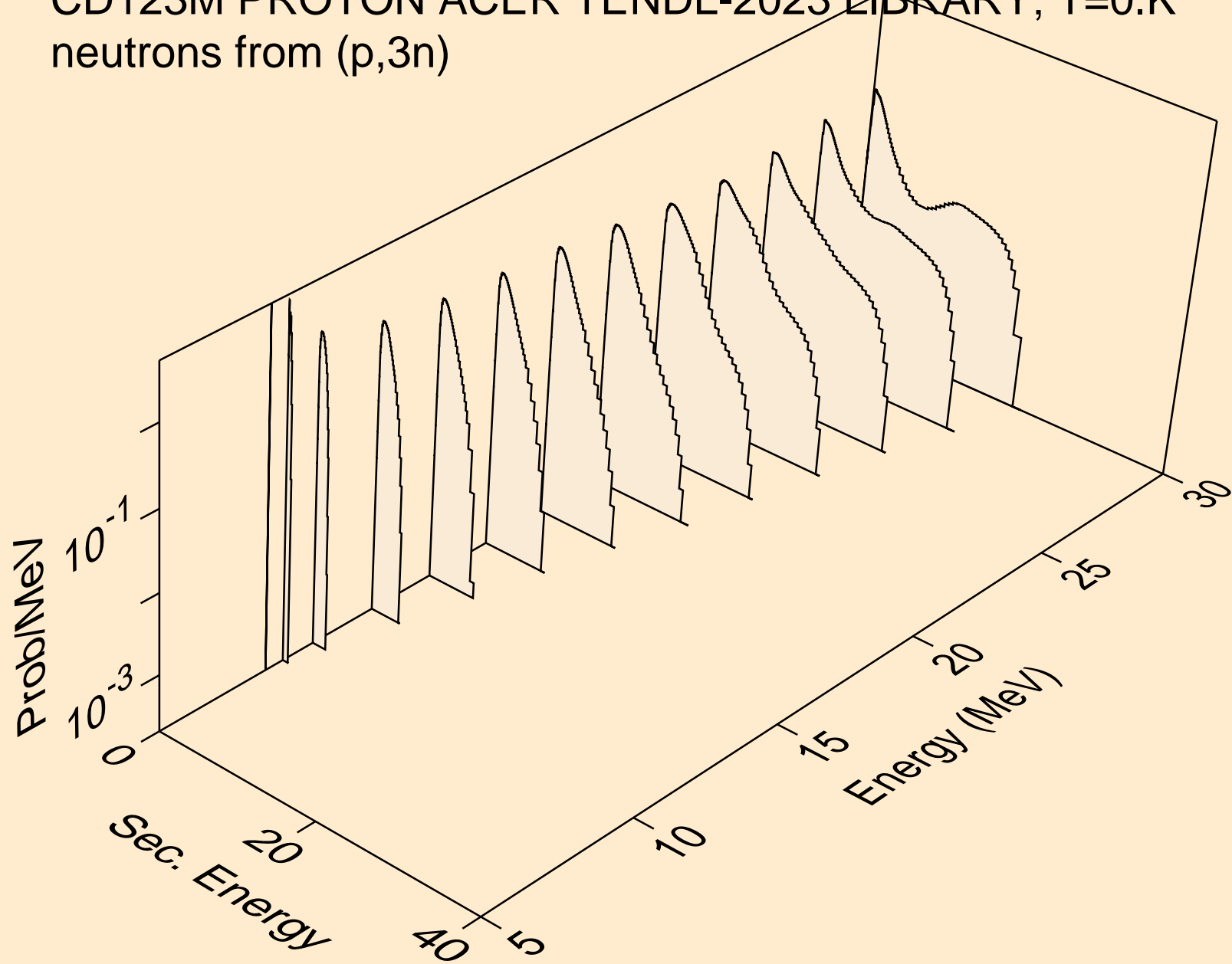



CD123M PROTON ACER TENDL-2023 LIBRARY; T=0.K  
neutrons from (p,n\*)a

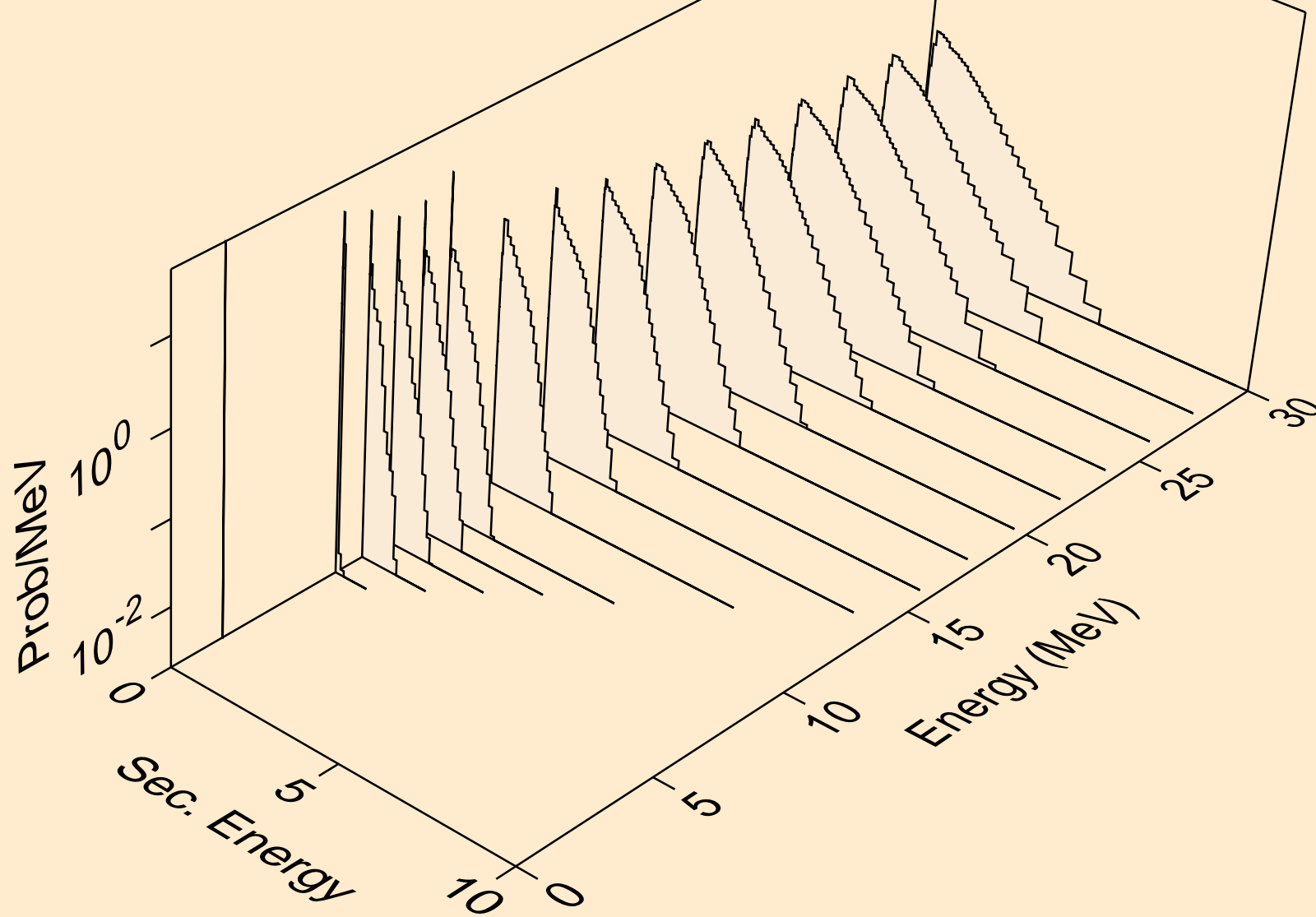

CD123M PROTON ACER TENDL-2023 LIBRARY; T=0.K  
neutrons from (p,2n)a

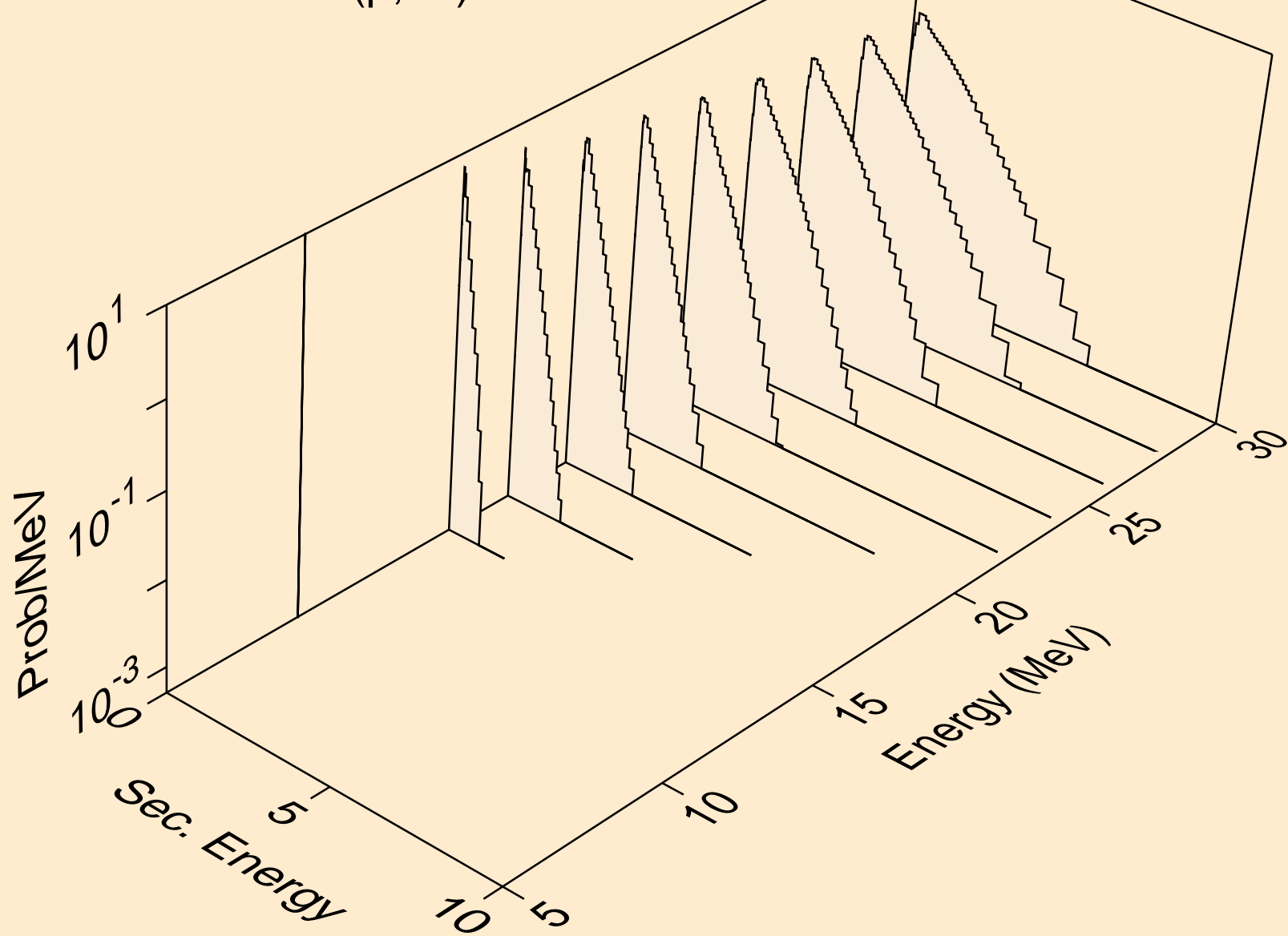

CD123M PROTON ACER TENDL-2023 LIBRARY; T=0.K  
neutrons from (p,3n)a

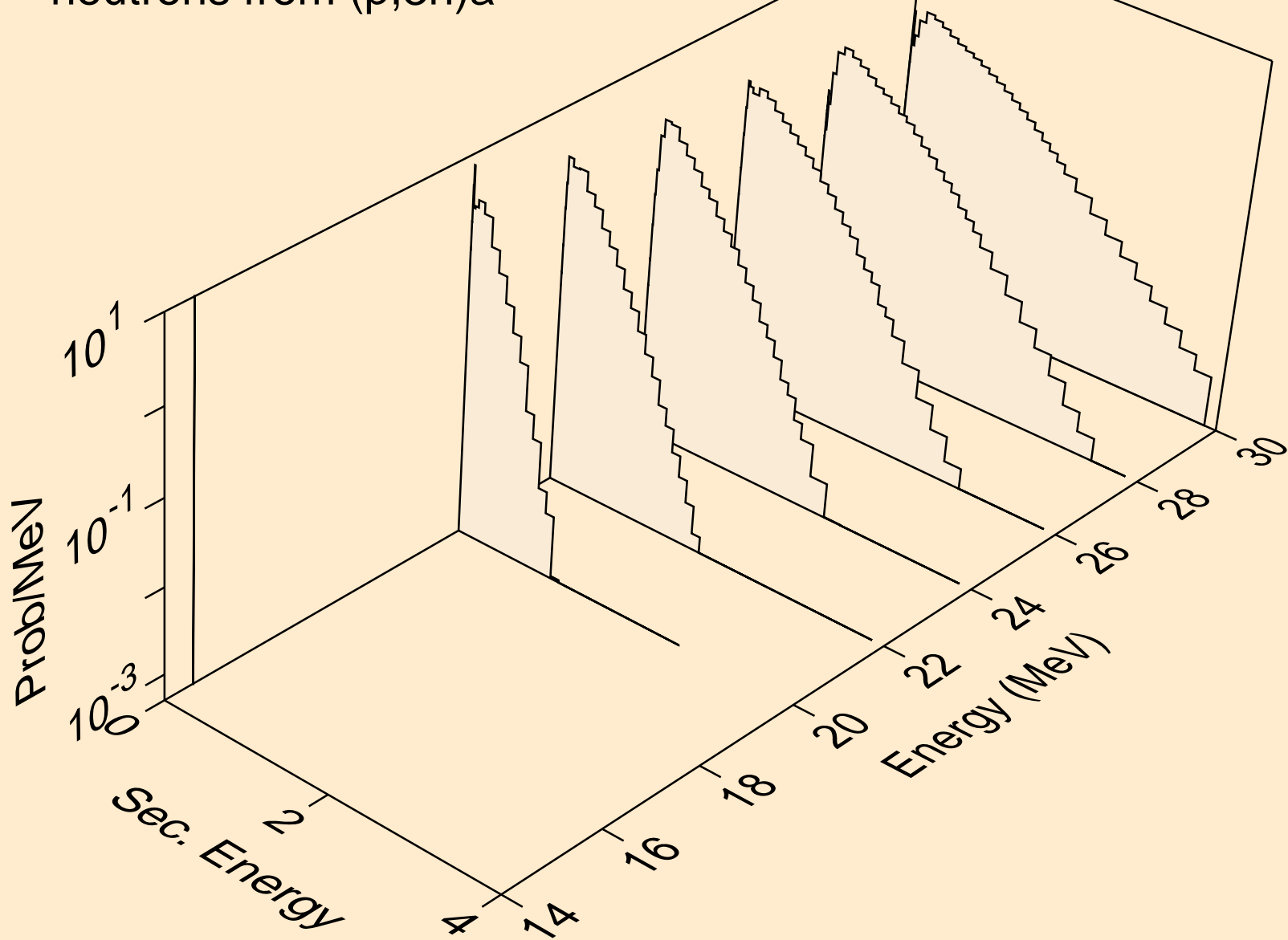

CD123M PROTON ACER TENDL-2023 LIBRARY; T=0.K  
neutrons from (p,n\*)p

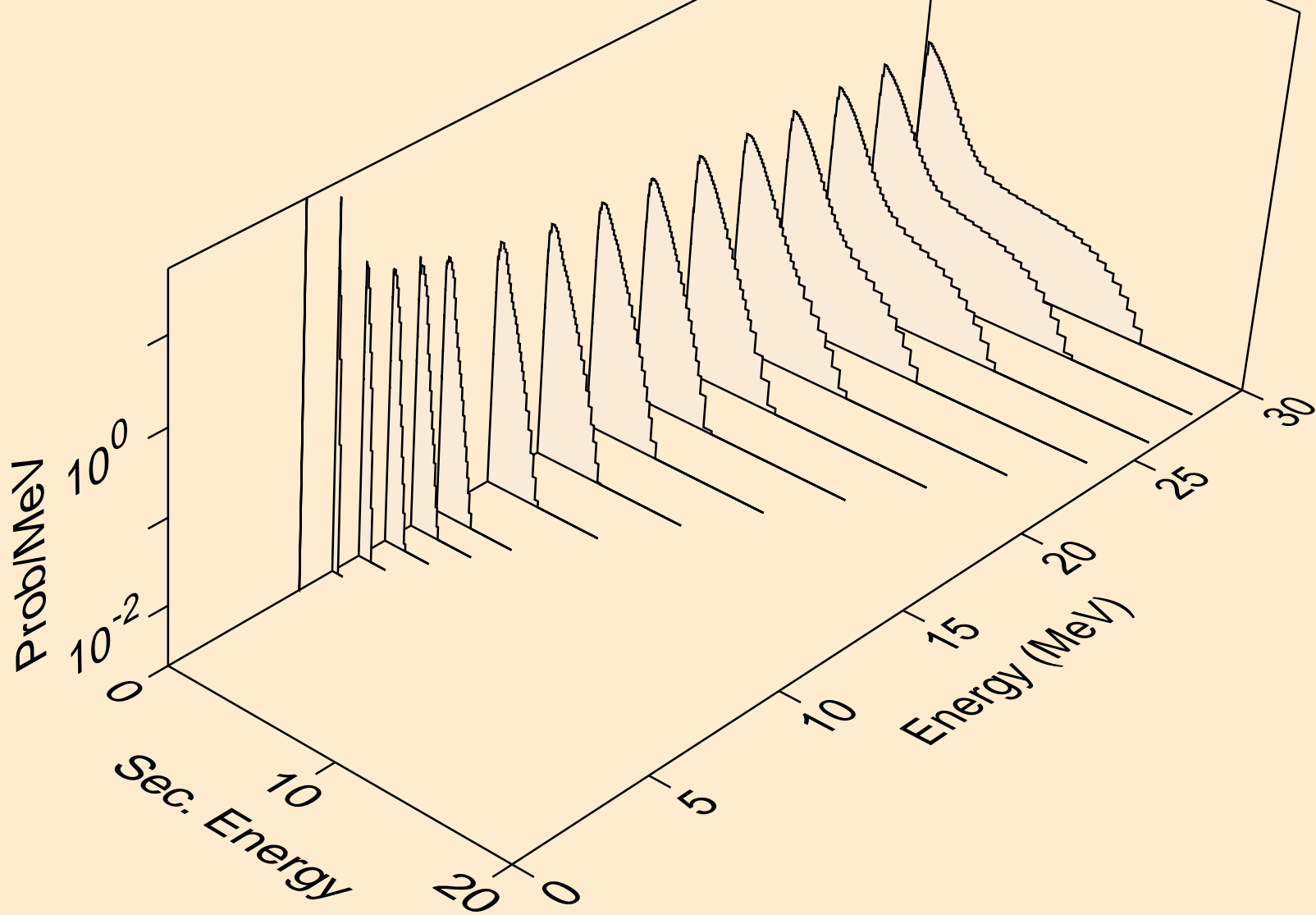

CD123M PROTON ACER TENDL-2023 LIBRARY; T=0.K  
neutrons from (p,n\*)d

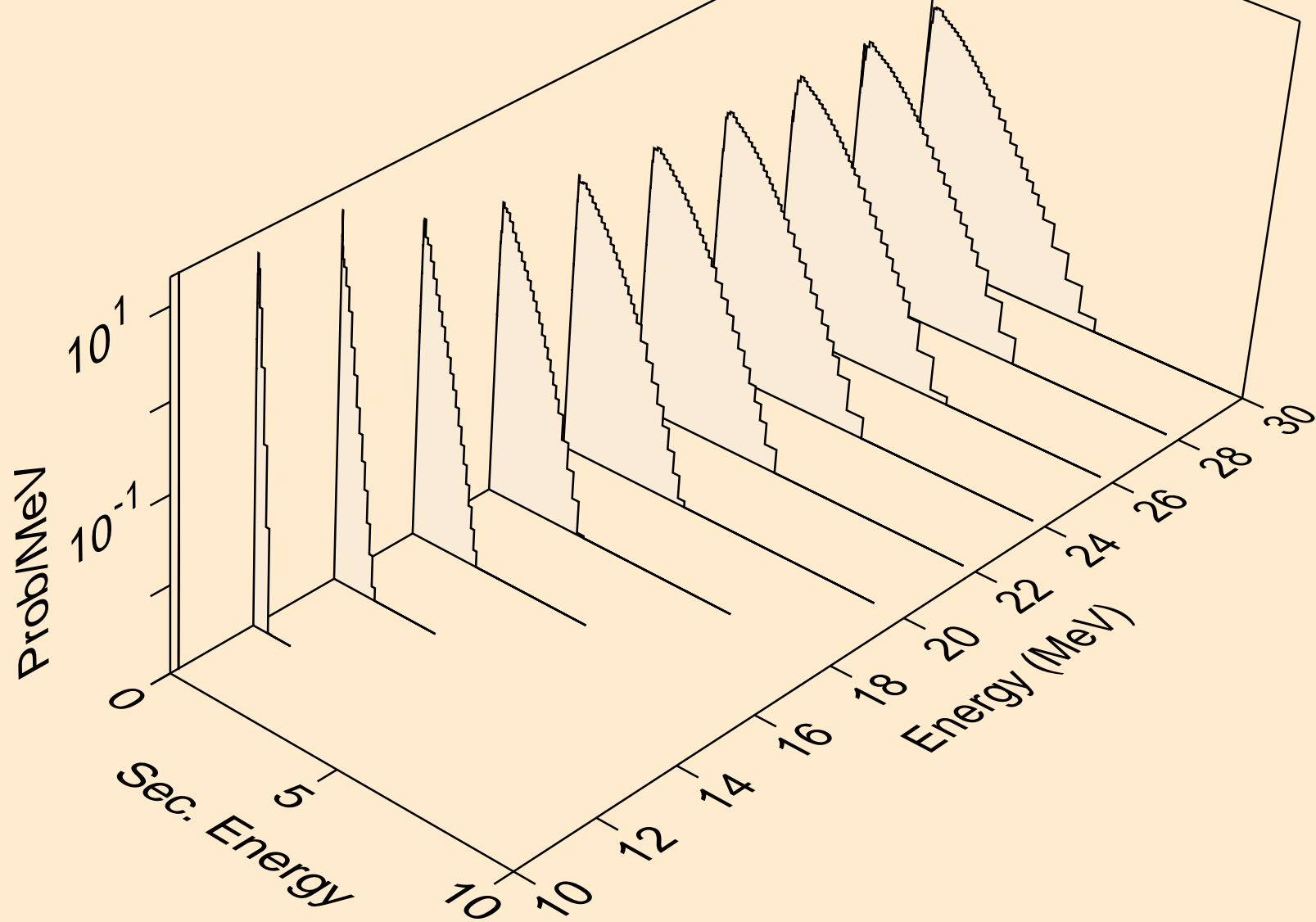

CD123M PROTON ACER TENDL-2023 LIBRARY; T=0.K  
neutrons from (p,n\*)t

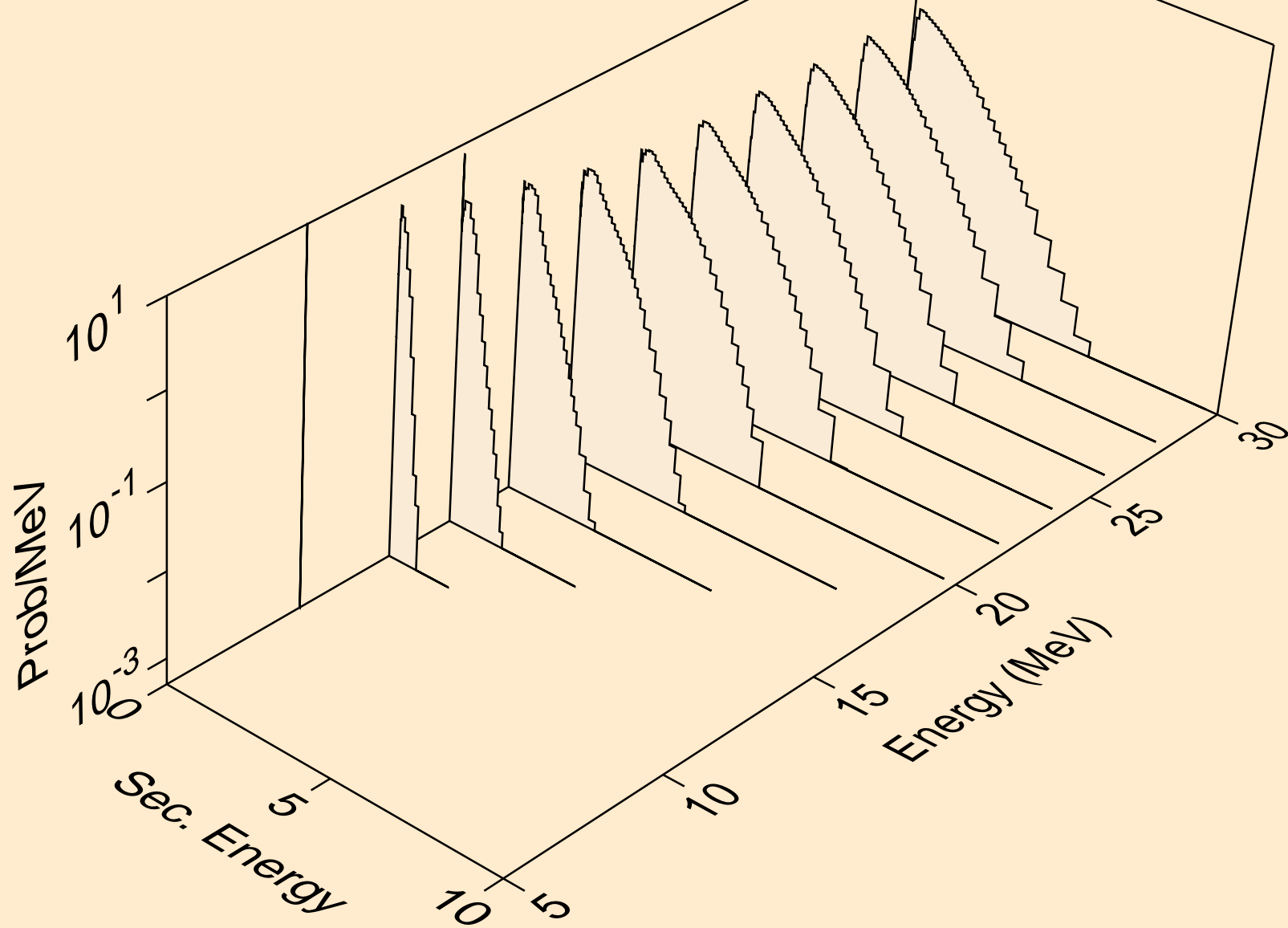

CD123M PROTON ACER TENDL-2023 LIBRARY; T=0.K  
neutrons from (p,n\*)he3

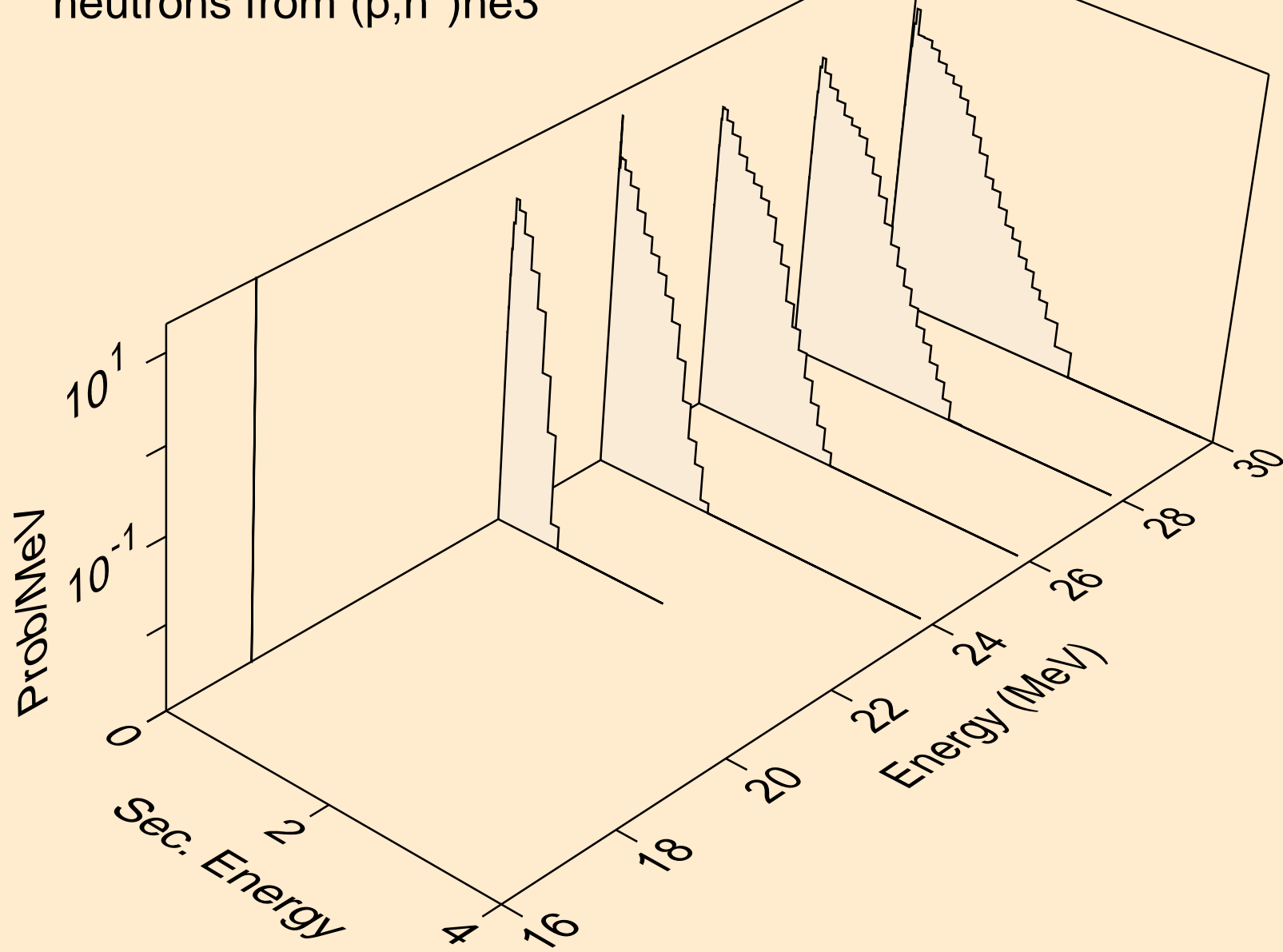

CD123M PROTON ACER TENDL-2023 LIBRARY; T=0.K  
neutrons from (p,4n)

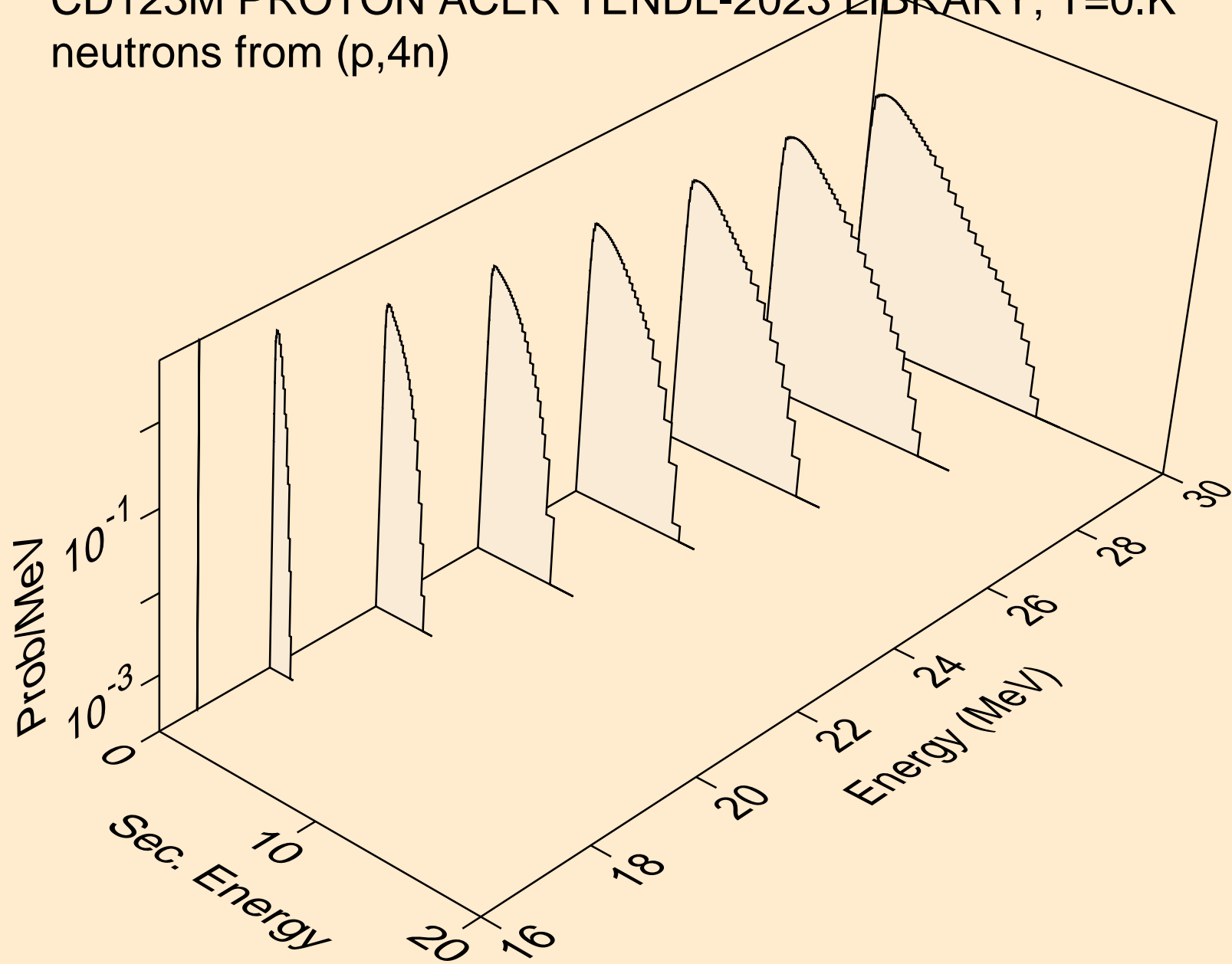



CD123M PROTON ACER TENDL-2023 LIBRARY; T=0.K  
neutrons from (p,2np)

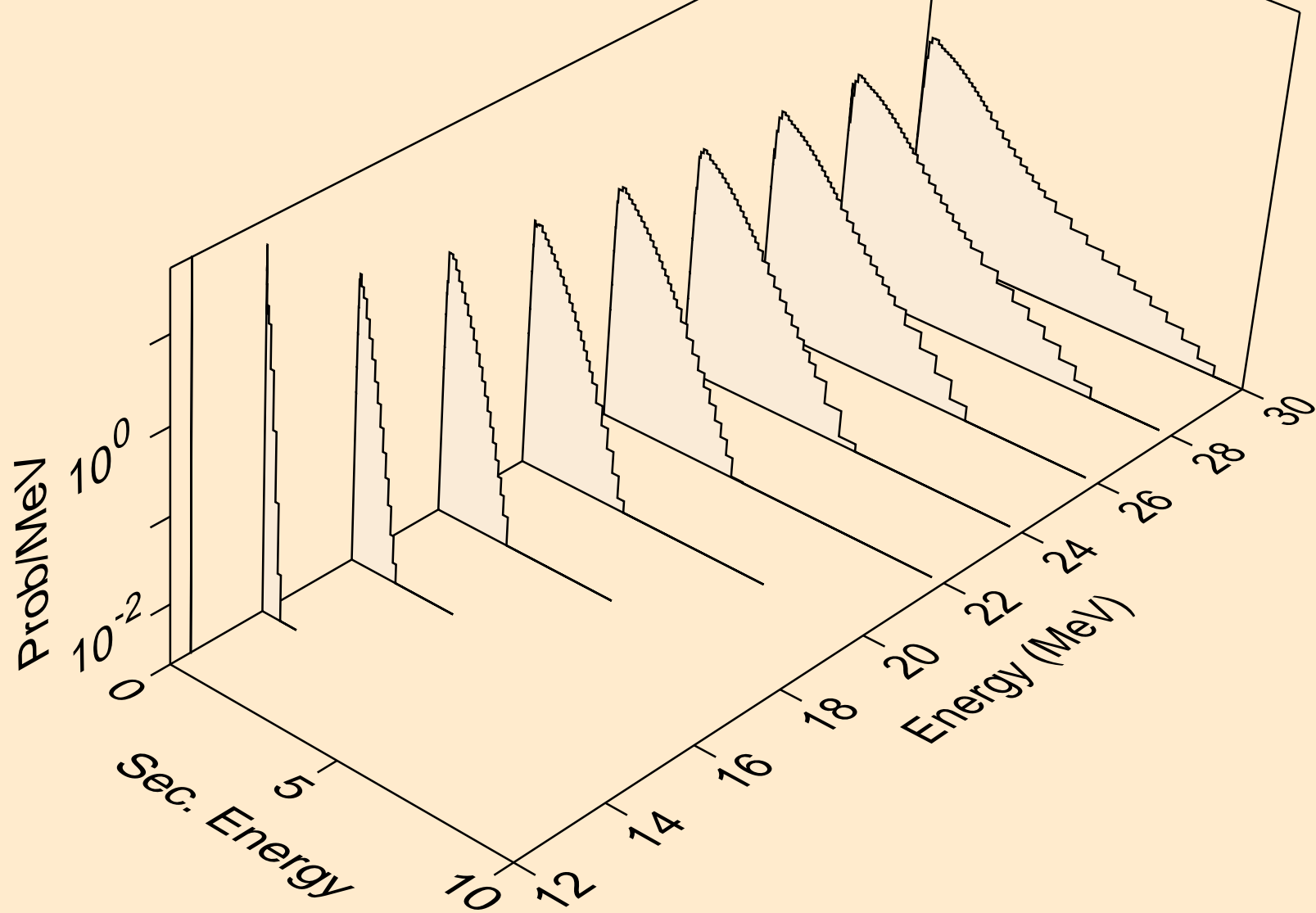

CD123M PROTON ACER TENDL-2023 LIBRARY; T=0.K  
neutrons from (p,3np)

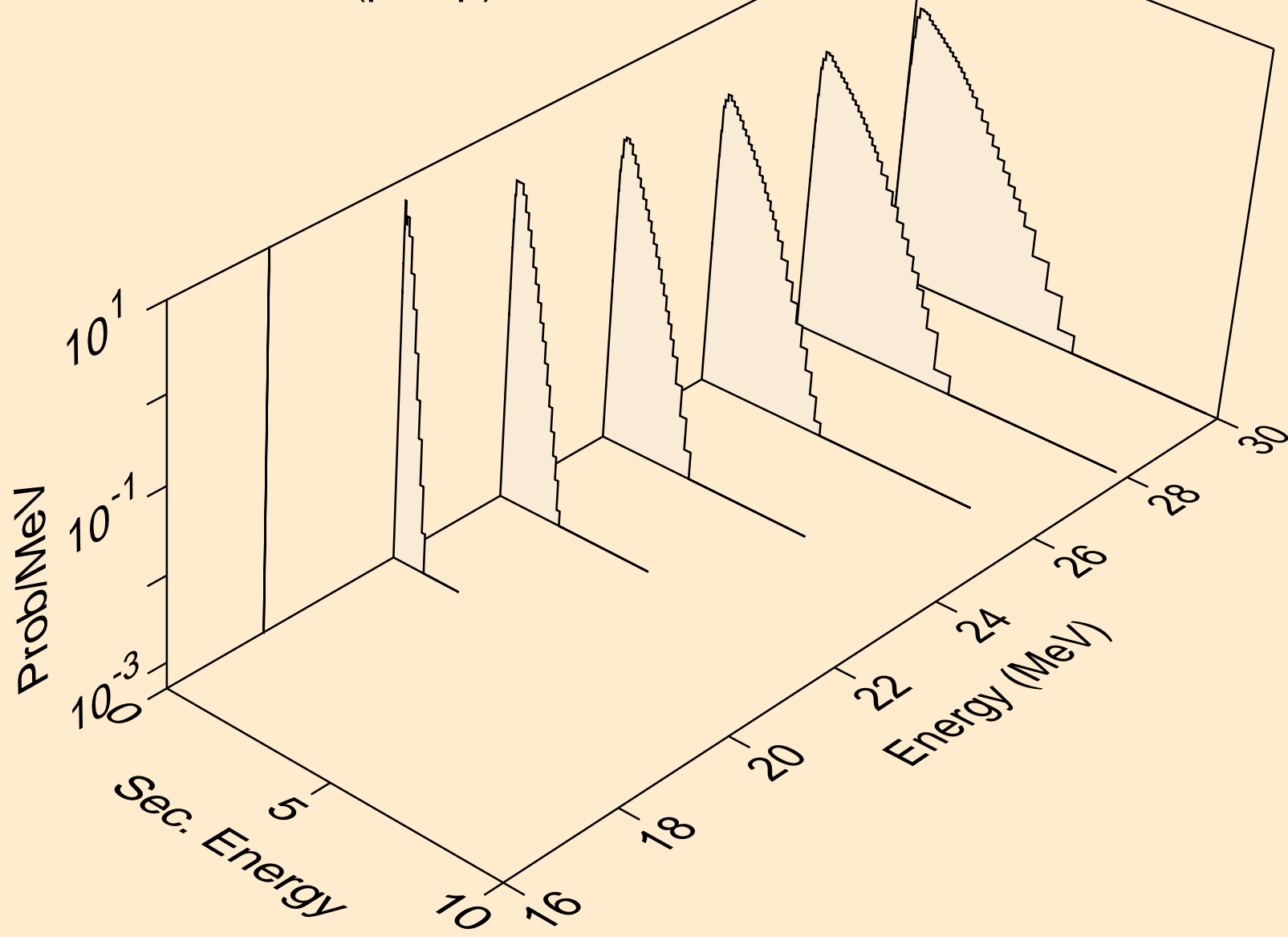

CD123M PROTON ACER TENDL-2023 LIBRARY; T=0.K  
neutrons from (p,n2p)

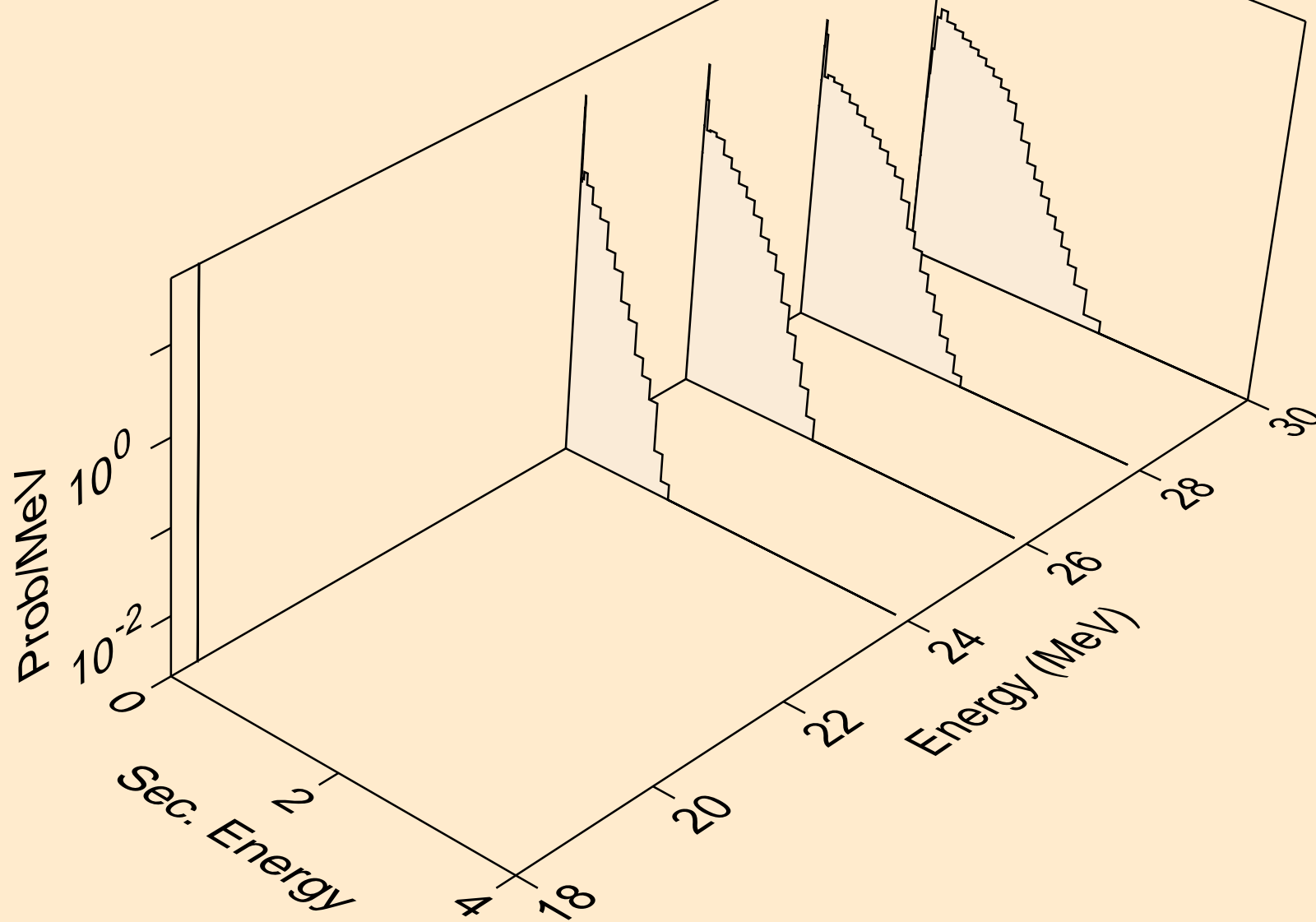

CD123M PROTON ACER TENDL-2023 LIBRARY; T=0.K  
deuterons from (p,x)

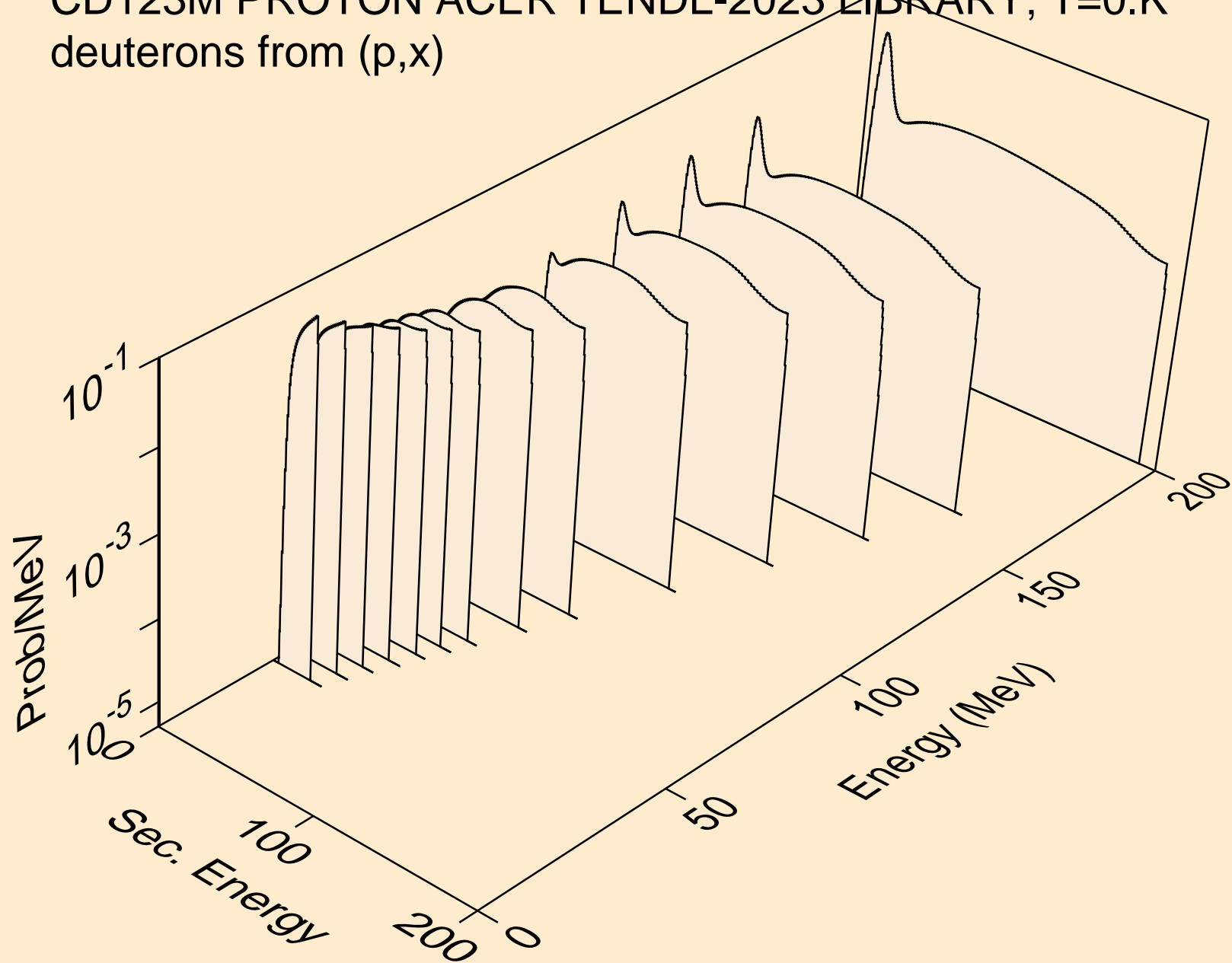

CD123M PROTON ACER TENDL-2023 LIBRARY; T=0.K  
deuterons from (p,2nd)

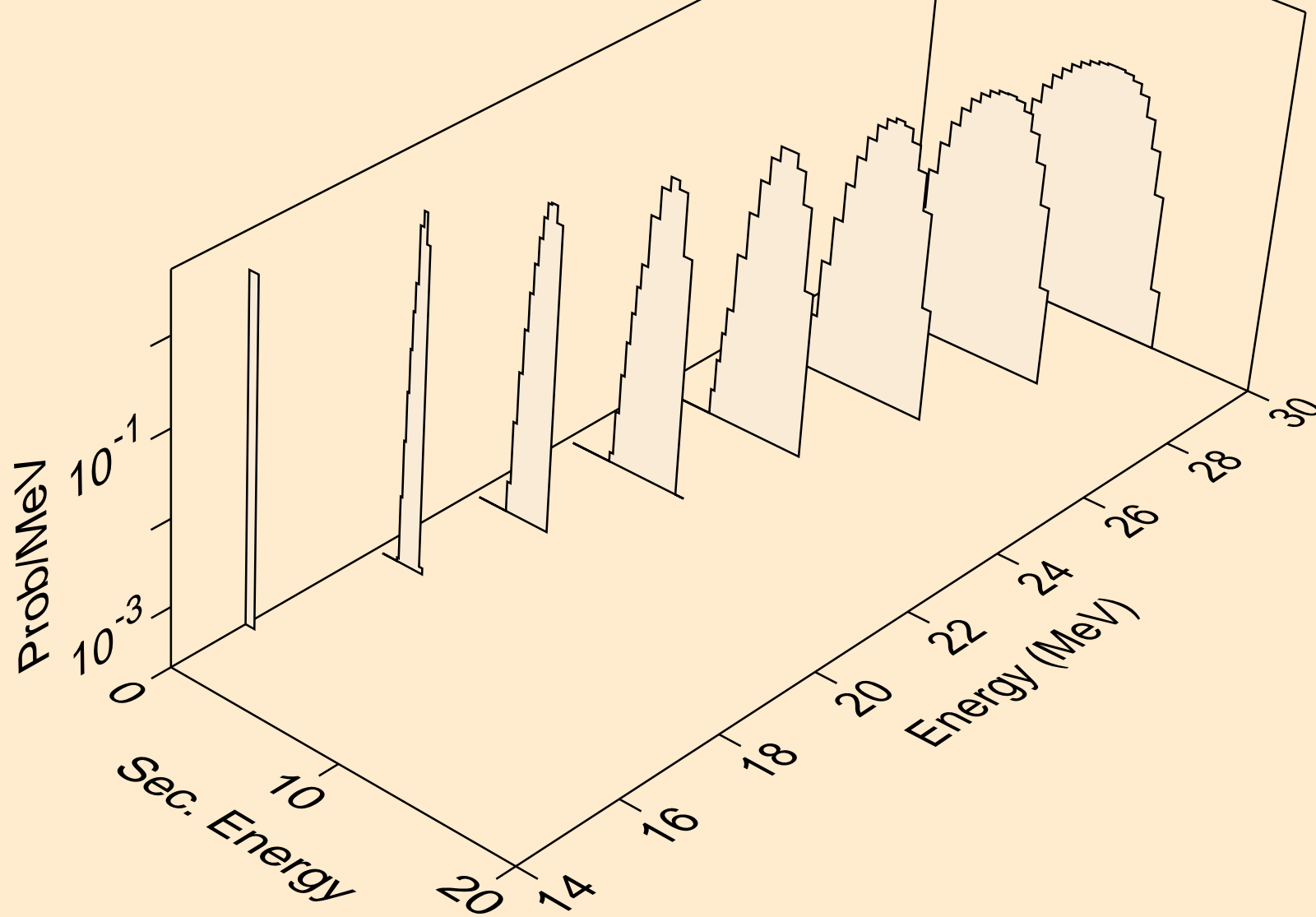

CD123M PROTON ACER TENDL-2023 LIBRARY; T=0.K  
deuterons from (p,n\*)d

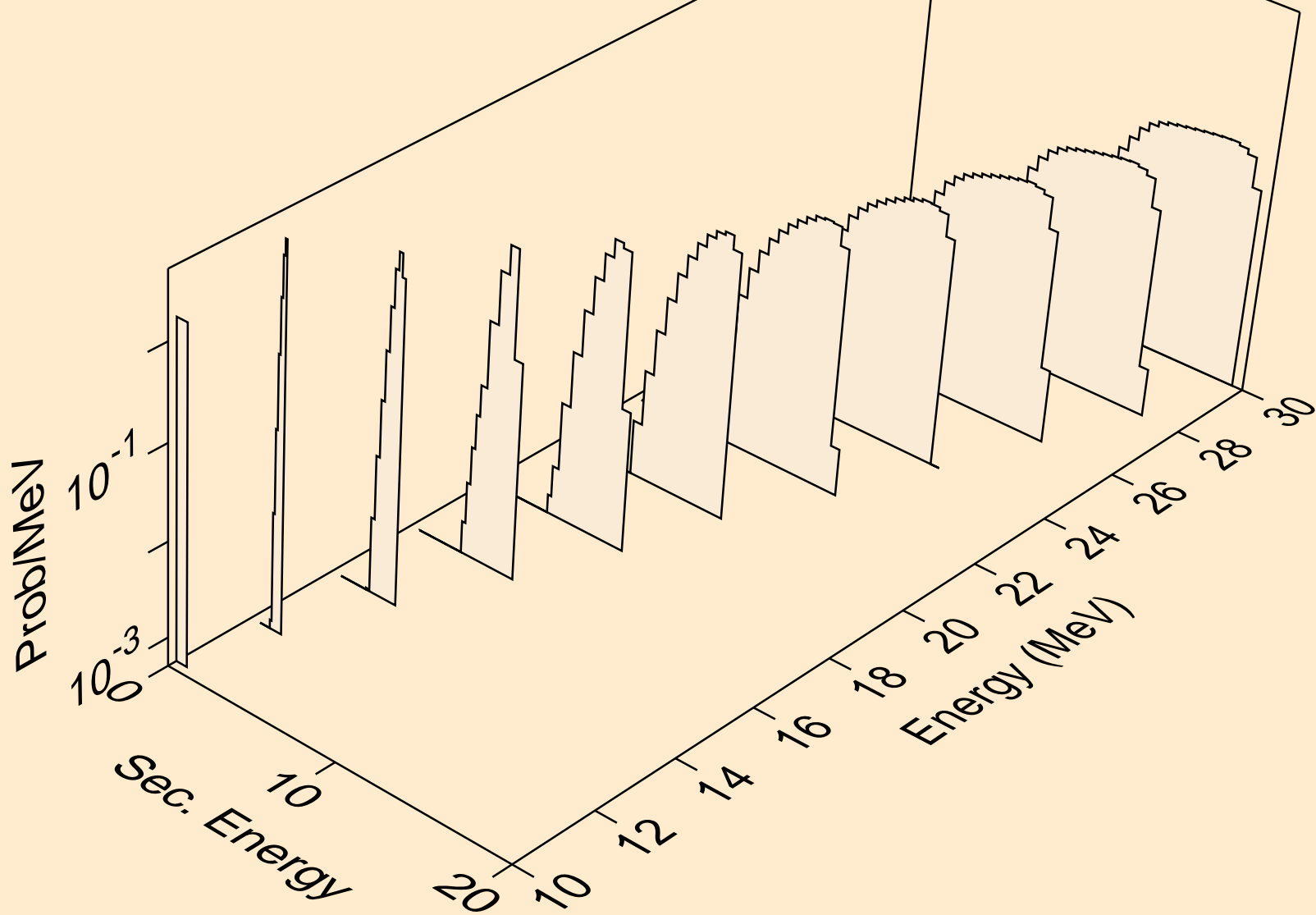

CD123M PROTON ACER TENDL-2023 LIBRARY; T=0.K  
deuterons from (p,d)

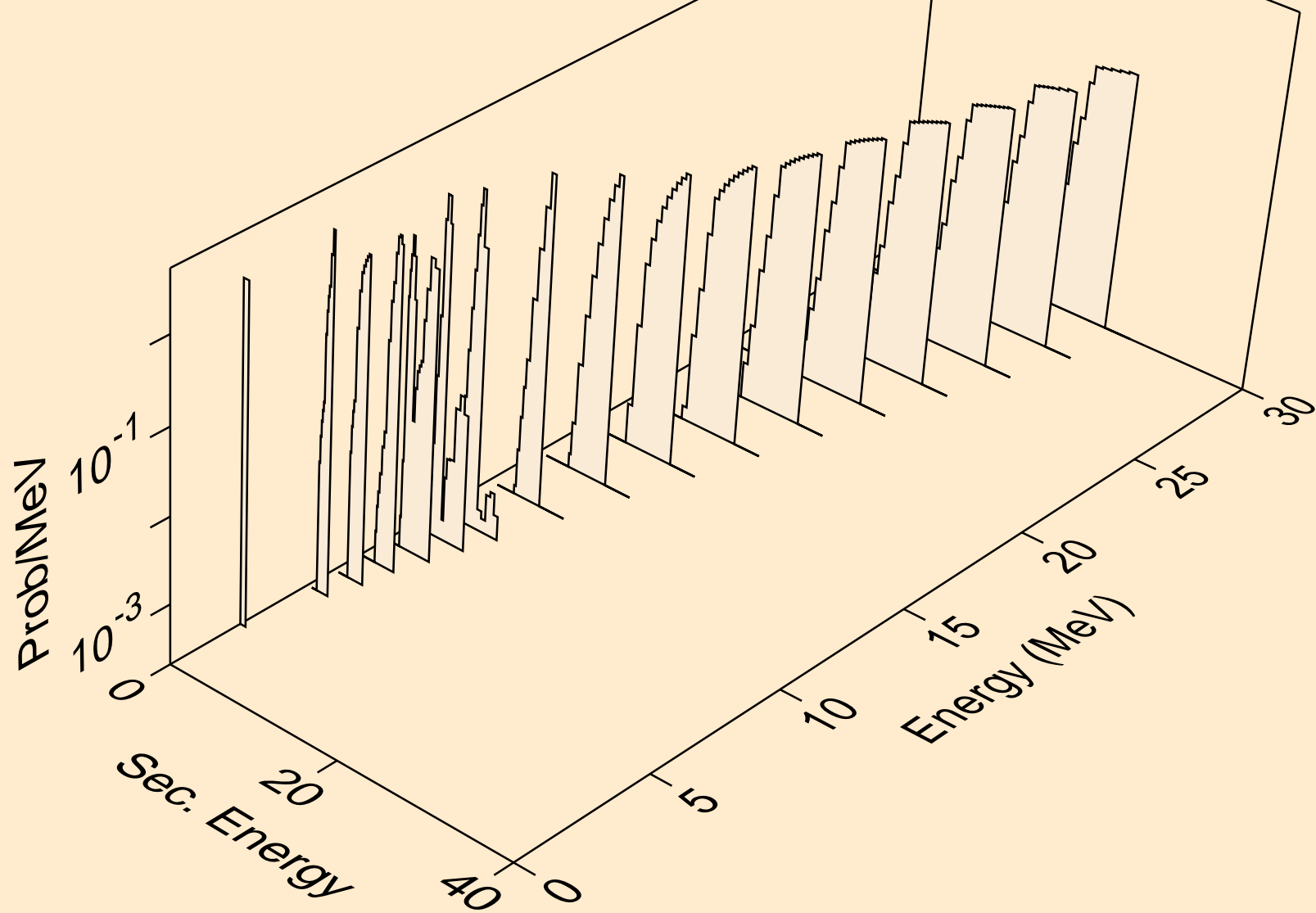

CD123M PROTON ACER TENDL-2023 LIBRARY; T=0.K  
tritons from (p,x)

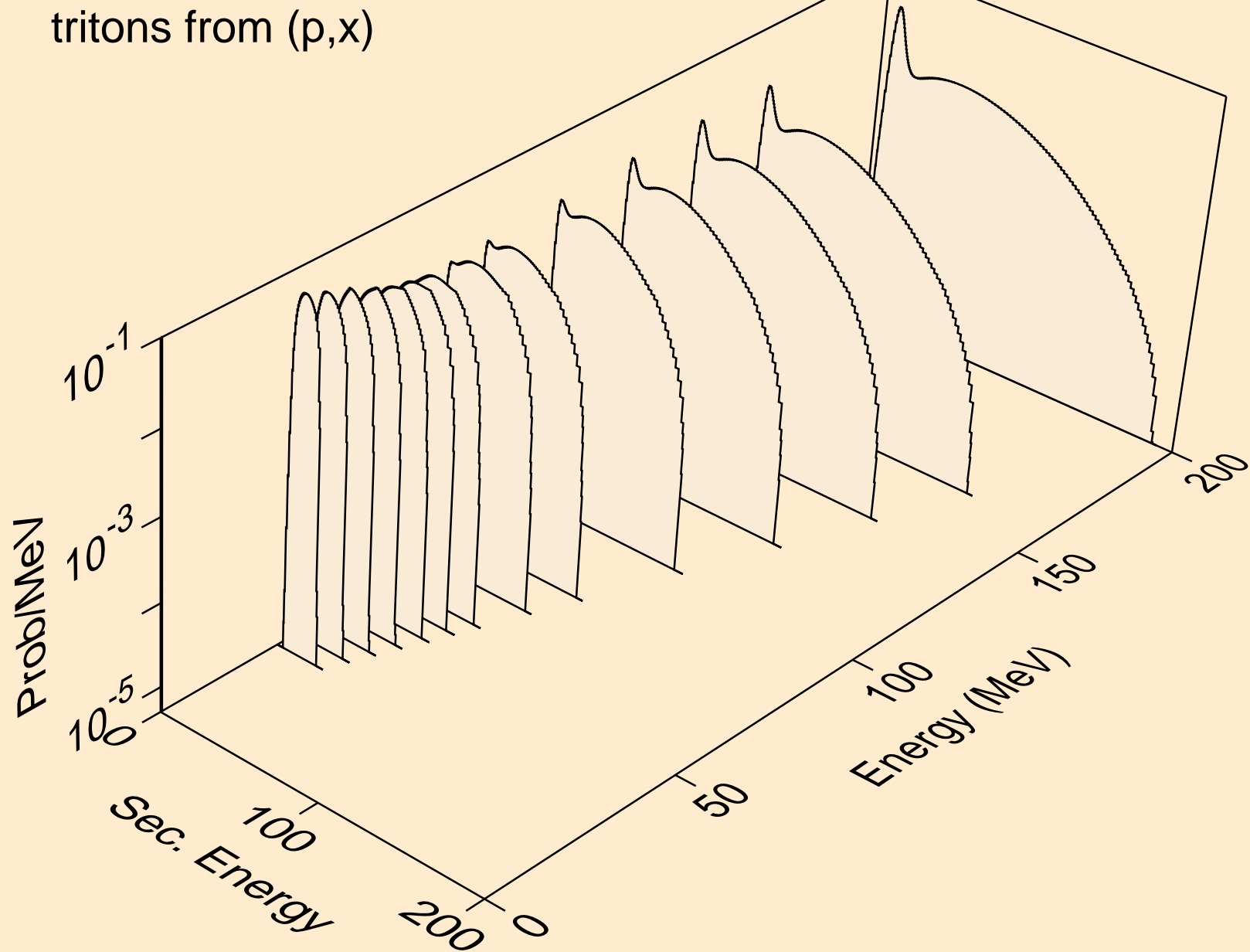



CD123M PROTON ACER TENDL-2023 LIBRARY; T=0.K  
tritons from (p,n\*)t

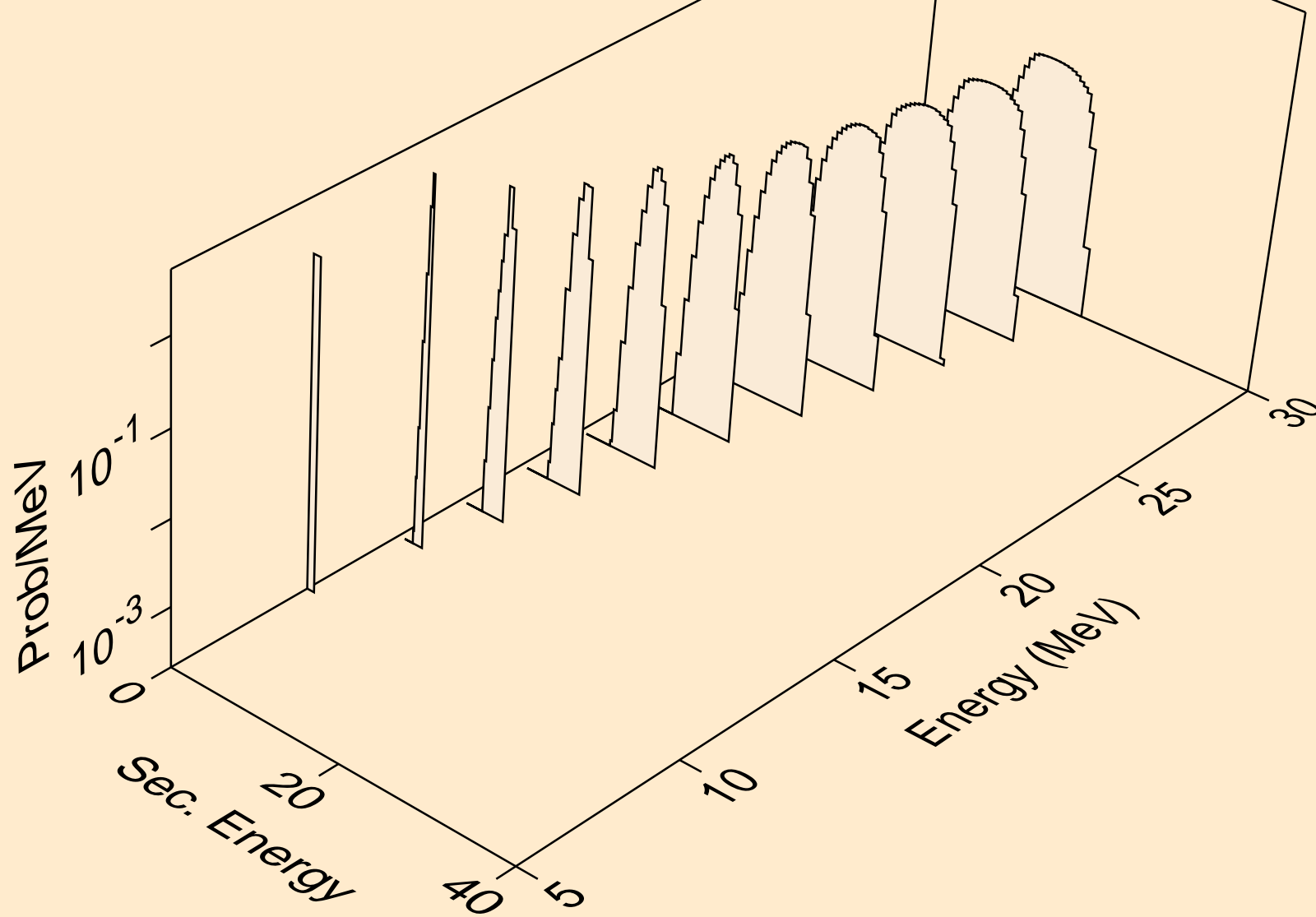

CD123M PROTON ACER TENDL-2023 LIBRARY; T=0.K  
tritons from (p,t)

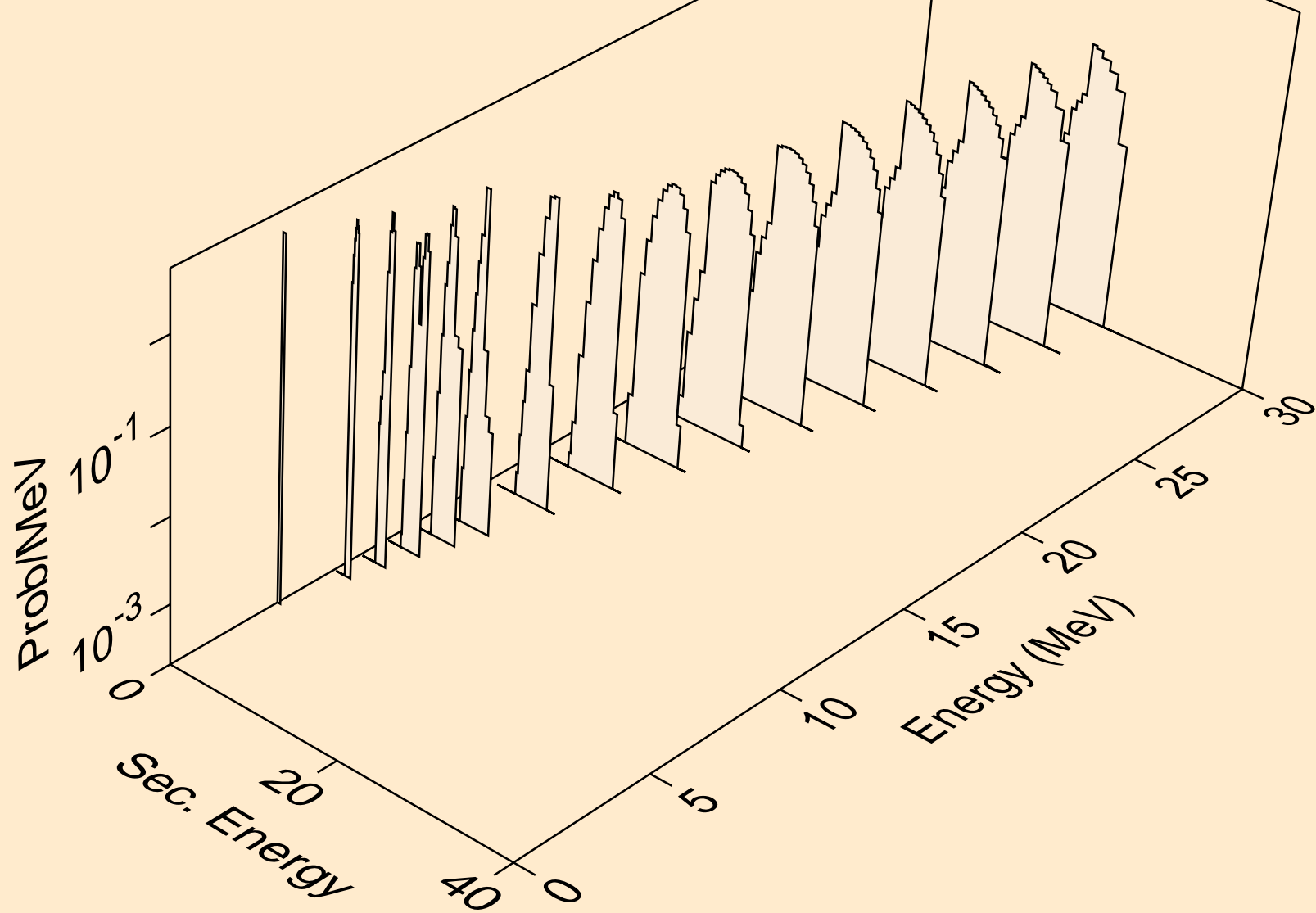

CD123M PROTON ACER TENDL-2023 LIBRARY; T=0.K  
he3s from (p,x)

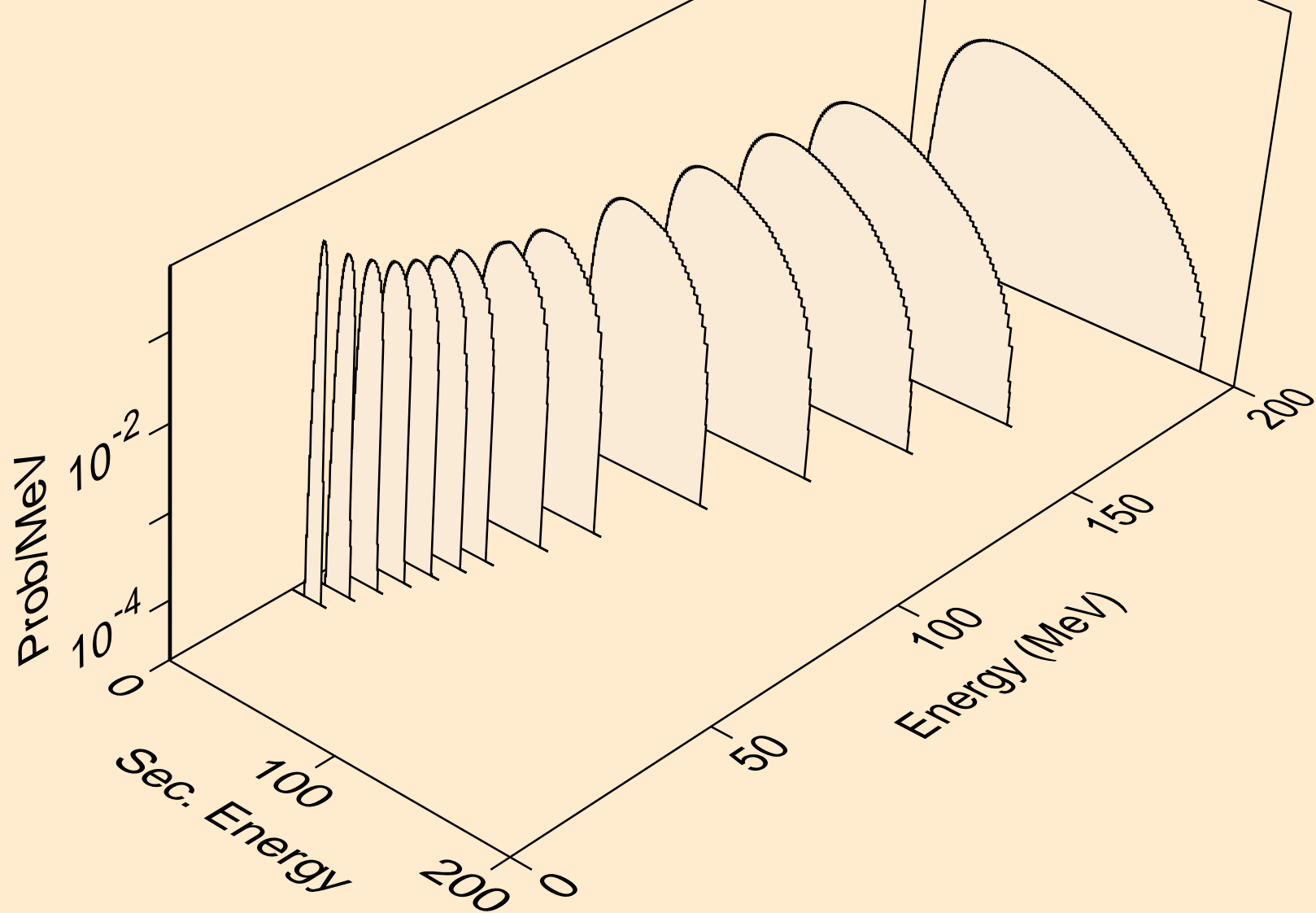

CD123M PROTON ACER TENDL-2023 LIBRARY; T=0.K  
he3s from (p,n\*)he3

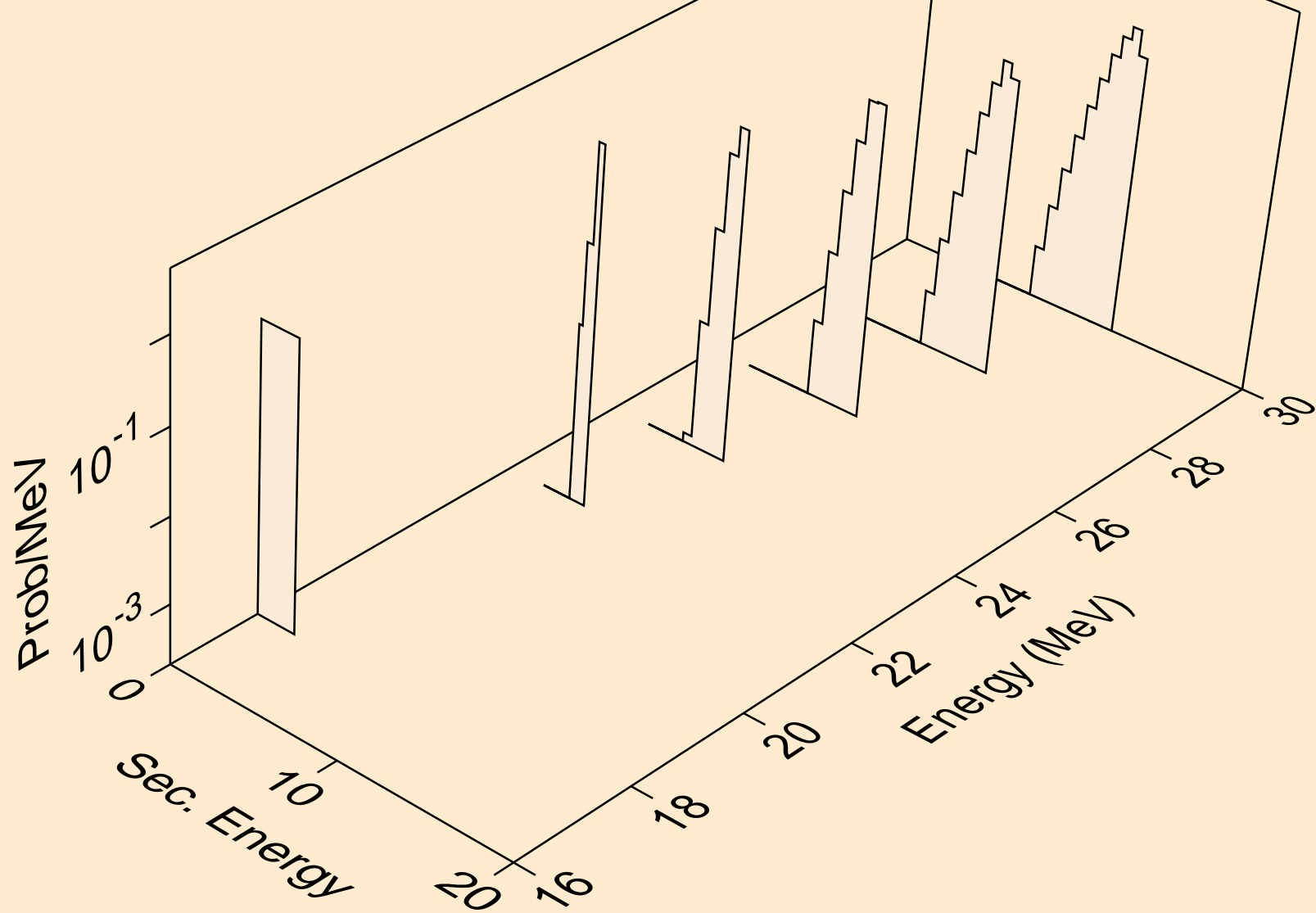

CD123M PROTON ACER TENDL-2023 LIBRARY; T=0.K  
he3s from (p,he3)

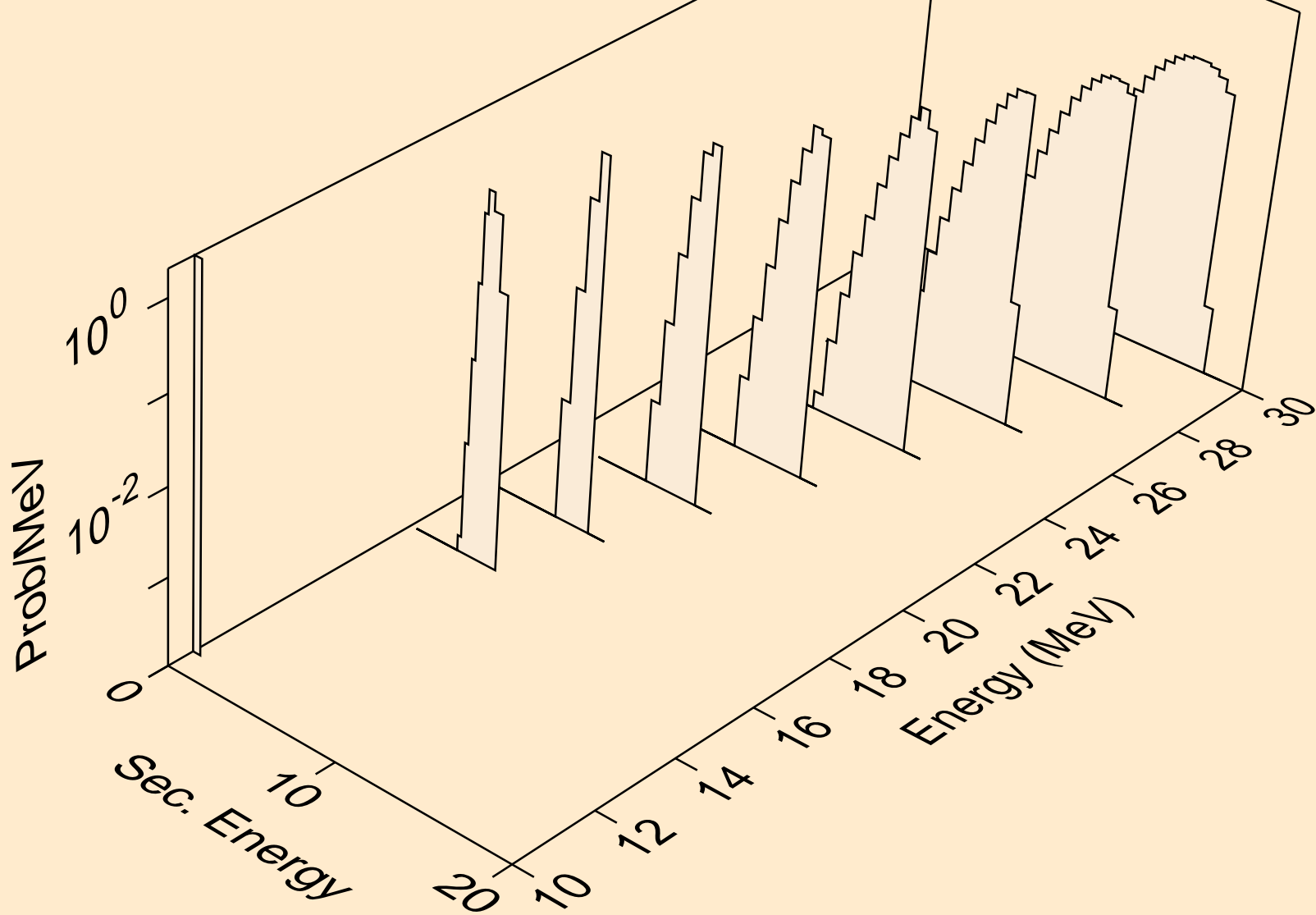

CD123M PROTON ACER TENDL-2023 LIBRARY; T=0.K  
alphas from (p,x)

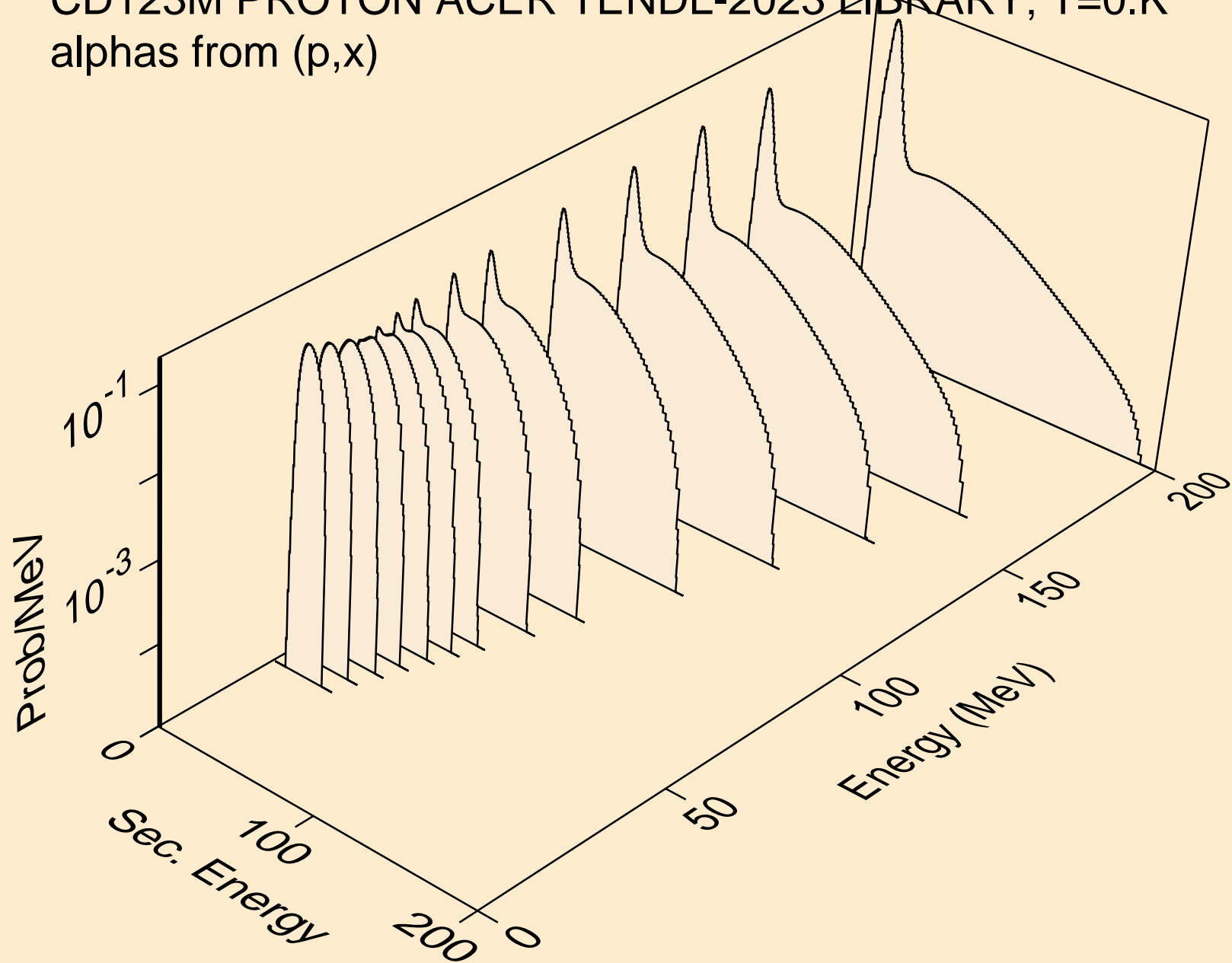

CD123M PROTON ACER TENDL-2023 LIBRARY; T=0.K  
alphas from (p,n\*)a

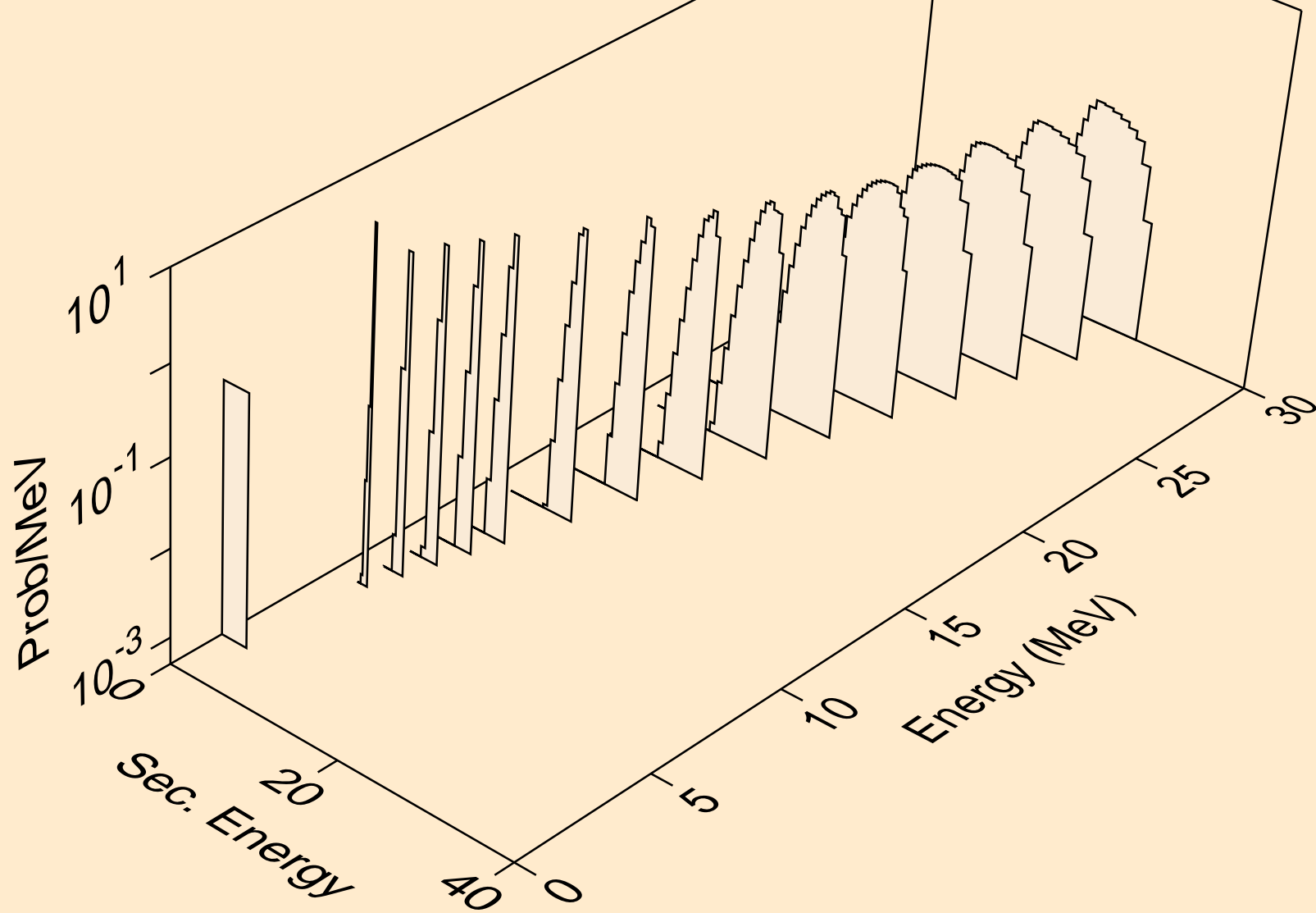

CD123M PROTON ACER TENDL-2023 LIBRARY; T=0.K  
alphas from (p,2n)a

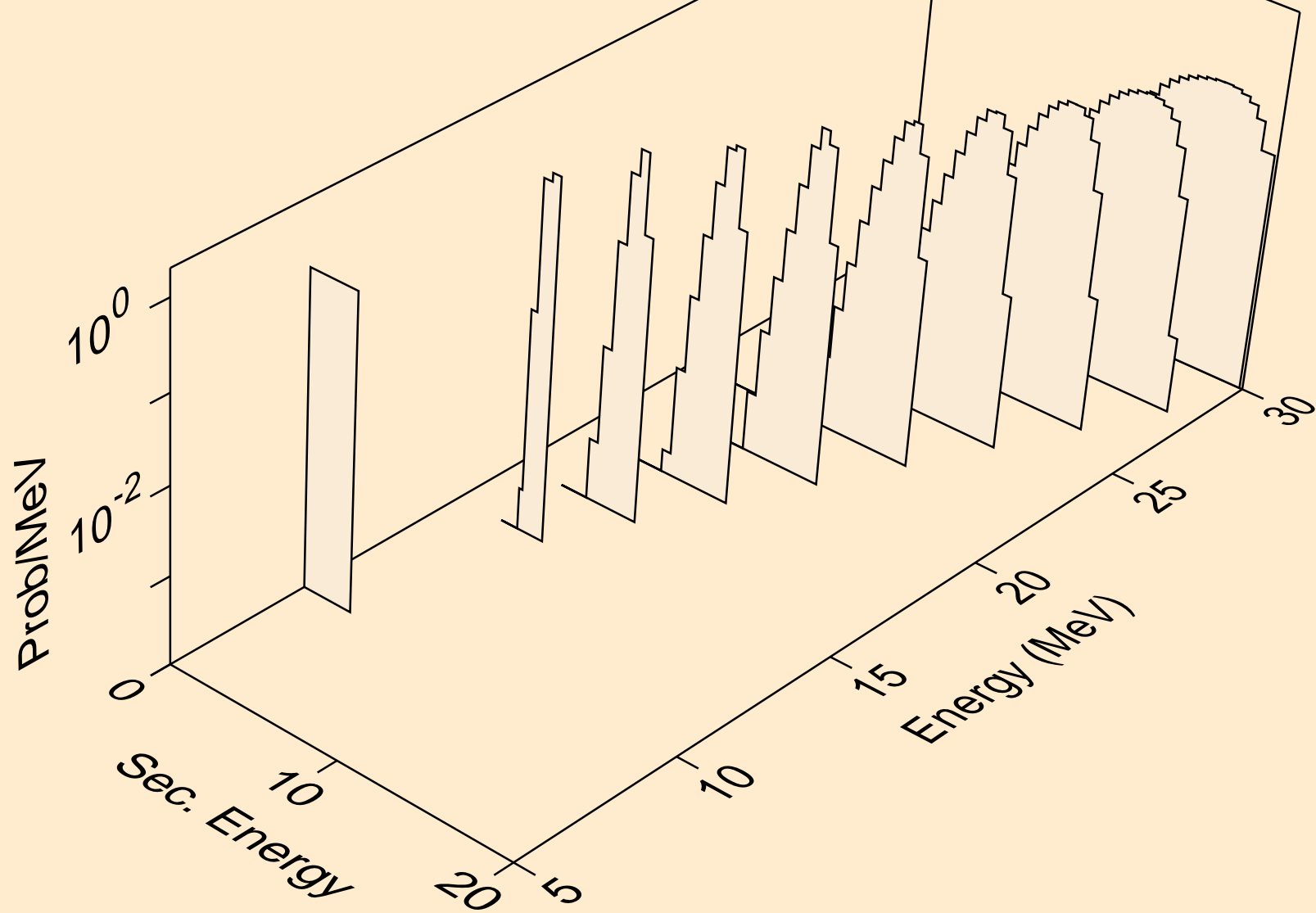



CD123M PROTON ACER TENDL-2023 LIBRARY; T=0.K  
alphas from (p,3n)a

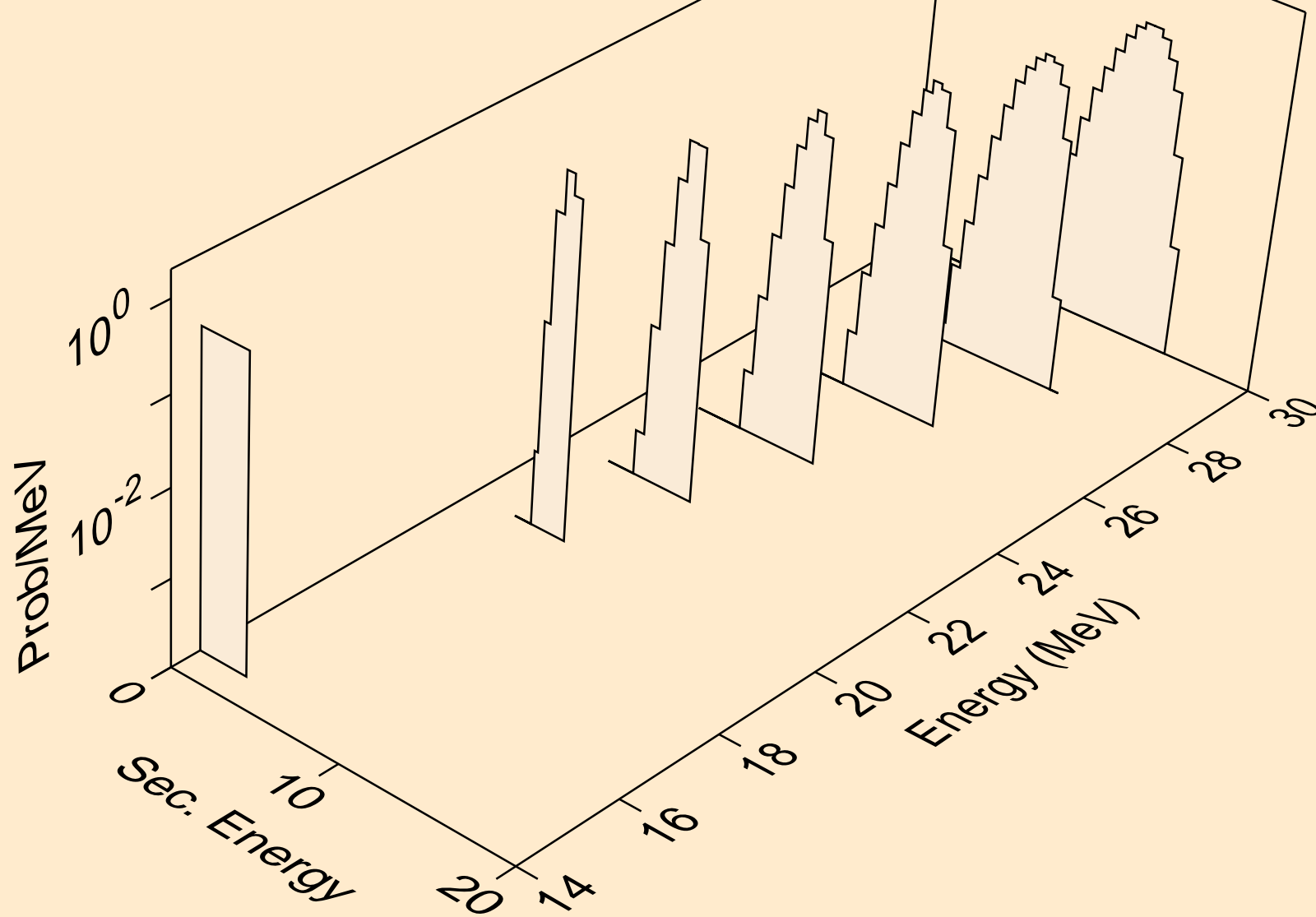

CD123M PROTON ACER TENDL-2023 LIBRARY; T=0.K  
alphas from (p,a)

