

# ER162 PROTON ACER TENDL-2023 LIBRARY; T=0.K

## Principal cross sections

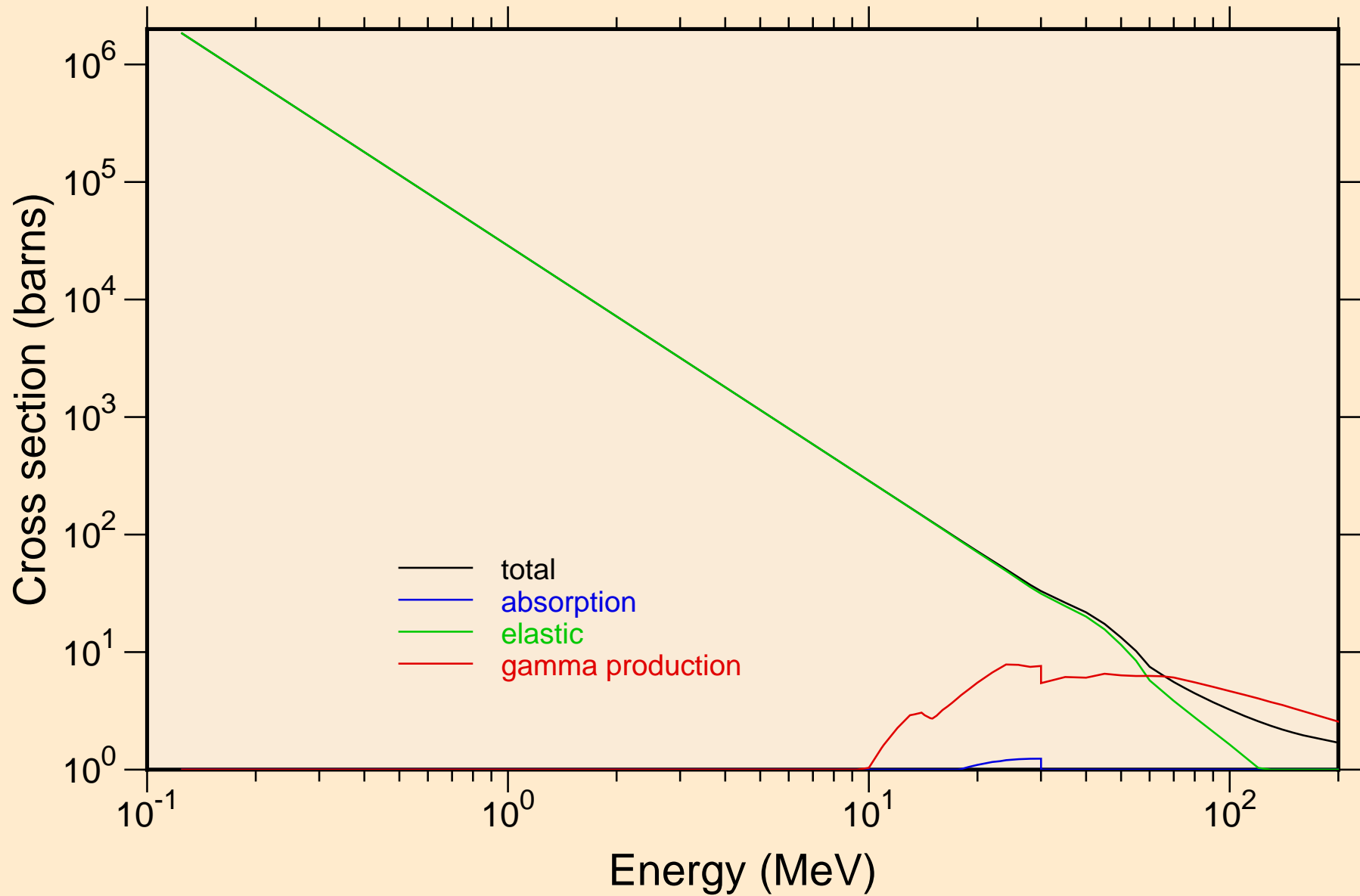

# ER162 PROTON ACER TENDL-2023 LIBRARY; T=0.K

## Heating

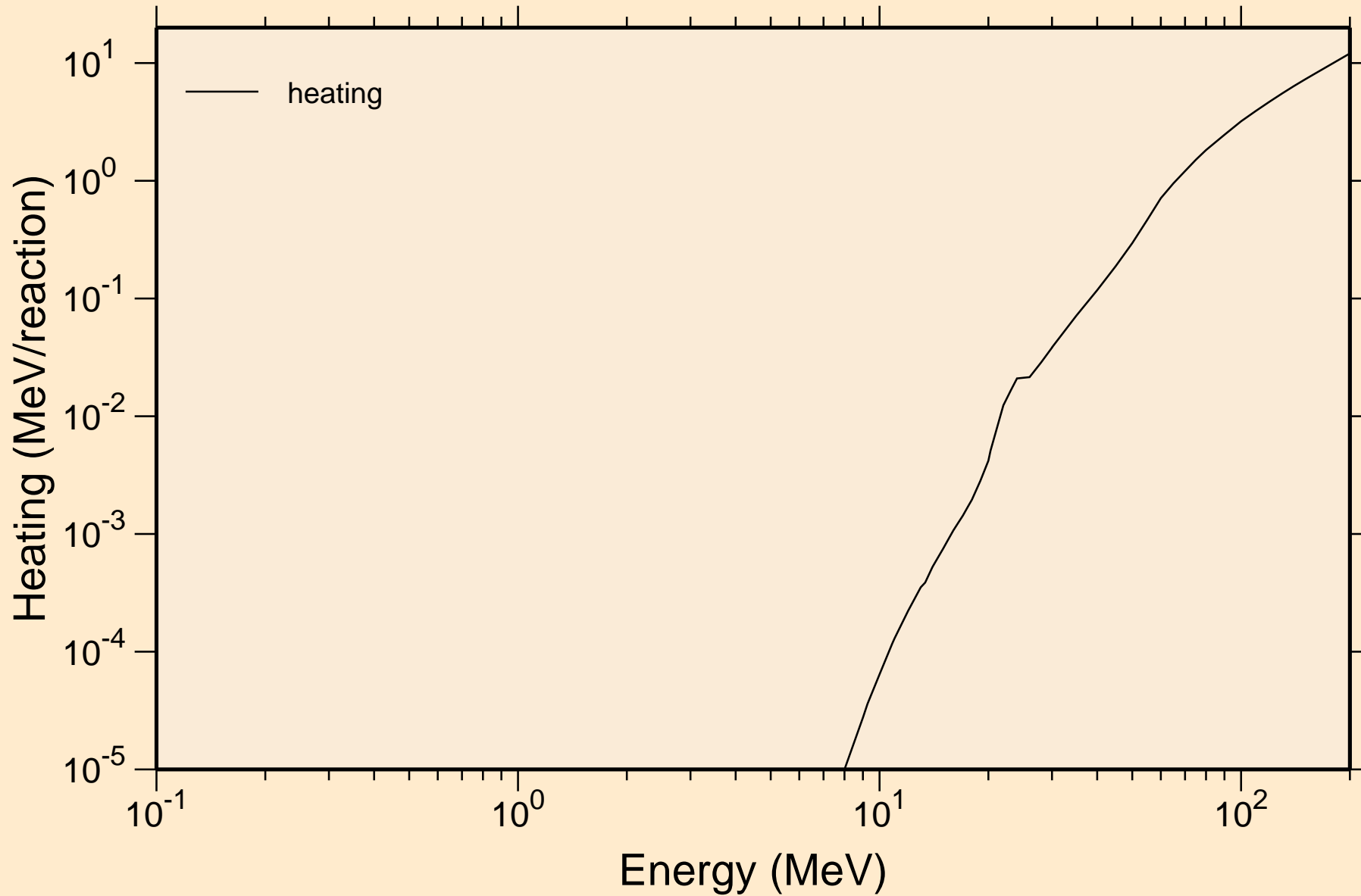

# ER162 PROTON ACER TENDL-2023 LIBRARY; T=0.K

## Principal cross sections

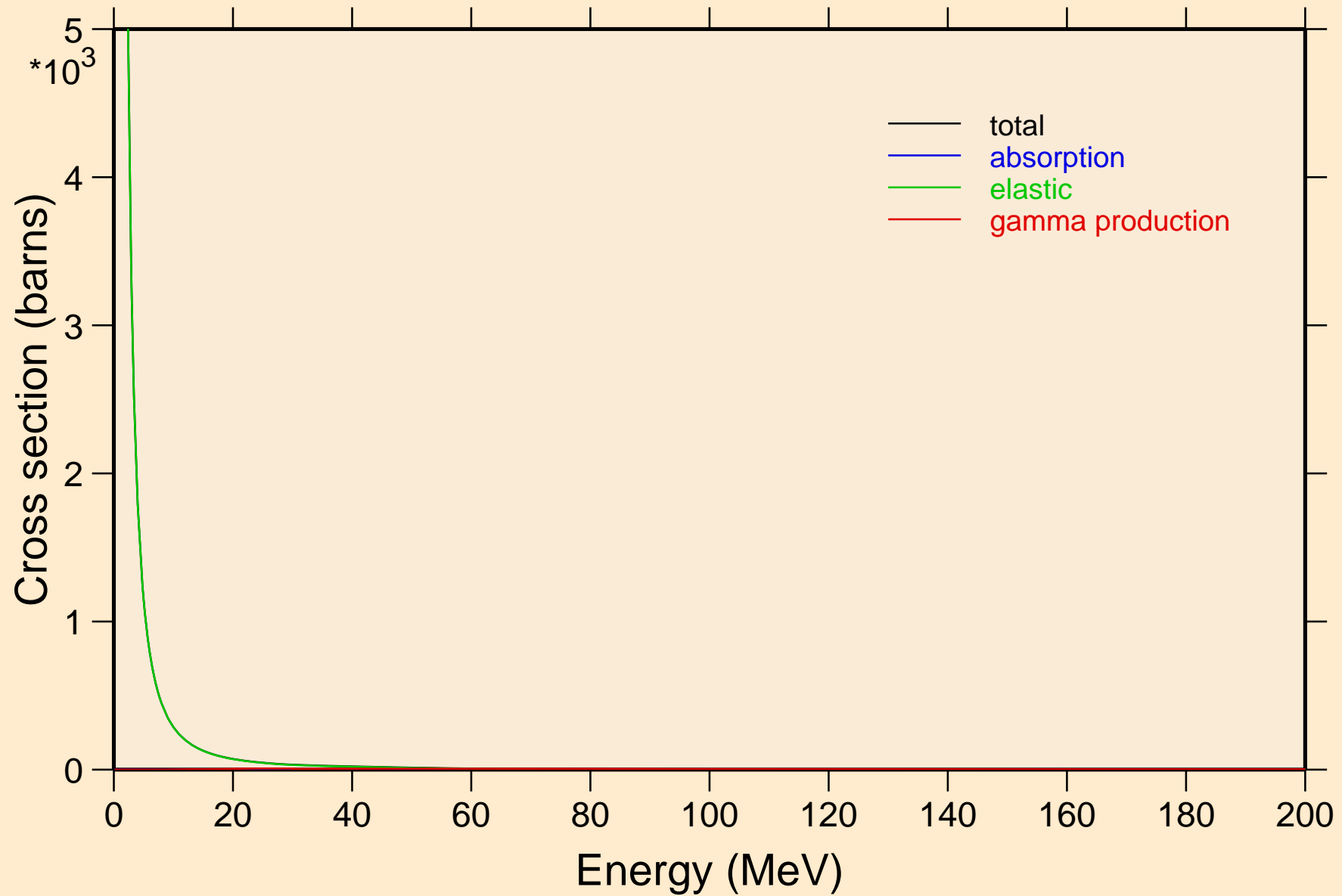

# ER162 PROTON ACER TENDL-2023 LIBRARY; T=0.K

## Heating

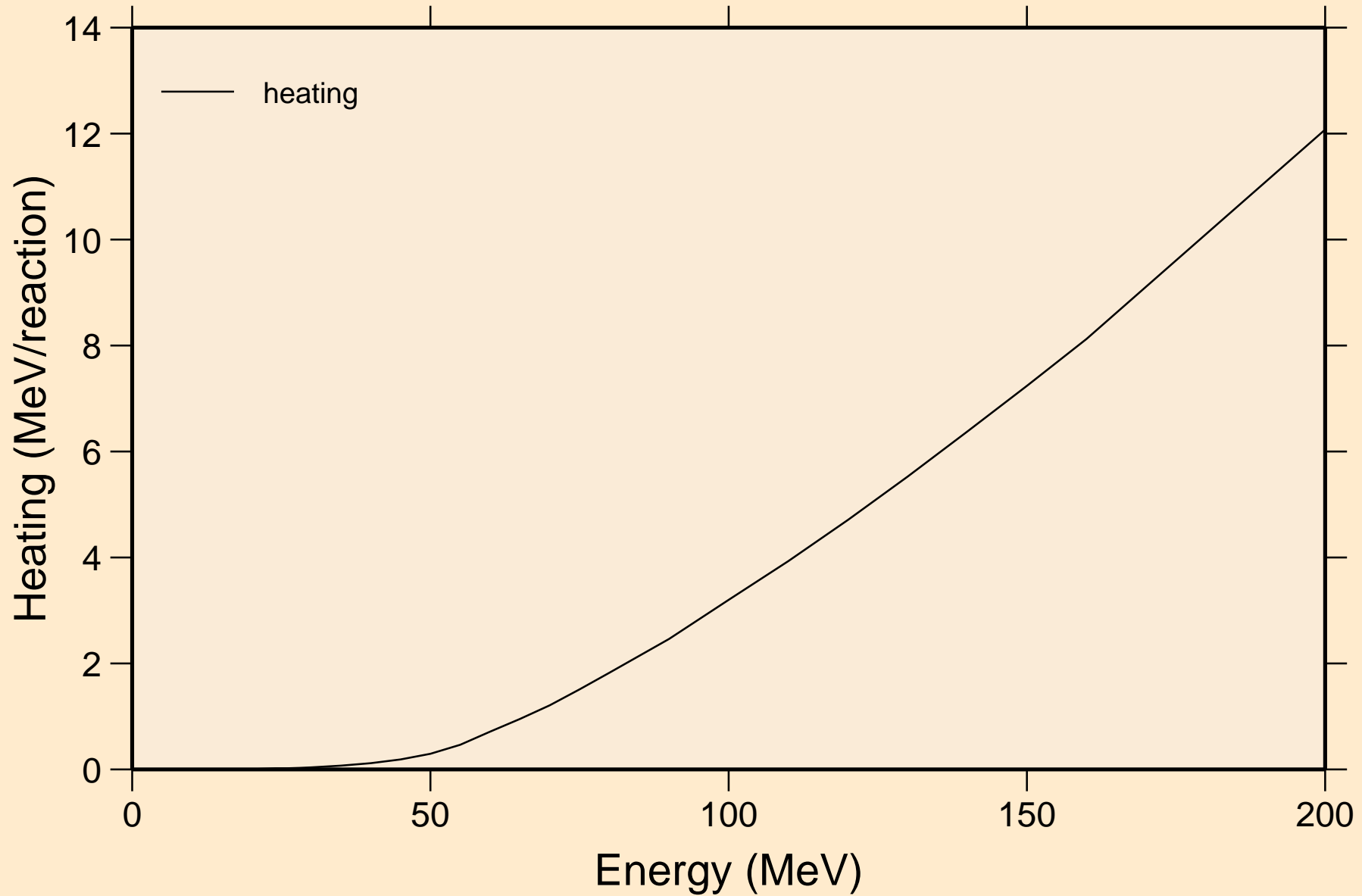

# ER162 PROTON ACER TENDL-2023 LIBRARY; T=0.K

## Threshold reactions

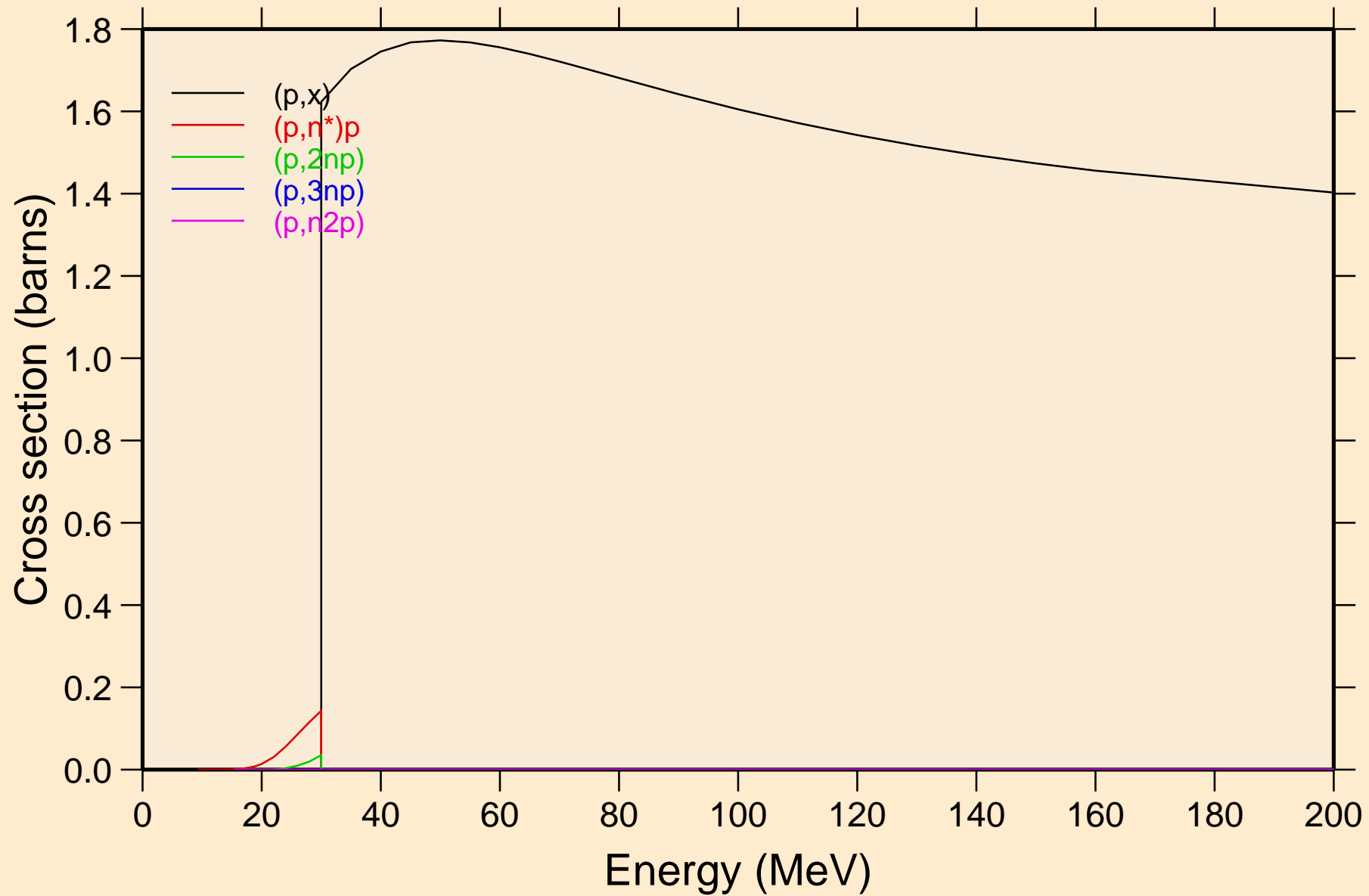

# ER162 PROTON ACER TENDL-2023 LIBRARY; T=0.K

## Threshold reactions

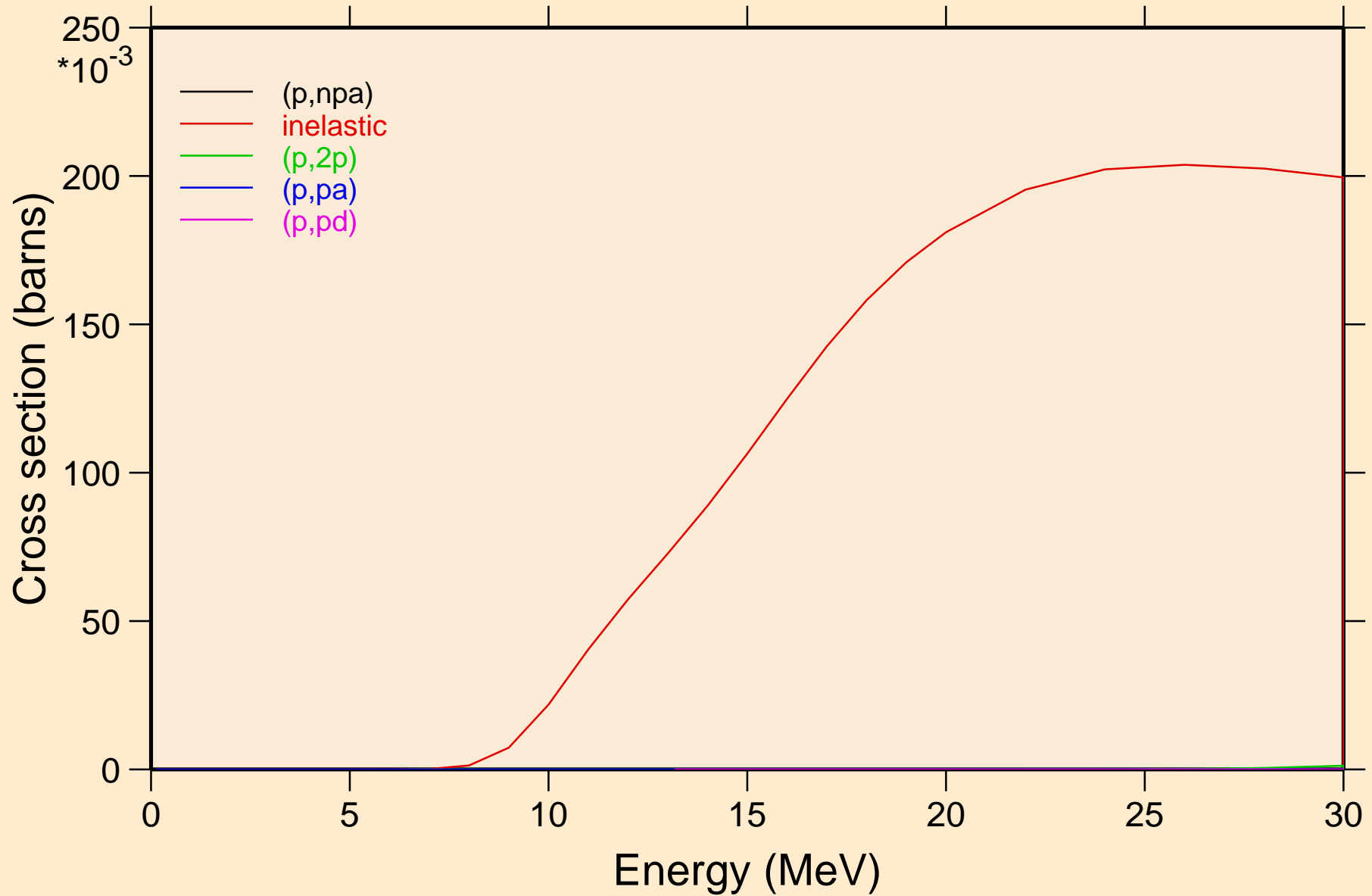

ER162 PROTON ACER TENDL-2023 LIBRARY; T=0.K  
Threshold reactions

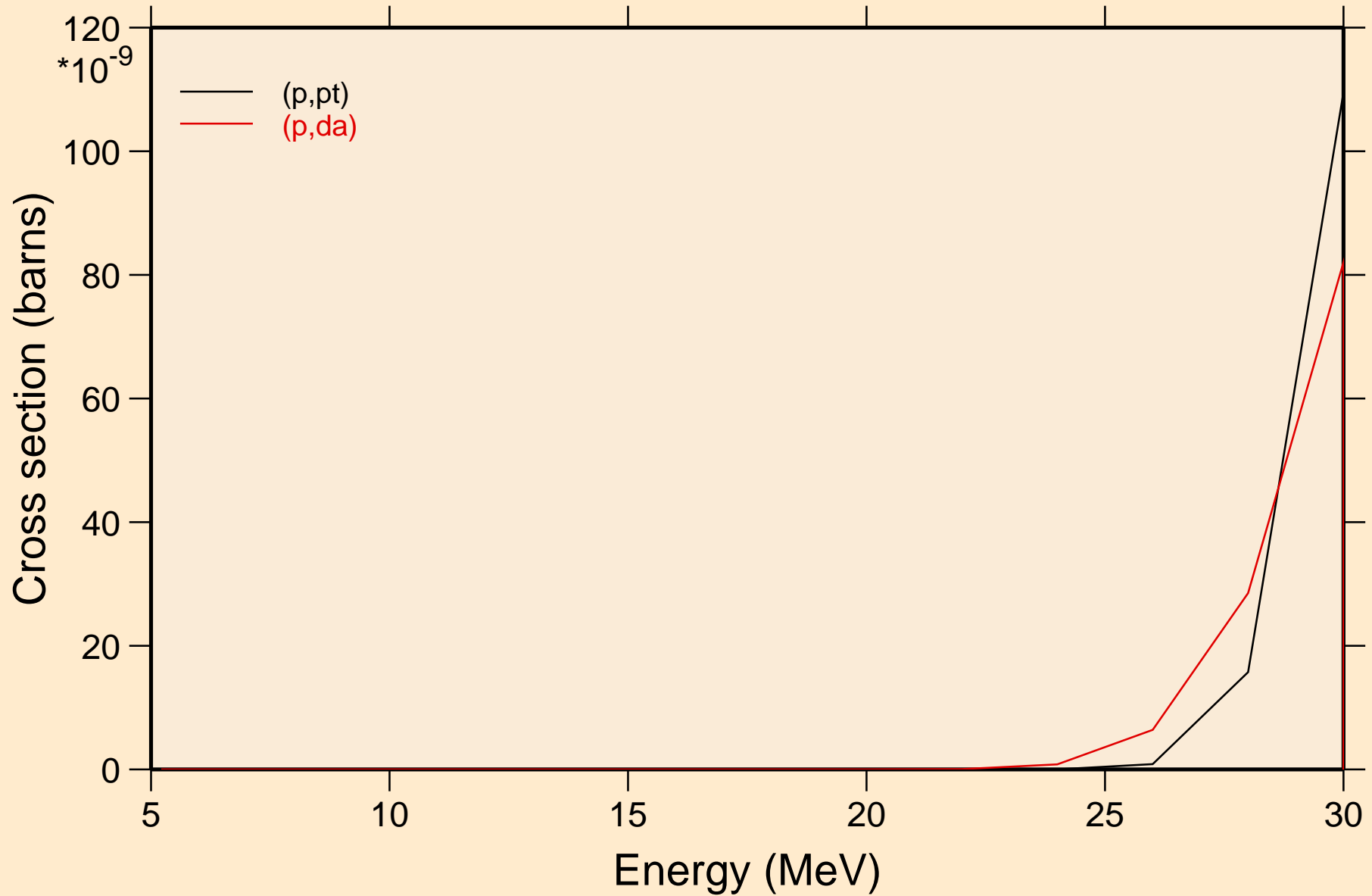

ER162 PROTON ACER TENDL-2023 LIBRARY; T=0.K  
angular distribution for elastic

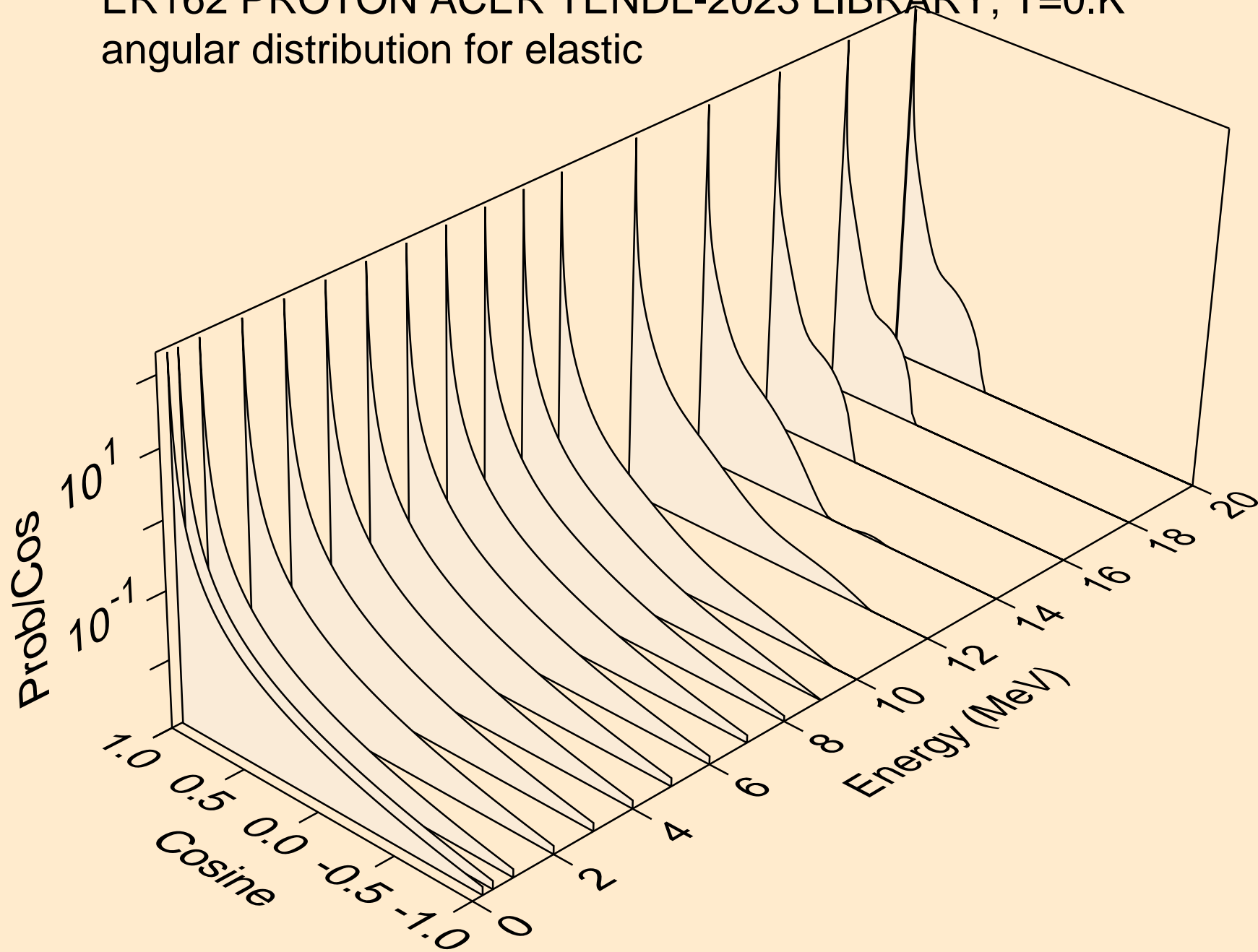



ER162 PROTON ACER TENDL-2023 LIBRARY; T=0.K  
angular distribution for elastic

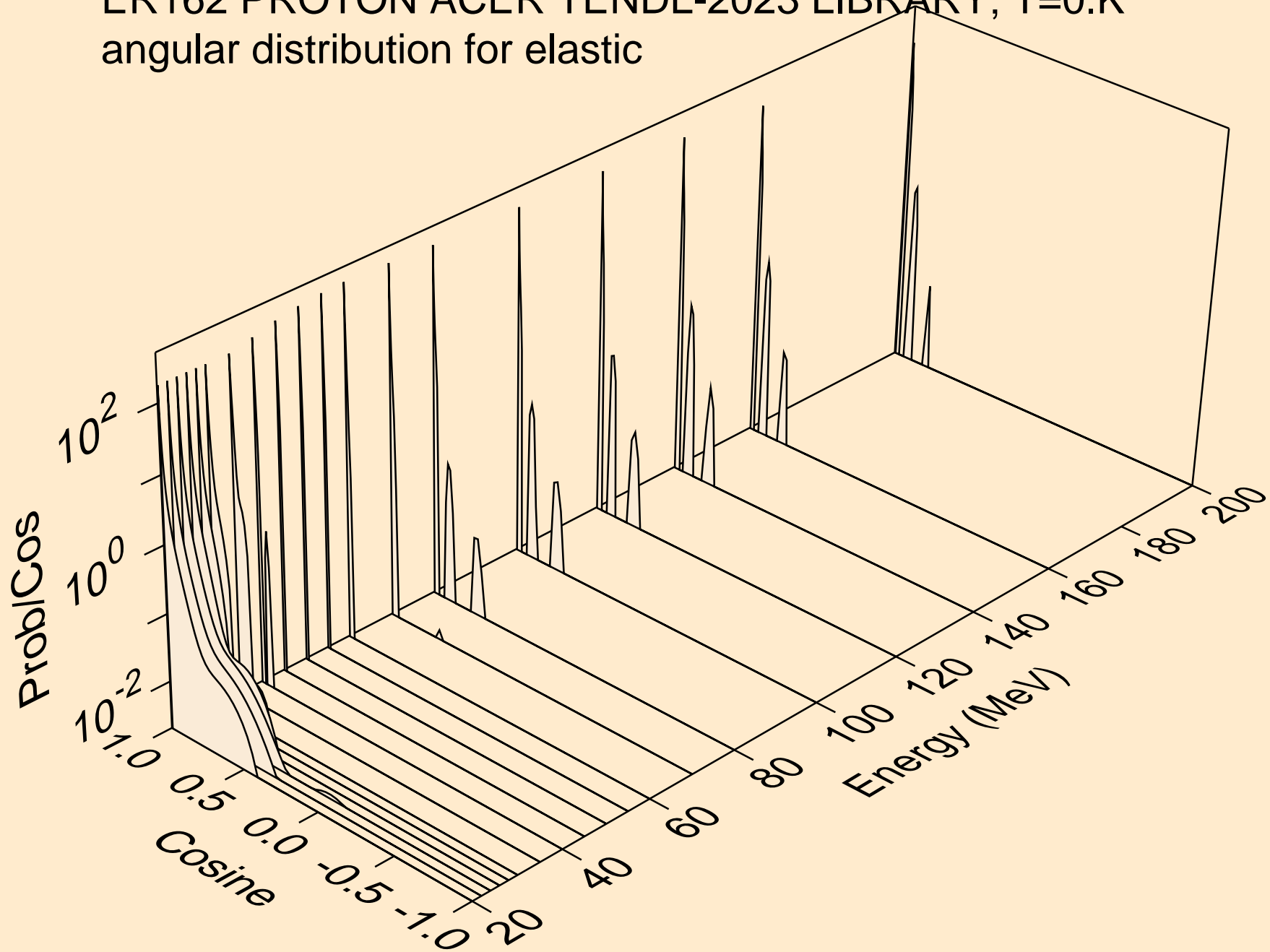

ER162 PROTON ACER TENDL-2023 LIBRARY; T=0.K  
Proton emission for (p,x)

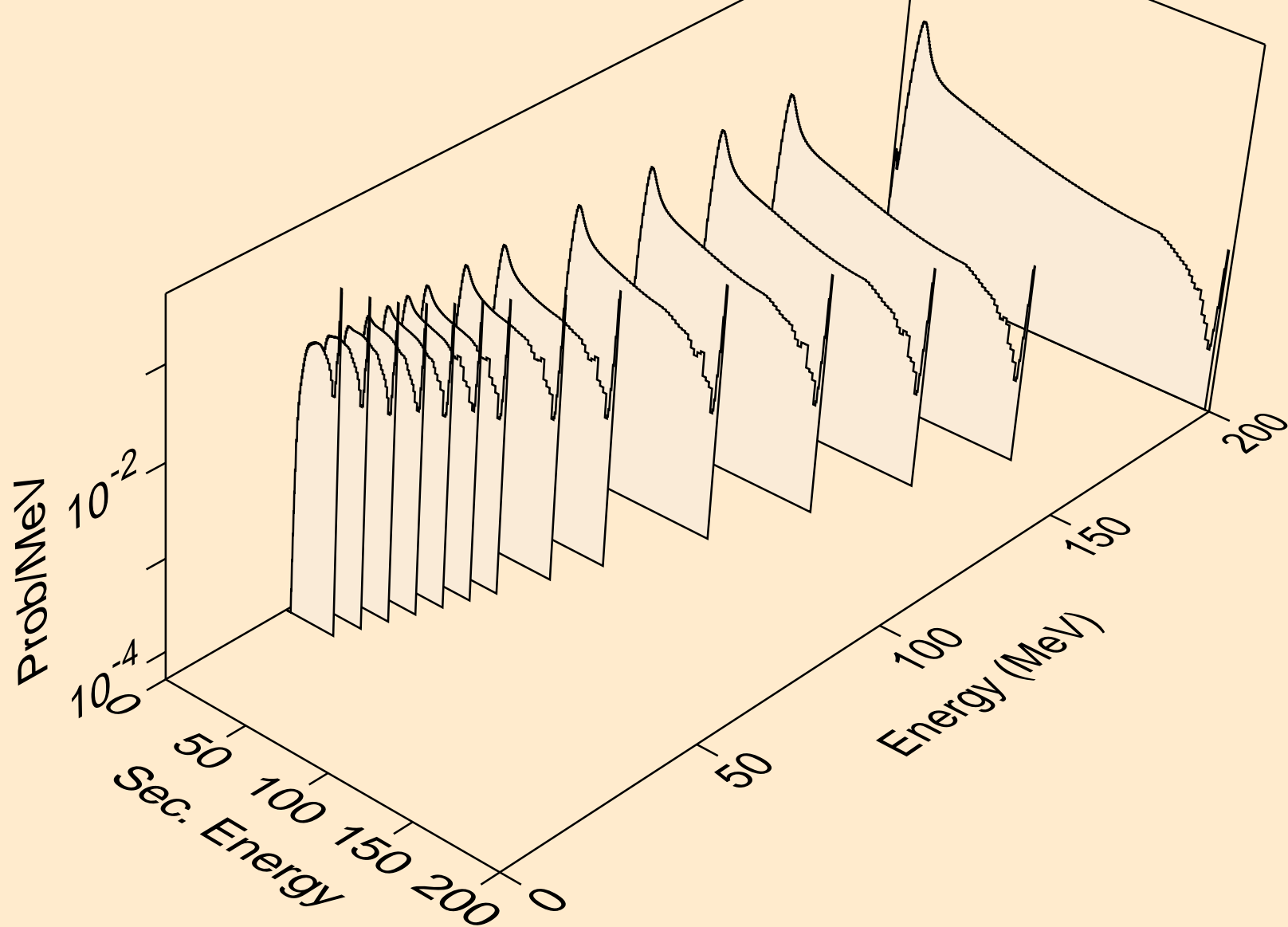

ER162 PROTON ACER TENDL-2023 LIBRARY; T=0.K  
Proton emission for (p,n\*)p

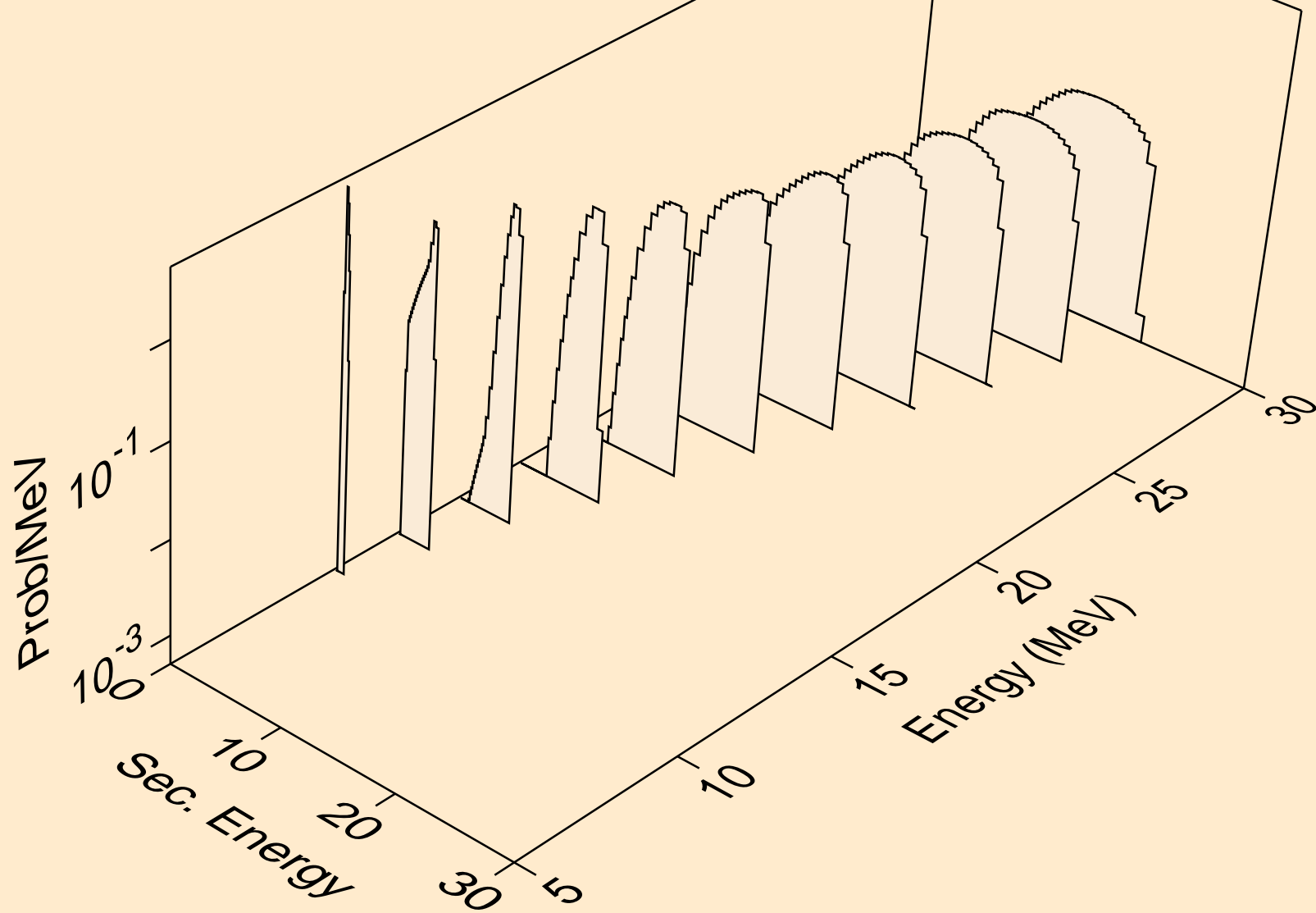

ER162 PROTON ACER TENDL-2023 LIBRARY; T=0.K  
Proton emission for (p,2np)

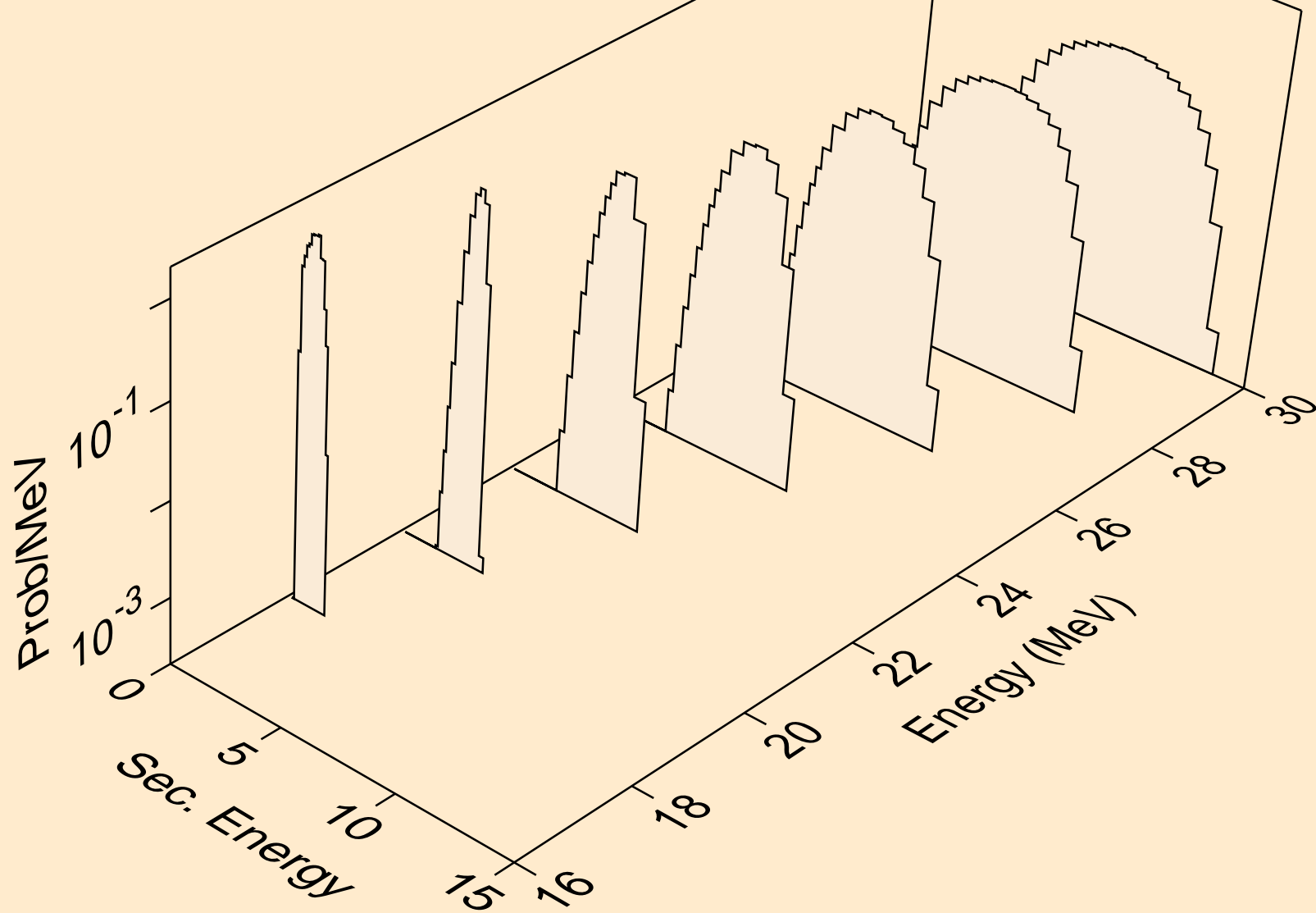

ER162 PROTON ACER TENDL-2023 LIBRARY; T=0.K  
Proton emission for (p,3np)

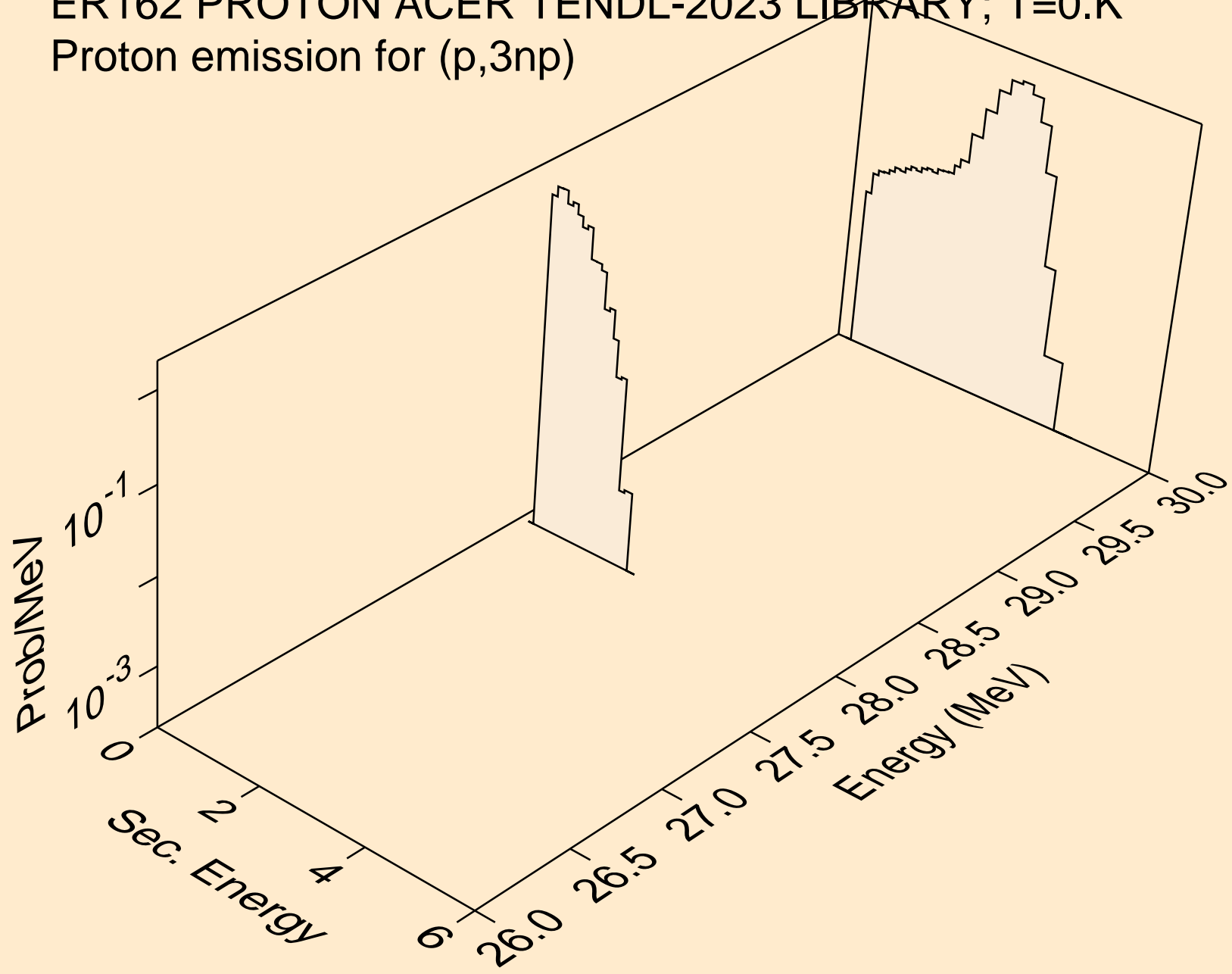

ER162 PROTON ACER TENDL-2023 LIBRARY; T=0.K  
Proton emission for (p,n2p)

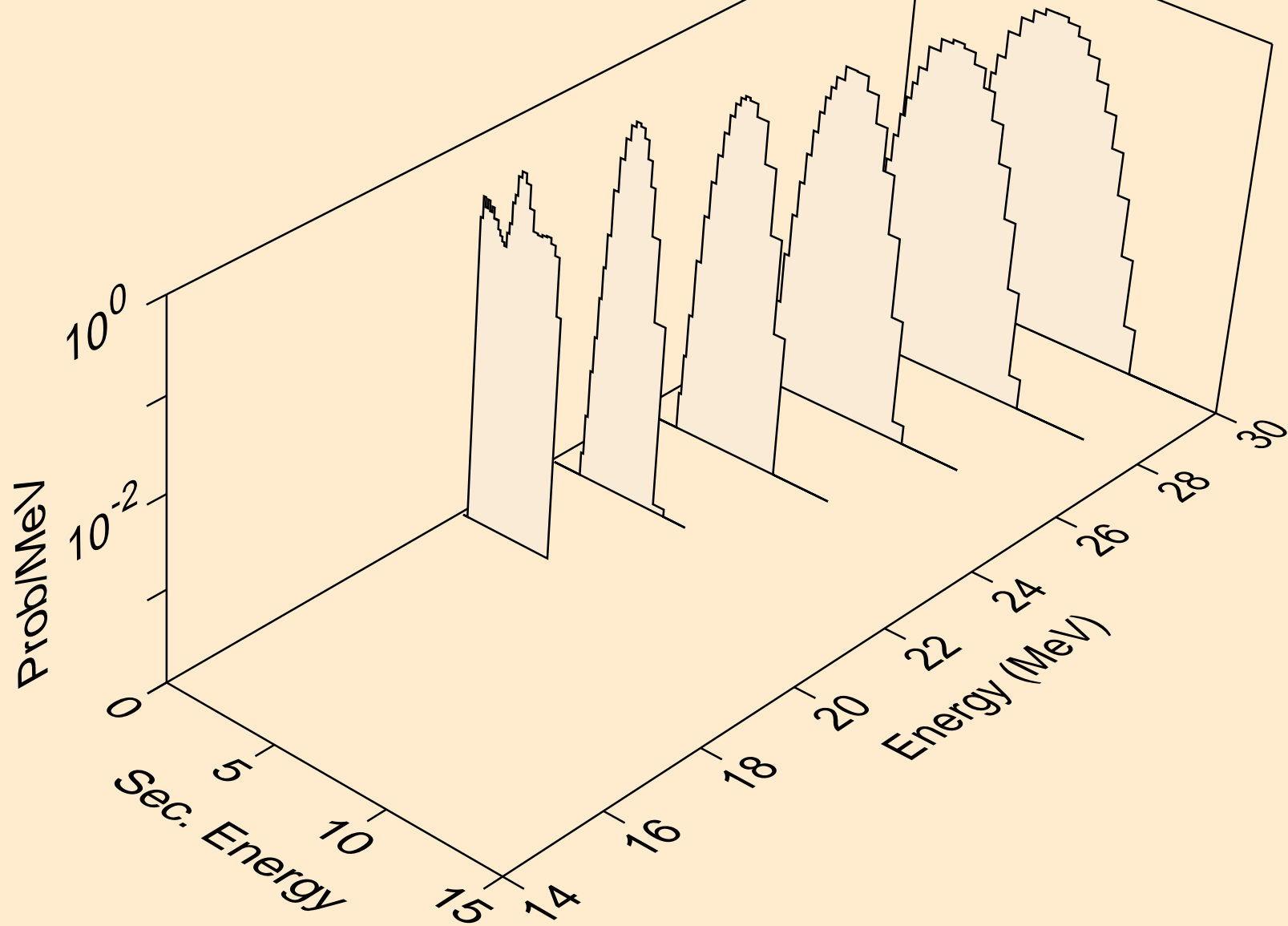

ER162 PROTON ACER TENDL-2023 LIBRARY; T=0.K  
Proton emission for (p,npa)

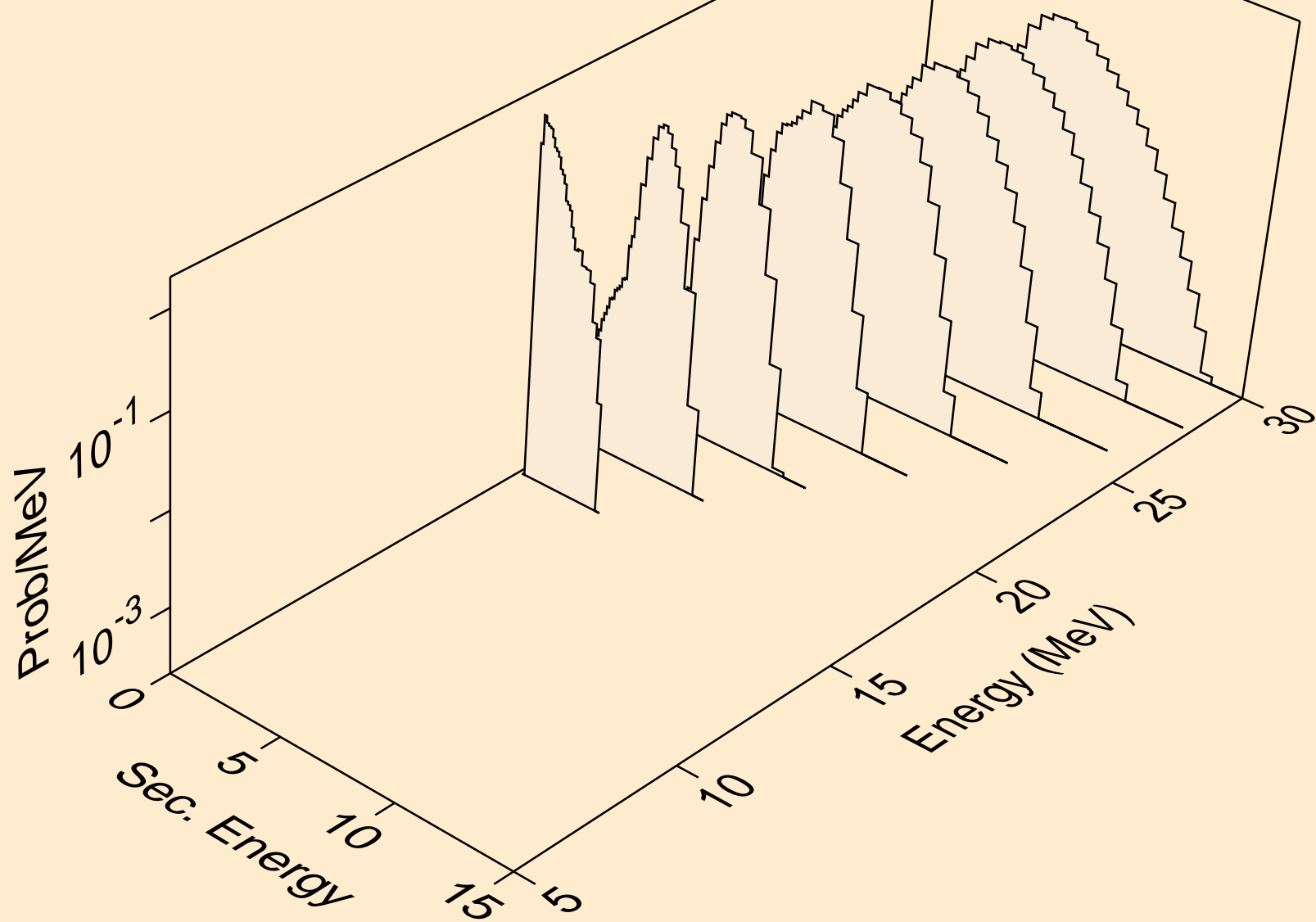

ER162 PROTON ACER TENDL-2023 LIBRARY; T=0.K  
Proton emission for inelastic

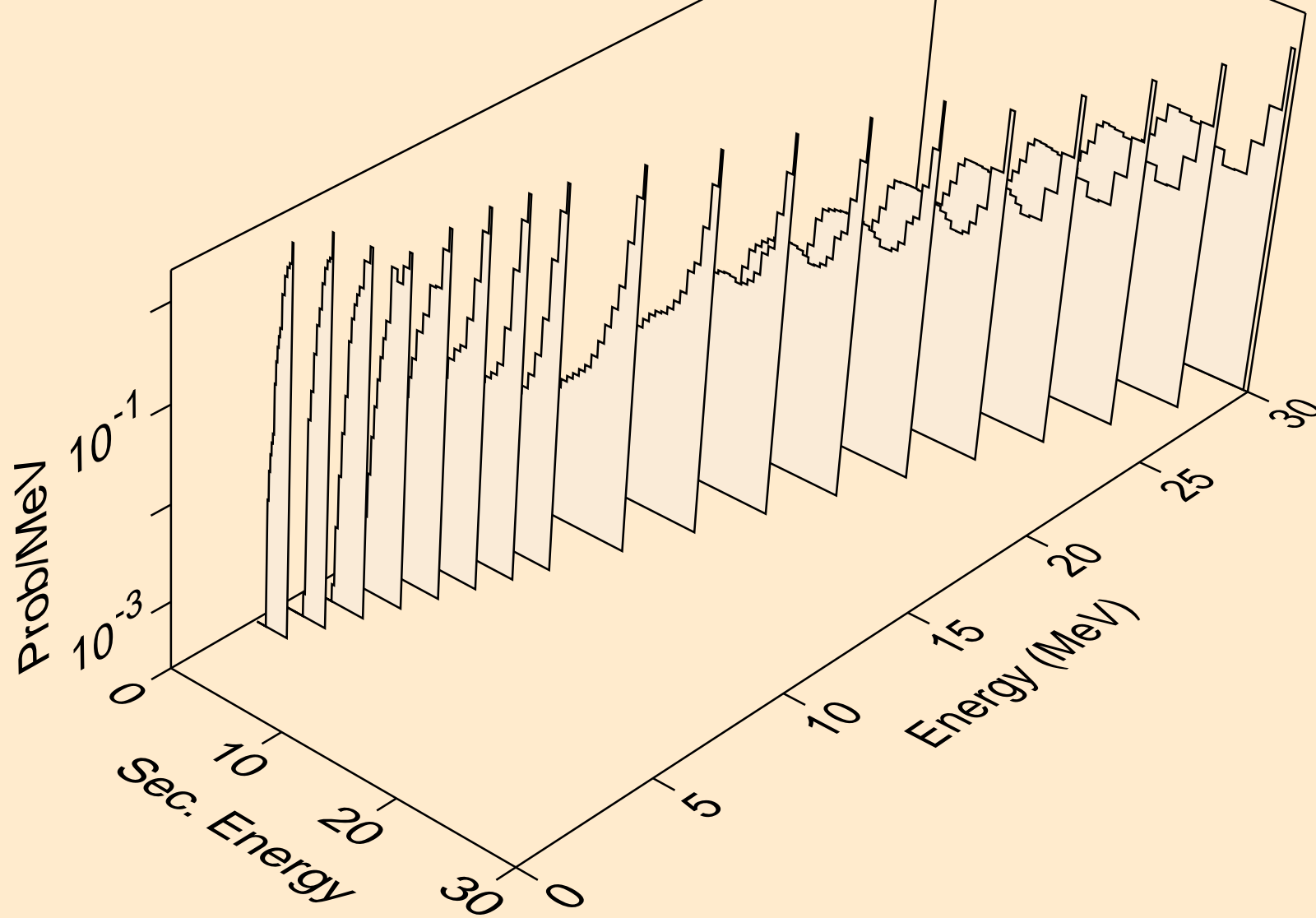



ER162 PROTON ACER TENDL-2023 LIBRARY; T=0.K  
Proton emission for (p,2p)

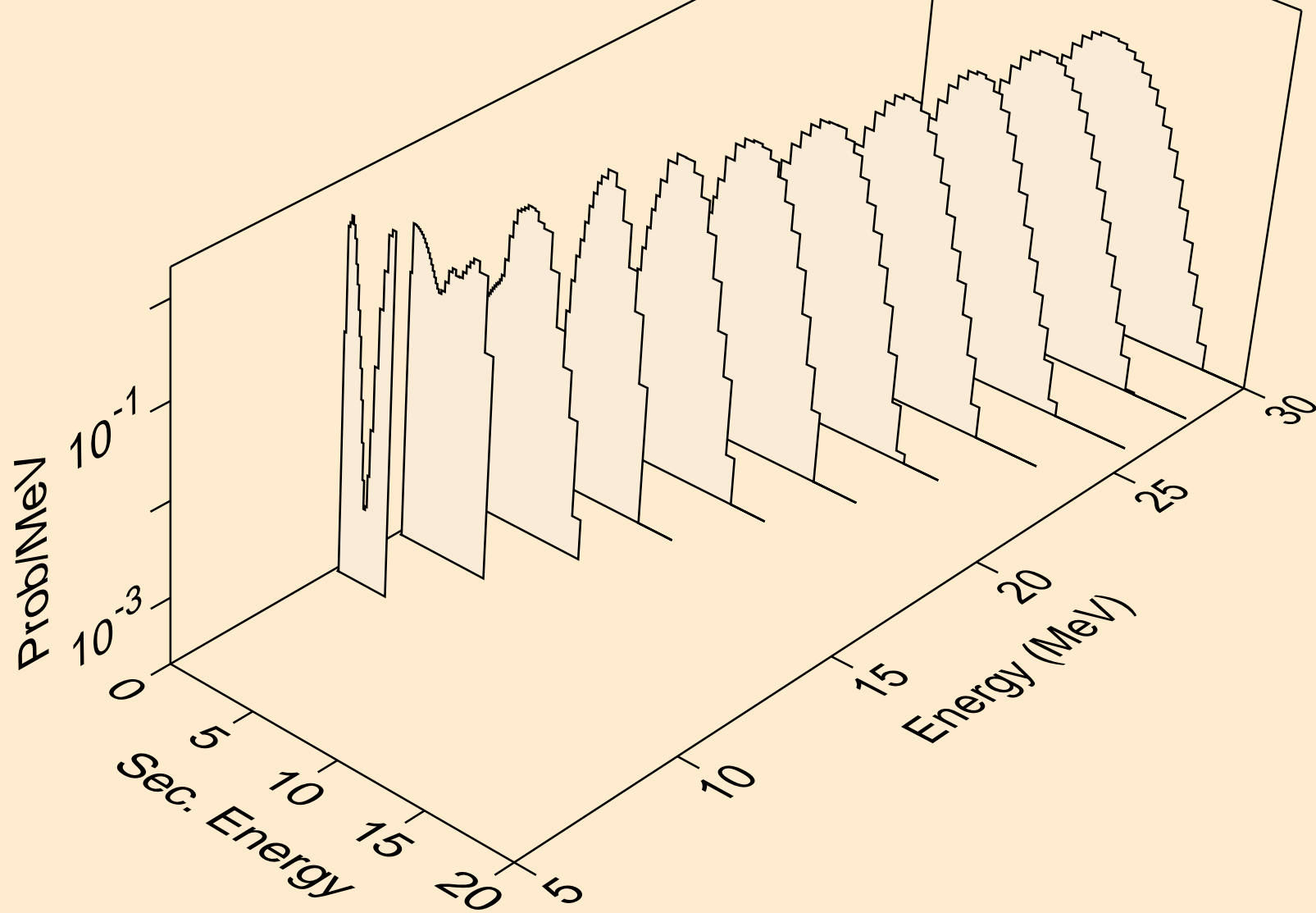

ER162 PROTON ACER TENDL-2023 LIBRARY; T=0.K  
Proton emission for (p,pa)

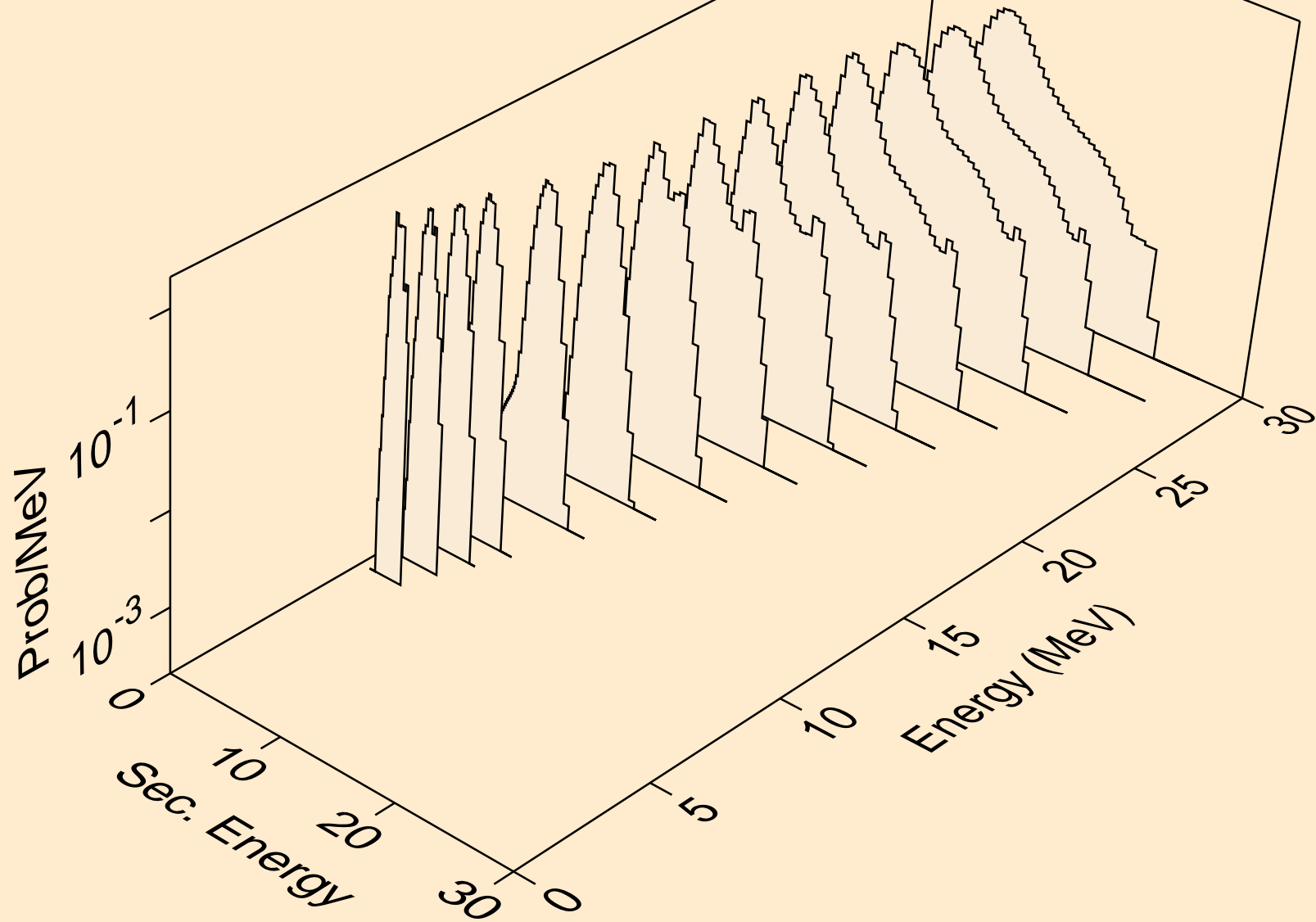

ER162 PROTON ACER TENDL-2023 LIBRARY; T=0.K  
Proton emission for (p,pd)

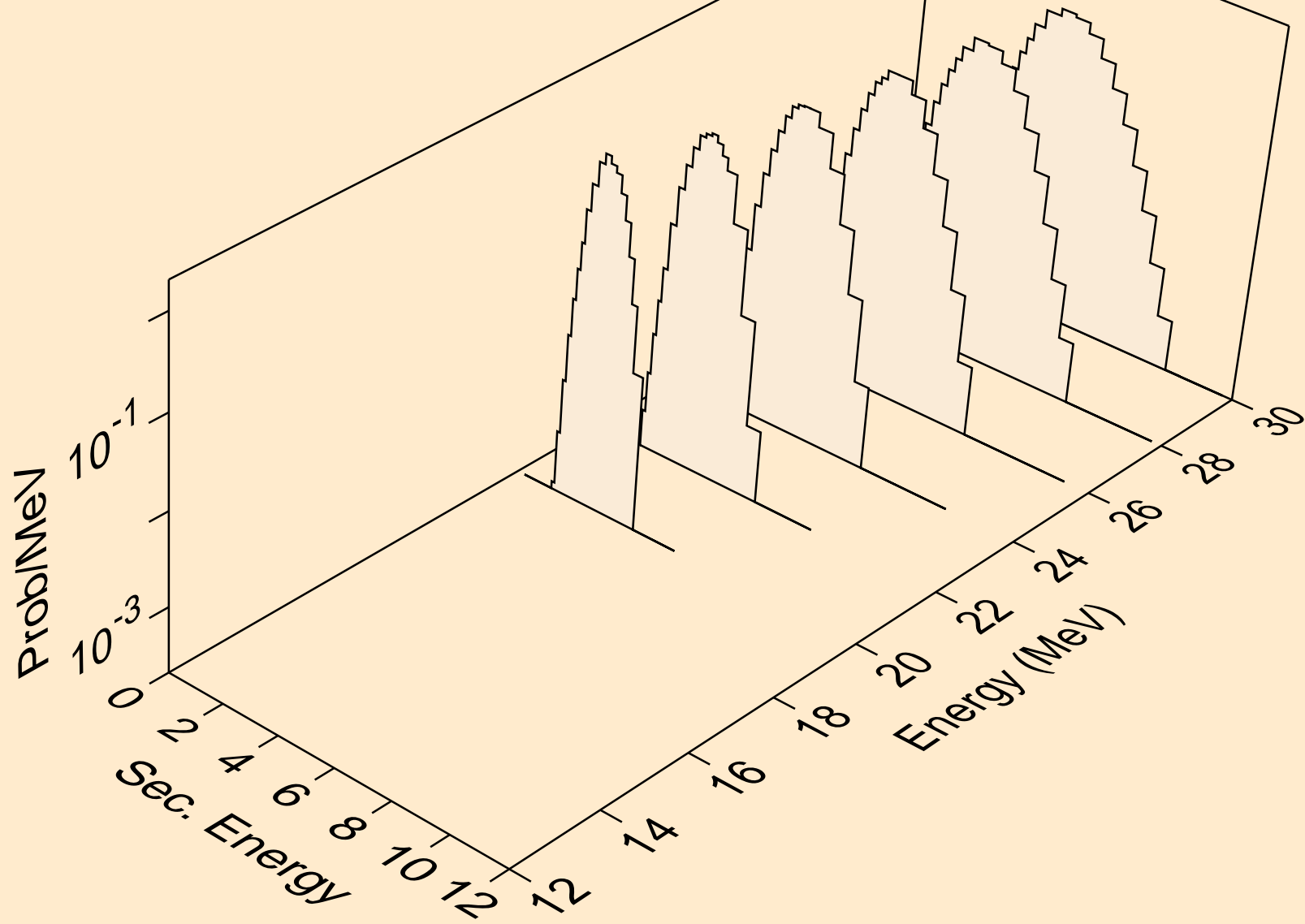

ER162 PROTON ACER TENDL-2023 LIBRARY; T=0.K  
Proton emission for (p,pt)

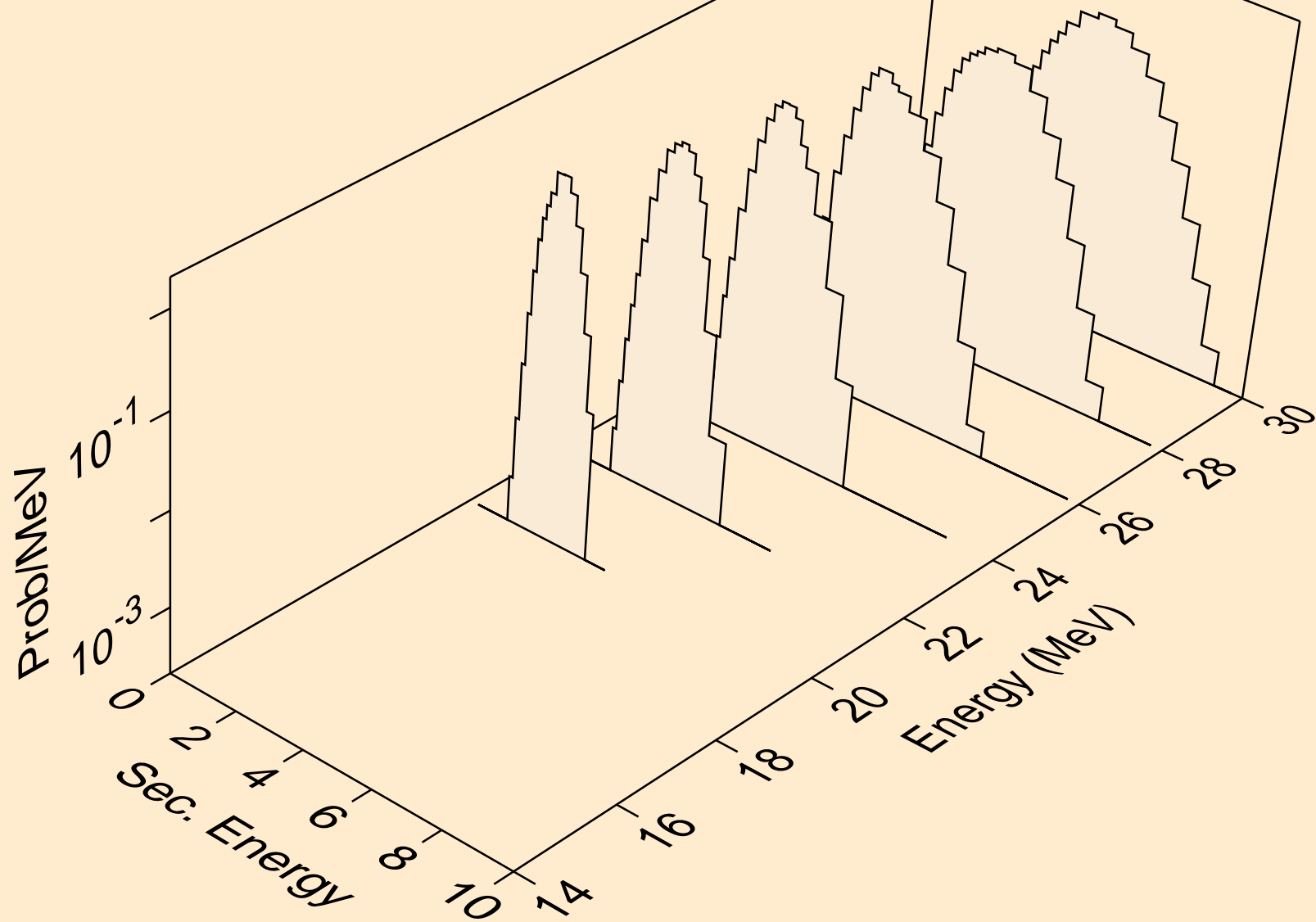

ER162 PROTON ACER TENDL-2023 LIBRARY; T=0.K  
Photon emission for (z,n)

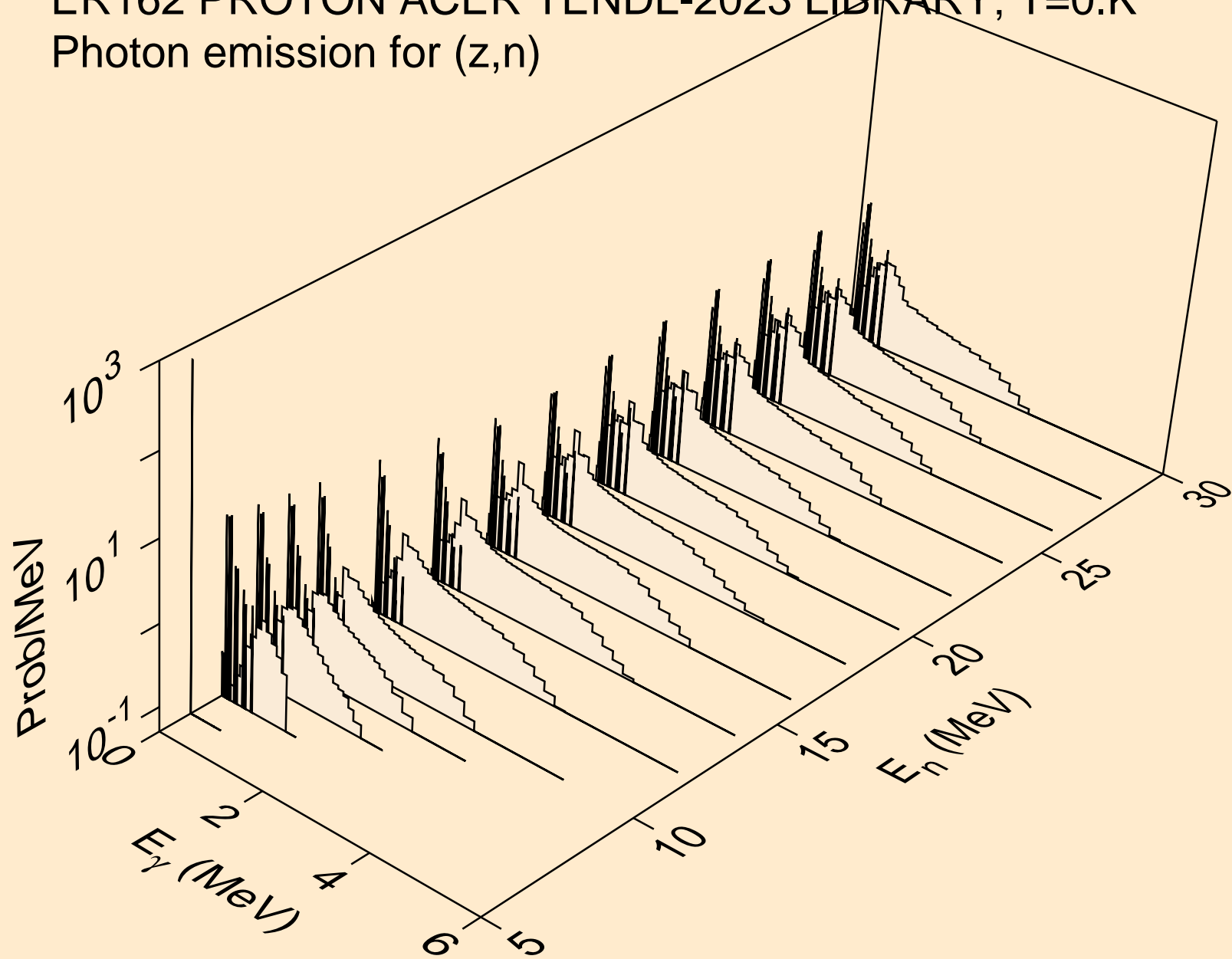

ER162 PROTON ACER TENDL-2023 LIBRARY; T=0.K  
Photon emission for (z,x)

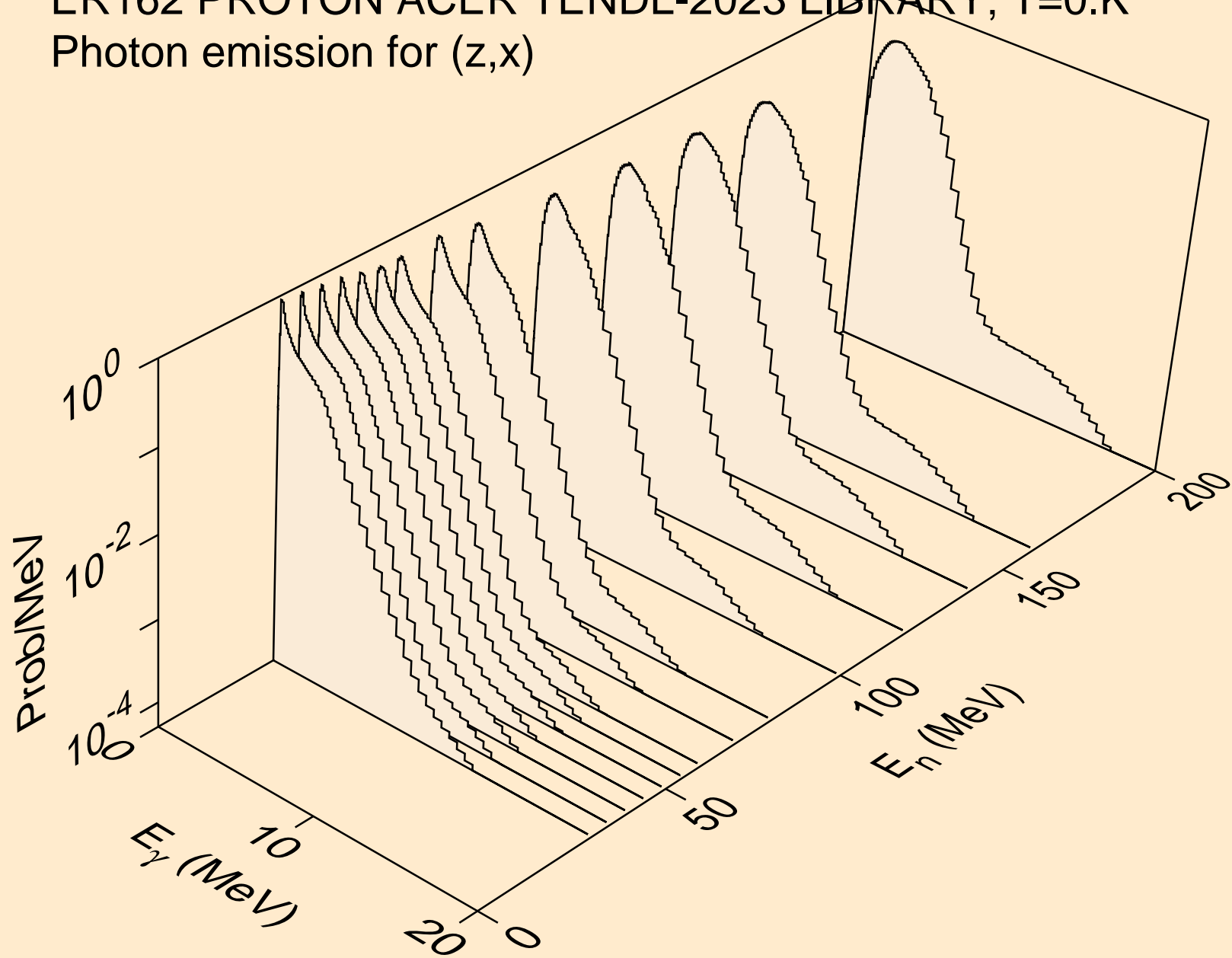

ER162 PROTON ACER TENDL-2023 LIBRARY; T=0.K  
Photon emission for (n,2nd)

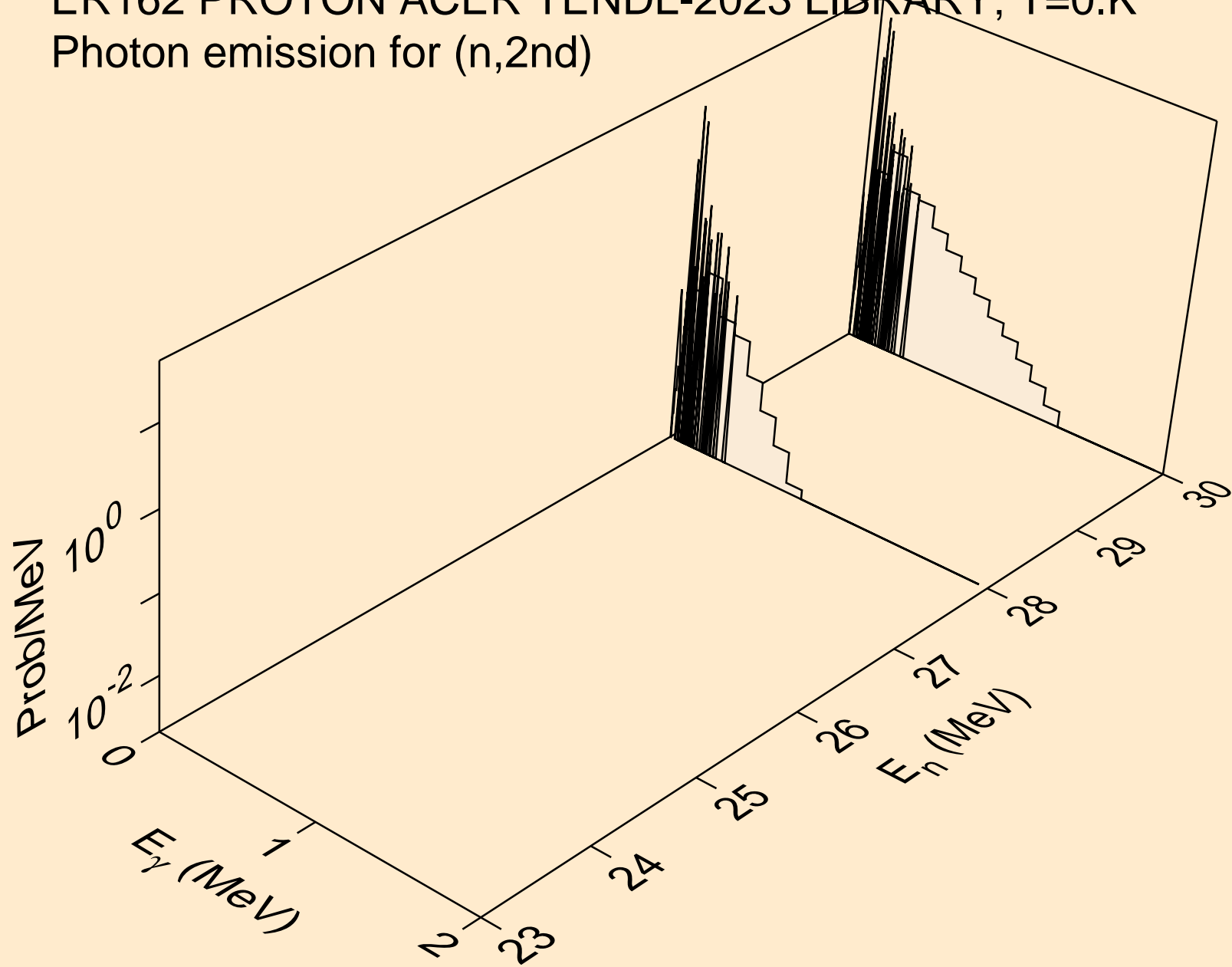

ER162 PROTON ACER TENDL-2023 LIBRARY; T=0.K  
Photon emission for (n,2n)

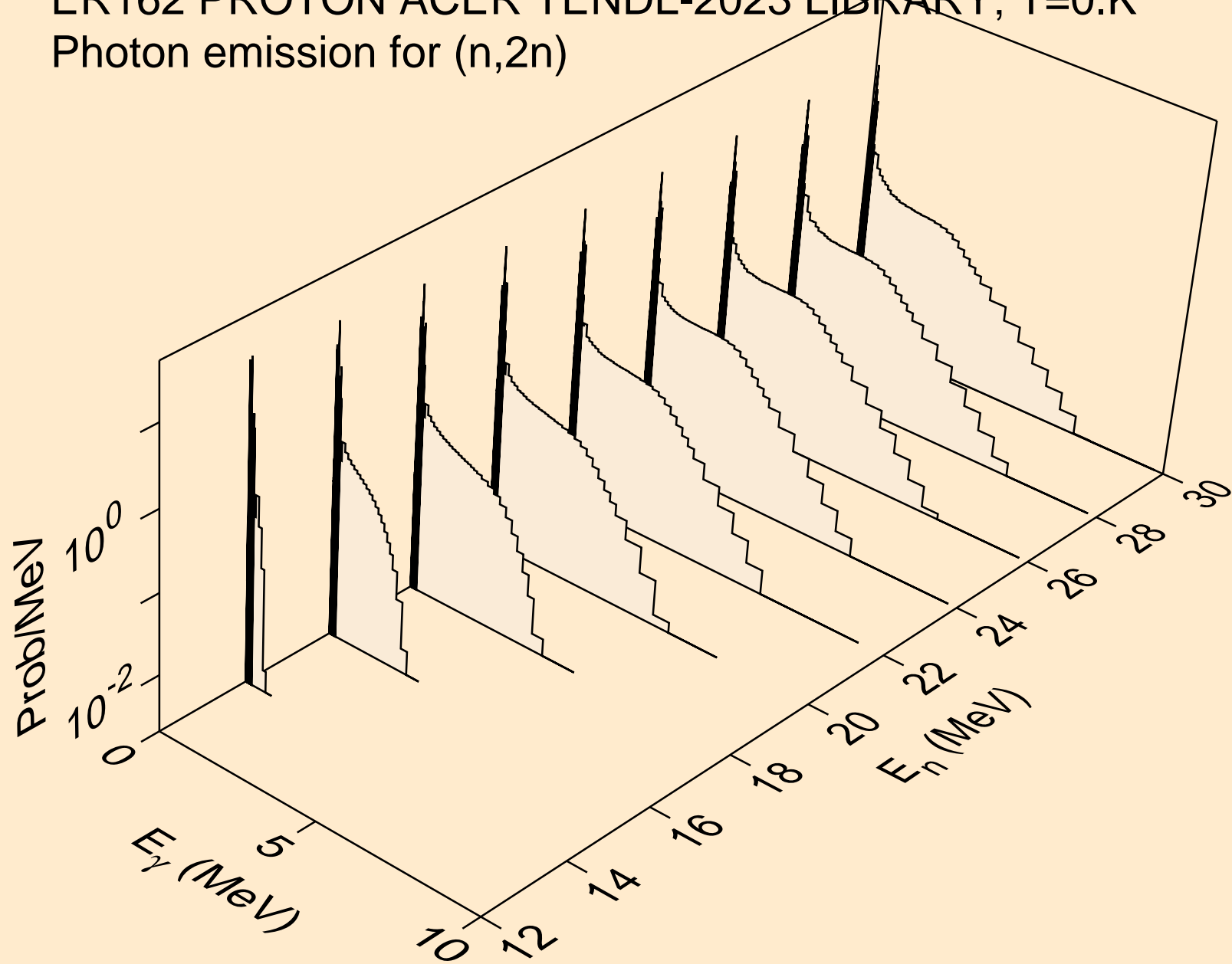



ER162 PROTON ACER TENDL-2023 LIBRARY; T=0.K  
Photon emission for (n,3n)

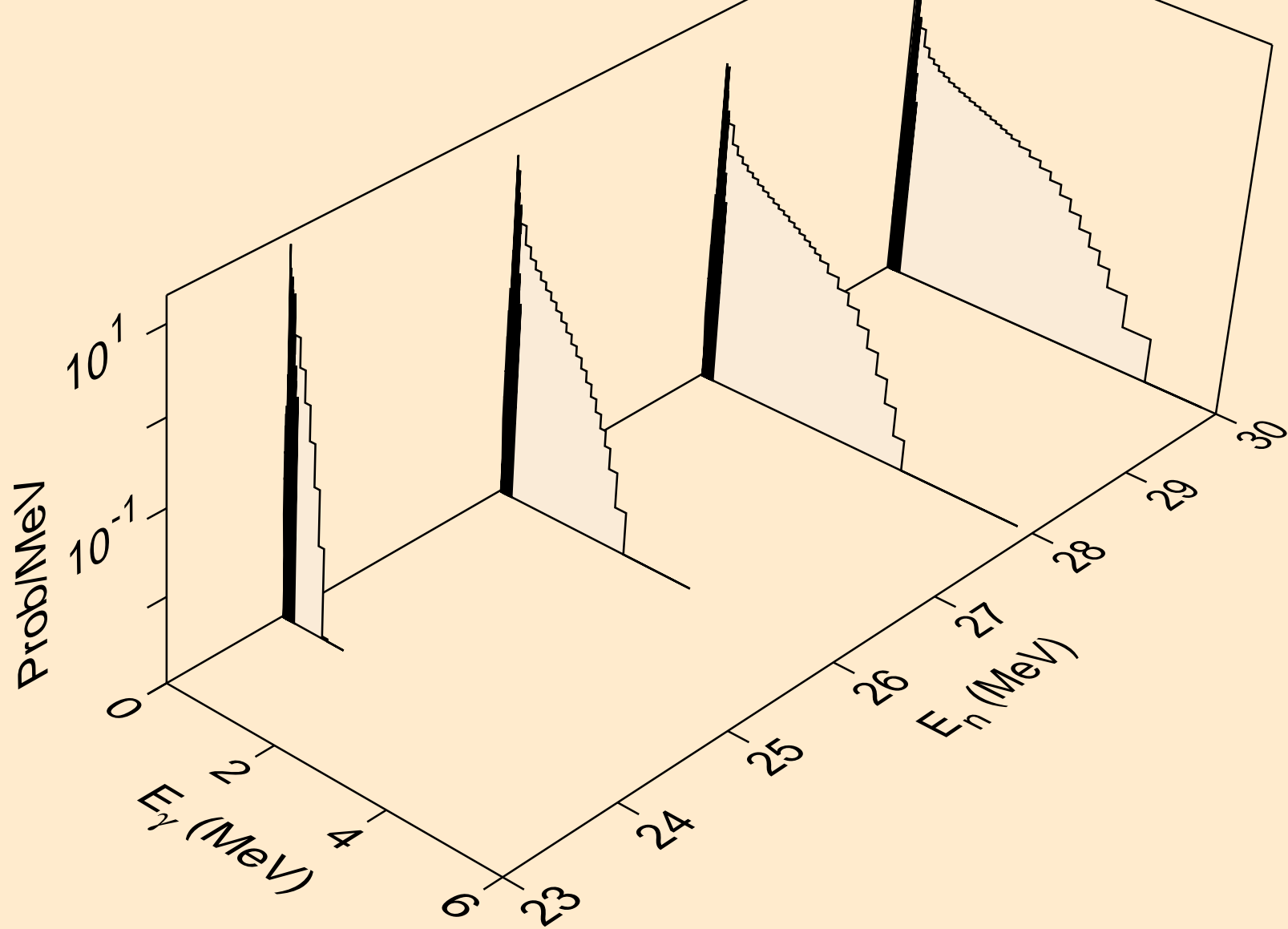

ER162 PROTON ACER TENDL-2023 LIBRARY; T=0.K  
Photon emission for (n,n\*)a

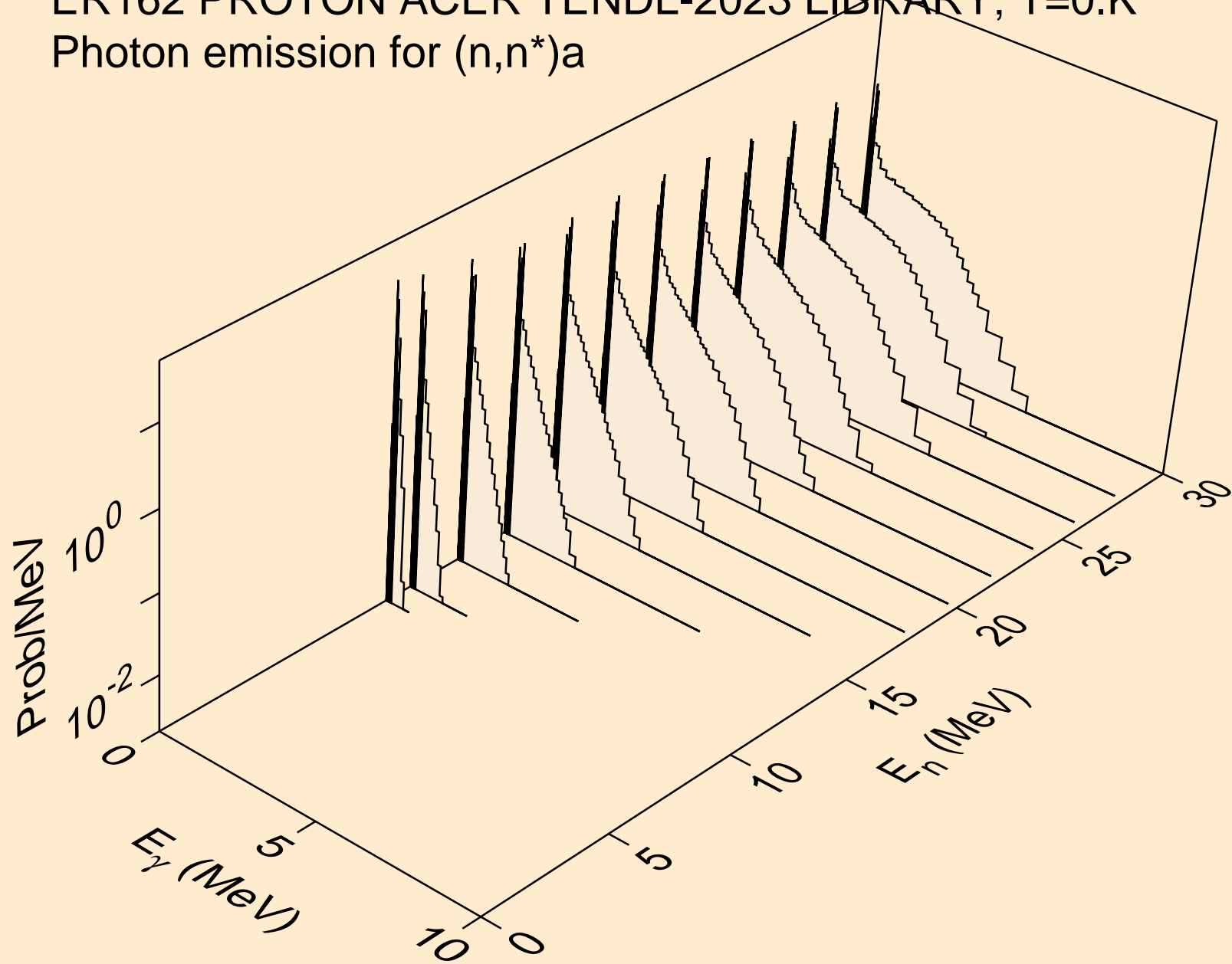

ER162 PROTON ACER TENDL-2023 LIBRARY; T=0.K  
Photon emission for (n,2n)a

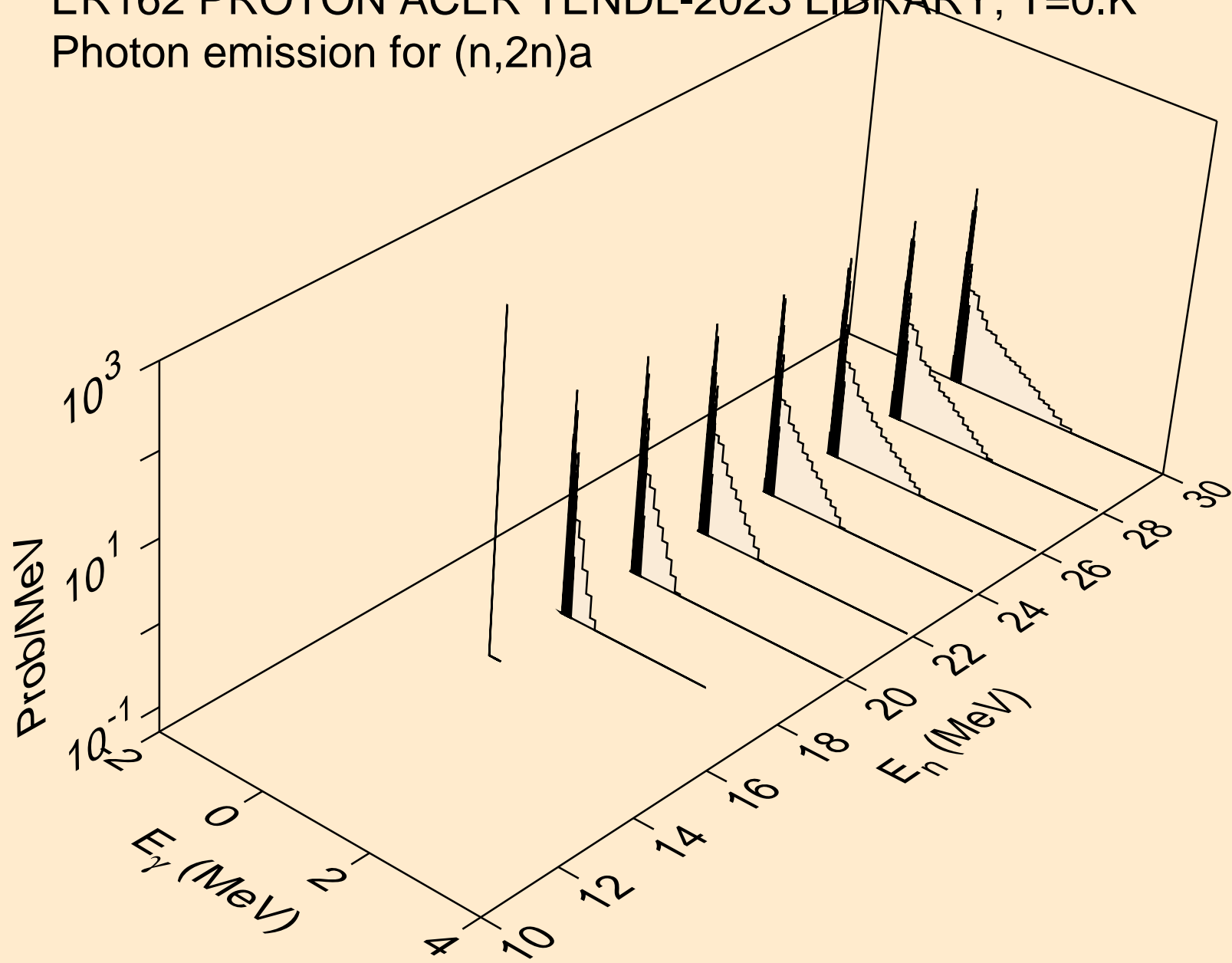

ER162 PROTON ACER TENDL-2023 LIBRARY; T=0.K  
Photon emission for (n,3n)a

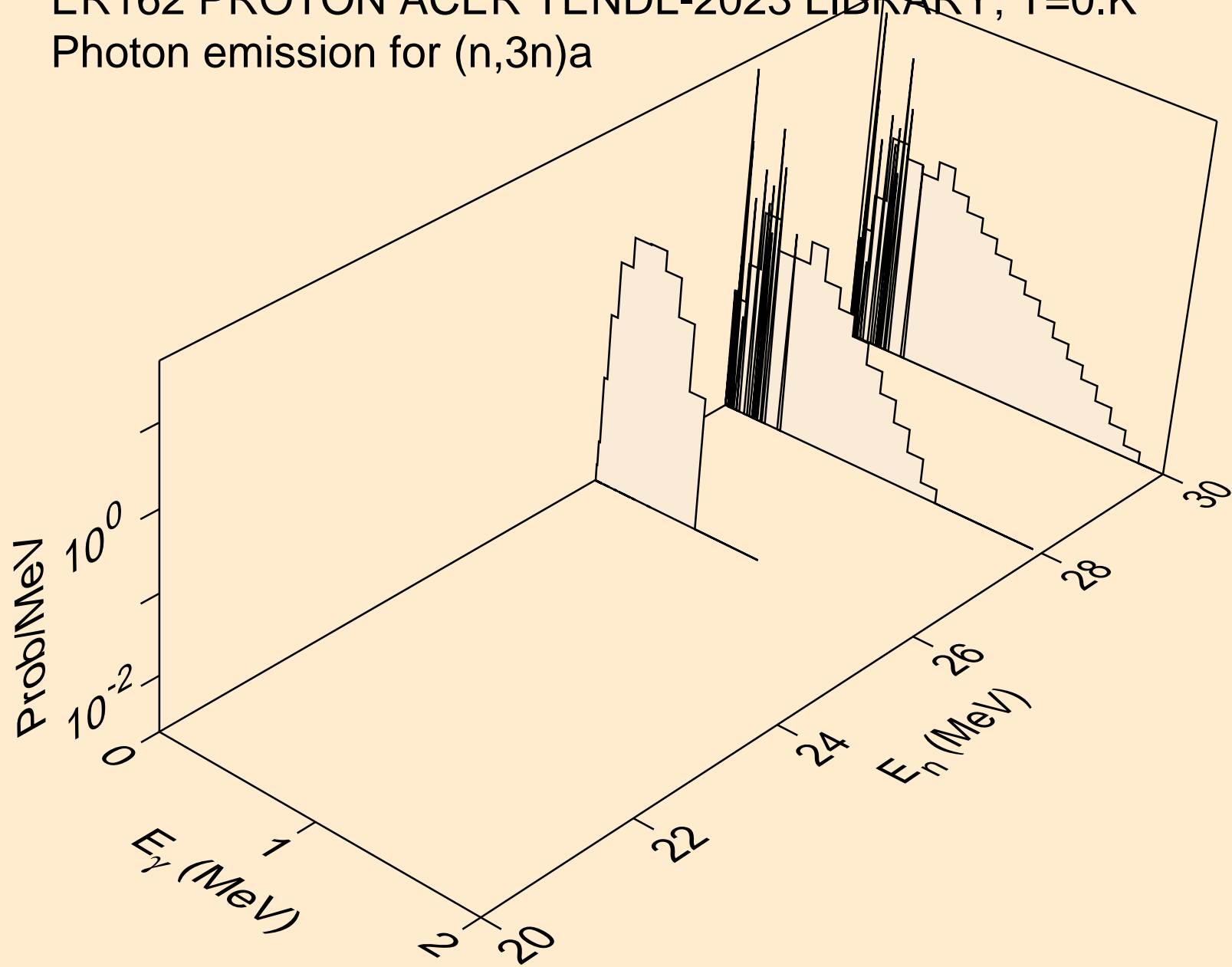

ER162 PROTON ACER TENDL-2023 LIBRARY; T=0.K  
Photon emission for (n,n\*)p

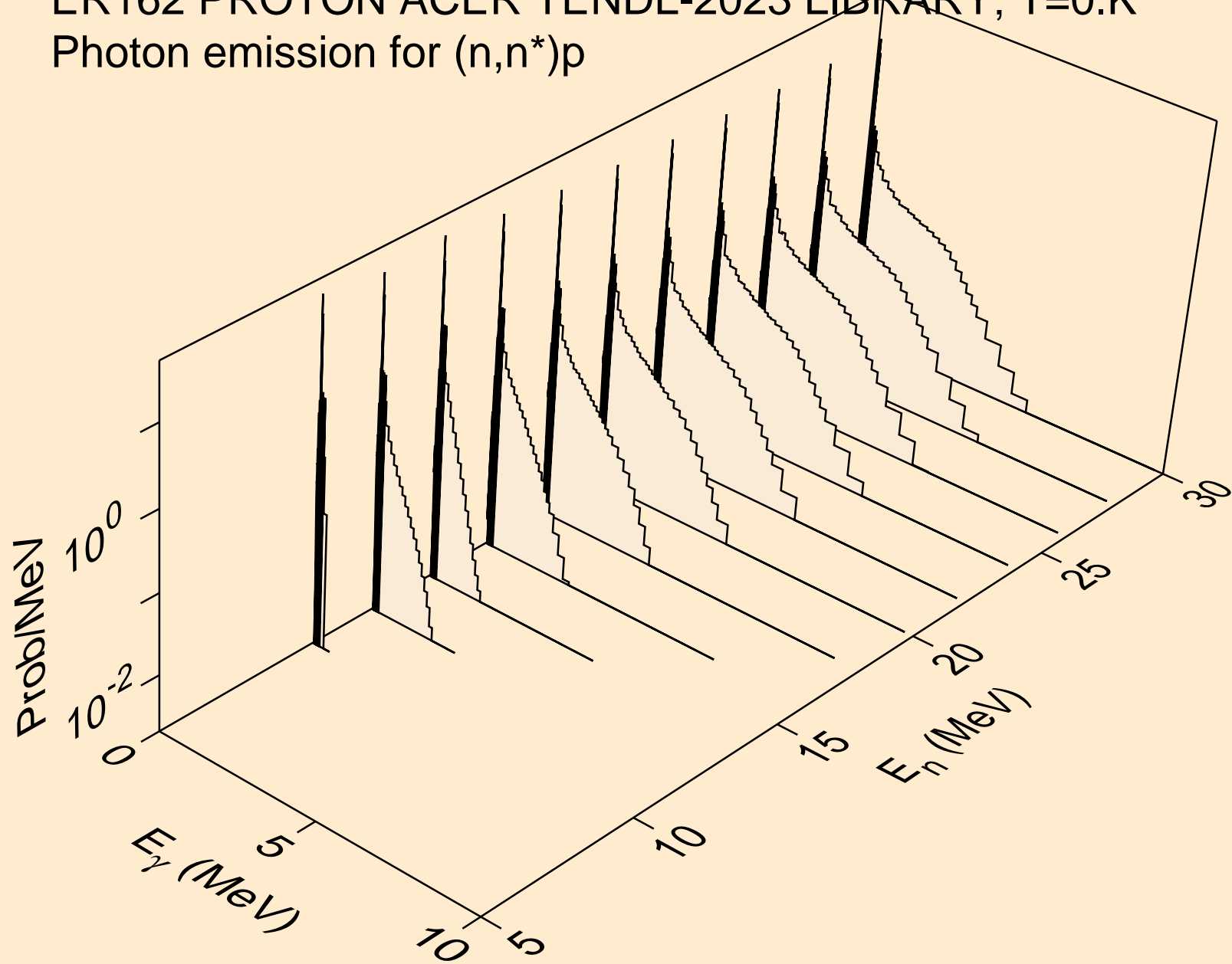

ER162 PROTON ACER TENDL-2023 LIBRARY; T=0.K  
Photon emission for (n,n\*)2a

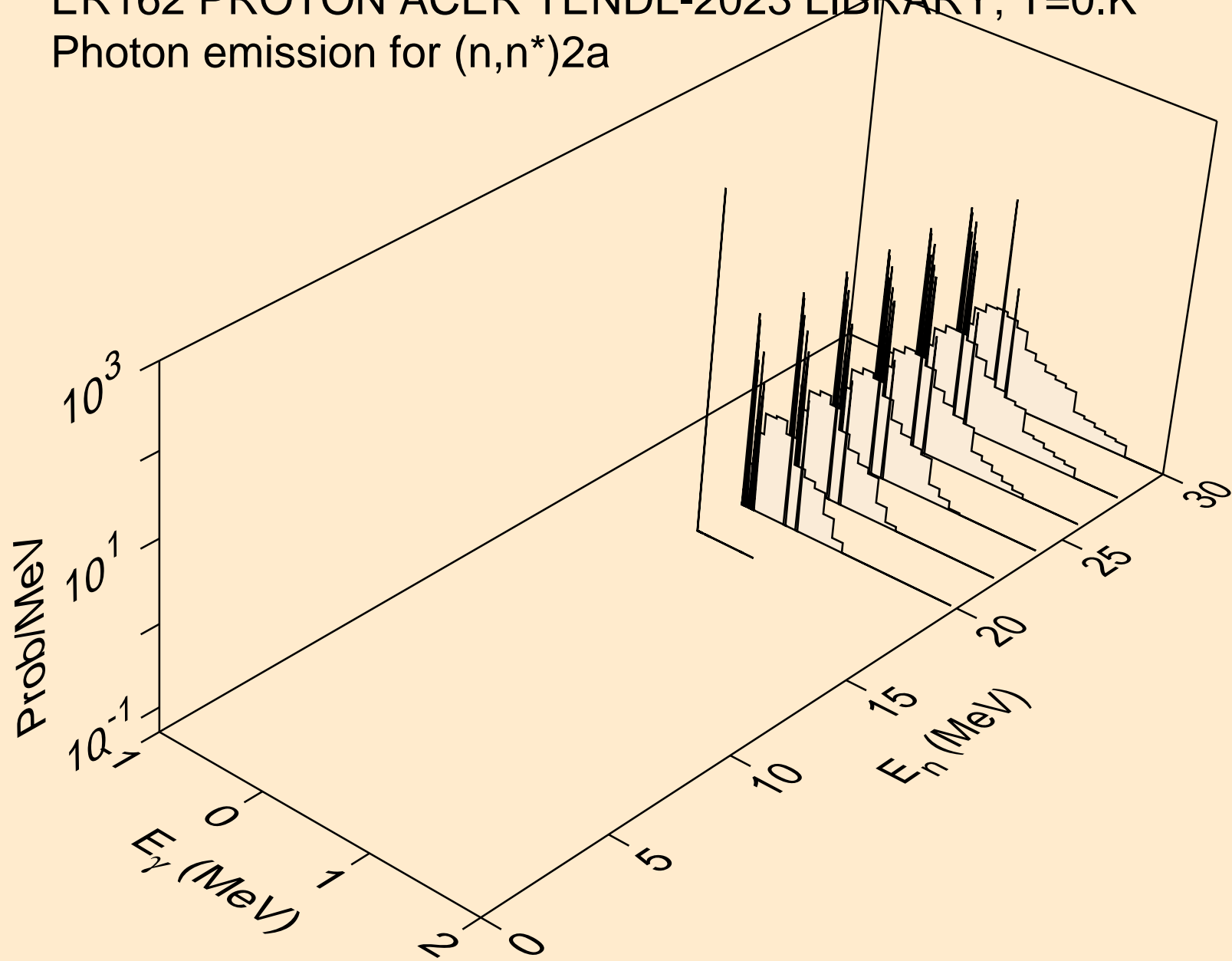

ER162 PROTON ACER TENDL-2023 LIBRARY; T=0.K  
Photon emission for (n,n\*)d

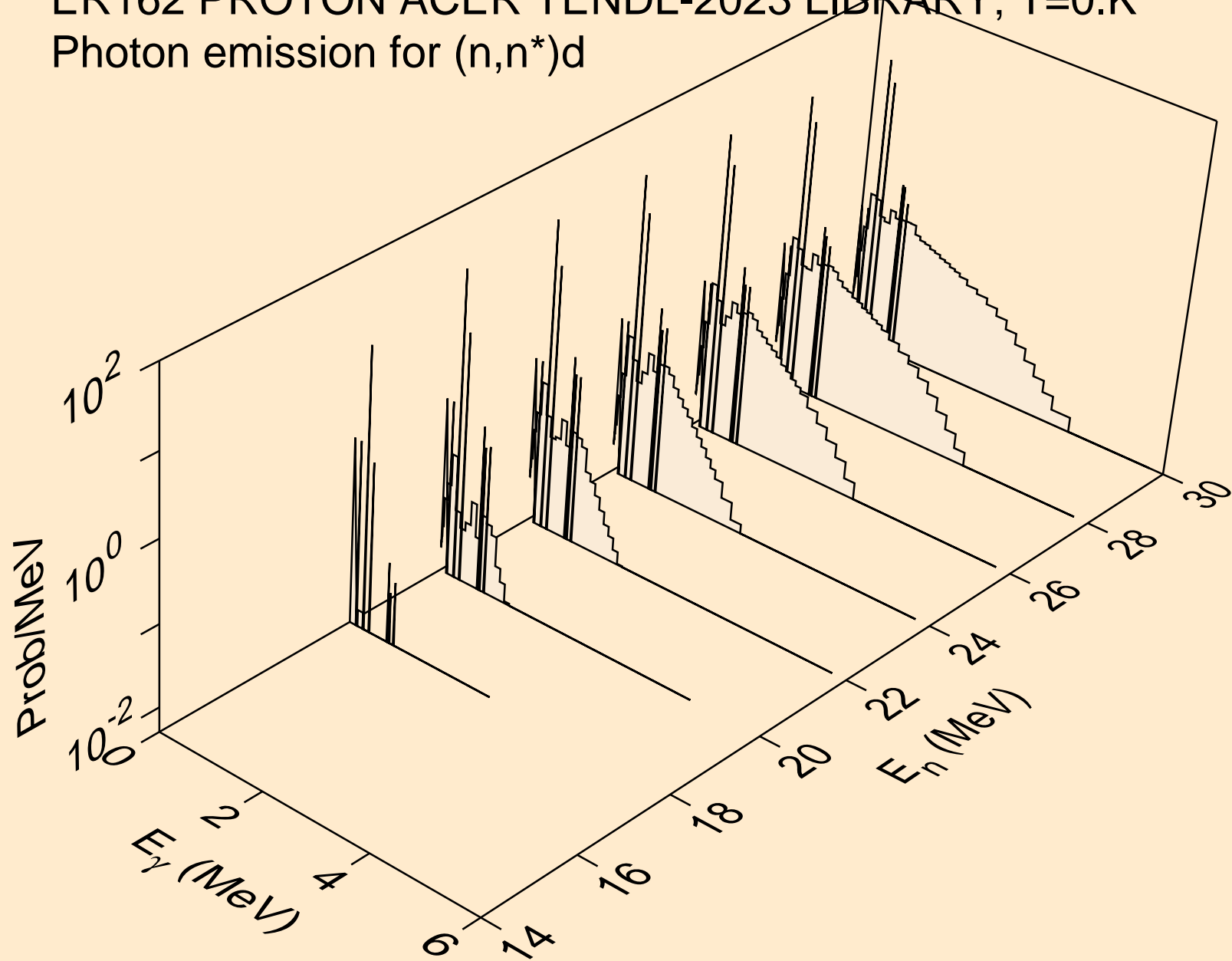

ER162 PROTON ACER TENDL-2023 LIBRARY; T=0.K  
Photon emission for (n,n\*)t

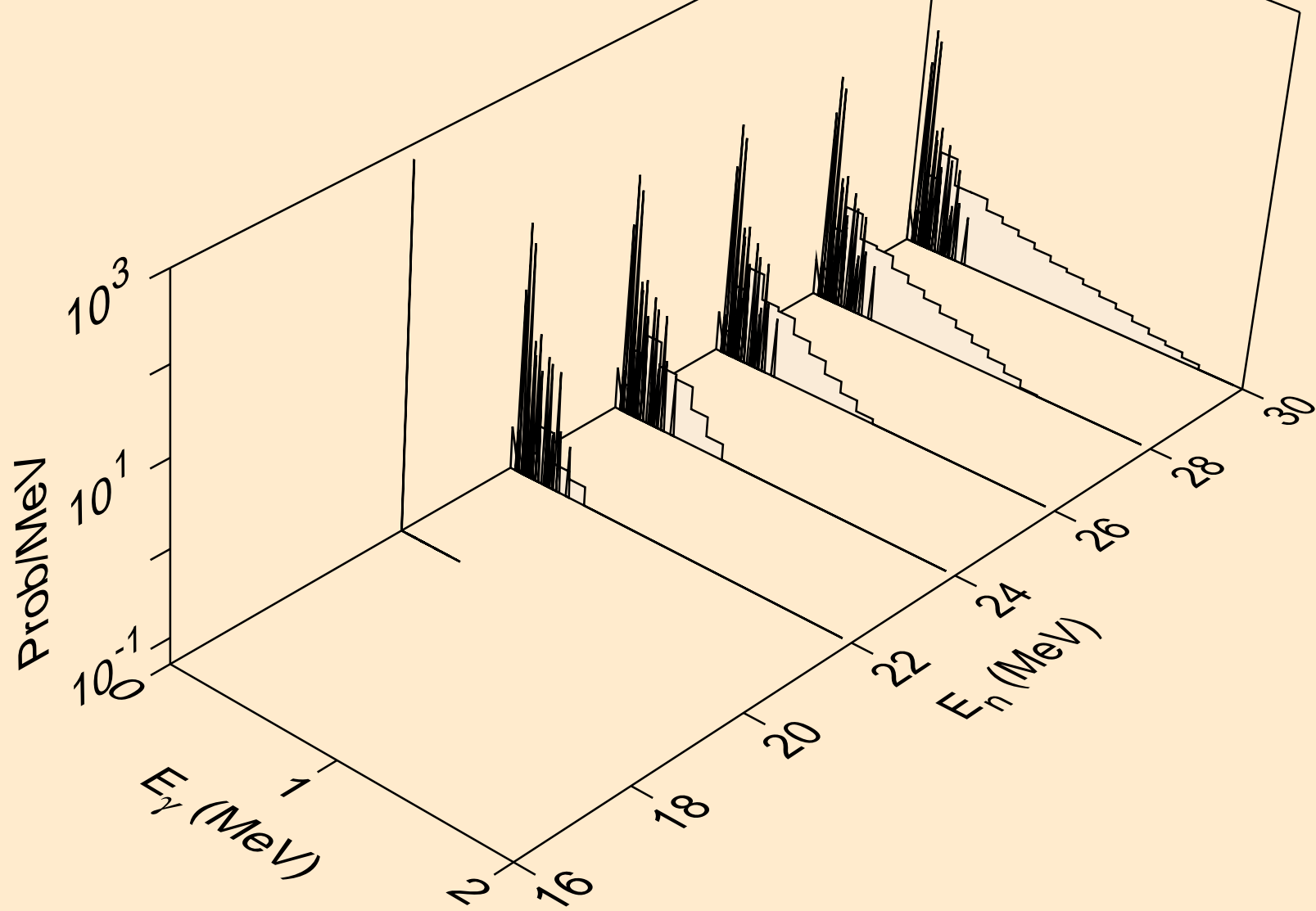



ER162 PROTON ACER TENDL-2023 LIBRARY; T=0.K  
Photon emission for (n,n\*)he3

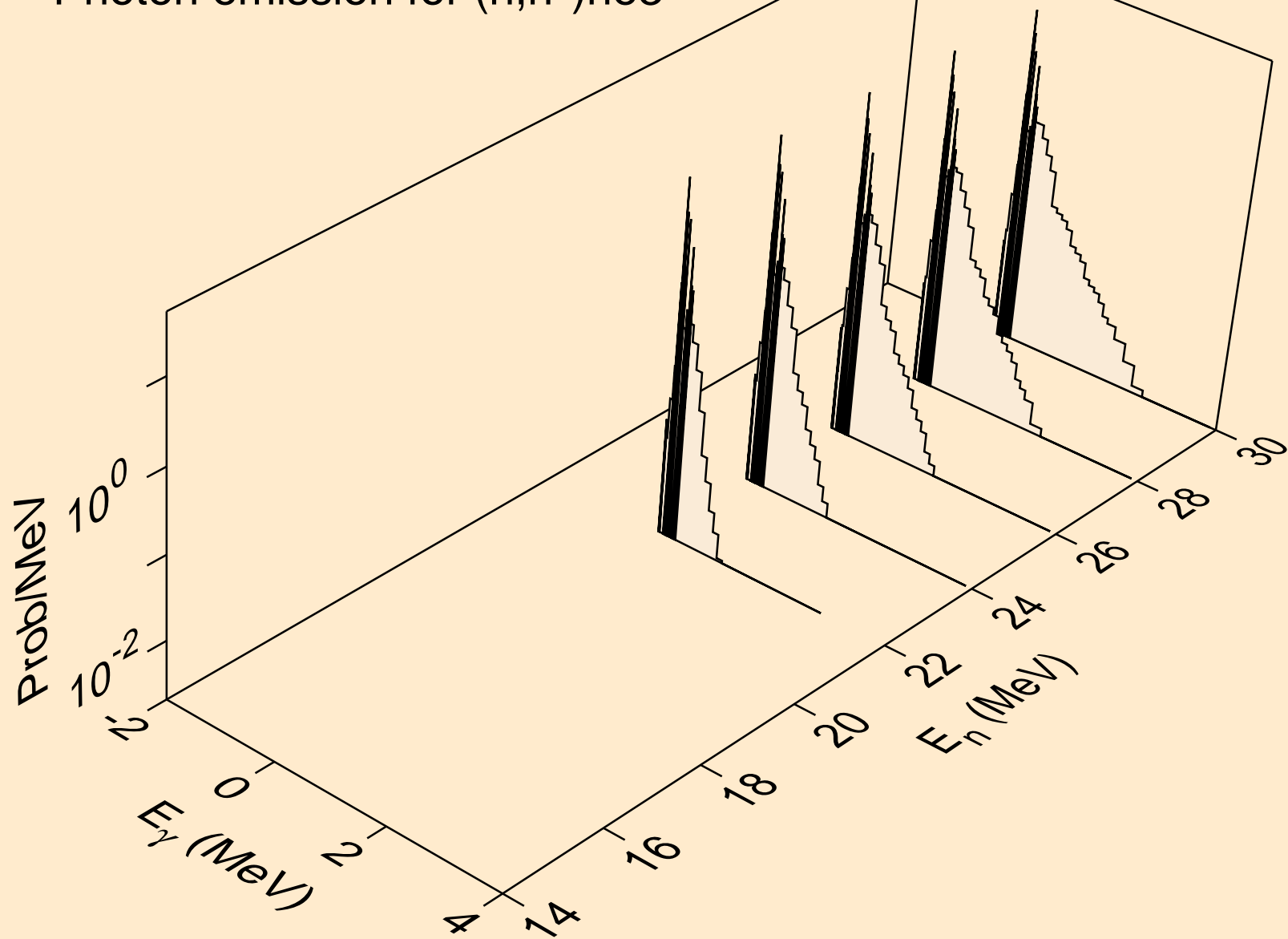

ER162 PROTON ACER TENDL-2023 LIBRARY; T=0.K  
Photon emission for (n,2np)

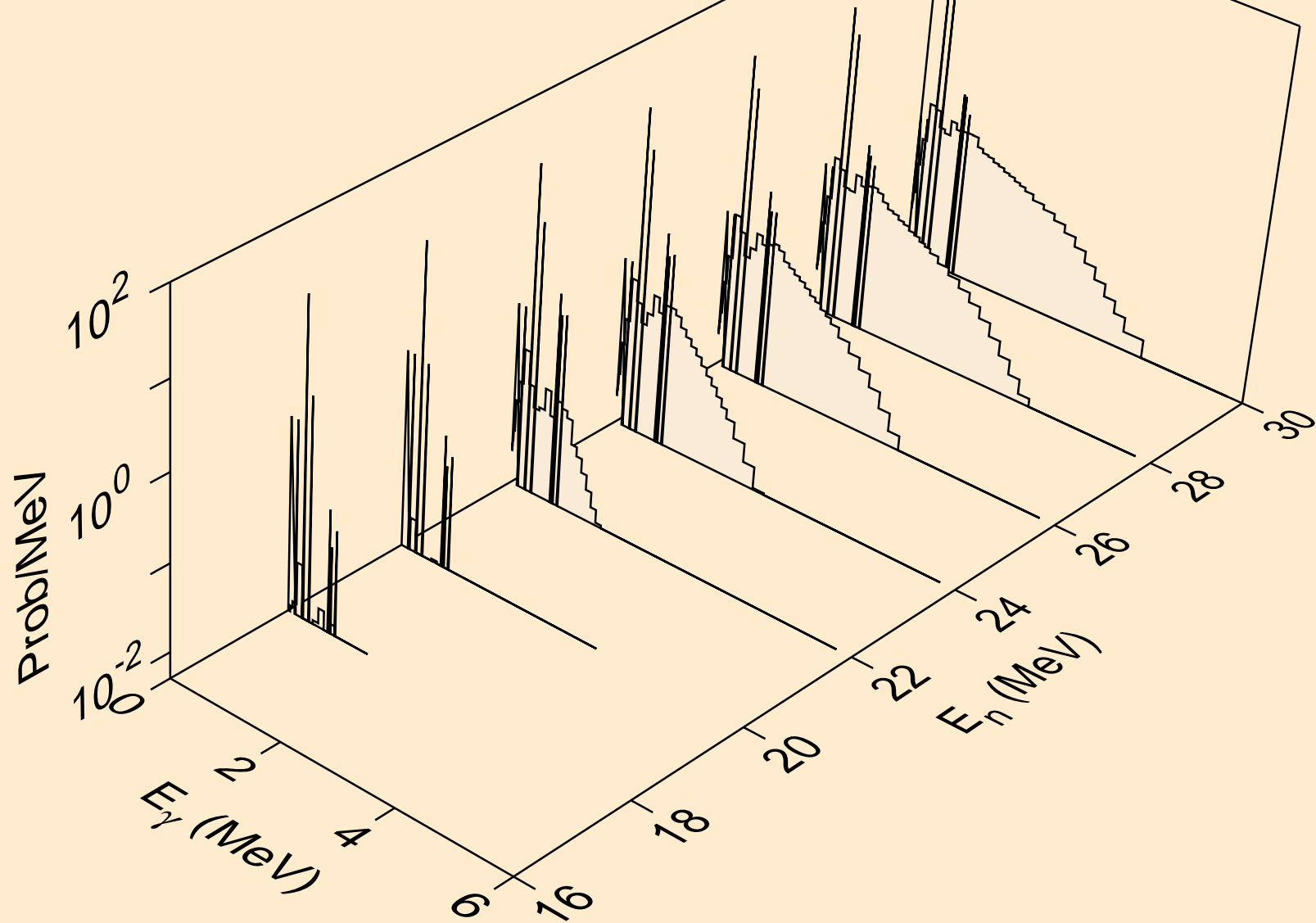

ER162 PROTON ACER TENDL-2023 LIBRARY; T=0.K  
Photon emission for (n,3np)

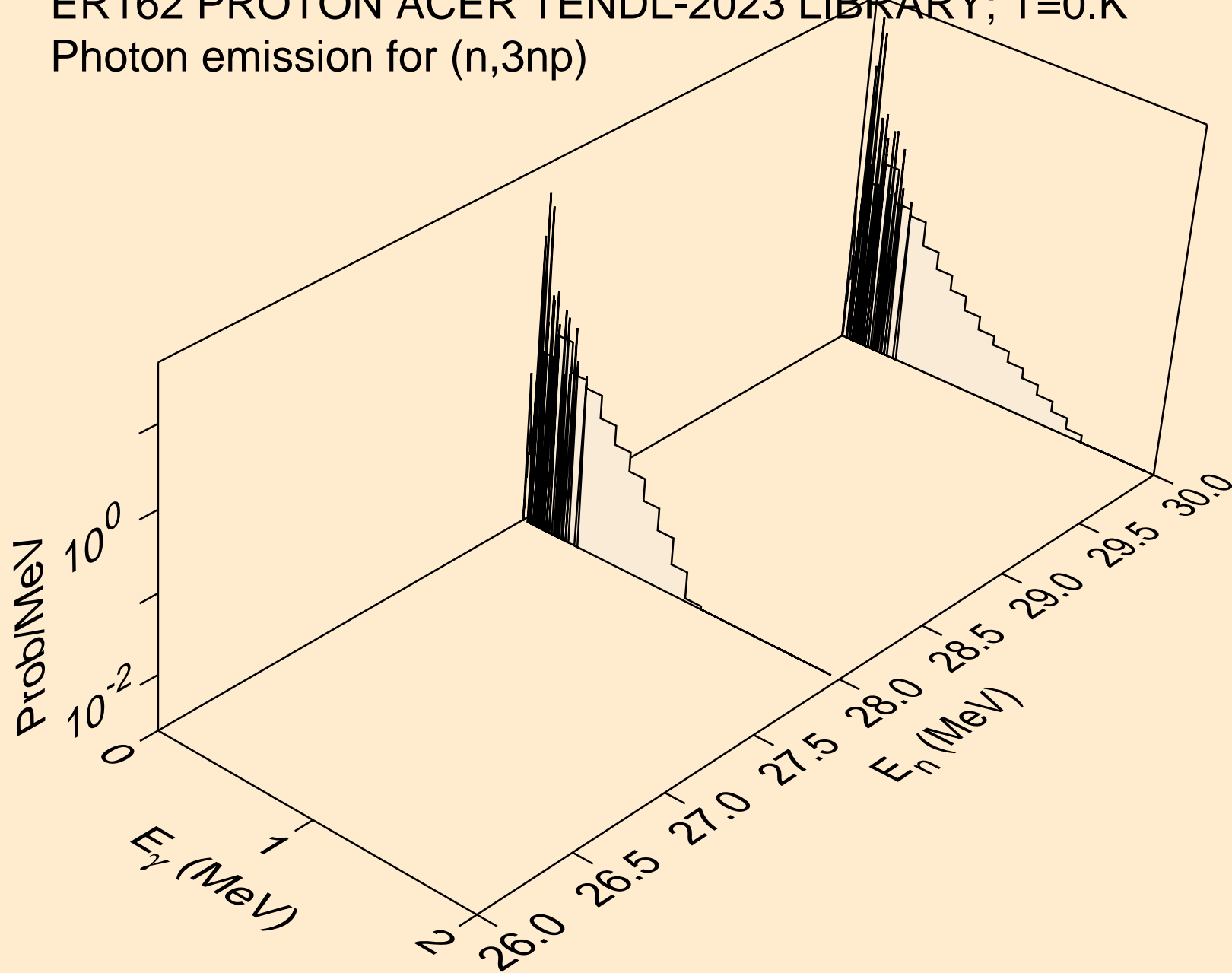

ER162 PROTON ACER TENDL-2023 LIBRARY; T=0.K  
Photon emission for (n,n2p)

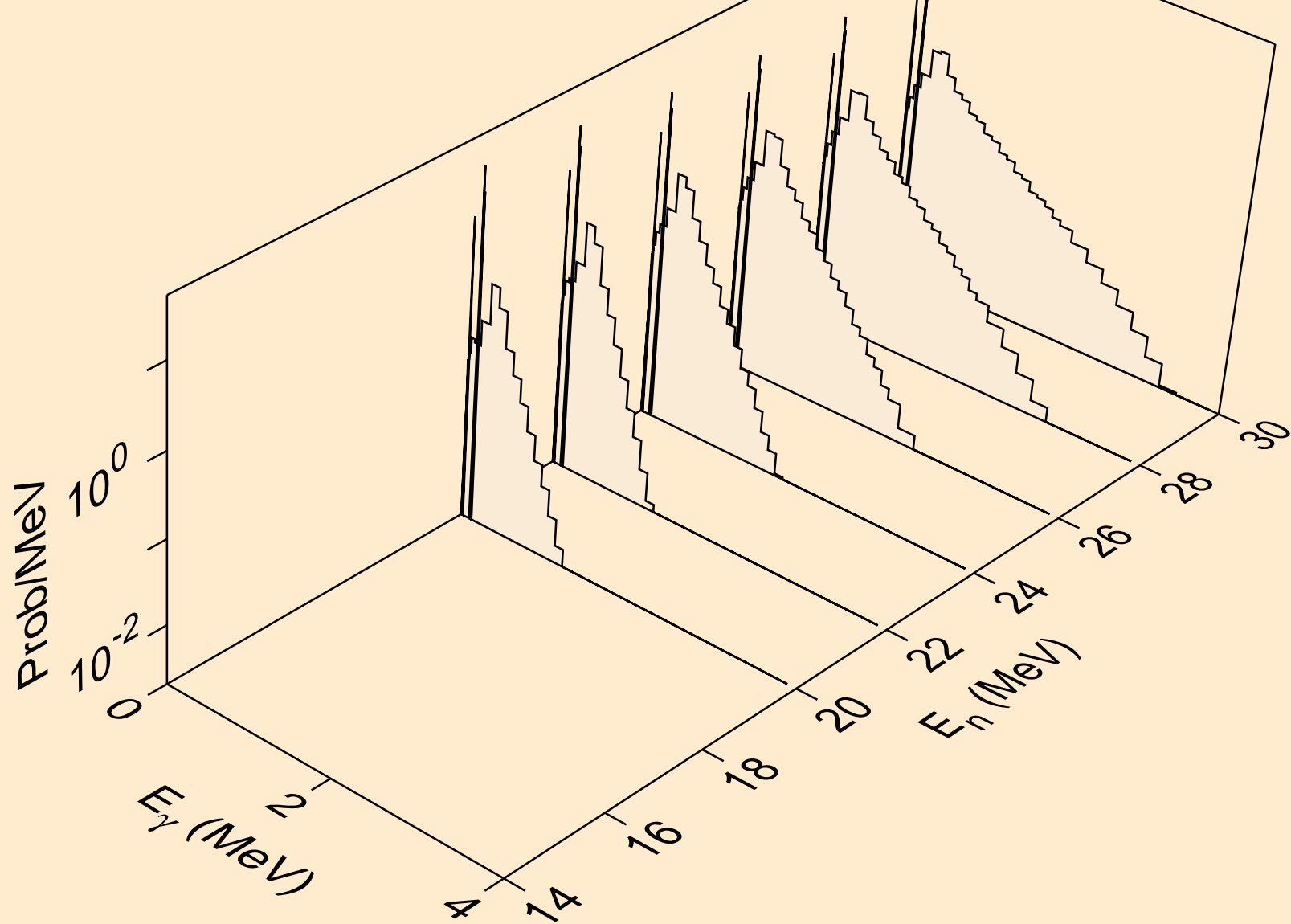

ER162 PROTON ACER TENDL-2023 LIBRARY; T=0.K  
Photon emission for (n,npa)

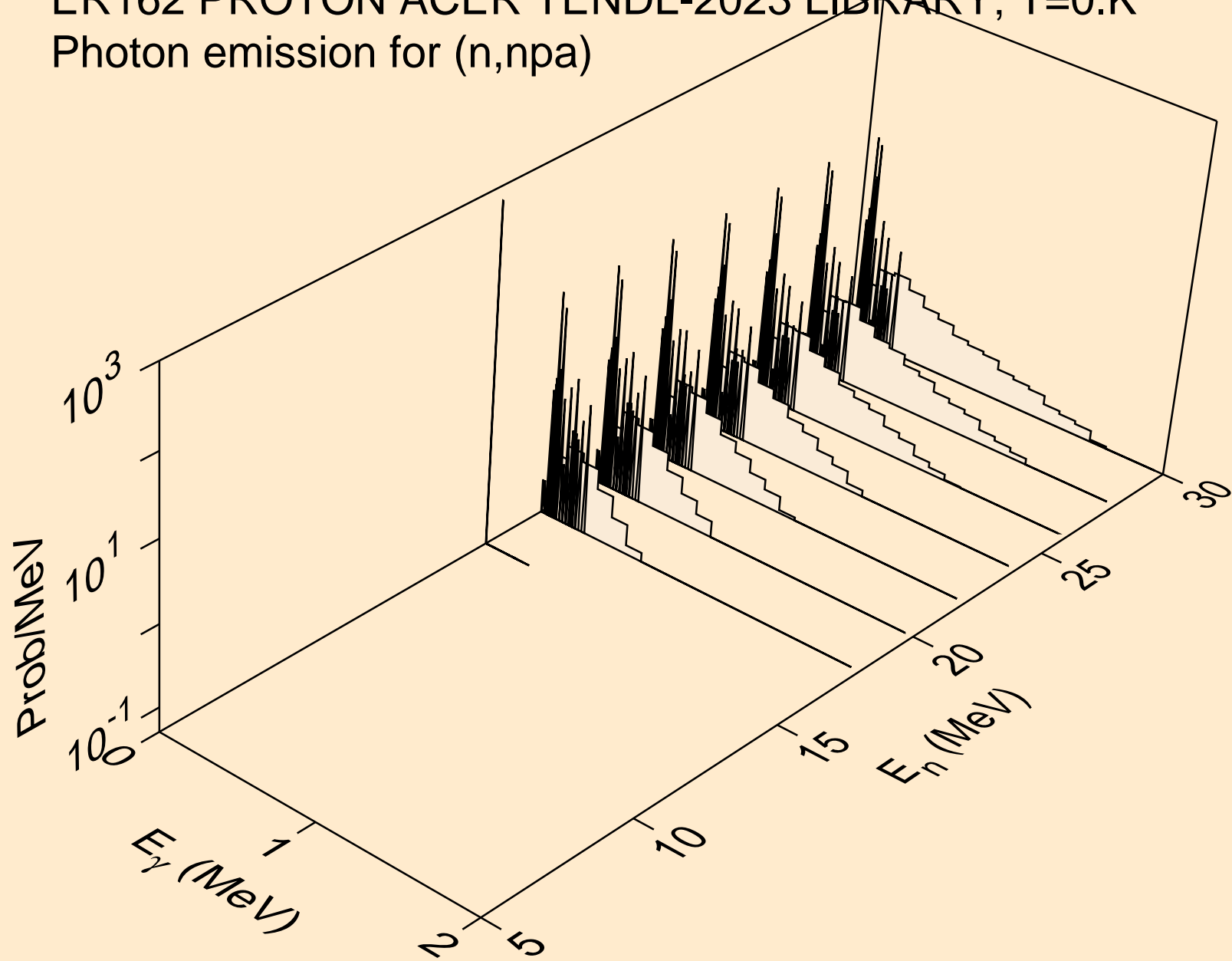

ER162 PROTON ACER TENDL-2023 LIBRARY; T=0.K  
Photon emission for (n,gma)

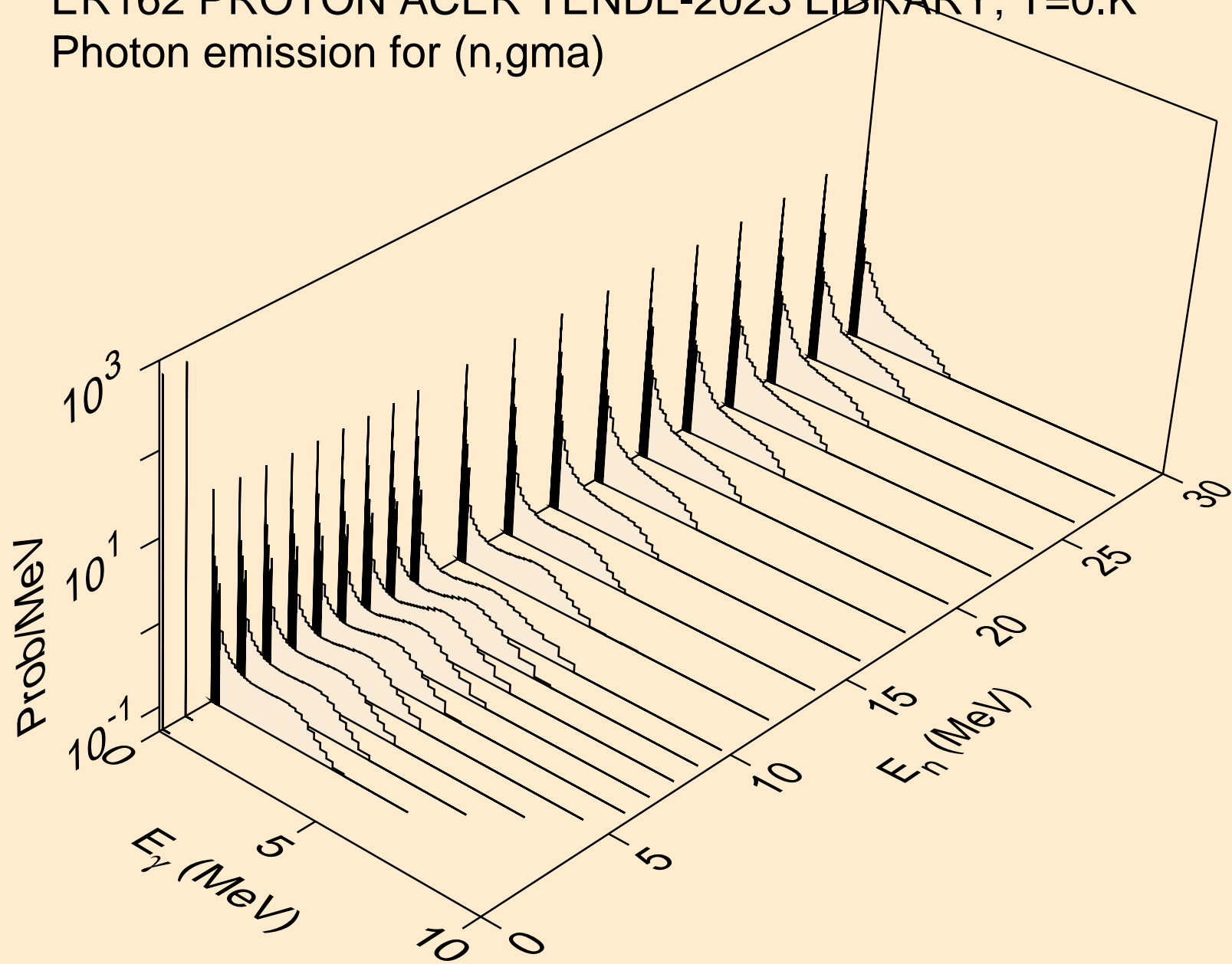

ER162 PROTON ACER TENDL-2023 LIBRARY; T=0.K  
Photon emission for inelastic

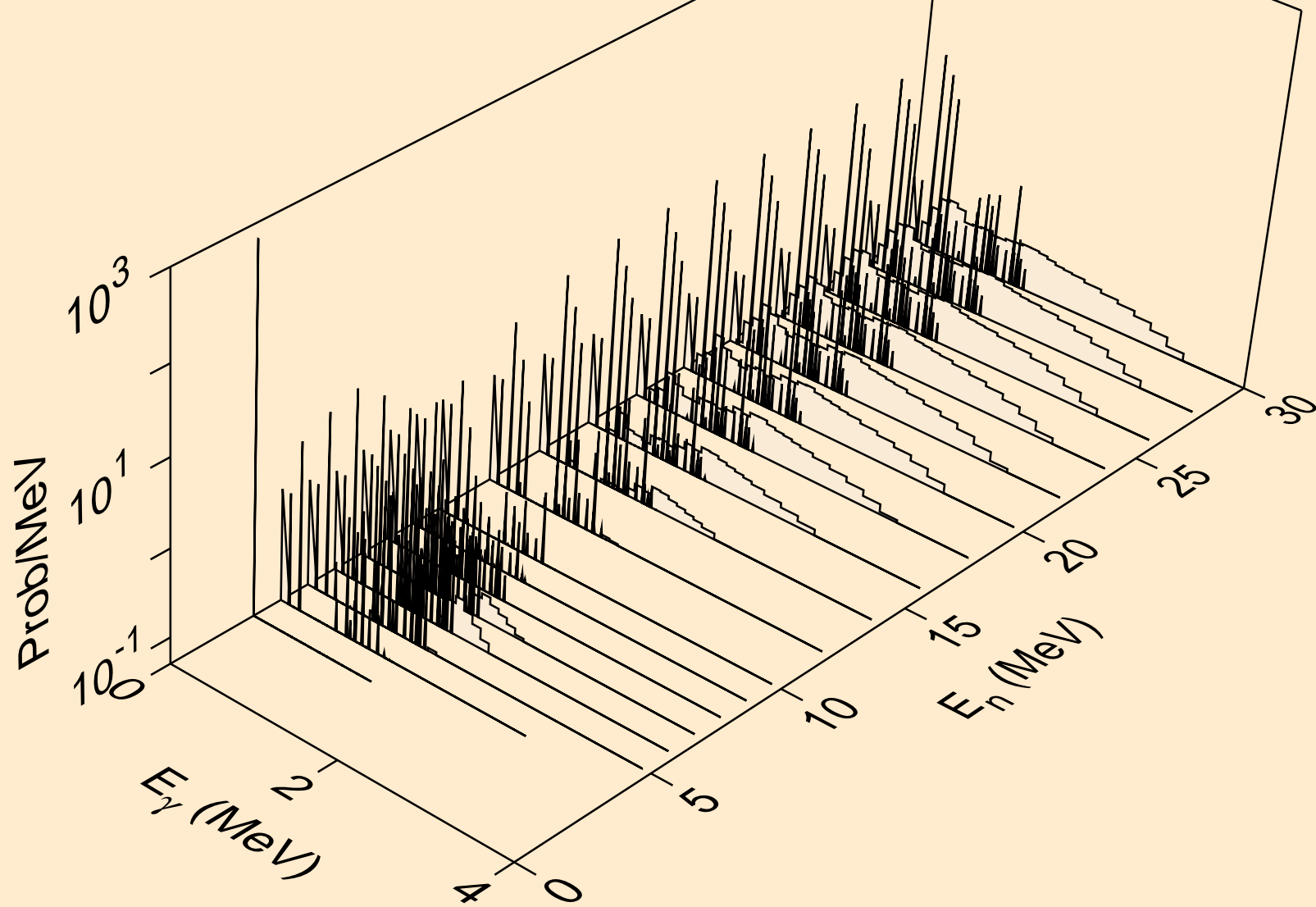

ER162 PROTON ACER TENDL-2023 LIBRARY; T=0.K  
Photon emission for (n,d)

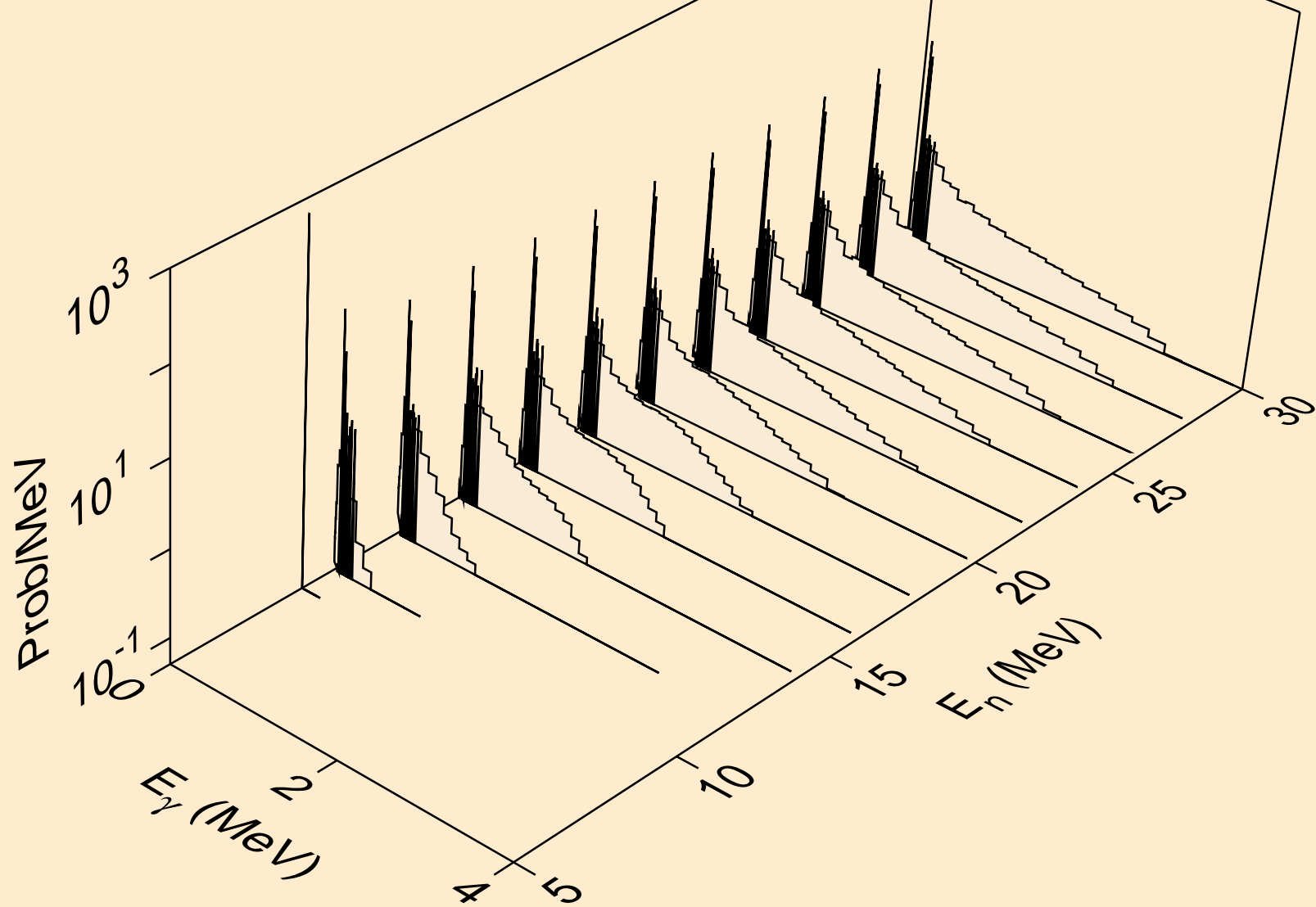



ER162 PROTON ACER TENDL-2023 LIBRARY; T=0.K  
Photon emission for (n,t)

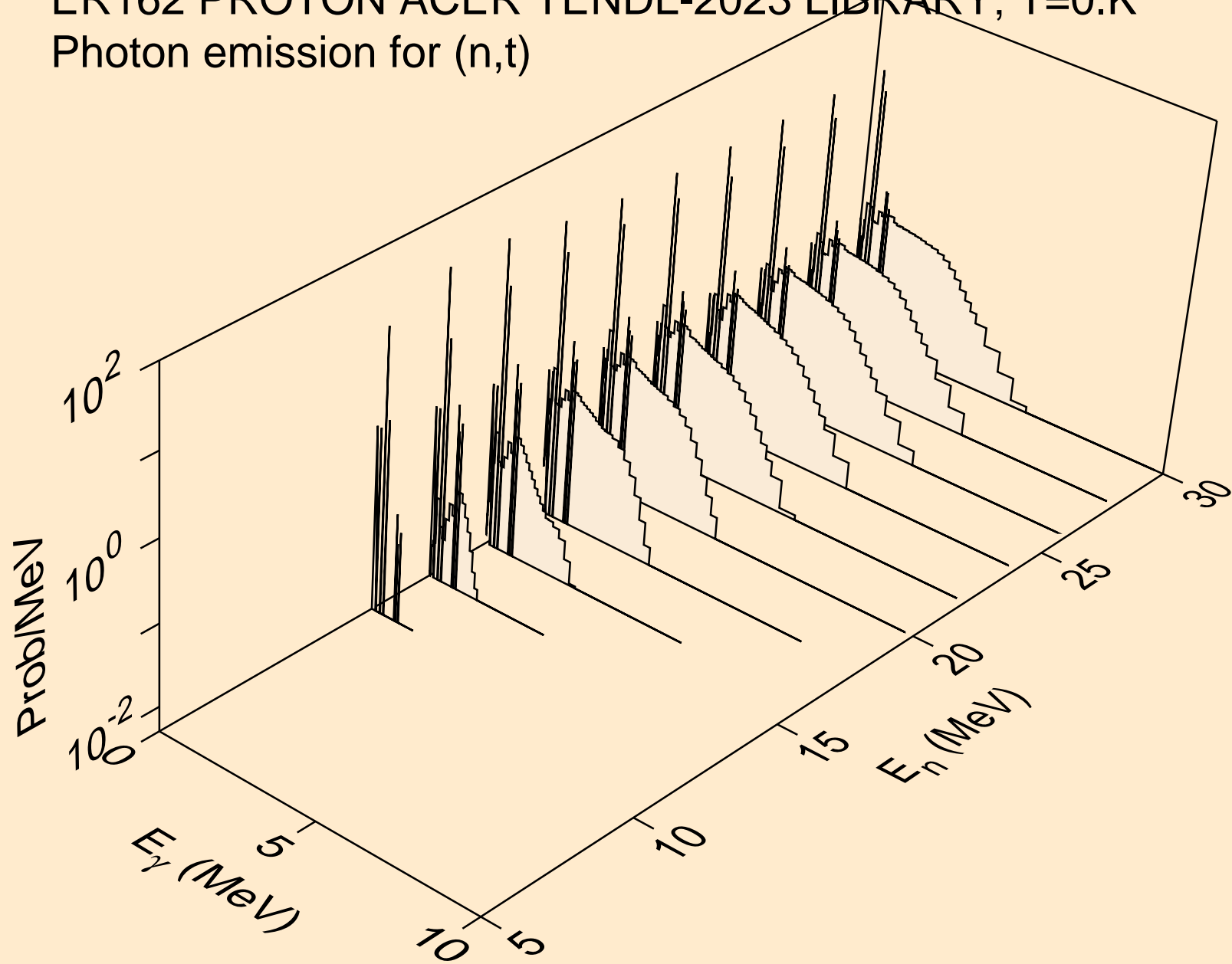

ER162 PROTON ACER TENDL-2023 LIBRARY; T=0.K  
Photon emission for (n,he3)

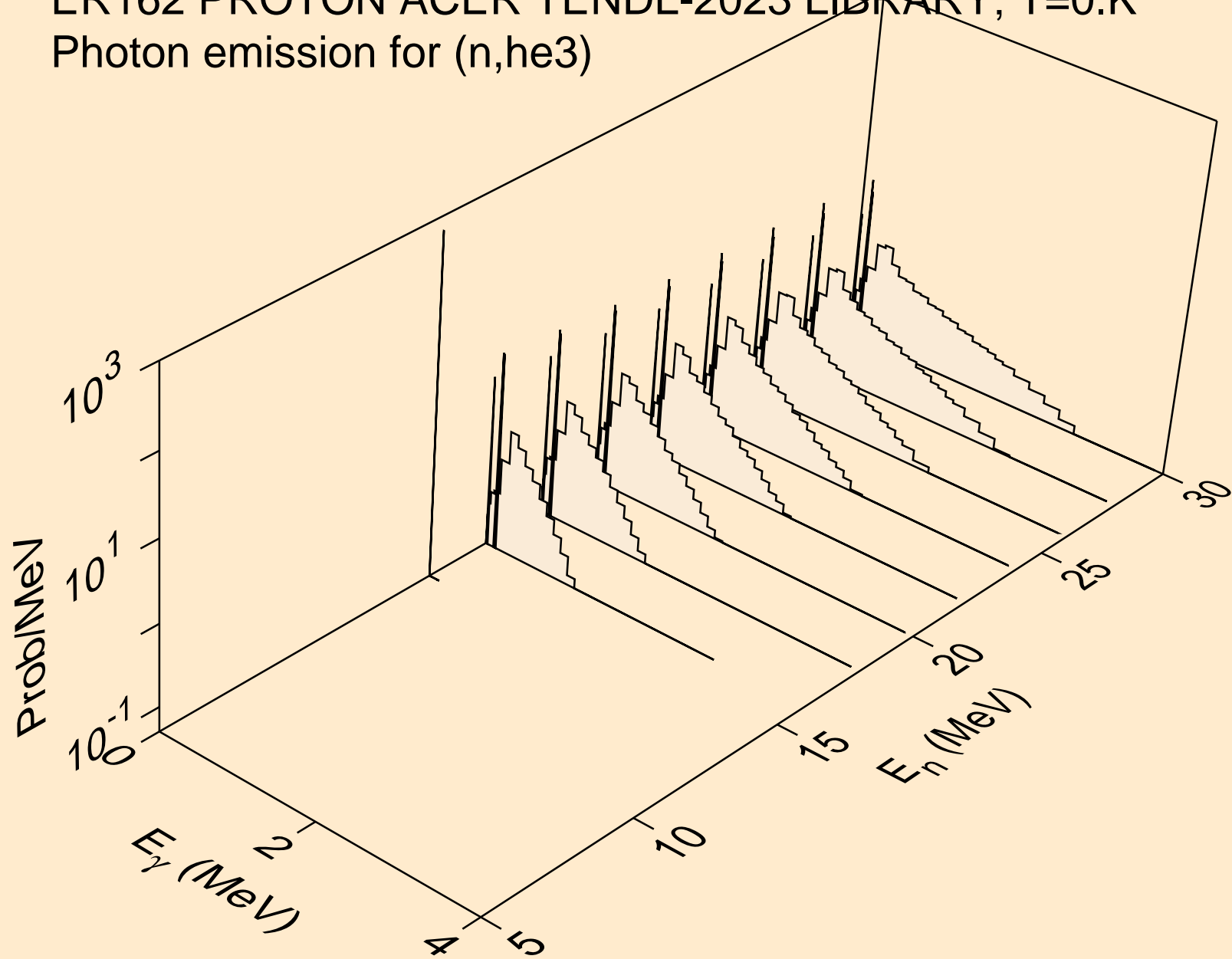

ER162 PROTON ACER TENDL-2023 LIBRARY; T=0.K  
Photon emission for (n,a)

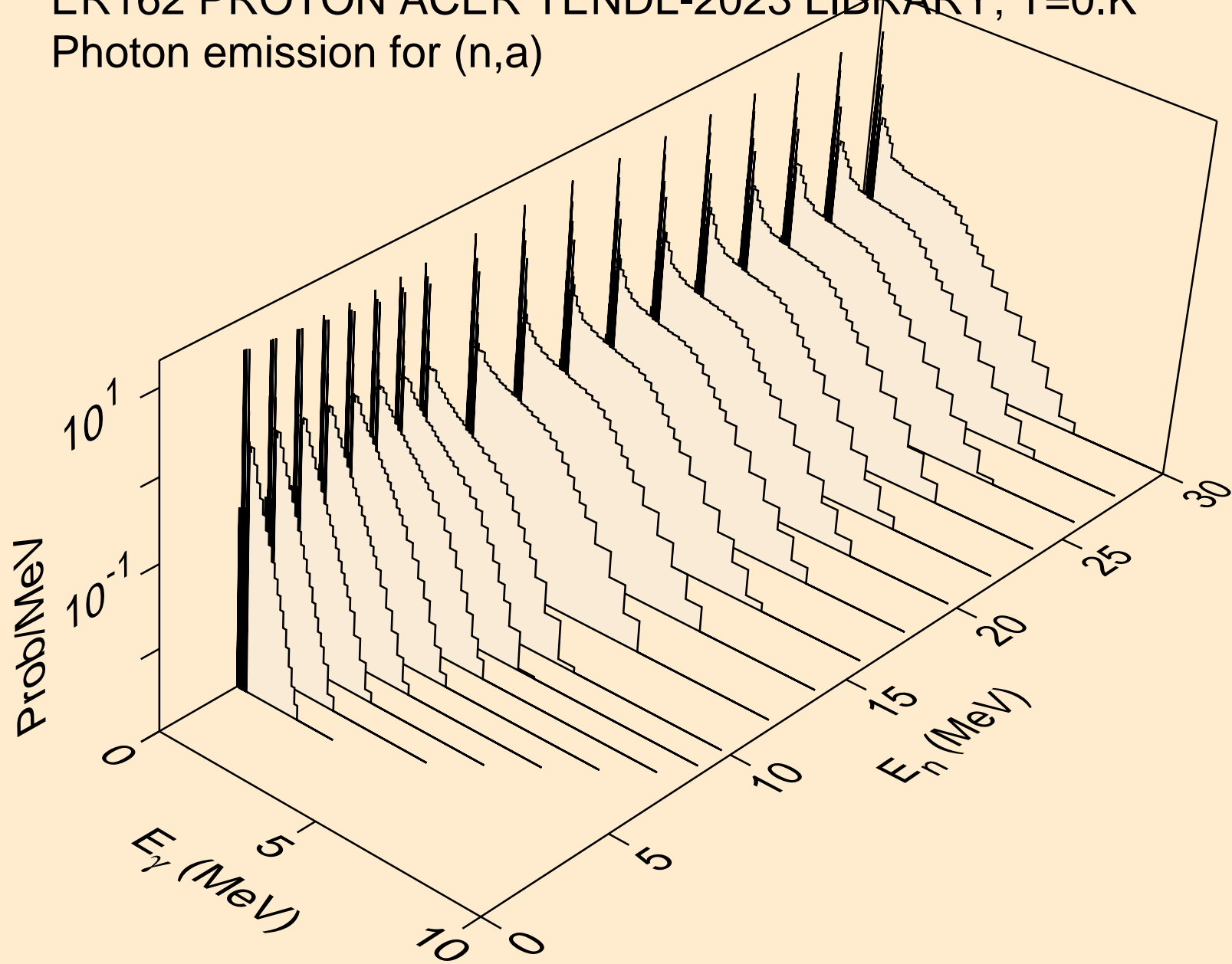

ER162 PROTON ACER TENDL-2023 LIBRARY; T=0.K  
Photon emission for (n,2a)

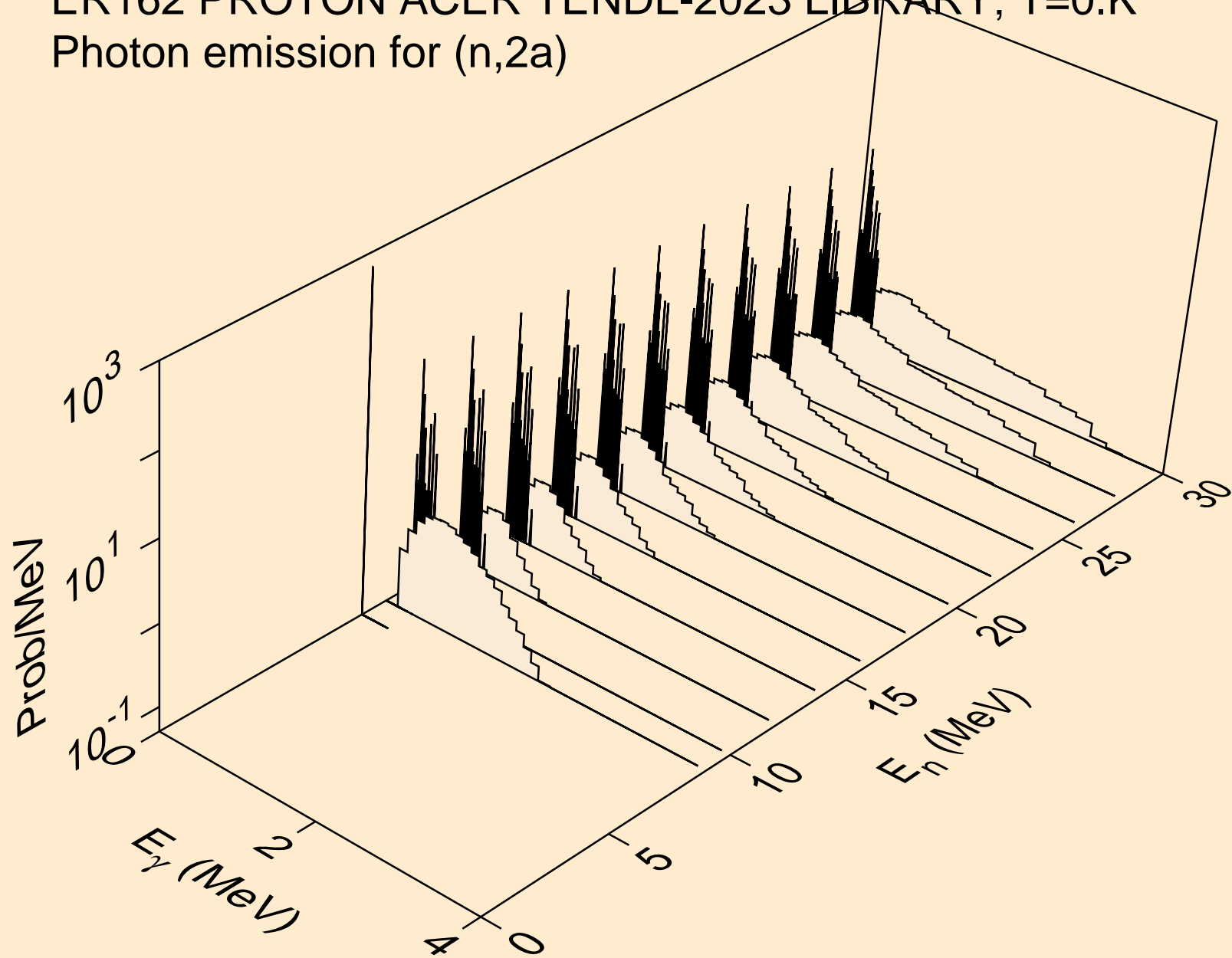

ER162 PROTON ACER TENDL-2023 LIBRARY; T=0.K  
Photon emission for (n,2p)

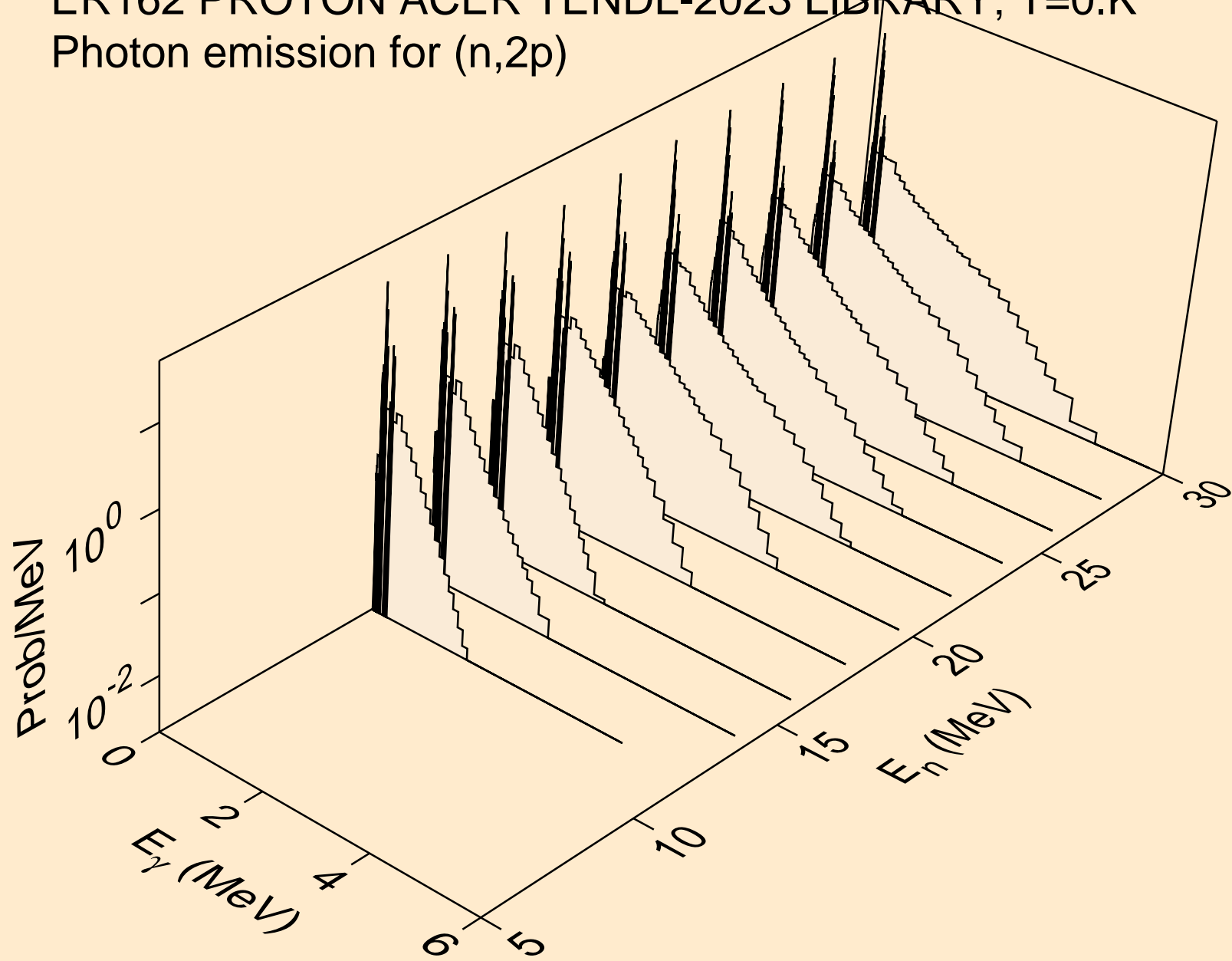

ER162 PROTON ACER TENDL-2023 LIBRARY; T=0.K  
Photon emission for (n,pa)

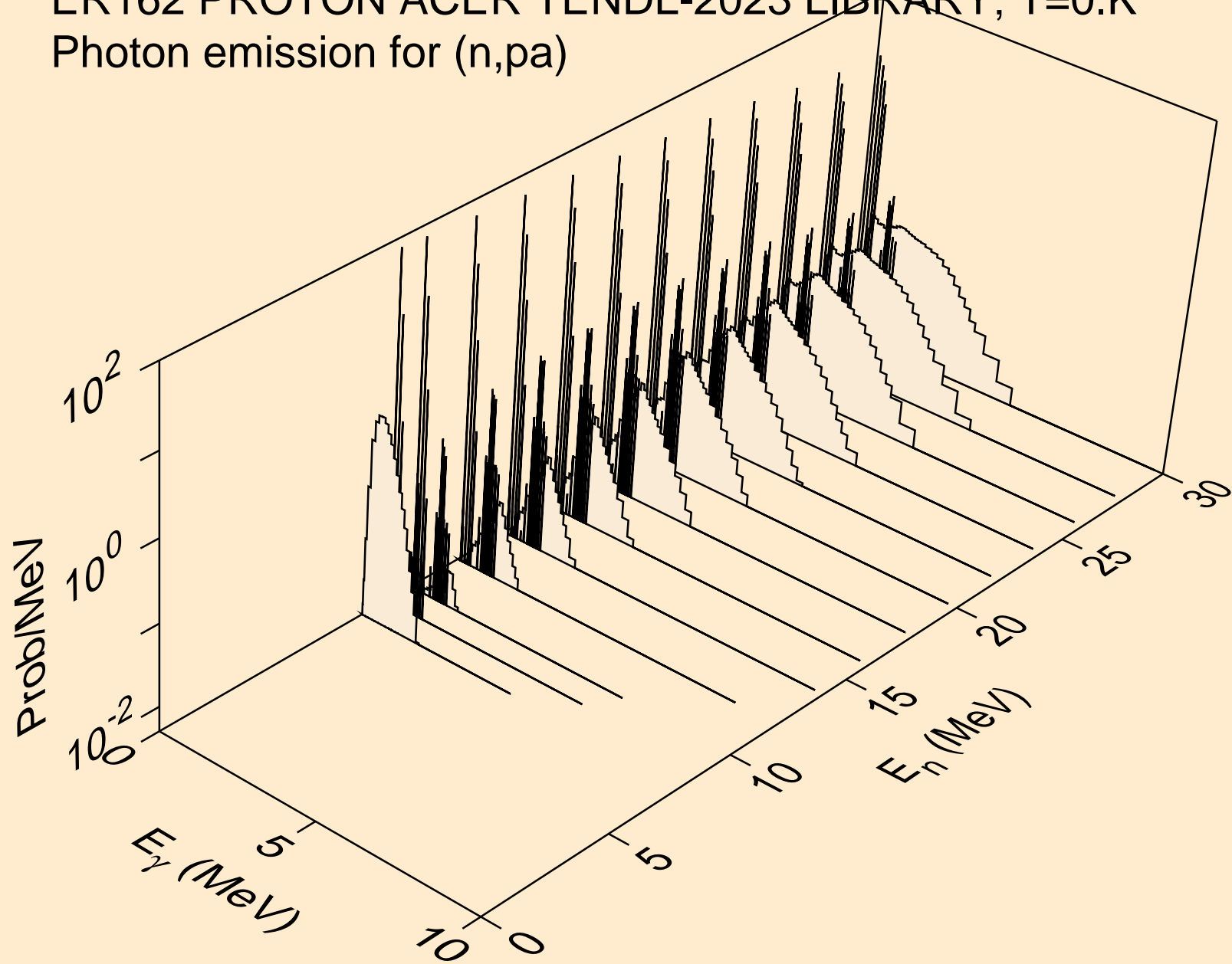

ER162 PROTON ACER TENDL-2023 LIBRARY; T=0.K  
Photon emission for (n,pd)

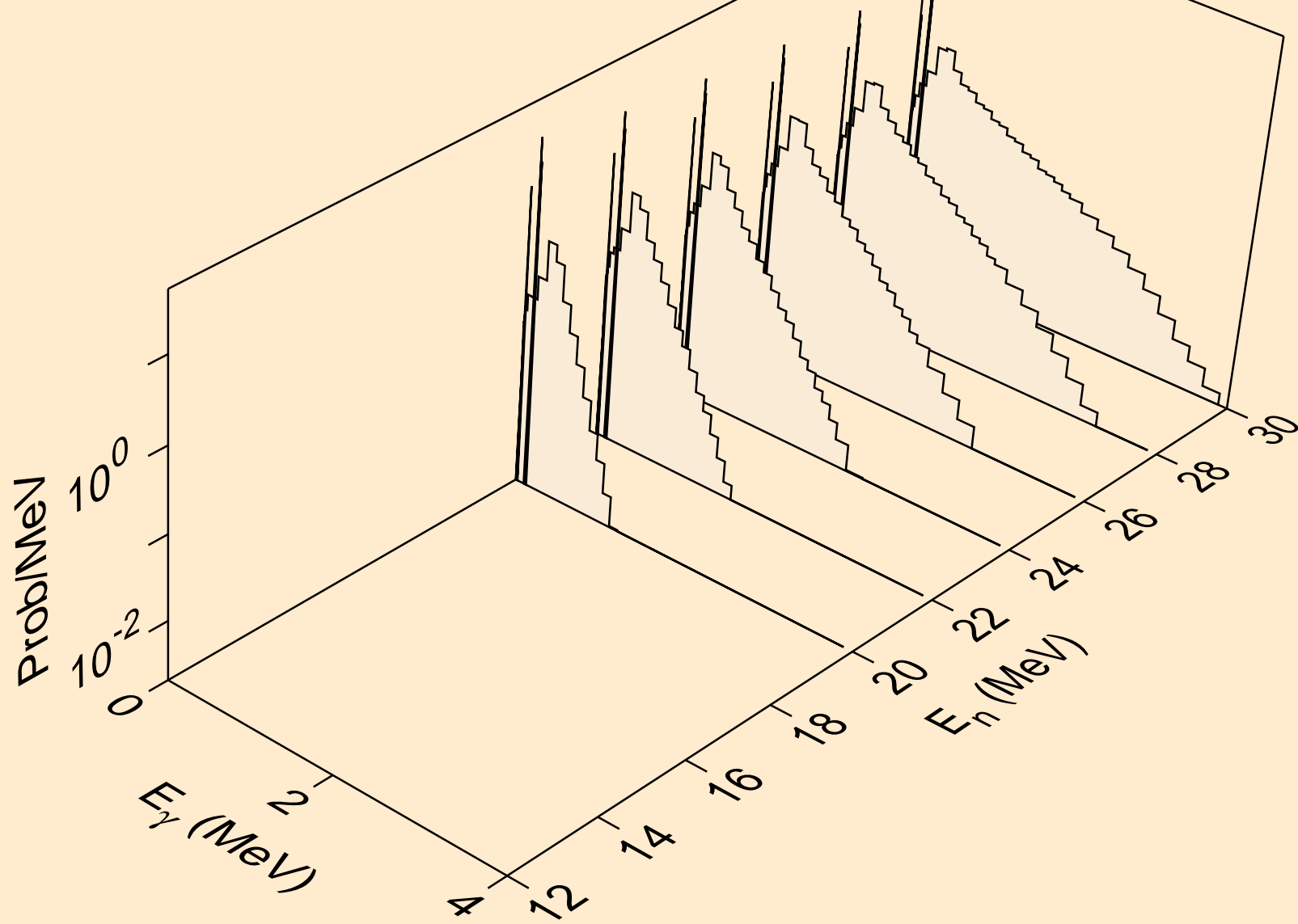

ER162 PROTON ACER TENDL-2023 LIBRARY; T=0.K  
Photon emission for (n,pt)

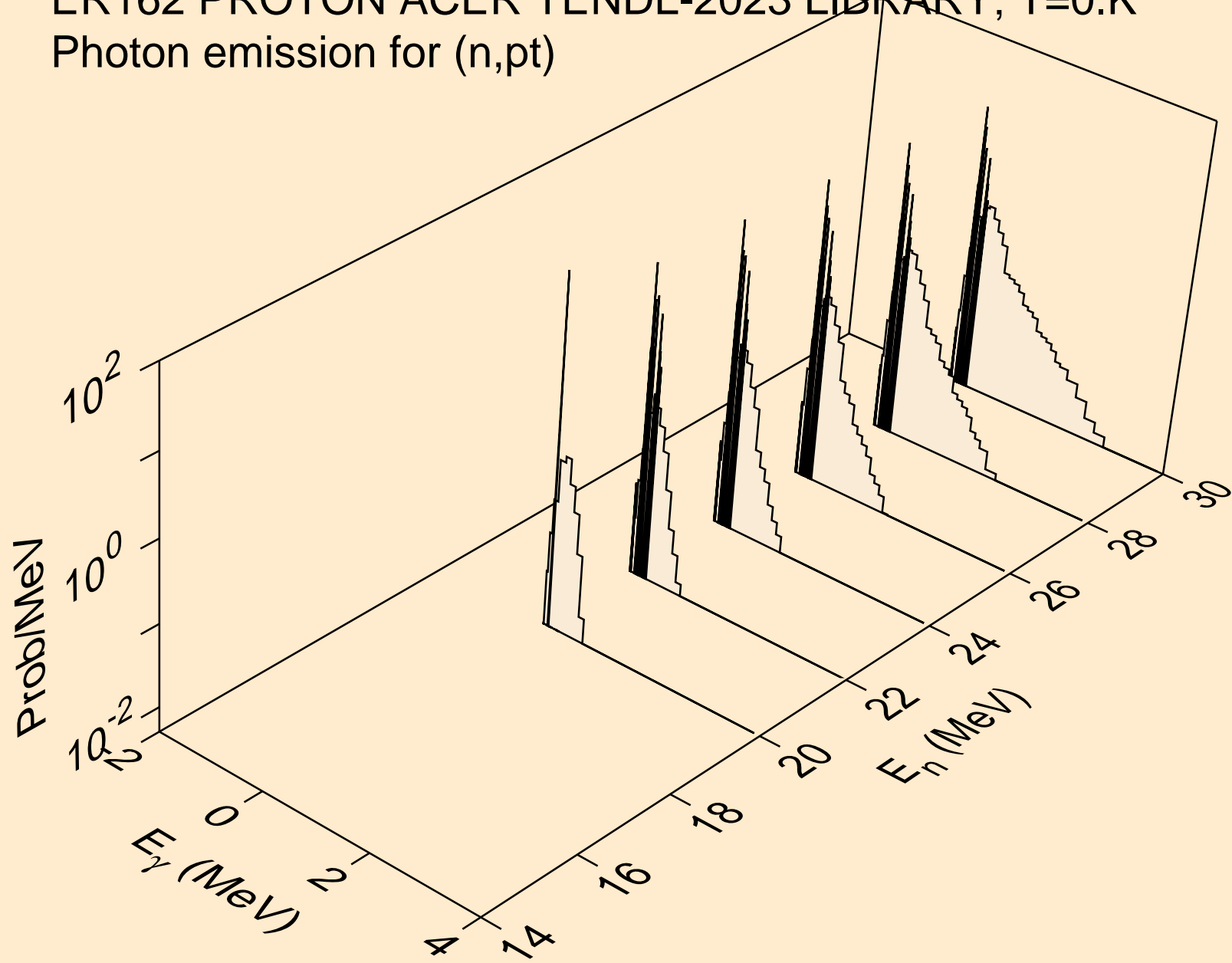



ER162 PROTON ACER TENDL-2023 LIBRARY; T=0.K  
Photon emission for (n,da)

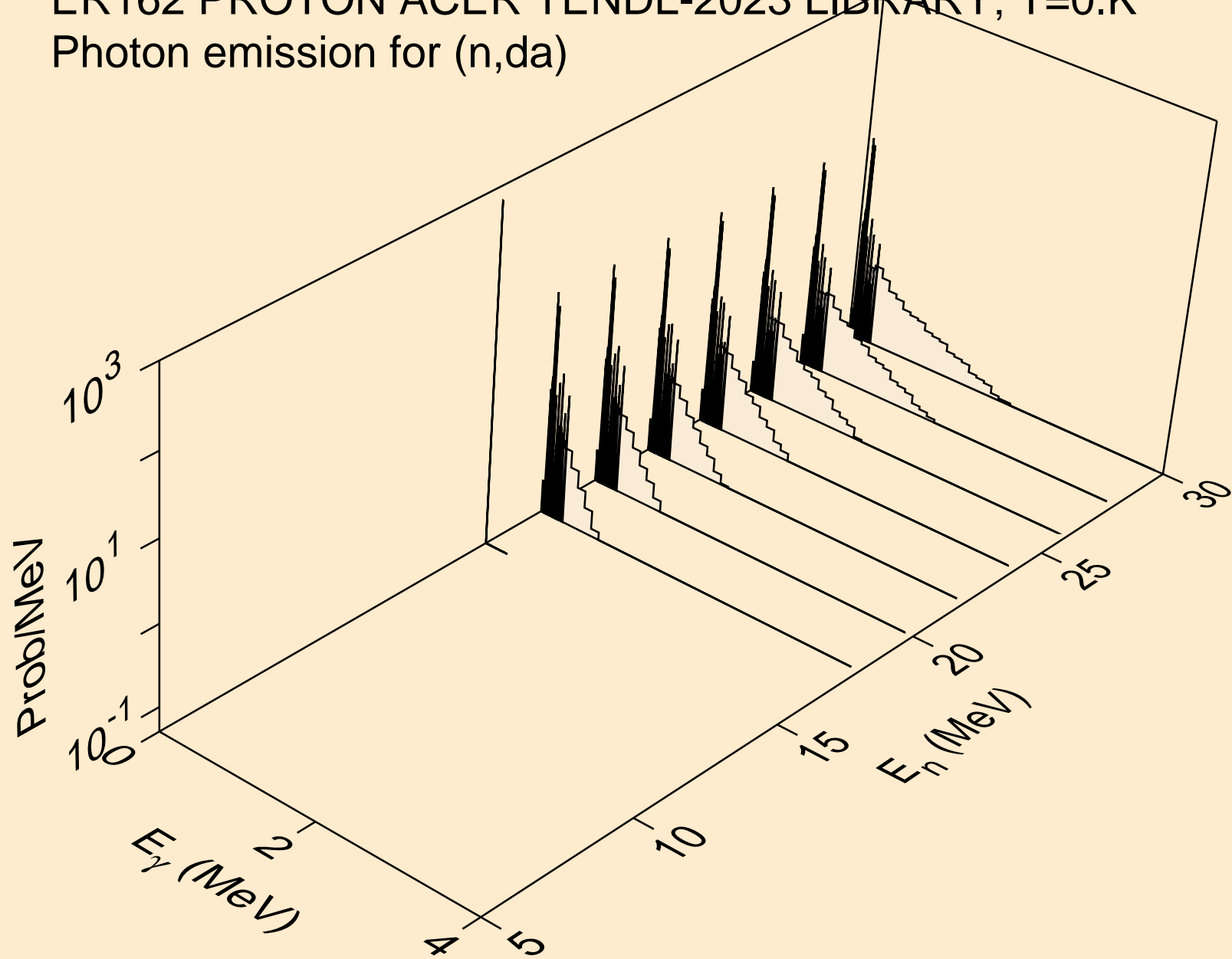

ER162 PROTON ACER TENDL-2023 LIBRARY; T=0.K  
Particle heating contributions

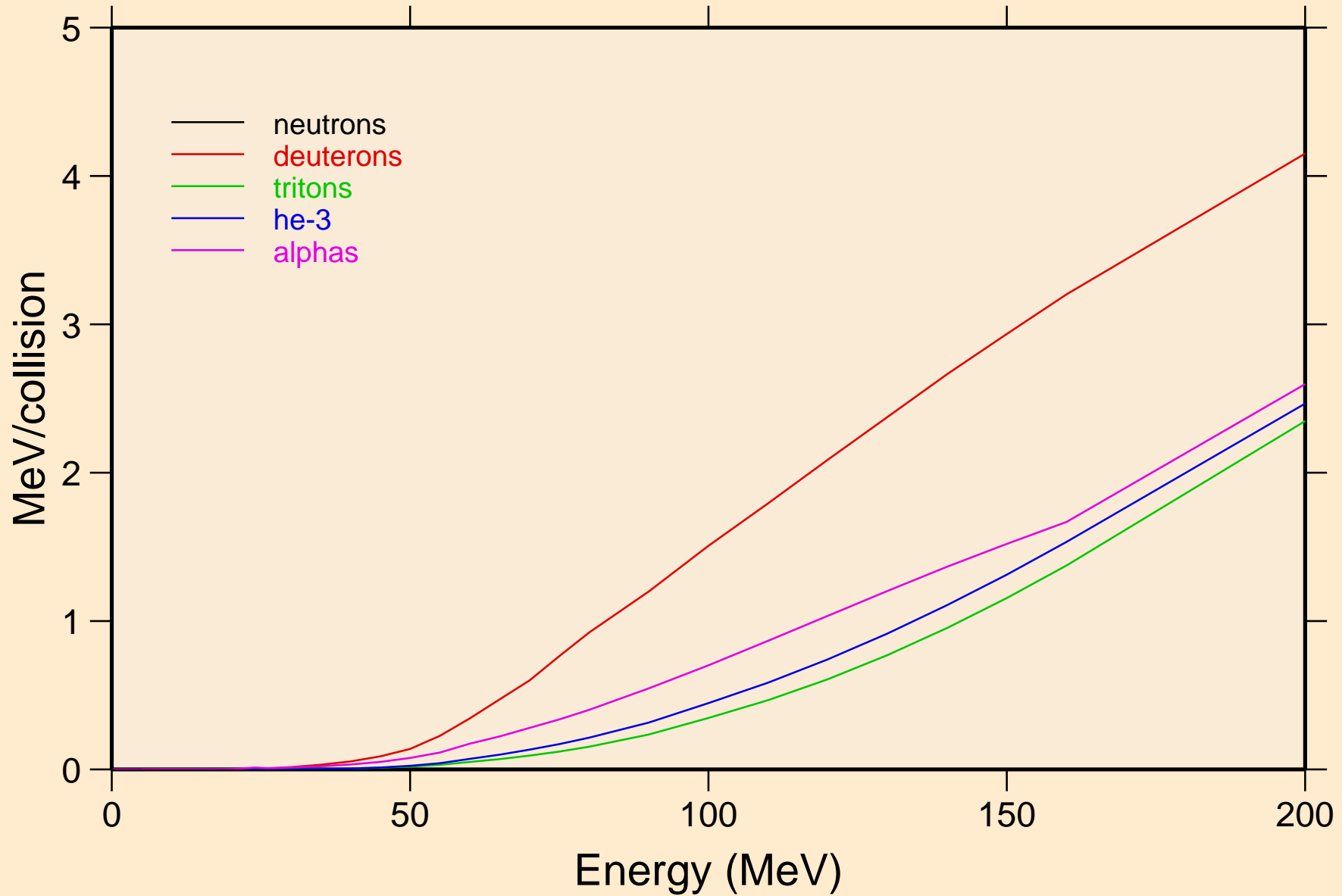

ER162 PROTON ACER TENDL-2023 LIBRARY; T=0.K

Recoil Heating

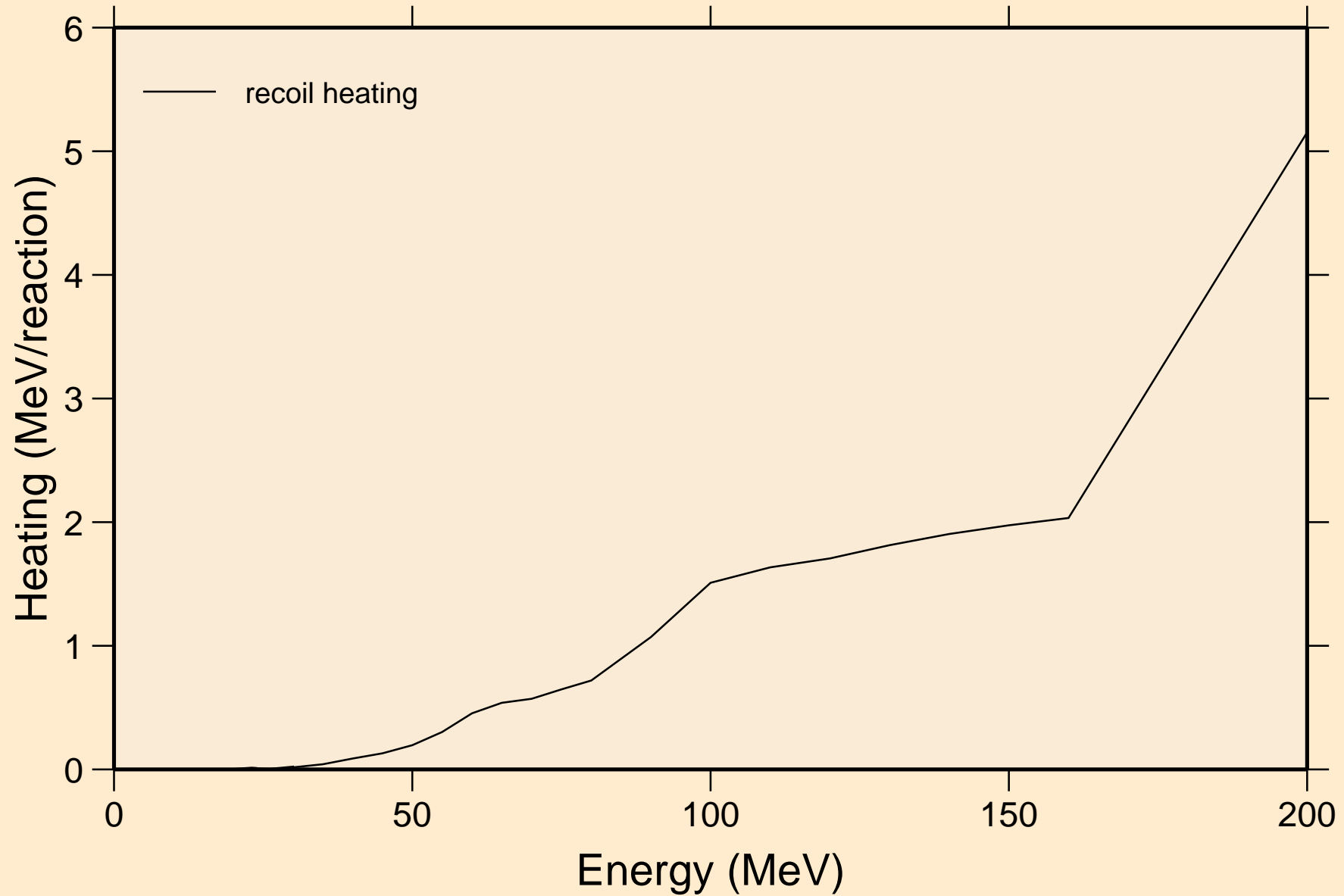

ER162 PROTON ACER TENDL-2023 LIBRARY; T=0.K  
Particle production cross sections

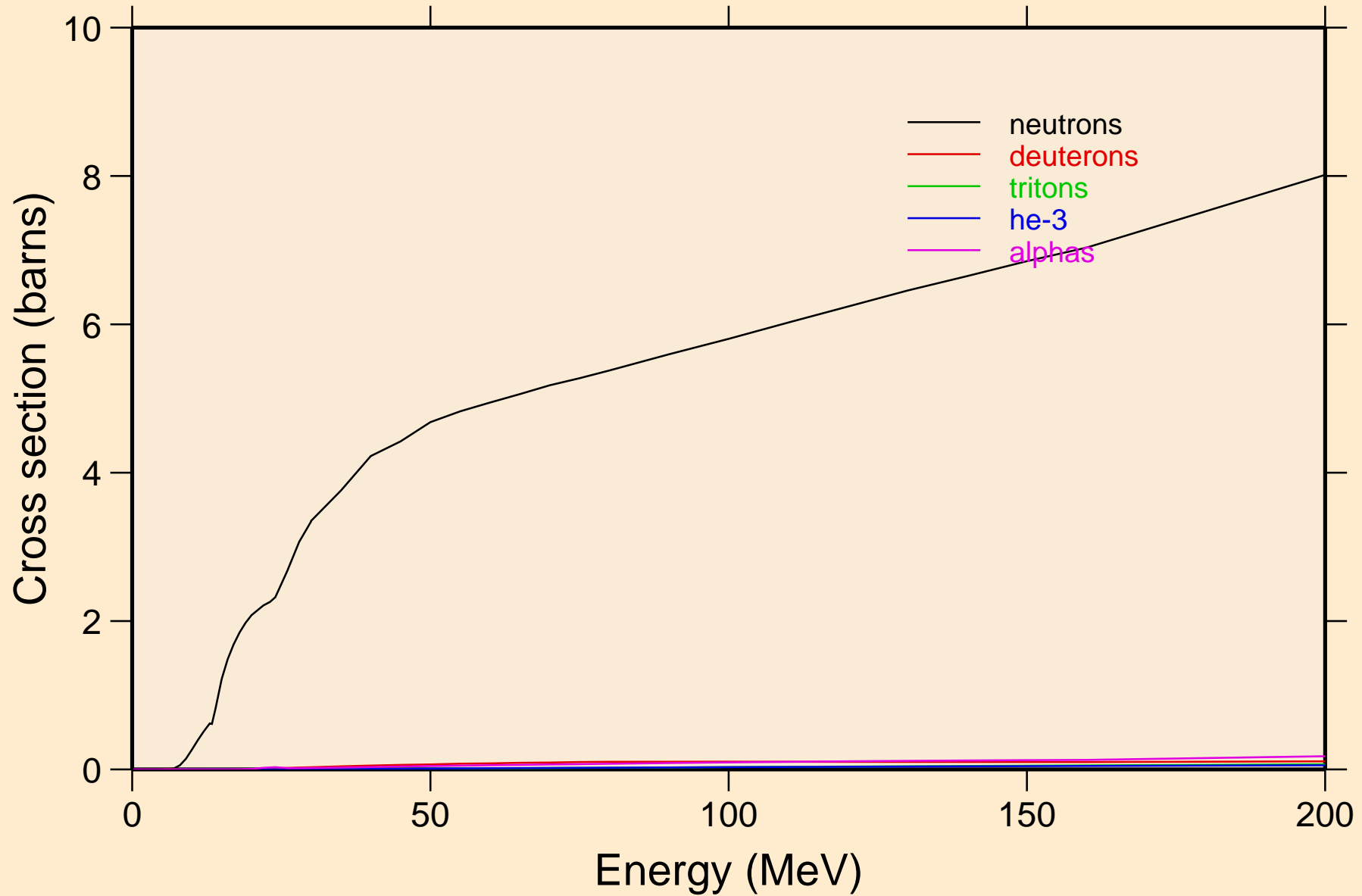

ER162 PROTON ACER TENDL-2023 LIBRARY; T=0.K  
neutrons from (p,n)

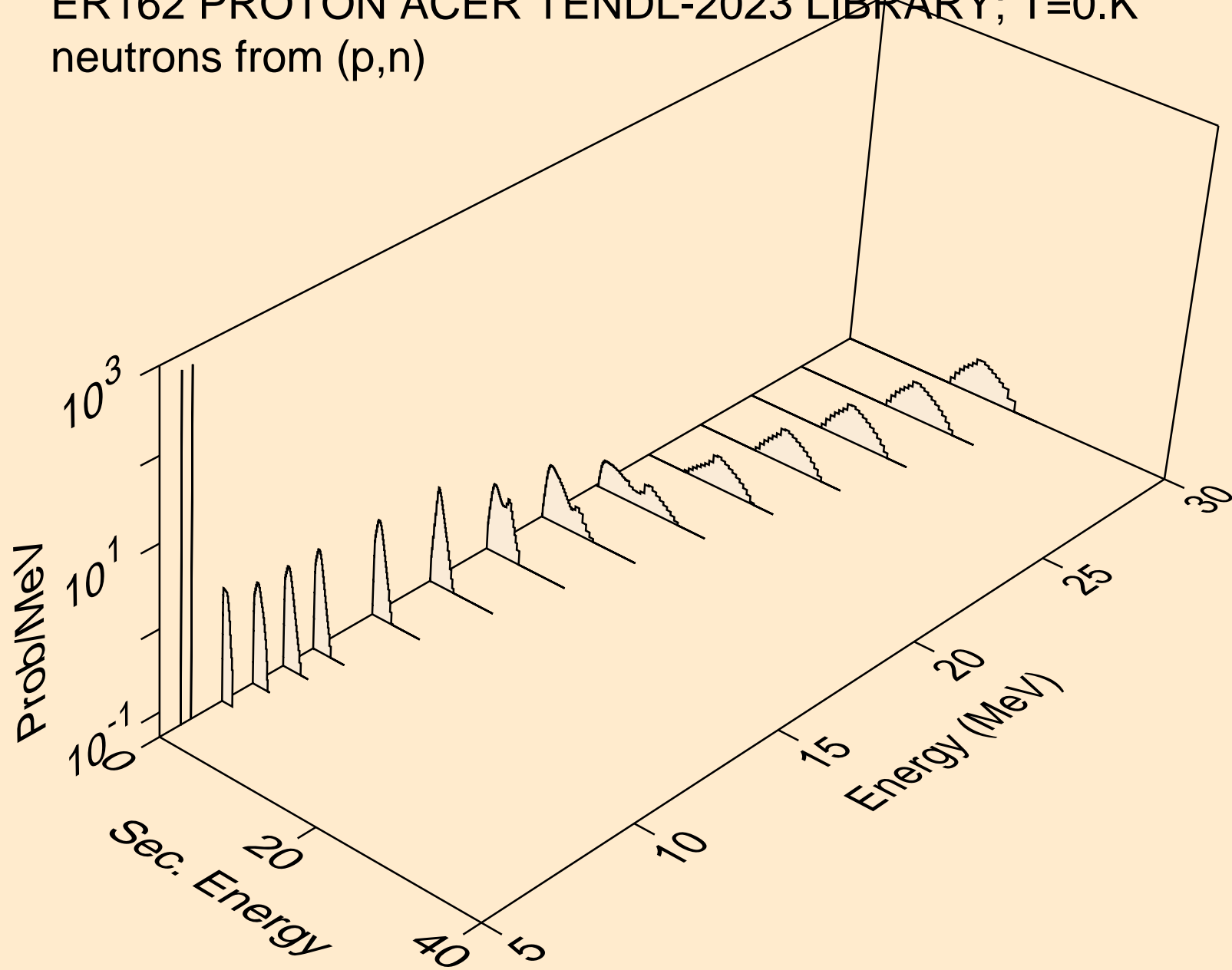

ER162 PROTON ACER TENDL-2023 LIBRARY; T=0.K  
neutrons from (p,x)

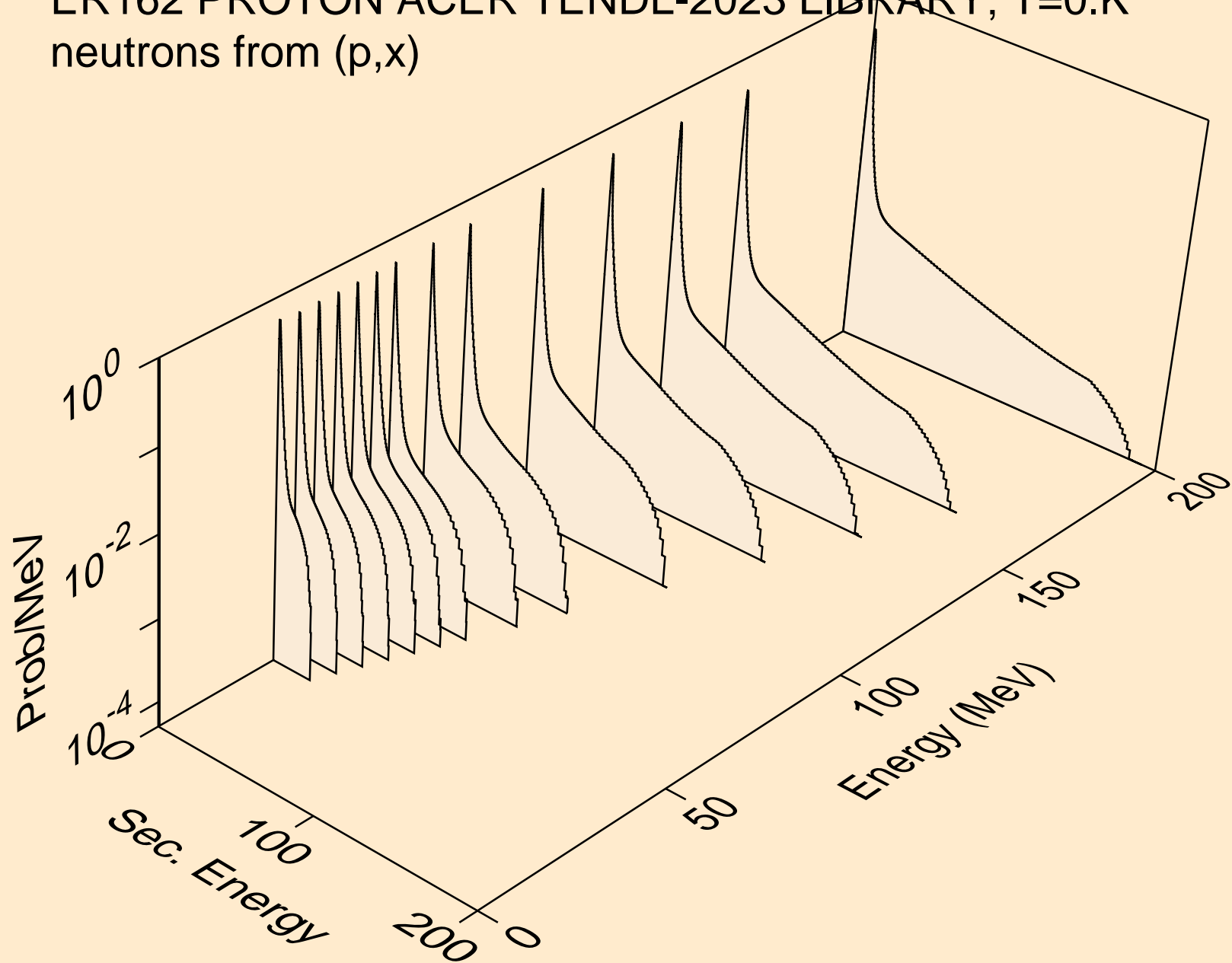

ER162 PROTON ACER TENDL-2023 LIBRARY; T=0.K  
neutrons from (p,2nd)

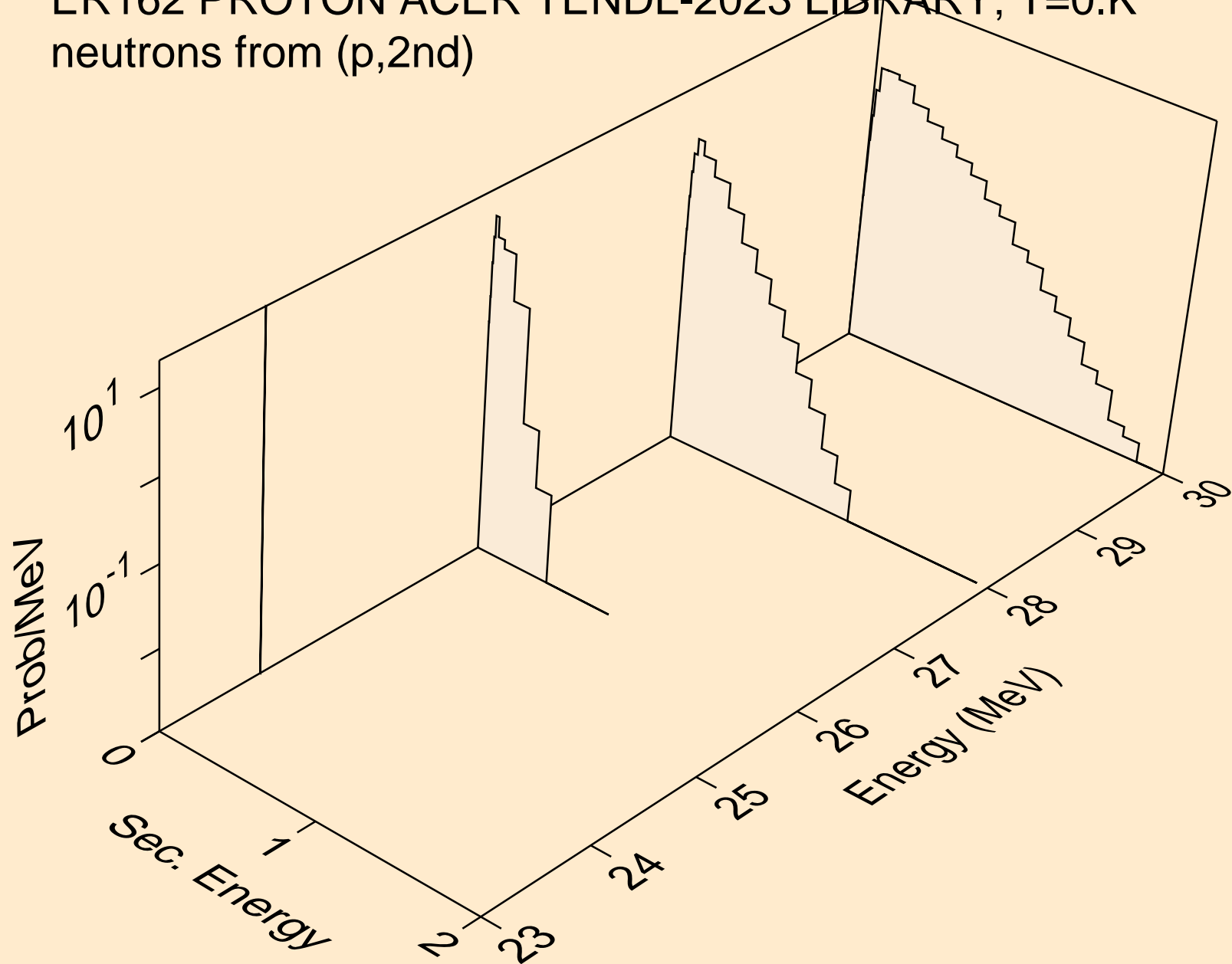

ER162 PROTON ACER TENDL-2023 LIBRARY; T=0.K  
neutrons from (p,2n)

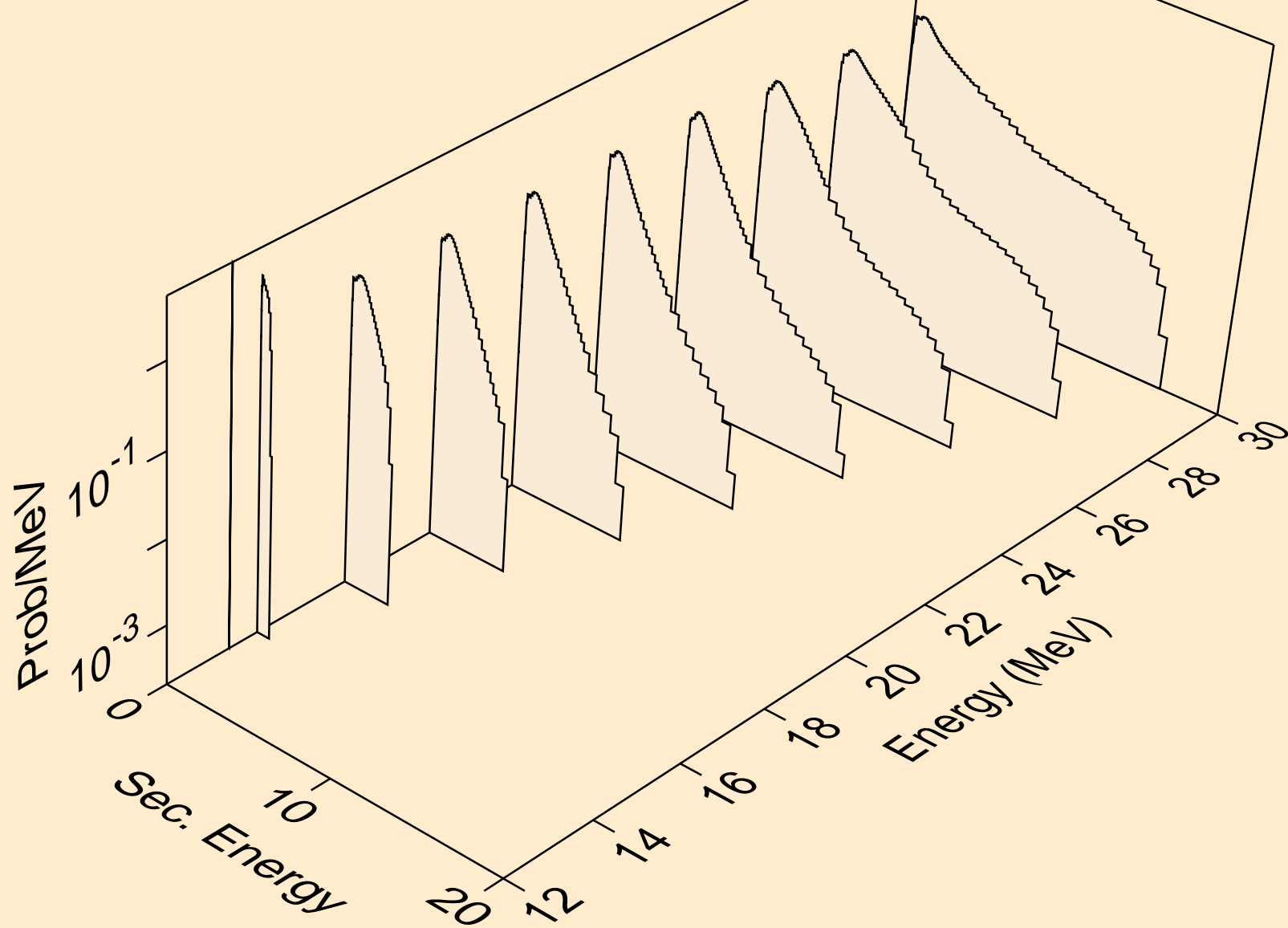



ER162 PROTON ACER TENDL-2023 LIBRARY; T=0.K  
neutrons from (p,3n)

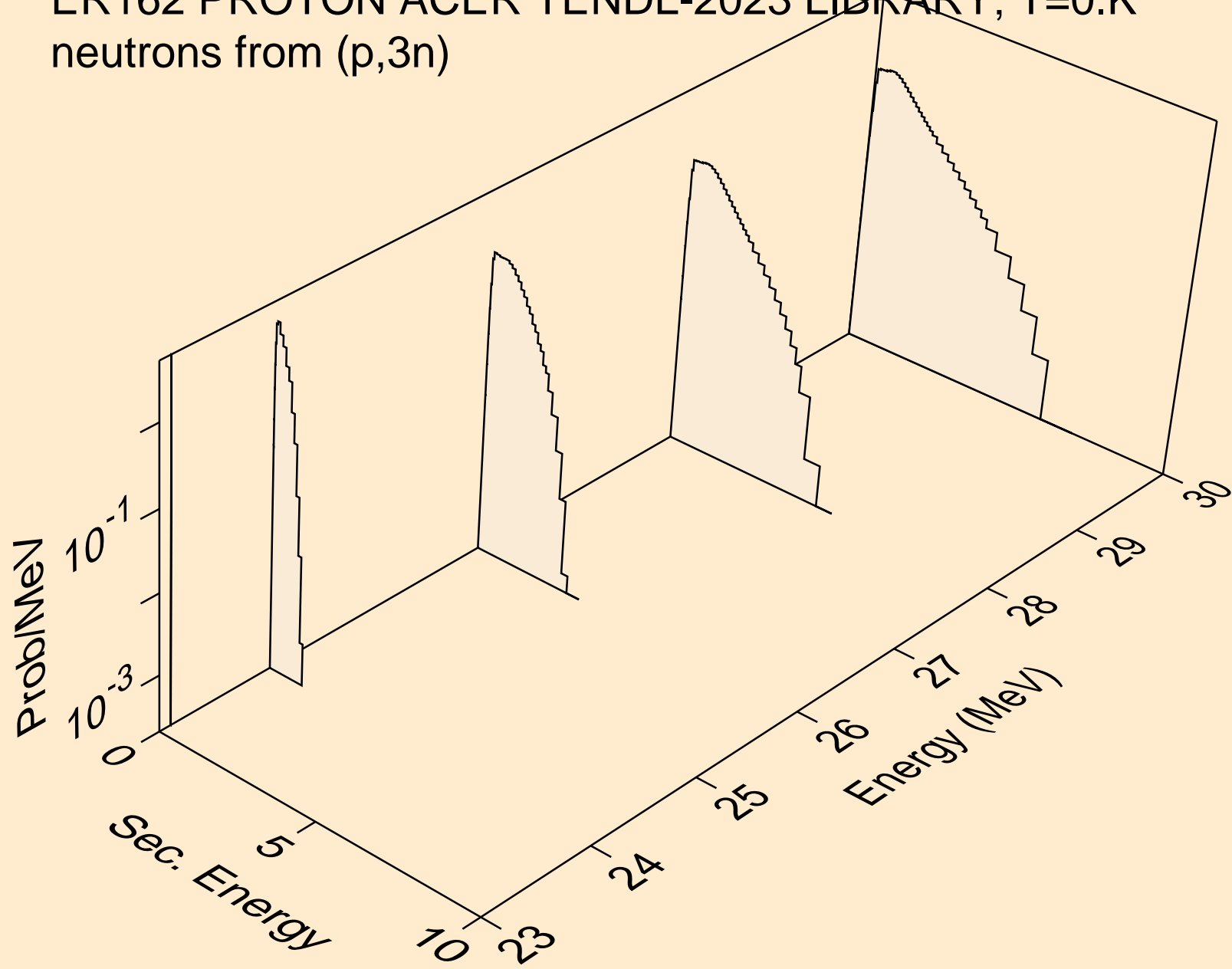

ER162 PROTON ACER TENDL-2023 LIBRARY; T=0.K  
neutrons from (p,n\*)a

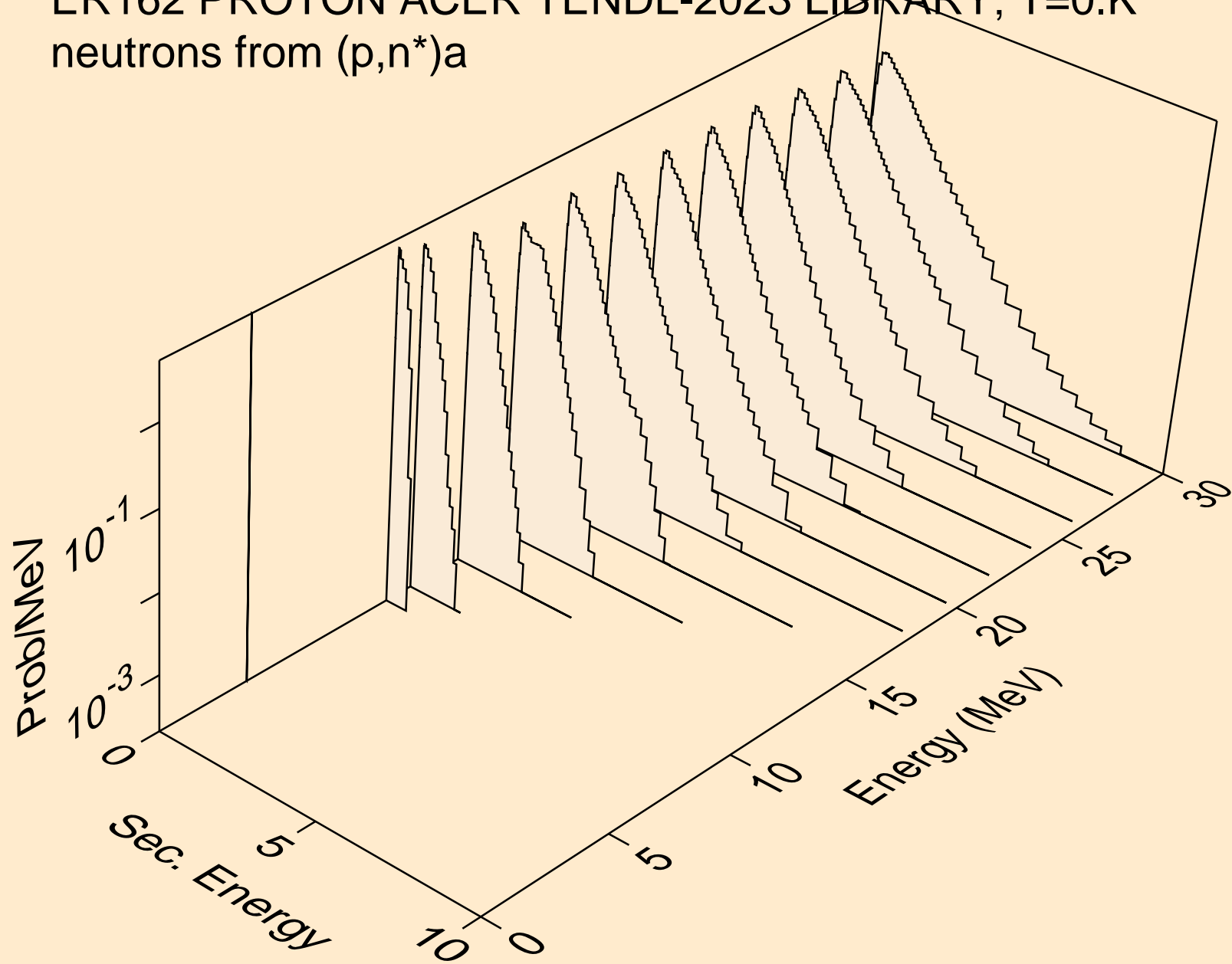

ER162 PROTON ACER TENDL-2023 LIBRARY; T=0.K  
neutrons from (p,2n)a

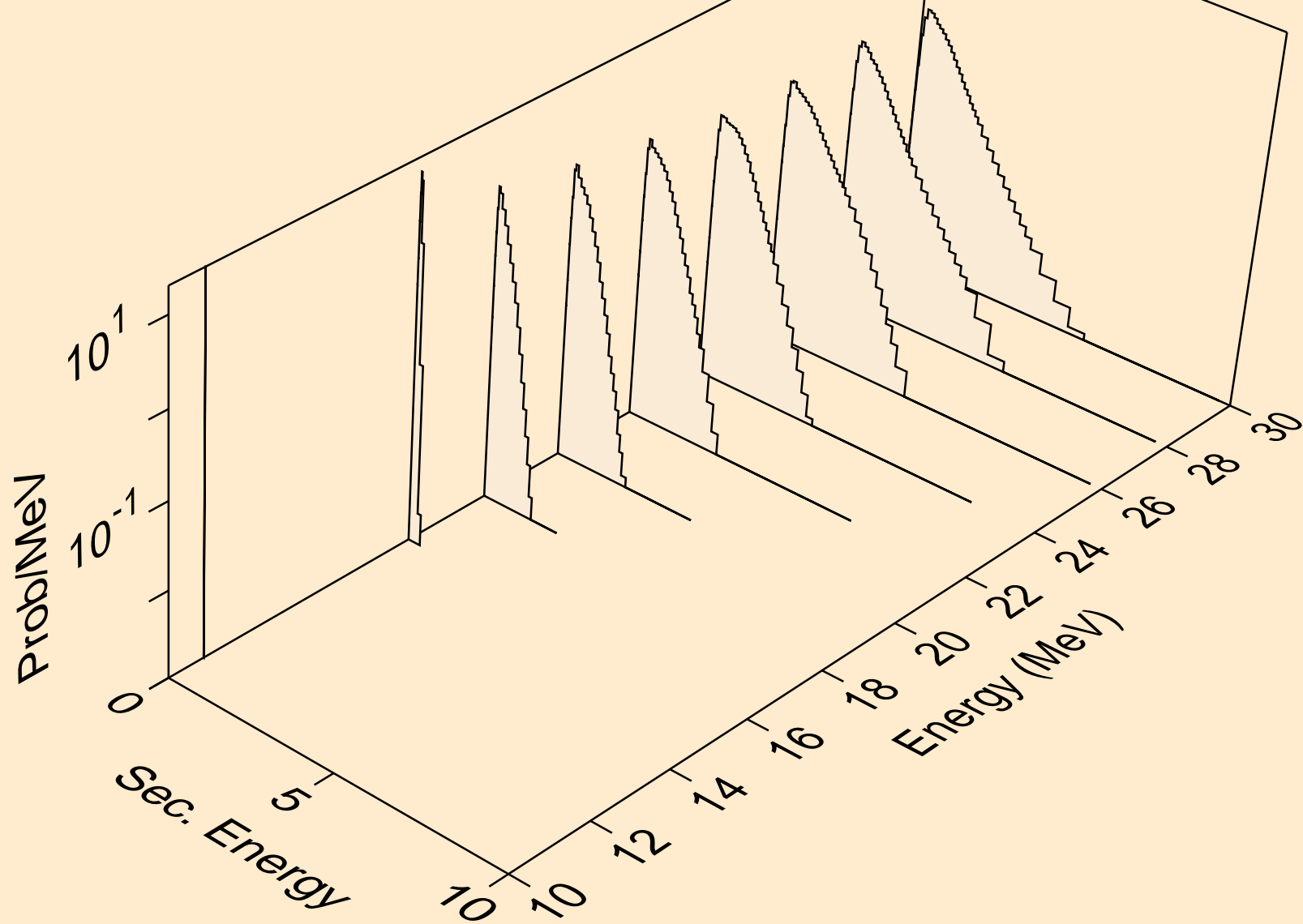

ER162 PROTON ACER TENDL-2023 LIBRARY; T=0.K  
neutrons from (p,3n)a

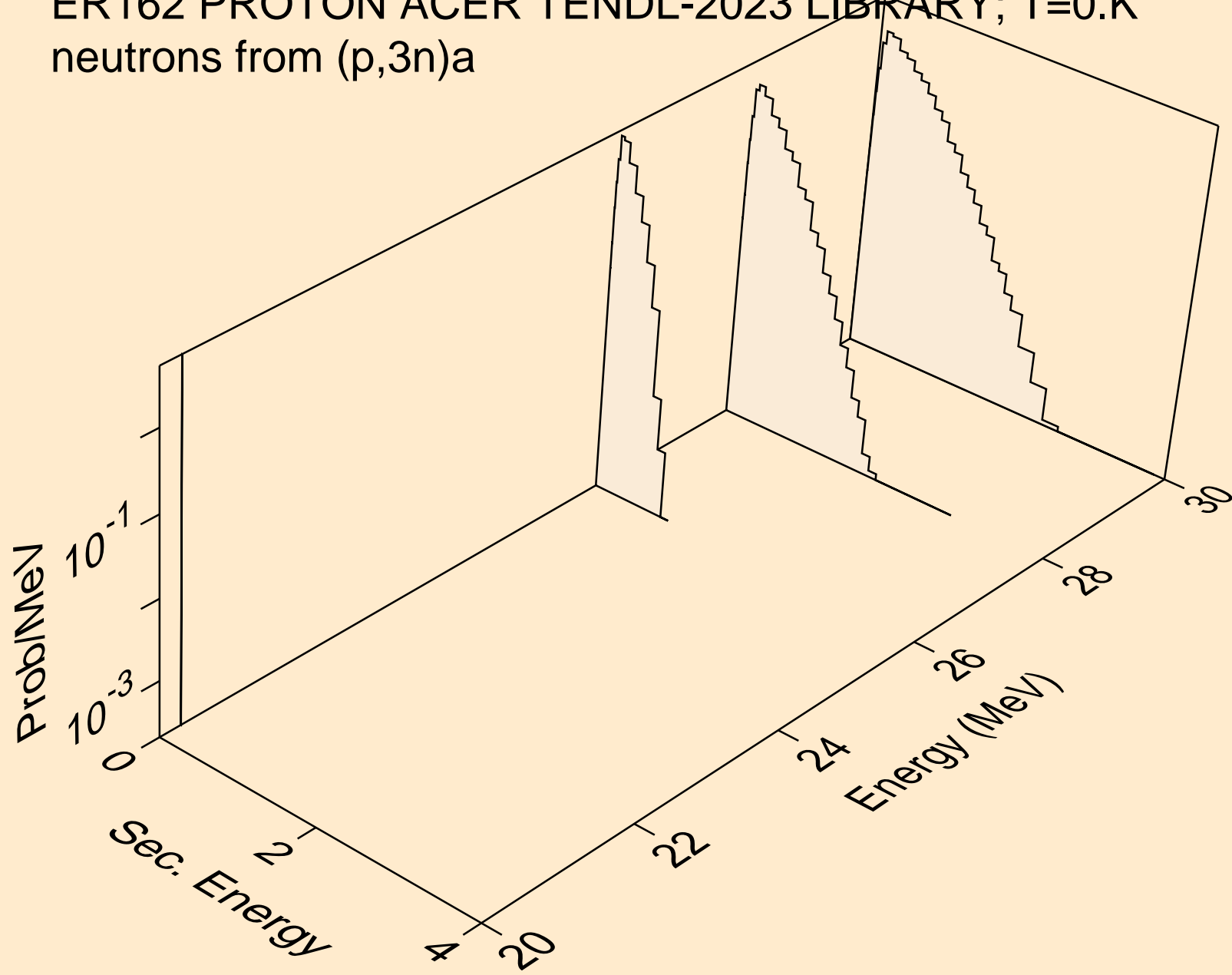

ER162 PROTON ACER TENDL-2023 LIBRARY; T=0.K  
neutrons from (p,n\*)p

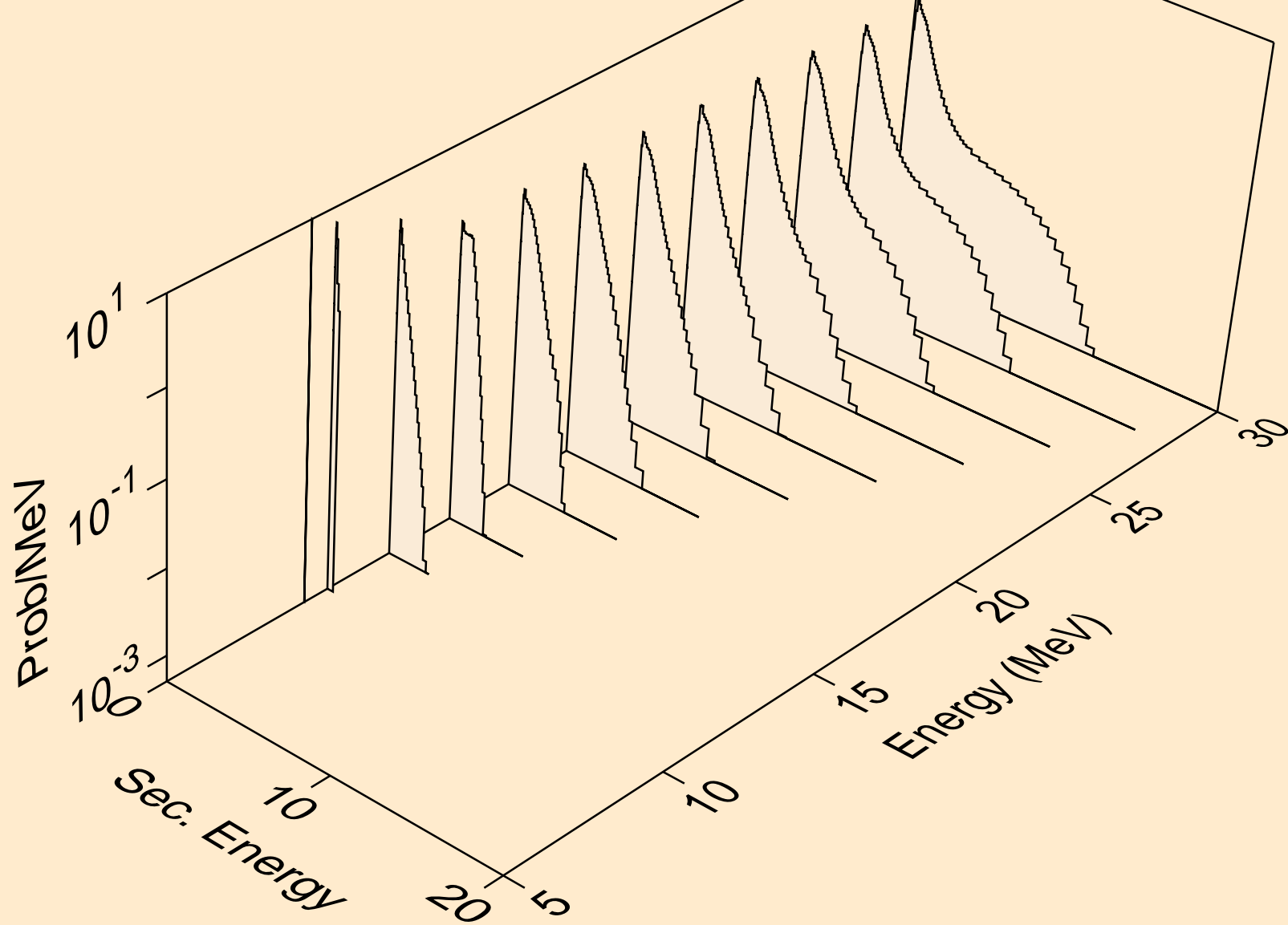

ER162 PROTON ACER TENDL-2023 LIBRARY; T=0.K  
neutrons from (p,n\*)2a

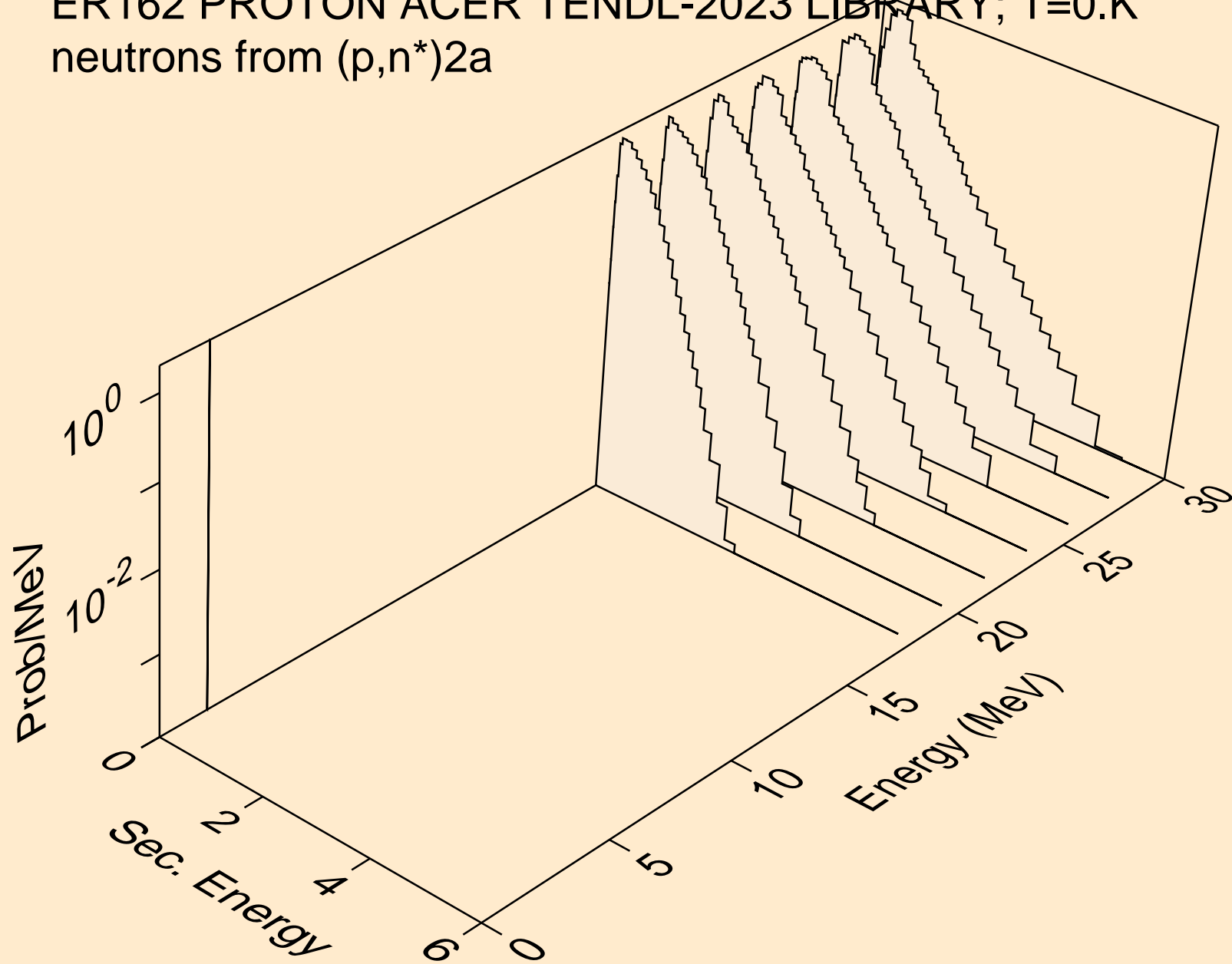

ER162 PROTON ACER TENDL-2023 LIBRARY; T=0.K  
neutrons from (p,n\*)d

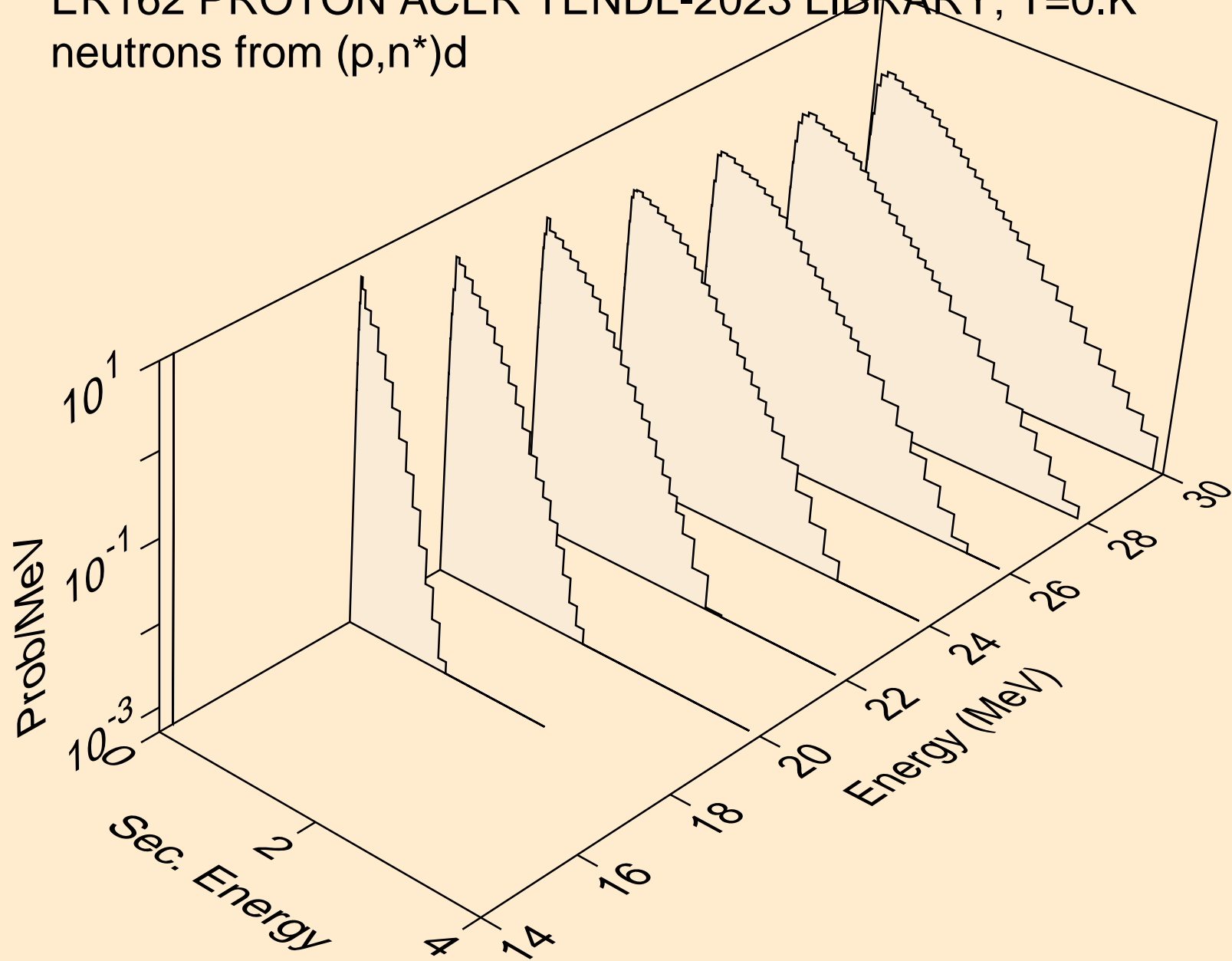

ER162 PROTON ACER TENDL-2023 LIBRARY; T=0.K  
neutrons from (p,n\*)t

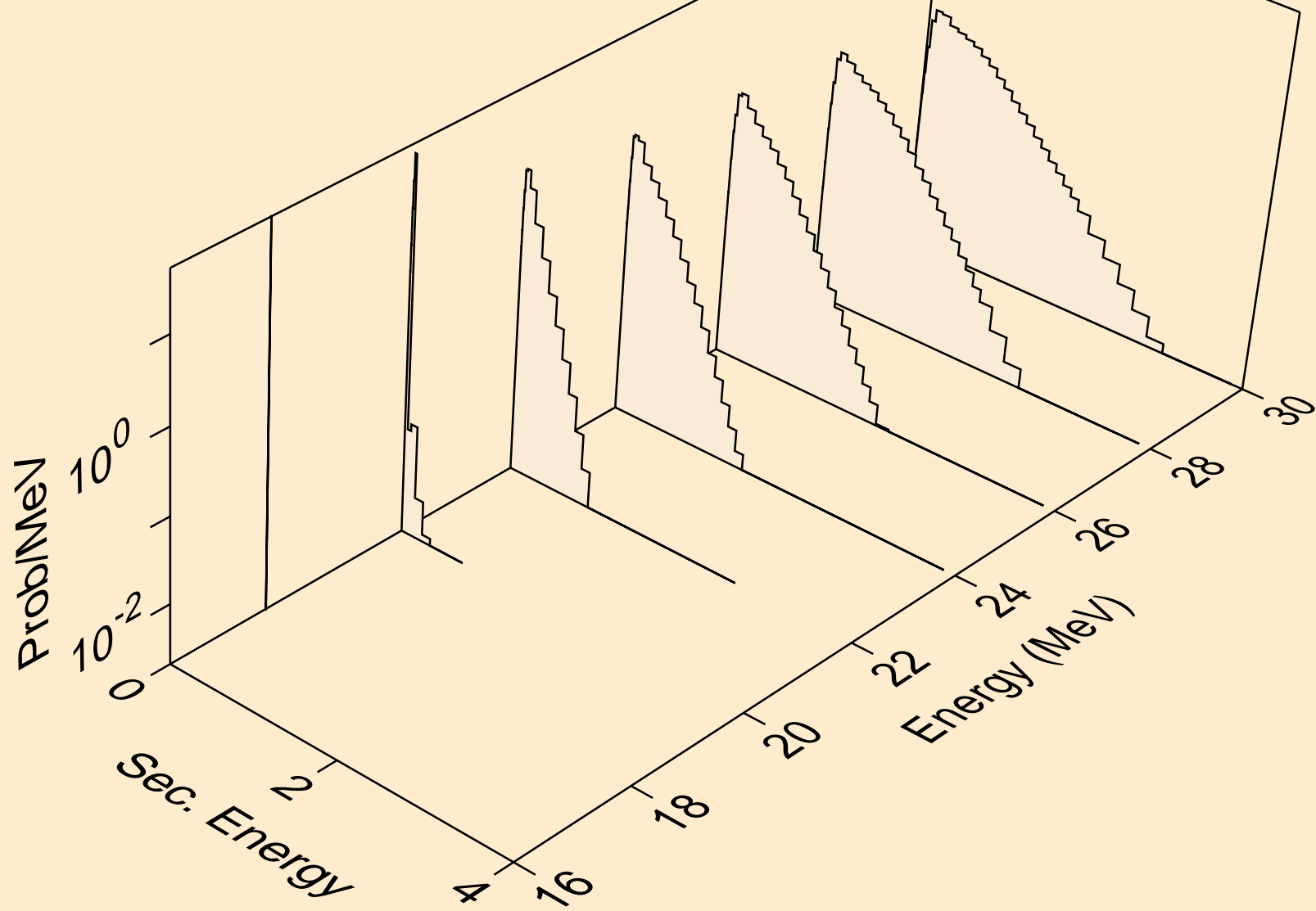



ER162 PROTON ACER TENDL-2023 LIBRARY; T=0.K  
neutrons from (p,n\*)he3

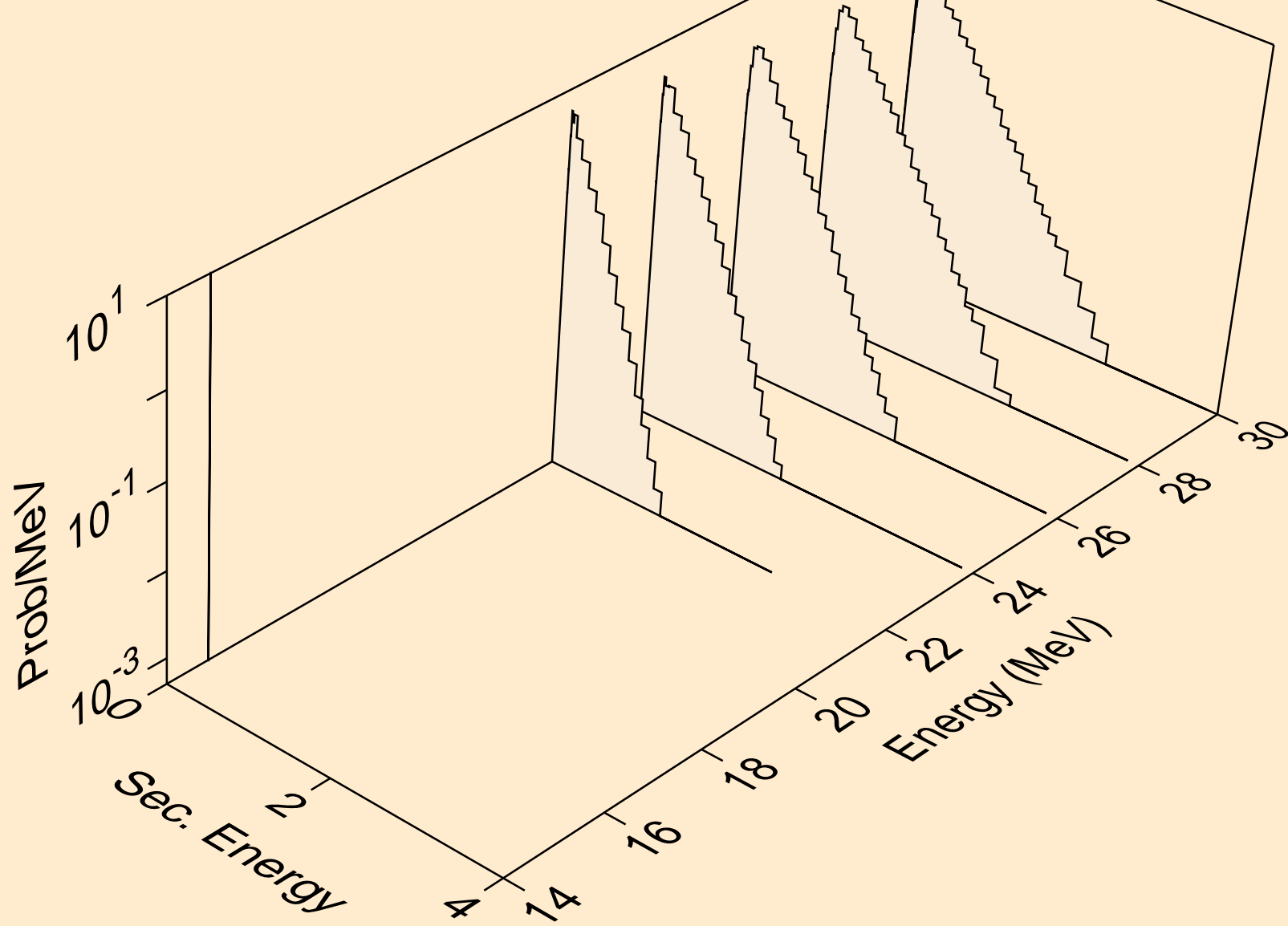

ER162 PROTON ACER TENDL-2023 LIBRARY; T=0.K  
neutrons from (p,2np)

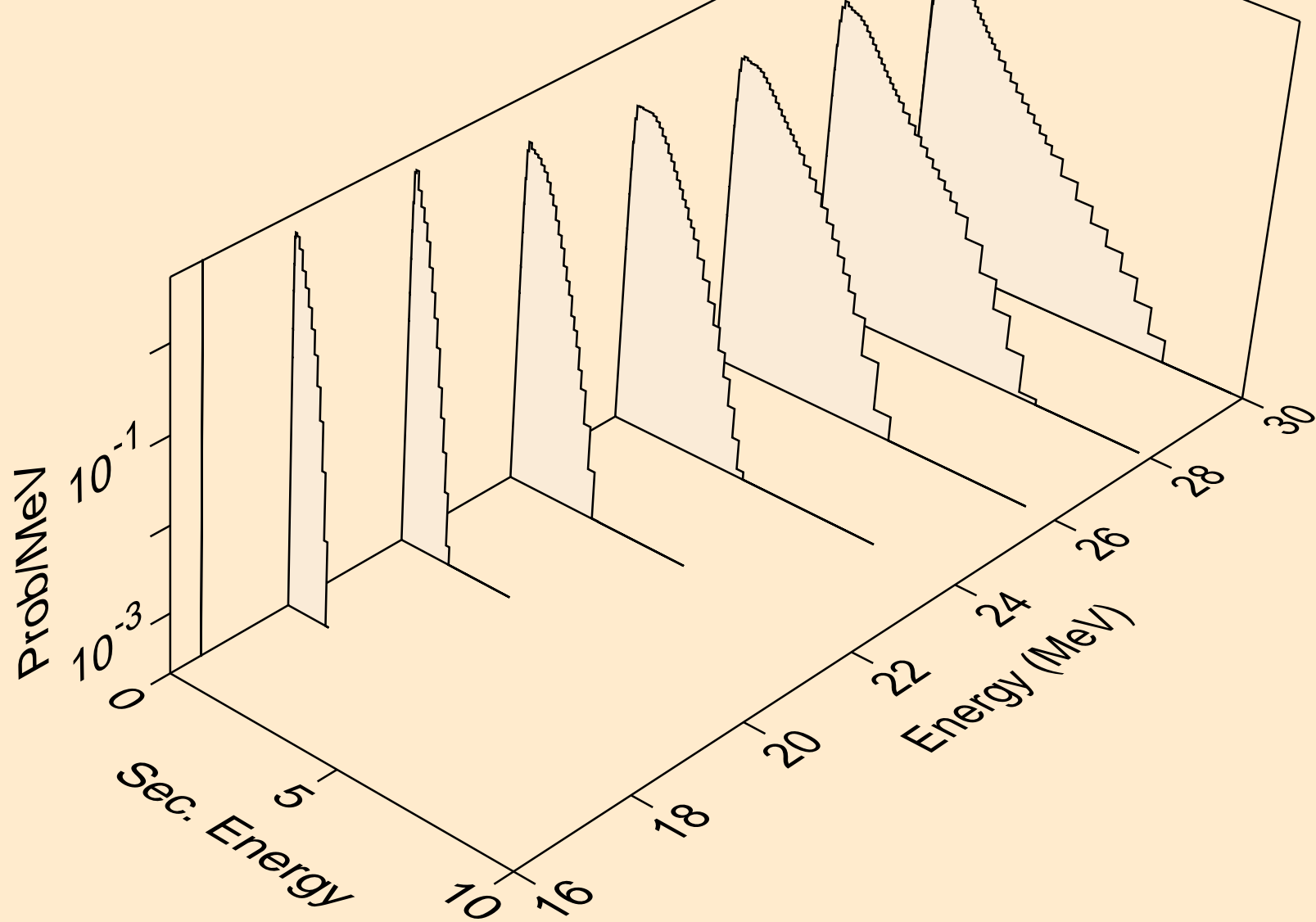

ER162 PROTON ACER TENDL-2023 LIBRARY; T=0.K  
neutrons from (p,3np)

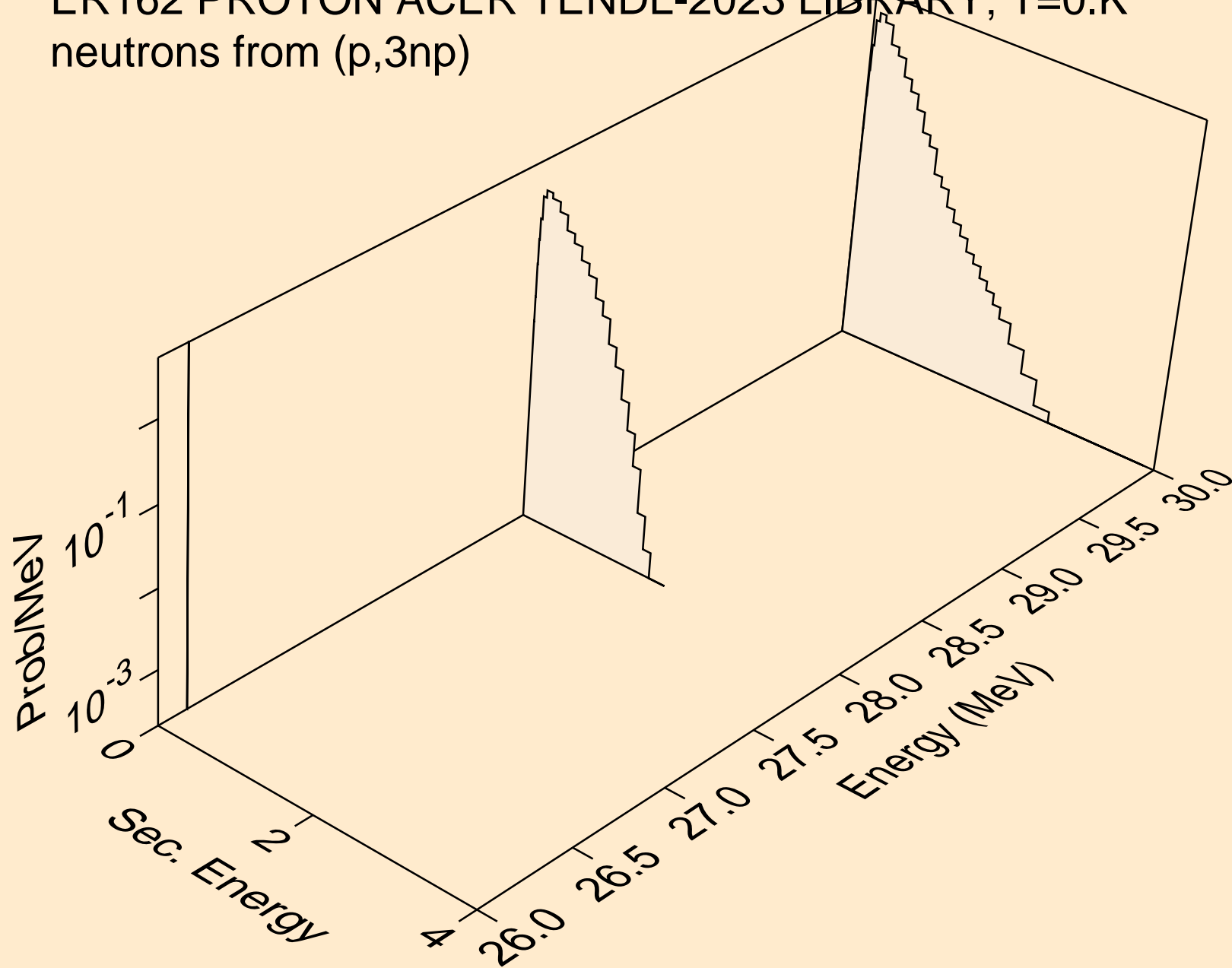

ER162 PROTON ACER TENDL-2023 LIBRARY; T=0.K  
neutrons from (p,n2p)

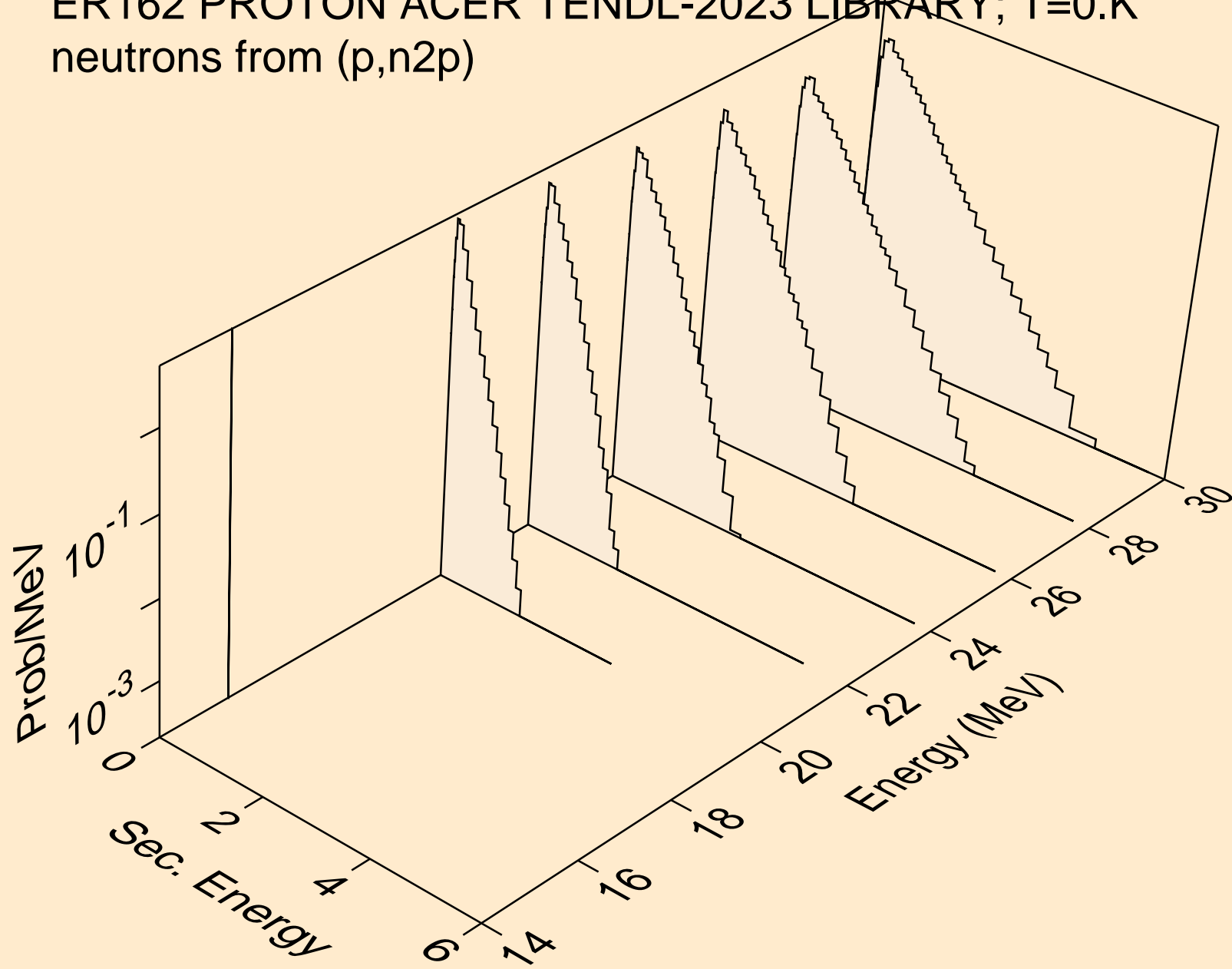

ER162 PROTON ACER TENDL-2023 LIBRARY; T=0.K  
neutrons from (p,npa)

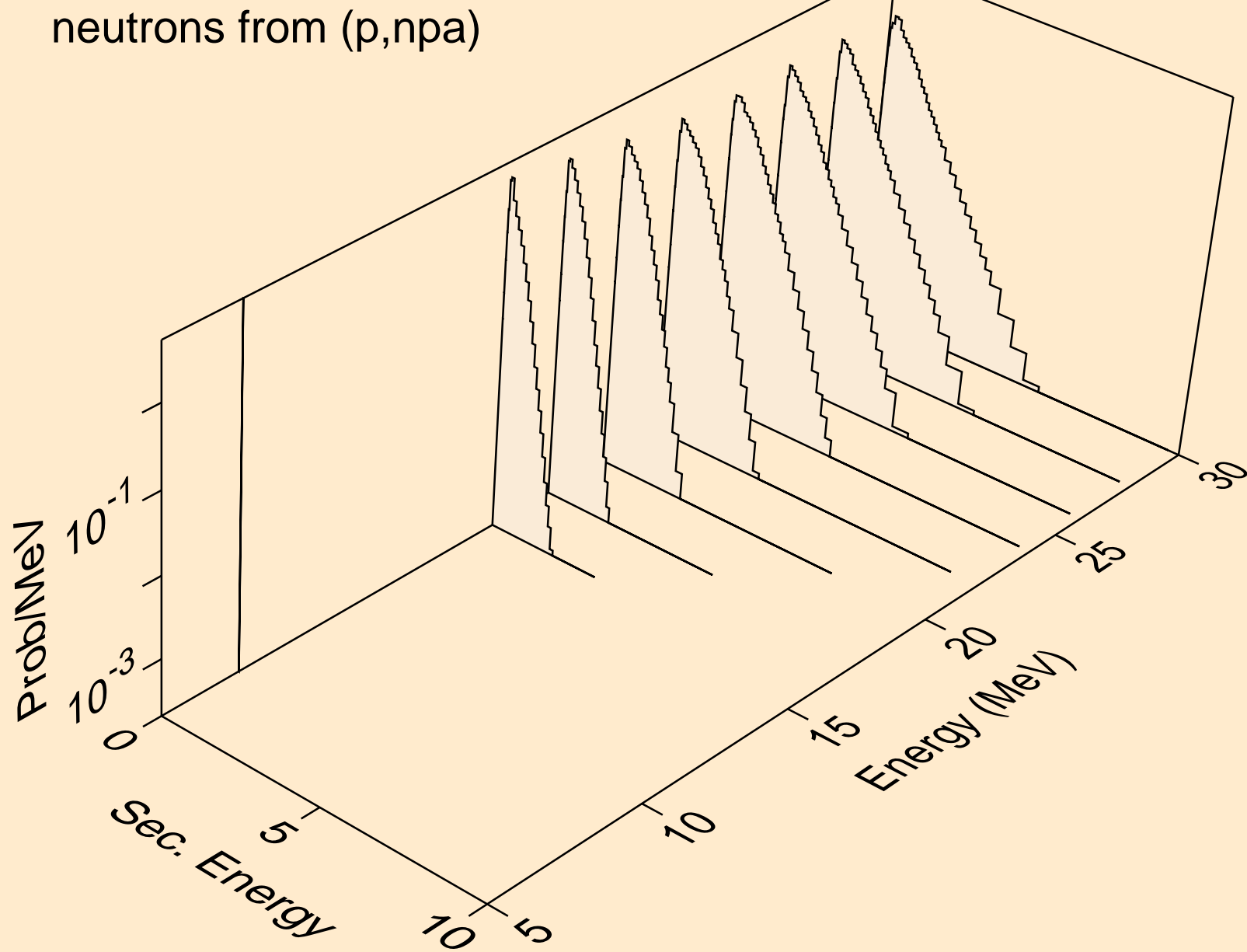

ER162 PROTON ACER TENDL-2023 LIBRARY; T=0.K  
deuterons from (p,x)

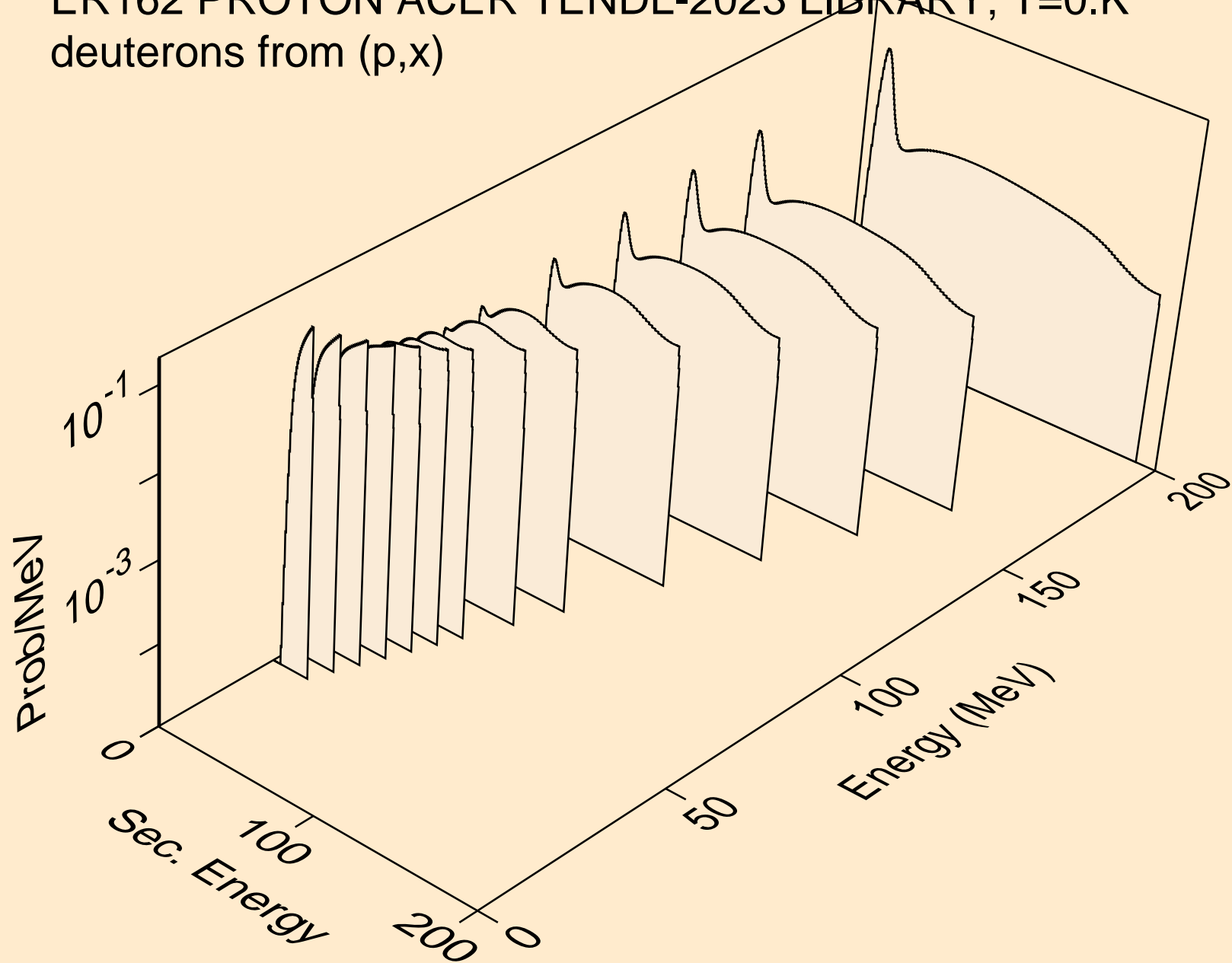

ER162 PROTON ACER TENDL-2023 LIBRARY; T=0.K  
deuterons from (p,2nd)

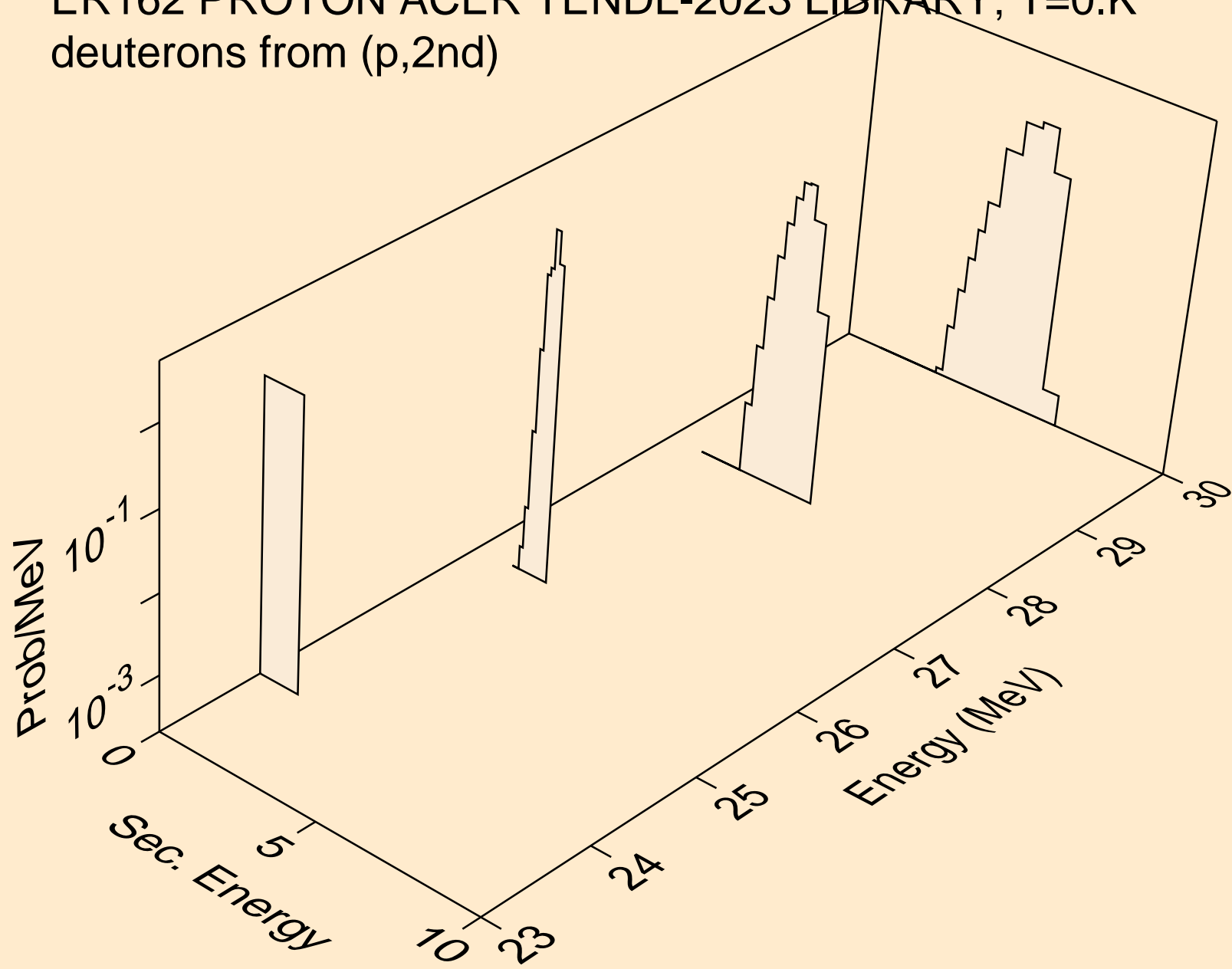

ER162 PROTON ACER TENDL-2023 LIBRARY; T=0.K  
deuterons from (p,n\*)d

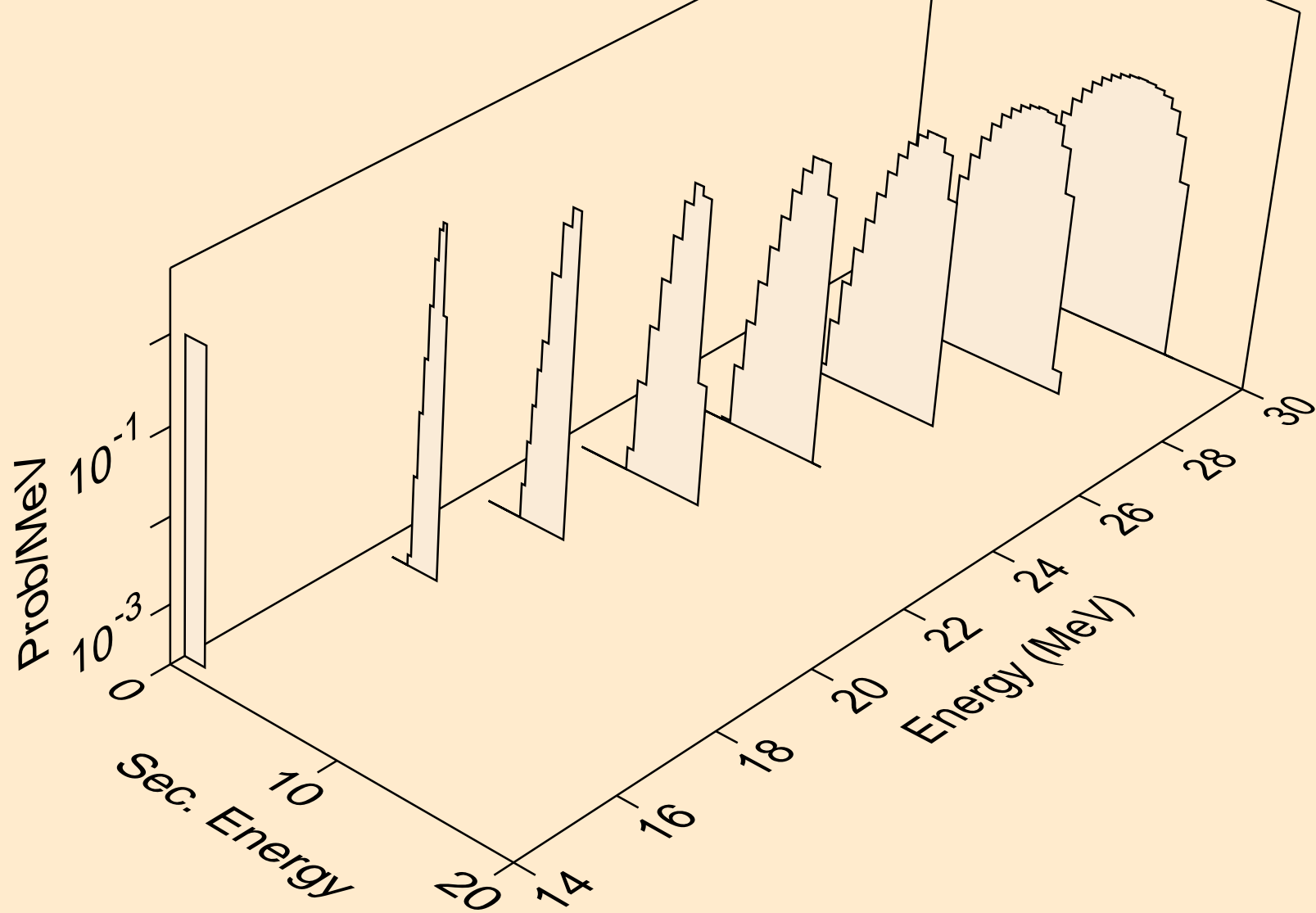



ER162 PROTON ACER TENDL-2023 LIBRARY; T=0.K  
deuterons from (p,d)

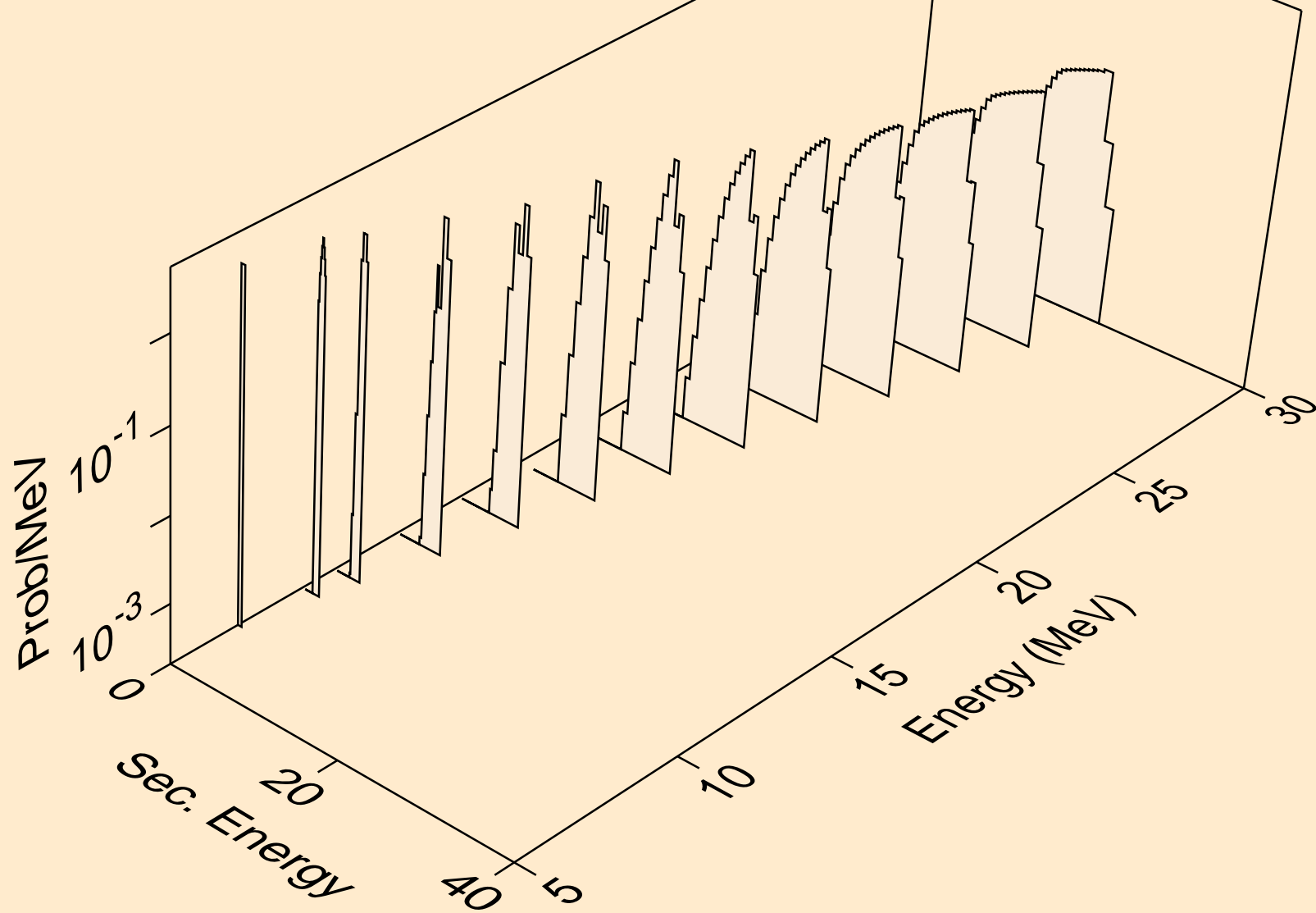

ER162 PROTON ACER TENDL-2023 LIBRARY; T=0.K  
deuterons from (p,pd)

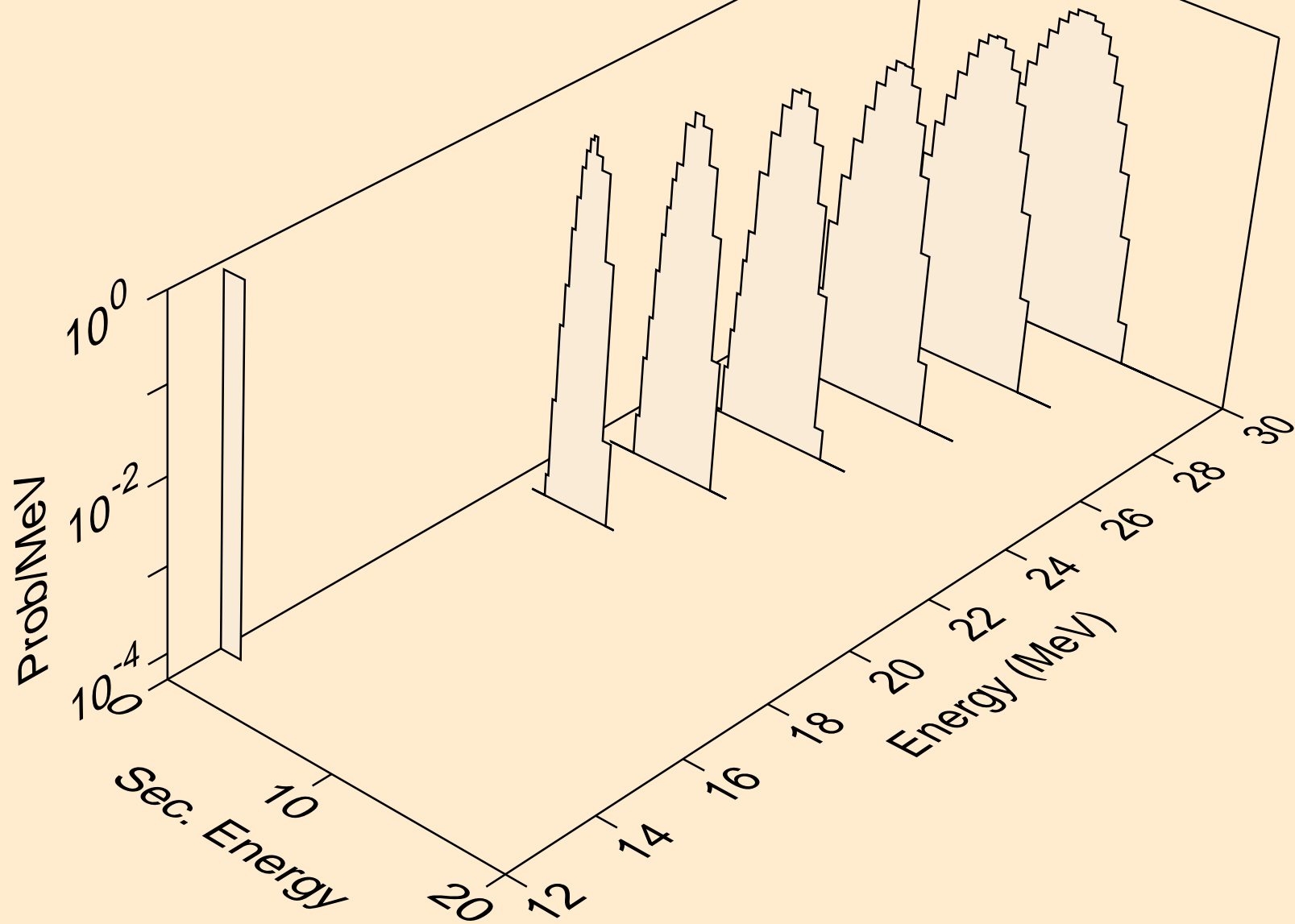

ER162 PROTON ACER TENDL-2023 LIBRARY; T=0.K  
deuterons from (p,da)

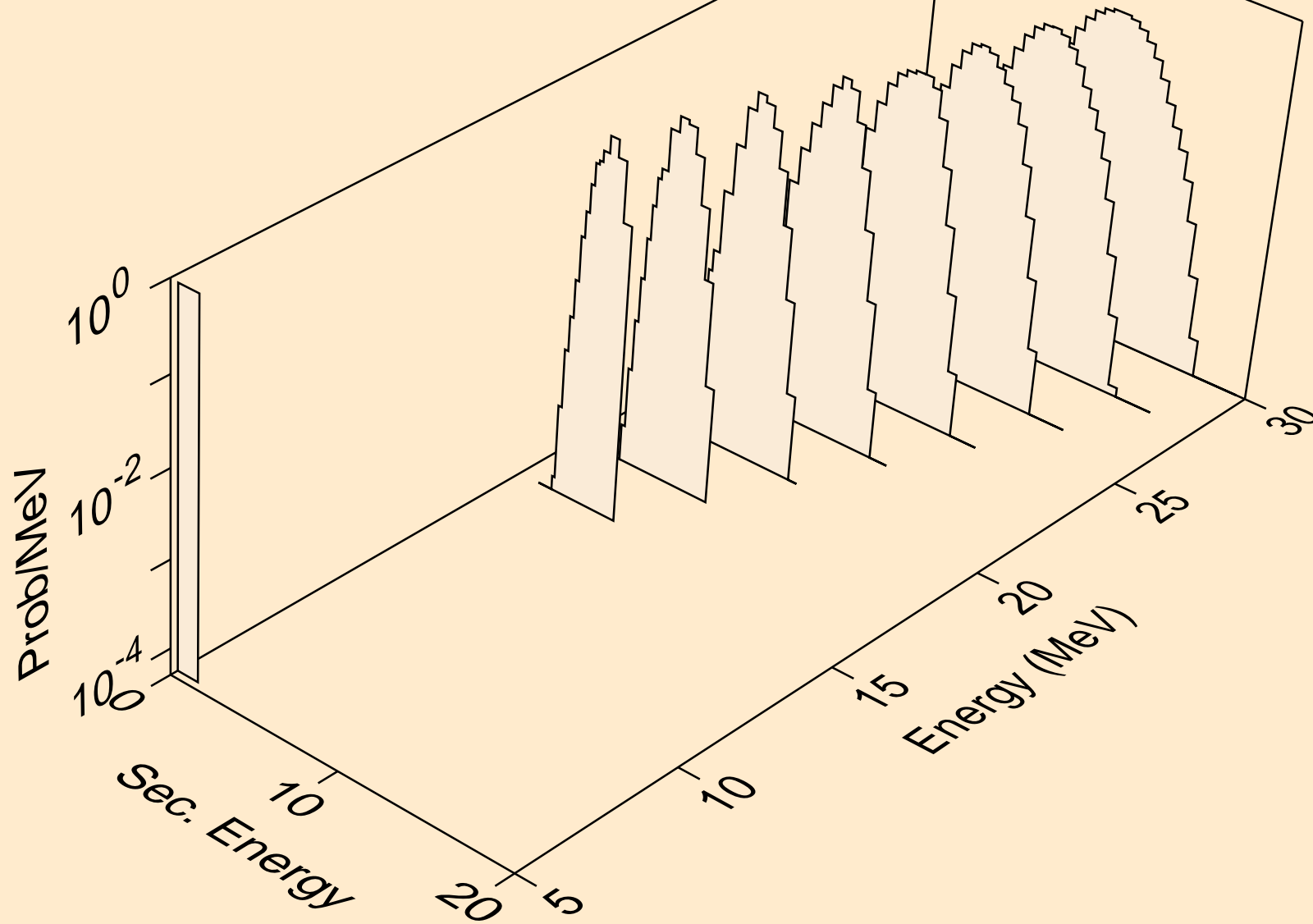

ER162 PROTON ACER TENDL-2023 LIBRARY; T=0.K  
tritons from (p,x)

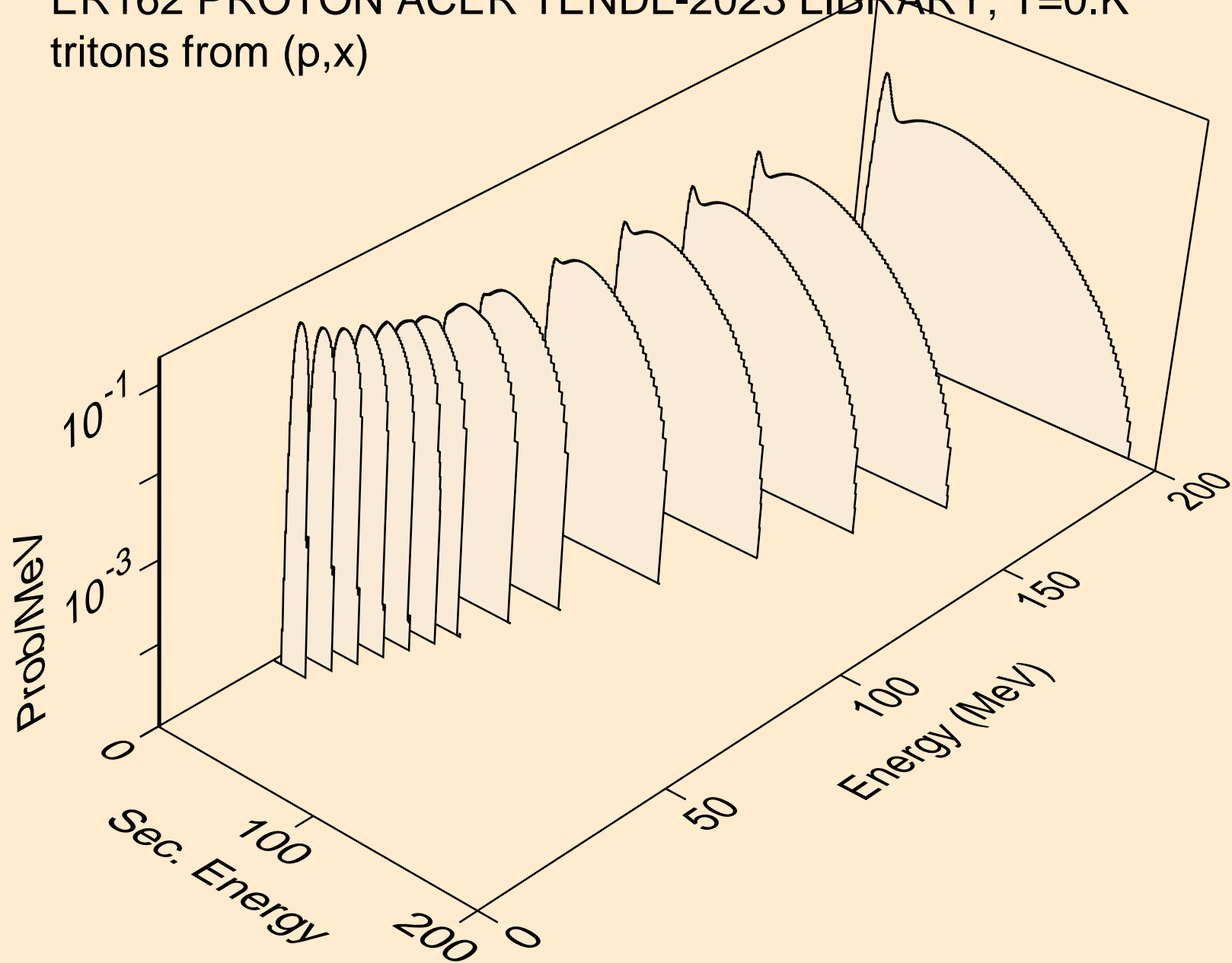

# ER162 PROTON ACER TENDL-2023 LIBRARY; T=0.K

tritons from (p,n\*)t

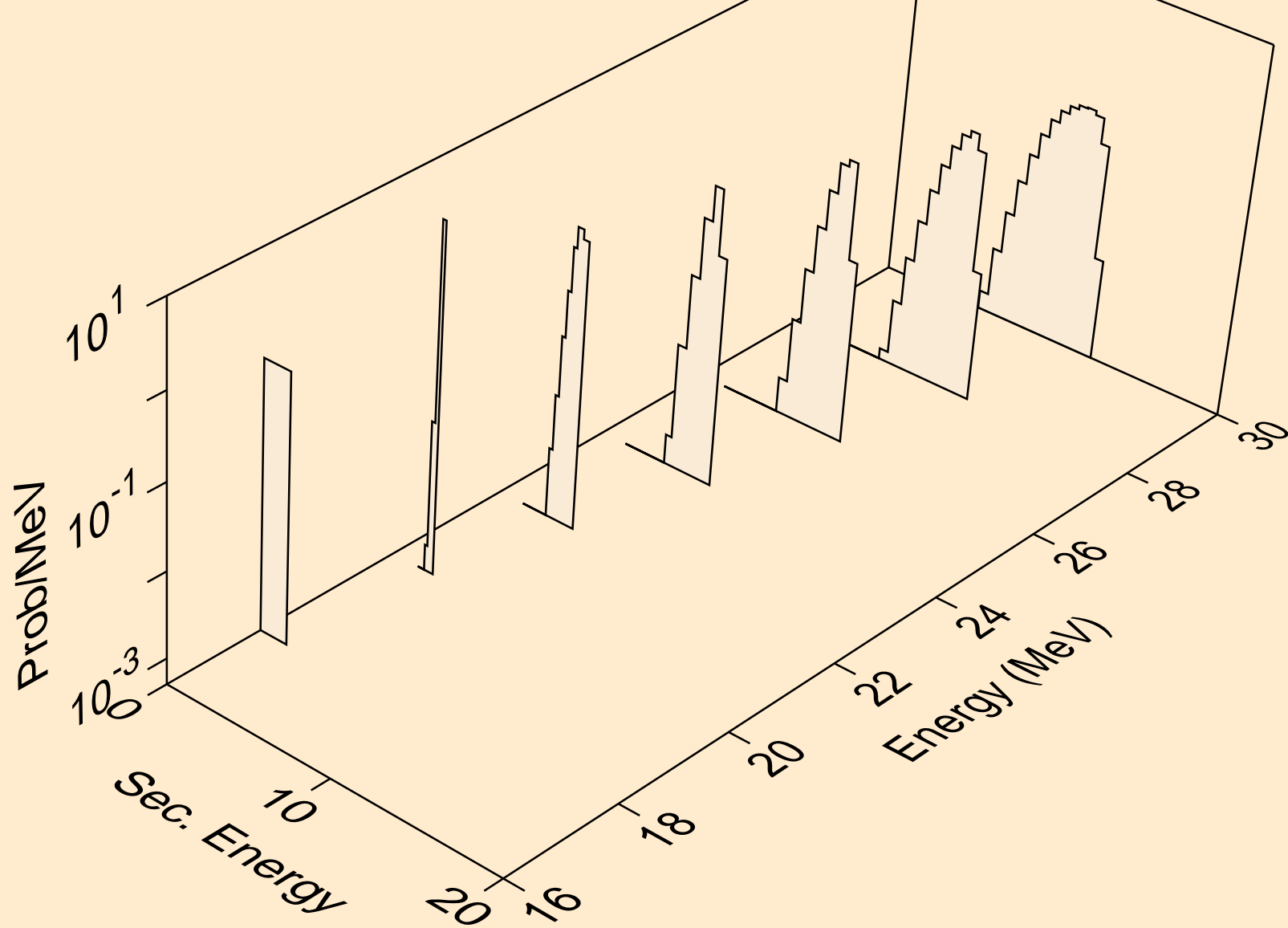

ER162 PROTON ACER TENDL-2023 LIBRARY; T=0.K  
tritons from (p,t)

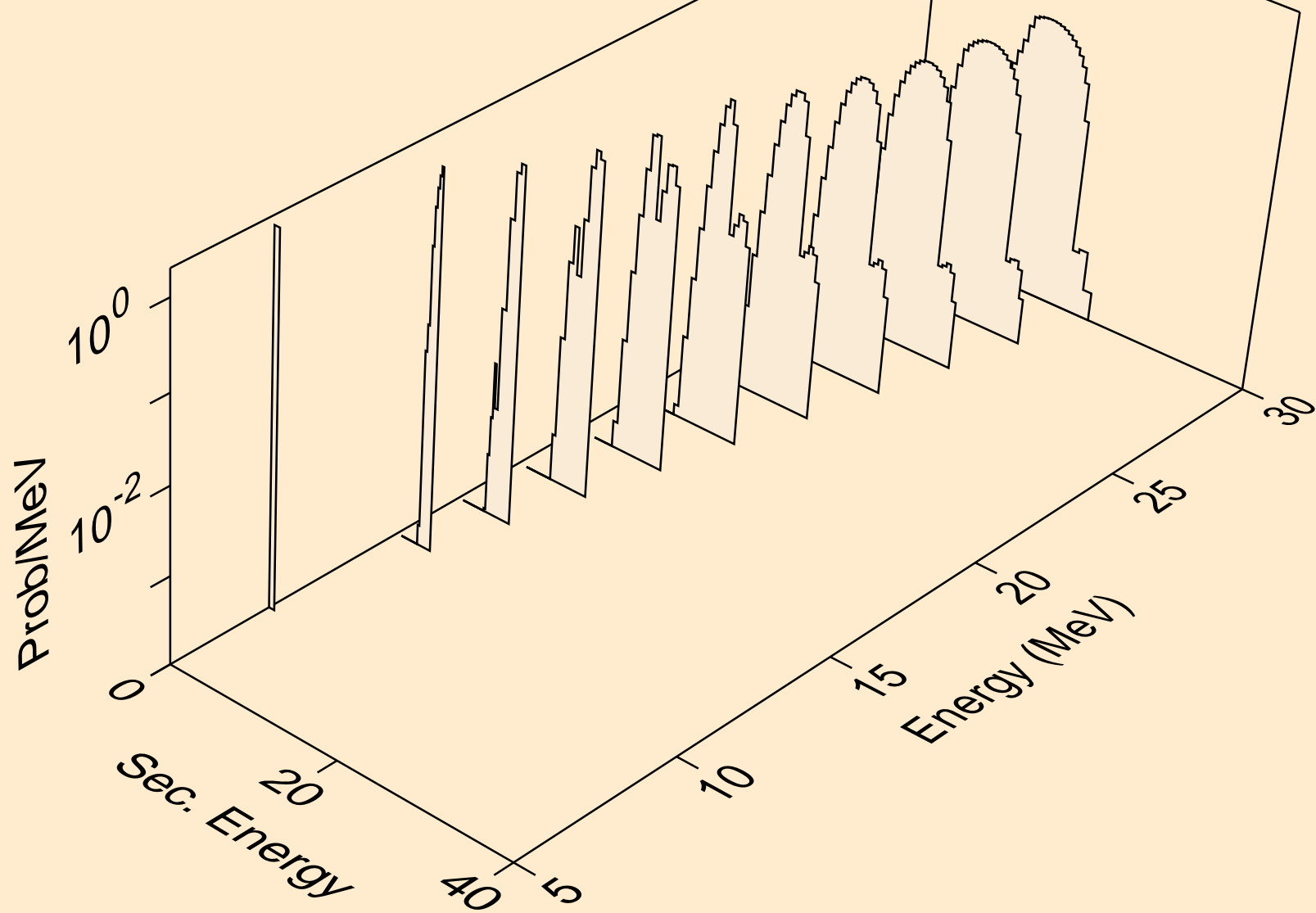

ER162 PROTON ACER TENDL-2023 LIBRARY; T=0.K  
tritons from (p,pt)

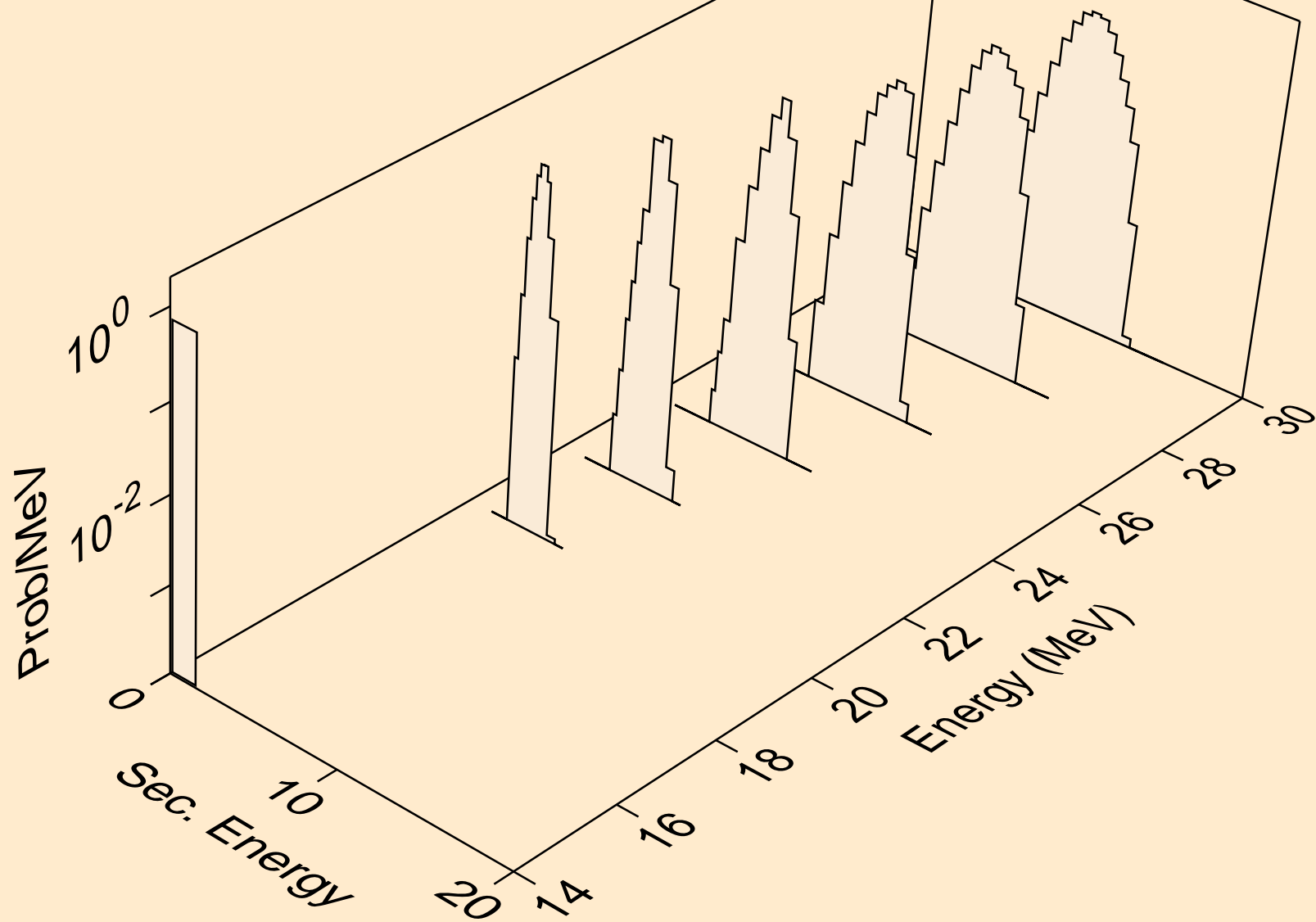

ER162 PROTON ACER TENDL-2023 LIBRARY; T=0.K  
he3s from (p,x)

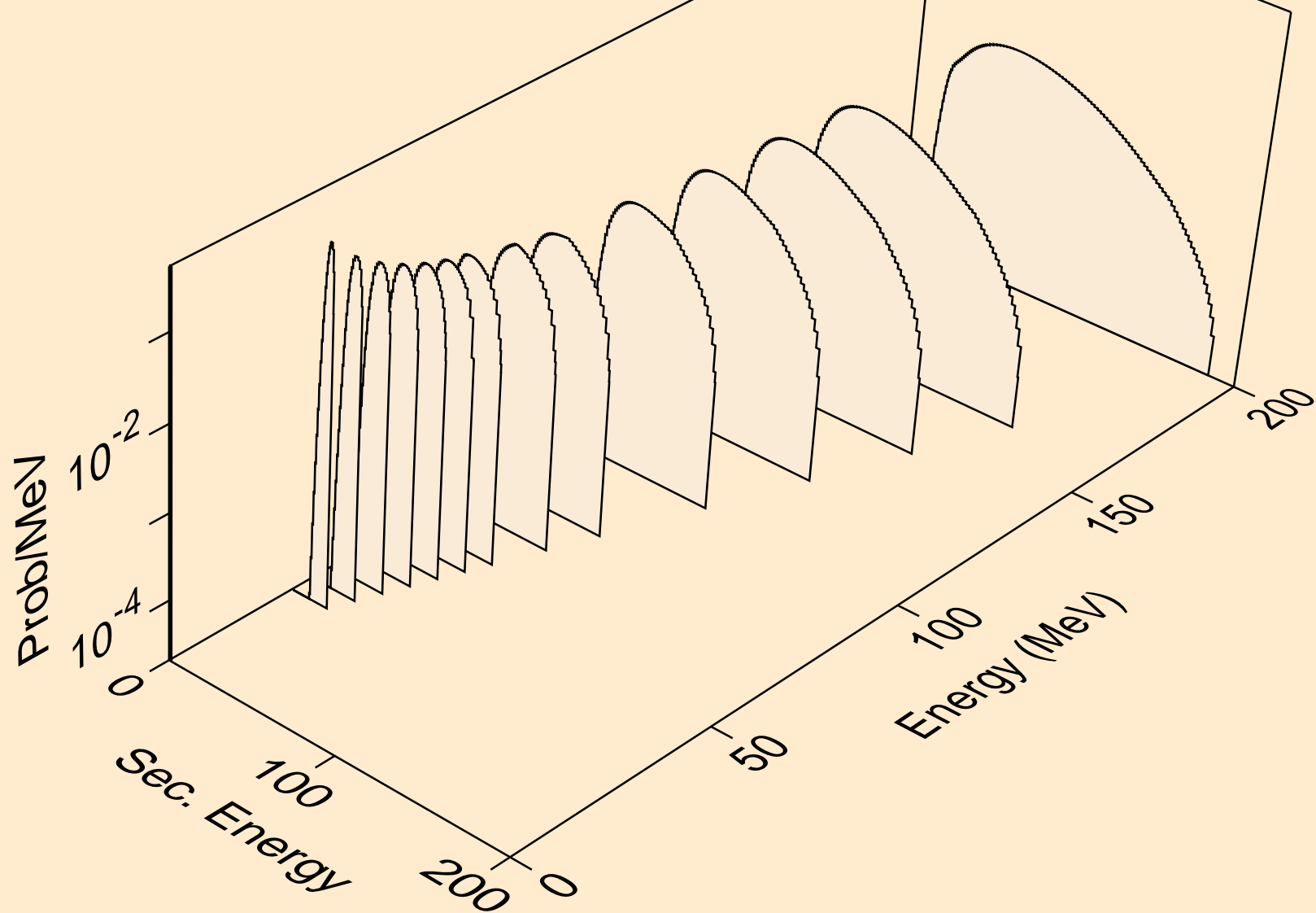



ER162 PROTON ACER TENDL-2023 LIBRARY; T=0.K  
he3s from (p,n\*)he3

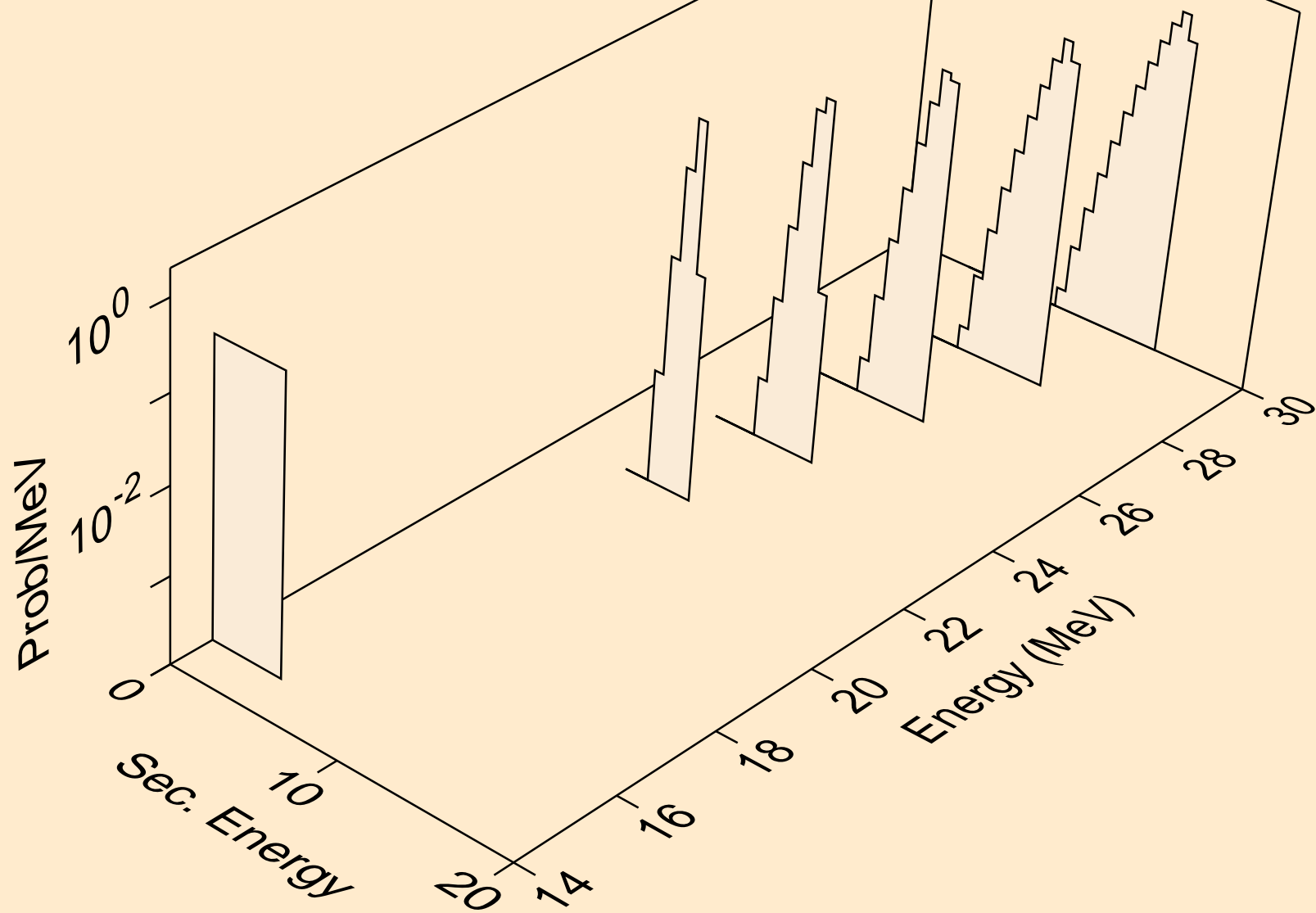

ER162 PROTON ACER TENDL-2023 LIBRARY; T=0.K  
he3s from (p,he3)

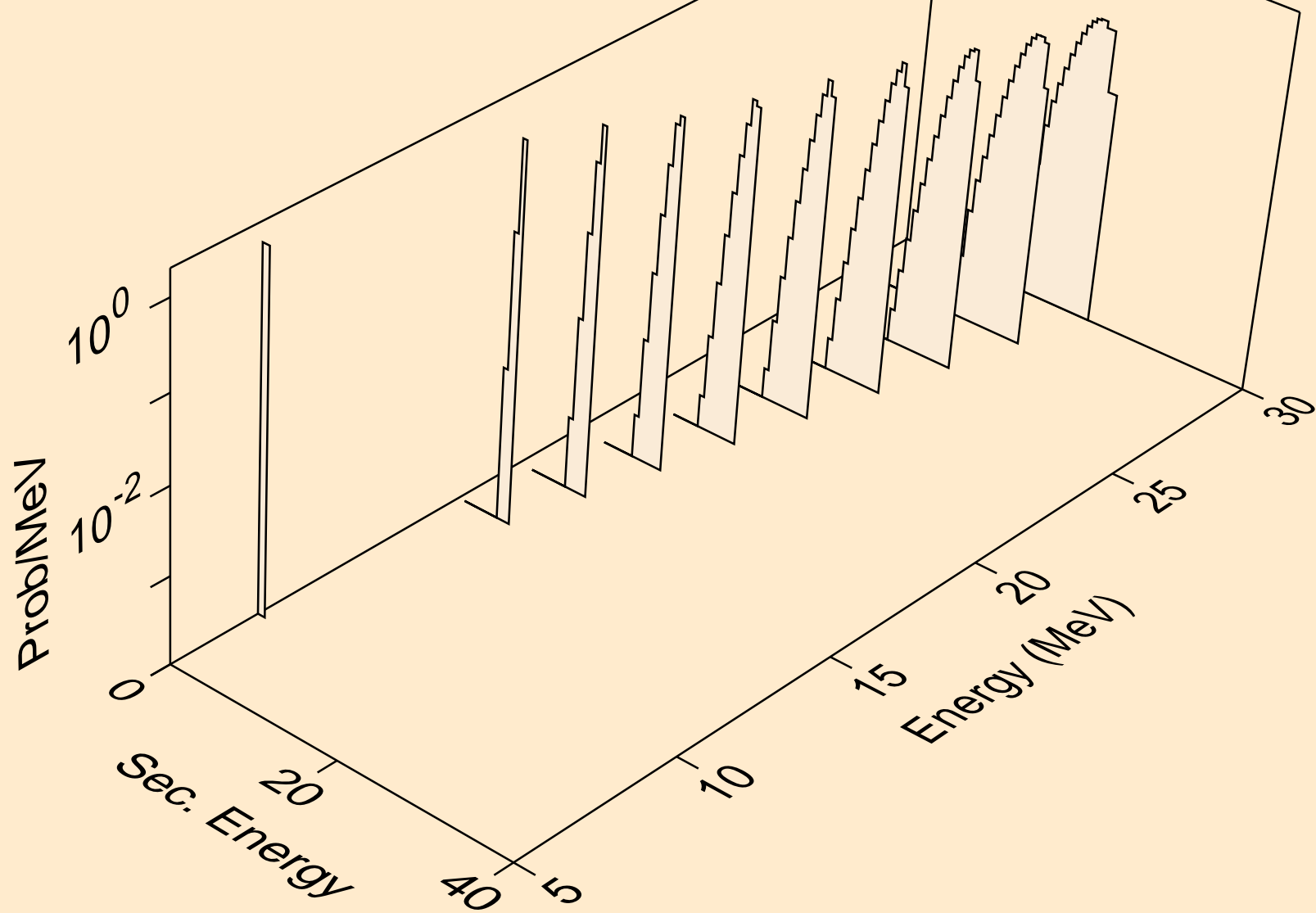

ER162 PROTON ACER TENDL-2023 LIBRARY; T=0.K  
alphas from (p,x)

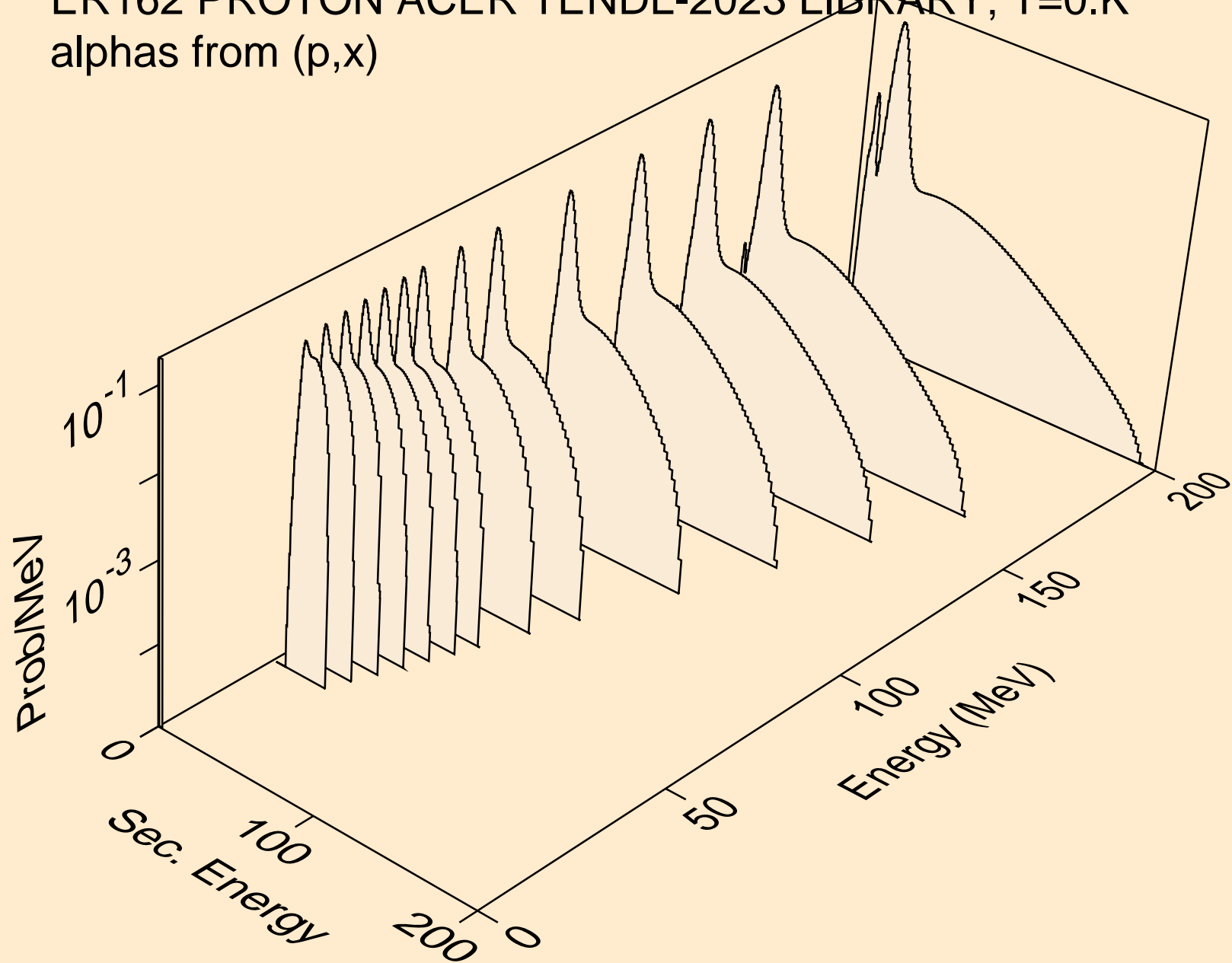

ER162 PROTON ACER TENDL-2023 LIBRARY; T=0.K  
alphas from (p,n\*)a

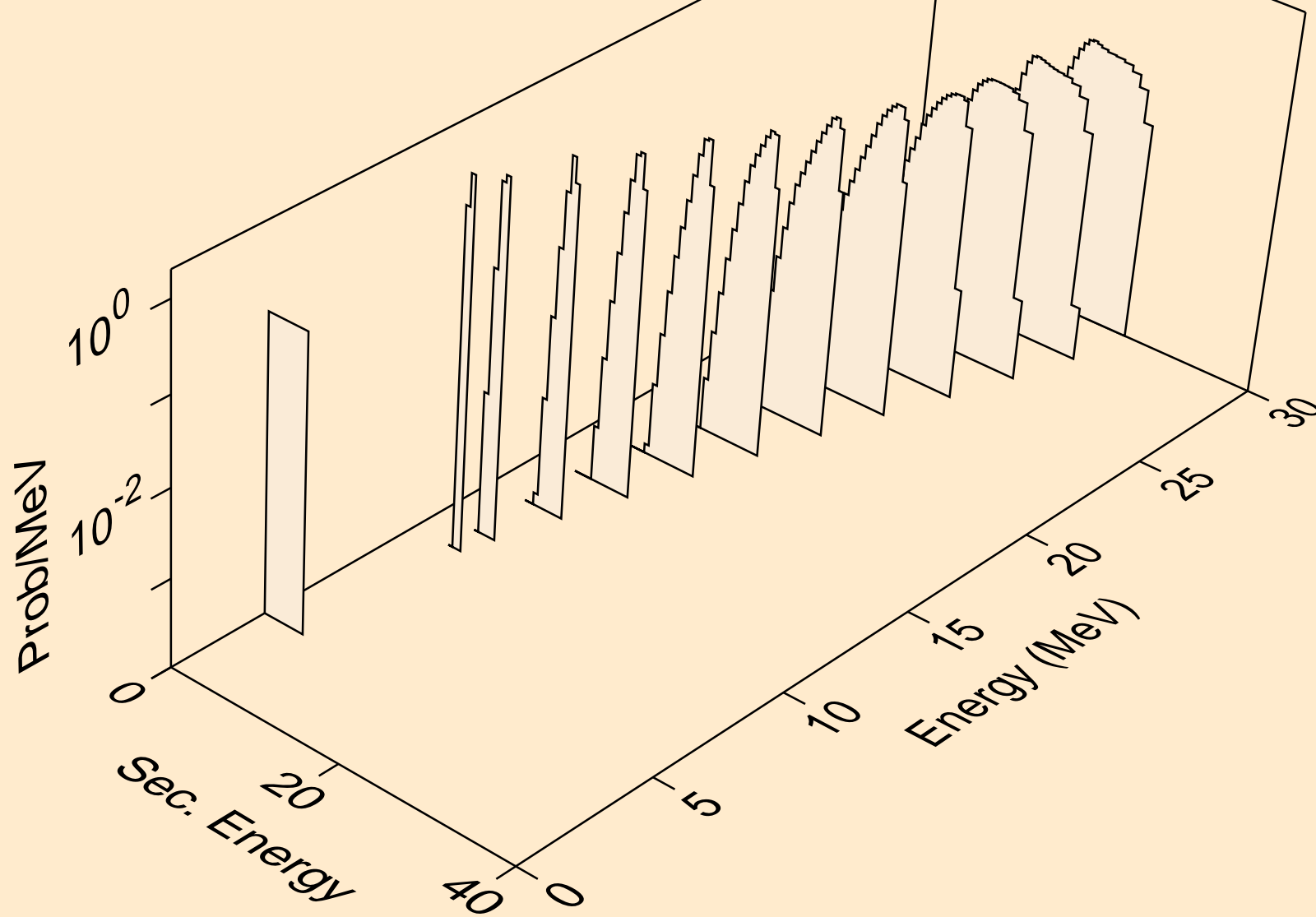

ER162 PROTON ACER TENDL-2023 LIBRARY; T=0.K  
alphas from (p,2n)a

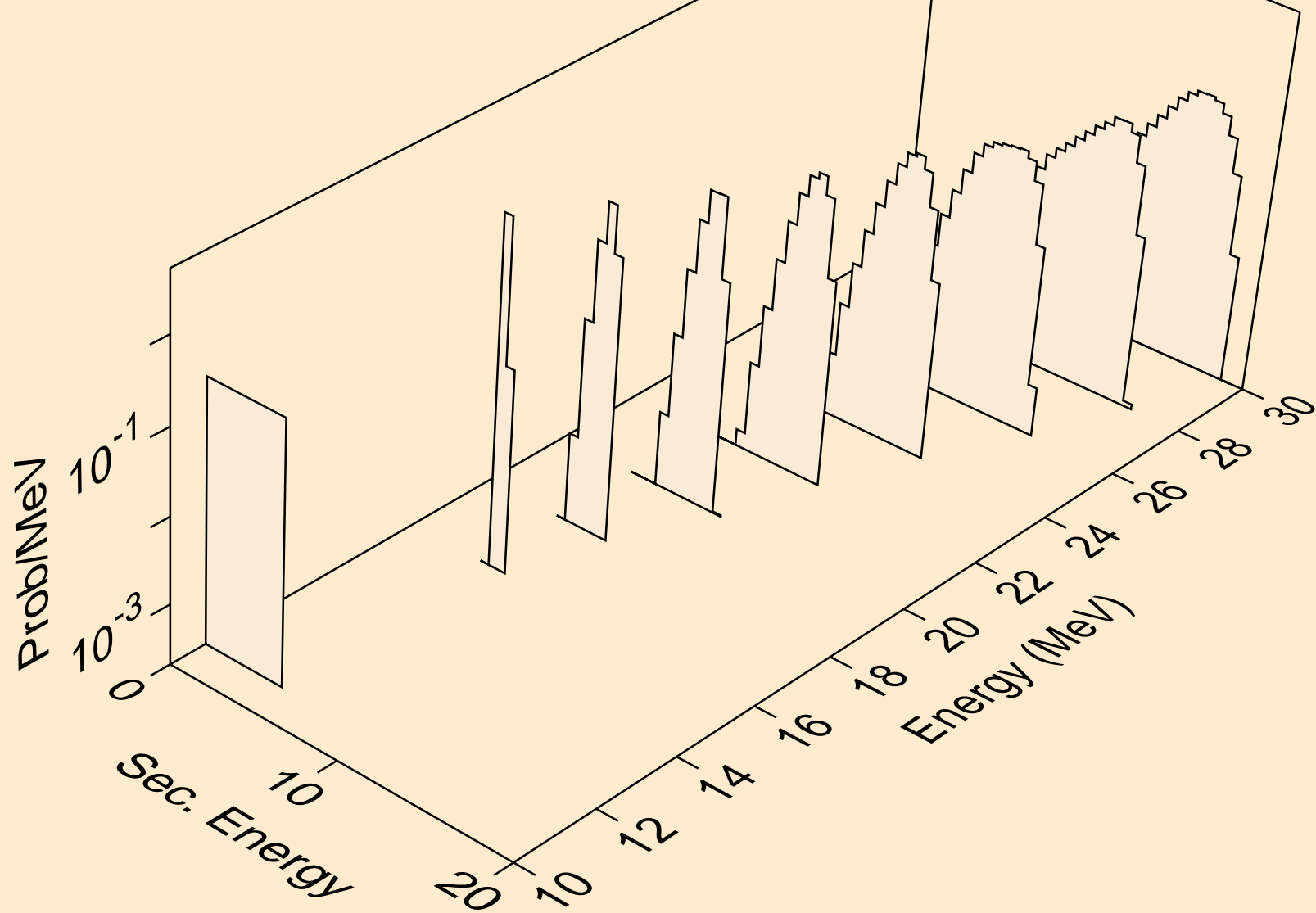

ER162 PROTON ACER TENDL-2023 LIBRARY; T=0.K  
alphas from (p,3n)a

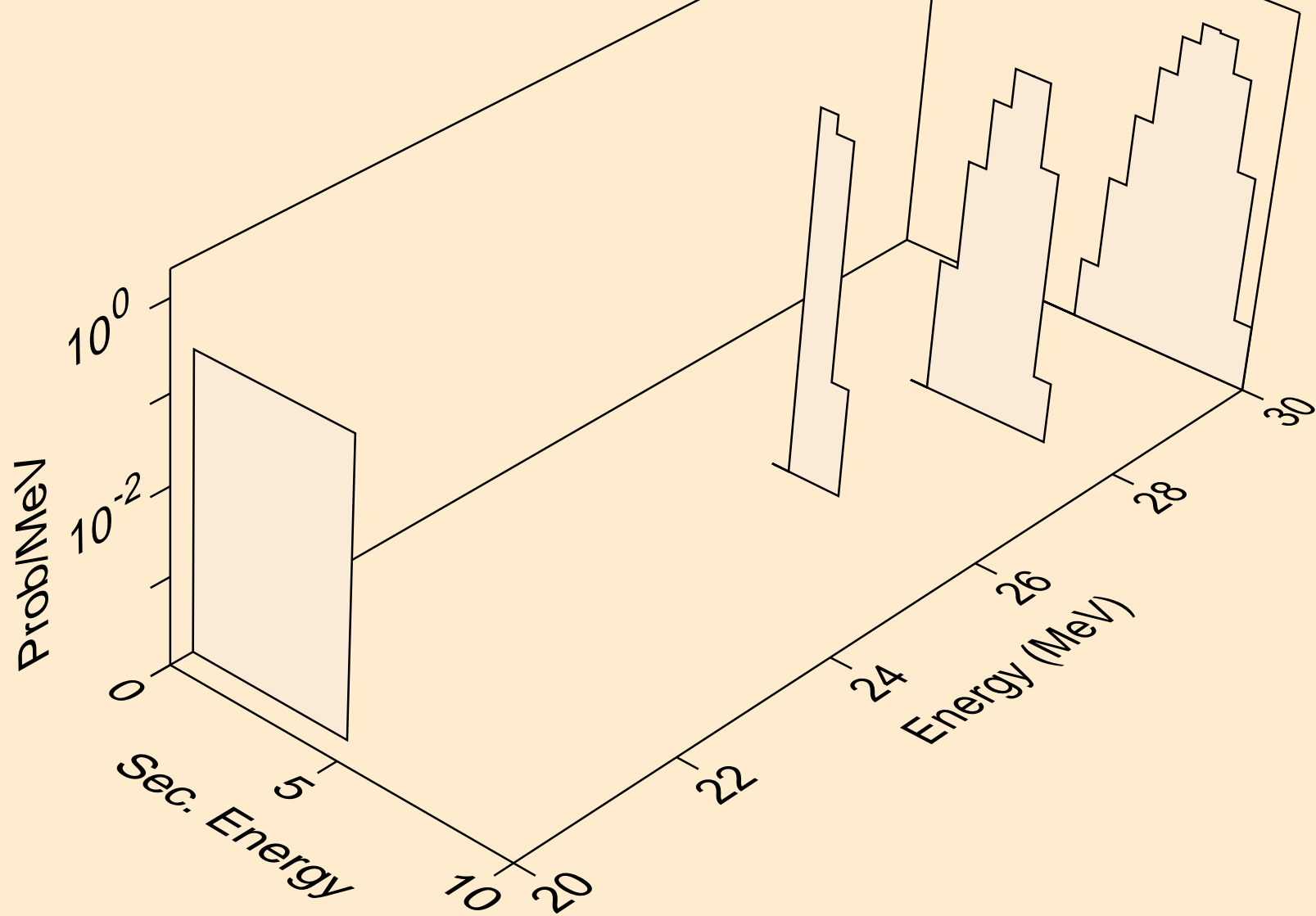

ER162 PROTON ACER TENDL-2023 LIBRARY; T=0.K  
alphas from (p,n\*)2a

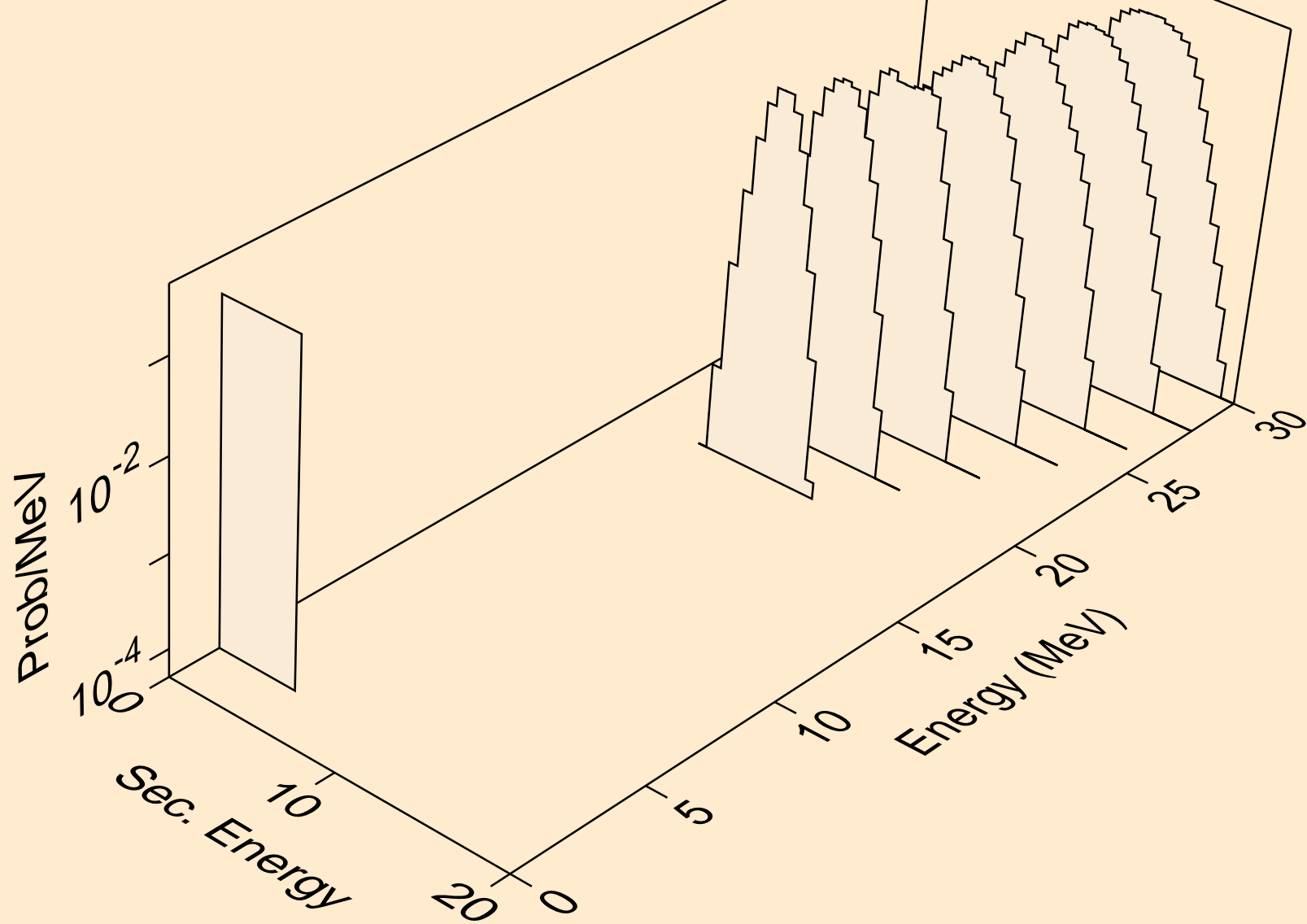

ER162 PROTON ACER TENDL-2023 LIBRARY; T=0.K  
alphas from (p,npa)

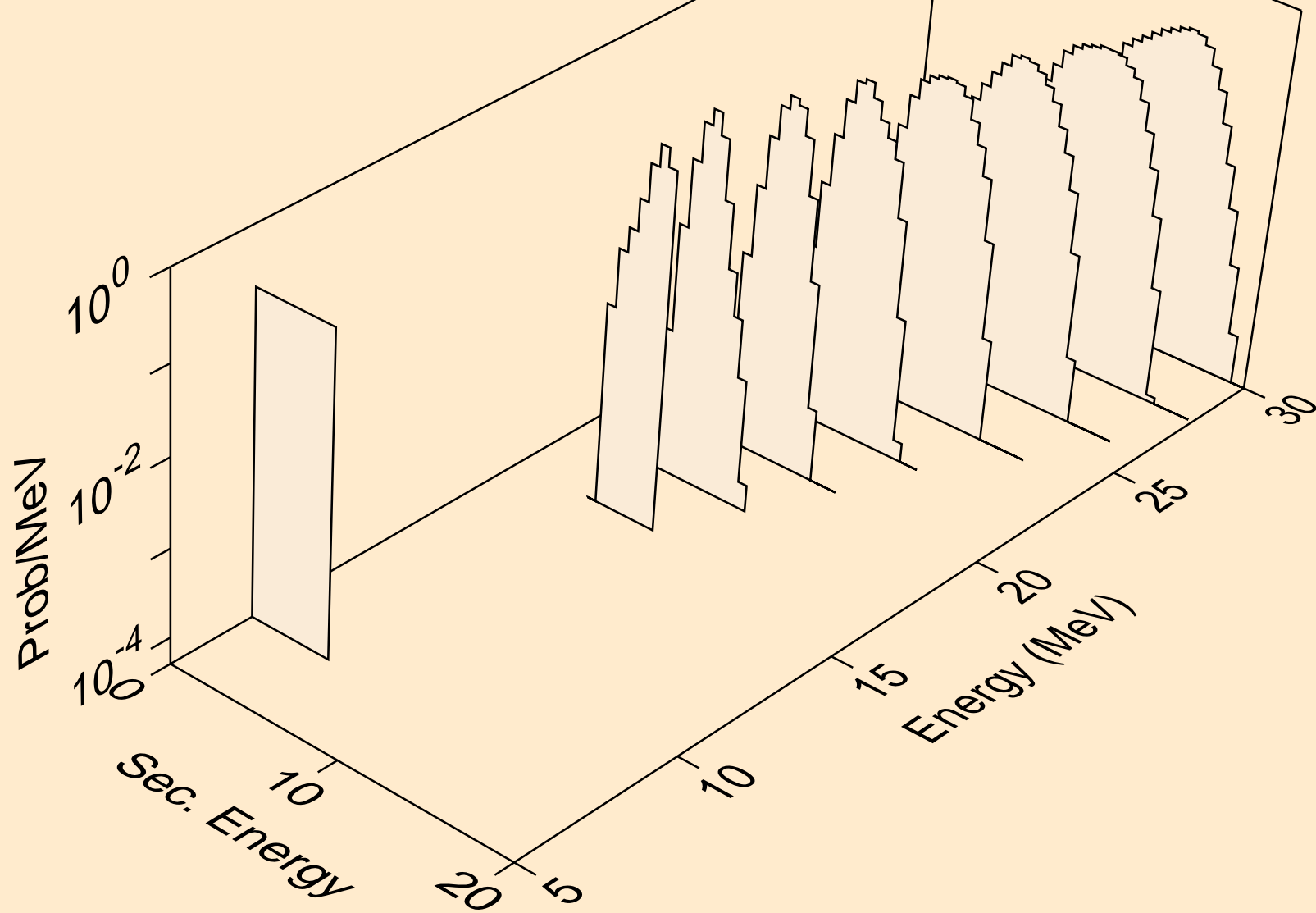



ER162 PROTON ACER TENDL-2023 LIBRARY; T=0.K  
alphas from (p,a)

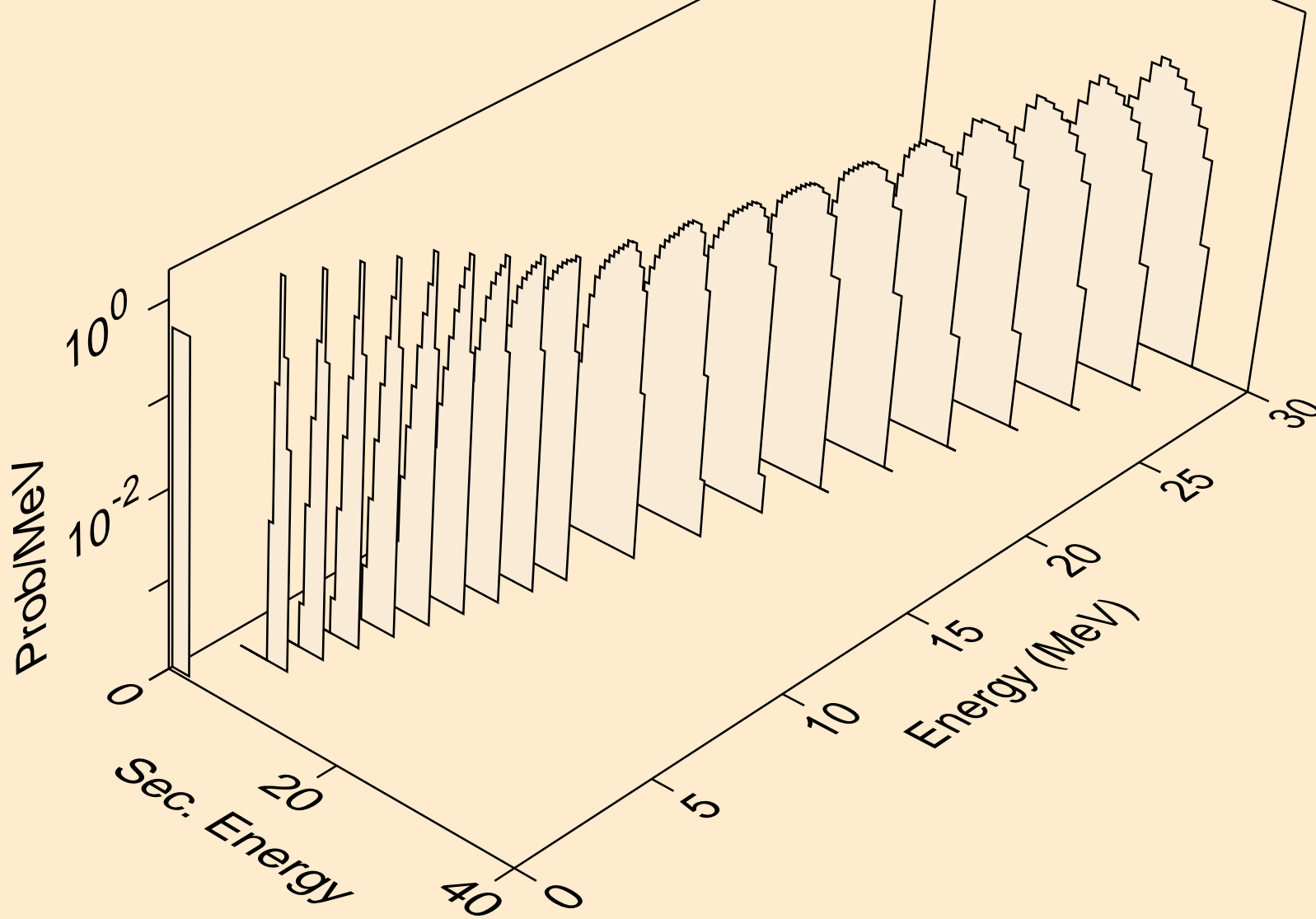

ER162 PROTON ACER TENDL-2023 LIBRARY; T=0.K  
alphas from (p,2a)

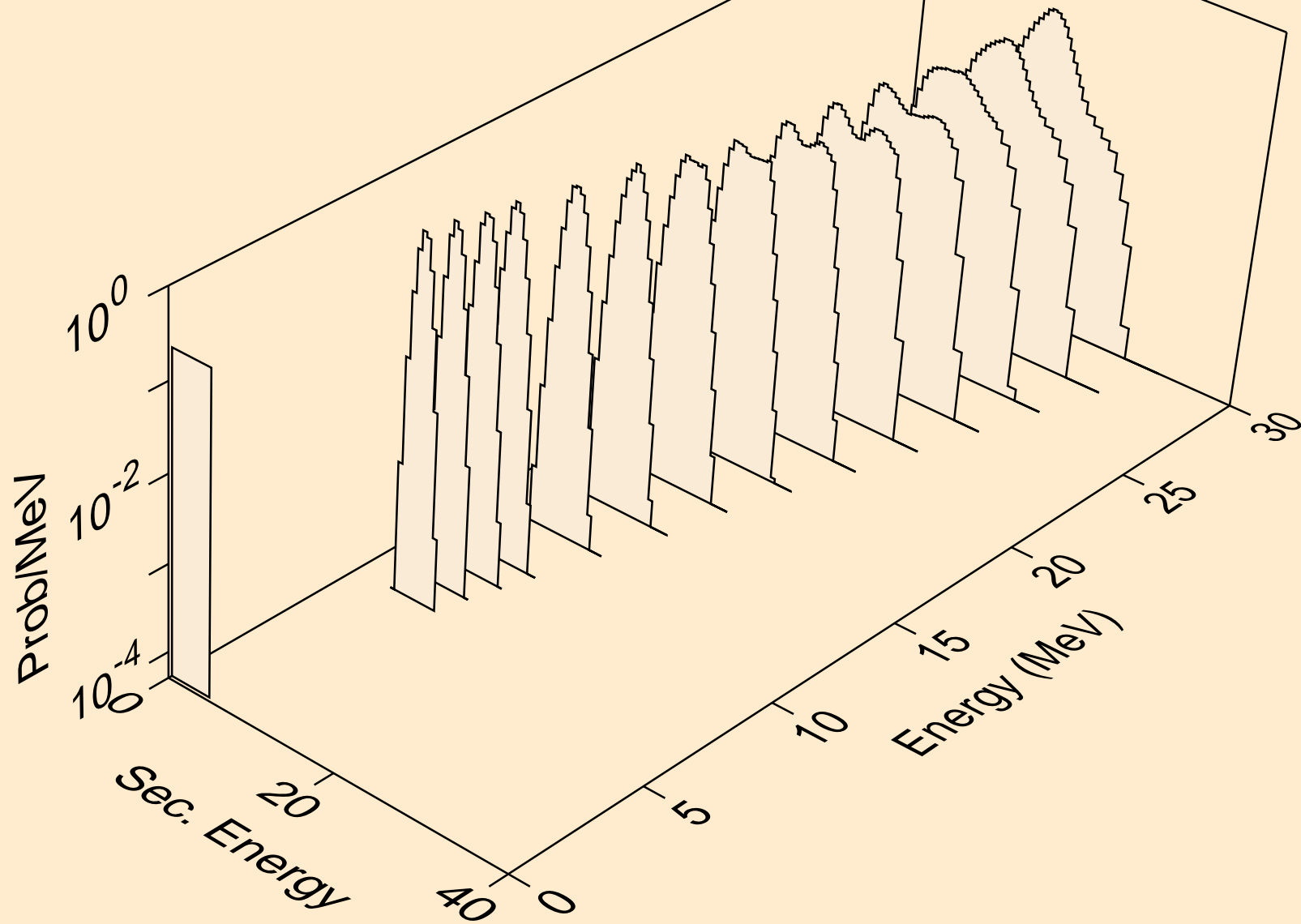

ER162 PROTON ACER TENDL-2023 LIBRARY; T=0.K  
alphas from (p,pa)

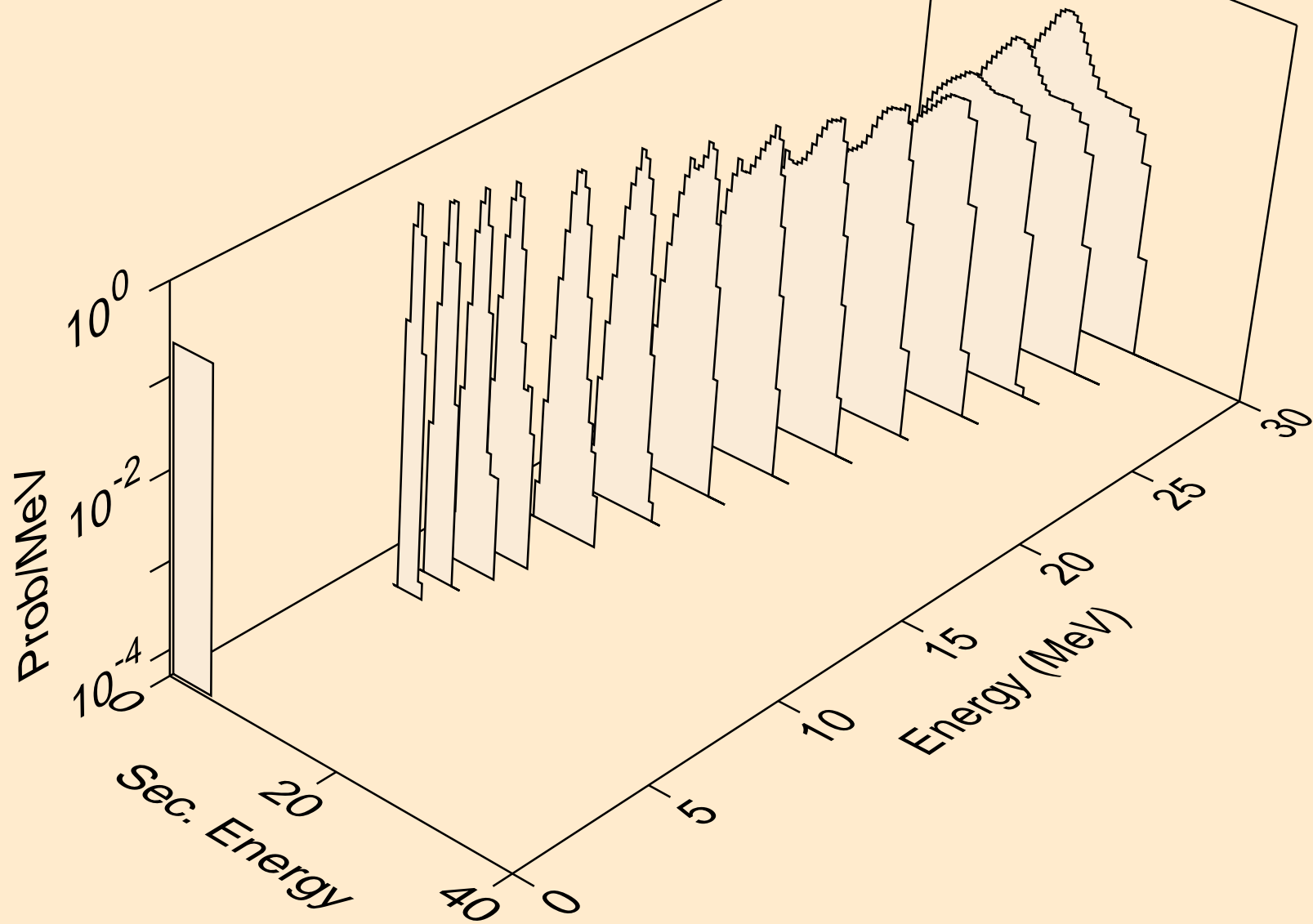

ER162 PROTON ACER TENDL-2023 LIBRARY; T=0.K  
alphas from (p,da)

