

# IN122 PROTON ACER TENDL-2023 LIBRARY; T=0.K

## Principal cross sections

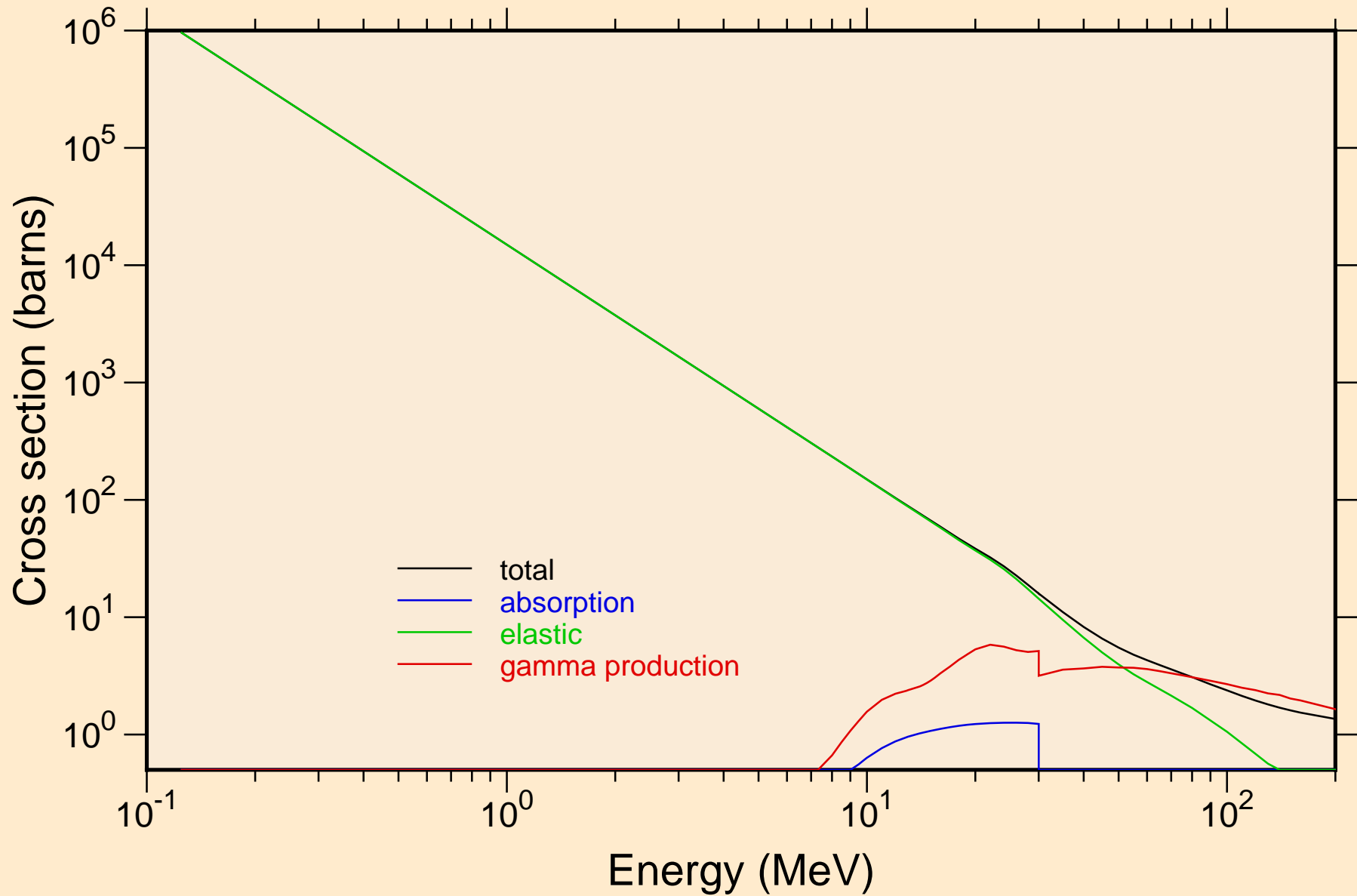

# IN122 PROTON ACER TENDL-2023 LIBRARY; T=0.K

## Heating

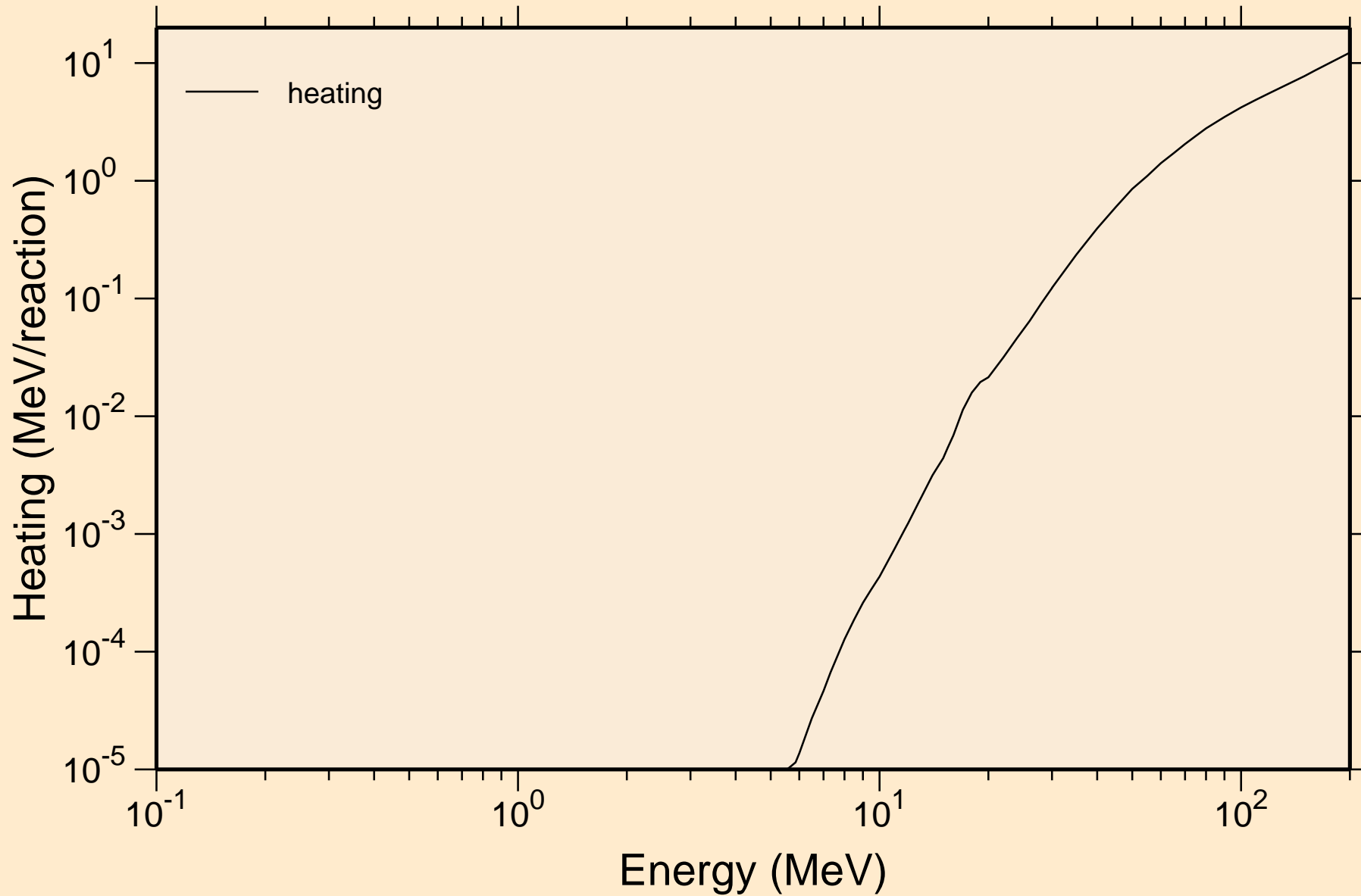

# IN122 PROTON ACER TENDL-2023 LIBRARY; T=0.K

## Principal cross sections

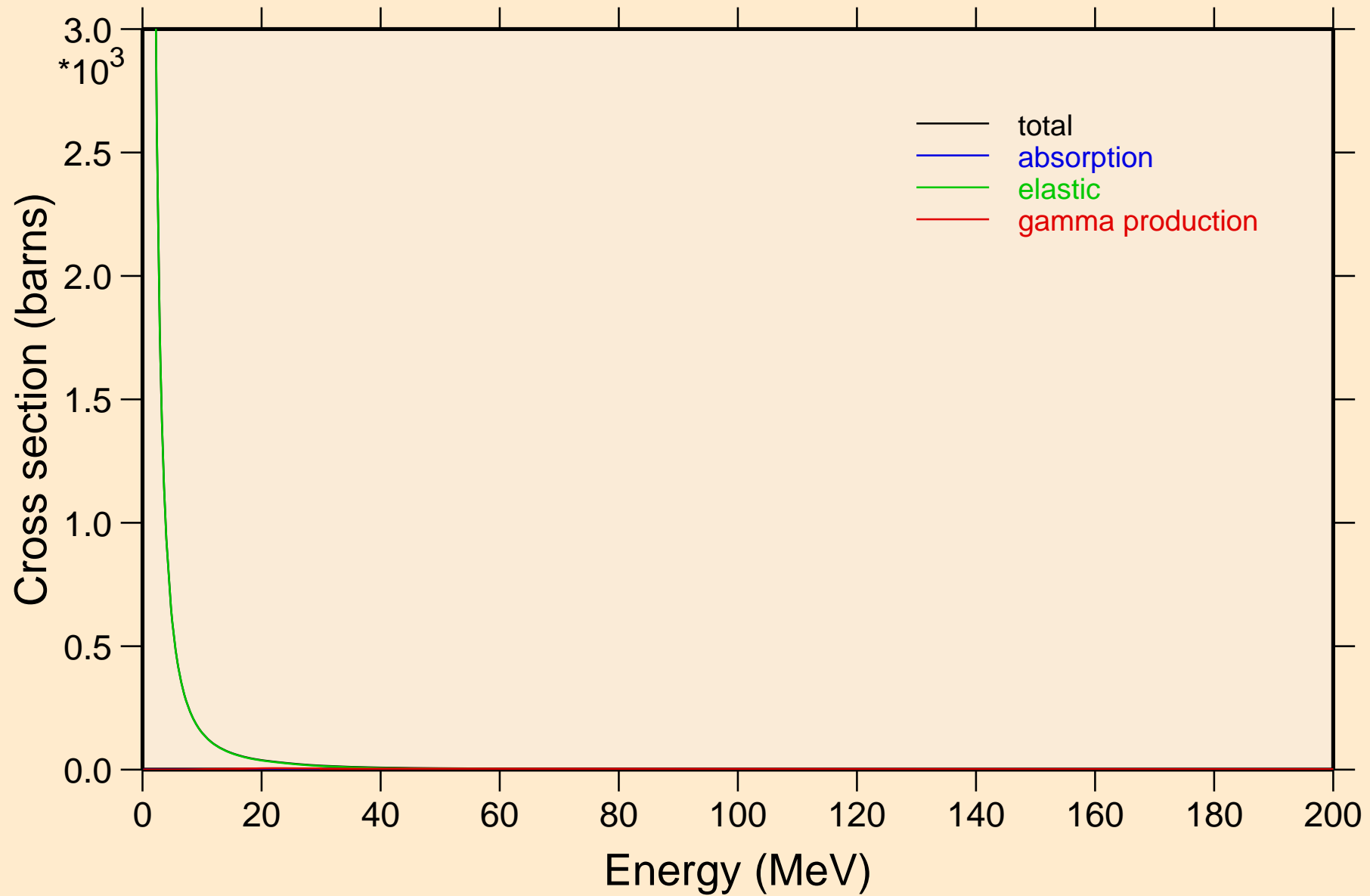

# IN122 PROTON ACER TENDL-2023 LIBRARY; T=0.K

## Heating

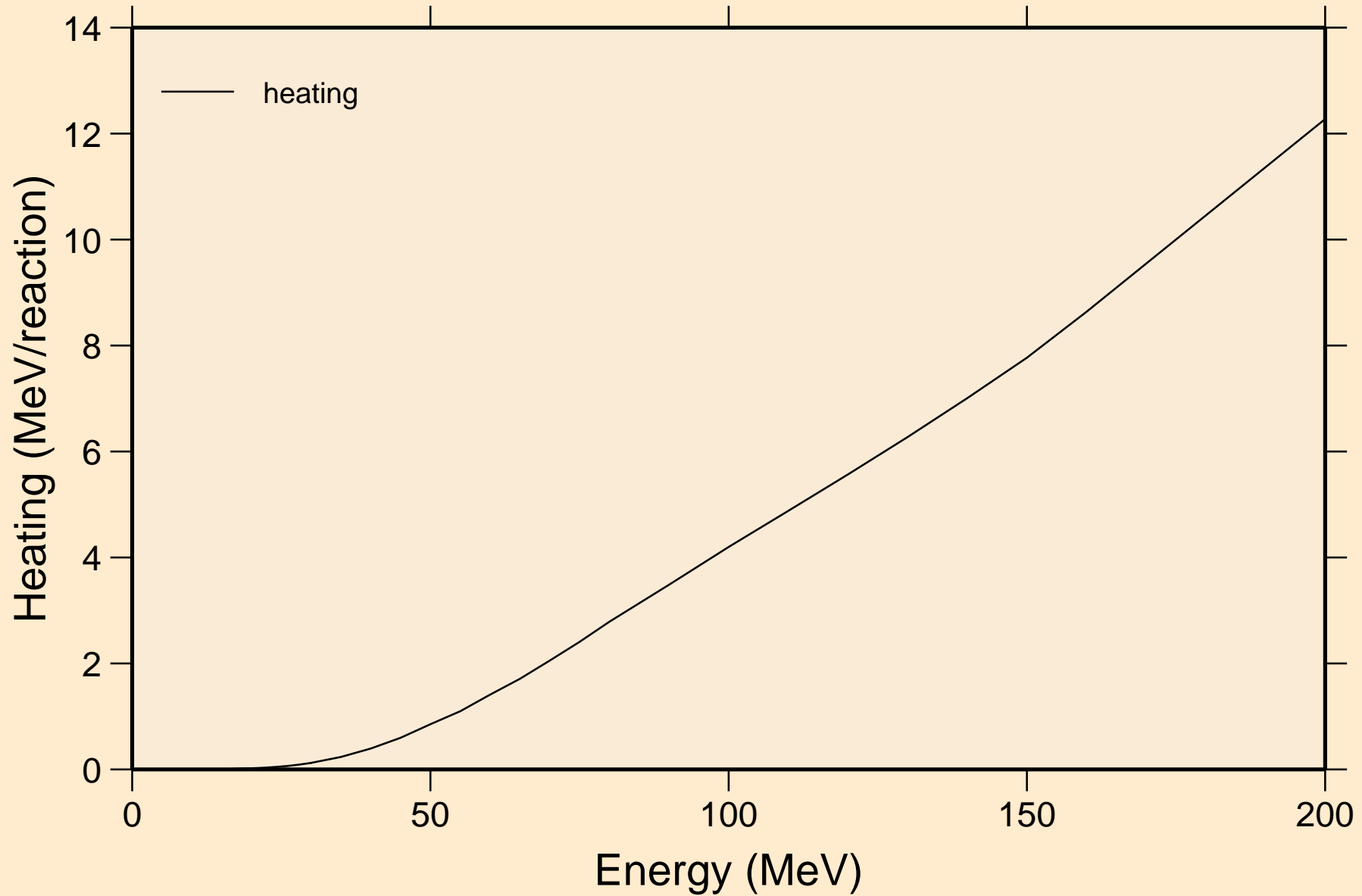

# IN122 PROTON ACER TENDL-2023 LIBRARY; T=0.K

## Threshold reactions

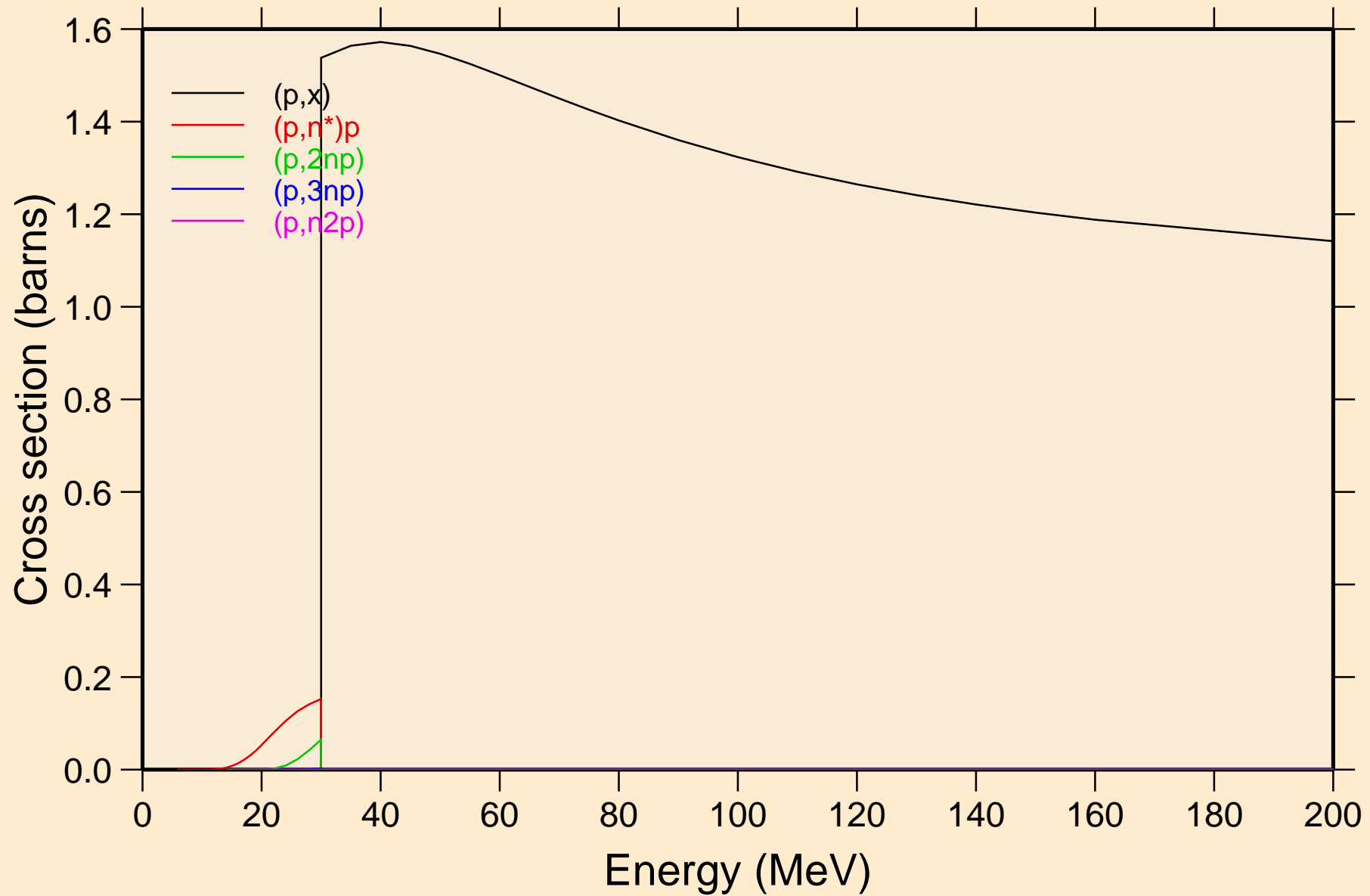

# IN122 PROTON ACER TENDL-2023 LIBRARY; T=0.K

## Threshold reactions

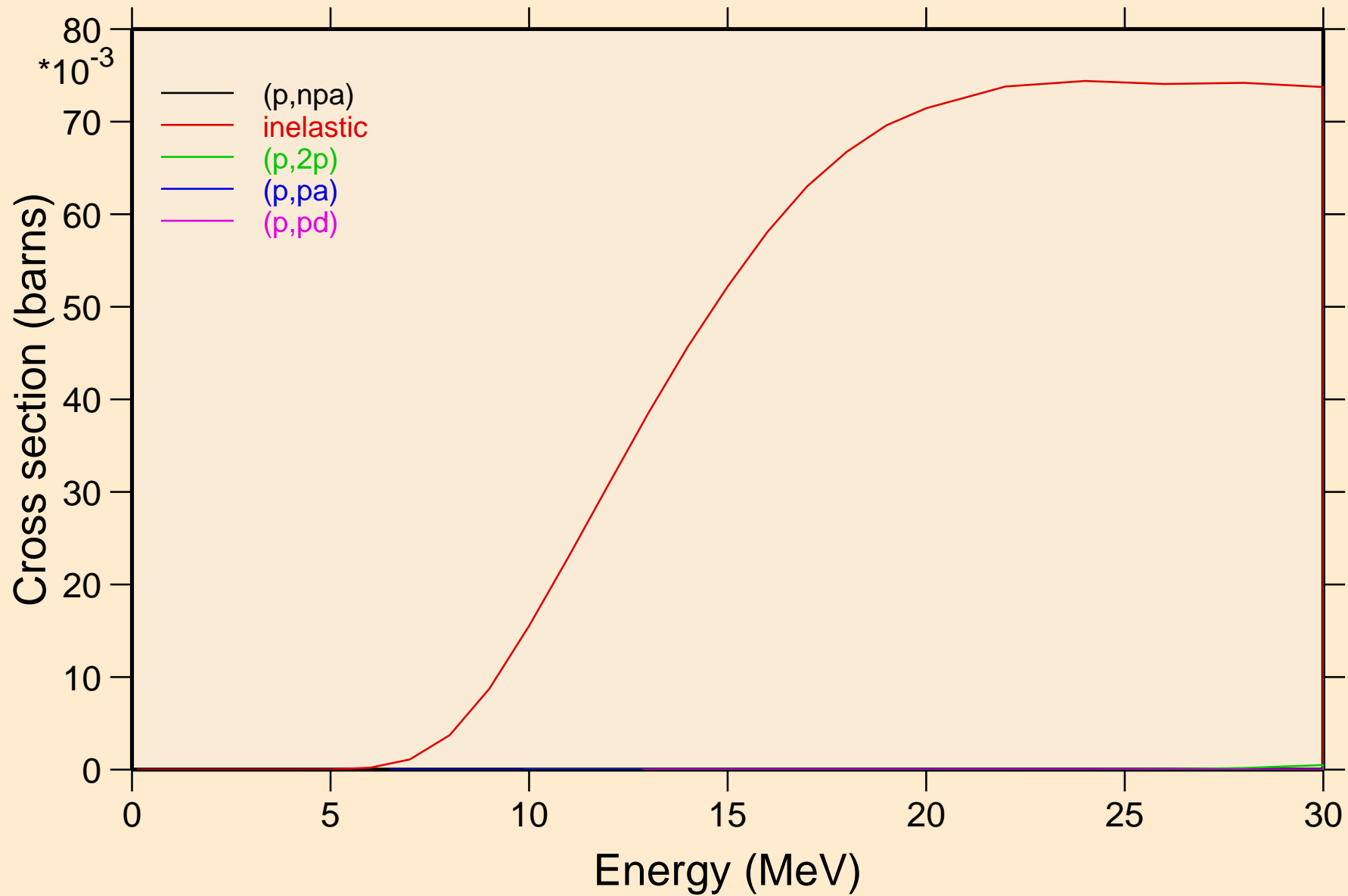

IN122 PROTON ACER TENDL-2023 LIBRARY; T=0.K  
Threshold reactions

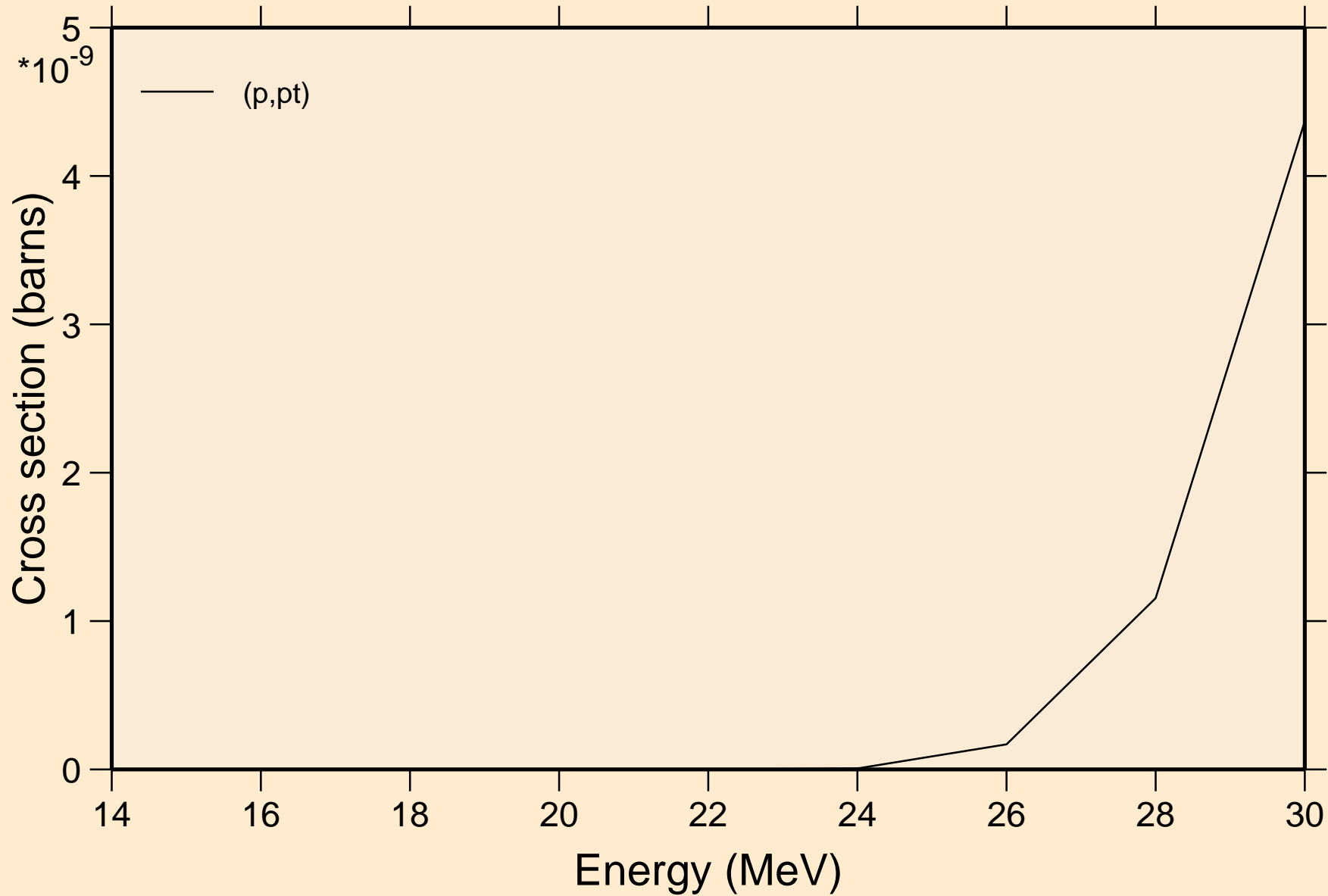

IN122 PROTON ACER TENDL-2023 LIBRARY; T=0.K  
angular distribution for elastic

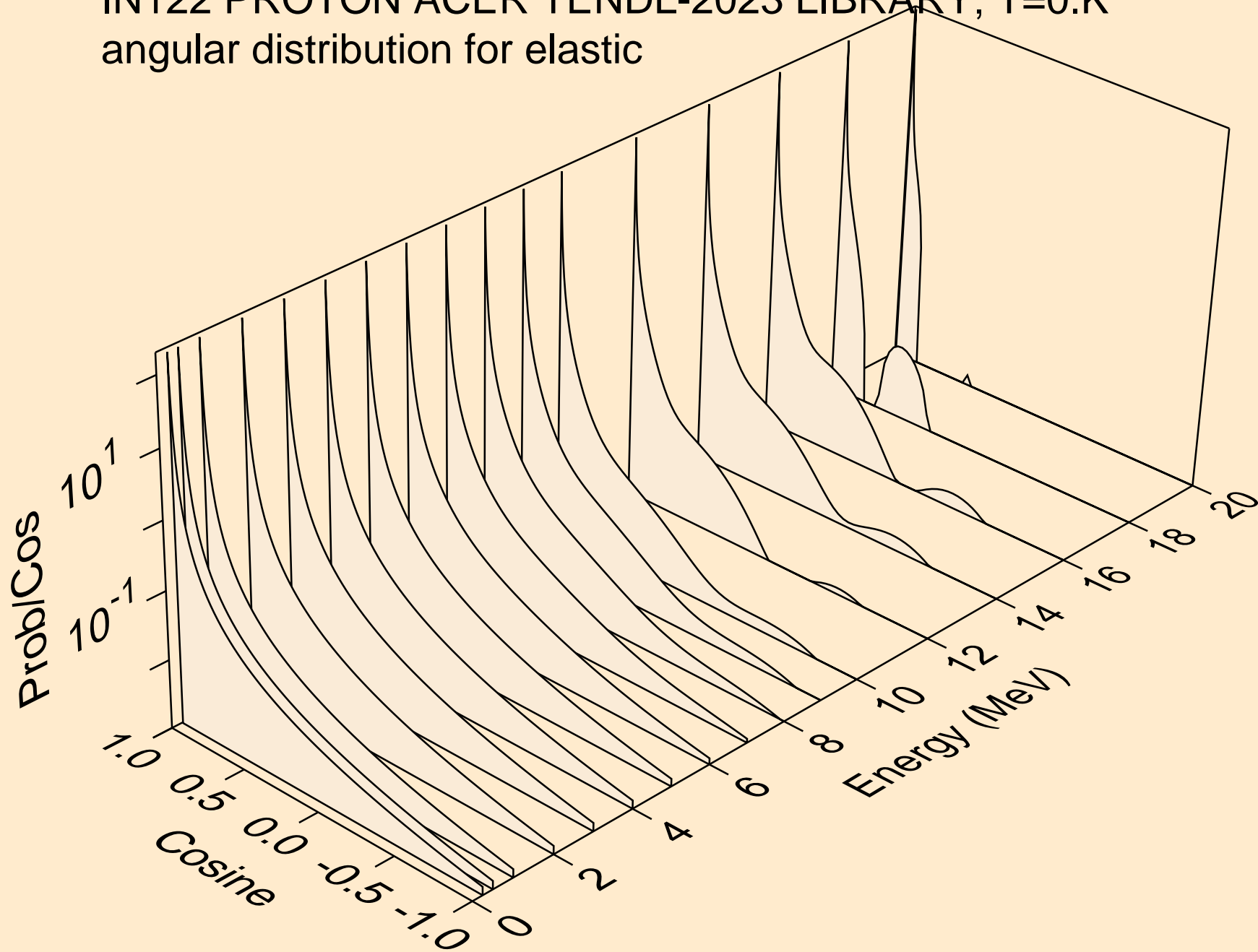



IN122 PROTON ACER TENDL-2023 LIBRARY; T=0.K  
angular distribution for elastic

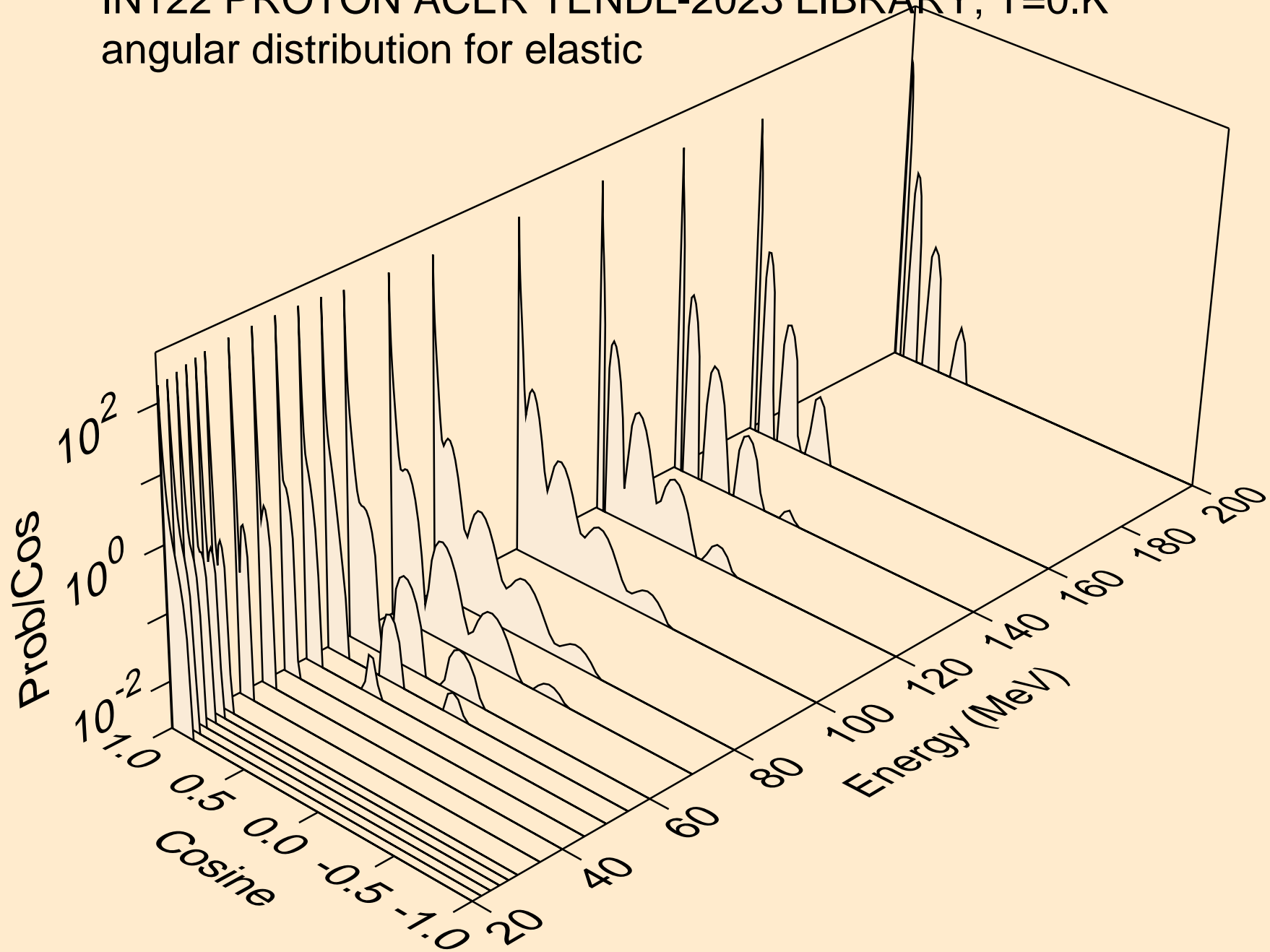

IN122 PROTON ACER TENDL-2023 LIBRARY; T=0.K  
Proton emission for (p,x)

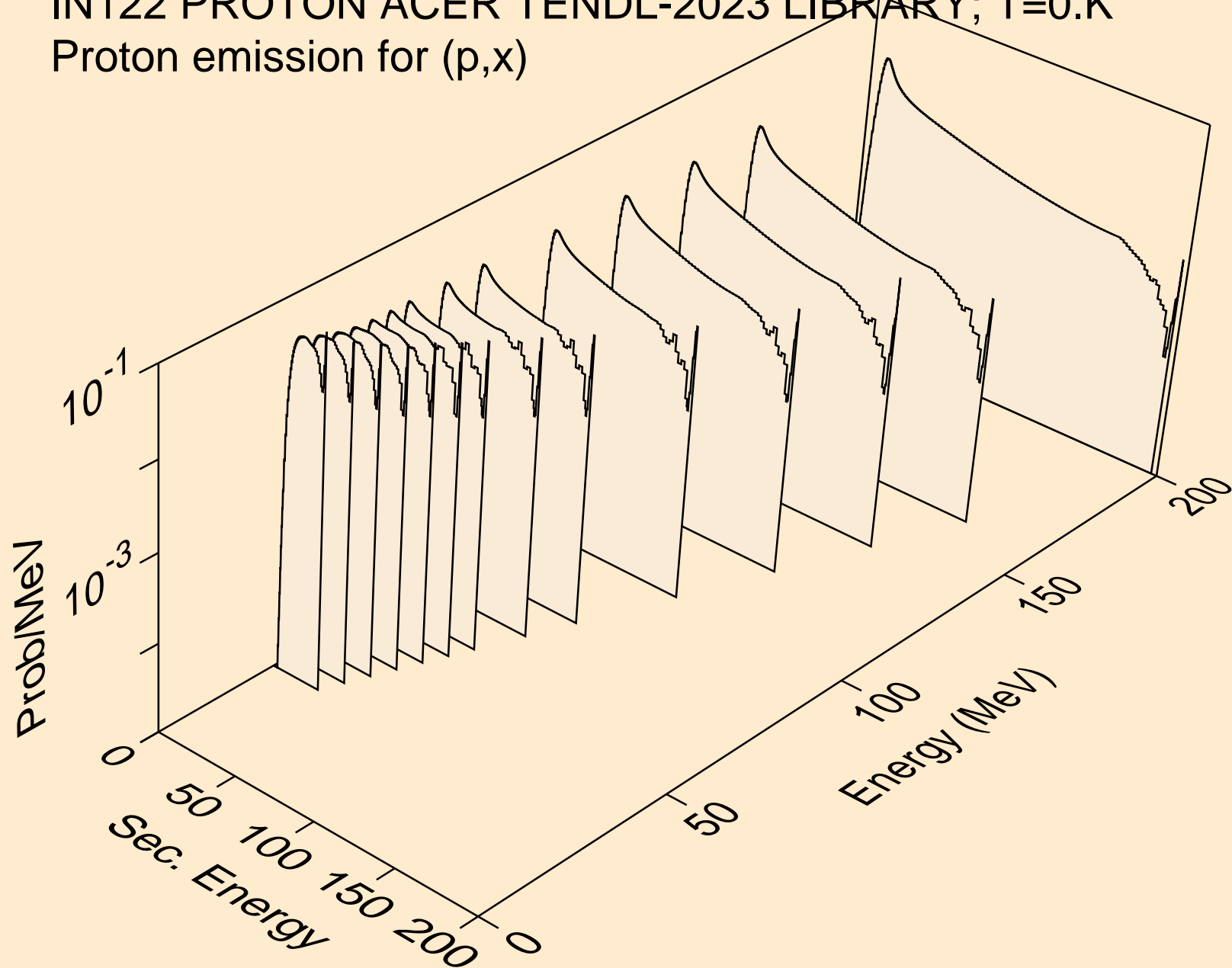

IN122 PROTON ACER TENDL-2023 LIBRARY; T=0.K  
Proton emission for (p,n\*)p

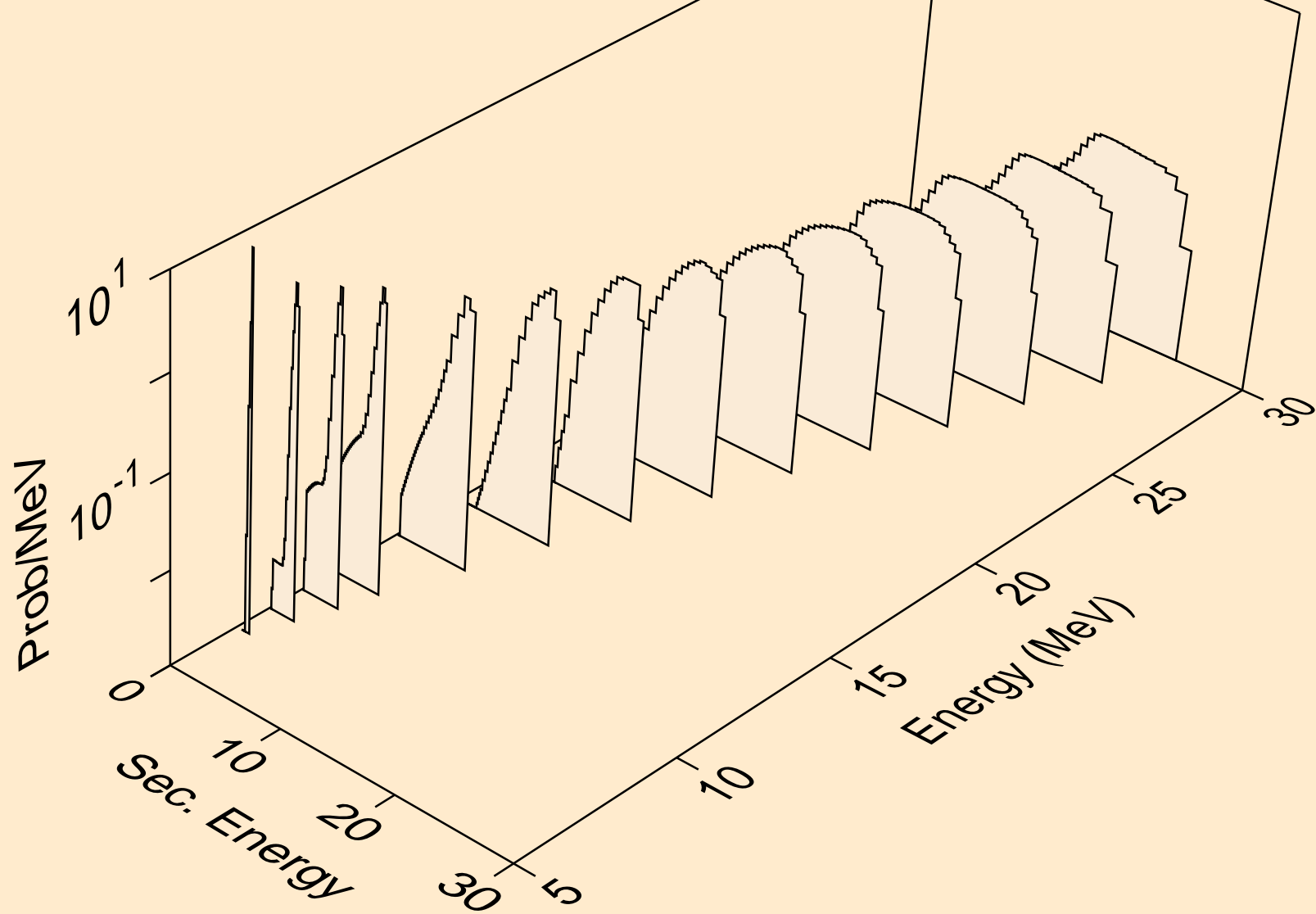

IN122 PROTON ACER TENDL-2023 LIBRARY; T=0.K  
Proton emission for (p,2np)

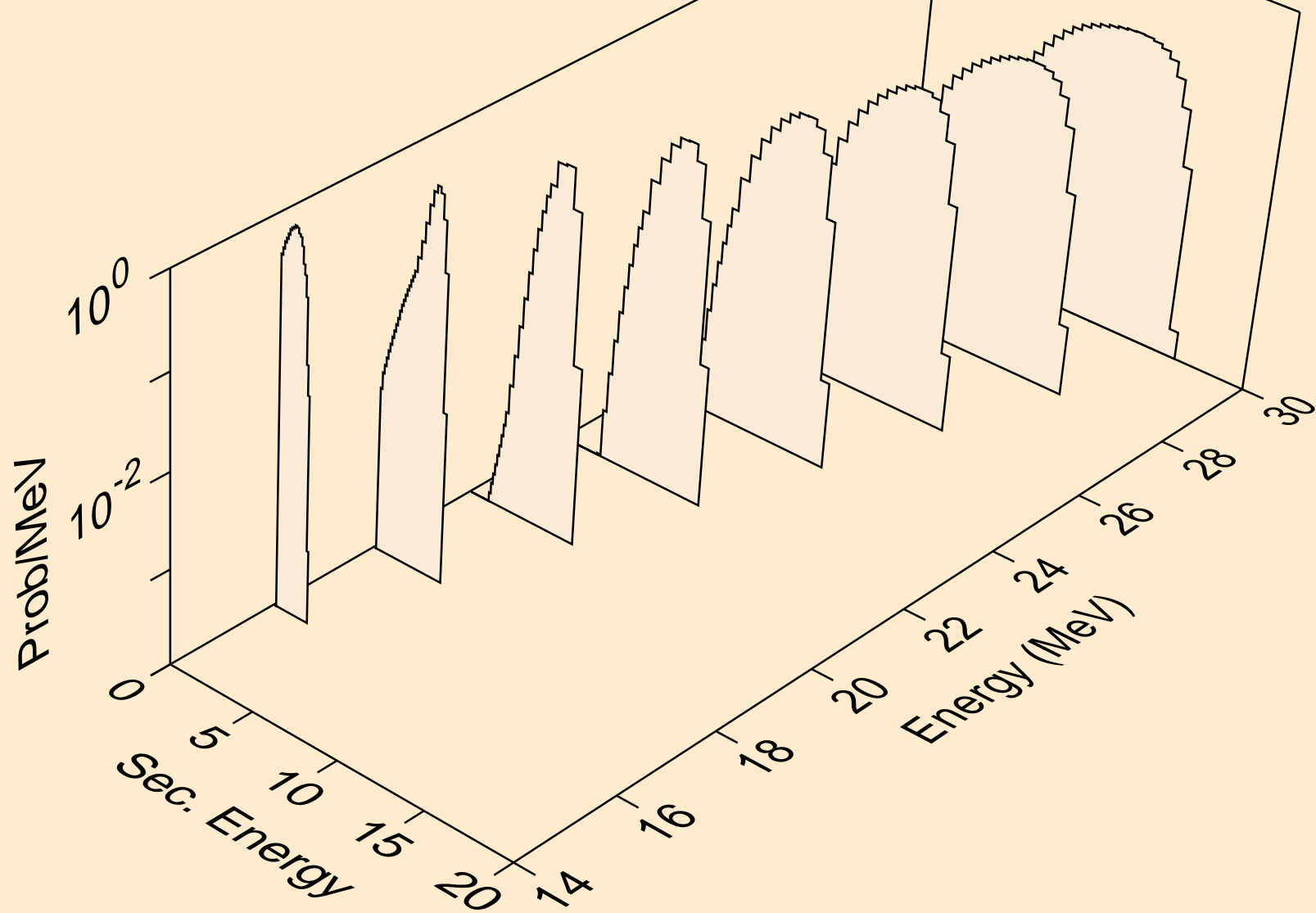

IN122 PROTON ACER TENDL-2023 LIBRARY; T=0.K  
Proton emission for (p,3np)

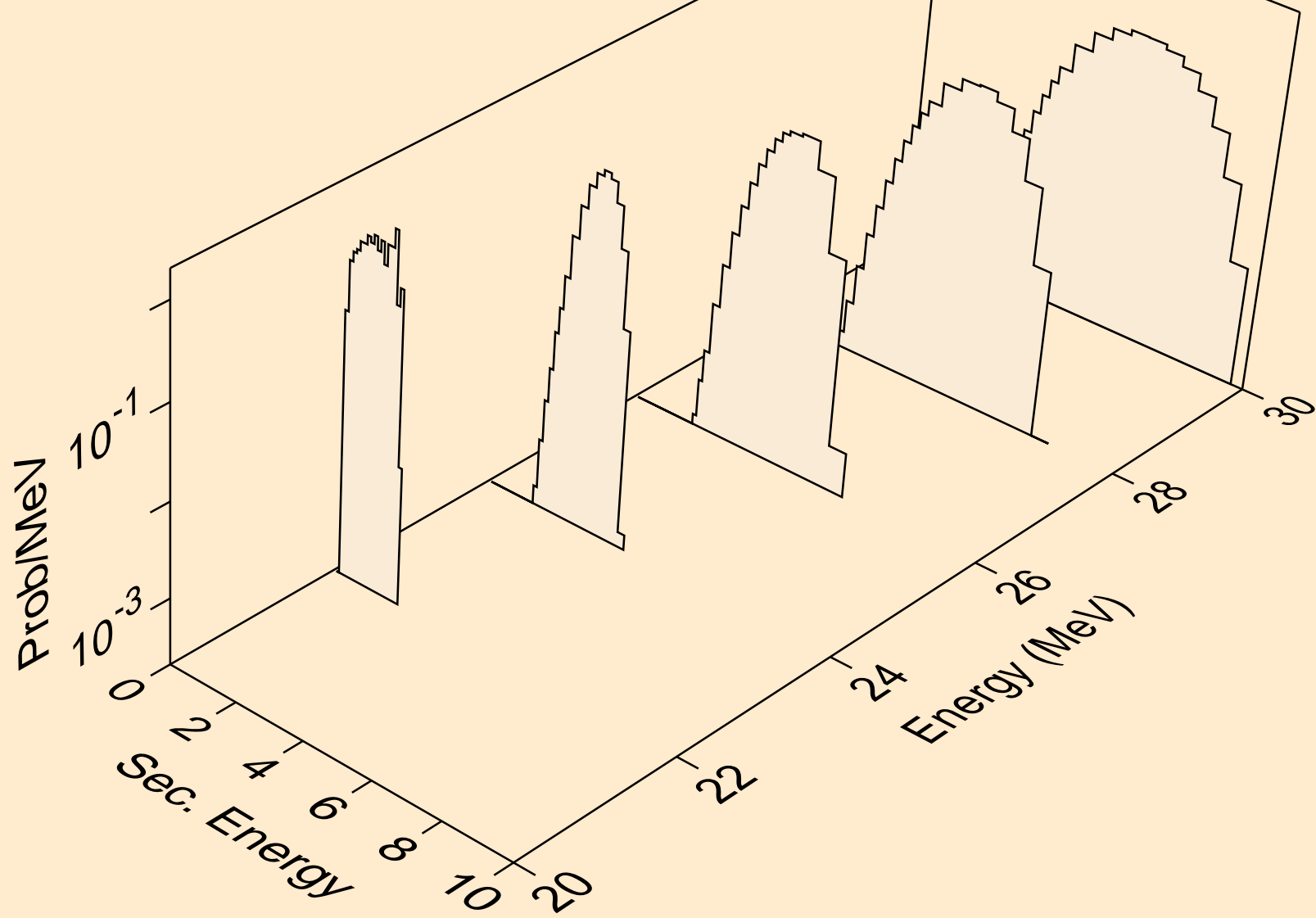

IN122 PROTON ACER TENDL-2023 LIBRARY; T=0.K  
Proton emission for (p,n2p)

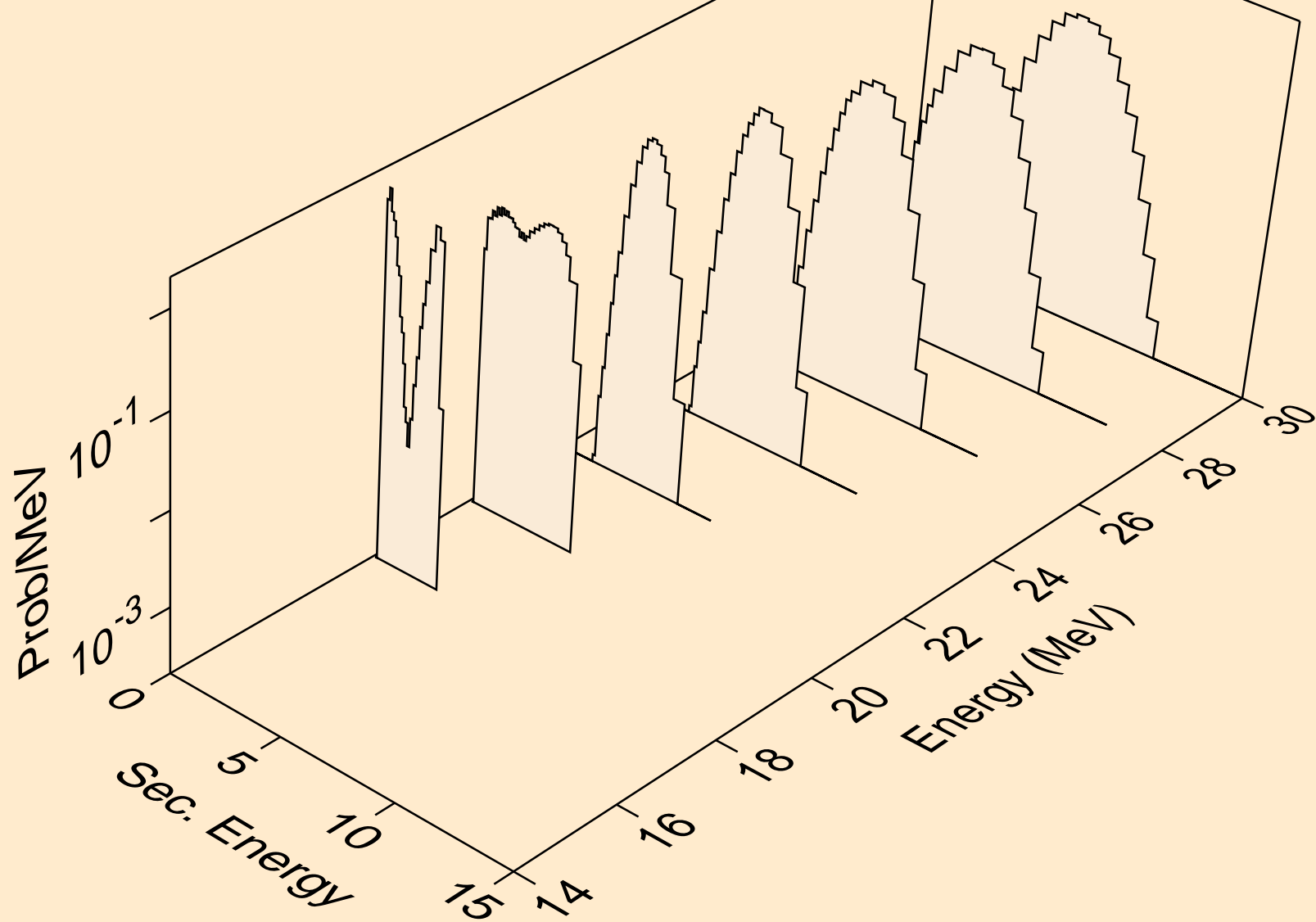

IN122 PROTON ACER TENDL-2023 LIBRARY; T=0.K  
Proton emission for (p,npa)

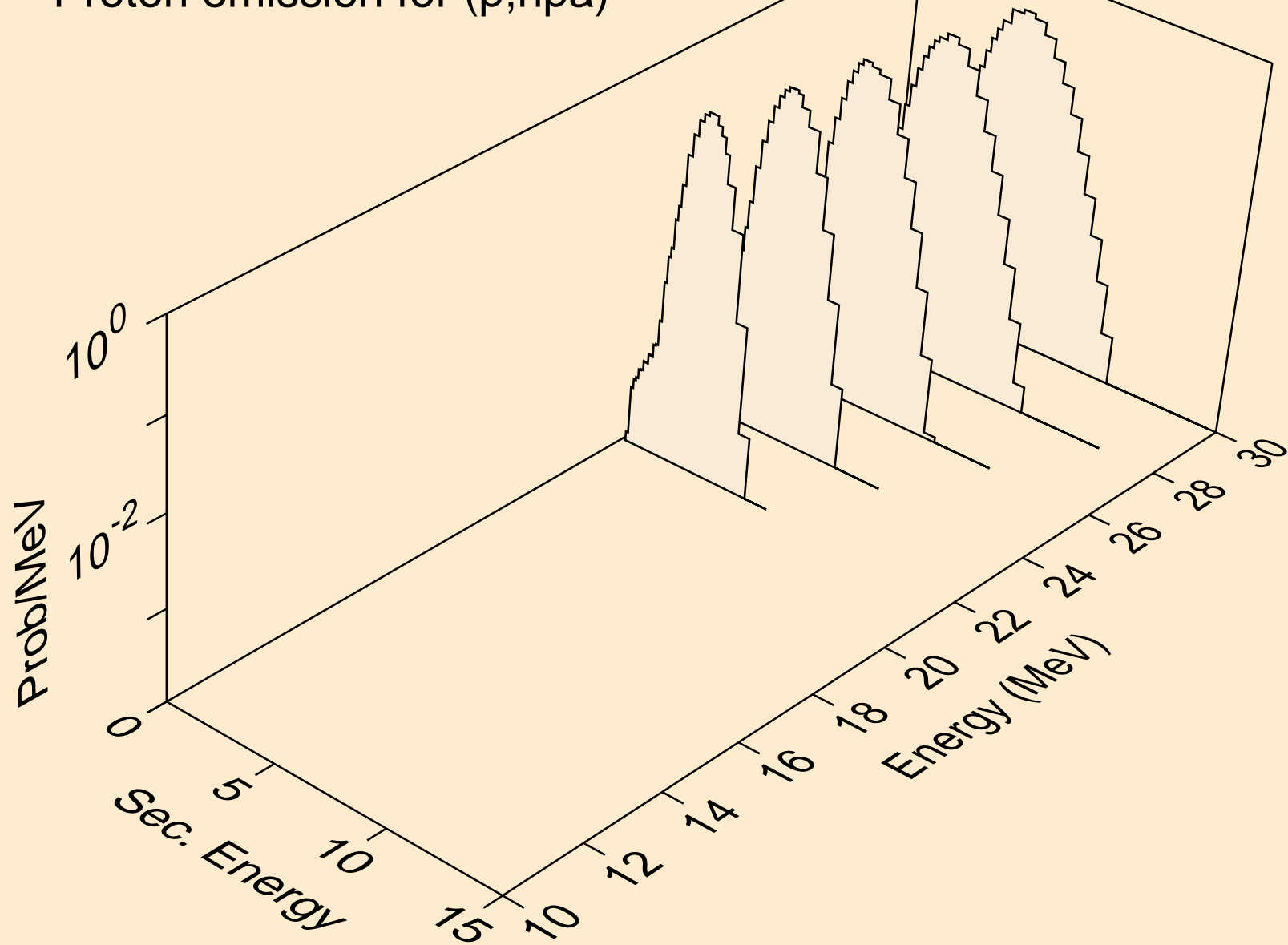

IN122 PROTON ACER TENDL-2023 LIBRARY; T=0.K  
Proton emission for inelastic

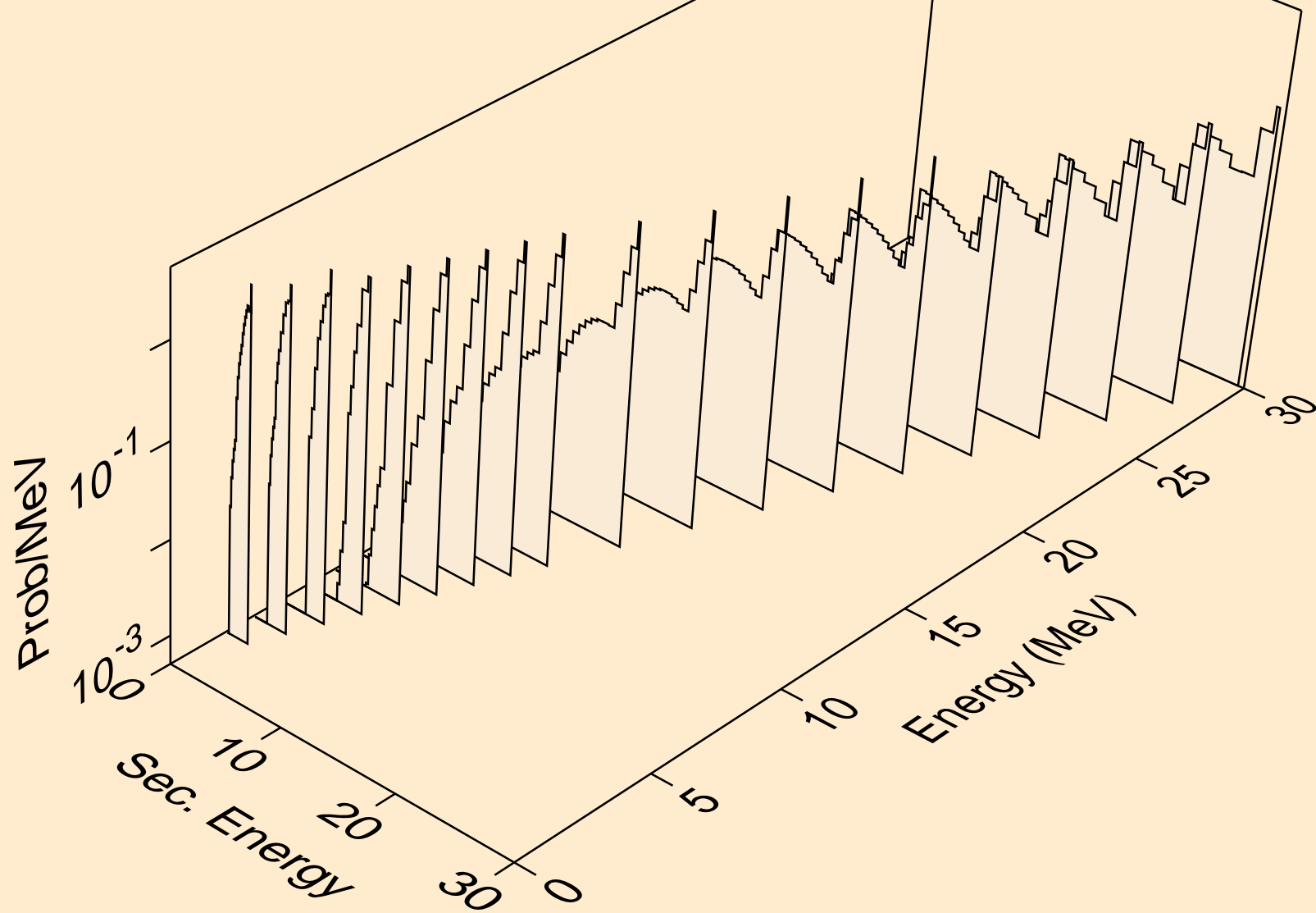



IN122 PROTON ACER TENDL-2023 LIBRARY; T=0.K  
Proton emission for (p,2p)

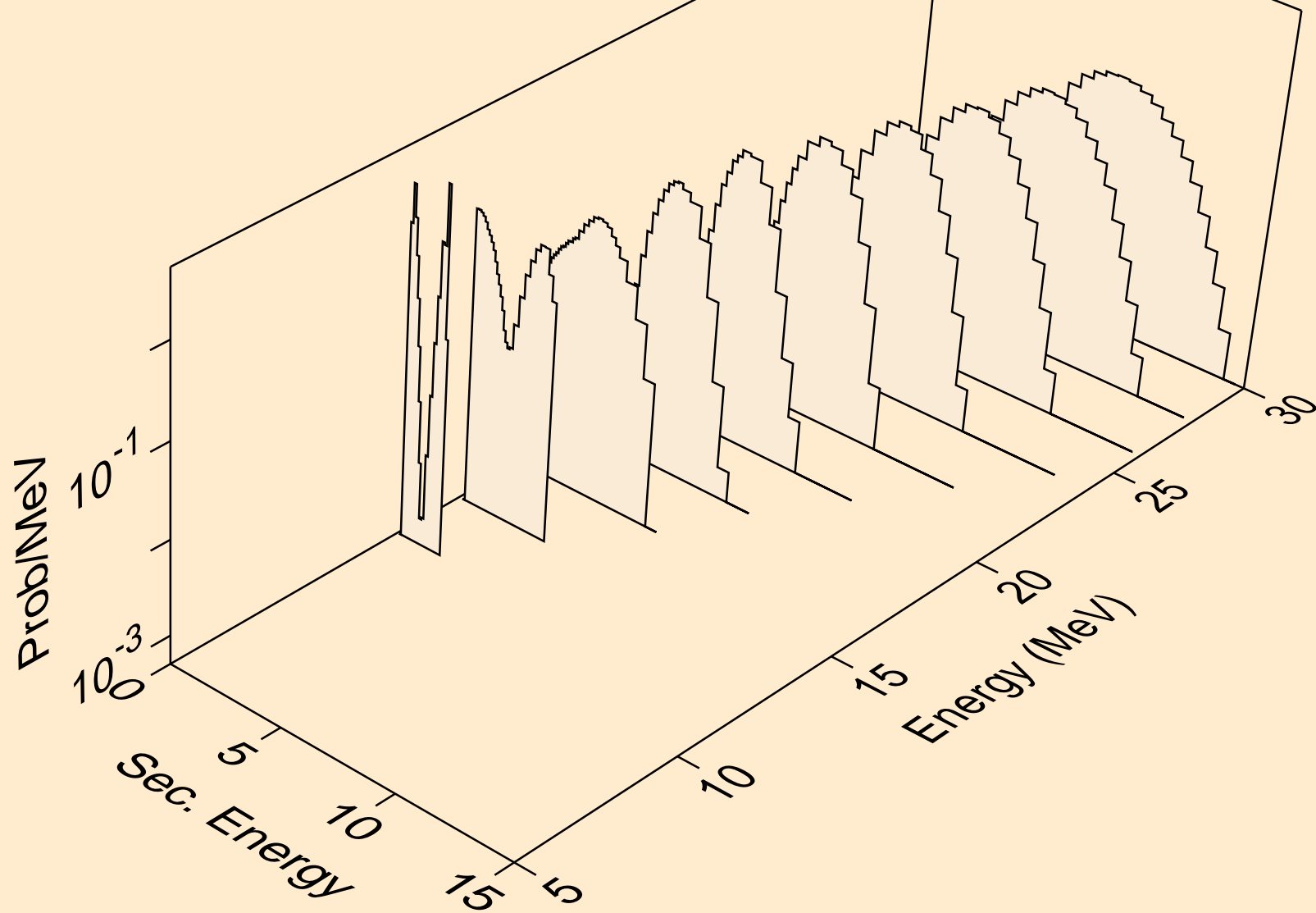

IN122 PROTON ACER TENDL-2023 LIBRARY; T=0.K  
Proton emission for (p,pa)

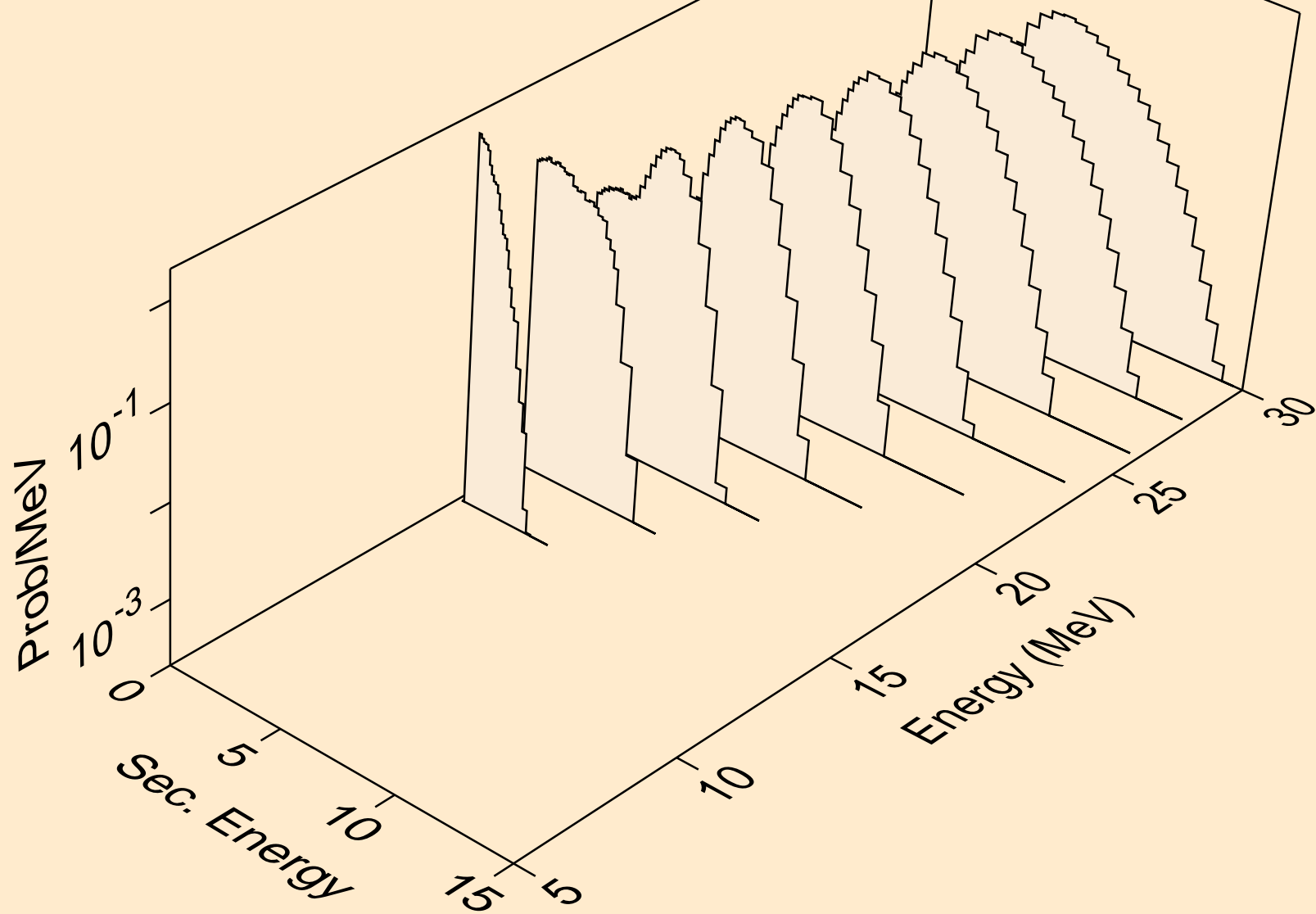

IN122 PROTON ACER TENDL-2023 LIBRARY; T=0.K  
Proton emission for (p,pd)

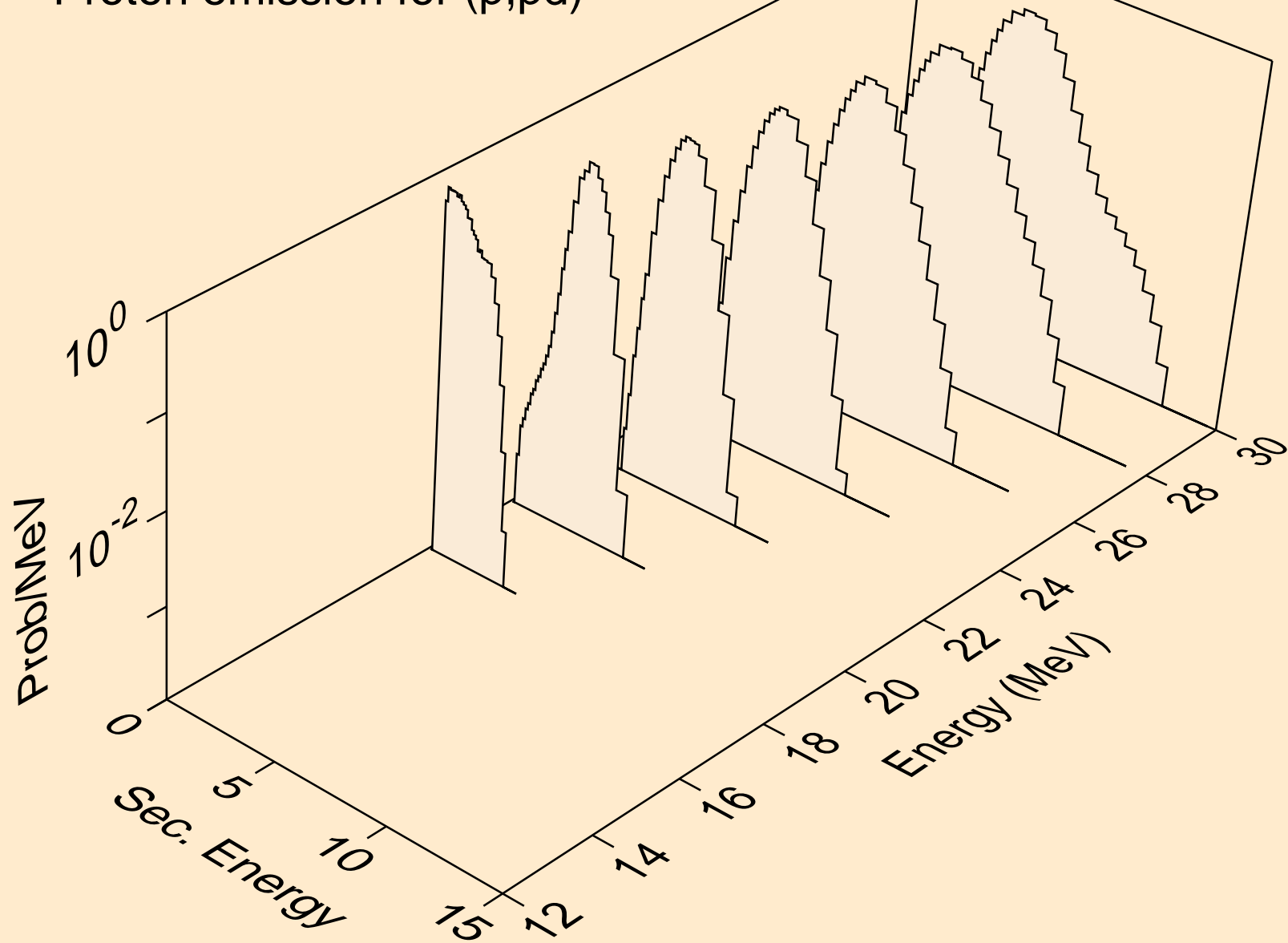

IN122 PROTON ACER TENDL-2023 LIBRARY; T=0.K  
Proton emission for (p,pt)

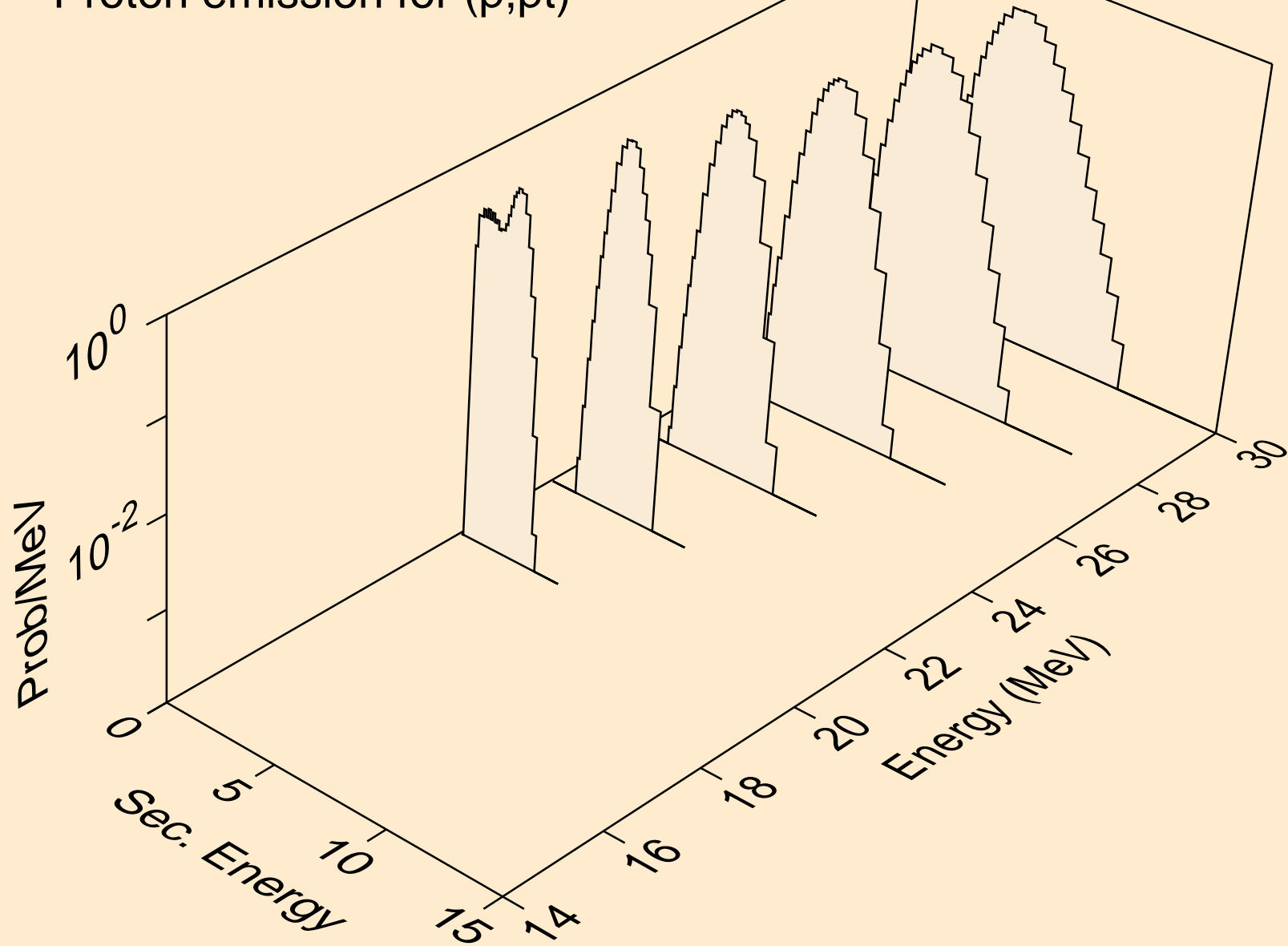

IN122 PROTON ACER TENDL-2023 LIBRARY; T=0.K  
Photon emission for (z,n)

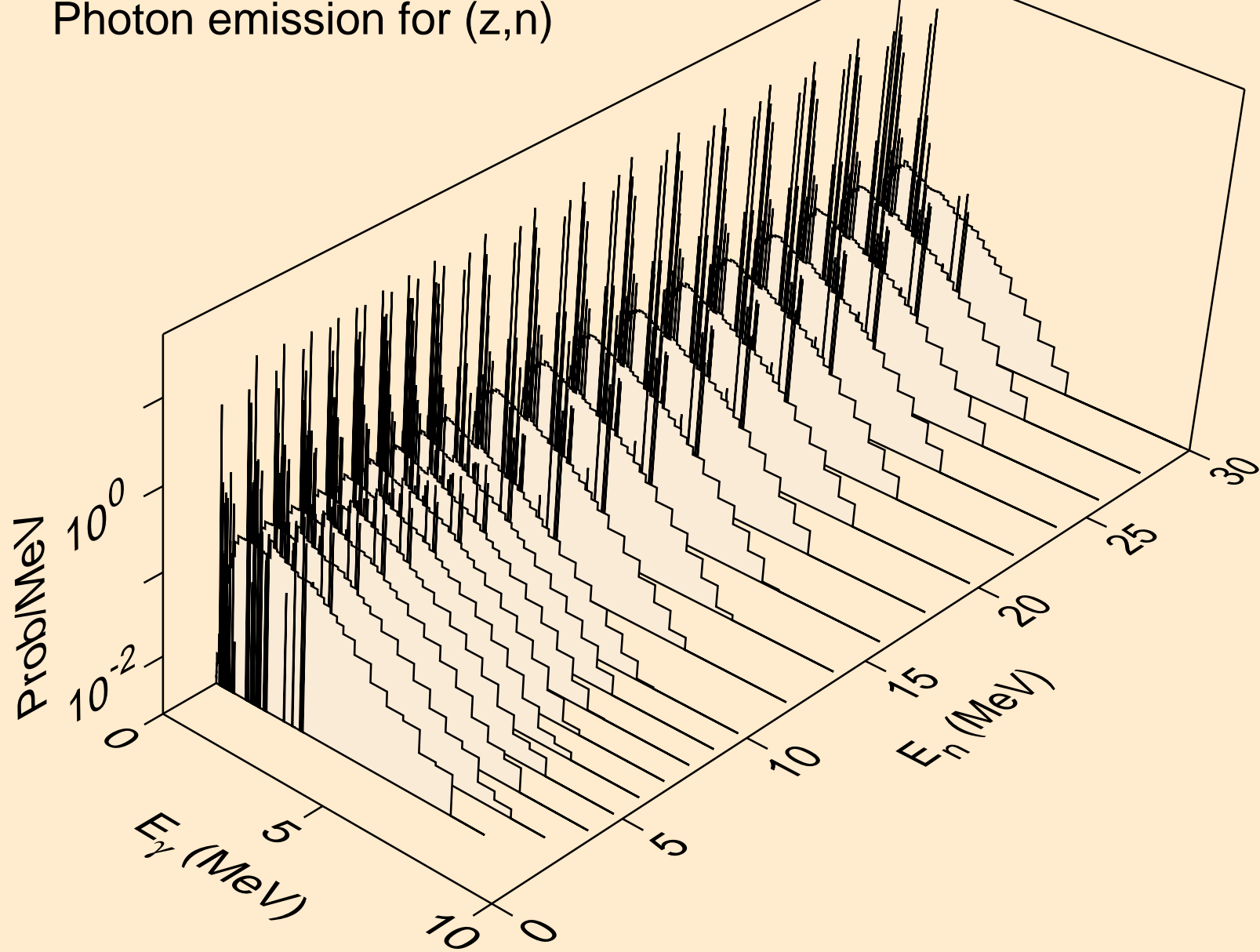

IN122 PROTON ACER TENDL-2023 LIBRARY; T=0.K  
Photon emission for (z,x)

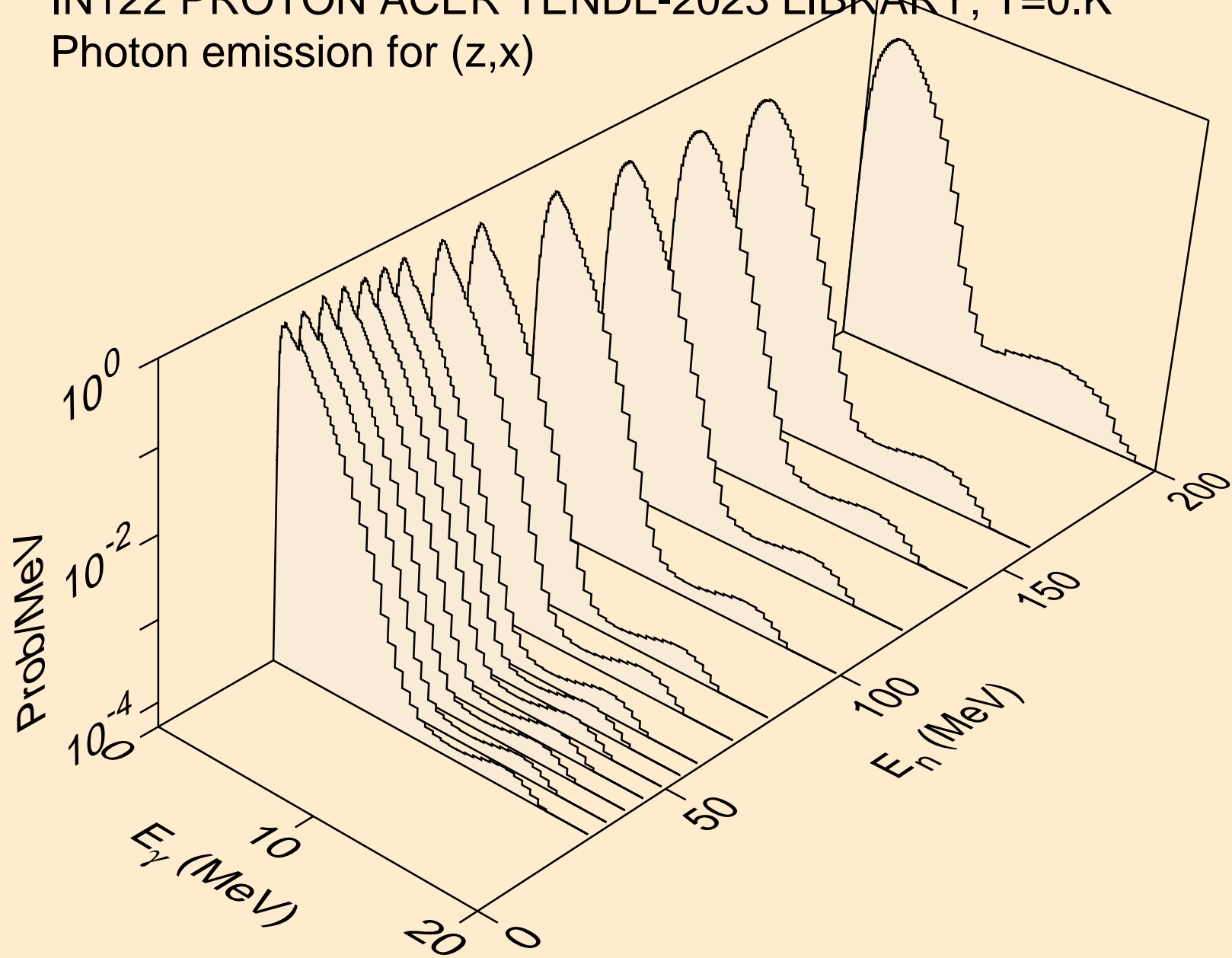

IN122 PROTON ACER TENDL-2023 LIBRARY; T=0.K  
Photon emission for (n,2nd)

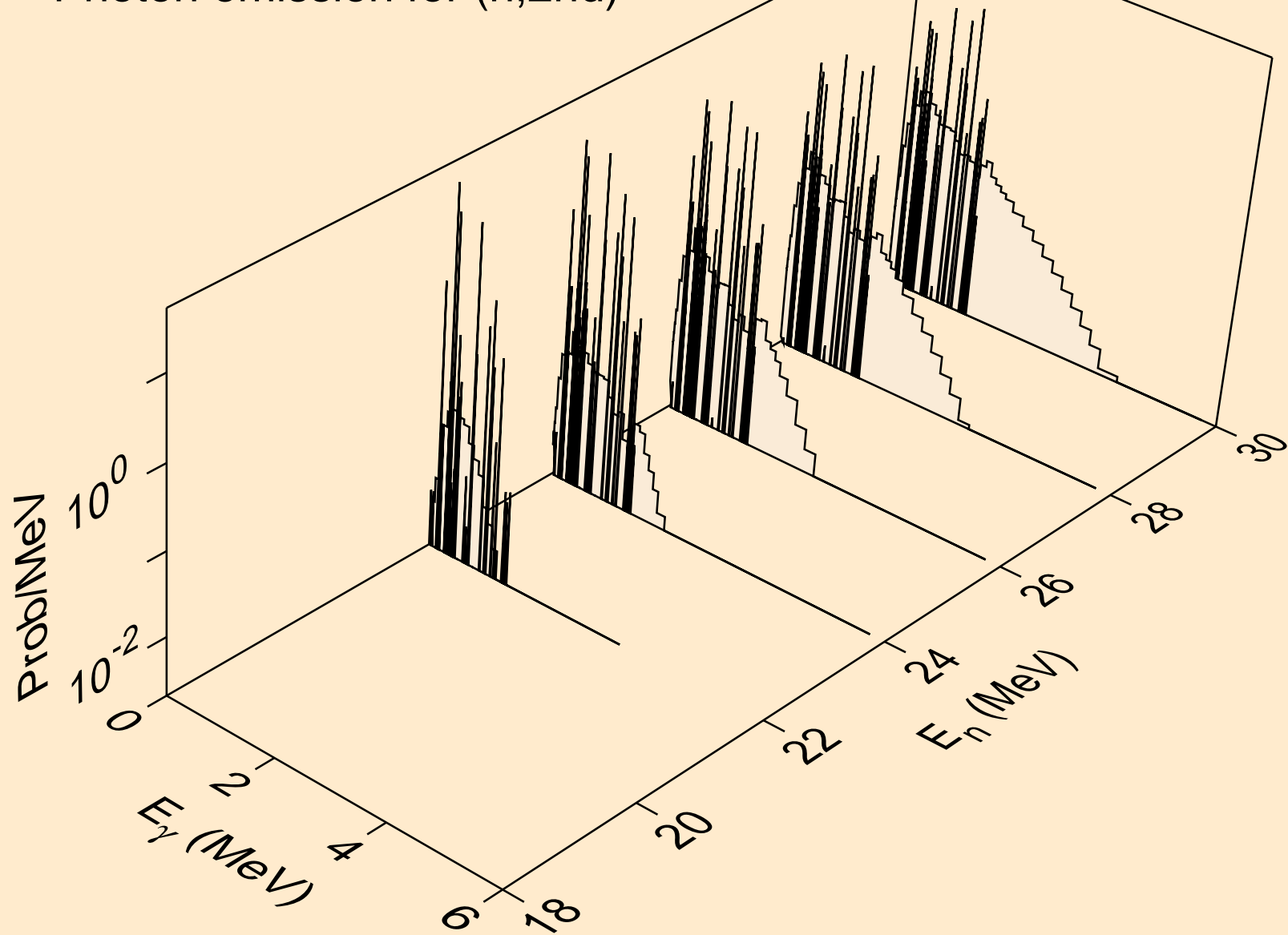

IN122 PROTON ACER TENDL-2023 LIBRARY; T=0.K  
Photon emission for (n,2n)

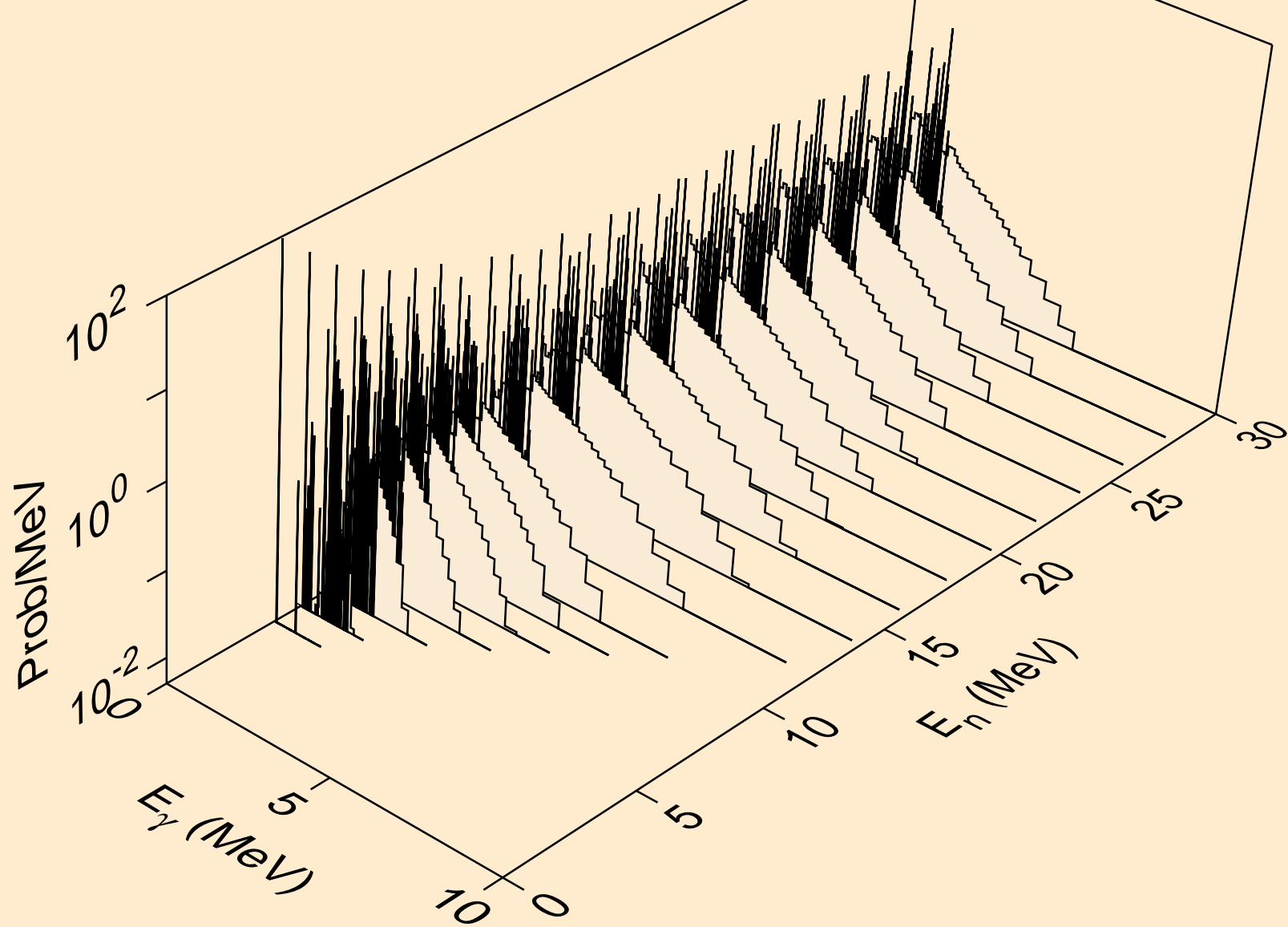



IN122 PROTON ACER TENDL-2023 LIBRARY; T=0.K  
Photon emission for (n,3n)

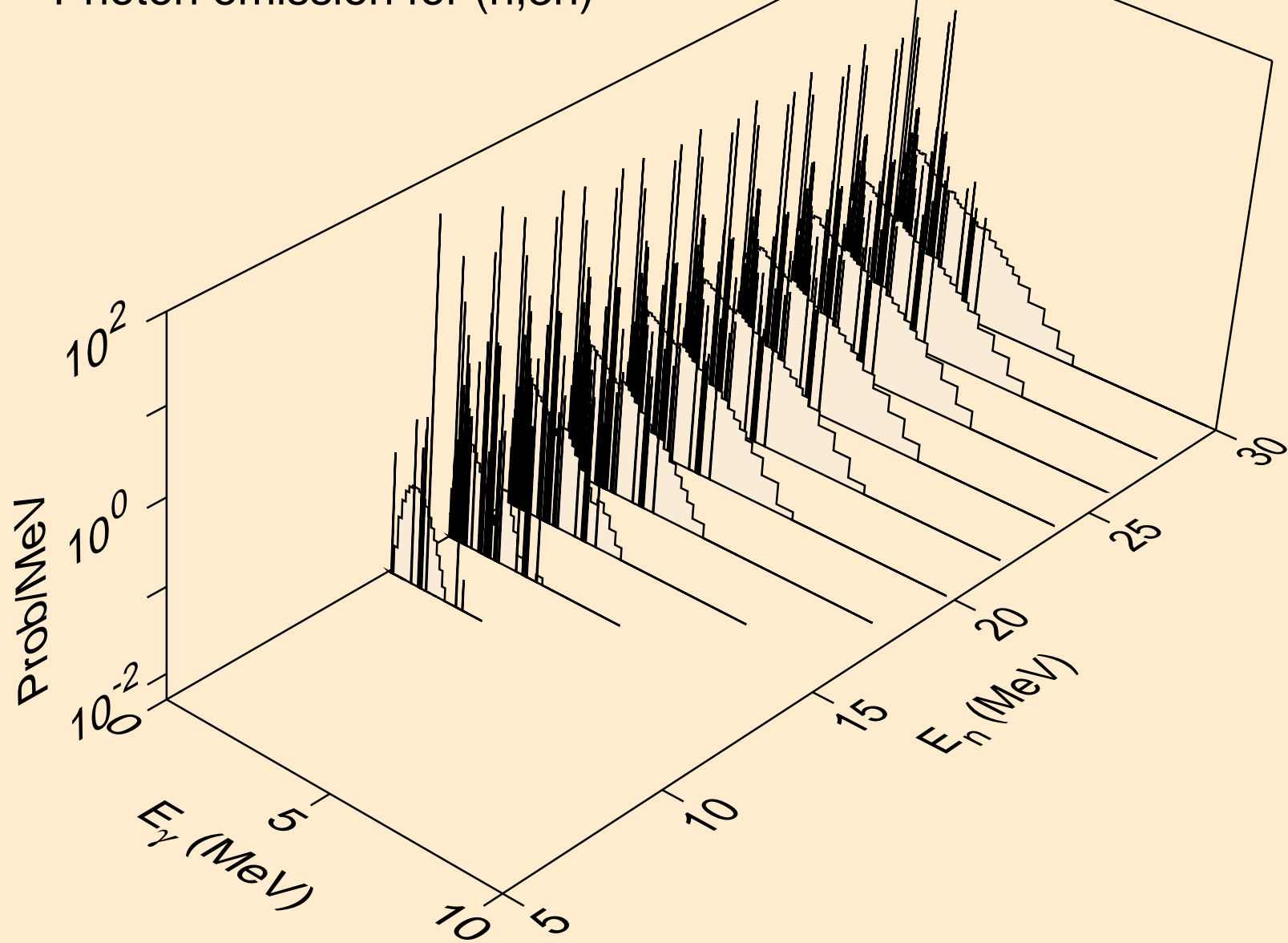

IN122 PROTON ACER TENDL-2023 LIBRARY; T=0.K  
Photon emission for (n,n\*)a

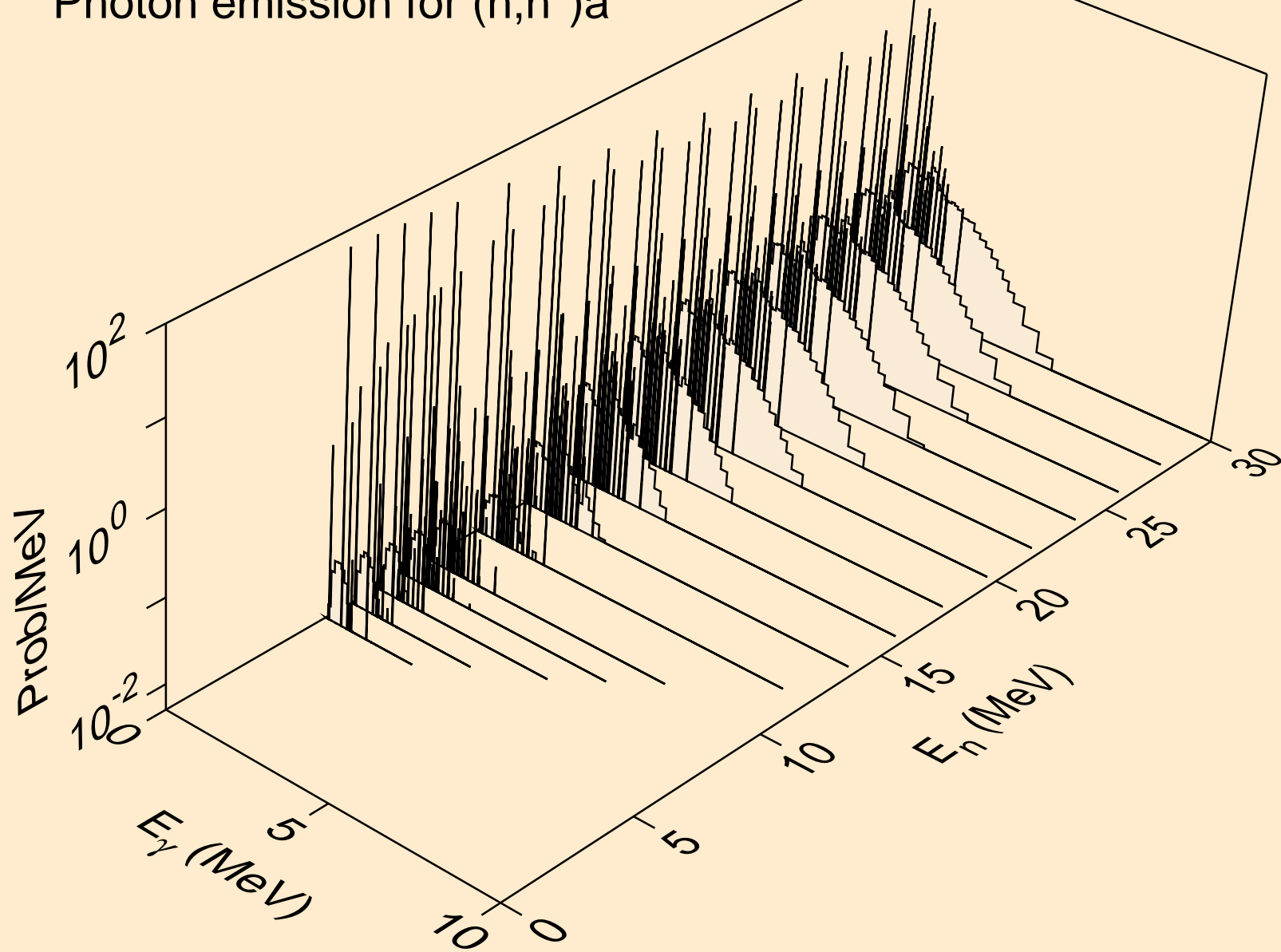

IN122 PROTON ACER TENDL-2023 LIBRARY; T=0.K  
Photon emission for (n,2n)a

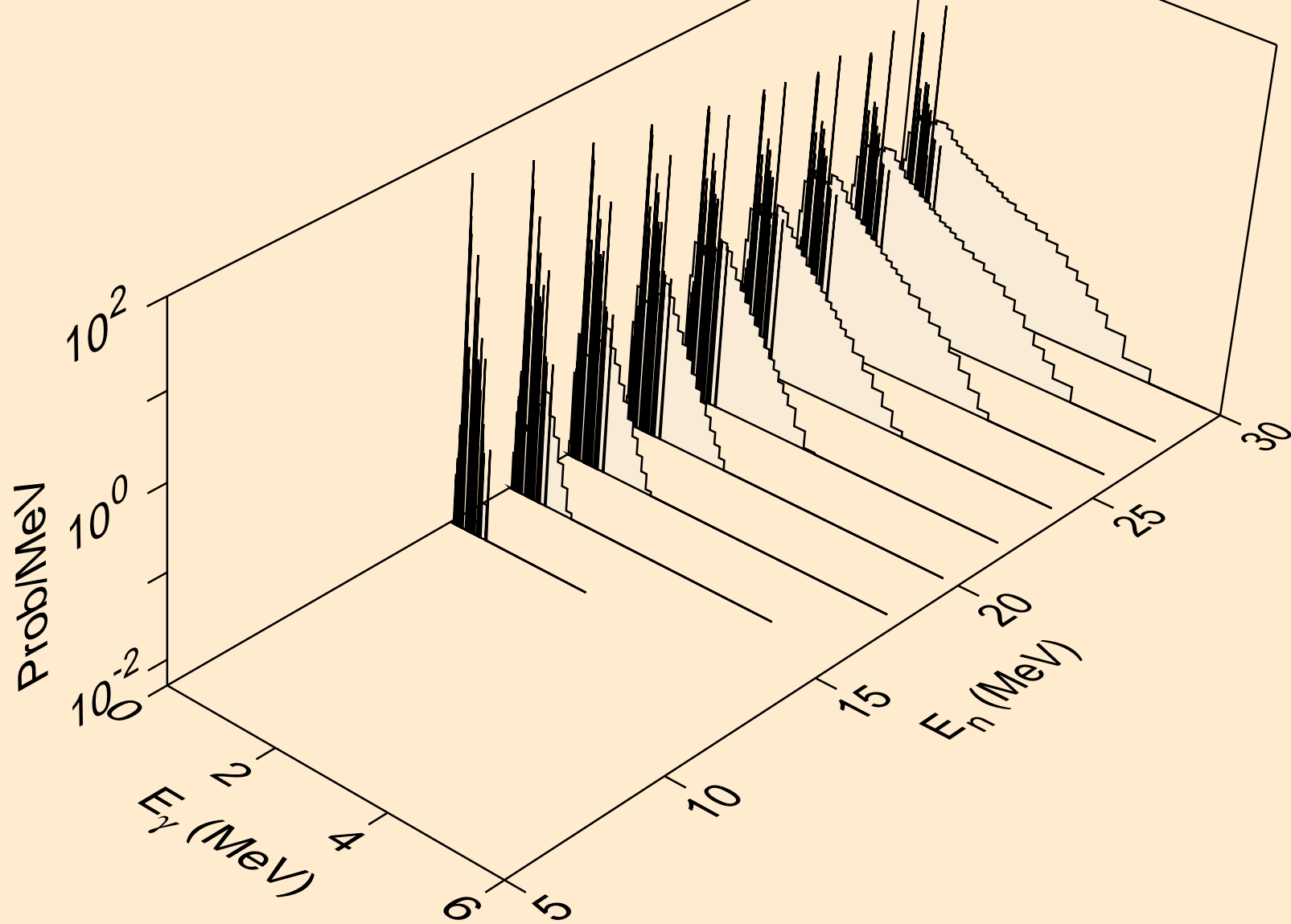

IN122 PROTON ACER TENDL-2023 LIBRARY; T=0.K  
Photon emission for (n,3n)a

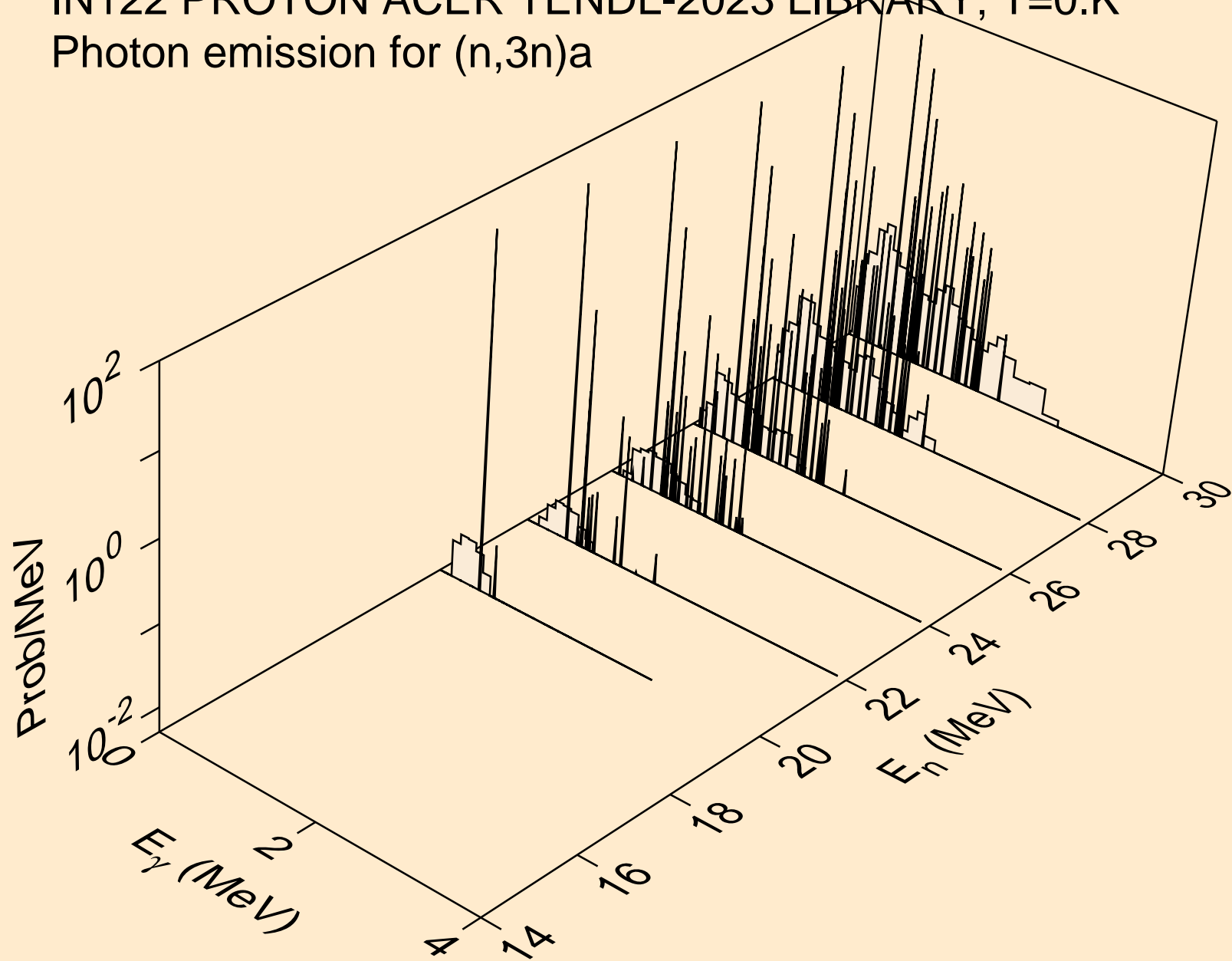

IN122 PROTON ACER TENDL-2023 LIBRARY; T=0.K  
Photon emission for (n,n\*)p

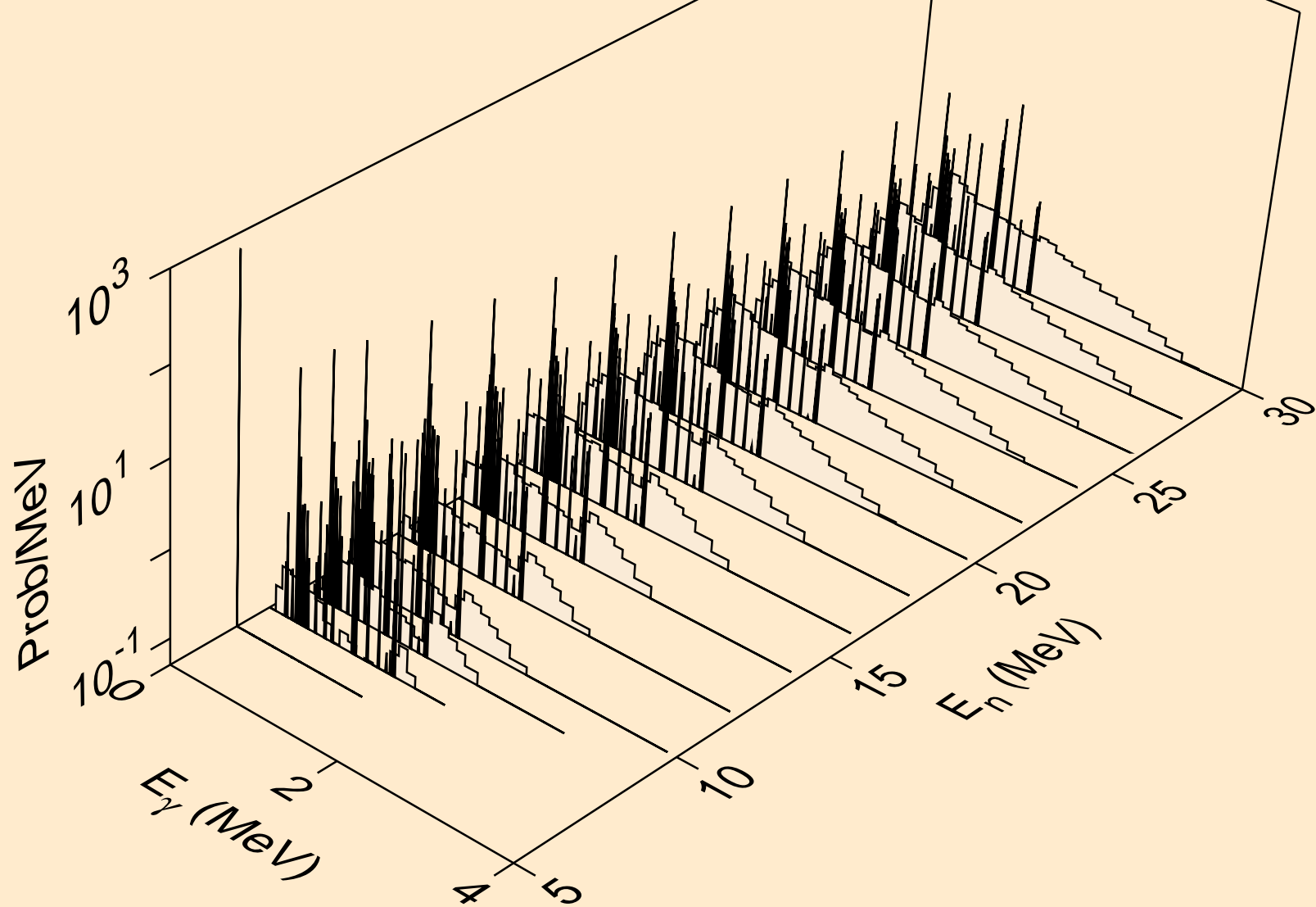

IN122 PROTON ACER TENDL-2023 LIBRARY; T=0.K  
Photon emission for (n,n\*)d

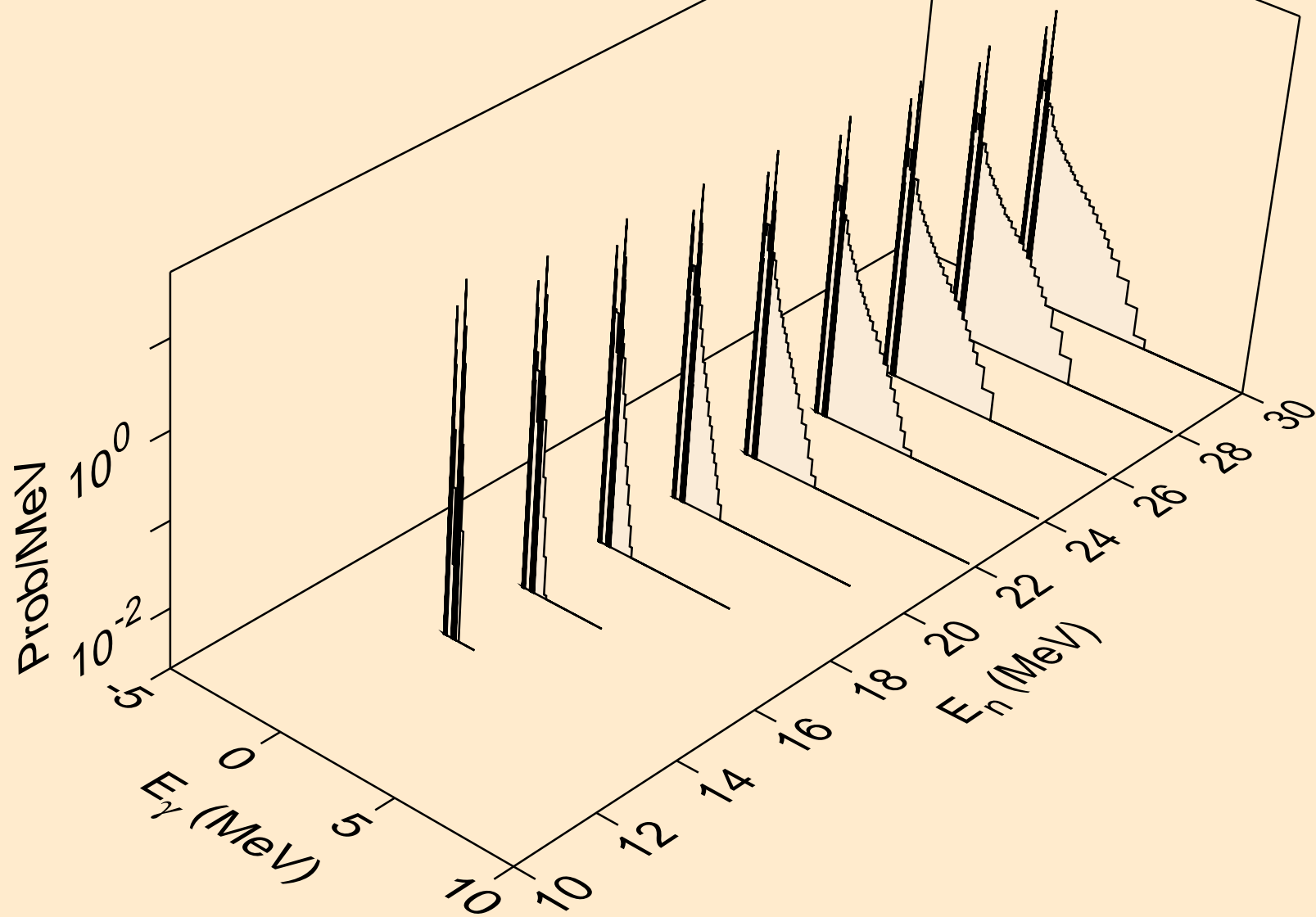

IN122 PROTON ACER TENDL-2023 LIBRARY; T=0.K  
Photon emission for (n,n\*)t

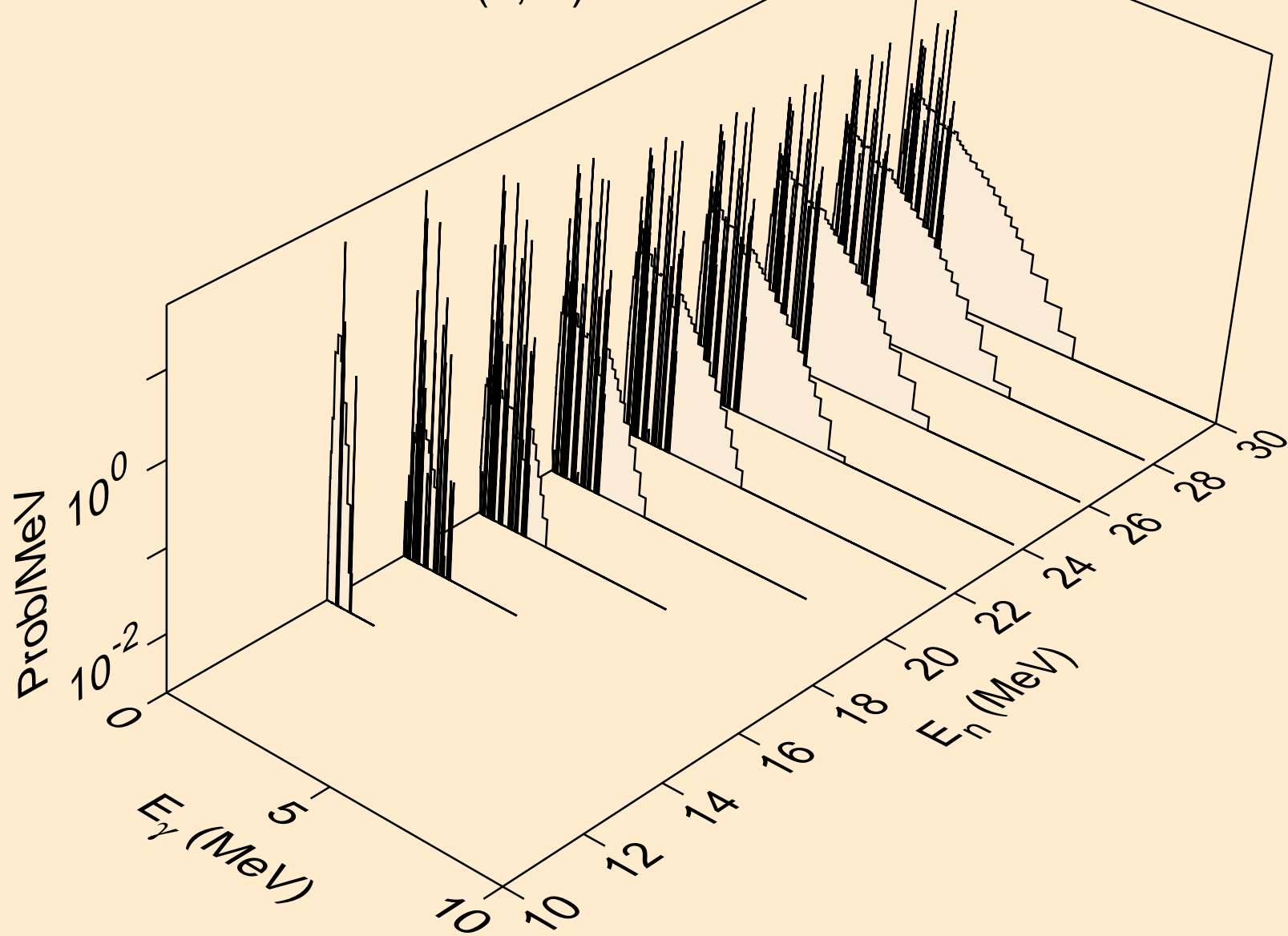

IN122 PROTON ACER TENDL-2023 LIBRARY; T=0.K  
Photon emission for (n,n\*)he3

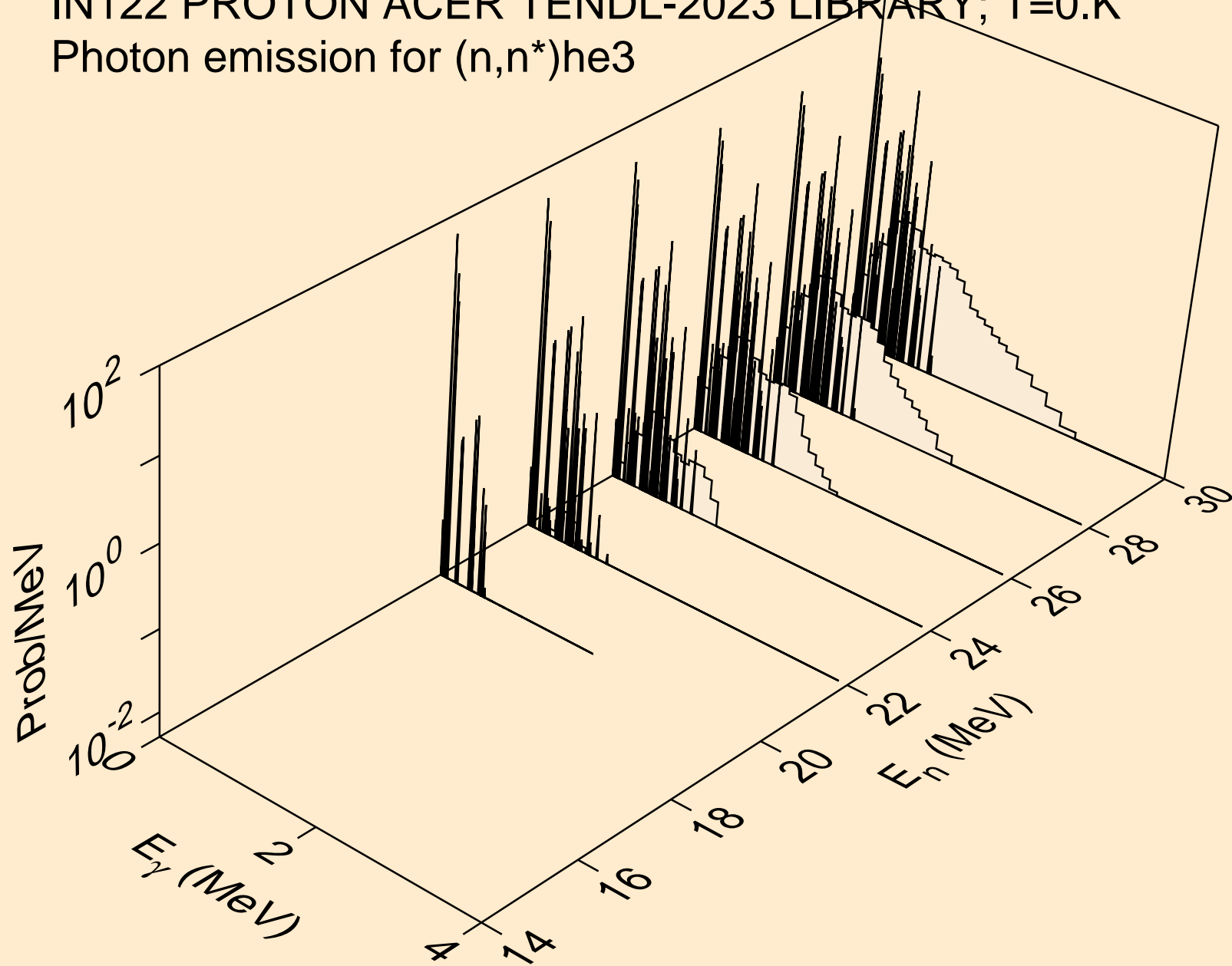



IN122 PROTON ACER TENDL-2023 LIBRARY; T=0.K  
Photon emission for (n,4n)

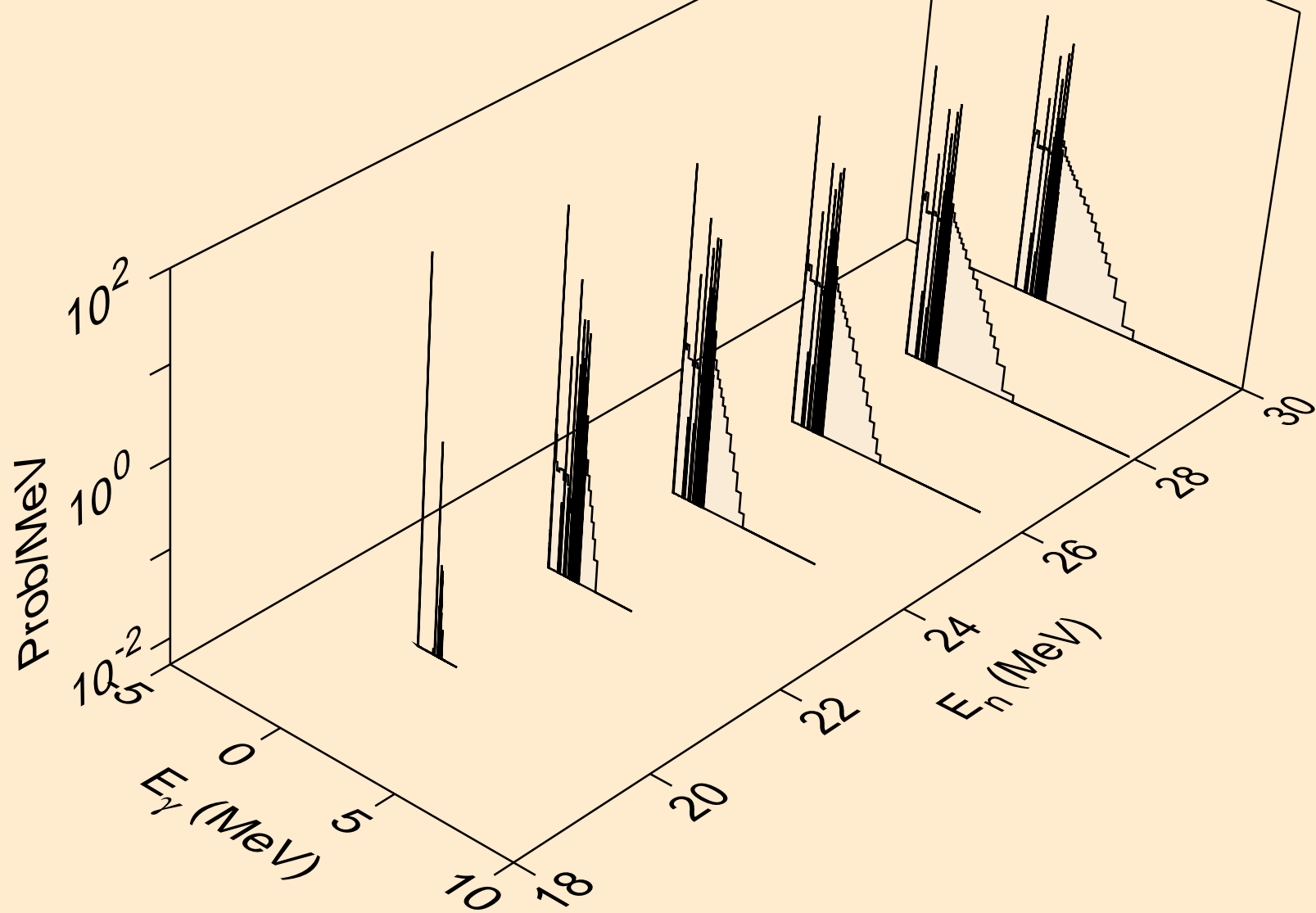

IN122 PROTON ACER TENDL-2023 LIBRARY; T=0.K  
Photon emission for (n,2np)

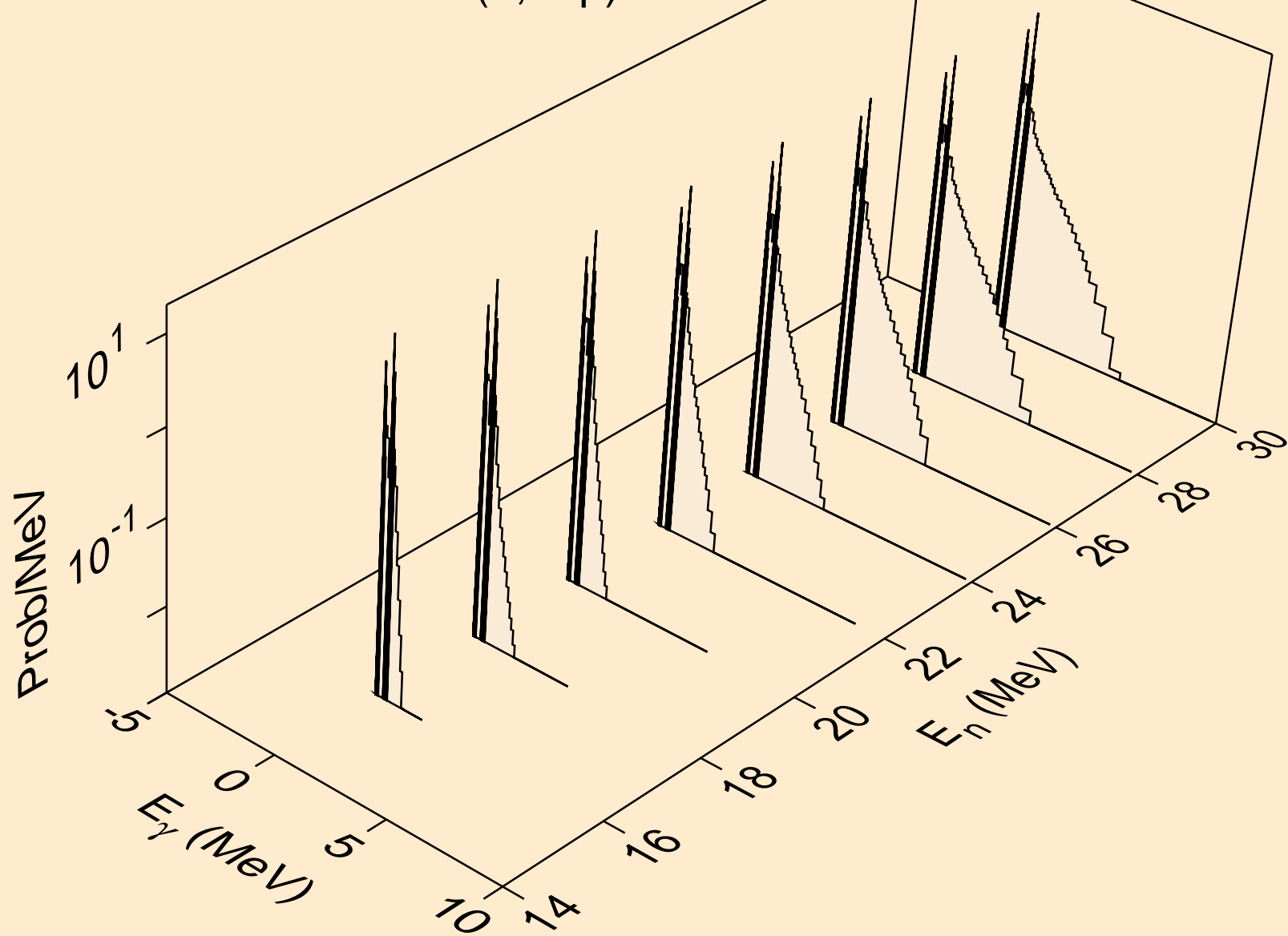

IN122 PROTON ACER TENDL-2023 LIBRARY; T=0.K  
Photon emission for (n,3np)

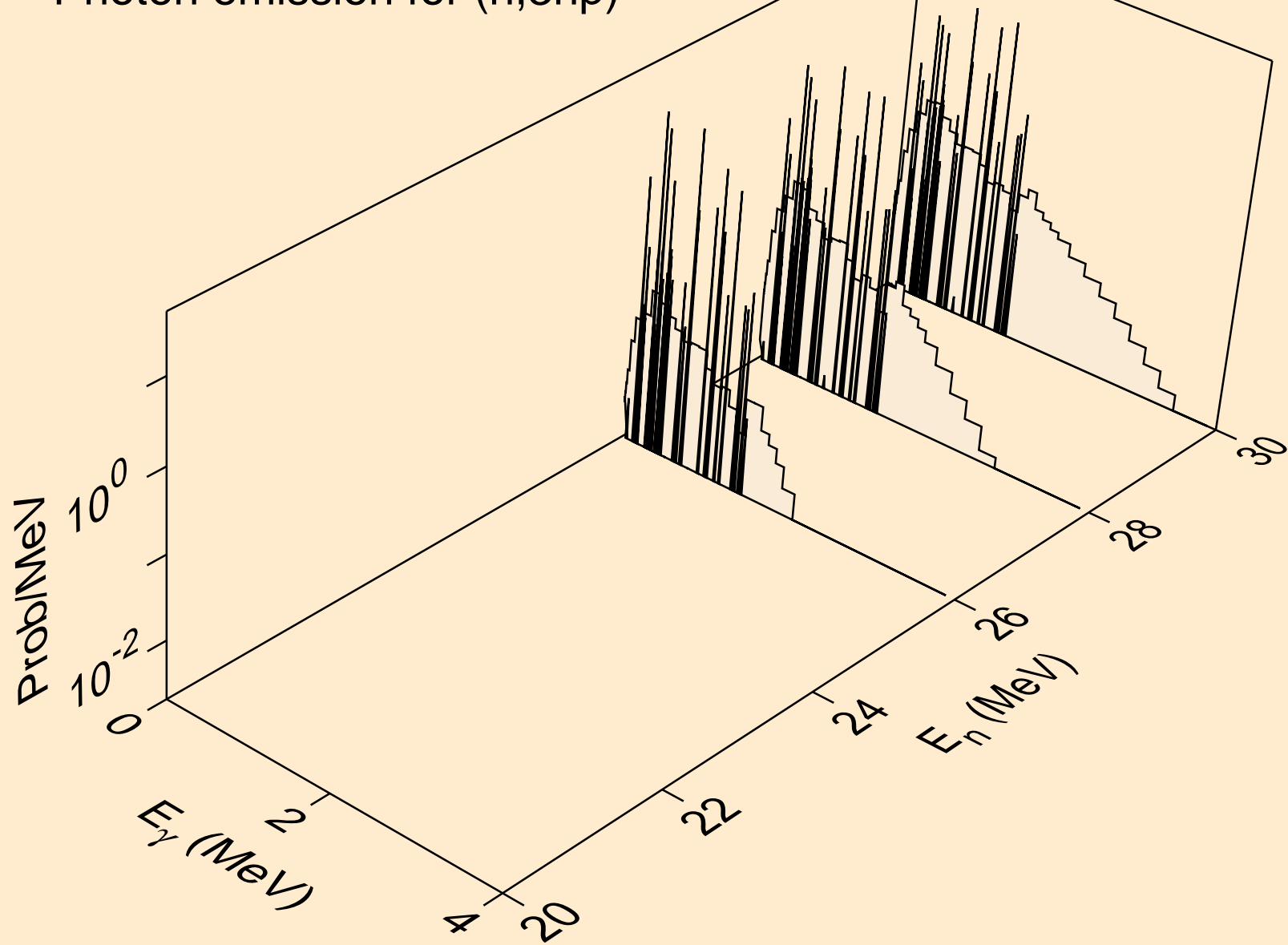

IN122 PROTON ACER TENDL-2023 LIBRARY; T=0.K  
Photon emission for (n,n2p)

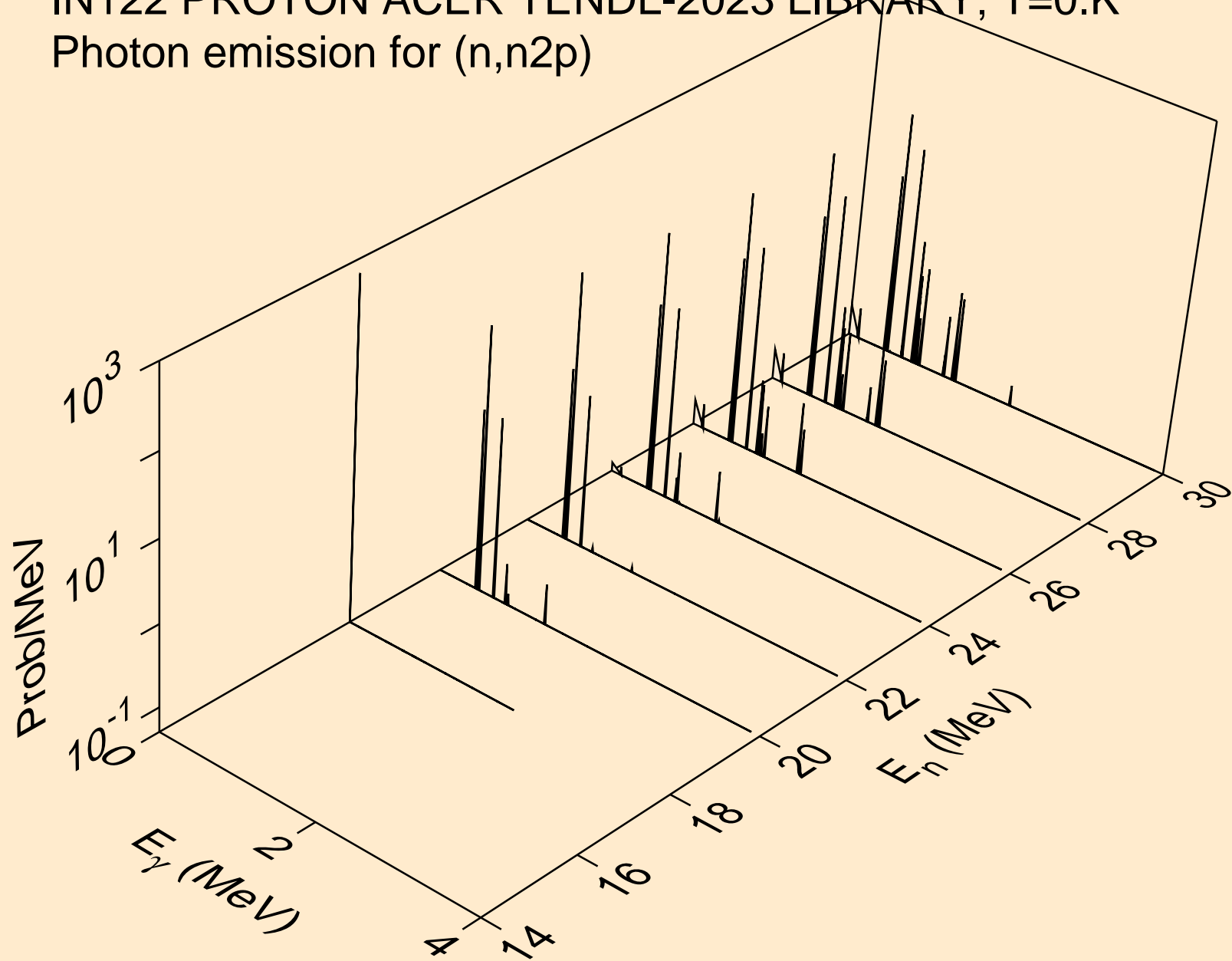

IN122 PROTON ACER TENDL-2023 LIBRARY; T=0.K  
Photon emission for (n,npa)

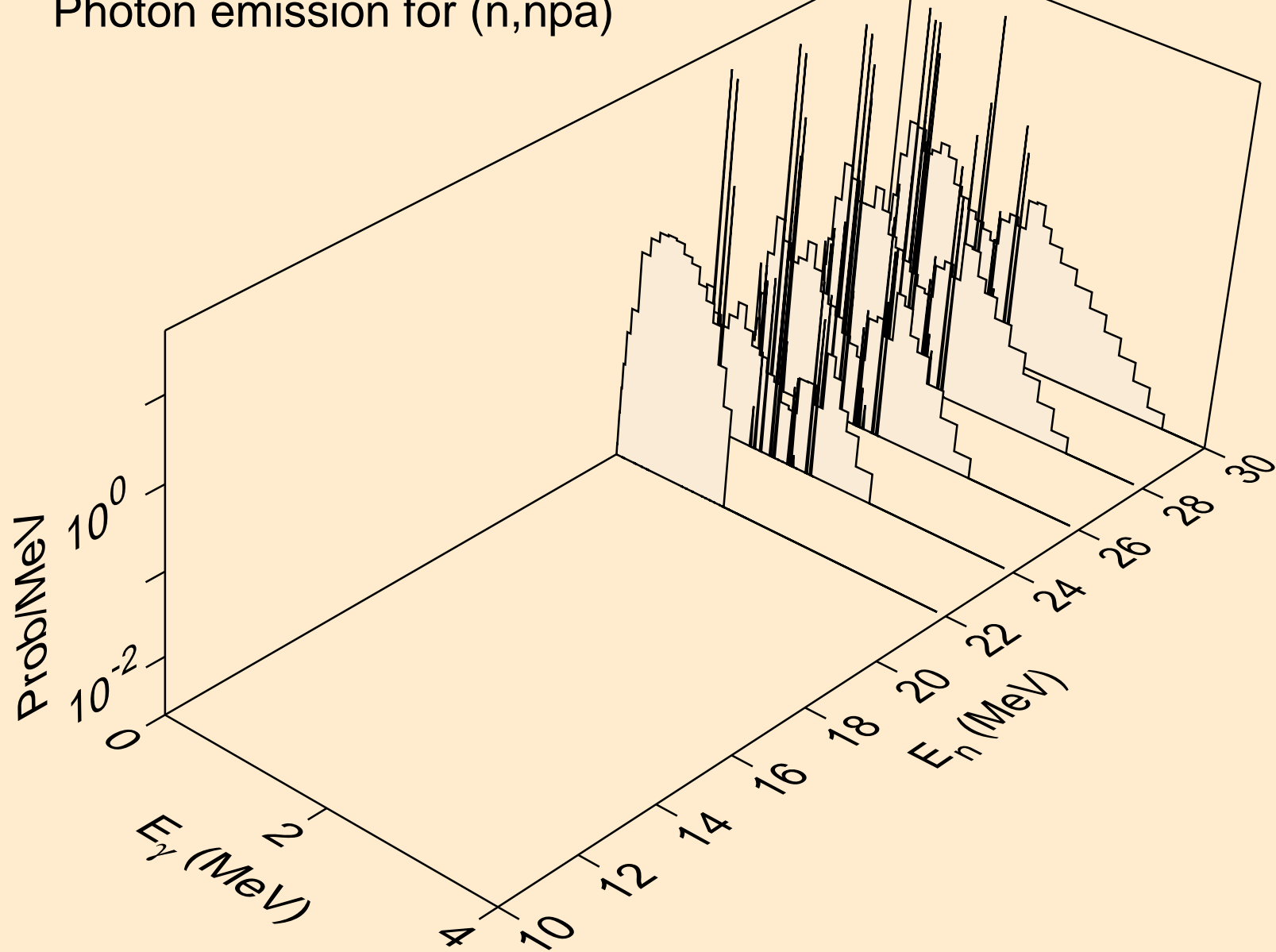

IN122 PROTON ACER TENDL-2023 LIBRARY; T=0.K  
Photon emission for (n,gma)

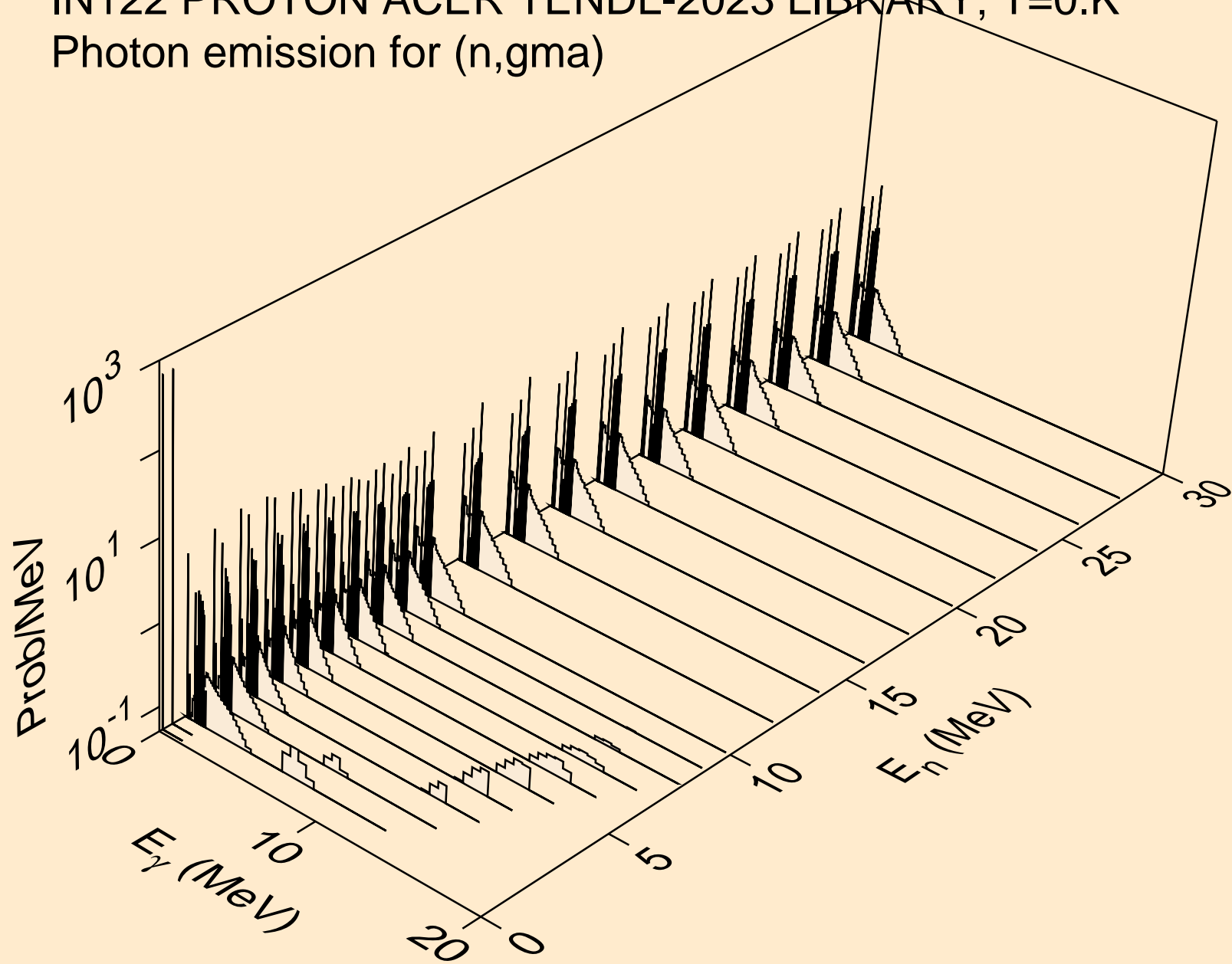

IN122 PROTON ACER TENDL-2023 LIBRARY; T=0.K  
Photon emission for inelastic

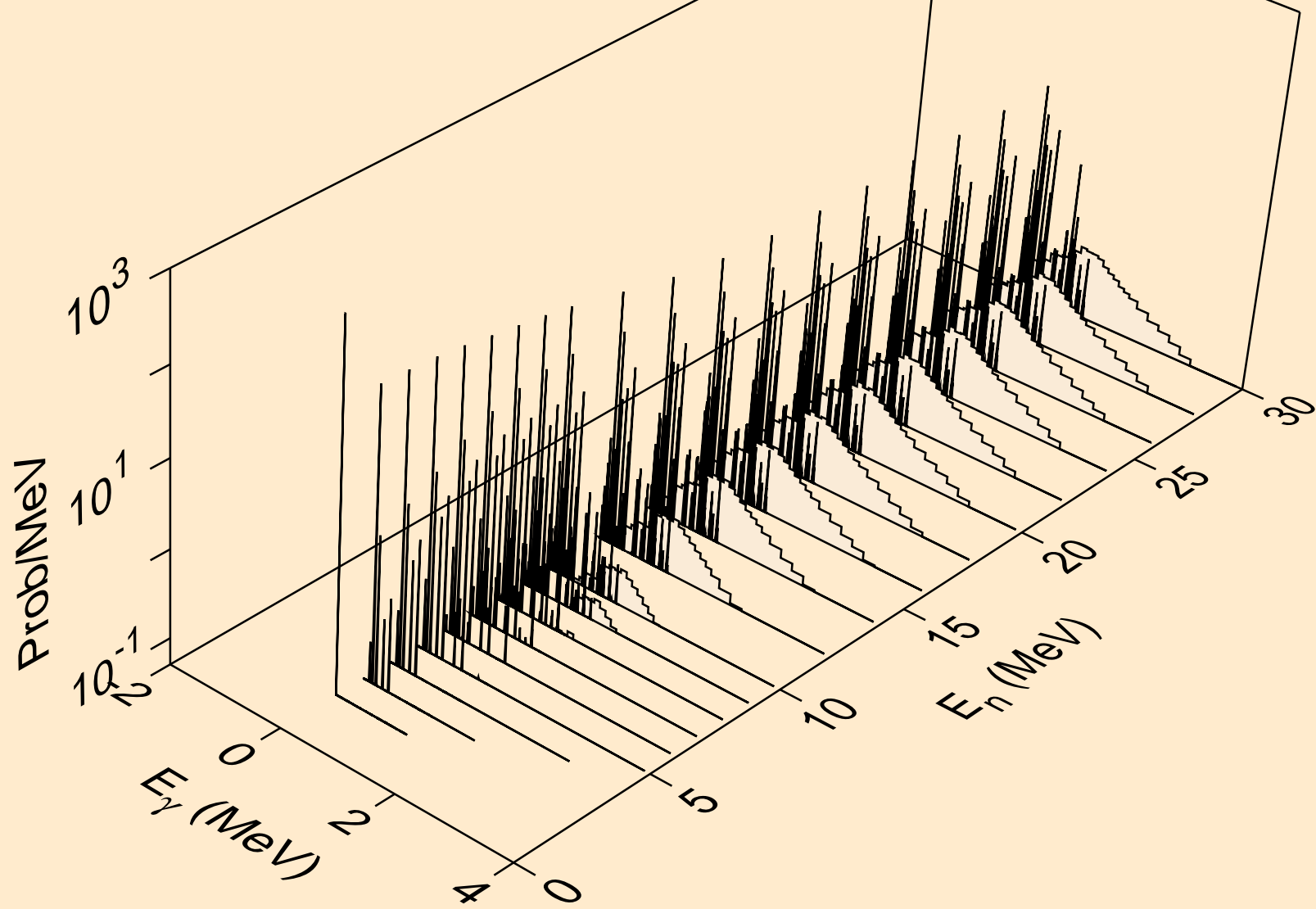

IN122 PROTON ACER TENDL-2023 LIBRARY; T=0.K  
Photon emission for (n,d)

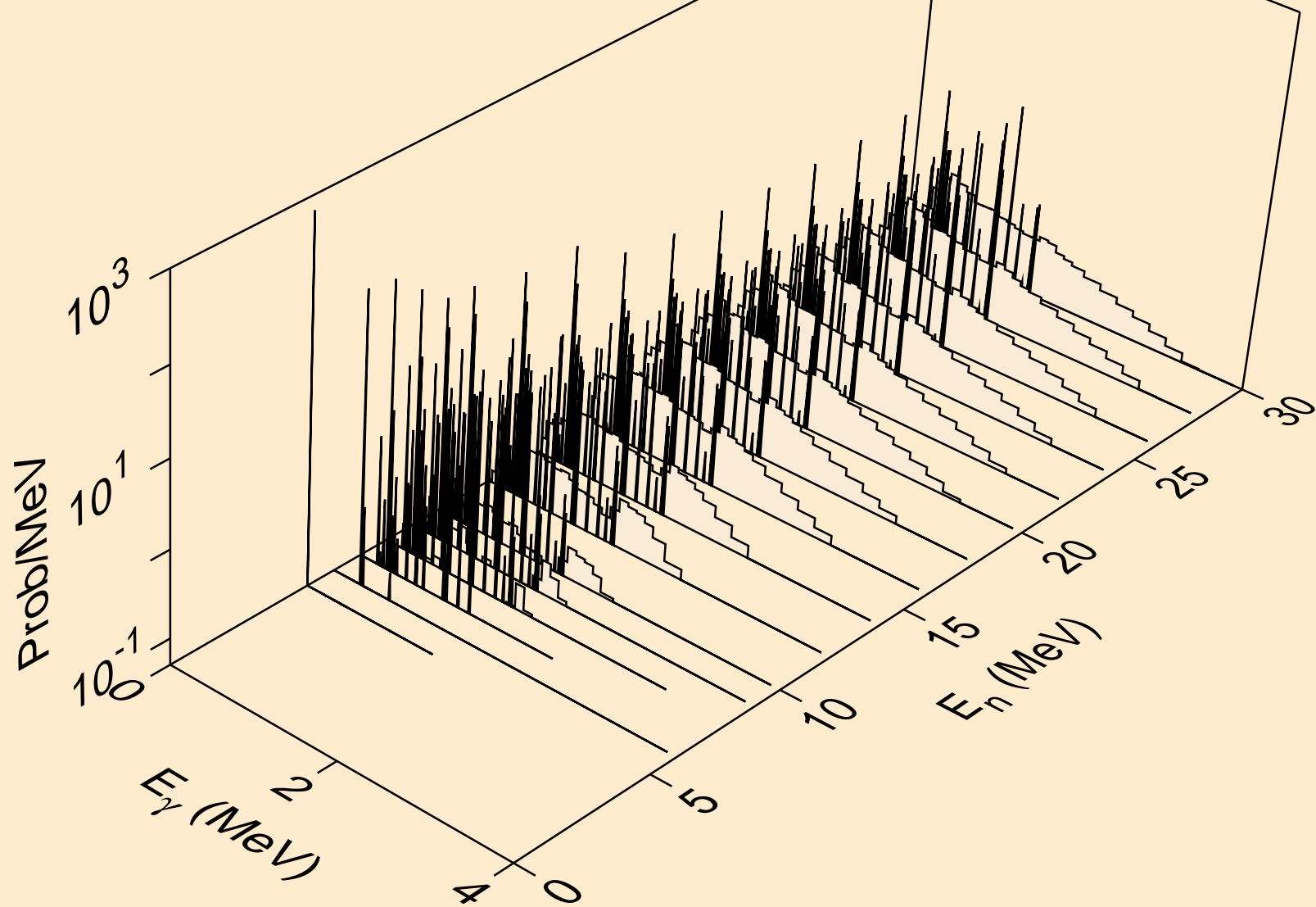



IN122 PROTON ACER TENDL-2023 LIBRARY; T=0.K  
Photon emission for (n,t)

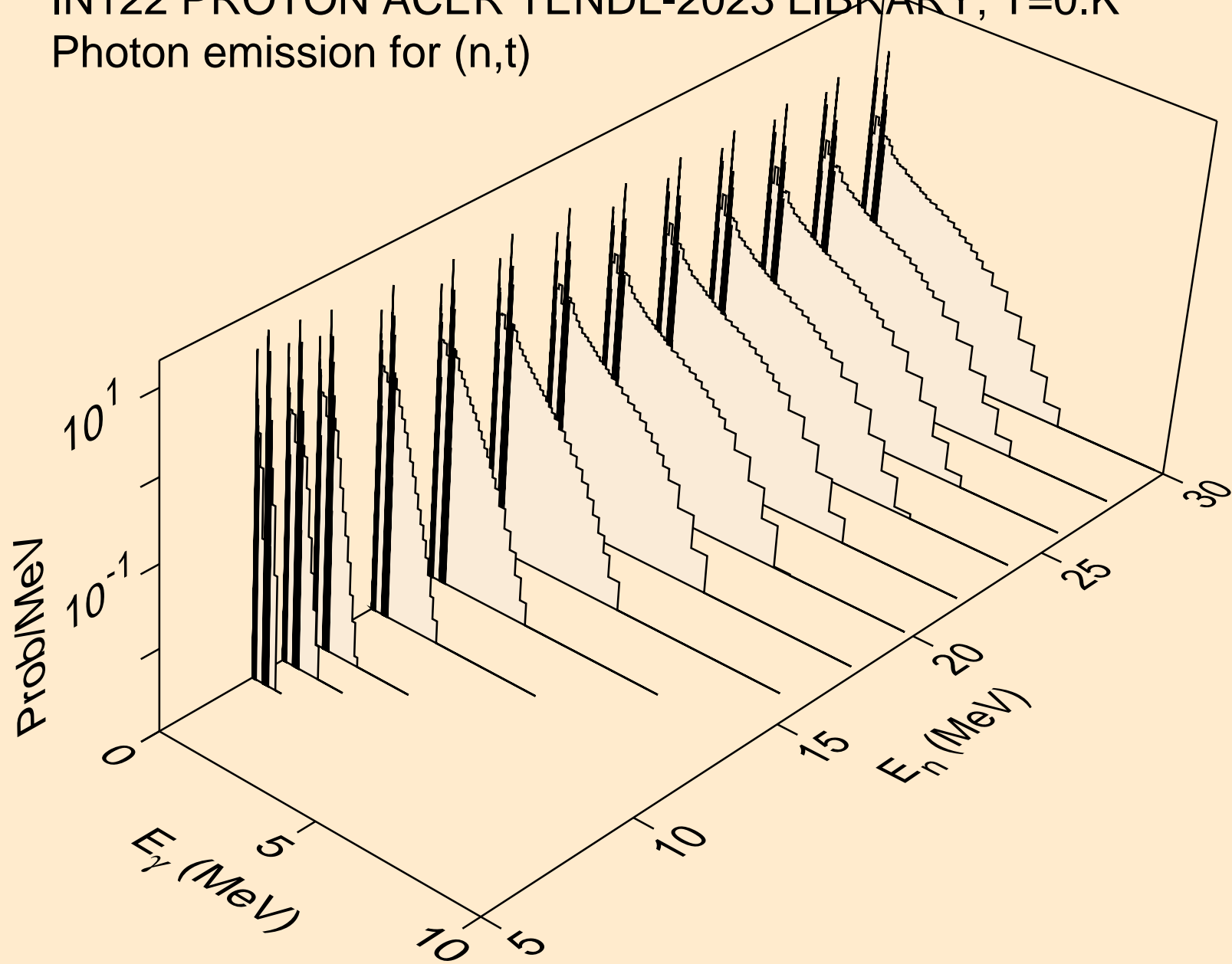

IN122 PROTON ACER TENDL-2023 LIBRARY; T=0.K  
Photon emission for (n,he3)

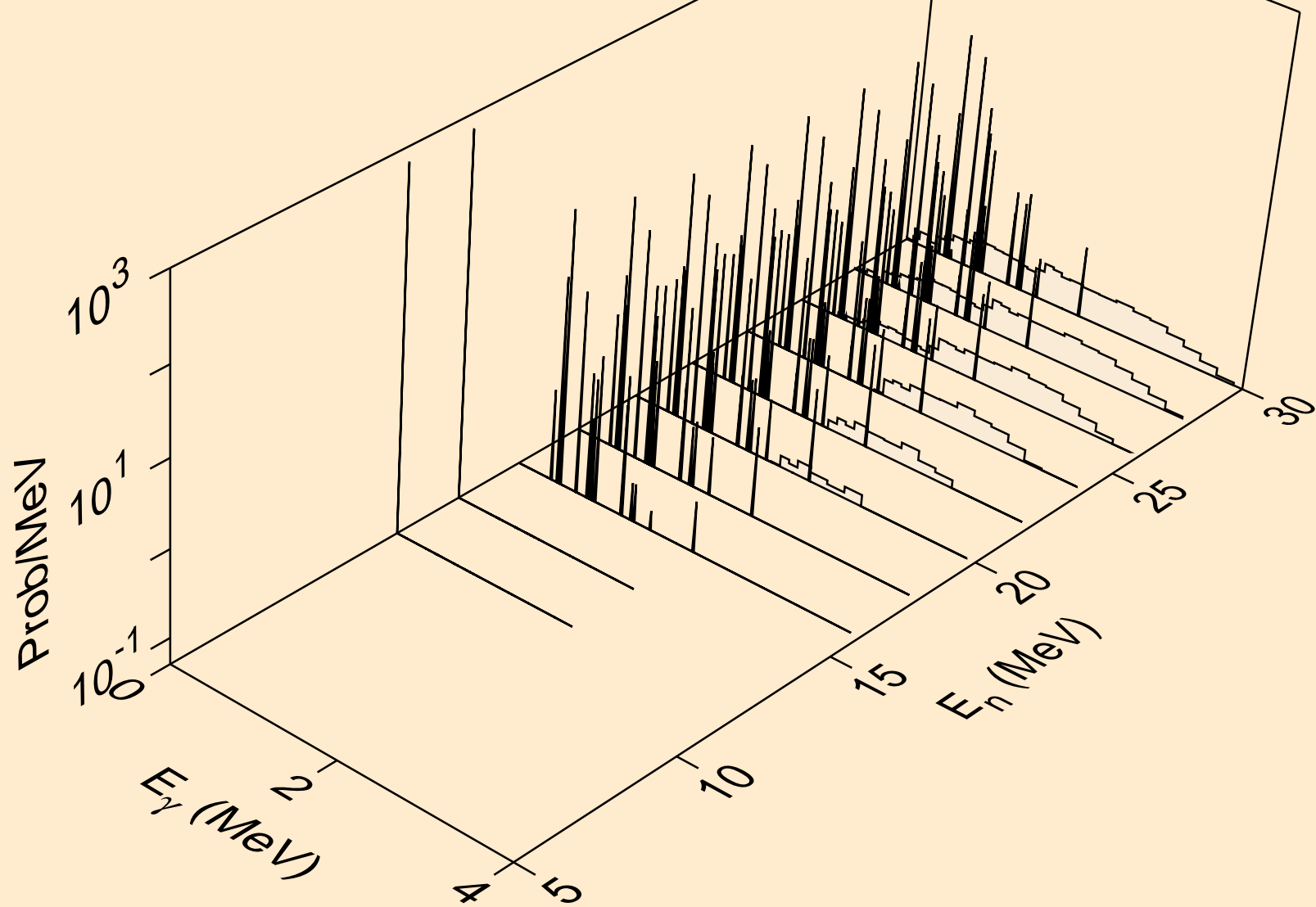

IN122 PROTON ACER TENDL-2023 LIBRARY; T=0.K  
Photon emission for (n,a)

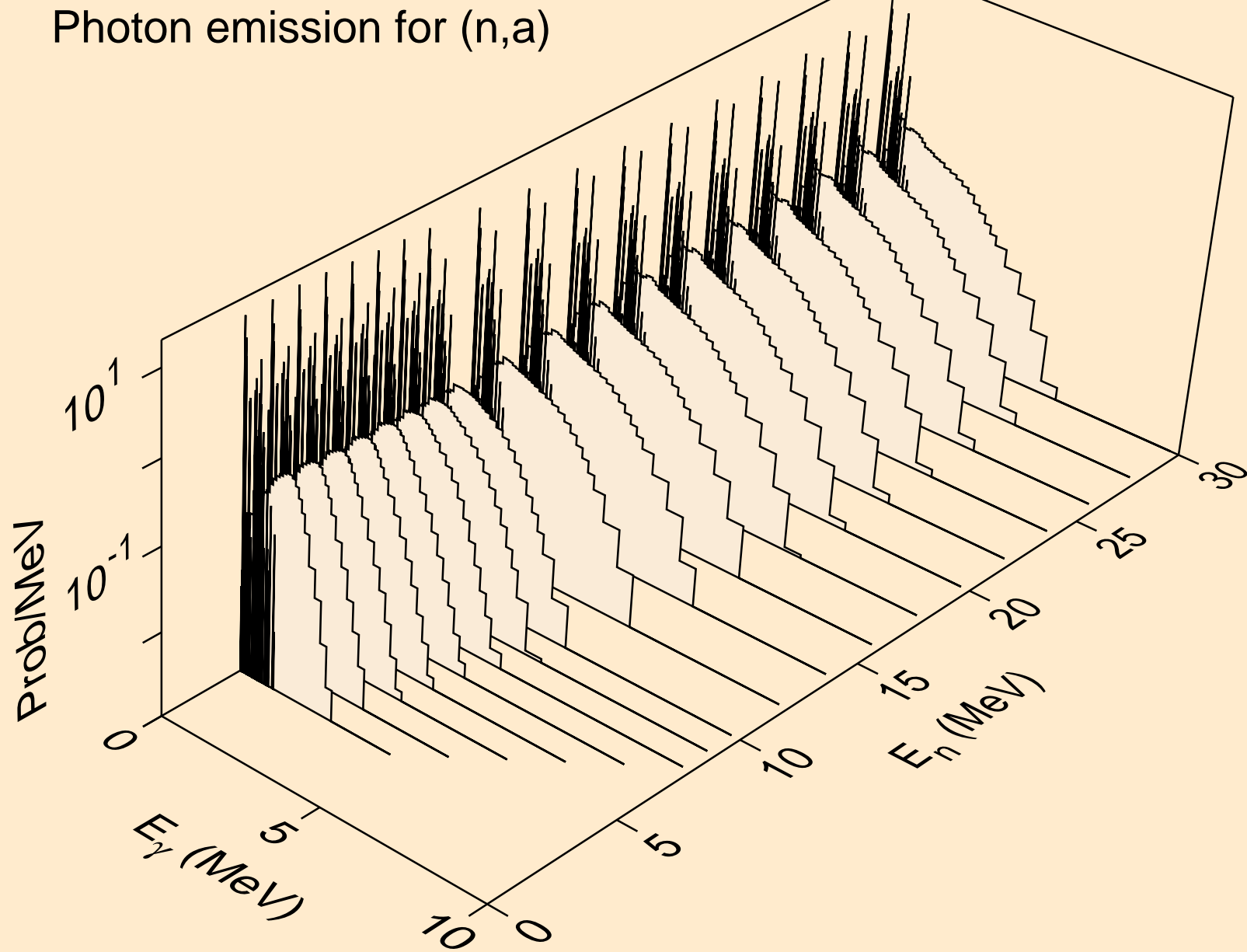

IN122 PROTON ACER TENDL-2023 LIBRARY; T=0.K  
Photon emission for (n,2a)

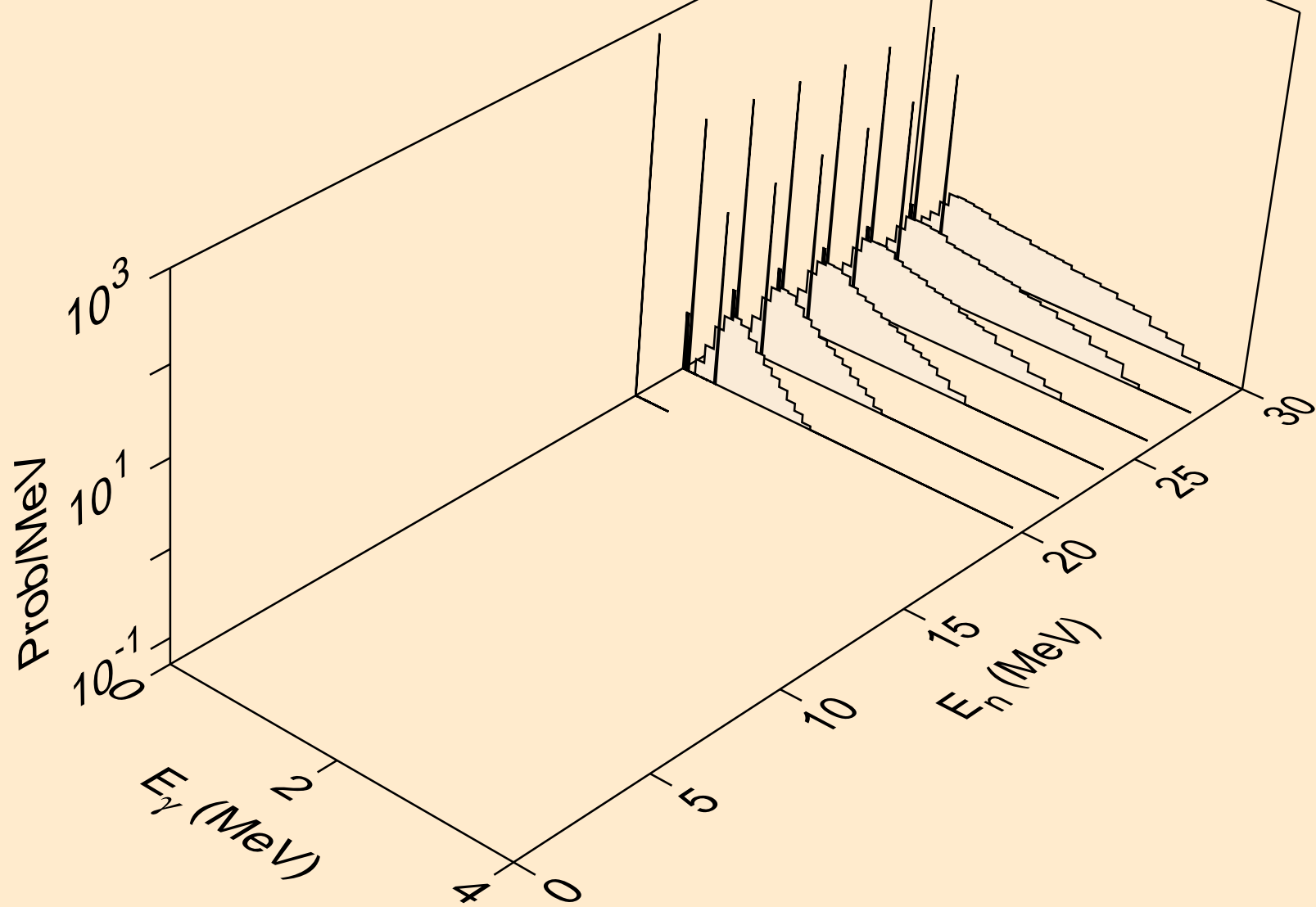

IN122 PROTON ACER TENDL-2023 LIBRARY; T=0.K  
Photon emission for (n,2p)

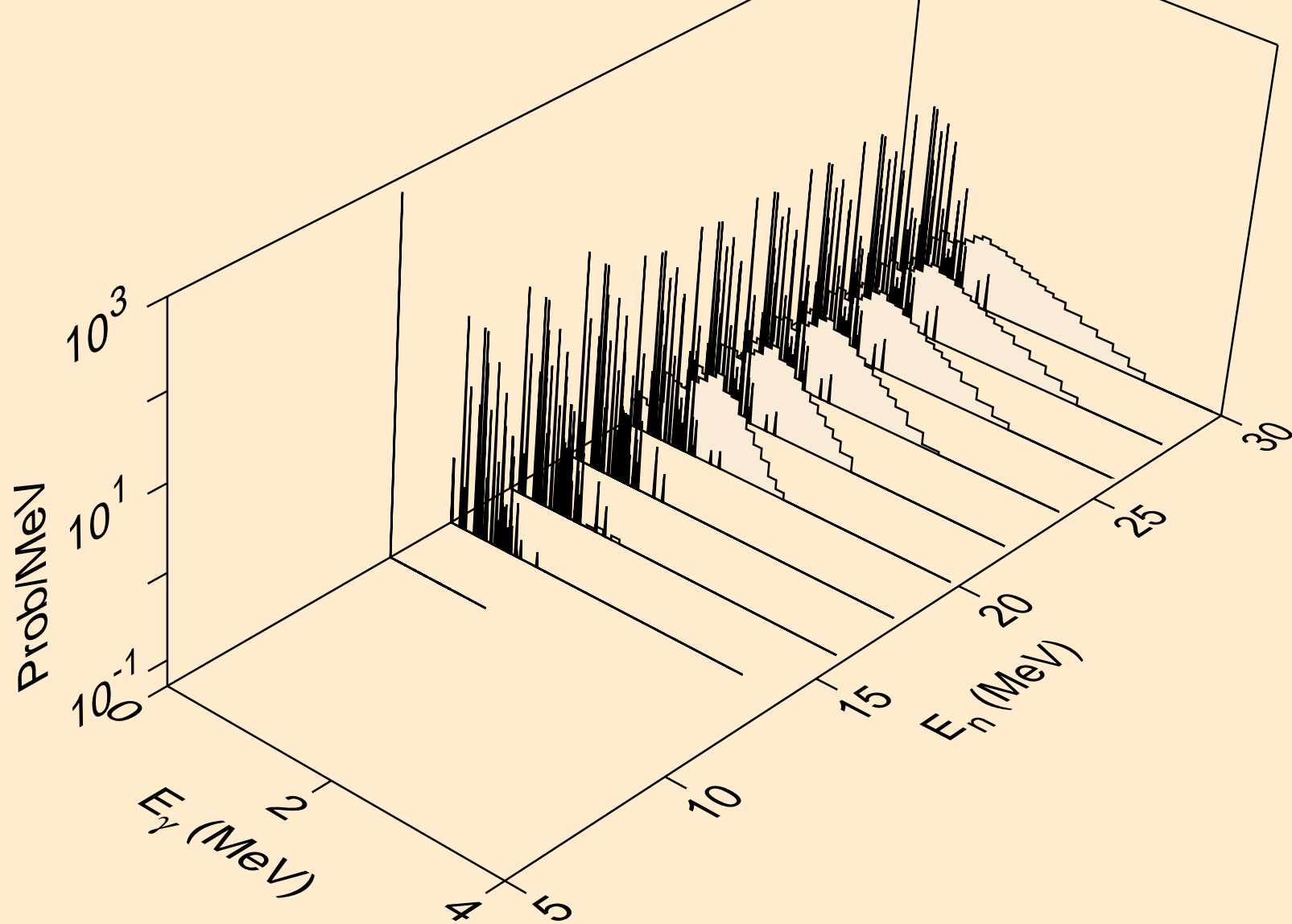

IN122 PROTON ACER TENDL-2023 LIBRARY; T=0.K  
Photon emission for (n,pa)

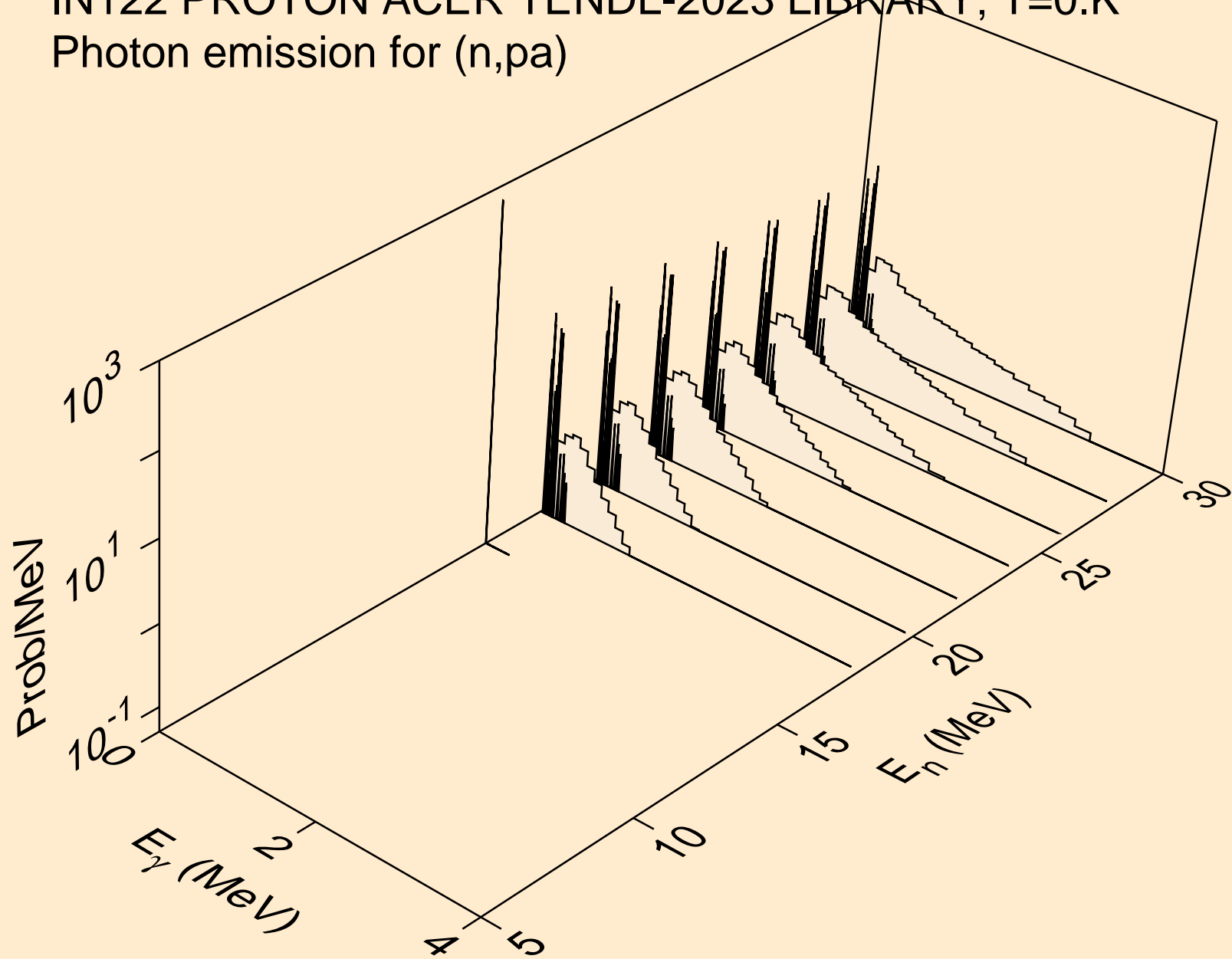

IN122 PROTON ACER TENDL-2023 LIBRARY; T=0.K  
Photon emission for (n,pd)

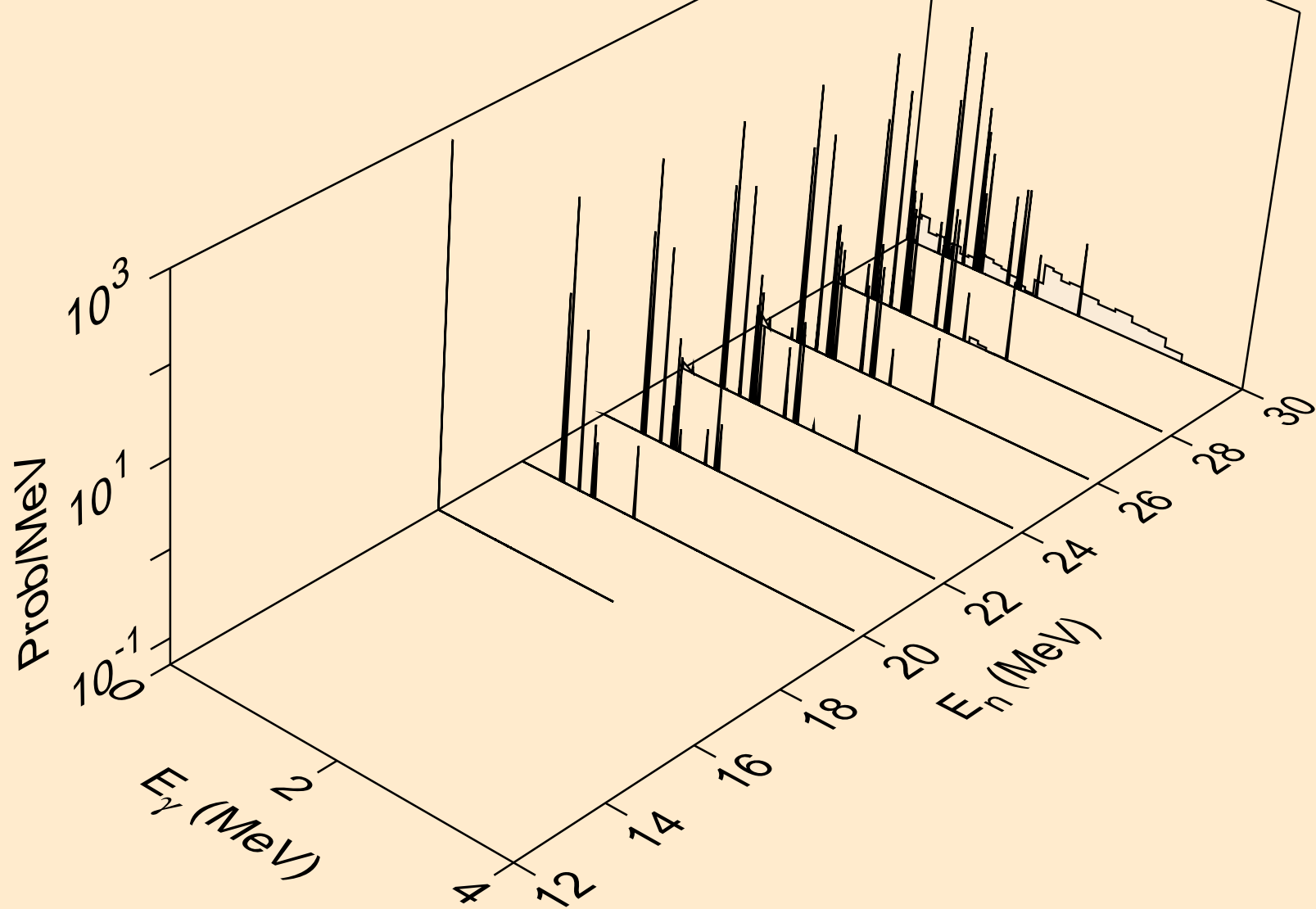

IN122 PROTON ACER TENDL-2023 LIBRARY; T=0.K  
Photon emission for (n,pt)

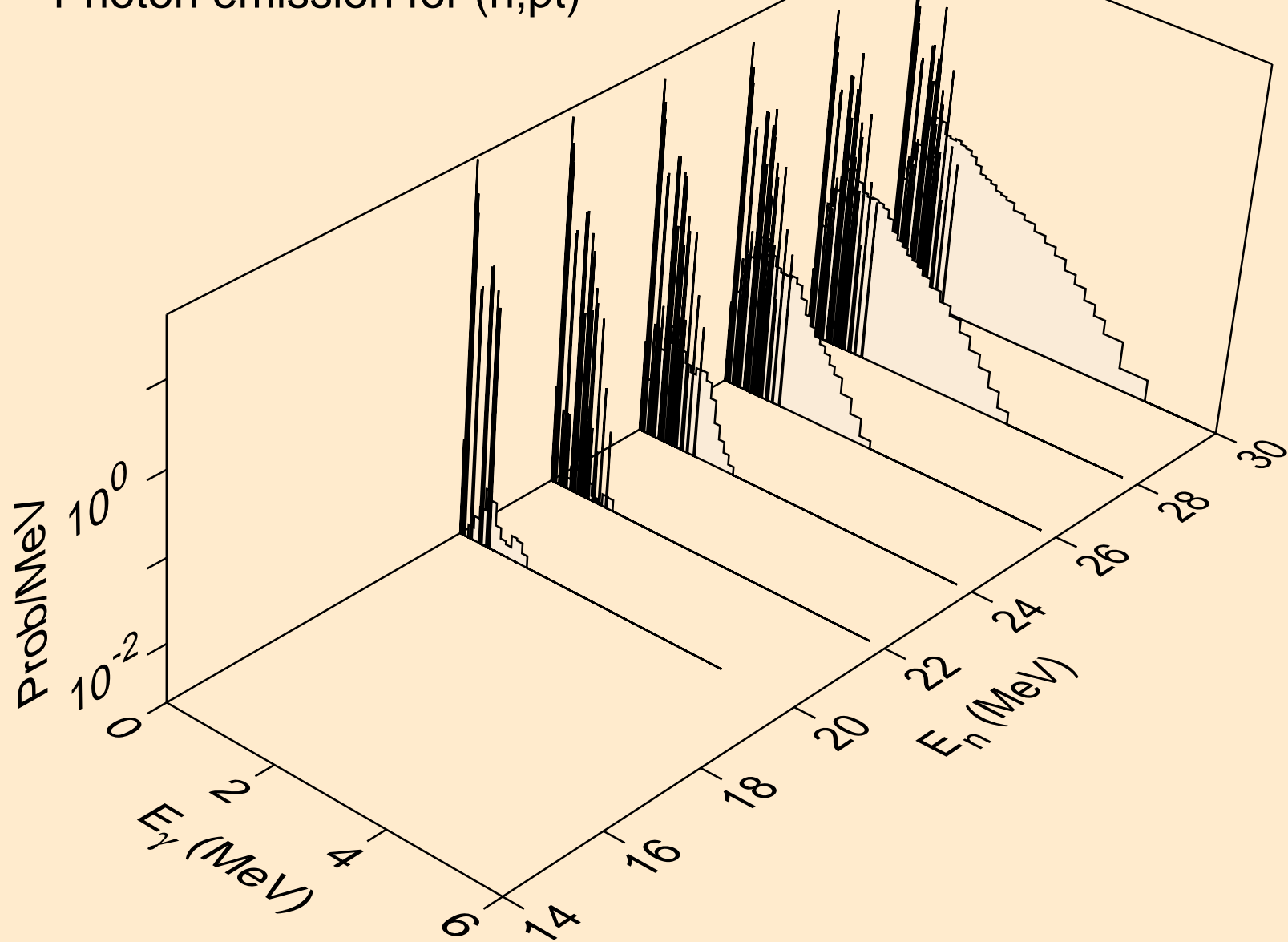



IN122 PROTON ACER TENDL-2023 LIBRARY; T=0.K  
Particle heating contributions

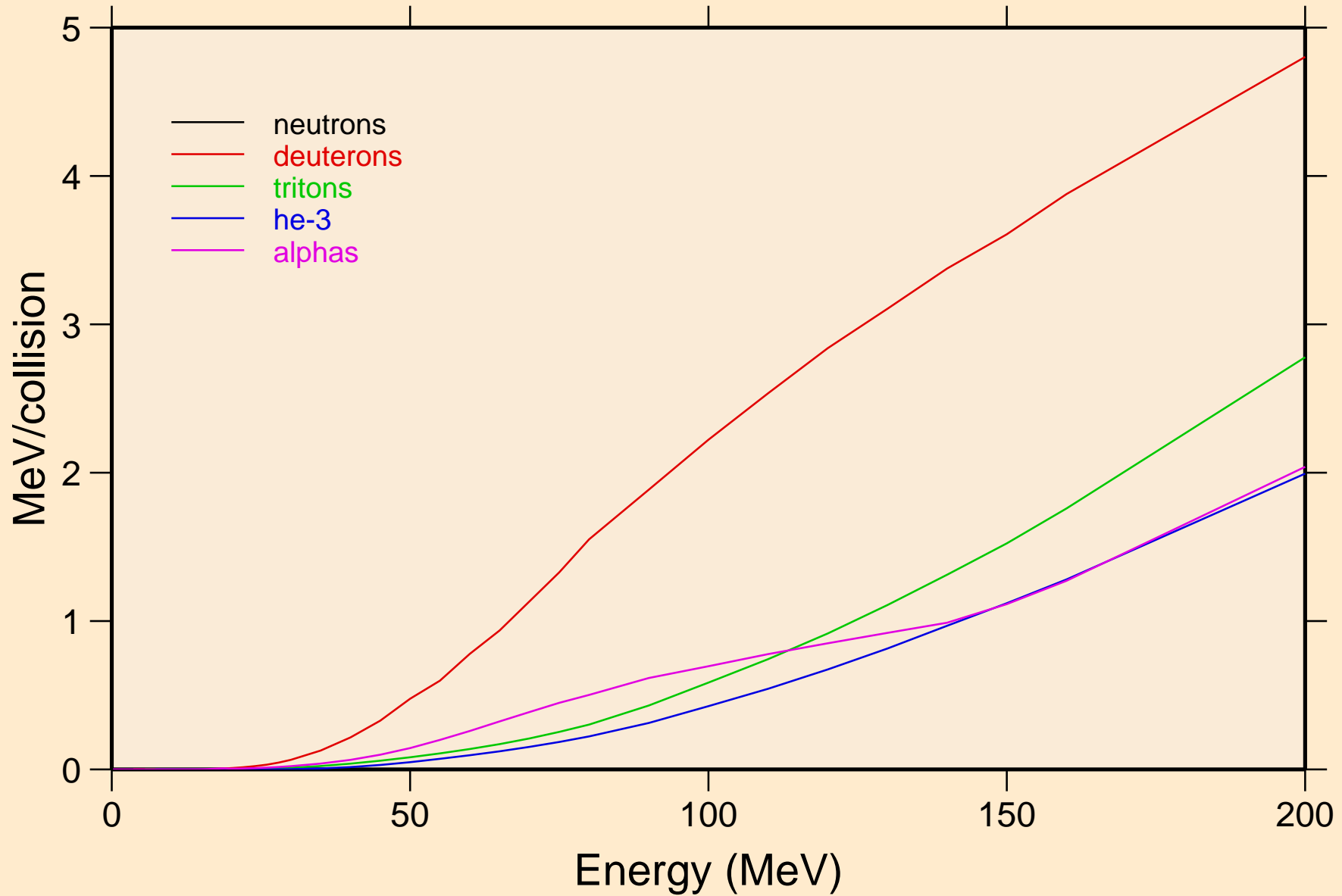

# IN122 PROTON ACER TENDL-2023 LIBRARY; T=0.K

## Recoil Heating

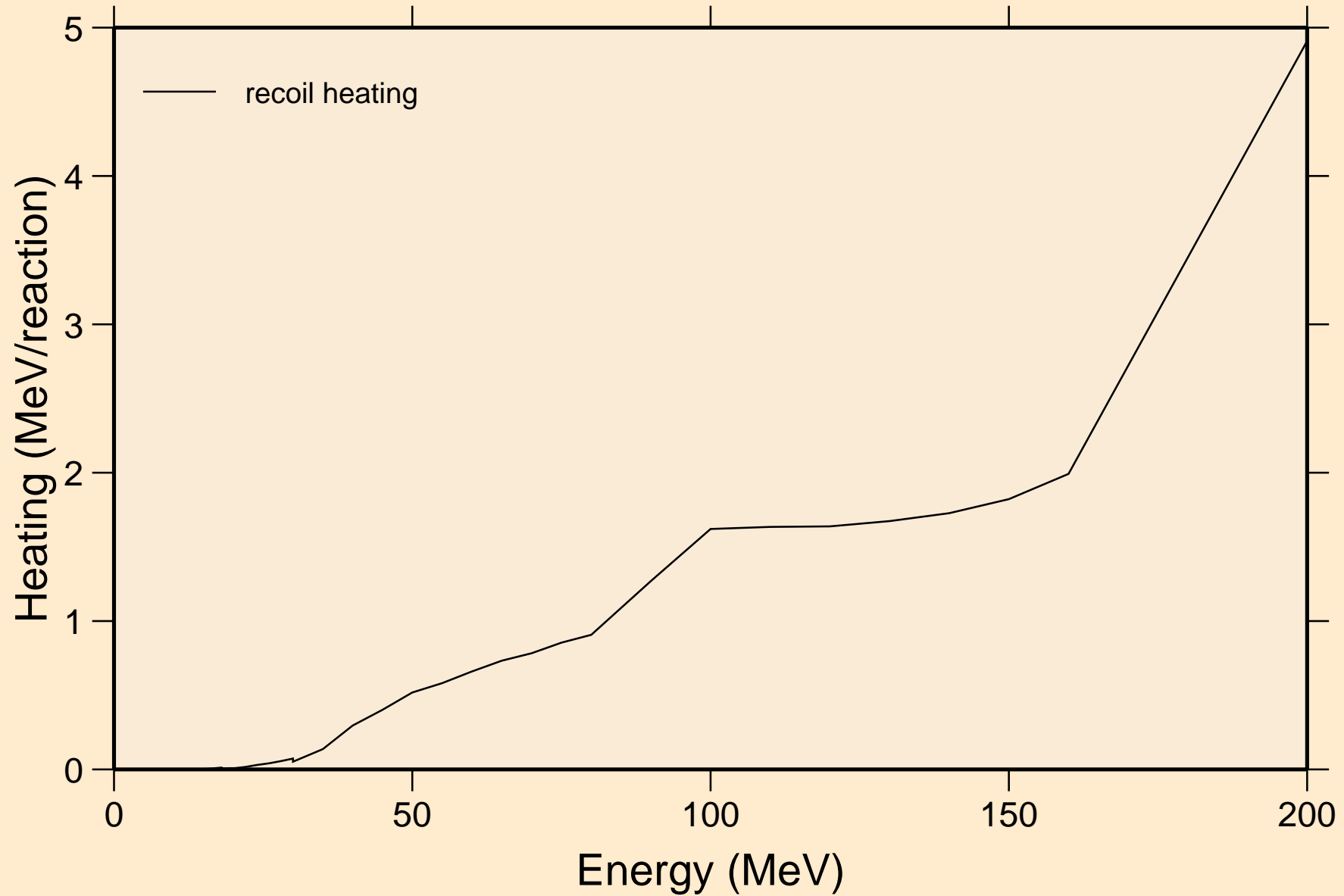

IN122 PROTON ACER TENDL-2023 LIBRARY; T=0.K  
Particle production cross sections

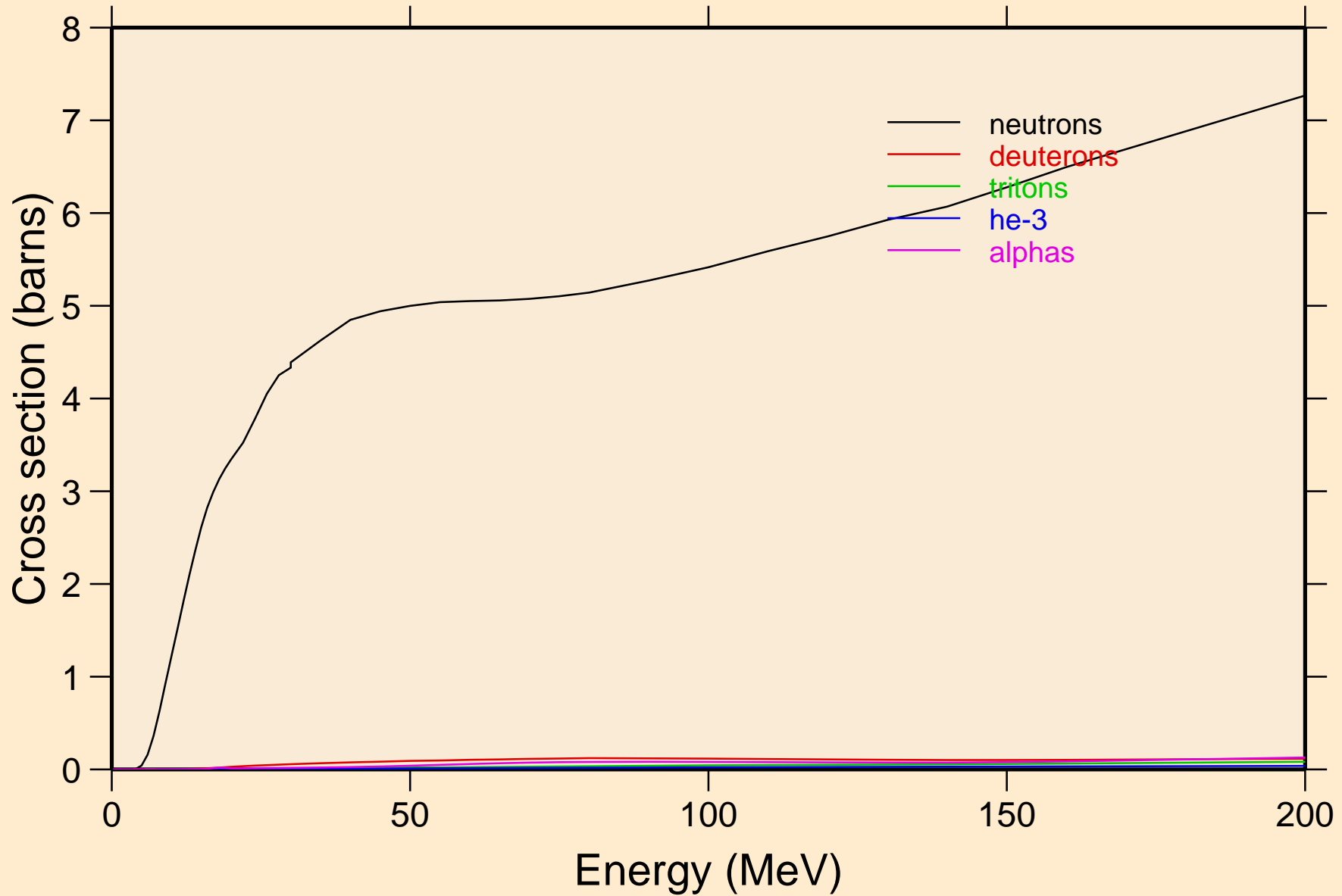

IN122 PROTON ACER TENDL-2023 LIBRARY; T=0.K  
neutrons from (p,n)

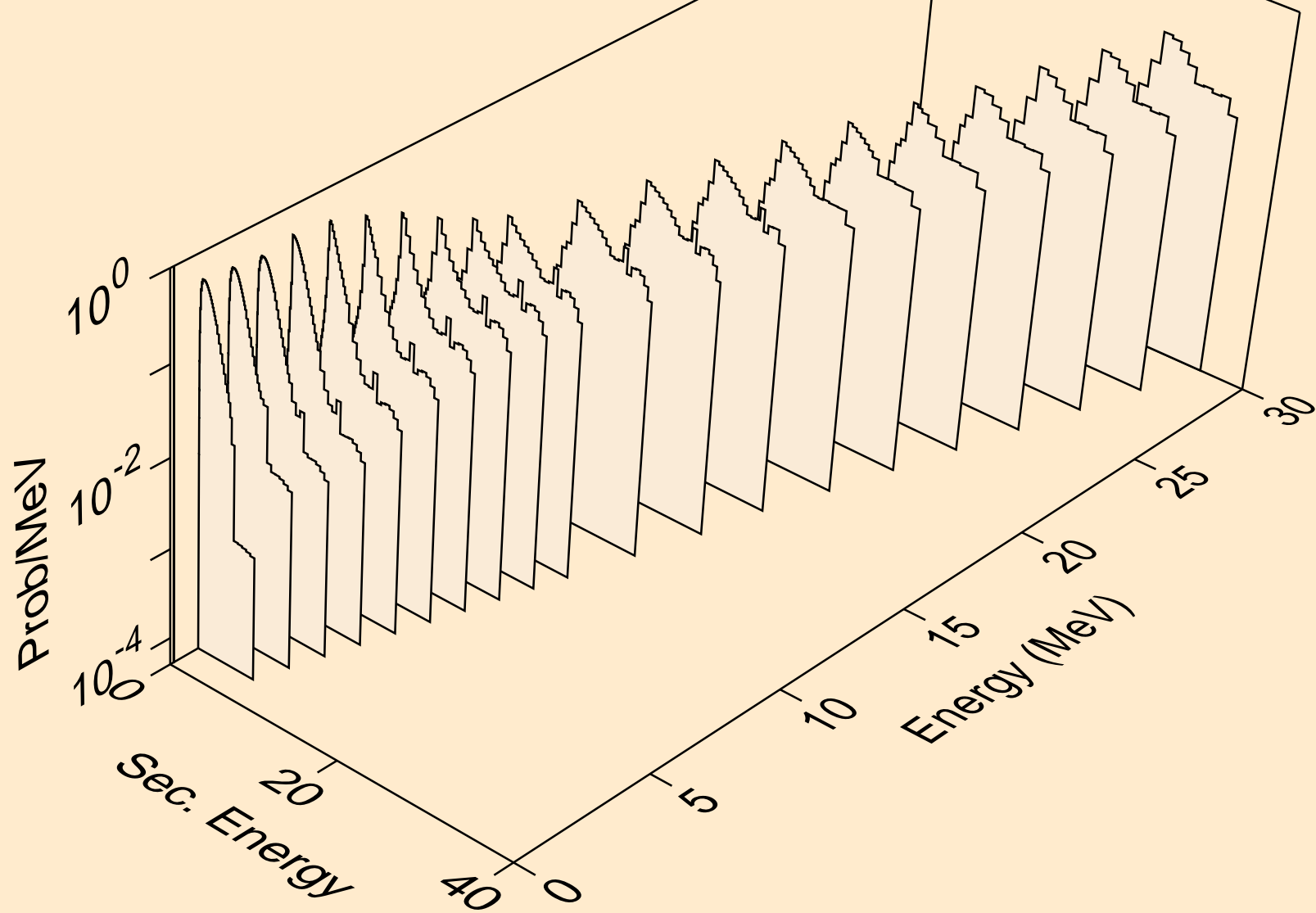

IN122 PROTON ACER TENDL-2023 LIBRARY; T=0.K  
neutrons from (p,x)

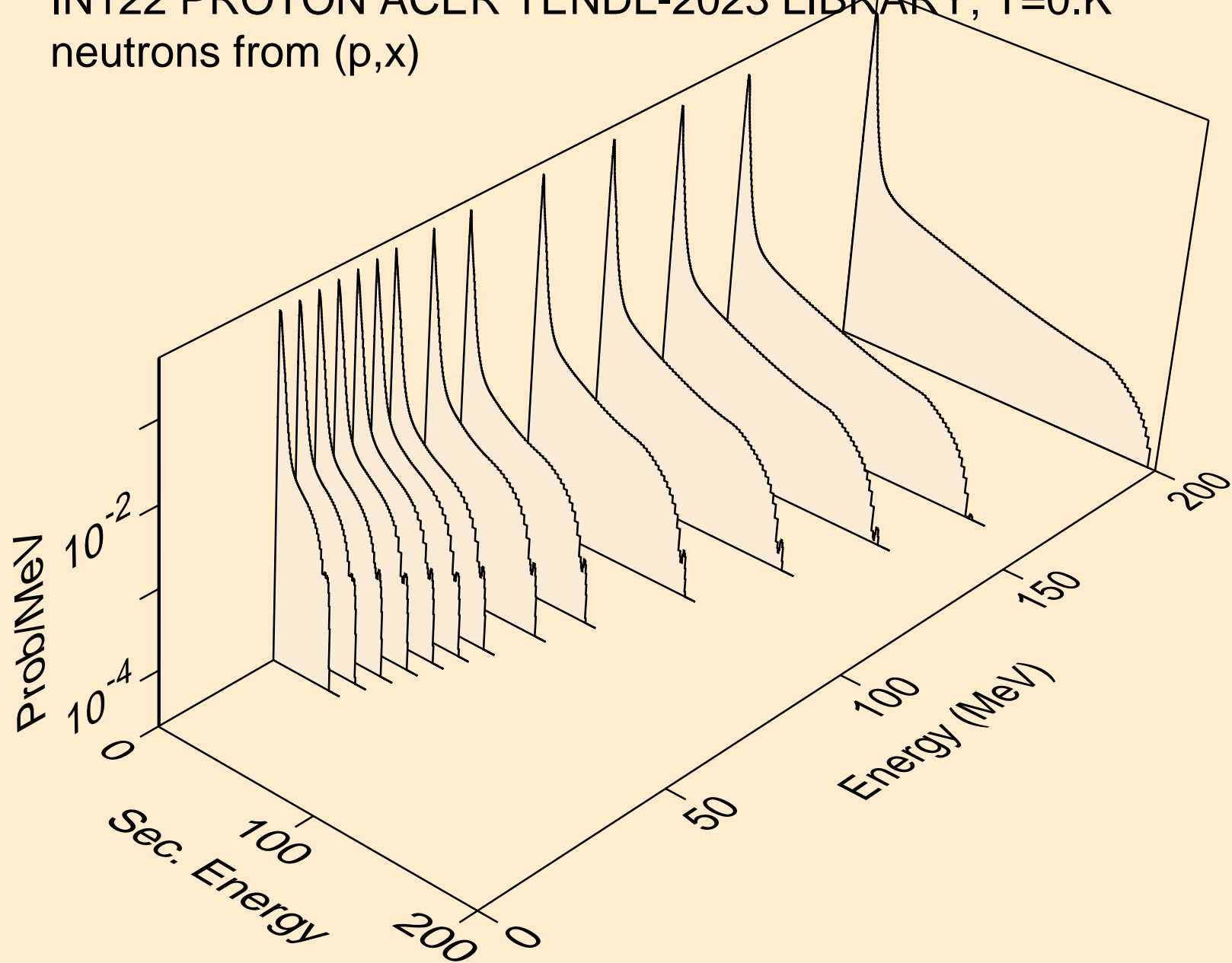

IN122 PROTON ACER TENDL-2023 LIBRARY; T=0.K  
neutrons from (p,2nd)

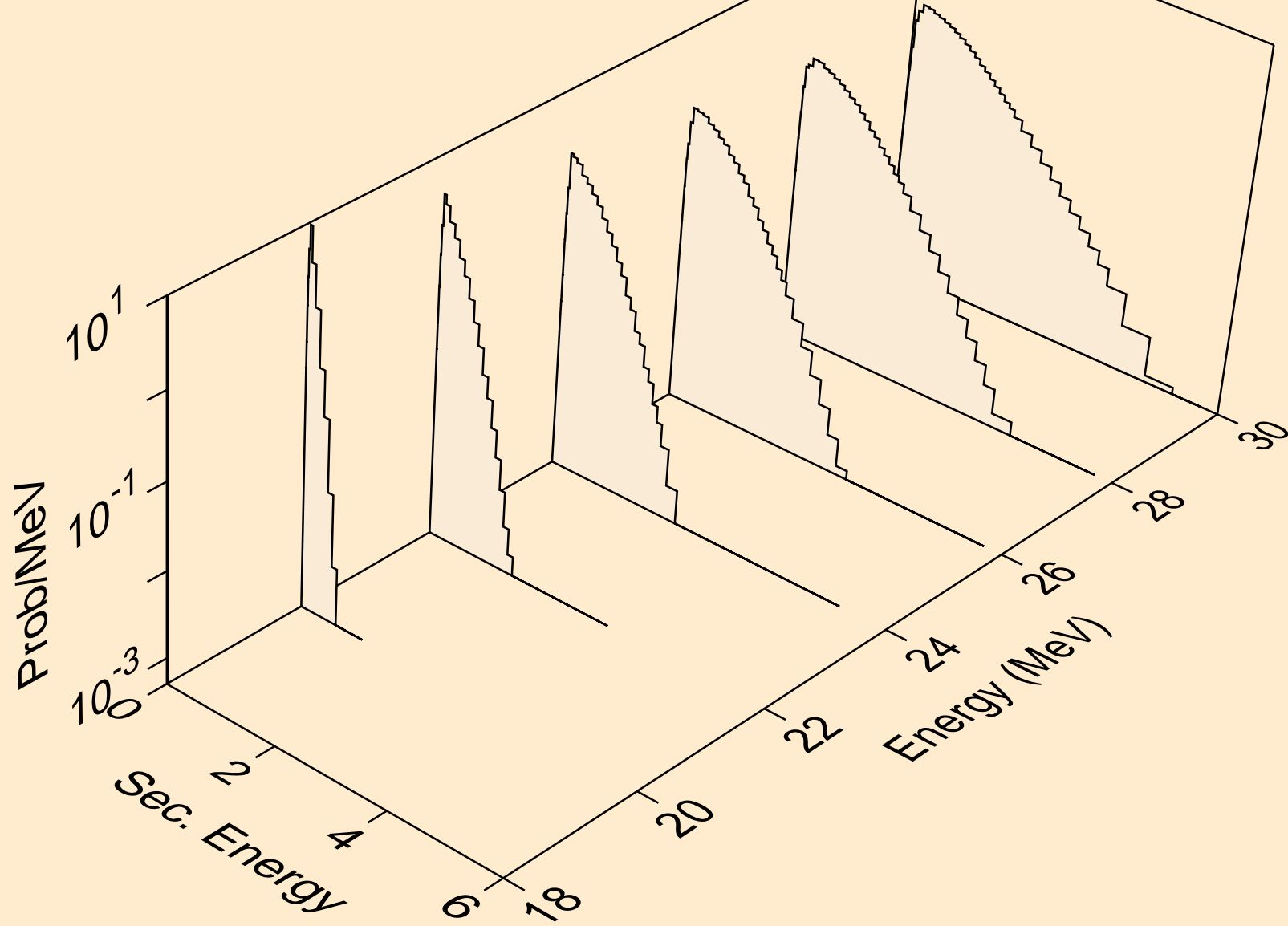

IN122 PROTON ACER TENDL-2023 LIBRARY; T=0.K  
neutrons from (p,2n)

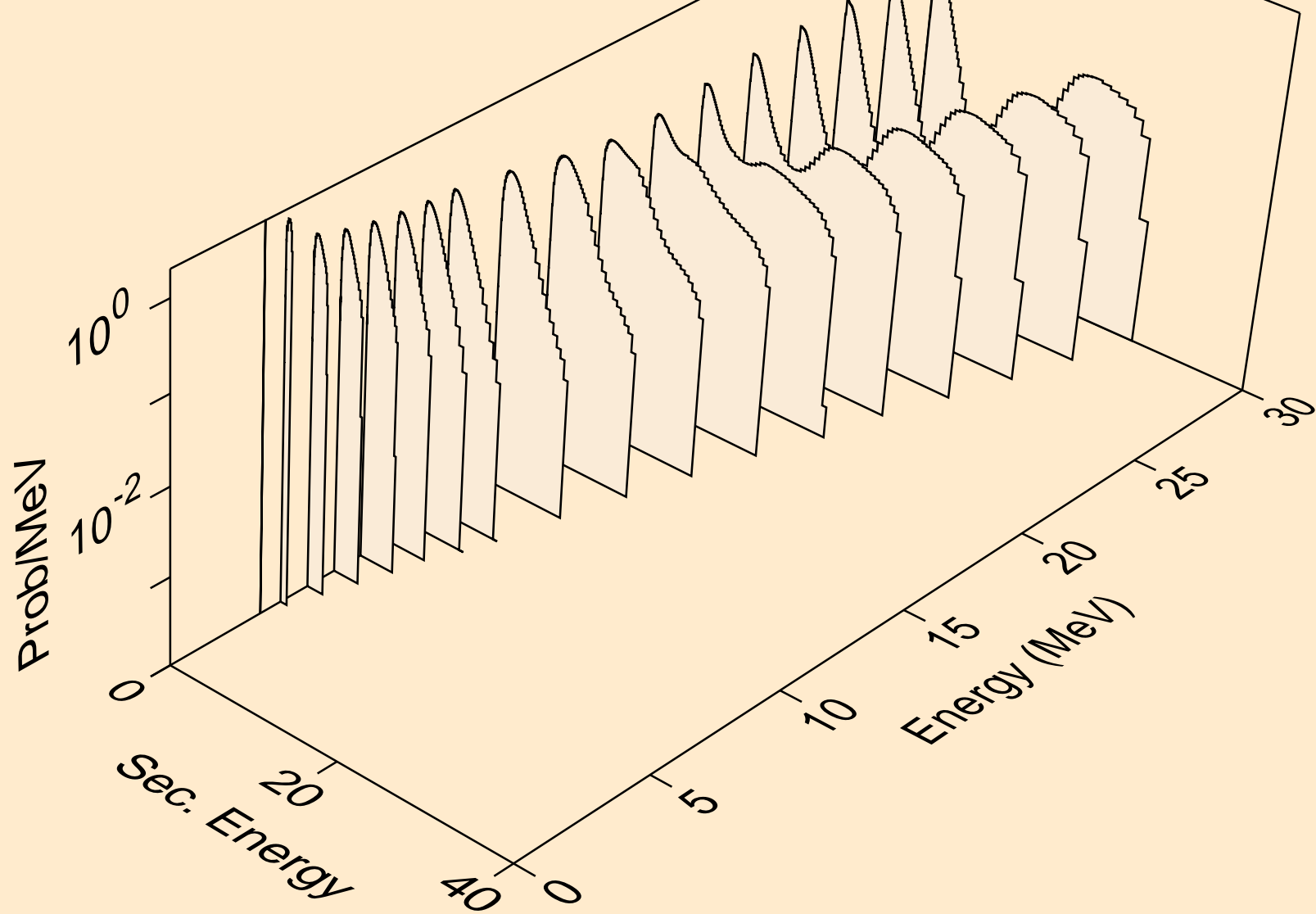

IN122 PROTON ACER TENDL-2023 LIBRARY; T=0.K  
neutrons from (p,3n)

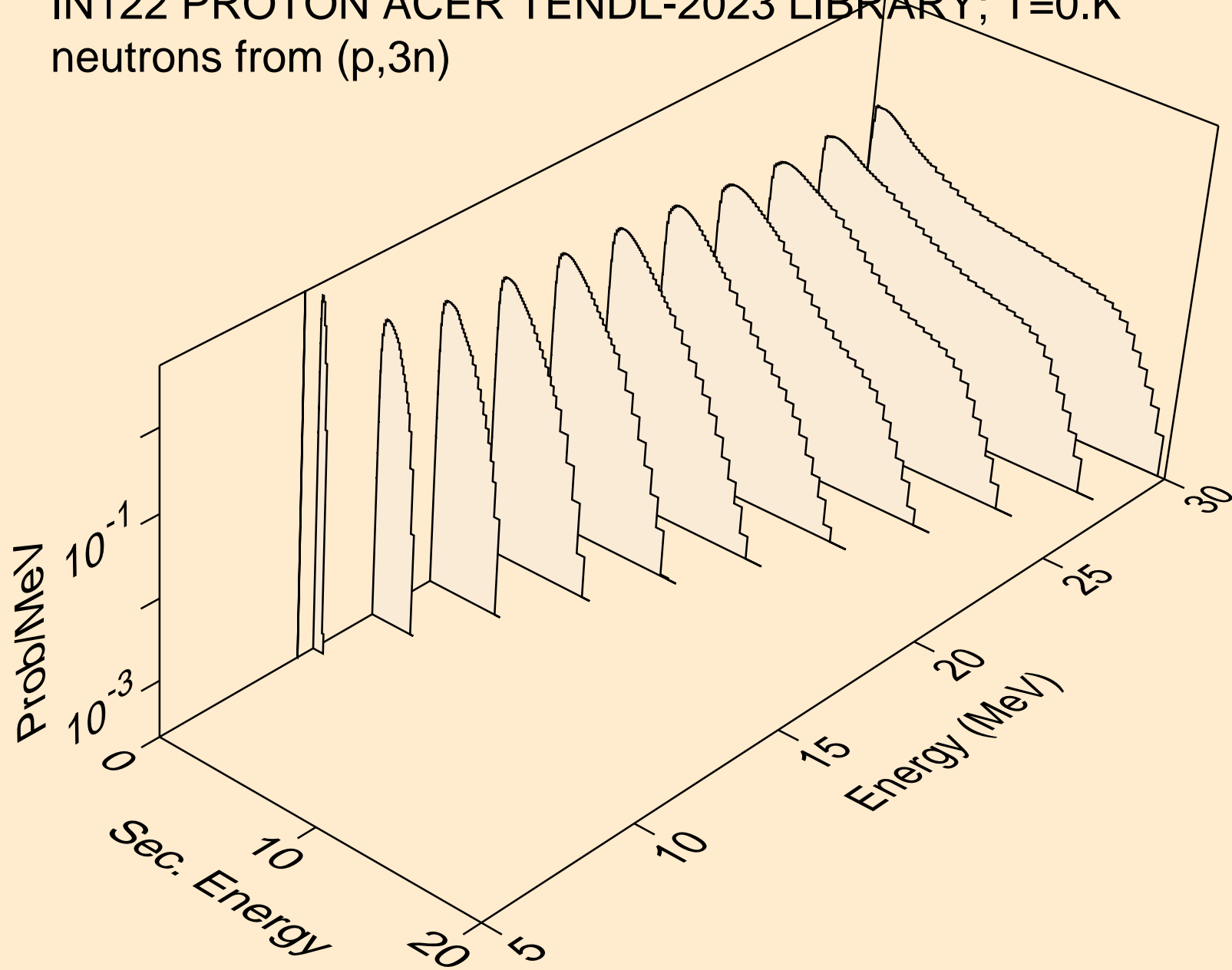



IN122 PROTON ACER TENDL-2023 LIBRARY; T=0.K  
neutrons from (p,n\*)a

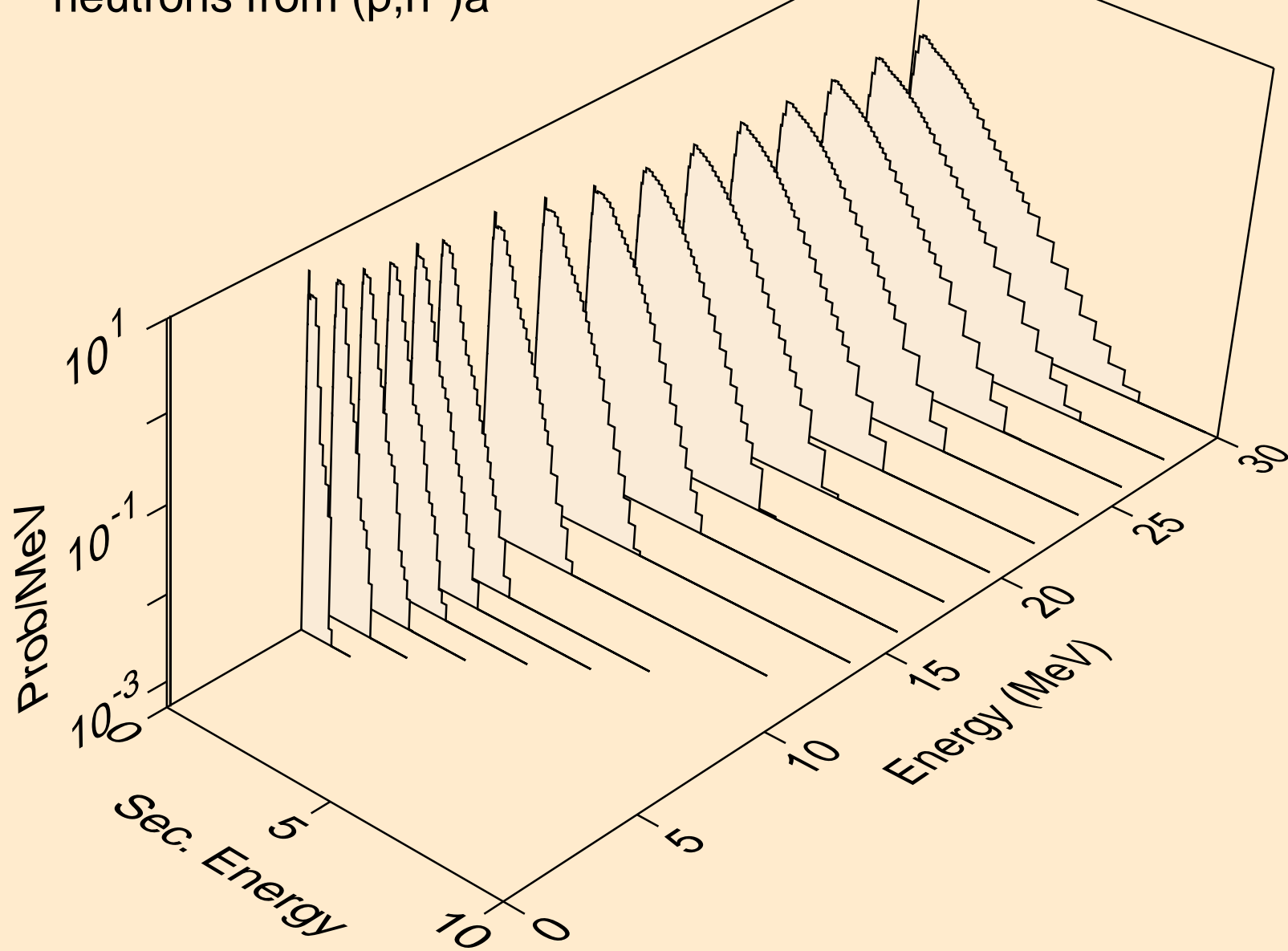

IN122 PROTON ACER TENDL-2023 LIBRARY; T=0.K  
neutrons from (p,2n)a

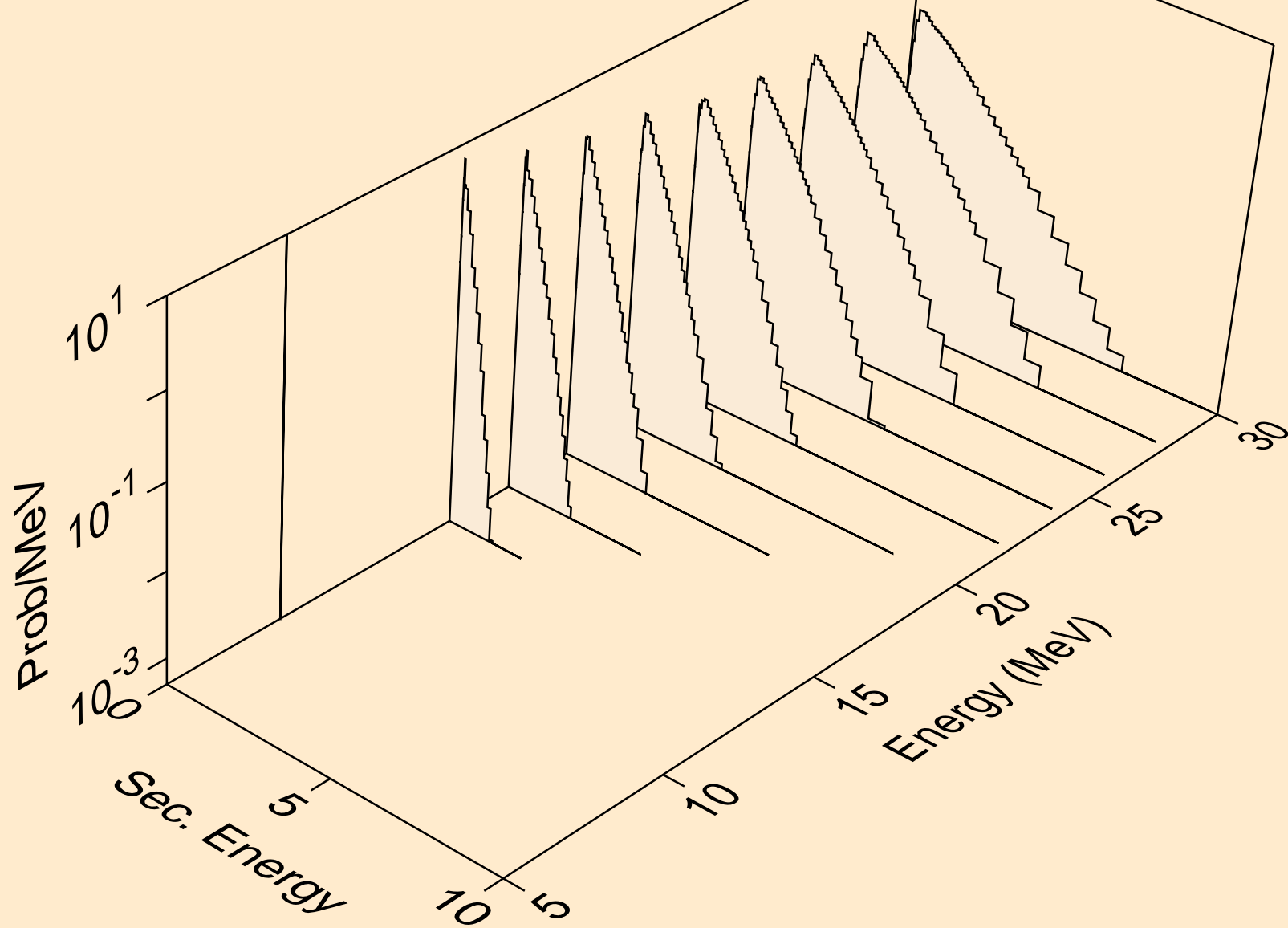

IN122 PROTON ACER TENDL-2023 LIBRARY; T=0.K  
neutrons from (p,3n)a

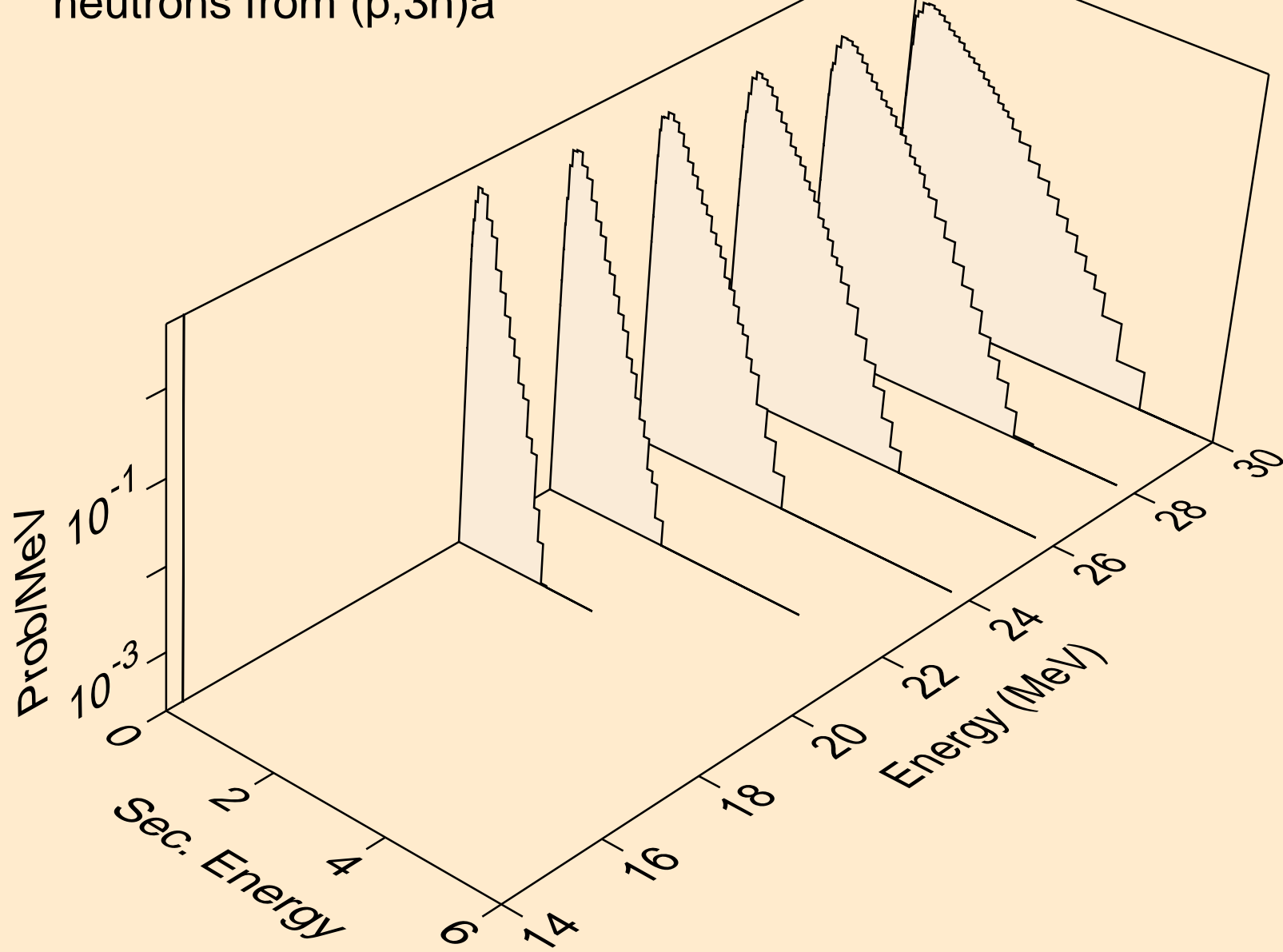

IN122 PROTON ACER TENDL-2023 LIBRARY; T=0.K  
neutrons from (p,n\*)p

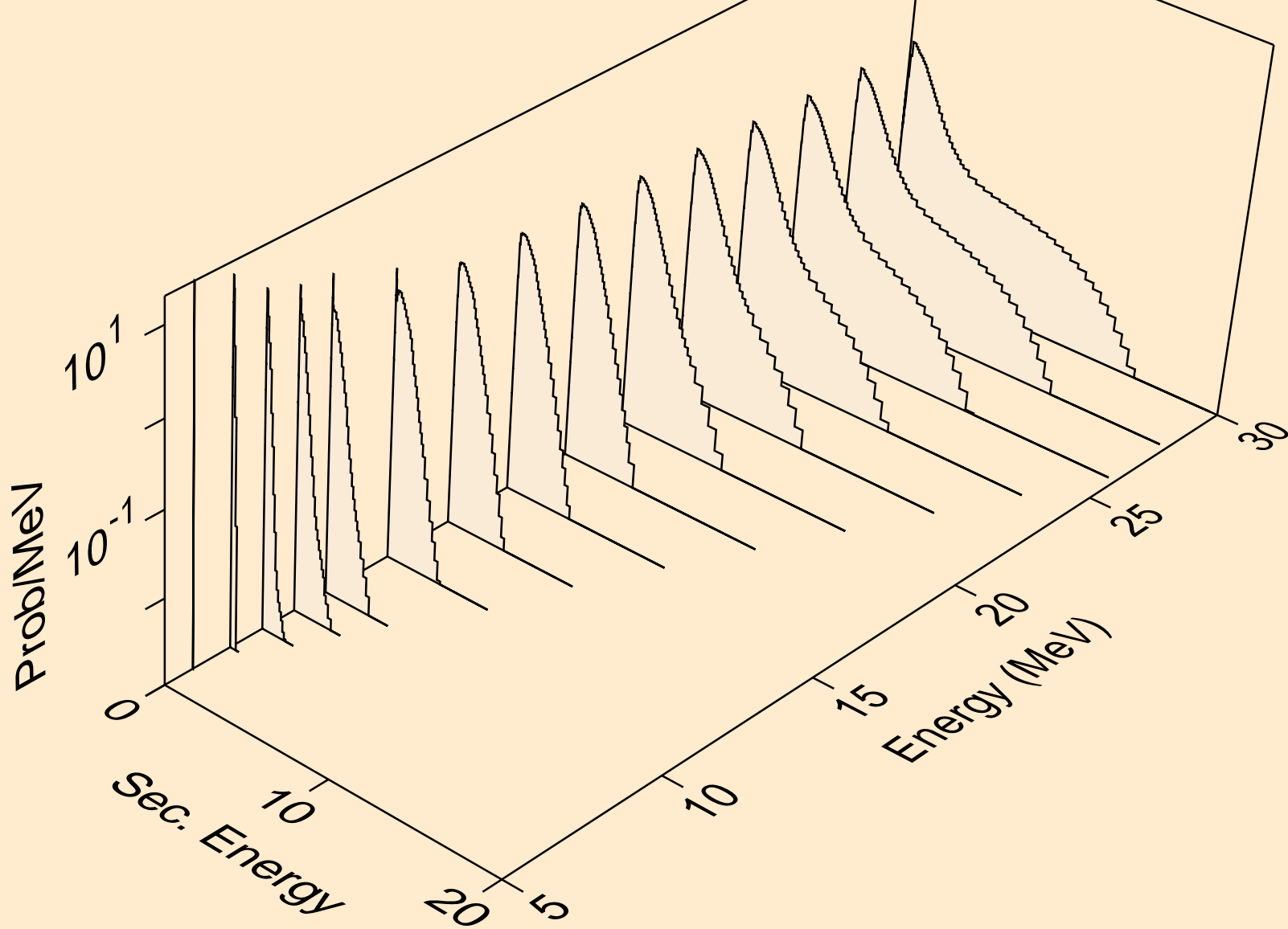

IN122 PROTON ACER TENDL-2023 LIBRARY; T=0.K  
neutrons from (p,n\*)d

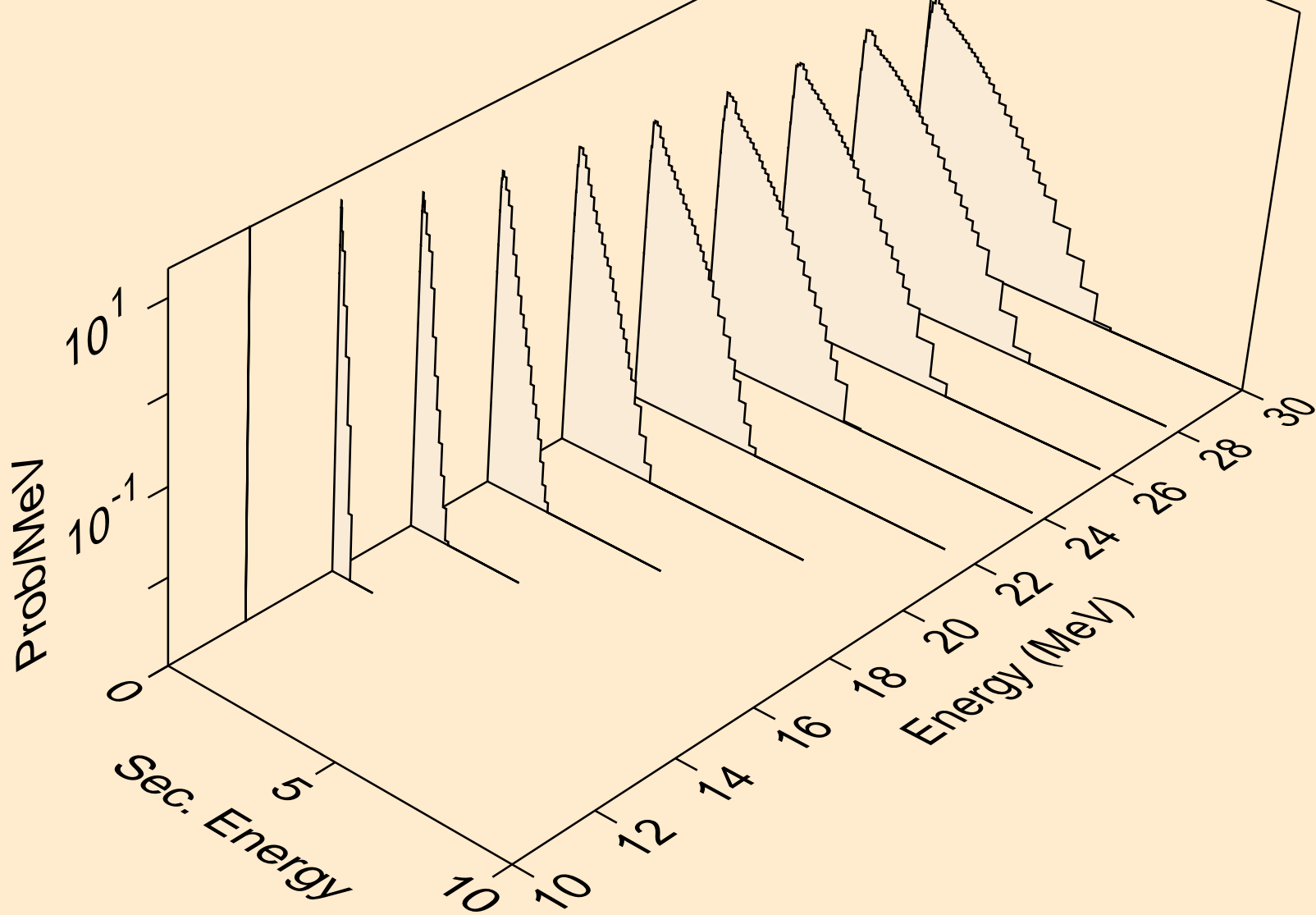

IN122 PROTON ACER TENDL-2023 LIBRARY; T=0.K  
neutrons from (p,n\*)t

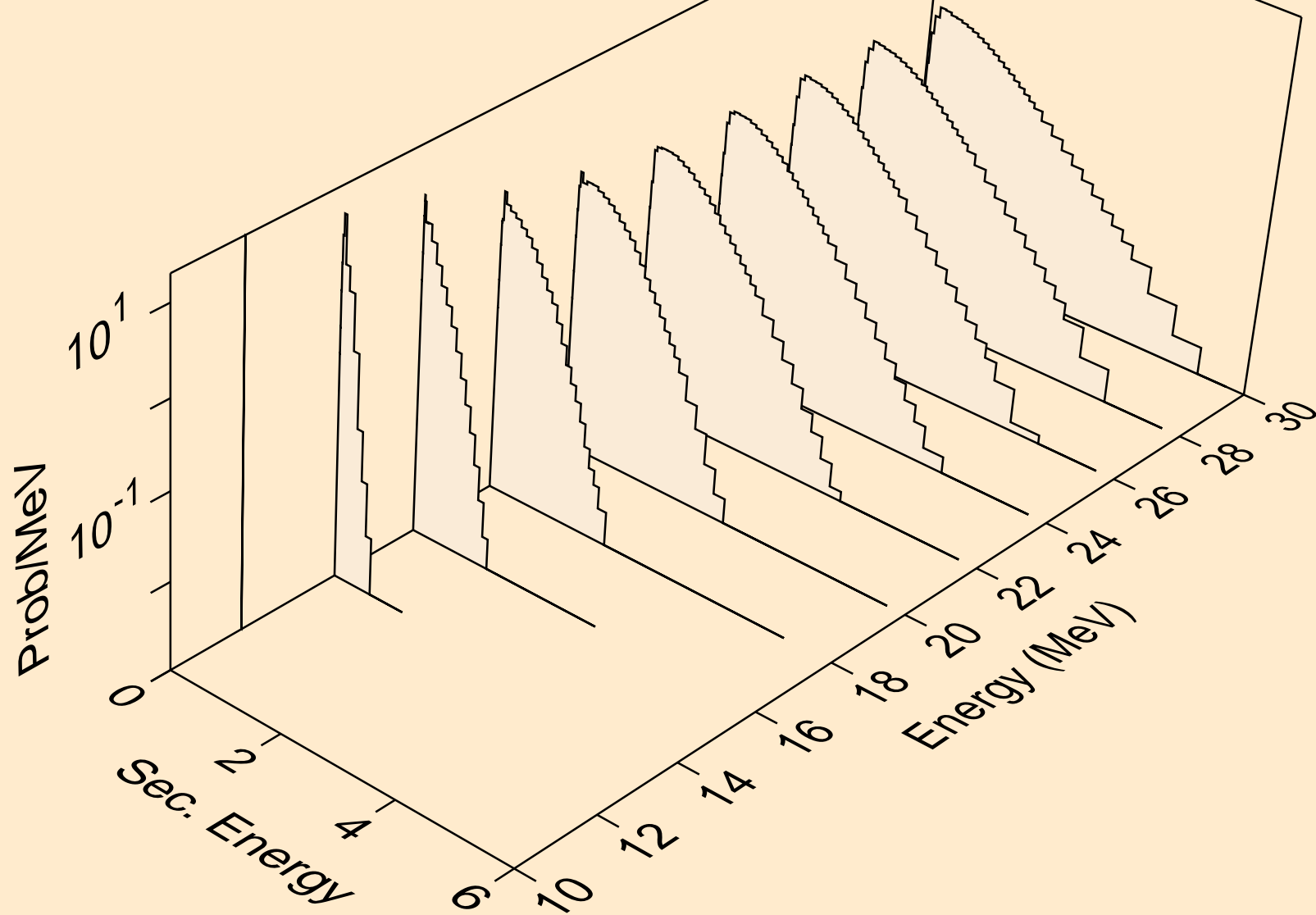

IN122 PROTON ACER TENDL-2023 LIBRARY; T=0.K  
neutrons from (p,n\*)he3

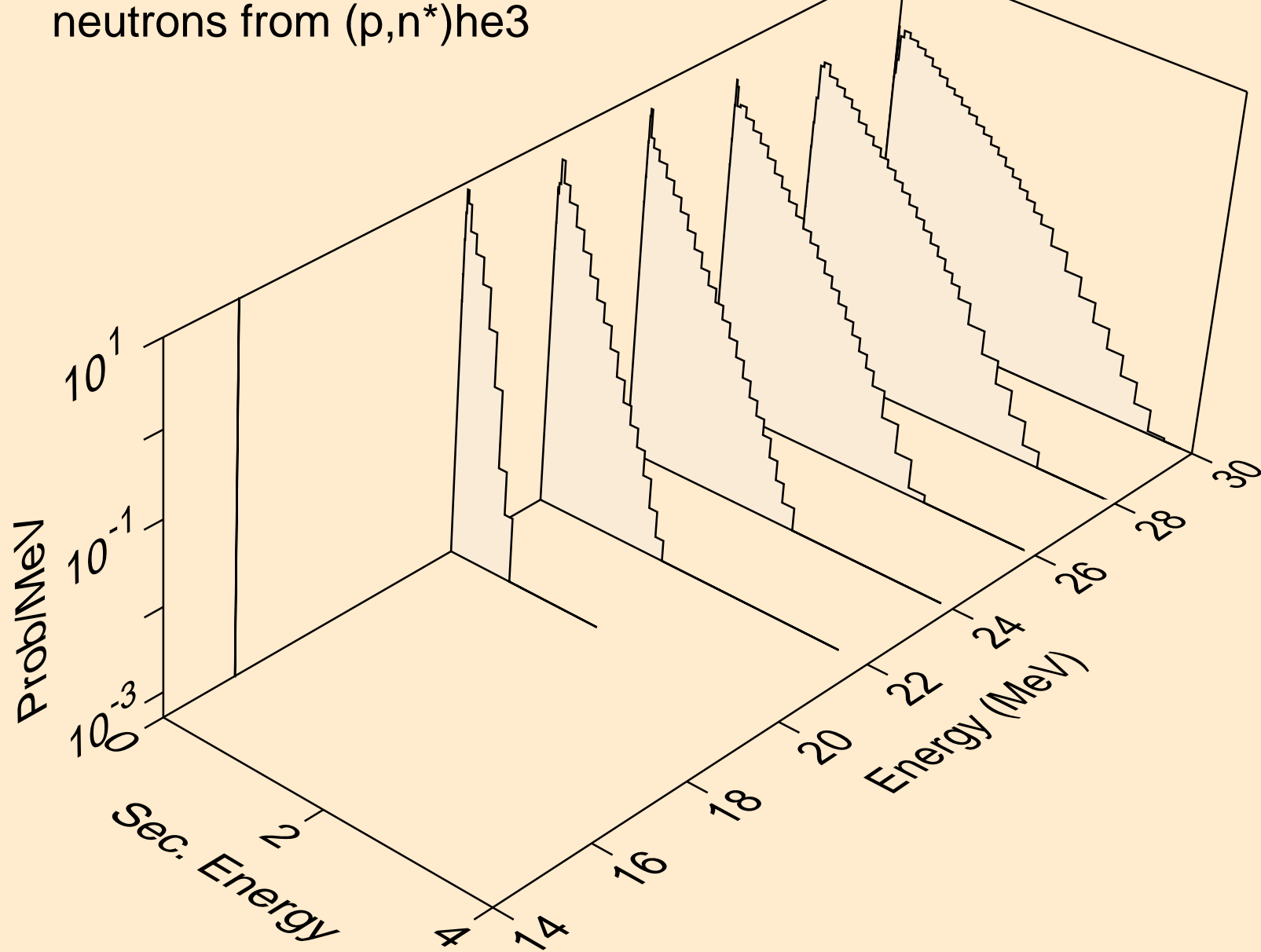

IN122 PROTON ACER TENDL-2023 LIBRARY; T=0.K  
neutrons from (p,4n)

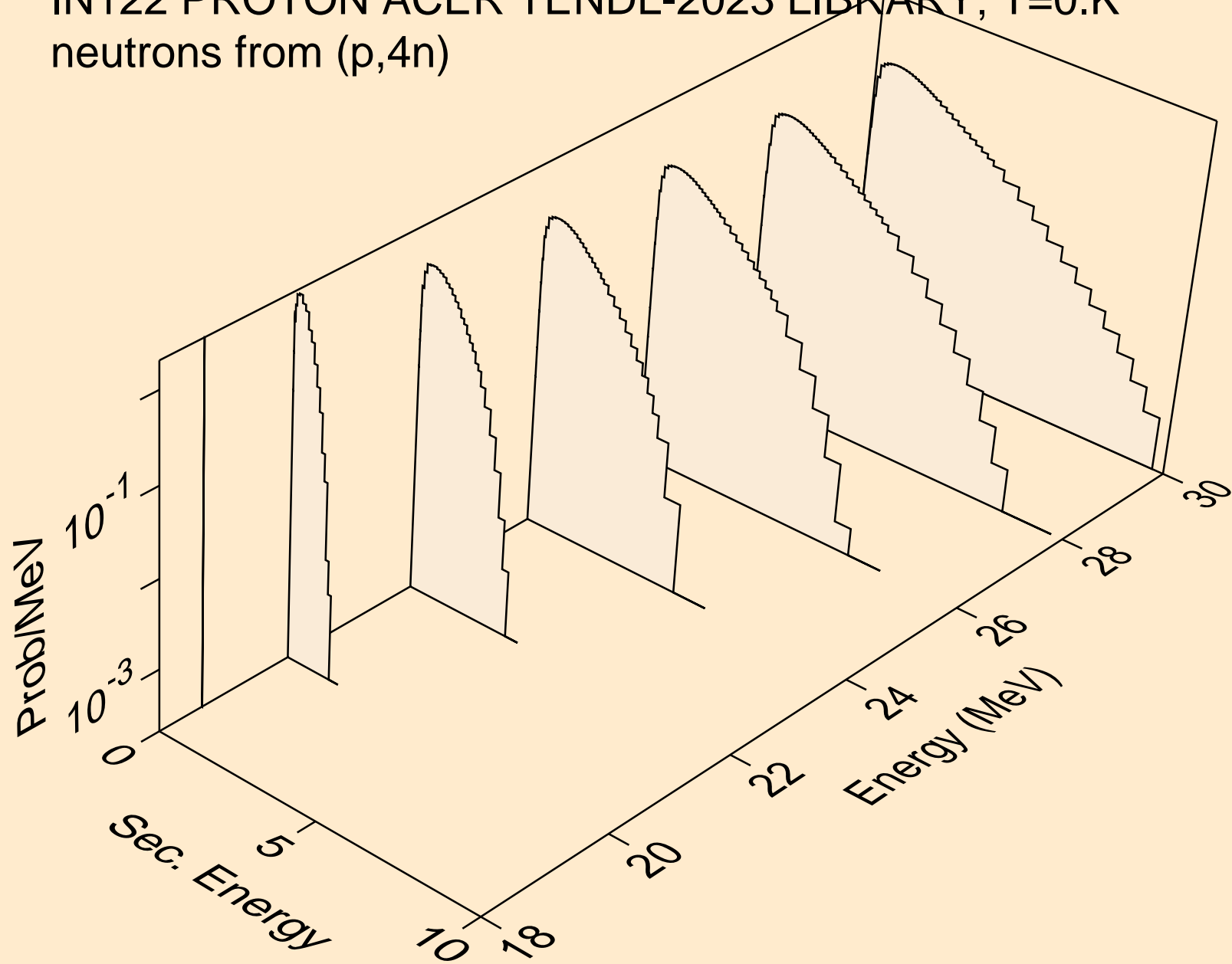



IN122 PROTON ACER TENDL-2023 LIBRARY; T=0.K  
neutrons from (p,2np)

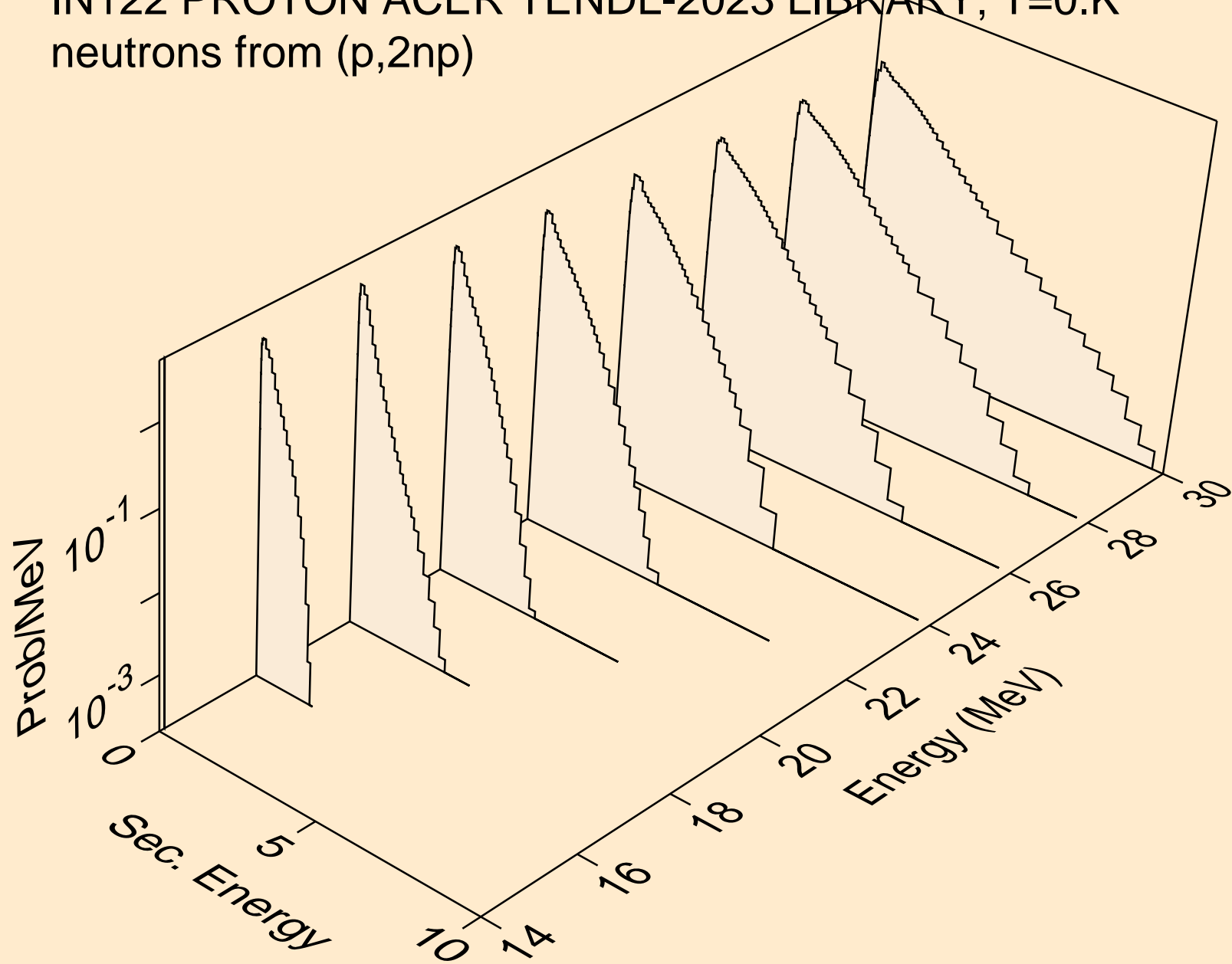

IN122 PROTON ACER TENDL-2023 LIBRARY; T=0.K  
neutrons from (p,3np)

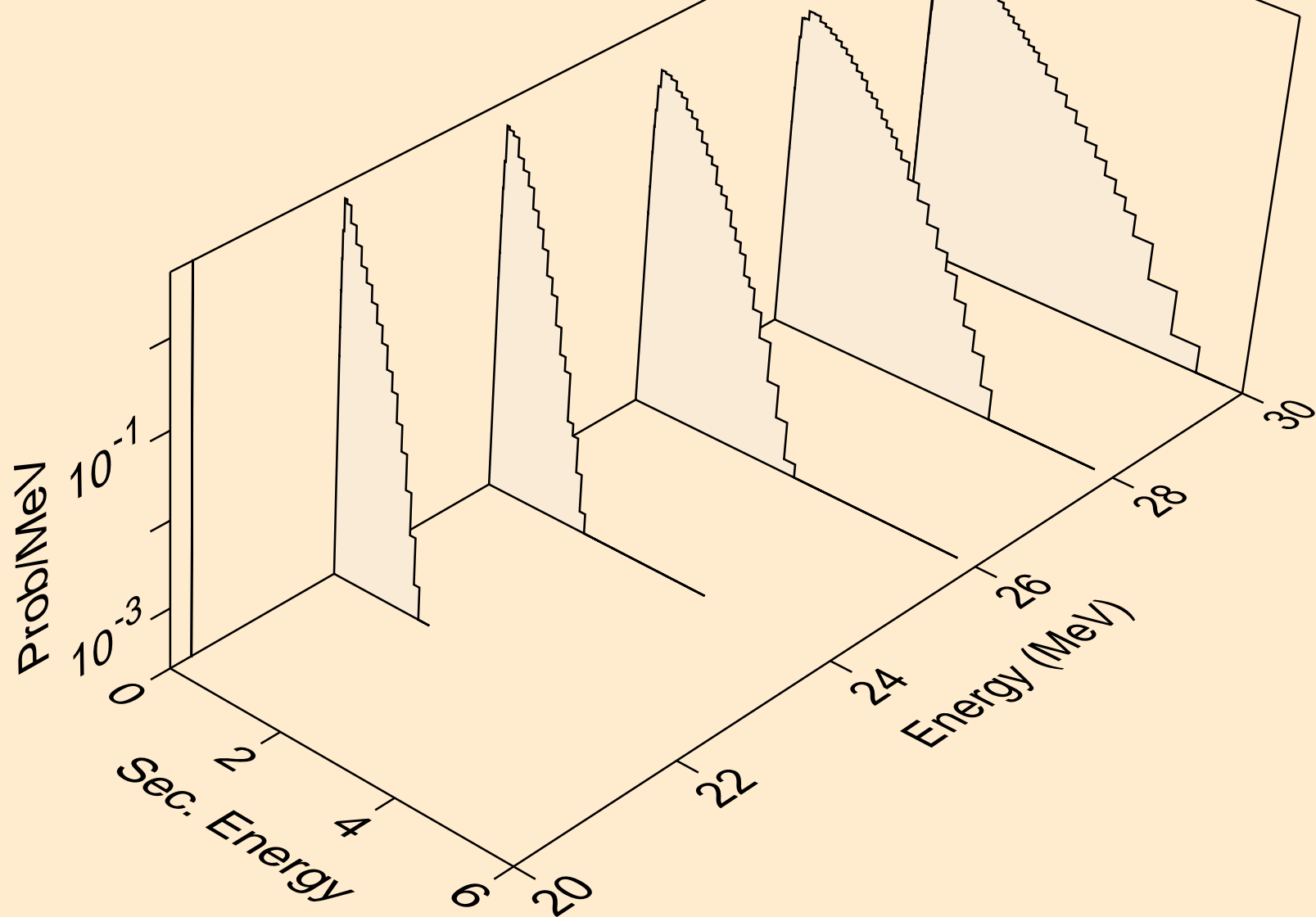

IN122 PROTON ACER TENDL-2023 LIBRARY; T=0.K  
neutrons from (p,n2p)

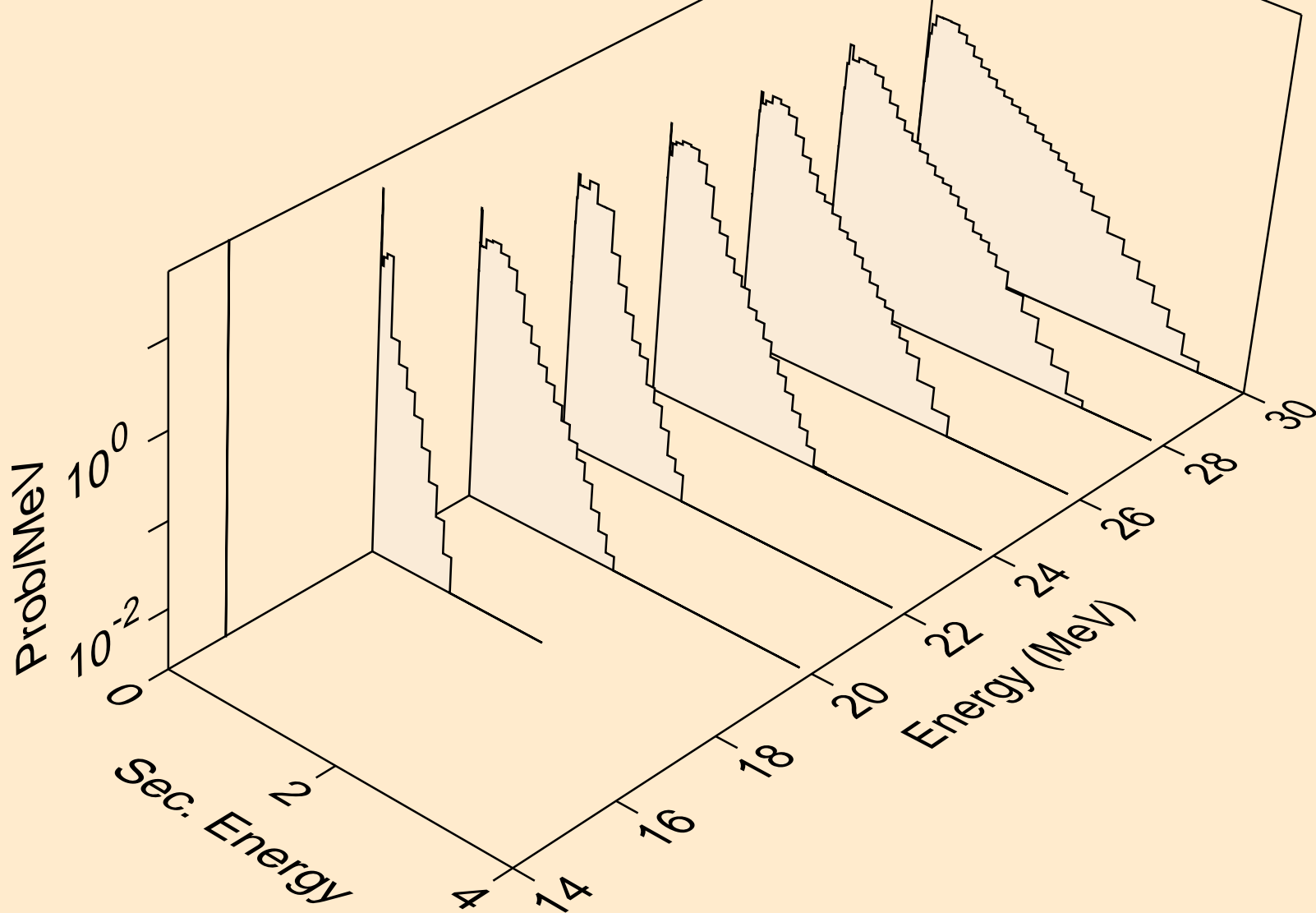

IN122 PROTON ACER TENDL-2023 LIBRARY; T=0.K  
neutrons from (p,npa)

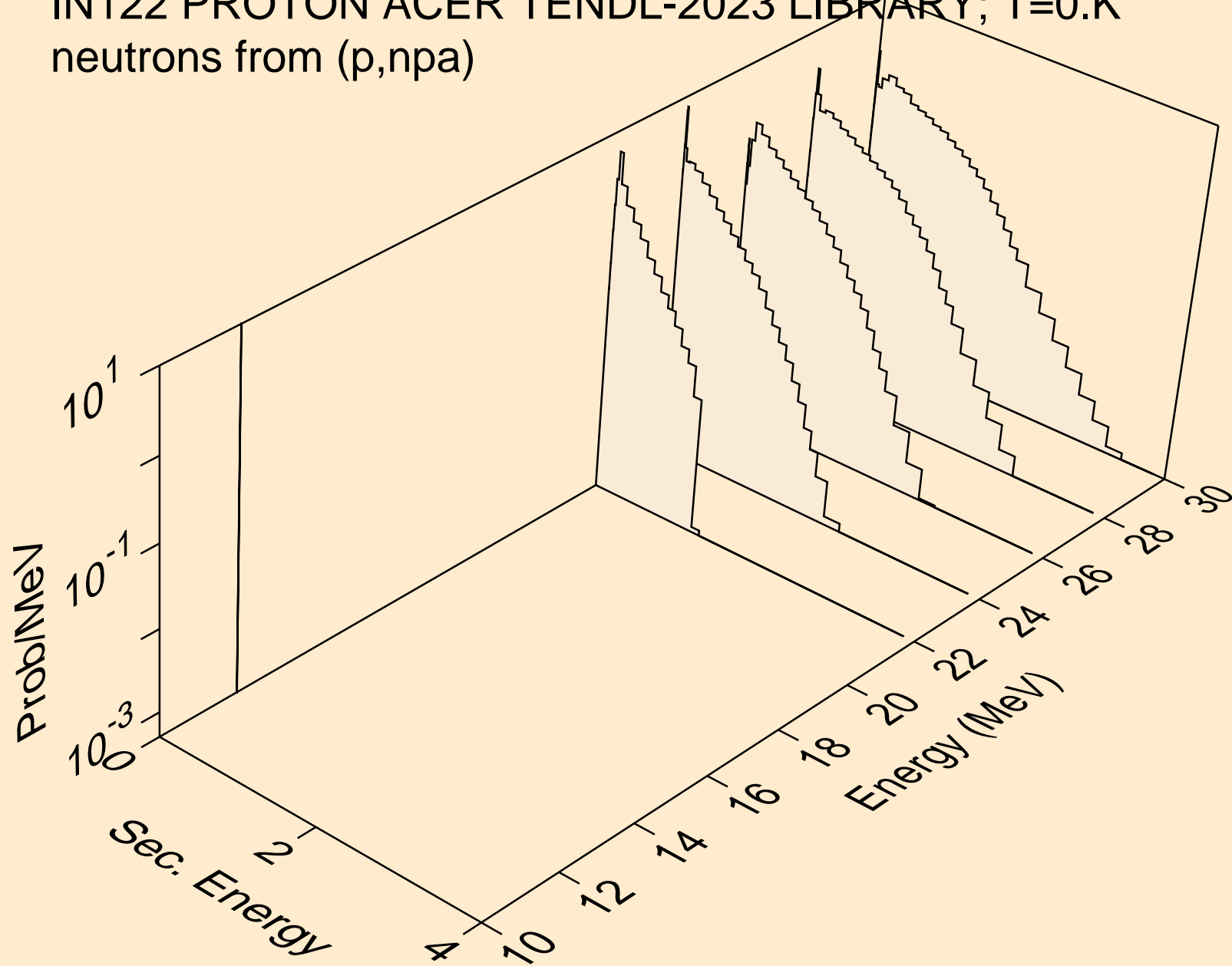

IN122 PROTON ACER TENDL-2023 LIBRARY; T=0.K  
deuterons from (p,x)

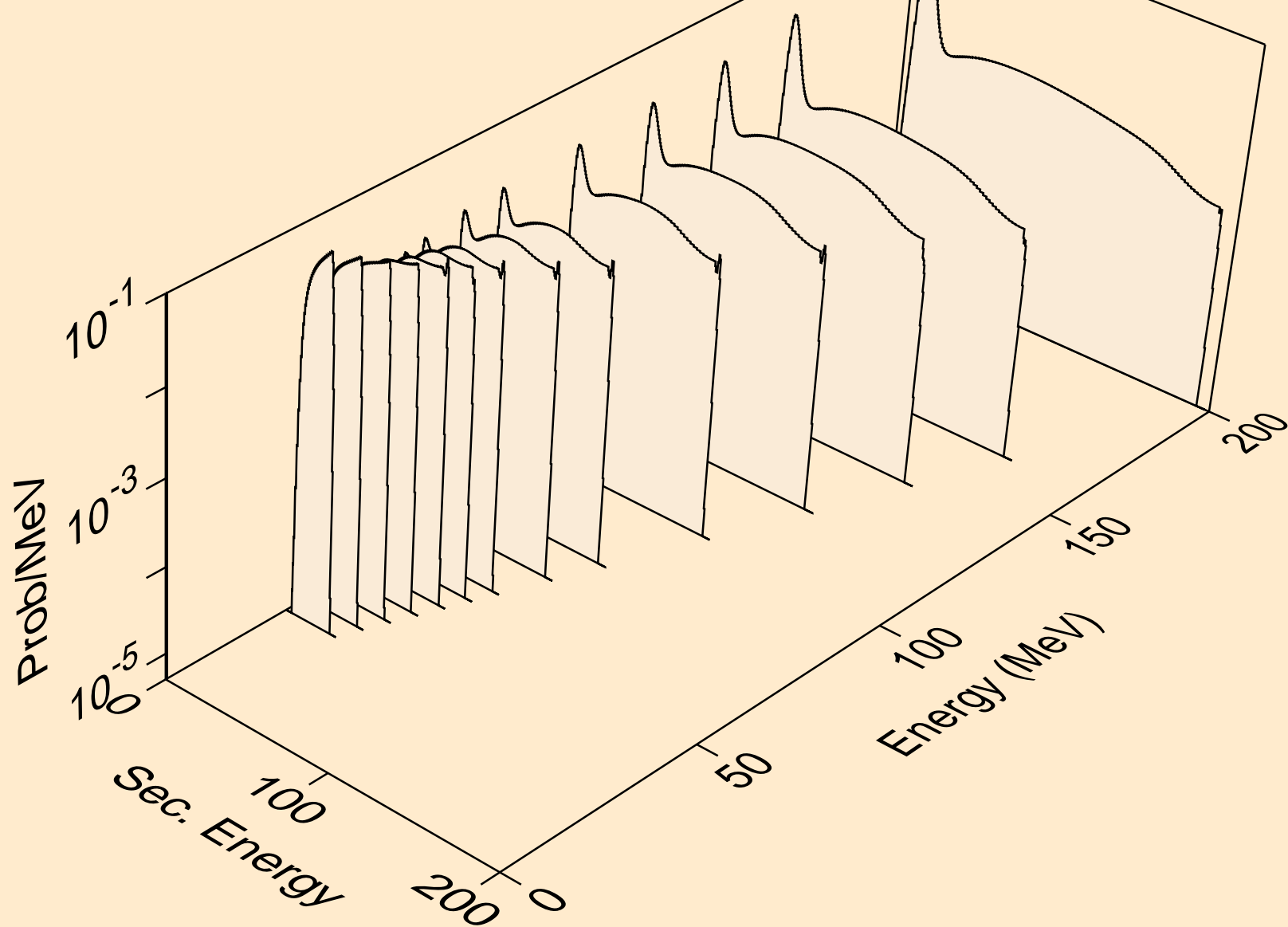

IN122 PROTON ACER TENDL-2023 LIBRARY; T=0.K  
deuterons from (p,2nd)

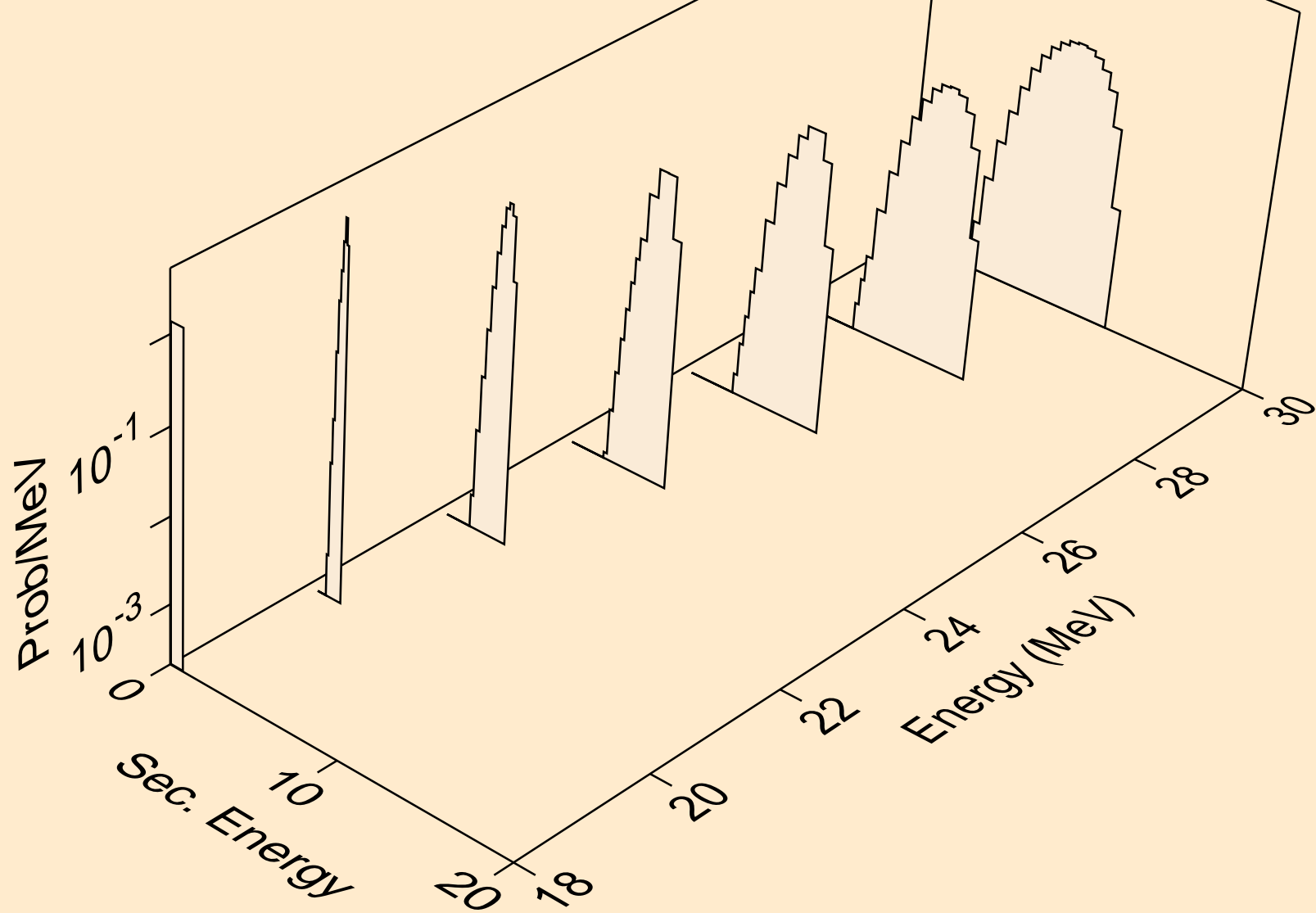

IN122 PROTON ACER TENDL-2023 LIBRARY; T=0.K  
deuterons from (p,n\*)d

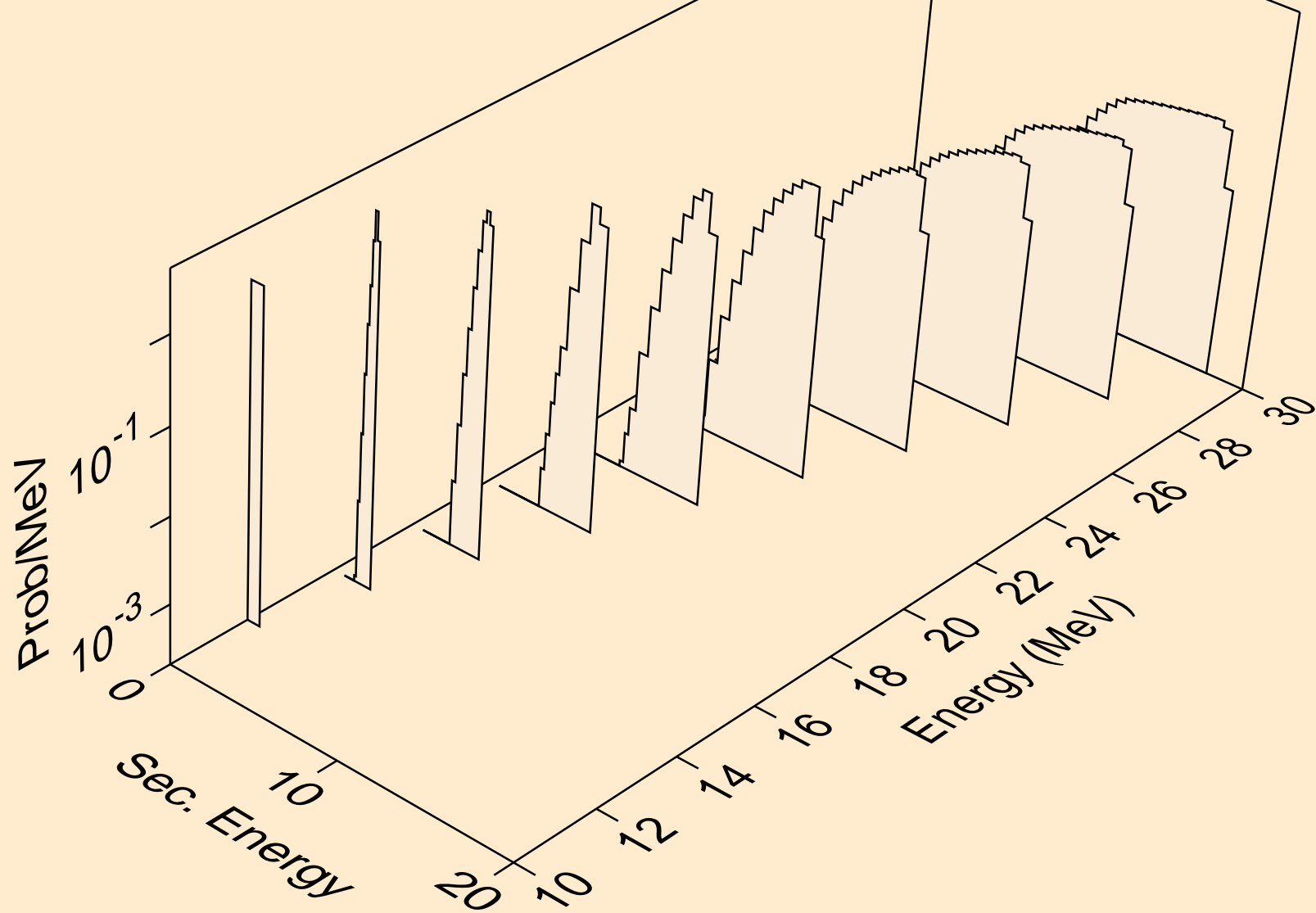

IN122 PROTON ACER TENDL-2023 LIBRARY; T=0.K  
deuterons from (p,d)

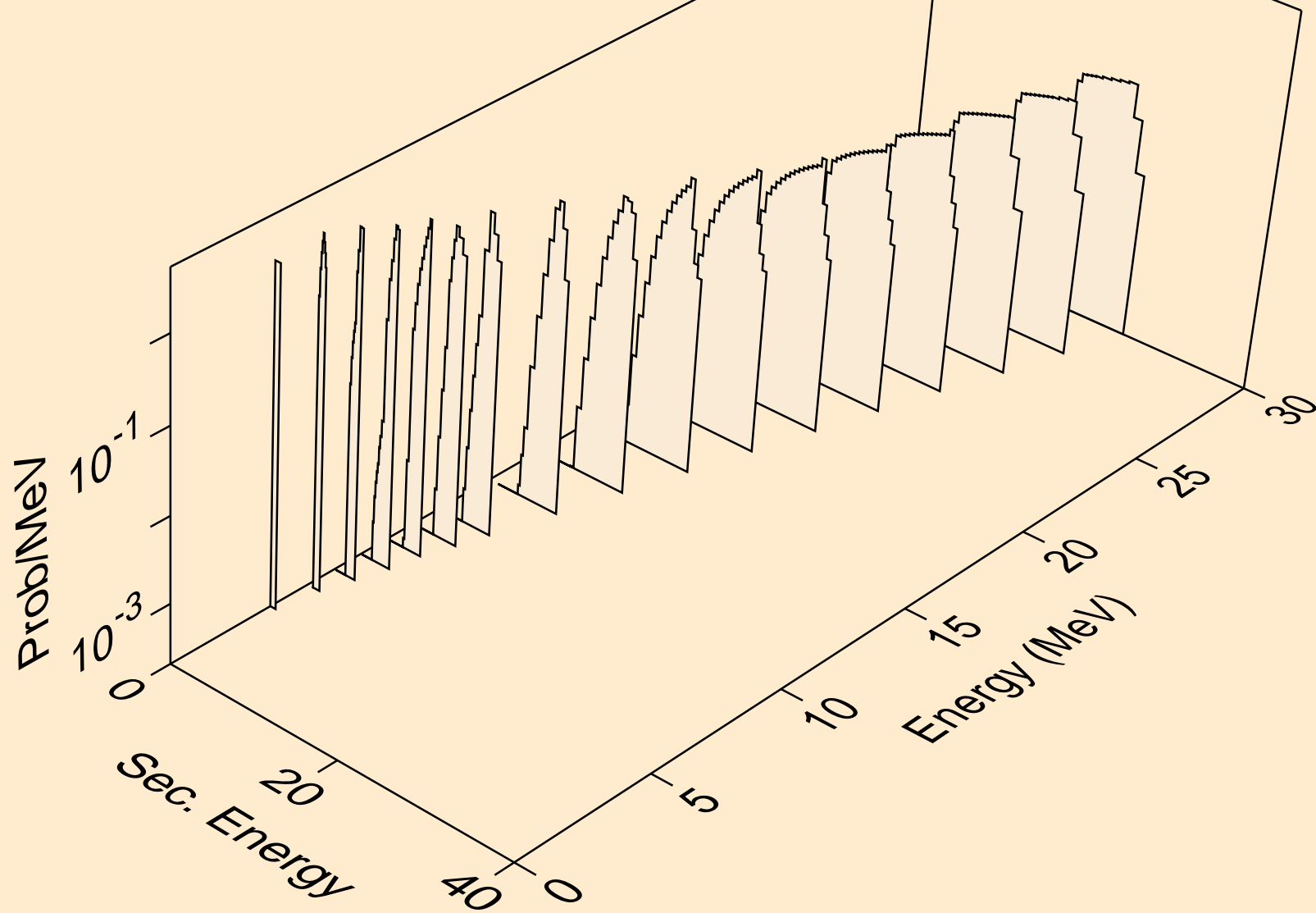



IN122 PROTON ACER TENDL-2023 LIBRARY; T=0.K  
deuterons from (p,pd)

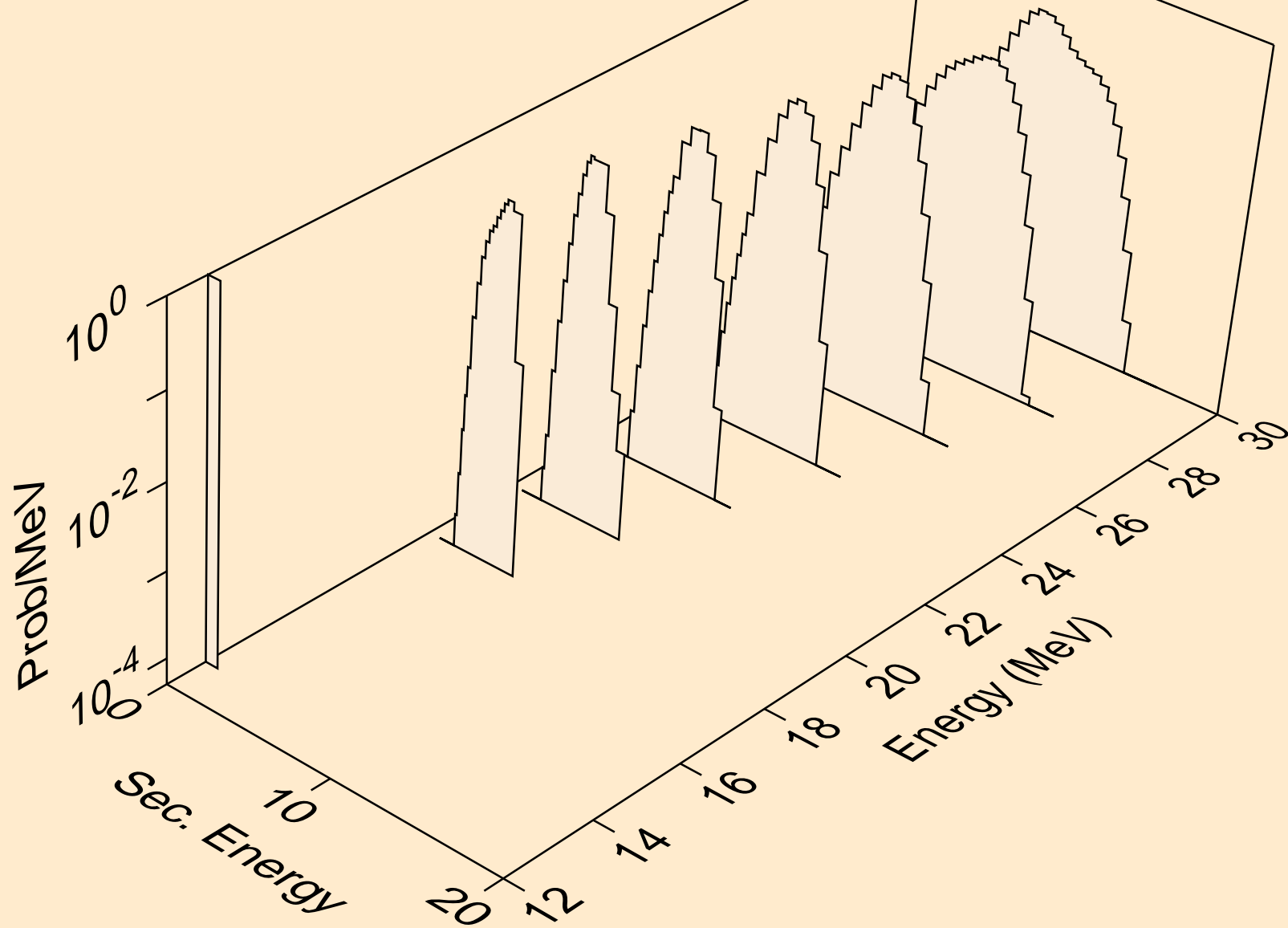

IN122 PROTON ACER TENDL-2023 LIBRARY; T=0.K  
tritons from (p,x)

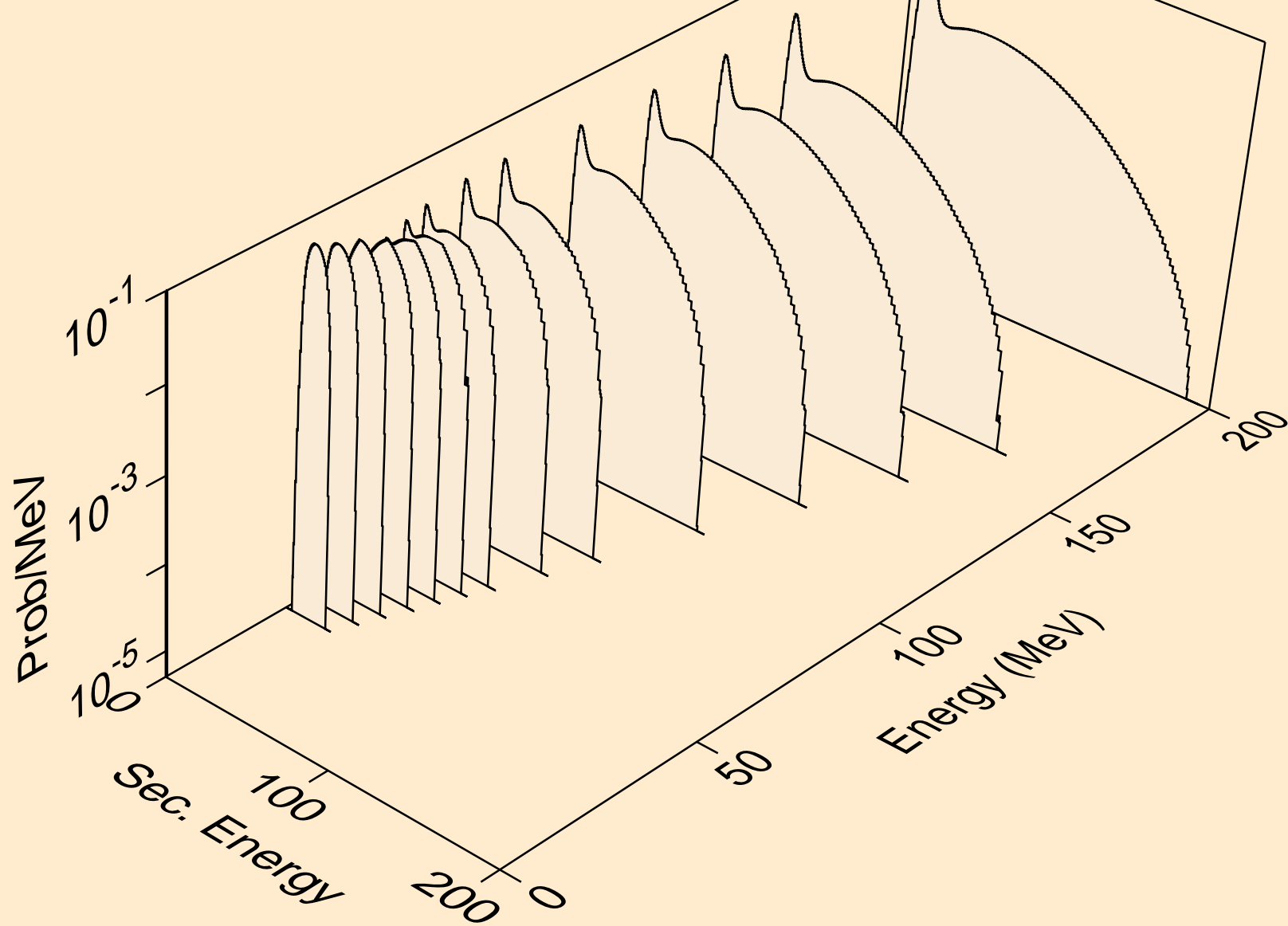

IN122 PROTON ACER TENDL-2023 LIBRARY; T=0.K  
tritons from (p,n\*)t

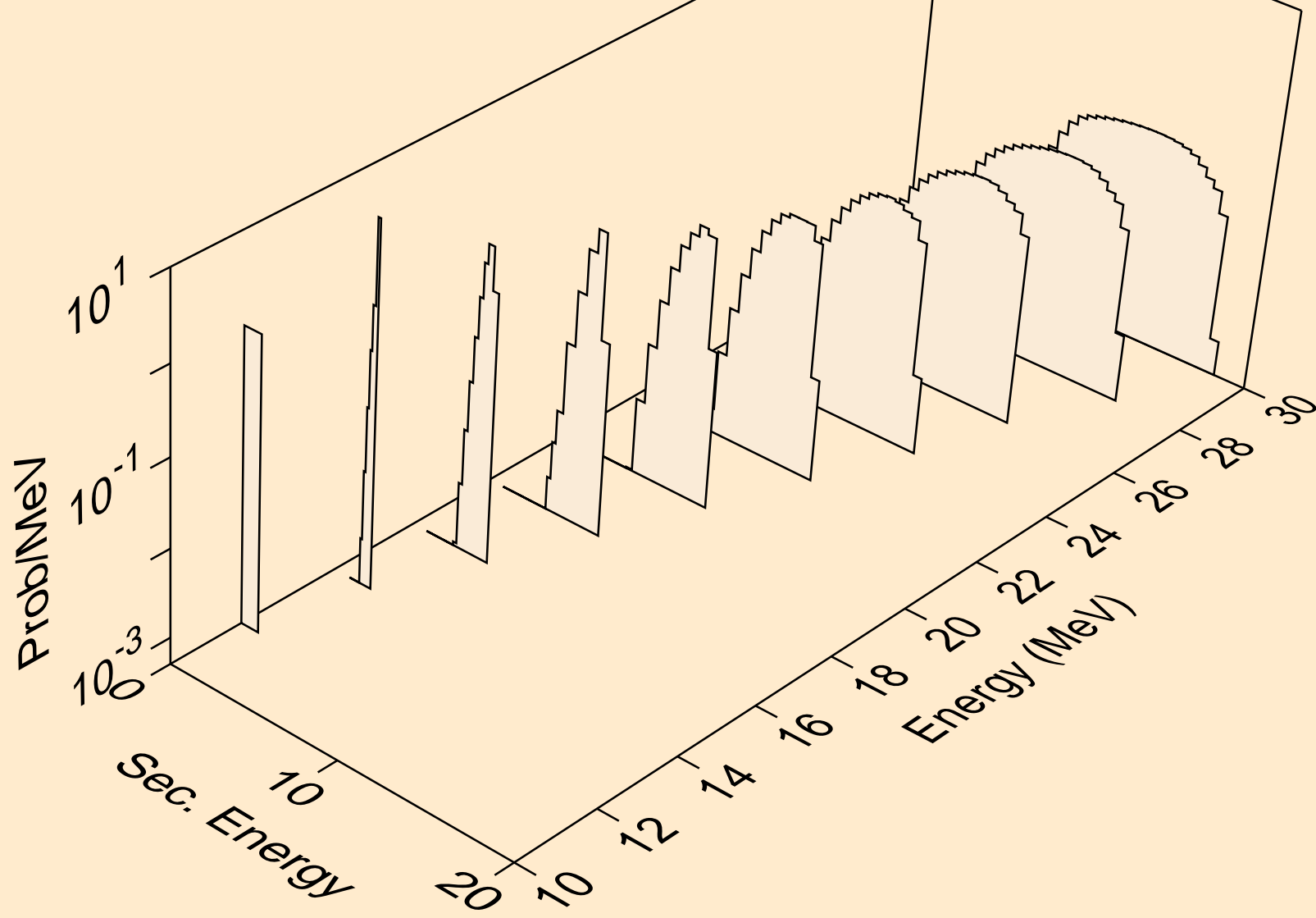

IN122 PROTON ACER TENDL-2023 LIBRARY; T=0.K  
tritons from (p,t)

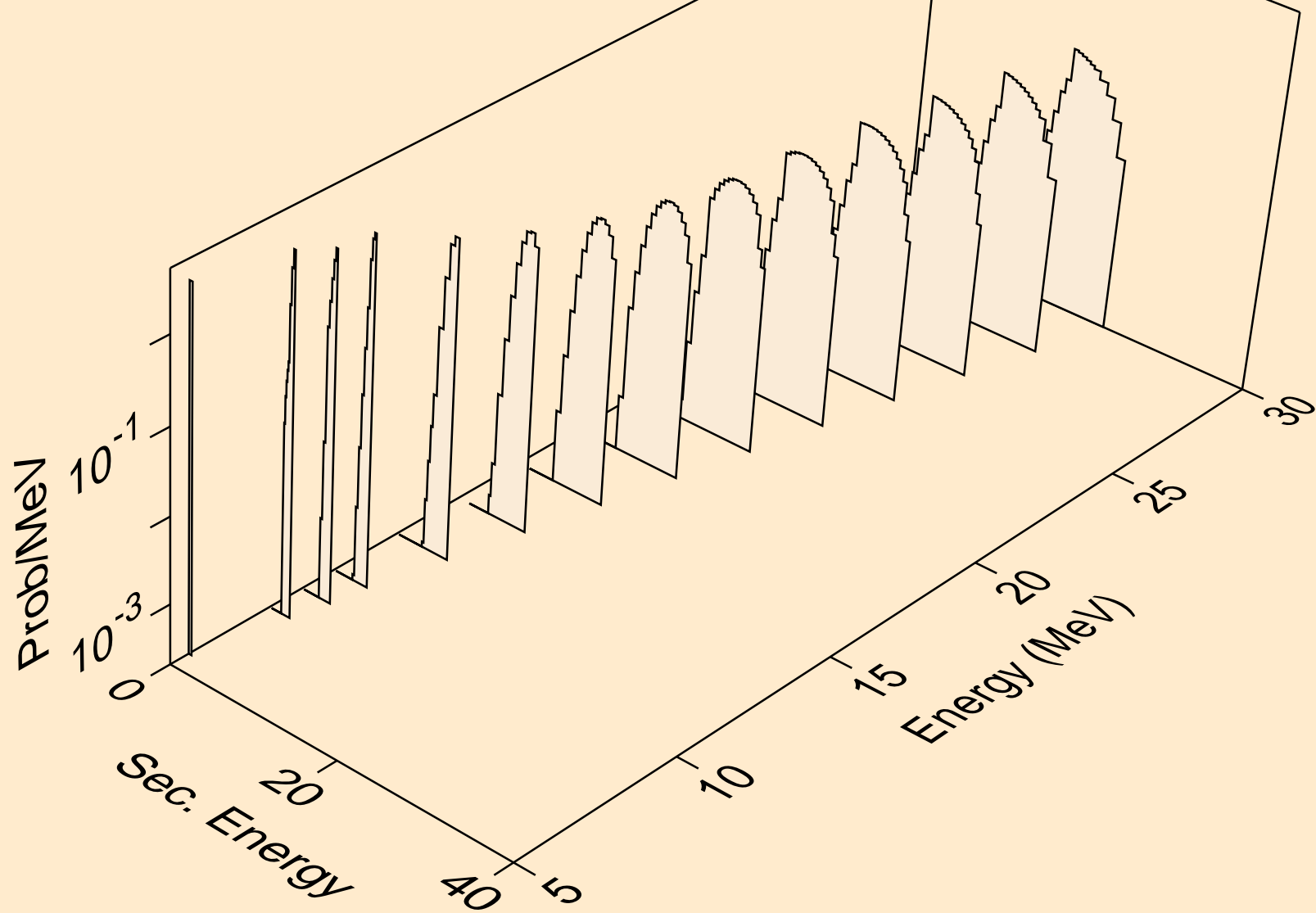

IN122 PROTON ACER TENDL-2023 LIBRARY; T=0.K  
tritons from (p,pt)

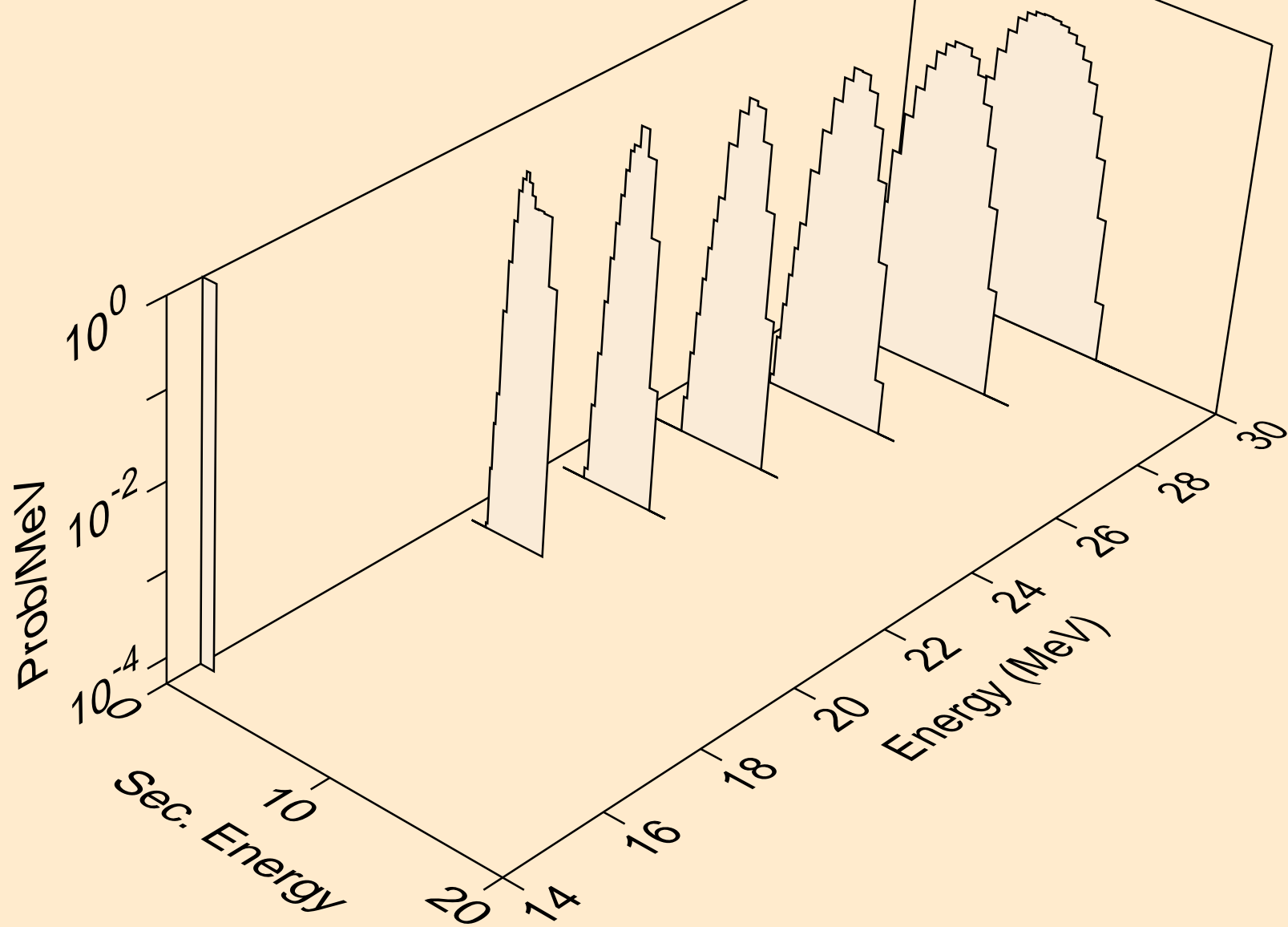

IN122 PROTON ACER TENDL-2023 LIBRARY; T=0.K  
he3s from (p,x)

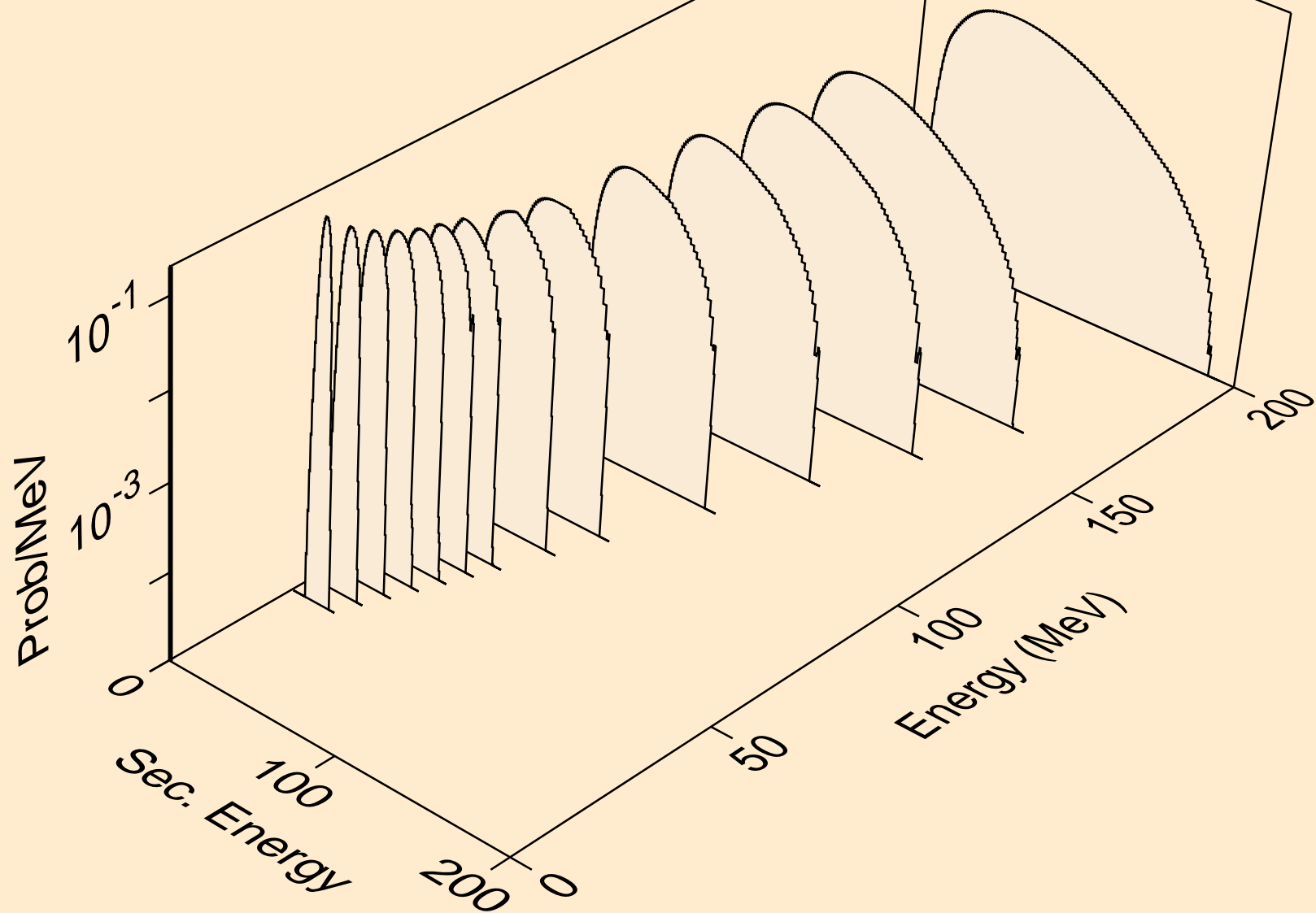

IN122 PROTON ACER TENDL-2023 LIBRARY; T=0.K  
he3s from (p,n\*)he3

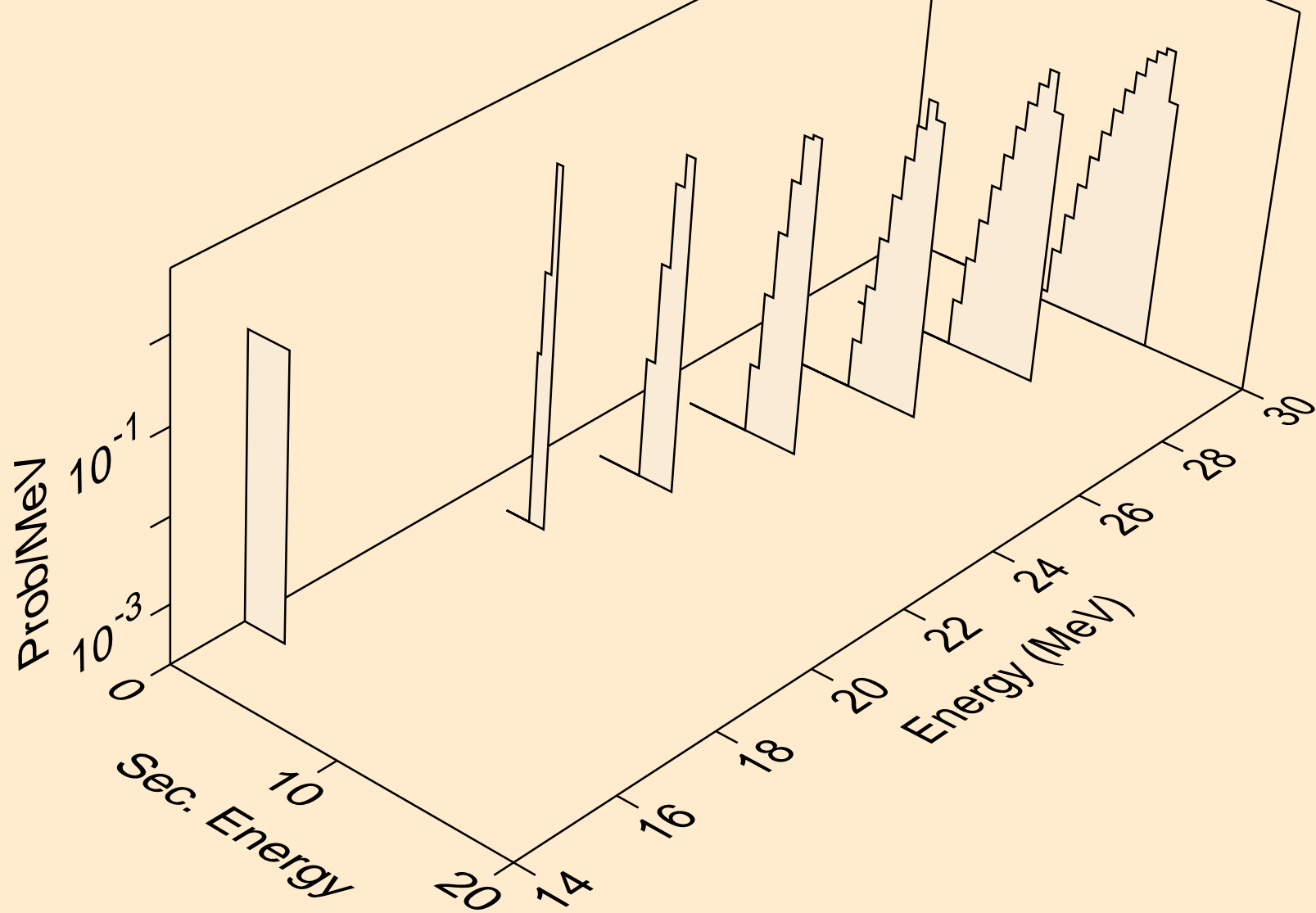

IN122 PROTON ACER TENDL-2023 LIBRARY; T=0.K  
he3s from (p,he3)

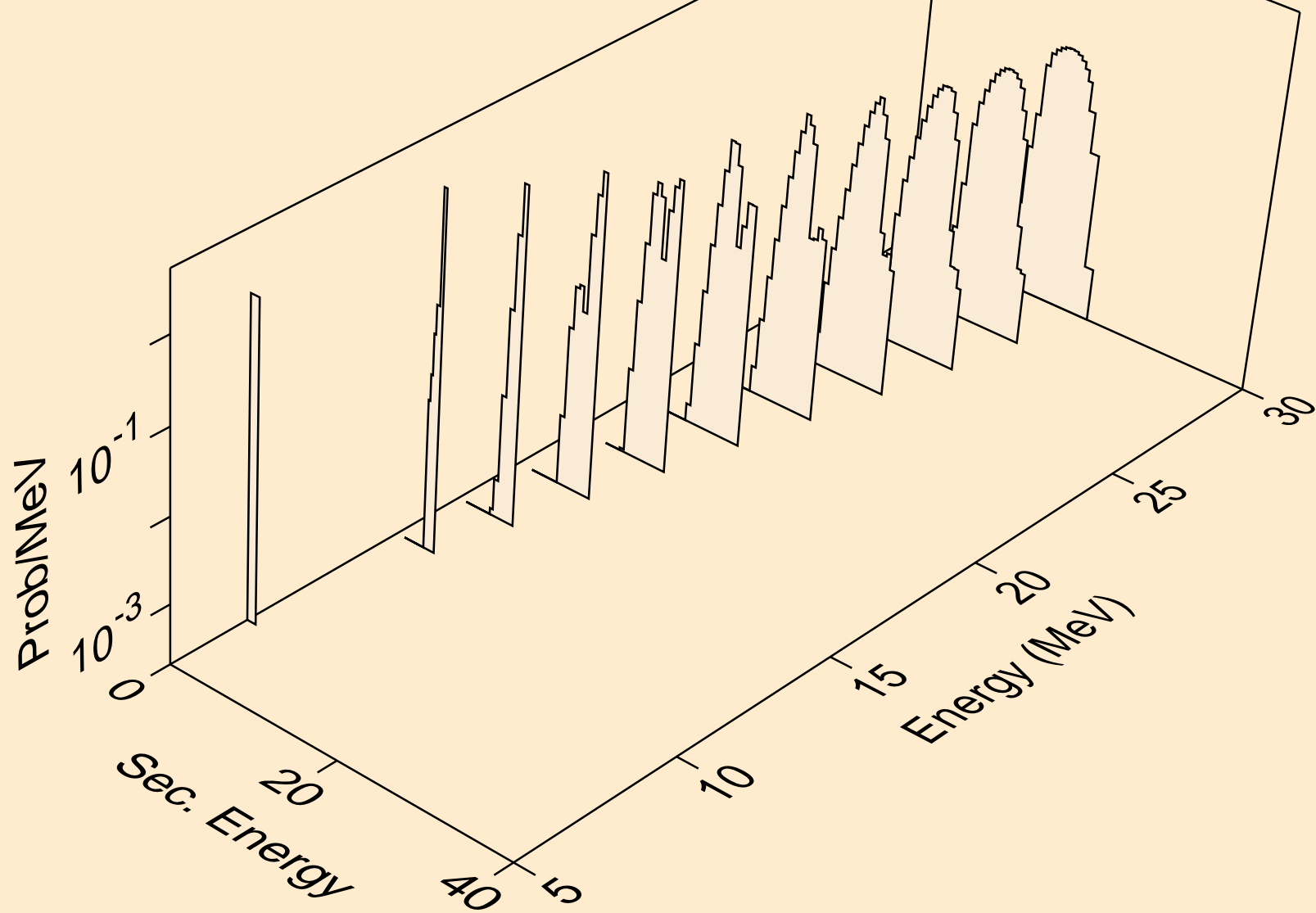



IN122 PROTON ACER TENDL-2023 LIBRARY; T=0.K  
alphas from (p,x)

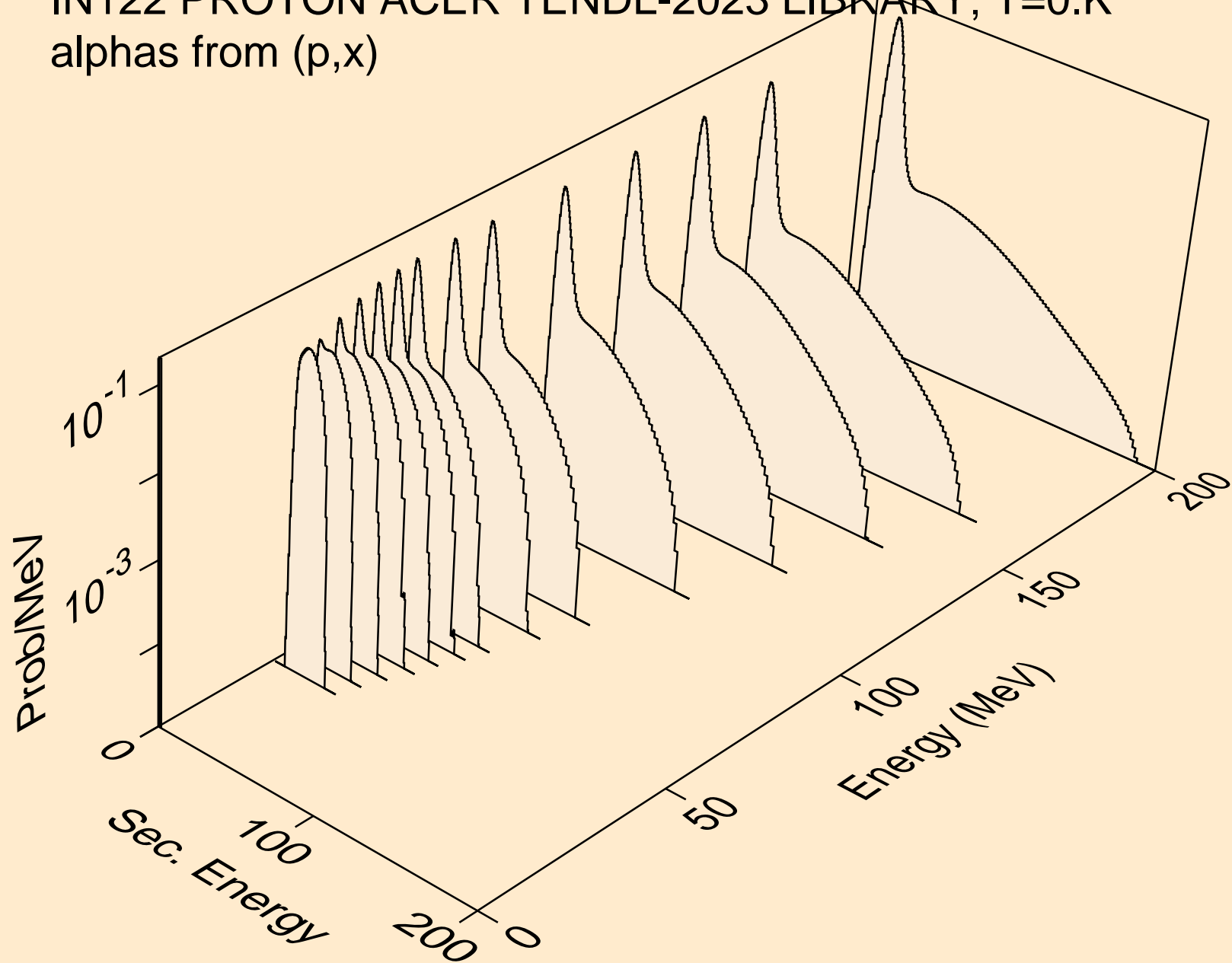

IN122 PROTON ACER TENDL-2023 LIBRARY; T=0.K  
alphas from (p,n\*)a

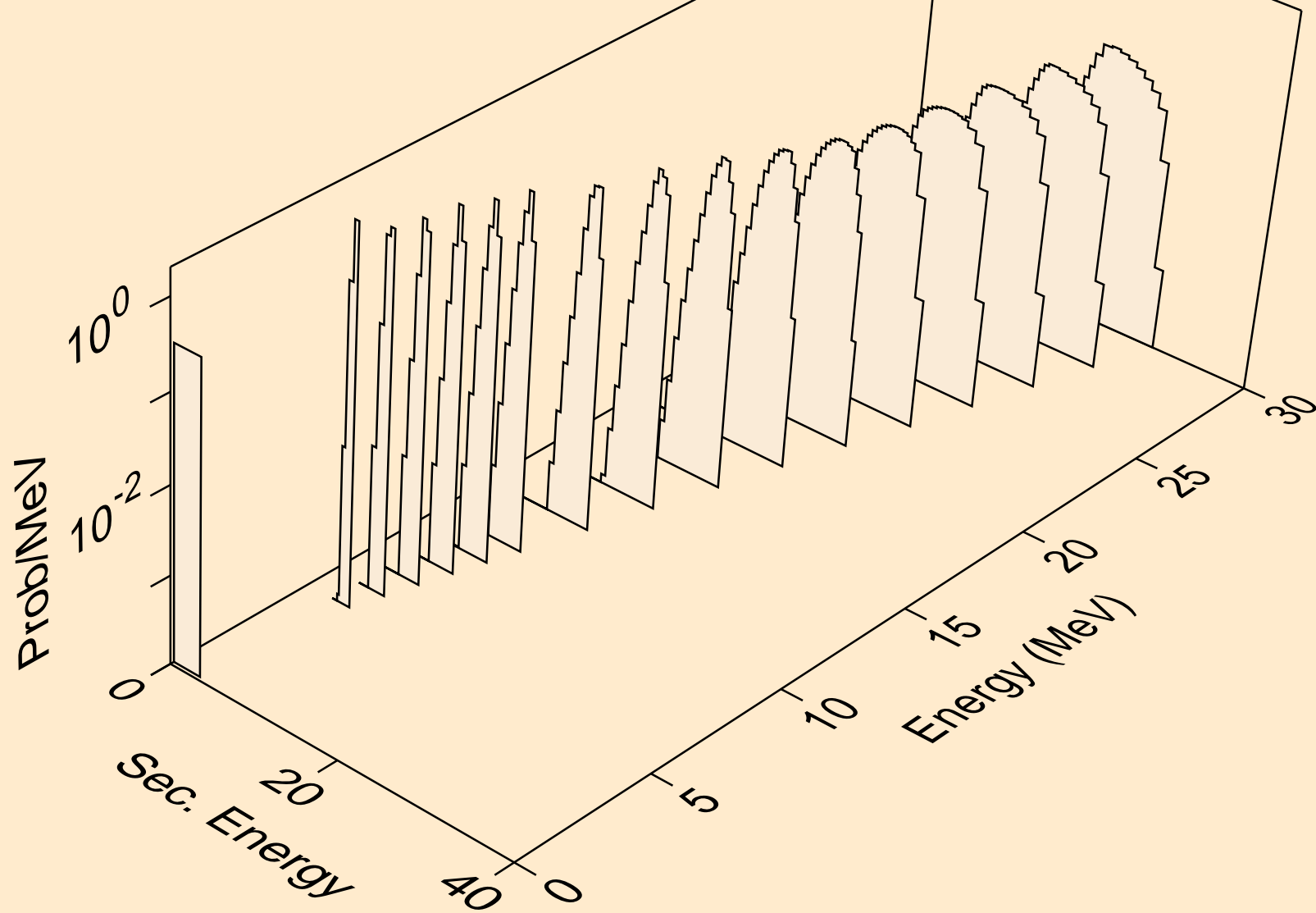

IN122 PROTON ACER TENDL-2023 LIBRARY; T=0.K  
alphas from (p,2n)a

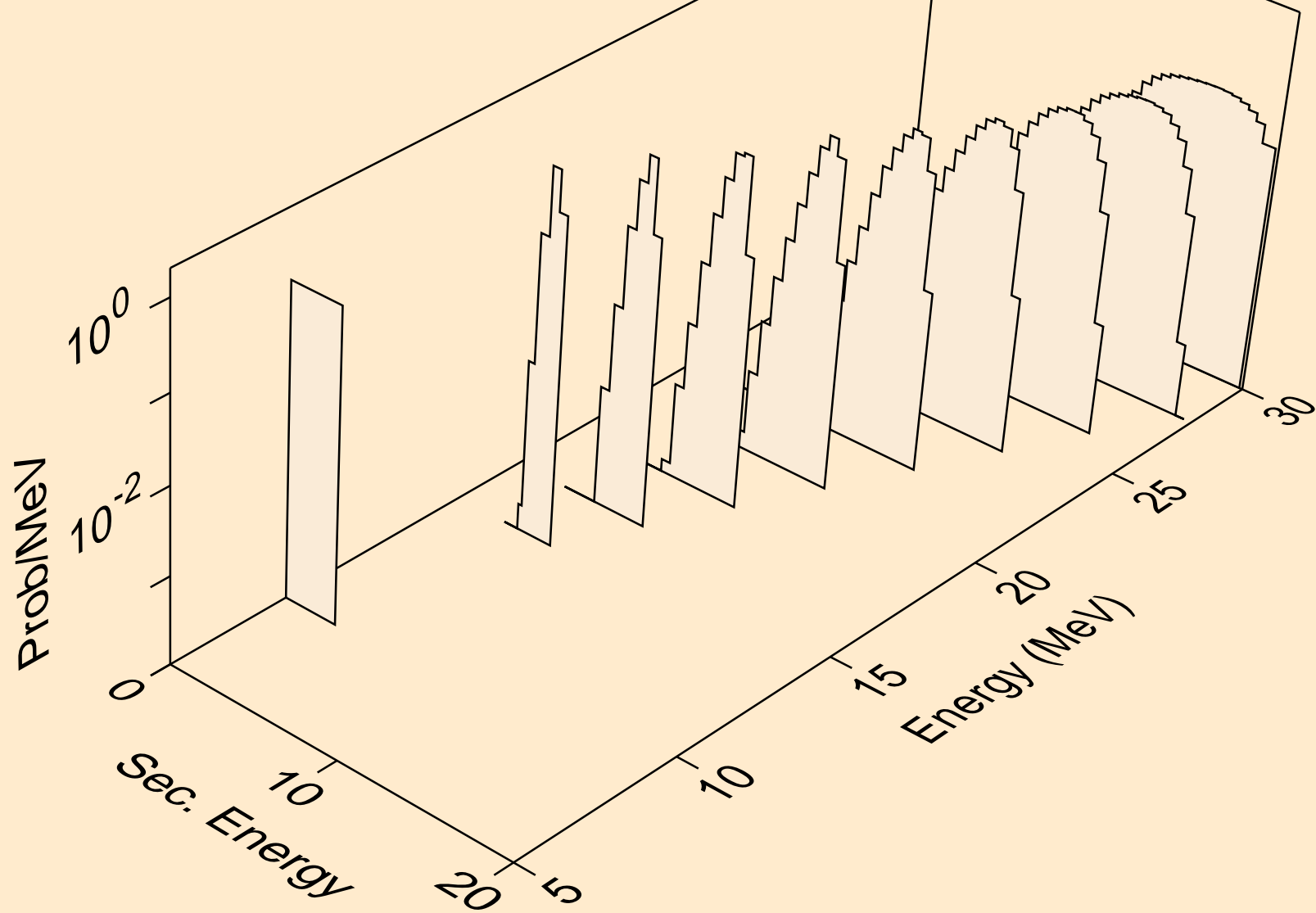

IN122 PROTON ACER TENDL-2023 LIBRARY; T=0.K  
alphas from (p,3n)a

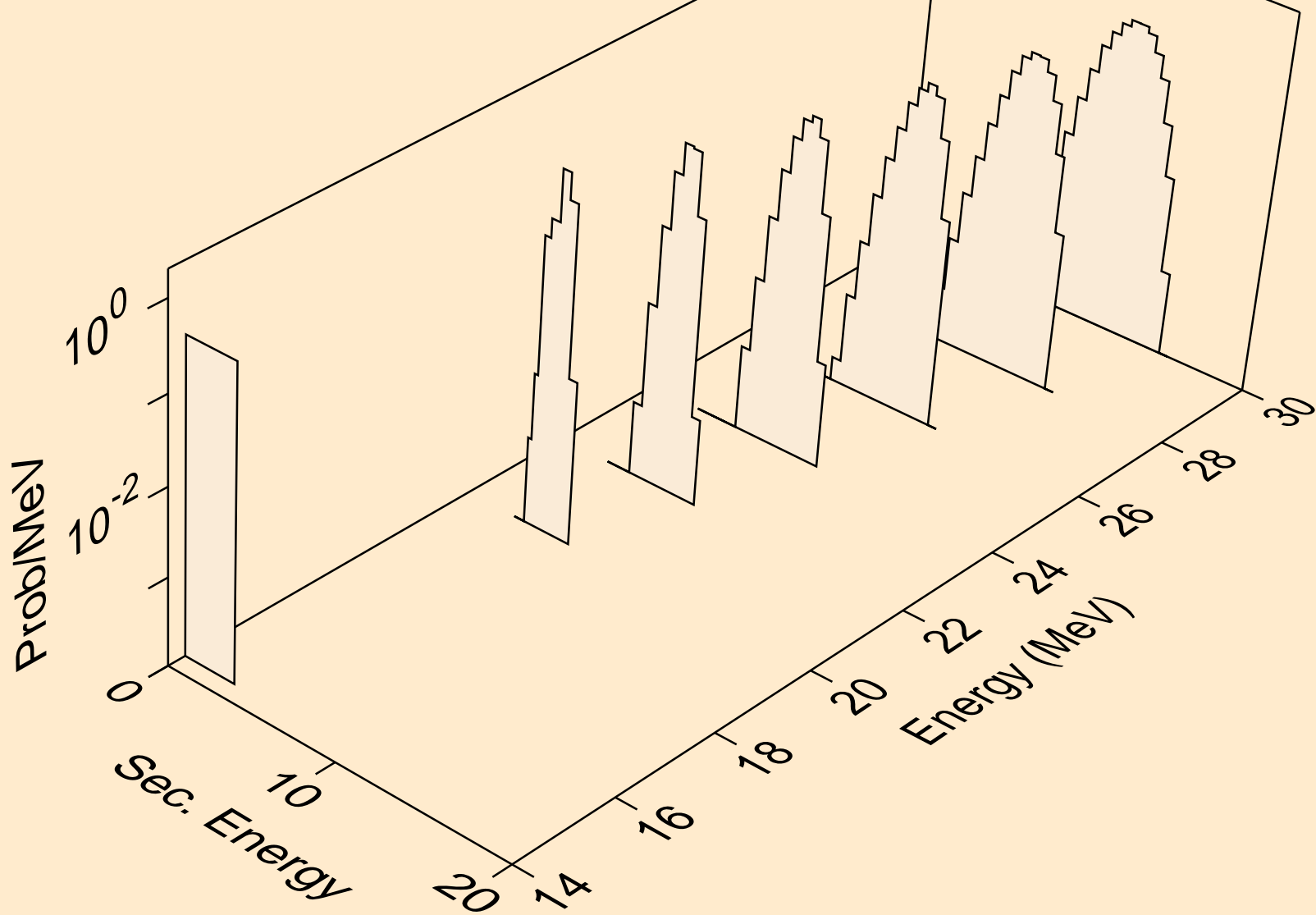

IN122 PROTON ACER TENDL-2023 LIBRARY; T=0.K  
alphas from (p,npa)

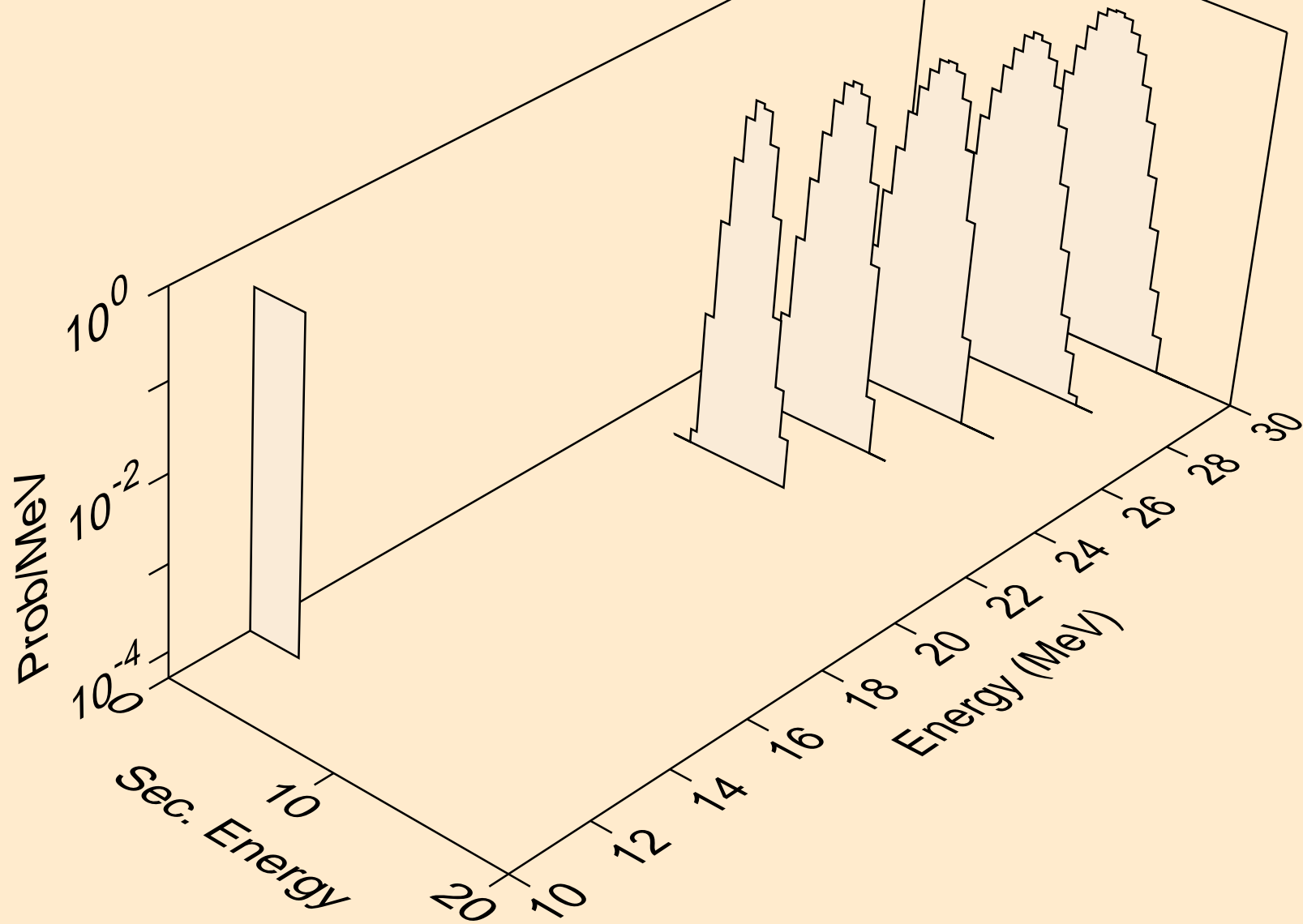

IN122 PROTON ACER TENDL-2023 LIBRARY; T=0.K  
alphas from (p,a)

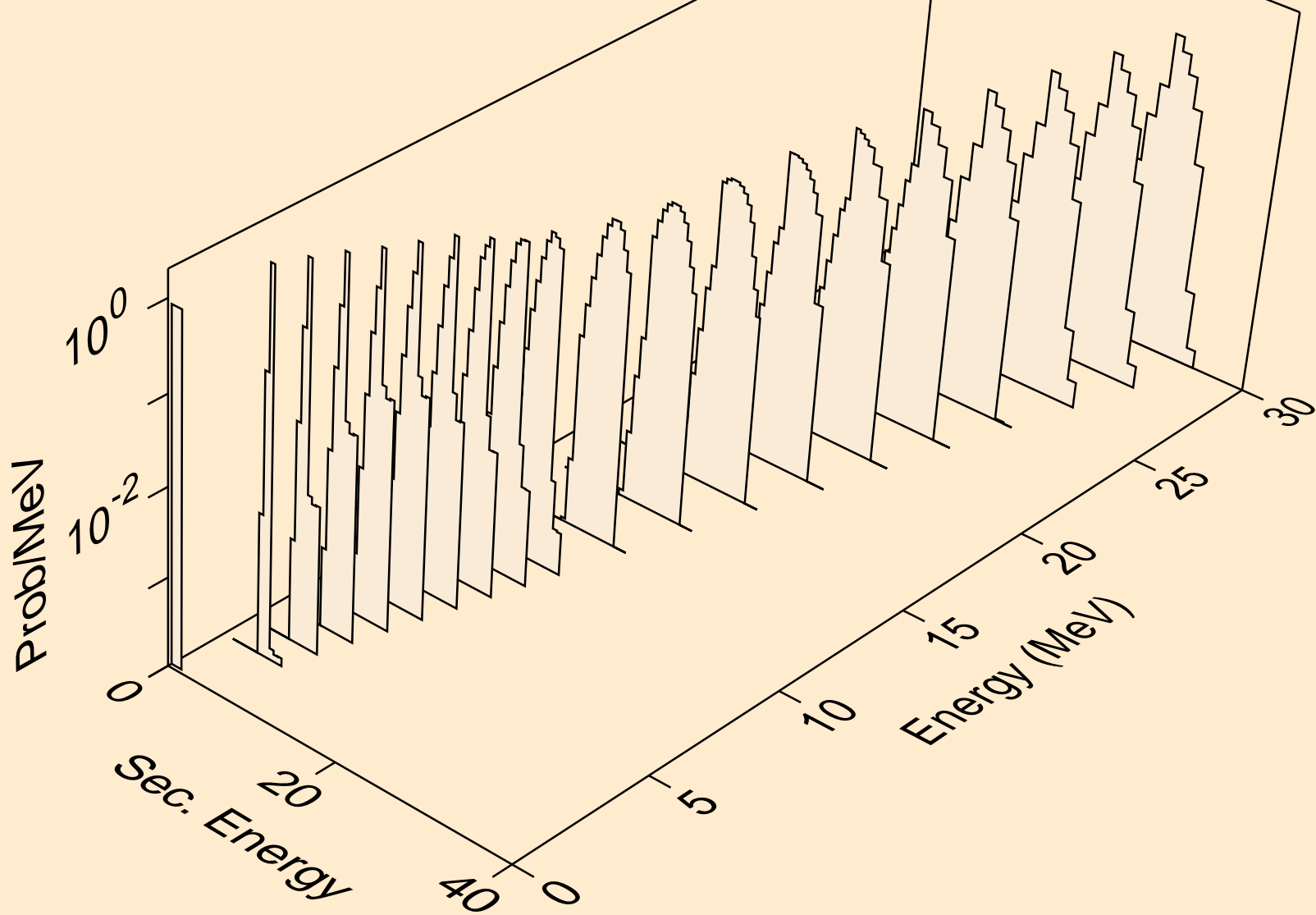

IN122 PROTON ACER TENDL-2023 LIBRARY; T=0.K  
alphas from (p,2a)

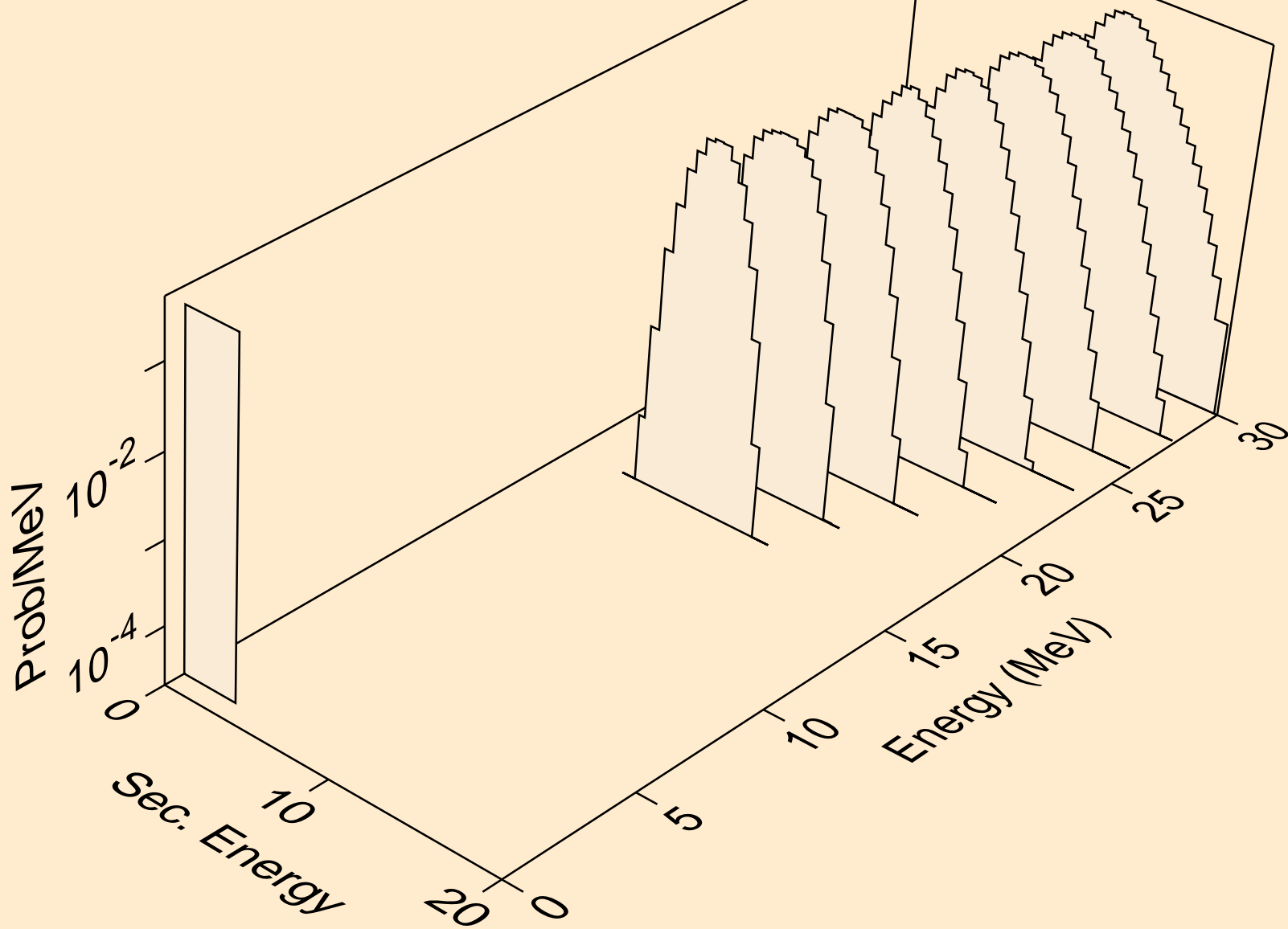

IN122 PROTON ACER TENDL-2023 LIBRARY; T=0.K  
alphas from (p,pa)

