

YB174 PROTON ACER TENDL-2023 LIBRARY; T=0.K  
Principal cross sections

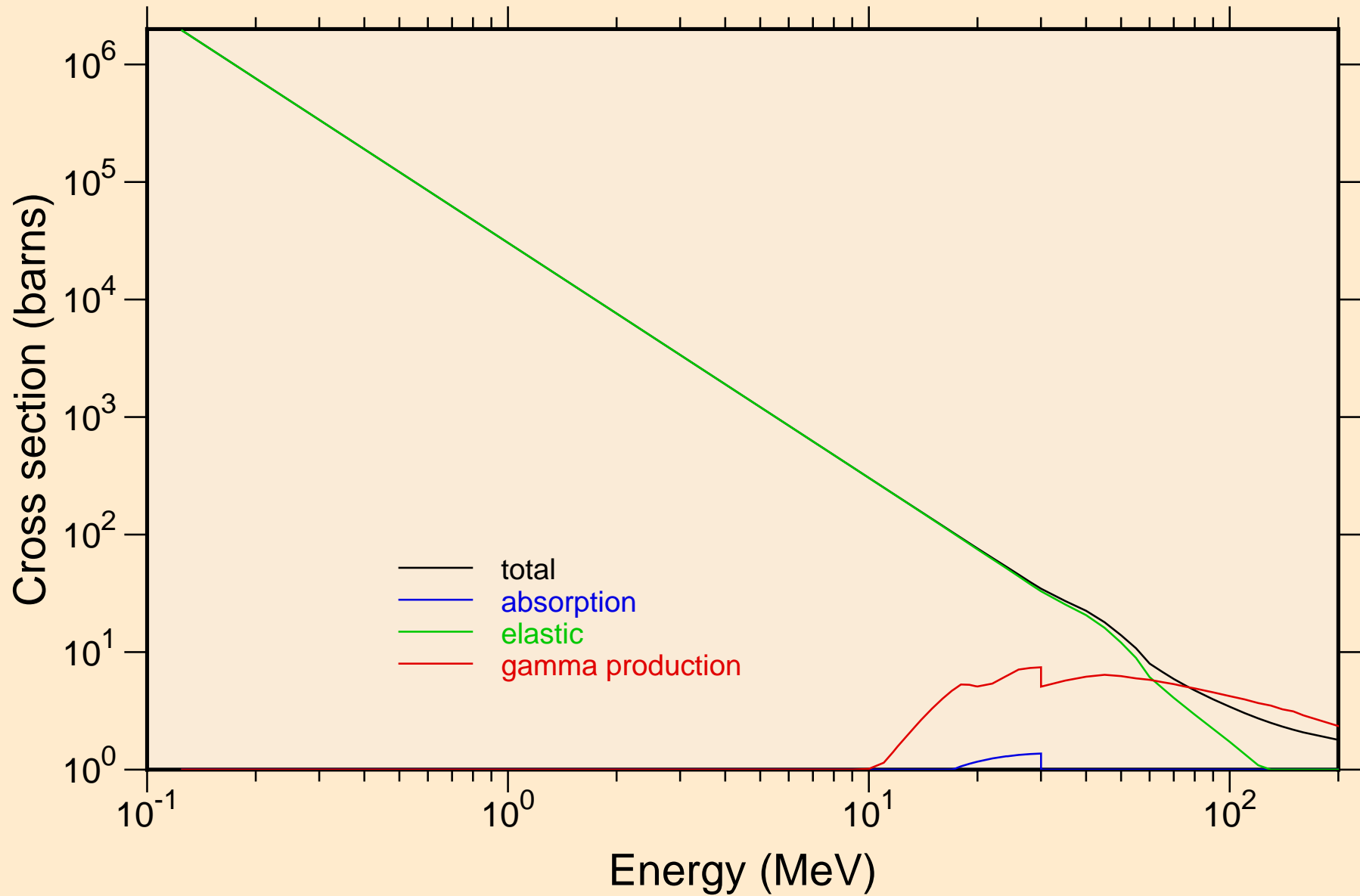

# YB174 PROTON ACER TENDL-2023 LIBRARY; T=0.K

## Heating

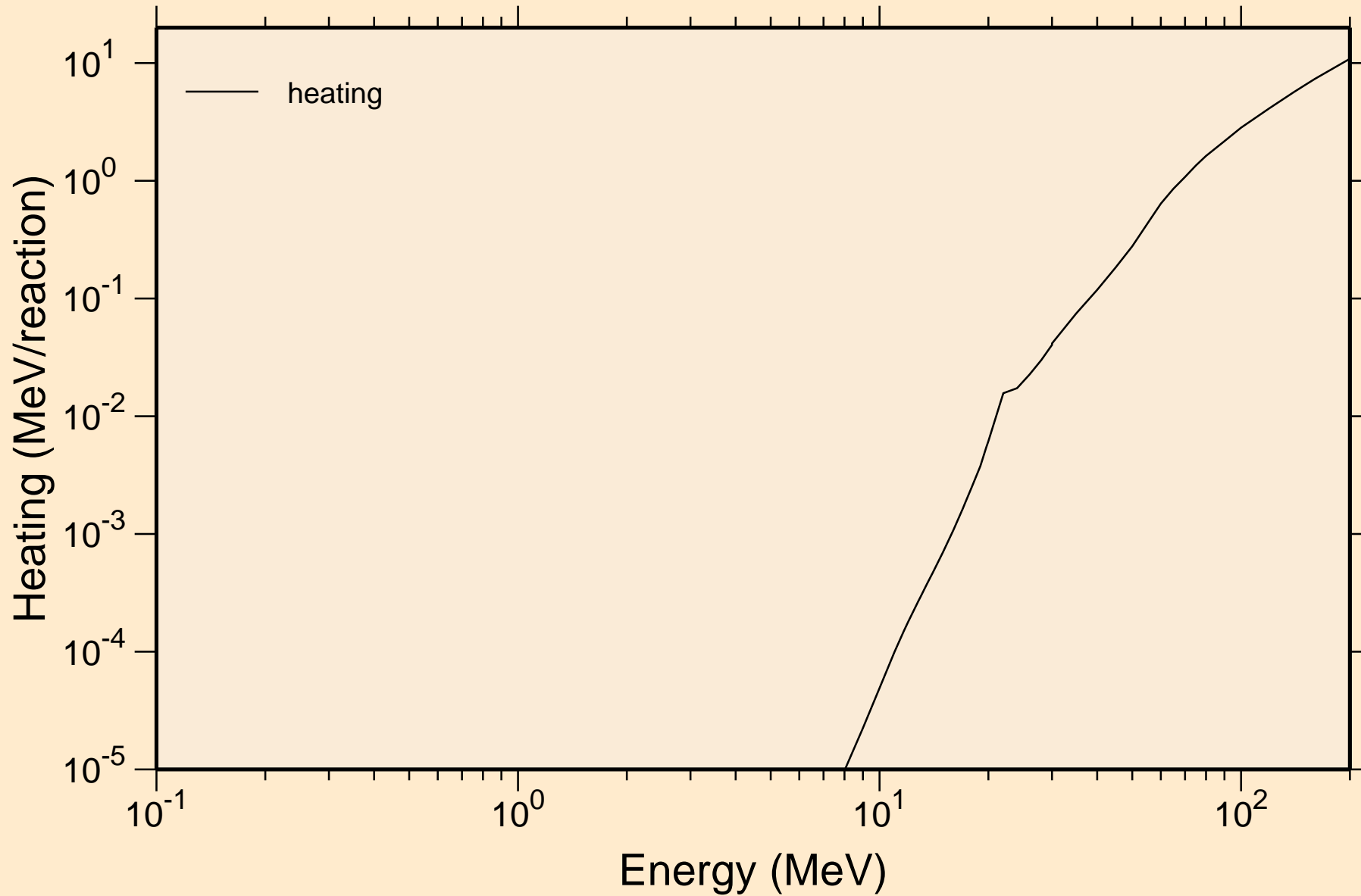

# YB174 PROTON ACER TENDL-2023 LIBRARY; T=0.K

## Principal cross sections

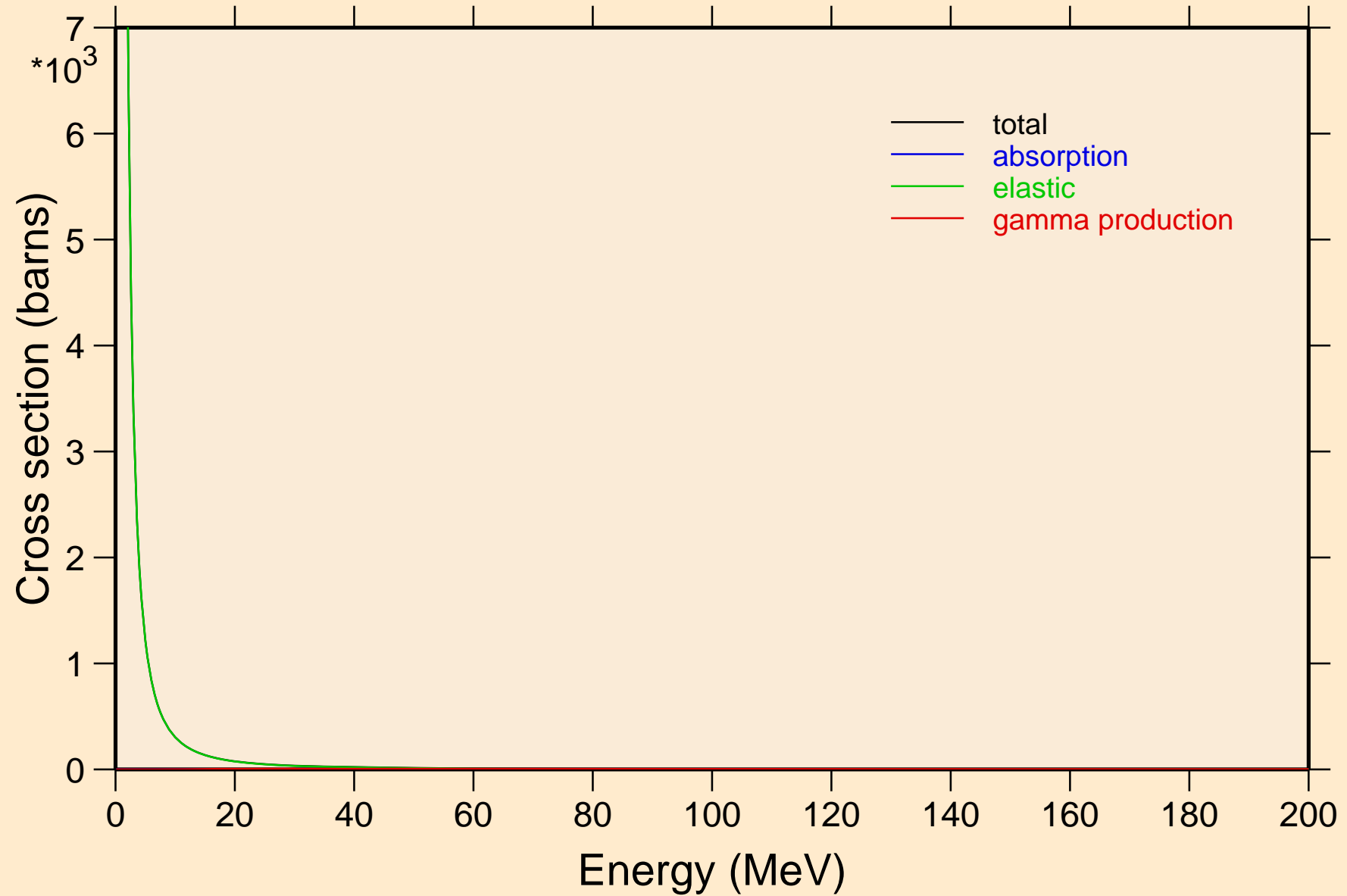

YB174 PROTON ACER TENDL-2023 LIBRARY; T=0.K

Heating

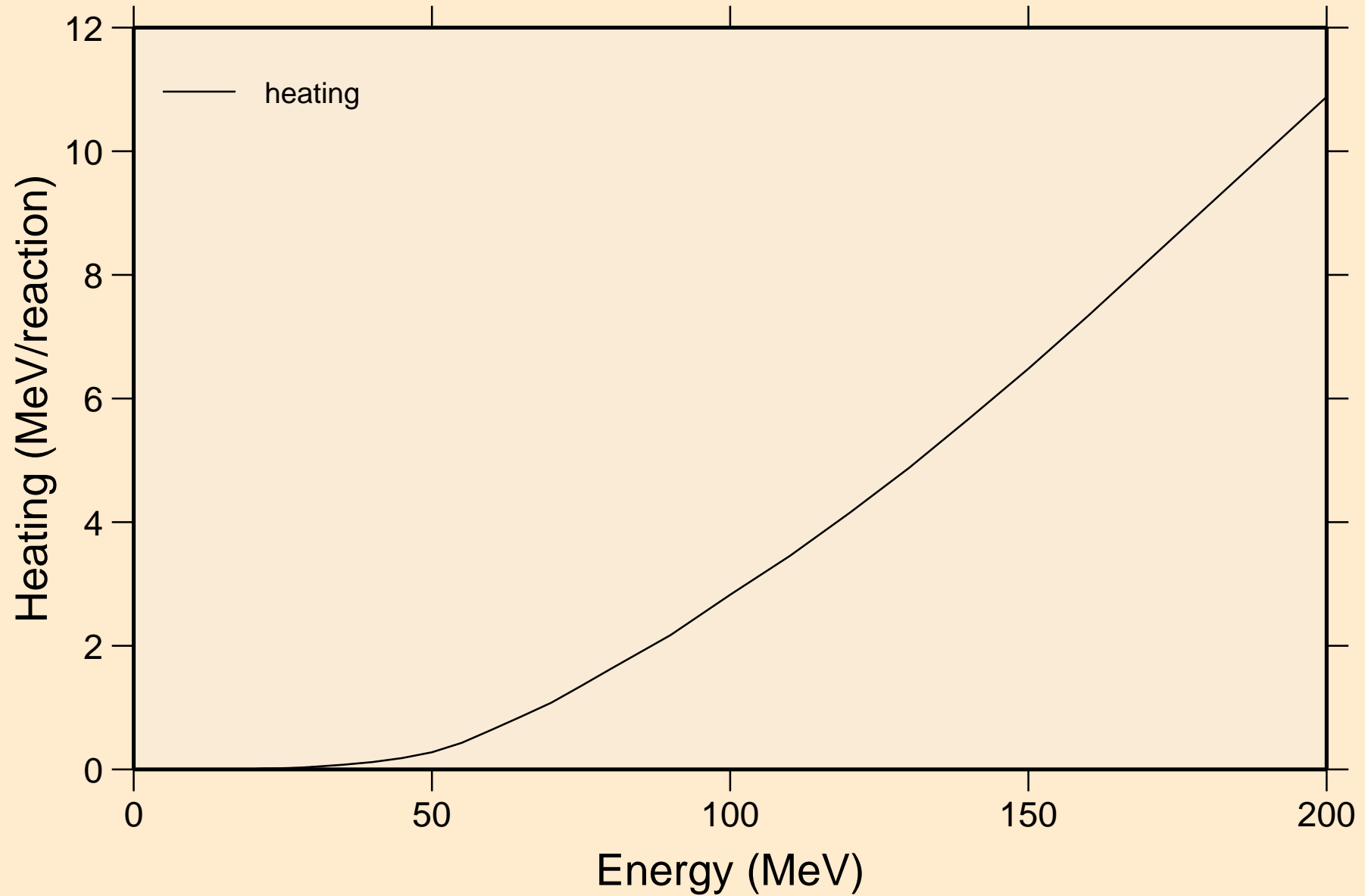

# YB174 PROTON ACER TENDL-2023 LIBRARY; T=0.K

## Threshold reactions

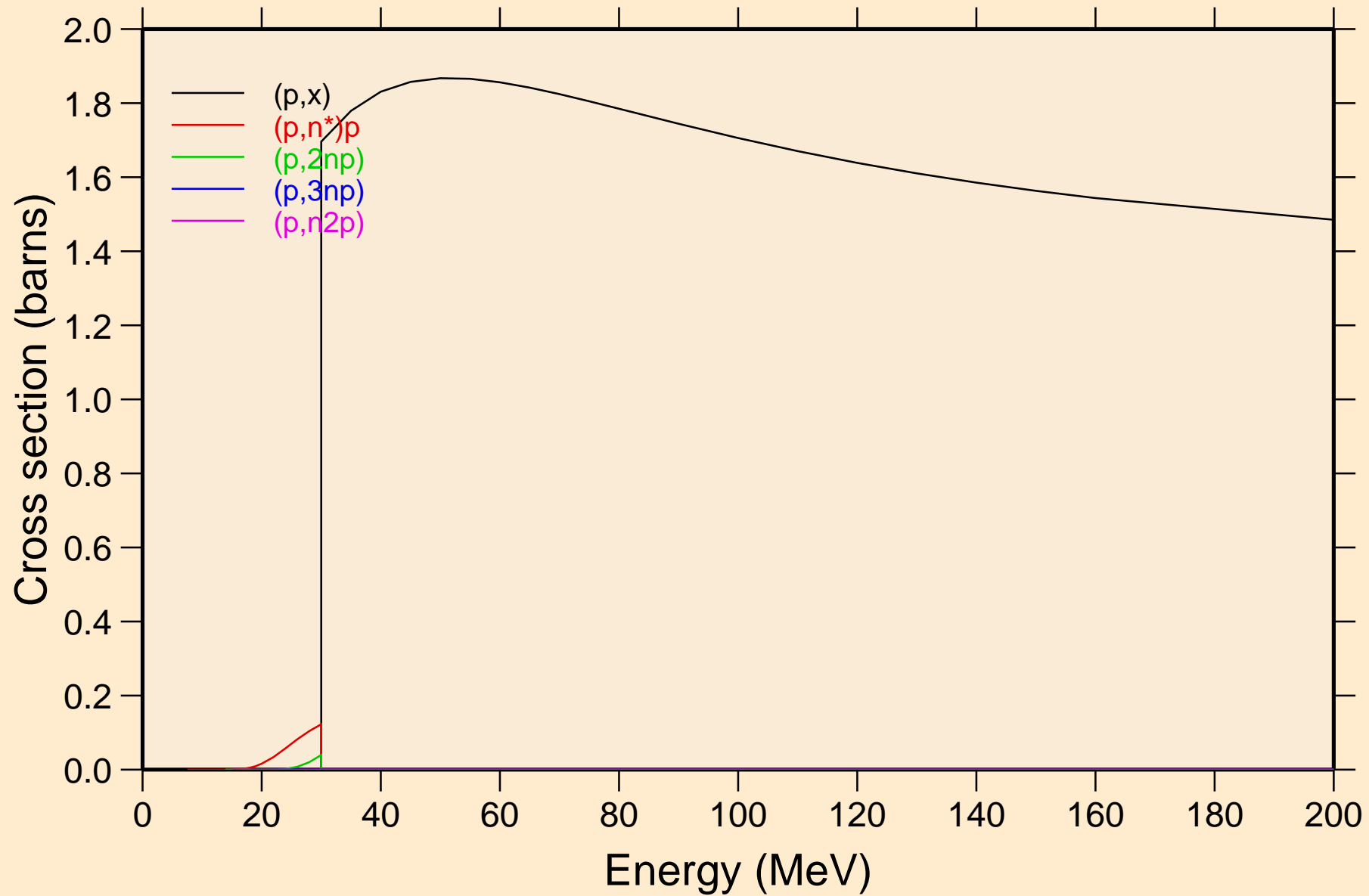

YB174 PROTON ACER TENDL-2023 LIBRARY; T=0.K  
Threshold reactions

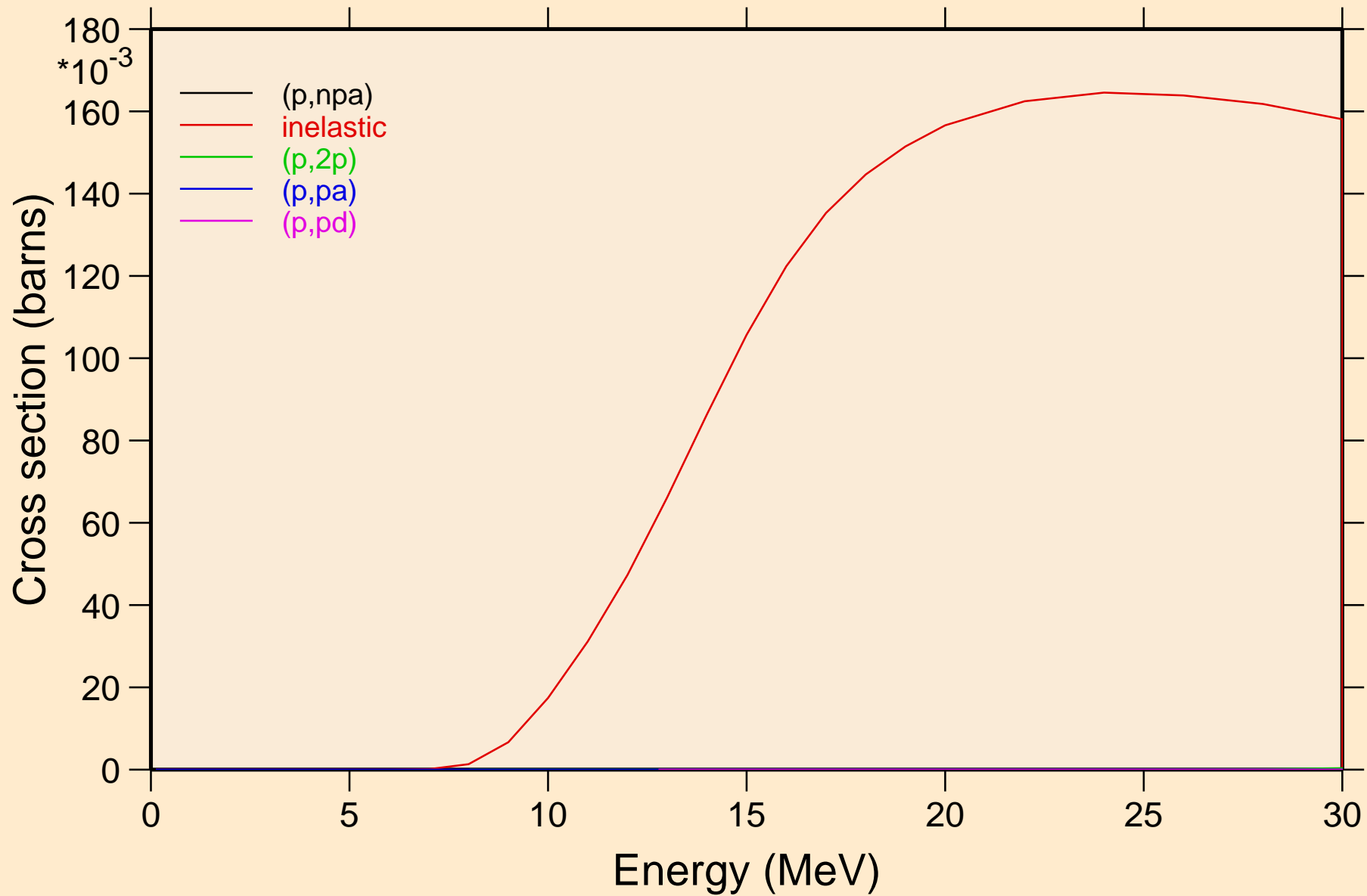

YB174 PROTON ACER TENDL-2023 LIBRARY; T=0.K  
Threshold reactions

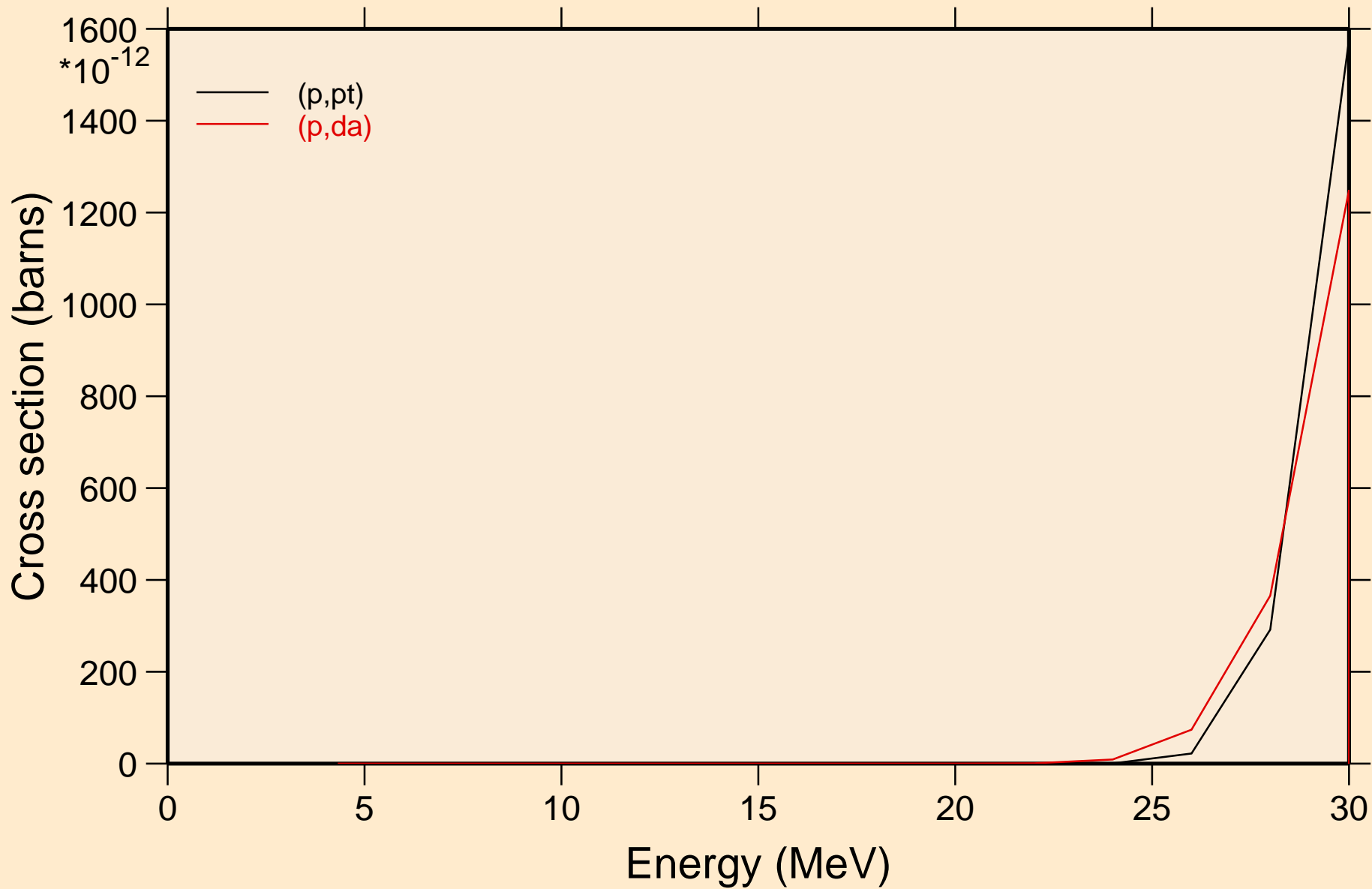

YB174 PROTON ACER TENDL-2023 LIBRARY; T=0.K  
angular distribution for elastic

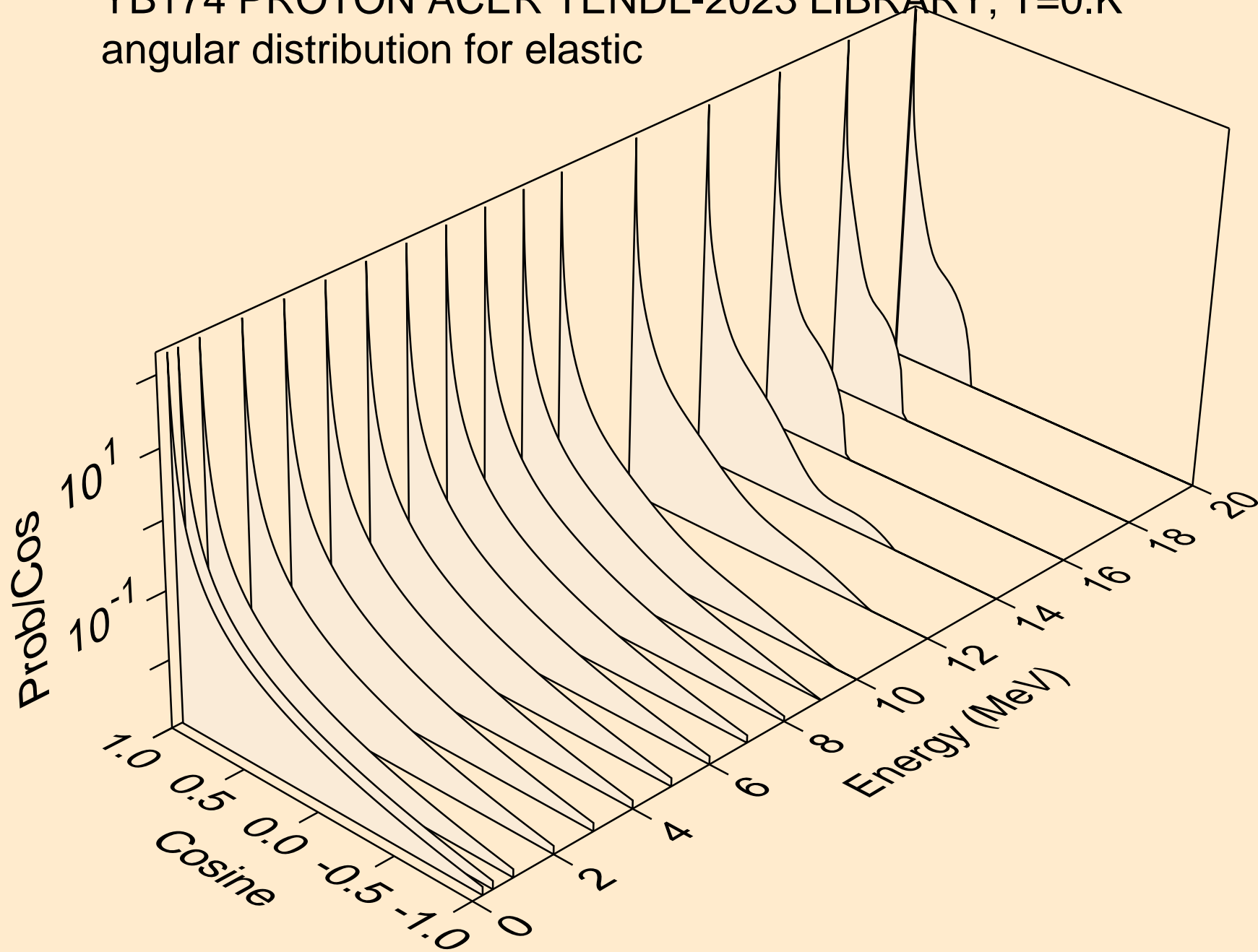



YB174 PROTON ACER TENDL-2023 LIBRARY; T=0.K  
angular distribution for elastic

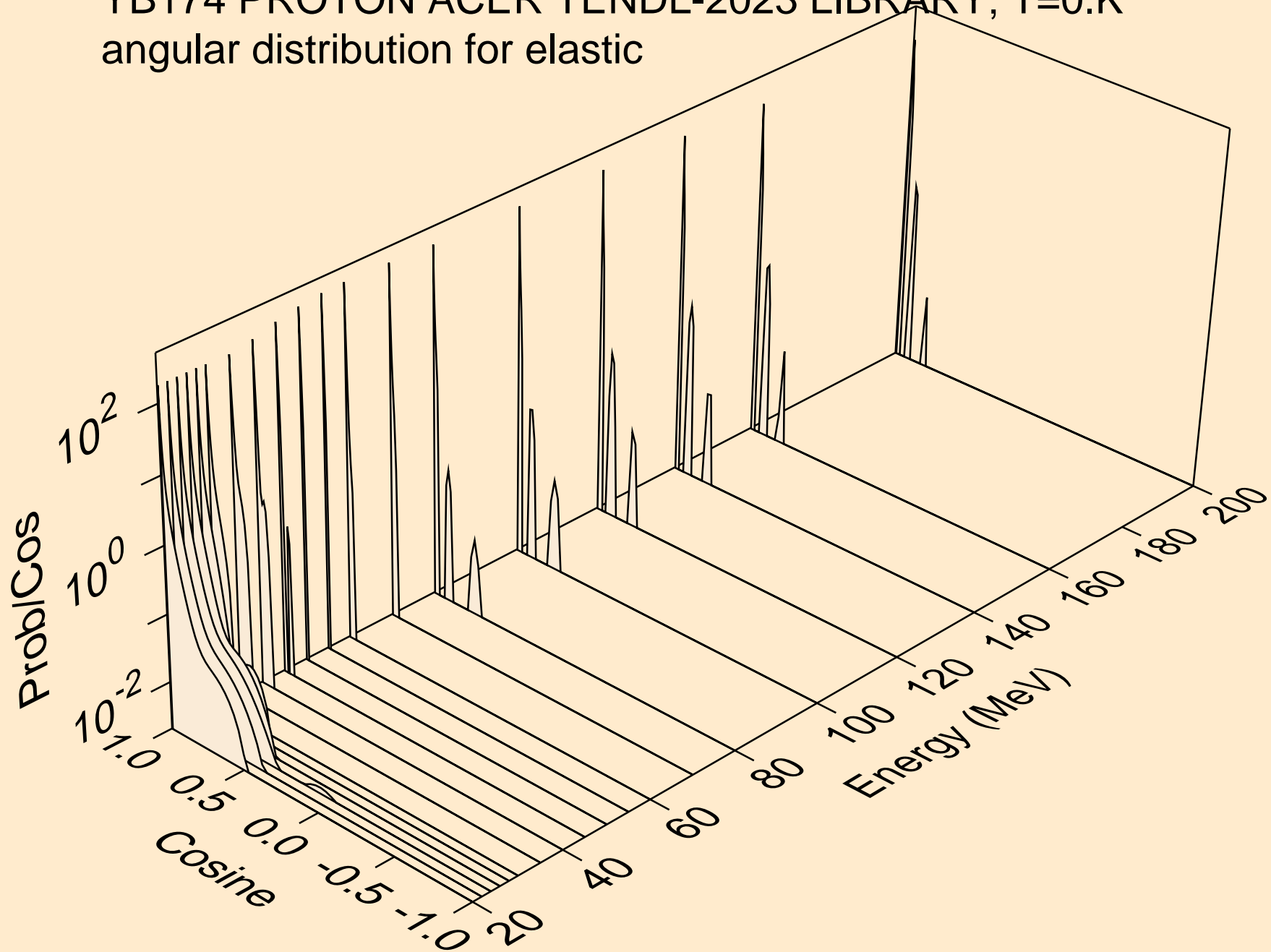

YB174 PROTON ACER TENDL-2023 LIBRARY; T=0.K  
Proton emission for (p,x)

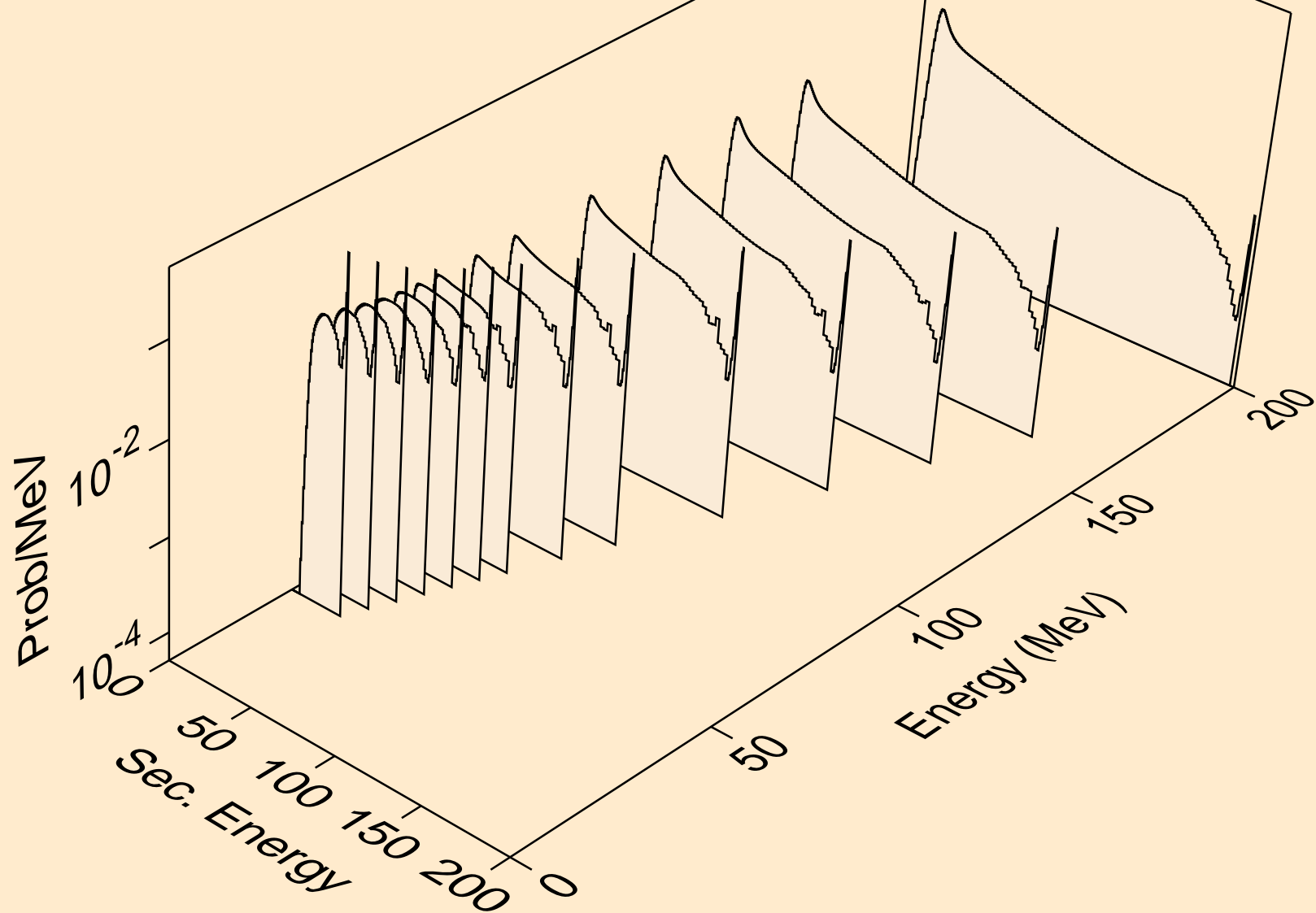

YB174 PROTON ACER TENDL-2023 LIBRARY; T=0.K  
Proton emission for (p,n\*)p

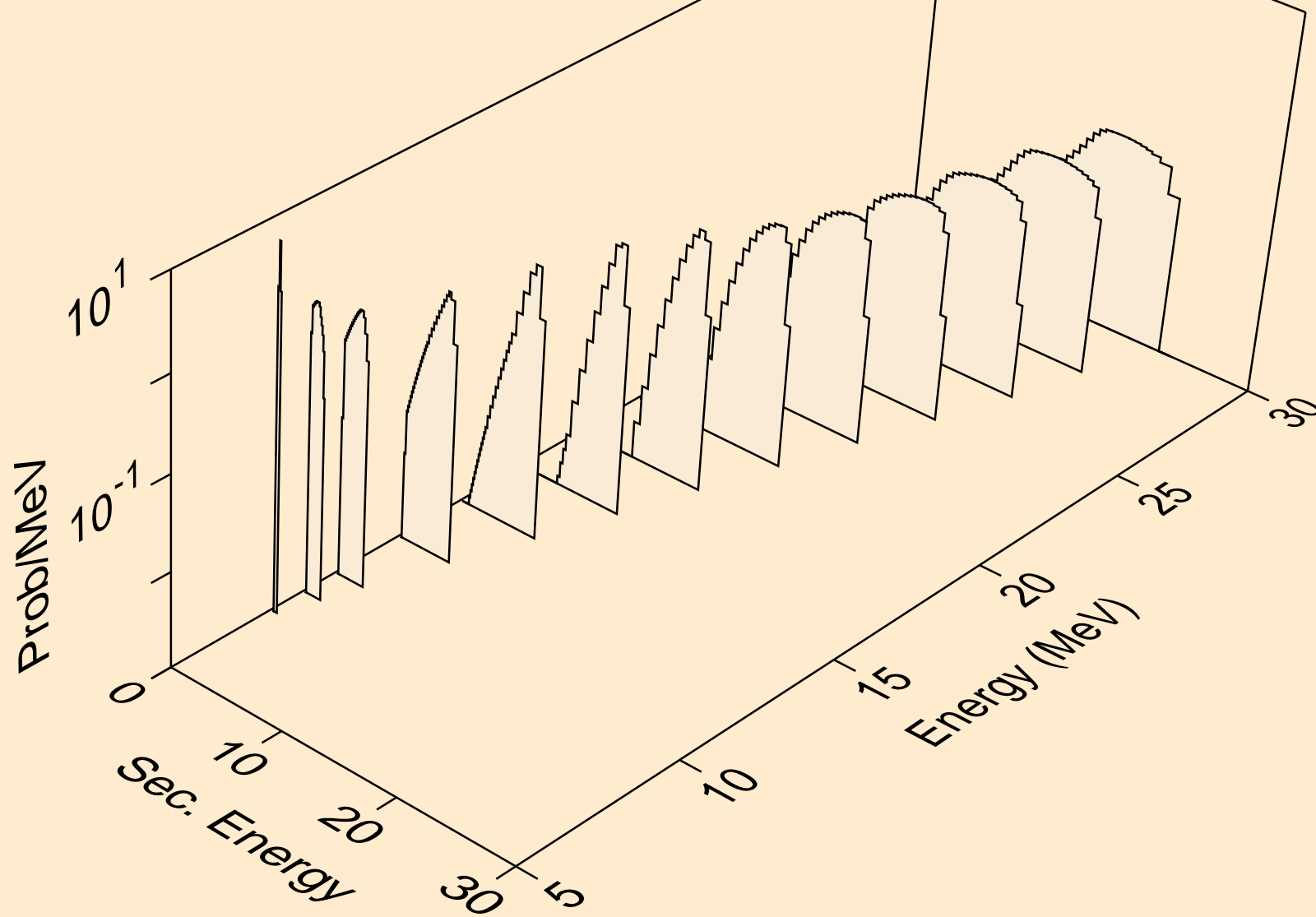

YB174 PROTON ACER TENDL-2023 LIBRARY; T=0.K  
Proton emission for (p,2np)

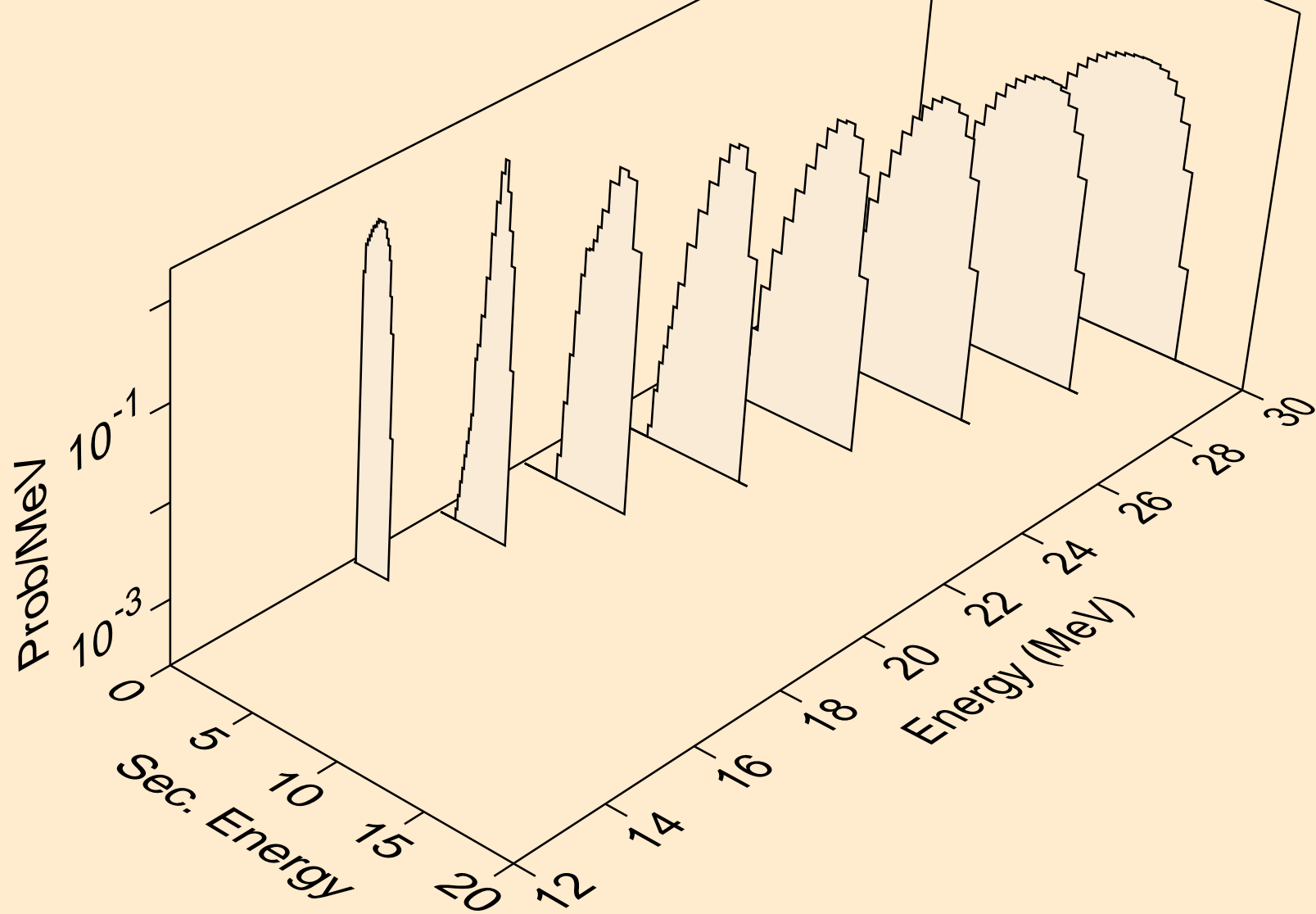

YB174 PROTON ACER TENDL-2023 LIBRARY; T=0.K  
Proton emission for (p,3np)

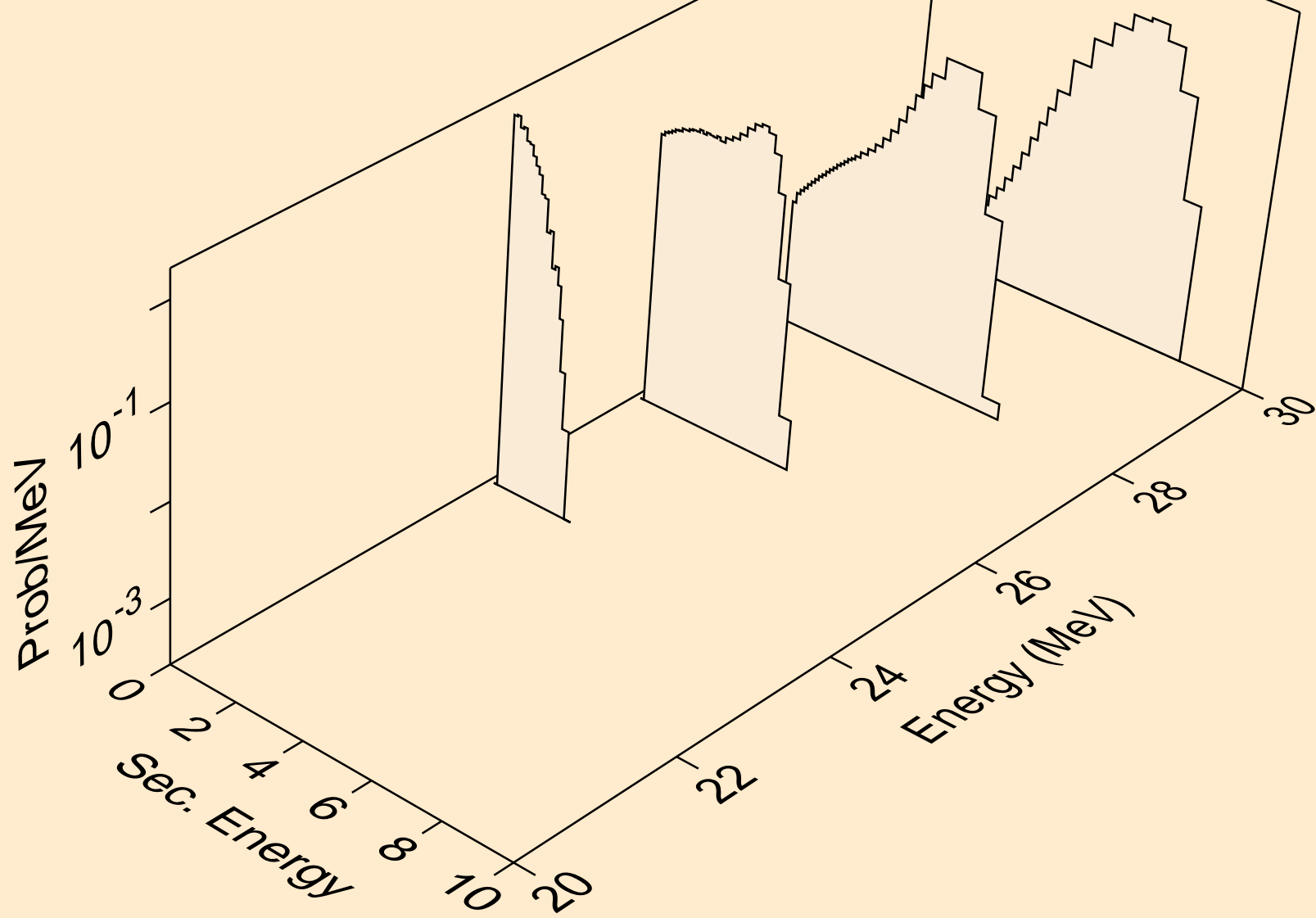

YB174 PROTON ACER TENDL-2023 LIBRARY; T=0.K  
Proton emission for (p,n2p)

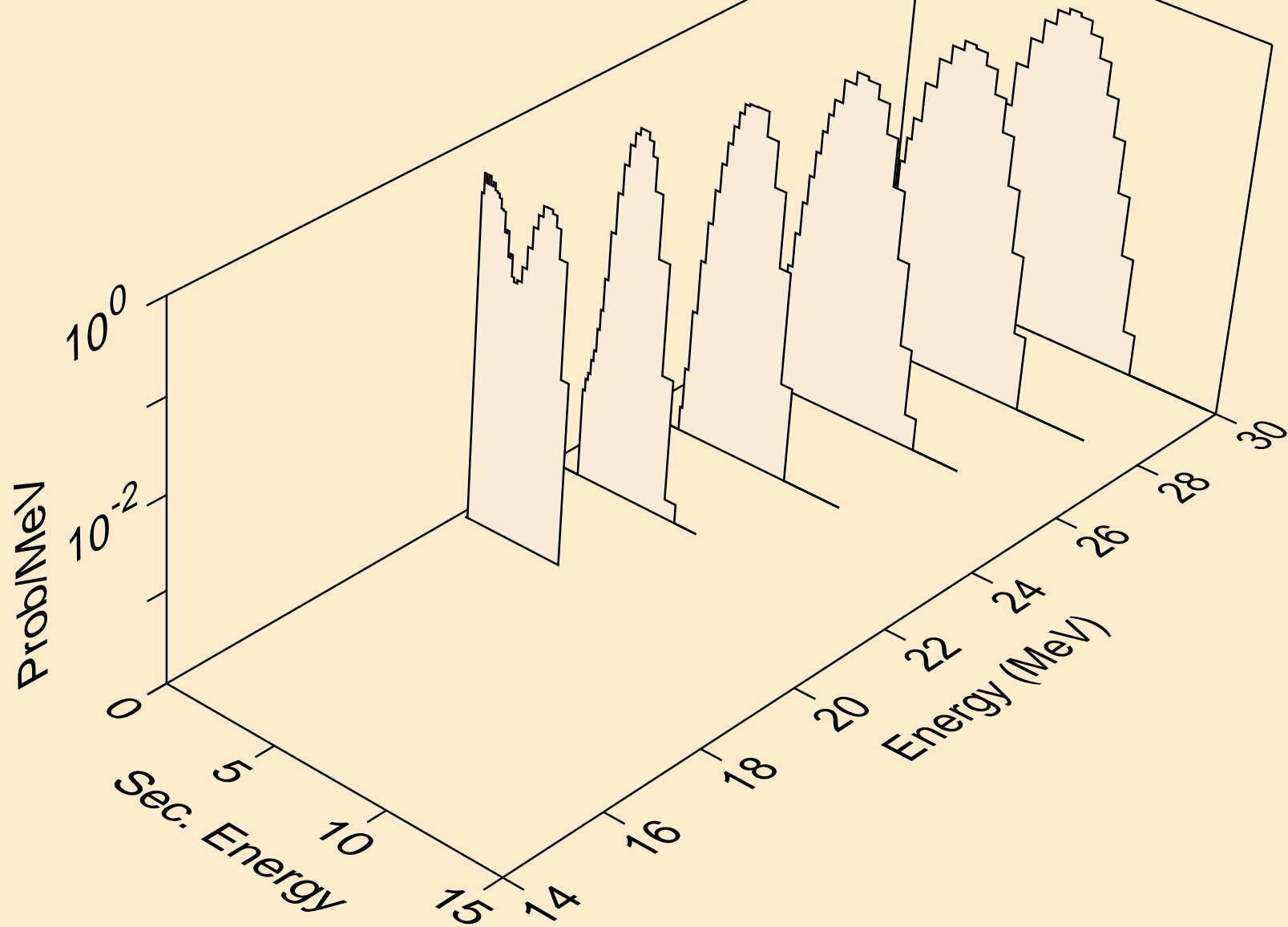

YB174 PROTON ACER TENDL-2023 LIBRARY; T=0.K  
Proton emission for (p,npa)

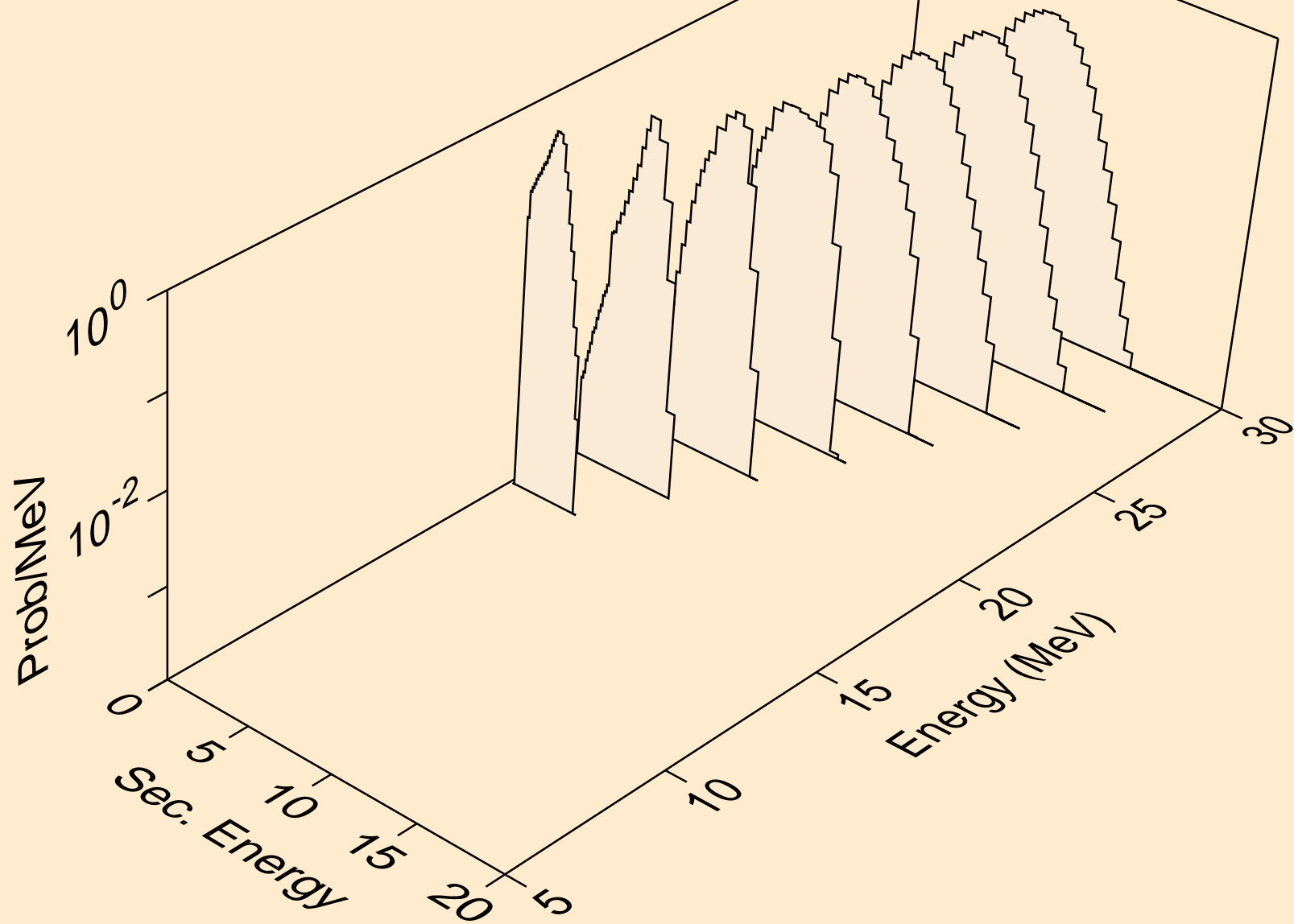

YB174 PROTON ACER TENDL-2023 LIBRARY; T=0.K  
Proton emission for inelastic

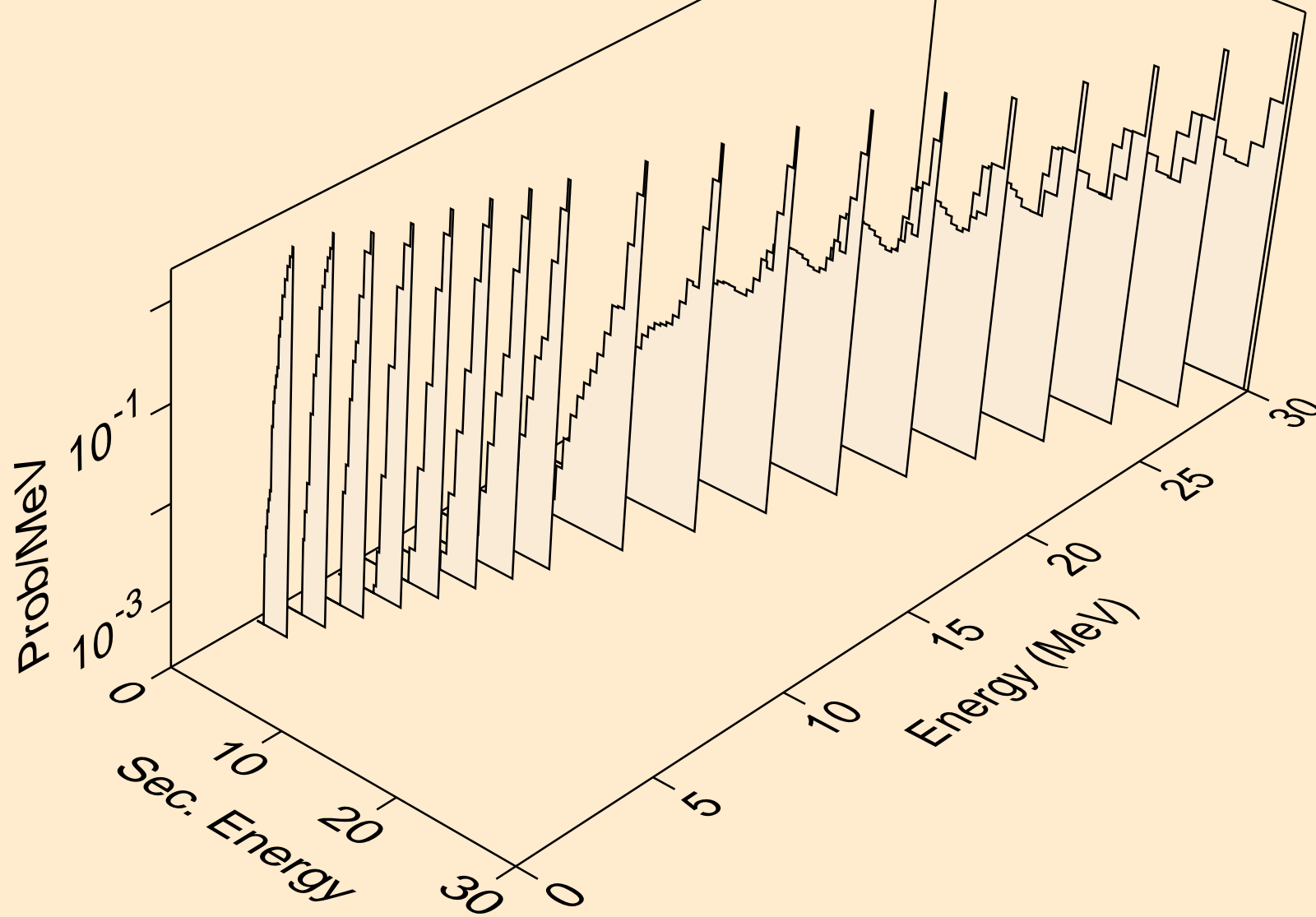



YB174 PROTON ACER TENDL-2023 LIBRARY; T=0.K  
Proton emission for (p,2p)

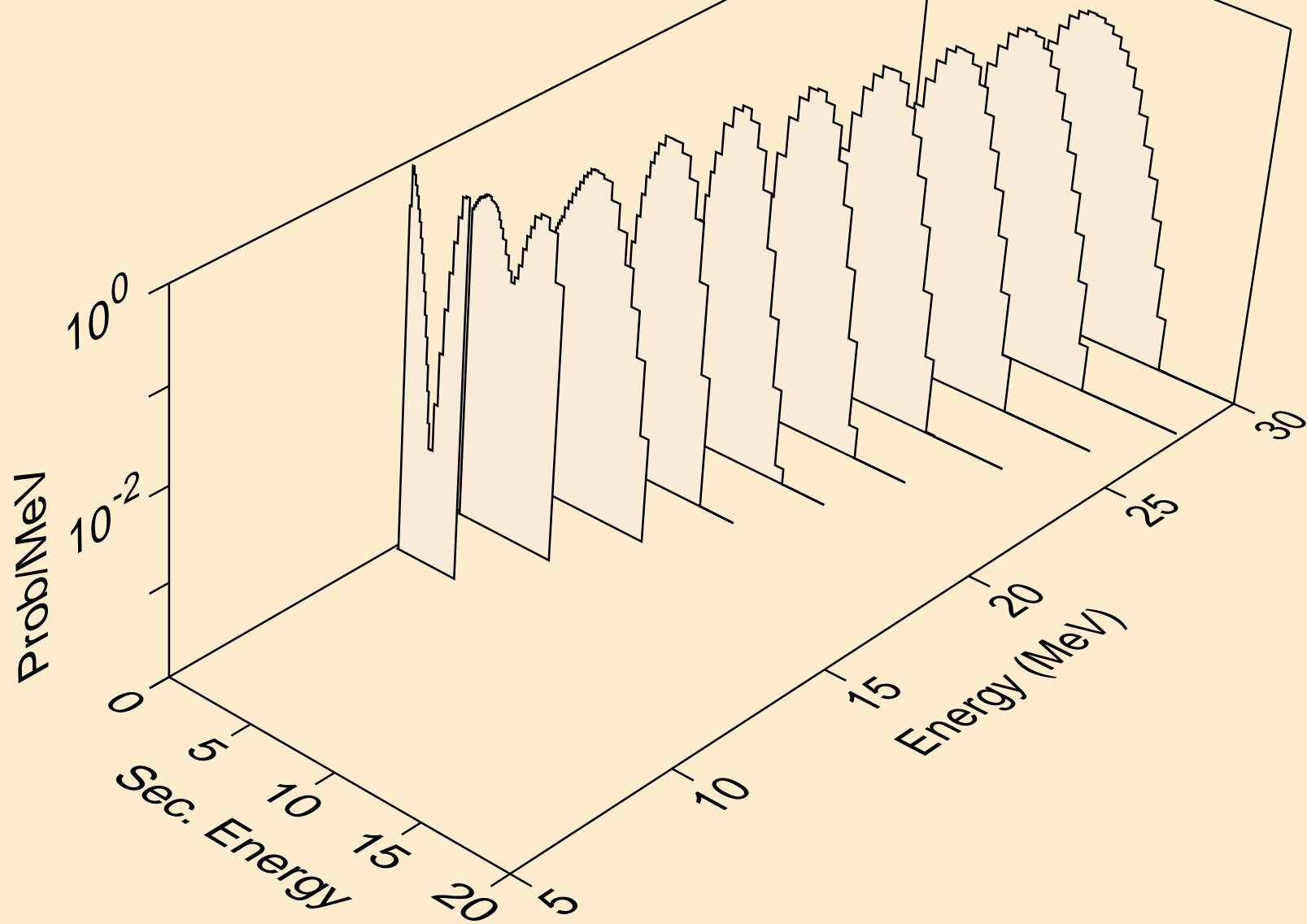

YB174 PROTON ACER TENDL-2023 LIBRARY; T=0.K  
Proton emission for (p,pa)

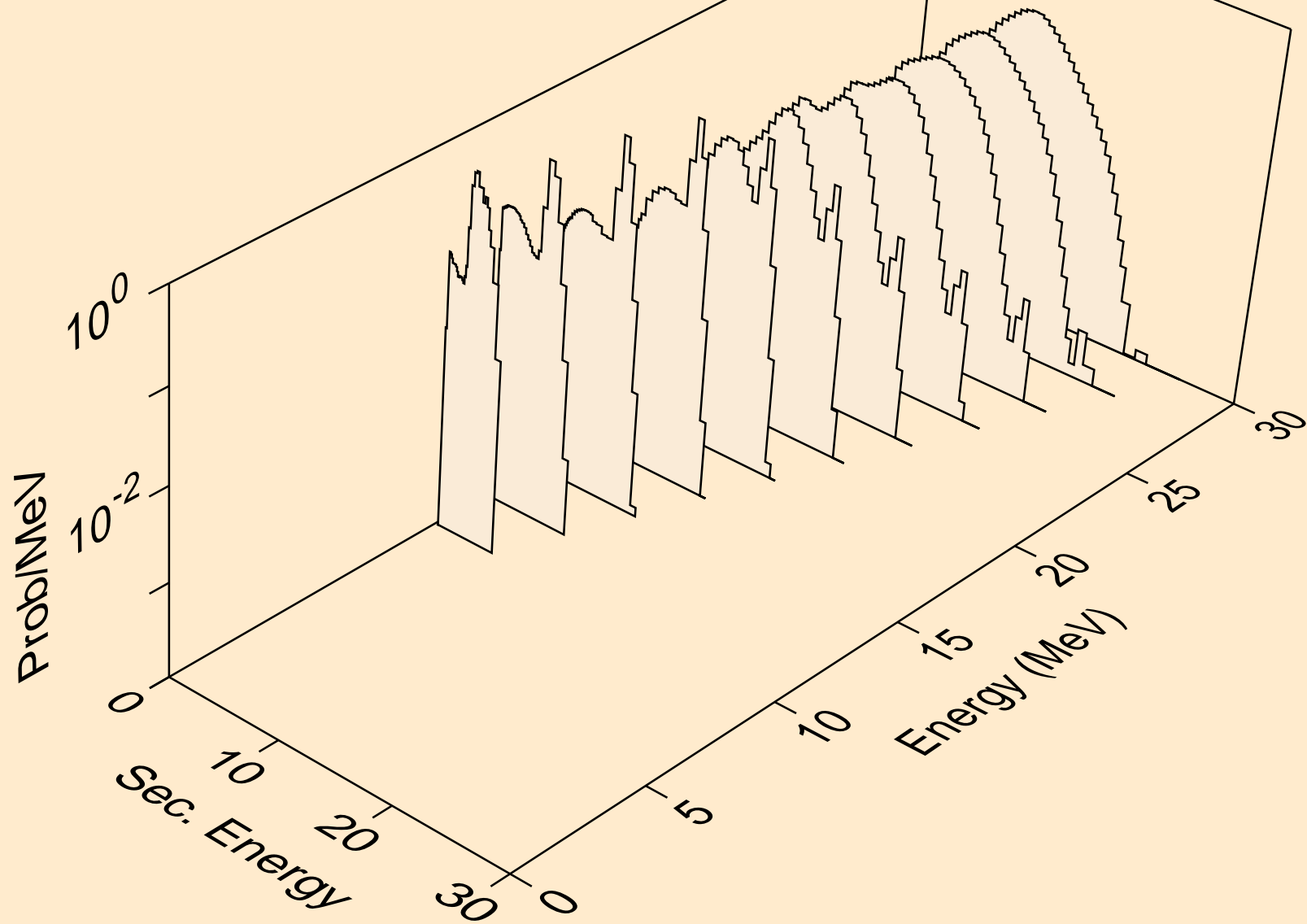

YB174 PROTON ACER TENDL-2023 LIBRARY; T=0.K  
Proton emission for (p,pd)

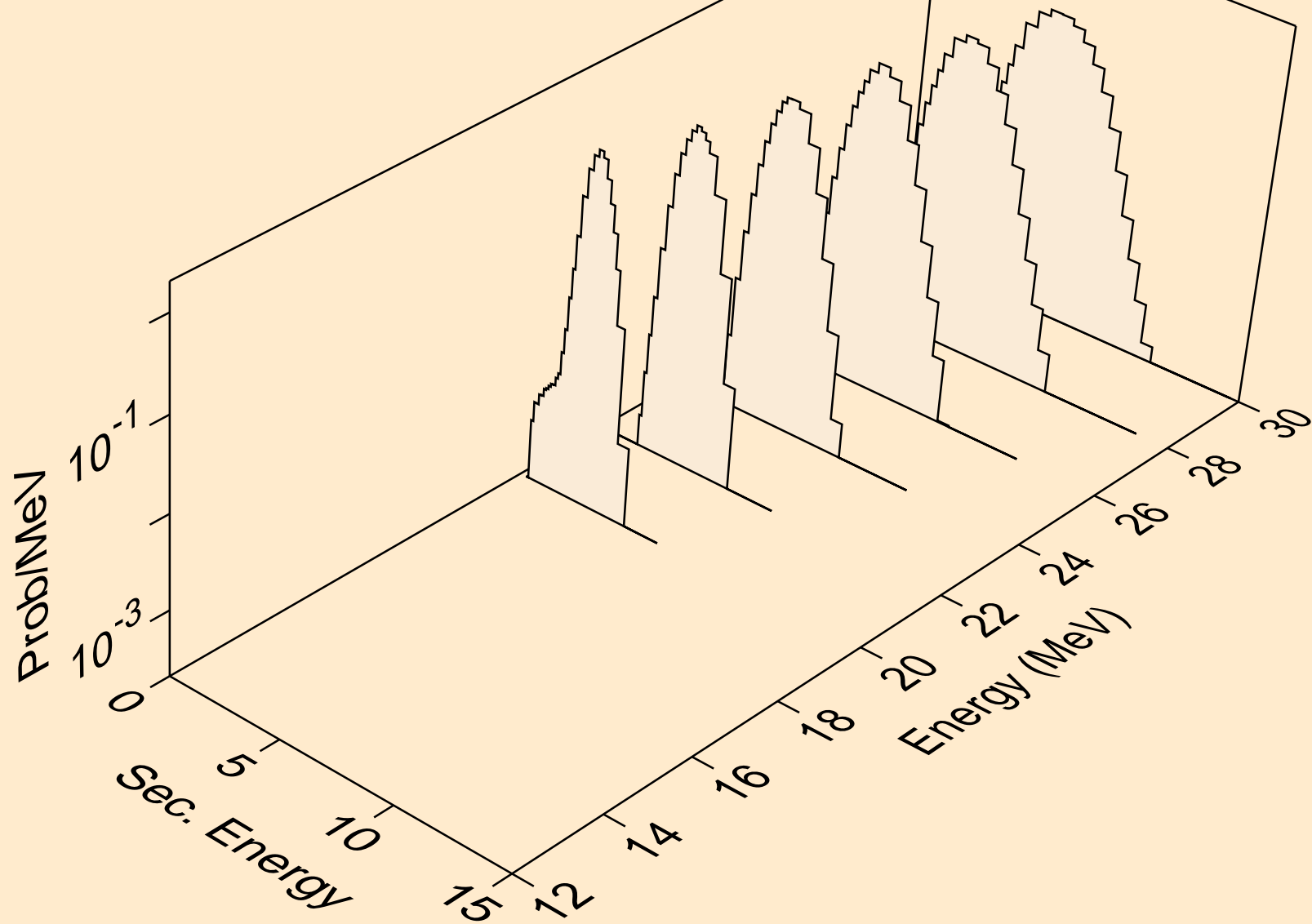

YB174 PROTON ACER TENDL-2023 LIBRARY; T=0.K  
Proton emission for (p,pt)

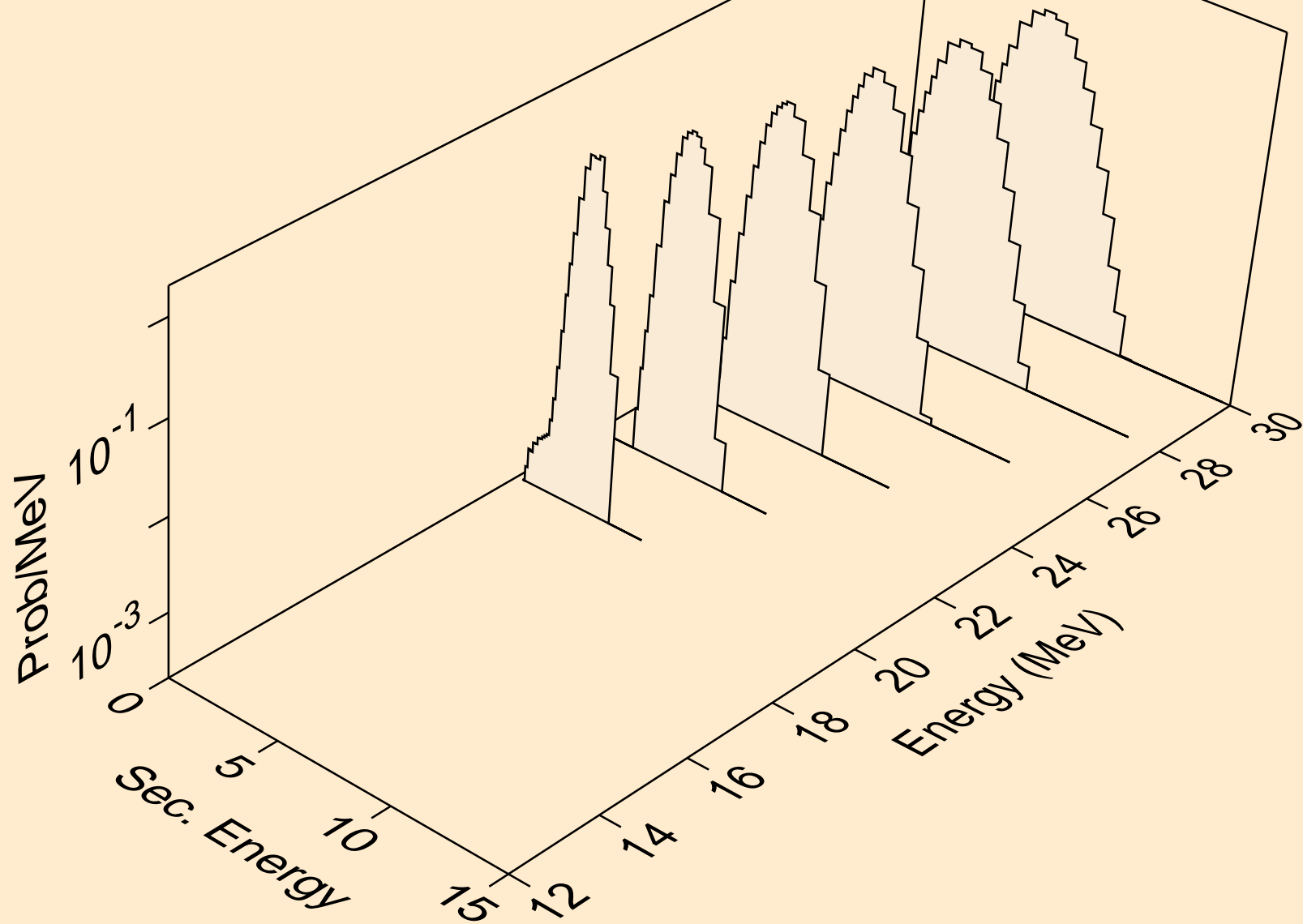

YB174 PROTON ACER TENDL-2023 LIBRARY; T=0.K  
Photon emission for (z,n)

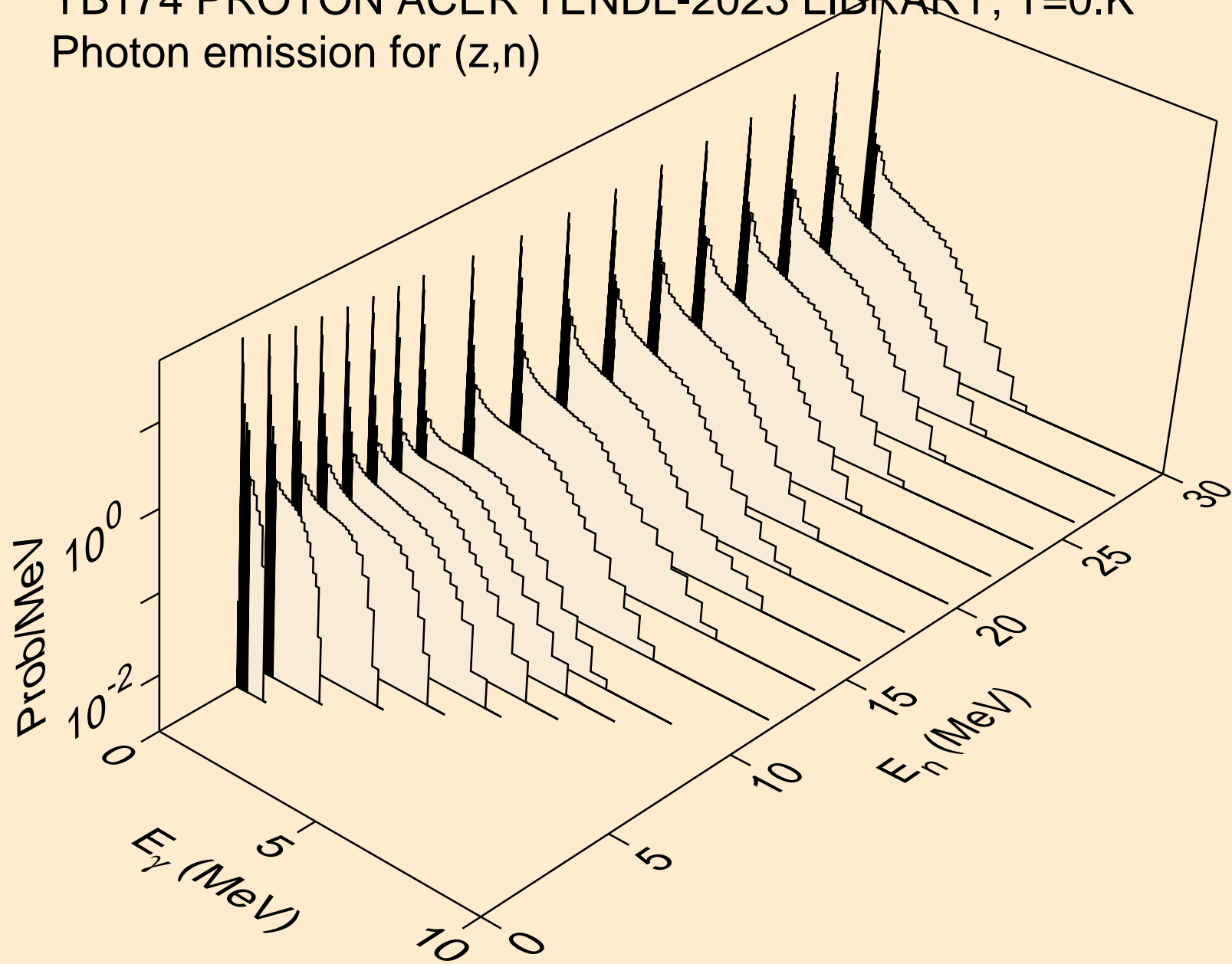

YB174 PROTON ACER TENDL-2023 LIBRARY; T=0.K  
Photon emission for (z,x)

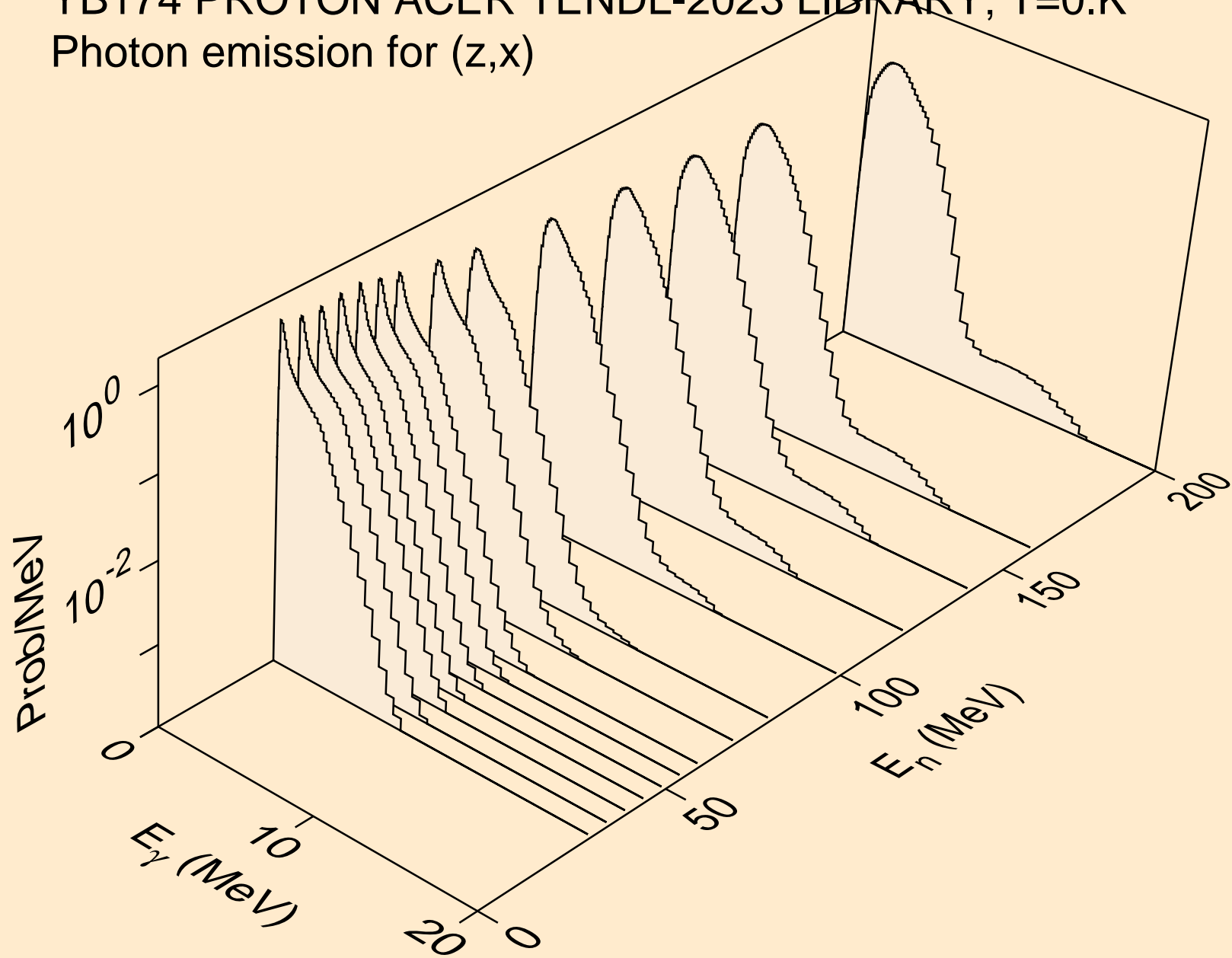

YB174 PROTON ACER TENDL-2023 LIBRARY; T=0.K  
Photon emission for (n,2nd)

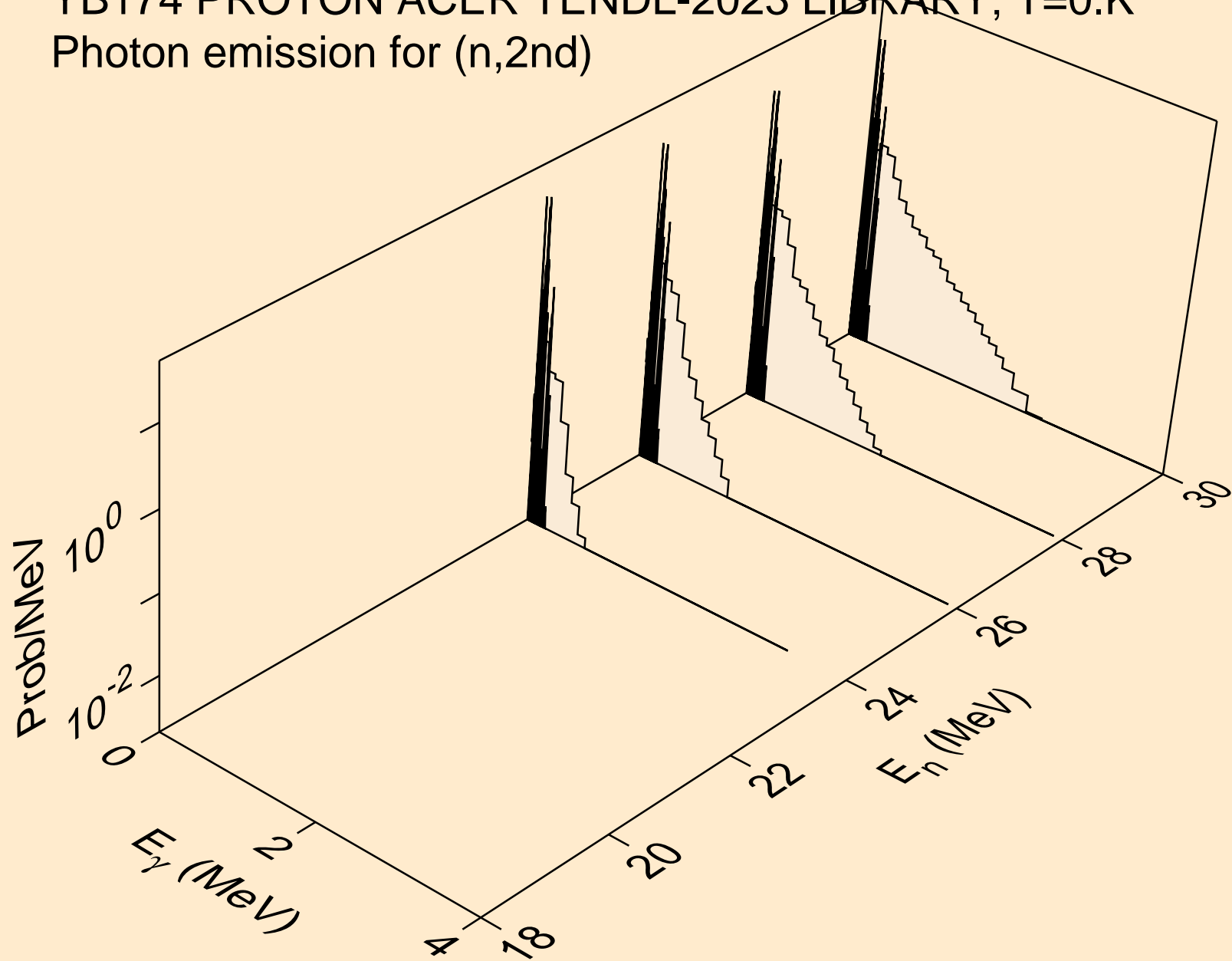

YB174 PROTON ACER TENDL-2023 LIBRARY; T=0.K  
Photon emission for (n,2n)

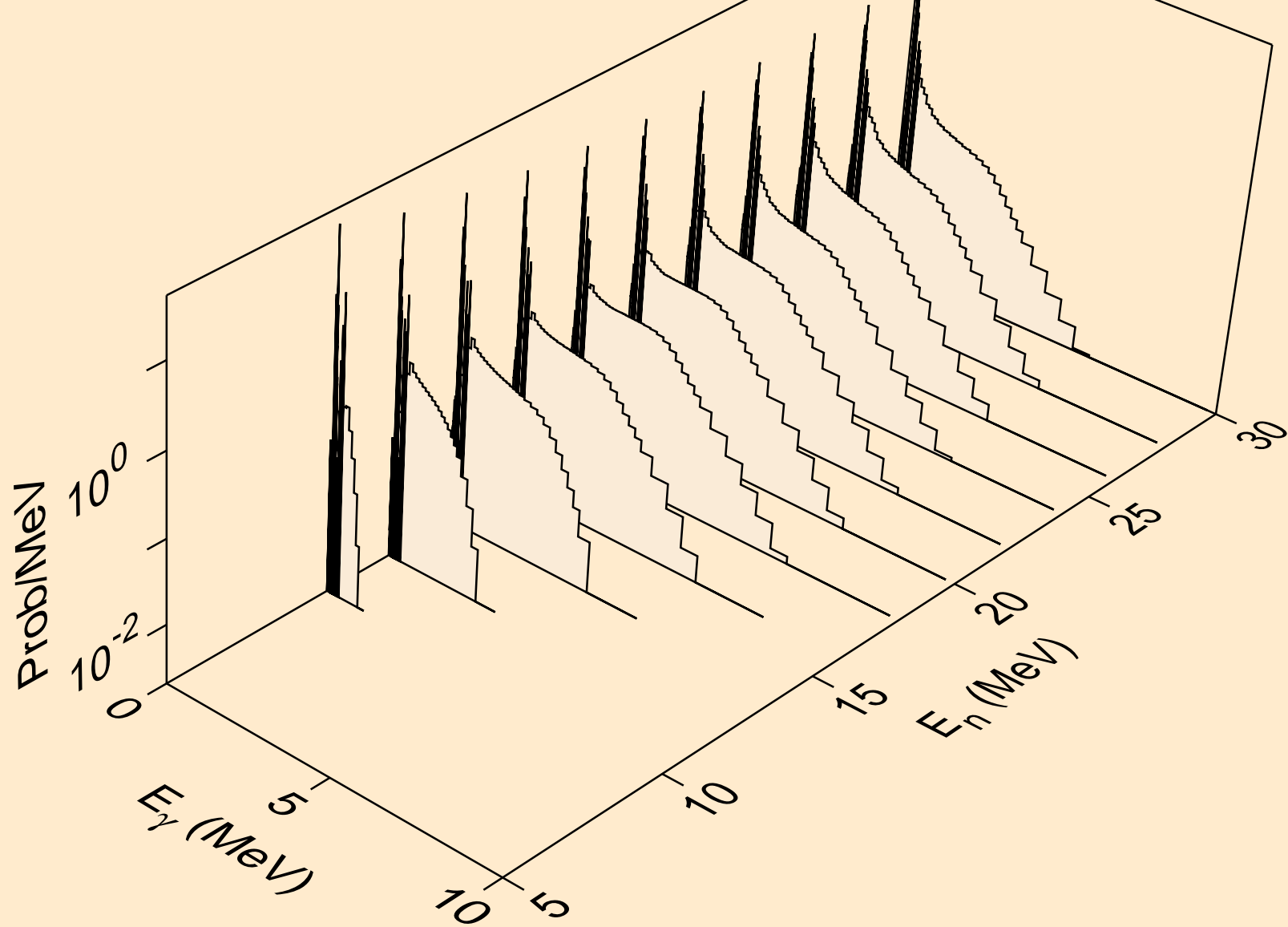



YB174 PROTON ACER TENDL-2023 LIBRARY; T=0.K  
Photon emission for (n,3n)

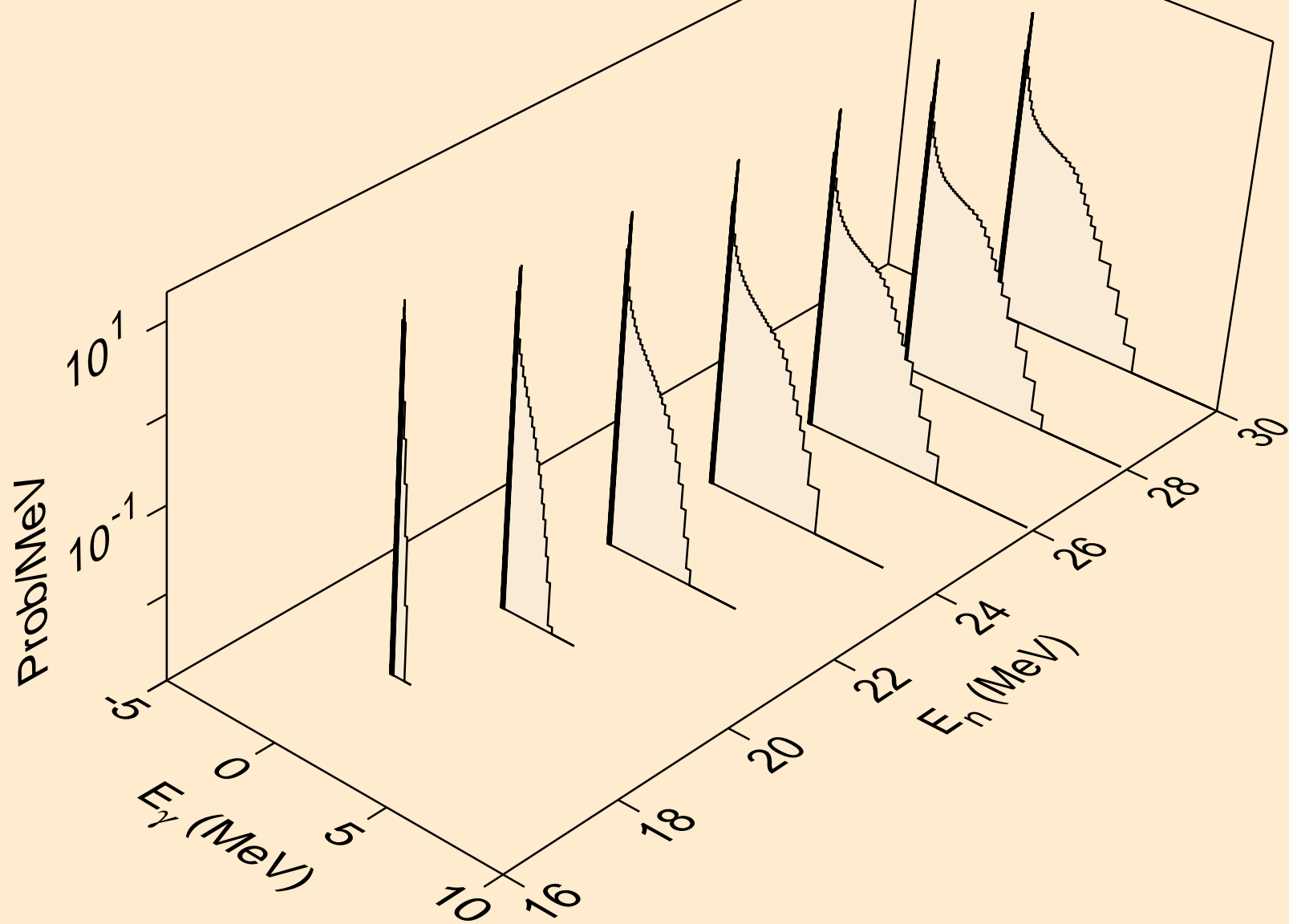

YB174 PROTON ACER TENDL-2023 LIBRARY; T=0.K  
Photon emission for (n,n\*)a

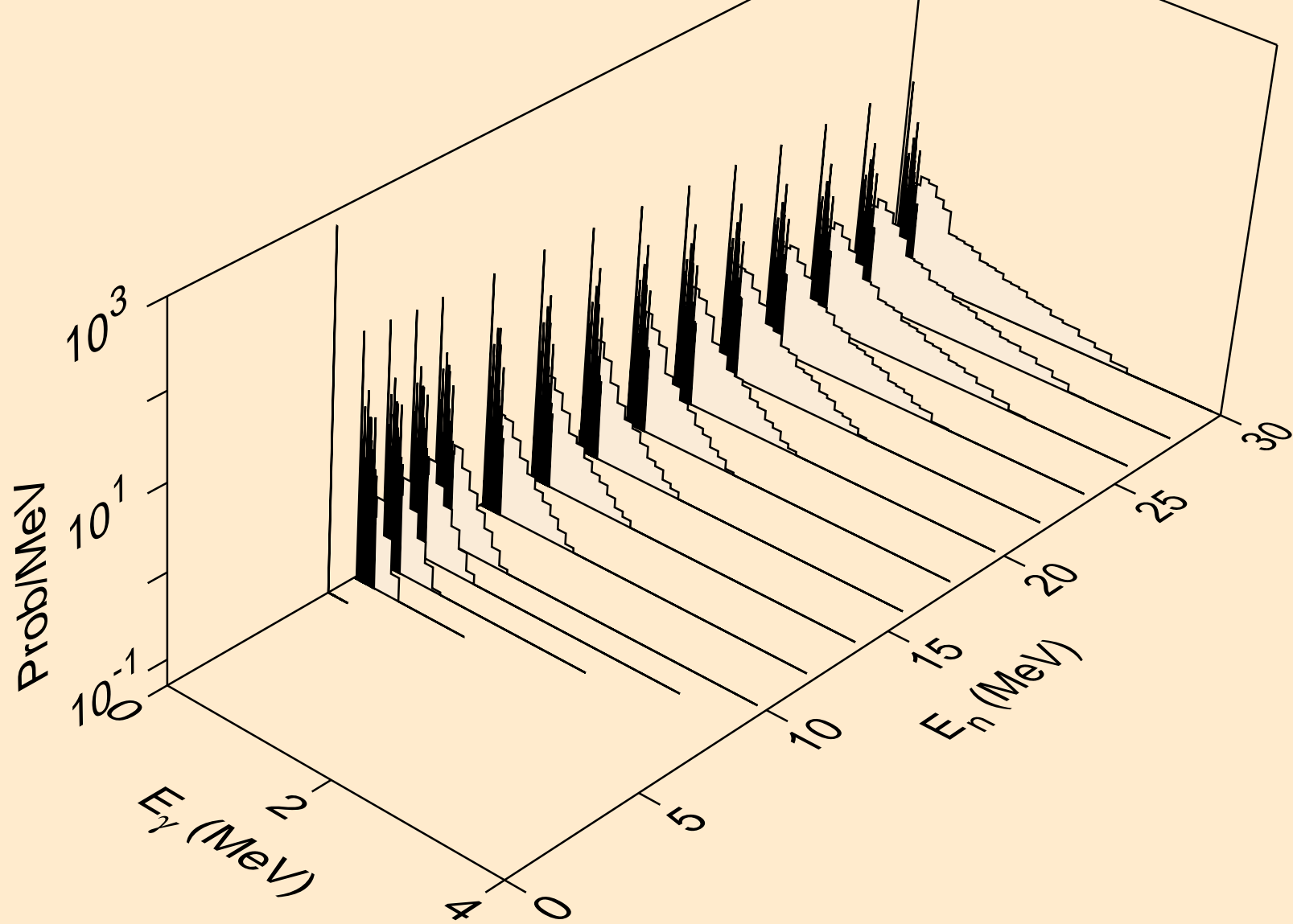

YB174 PROTON ACER TENDL-2023 LIBRARY; T=0.K  
Photon emission for (n,2n)a

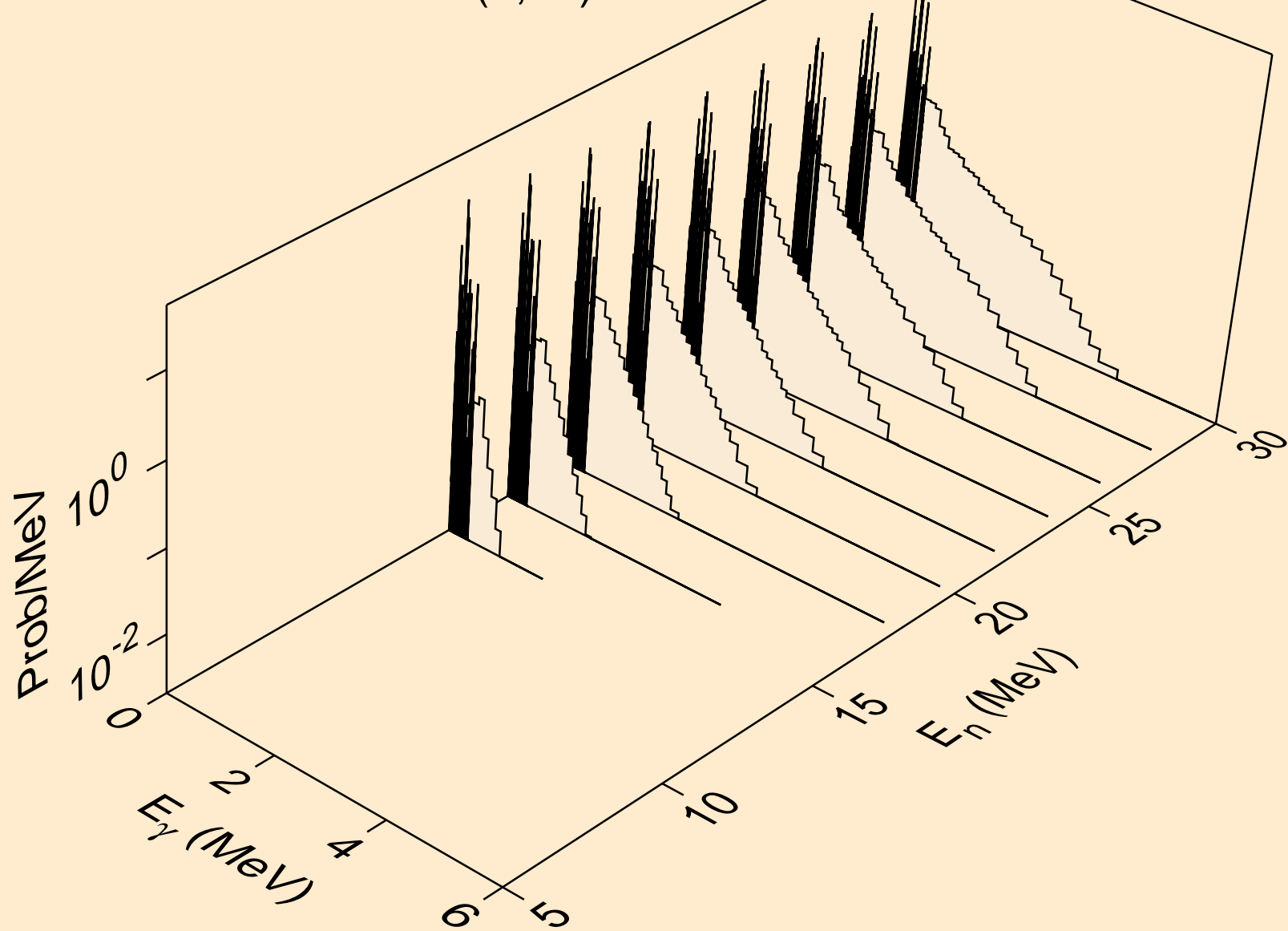

YB174 PROTON ACER TENDL-2023 LIBRARY; T=0.K  
Photon emission for (n,3n)a

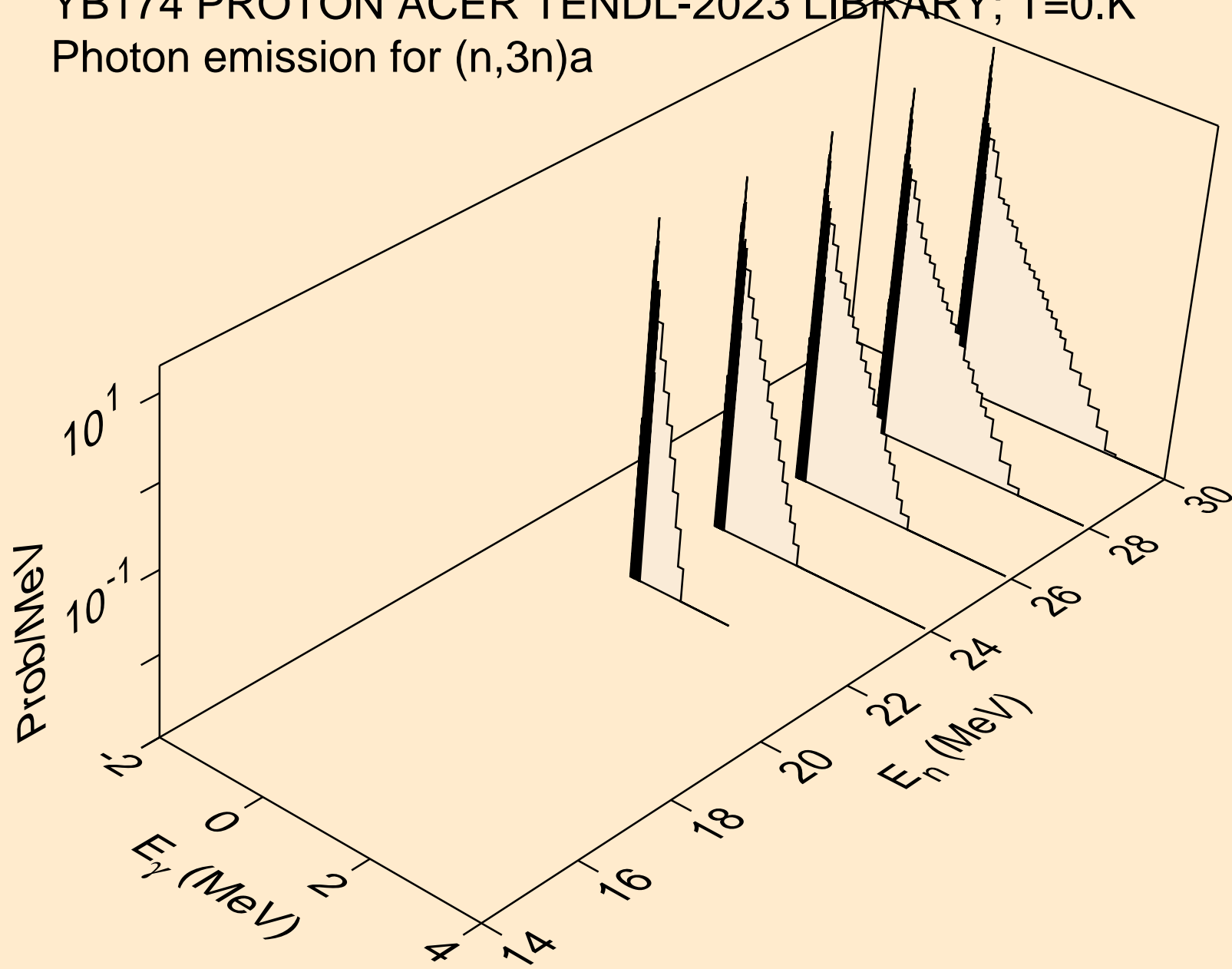

YB174 PROTON ACER TENDL-2023 LIBRARY; T=0.K  
Photon emission for (n,n\*)p

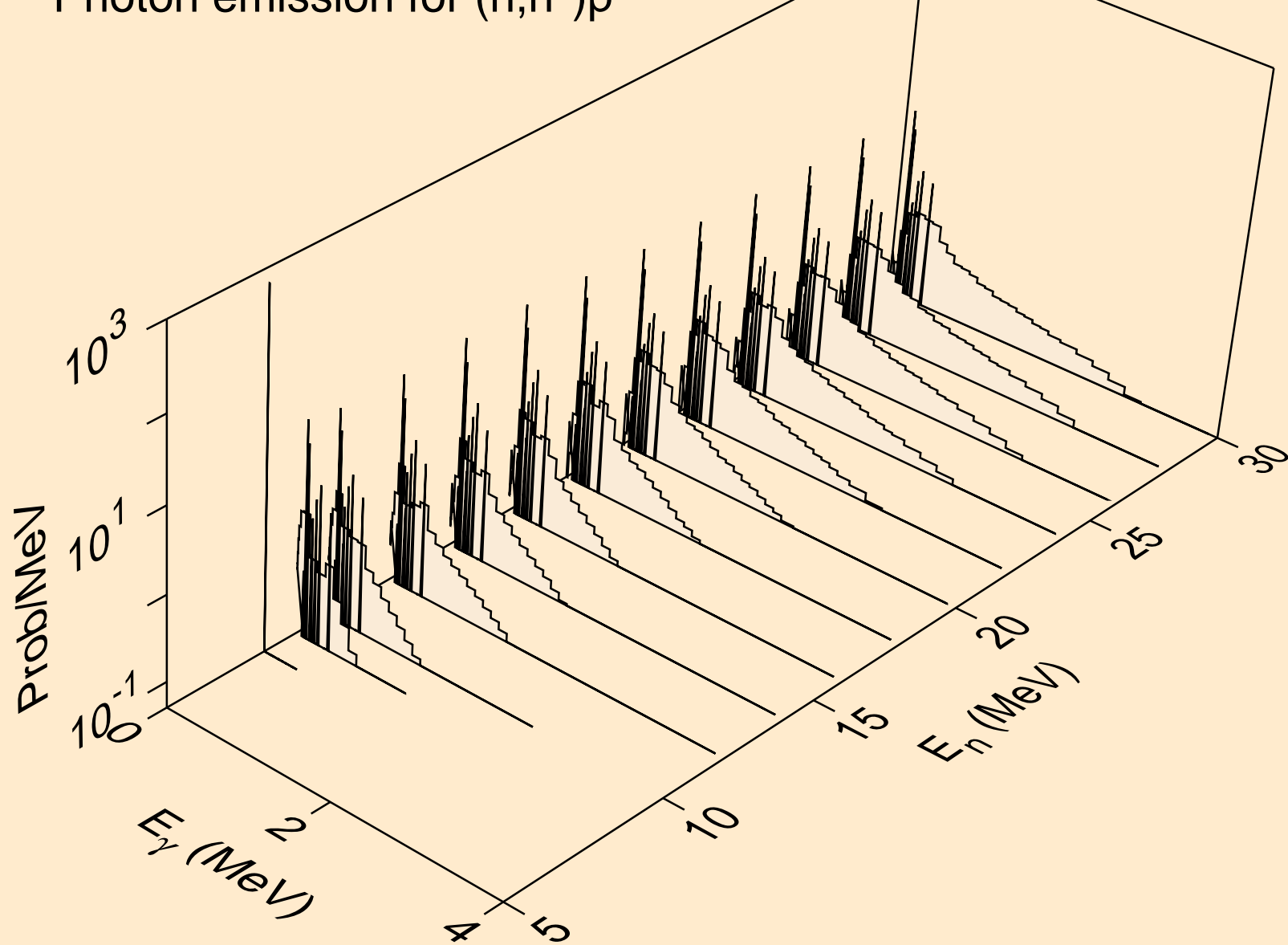

YB174 PROTON ACER TENDL-2023 LIBRARY; T=0.K  
Photon emission for (n,n\*)2a

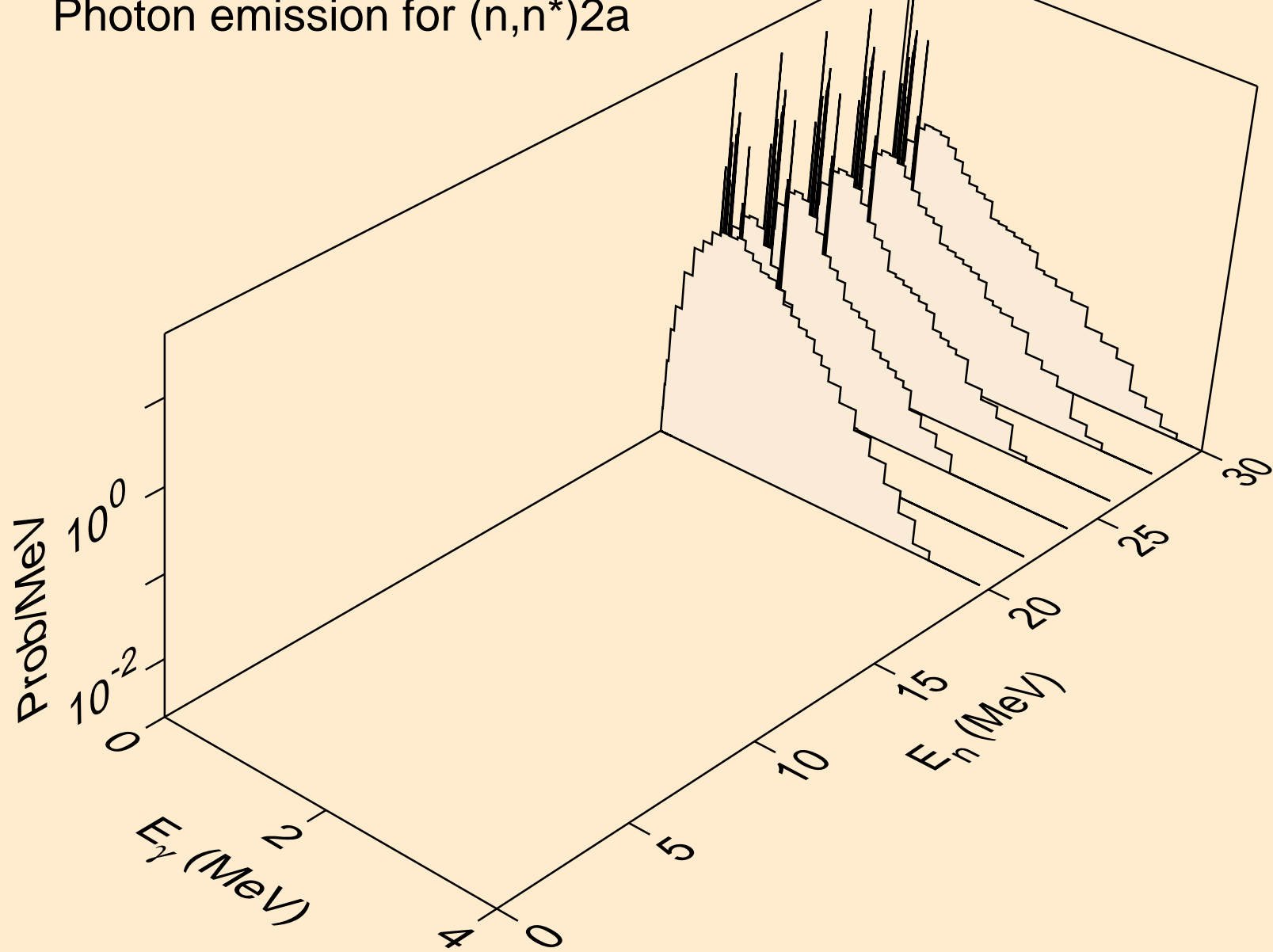

YB174 PROTON ACER TENDL-2023 LIBRARY; T=0.K  
Photon emission for (n,n\*)d

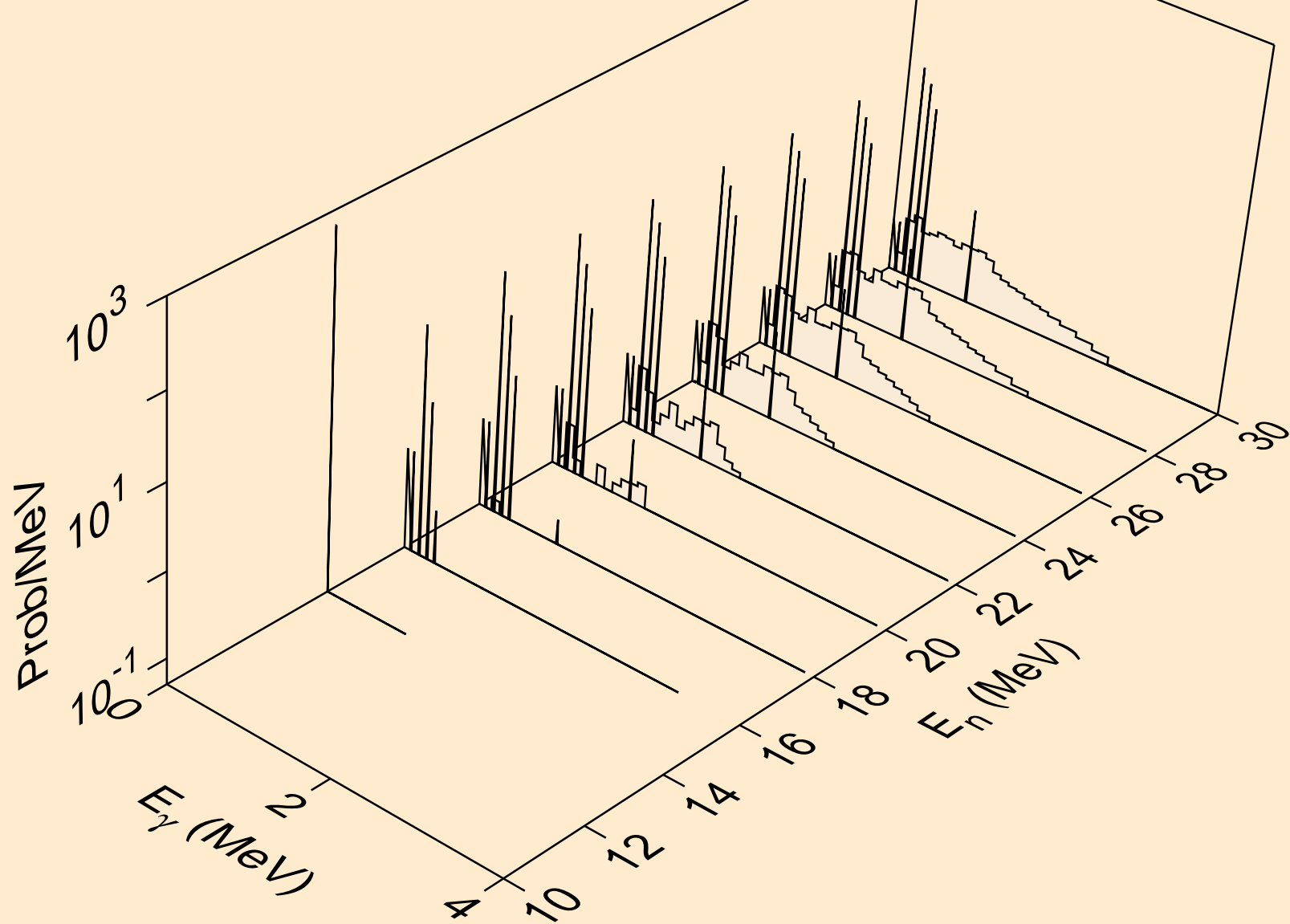

YB174 PROTON ACER TENDL-2023 LIBRARY; T=0.K  
Photon emission for (n,n\*)t

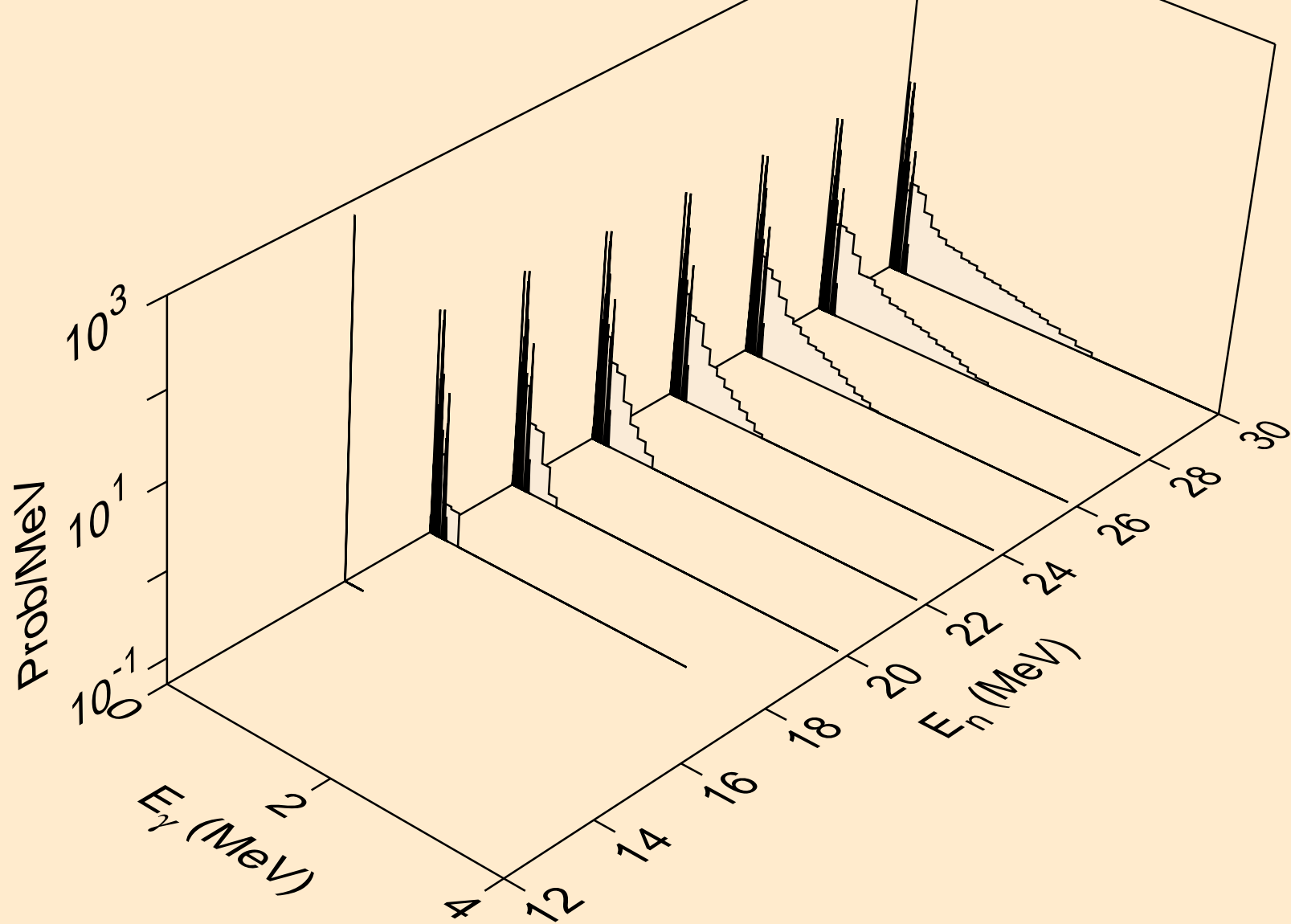



YB174 PROTON ACER TENDL-2023 LIBRARY; T=0.K  
Photon emission for (n,n\*)he3

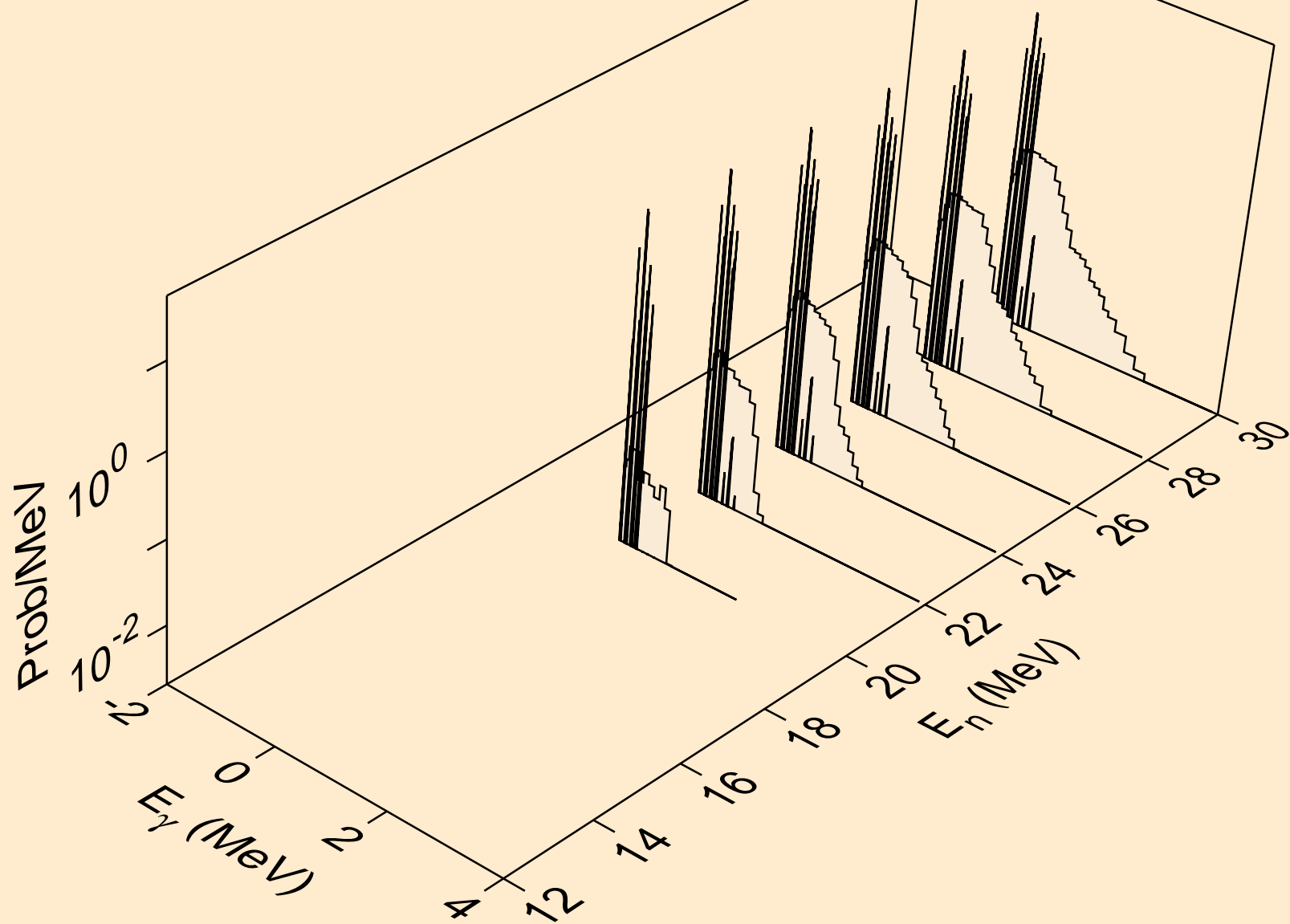

YB174 PROTON ACER TENDL-2023 LIBRARY; T=0.K  
Photon emission for (n,4n)

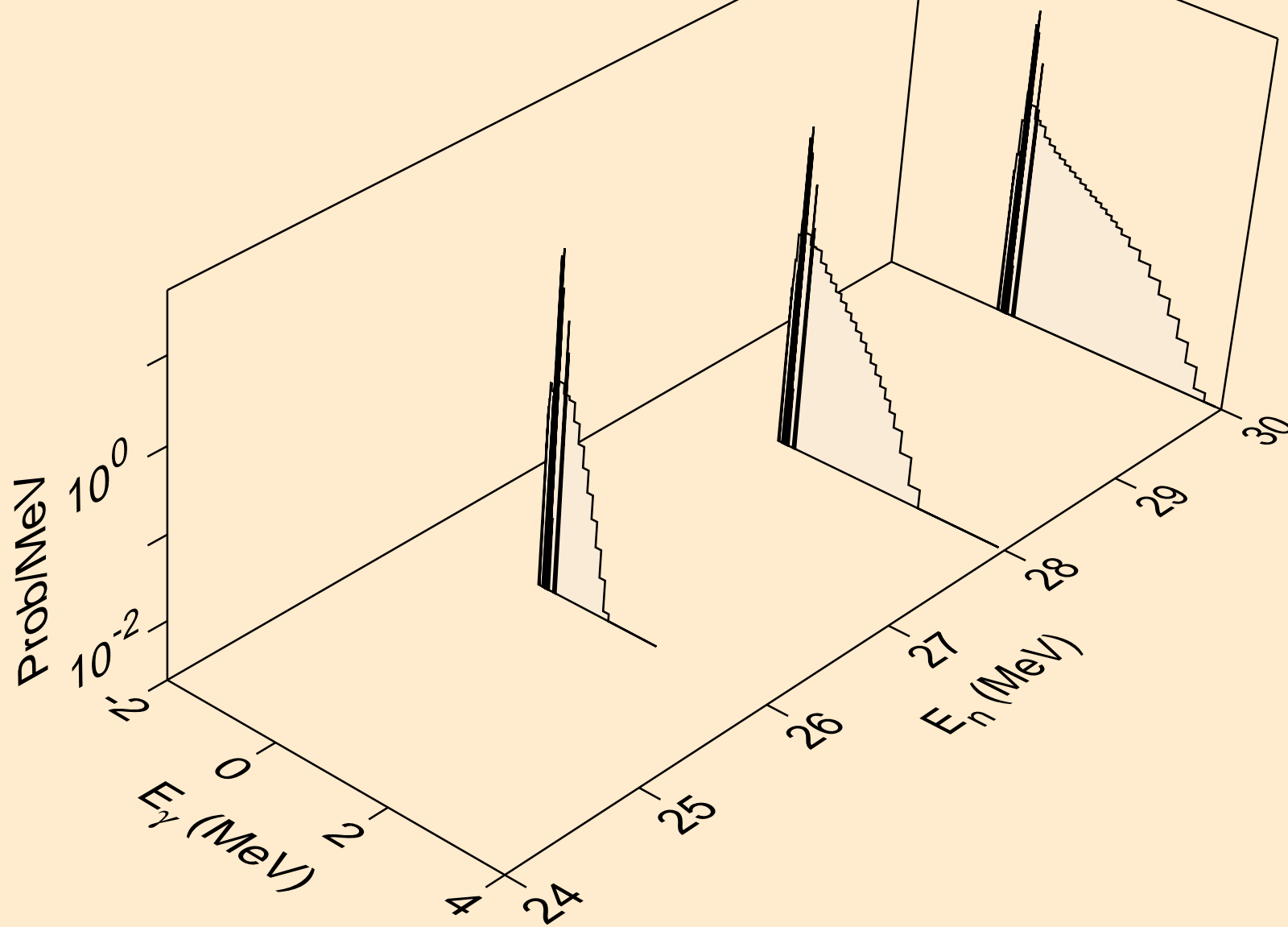

YB174 PROTON ACER TENDL-2023 LIBRARY; T=0.K  
Photon emission for (n,2np)

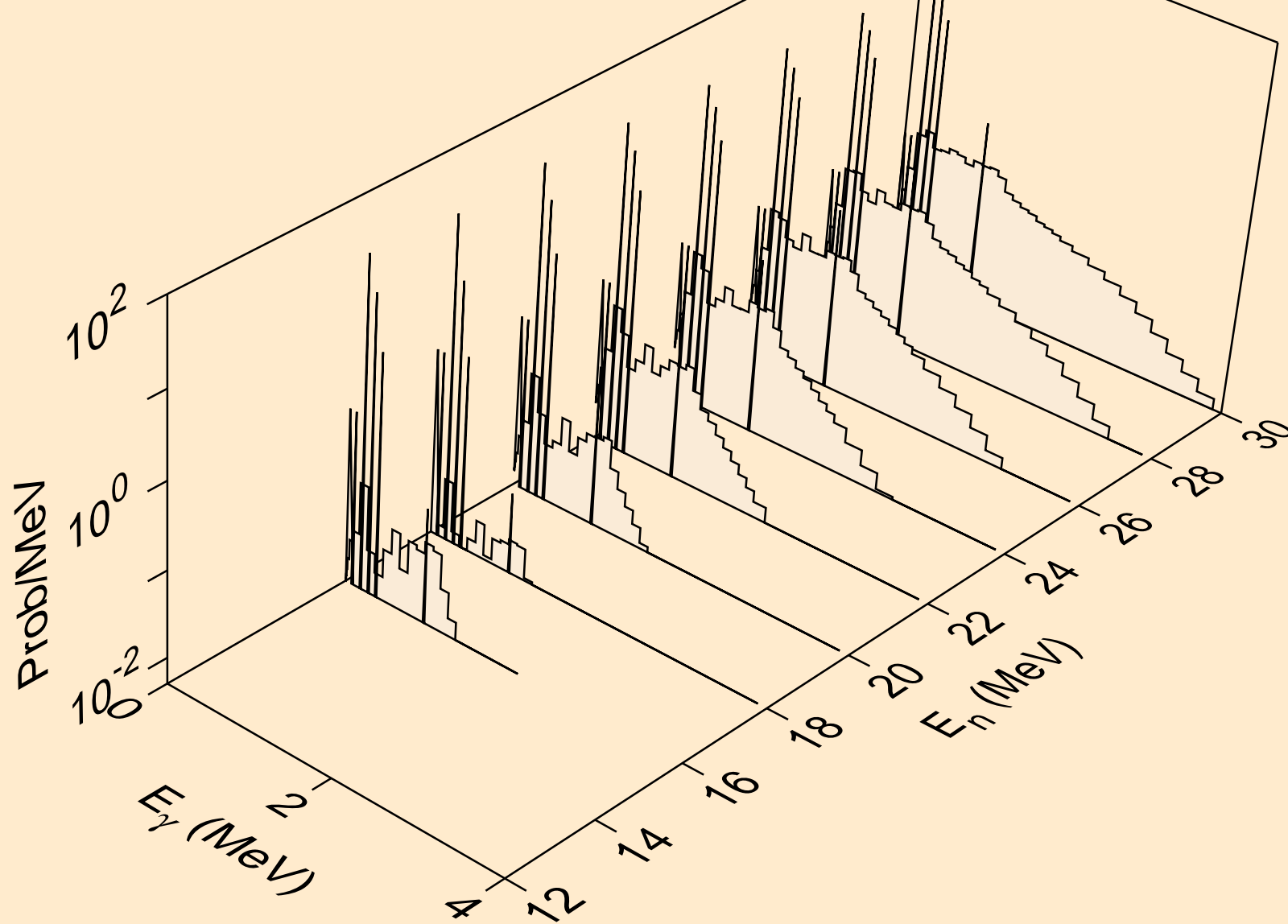

YB174 PROTON ACER TENDL-2023 LIBRARY; T=0.K  
Photon emission for (n,3np)

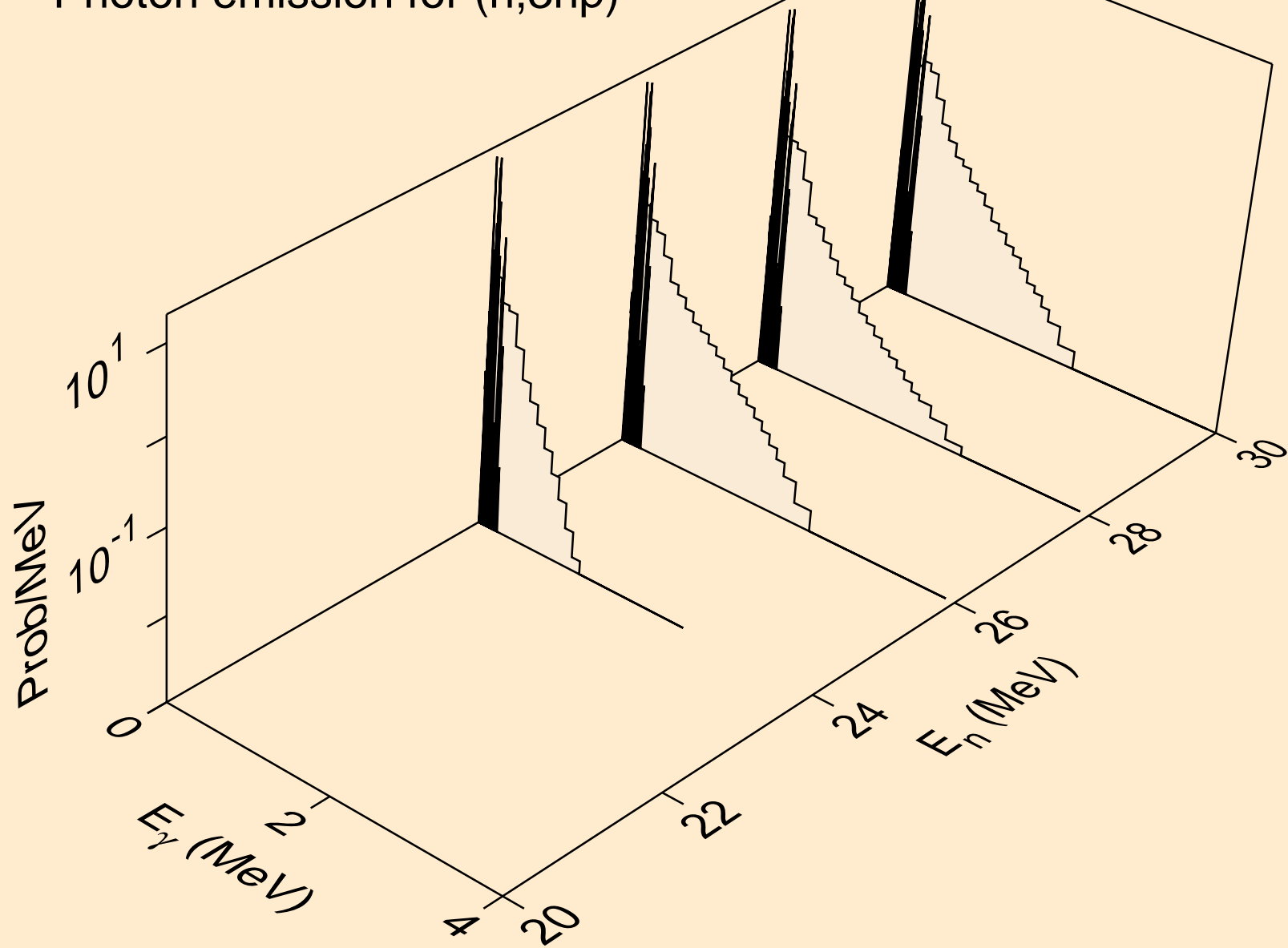

YB174 PROTON ACER TENDL-2023 LIBRARY; T=0.K  
Photon emission for (n,n2p)

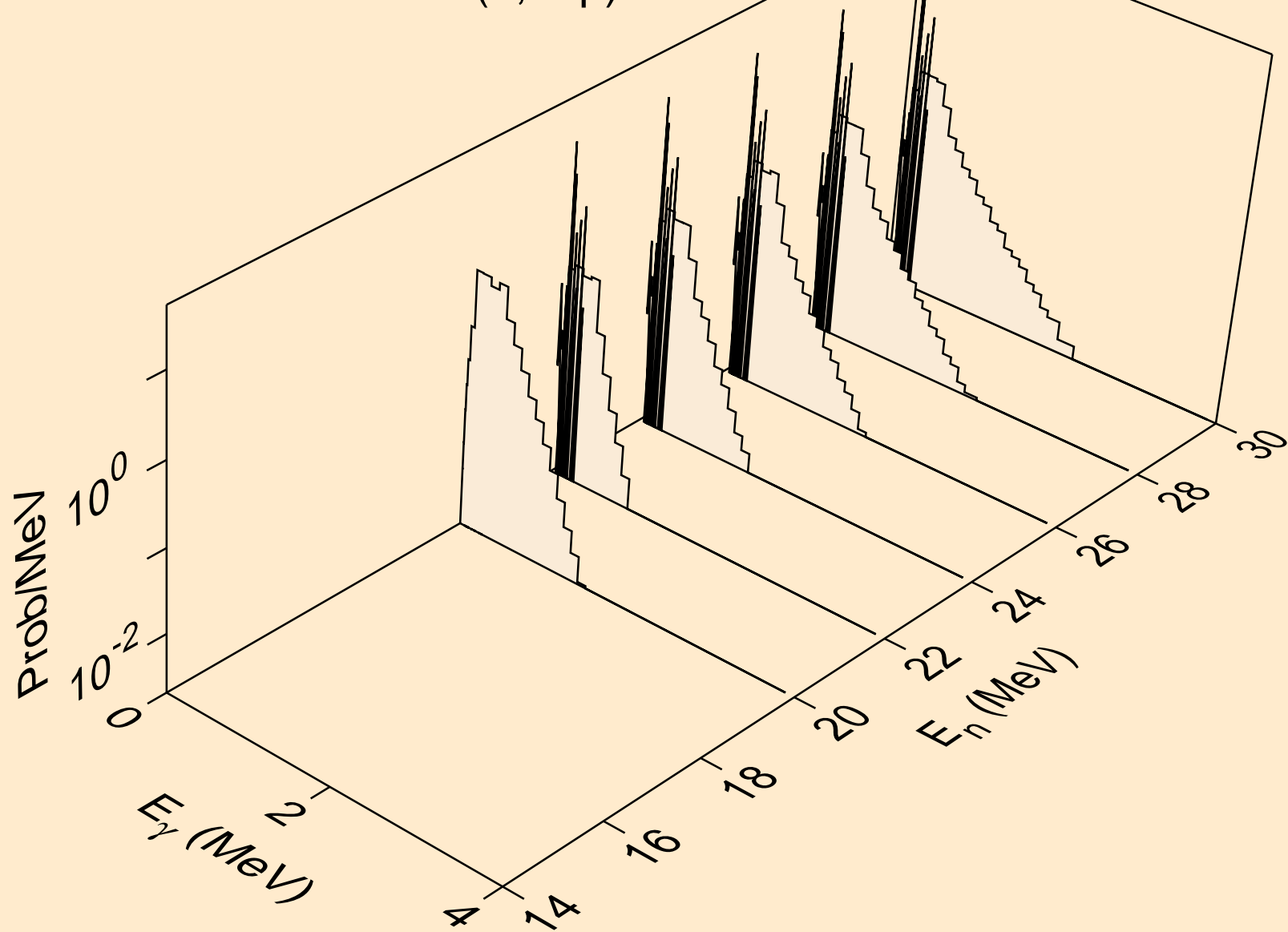

YB174 PROTON ACER TENDL-2023 LIBRARY; T=0.K  
Photon emission for (n,npa)

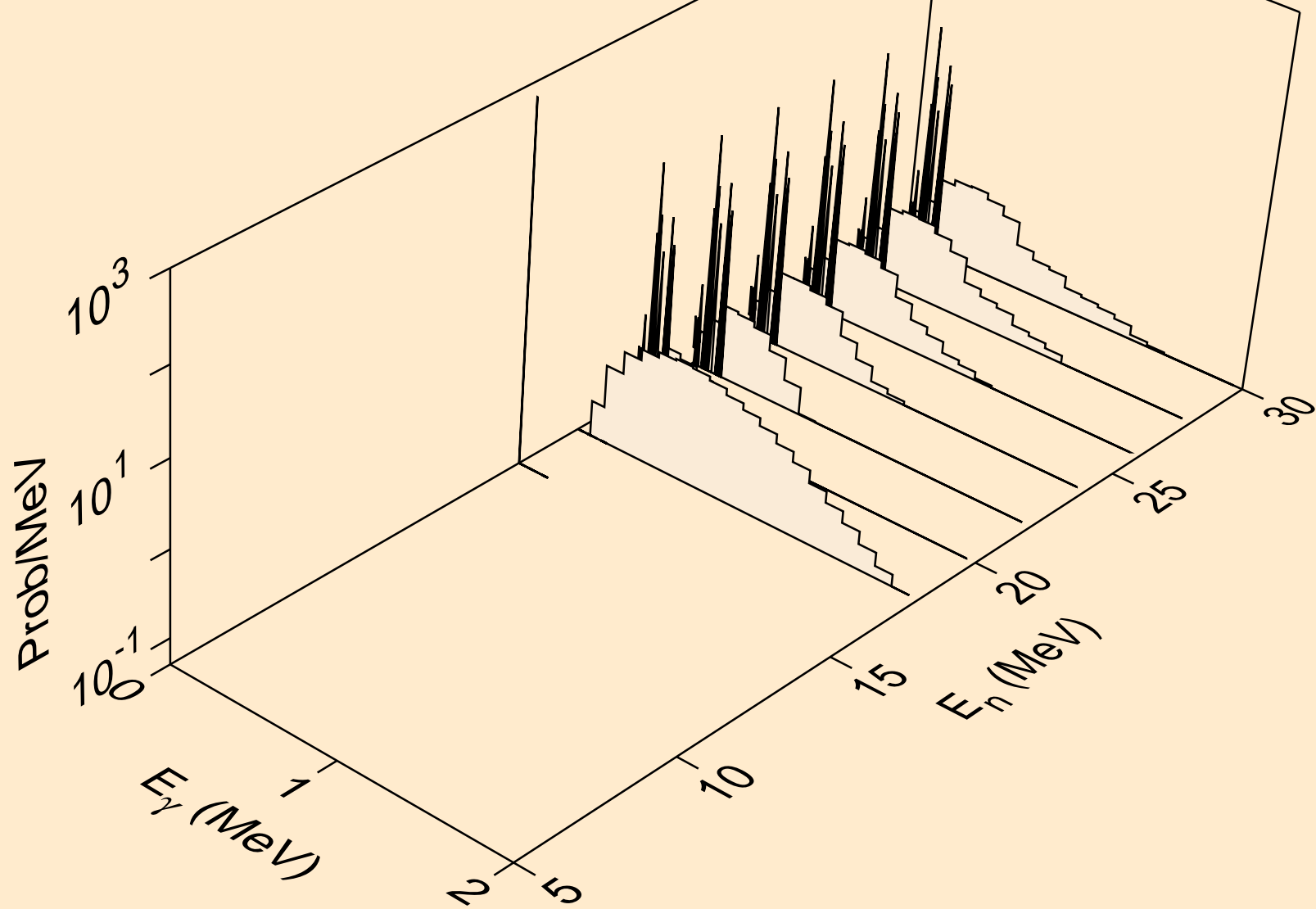

YB174 PROTON ACER TENDL-2023 LIBRARY; T=0.K  
Photon emission for (n,gma)

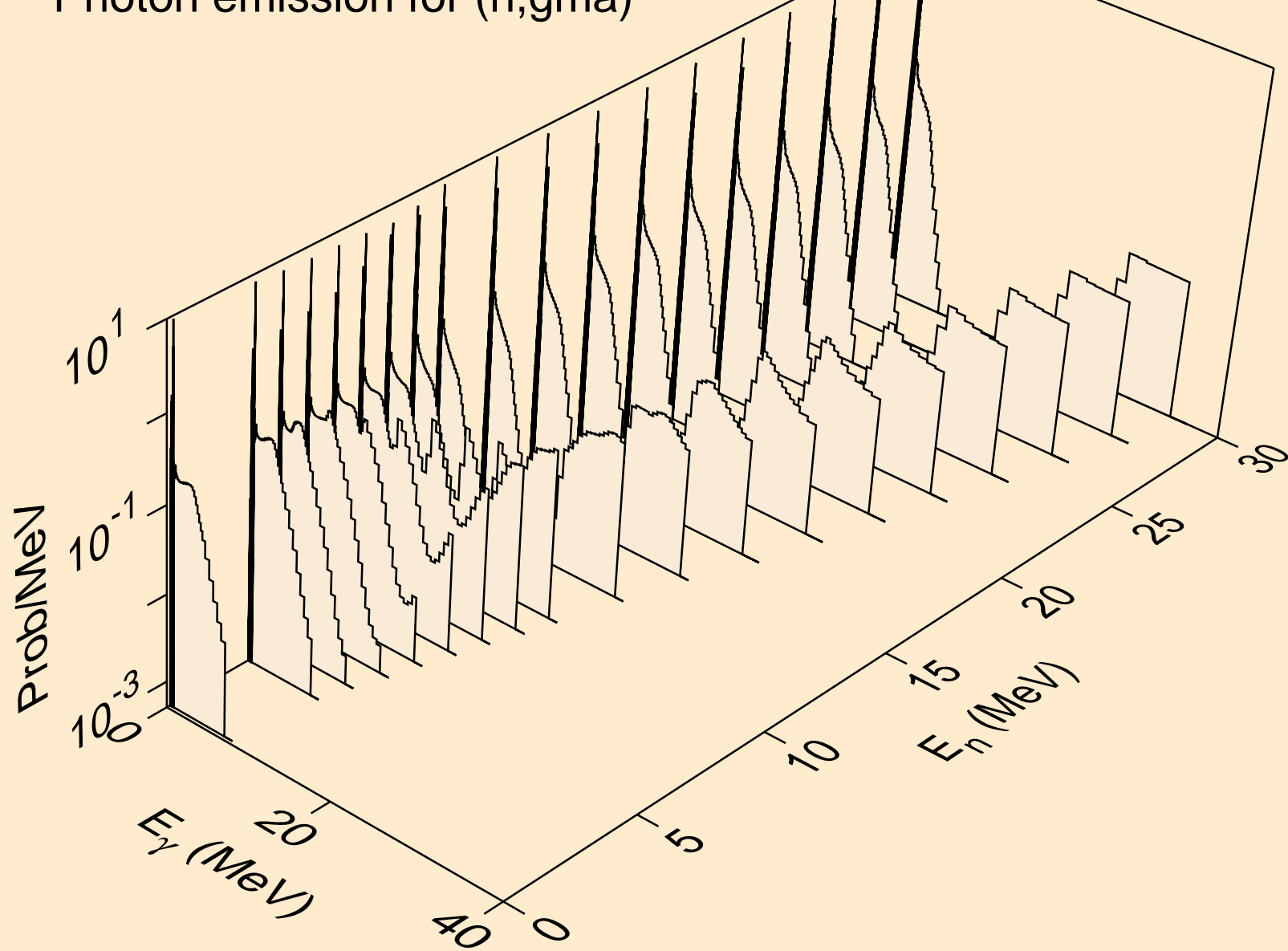

YB174 PROTON ACER TENDL-2023 LIBRARY; T=0.K  
Photon emission for inelastic

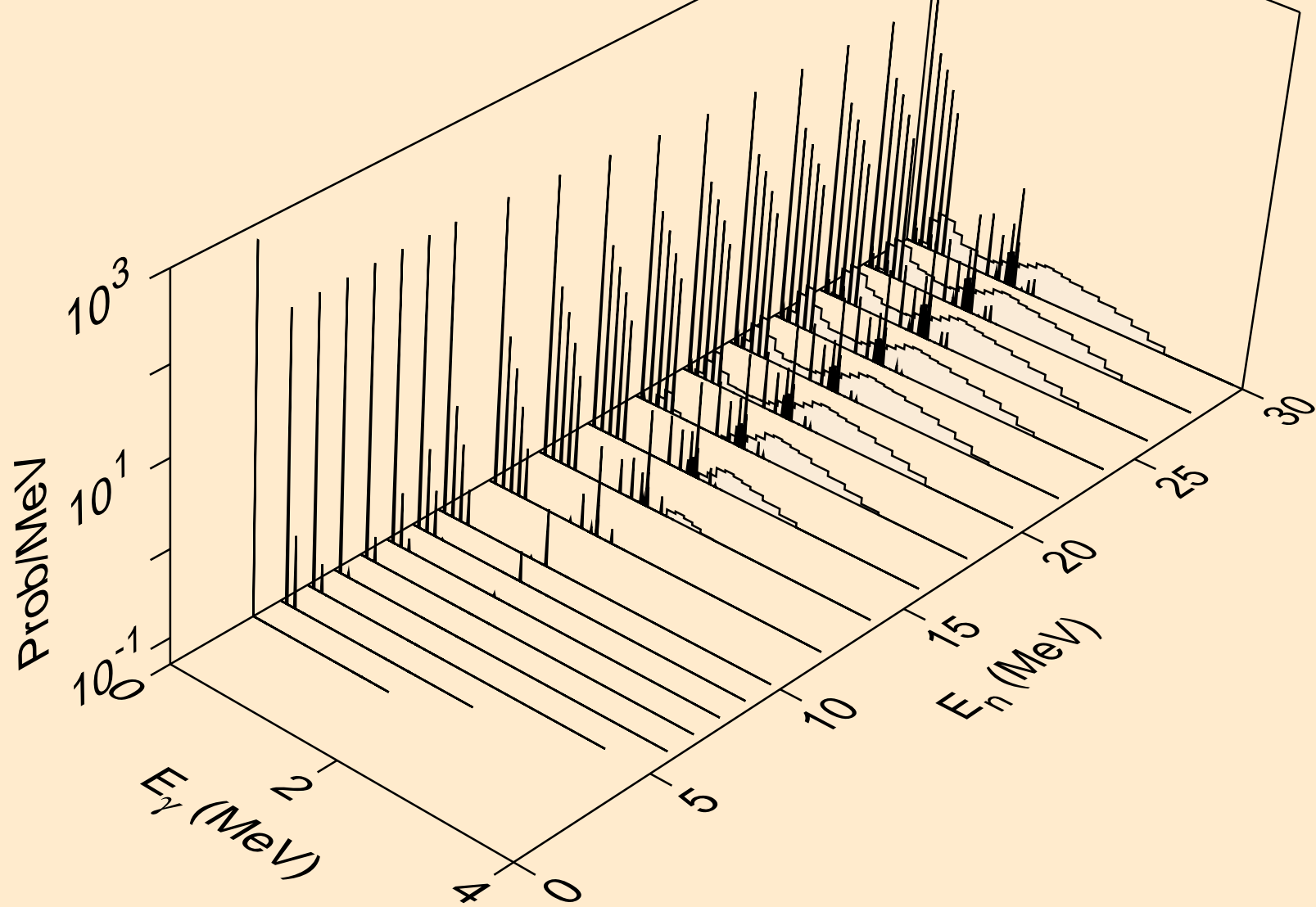



YB174 PROTON ACER TENDL-2023 LIBRARY; T=0.K  
Photon emission for (n,d)

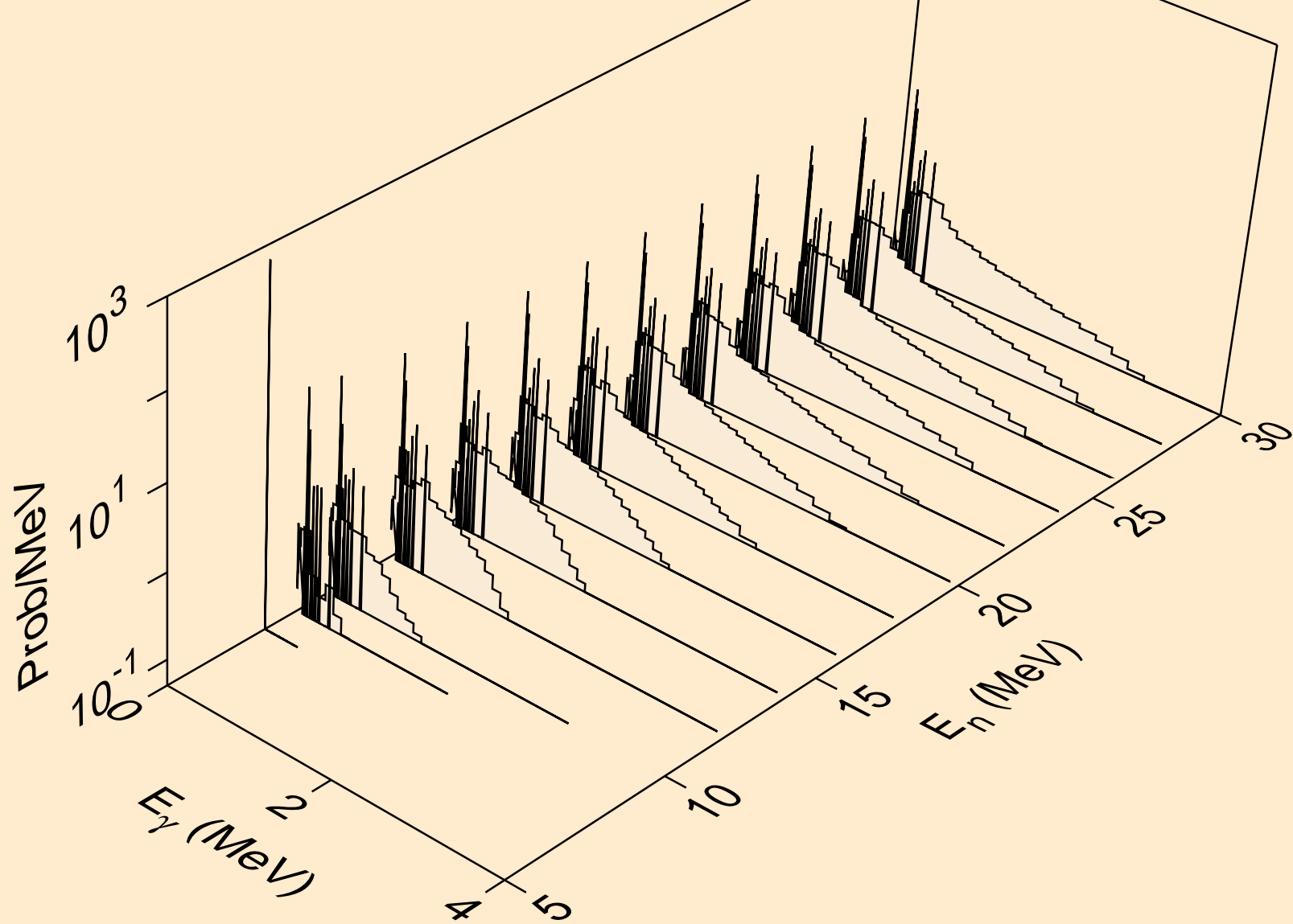

YB174 PROTON ACER TENDL-2023 LIBRARY; T=0.K  
Photon emission for (n,t)

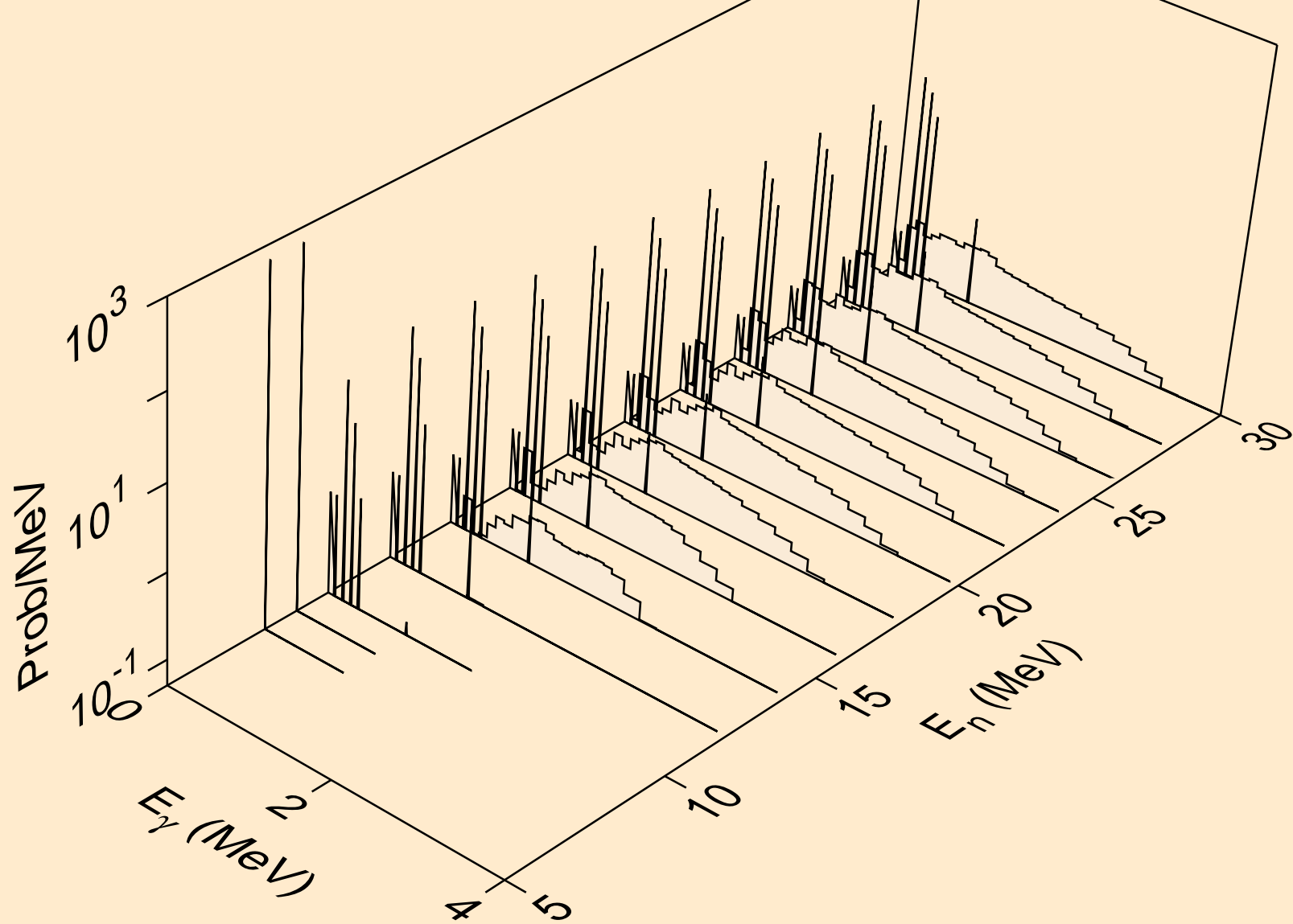

YB174 PROTON ACER TENDL-2023 LIBRARY; T=0.K  
Photon emission for (n,he3)

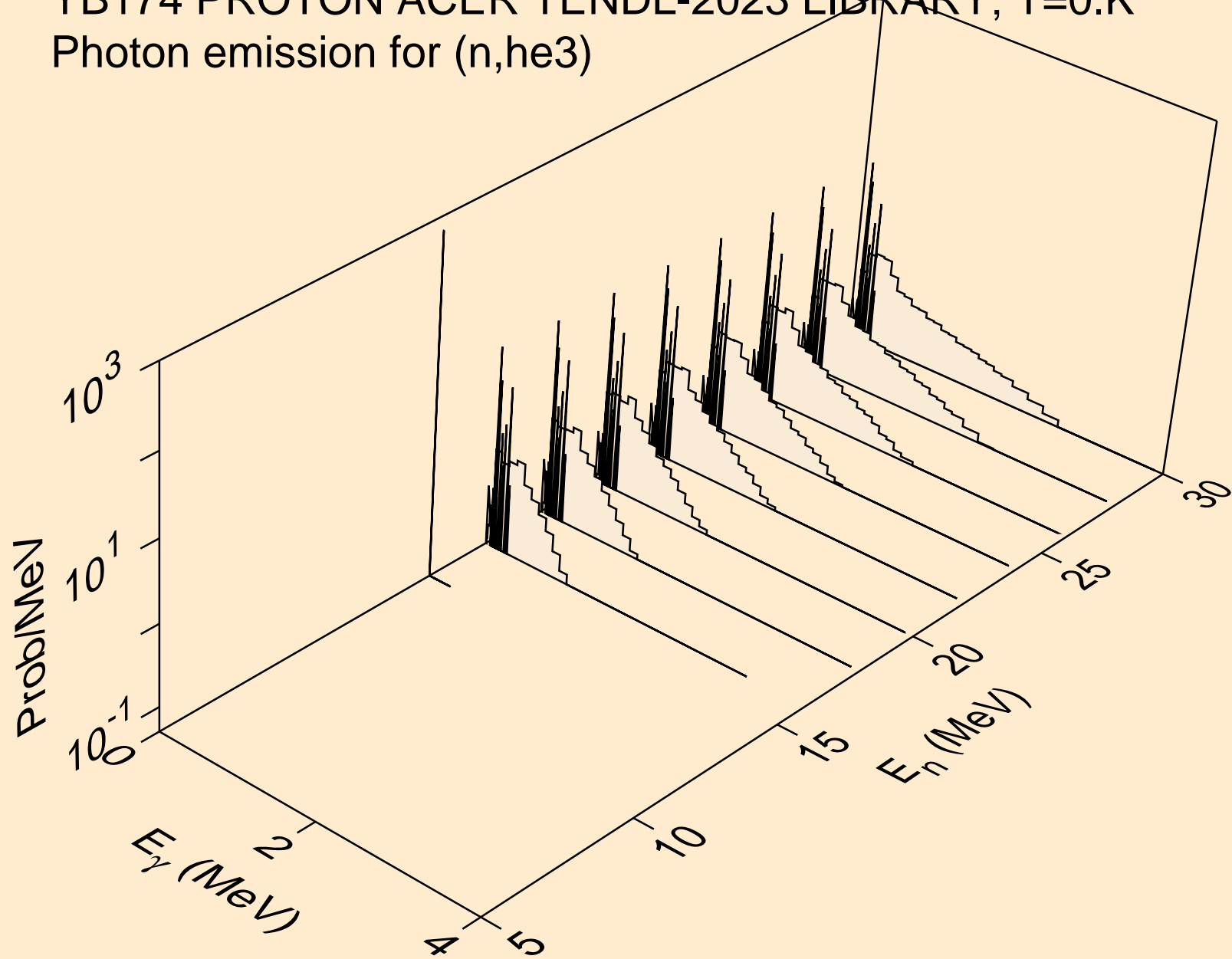

YB174 PROTON ACER TENDL-2023 LIBRARY; T=0.K  
Photon emission for (n,a)

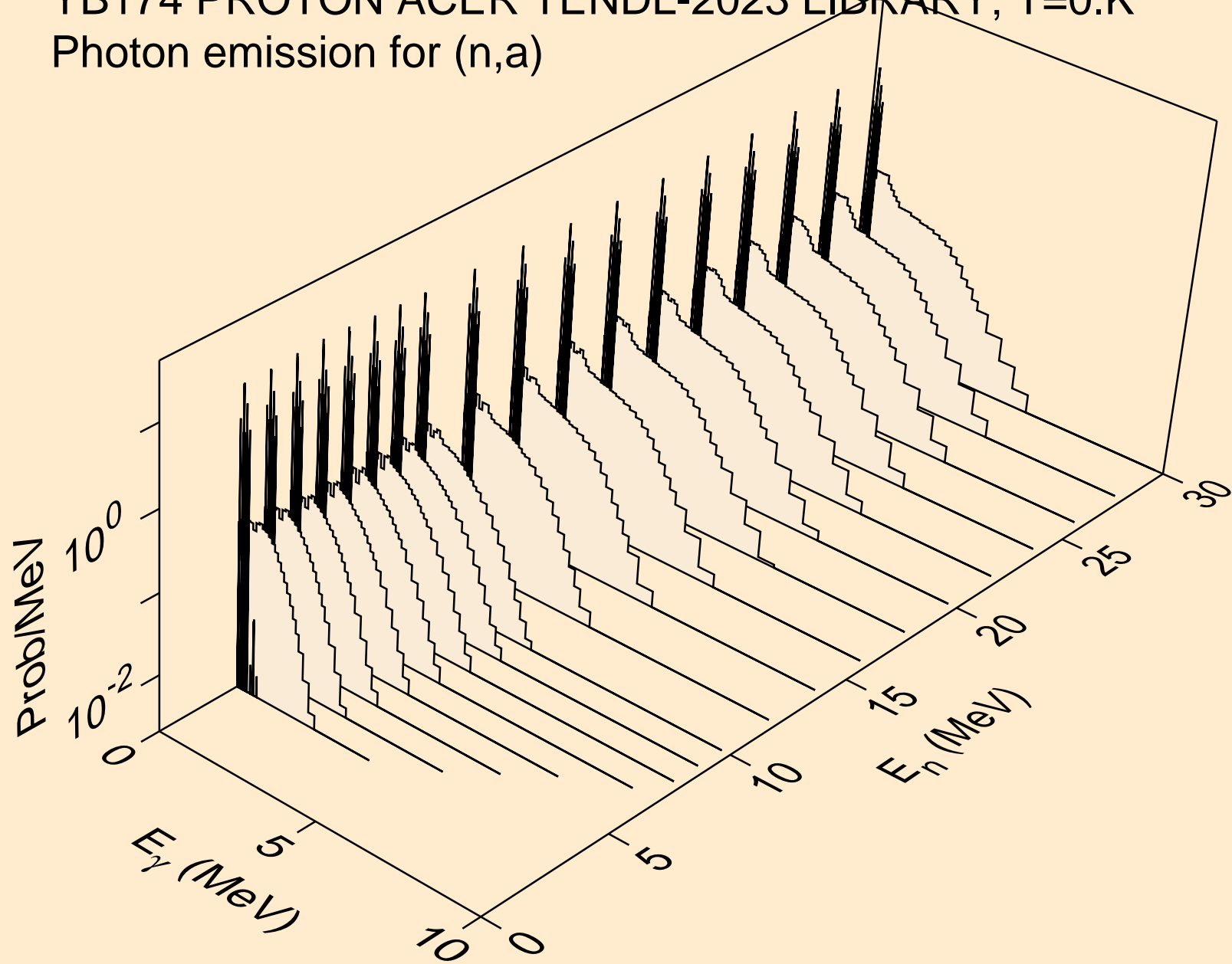

YB174 PROTON ACER TENDL-2023 LIBRARY; T=0.K  
Photon emission for (n,2a)

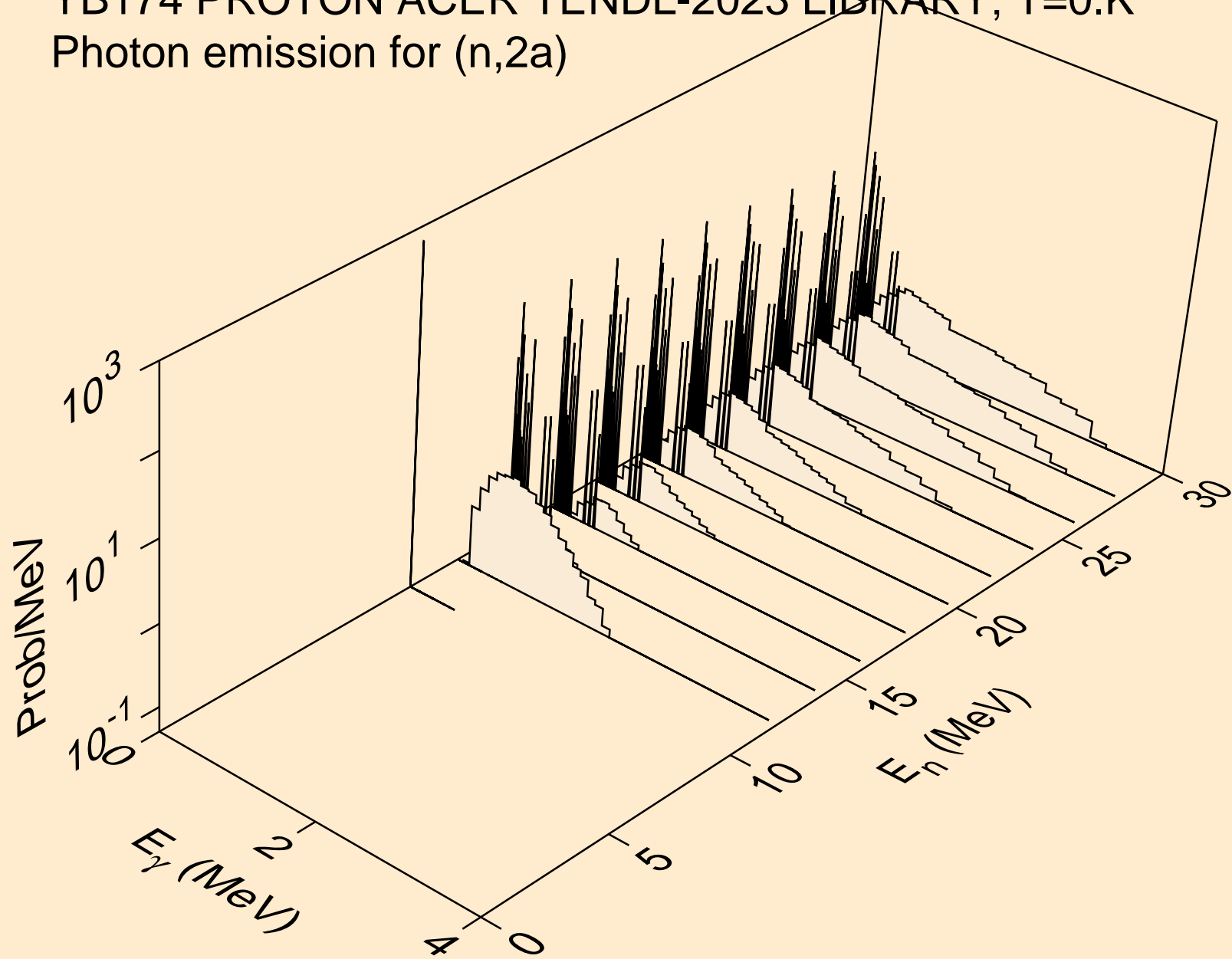

YB174 PROTON ACER TENDL-2023 LIBRARY; T=0.K  
Photon emission for (n,2p)

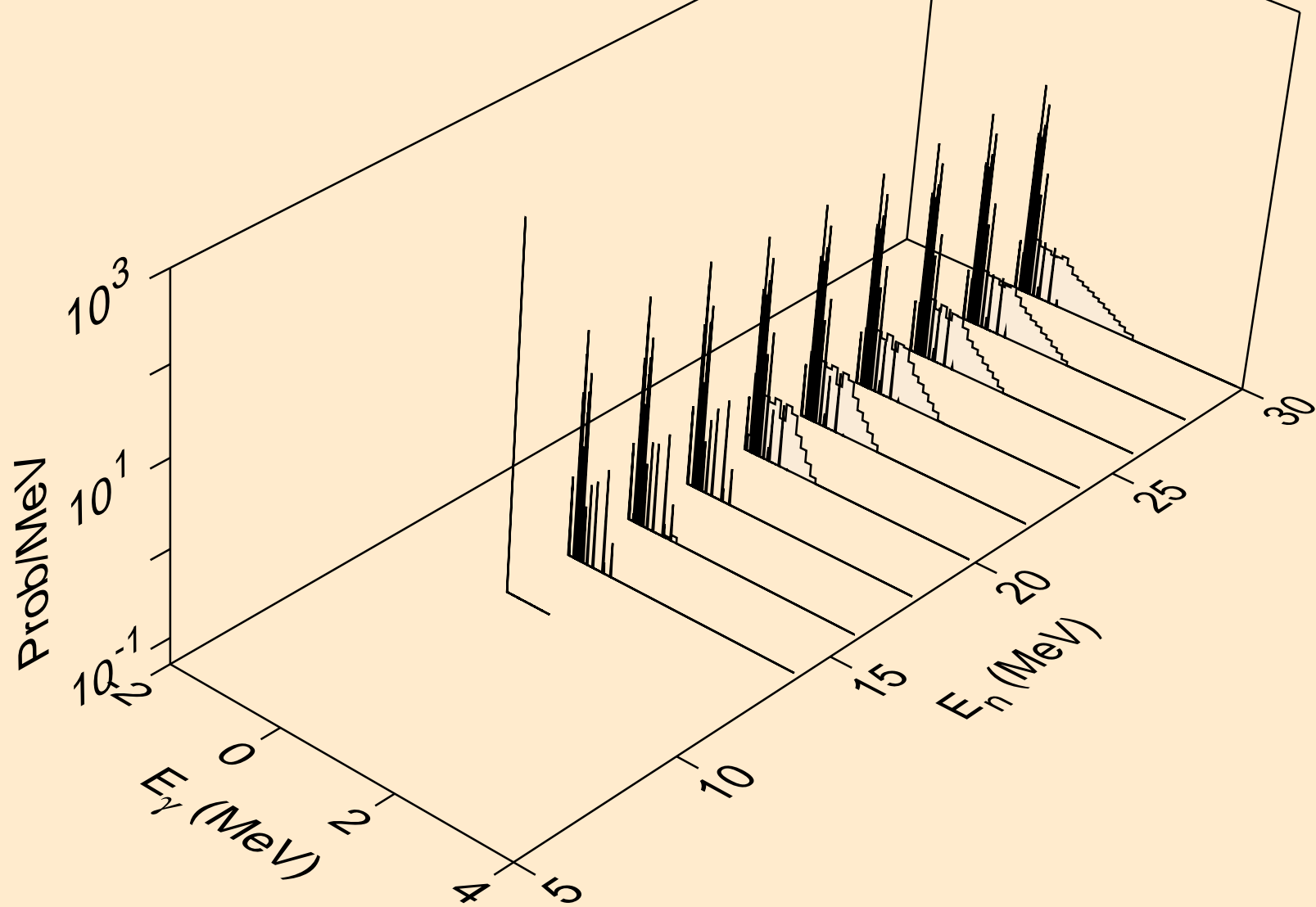

YB174 PROTON ACER TENDL-2023 LIBRARY; T=0.K  
Photon emission for (n,p $\alpha$ )

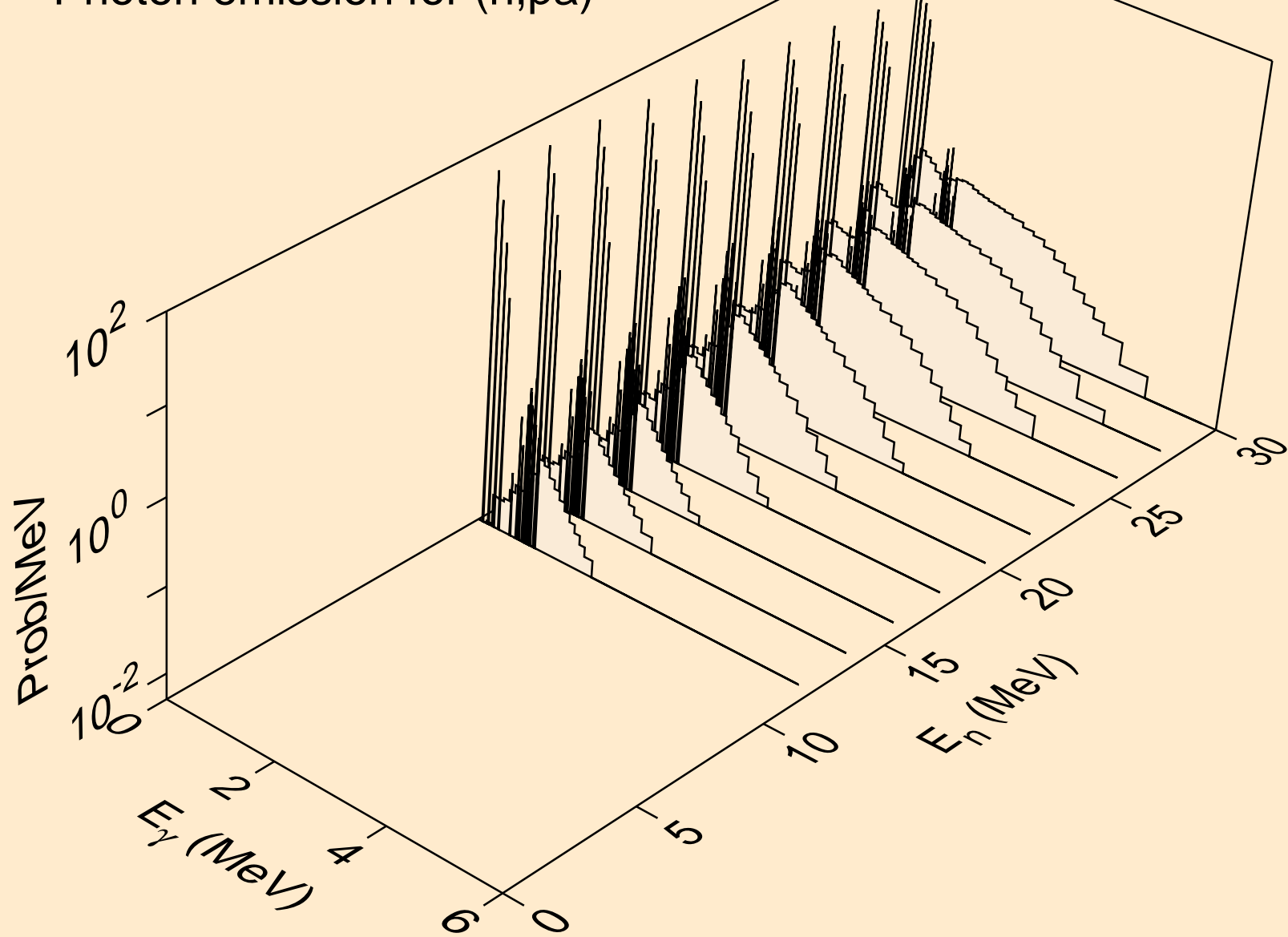

YB174 PROTON ACER TENDL-2023 LIBRARY; T=0.K  
Photon emission for (n,pd)

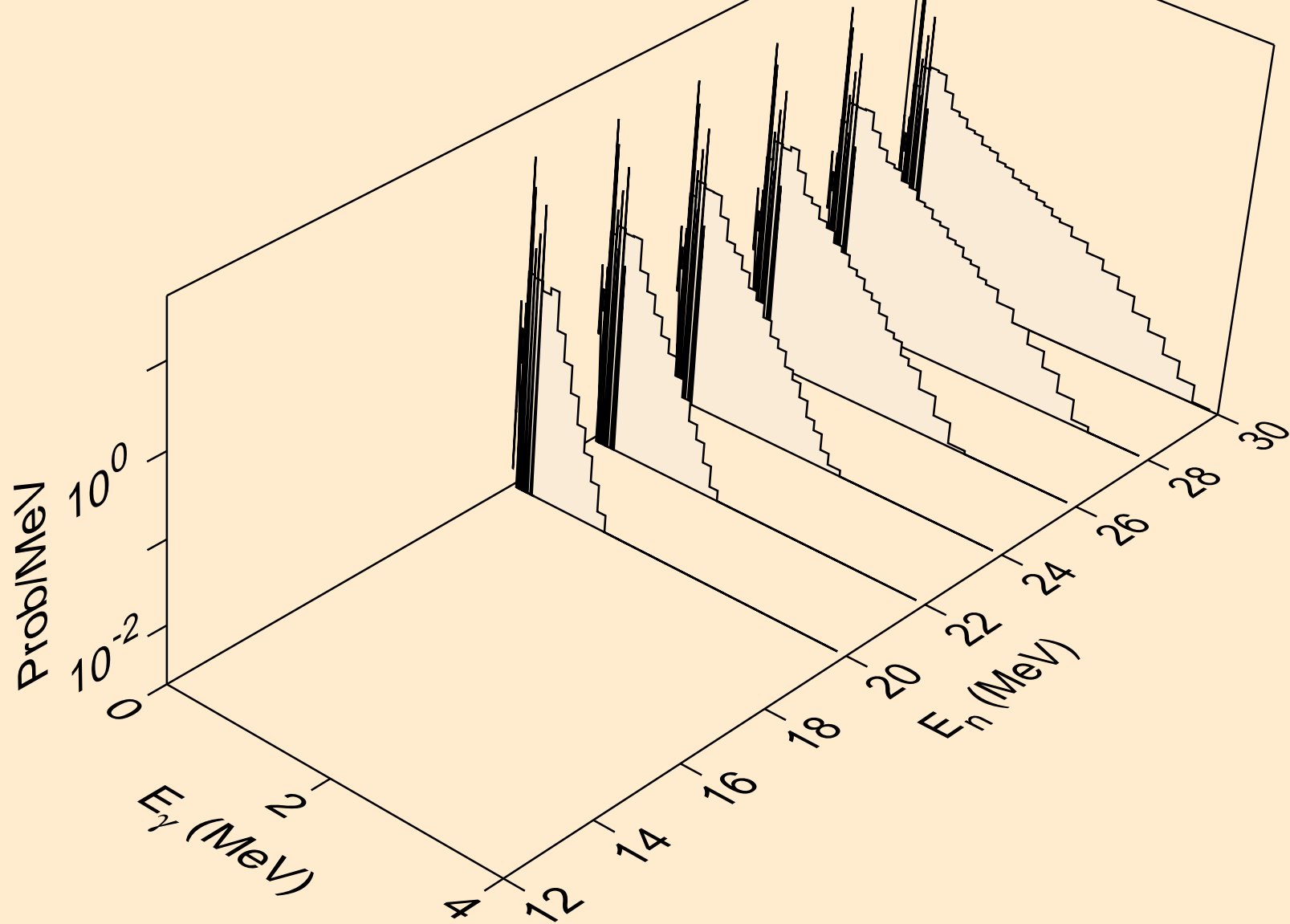



YB174 PROTON ACER TENDL-2023 LIBRARY; T=0.K  
Photon emission for (n,pt)

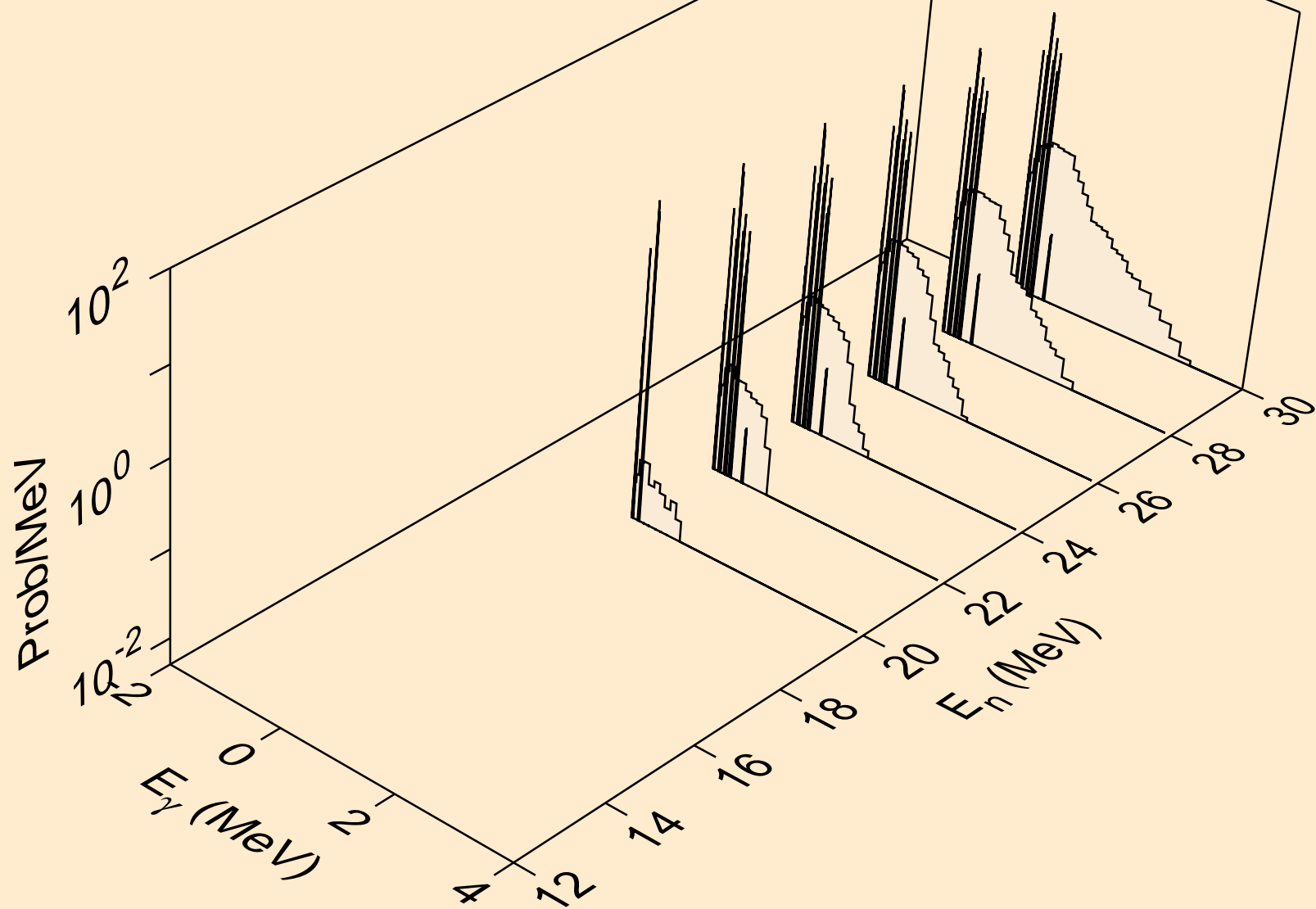

YB174 PROTON ACER TENDL-2023 LIBRARY; T=0.K  
Photon emission for (n,da)

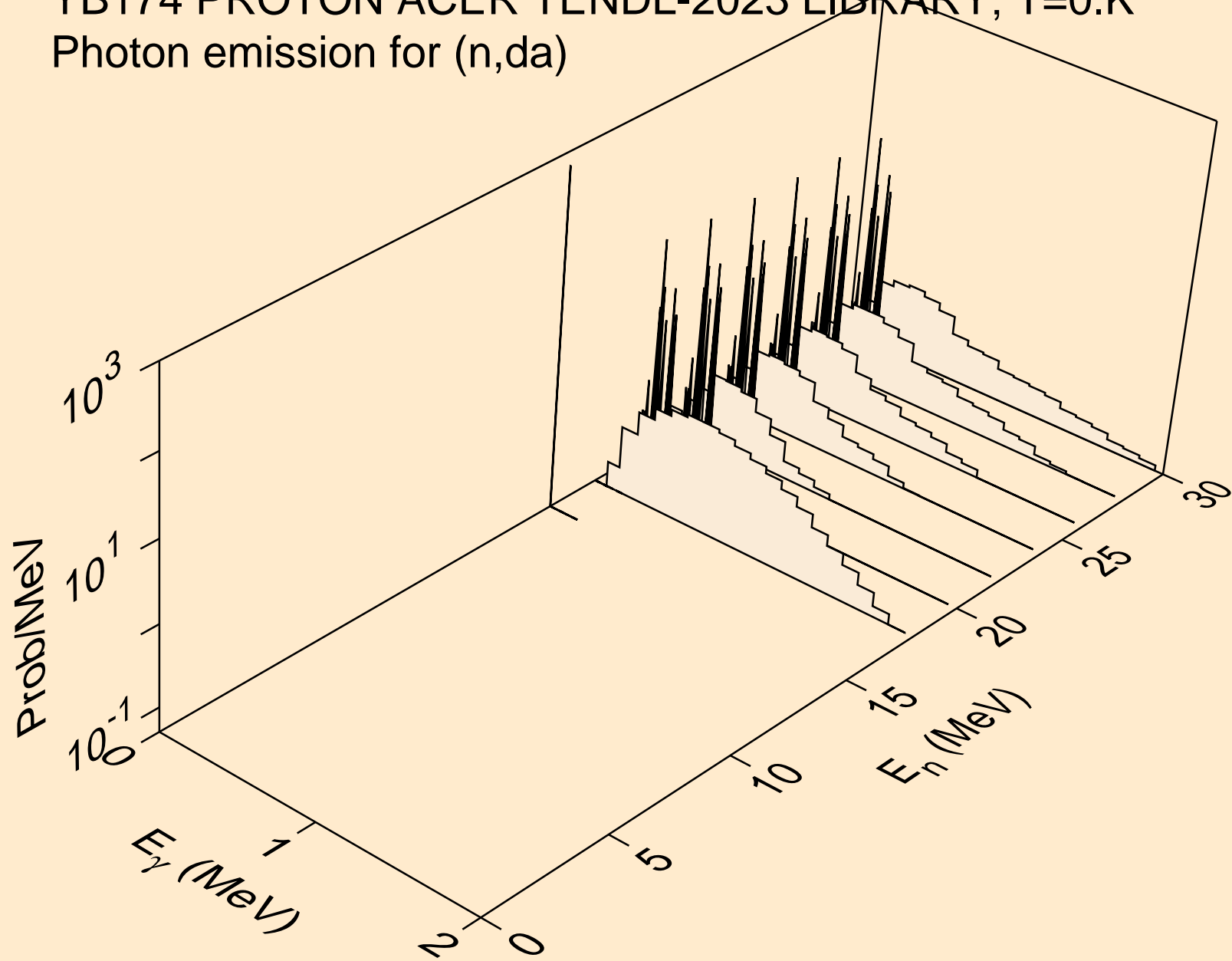

YB174 PROTON ACER TENDL-2023 LIBRARY; T=0.K  
Particle heating contributions

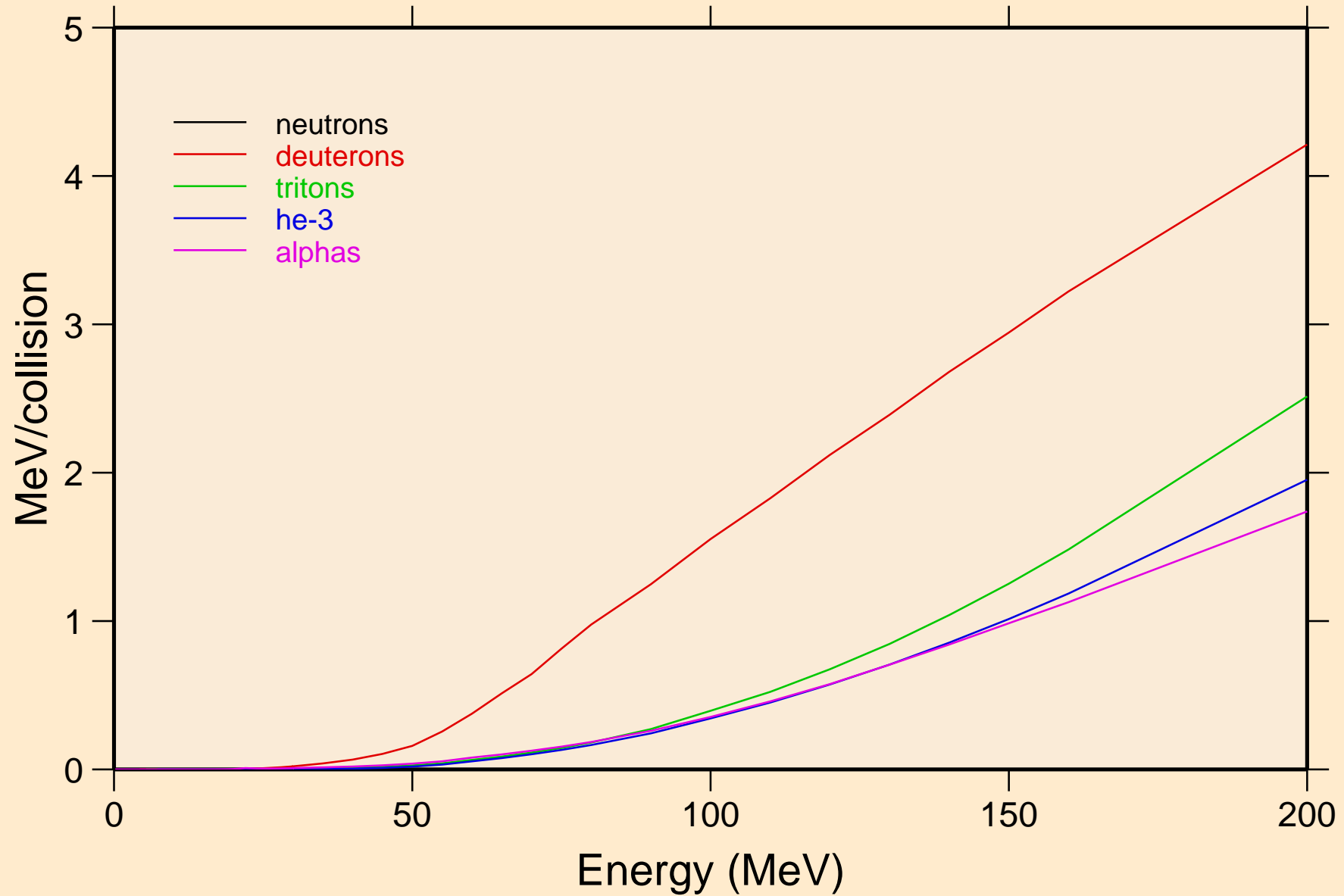

# YB174 PROTON ACER TENDL-2023 LIBRARY; T=0.K

## Recoil Heating

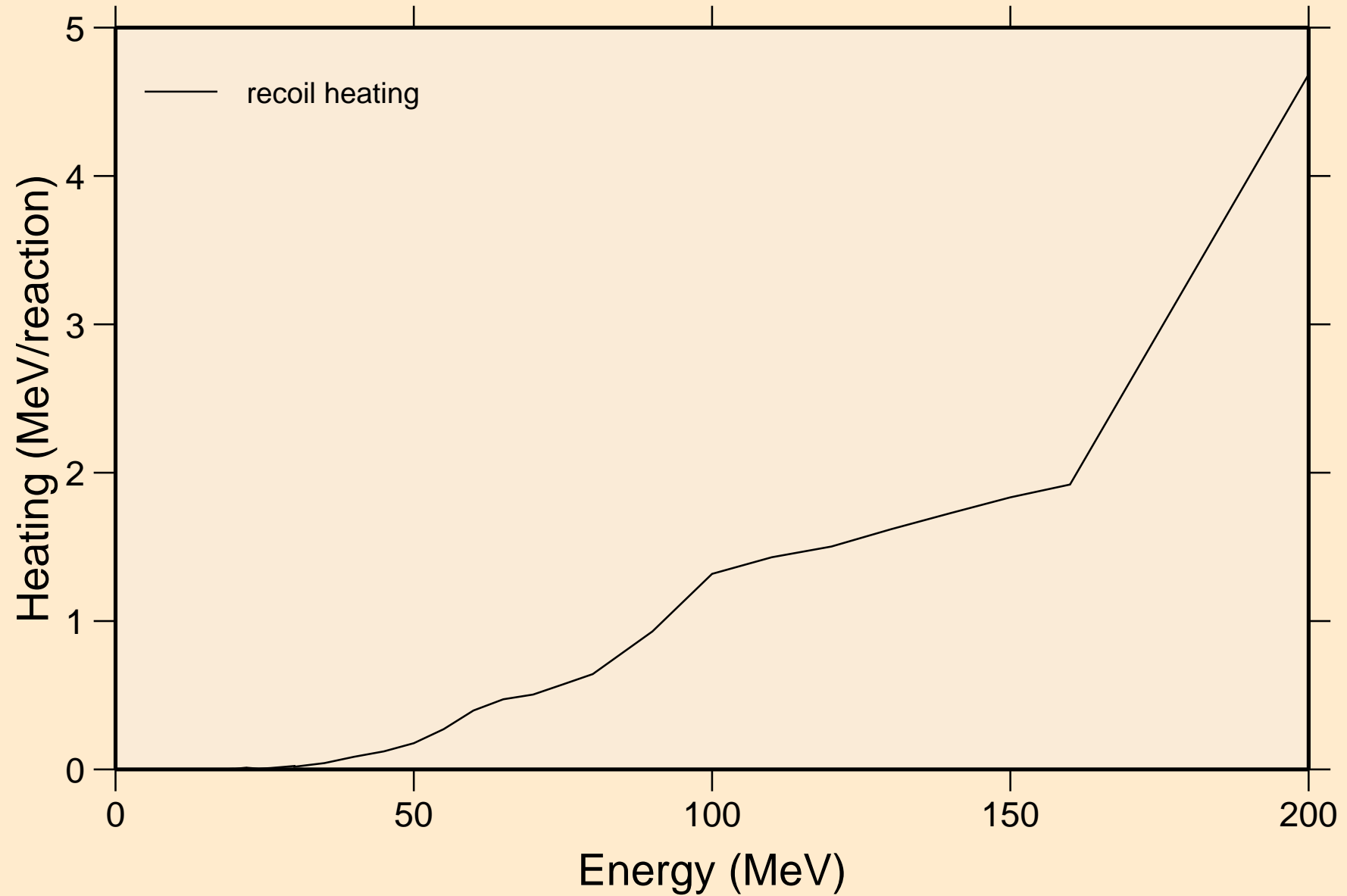

YB174 PROTON ACER TENDL-2023 LIBRARY; T=0.K  
Particle production cross sections

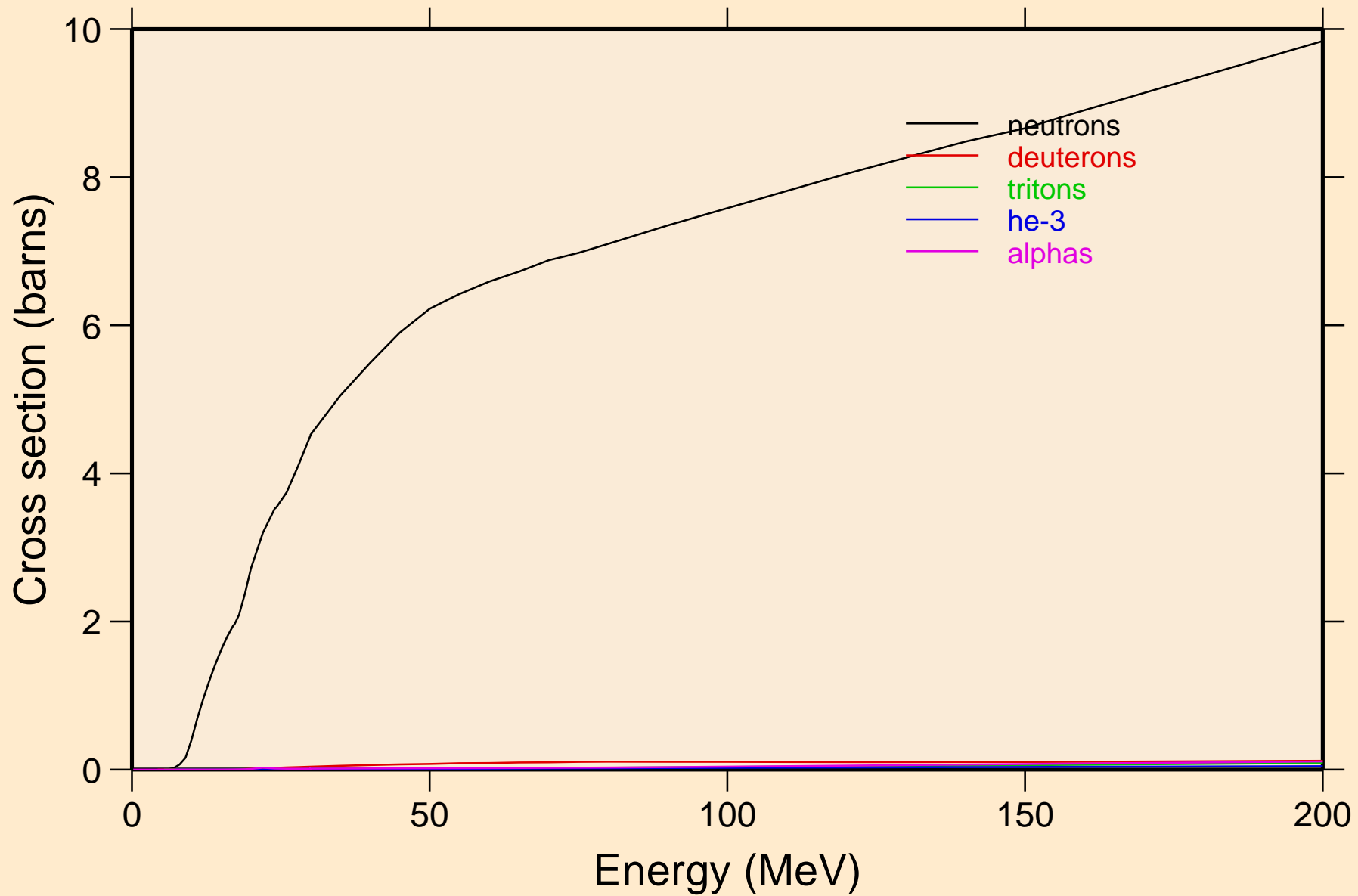

YB174 PROTON ACER TENDL-2023 LIBRARY; T=0.K  
neutrons from (p,n)

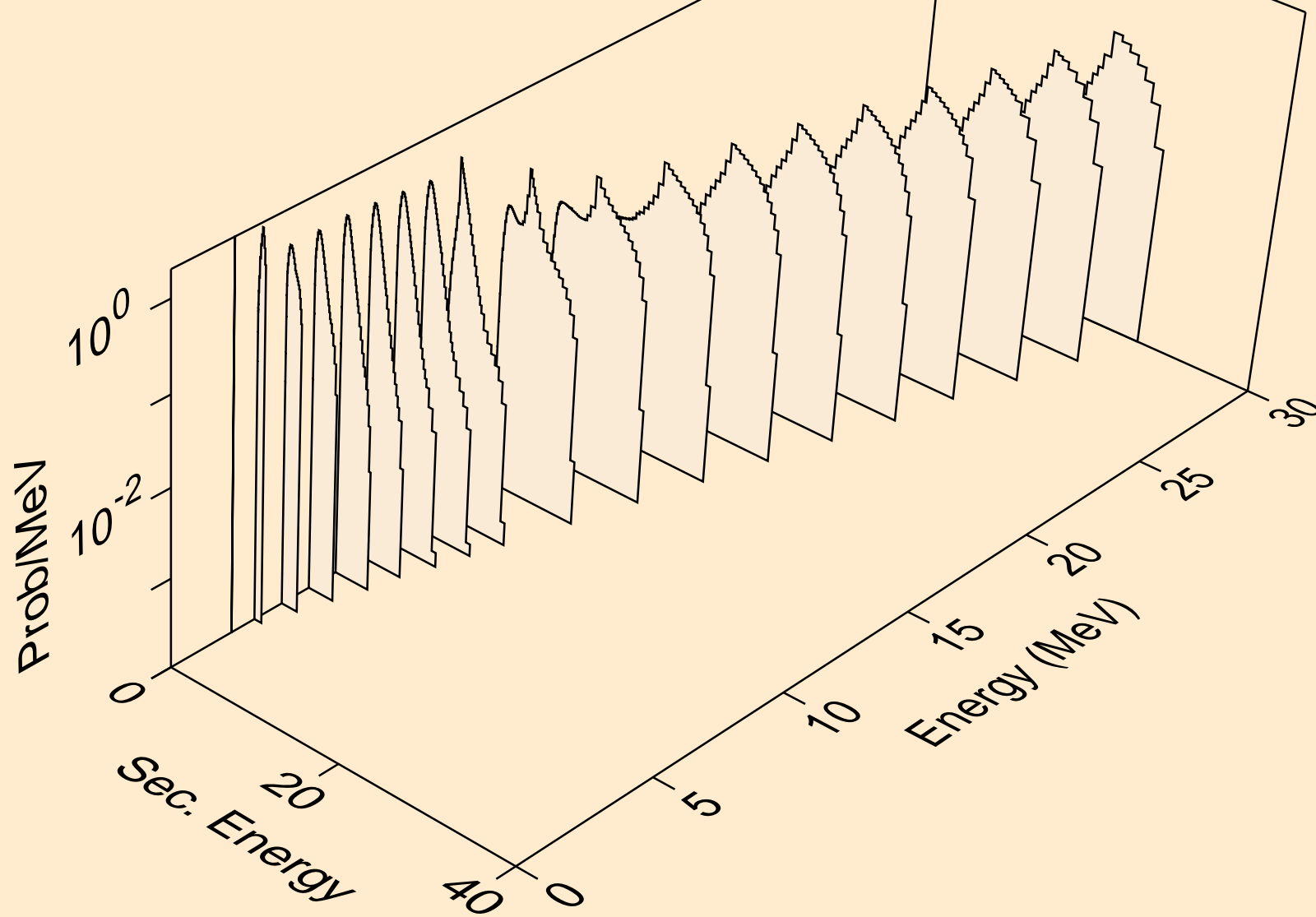

YB174 PROTON ACER TENDL-2023 LIBRARY; T=0.K  
neutrons from (p,x)

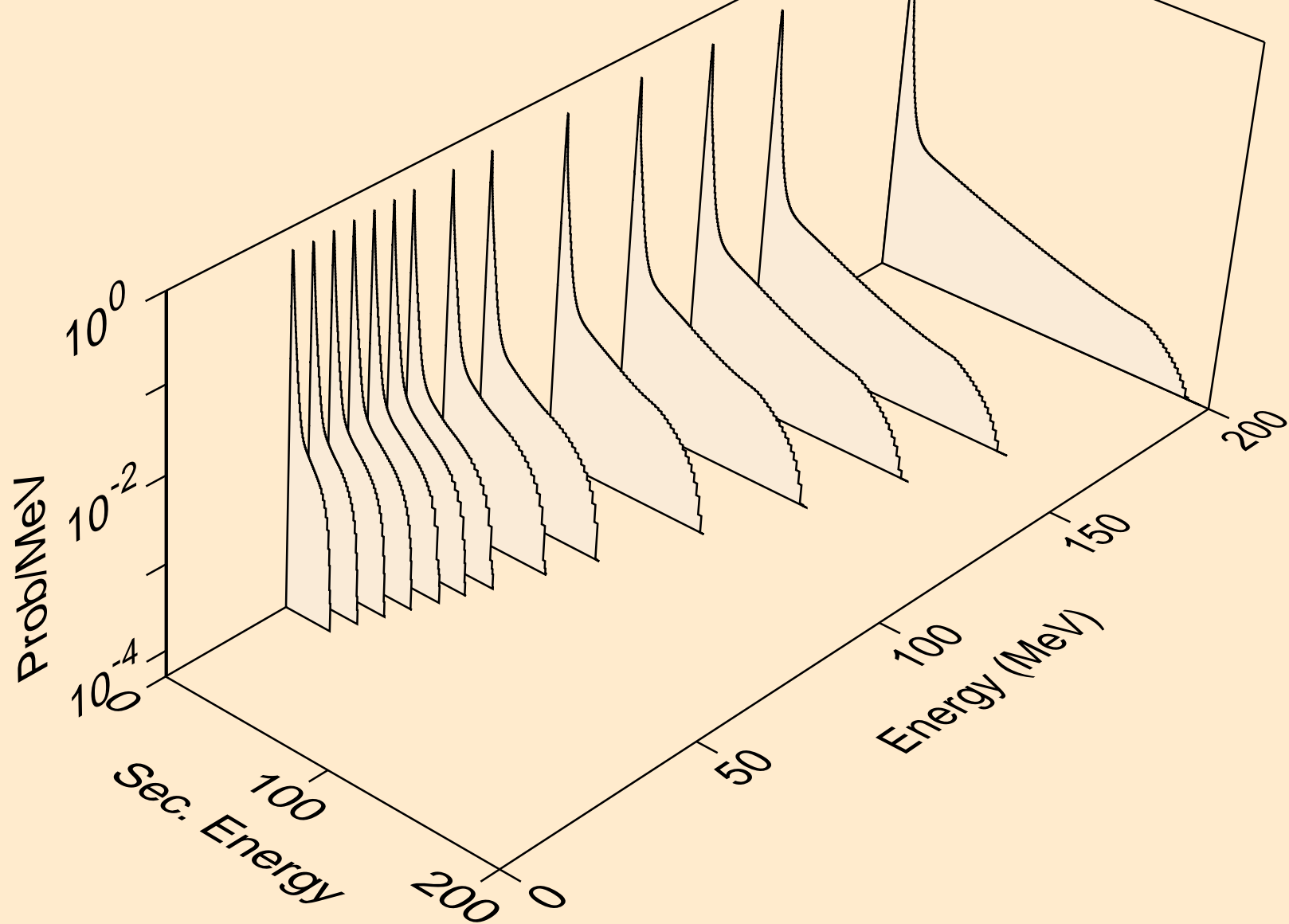

YB174 PROTON ACER TENDL-2023 LIBRARY; T=0.K  
neutrons from (p,2nd)

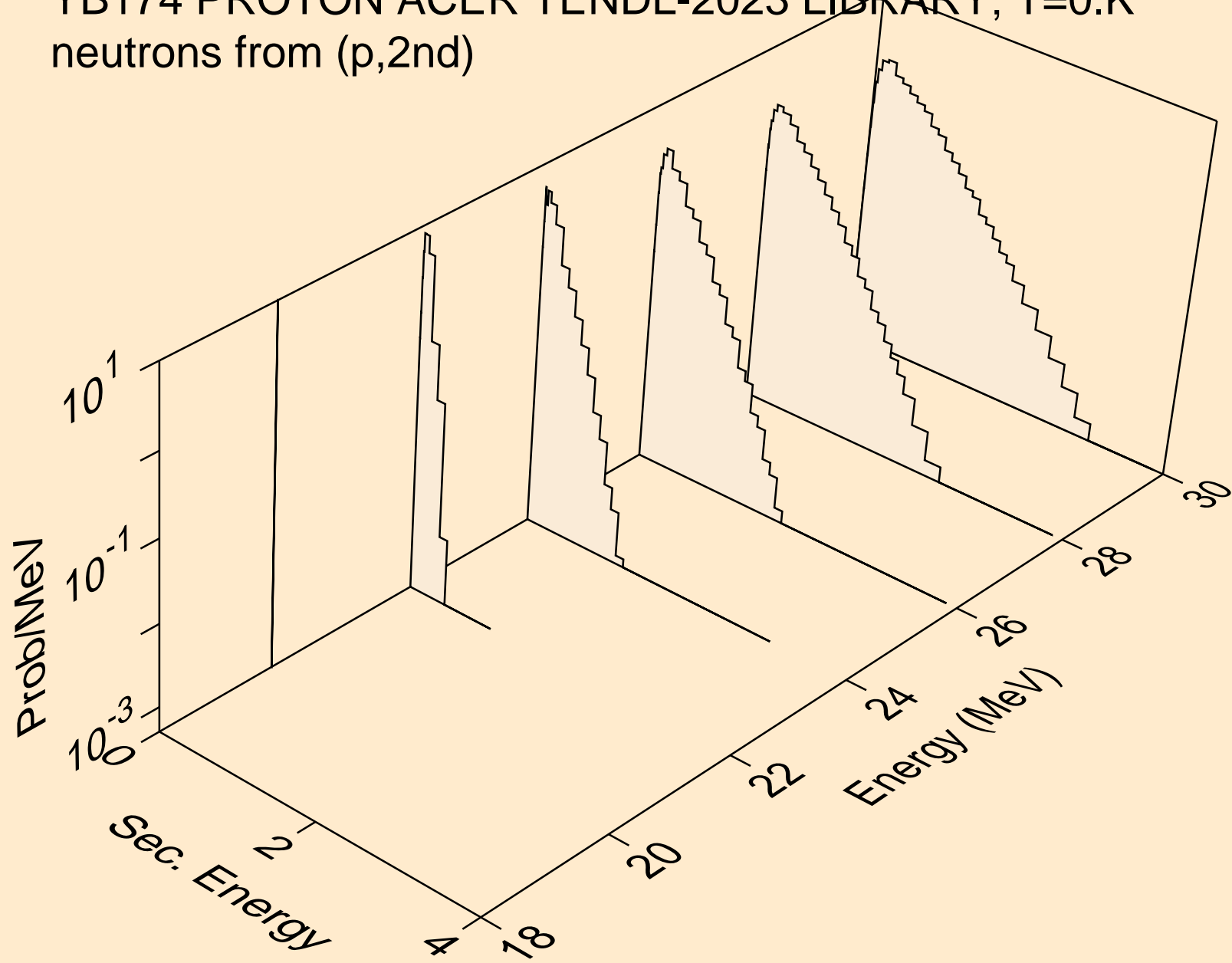



YB174 PROTON ACER TENDL-2023 LIBRARY; T=0.K  
neutrons from (p,2n)

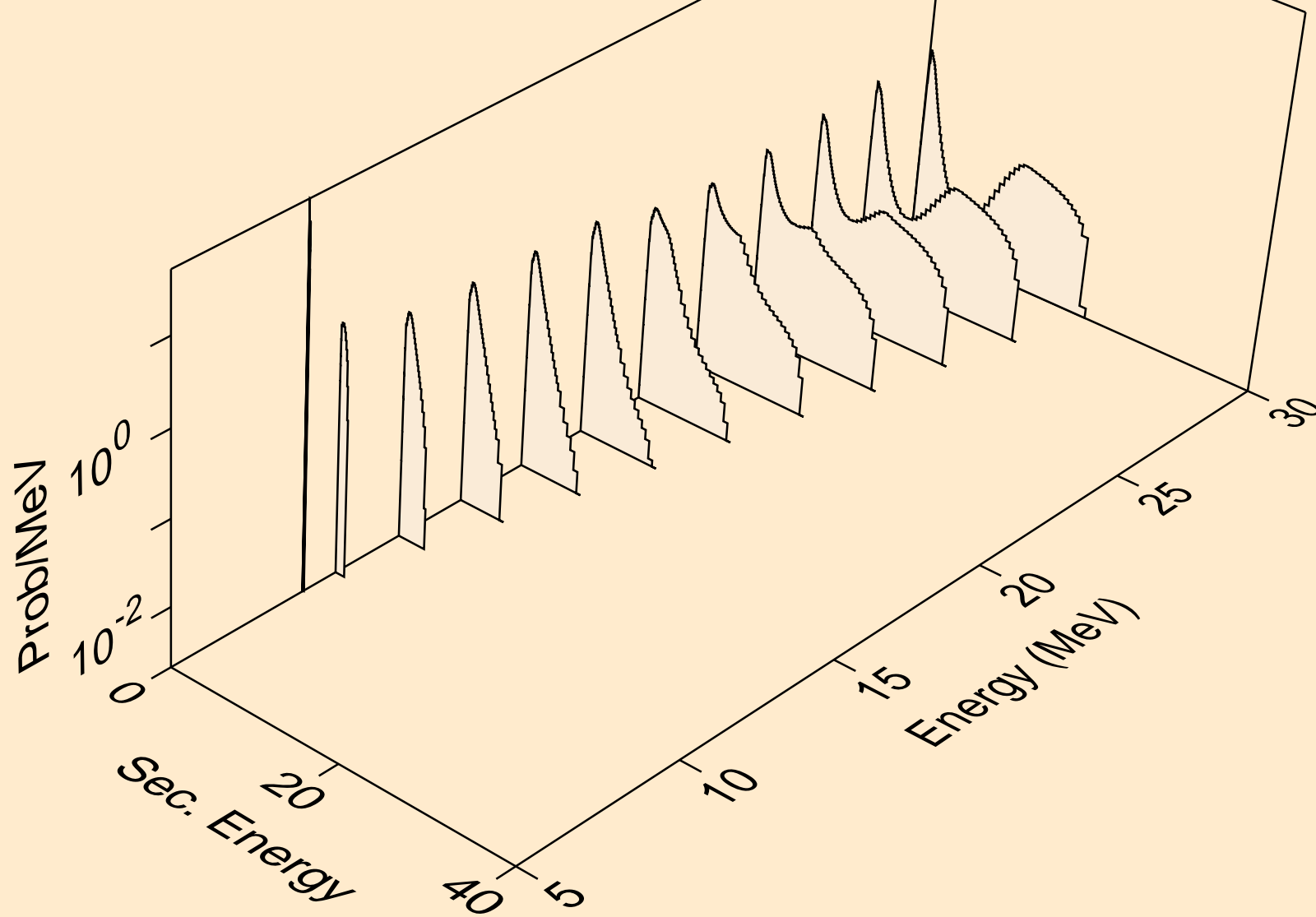

YB174 PROTON ACER TENDL-2023 LIBRARY; T=0.K  
neutrons from (p,3n)

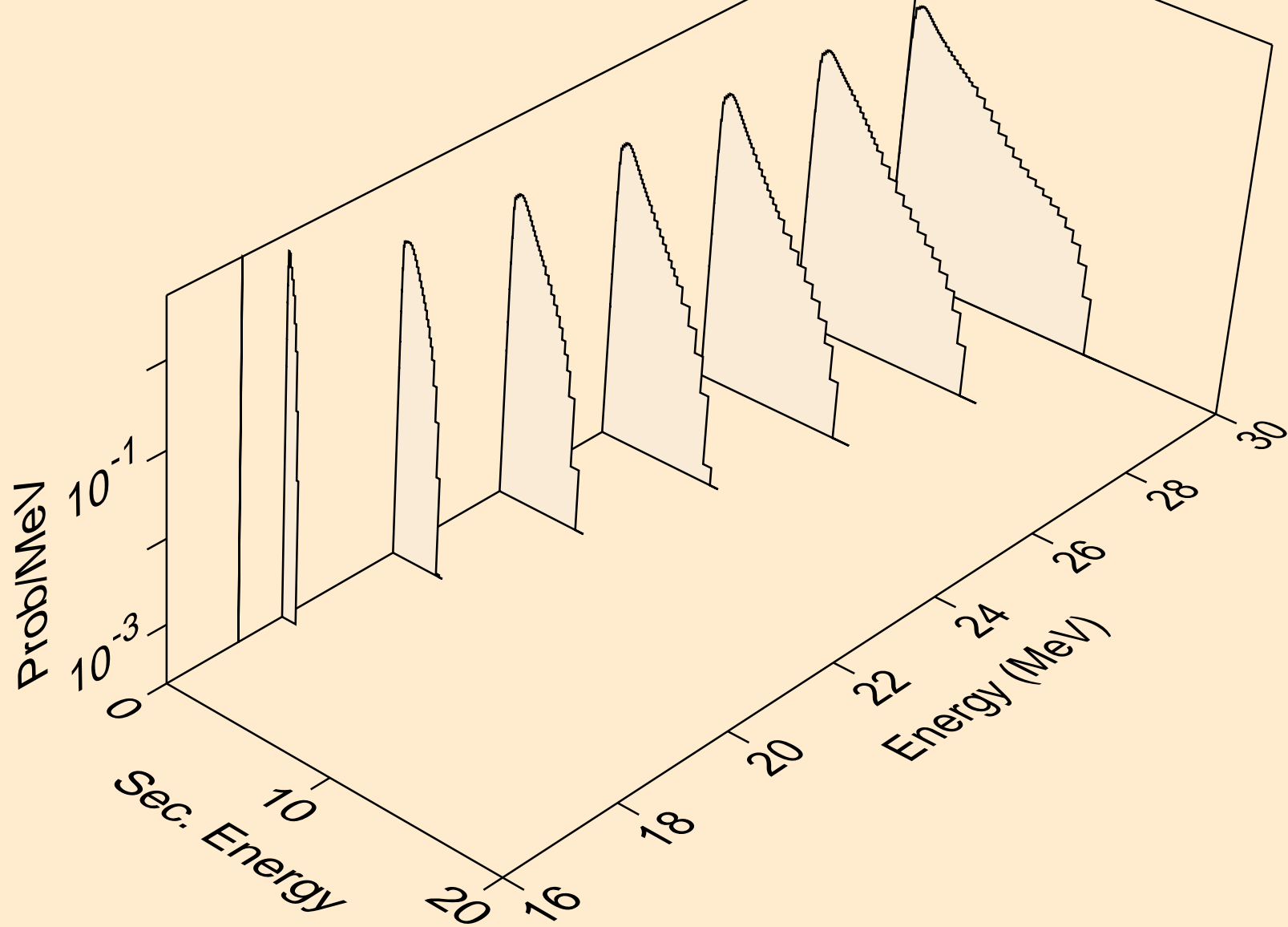

YB174 PROTON ACER TENDL-2023 LIBRARY; T=0.K  
neutrons from (p,n\*)a

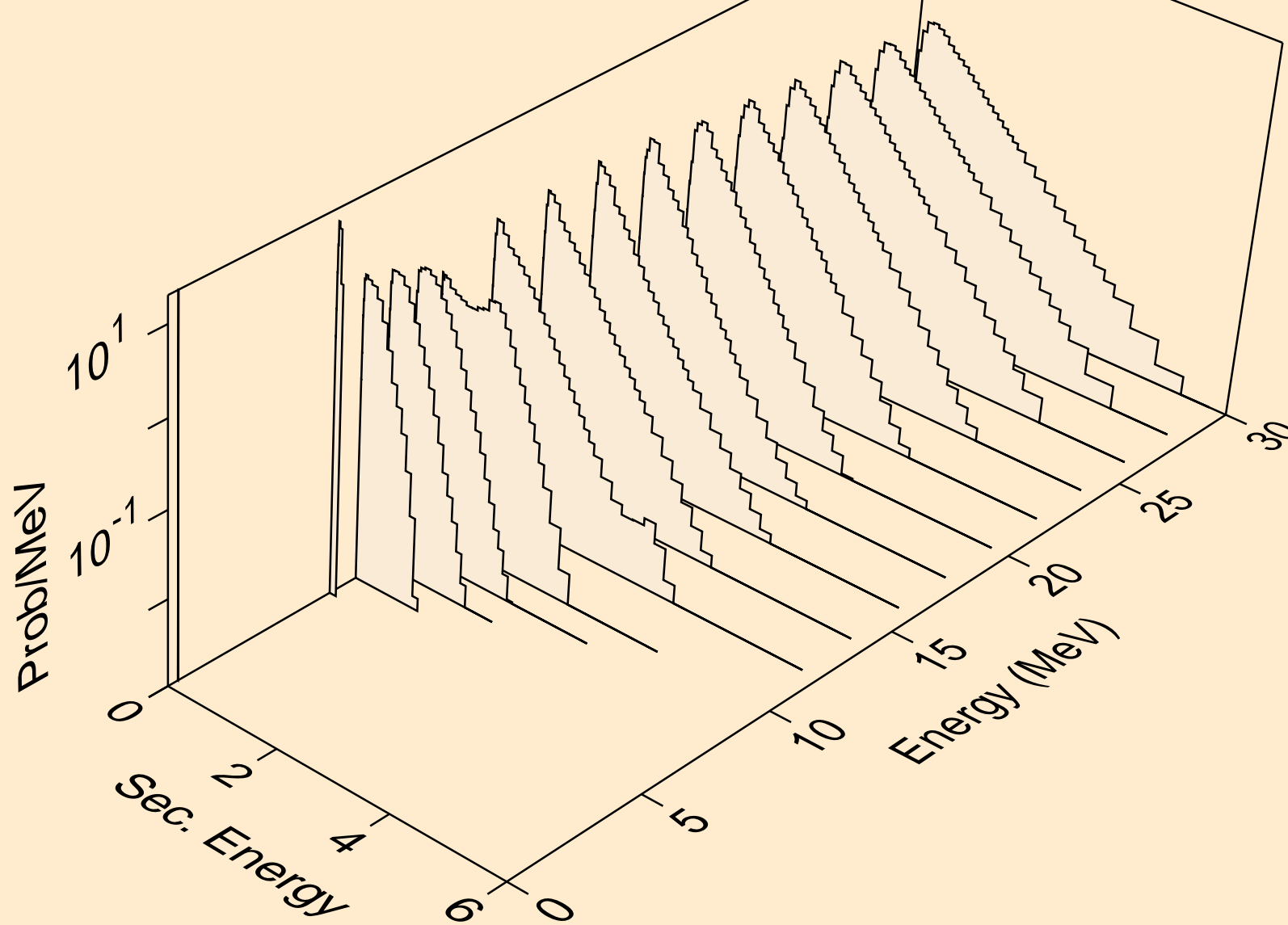

YB174 PROTON ACER TENDL-2023 LIBRARY; T=0.K  
neutrons from (p,2n)a

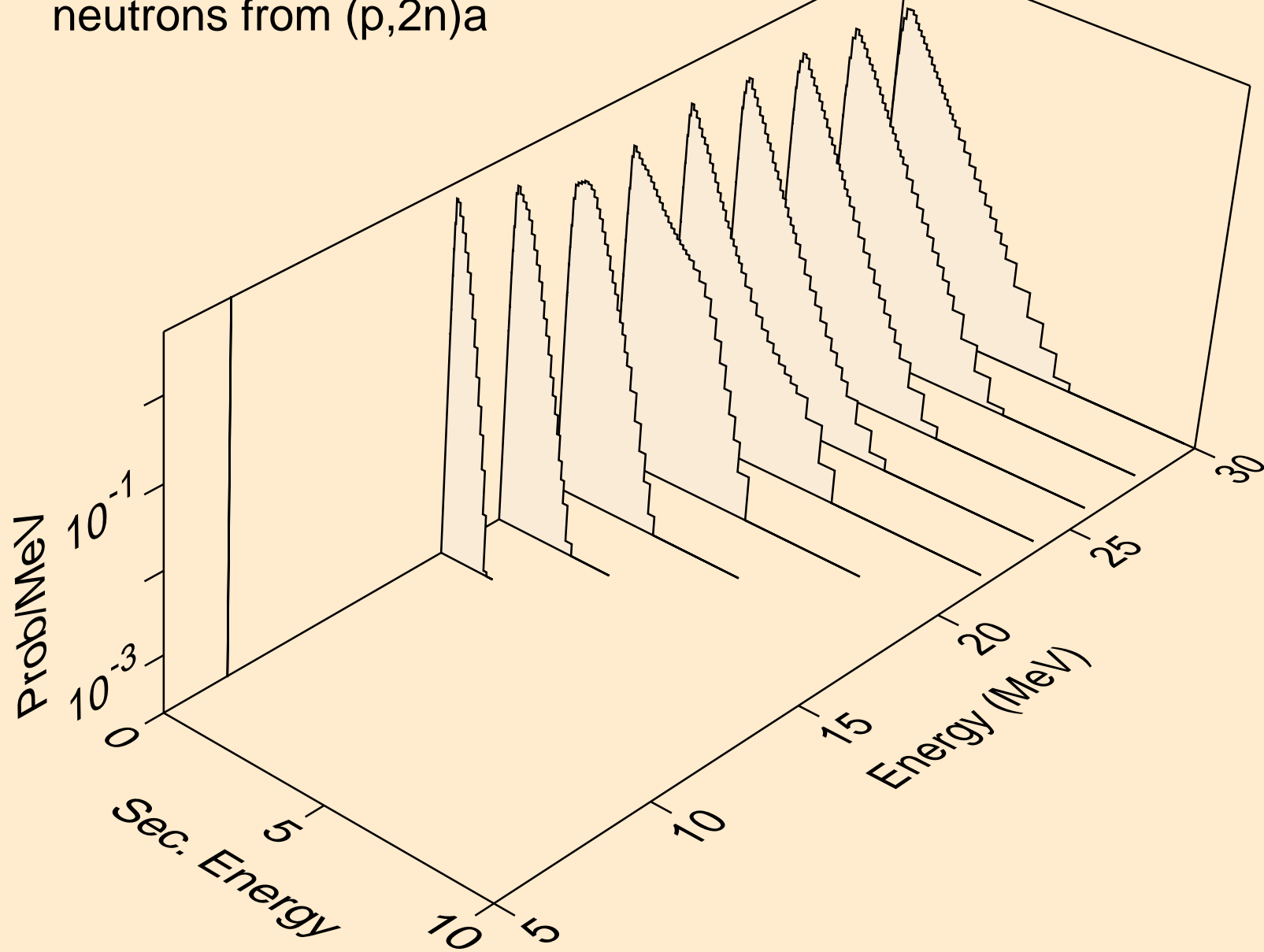

YB174 PROTON ACER TENDL-2023 LIBRARY; T=0.K  
neutrons from (p,3n)a

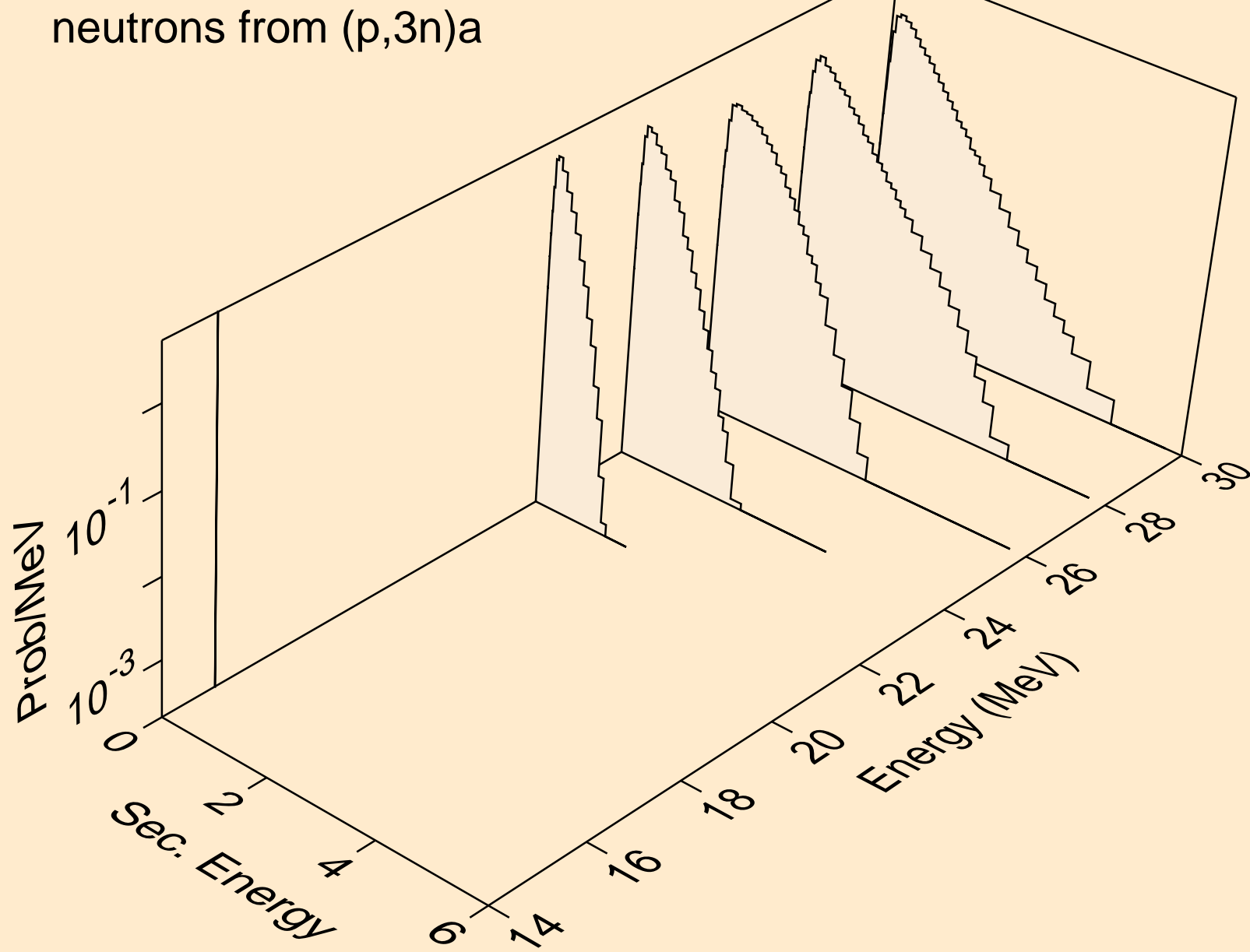

YB174 PROTON ACER TENDL-2023 LIBRARY; T=0.K  
neutrons from (p,n\*)p

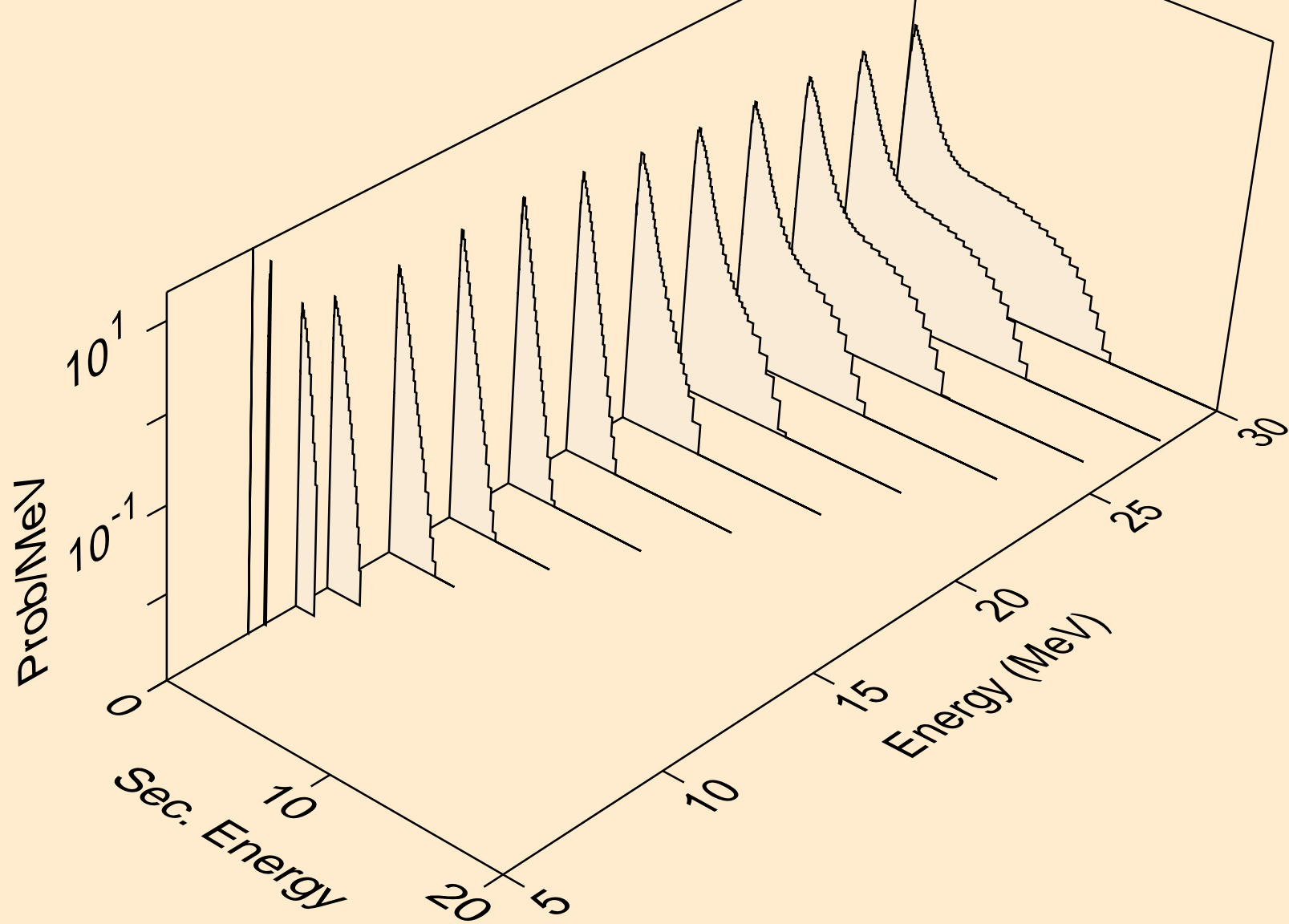

YB174 PROTON ACER TENDL-2023 LIBRARY; T=0.K  
neutrons from (p,n\*)2a

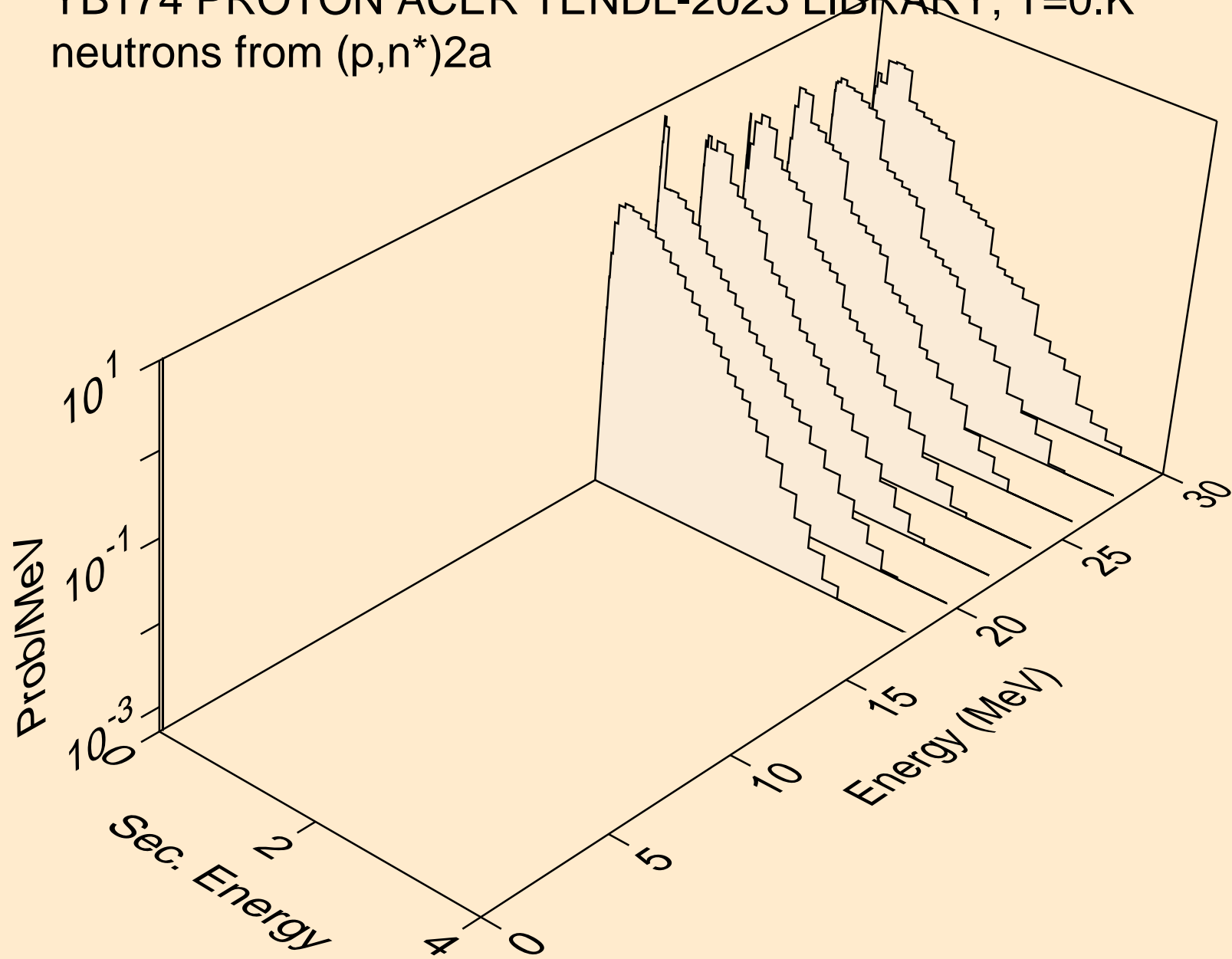

YB174 PROTON ACER TENDL-2023 LIBRARY; T=0.K  
neutrons from (p,n\*)d

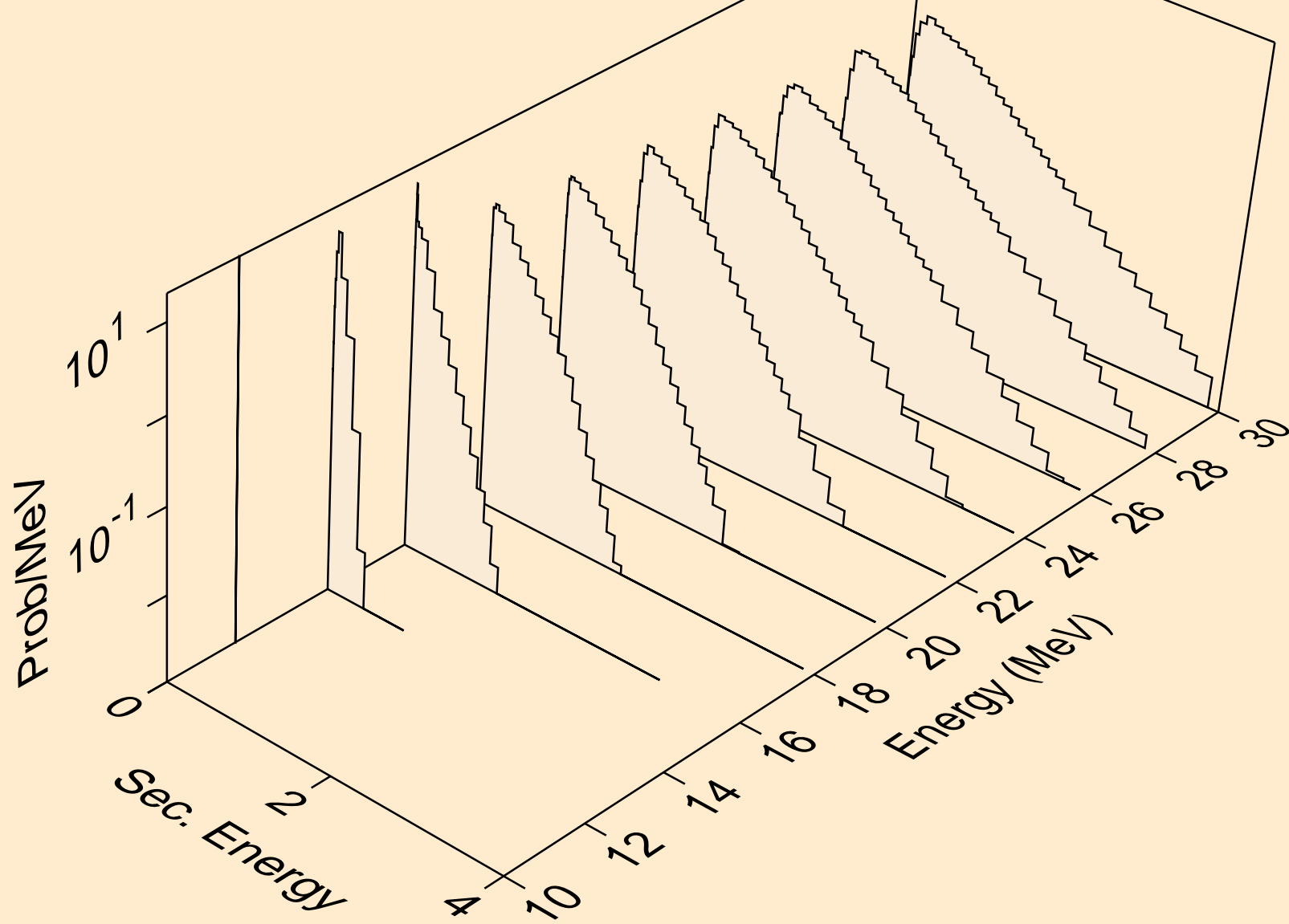



YB174 PROTON ACER TENDL-2023 LIBRARY; T=0.K  
neutrons from (p,n\*)t

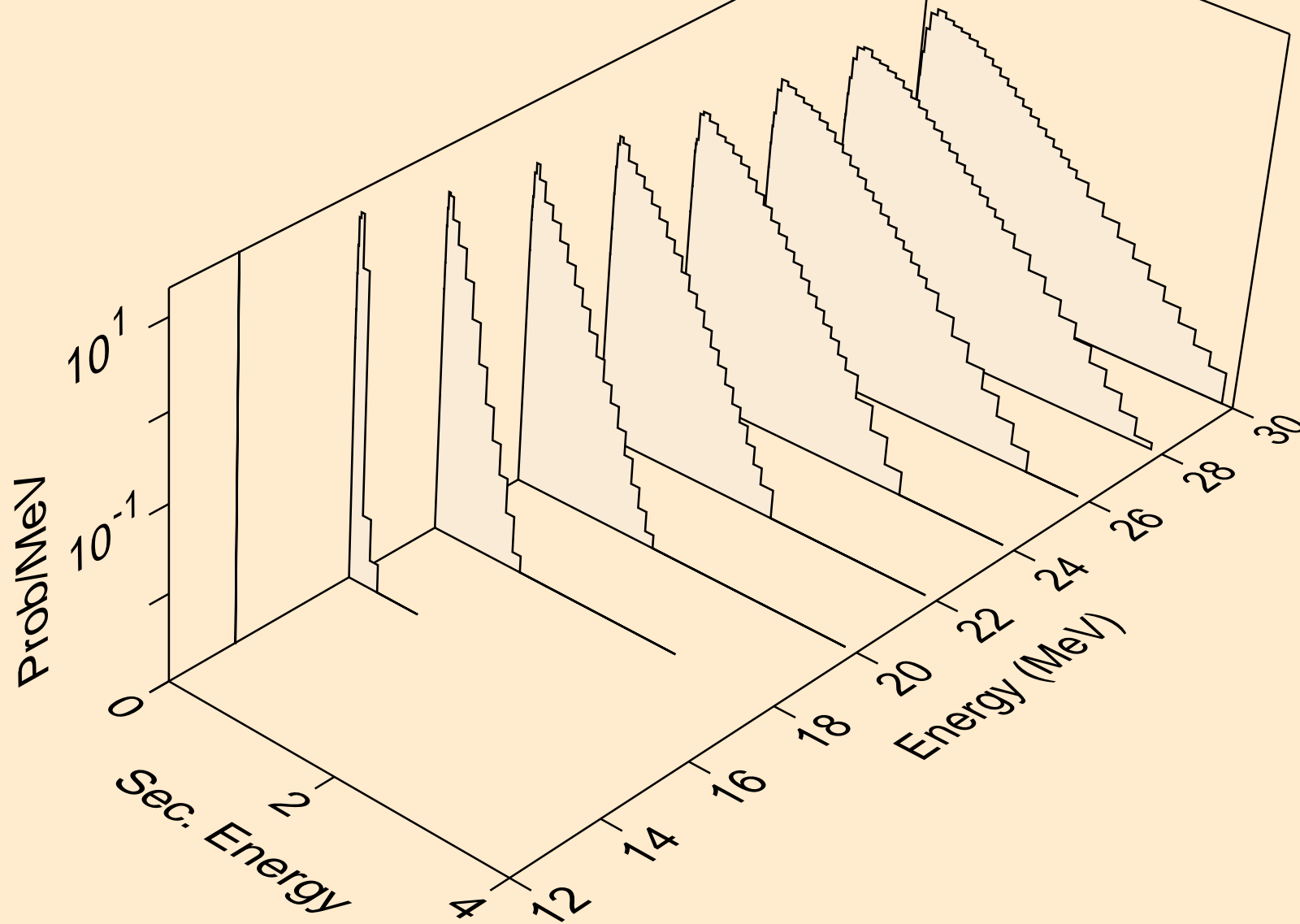

YB174 PROTON ACER TENDL-2023 LIBRARY; T=0.K  
neutrons from (p,n\*)he3

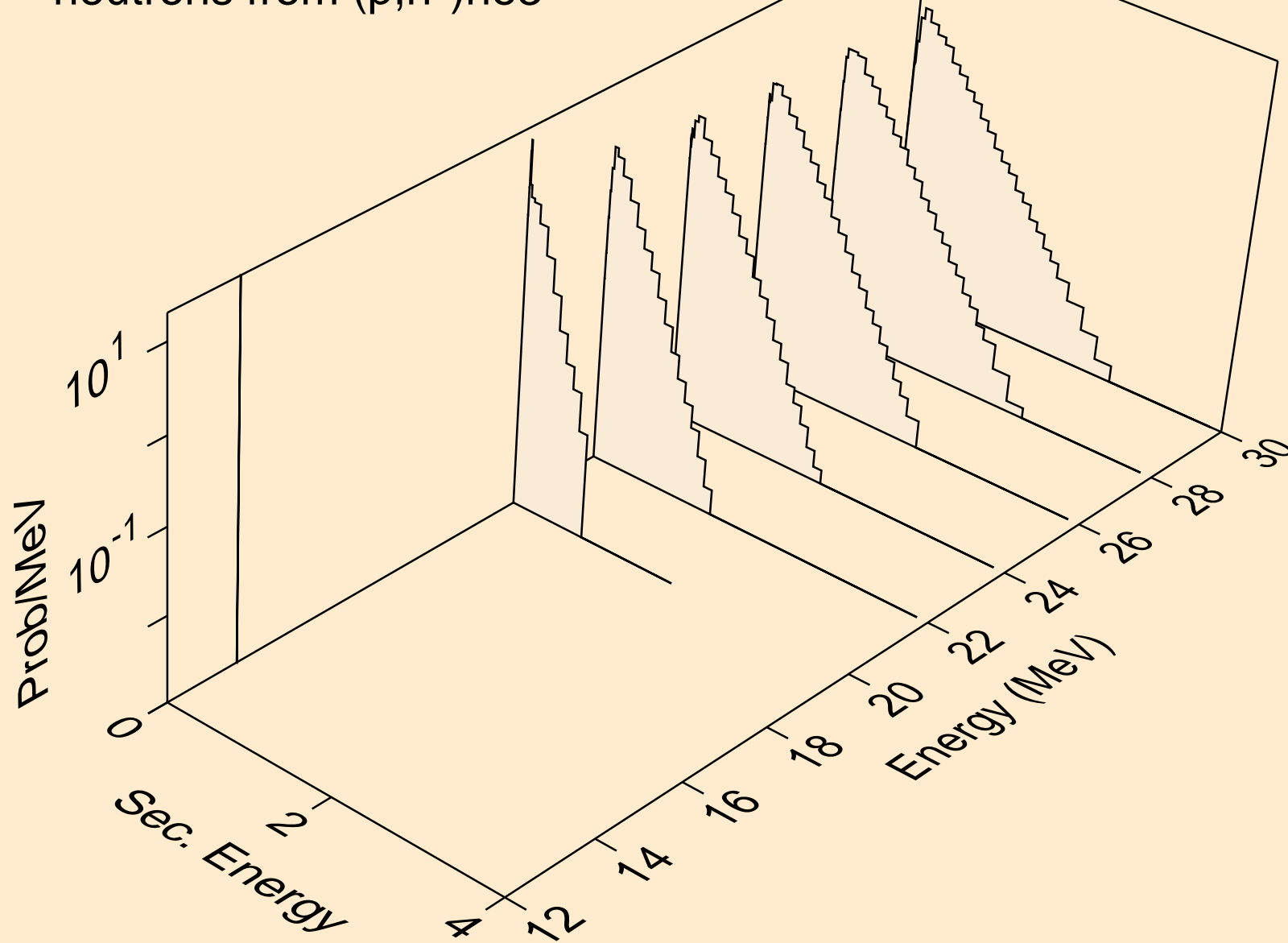

YB174 PROTON ACER TENDL-2023 LIBRARY; T=0.K  
neutrons from (p,4n)

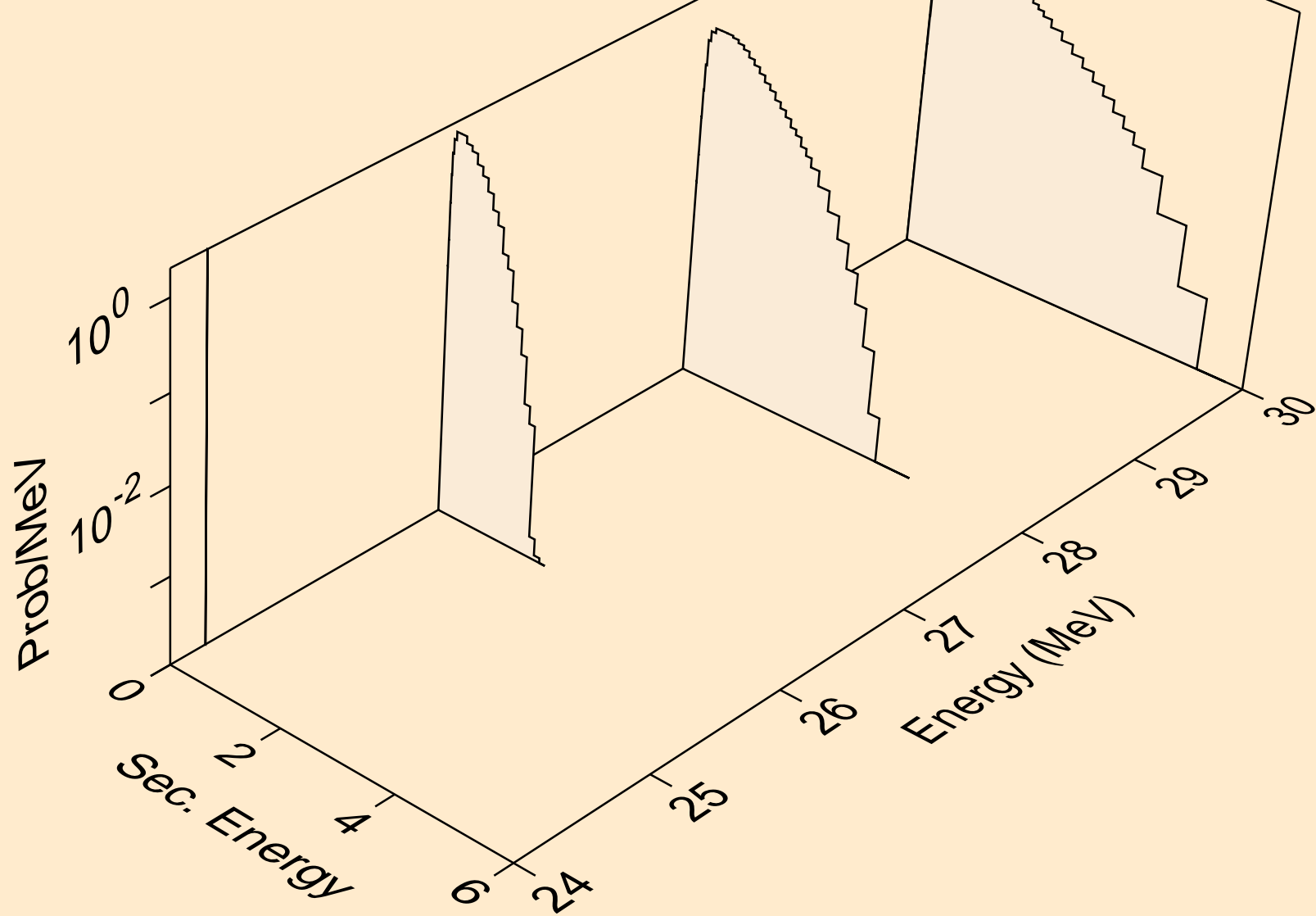

YB174 PROTON ACER TENDL-2023 LIBRARY; T=0.K  
neutrons from (p,2np)

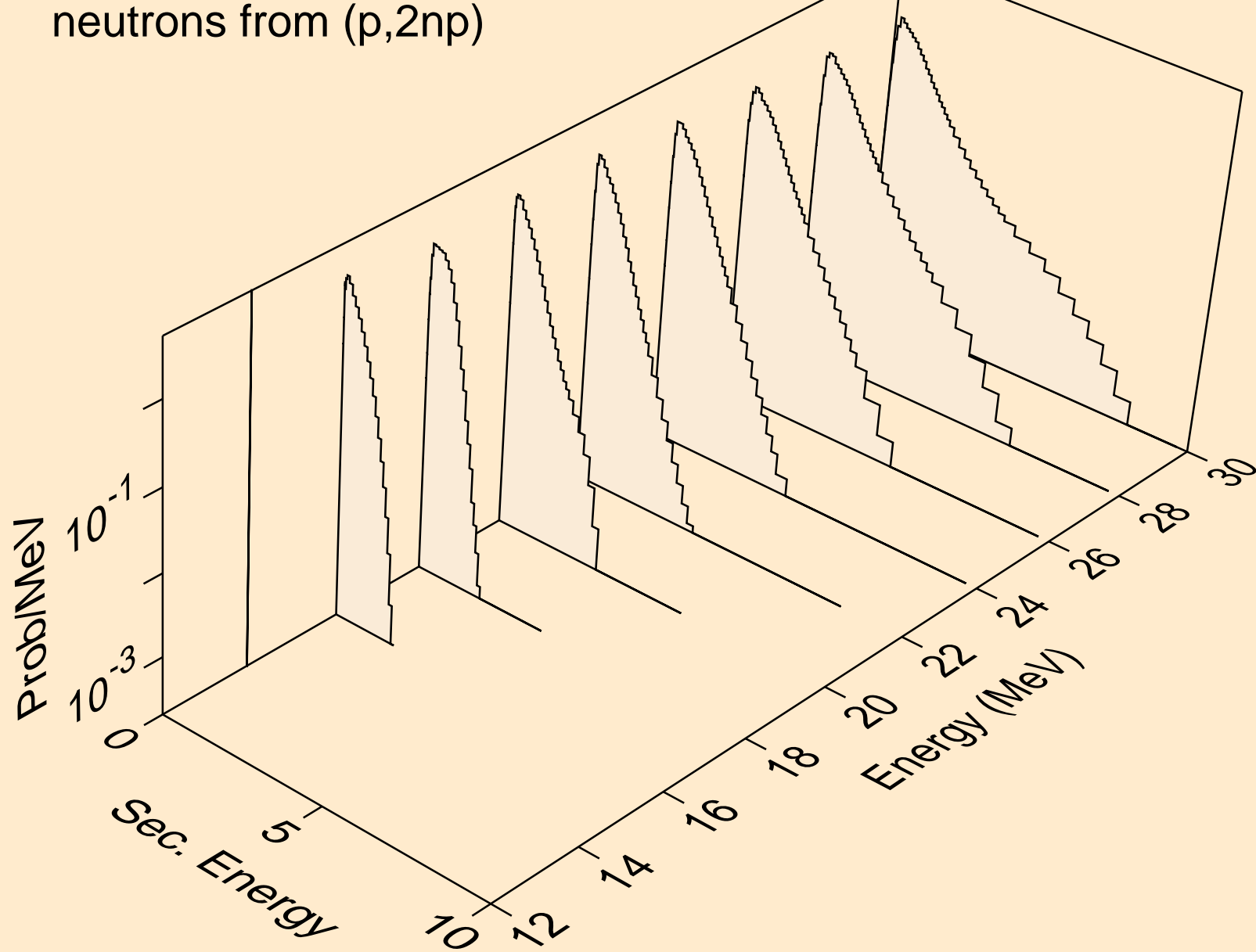

YB174 PROTON ACER TENDL-2023 LIBRARY; T=0.K  
neutrons from (p,3np)

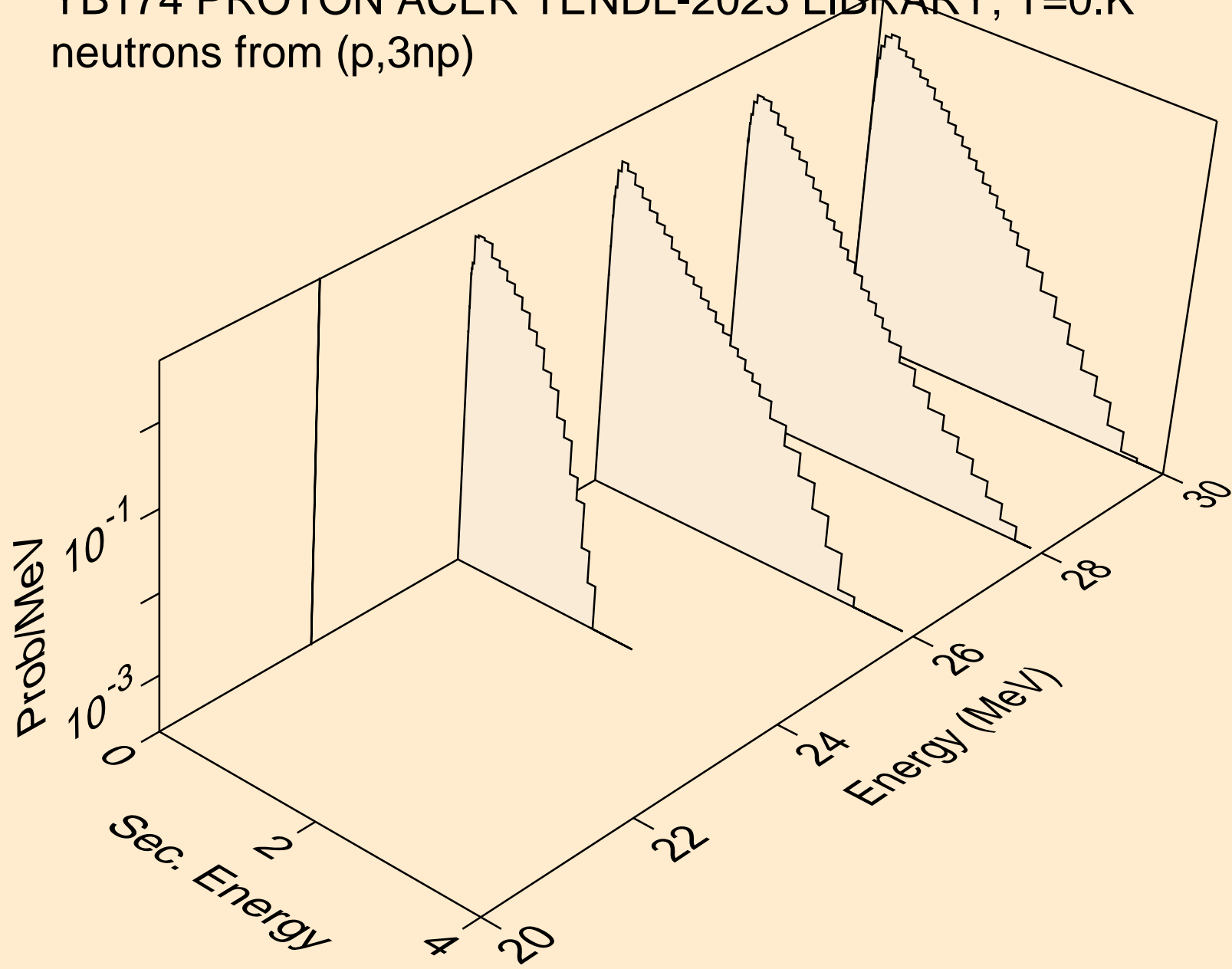

YB174 PROTON ACER TENDL-2023 LIBRARY; T=0.K  
neutrons from (p,n2p)

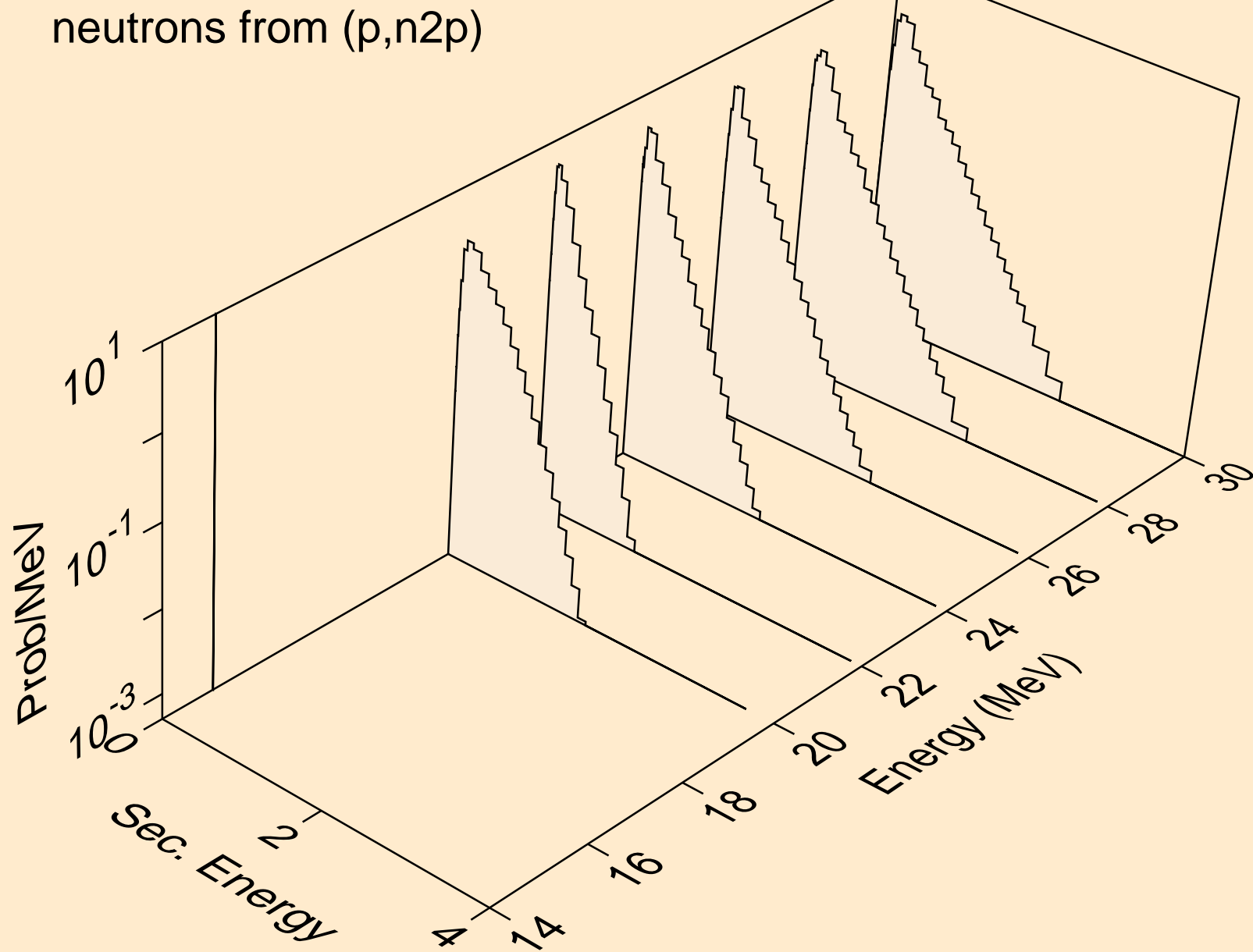

YB174 PROTON ACER TENDL-2023 LIBRARY; T=0.K  
neutrons from (p,npa)

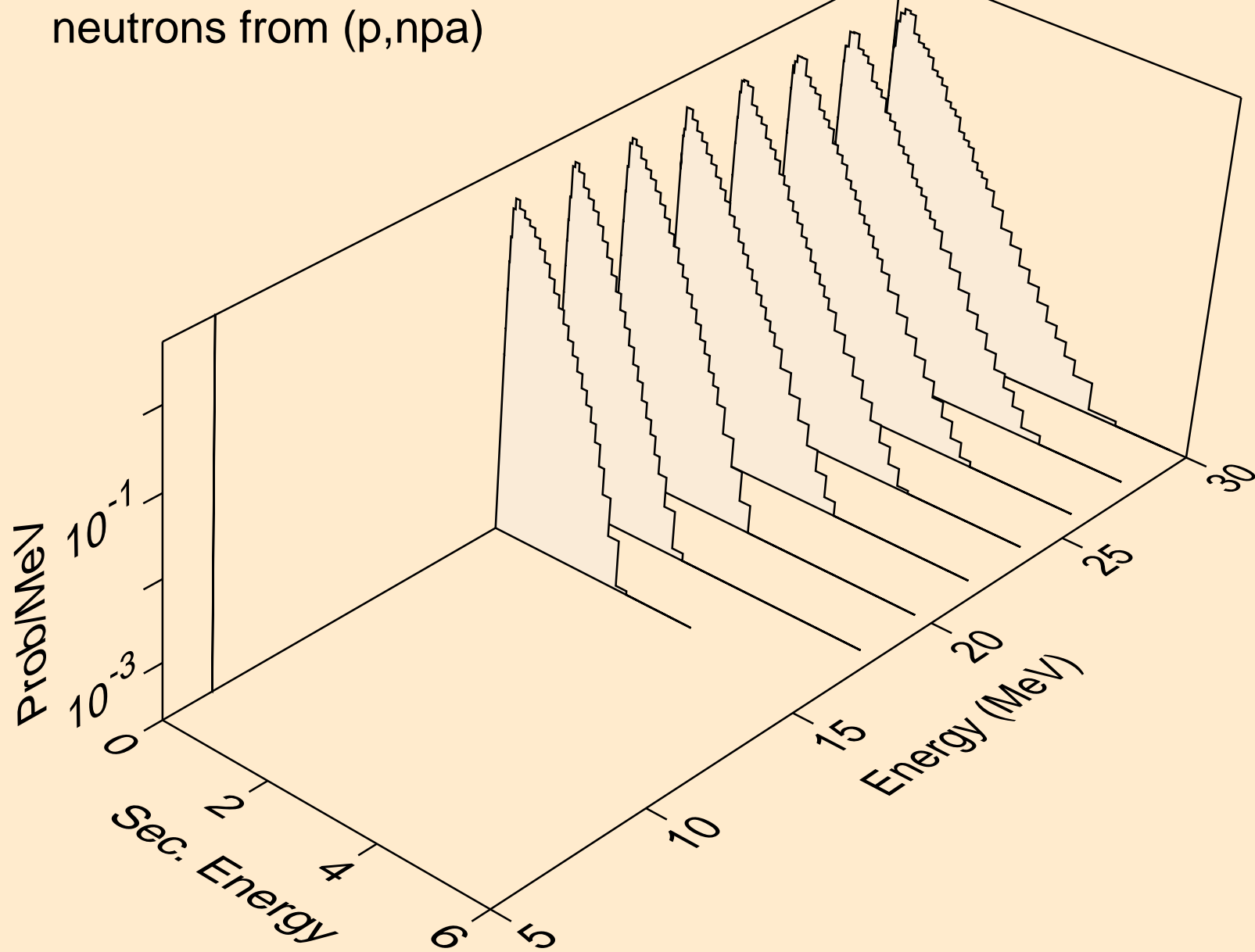

YB174 PROTON ACER TENDL-2023 LIBRARY; T=0.K  
deuterons from (p,x)

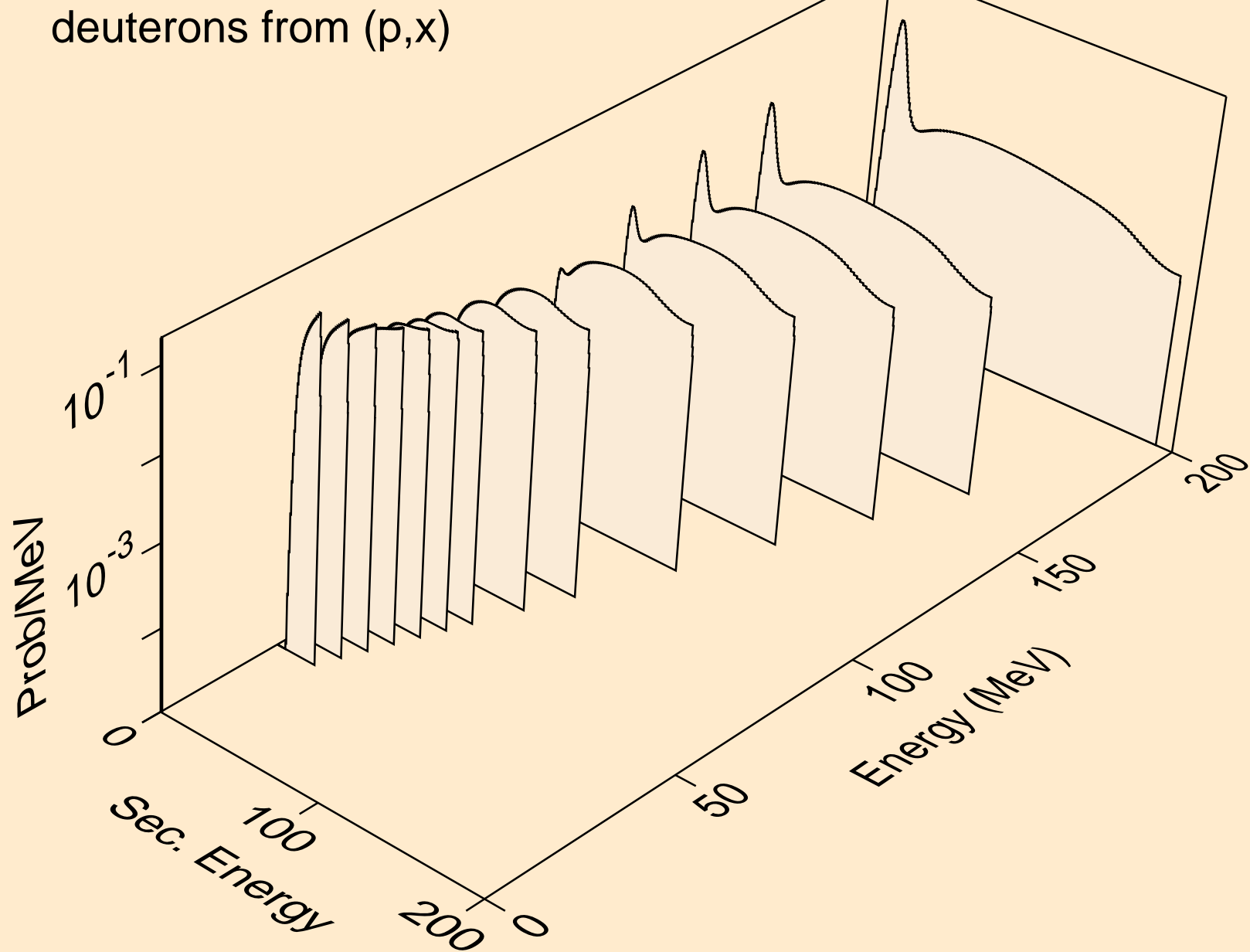



YB174 PROTON ACER TENDL-2023 LIBRARY; T=0.K  
deuterons from (p,2nd)

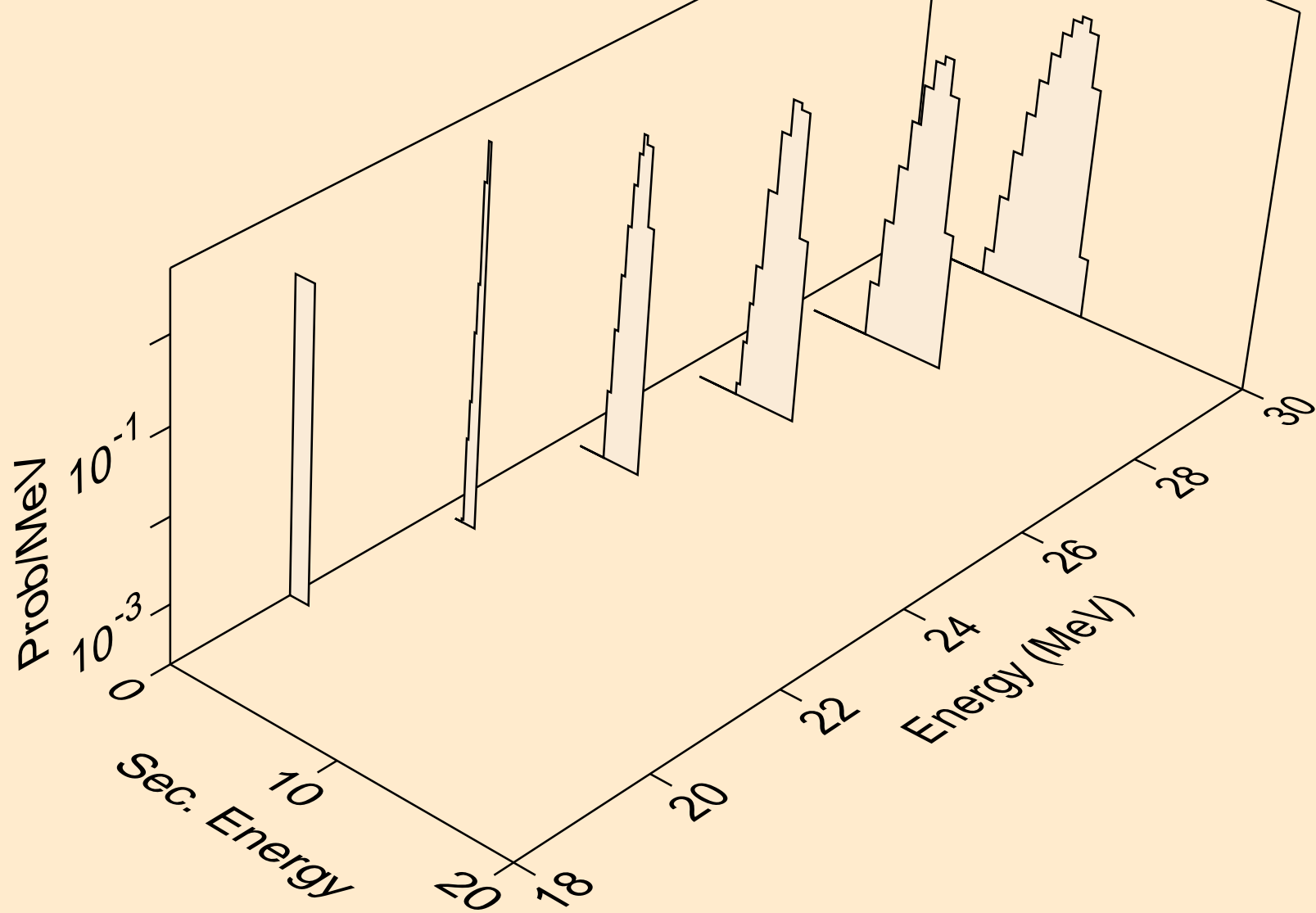

YB174 PROTON ACER TENDL-2023 LIBRARY; T=0.K  
deuterons from (p,n\*)d

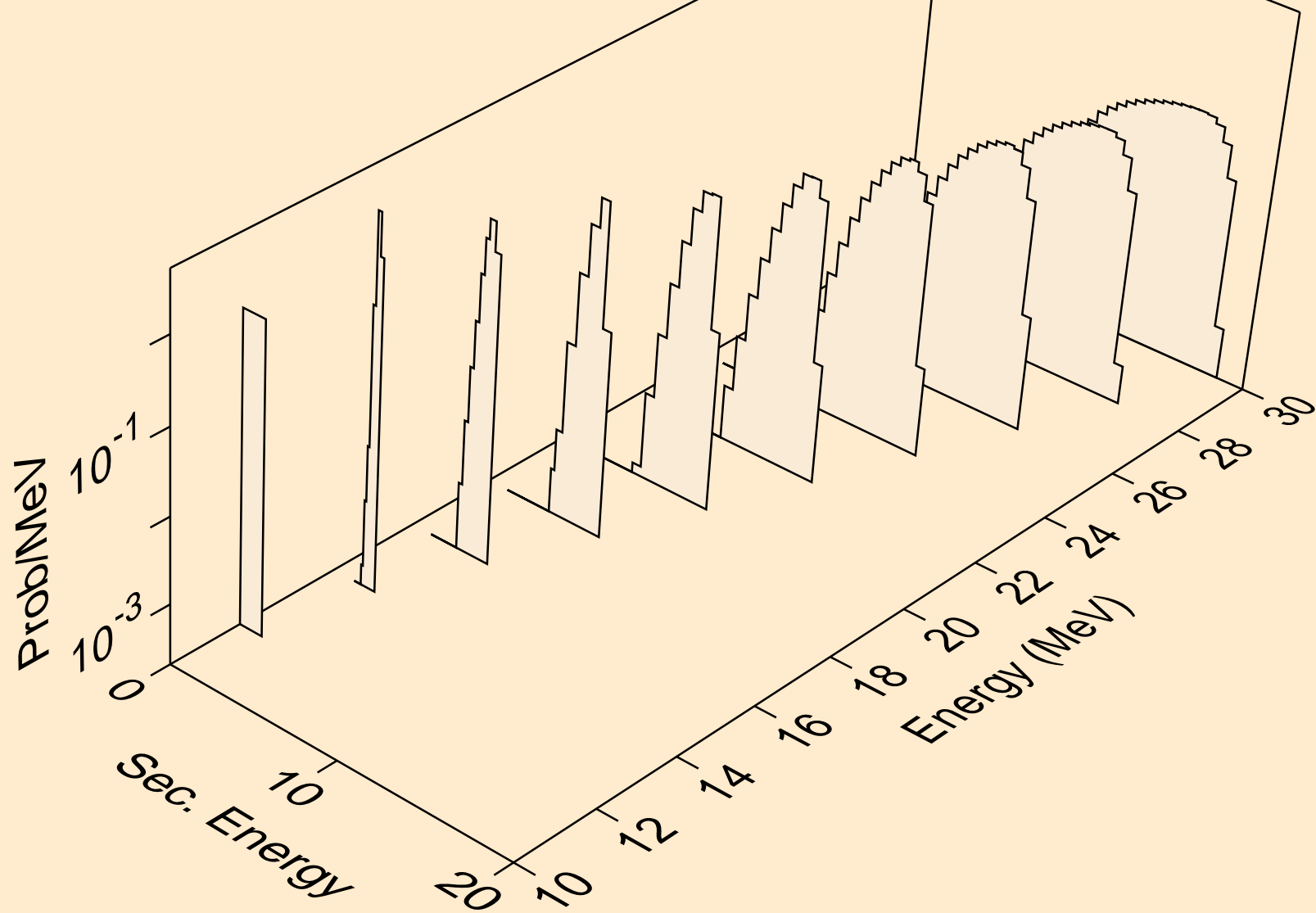

YB174 PROTON ACER TENDL-2023 LIBRARY; T=0.K  
deuterons from (p,d)

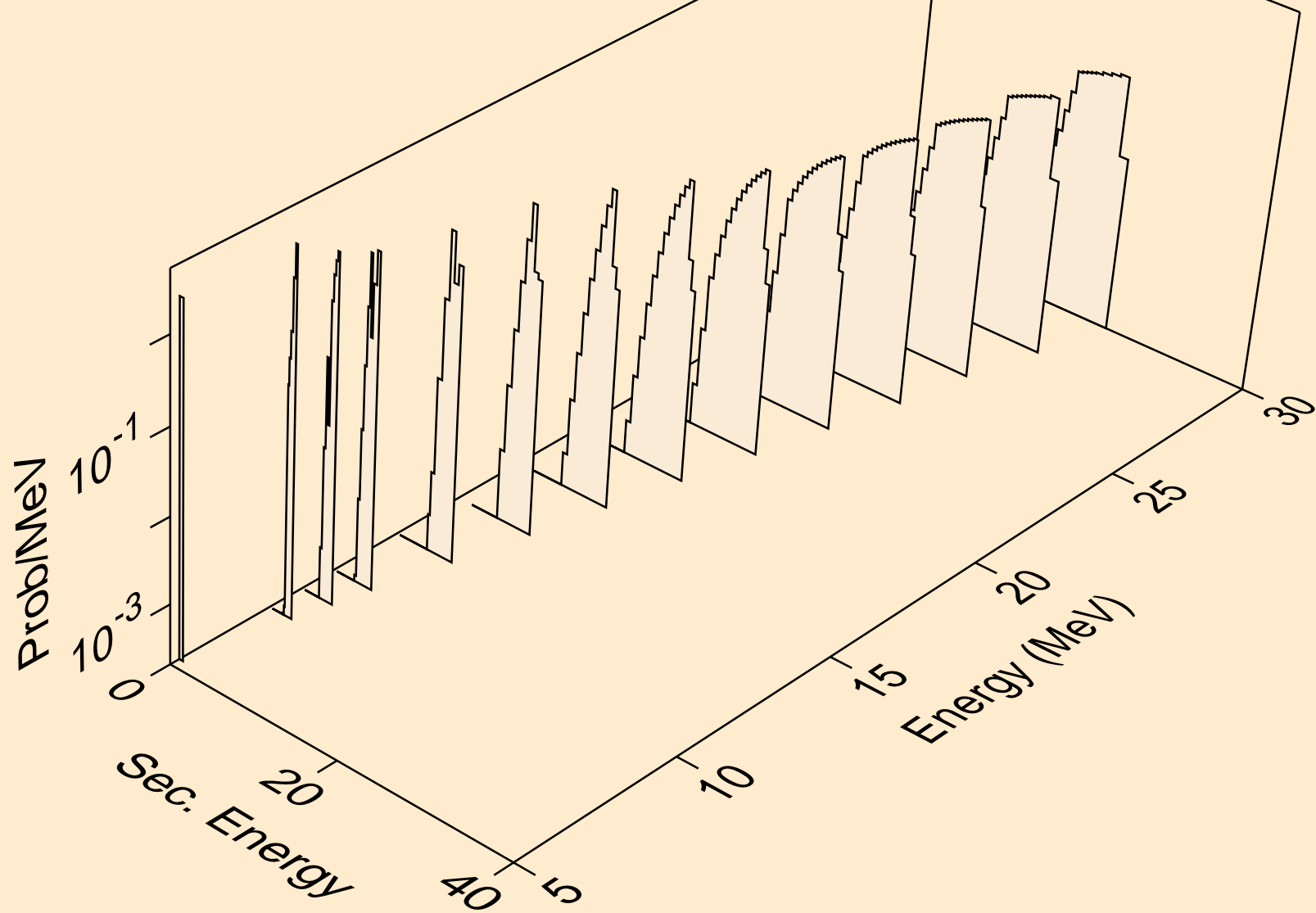

YB174 PROTON ACER TENDL-2023 LIBRARY; T=0.K  
deuterons from (p,pd)

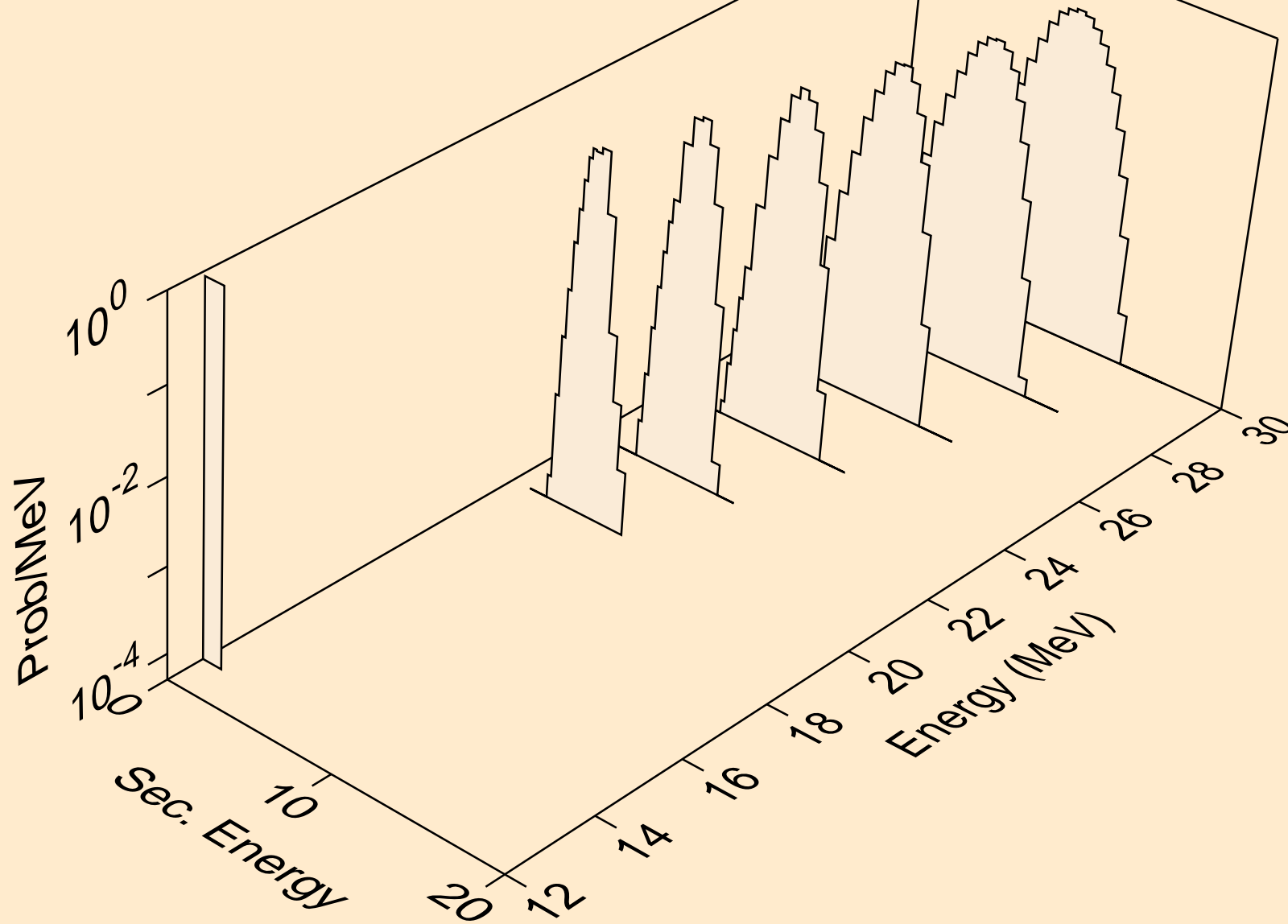

YB174 PROTON ACER TENDL-2023 LIBRARY; T=0.K  
deuterons from (p,da)

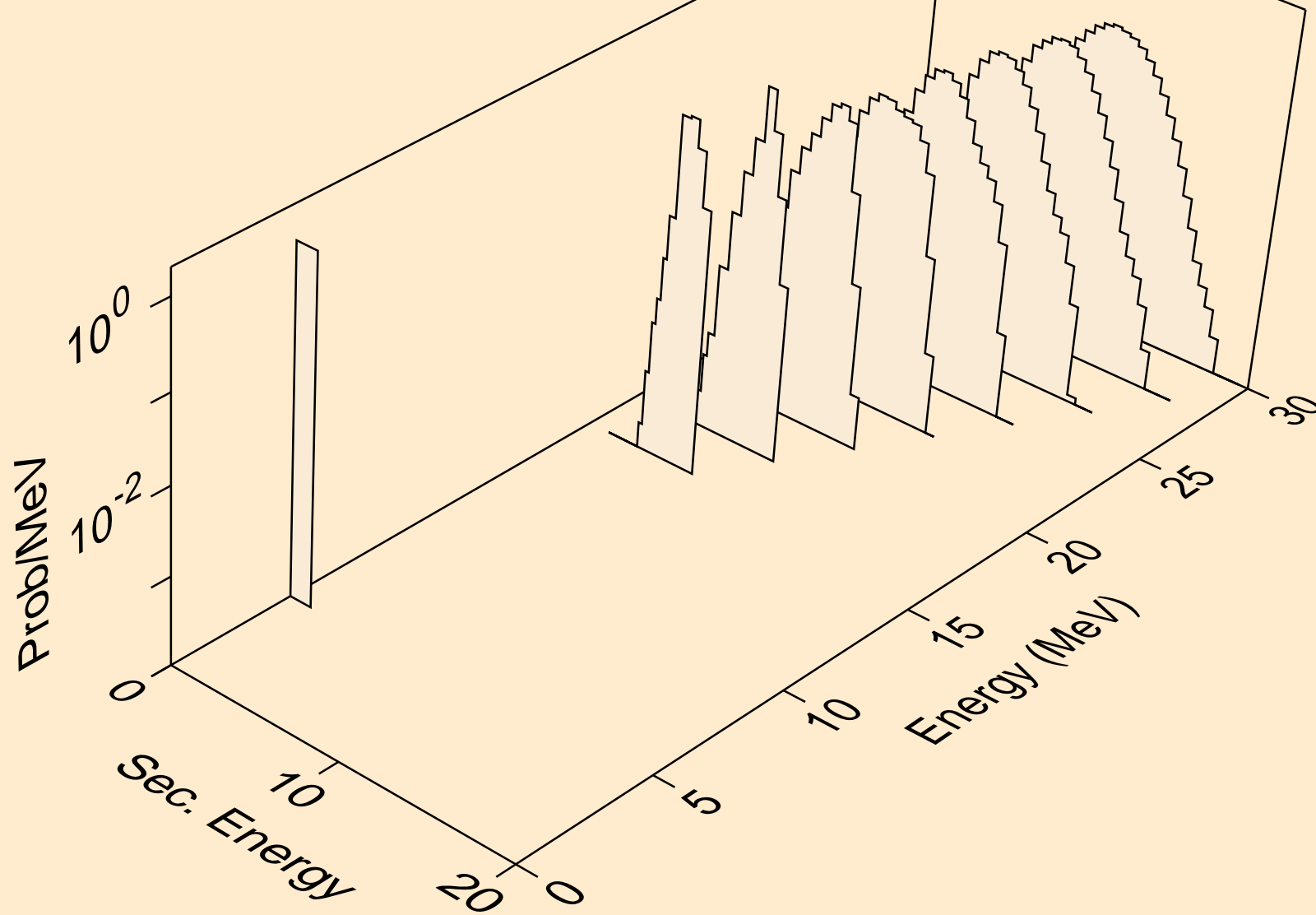

YB174 PROTON ACER TENDL-2023 LIBRARY; T=0.K  
tritons from (p,x)

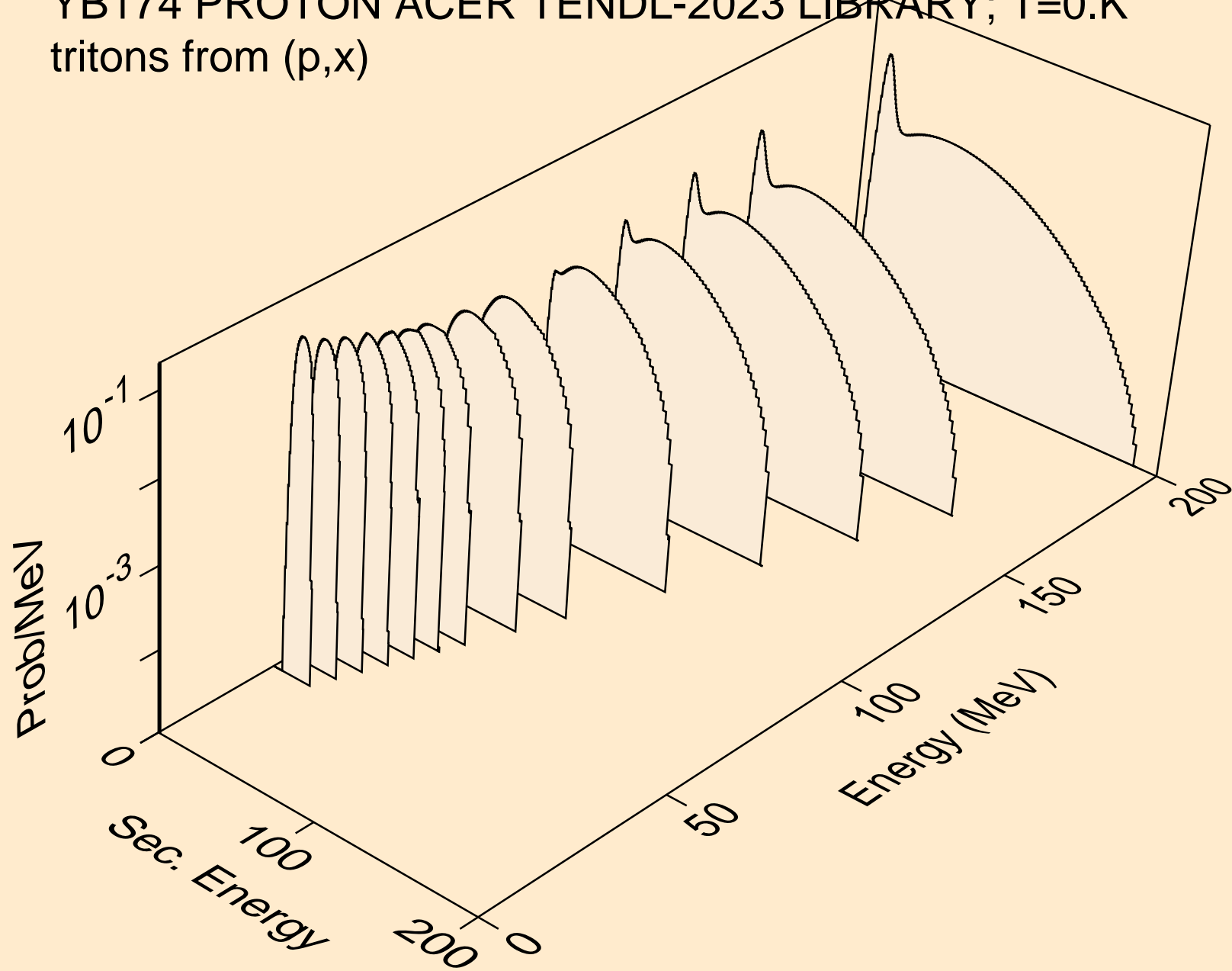

YB174 PROTON ACER TENDL-2023 LIBRARY; T=0.K  
tritons from (p,n\*)t

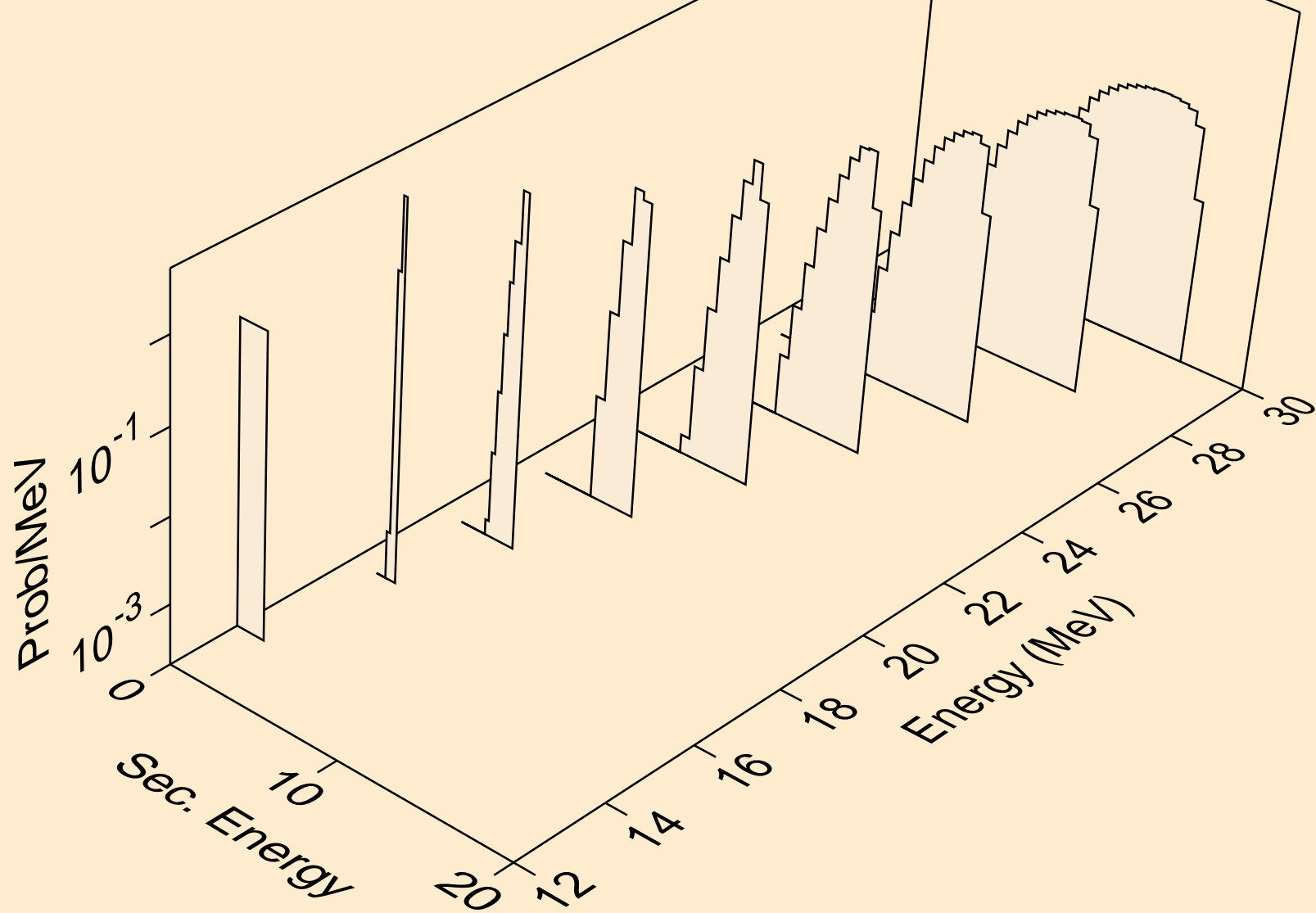

YB174 PROTON ACER TENDL-2023 LIBRARY; T=0.K  
tritons from (p,t)

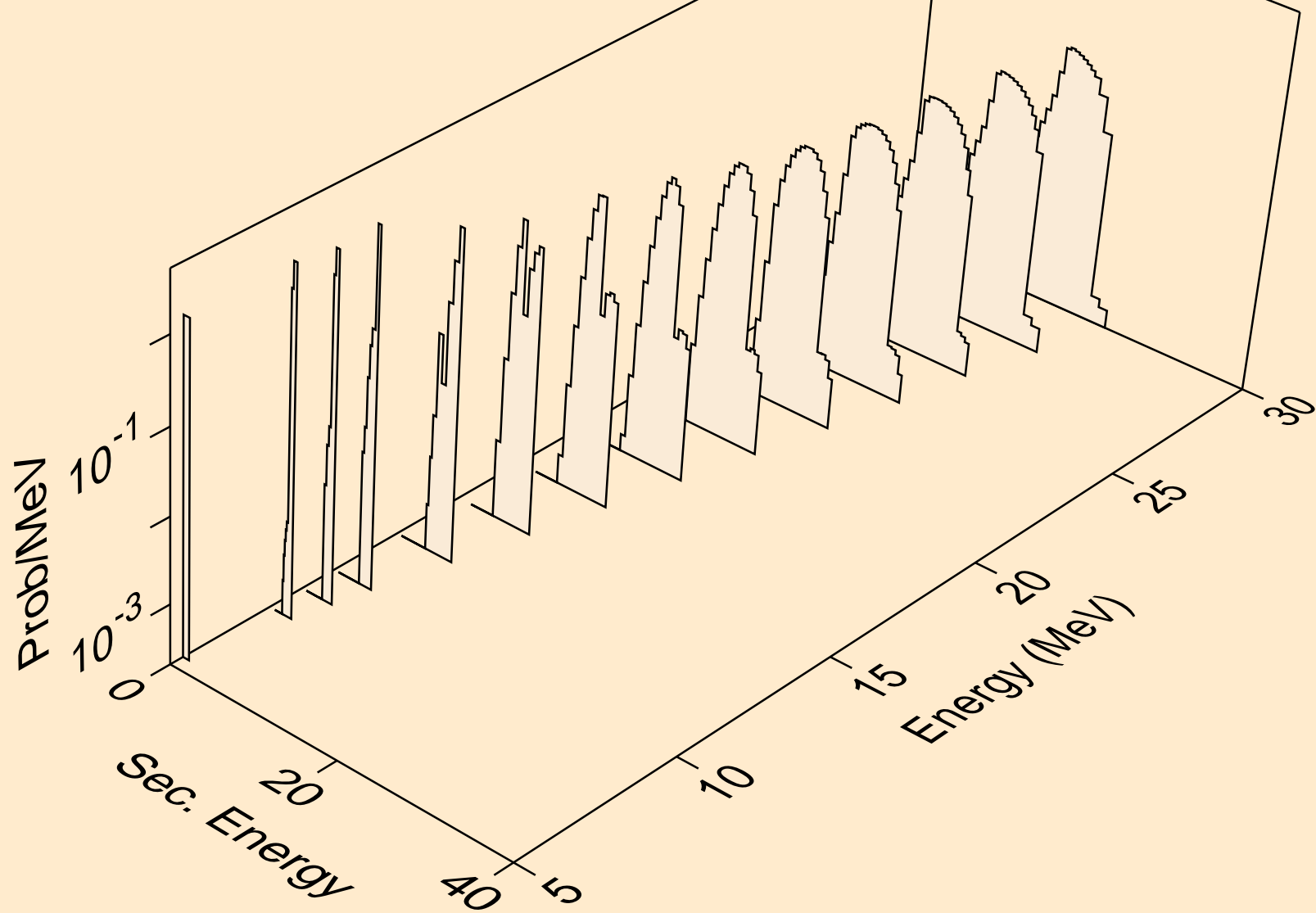



YB174 PROTON ACER TENDL-2023 LIBRARY; T=0.K  
tritons from (p,pt)

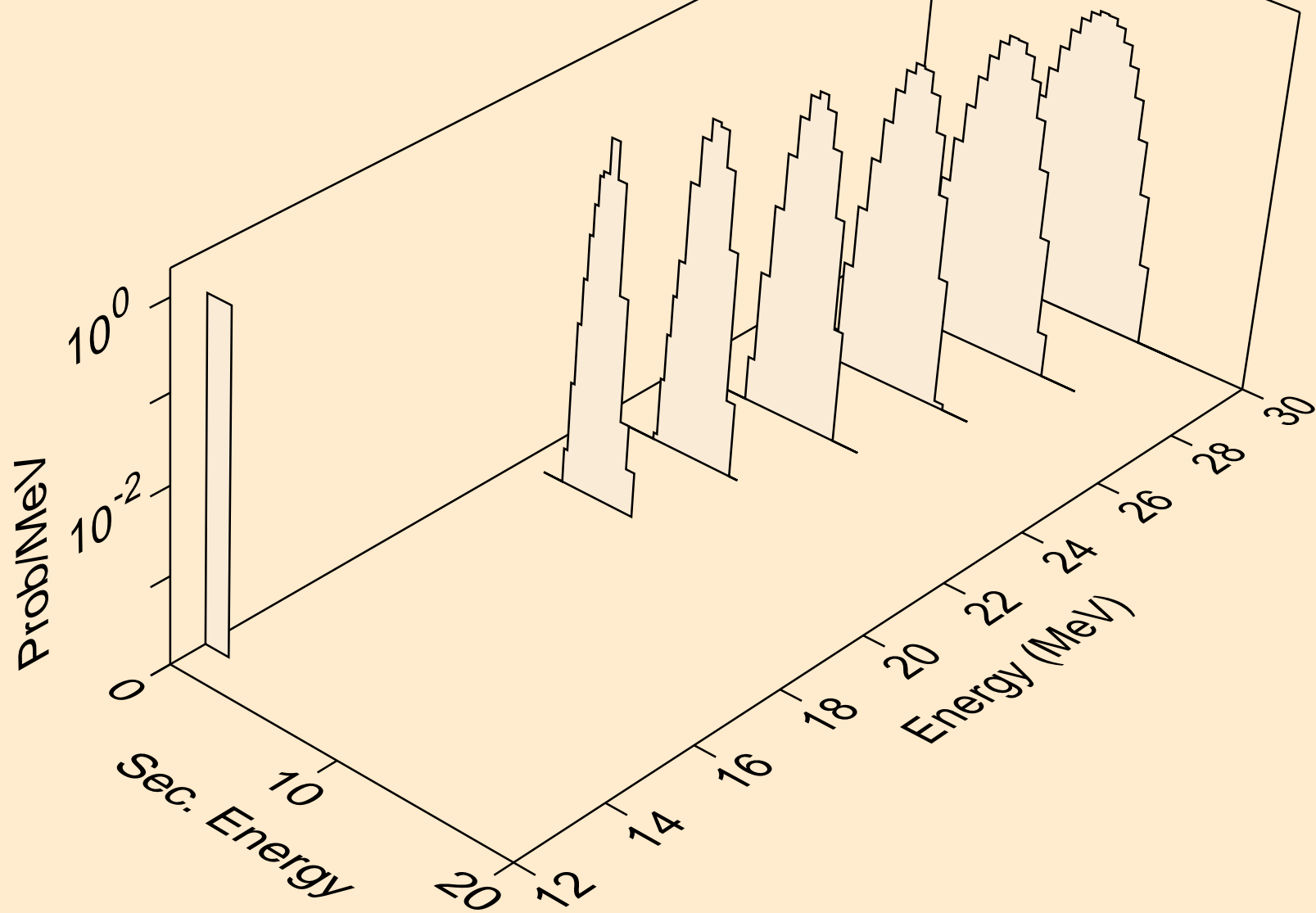

YB174 PROTON ACER TENDL-2023 LIBRARY; T=0.K  
he3s from (p,x)

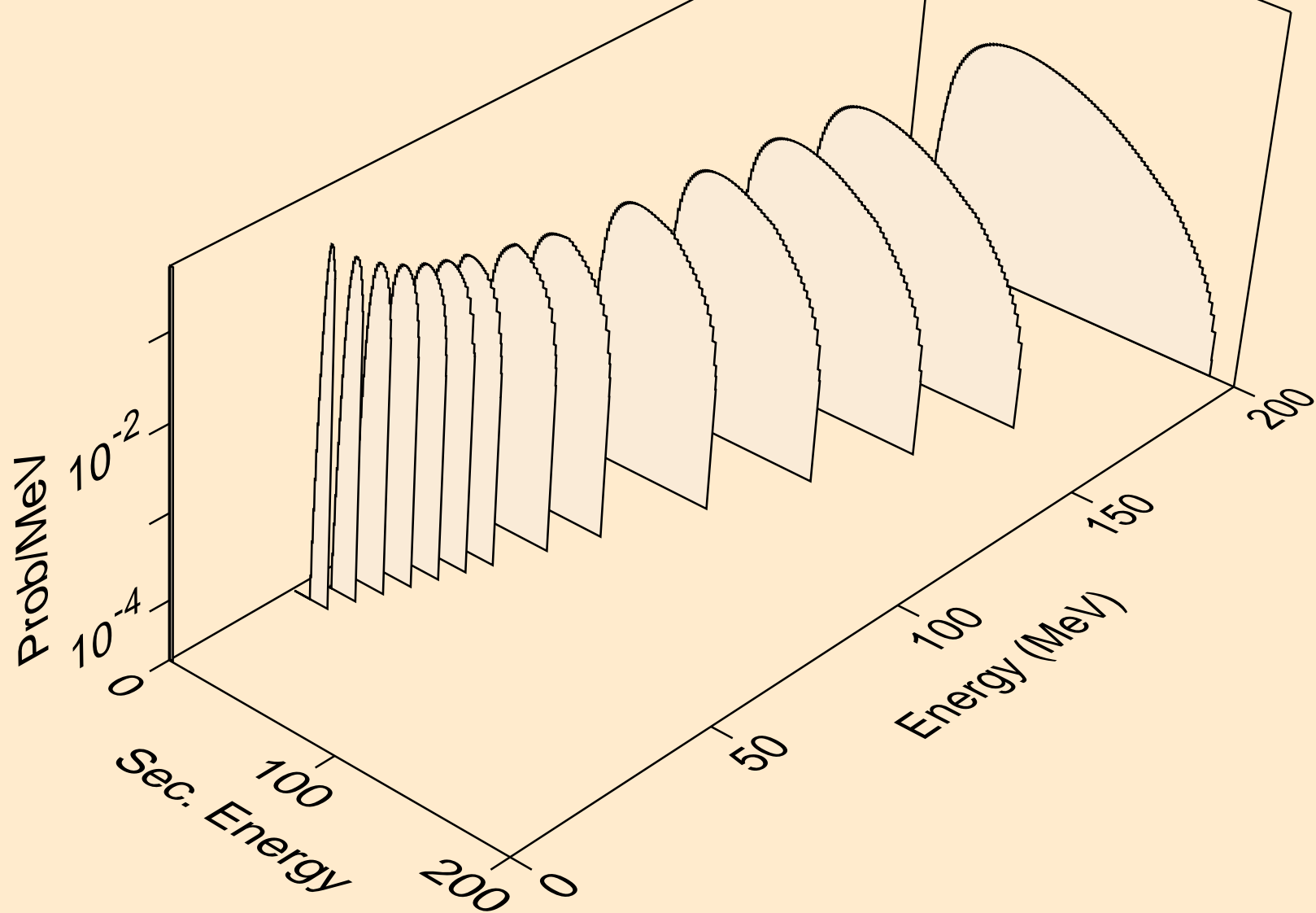

YB174 PROTON ACER TENDL-2023 LIBRARY; T=0.K  
he3s from (p,n\*)he3

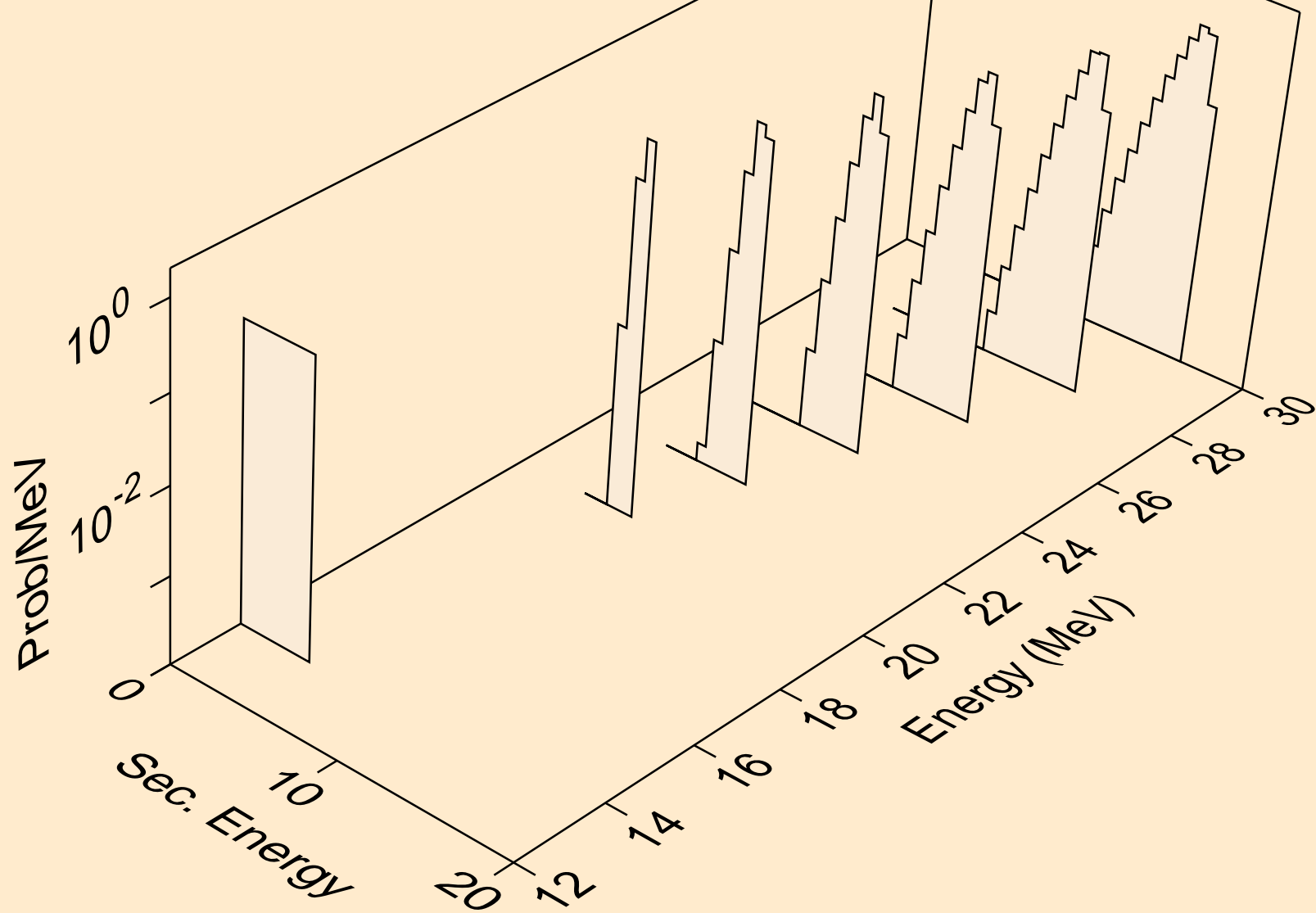

YB174 PROTON ACER TENDL-2023 LIBRARY; T=0.K  
he3s from (p,he3)

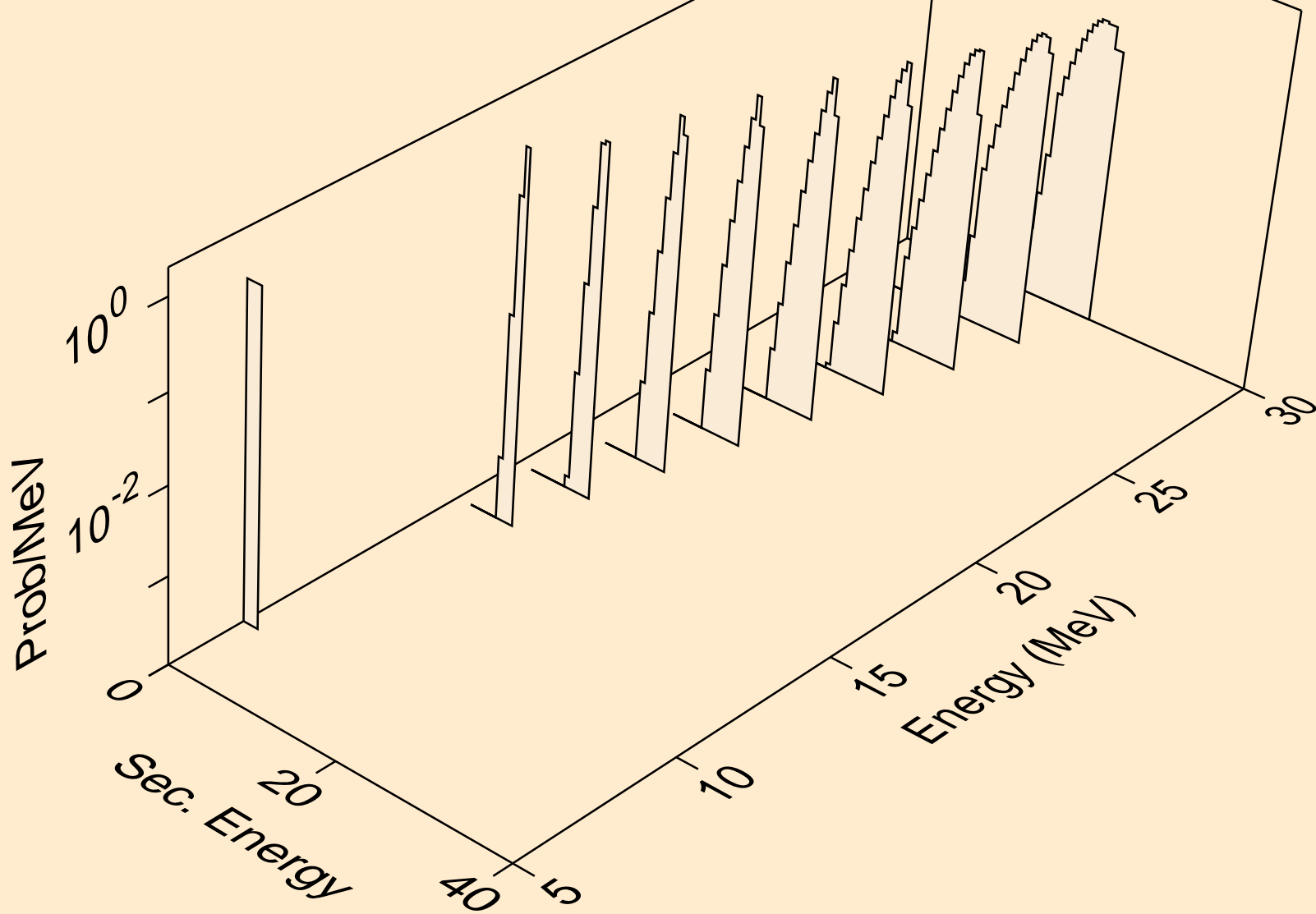

YB174 PROTON ACER TENDL-2023 LIBRARY; T=0.K  
alphas from (p,x)

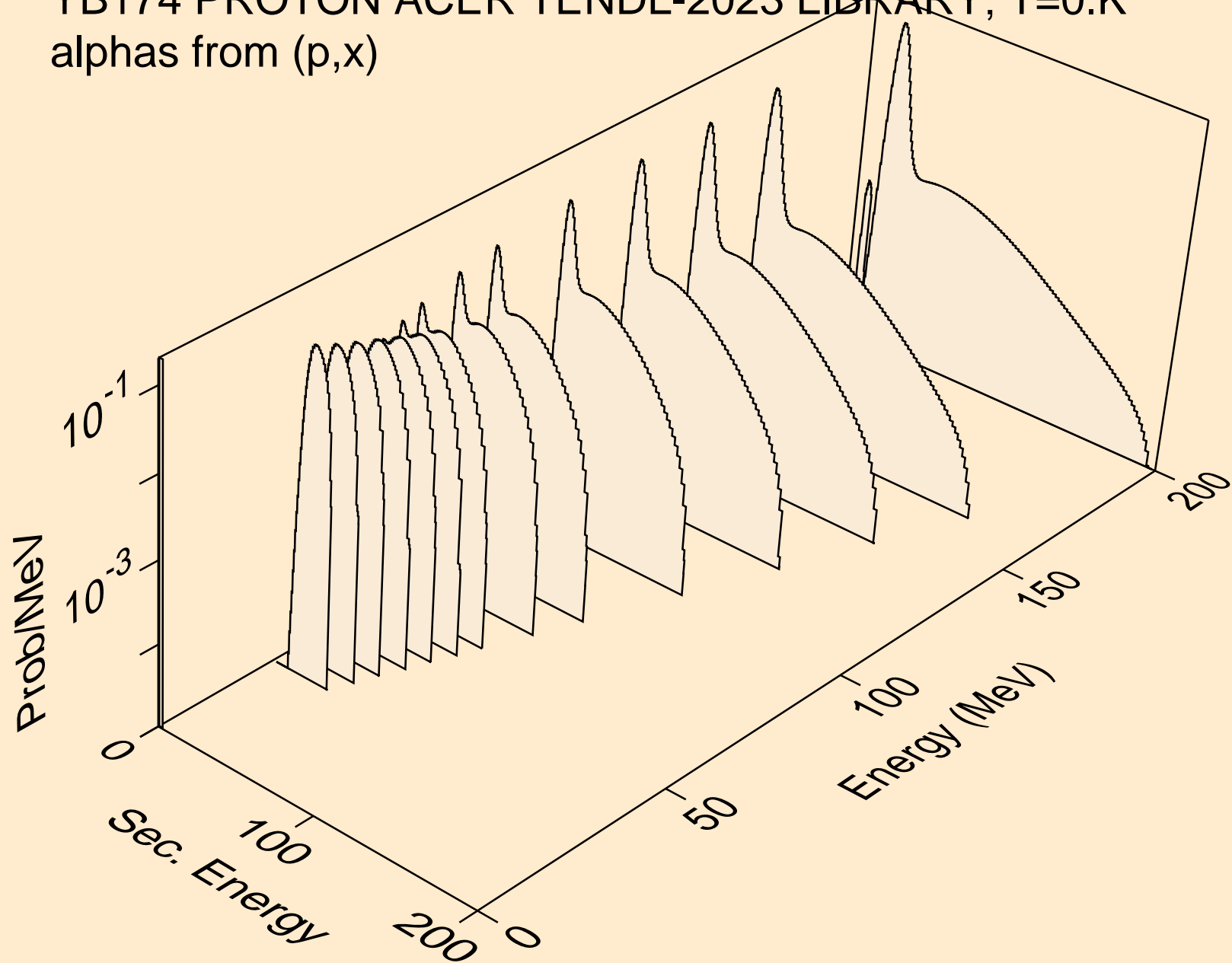

YB174 PROTON ACER TENDL-2023 LIBRARY; T=0.K  
alphas from (p,n\*)a

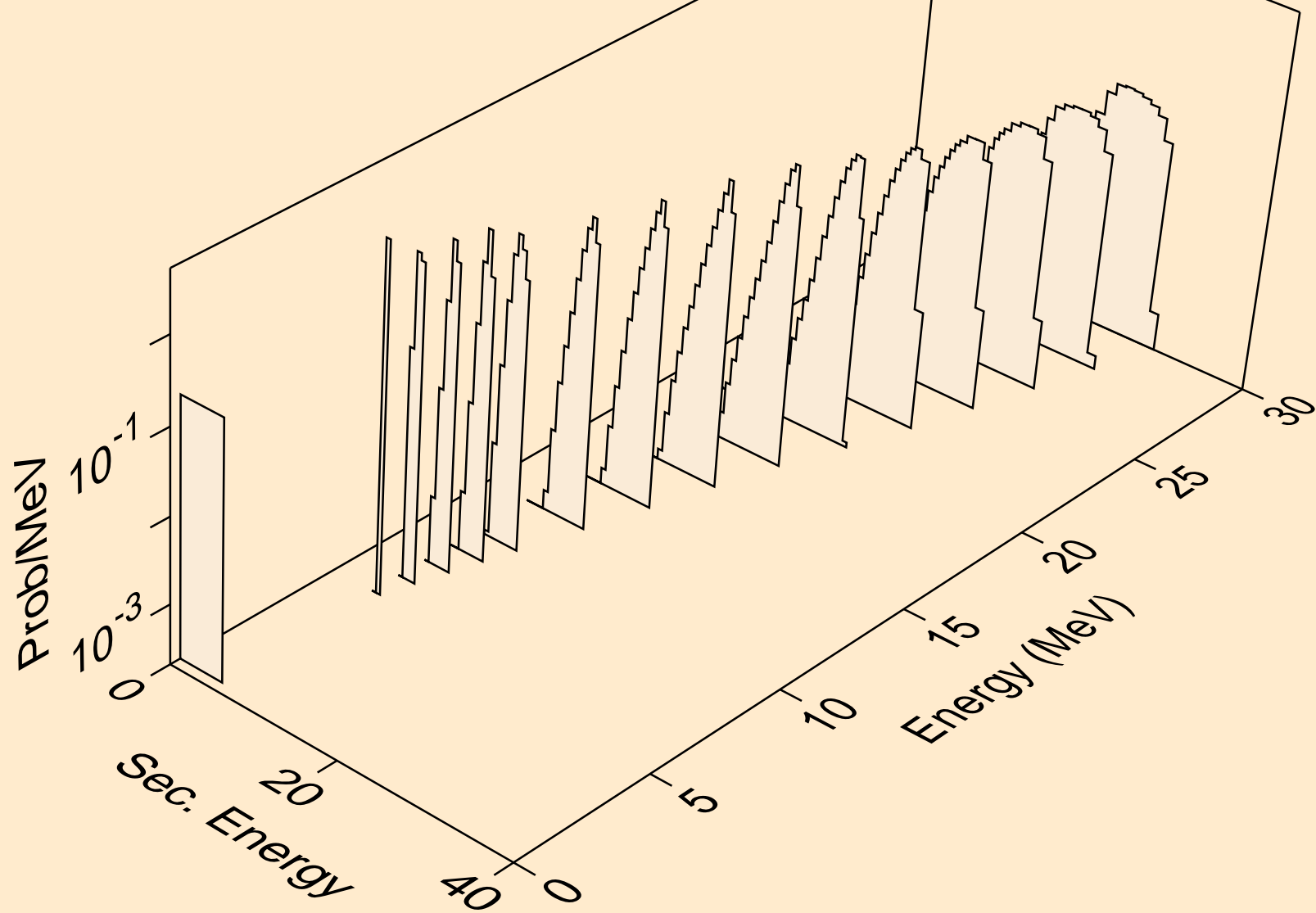

YB174 PROTON ACER TENDL-2023 LIBRARY; T=0.K  
alphas from (p,2n)a

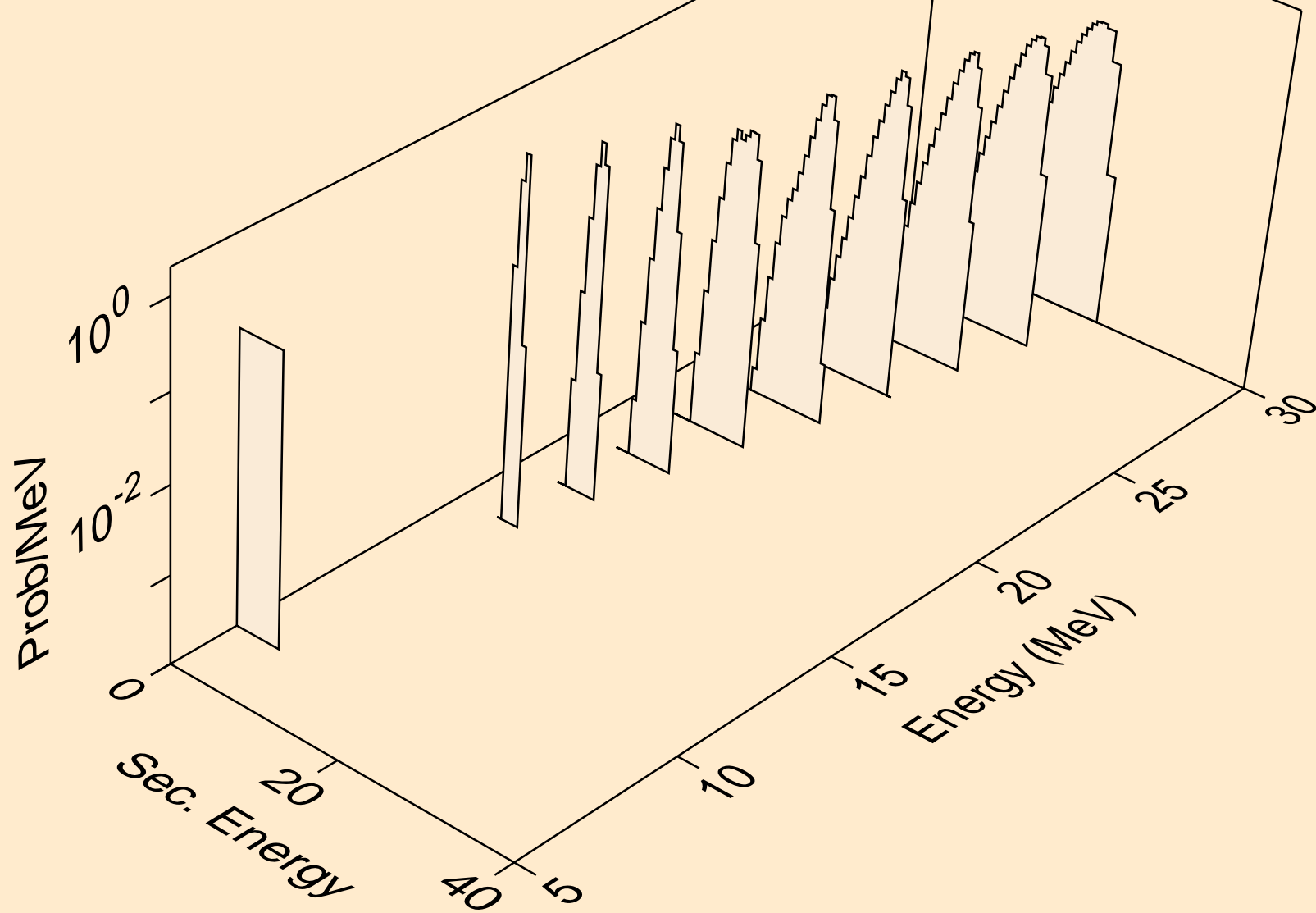

YB174 PROTON ACER TENDL-2023 LIBRARY; T=0.K  
alphas from (p,3n)a

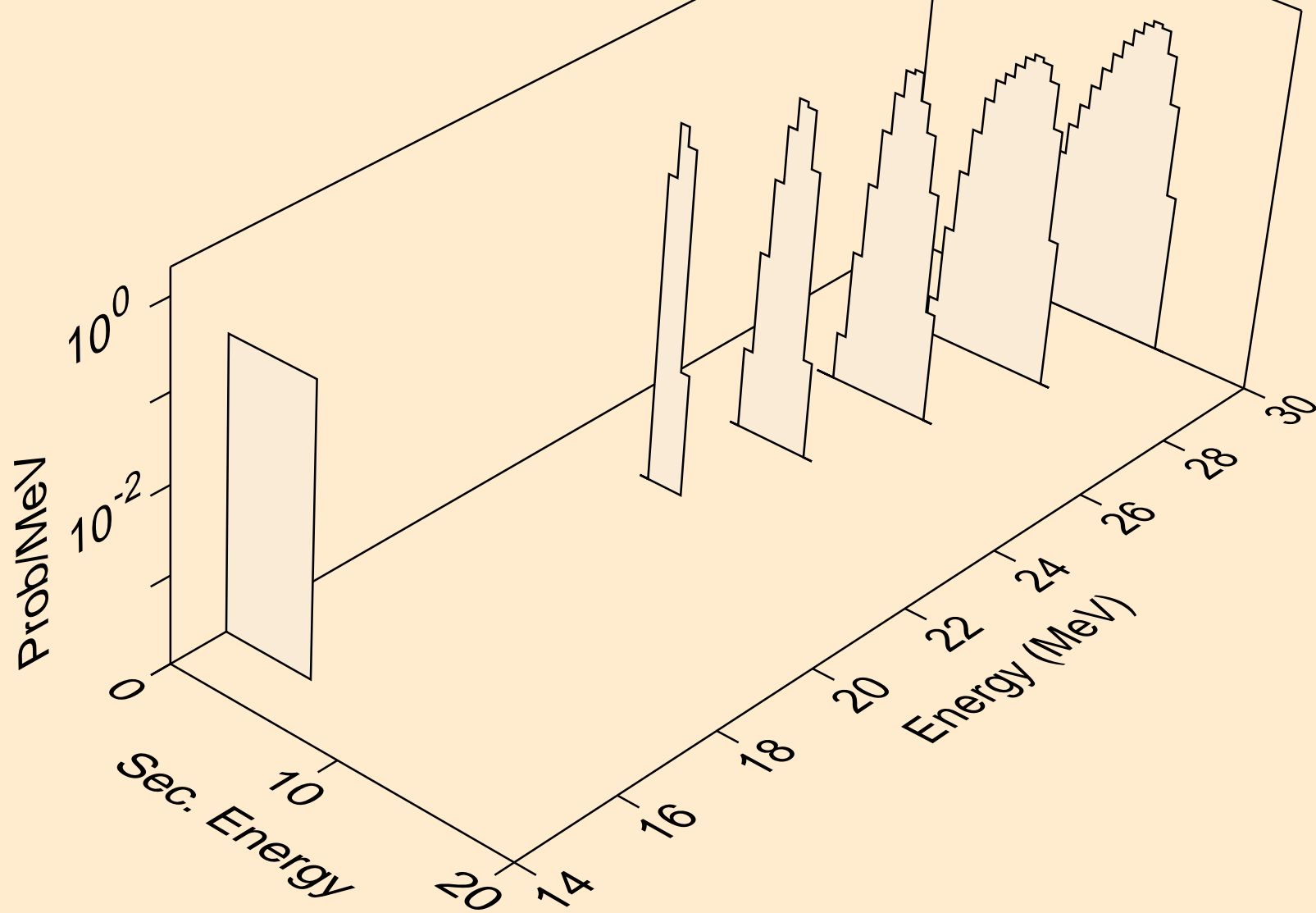



YB174 PROTON ACER TENDL-2023 LIBRARY; T=0.K  
alphas from (p,n\*)2a

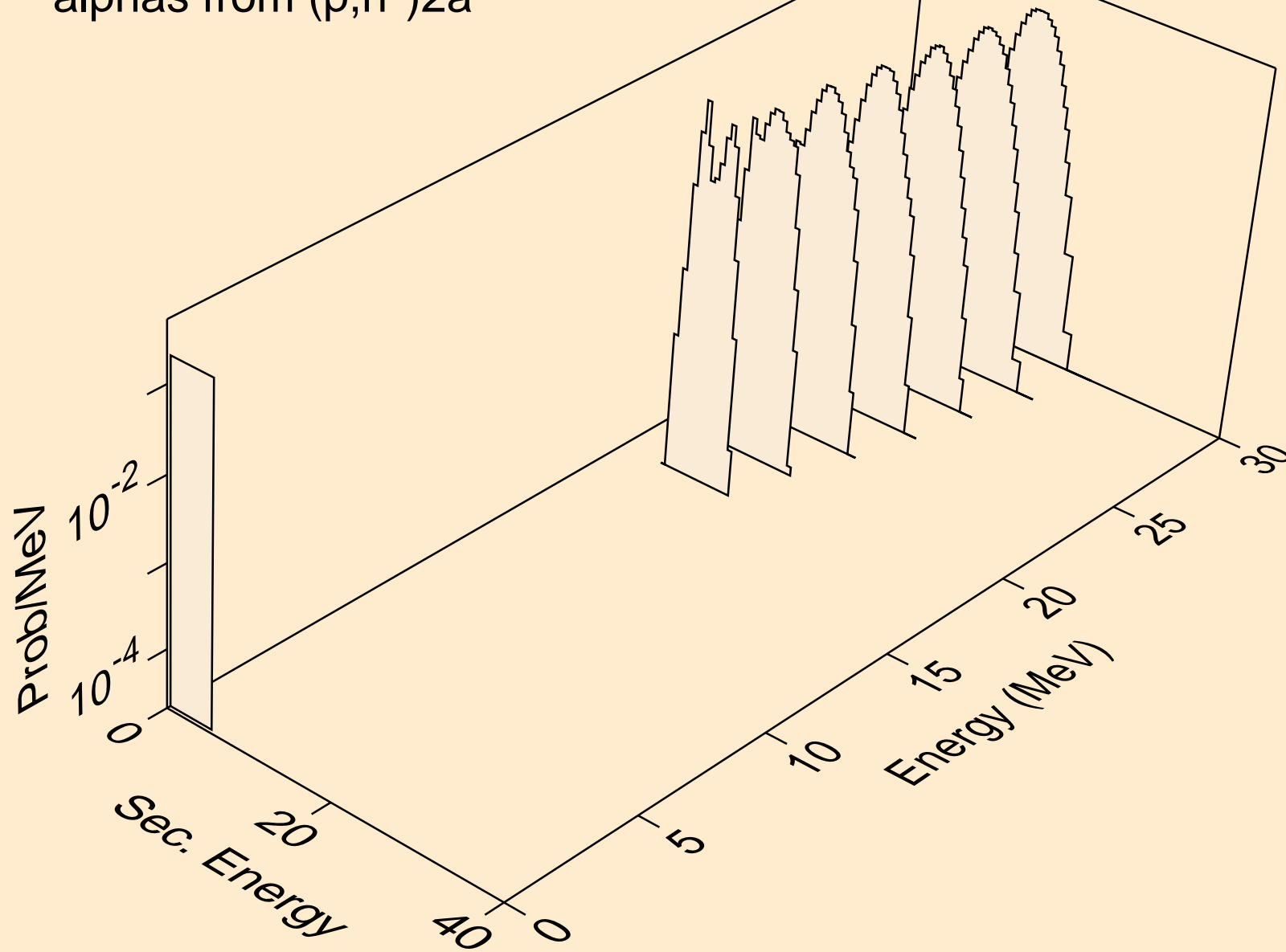

YB174 PROTON ACER TENDL-2023 LIBRARY; T=0.K  
alphas from (p,npa)

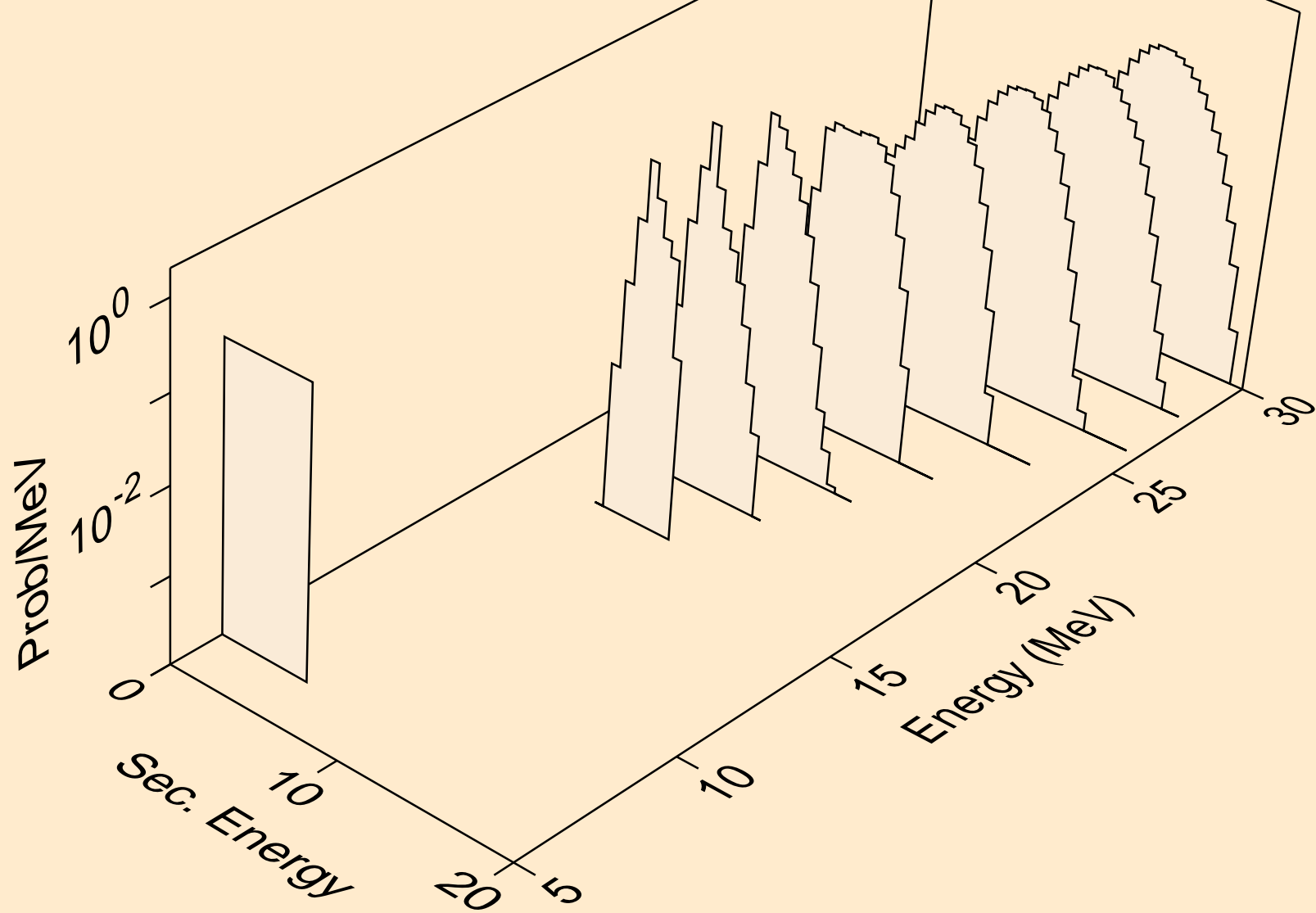

YB174 PROTON ACER TENDL-2023 LIBRARY; T=0.K  
alphas from (p,a)

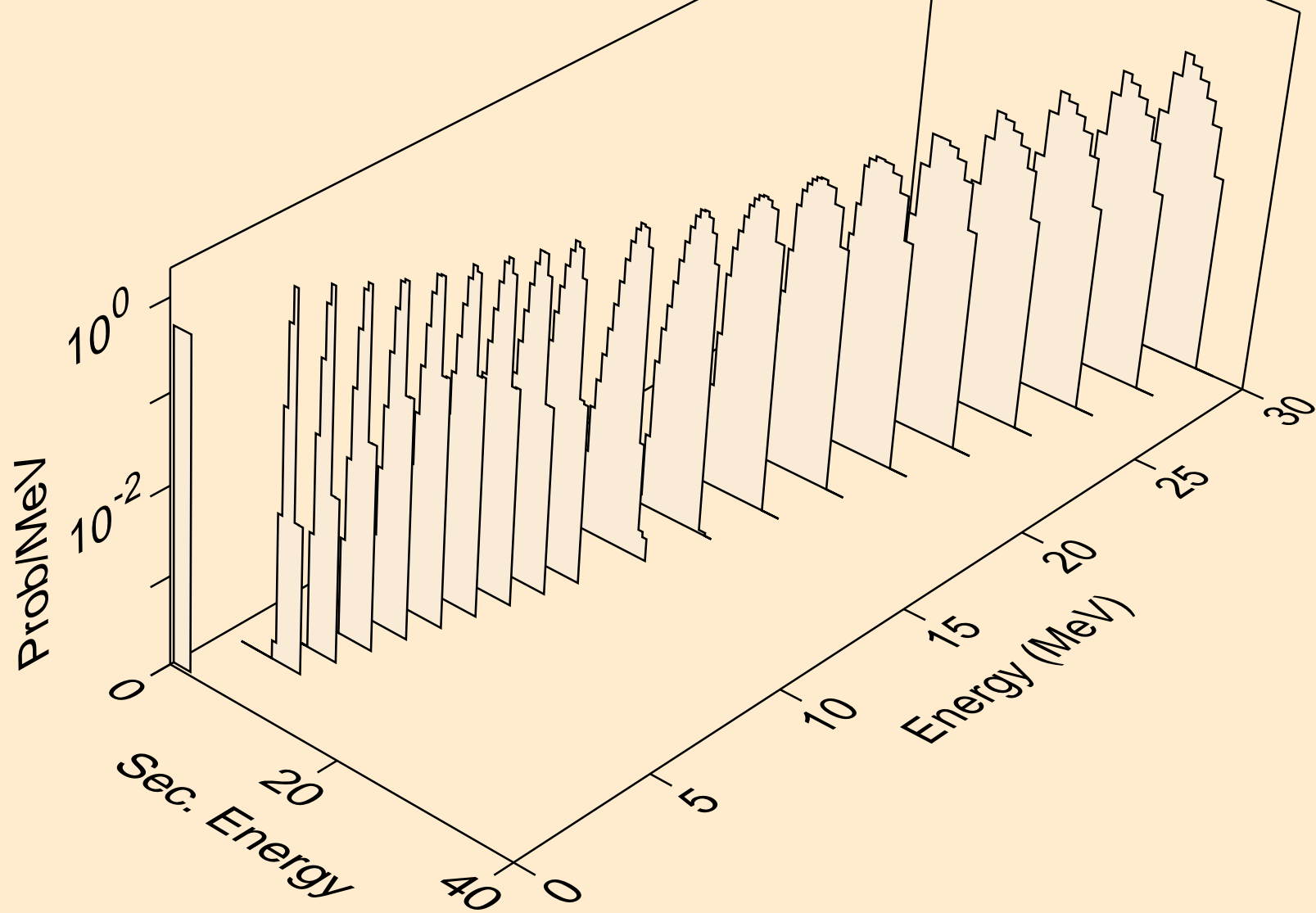

YB174 PROTON ACER TENDL-2023 LIBRARY; T=0.K  
alphas from (p,2a)

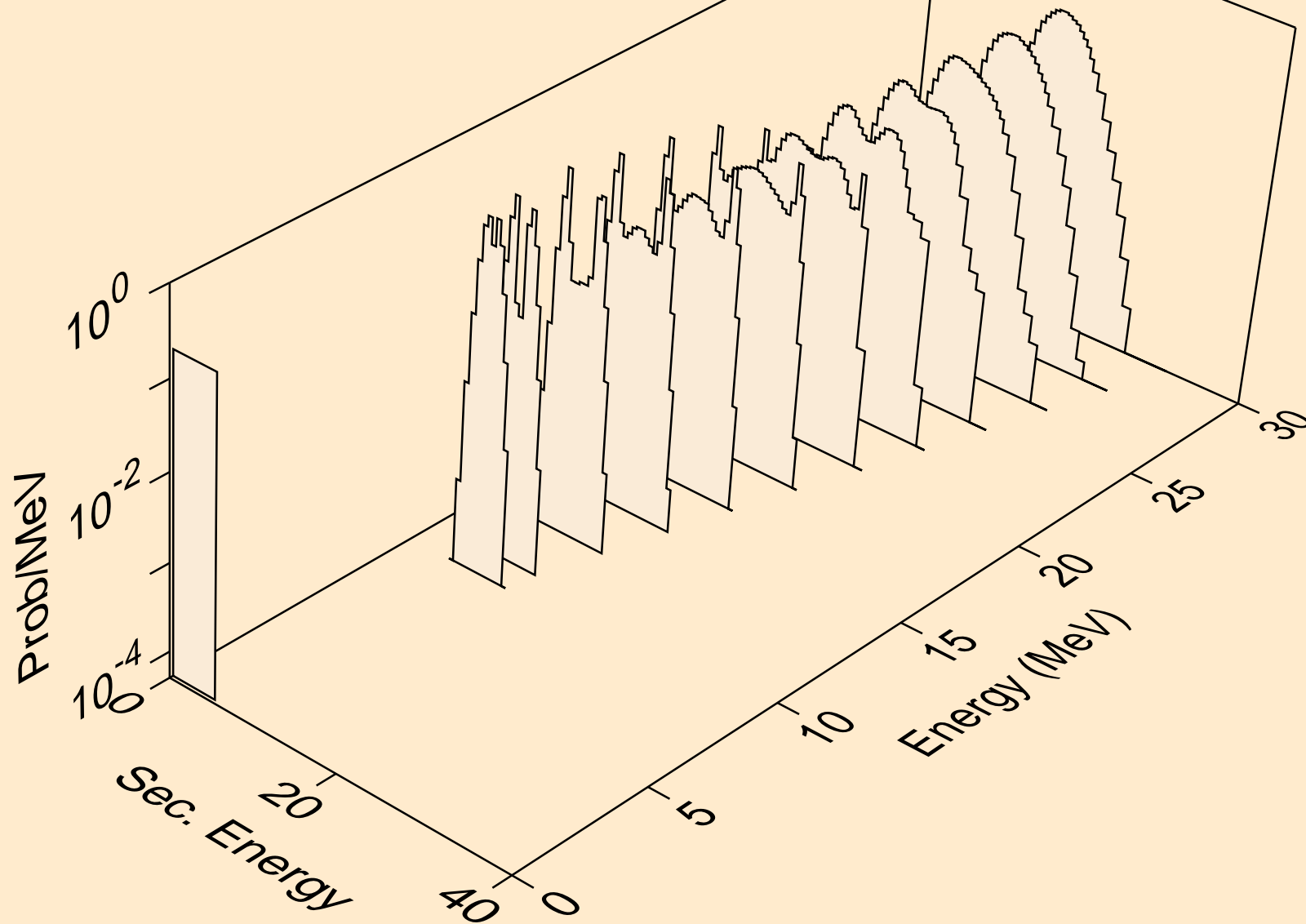

YB174 PROTON ACER TENDL-2023 LIBRARY; T=0.K  
alphas from (p,pa)

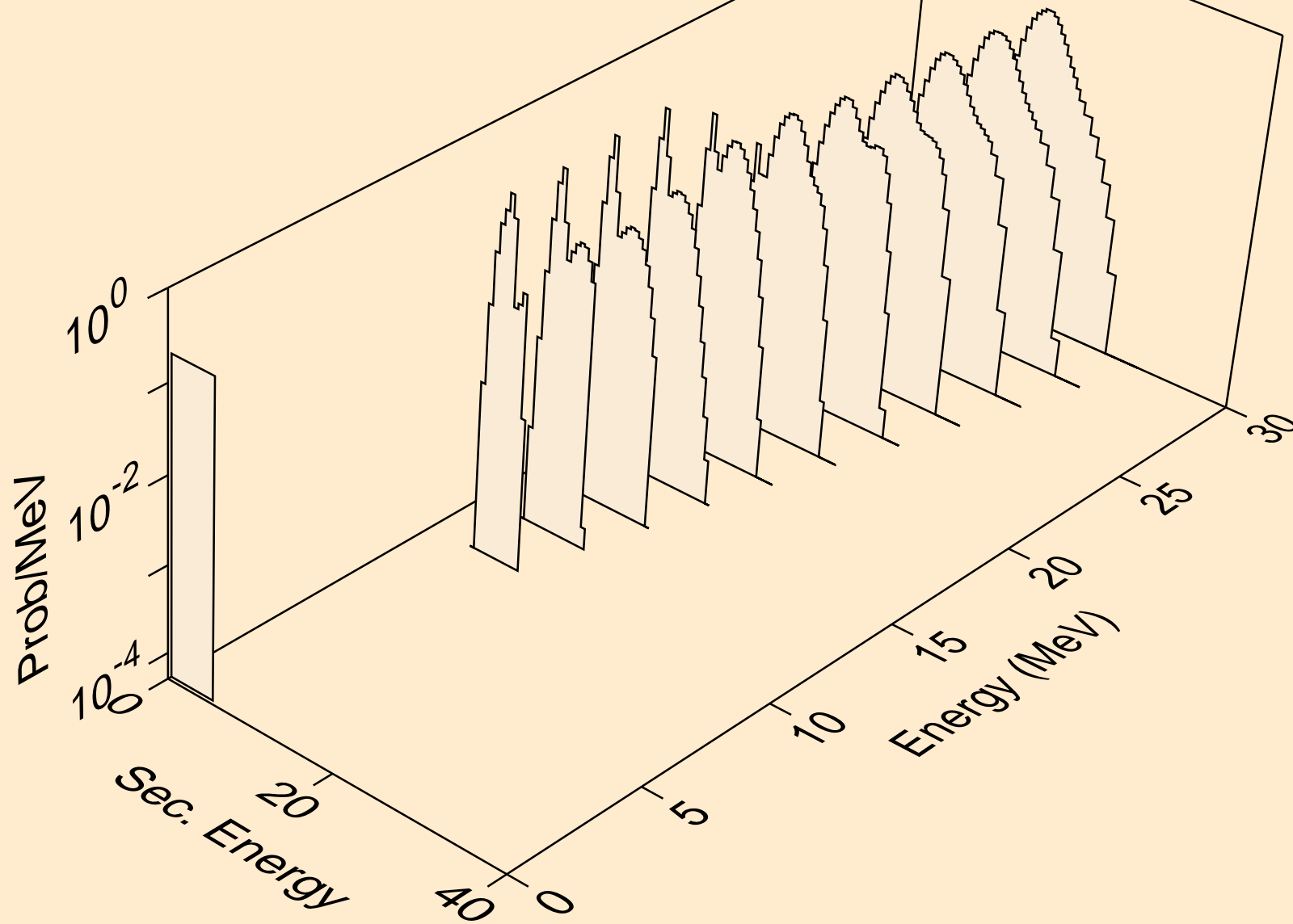

YB174 PROTON ACER TENDL-2023 LIBRARY; T=0.K  
alphas from (p,da)

