

BE010 TRITON ACER TENDL-2023 LIBRARY; T=0.K  
Principal cross sections

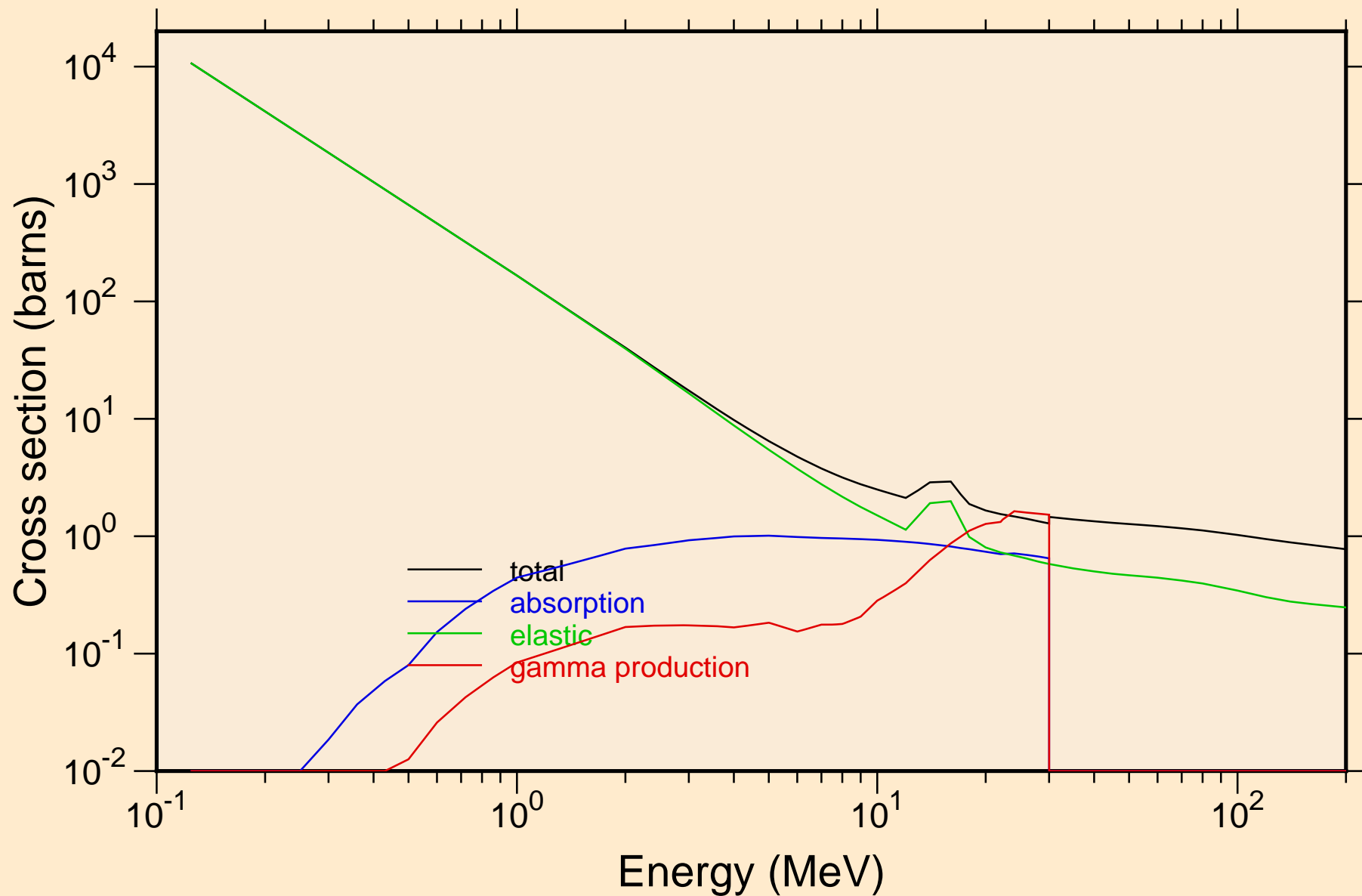

BE010 TRITON ACER TENDL-2023 LIBRARY; T=0.K  
Heating

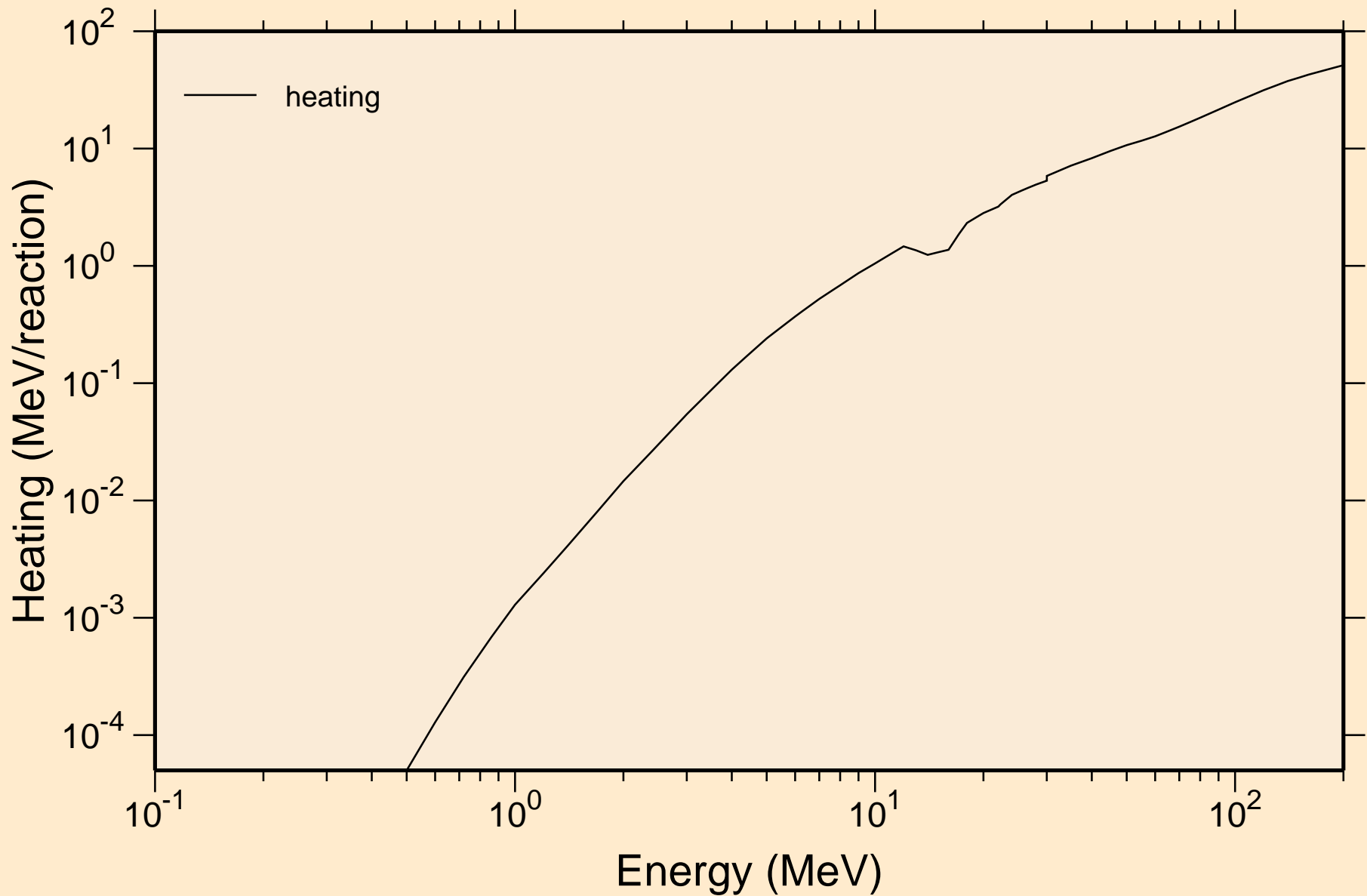

# BE010 TRITON ACER TENDL-2023 LIBRARY; T=0.K

## Principal cross sections

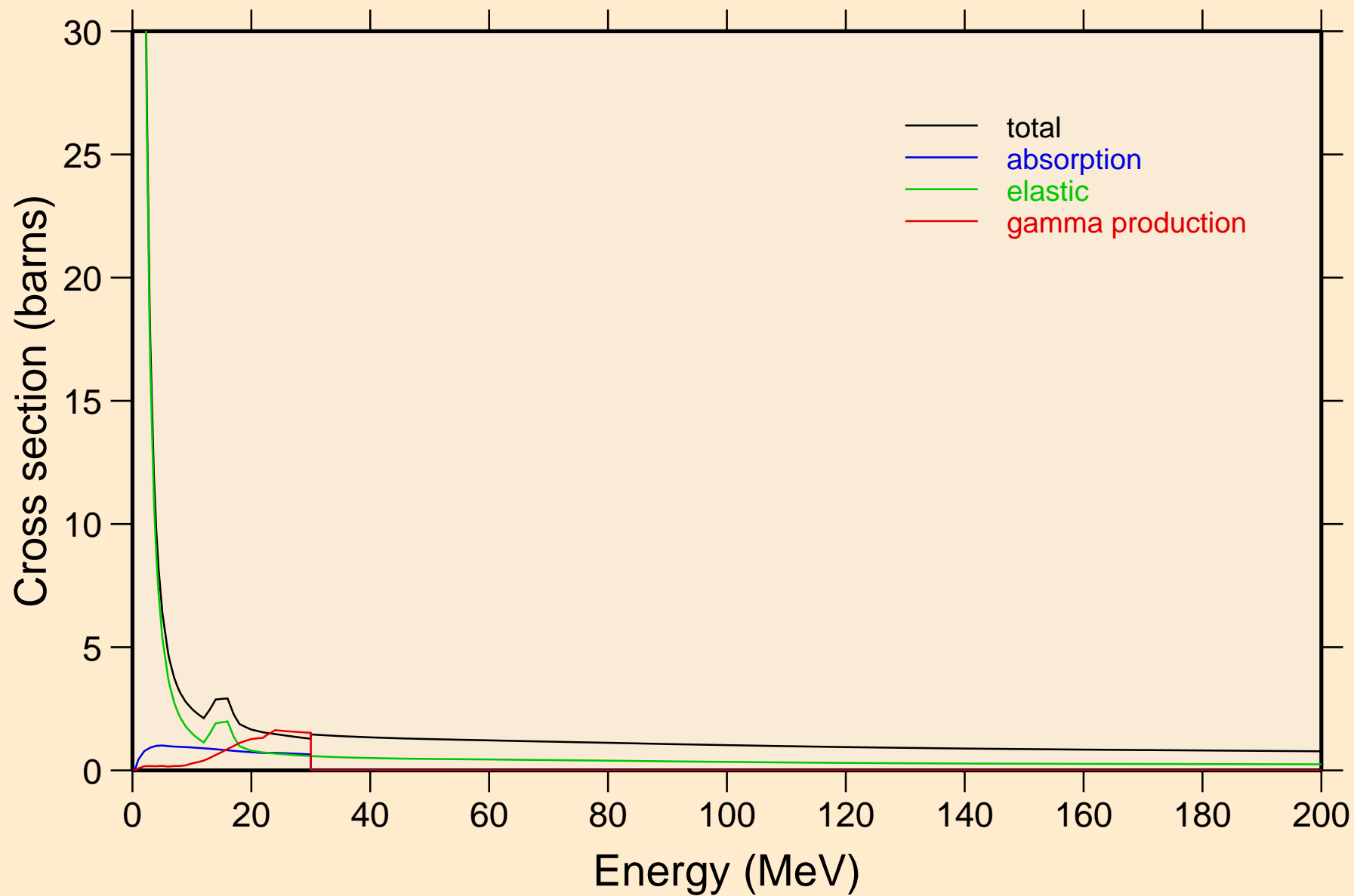

BE010 TRITON ACER TENDL-2023 LIBRARY; T=0.K

Heating

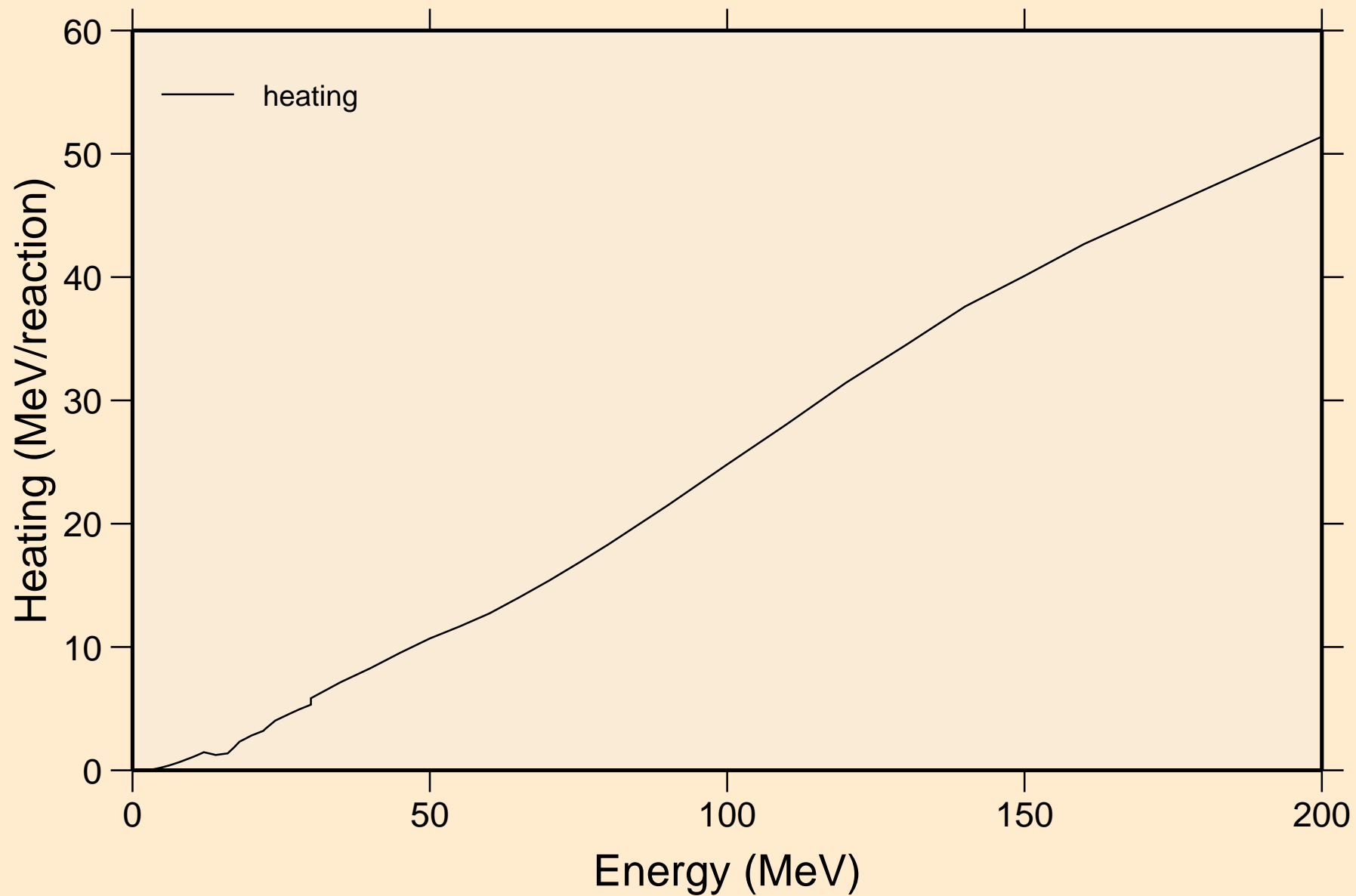

# BE010 TRITON ACER TENDL-2023 LIBRARY; T=0.K

## Threshold reactions

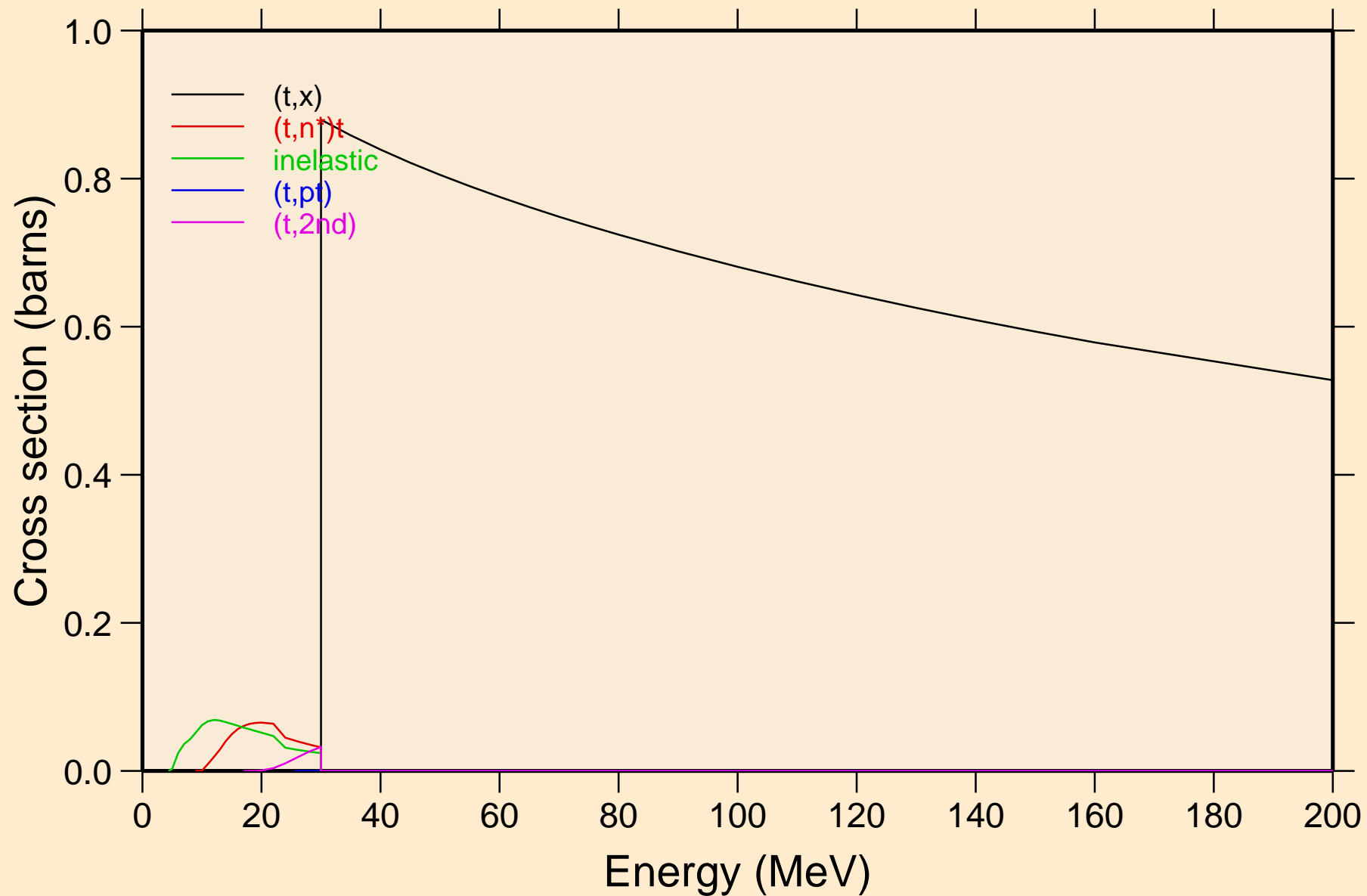

BE010 TRITON ACER TENDL-2023 LIBRARY; T=0.K  
Threshold reactions

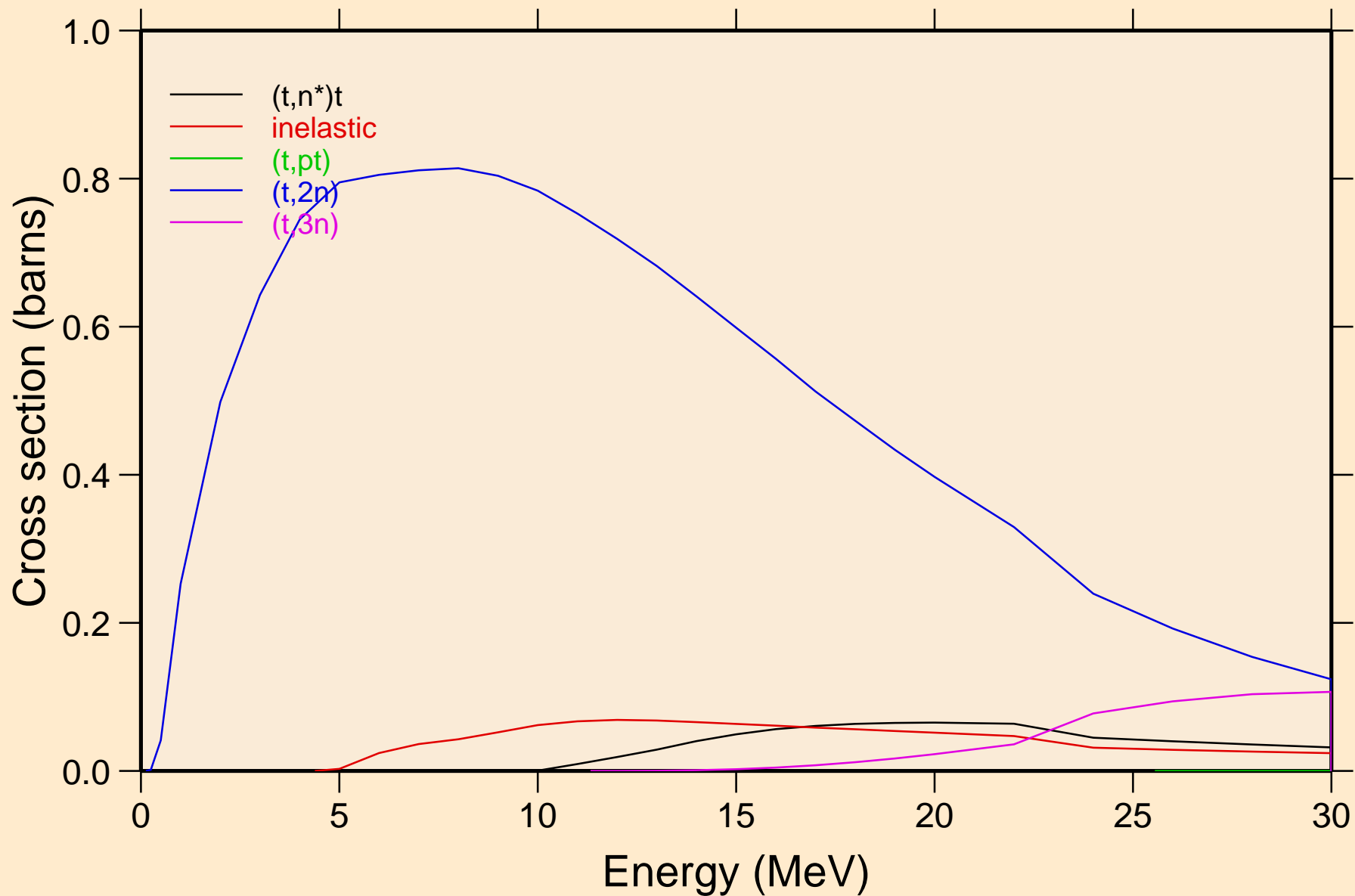

BE010 TRITON ACER TENDL-2023 LIBRARY; T=0.K  
Threshold reactions

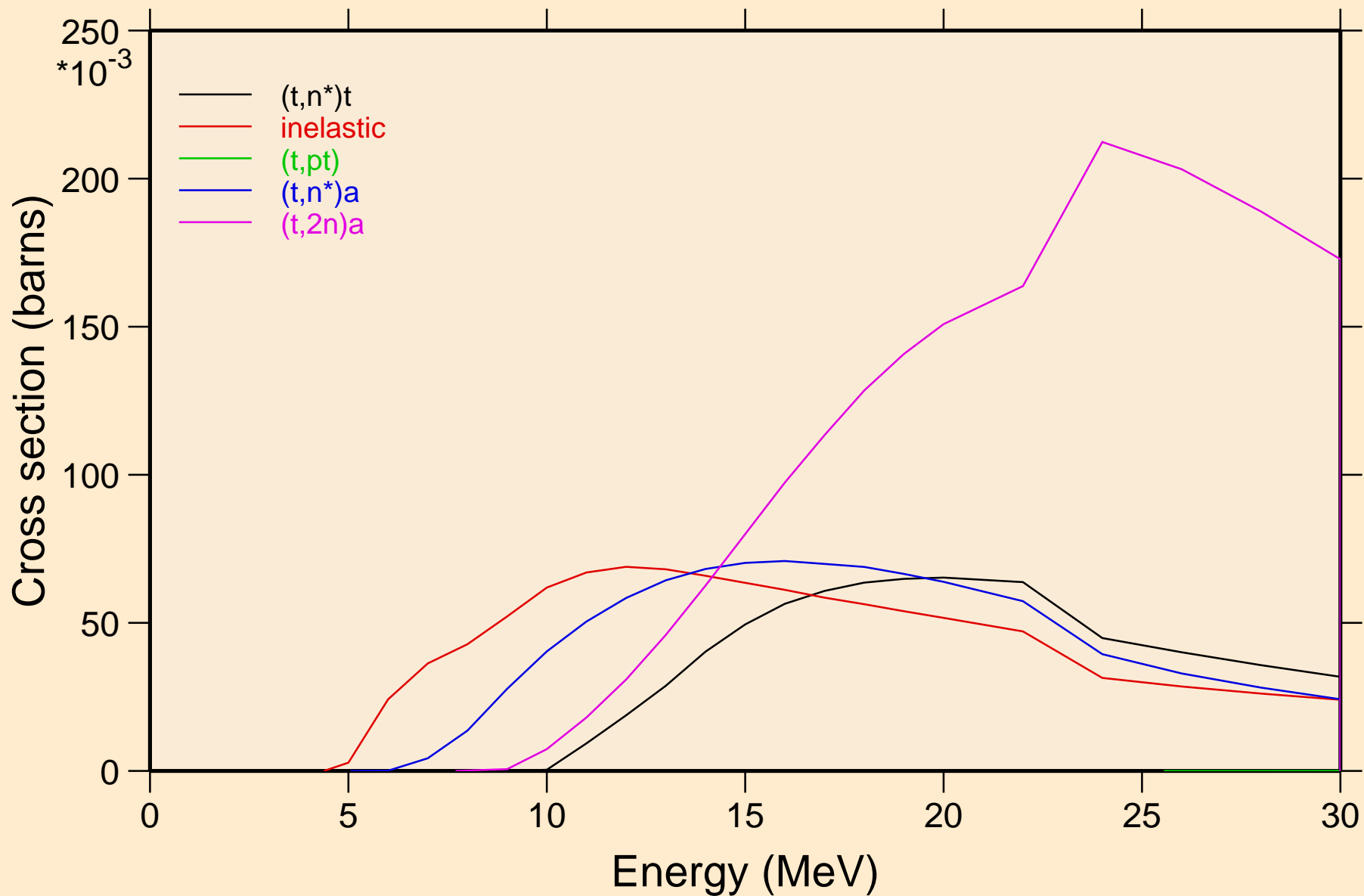

BE010 TRITON ACER TENDL-2023 LIBRARY; T=0.K  
Threshold reactions

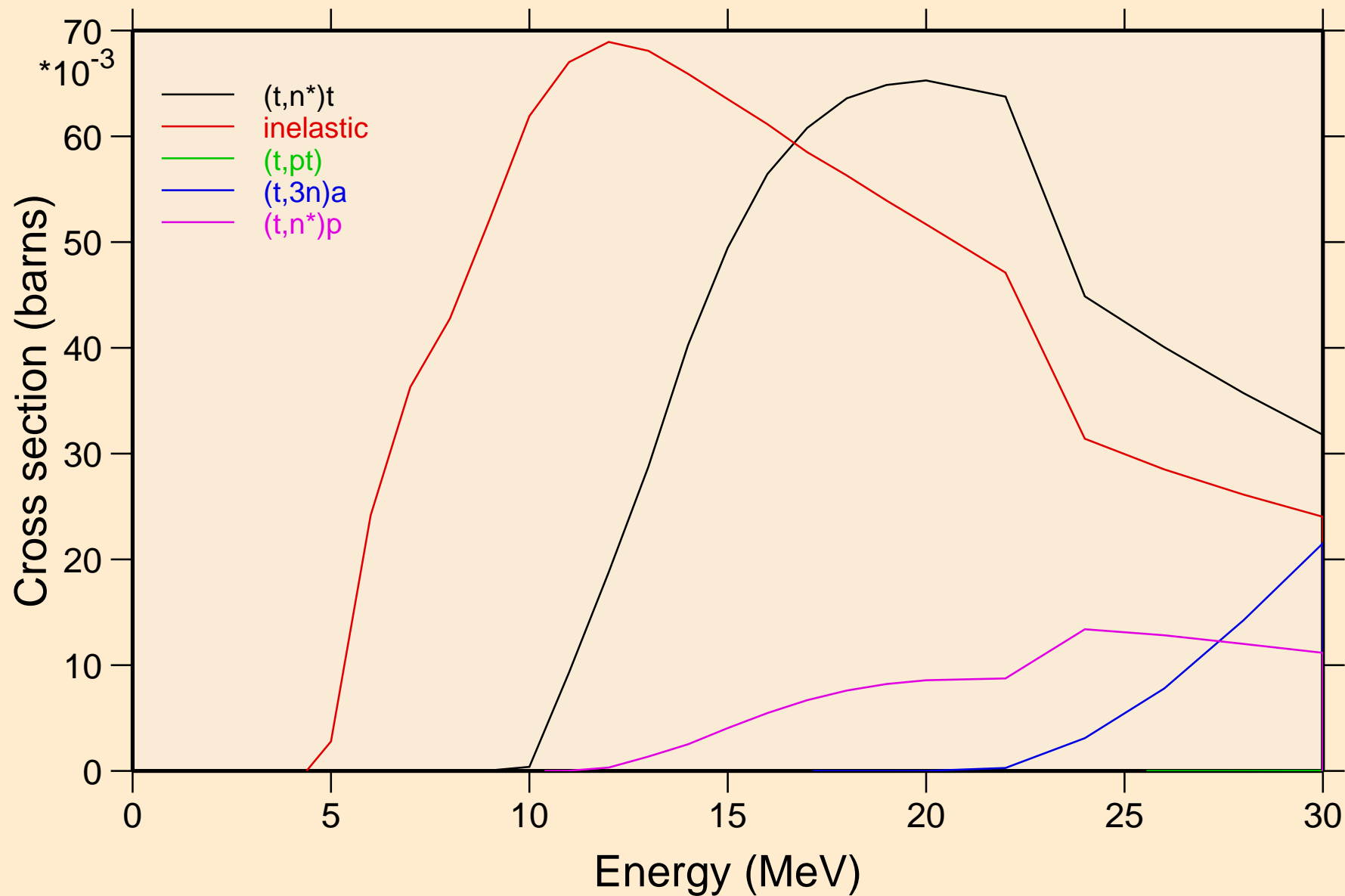



BE010 TRITON ACER TENDL-2023 LIBRARY; T=0.K  
Threshold reactions

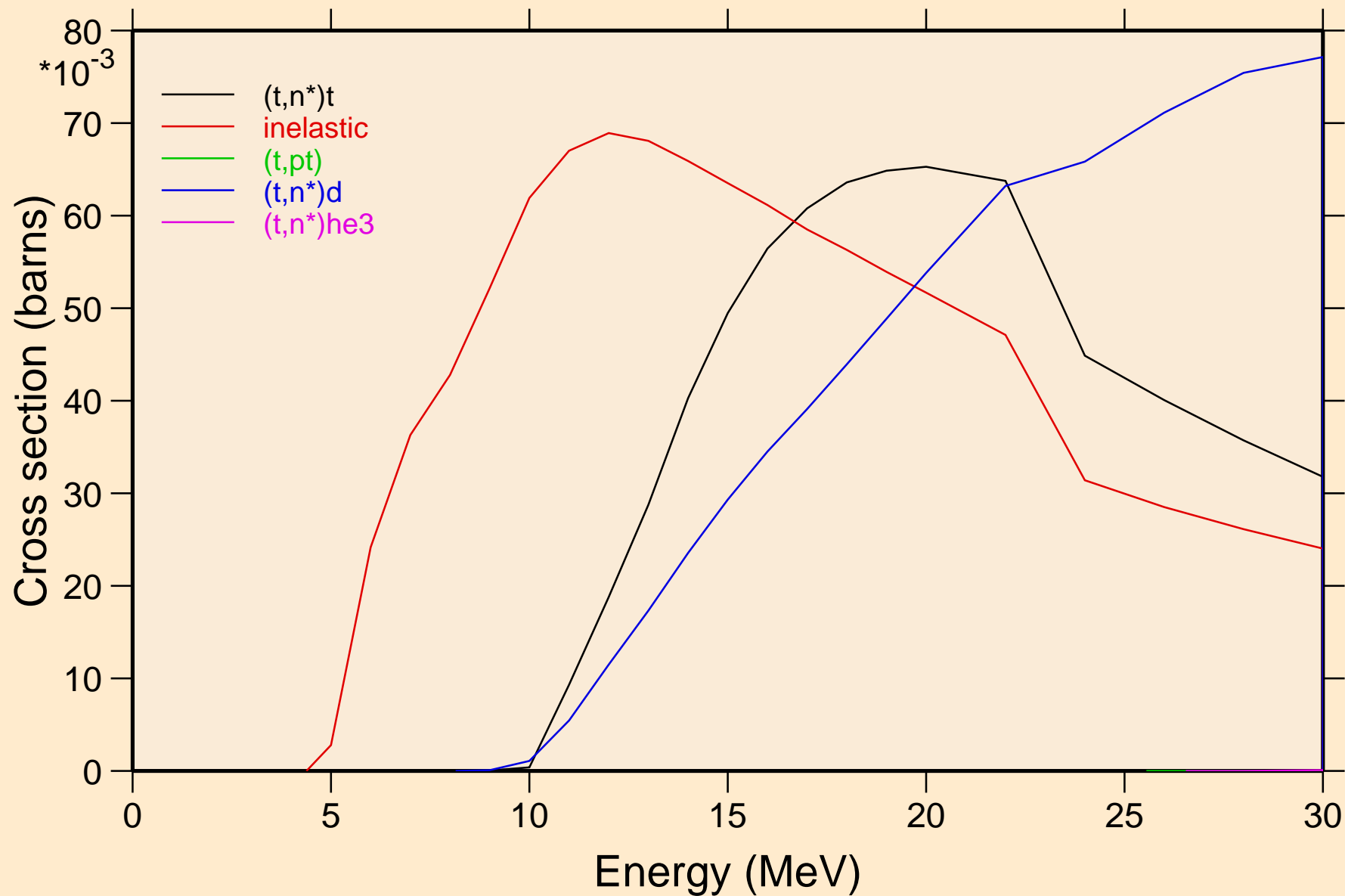

# BE010 TRITON ACER TENDL-2023 LIBRARY; T=0.K

## Threshold reactions

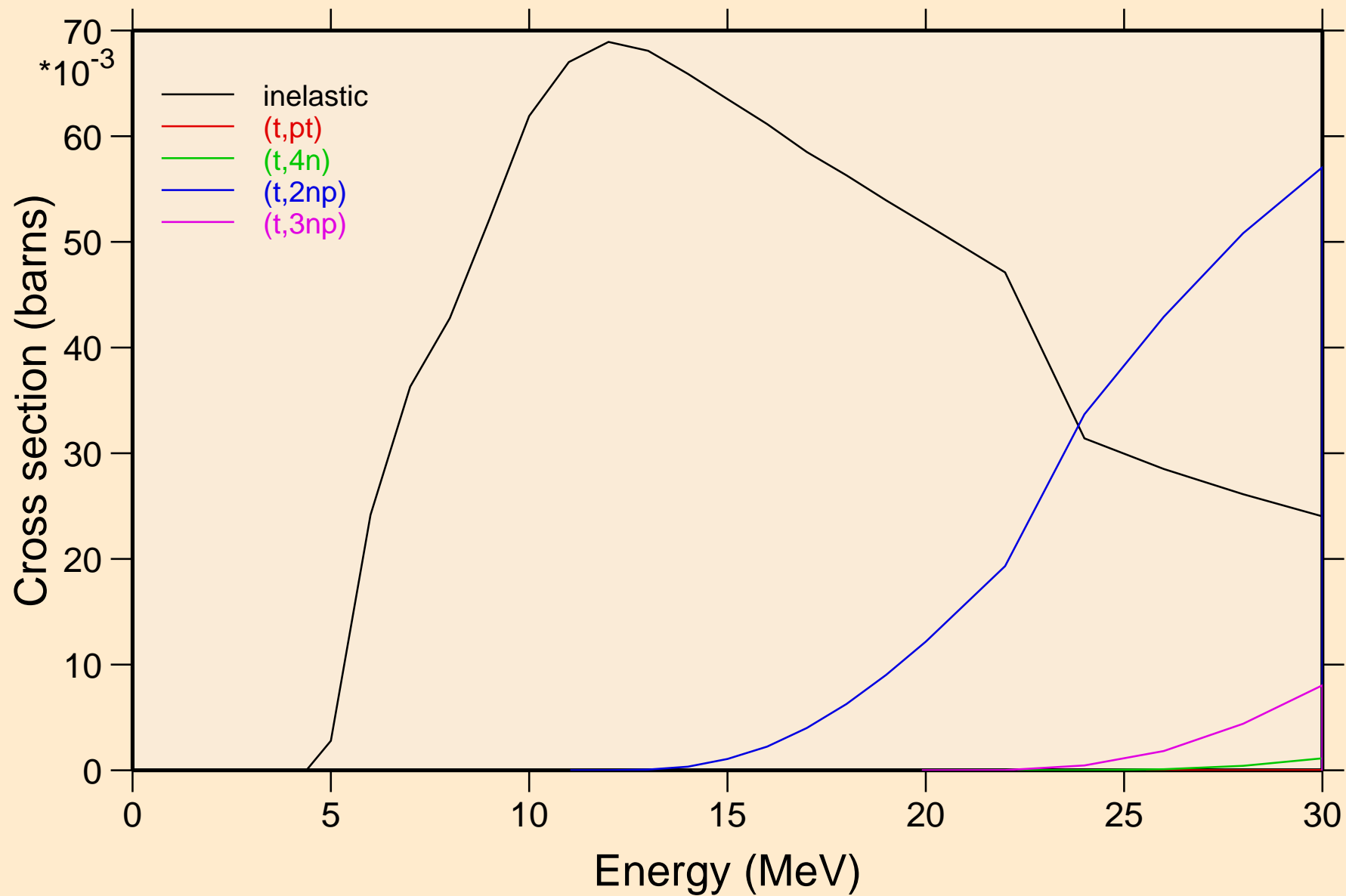

BE010 TRITON ACER TENDL-2023 LIBRARY; T=0.K  
Threshold reactions

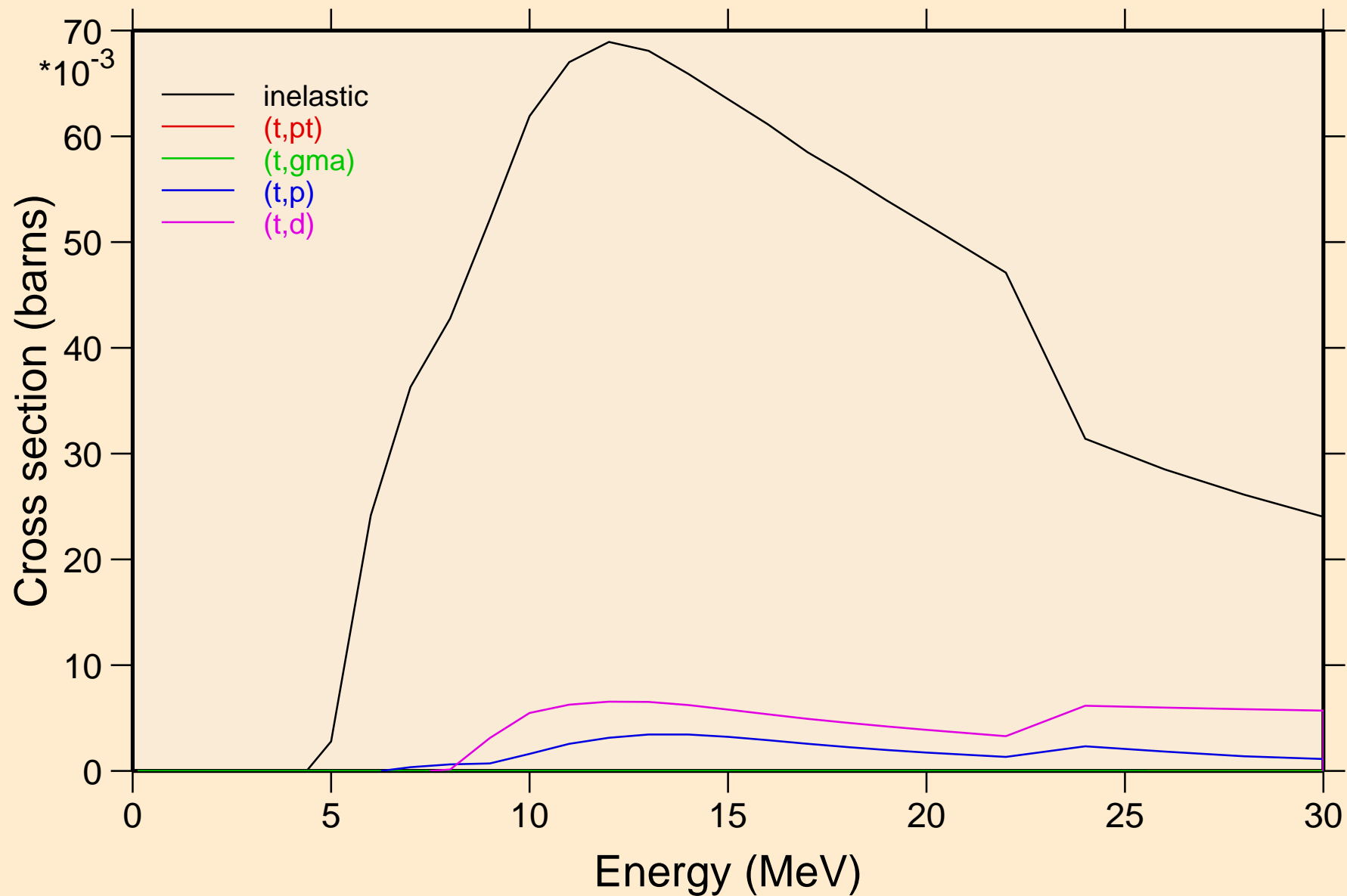

BE010 TRITON ACER TENDL-2023 LIBRARY; T=0.K  
Threshold reactions

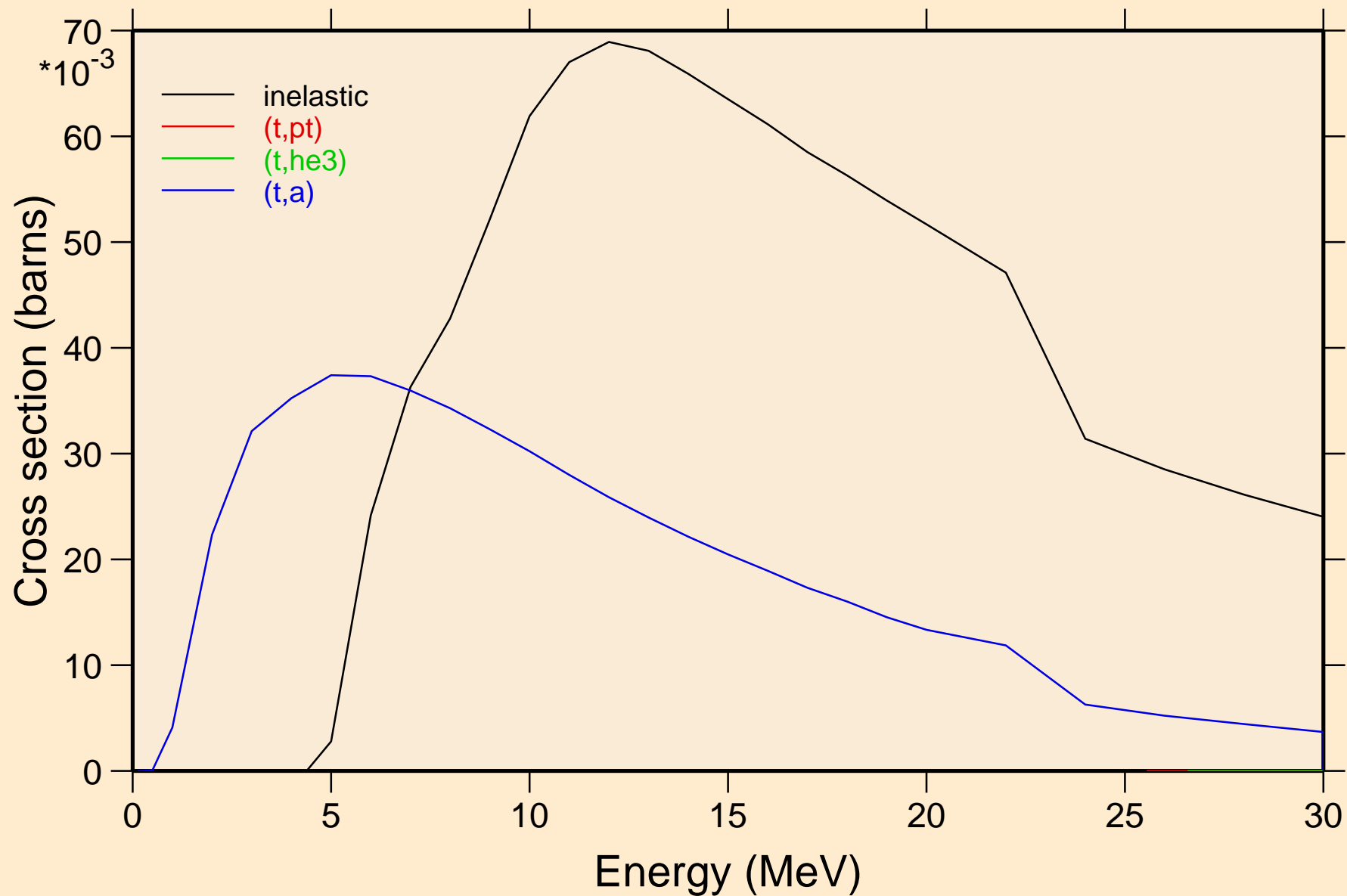

BE010 TRITON ACER TENDL-2023 LIBRARY; T=0.K  
Threshold reactions

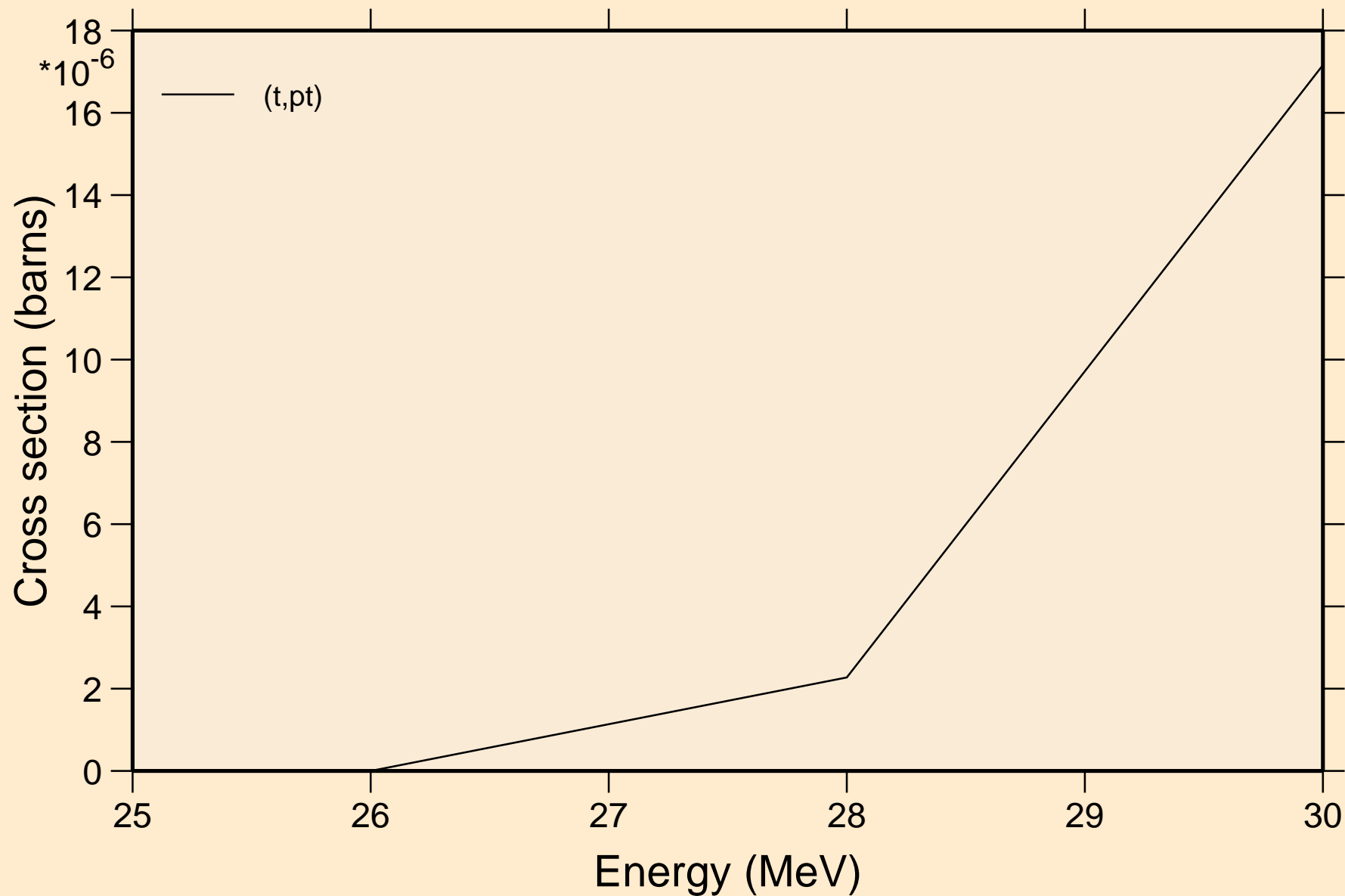

BE010 TRITON ACER TENDL-2023 LIBRARY; T=0.K  
angular distribution for elastic

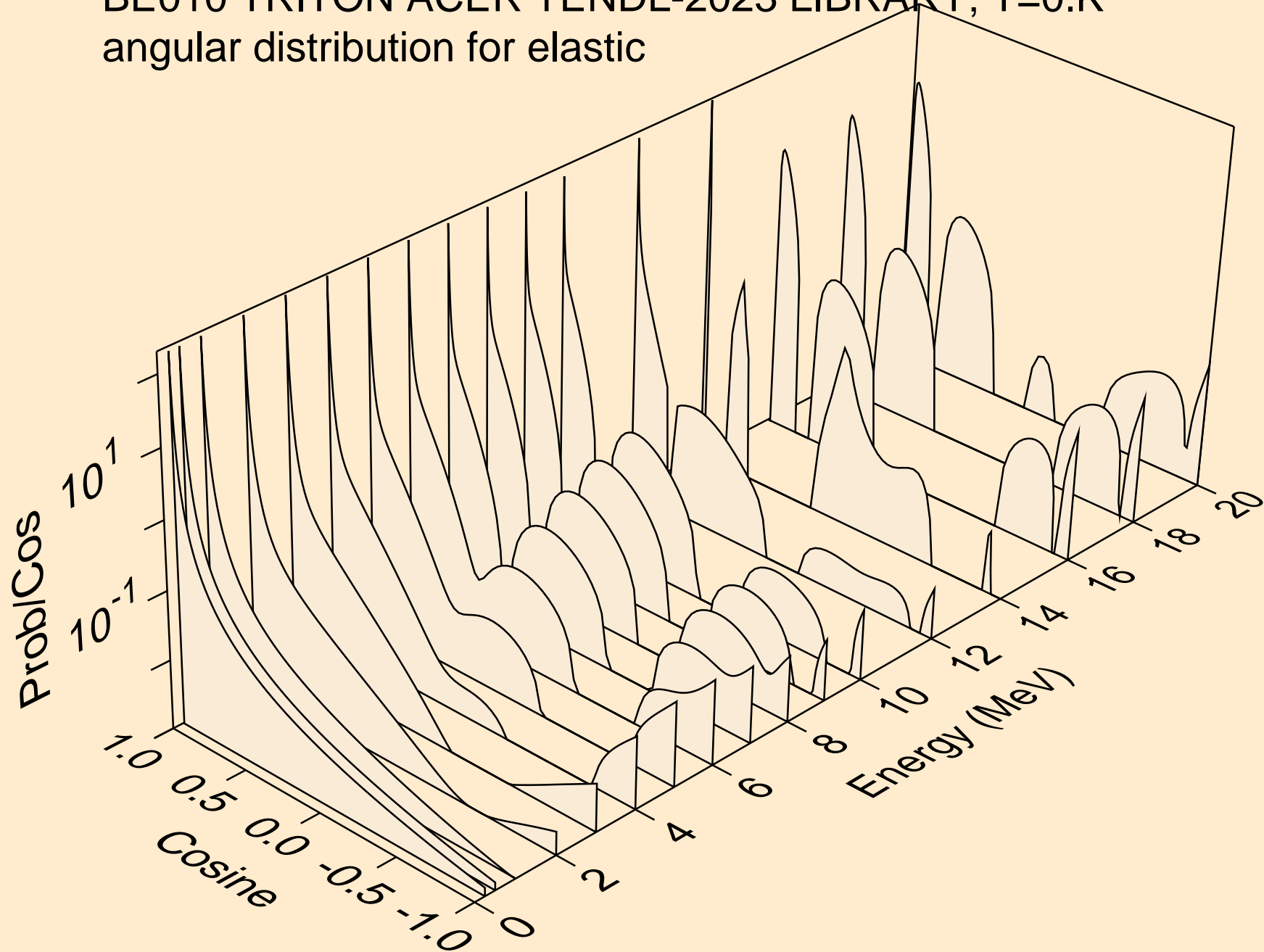

BE010 TRITON ACER TENDL-2023 LIBRARY; T=0.K  
angular distribution for elastic

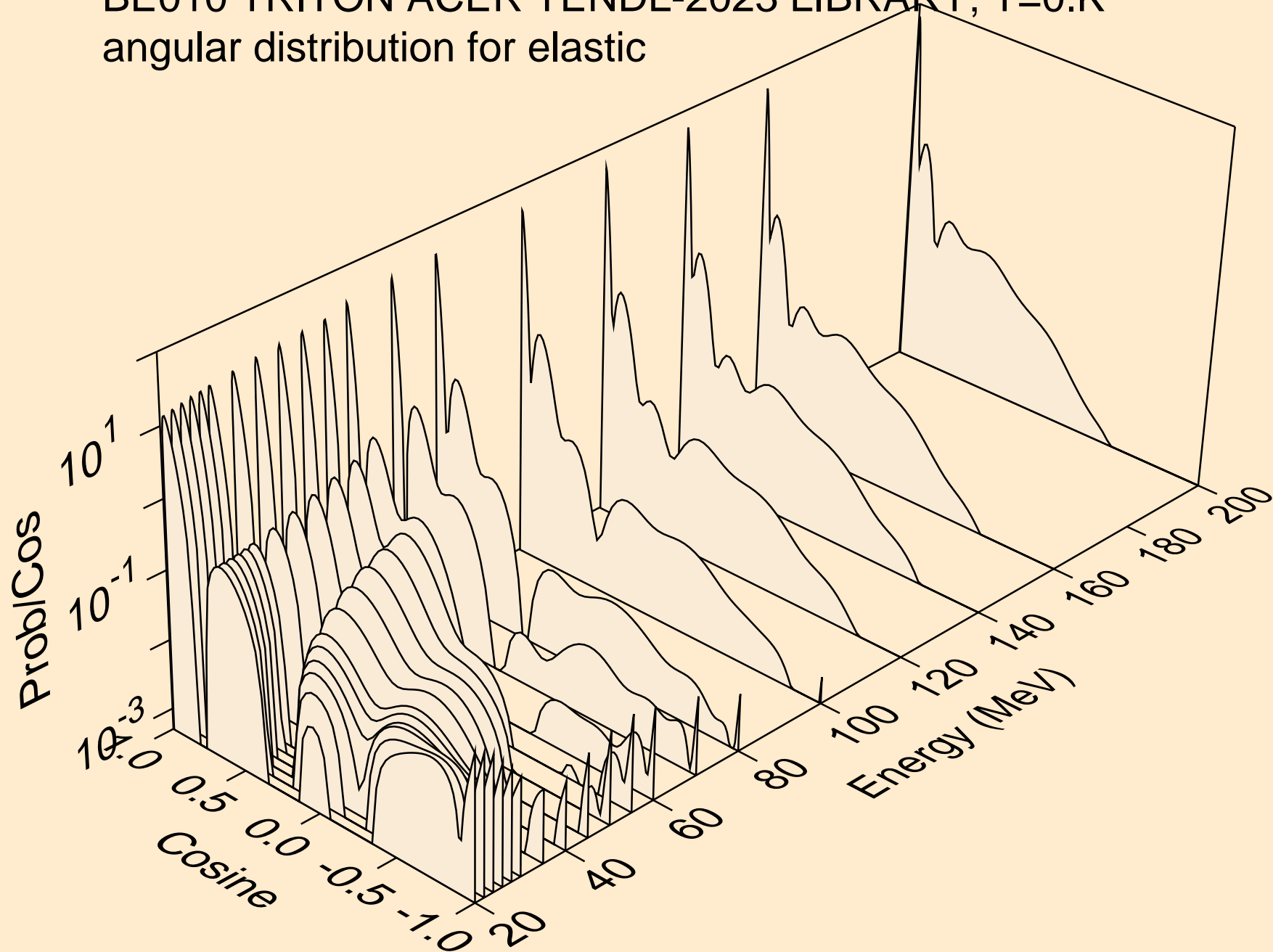

BE010 TRITON ACER TENDL-2023 LIBRARY; T=0.K  
Triton emission for (t,x)

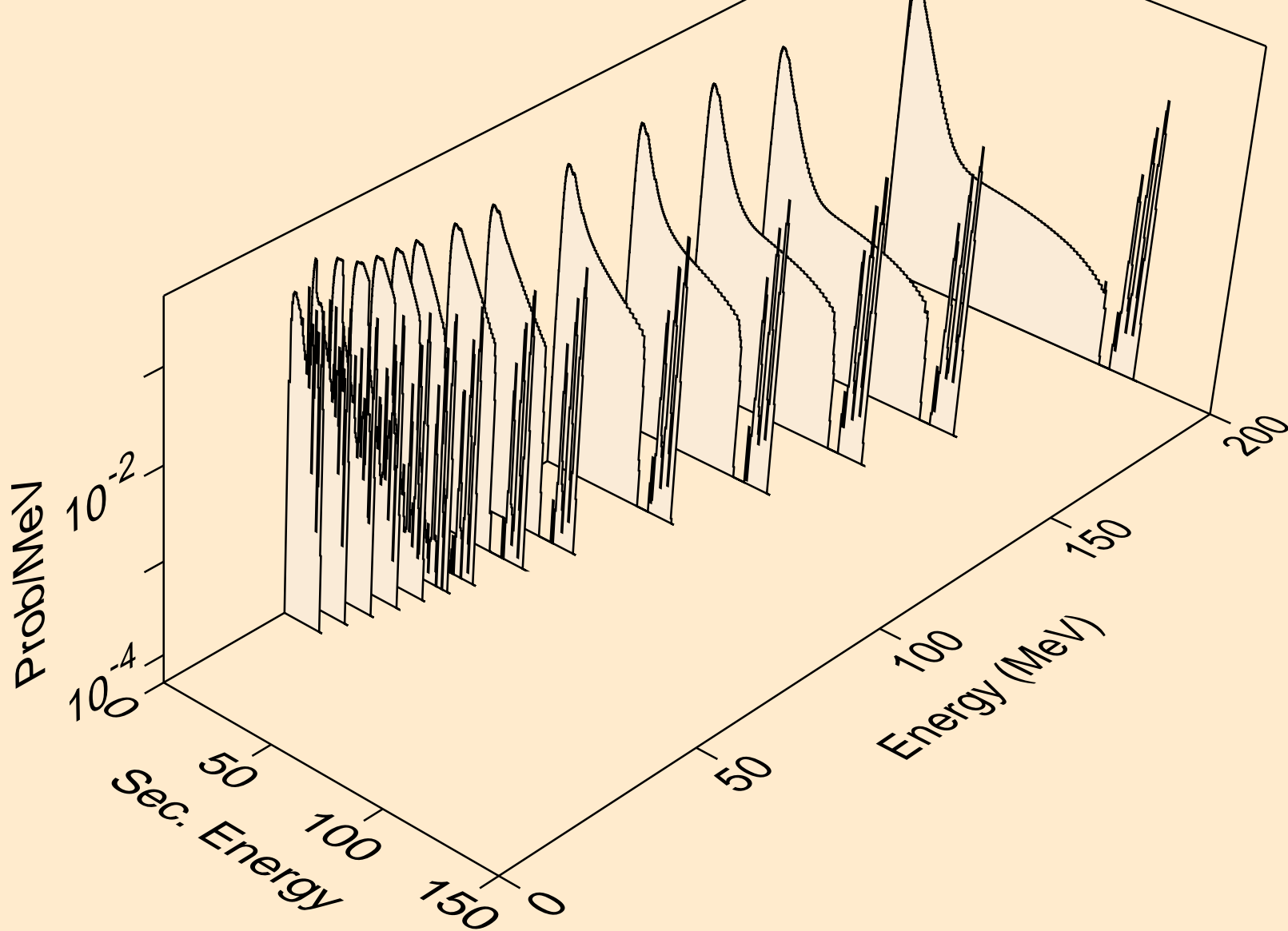



BE010 TRITON ACER TENDL-2023 LIBRARY; T=0.K  
Triton emission for (t,n\*)t

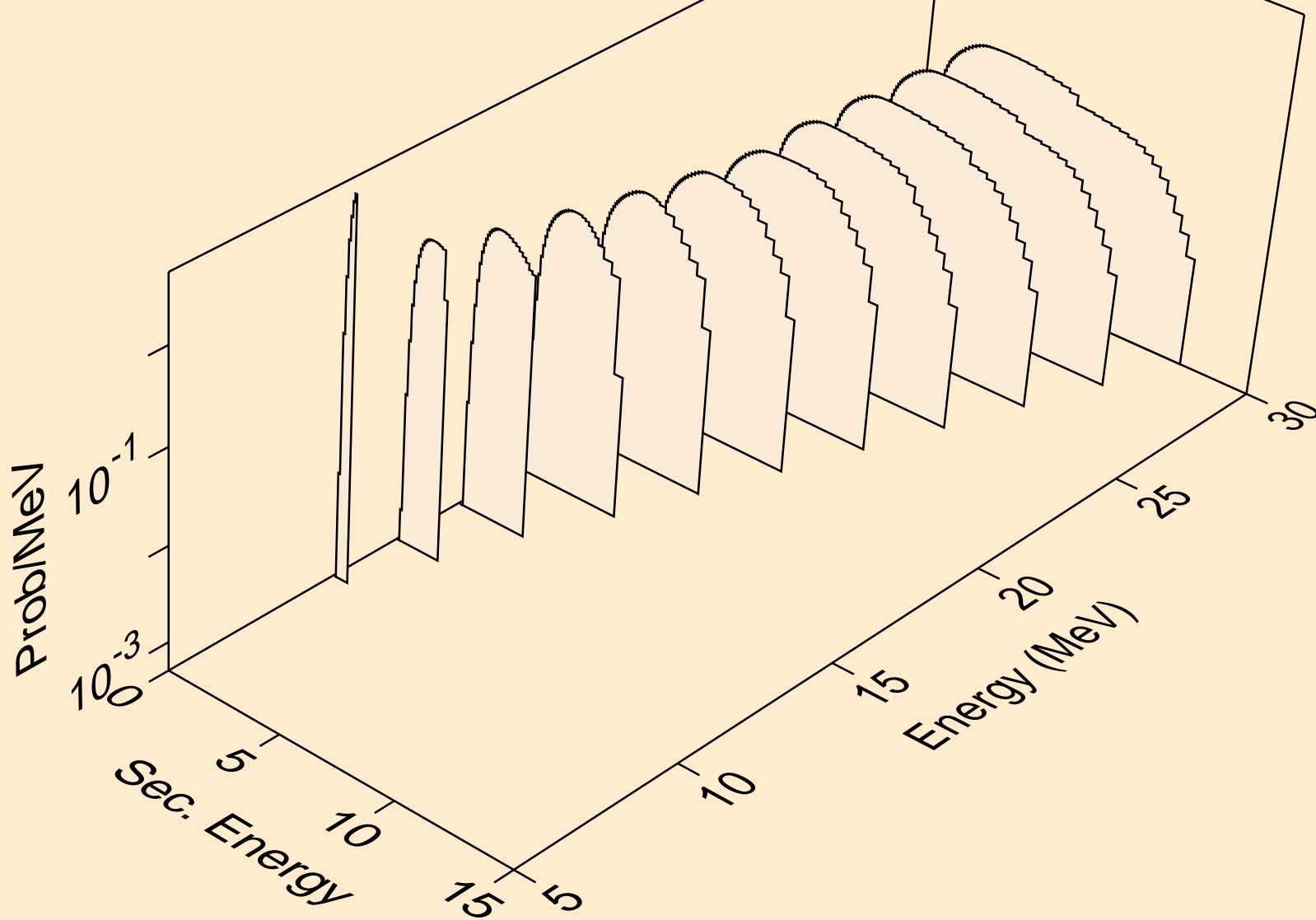

BE010 TRITON ACER TENDL-2023 LIBRARY; T=0.K  
Triton emission for inelastic

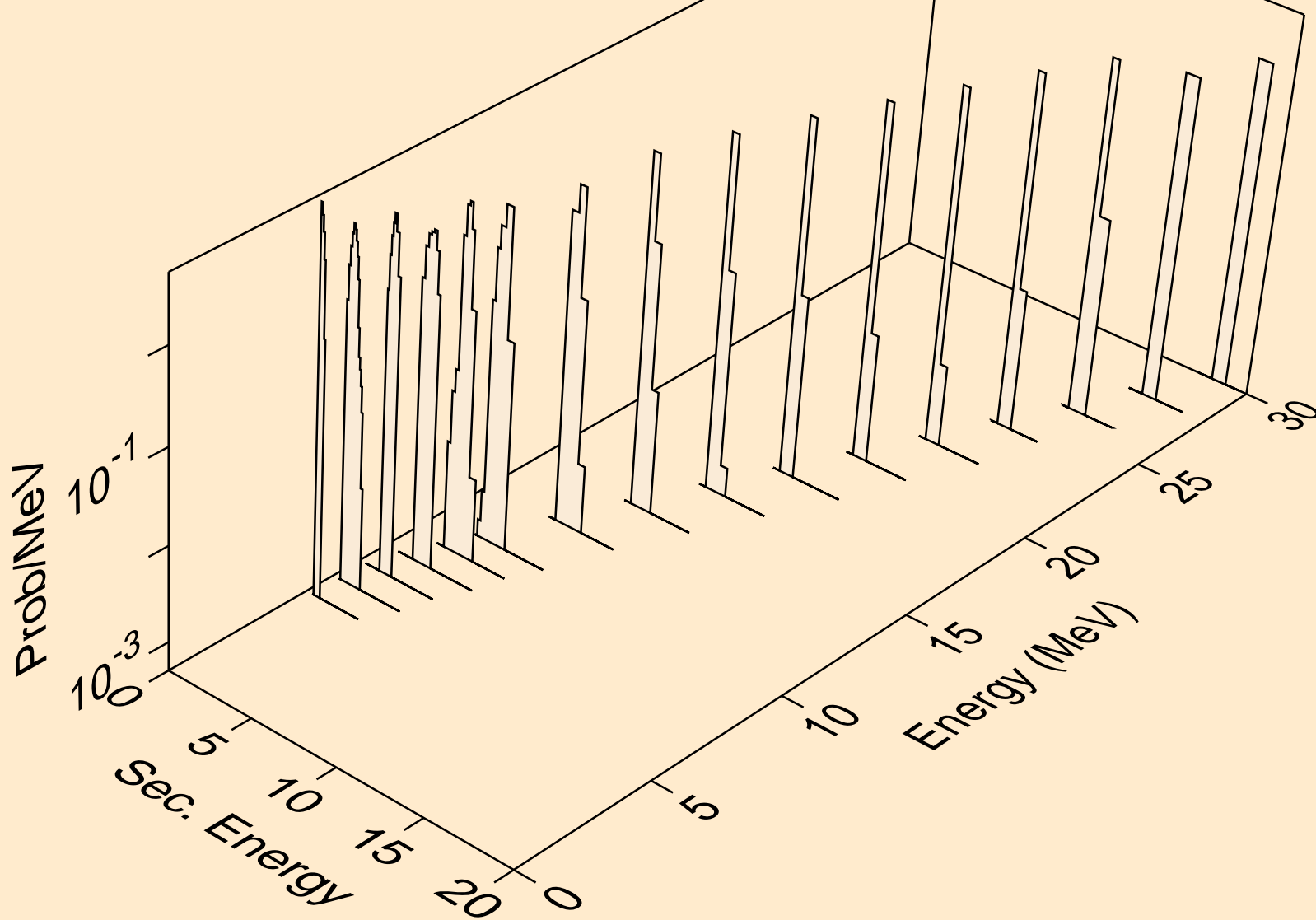

BE010 TRITON ACER TENDL-2023 LIBRARY; T=0.K  
Triton emission for (t,pt)

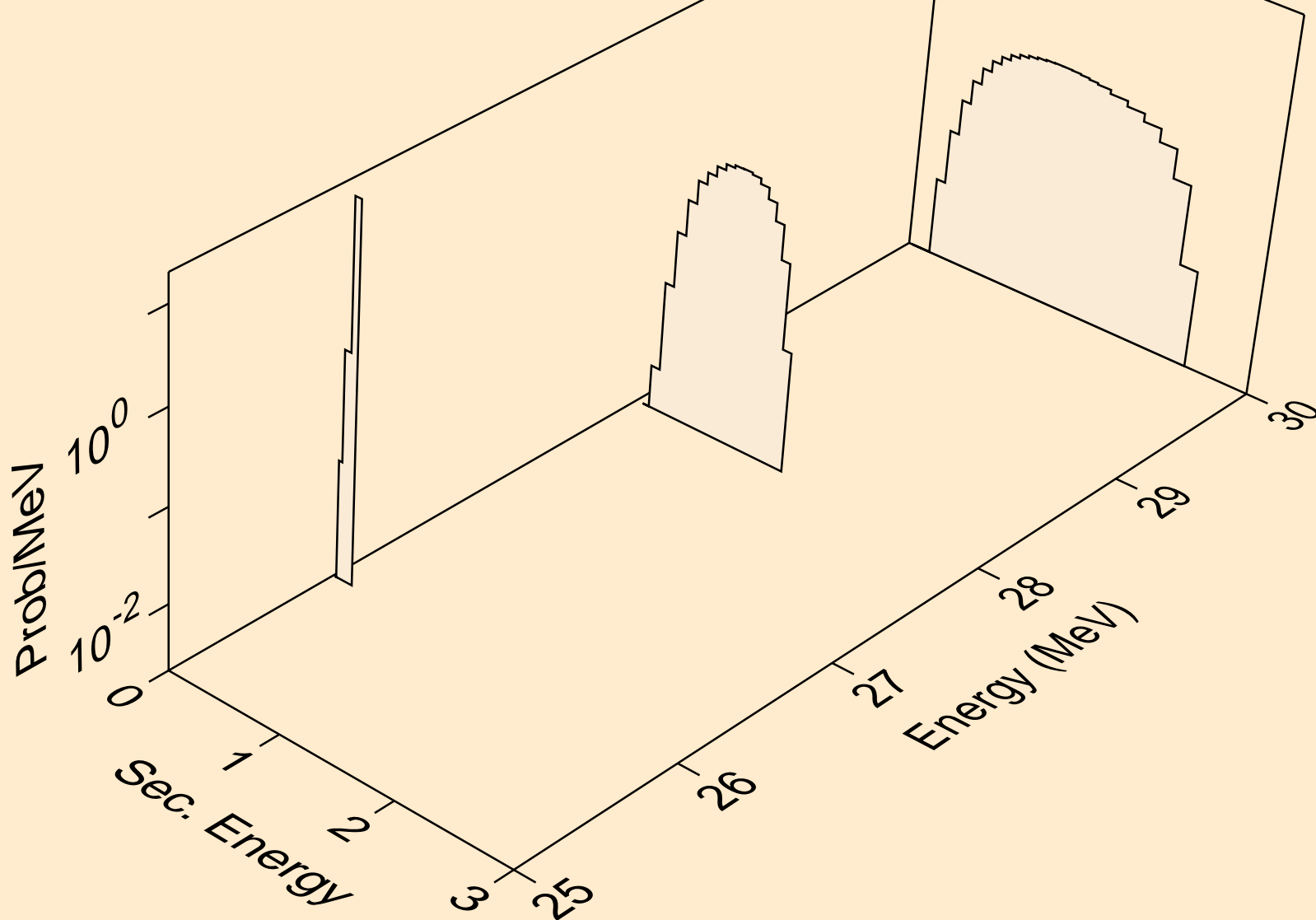

BE010 TRITON ACER TENDL-2023 LIBRARY; T=0.K  
Photon emission for (z,n)

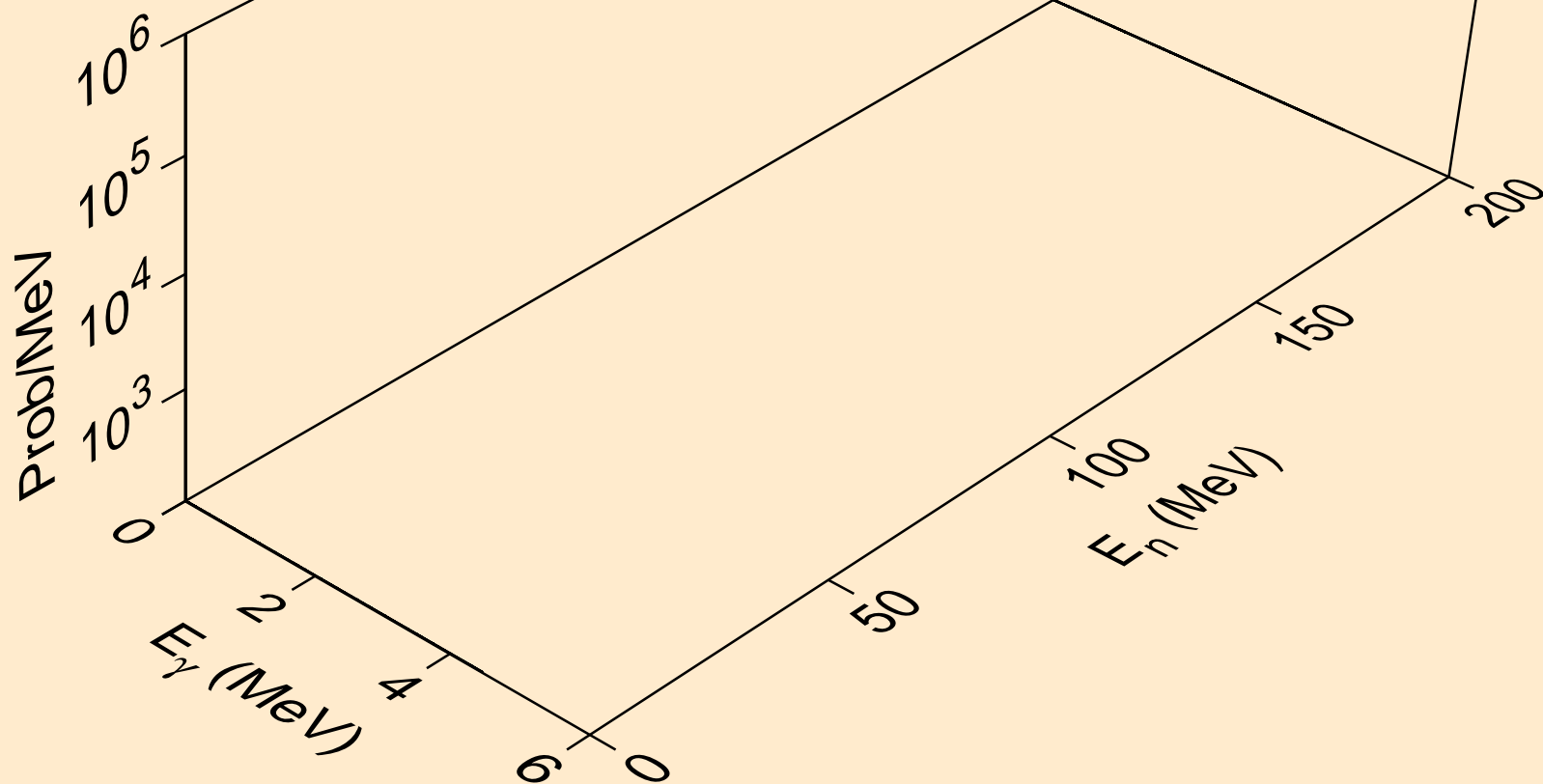

BE010 TRITON ACER TENDL-2023 LIBRARY; T=0.K  
Photon emission for (z,x)

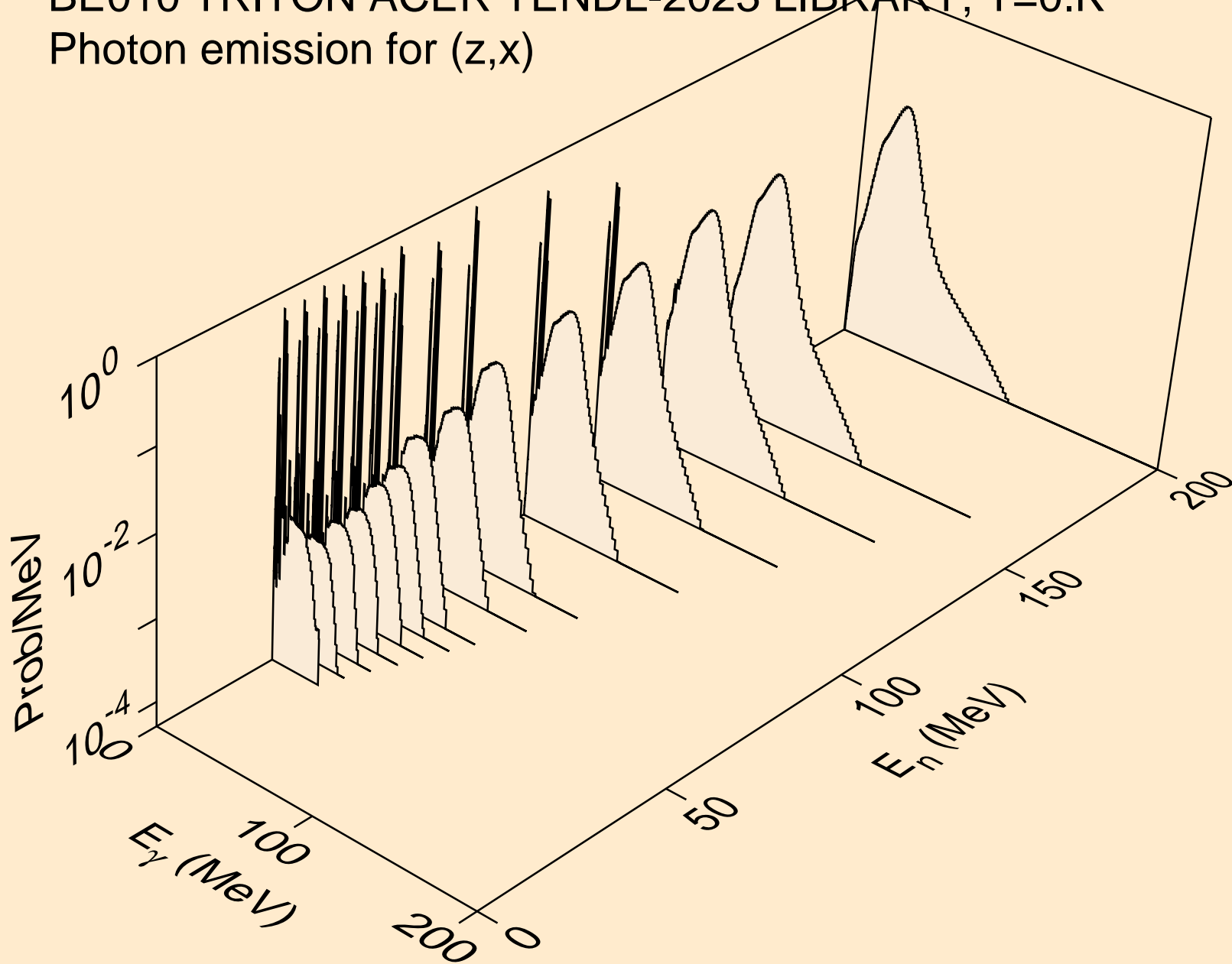

BE010 TRITON ACER TENDL-2023 LIBRARY; T=0.K  
Photon emission for (n,2nd)

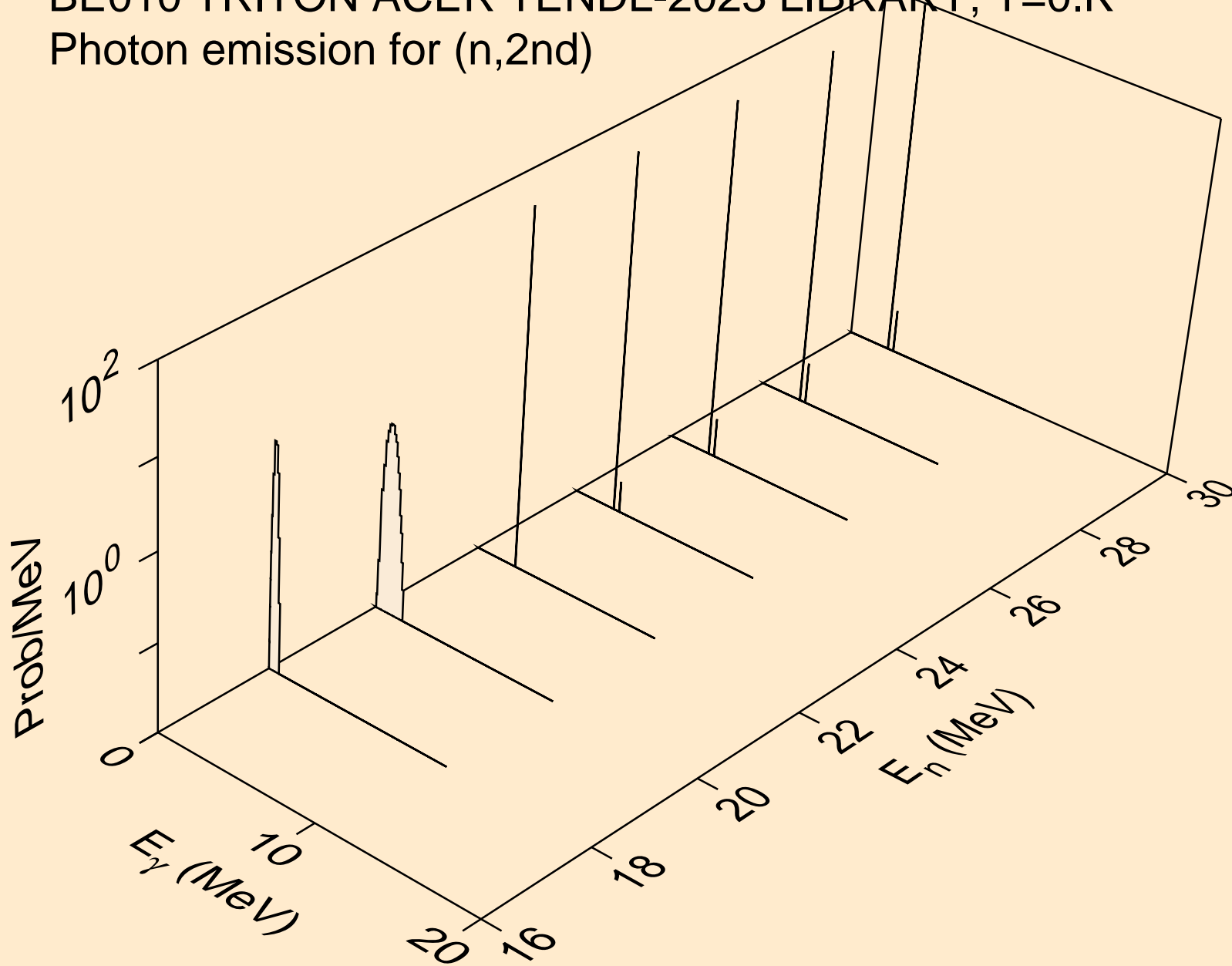

BE010 TRITON ACER TENDL-2023 LIBRARY; T=0.K  
Photon emission for (n,2n)

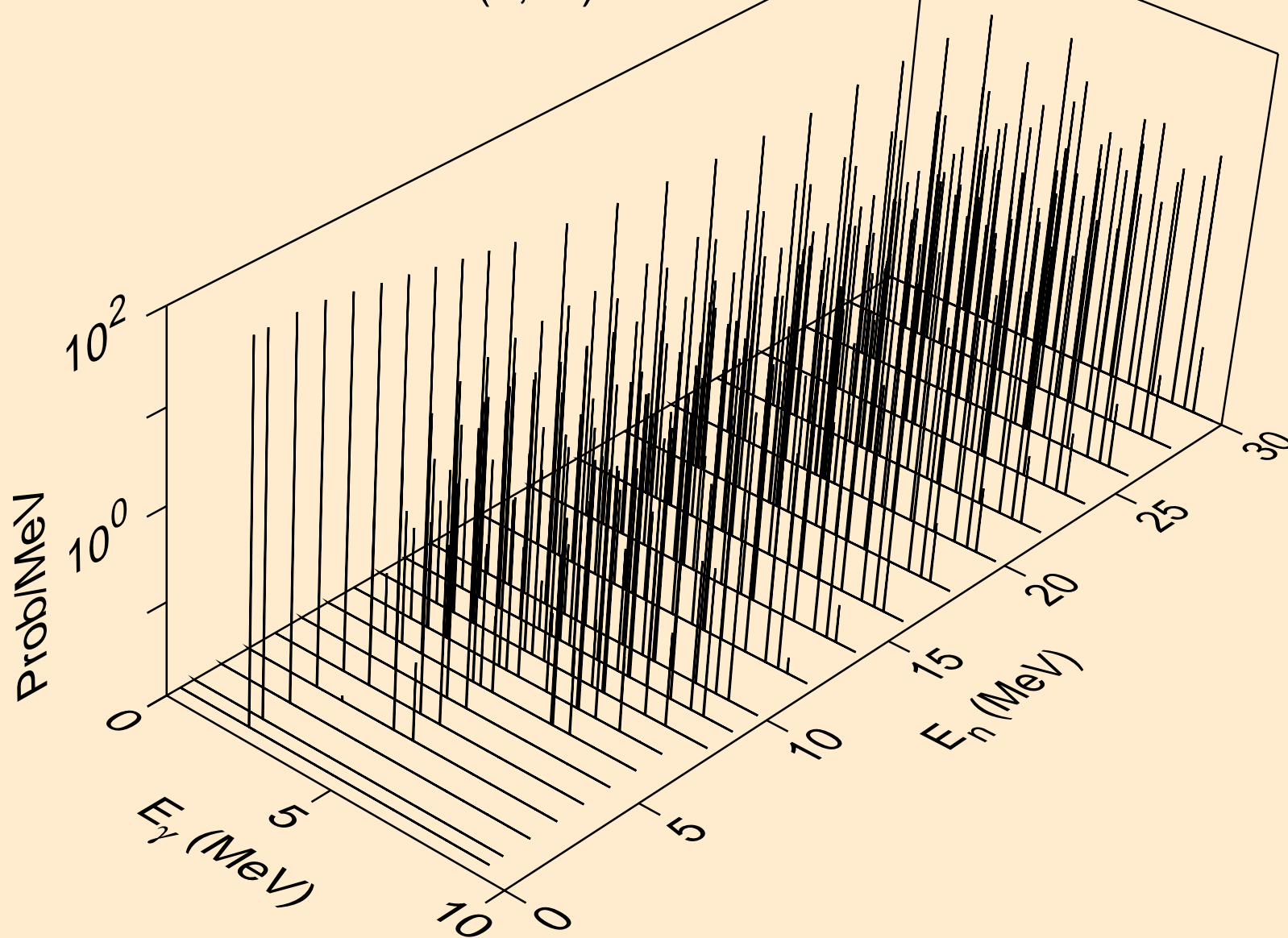

BE010 TRITON ACER TENDL-2023 LIBRARY; T=0.K  
Photon emission for (n,3n)

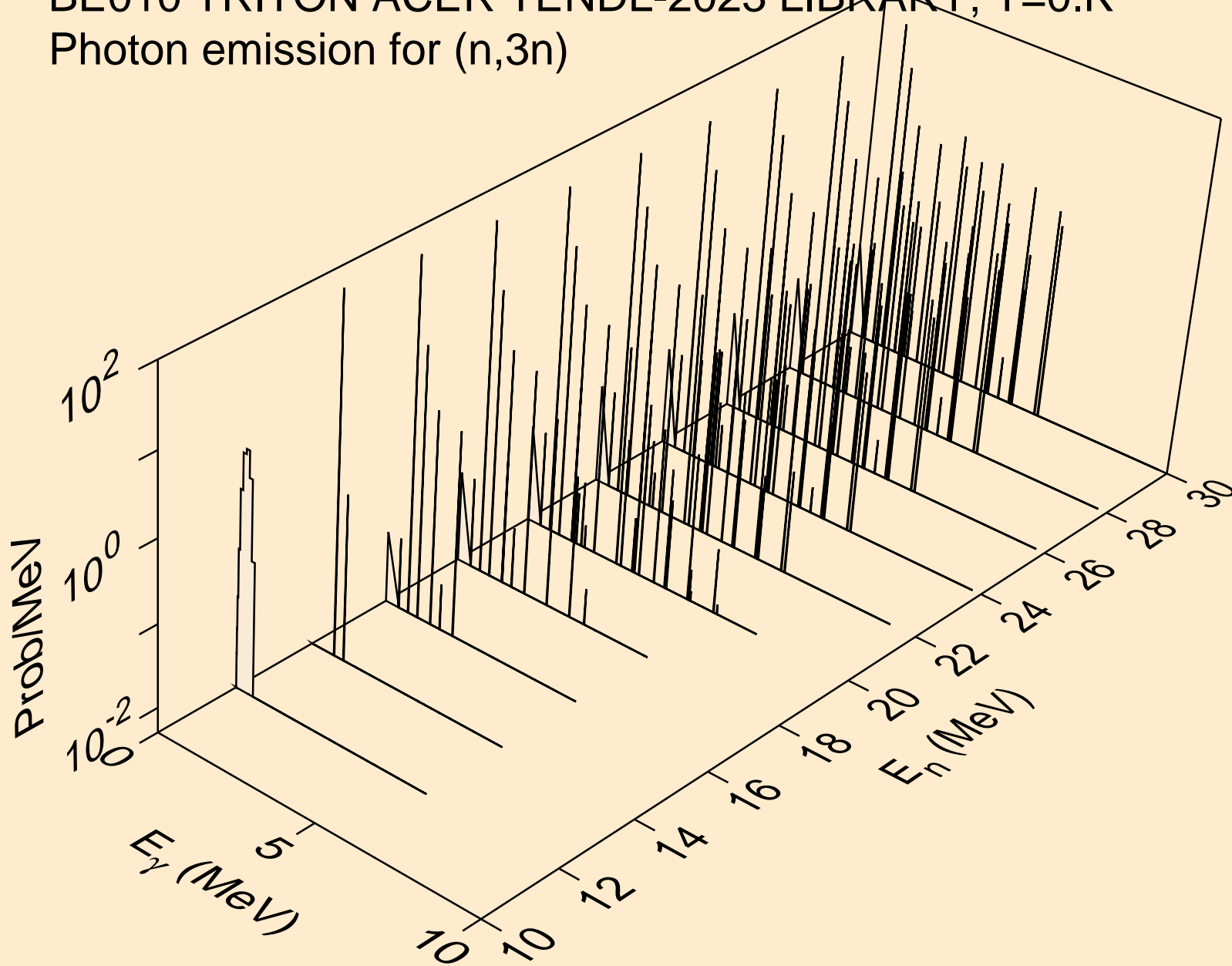



BE010 TRITON ACER TENDL-2023 LIBRARY; T=0.K  
Photon emission for (n,n\*)a

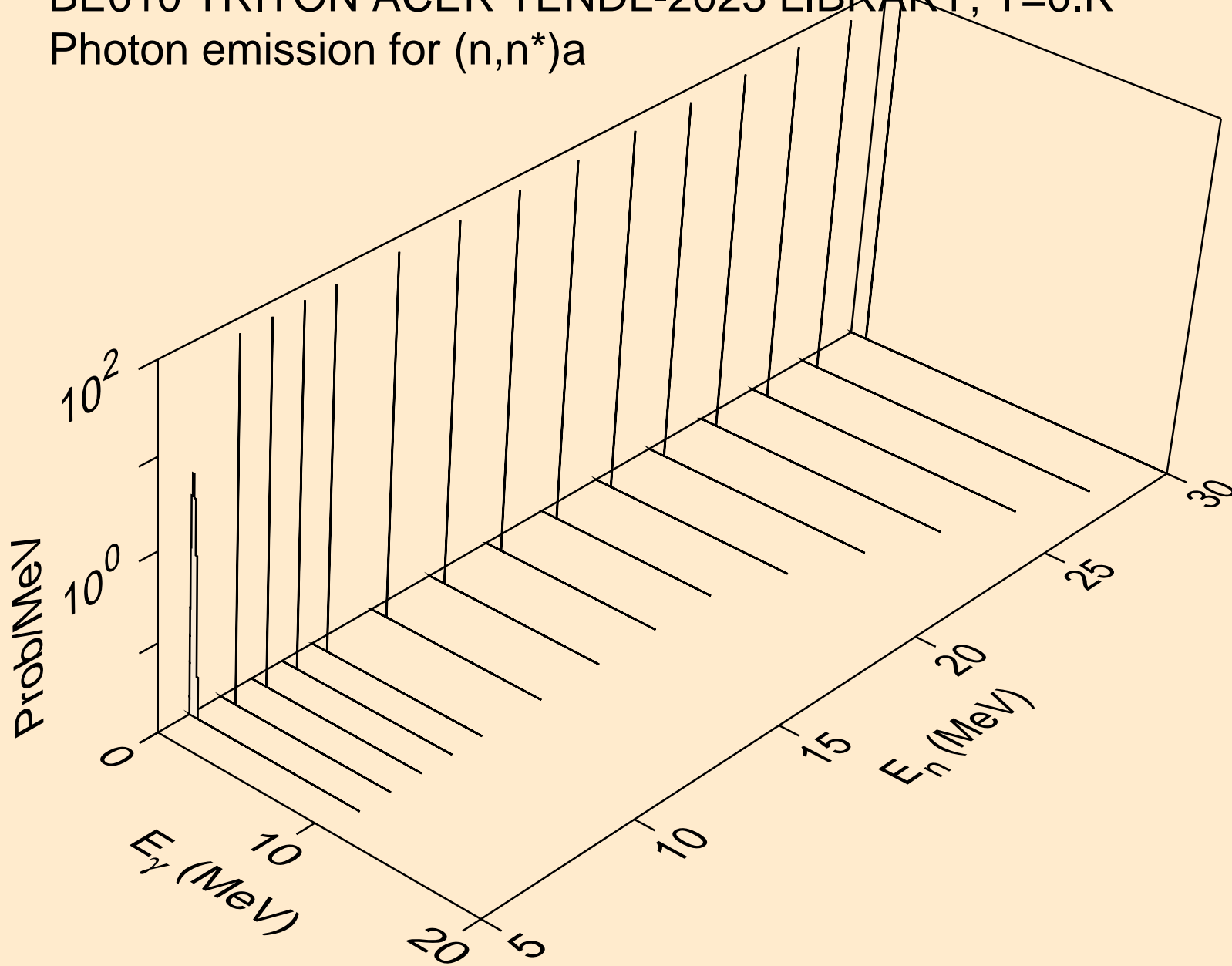

BE010 TRITON ACER TENDL-2023 LIBRARY; T=0.K  
Photon emission for (n,2n)a

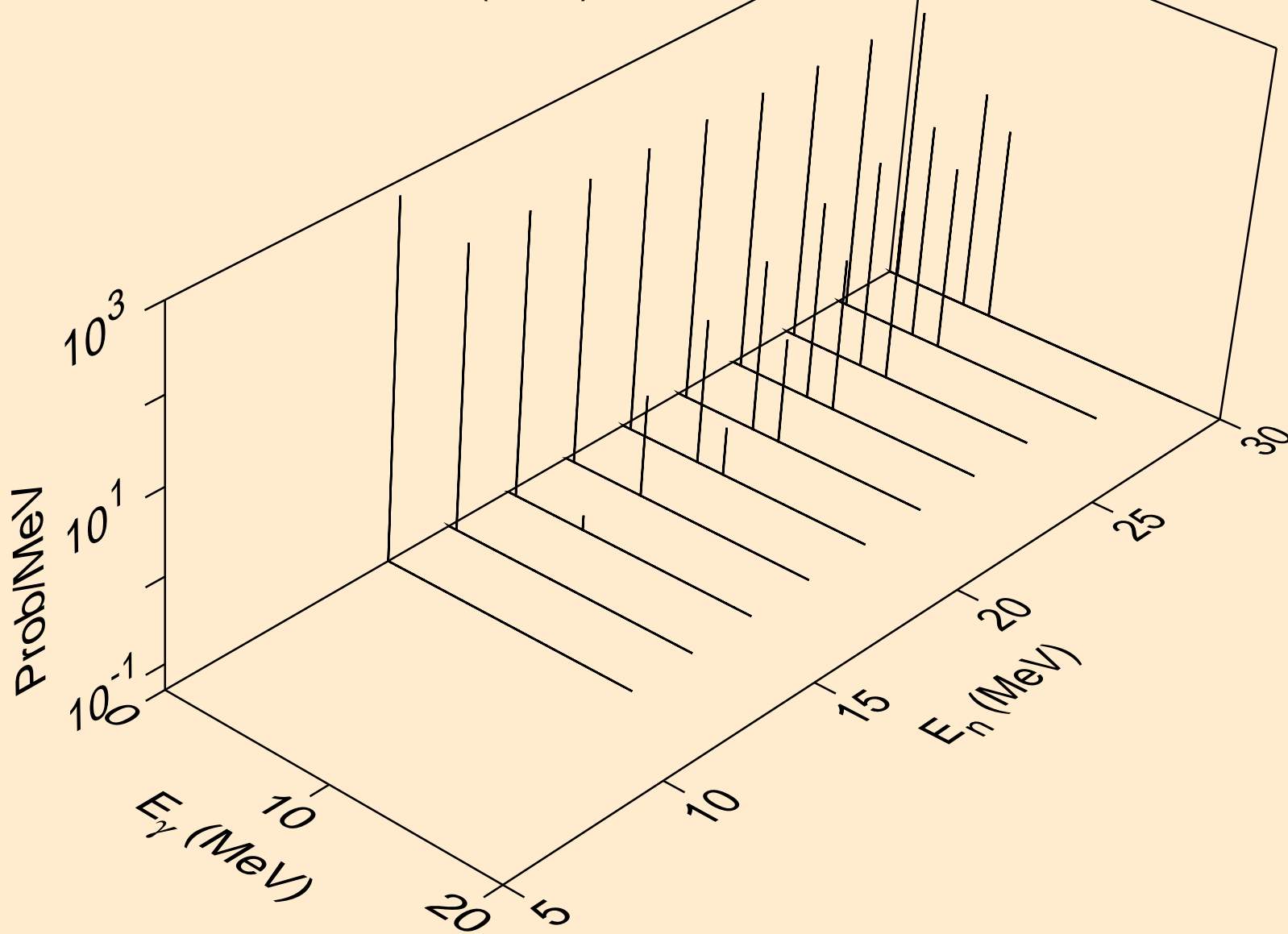

BE010 TRITON ACER TENDL-2023 LIBRARY; T=0.K  
Photon emission for (n,3n)a

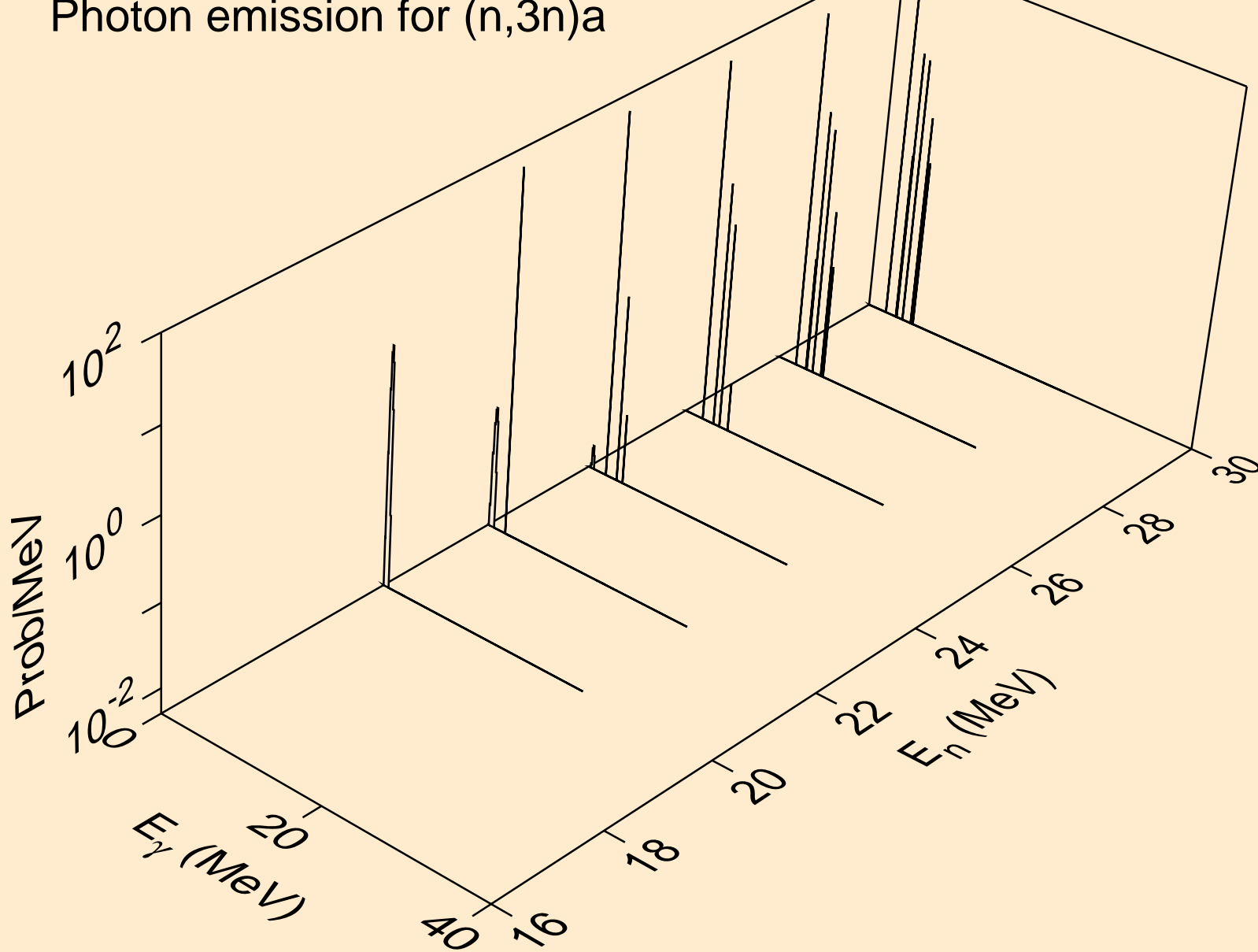

BE010 TRITON ACER TENDL-2023 LIBRARY; T=0.K  
Photon emission for (n,n\*)p

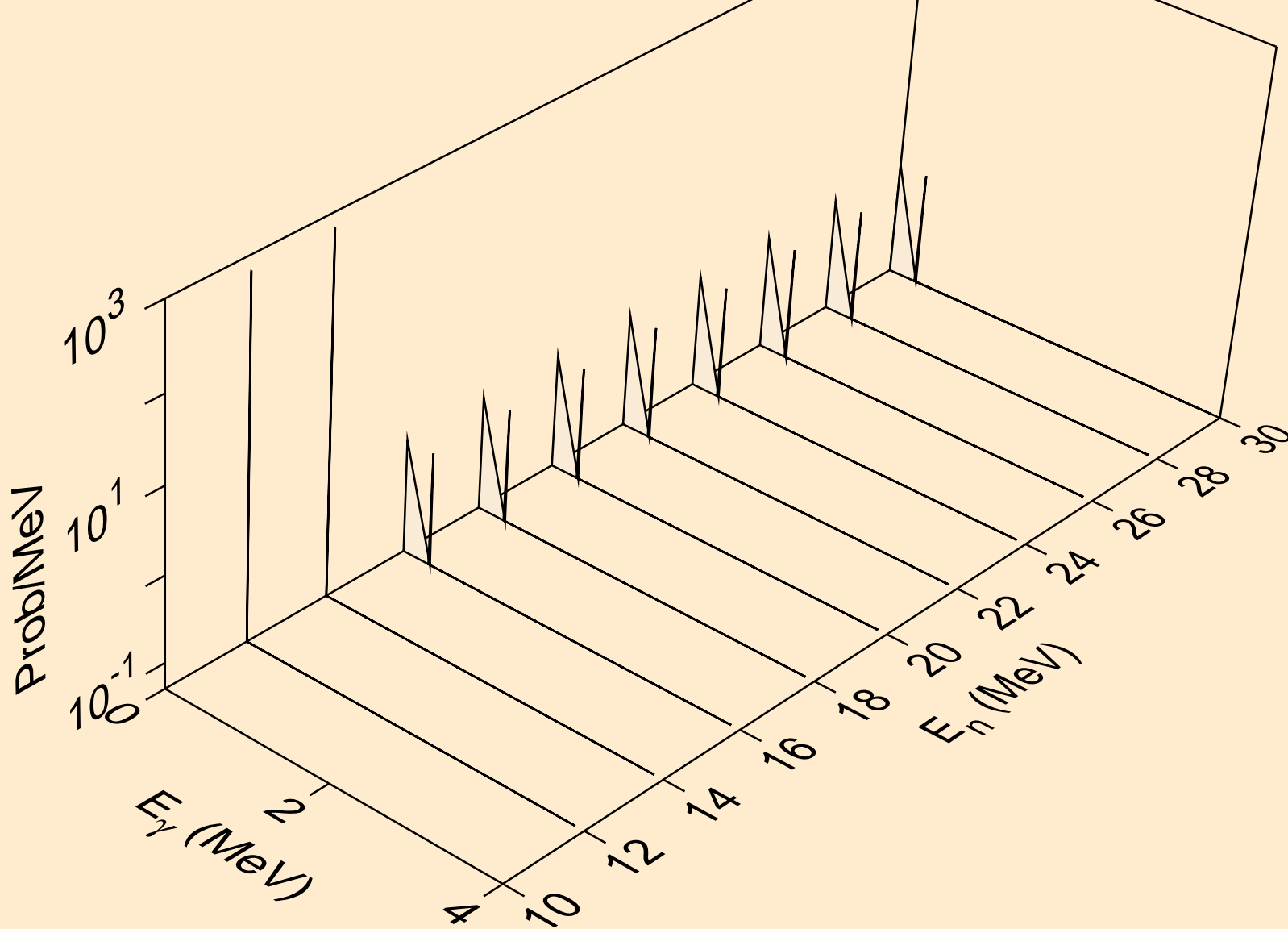

BE010 TRITON ACER TENDL-2023 LIBRARY; T=0.K  
Photon emission for (n,n\*)d

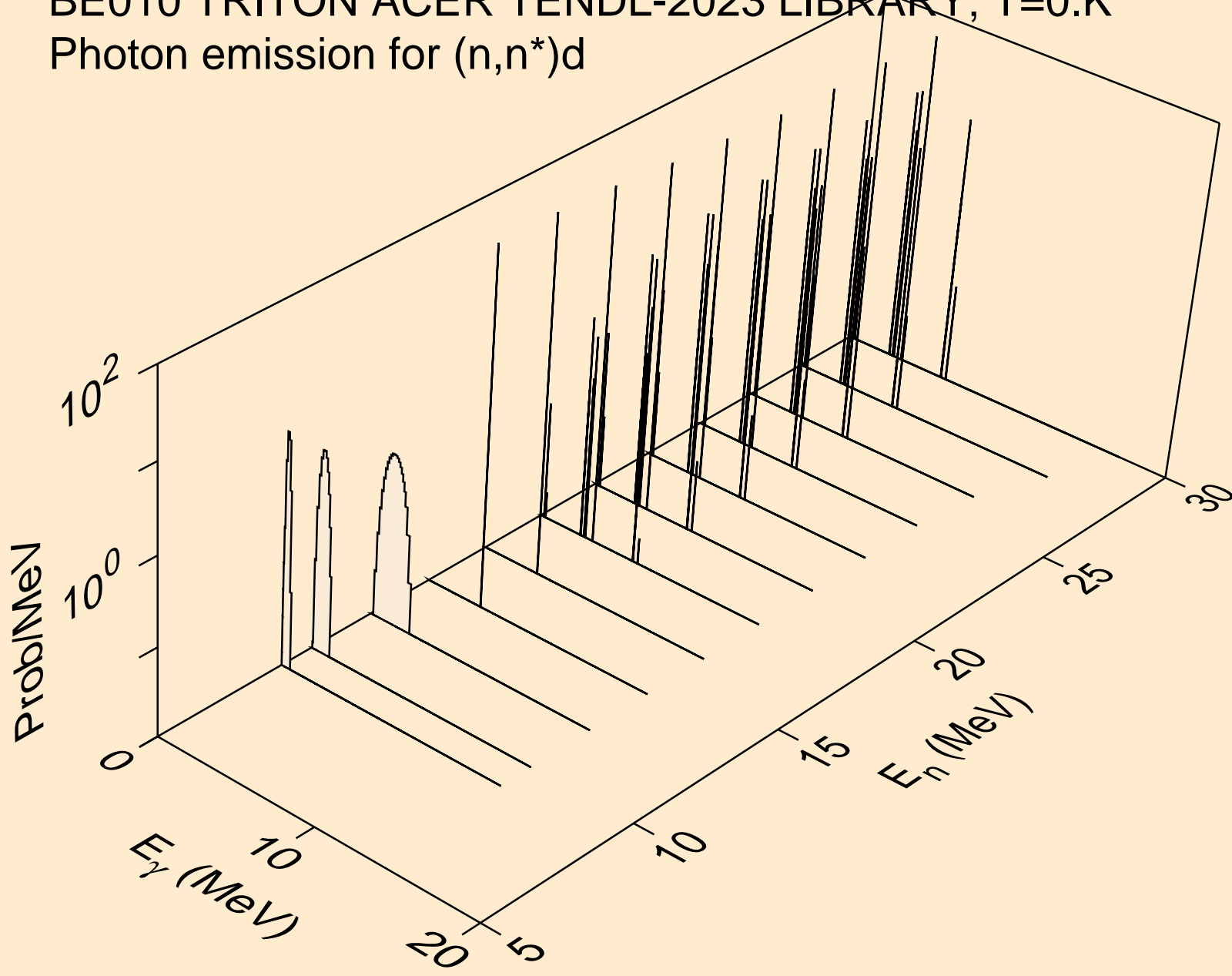

BE010 TRITON ACER TENDL-2023 LIBRARY; T=0.K  
Photon emission for (n,n\*)t

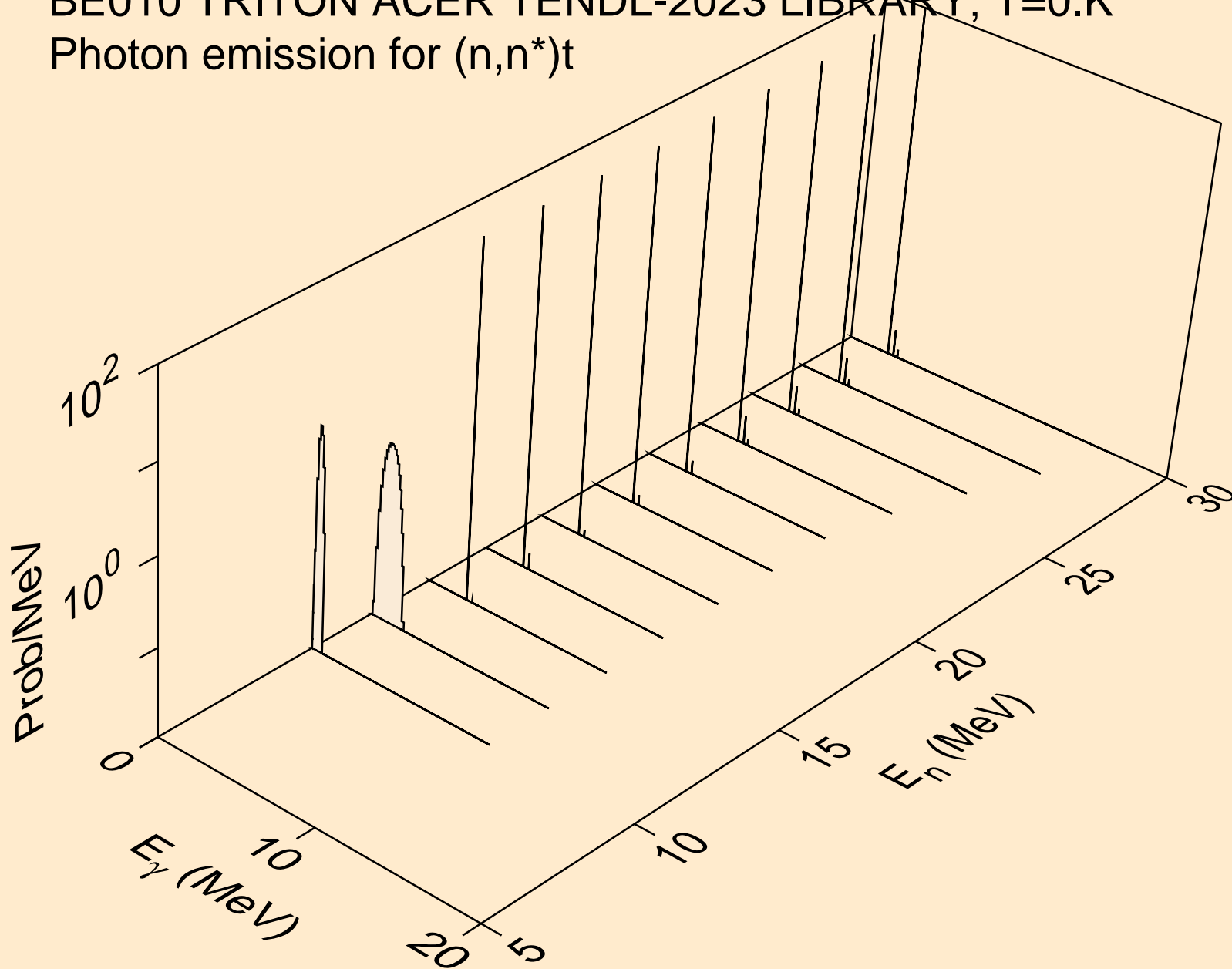

BE010 TRITON ACER TENDL-2023 LIBRARY; T=0.K  
Photon emission for (n,n\*)he3

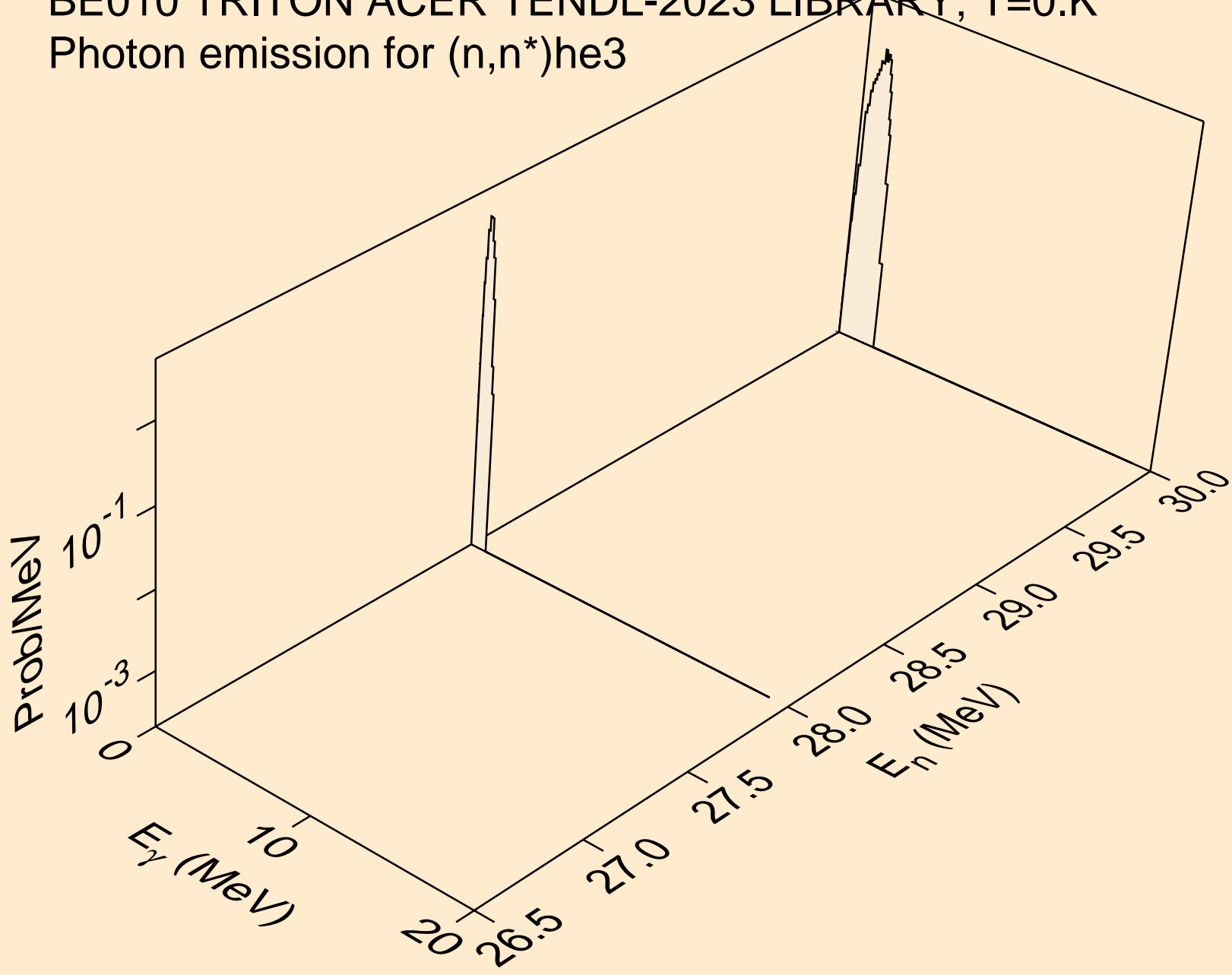

BE010 TRITON ACER TENDL-2023 LIBRARY; T=0.K  
Photon emission for (n,4n)

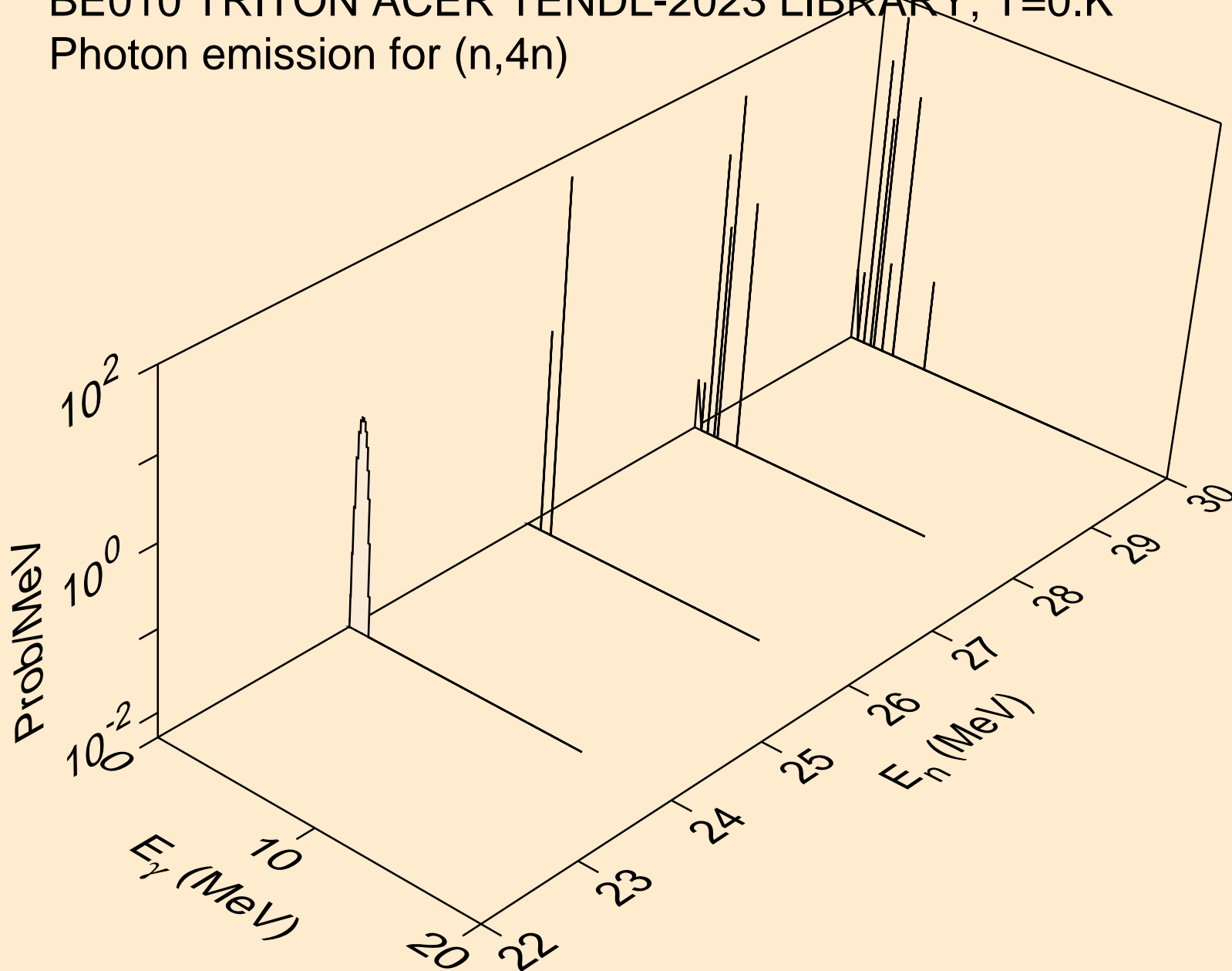



BE010 TRITON ACER TENDL-2023 LIBRARY; T=0.K  
Photon emission for (n,2np)

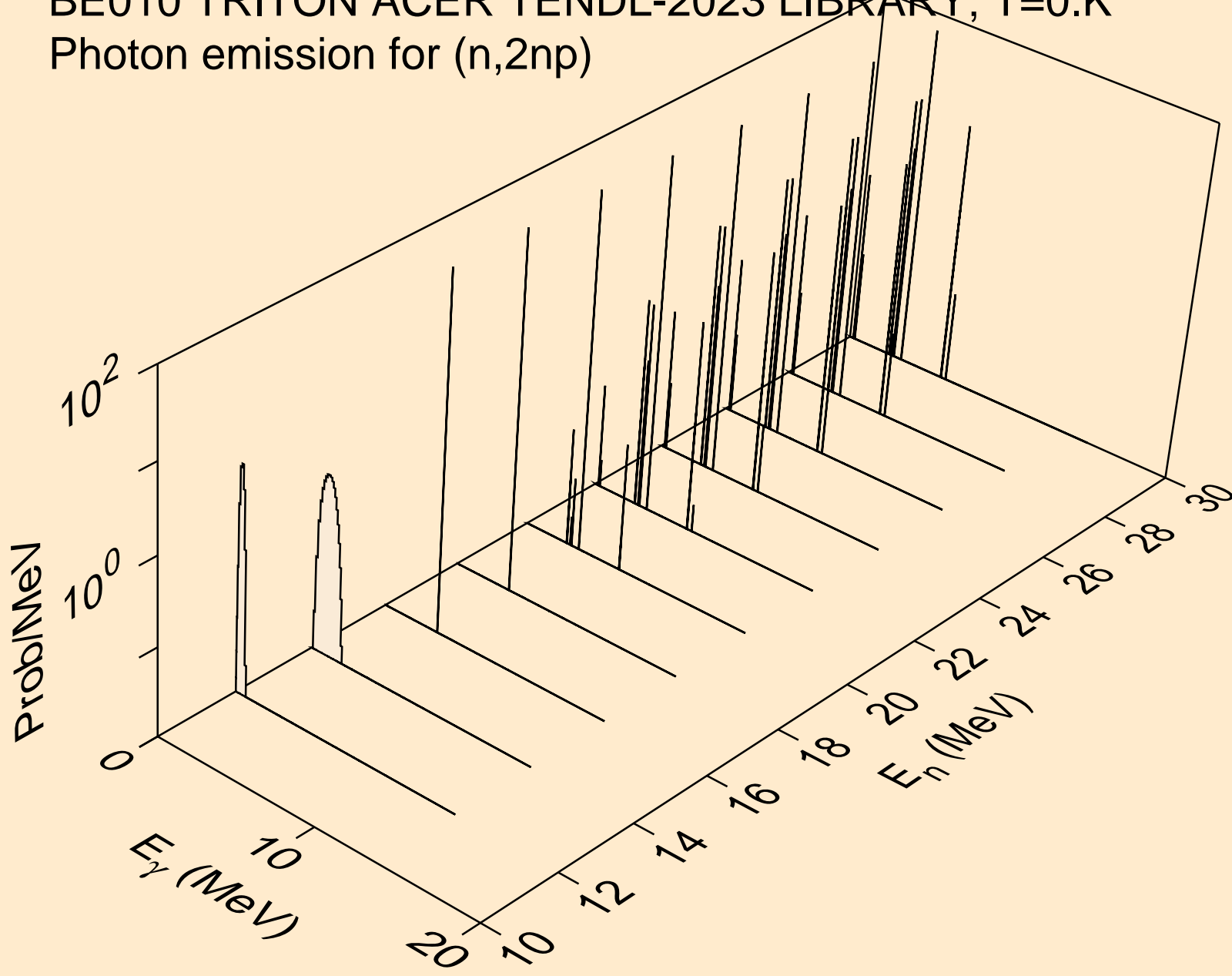

BE010 TRITON ACER TENDL-2023 LIBRARY; T=0.K  
Photon emission for (n,3np)

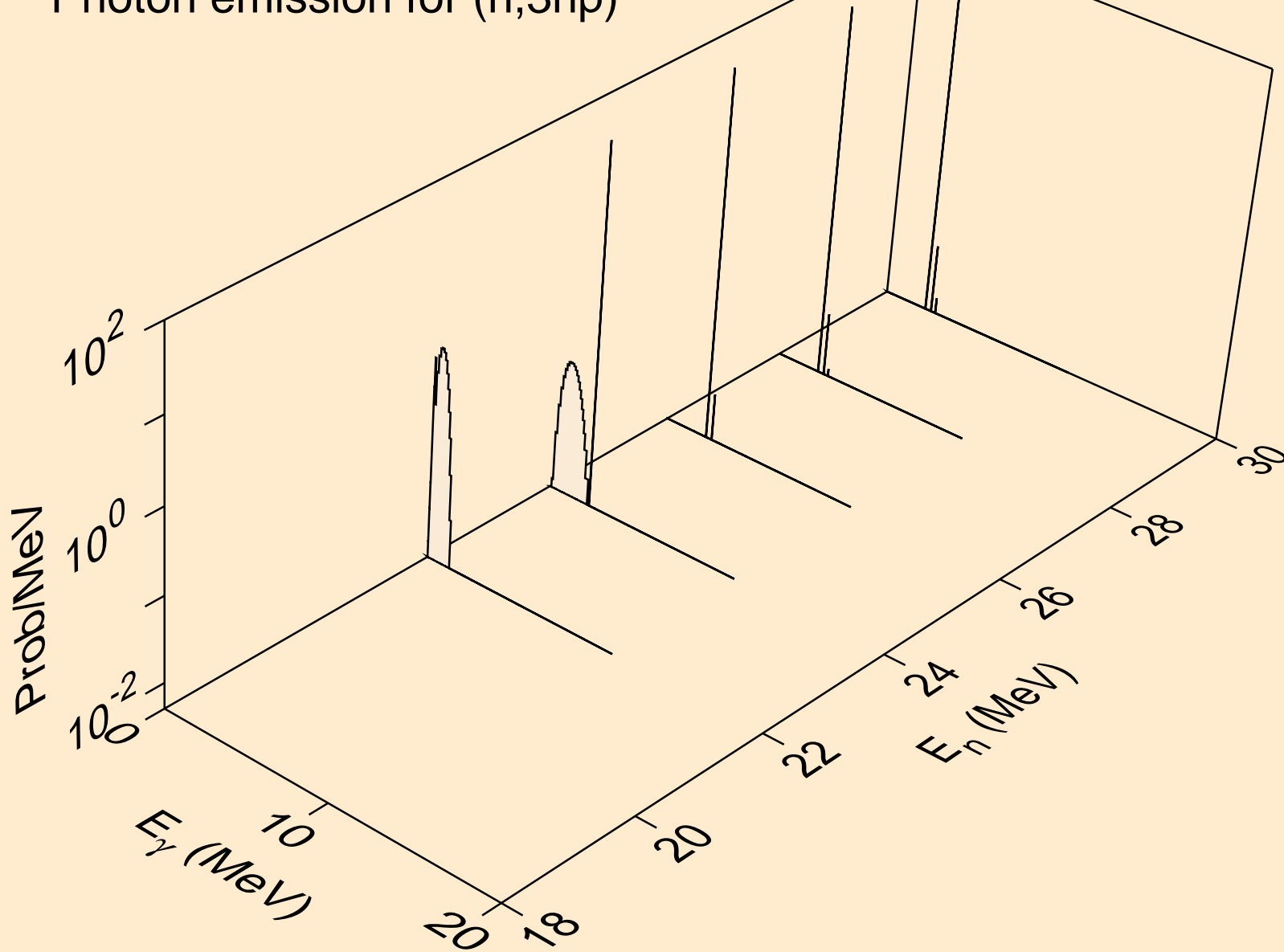

BE010 TRITON ACER TENDL-2023 LIBRARY; T=0.K  
Photon emission for (n,gma)

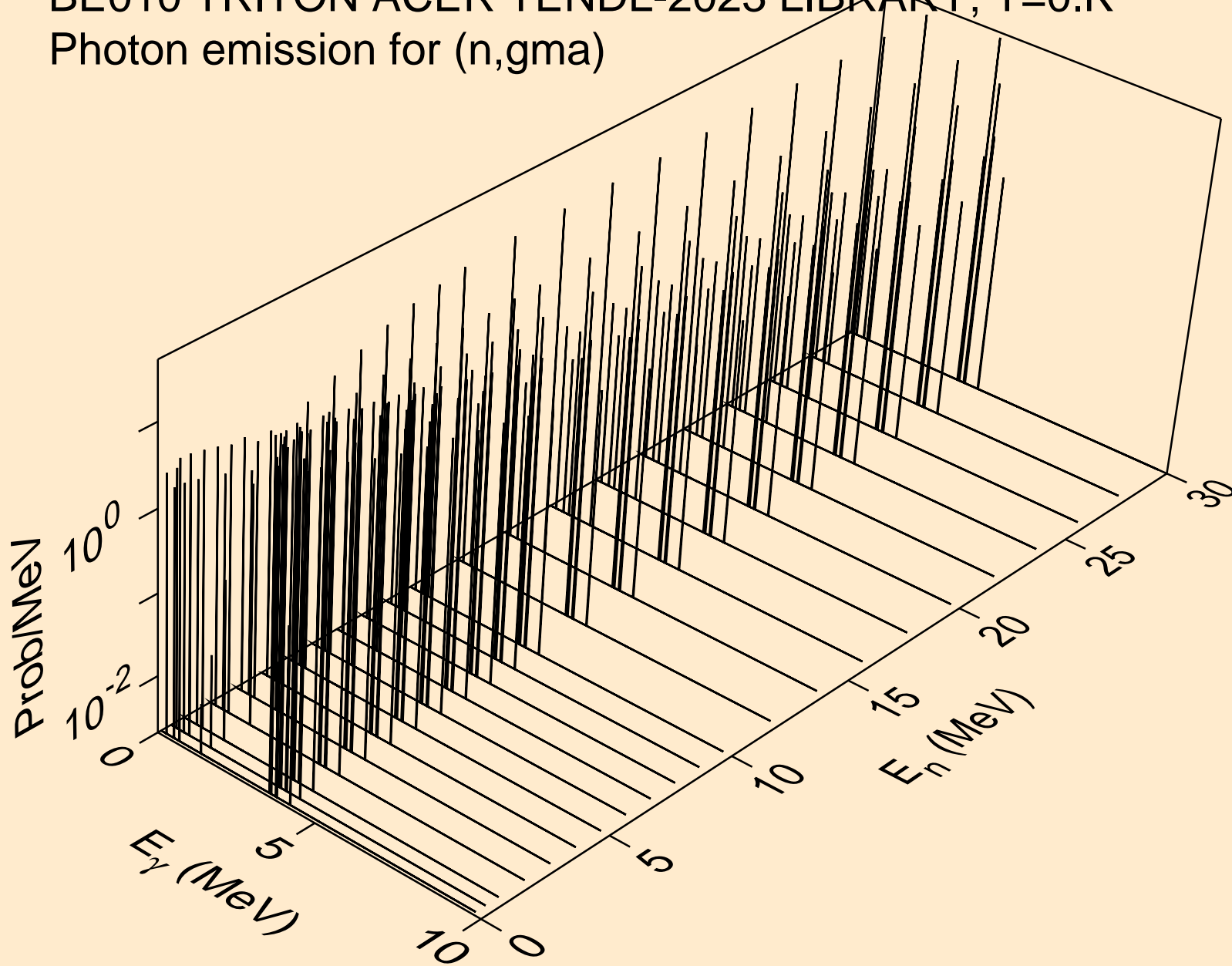

BE010 TRITON ACER TENDL-2023 LIBRARY; T=0.K  
Photon emission for (n,p)

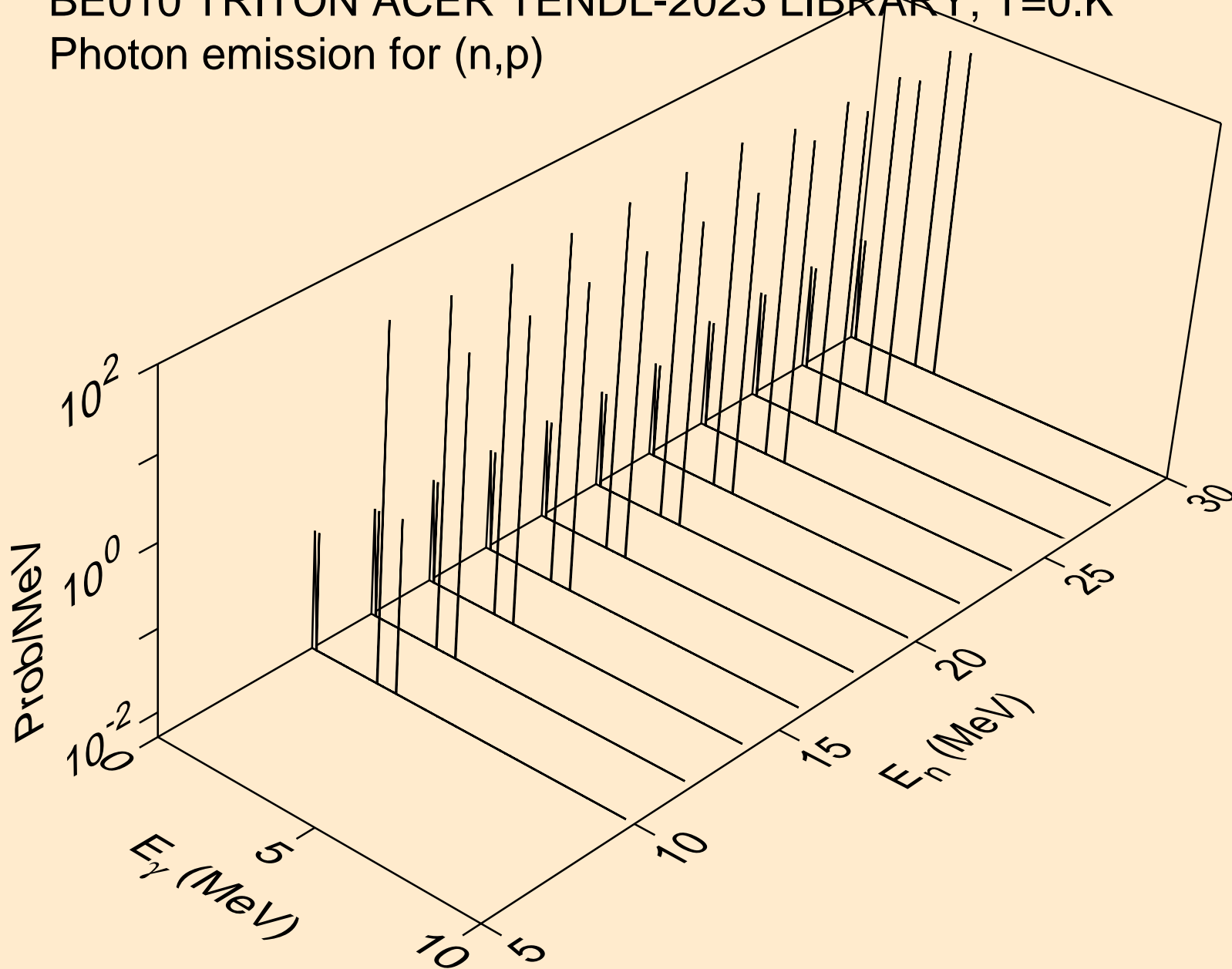

BE010 TRITON ACER TENDL-2023 LIBRARY; T=0.K  
Photon emission for (n,d)

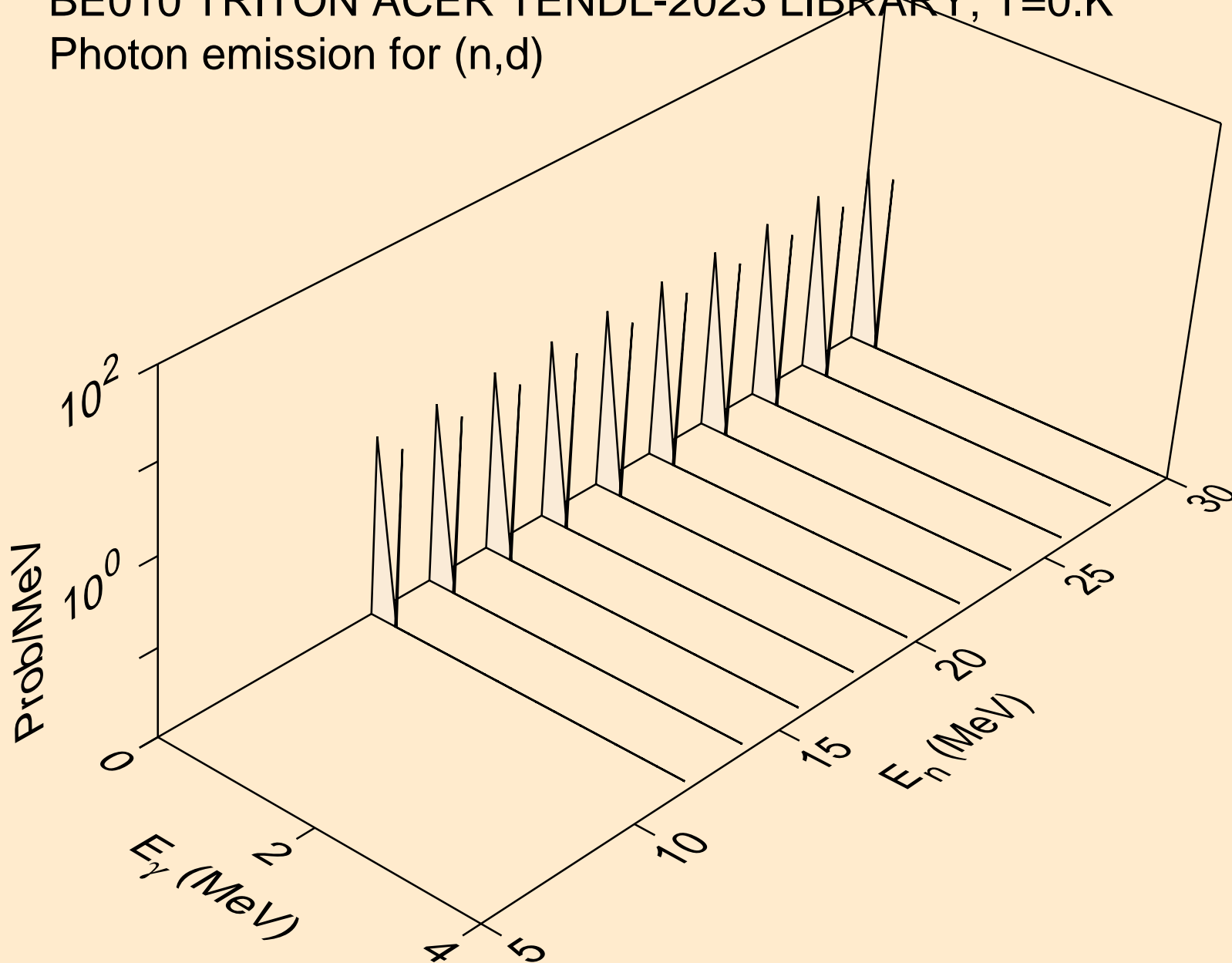

BE010 TRITON ACER TENDL-2023 LIBRARY; T=0.K  
Photon emission for inelastic

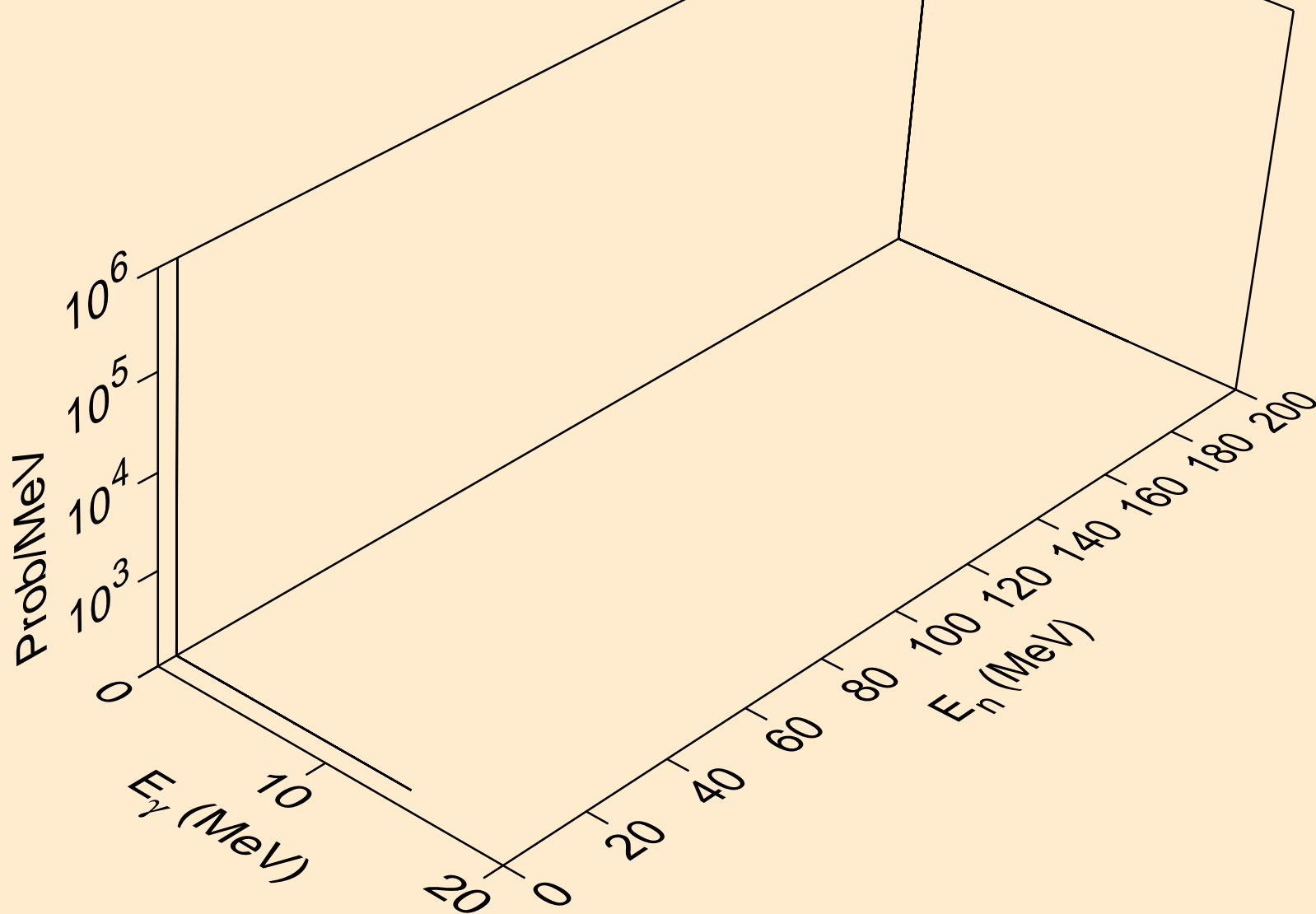

BE010 TRITON ACER TENDL-2023 LIBRARY; T=0.K  
Photon emission for (n,he3)

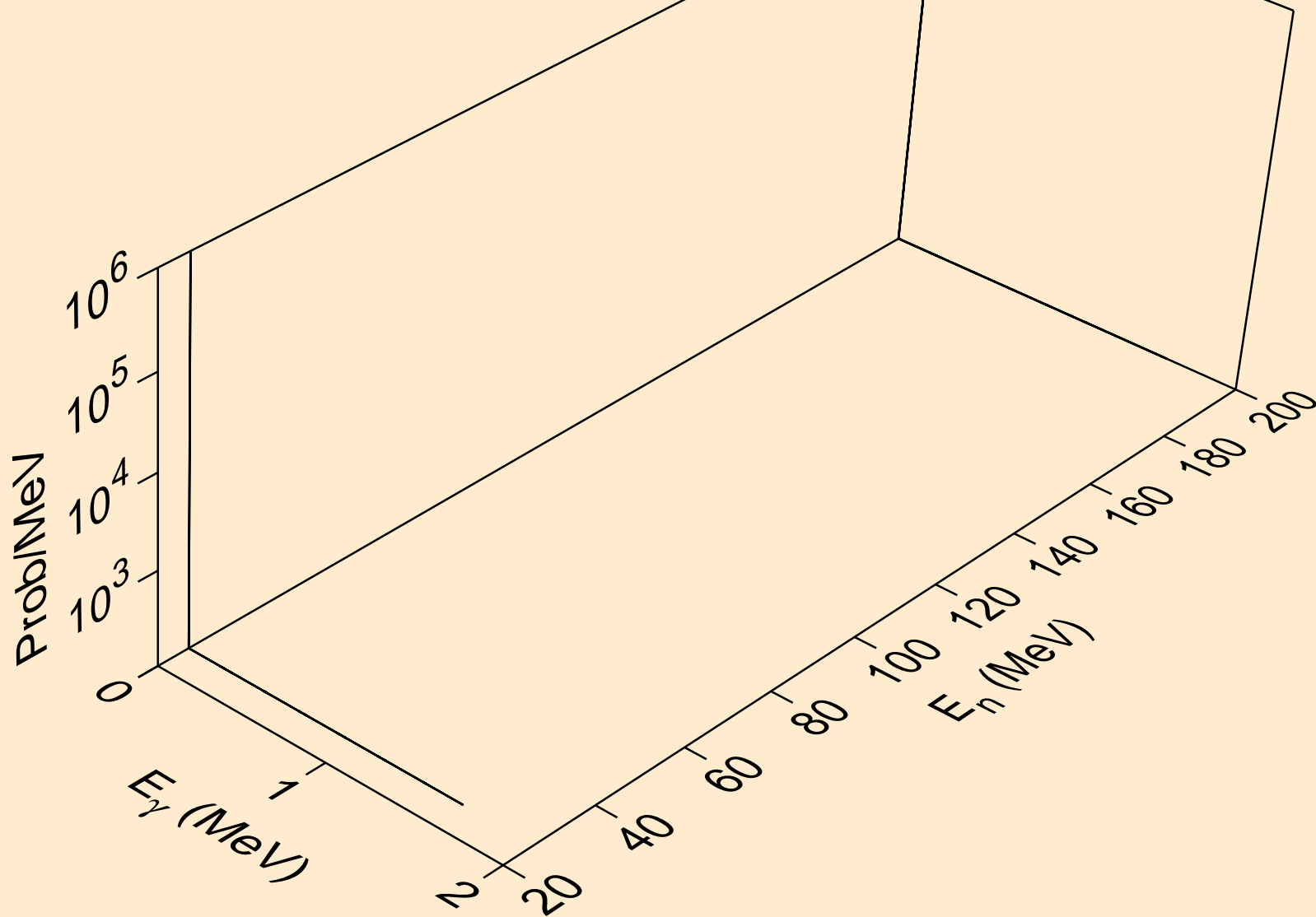

BE010 TRITON ACER TENDL-2023 LIBRARY; T=0.K  
Photon emission for (n,a)

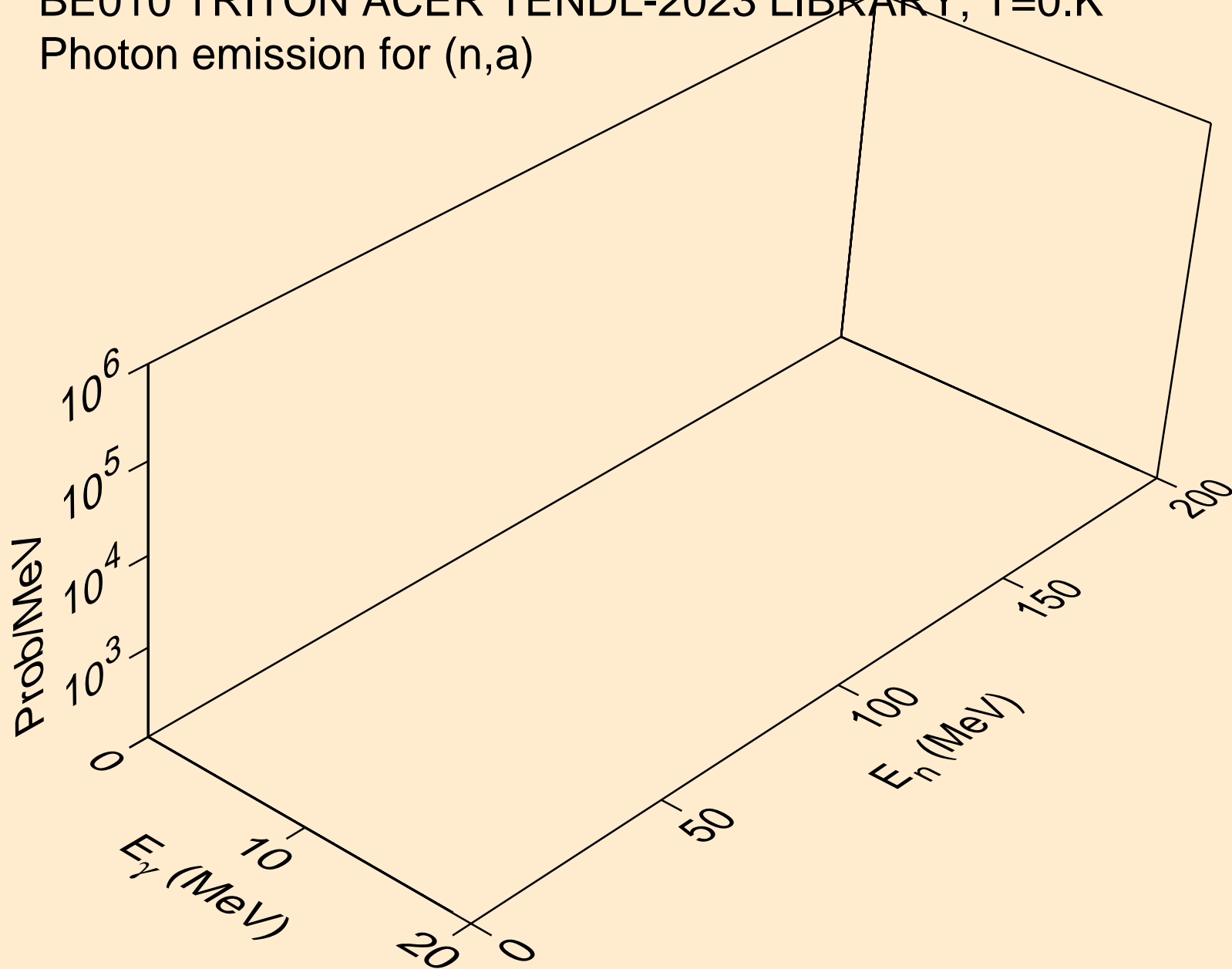



BE010 TRITON ACER TENDL-2023 LIBRARY; T=0.K  
Photon emission for (n,pt)

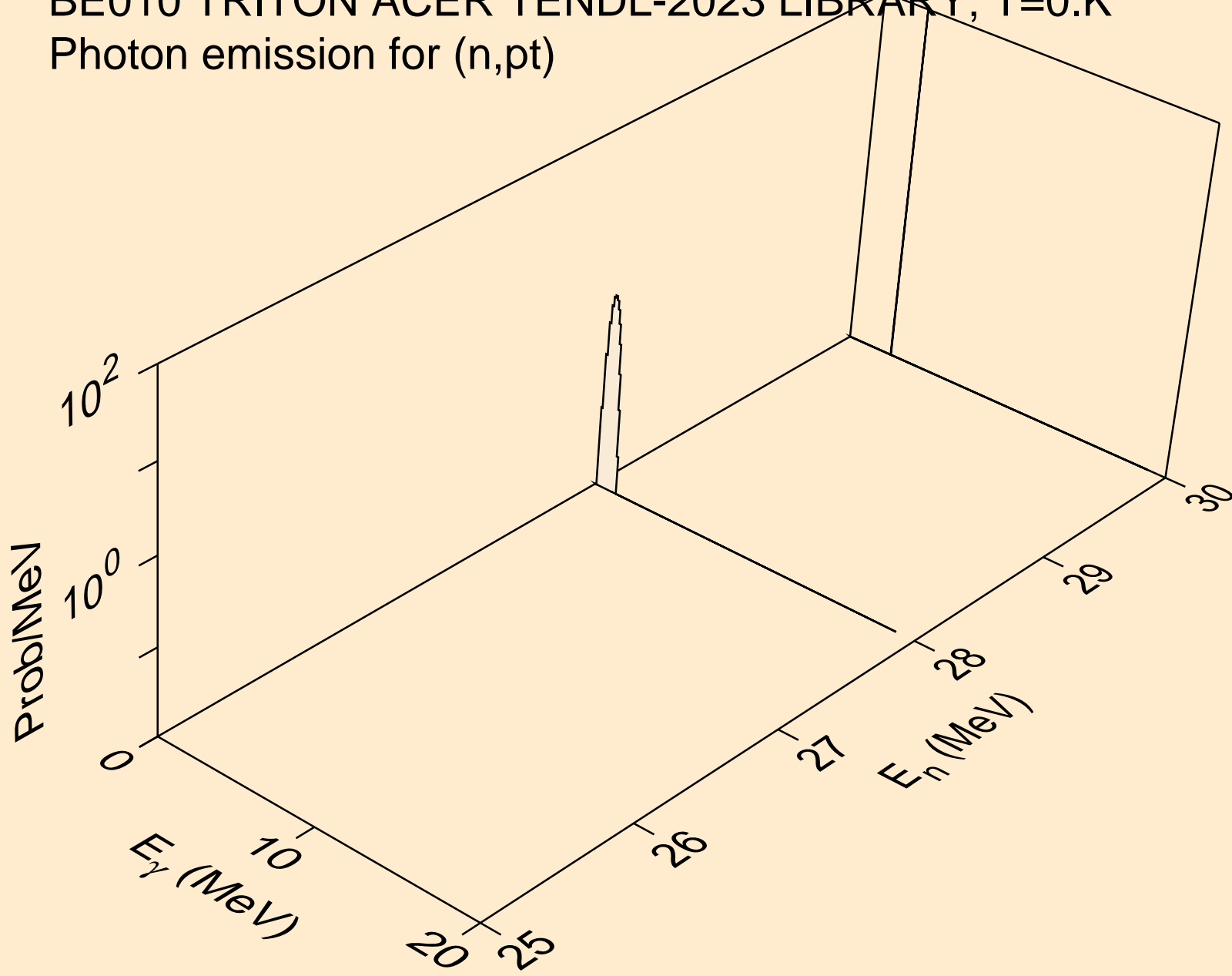

BE010 TRITON ACER TENDL-2023 LIBRARY; T=0.K  
Particle heating contributions

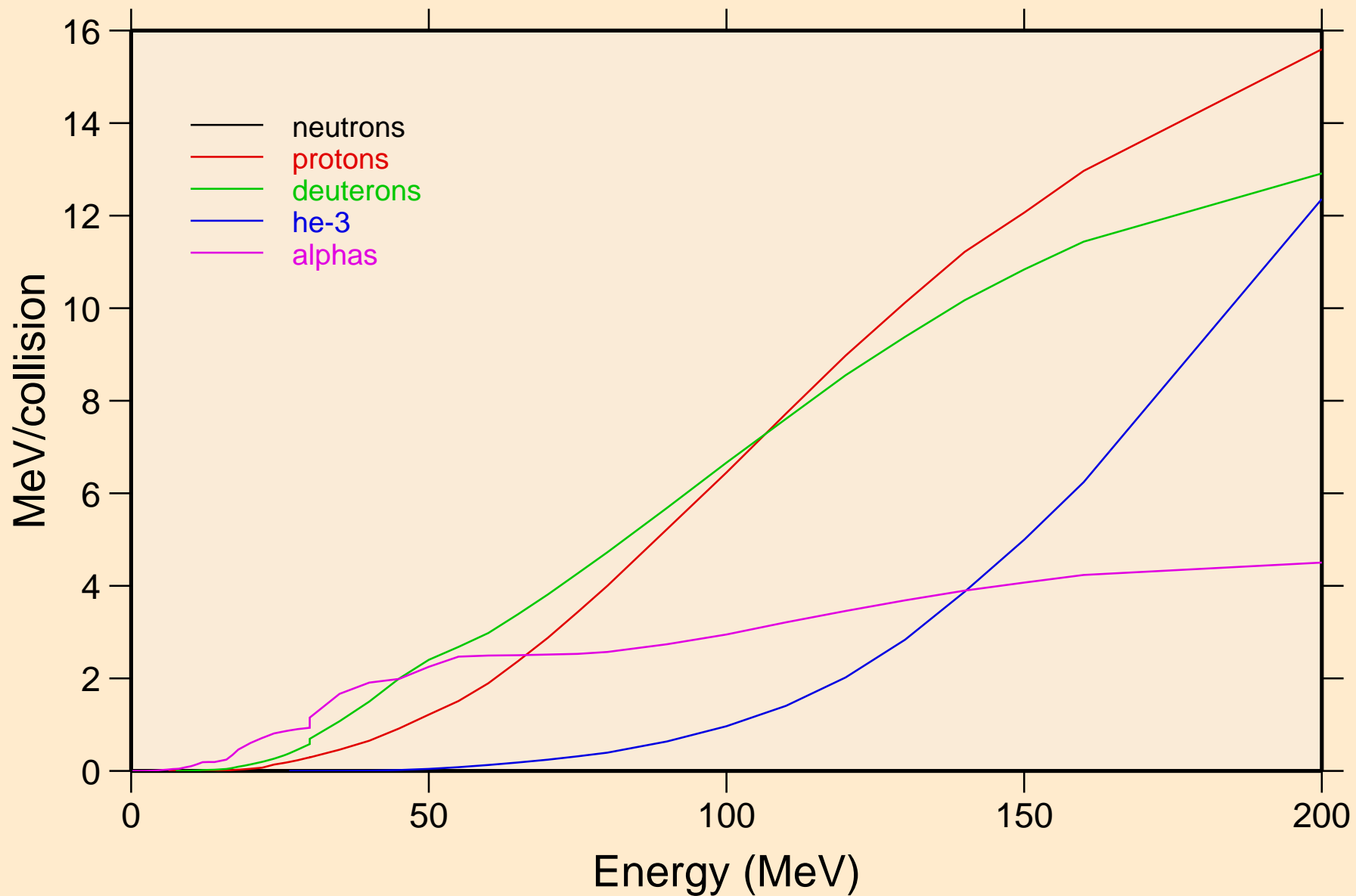

BE010 TRITON ACER TENDL-2023 LIBRARY; T=0.K  
Recoil Heating

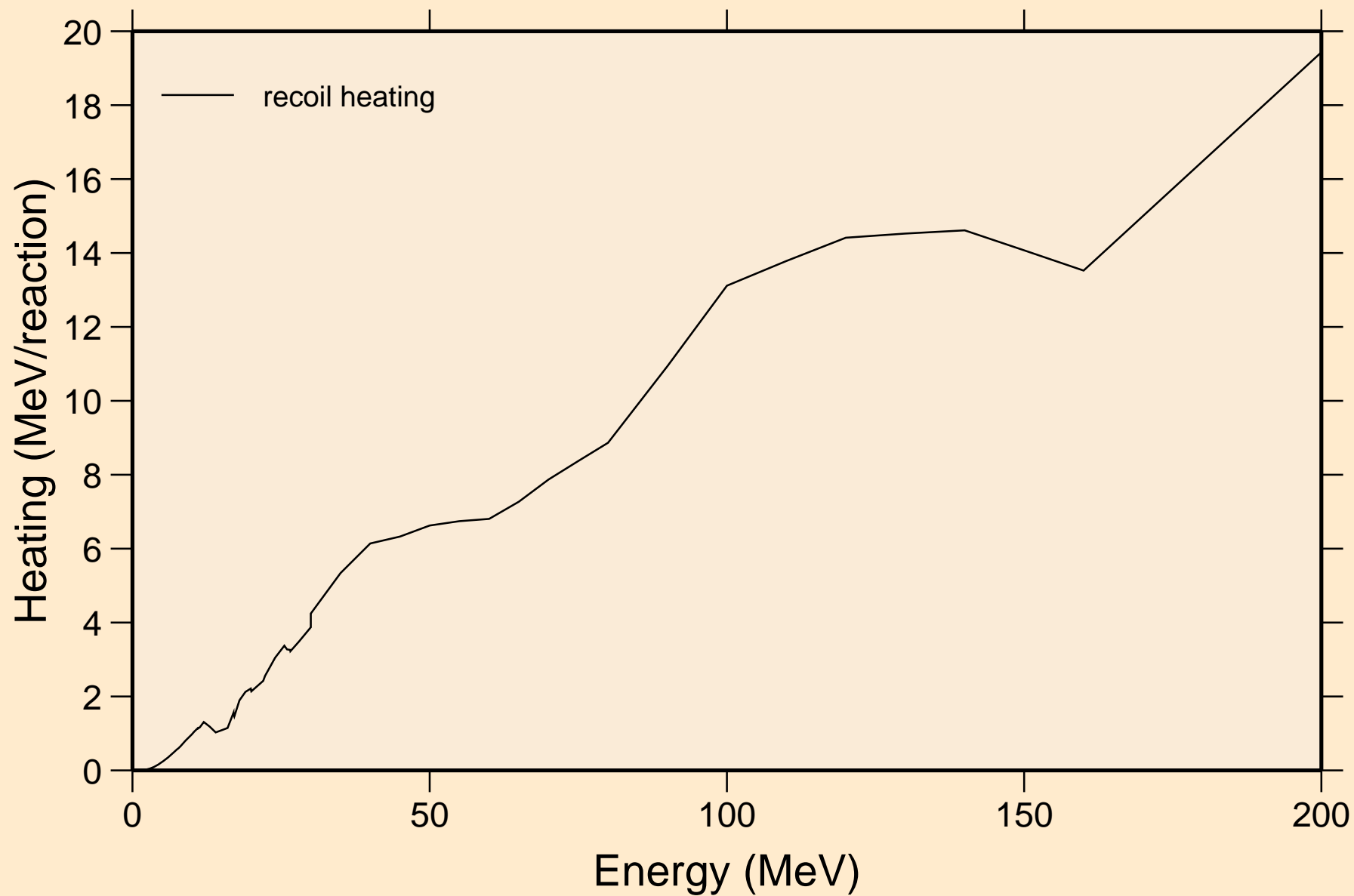

BE010 TRITON ACER TENDL-2023 LIBRARY; T=0.K  
Particle production cross sections

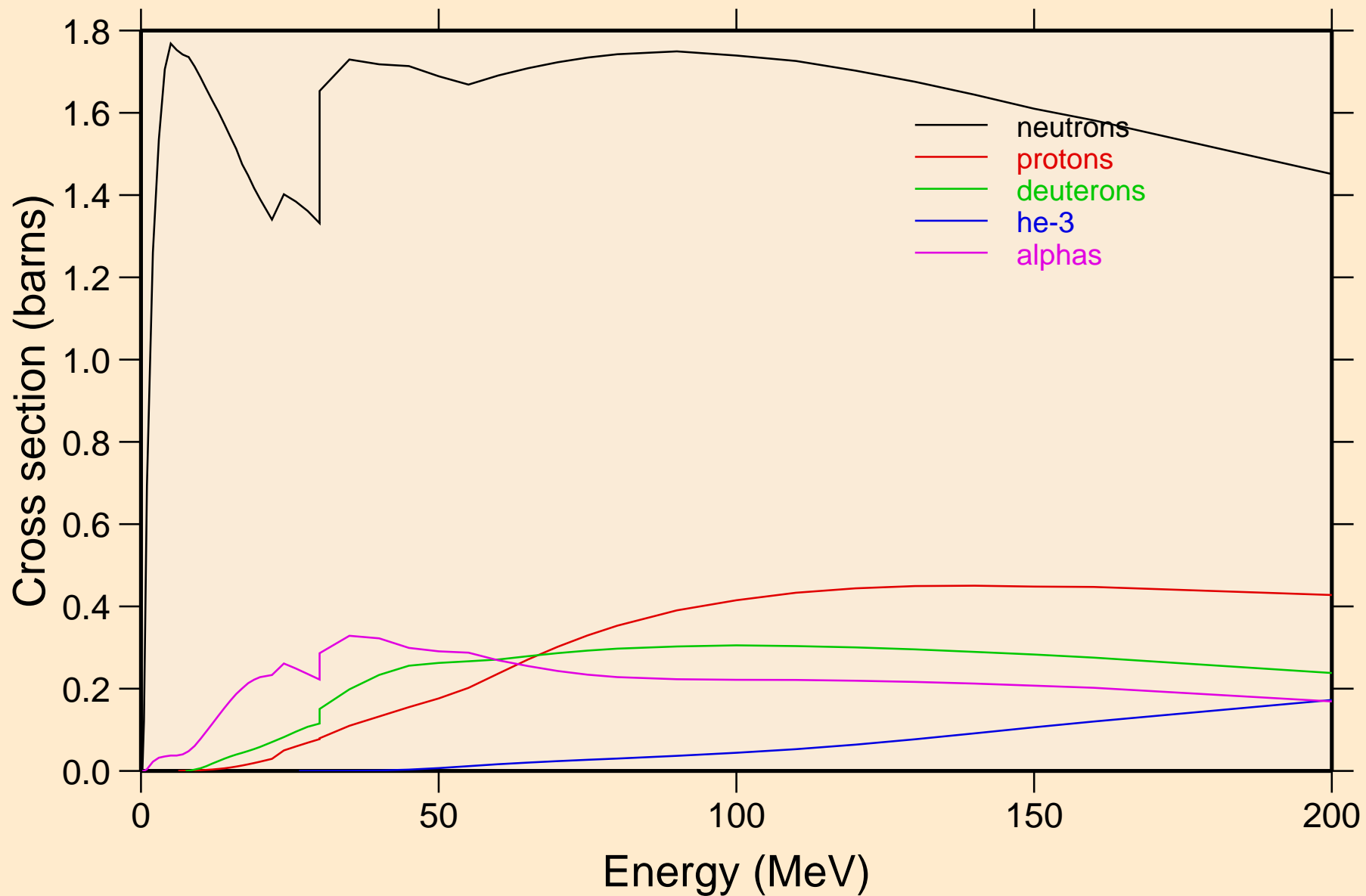

BE010 TRITON ACER TENDL-2023 LIBRARY; T=0.K  
neutrons from (t,n)

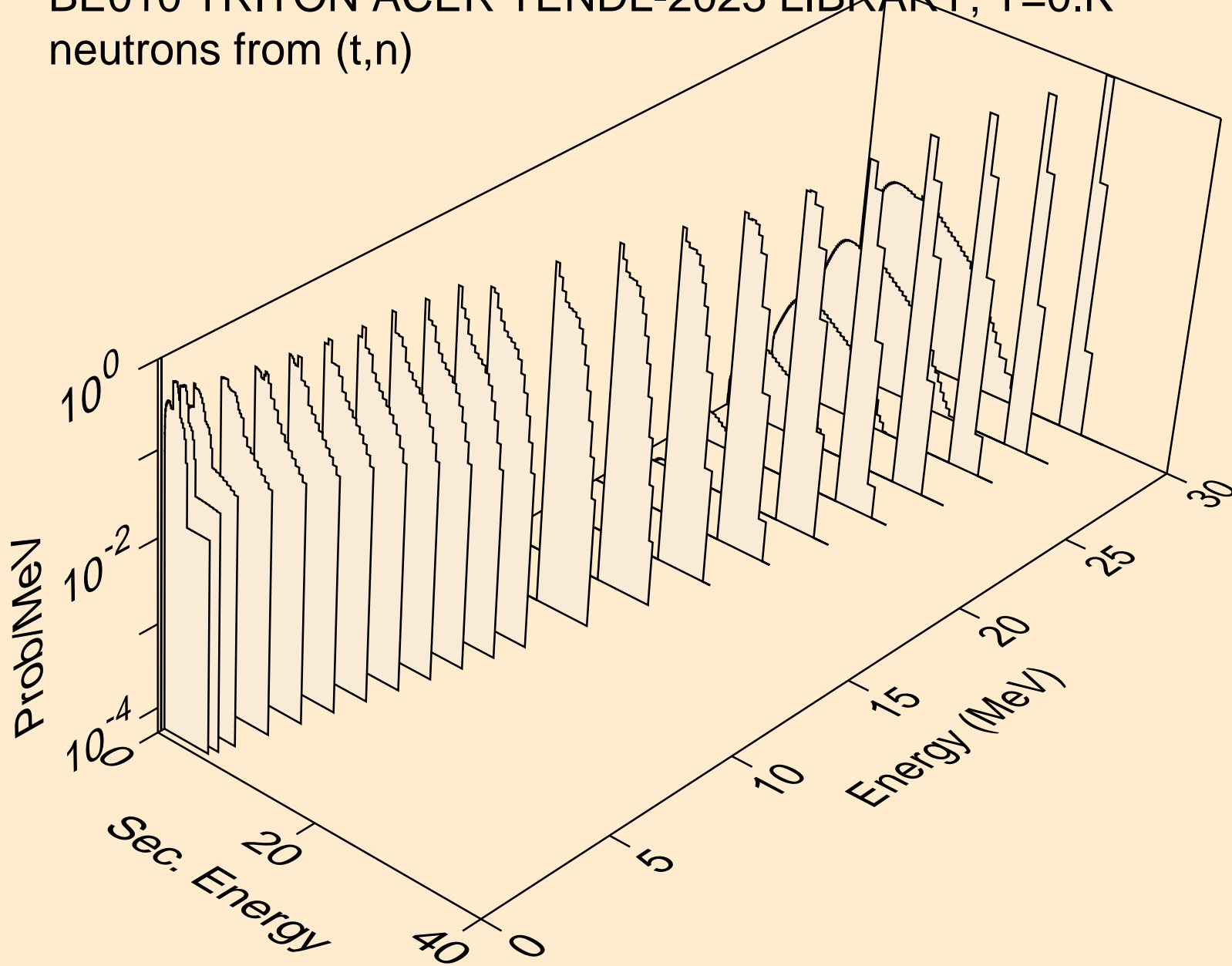

BE010 TRITON ACER TENDL-2023 LIBRARY; T=0.K  
neutrons from (t,x)

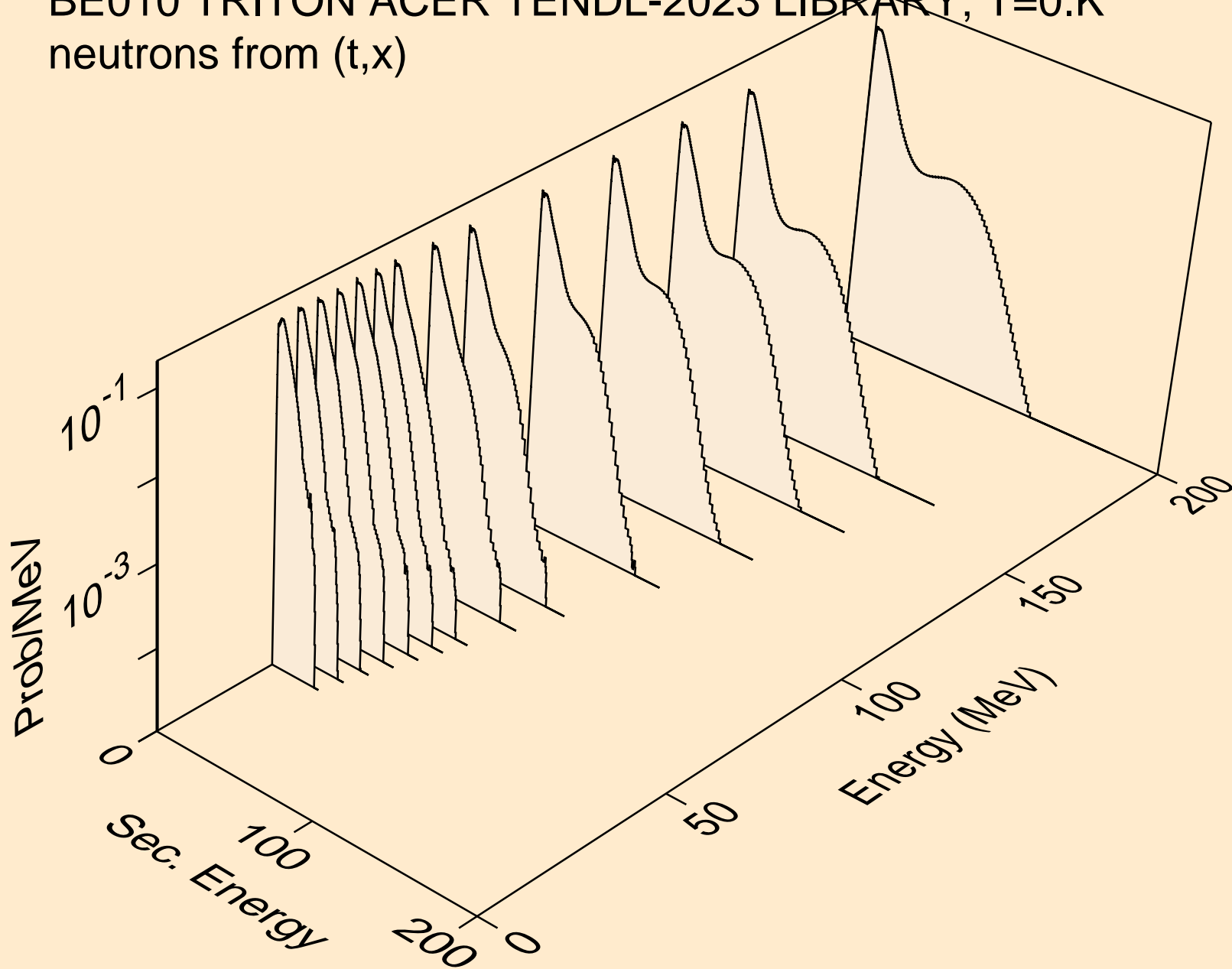

BE010 TRITON ACER TENDL-2023 LIBRARY; T=0.K  
neutrons from (t,2nd)

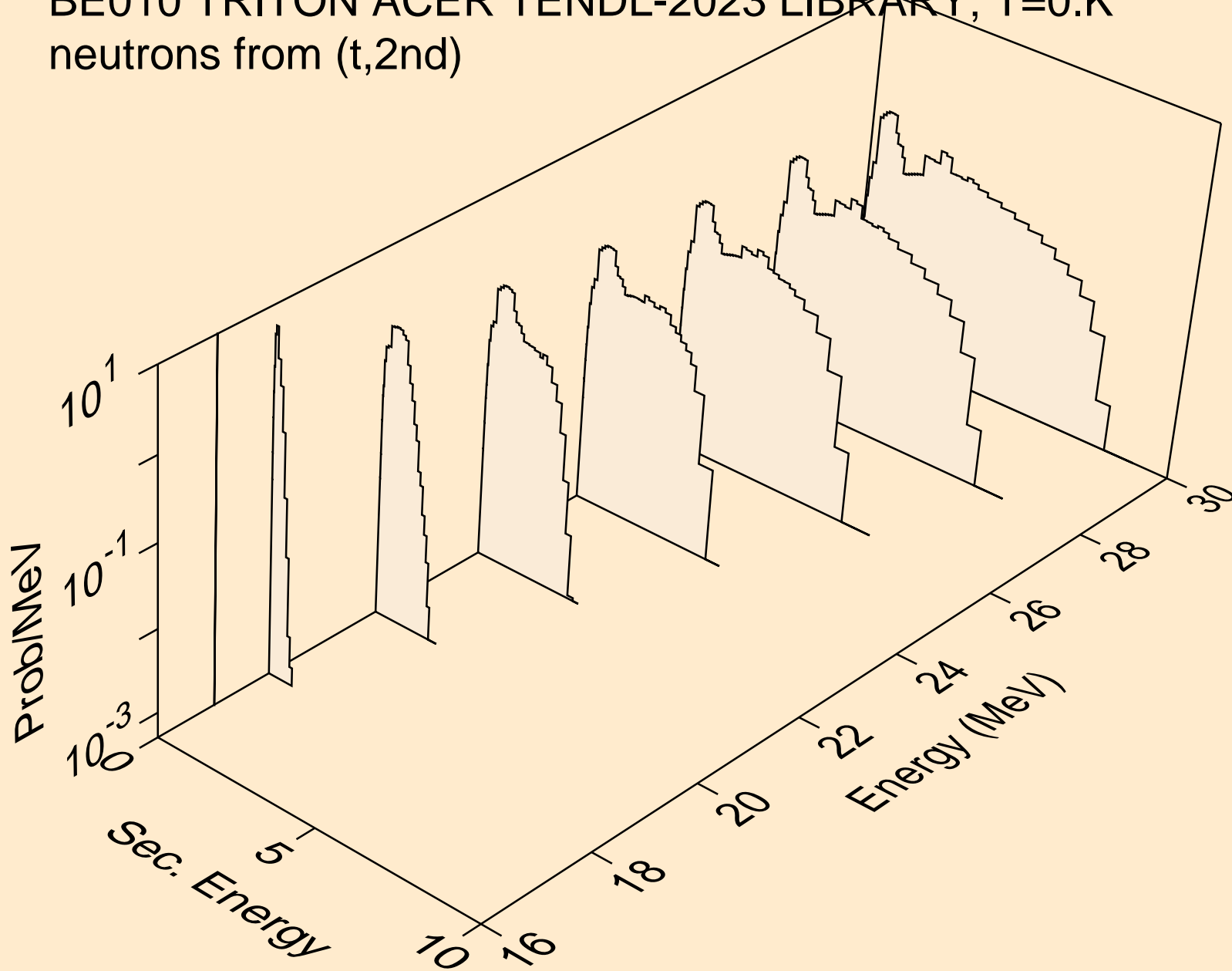

BE010 TRITON ACER TENDL-2023 LIBRARY; T=0.K  
neutrons from (t,2n)

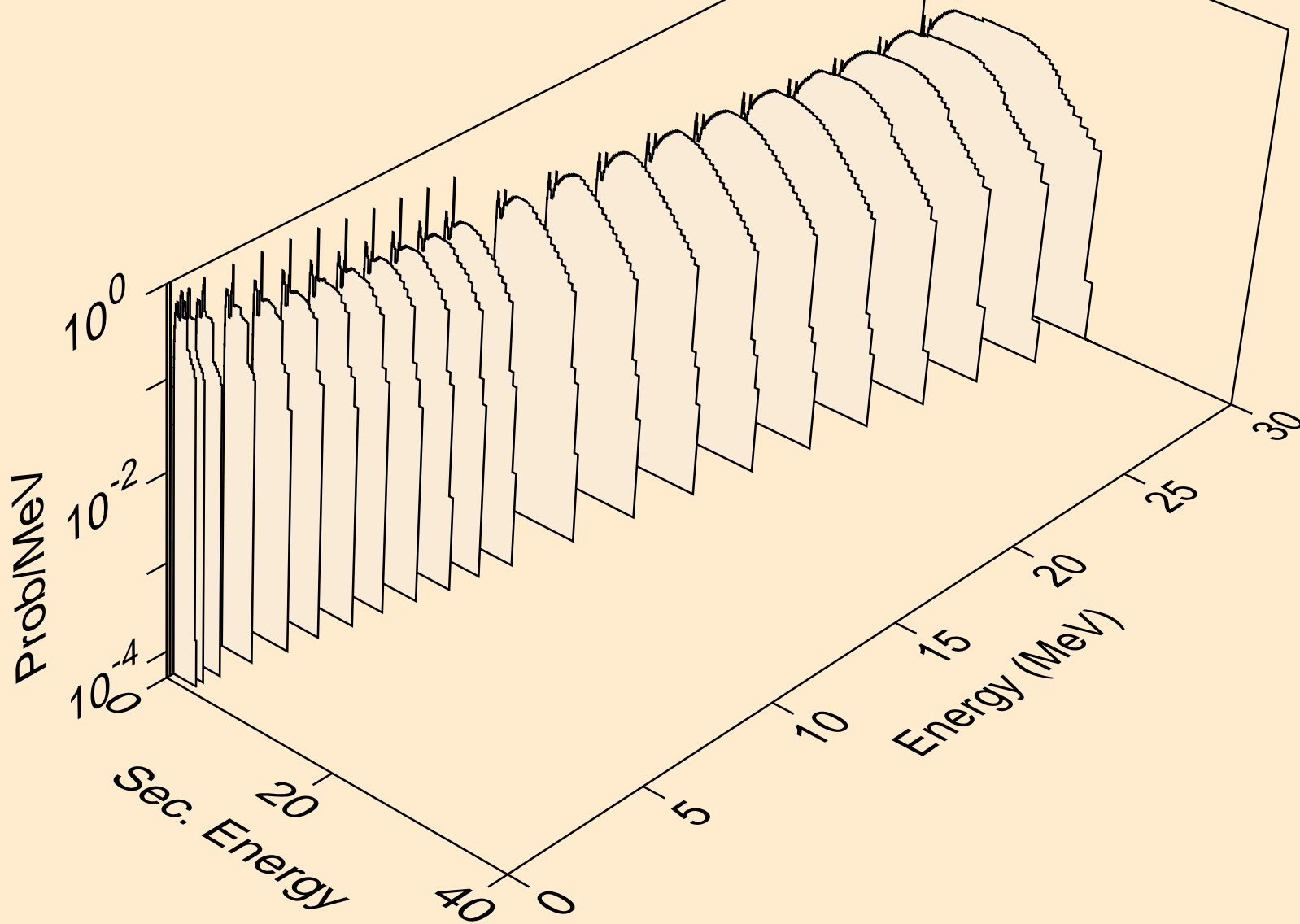



BE010 TRITON ACER TENDL-2023 LIBRARY; T=0.K  
neutrons from (t,3n)

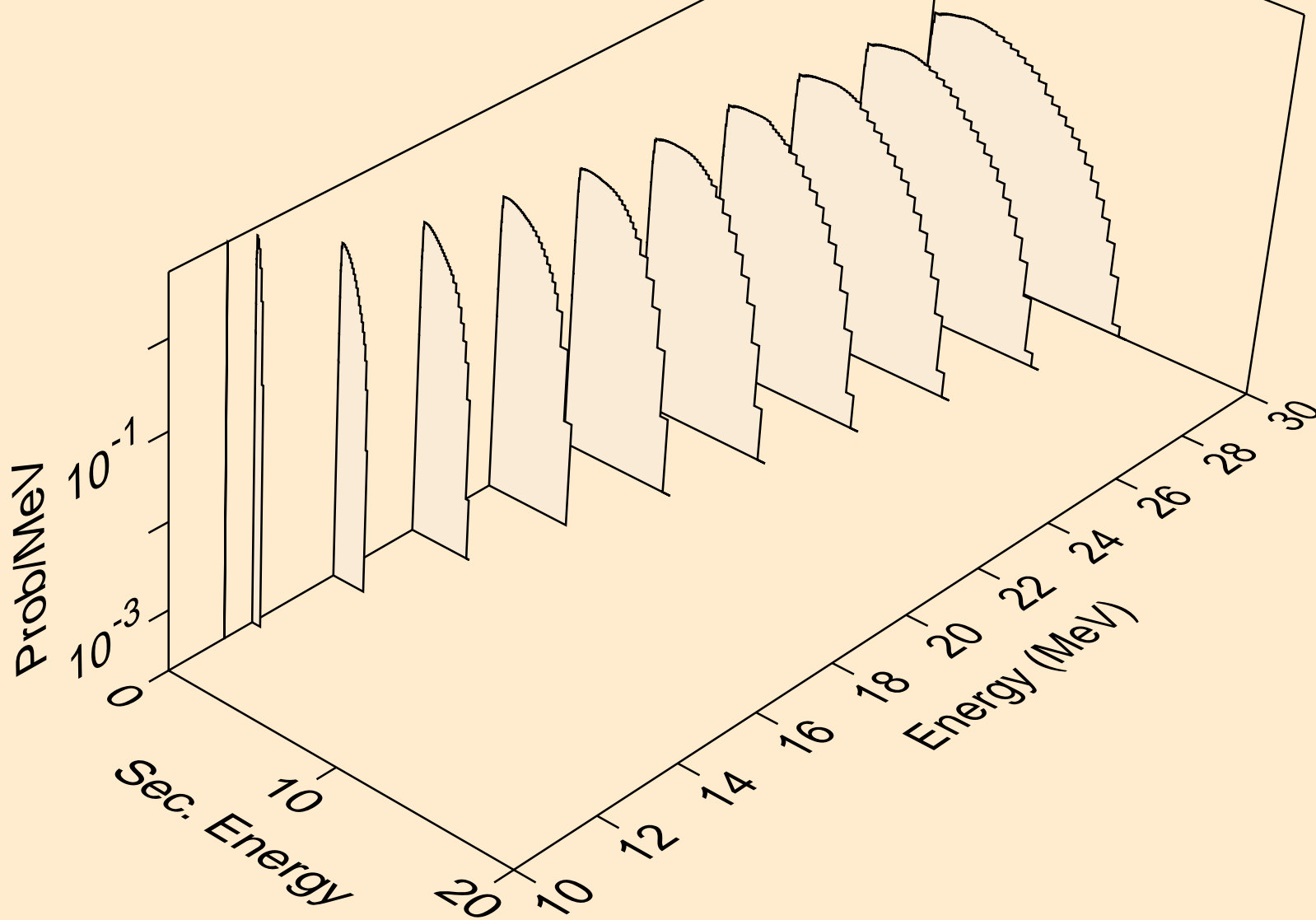

BE010 TRITON ACER TENDL-2023 LIBRARY; T=0.K  
neutrons from (t,n\*)a

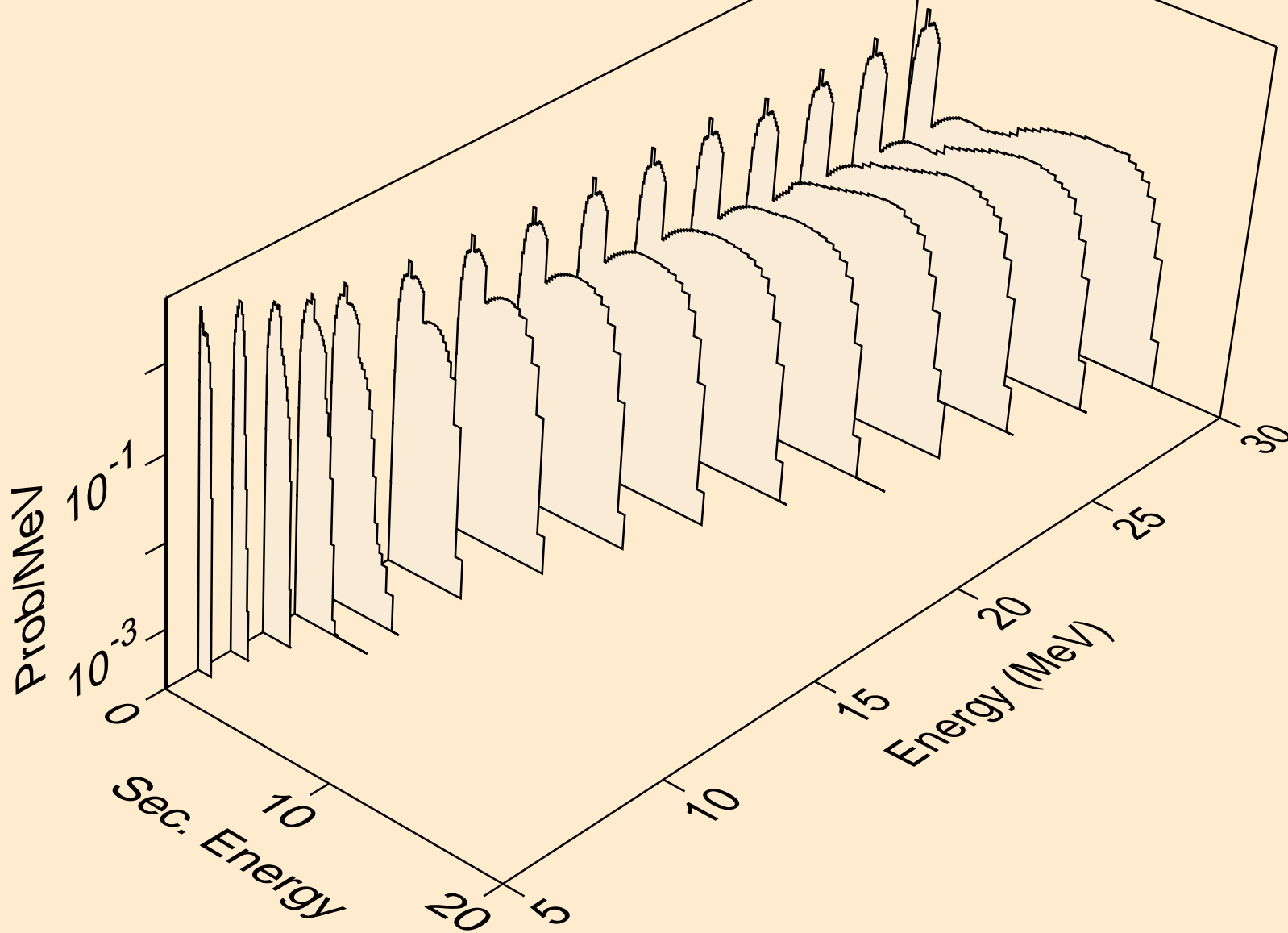

BE010 TRITON ACER TENDL-2023 LIBRARY; T=0.K  
neutrons from (t,2n)a

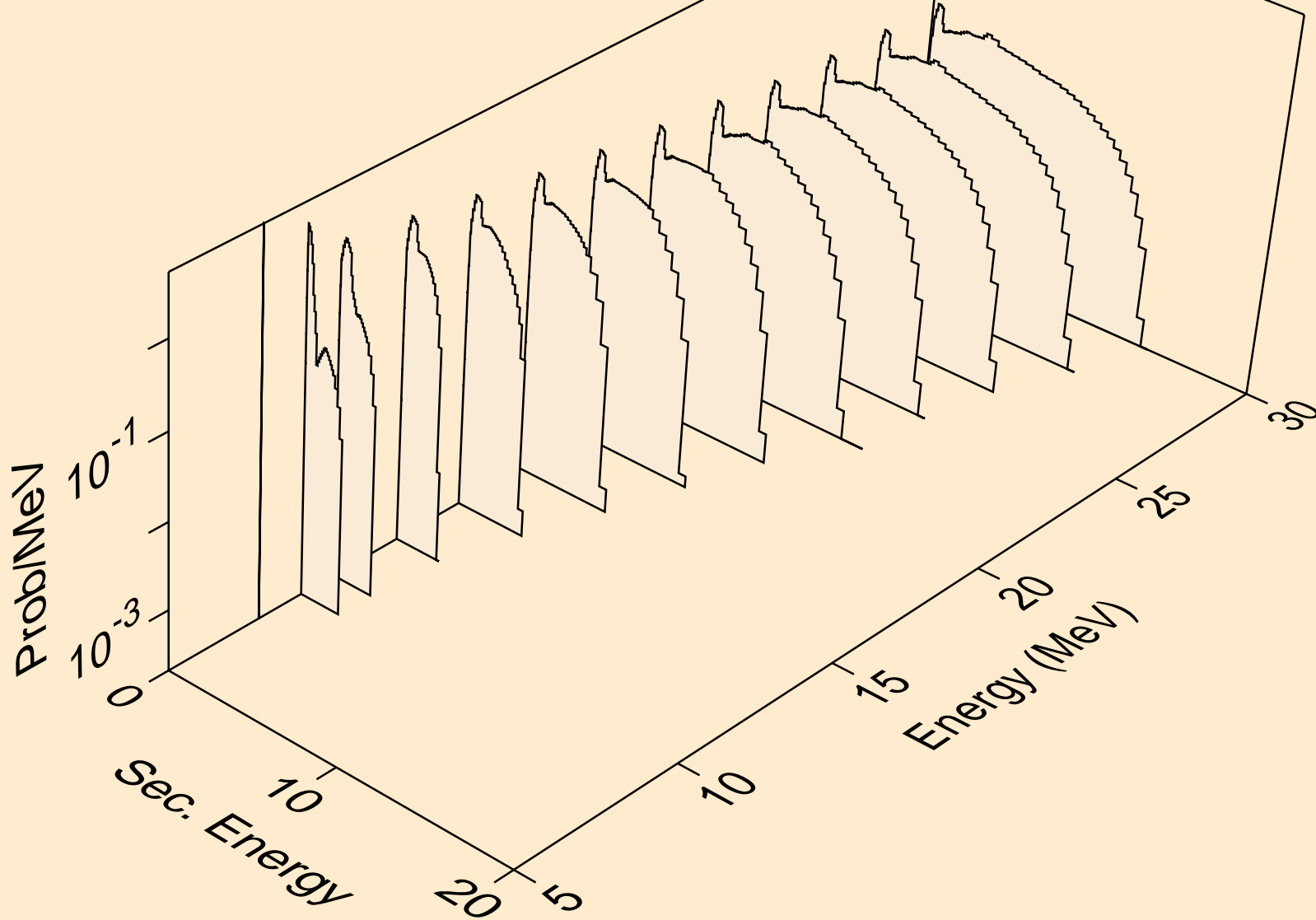

BE010 TRITON ACER TENDL-2023 LIBRARY; T=0.K  
neutrons from (t,3n)a

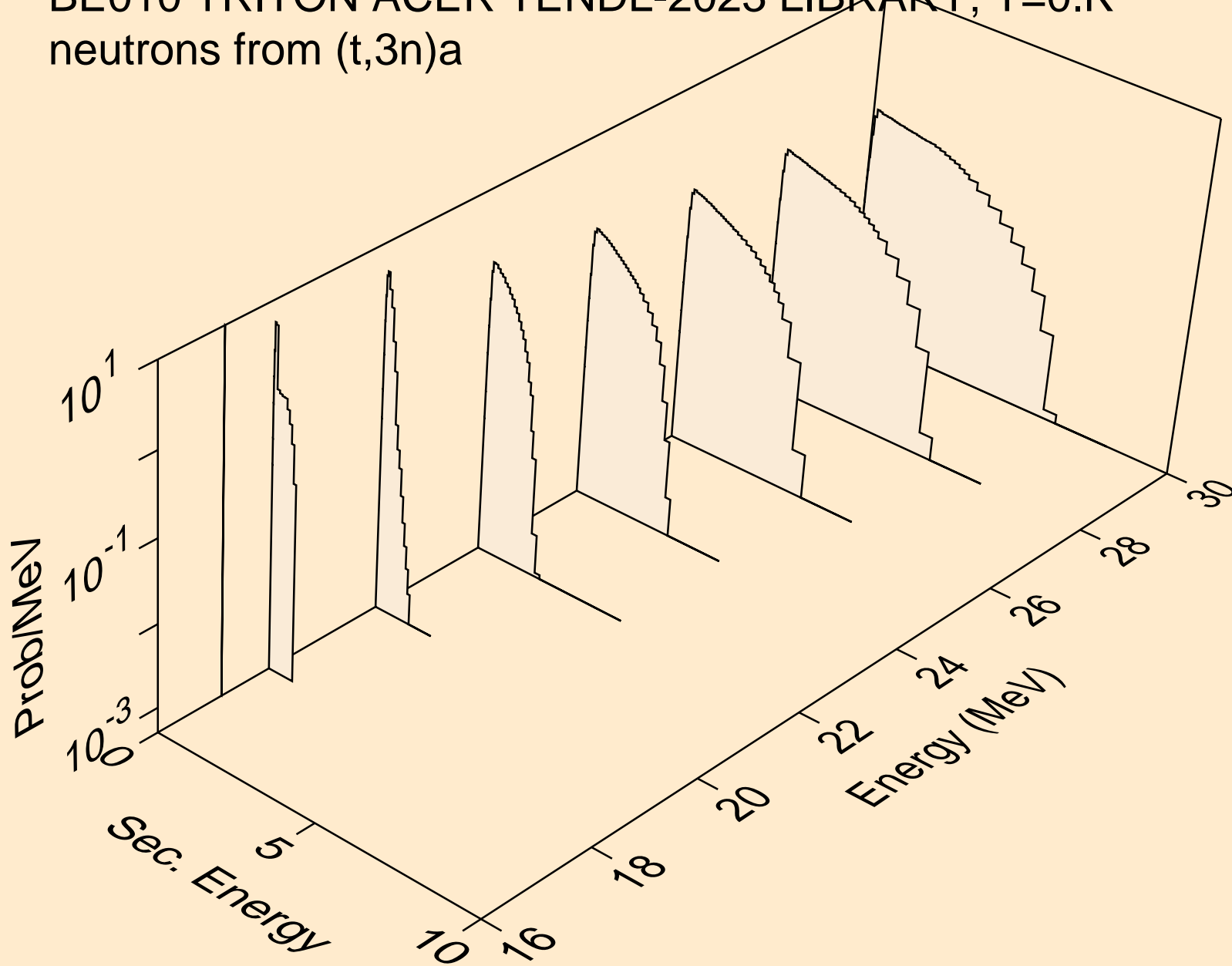

BE010 TRITON ACER TENDL-2023 LIBRARY; T=0.K  
neutrons from (t,n\*)p

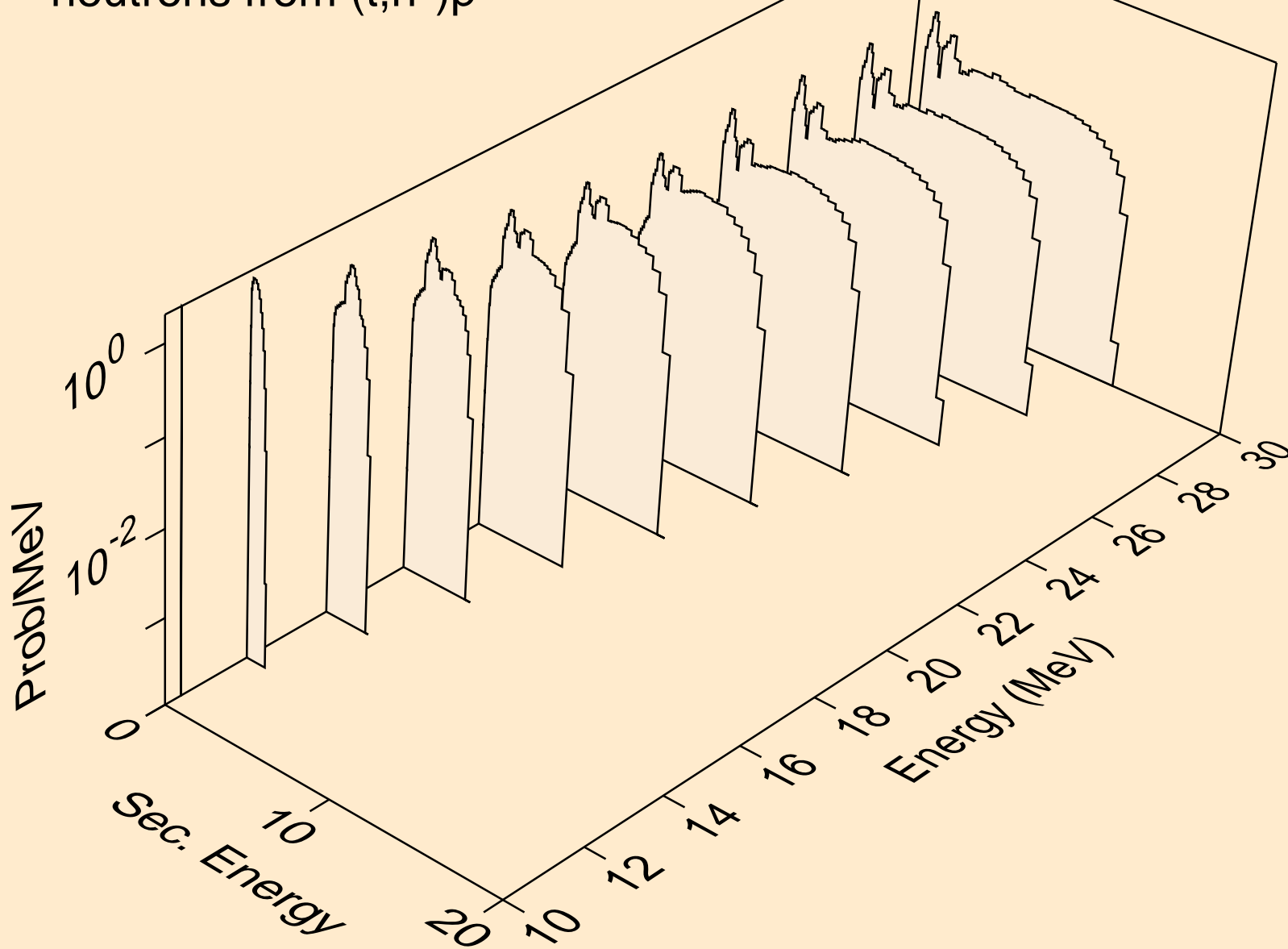

BE010 TRITON ACER TENDL-2023 LIBRARY; T=0.K  
neutrons from (t,n\*)d

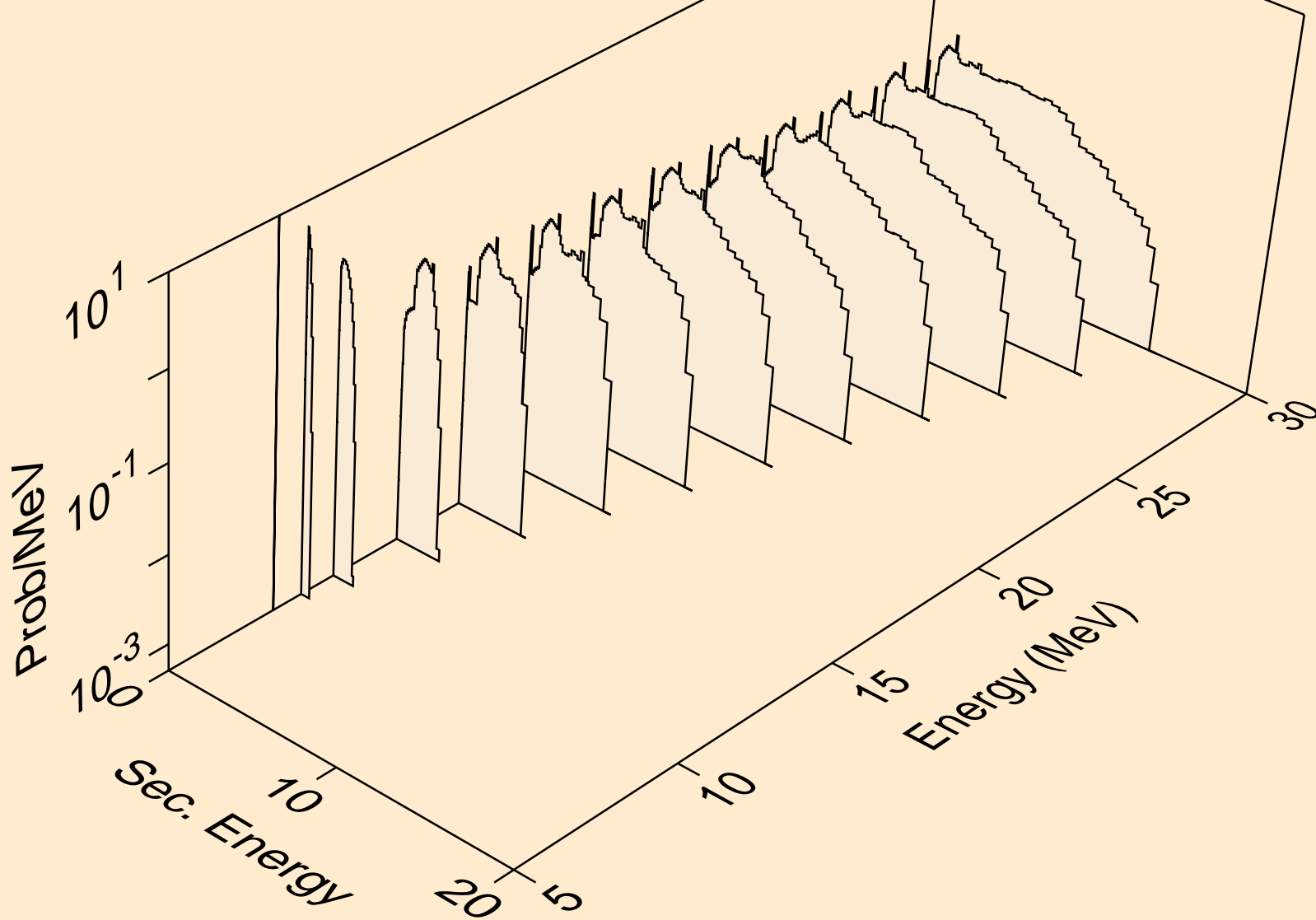

BE010 TRITON ACER TENDL-2023 LIBRARY; T=0.K  
neutrons from (t,n\*)t

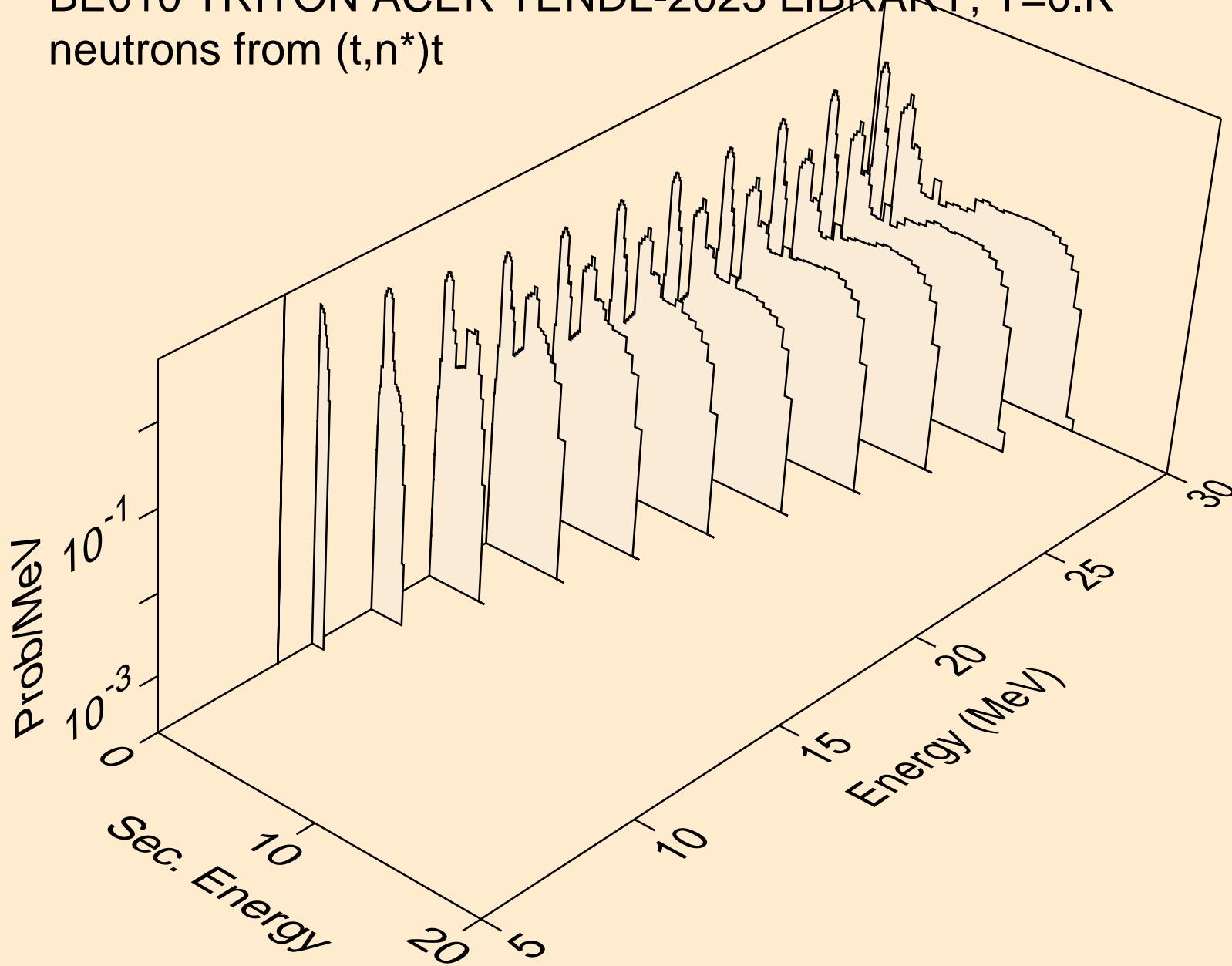

BE010 TRITON ACER TENDL-2023 LIBRARY; T=0.K  
neutrons from (t,n\*)he3

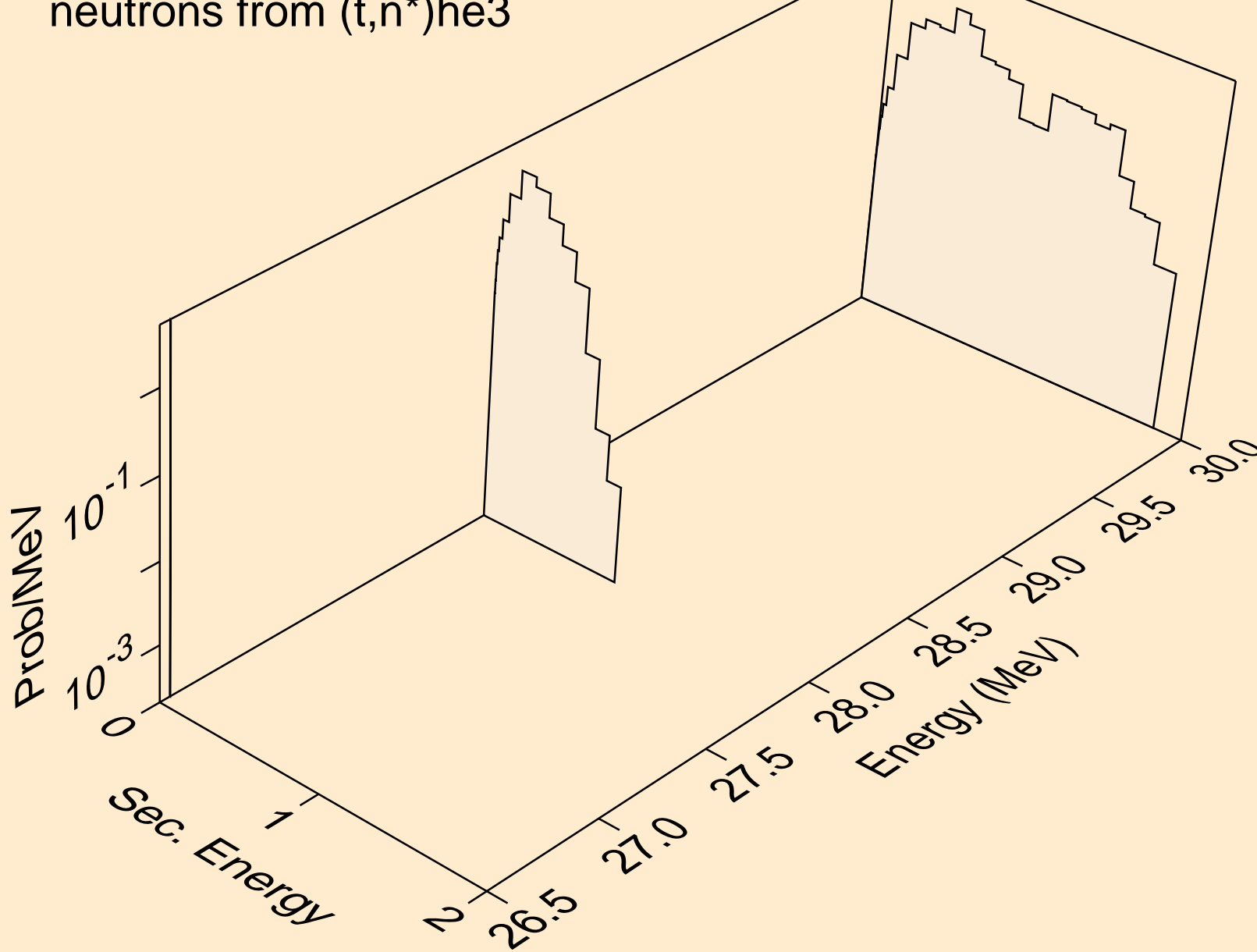



BE010 TRITON ACER TENDL-2023 LIBRARY; T=0.K  
neutrons from (t,4n)

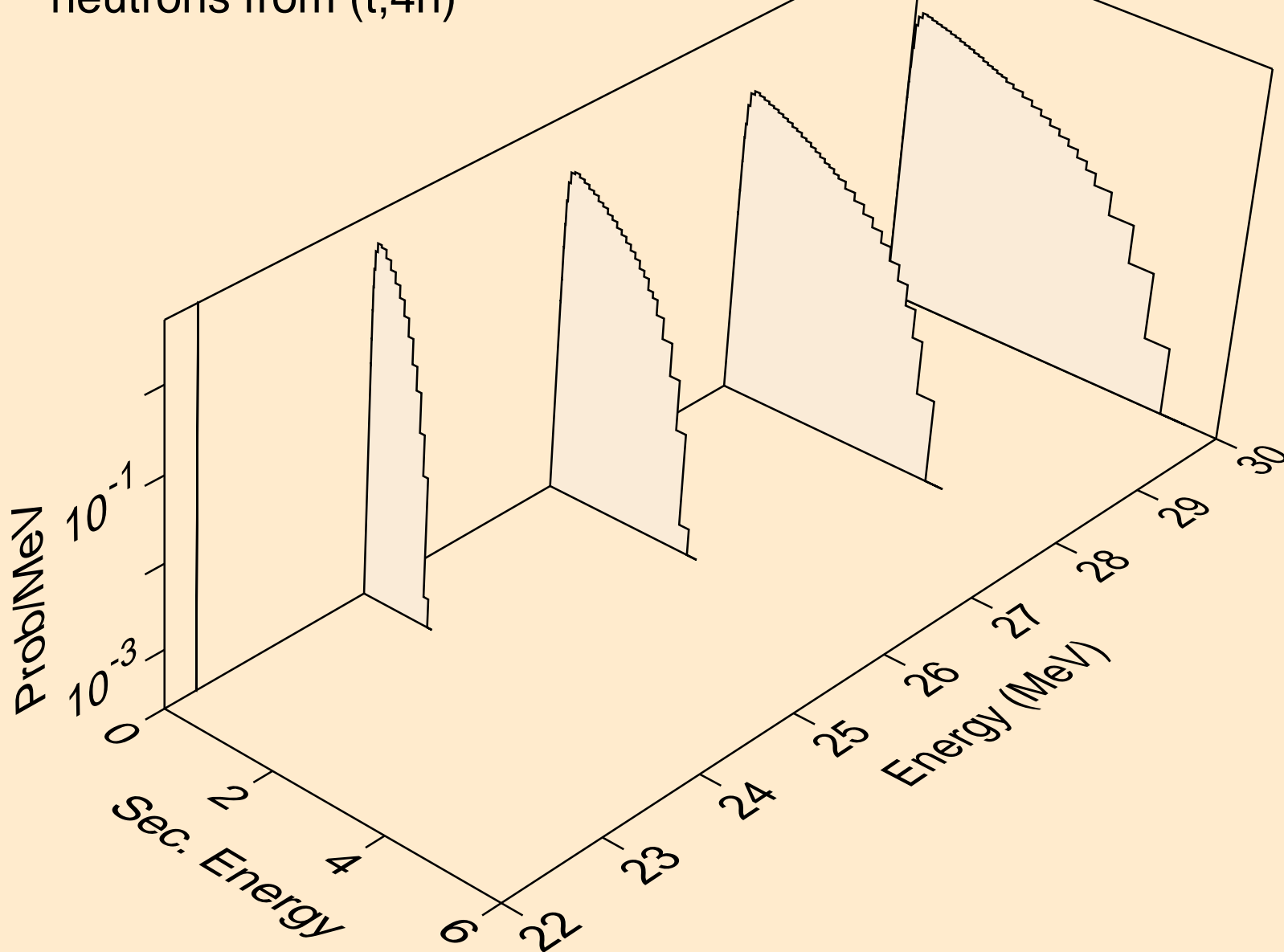

BE010 TRITON ACER TENDL-2023 LIBRARY; T=0.K  
neutrons from (t,2np)

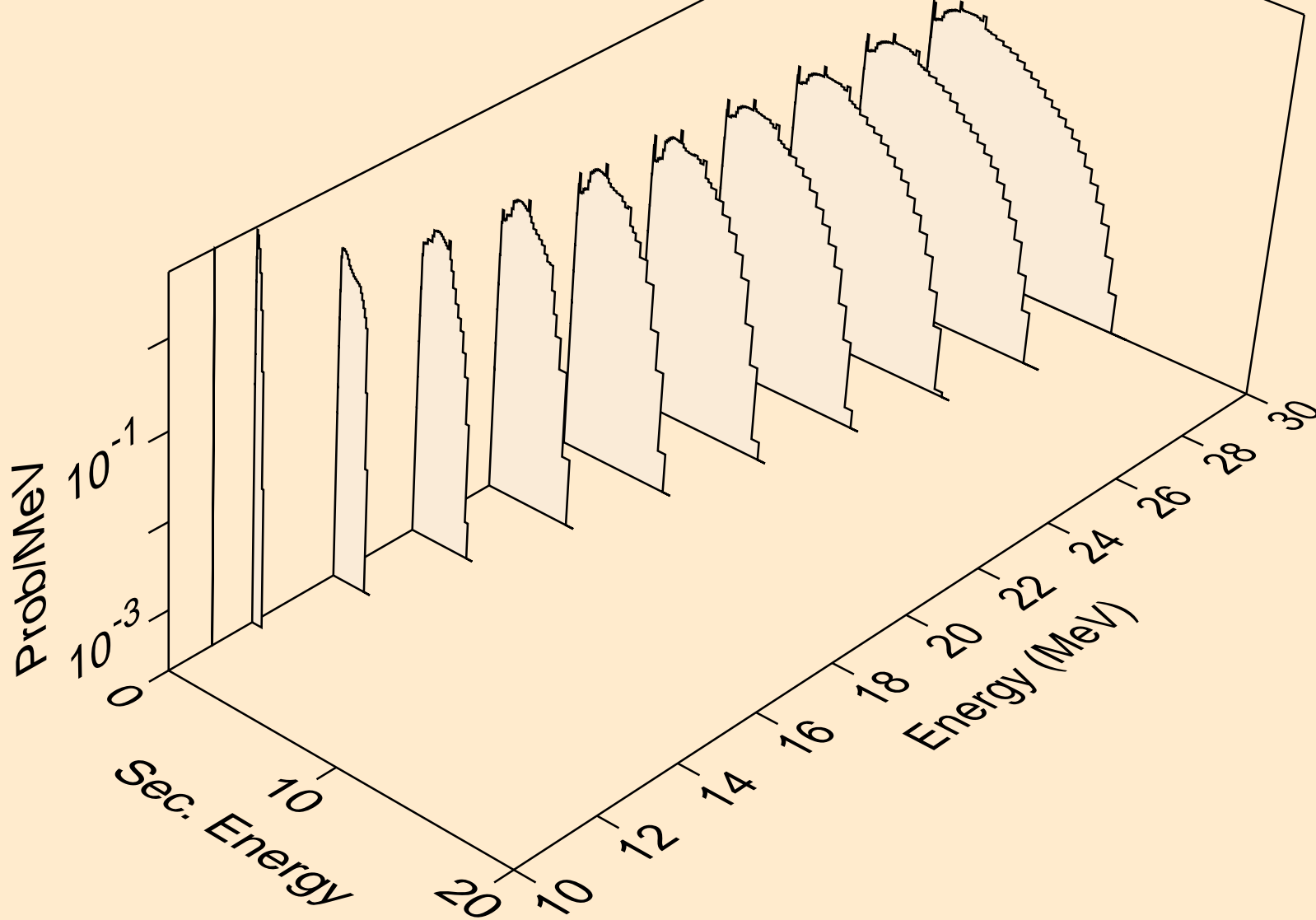

BE010 TRITON ACER TENDL-2023 LIBRARY; T=0.K  
neutrons from (t,3np)

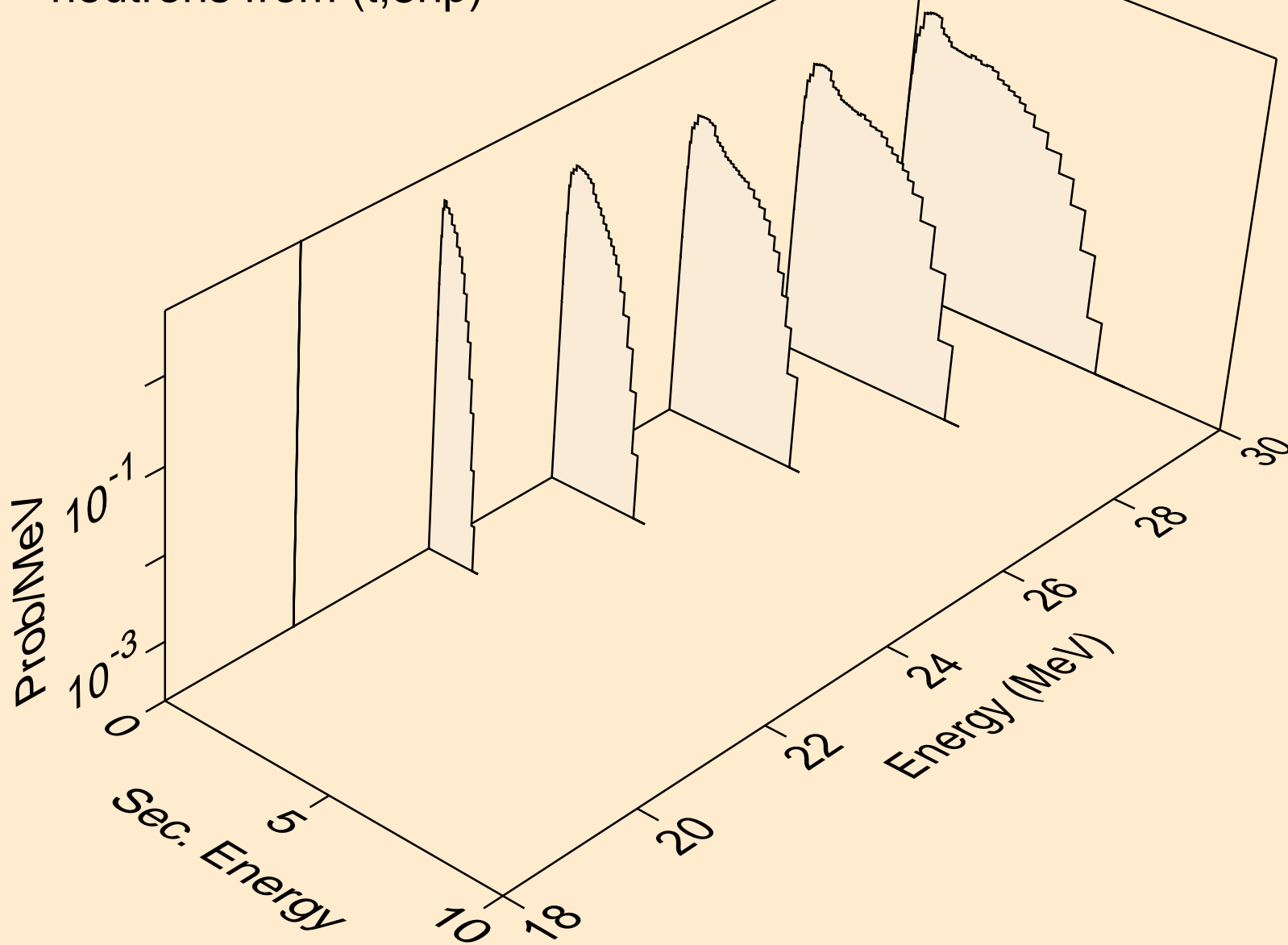

BE010 TRITON ACER TENDL-2023 LIBRARY; T=0.K  
protons from (t,x)

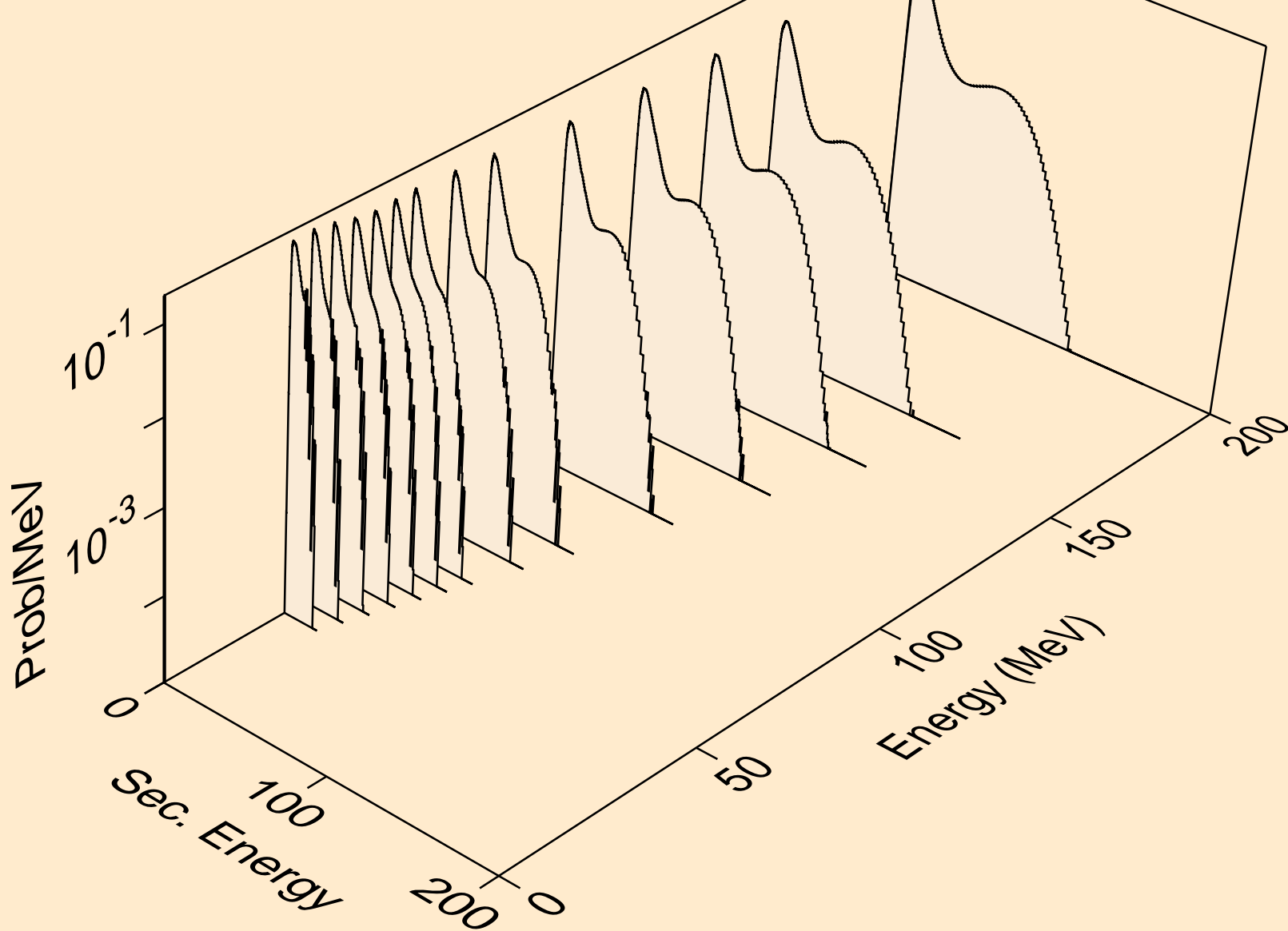

BE010 TRITON ACER TENDL-2023 LIBRARY; T=0.K  
protons from (t,n\*)p

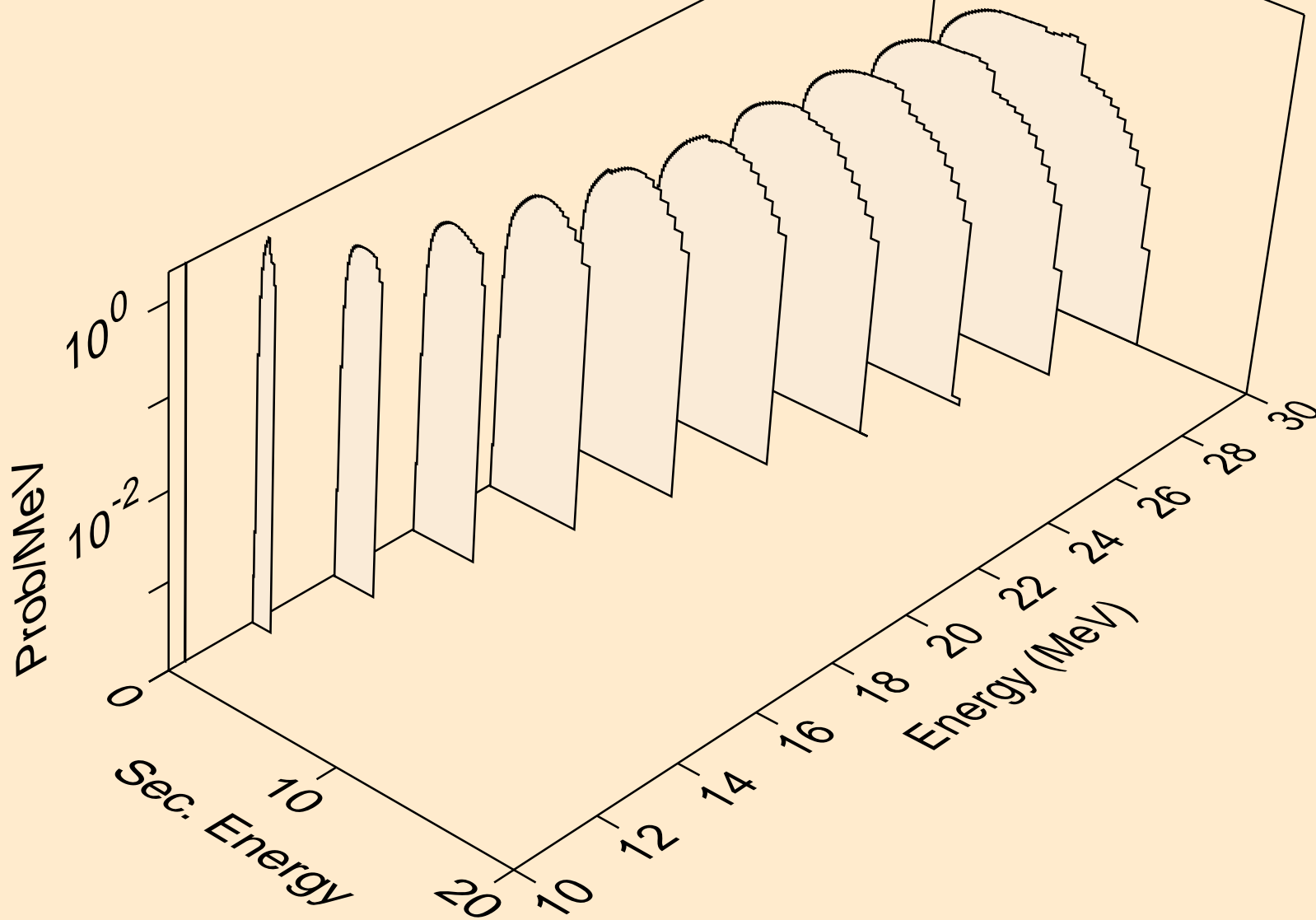

BE010 TRITON ACER TENDL-2023 LIBRARY; T=0.K  
protons from (t,2np)

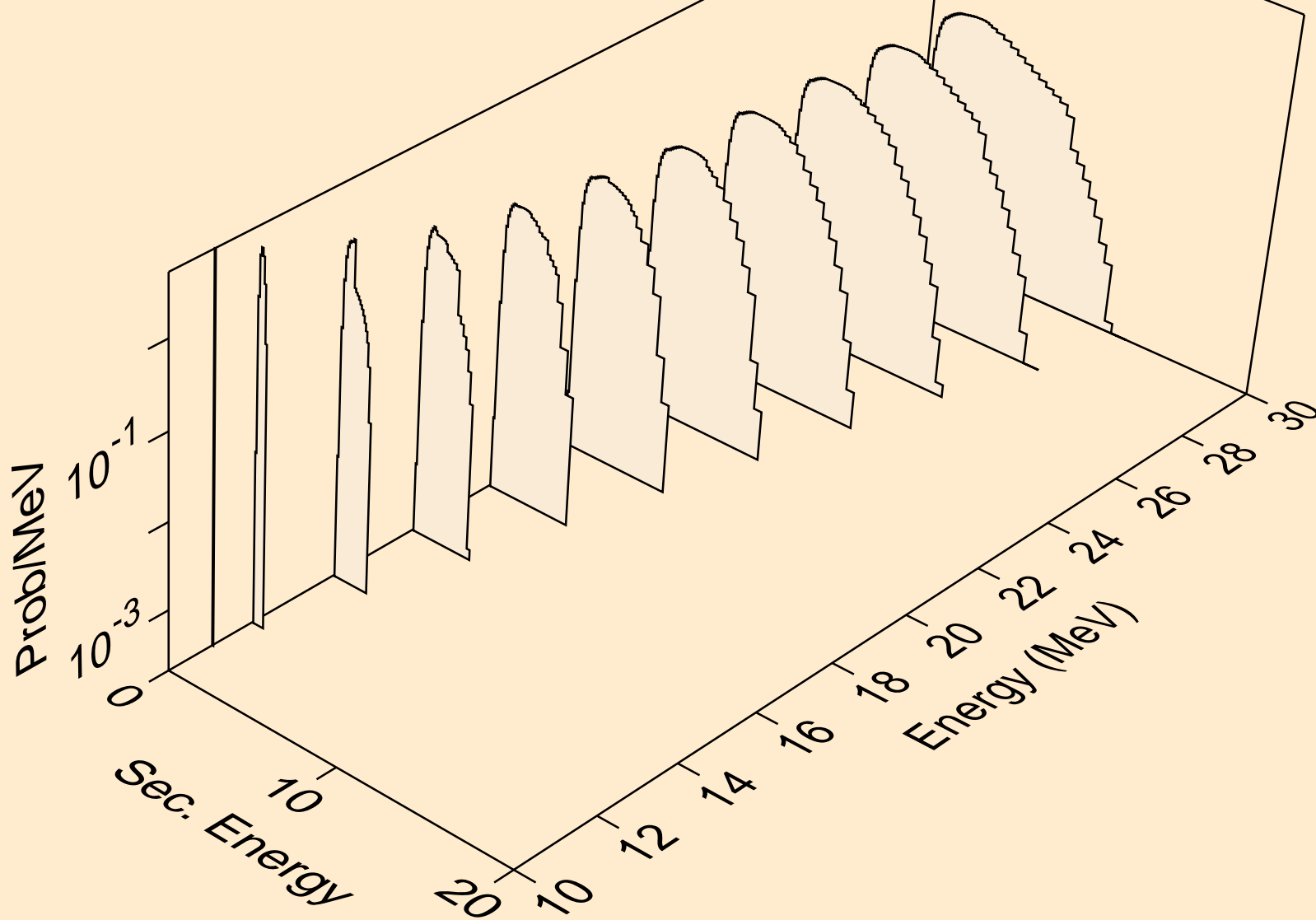

BE010 TRITON ACER TENDL-2023 LIBRARY; T=0.K  
protons from (t,3np)

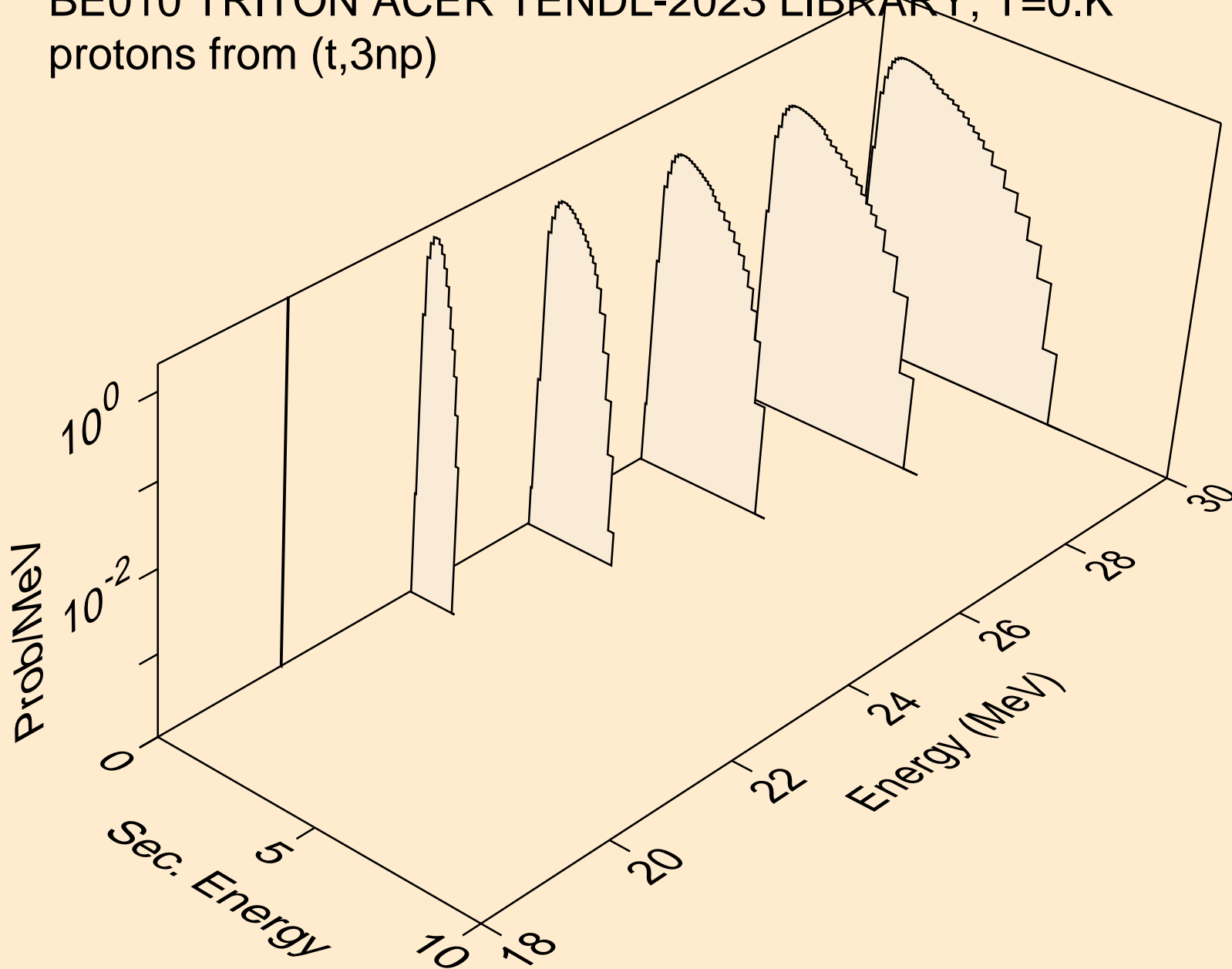

BE010 TRITON ACER TENDL-2023 LIBRARY; T=0.K  
protons from (t,p)

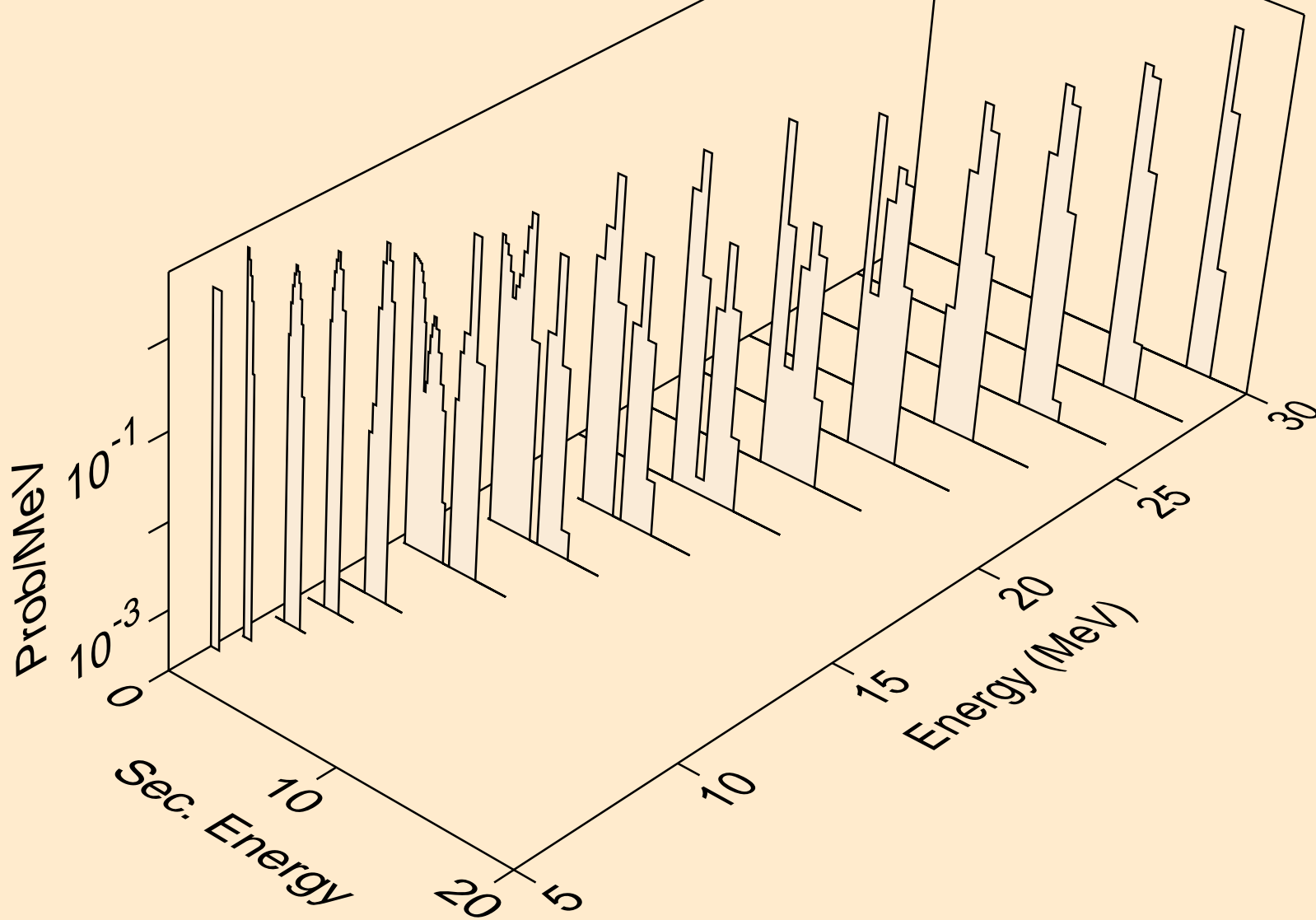



BE010 TRITON ACER TENDL-2023 LIBRARY; T=0.K  
protons from (t,pt)

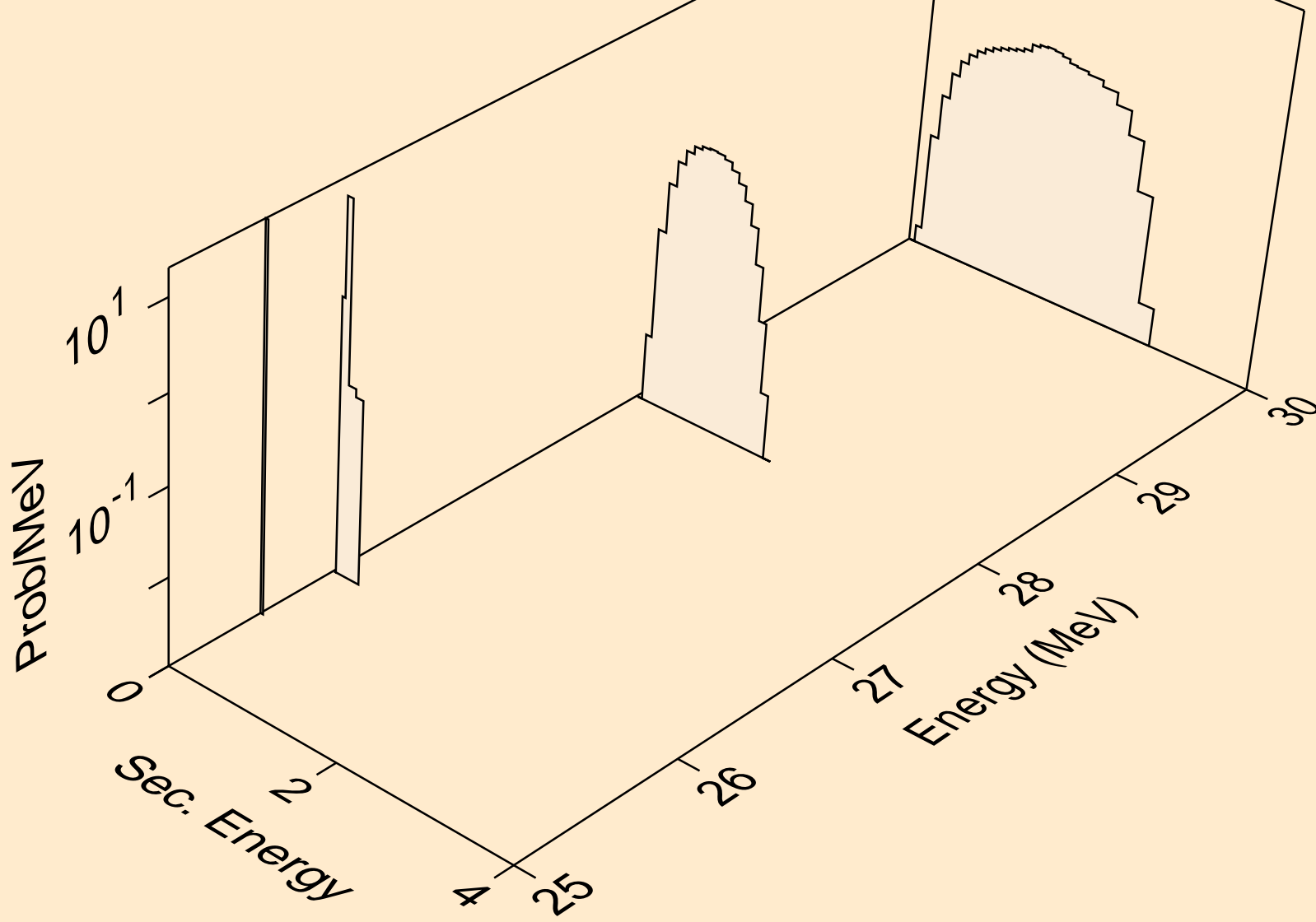

BE010 TRITON ACER TENDL-2023 LIBRARY; T=0.K  
deuterons from (t,x)

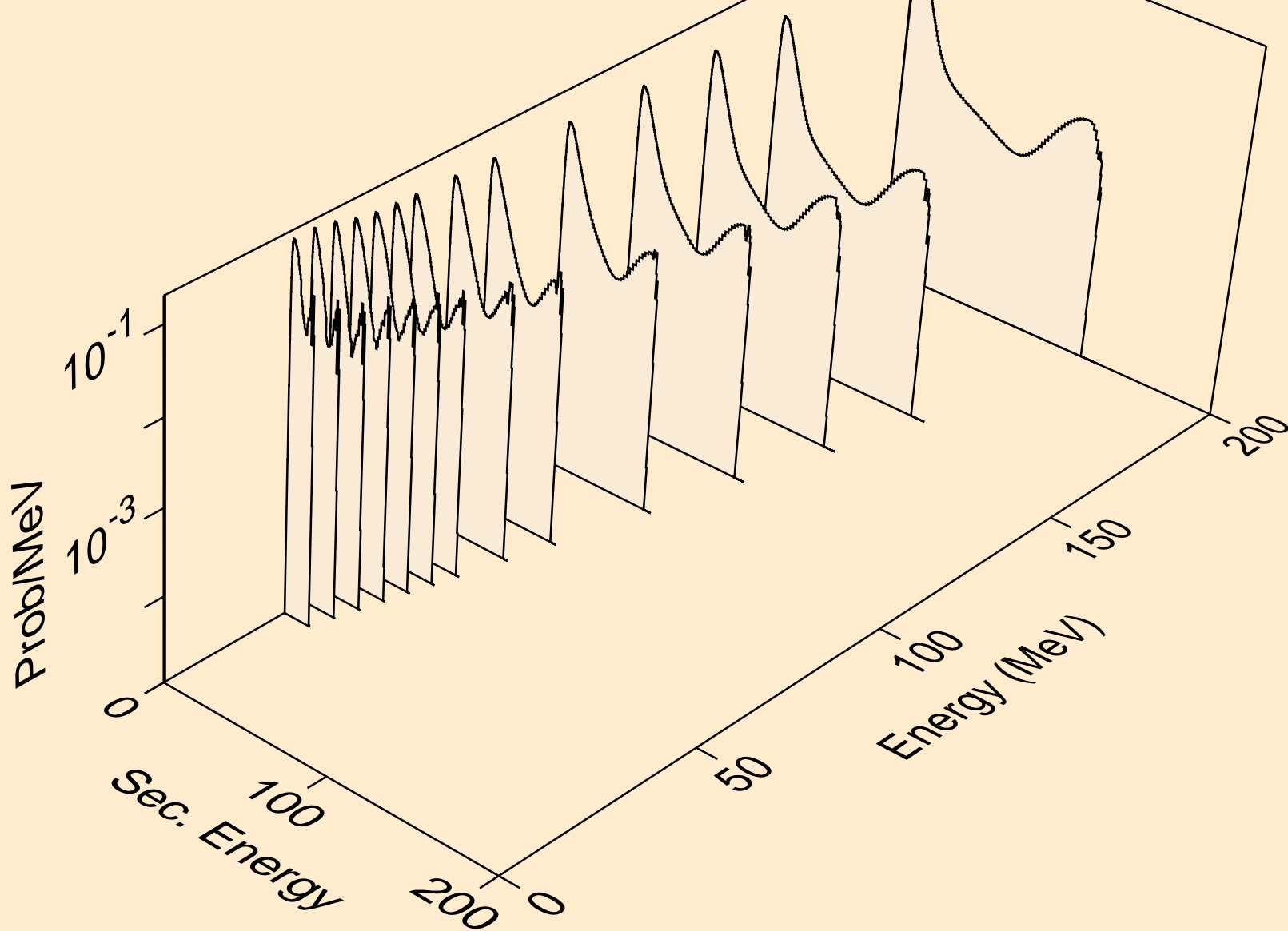

BE010 TRITON ACER TENDL-2023 LIBRARY; T=0.K  
deuterons from (t,2nd)

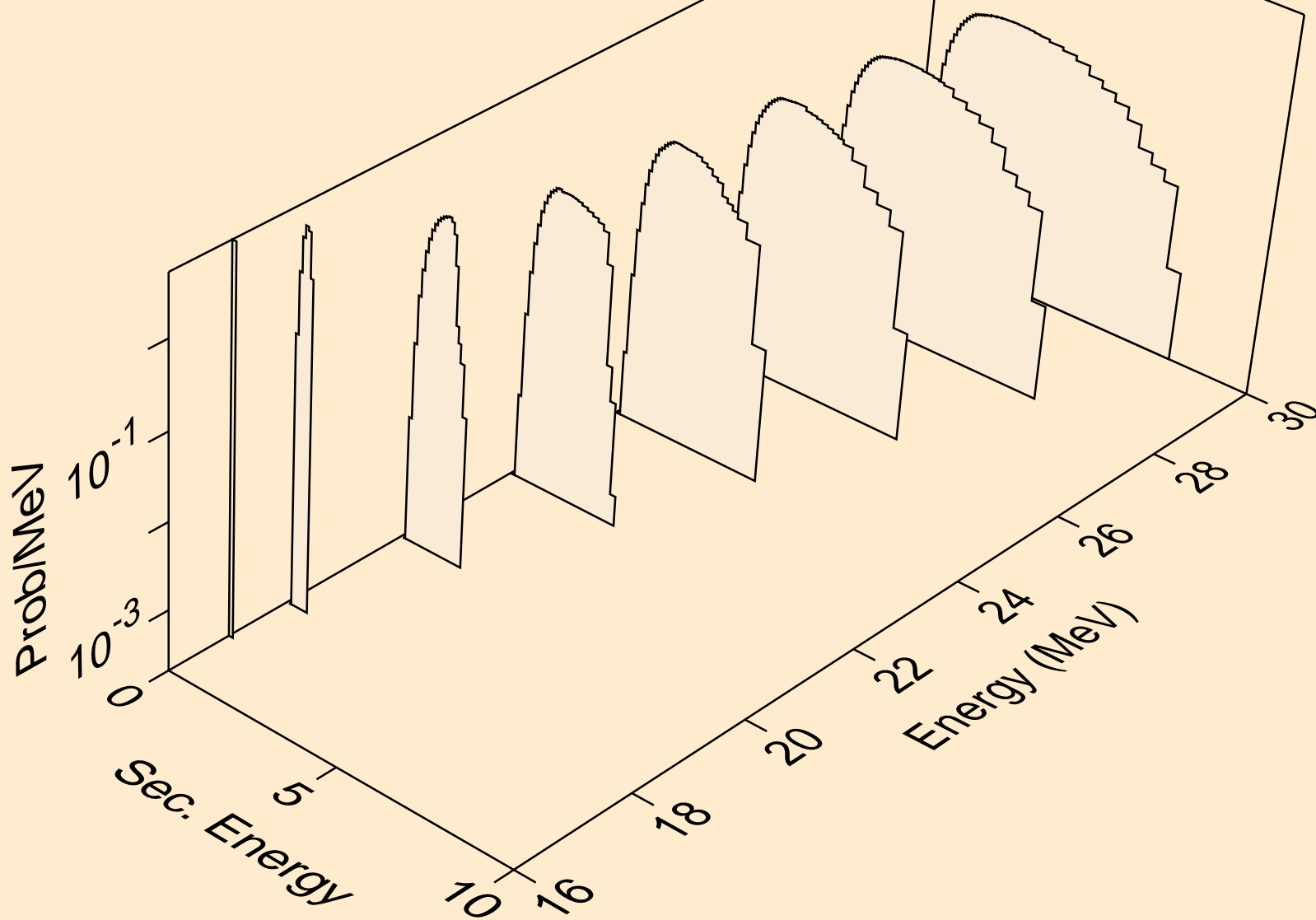

BE010 TRITON ACER TENDL-2023 LIBRARY; T=0.K  
deuterons from (t,n\*)d

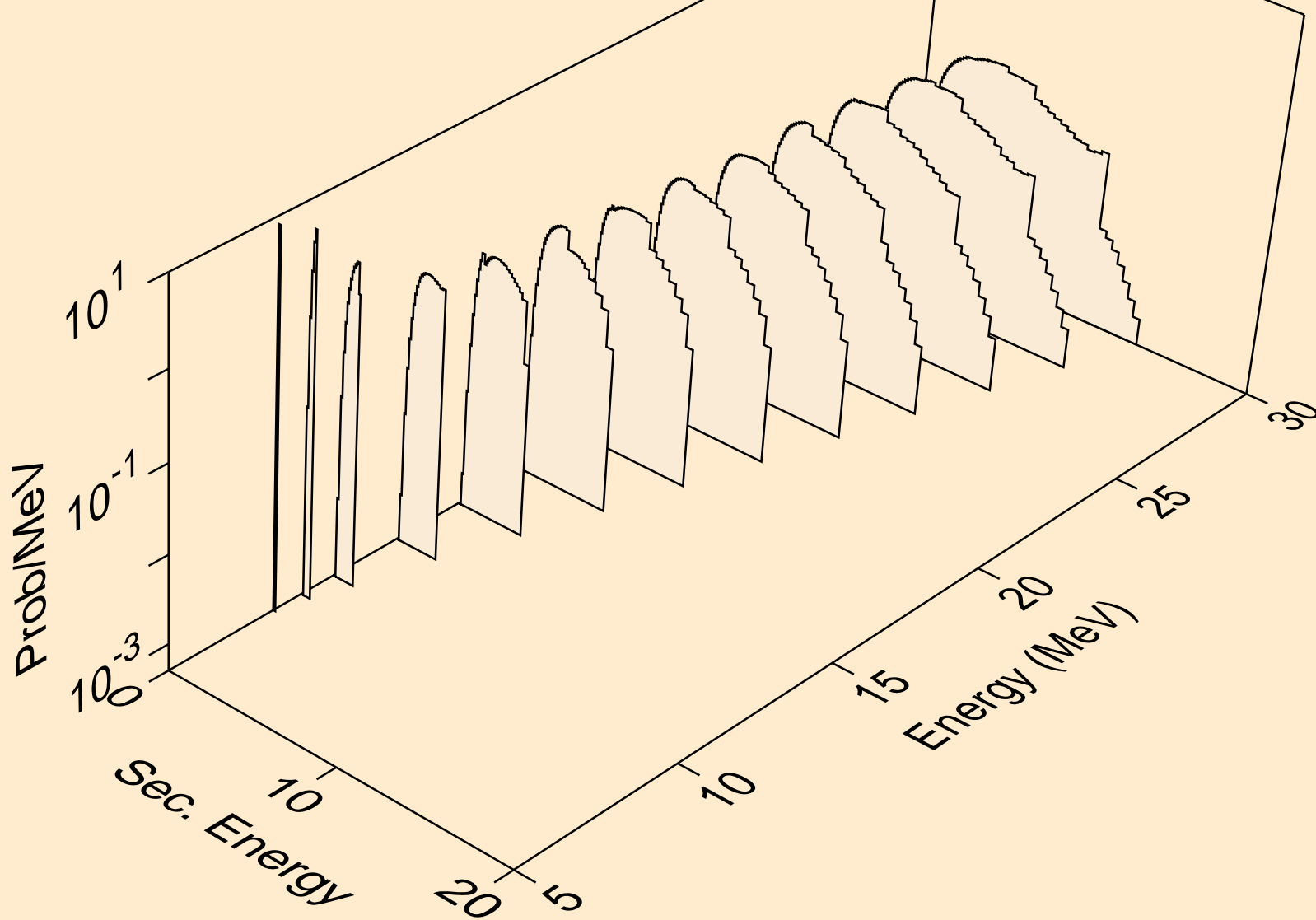

BE010 TRITON ACER TENDL-2023 LIBRARY; T=0.K  
deuterons from (t,d)

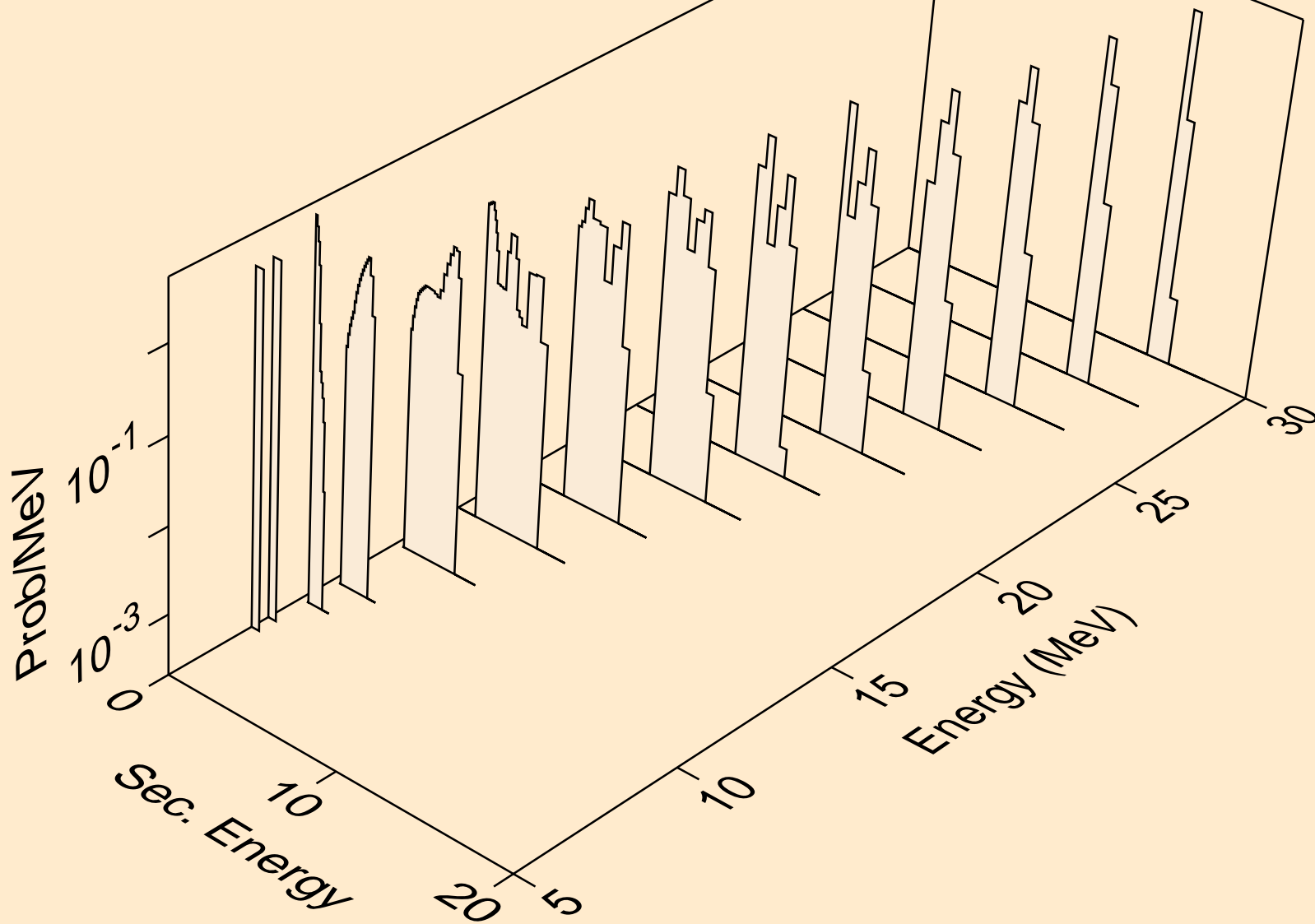

BE010 TRITON ACER TENDL-2023 LIBRARY; T=0.K  
he3s from (t,x)

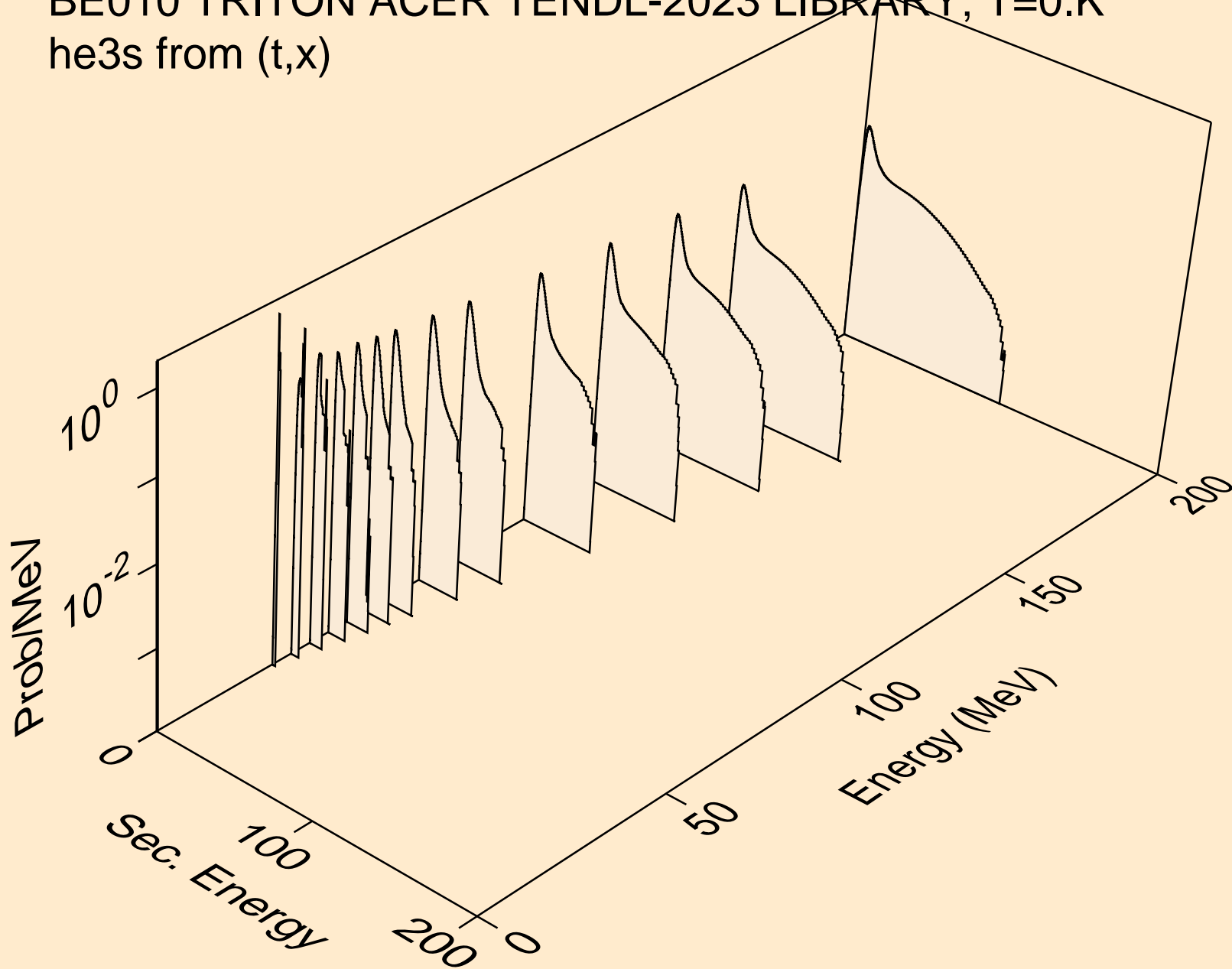

BE010 TRITON ACER TENDL-2023 LIBRARY; T=0.K  
he3s from (t,n\*)he3

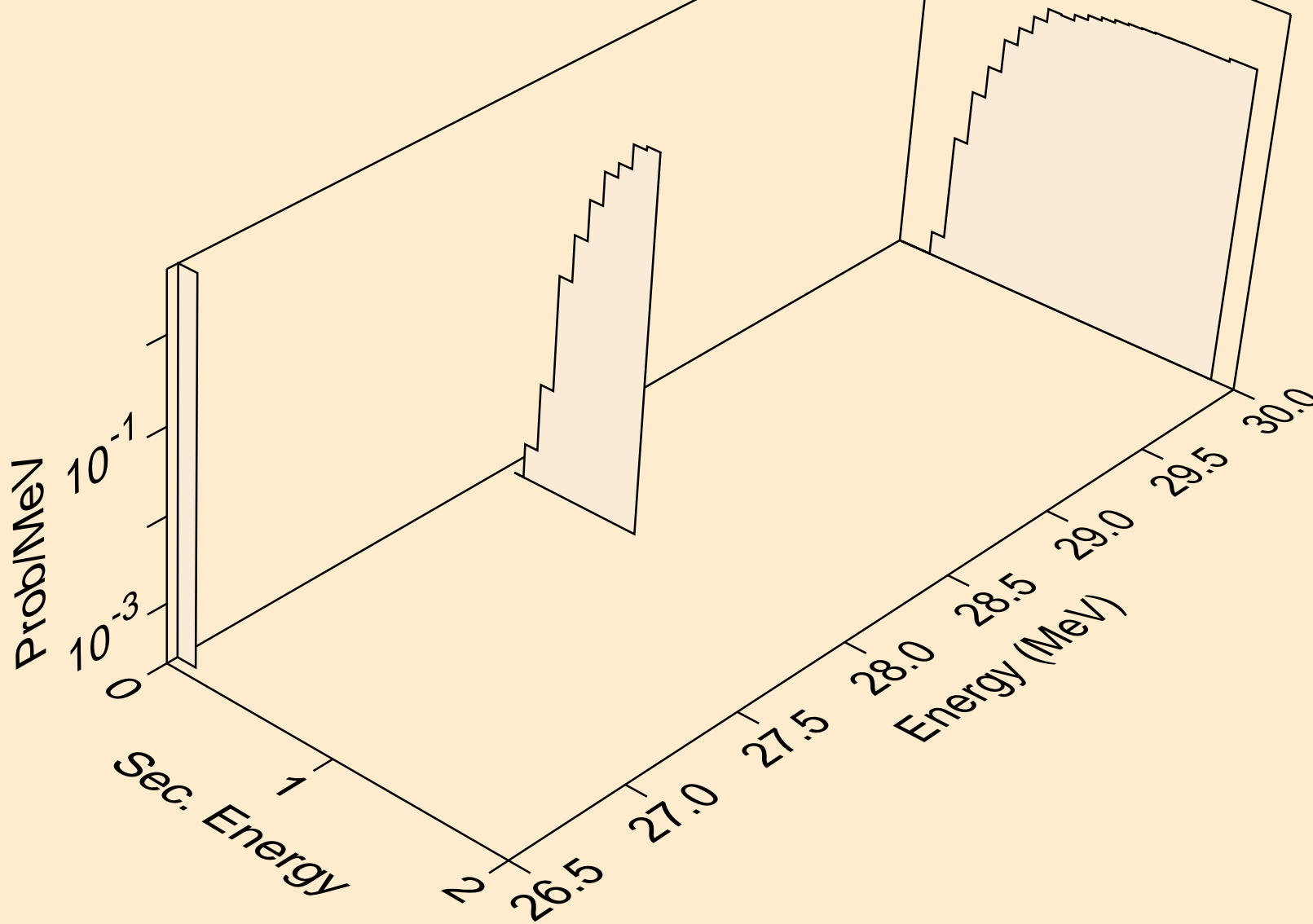

BE010 TRITON ACER TENDL-2023 LIBRARY; T=0.K  
he3s from (t,he3)

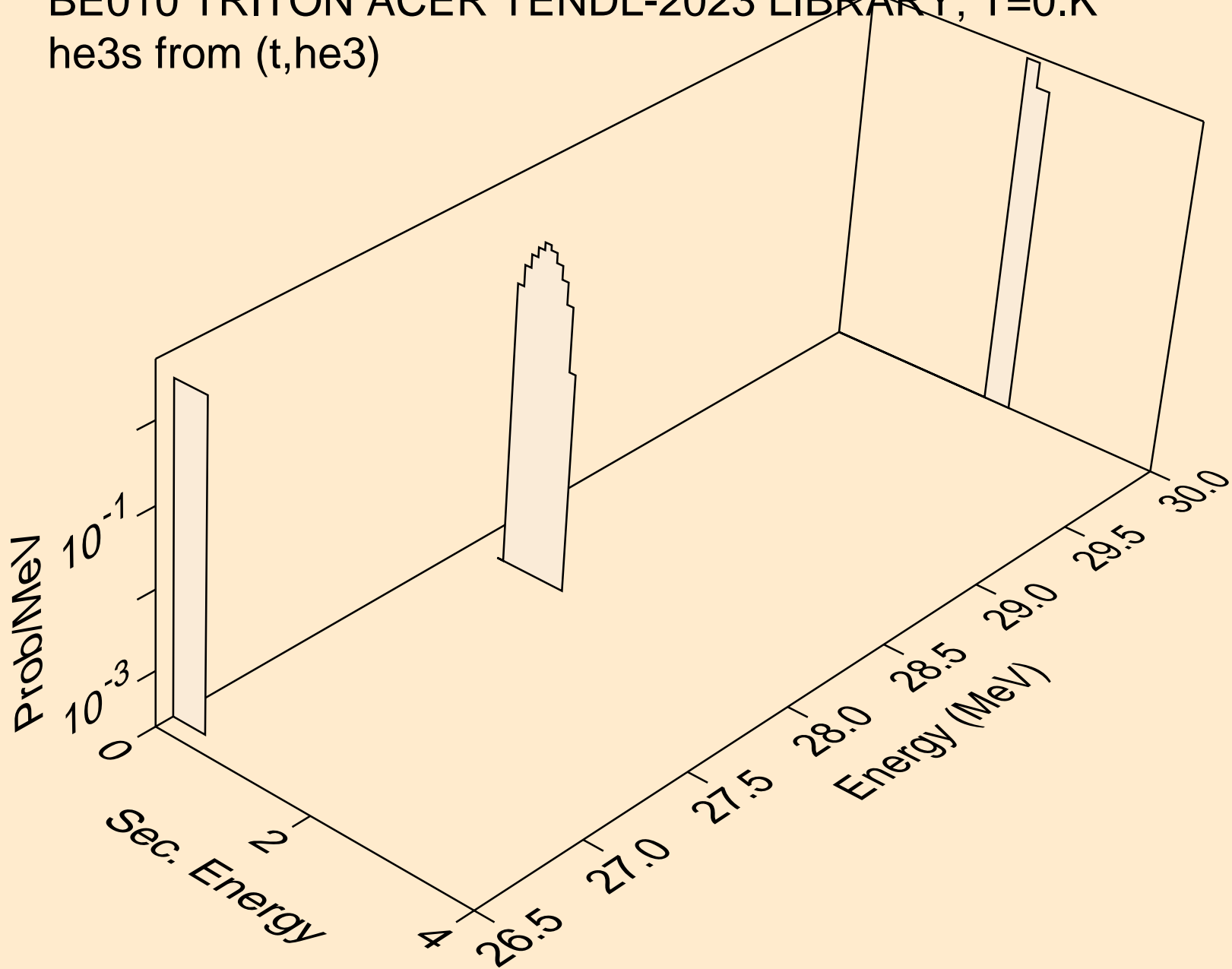



BE010 TRITON ACER TENDL-2023 LIBRARY; T=0.K  
alphas from (t,x)

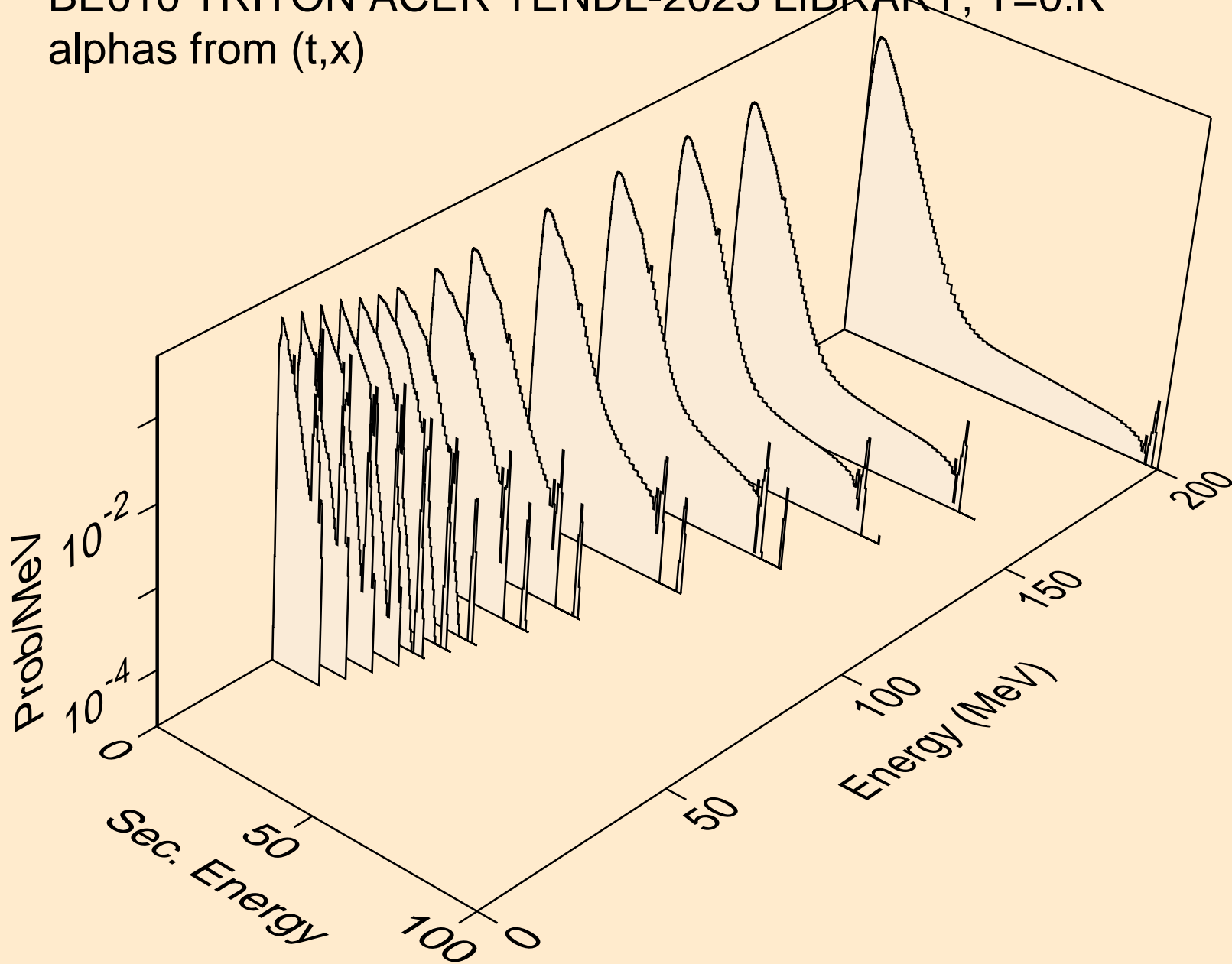

BE010 TRITON ACER TENDL-2023 LIBRARY; T=0.K  
alphas from (t,n\*)a

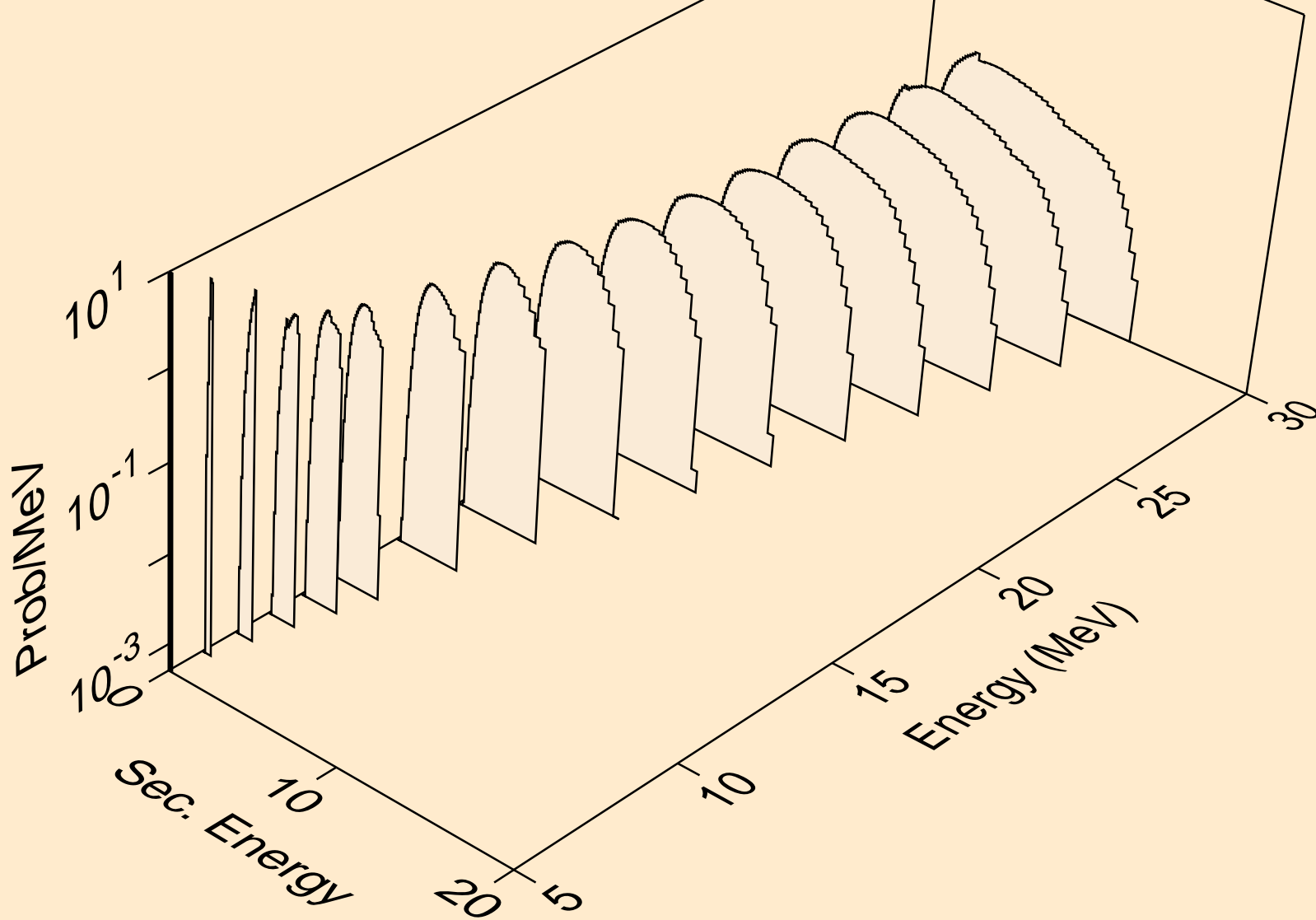

BE010 TRITON ACER TENDL-2023 LIBRARY; T=0.K  
alphas from (t,2n)a

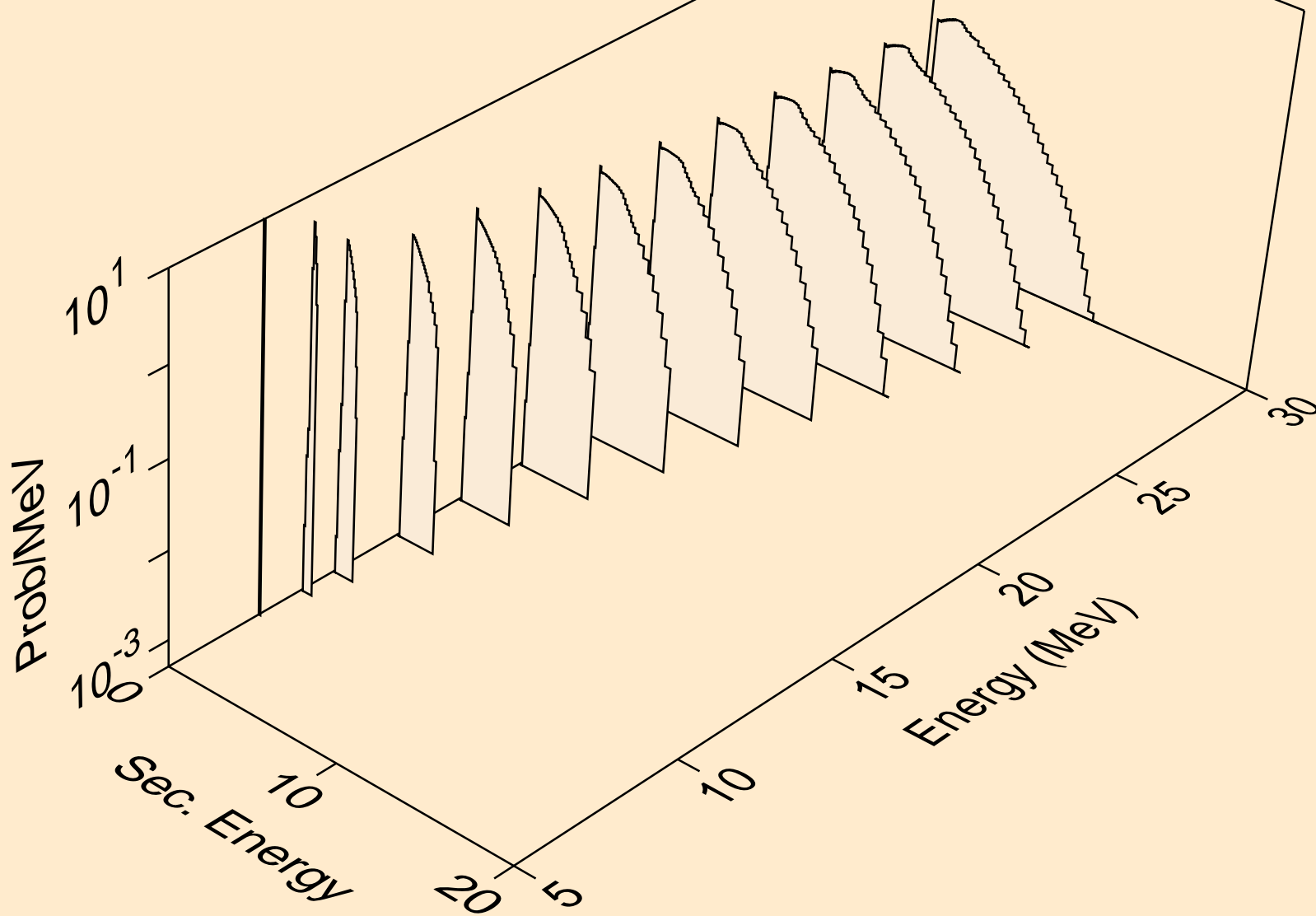

BE010 TRITON ACER TENDL-2023 LIBRARY; T=0.K  
alphas from (t,3n)a

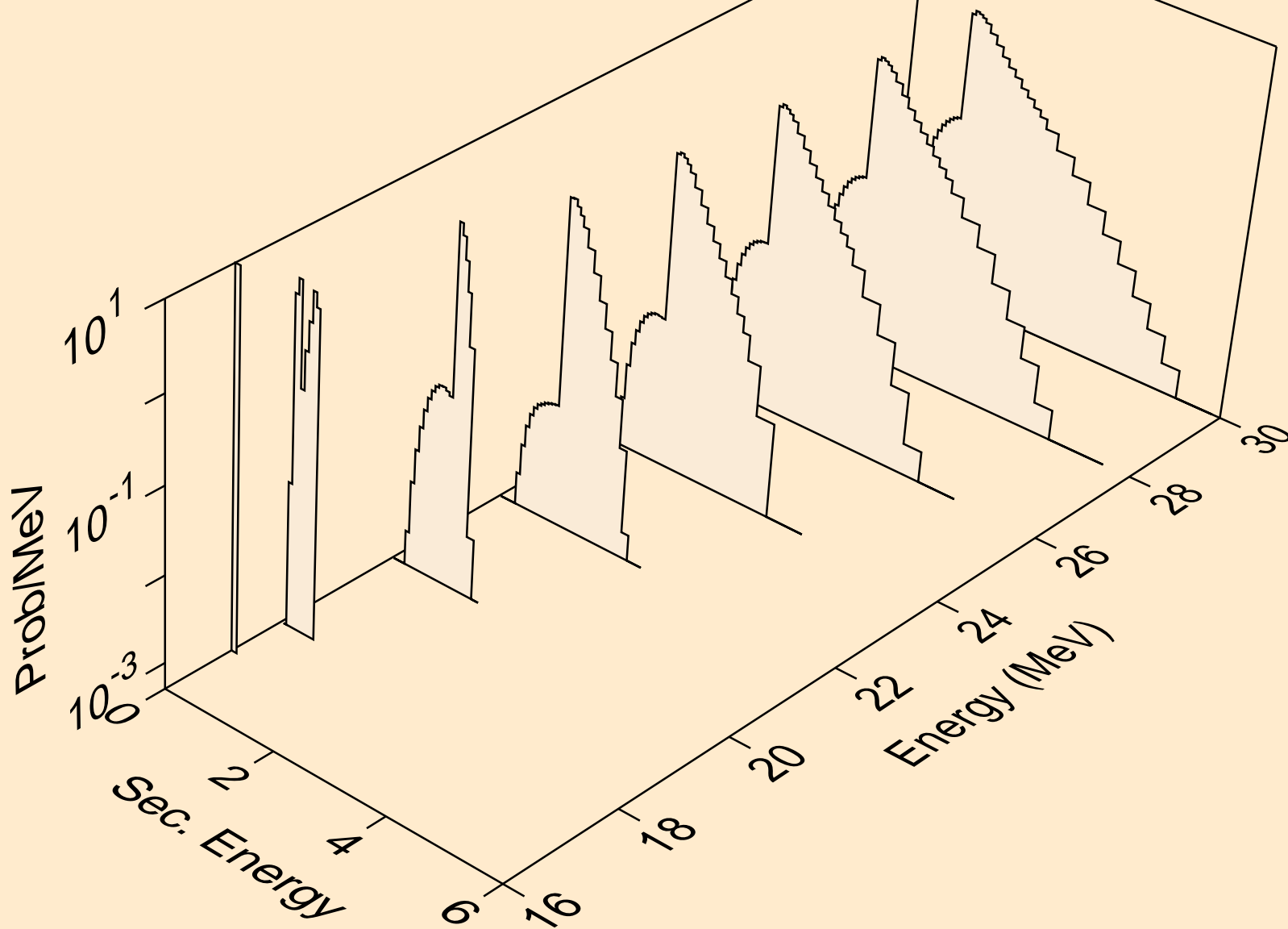

BE010 TRITON ACER TENDL-2023 LIBRARY; T=0.K  
alphas from (t,a)

